

# BH274 NRG TENDL-2015, AKONING

## Principal cross sections

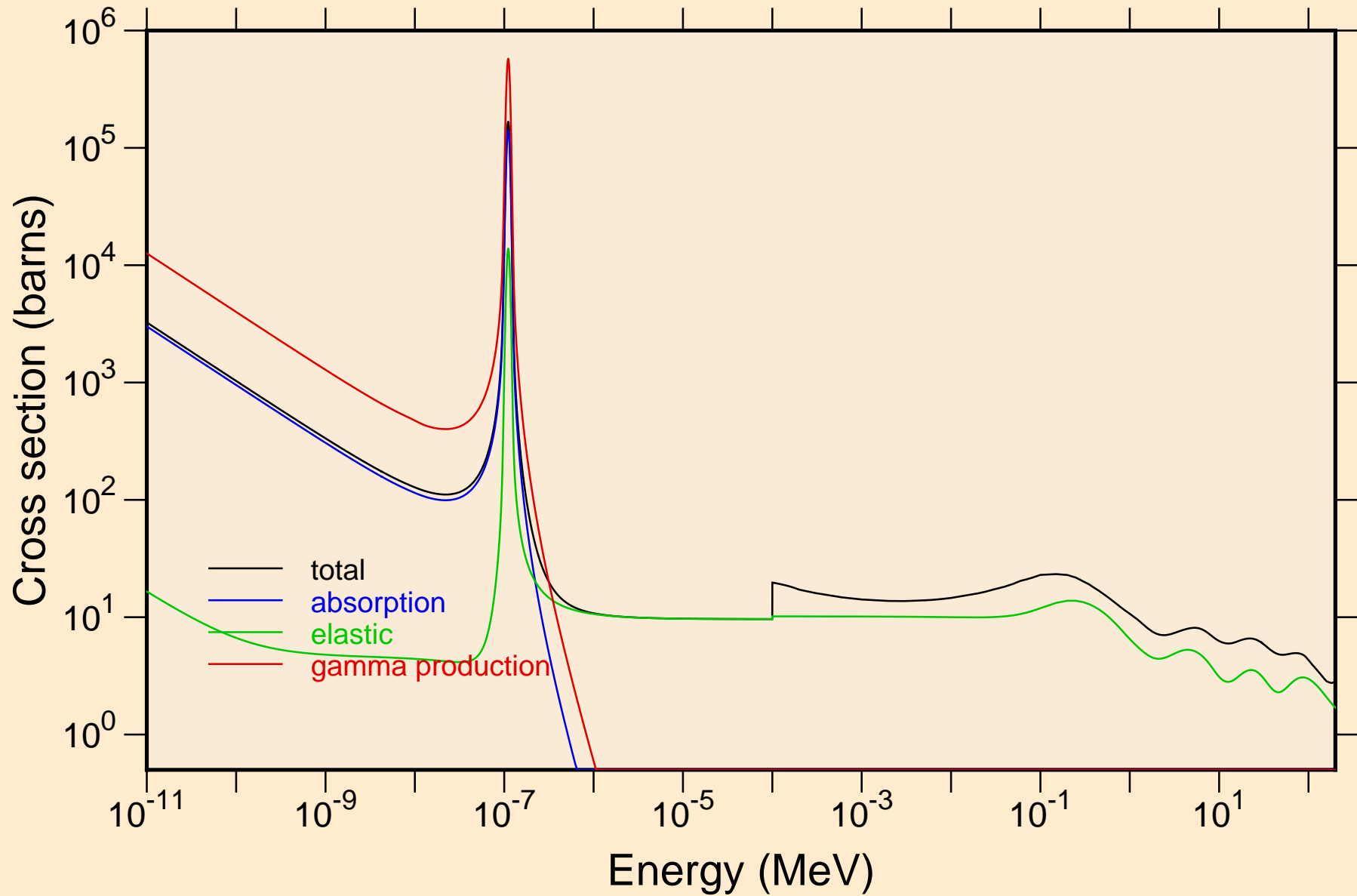

# BH274 NRG TENDL-2015, AKONING

## Non-threshold reactions

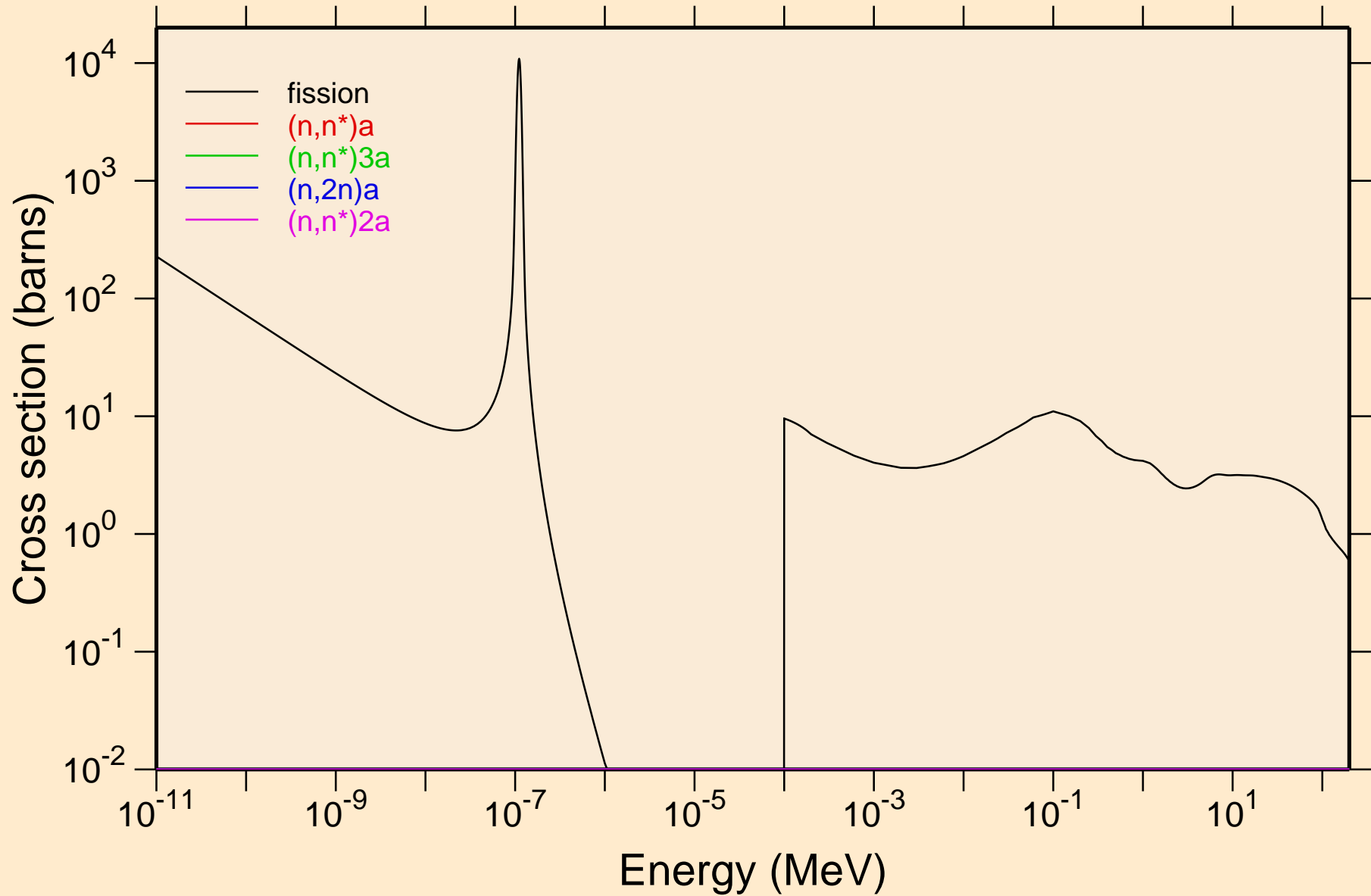

# BH274 NRG TENDL-2015, AKONING

## Non-threshold reactions

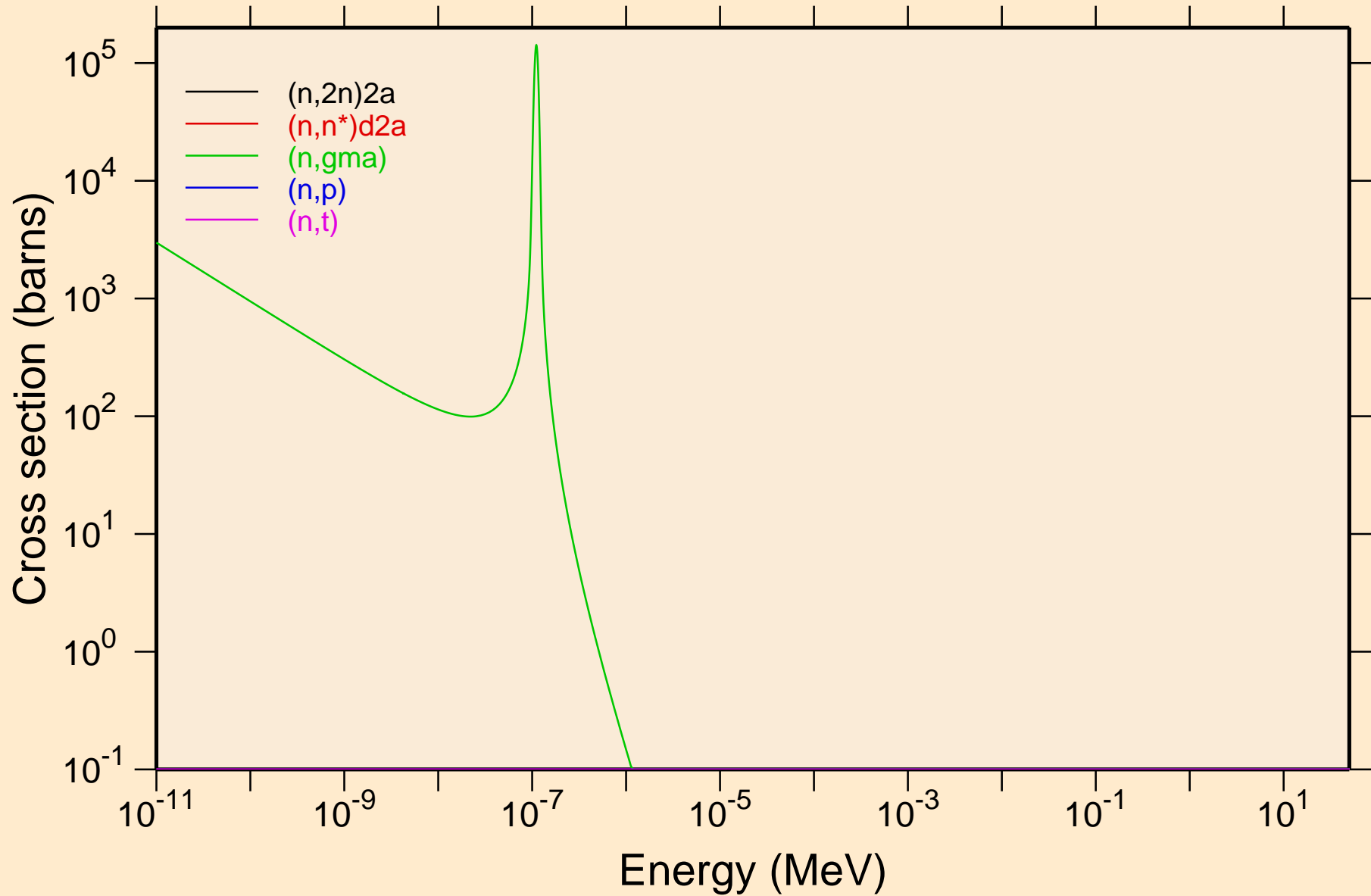

# BH274 NRG TENDL-2015, AKONING

## Non-threshold reactions

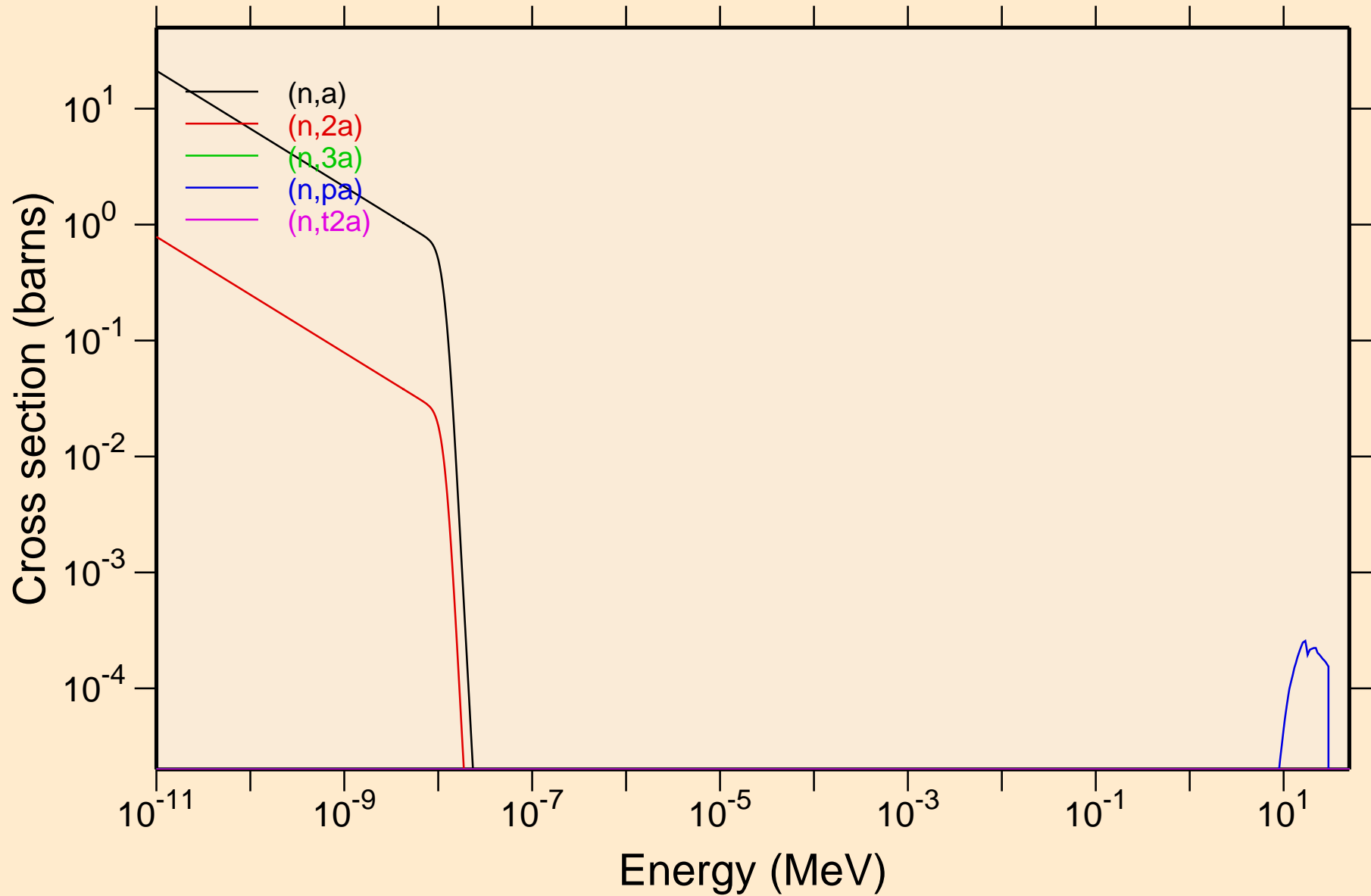

# BH274 NRG TENDL-2015, AKONING

## Principal cross sections

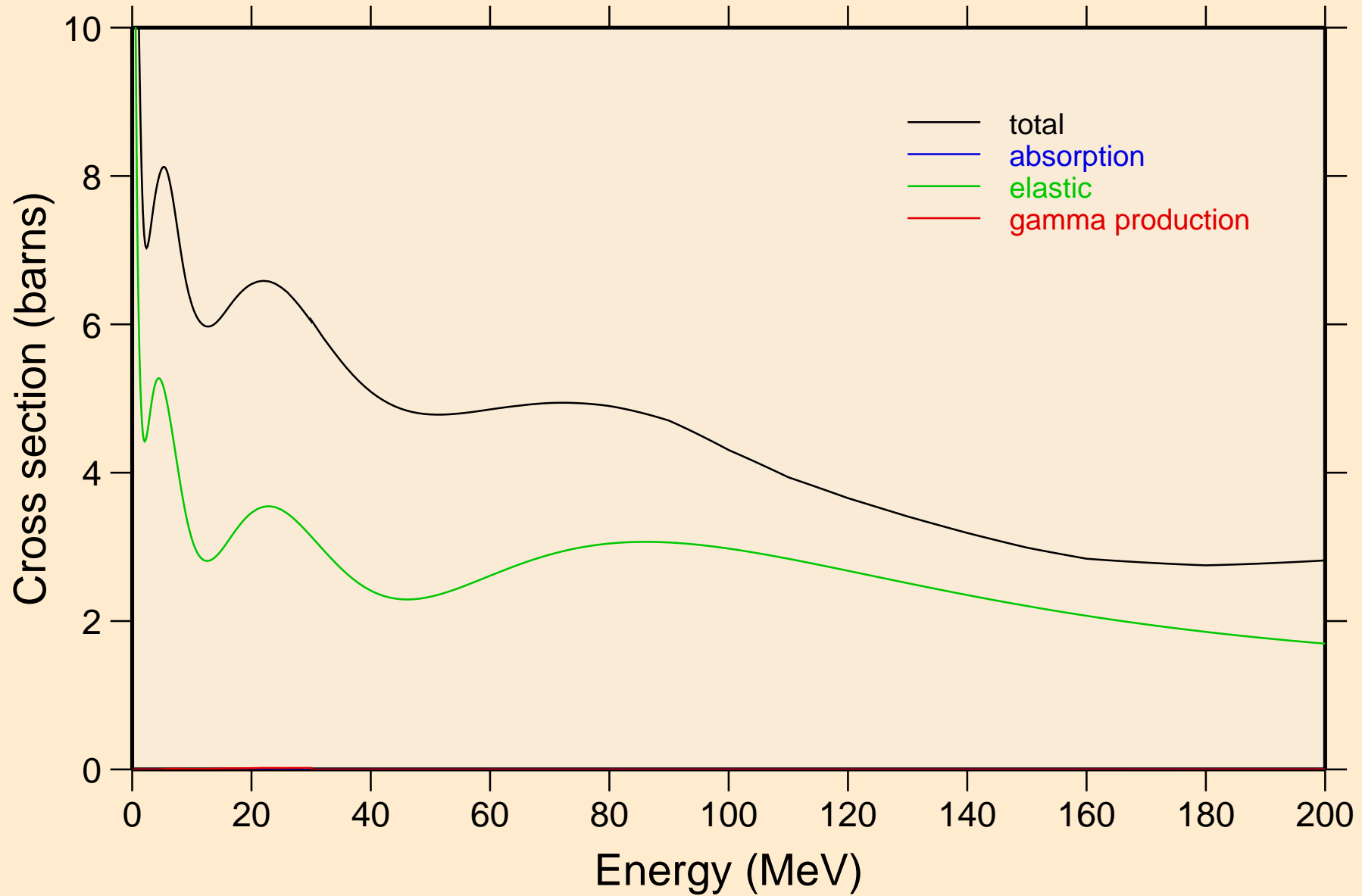

# BH274 NRG TENDL-2015, AKONING

## Non-threshold reactions

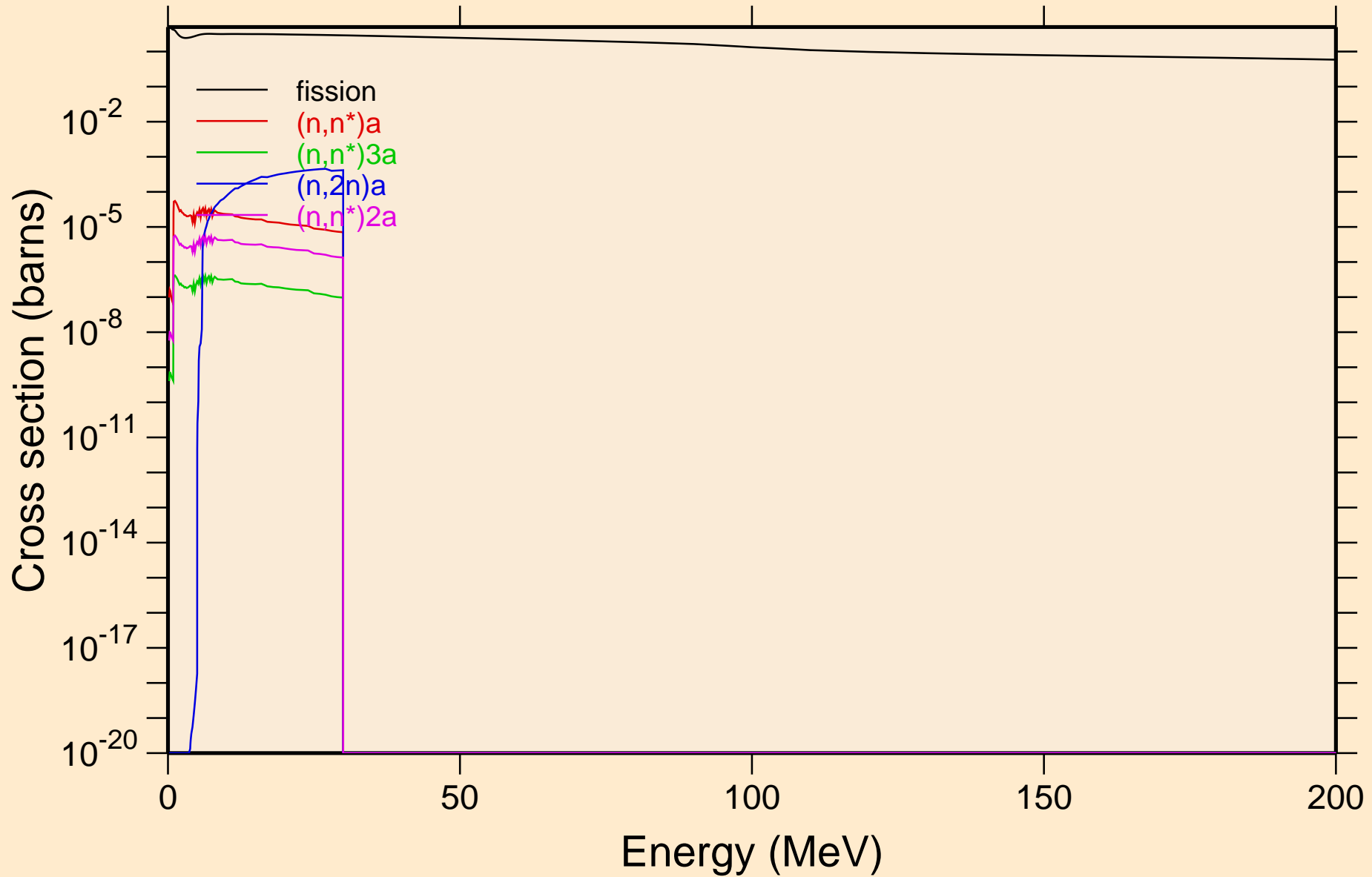

# BH274 NRG TENDL-2015, AKONING

## Non-threshold reactions

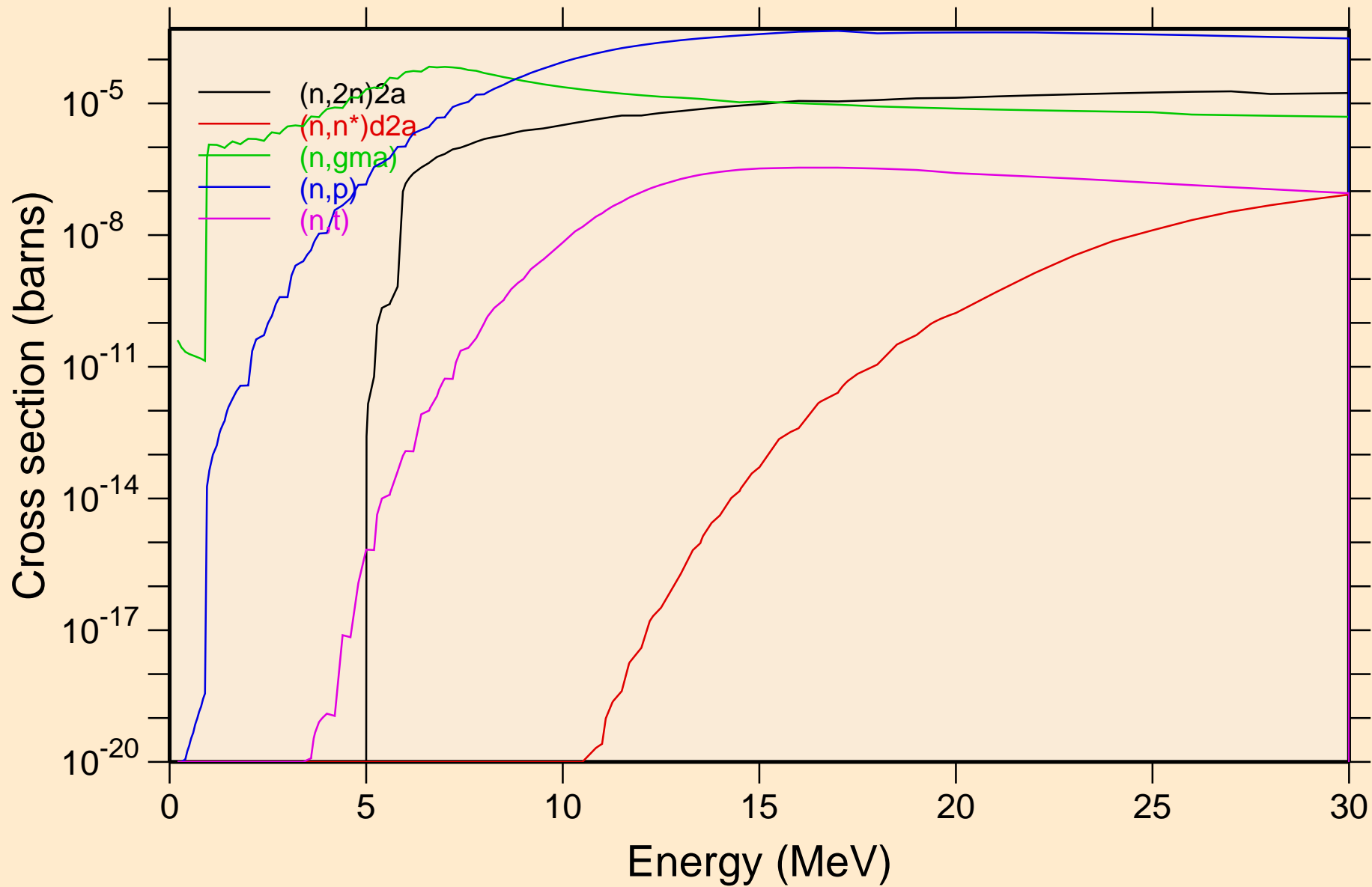

# BH274 NRG TENDL-2015, AKONING

## Non-threshold reactions

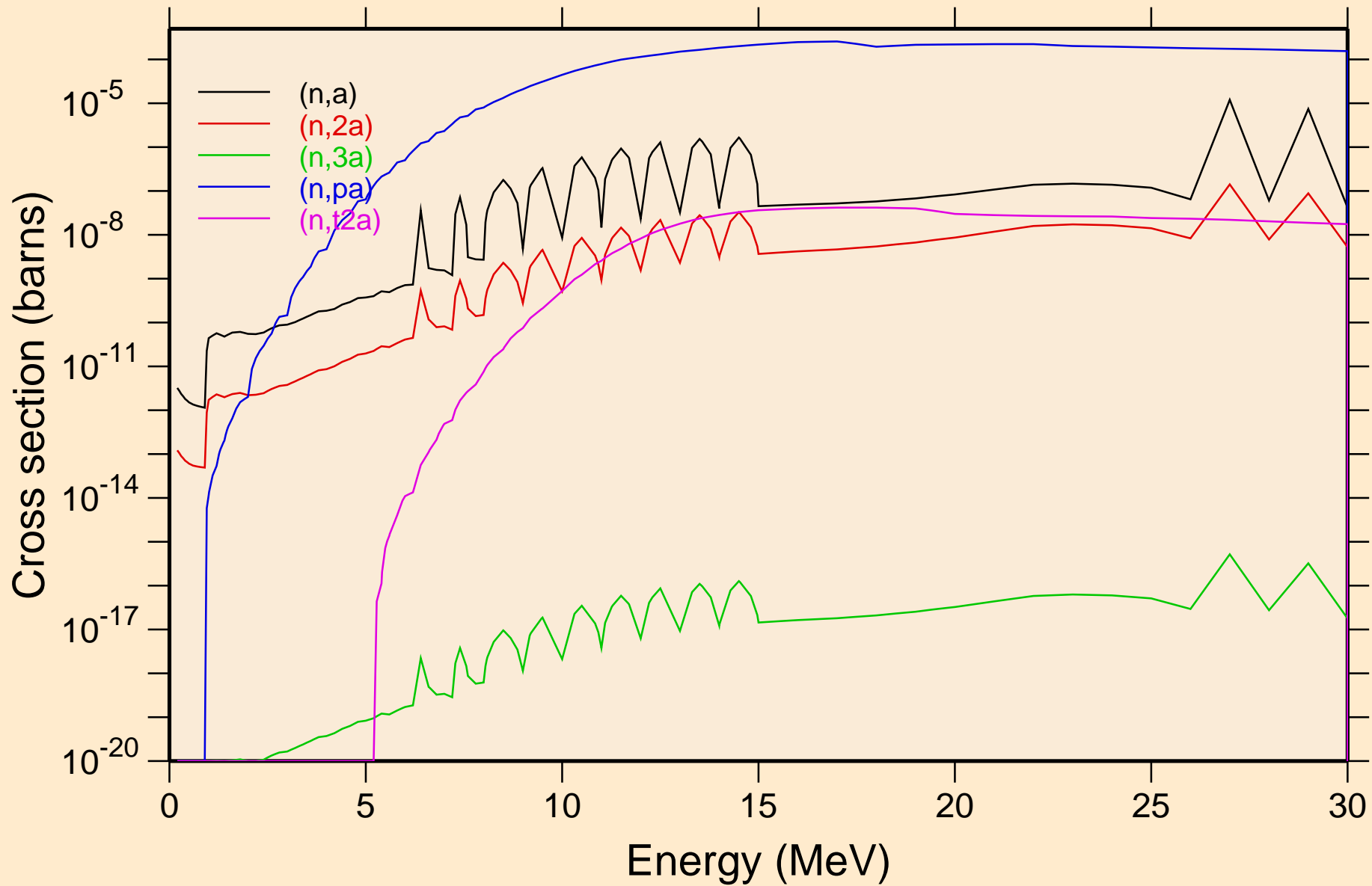



BH274 NRG TENDL-2015, AKONING  
Inelastic levels

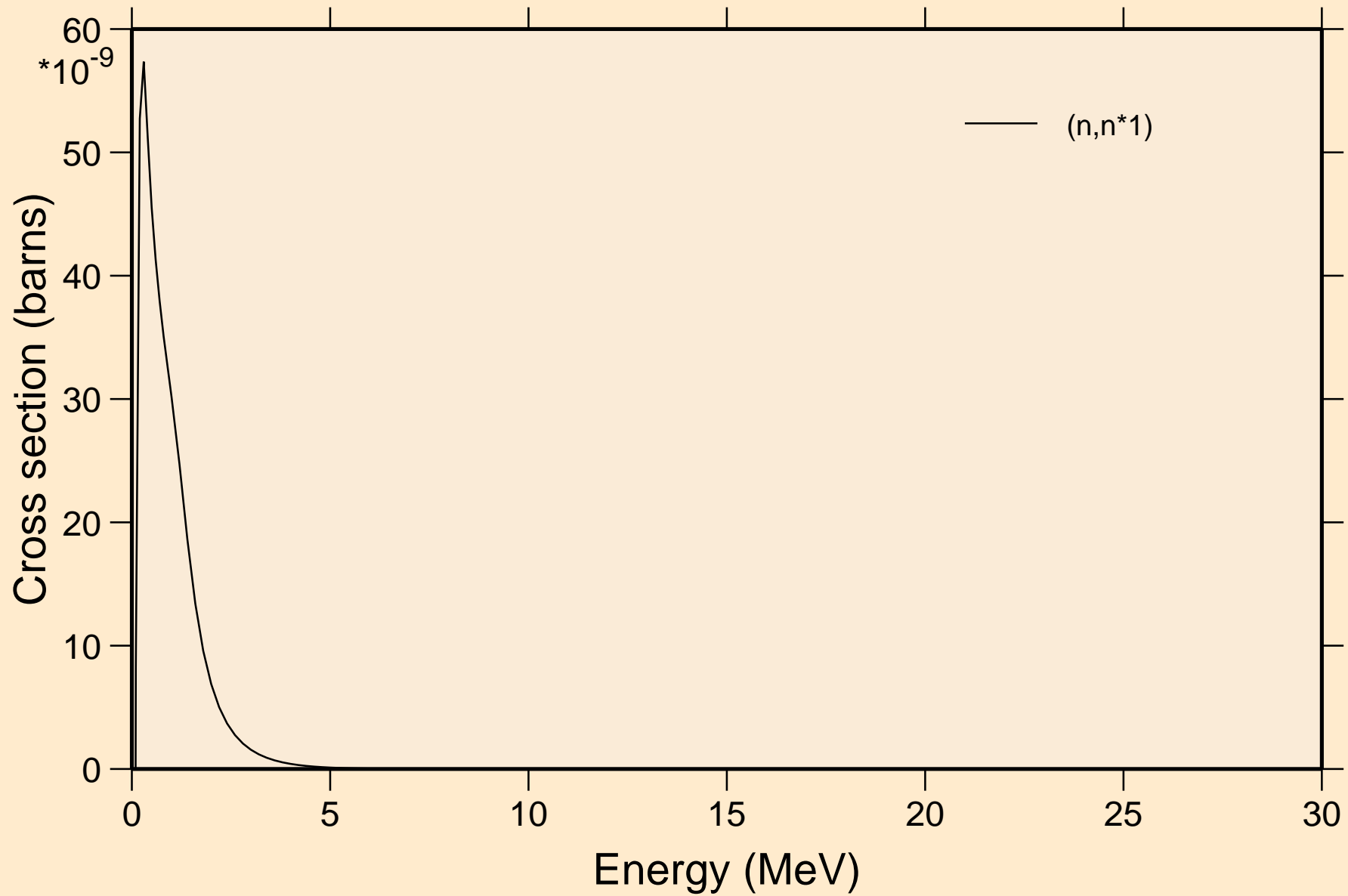

# BH274 NRG TENDL-2015, AKONING

## Threshold reactions

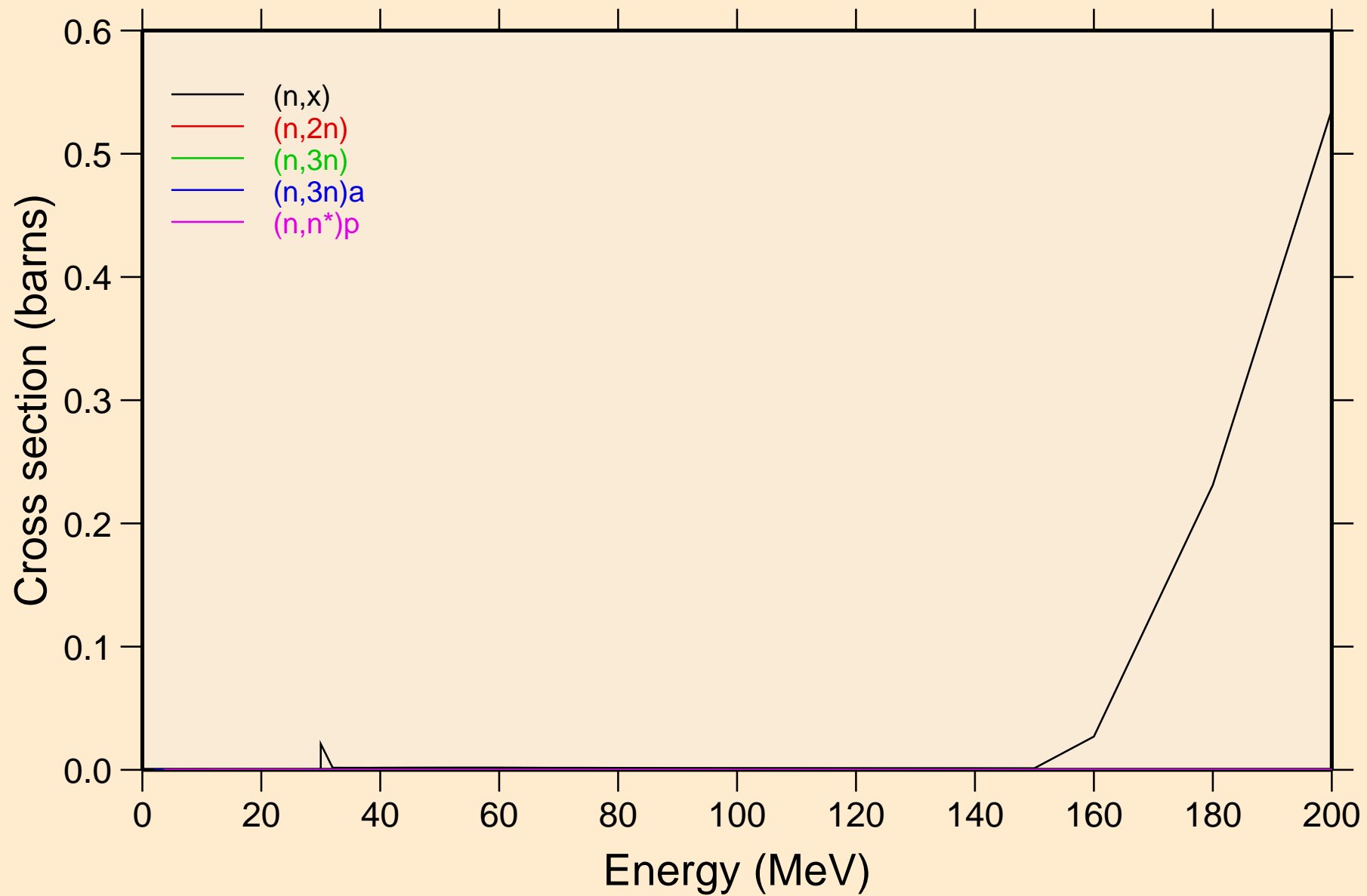

# BH274 NRG TENDL-2015, AKONING

## Threshold reactions

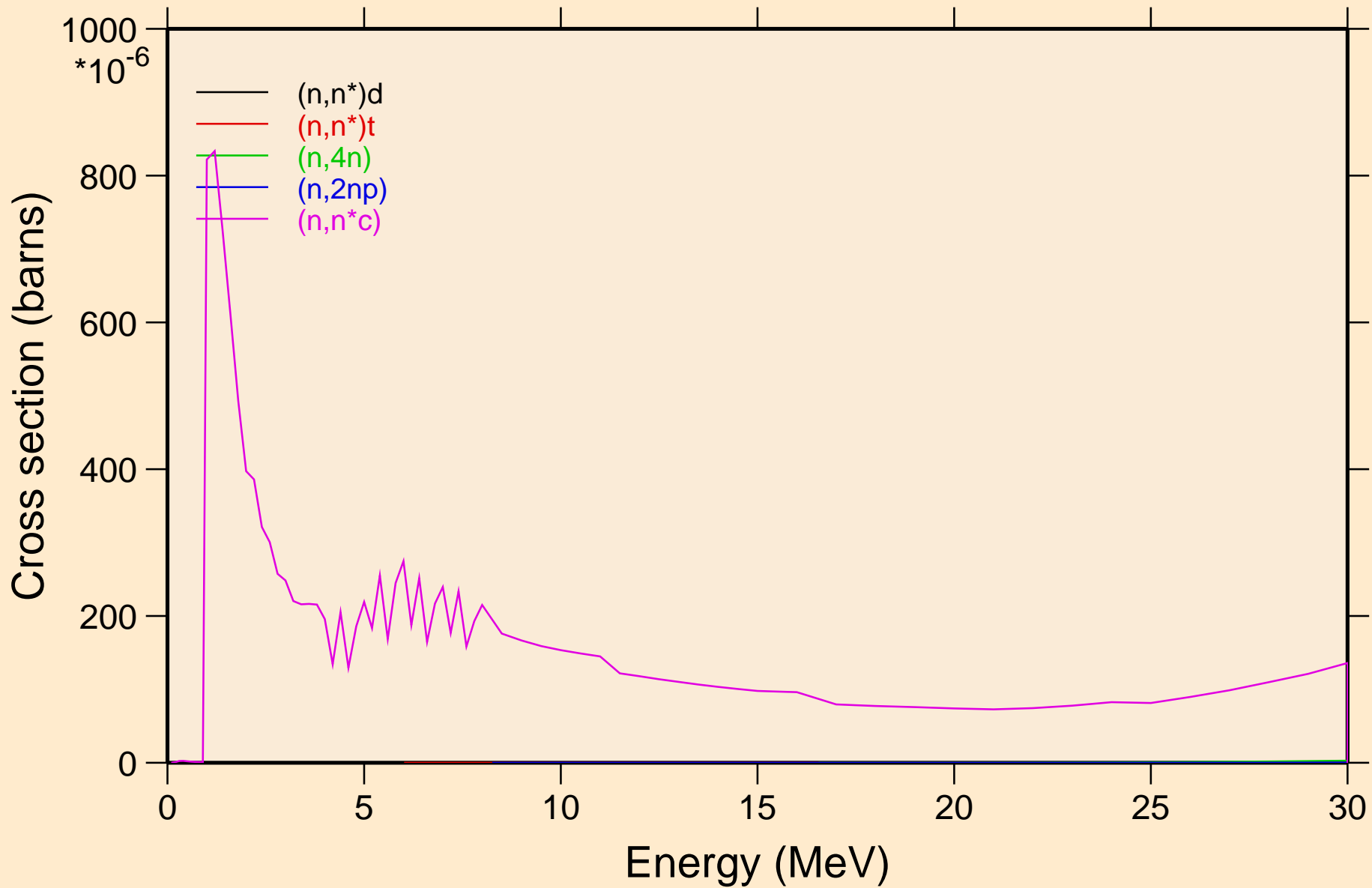

# BH274 NRG TENDL-2015, AKONING

## Threshold reactions

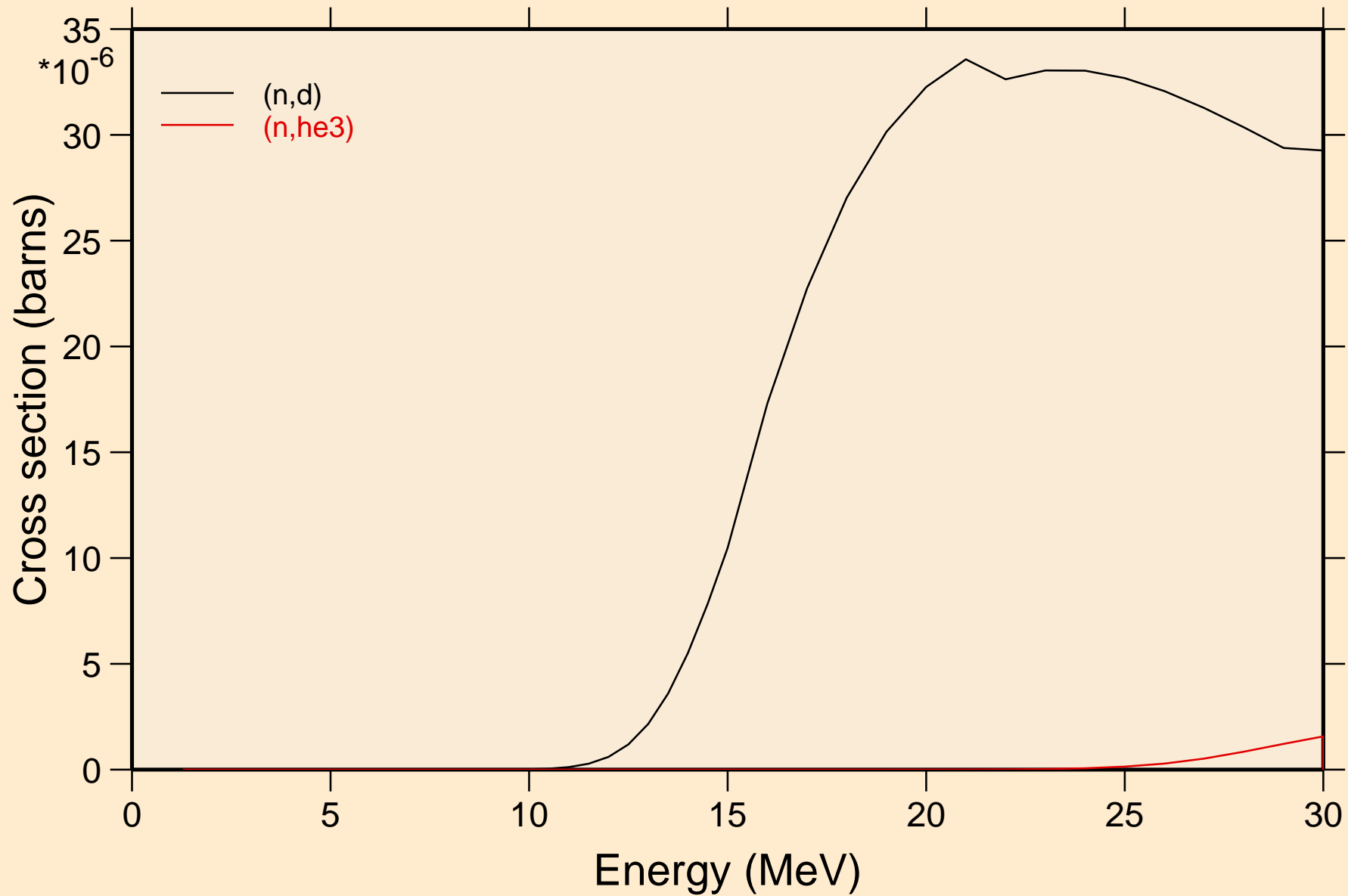

BH274 NRG TENDL-2015, AKONING  
angular distribution for elastic

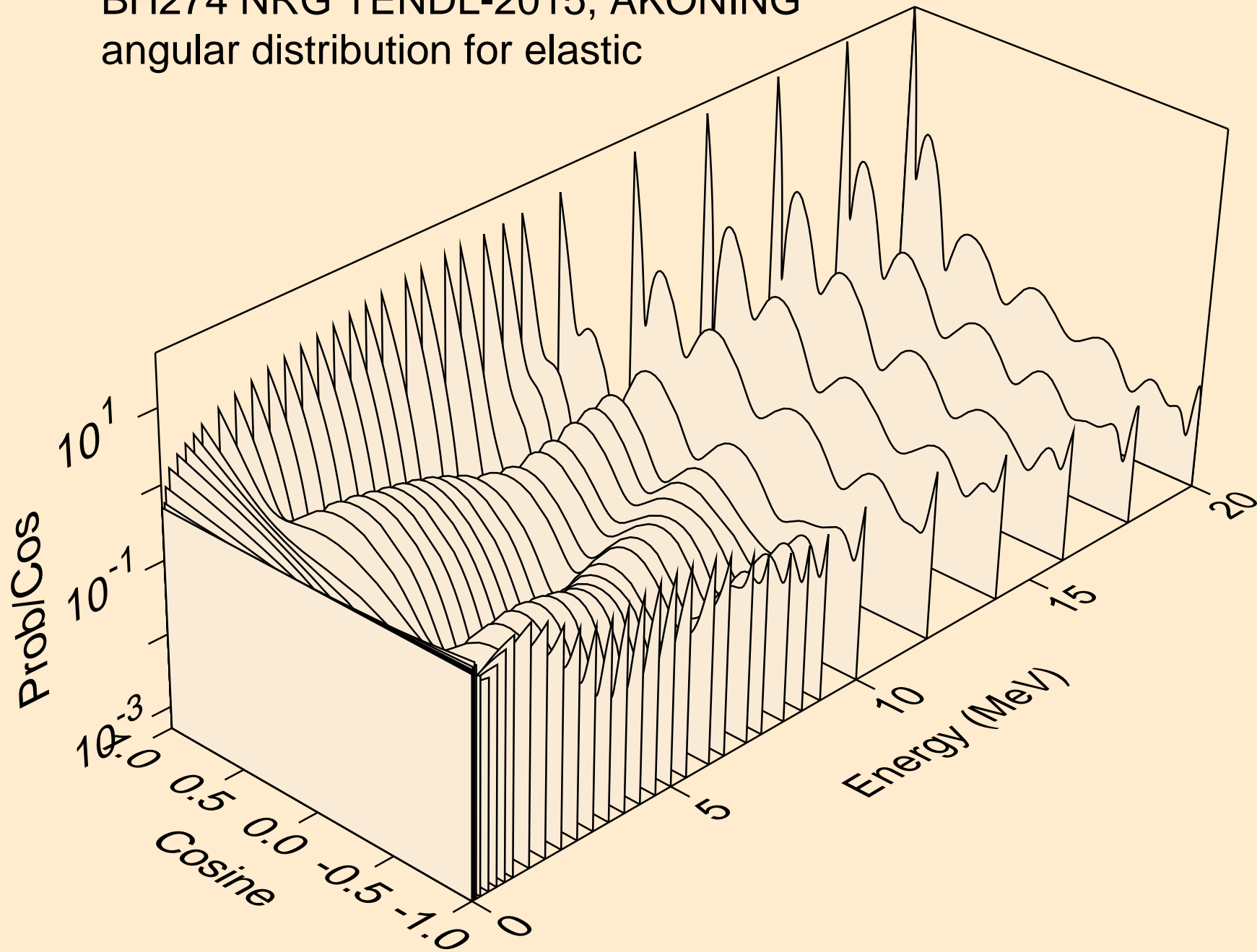

BH274 NRG TENDL-2015, AKONING  
angular distribution for elastic

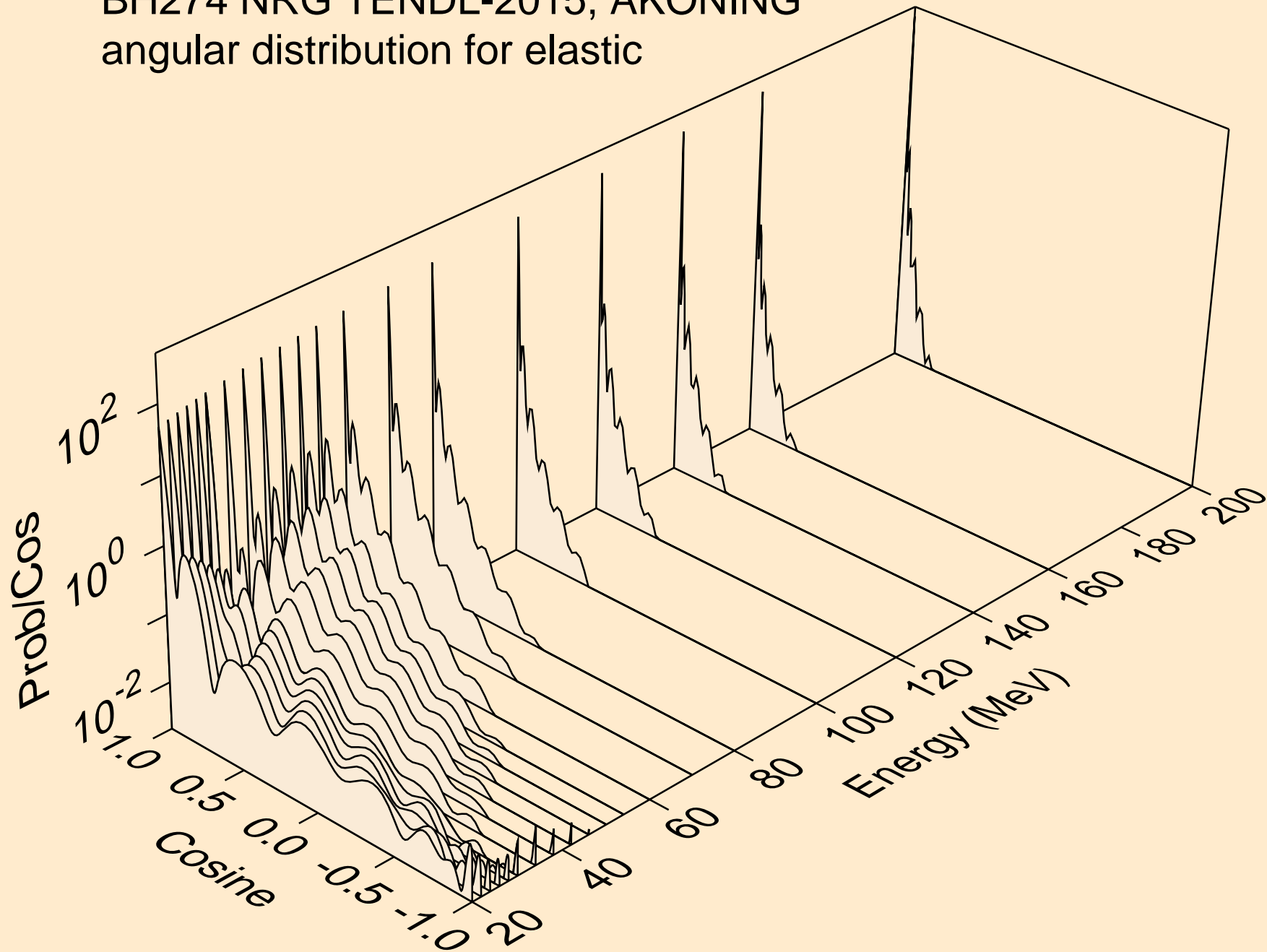

BH274 NRG TENDL-2015, AKONING  
angular distribution for (n,n\*1)

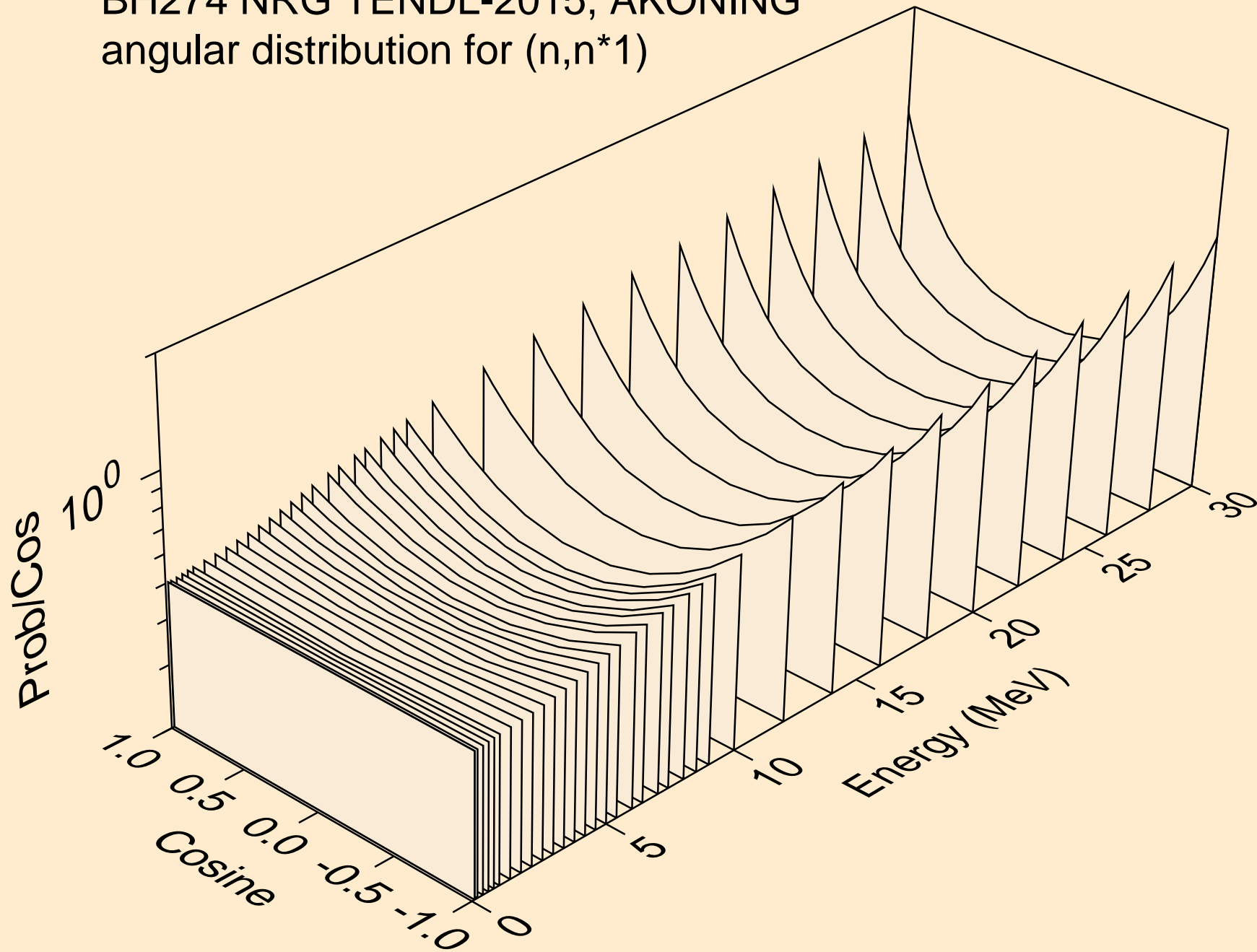

# BH274 NRG TENDL-2015, AKONING

Total fission nubar

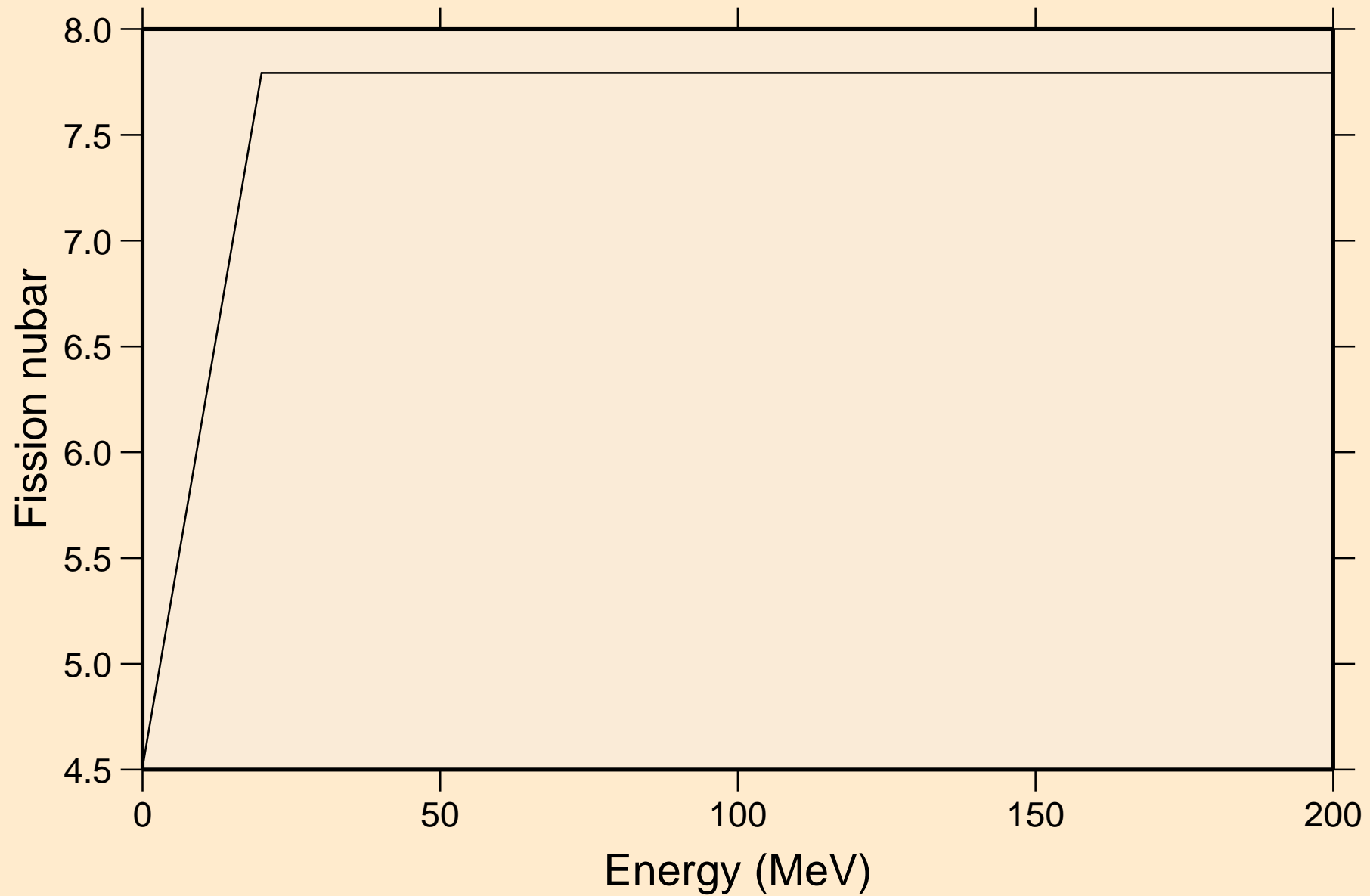



BH274 NRG TENDL-2015, AKONING  
Neutron emission for (n,x)

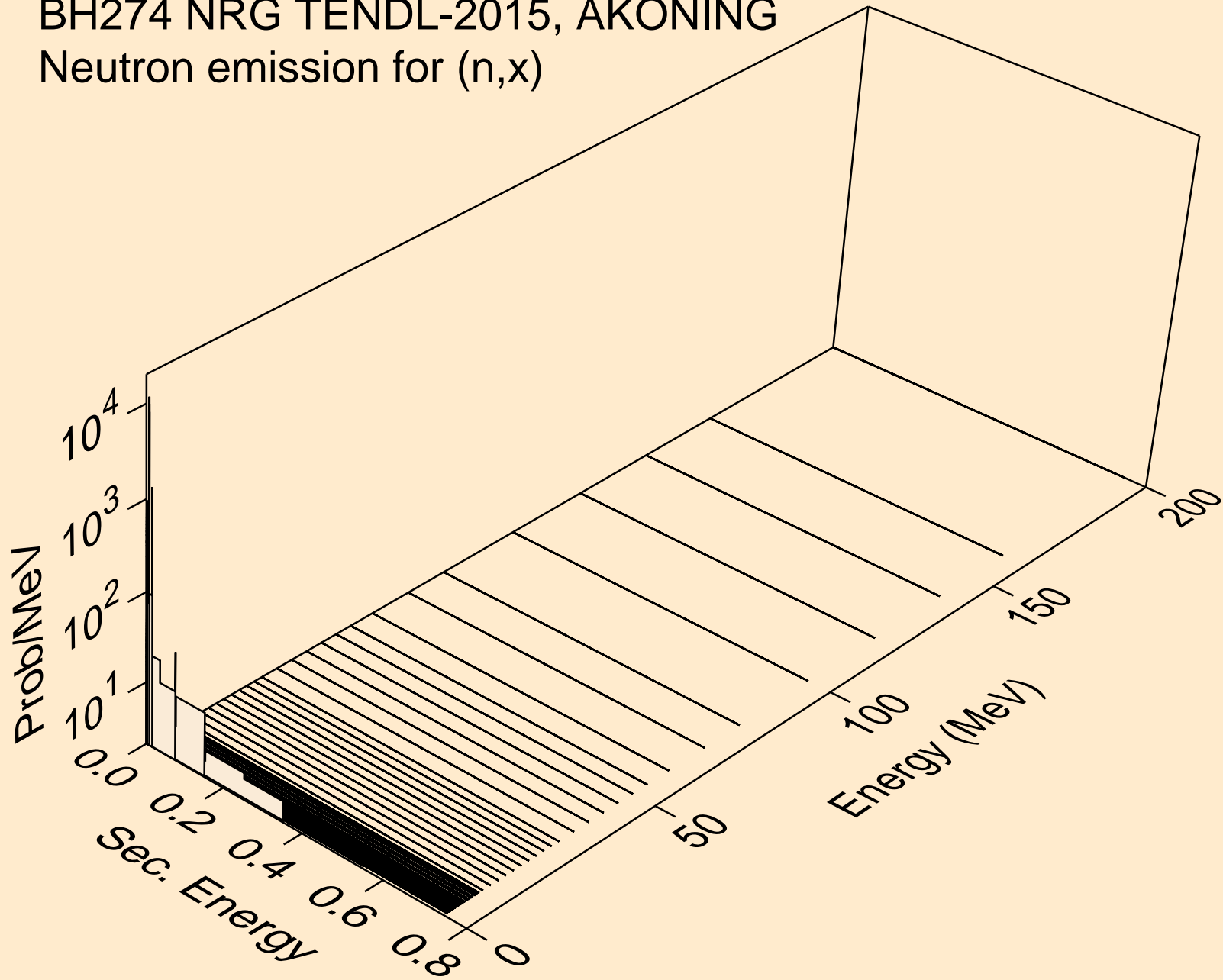

BH274 NRG TENDL-2015, AKONING  
Neutron emission for (n,2n)

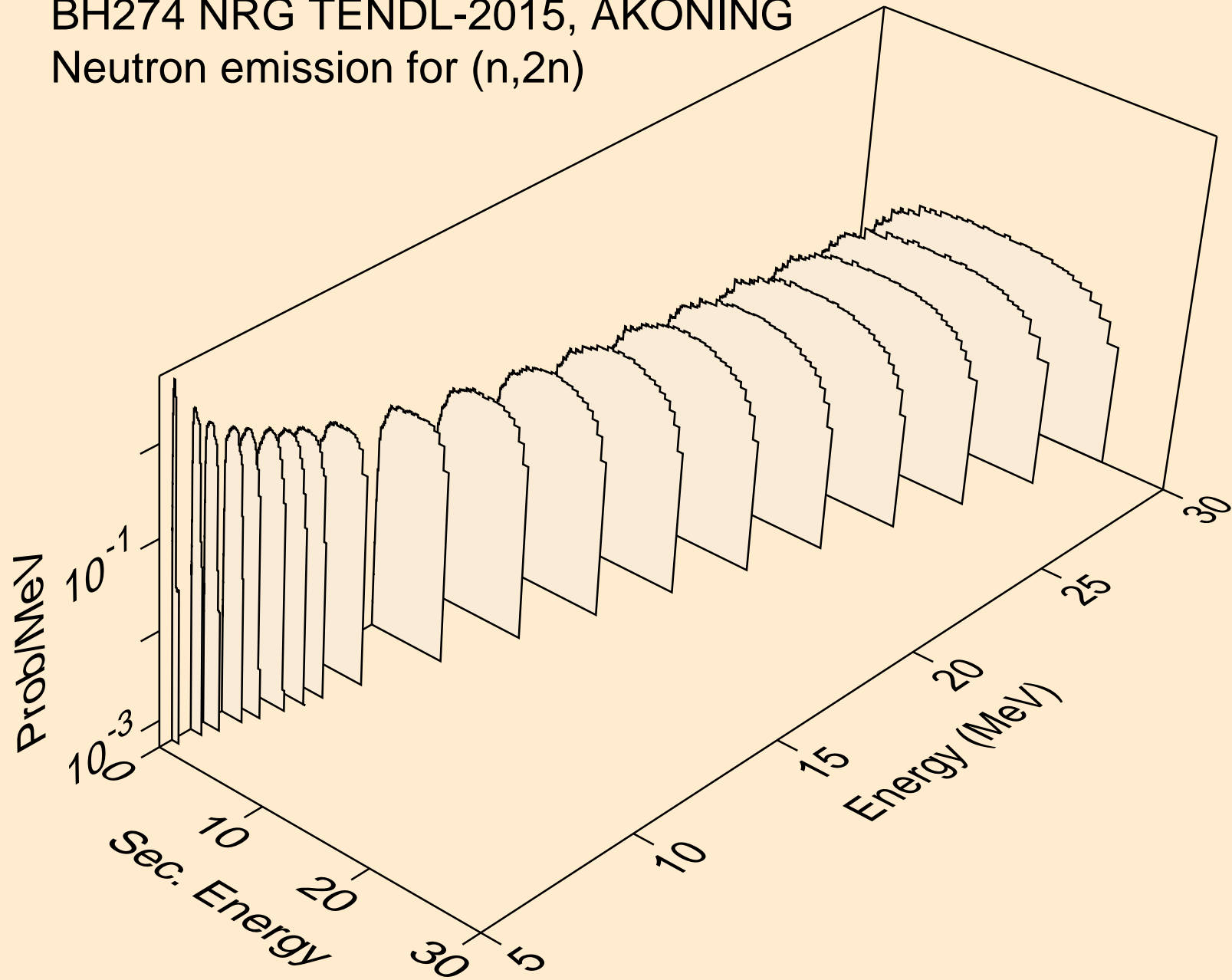

BH274 NRG TENDL-2015, AKONING  
Neutron emission for (n,3n)

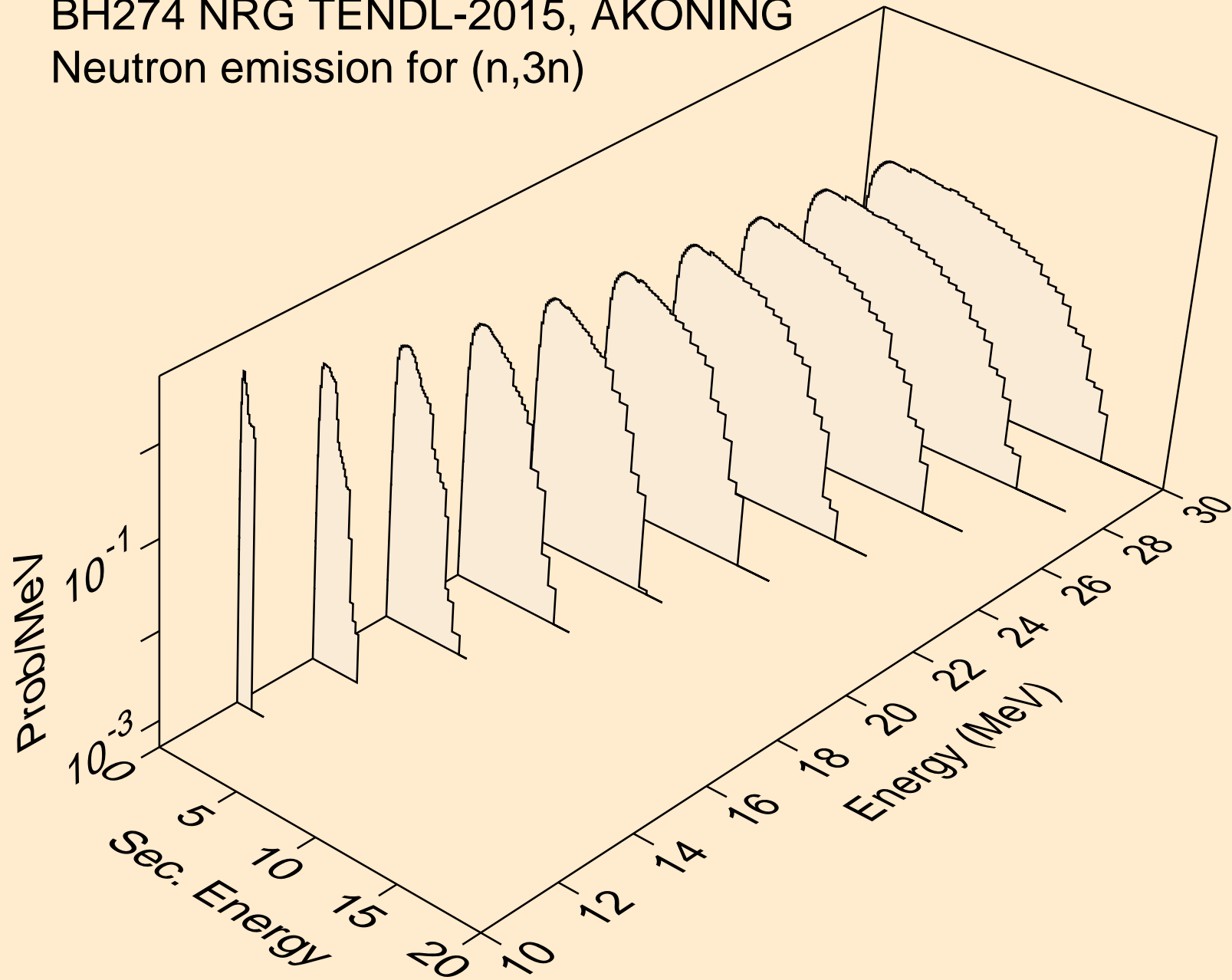

BH274 NRG TENDL-2015, AKONING  
Neutron emission for fission

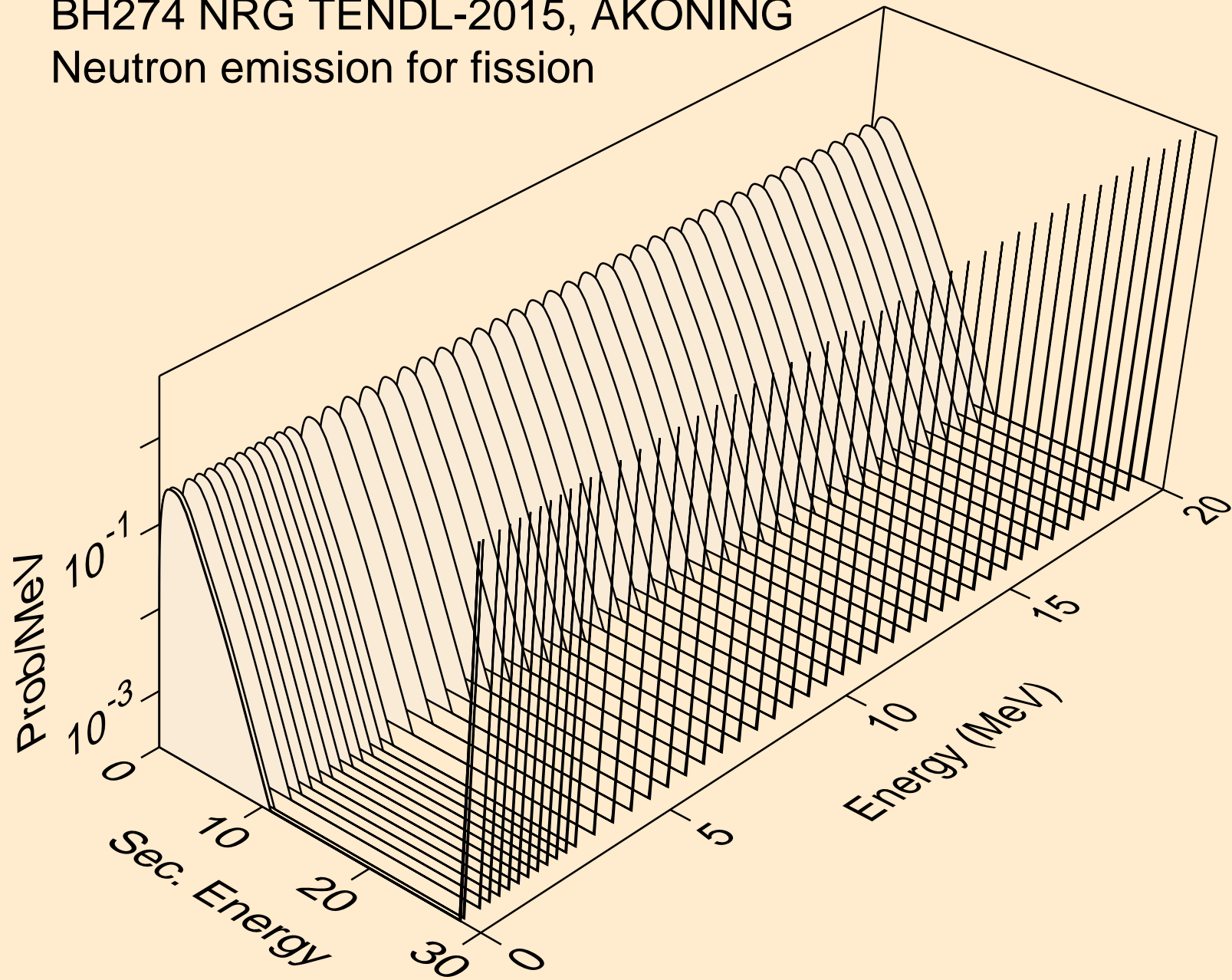

BH274 NRG TENDL-2015, AKONING  
Neutron emission for (n,n\*)a

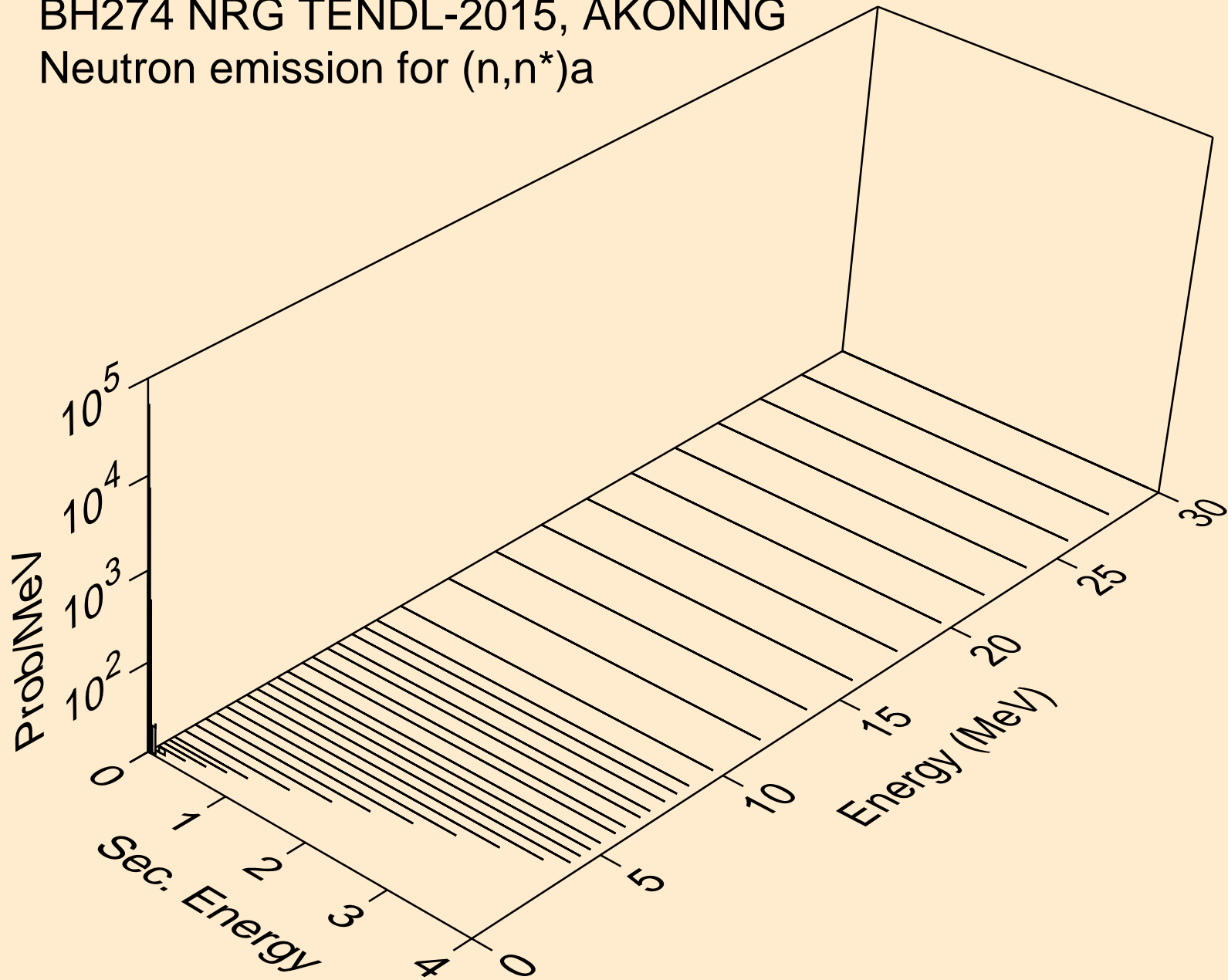

BH274 NRG TENDL-2015, AKONING  
Neutron emission for (n,n\*)3a

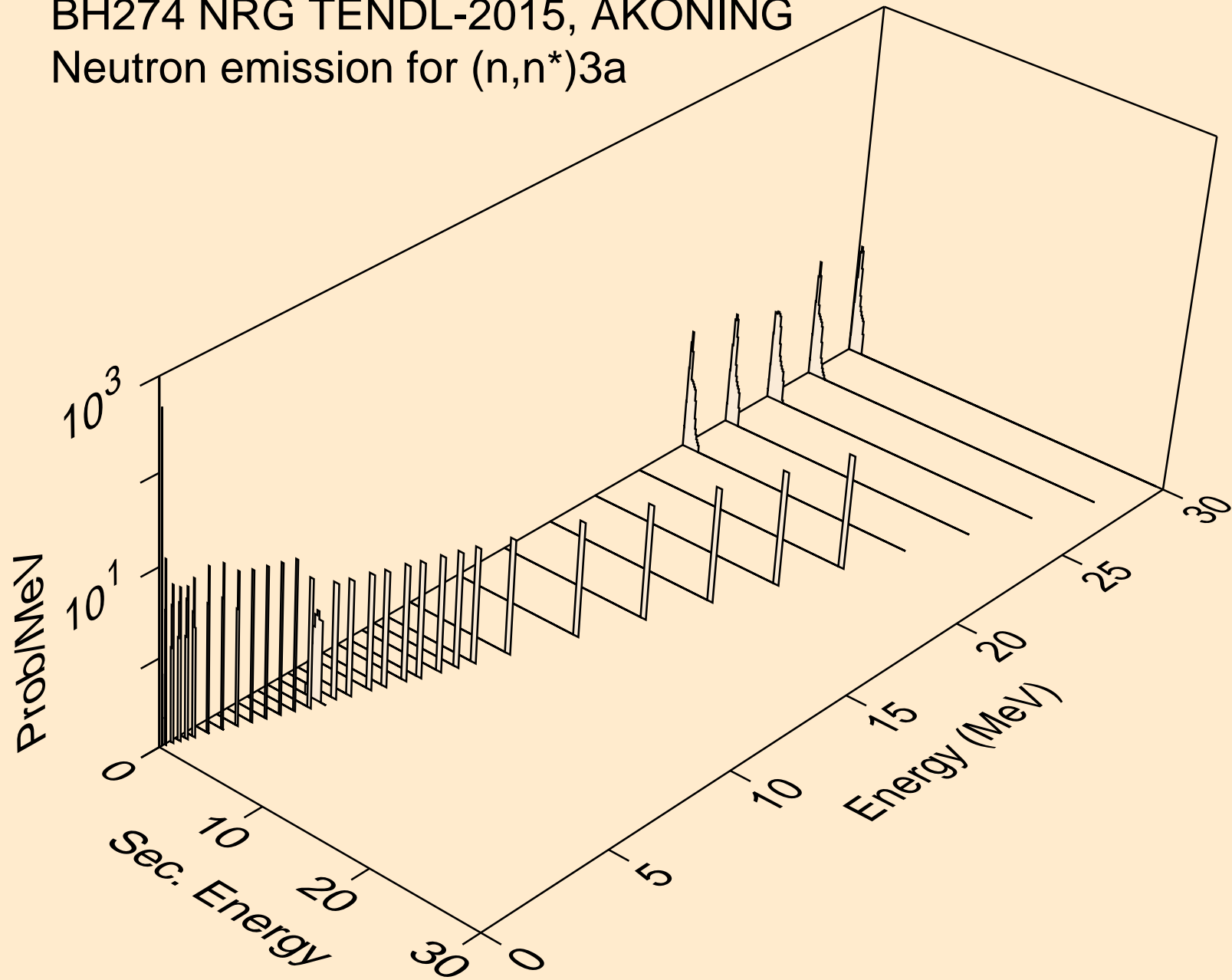

BH274 NRG TENDL-2015, AKONING  
Neutron emission for (n,2n)a

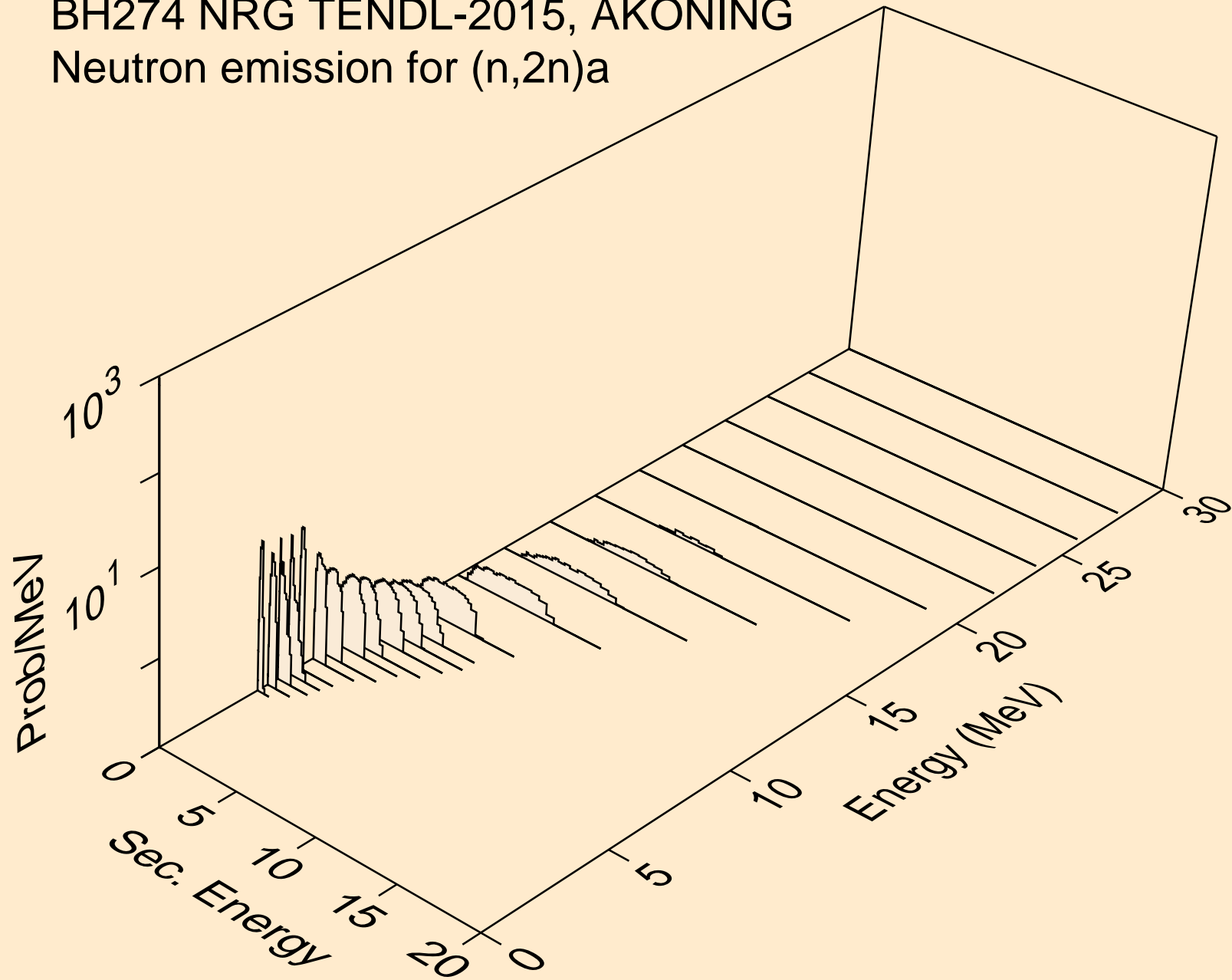

BH274 NRG TENDL-2015, AKONING  
Neutron emission for (n,3n)a

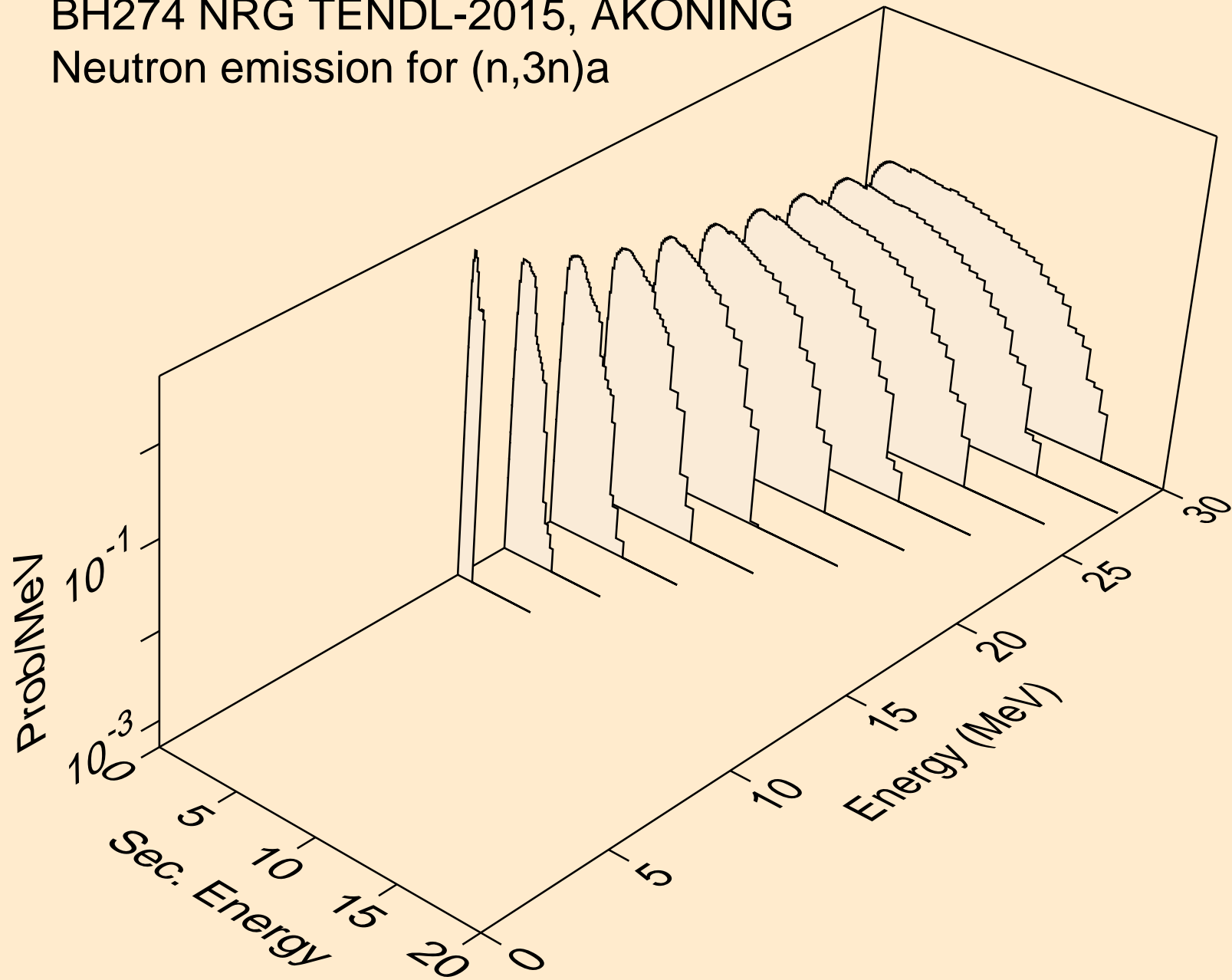



BH274 NRG TENDL-2015, AKONING

Neutron emission for (n,n\*)p

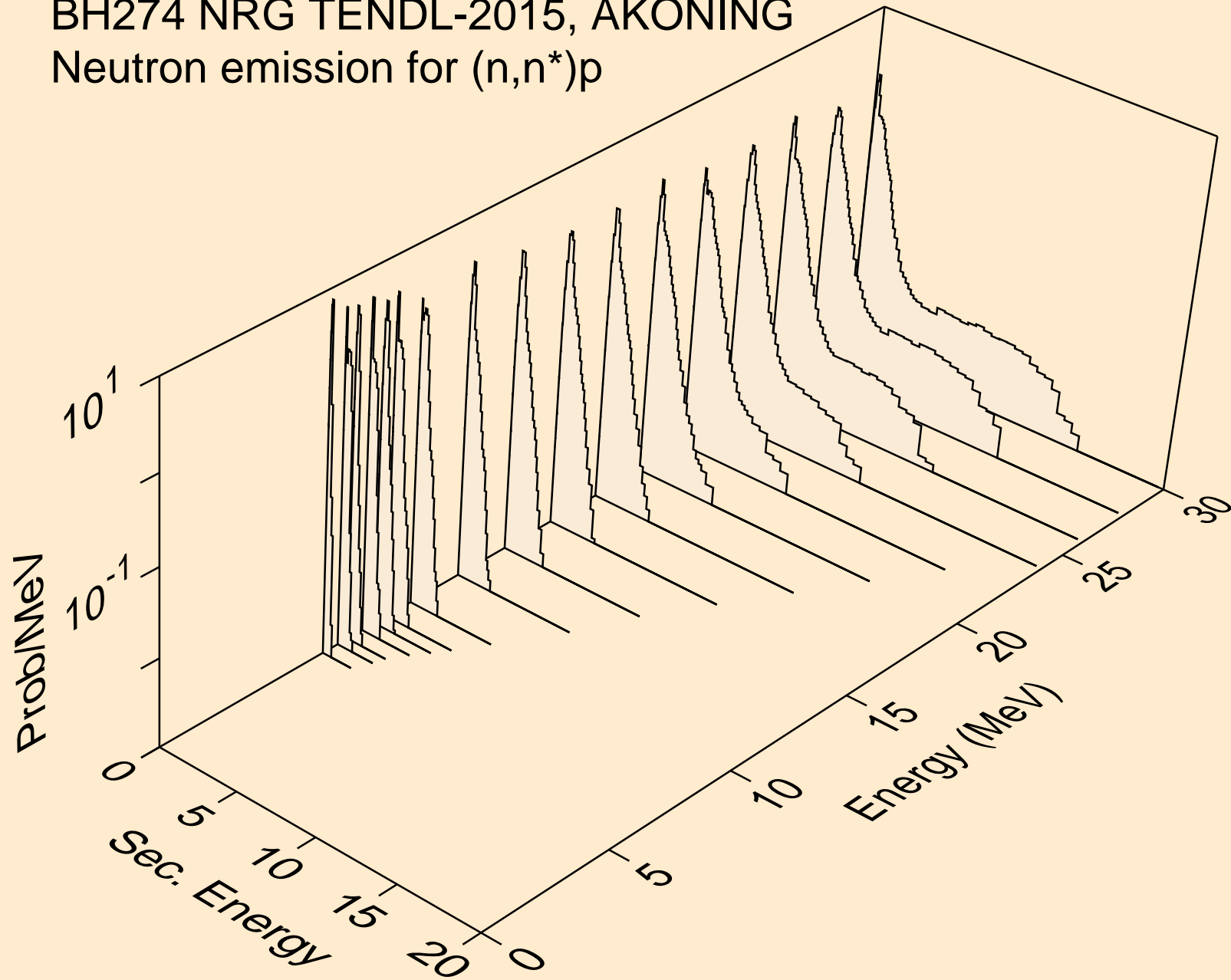

BH274 NRG TENDL-2015, AKONING  
Neutron emission for (n,n\*)2a

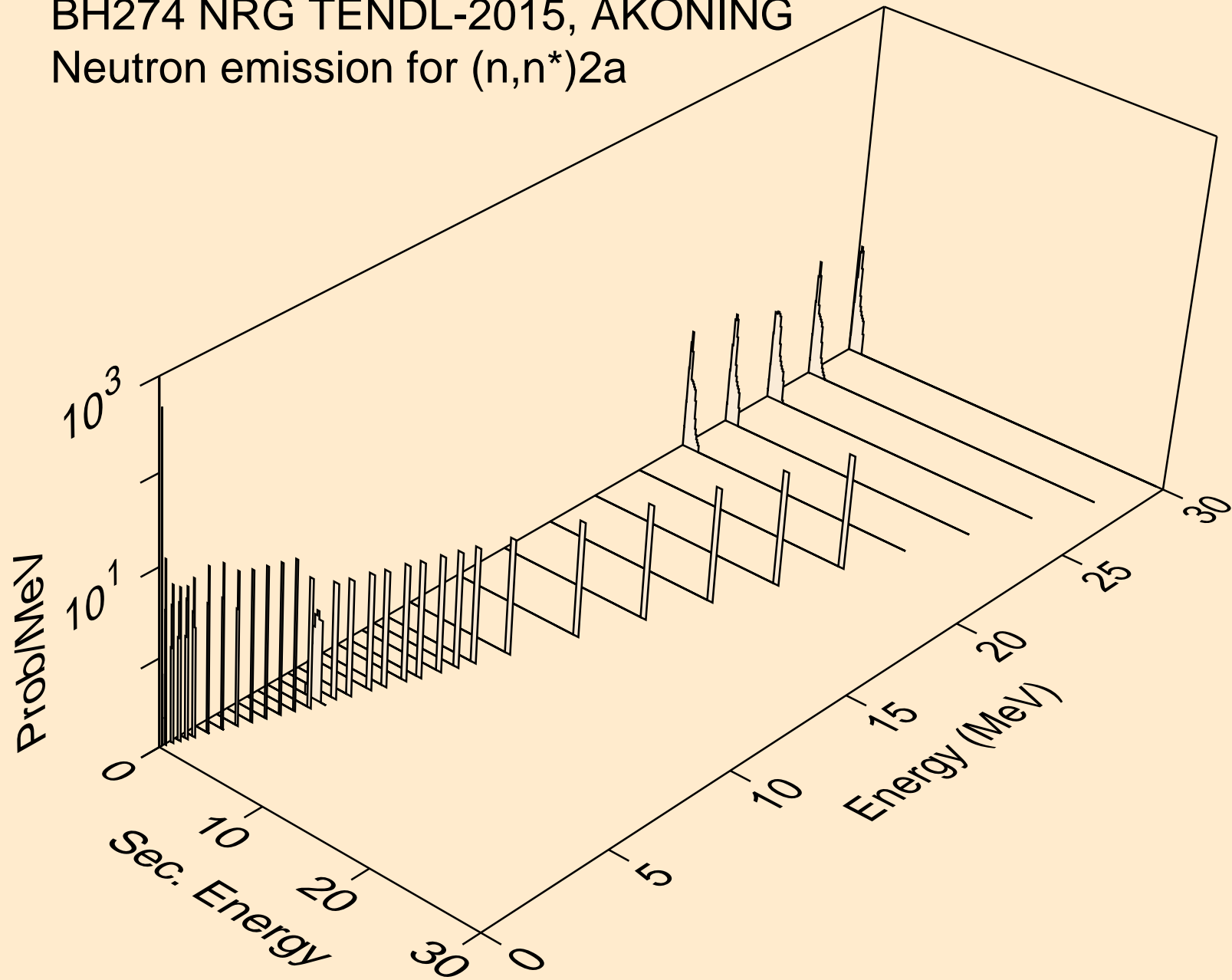

BH274 NRG TENDL-2015, AKONING  
Neutron emission for (n,2n)2a

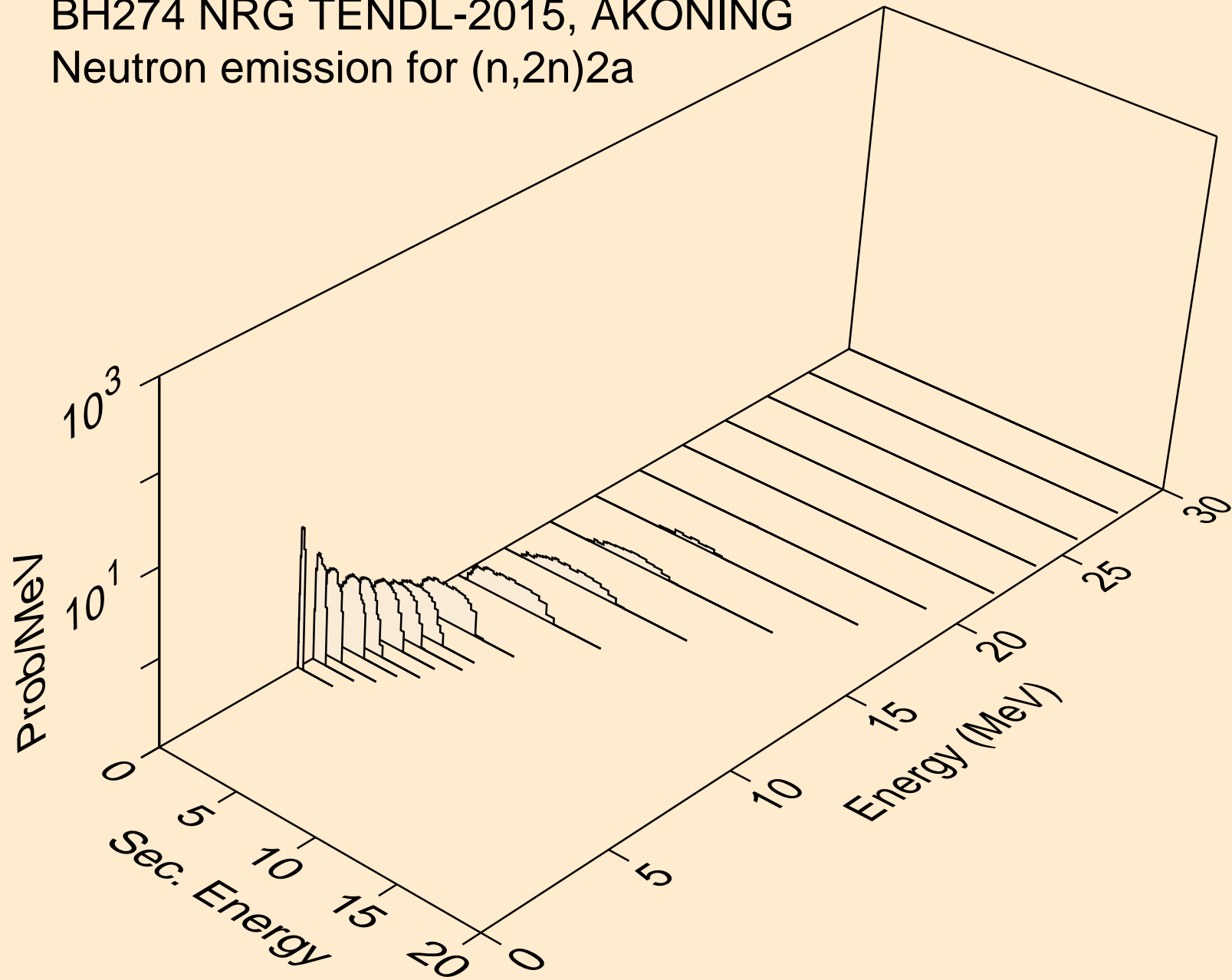

BH274 NRG TENDL-2015, AKONING  
Neutron emission for (n,n\*)d

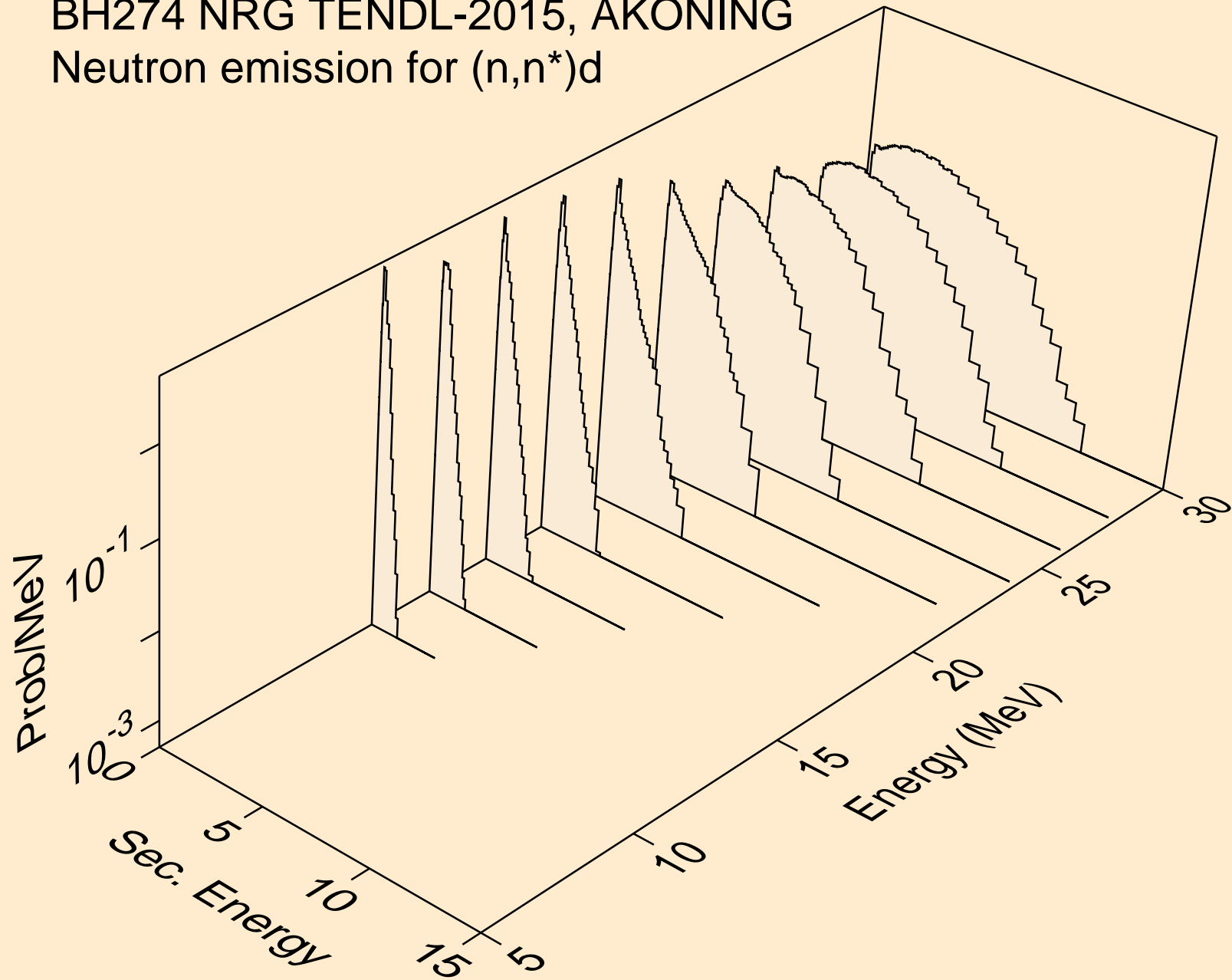

BH274 NRG TENDL-2015, AKONING  
Neutron emission for (n,n\*)t

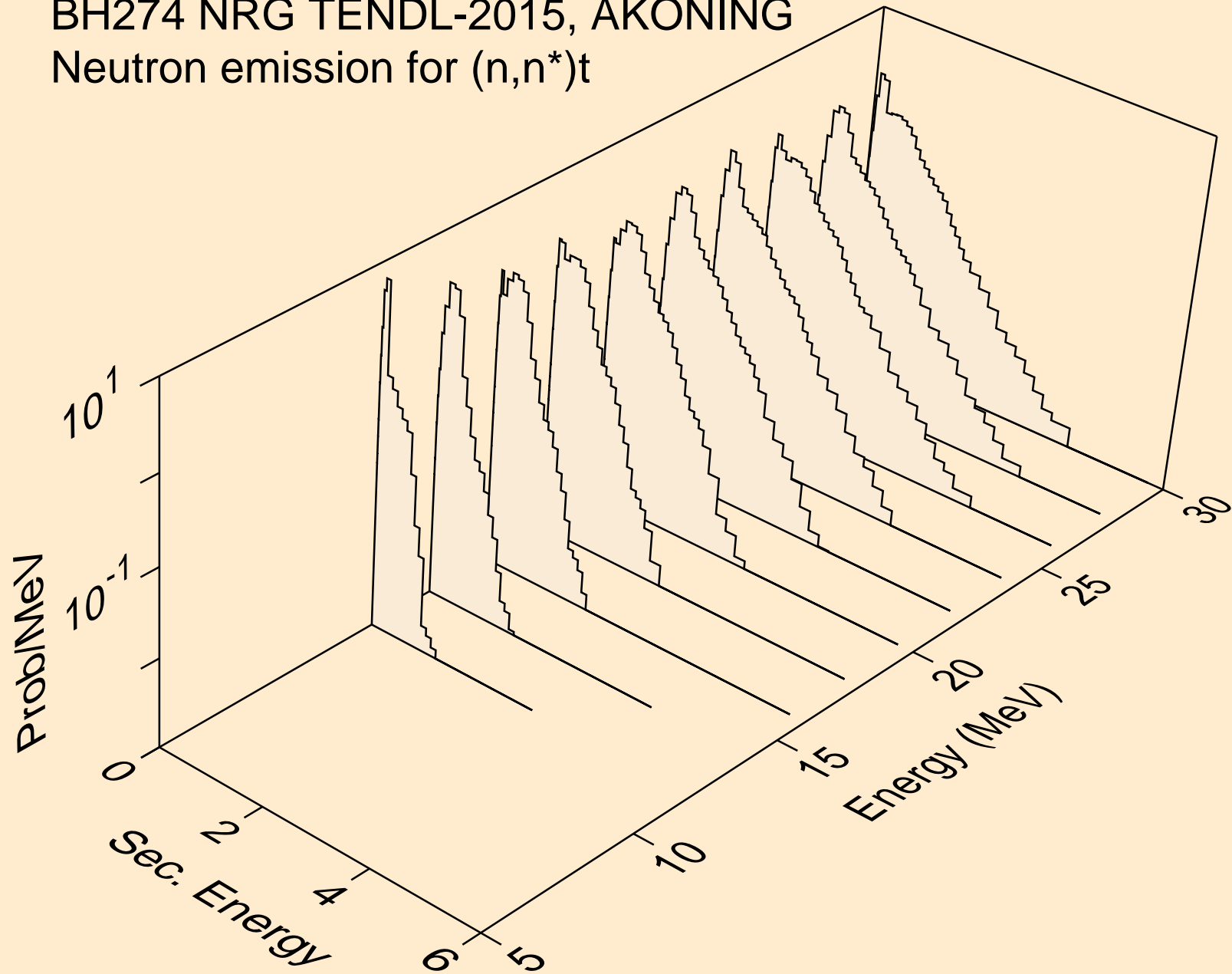

BH274 NRG TENDL-2015, AKONING  
Neutron emission for (n,n\*)d2a

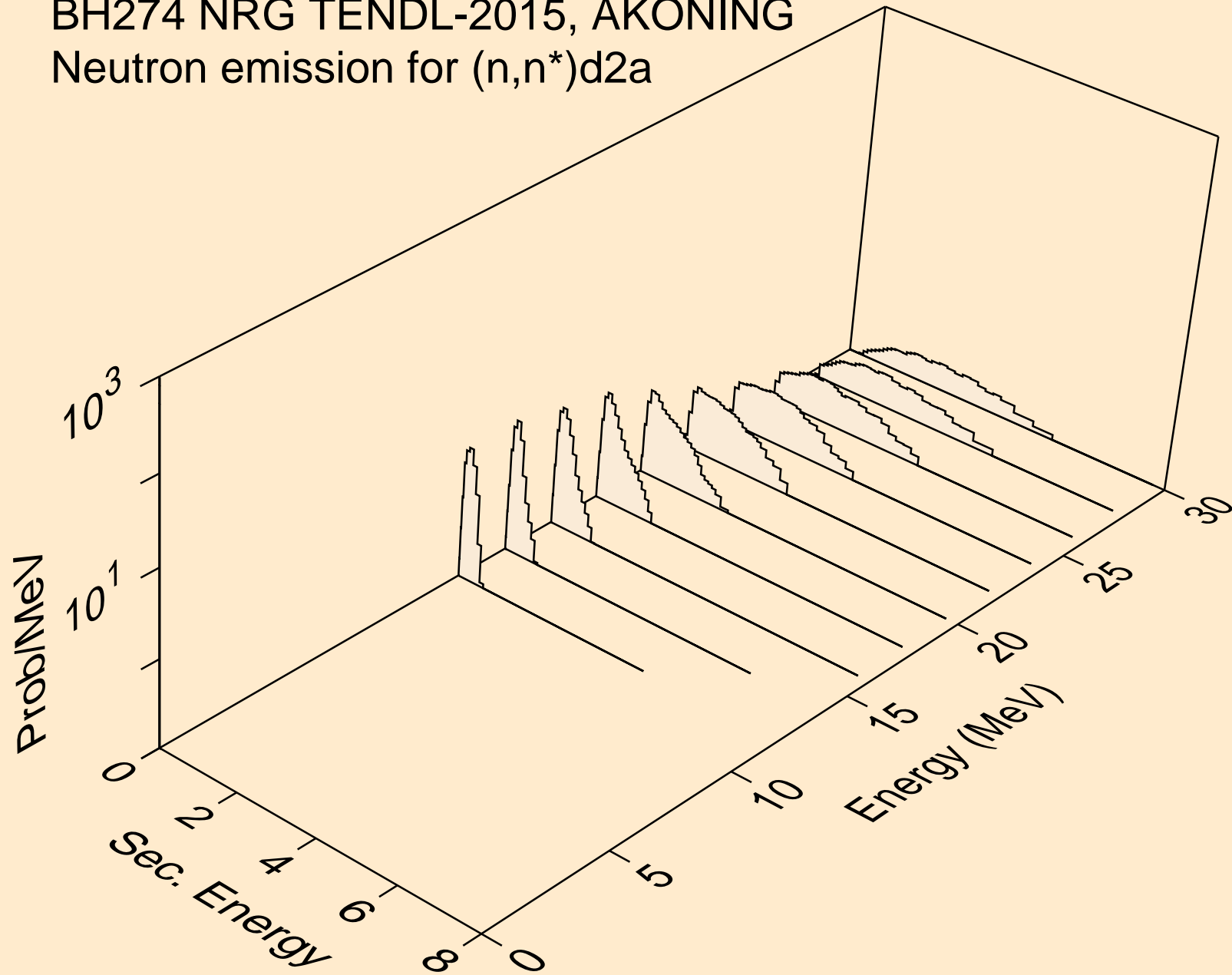

BH274 NRG TENDL-2015, AKONING  
Neutron emission for (n,4n)

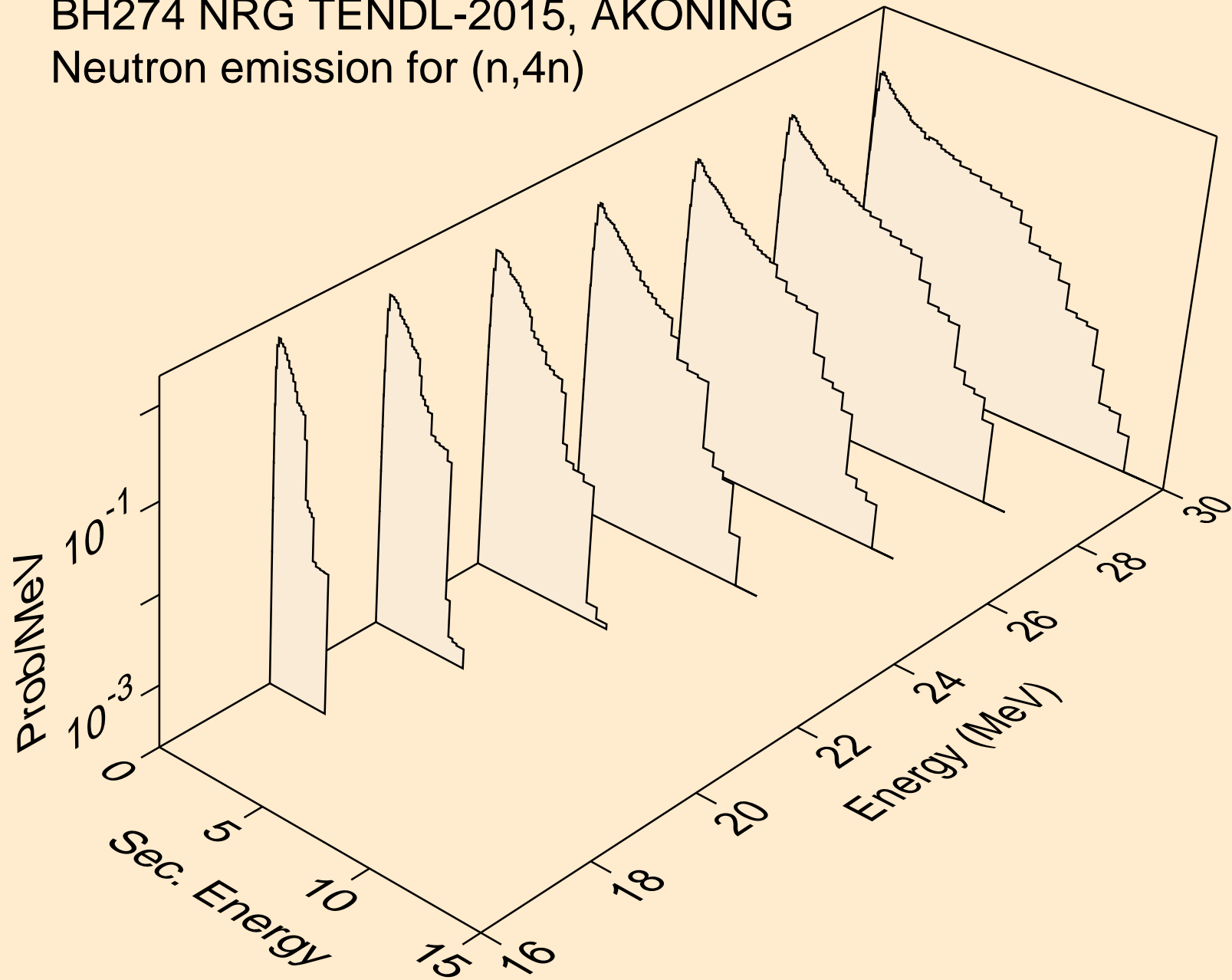

BH274 NRG TENDL-2015, AKONING  
Neutron emission for (n,2np)

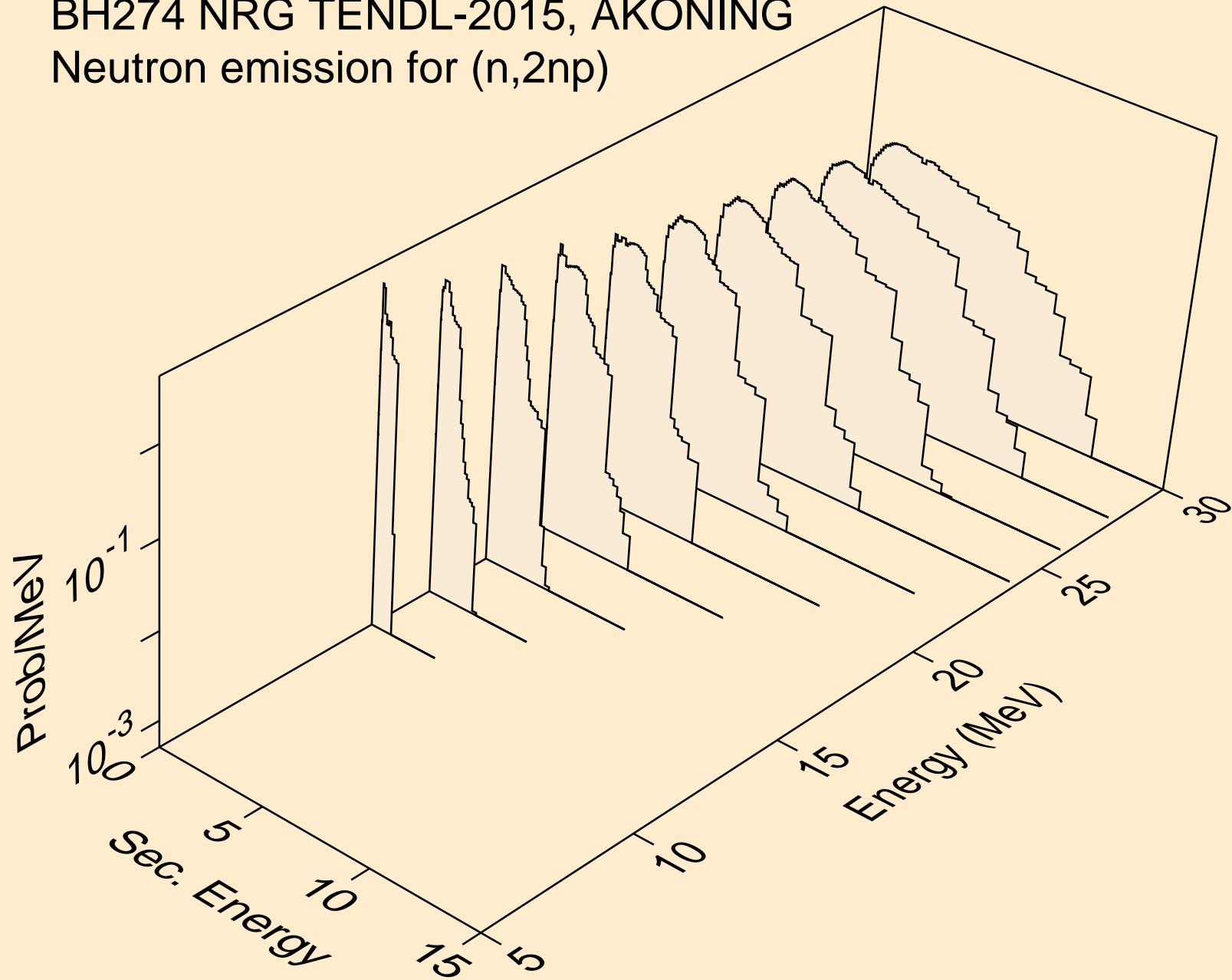



BH274 NRG TENDL-2015, AKONING  
Neutron emission for (n,n\*c)

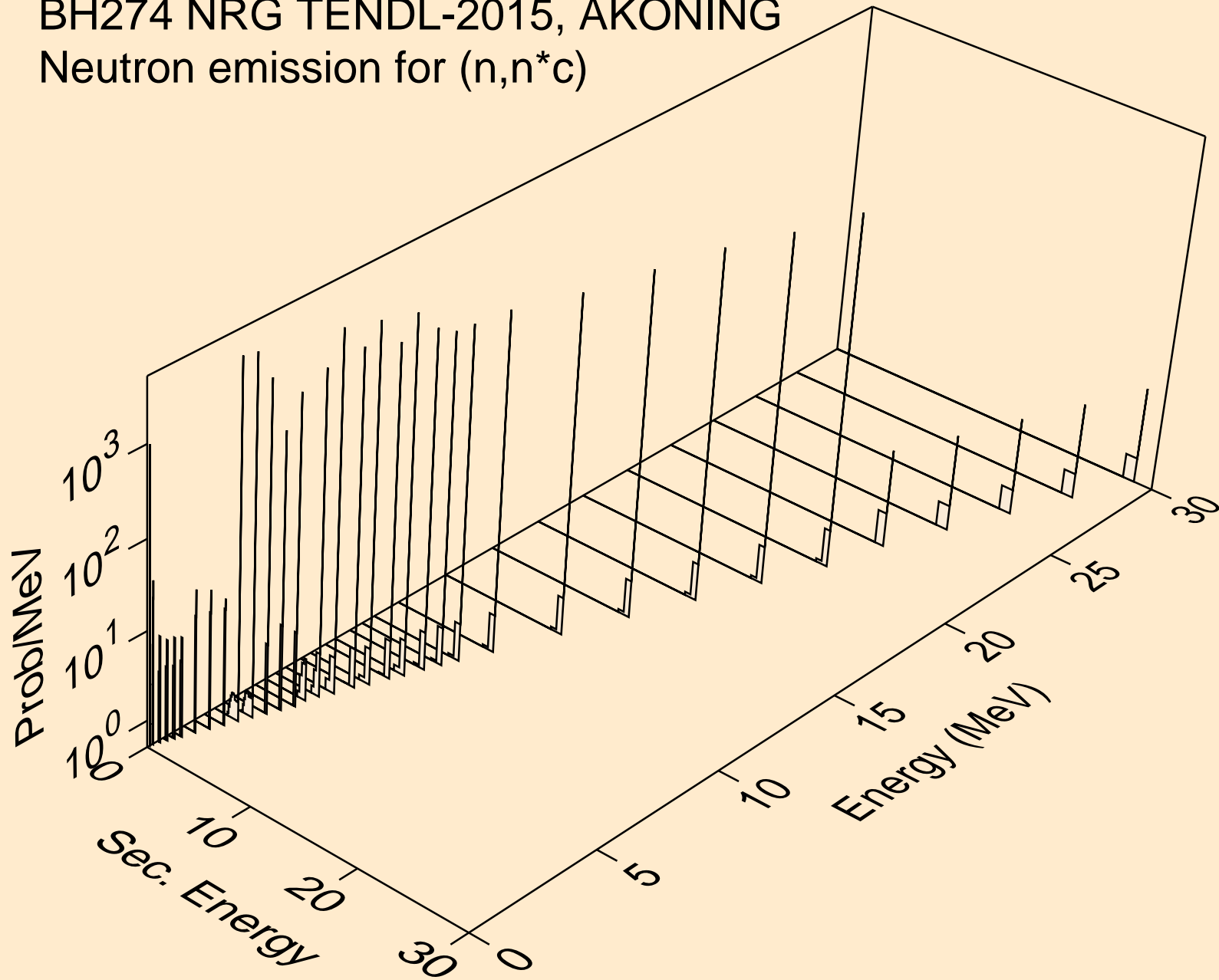

# BH274 NRG TENDL-2015, AKONING

## Delayed nubar

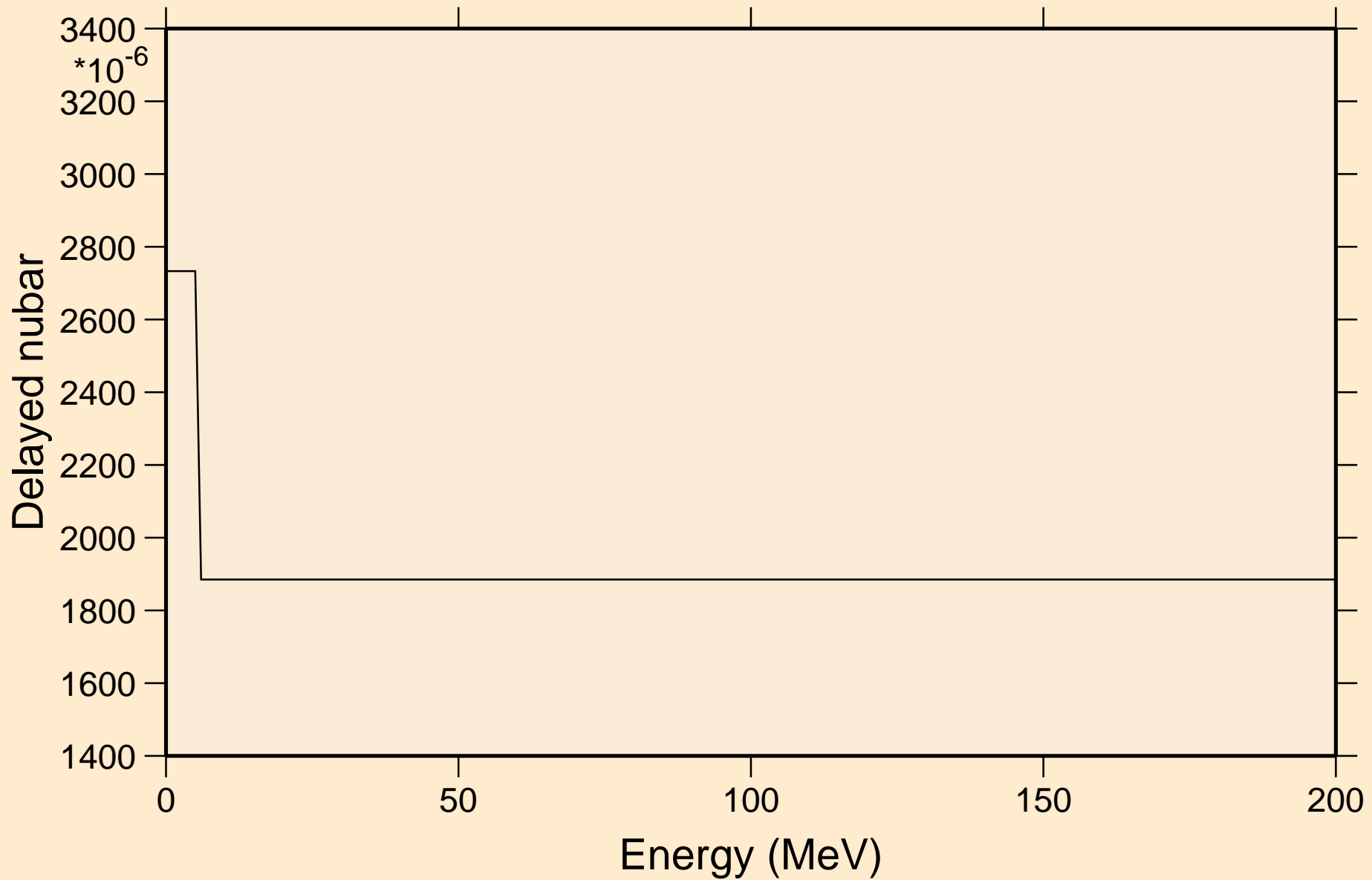

# BH274 NRG TENDL-2015, AKONING

## Delayed neutron spectra

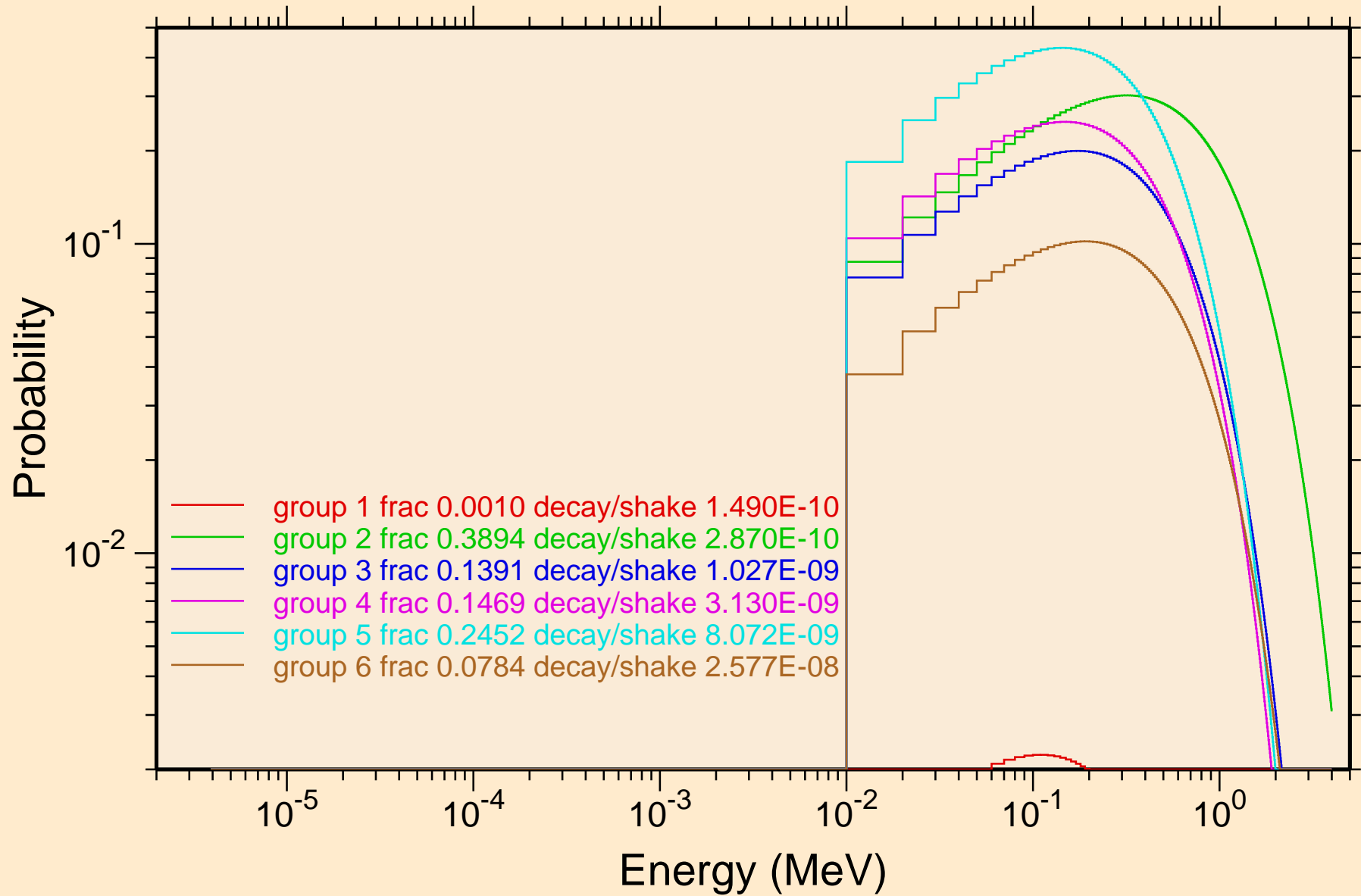

BH274 NRG TENDL-2015, AKONING  
Photon emission for (n,x)

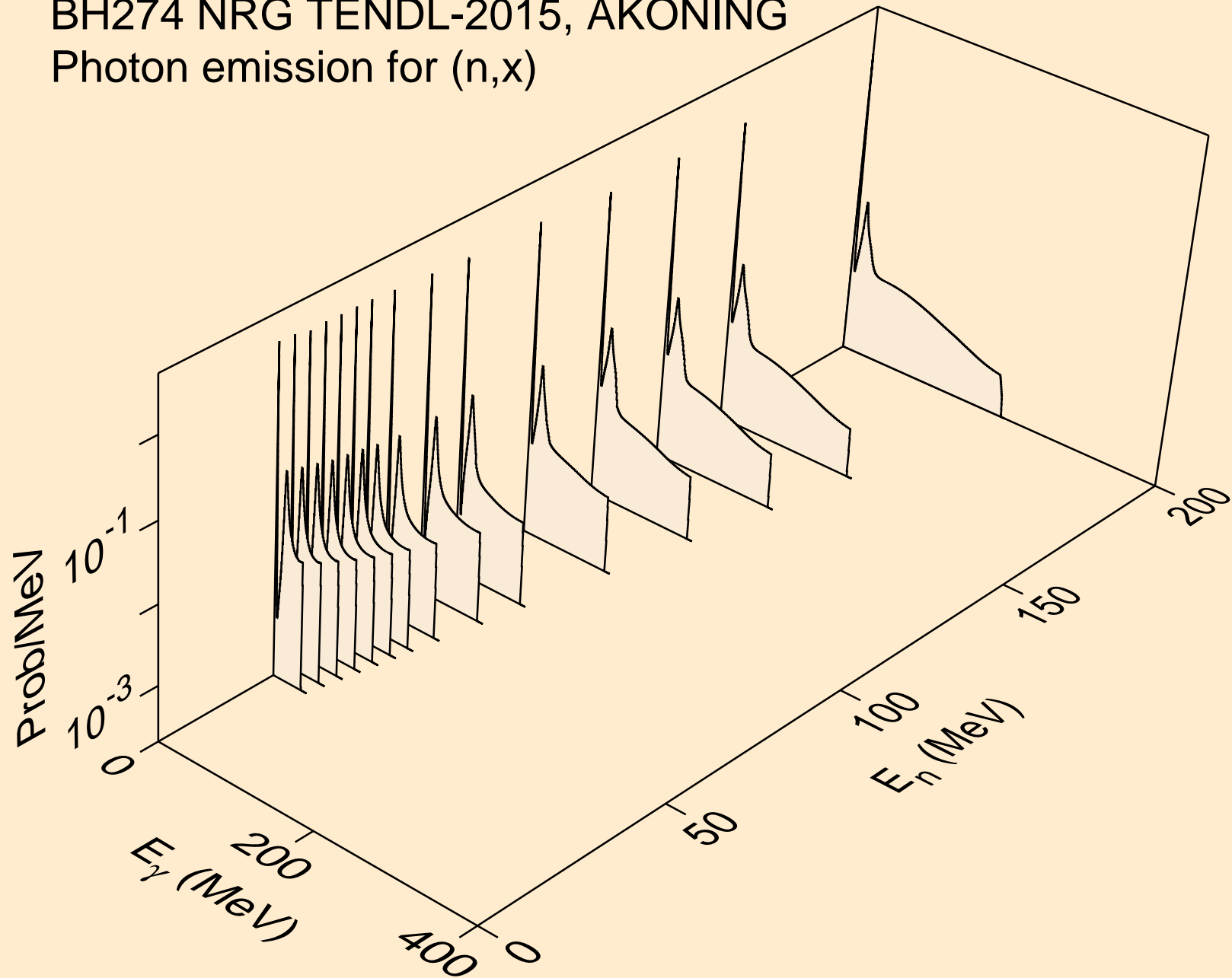

BH274 NRG TENDL-2015, AKONING  
Photon emission for (n,2n)

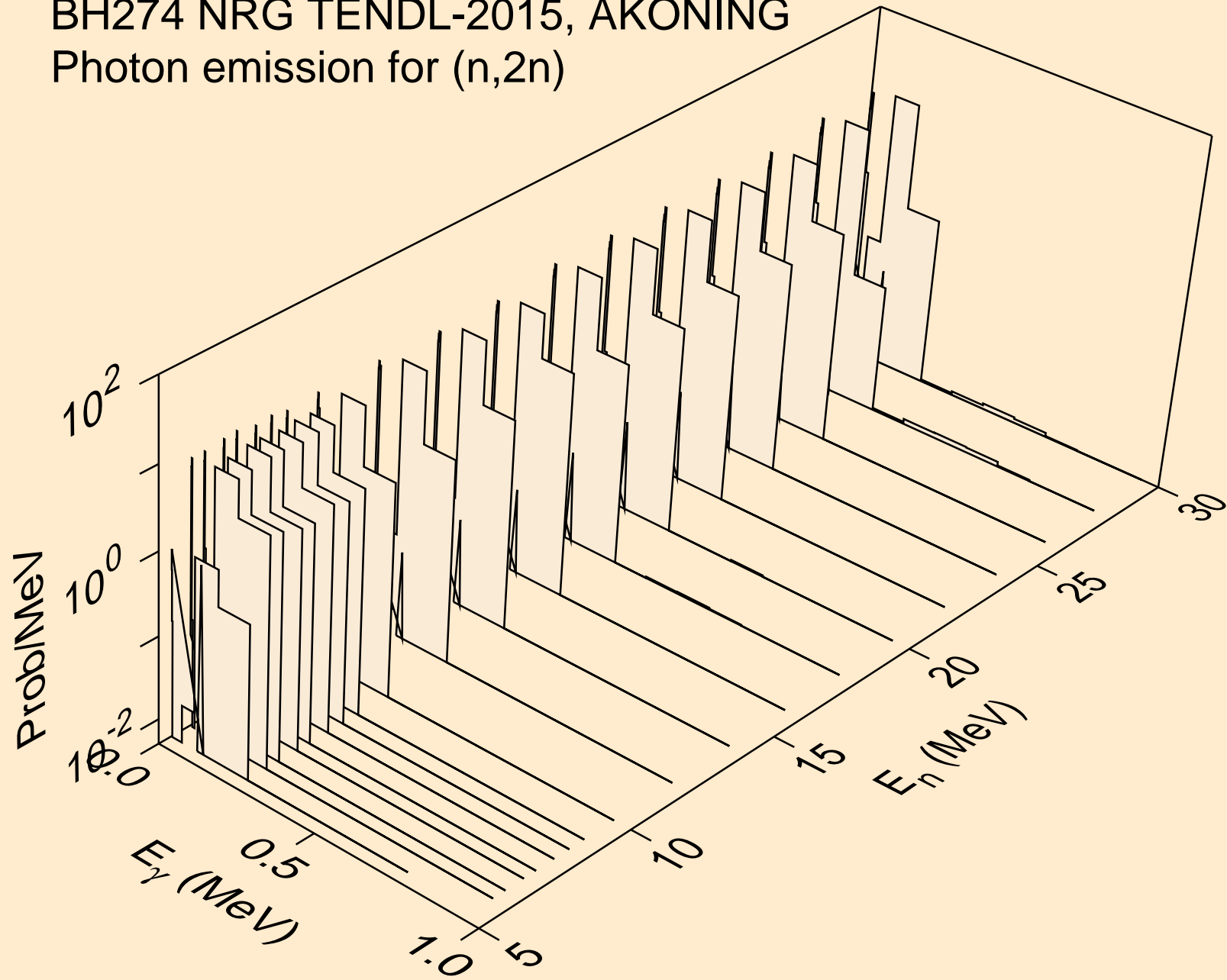

BH274 NRG TENDL-2015, AKONING  
Photon emission for (n,3n)

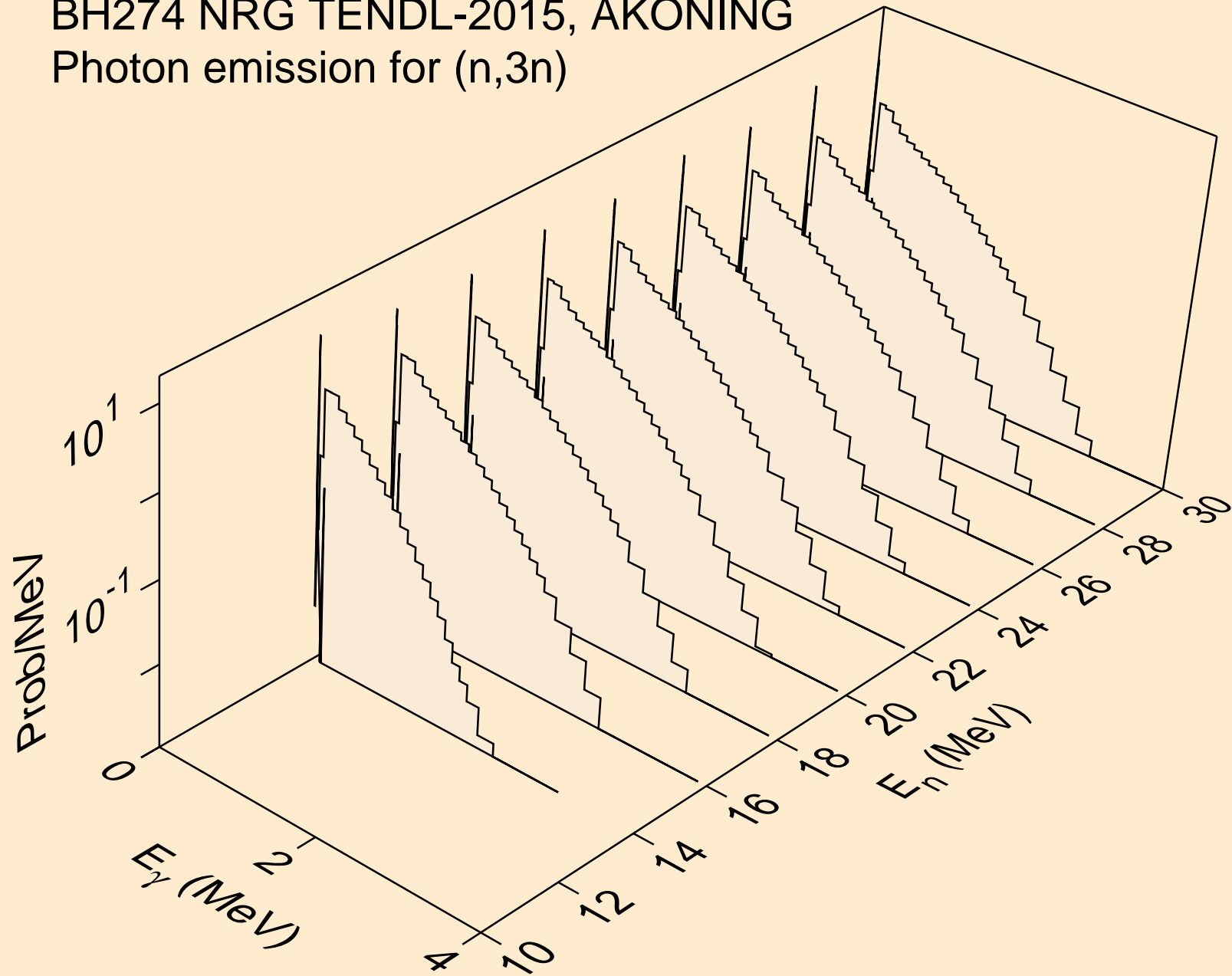

BH274 NRG TENDL-2015, AKONING  
Photon emission for (n,n\*)a

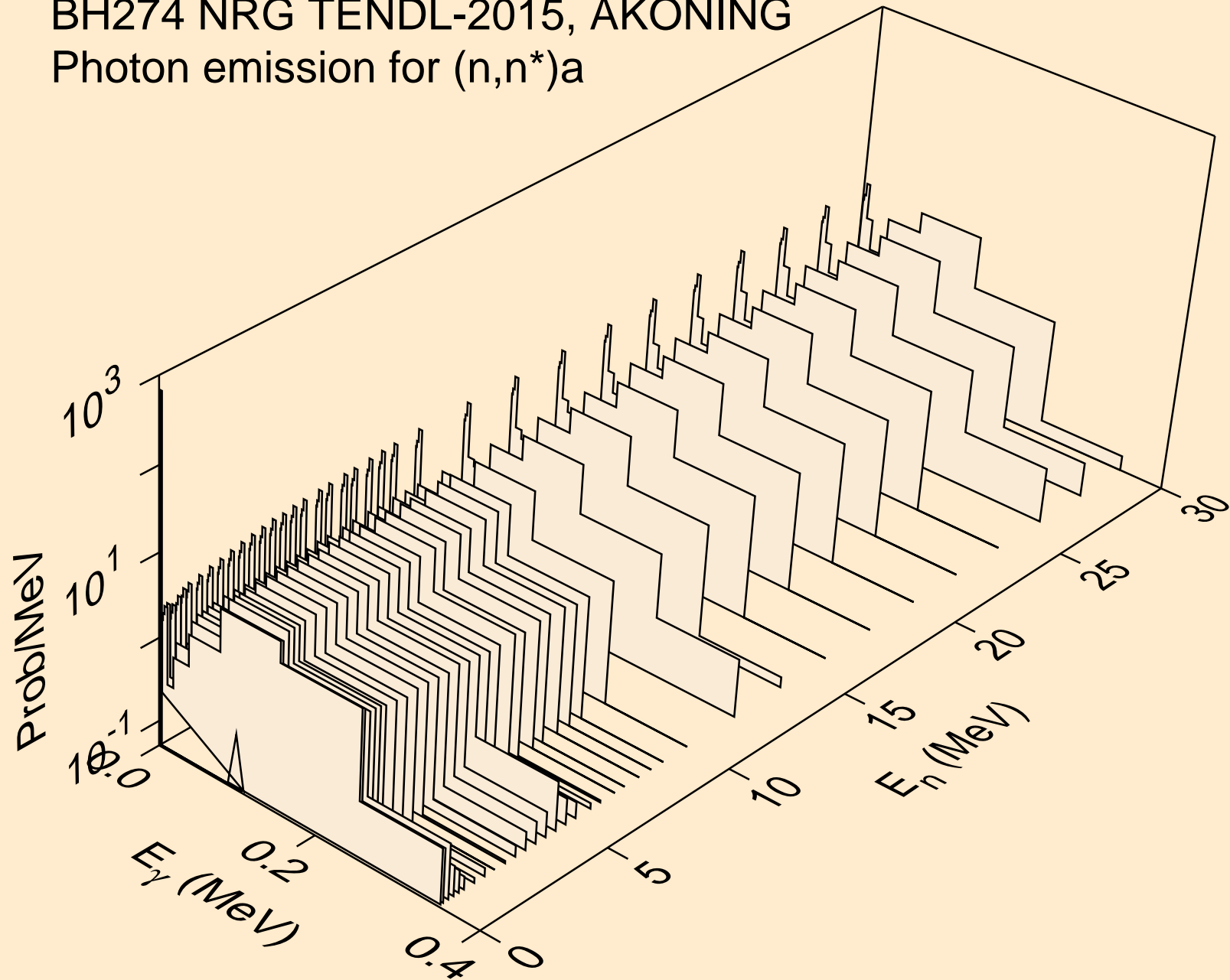

BH274 NRG TENDL-2015, AKONING  
Photon emission for (n,n\*)3a

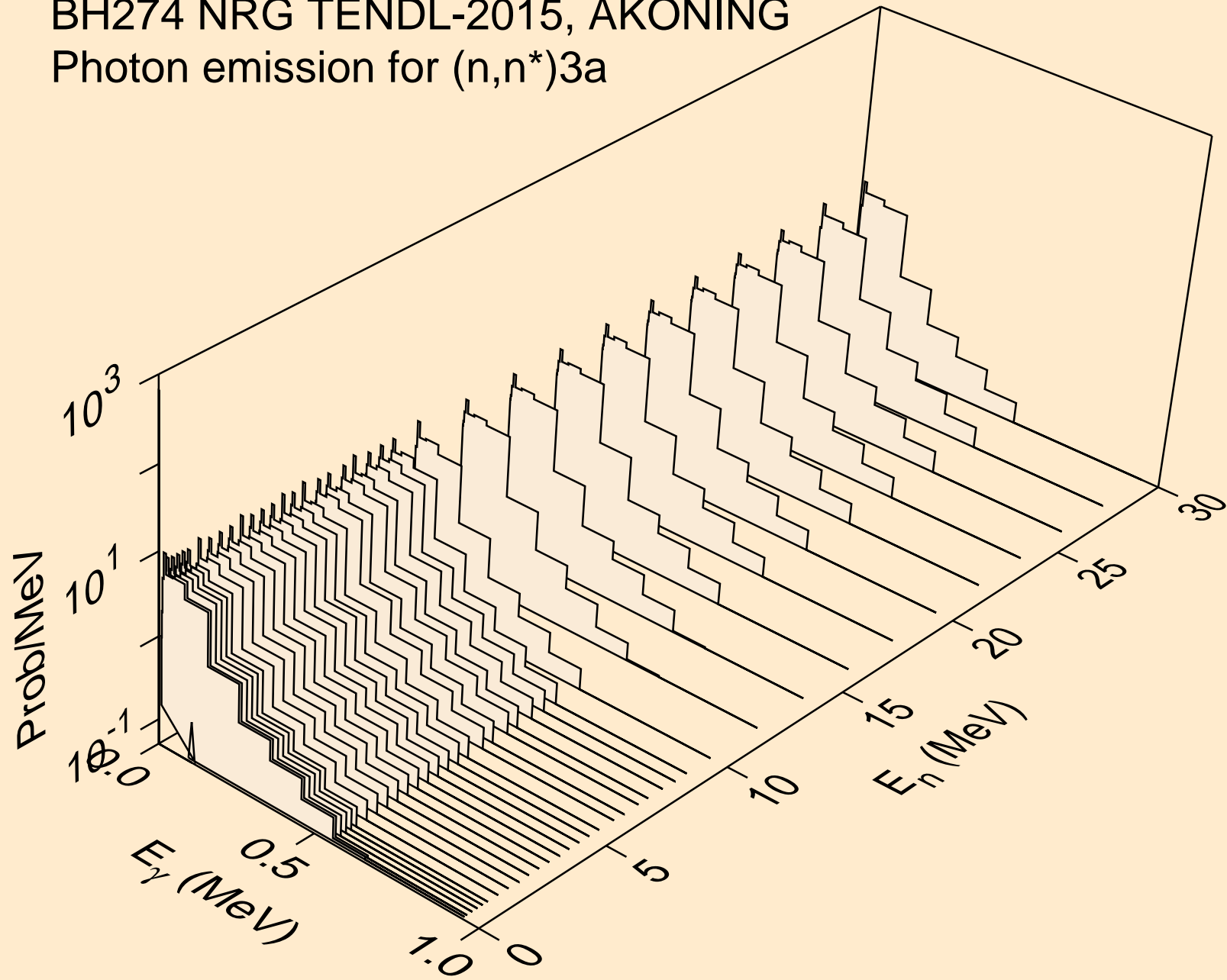



BH274 NRG TENDL-2015, AKONING  
Photon emission for (n,2n)a

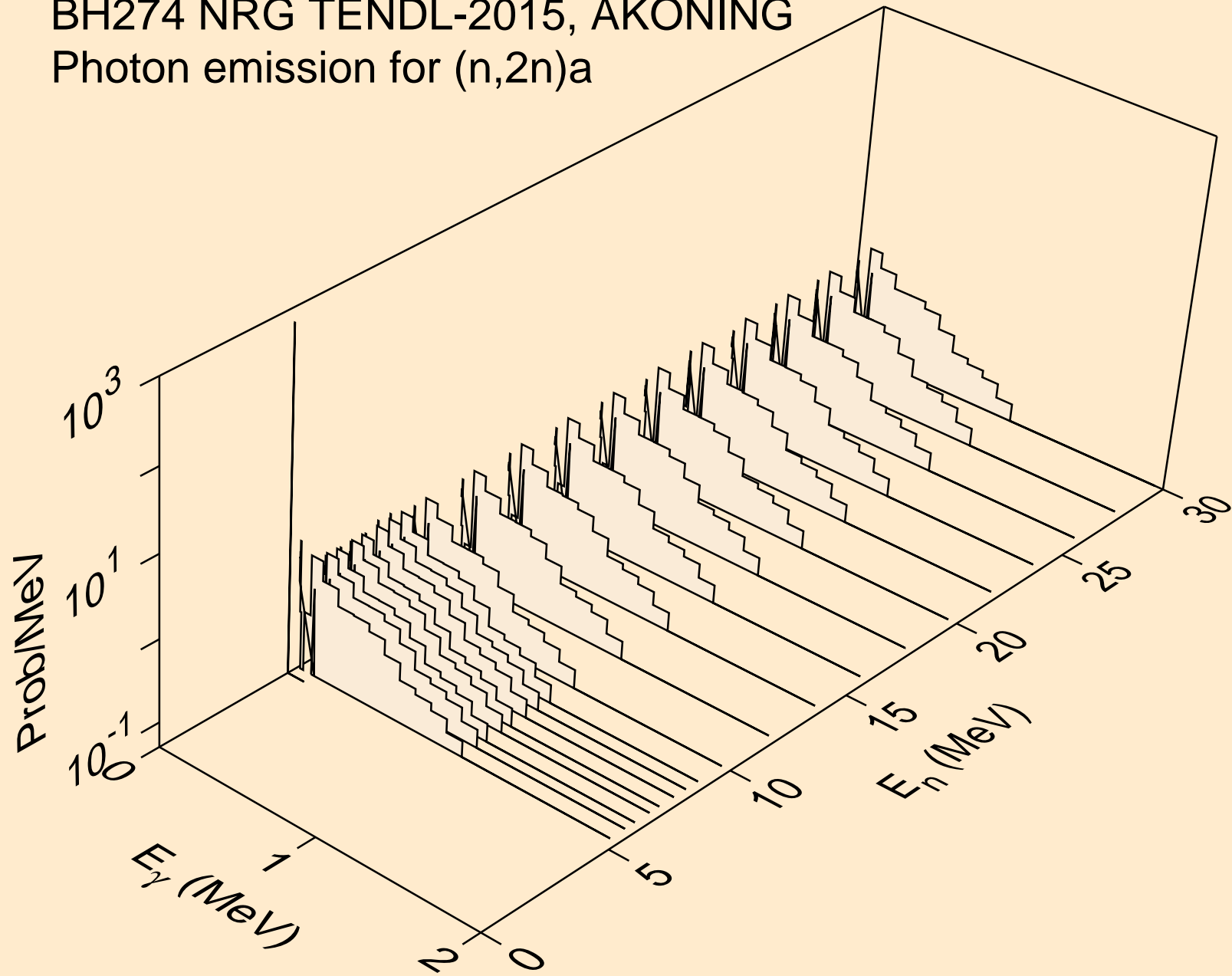

BH274 NRG TENDL-2015, AKONING

Photon emission for (n,3n) $\alpha$

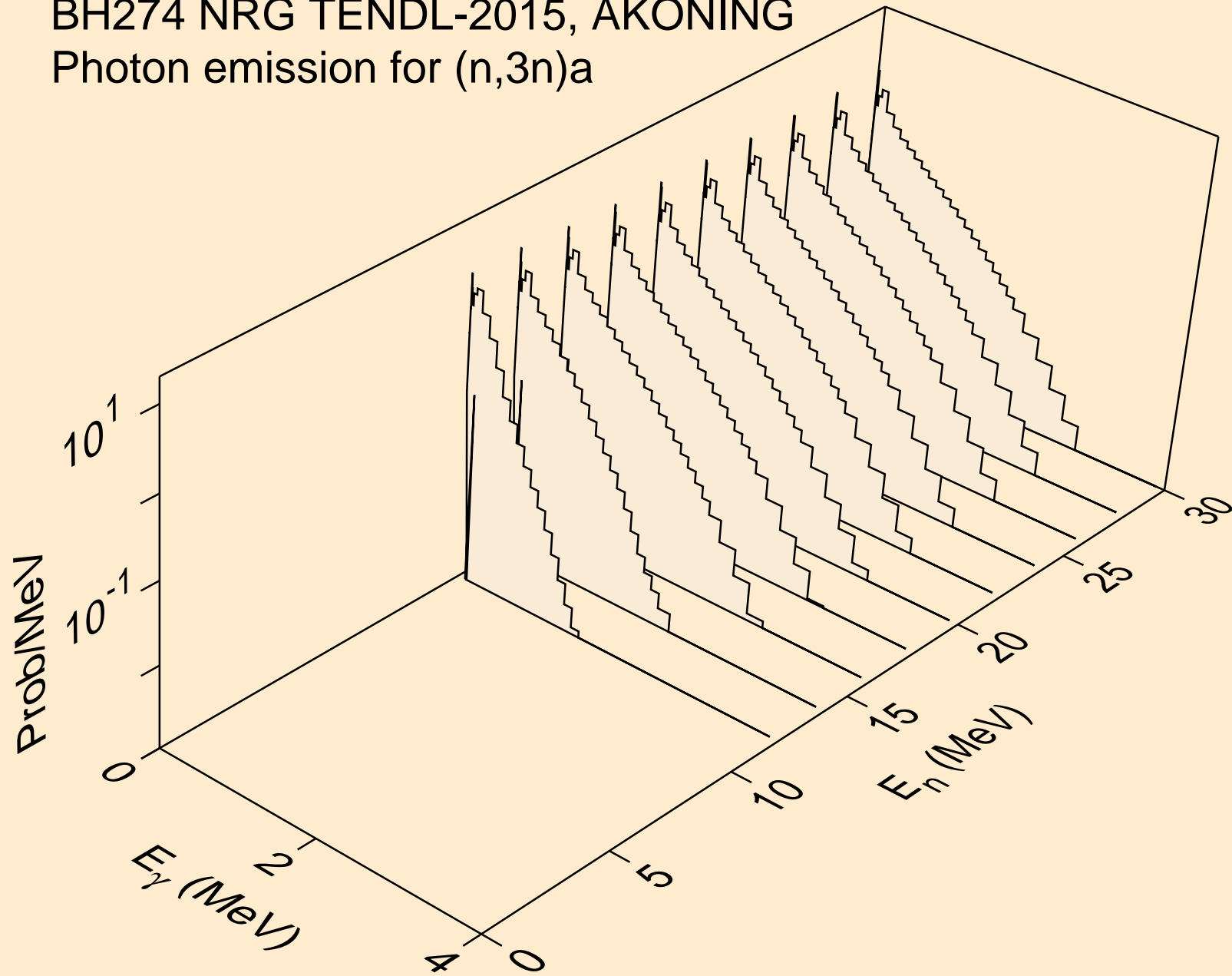

BH274 NRG TENDL-2015, AKONING  
Photon emission for (n,n\*)p

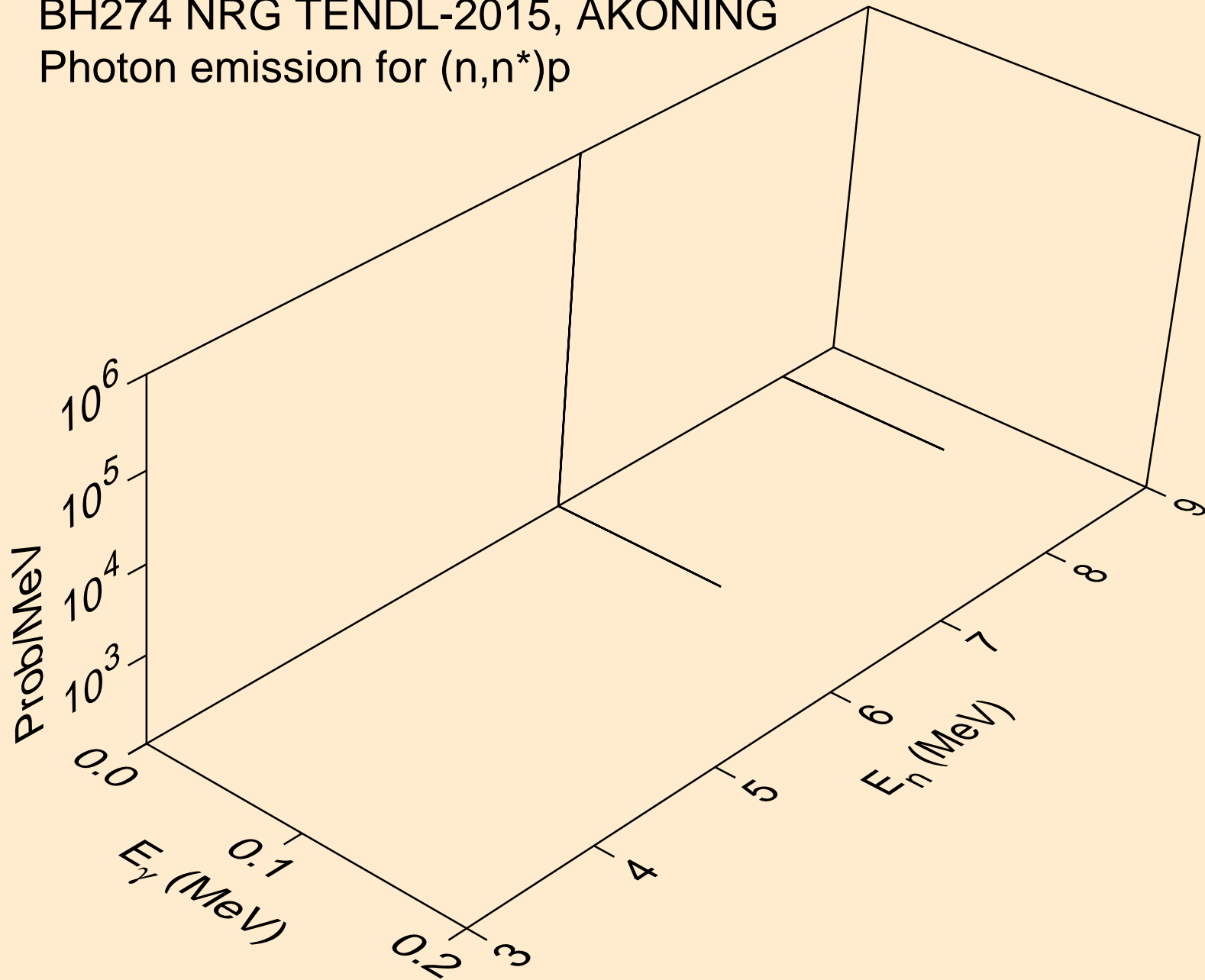

BH274 NRG TENDL-2015, AKONING  
Photon emission for (n,n\*)2a

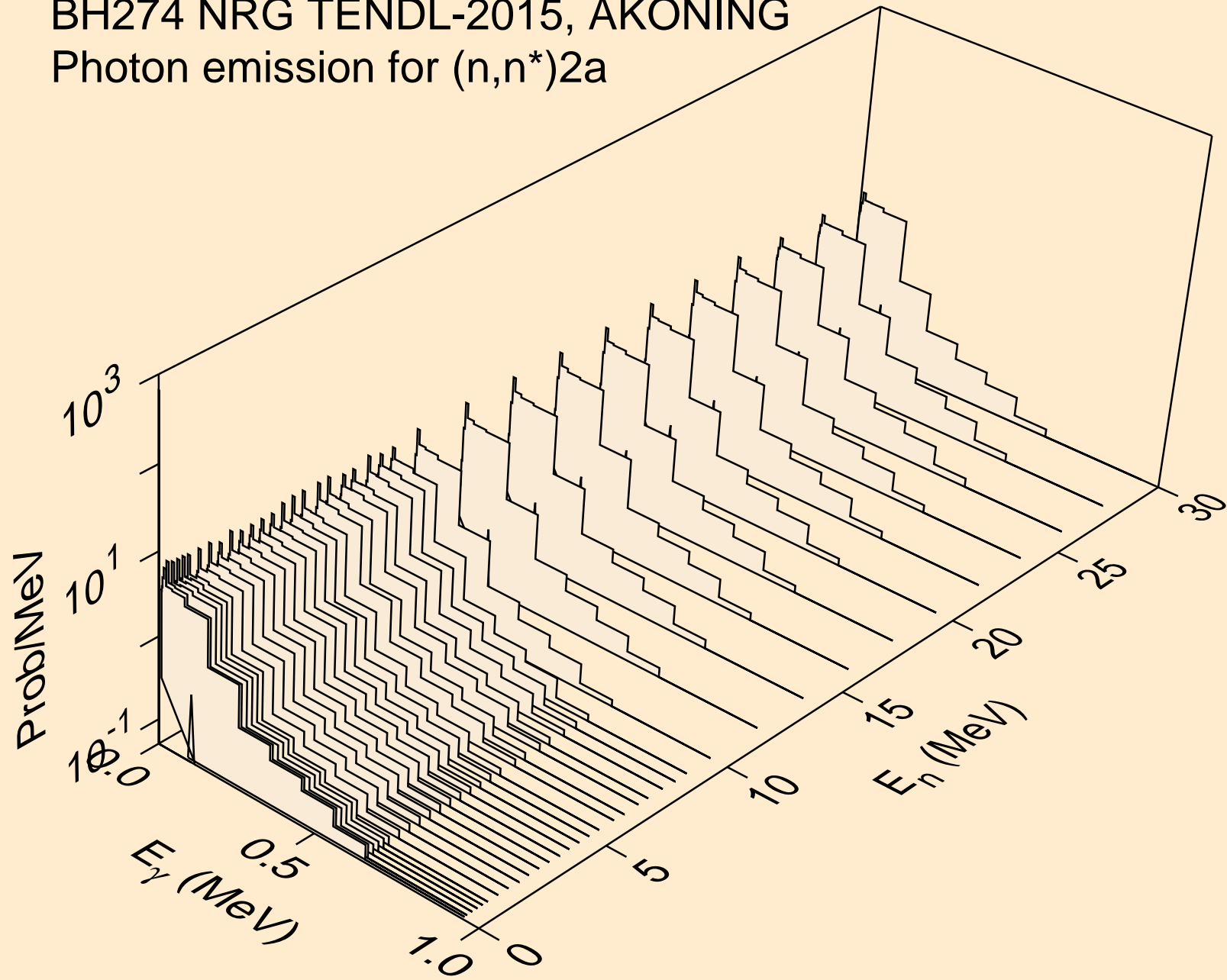

BH274 NRG TENDL-2015, AKONING  
Photon emission for (n,2n)2a

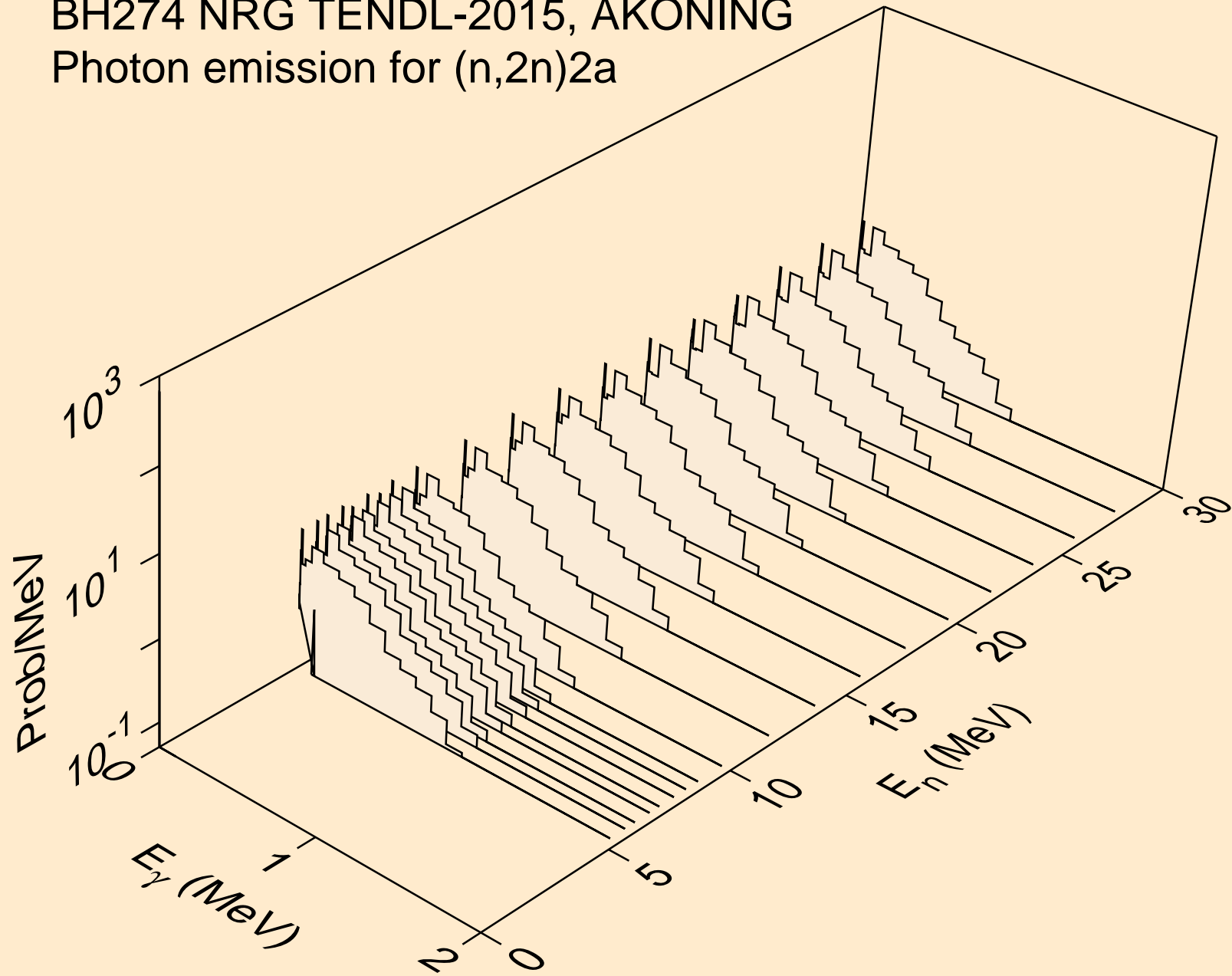

BH274 NRG TENDL-2015, AKONING  
Photon emission for (n,n\*)d

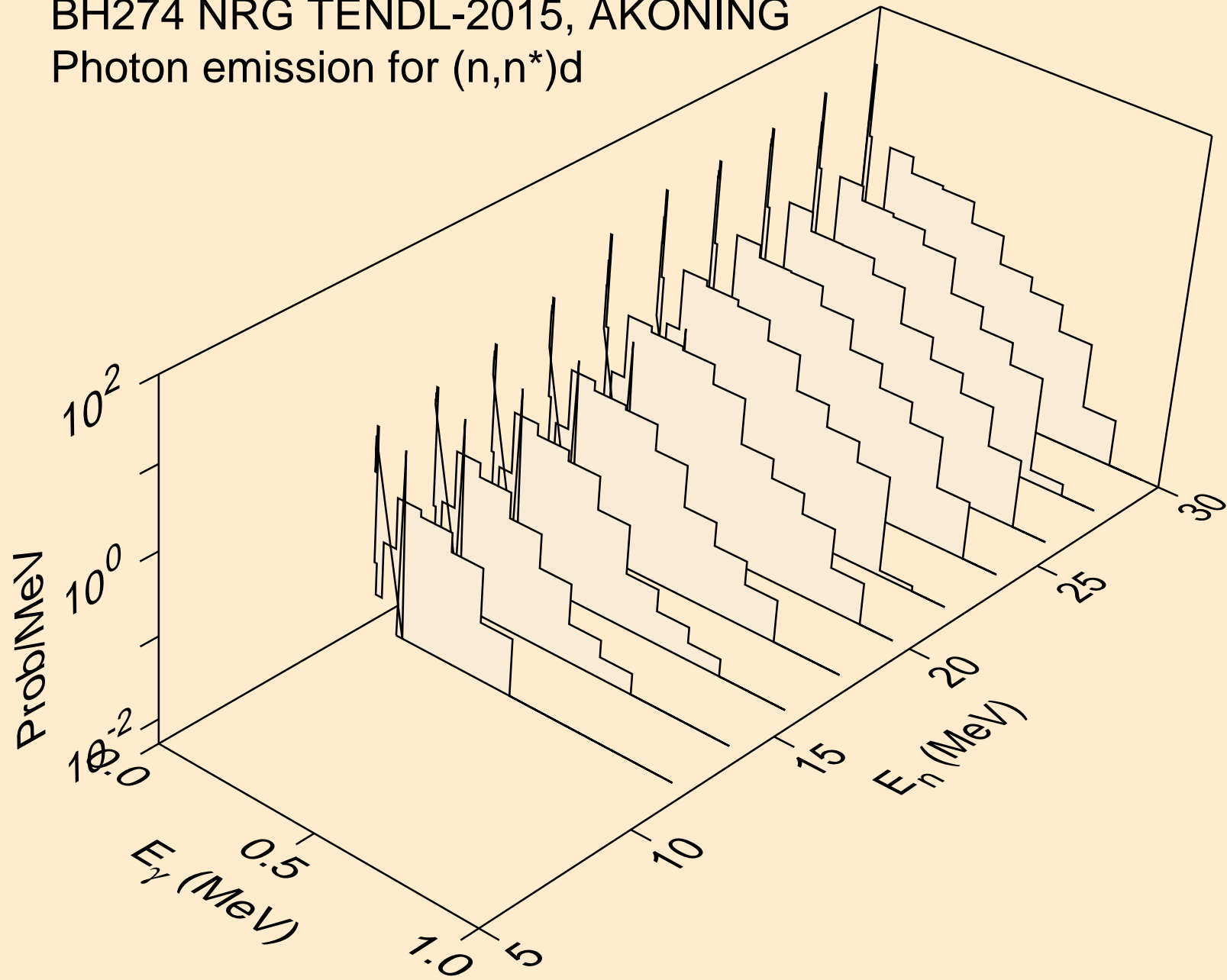

BH274 NRG TENDL-2015, AKONING  
Photon emission for (n,n\*)t

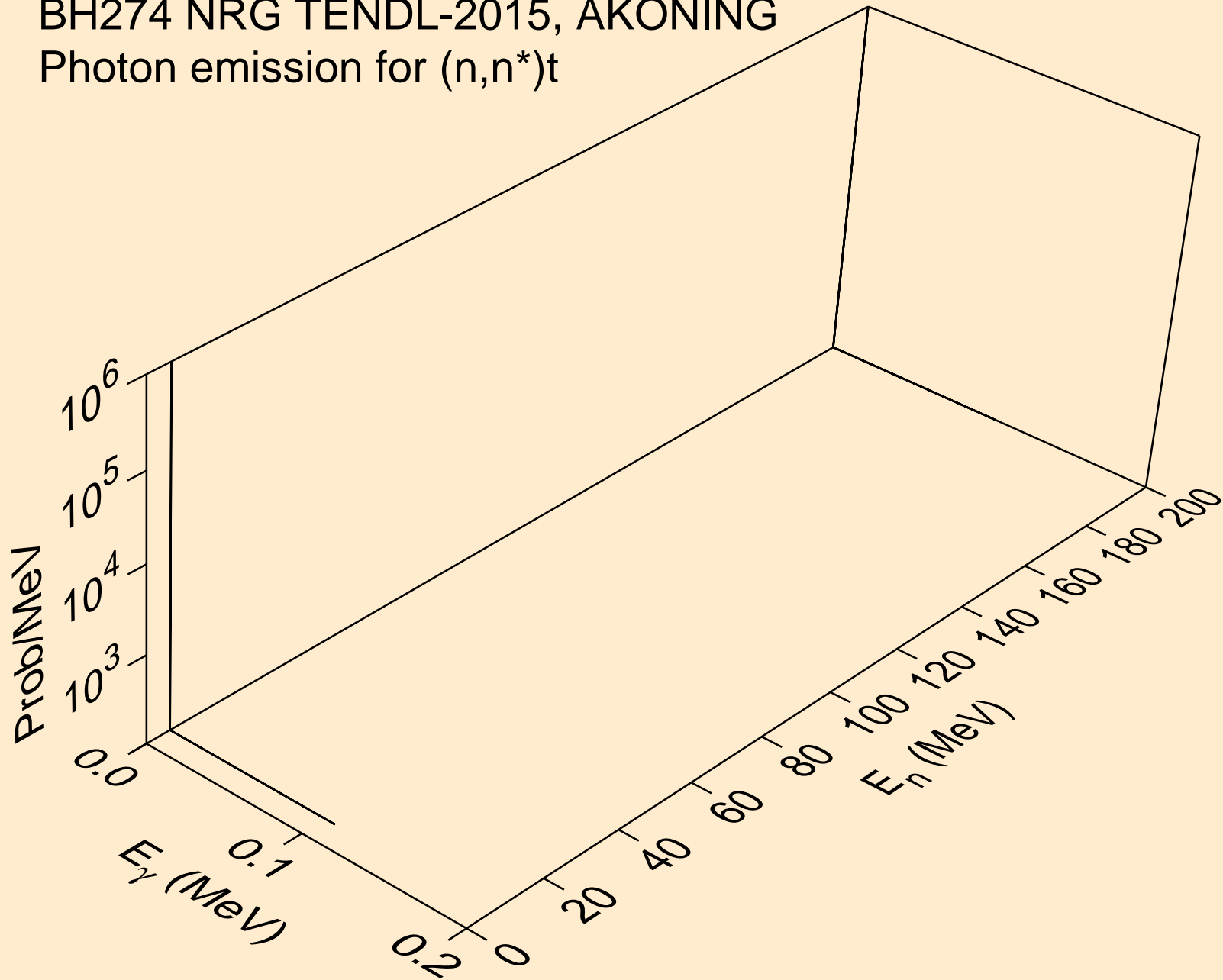

BH274 NRG TENDL-2015, AKONING  
Photon emission for (n,n\*)d2a

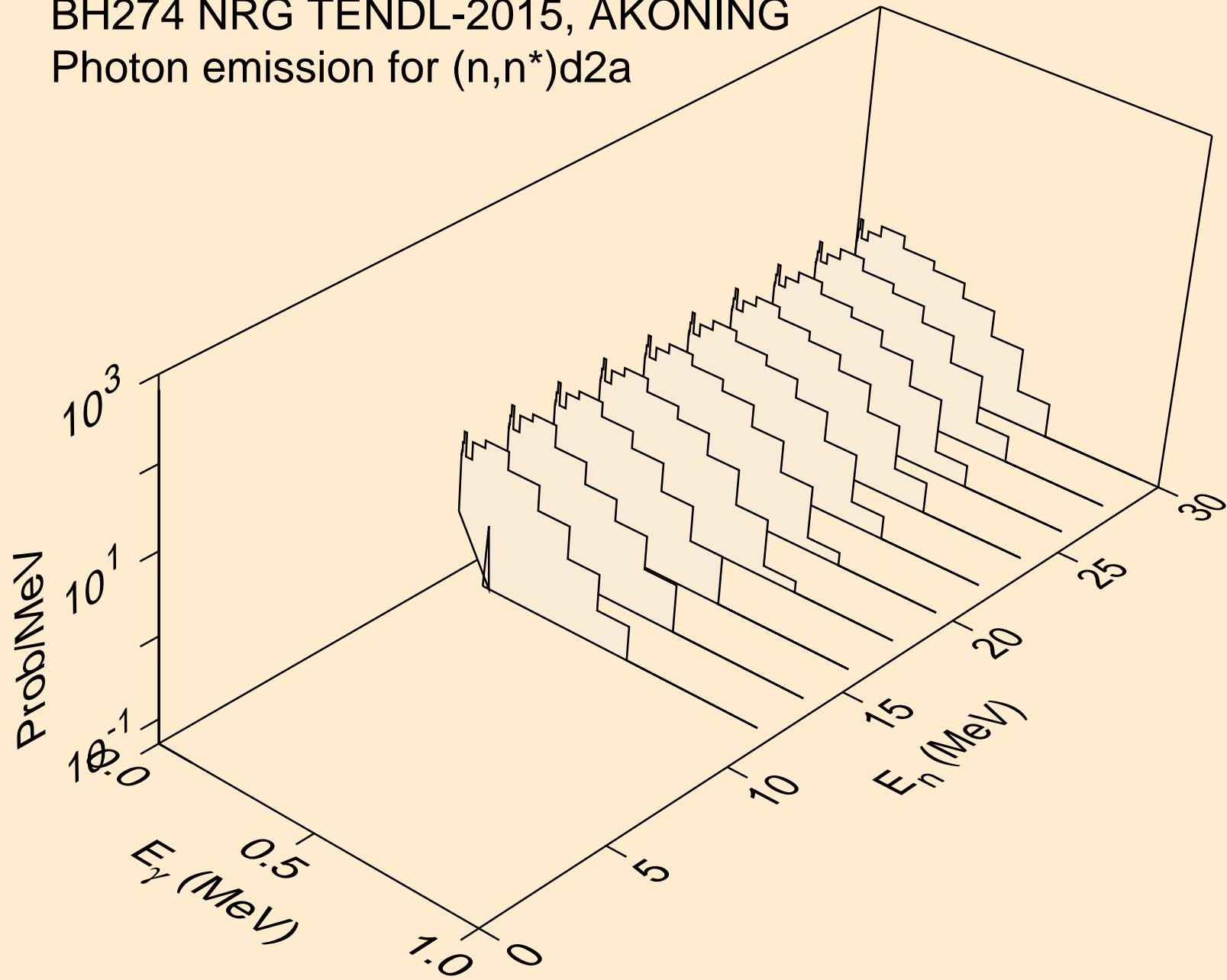



BH274 NRG TENDL-2015, AKONING  
Photon emission for (n,4n)

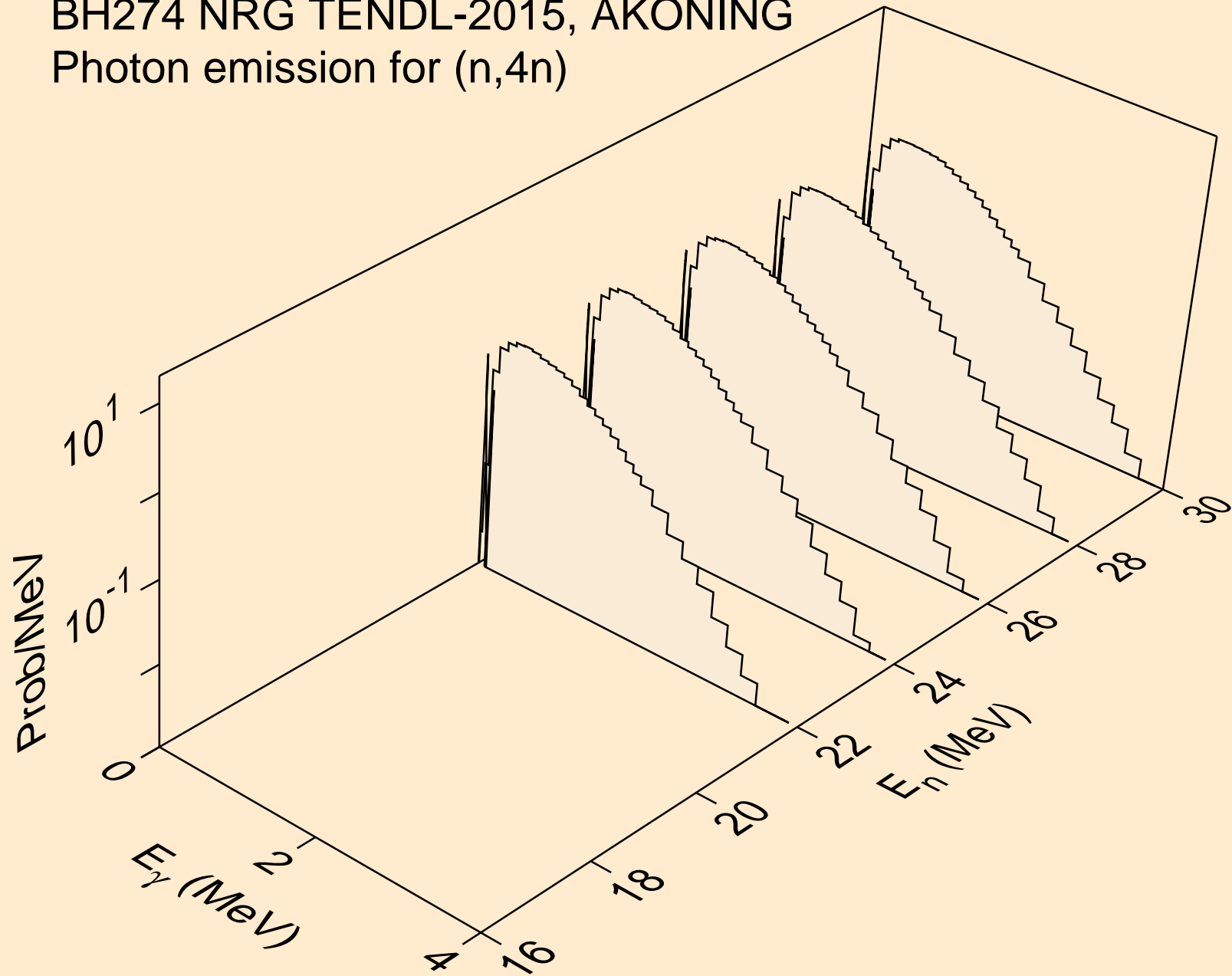

BH274 NRG TENDL-2015, AKONING  
Photon emission for (n,2np)

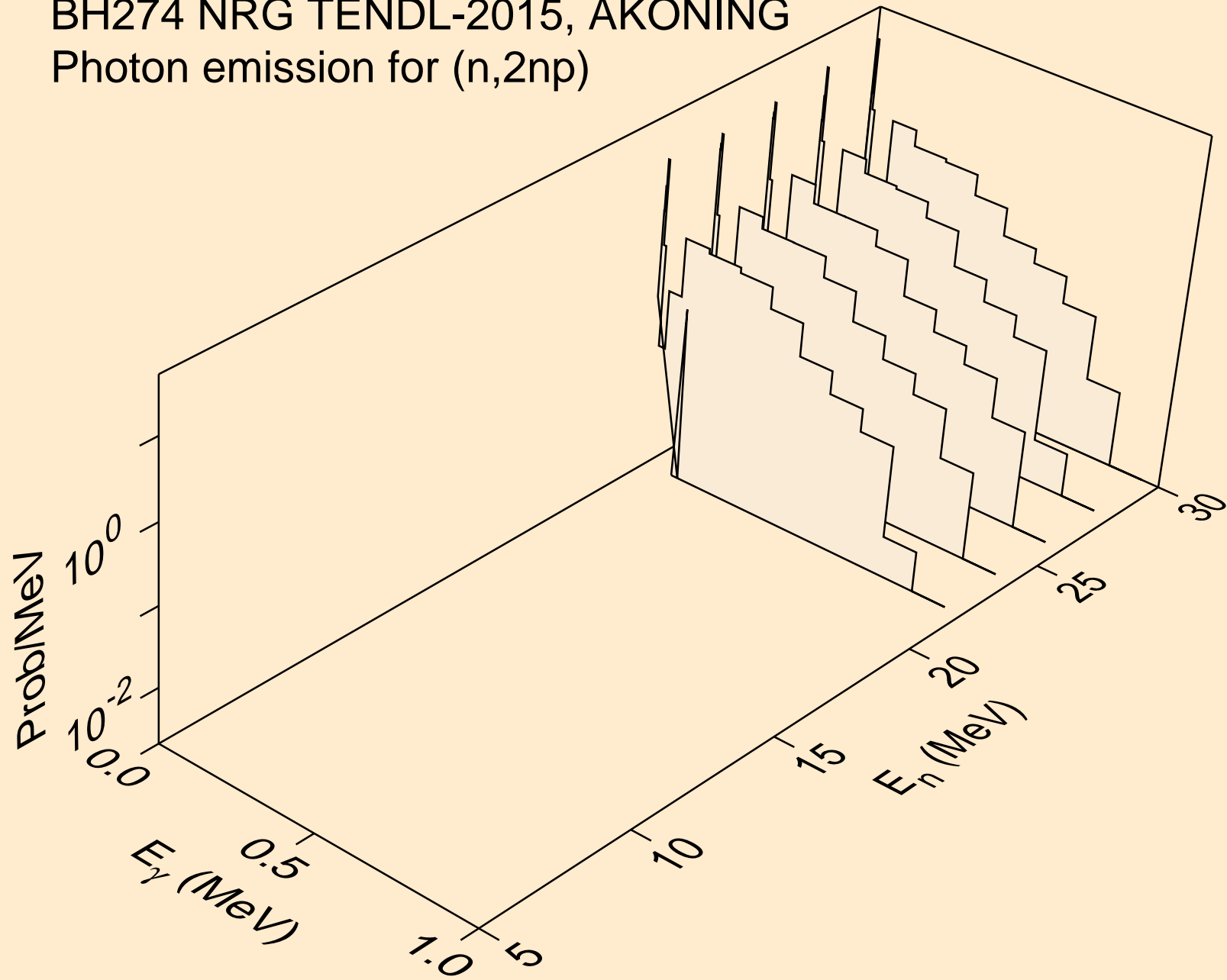

BH274 NRG TENDL-2015, AKONING  
Photon emission for (n,n\*c)

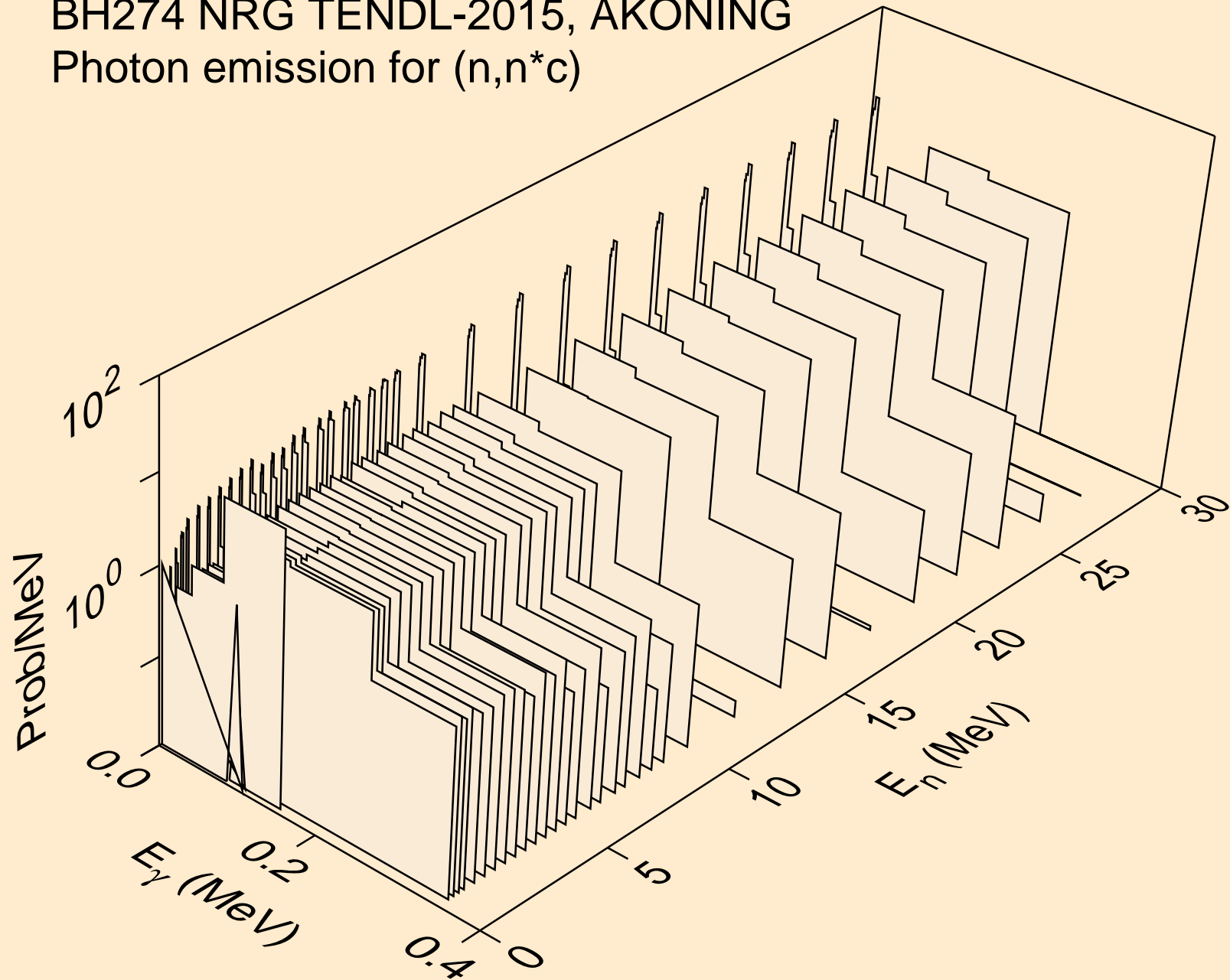

BH274 NRG TENDL-2015, AKONING  
Photon emission for (n,gma)

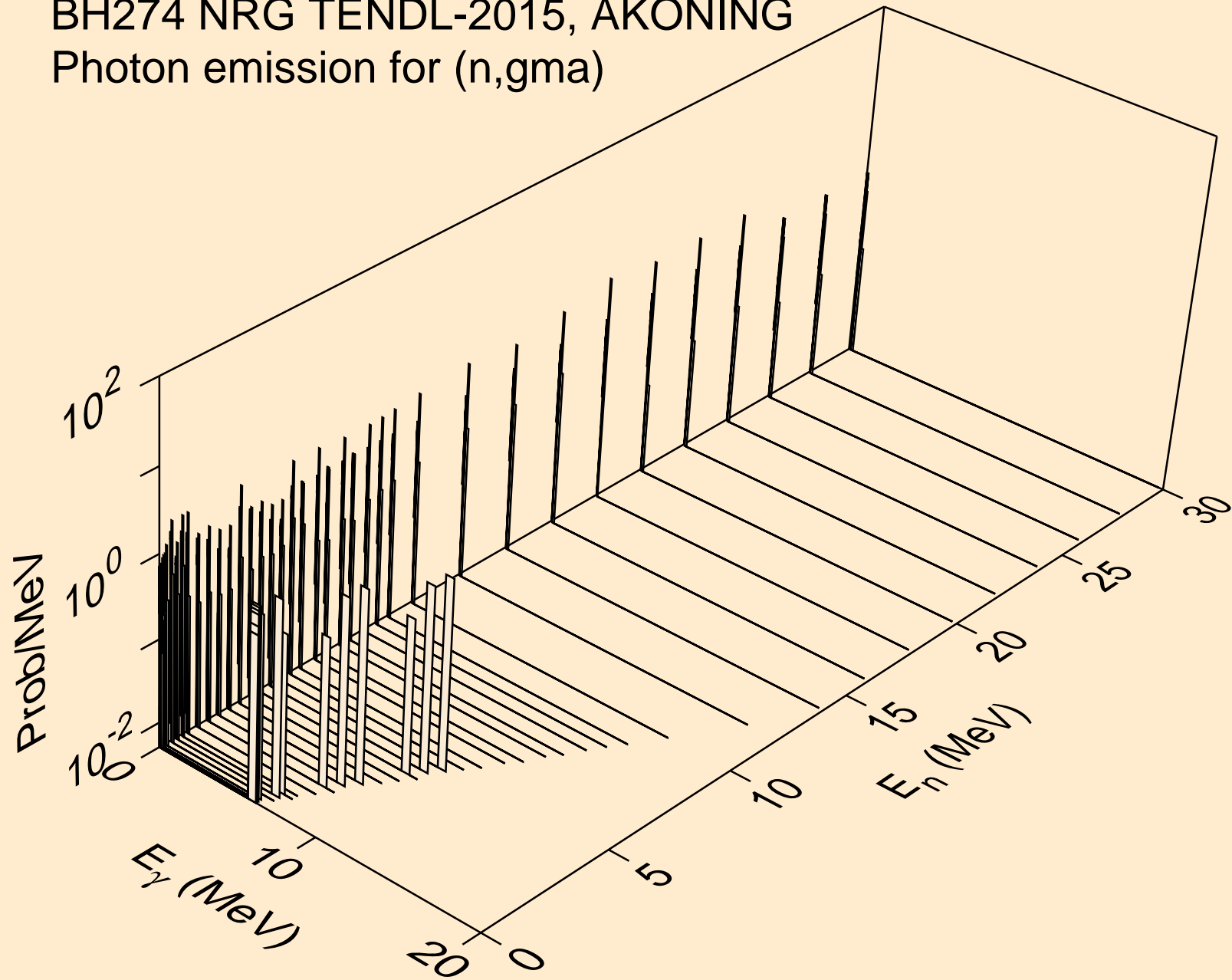

BH274 NRG TENDL-2015, AKONING  
Photon emission for (n,p)

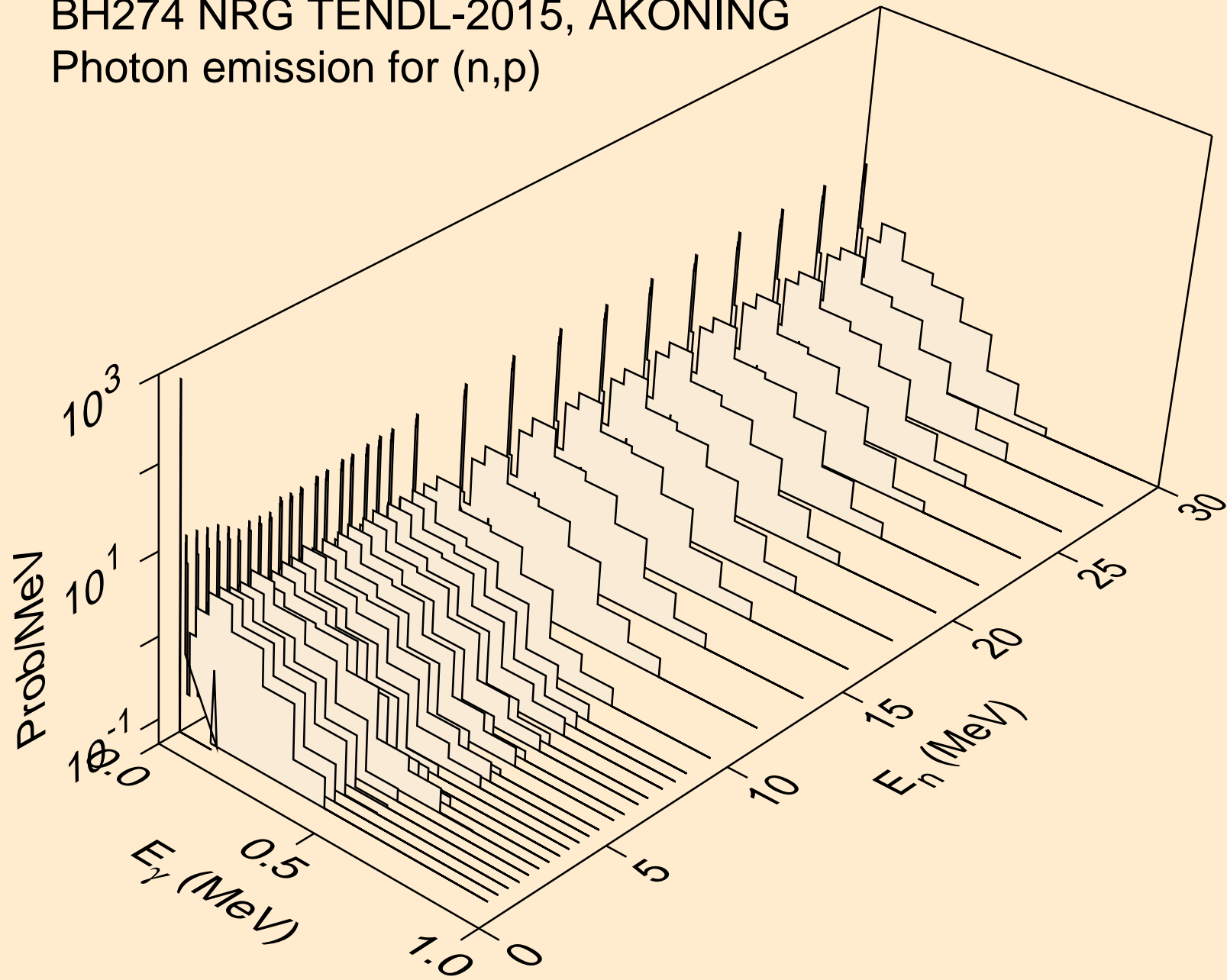

BH274 NRG TENDL-2015, AKONING  
Photon emission for (n,d)

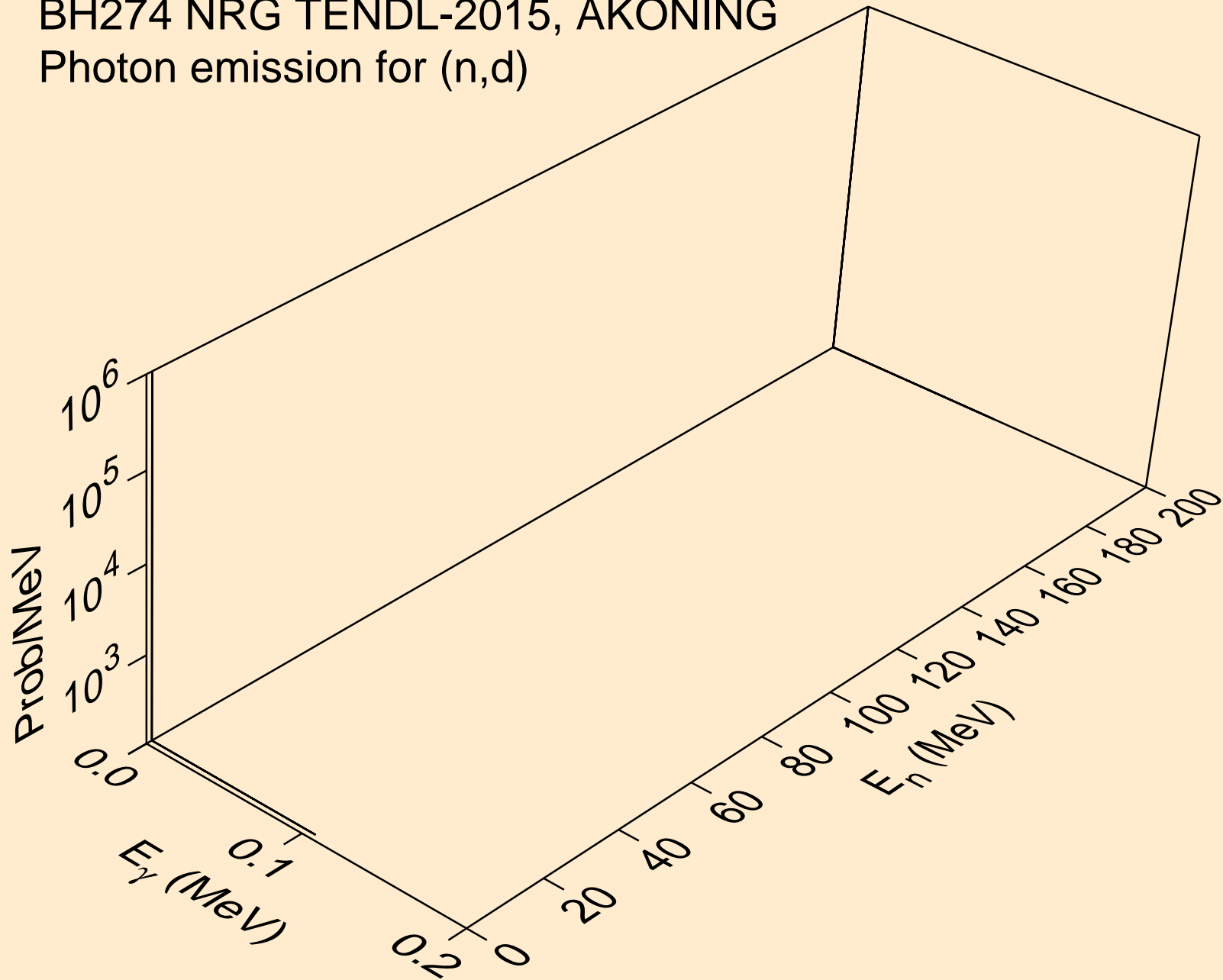

BH274 NRG TENDL-2015, AKONING  
Photon emission for (n,t)

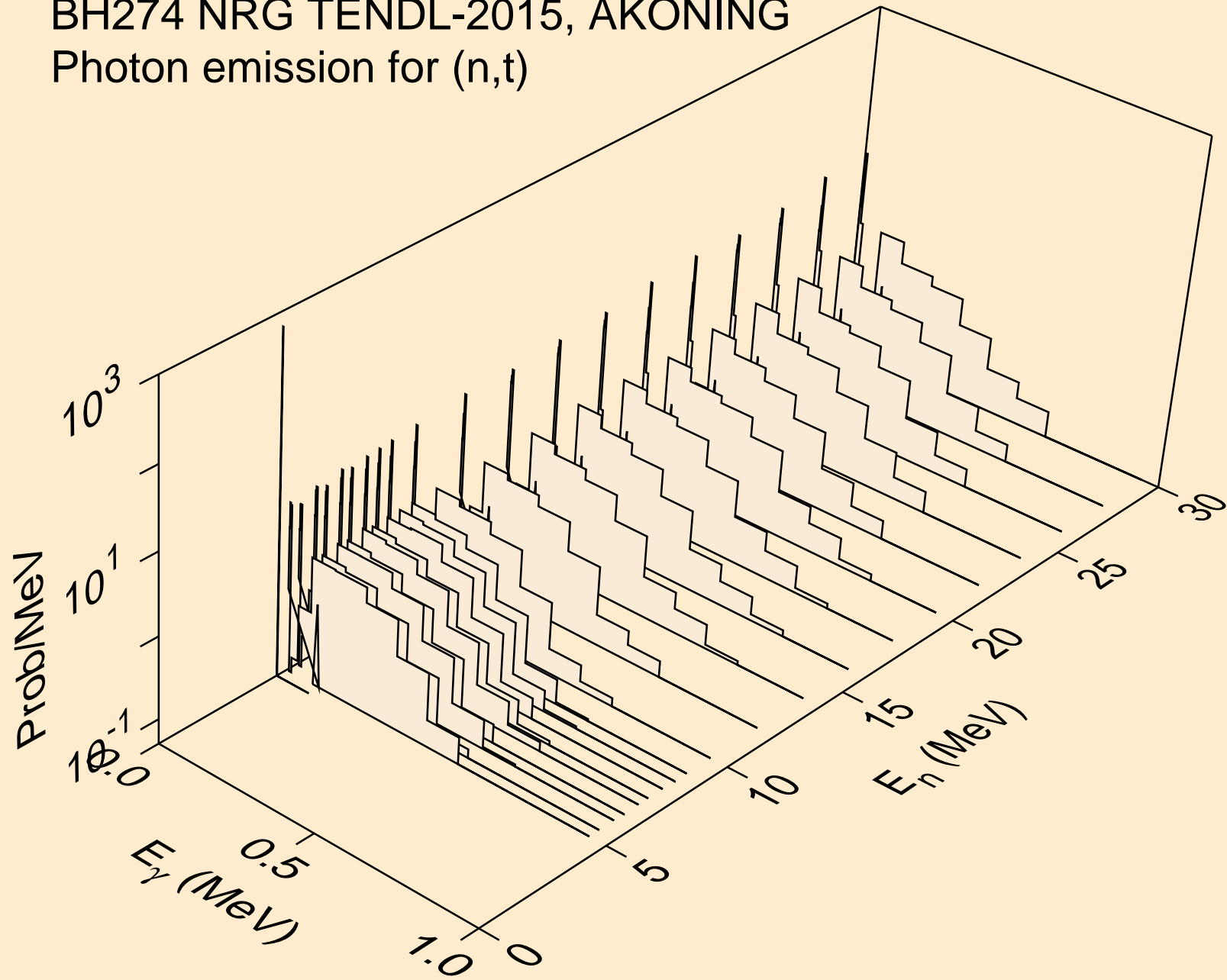

BH274 NRG TENDL-2015, AKONING  
Photon emission for (n,he3)

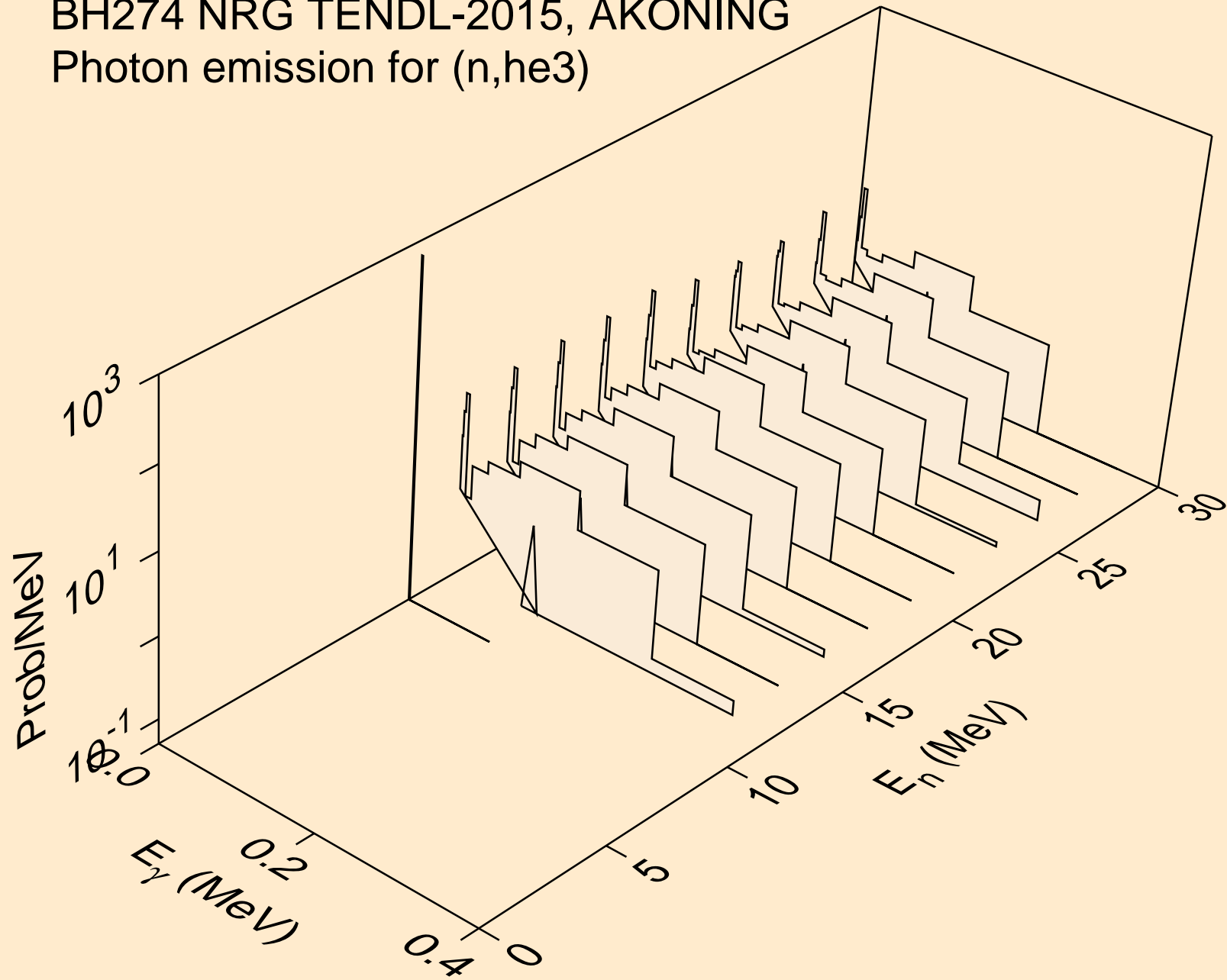



BH274 NRG TENDL-2015, AKONING  
Photon emission for (n,a)

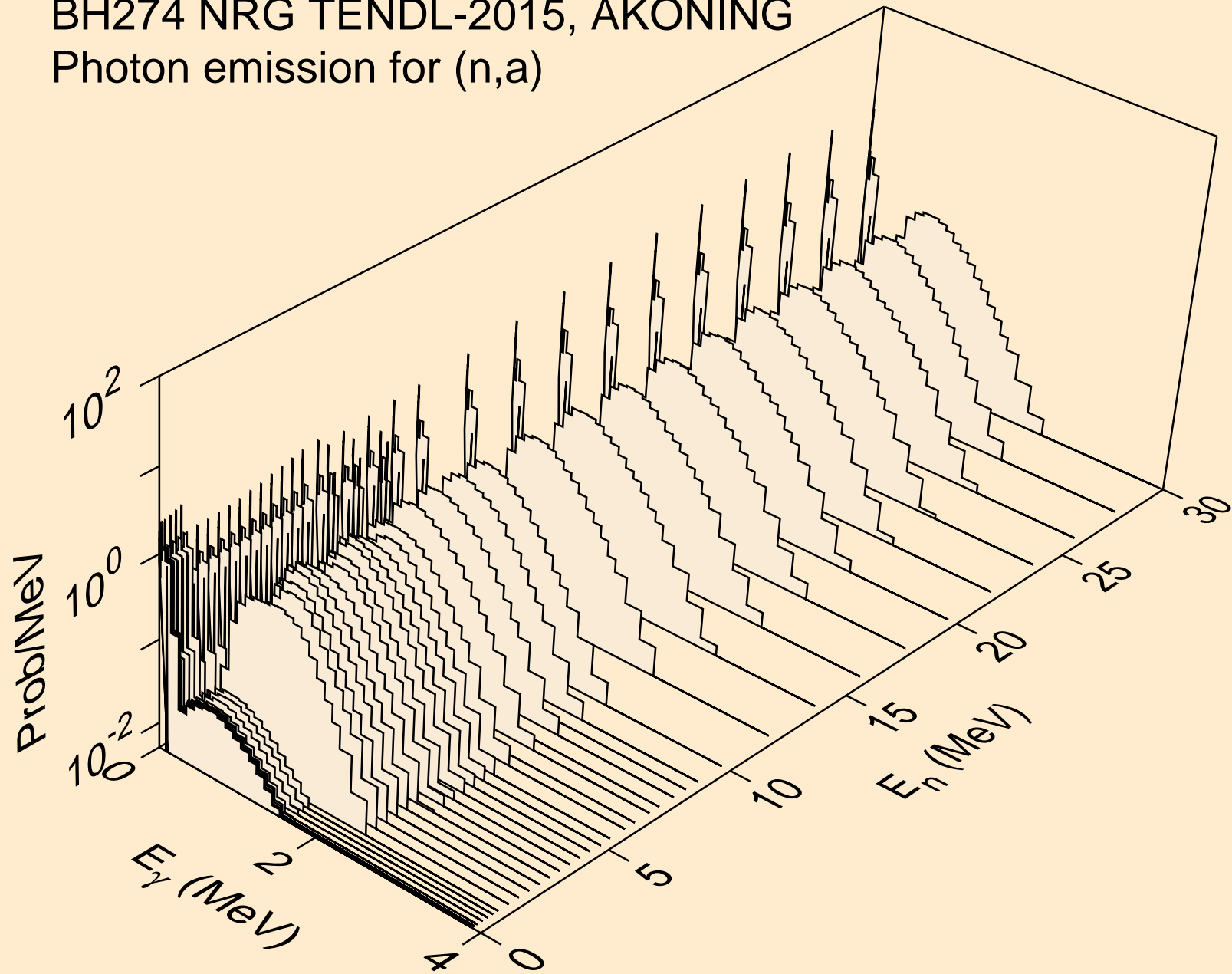

BH274 NRG TENDL-2015, AKONING  
Photon emission for (n,2a)

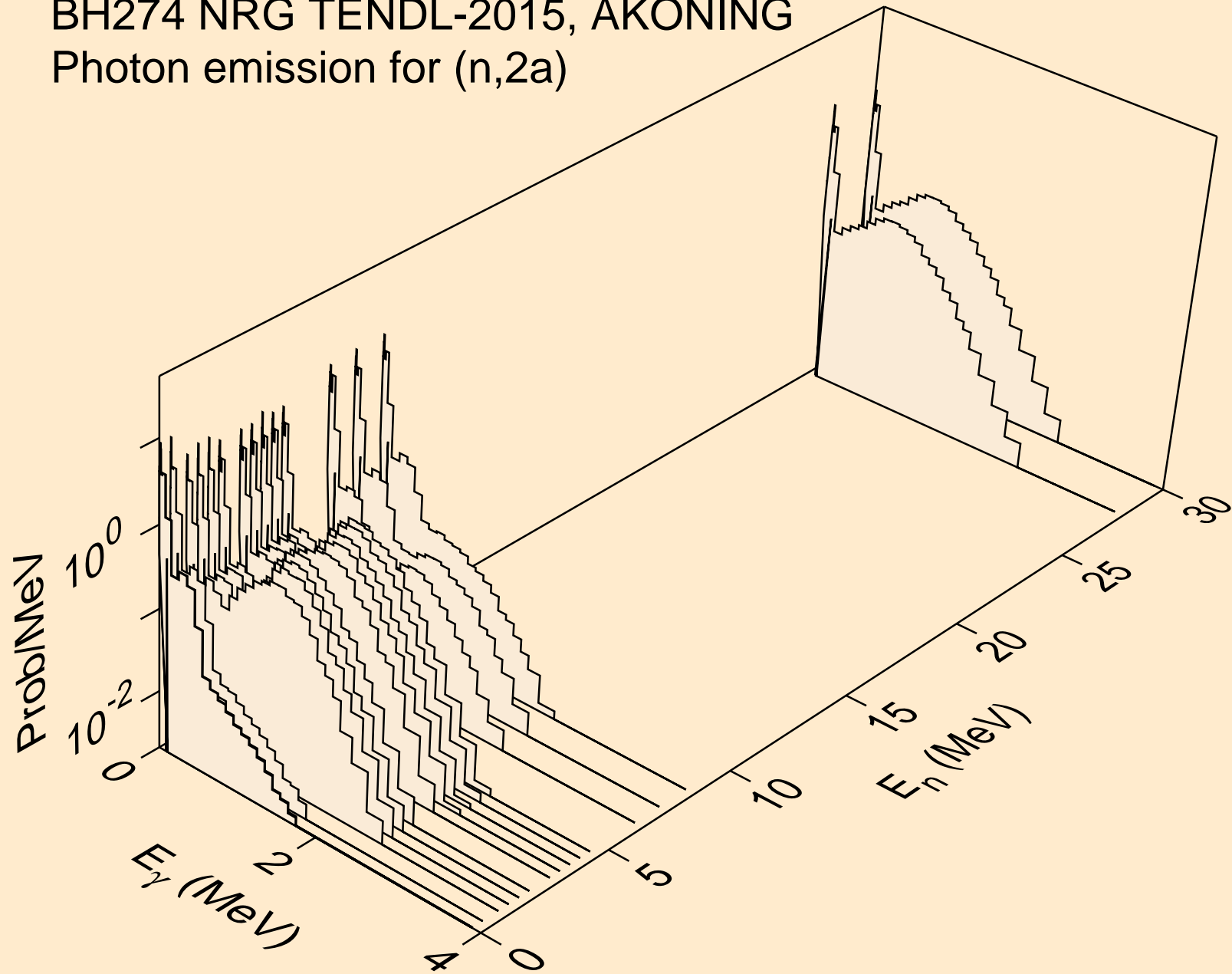

BH274 NRG TENDL-2015, AKONING  
Photon emission for (n,3a)

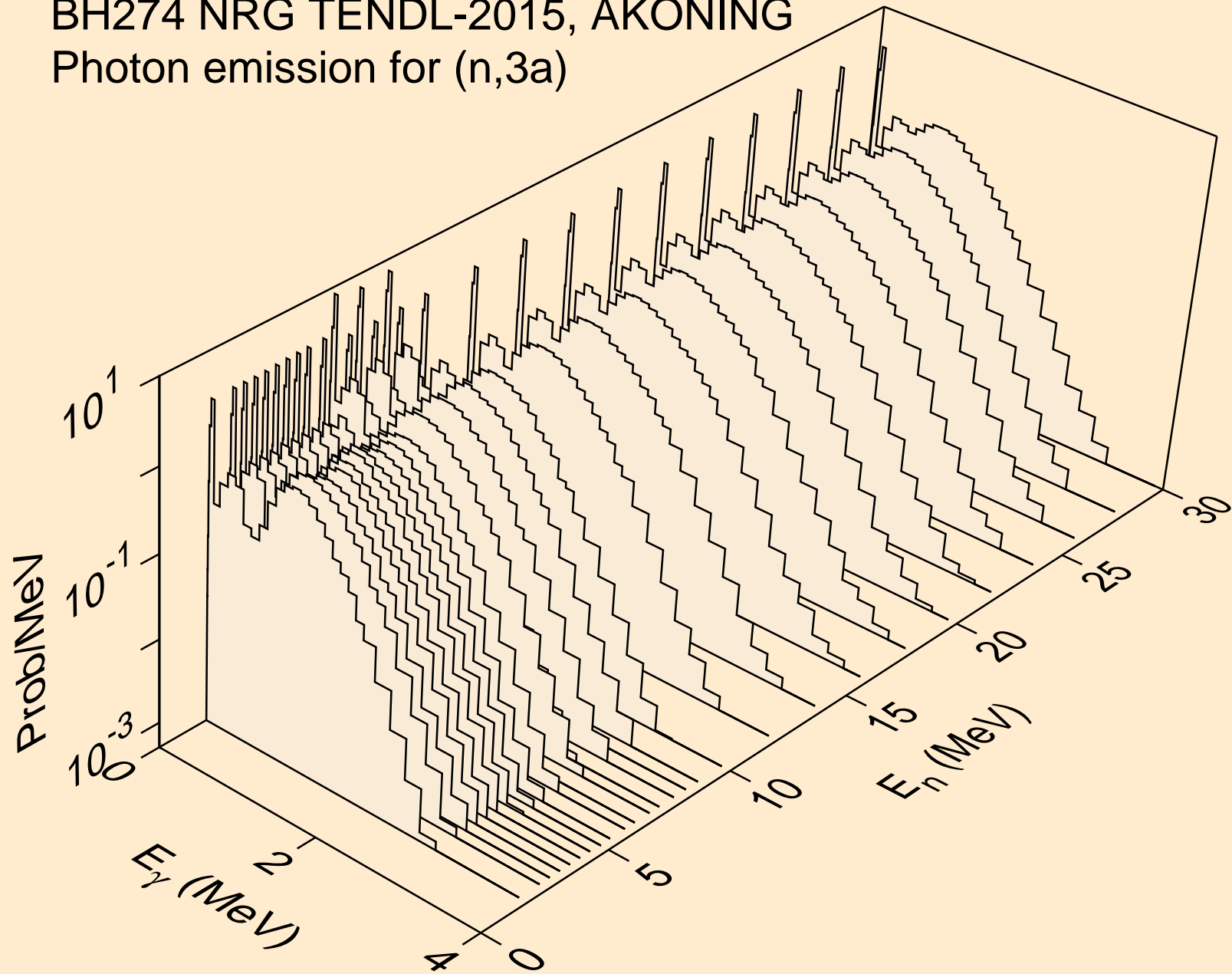

BH274 NRG TENDL-2015, AKONING  
Photon emission for (n,p)

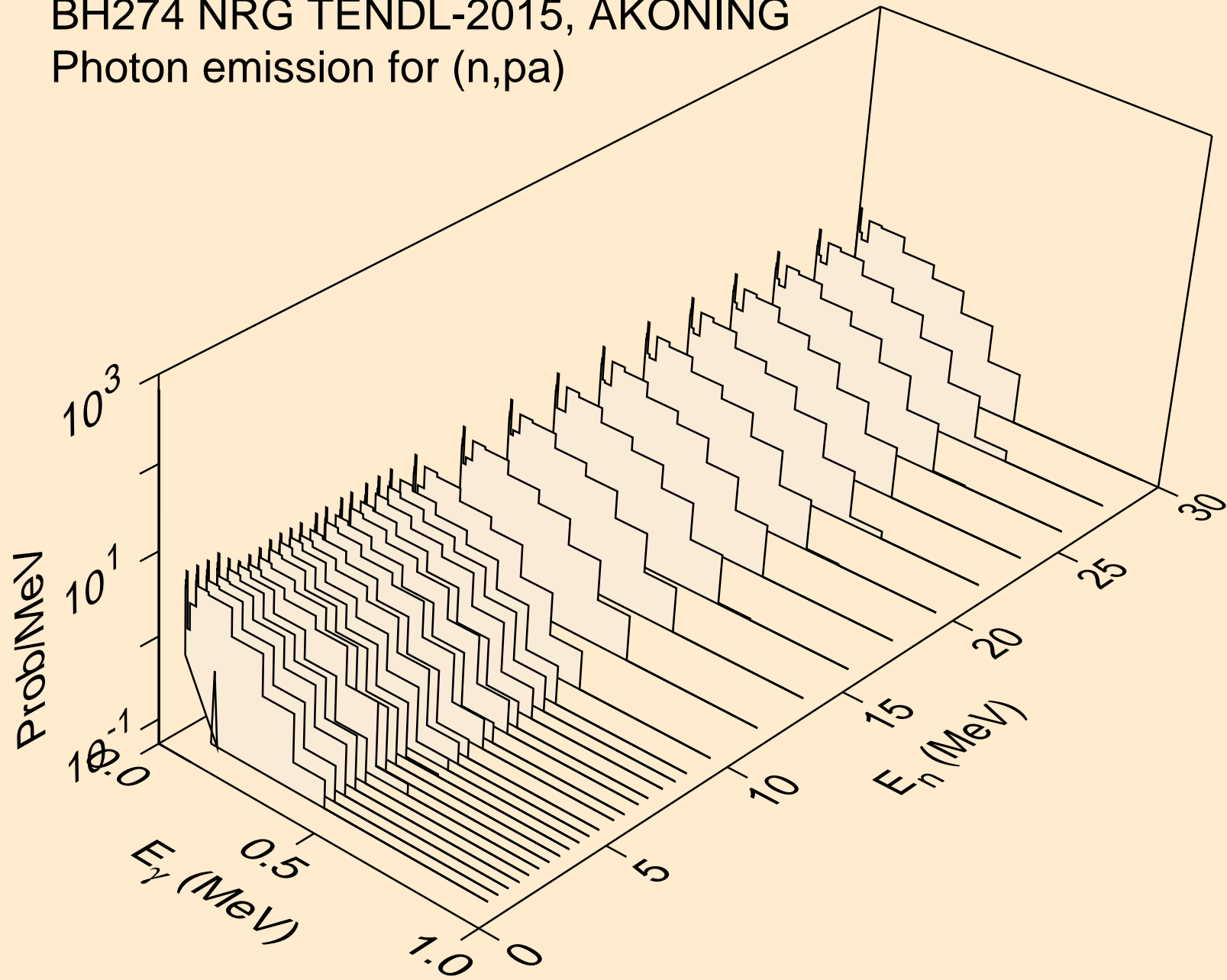

BH274 NRG TENDL-2015, AKONING  
Photon emission for (n,t2a)

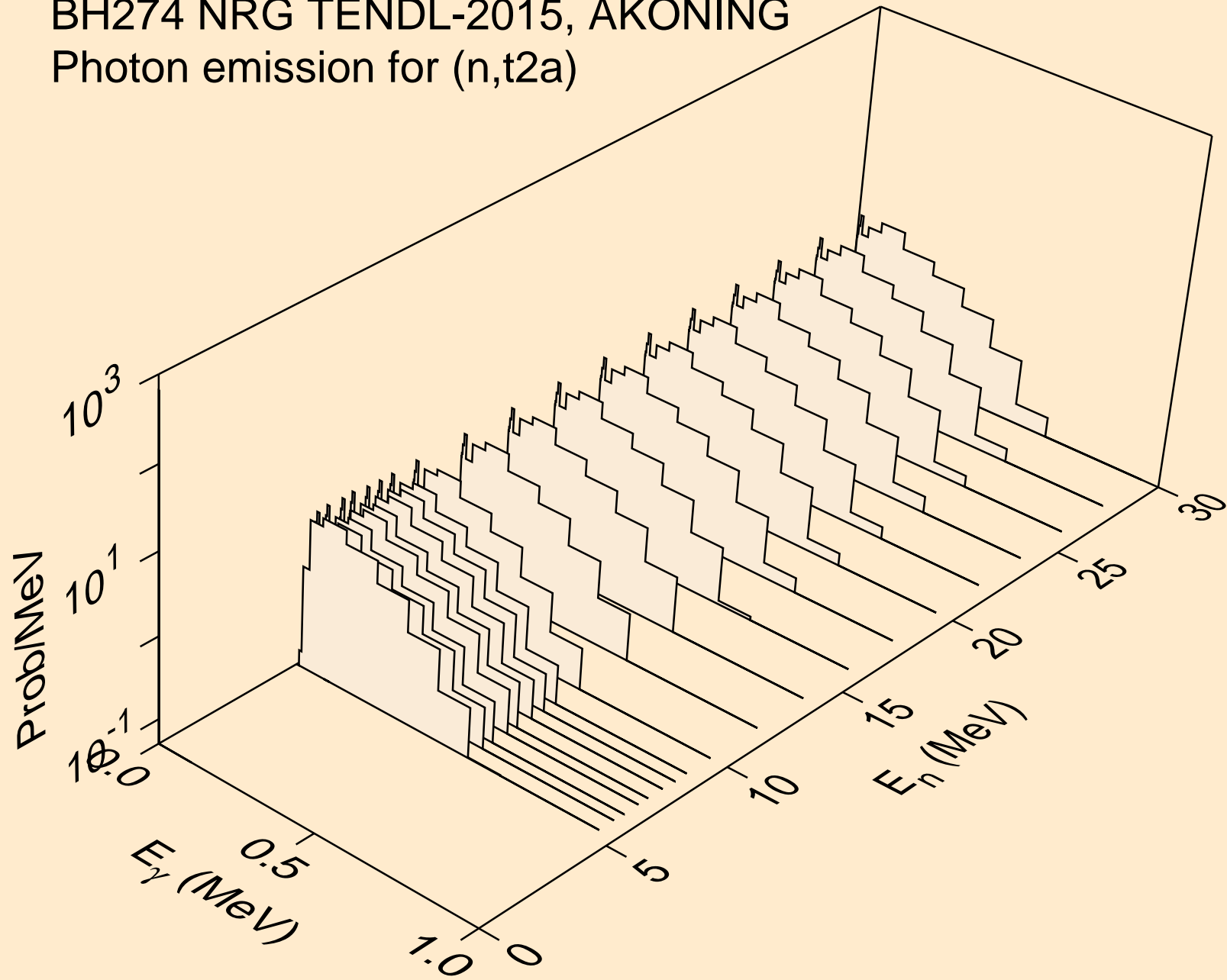

BH274 NRG TENDL-2015, AKONING  
thermal capture photon spectrum

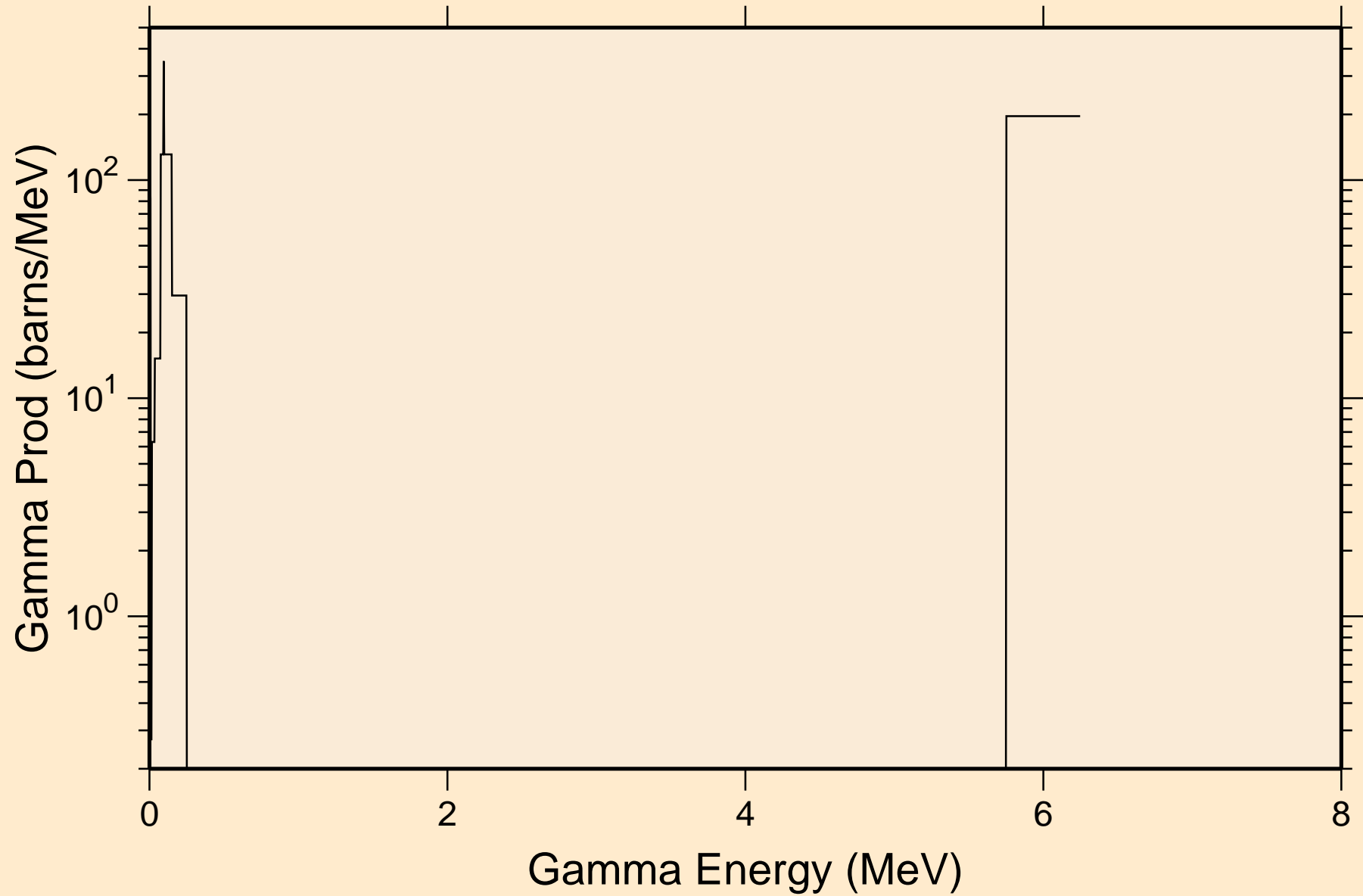

# BH274 NRG TENDL-2015, AKONING

## 14 MeV photon spectrum

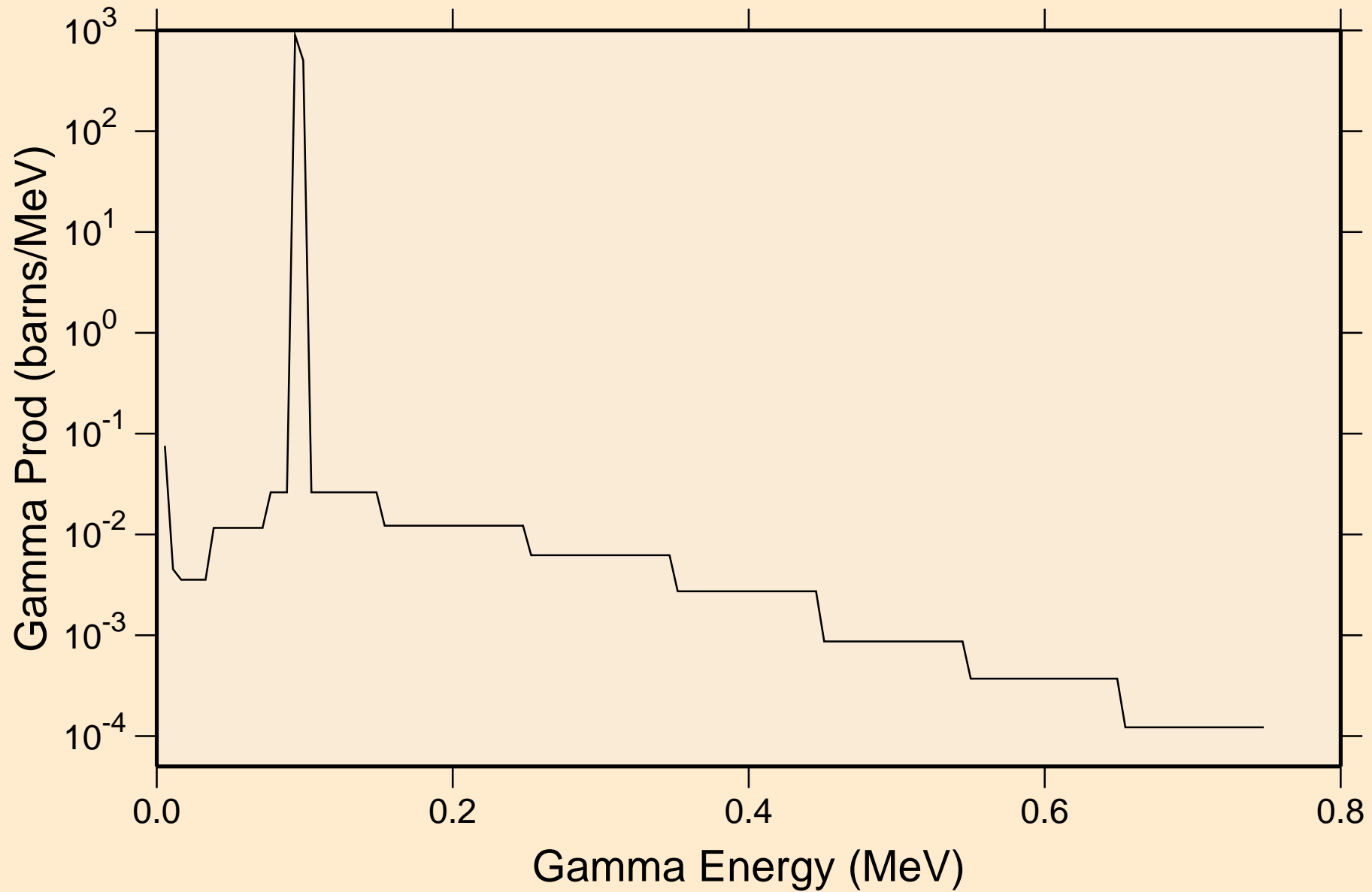

# BH274 NRG TENDL-2015, AKONING

## Particle heating contributions

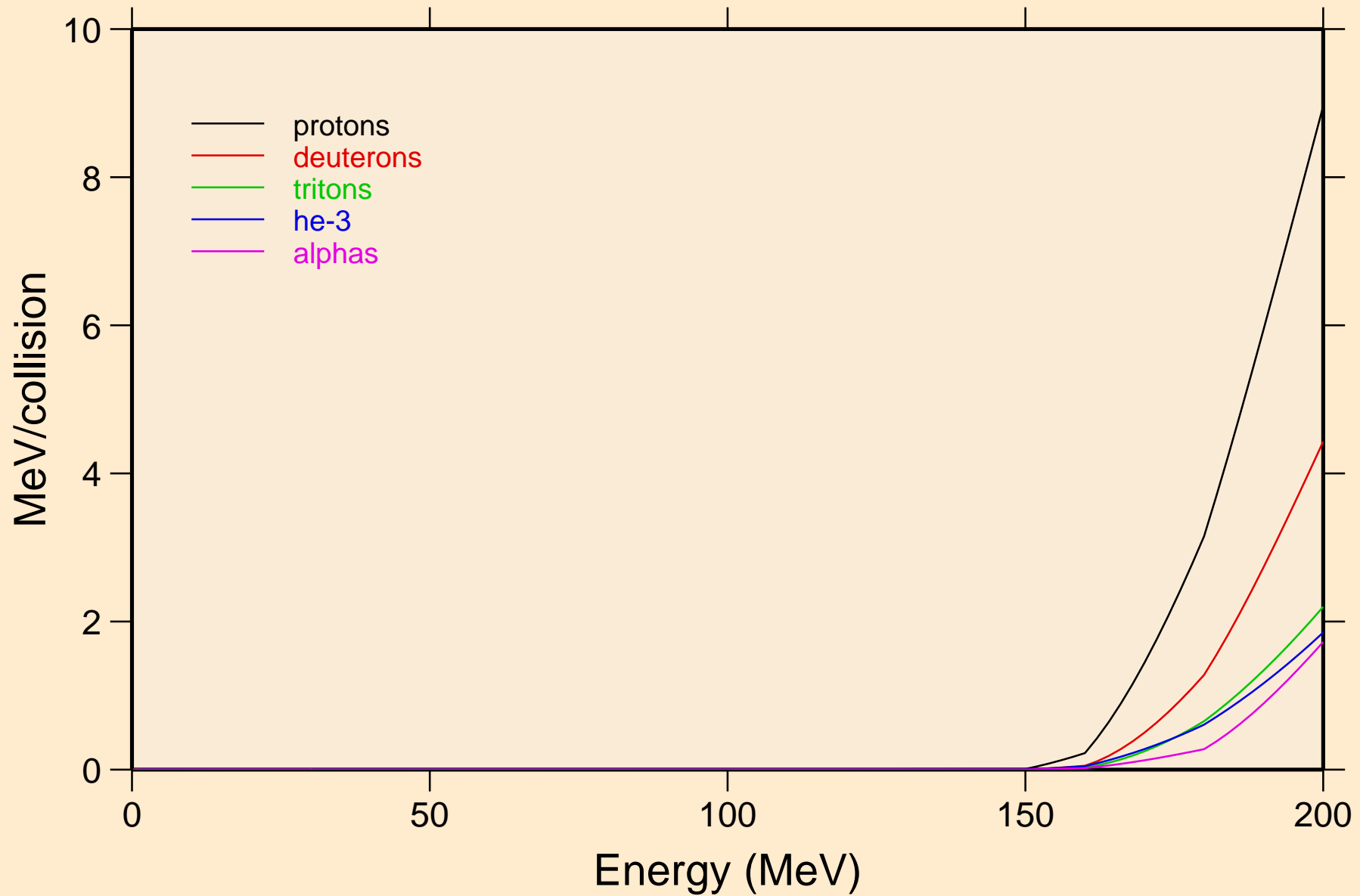



# BH274 NRG TENDL-2015, AKONING

## Recoil Heating

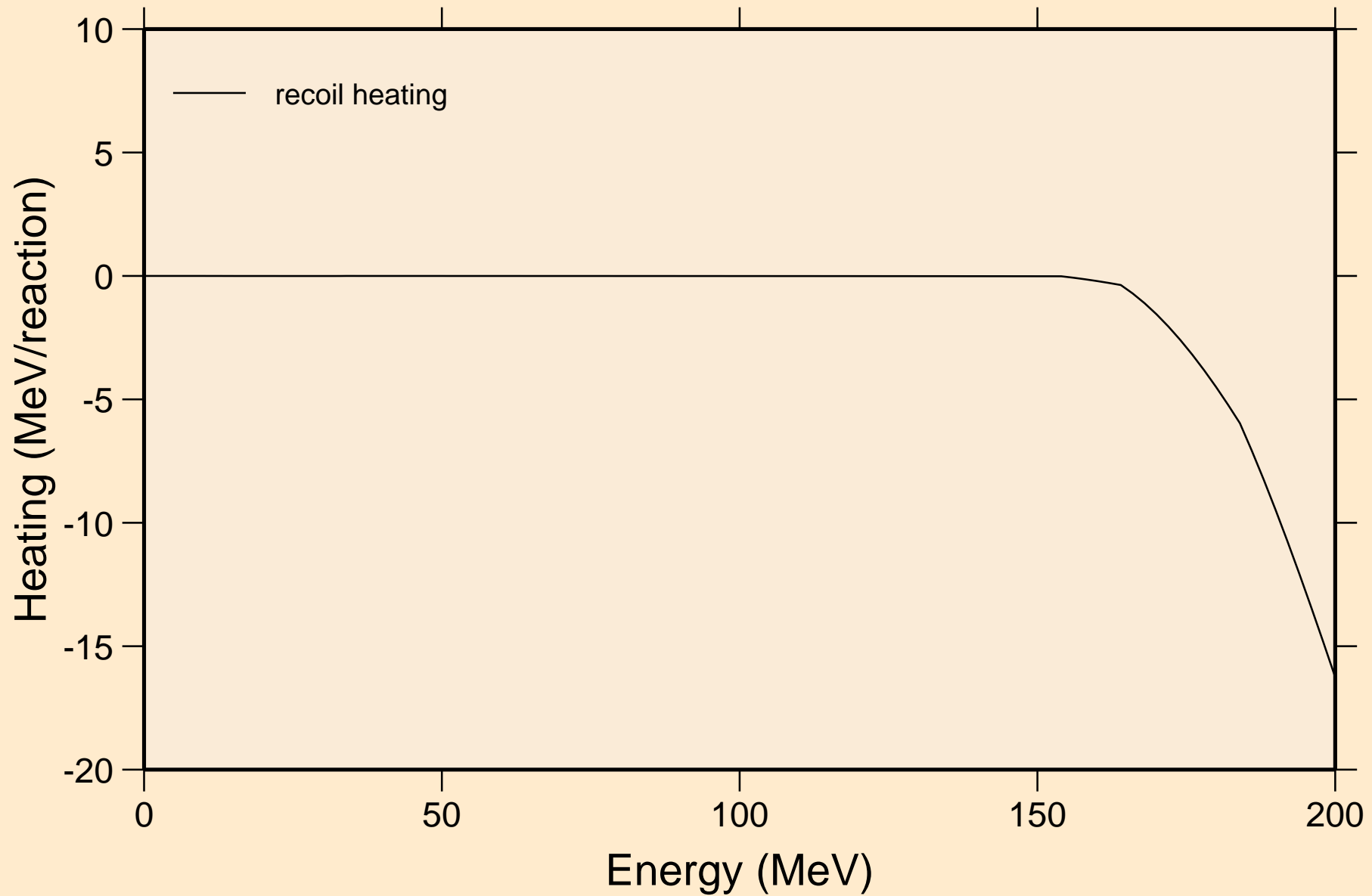

# BH274 NRG TENDL-2015, AKONING

## Particle production cross sections

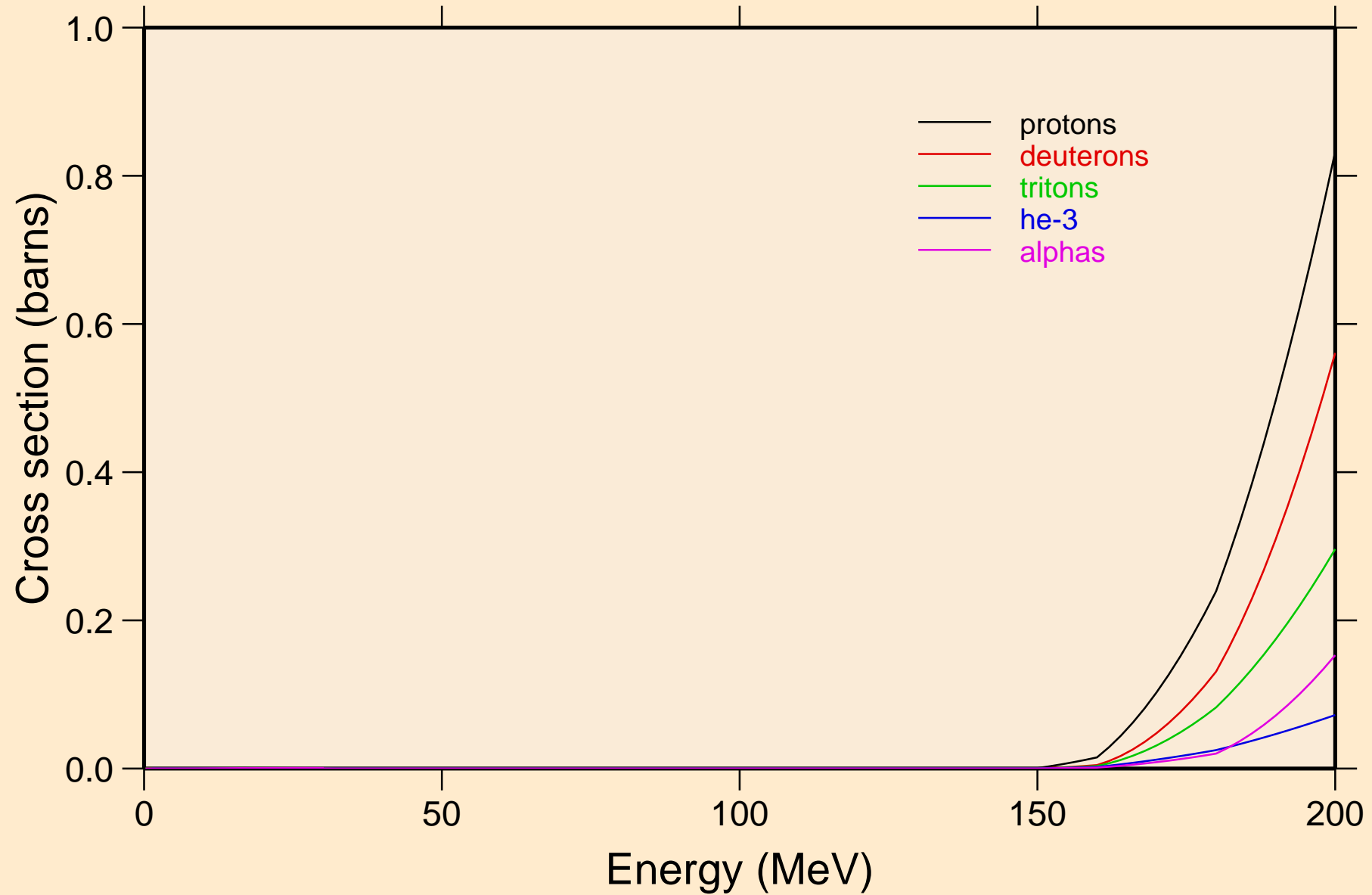

BH274 NRG TENDL-2015, AKONING  
protons from (n,x)

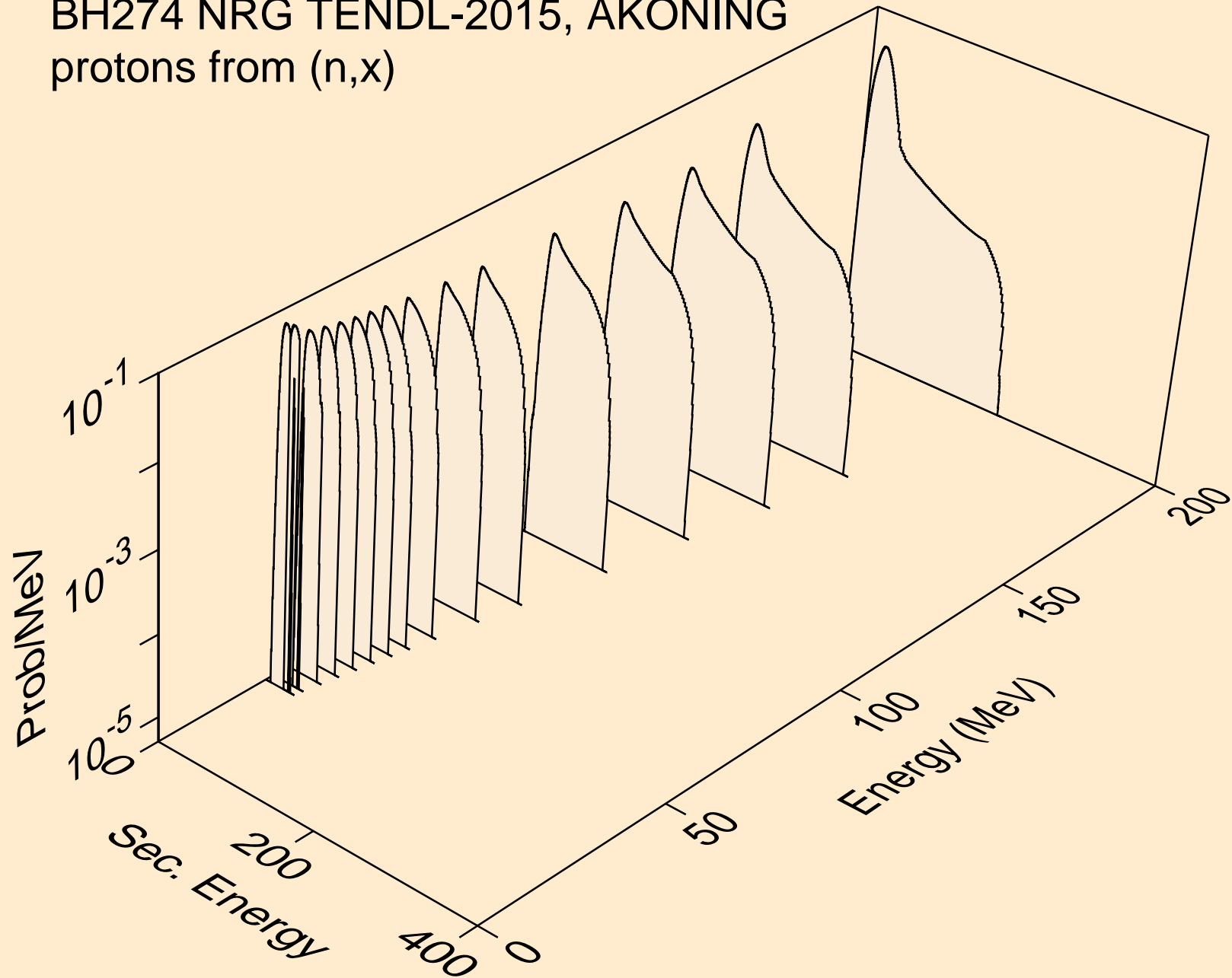

BH274 NRG TENDL-2015, AKONING  
protons from (n,n\*)p

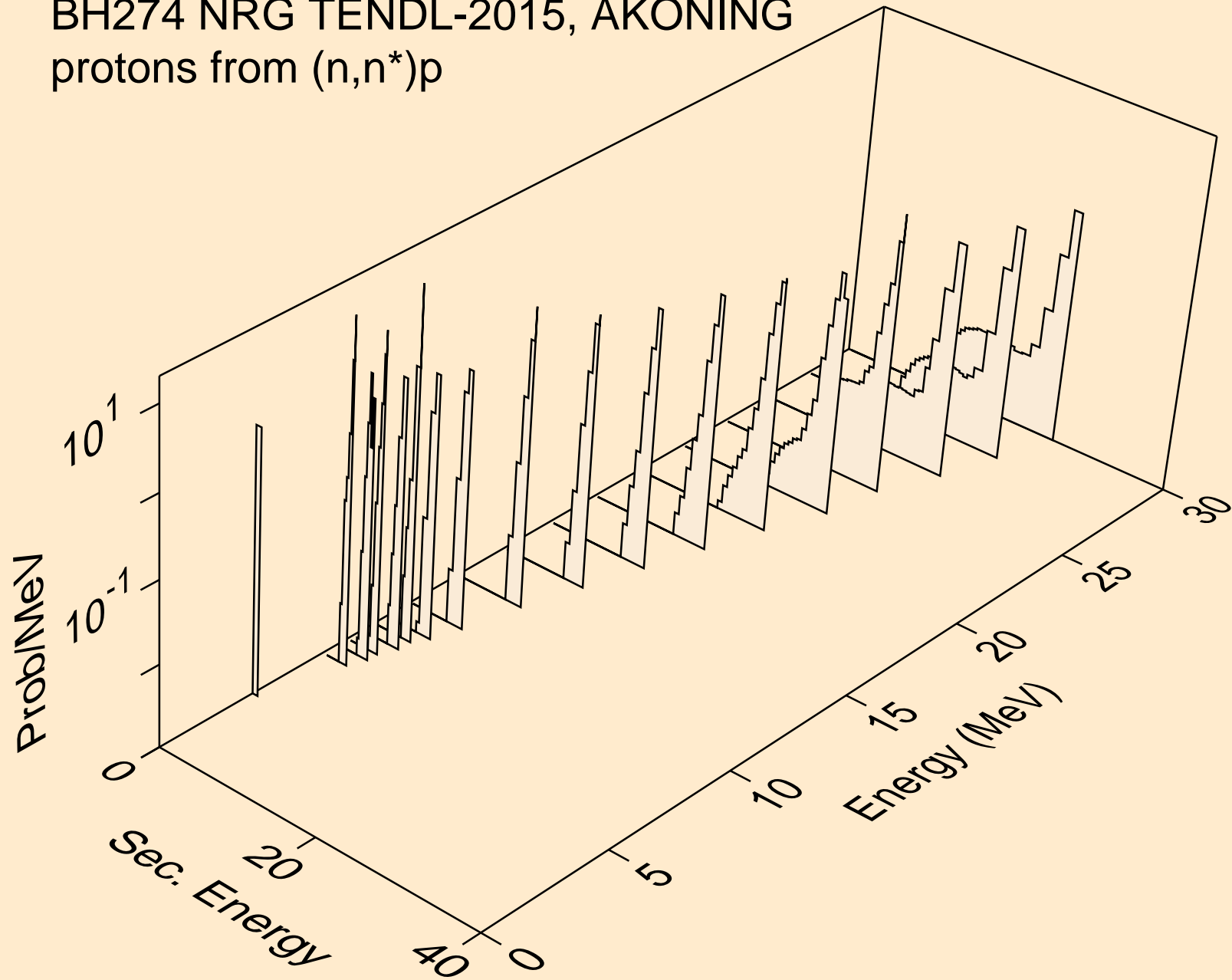

BH274 NRG TENDL-2015, AKONING  
protons from (n,2np)

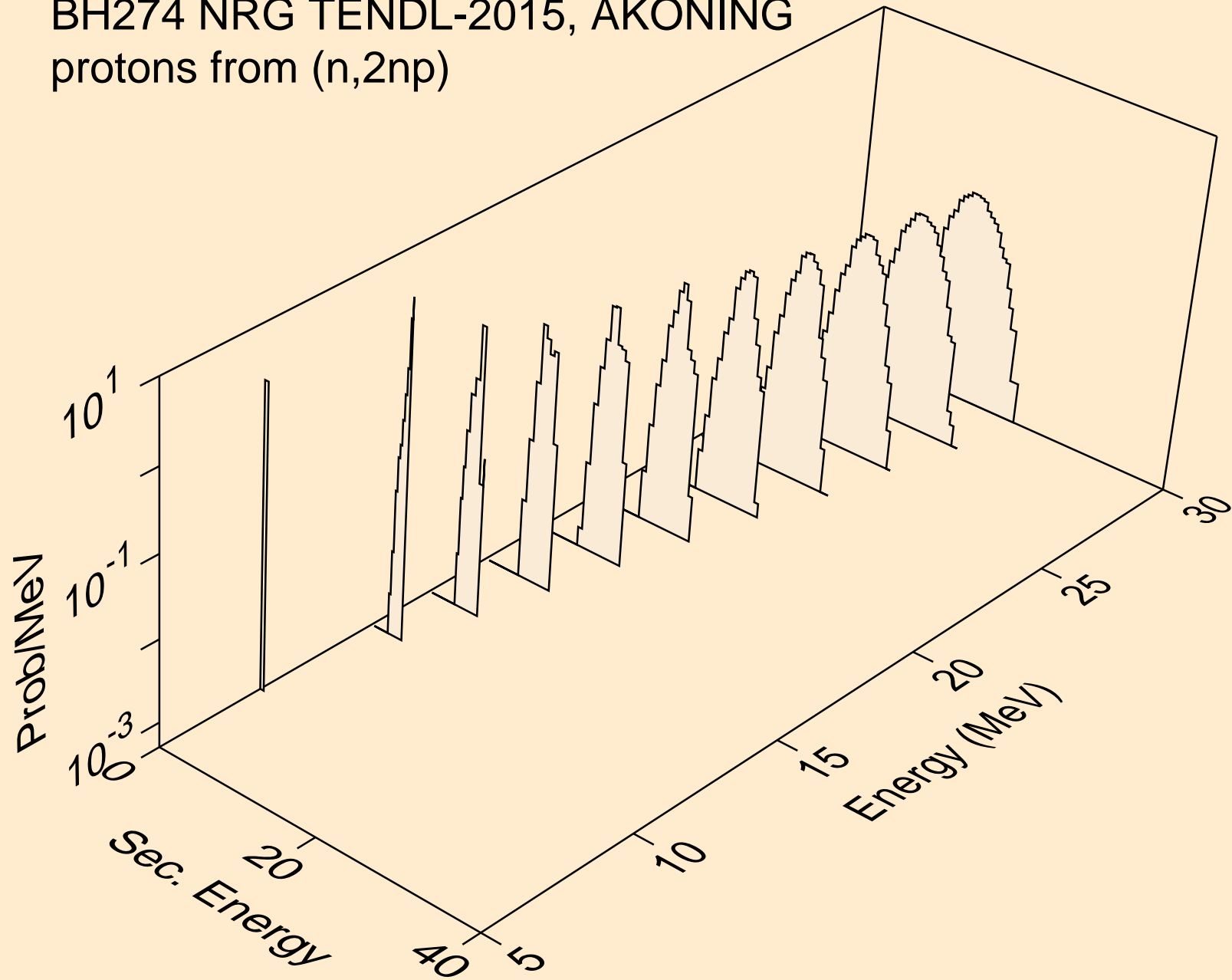

BH274 NRG TENDL-2015, AKONING  
protons from (n,p)

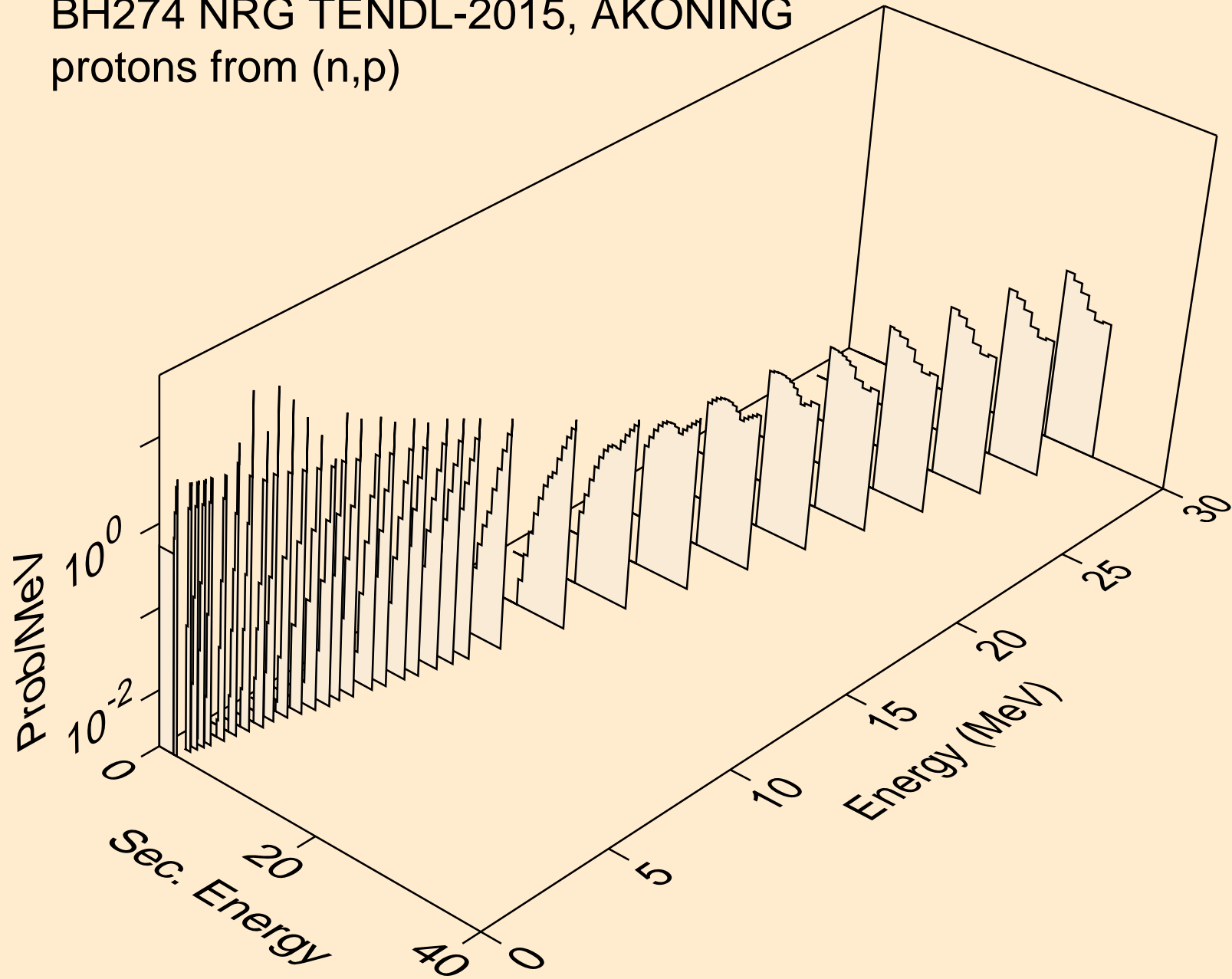

BH274 NRG TENDL-2015, AKONING  
protons from (n,pa)

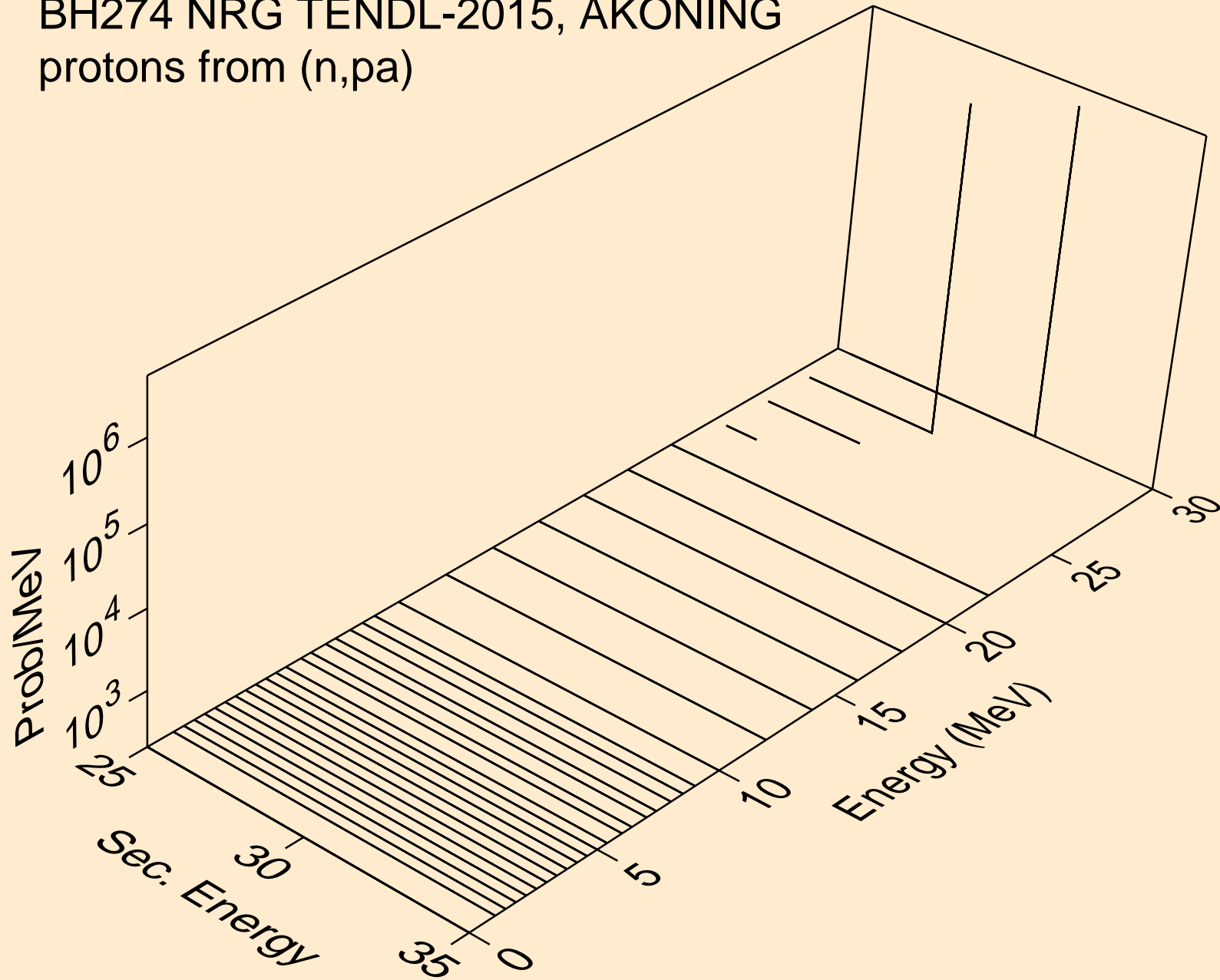

BH274 NRG TENDL-2015, AKONING  
deuterons from (n,x)

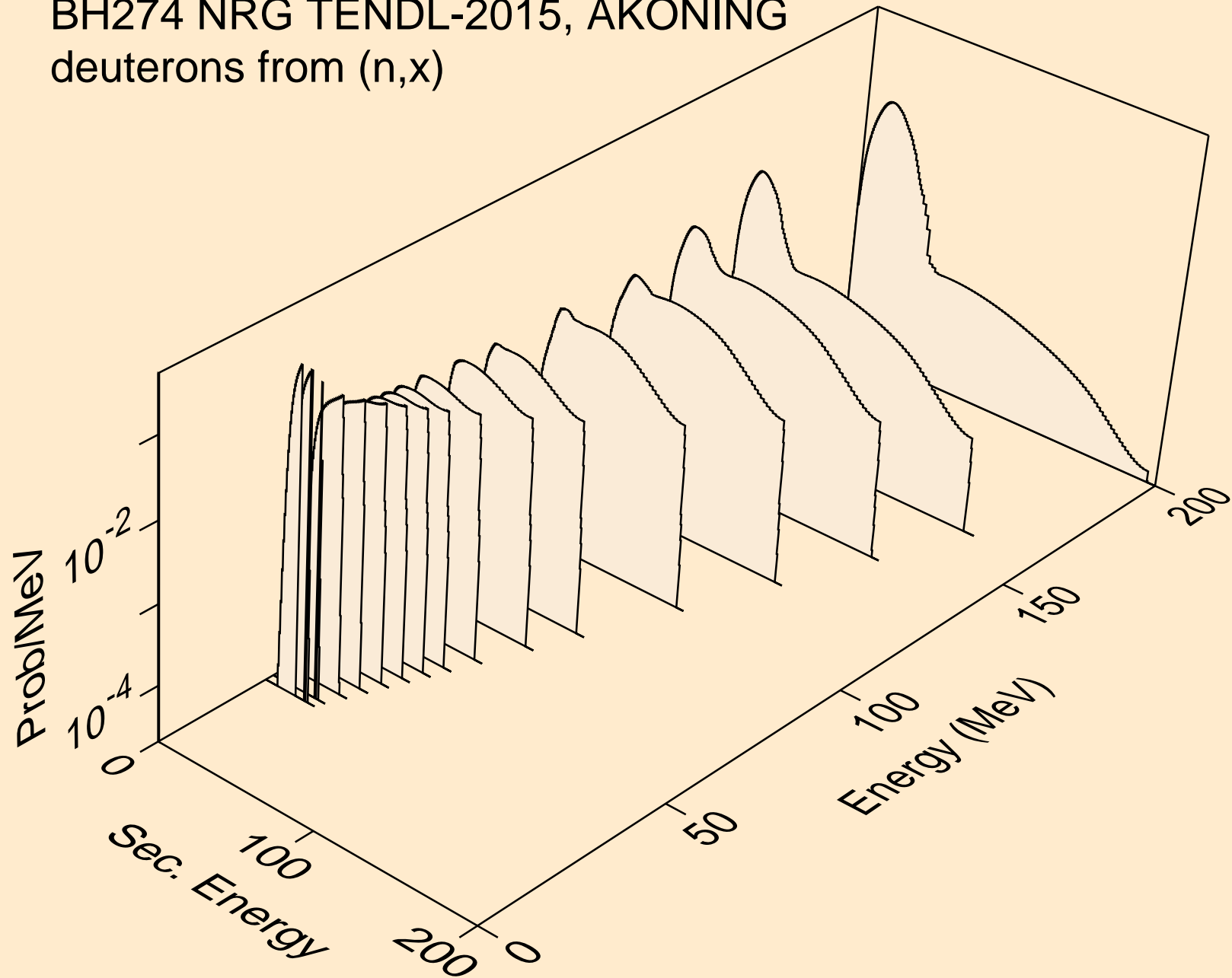



BH274 NRG TENDL-2015, AKONING  
deuterons from (n,n\*)d

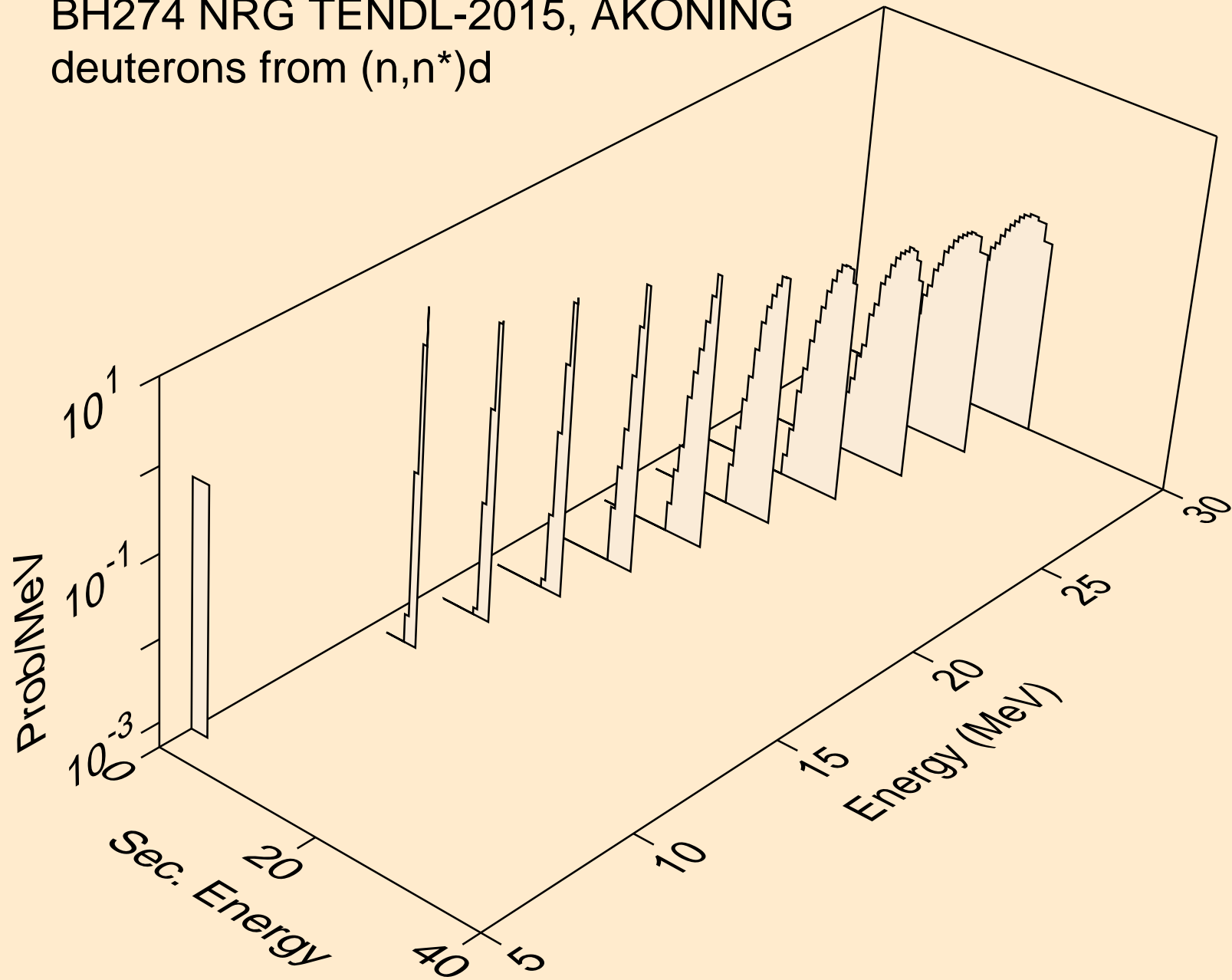

BH274 NRG TENDL-2015, AKONING  
deuterons from (n,n\*)d2a

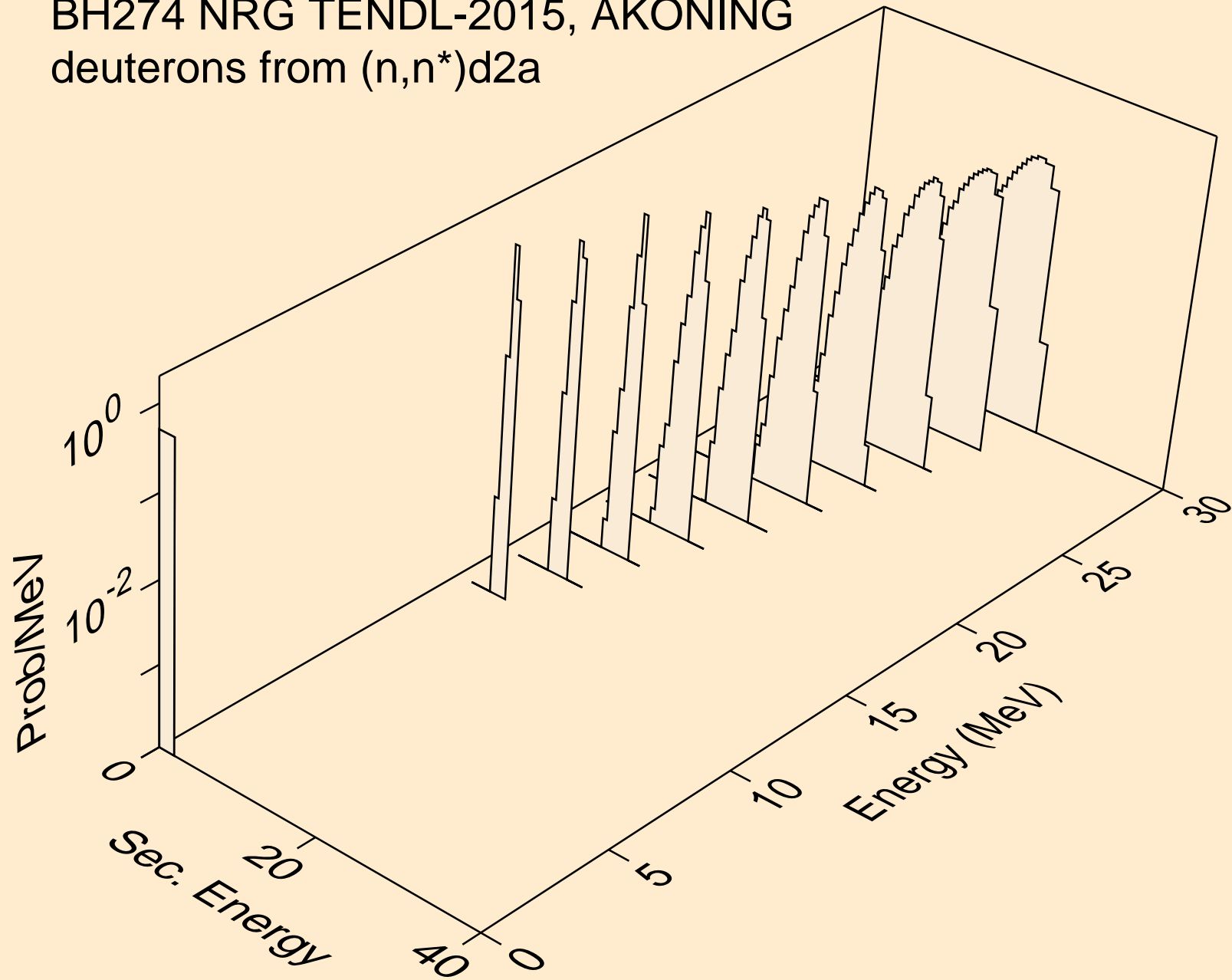

BH274 NRG TENDL-2015, AKONING  
deuterons from (n,d)

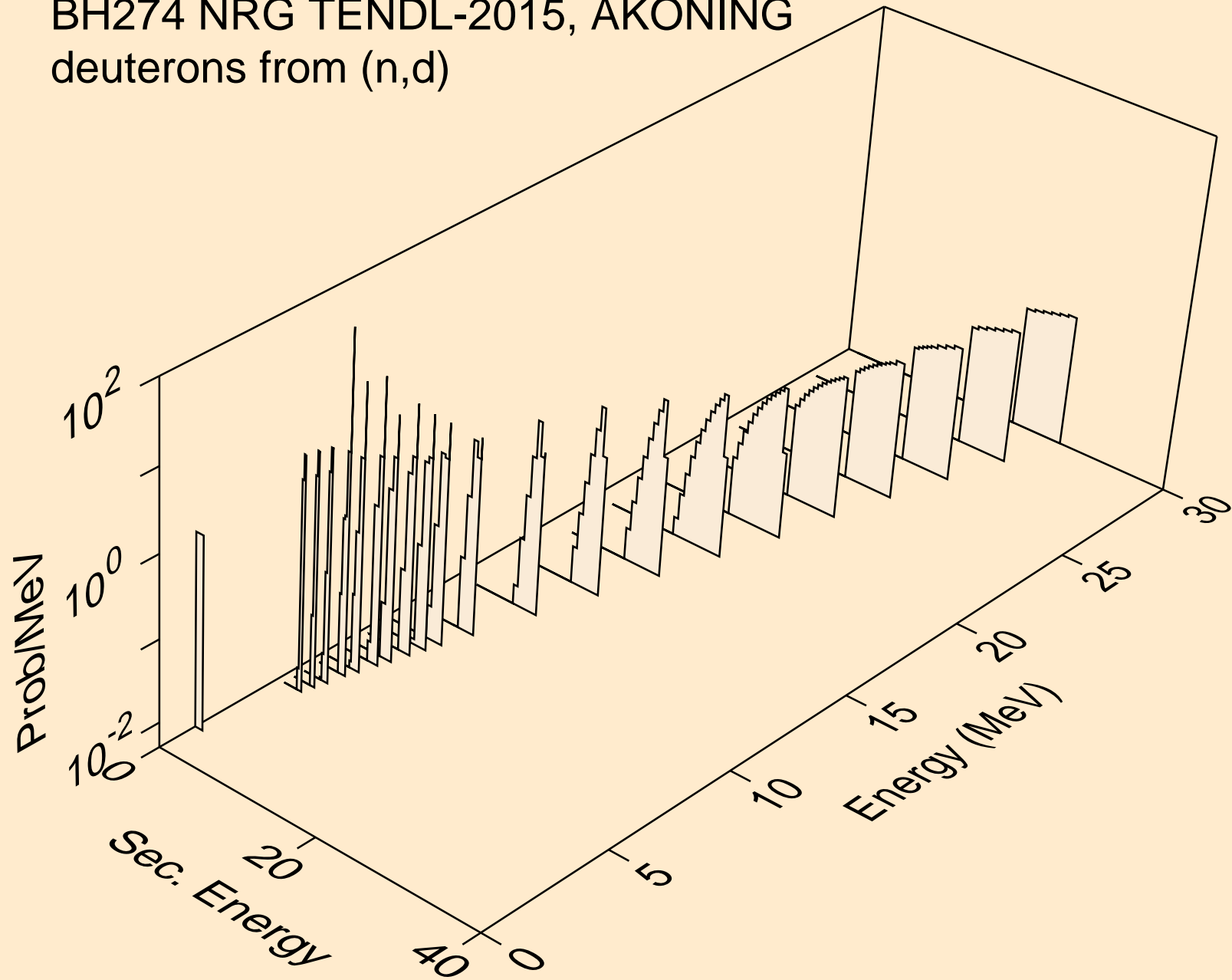

BH274 NRG TENDL-2015, AKONING  
tritons from (n,x)

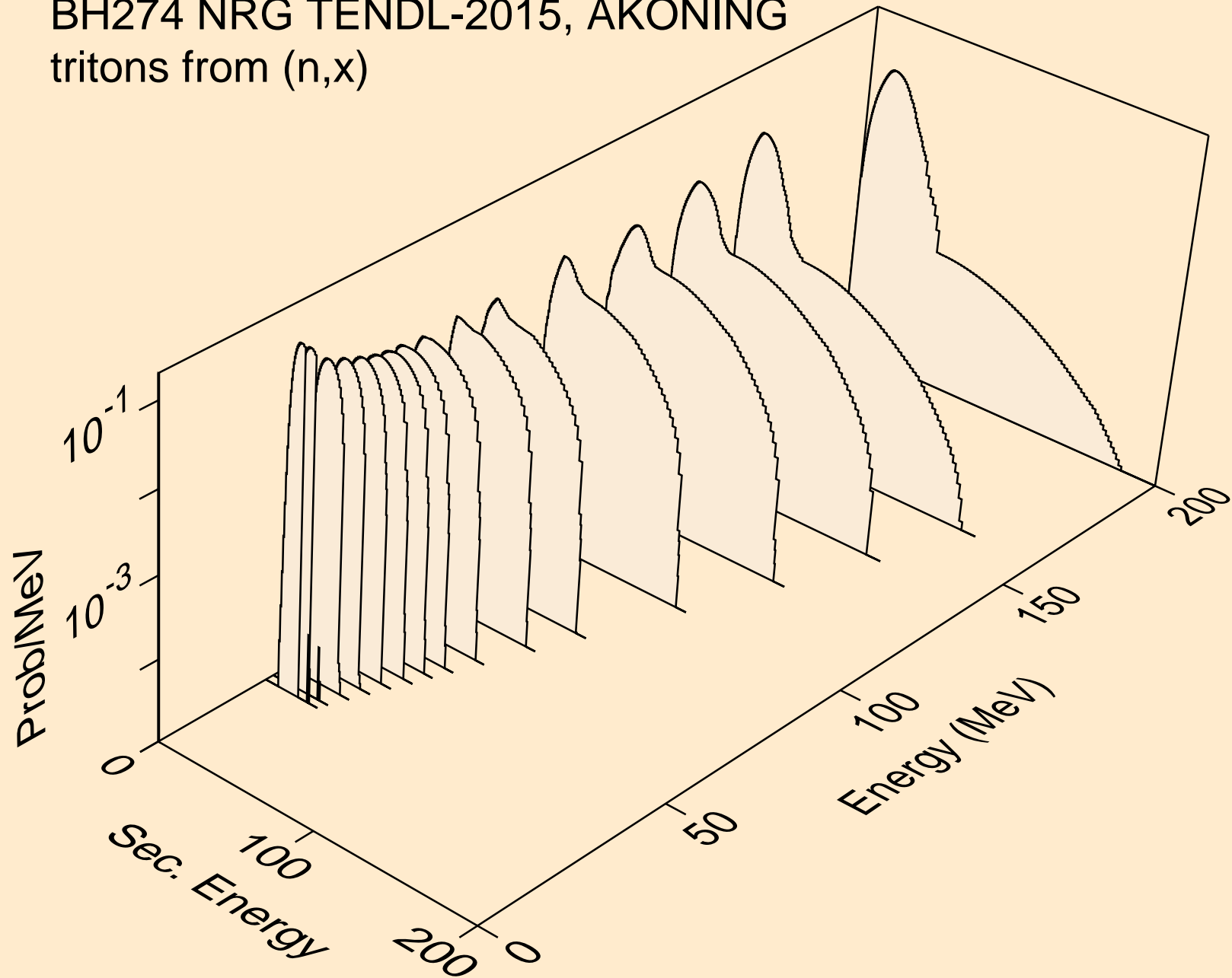

BH274 NRG TENDL-2015, AKONING  
tritons from (n,n\*)t

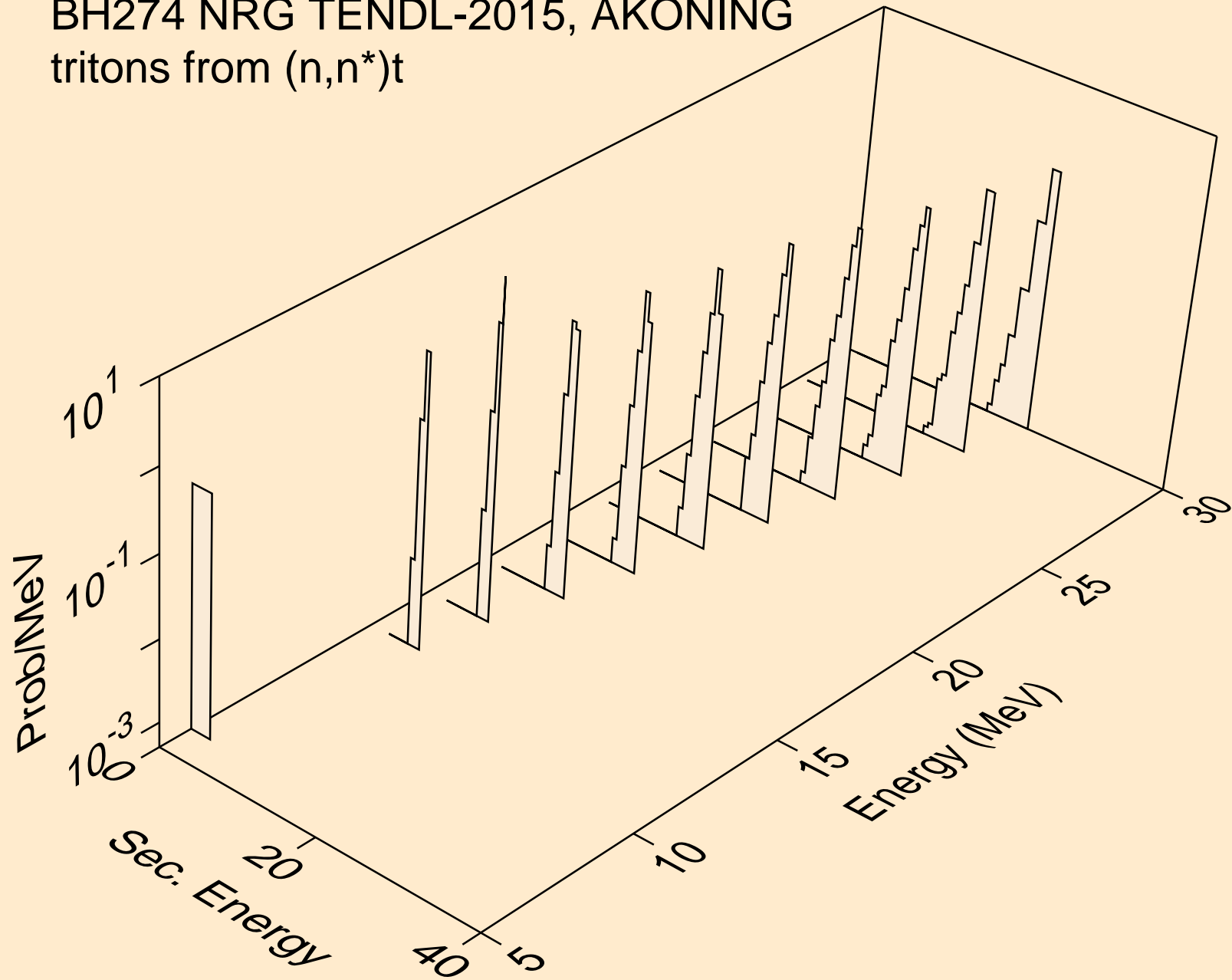

BH274 NRG TENDL-2015, AKONING  
tritons from (n,t)

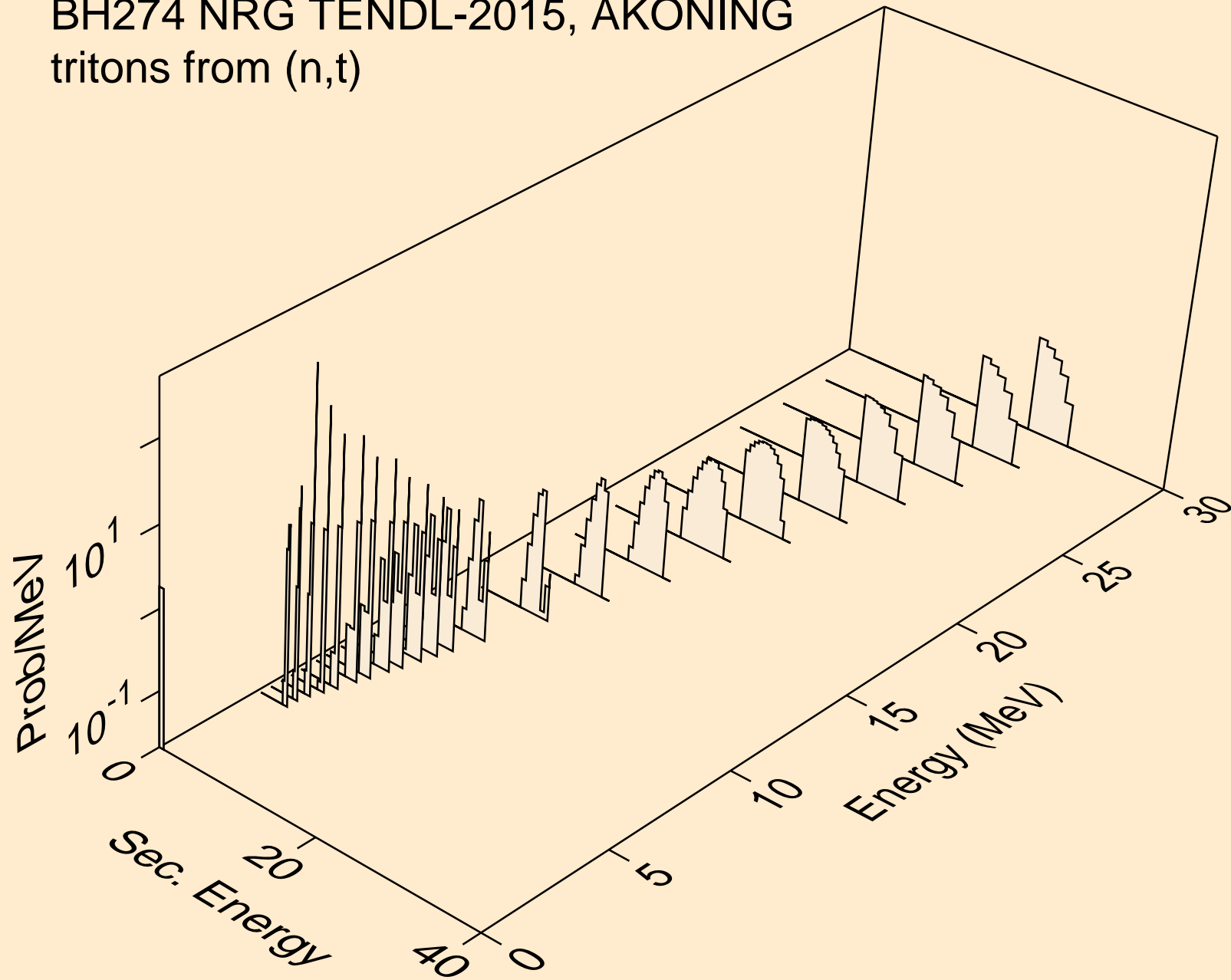

BH274 NRG TENDL-2015, AKONING  
tritons from (n,t2a)

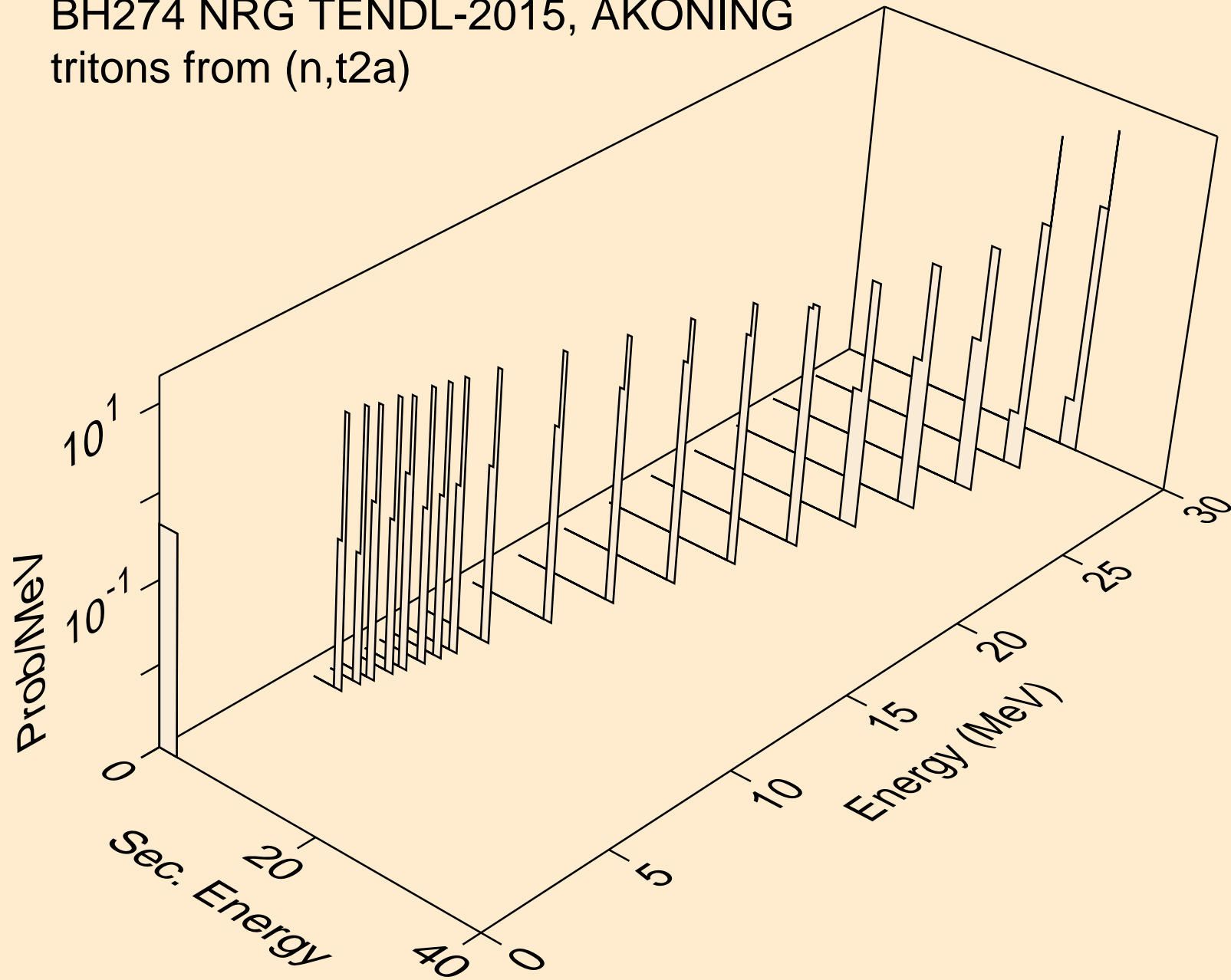

BH274 NRG TENDL-2015, AKONING  
he3s from (n,x)

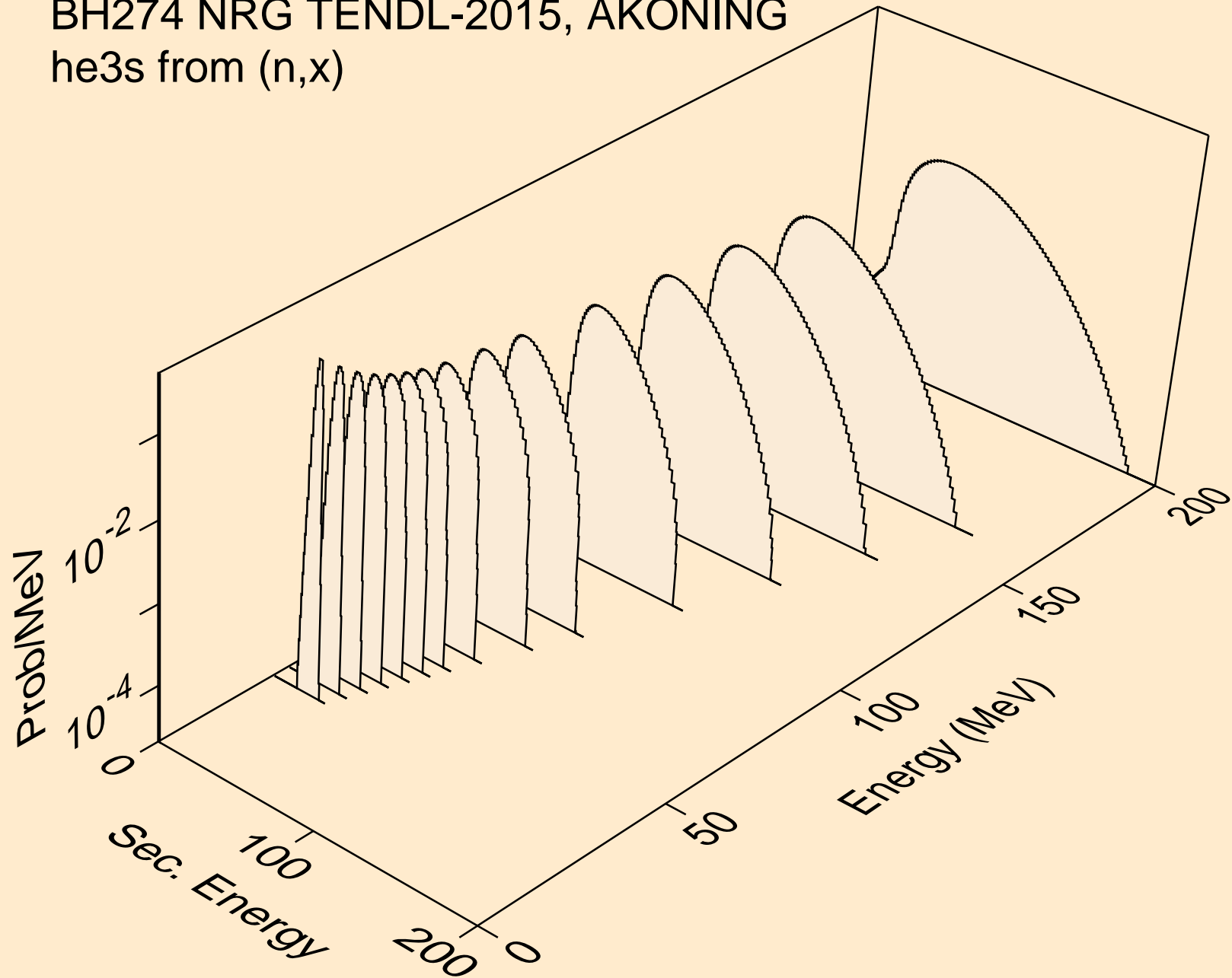



BH274 NRG TENDL-2015, AKONING  
he3s from (n,he3)

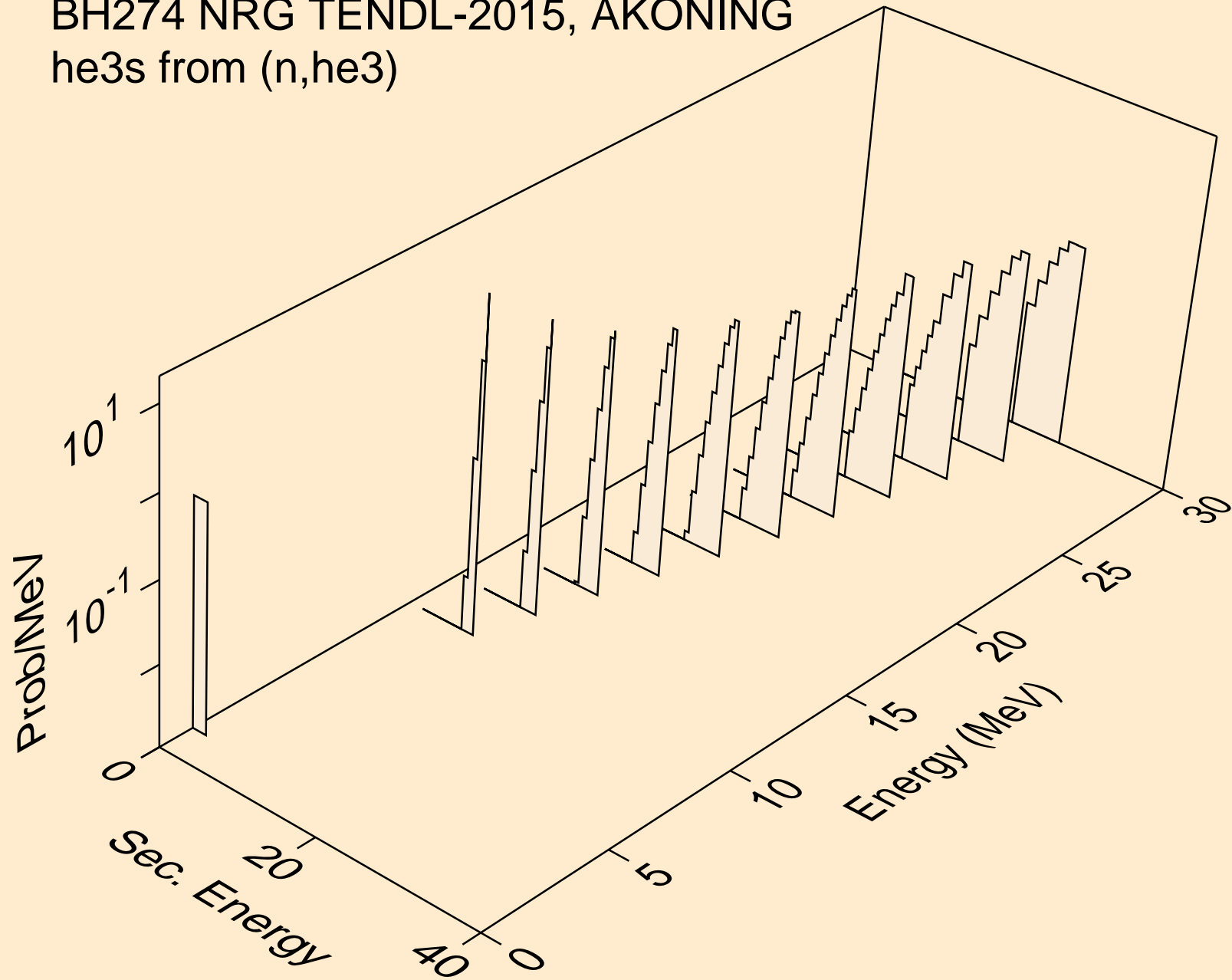

BH274 NRG TENDL-2015, AKONING  
alphas from (n,x)

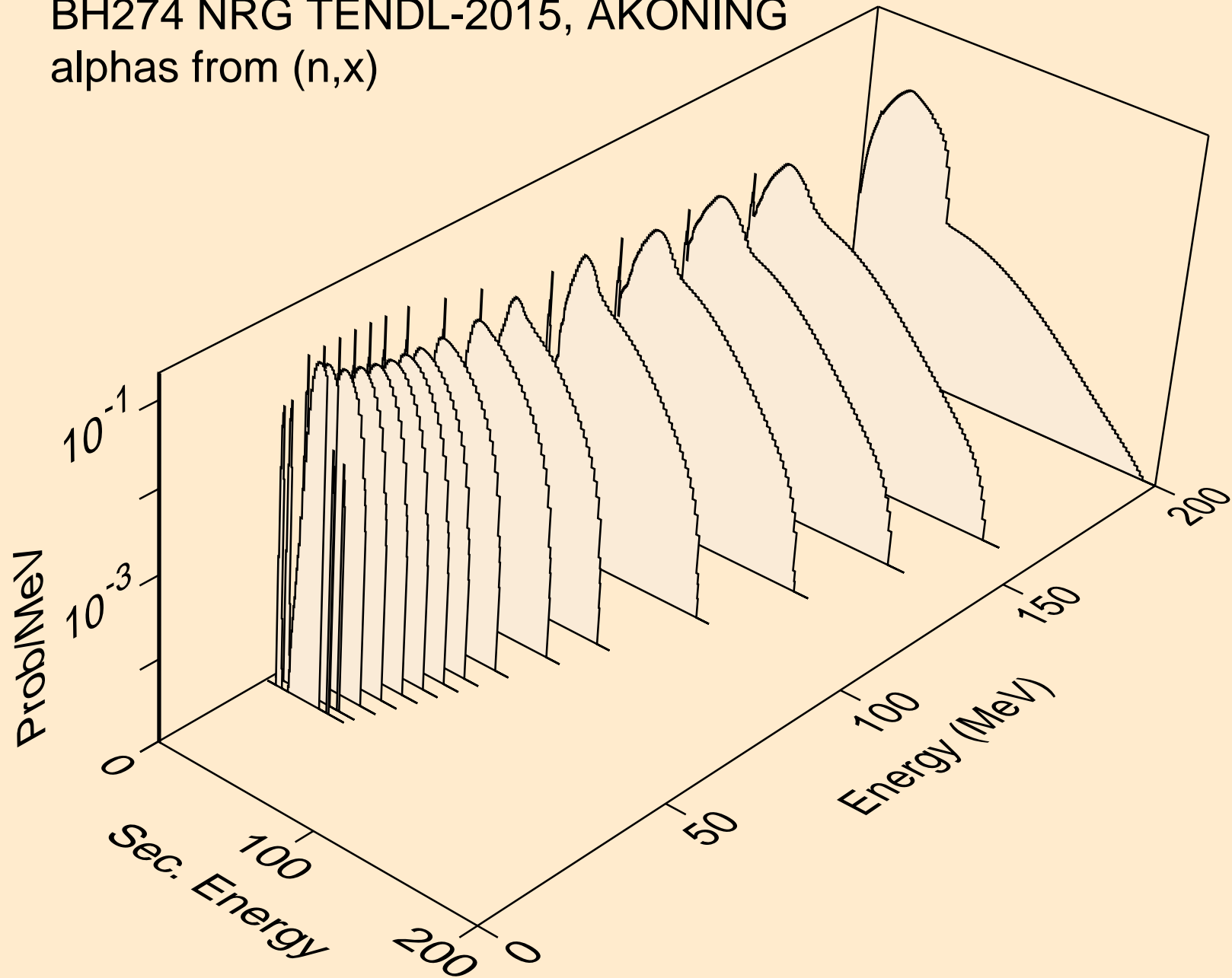

BH274 NRG TENDL-2015, AKONING  
alphas from (n,n\*)a

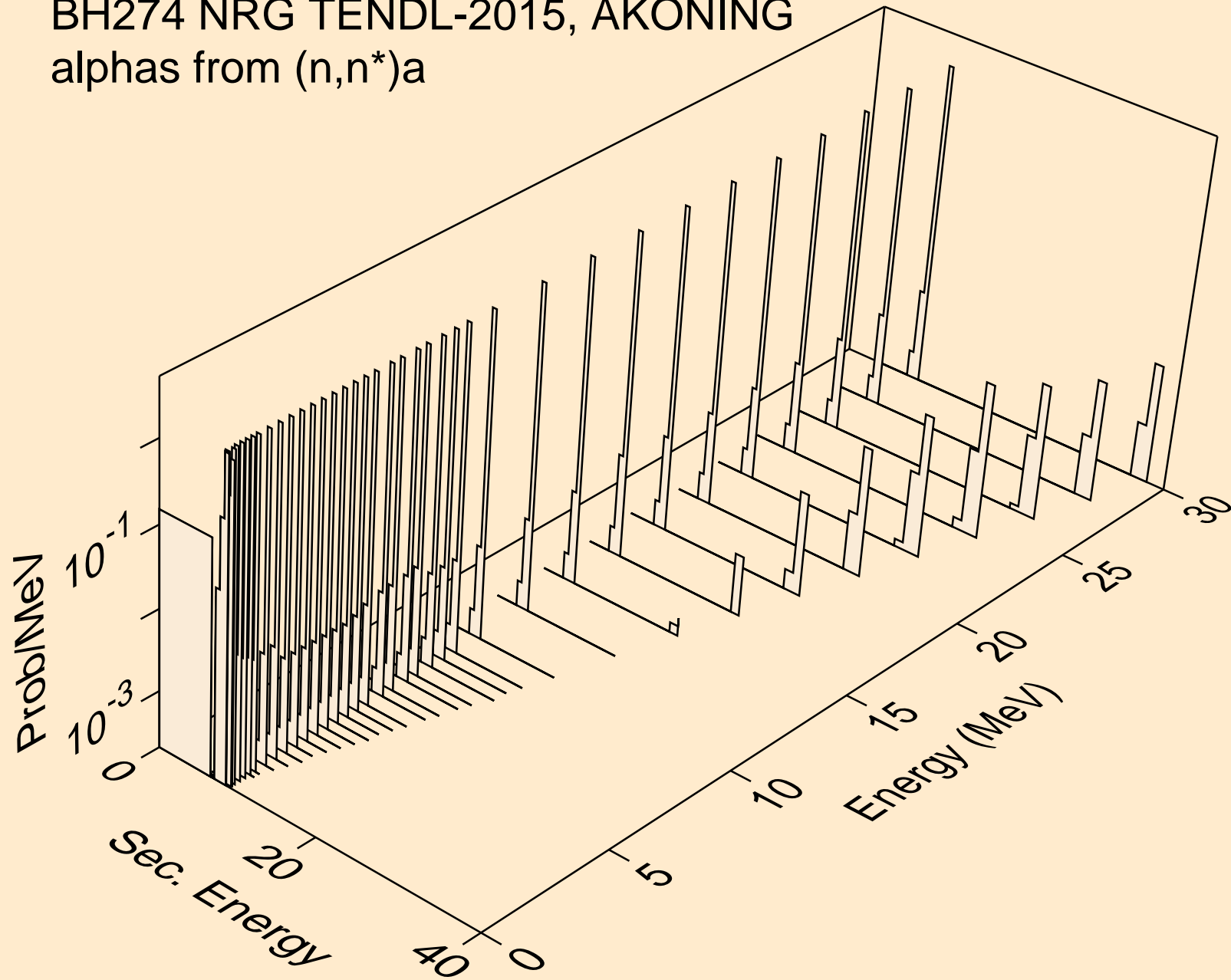

BH274 NRG TENDL-2015, AKONING  
alphas from (n,n\*)3a

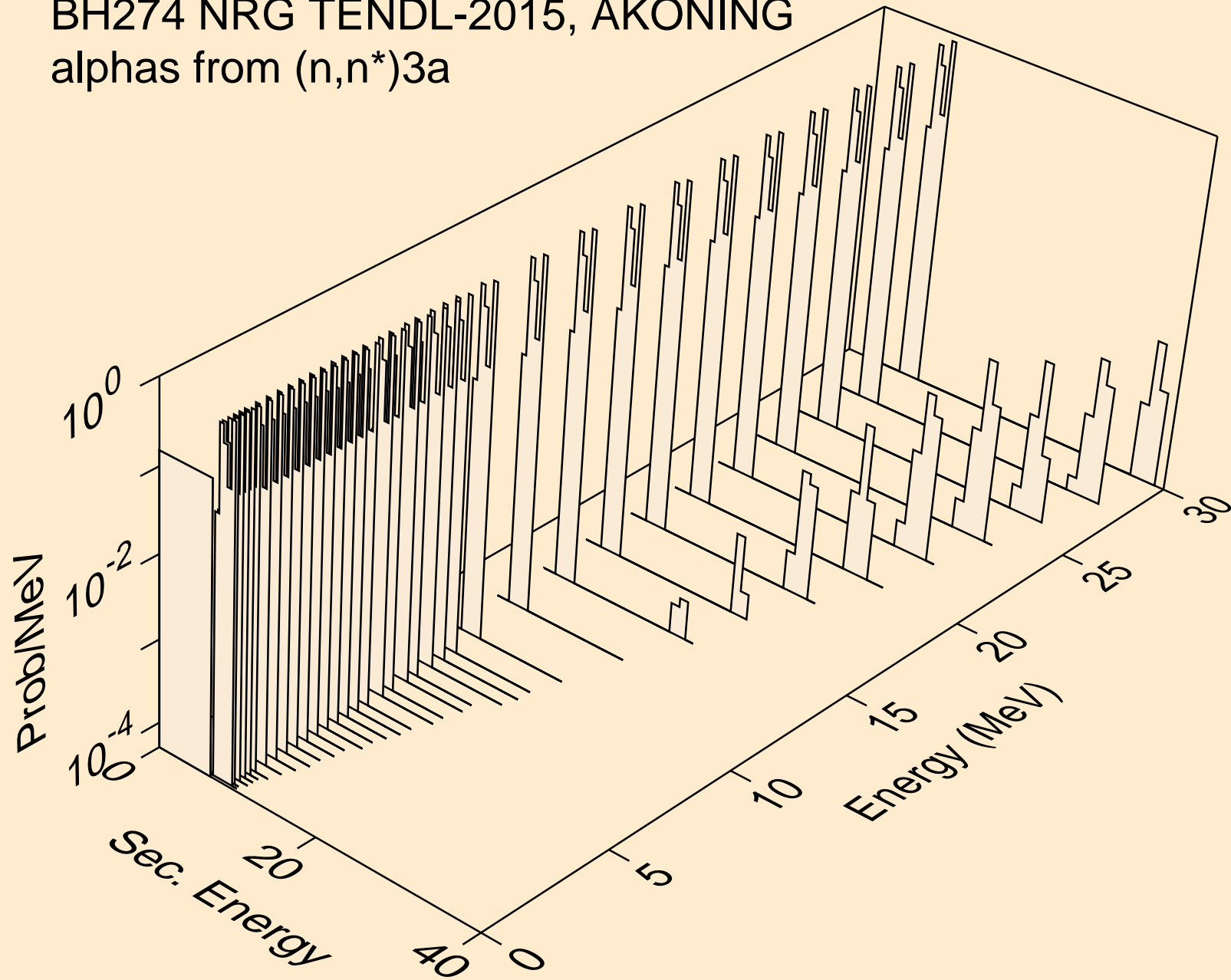

BH274 NRG TENDL-2015, AKONING  
alphas from (n,2n)a

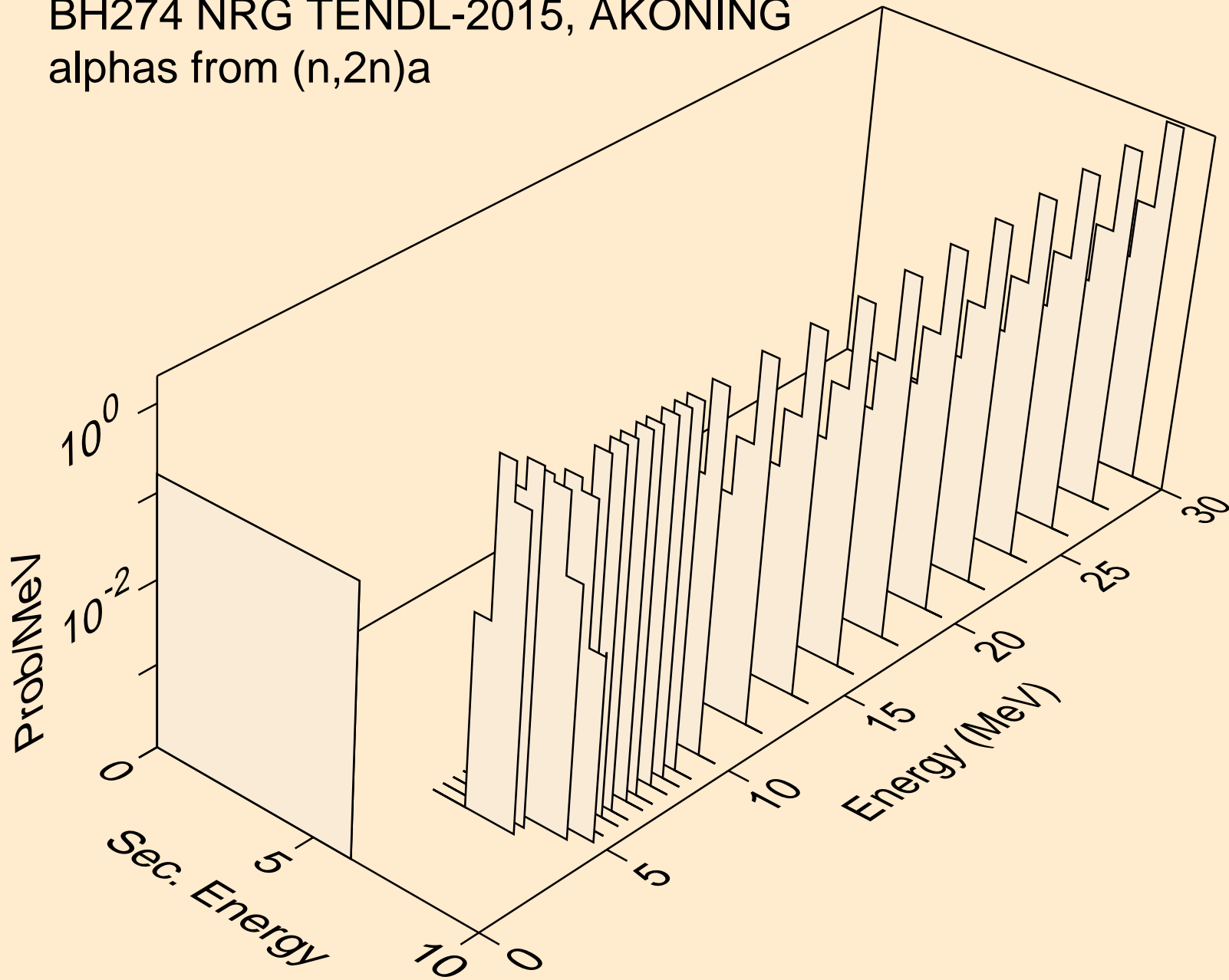

BH274 NRG TENDL-2015, AKONING  
alphas from (n,3n)a

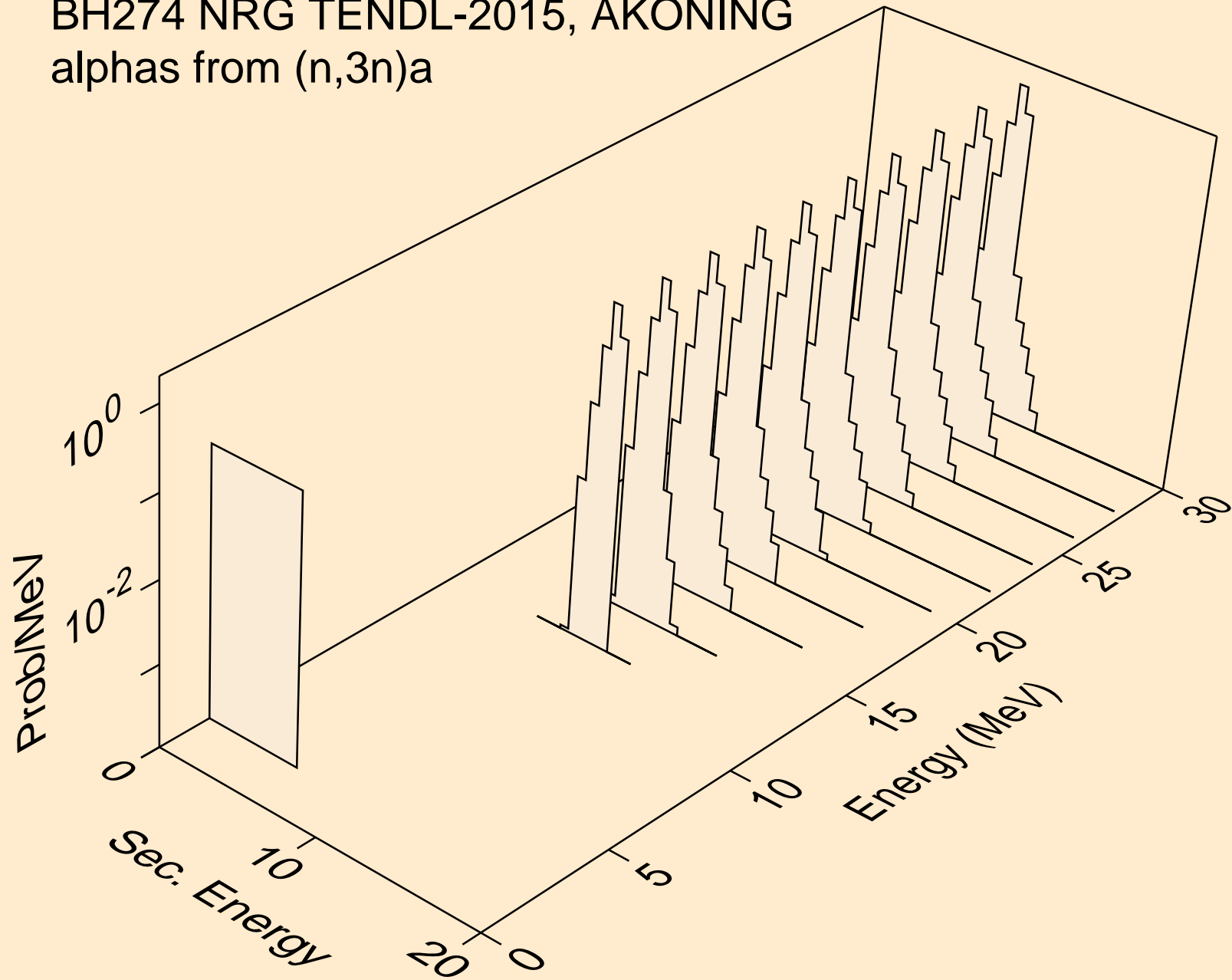

BH274 NRG TENDL-2015, AKONING  
alphas from (n,n\*)2a

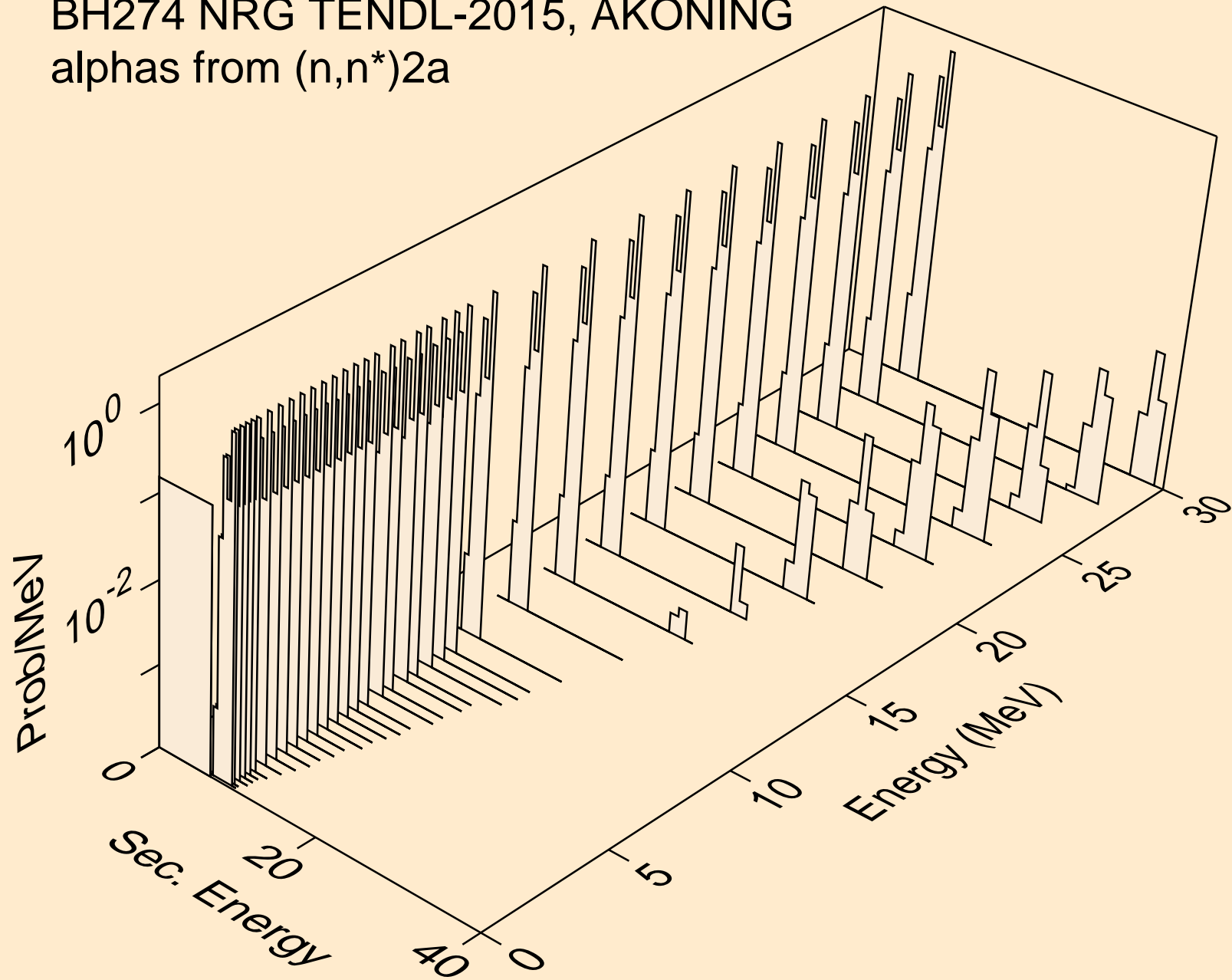

BH274 NRG TENDL-2015, AKONING  
alphas from (n,2n)2a

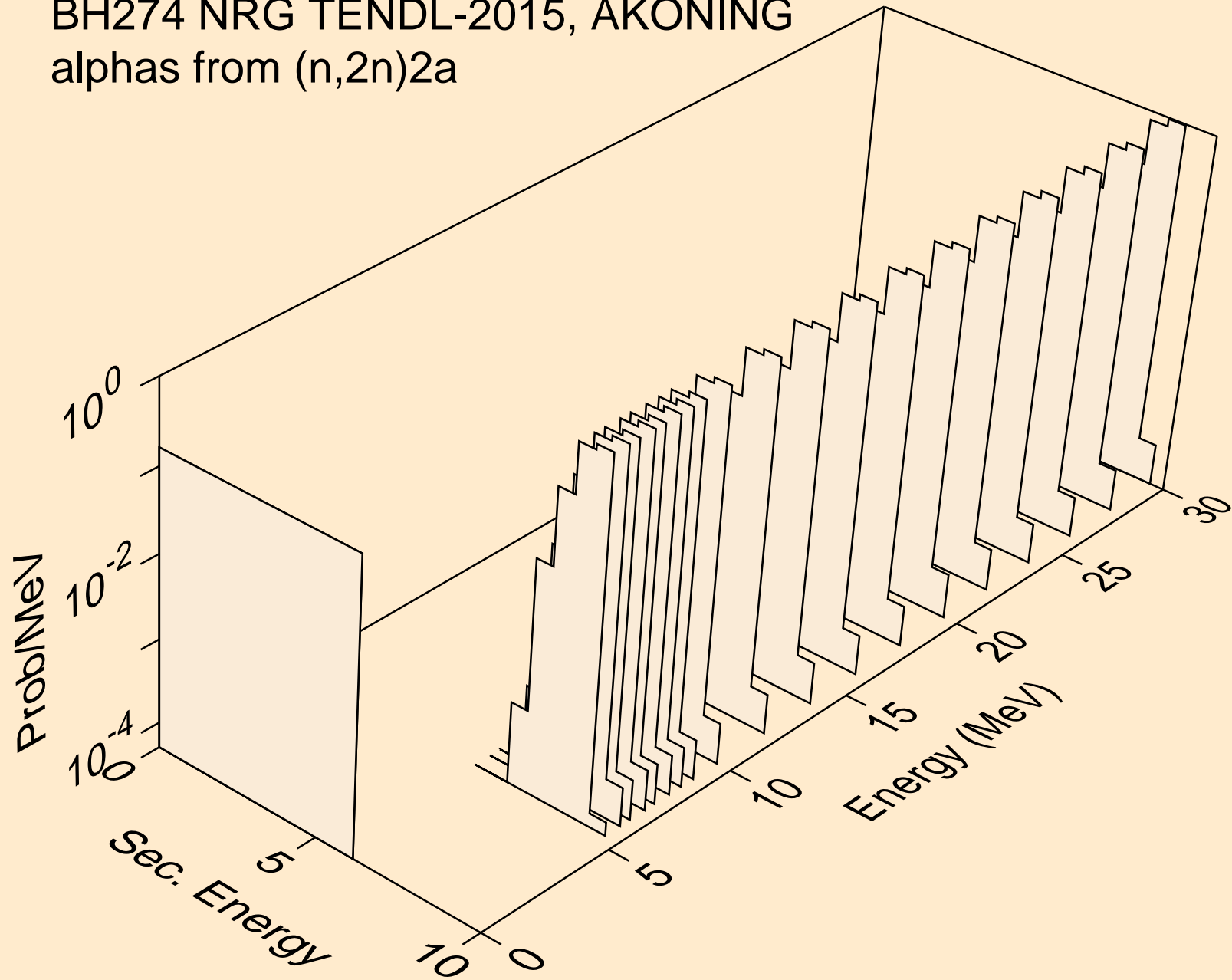



BH274 NRG TENDL-2015, AKONING  
alphas from (n,n\*)d2a

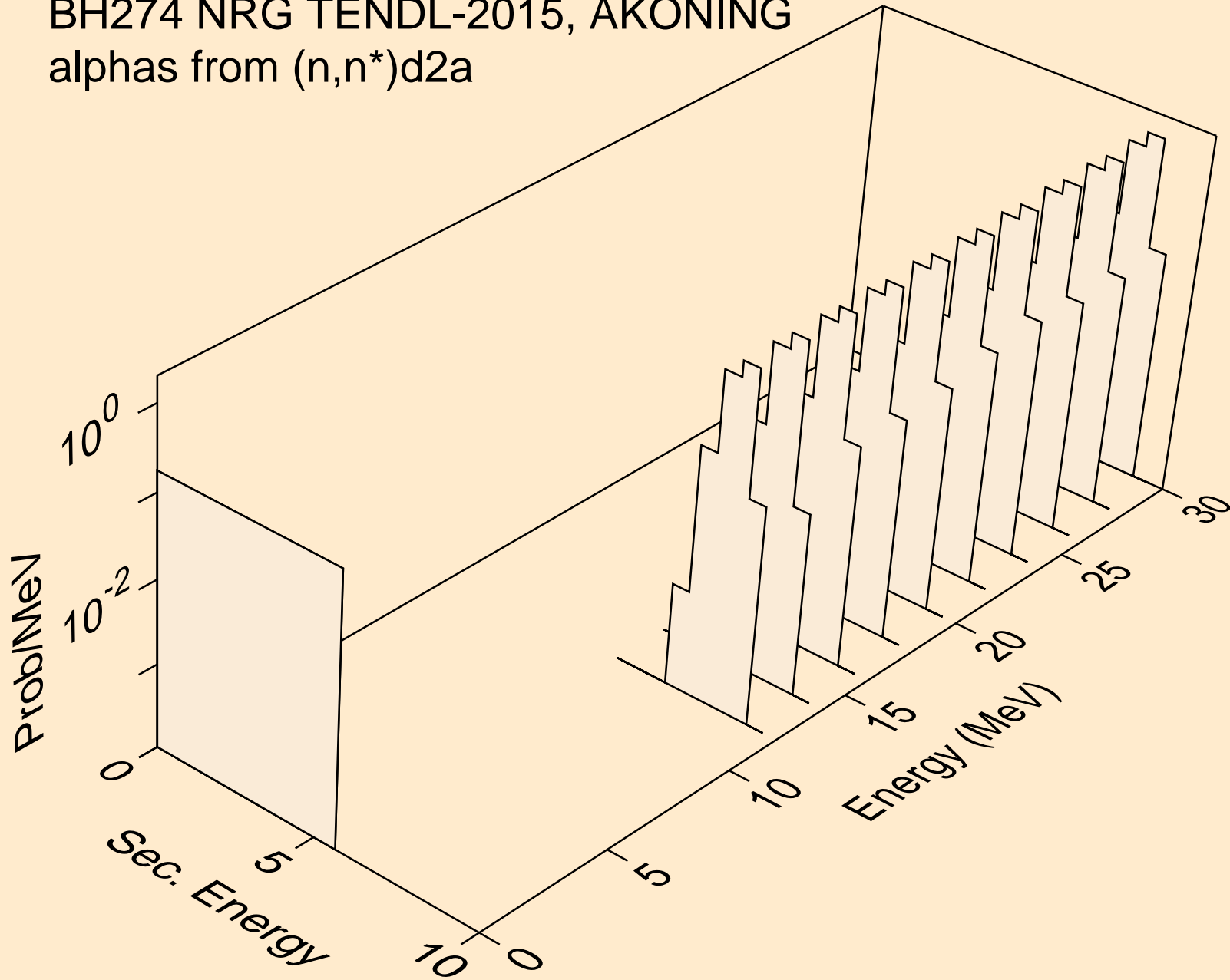

BH274 NRG TENDL-2015, AKONING  
alphas from (n,a)

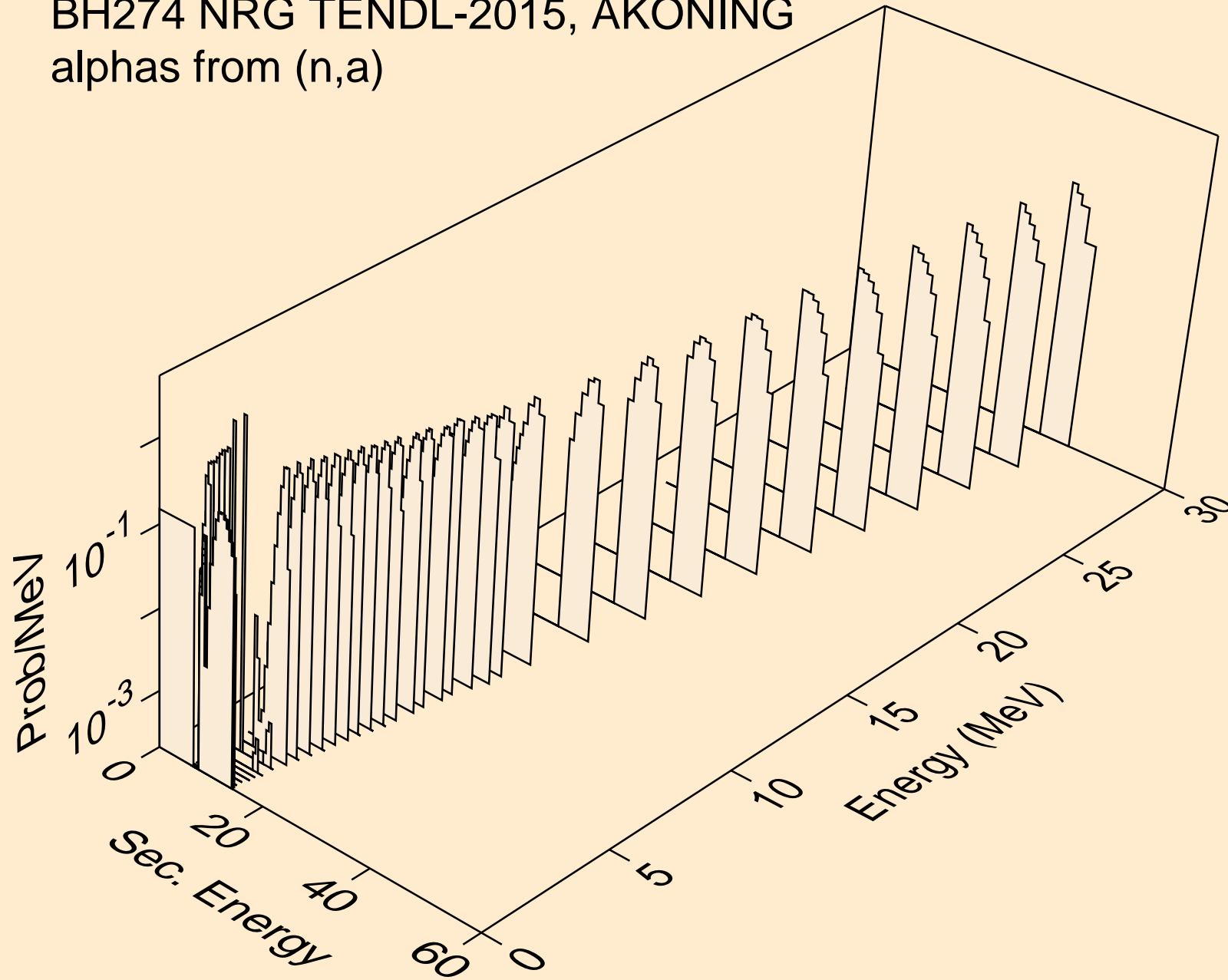

BH274 NRG TENDL-2015, AKONING  
alphas from (n,2a)

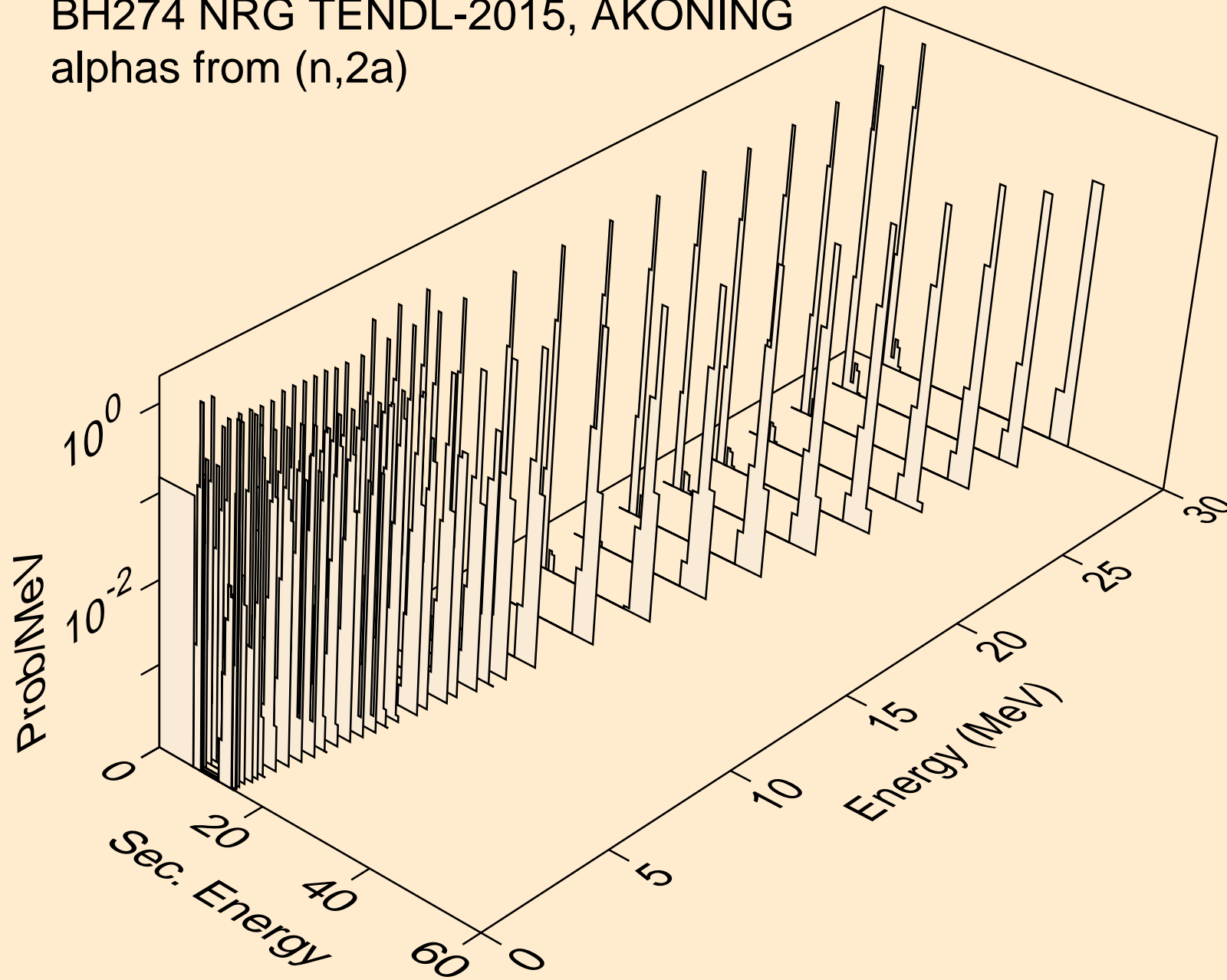

BH274 NRG TENDL-2015, AKONING  
alphas from (n,3a)

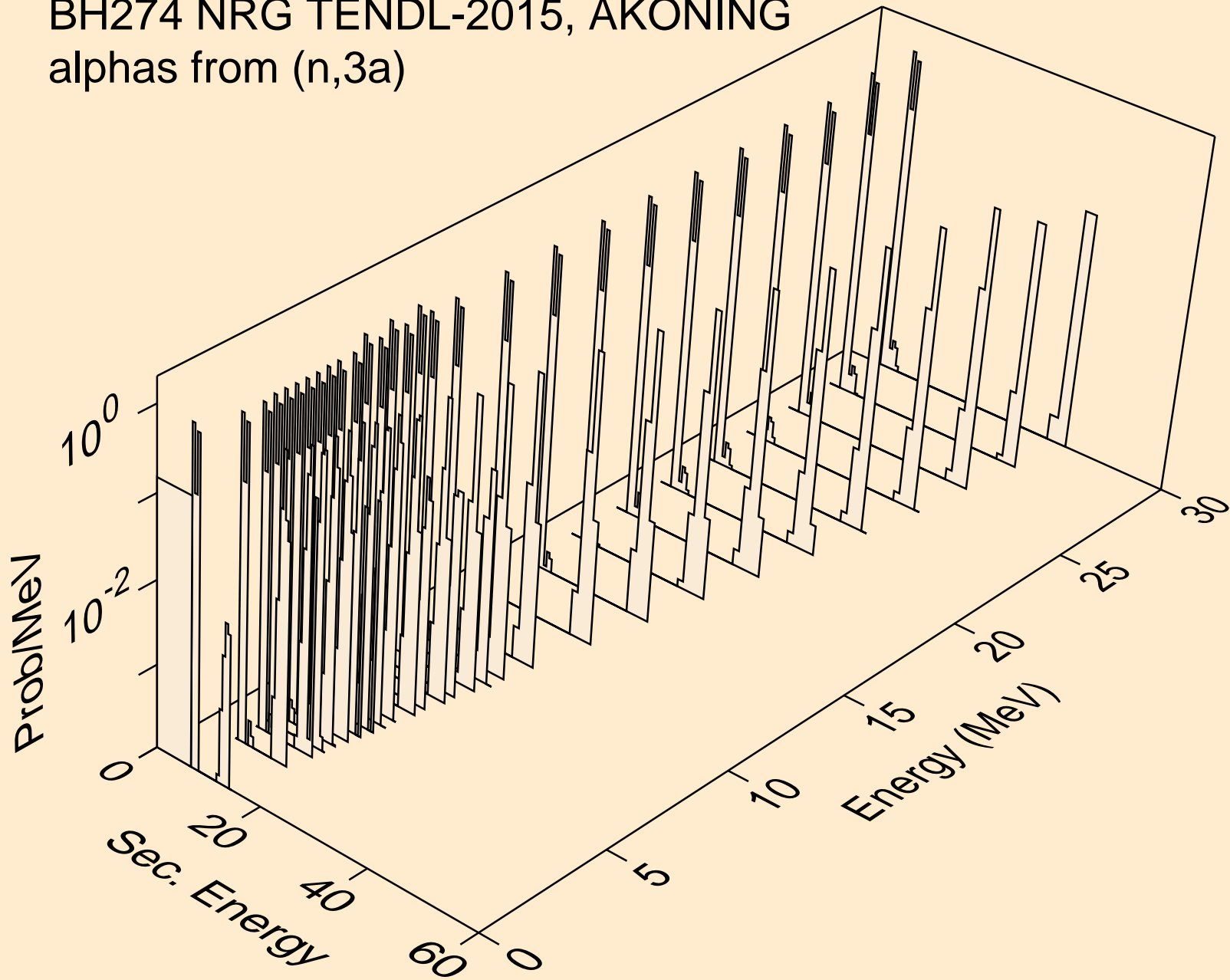

BH274 NRG TENDL-2015, AKONING  
alphas from (n,pa)

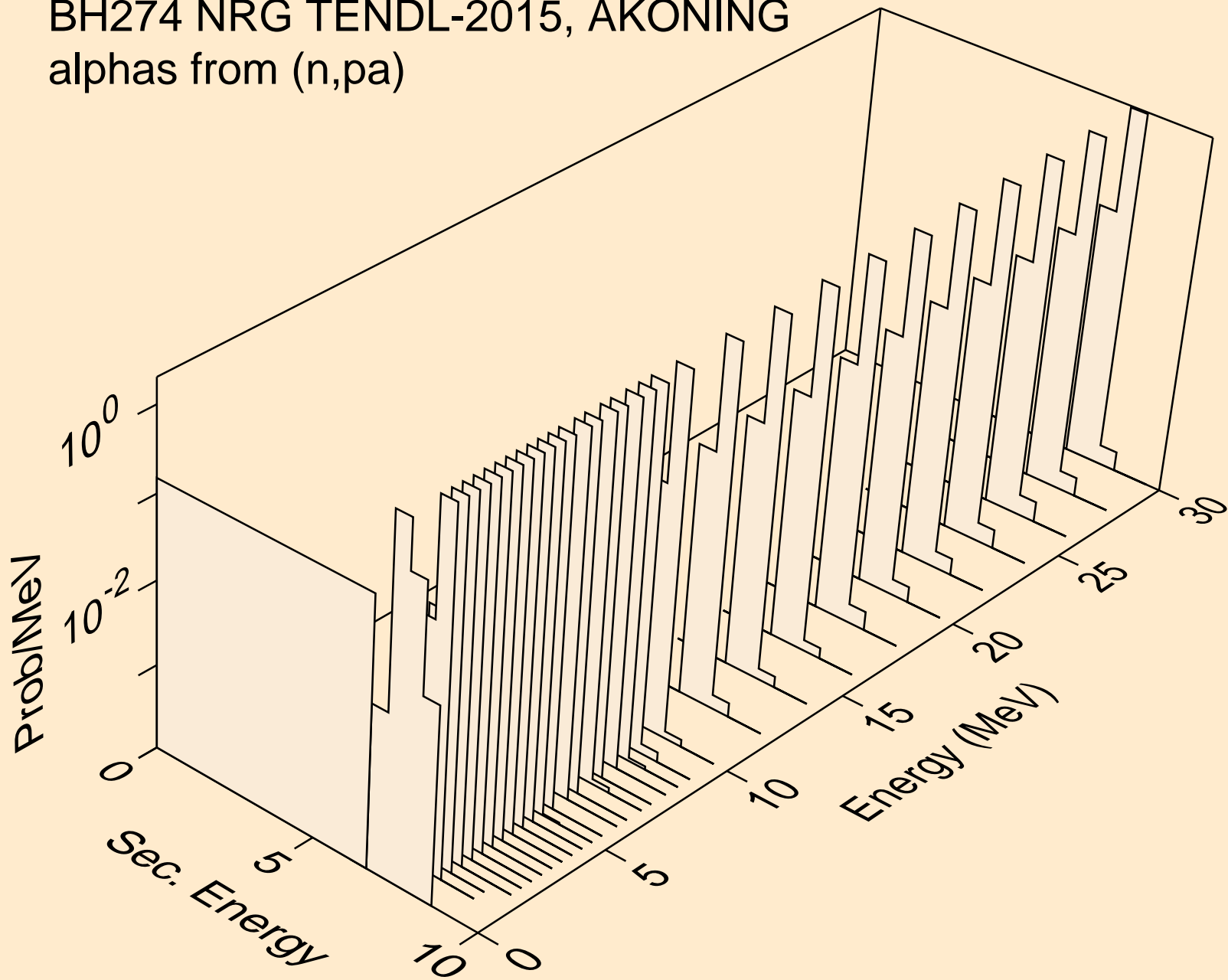

BH274 NRG TENDL-2015, AKONING  
alphas from (n,t2a)

