

BI215M NRG TENDL-2015, AKONING

Principal cross sections

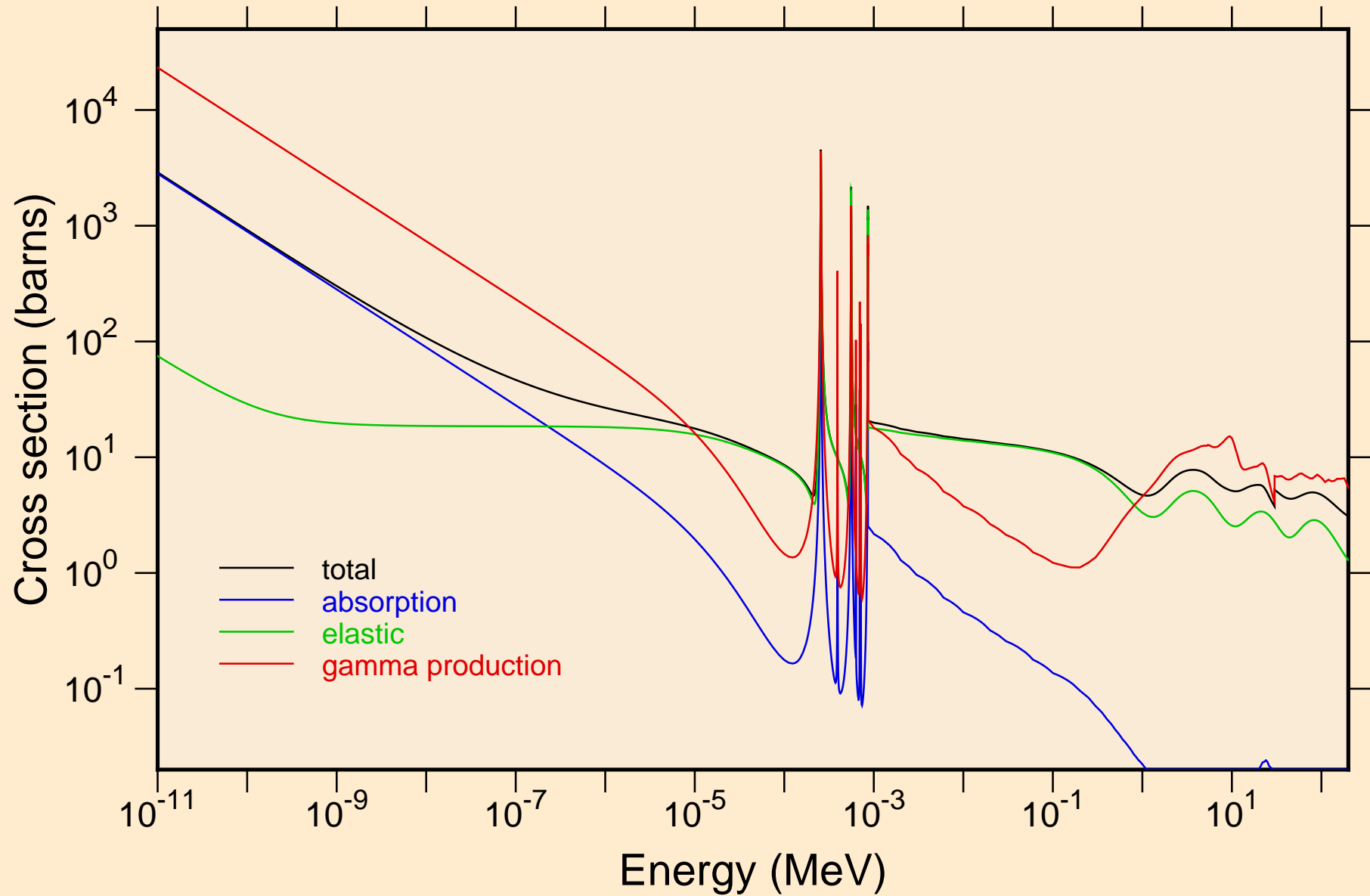

BI215M NRG TENDL-2015, AKONING

Non-threshold reactions

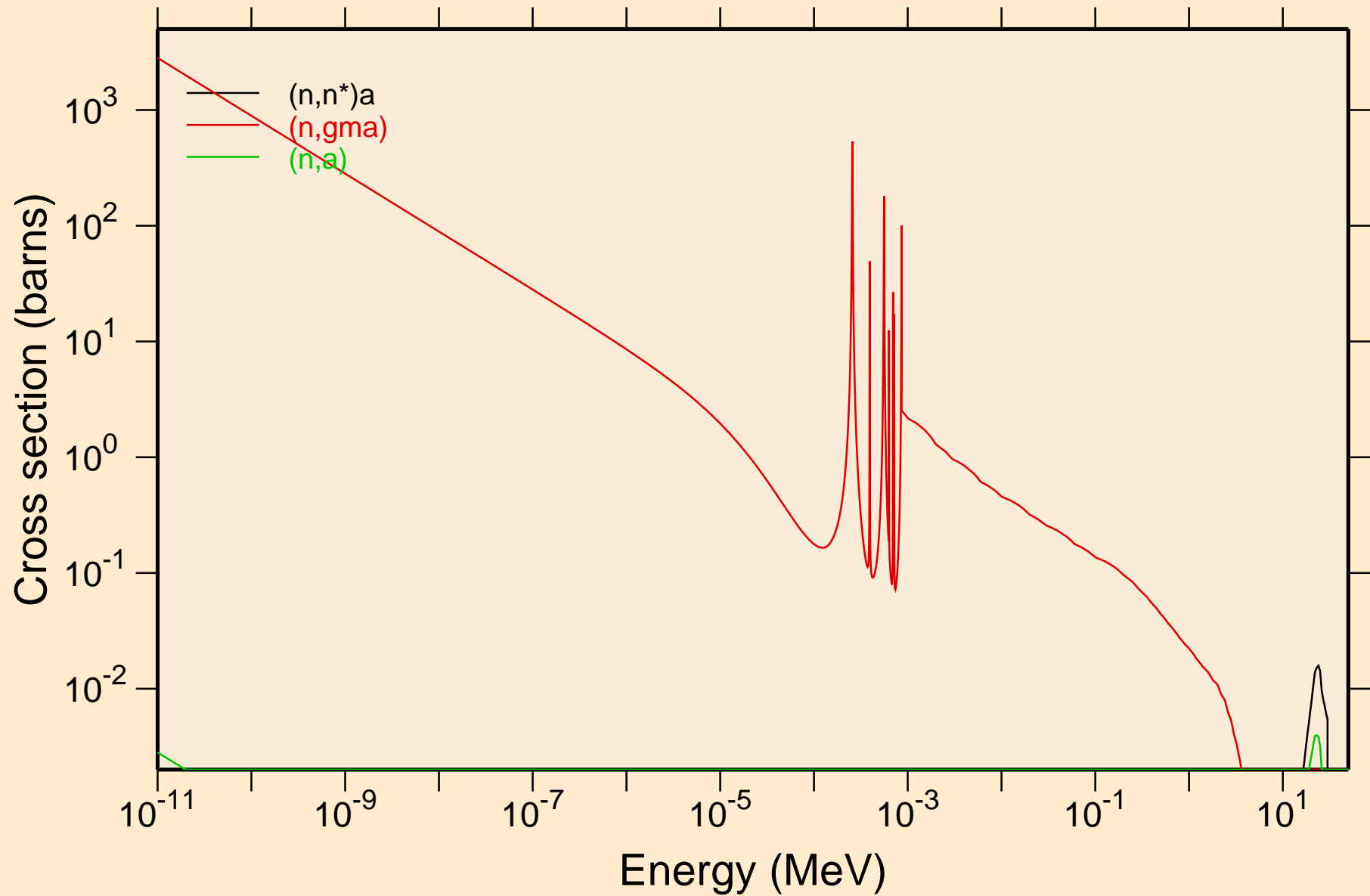

BI215M NRG TENDL-2015, AKONING

Principal cross sections

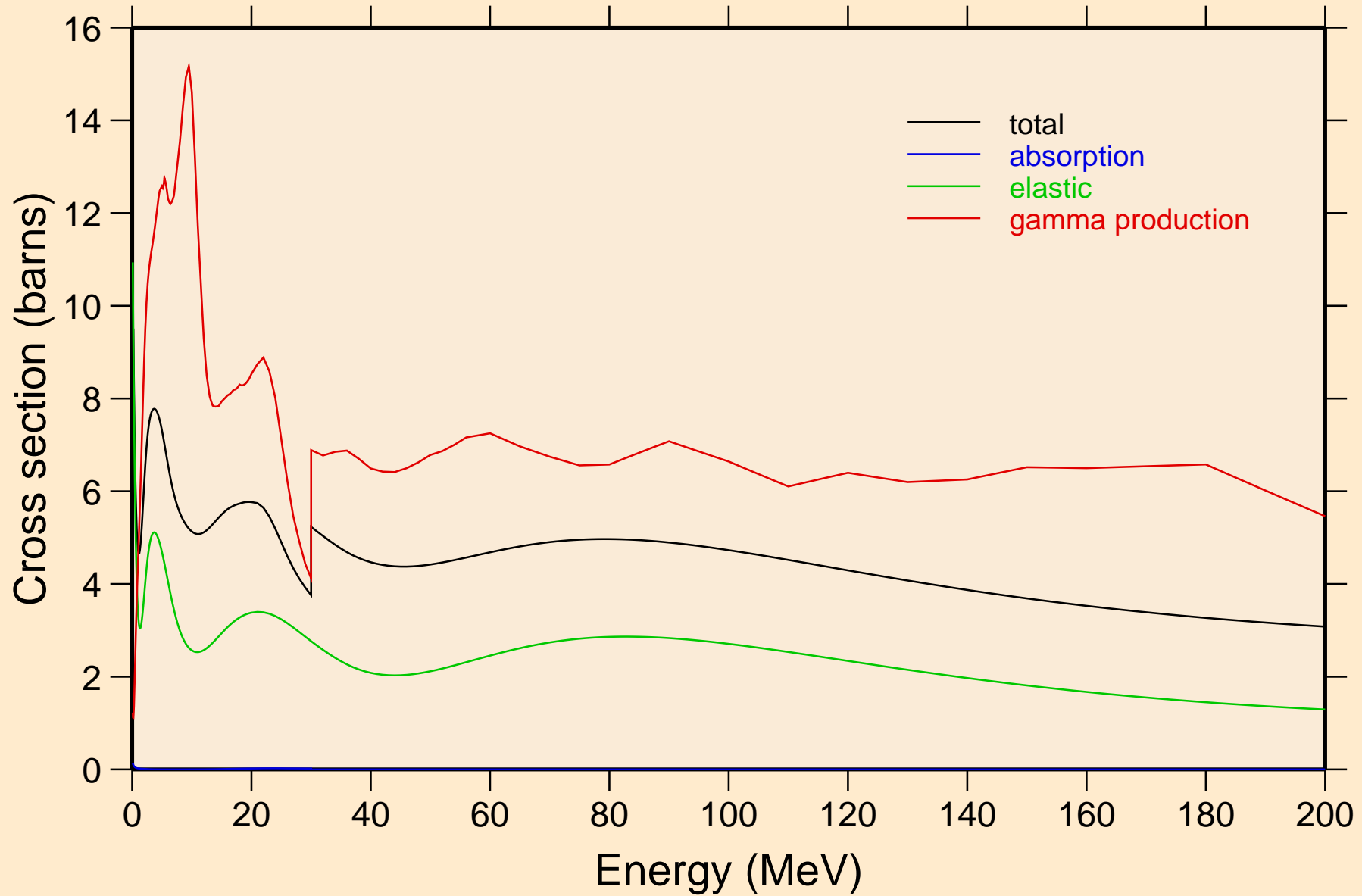

BI215M NRG TENDL-2015, AKONING
Non-threshold reactions

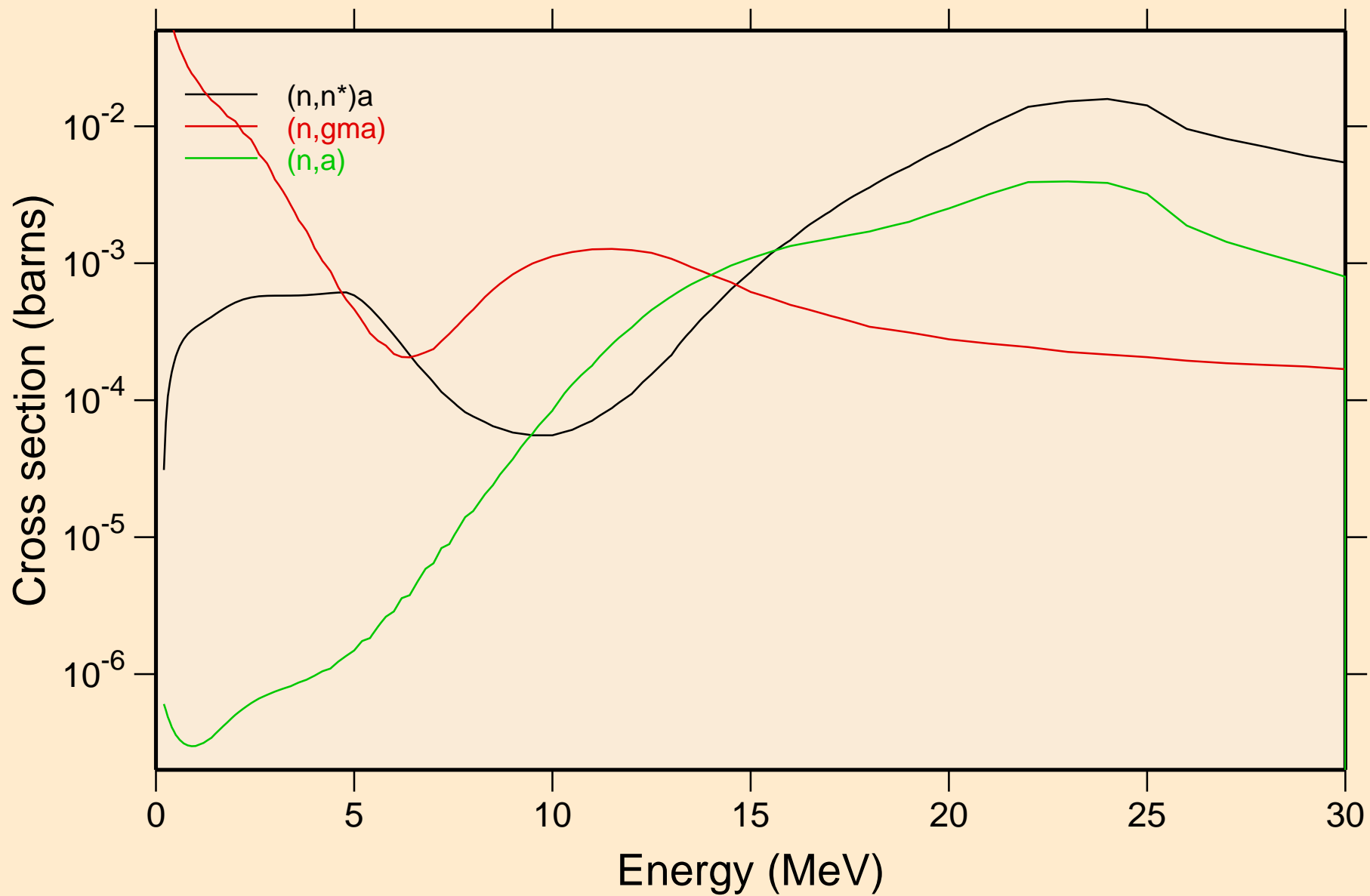

BI215M NRG TENDL-2015, AKONING

Inelastic levels

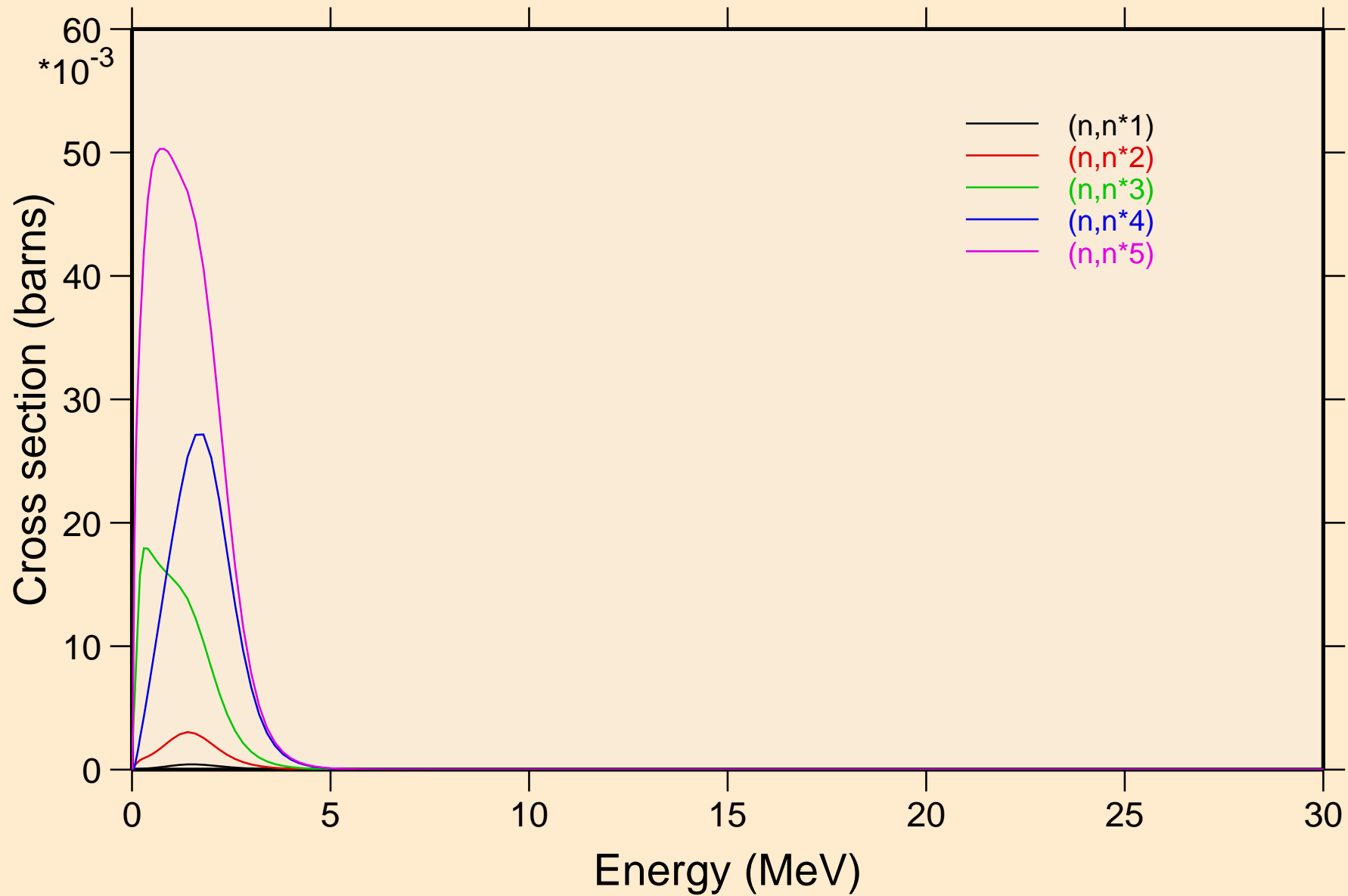

BI215M NRG TENDL-2015, AKONING

Inelastic levels

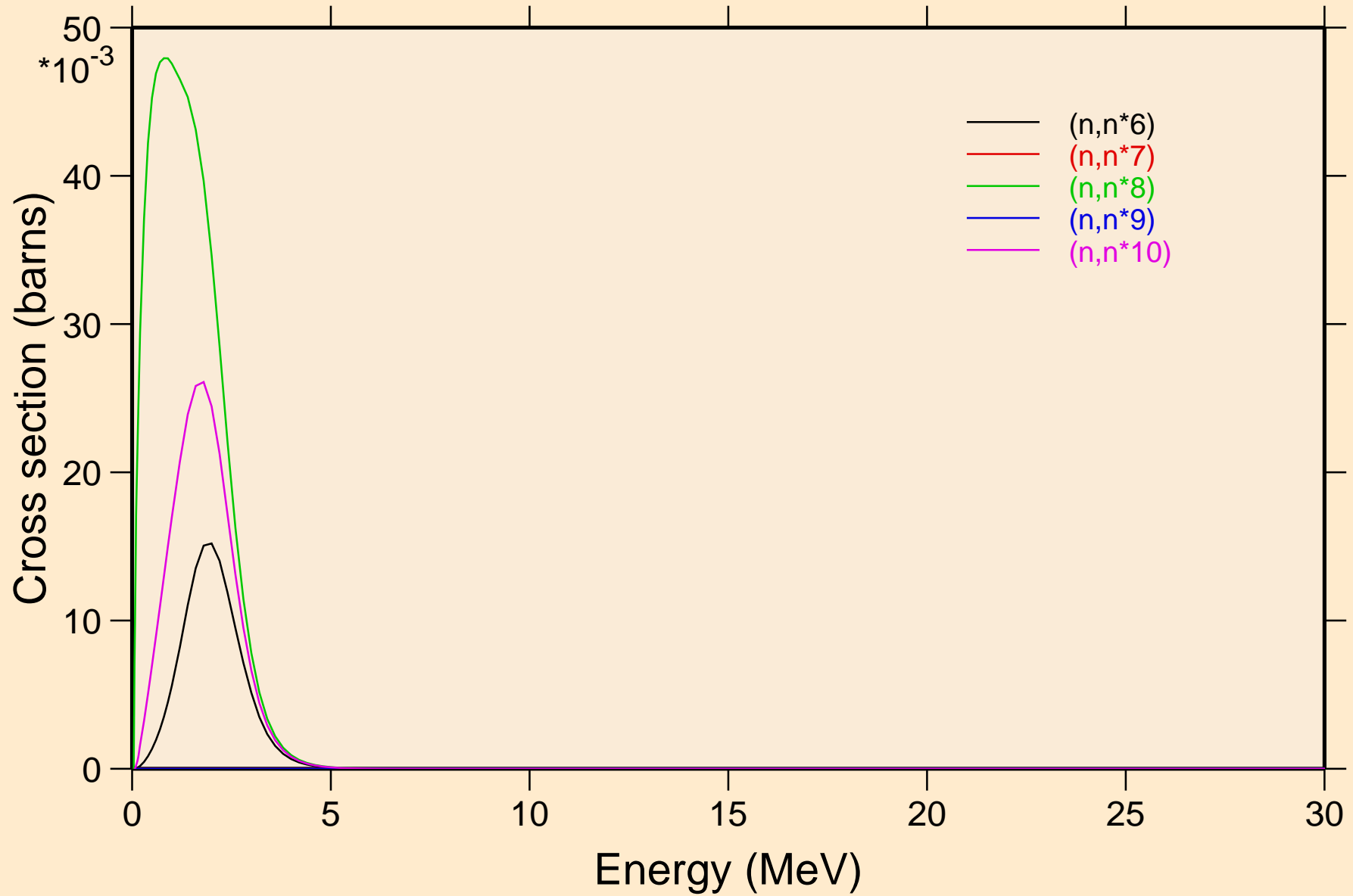

BI215M NRG TENDL-2015, AKONING

Inelastic levels

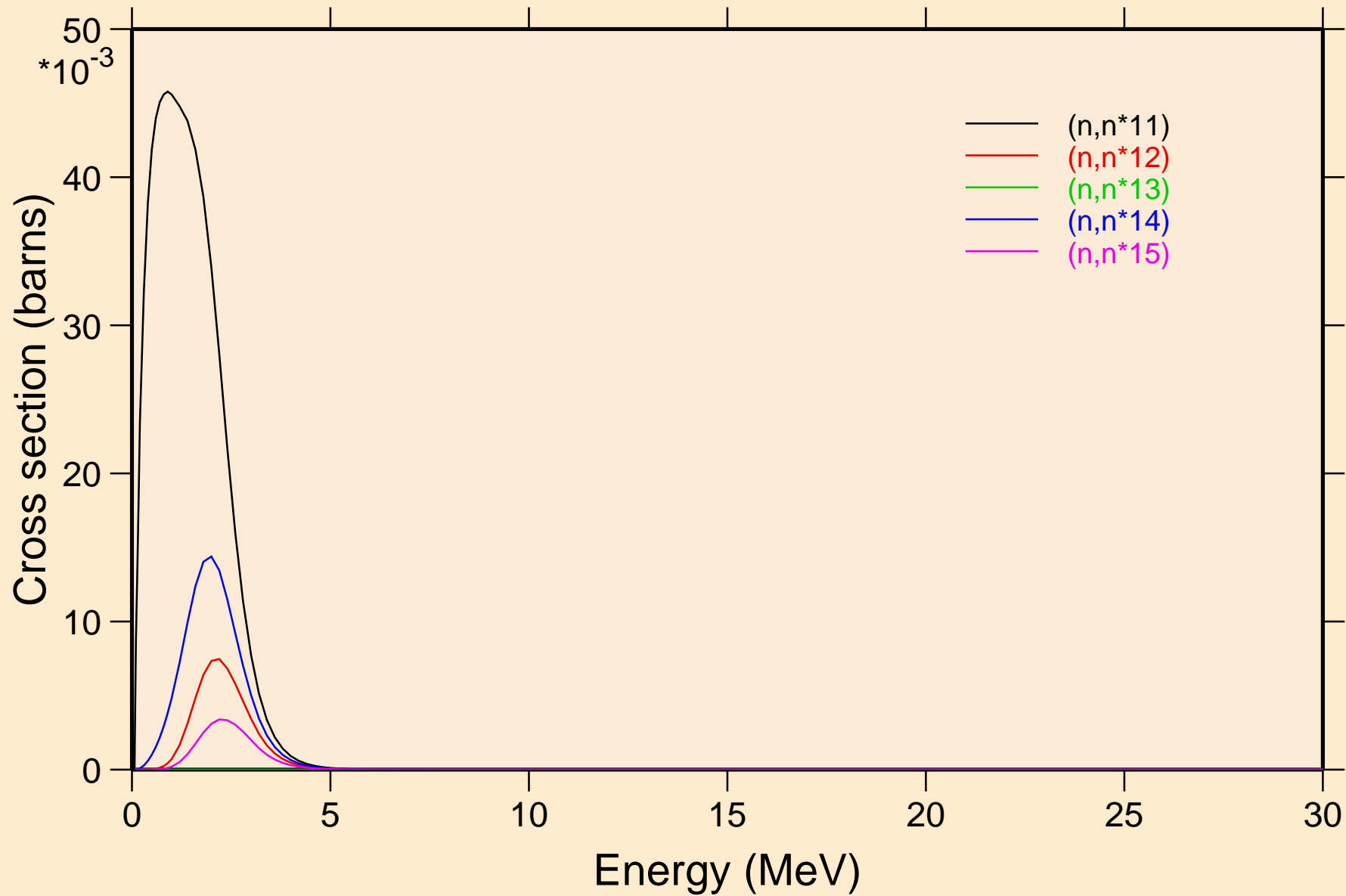

BI215M NRG TENDL-2015, AKONING

Inelastic levels

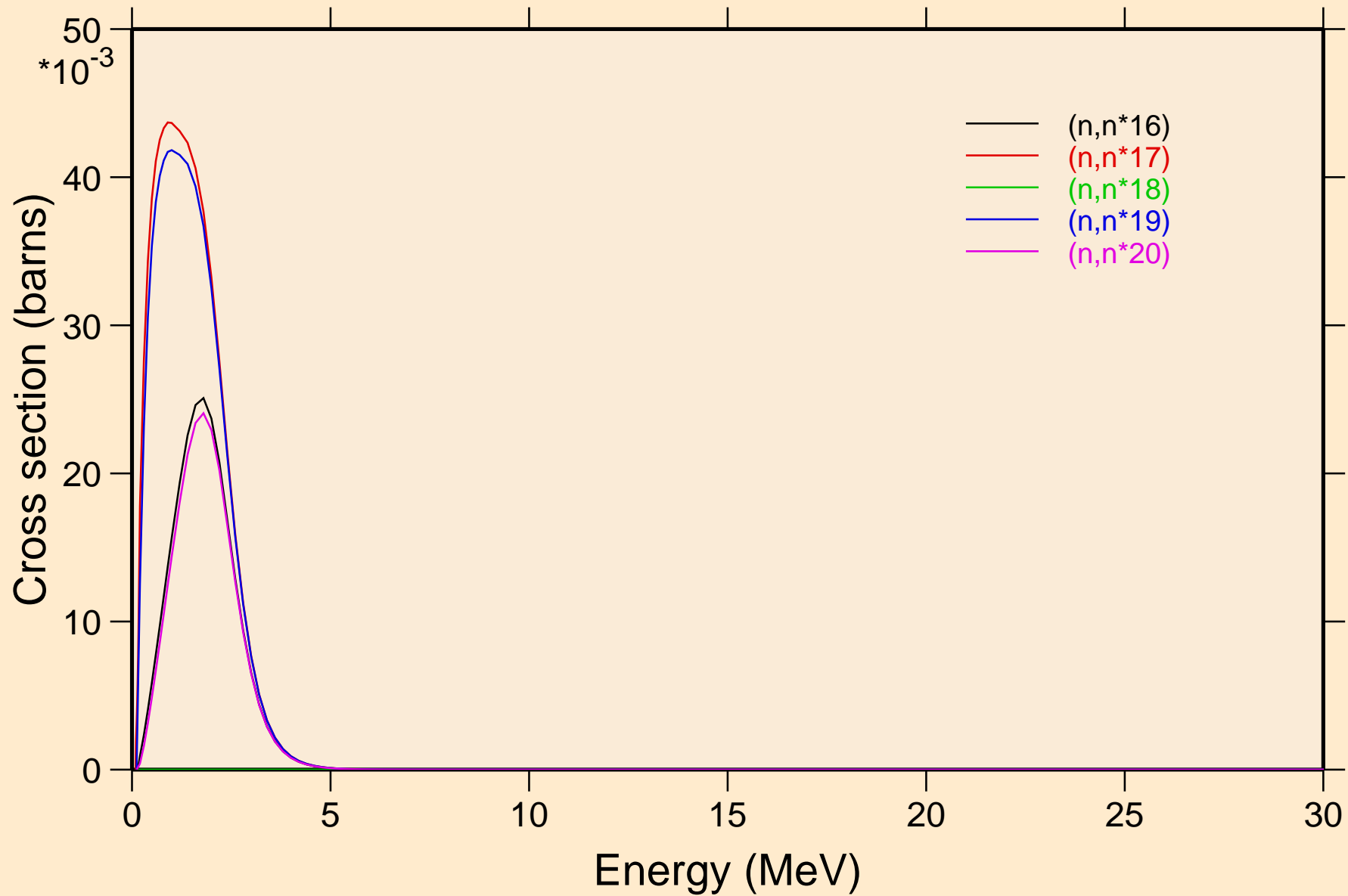

BI215M NRG TENDL-2015, AKONING

Inelastic levels

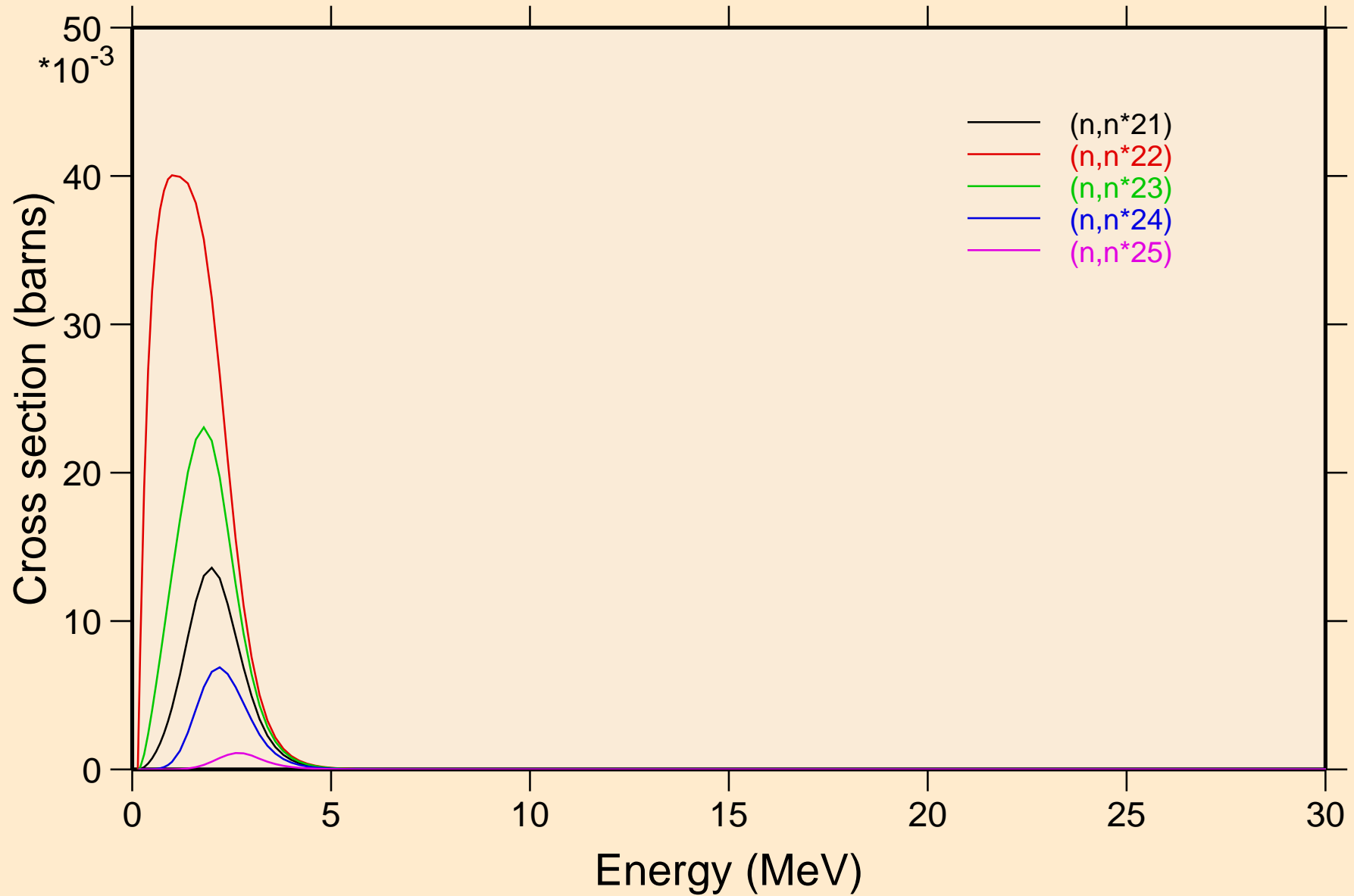

BI215M NRG TENDL-2015, AKONING

Inelastic levels

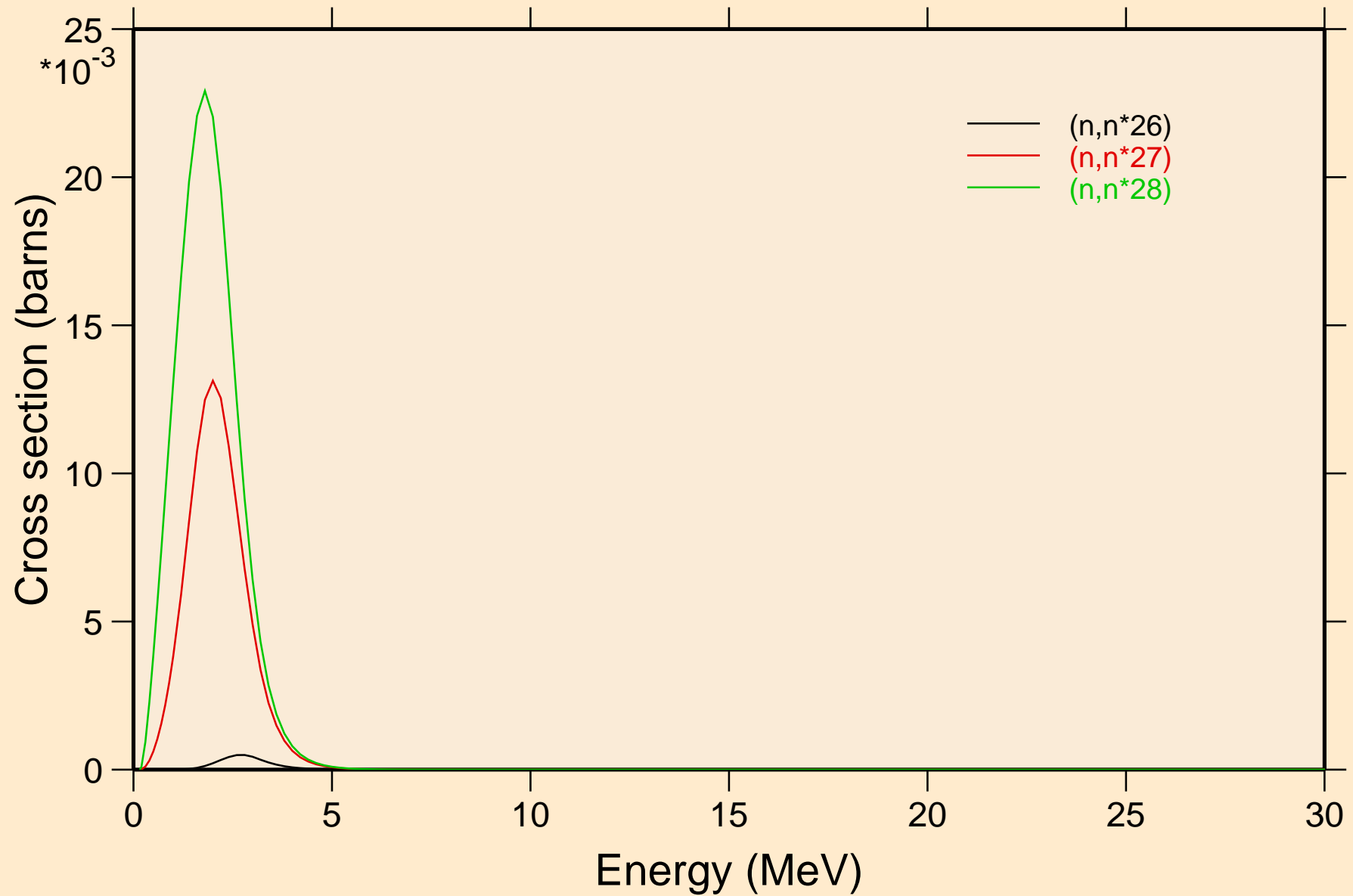

BI215M NRG TENDL-2015, AKONING

Threshold reactions

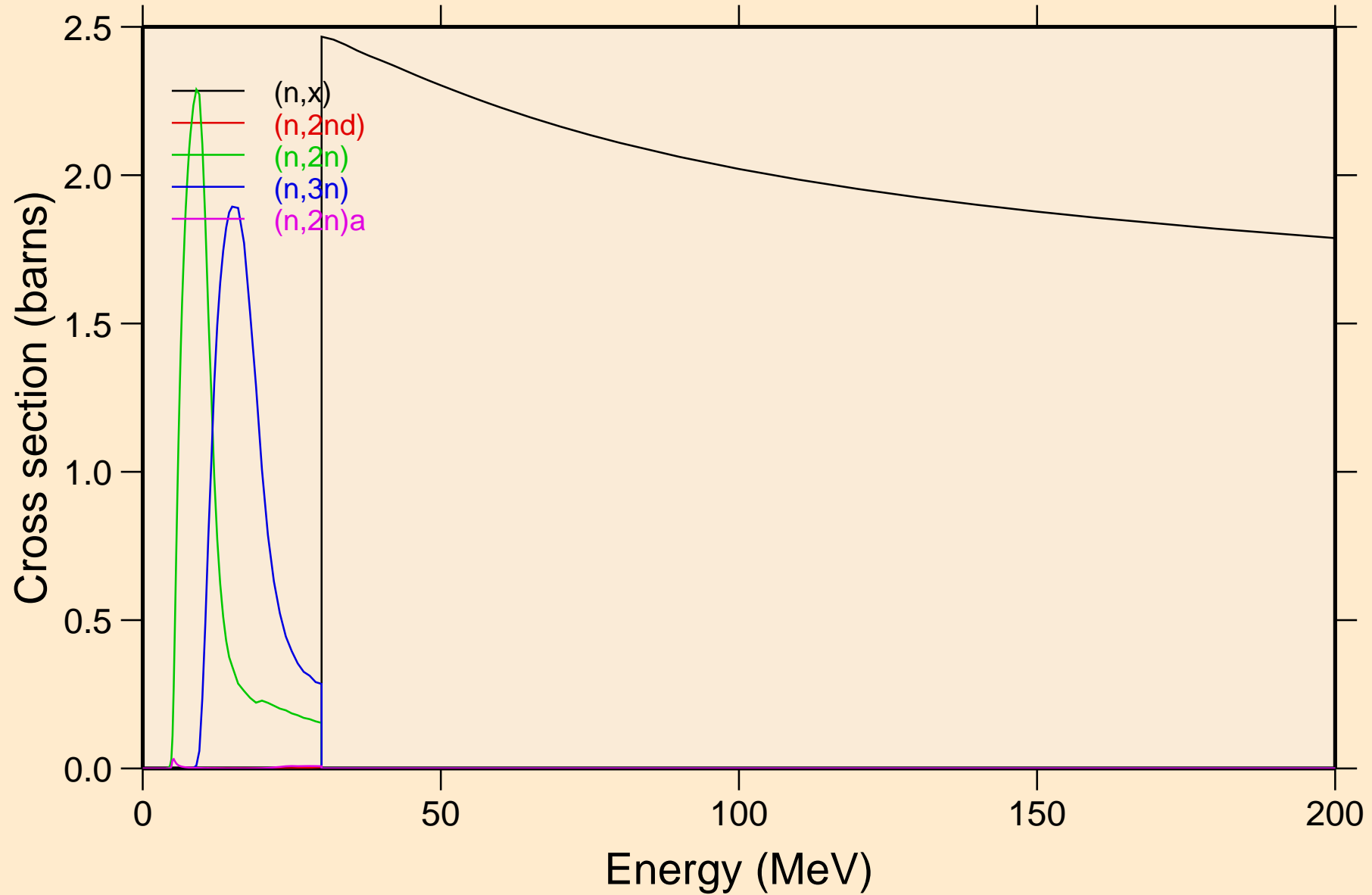

BI215M NRG TENDL-2015, AKONING

Threshold reactions

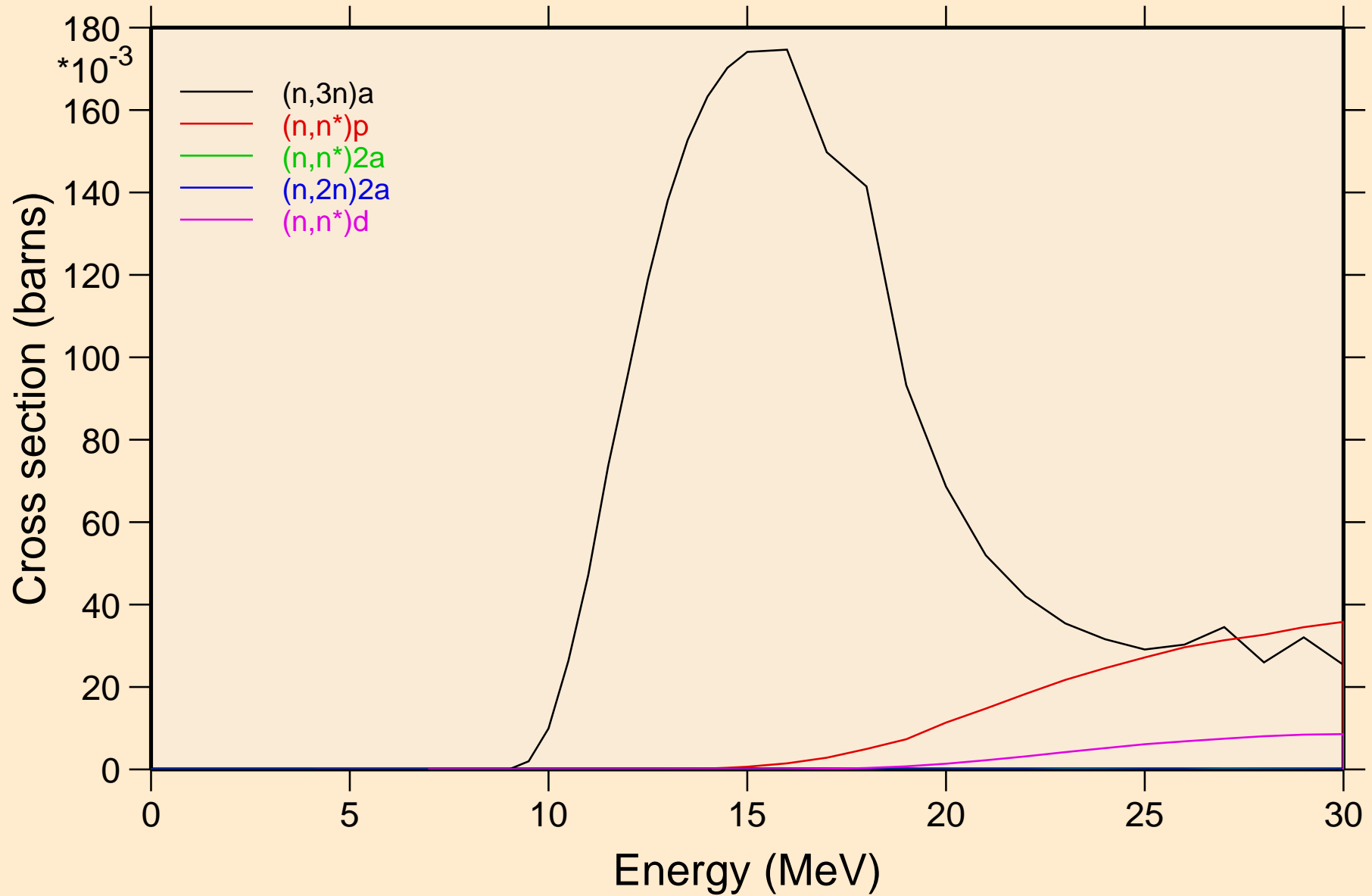

BI215M NRG TENDL-2015, AKONING

Threshold reactions

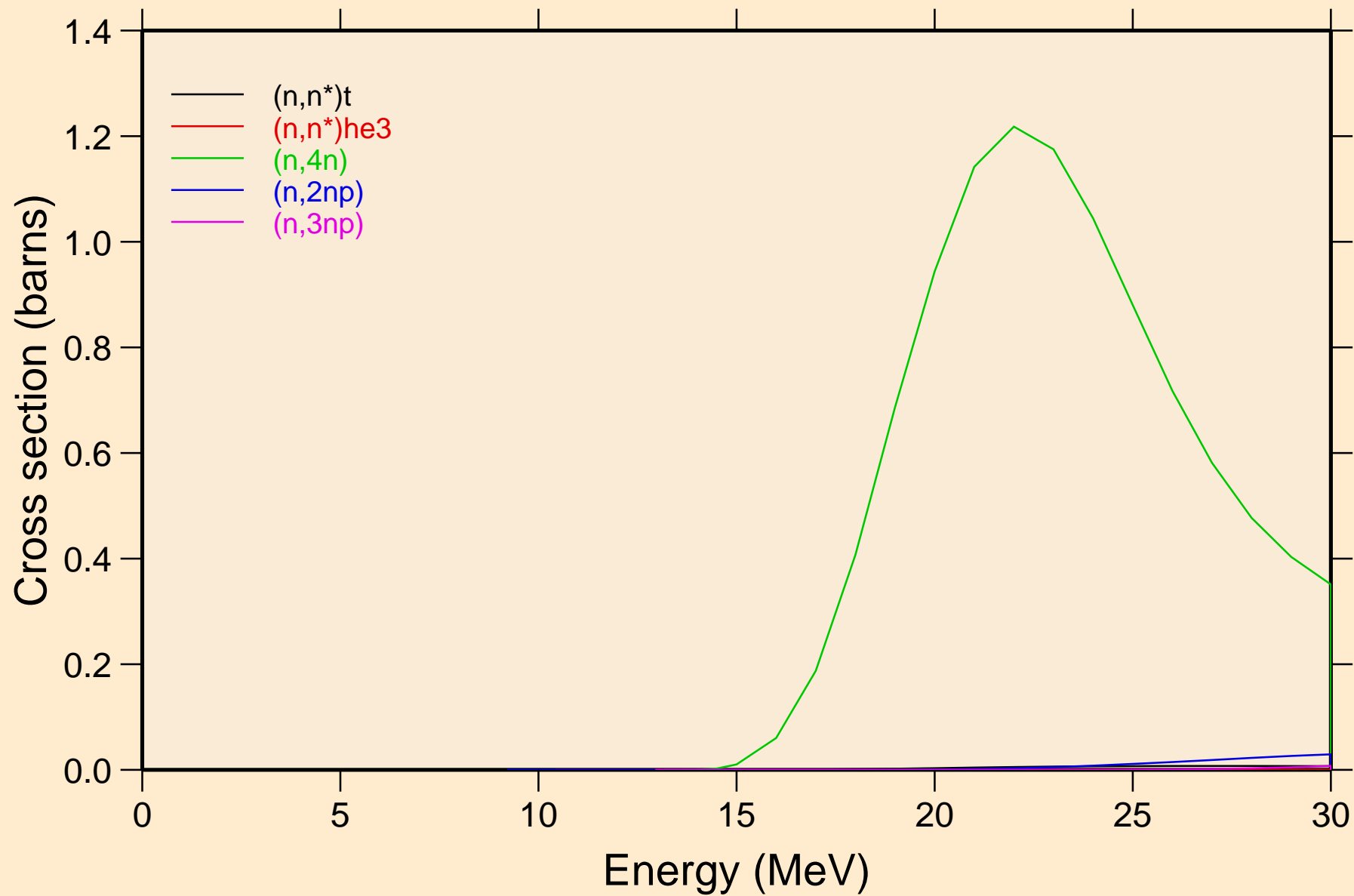

BI215M NRG TENDL-2015, AKONING

Threshold reactions

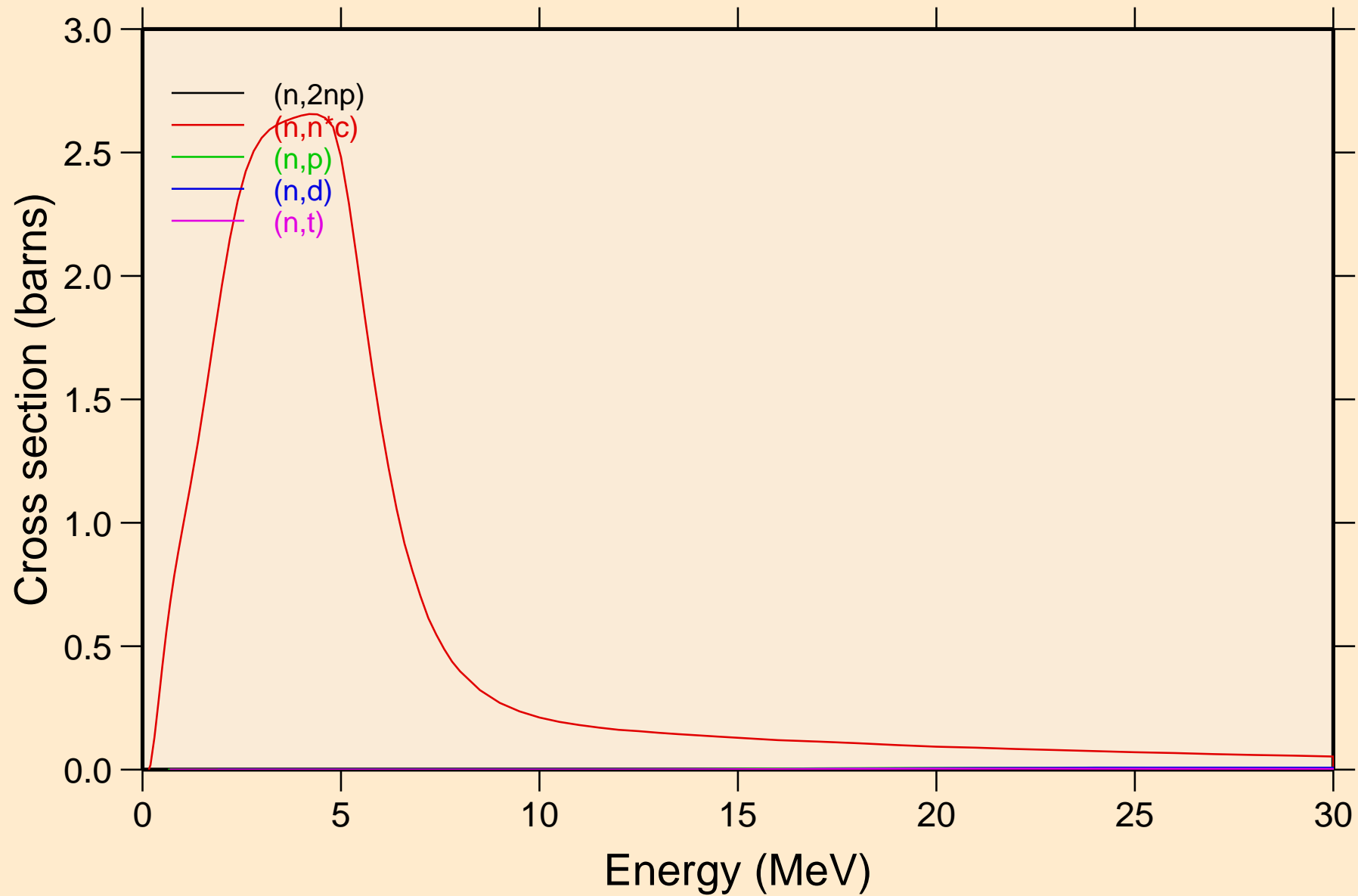

BI215M NRG TENDL-2015, AKONING

Threshold reactions

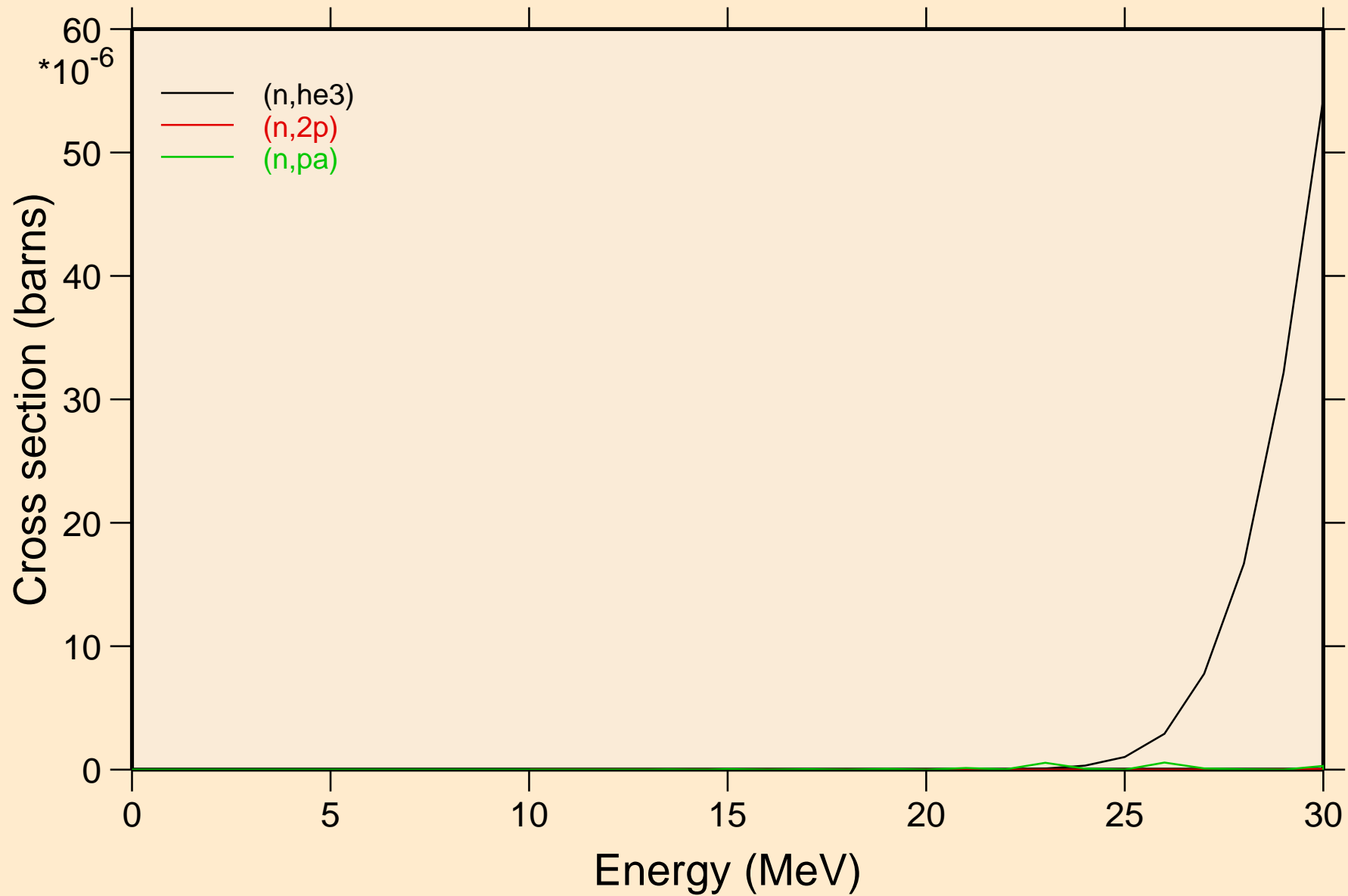

BI215M NRG TENDL-2015, AKONING
angular distribution for elastic

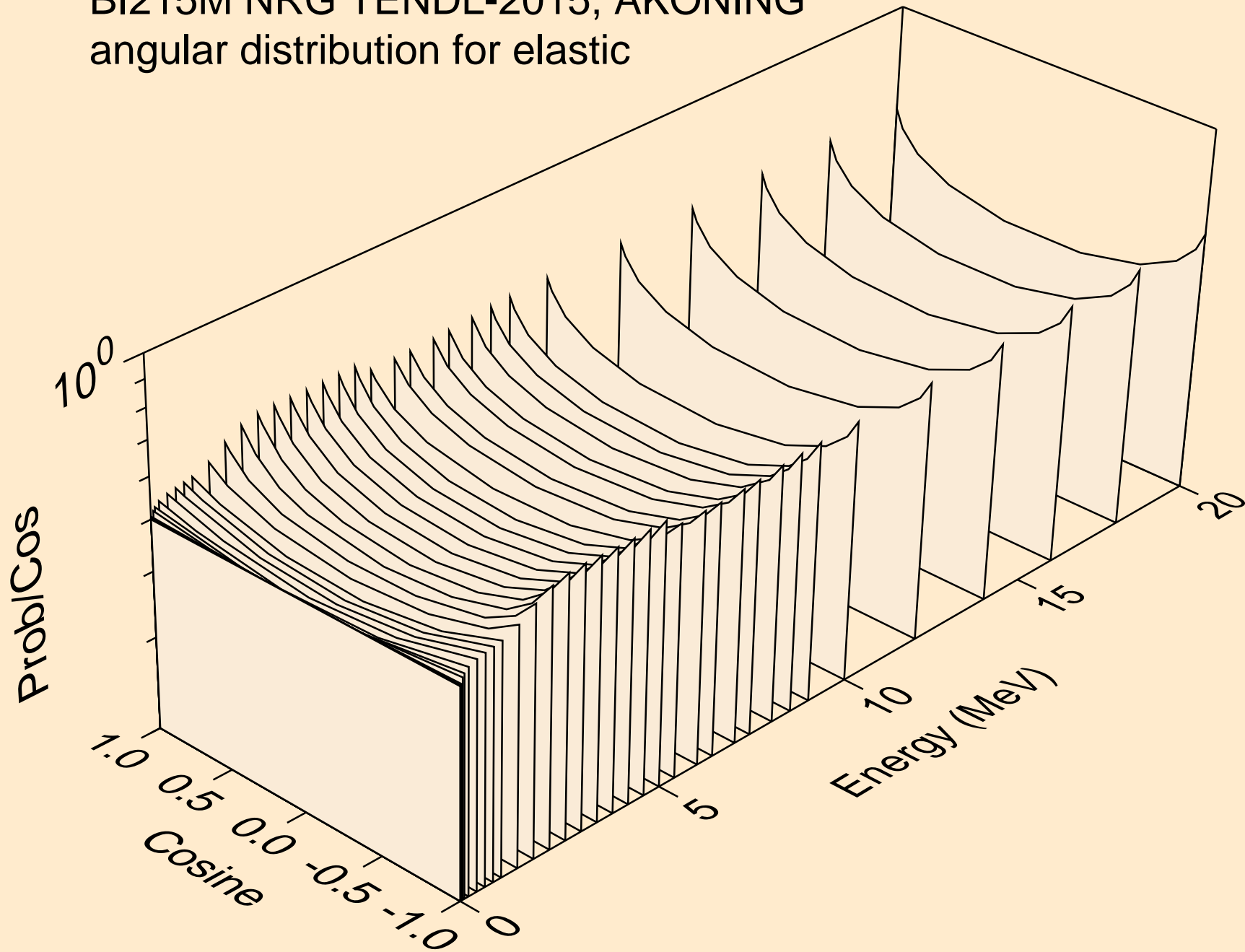

BI215M NRG TENDL-2015, AKONING
angular distribution for elastic

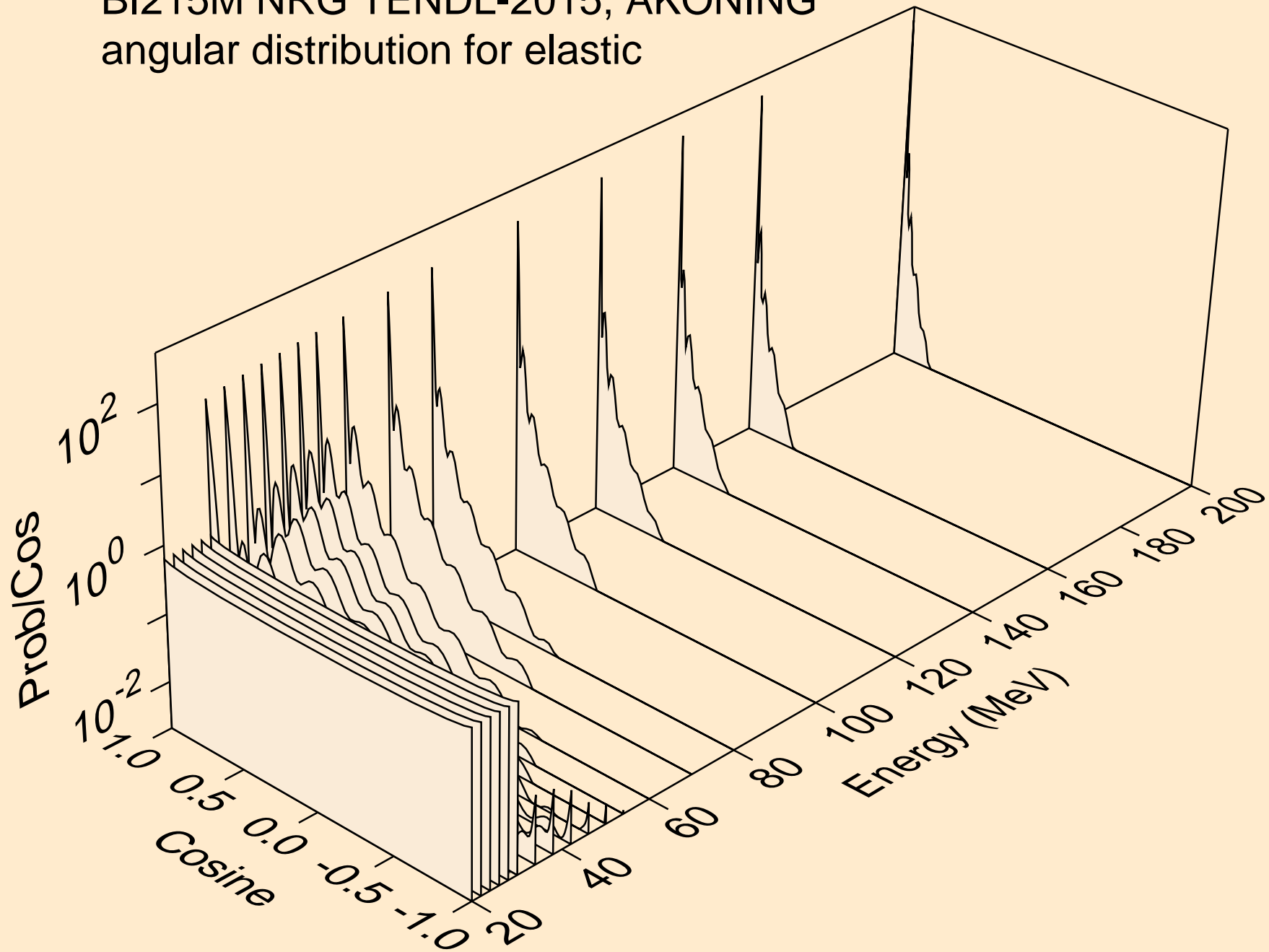

BI215M NRG TENDL-2015, AKONING
angular distribution for (n,n*1)

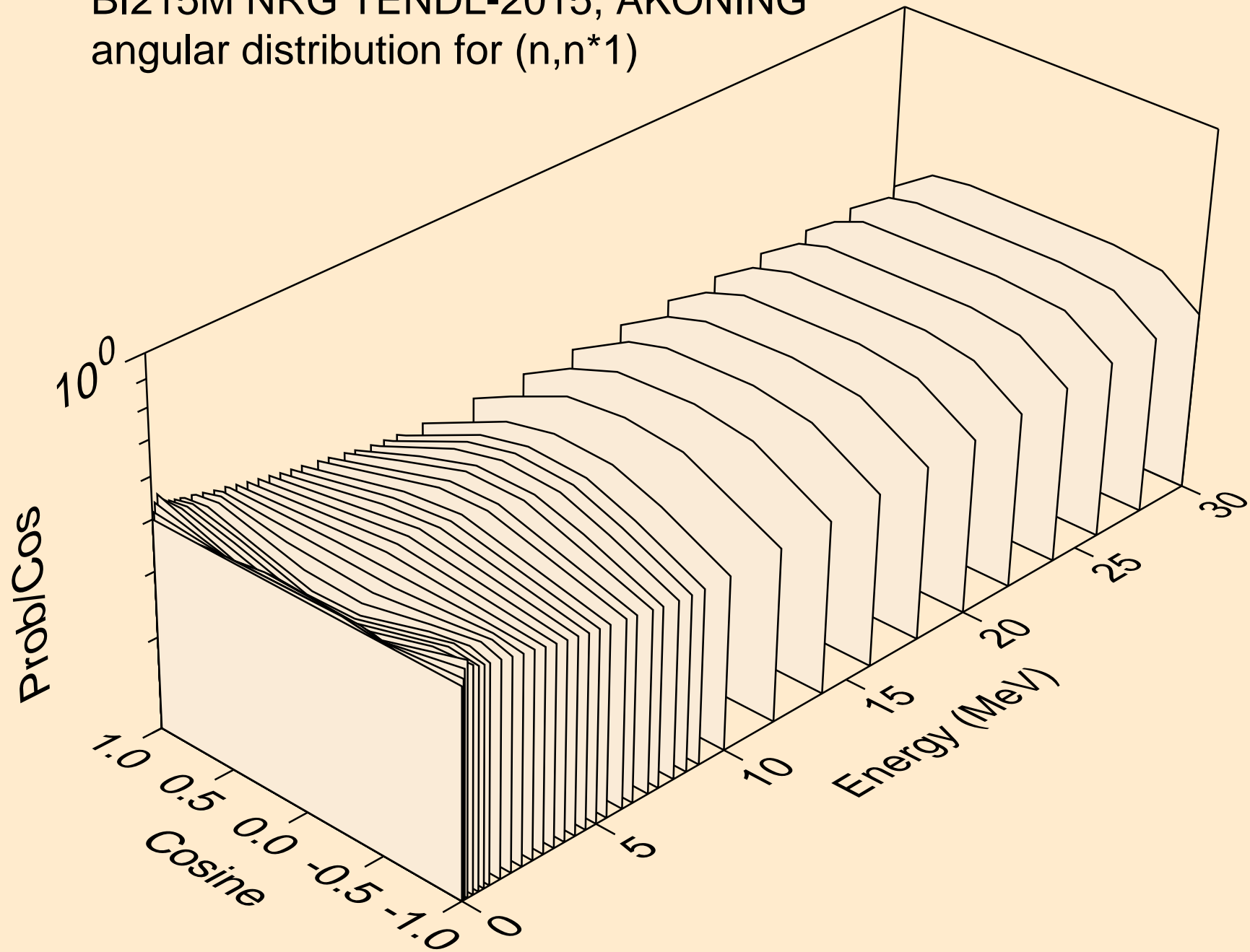

BI215M NRG TENDL-2015, AKONING
angular distribution for (n,n*2)

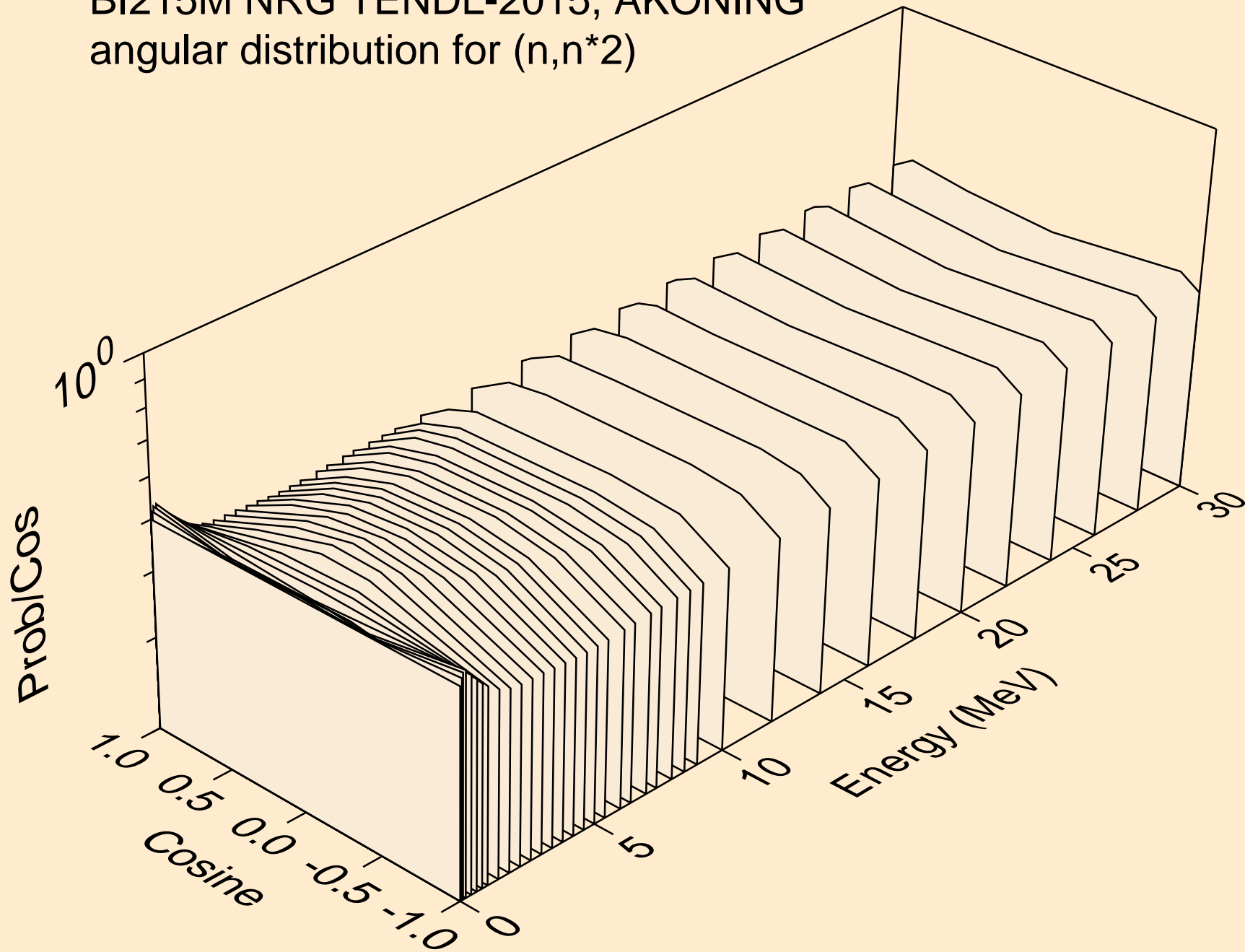

BI215M NRG TENDL-2015, AKONING
angular distribution for (n,n*3)

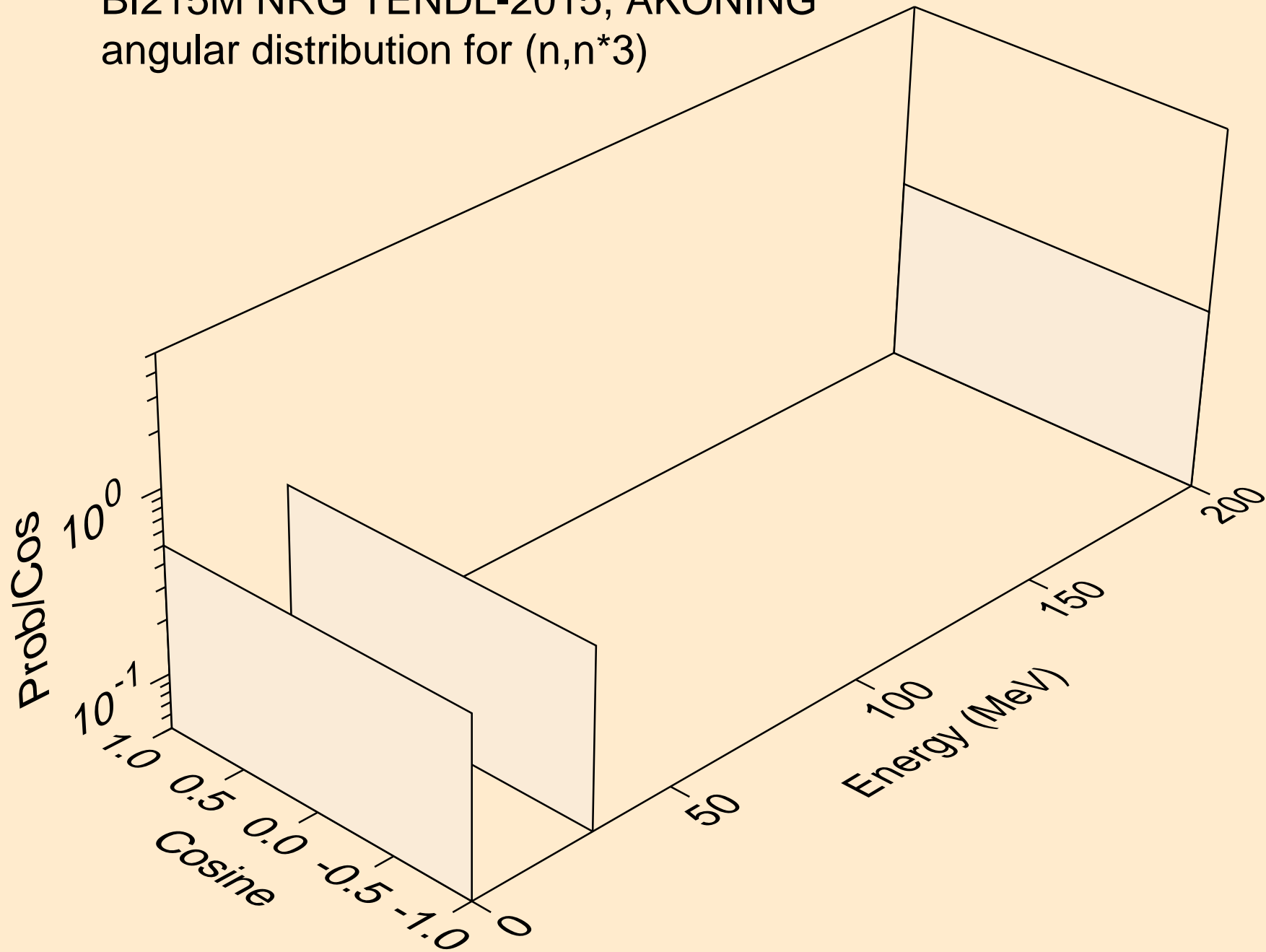

BI215M NRG TENDL-2015, AKONING
angular distribution for (n,n*4)

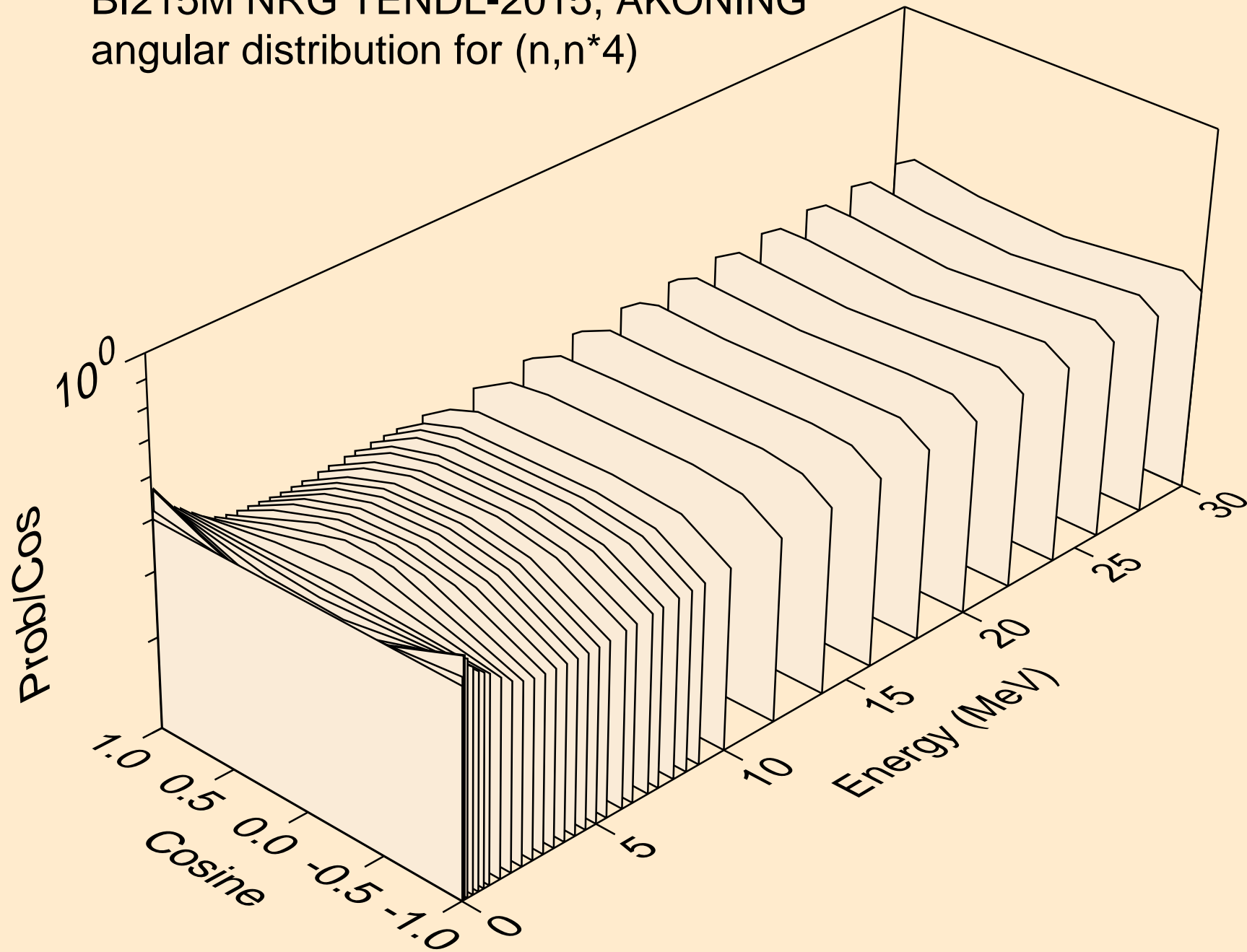

BI215M NRG TENDL-2015, AKONING
angular distribution for (n,n*5)

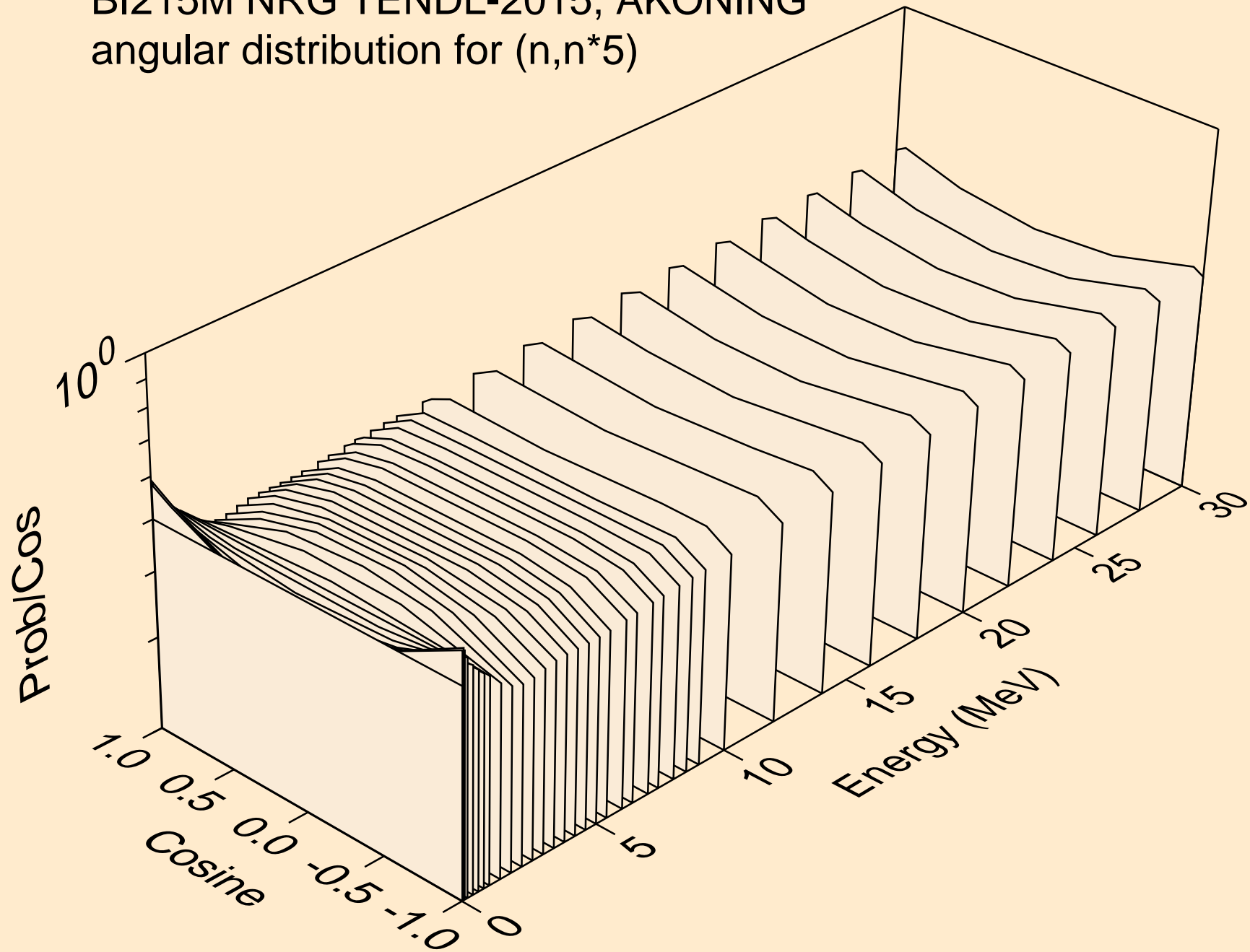

BI215M NRG TENDL-2015, AKONING
angular distribution for (n,n*6)

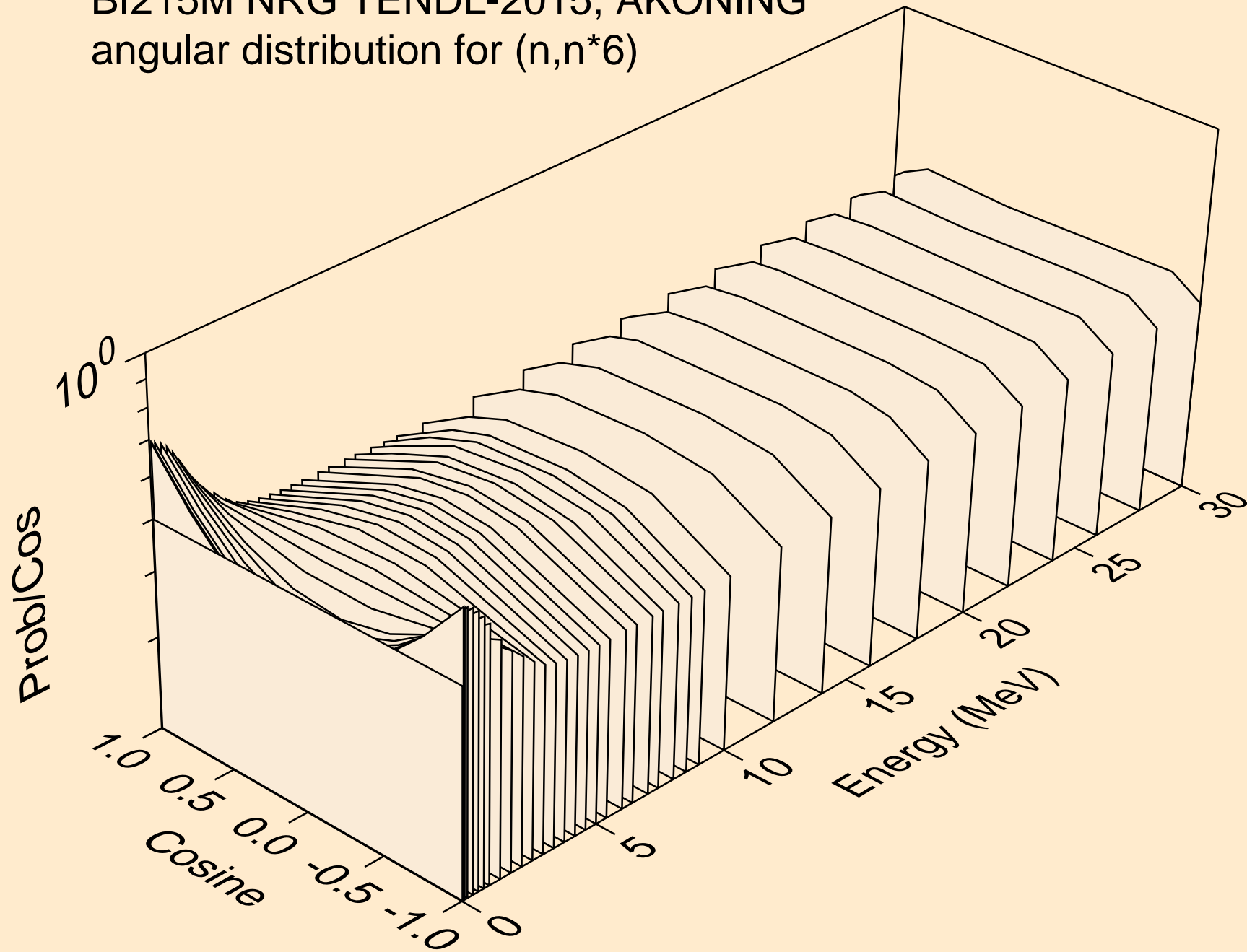

BI215M NRG TENDL-2015, AKONING
angular distribution for (n,n*7)

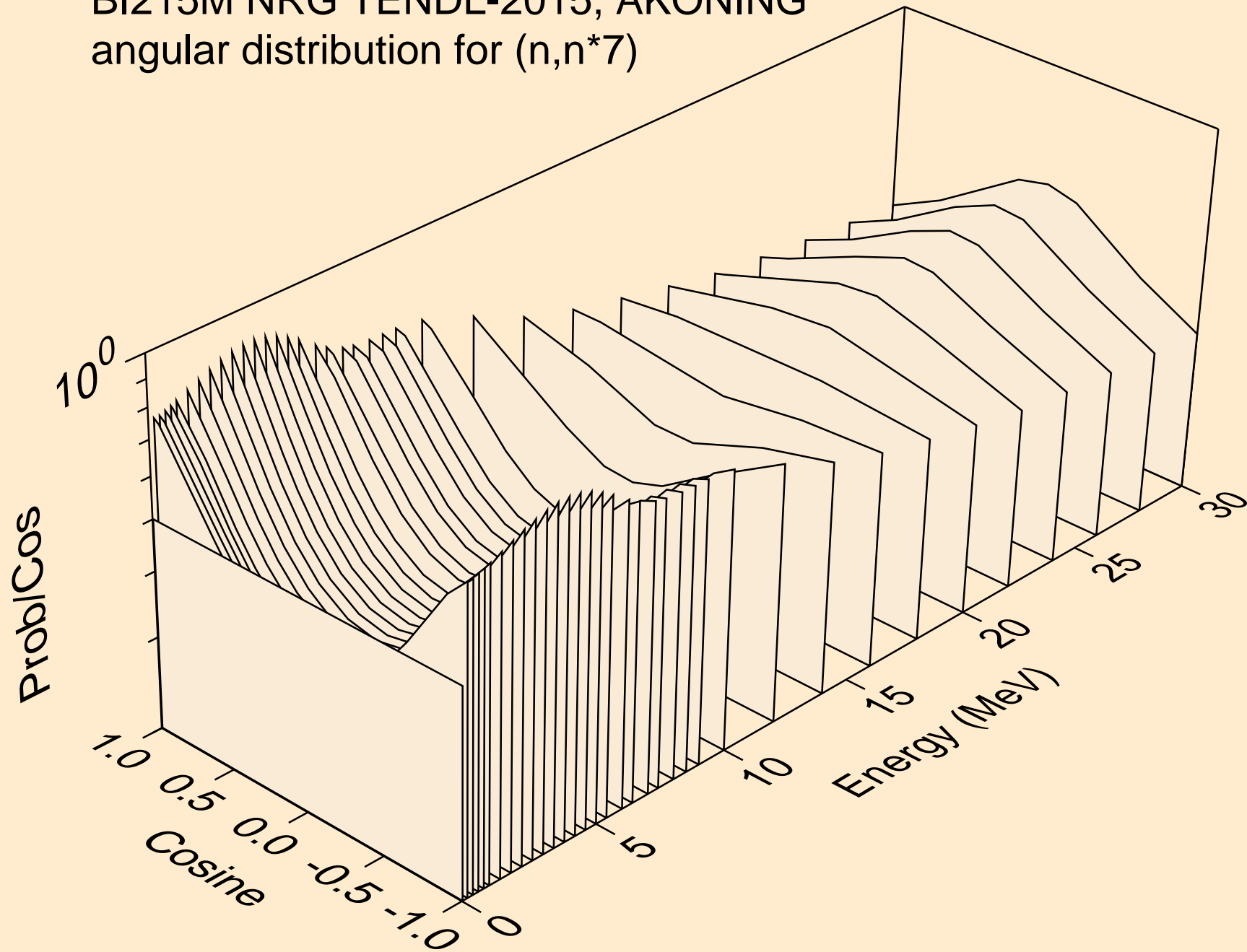

BI215M NRG TENDL-2015, AKONING
angular distribution for (n,n*8)

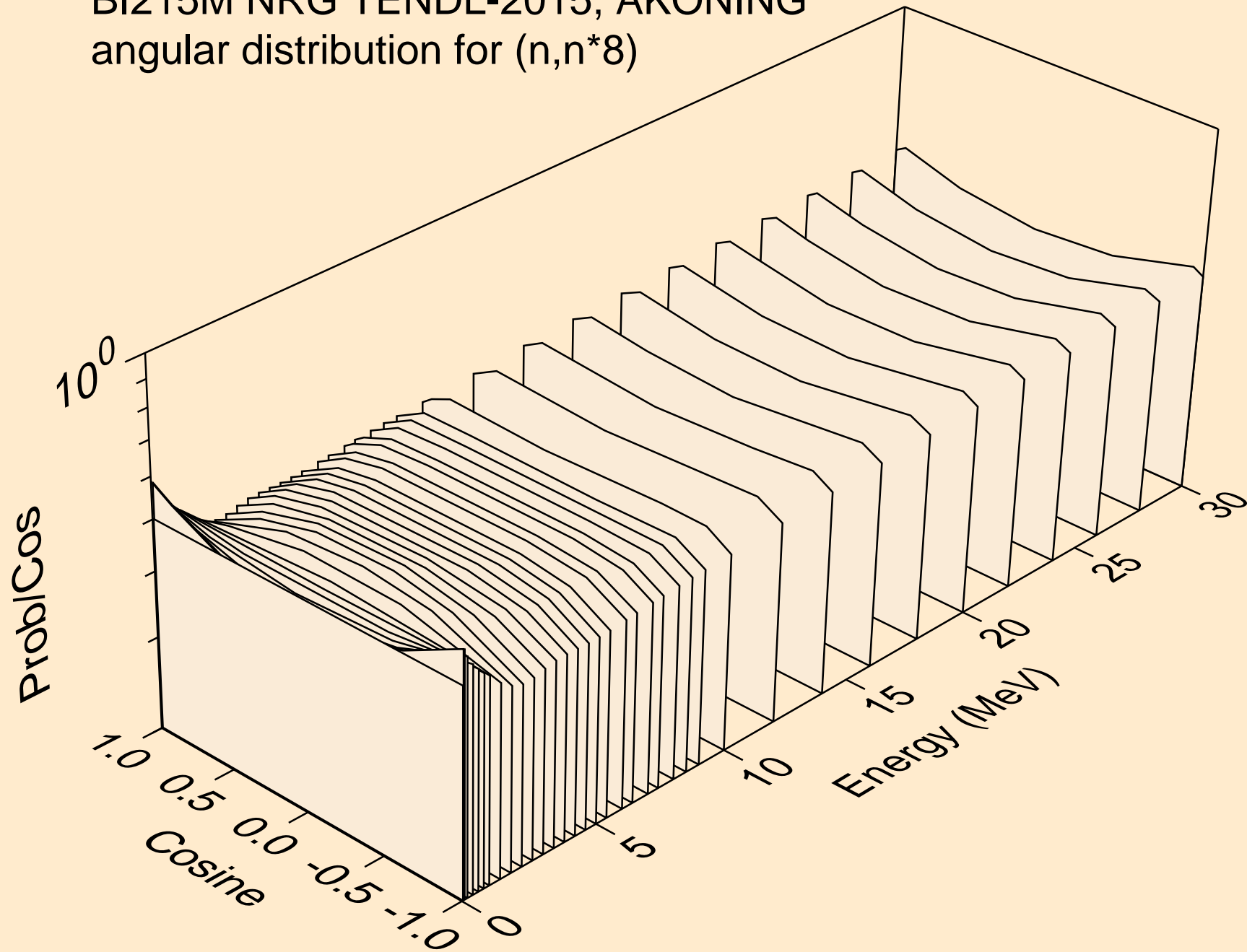

BI215M NRG TENDL-2015, AKONING
angular distribution for (n,n*9)

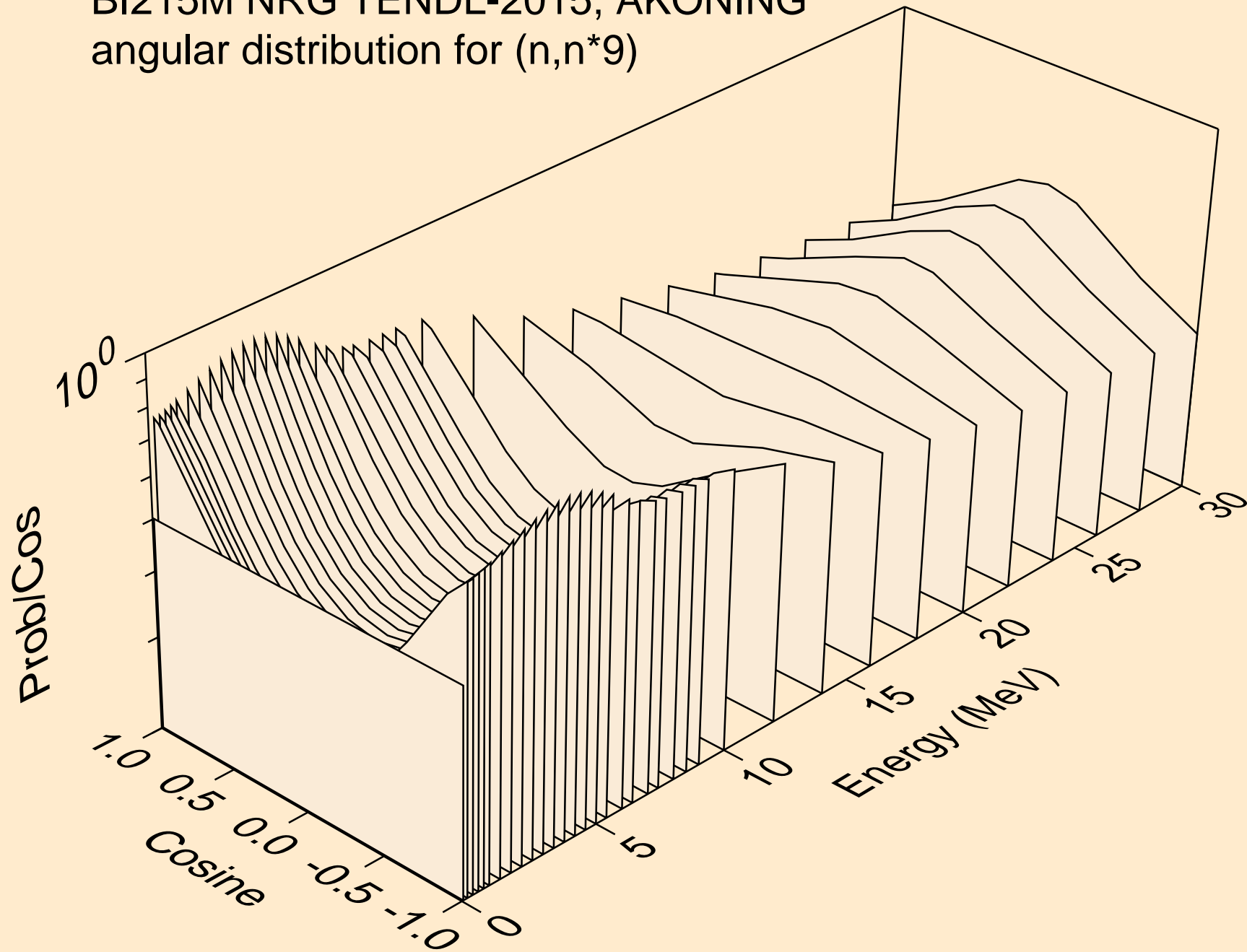

BI215M NRG TENDL-2015, AKONING
angular distribution for (n,n*10)

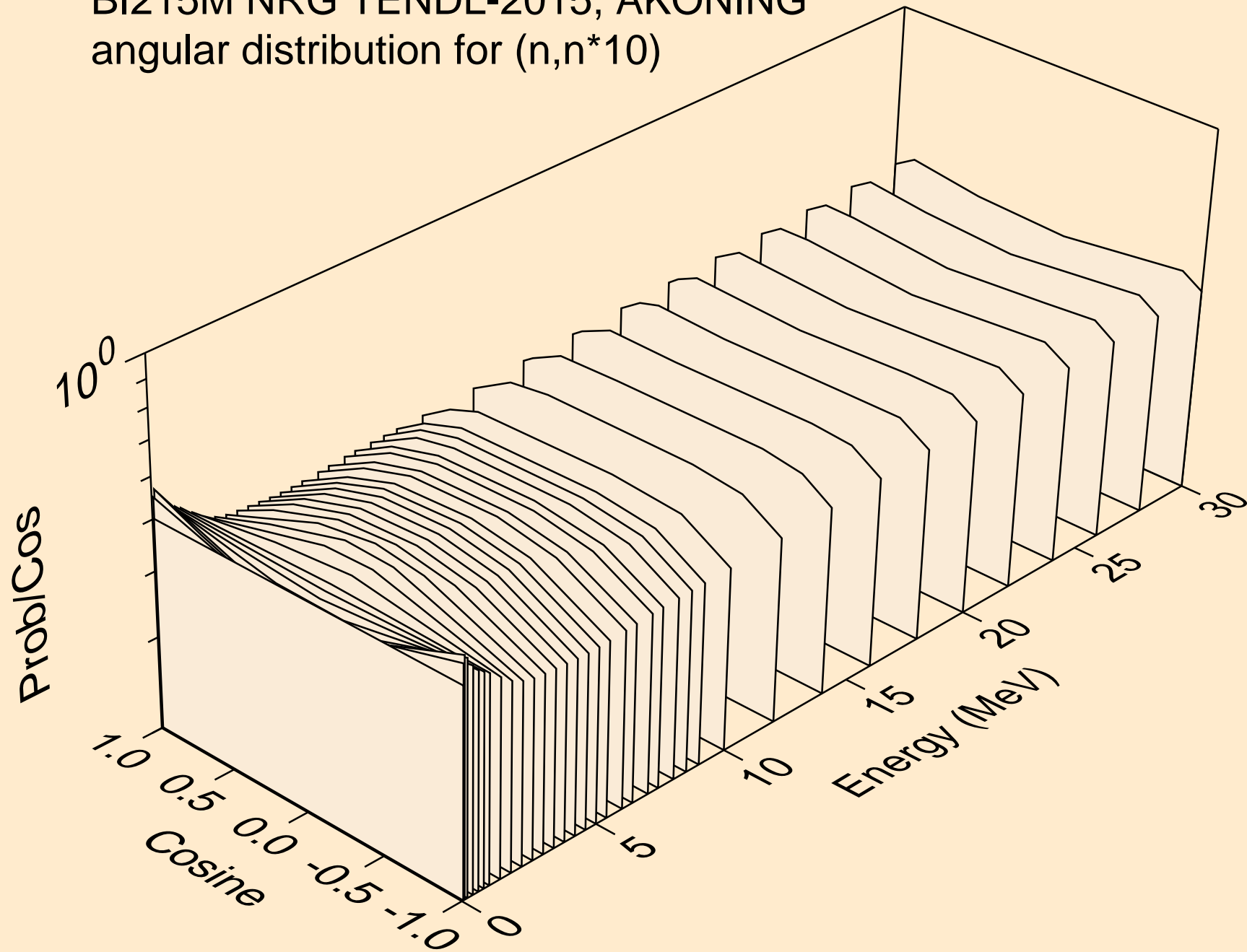

BI215M NRG TENDL-2015, AKONING
angular distribution for (n,n*11)

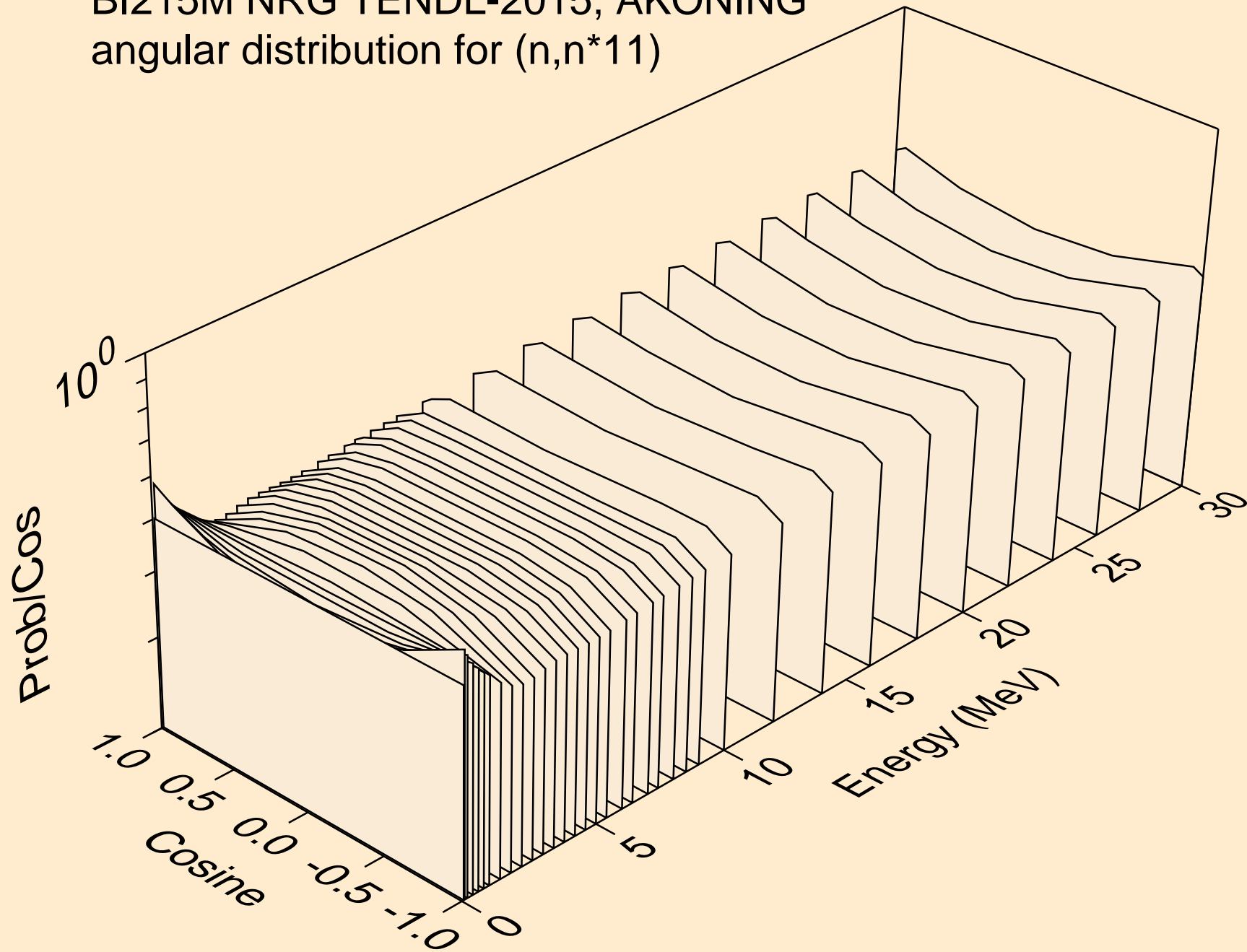

BI215M NRG TENDL-2015, AKONING
angular distribution for (n,n*12)

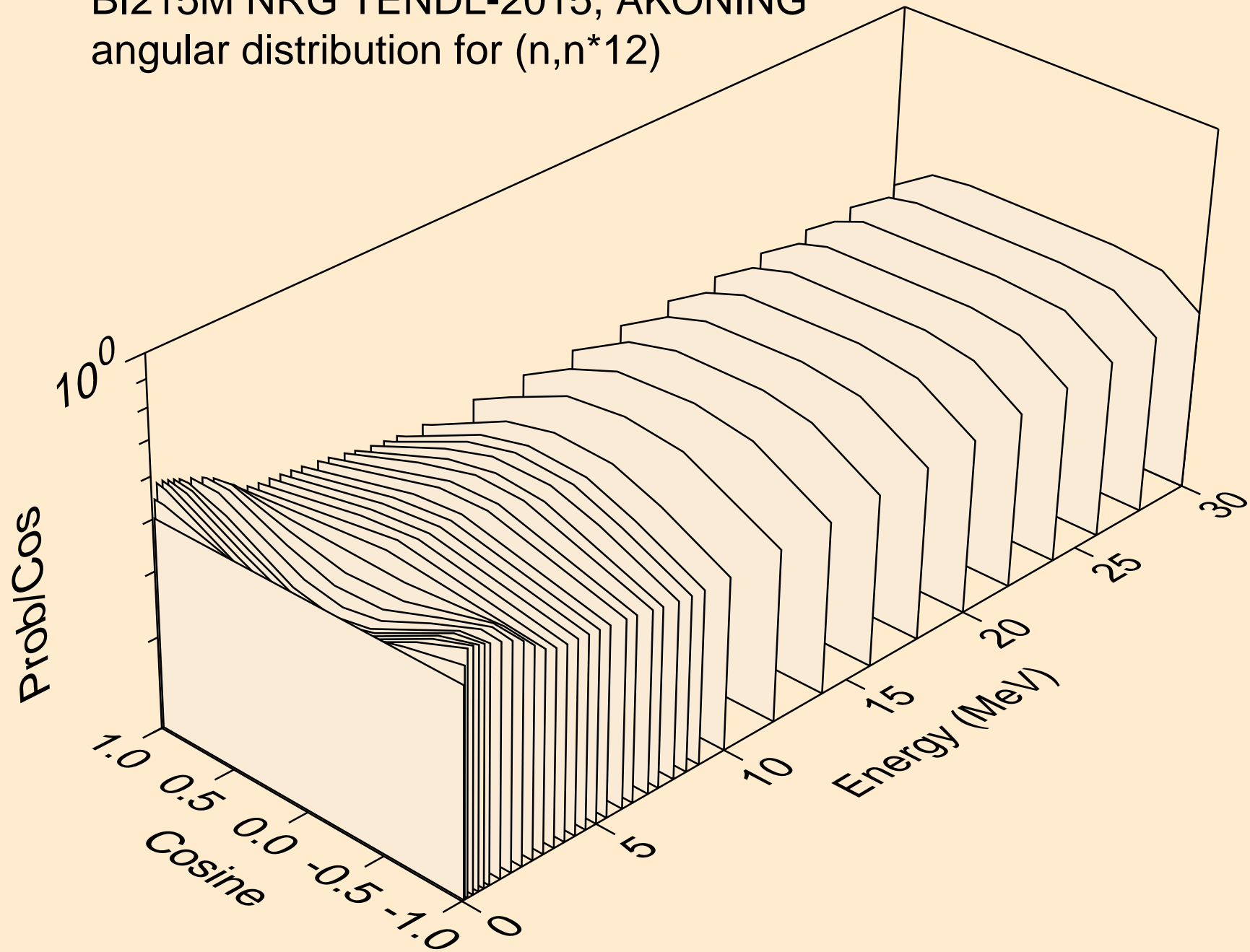

BI215M NRG TENDL-2015, AKONING
angular distribution for (n,n*13)

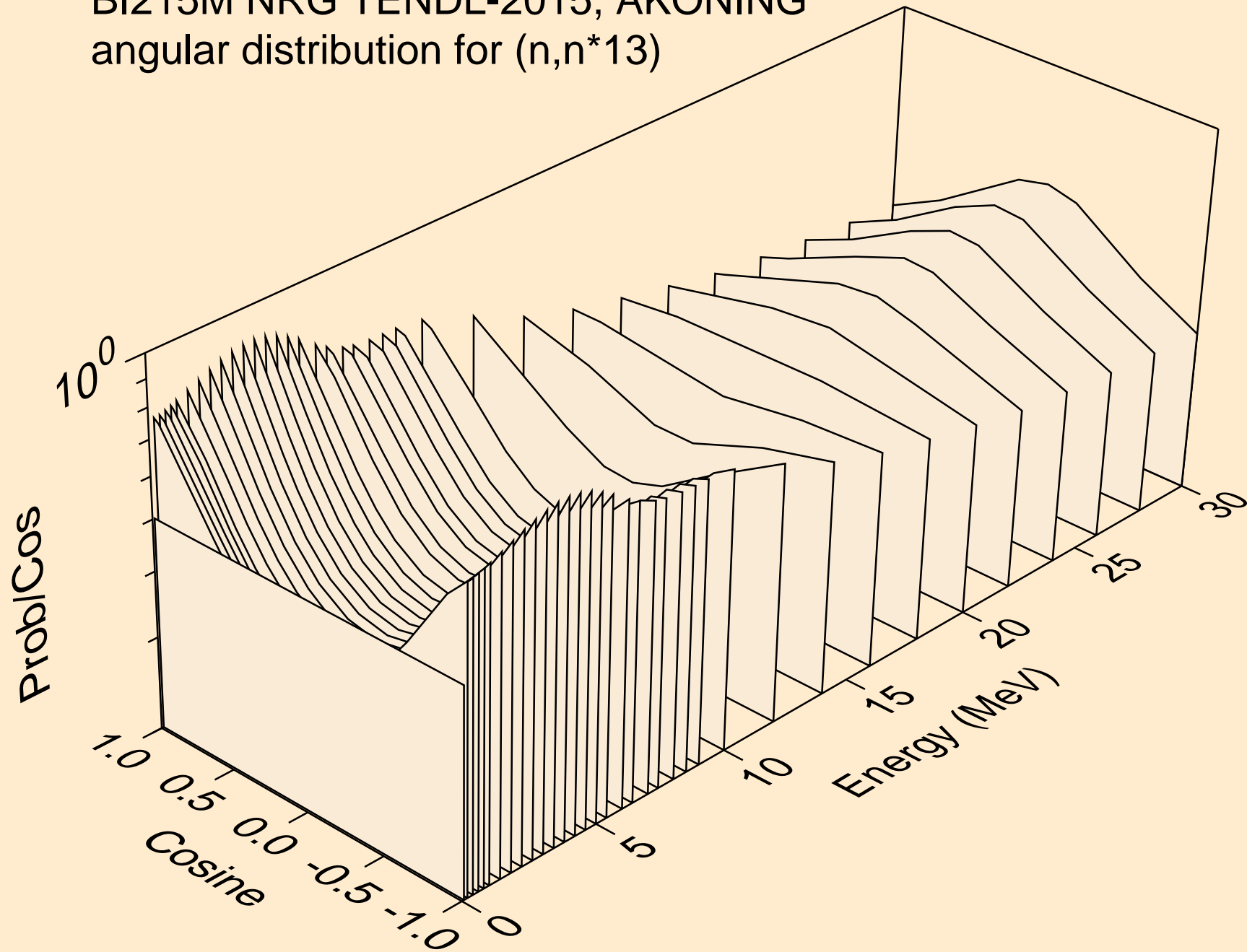

BI215M NRG TENDL-2015, AKONING
angular distribution for (n,n*14)

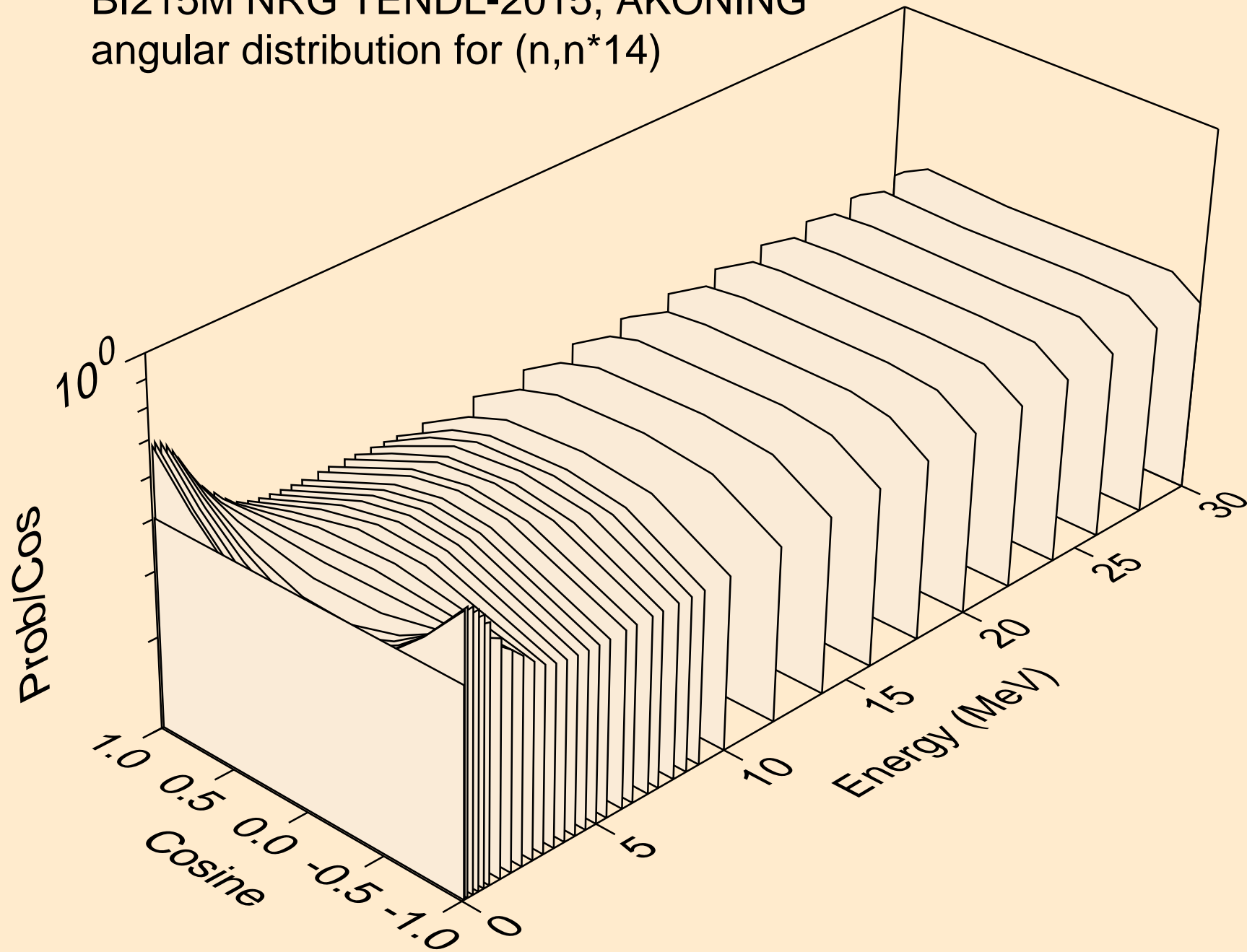

BI215M NRG TENDL-2015, AKONING
angular distribution for (n,n*15)

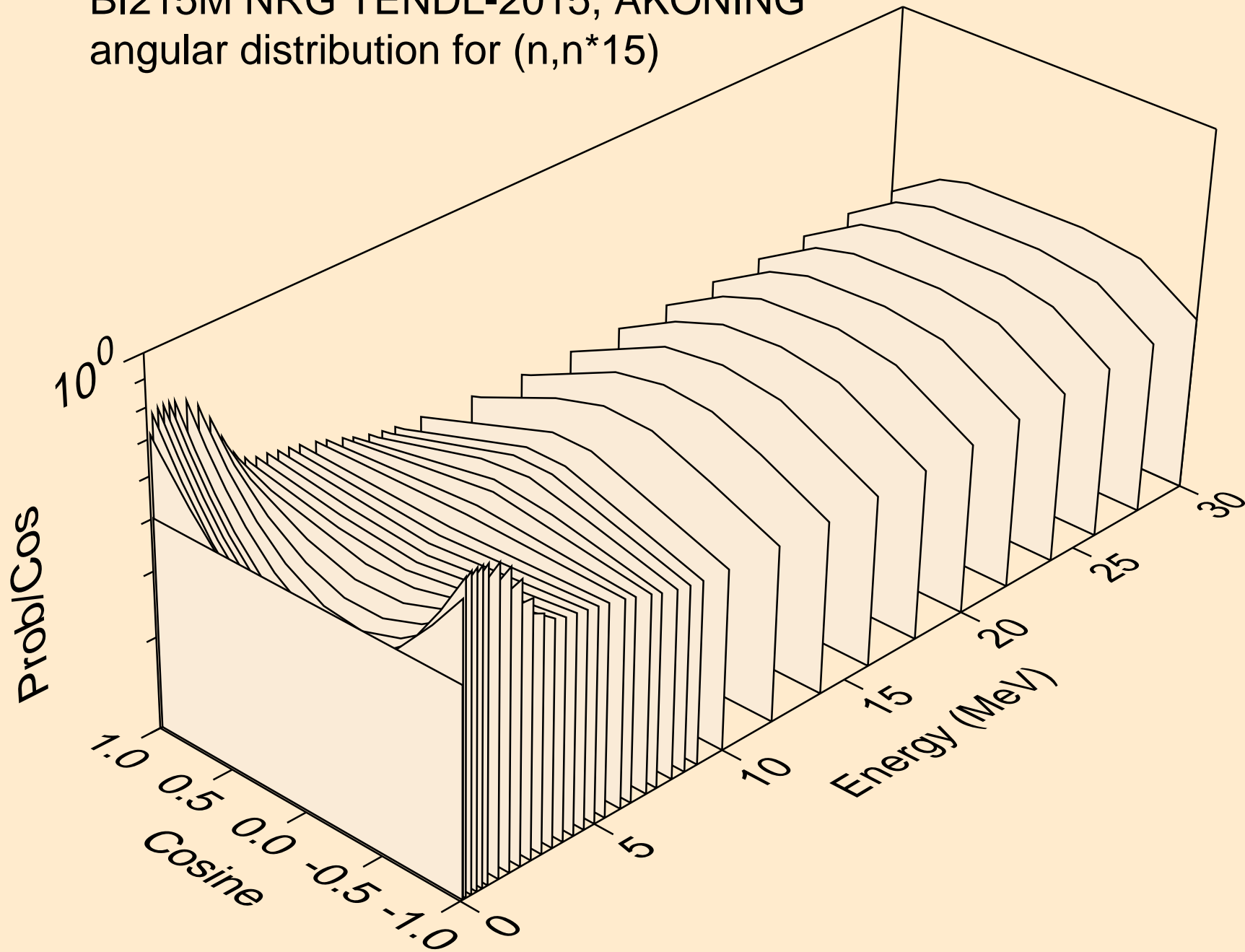

BI215M NRG TENDL-2015, AKONING
angular distribution for (n,n*16)

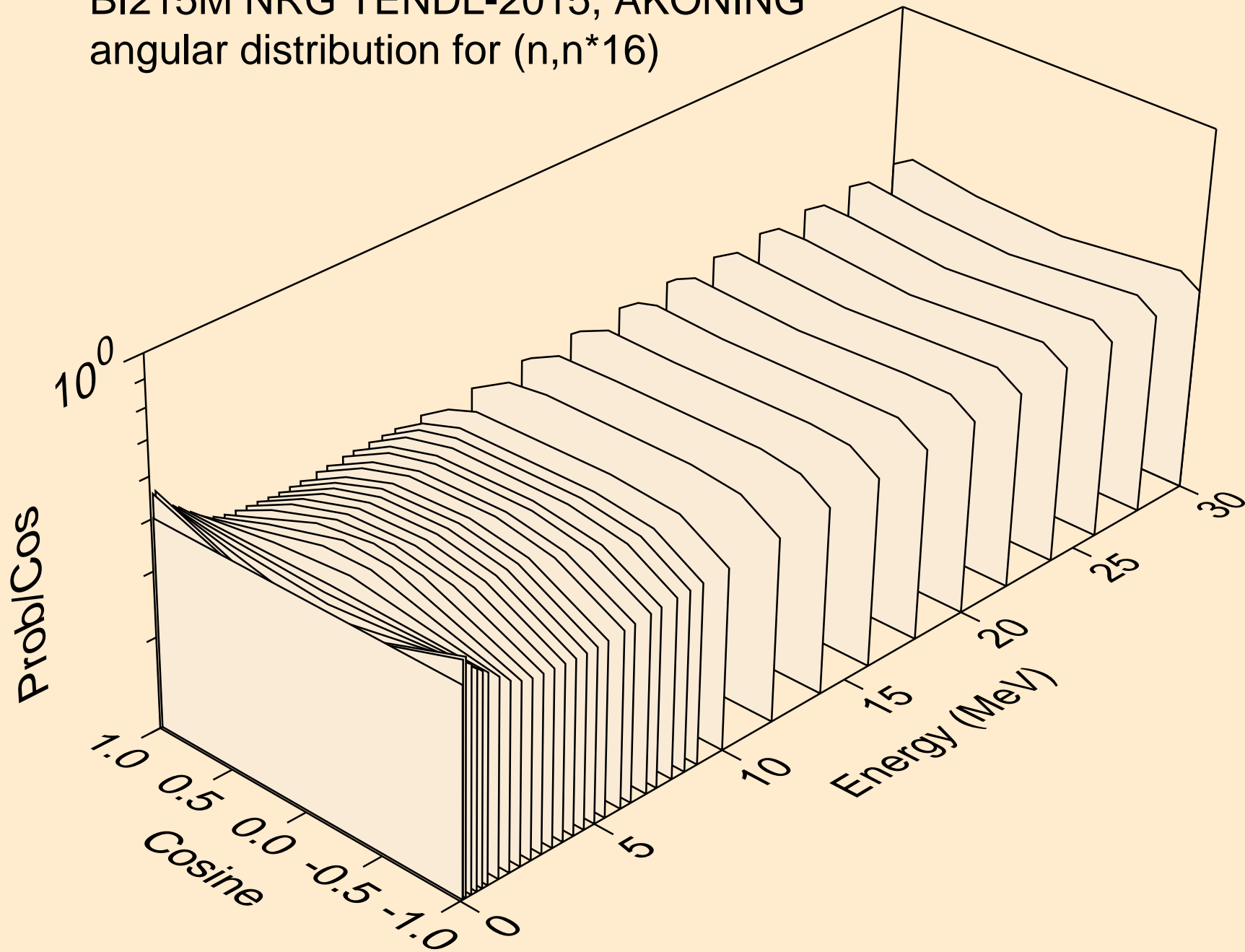

BI215M NRG TENDL-2015, AKONING
angular distribution for (n,n*17)

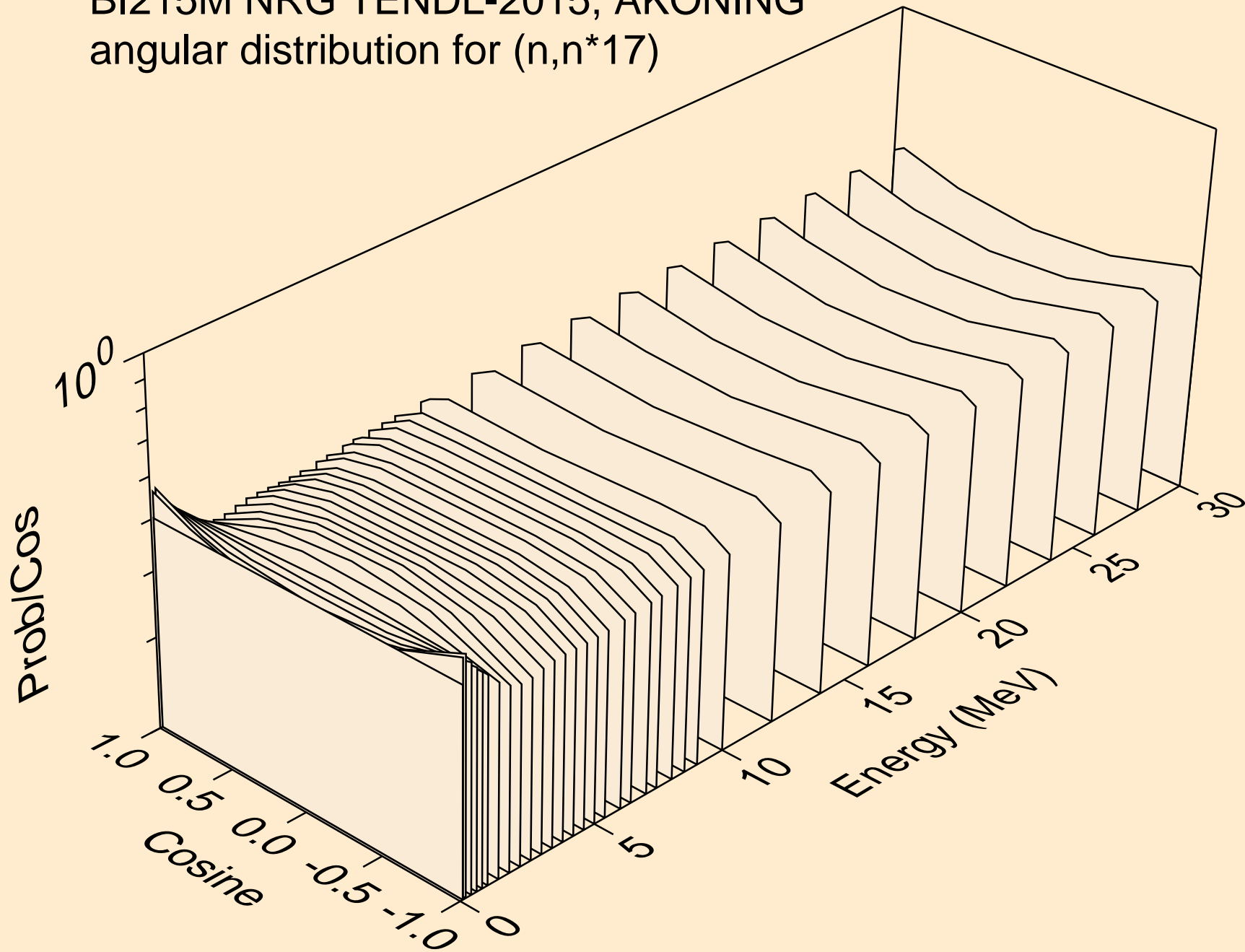

BI215M NRG TENDL-2015, AKONING
angular distribution for (n,n*18)

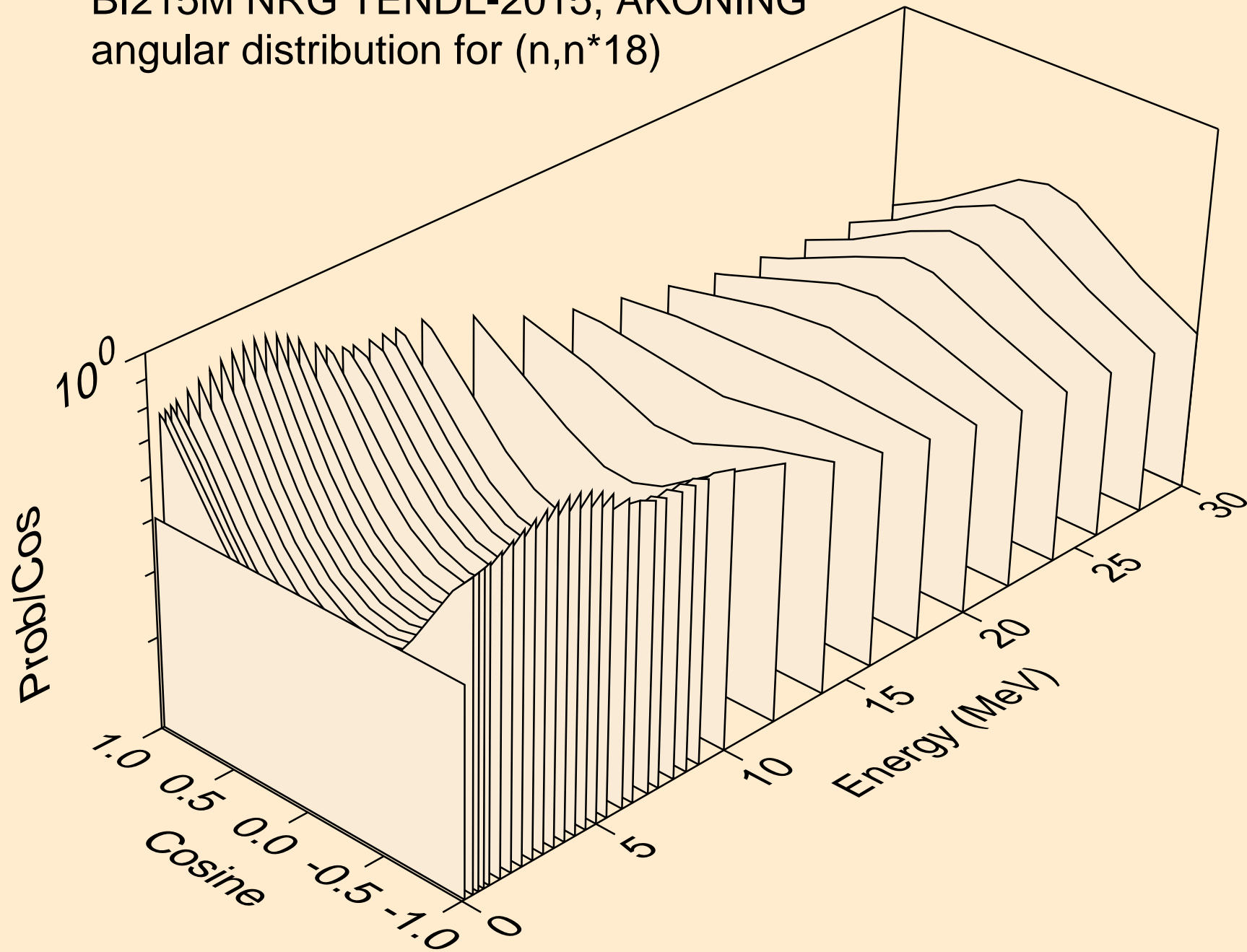

BI215M NRG TENDL-2015, AKONING
angular distribution for (n,n*19)

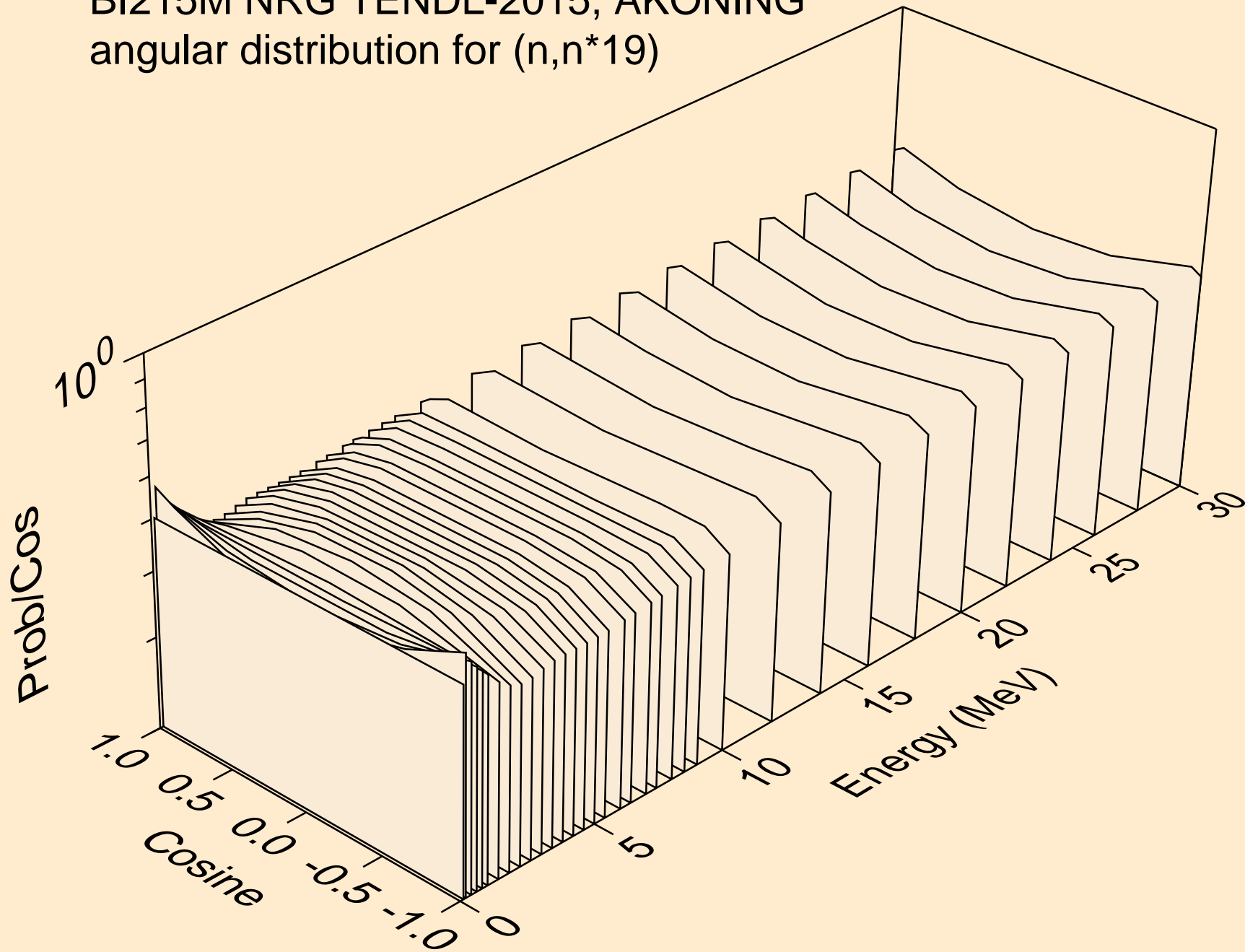

BI215M NRG TENDL-2015, AKONING
angular distribution for (n,n*20)

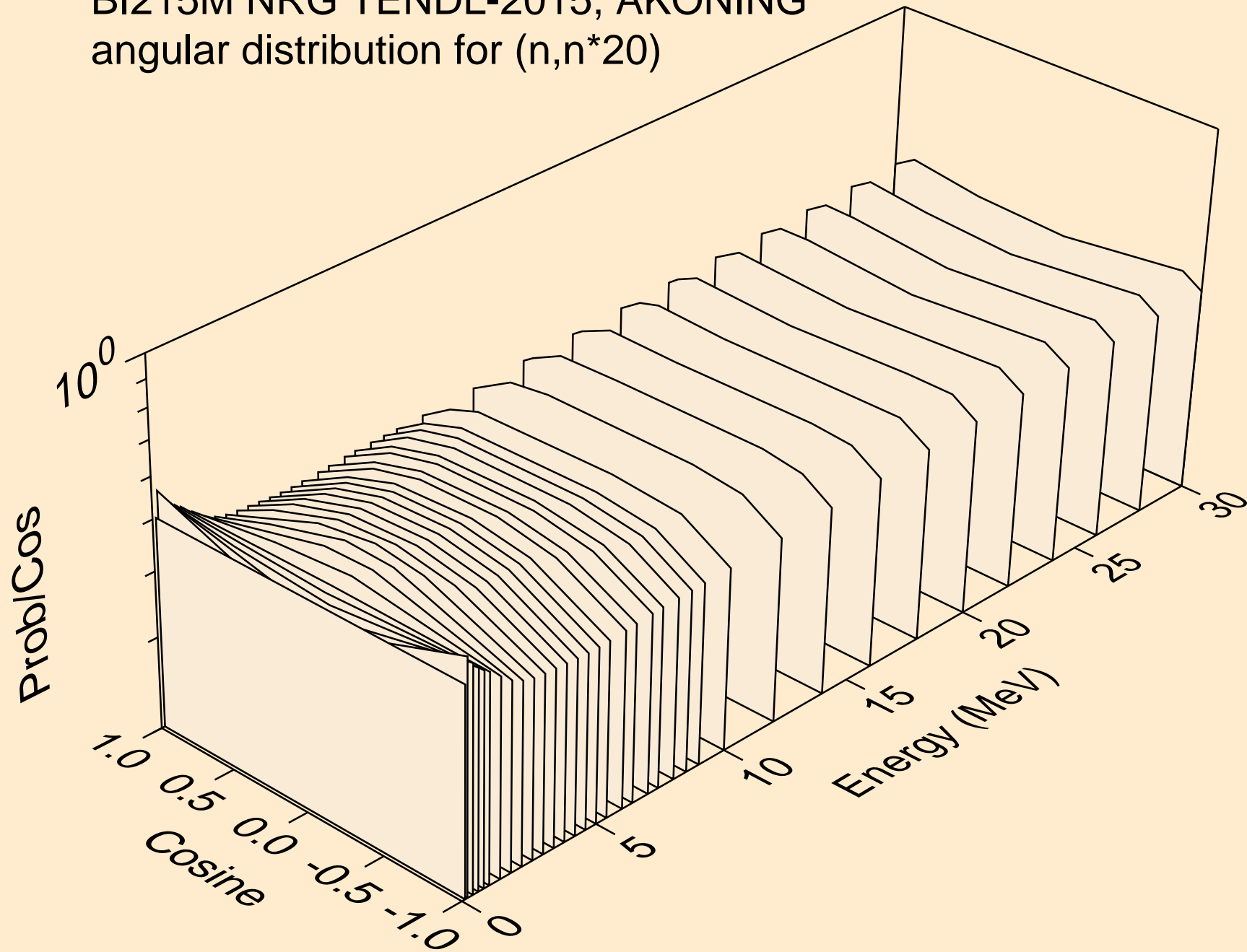

BI215M NRG TENDL-2015, AKONING
angular distribution for (n,n*21)

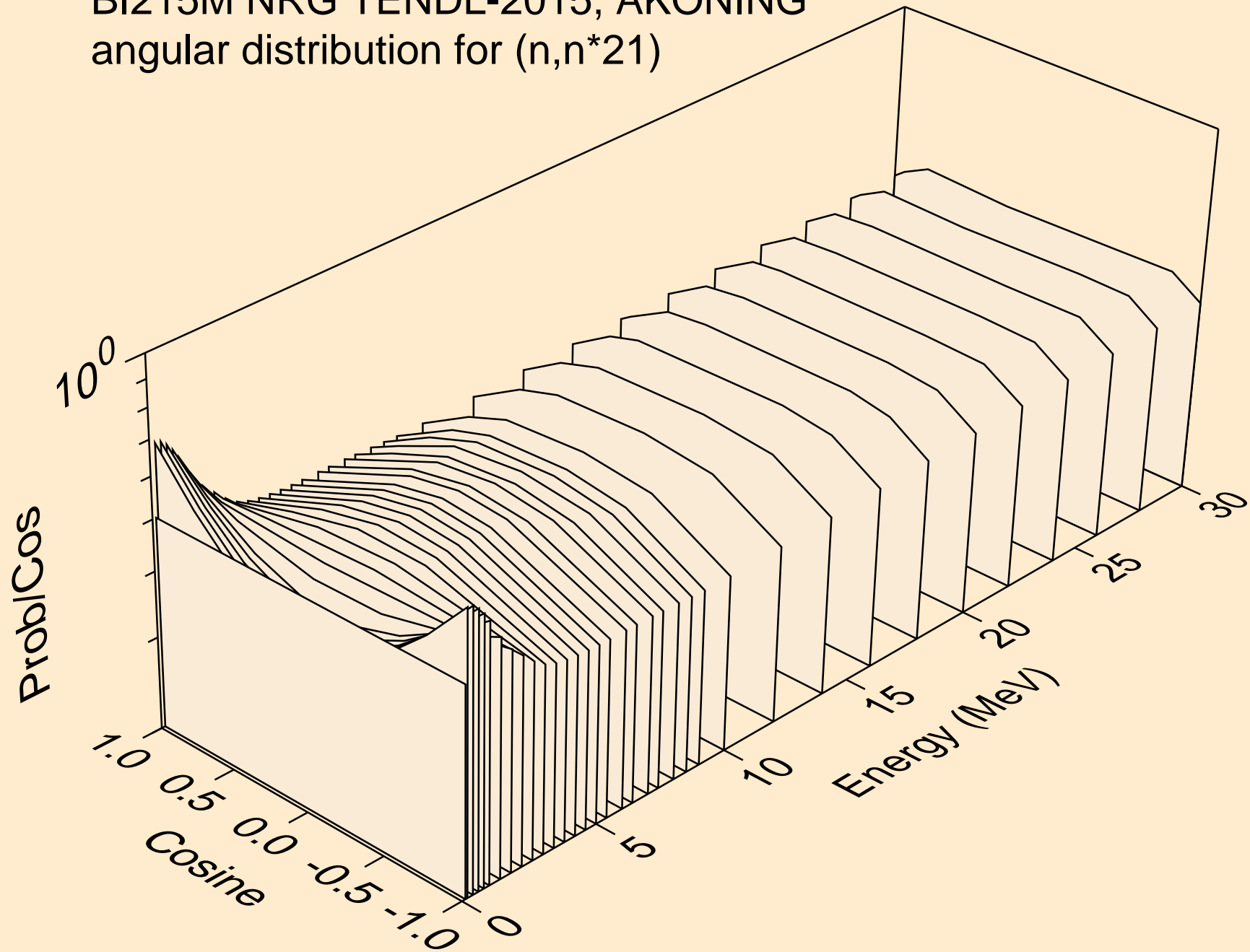

BI215M NRG TENDL-2015, AKONING
angular distribution for (n,n*22)

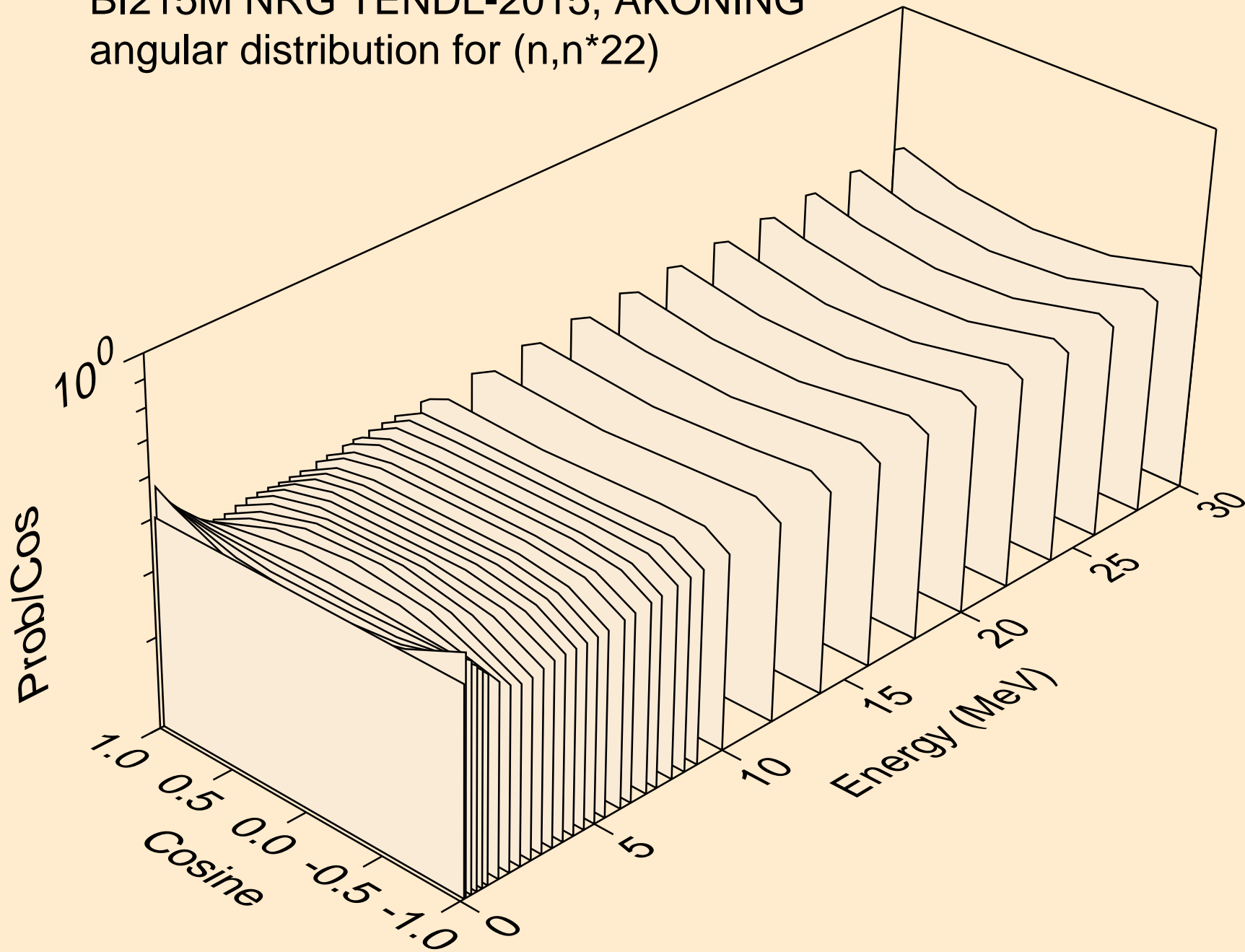

BI215M NRG TENDL-2015, AKONING
angular distribution for (n,n*23)

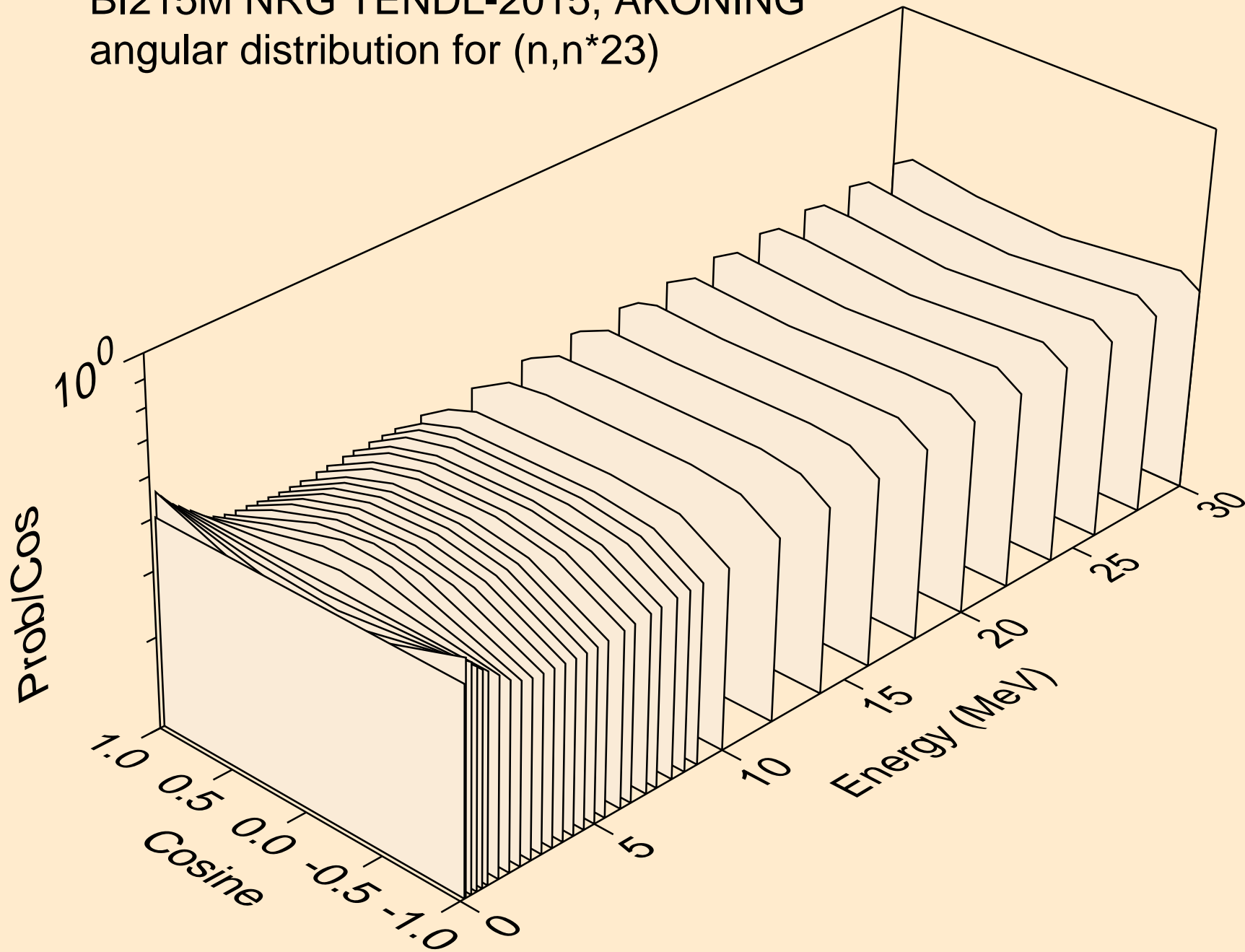

BI215M NRG TENDL-2015, AKONING
angular distribution for (n,n*24)

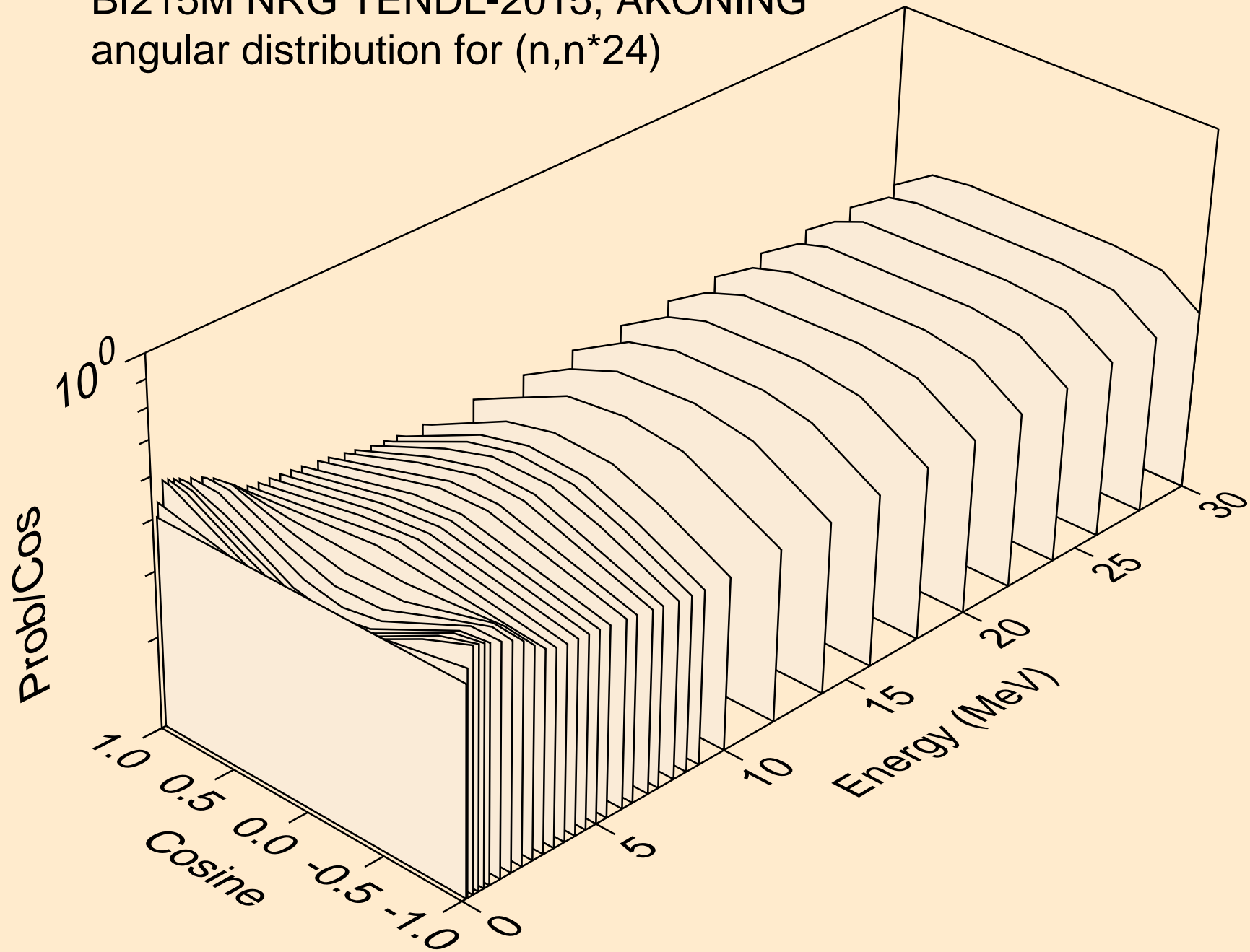

BI215M NRG TENDL-2015, AKONING
angular distribution for (n,n*25)

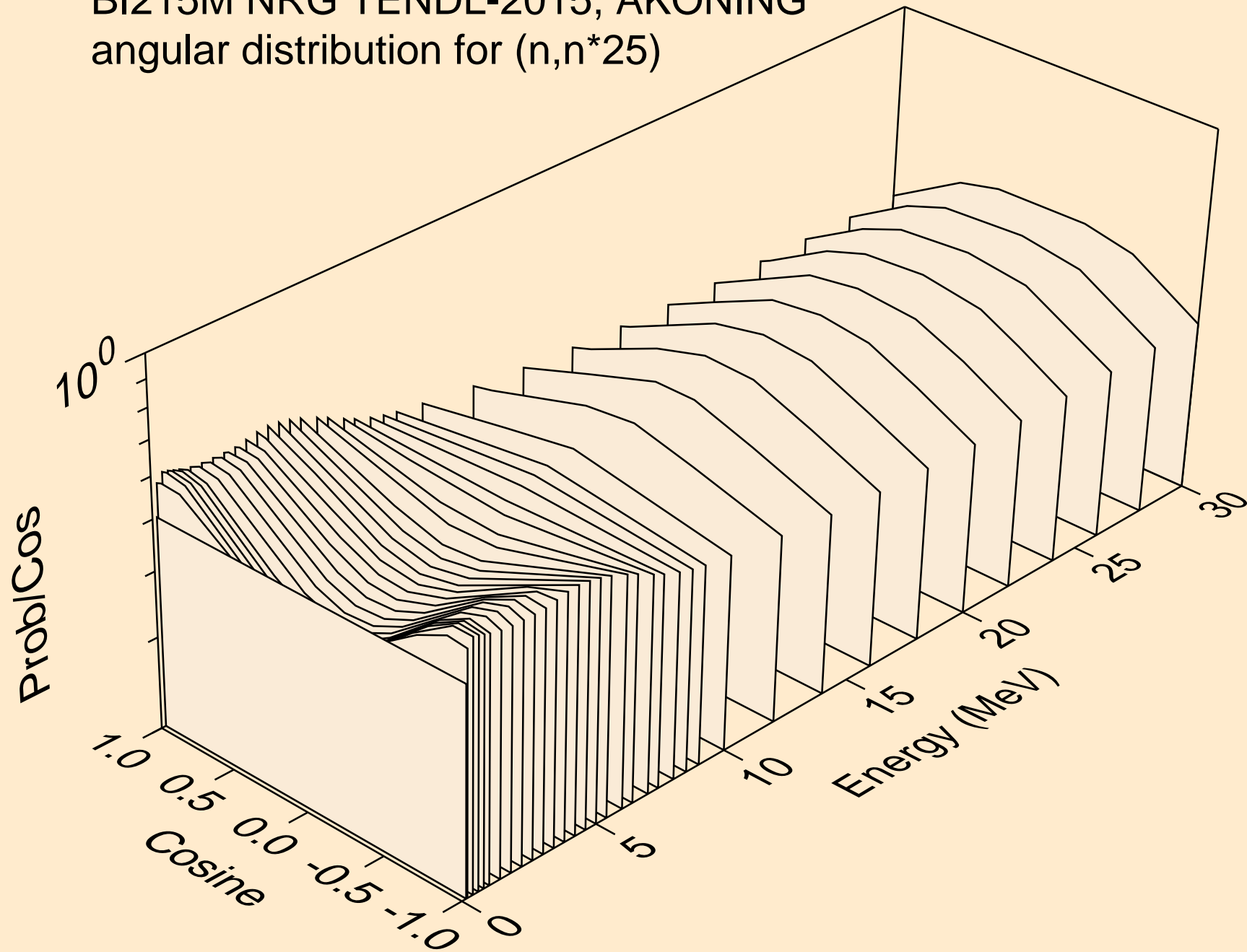

BI215M NRG TENDL-2015, AKONING
angular distribution for (n,n*26)

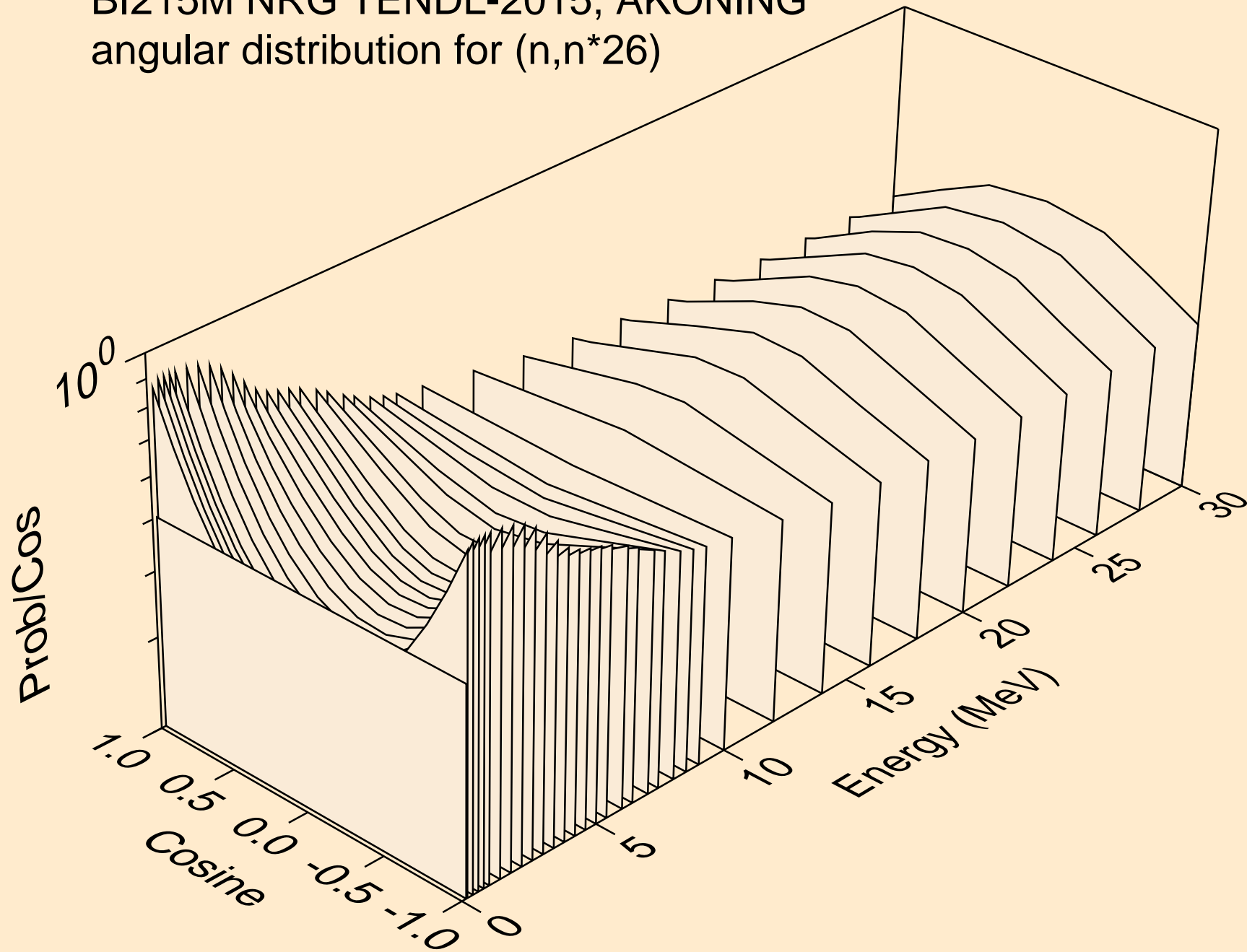

BI215M NRG TENDL-2015, AKONING
angular distribution for (n,n*27)

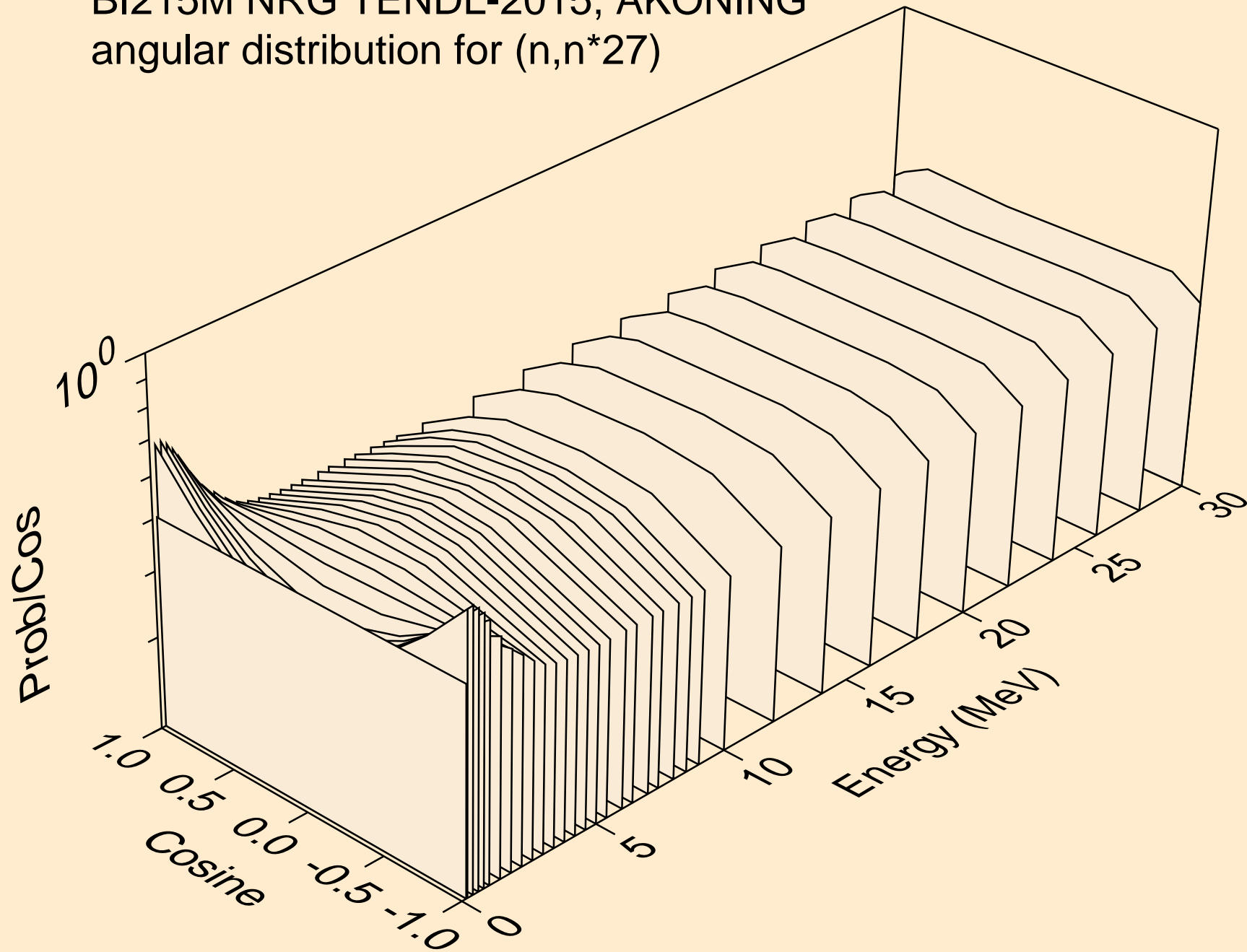

BI215M NRG TENDL-2015, AKONING
angular distribution for (n,n*28)

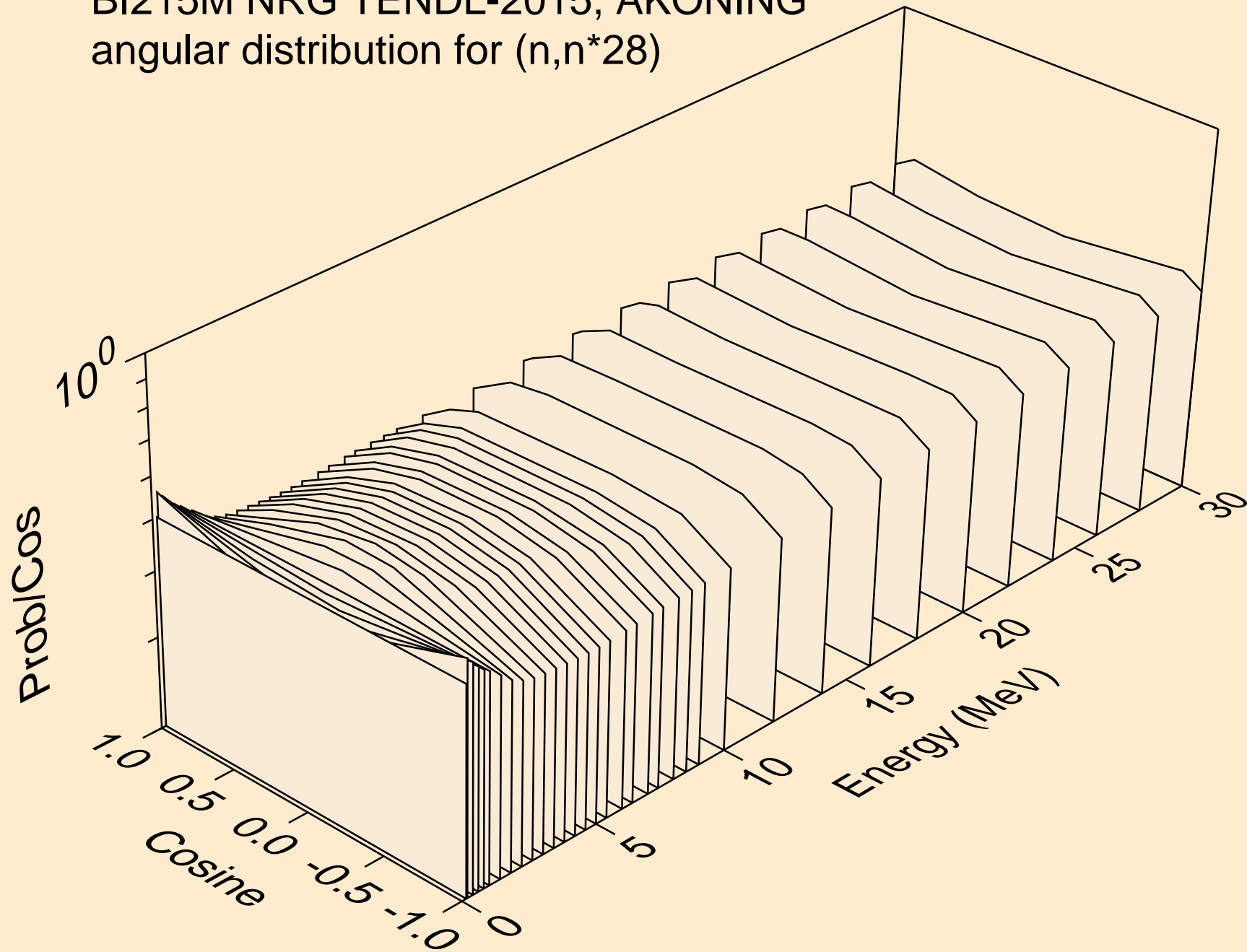

BI215M NRG TENDL-2015, AKONING
Neutron emission for (n,x)

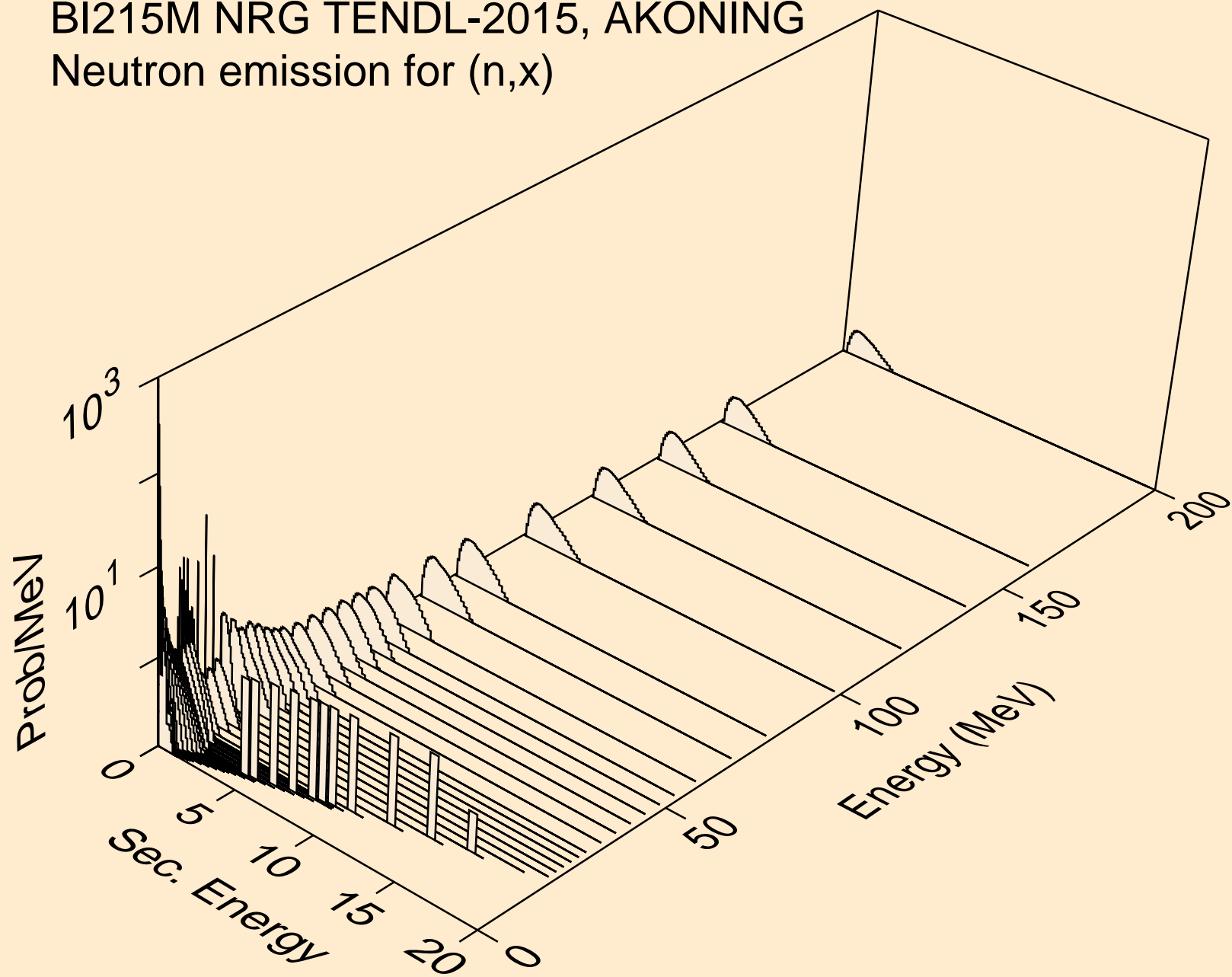

BI215M NRG TENDL-2015, AKONING
Neutron emission for (n,2nd)

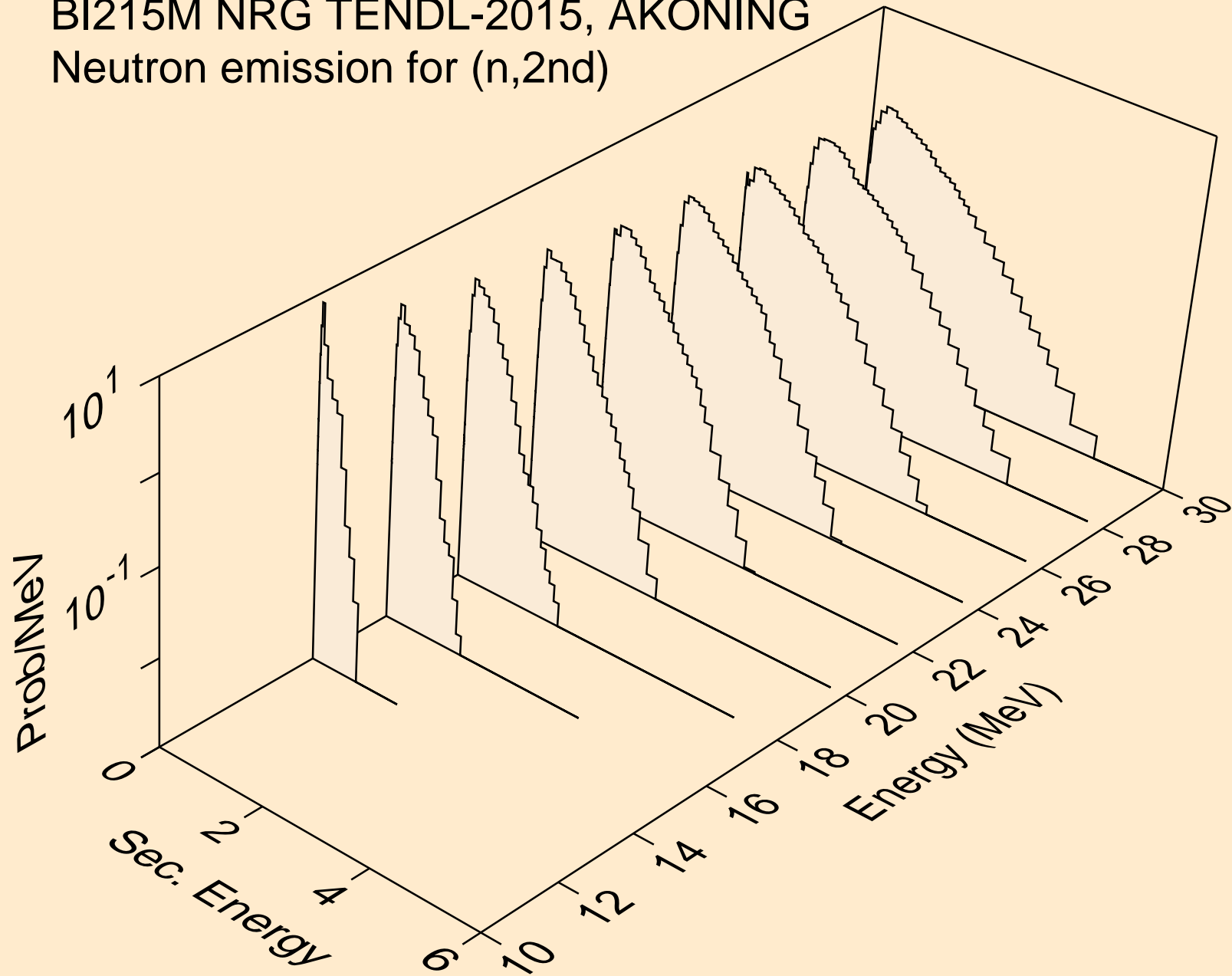

BI215M NRG TENDL-2015, AKONING
Neutron emission for (n,2n)

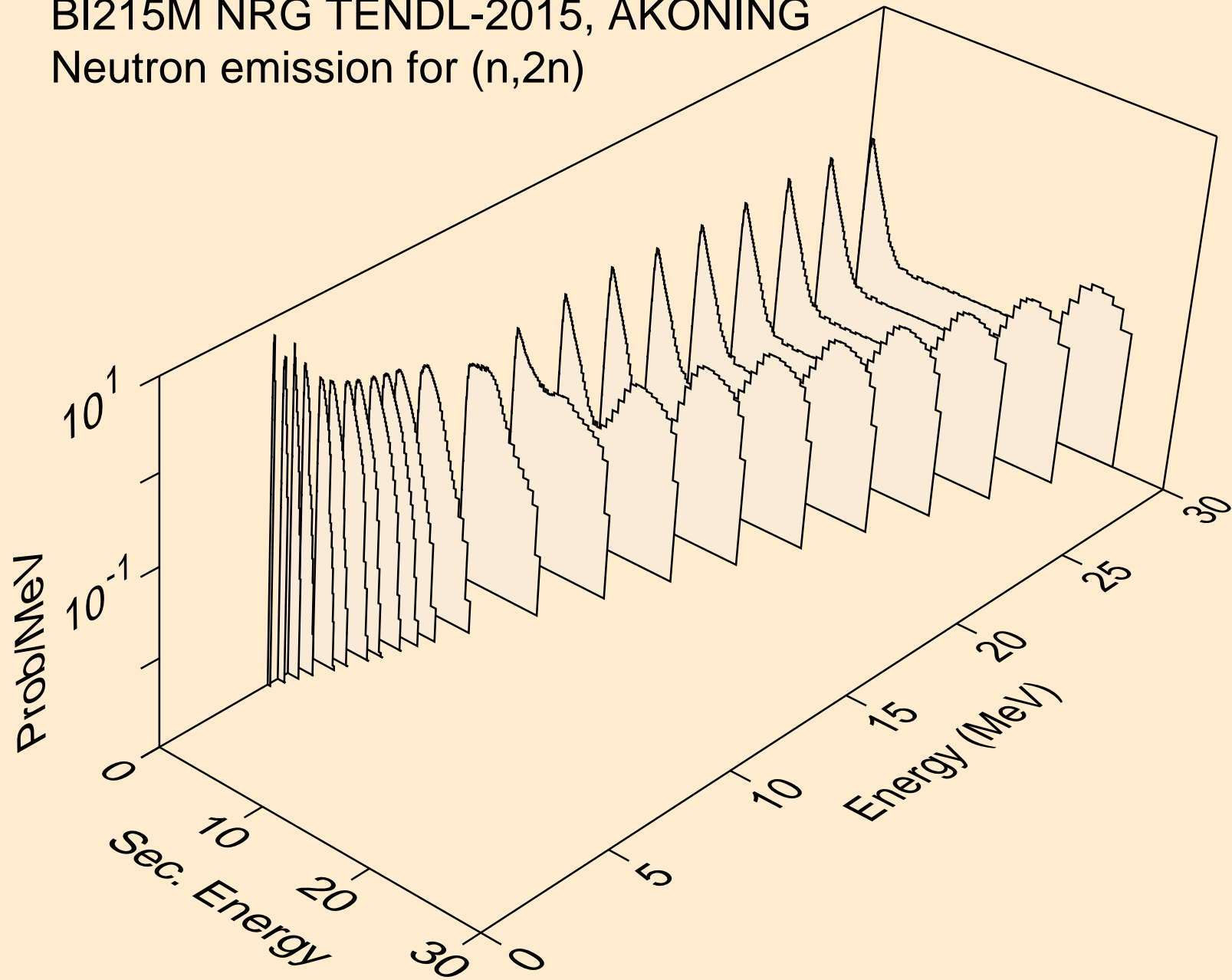

BI215M NRG TENDL-2015, AKONING
Neutron emission for (n,3n)

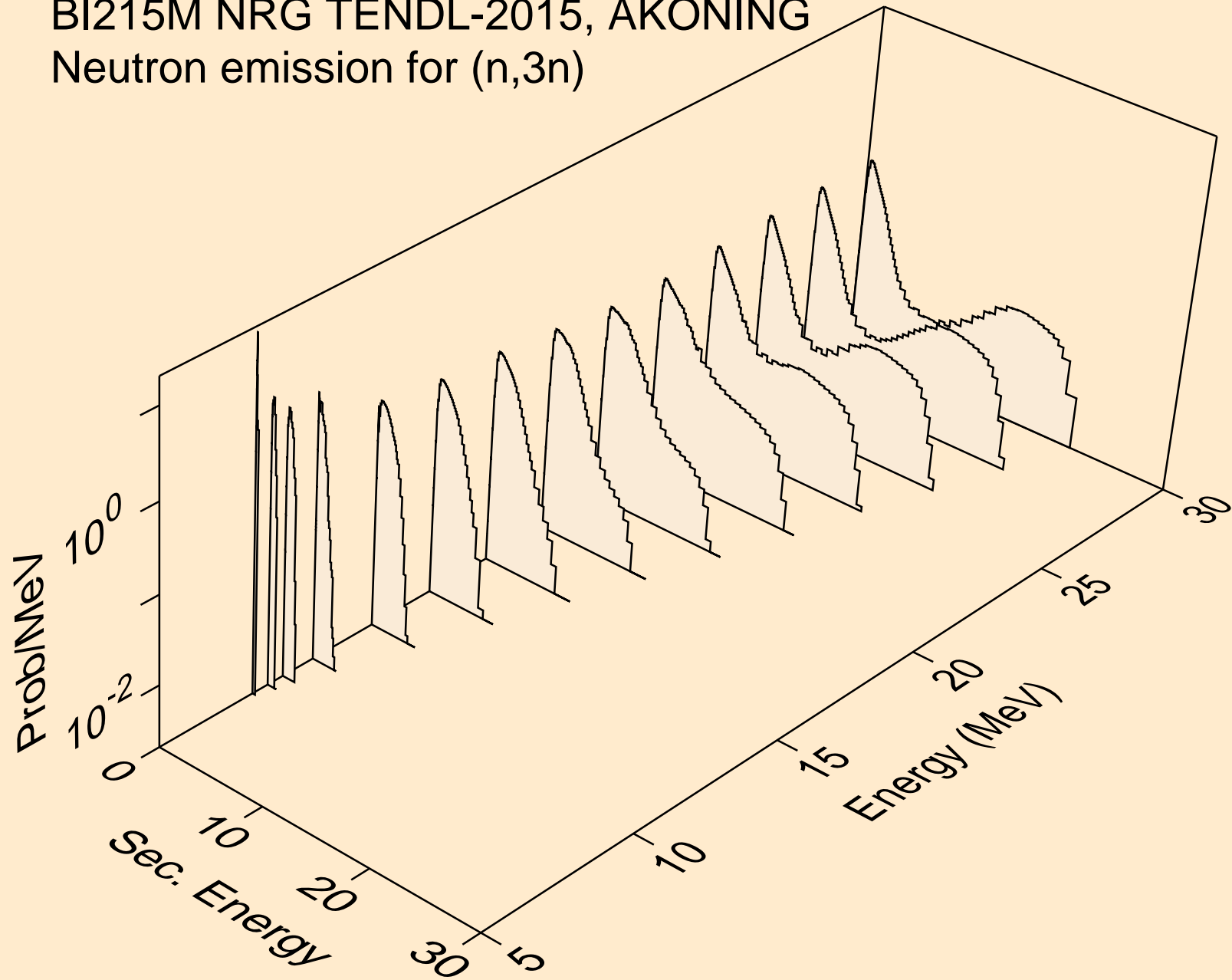

BI215M NRG TENDL-2015, AKONING
Neutron emission for (n,n*)a

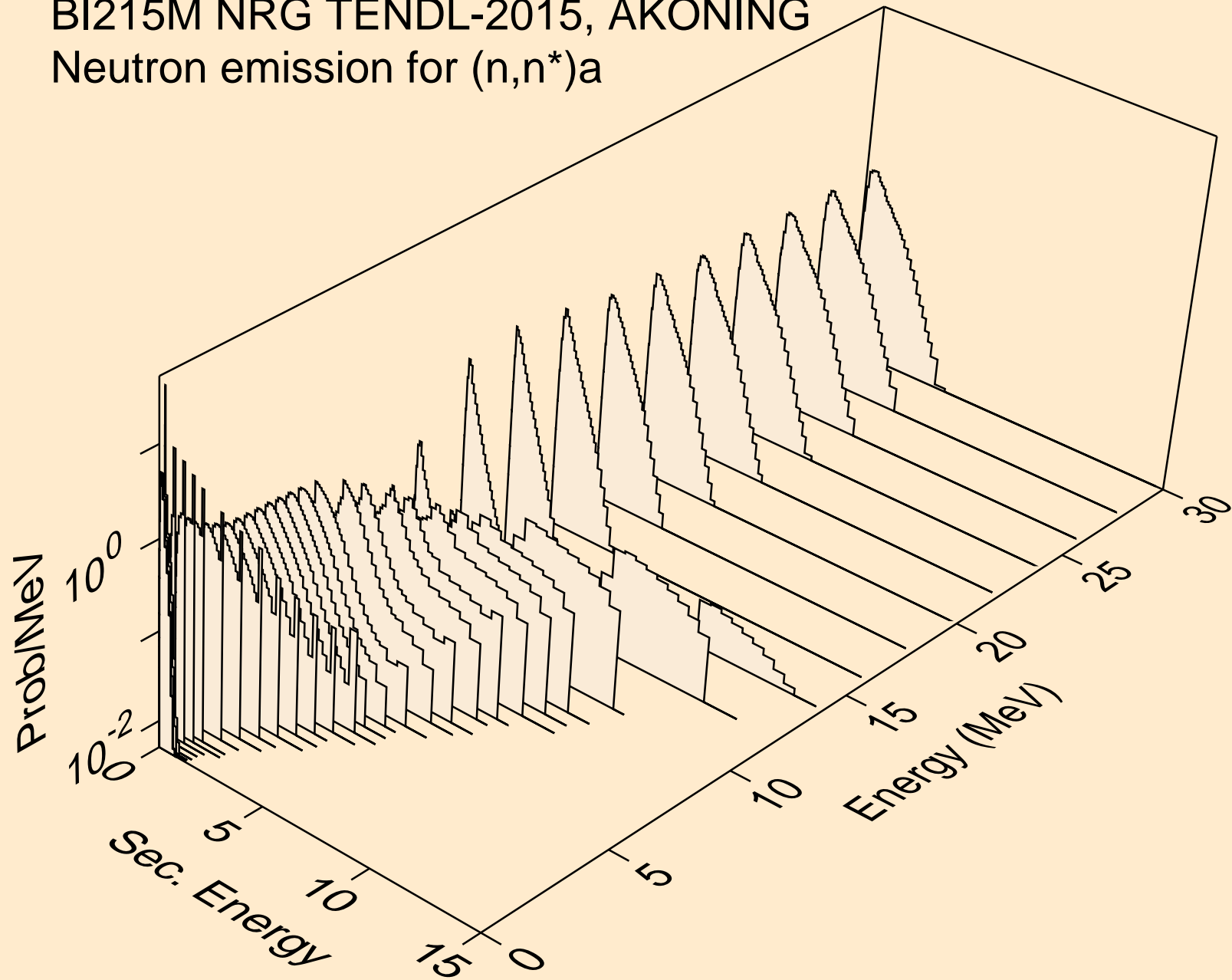

BI215M NRG TENDL-2015, AKONING
Neutron emission for (n,2n)a

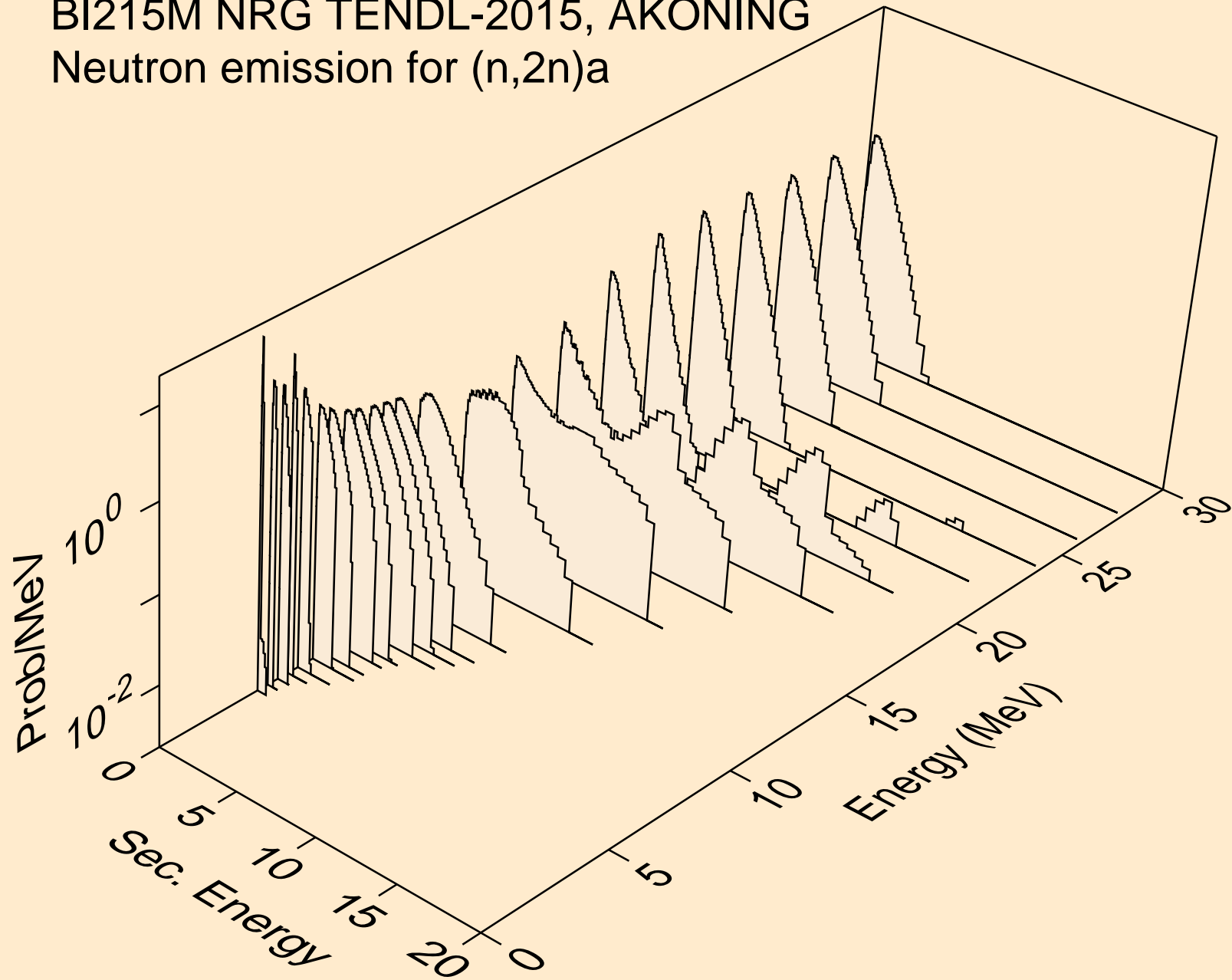

BI215M NRG TENDL-2015, AKONING
Neutron emission for (n,3n)a

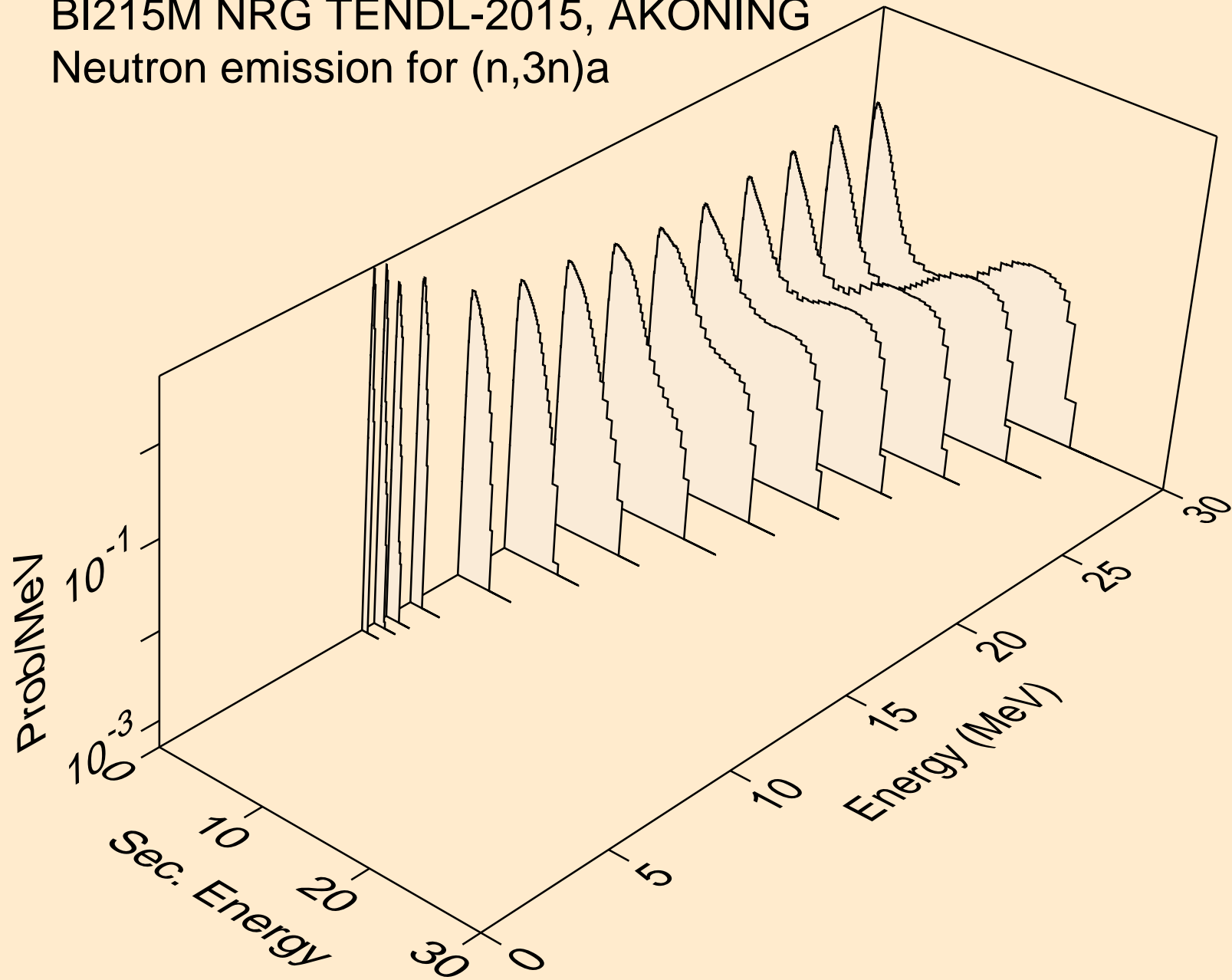

BI215M NRG TENDL-2015, AKONING
Neutron emission for (n,n*)p

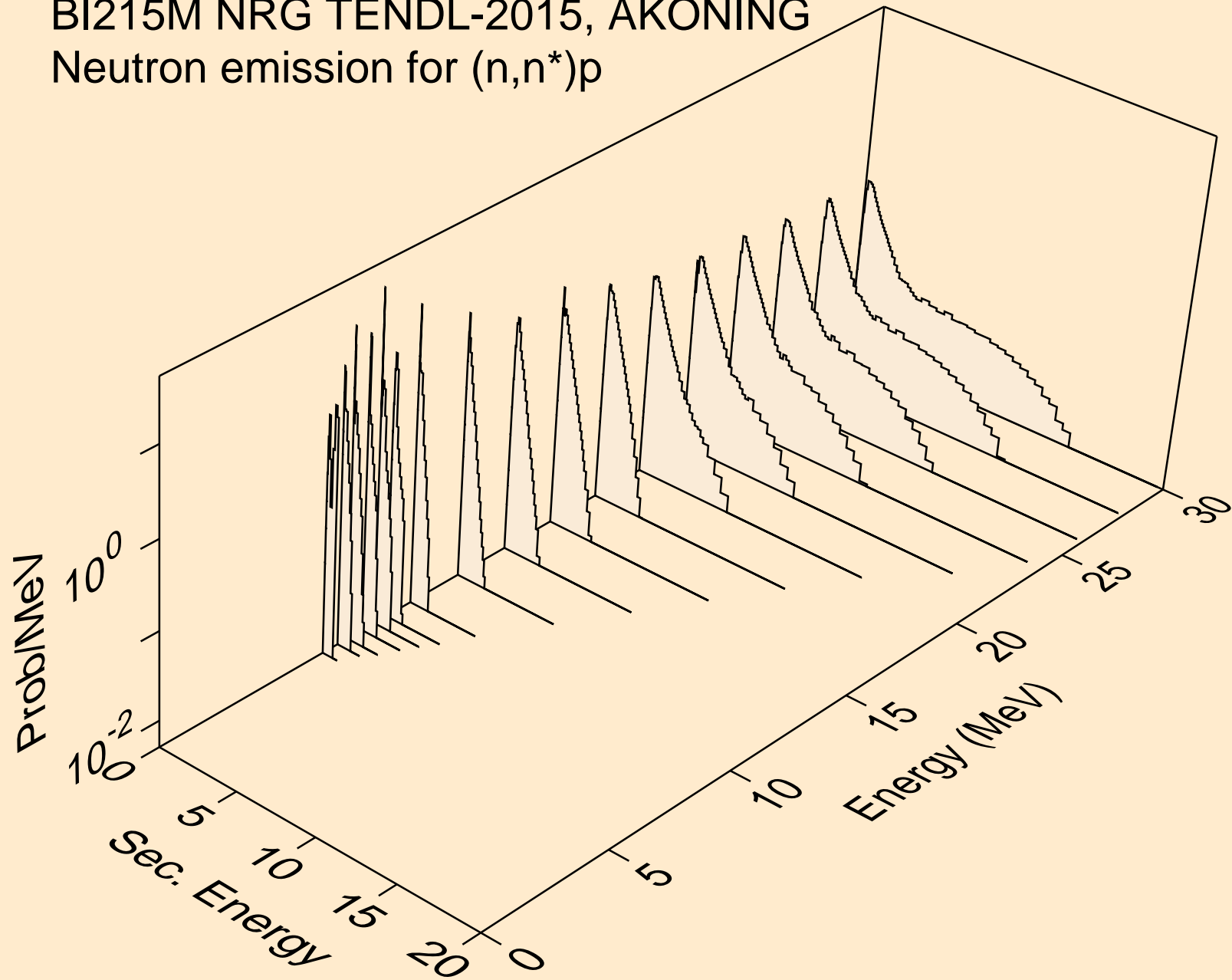

BI215M NRG TENDL-2015, AKONING
Neutron emission for (n,n*)2a

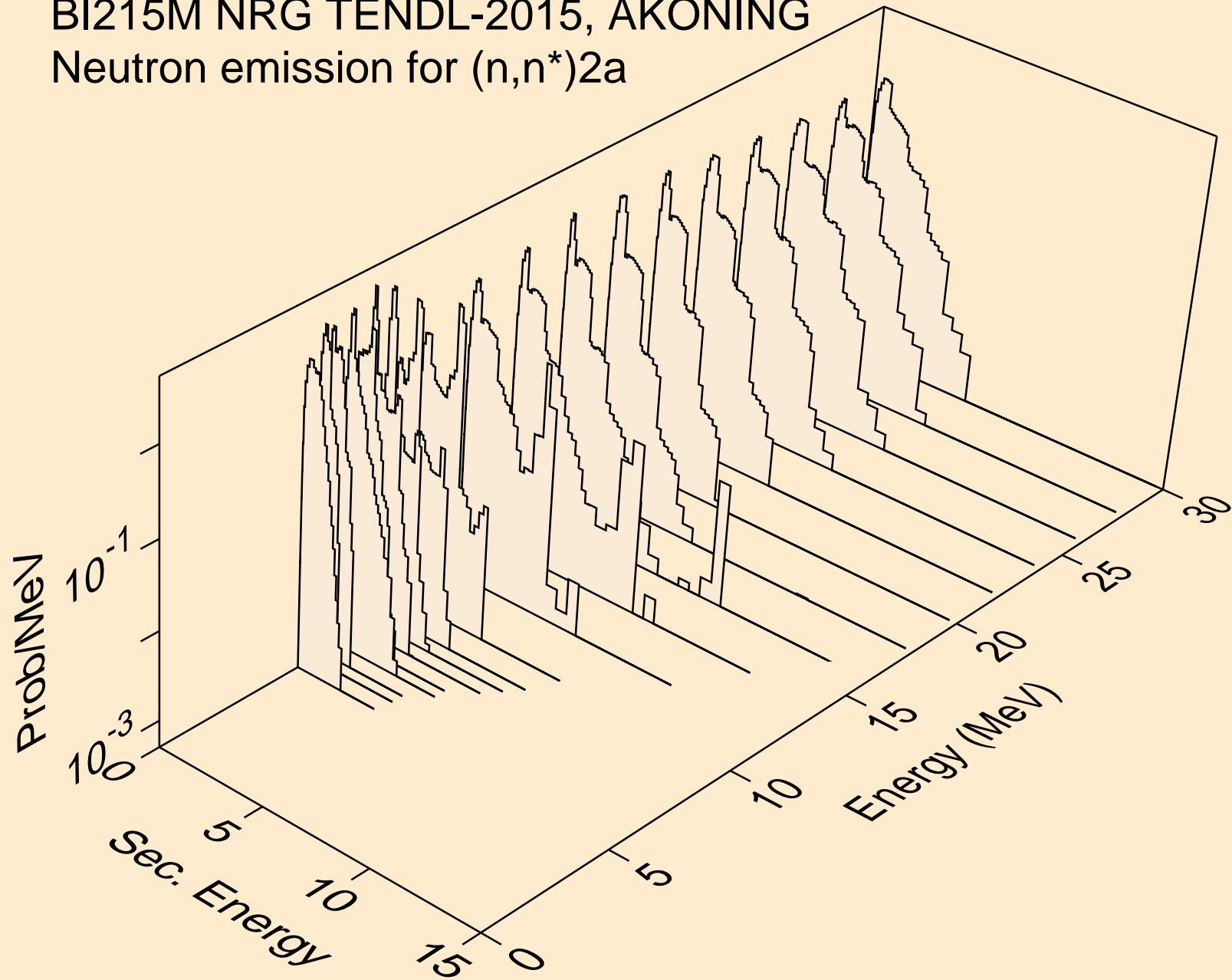

BI215M NRG TENDL-2015, AKONING
Neutron emission for (n,2n)2a

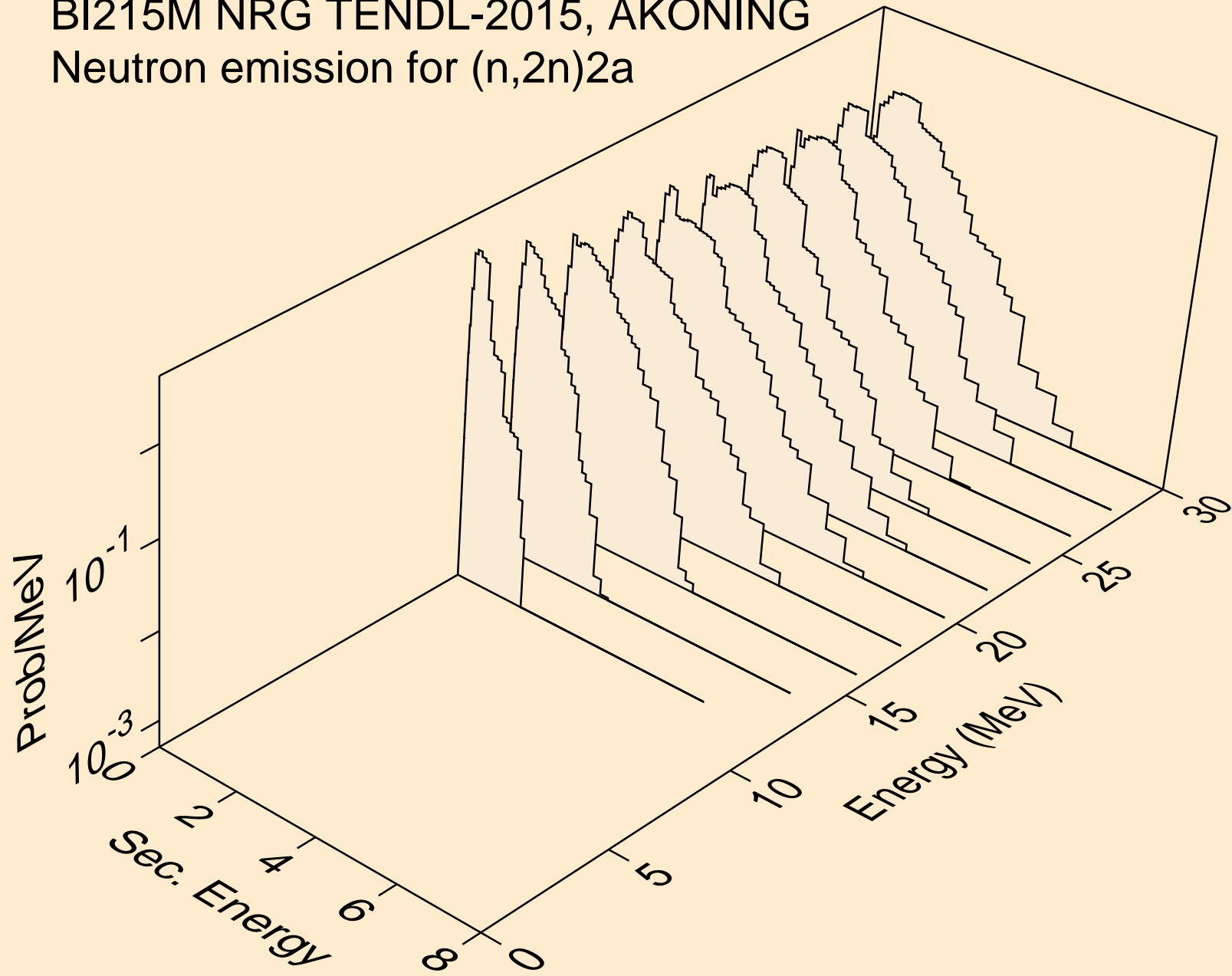

BI215M NRG TENDL-2015, AKONING
Neutron emission for (n,n*)d

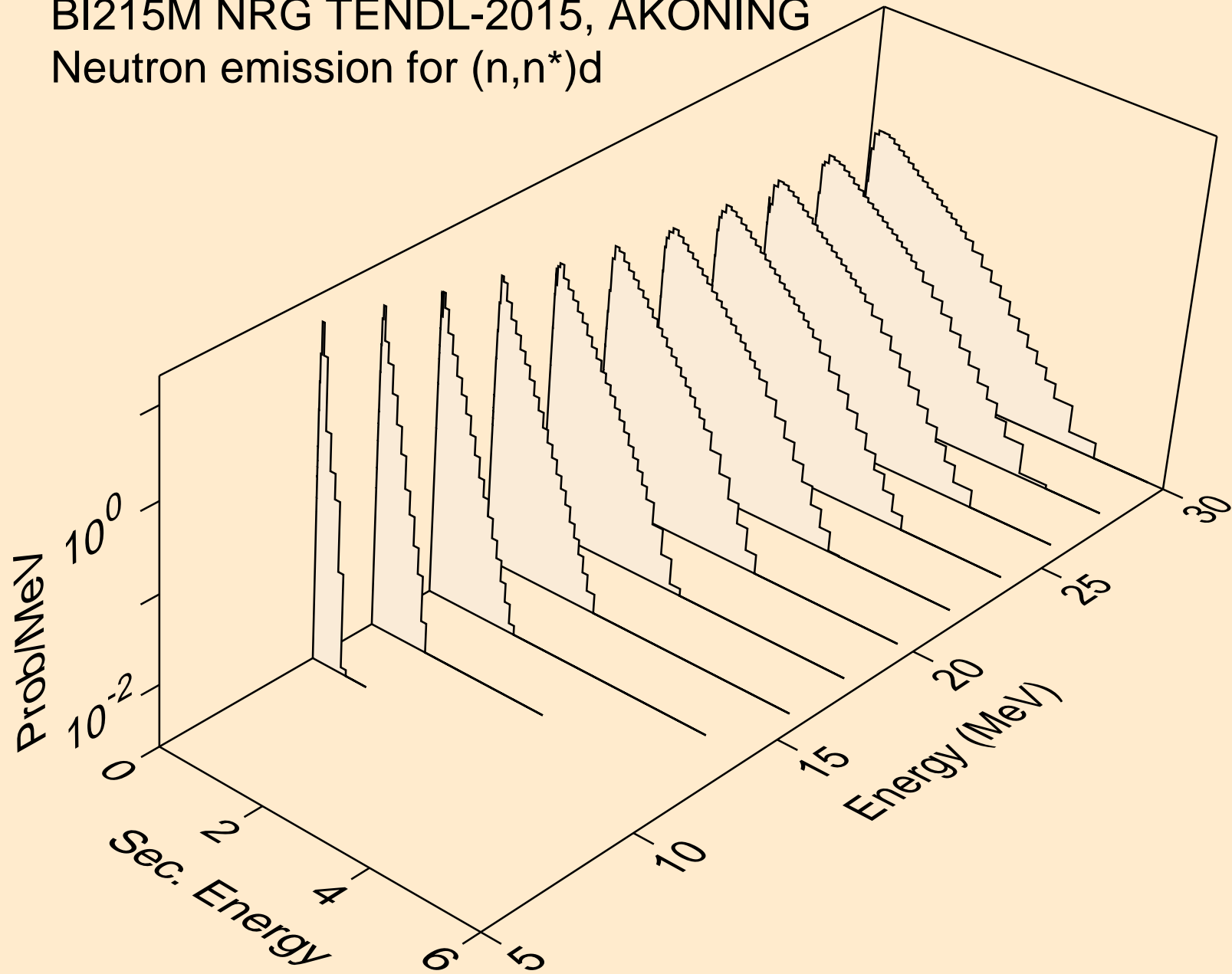

BI215M NRG TENDL-2015, AKONING
Neutron emission for (n,n*)t

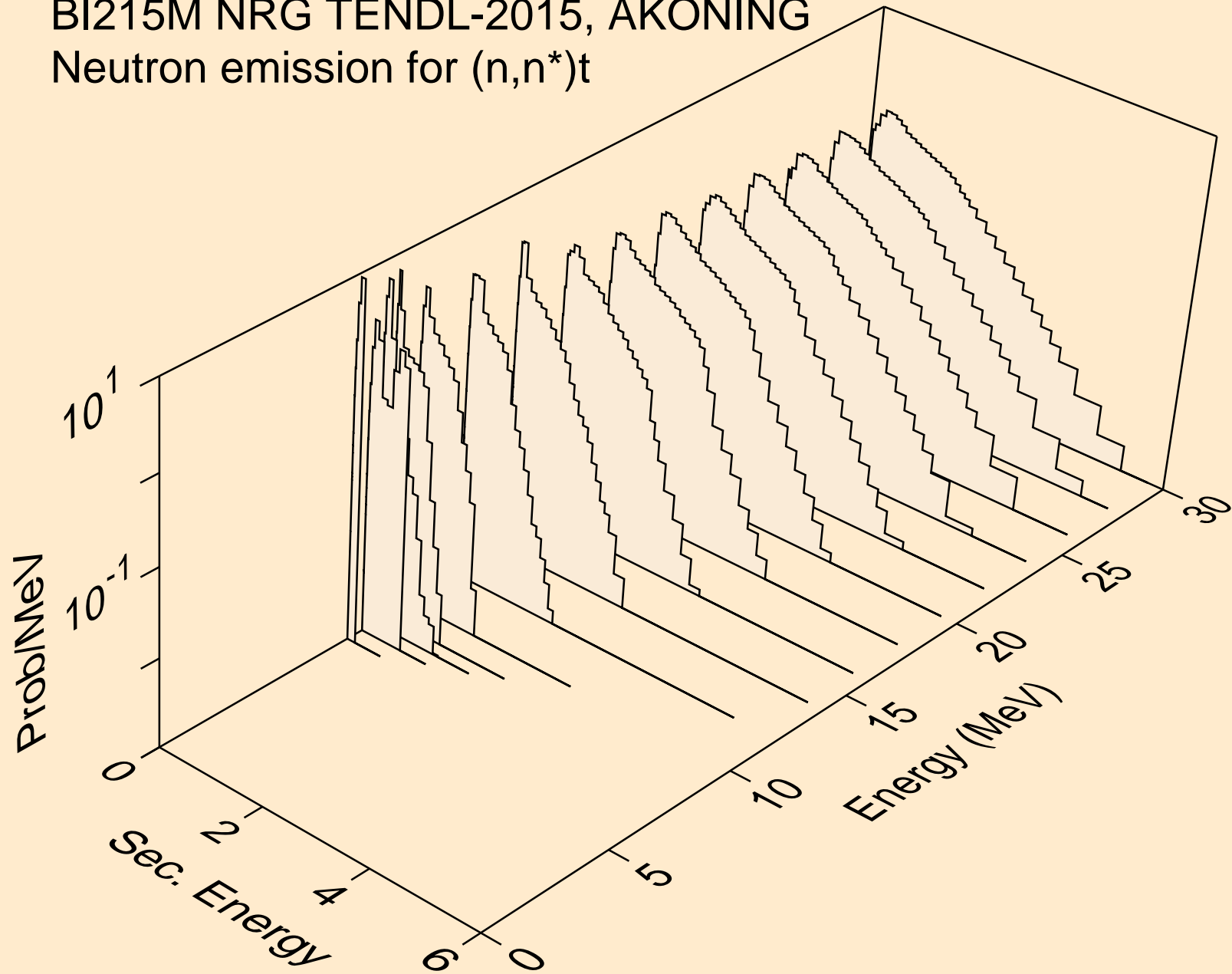

BI215M NRG TENDL-2015, AKONING
Neutron emission for (n,n*)he3

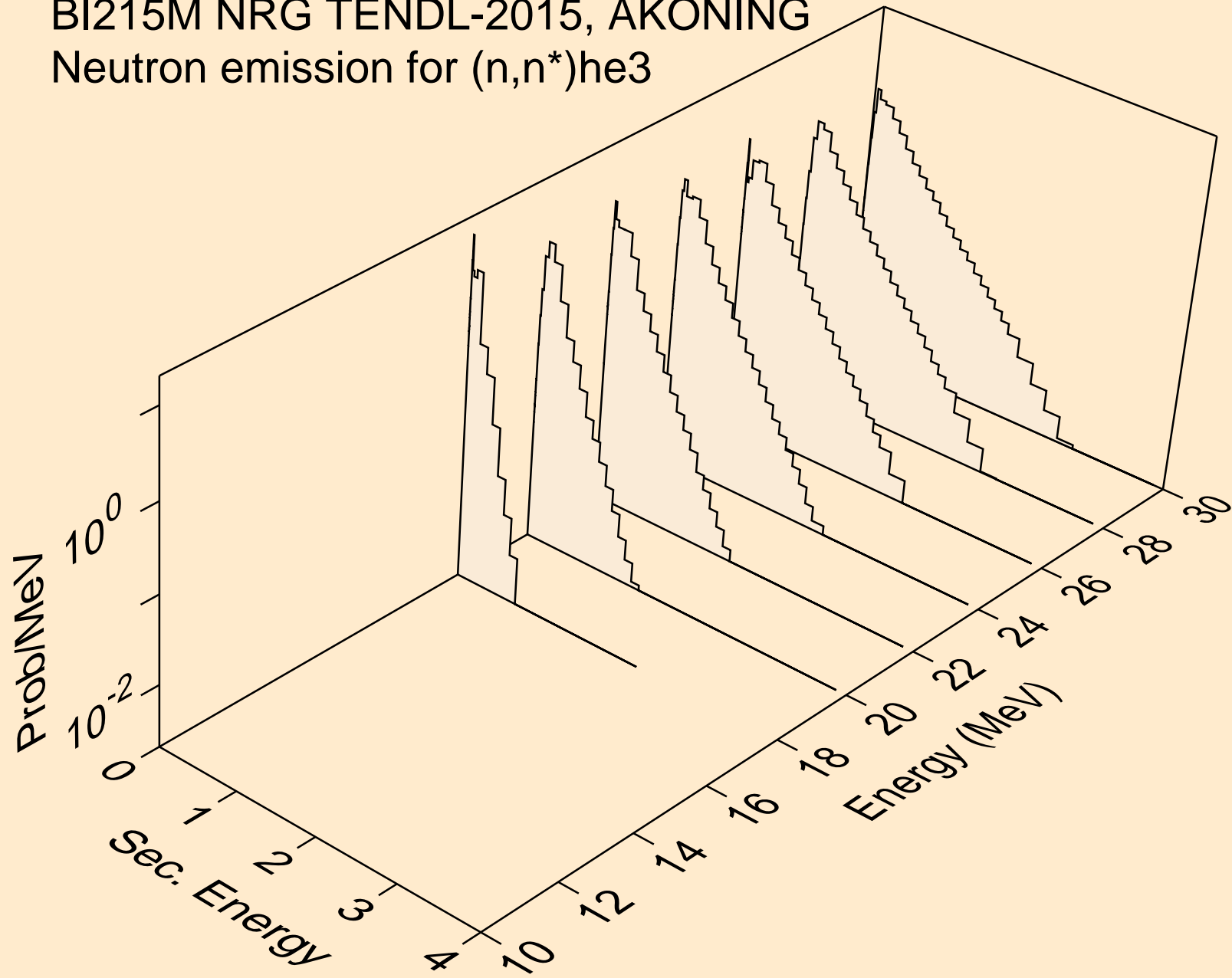

BI215M NRG TENDL-2015, AKONING
Neutron emission for (n,4n)

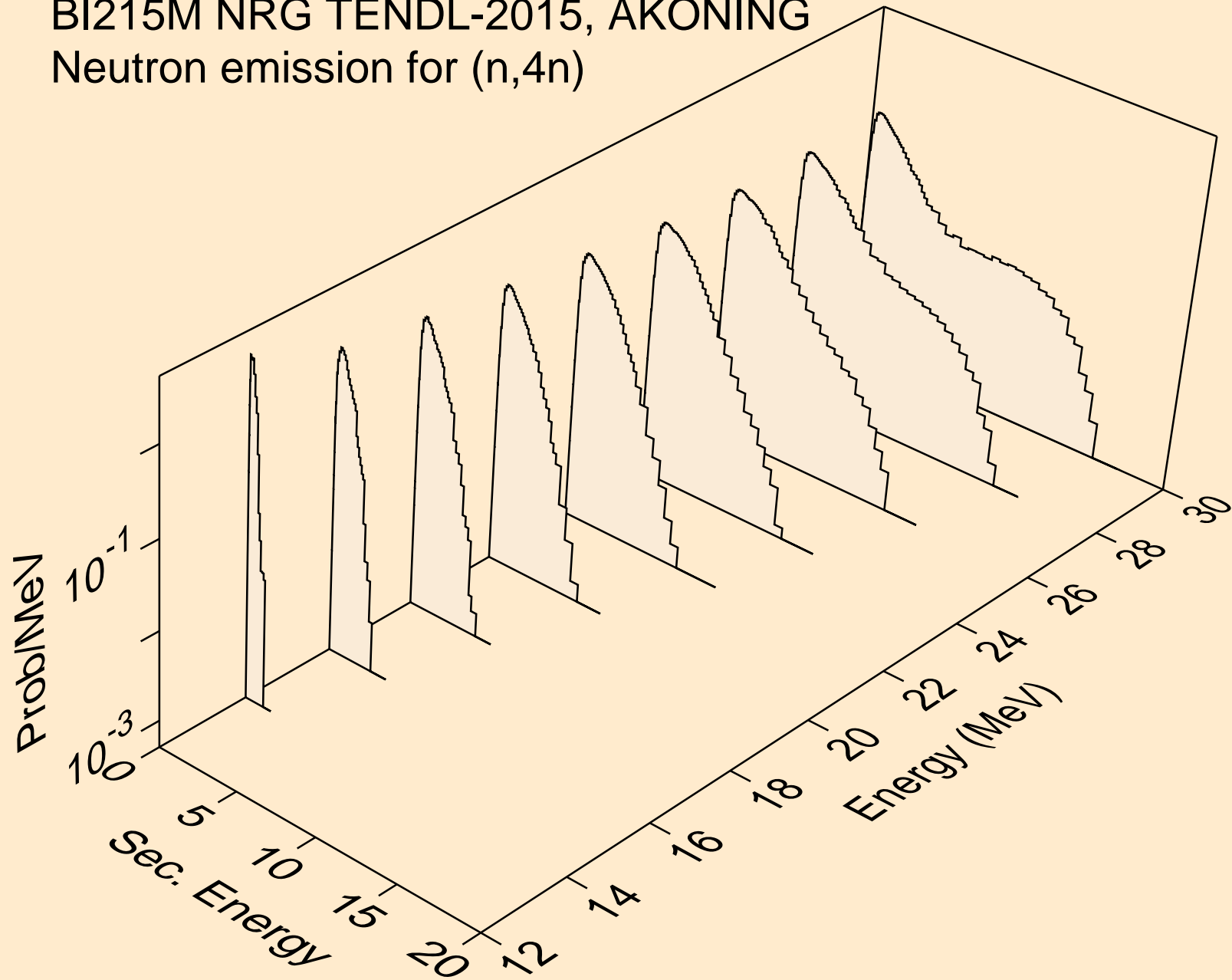

BI215M NRG TENDL-2015, AKONING
Neutron emission for (n,2np)

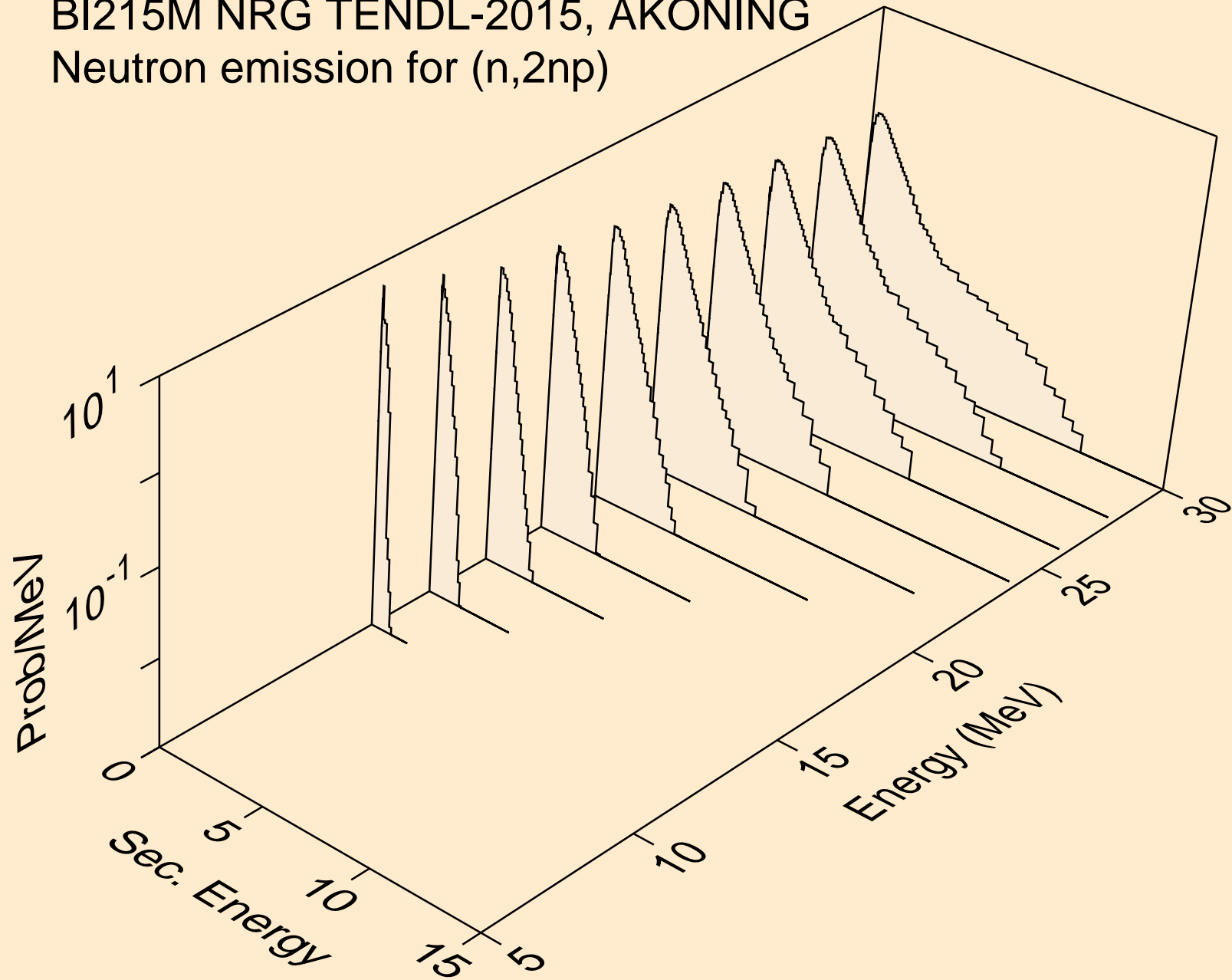

BI215M NRG TENDL-2015, AKONING
Neutron emission for (n,3np)

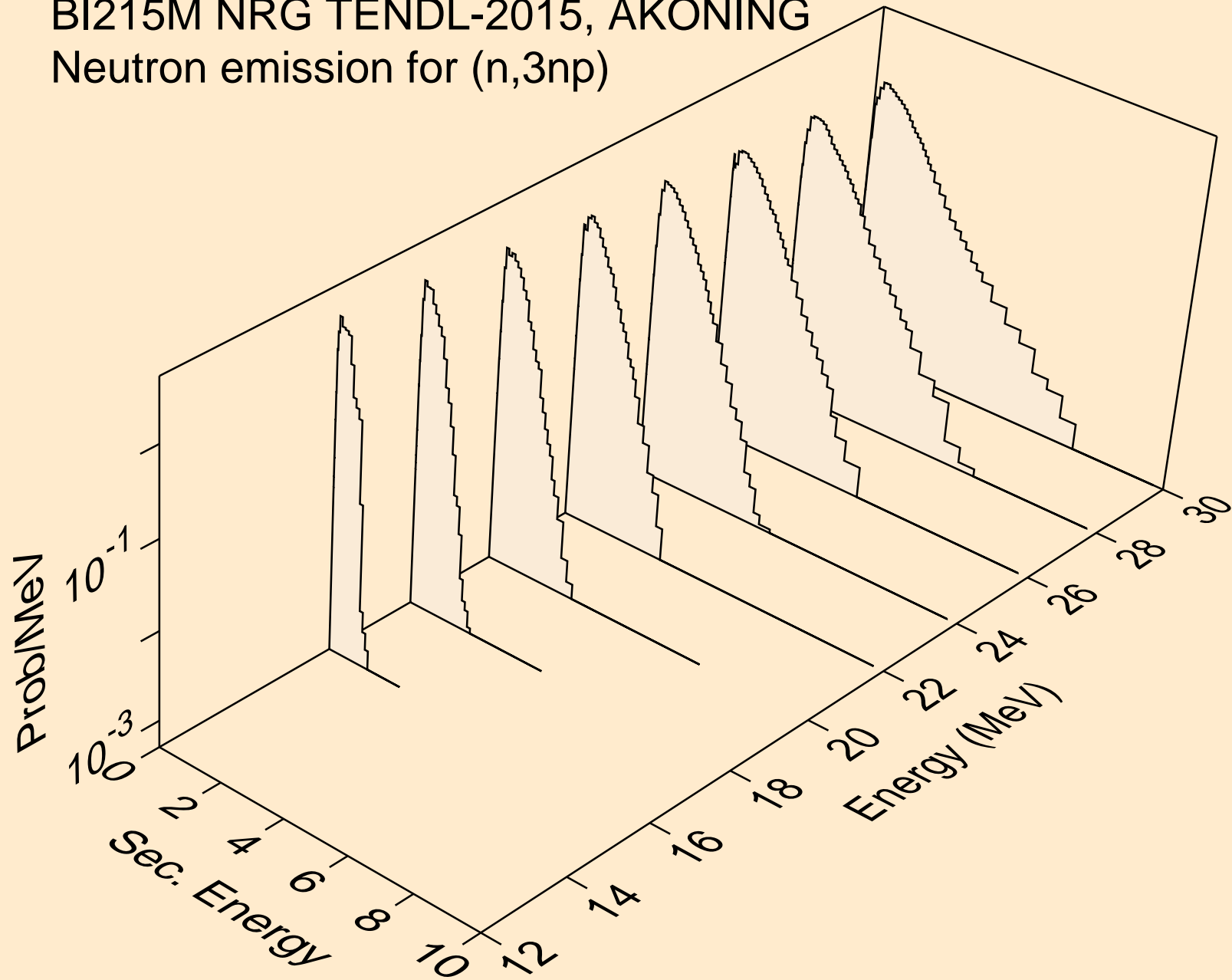

BI215M NRG TENDL-2015, AKONING
Neutron emission for (n,2np)

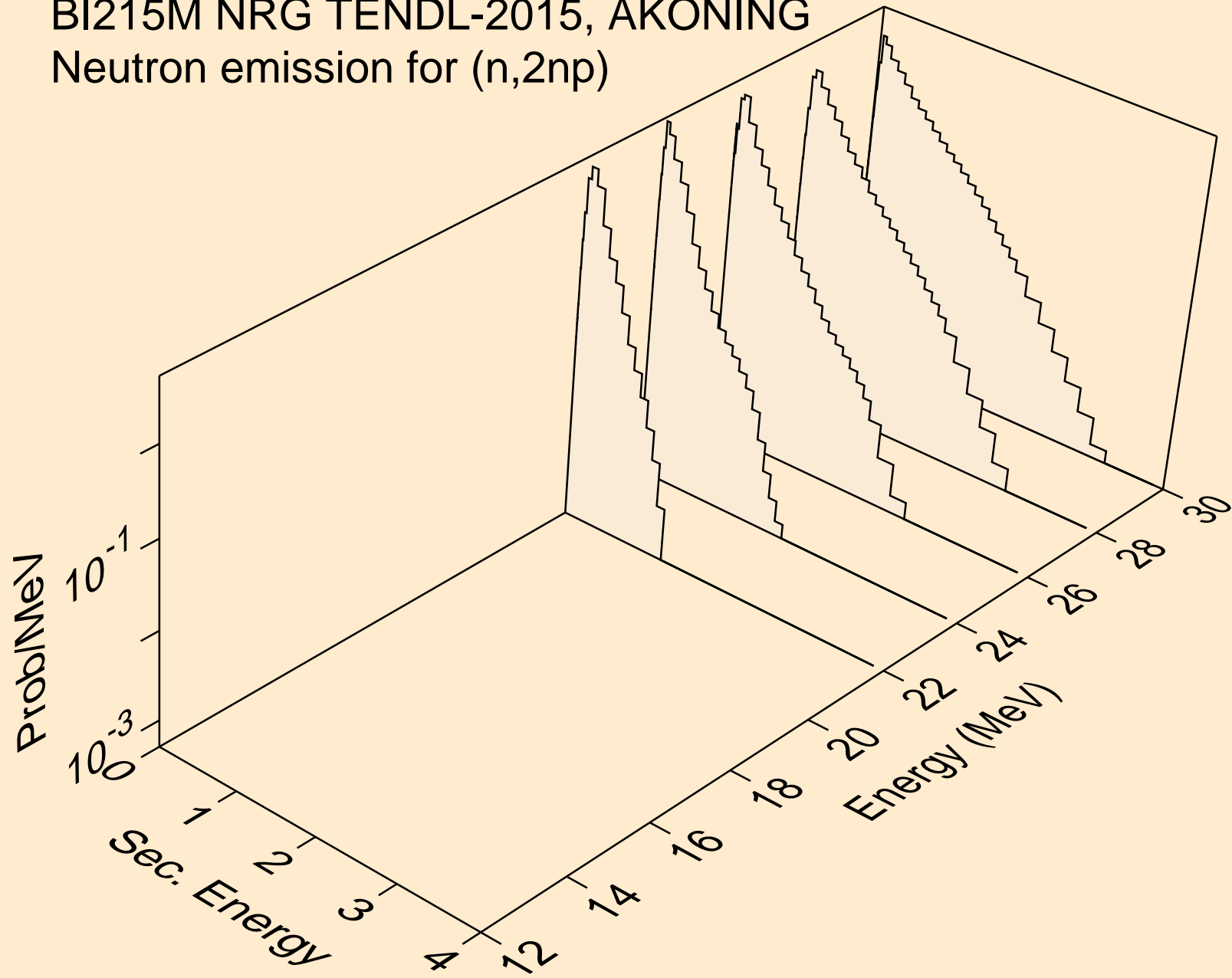

BI215M NRG TENDL-2015, AKONING
Neutron emission for (n,n*c)

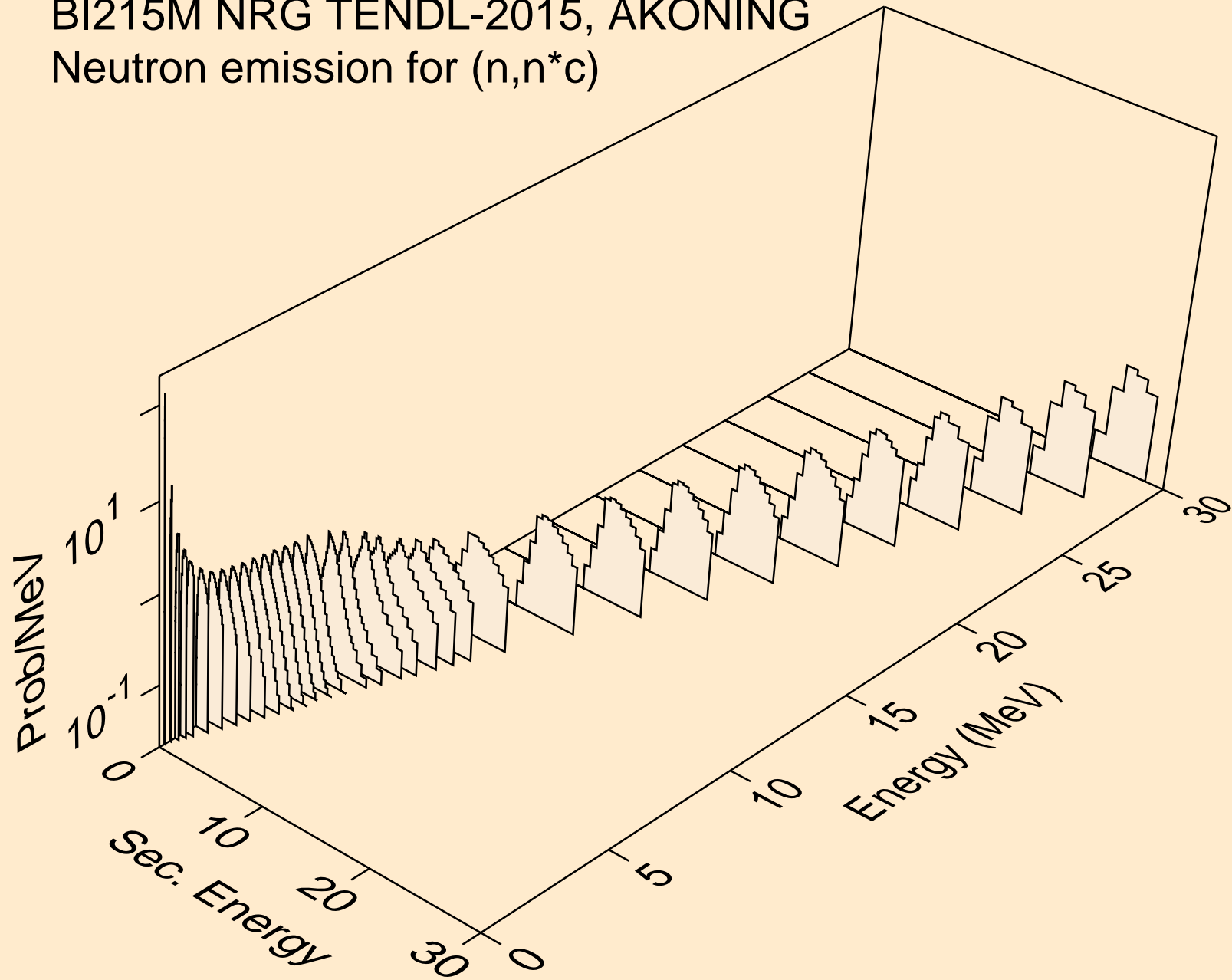

BI215M NRG TENDL-2015, AKONING
Photon emission for (n,x)

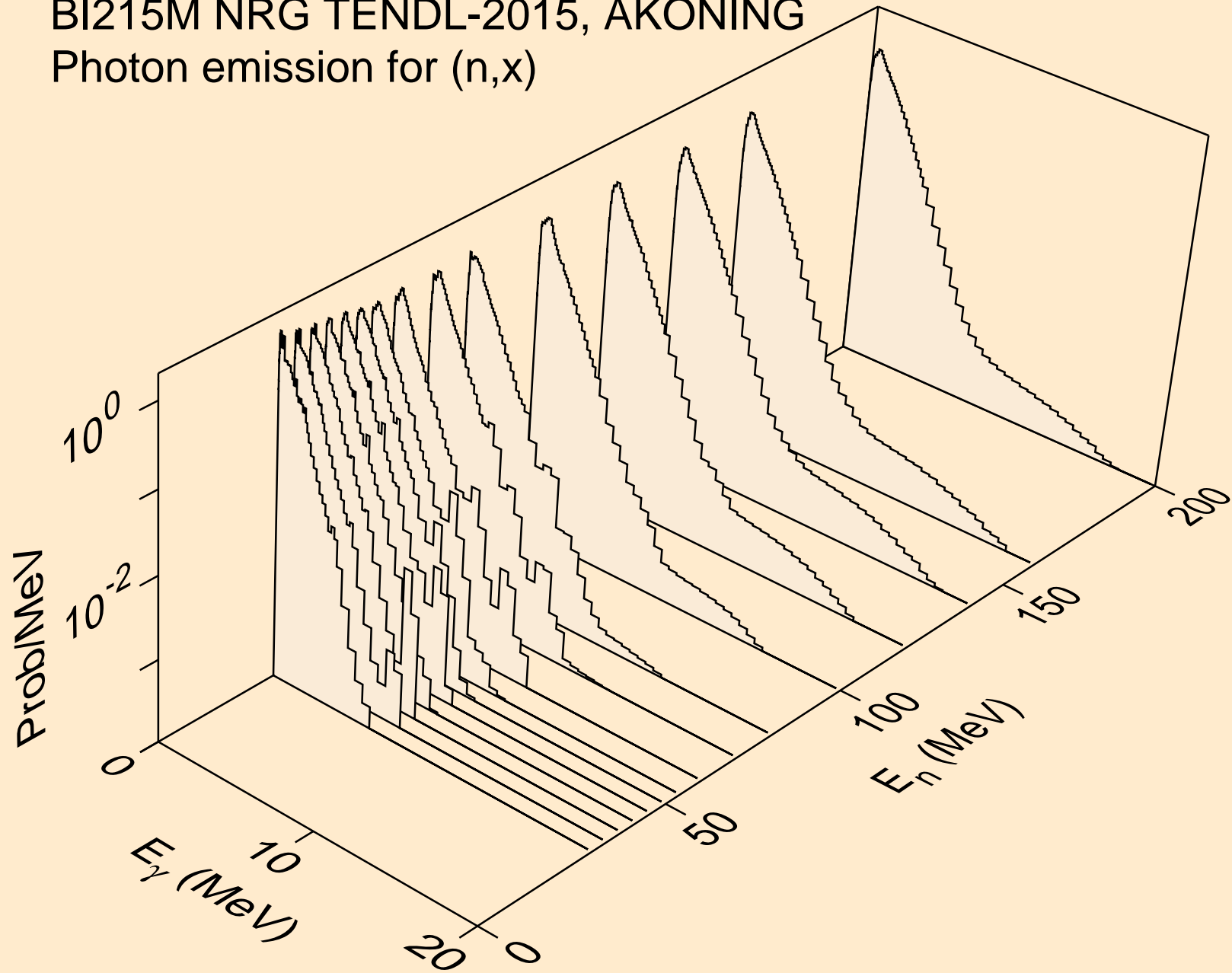

BI215M NRG TENDL-2015, AKONING
Photon emission for (n,2nd)

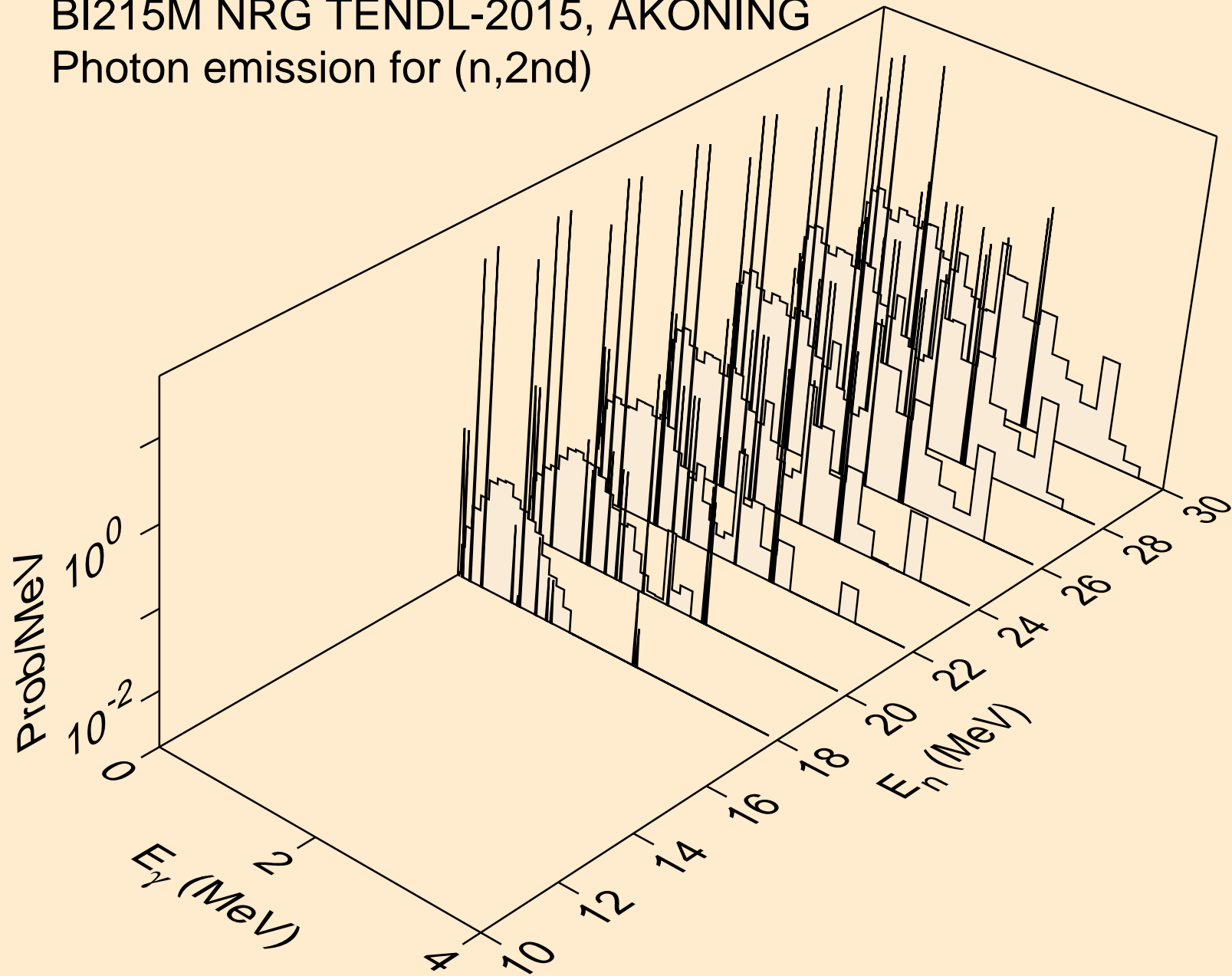

BI215M NRG TENDL-2015, AKONING
Photon emission for (n,2n)

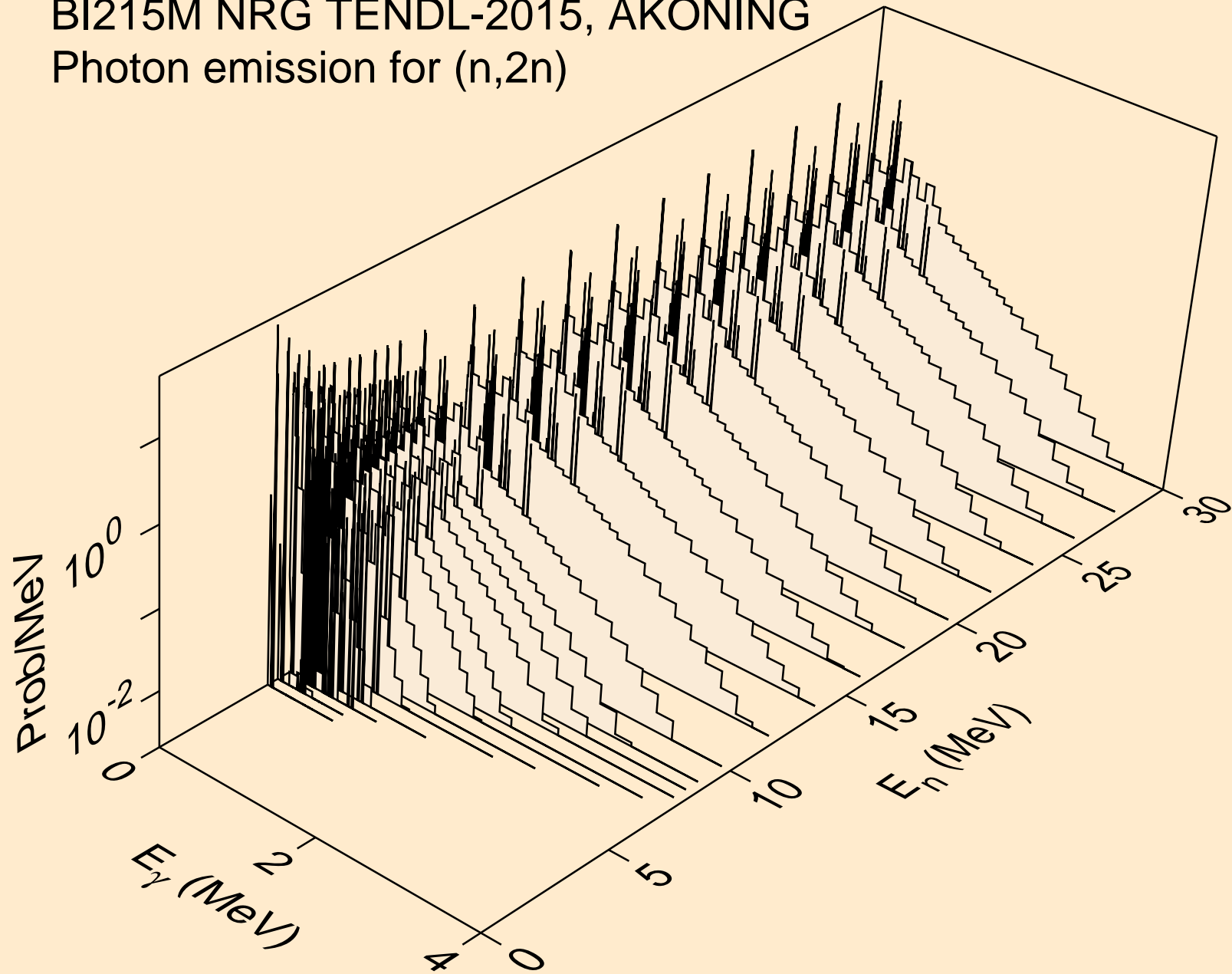

BI215M NRG TENDL-2015, AKONING
Photon emission for (n,3n)

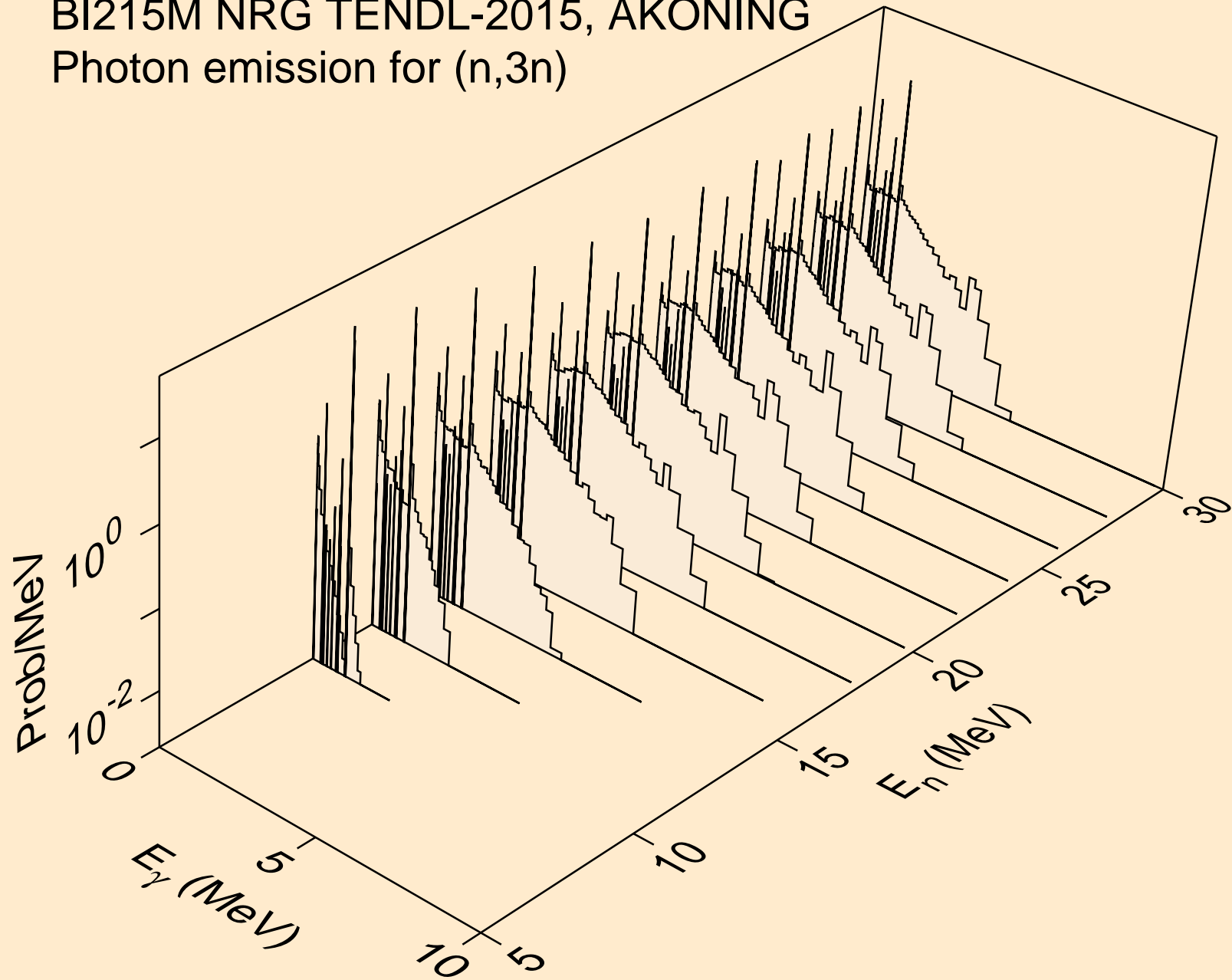

BI215M NRG TENDL-2015, AKONING
Photon emission for (n,n*)a

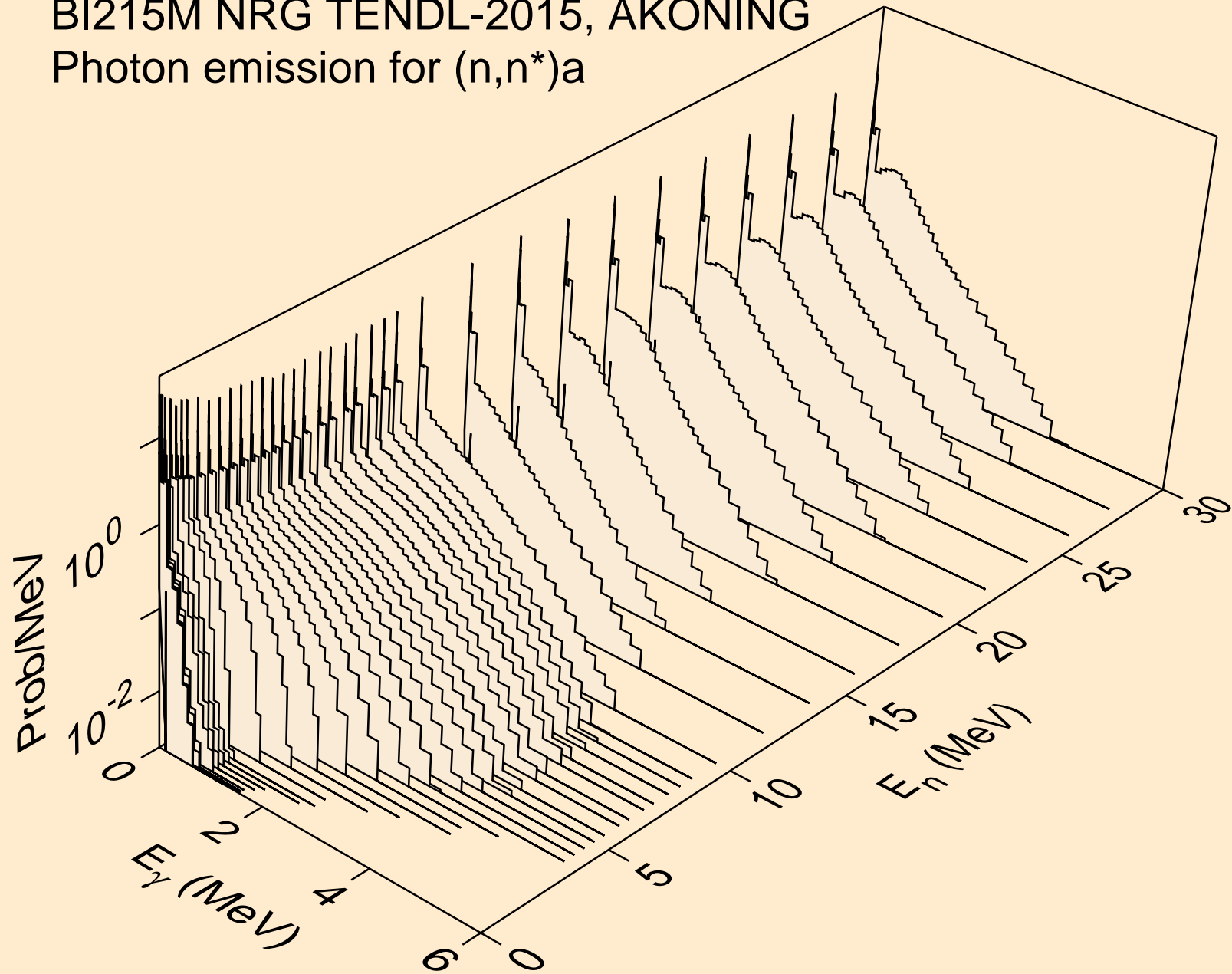

BI215M NRG TENDL-2015, AKONING
Photon emission for (n,2n)a

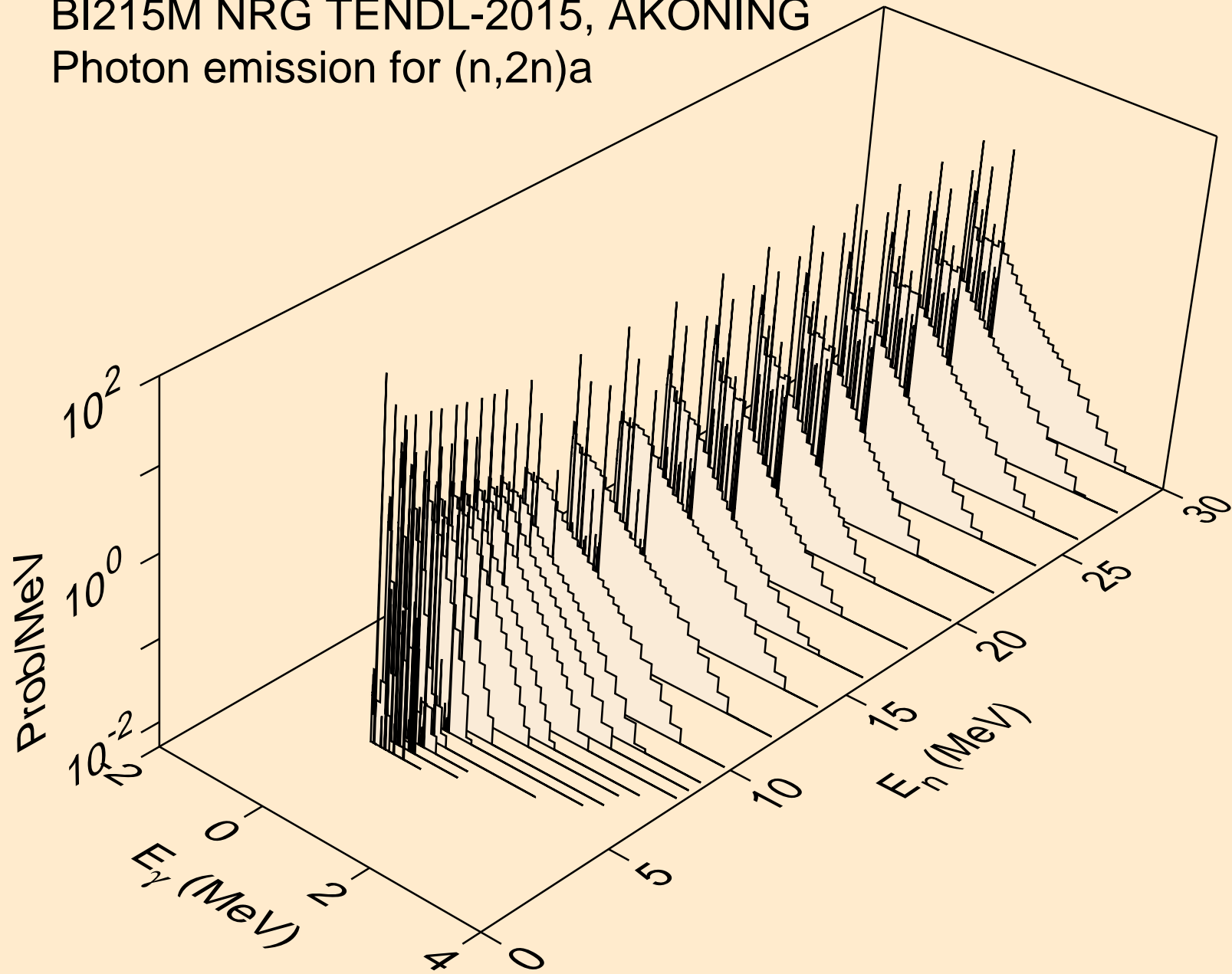

BI215M NRG TENDL-2015, AKONING
Photon emission for (n,3n)a

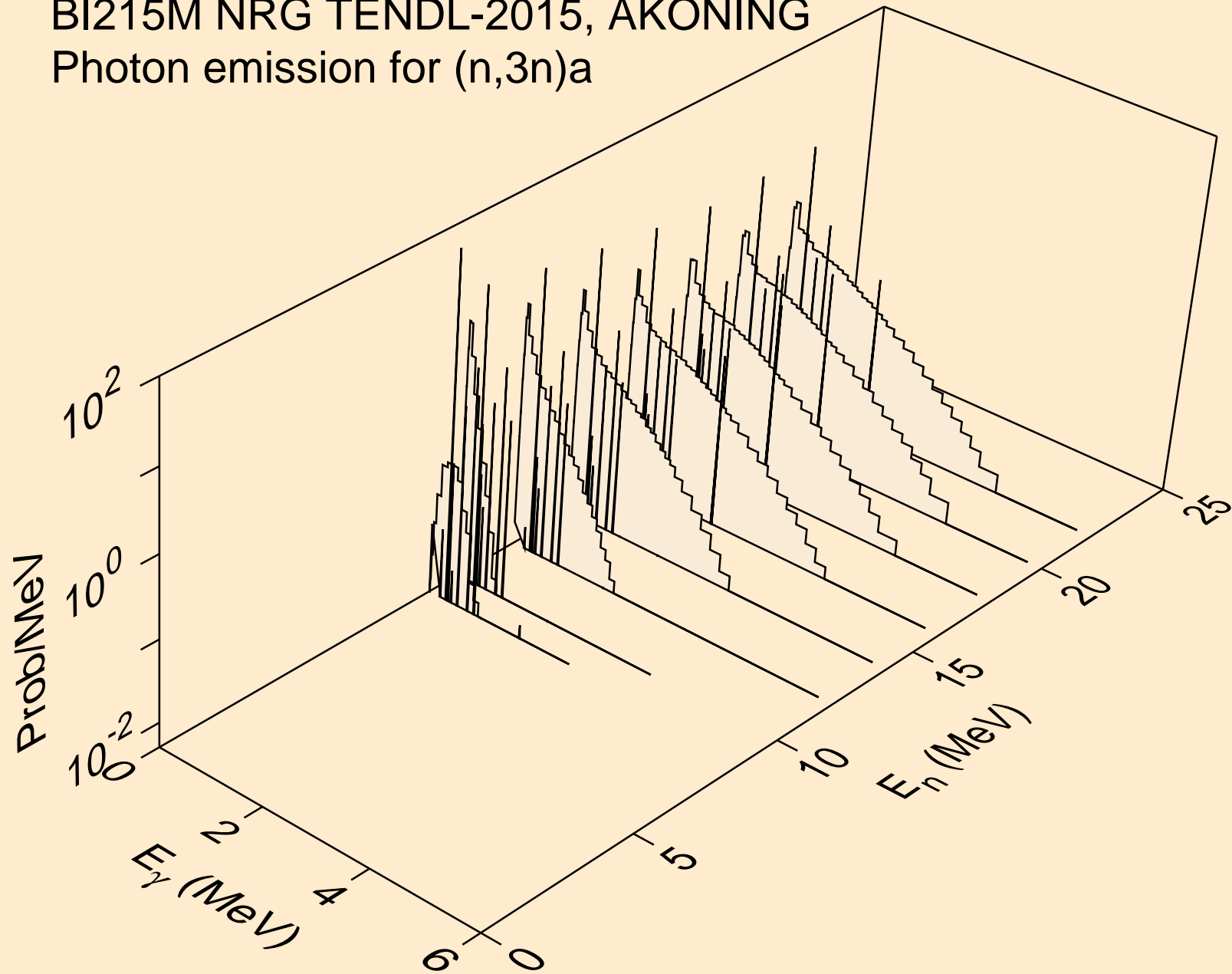

BI215M NRG TENDL-2015, AKONING
Photon emission for (n,n*)p

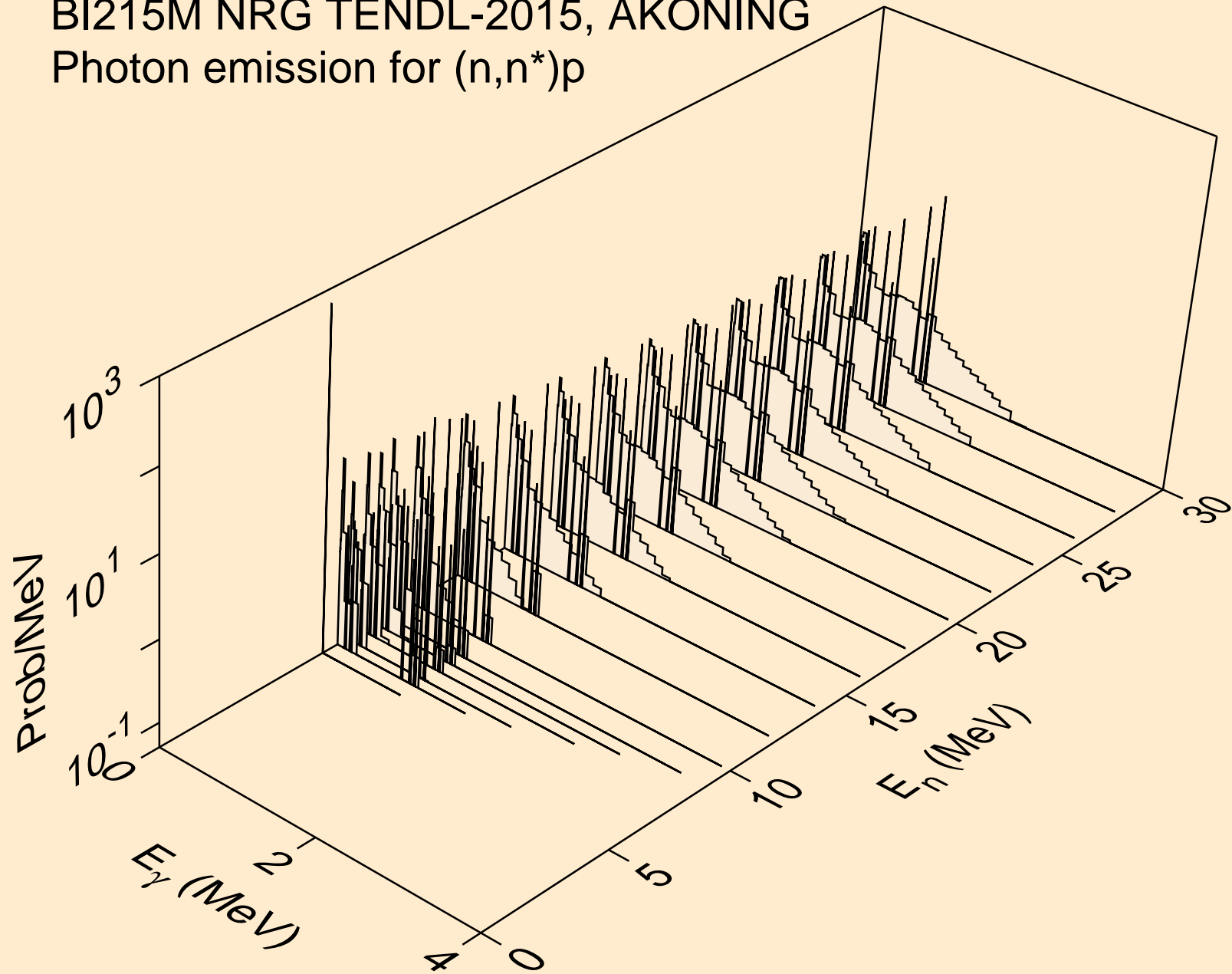

BI215M NRG TENDL-2015, AKONING
Photon emission for (n,n*)2a

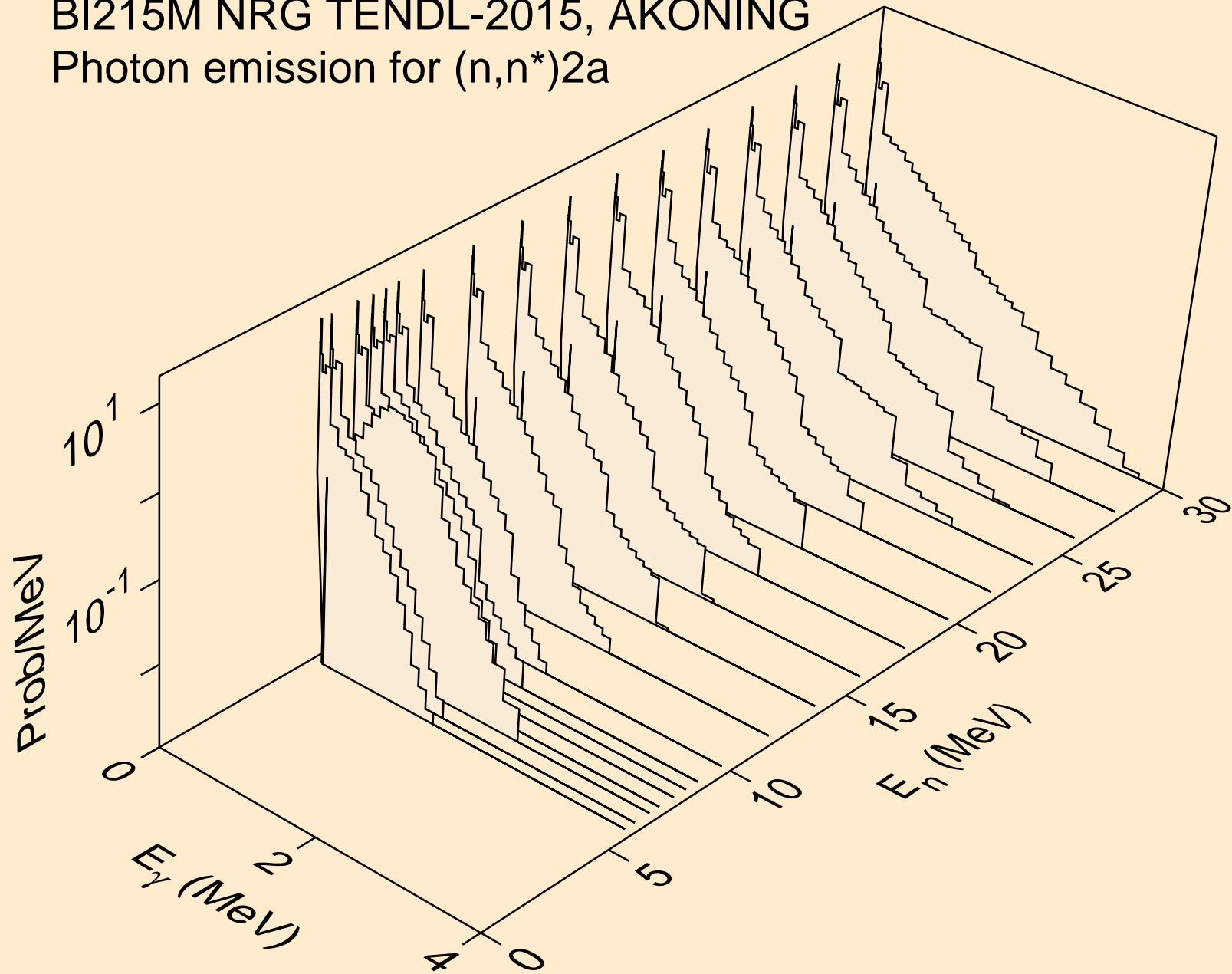

BI215M NRG TENDL-2015, AKONING
Photon emission for (n,2n)2a

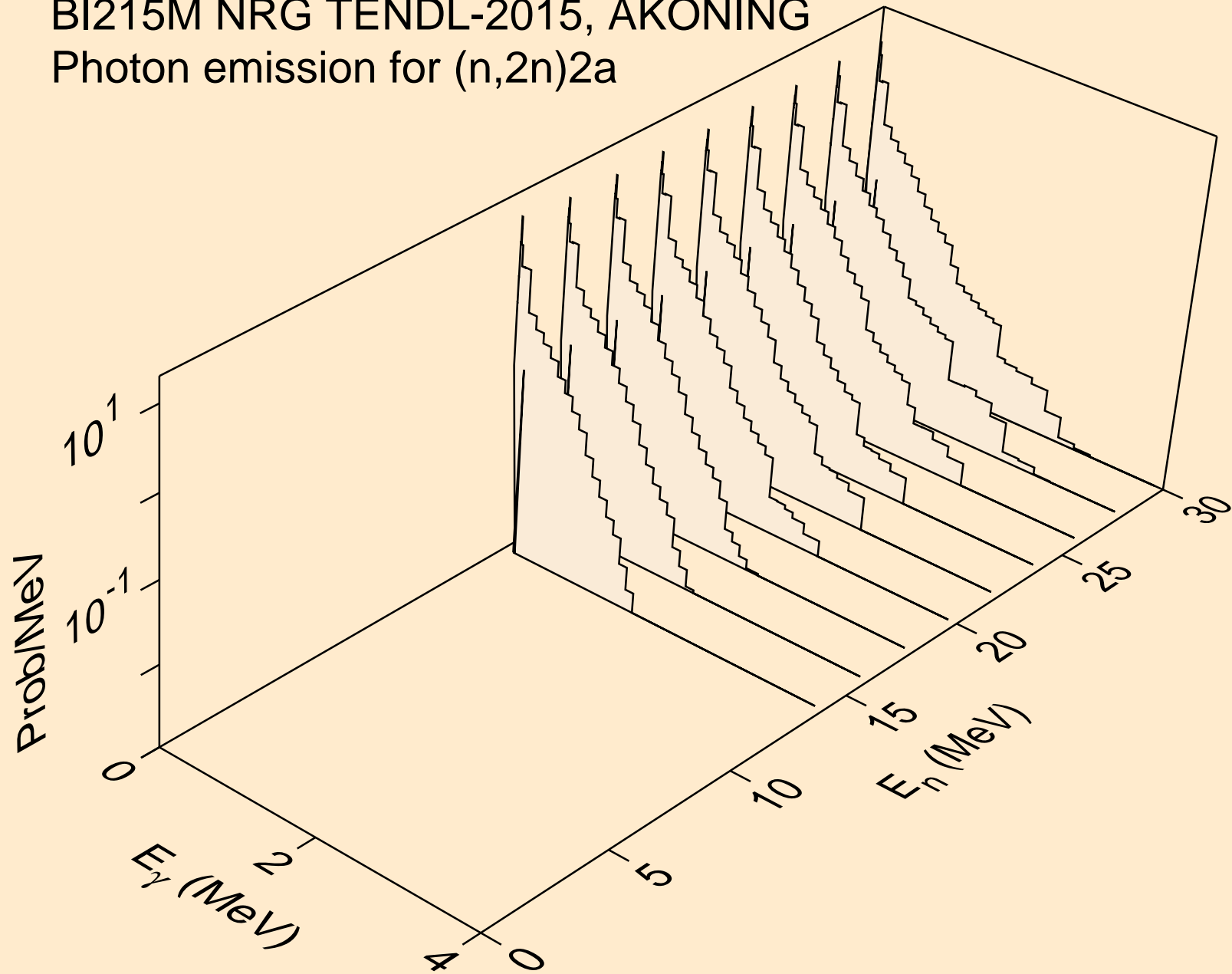

BI215M NRG TENDL-2015, AKONING
Photon emission for (n,n*)d

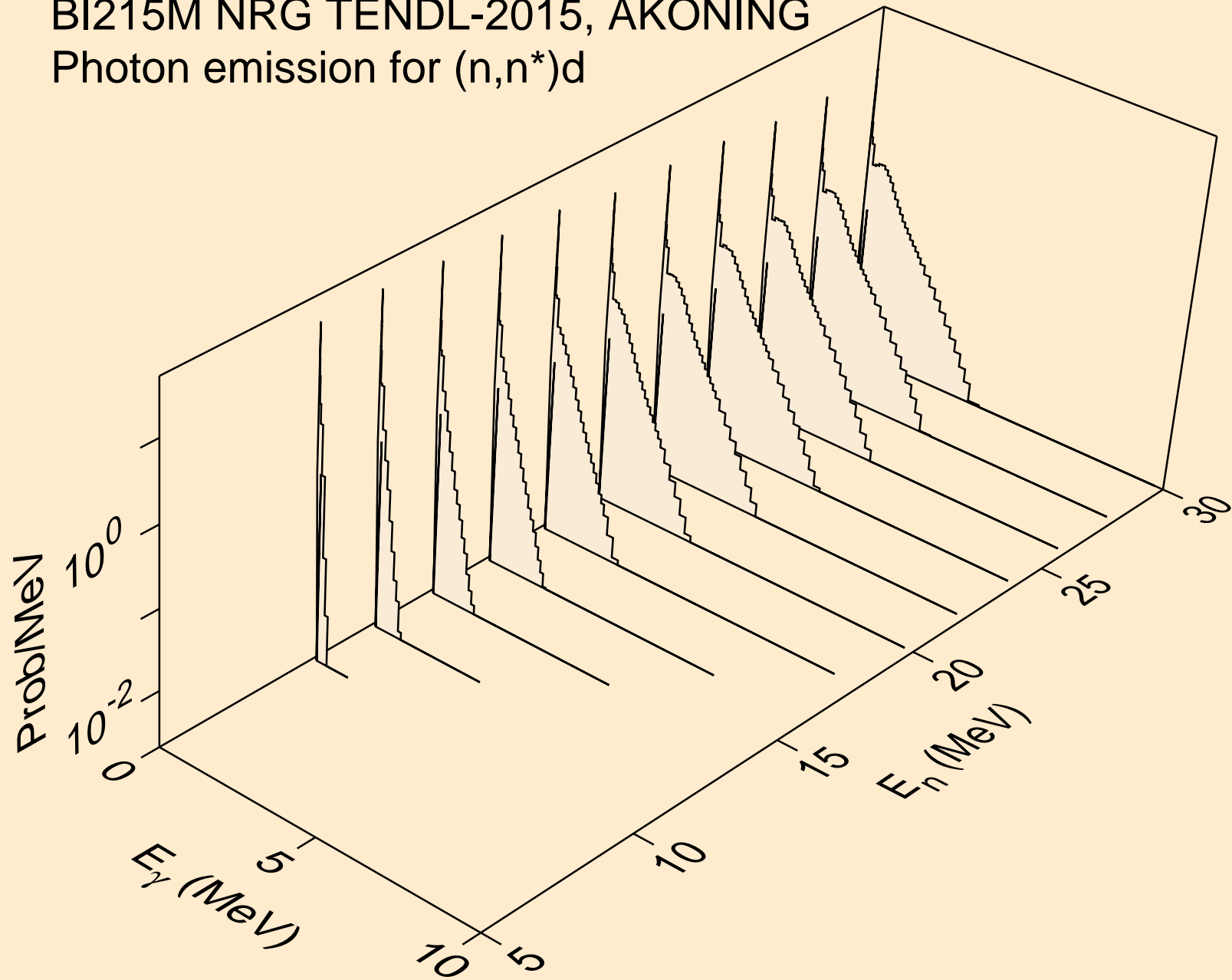

BI215M NRG TENDL-2015, AKONING
Photon emission for (n,n*)t

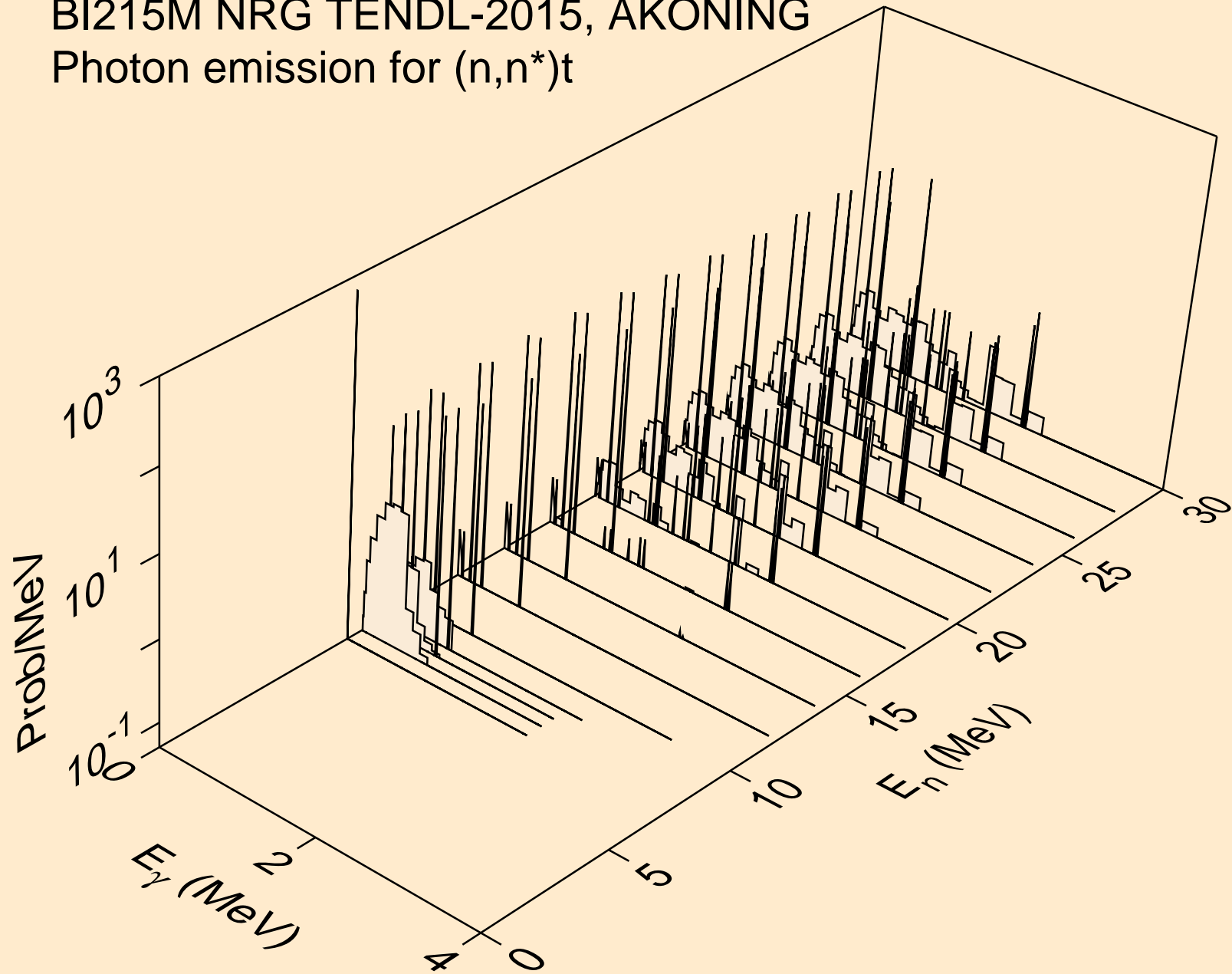

BI215M NRG TENDL-2015, AKONING
Photon emission for (n,n*)he3

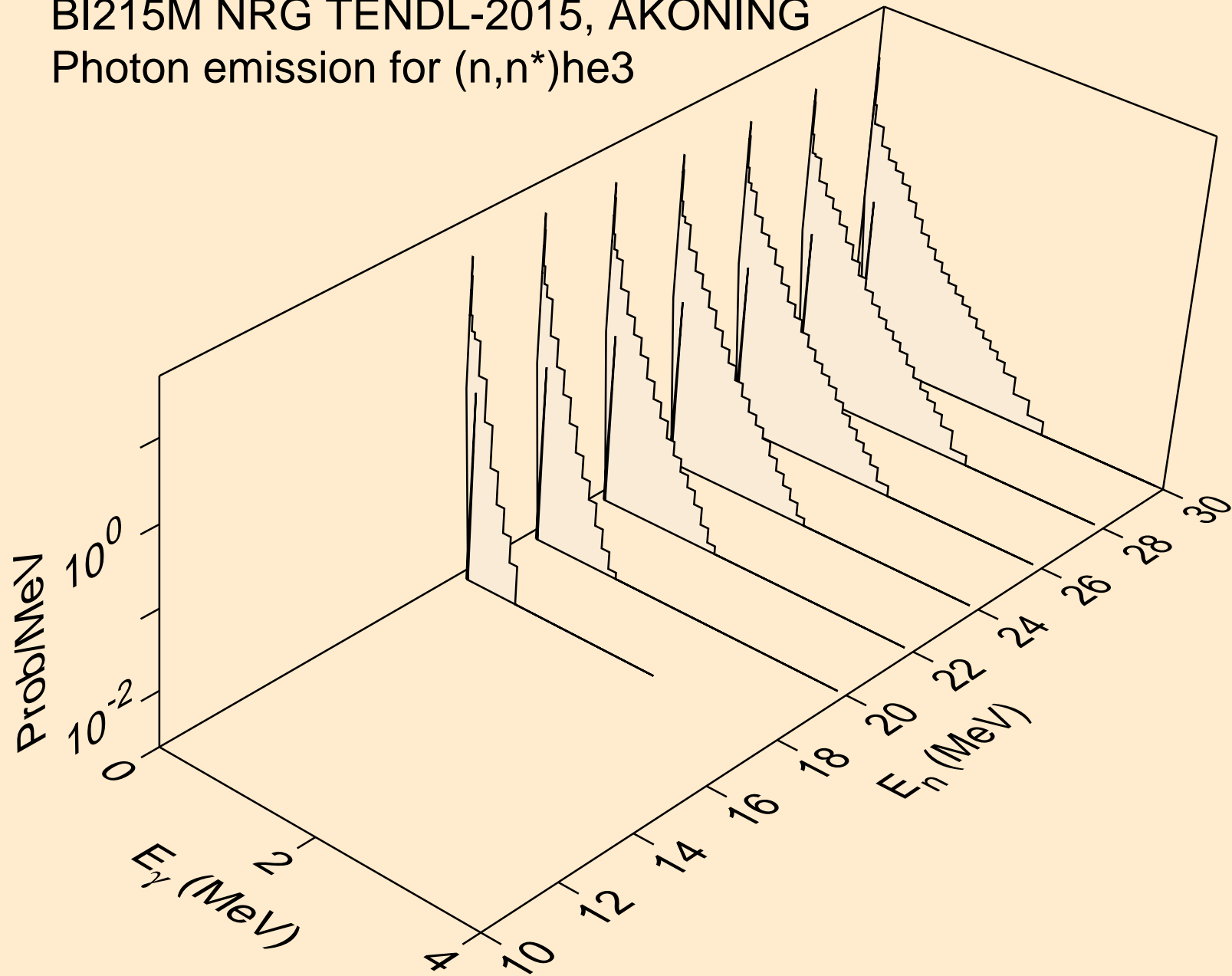

BI215M NRG TENDL-2015, AKONING
Photon emission for (n,4n)

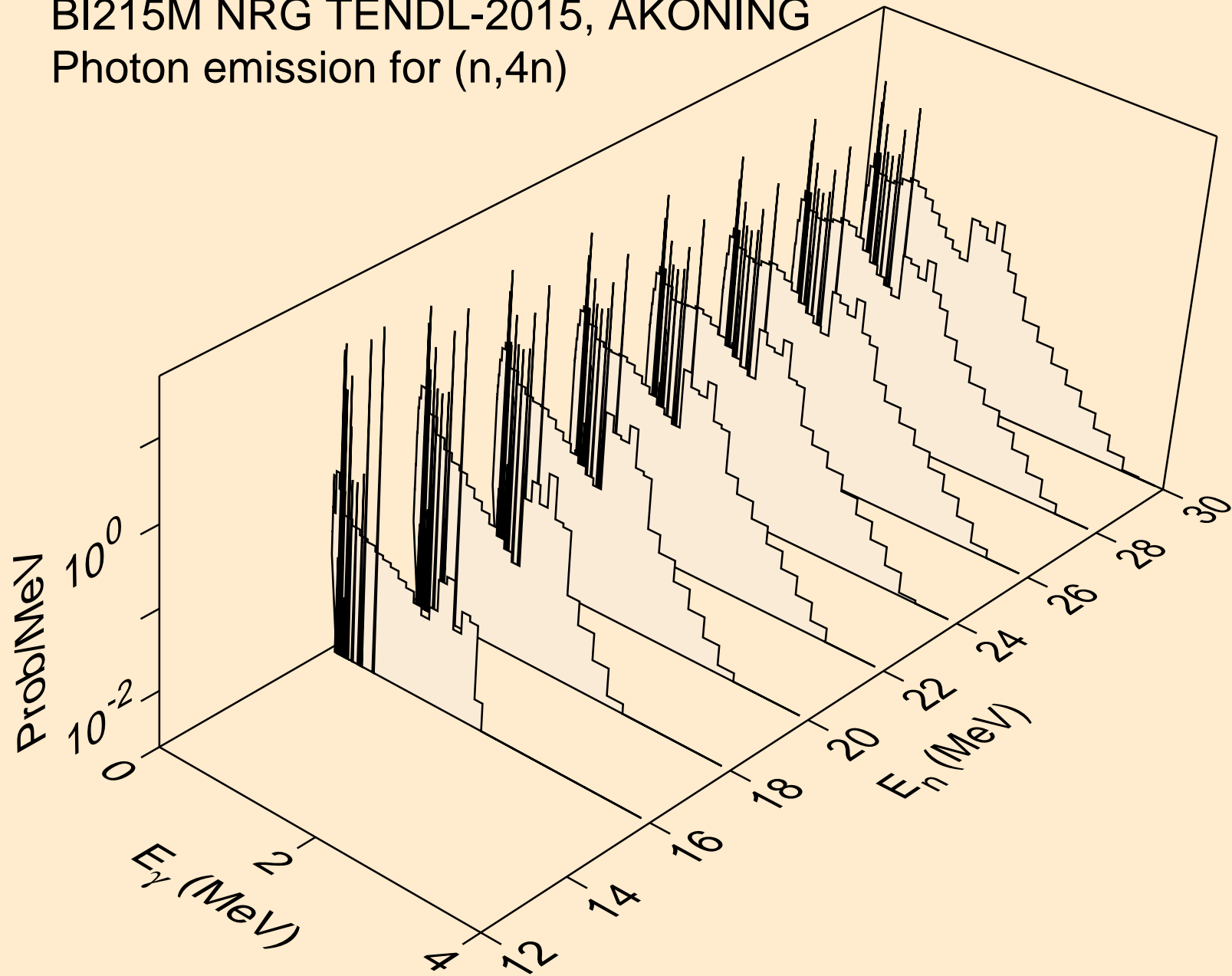

BI215M NRG TENDL-2015, AKONING
Photon emission for (n,2np)

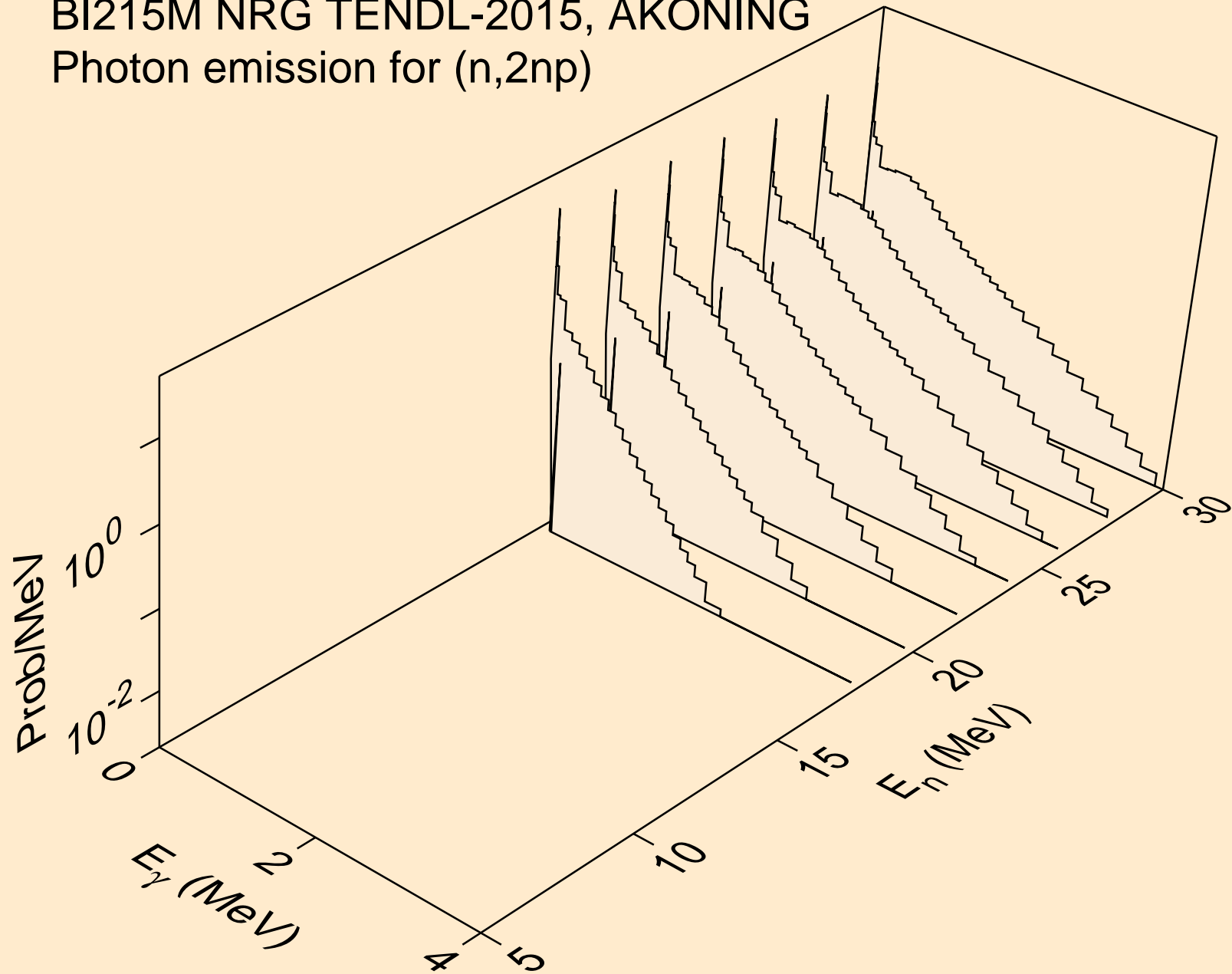

BI215M NRG TENDL-2015, AKONING
Photon emission for (n,3np)

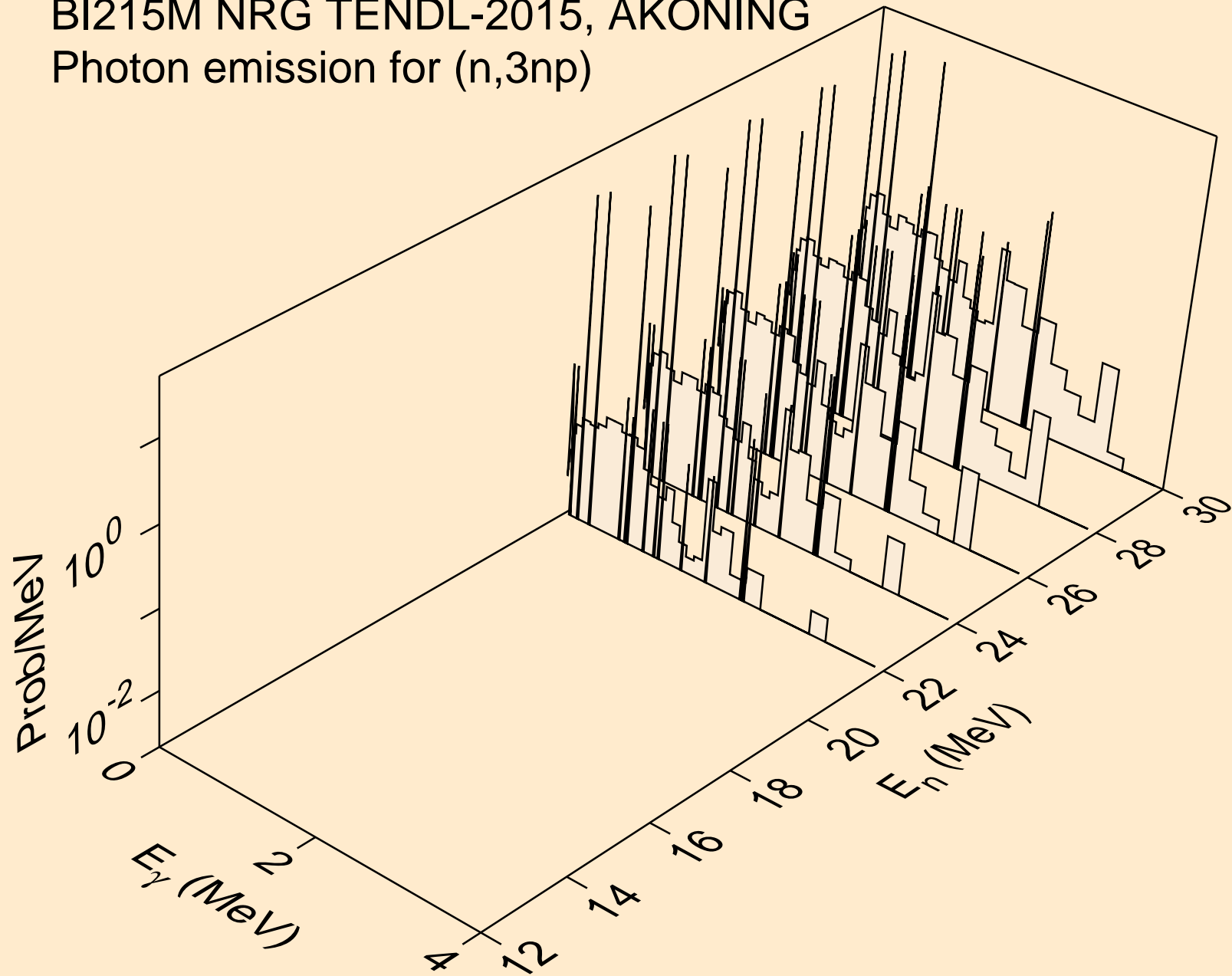

BI215M NRG TENDL-2015, AKONING
Photon emission for (n,2np)

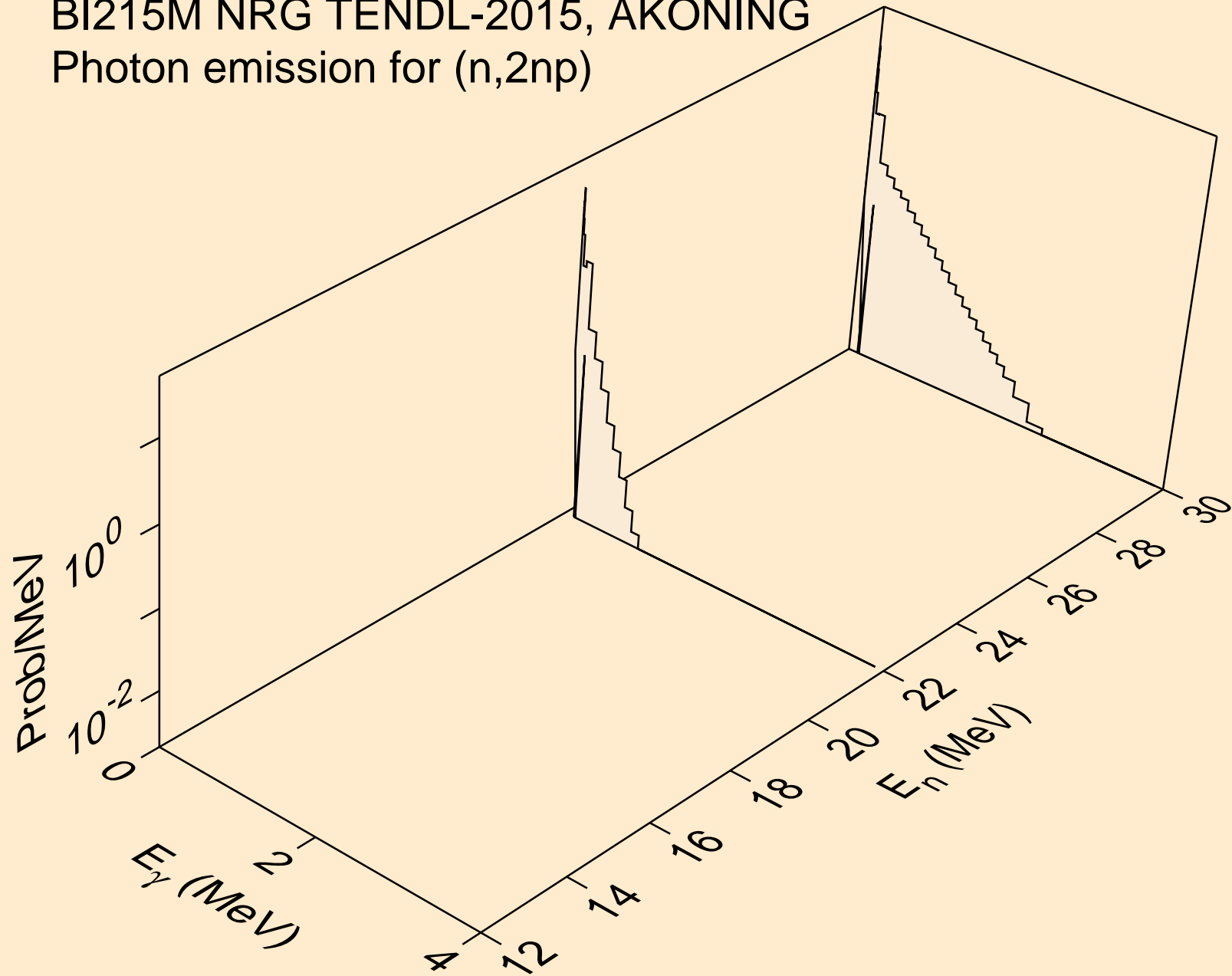

BI215M NRG TENDL-2015, AKONING
Photon emission for (n,n*1)

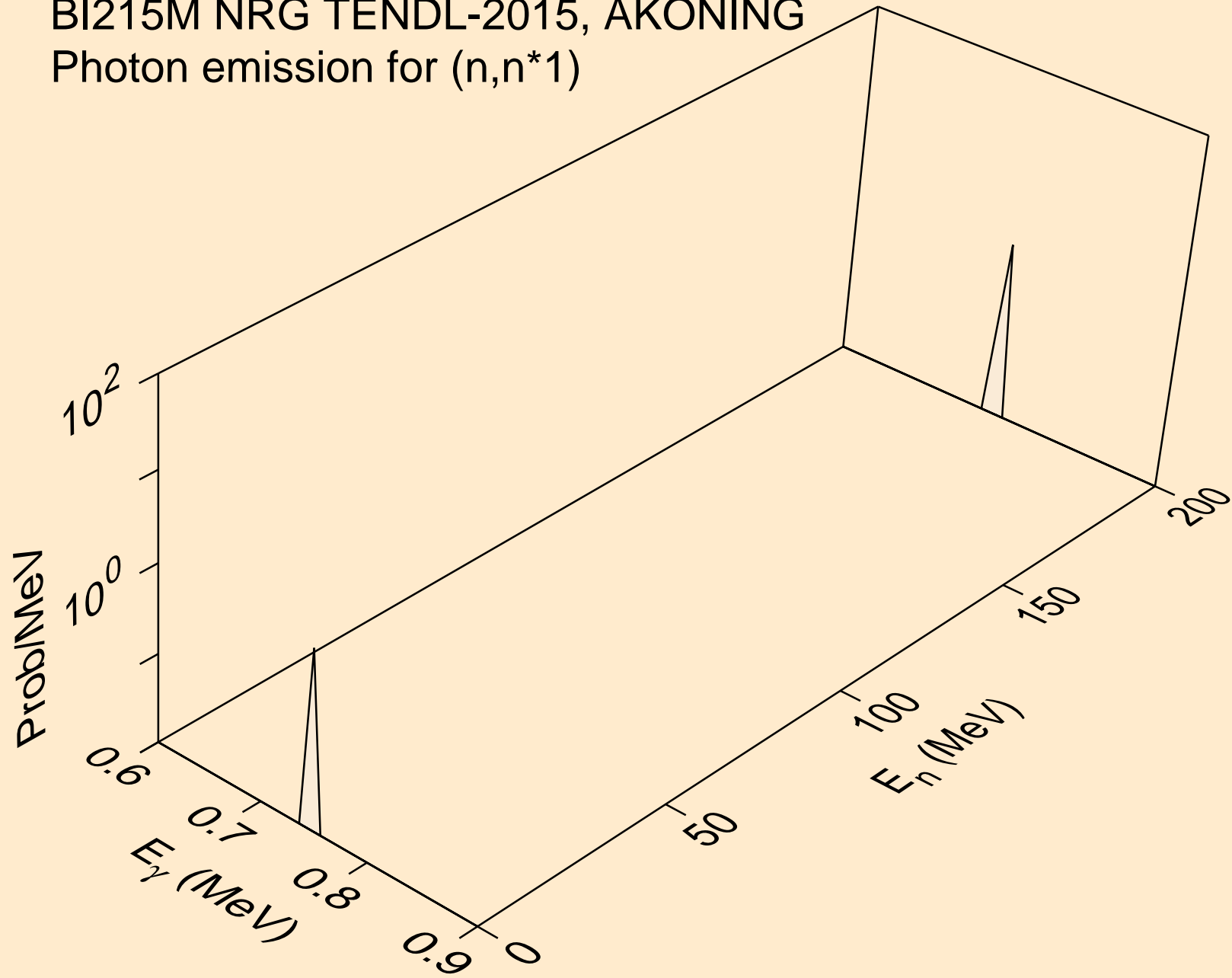

BI215M NRG TENDL-2015, AKONING
Photon emission for (n,n*2)

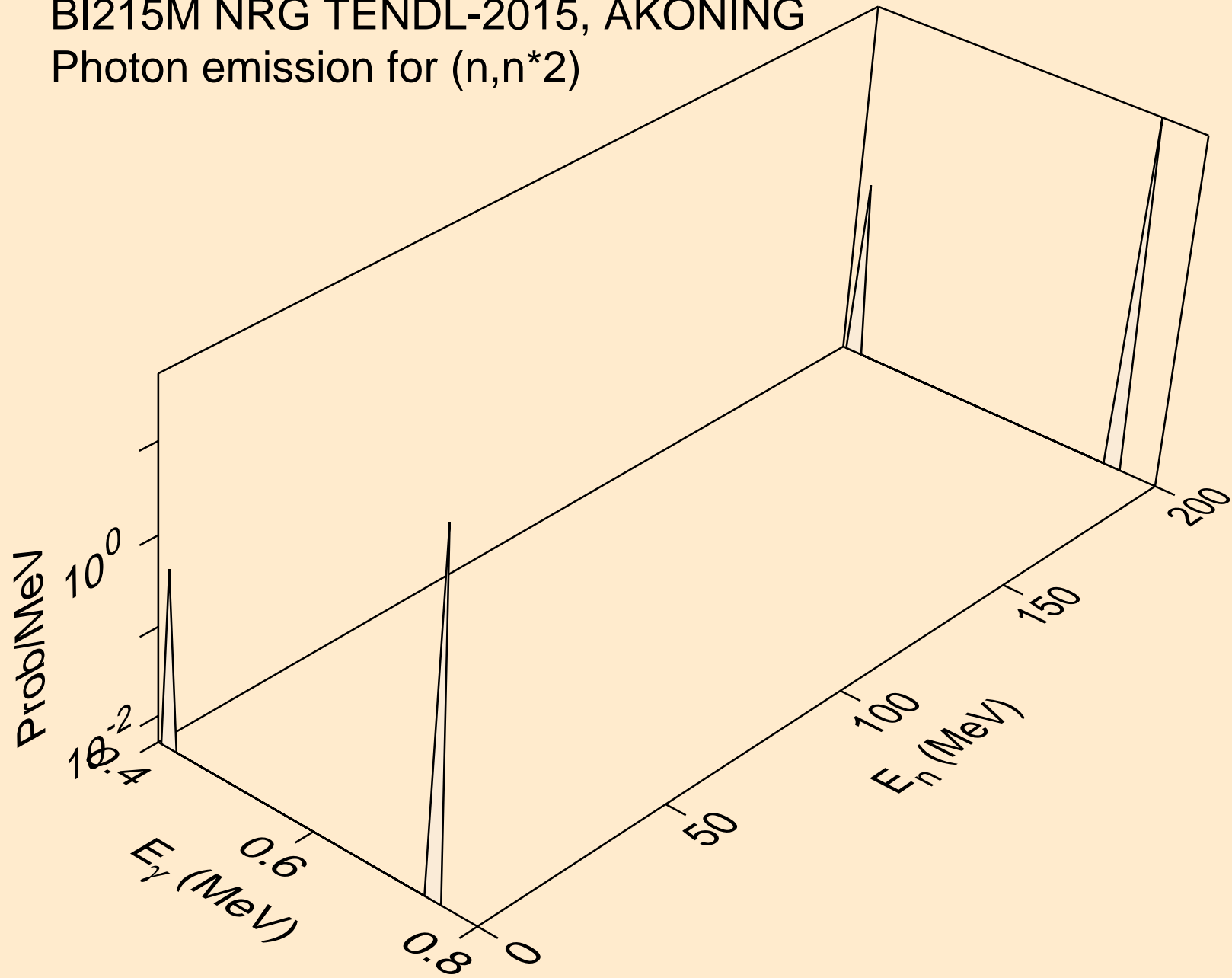

BI215M NRG TENDL-2015, AKONING
Photon emission for (n,n*4)

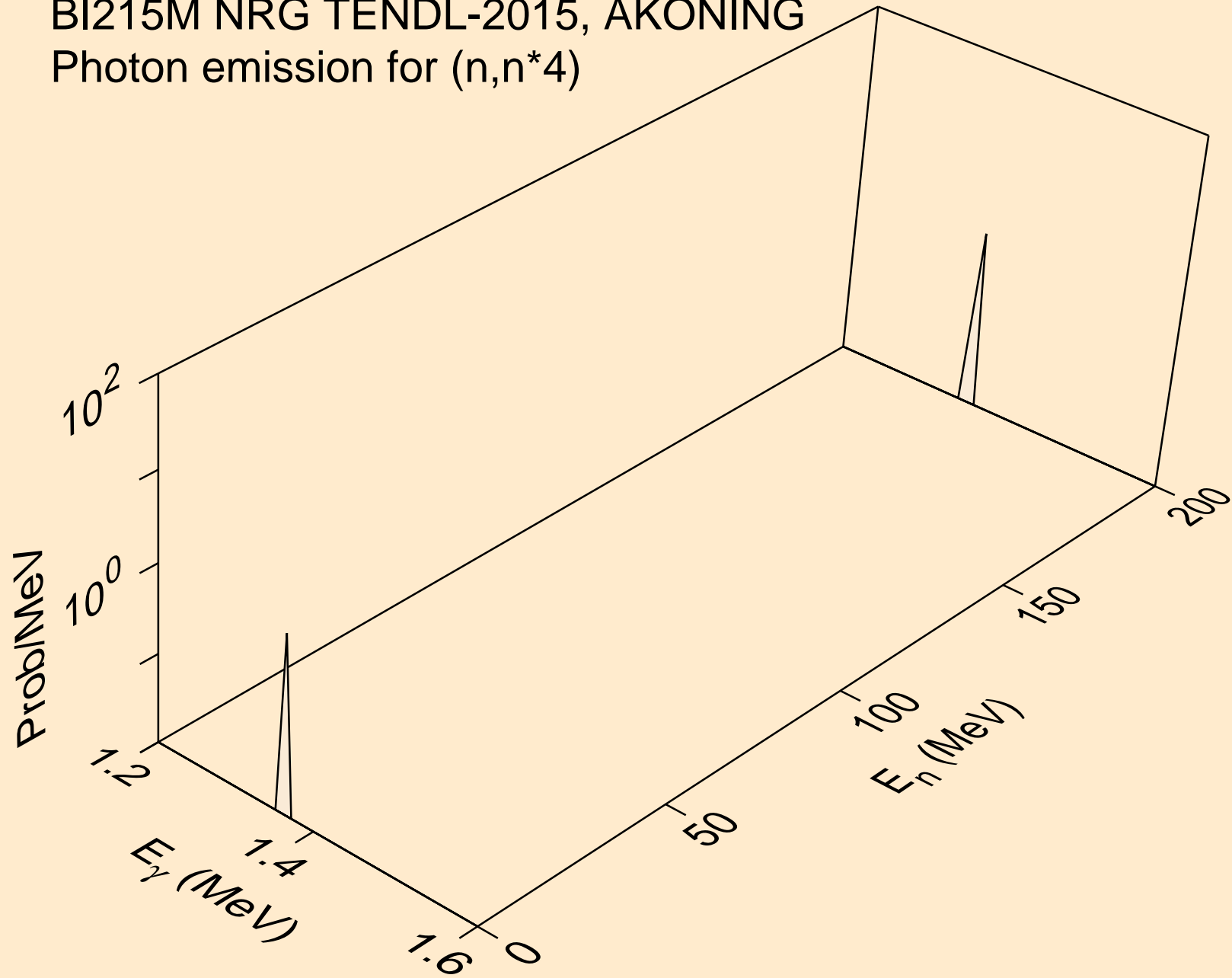

BI215M NRG TENDL-2015, AKONING
Photon emission for (n,n*5)

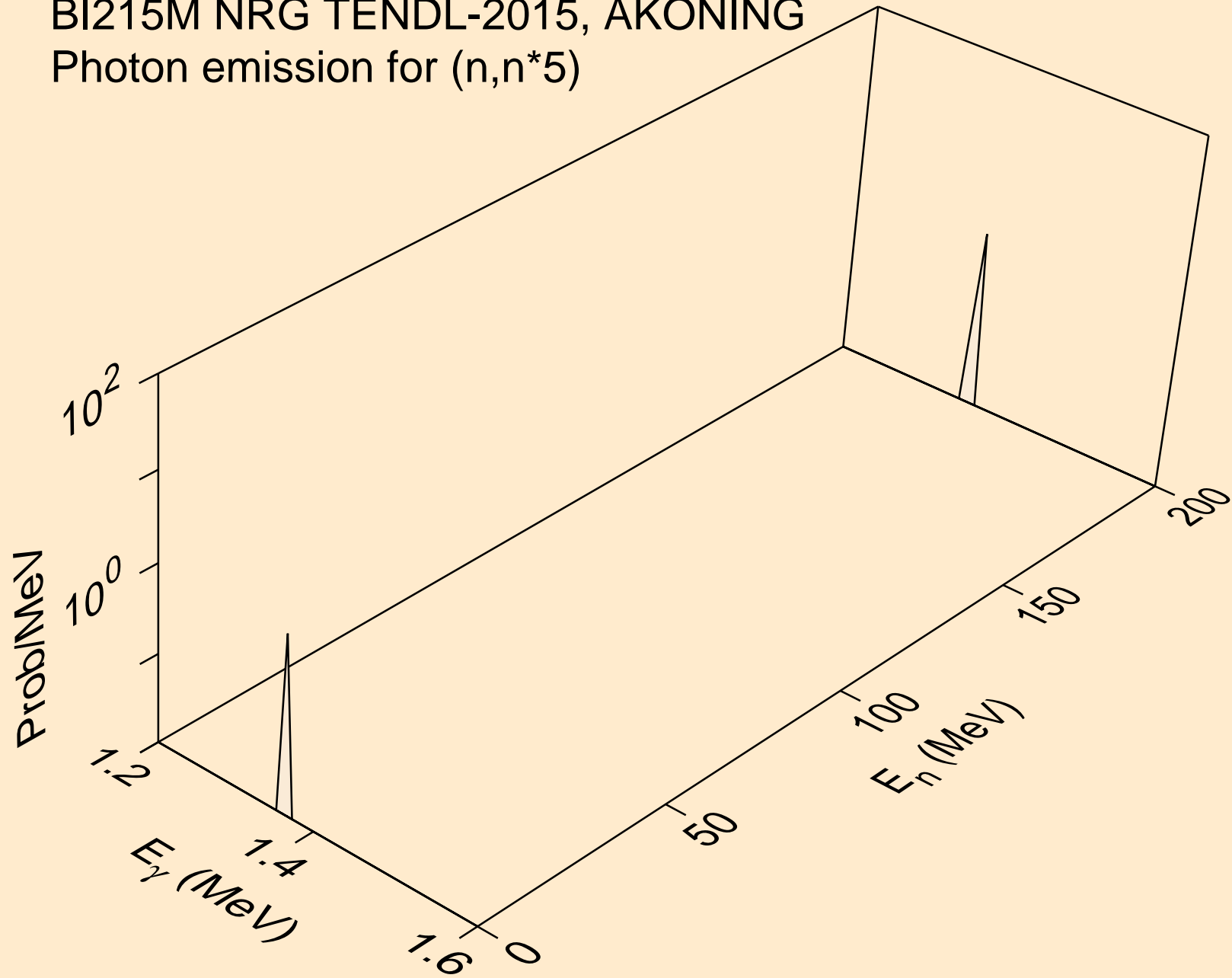

BI215M NRG TENDL-2015, AKONING
Photon emission for (n,n*6)

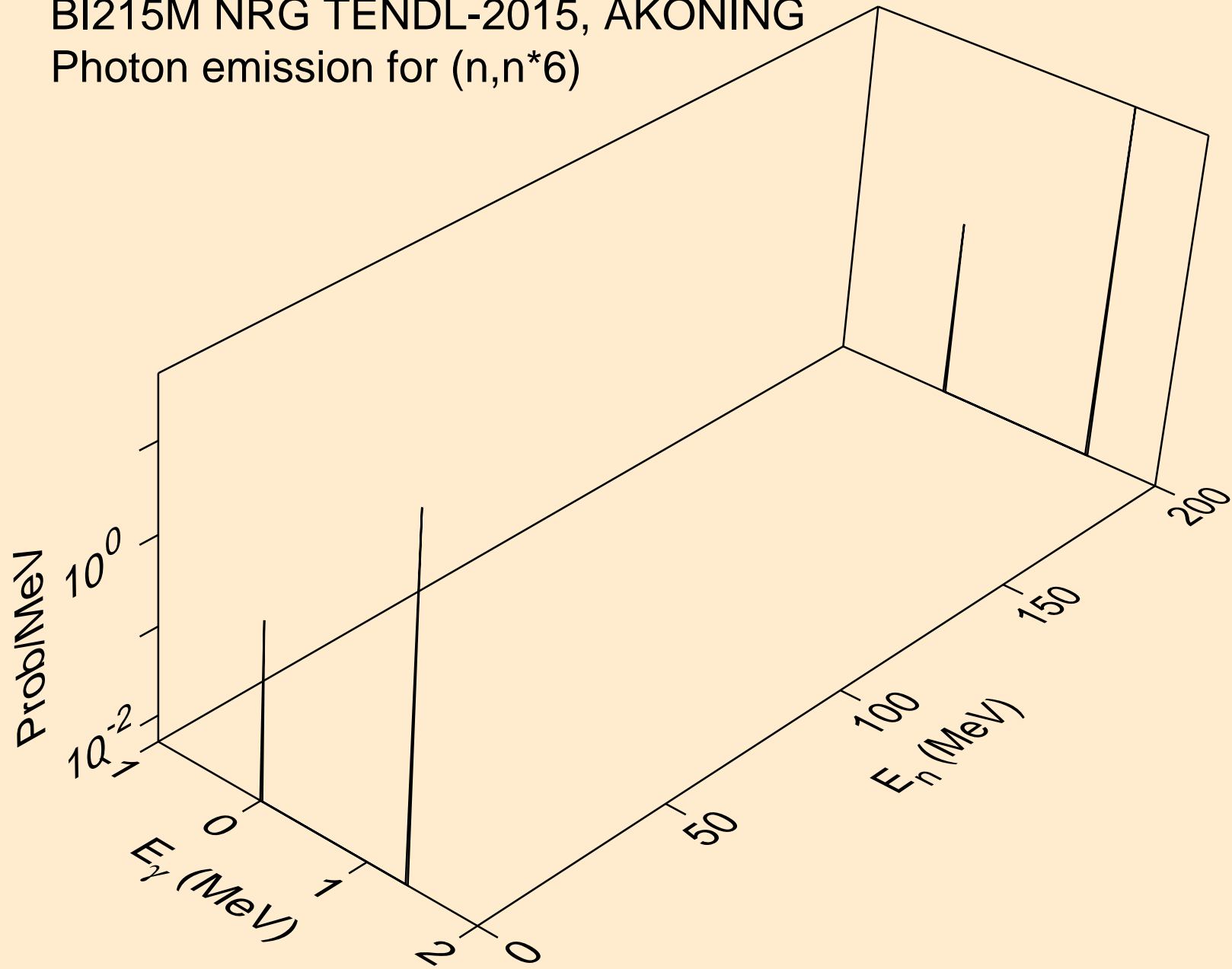

BI215M NRG TENDL-2015, AKONING
Photon emission for (n,n*7)

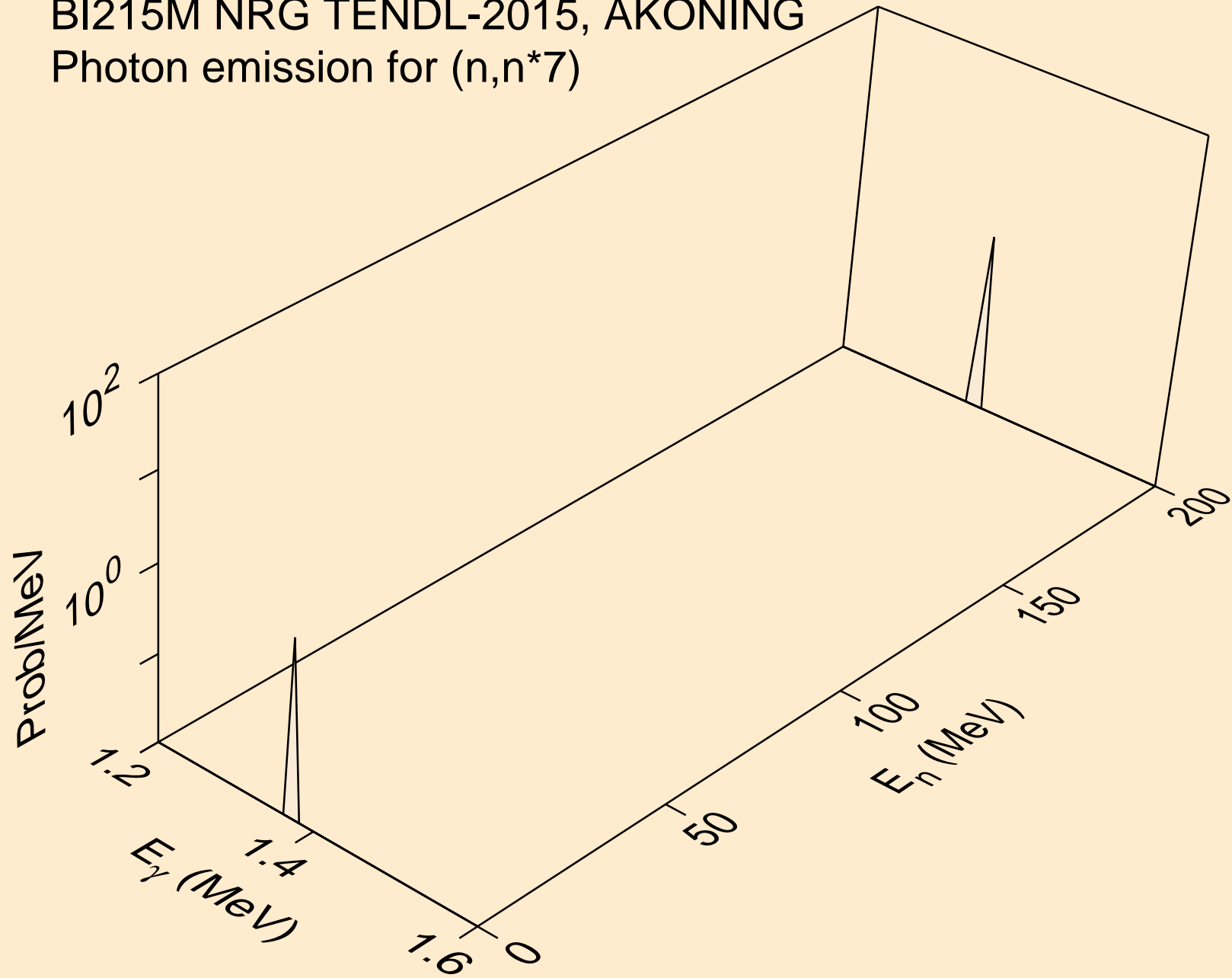

BI215M NRG TENDL-2015, AKONING
Photon emission for (n,n*8)

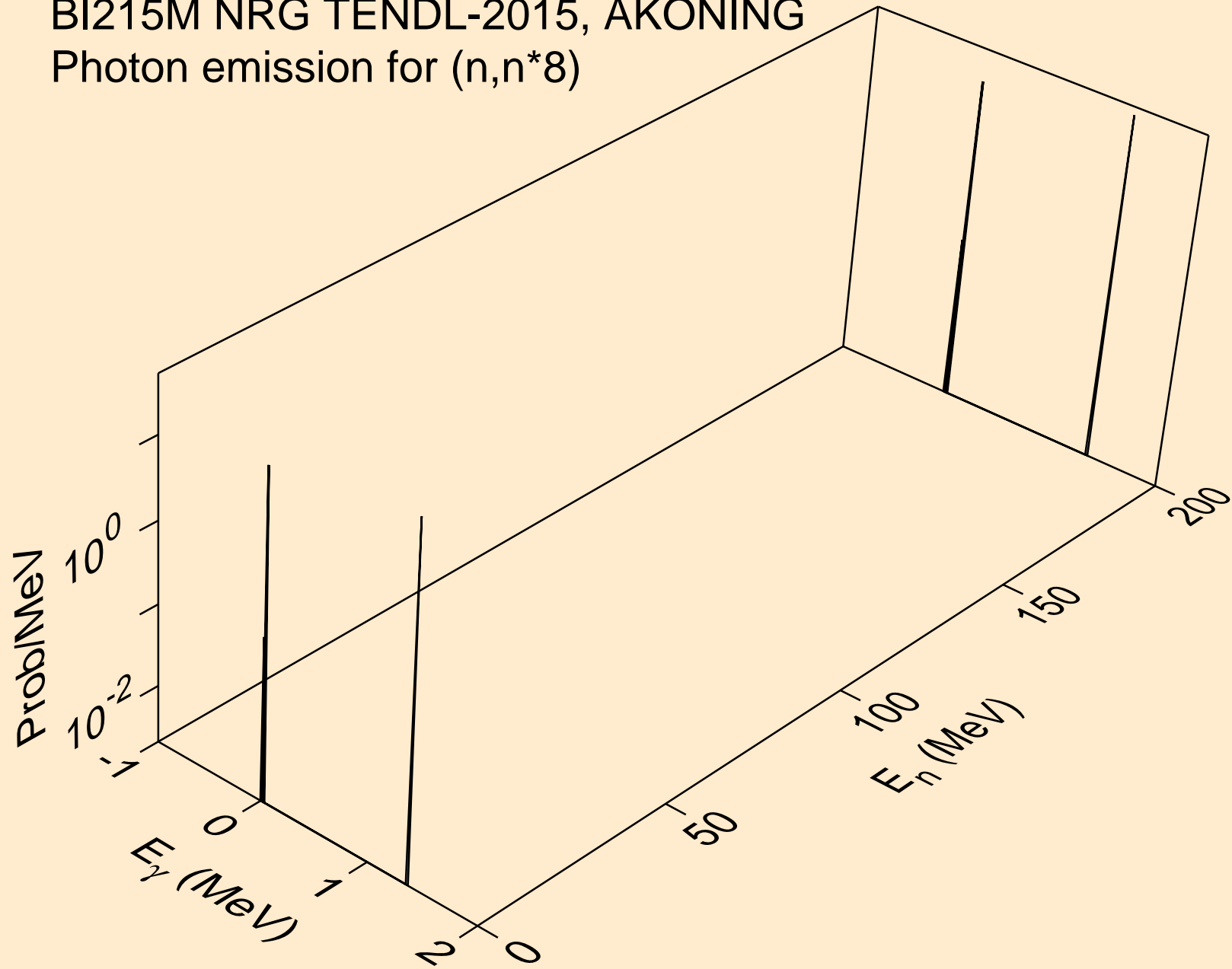

BI215M NRG TENDL-2015, AKONING
Photon emission for (n,n*9)

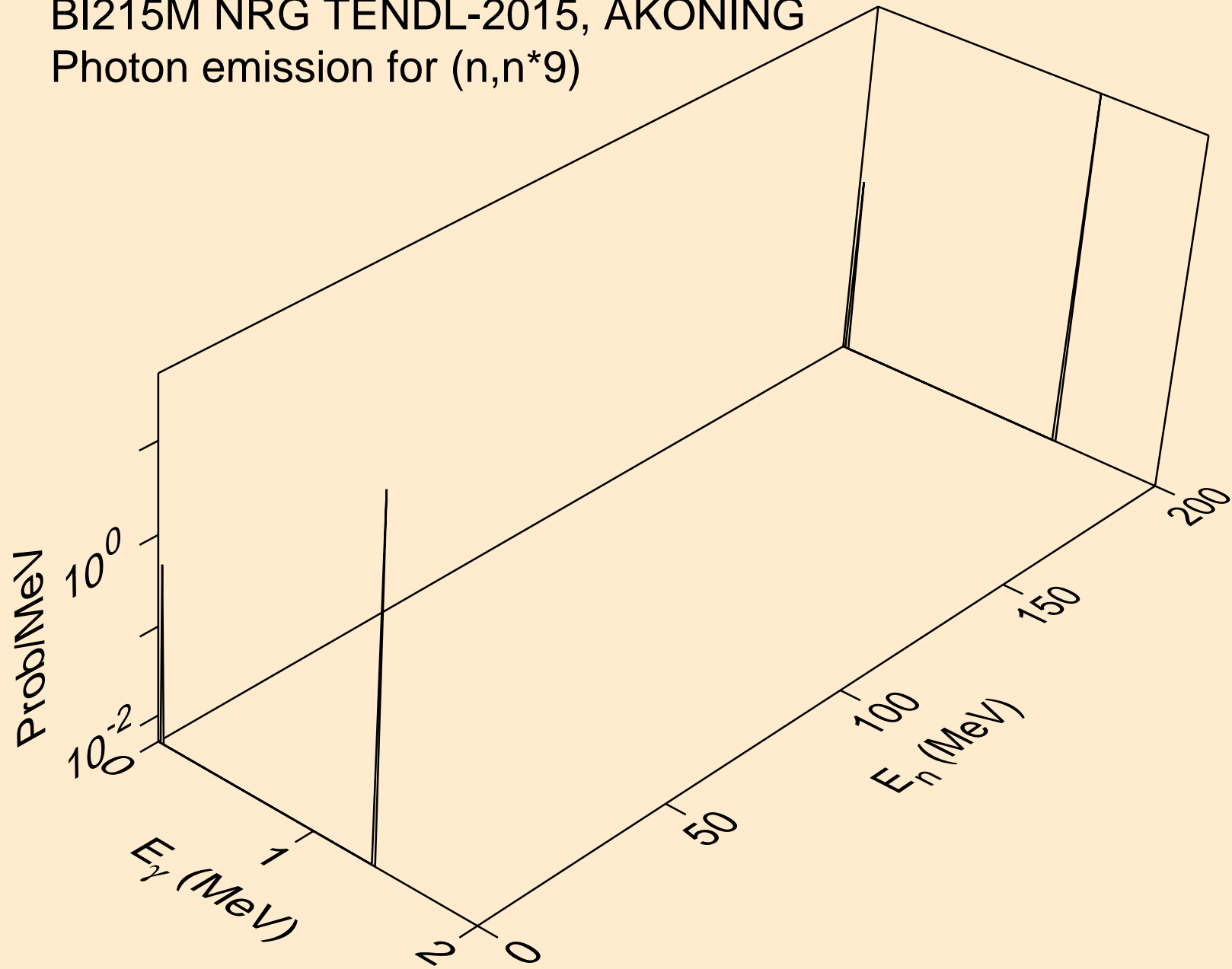

BI215M NRG TENDL-2015, AKONING
Photon emission for (n,n*10)

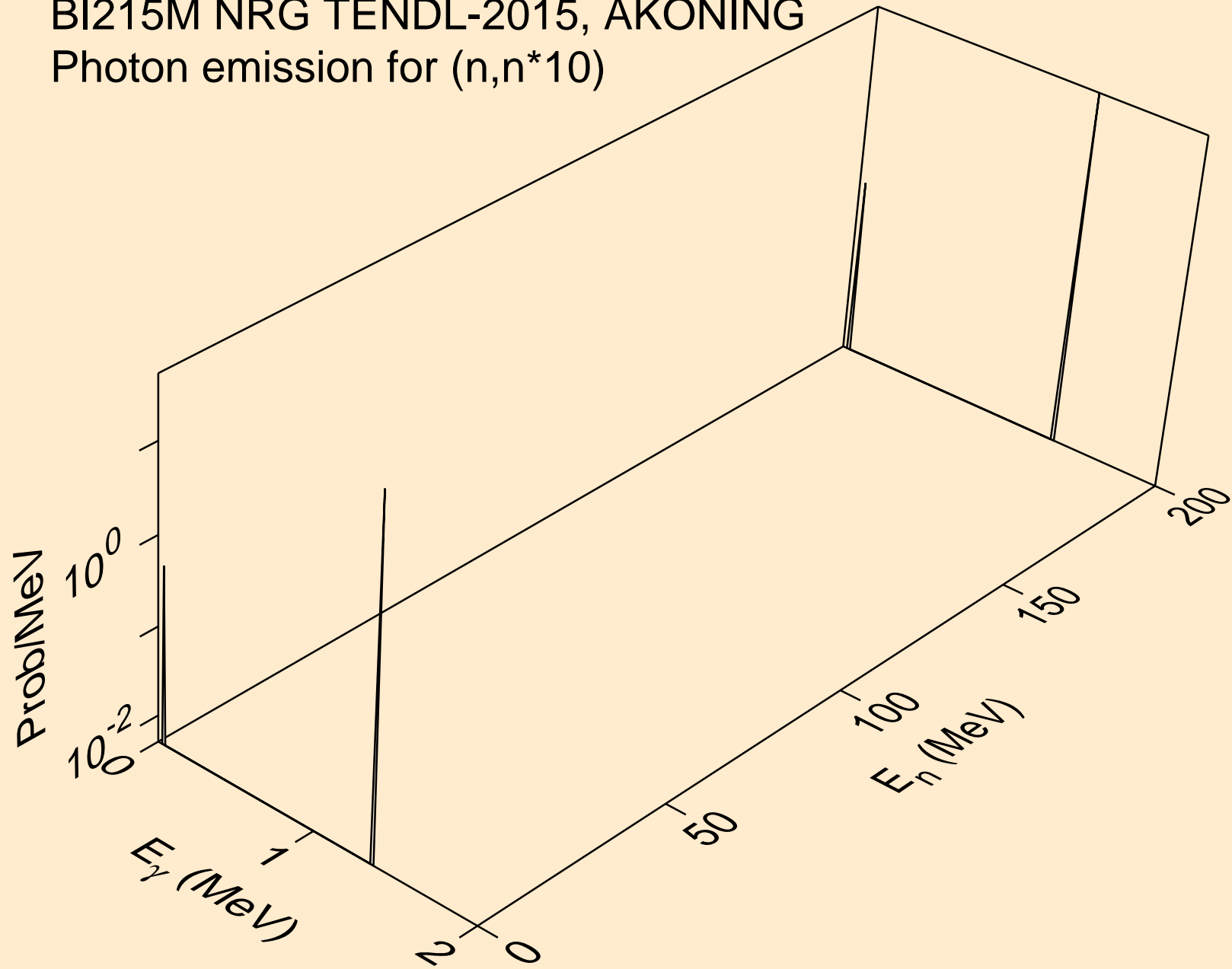

BI215M NRG TENDL-2015, AKONING
Photon emission for (n,n*11)

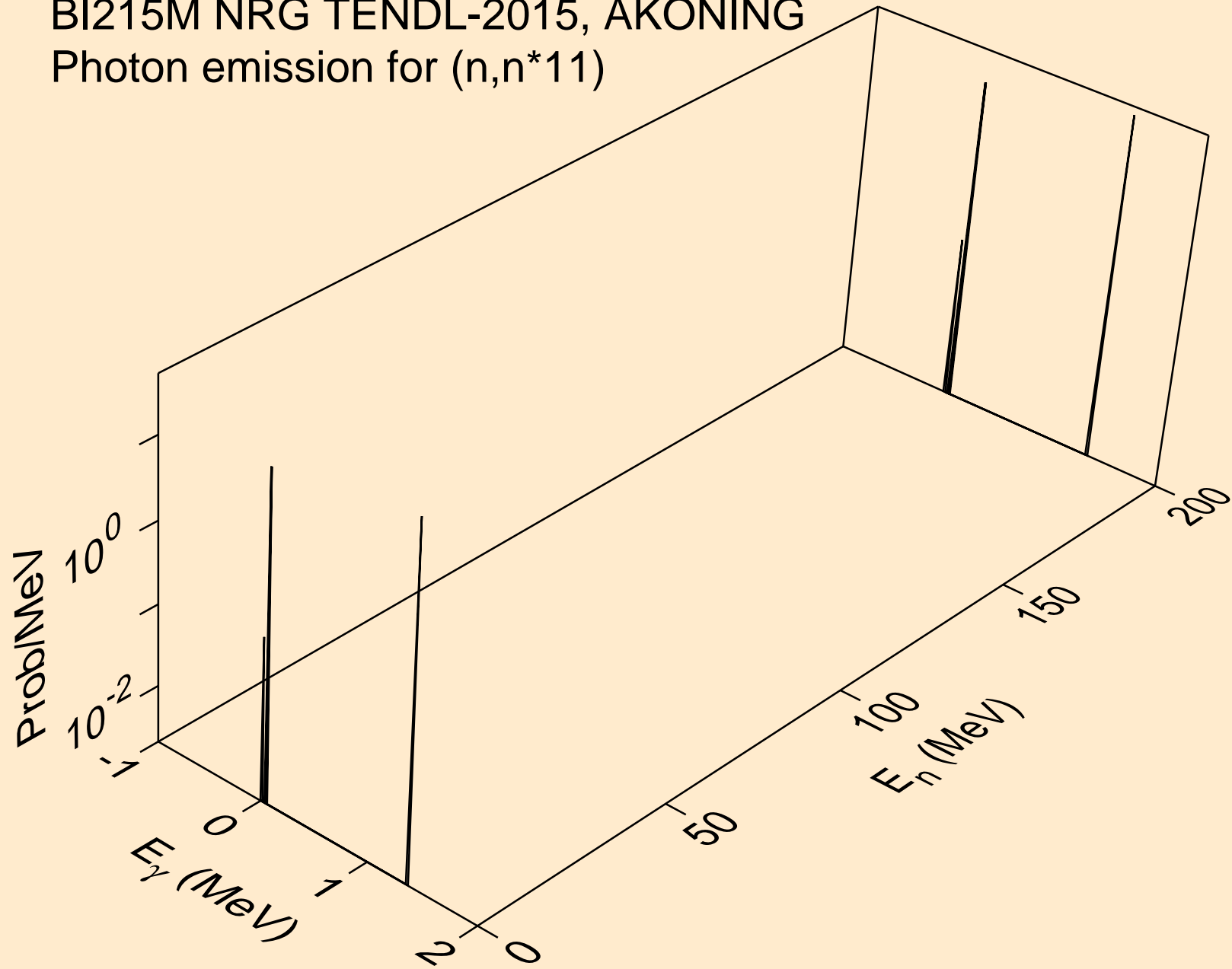

BI215M NRG TENDL-2015, AKONING
Photon emission for (n,n*12)

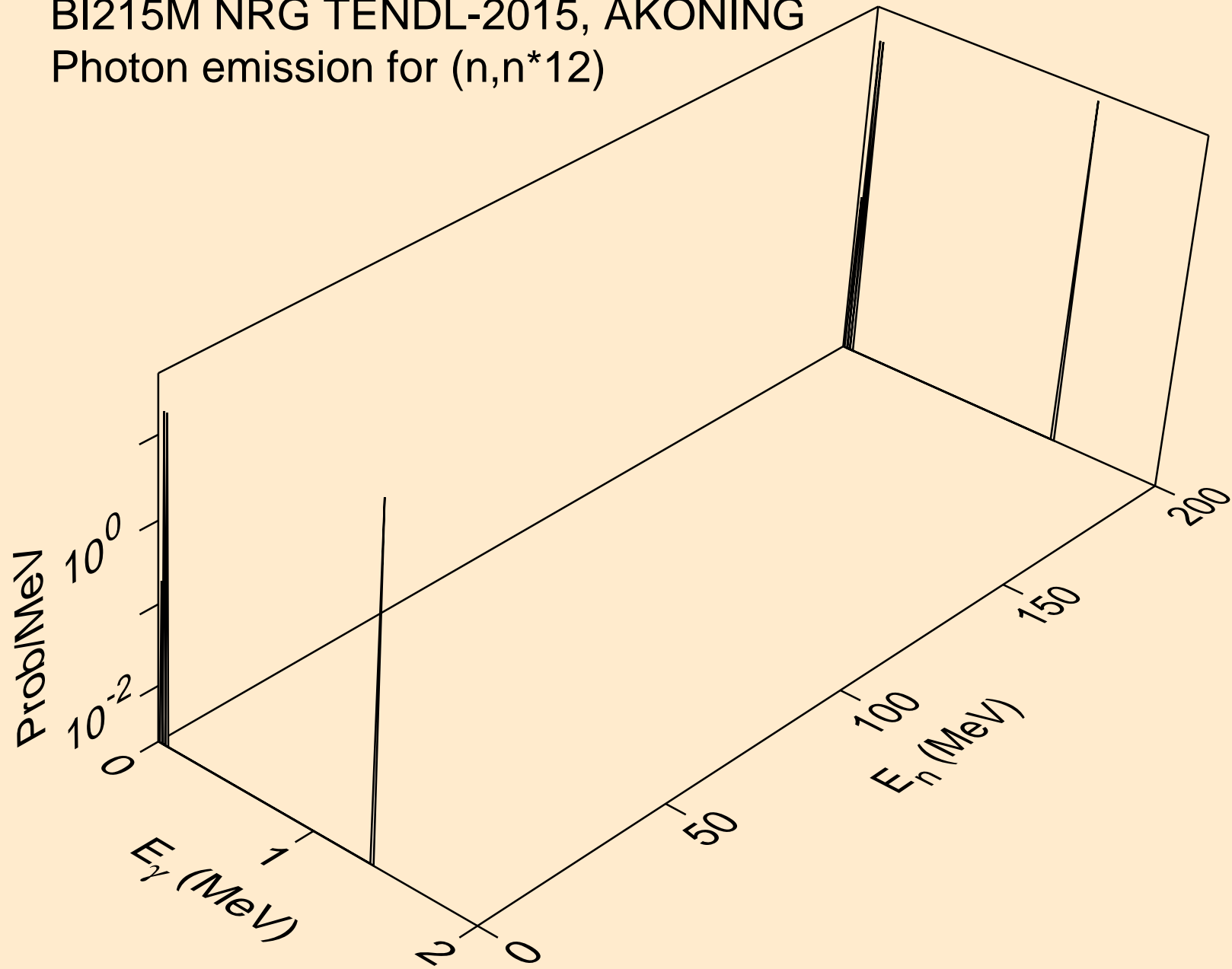

BI215M NRG TENDL-2015, AKONING
Photon emission for (n,n*13)

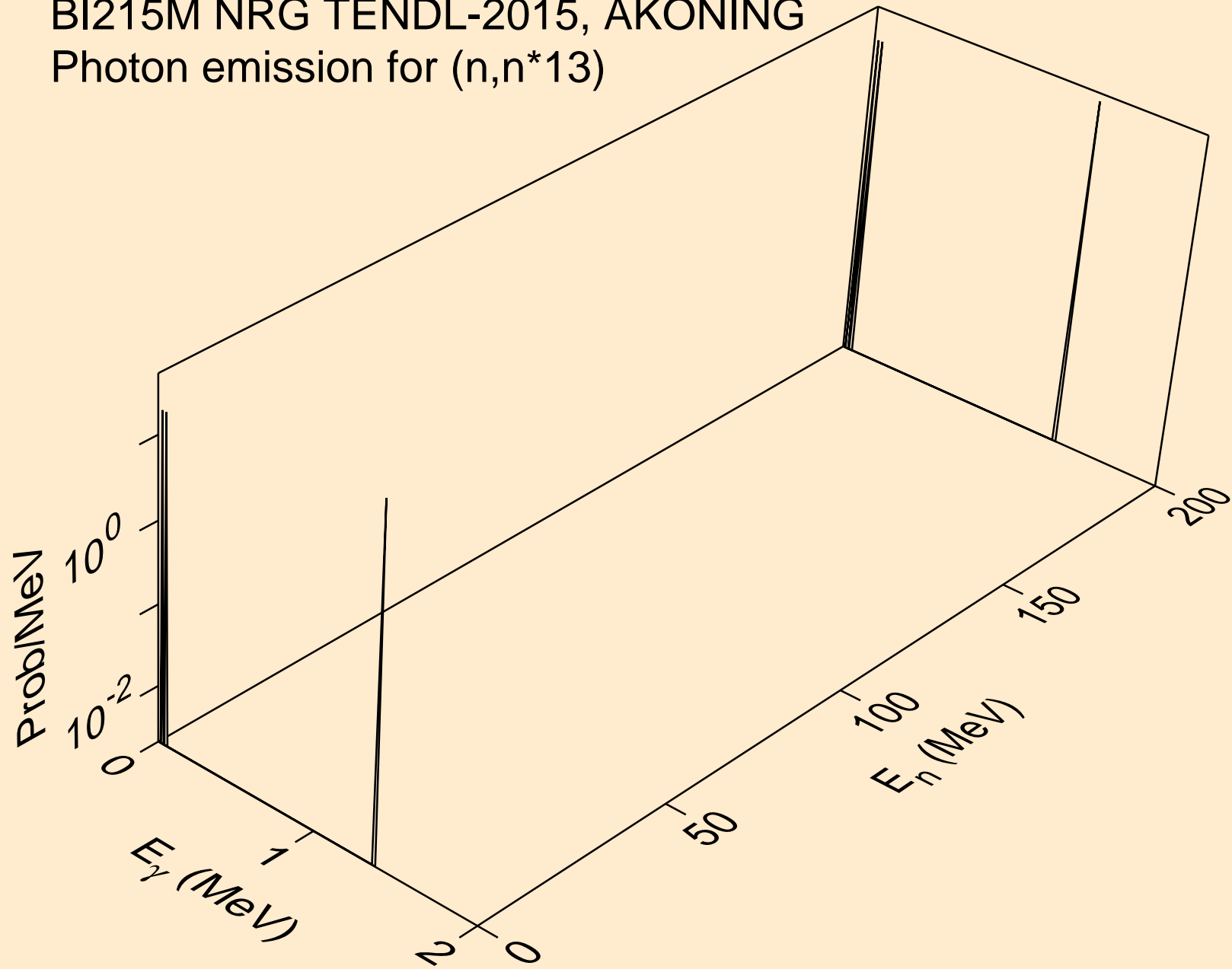

BI215M NRG TENDL-2015, AKONING
Photon emission for (n,n*14)

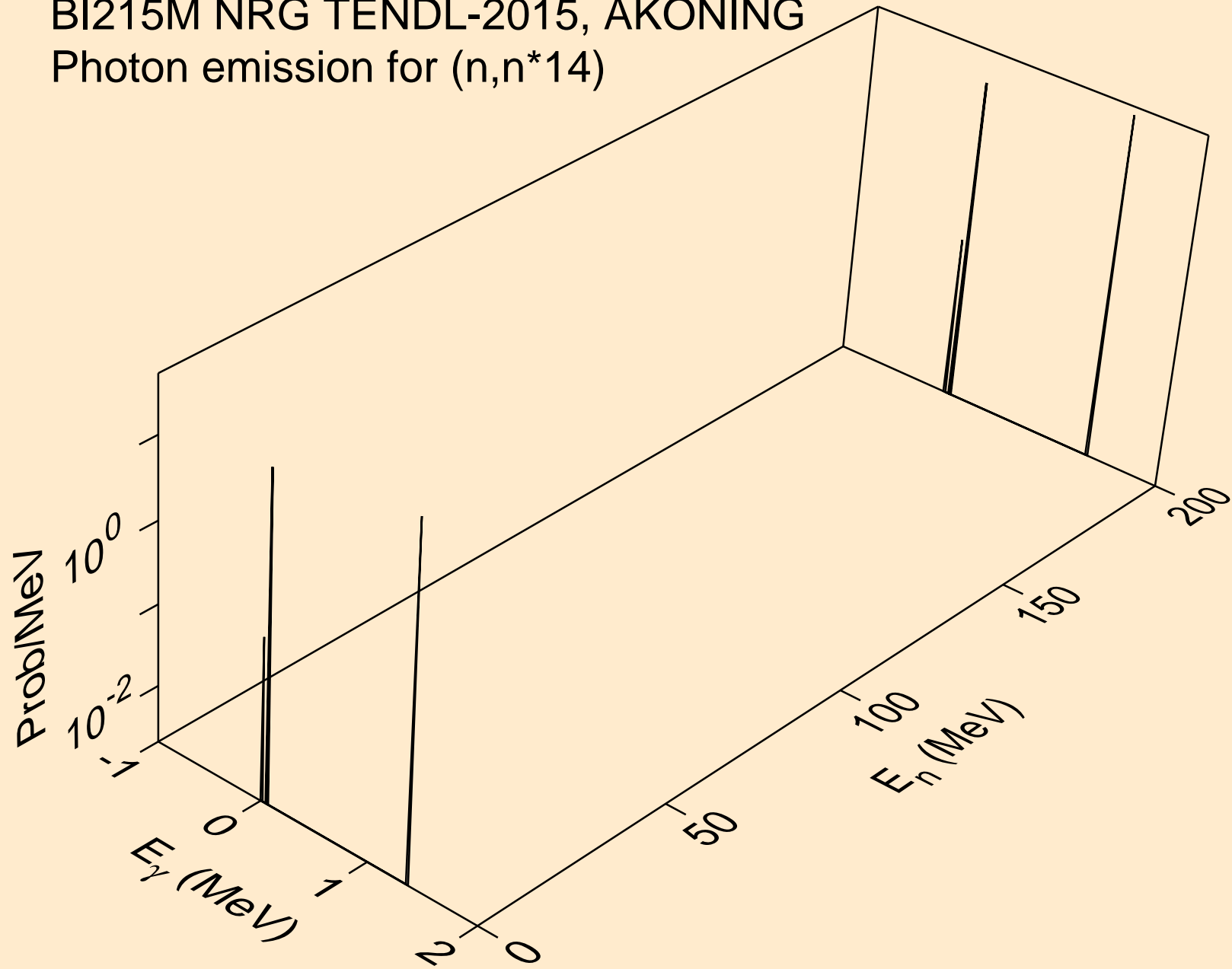

BI215M NRG TENDL-2015, AKONING
Photon emission for (n,n*15)

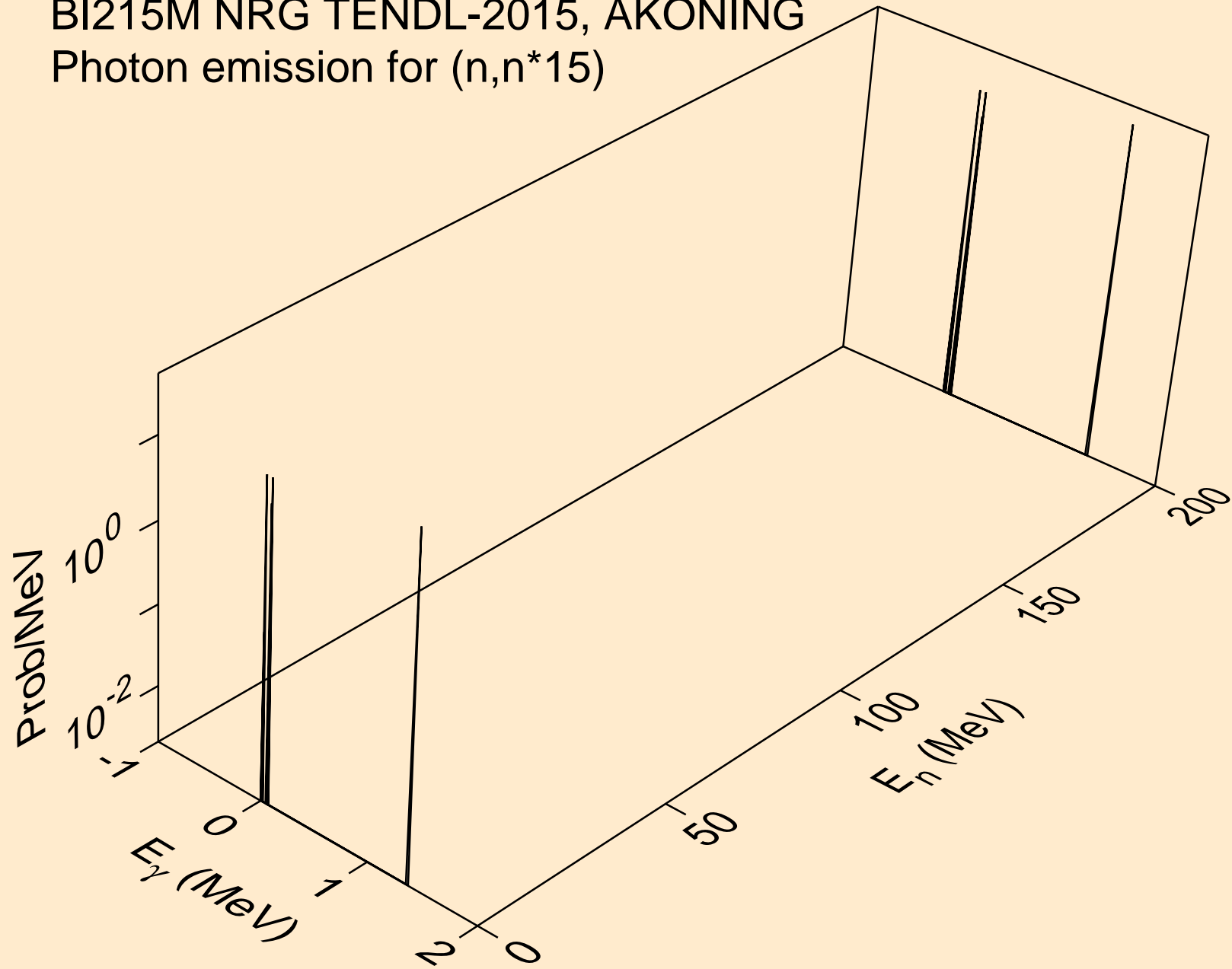

BI215M NRG TENDL-2015, AKONING
Photon emission for (n,n*16)

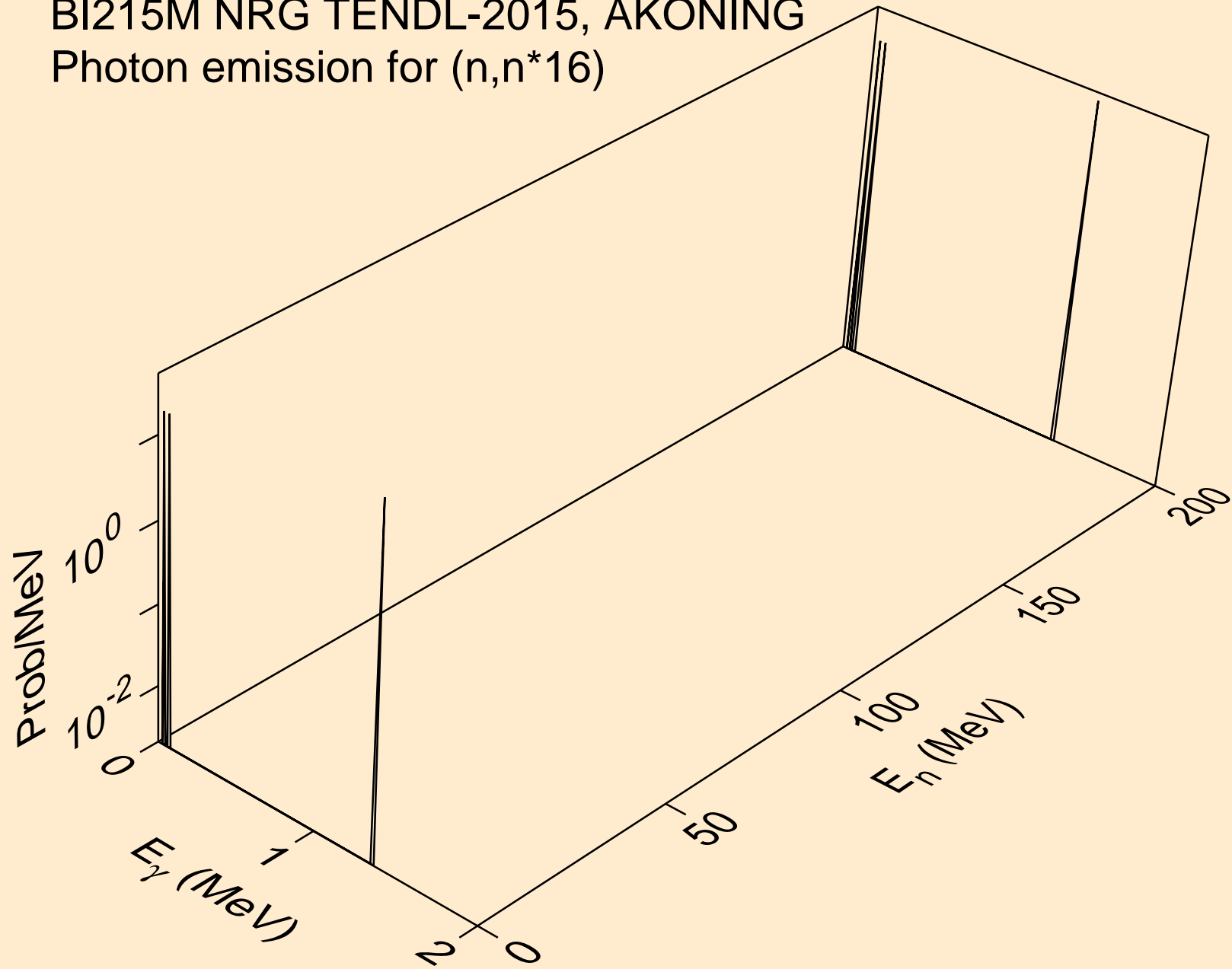

BI215M NRG TENDL-2015, AKONING
Photon emission for (n,n*17)

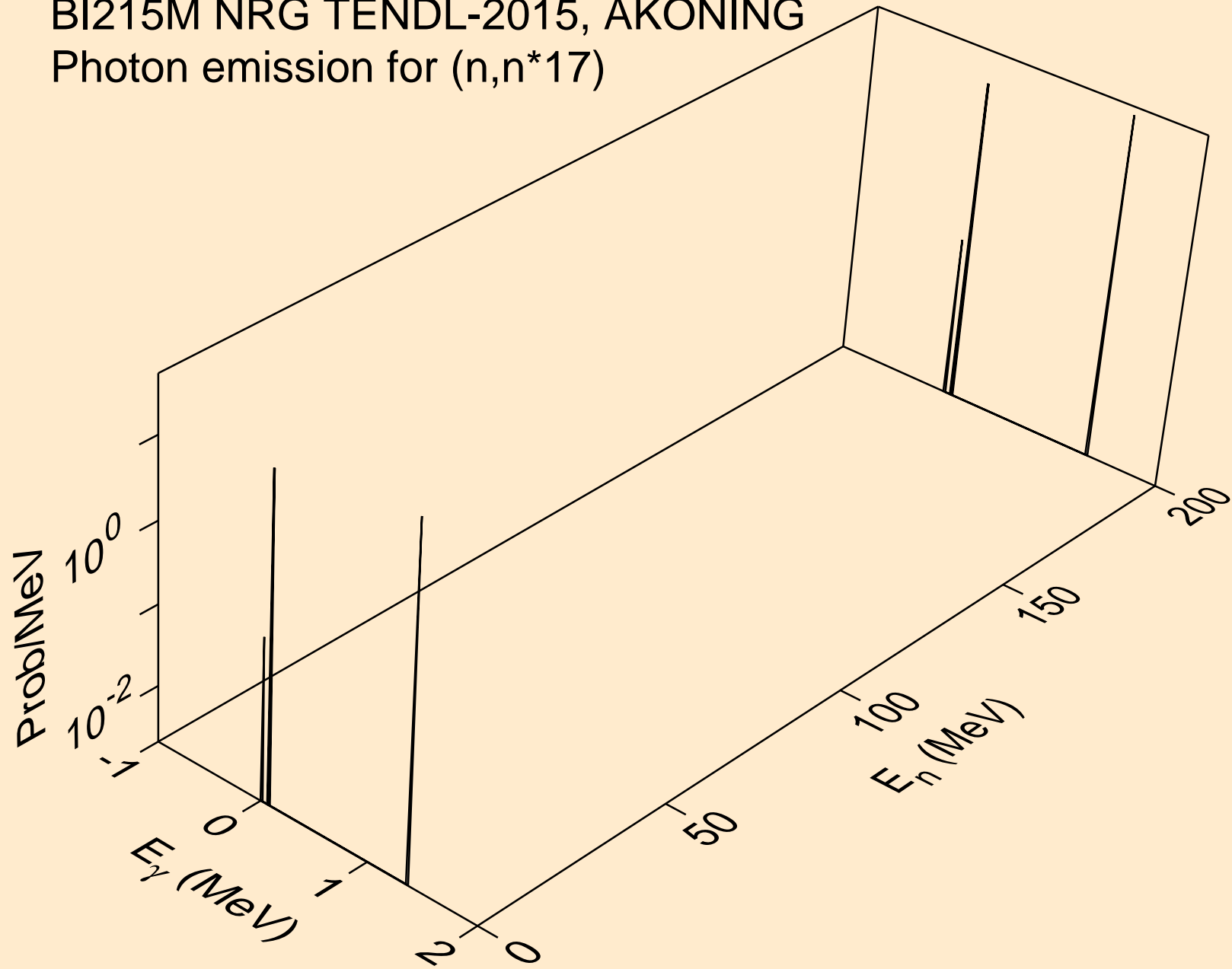

BI215M NRG TENDL-2015, AKONING
Photon emission for (n,n*18)

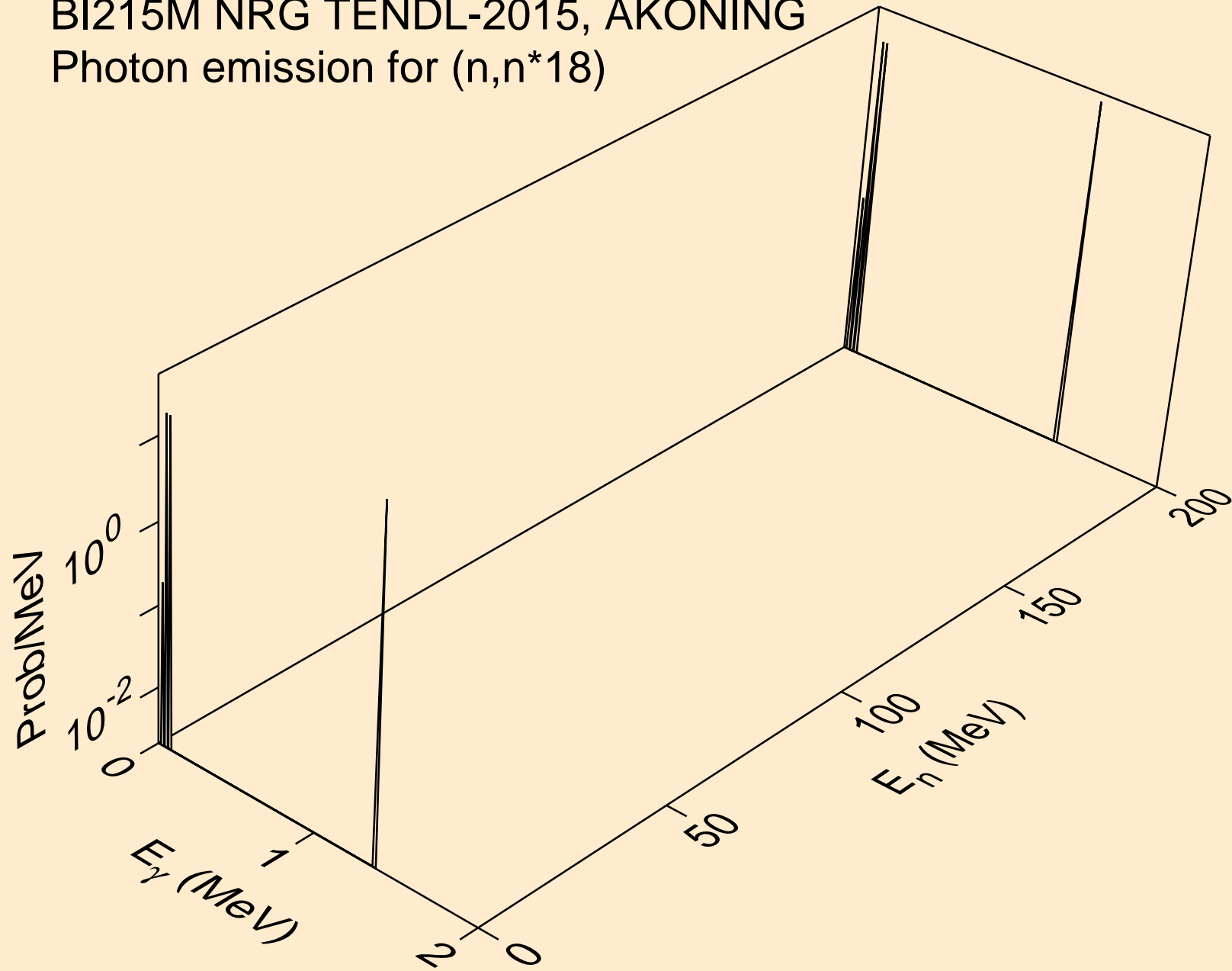

BI215M NRG TENDL-2015, AKONING
Photon emission for (n,n*19)

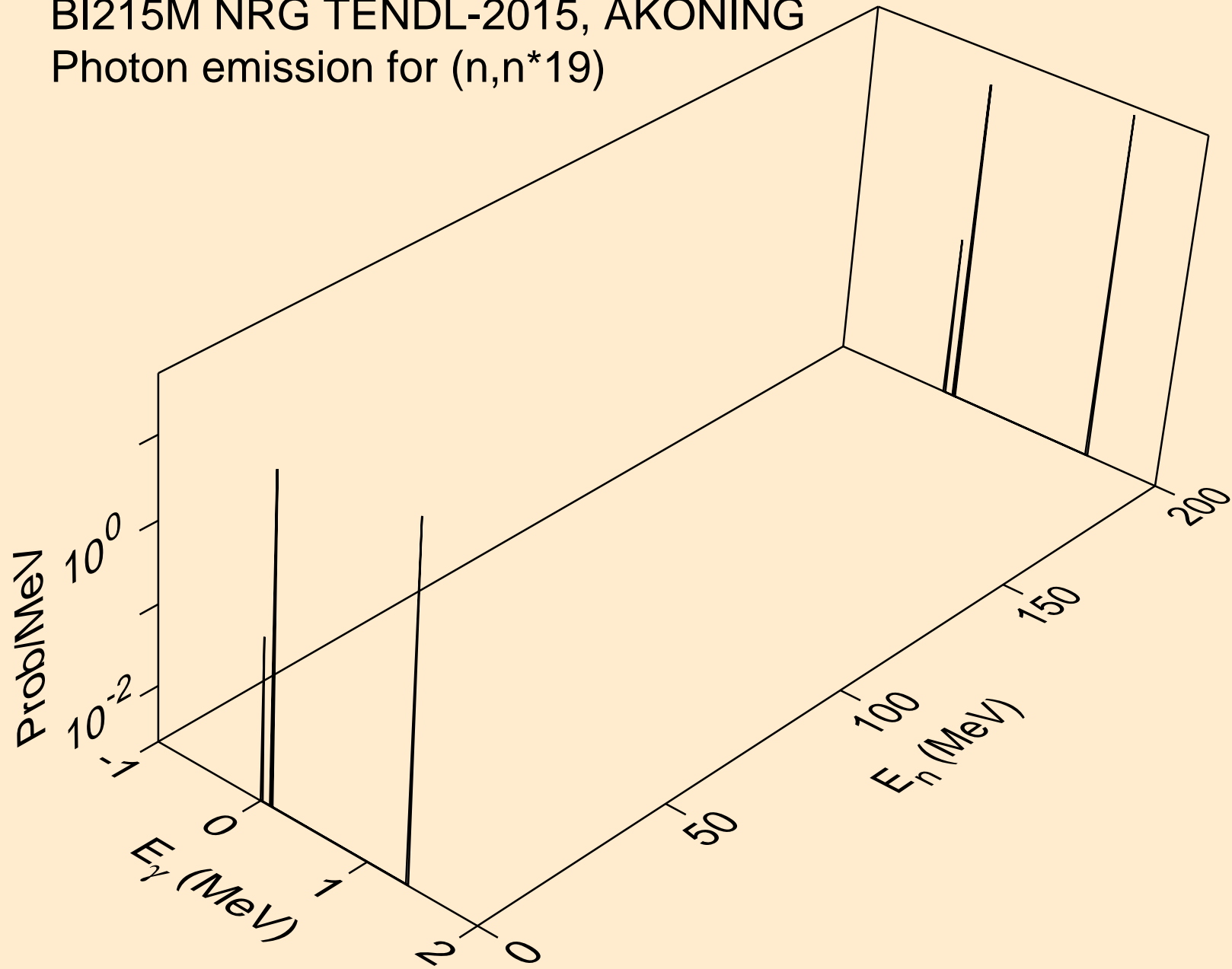

BI215M NRG TENDL-2015, AKONING
Photon emission for (n,n*20)

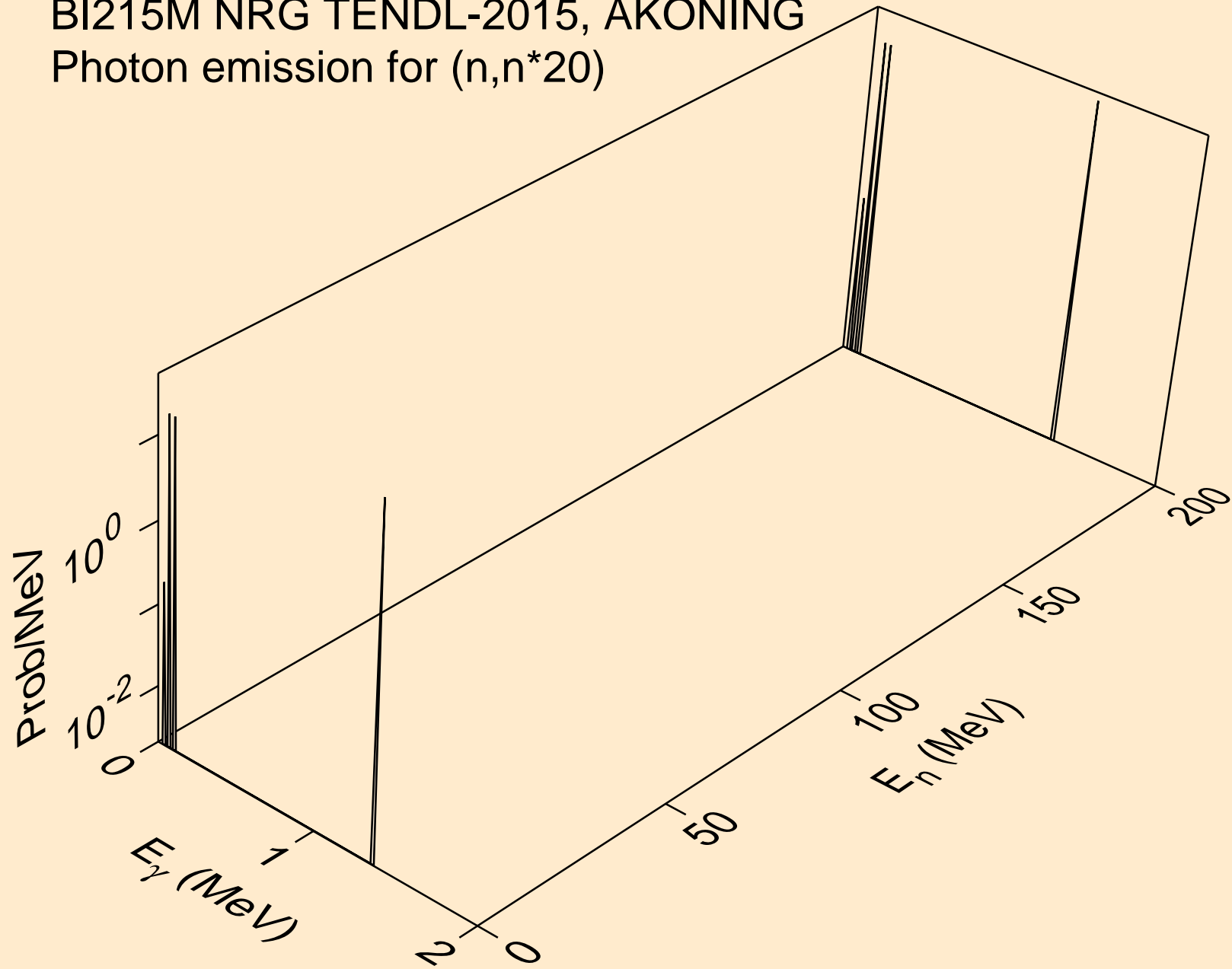

BI215M NRG TENDL-2015, AKONING
Photon emission for (n,n*21)

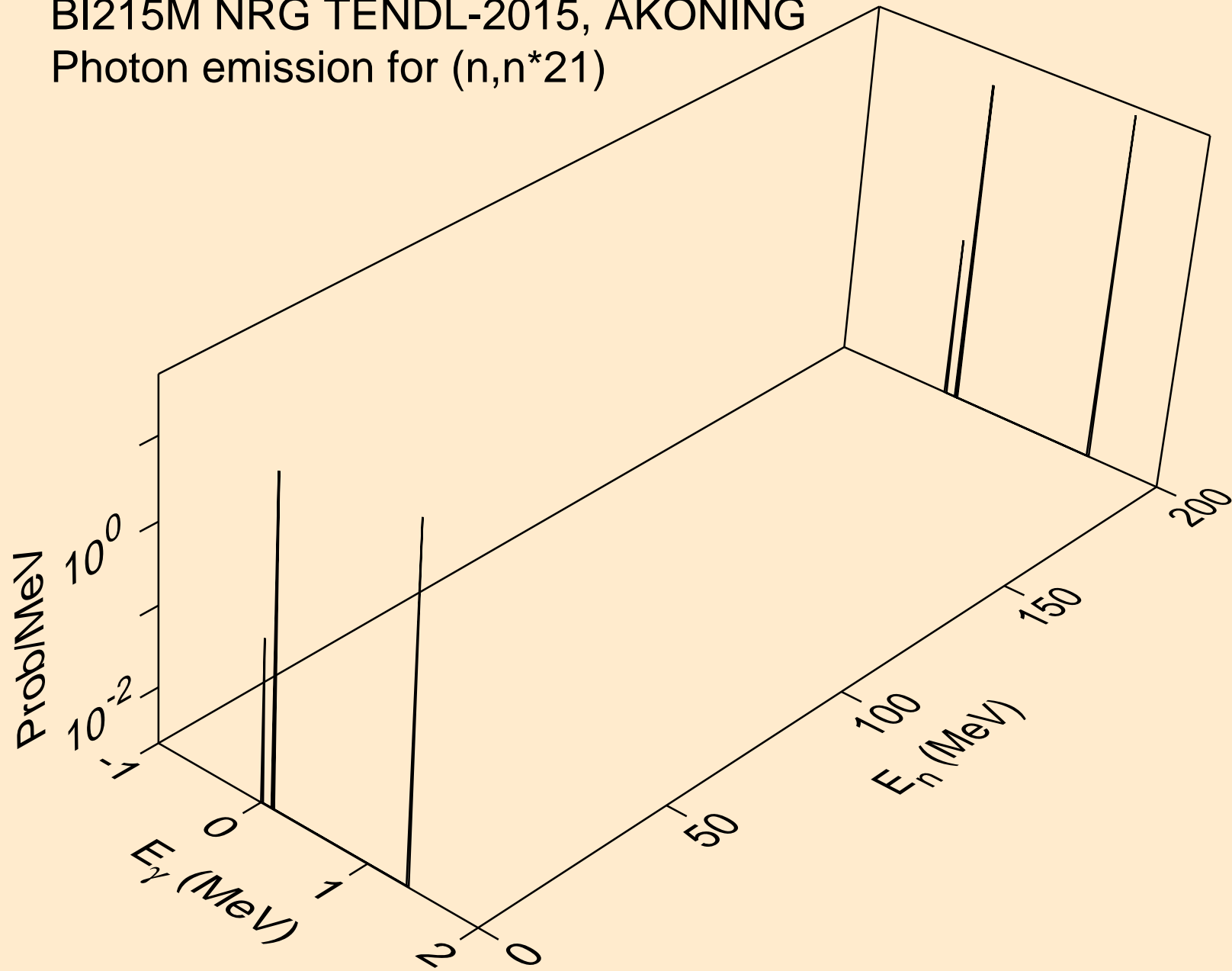

BI215M NRG TENDL-2015, AKONING
Photon emission for (n,n*22)

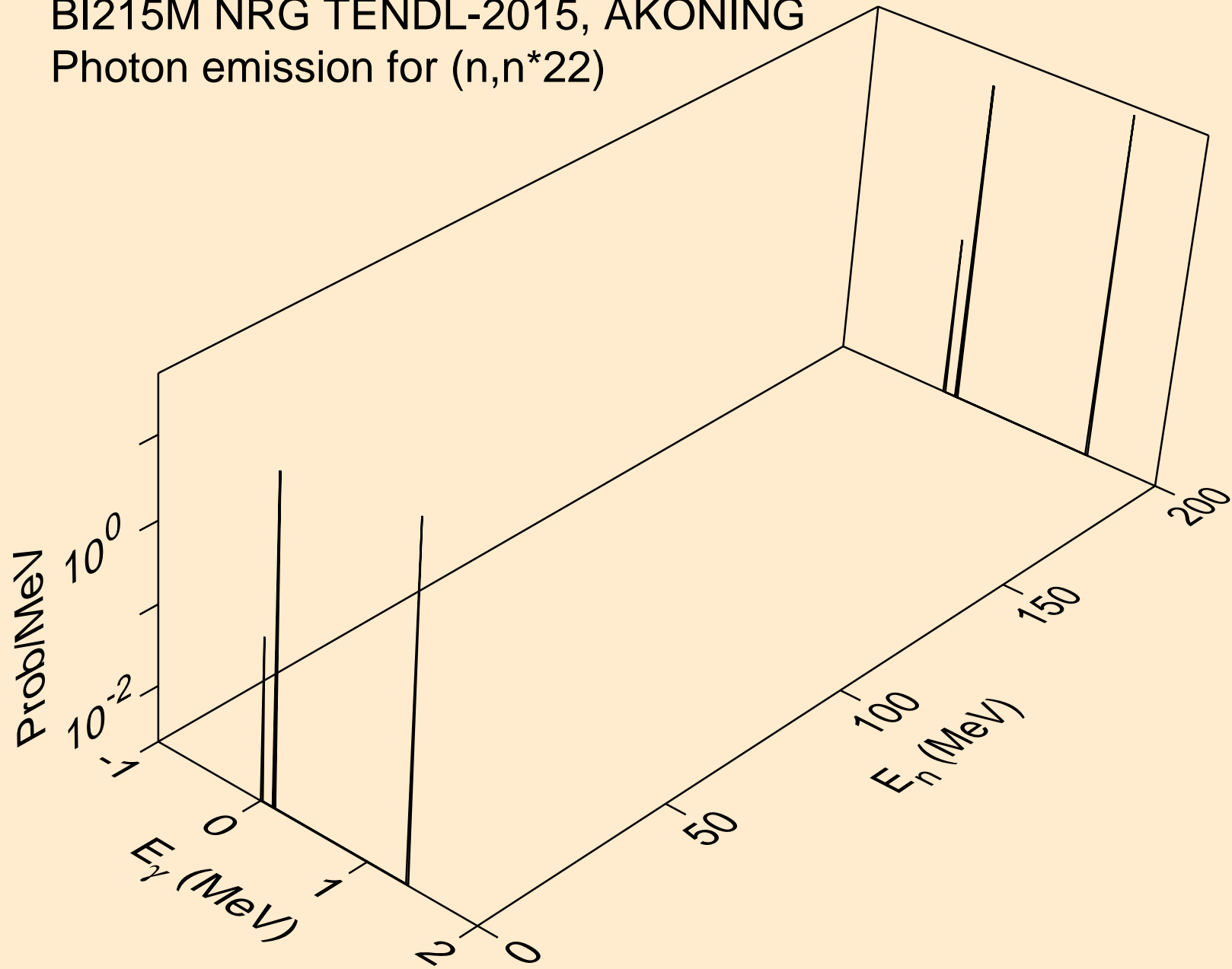

BI215M NRG TENDL-2015, AKONING
Photon emission for (n,n*23)

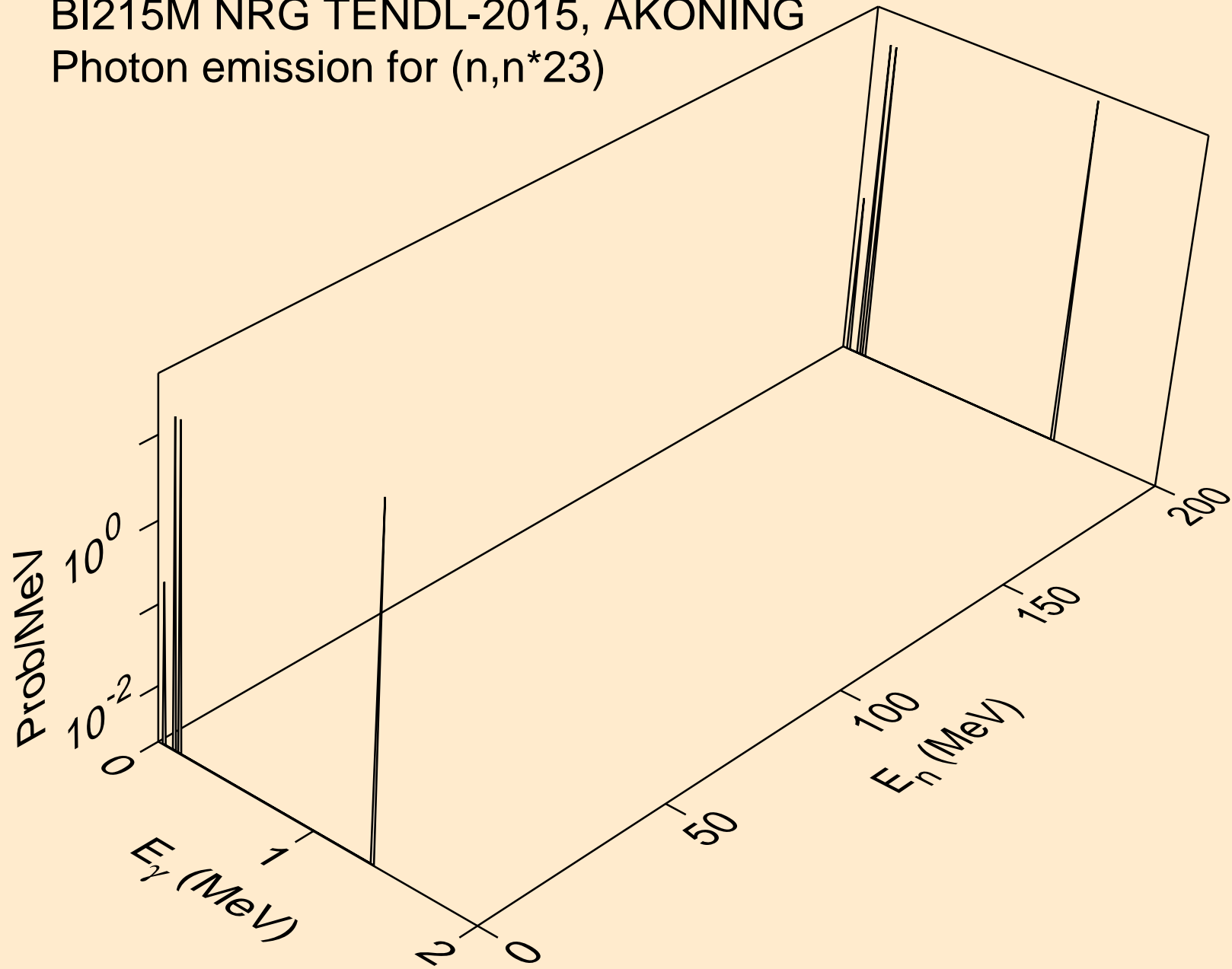

BI215M NRG TENDL-2015, AKONING
Photon emission for (n,n*24)

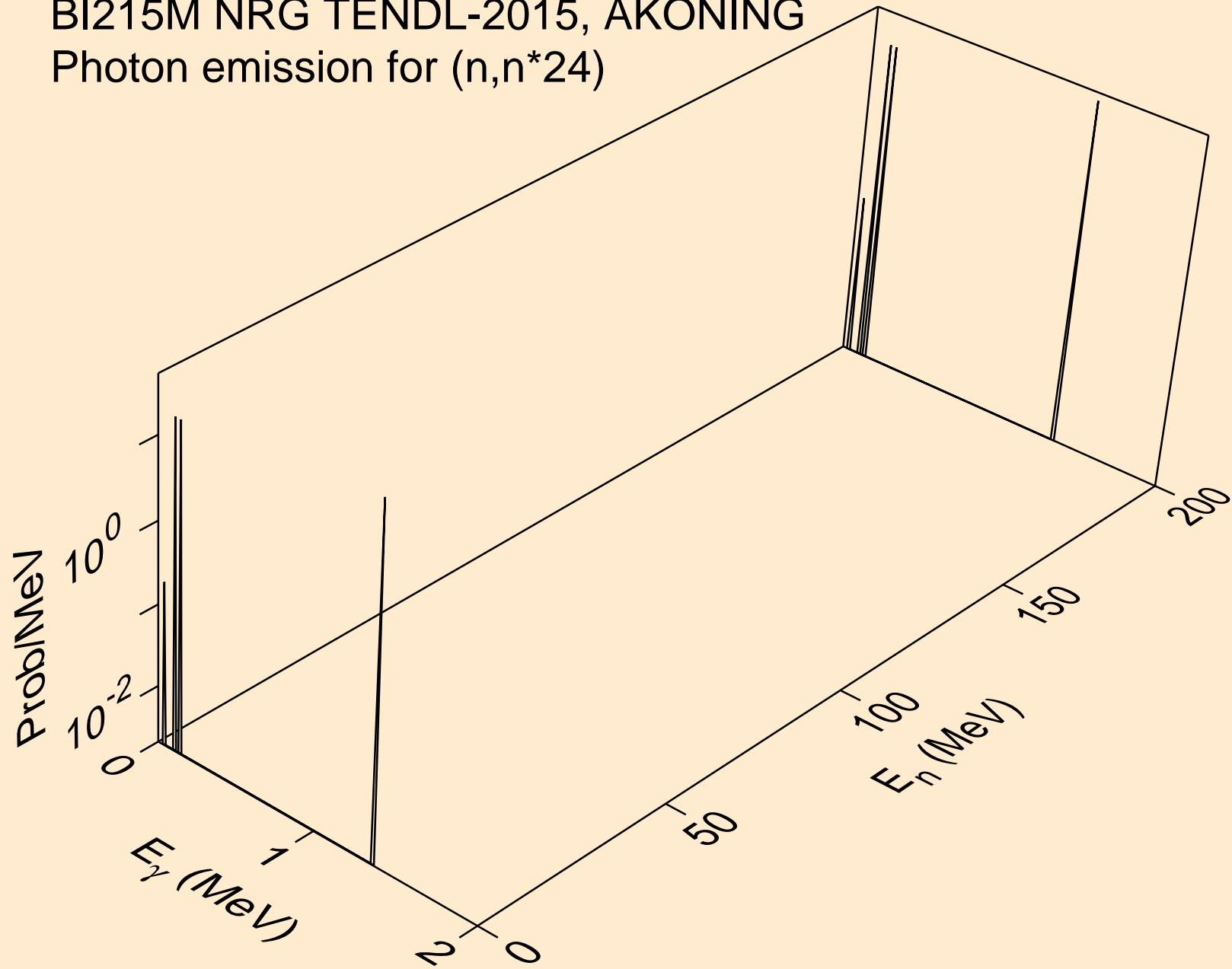

BI215M NRG TENDL-2015, AKONING
Photon emission for (n,n*25)

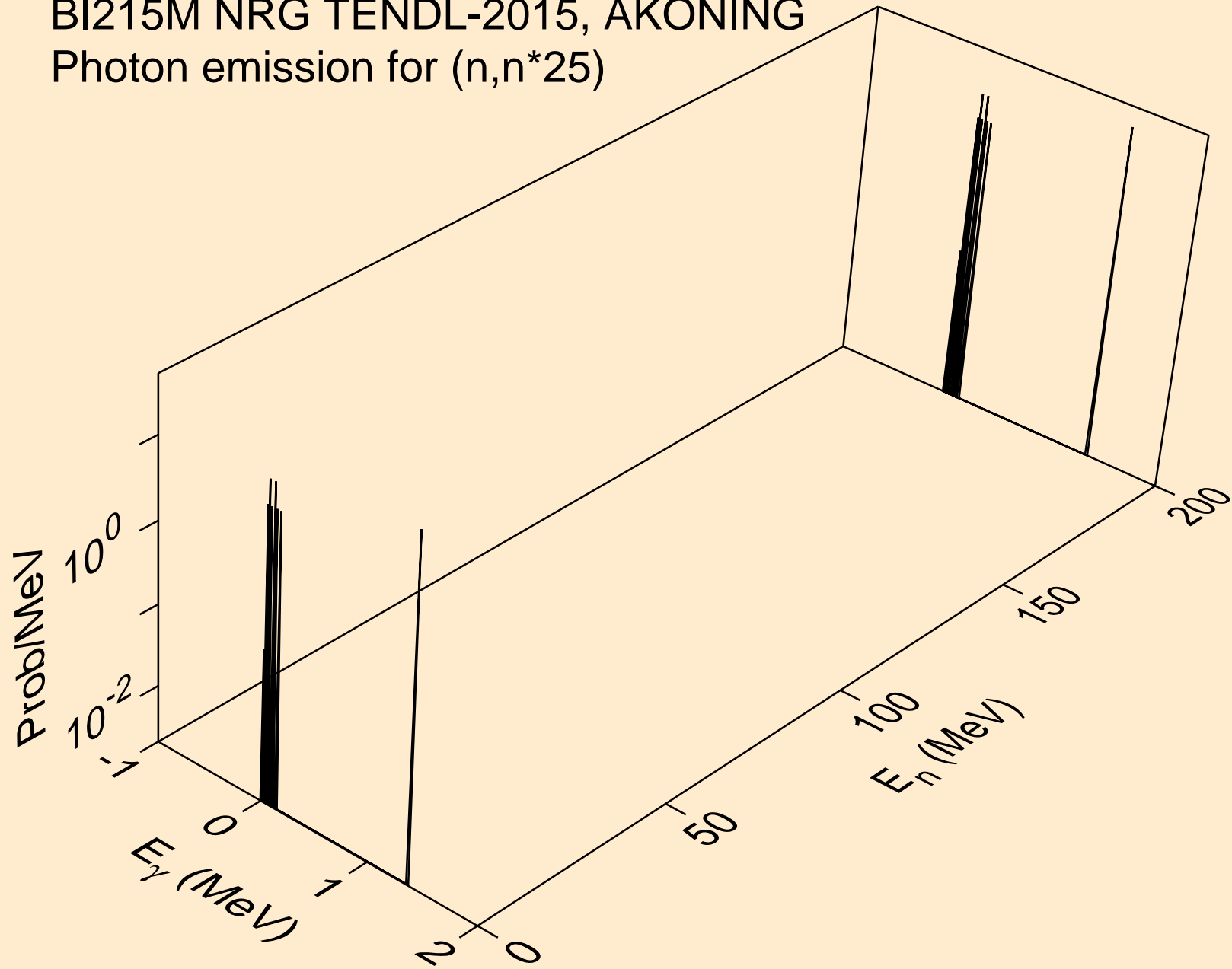

BI215M NRG TENDL-2015, AKONING
Photon emission for (n,n*26)

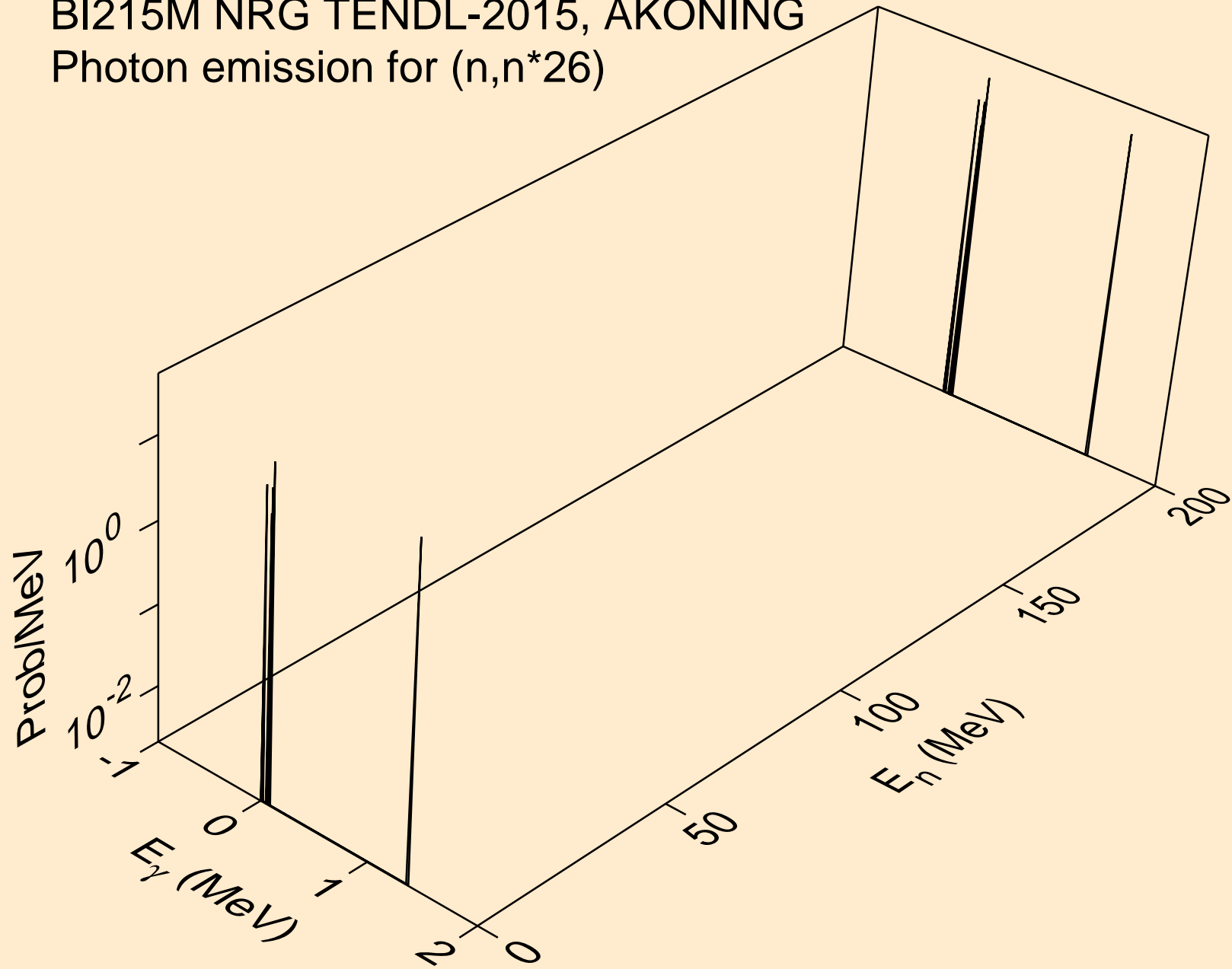

BI215M NRG TENDL-2015, AKONING
Photon emission for (n,n*27)

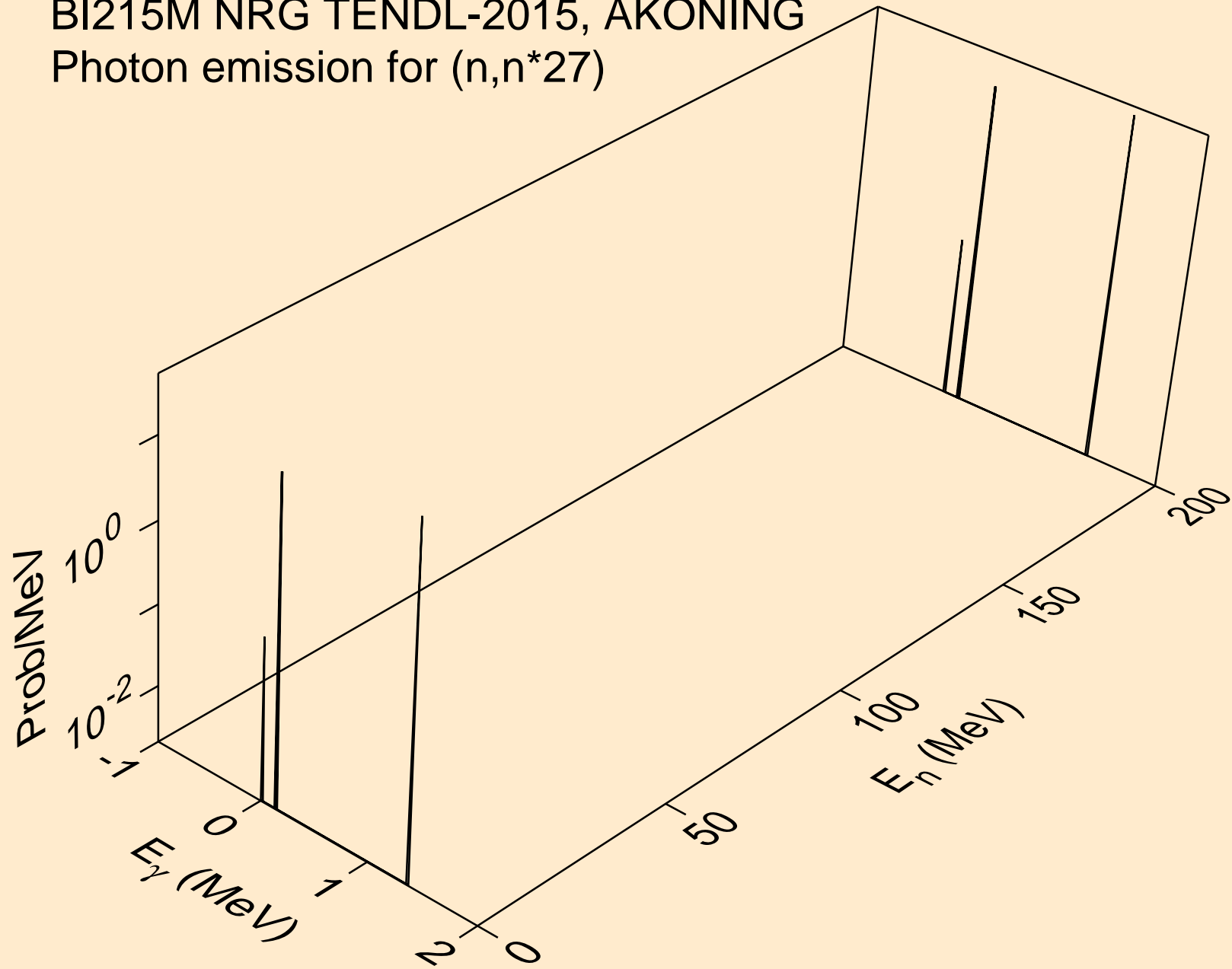

BI215M NRG TENDL-2015, AKONING
Photon emission for (n,n*28)

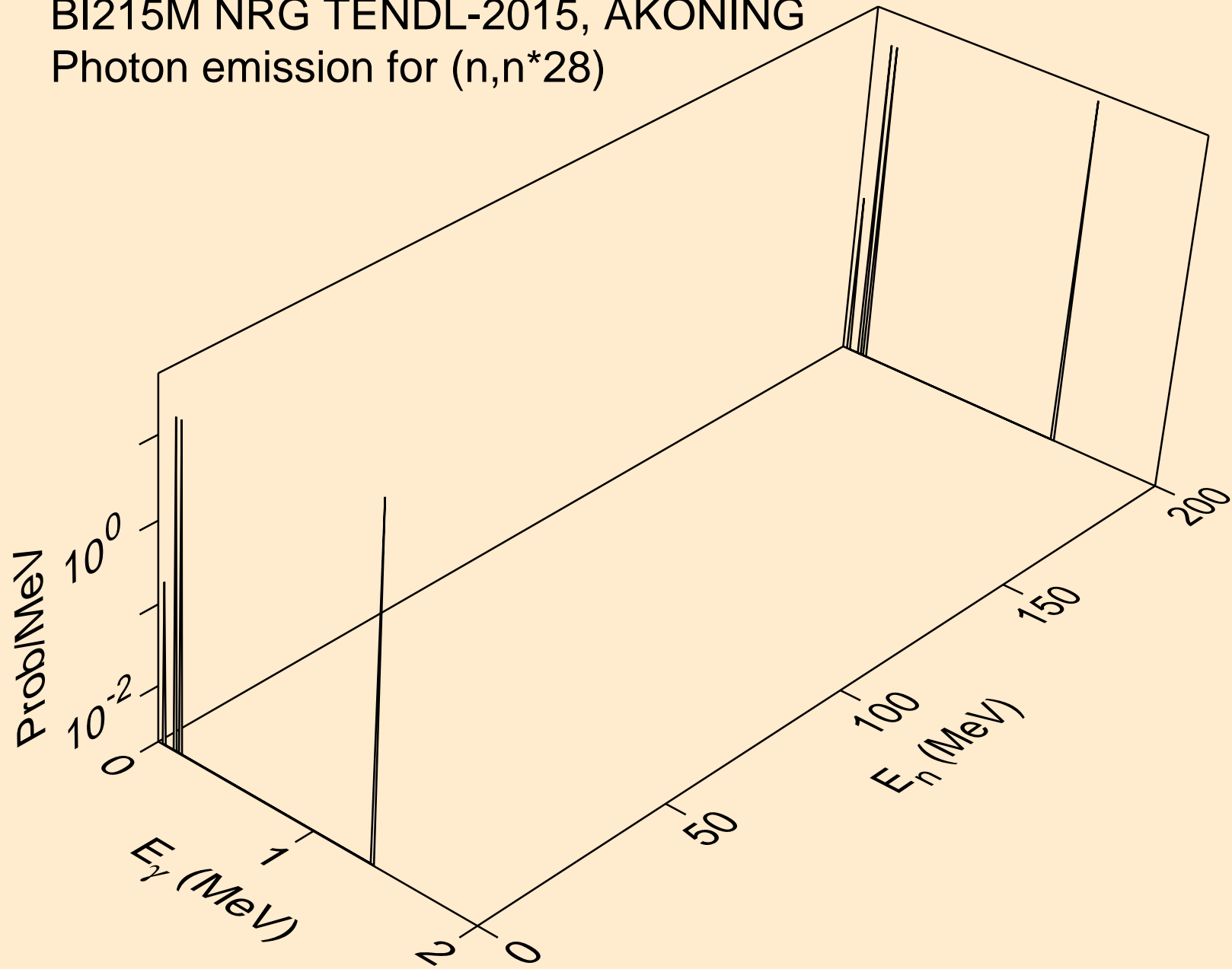

BI215M NRG TENDL-2015, AKONING
Photon emission for (n,n*c)

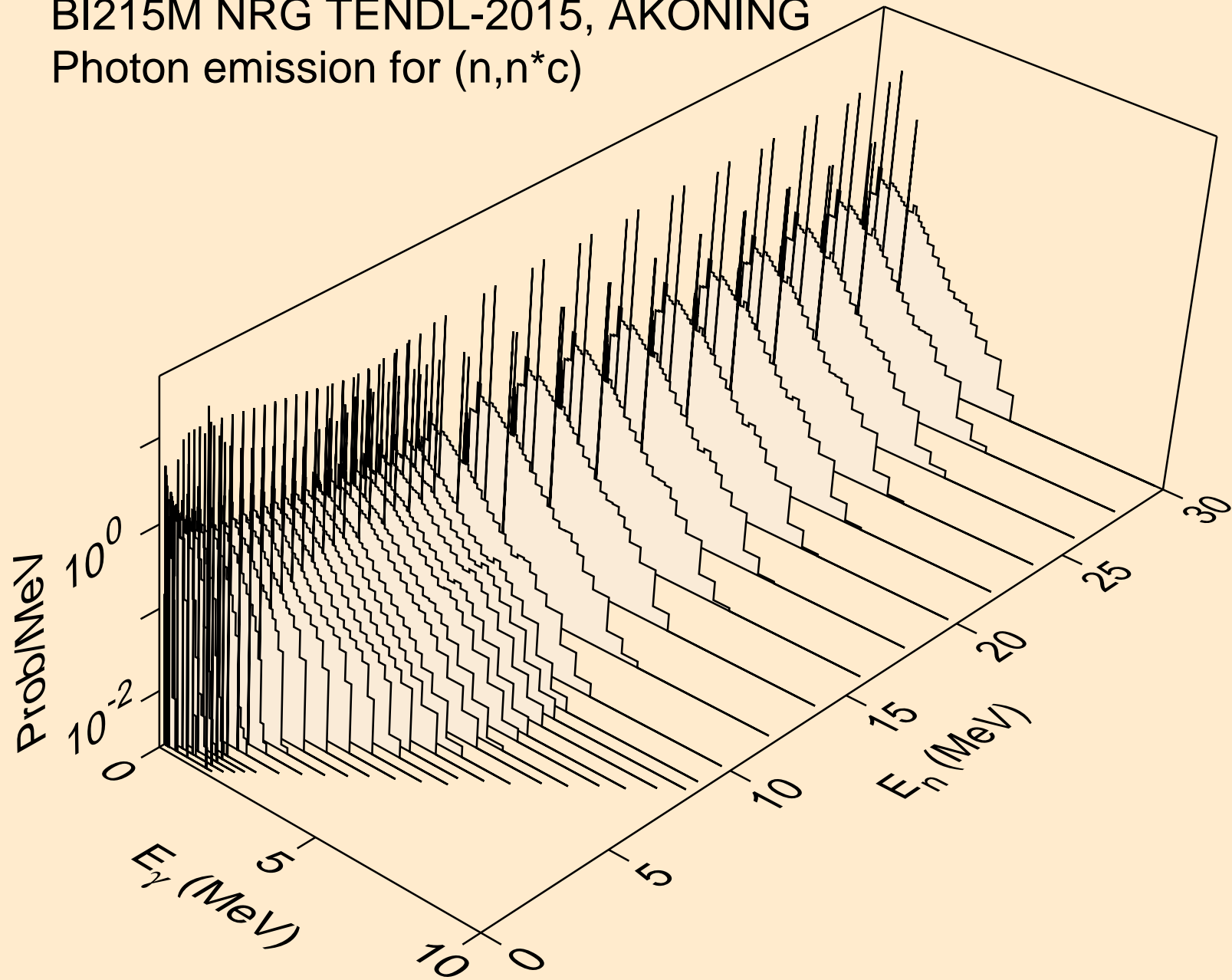

BI215M NRG TENDL-2015, AKONING
Photon emission for (n,gma)

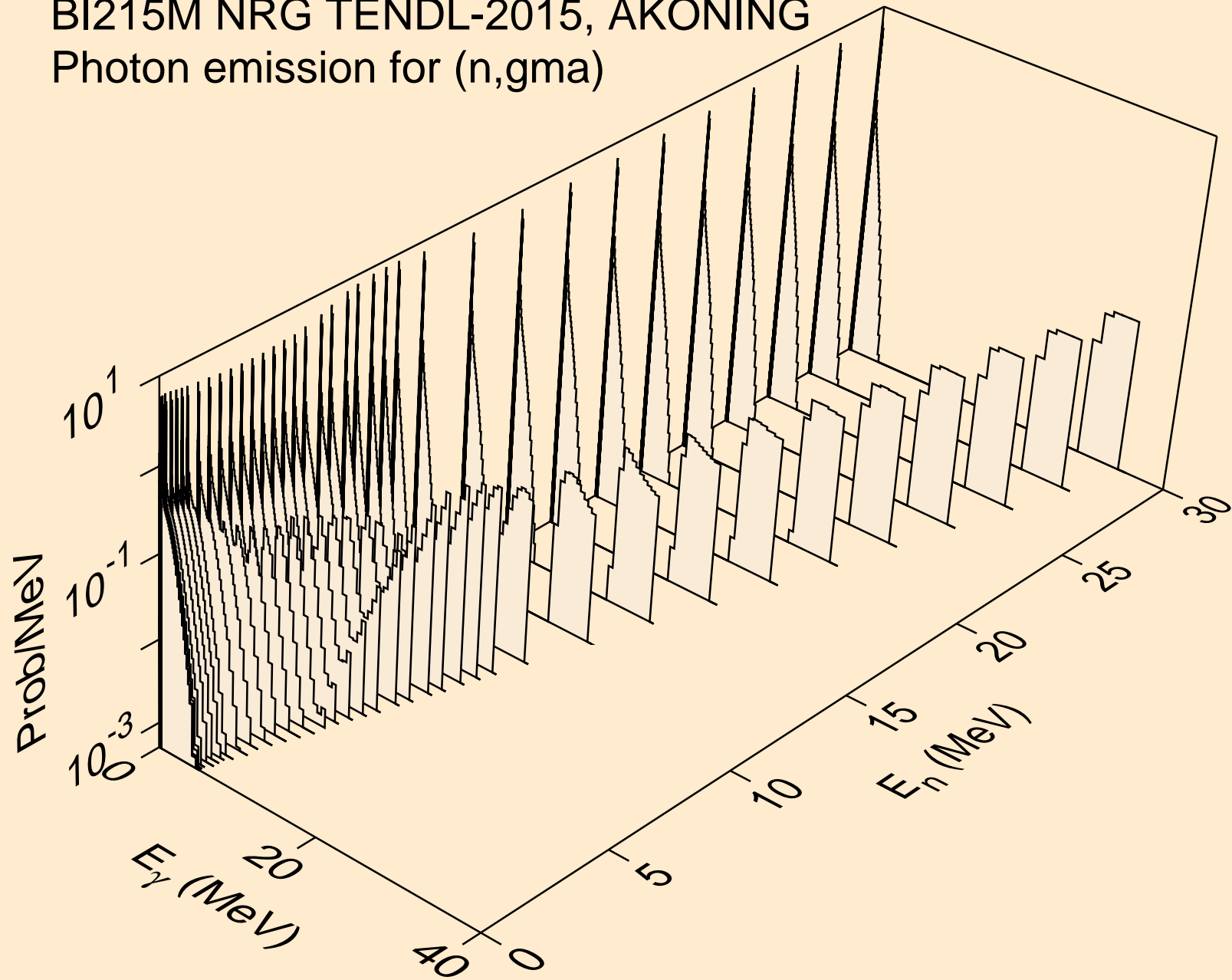

BI215M NRG TENDL-2015, AKONING
Photon emission for (n,p)

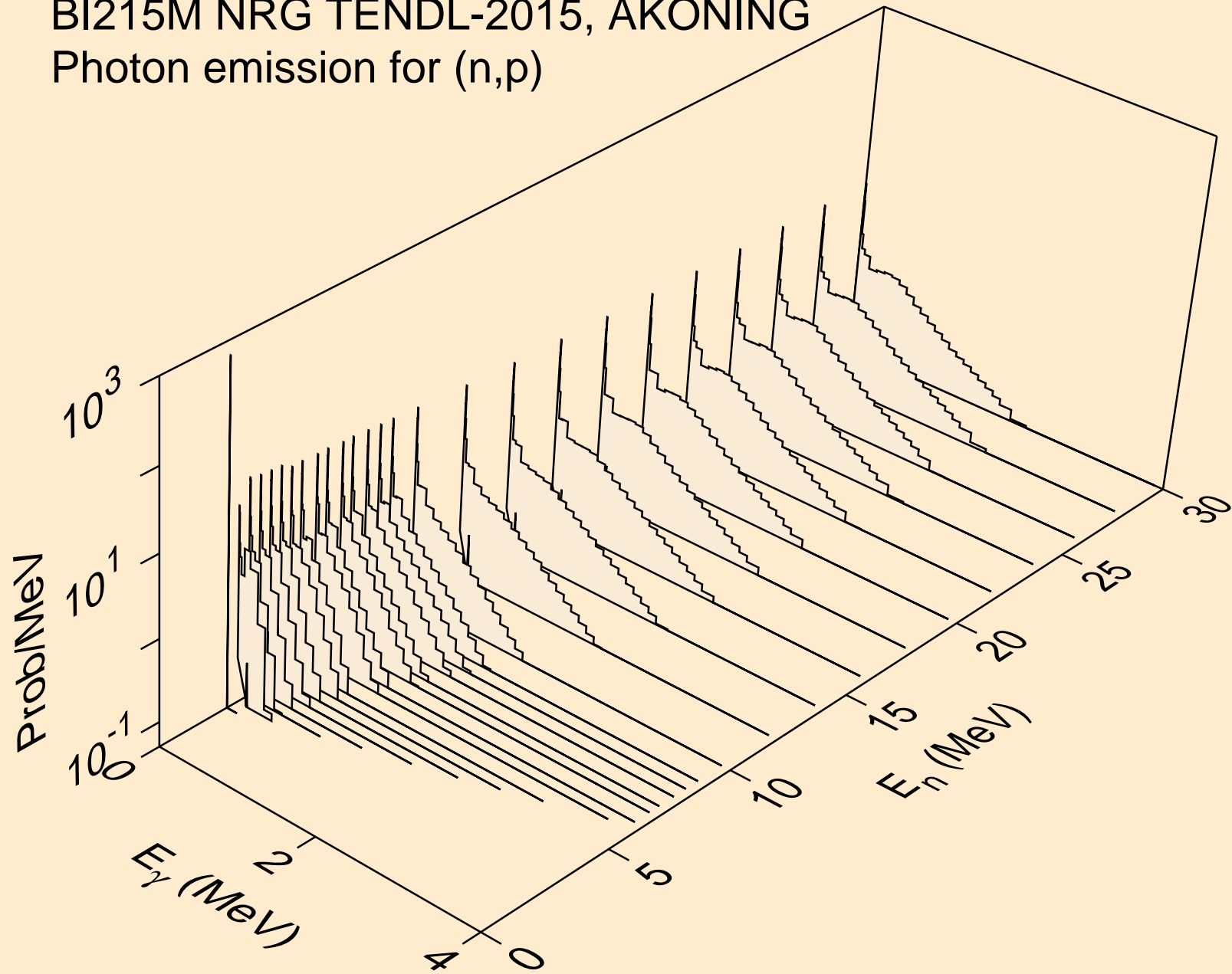

BI215M NRG TENDL-2015, AKONING
Photon emission for (n,d)

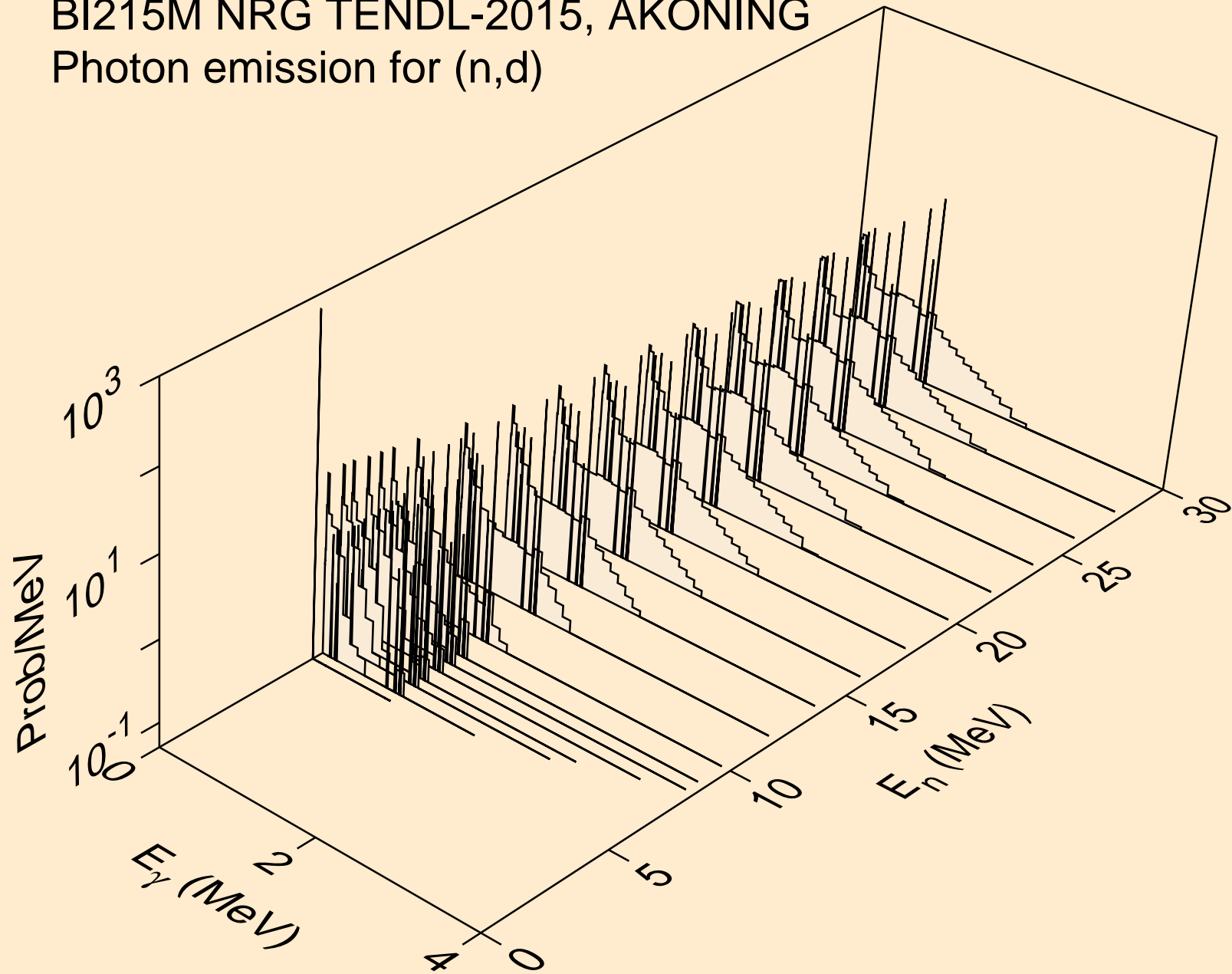

BI215M NRG TENDL-2015, AKONING
Photon emission for (n,t)

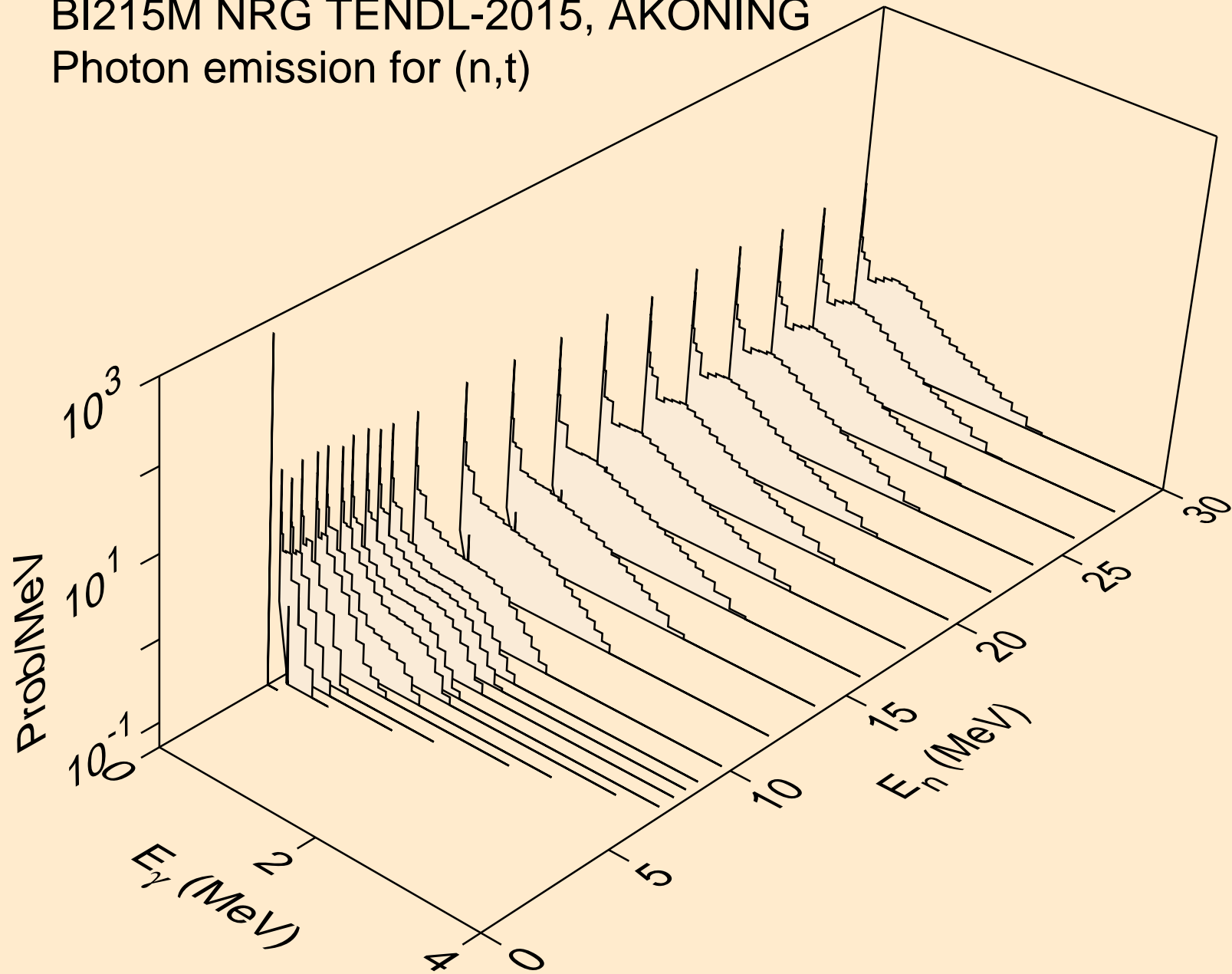

BI215M NRG TENDL-2015, AKONING
Photon emission for (n,he3)

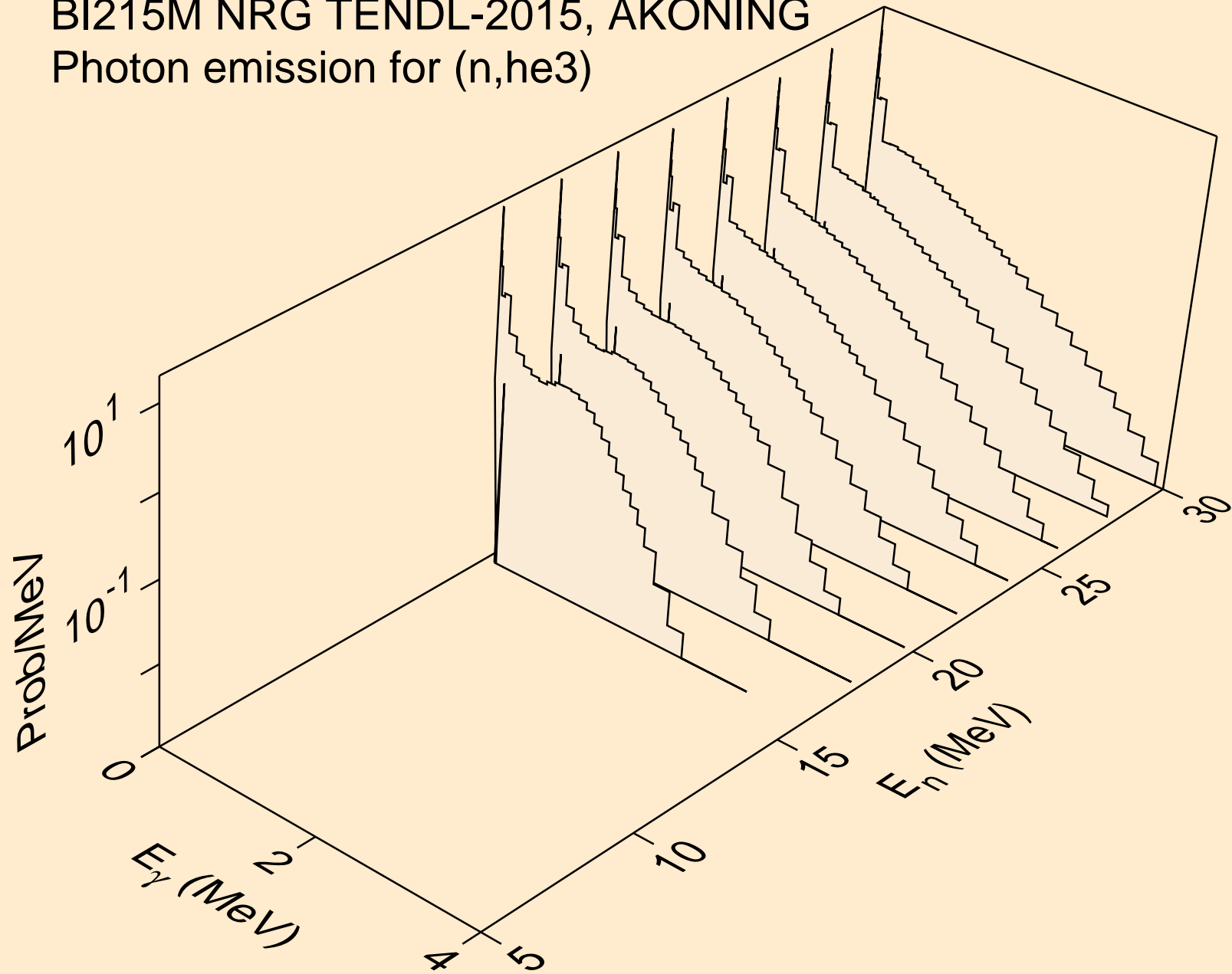

BI215M NRG TENDL-2015, AKONING
Photon emission for (n,a)

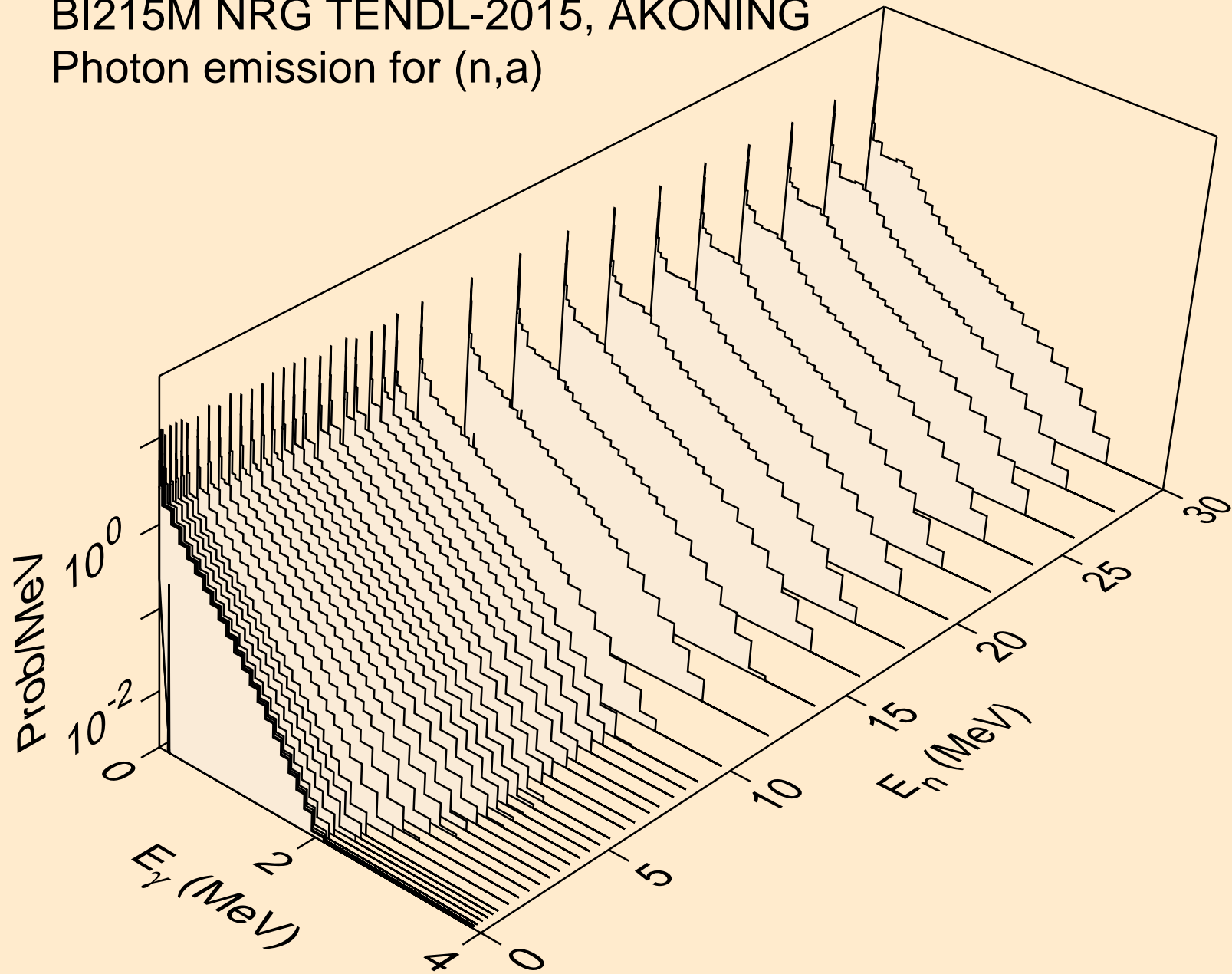

BI215M NRG TENDL-2015, AKONING
Photon emission for (n,2p)

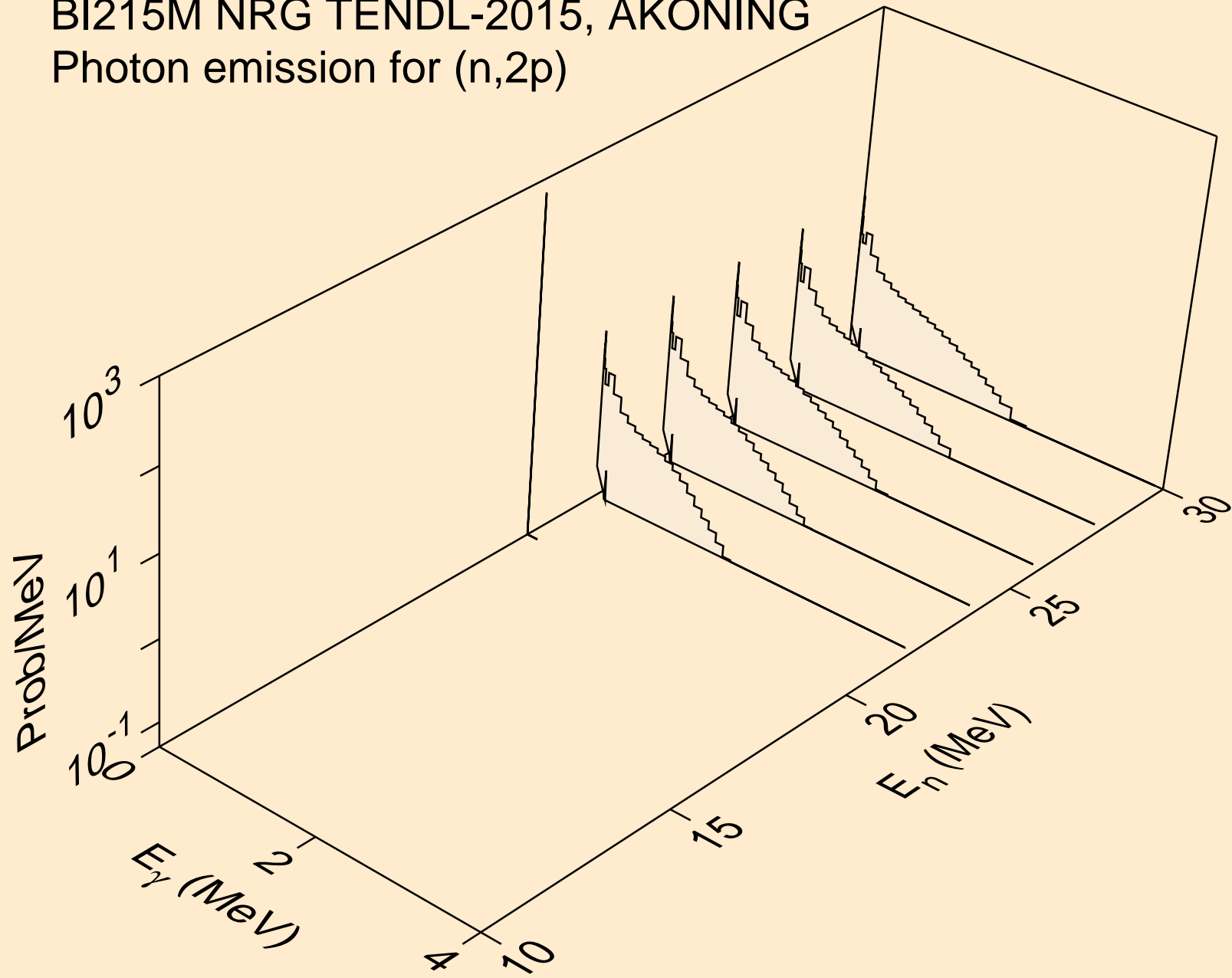

BI215M NRG TENDL-2015, AKONING
Photon emission for (n,p α)

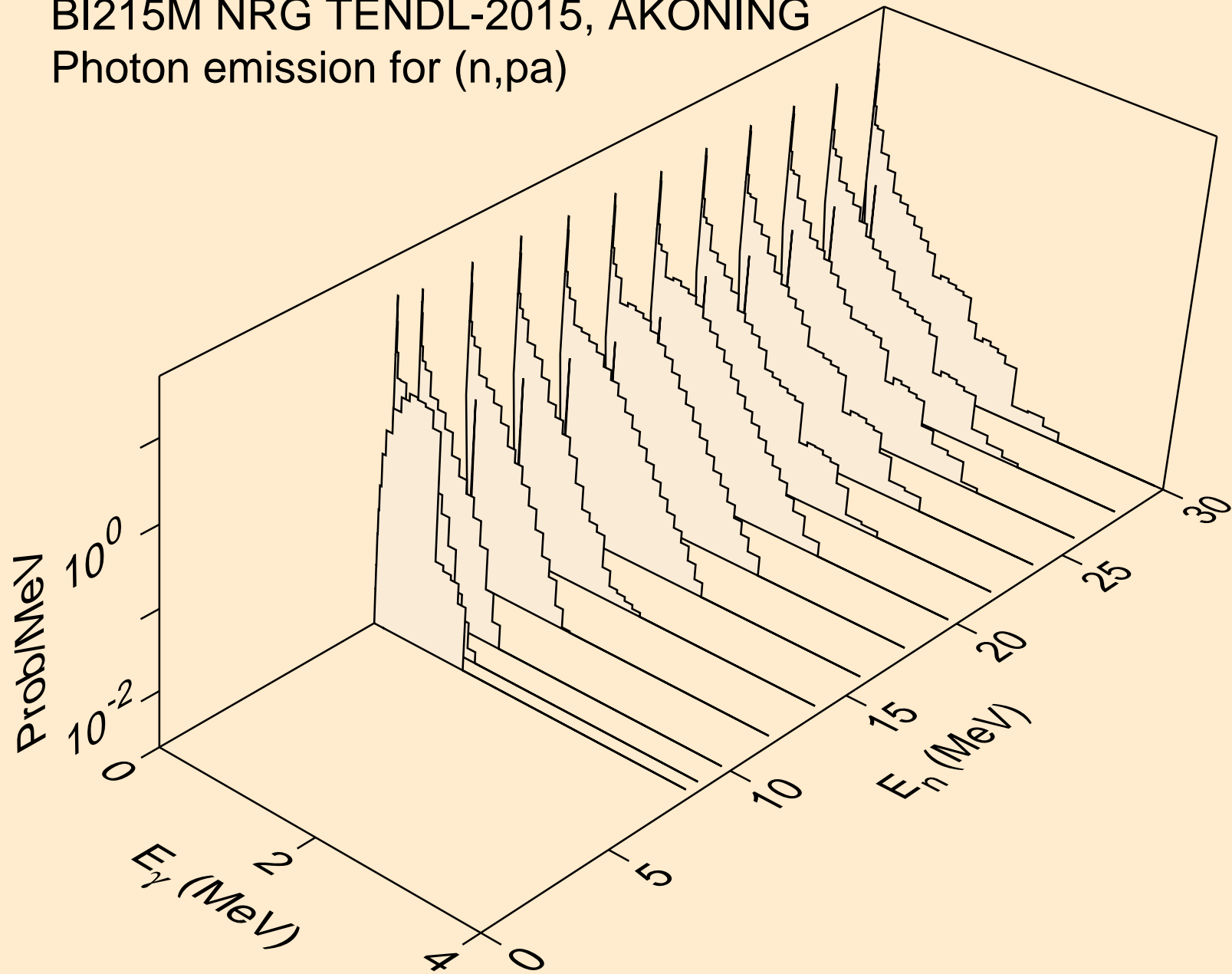

BI215M NRG TENDL-2015, AKONING
thermal capture photon spectrum

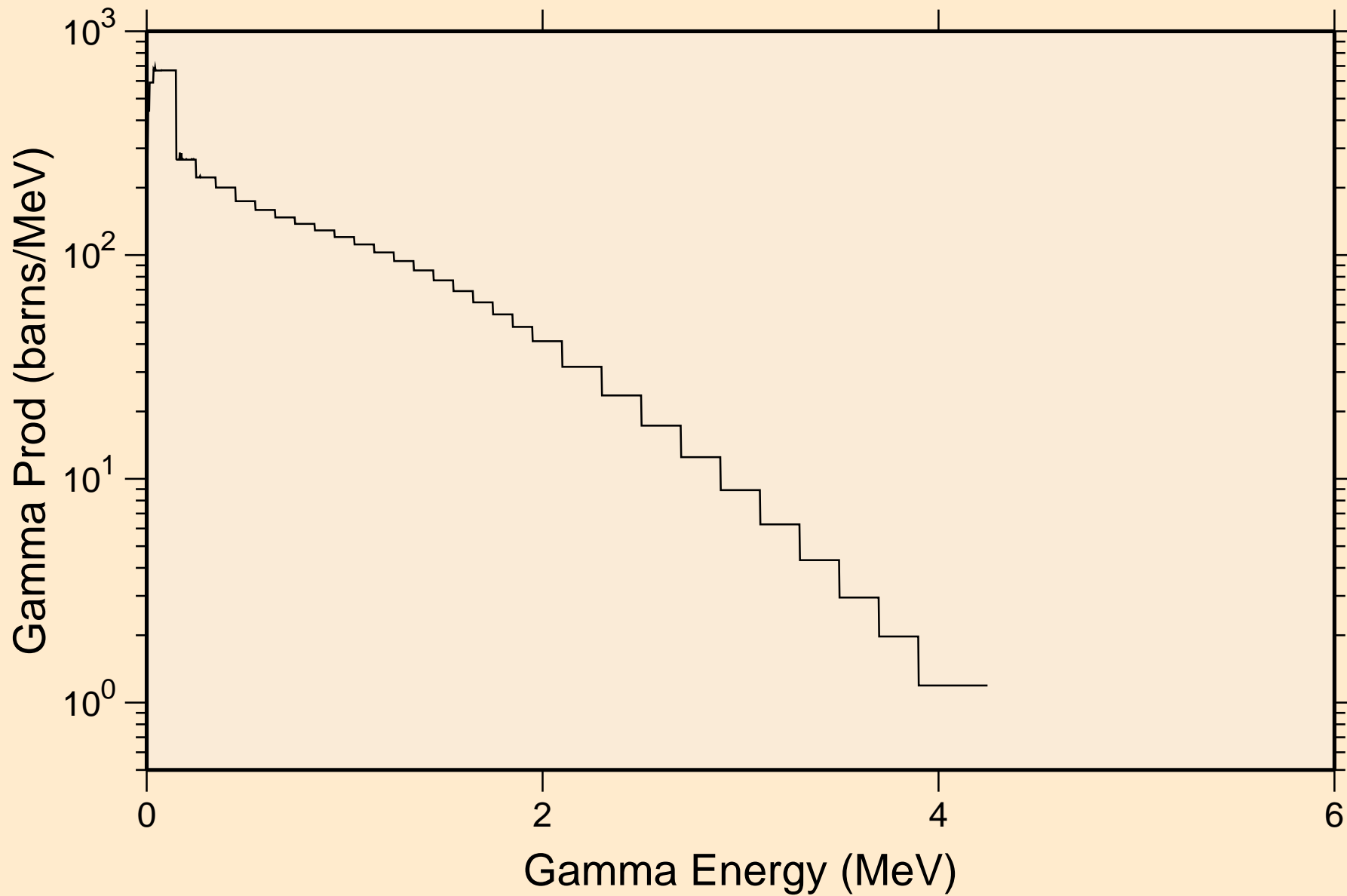

BI215M NRG TENDL-2015, AKONING
14 MeV photon spectrum

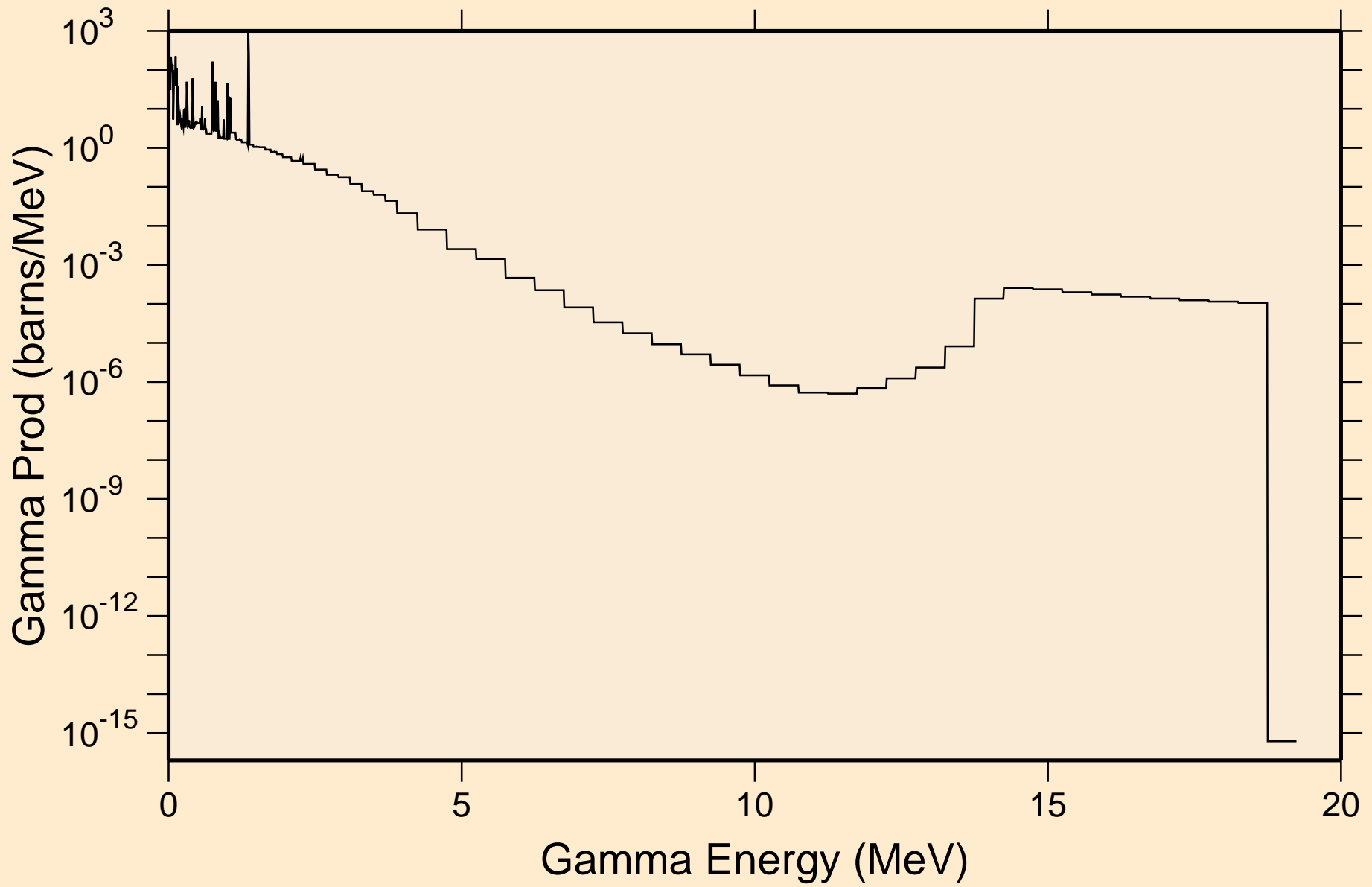

BI215M NRG TENDL-2015, AKONING

Particle heating contributions

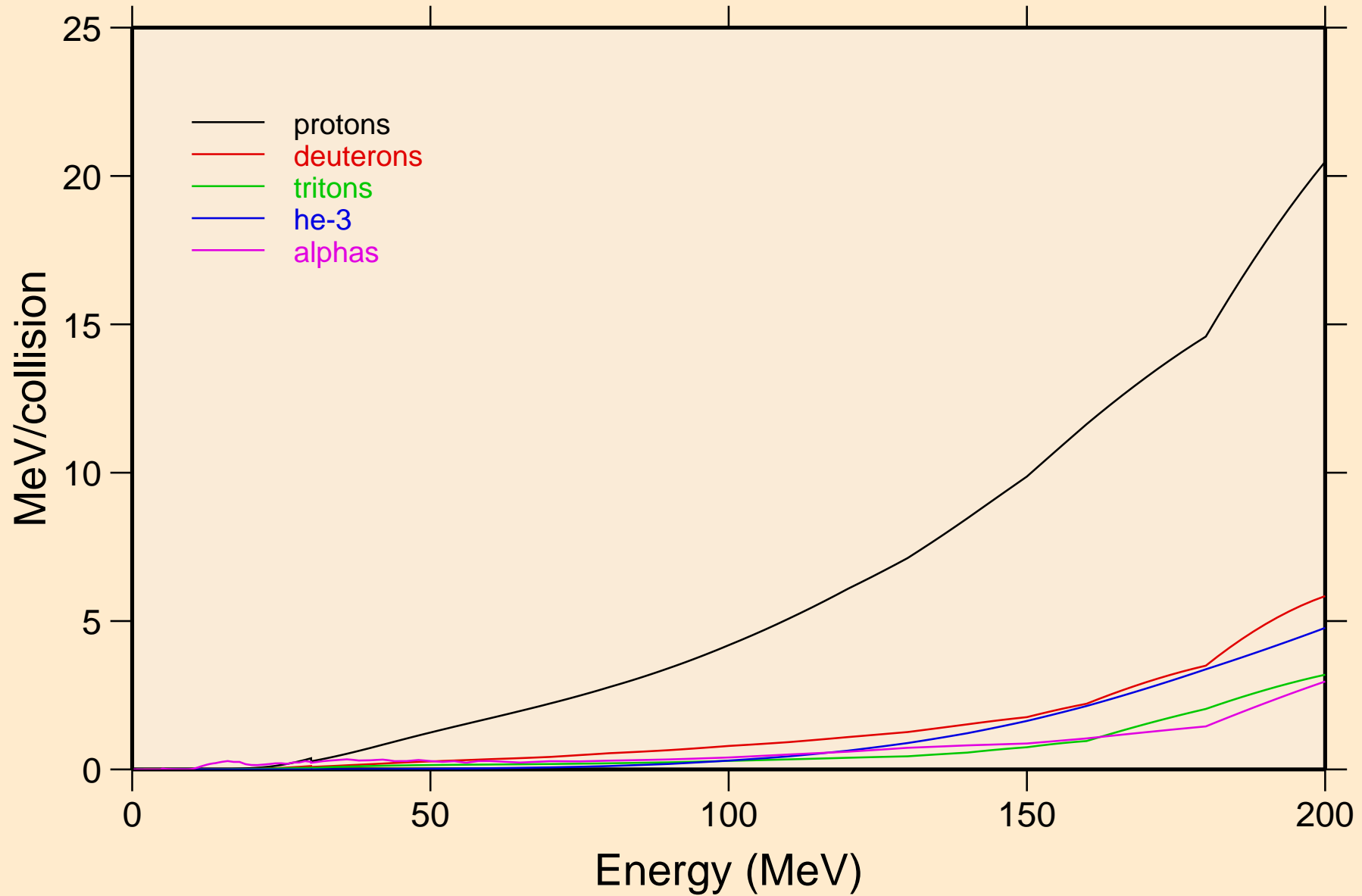

BI215M NRG TENDL-2015, AKONING

Recoil Heating

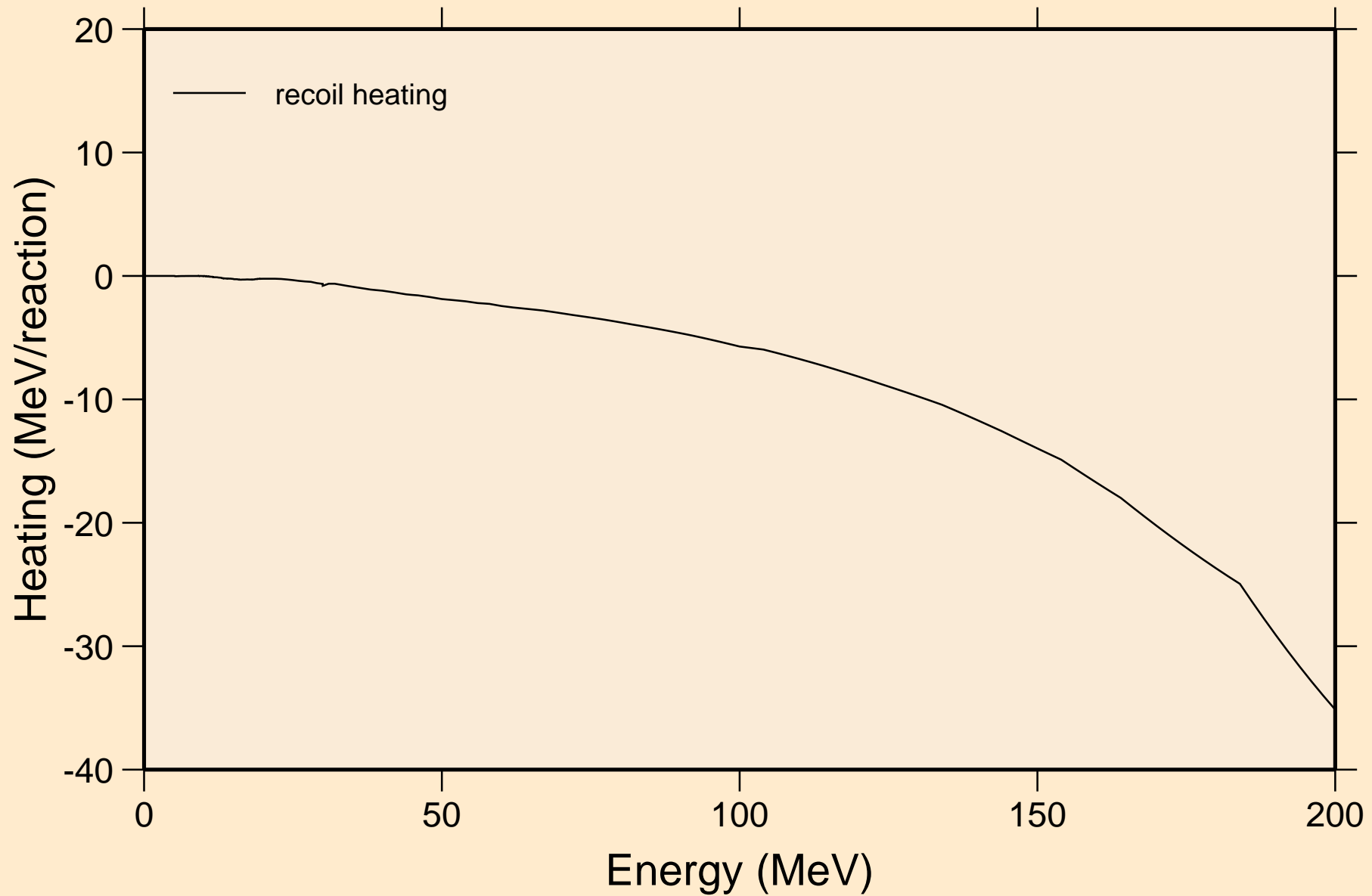

BI215M NRG TENDL-2015, AKONING

Particle production cross sections

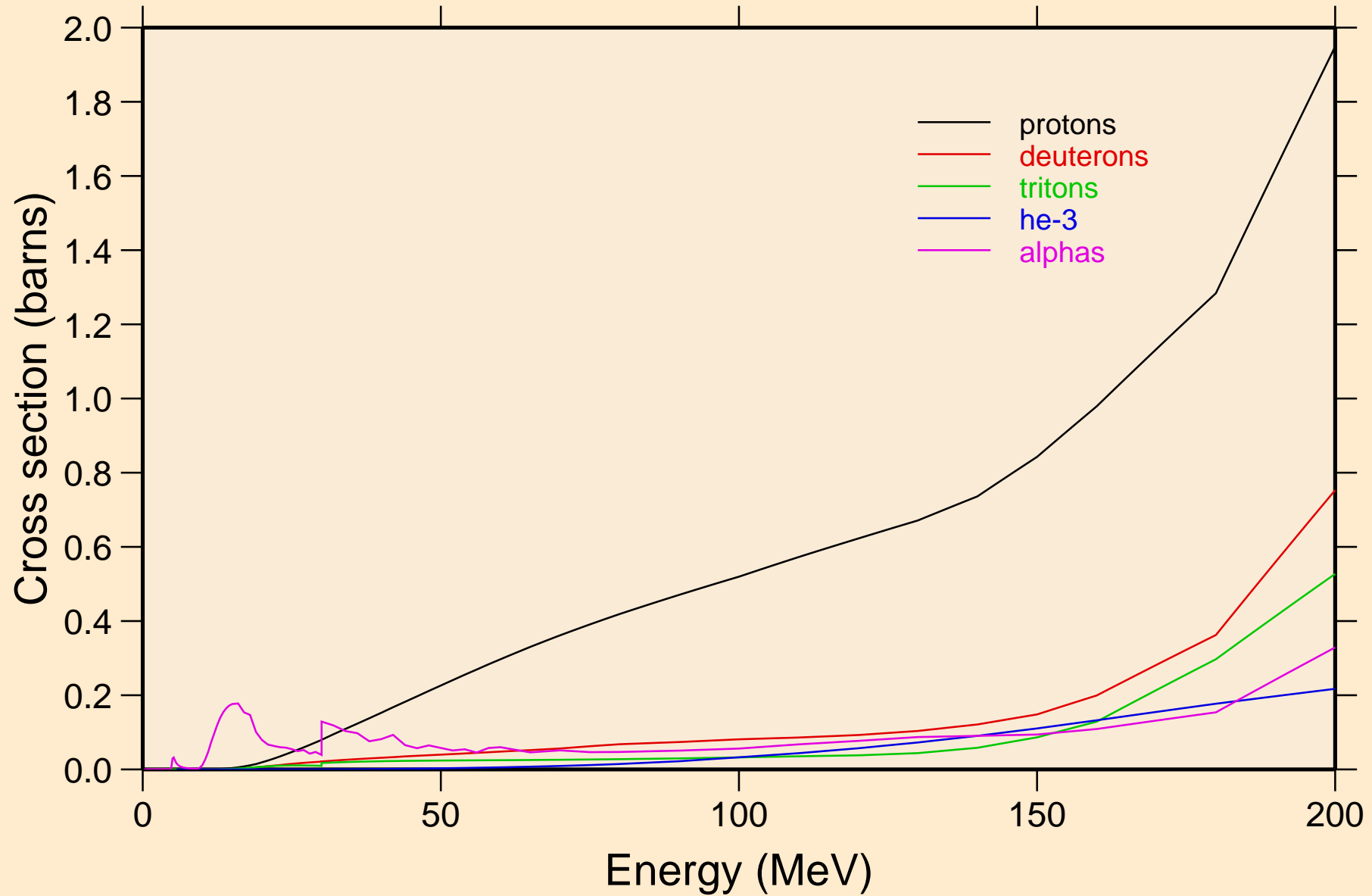

BI215M NRG TENDL-2015, AKONING
protons from (n,x)

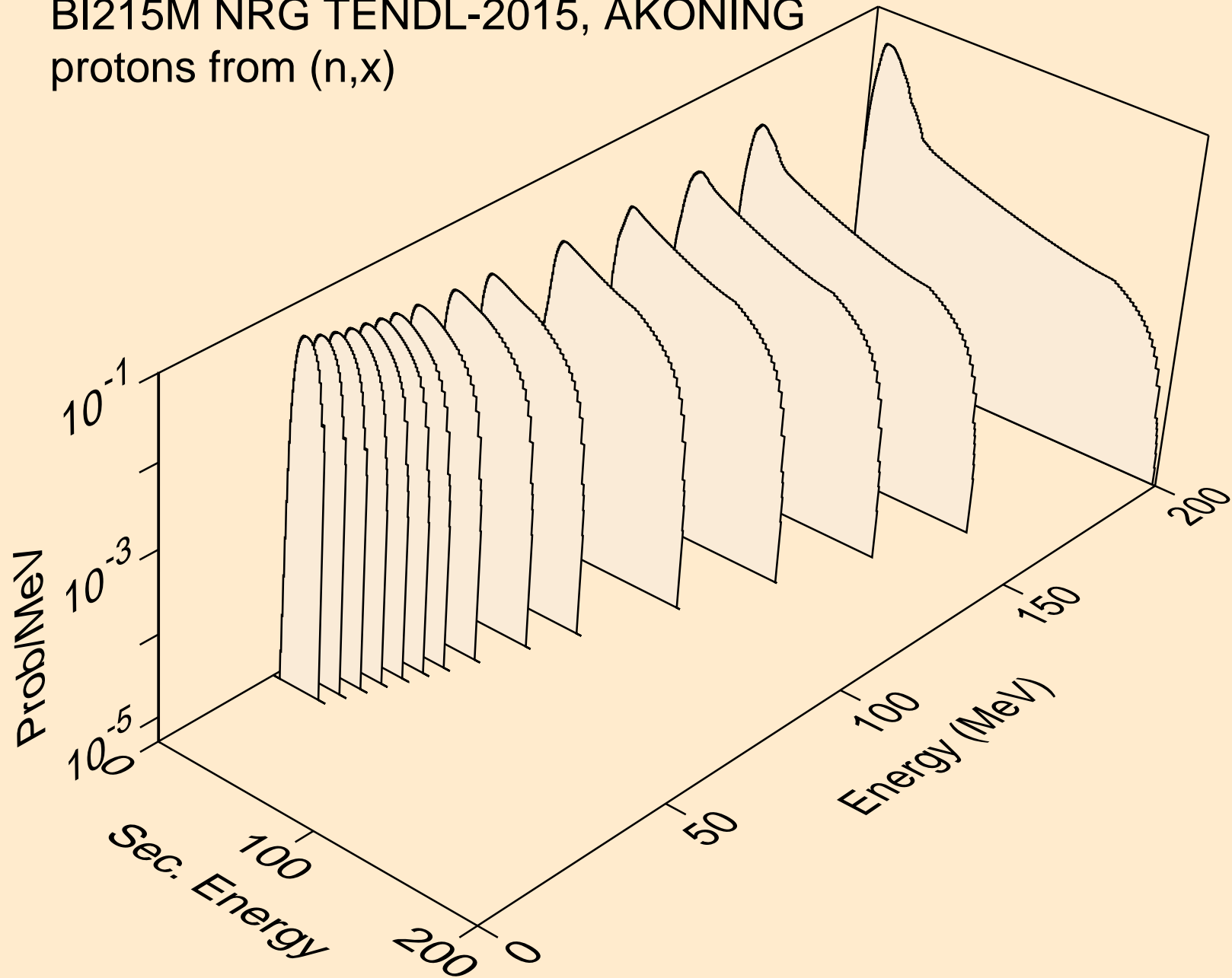

BI215M NRG TENDL-2015, AKONING
protons from (n,n*)p

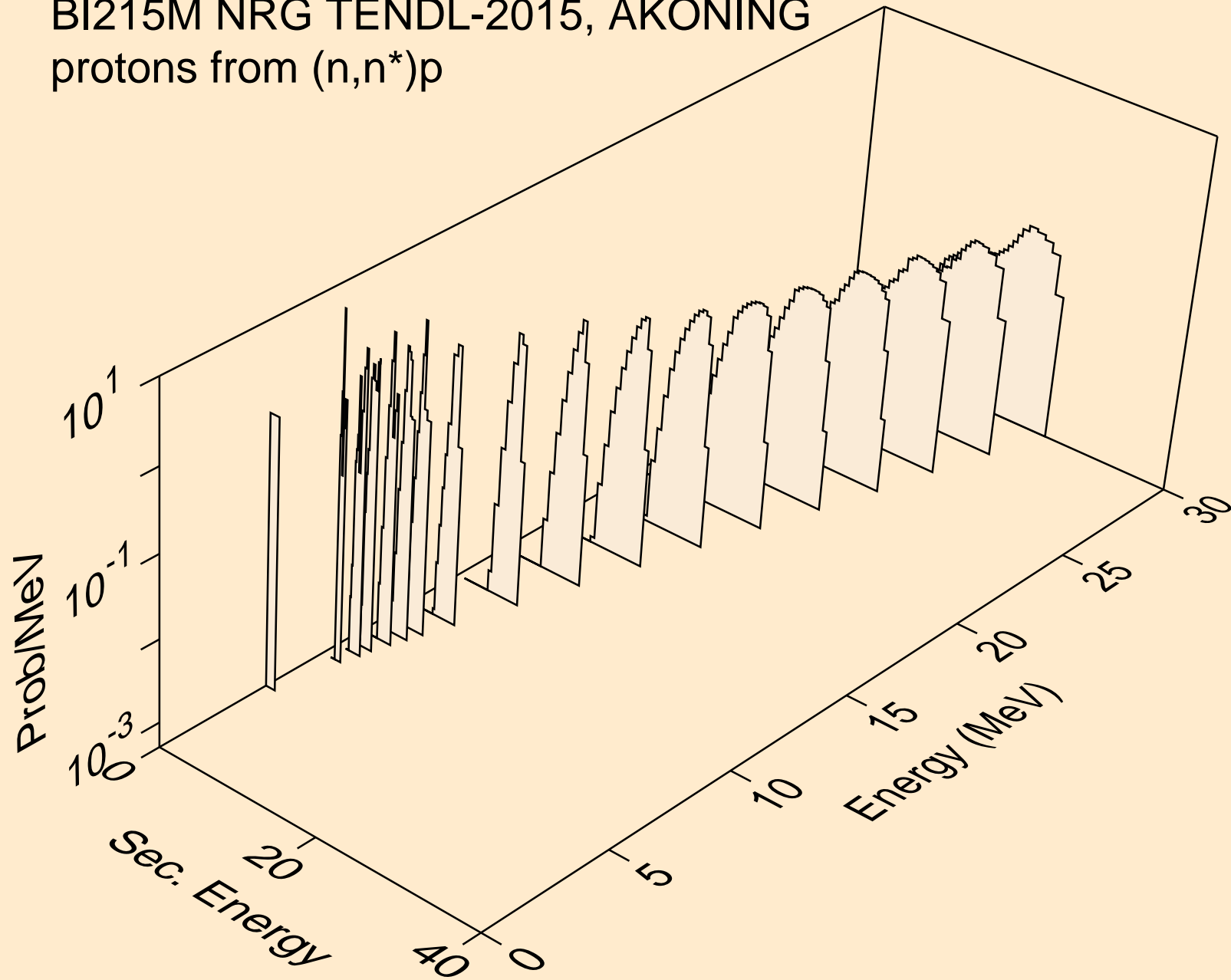

BI215M NRG TENDL-2015, AKONING
protons from (n,2np)

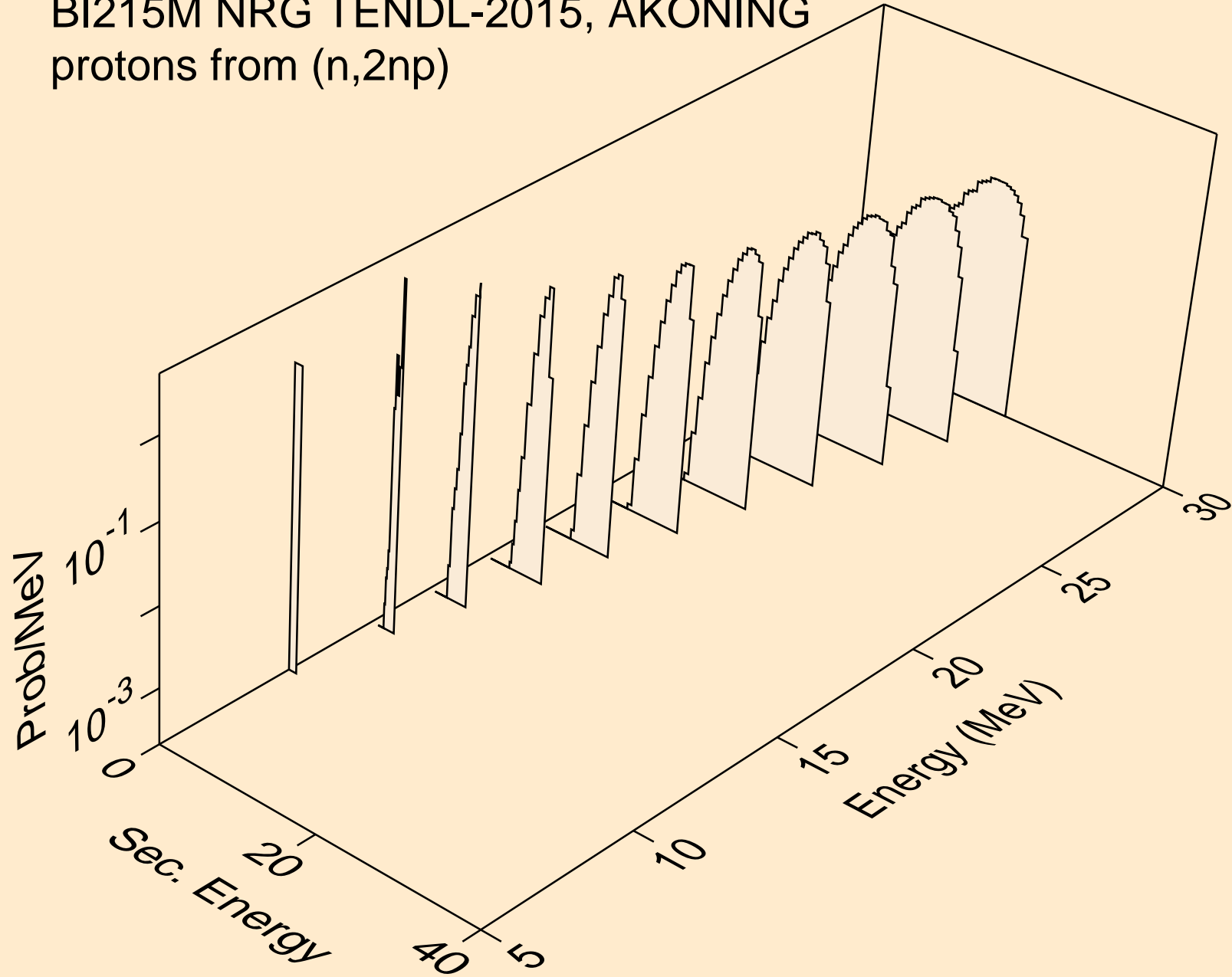

BI215M NRG TENDL-2015, AKONING
protons from (n,3np)

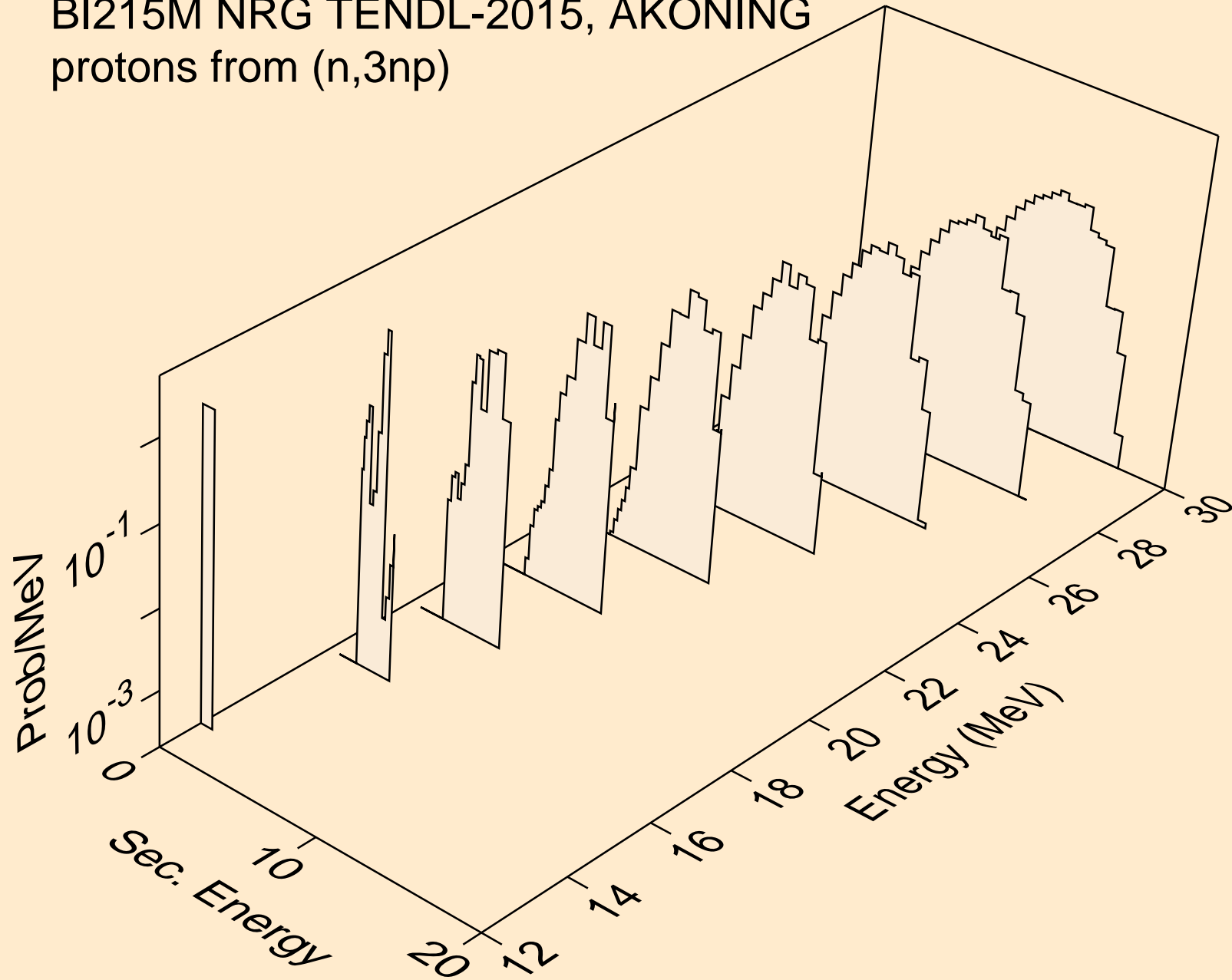

BI215M NRG TENDL-2015, AKONING
protons from (n,2np)

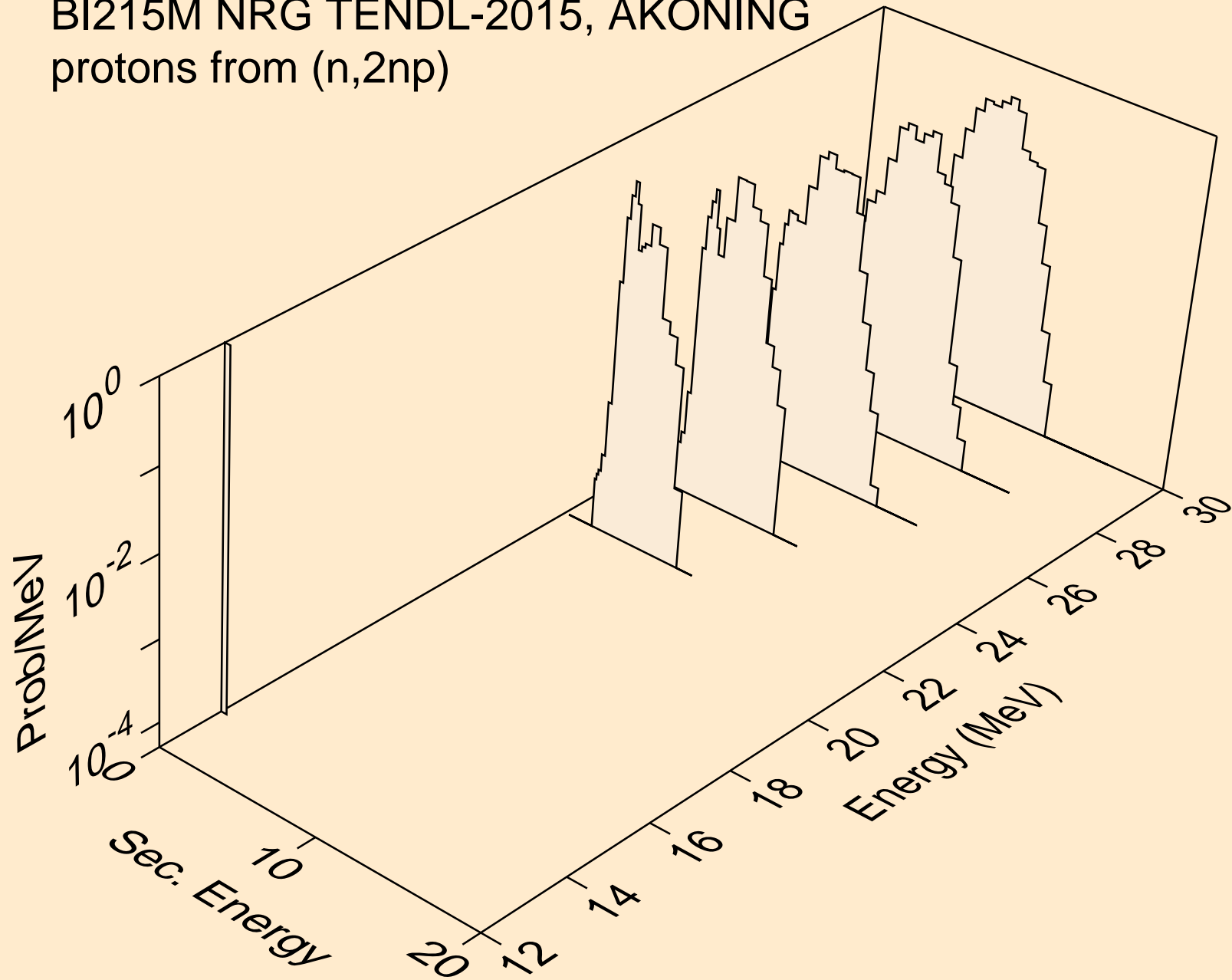

BI215M NRG TENDL-2015, AKONING
protons from (n,p)

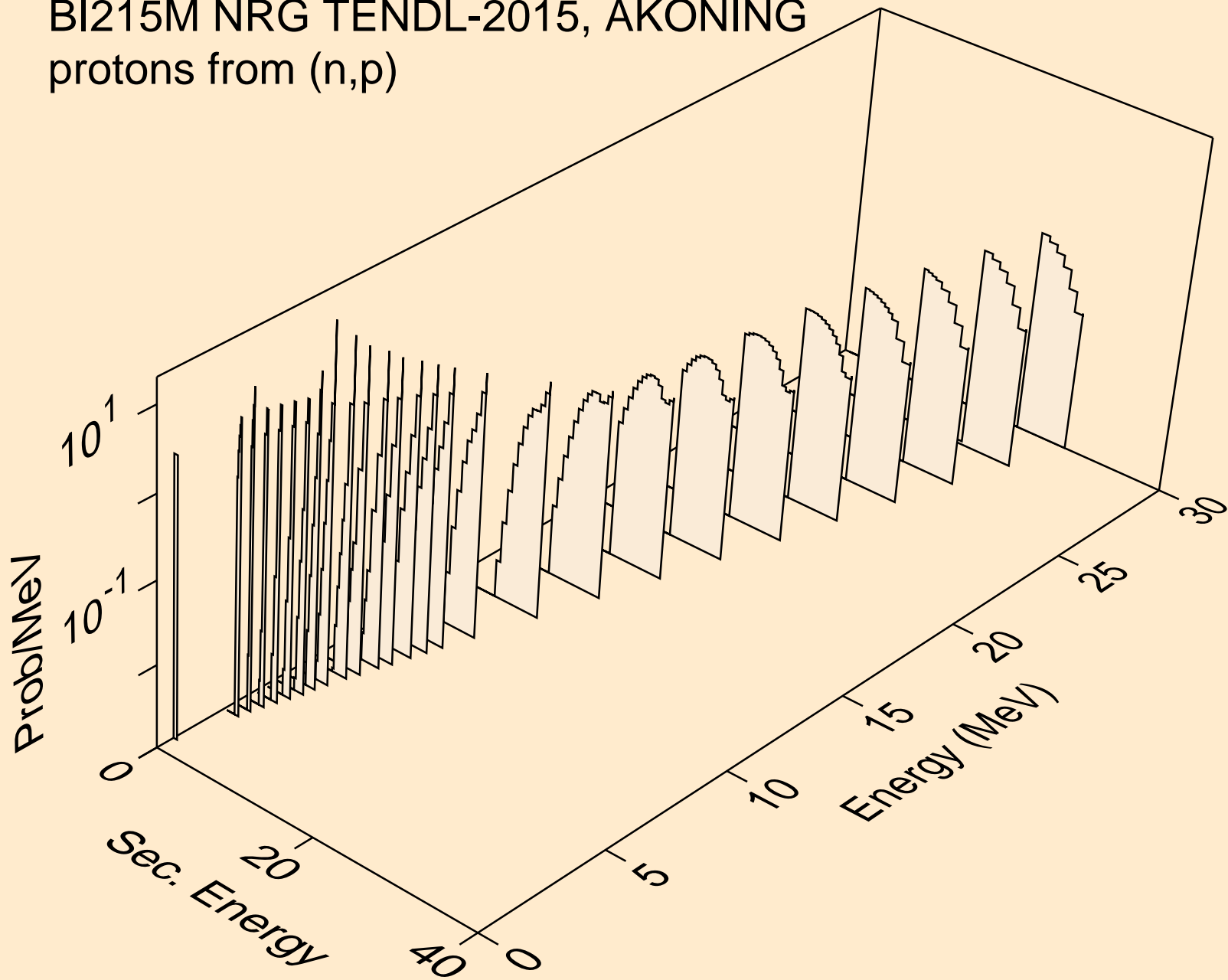

BI215M NRG TENDL-2015, AKONING
protons from (n,2p)

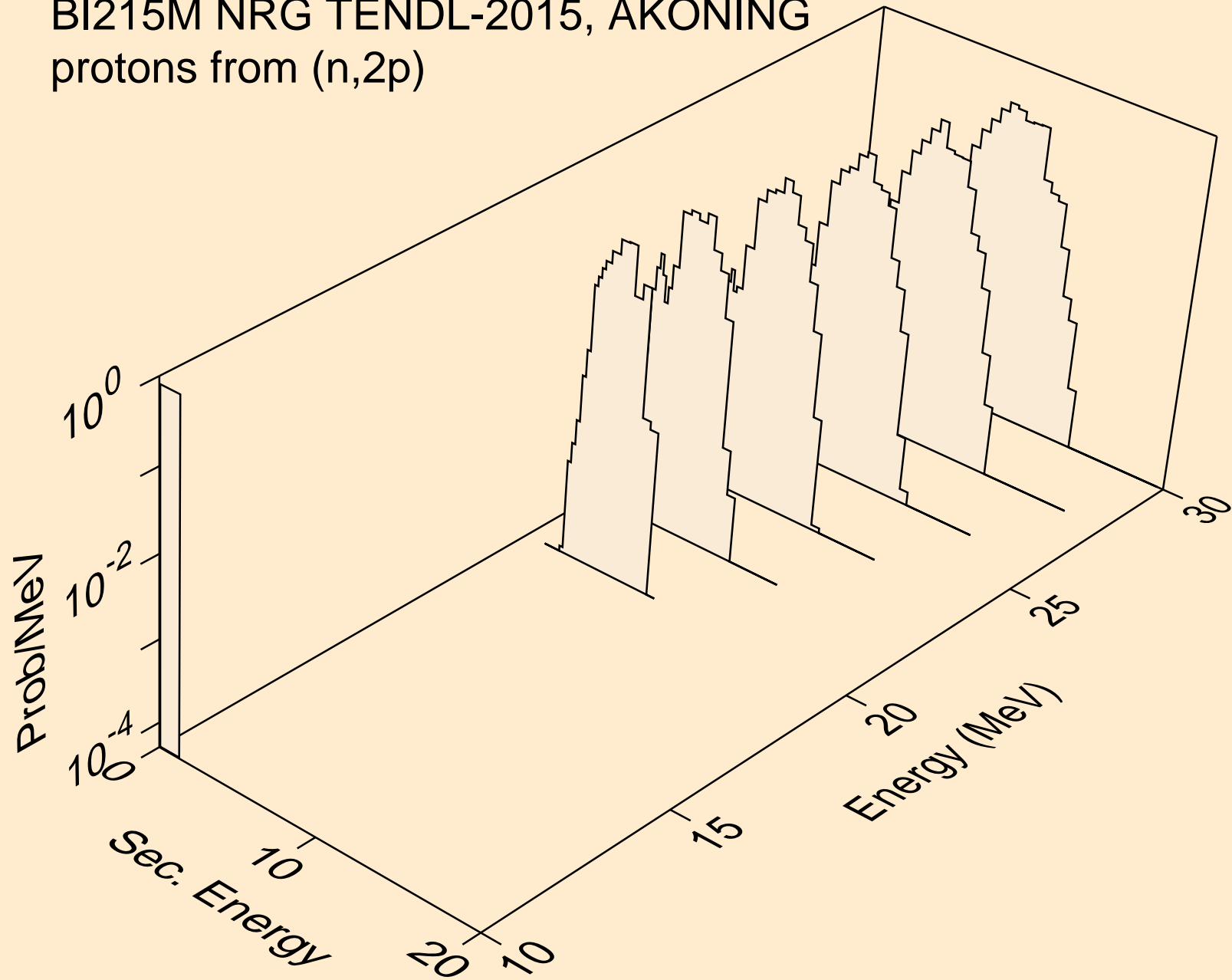

BI215M NRG TENDL-2015, AKONING
protons from (n,pa)

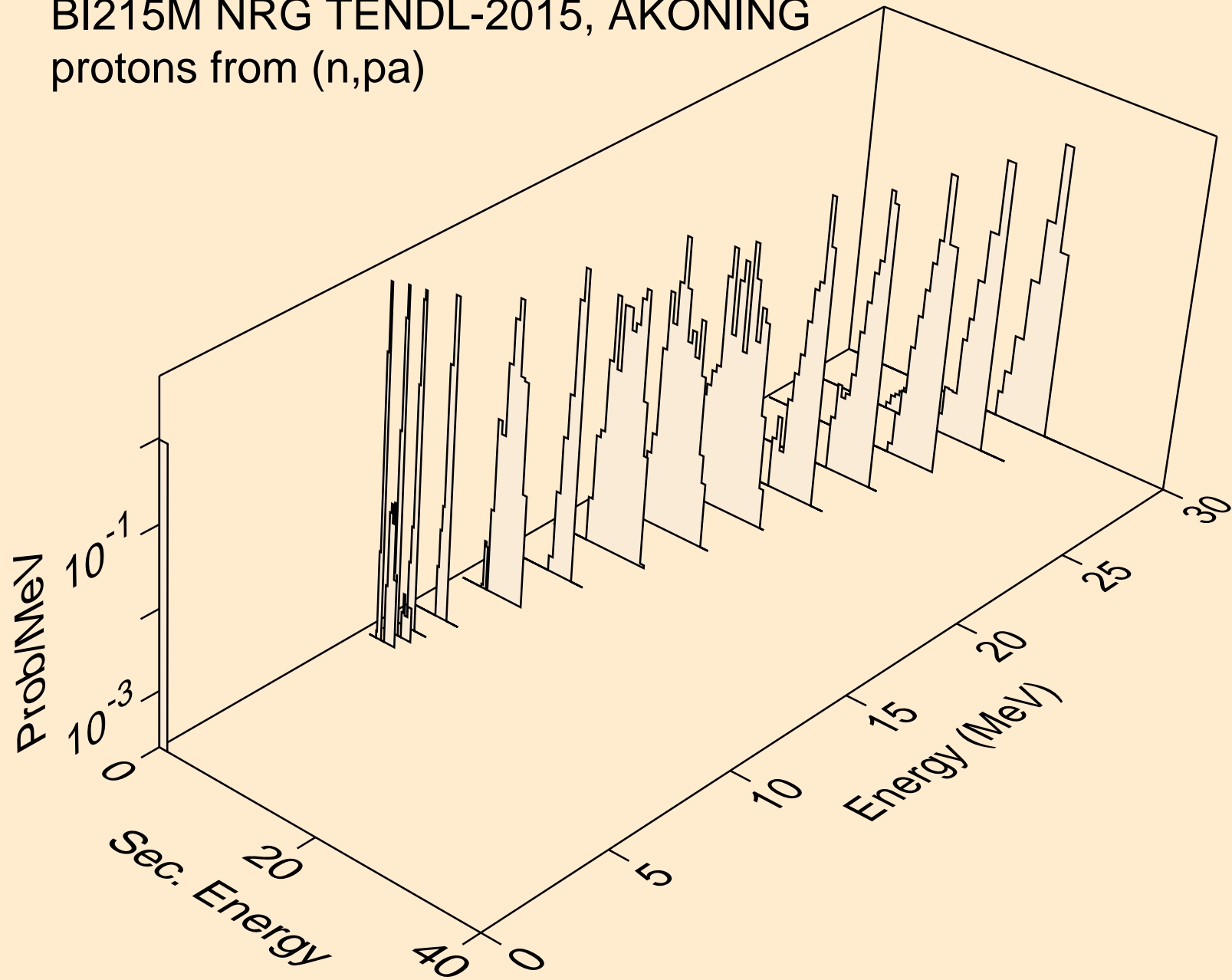

BI215M NRG TENDL-2015, AKONING
deuterons from (n,x)

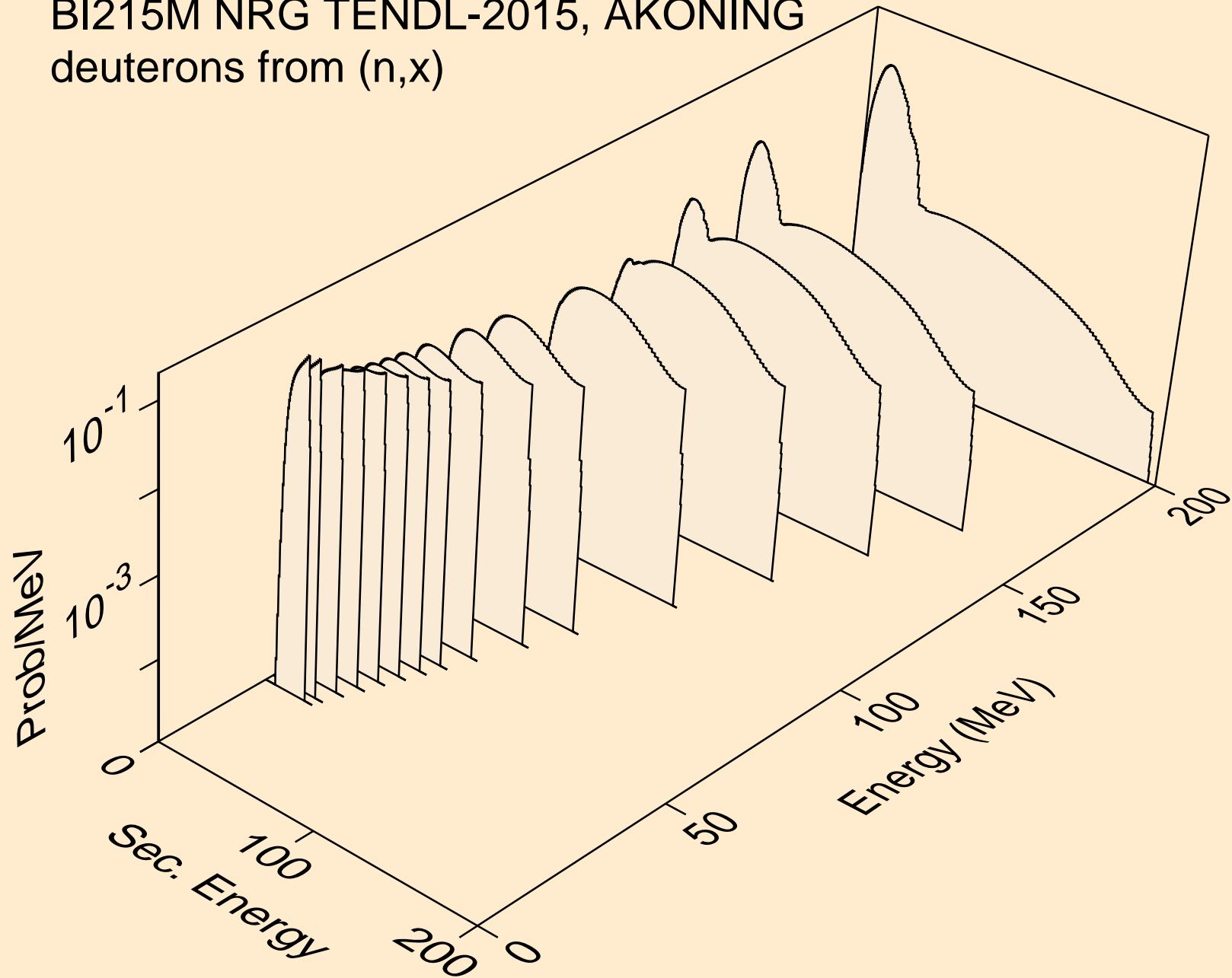

BI215M NRG TENDL-2015, AKONING
deuterons from (n,2nd)

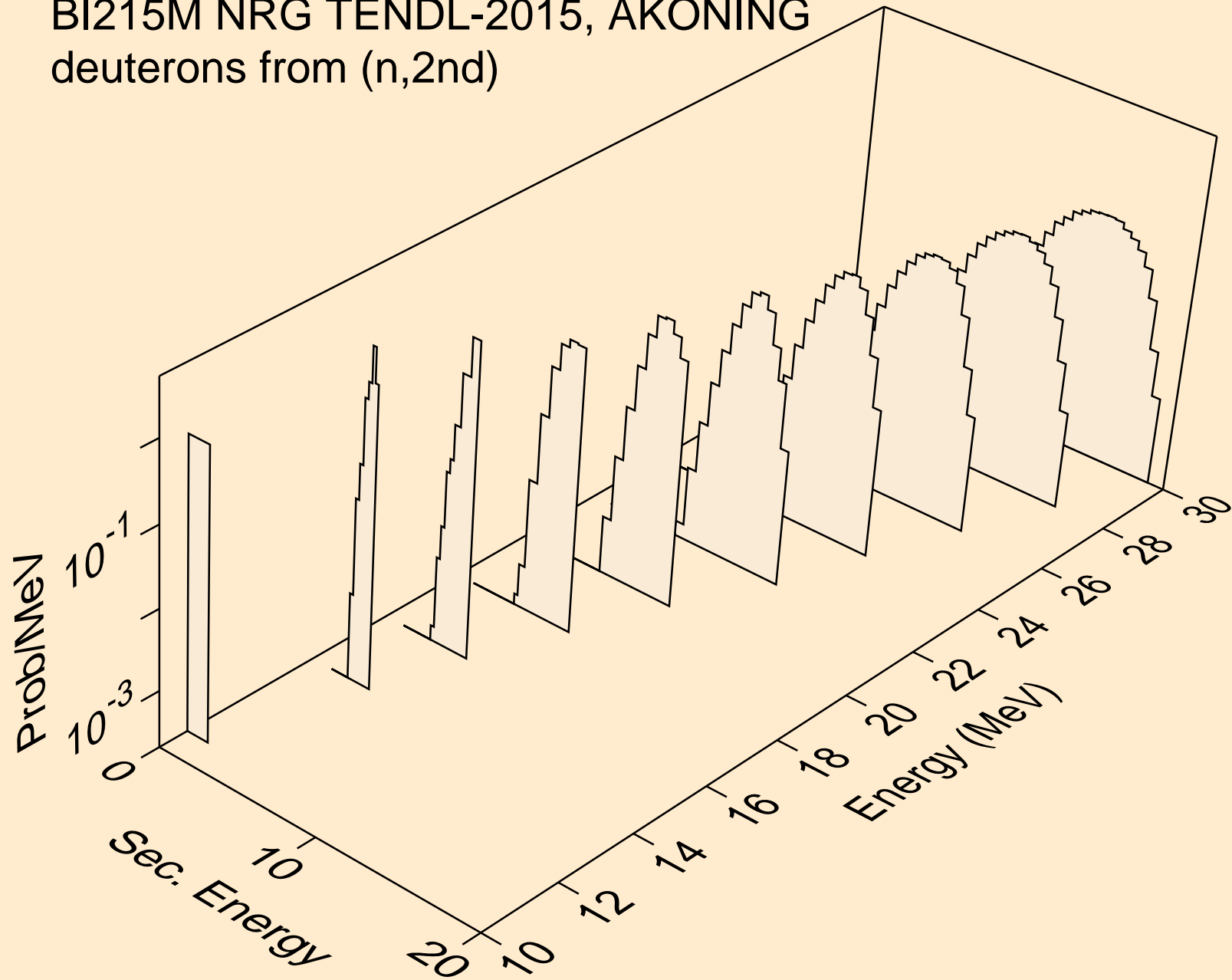

BI215M NRG TENDL-2015, AKONING
deuterons from (n,n*)d

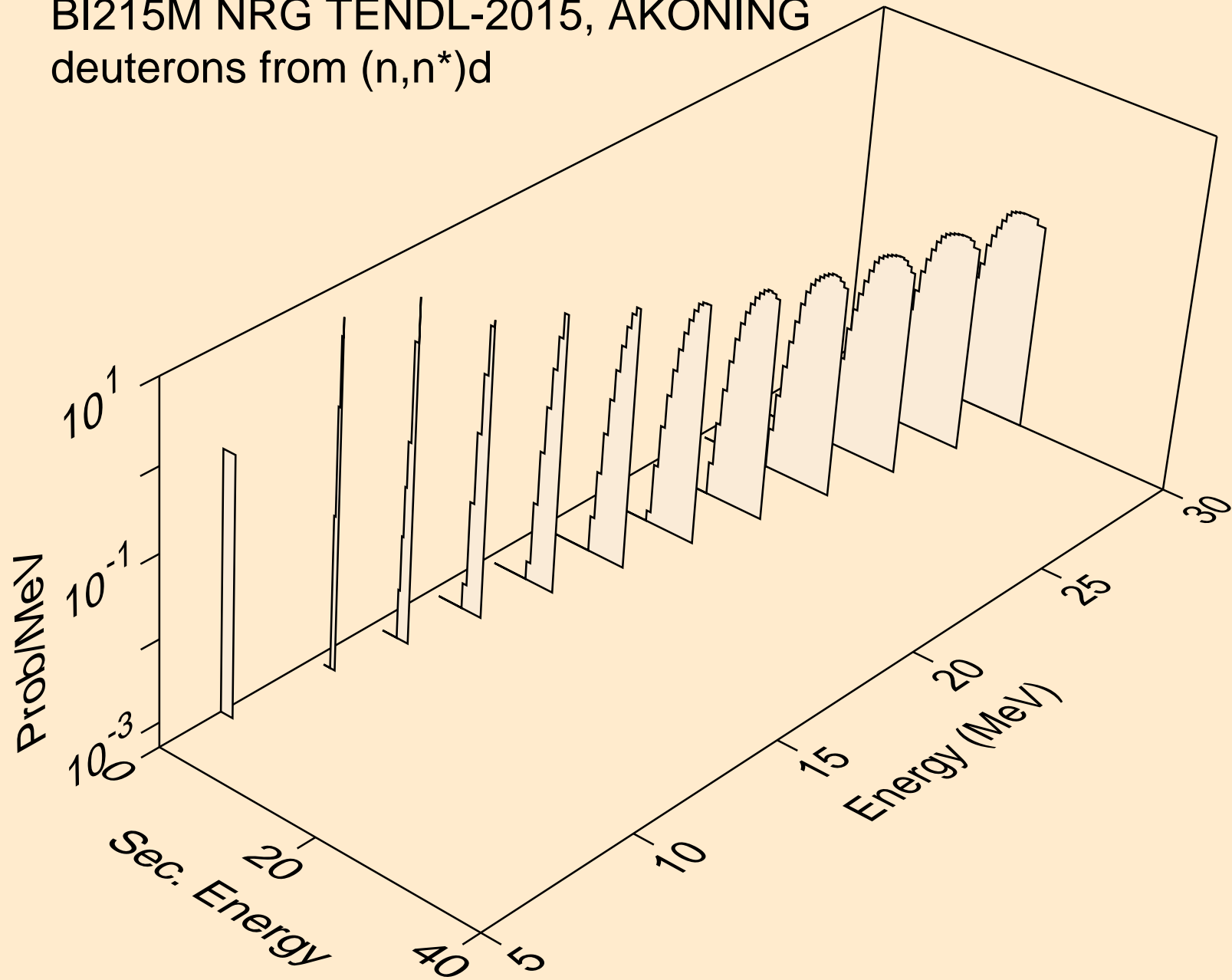

BI215M NRG TENDL-2015, AKONING
deuterons from (n,d)

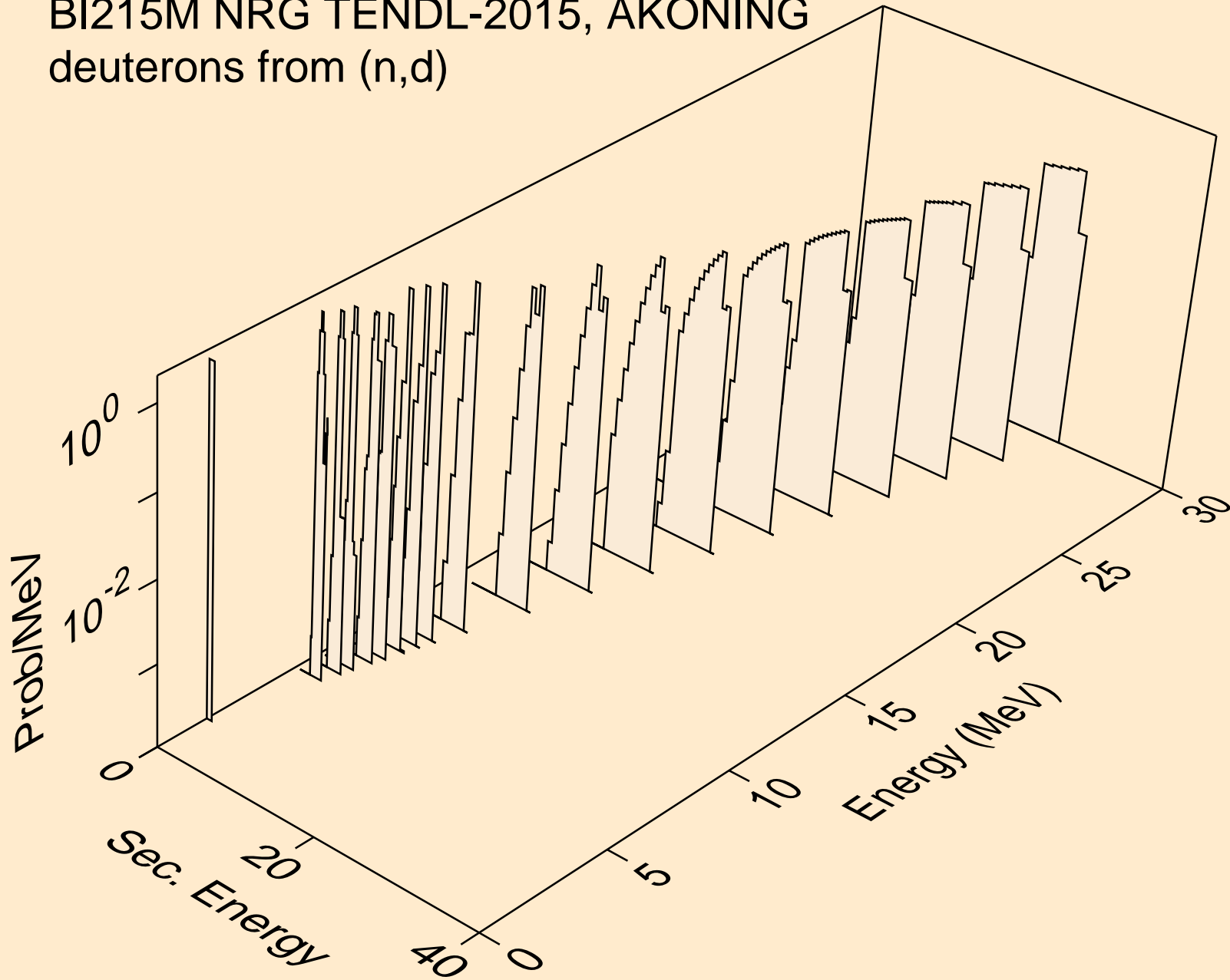

BI215M NRG TENDL-2015, AKONING
tritons from (n,x)

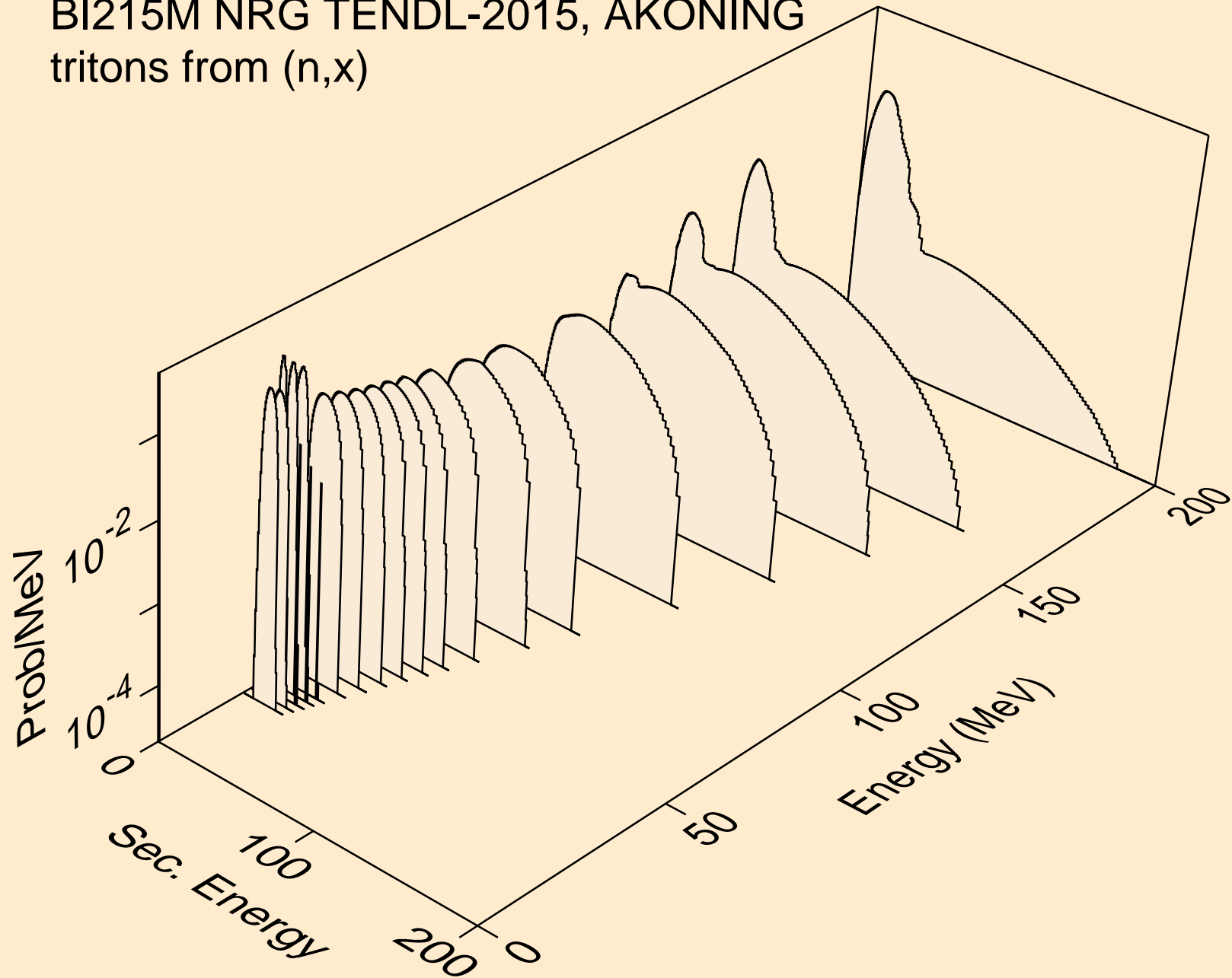

BI215M NRG TENDL-2015, AKONING
tritons from (n,n*)t

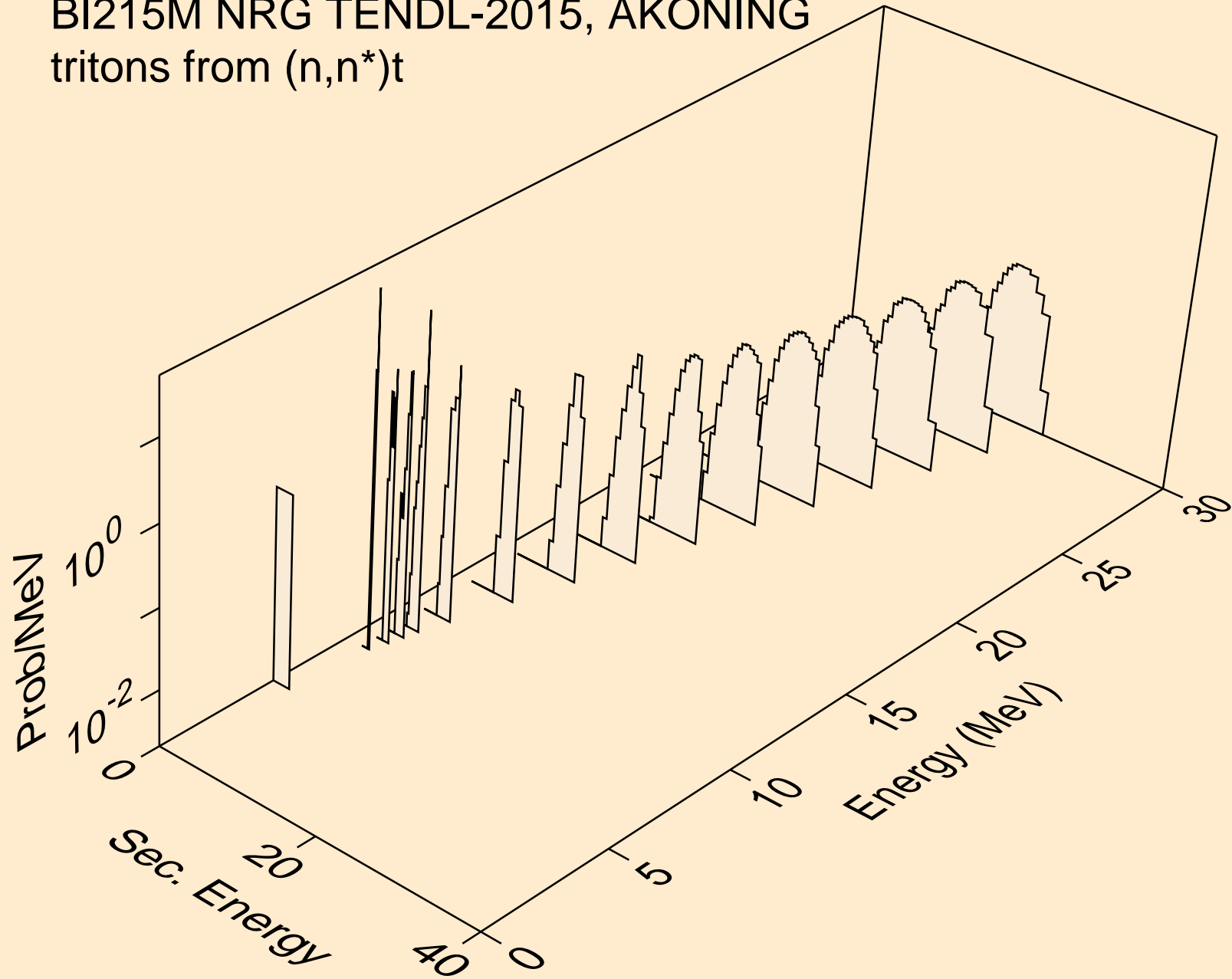

BI215M NRG TENDL-2015, AKONING
tritons from (n,t)

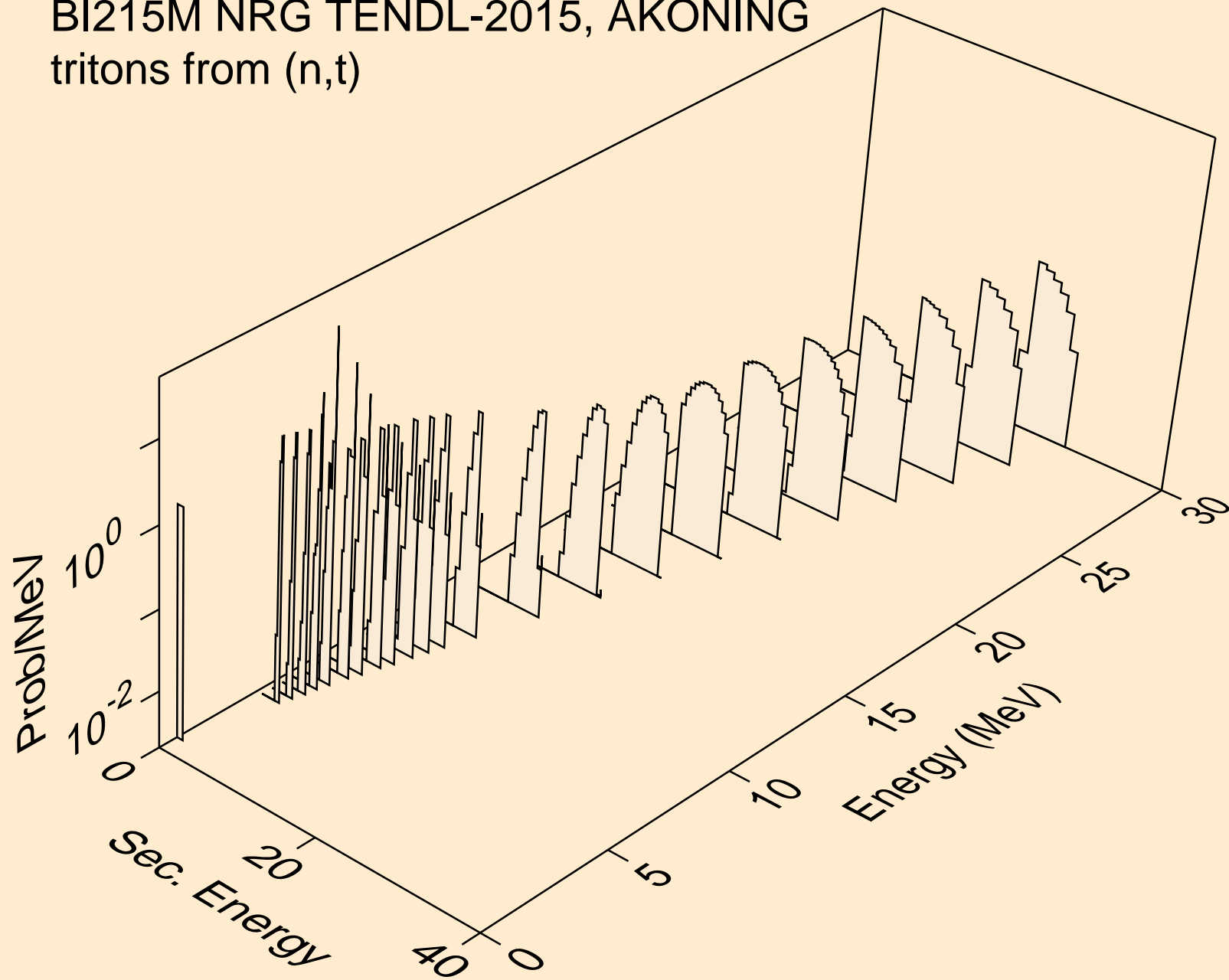

BI215M NRG TENDL-2015, AKONING
he3s from (n,x)

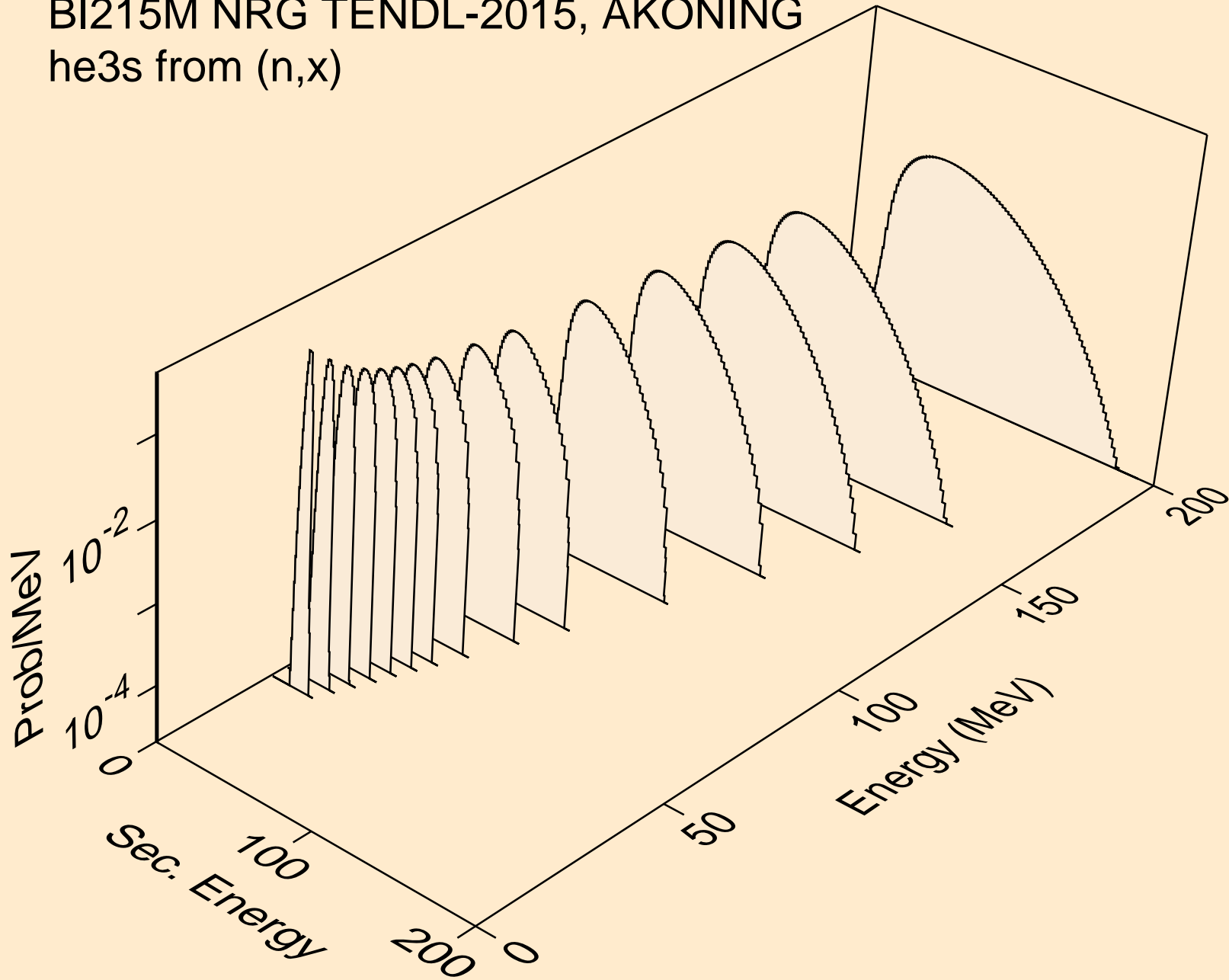

BI215M NRG TENDL-2015, AKONING
he3s from (n,n*)he3

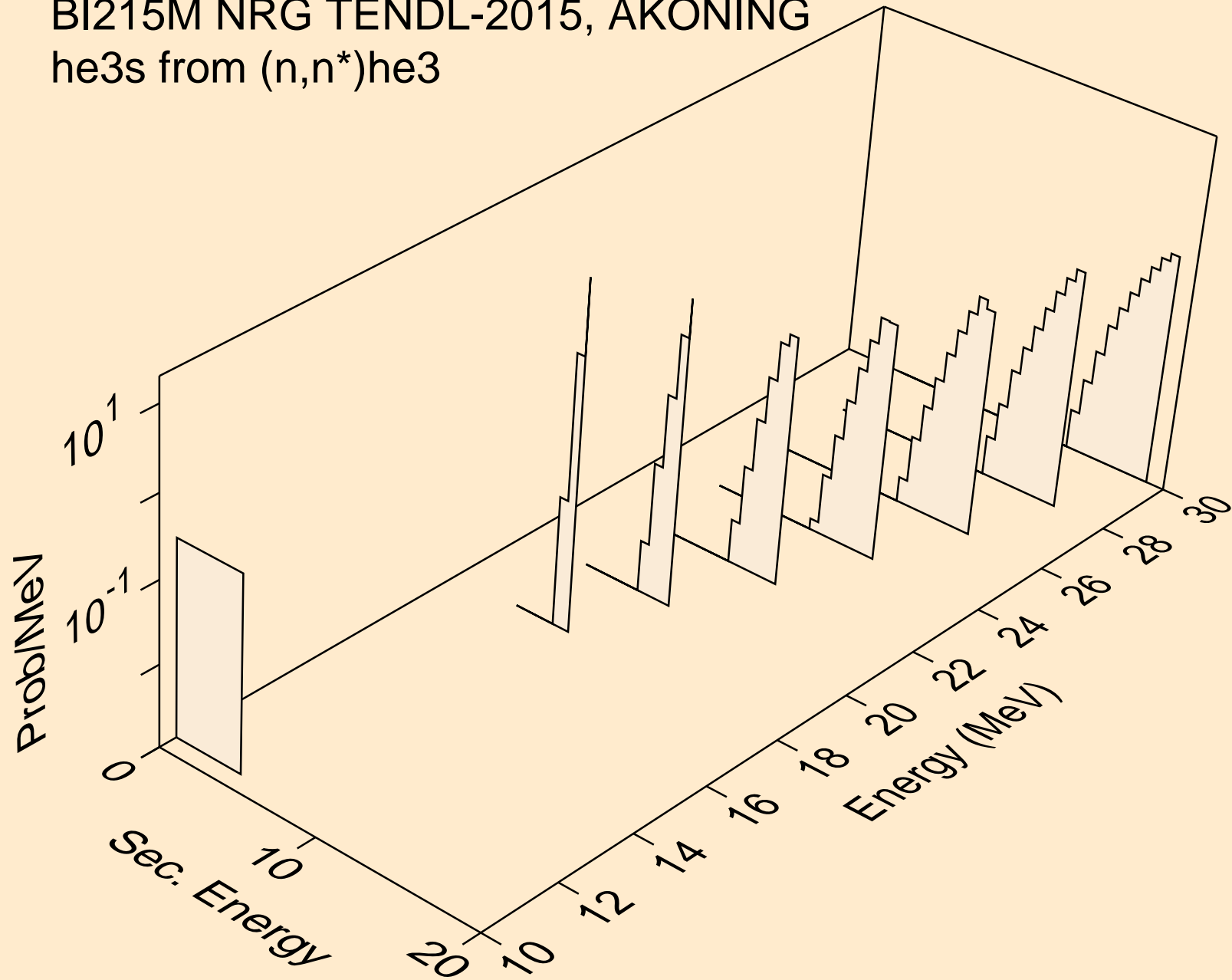

BI215M NRG TENDL-2015, AKONING
he3s from (n,he3)

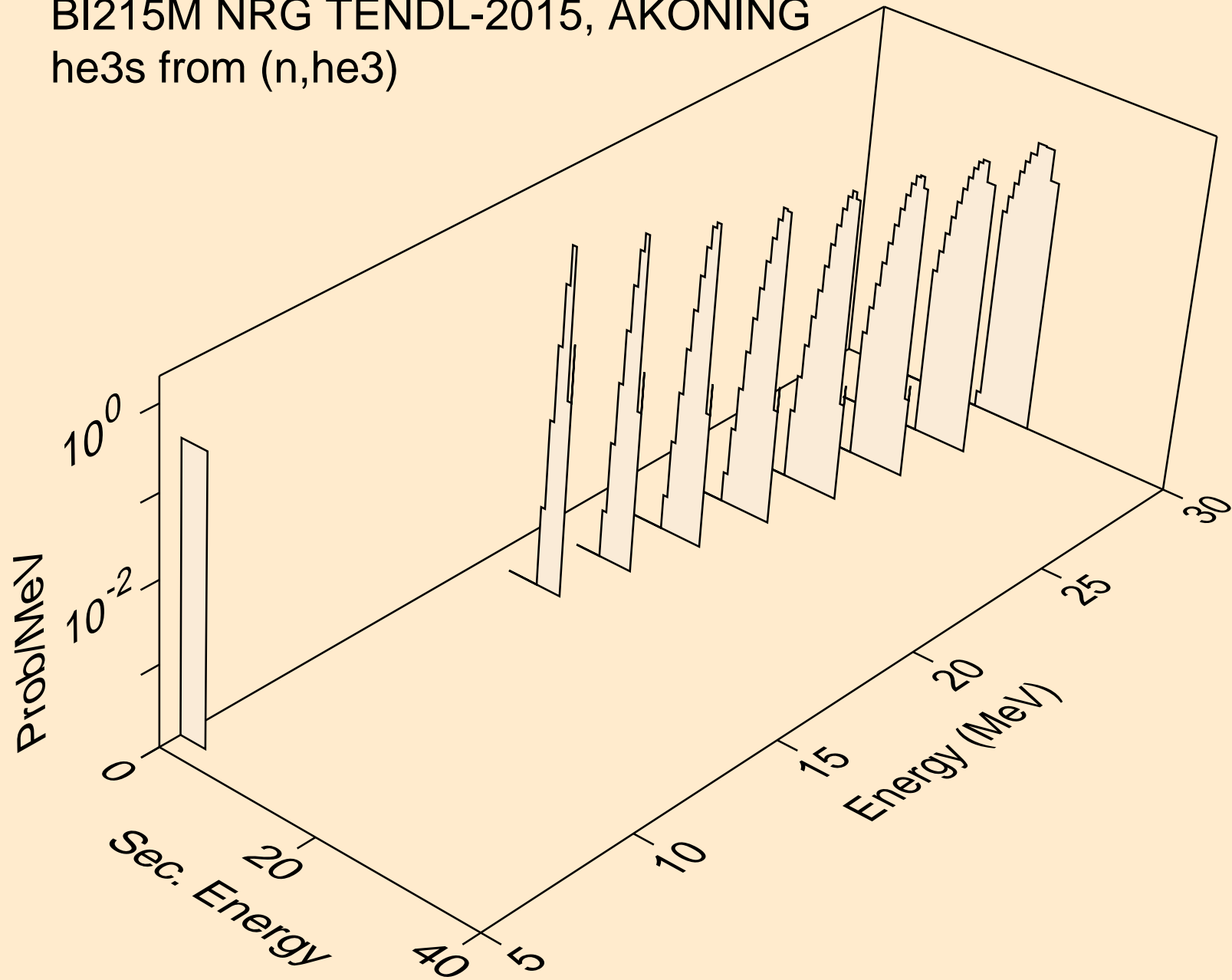

BI215M NRG TENDL-2015, AKONING
alphas from (n,x)

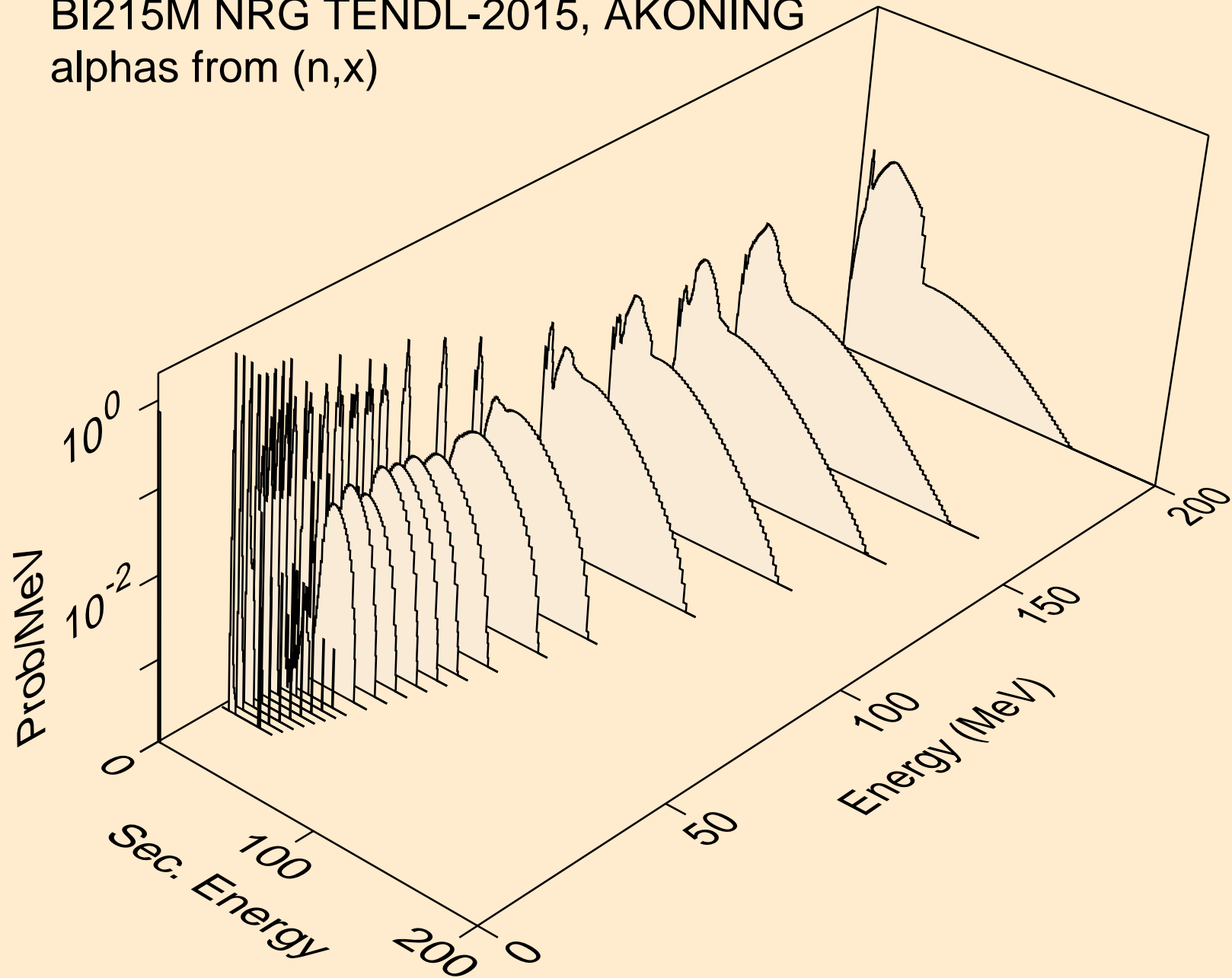

BI215M NRG TENDL-2015, AKONING
alphas from (n,n*)a

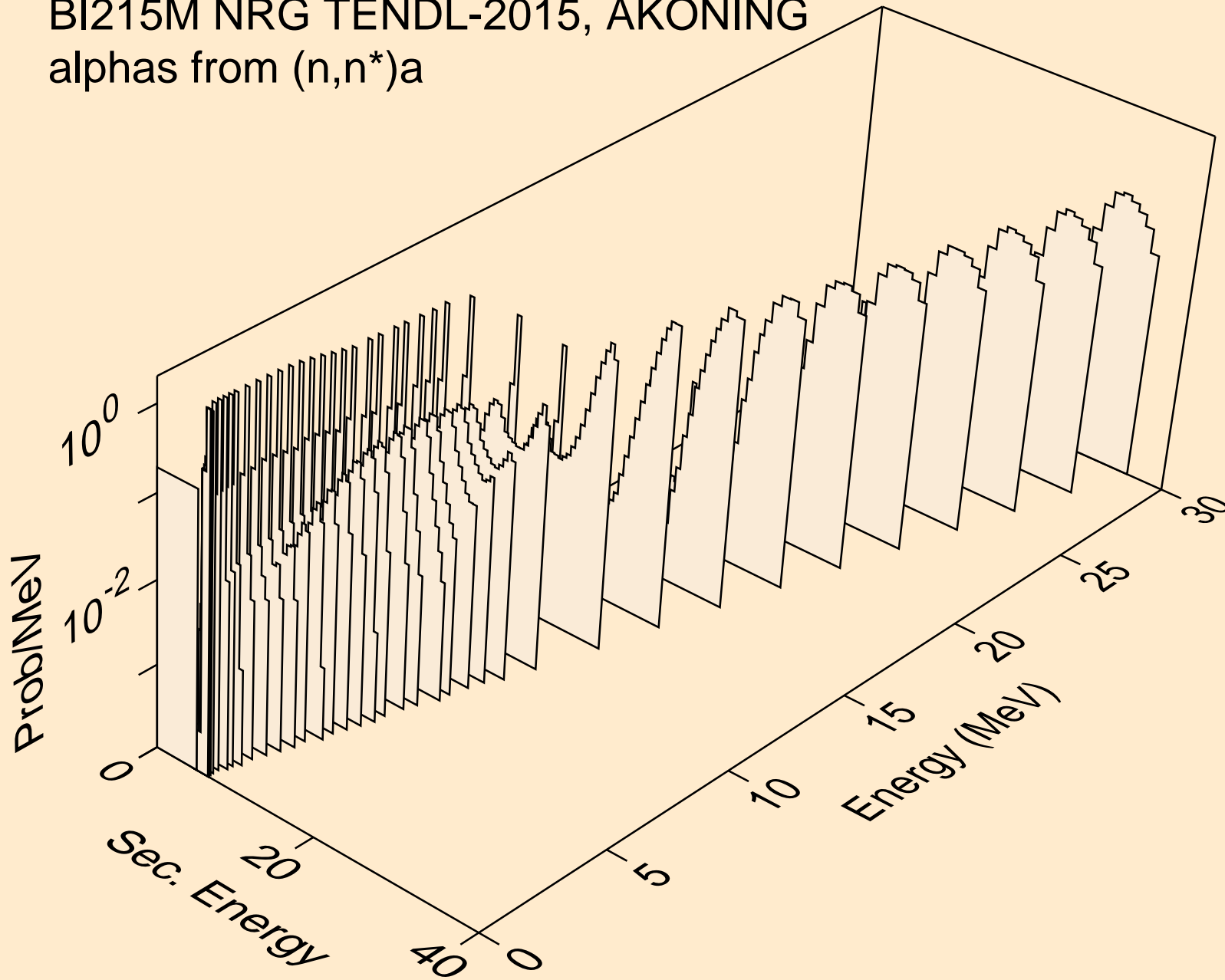

BI215M NRG TENDL-2015, AKONING
alphas from (n,2n)a

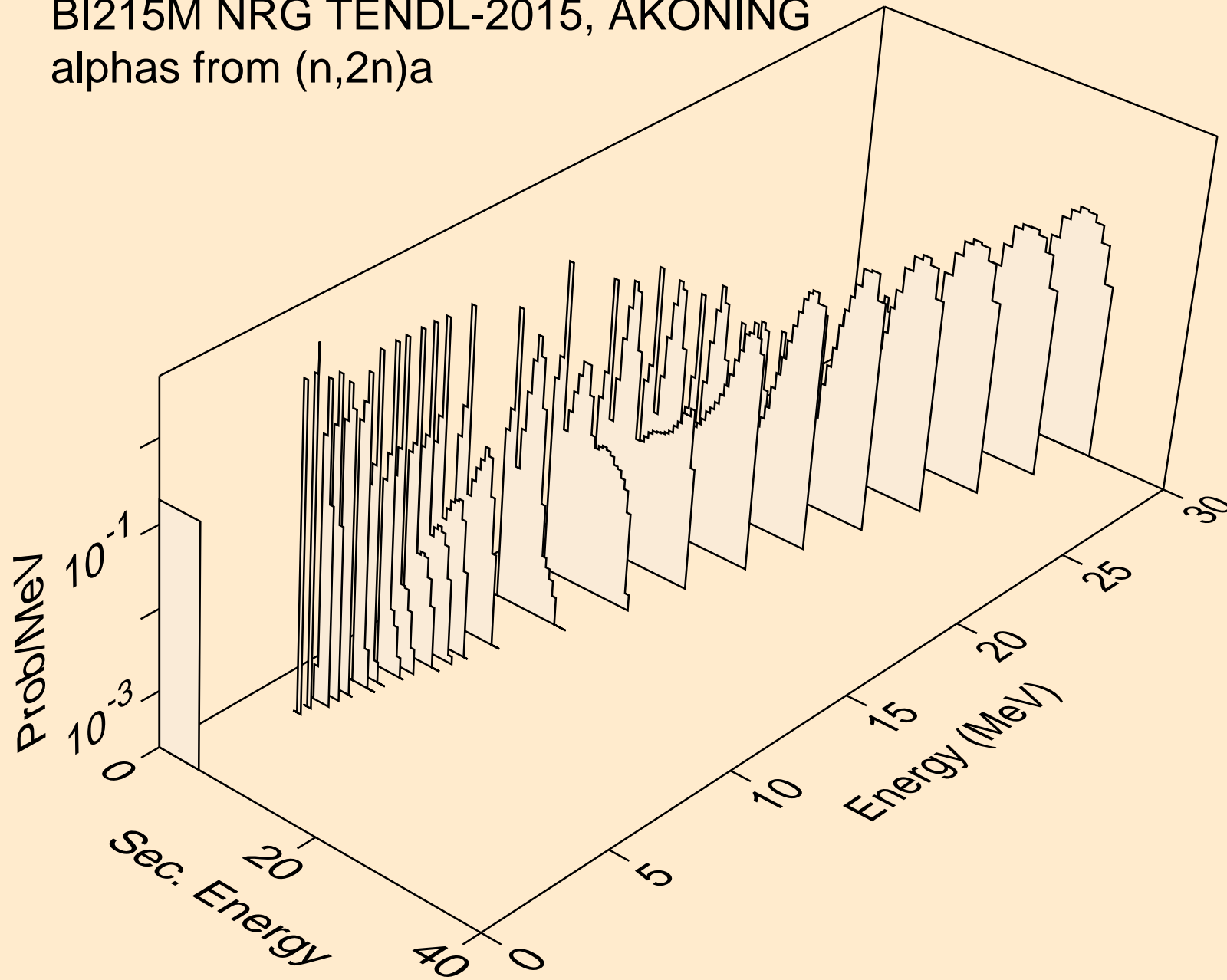

BI215M NRG TENDL-2015, AKONING
alphas from (n,3n)a

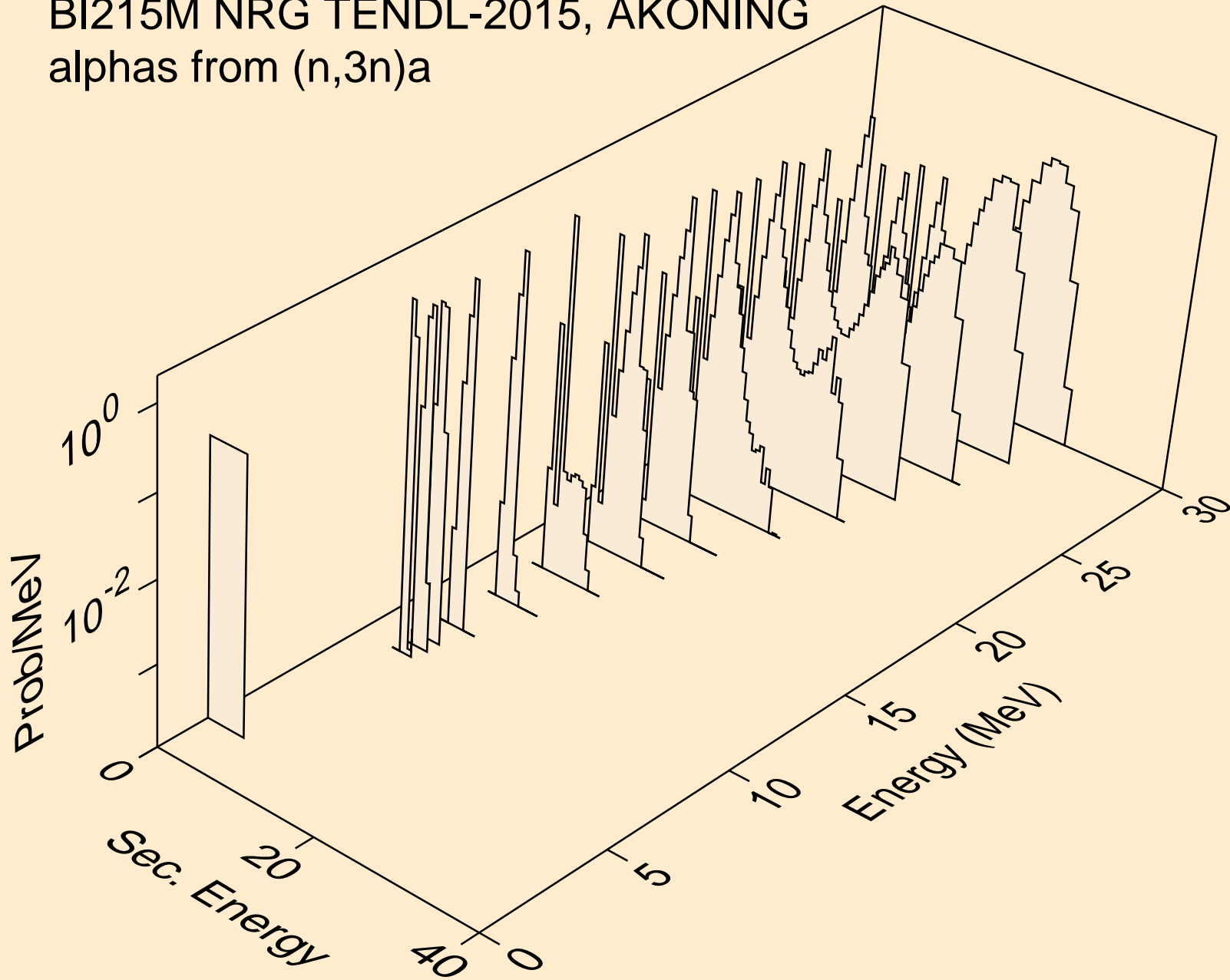

BI215M NRG TENDL-2015, AKONING
alphas from (n,n*)2a

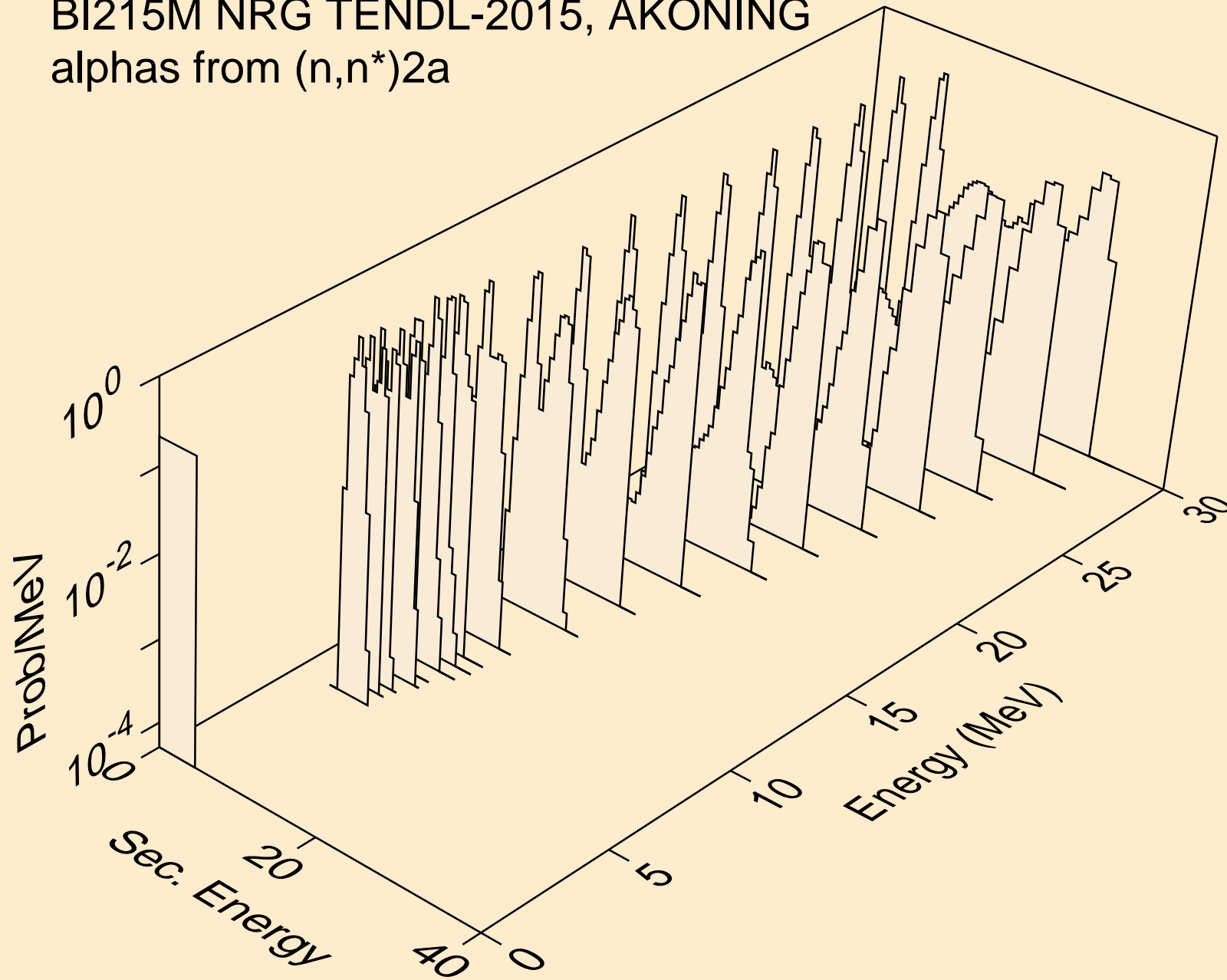

BI215M NRG TENDL-2015, AKONING
alphas from (n,2n)2a

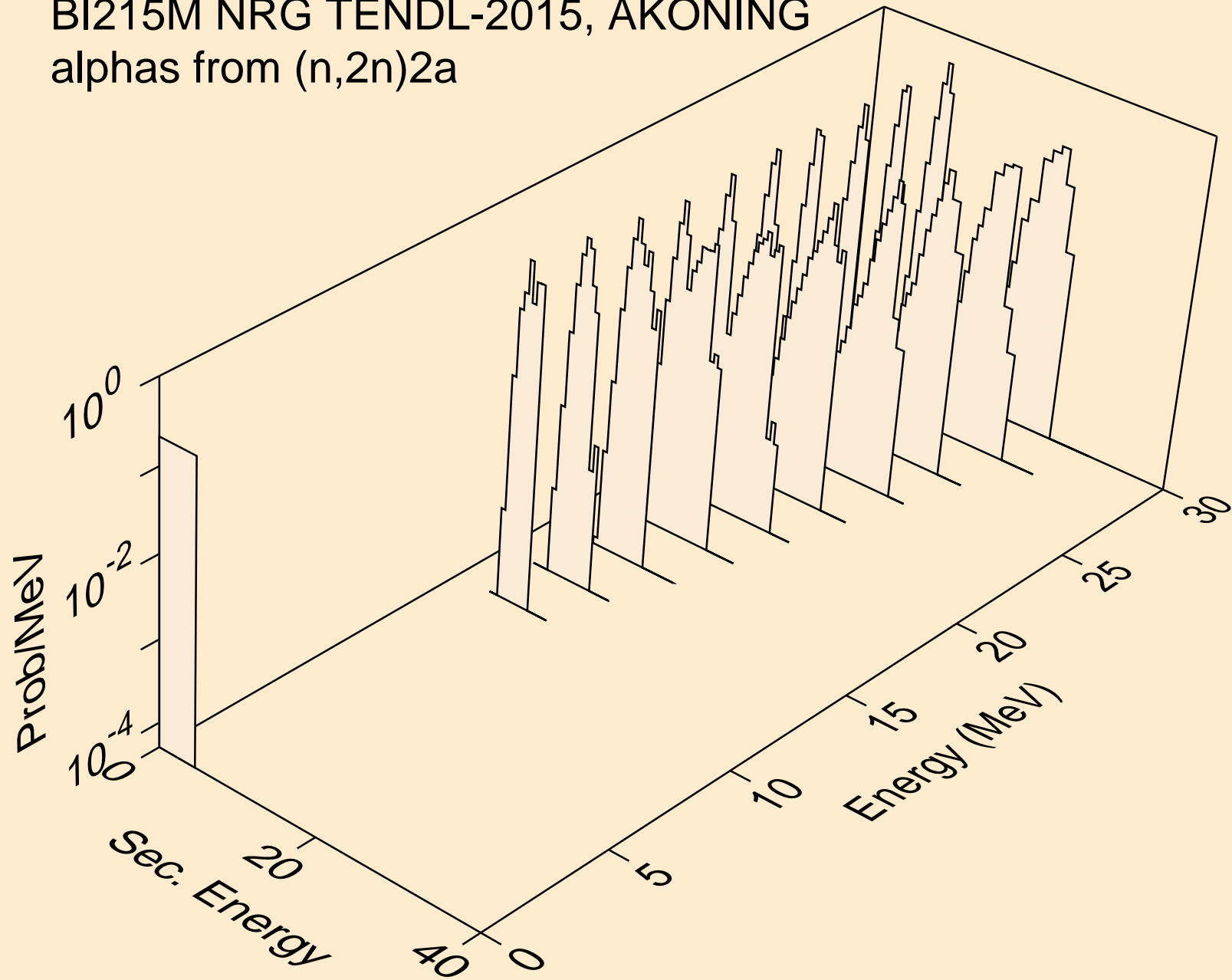

BI215M NRG TENDL-2015, AKONING
alphas from (n,a)

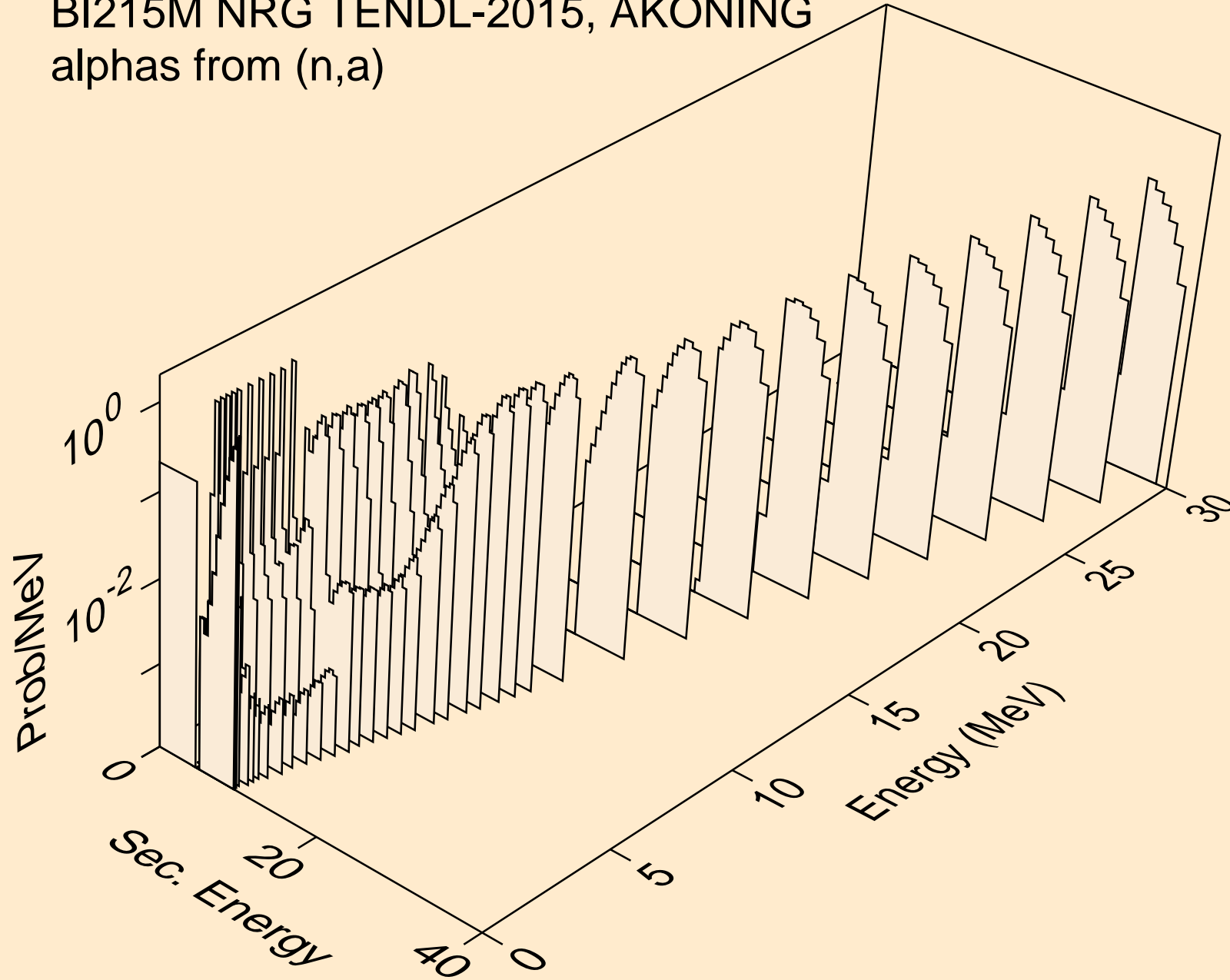

BI215M NRG TENDL-2015, AKONING
alphas from (n,pa)

