

PO217 NRG TENDL-2015, AKONING

Principal cross sections

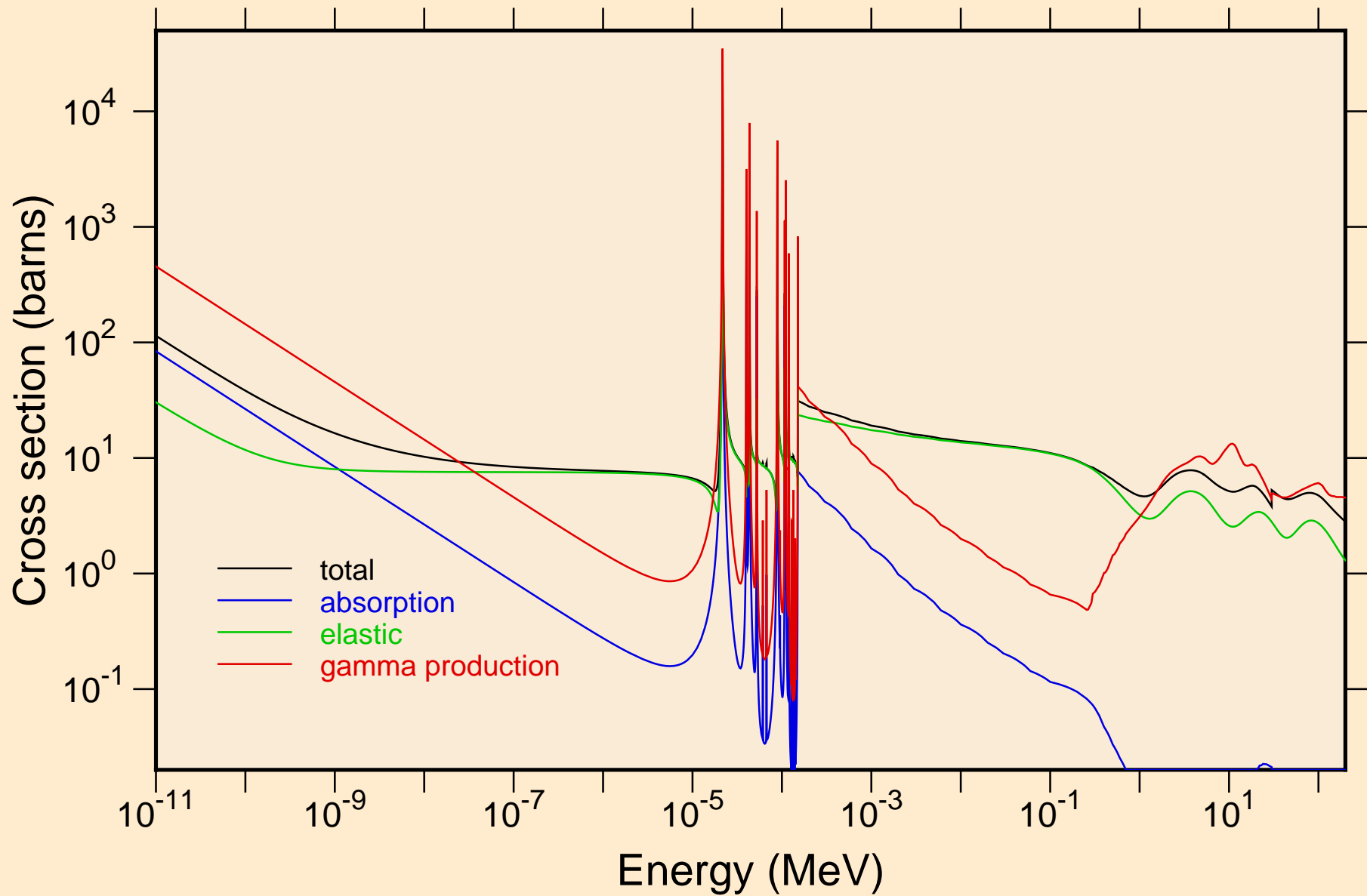

PO217 NRG TENDL-2015, AKONING
resonance total cross section

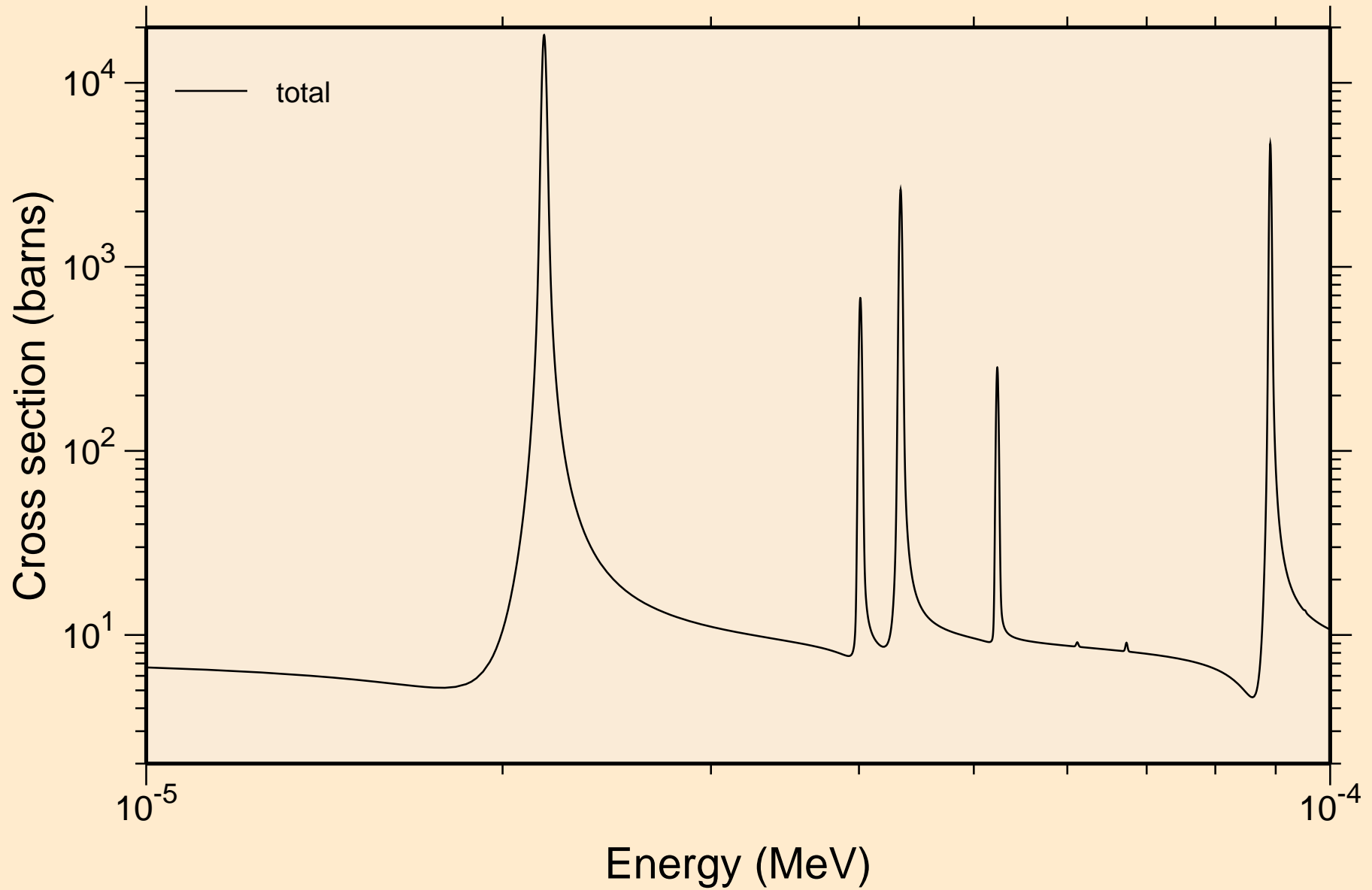

PO217 NRG TENDL-2015, AKONING
resonance total cross section

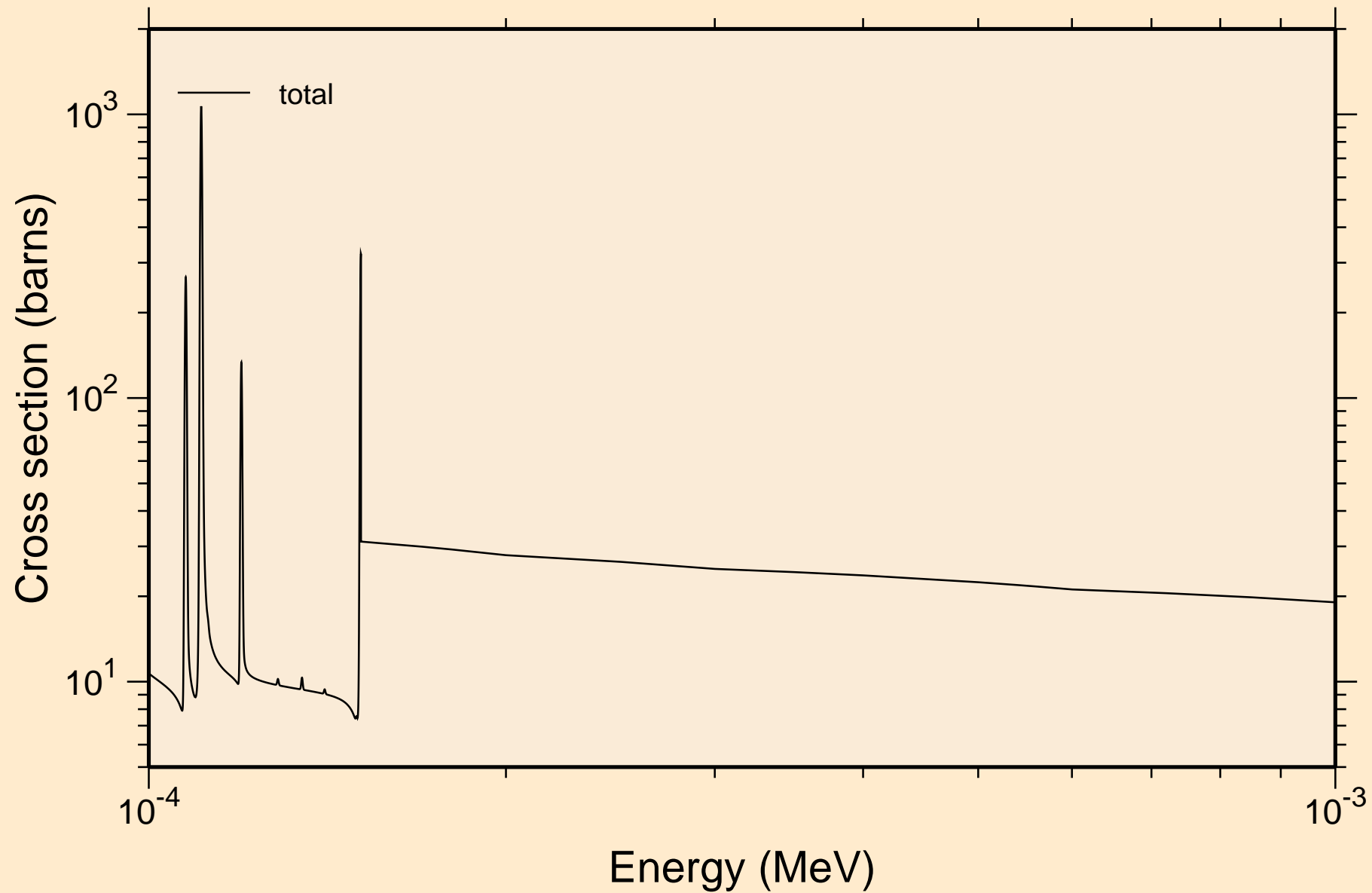

PO217 NRG TENDL-2015, AKONING
resonance total cross section

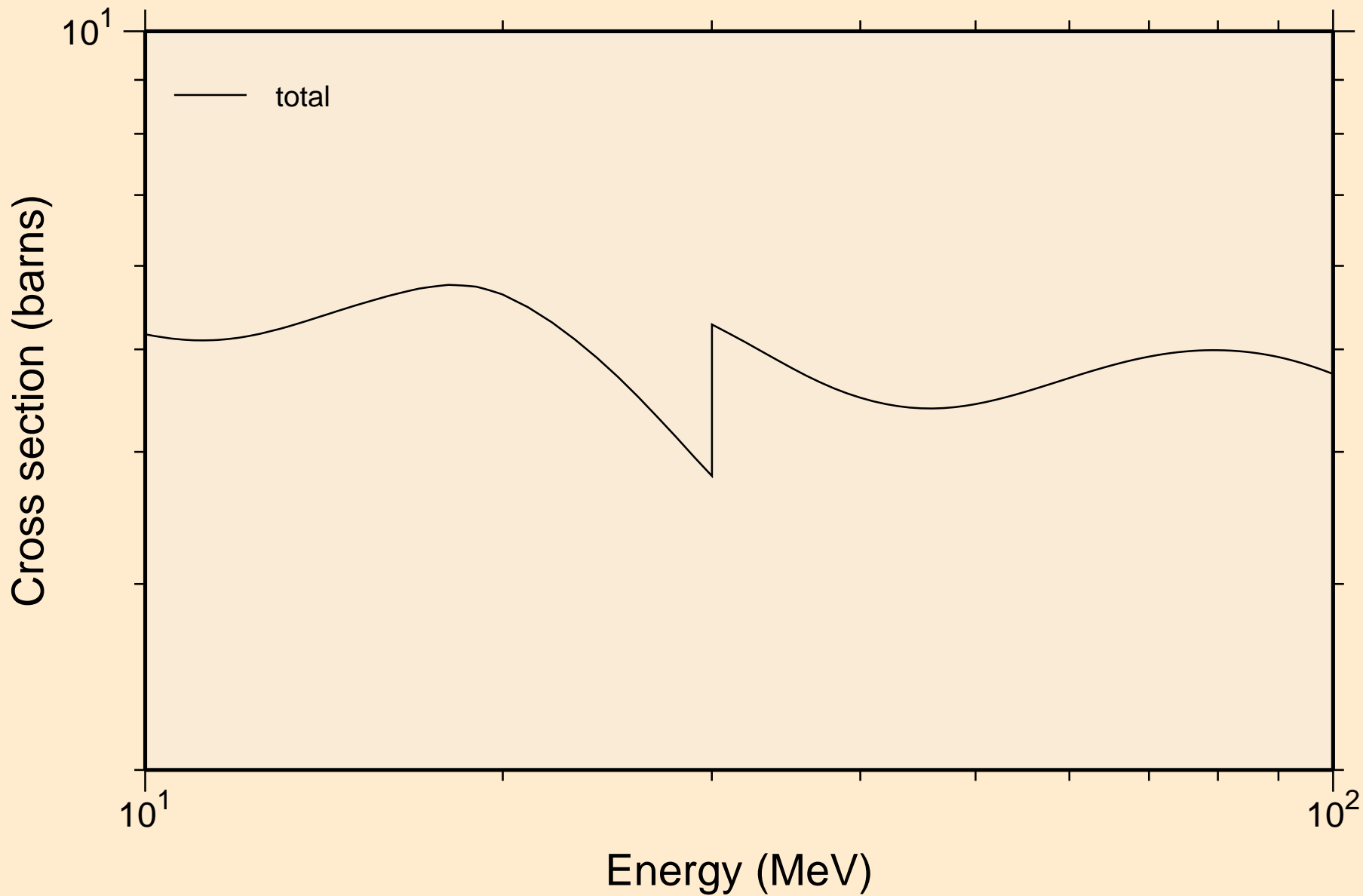

PO217 NRG TENDL-2015, AKONING resonance absorption cross sections

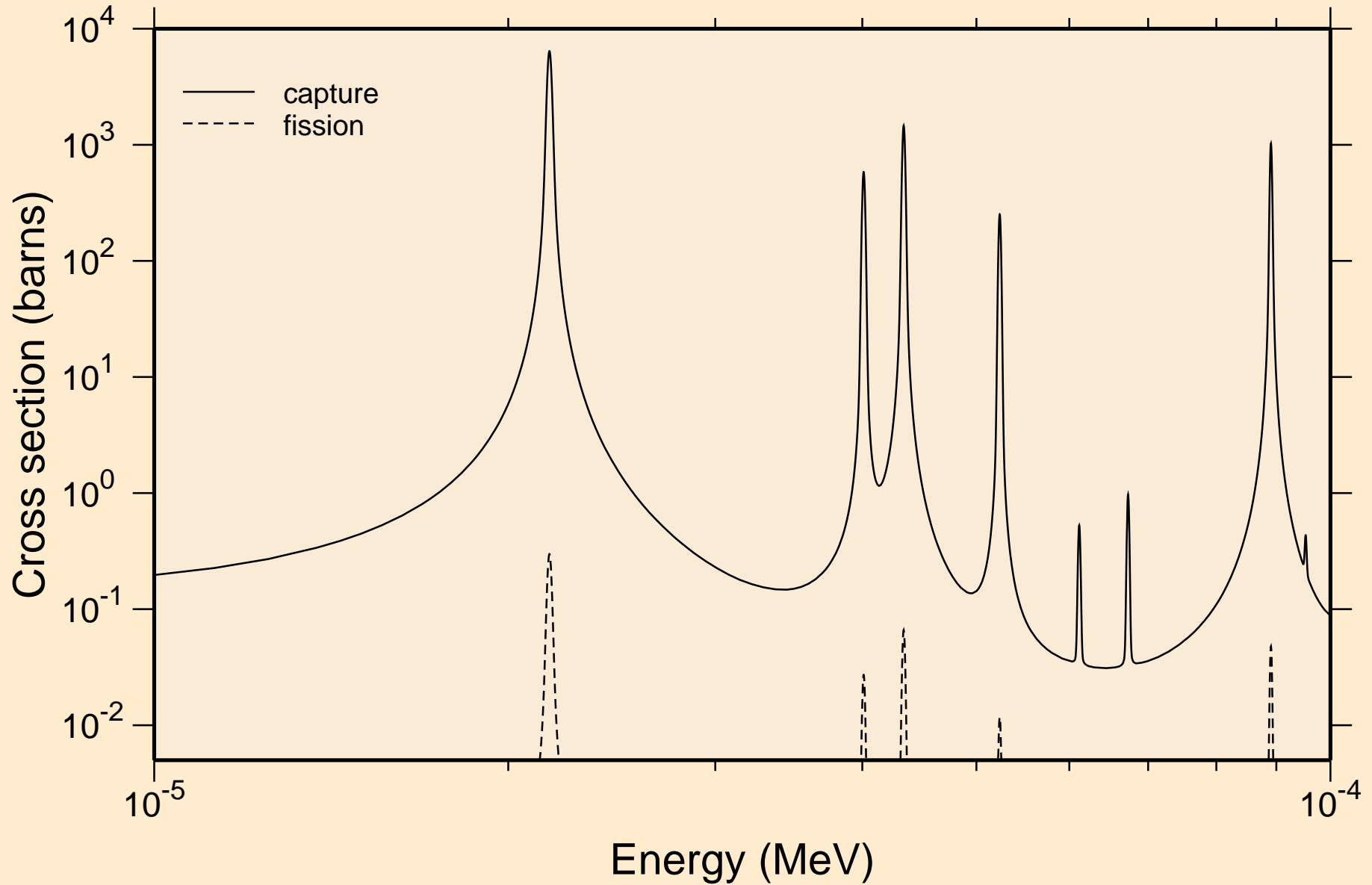

PO217 NRG TENDL-2015, AKONING
resonance absorption cross sections

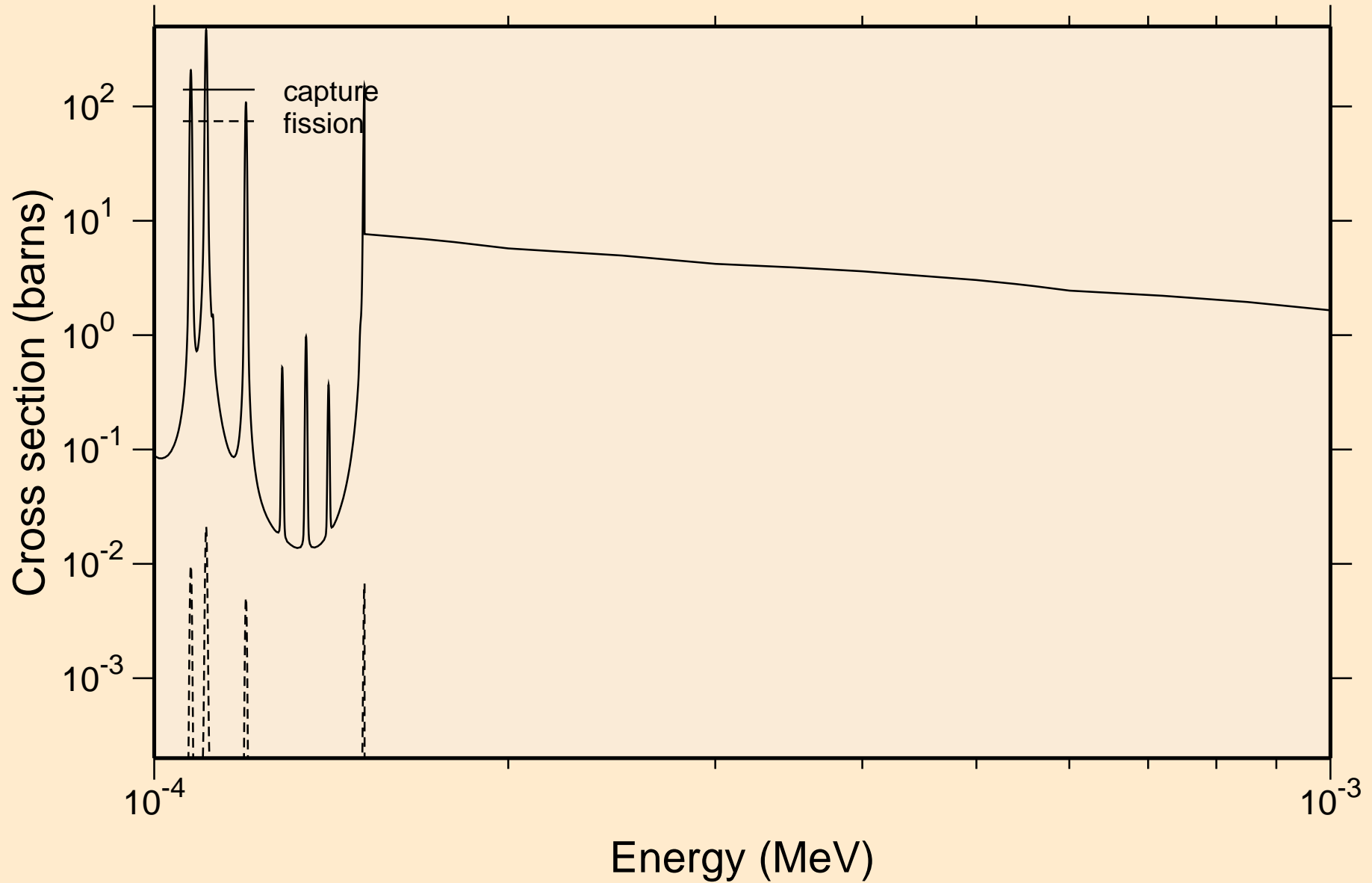

PO217 NRG TENDL-2015, AKONING
resonance absorption cross sections

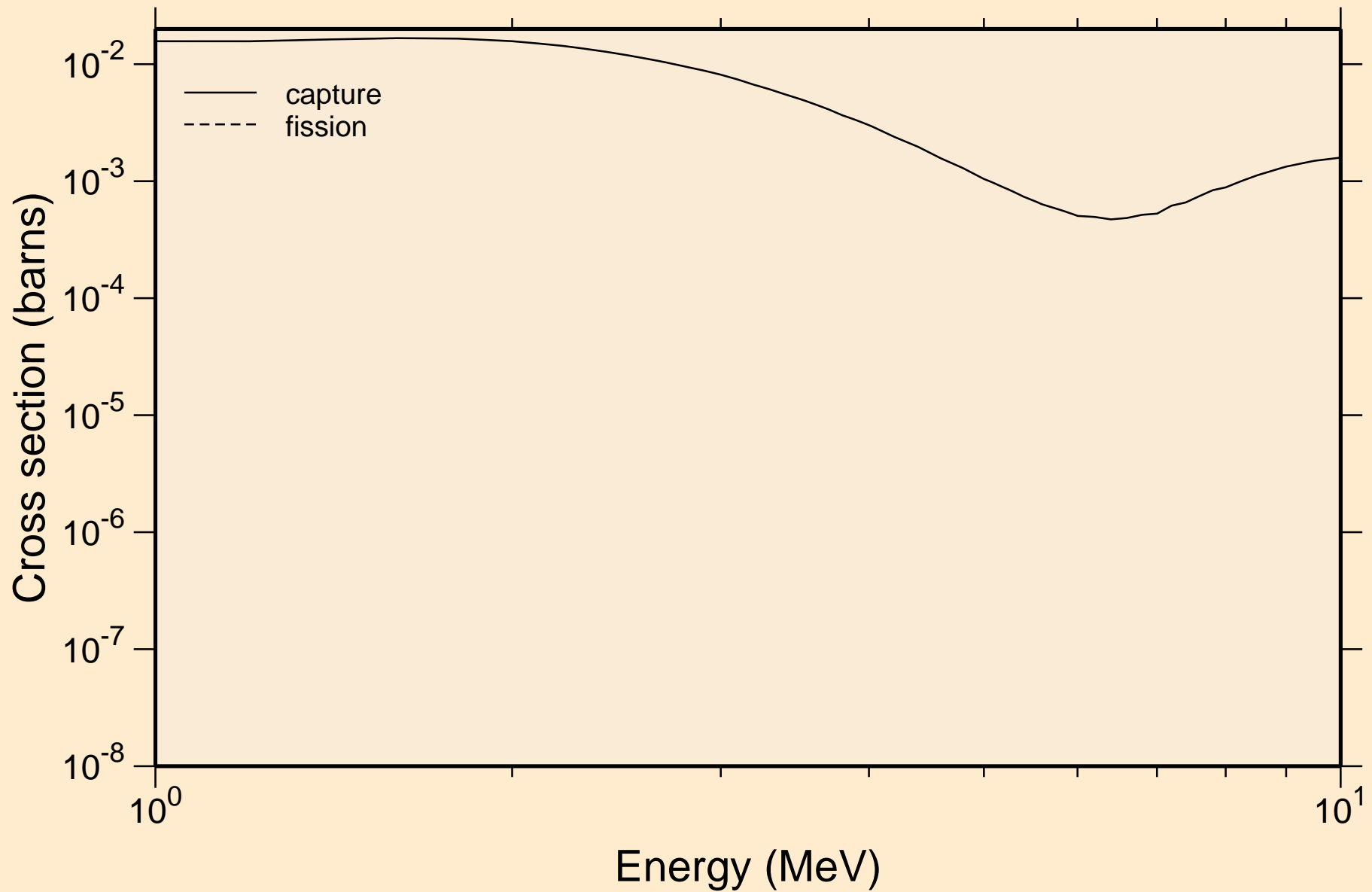

PO217 NRG TENDL-2015, AKONING

Non-threshold reactions

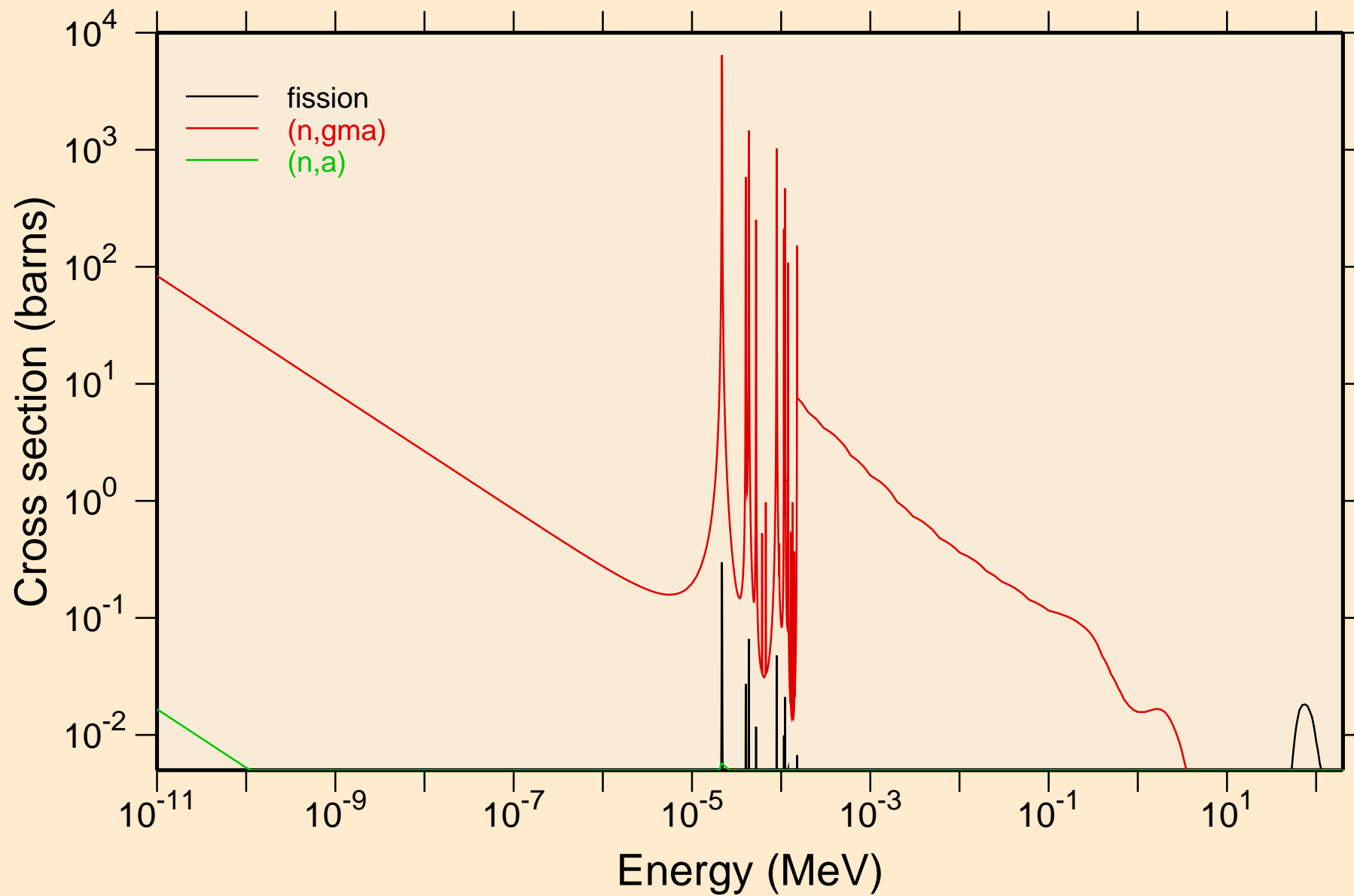

PO217 NRG TENDL-2015, AKONING

Principal cross sections

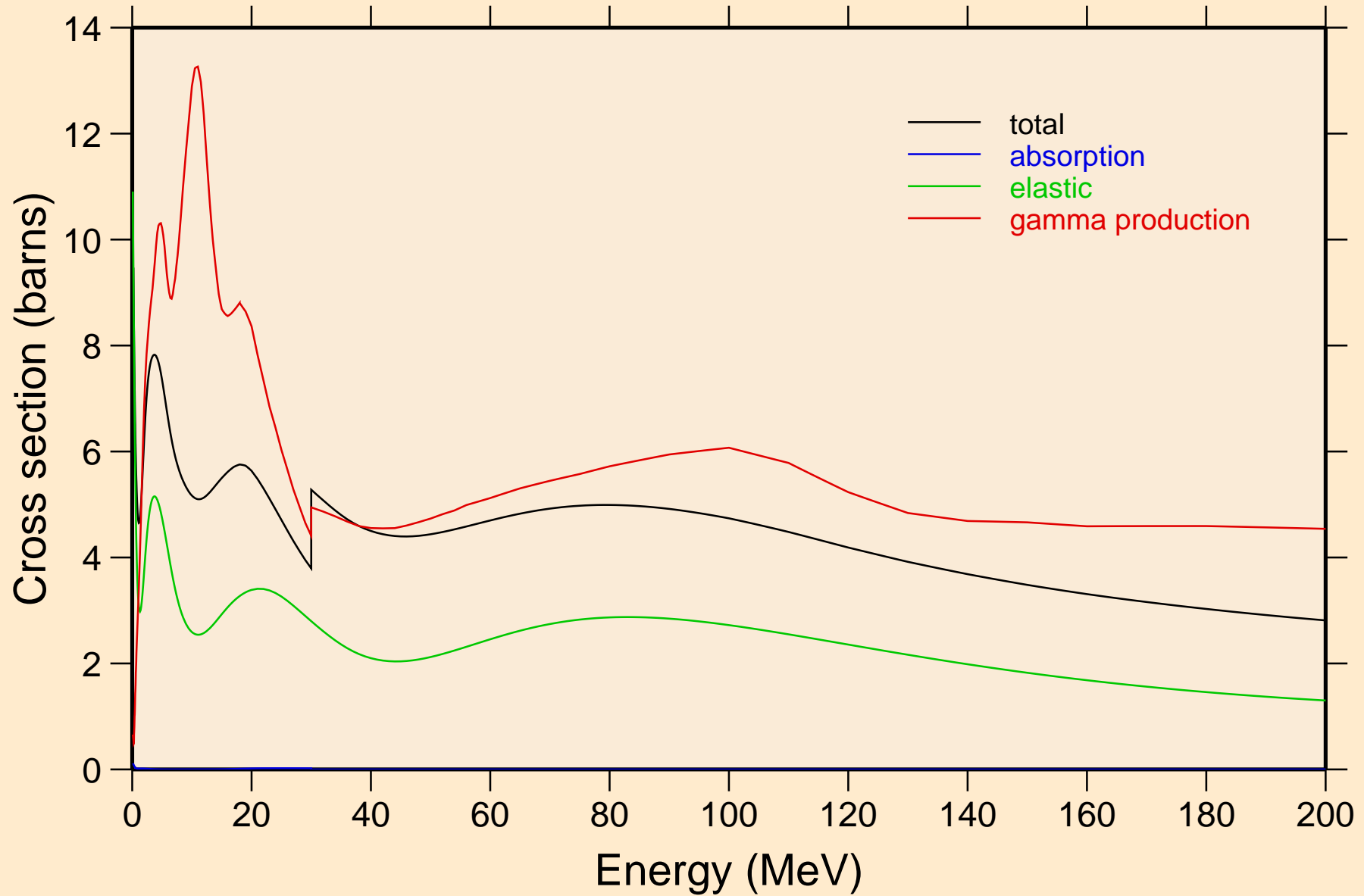

PO217 NRG TENDL-2015, AKONING

Non-threshold reactions

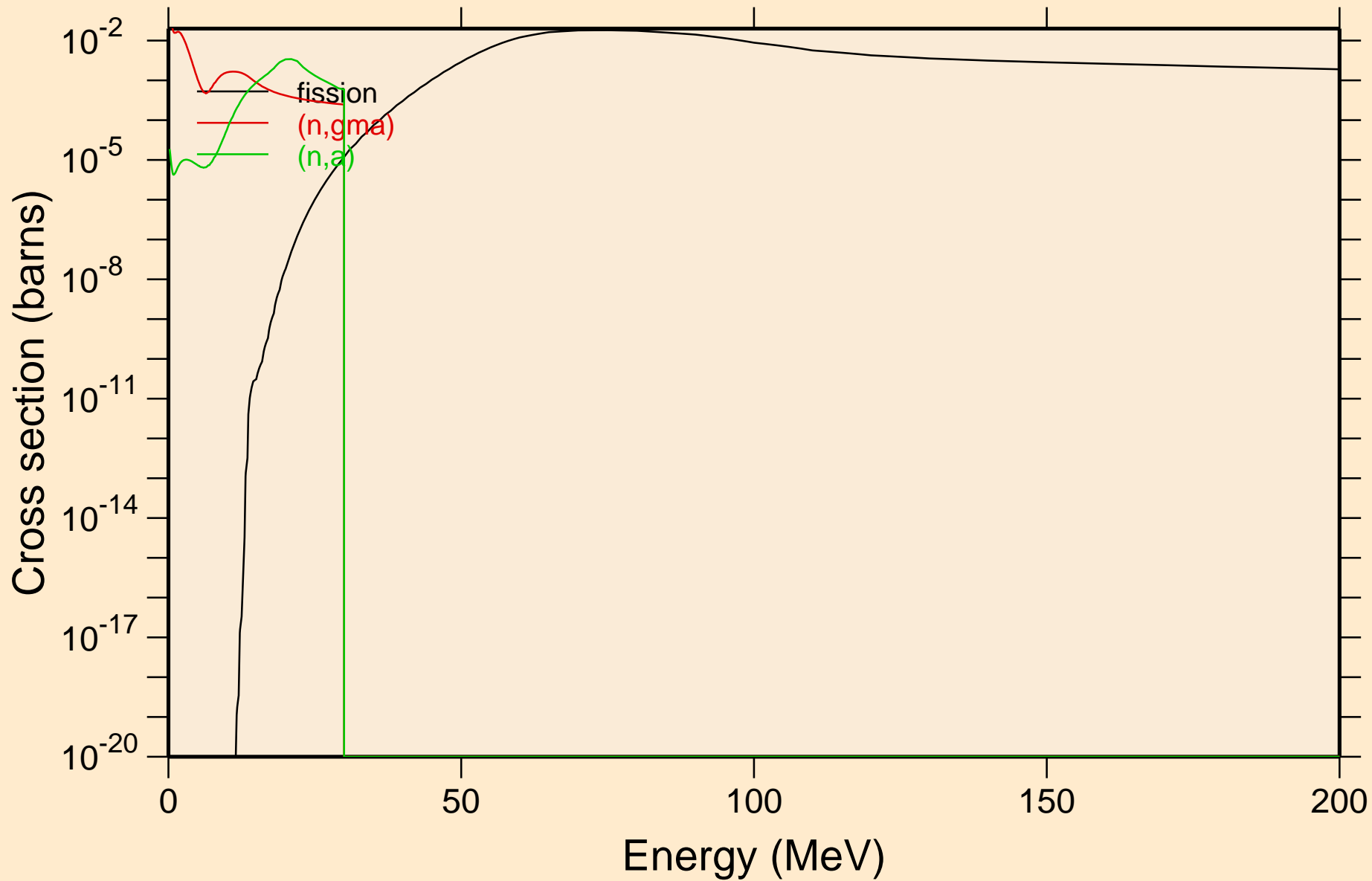

PO217 NRG TENDL-2015, AKONING

Inelastic levels

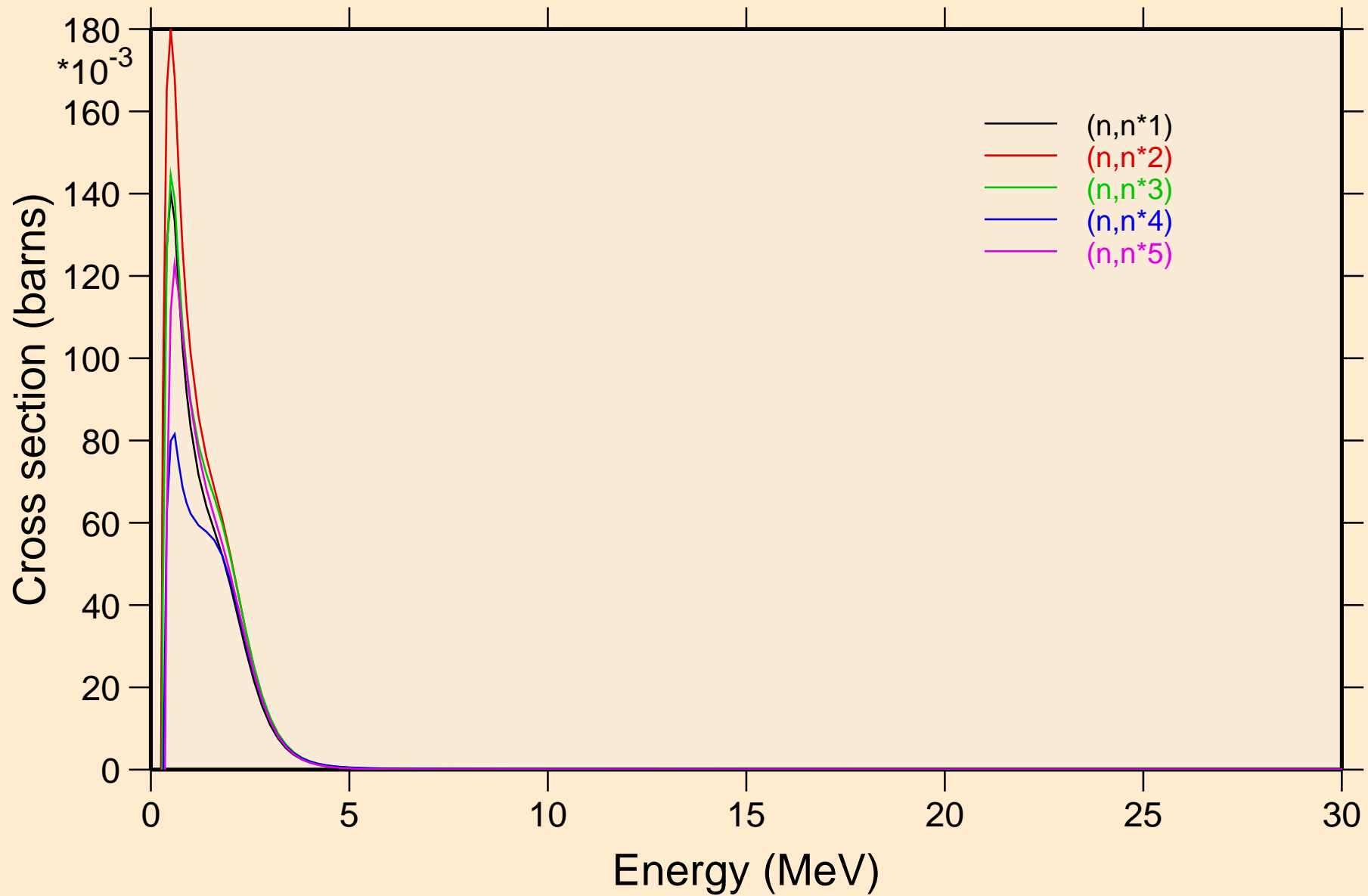

PO217 NRG TENDL-2015, AKONING

Inelastic levels

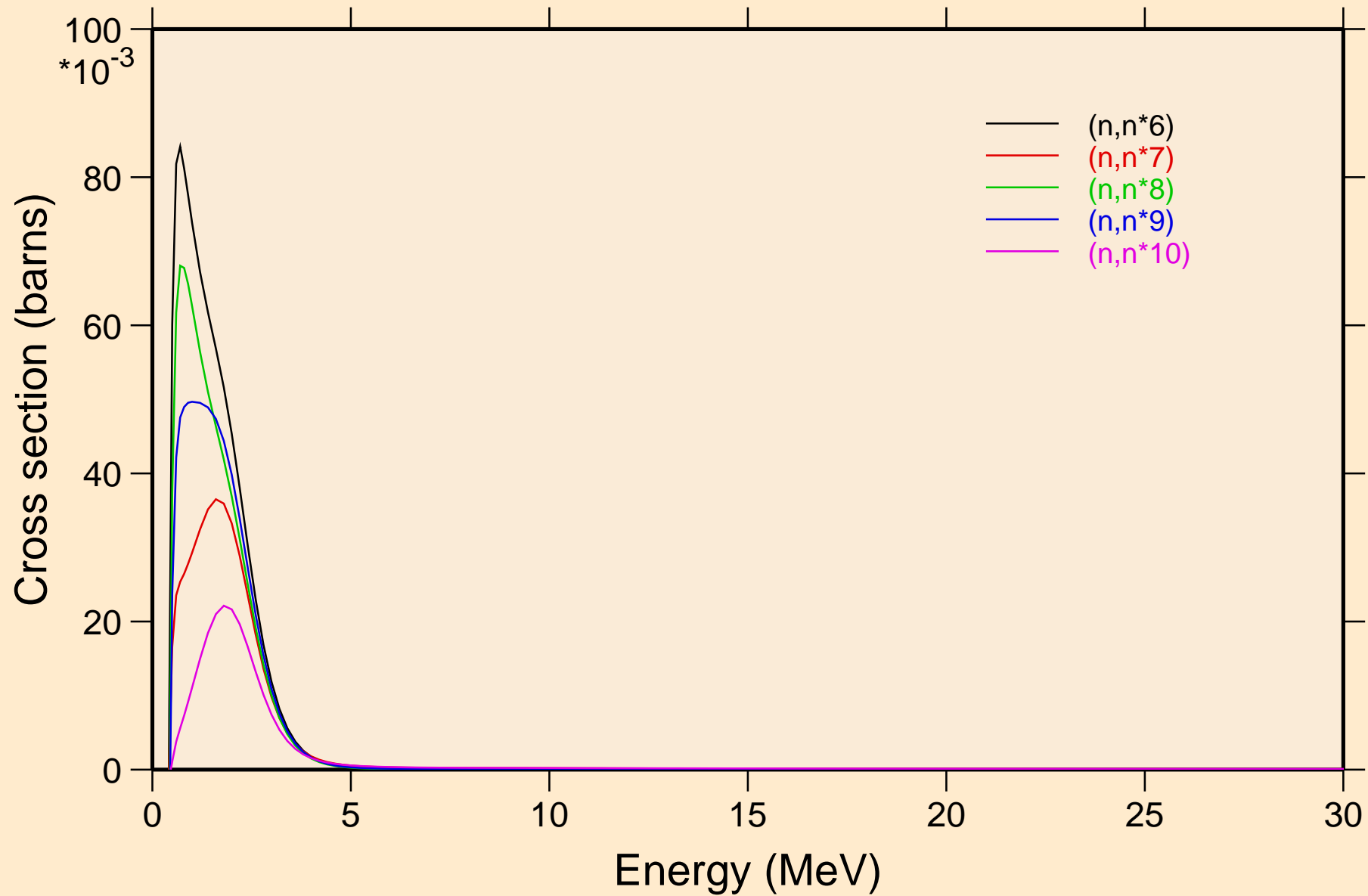

PO217 NRG TENDL-2015, AKONING

Inelastic levels

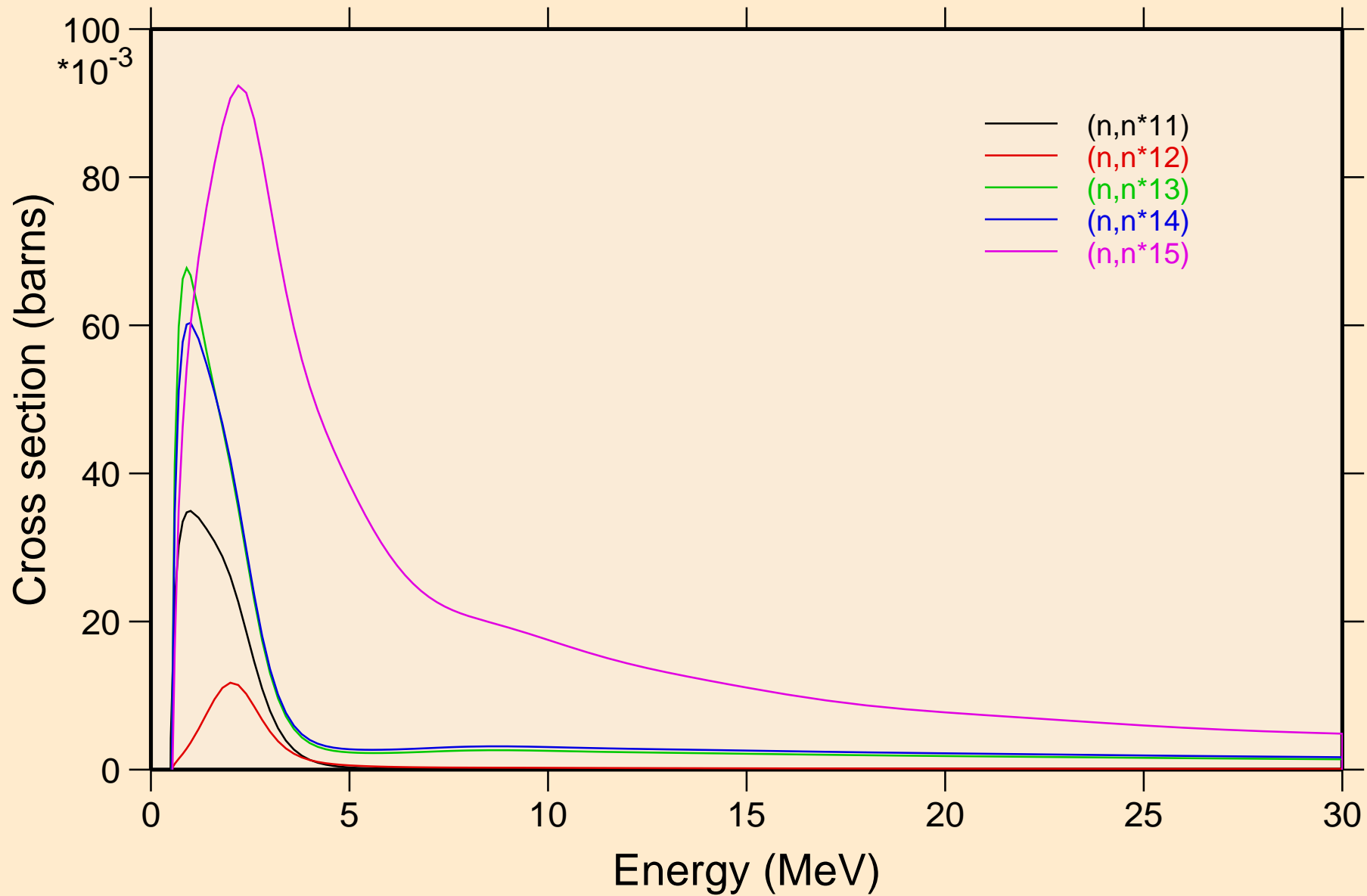

PO217 NRG TENDL-2015, AKONING

Inelastic levels

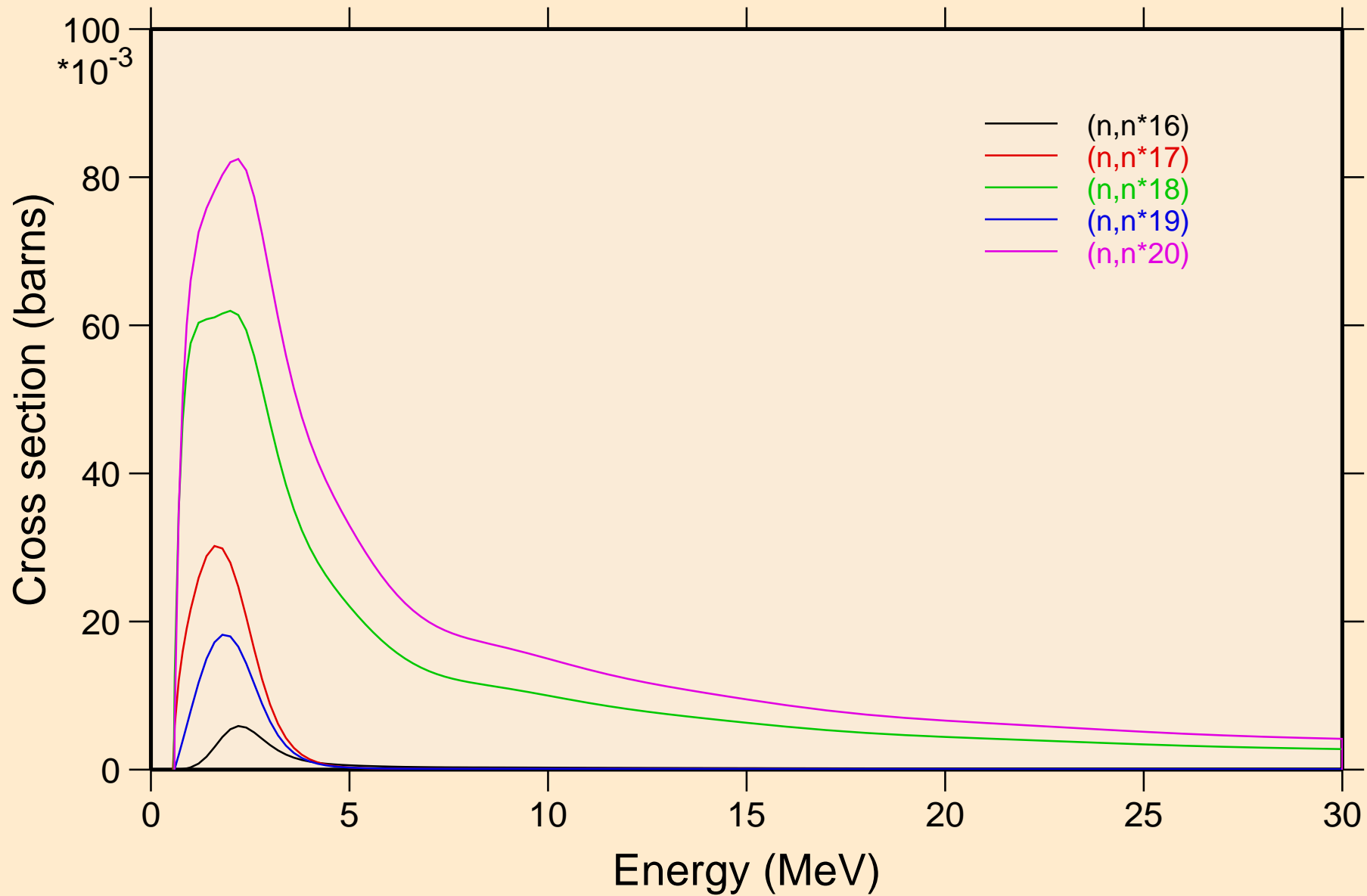

PO217 NRG TENDL-2015, AKONING

Inelastic levels

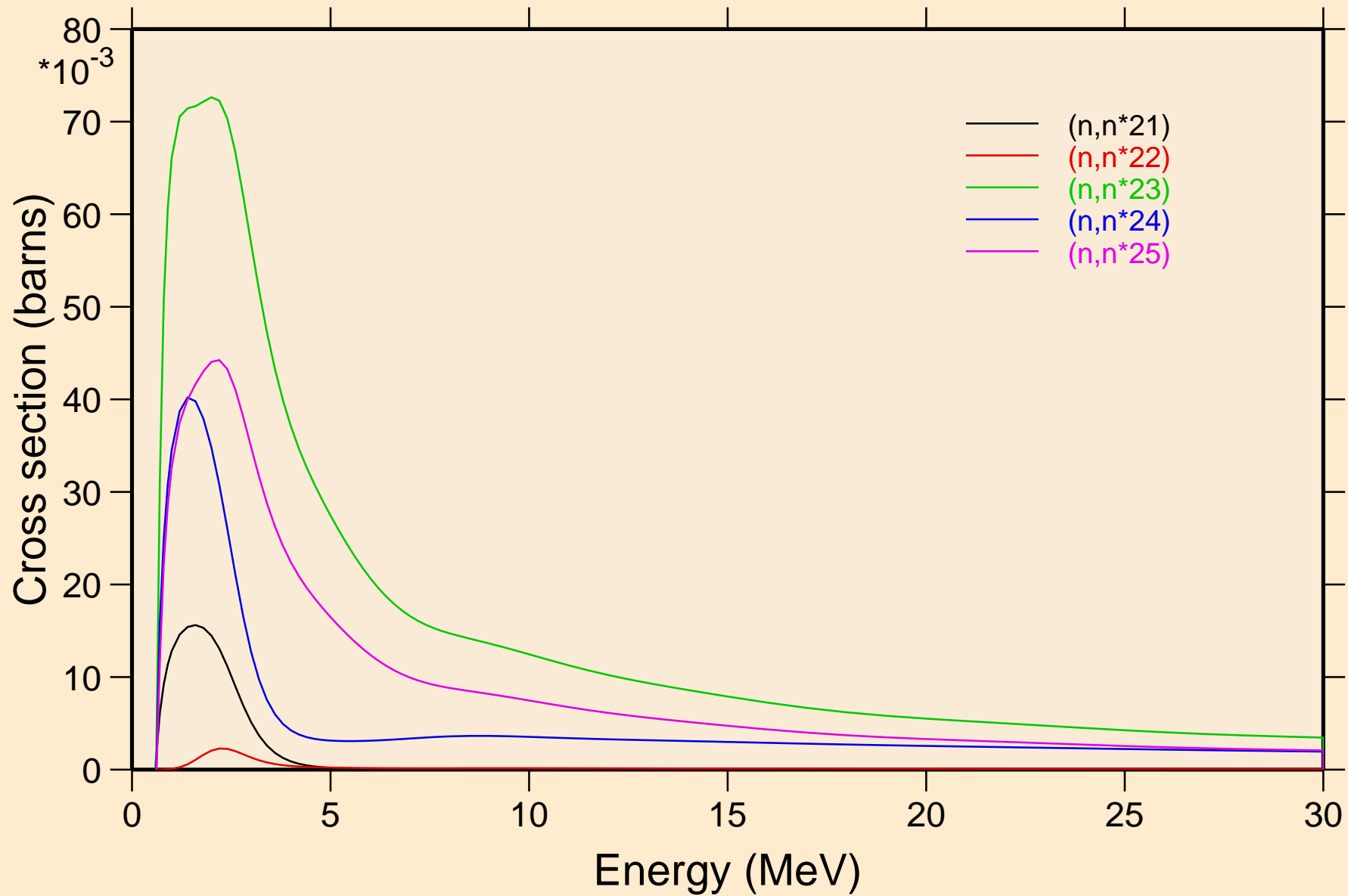

PO217 NRG TENDL-2015, AKONING

Inelastic levels

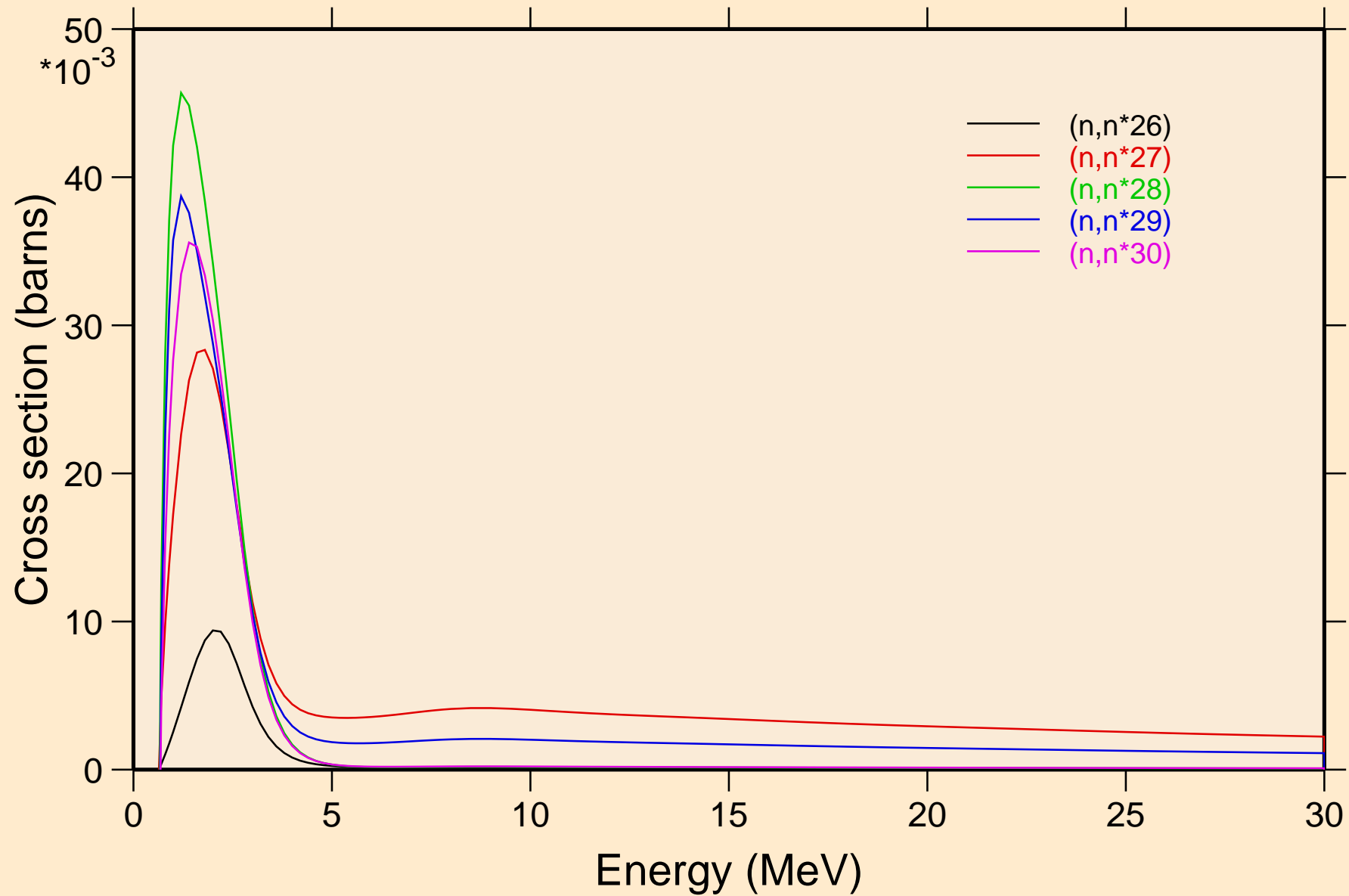

PO217 NRG TENDL-2015, AKONING

Threshold reactions

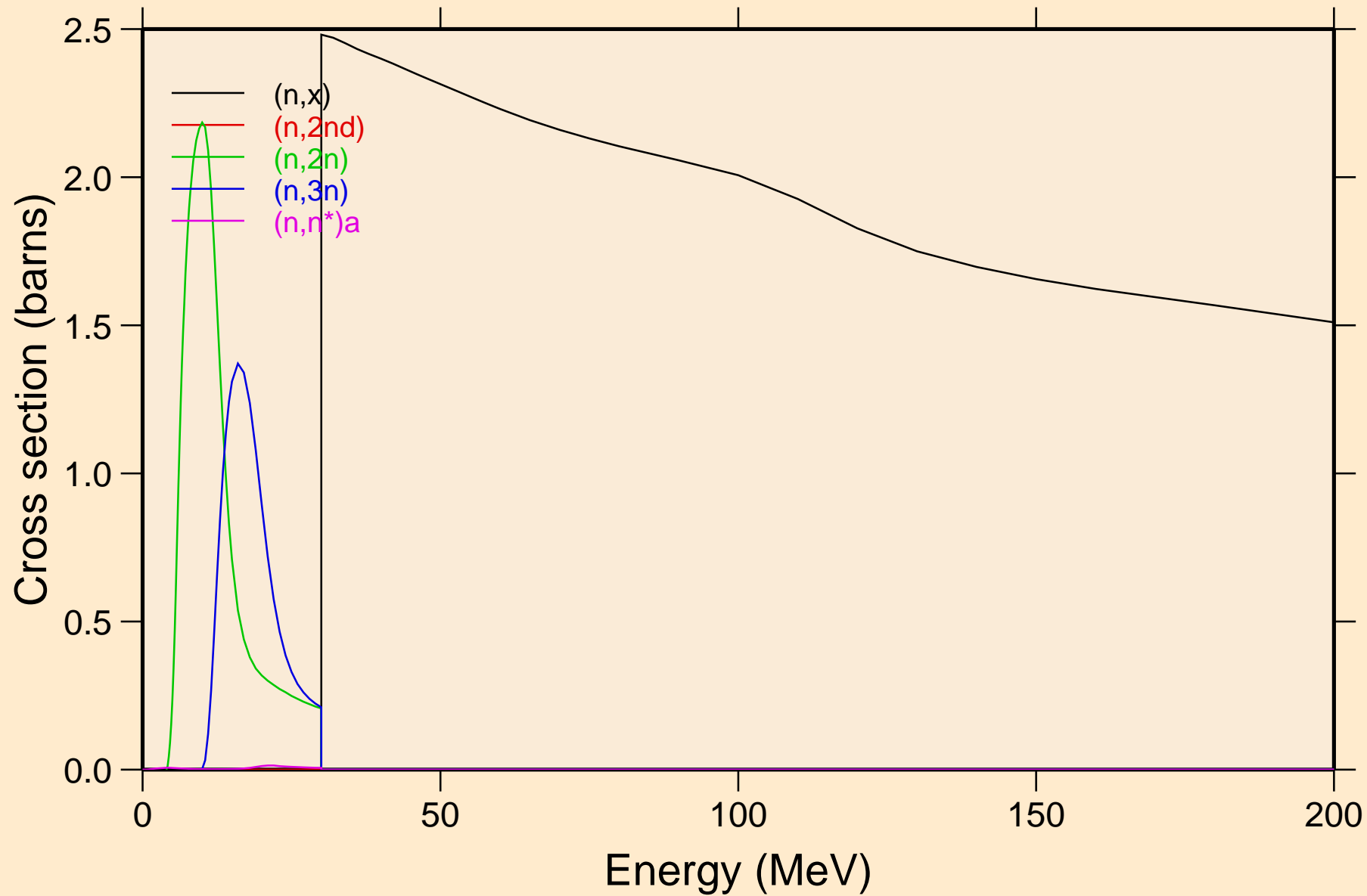

PO217 NRG TENDL-2015, AKONING

Threshold reactions

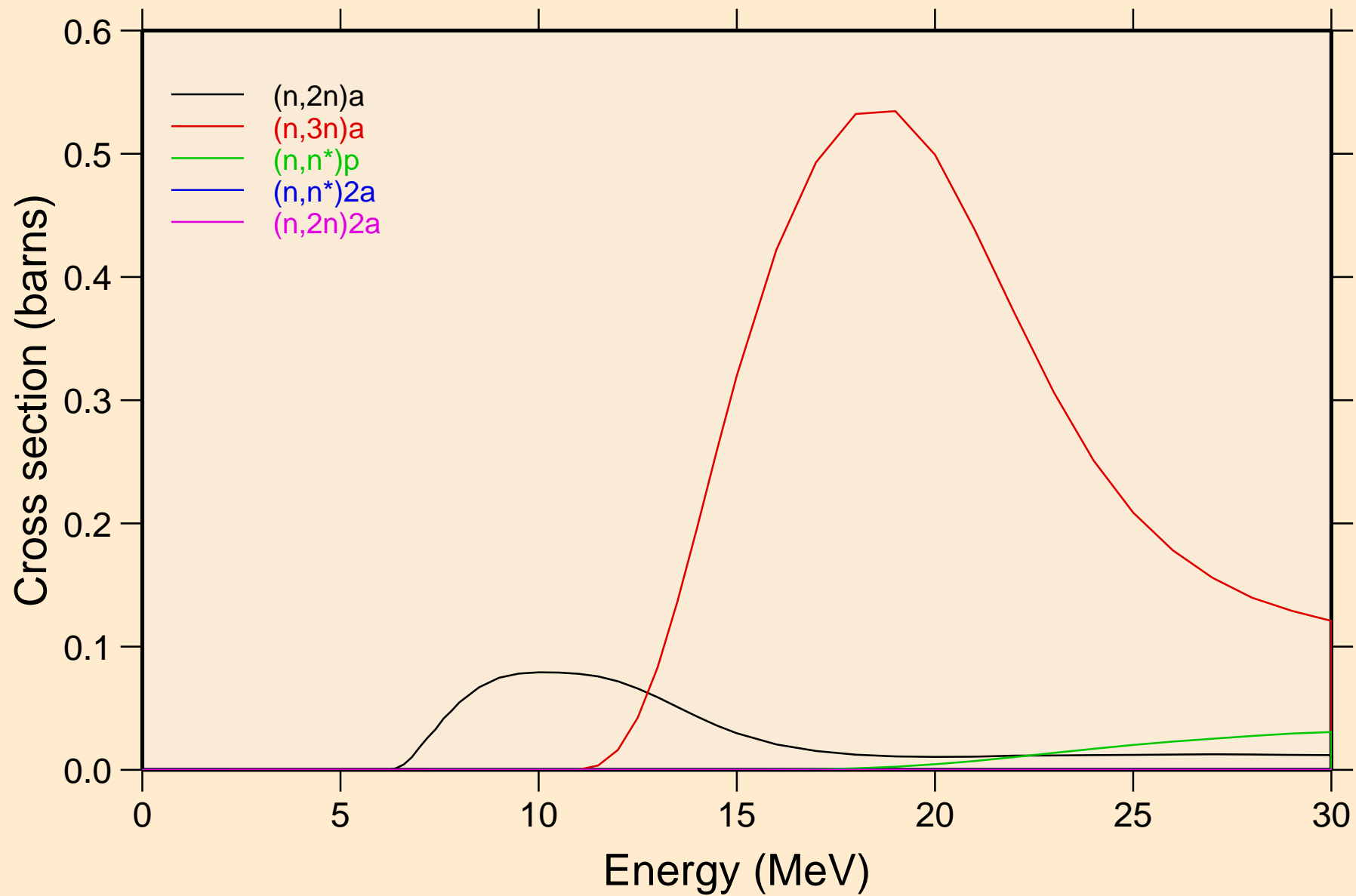

PO217 NRG TENDL-2015, AKONING

Threshold reactions

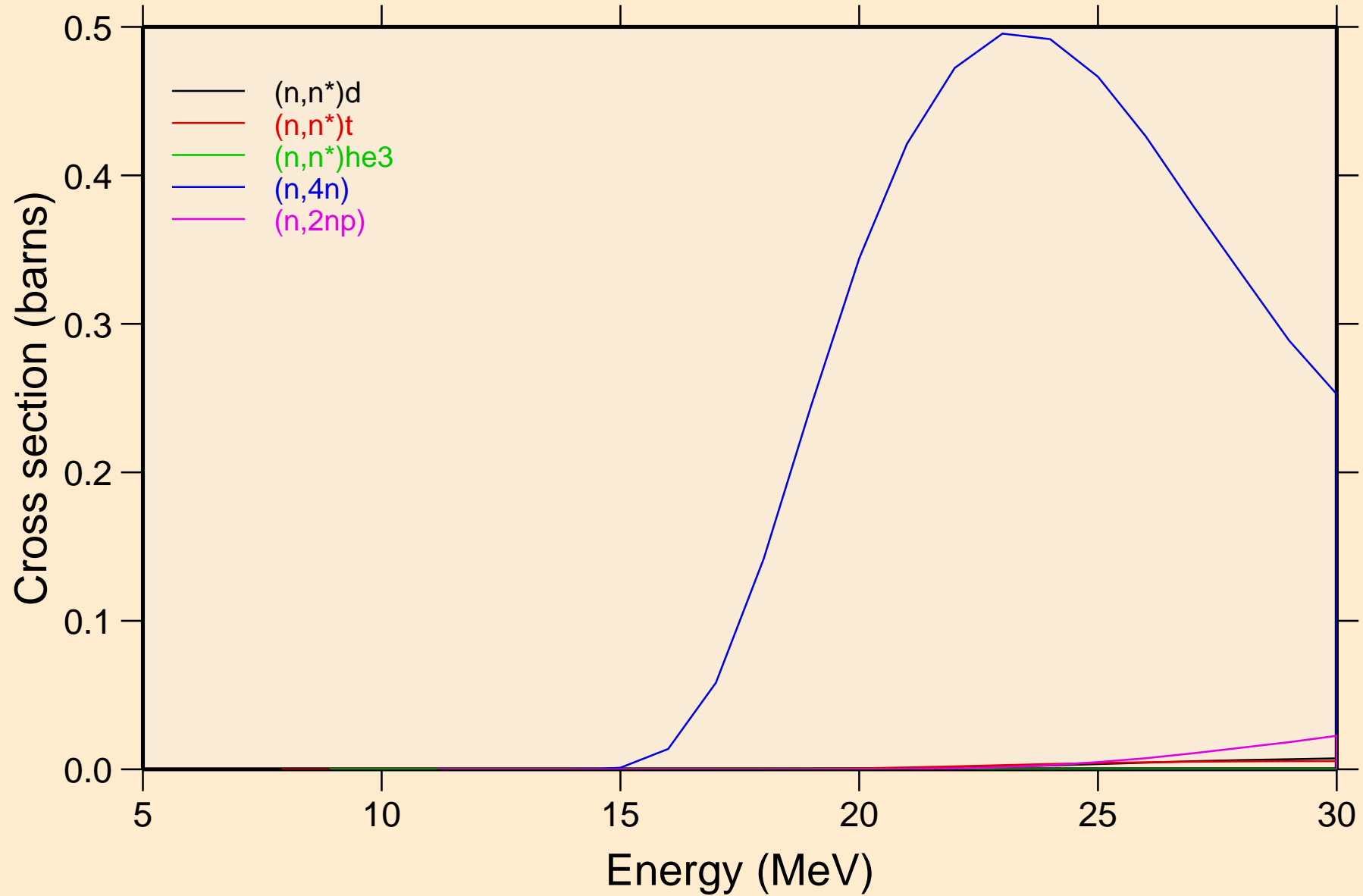

PO217 NRG TENDL-2015, AKONING

Threshold reactions

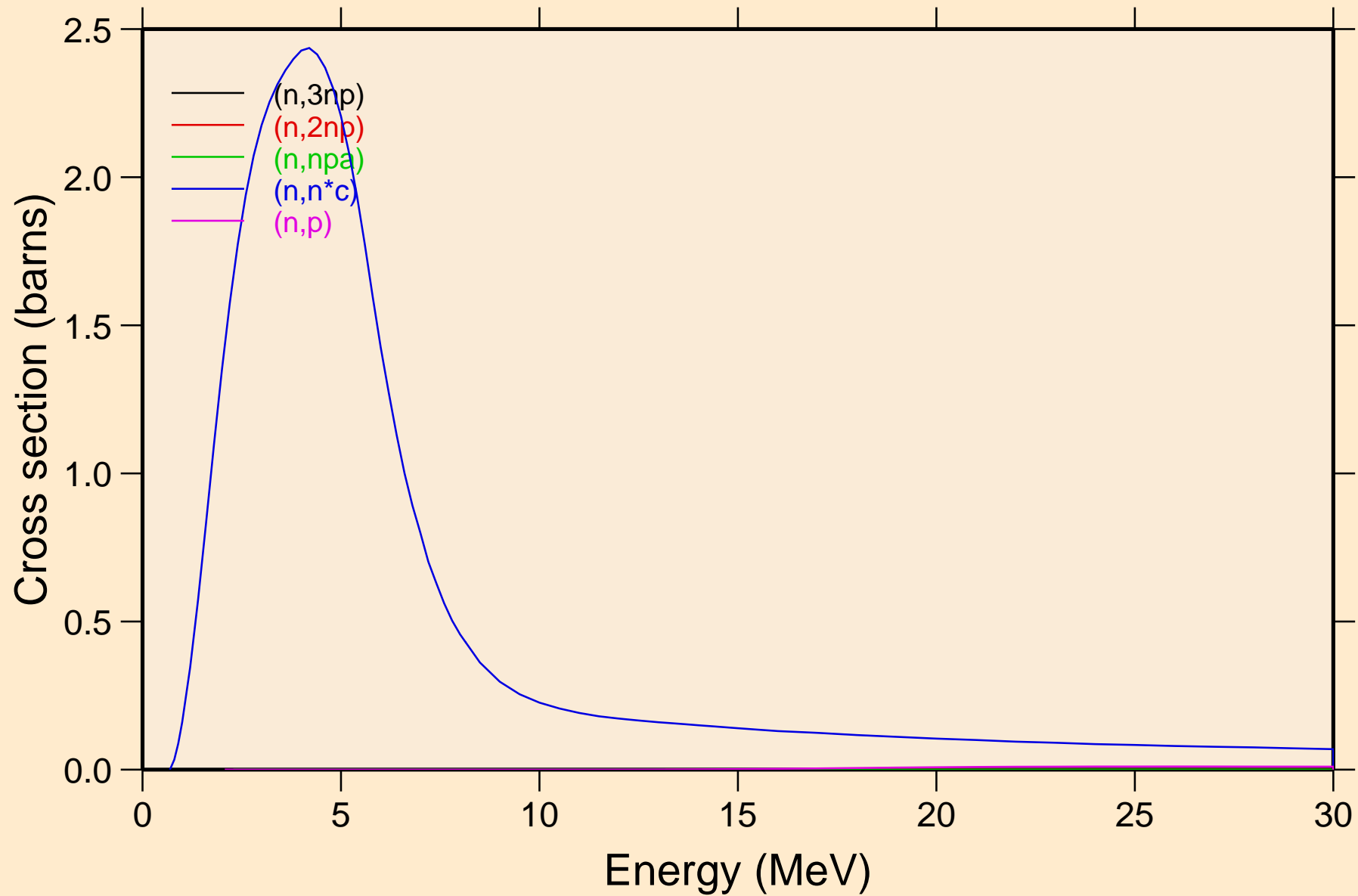

PO217 NRG TENDL-2015, AKONING

Threshold reactions

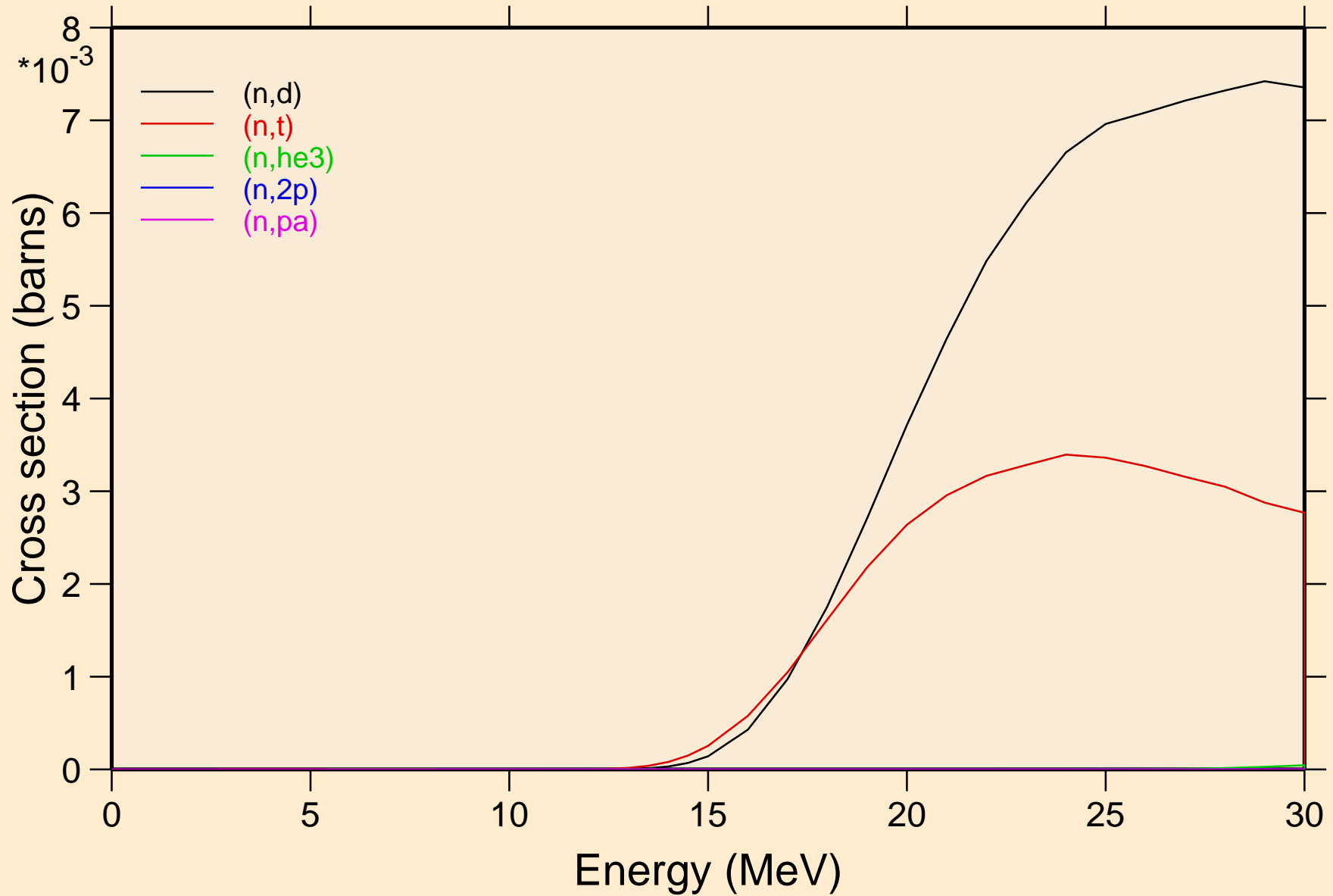

PO217 NRG TENDL-2015, AKONING
Threshold reactions

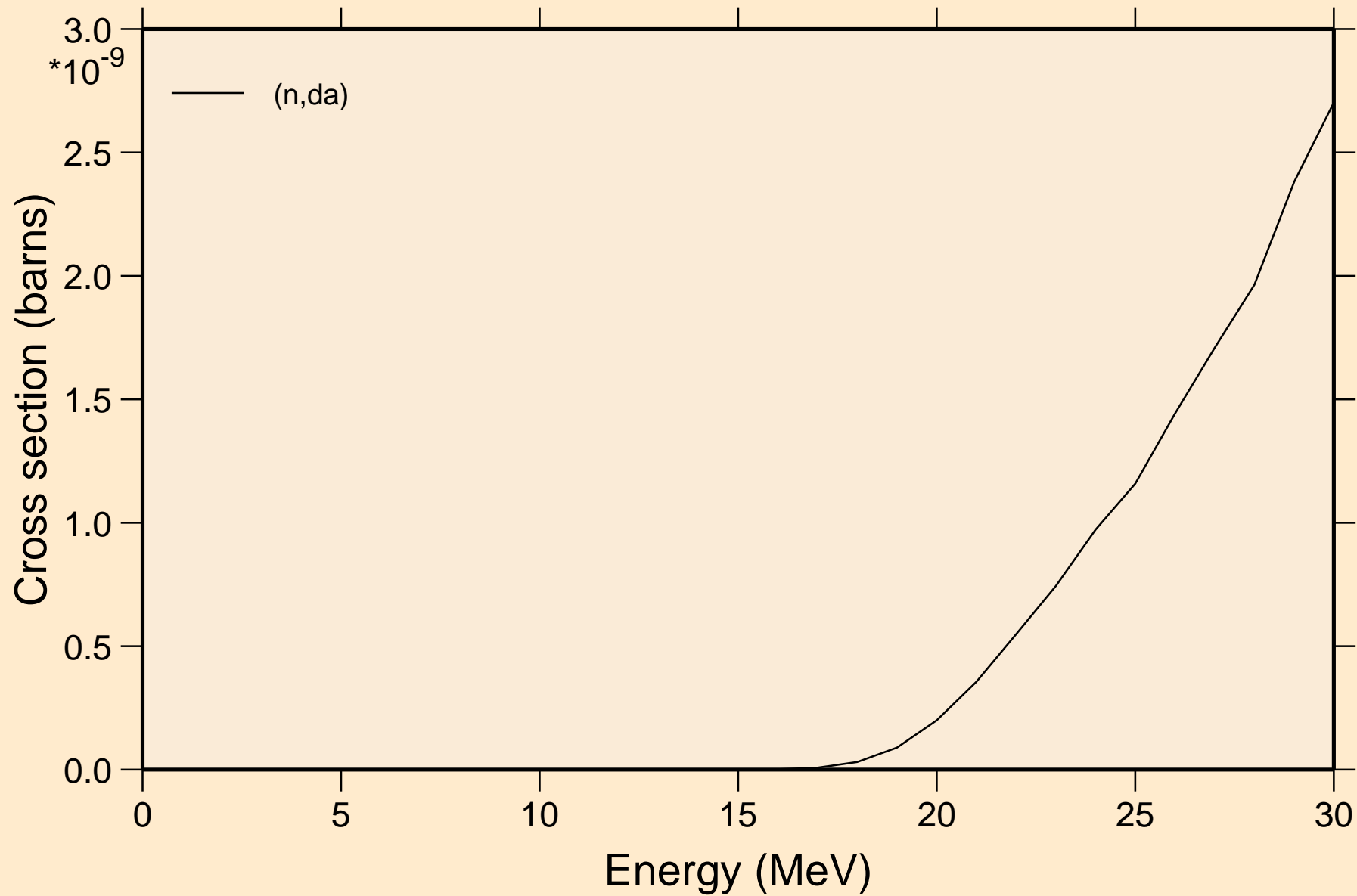

PO217 NRG TENDL-2015, AKONING
angular distribution for elastic

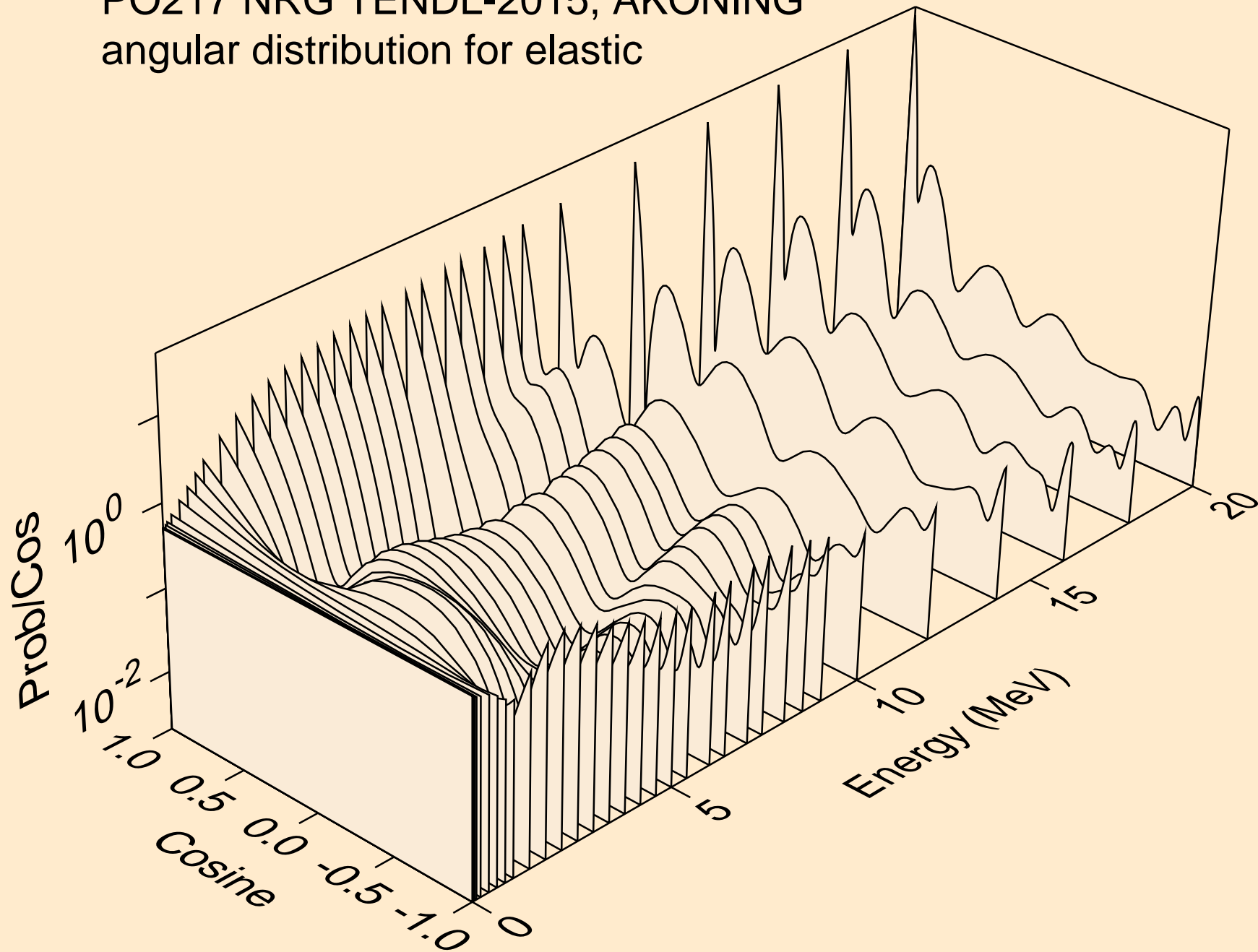

PO217 NRG TENDL-2015, AKONING
angular distribution for elastic

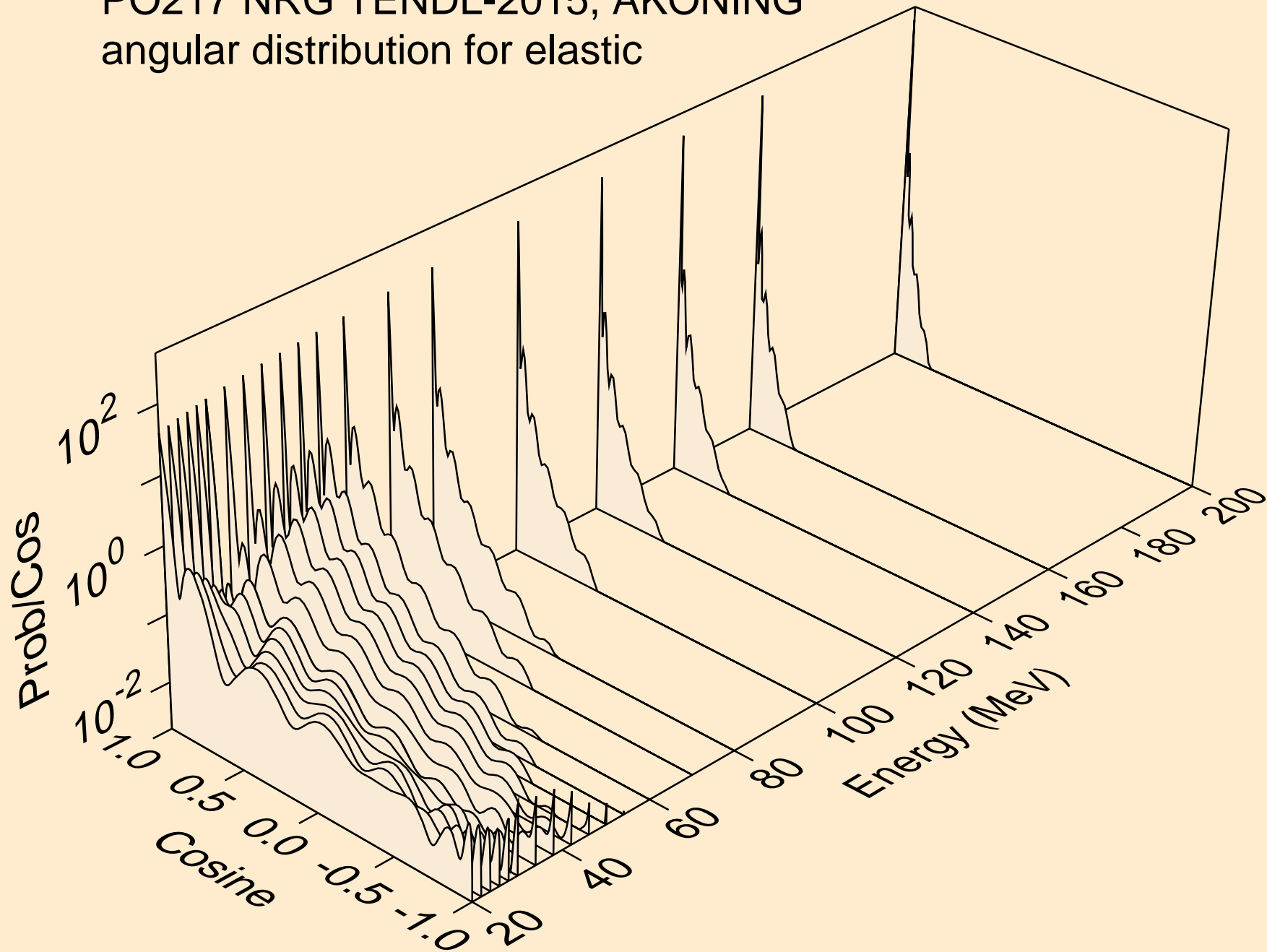

PO217 NRG TENDL-2015, AKONING
angular distribution for (n,n*1)

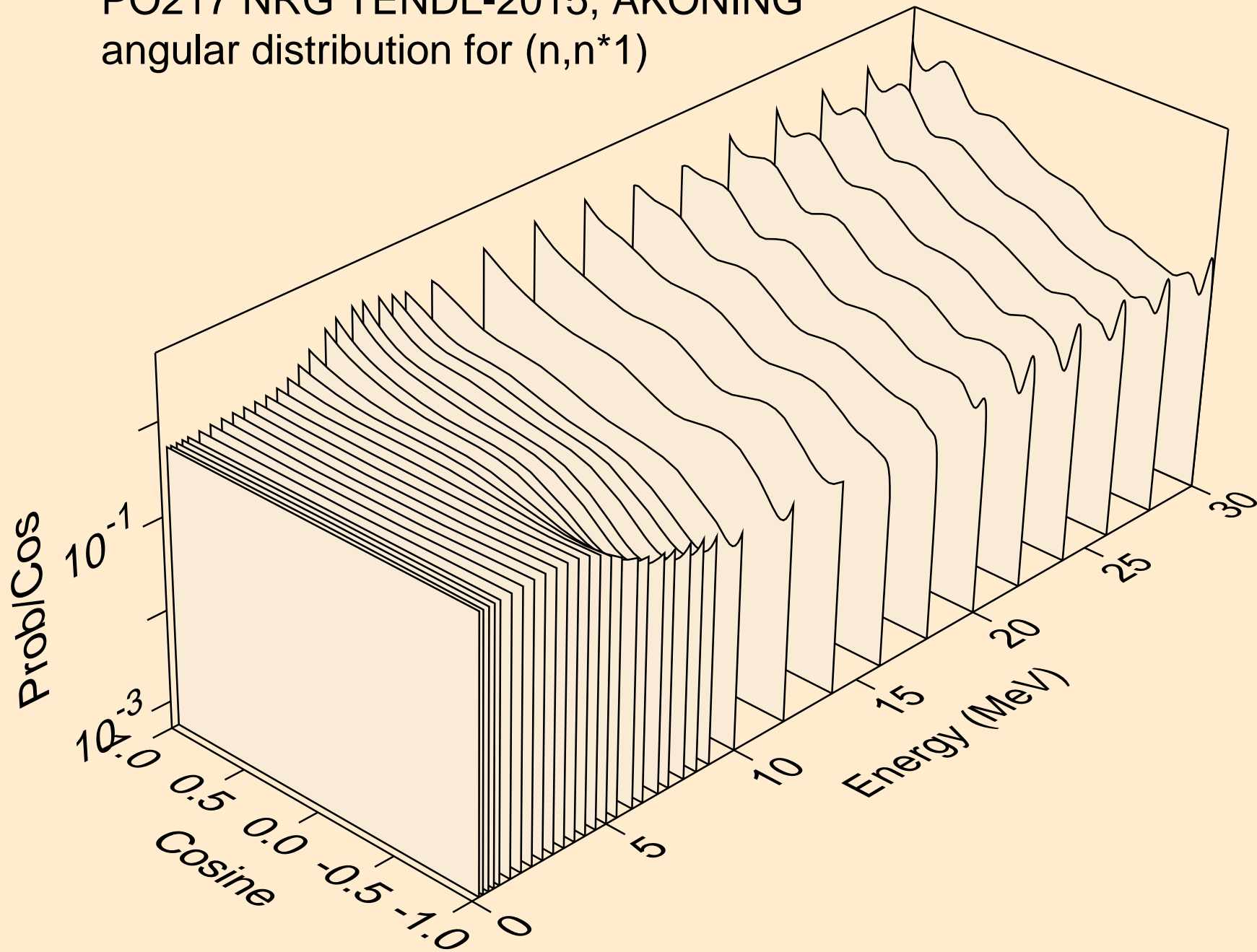

PO217 NRG TENDL-2015, AKONING
angular distribution for (n,n*2)

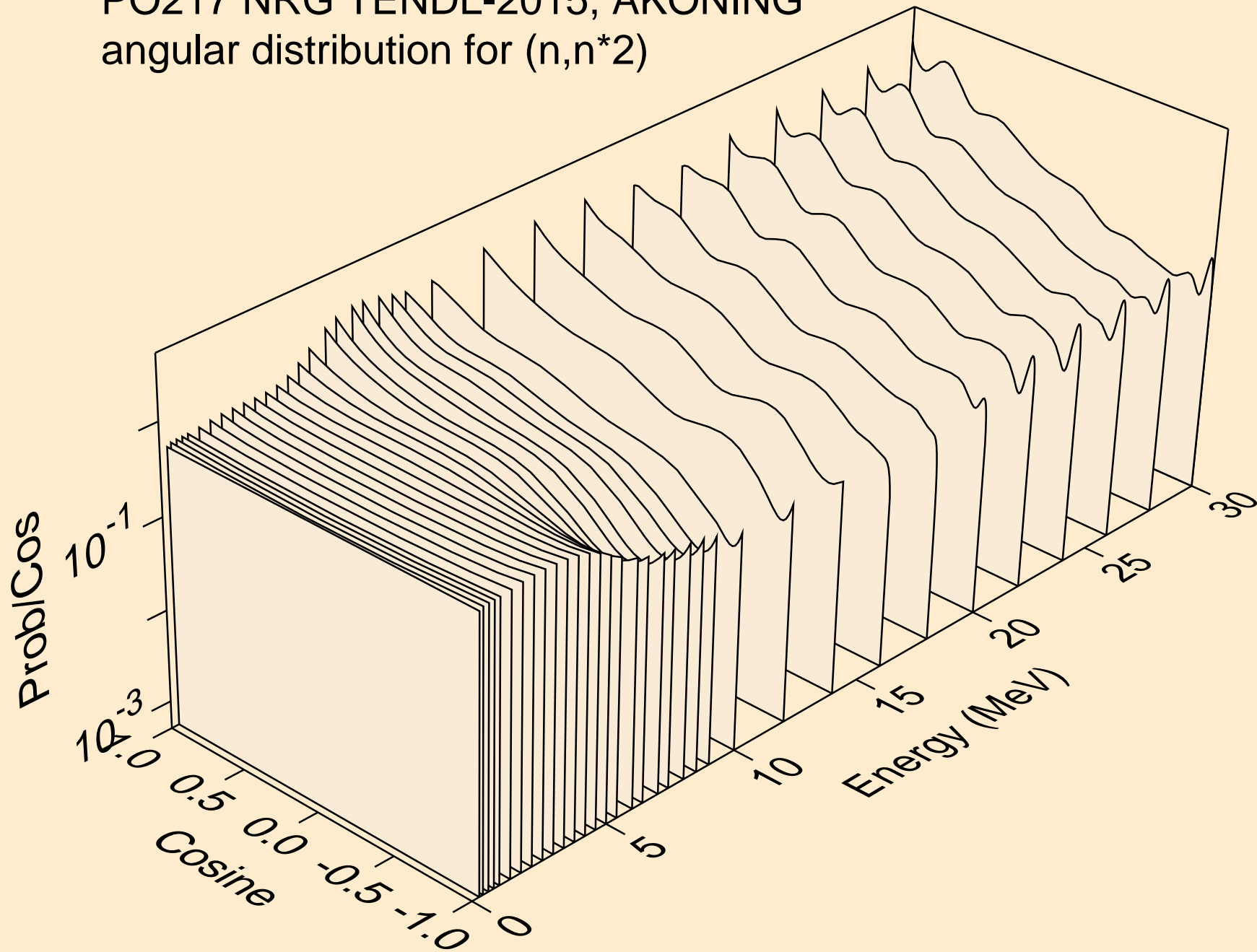

PO217 NRG TENDL-2015, AKONING
angular distribution for (n,n*3)

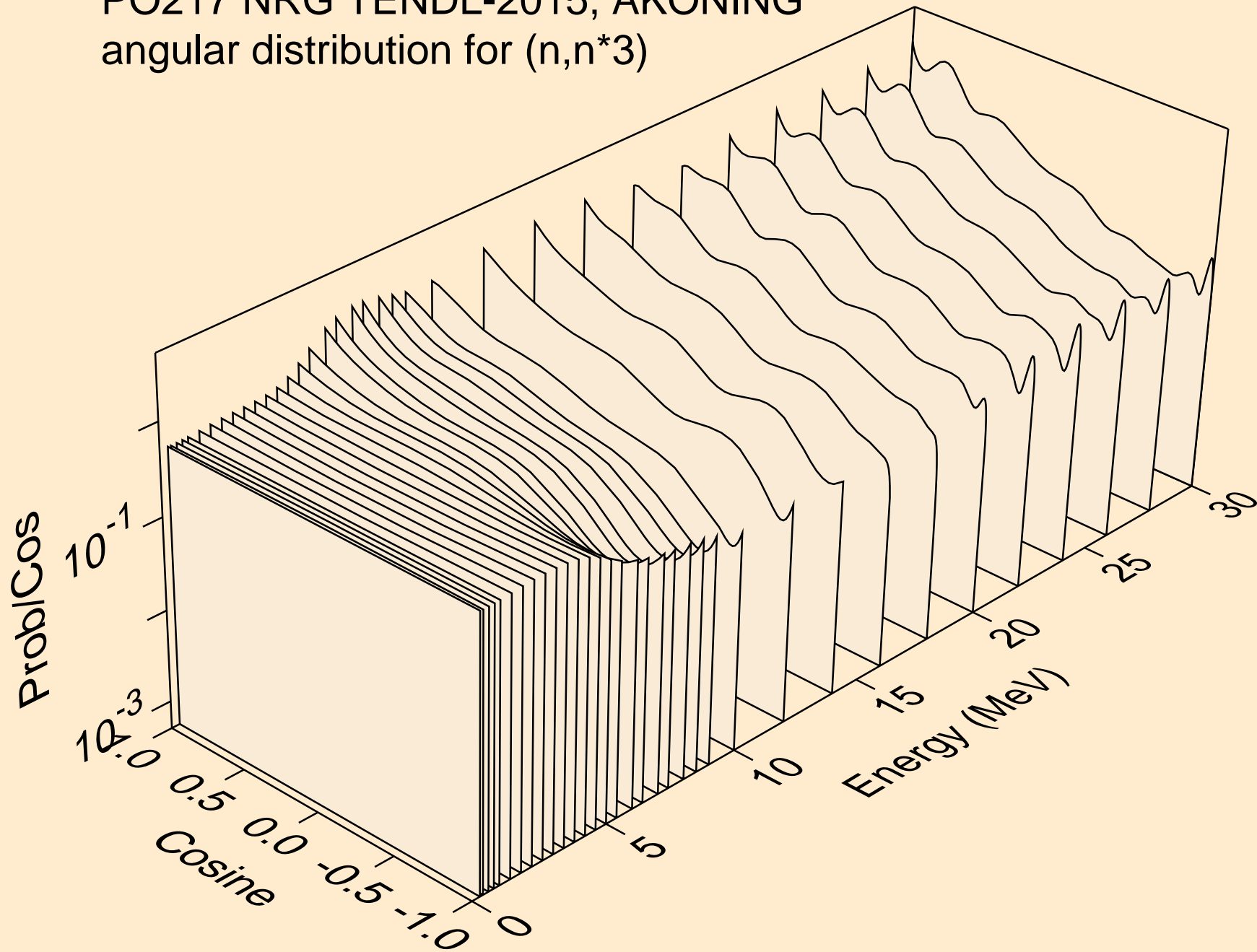

PO217 NRG TENDL-2015, AKONING
angular distribution for (n,n*4)

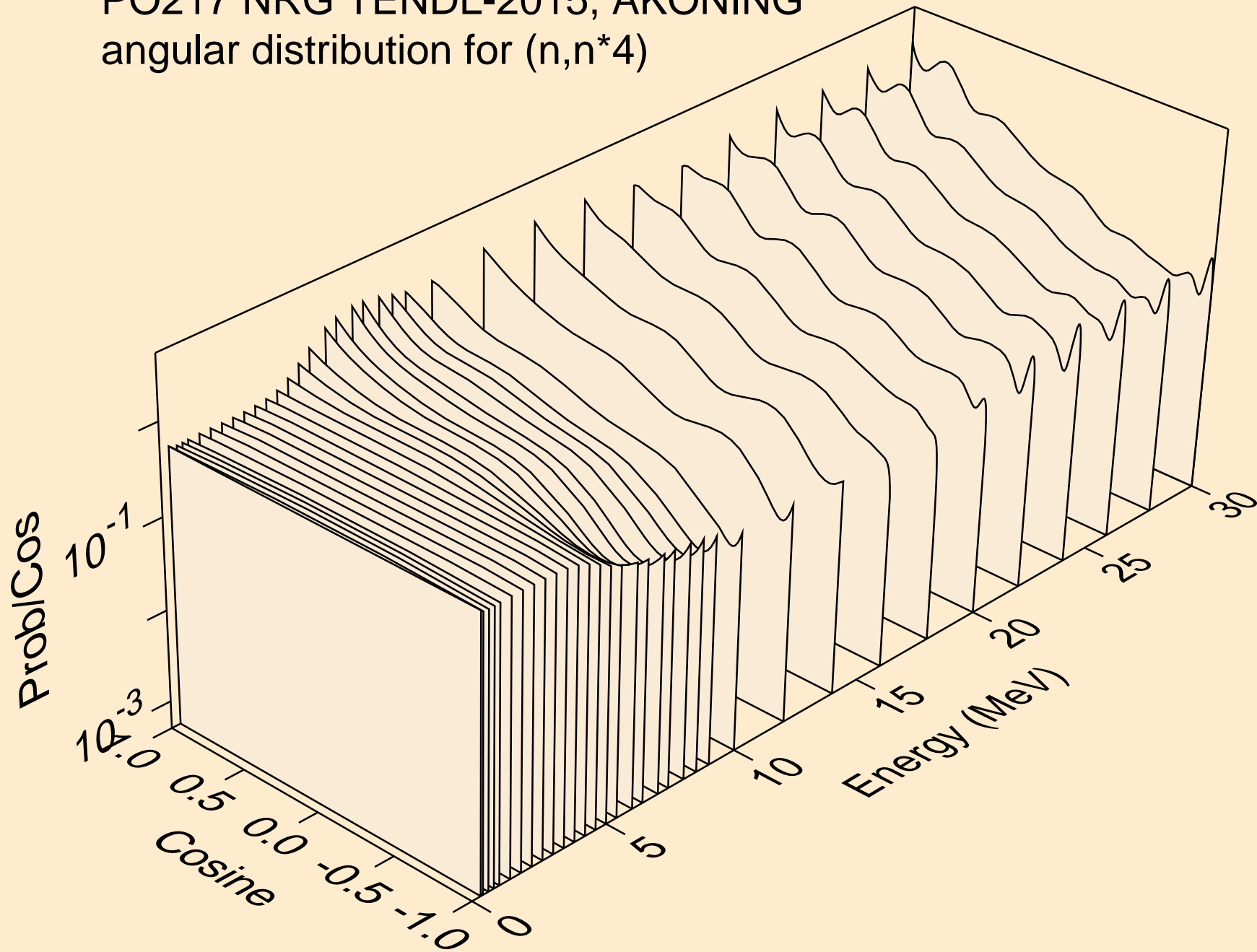

PO217 NRG TENDL-2015, AKONING
angular distribution for (n,n*5)

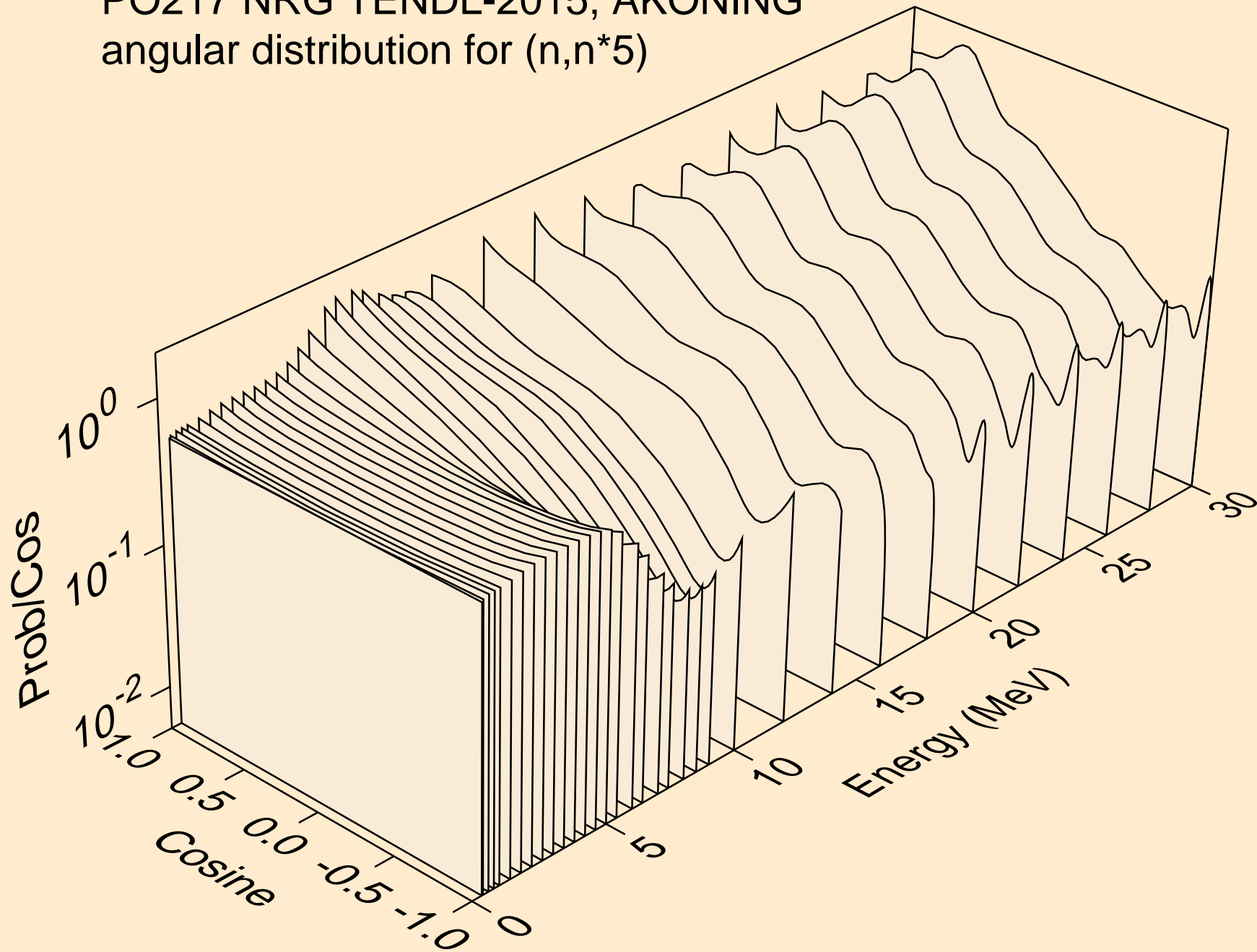

PO217 NRG TENDL-2015, AKONING
angular distribution for (n,n*6)

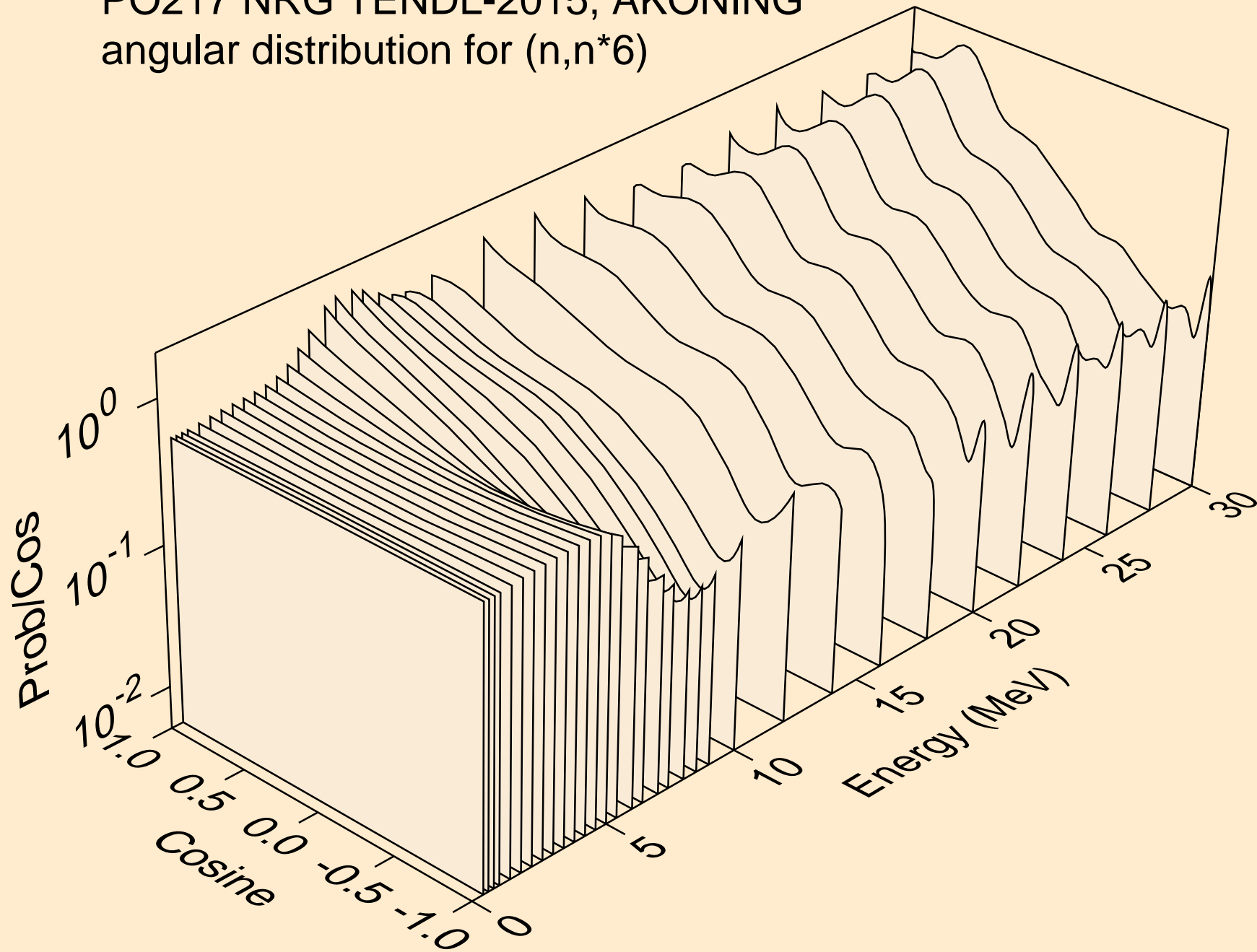

PO217 NRG TENDL-2015, AKONING
angular distribution for (n,n*7)

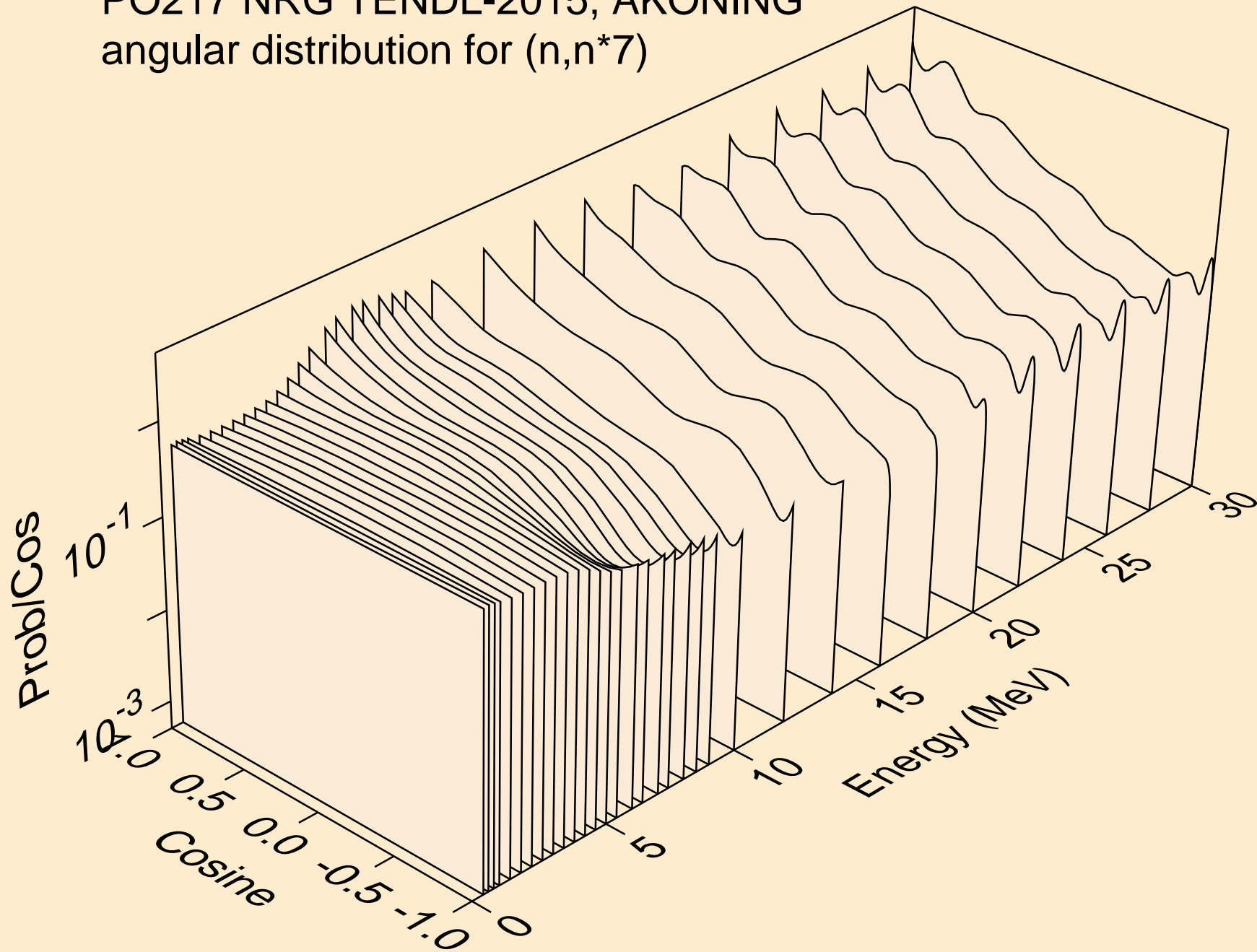

PO217 NRG TENDL-2015, AKONING
angular distribution for (n,n*8)

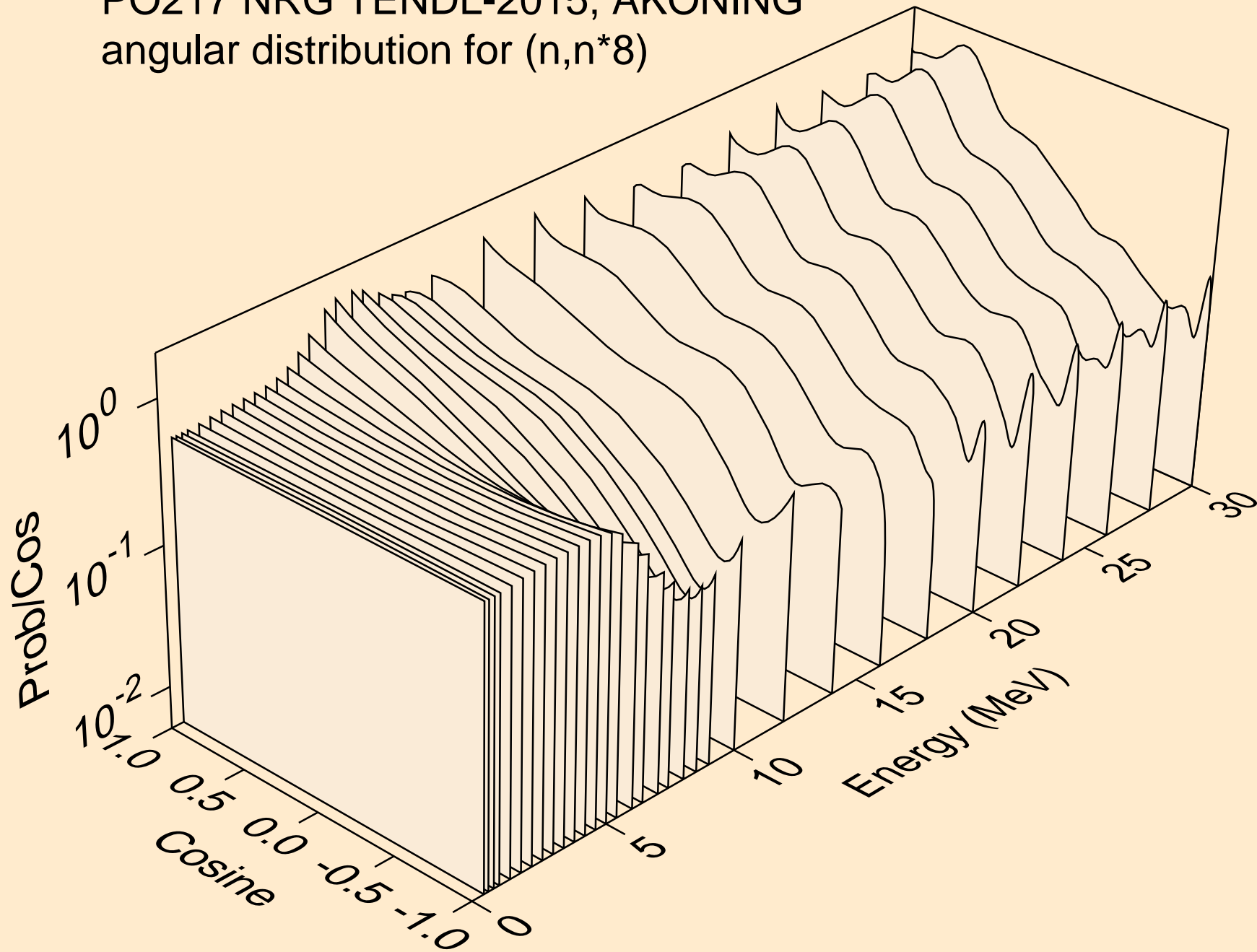

PO217 NRG TENDL-2015, AKONING
angular distribution for (n,n*9)

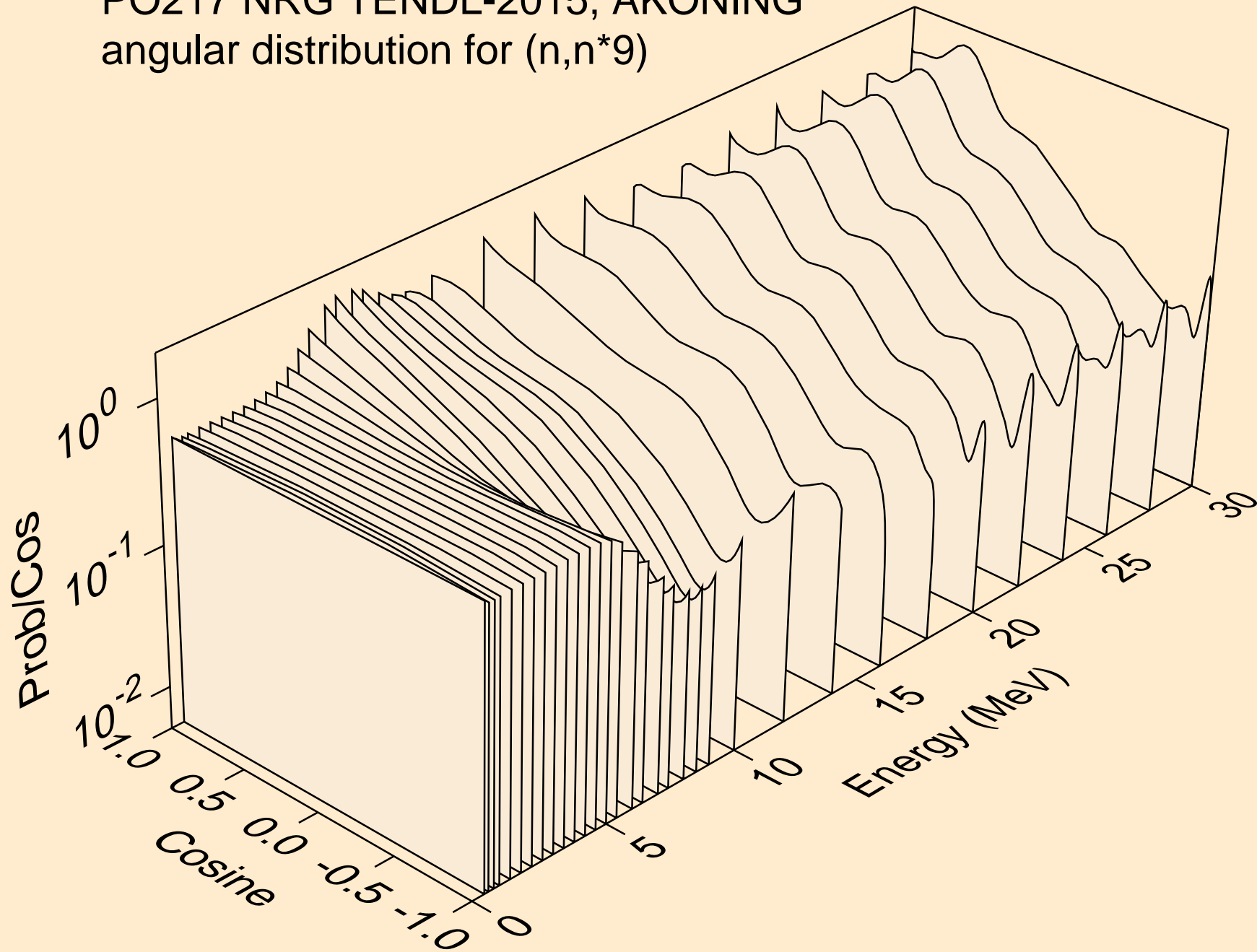

PO217 NRG TENDL-2015, AKONING
angular distribution for (n,n*10)

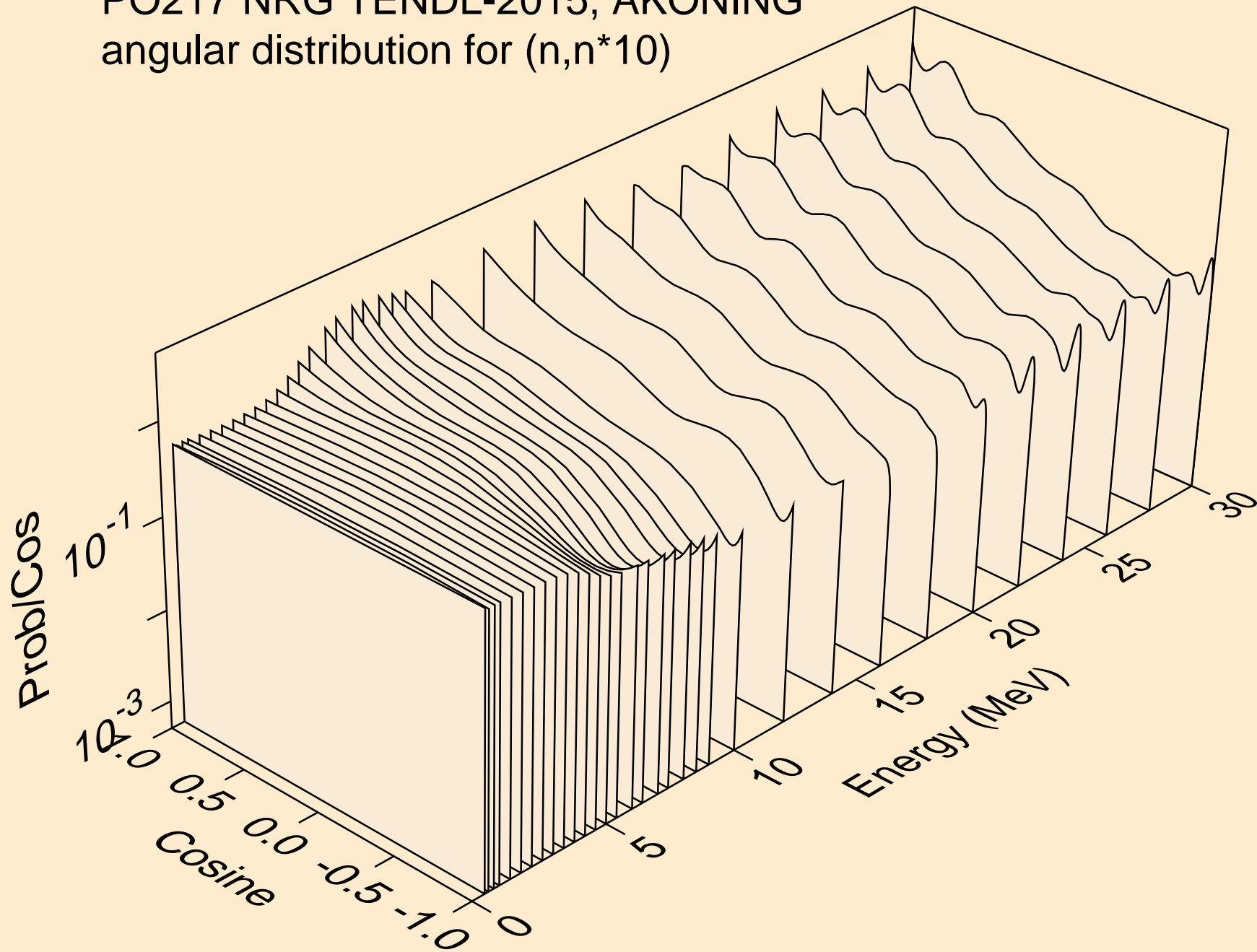

PO217 NRG TENDL-2015, AKONING
angular distribution for (n,n*11)

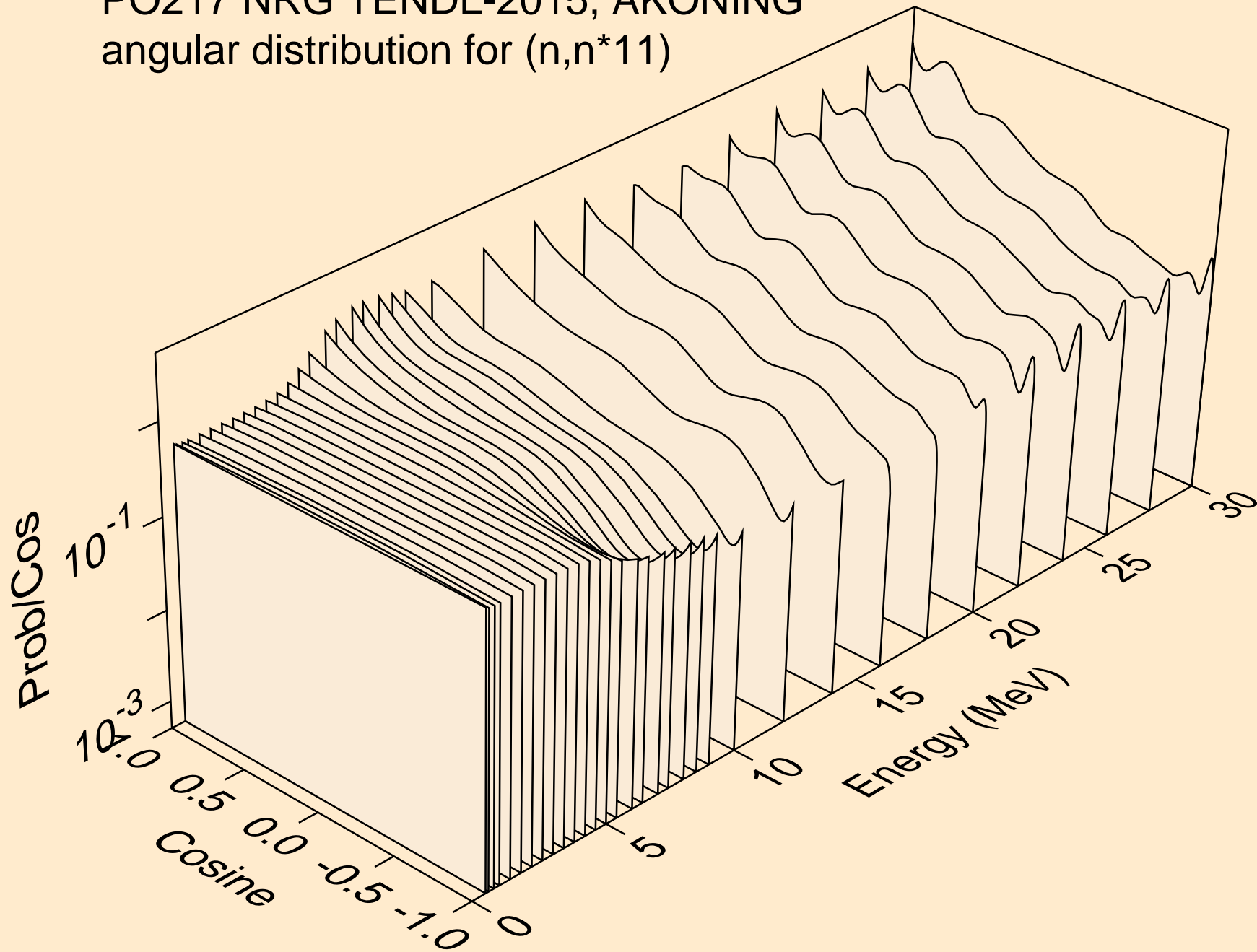

PO217 NRG TENDL-2015, AKONING
angular distribution for (n,n*12)

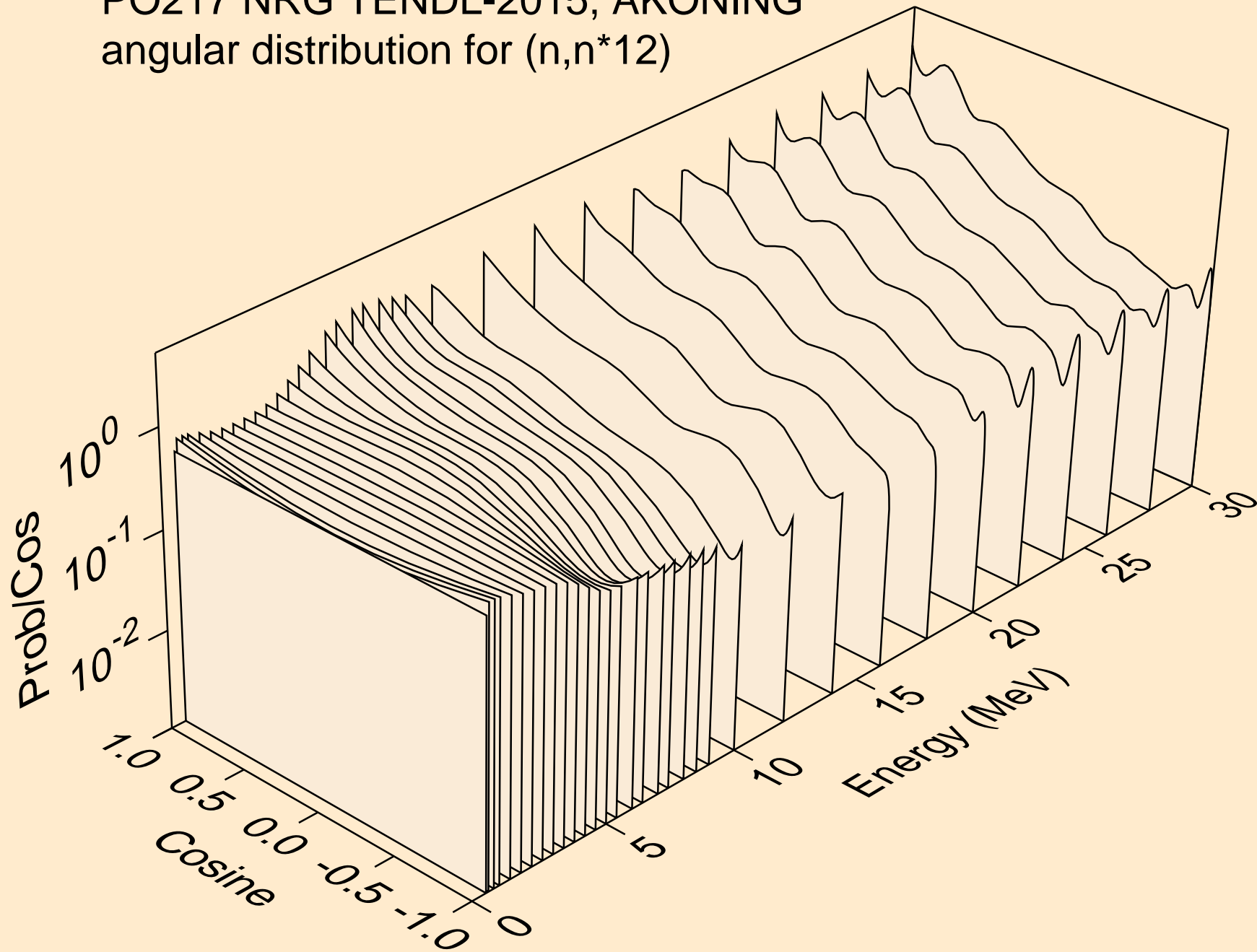

PO217 NRG TENDL-2015, AKONING
angular distribution for (n,n*13)

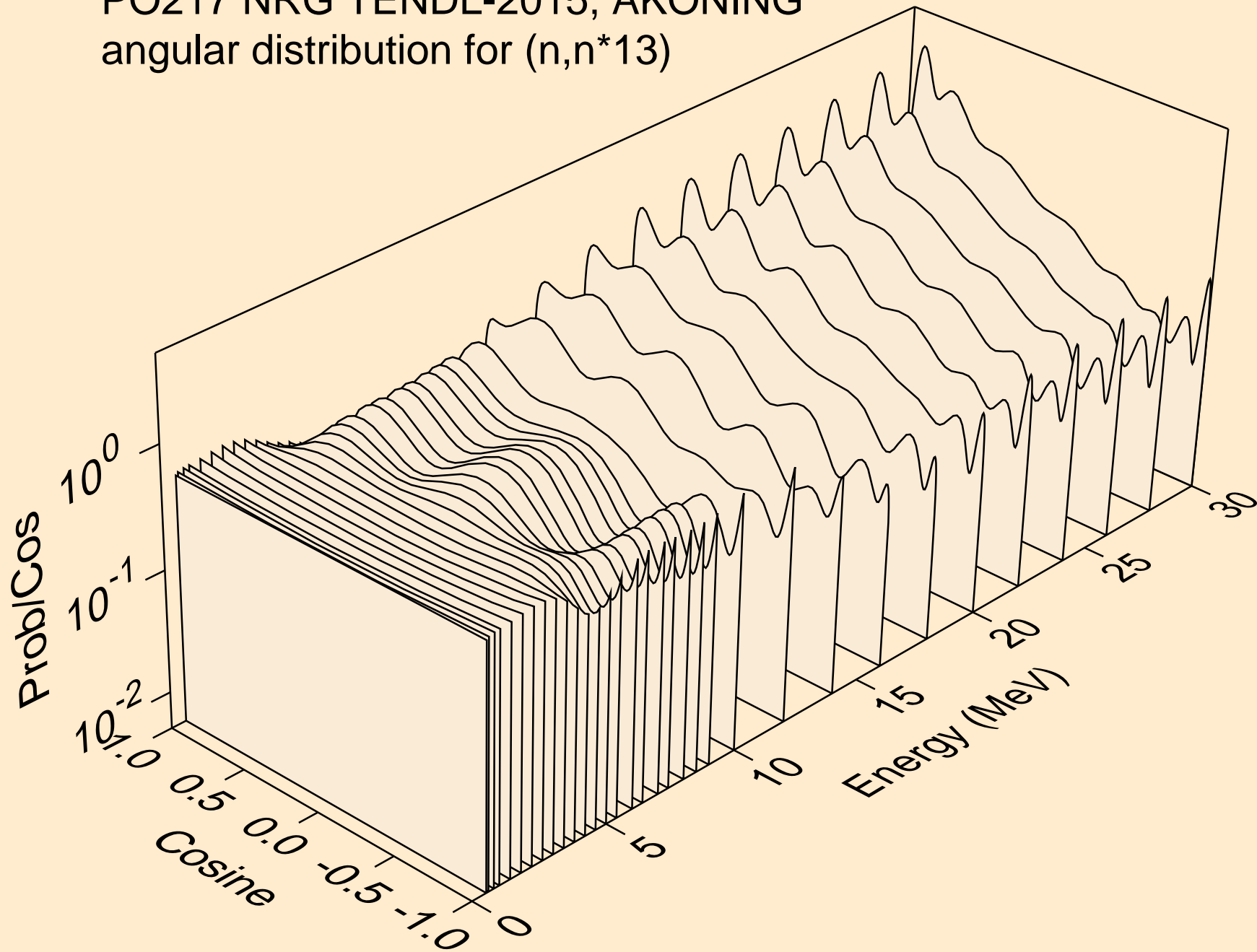

PO217 NRG TENDL-2015, AKONING
angular distribution for (n,n*14)

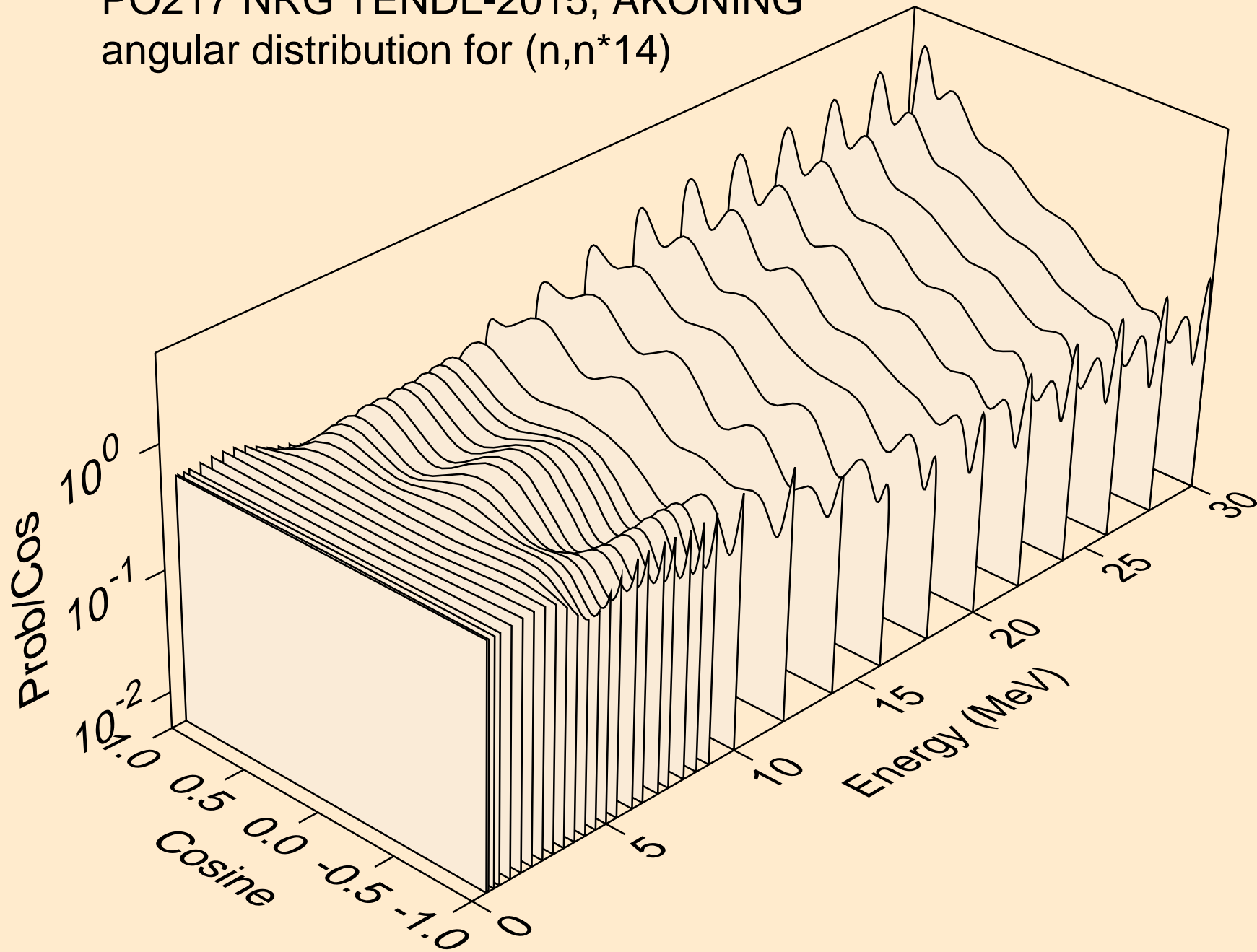

PO217 NRG TENDL-2015, AKONING
angular distribution for (n,n*15)

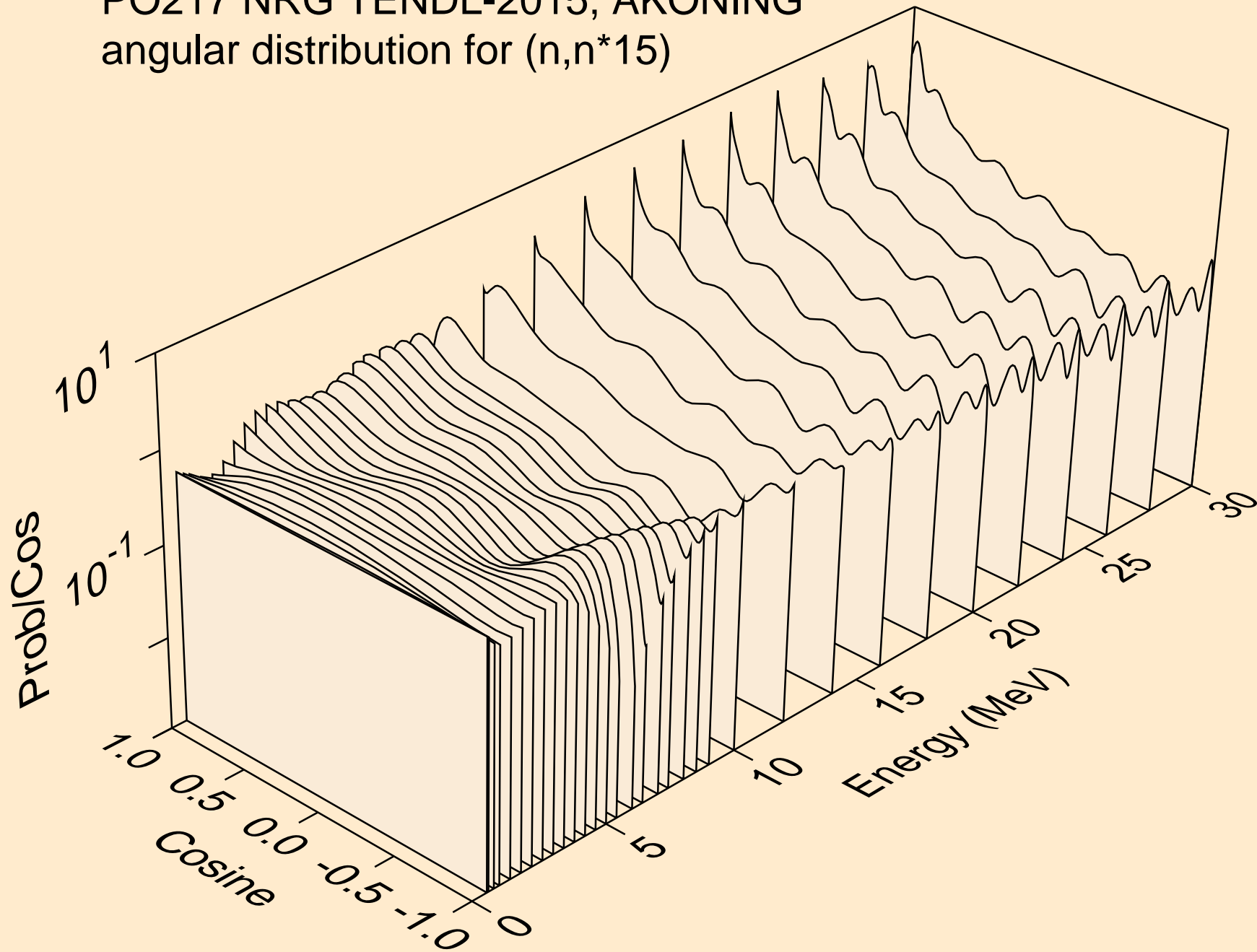

PO217 NRG TENDL-2015, AKONING
angular distribution for (n,n*16)

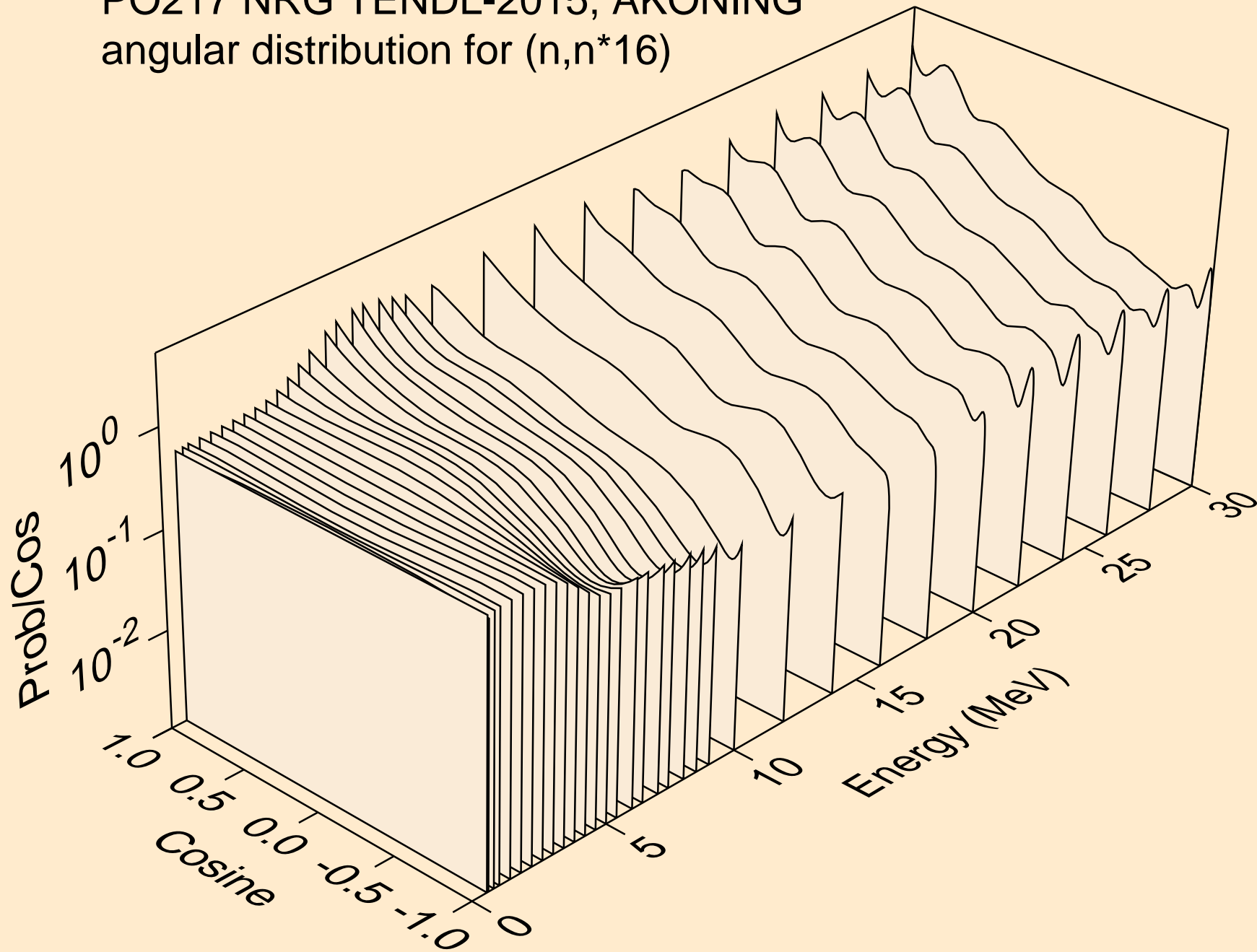

PO217 NRG TENDL-2015, AKONING
angular distribution for (n,n*17)

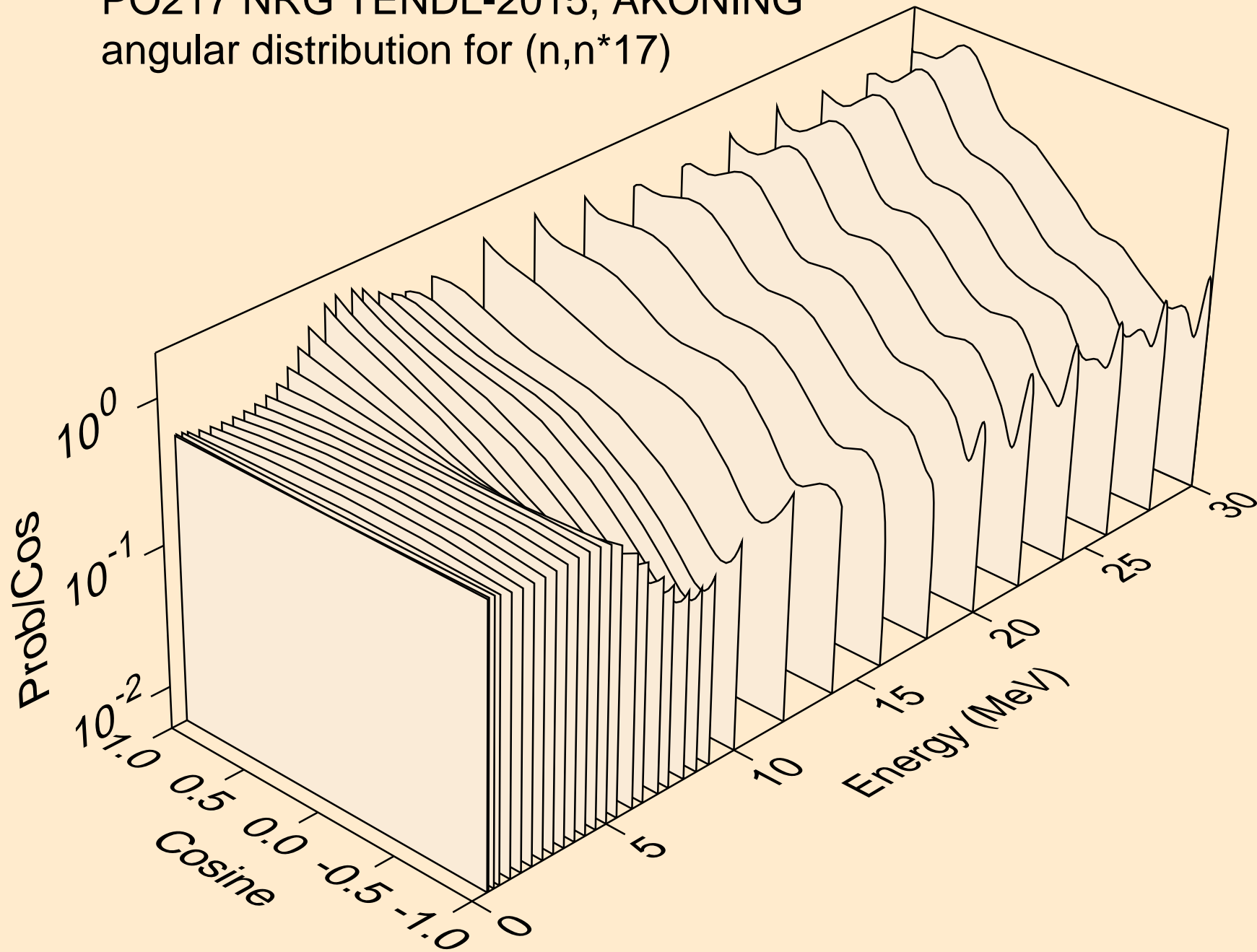

PO217 NRG TENDL-2015, AKONING
angular distribution for (n,n*18)

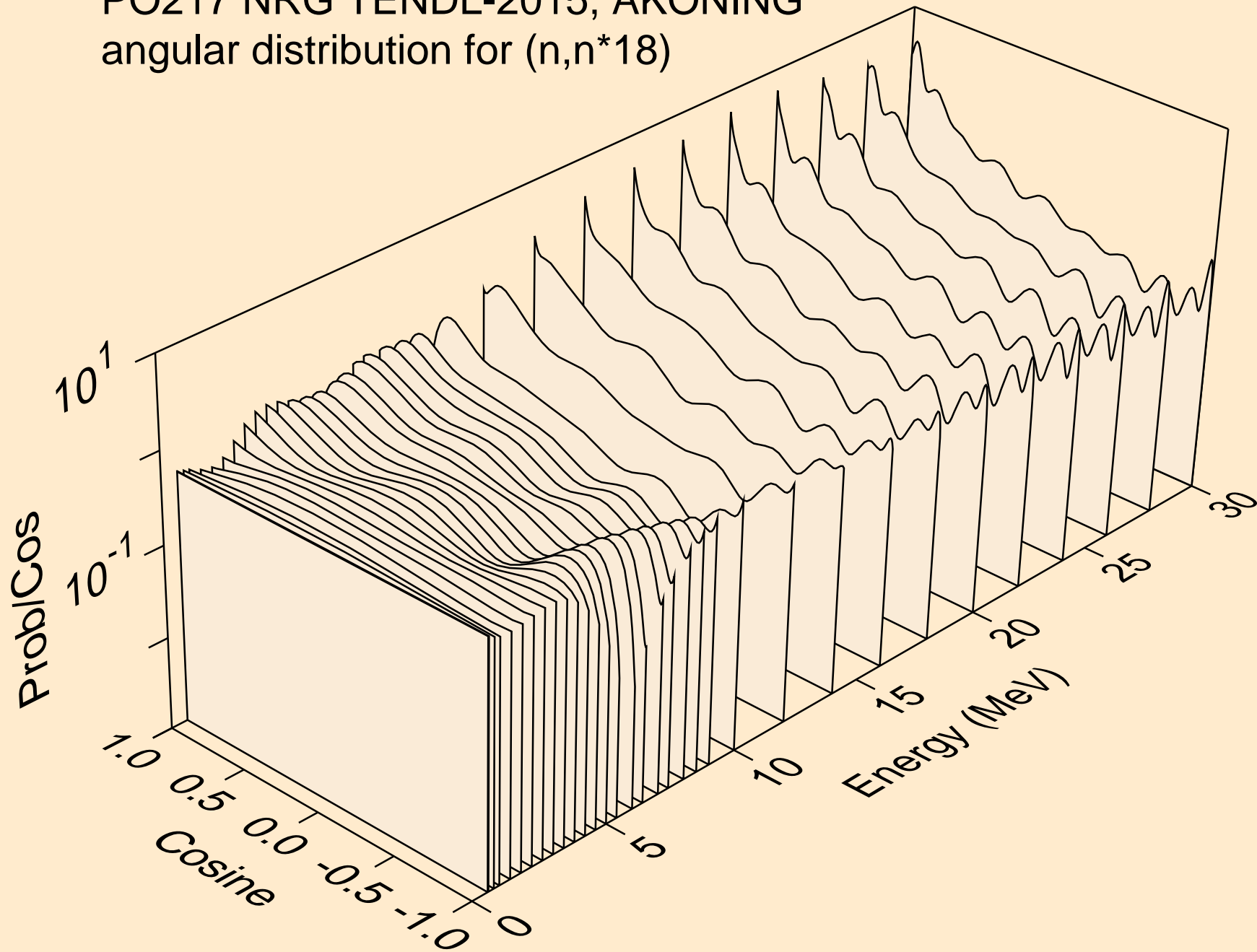

PO217 NRG TENDL-2015, AKONING
angular distribution for (n,n*19)

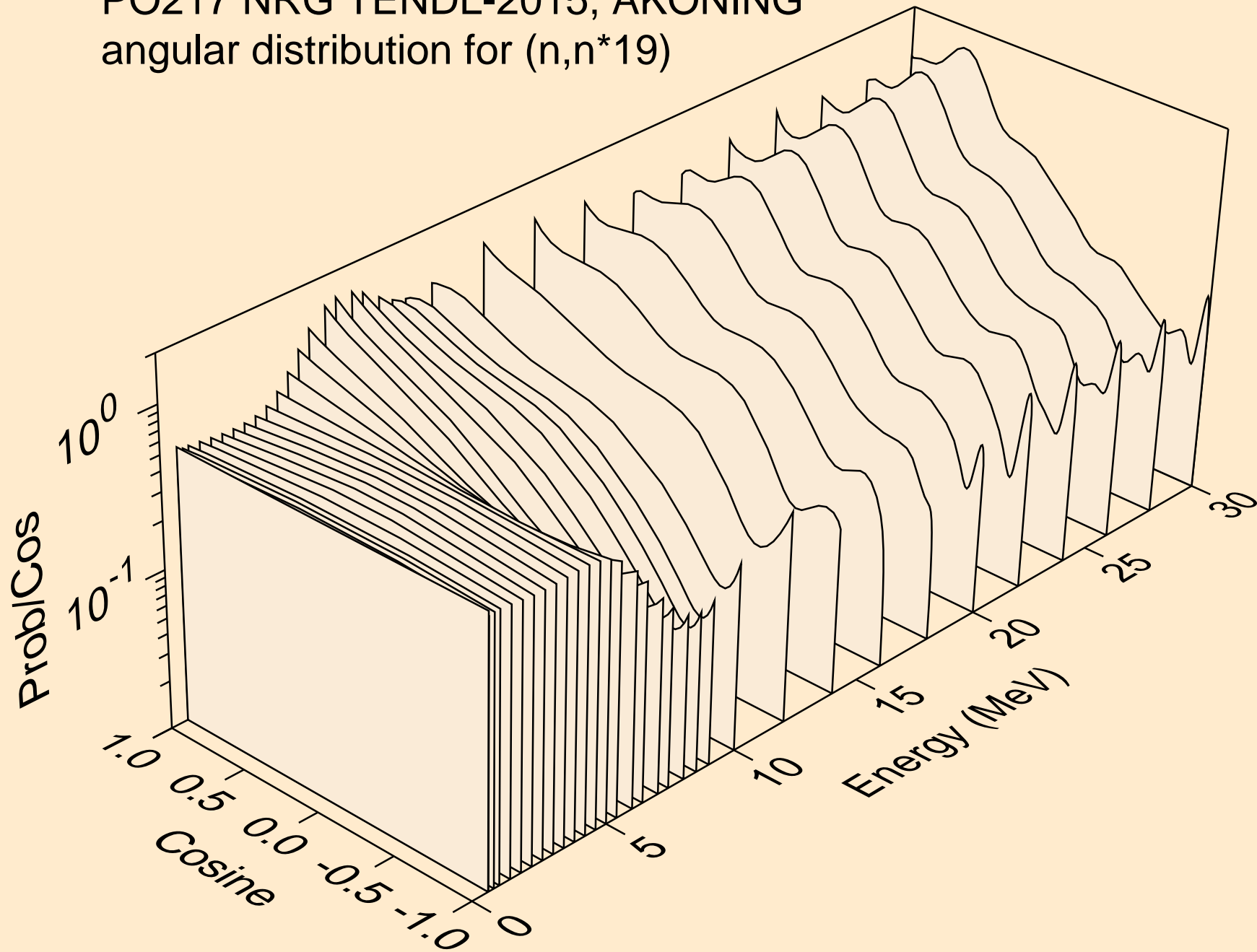

PO217 NRG TENDL-2015, AKONING
angular distribution for (n,n*20)

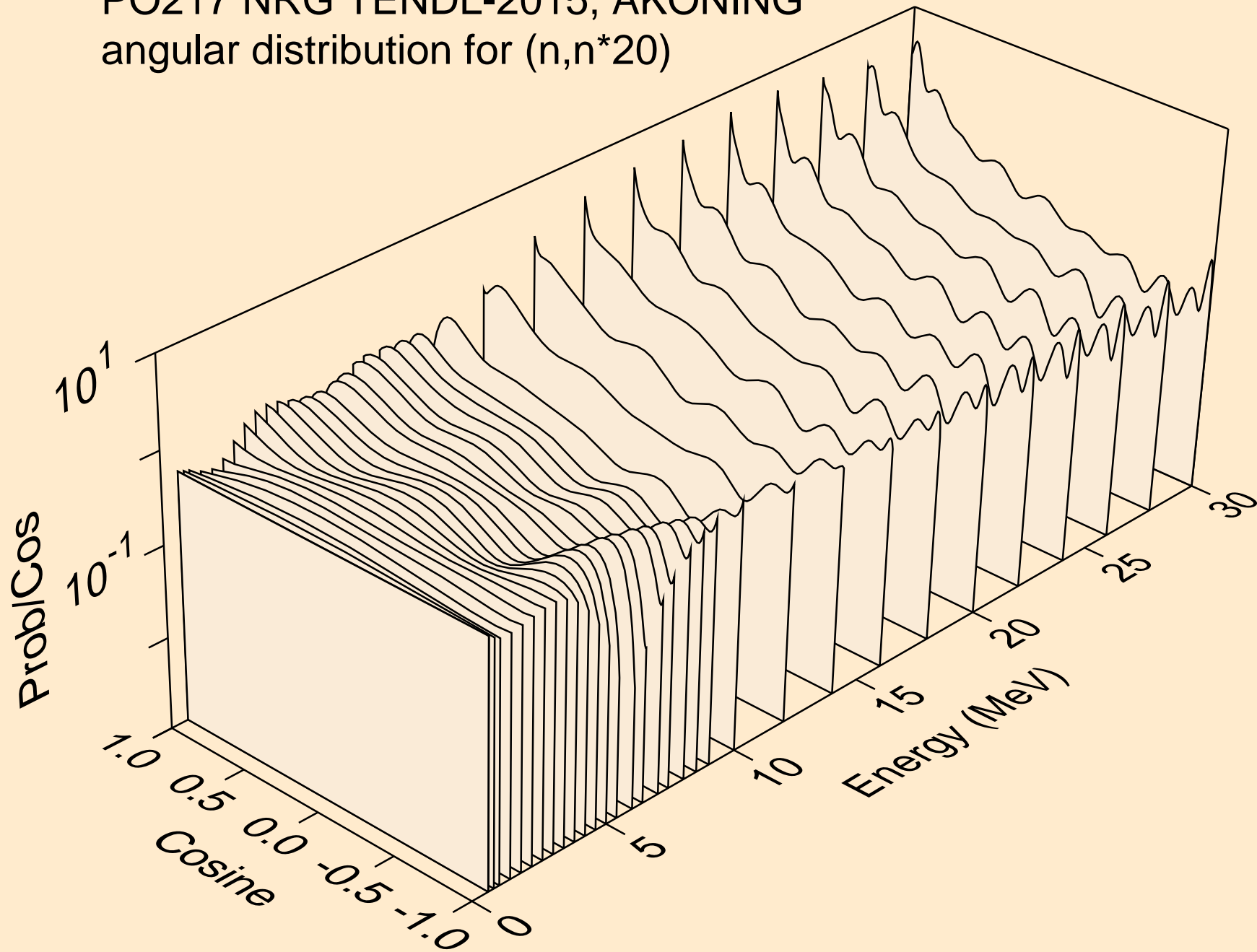

PO217 NRG TENDL-2015, AKONING
angular distribution for (n,n*21)

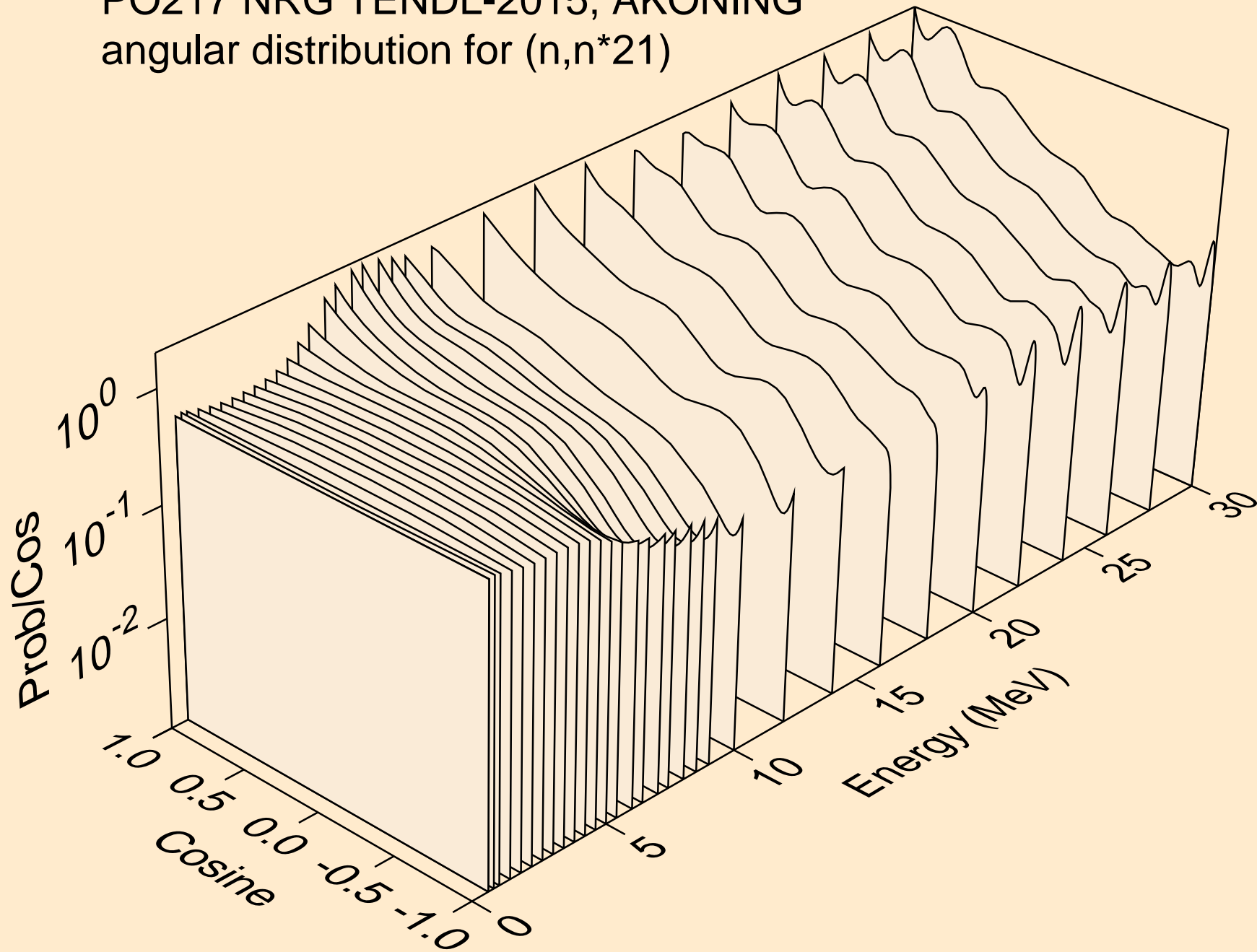

PO217 NRG TENDL-2015, AKONING
angular distribution for (n,n*22)

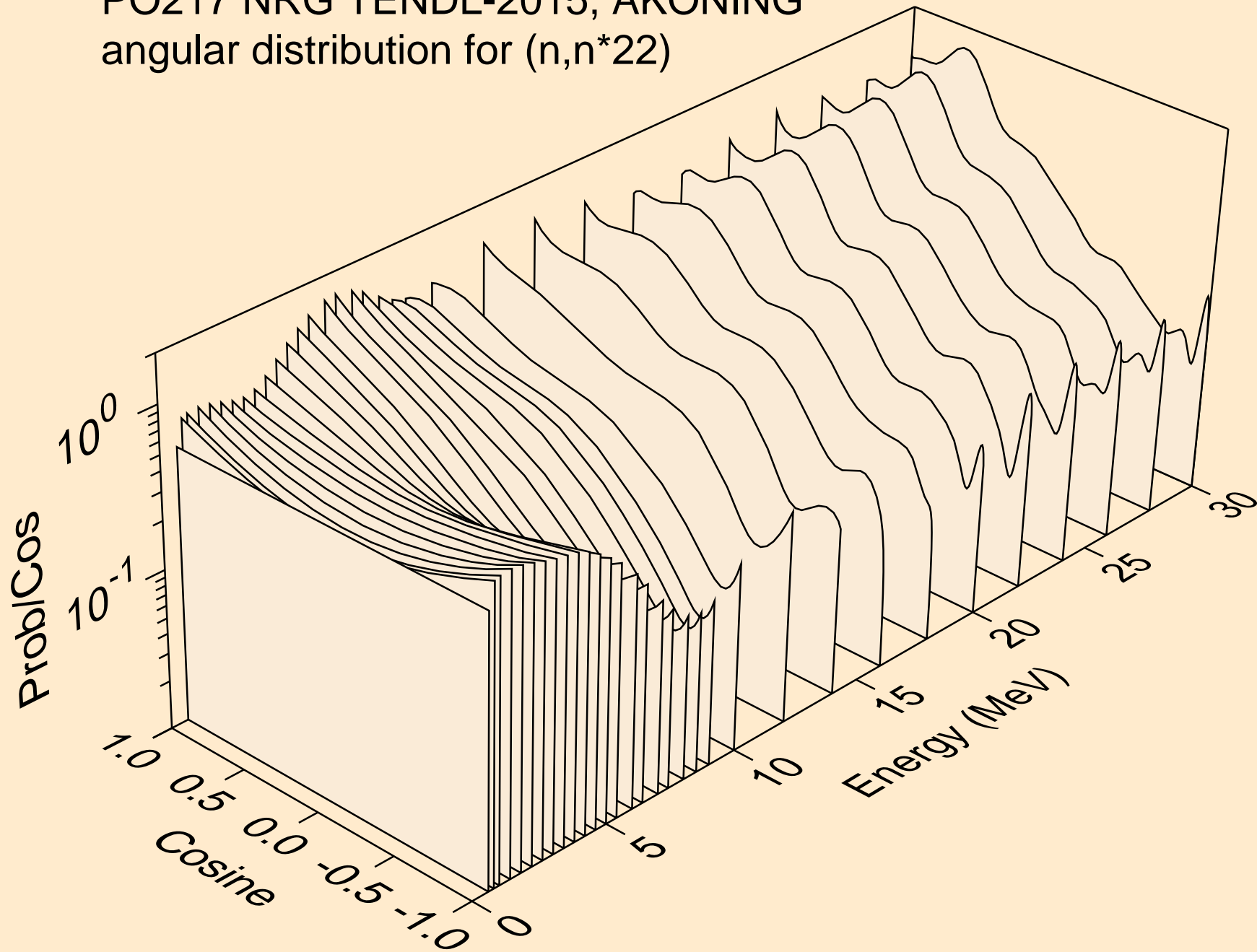

PO217 NRG TENDL-2015, AKONING
angular distribution for (n,n*23)

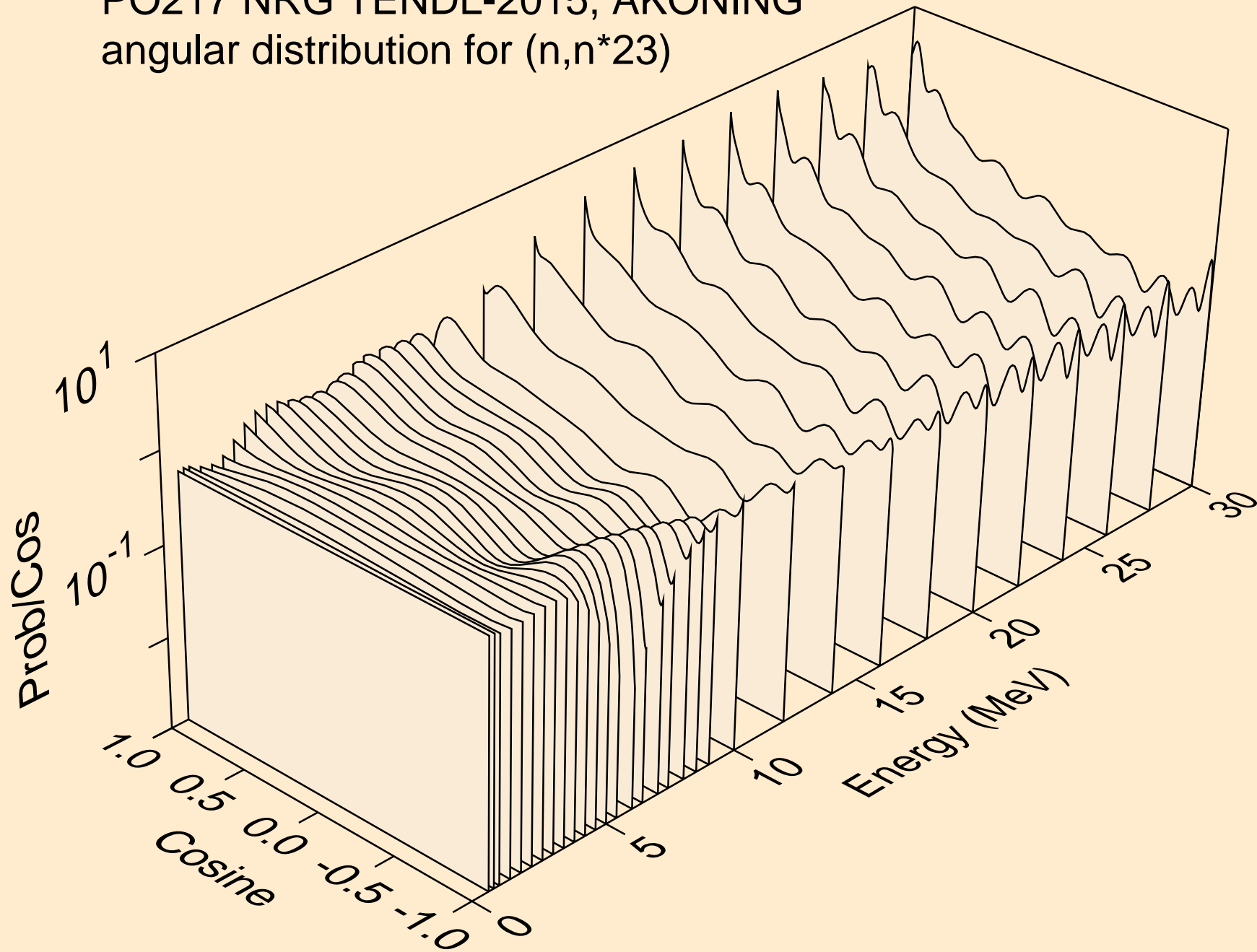

PO217 NRG TENDL-2015, AKONING
angular distribution for (n,n*24)

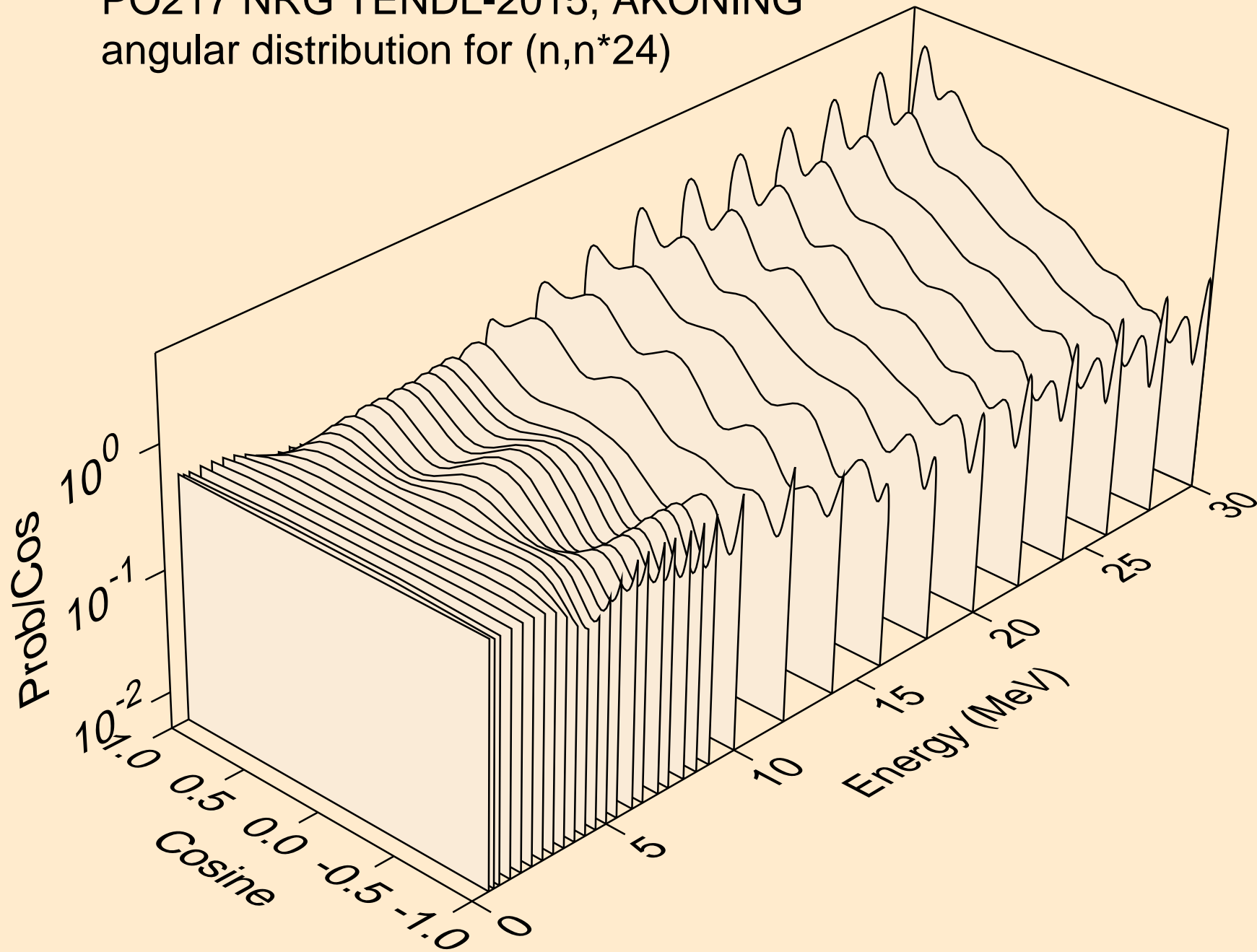

PO217 NRG TENDL-2015, AKONING
angular distribution for (n,n*25)

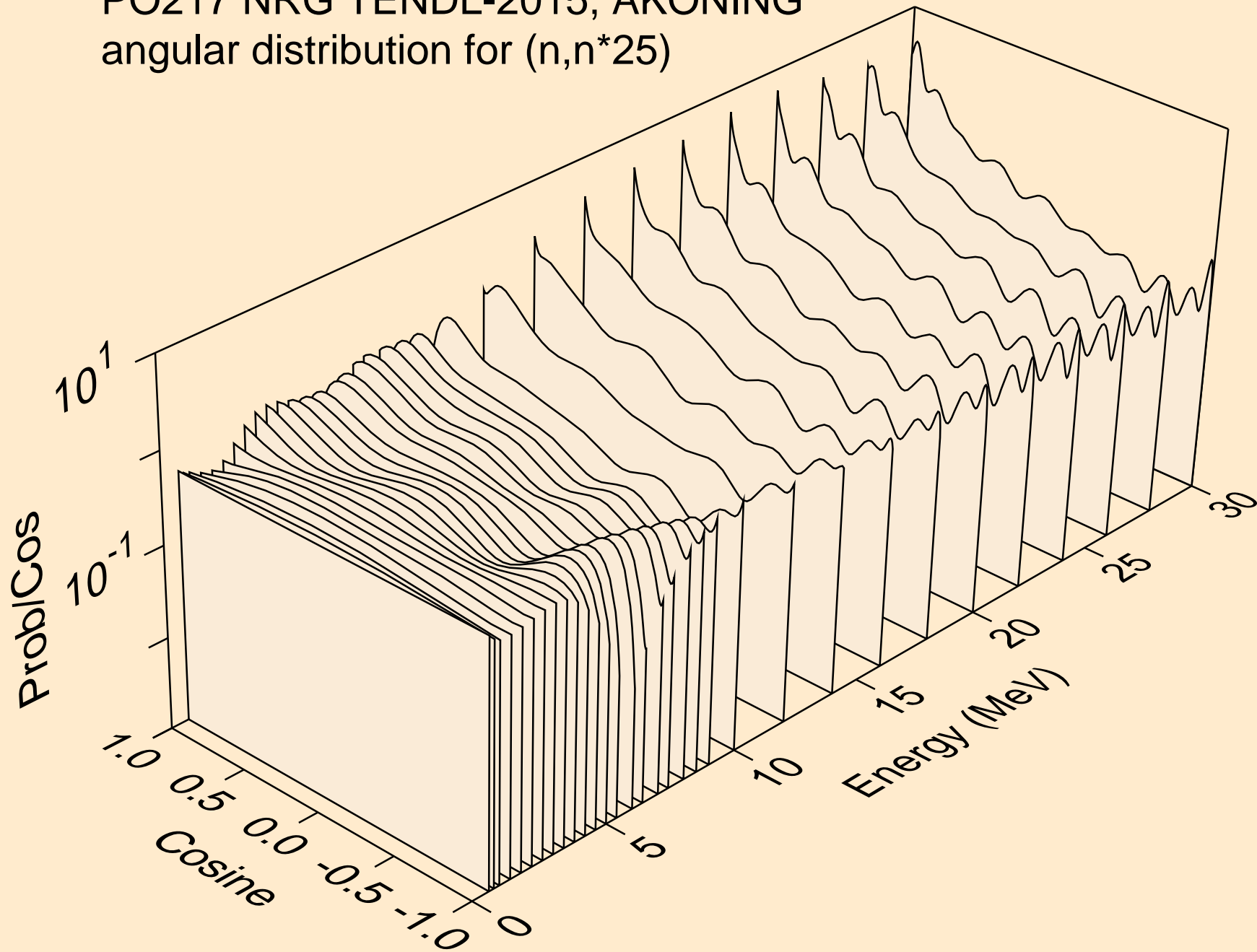

PO217 NRG TENDL-2015, AKONING
angular distribution for (n,n*26)

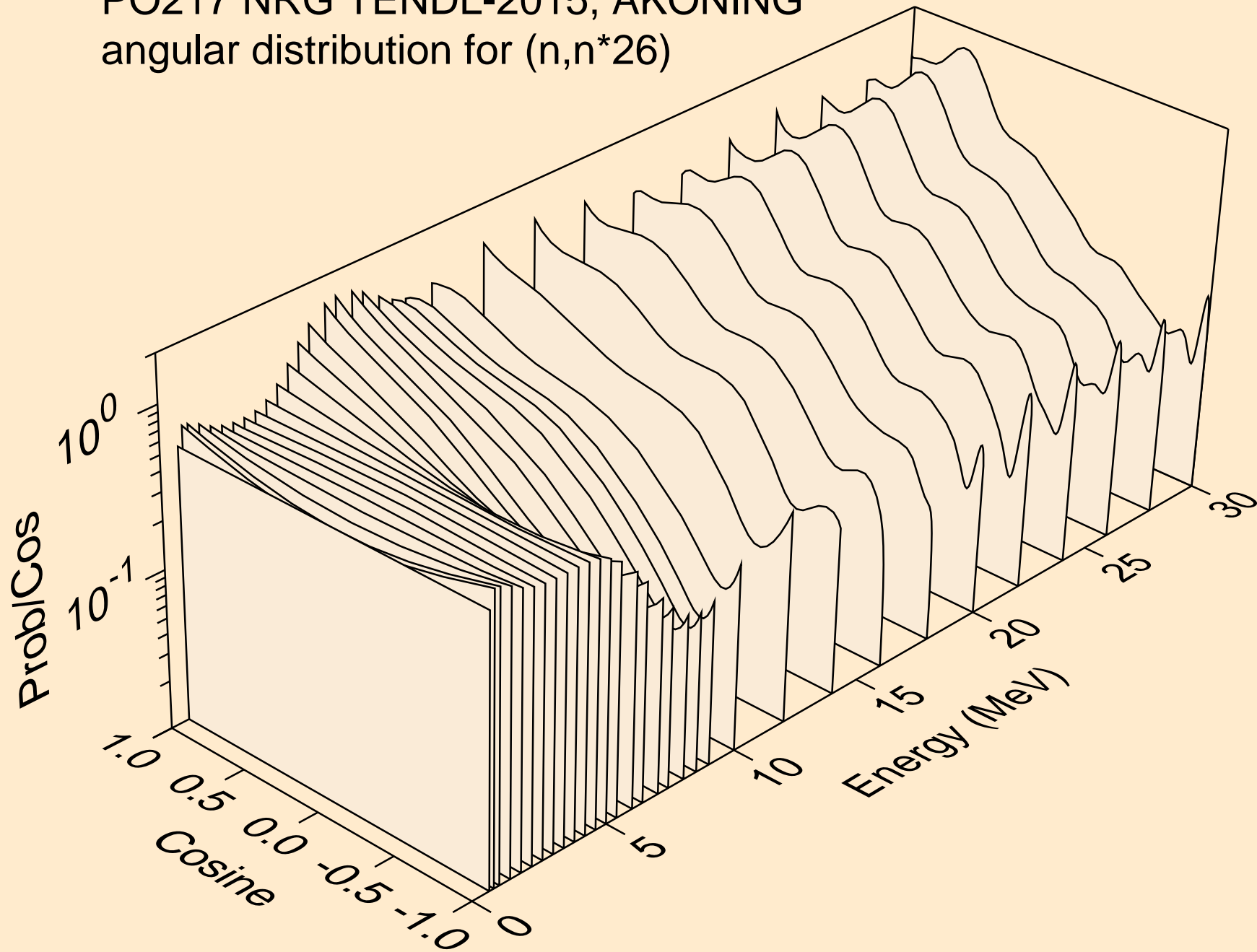

PO217 NRG TENDL-2015, AKONING
angular distribution for (n,n*27)

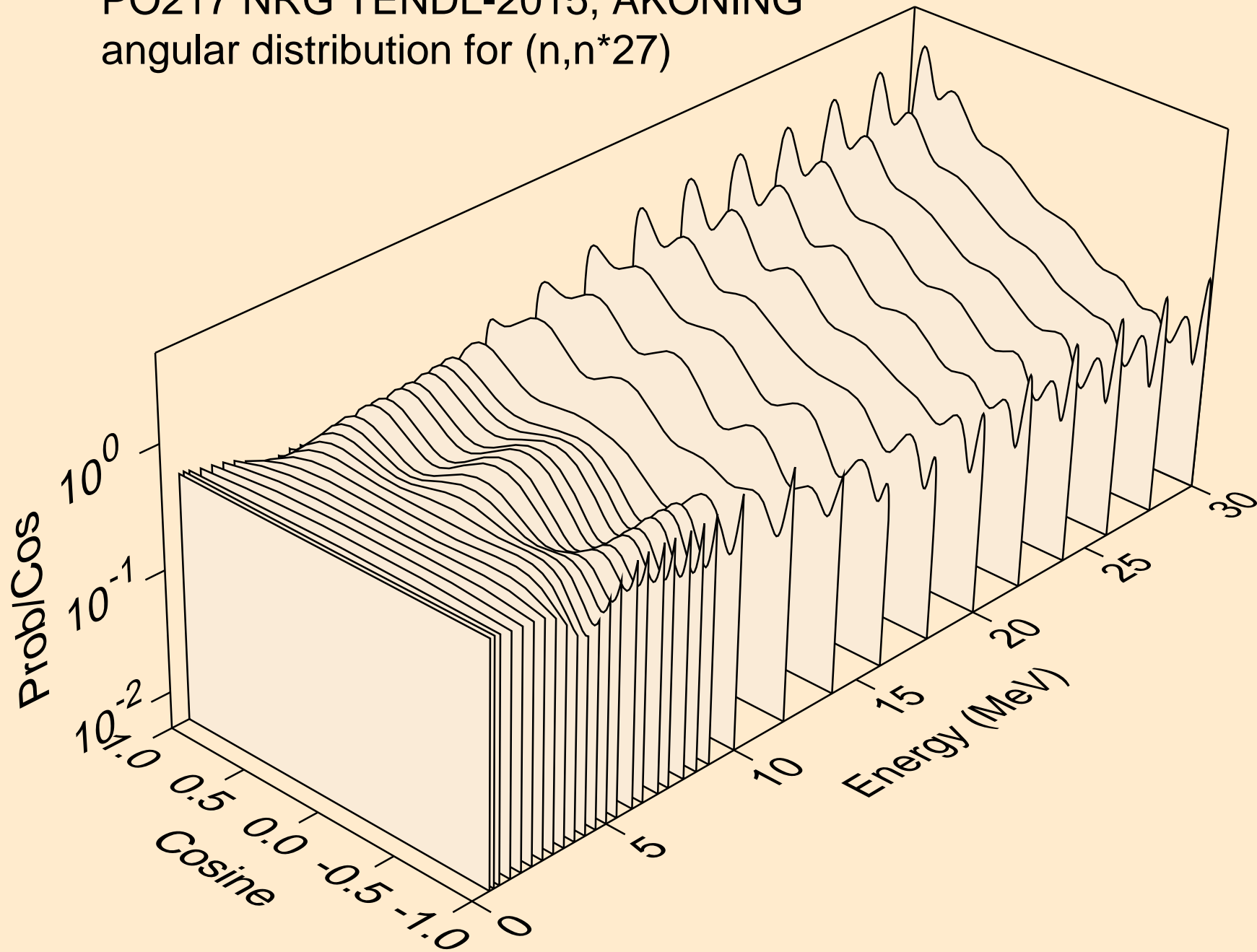

PO217 NRG TENDL-2015, AKONING
angular distribution for (n,n*28)

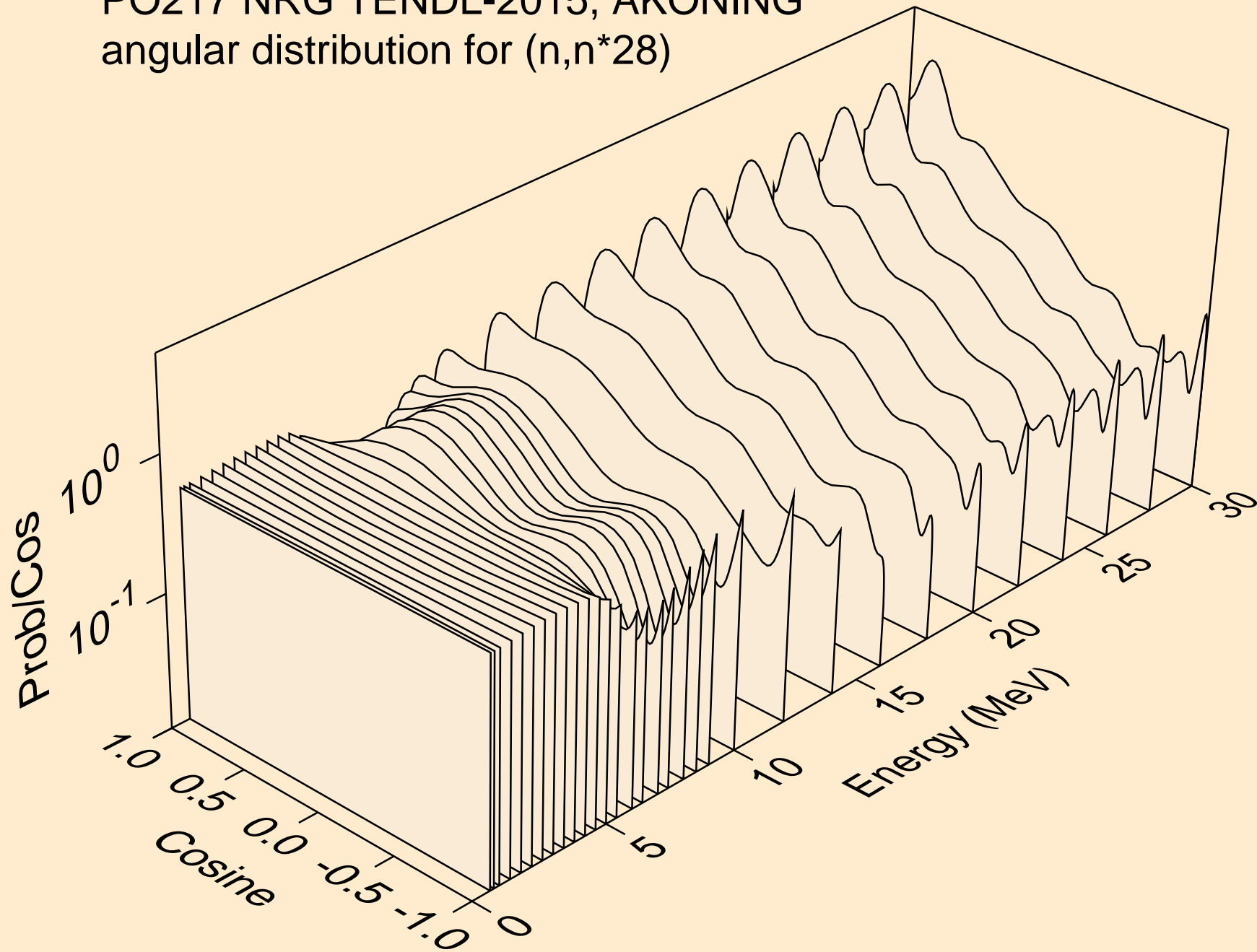

PO217 NRG TENDL-2015, AKONING
angular distribution for (n,n*29)

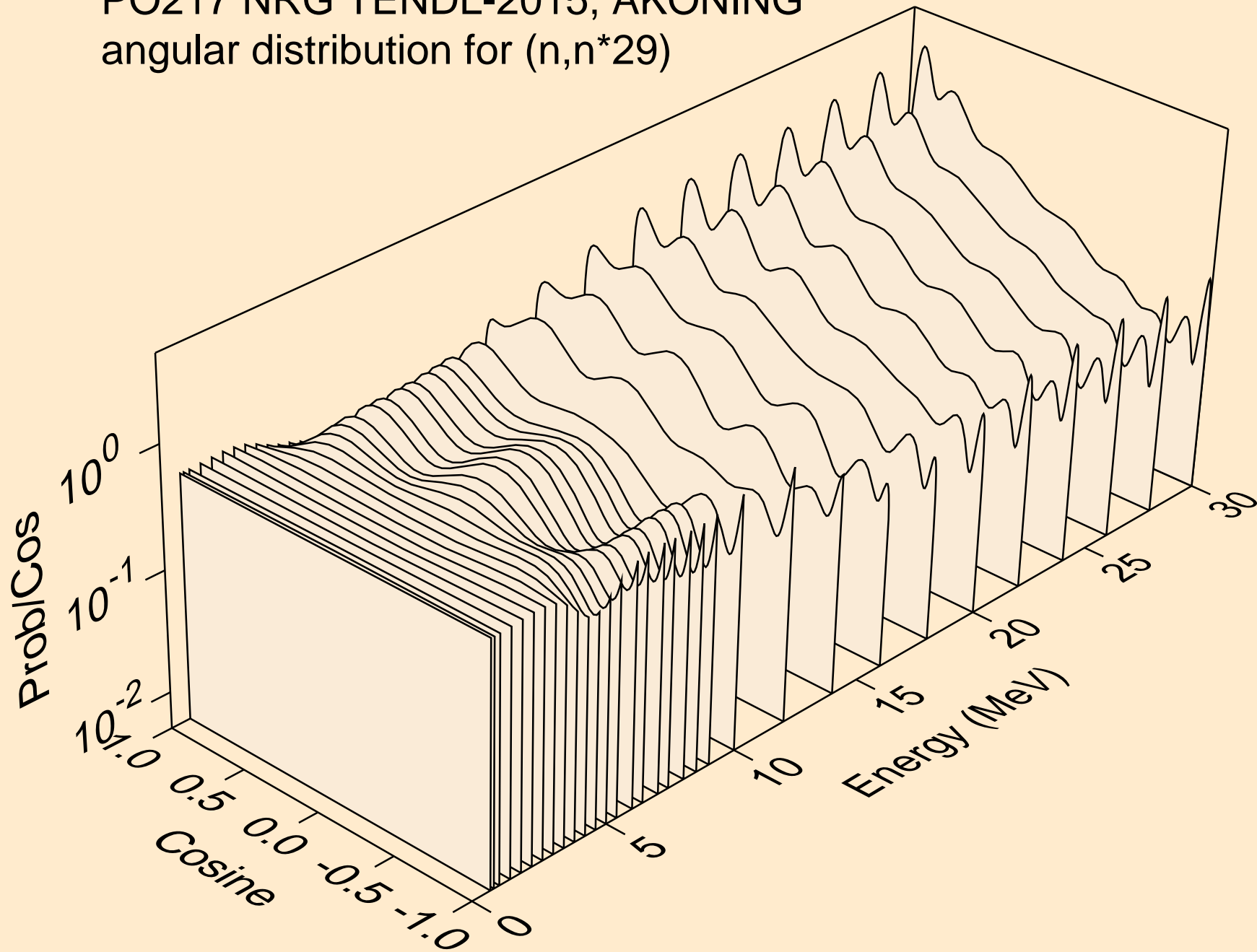

PO217 NRG TENDL-2015, AKONING
angular distribution for (n,n*30)

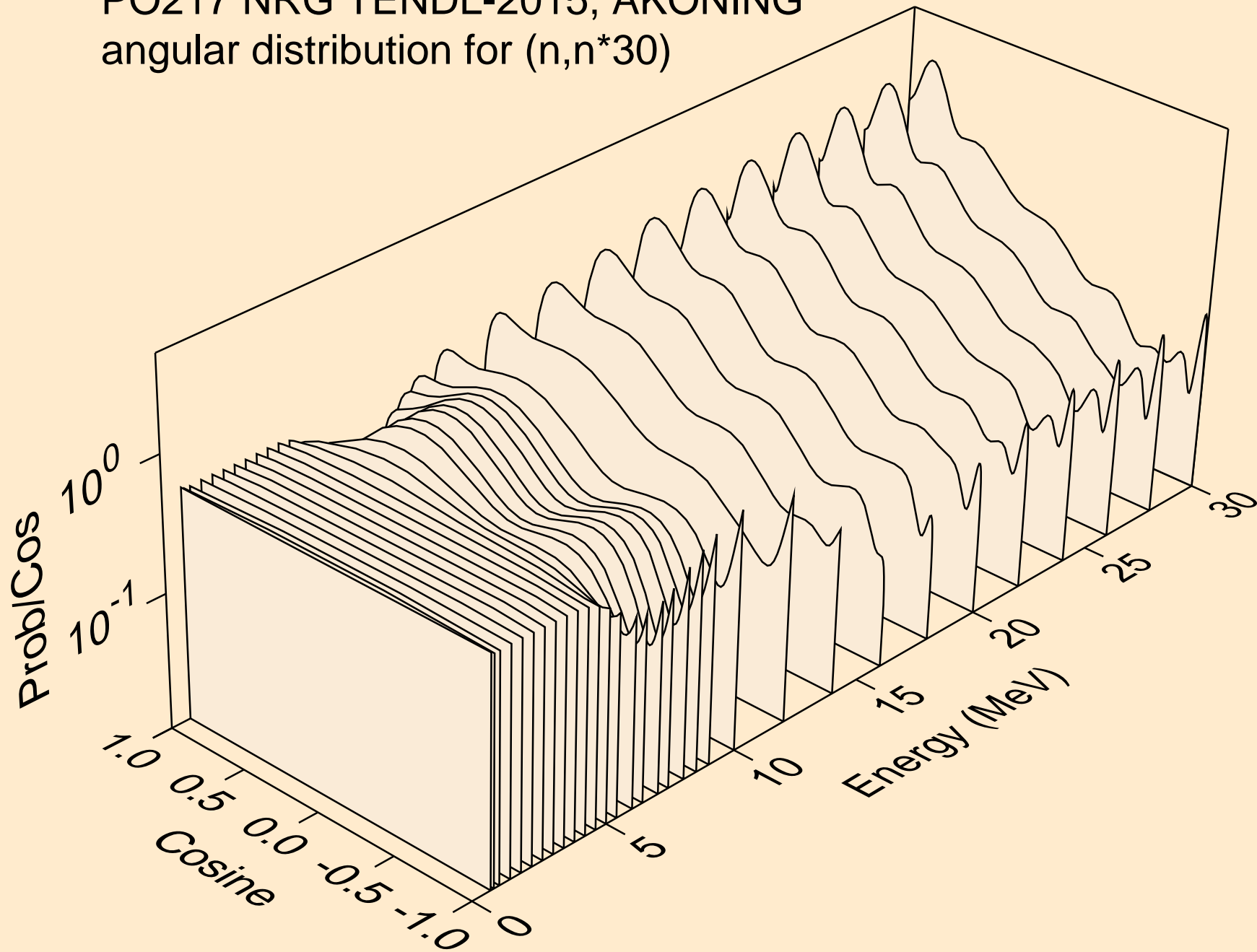

PO217 NRG TENDL-2015, AKONING

Total fission nubar

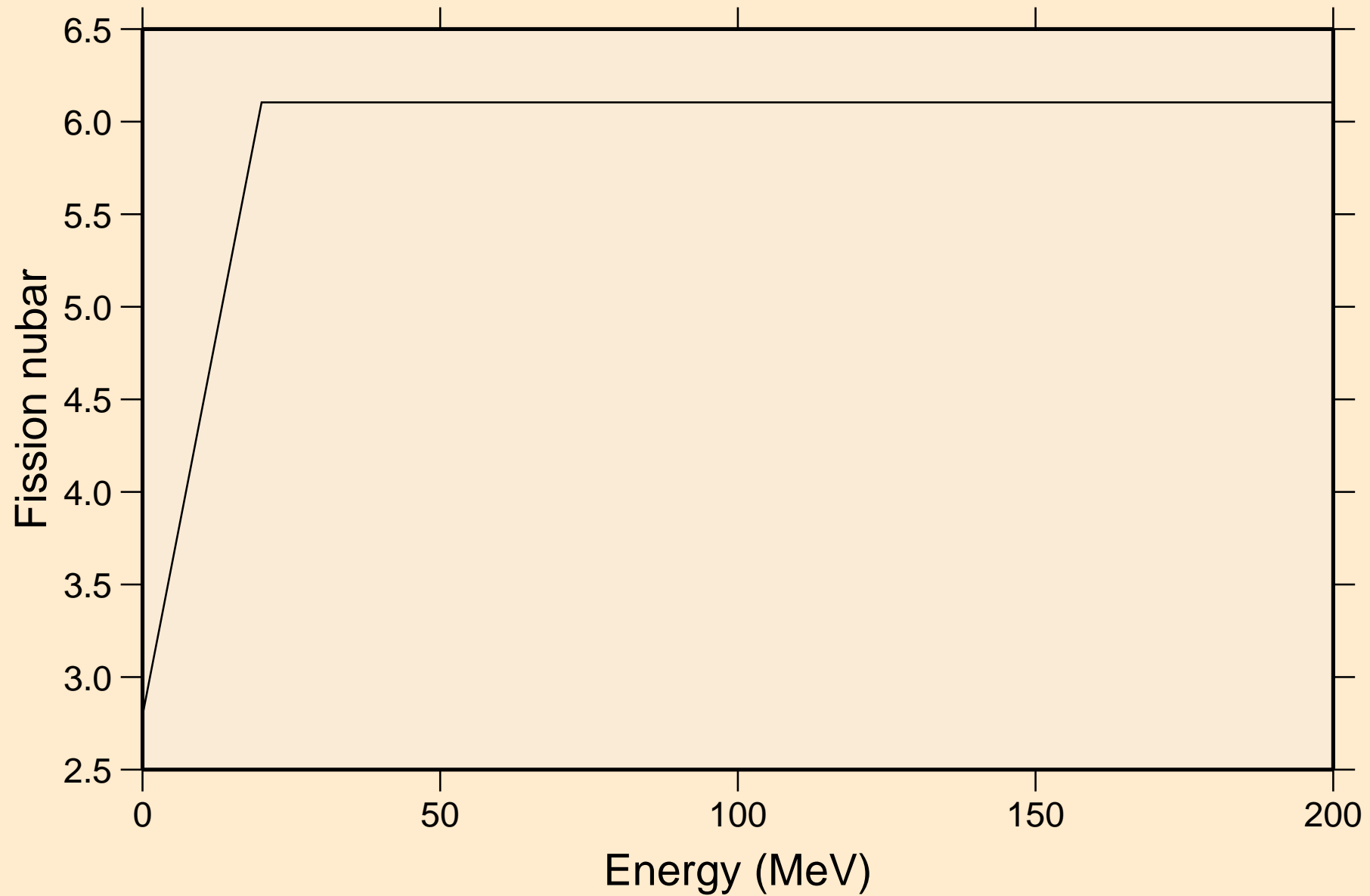

PO217 NRG TENDL-2015, AKONING
Neutron emission for (n,x)

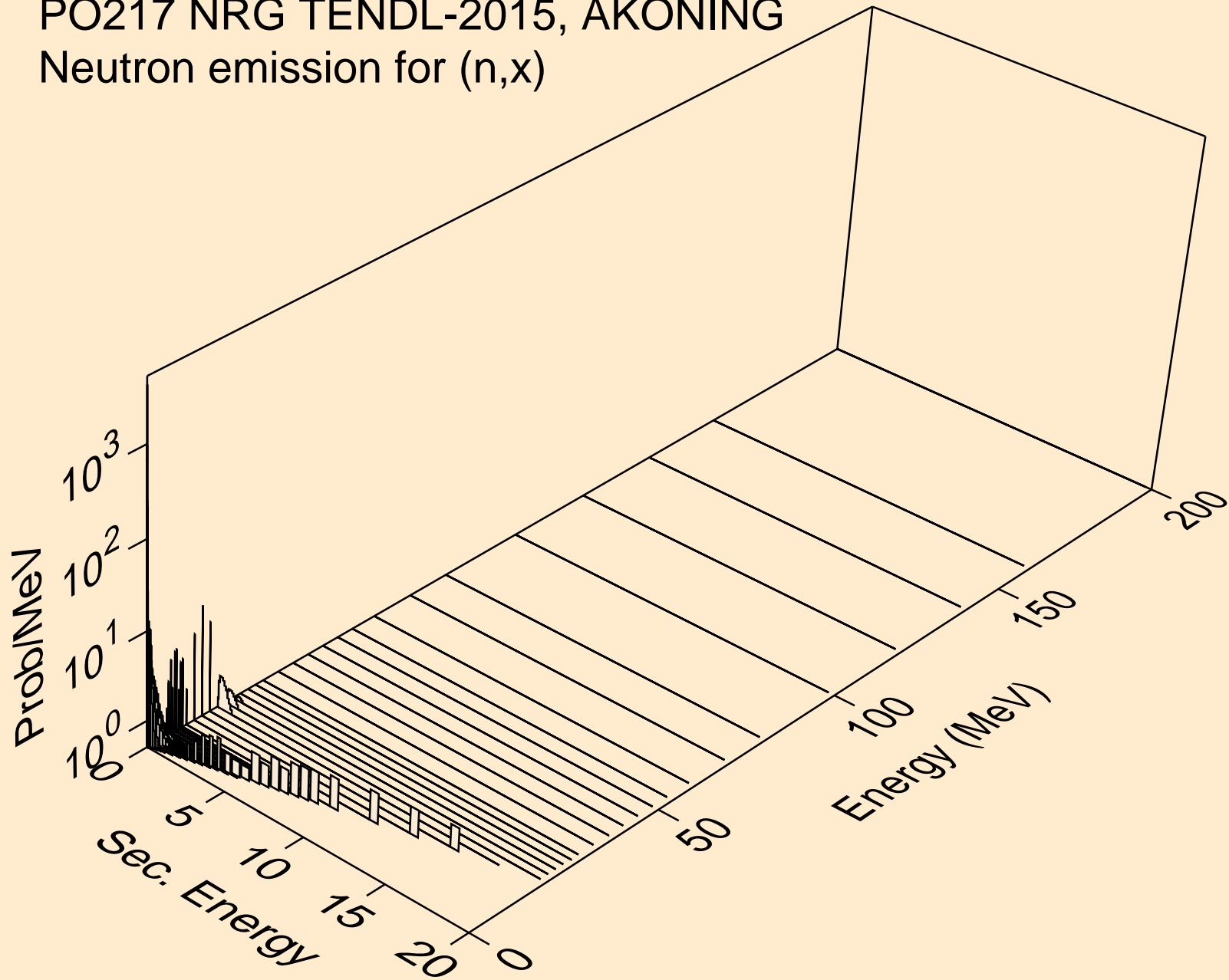

PO217 NRG TENDL-2015, AKONING
Neutron emission for (n,2nd)

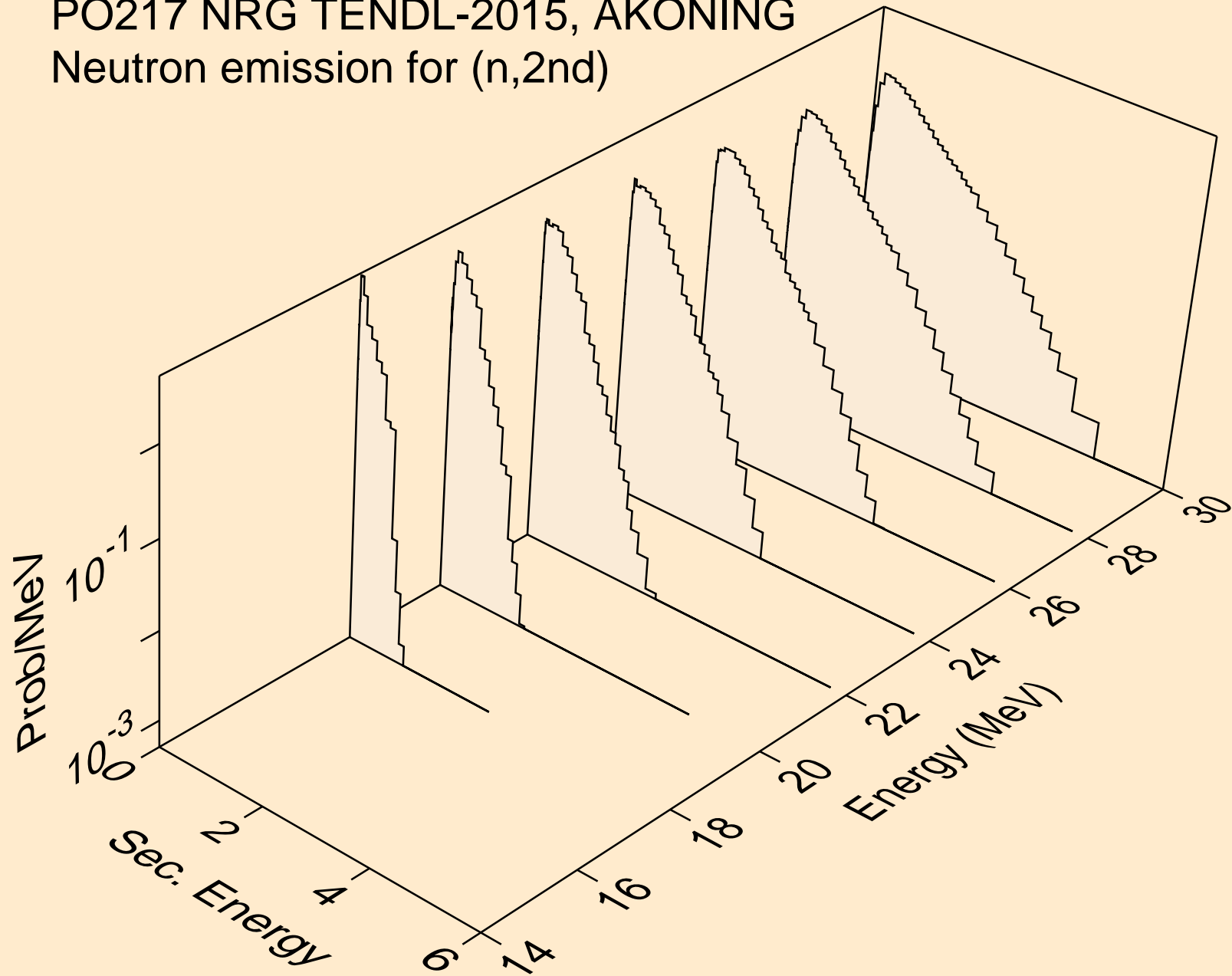

PO217 NRG TENDL-2015, AKONING
Neutron emission for (n,2n)

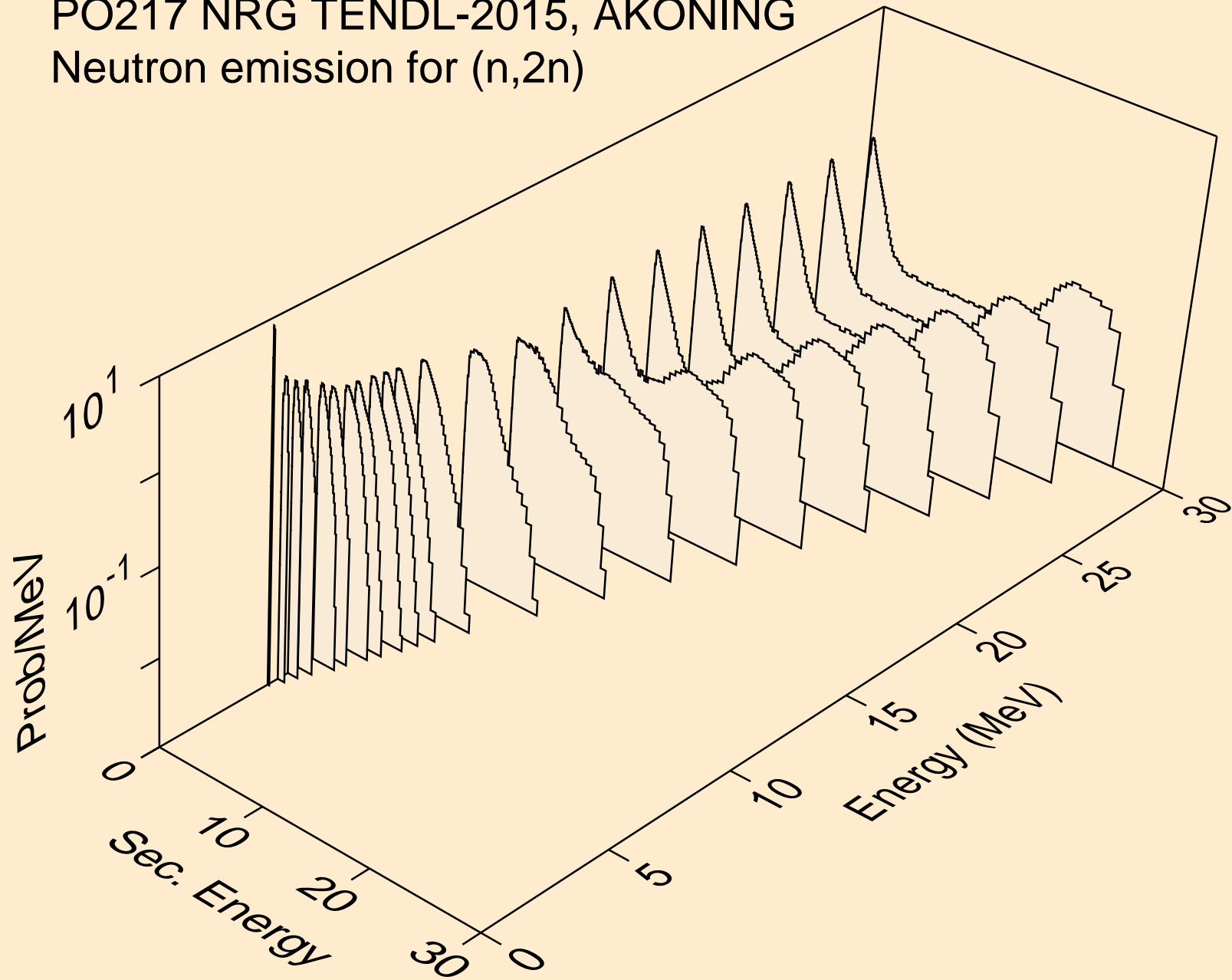

PO217 NRG TENDL-2015, AKONING
Neutron emission for (n,3n)

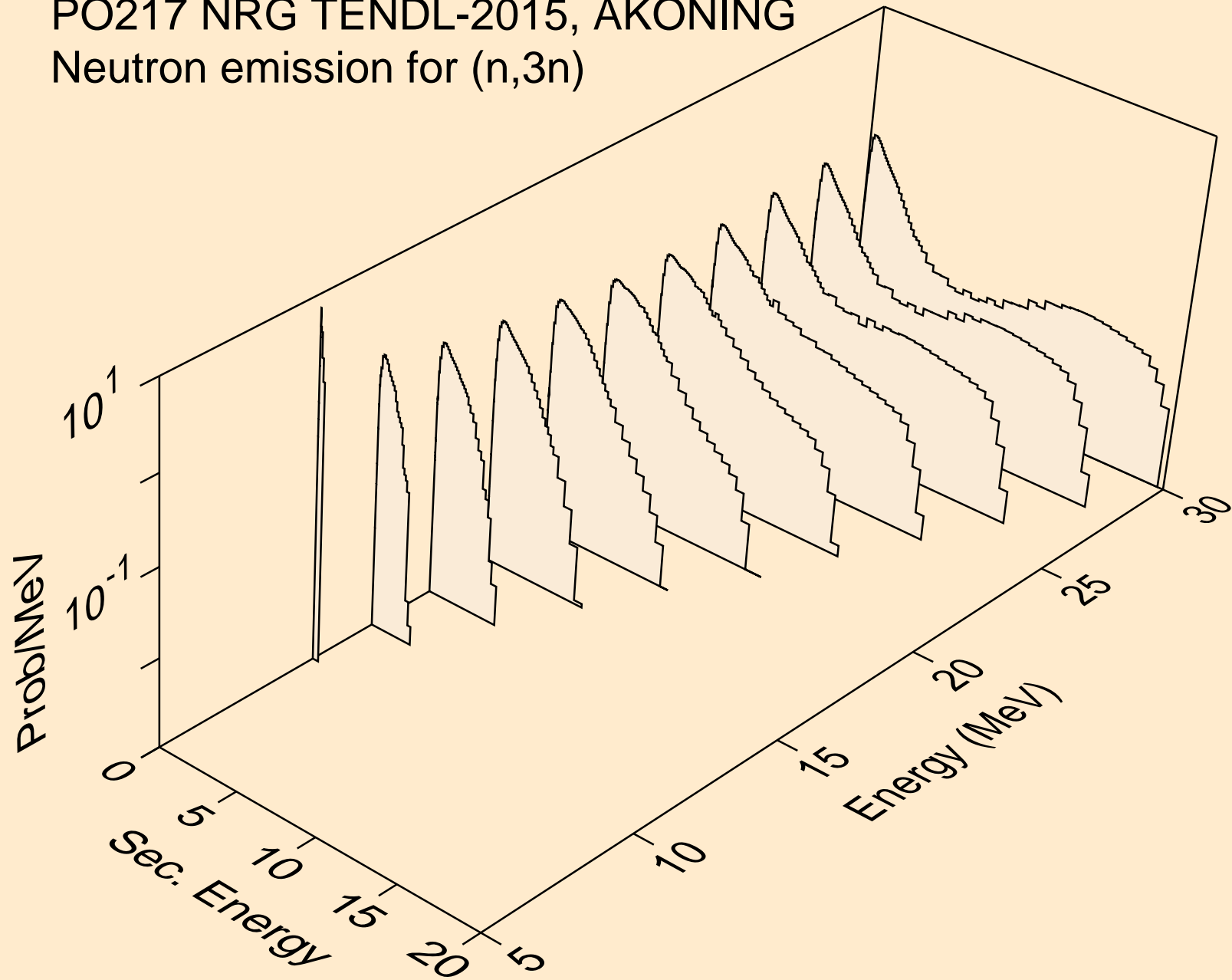

PO217 NRG TENDL-2015, AKONING
Neutron emission for fission

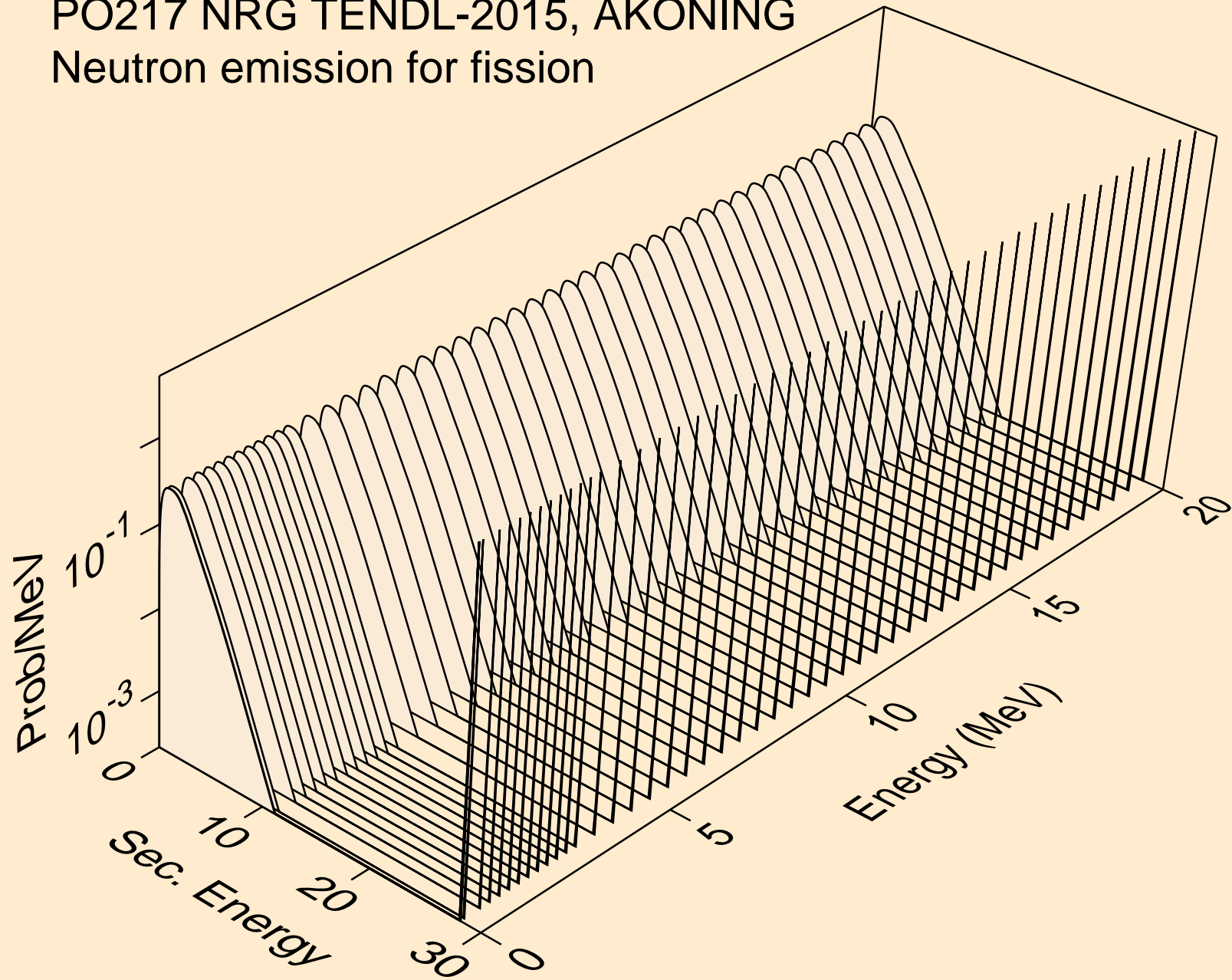

PO217 NRG TENDL-2015, AKONING
Neutron emission for (n,n*)a

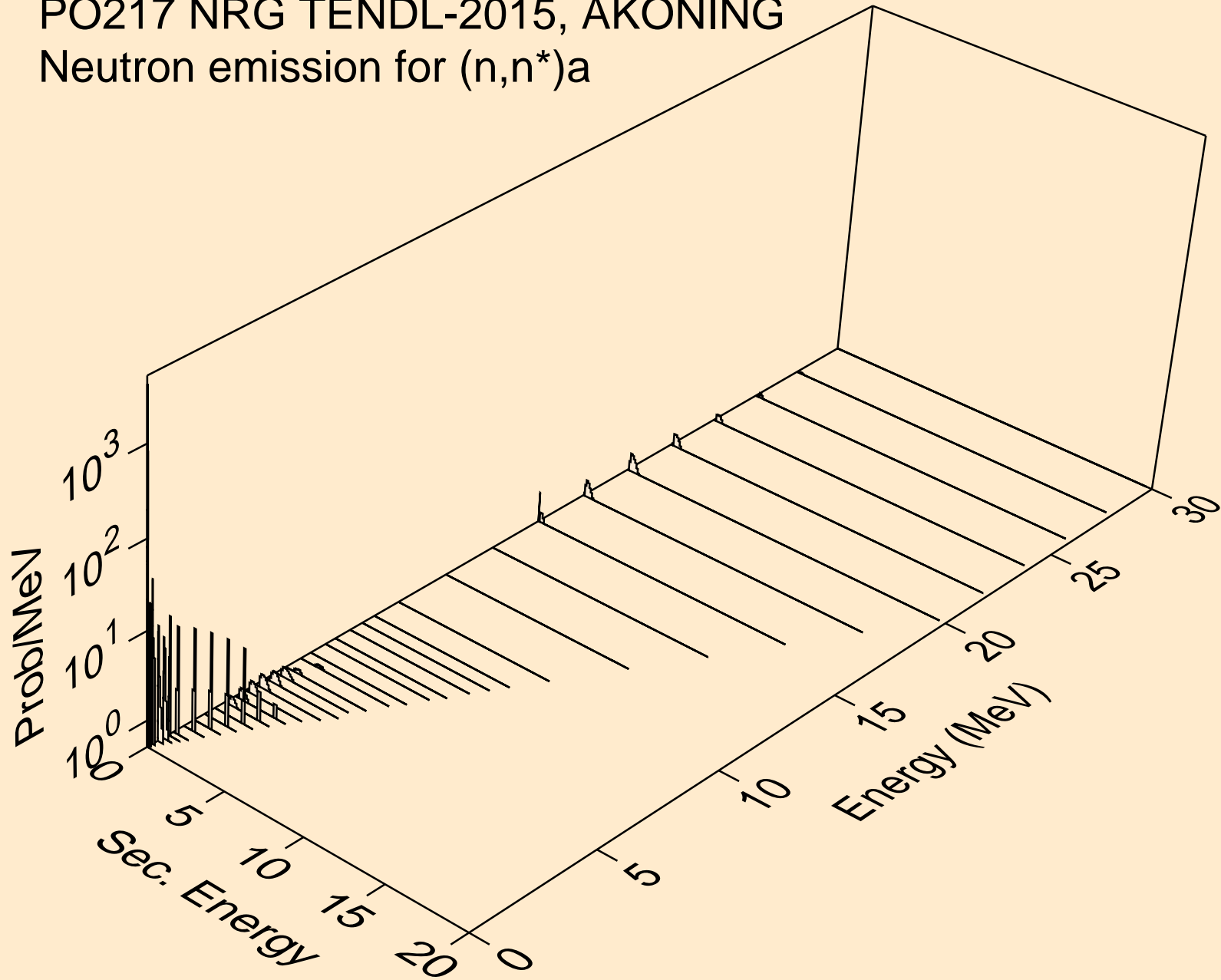

PO217 NRG TENDL-2015, AKONING
Neutron emission for (n,2n)a

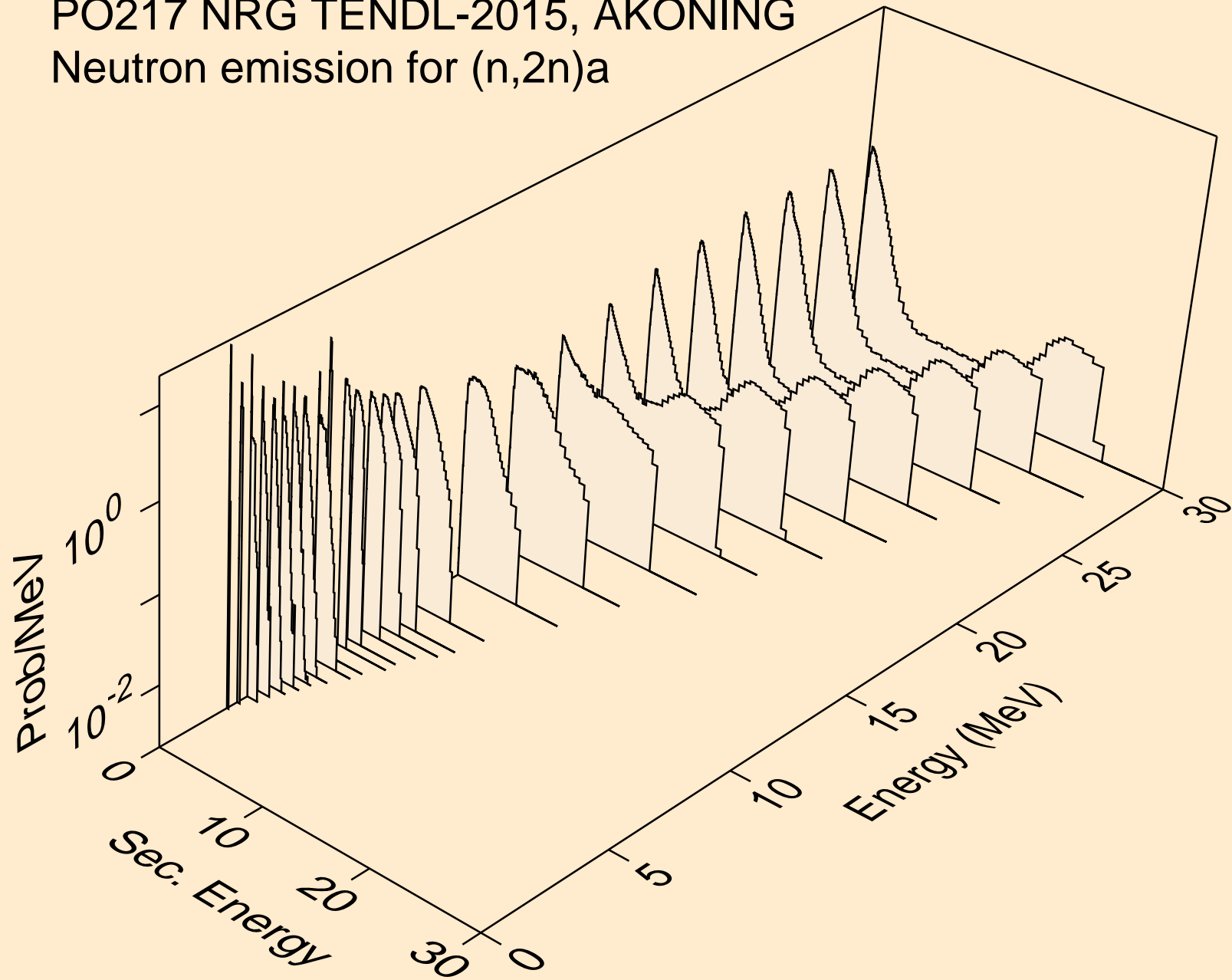

PO217 NRG TENDL-2015, AKONING
Neutron emission for (n,3n)a

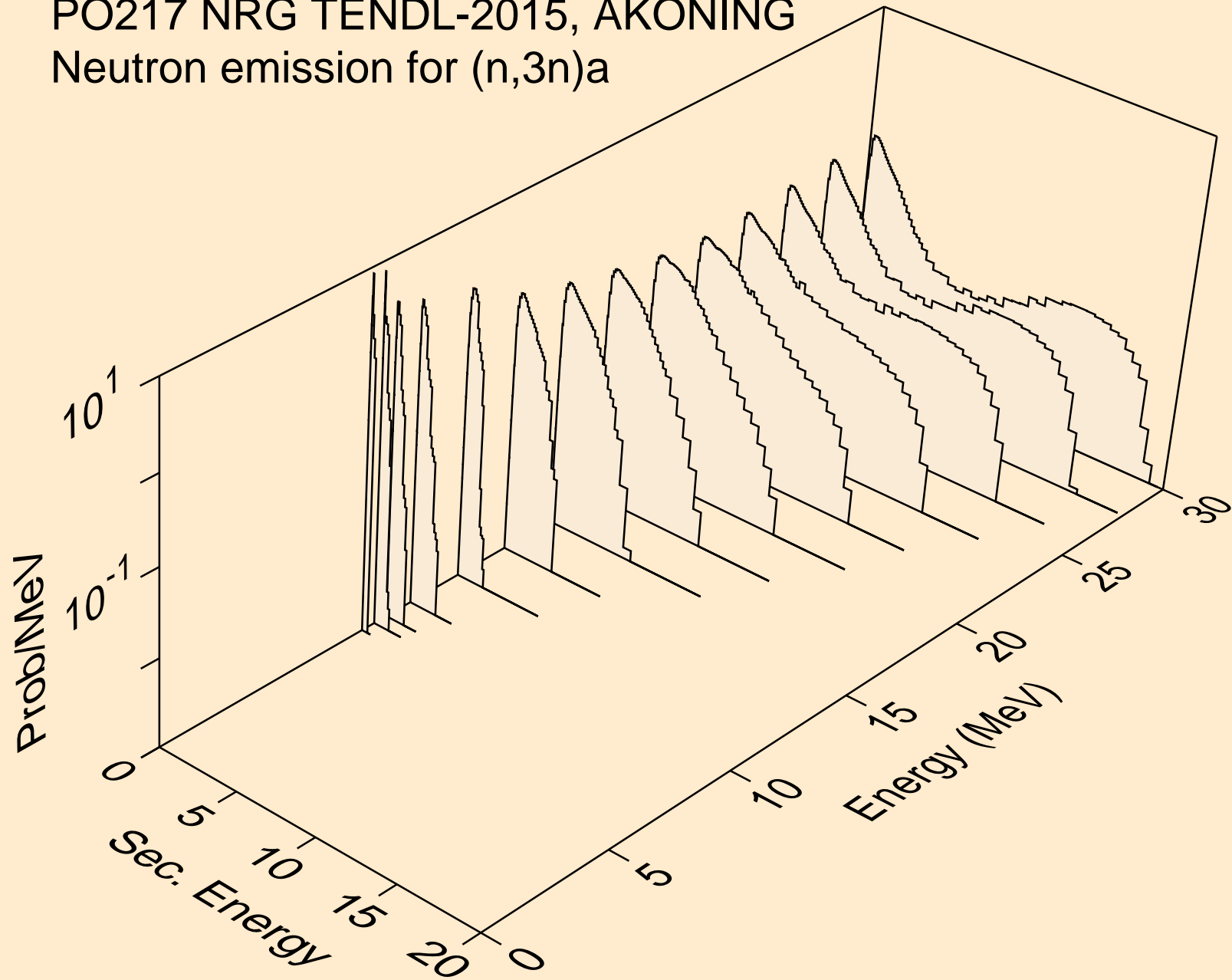

PO217 NRG TENDL-2015, AKONING
Neutron emission for (n,n*)p

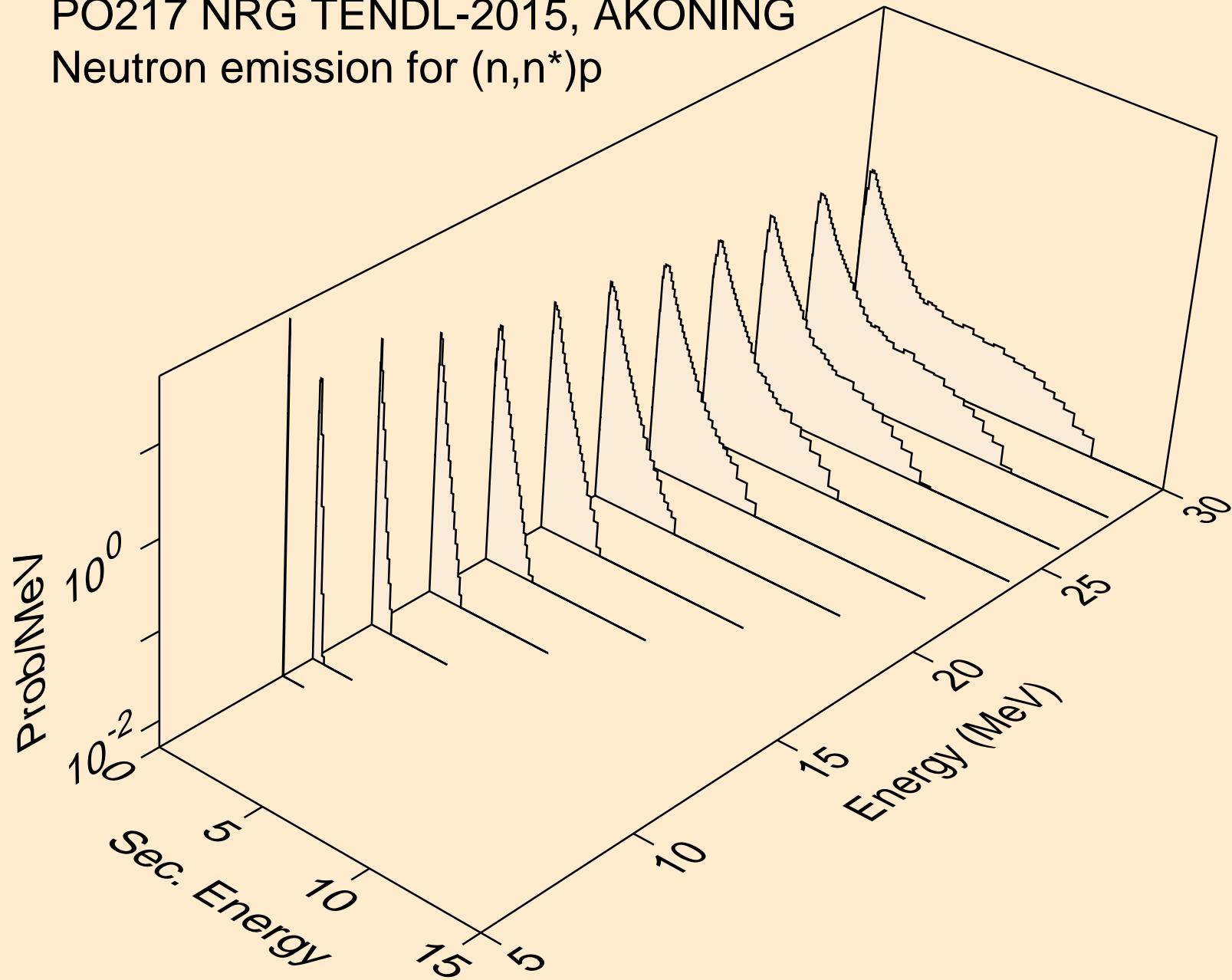

PO217 NRG TENDL-2015, AKONING
Neutron emission for (n,n*)2a

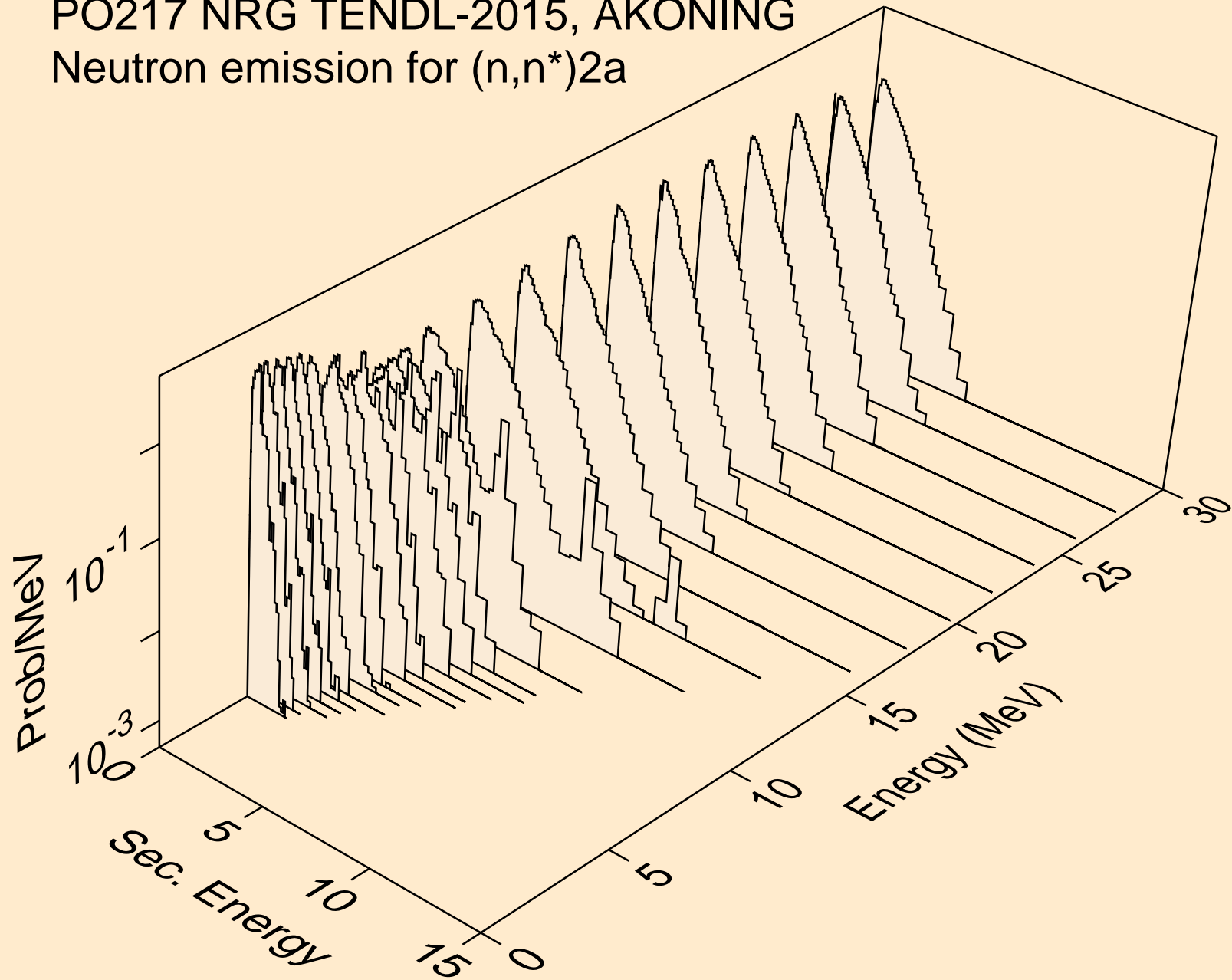

PO217 NRG TENDL-2015, AKONING
Neutron emission for (n,2n)2a

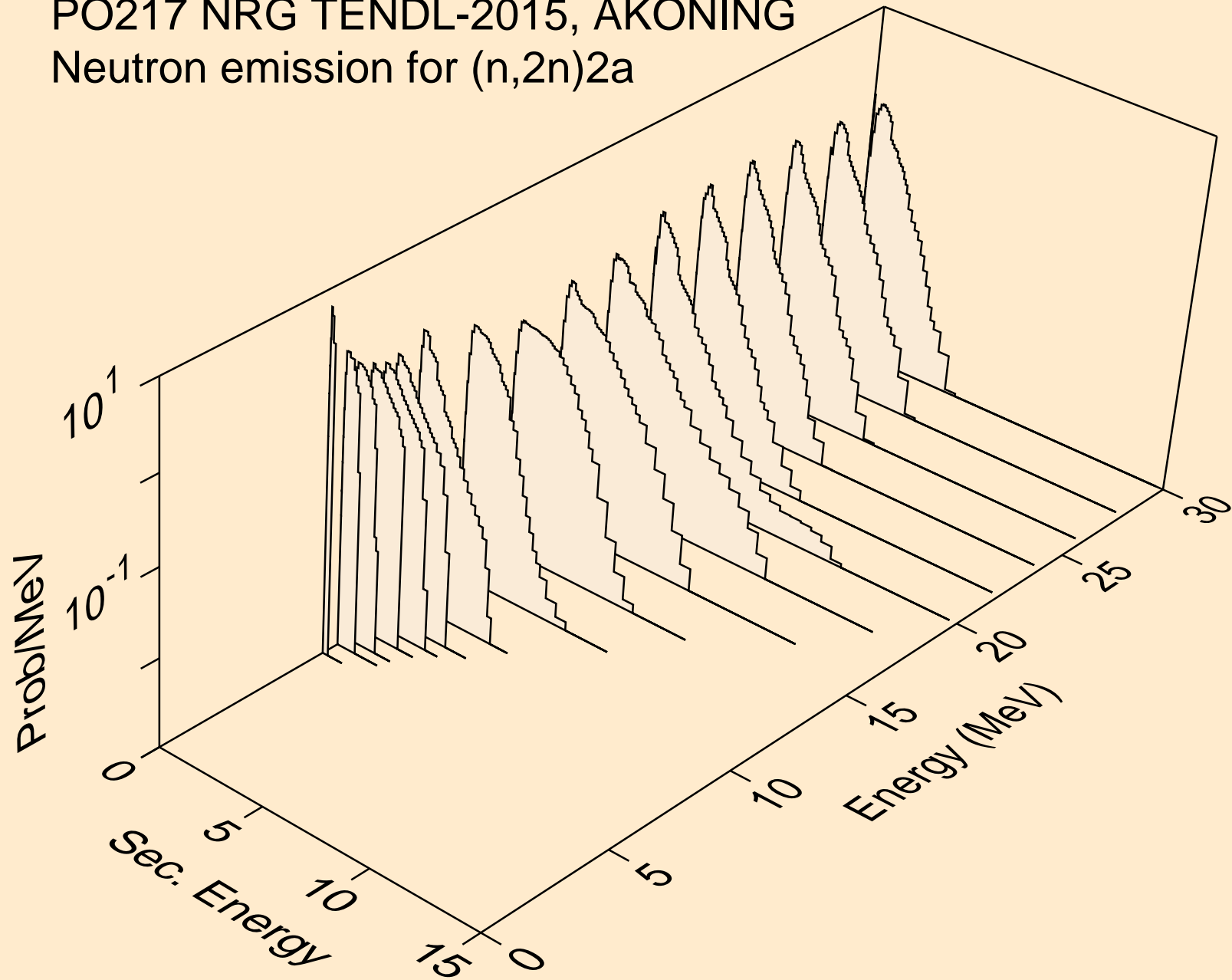

PO217 NRG TENDL-2015, AKONING
Neutron emission for (n,n*)d

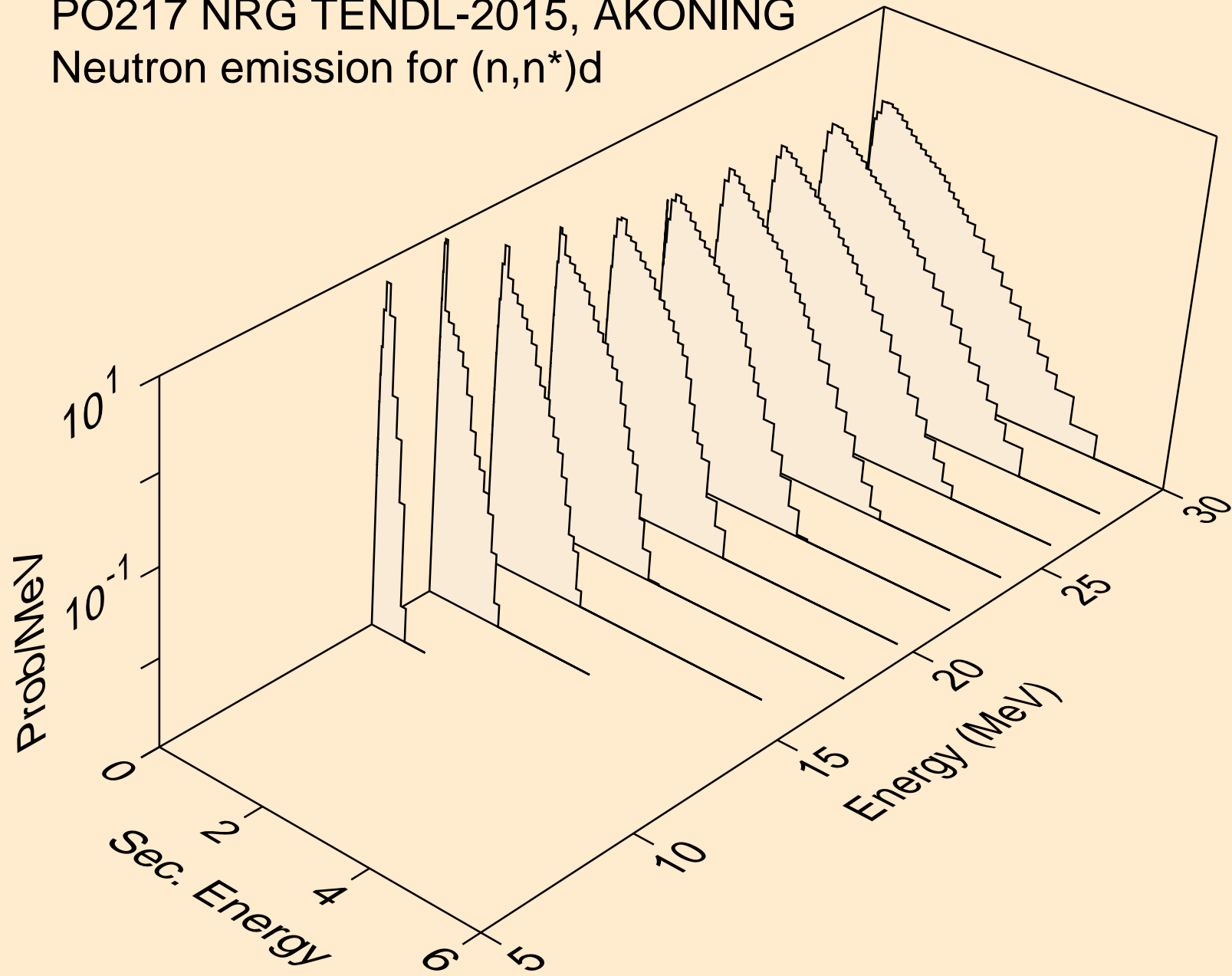

PO217 NRG TENDL-2015, AKONING
Neutron emission for (n,n*)t

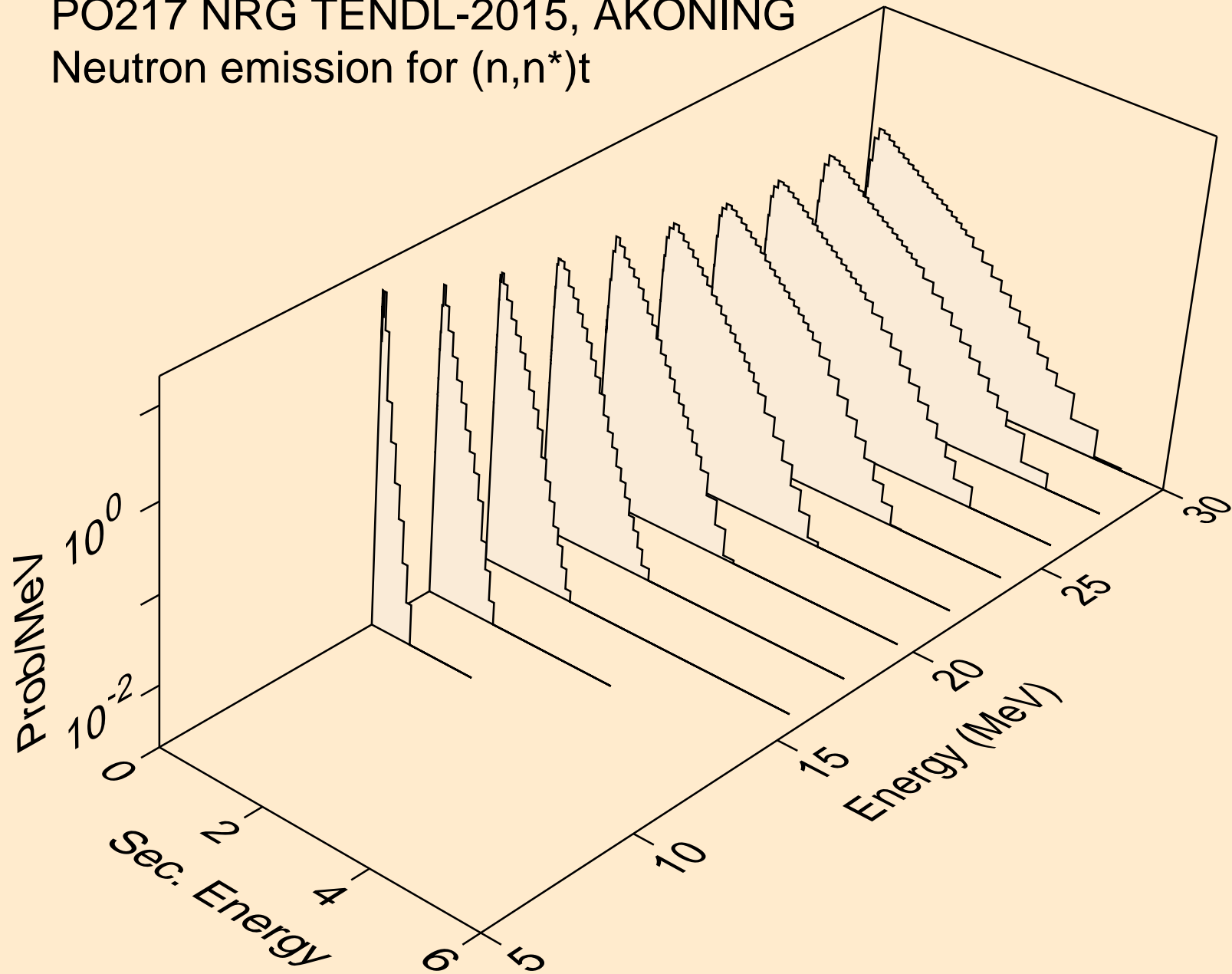

PO217 NRG TENDL-2015, AKONING
Neutron emission for (n,n*)he3

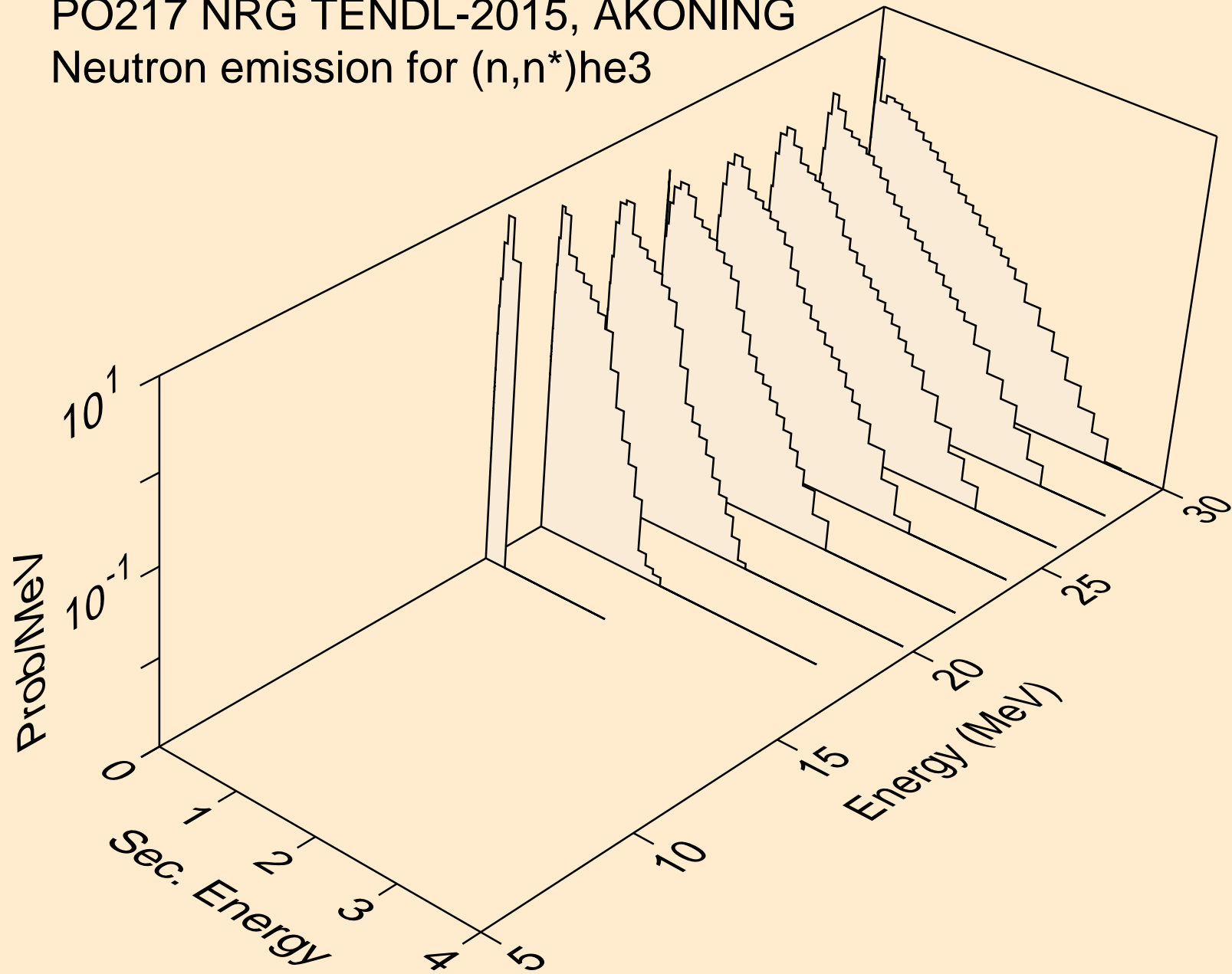

PO217 NRG TENDL-2015, AKONING
Neutron emission for (n,4n)

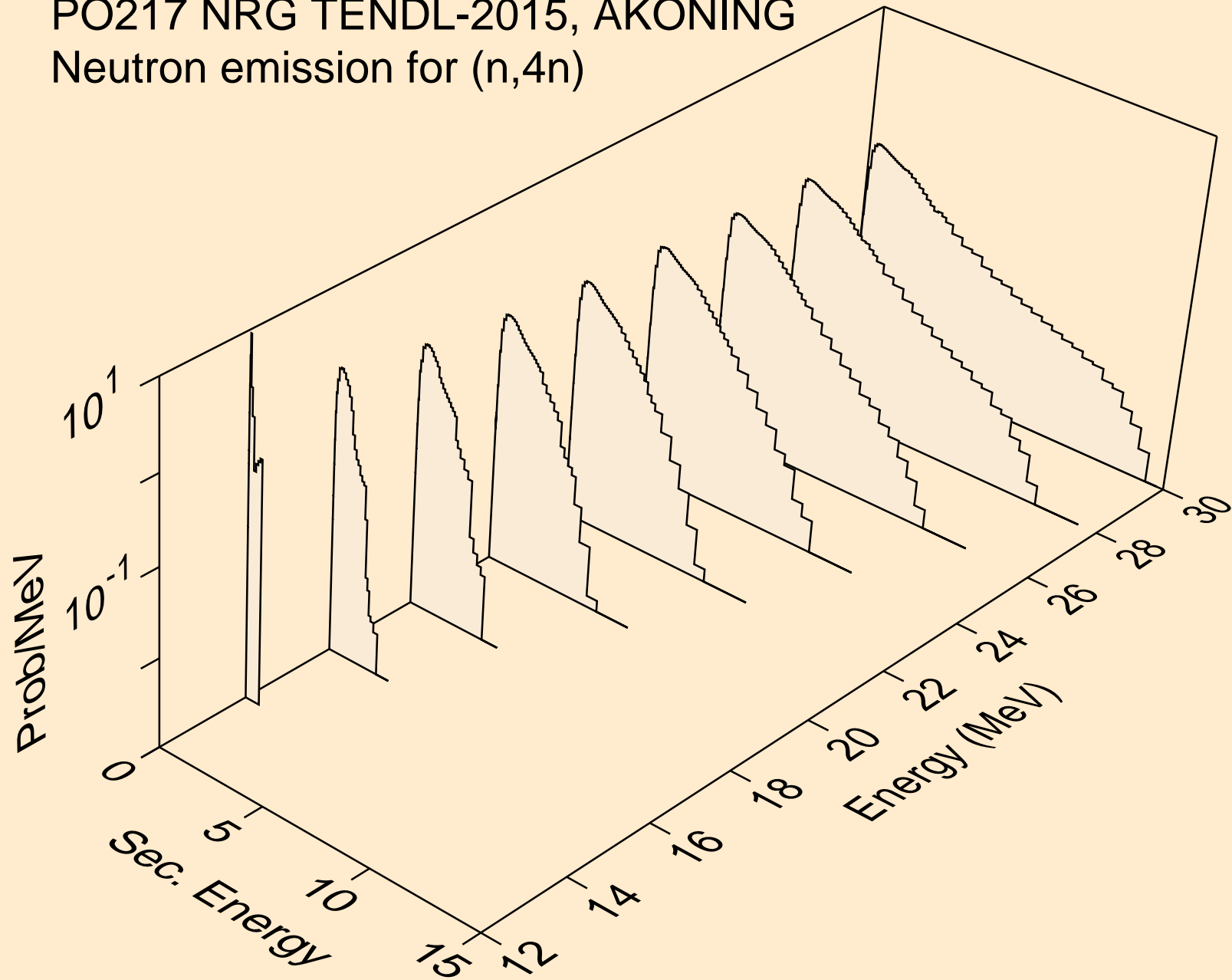

PO217 NRG TENDL-2015, AKONING
Neutron emission for (n,2np)

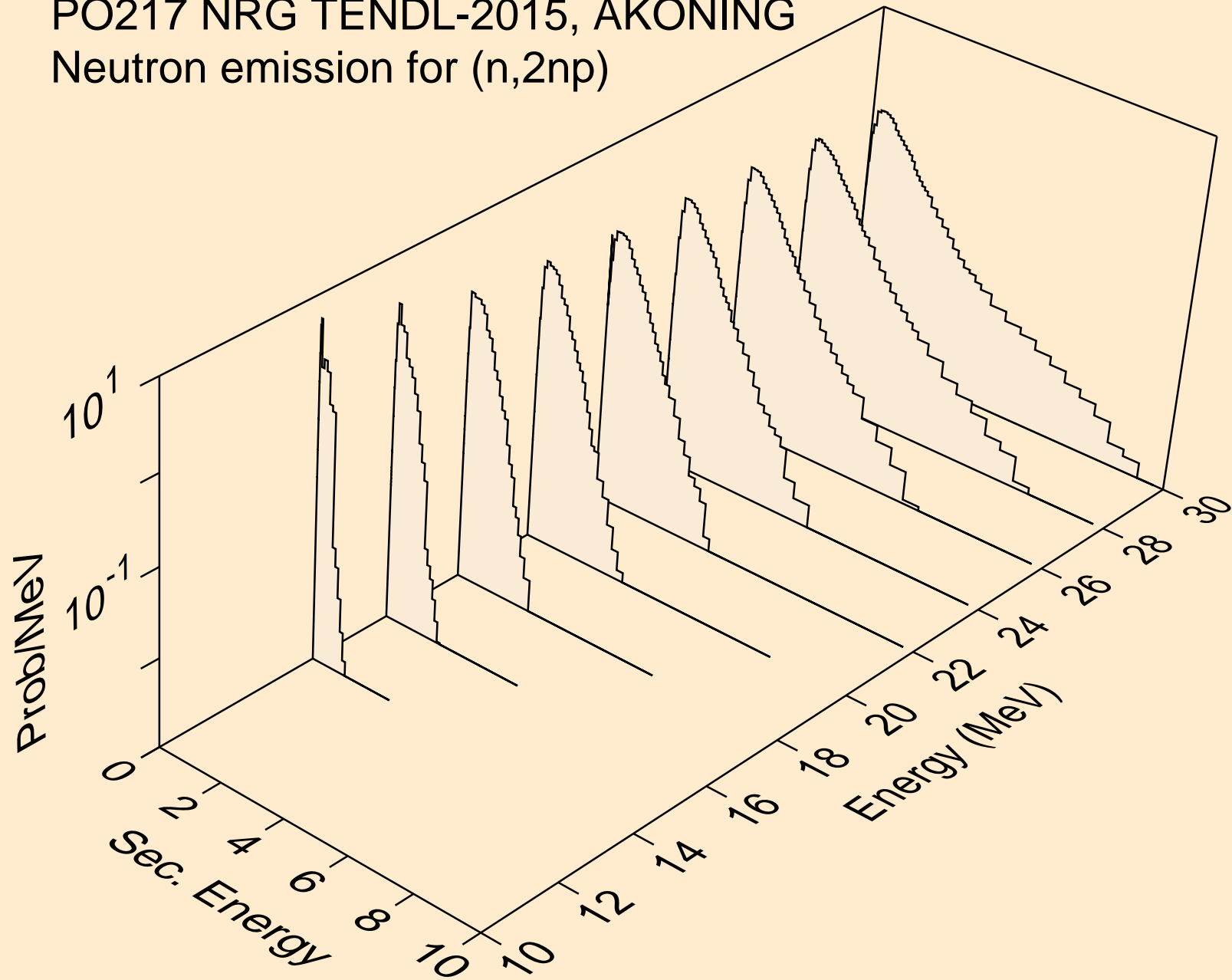

PO217 NRG TENDL-2015, AKONING
Neutron emission for (n,3np)

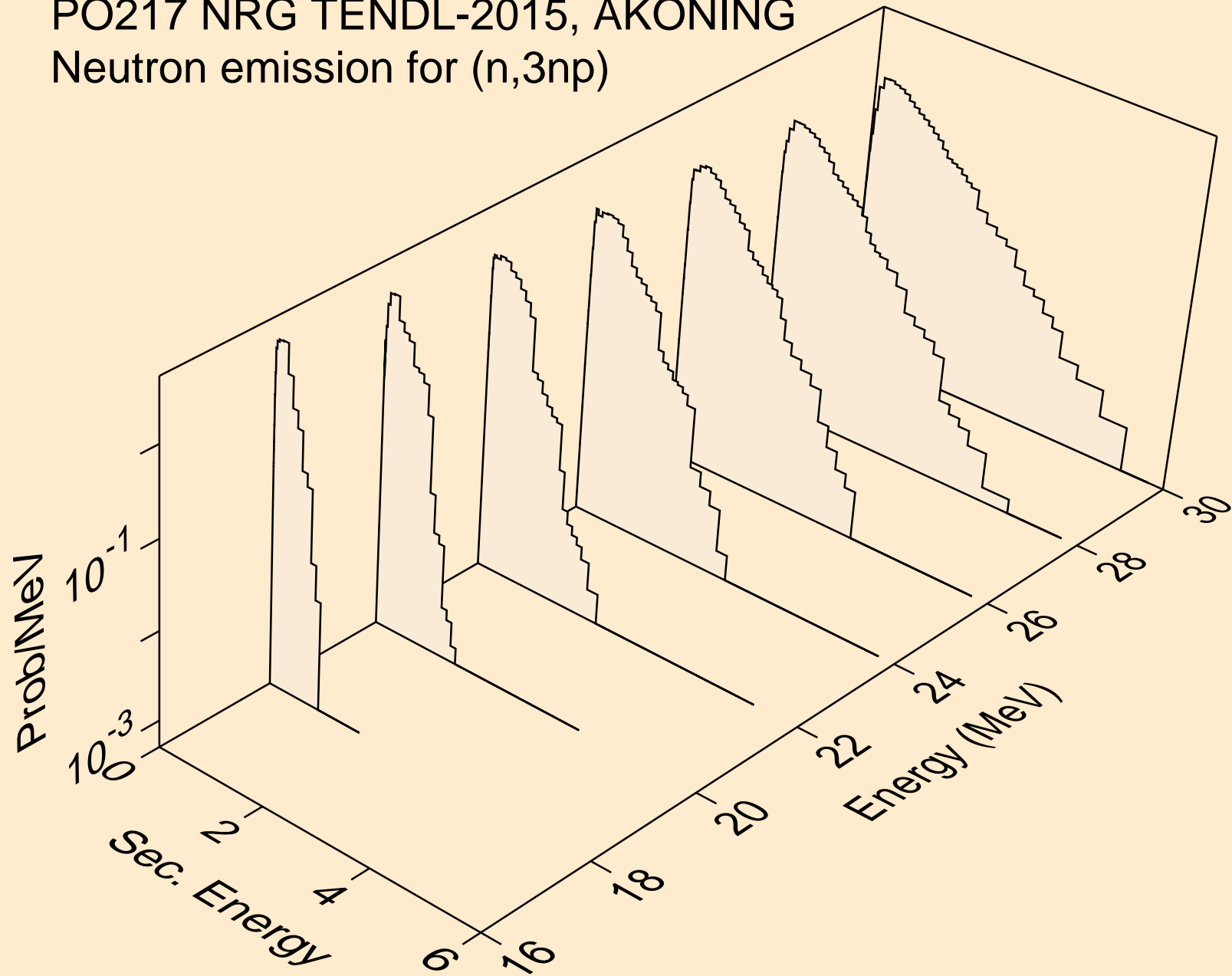

PO217 NRG TENDL-2015, AKONING
Neutron emission for (n,2np)

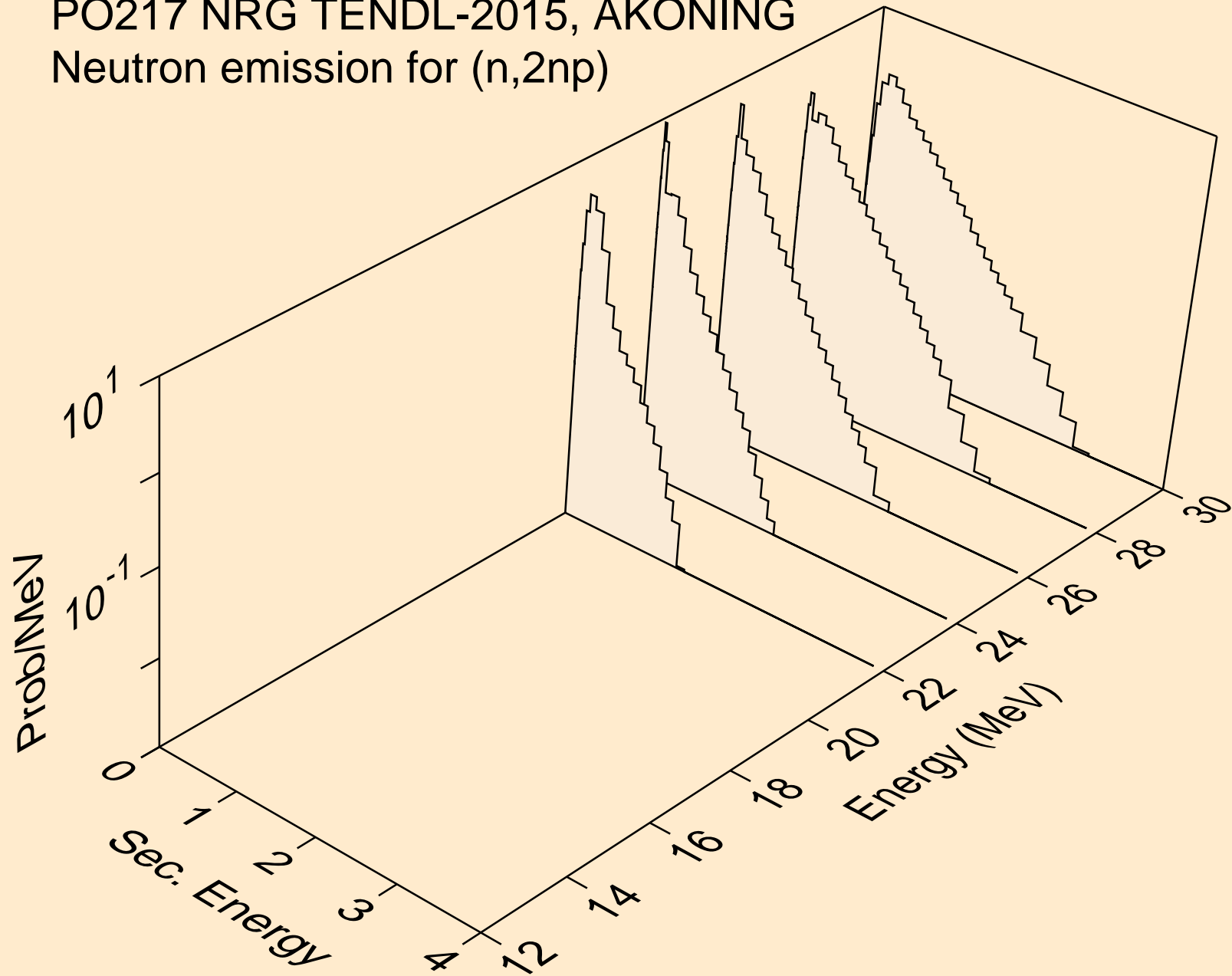

PO217 NRG TENDL-2015, AKONING
Neutron emission for (n,npa)

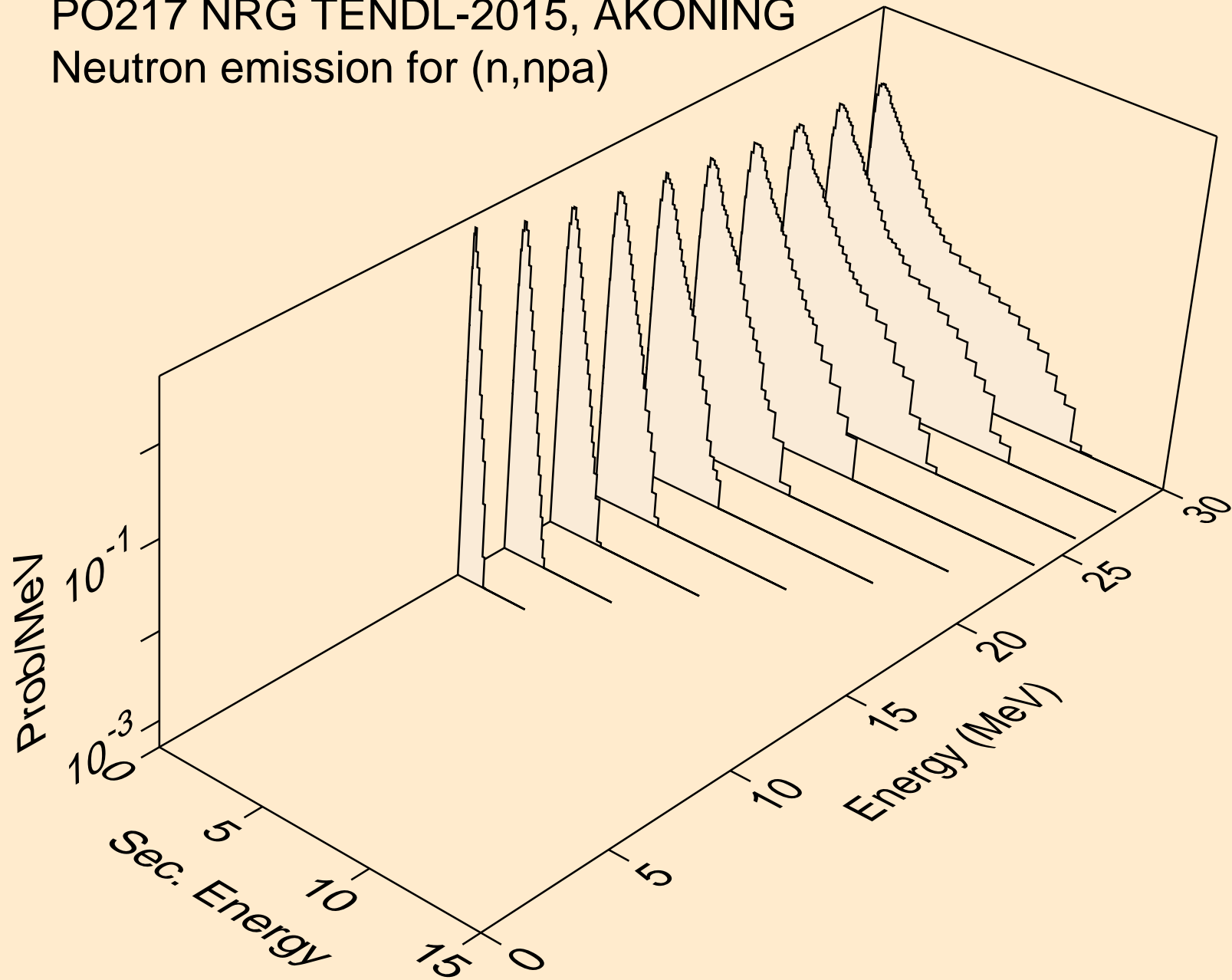

PO217 NRG TENDL-2015, AKONING
Neutron emission for (n,n*c)

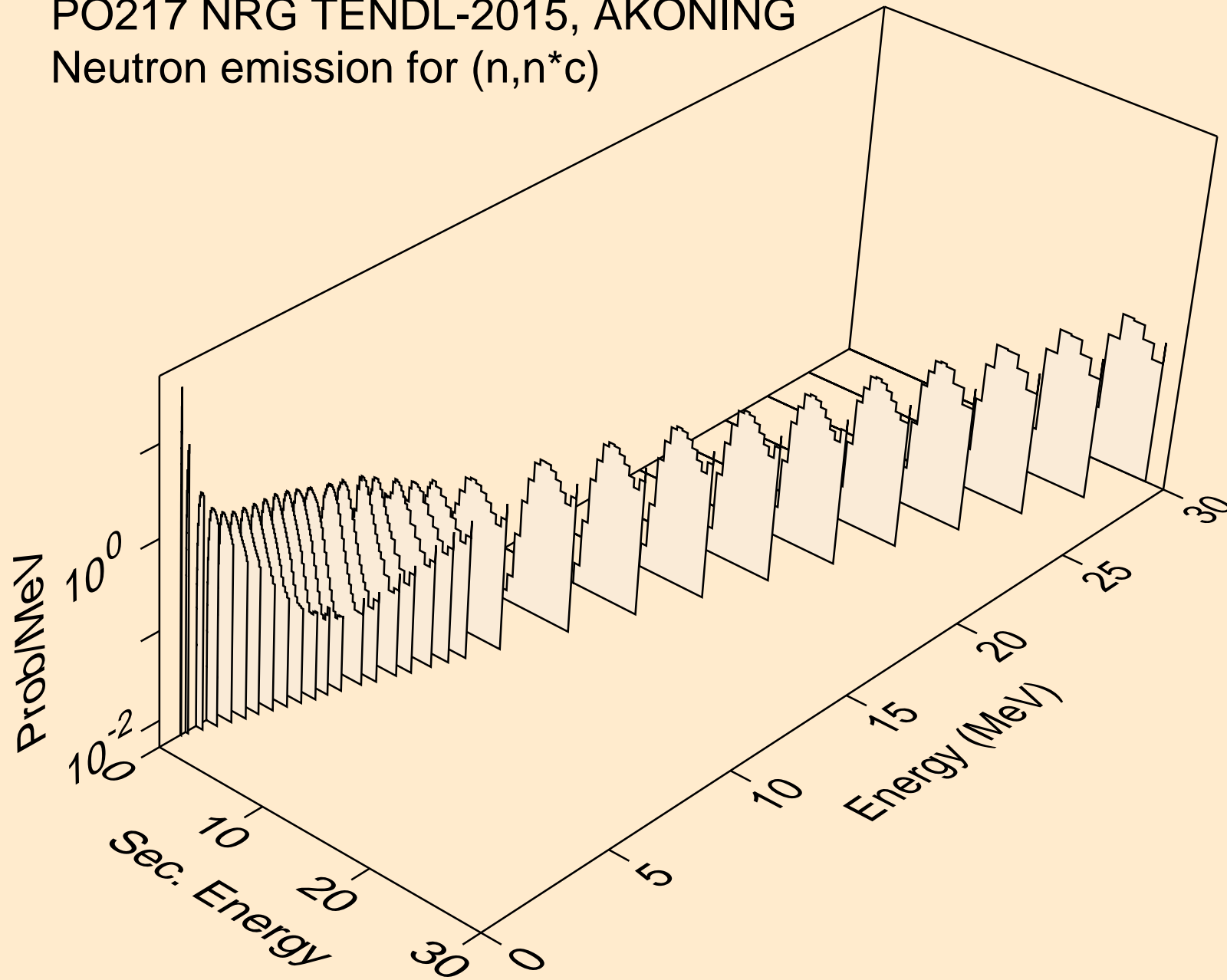

PO217 NRG TENDL-2015, AKONING

Delayed nubar

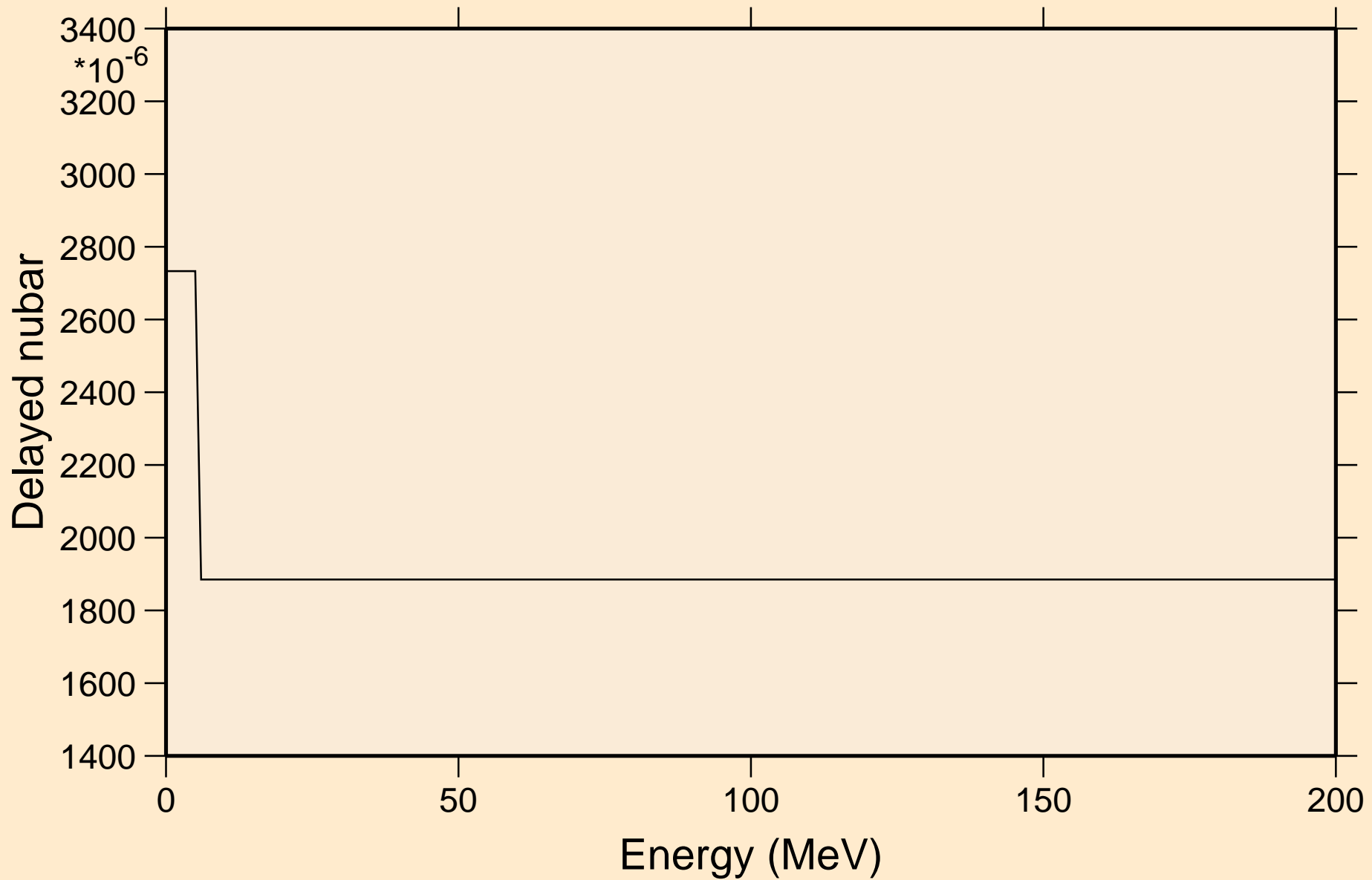

PO217 NRG TENDL-2015, AKONING

Delayed neutron spectra

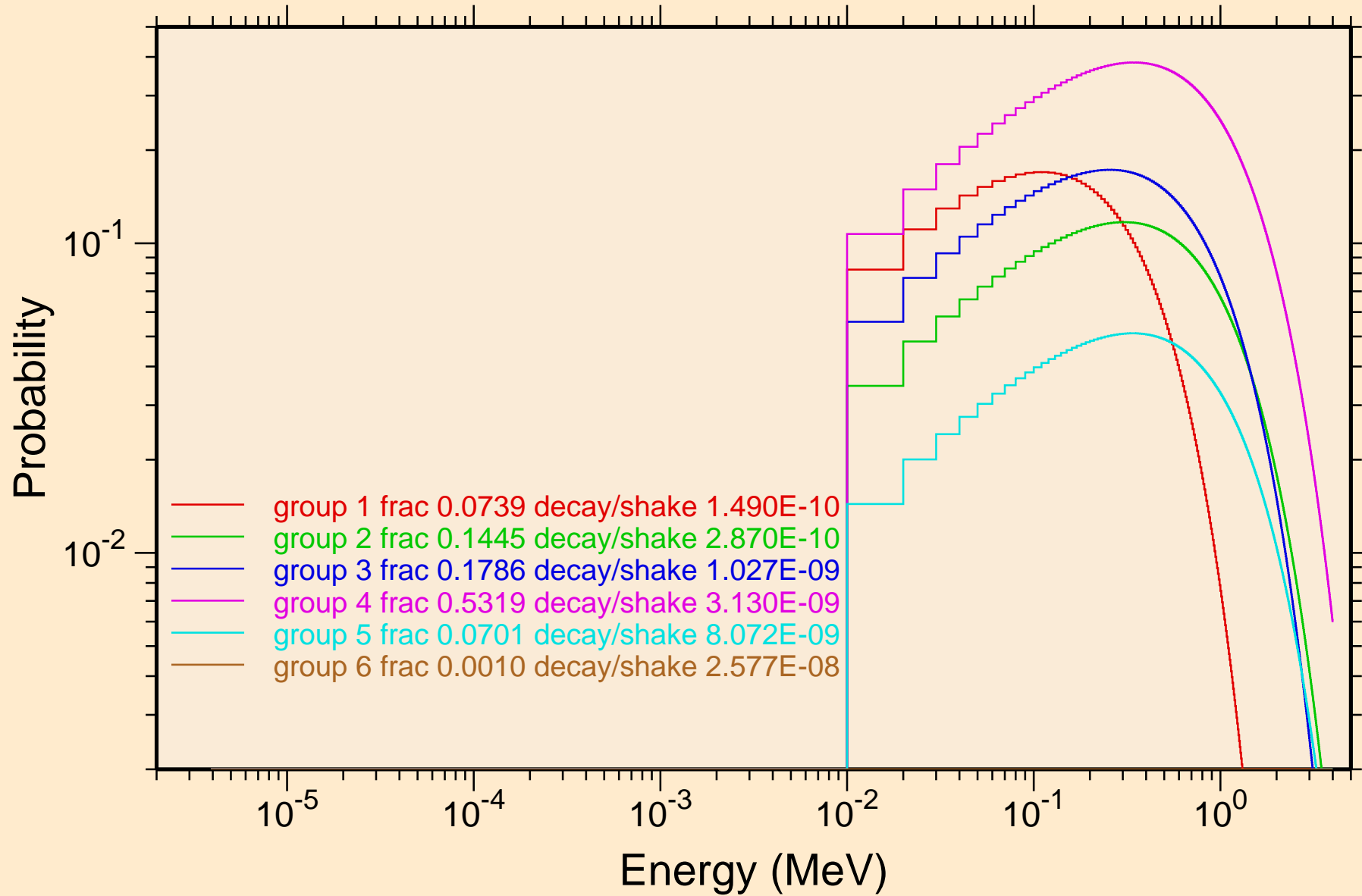

PO217 NRG TENDL-2015, AKONING
Photon emission for (n,x)

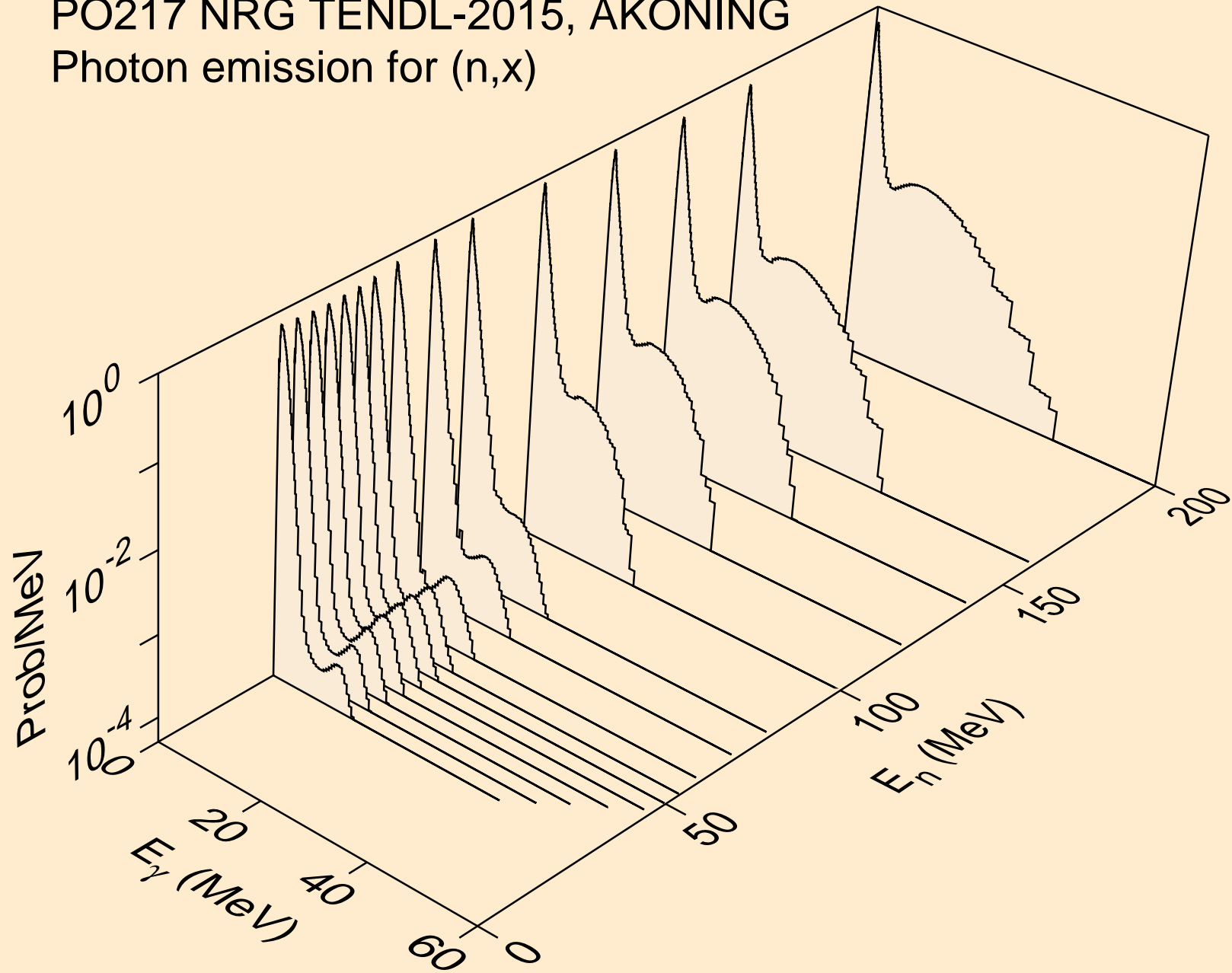

PO217 NRG TENDL-2015, AKONING
Photon emission for (n,2nd)

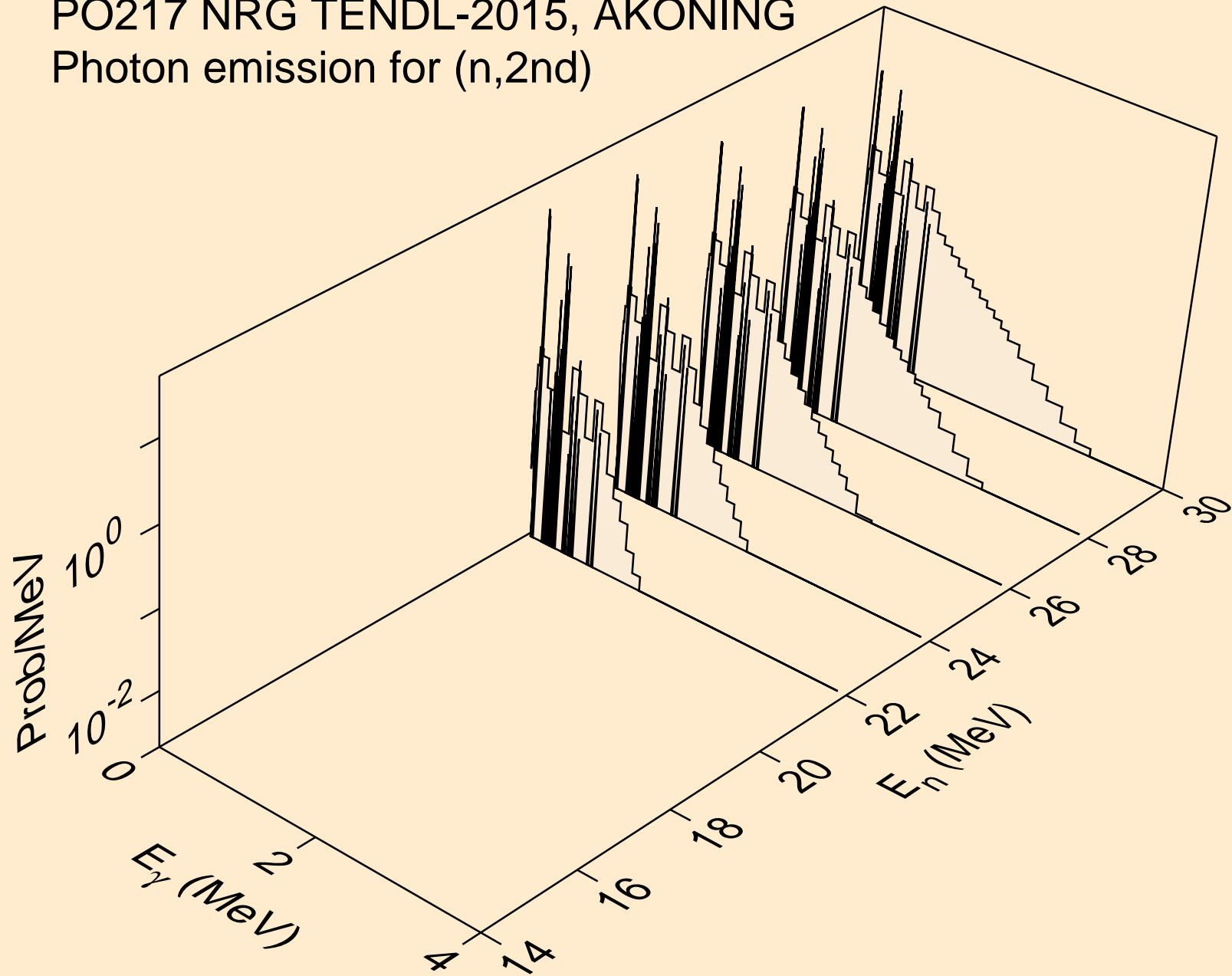

PO217 NRG TENDL-2015, AKONING
Photon emission for (n,2n)

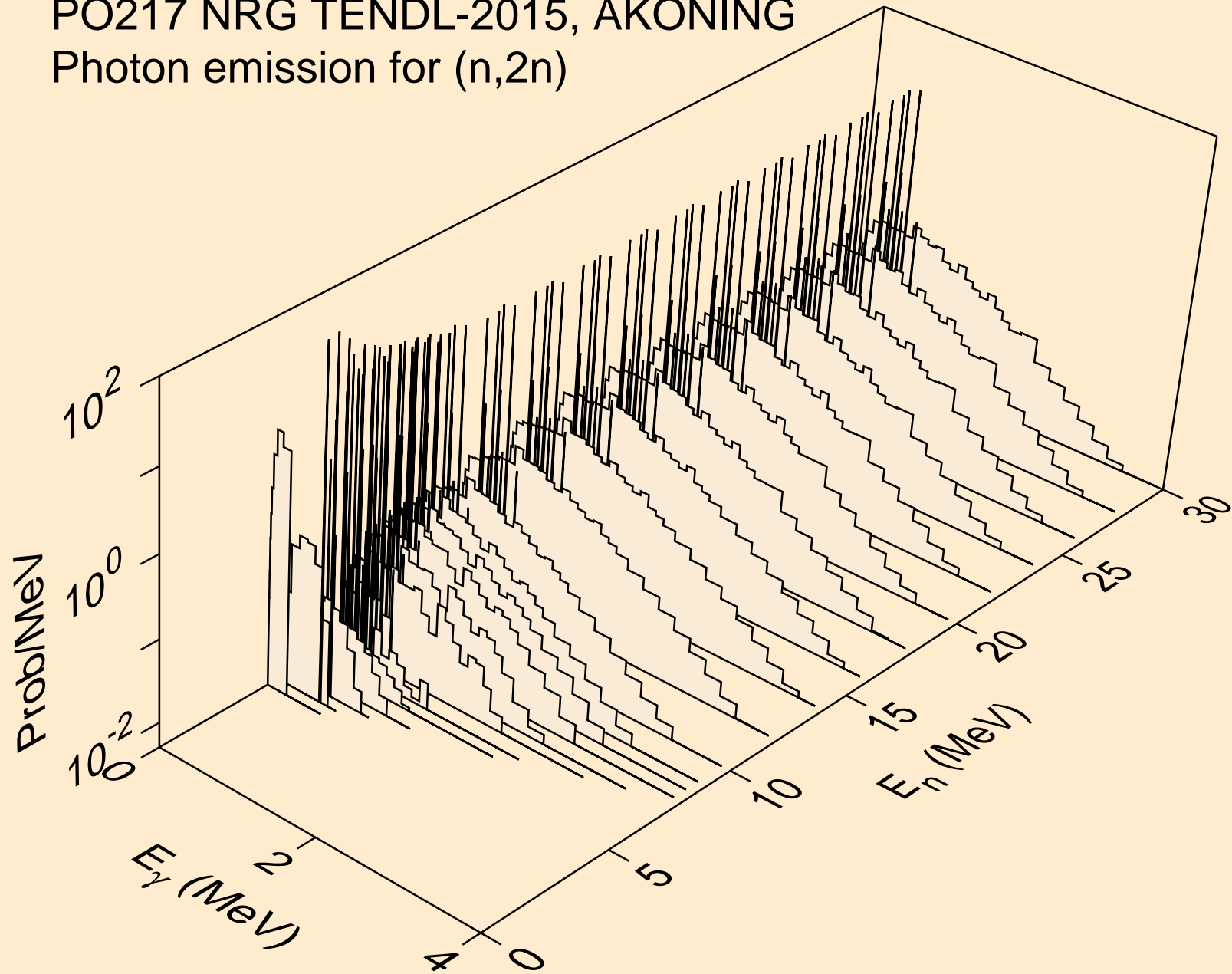

PO217 NRG TENDL-2015, AKONING
Photon emission for (n,3n)

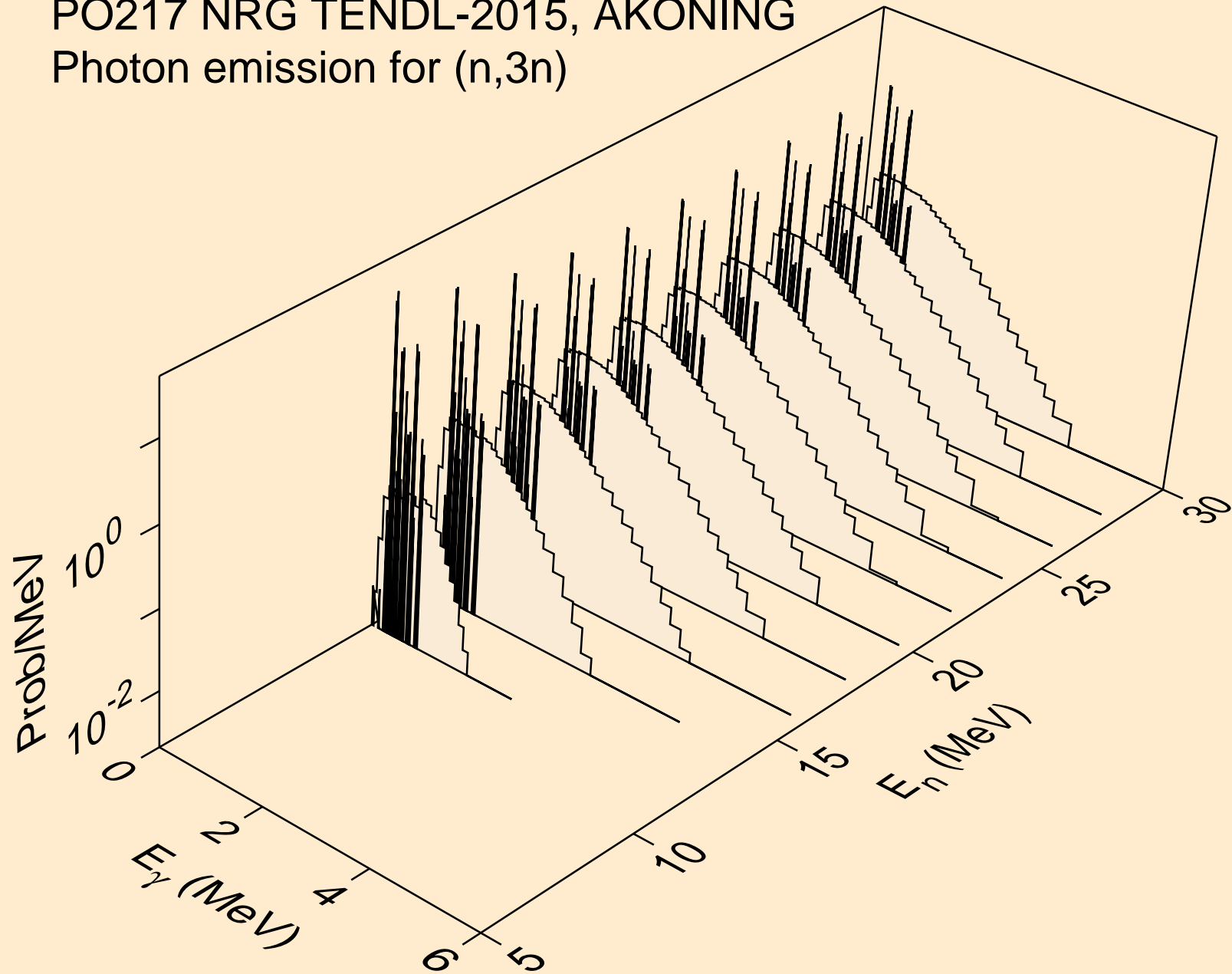

PO217 NRG TENDL-2015, AKONING
Photon emission for (n,n*)a

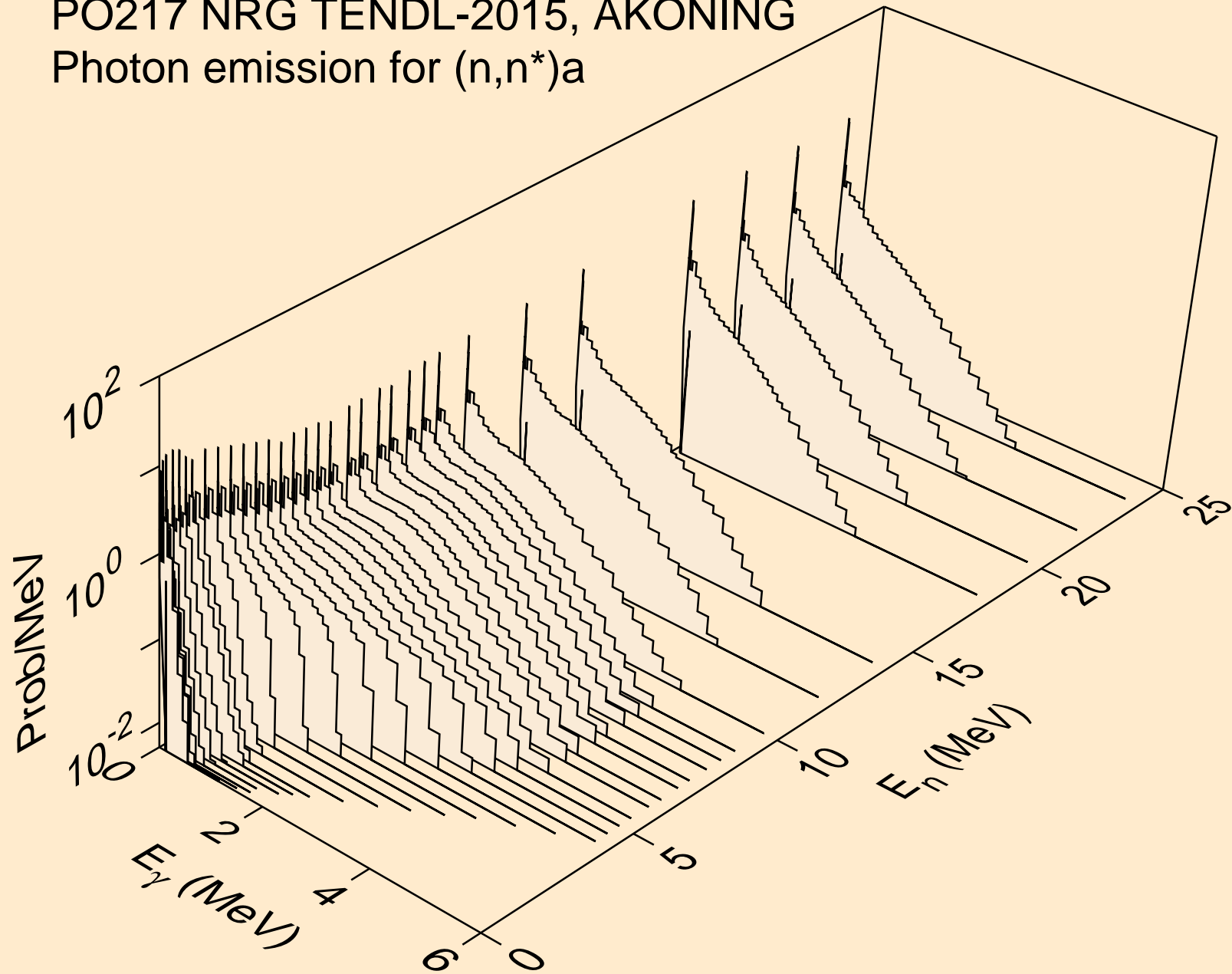

PO217 NRG TENDL-2015, AKONING
Photon emission for (n,2n)a

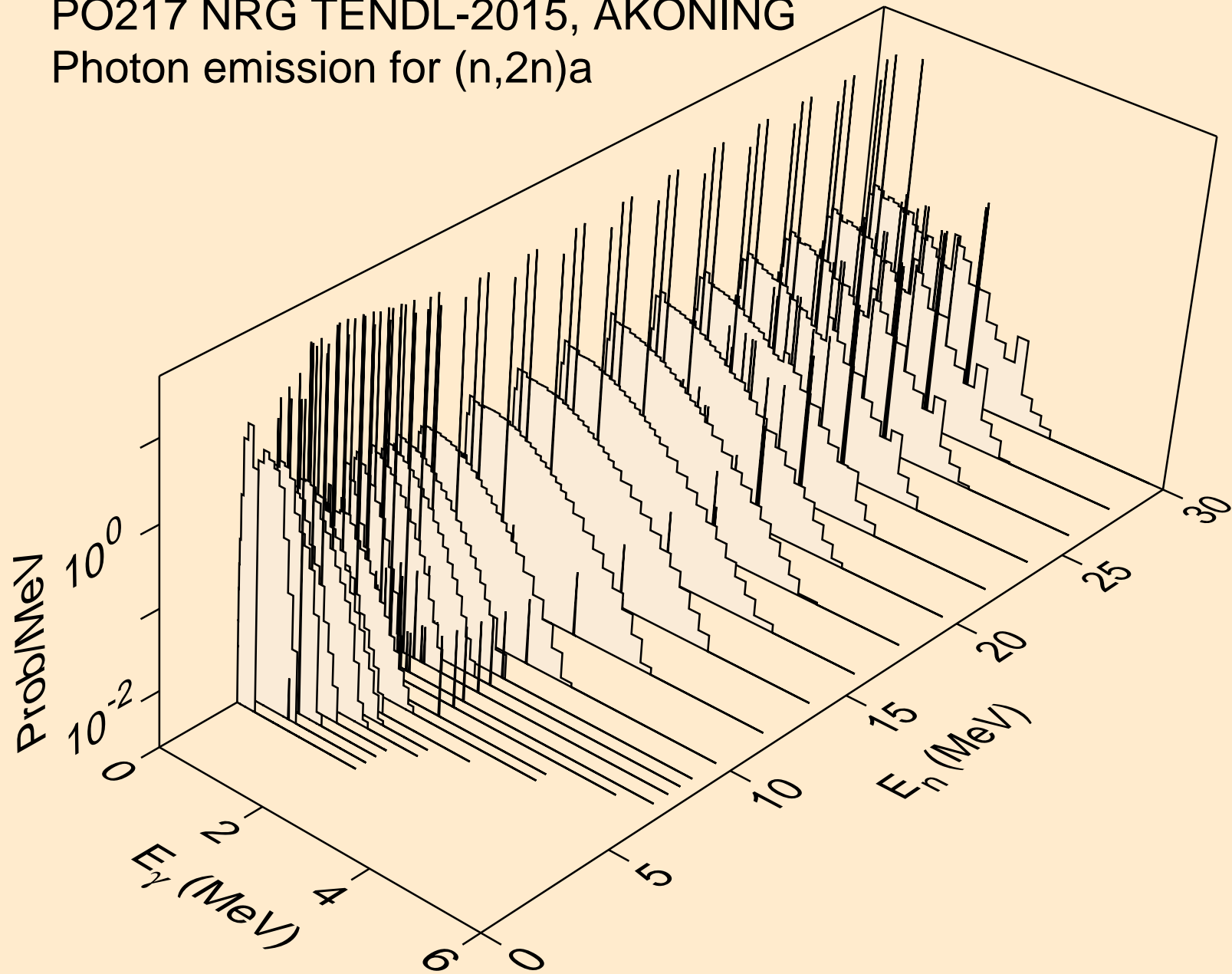

PO217 NRG TENDL-2015, AKONING
Photon emission for (n,3n)a

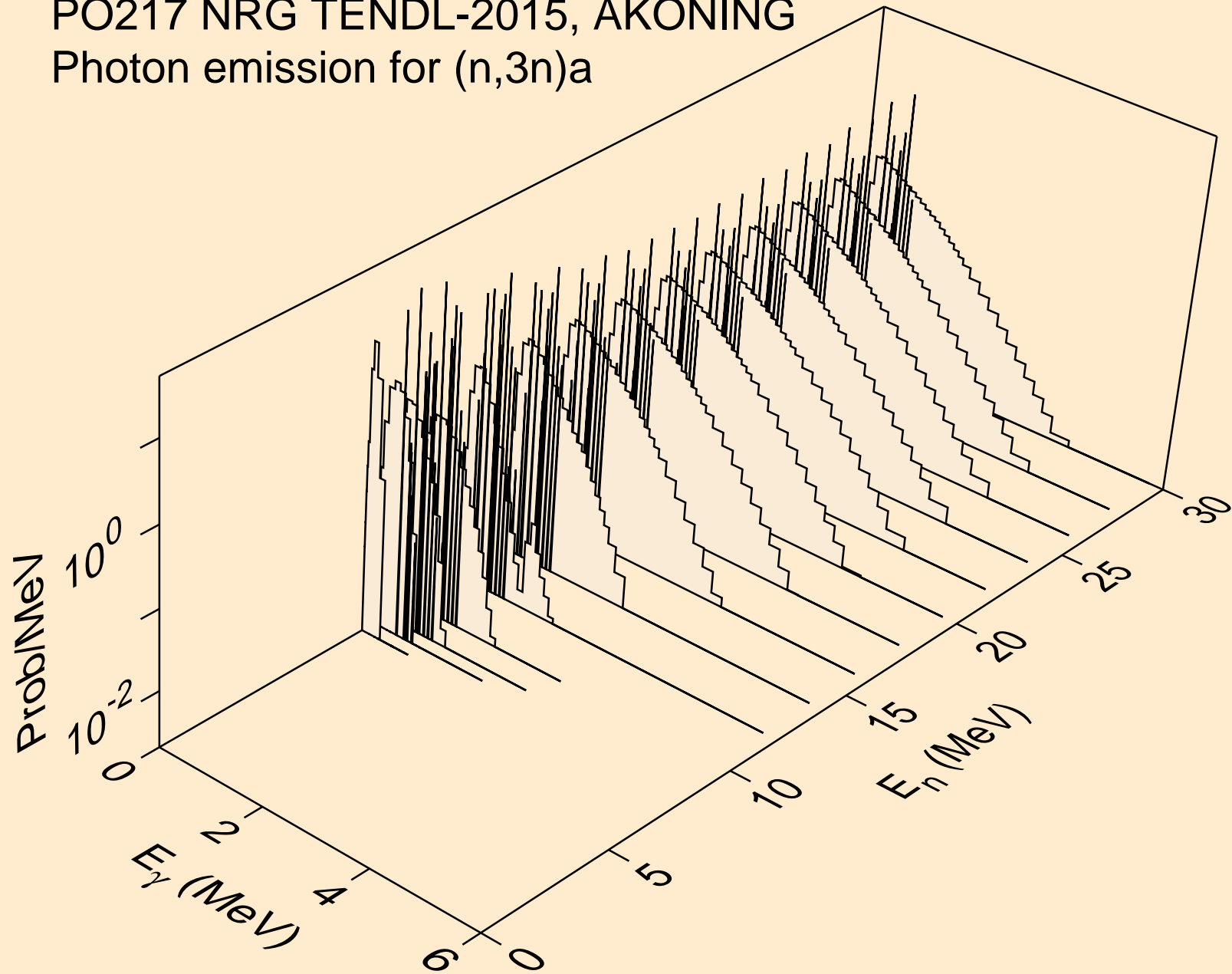

PO217 NRG TENDL-2015, AKONING
Photon emission for (n,n*)p

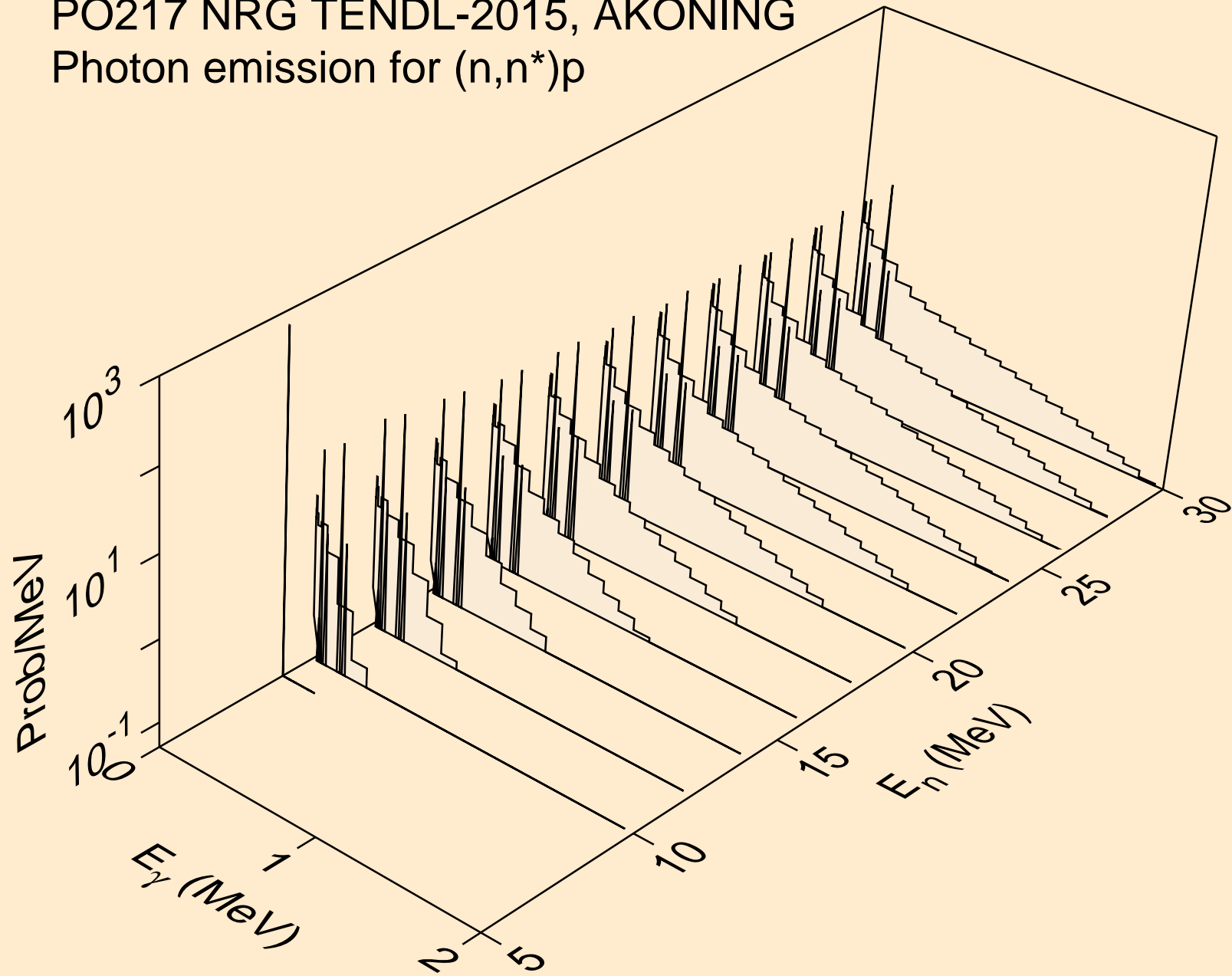

PO217 NRG TENDL-2015, AKONING
Photon emission for (n,n*)2a

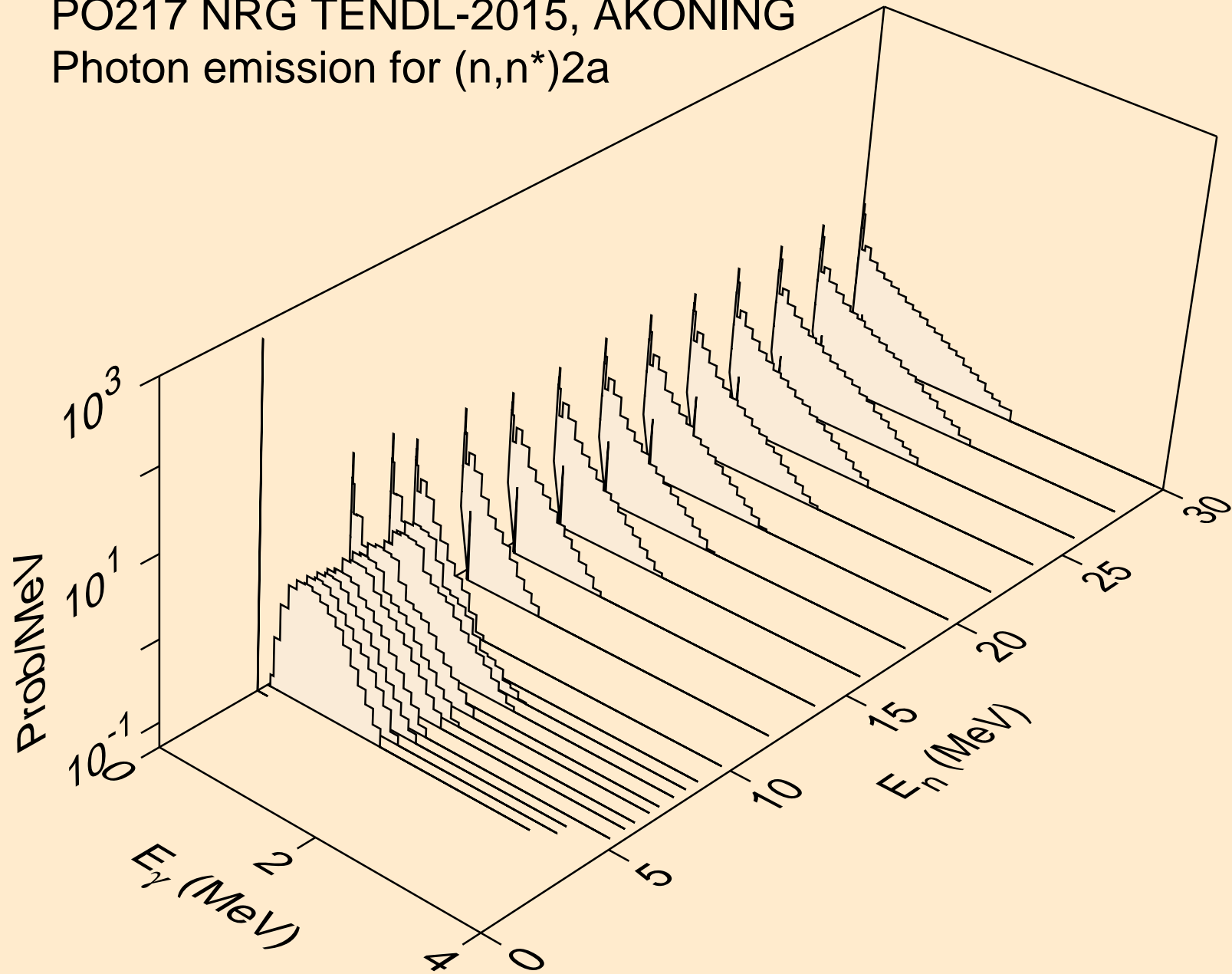

PO217 NRG TENDL-2015, AKONING
Photon emission for (n,2n)2a

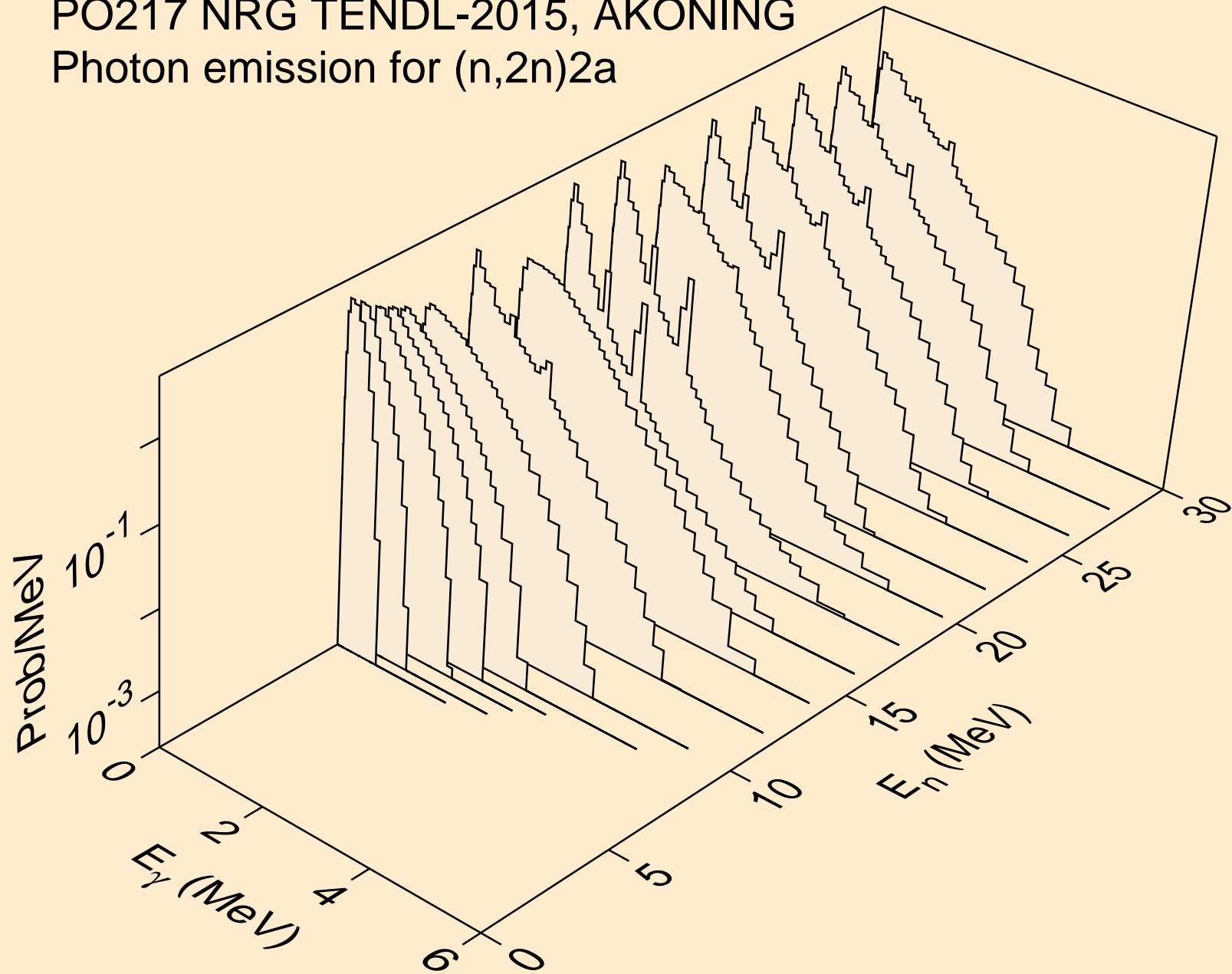

PO217 NRG TENDL-2015, AKONING
Photon emission for (n,n*)d

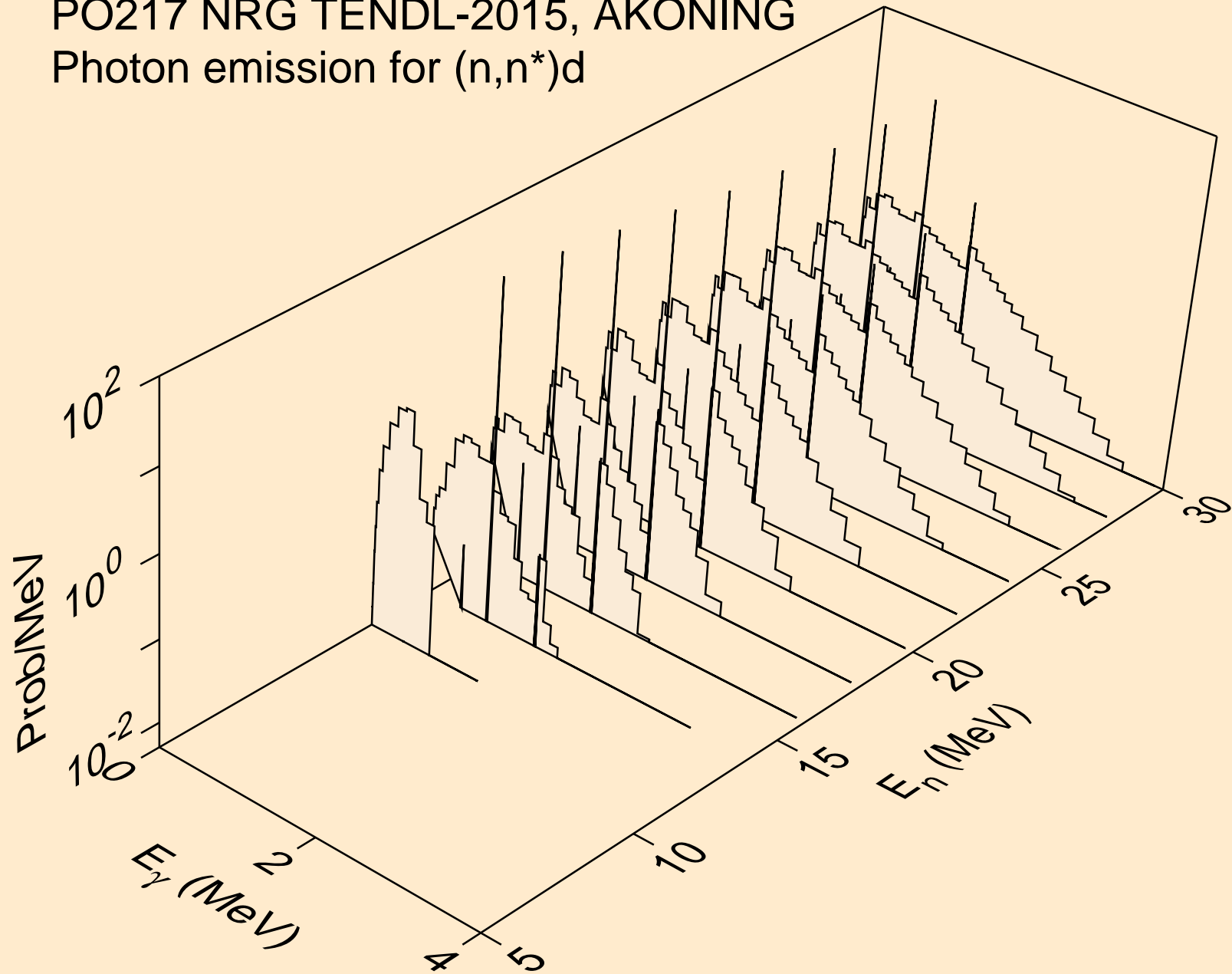

PO217 NRG TENDL-2015, AKONING
Photon emission for (n,n*)t

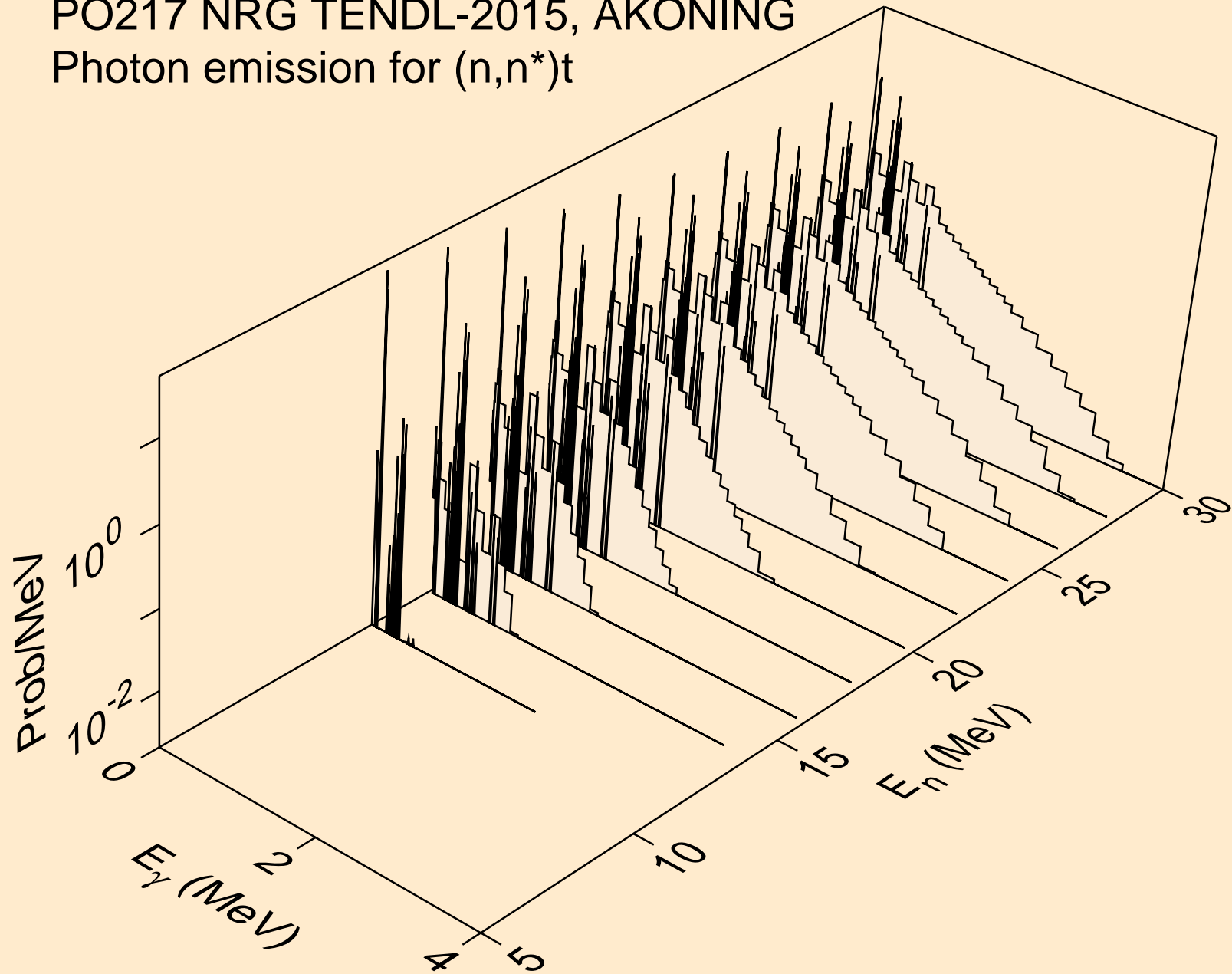

PO217 NRG TENDL-2015, AKONING
Photon emission for (n,n*)he3

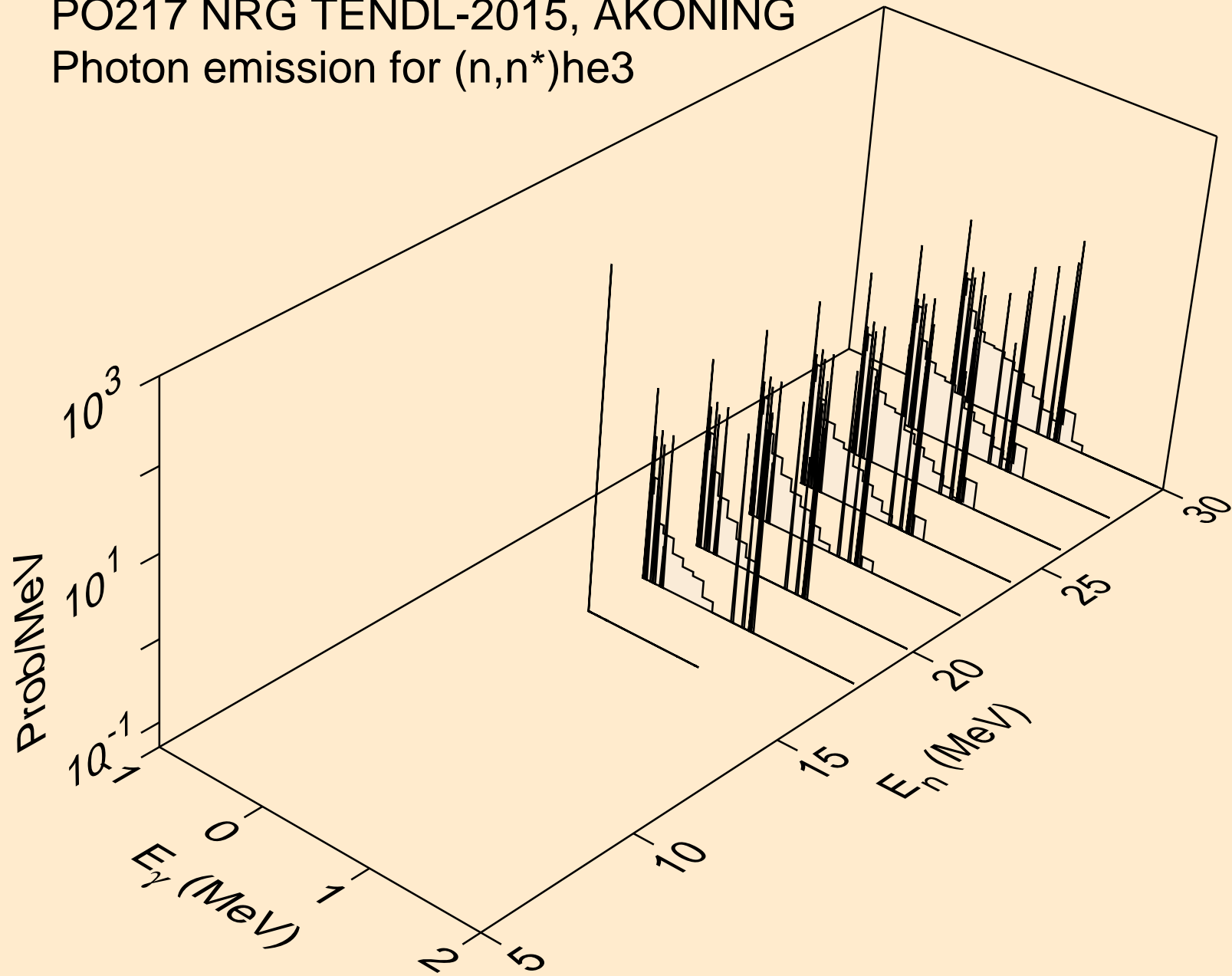

PO217 NRG TENDL-2015, AKONING
Photon emission for (n,4n)

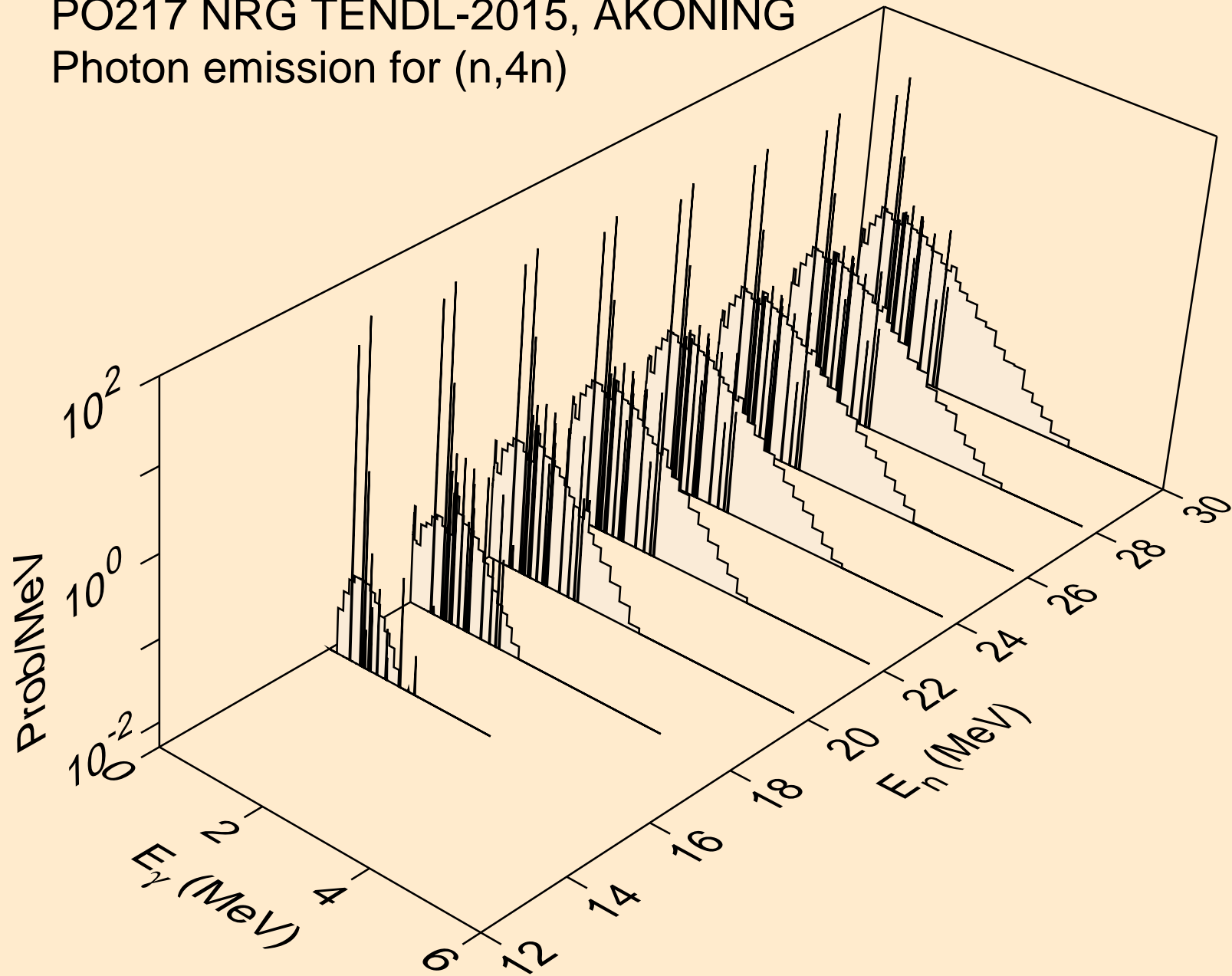

PO217 NRG TENDL-2015, AKONING
Photon emission for (n,2np)

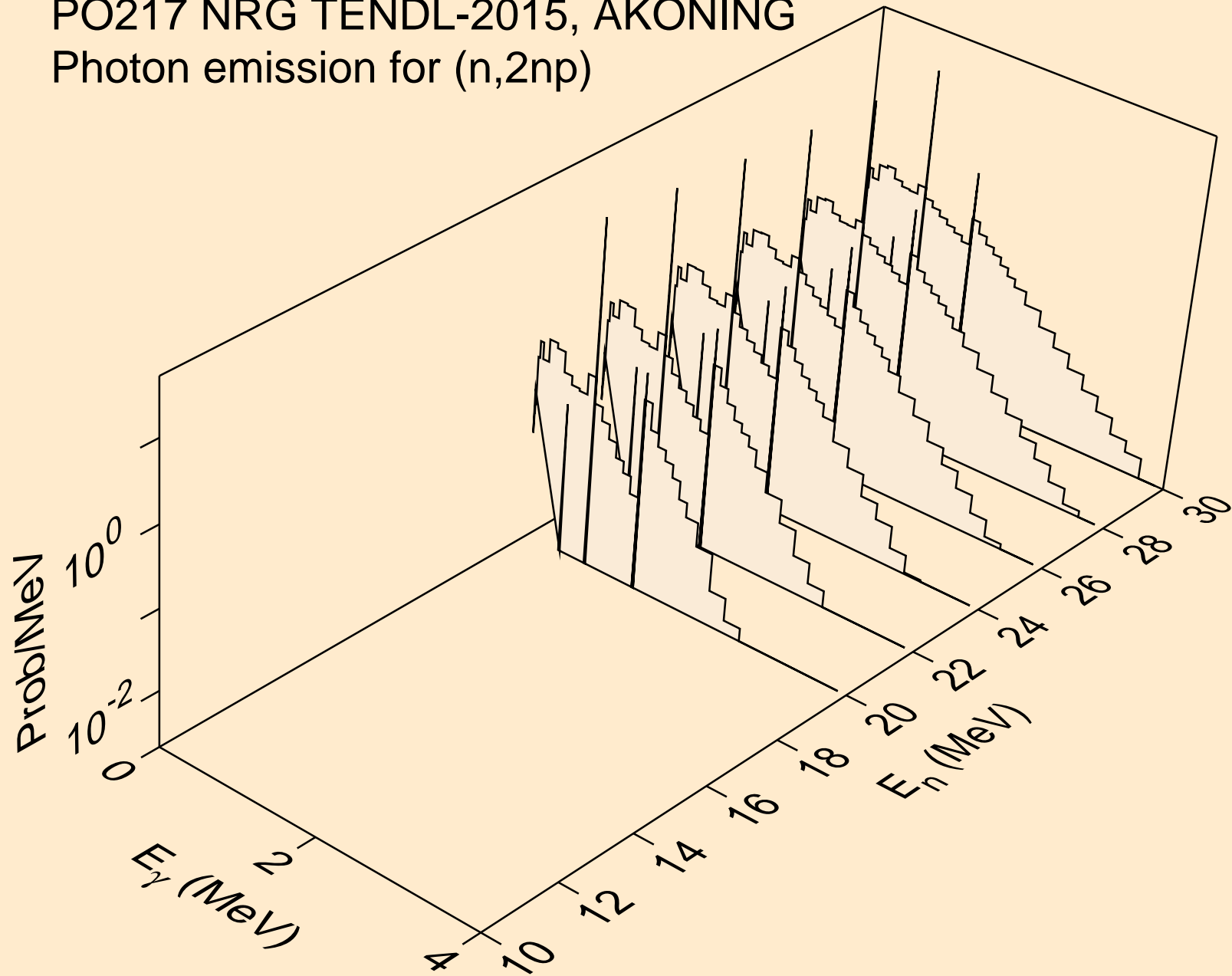

PO217 NRG TENDL-2015, AKONING
Photon emission for (n,3np)

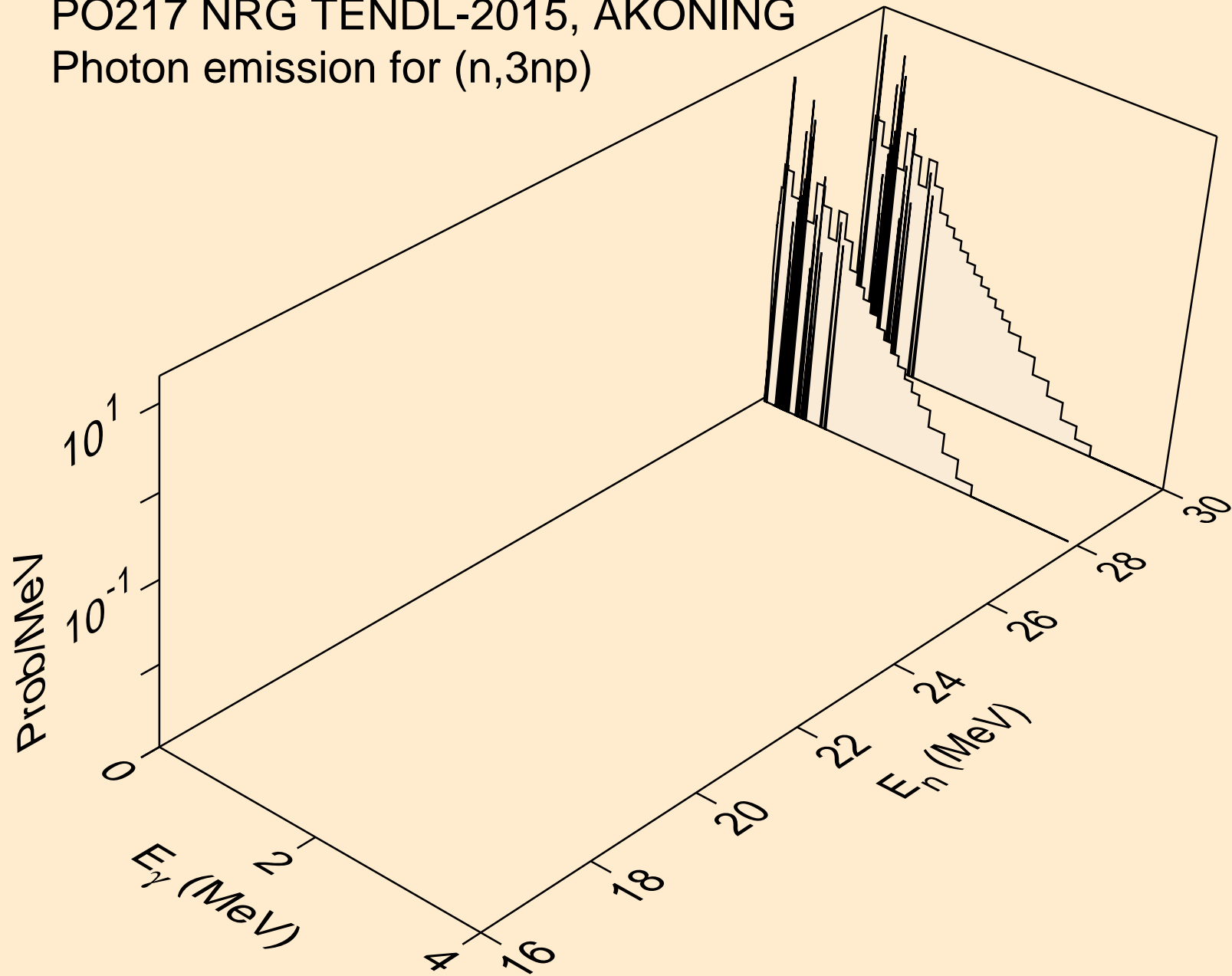

PO217 NRG TENDL-2015, AKONING
Photon emission for (n,2np)

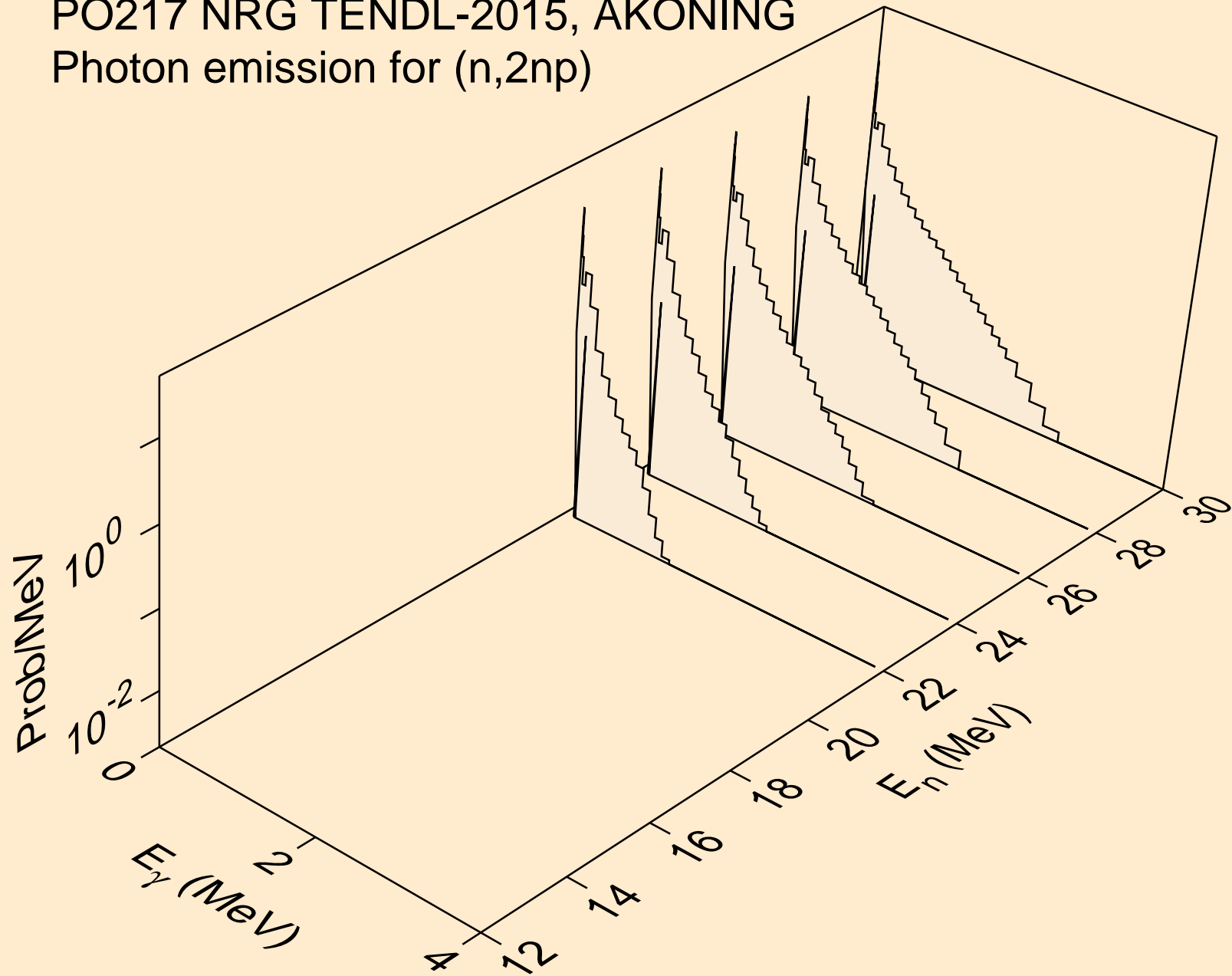

PO217 NRG TENDL-2015, AKONING
Photon emission for (n,npa)

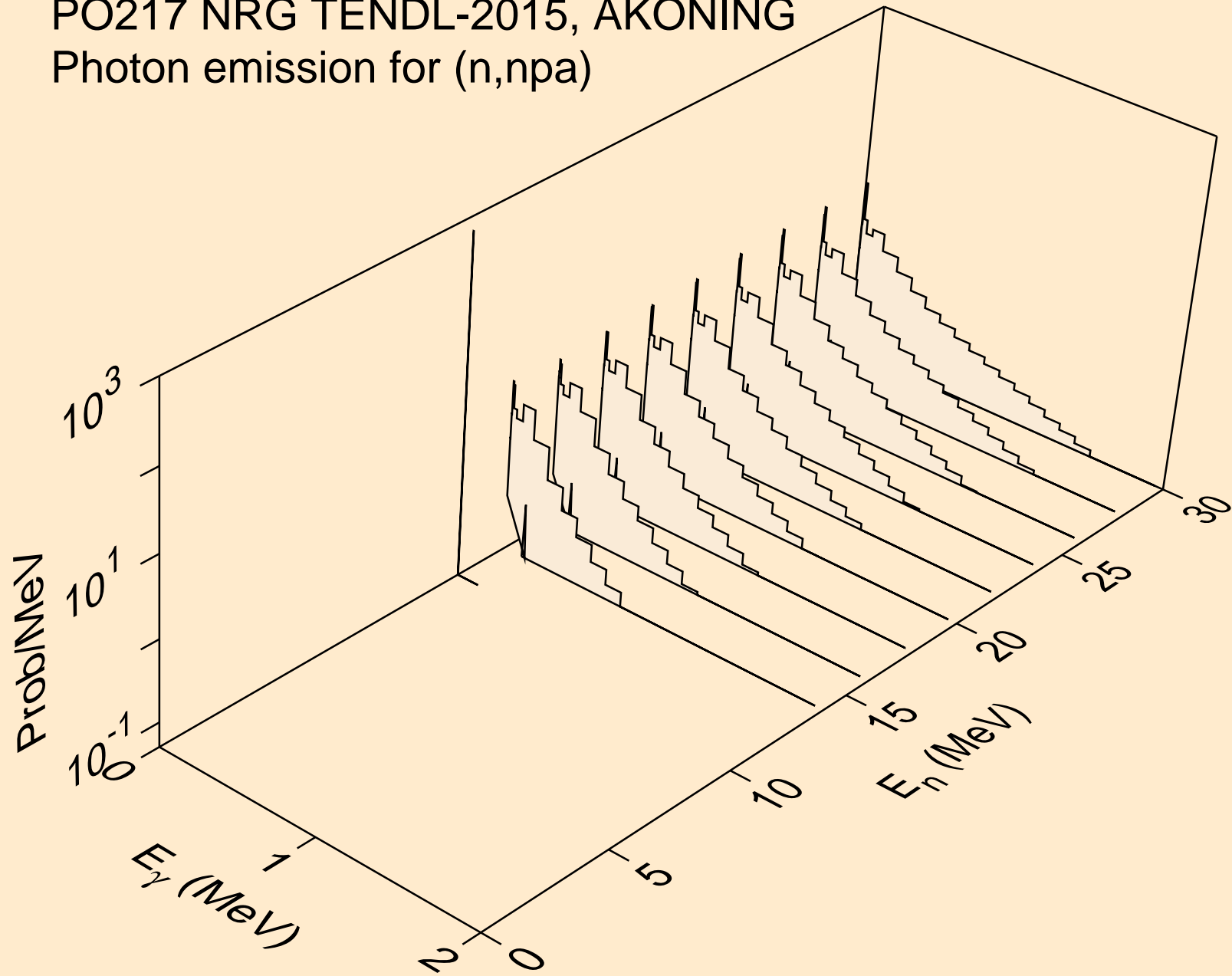

PO217 NRG TENDL-2015, AKONING
Photon emission for (n,n*c)

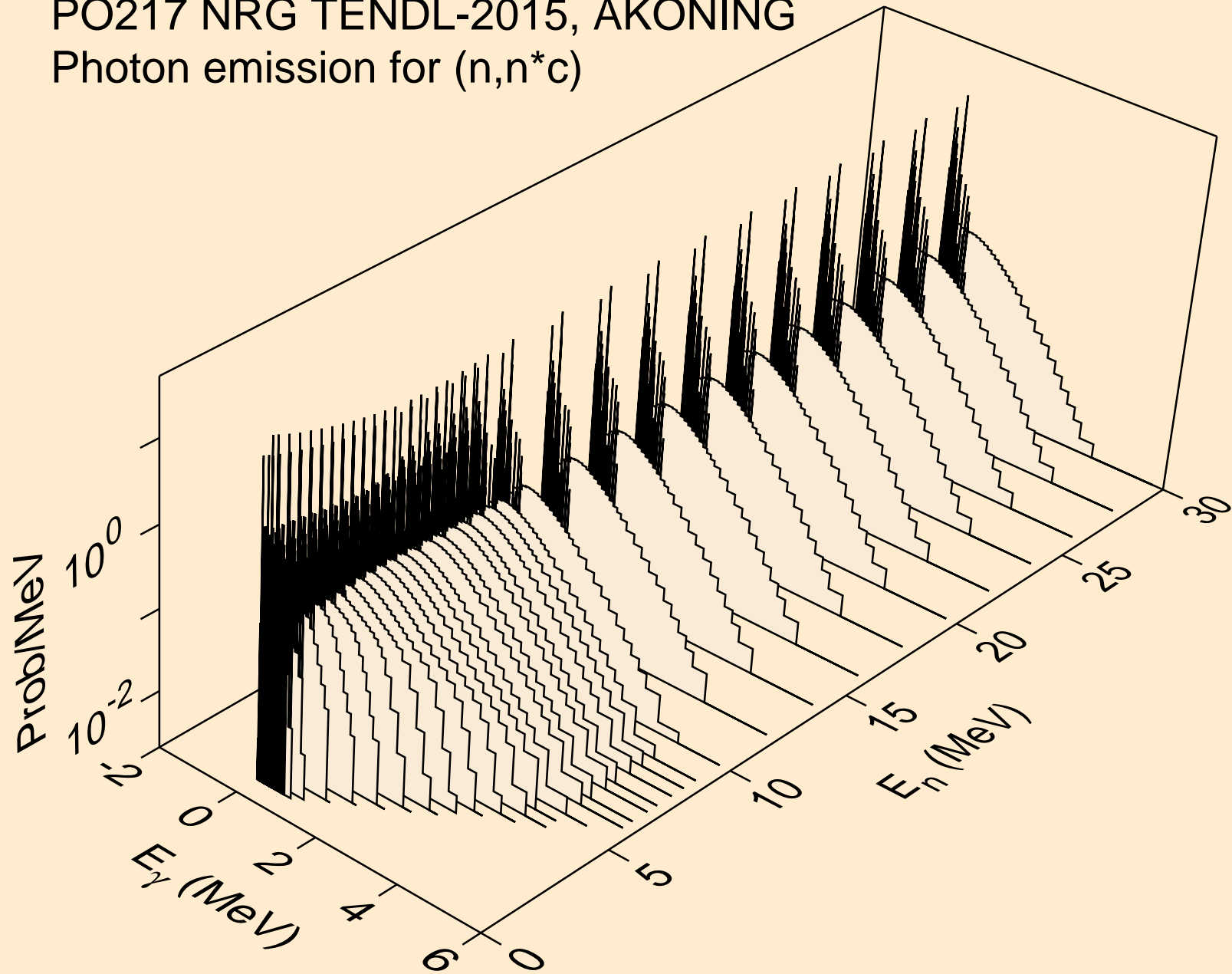

PO217 NRG TENDL-2015, AKONING
Photon emission for (n,gma)

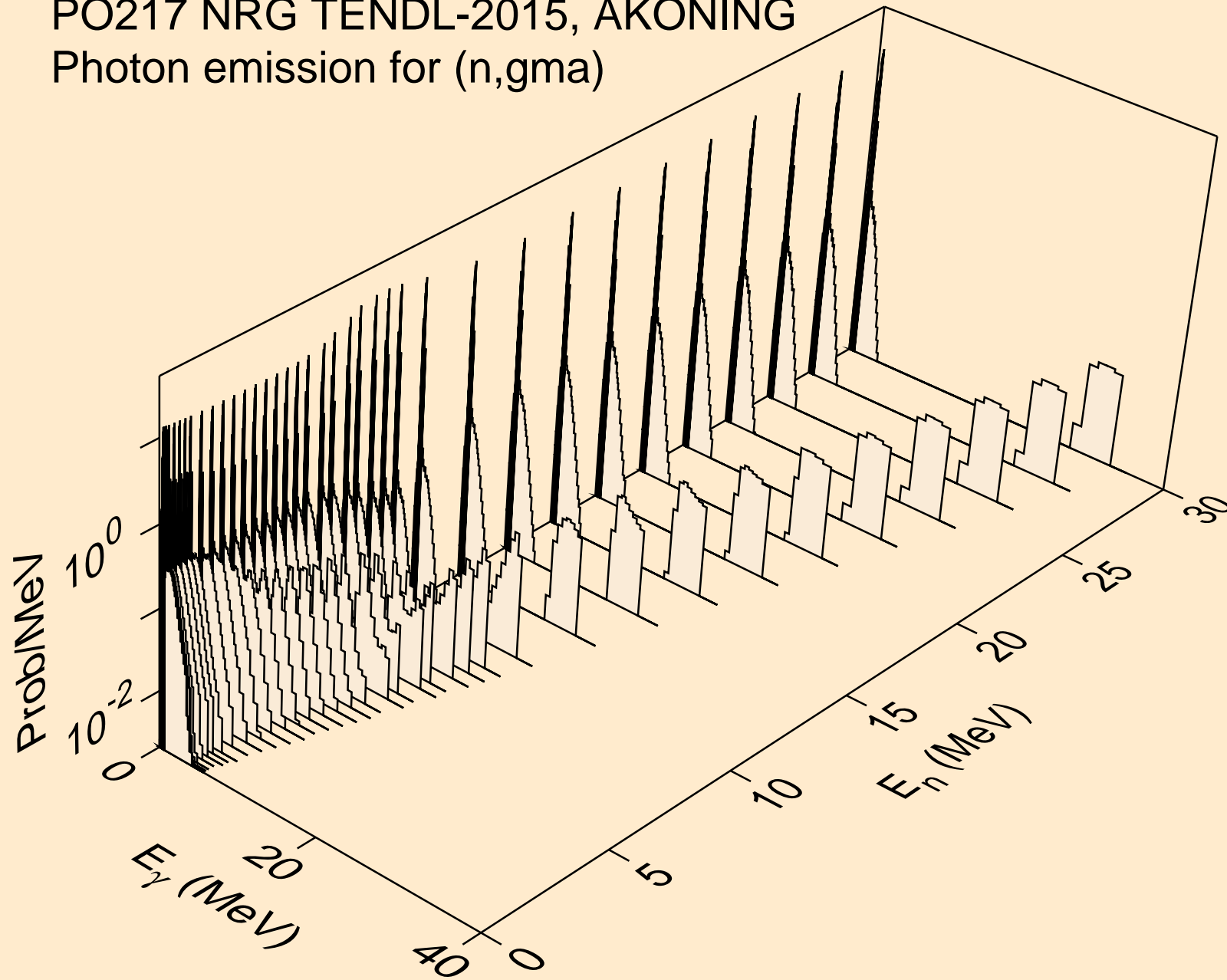

PO217 NRG TENDL-2015, AKONING
Photon emission for (n,p)

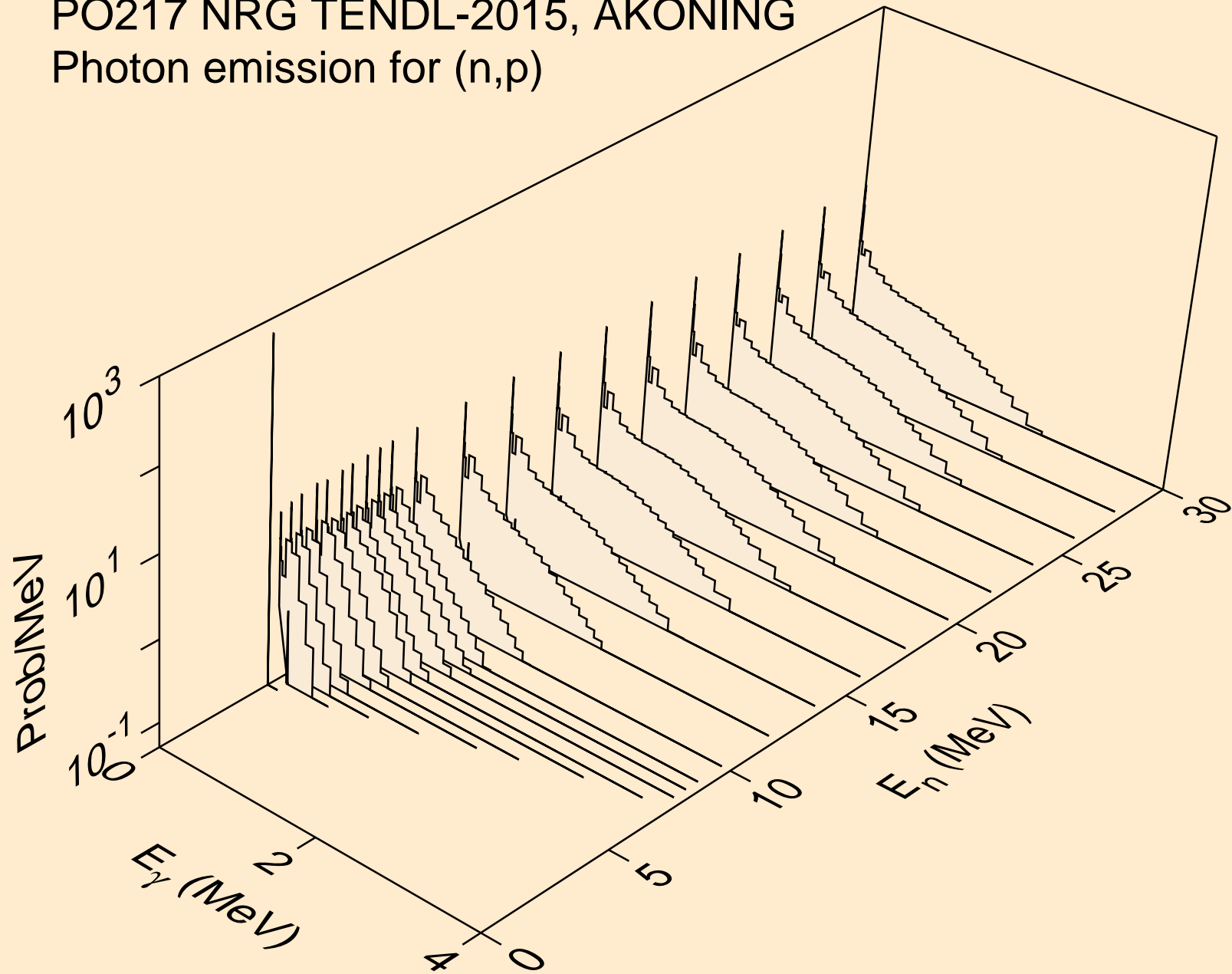

PO217 NRG TENDL-2015, AKONING
Photon emission for (n,d)

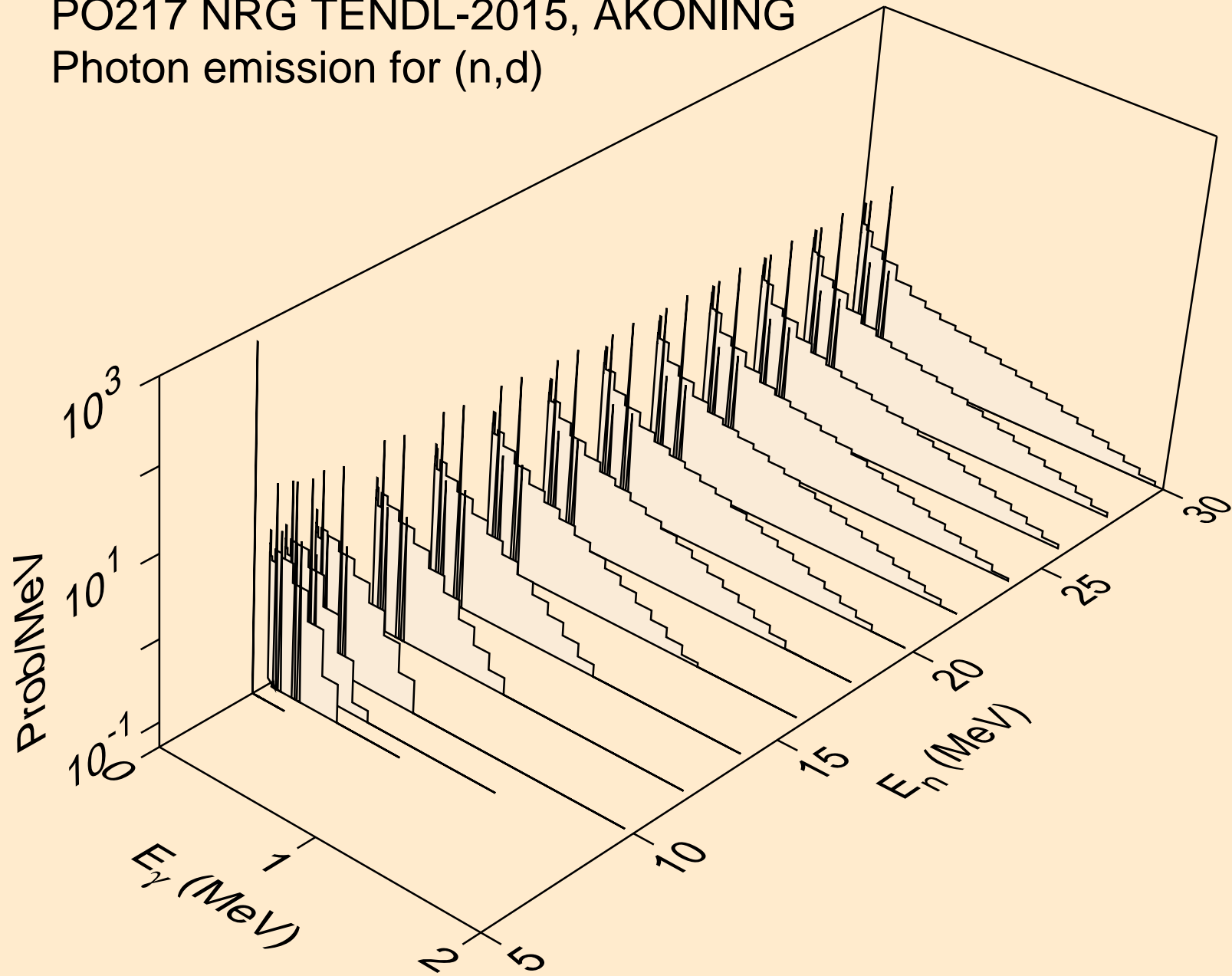

PO217 NRG TENDL-2015, AKONING
Photon emission for (n,t)

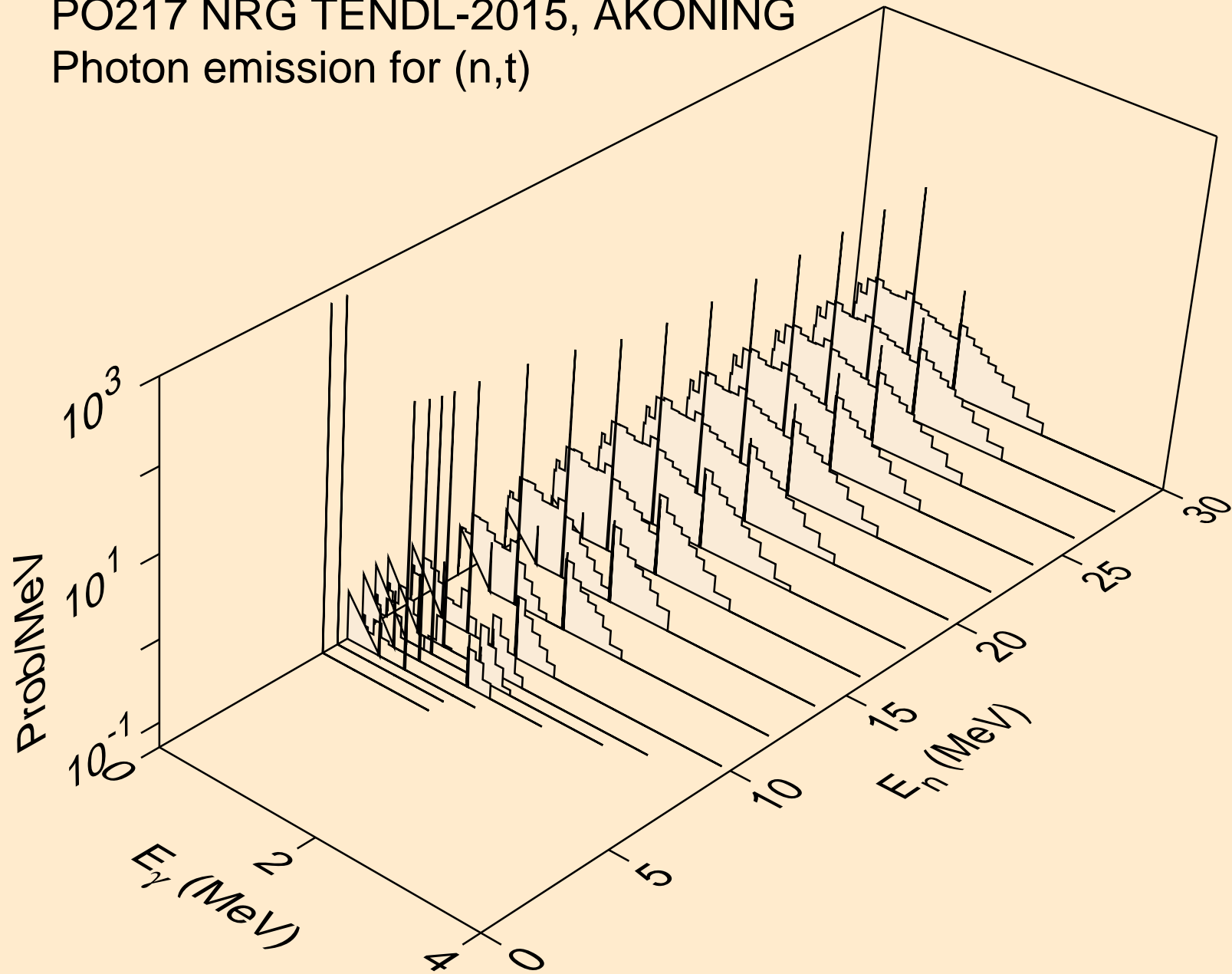

PO217 NRG TENDL-2015, AKONING
Photon emission for (n,he3)

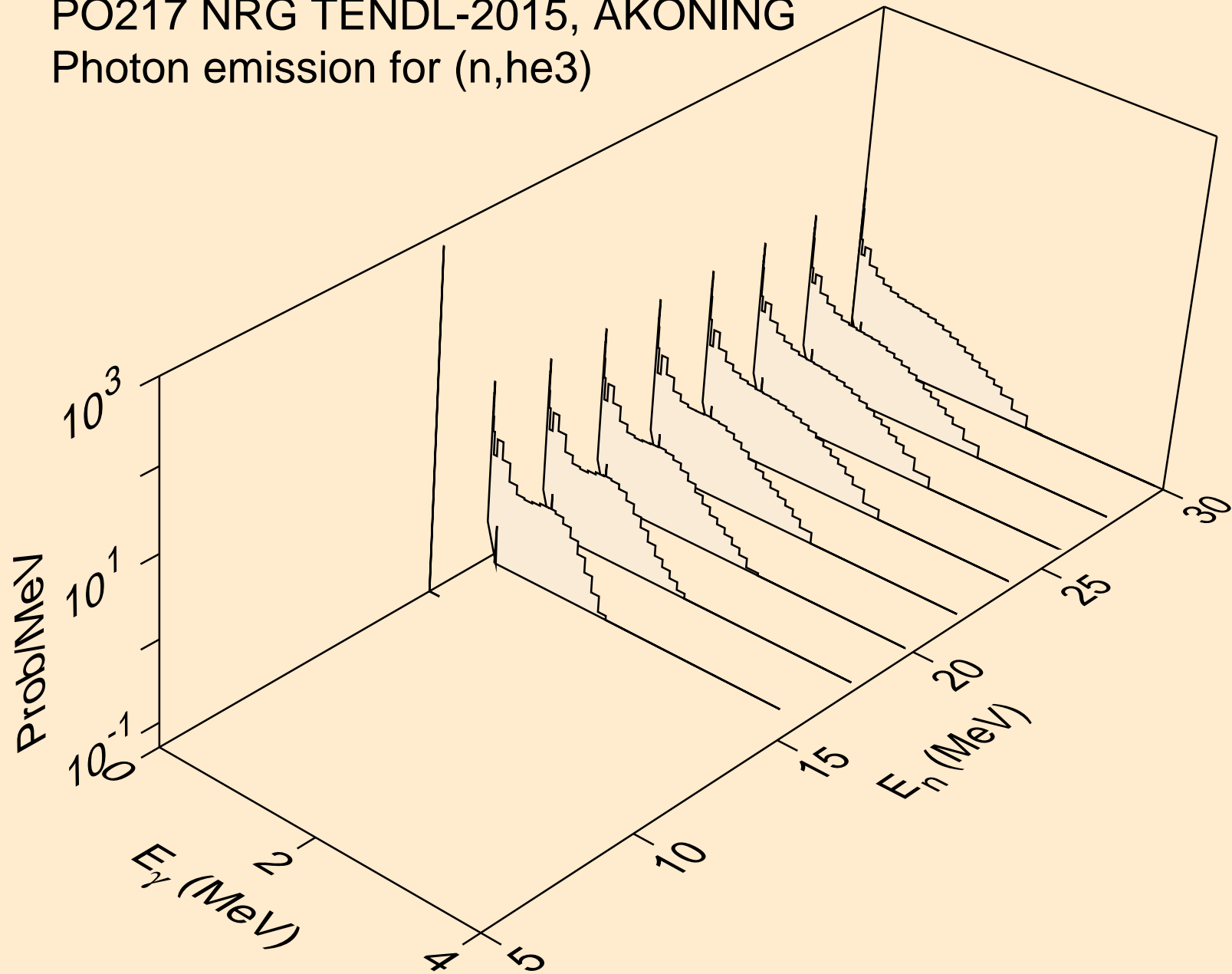

PO217 NRG TENDL-2015, AKONING
Photon emission for (n,a)

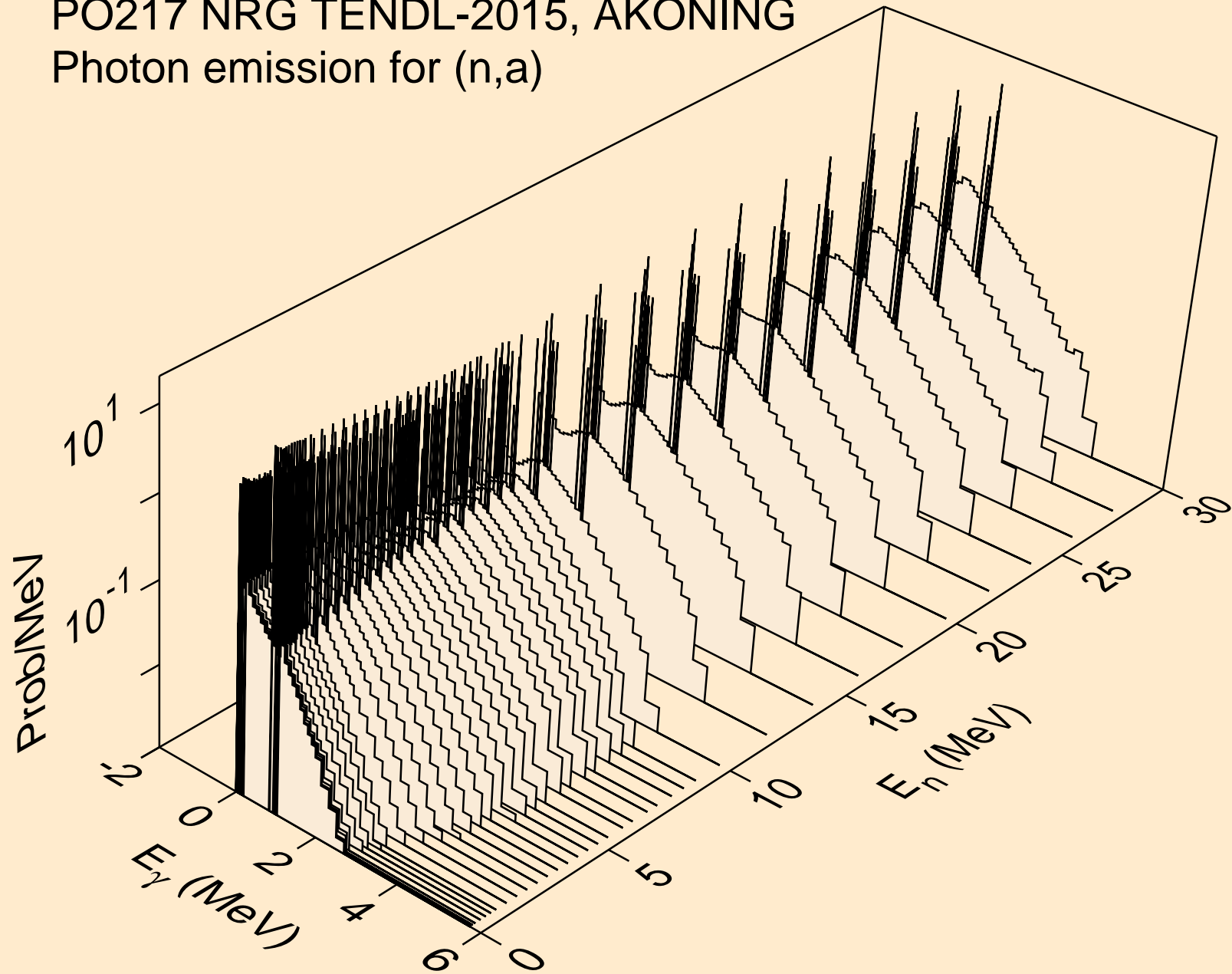

PO217 NRG TENDL-2015, AKONING
Photon emission for (n,2p)

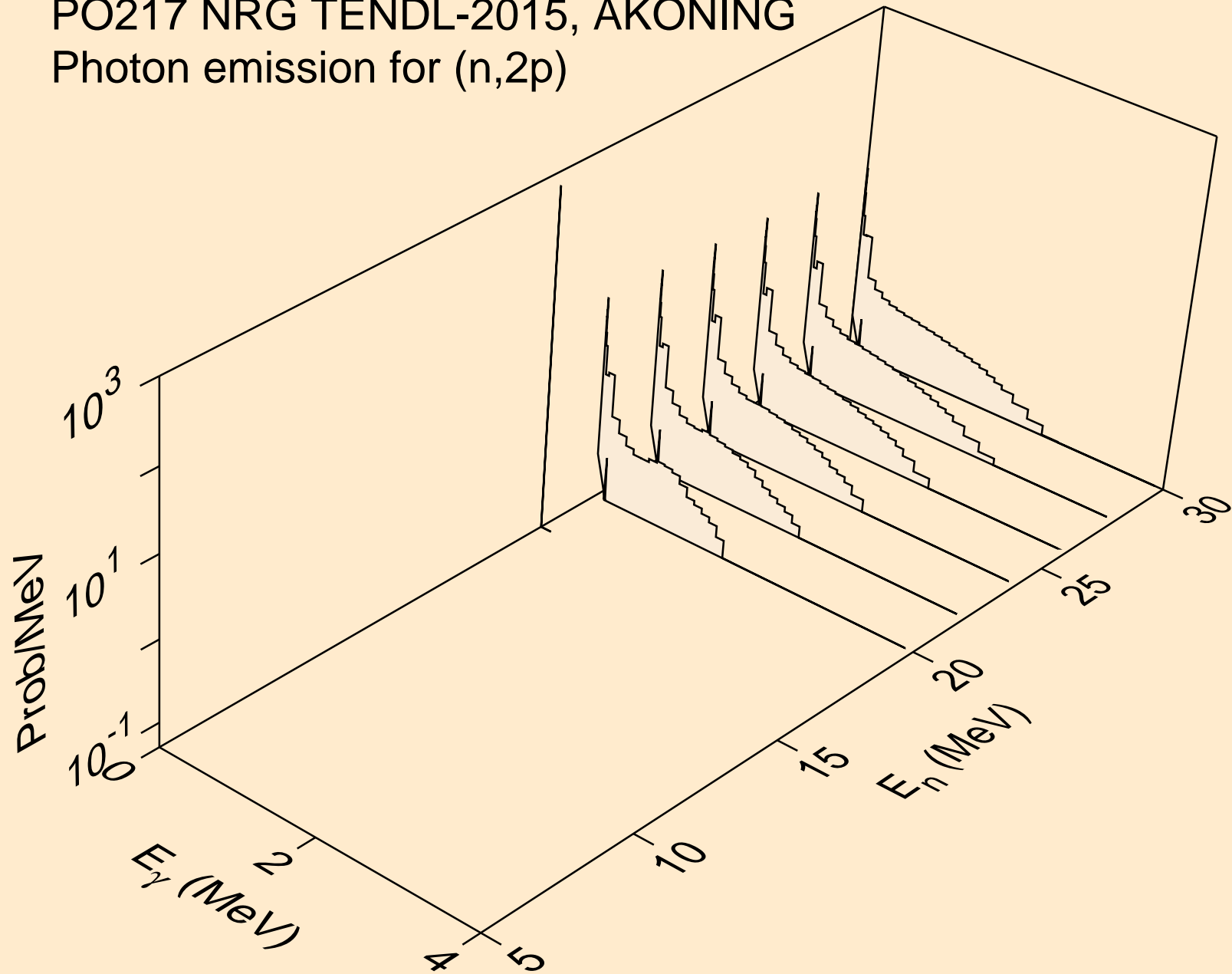

PO217 NRG TENDL-2015, AKONING
Photon emission for (n,p α)

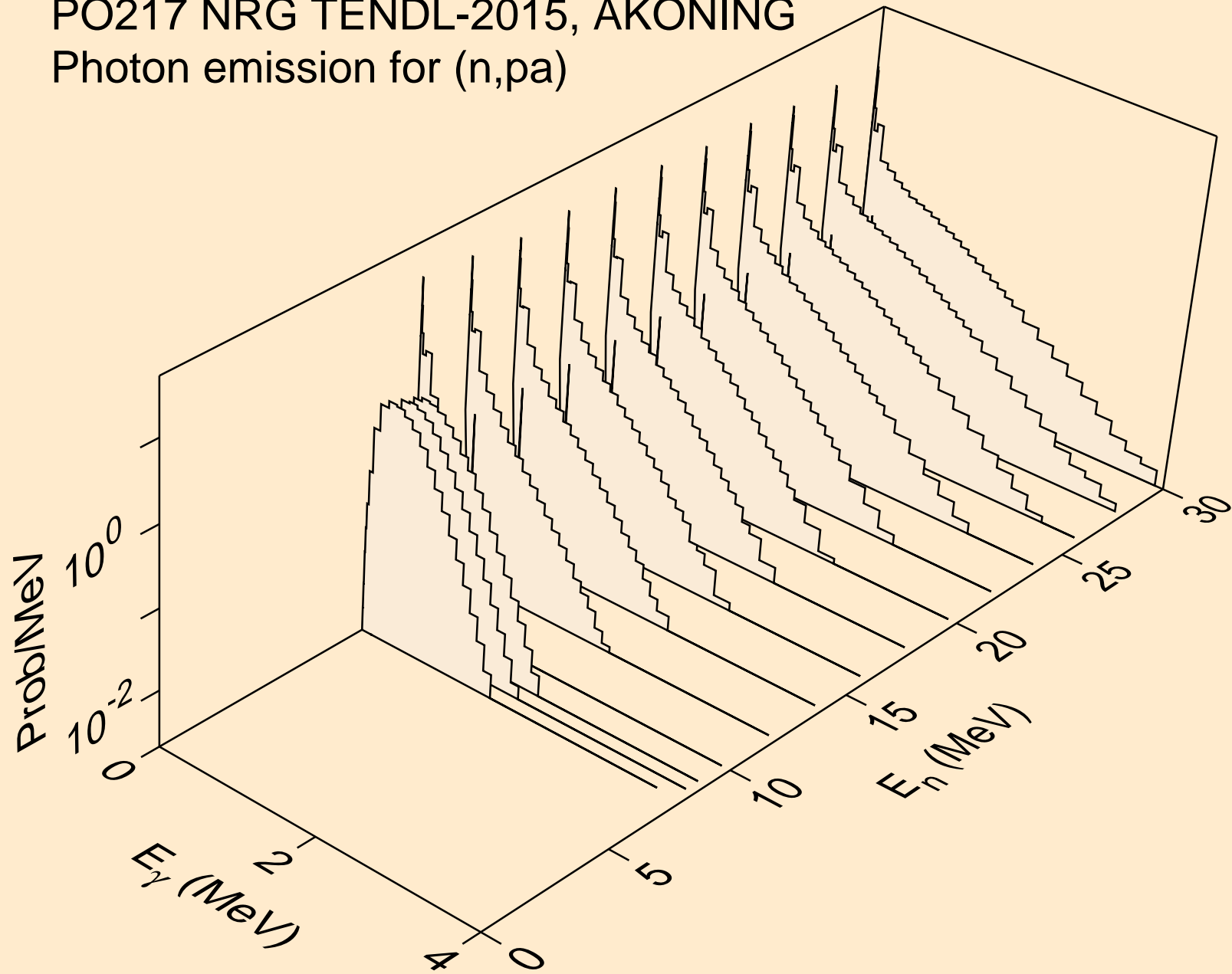

PO217 NRG TENDL-2015, AKONING
Photon emission for (n,da)

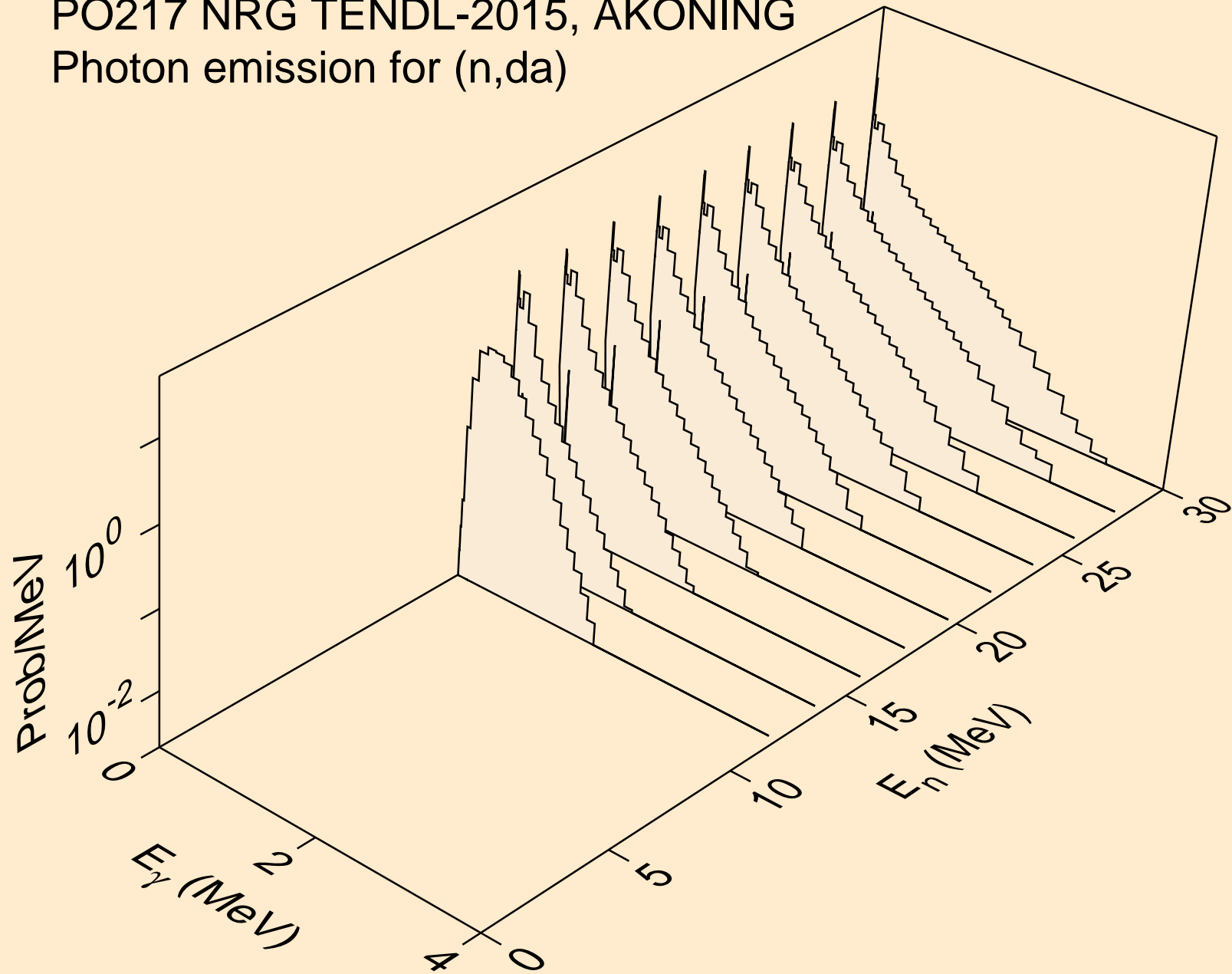

PO217 NRG TENDL-2015, AKONING
thermal capture photon spectrum

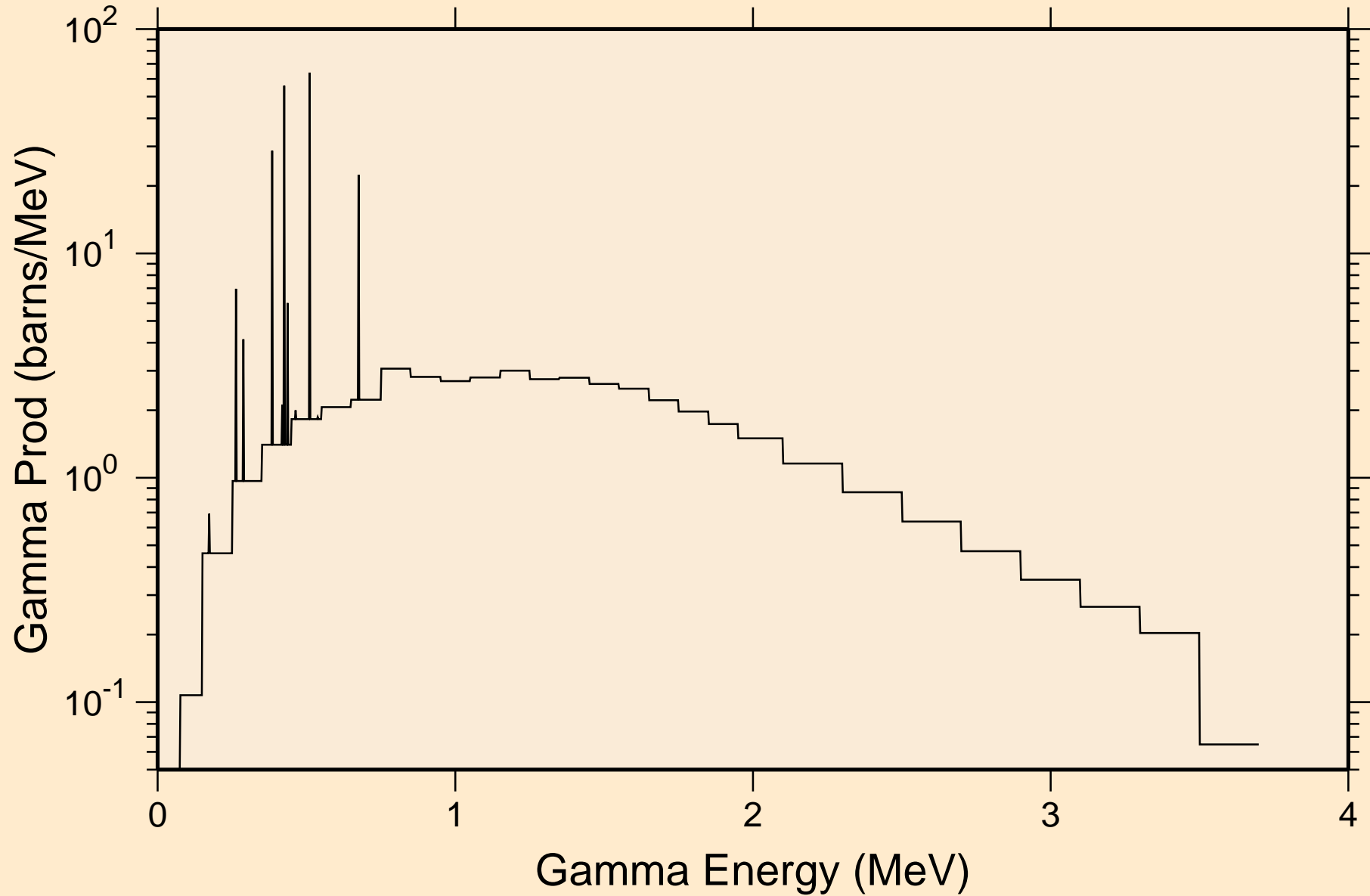

PO217 NRG TENDL-2015, AKONING
14 MeV photon spectrum

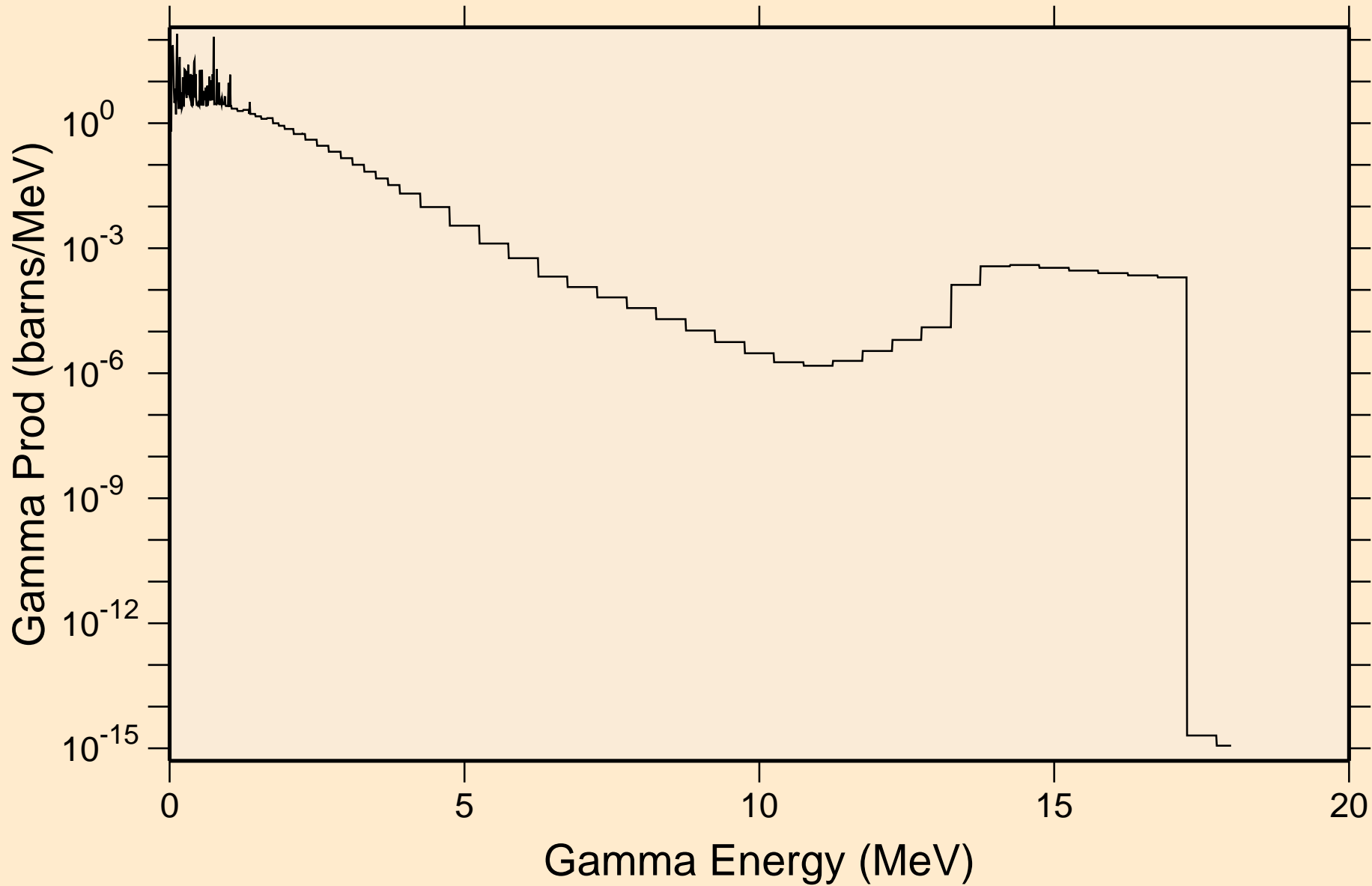

PO217 NRG TENDL-2015, AKONING

Particle heating contributions

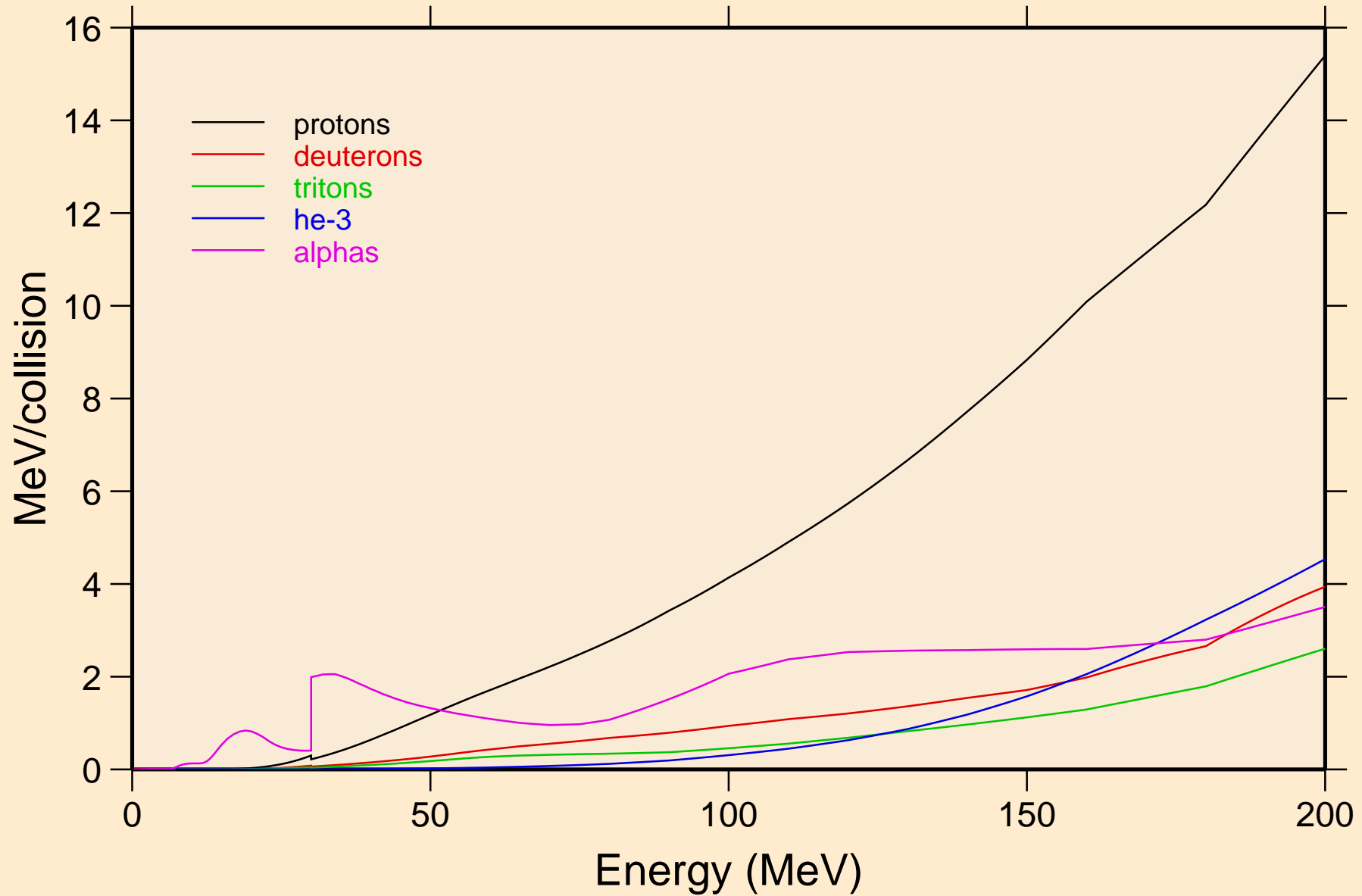

PO217 NRG TENDL-2015, AKONING

Recoil Heating

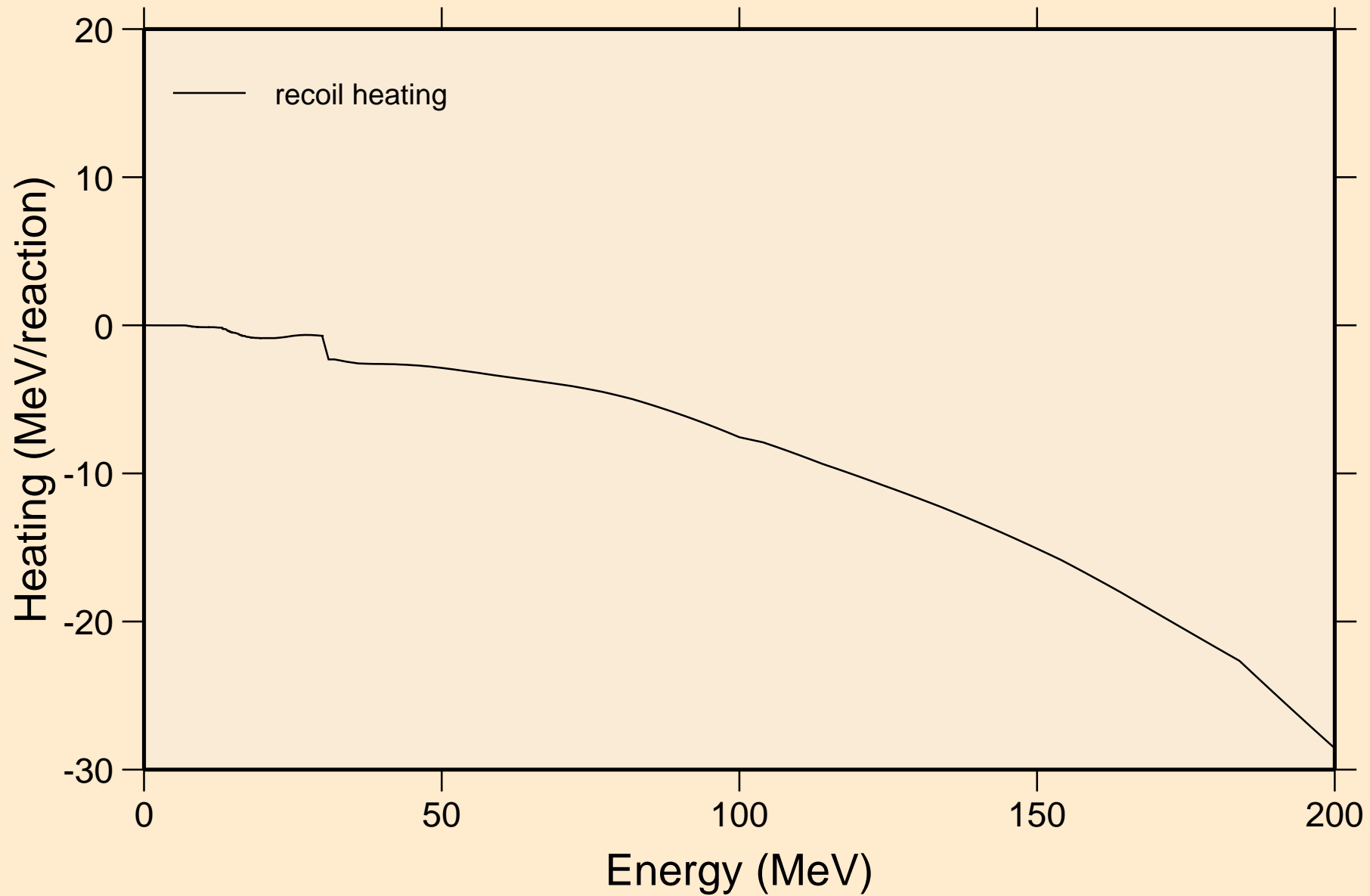

PO217 NRG TENDL-2015, AKONING

Particle production cross sections

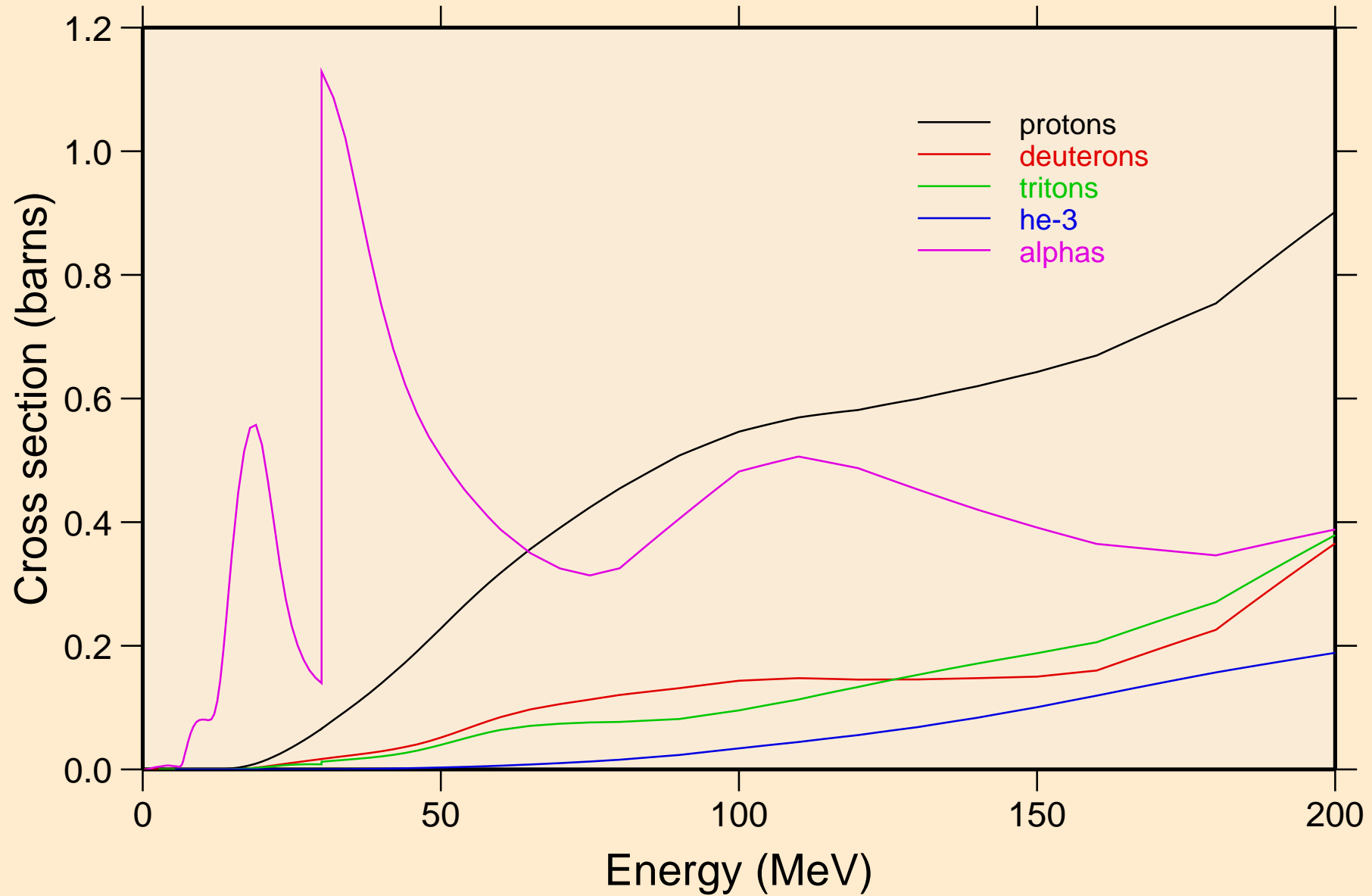

PO217 NRG TENDL-2015, AKONING
protons from (n,x)

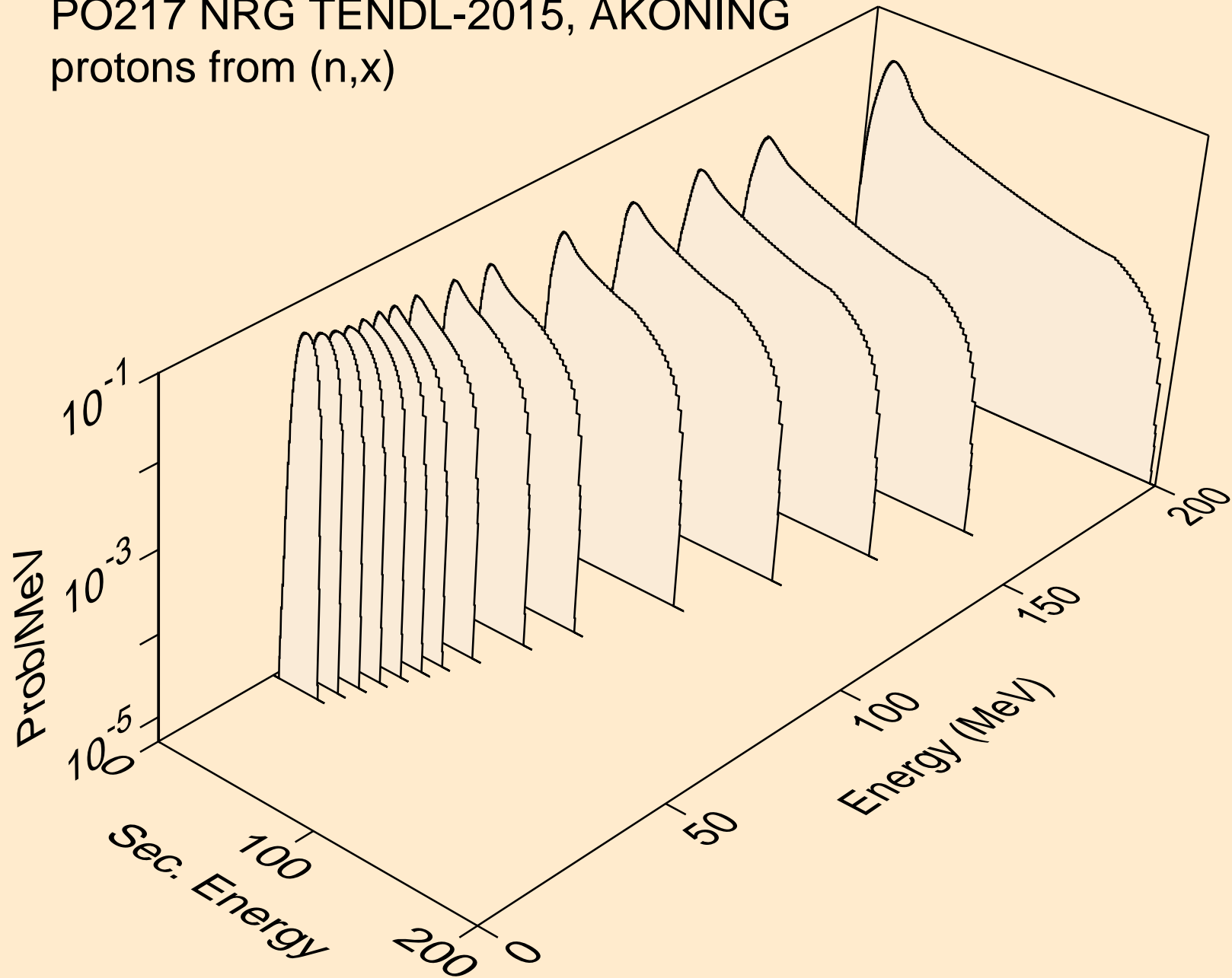

PO217 NRG TENDL-2015, AKONING
protons from (n,n*)p

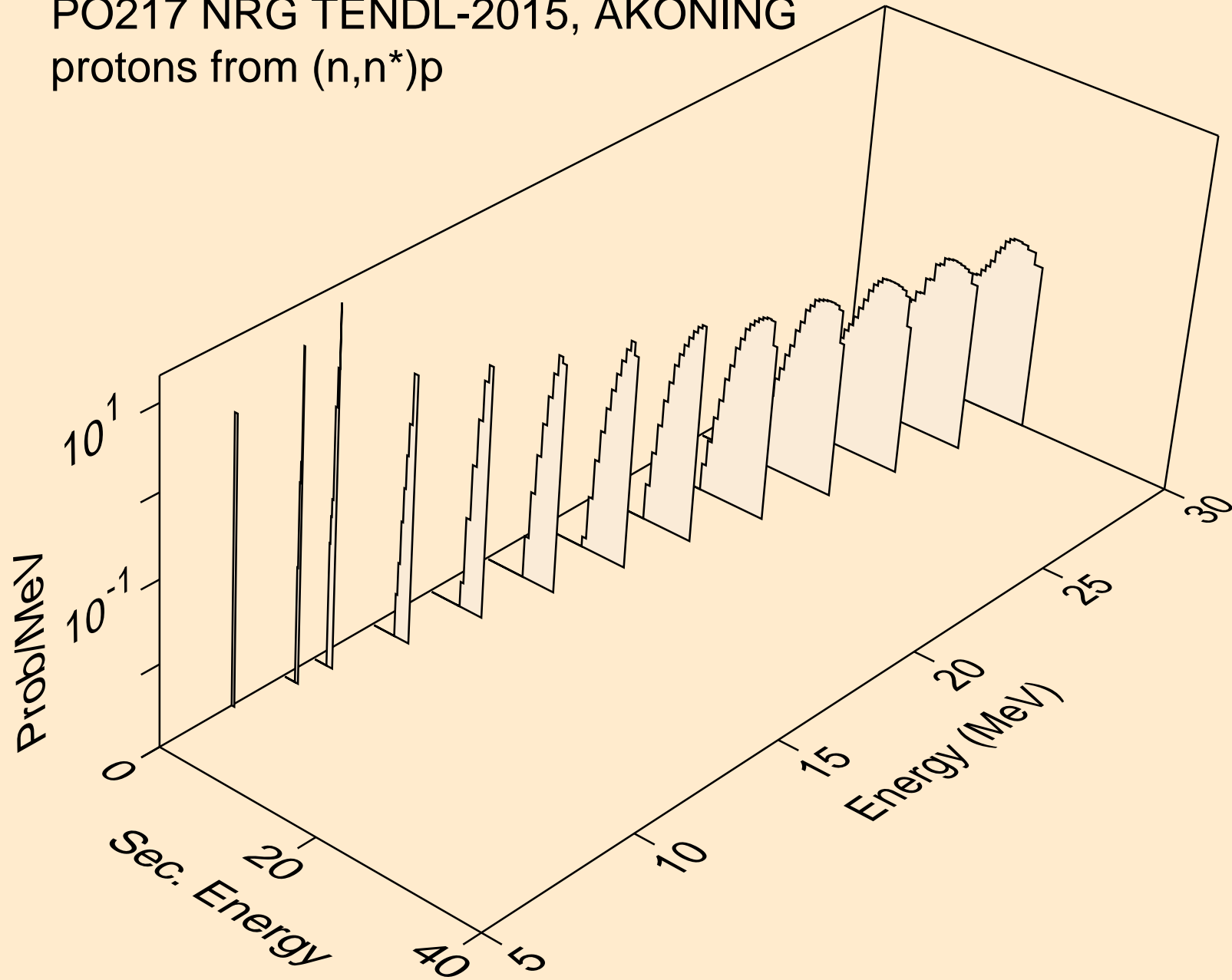

PO217 NRG TENDL-2015, AKONING
protons from (n,2np)

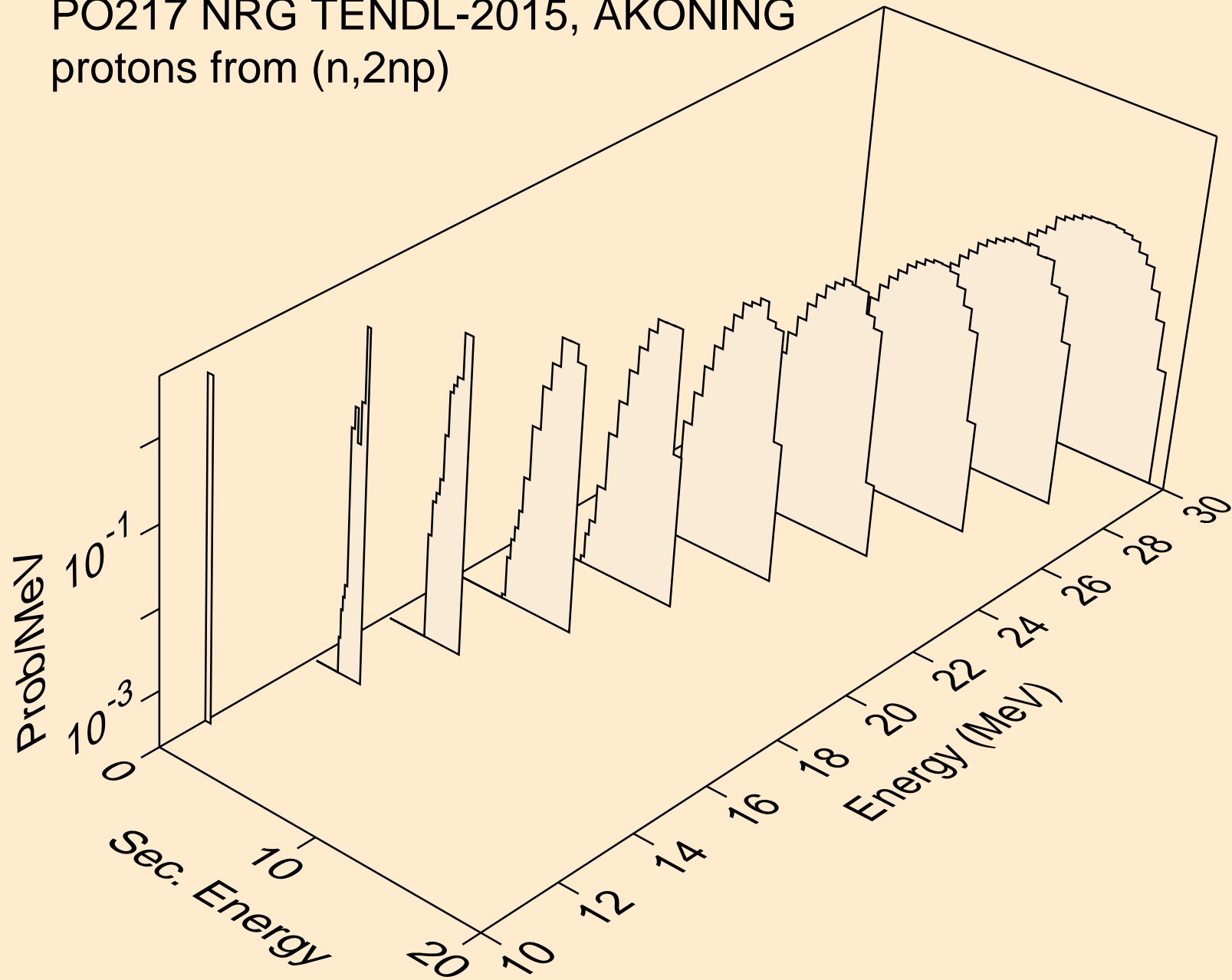

PO217 NRG TENDL-2015, AKONING
protons from (n,3np)

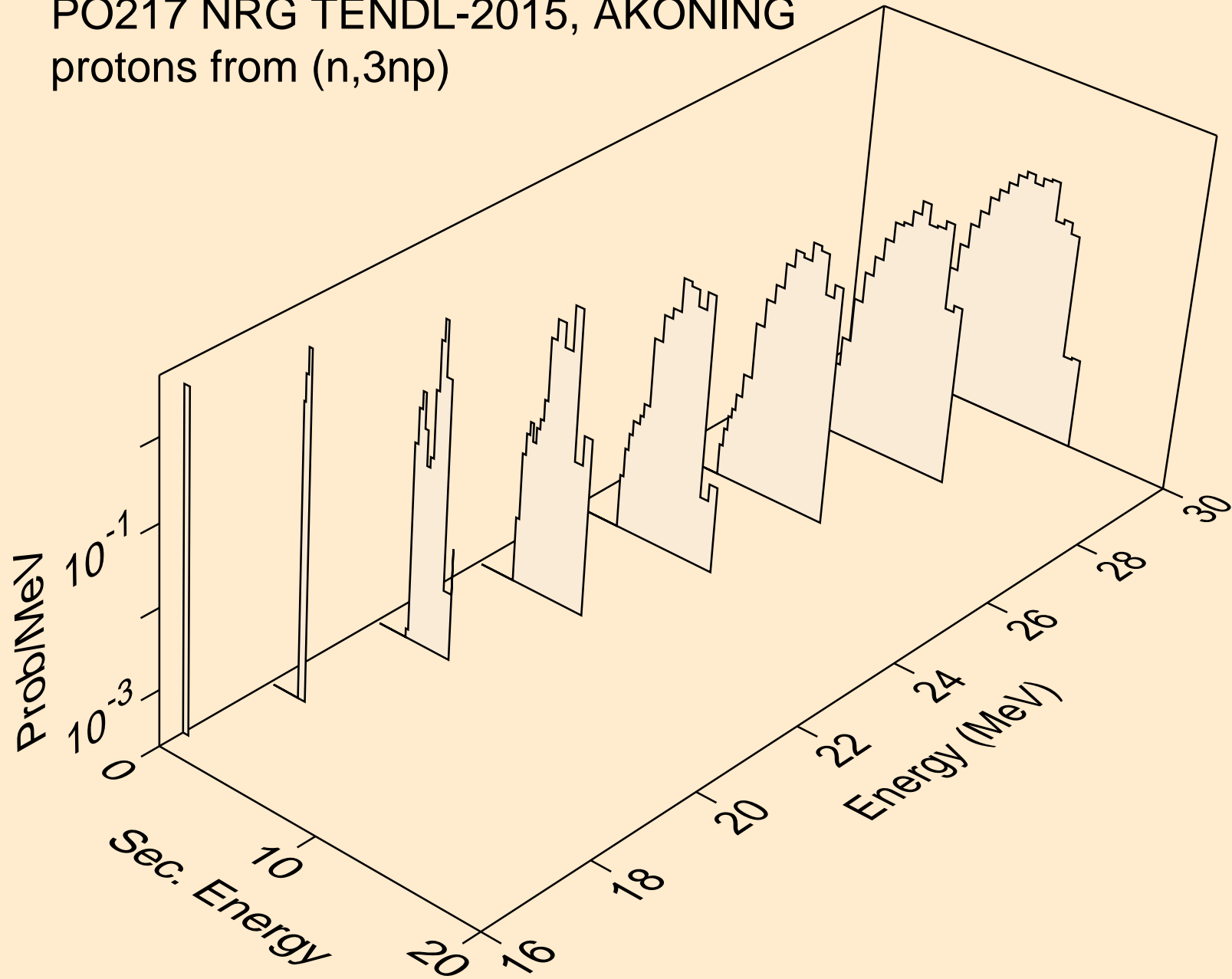

PO217 NRG TENDL-2015, AKONING
protons from (n,2np)

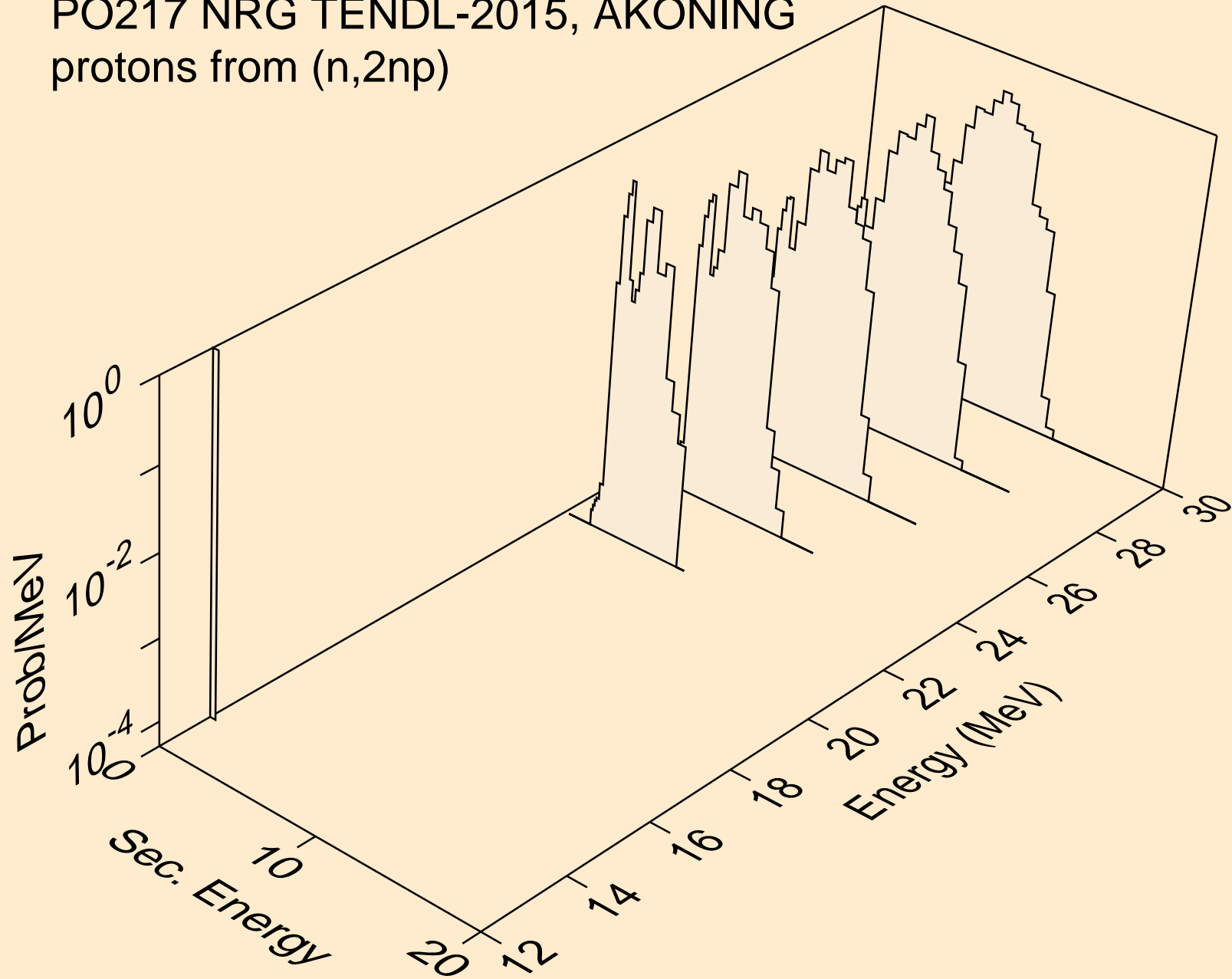

PO217 NRG TENDL-2015, AKONING
protons from (n,npa)

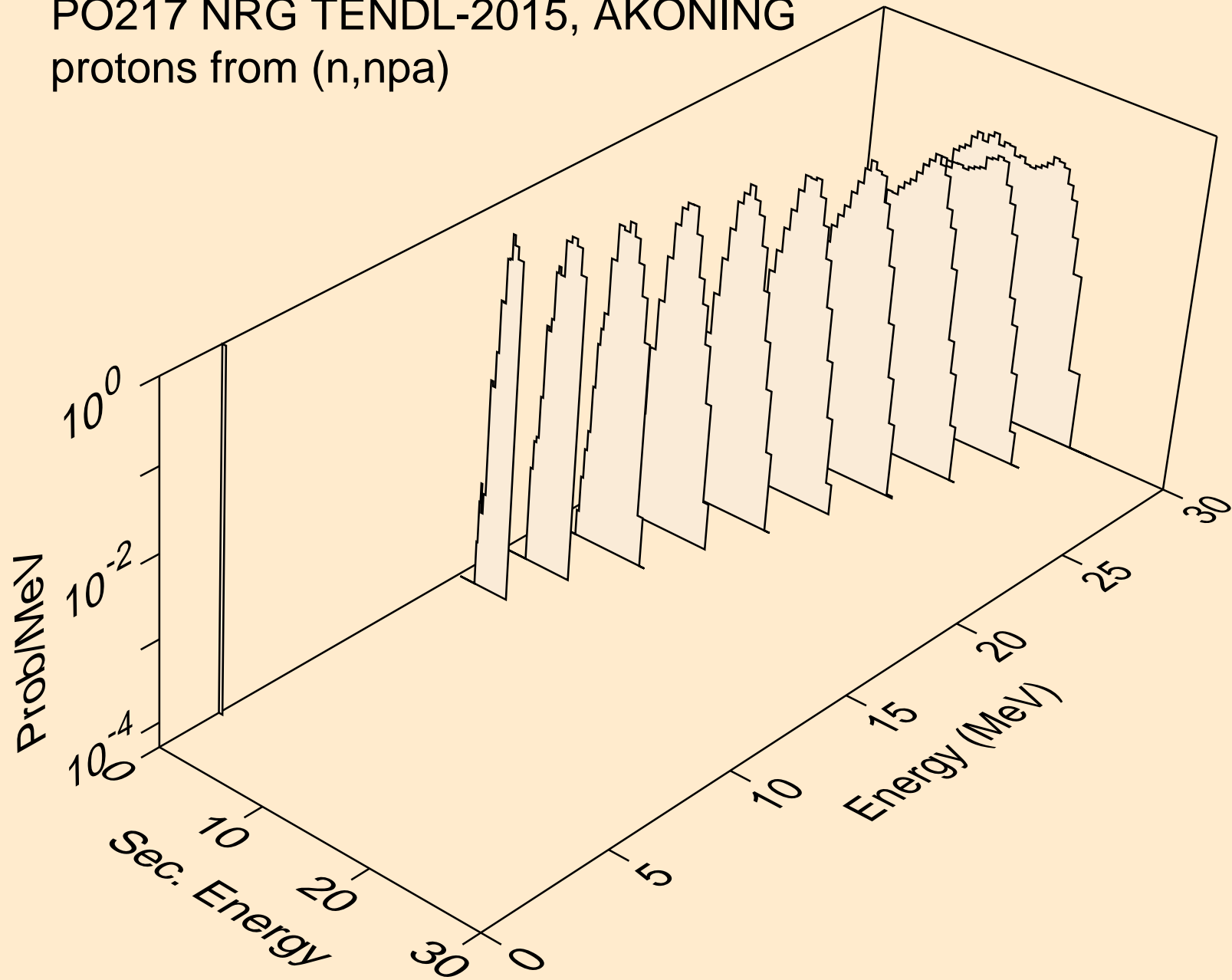

PO217 NRG TENDL-2015, AKONING
protons from (n,p)

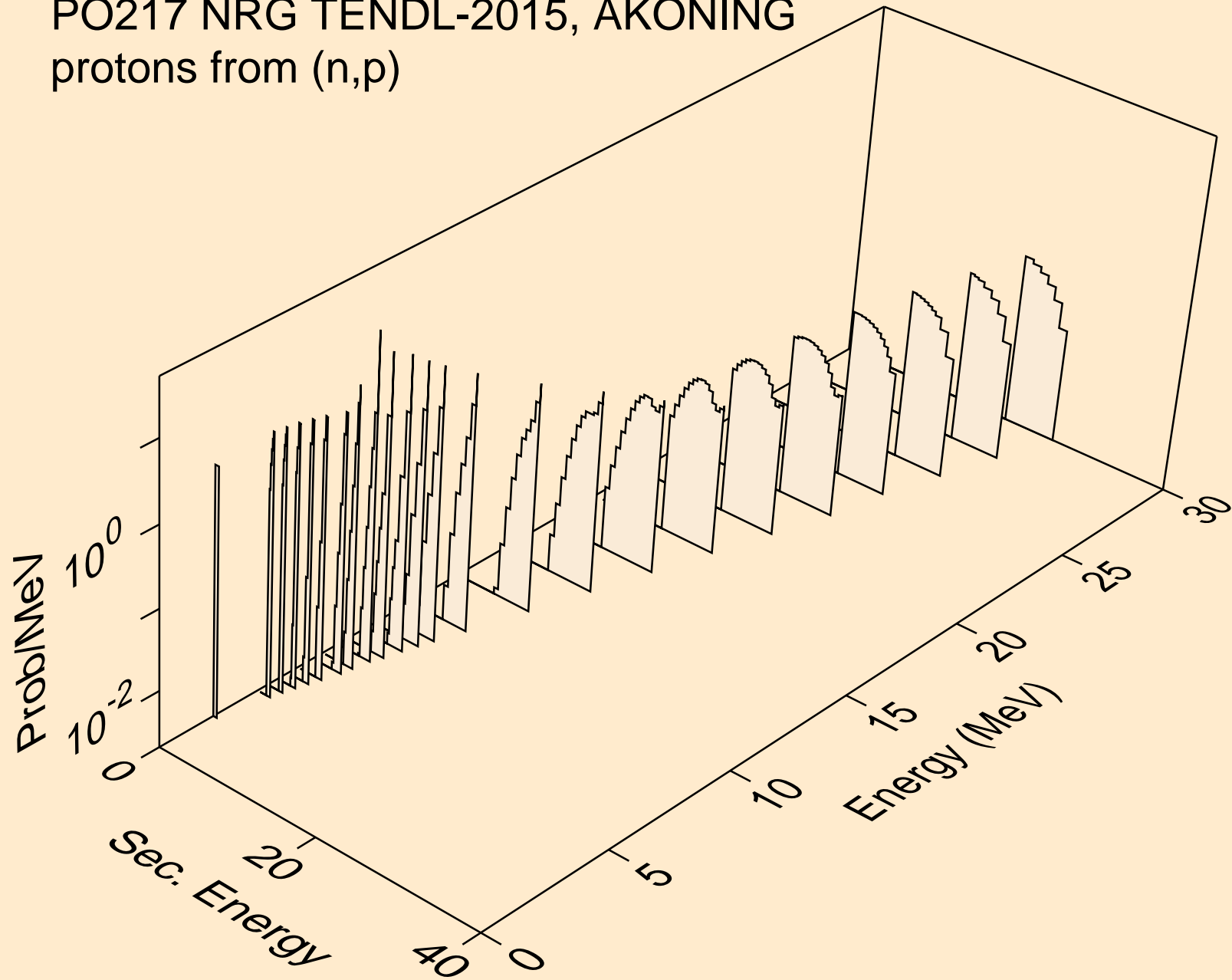

PO217 NRG TENDL-2015, AKONING
protons from (n,2p)

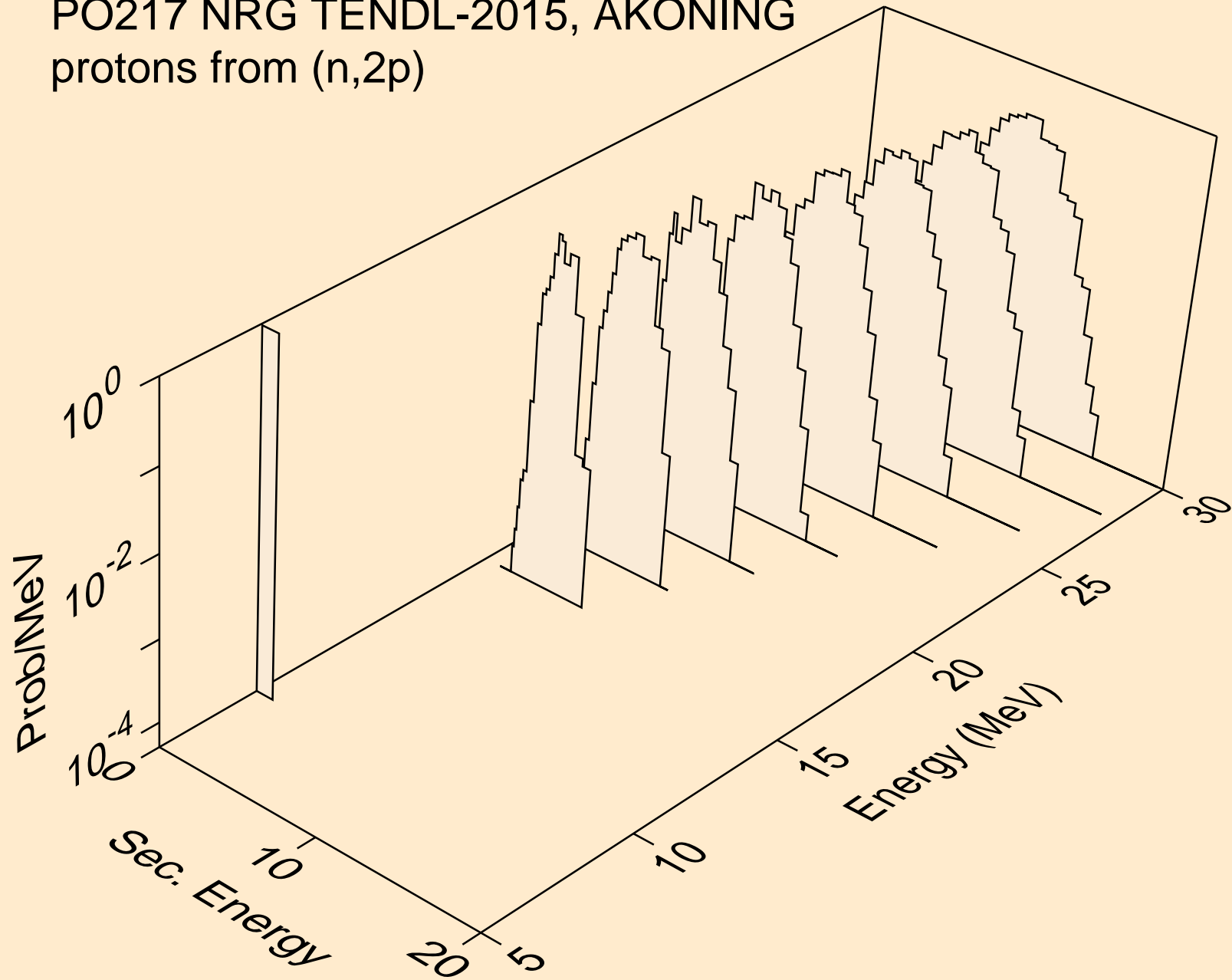

PO217 NRG TENDL-2015, AKONING
protons from (n,pa)

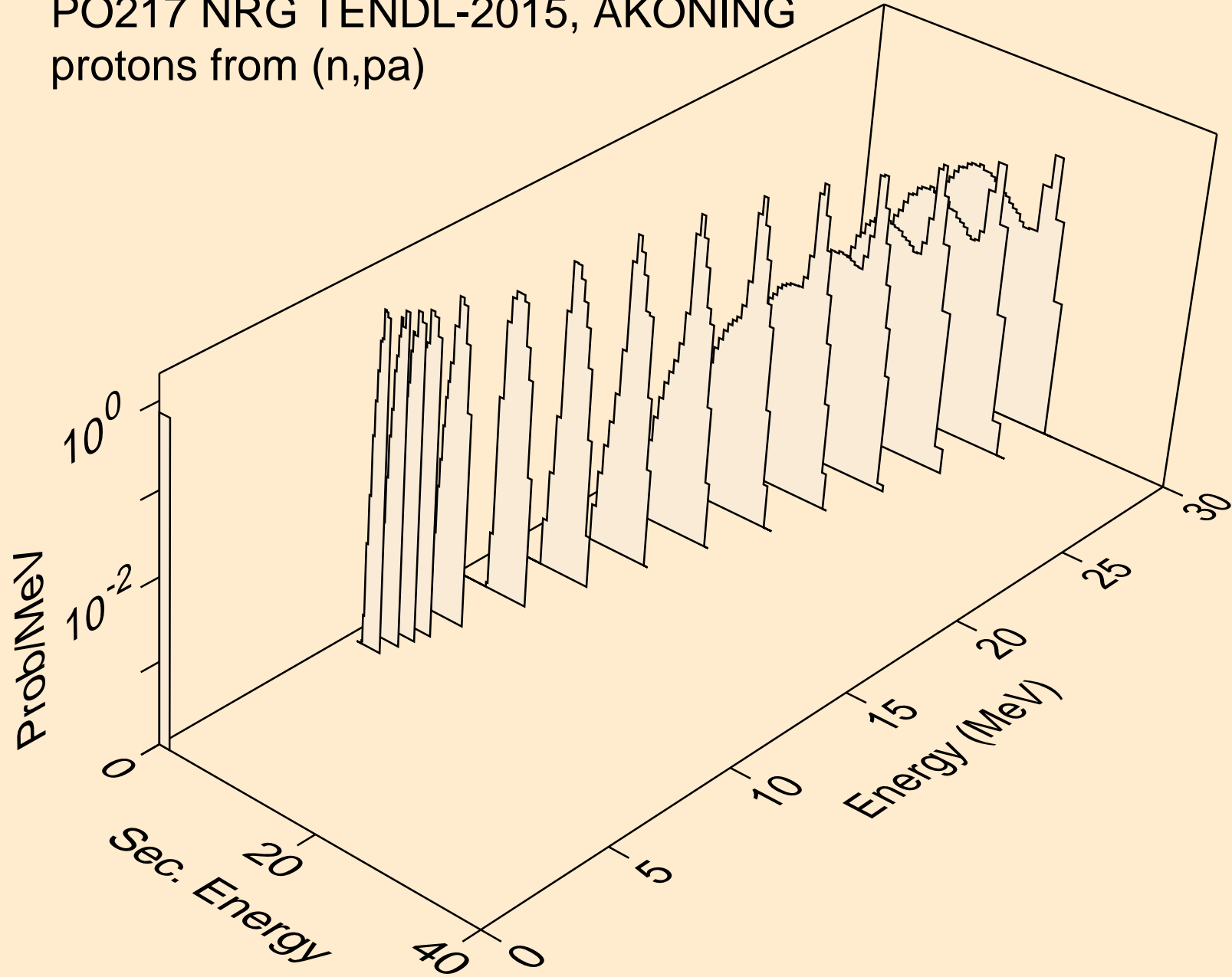

PO217 NRG TENDL-2015, AKONING
deuterons from (n,x)

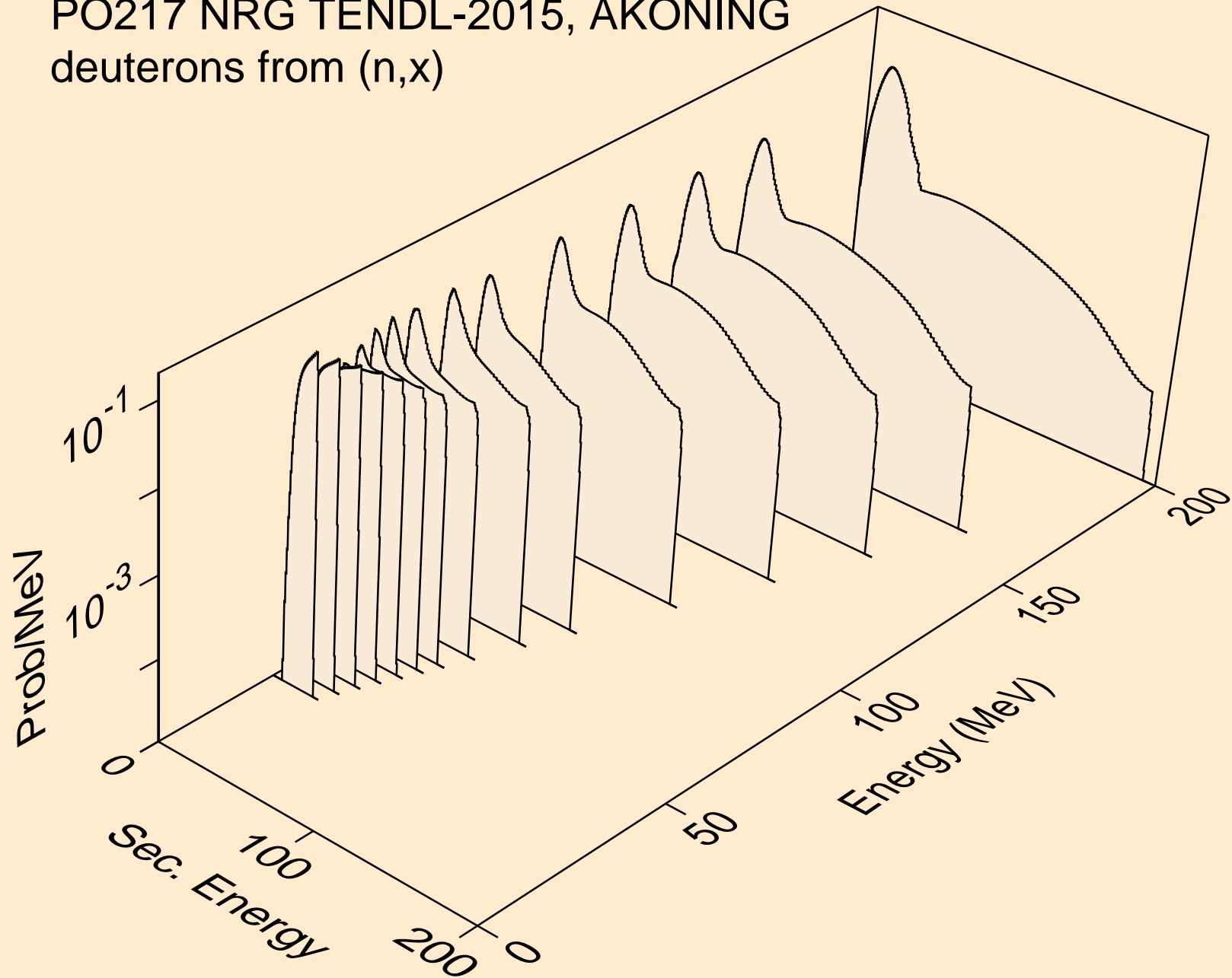

PO217 NRG TENDL-2015, AKONING
deuterons from (n,2nd)

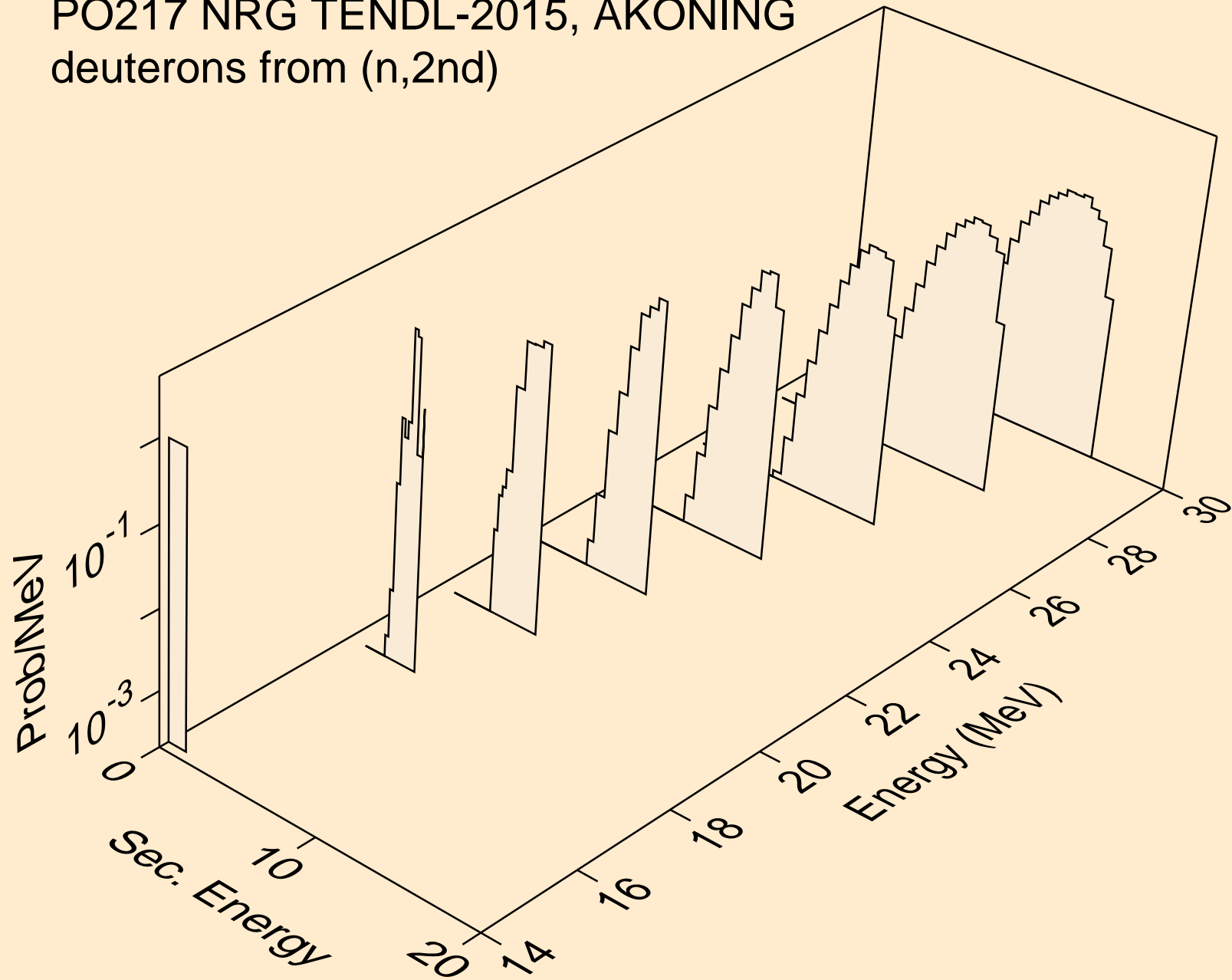

PO217 NRG TENDL-2015, AKONING
deuterons from (n,n*)d

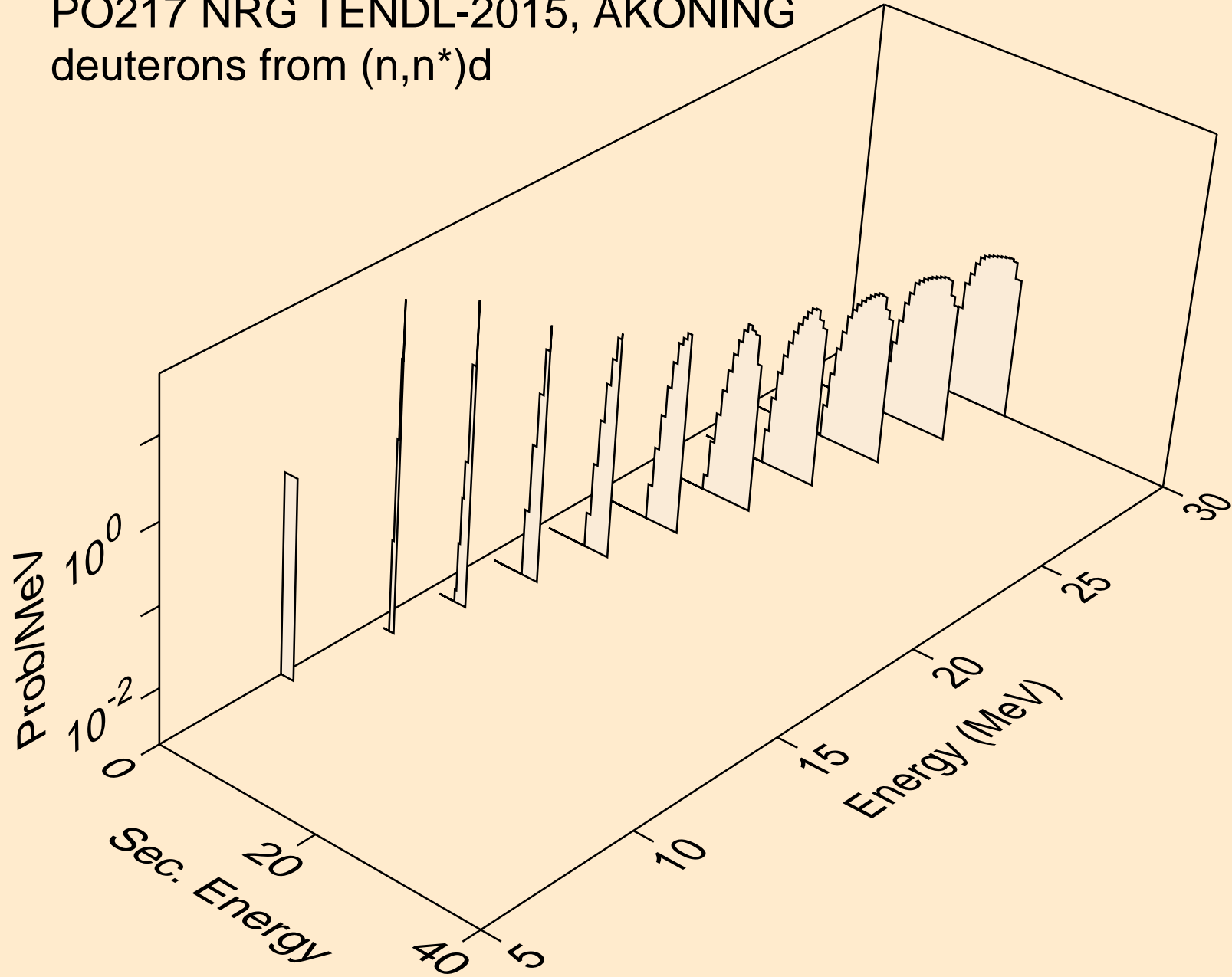

PO217 NRG TENDL-2015, AKONING
deuterons from (n,d)

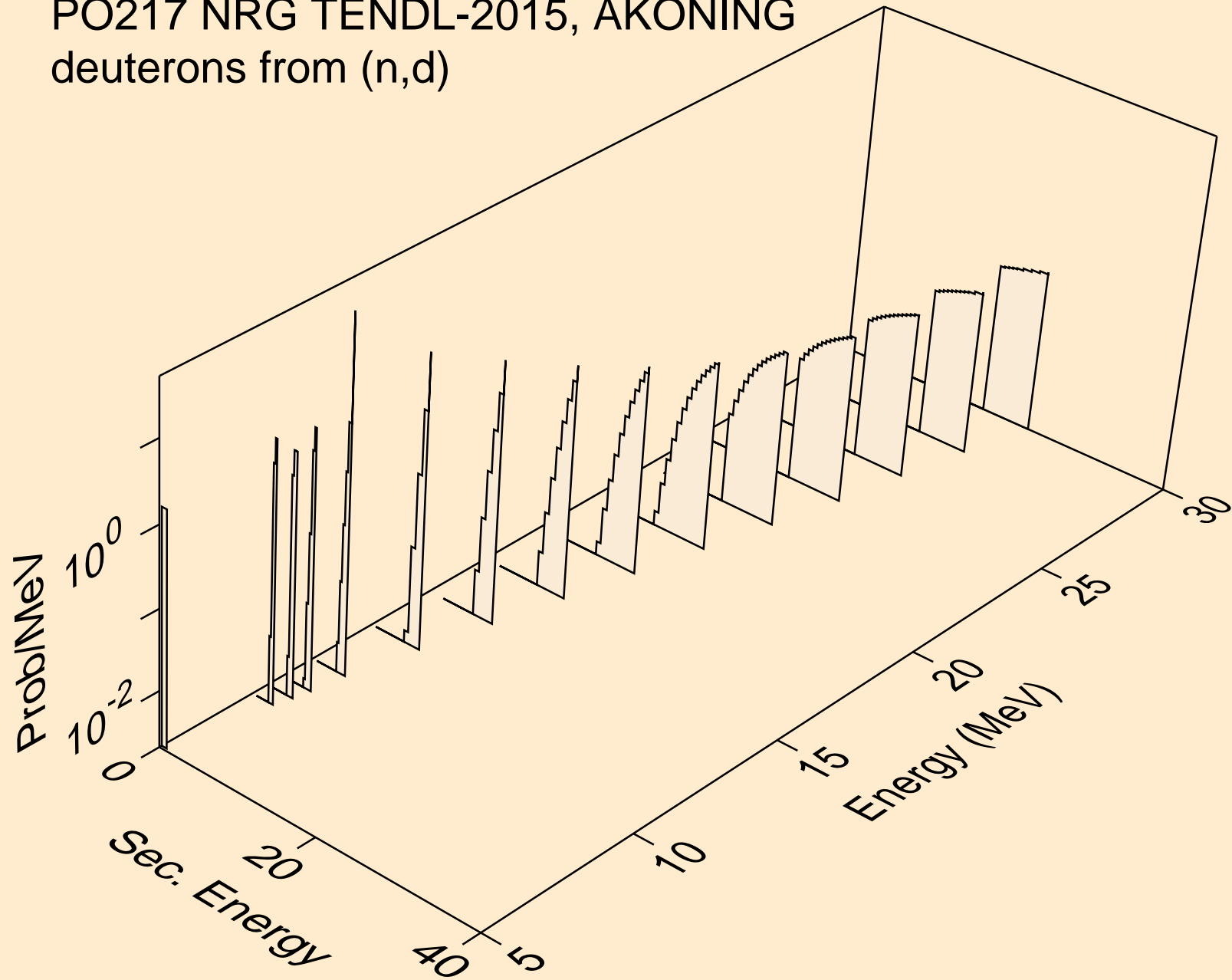

PO217 NRG TENDL-2015, AKONING
deuterons from (n,da)

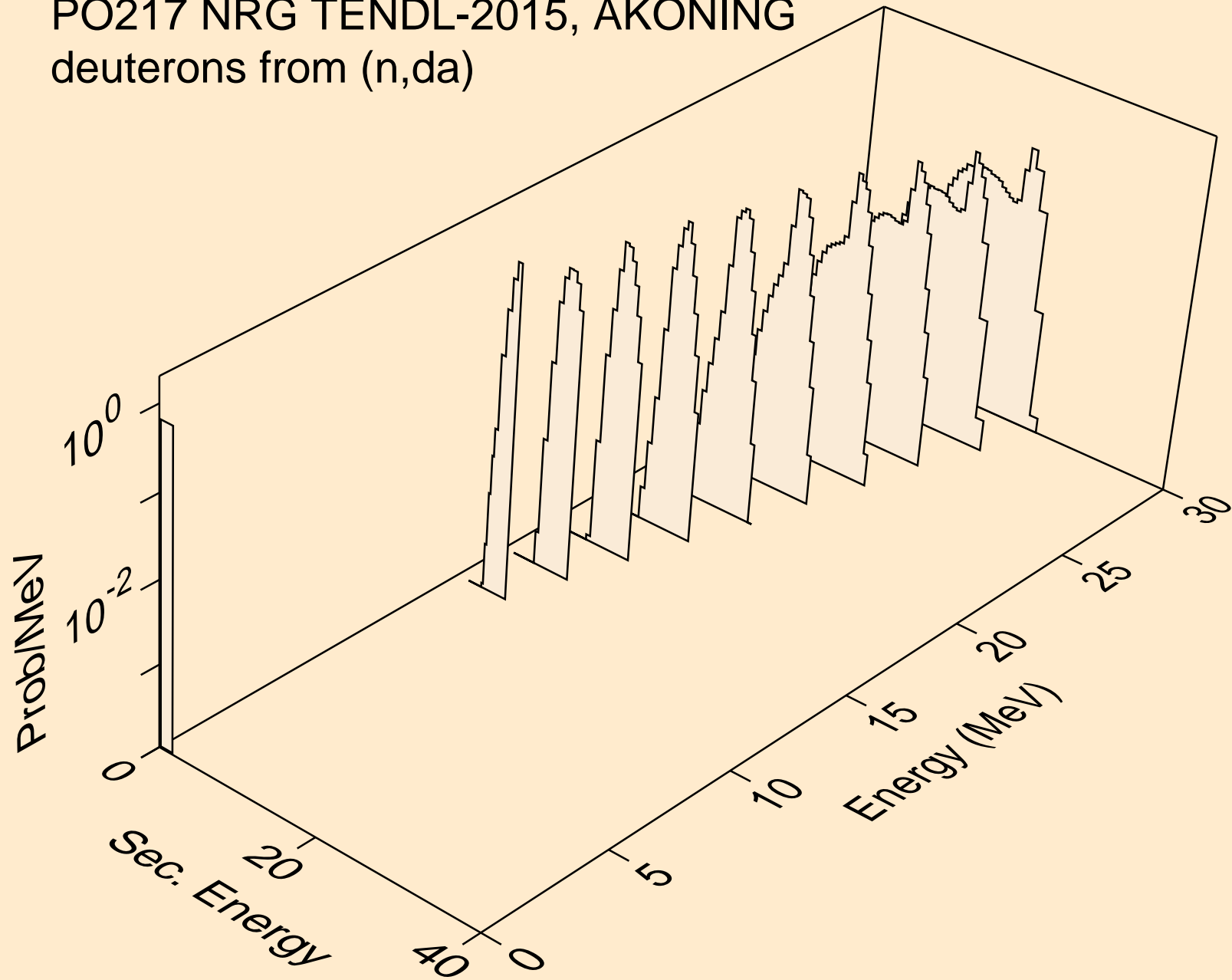

PO217 NRG TENDL-2015, AKONING
tritons from (n,x)

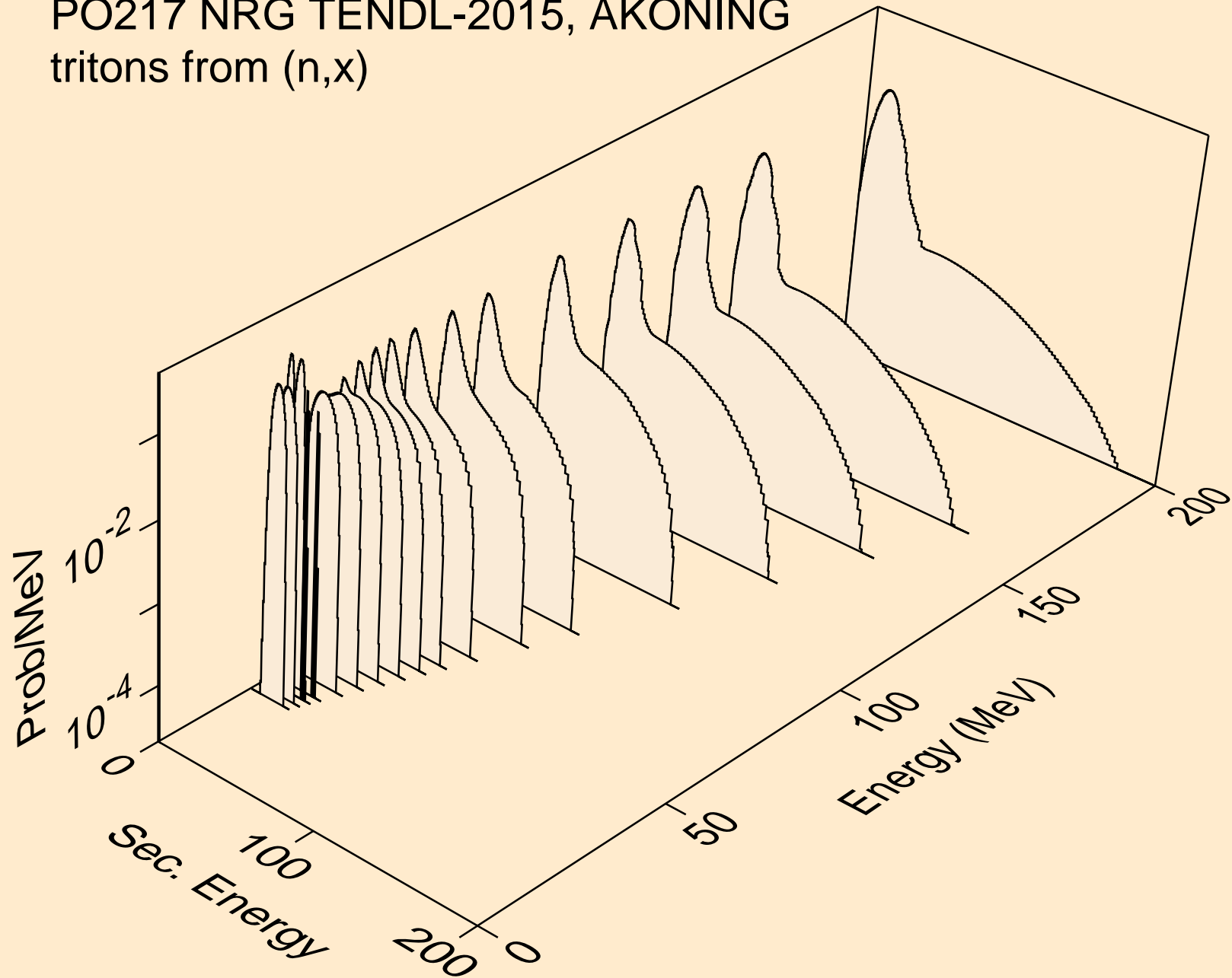

PO217 NRG TENDL-2015, AKONING
tritons from (n,n*)t

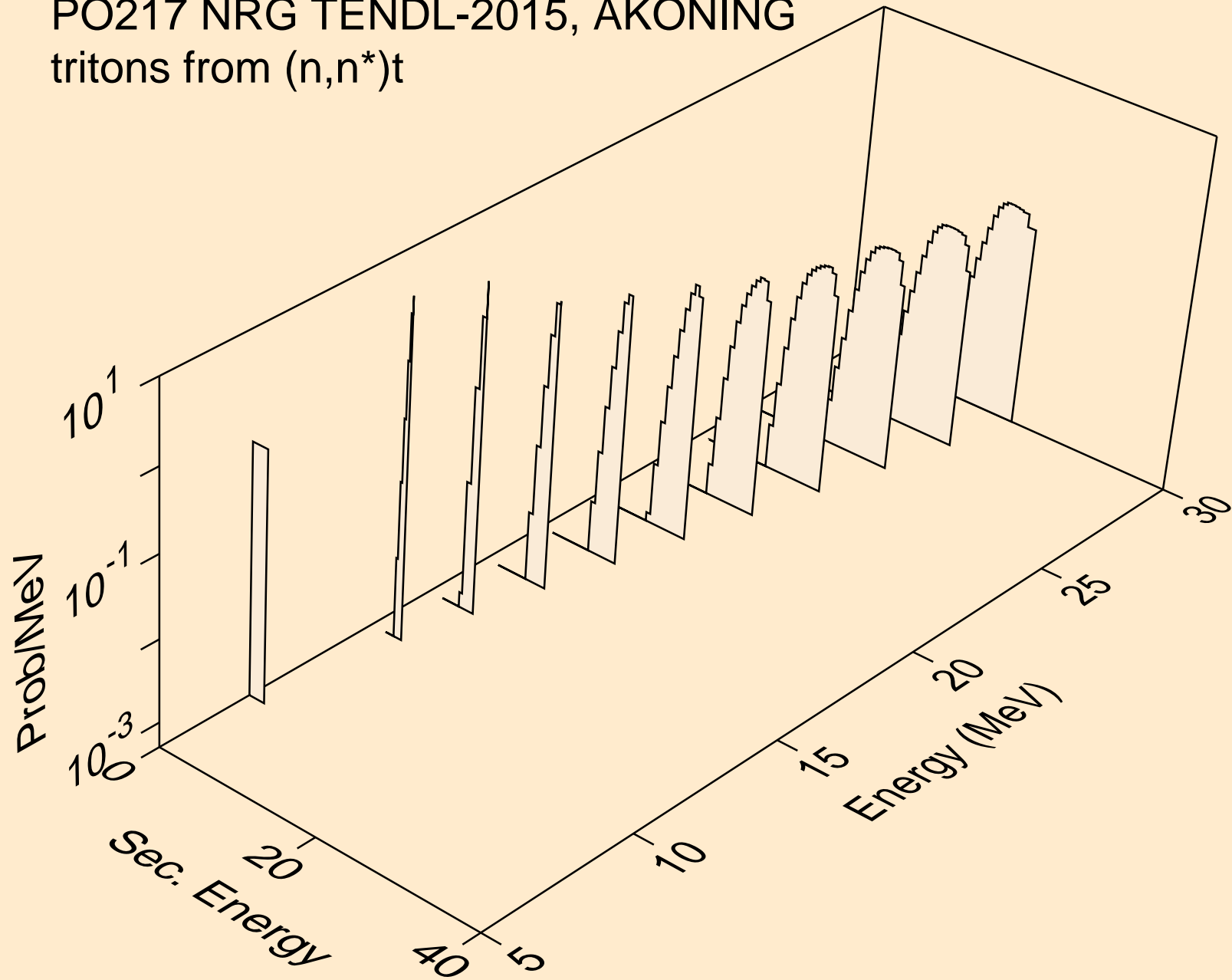

PO217 NRG TENDL-2015, AKONING
tritons from (n,t)

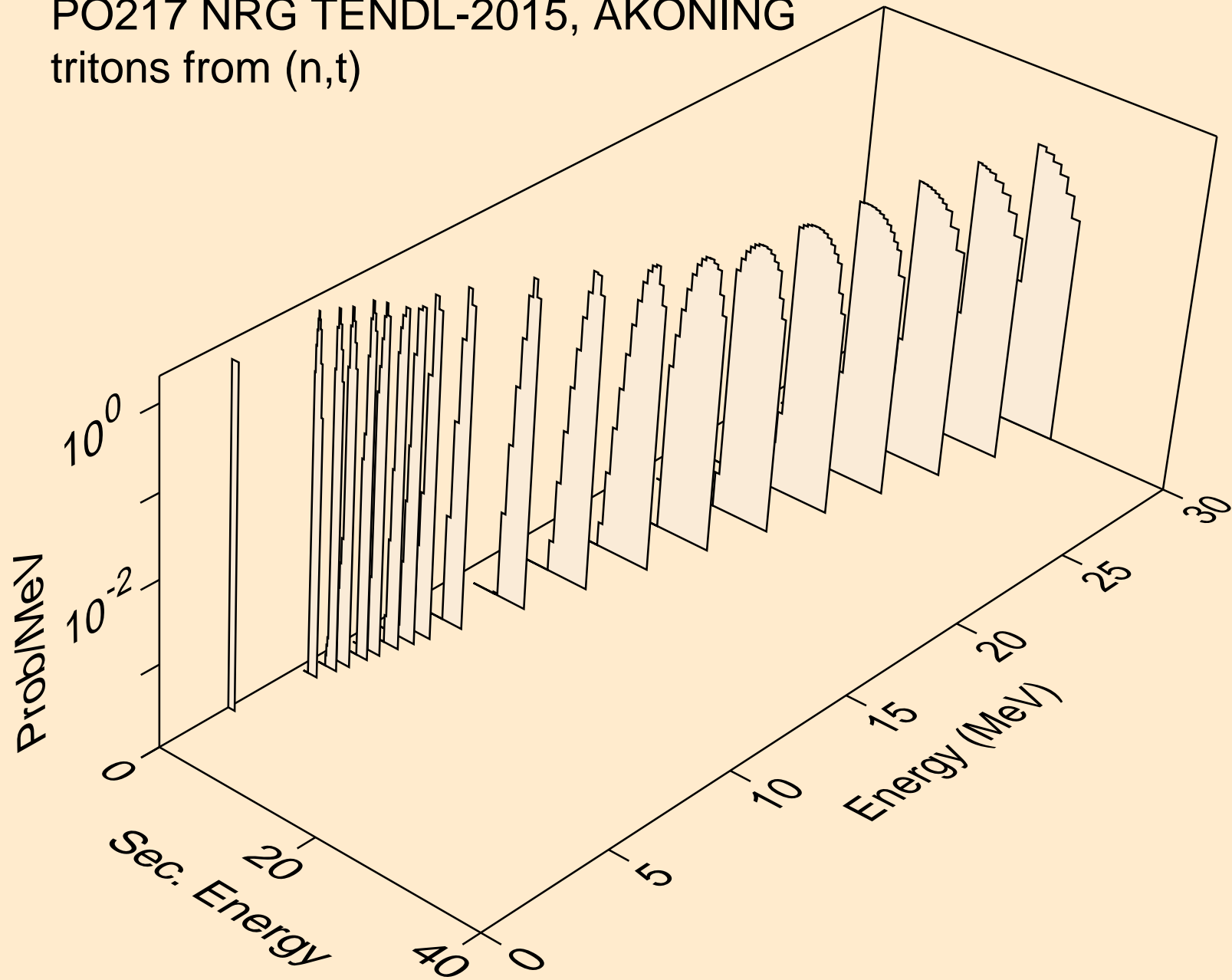

PO217 NRG TENDL-2015, AKONING
he3s from (n,x)

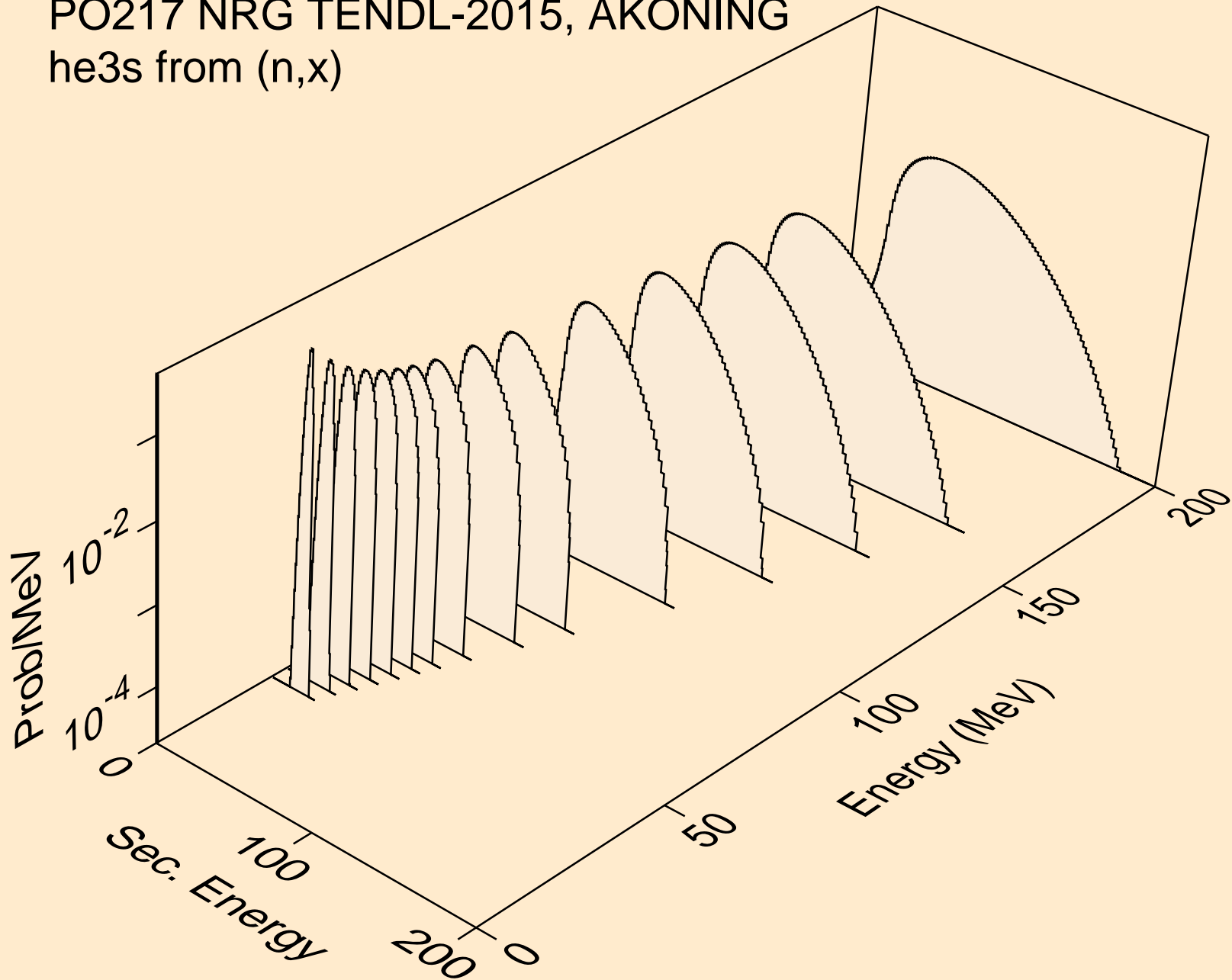

PO217 NRG TENDL-2015, AKONING
he3s from (n,n*)he3

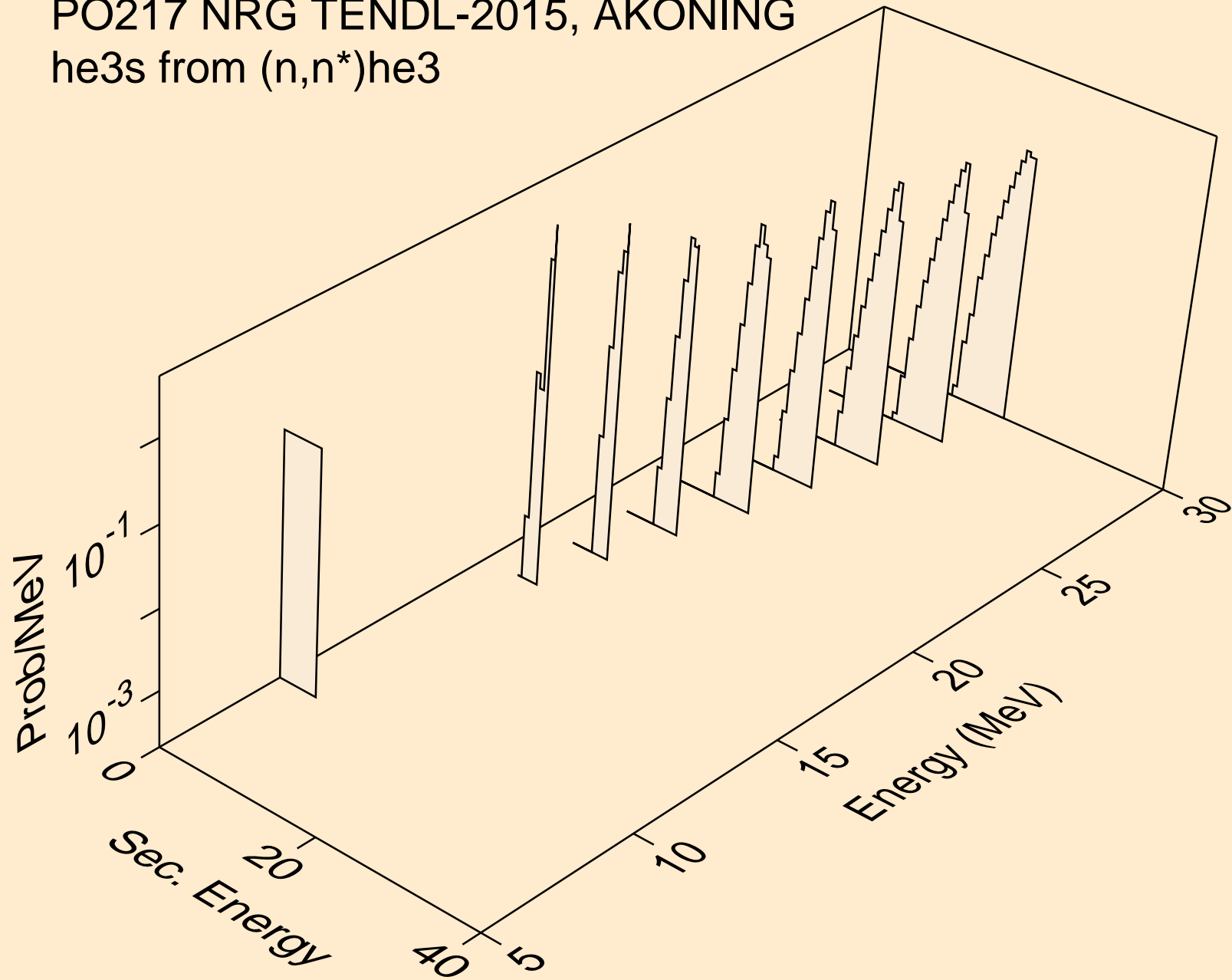

PO217 NRG TENDL-2015, AKONING
he3s from (n,he3)

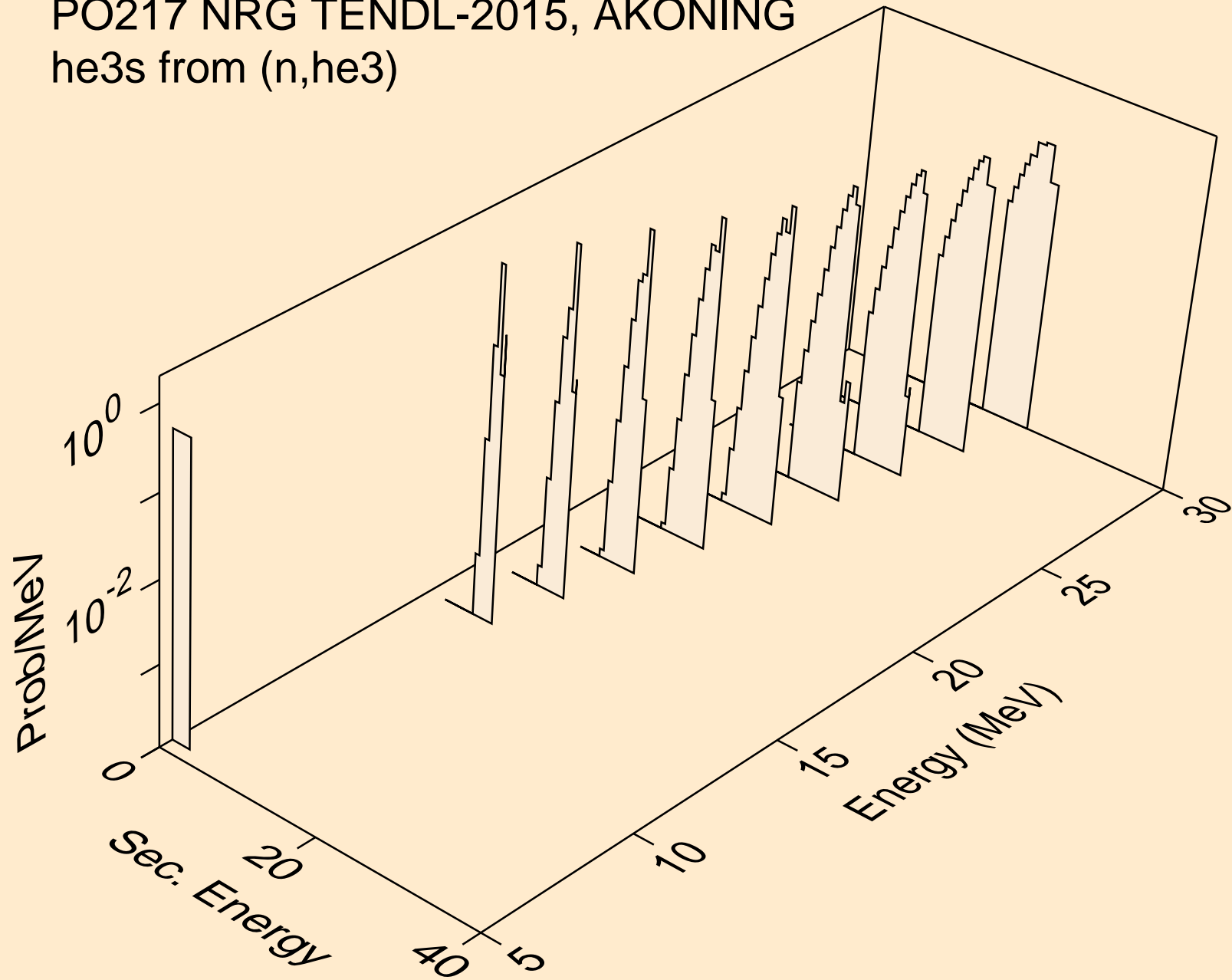

PO217 NRG TENDL-2015, AKONING
alphas from (n,x)

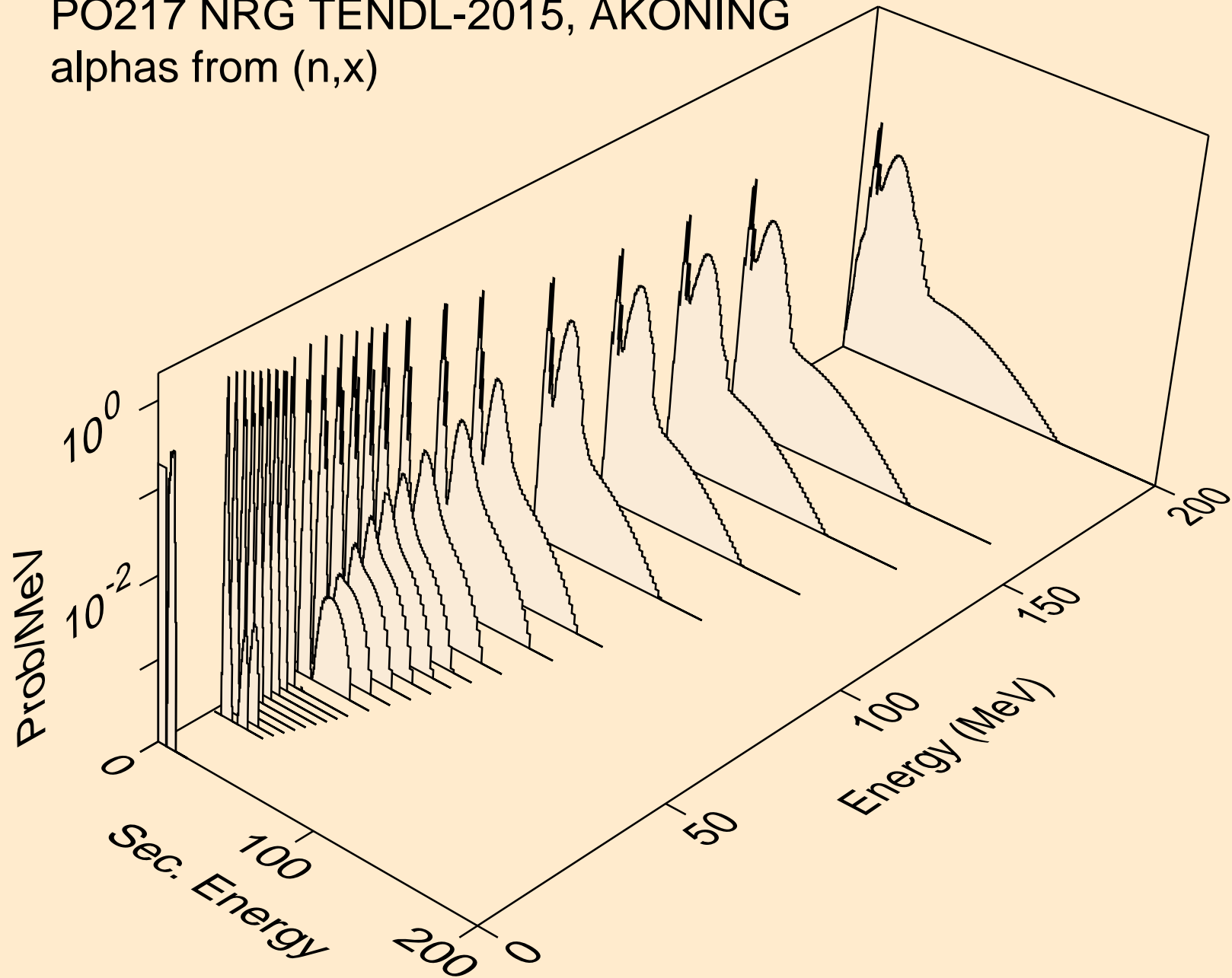

PO217 NRG TENDL-2015, AKONING
alphas from (n,n*)a

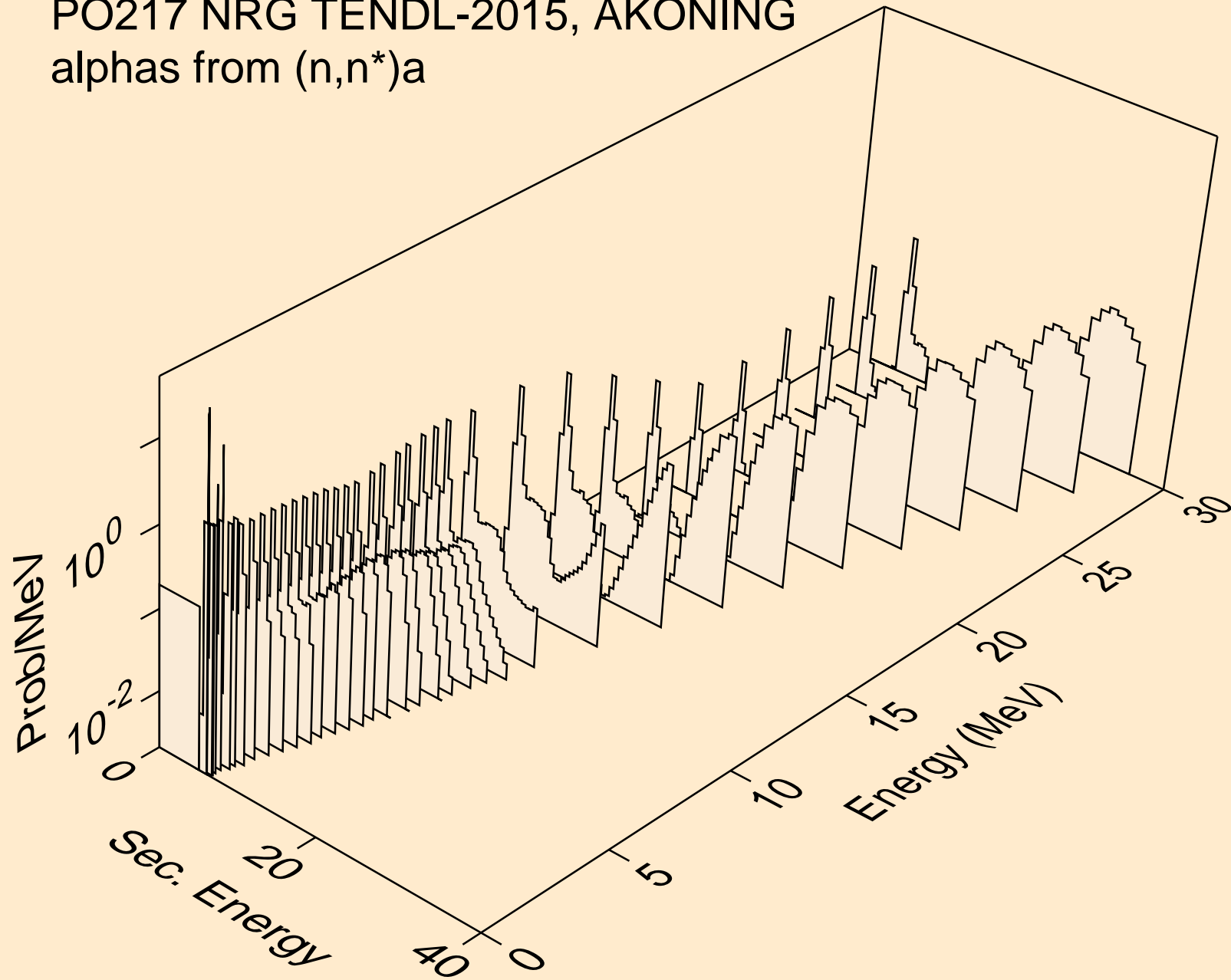

PO217 NRG TENDL-2015, AKONING
alphas from (n,2n)a

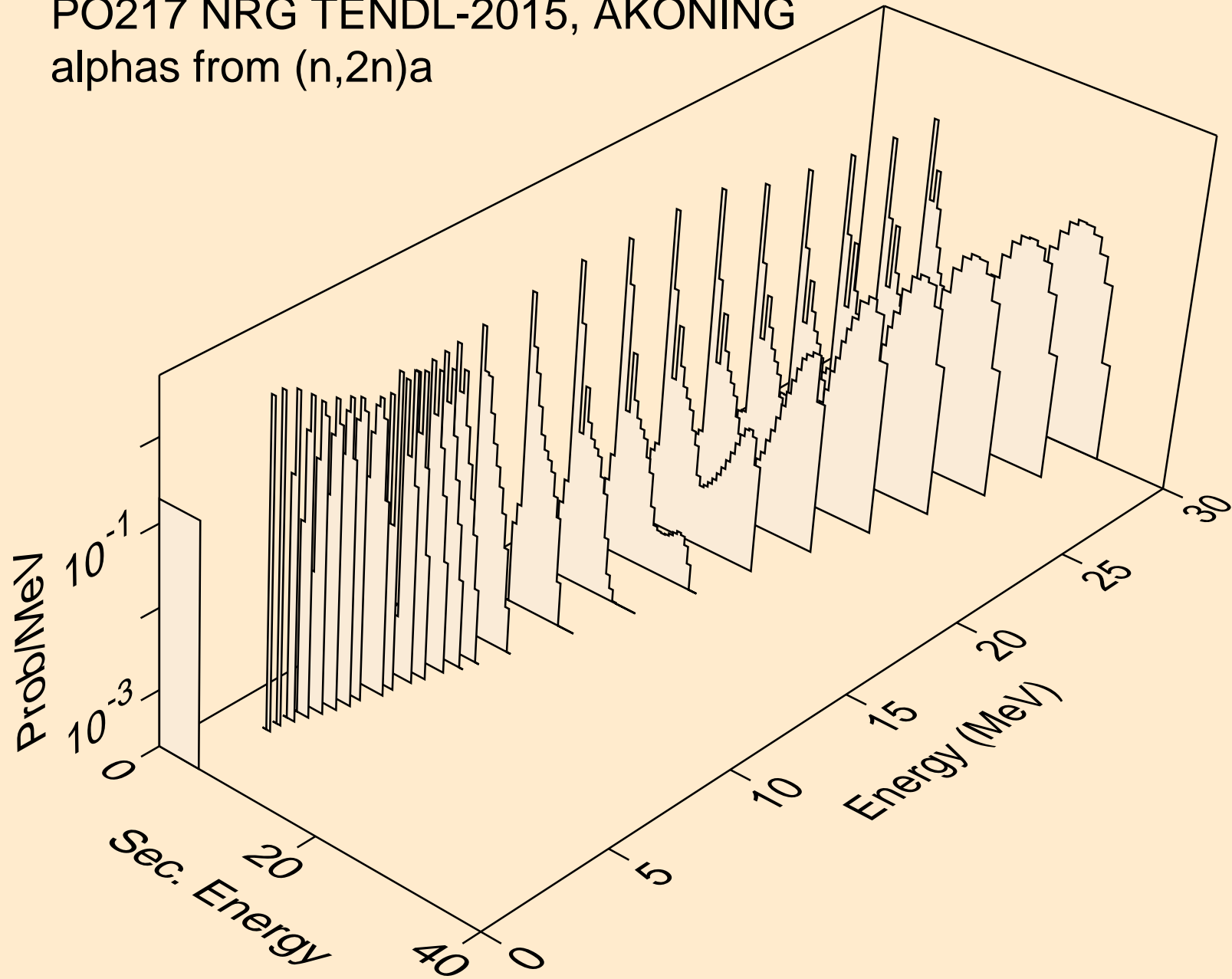

PO217 NRG TENDL-2015, AKONING
alphas from (n,3n)a

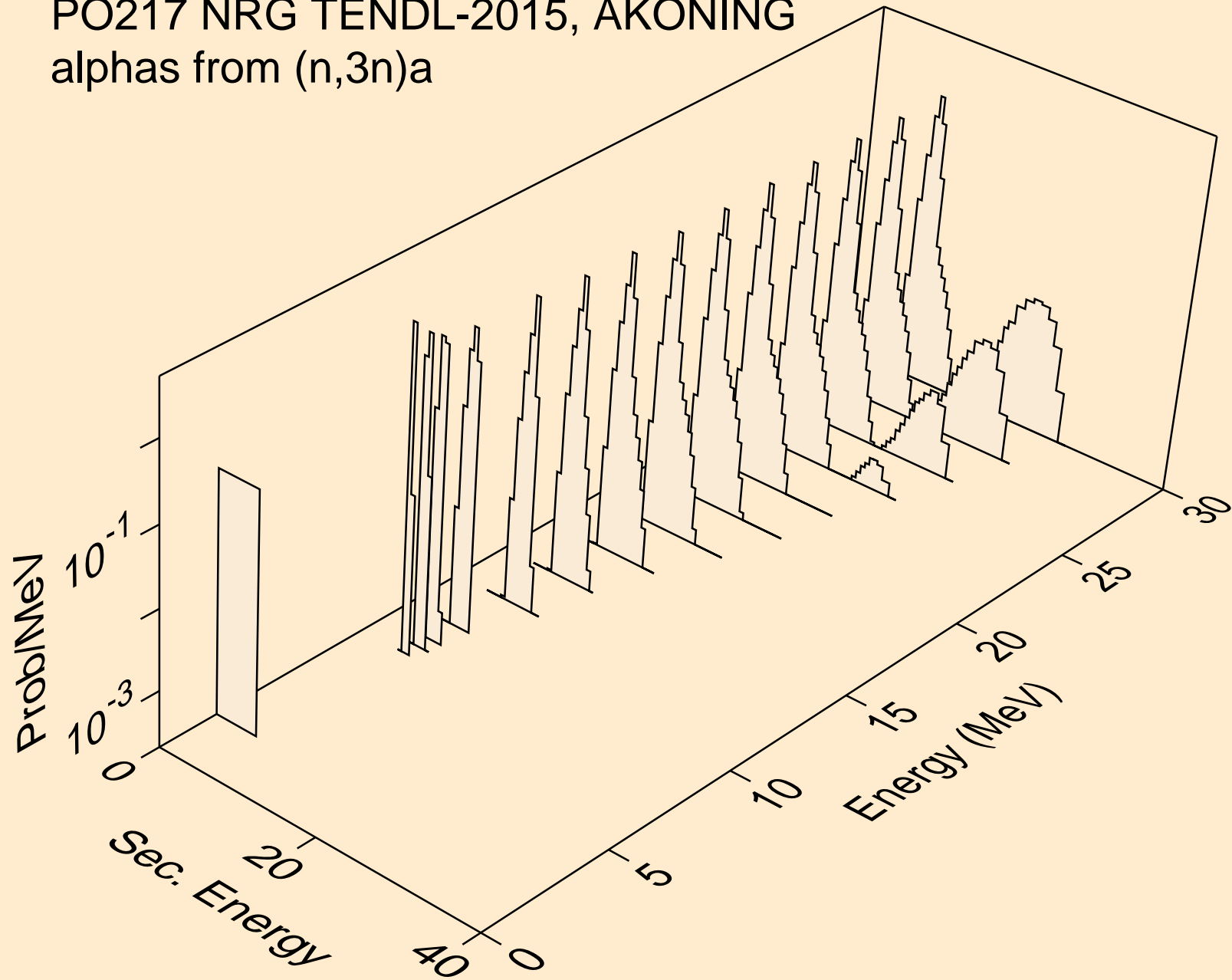

PO217 NRG TENDL-2015, AKONING
alphas from (n,n*)2a

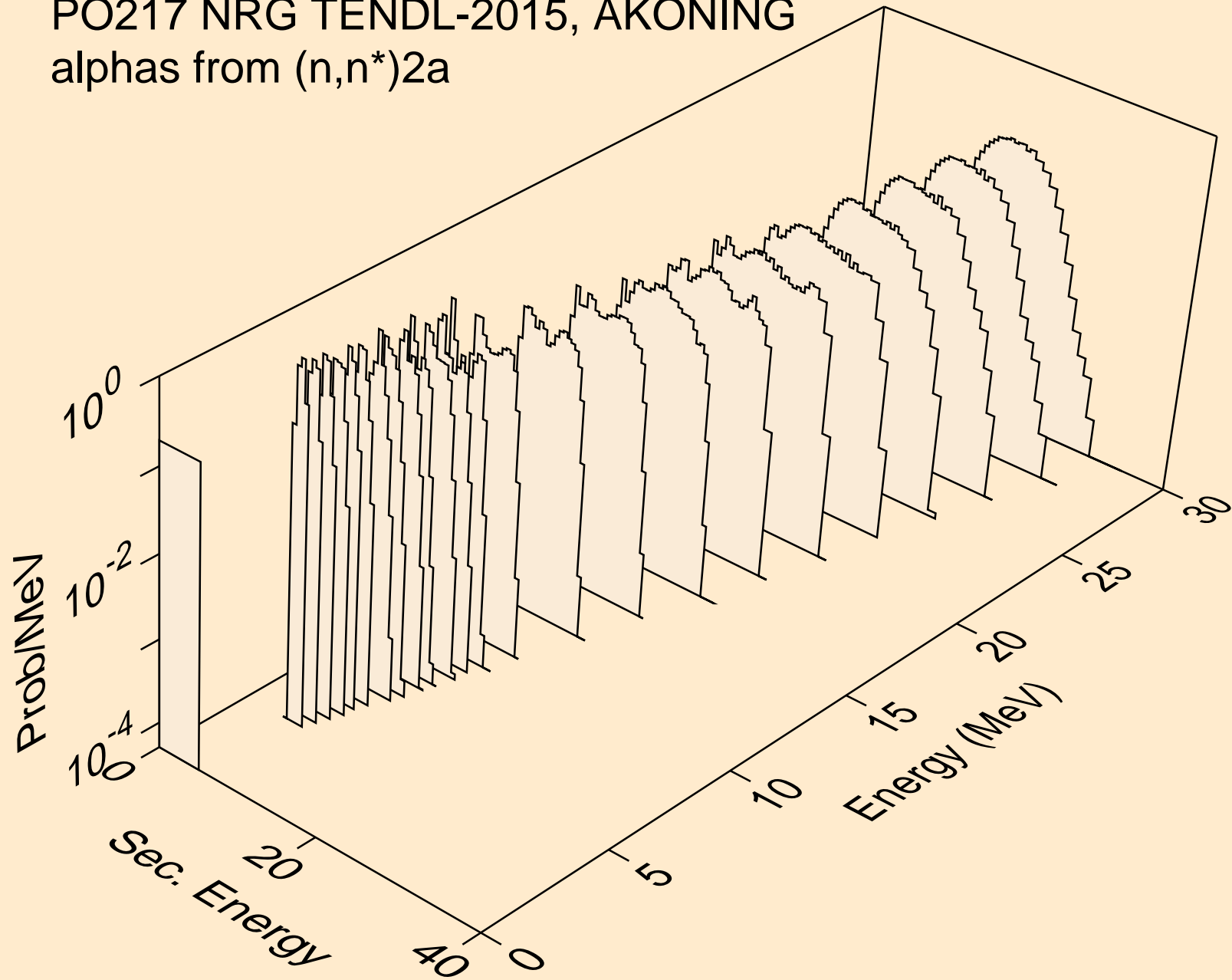

PO217 NRG TENDL-2015, AKONING
alphas from (n,2n)2a

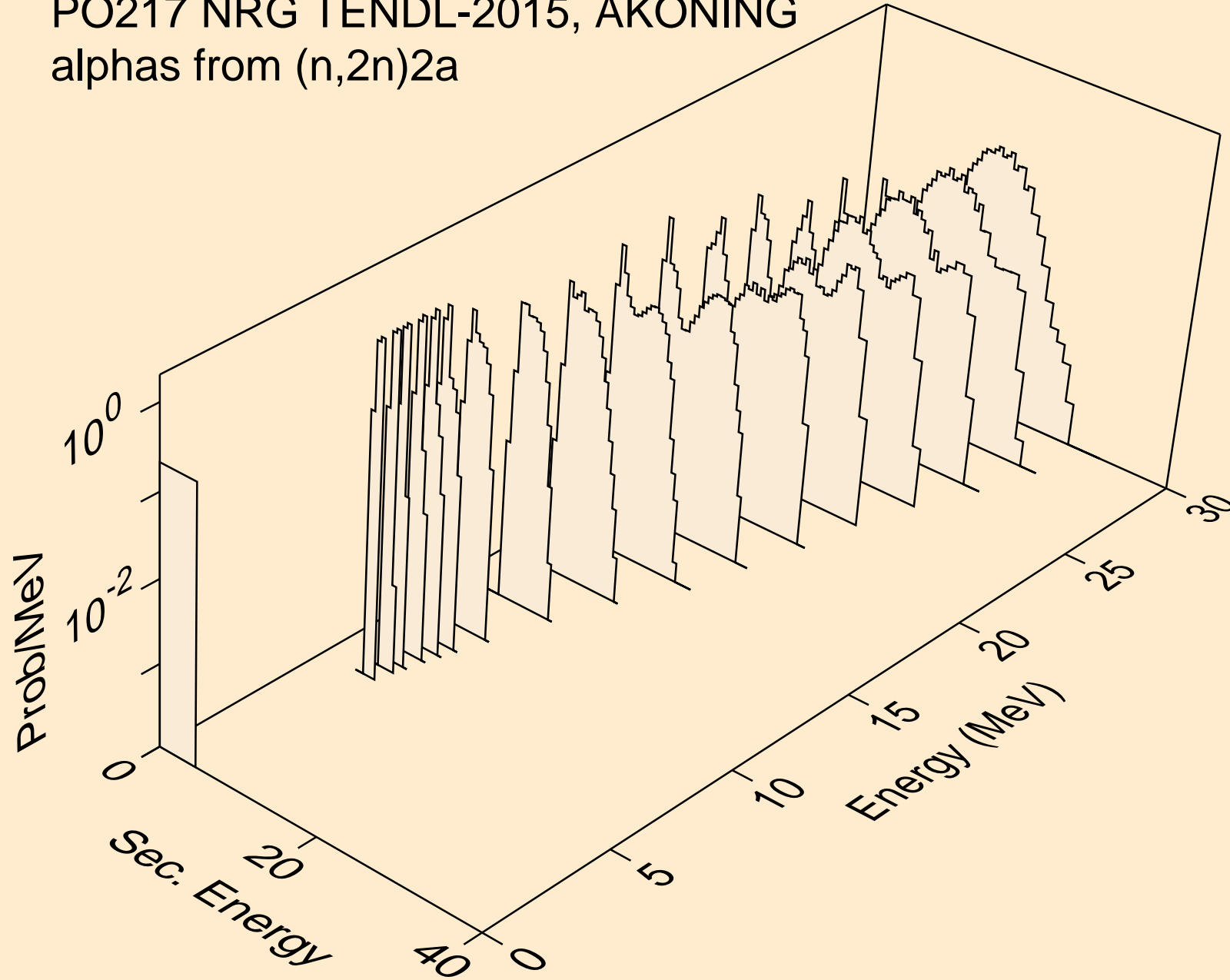

PO217 NRG TENDL-2015, AKONING
alphas from (n,npa)

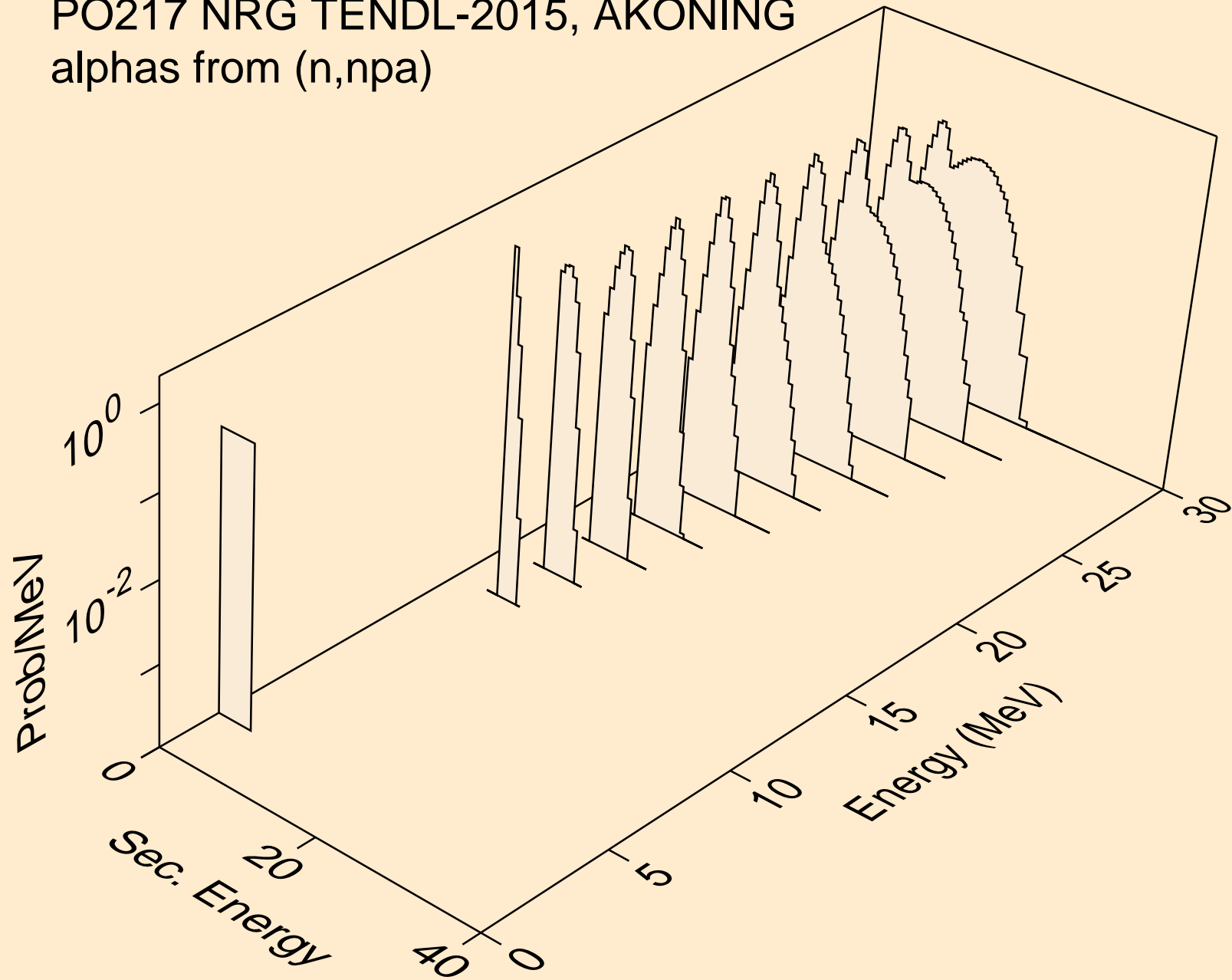

PO217 NRG TENDL-2015, AKONING
alphas from (n,a)

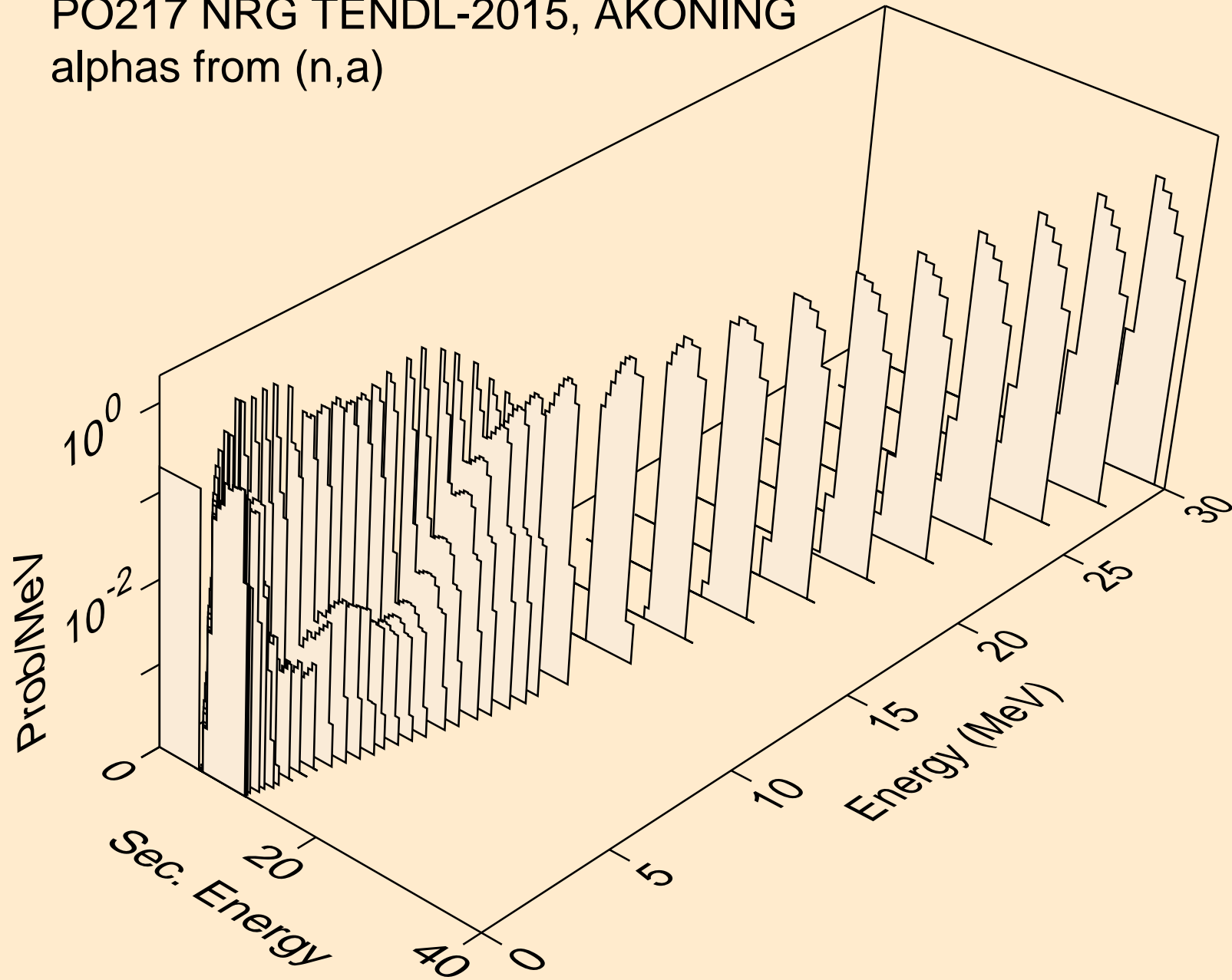

PO217 NRG TENDL-2015, AKONING
alphas from (n,pa)

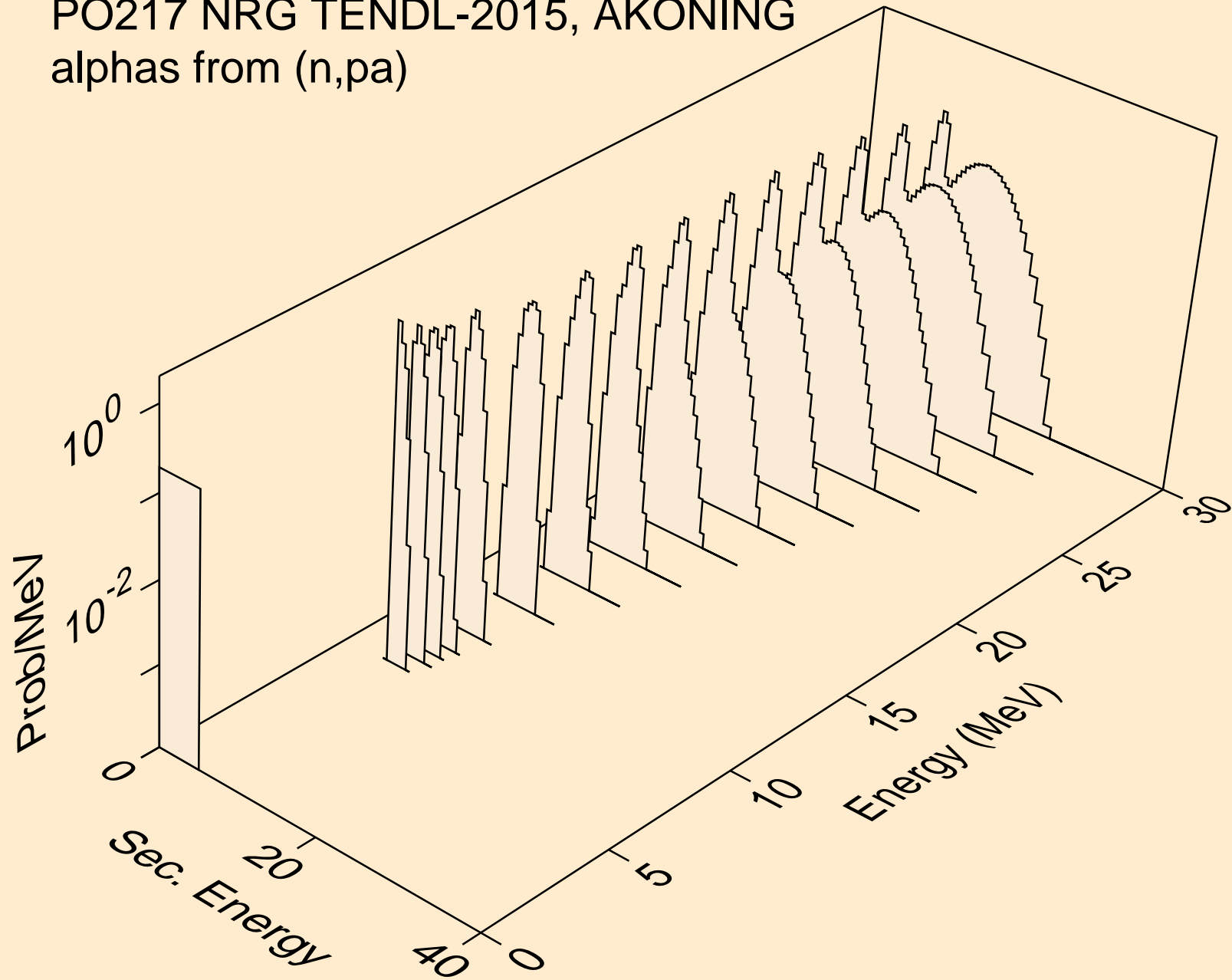

PO217 NRG TENDL-2015, AKONING
alphas from (n,da)

