

# PO219 NRG TENDL-2015, AKONING

## Principal cross sections

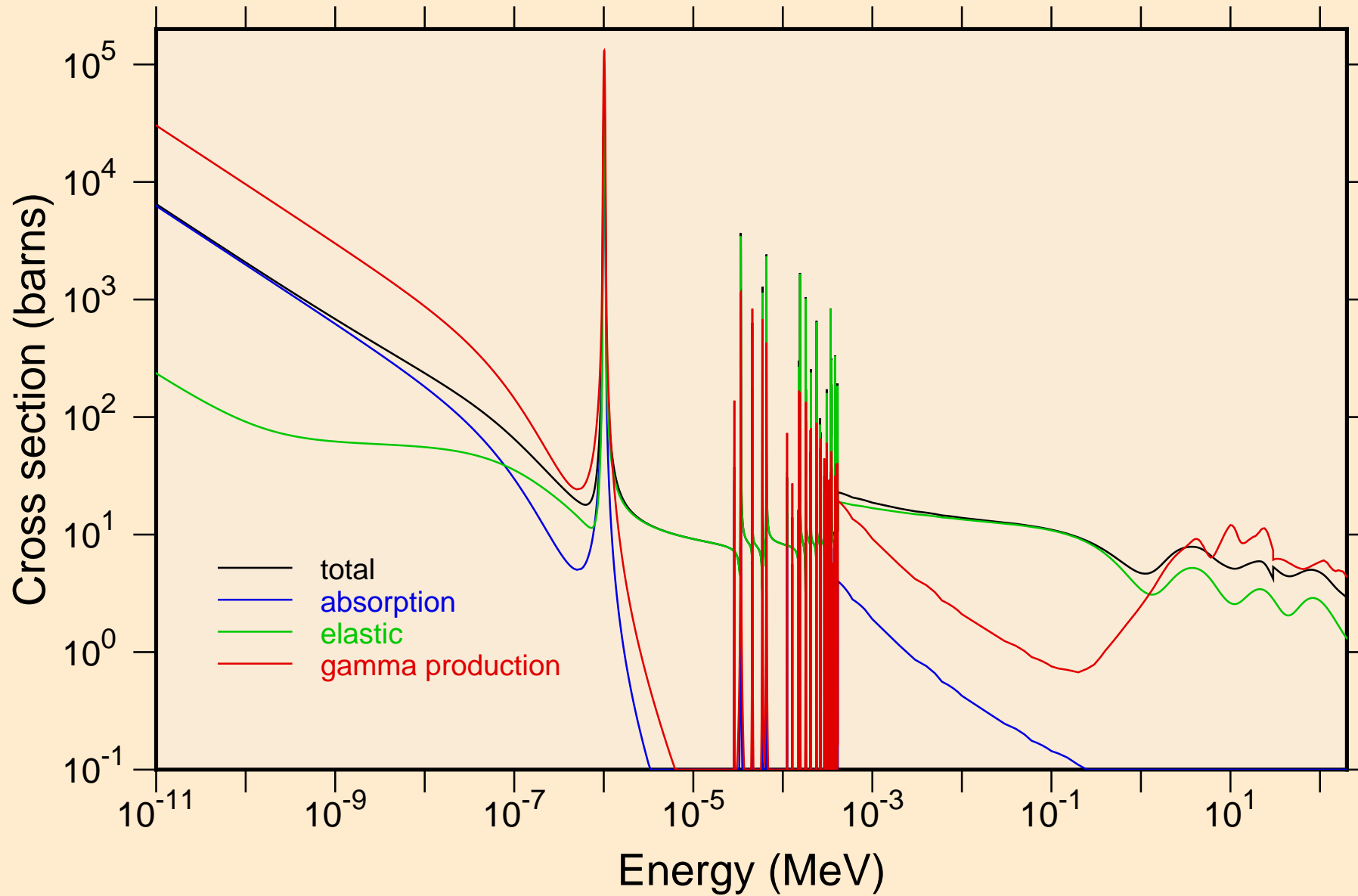

PO219 NRG TENDL-2015, AKONING  
resonance total cross section

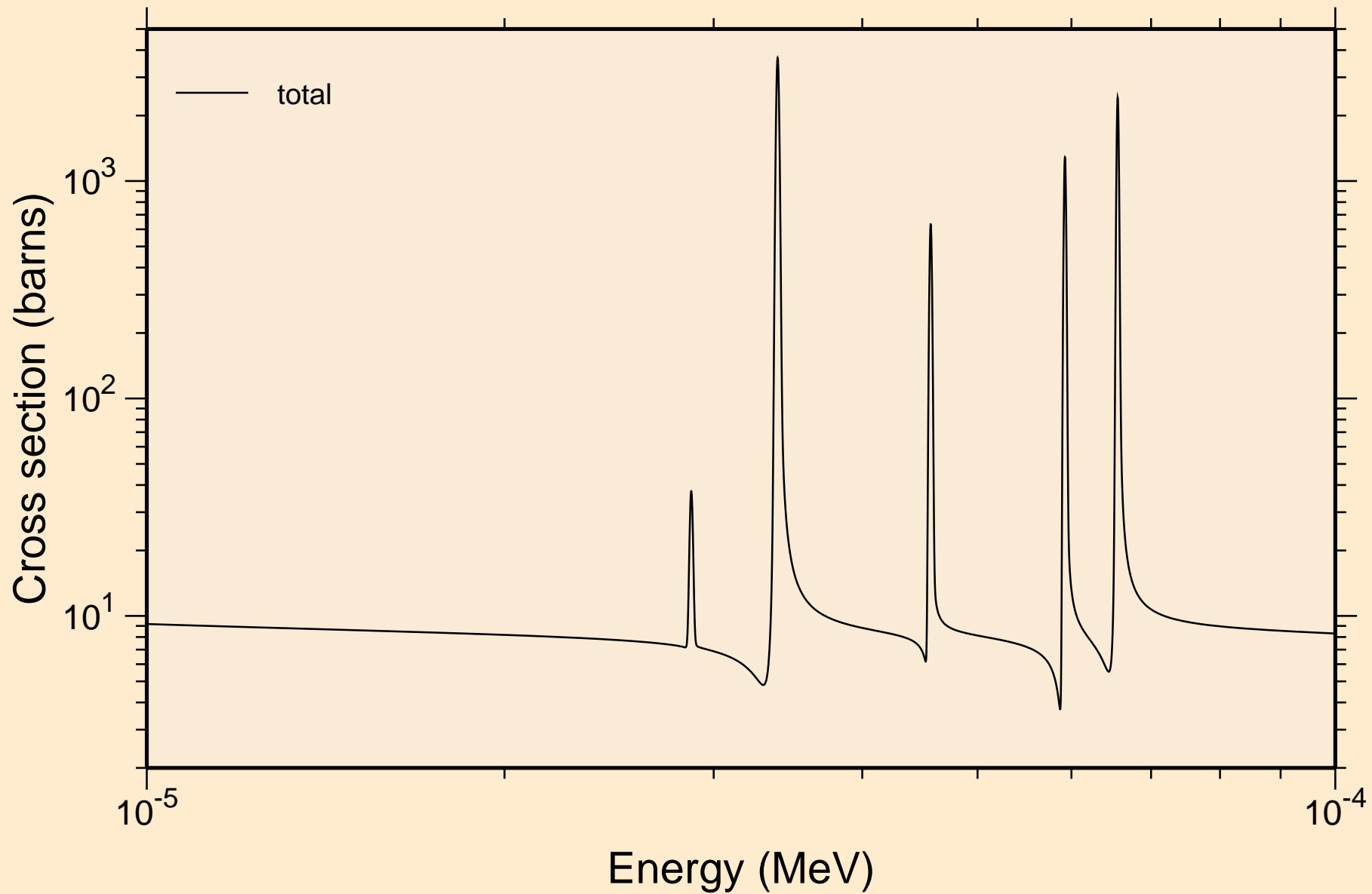

PO219 NRG TENDL-2015, AKONING  
resonance total cross section

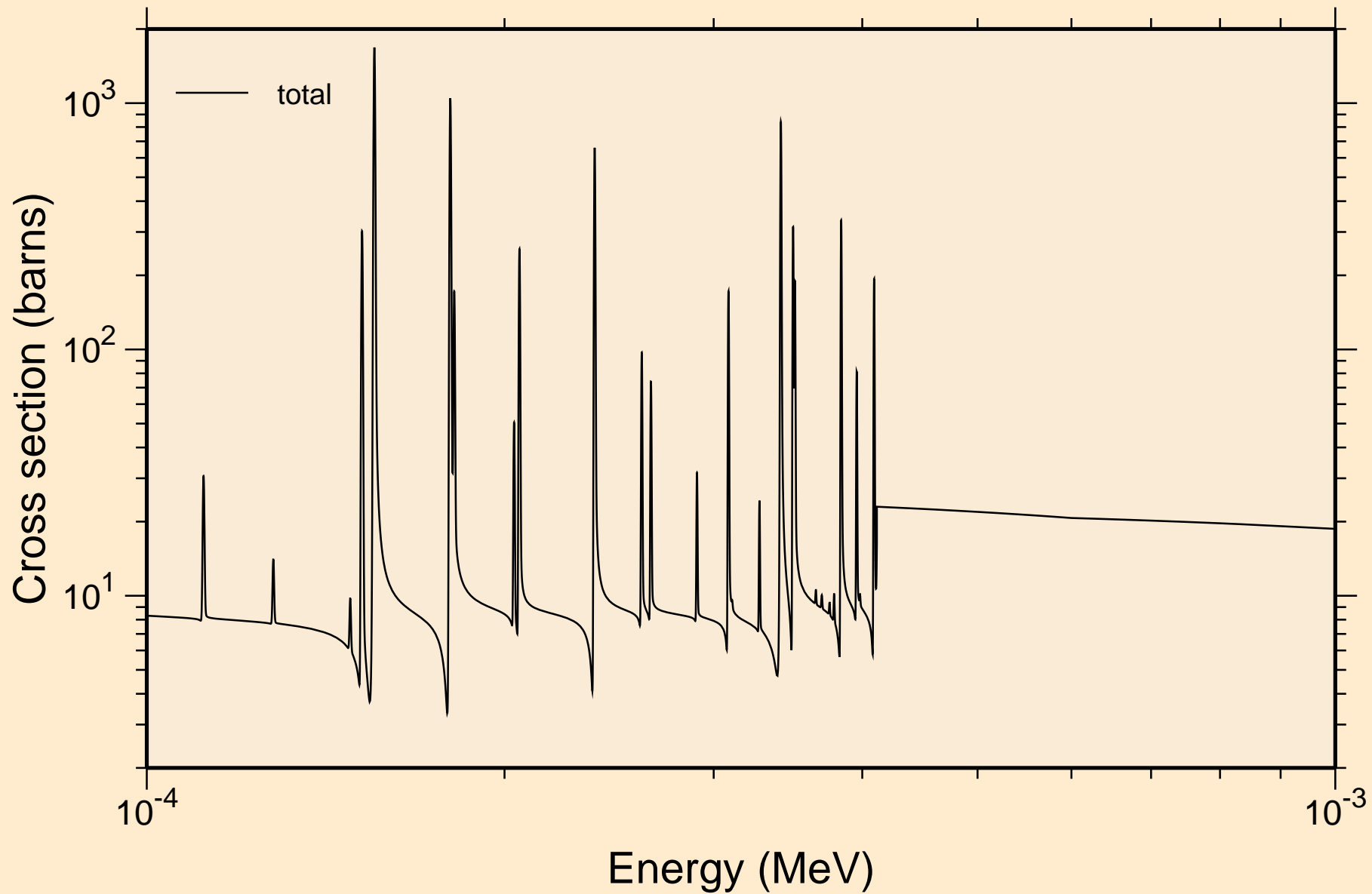

PO219 NRG TENDL-2015, AKONING  
resonance total cross section

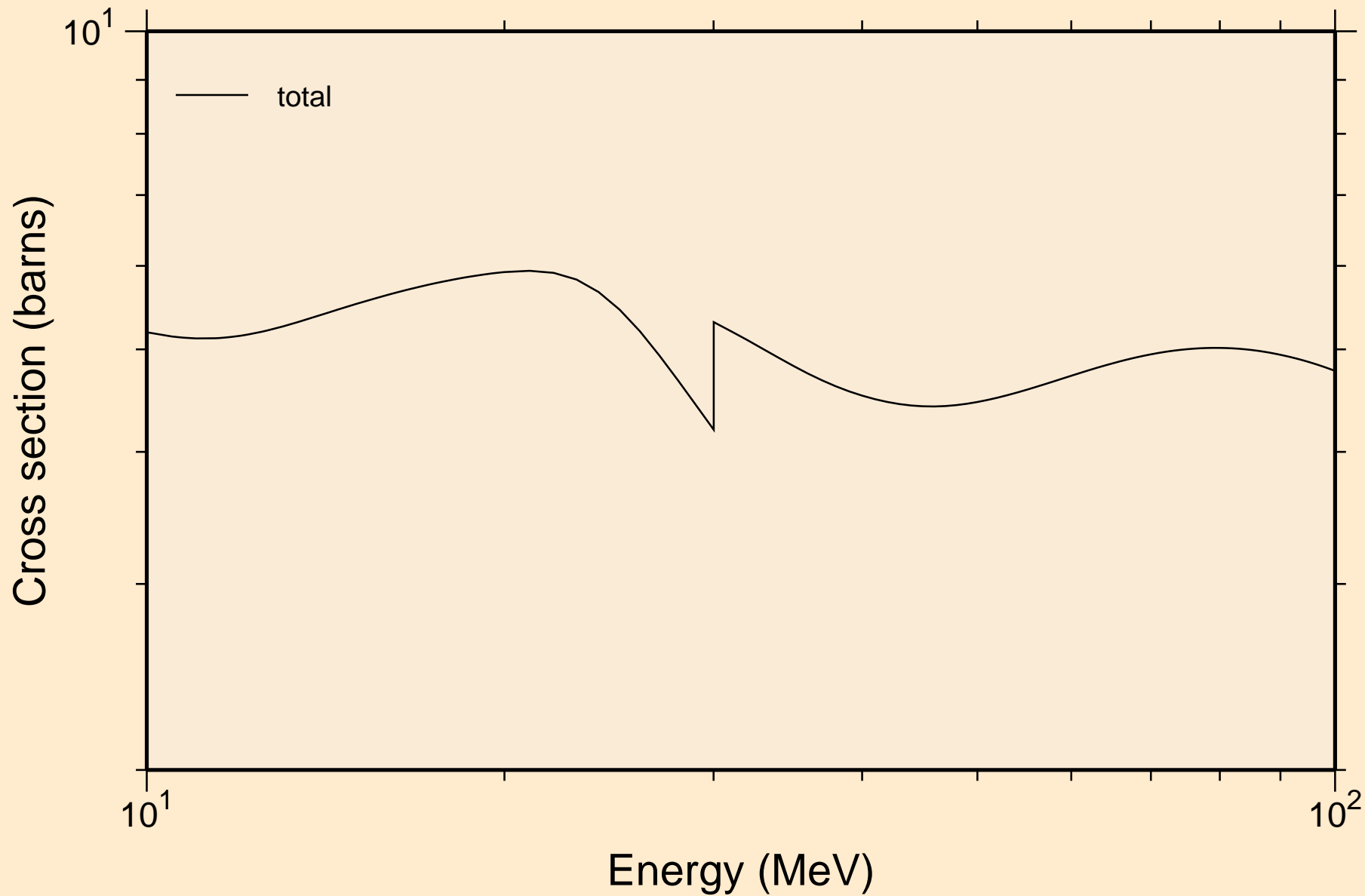

PO219 NRG TENDL-2015, AKONING  
resonance absorption cross sections

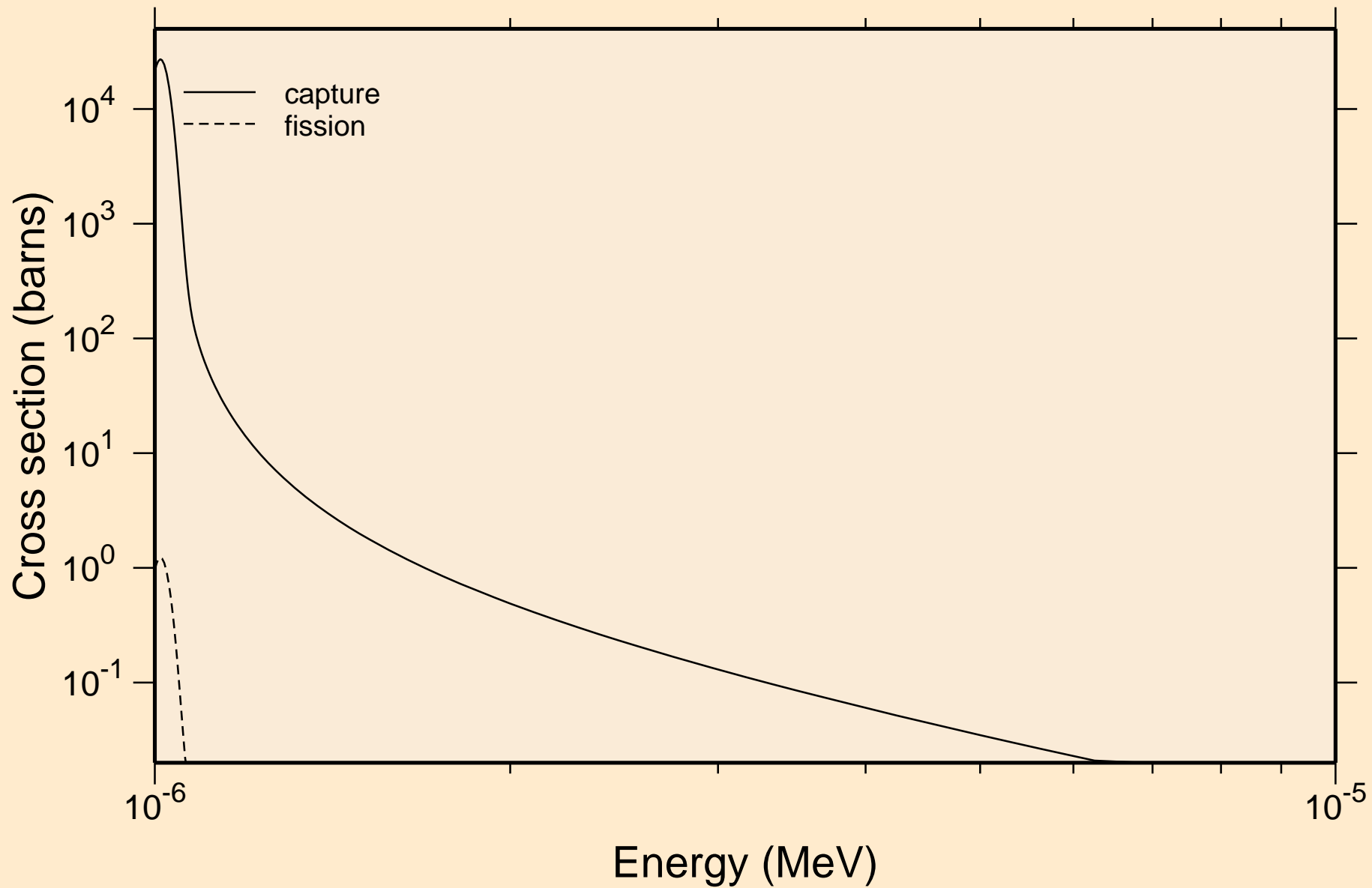

PO219 NRG TENDL-2015, AKONING  
resonance absorption cross sections

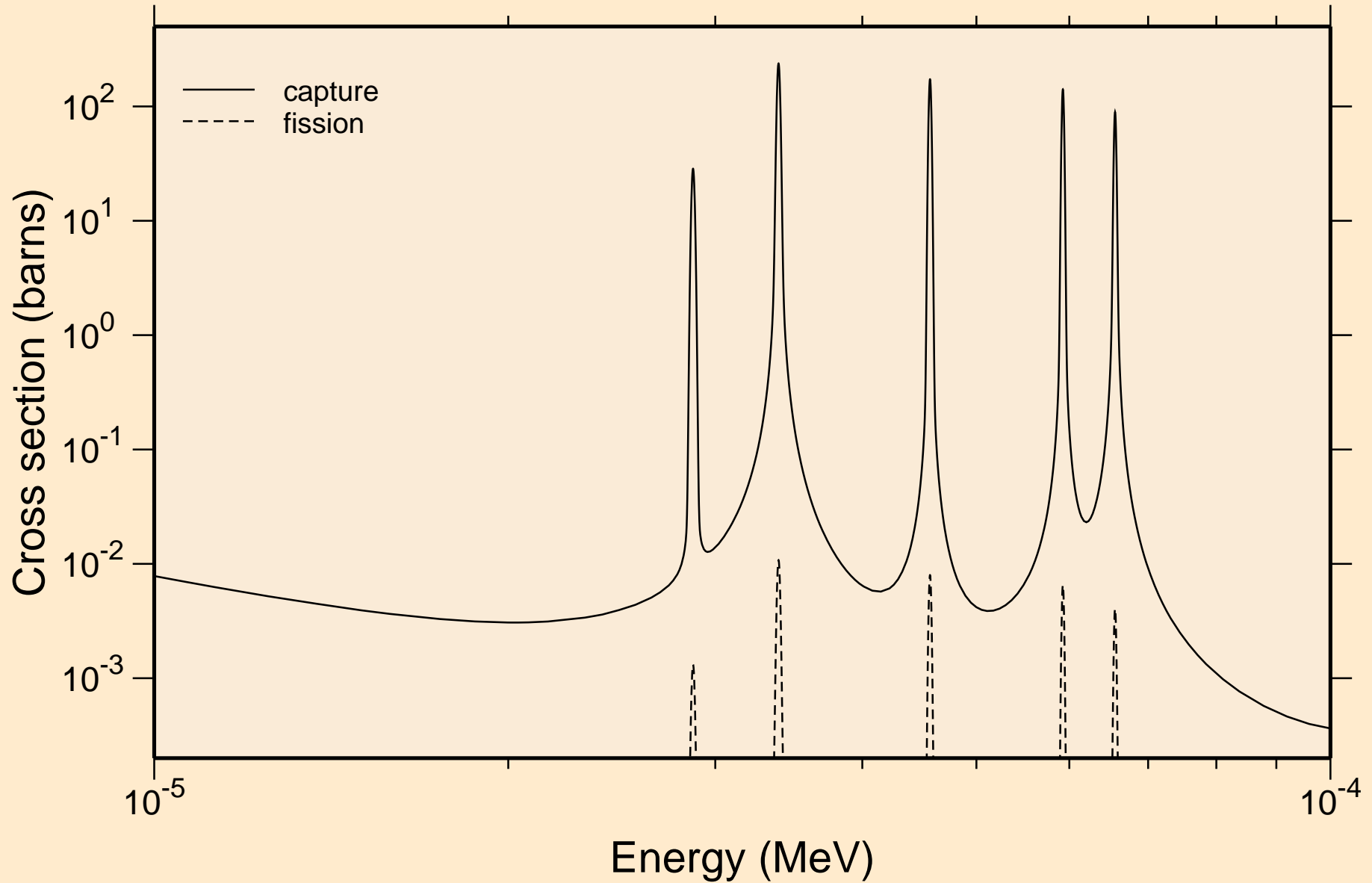

PO219 NRG TENDL-2015, AKONING  
resonance absorption cross sections

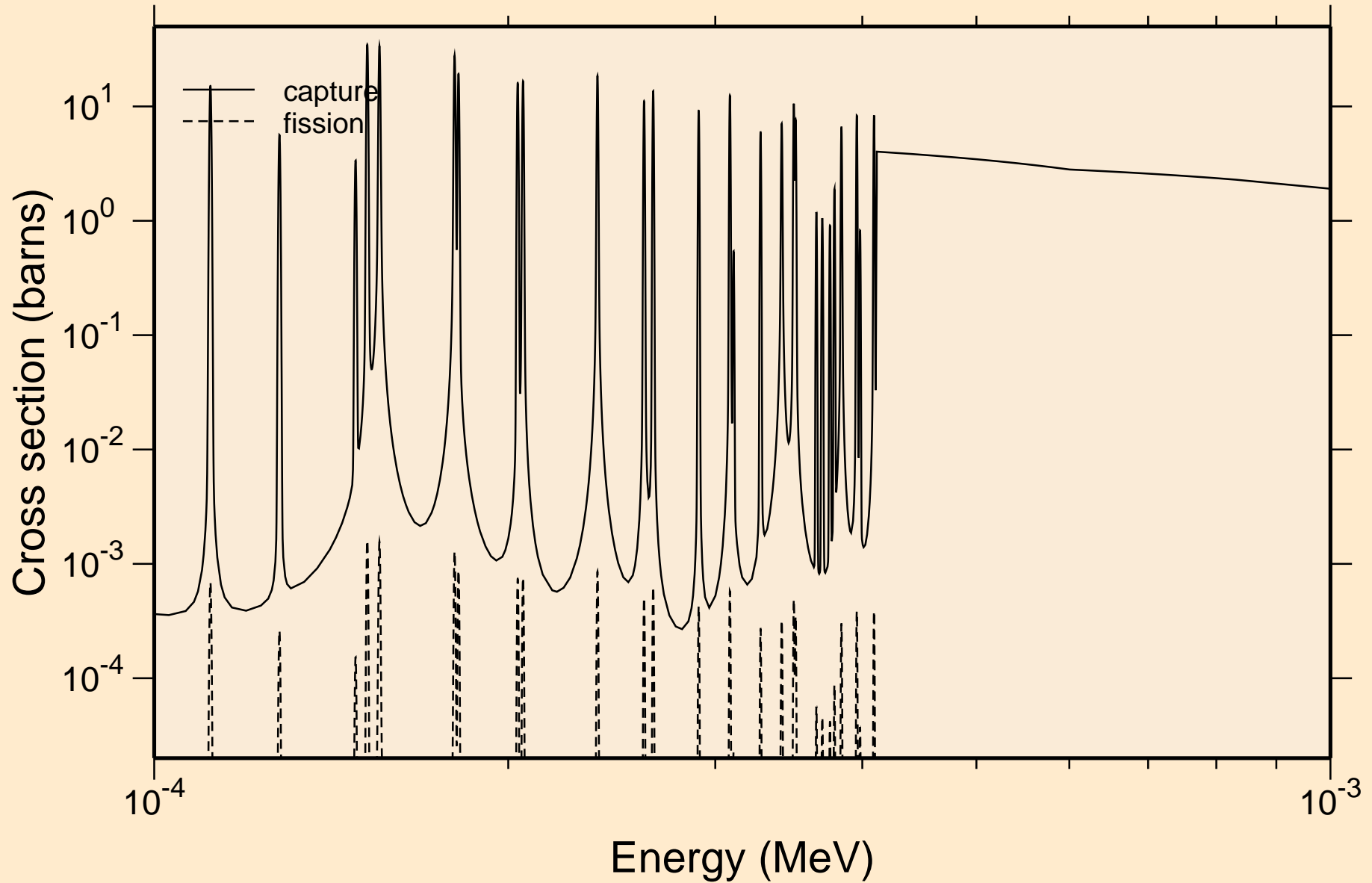

PO219 NRG TENDL-2015, AKONING  
resonance absorption cross sections

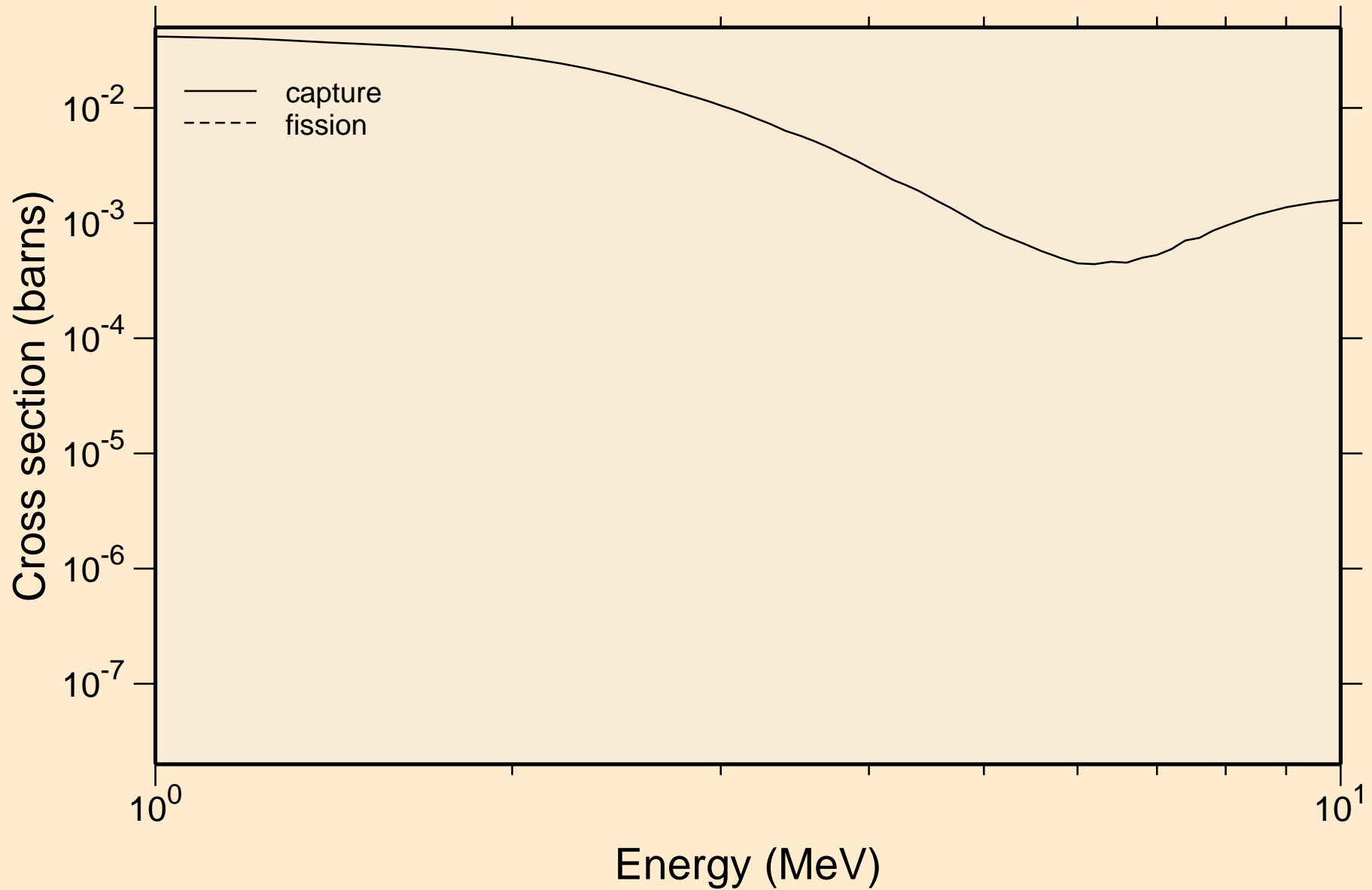



# PO219 NRG TENDL-2015, AKONING

## Non-threshold reactions

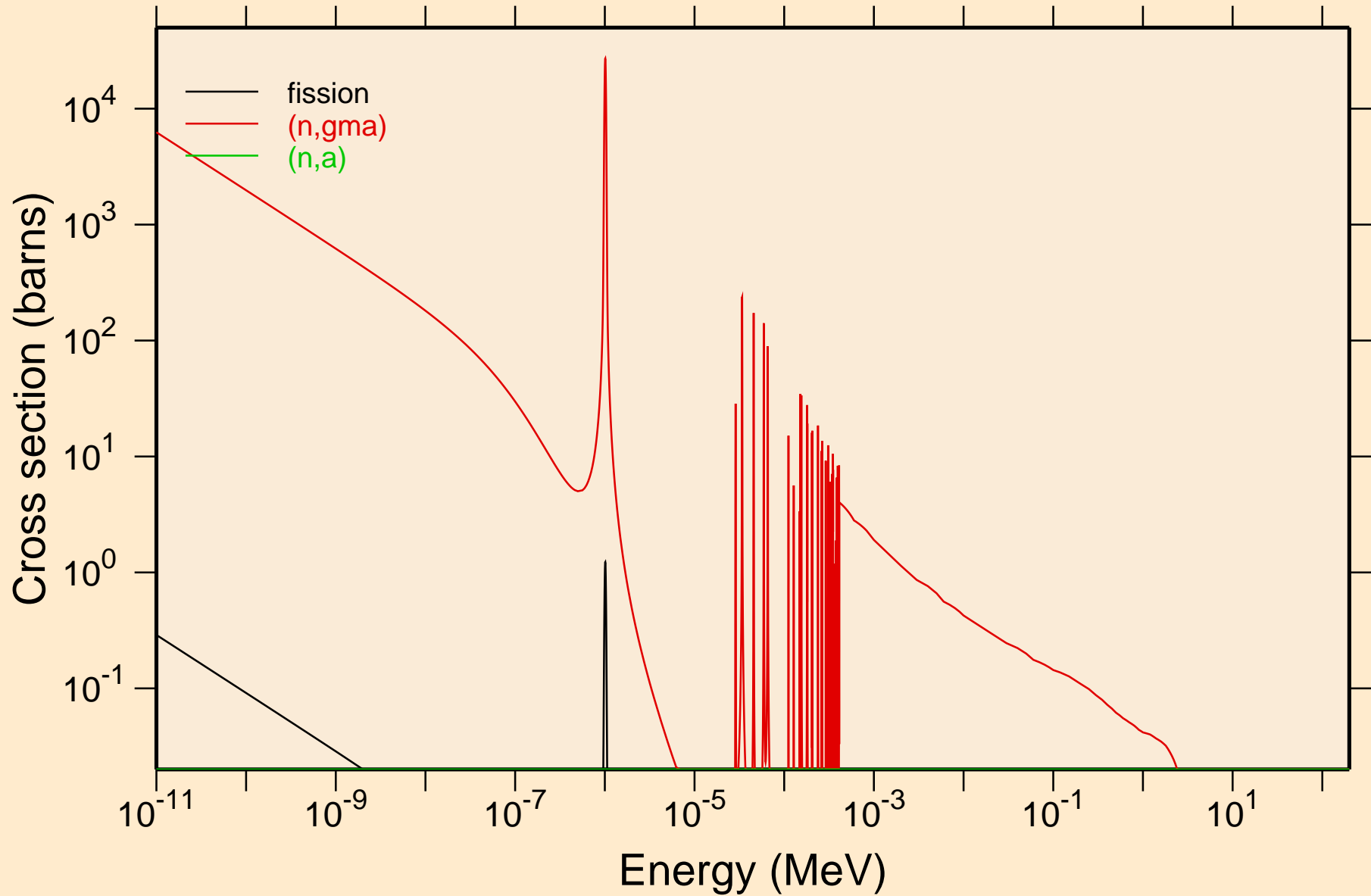

# PO219 NRG TENDL-2015, AKONING

## Principal cross sections

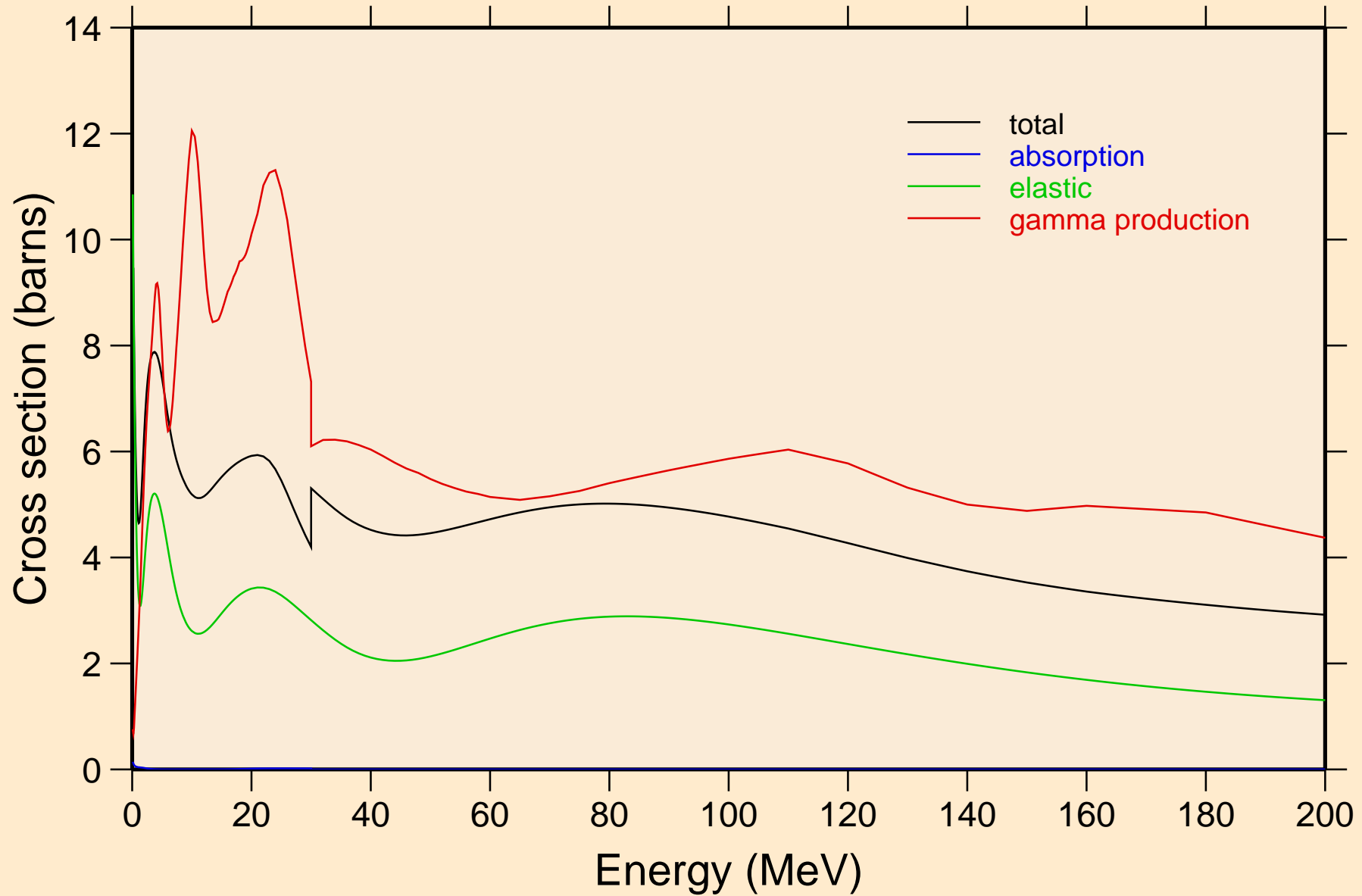

# PO219 NRG TENDL-2015, AKONING

## Non-threshold reactions

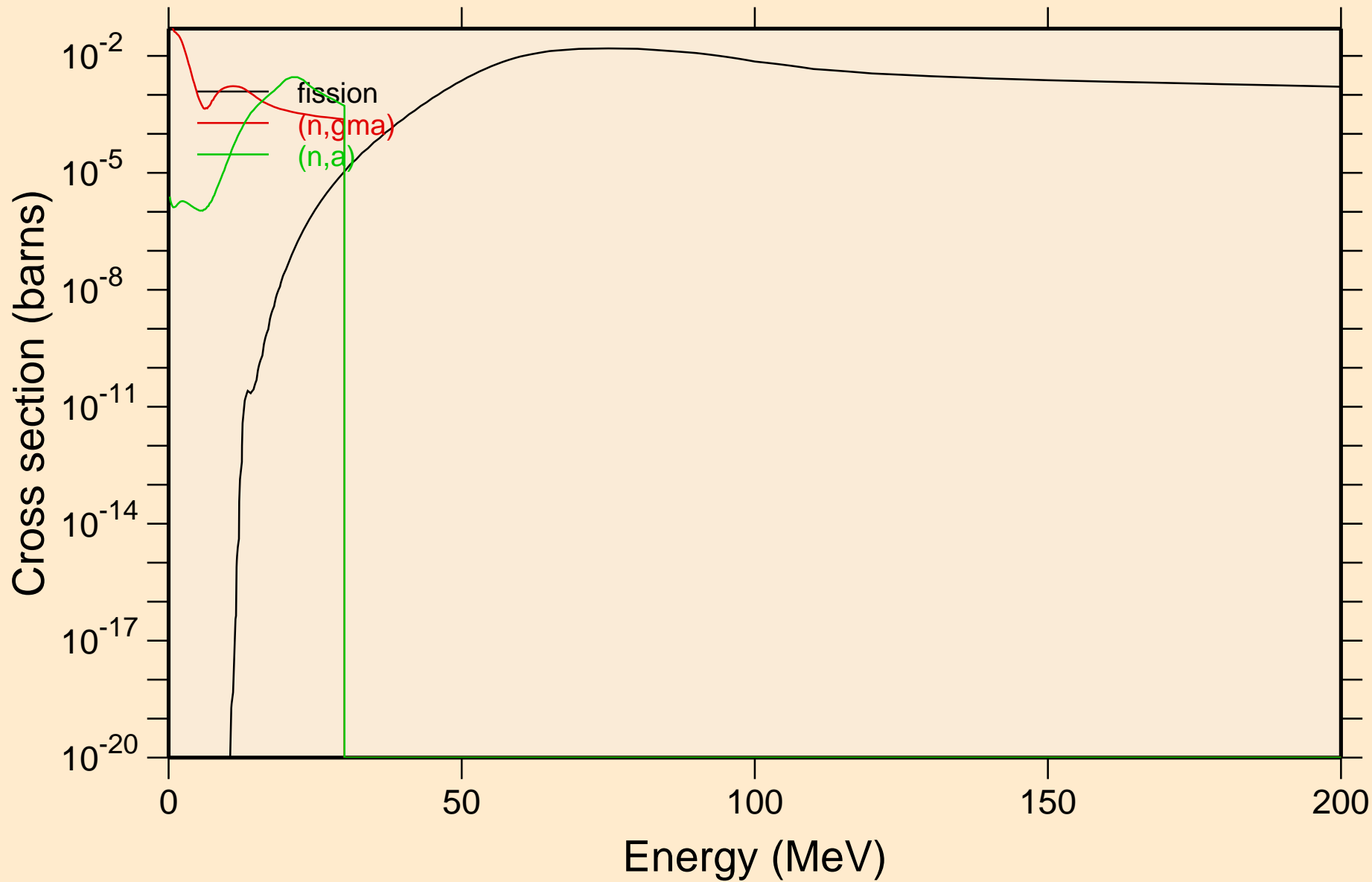

PO219 NRG TENDL-2015, AKONING  
Inelastic levels

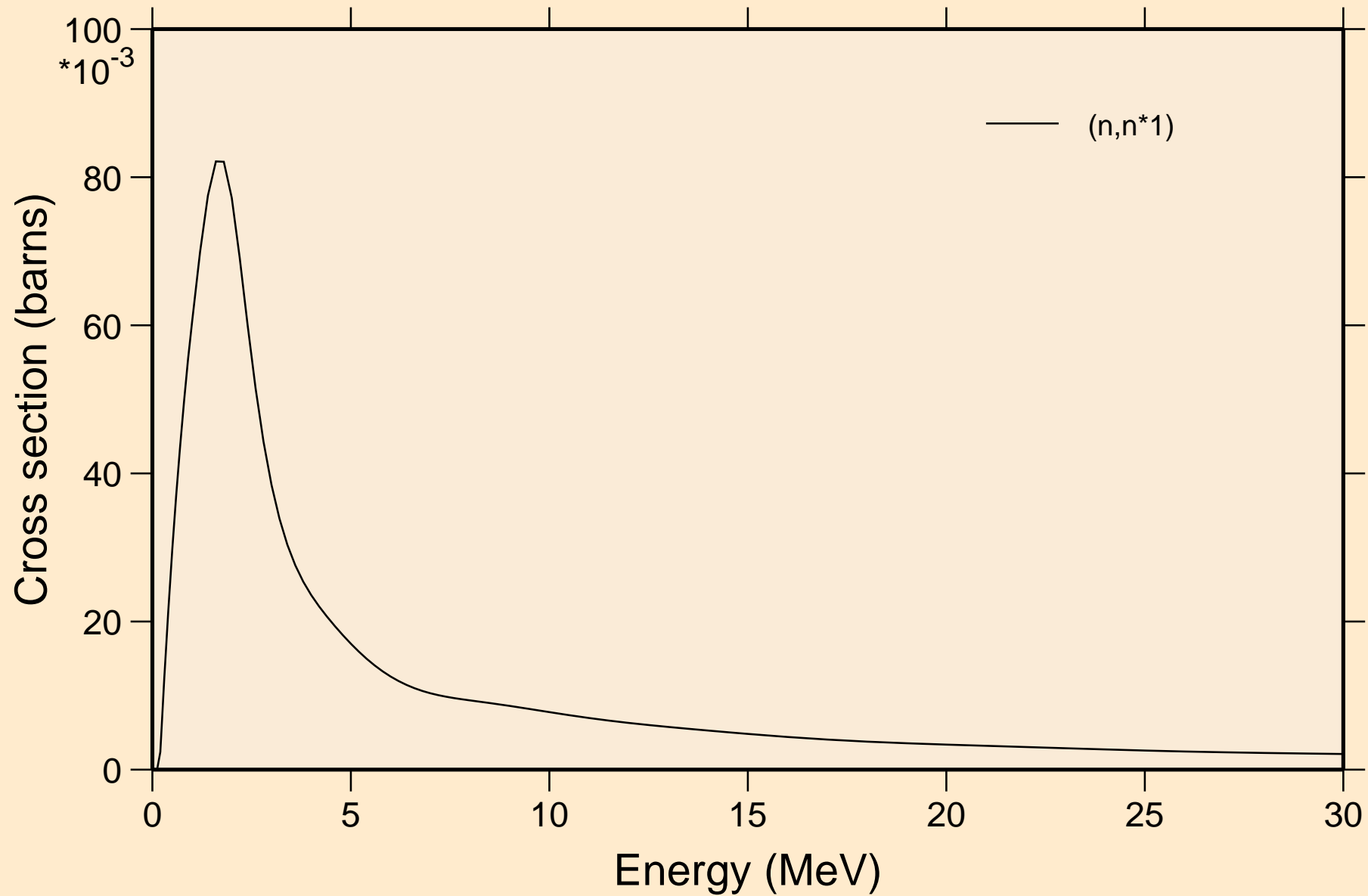

# PO219 NRG TENDL-2015, AKONING

## Threshold reactions

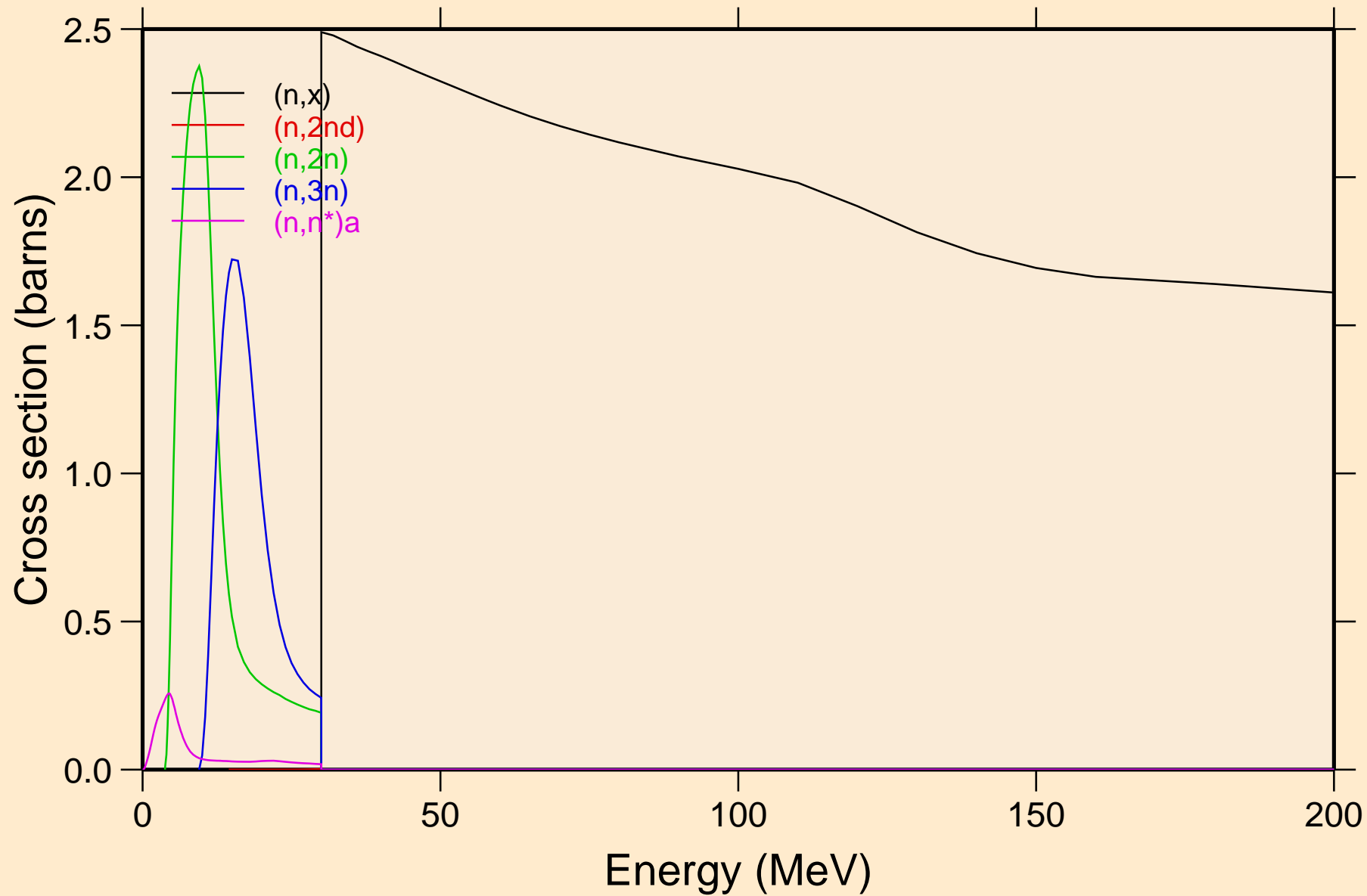

# PO219 NRG TENDL-2015, AKONING

## Threshold reactions

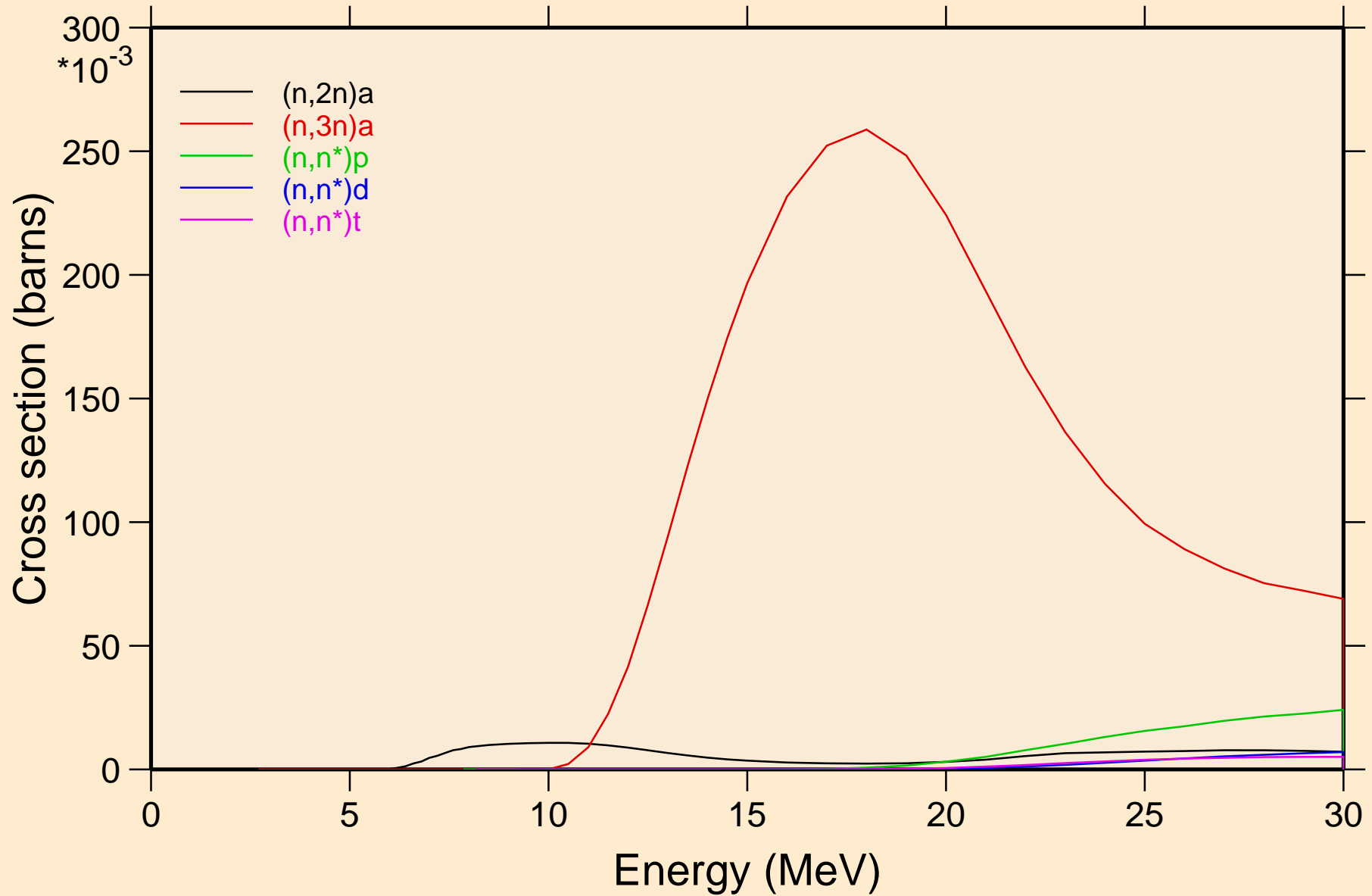

# PO219 NRG TENDL-2015, AKONING

## Threshold reactions

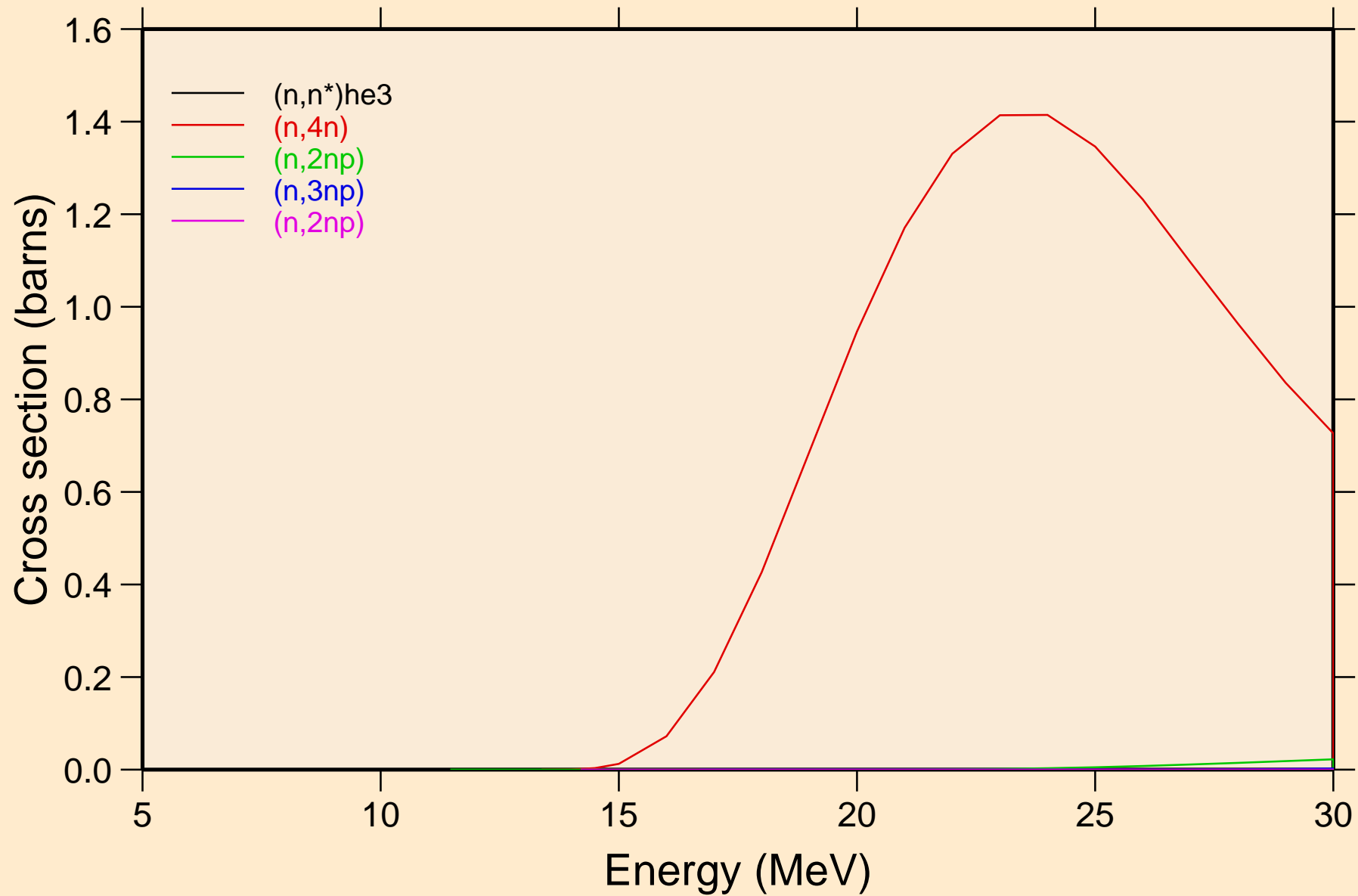

# PO219 NRG TENDL-2015, AKONING

## Threshold reactions

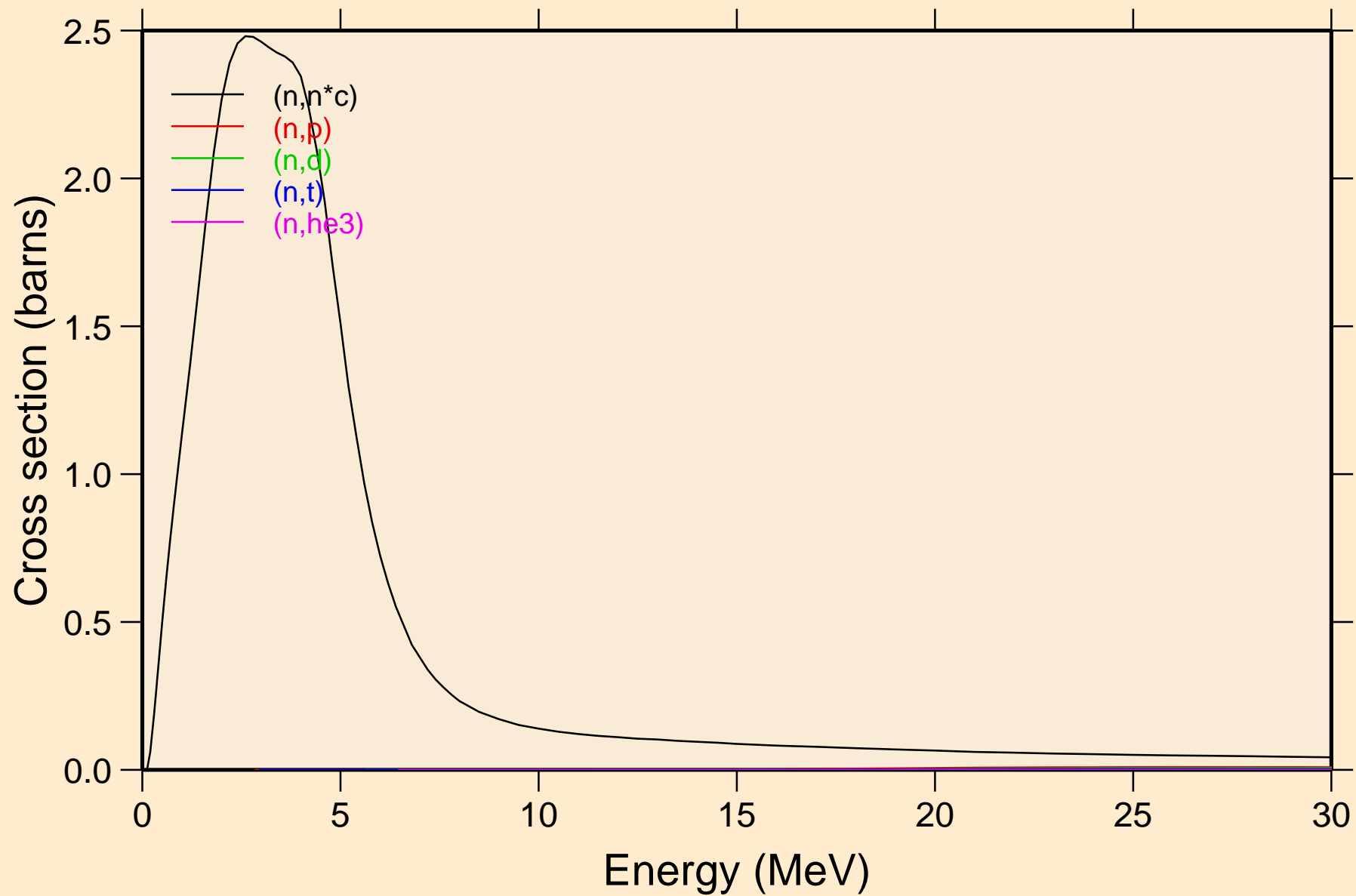



# PO219 NRG TENDL-2015, AKONING

## Threshold reactions

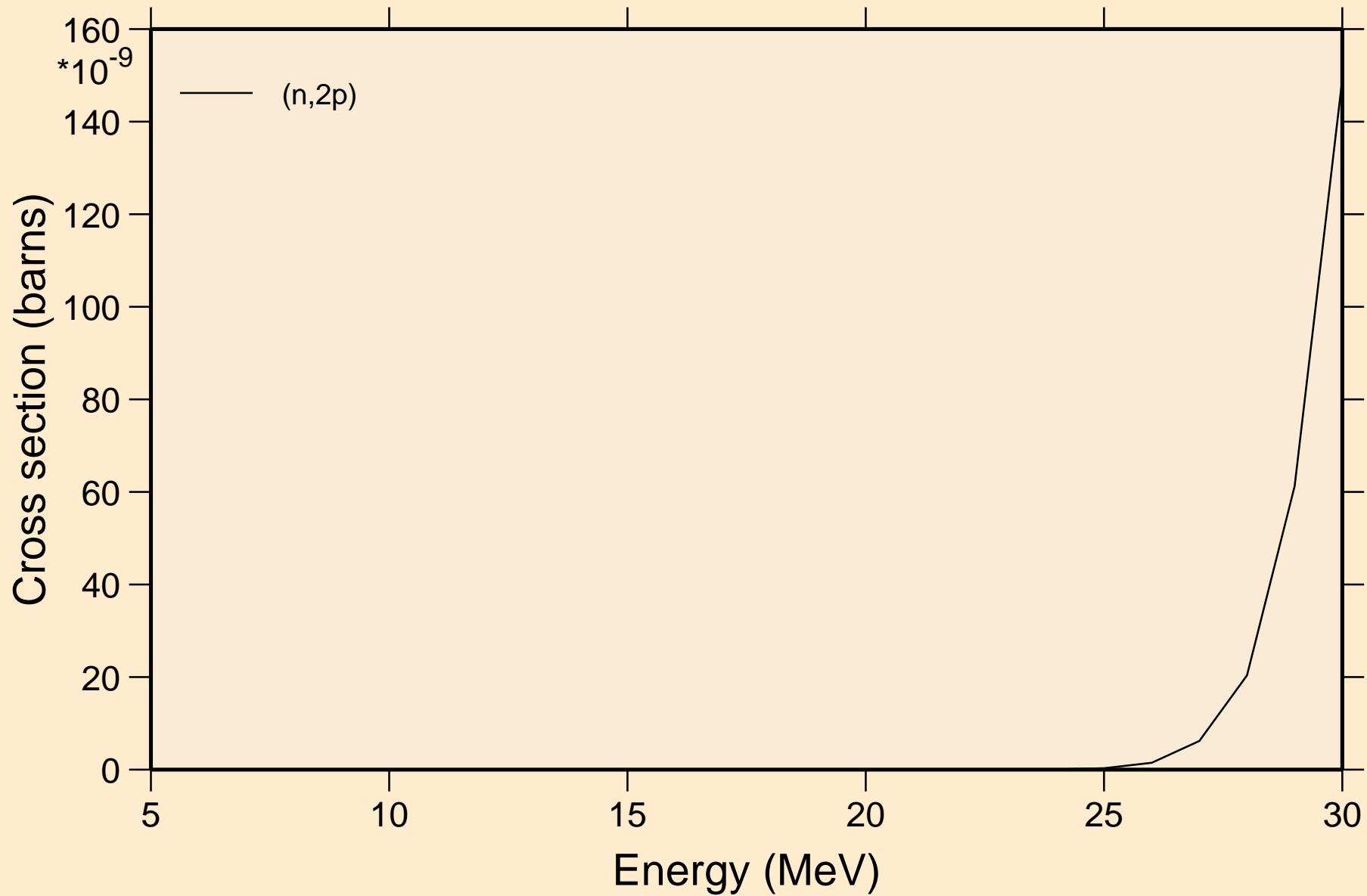

PO219 NRG TENDL-2015, AKONING  
angular distribution for elastic

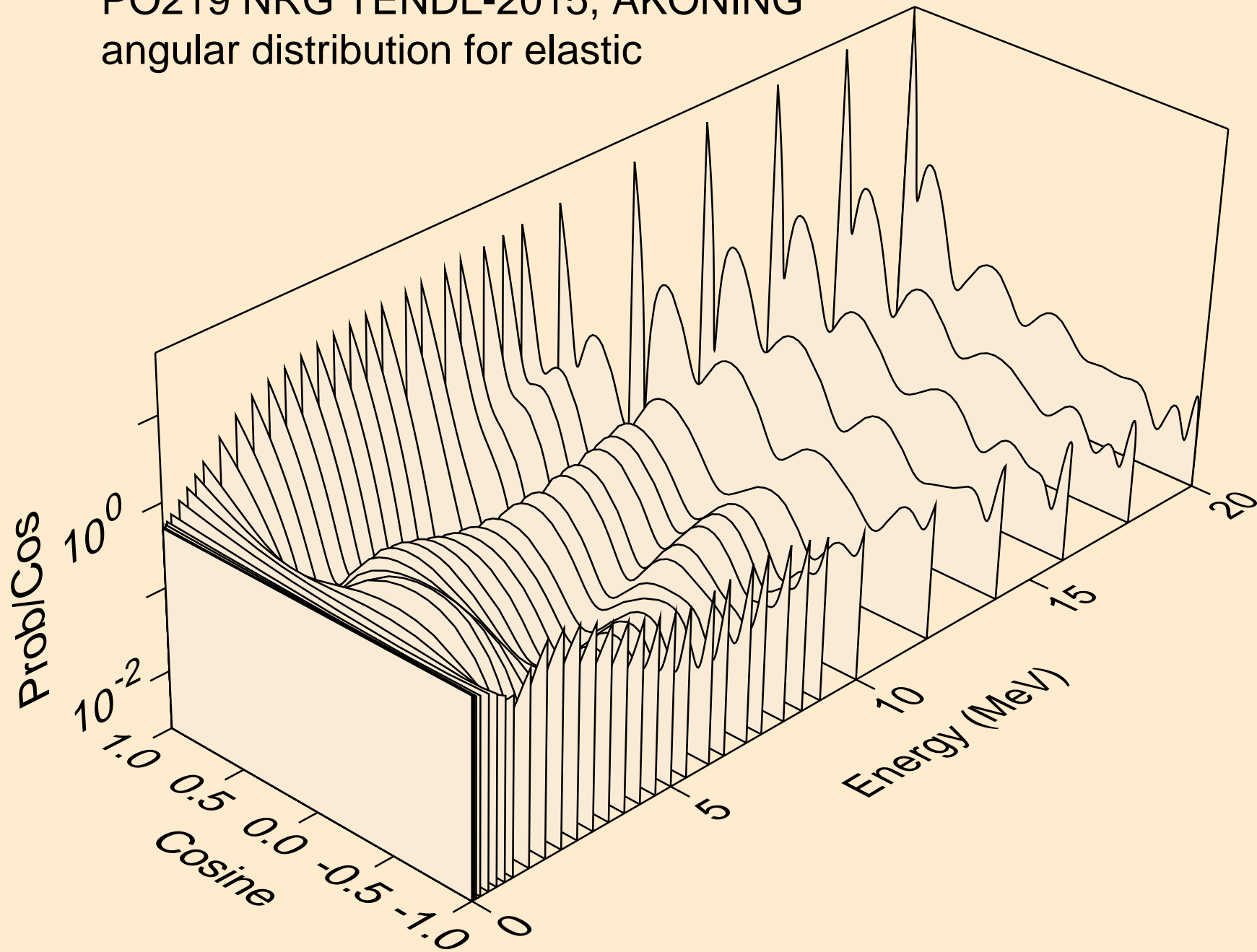

PO219 NRG TENDL-2015, AKONING  
angular distribution for elastic

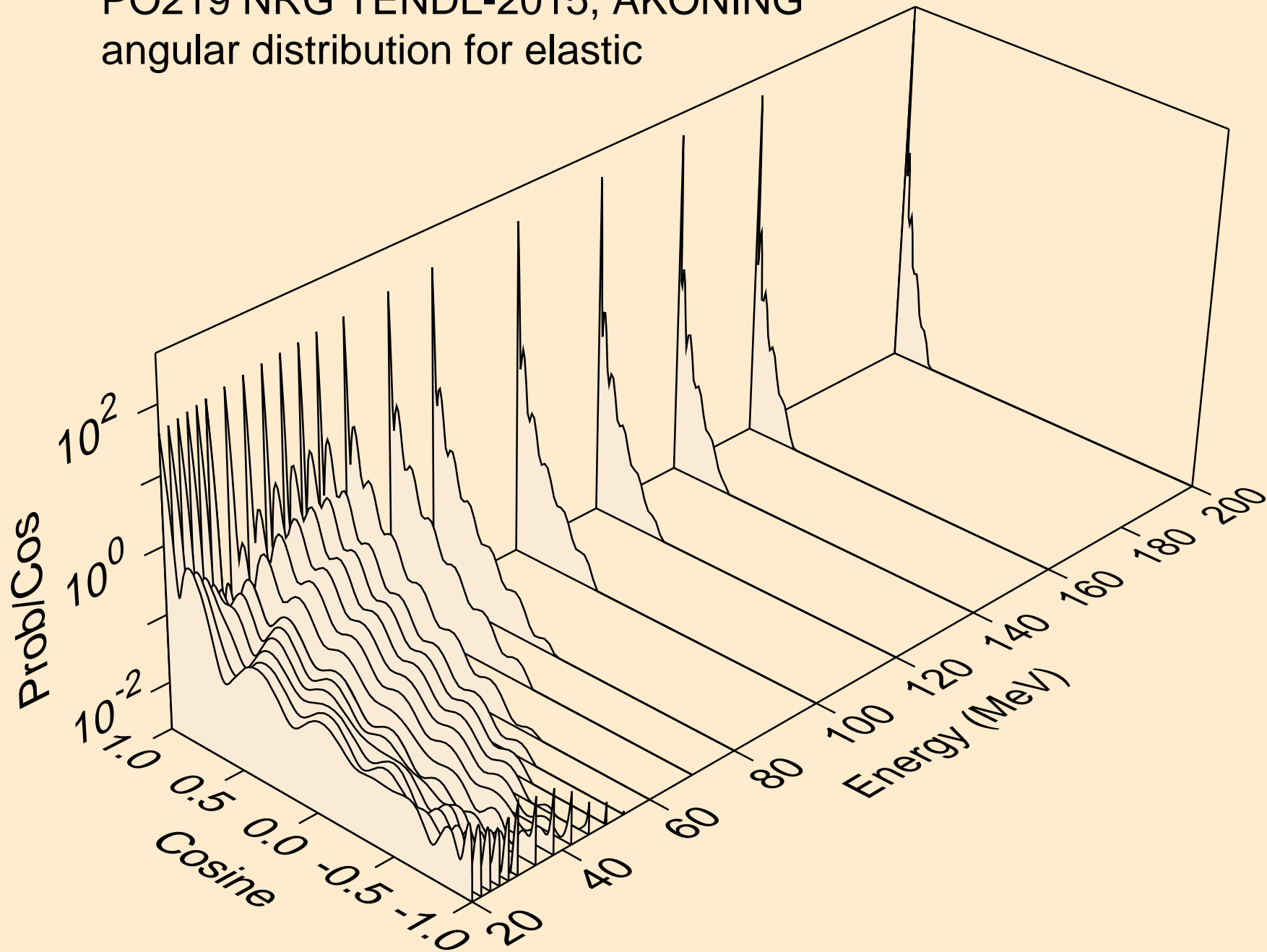

PO219 NRG TENDL-2015, AKONING  
angular distribution for (n,n\*1)

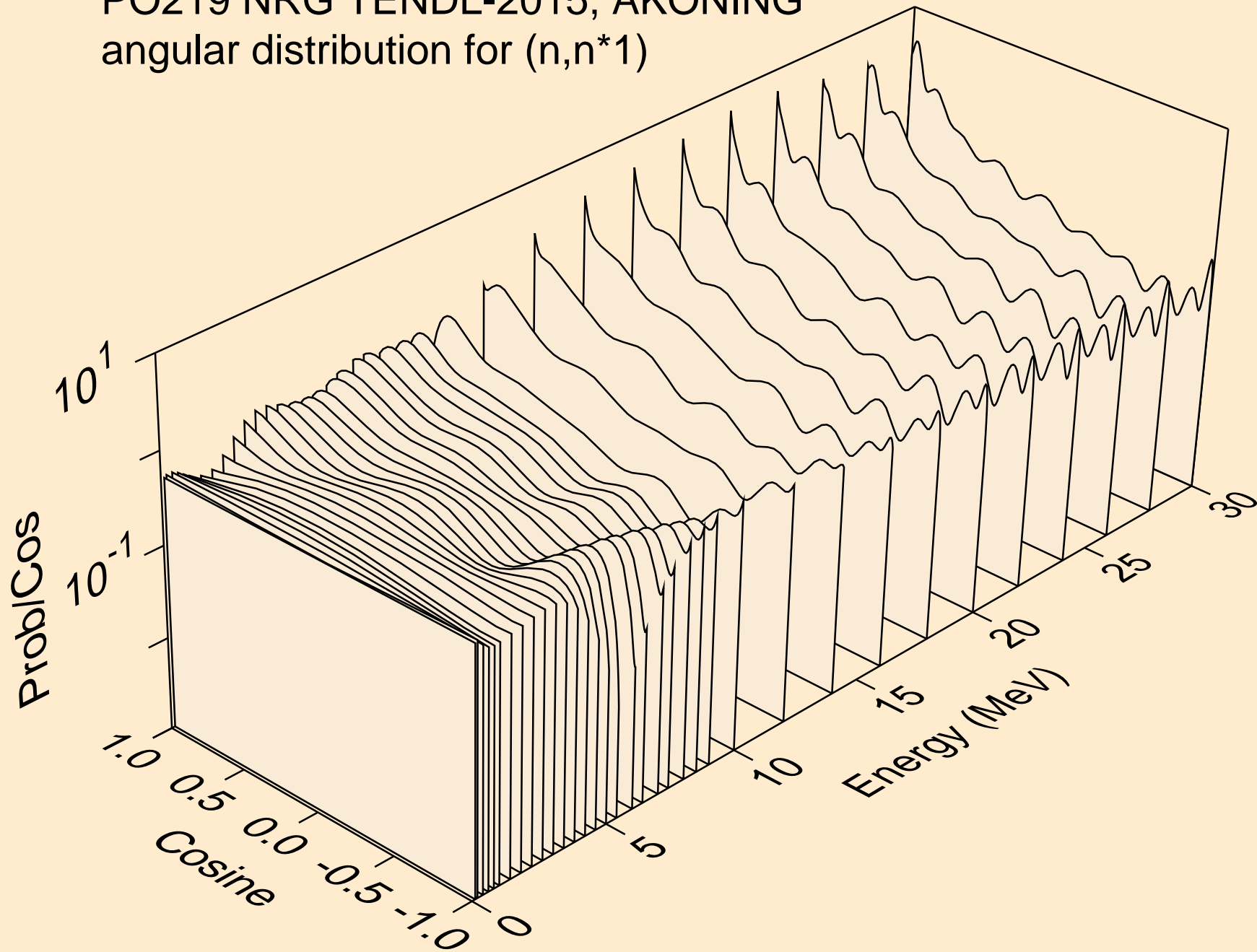

# PO219 NRG TENDL-2015, AKONING

Total fission nubar

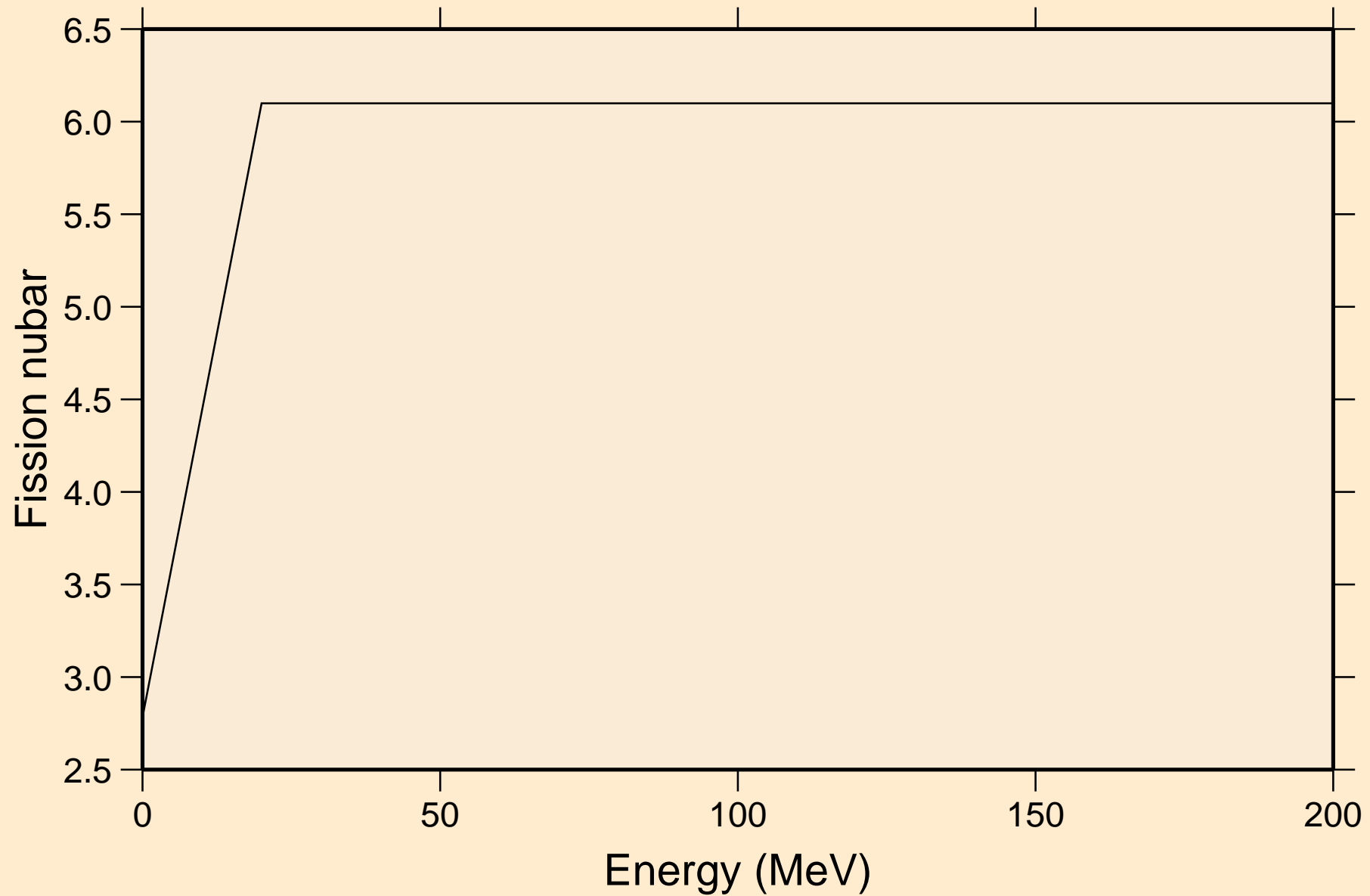

PO219 NRG TENDL-2015, AKONING  
Neutron emission for (n,x)

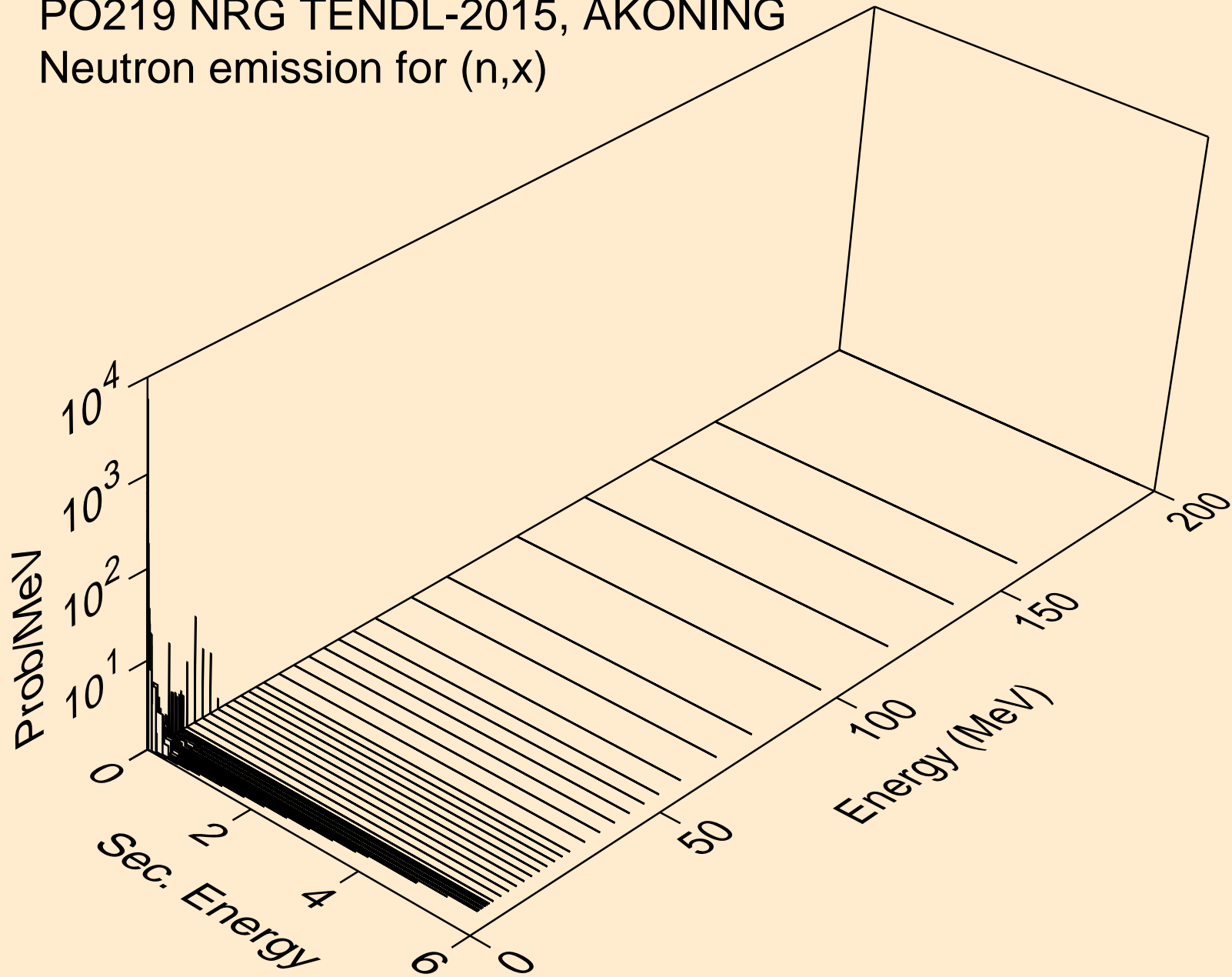

PO219 NRG TENDL-2015, AKONING  
Neutron emission for (n,2nd)

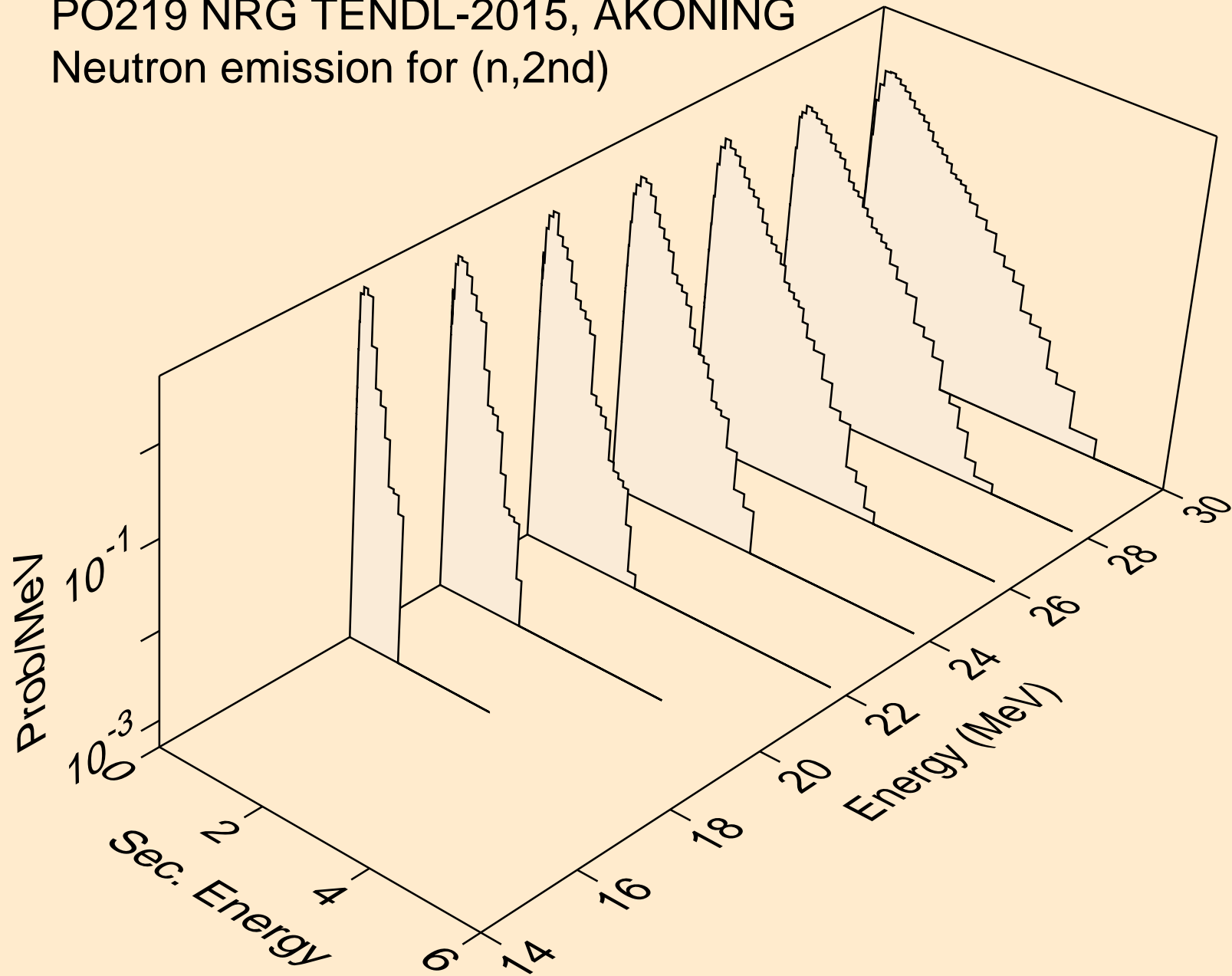

PO219 NRG TENDL-2015, AKONING  
Neutron emission for (n,2n)

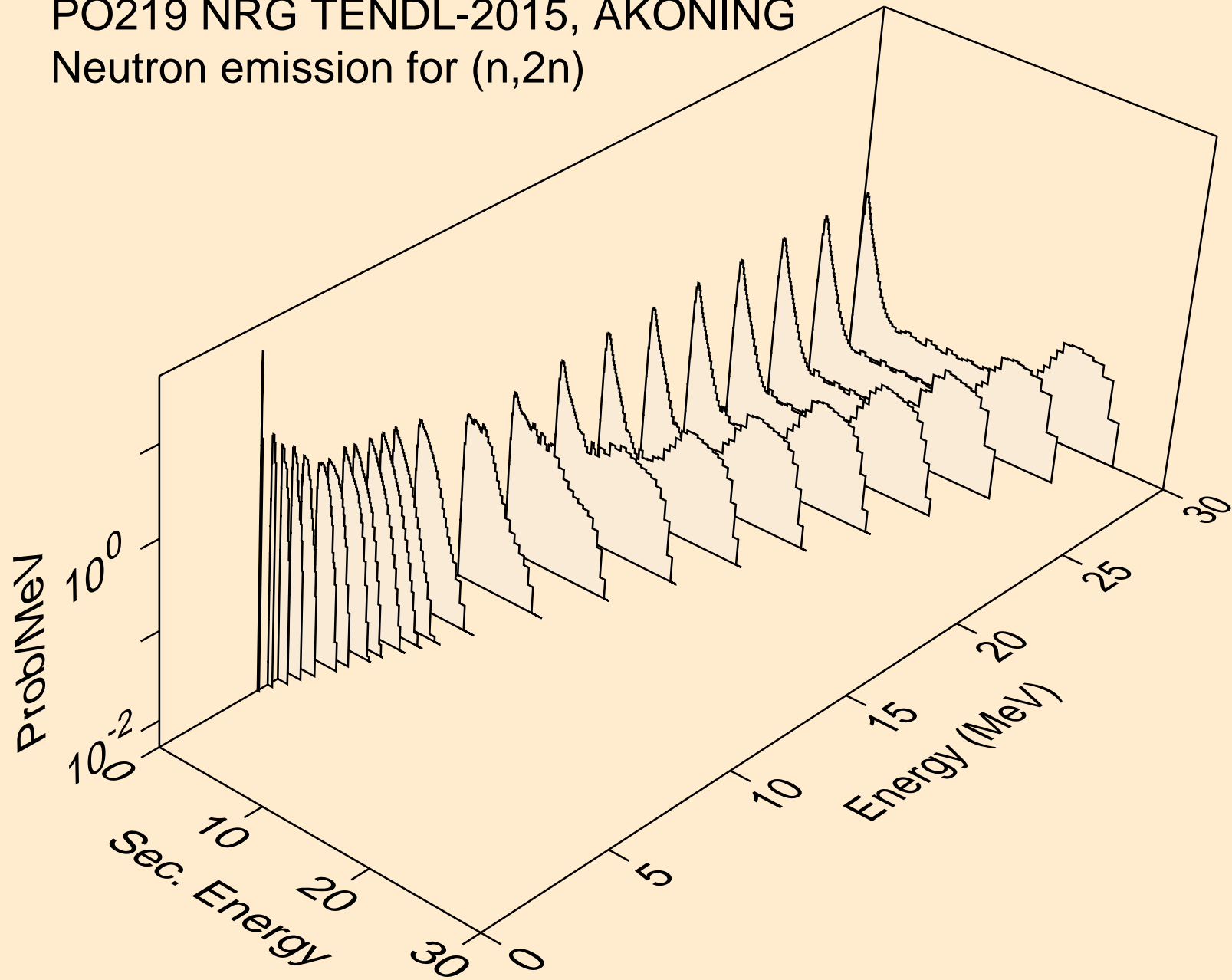



PO219 NRG TENDL-2015, AKONING  
Neutron emission for (n,3n)

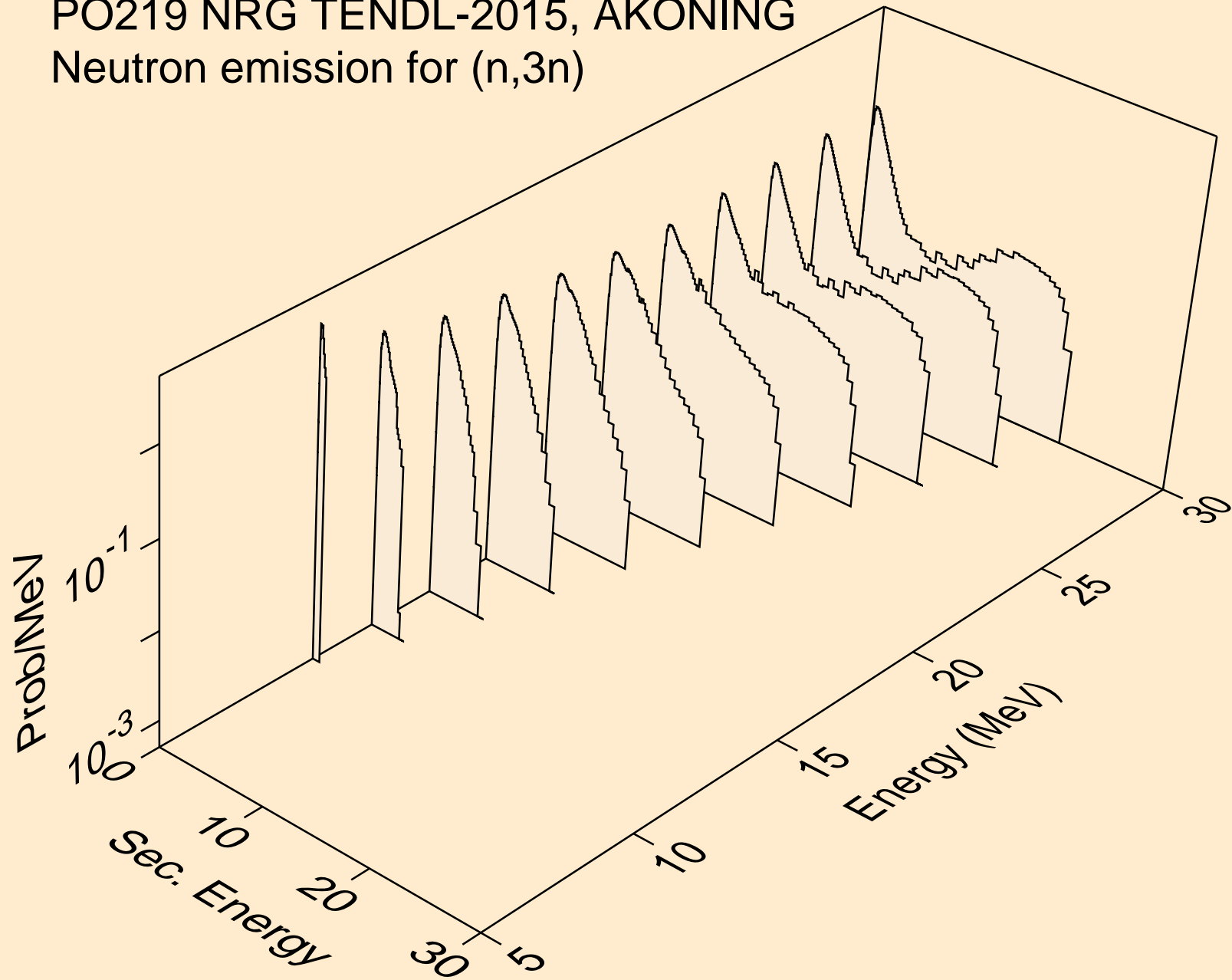

PO219 NRG TENDL-2015, AKONING  
Neutron emission for fission

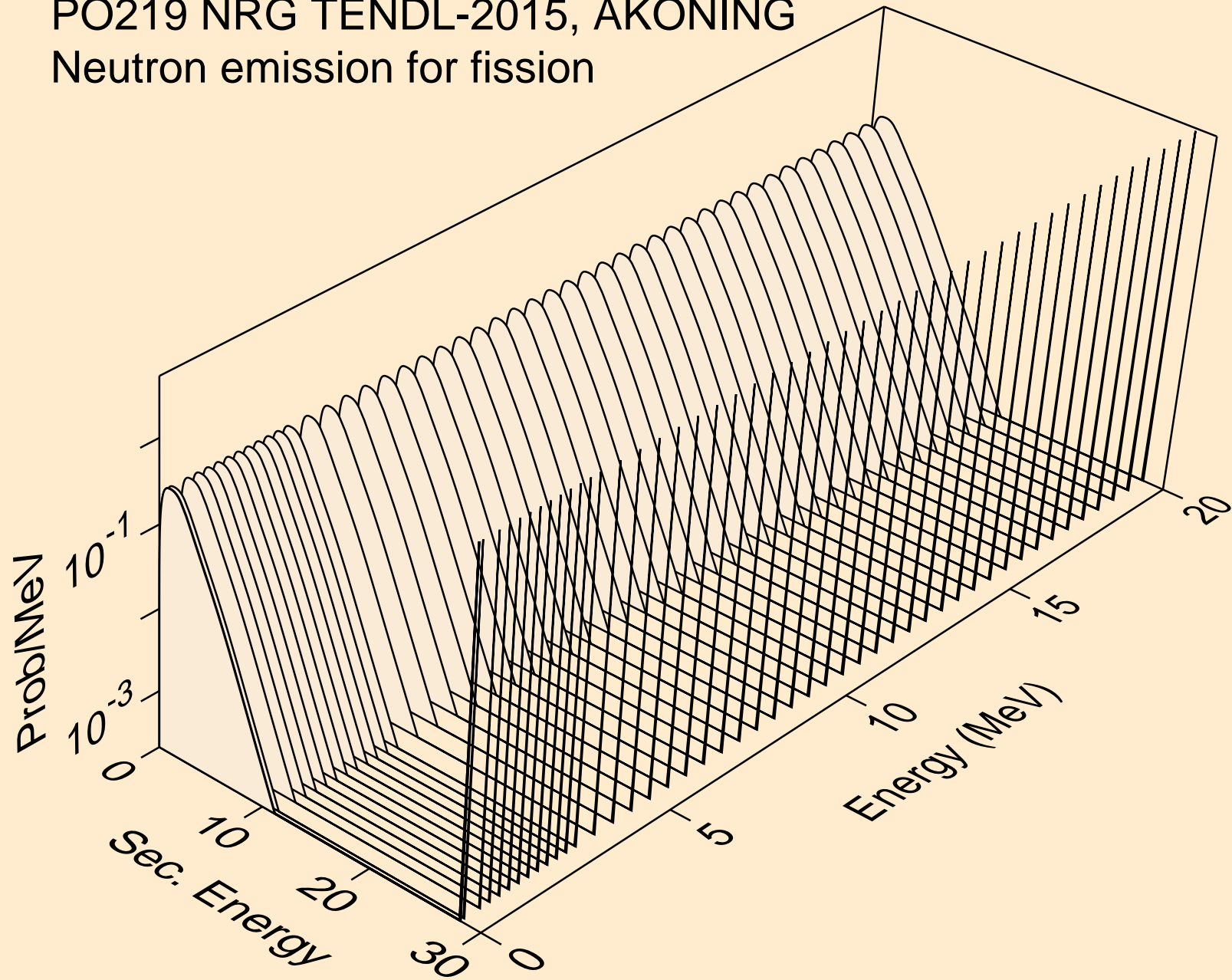

PO219 NRG TENDL-2015, AKONING  
Neutron emission for (n,n\*)a

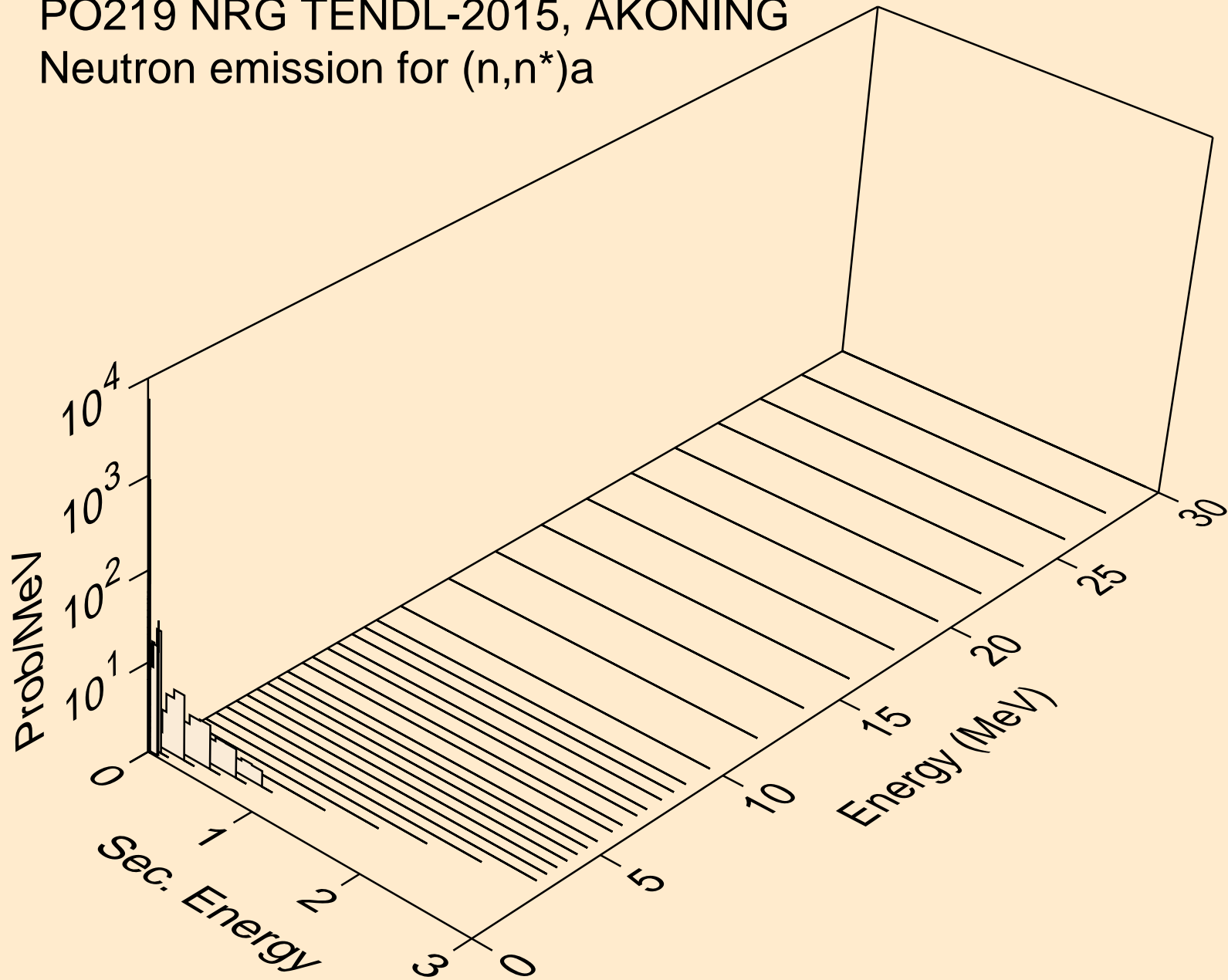

PO219 NRG TENDL-2015, AKONING  
Neutron emission for (n,2n)a

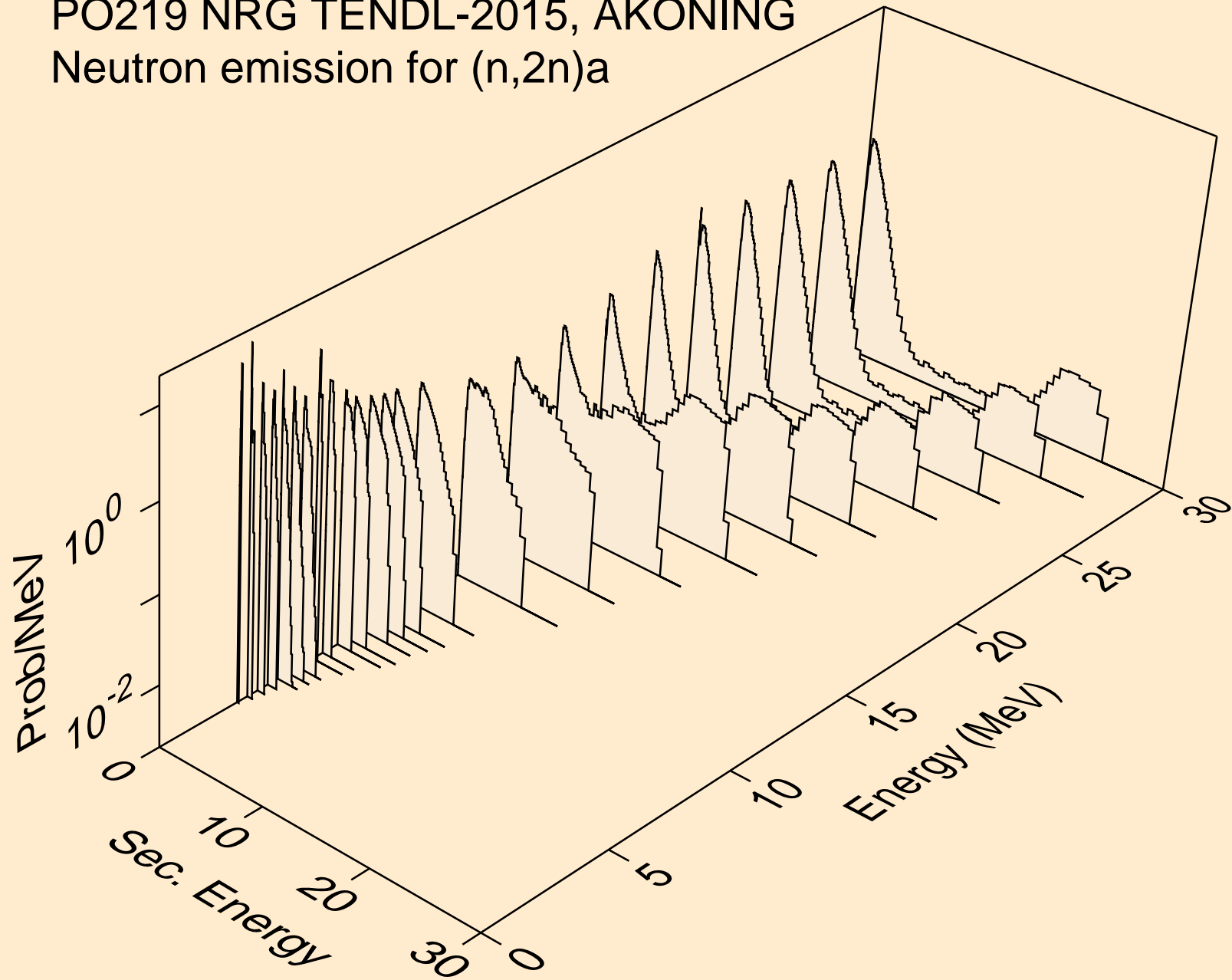

PO219 NRG TENDL-2015, AKONING  
Neutron emission for (n,3n)a

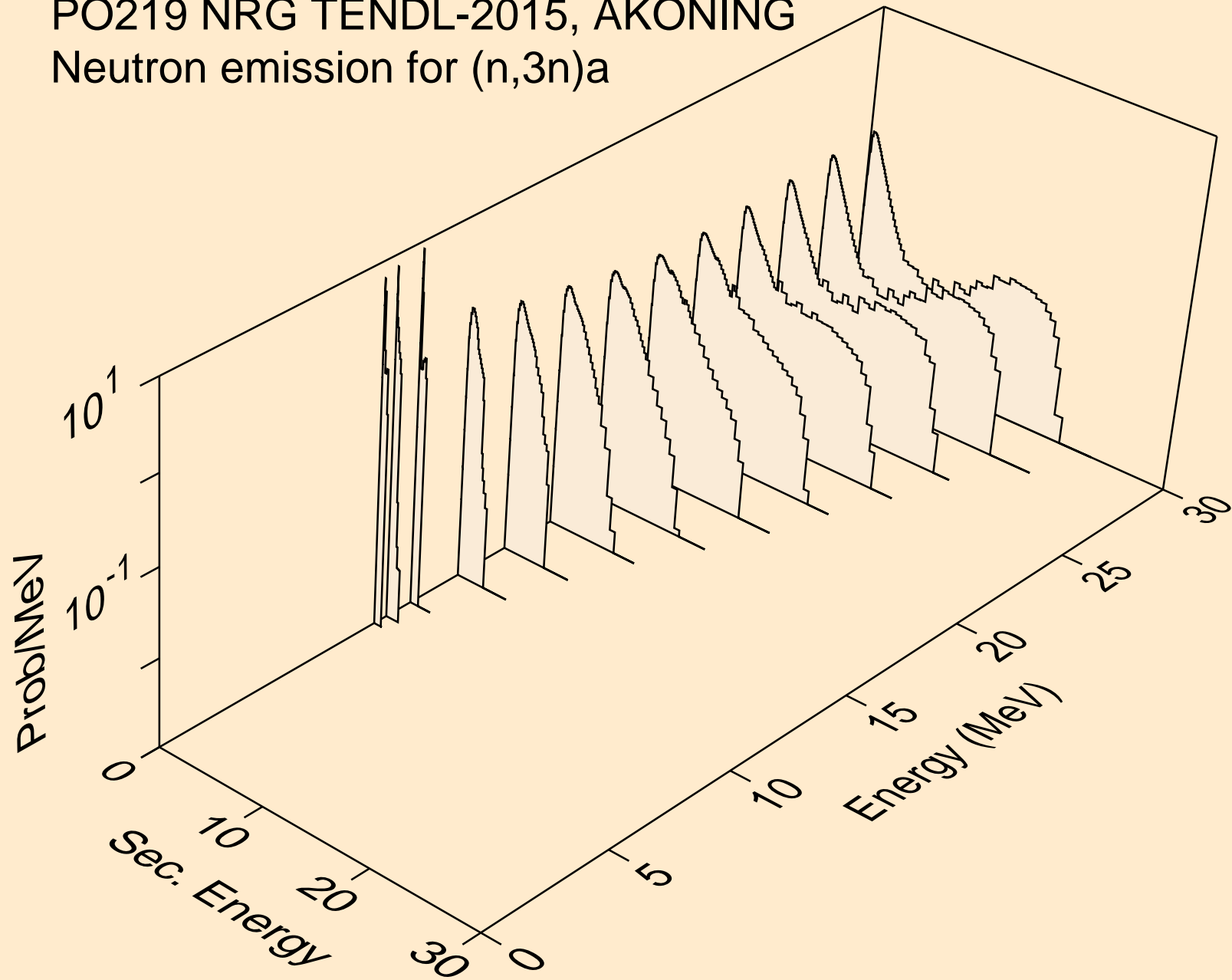

PO219 NRG TENDL-2015, AKONING  
Neutron emission for (n,n\*)p

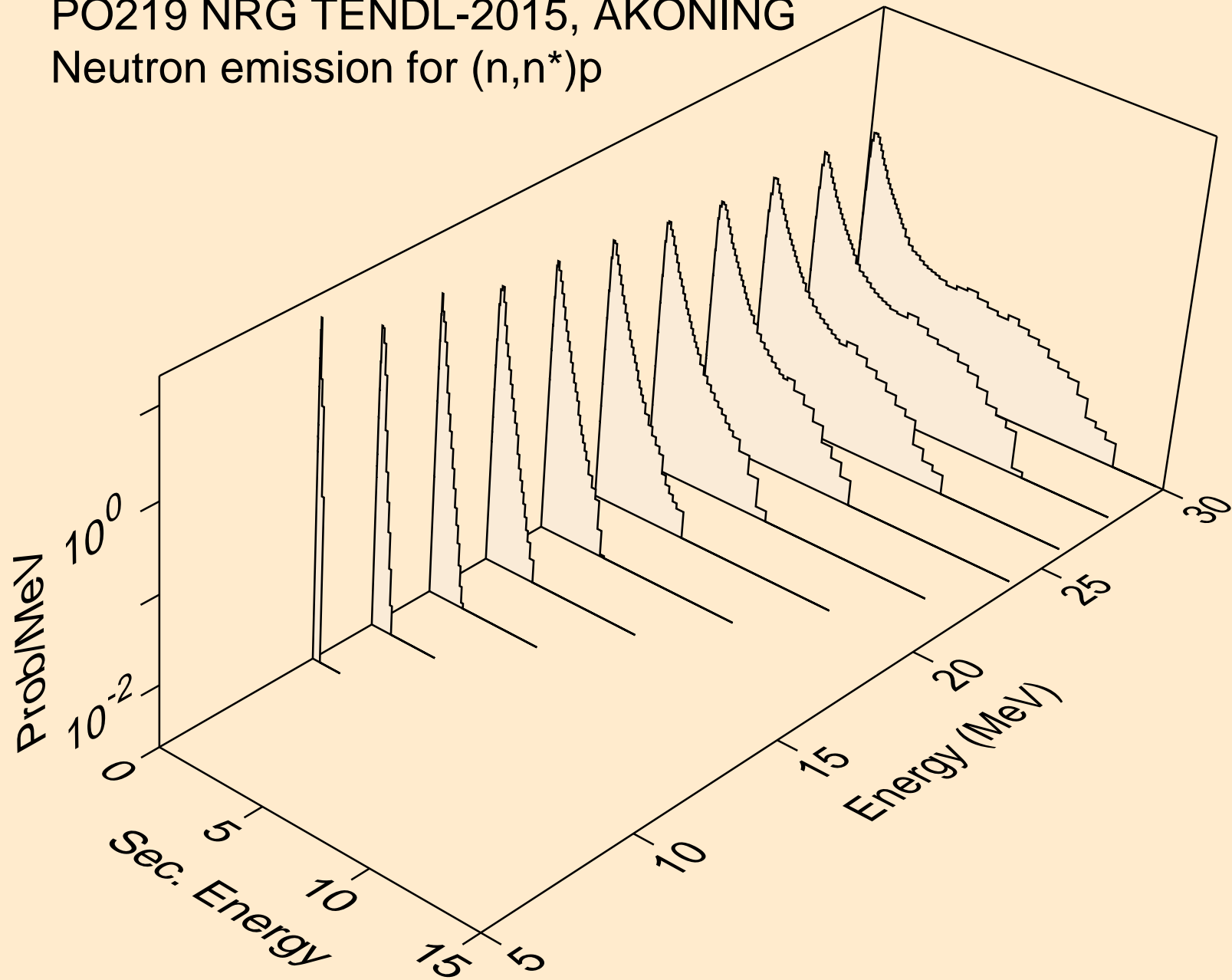

PO219 NRG TENDL-2015, AKONING  
Neutron emission for (n,n\*)d

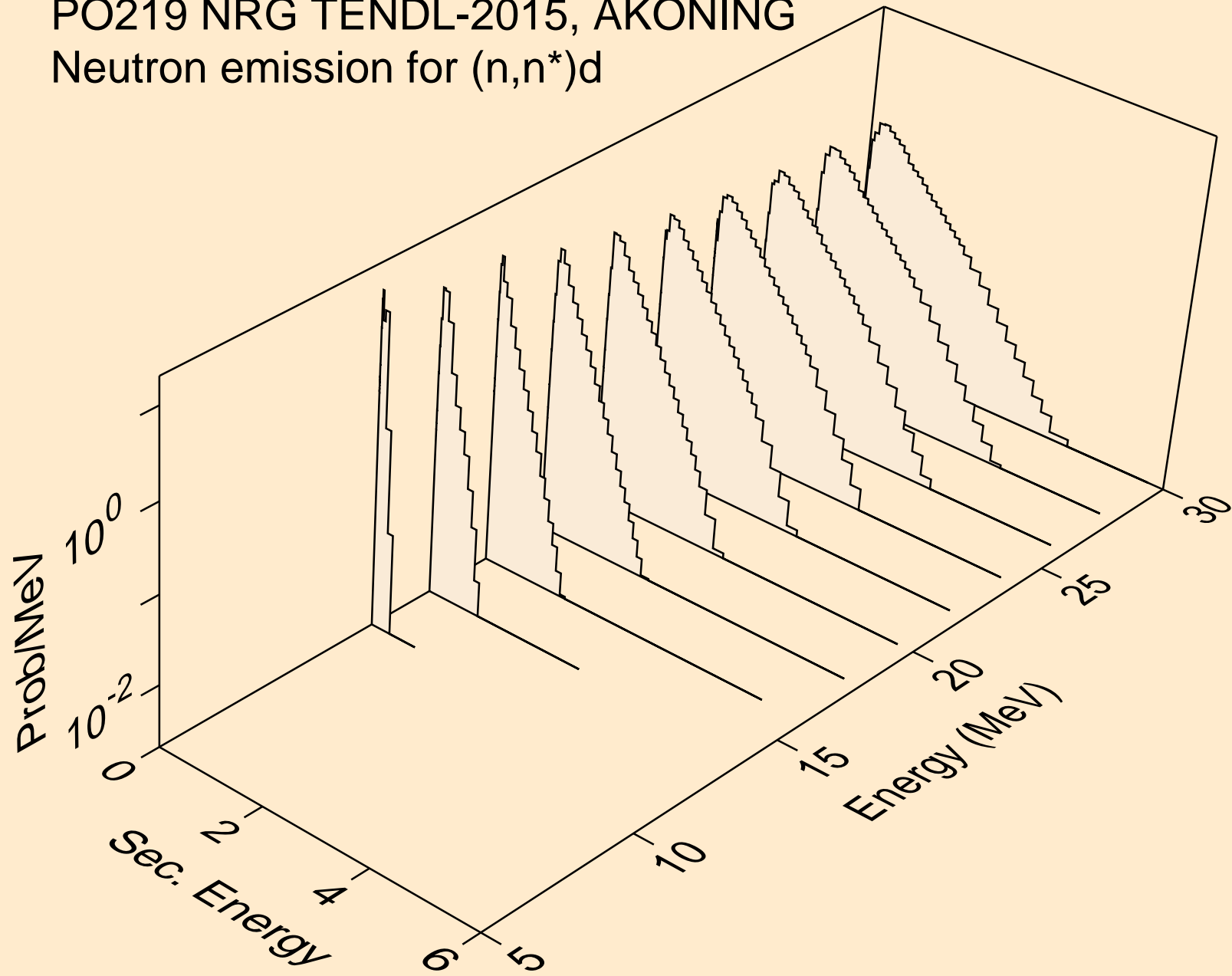

PO219 NRG TENDL-2015, AKONING  
Neutron emission for (n,n\*)t

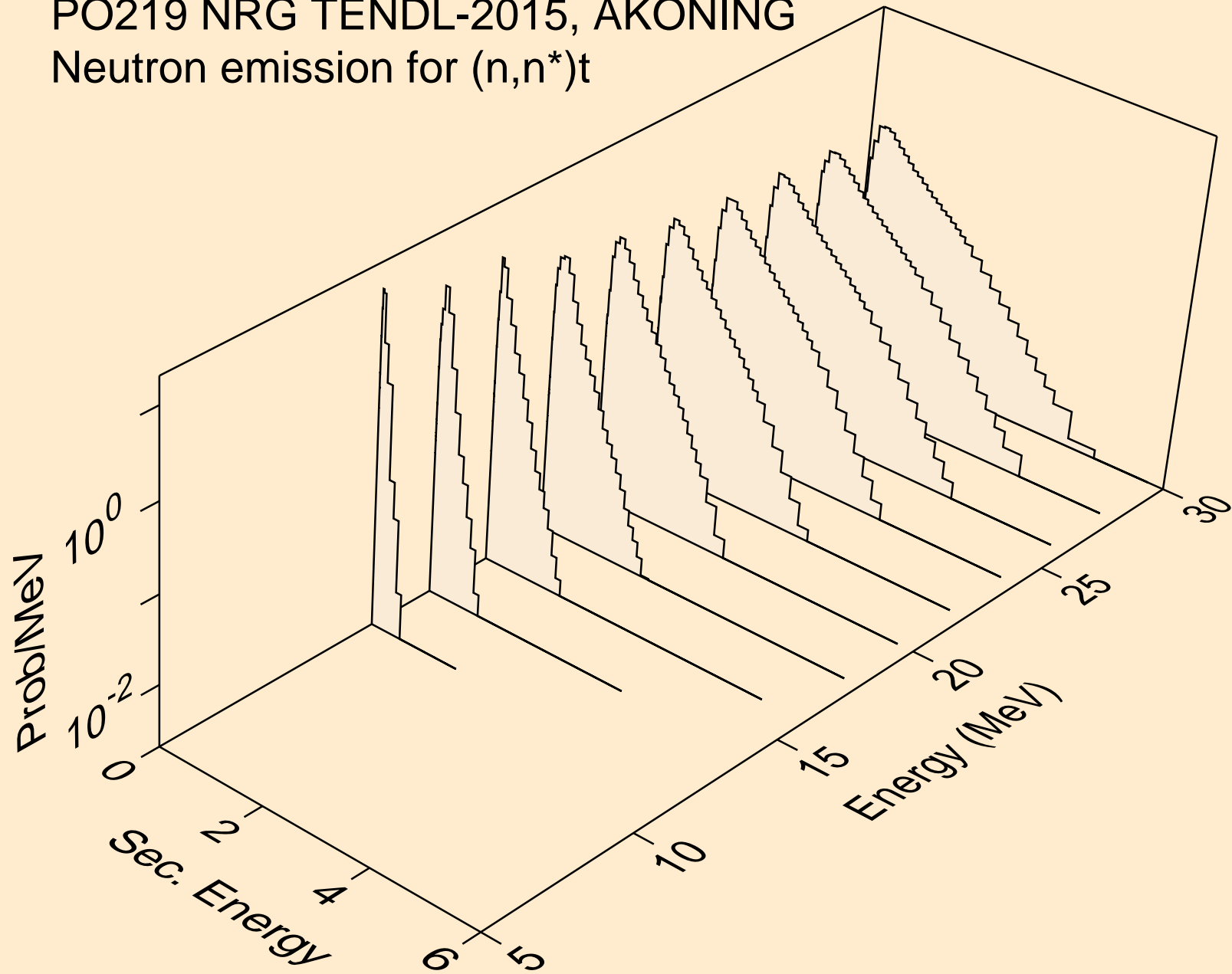



PO219 NRG TENDL-2015, AKONING  
Neutron emission for (n,n\*)he3

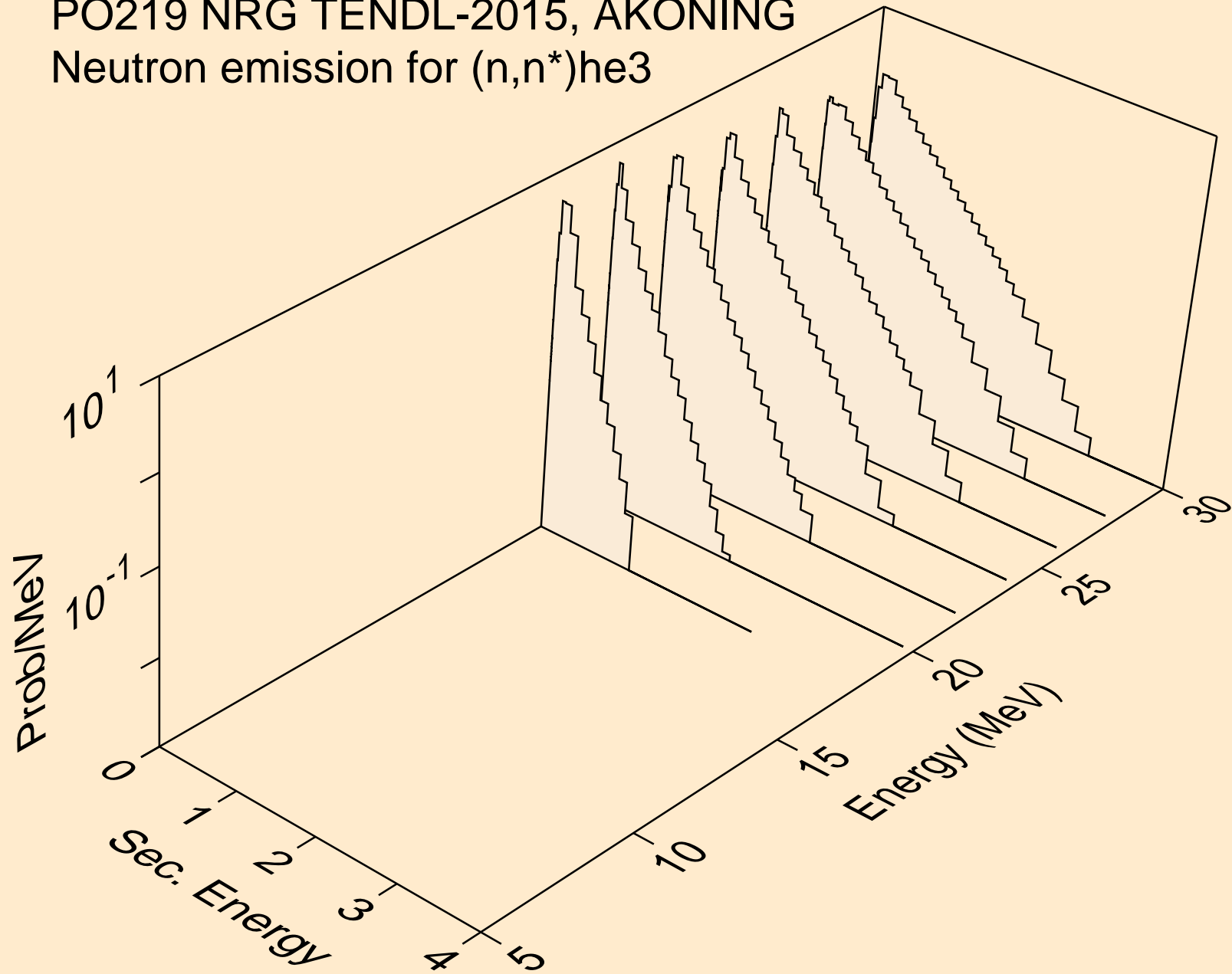

PO219 NRG TENDL-2015, AKONING  
Neutron emission for (n,4n)

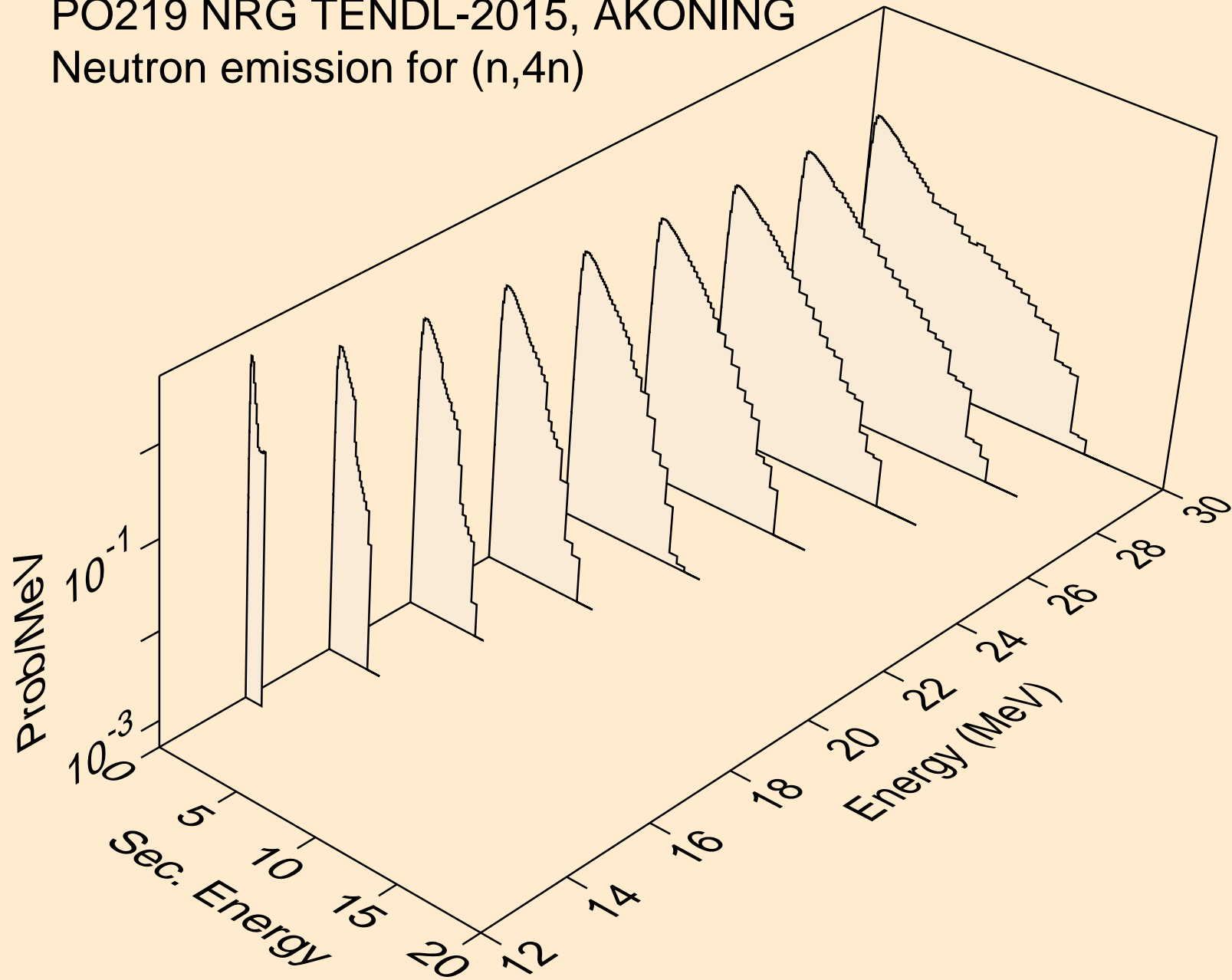

PO219 NRG TENDL-2015, AKONING  
Neutron emission for (n,2np)

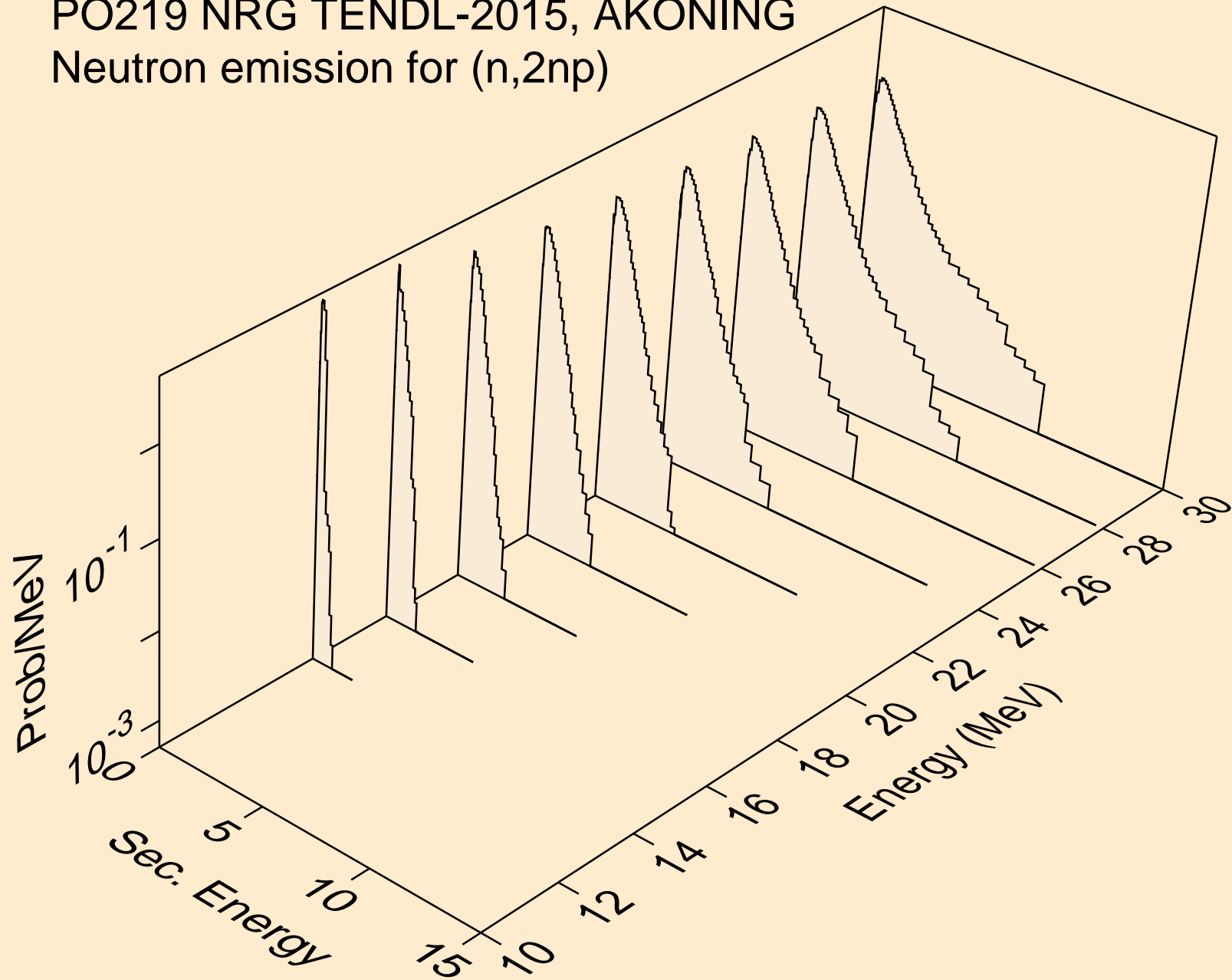

PO219 NRG TENDL-2015, AKONING  
Neutron emission for (n,3np)

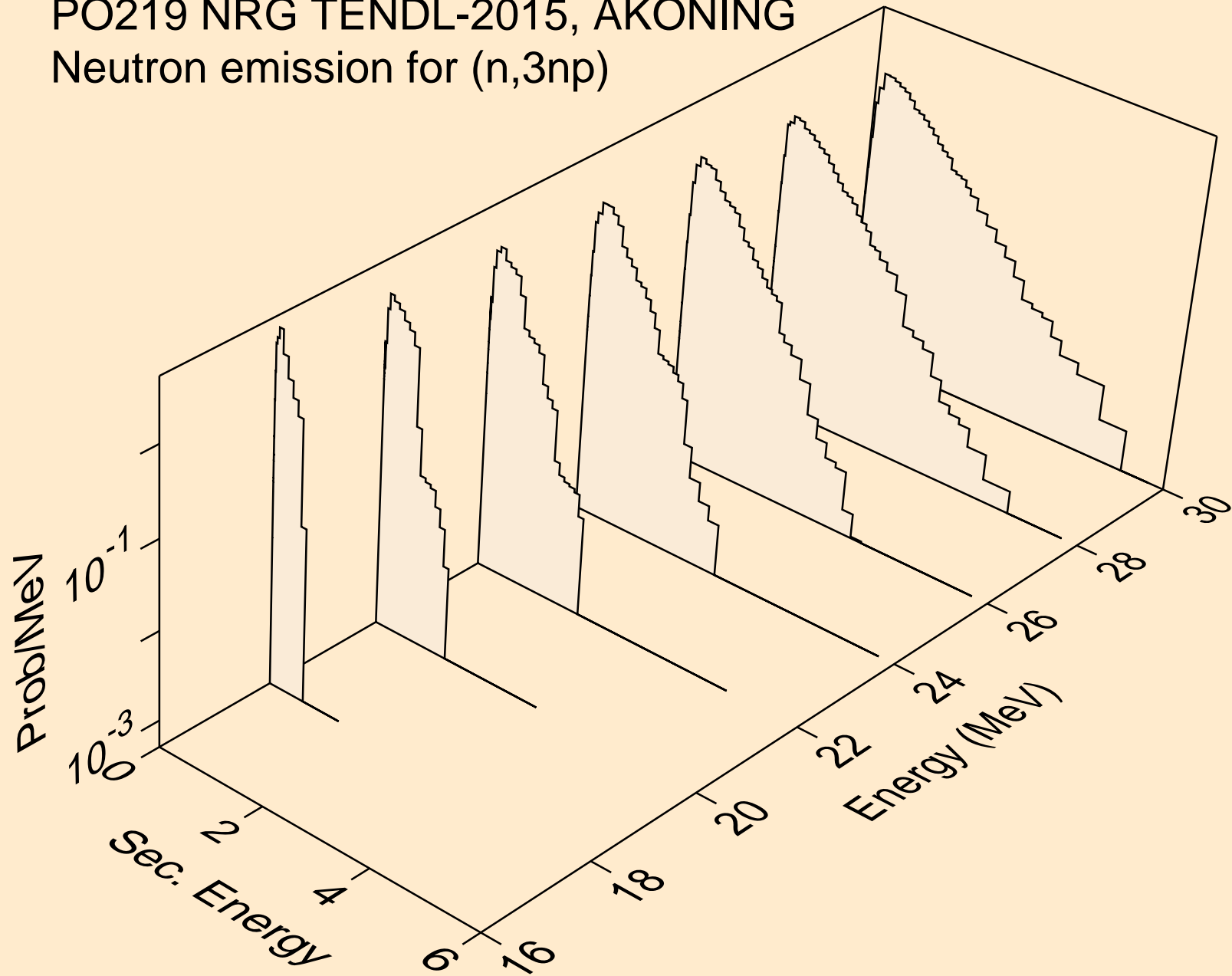

PO219 NRG TENDL-2015, AKONING  
Neutron emission for (n,2np)

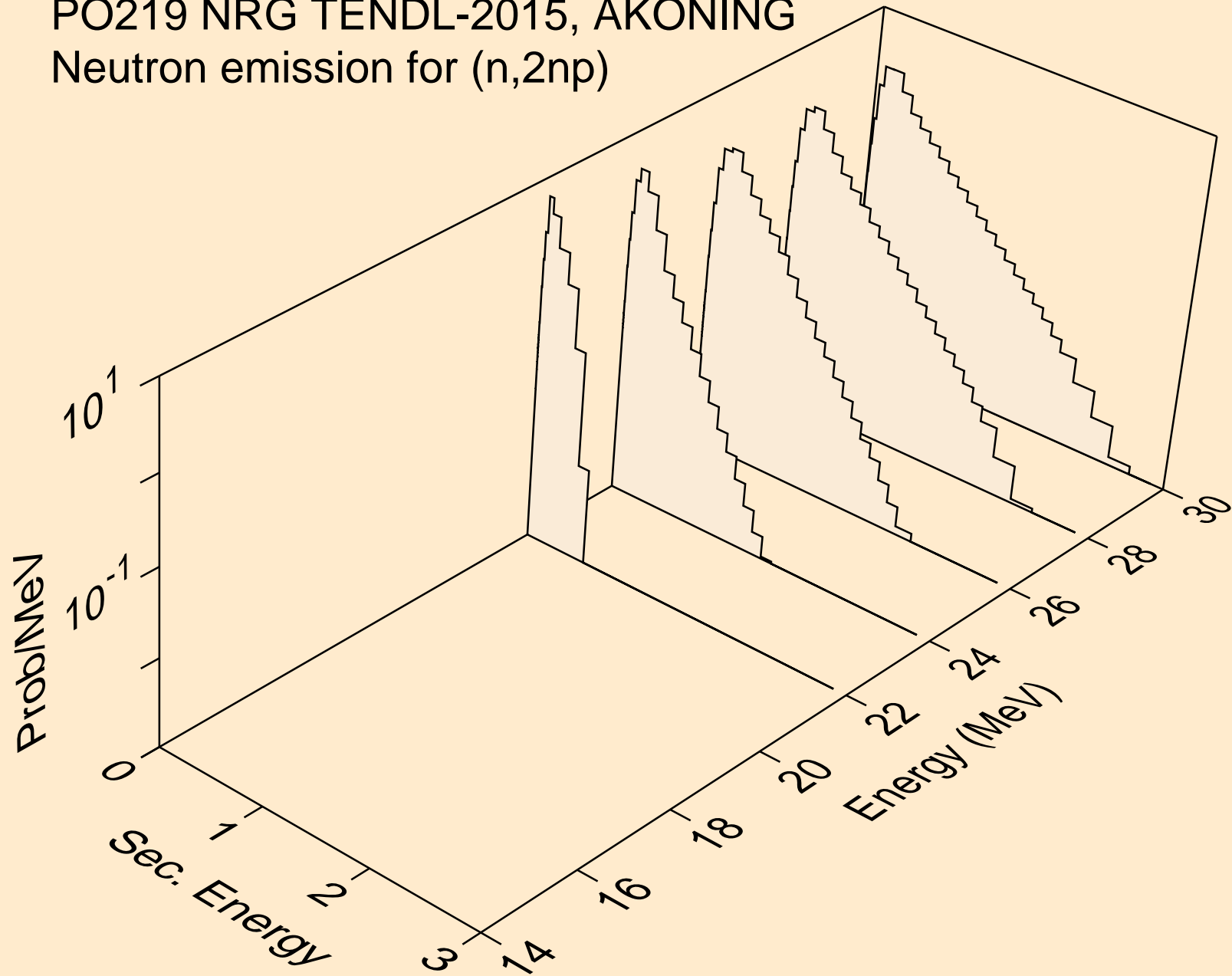

PO219 NRG TENDL-2015, AKONING  
Neutron emission for (n,n\*c)

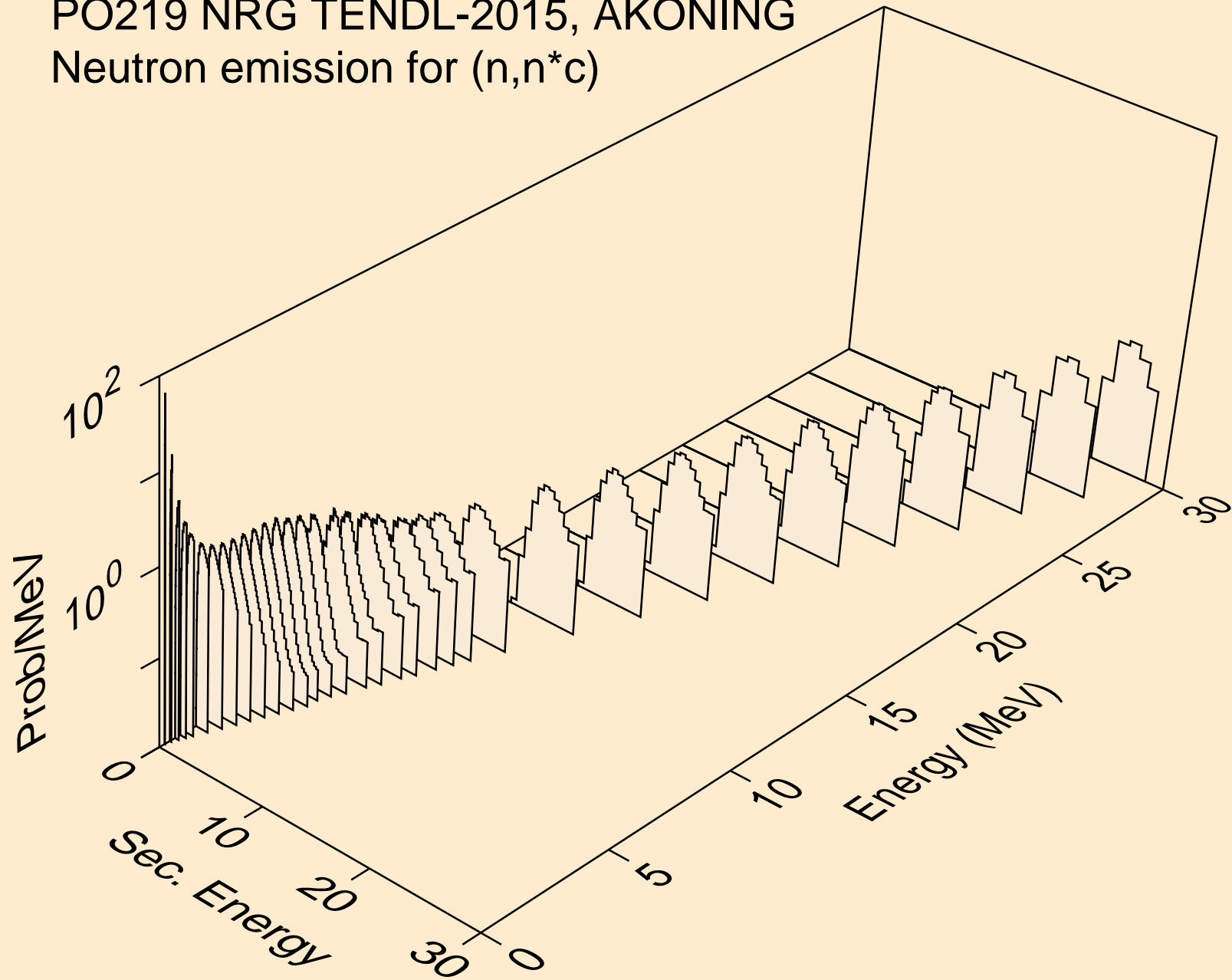

# PO219 NRG TENDL-2015, AKONING

## Delayed nubar

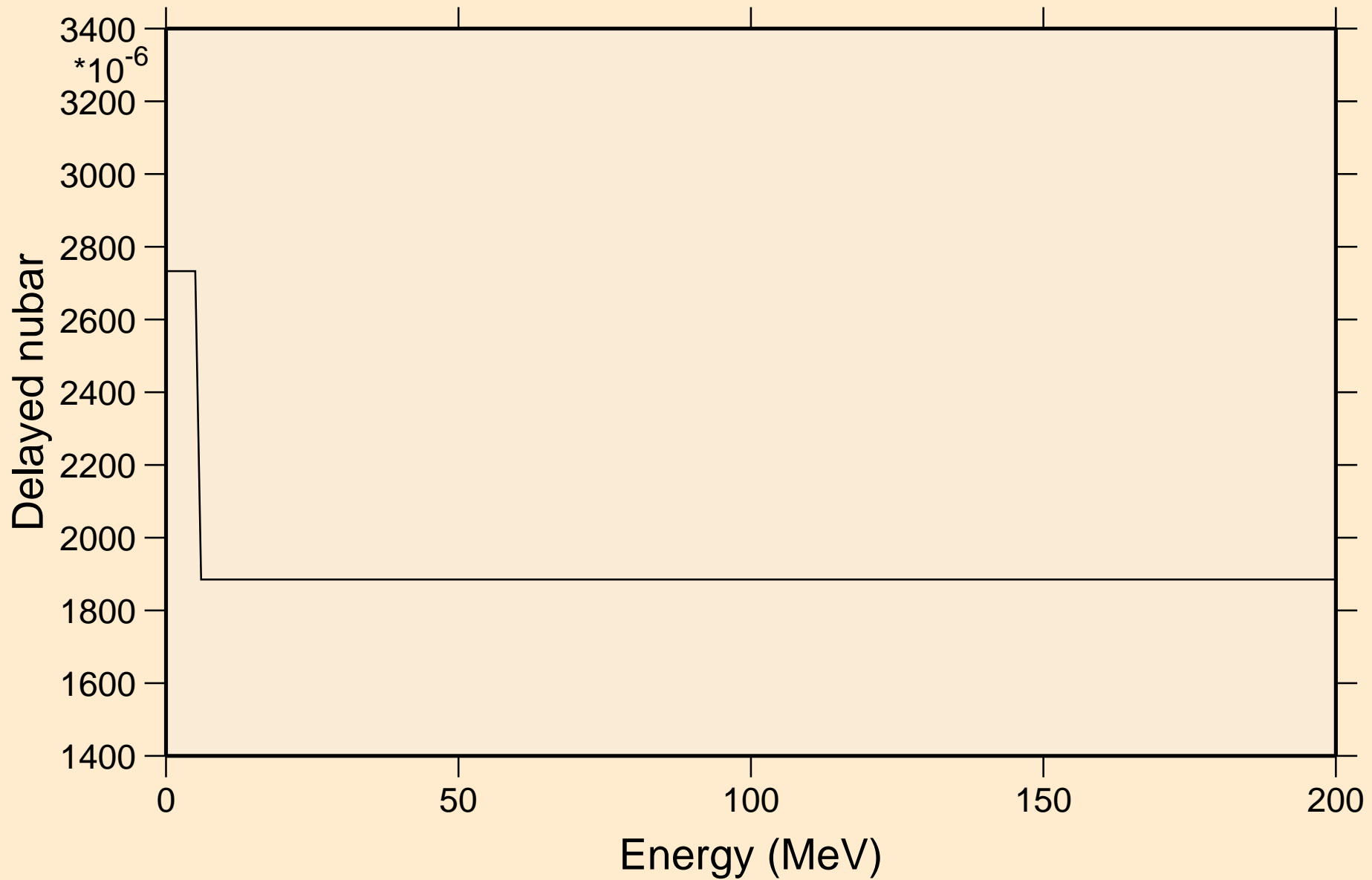

# PO219 NRG TENDL-2015, AKONING

## Delayed neutron spectra

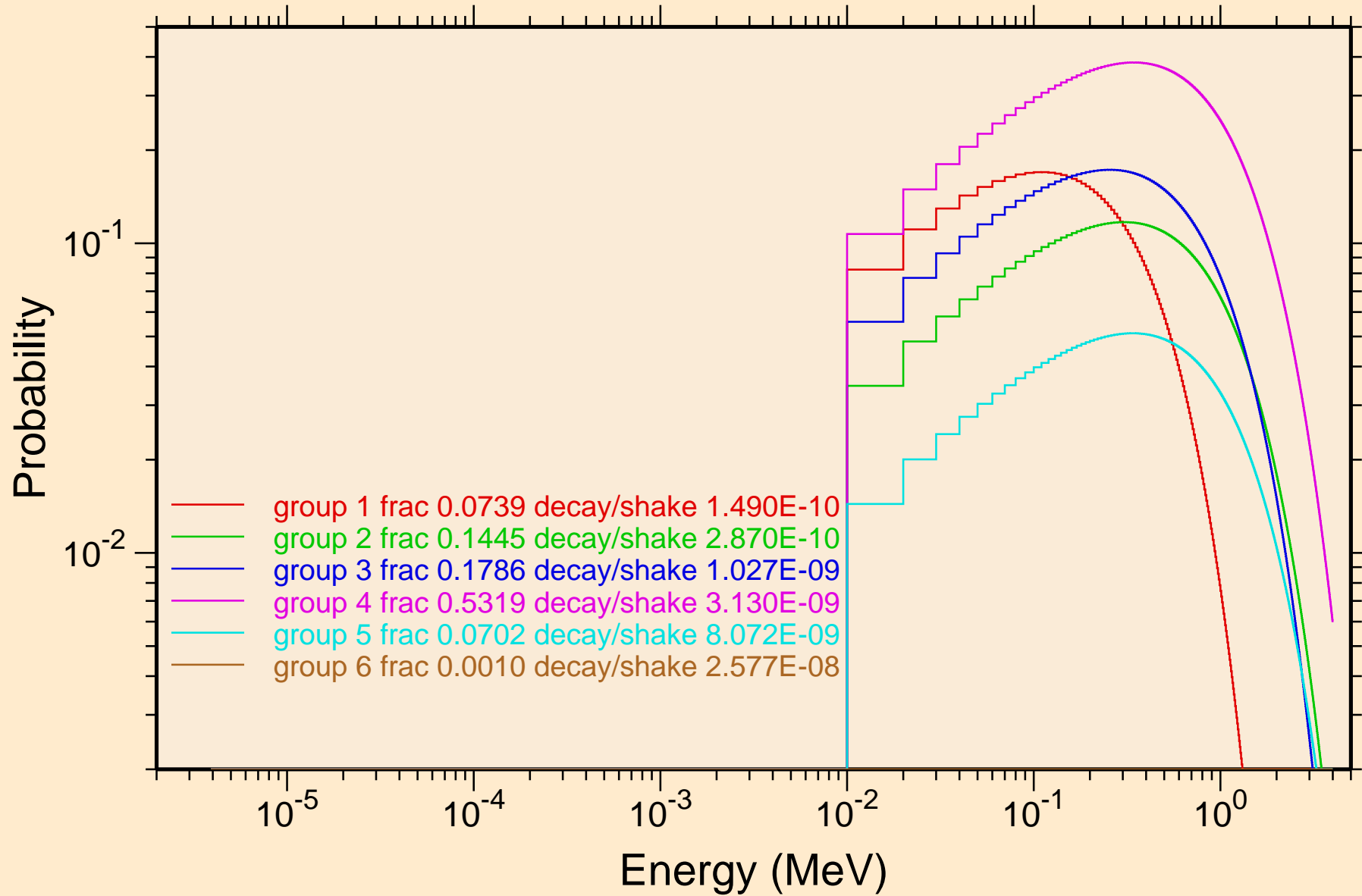



PO219 NRG TENDL-2015, AKONING  
Photon emission for (n,x)

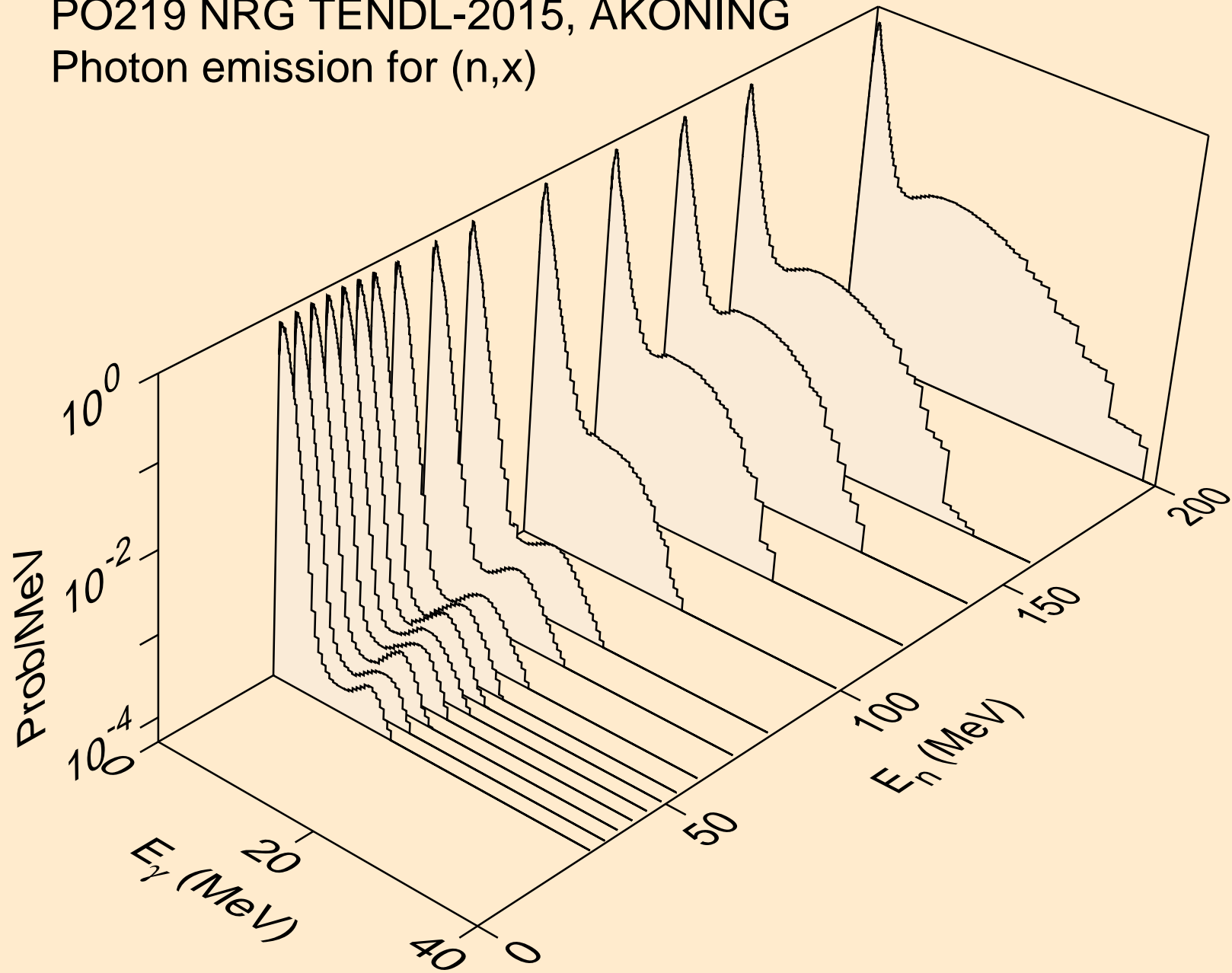

PO219 NRG TENDL-2015, AKONING  
Photon emission for (n,2nd)

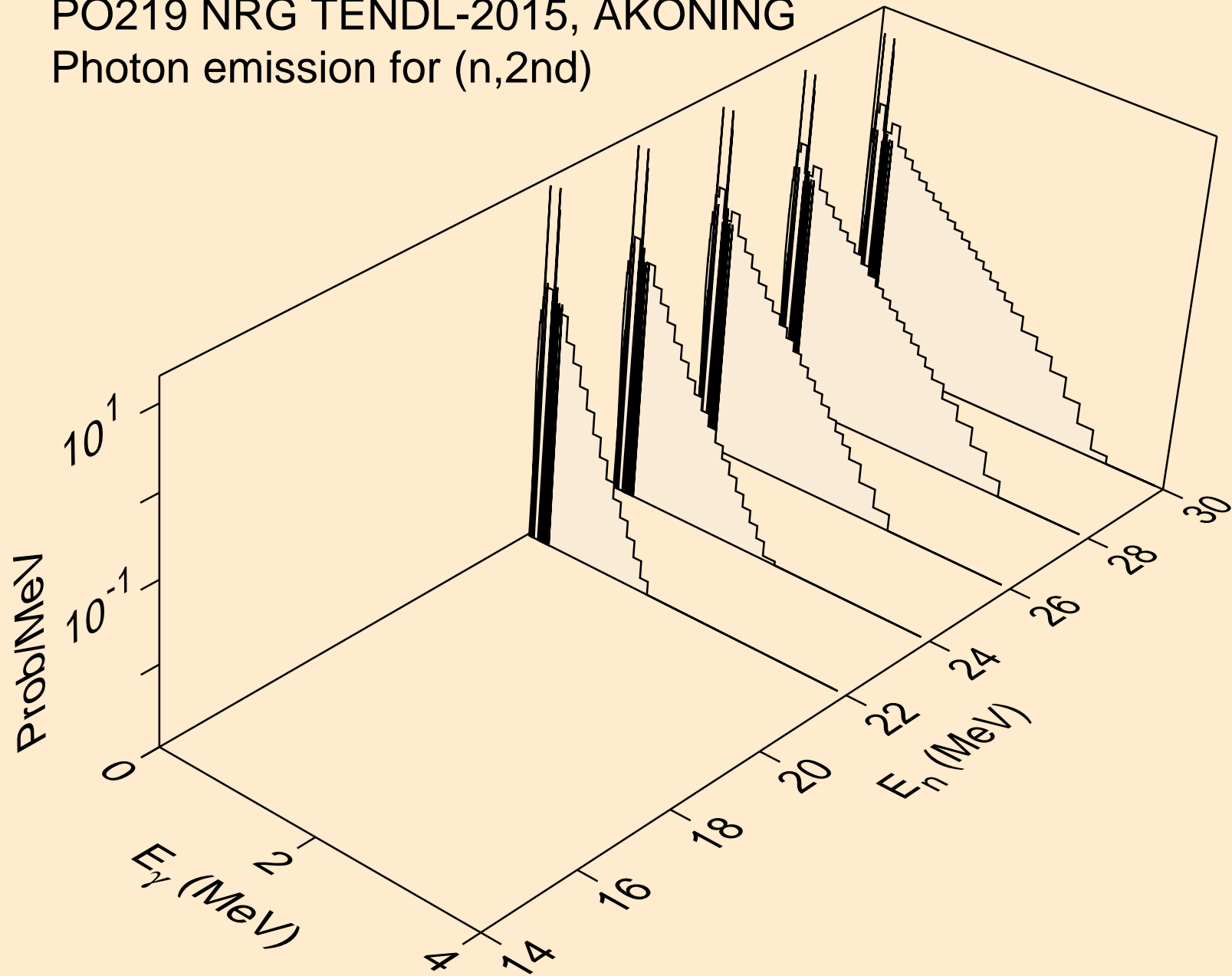

PO219 NRG TENDL-2015, AKONING  
Photon emission for (n,2n)

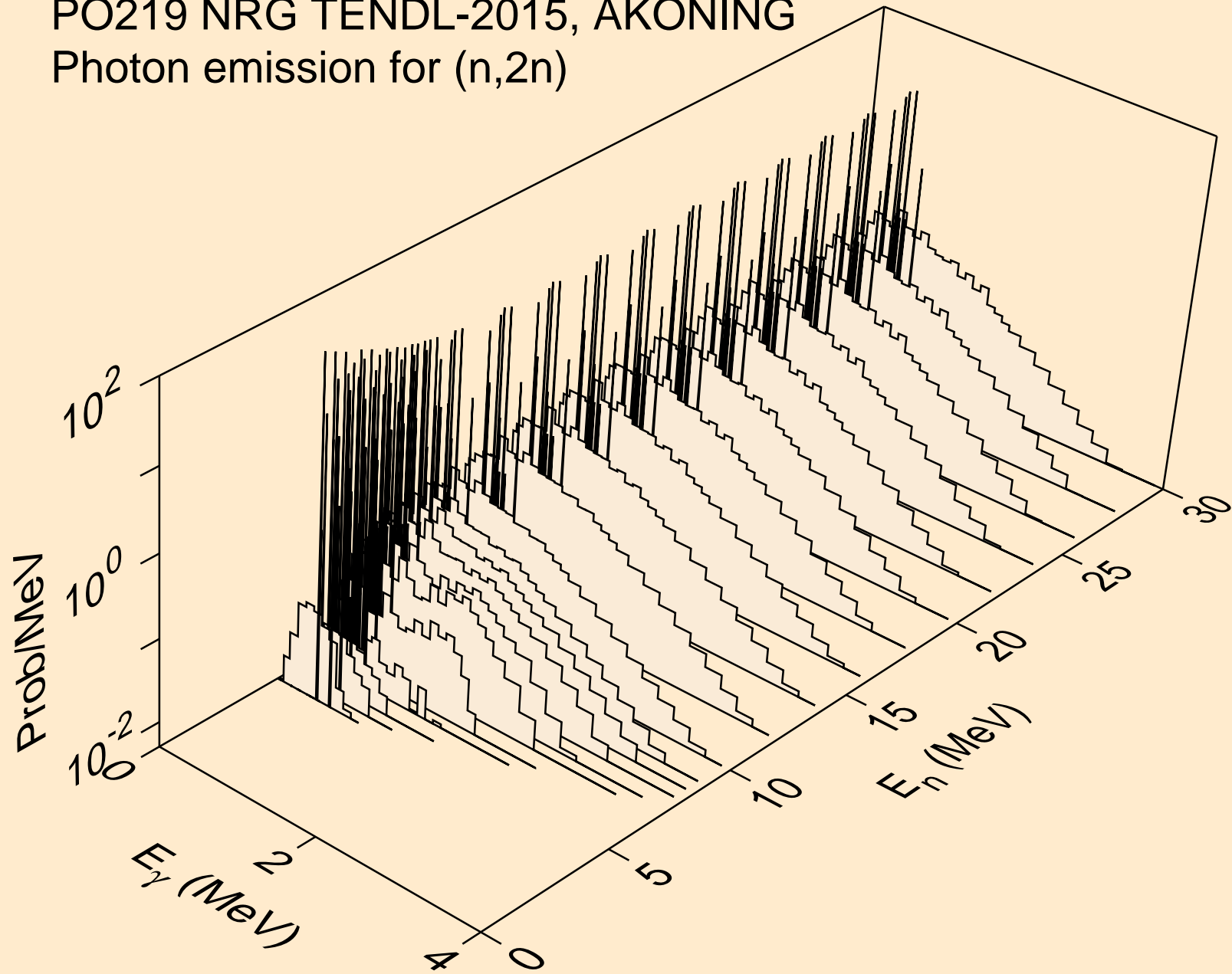

PO219 NRG TENDL-2015, AKONING  
Photon emission for (n,3n)

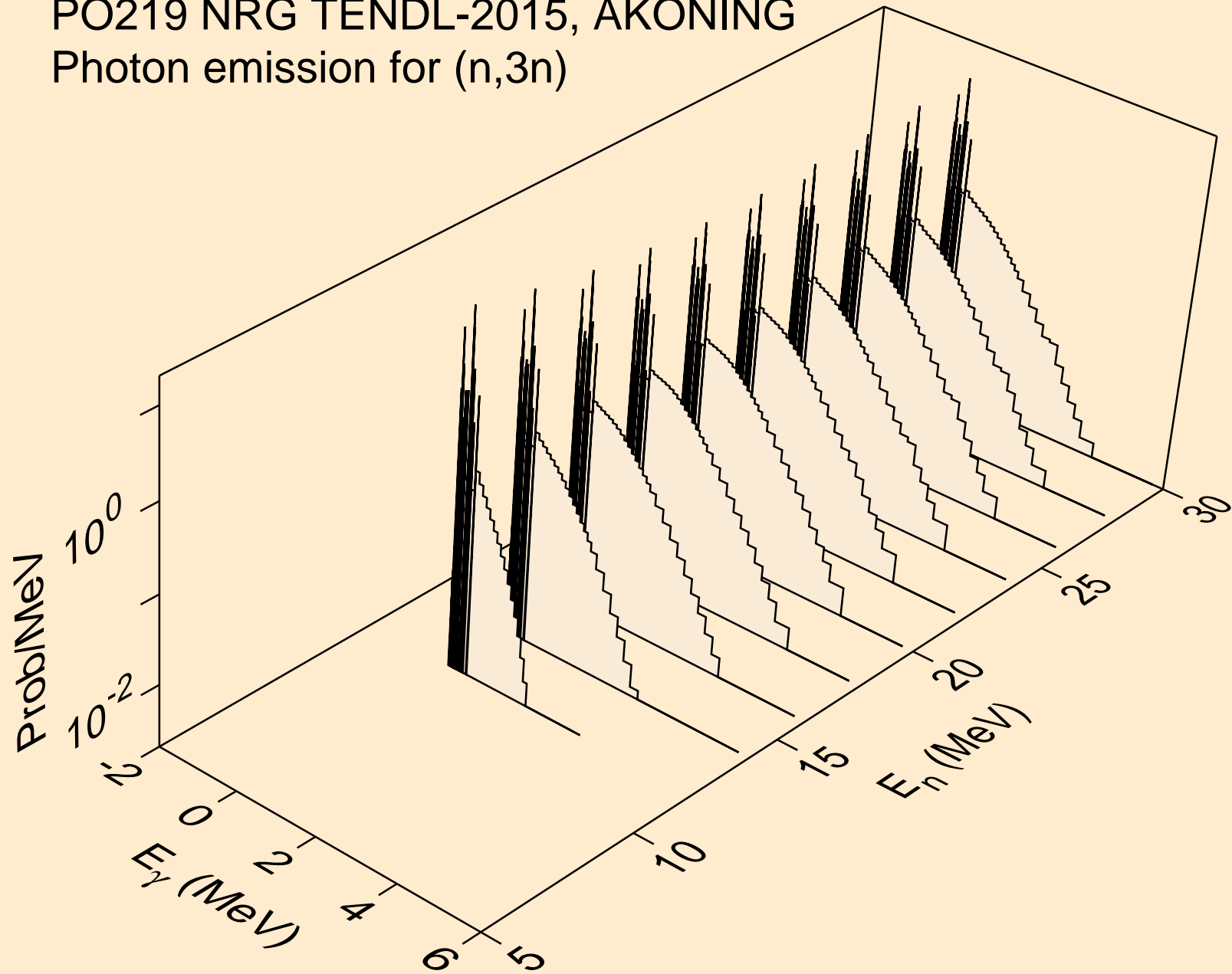

PO219 NRG TENDL-2015, AKONING  
Photon emission for (n,n\*)a

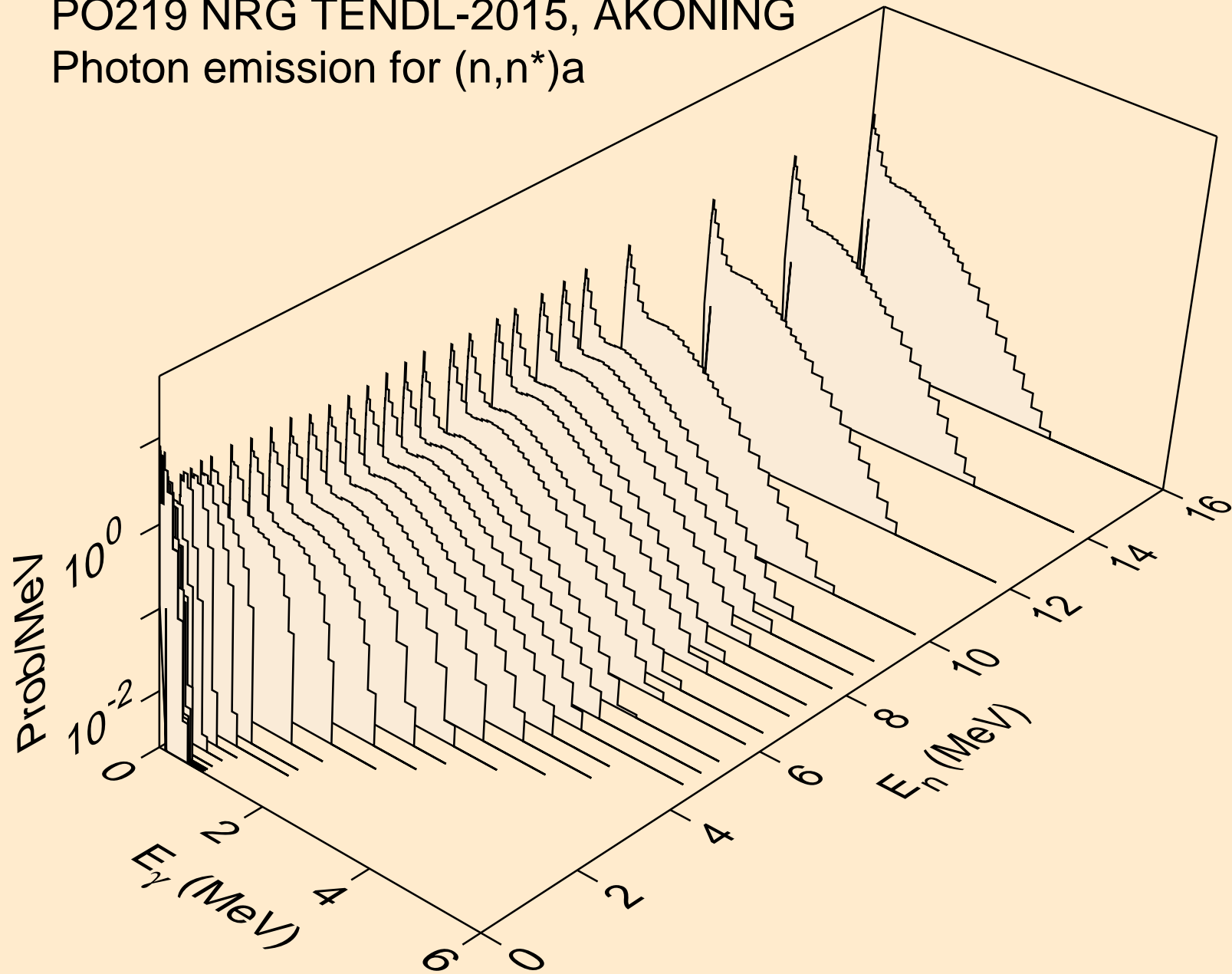

PO219 NRG TENDL-2015, AKONING  
Photon emission for (n,2n)a

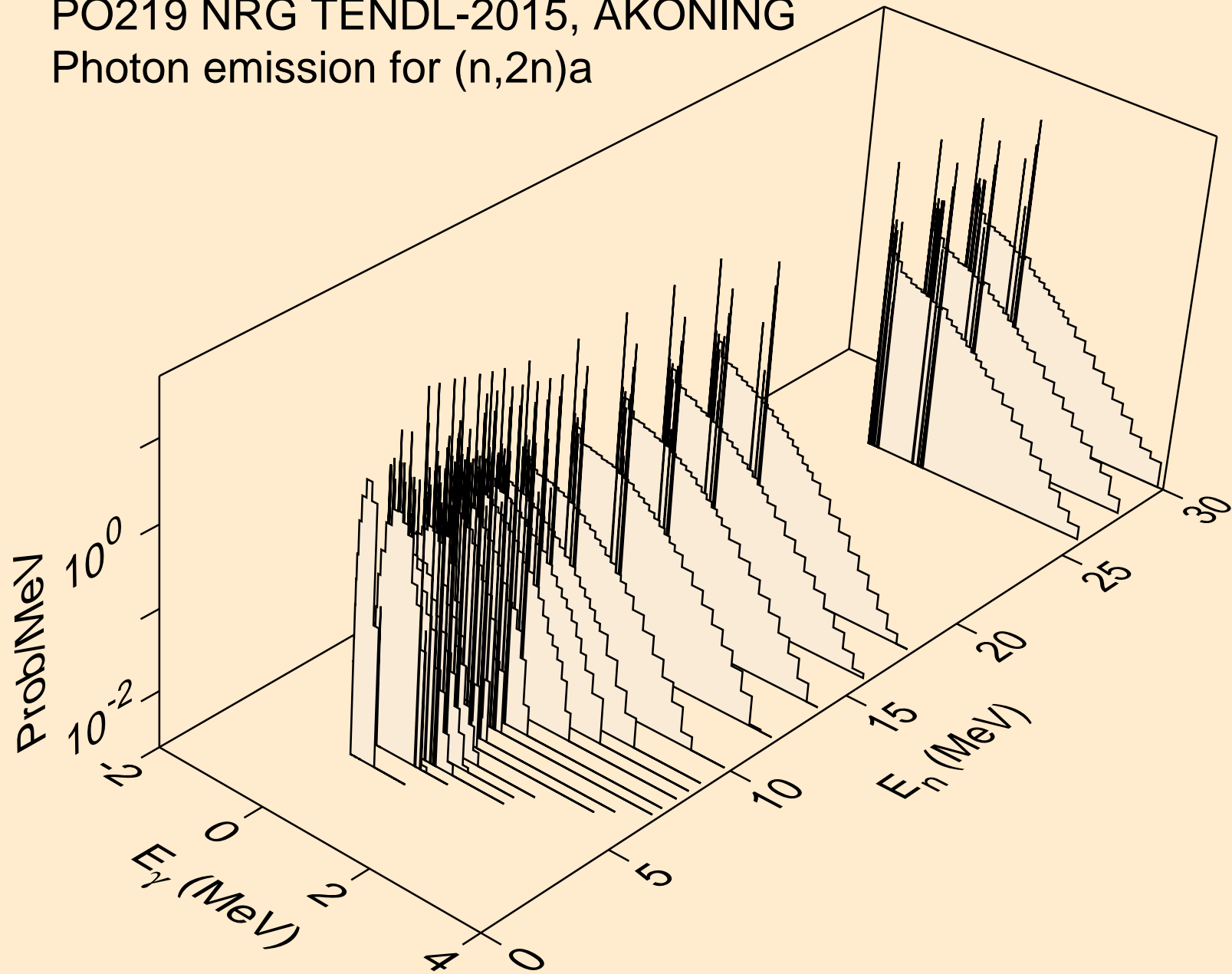

PO219 NRG TENDL-2015, AKONING  
Photon emission for (n,3n)a

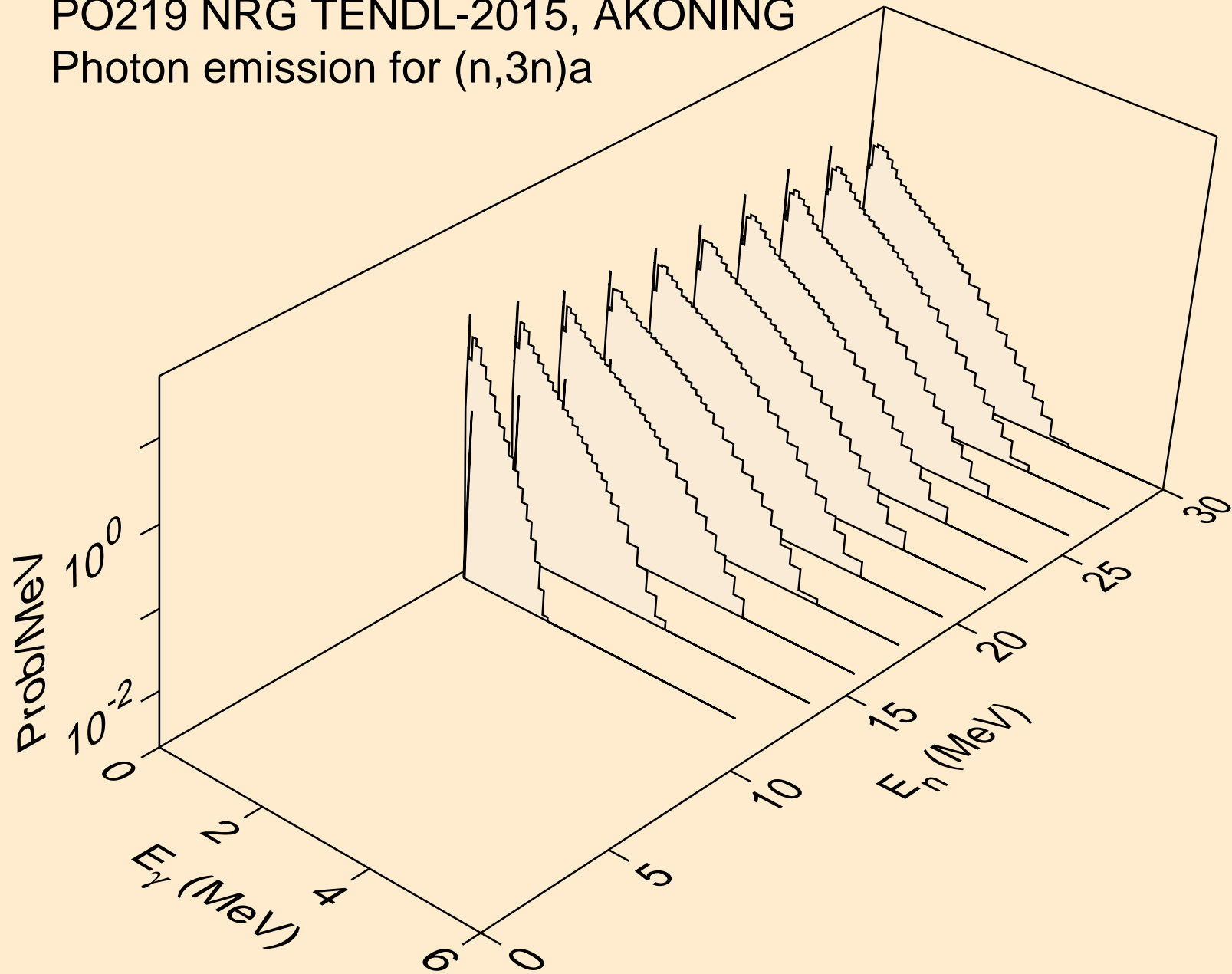

PO219 NRG TENDL-2015, AKONING  
Photon emission for (n,n\*)p

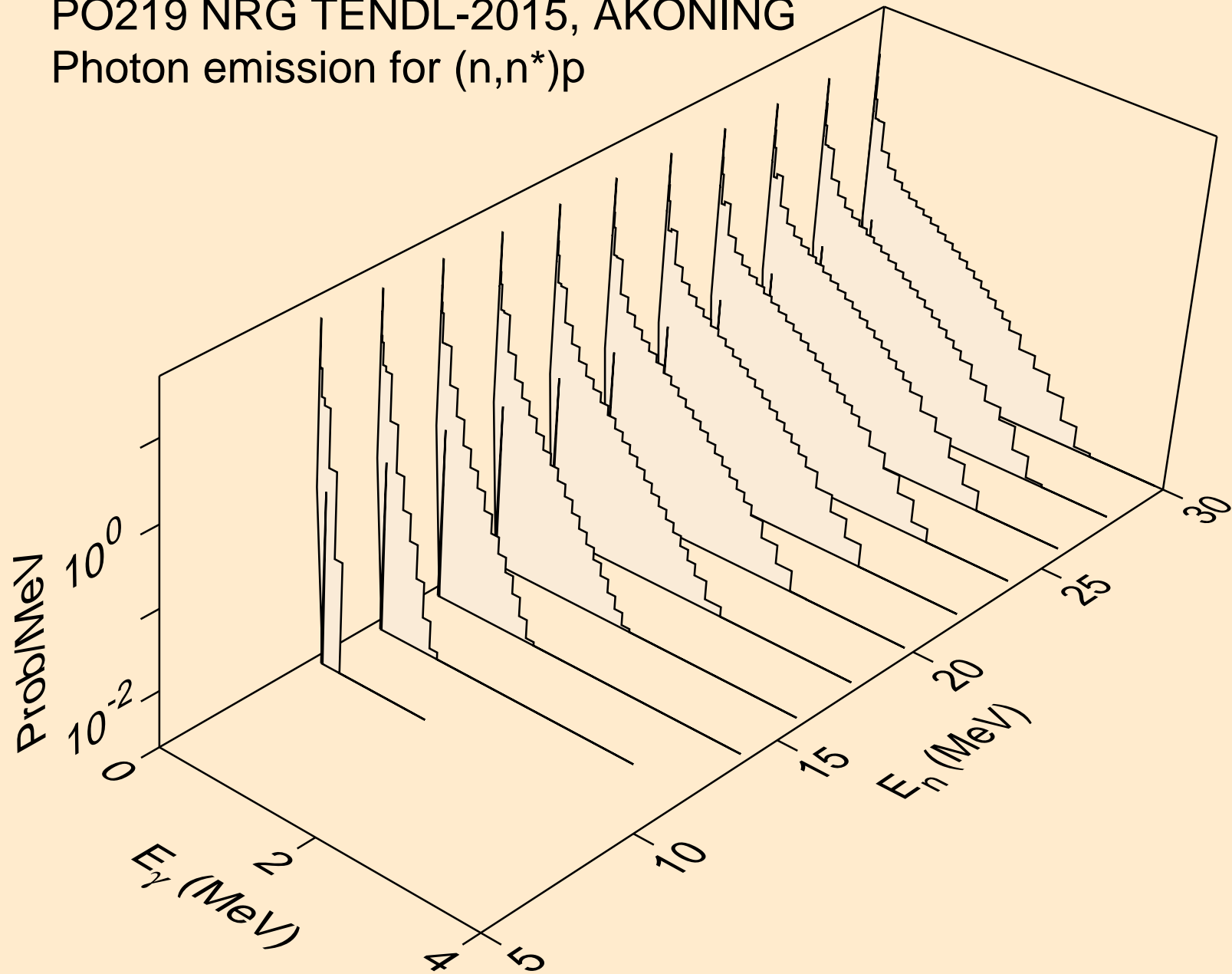



PO219 NRG TENDL-2015, AKONING  
Photon emission for (n,n\*)d

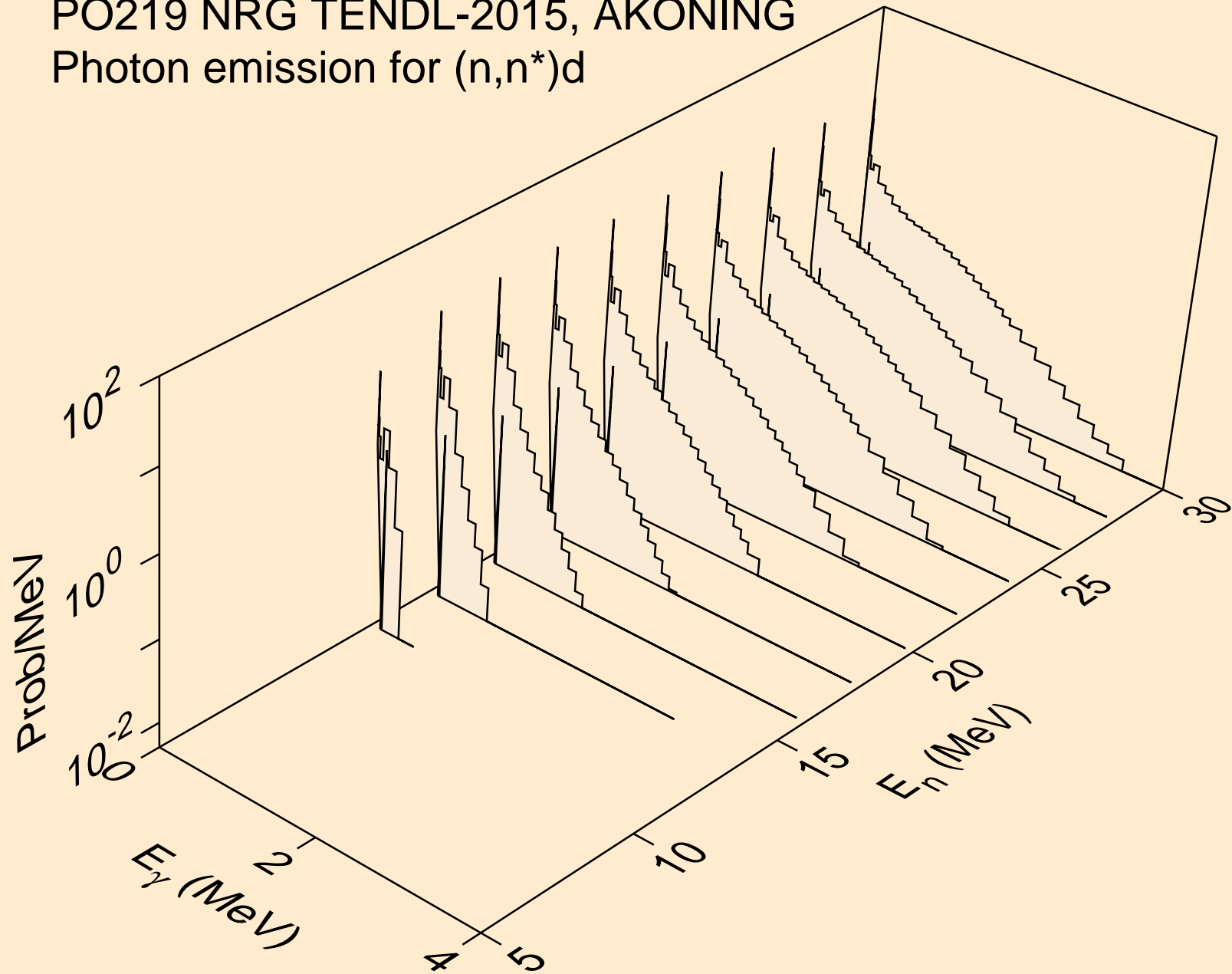

PO219 NRG TENDL-2015, AKONING  
Photon emission for (n,n\*)t

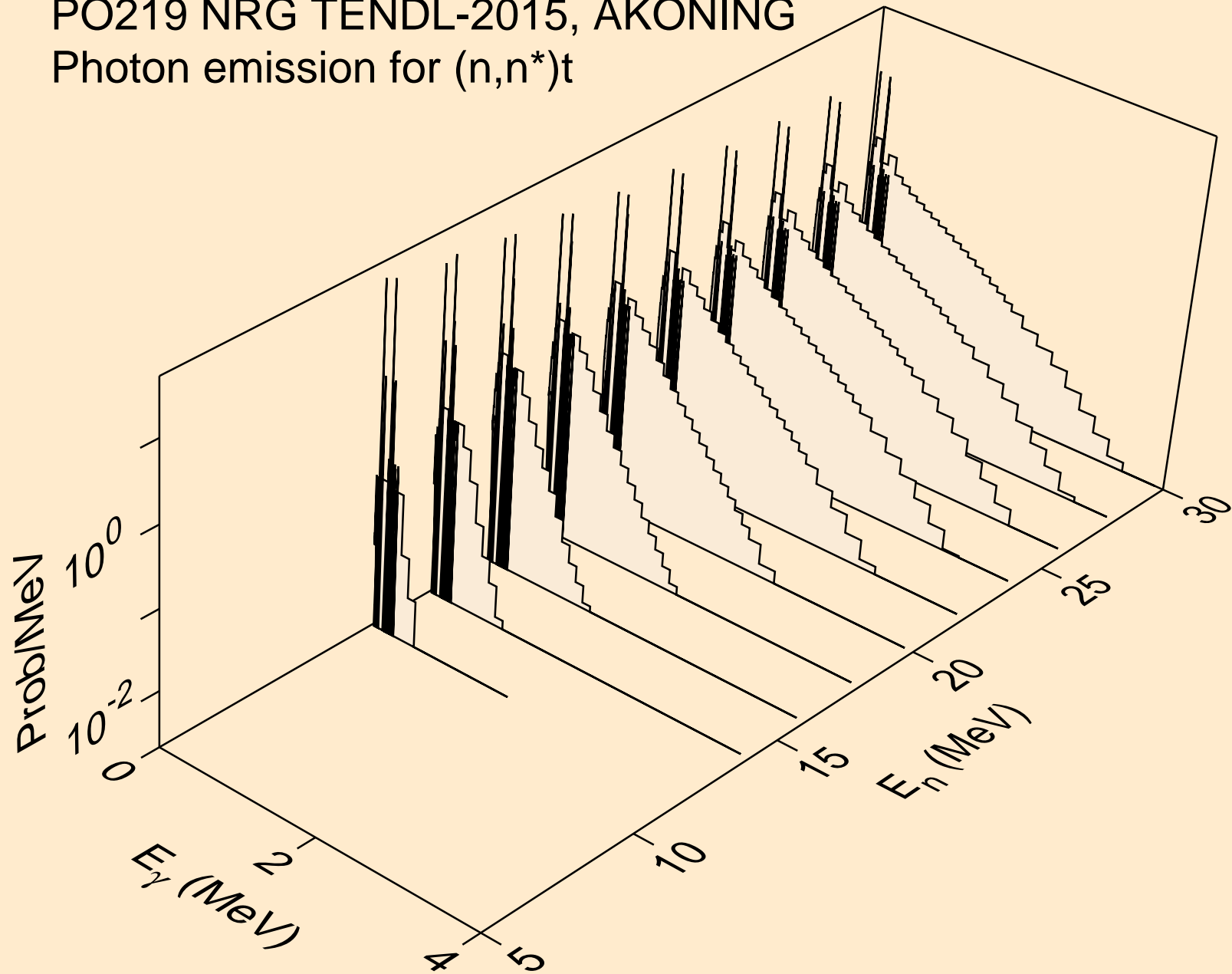

PO219 NRG TENDL-2015, AKONING  
Photon emission for (n,n\*)he3

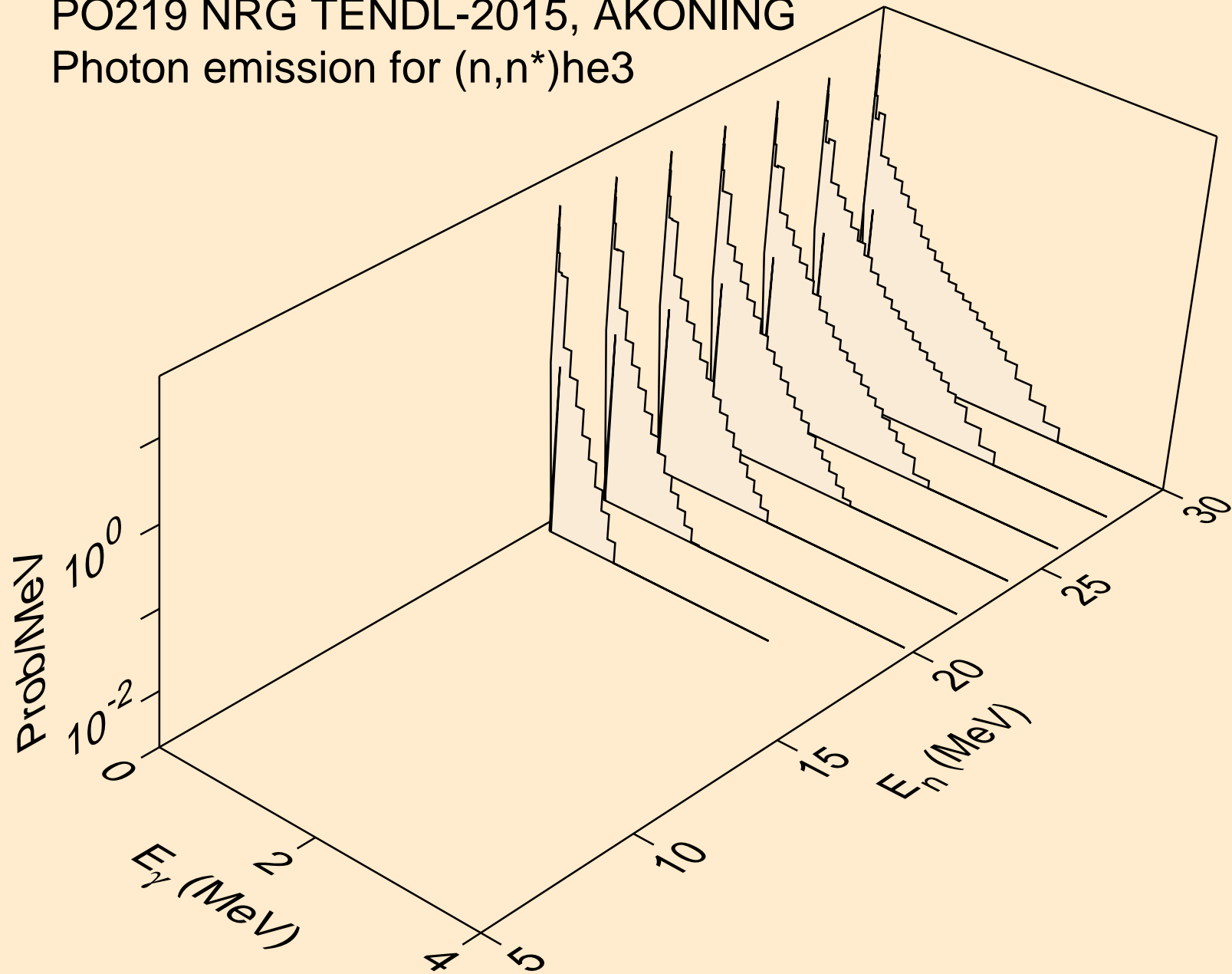

PO219 NRG TENDL-2015, AKONING  
Photon emission for (n,4n)

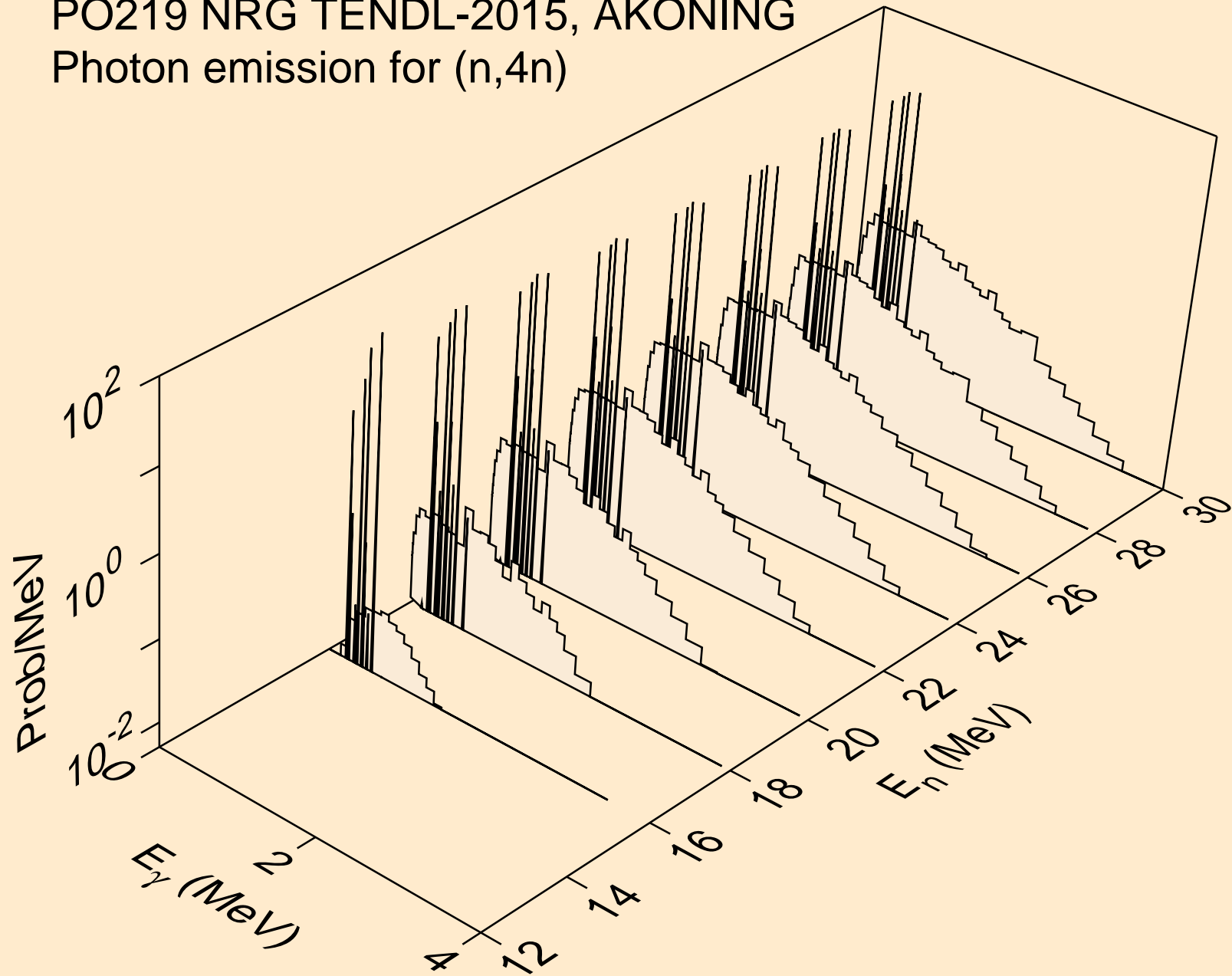

PO219 NRG TENDL-2015, AKONING  
Photon emission for (n,2np)

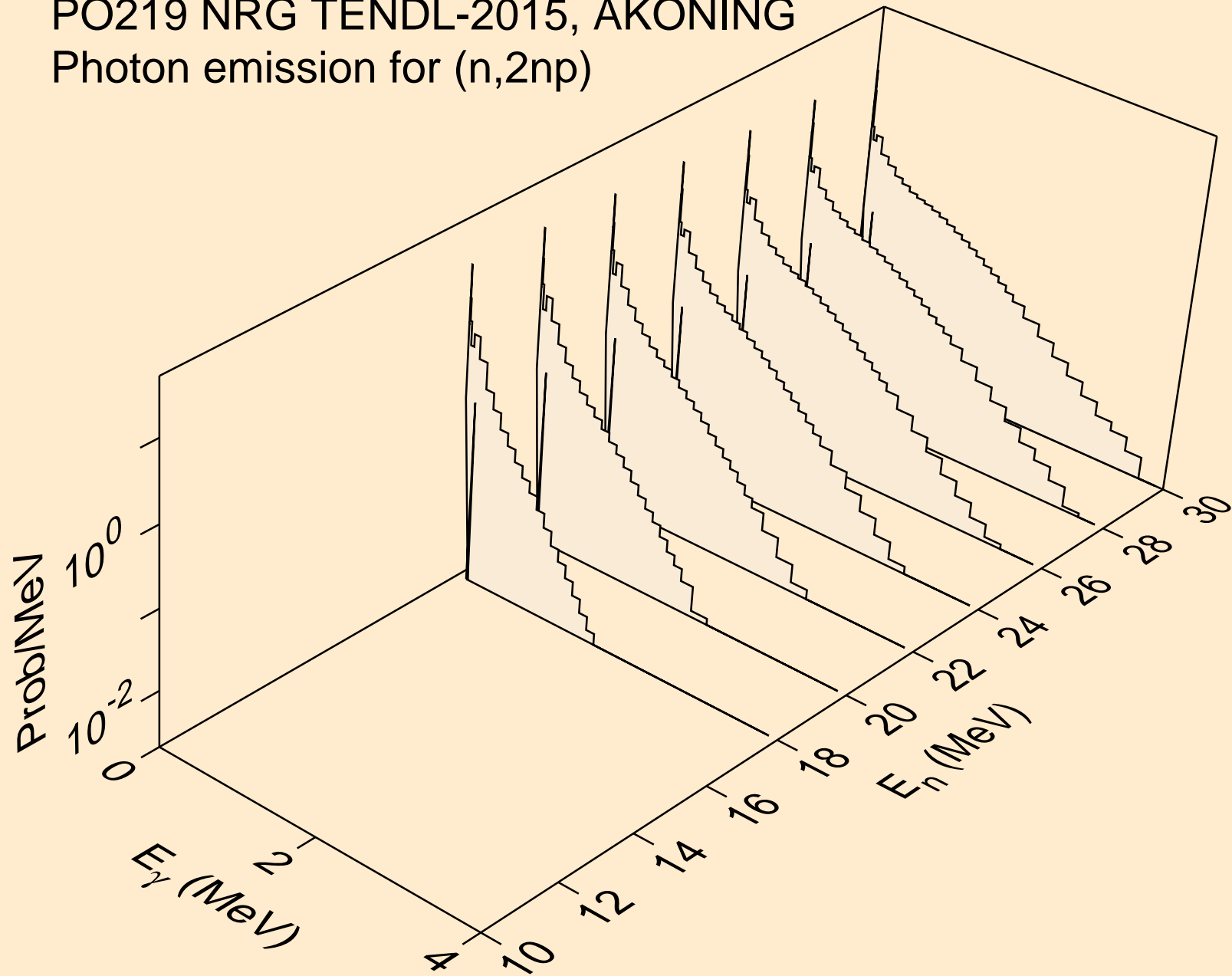

PO219 NRG TENDL-2015, AKONING  
Photon emission for (n,3np)

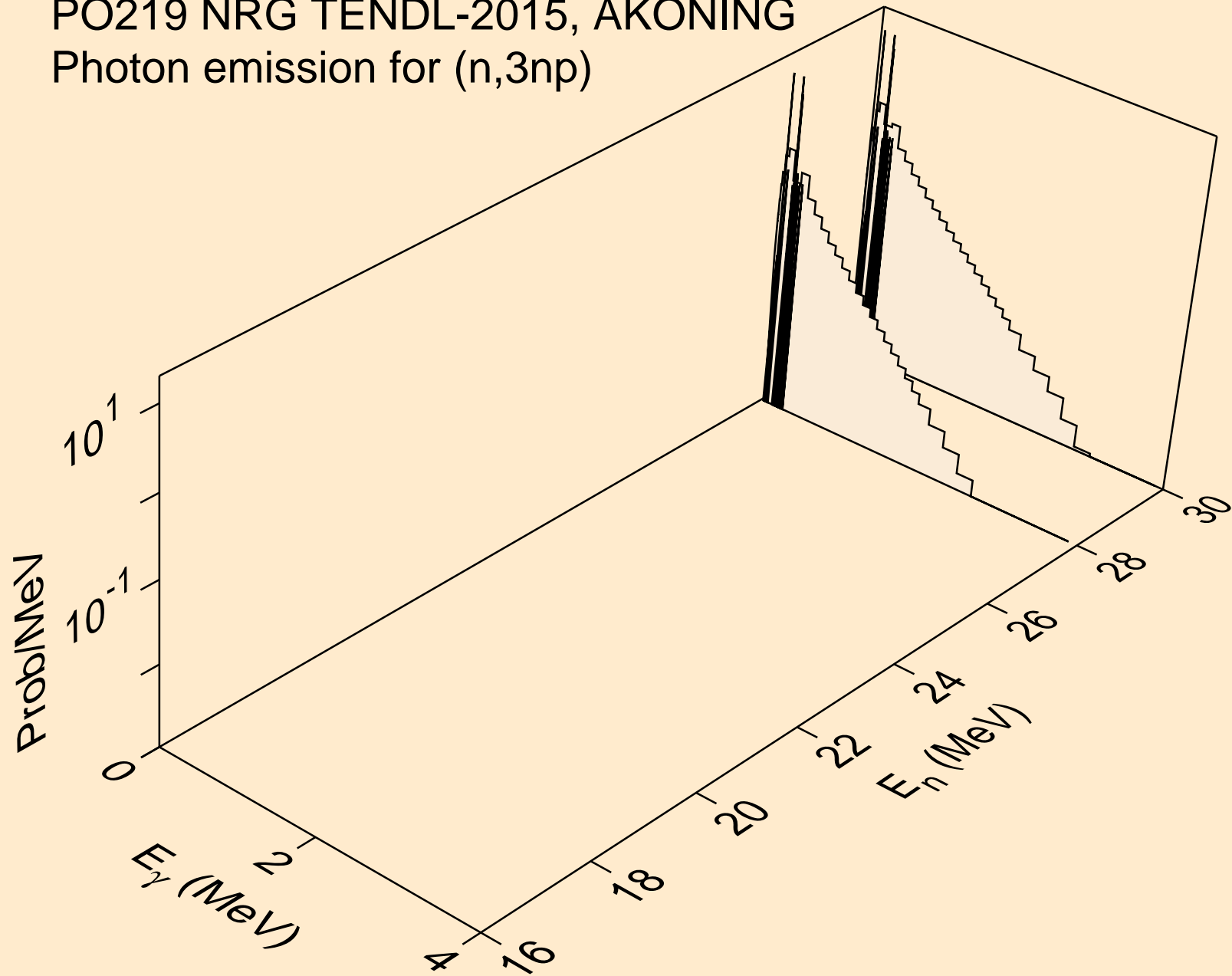

PO219 NRG TENDL-2015, AKONING  
Photon emission for (n,2np)

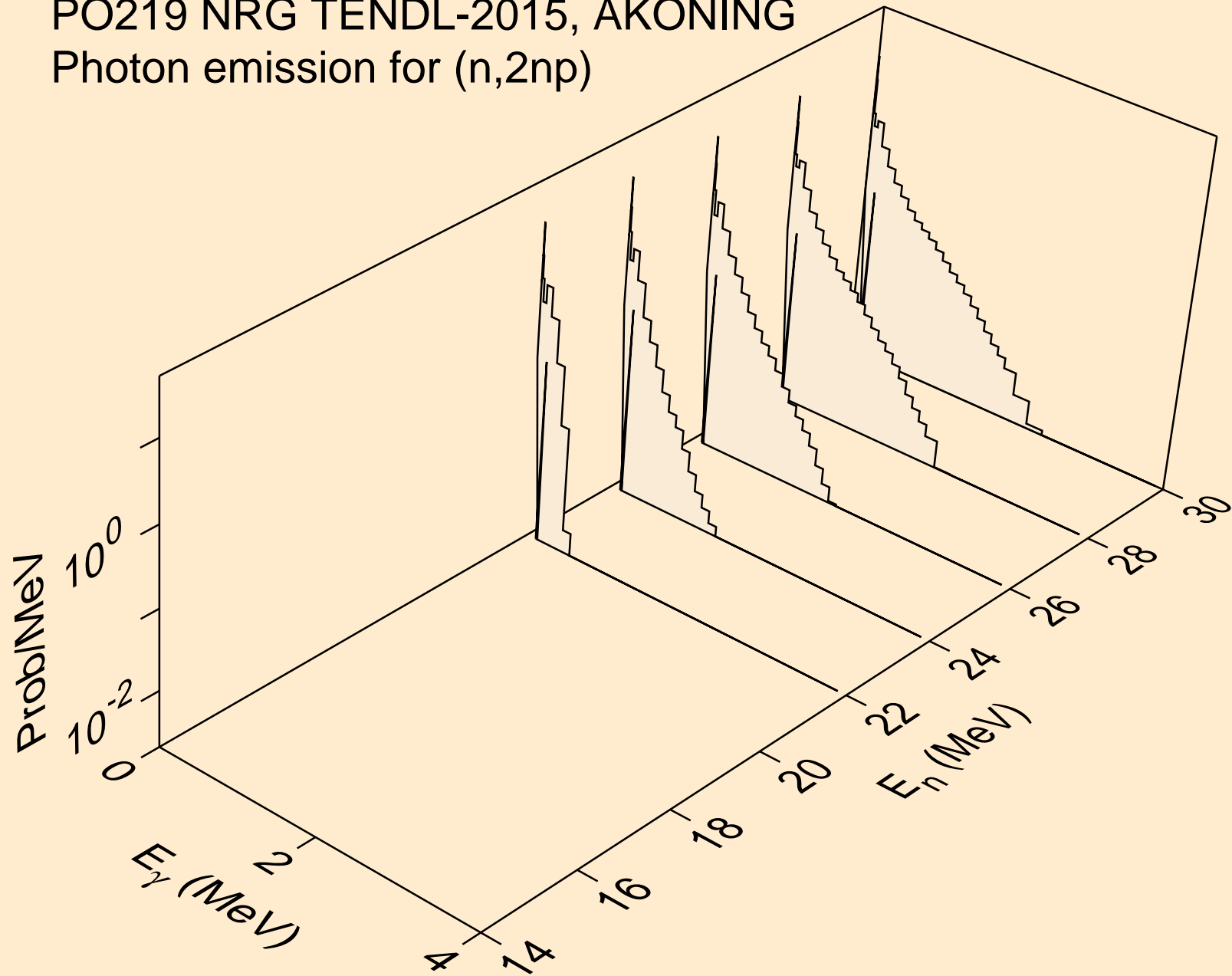

PO219 NRG TENDL-2015, AKONING  
Photon emission for (n,n\*c)

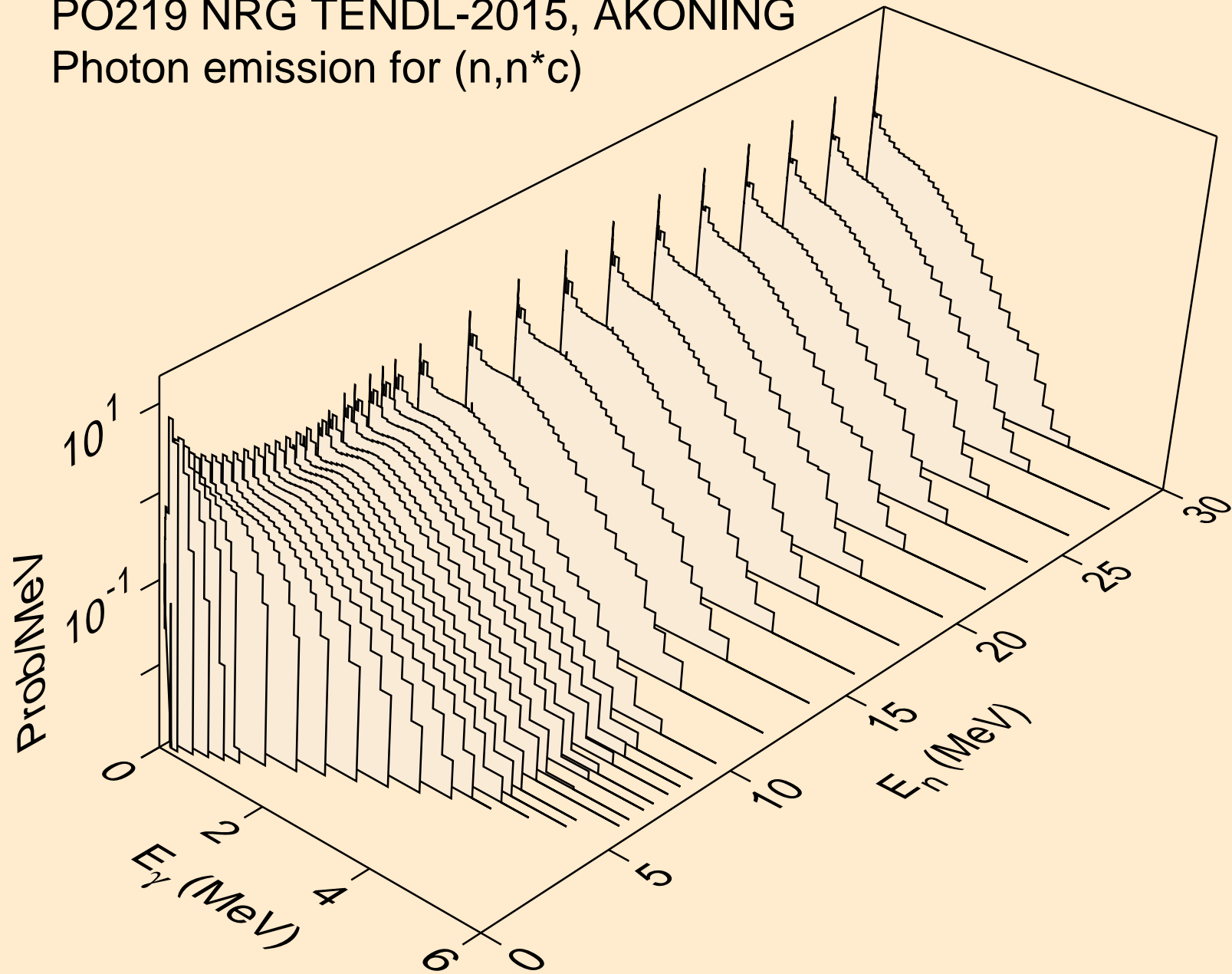



PO219 NRG TENDL-2015, AKONING  
Photon emission for (n,gma)

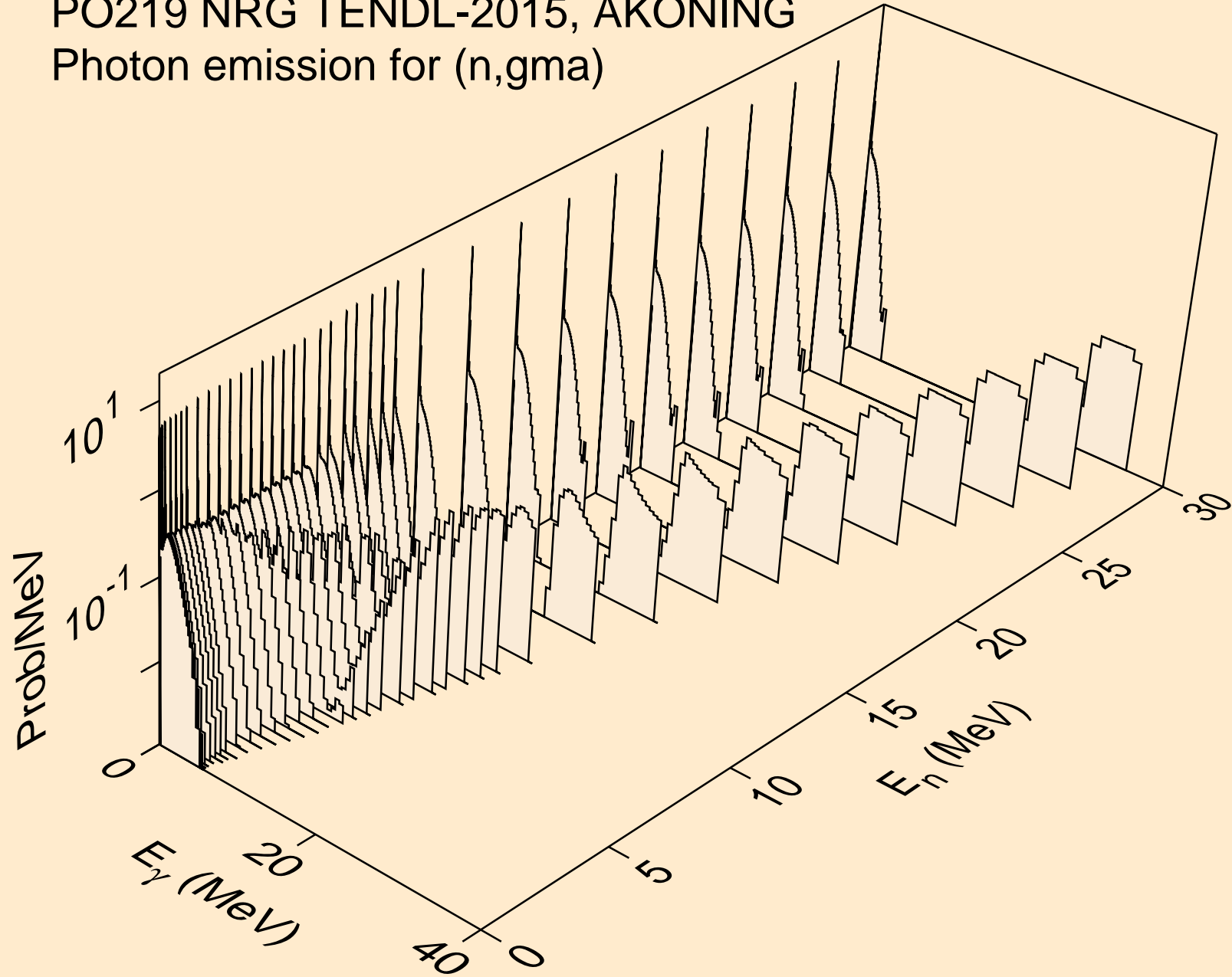

PO219 NRG TENDL-2015, AKONING  
Photon emission for (n,p)

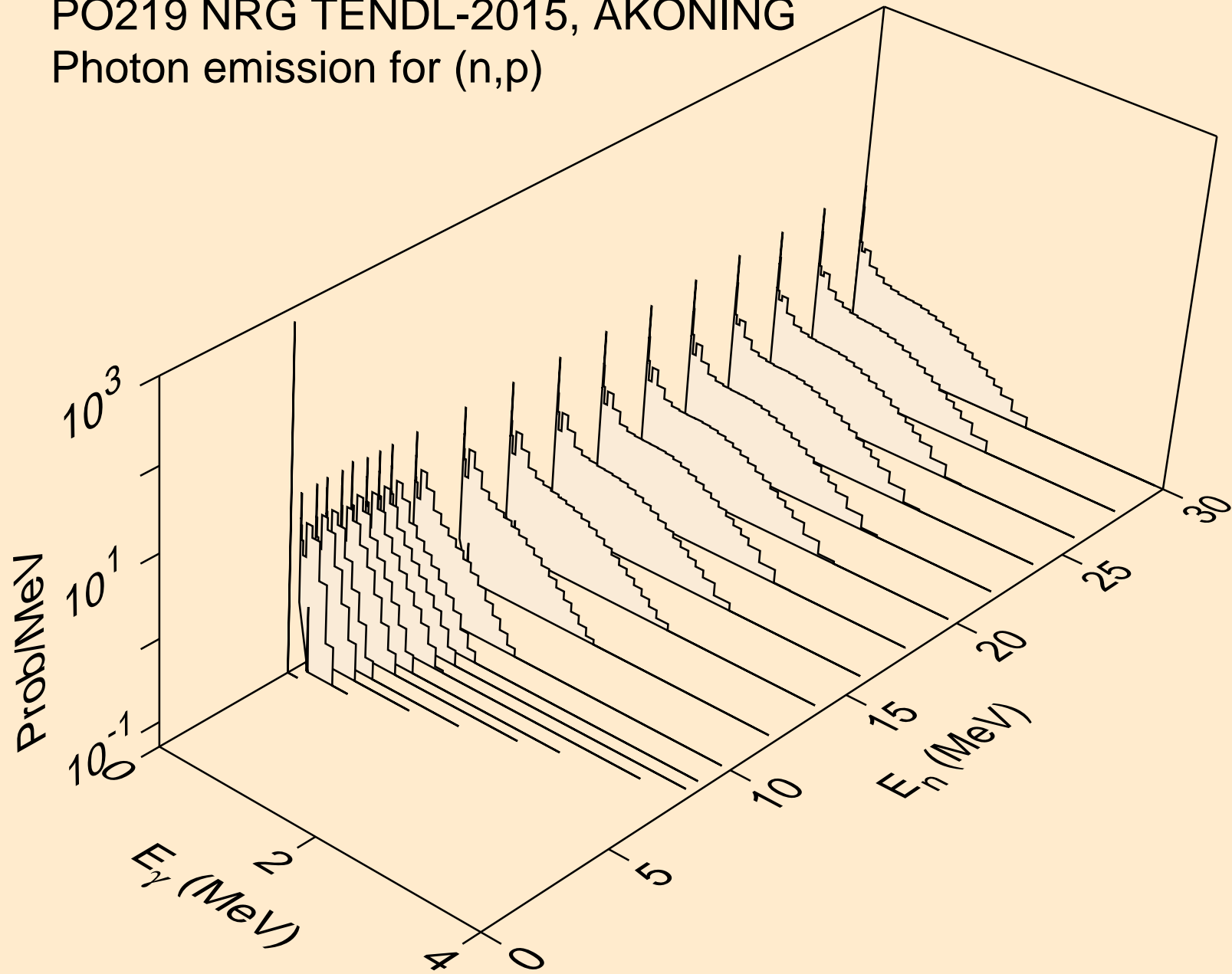

PO219 NRG TENDL-2015, AKONING  
Photon emission for (n,d)

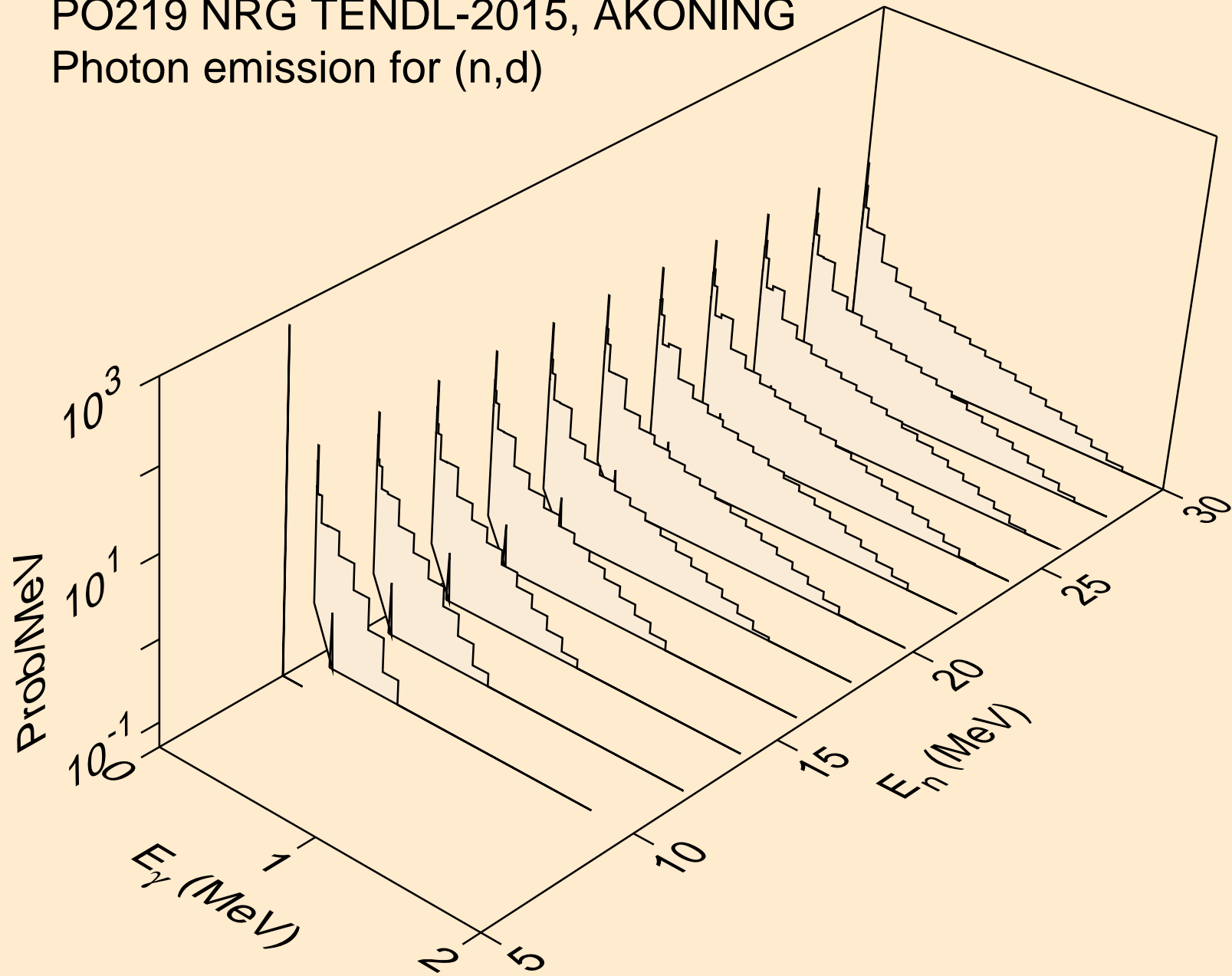

PO219 NRG TENDL-2015, AKONING  
Photon emission for (n,t)

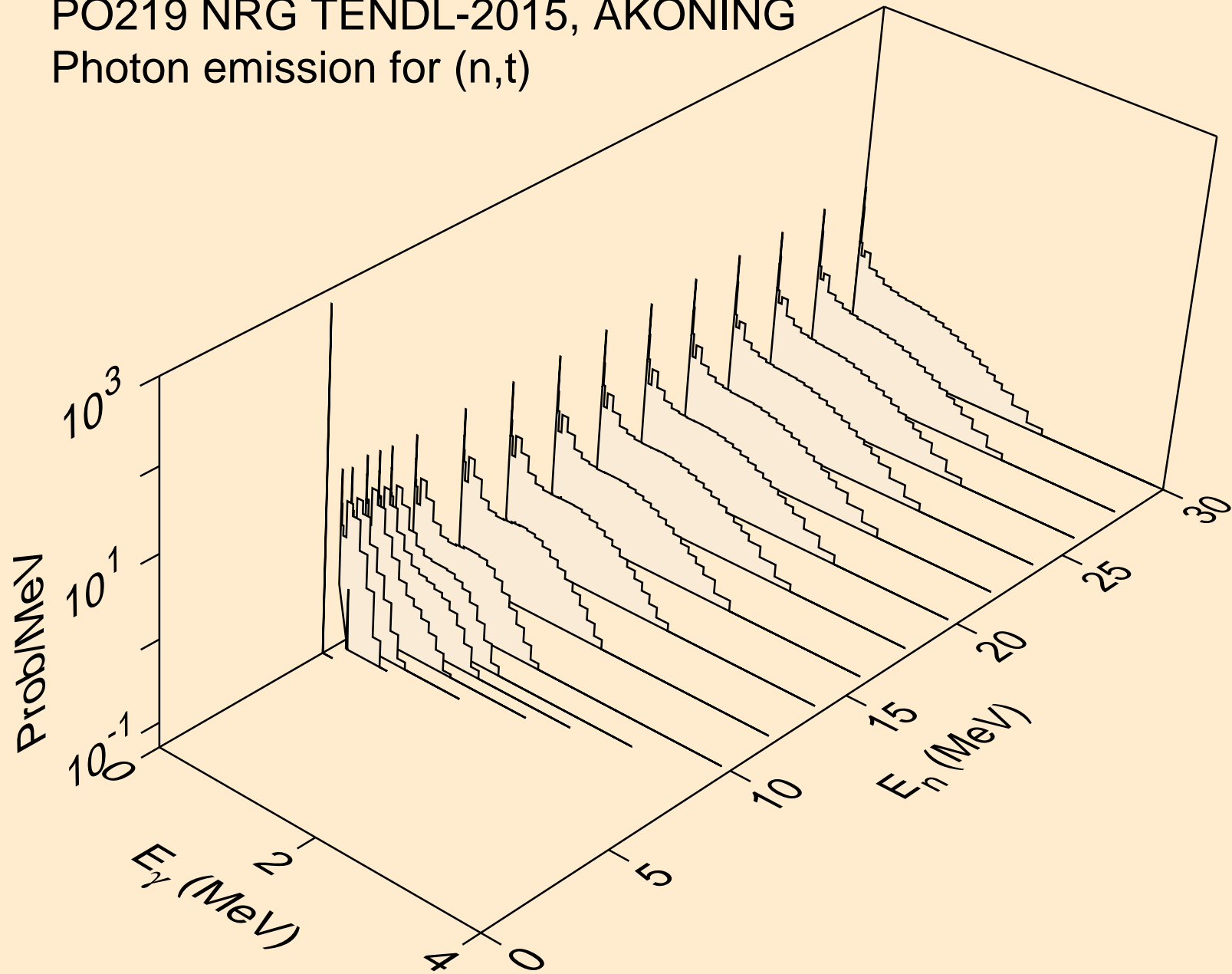

PO219 NRG TENDL-2015, AKONING  
Photon emission for (n,he3)

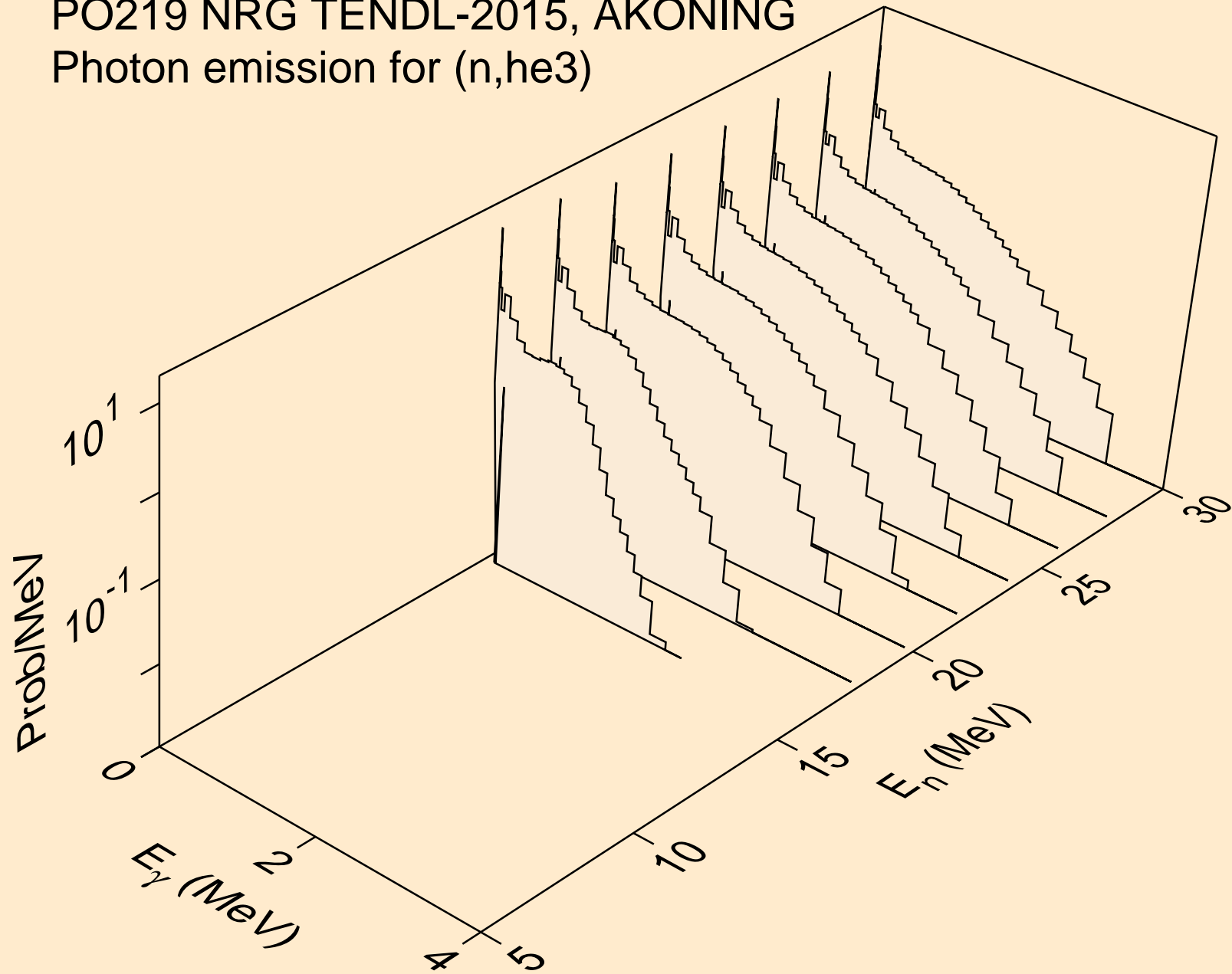

PO219 NRG TENDL-2015, AKONING  
Photon emission for (n,a)

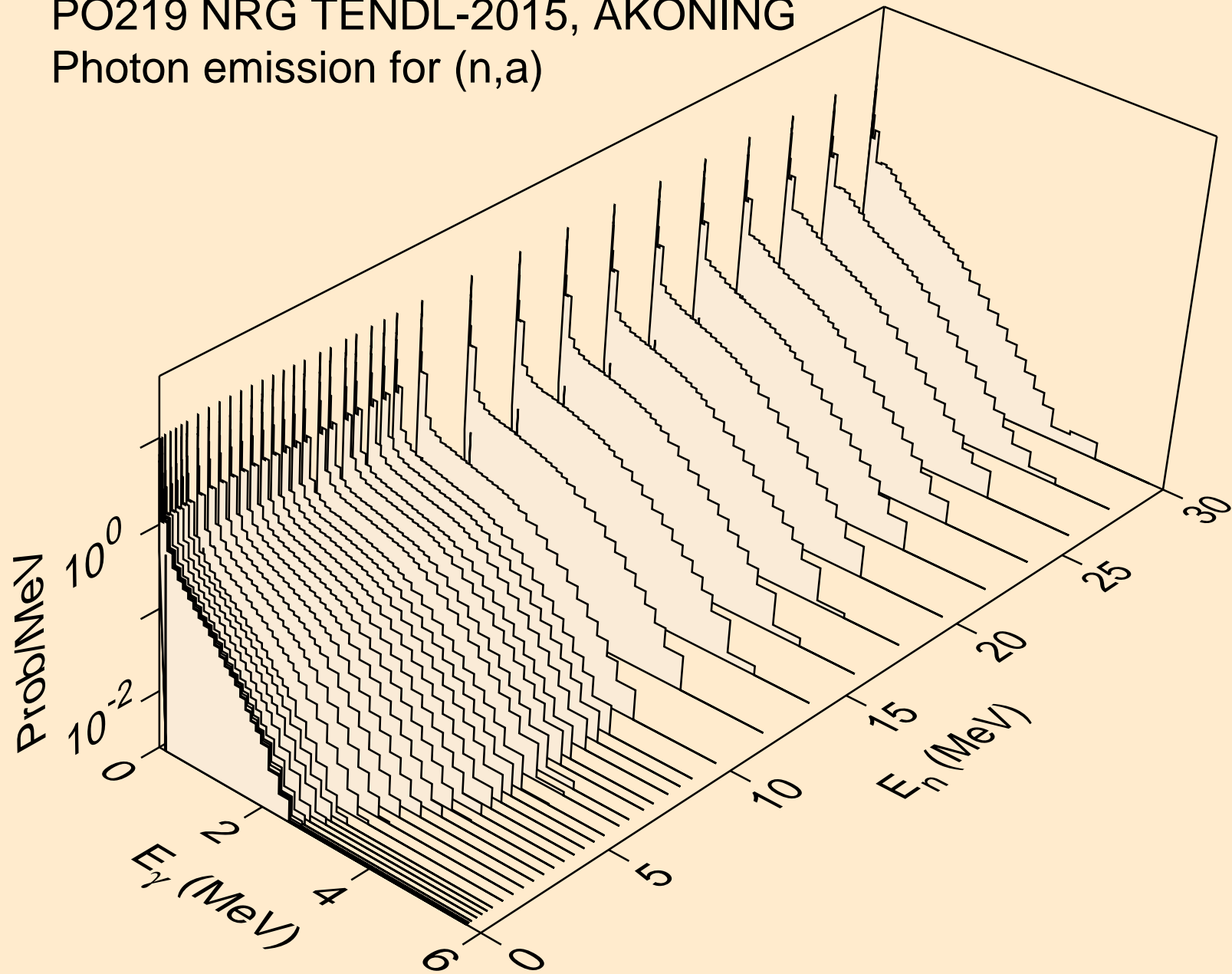

PO219 NRG TENDL-2015, AKONING  
Photon emission for (n,2p)

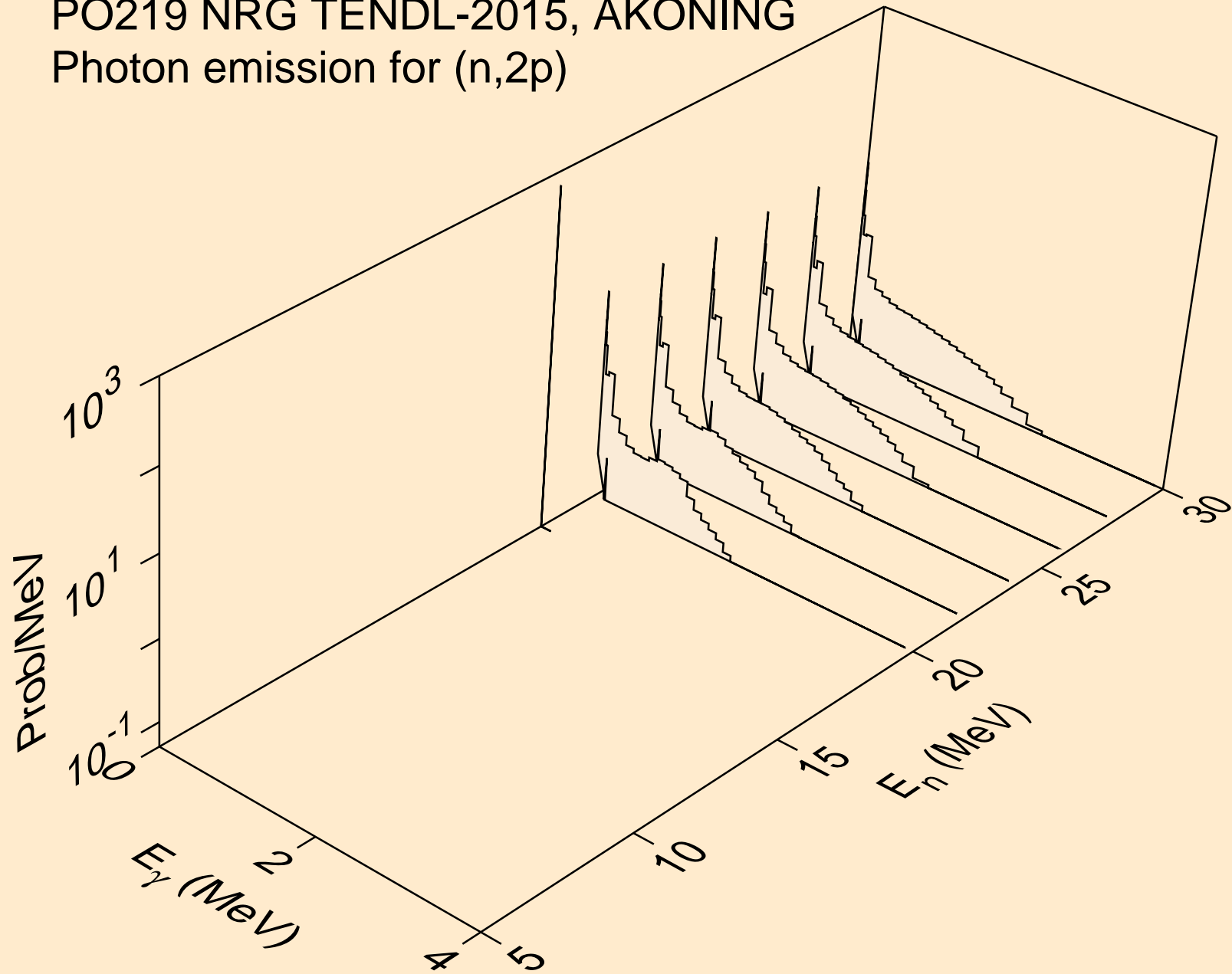

PO219 NRG TENDL-2015, AKONING  
thermal capture photon spectrum

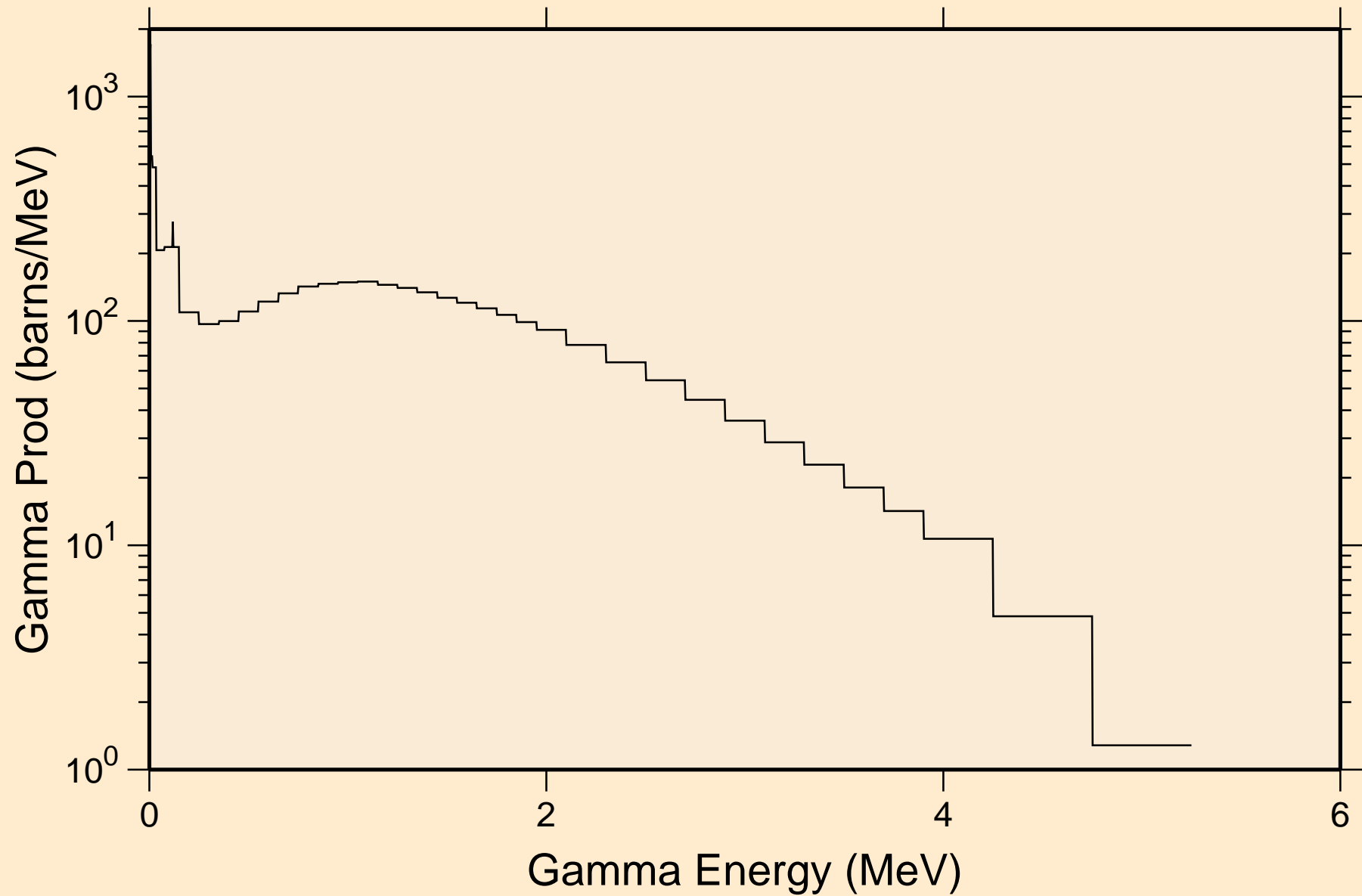



PO219 NRG TENDL-2015, AKONING  
14 MeV photon spectrum

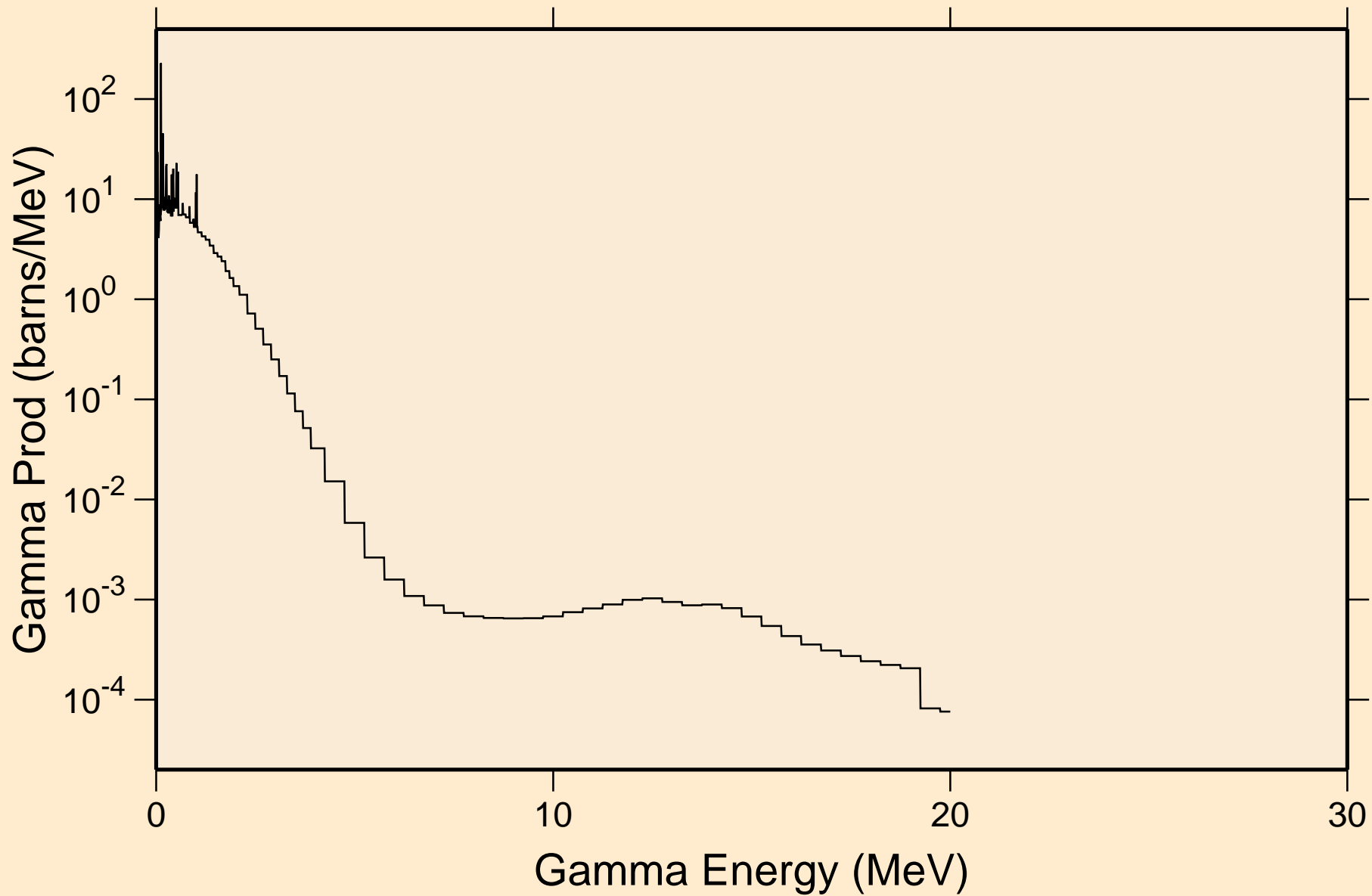

# PO219 NRG TENDL-2015, AKONING

## Particle heating contributions

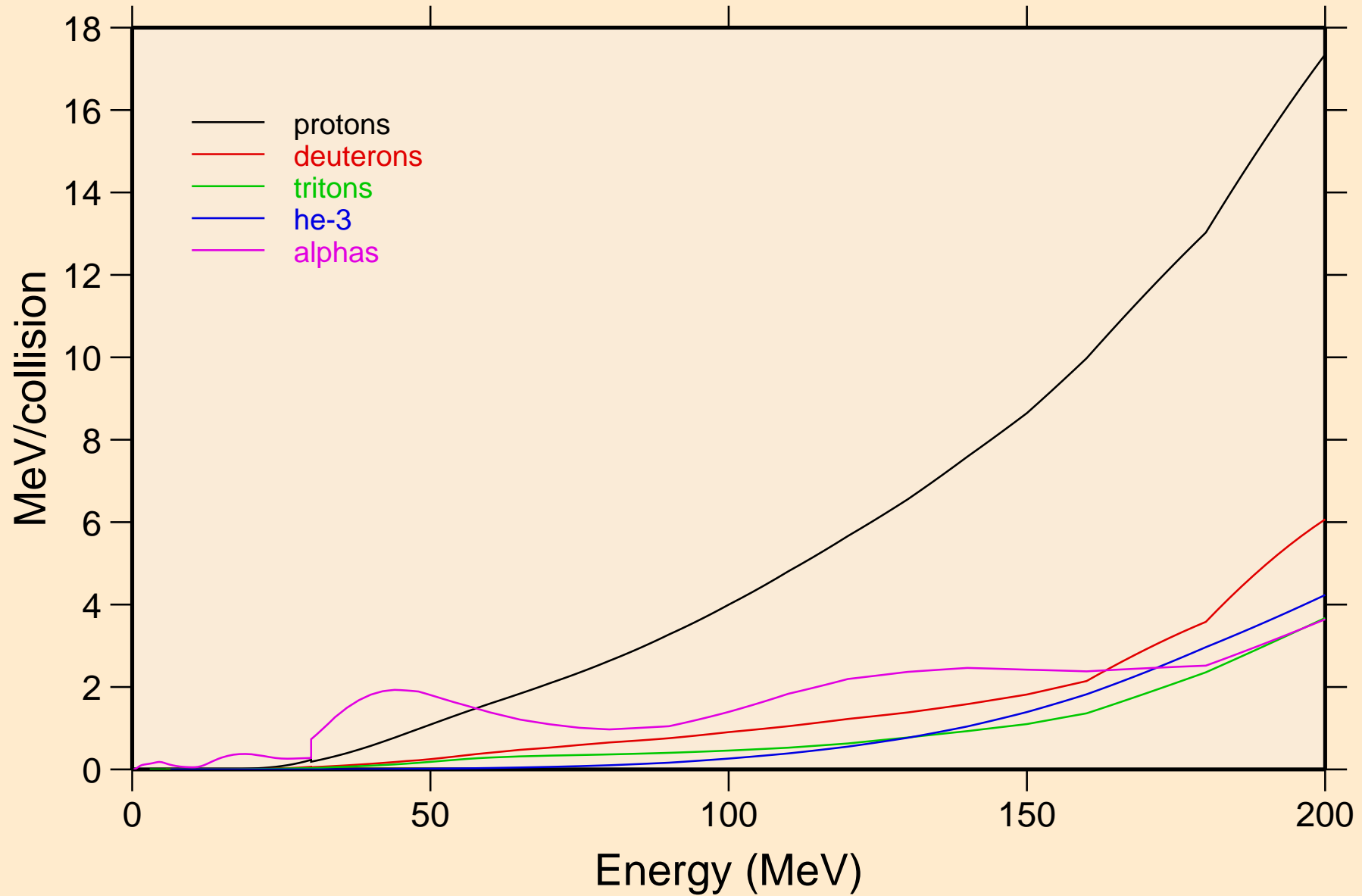

# PO219 NRG TENDL-2015, AKONING

## Recoil Heating

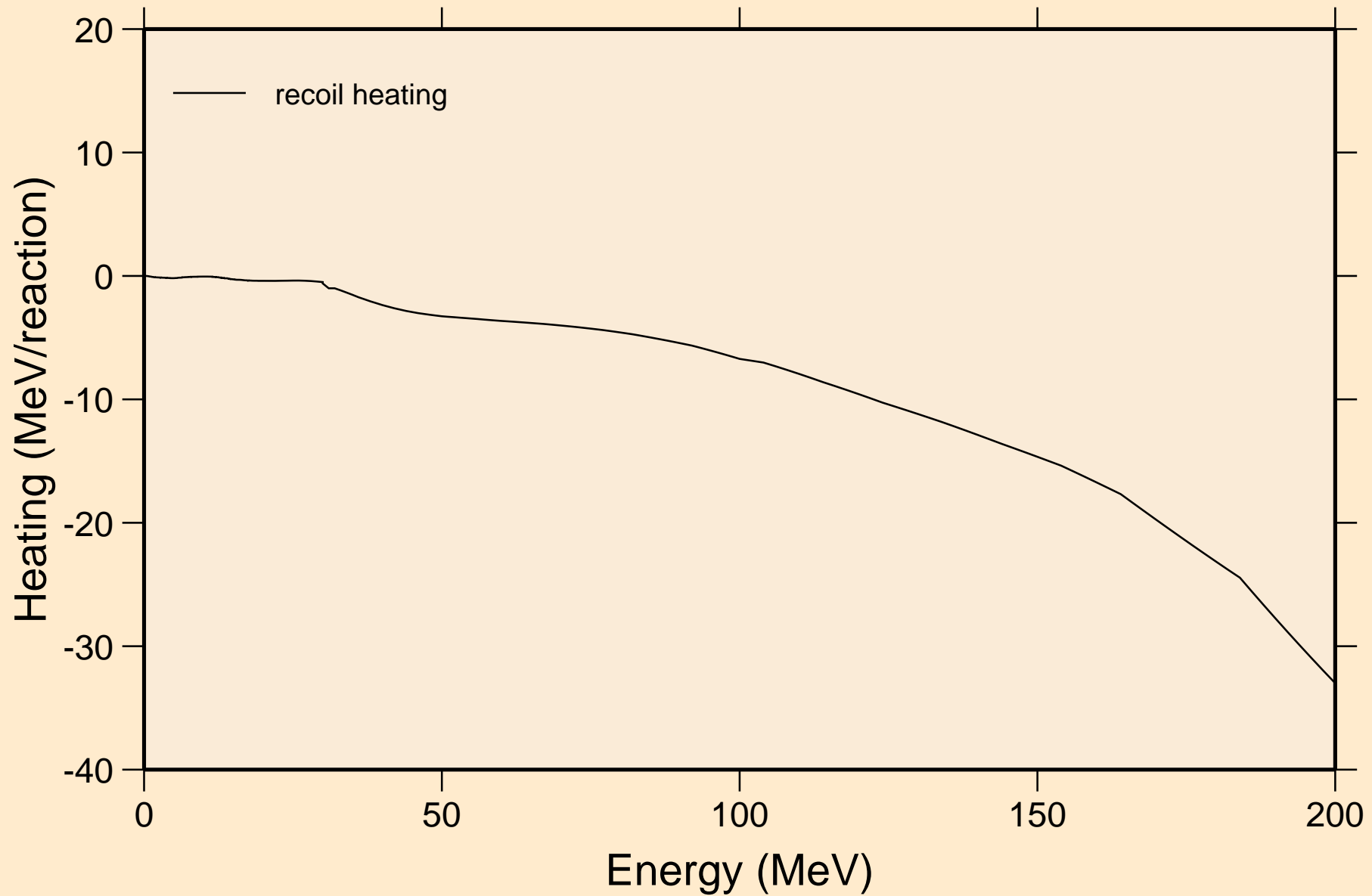

# PO219 NRG TENDL-2015, AKONING

## Particle production cross sections

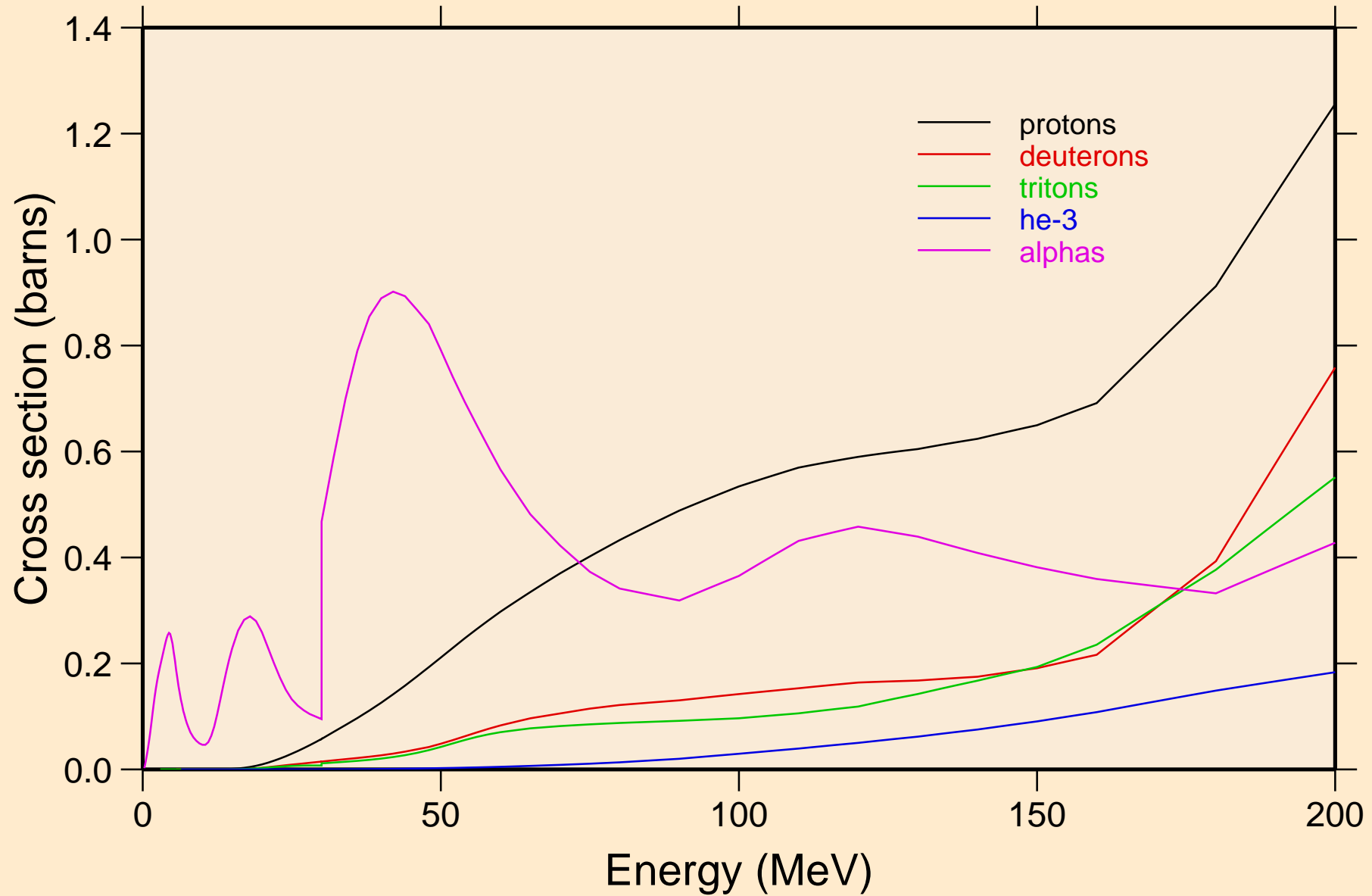

PO219 NRG TENDL-2015, AKONING  
protons from (n,x)

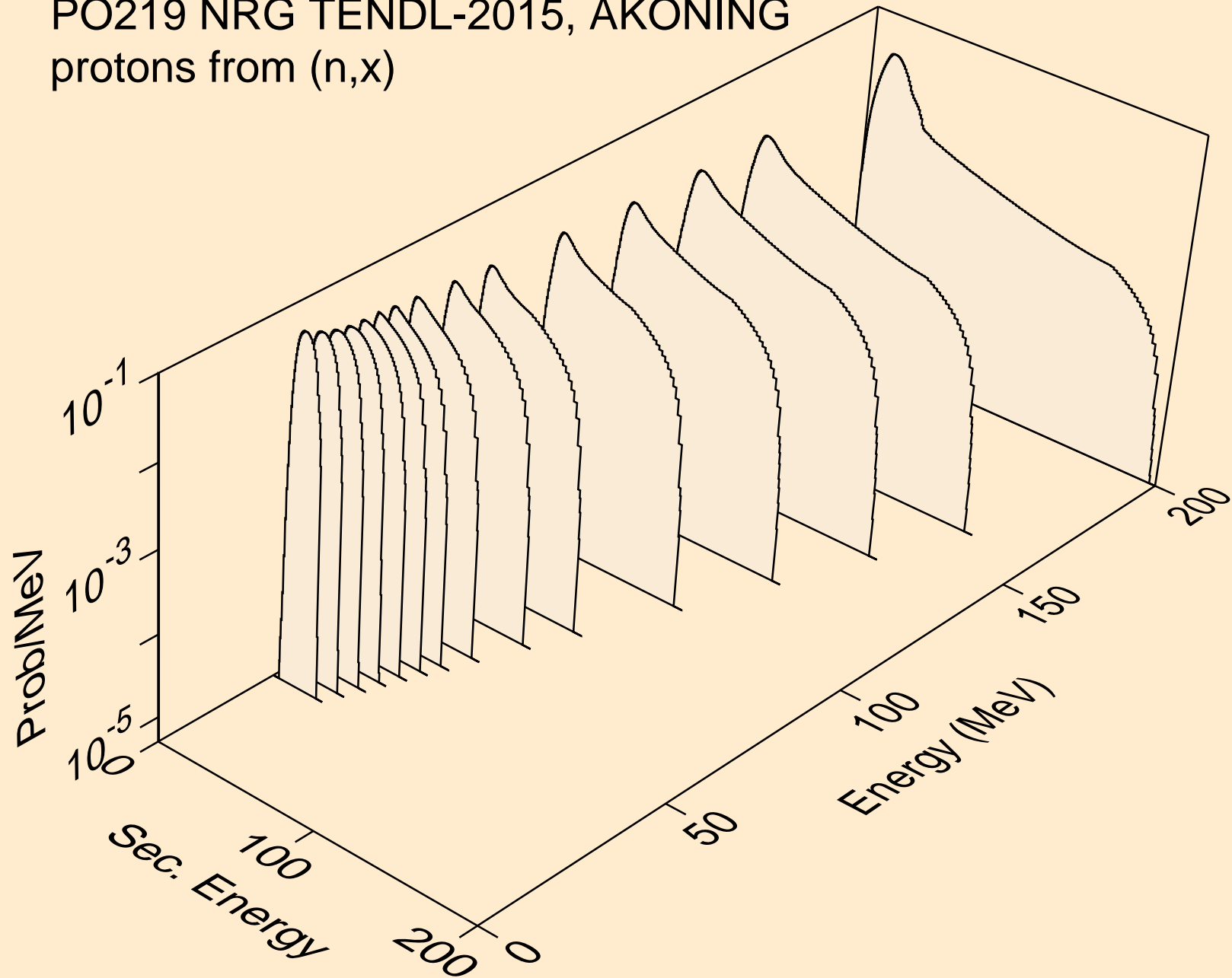

PO219 NRG TENDL-2015, AKONING  
protons from (n,n\*)p

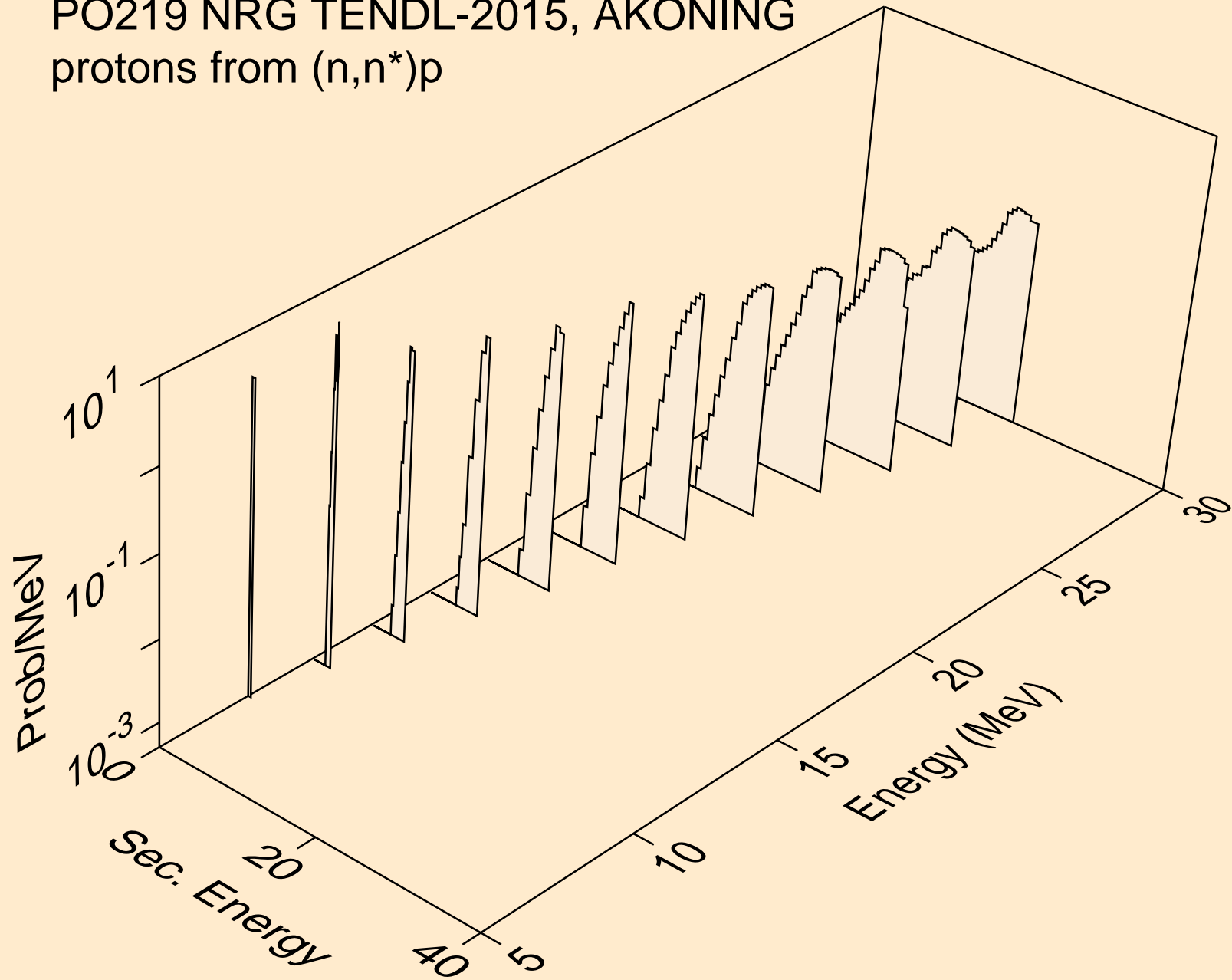

PO219 NRG TENDL-2015, AKONING  
protons from (n,2np)

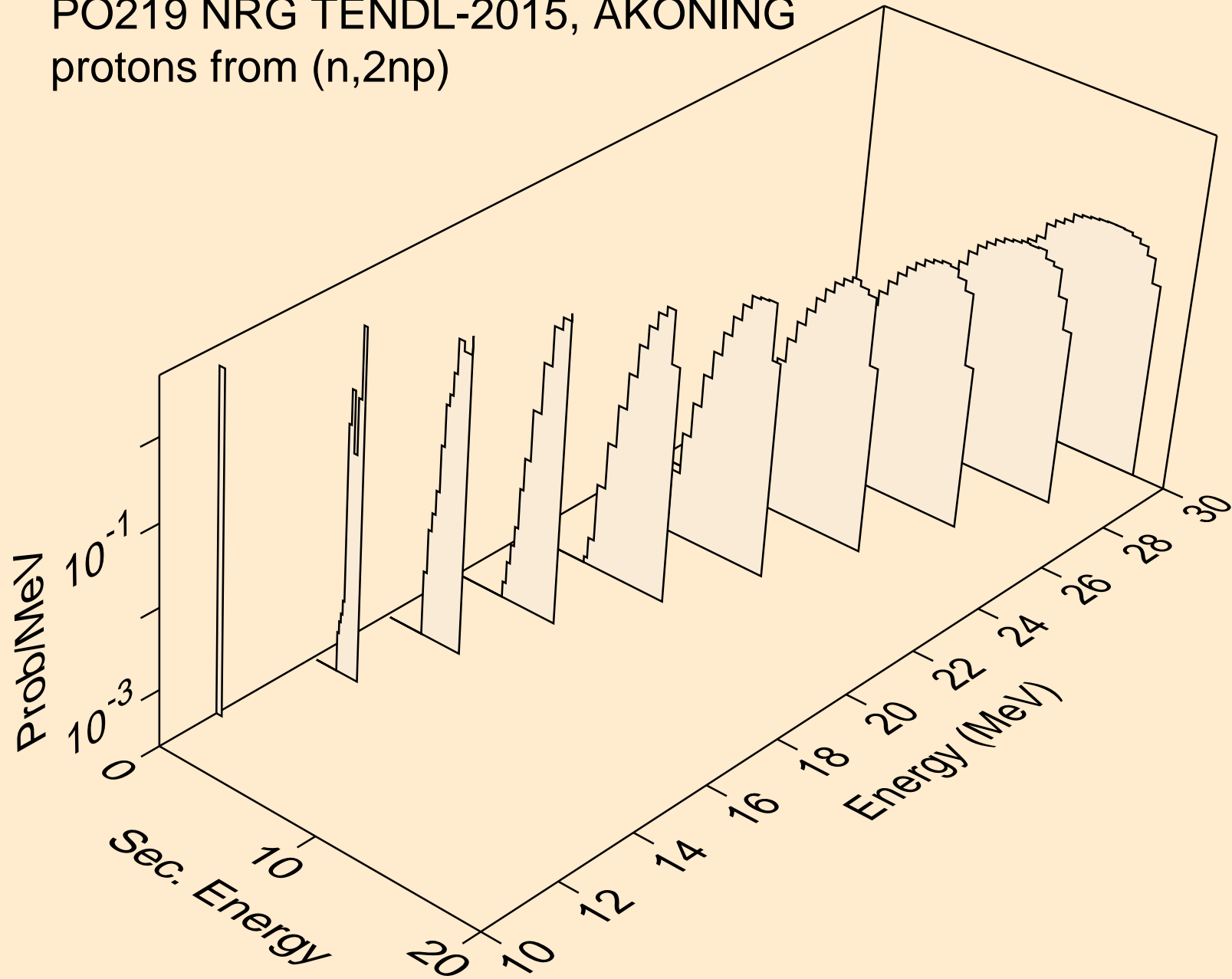

PO219 NRG TENDL-2015, AKONING  
protons from (n,3np)

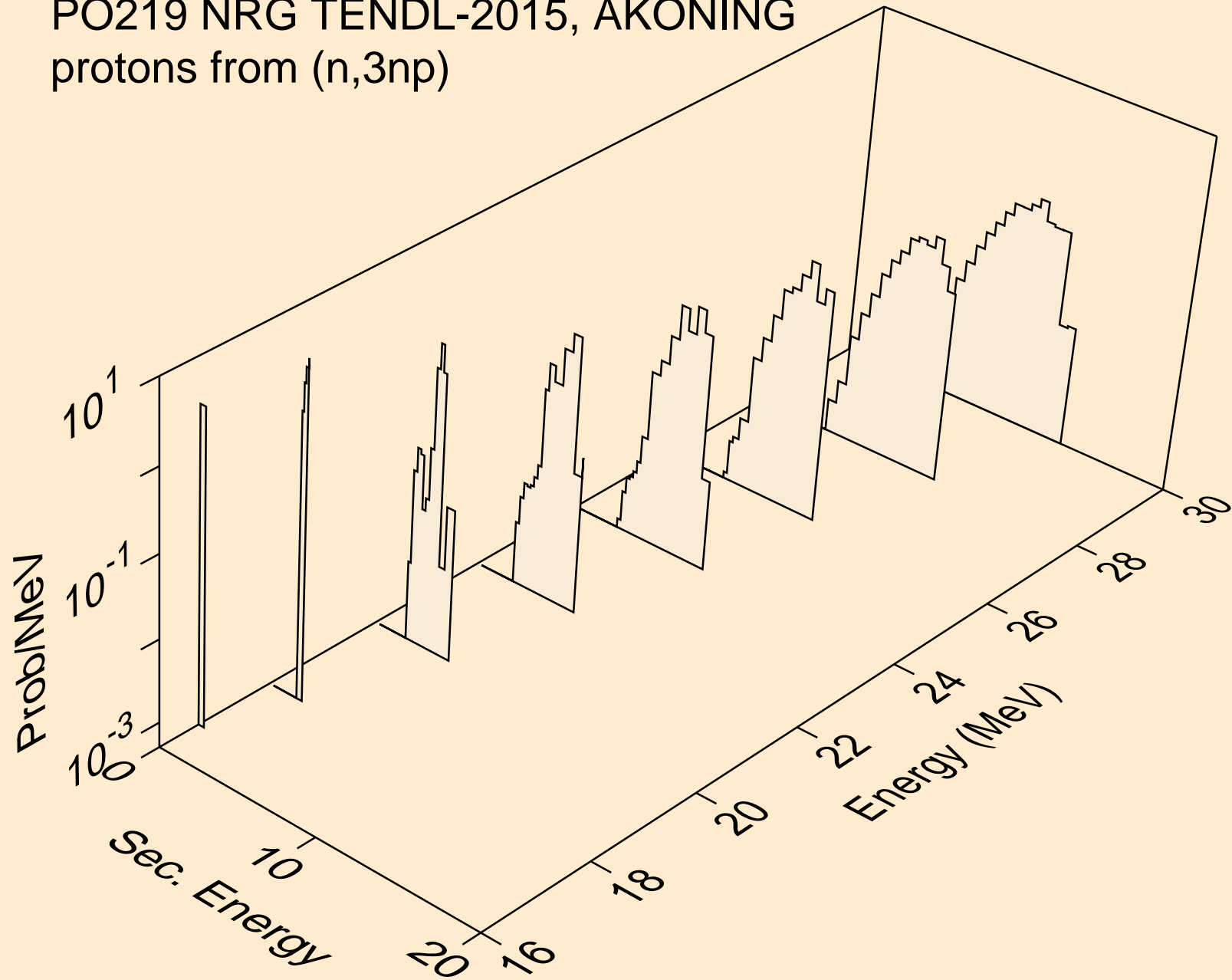



PO219 NRG TENDL-2015, AKONING  
protons from (n,2np)

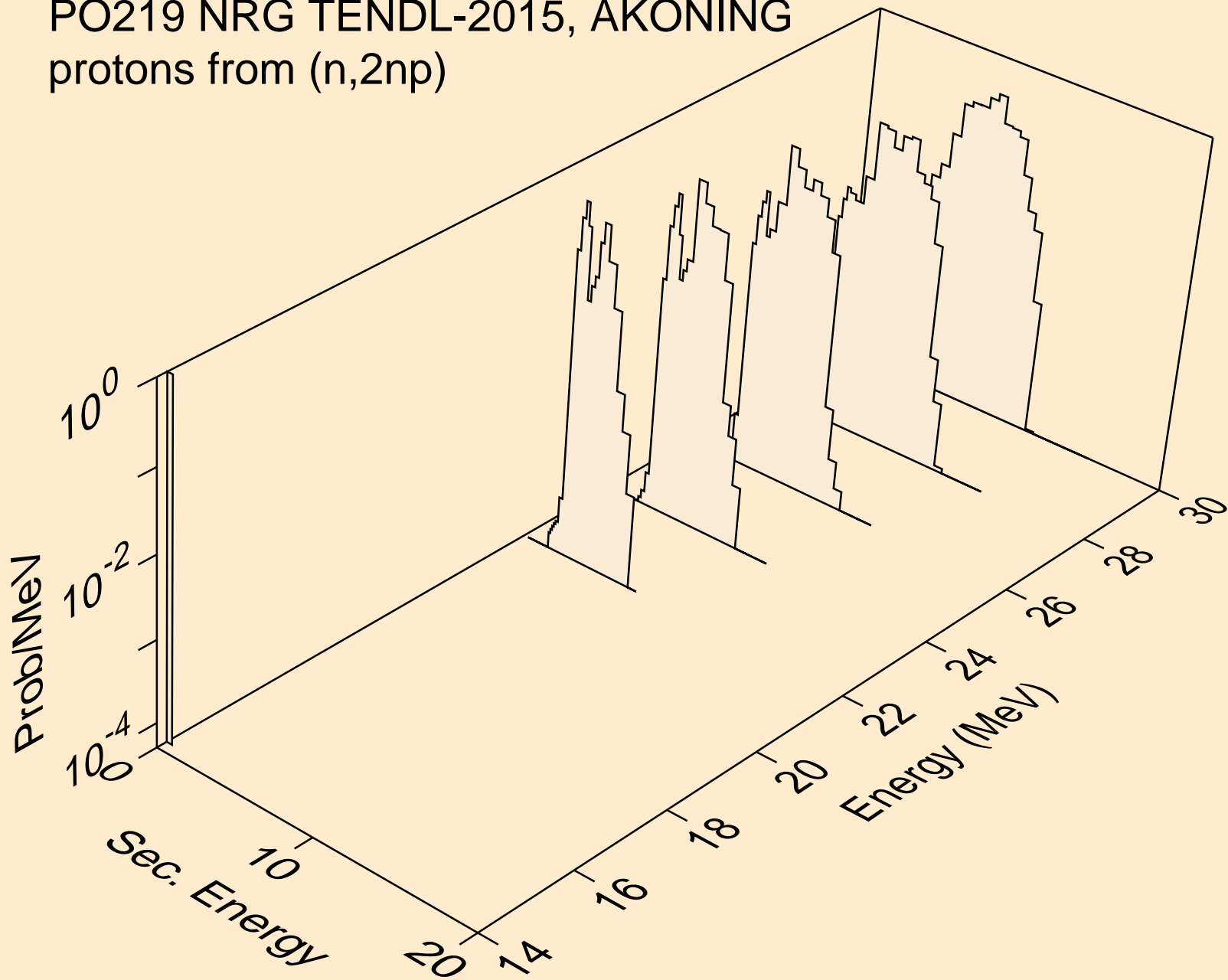

PO219 NRG TENDL-2015, AKONING  
protons from (n,p)

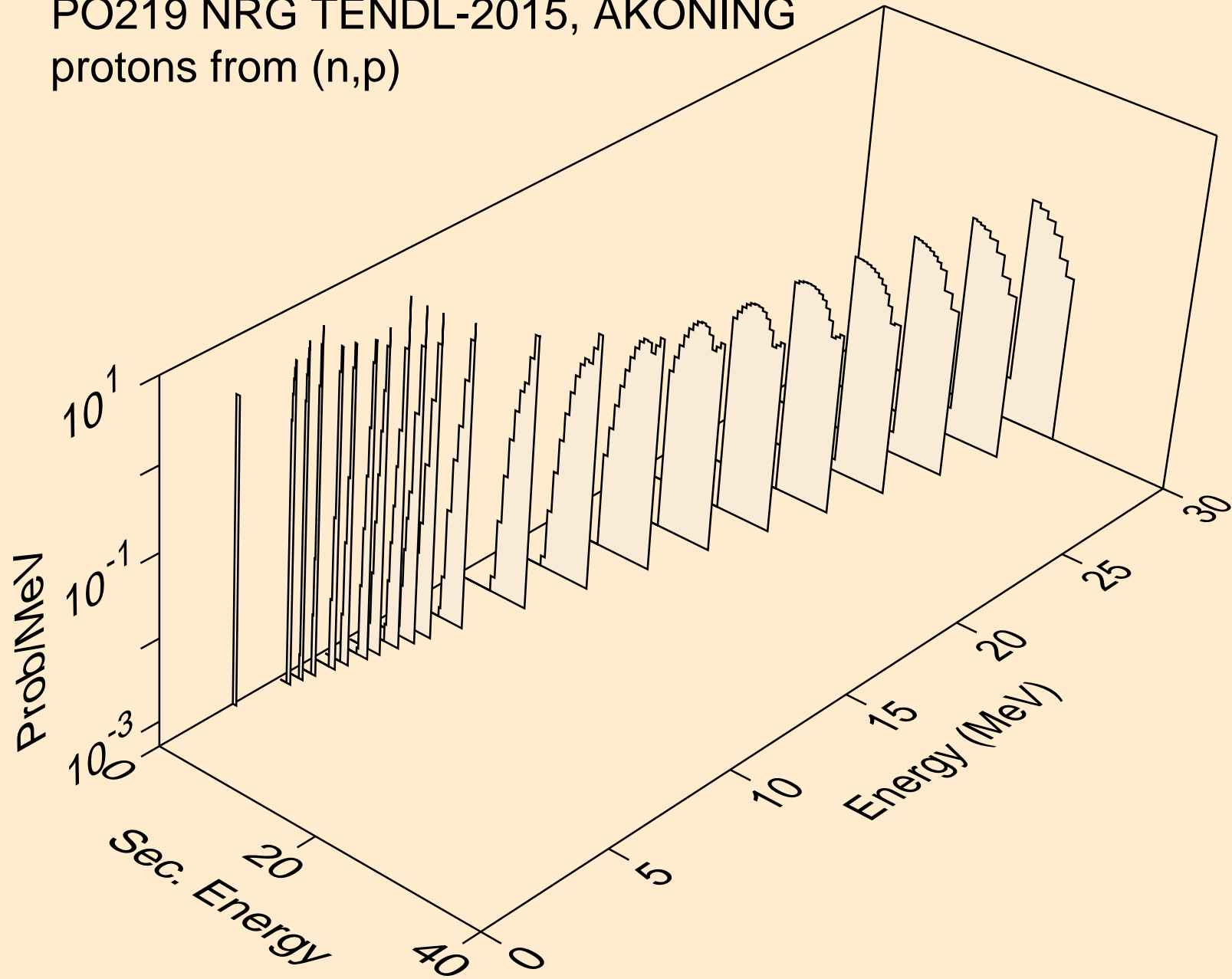

PO219 NRG TENDL-2015, AKONING  
protons from (n,2p)

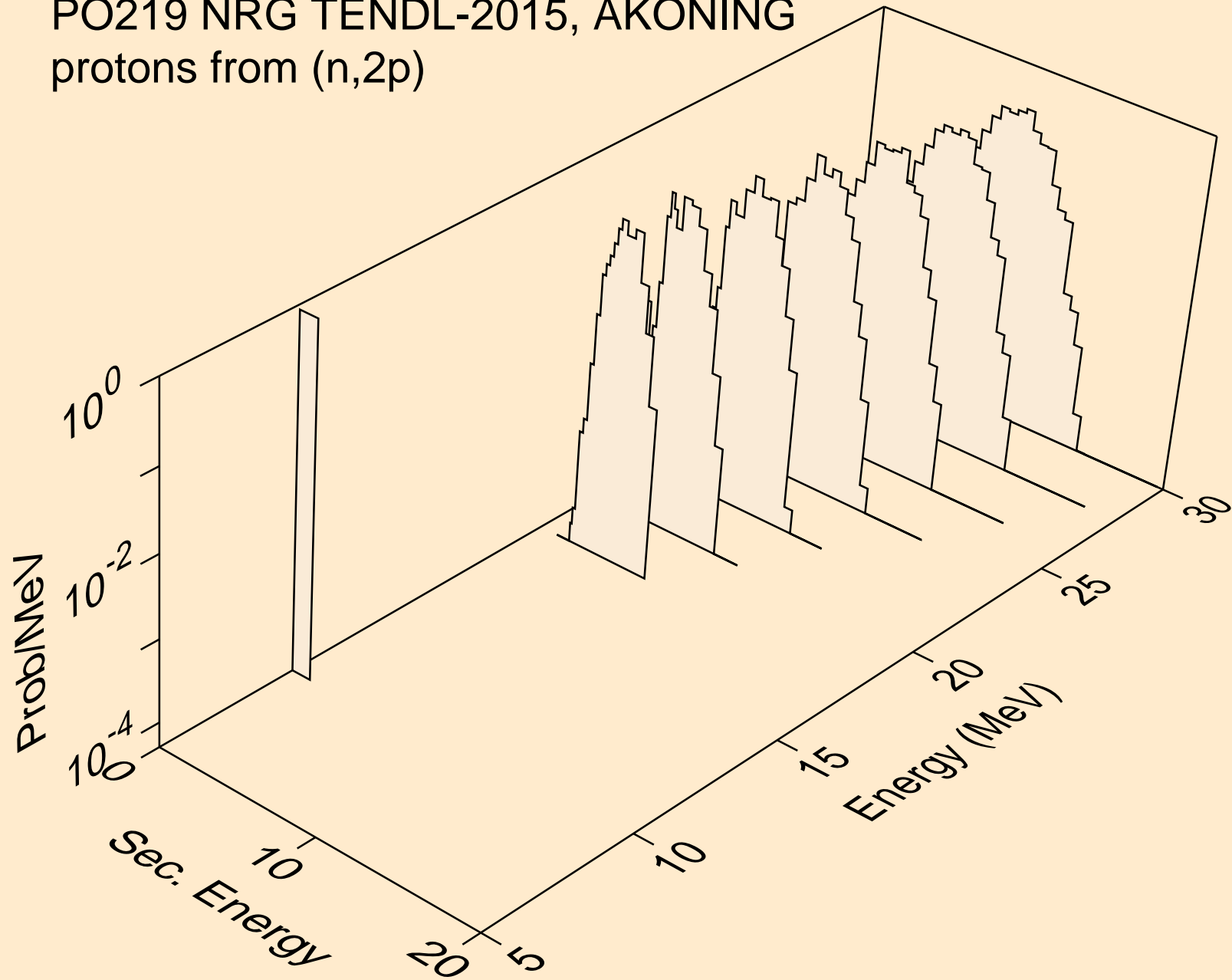

PO219 NRG TENDL-2015, AKONING  
deuterons from (n,x)

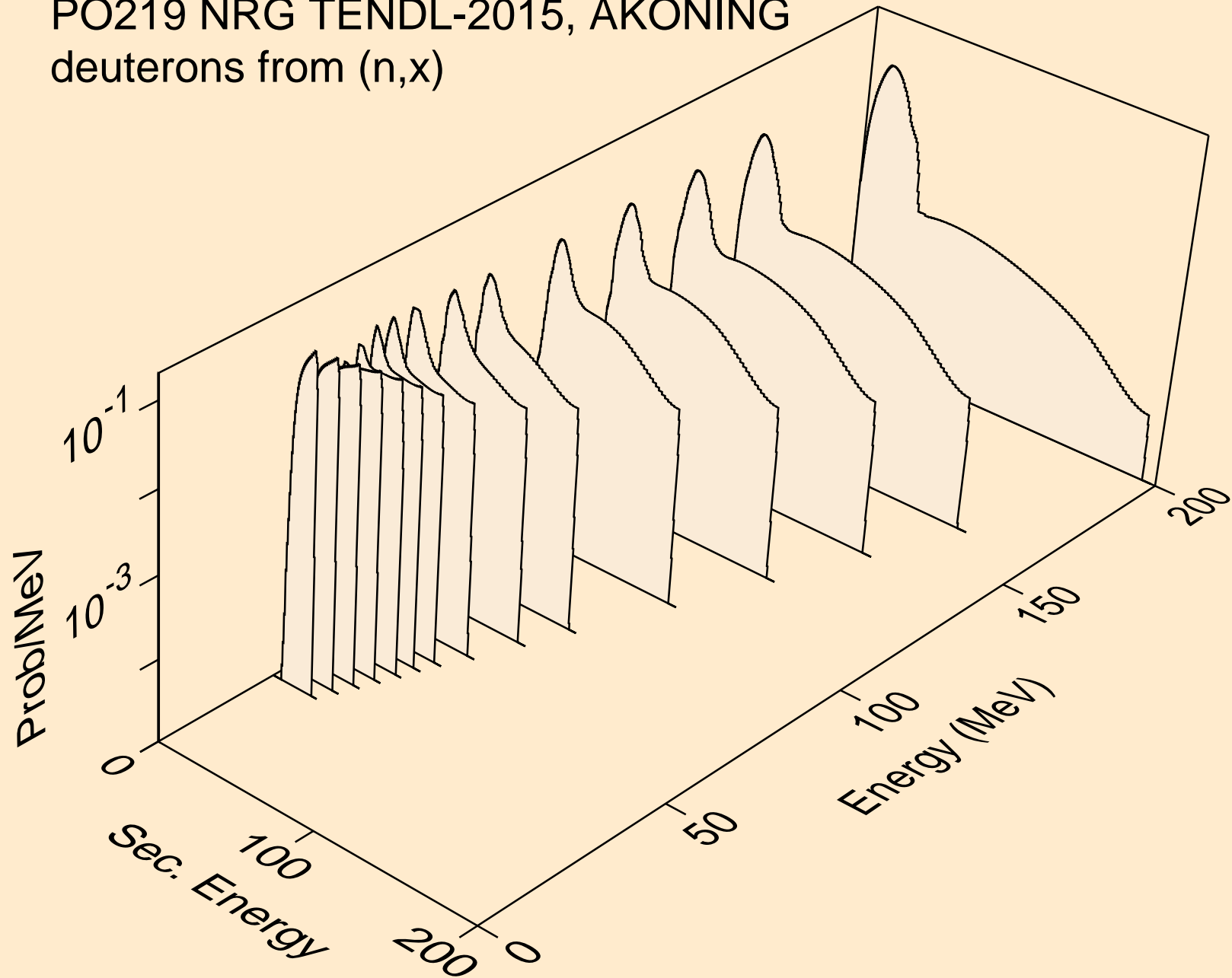

PO219 NRG TENDL-2015, AKONING  
deuterons from (n,2nd)

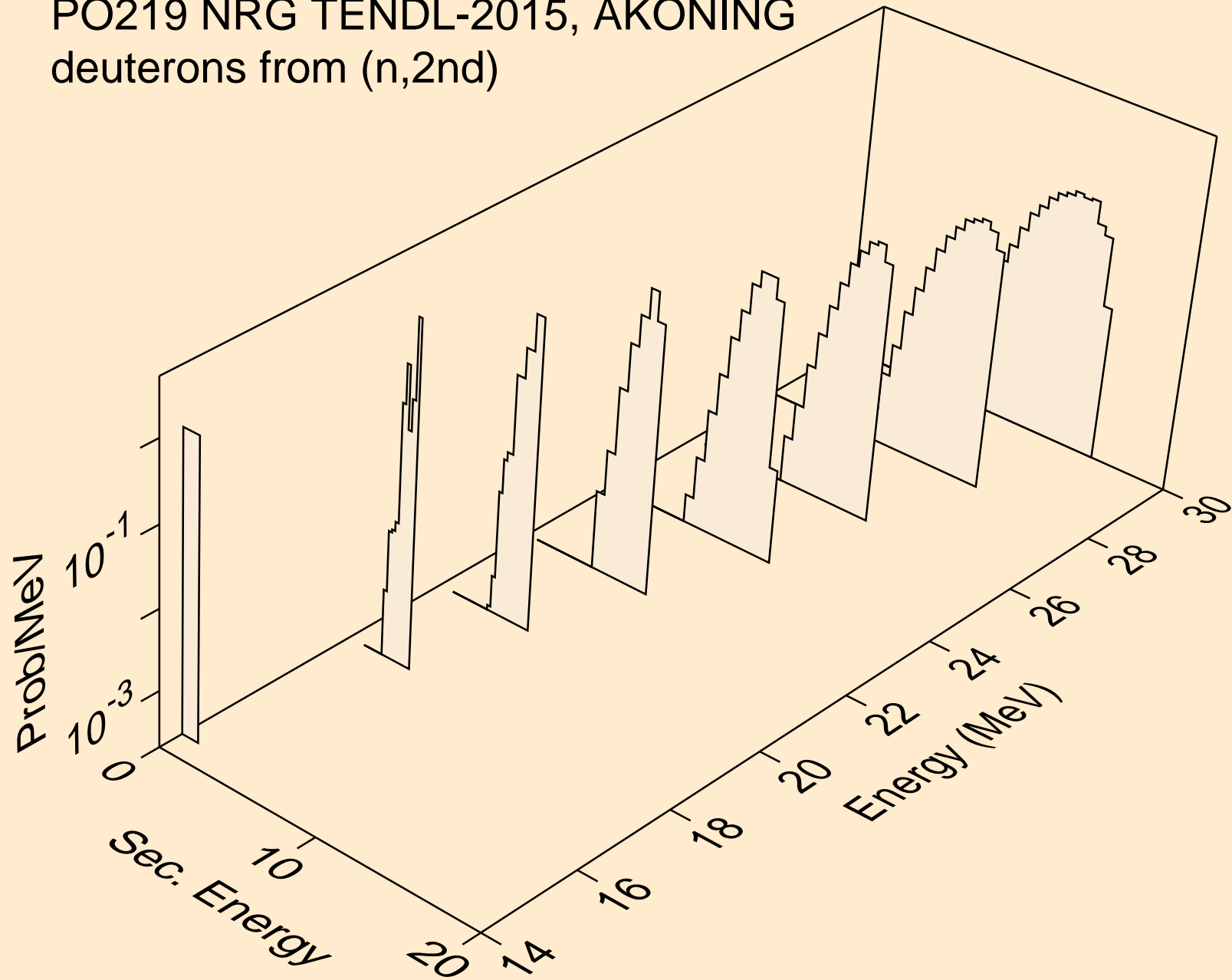

PO219 NRG TENDL-2015, AKONING  
deuterons from (n,n\*)d

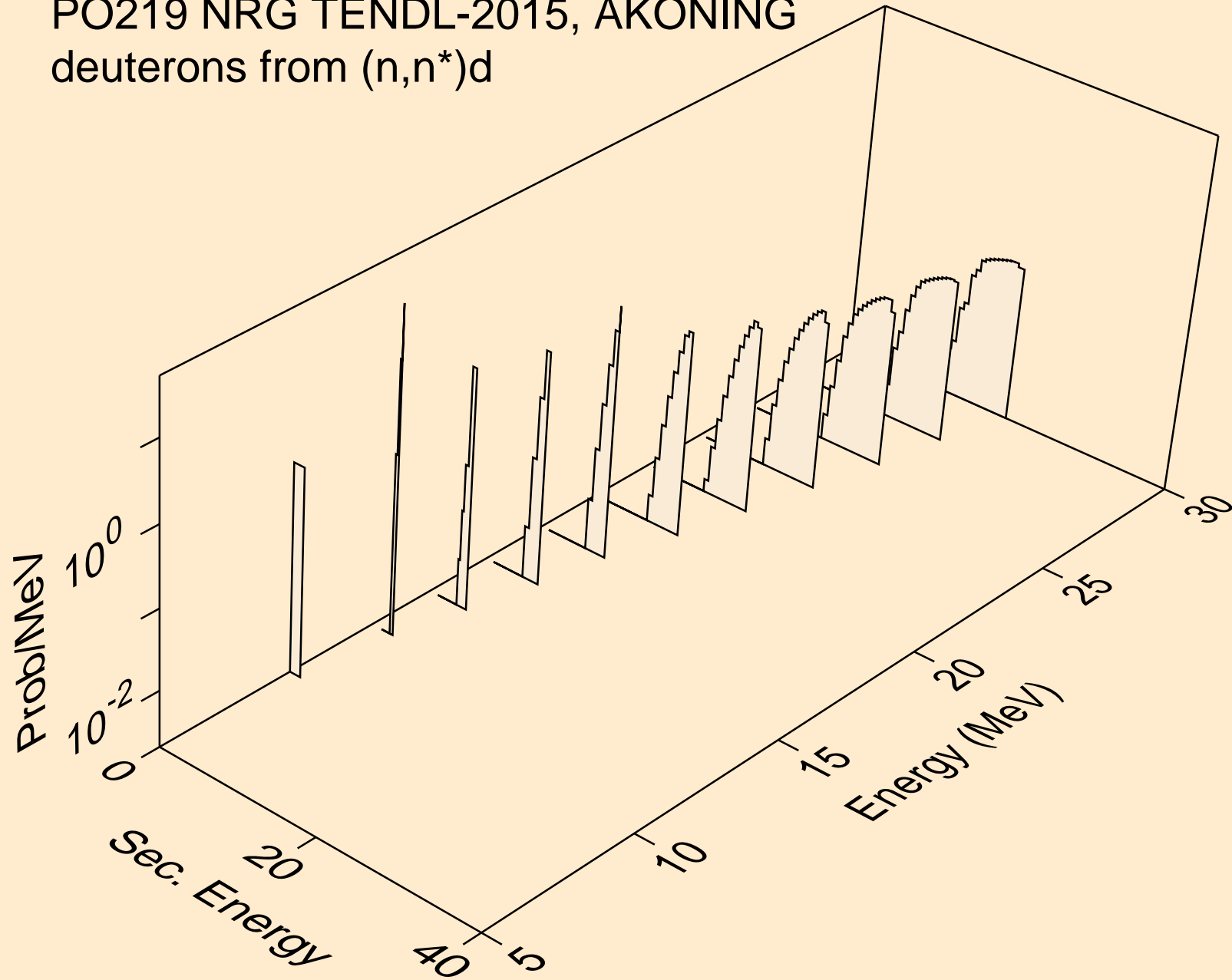

PO219 NRG TENDL-2015, AKONING  
deuterons from (n,d)

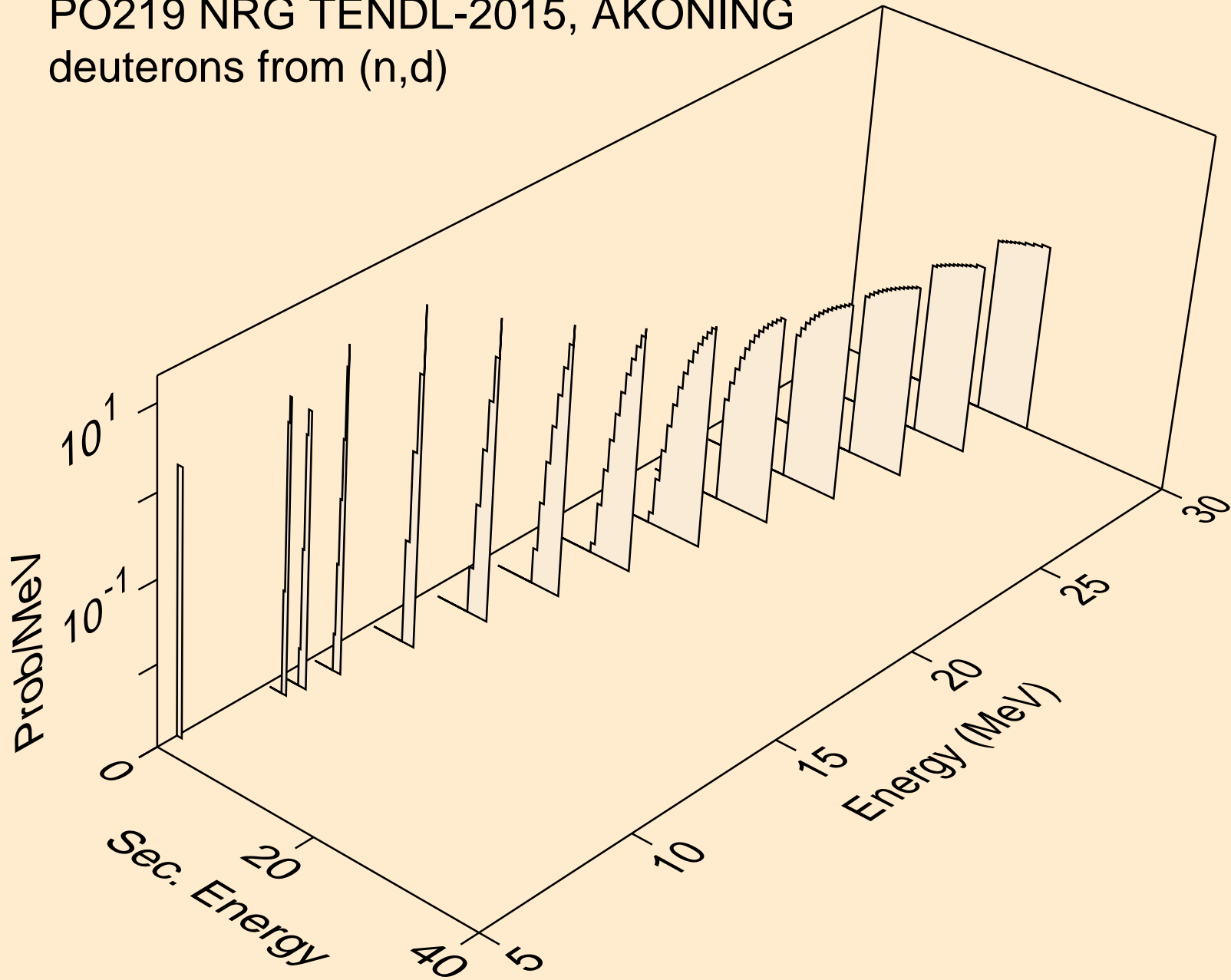

PO219 NRG TENDL-2015, AKONING  
tritons from (n,x)

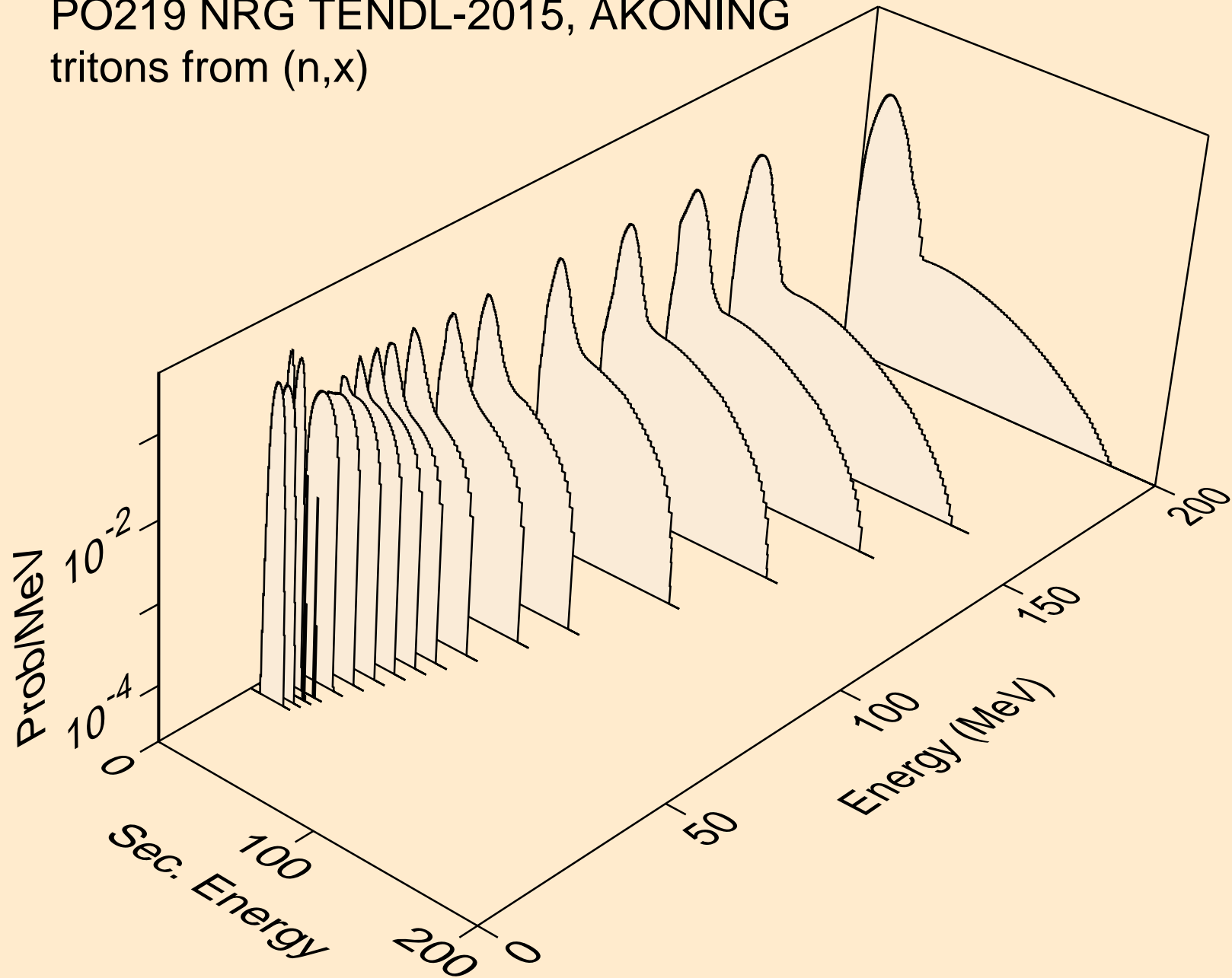



PO219 NRG TENDL-2015, AKONING  
tritons from (n,n\*)t

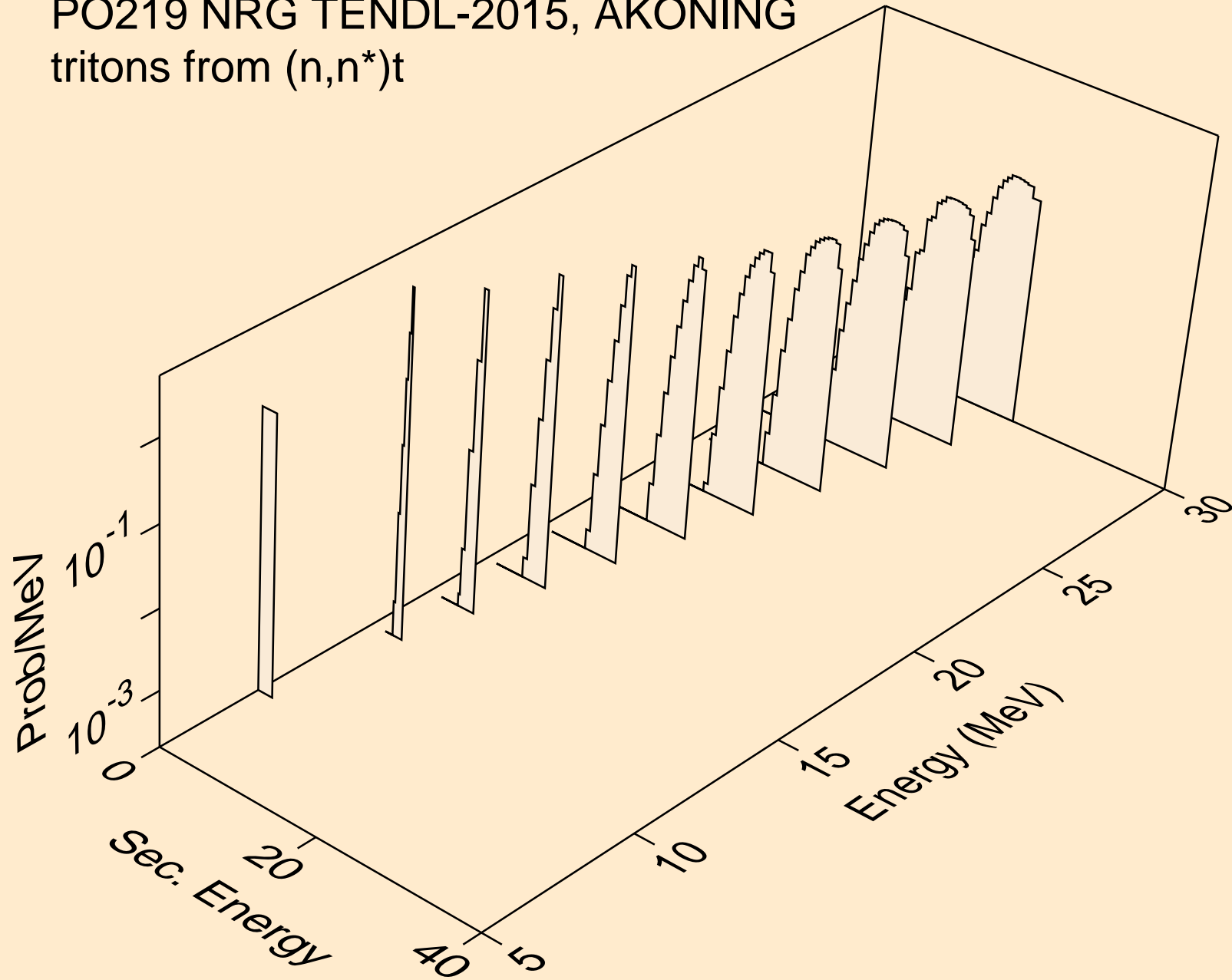

PO219 NRG TENDL-2015, AKONING  
tritons from (n,t)

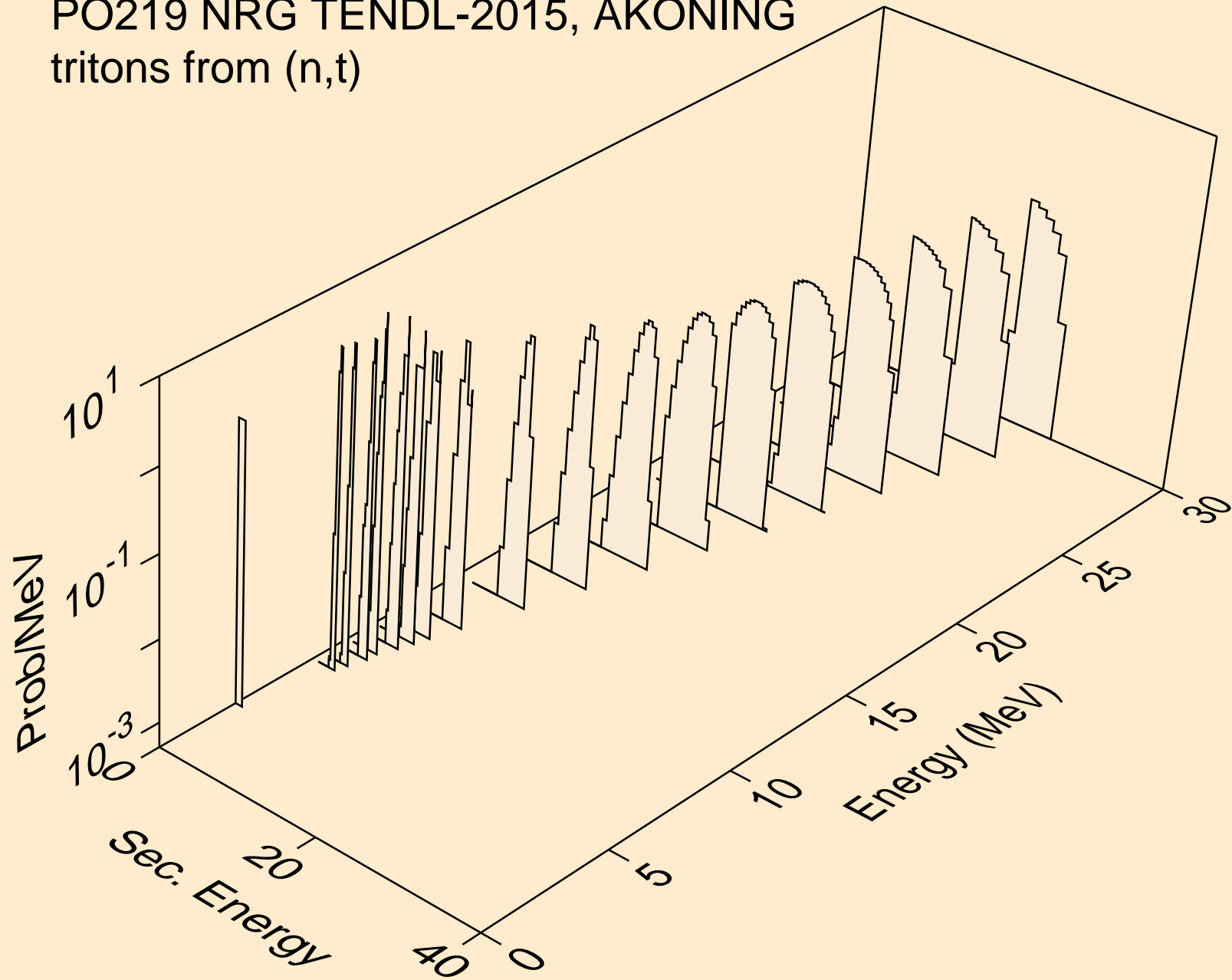

PO219 NRG TENDL-2015, AKONING  
he3s from (n,x)

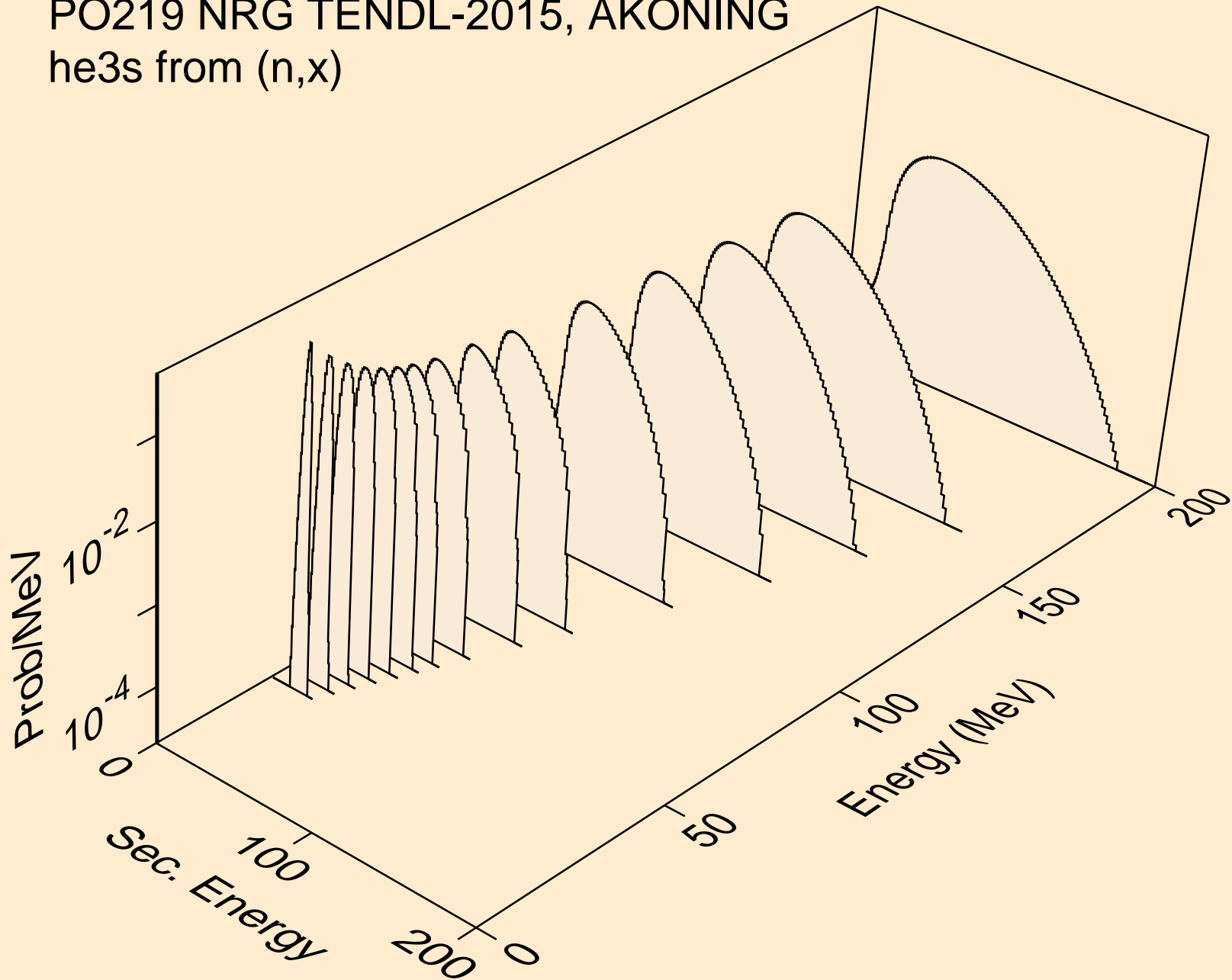

PO219 NRG TENDL-2015, AKONING  
he3s from (n,n\*)he3

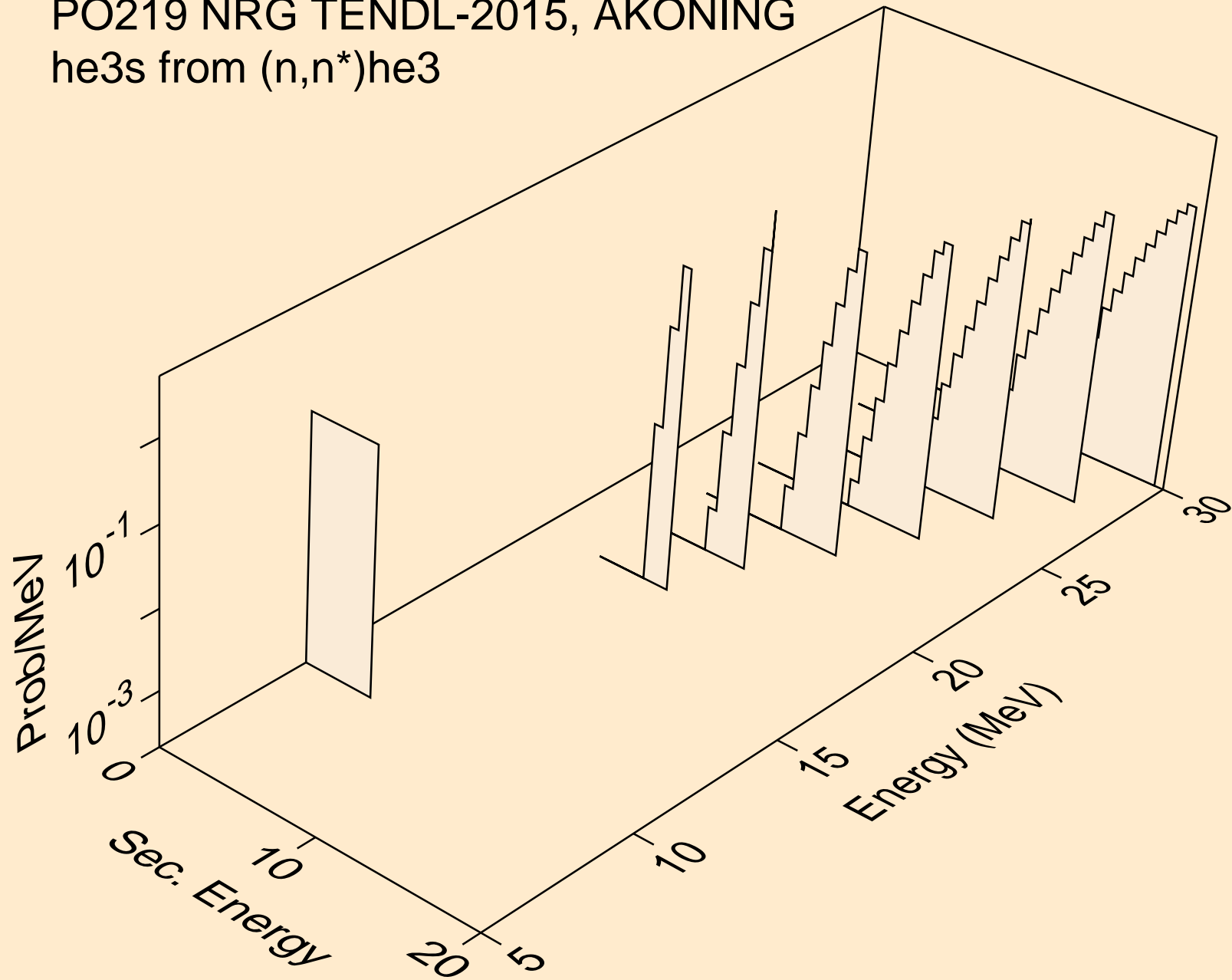

PO219 NRG TENDL-2015, AKONING  
he3s from (n,he3)

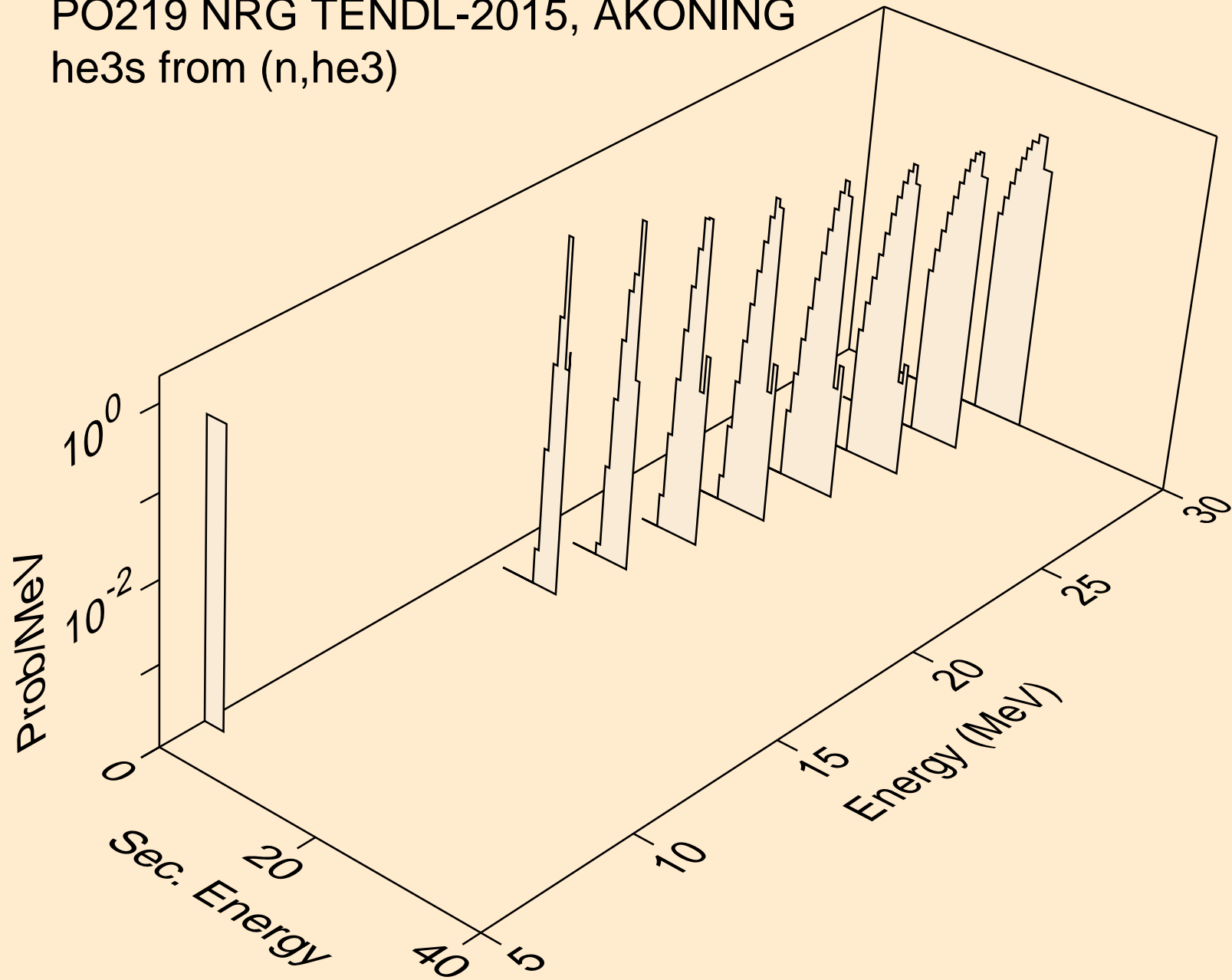

PO219 NRG TENDL-2015, AKONING  
alphas from (n,x)

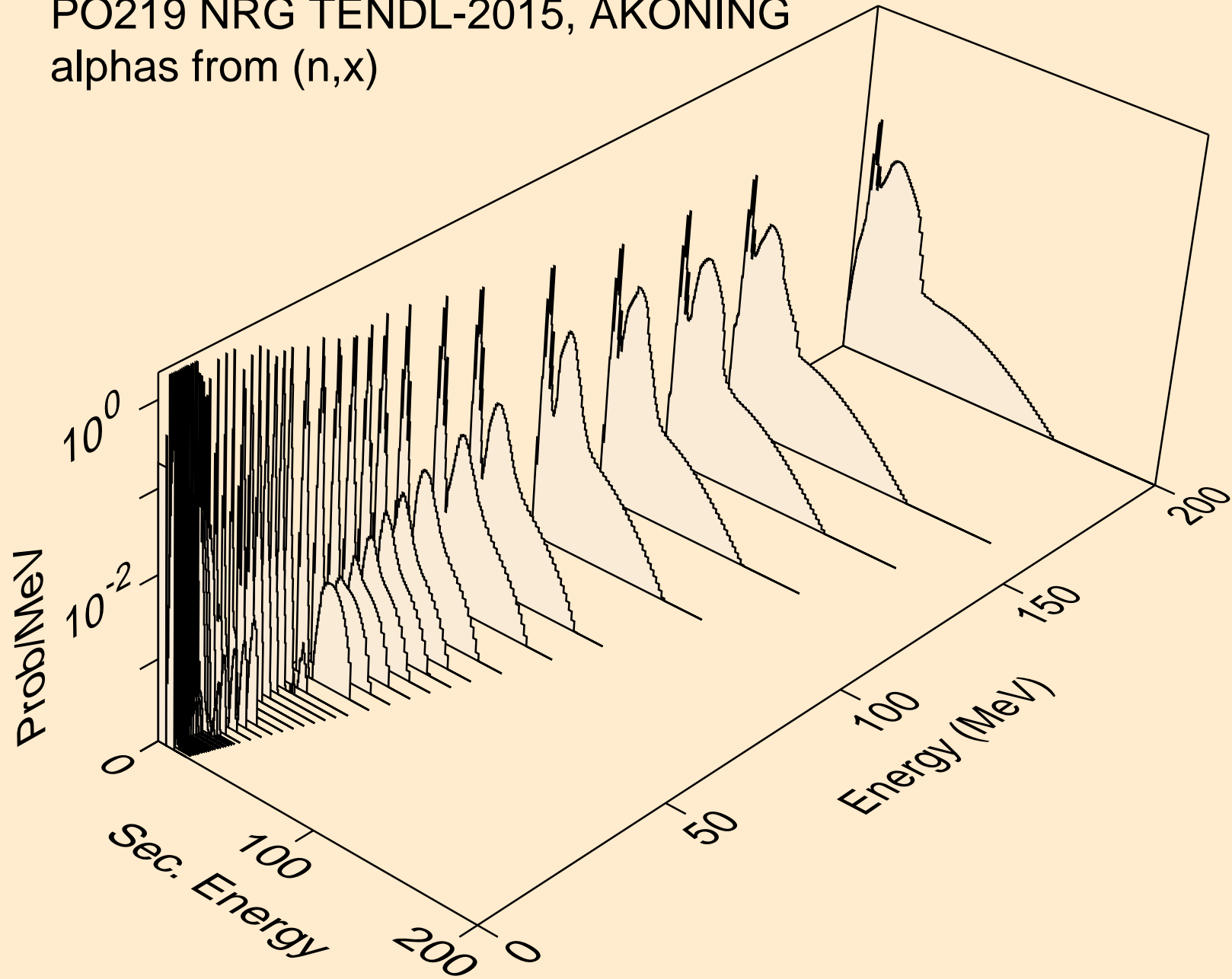

PO219 NRG TENDL-2015, AKONING  
alphas from (n,n\*)a

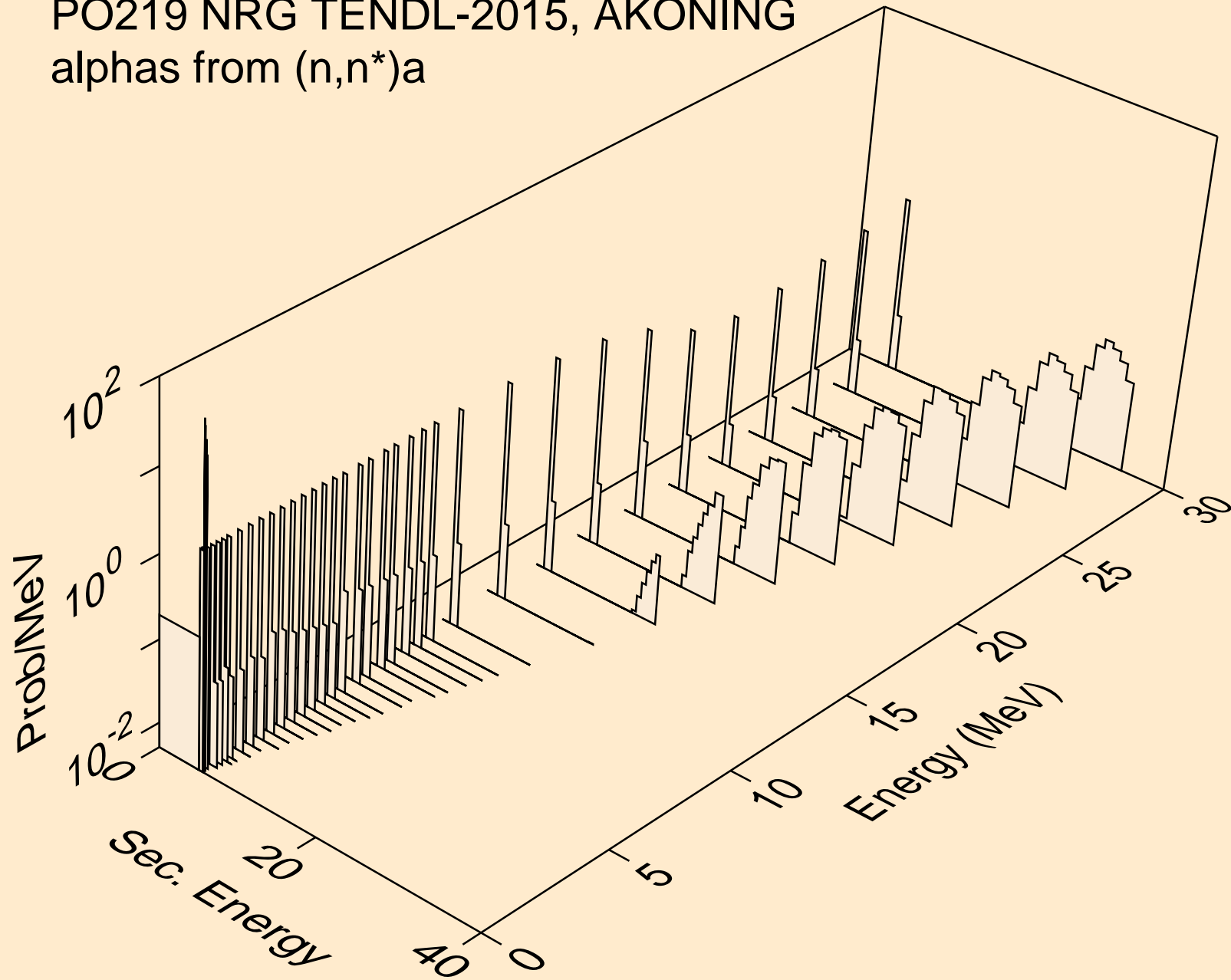

PO219 NRG TENDL-2015, AKONING  
alphas from (n,2n)a

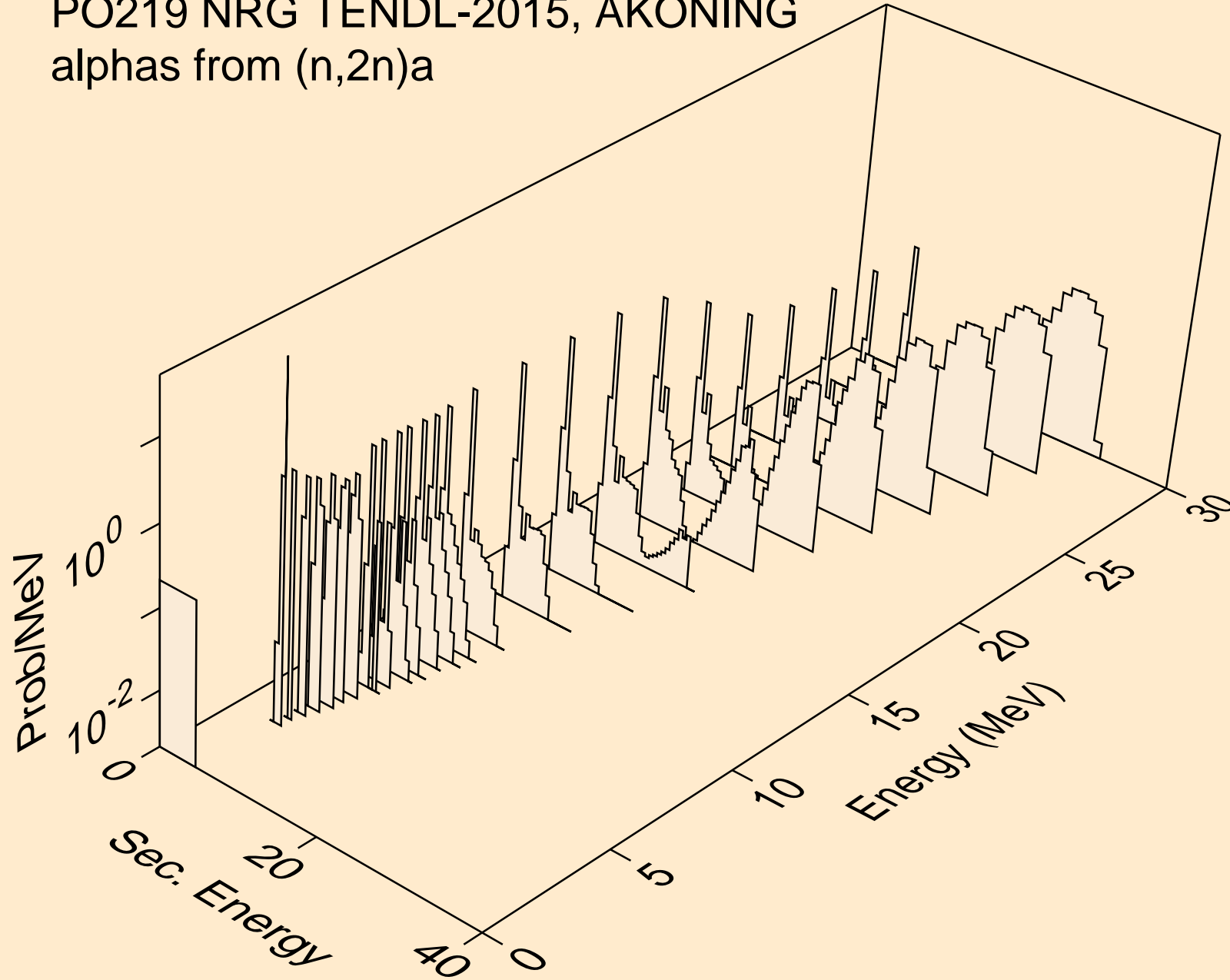



PO219 NRG TENDL-2015, AKONING  
alphas from (n,3n)a

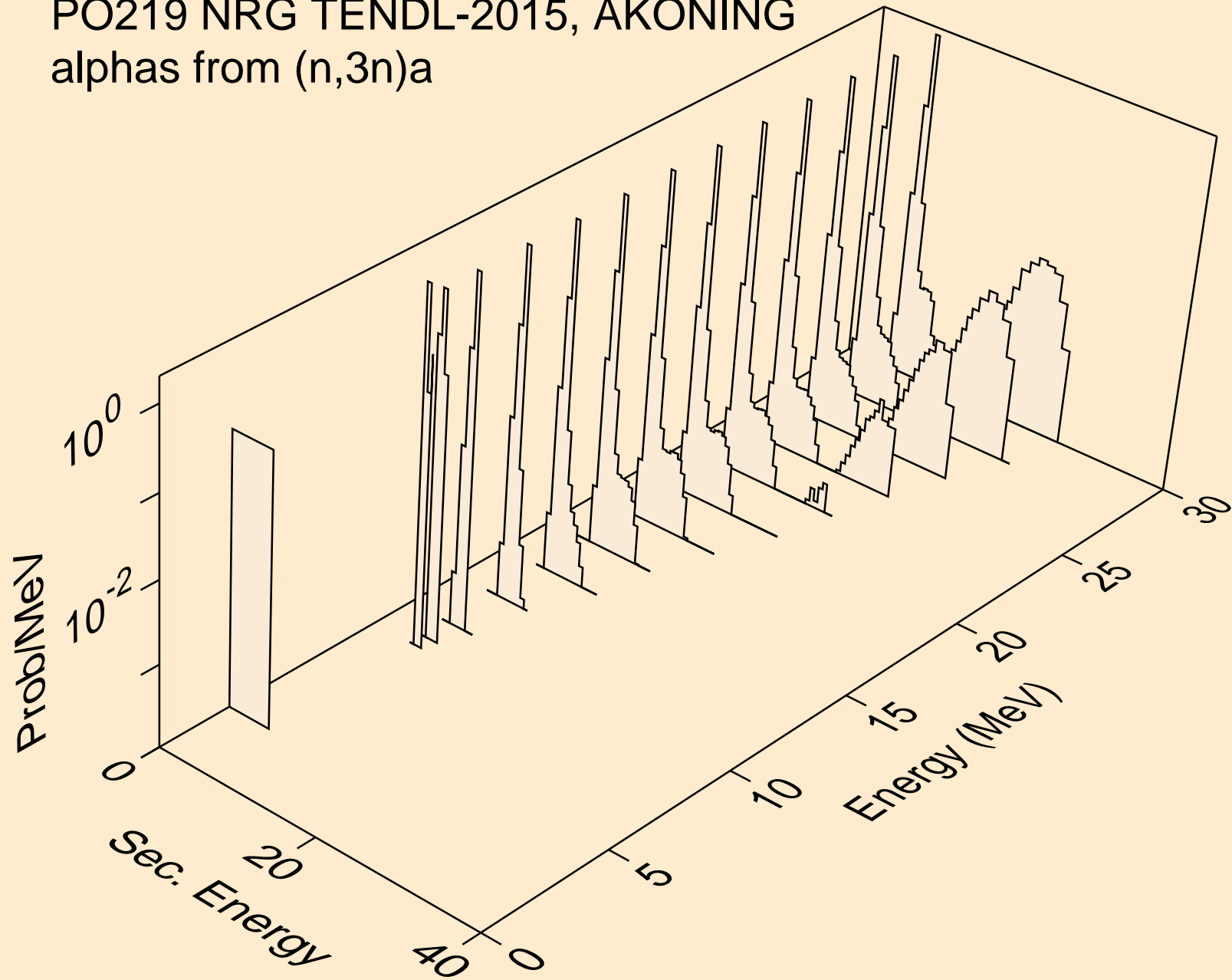

PO219 NRG TENDL-2015, AKONING  
alphas from (n,a)

