

# RF259 NRG TENDL-2015, AKONING

## Principal cross sections

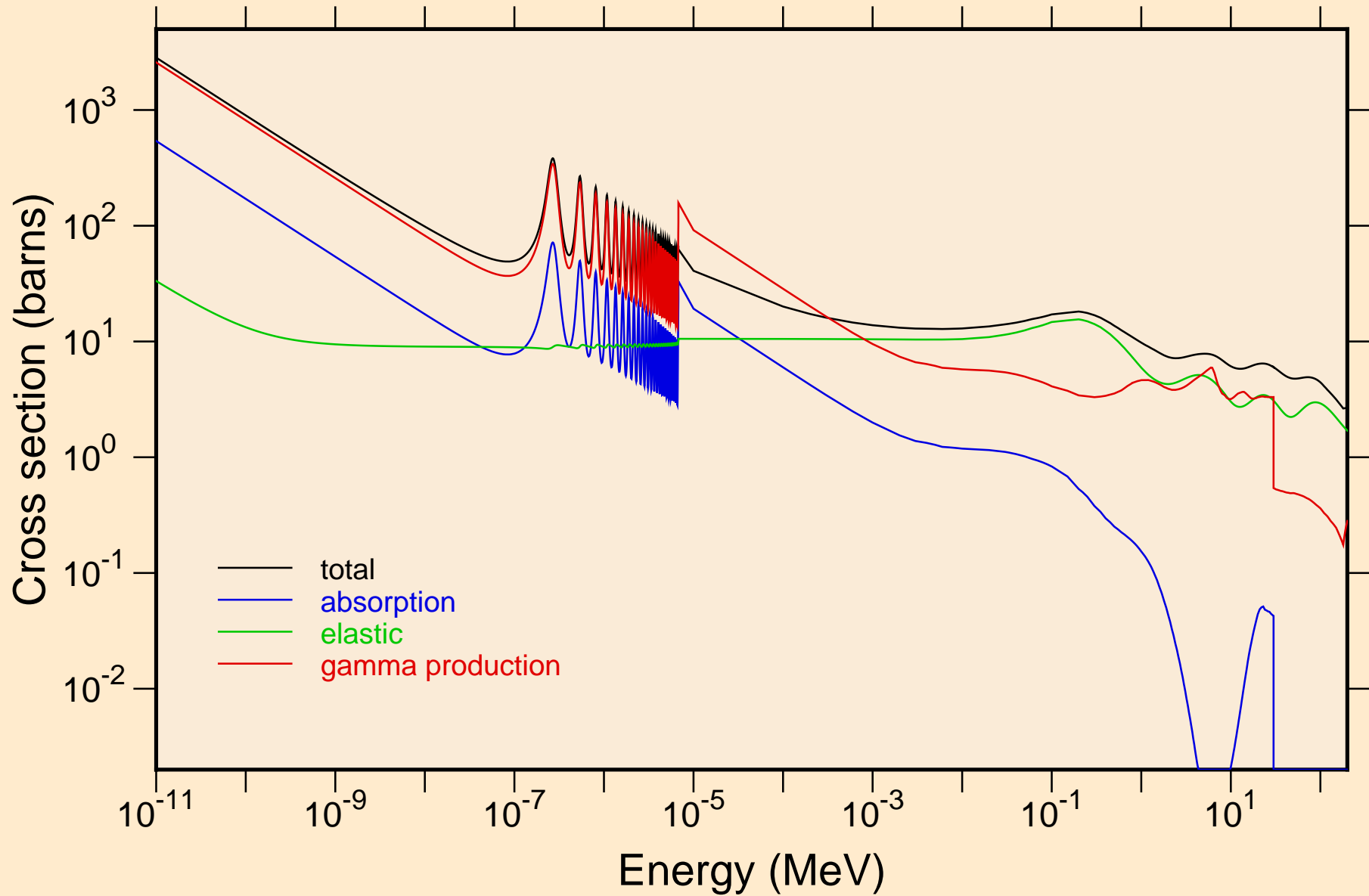

# RF259 NRG TENDL-2015, AKONING

## Non-threshold reactions

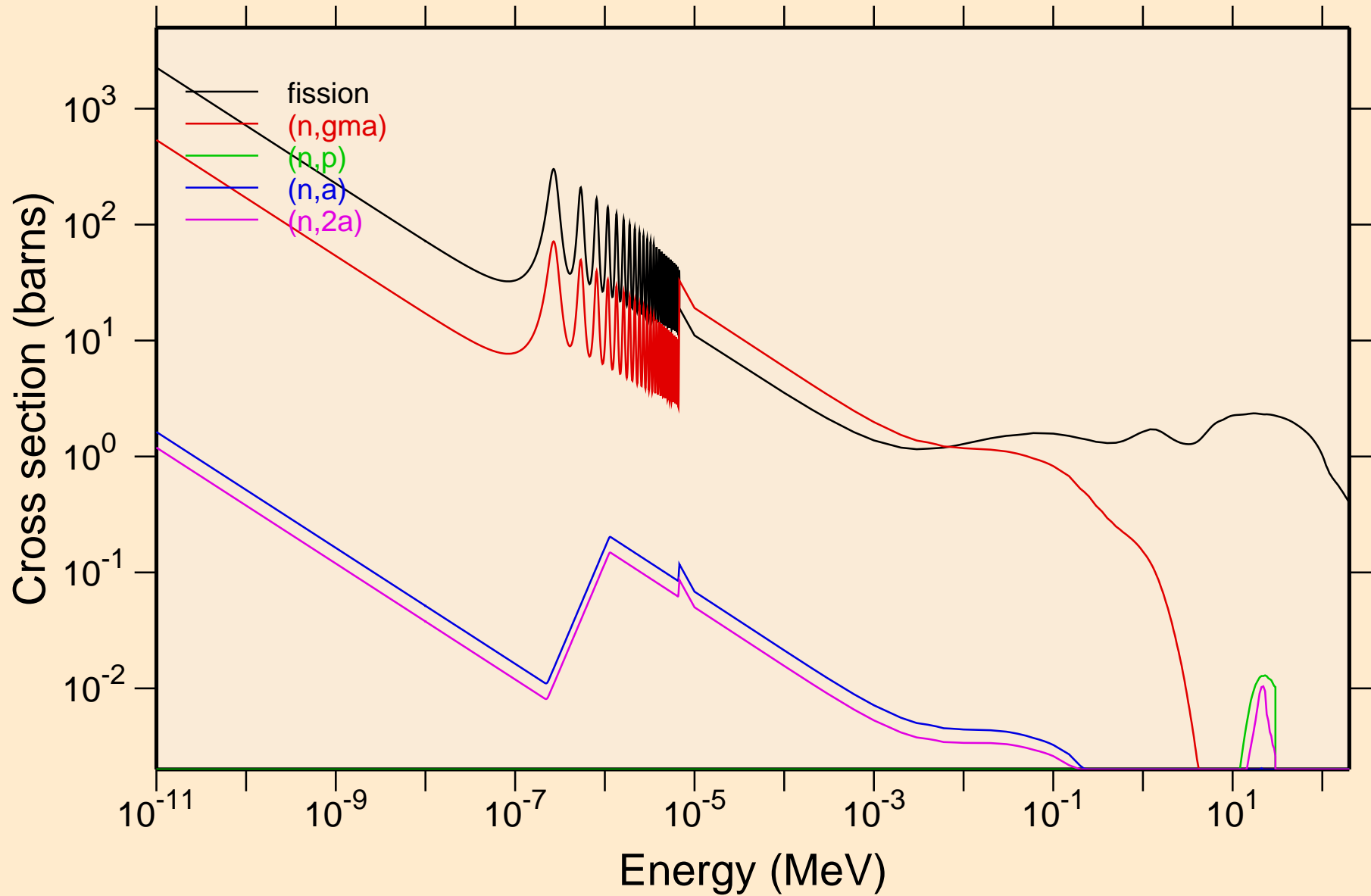

# RF259 NRG TENDL-2015, AKONING

## Non-threshold reactions

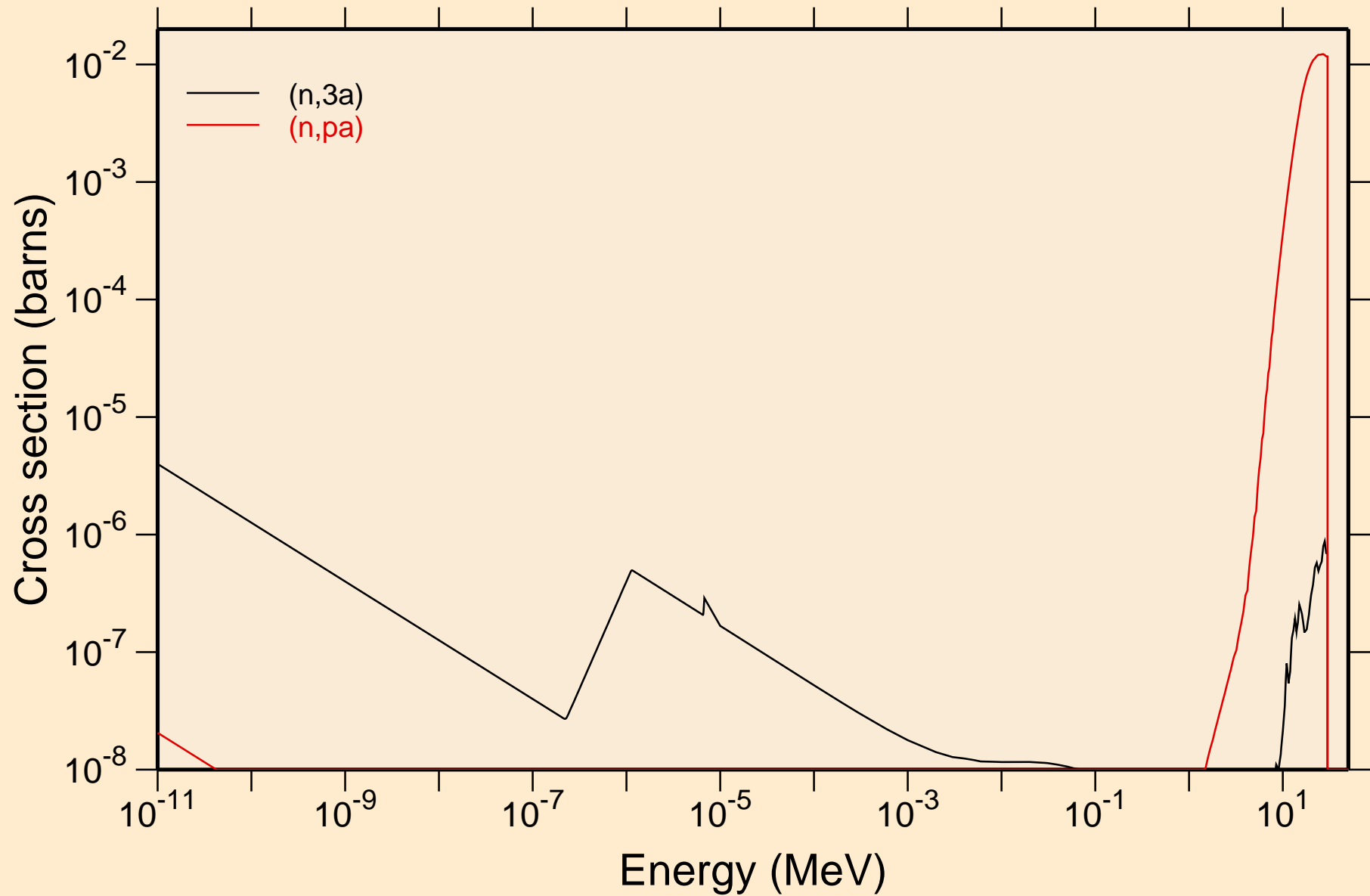

# RF259 NRG TENDL-2015, AKONING

## Principal cross sections

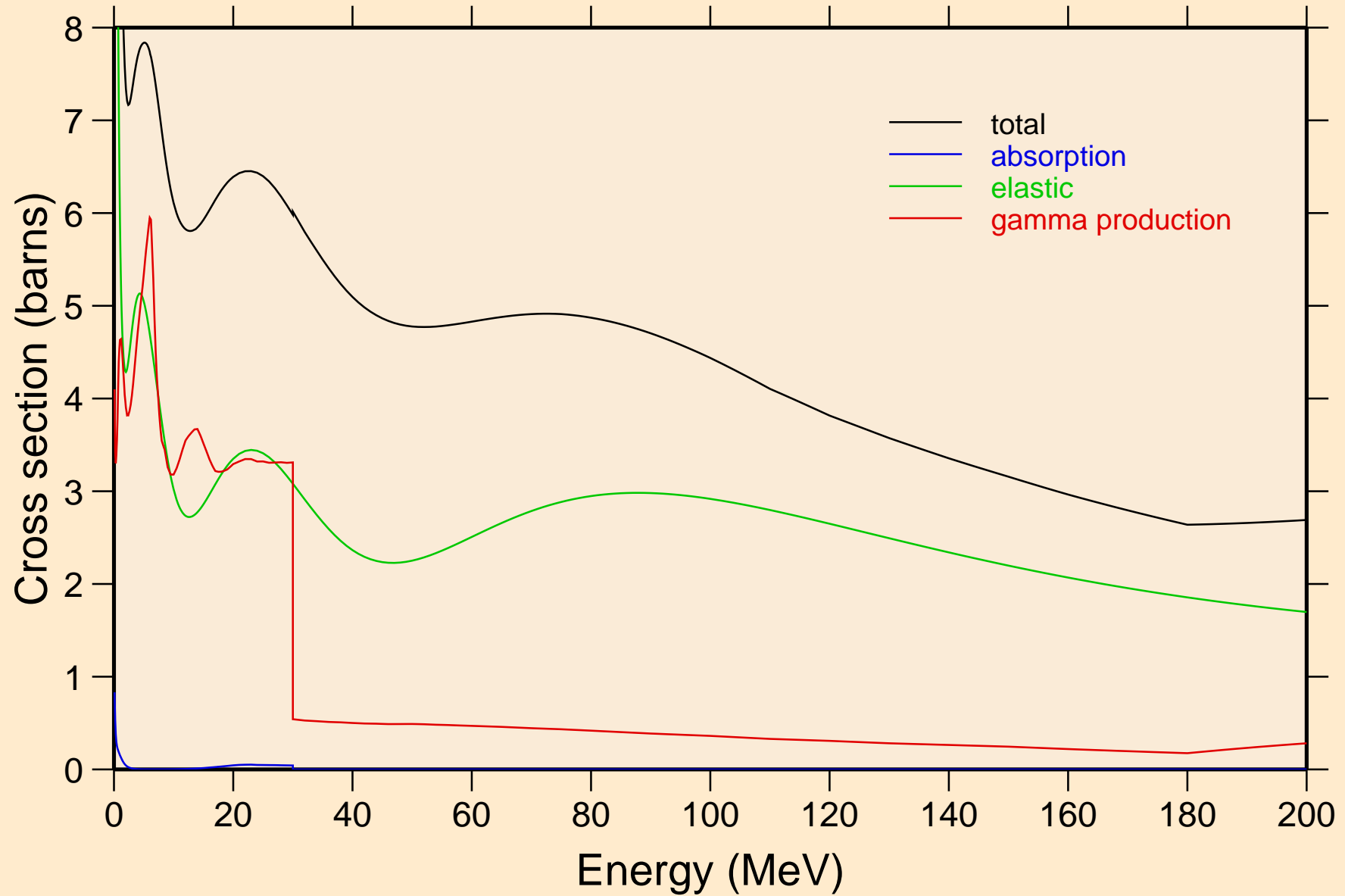

# RF259 NRG TENDL-2015, AKONING

## Non-threshold reactions

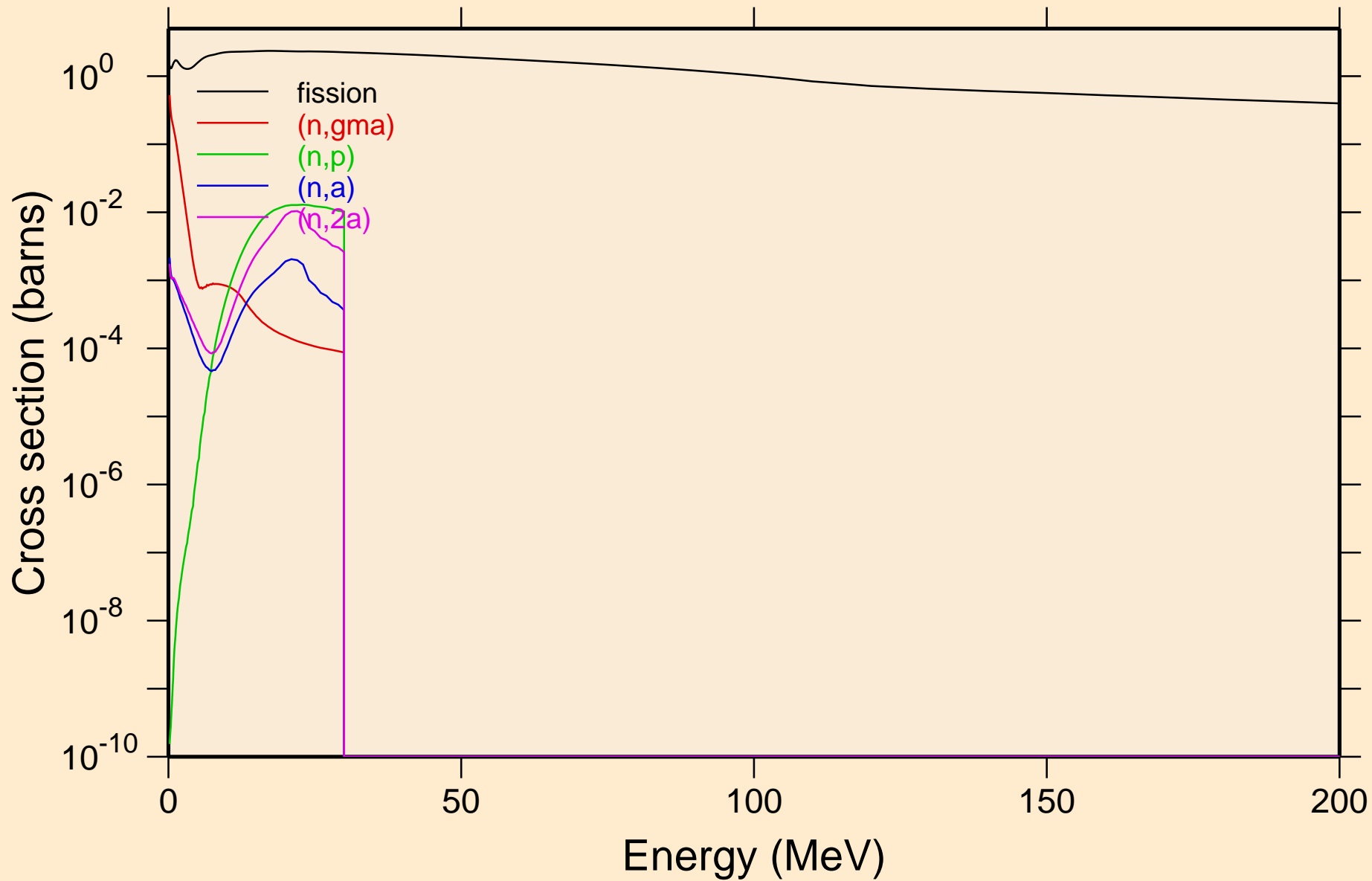

RF259 NRG TENDL-2015, AKONING  
Non-threshold reactions

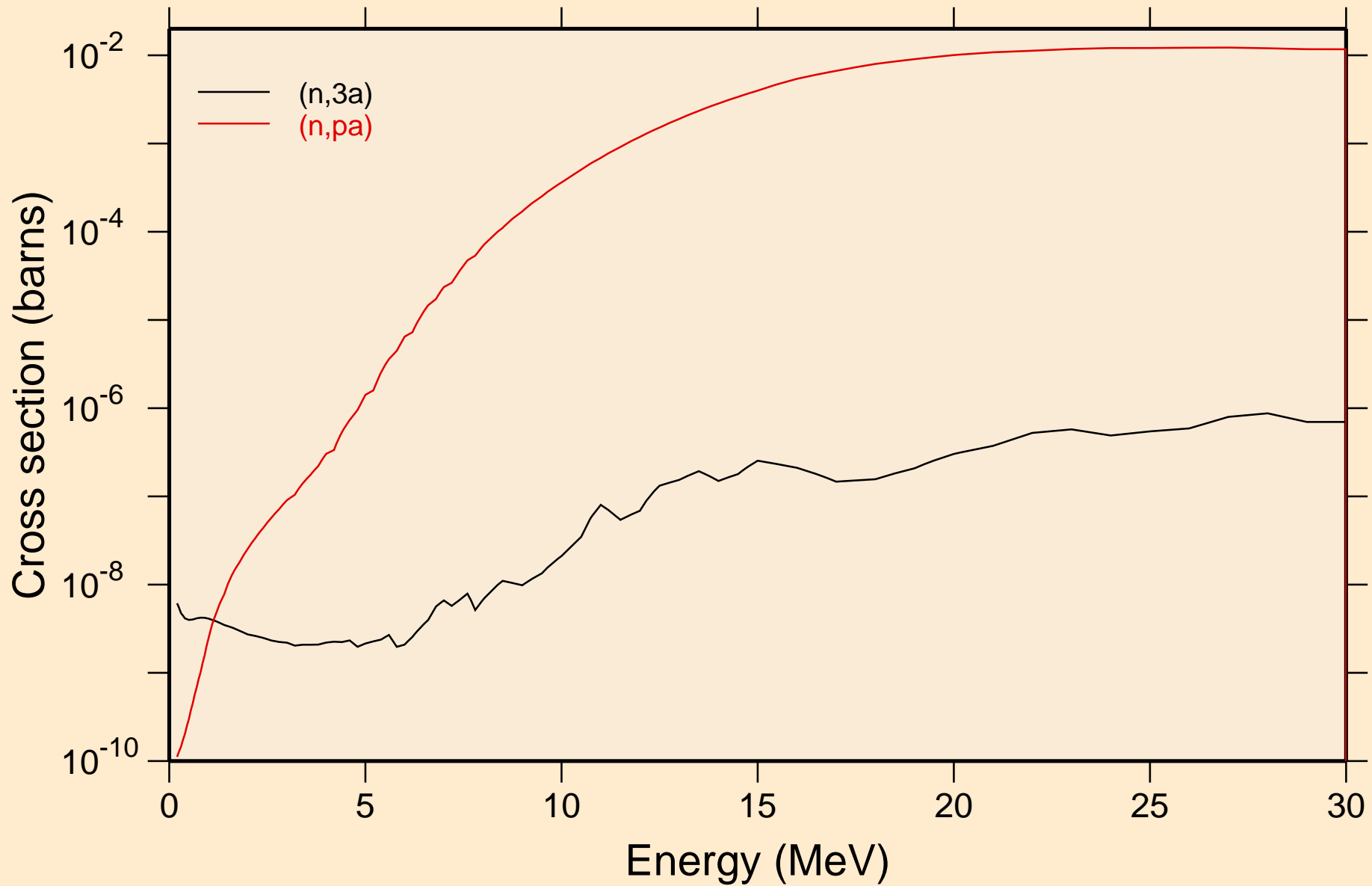

RF259 NRG TENDL-2015, AKONING  
Inelastic levels

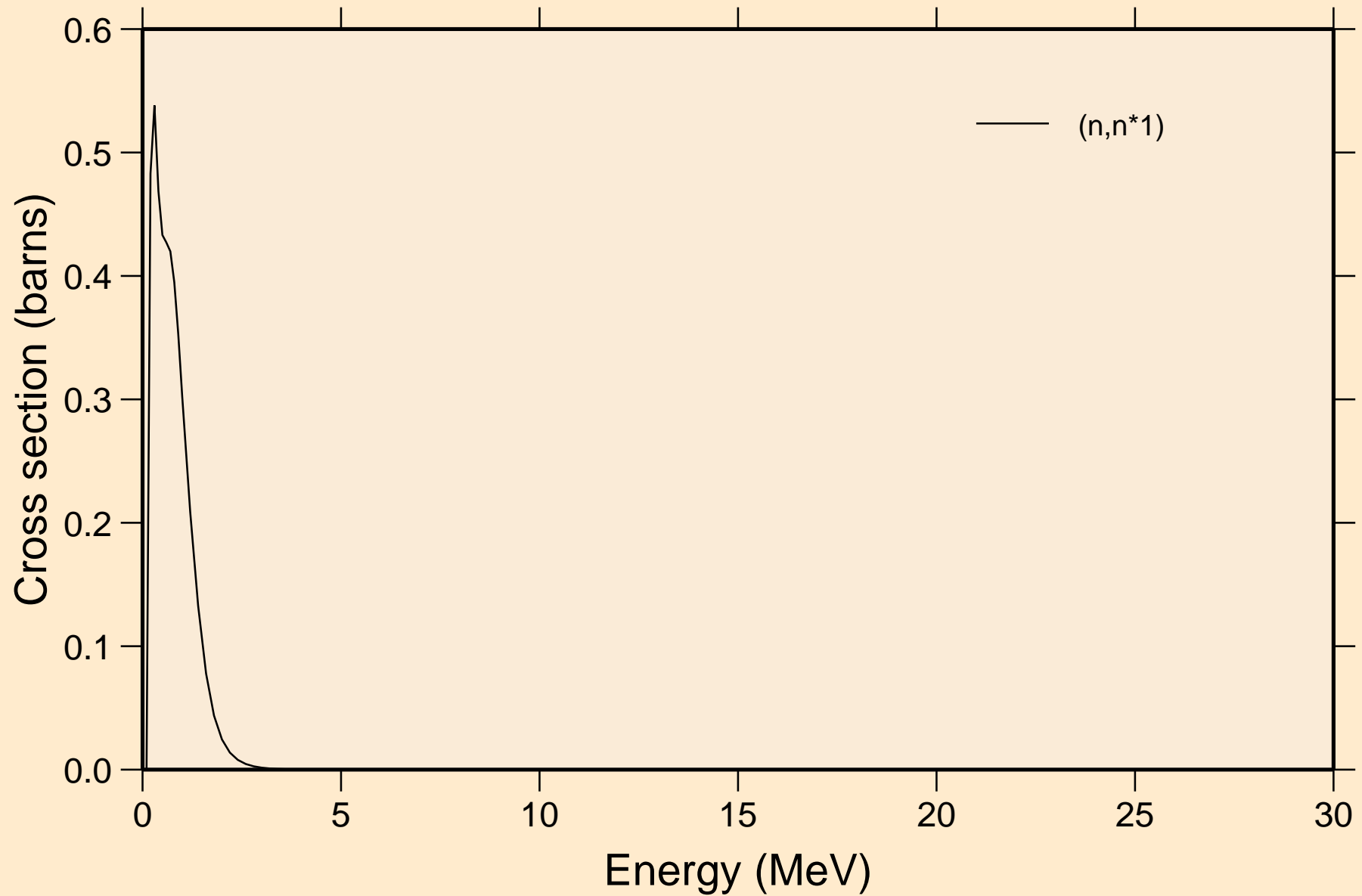

# RF259 NRG TENDL-2015, AKONING

## Threshold reactions

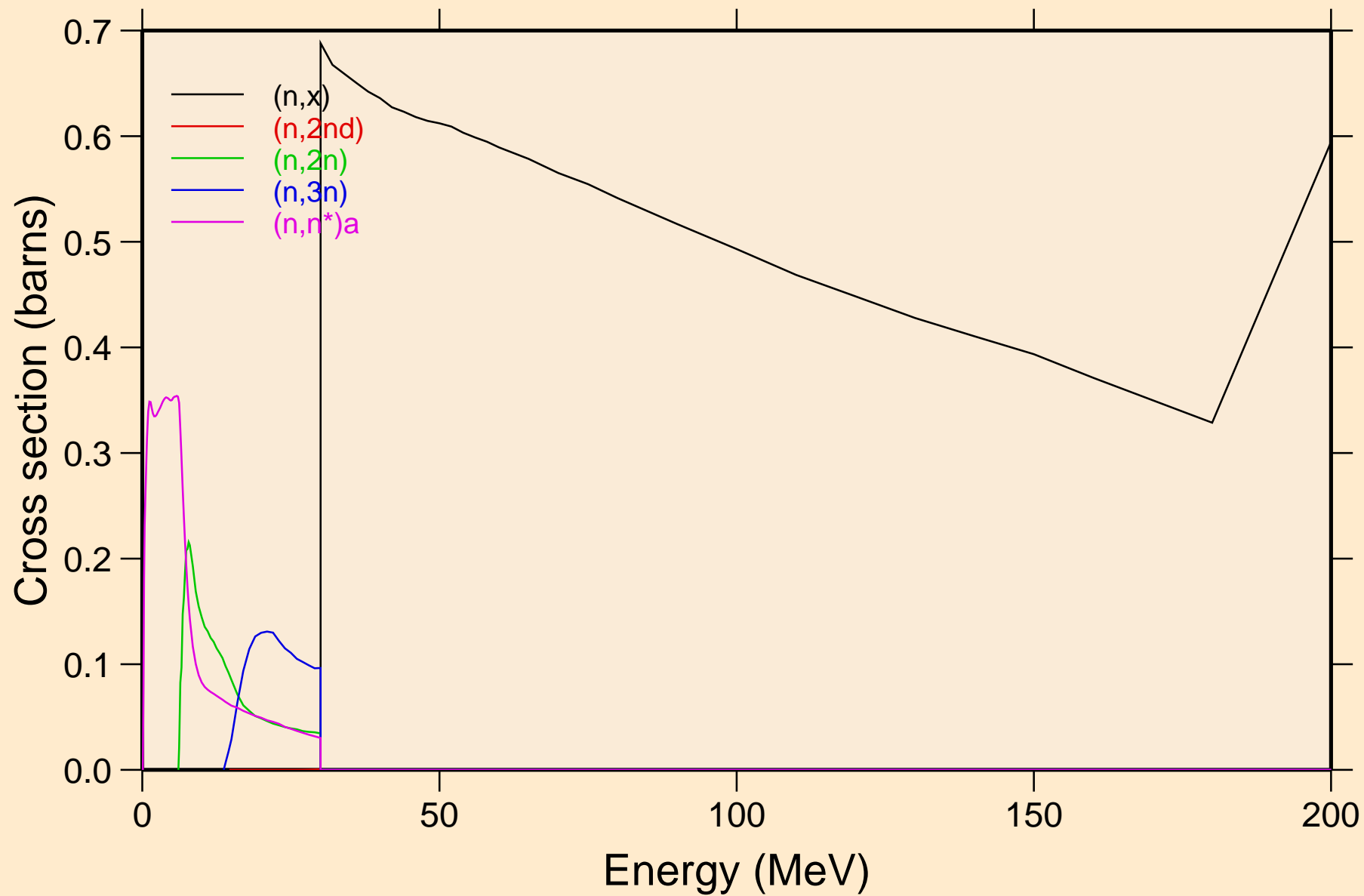



# RF259 NRG TENDL-2015, AKONING

## Threshold reactions

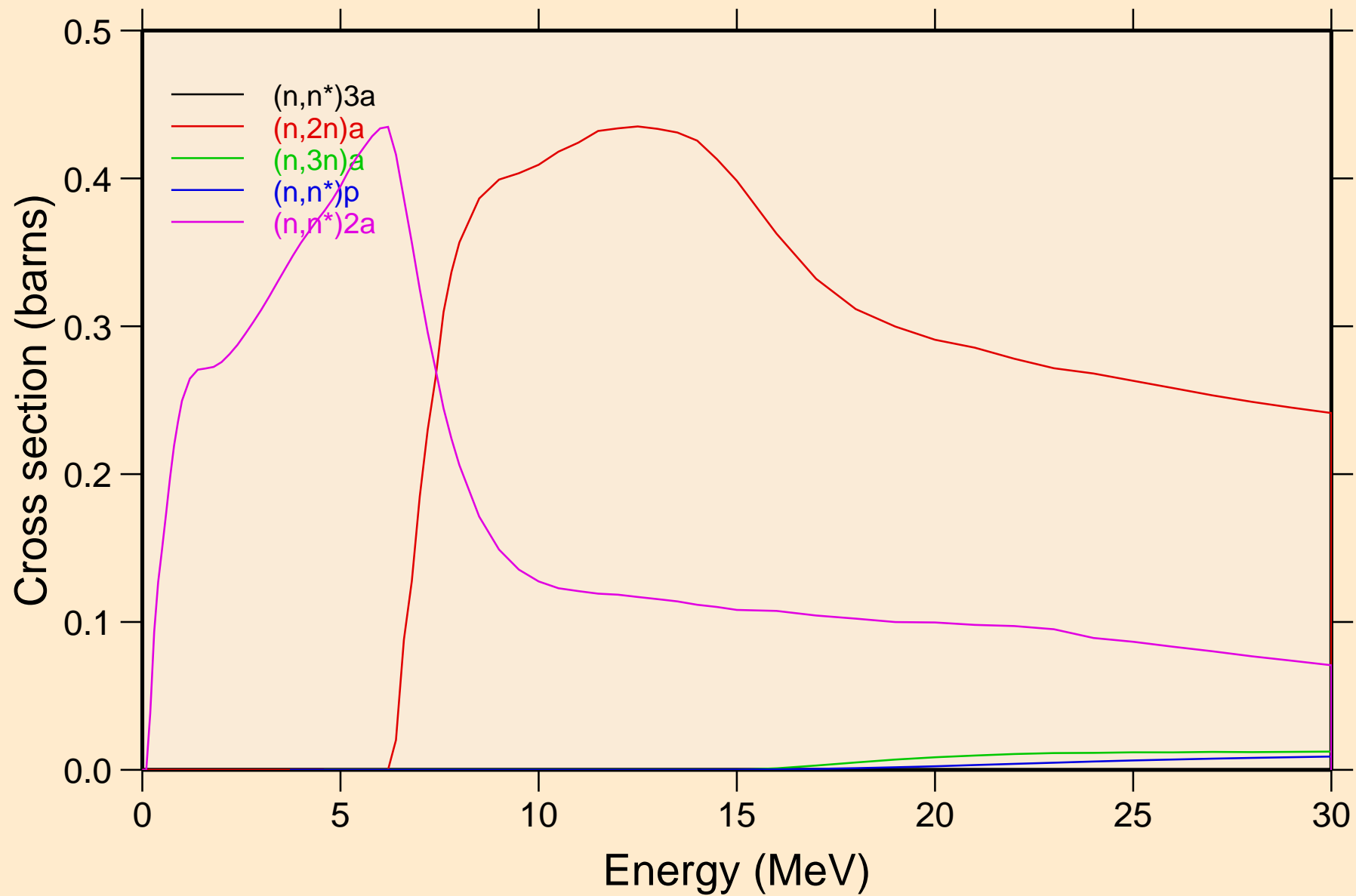

# RF259 NRG TENDL-2015, AKONING

## Threshold reactions

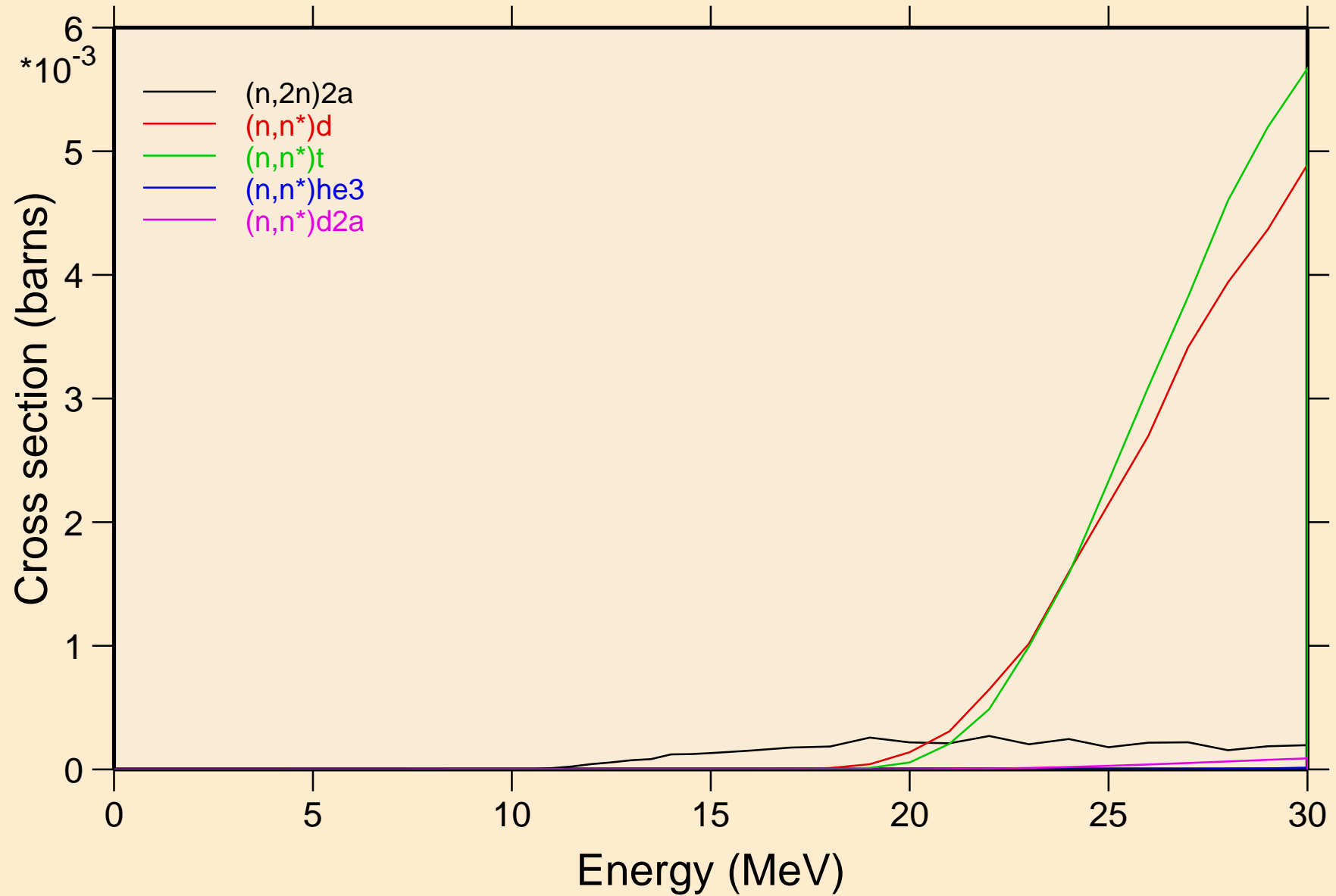

# RF259 NRG TENDL-2015, AKONING

## Threshold reactions

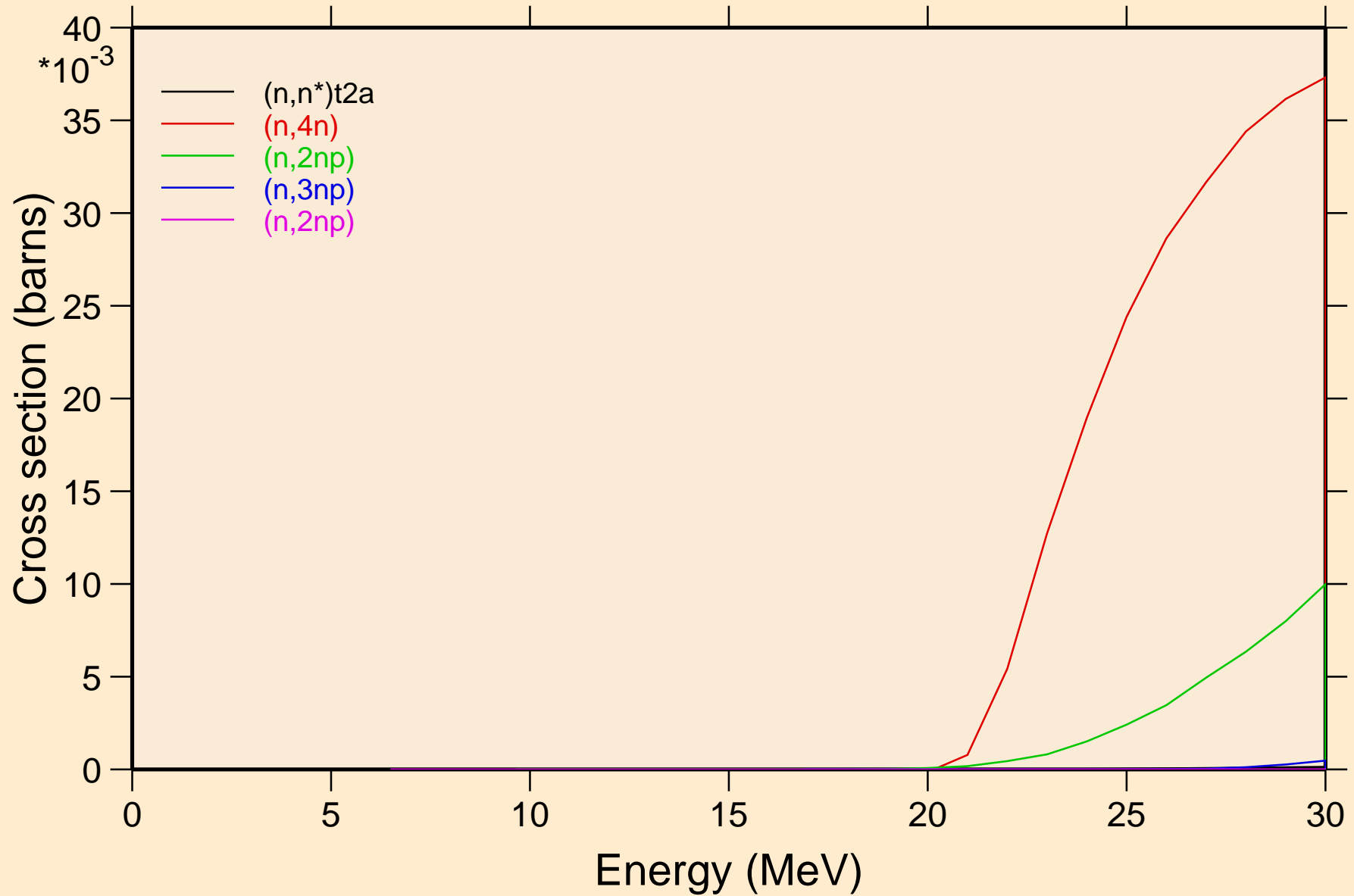

# RF259 NRG TENDL-2015, AKONING

## Threshold reactions

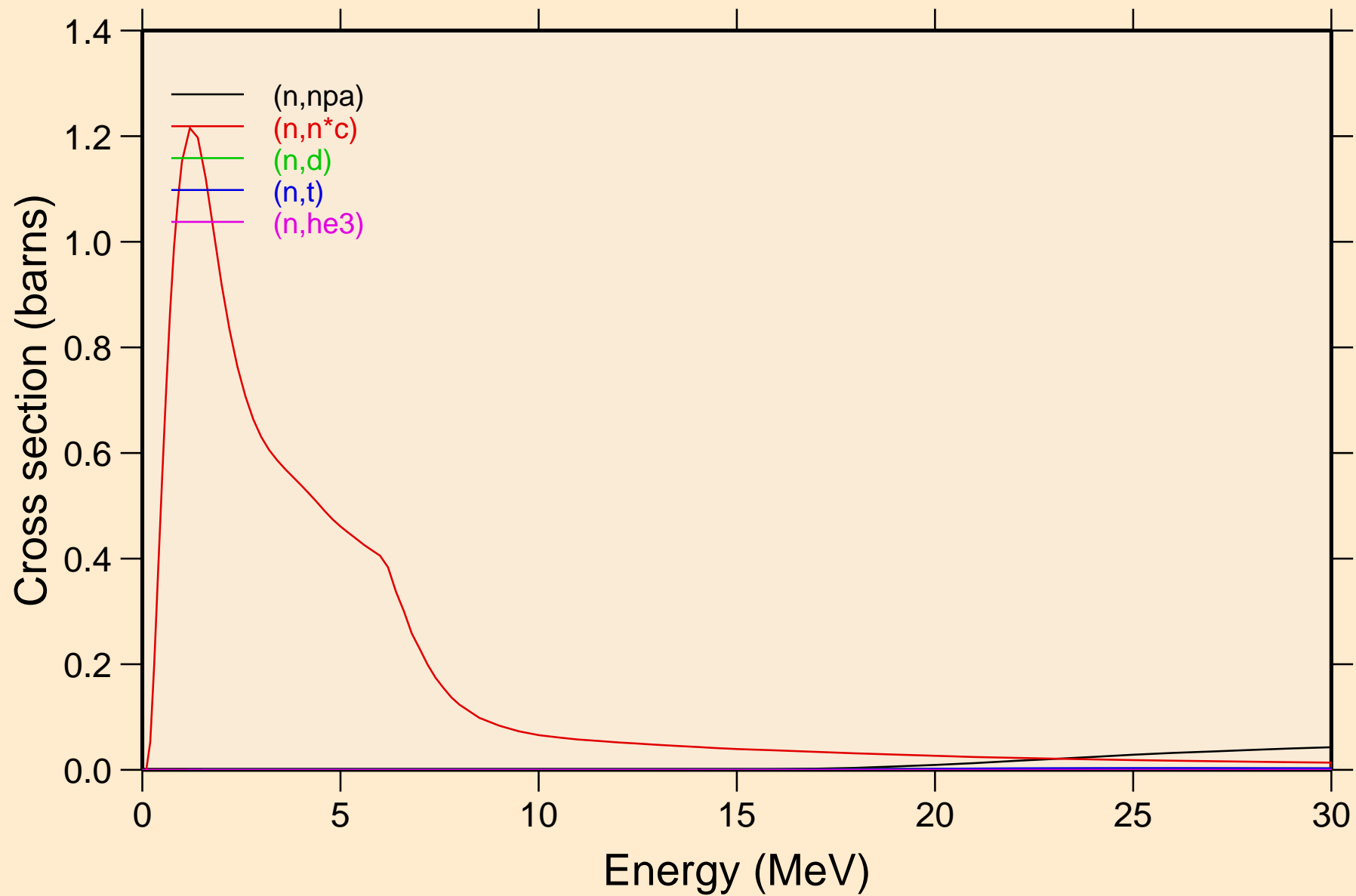

# RF259 NRG TENDL-2015, AKONING

## Threshold reactions

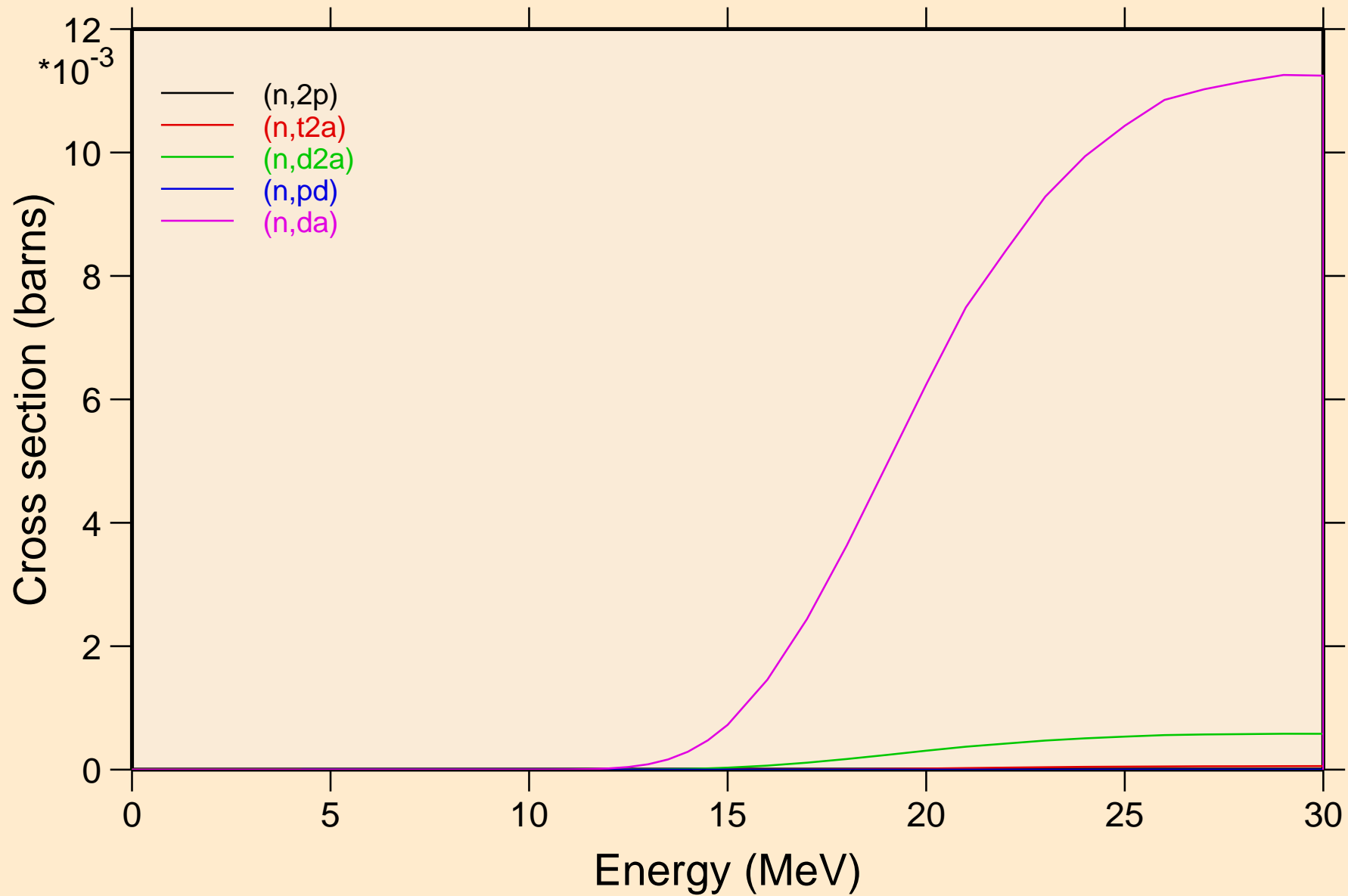

RF259 NRG TENDL-2015, AKONING  
angular distribution for elastic

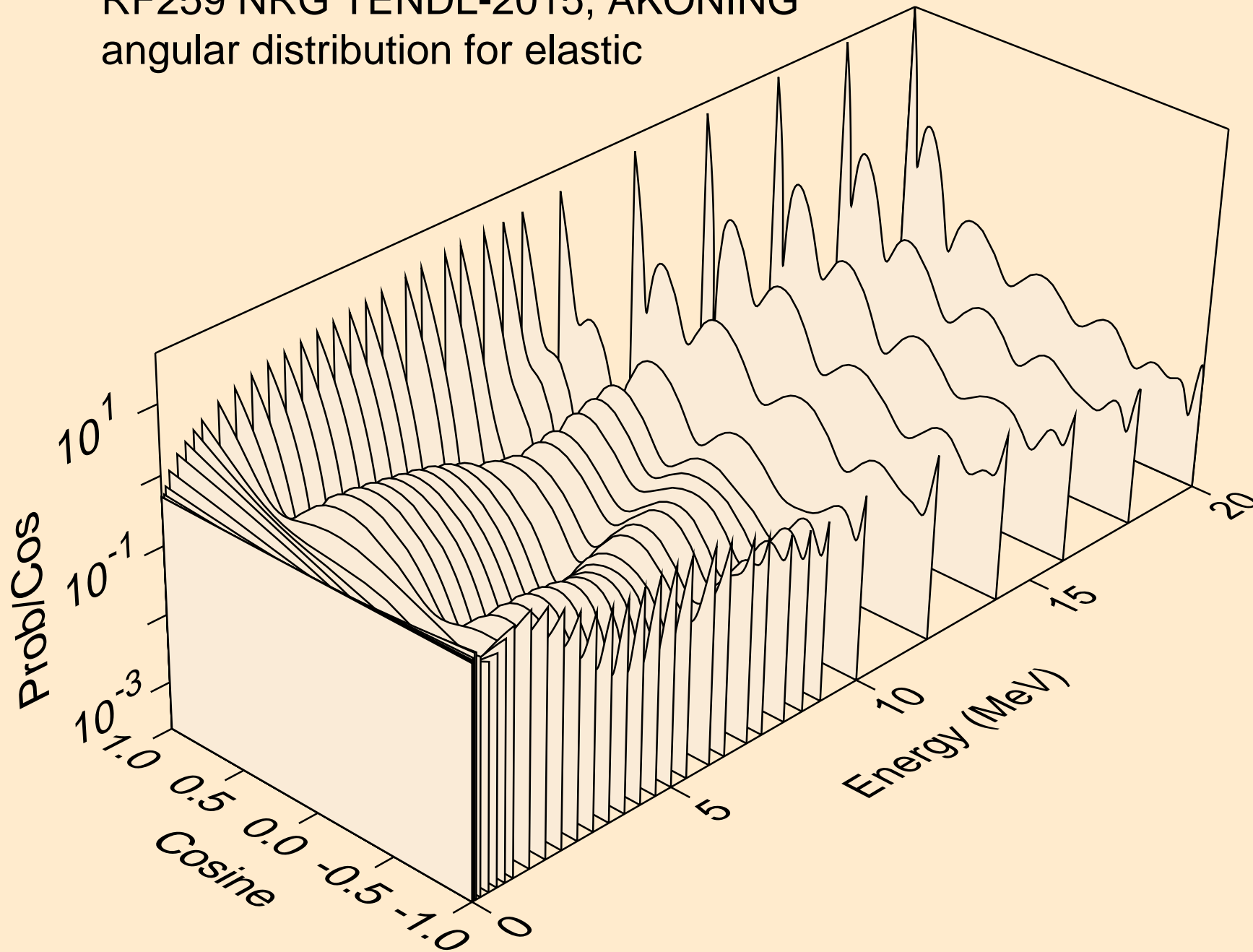

RF259 NRG TENDL-2015, AKONING  
angular distribution for elastic

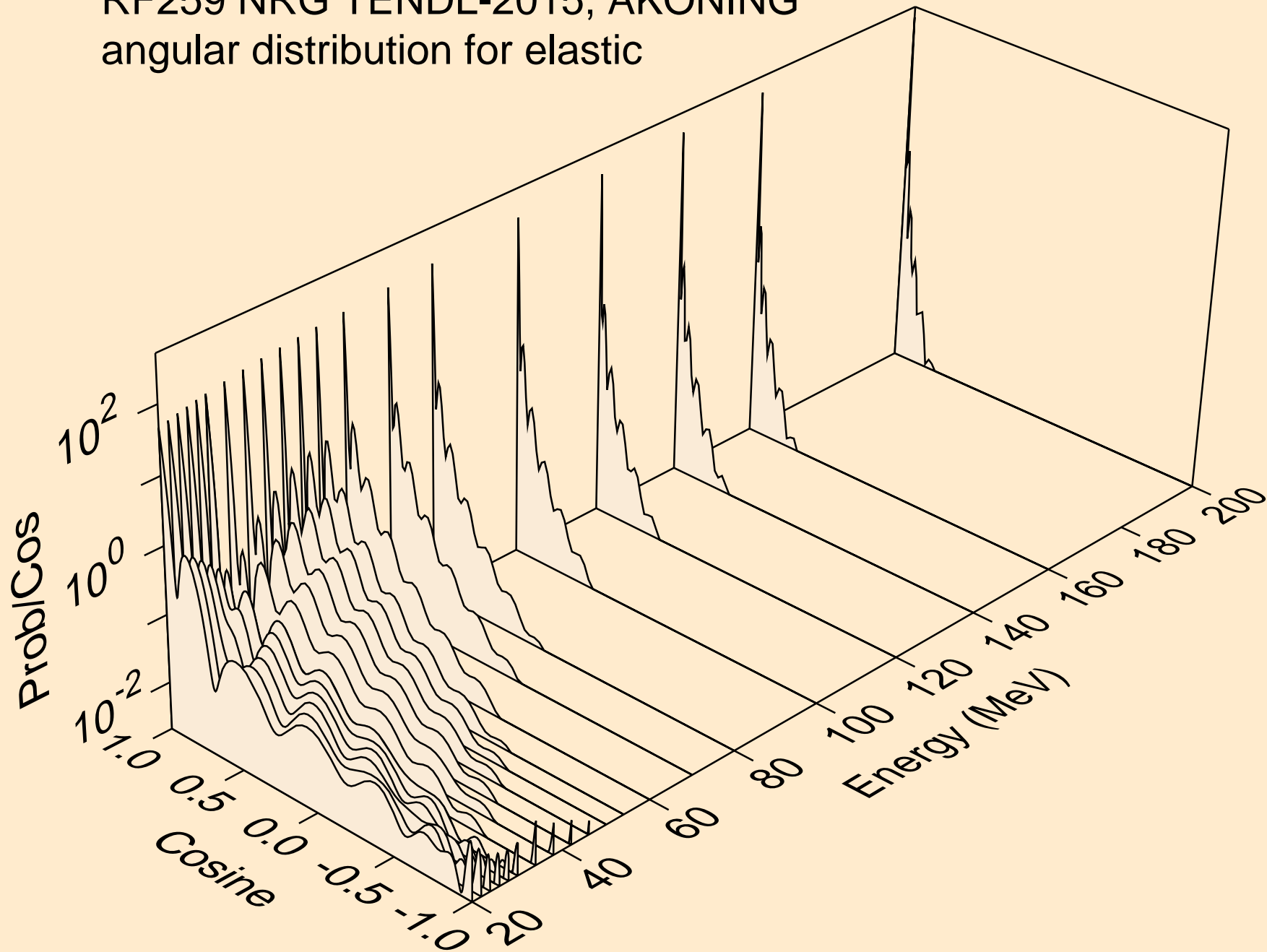

RF259 NRG TENDL-2015, AKONING  
angular distribution for (n,n\*1)

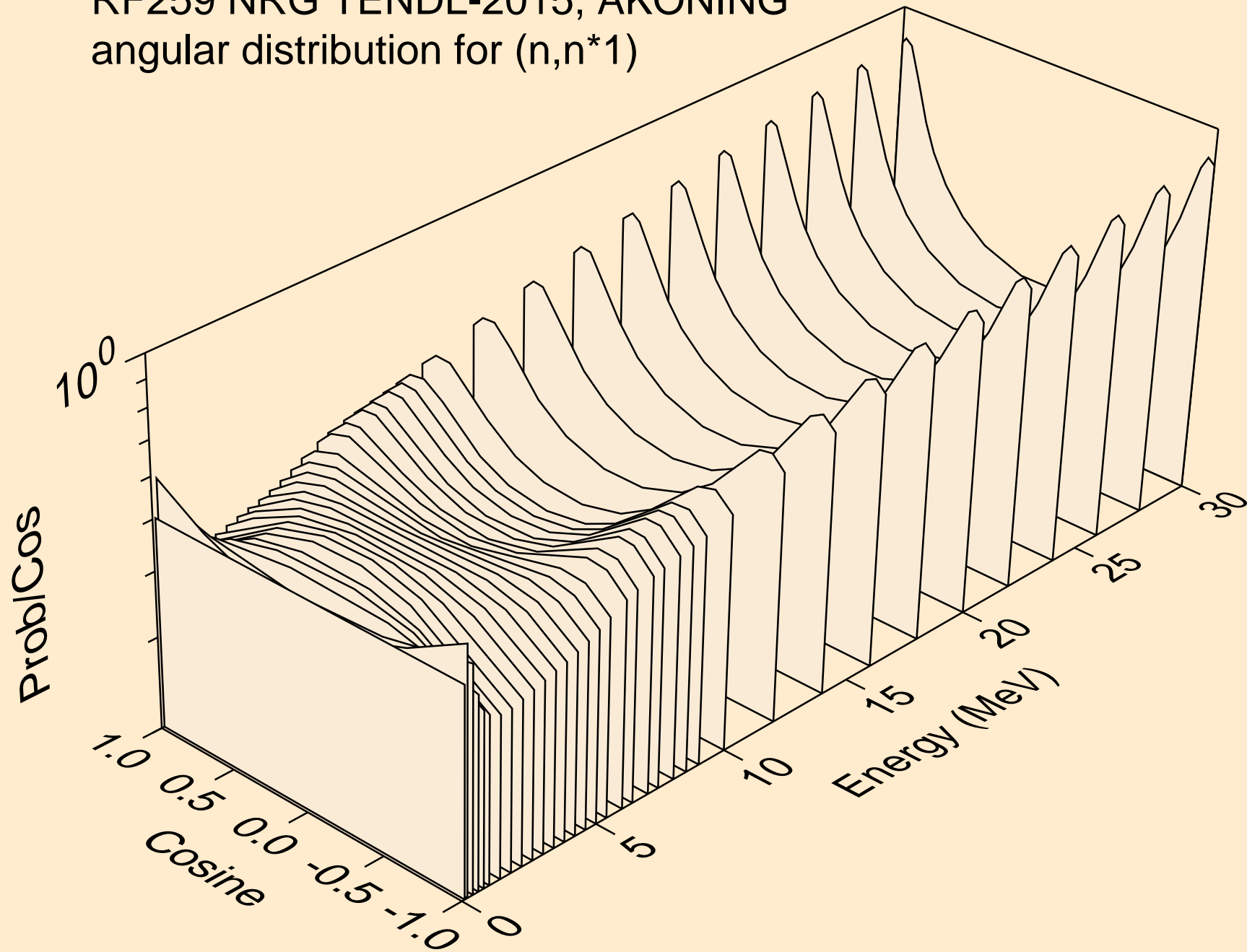



# RF259 NRG TENDL-2015, AKONING

Total fission nubar

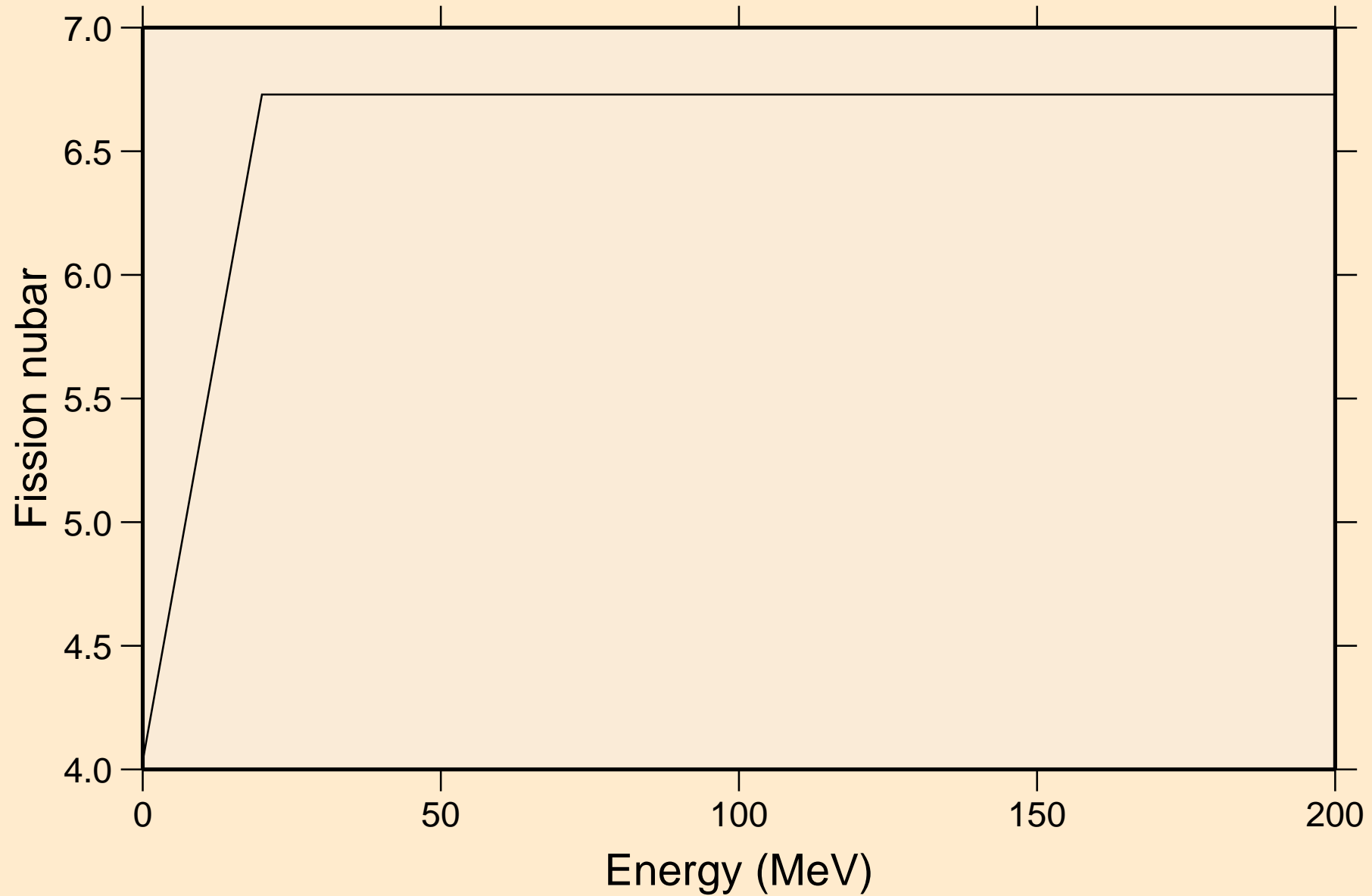

RF259 NRG TENDL-2015, AKONING  
Neutron emission for (n,x)

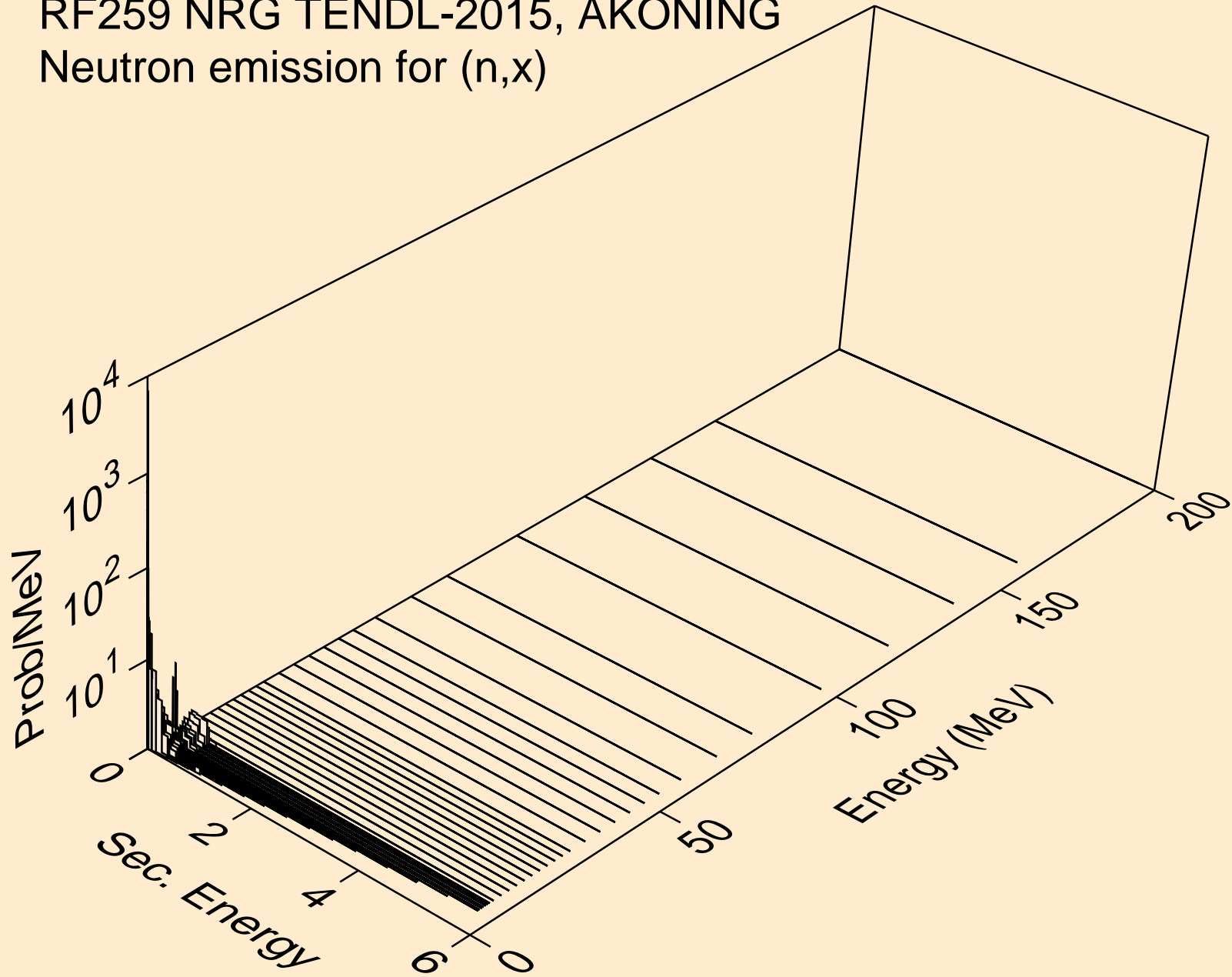

RF259 NRG TENDL-2015, AKONING  
Neutron emission for (n,2nd)

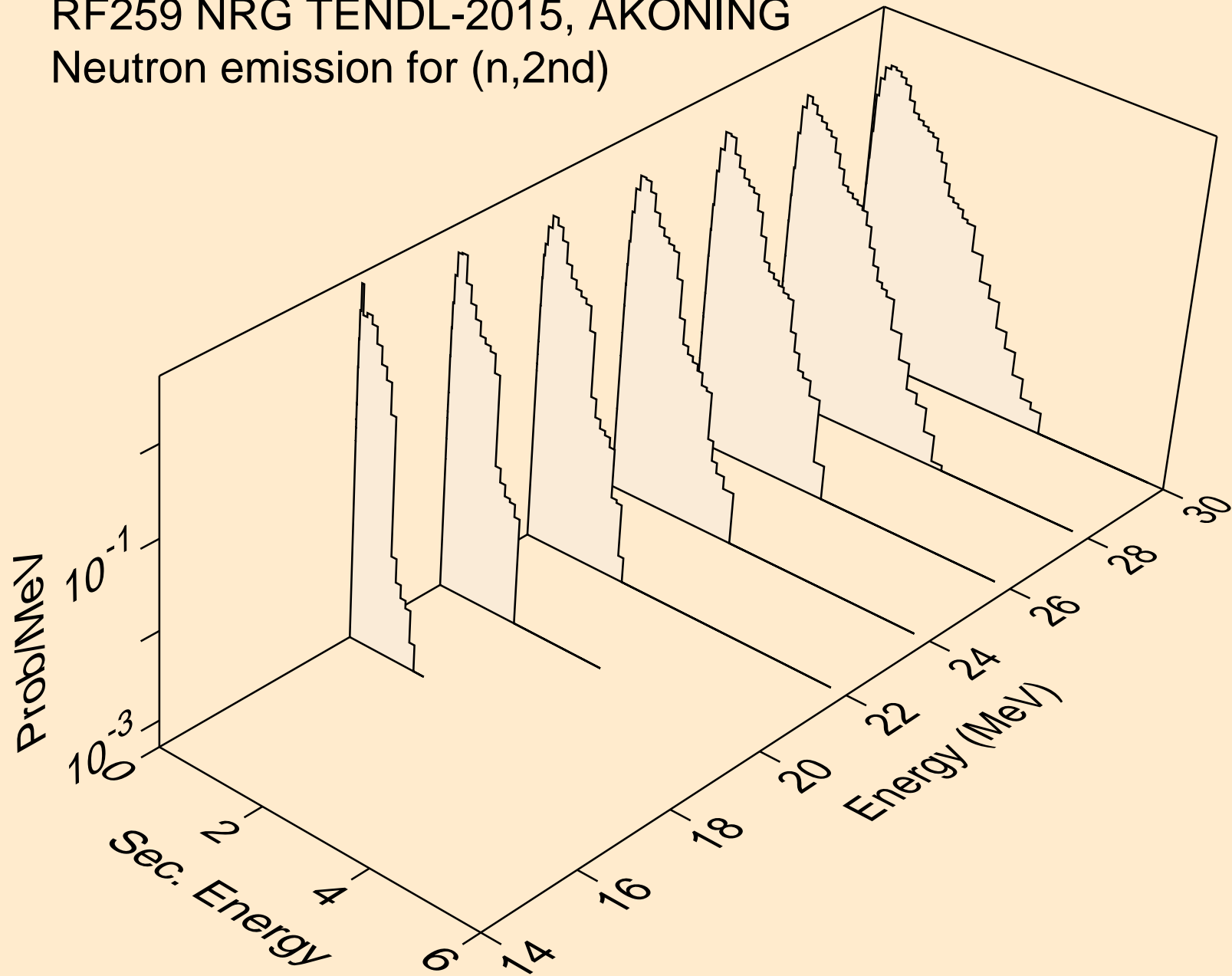

RF259 NRG TENDL-2015, AKONING  
Neutron emission for (n,2n)

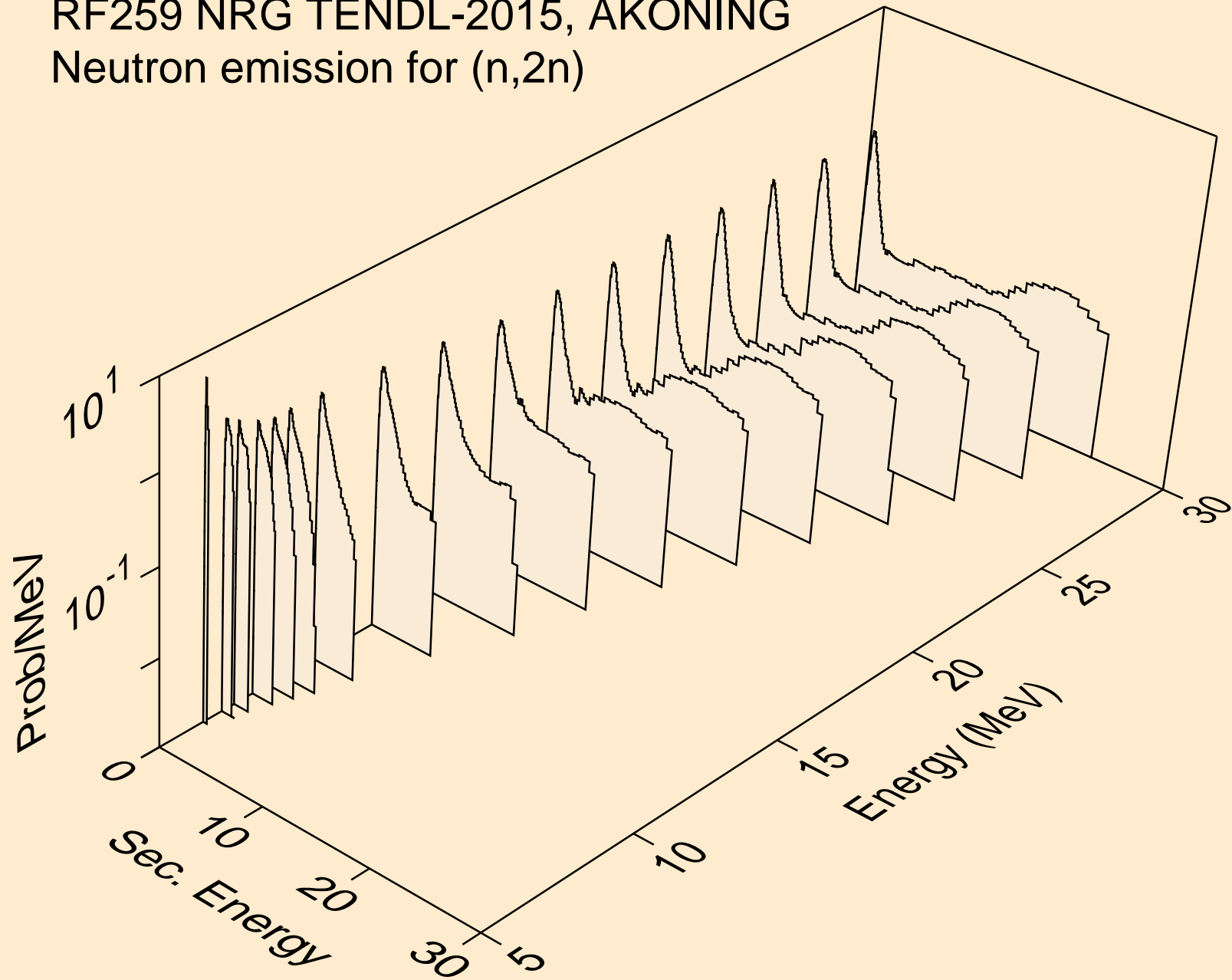

RF259 NRG TENDL-2015, AKONING  
Neutron emission for (n,3n)

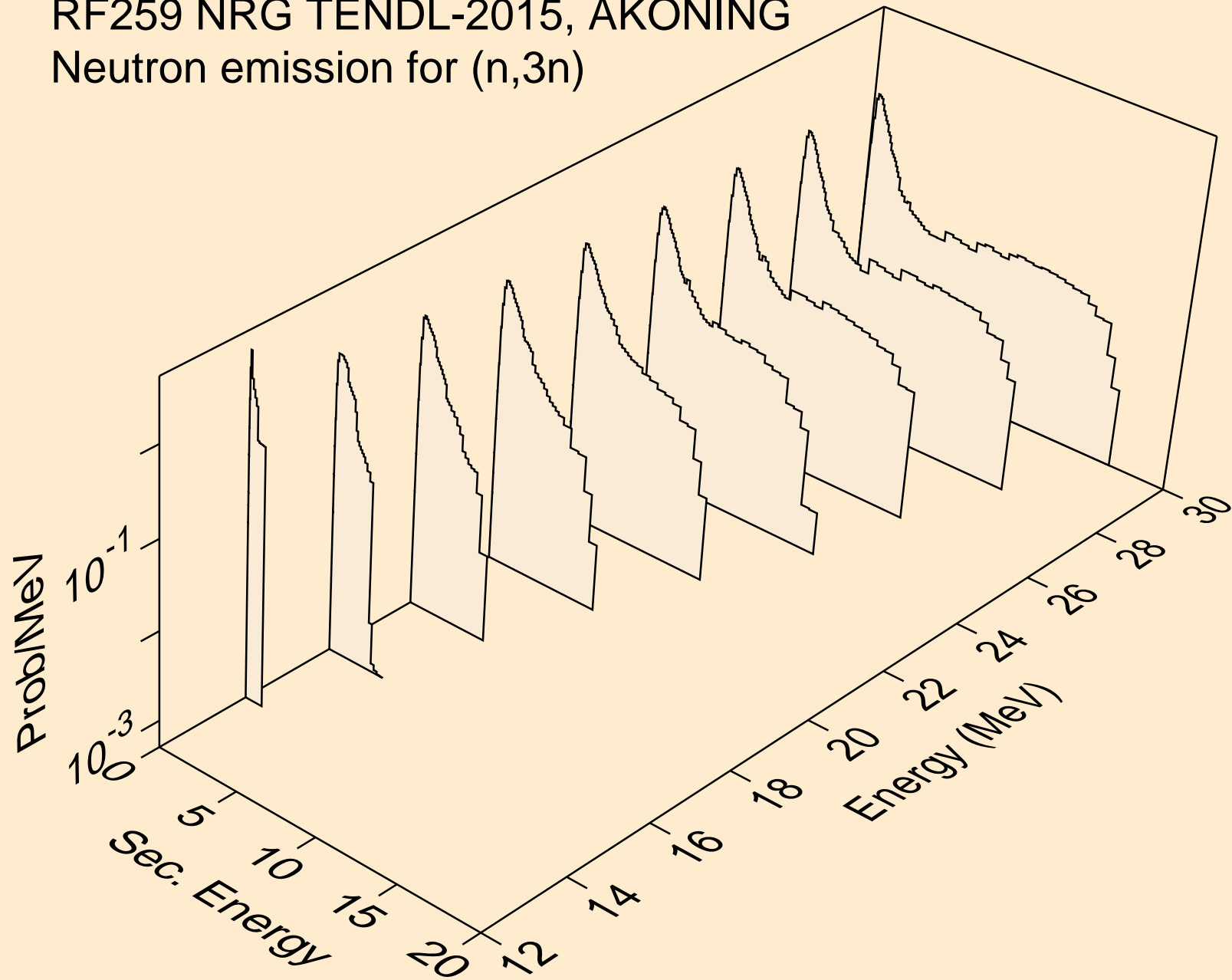

RF259 NRG TENDL-2015, AKONING  
Neutron emission for fission

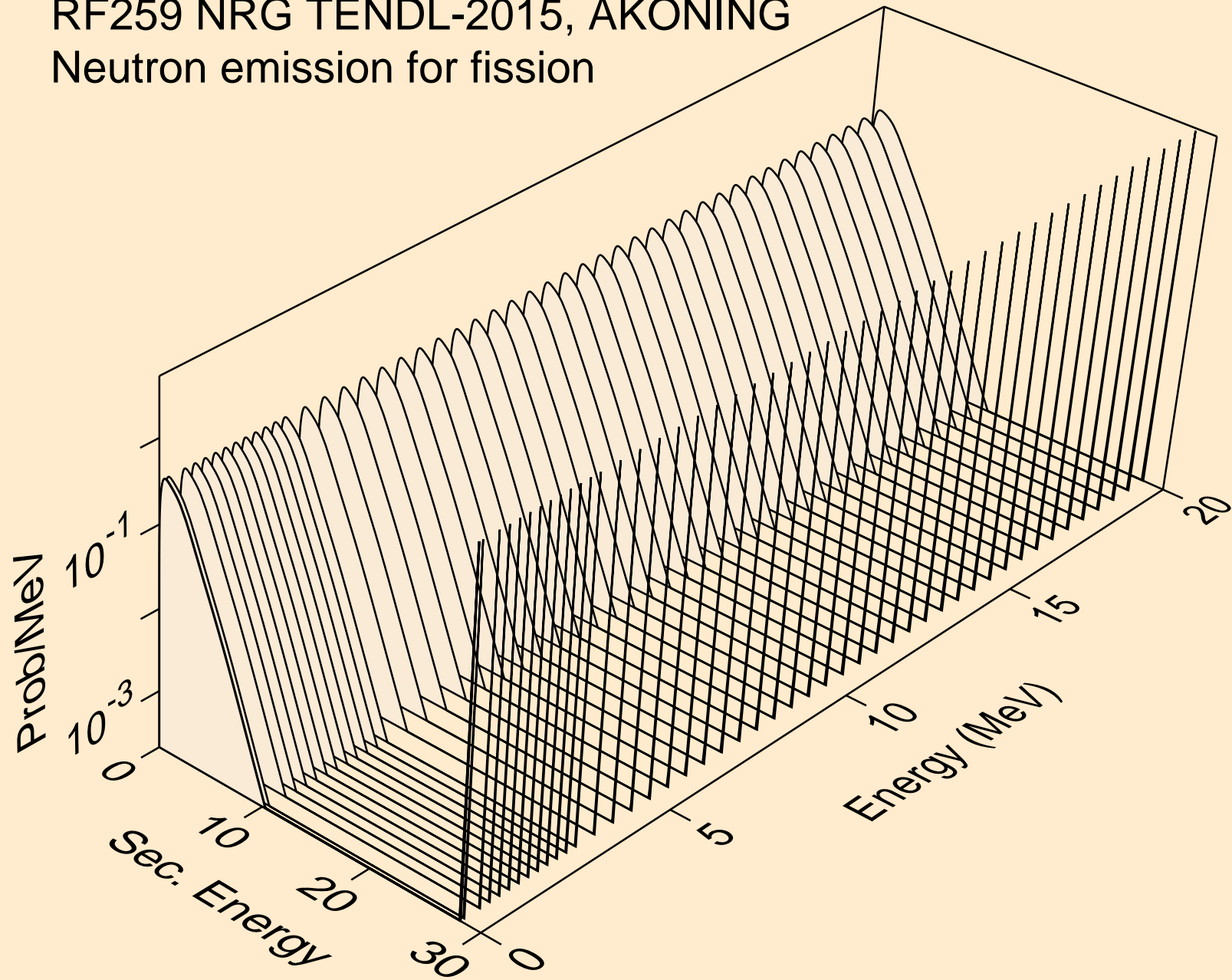

RF259 NRG TENDL-2015, AKONING  
Neutron emission for (n,n\*)a

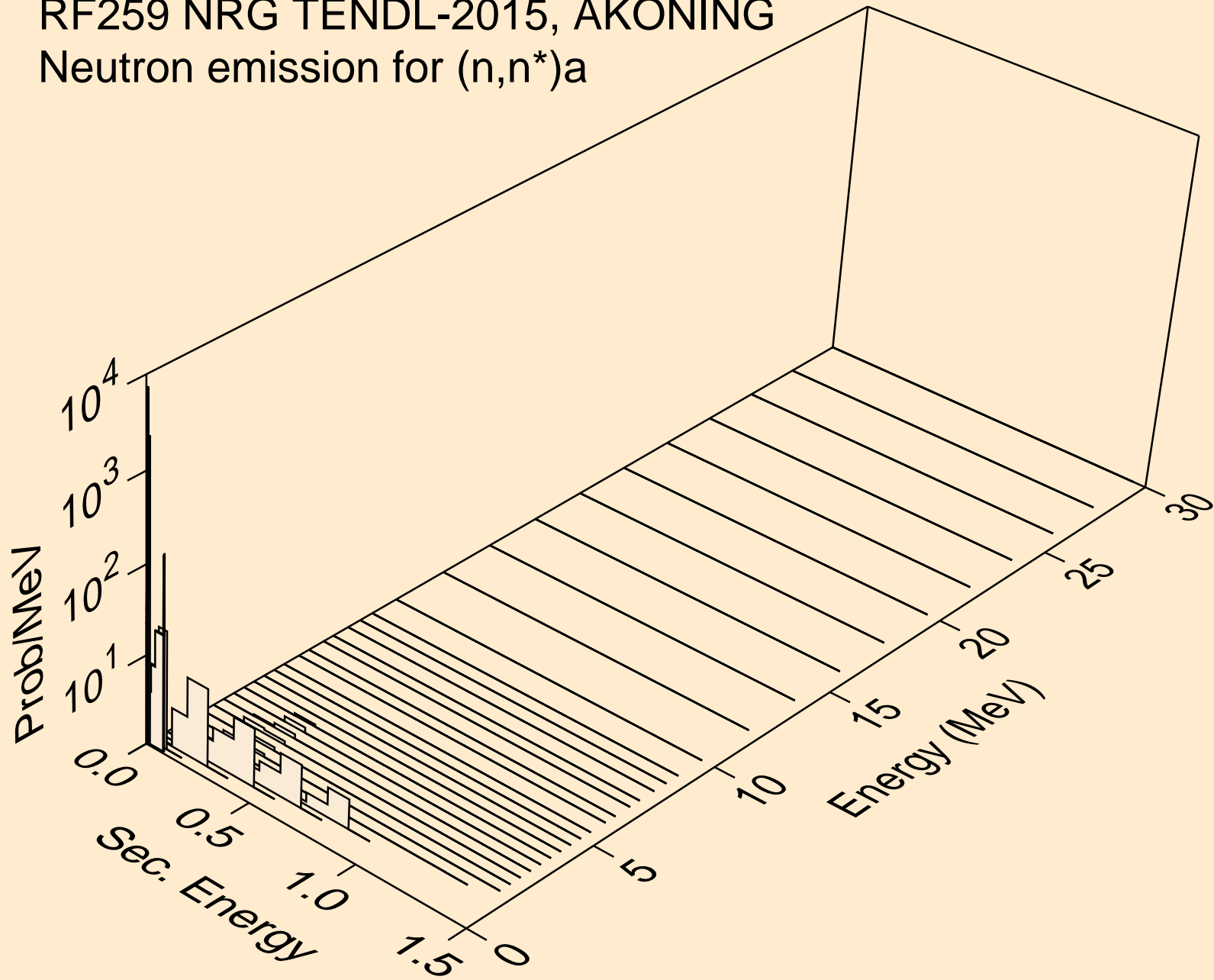

RF259 NRG TENDL-2015, AKONING  
Neutron emission for (n,n\*)3a

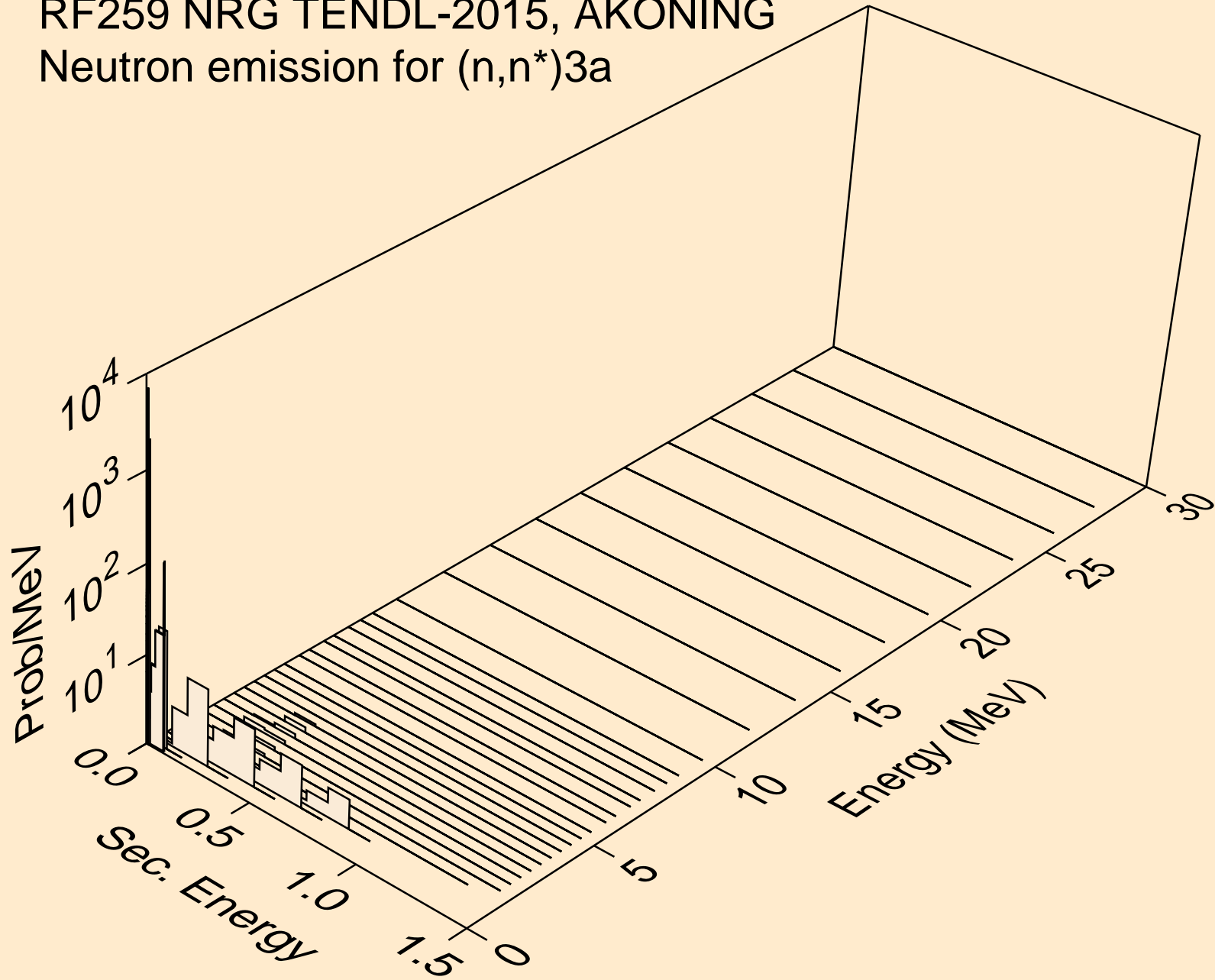



RF259 NRG TENDL-2015, AKONING  
Neutron emission for (n,2n)a

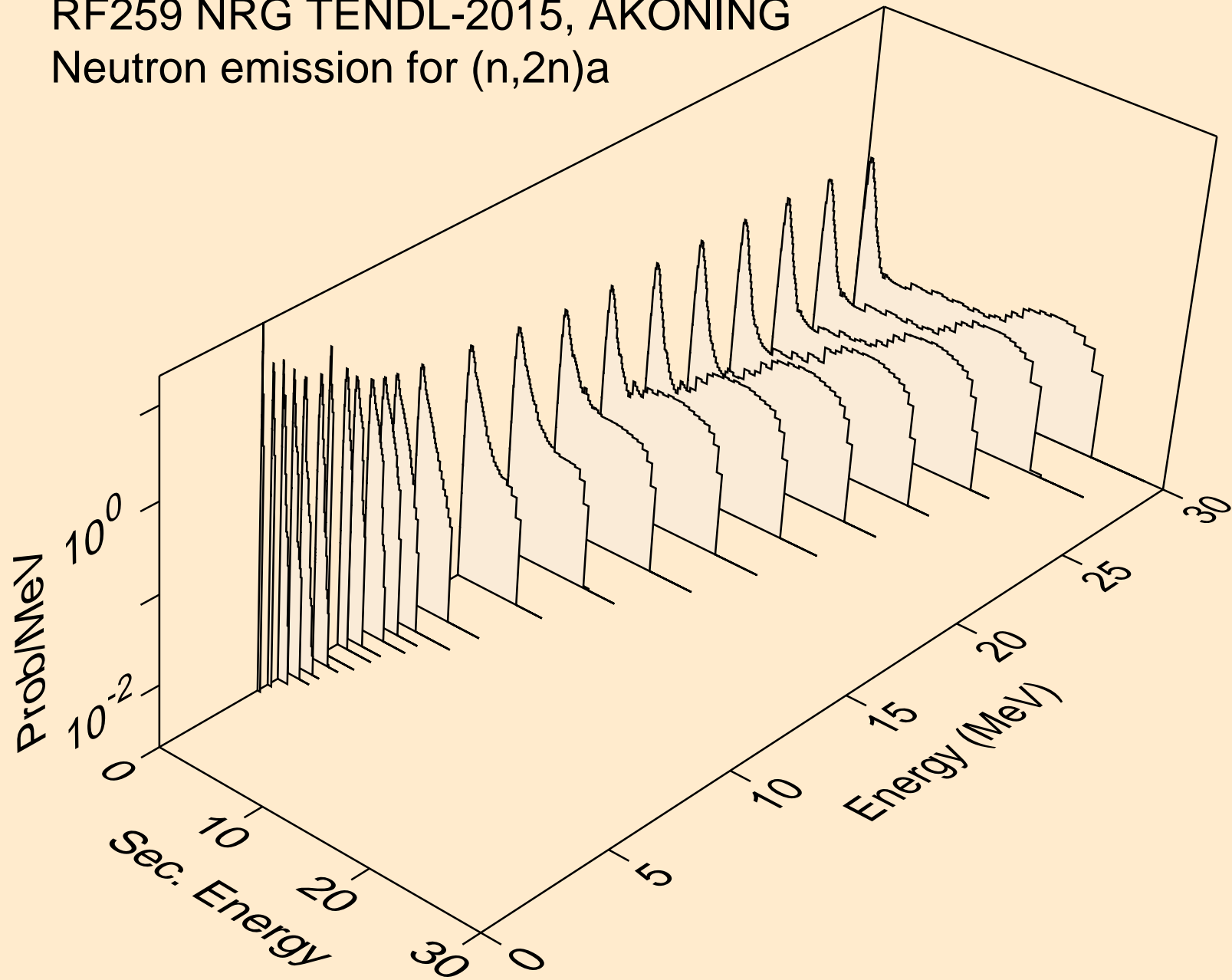

RF259 NRG TENDL-2015, AKONING  
Neutron emission for (n,3n)a

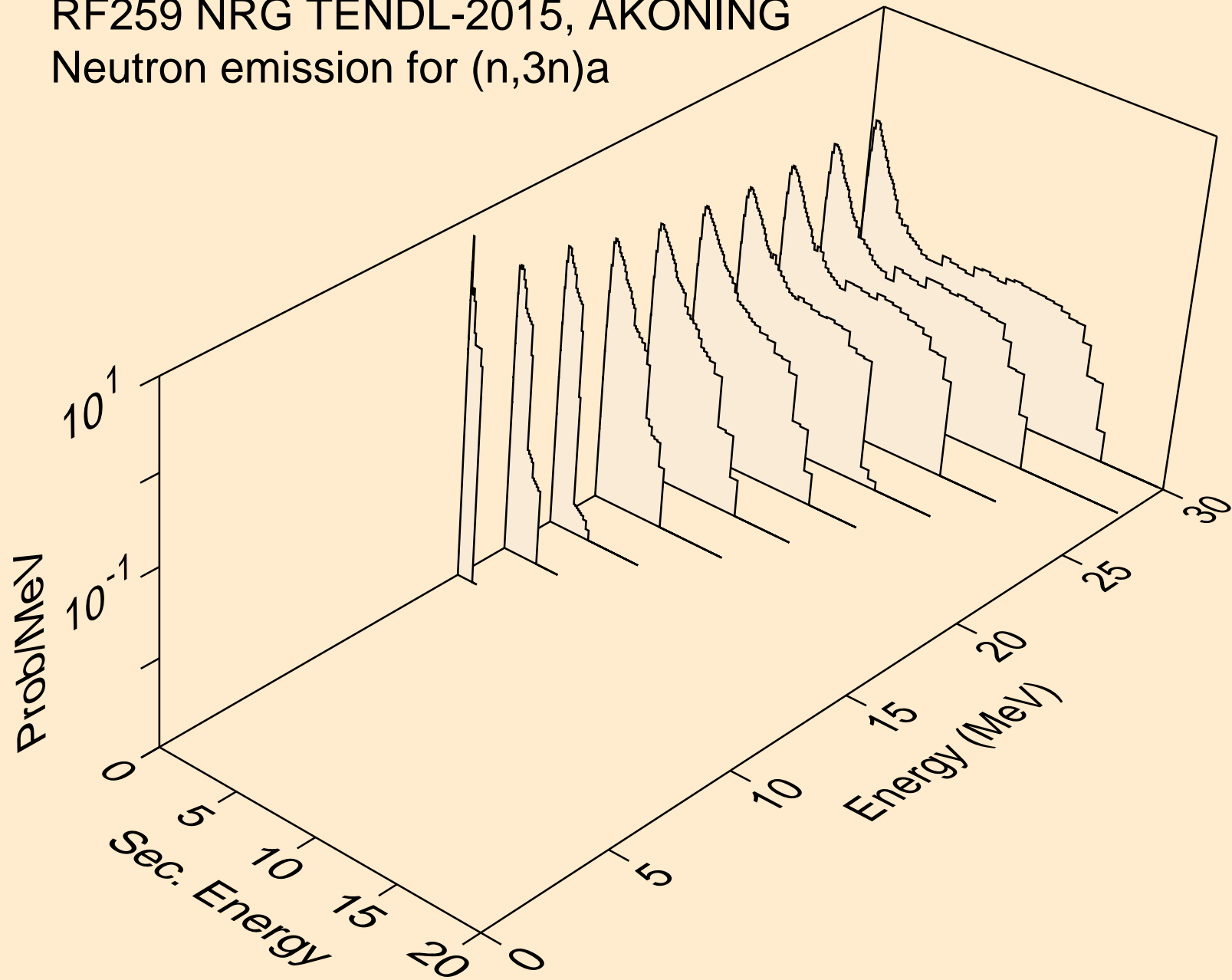

RF259 NRG TENDL-2015, AKONING  
Neutron emission for (n,n\*)p

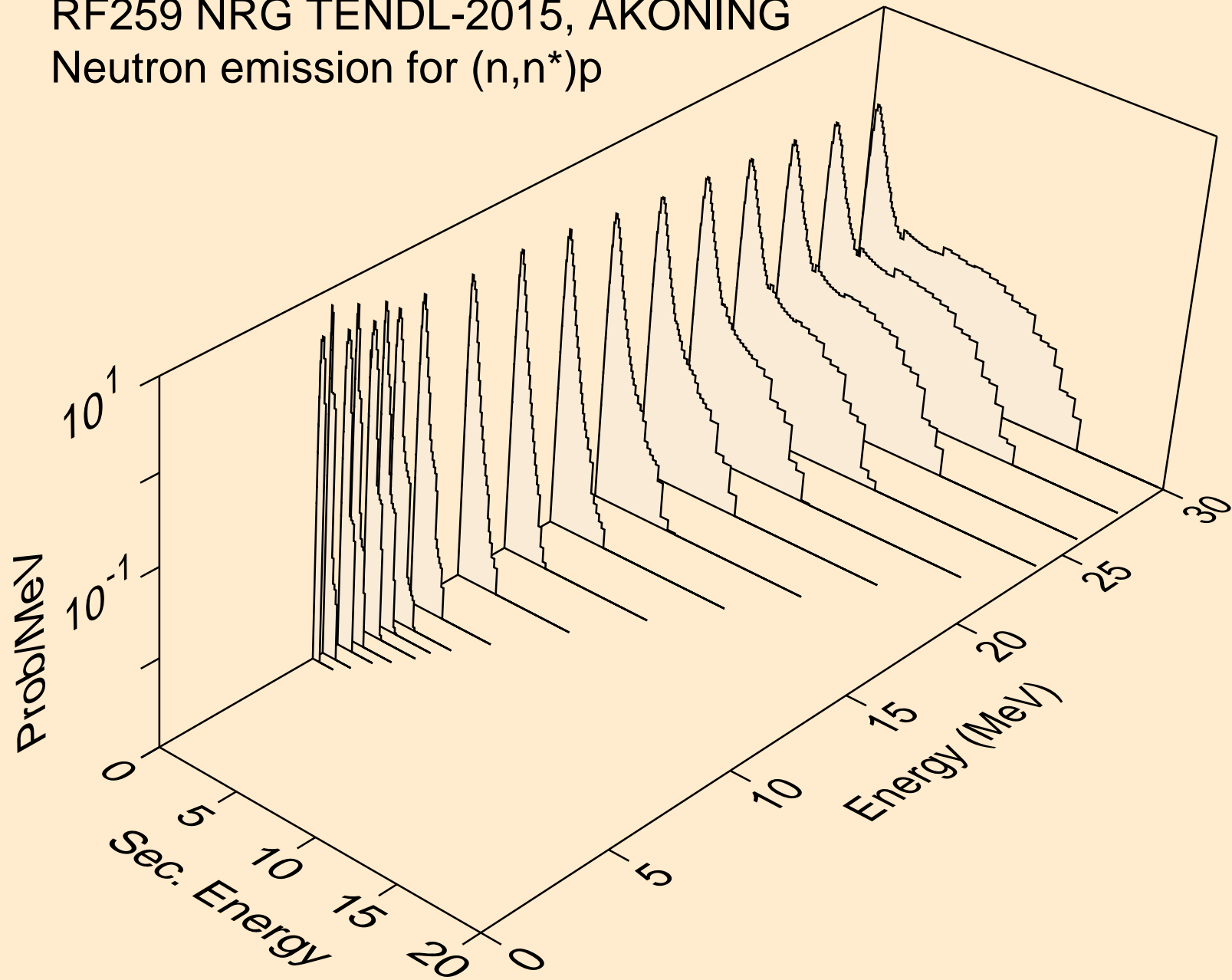

RF259 NRG TENDL-2015, AKONING  
Neutron emission for (n,n\*)2a

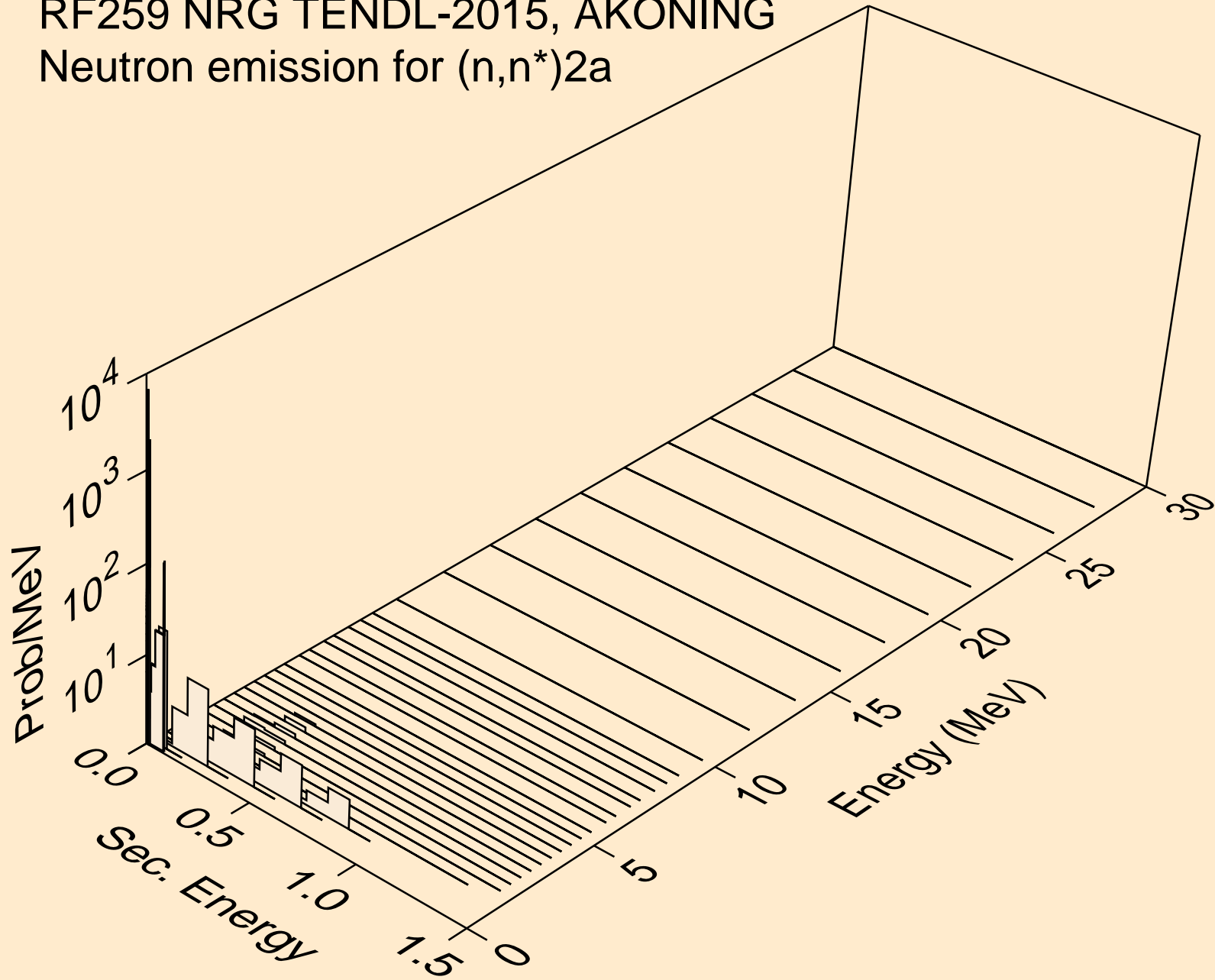

RF259 NRG TENDL-2015, AKONING  
Neutron emission for (n,2n)2a

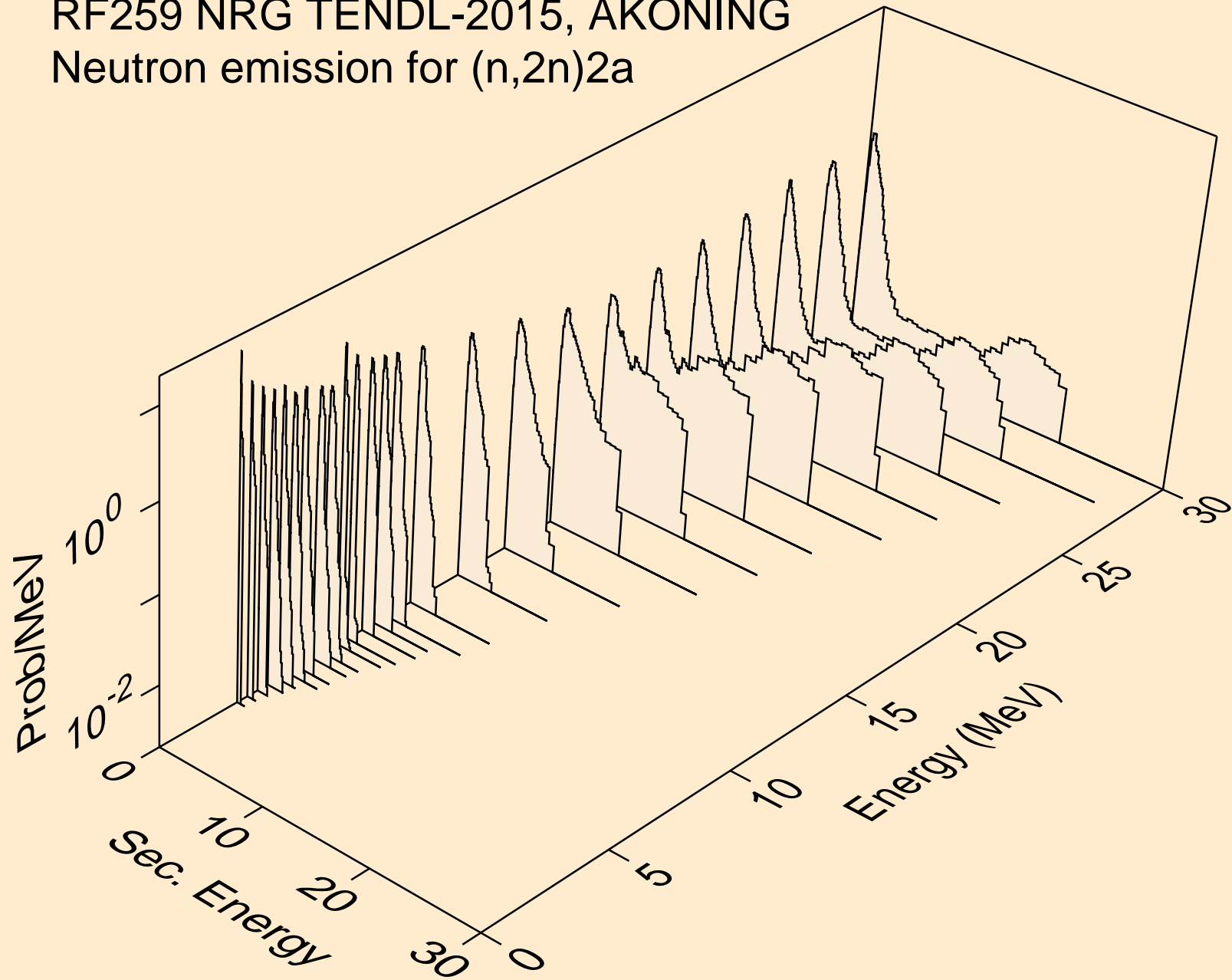

RF259 NRG TENDL-2015, AKONING  
Neutron emission for (n,n\*)d

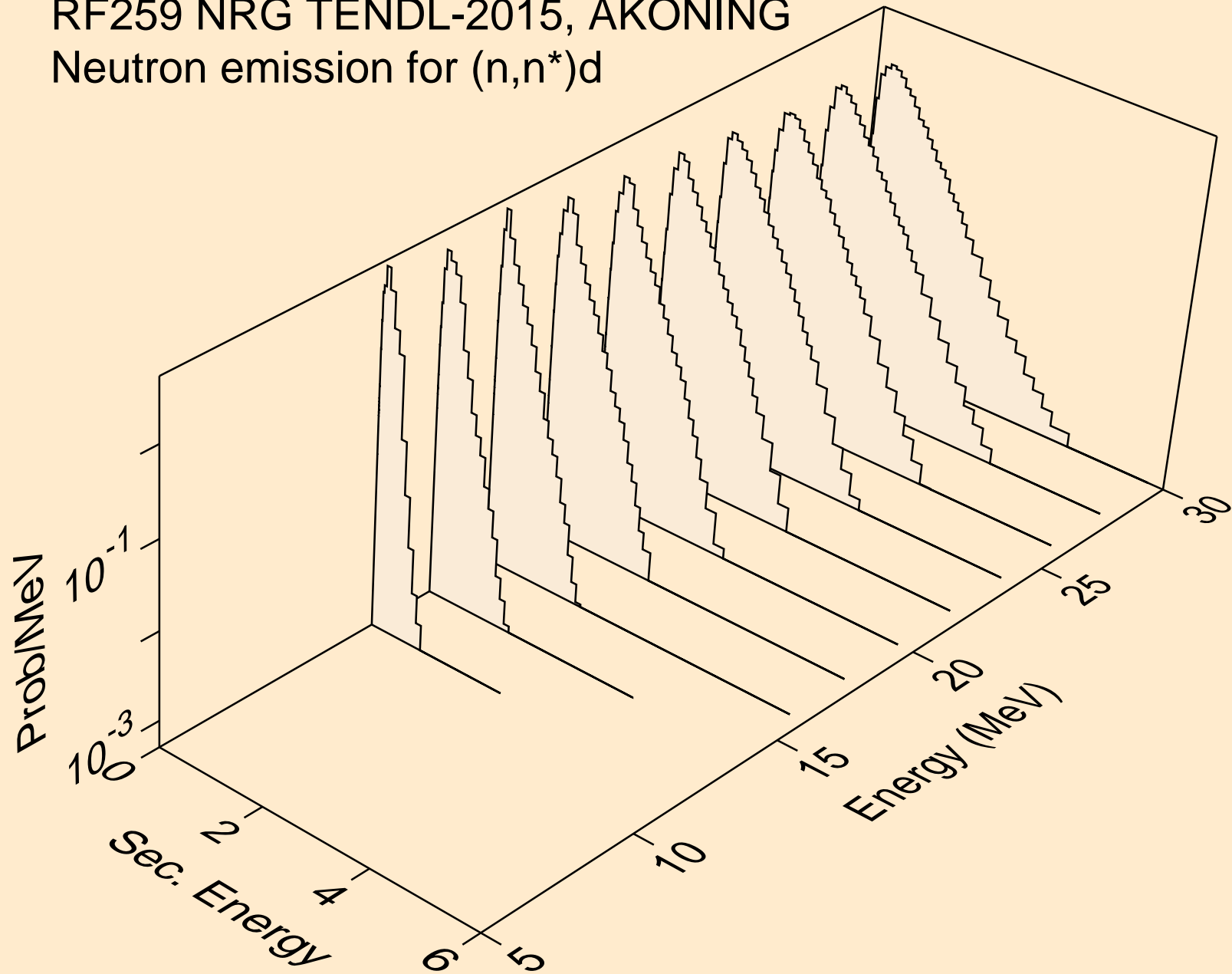

RF259 NRG TENDL-2015, AKONING  
Neutron emission for (n,n\*)t

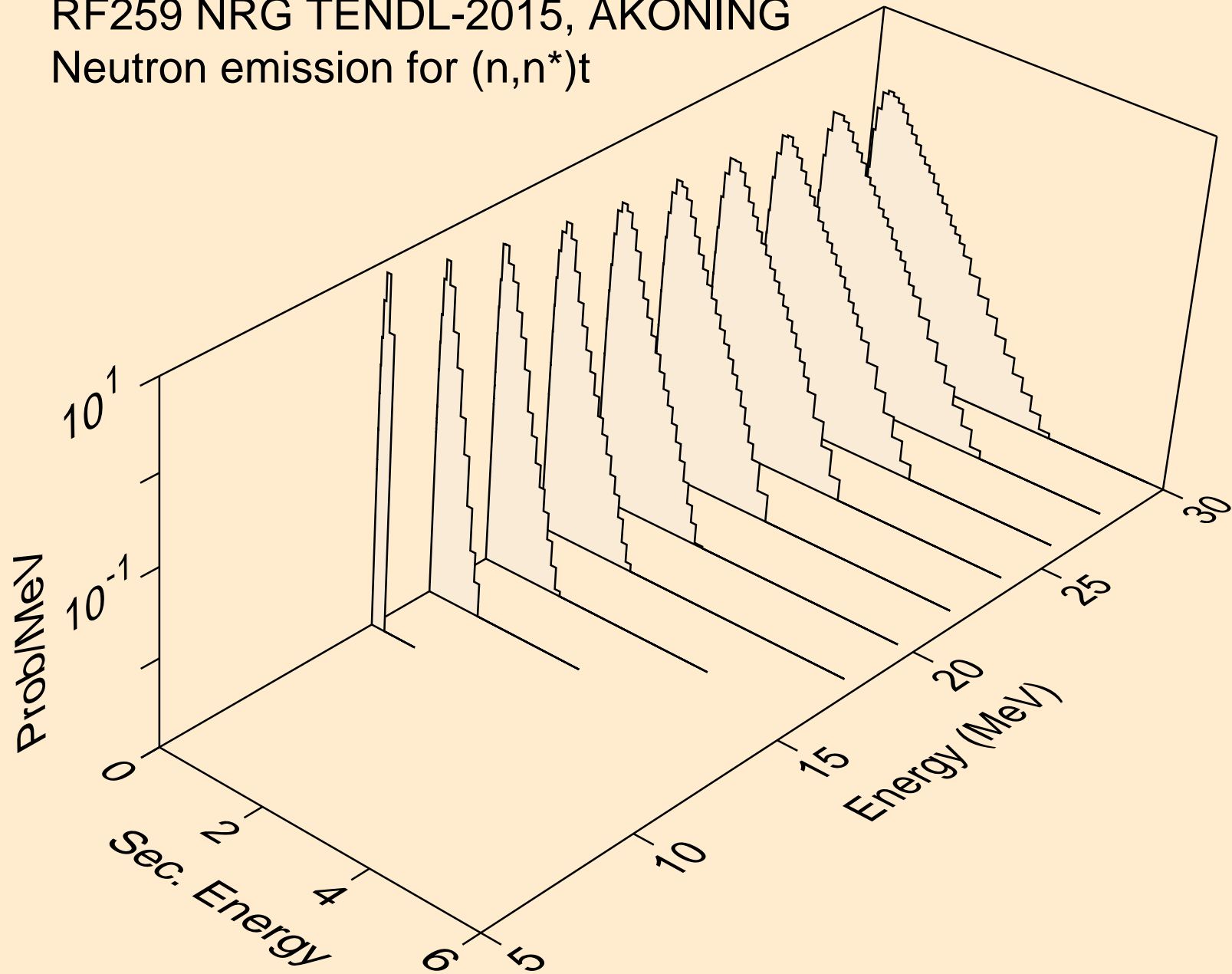

RF259 NRG TENDL-2015, AKONING  
Neutron emission for (n,n\*)he3

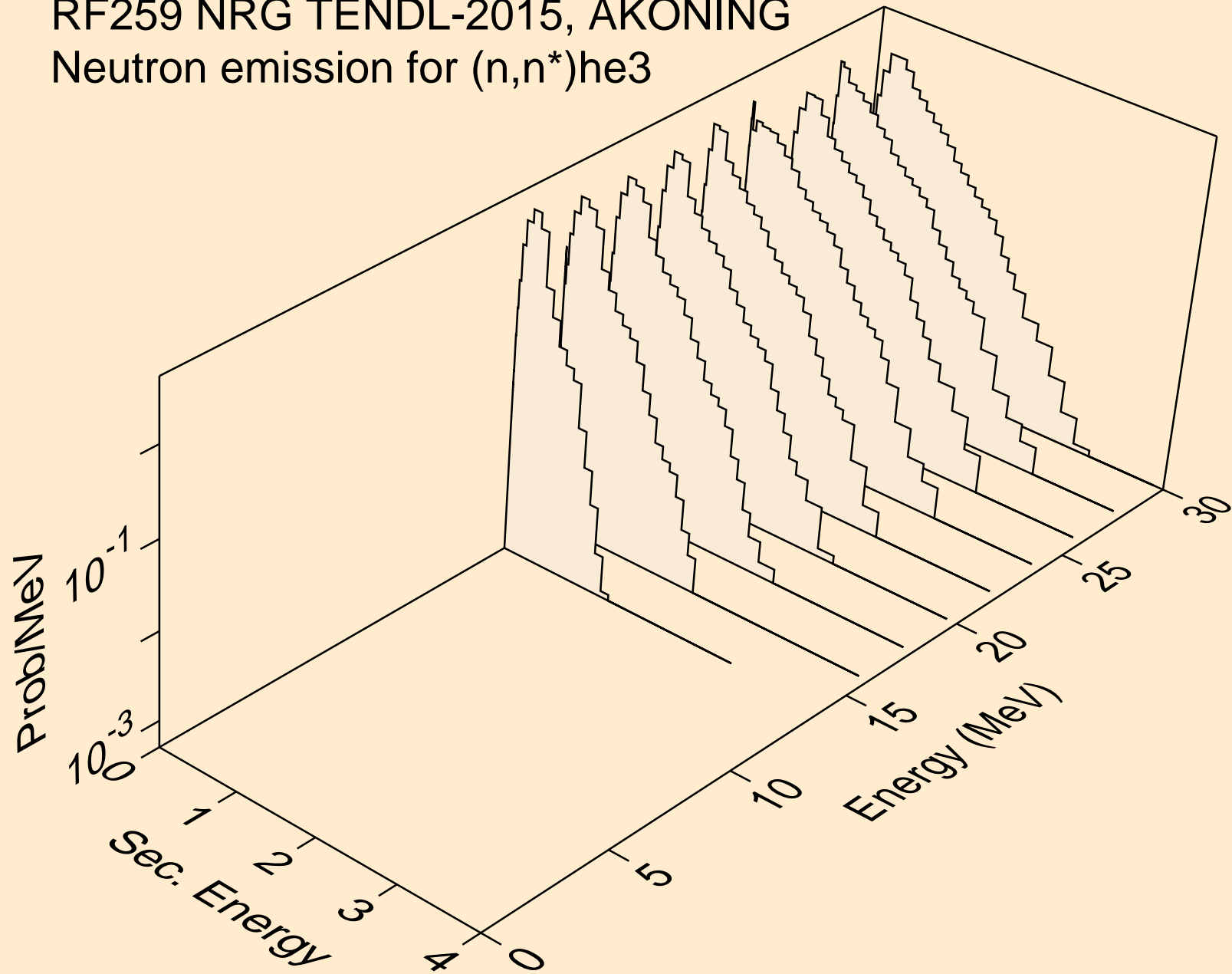



RF259 NRG TENDL-2015, AKONING  
Neutron emission for (n,n\*)d2a

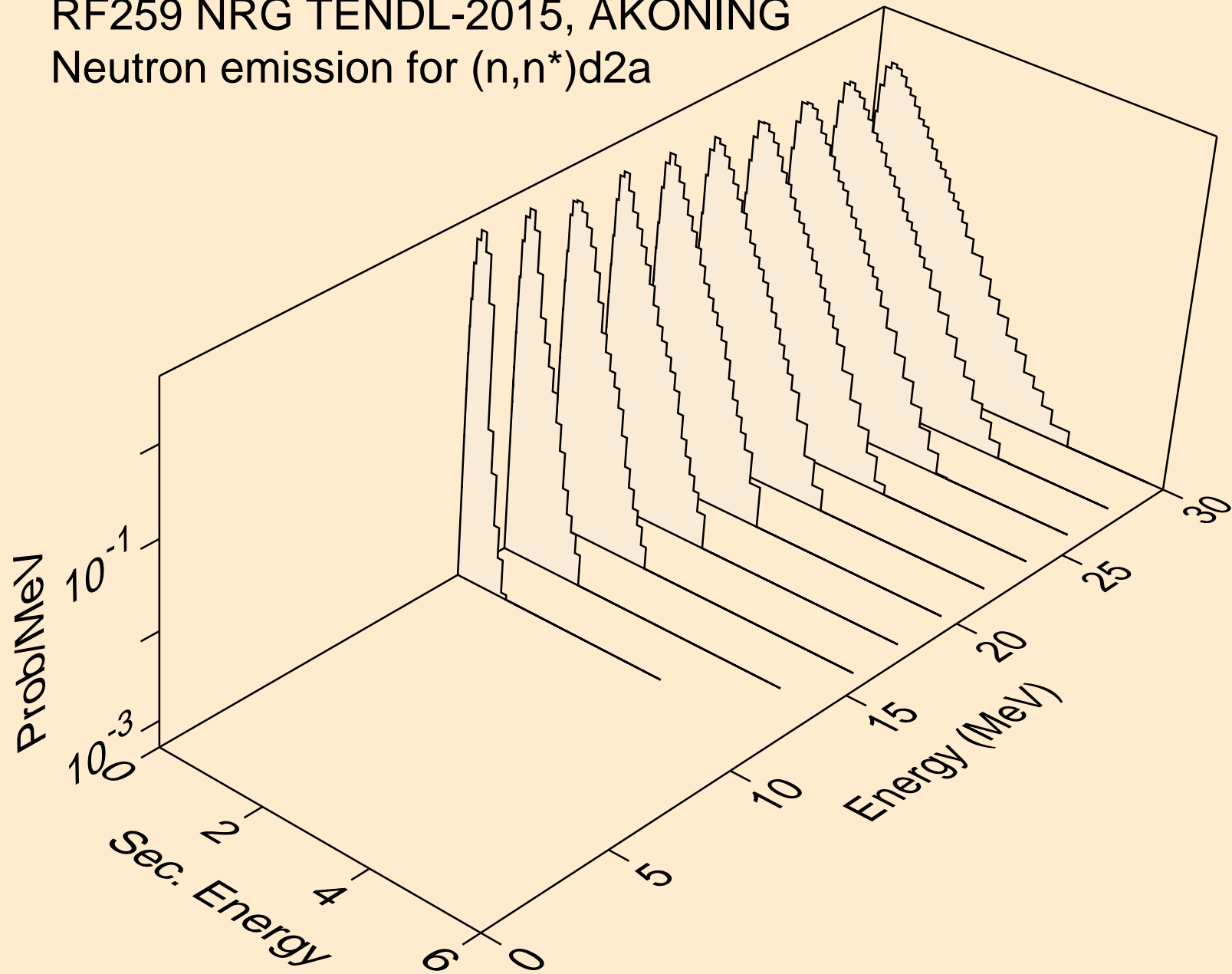

RF259 NRG TENDL-2015, AKONING  
Neutron emission for (n,n\*)t2a

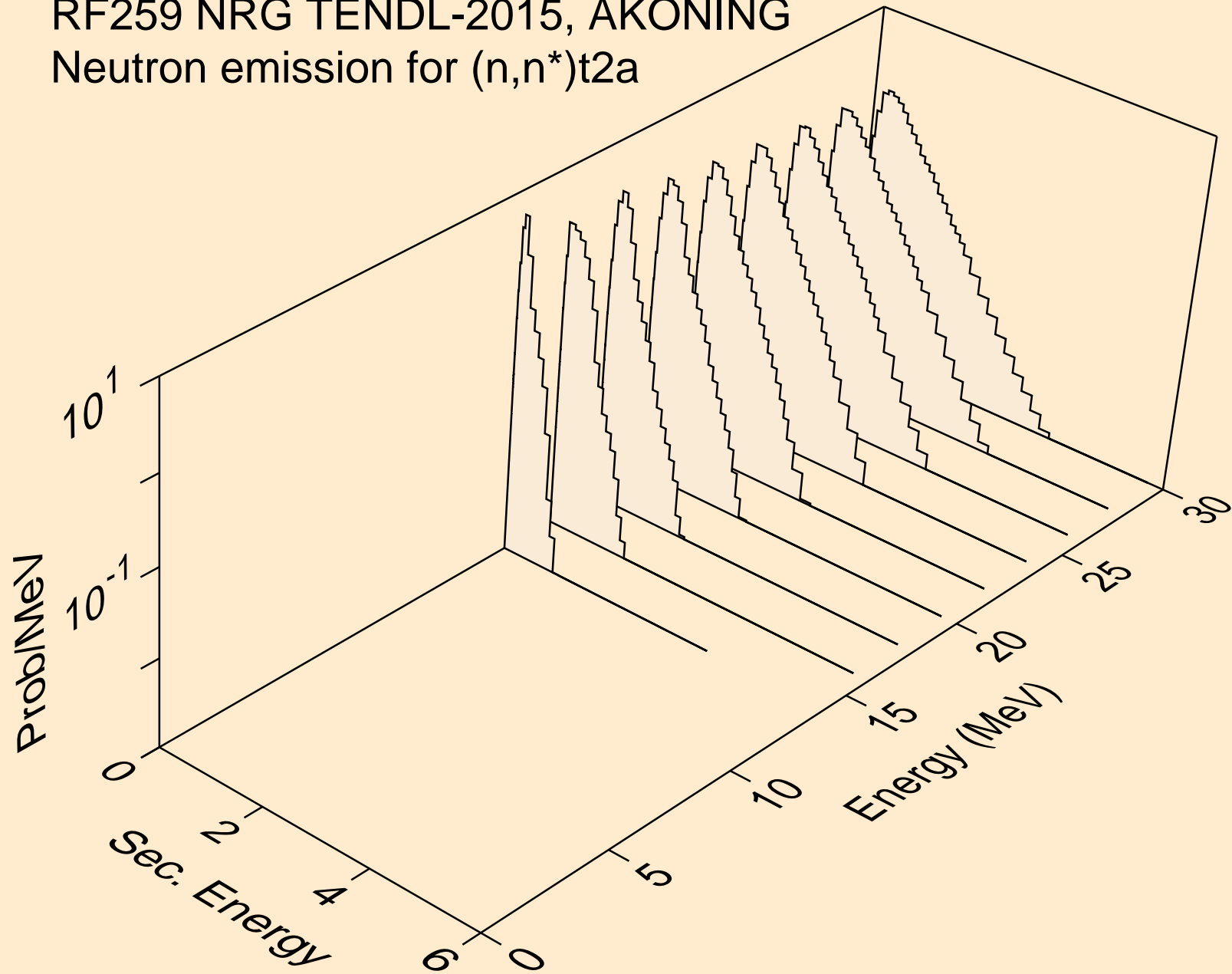

RF259 NRG TENDL-2015, AKONING  
Neutron emission for (n,4n)

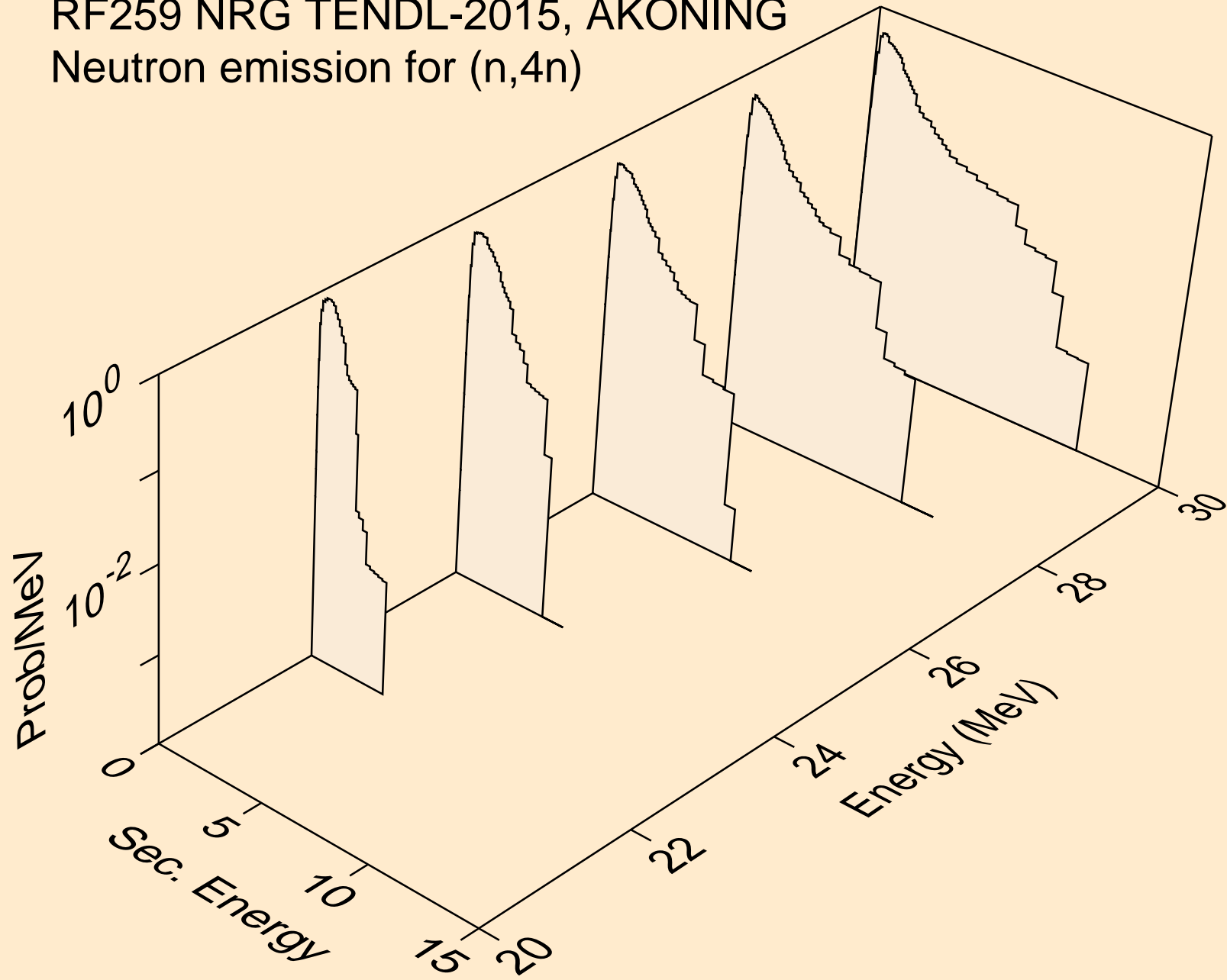

RF259 NRG TENDL-2015, AKONING  
Neutron emission for (n,2np)

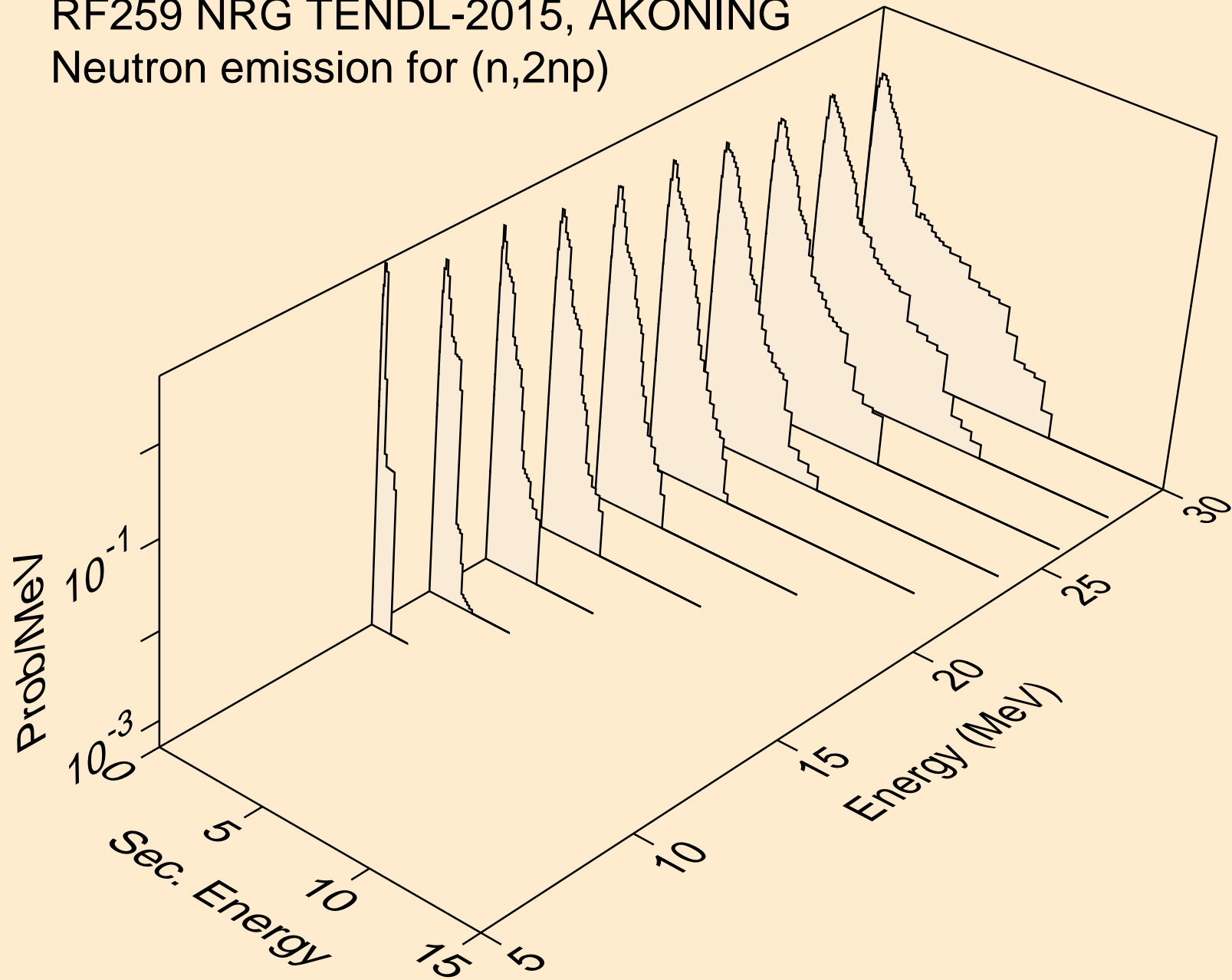

RF259 NRG TENDL-2015, AKONING  
Neutron emission for (n,3np)

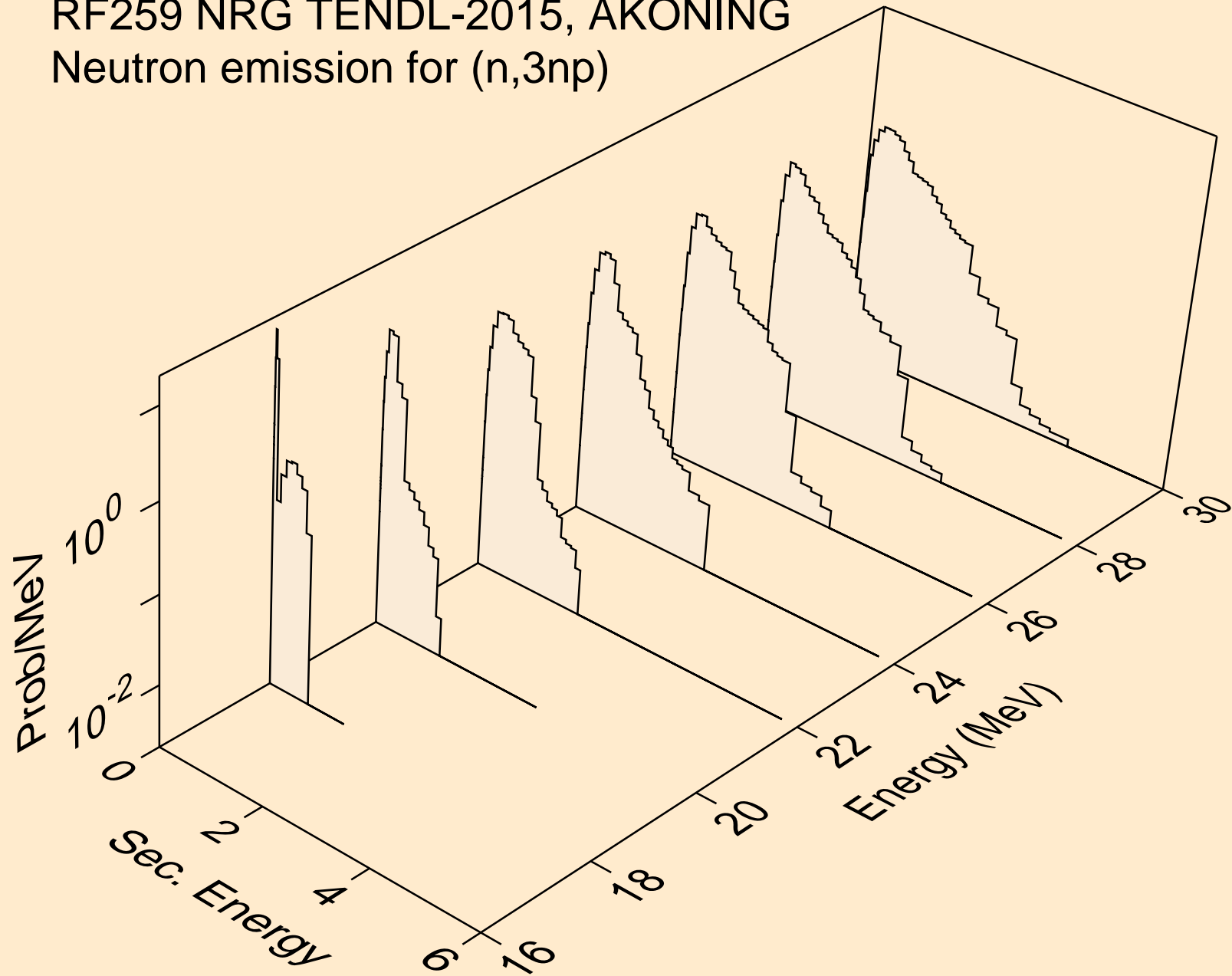

RF259 NRG TENDL-2015, AKONING  
Neutron emission for (n,2np)

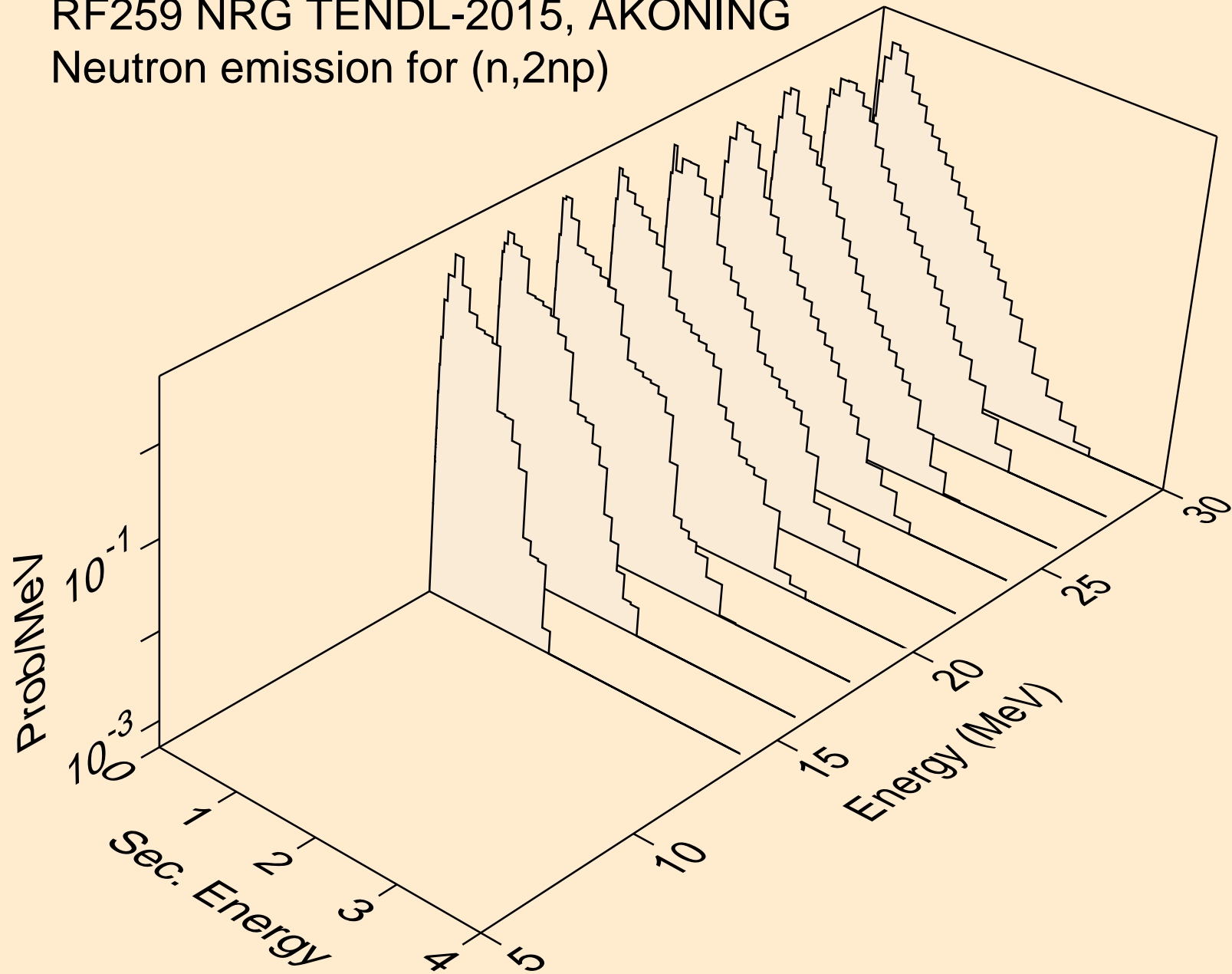

RF259 NRG TENDL-2015, AKONING  
Neutron emission for (n,npa)

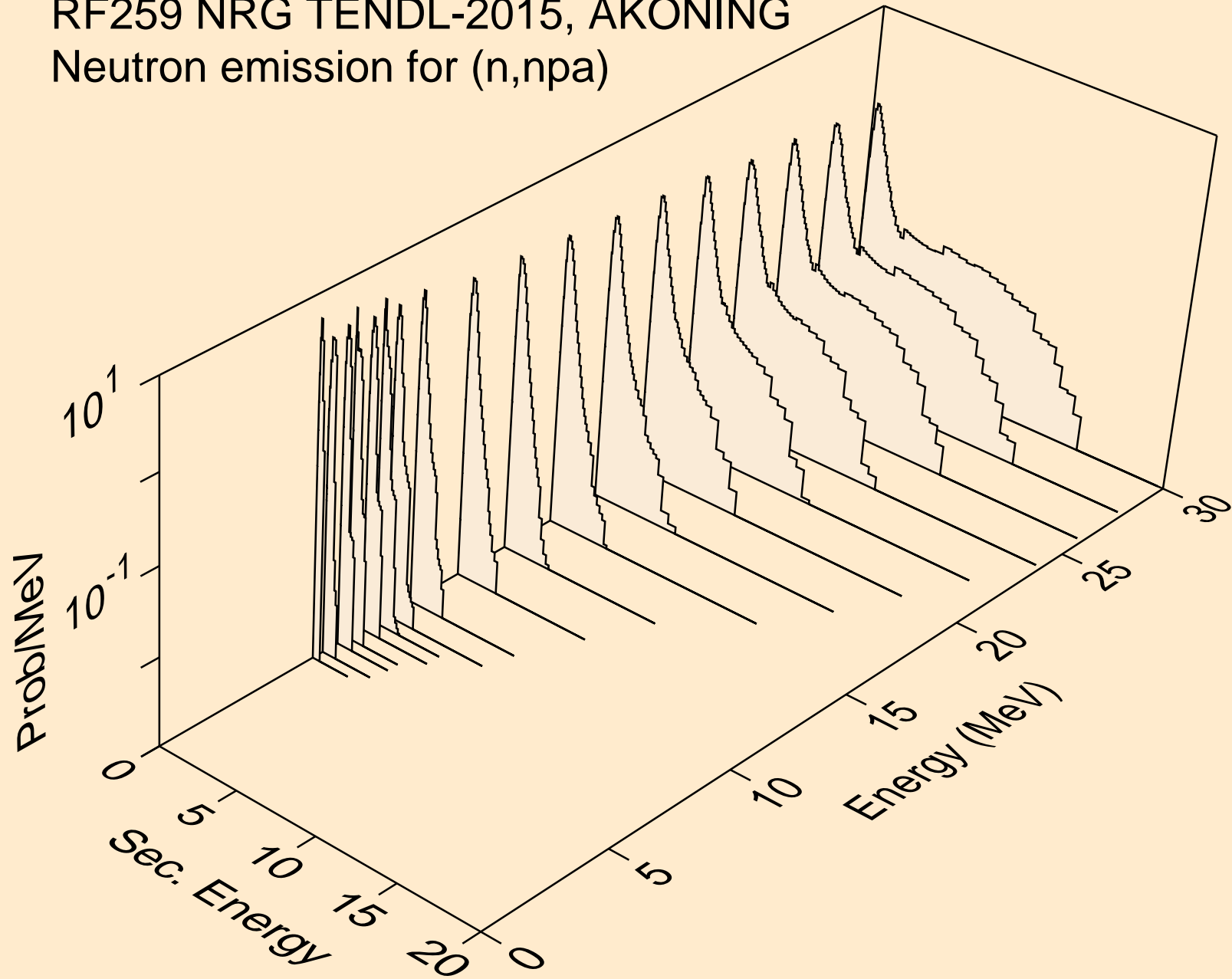

RF259 NRG TENDL-2015, AKONING  
Neutron emission for (n,n\*c)

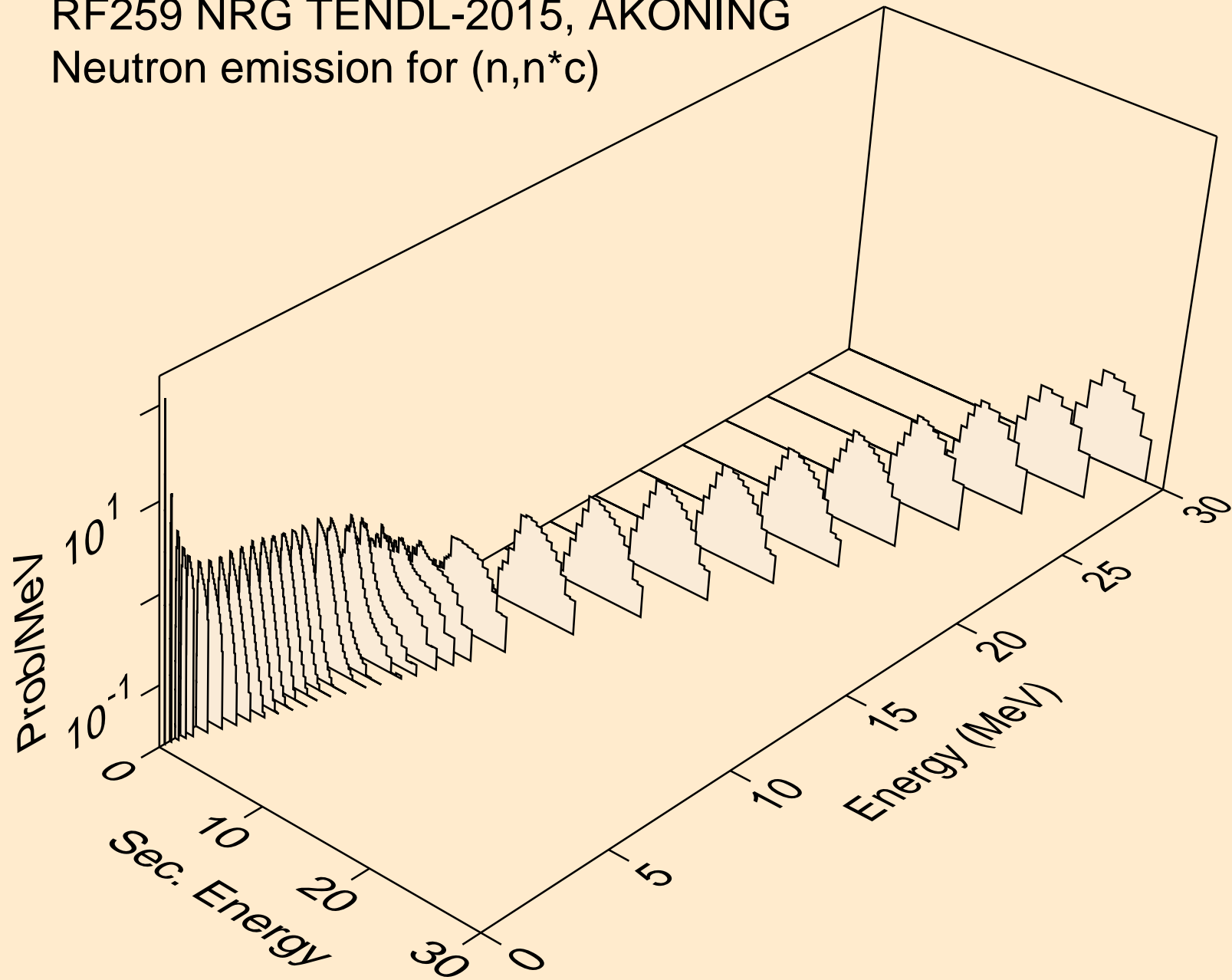



# RF259 NRG TENDL-2015, AKONING

Delayed nubar

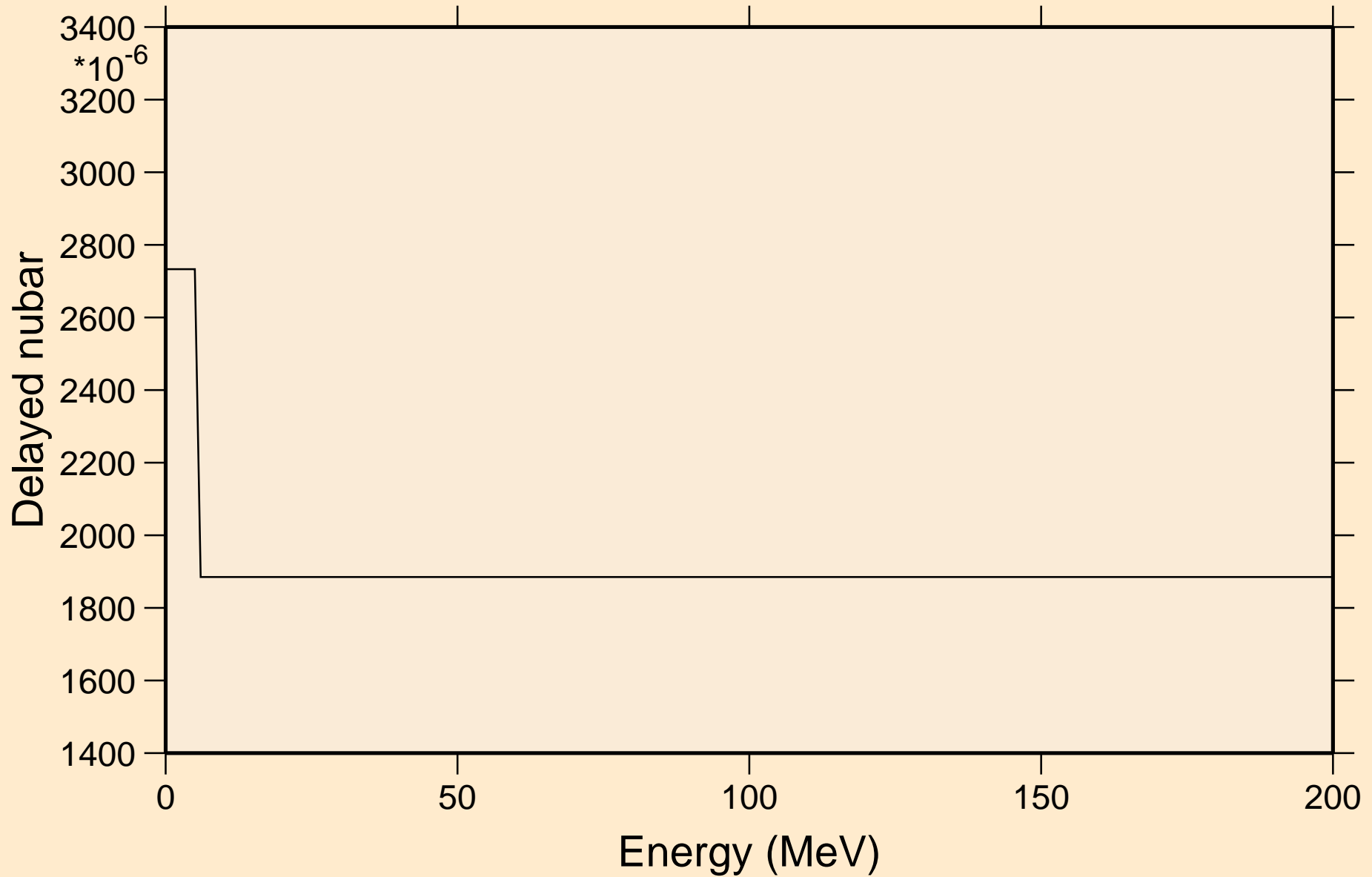

# RF259 NRG TENDL-2015, AKONING

## Delayed neutron spectra

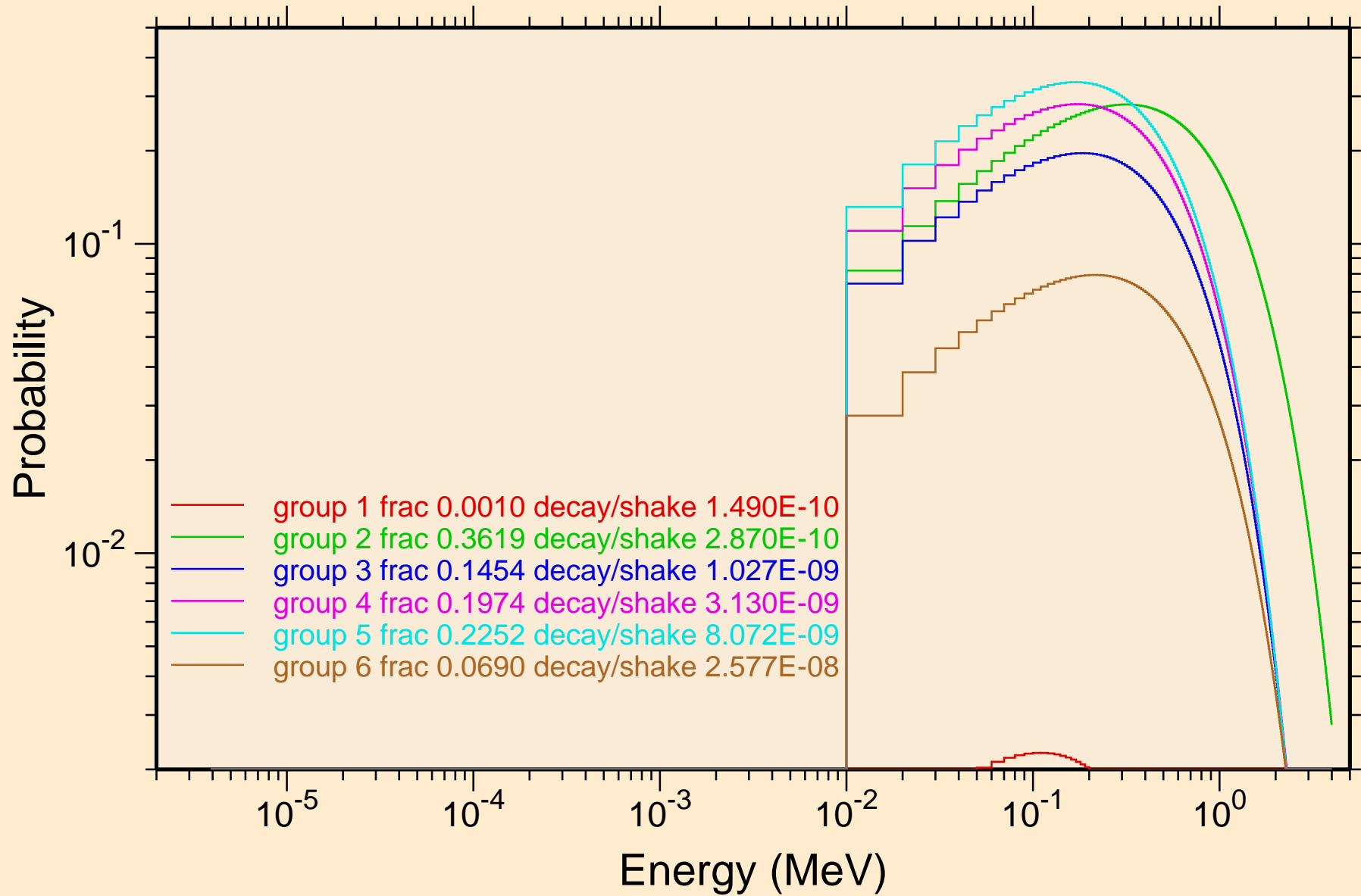

RF259 NRG TENDL-2015, AKONING  
Photon emission for (n,x)

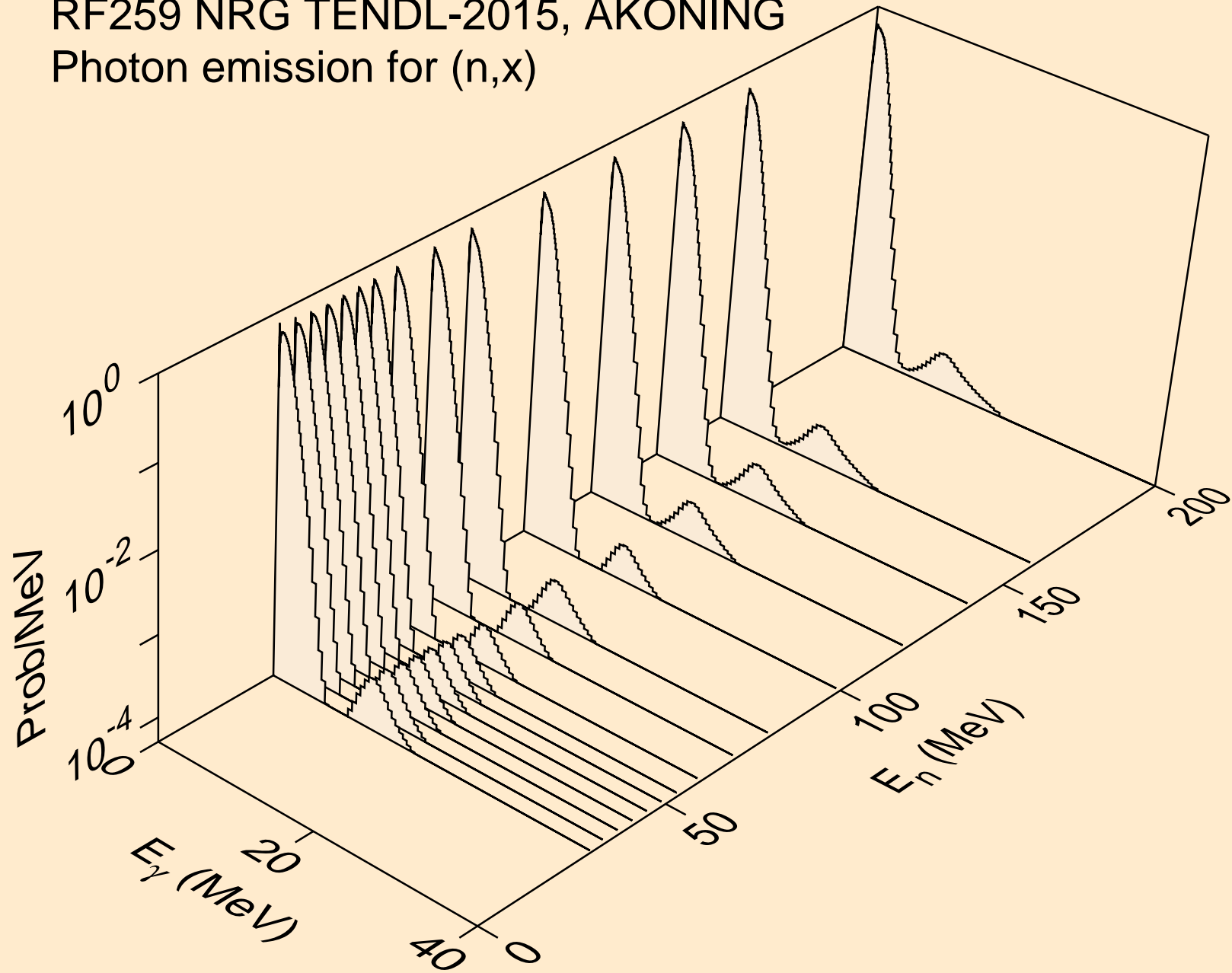

RF259 NRG TENDL-2015, AKONING  
Photon emission for (n,2nd)

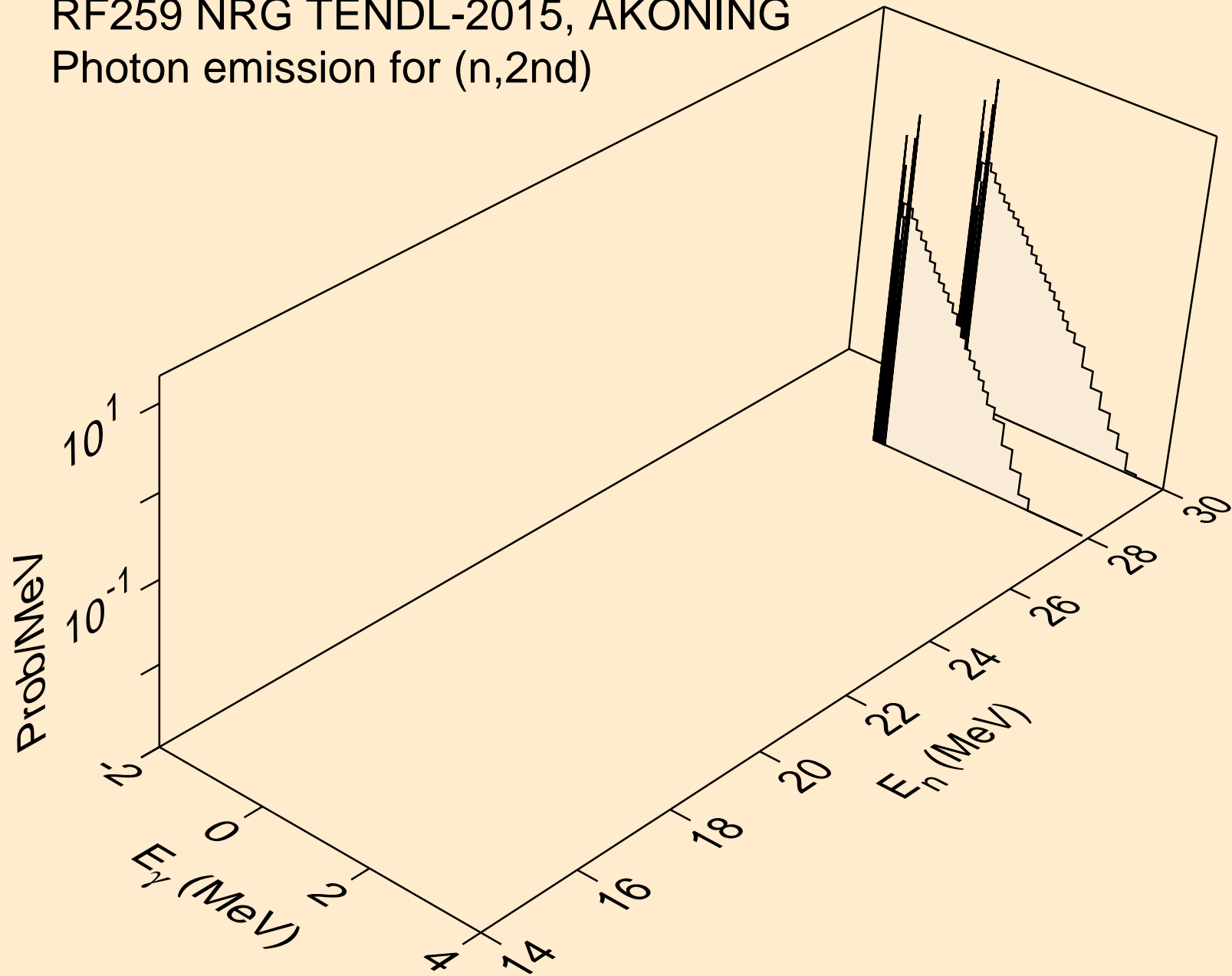

RF259 NRG TENDL-2015, AKONING  
Photon emission for (n,2n)

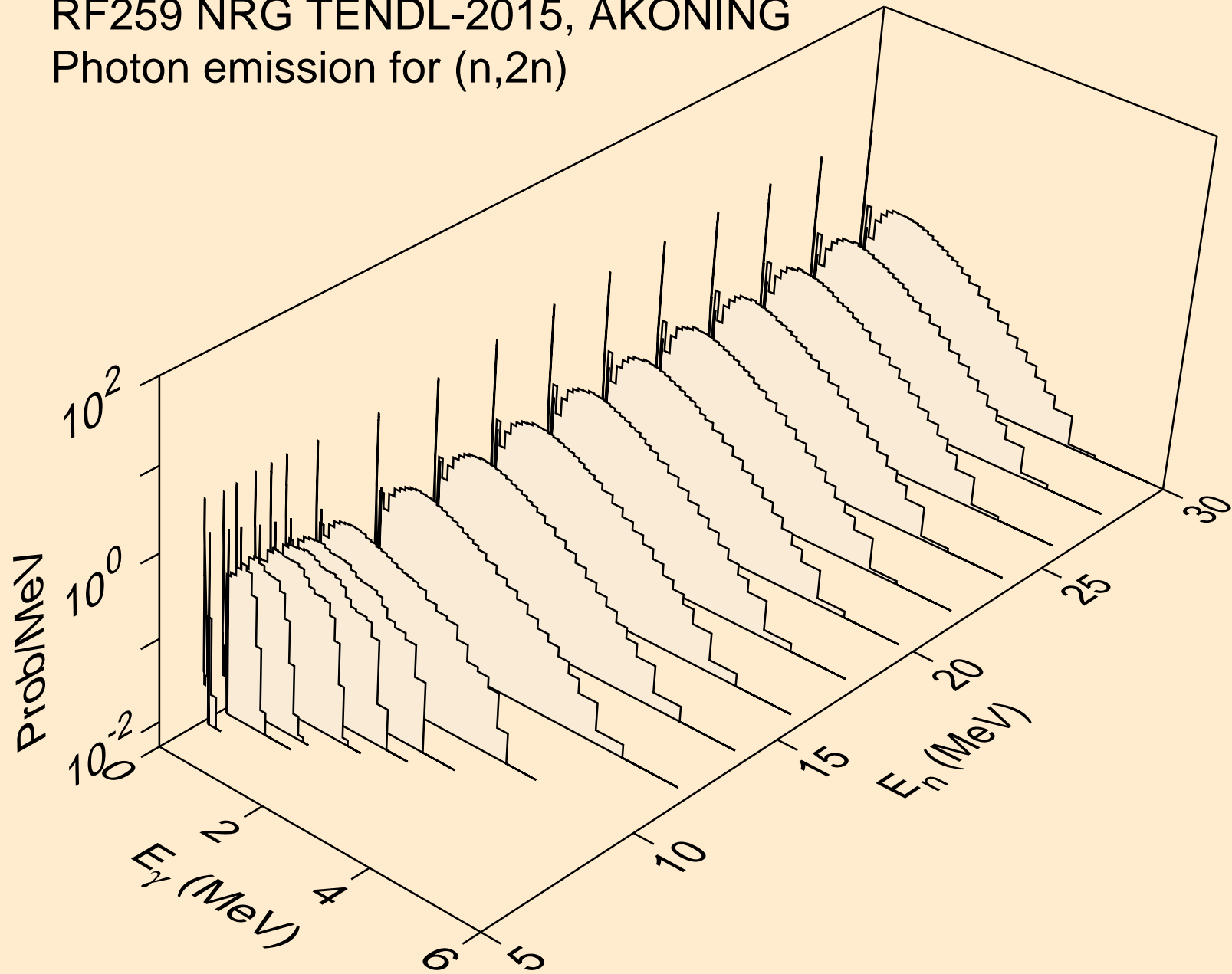

RF259 NRG TENDL-2015, AKONING  
Photon emission for (n,3n)

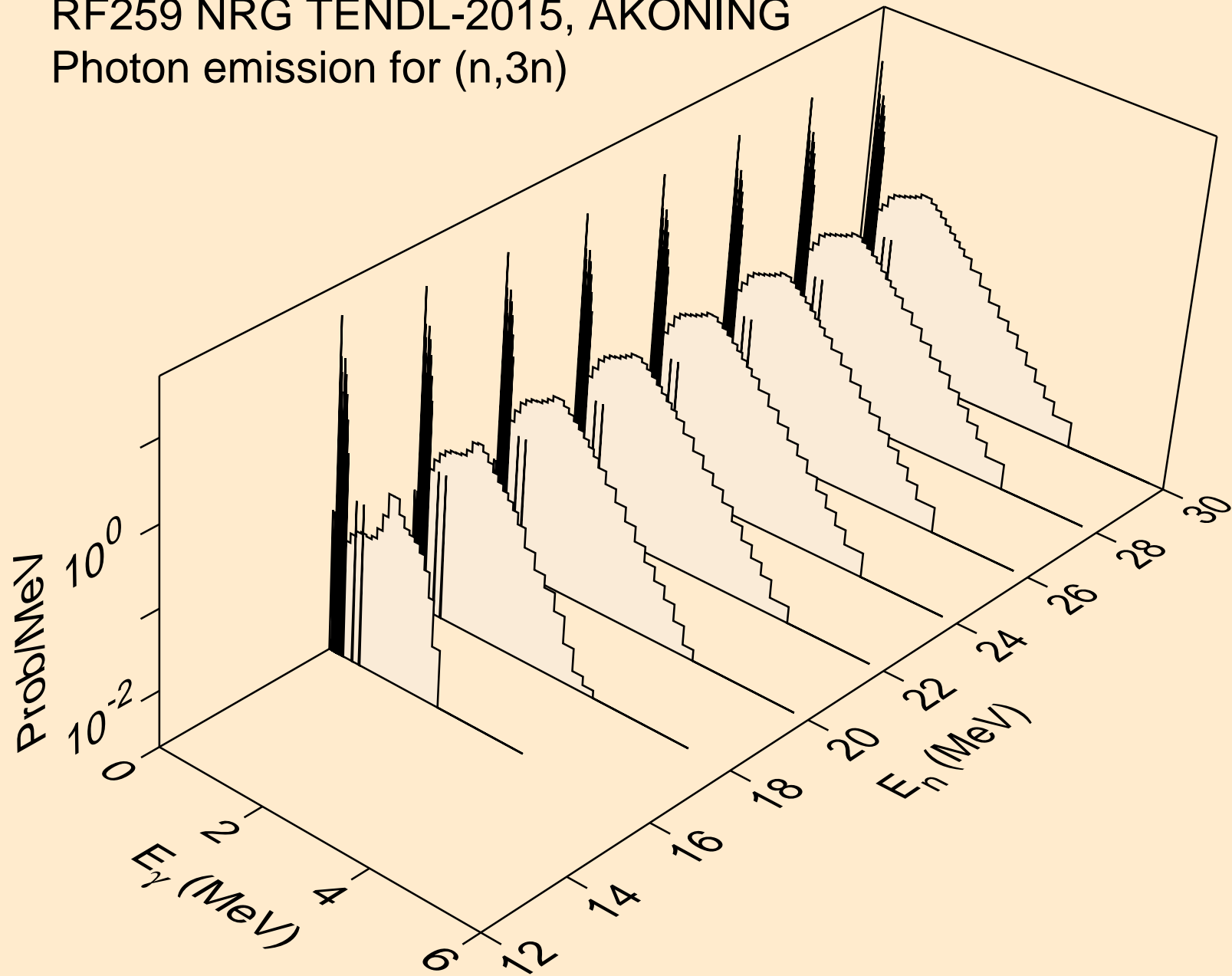

RF259 NRG TENDL-2015, AKONING  
Photon emission for (n,n\*)a

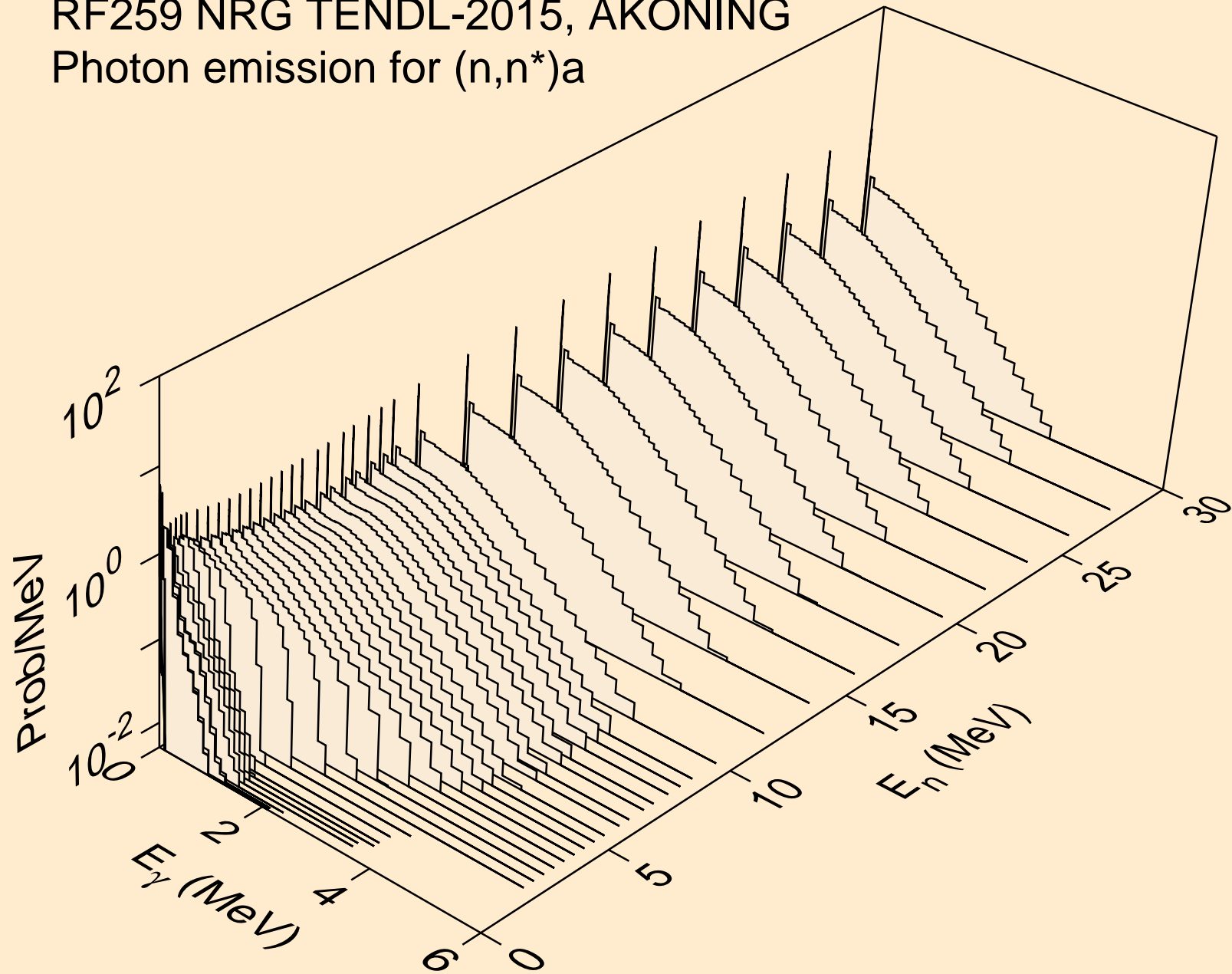

RF259 NRG TENDL-2015, AKONING  
Photon emission for (n,n\*)3a

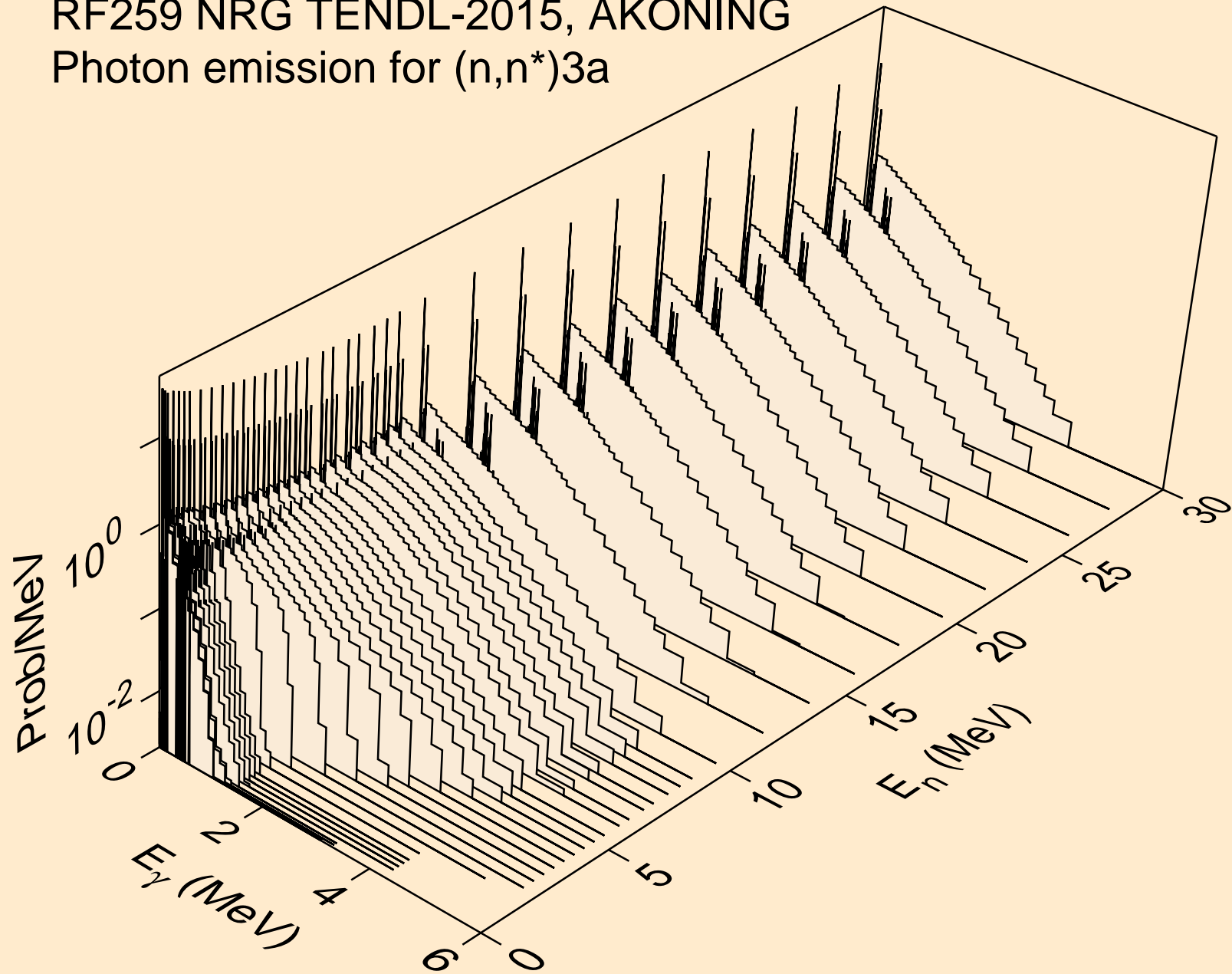



RF259 NRG TENDL-2015, AKONING  
Photon emission for (n,2n)a

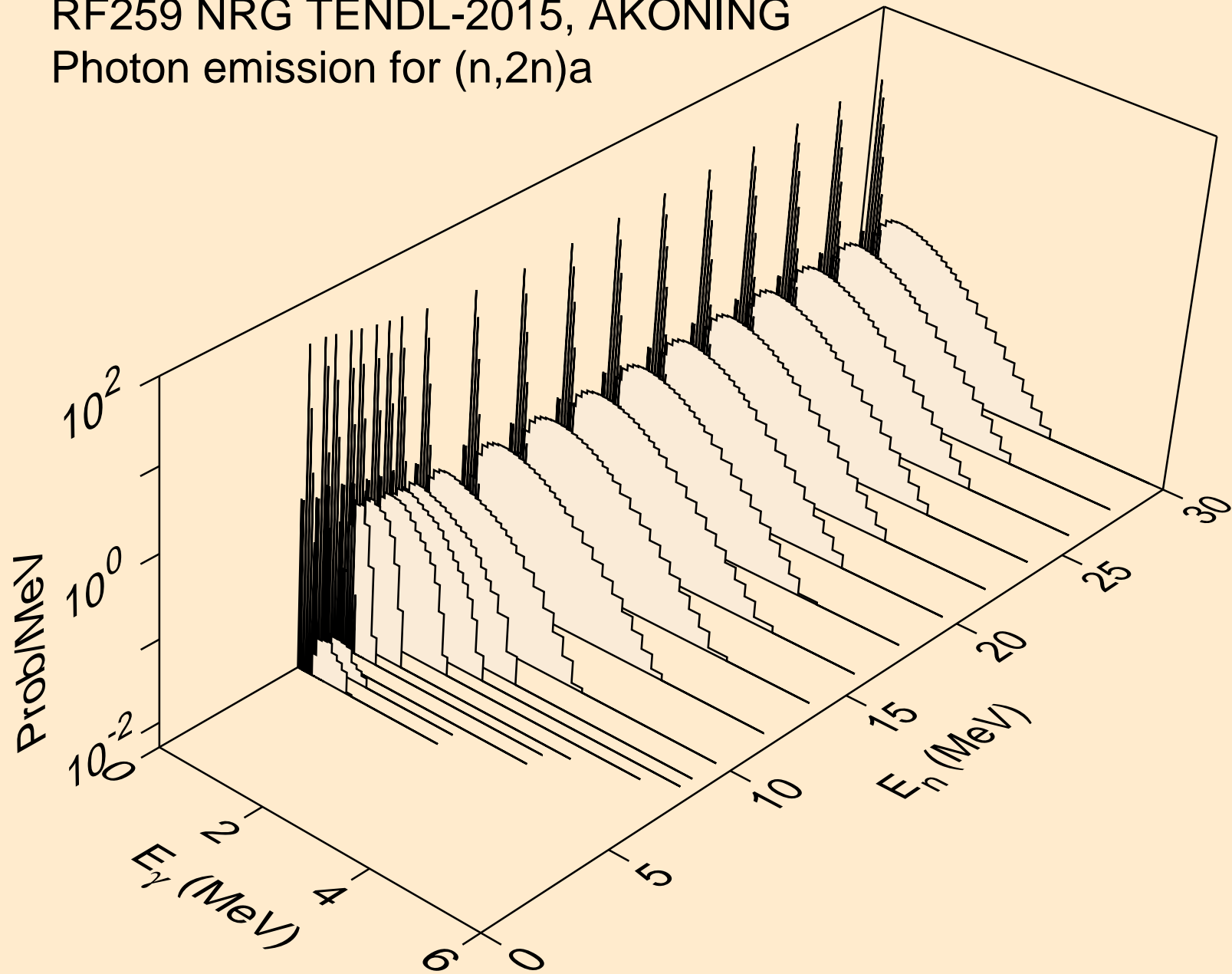

RF259 NRG TENDL-2015, AKONING  
Photon emission for (n,3n)a

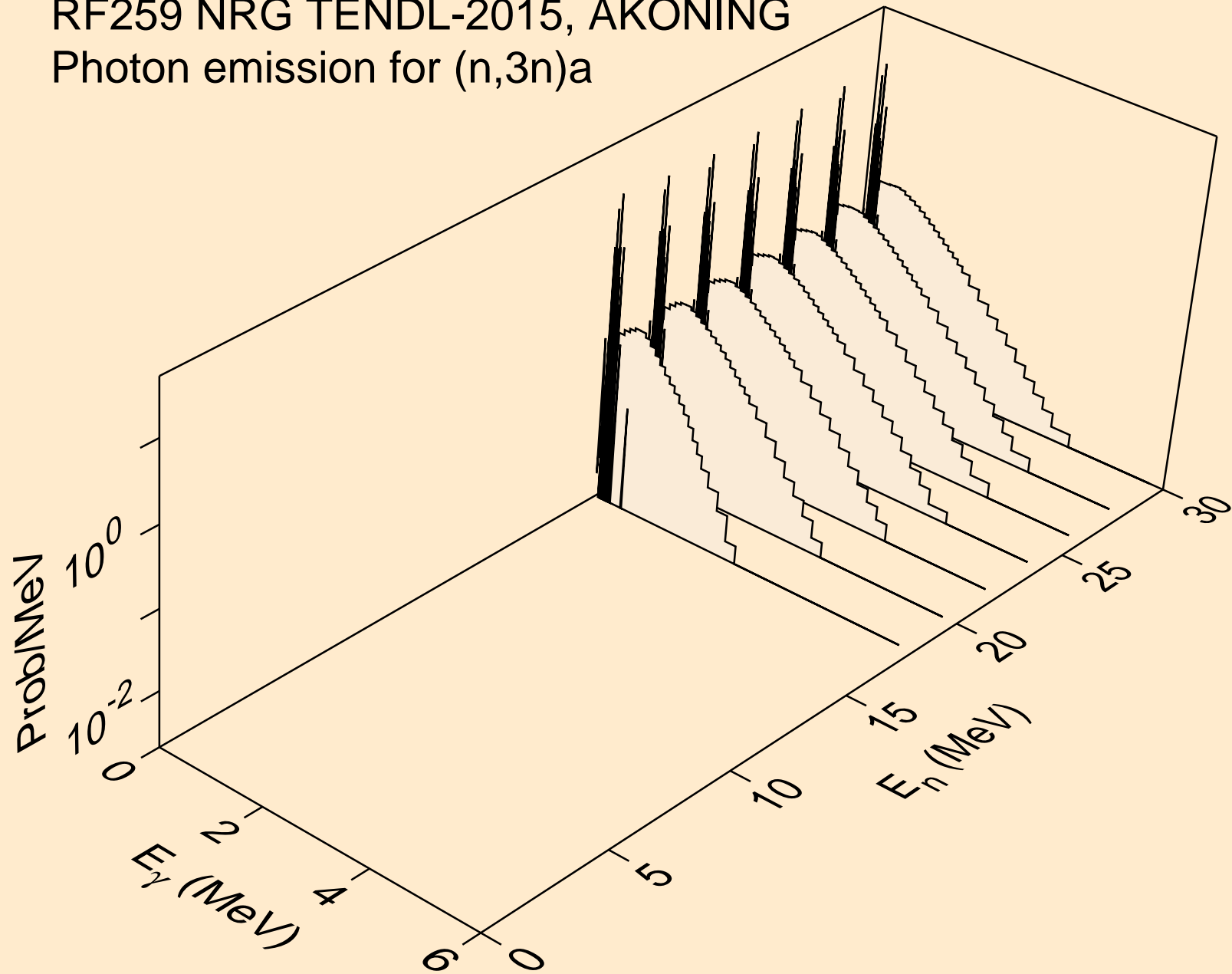

RF259 NRG TENDL-2015, AKONING  
Photon emission for (n,n\*)p

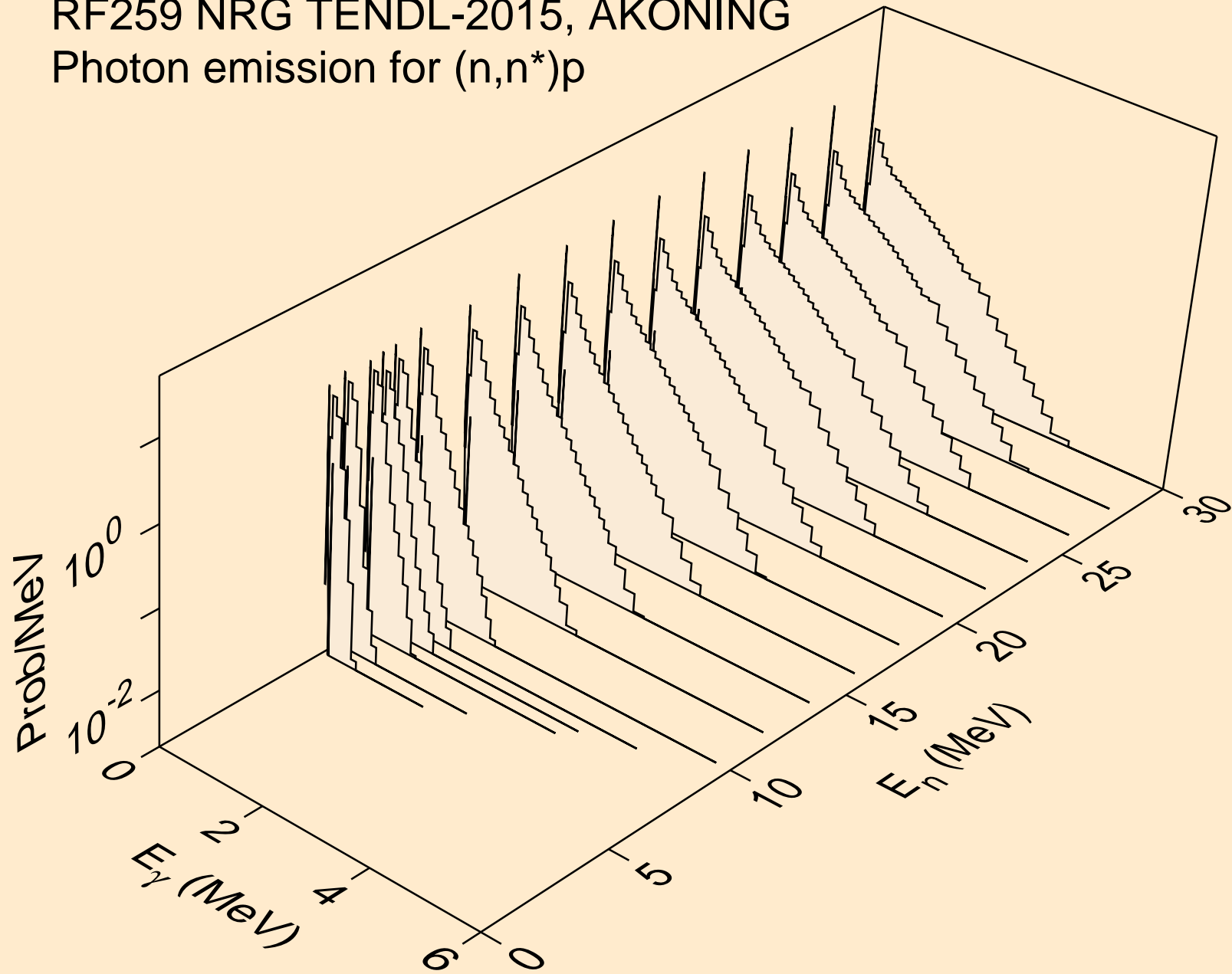

RF259 NRG TENDL-2015, AKONING  
Photon emission for (n,n\*)2a

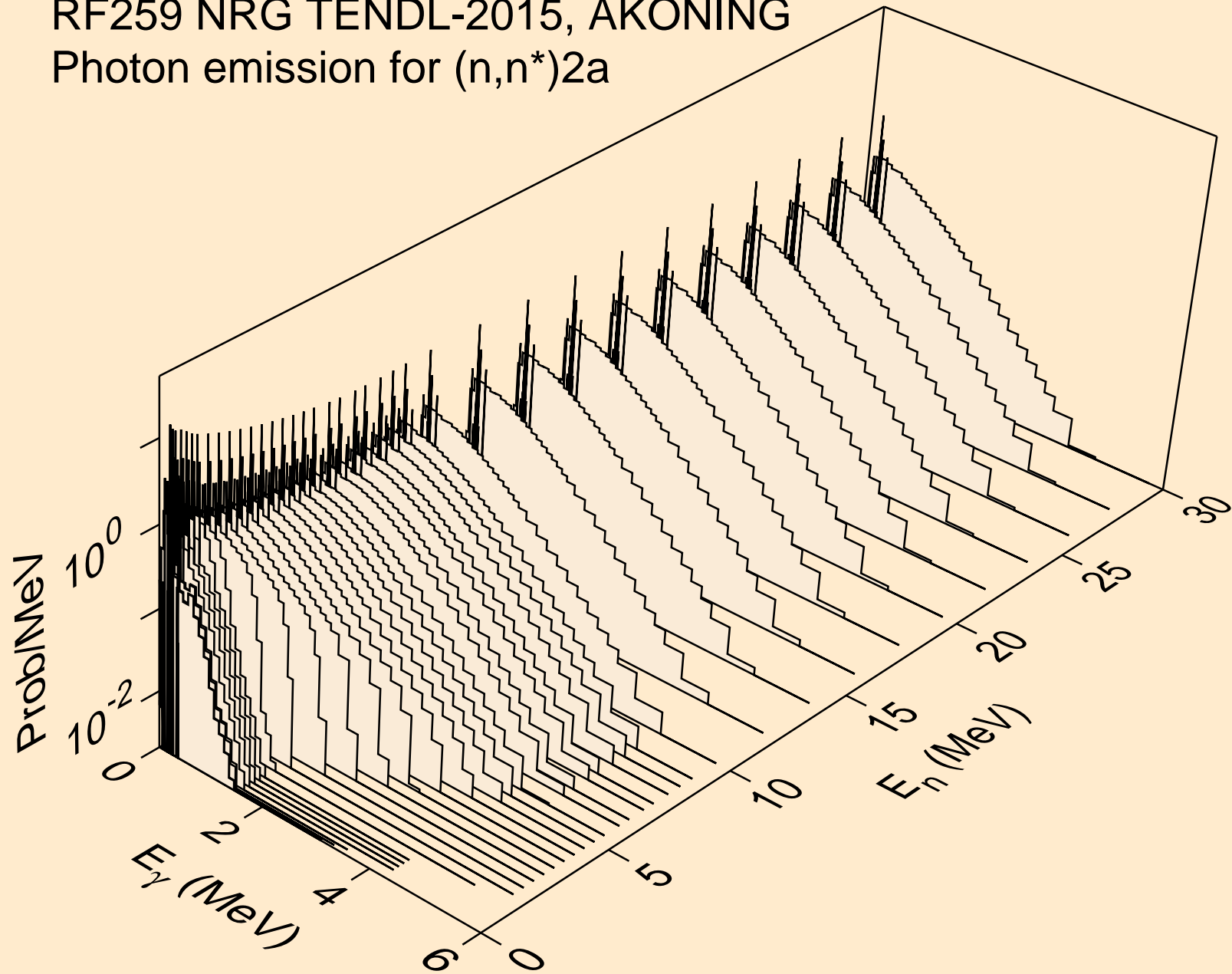

RF259 NRG TENDL-2015, AKONING  
Photon emission for (n,2n)2a

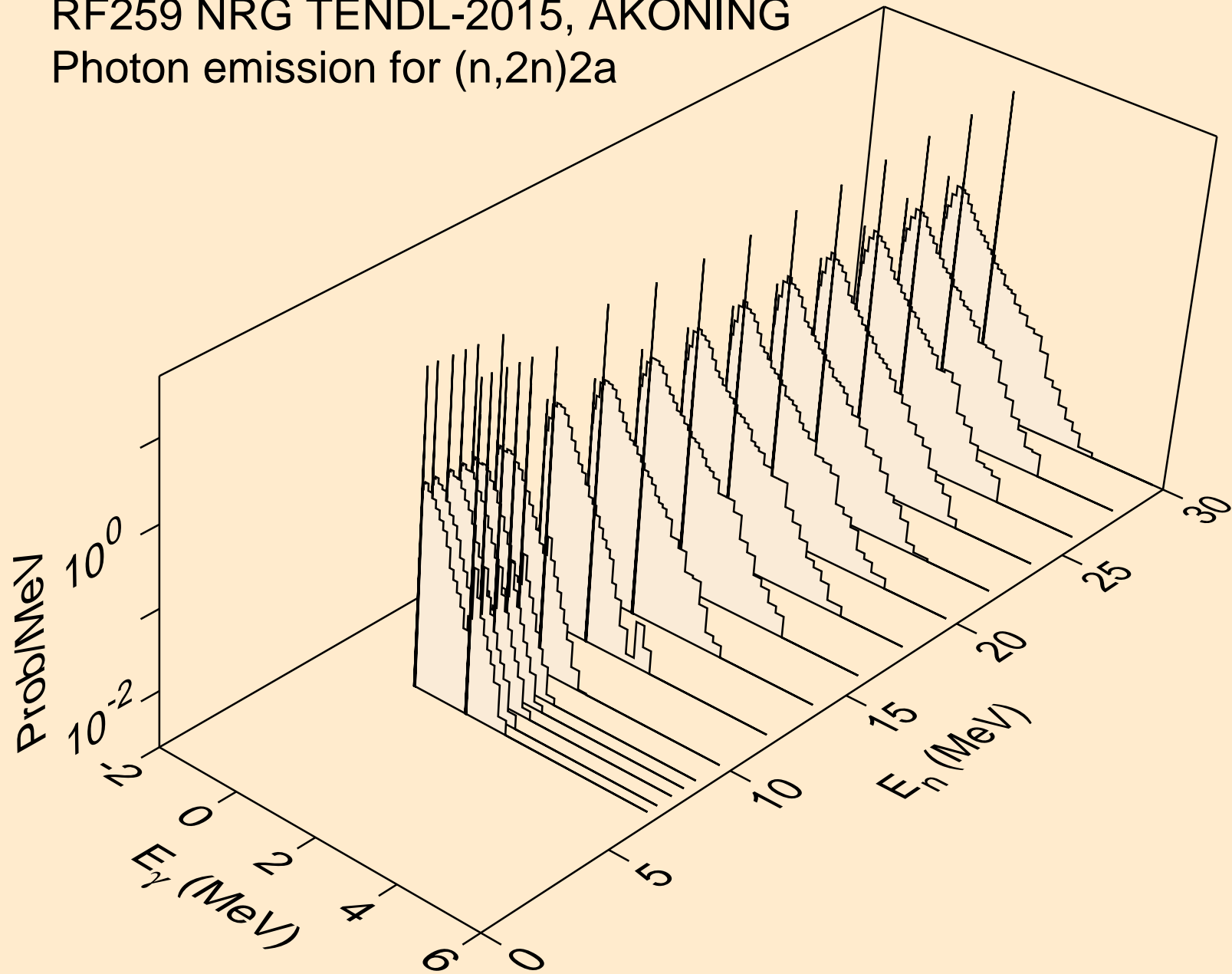

RF259 NRG TENDL-2015, AKONING  
Photon emission for (n,n\*)d

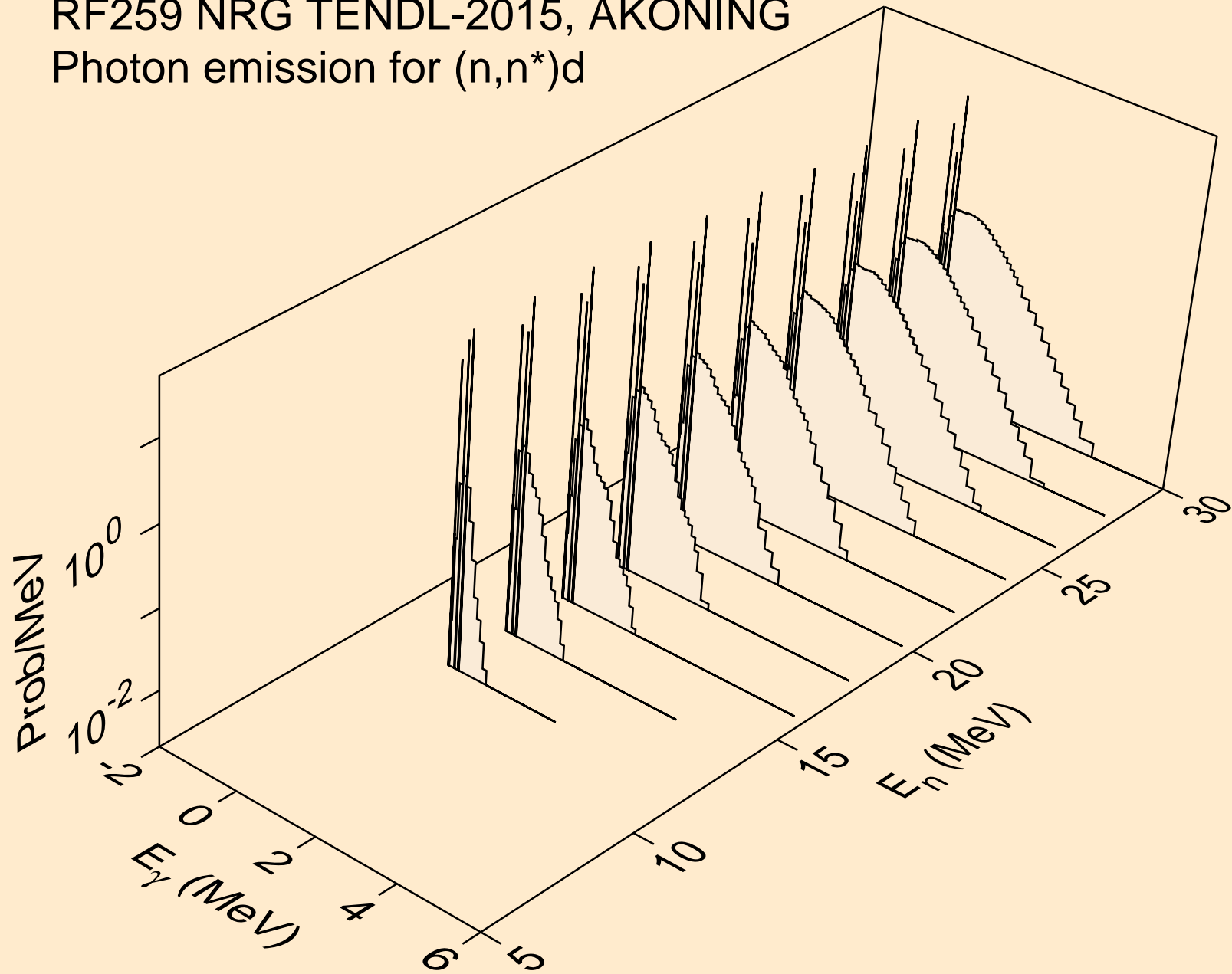

RF259 NRG TENDL-2015, AKONING  
Photon emission for (n,n\*)t

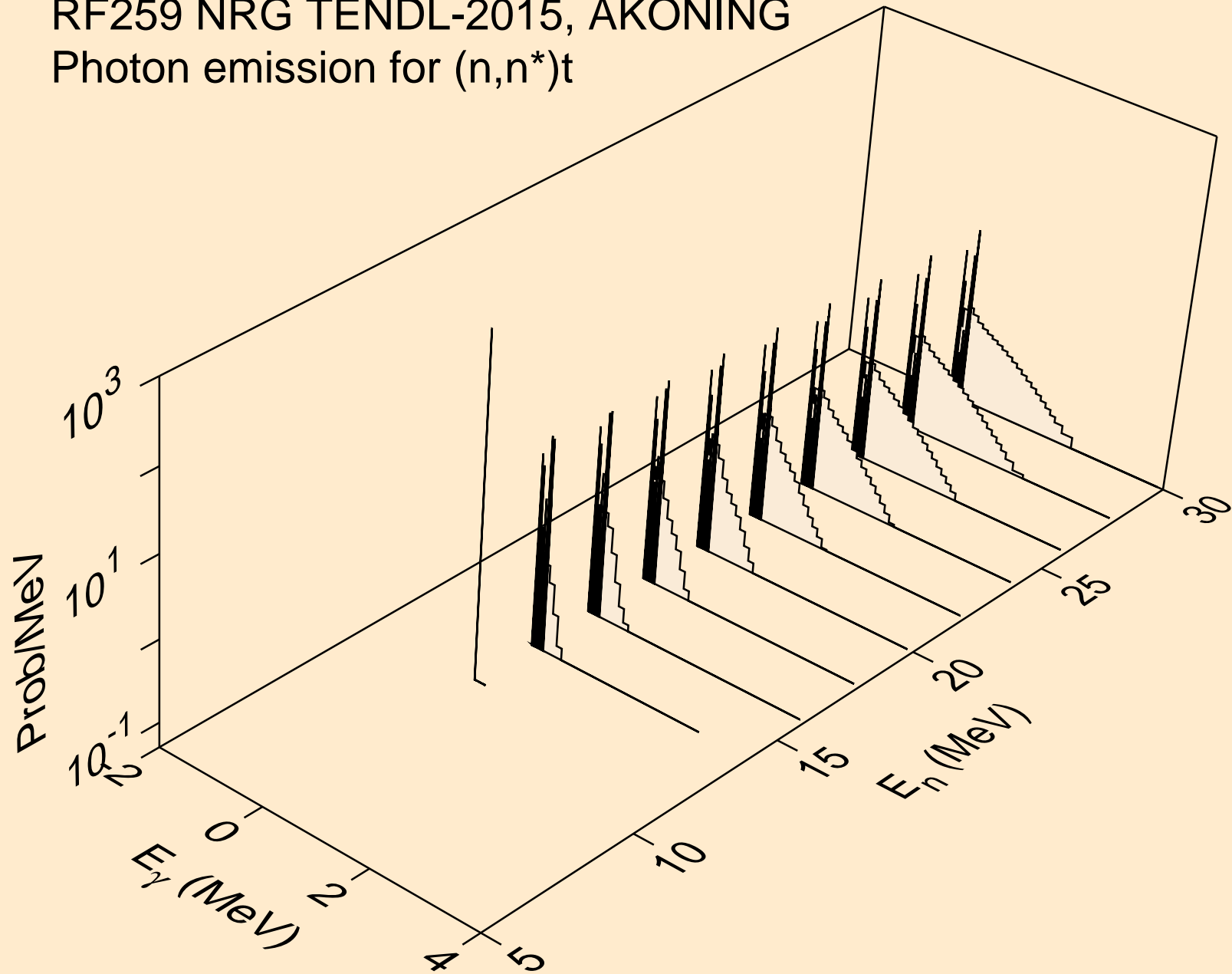

RF259 NRG TENDL-2015, AKONING  
Photon emission for (n,n\*)he3

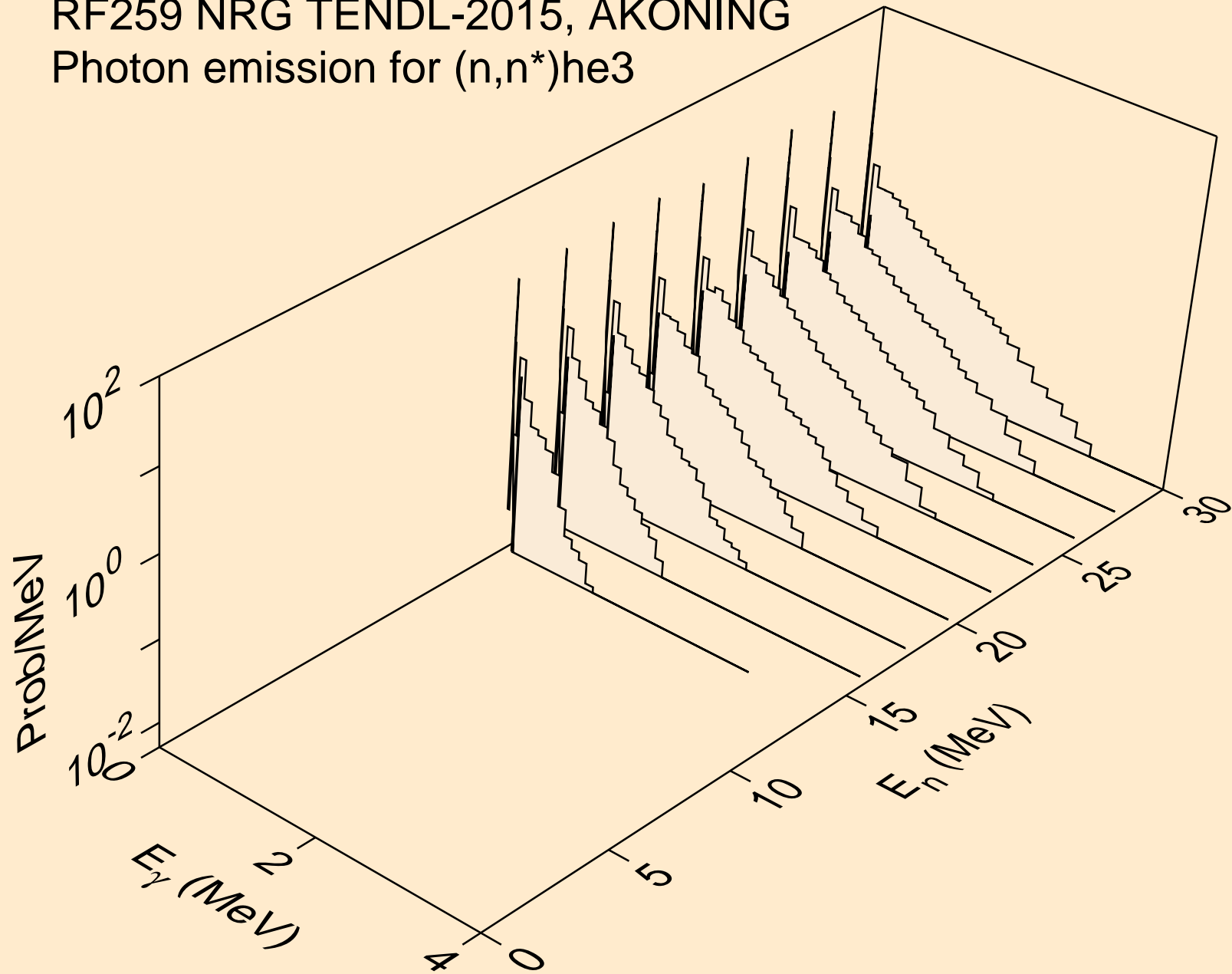



RF259 NRG TENDL-2015, AKONING  
Photon emission for (n,n\*)d2a

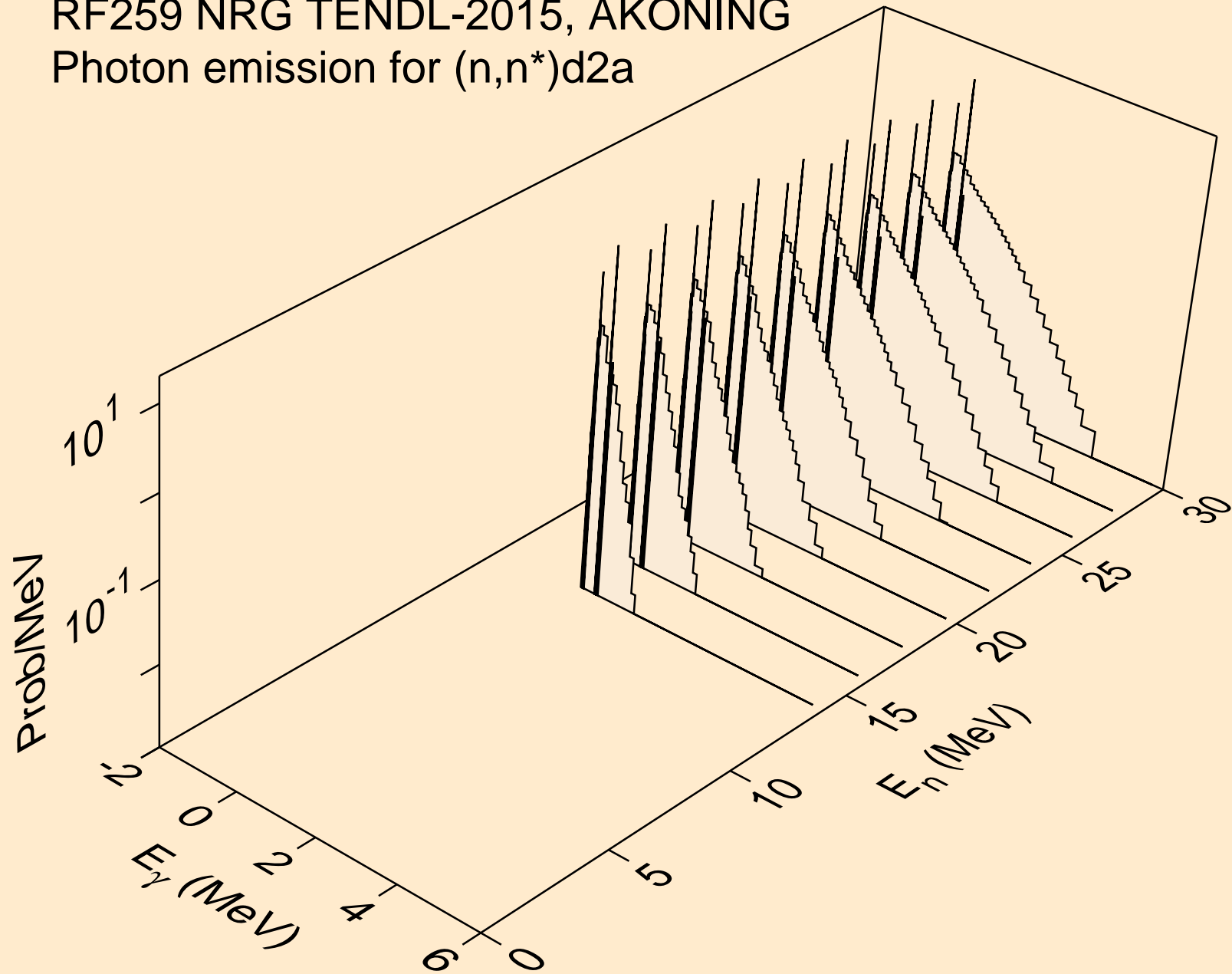

RF259 NRG TENDL-2015, AKONING  
Photon emission for (n,n\*)t2a

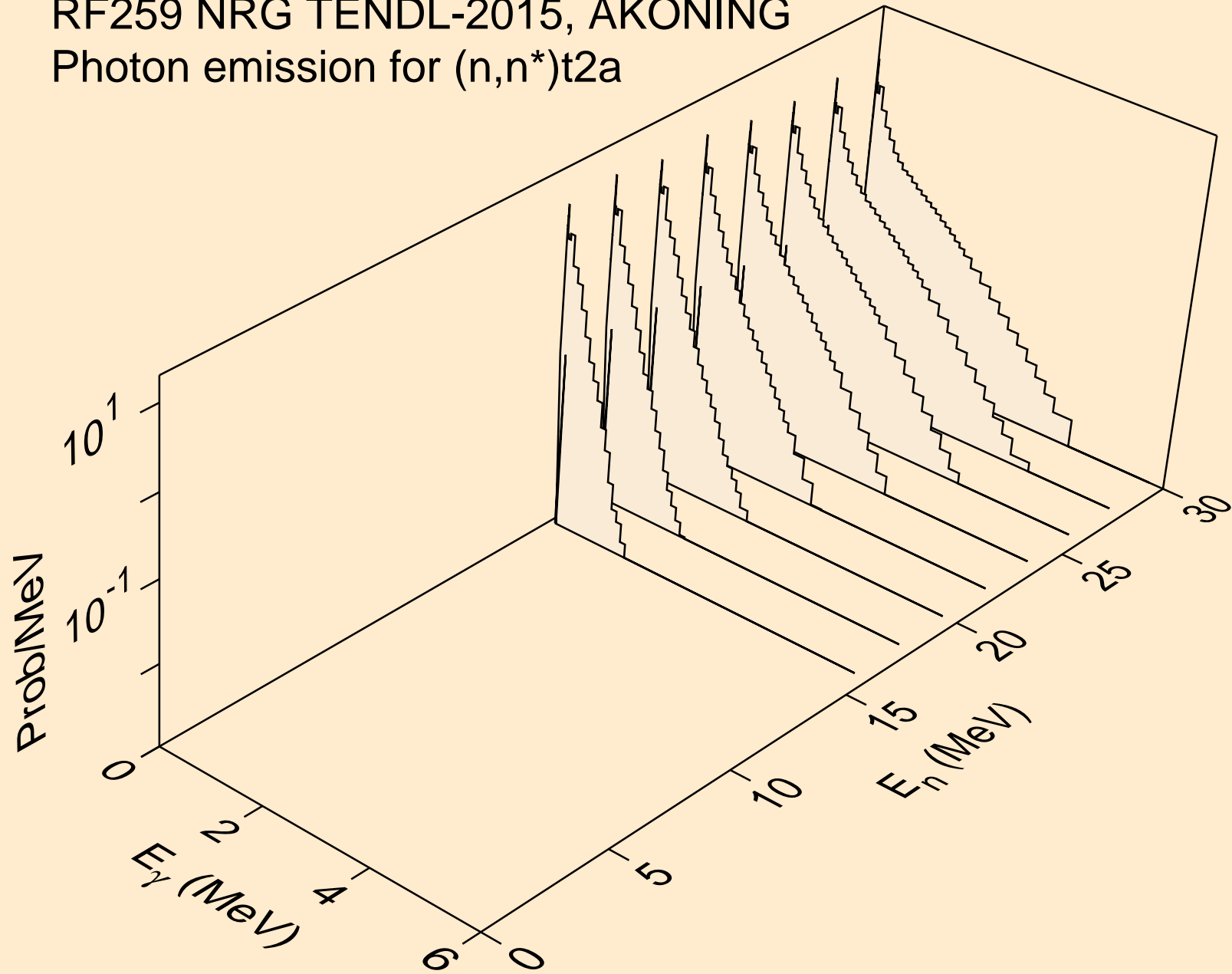

RF259 NRG TENDL-2015, AKONING  
Photon emission for (n,4n)

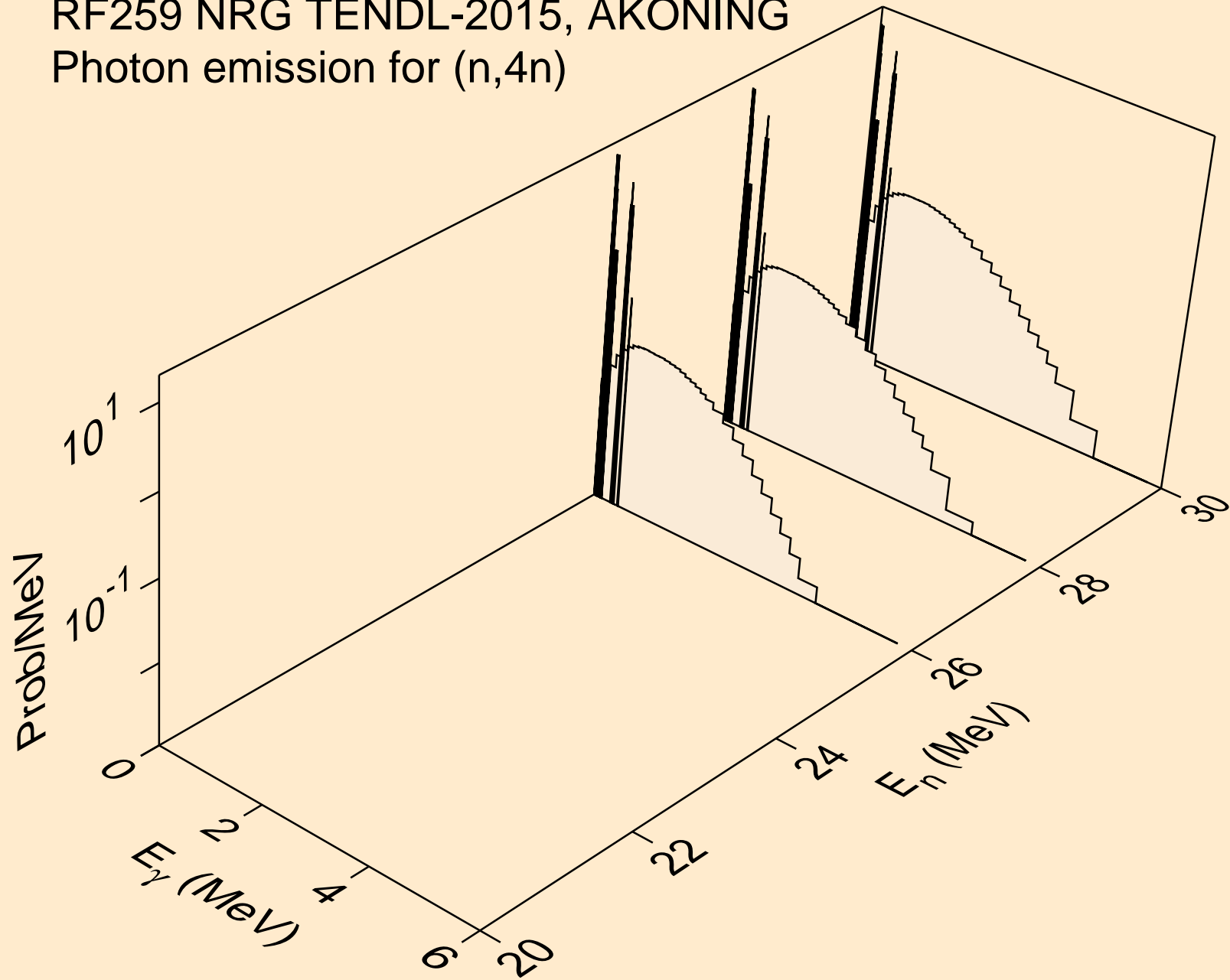

RF259 NRG TENDL-2015, AKONING  
Photon emission for (n,2np)

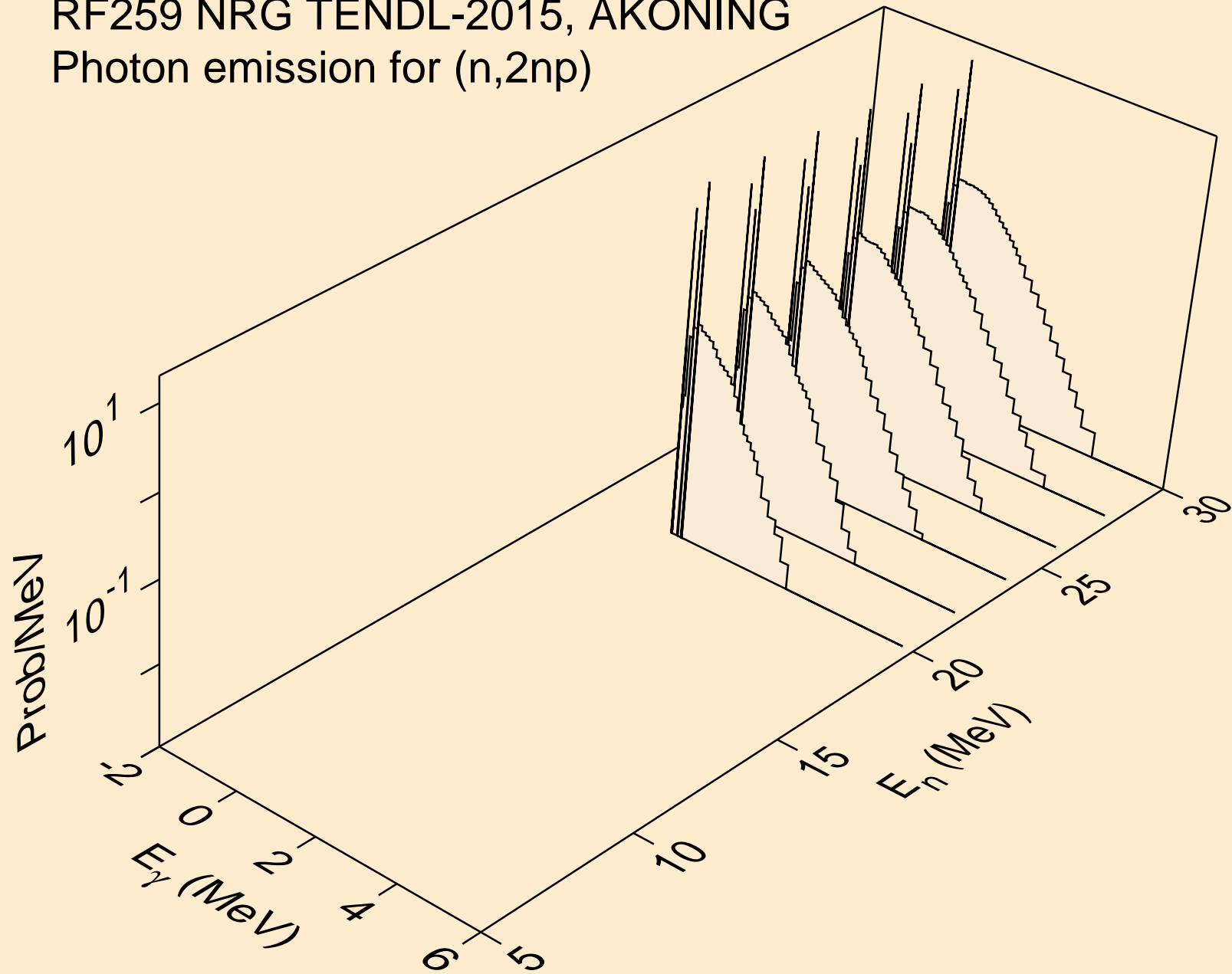

RF259 NRG TENDL-2015, AKONING  
Photon emission for (n,3np)

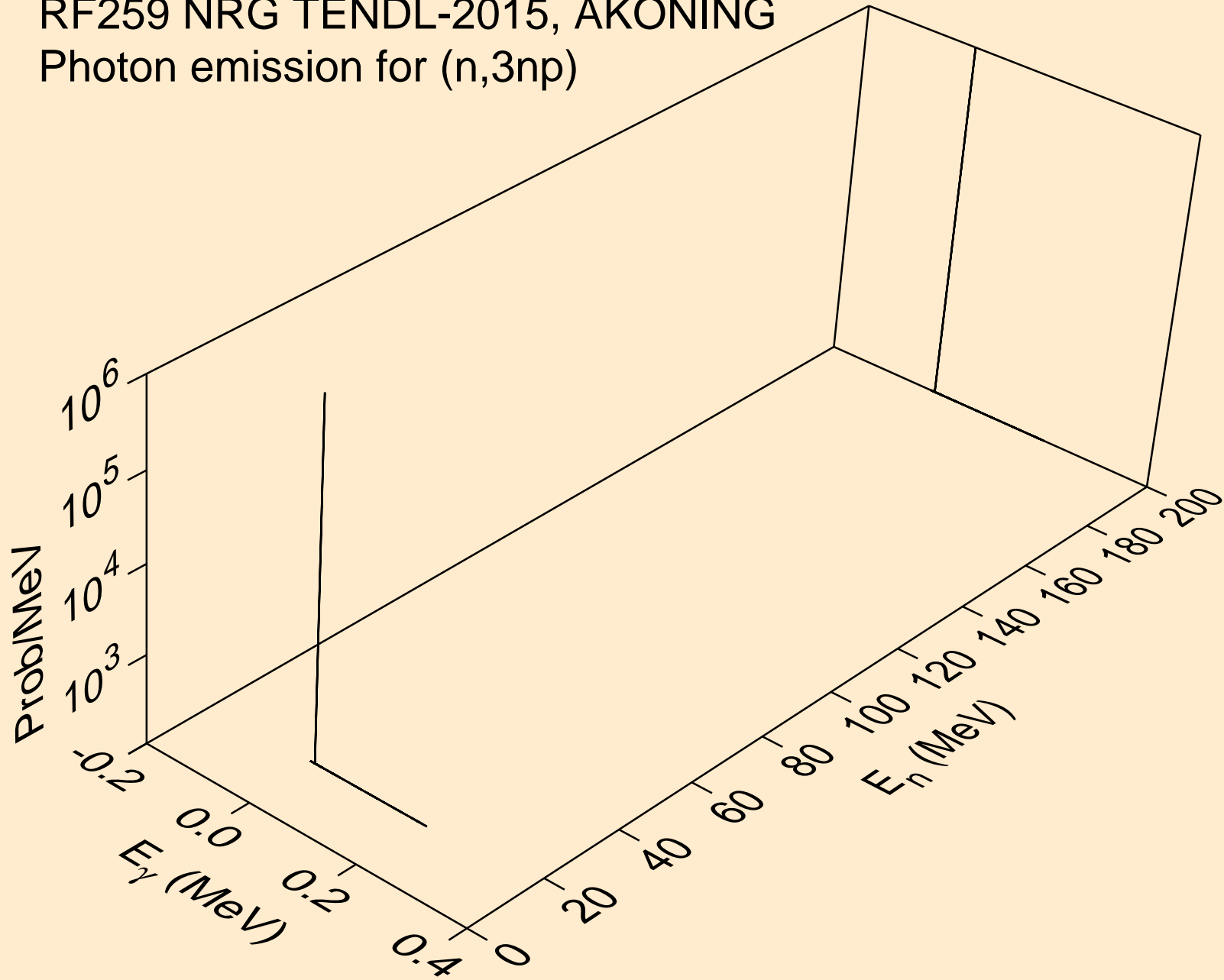

RF259 NRG TENDL-2015, AKONING  
Photon emission for (n,2np)

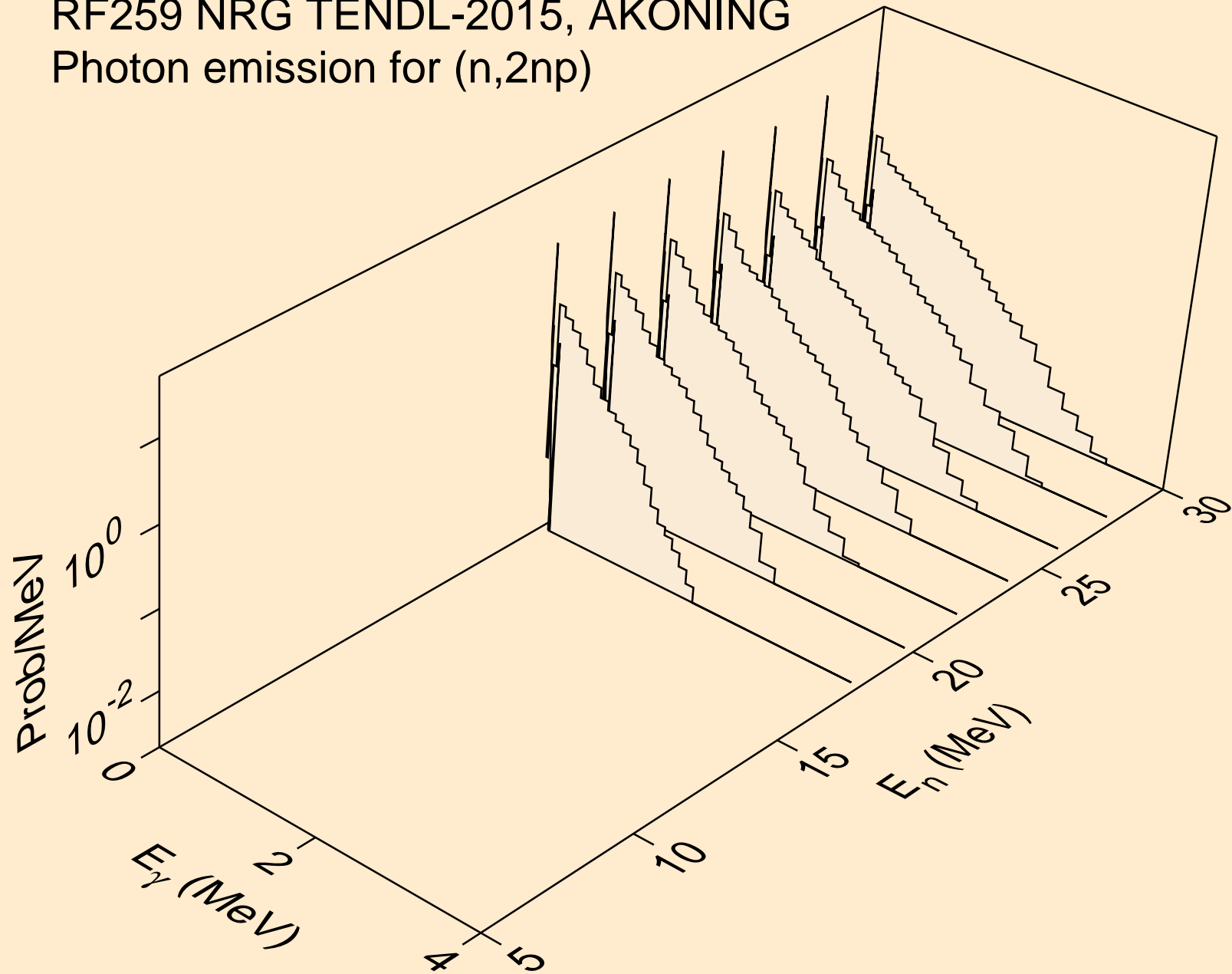

RF259 NRG TENDL-2015, AKONING  
Photon emission for (n,npa)

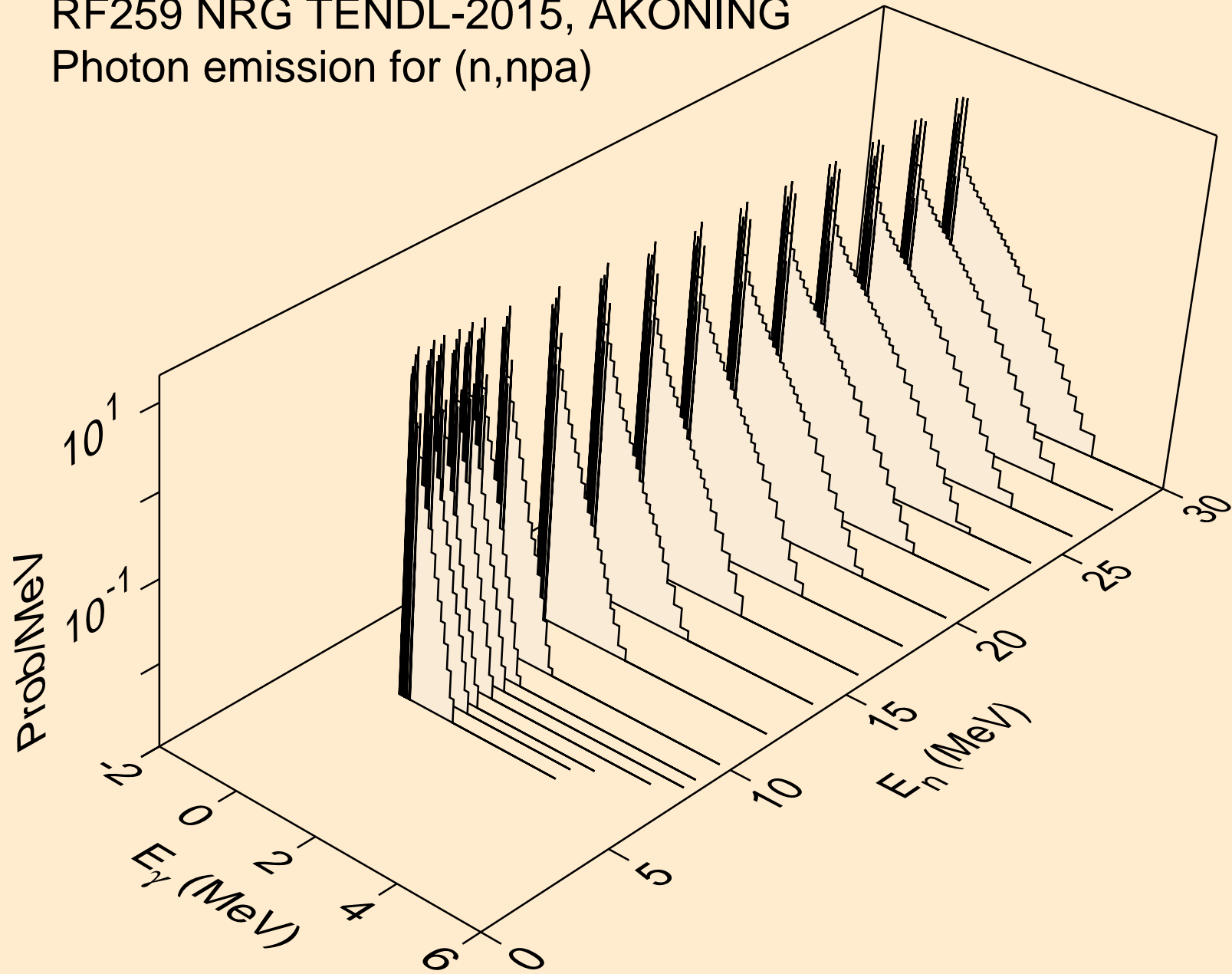

RF259 NRG TENDL-2015, AKONING  
Photon emission for (n,n\*c)

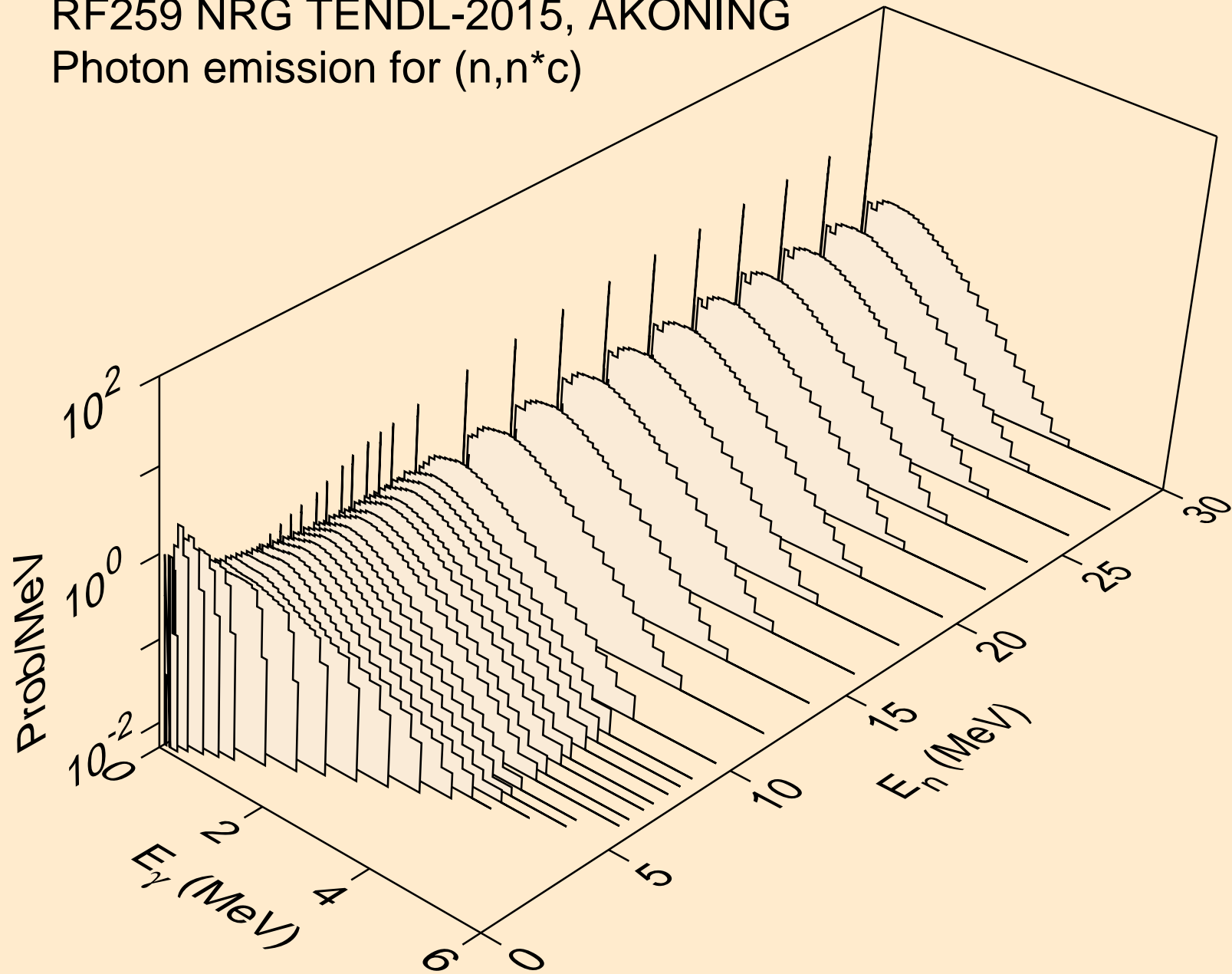



RF259 NRG TENDL-2015, AKONING  
Photon emission for (n,gma)

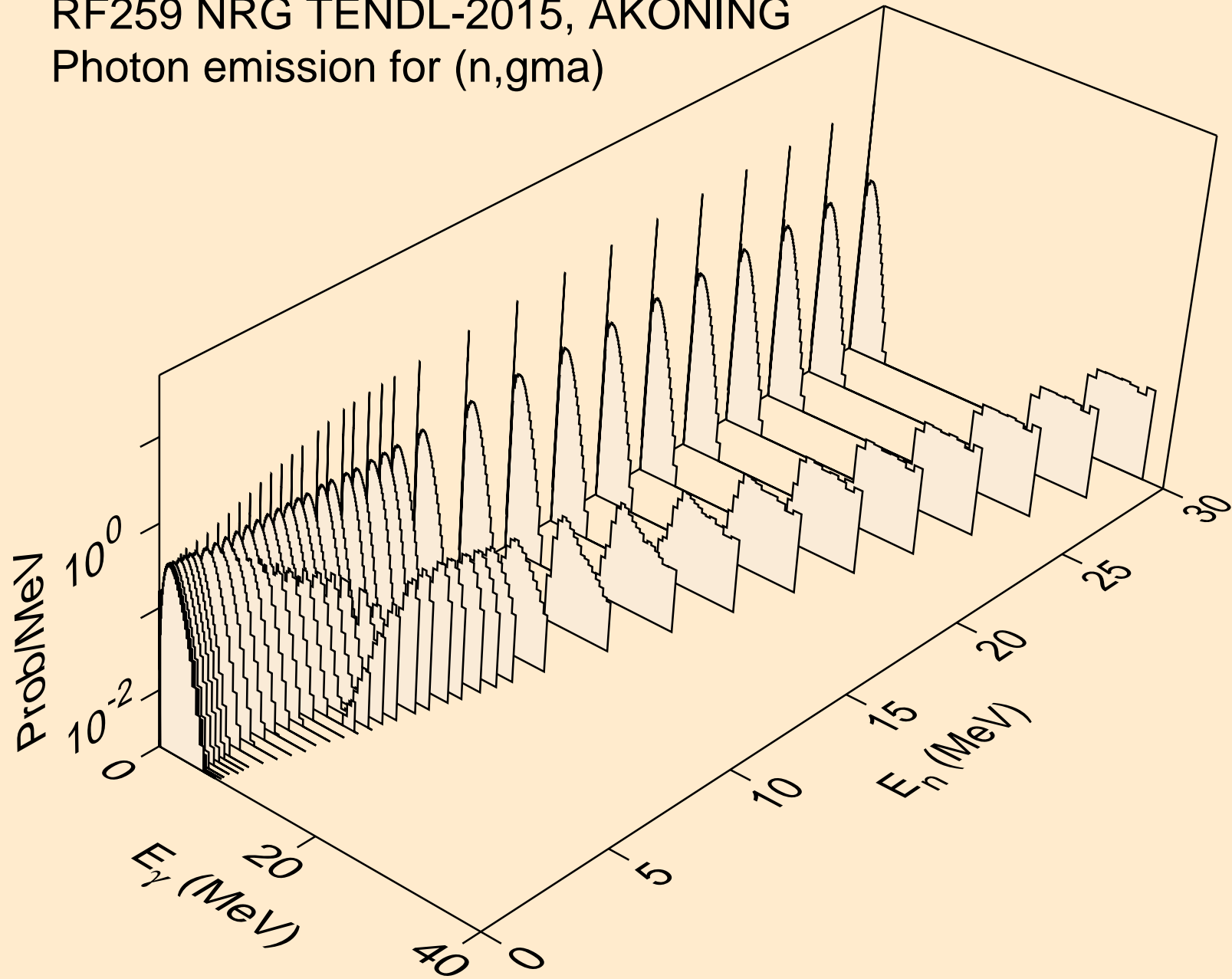

RF259 NRG TENDL-2015, AKONING  
Photon emission for (n,p)

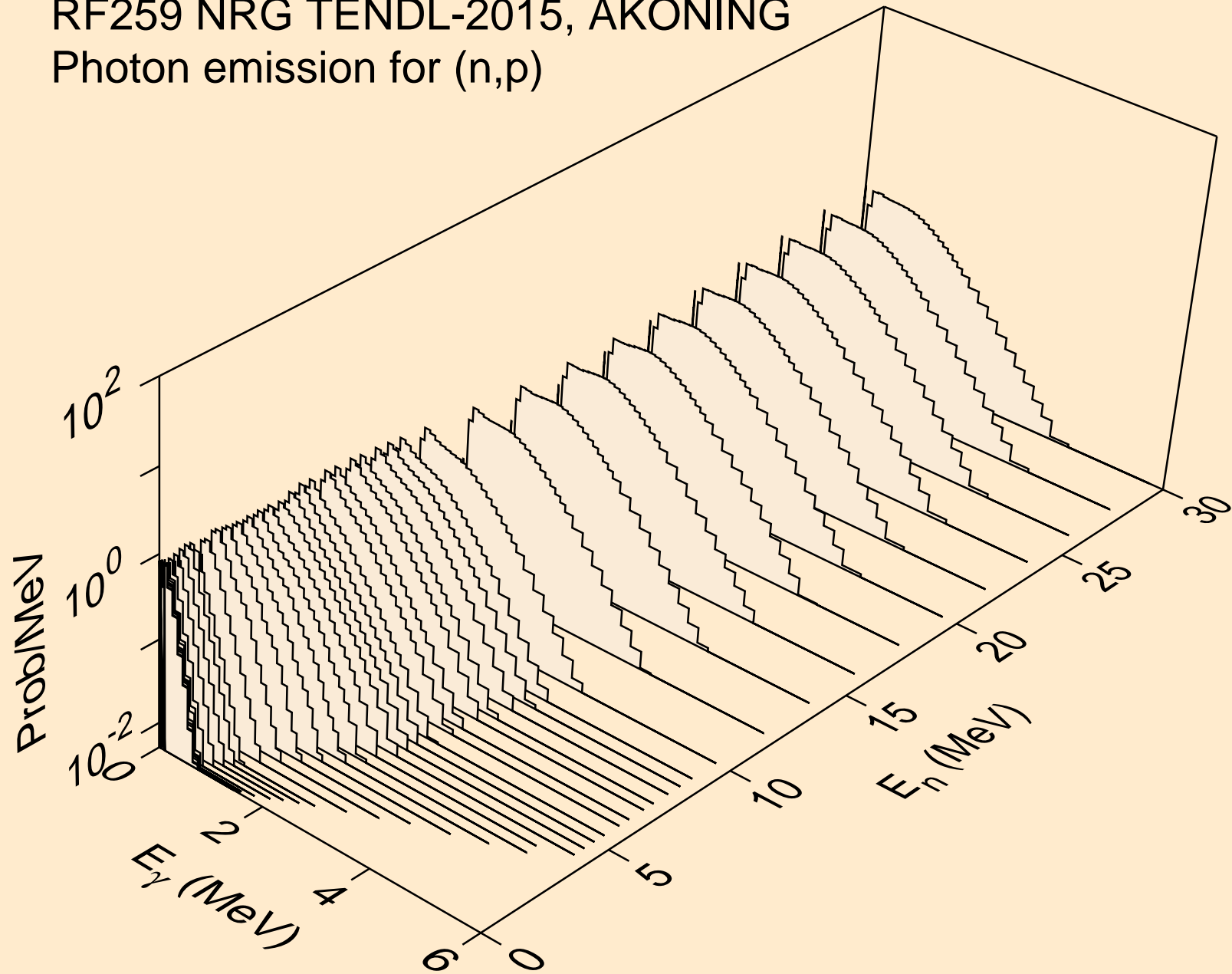

RF259 NRG TENDL-2015, AKONING  
Photon emission for (n,d)

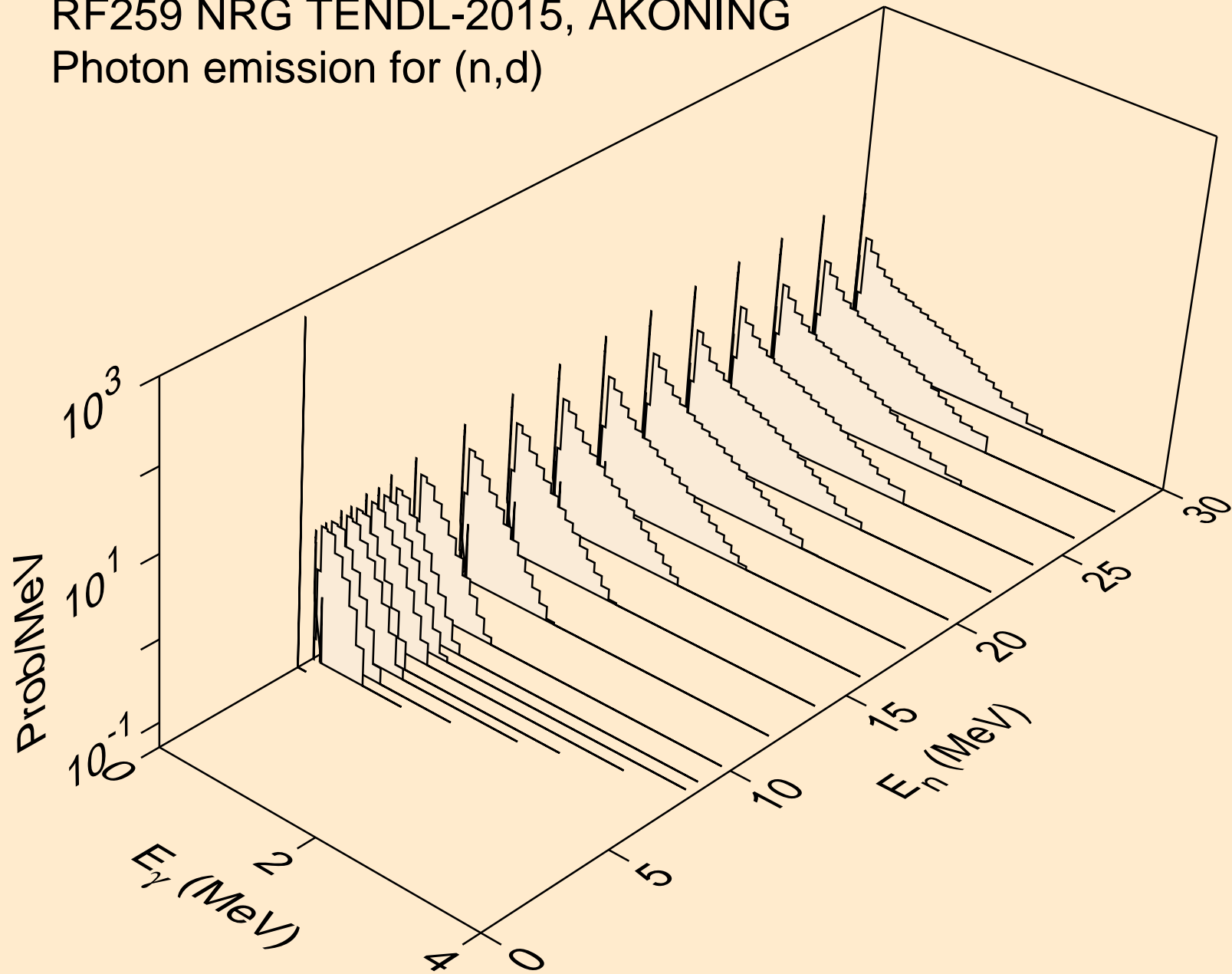

RF259 NRG TENDL-2015, AKONING  
Photon emission for (n,t)

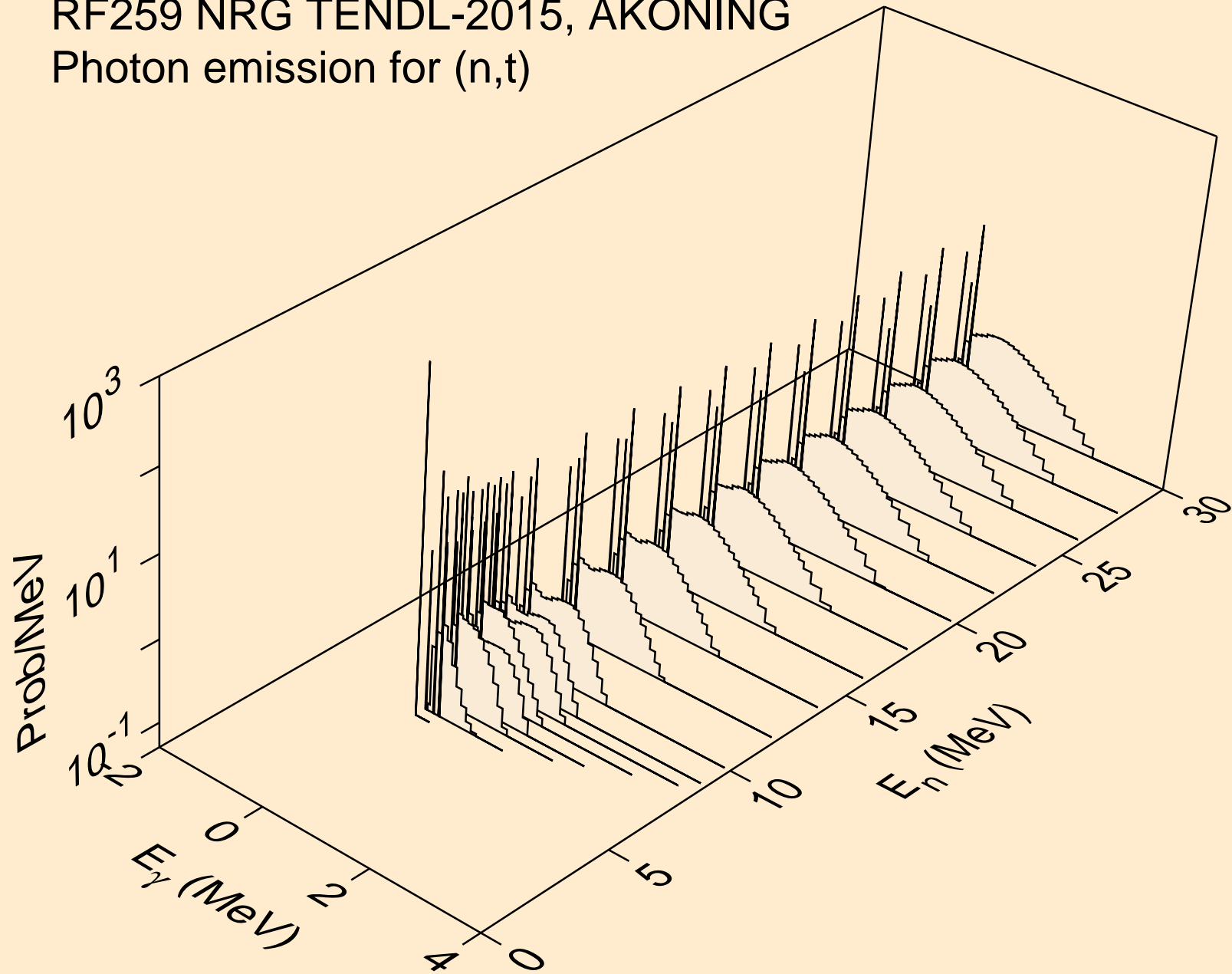

RF259 NRG TENDL-2015, AKONING  
Photon emission for (n,he3)

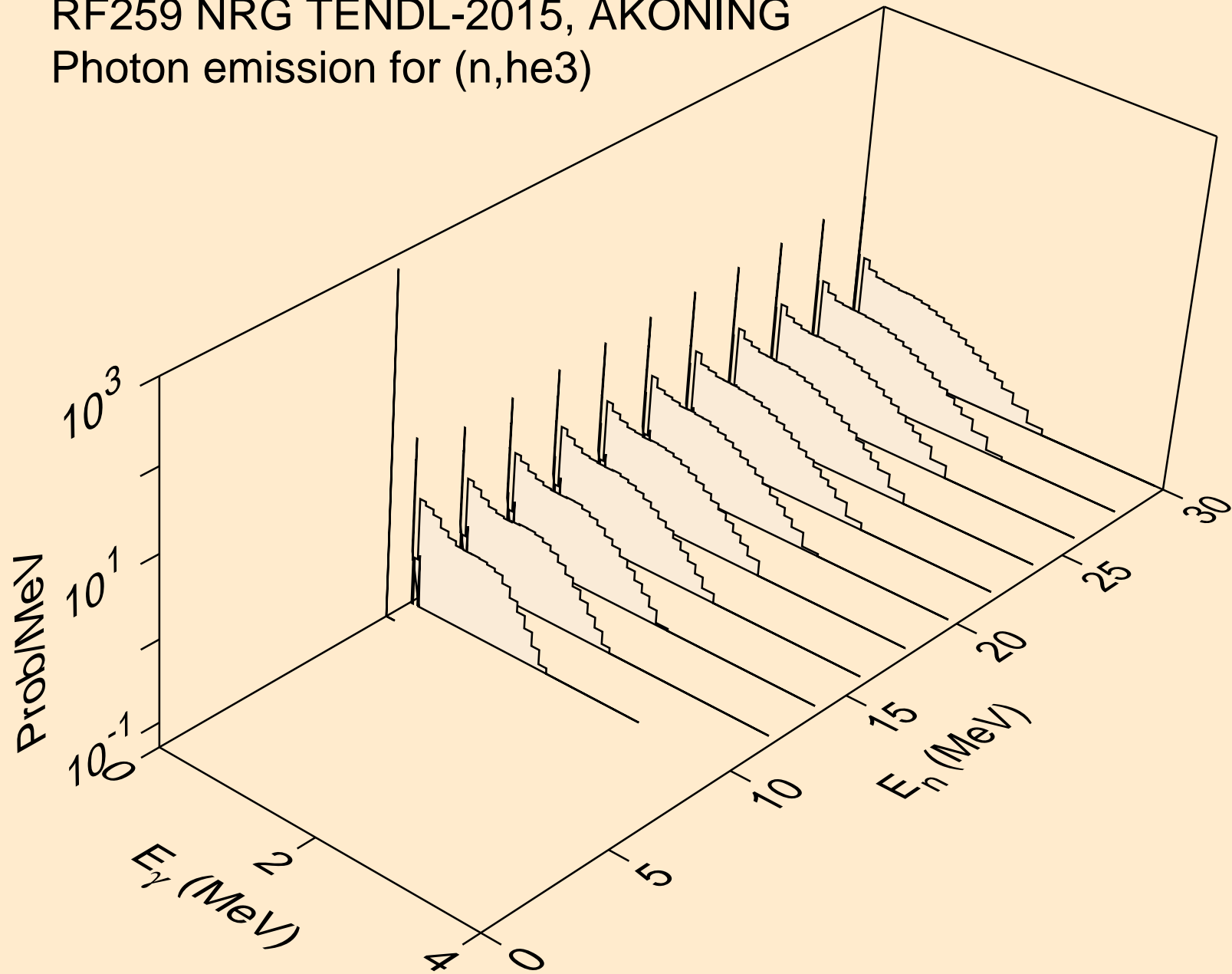

RF259 NRG TENDL-2015, AKONING  
Photon emission for (n,a)

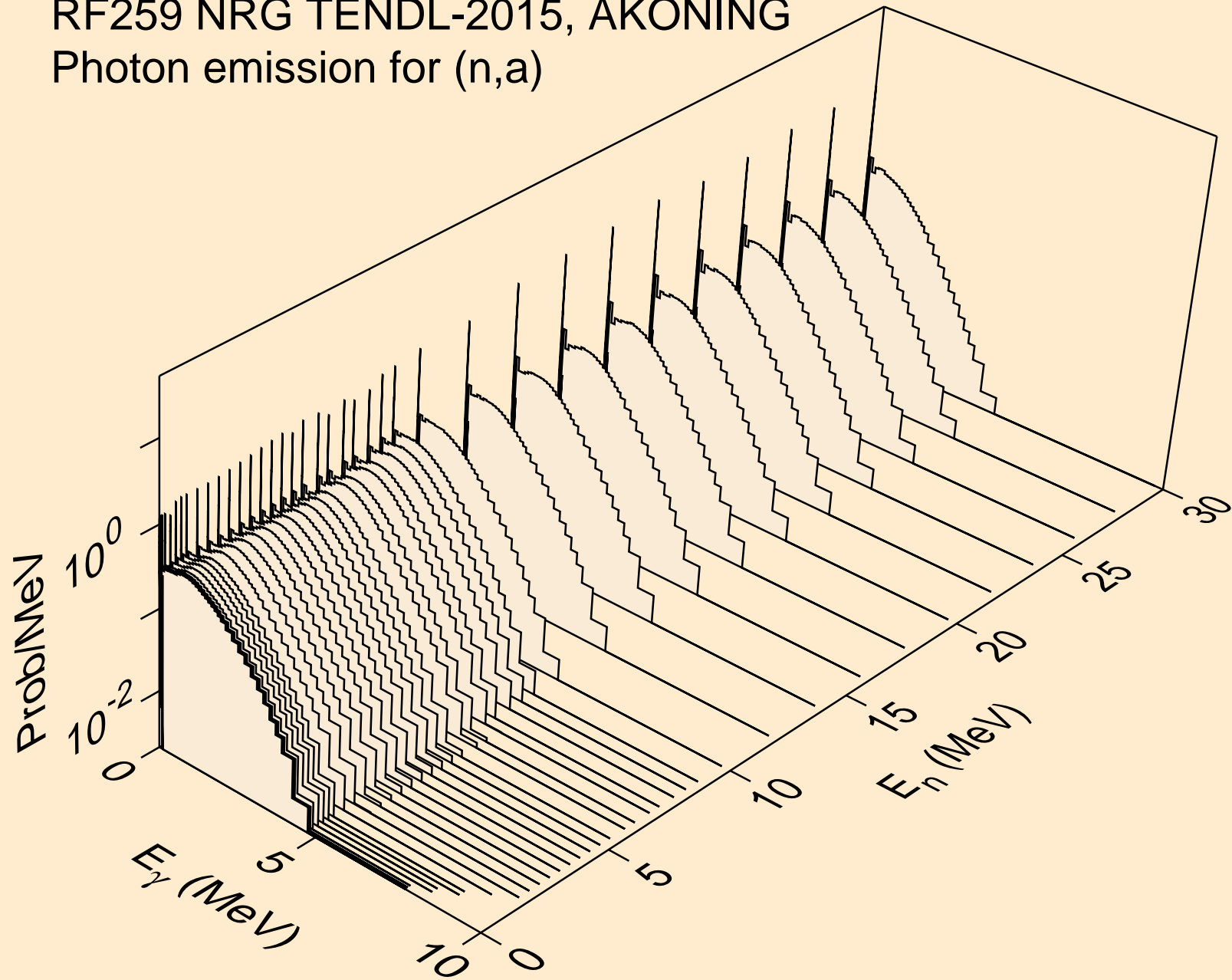

RF259 NRG TENDL-2015, AKONING  
Photon emission for (n,2a)

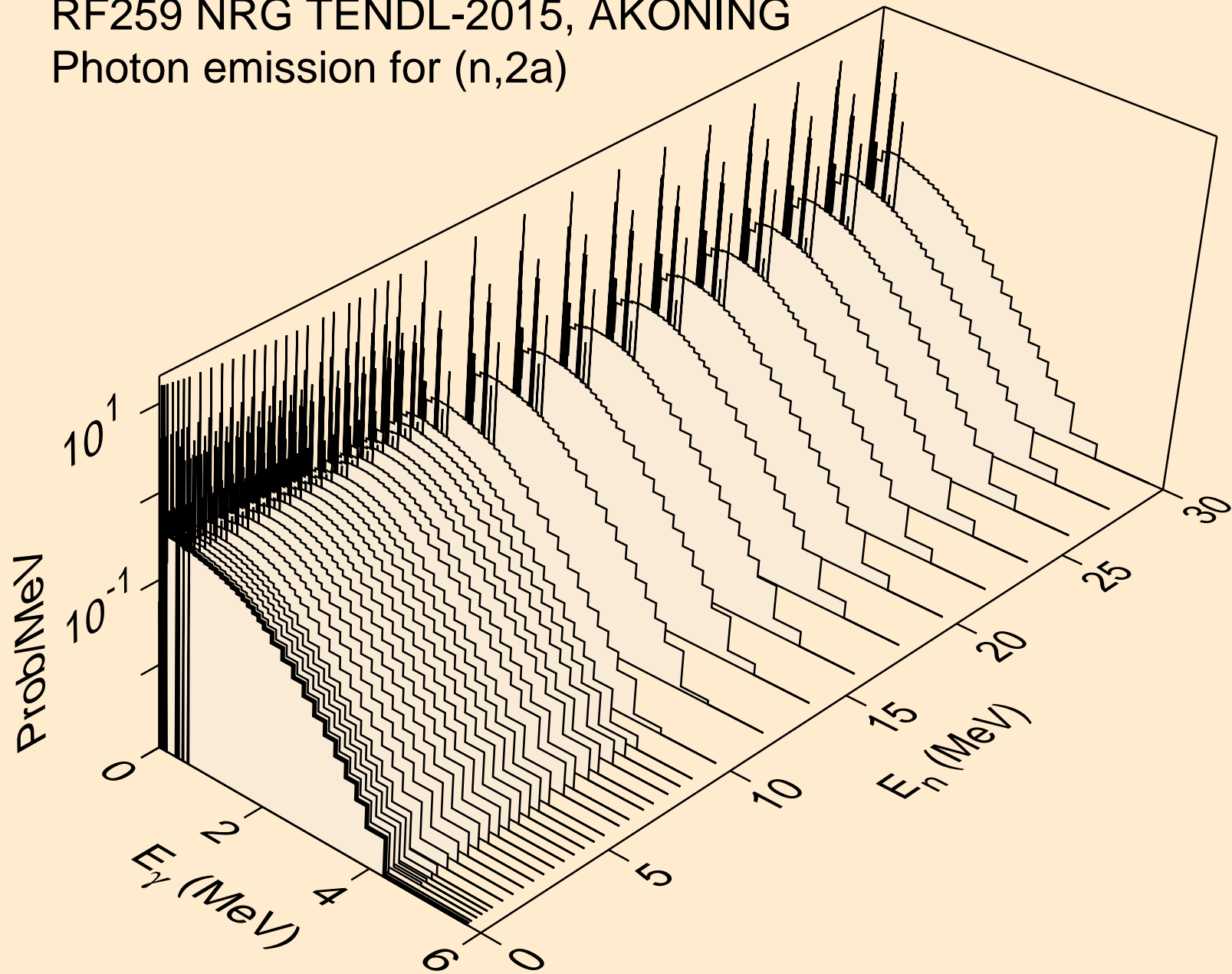

RF259 NRG TENDL-2015, AKONING  
Photon emission for (n,3a)

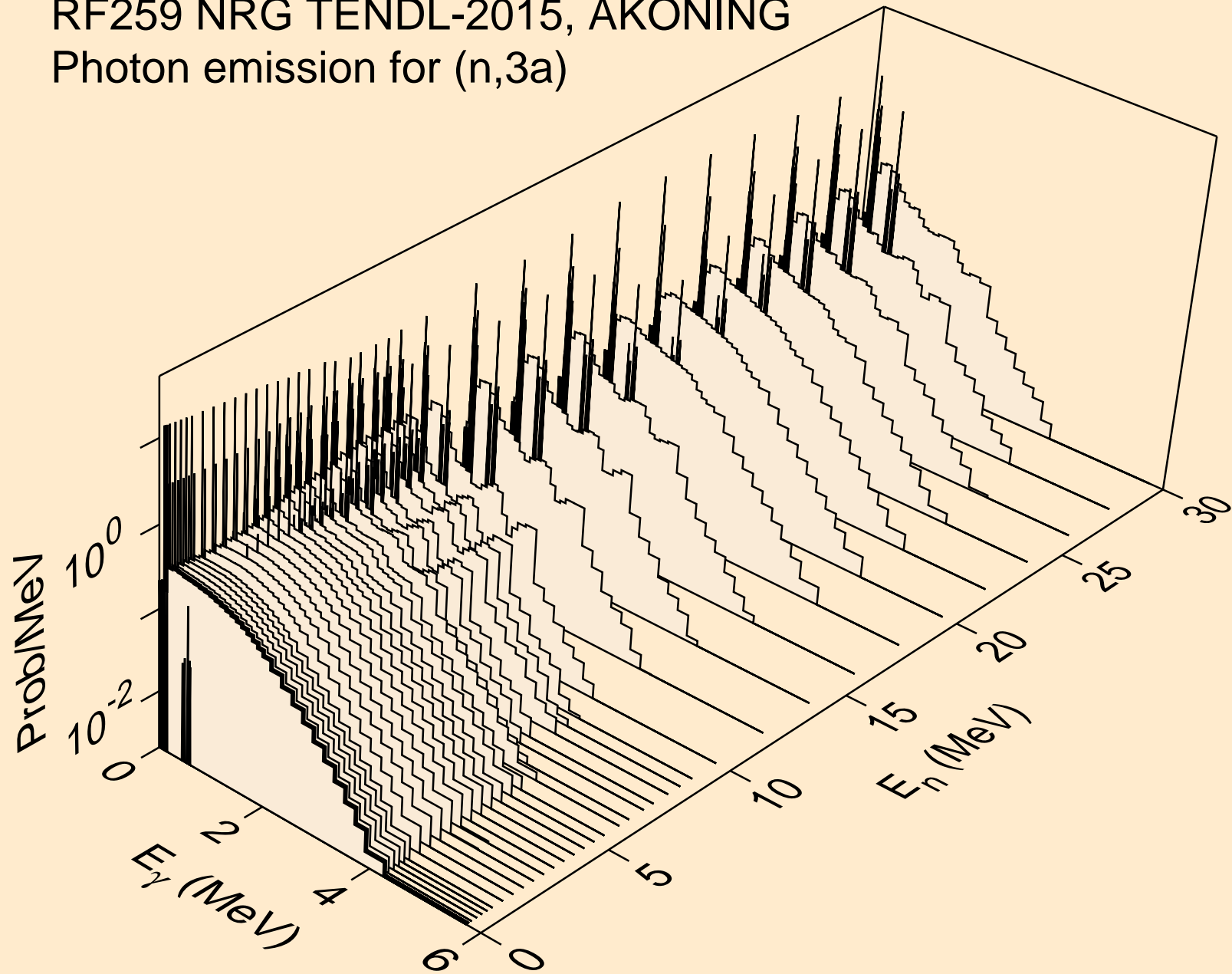



RF259 NRG TENDL-2015, AKONING  
Photon emission for (n,2p)

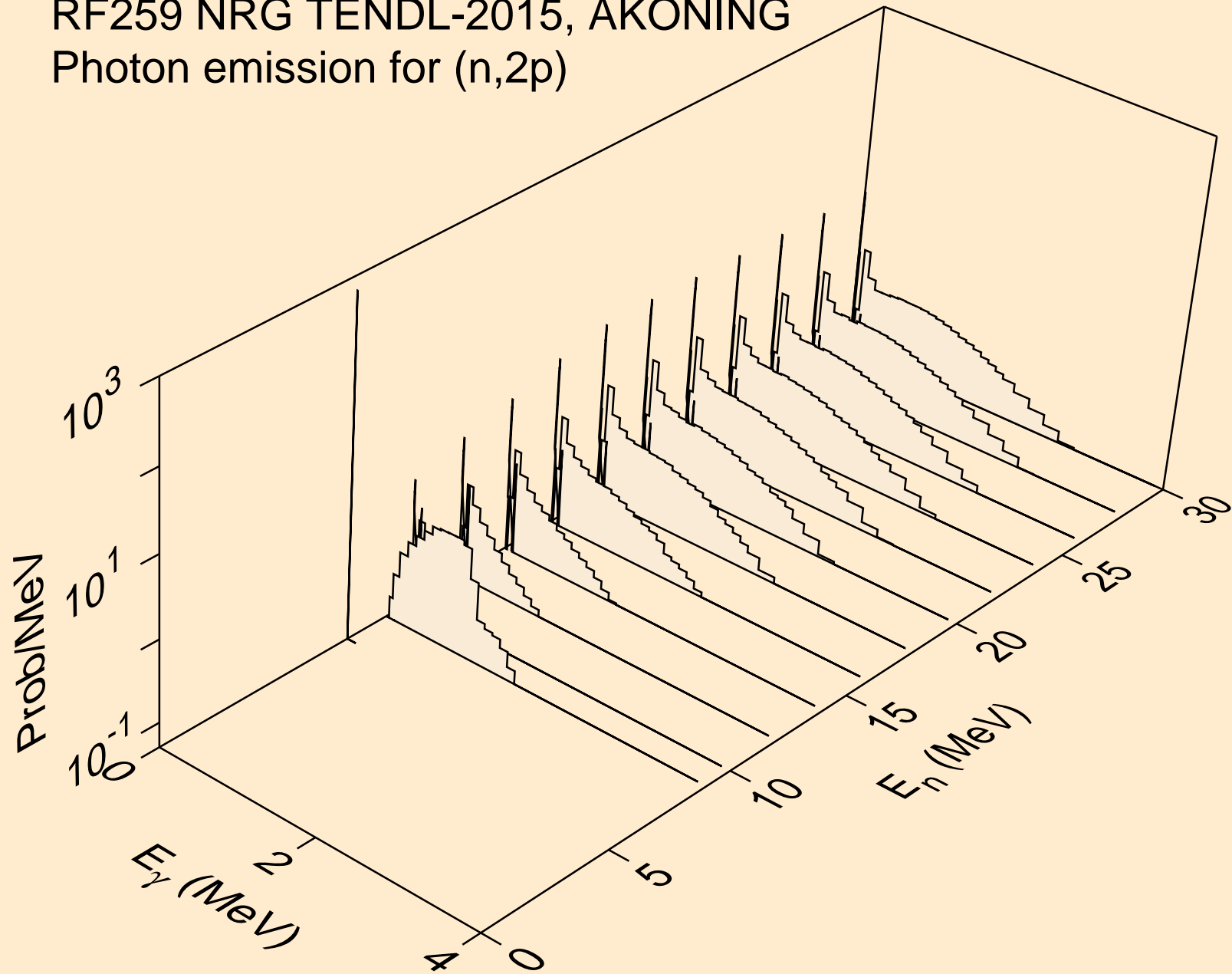

RF259 NRG TENDL-2015, AKONING  
Photon emission for (n,p)

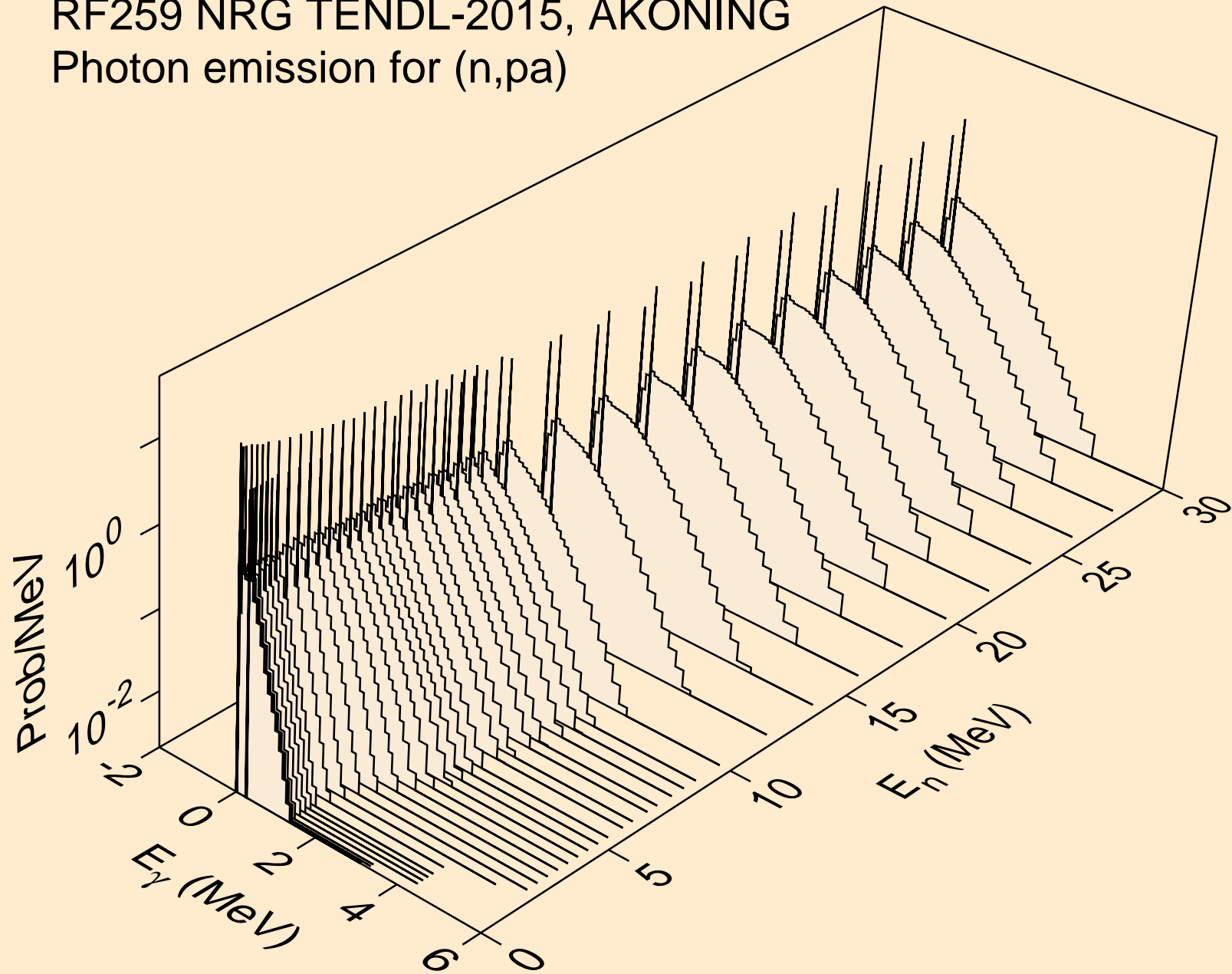

RF259 NRG TENDL-2015, AKONING  
Photon emission for (n,t2a)

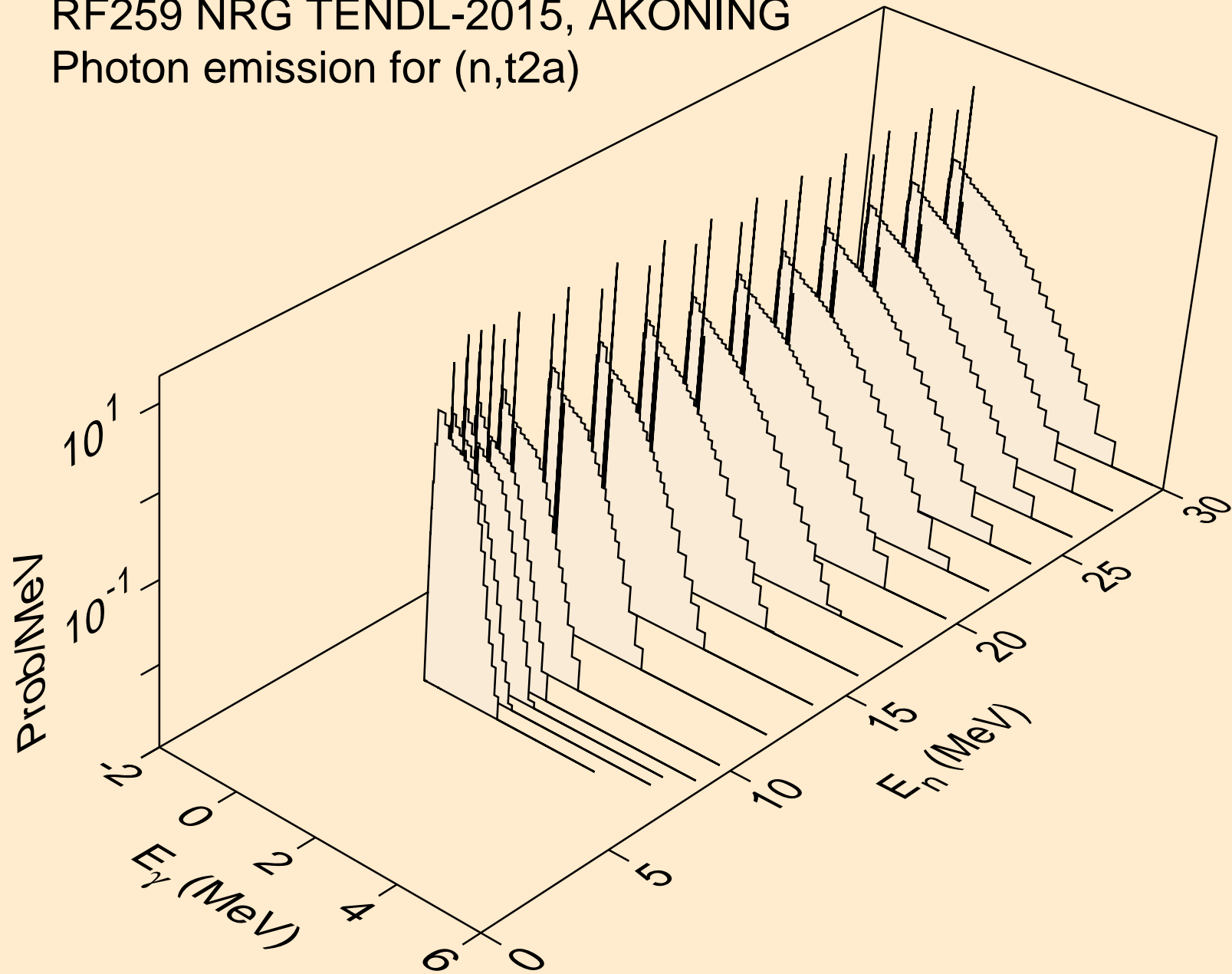

RF259 NRG TENDL-2015, AKONING  
Photon emission for (n,d2a)

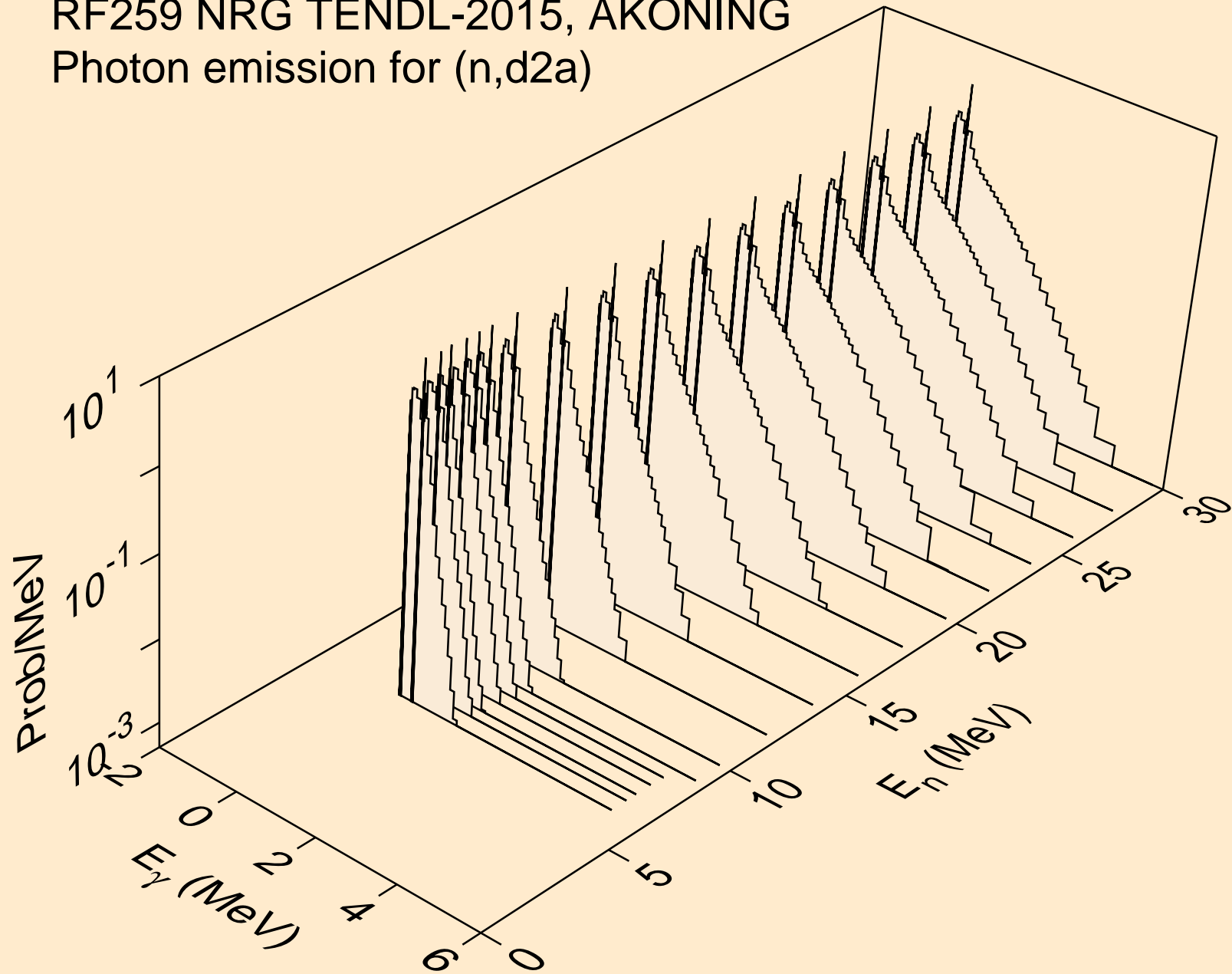

RF259 NRG TENDL-2015, AKONING  
Photon emission for (n,pd)

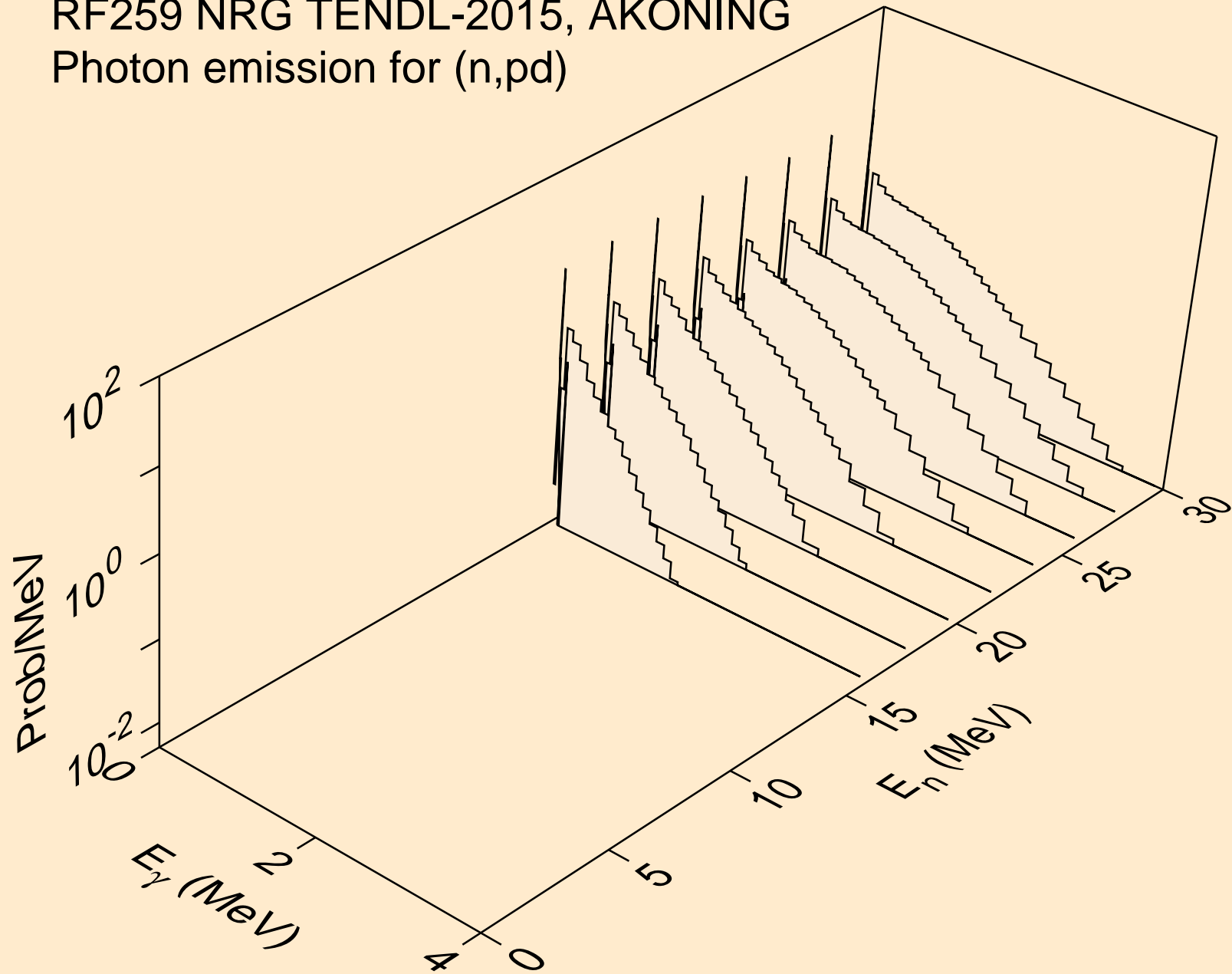

RF259 NRG TENDL-2015, AKONING  
Photon emission for (n,da)

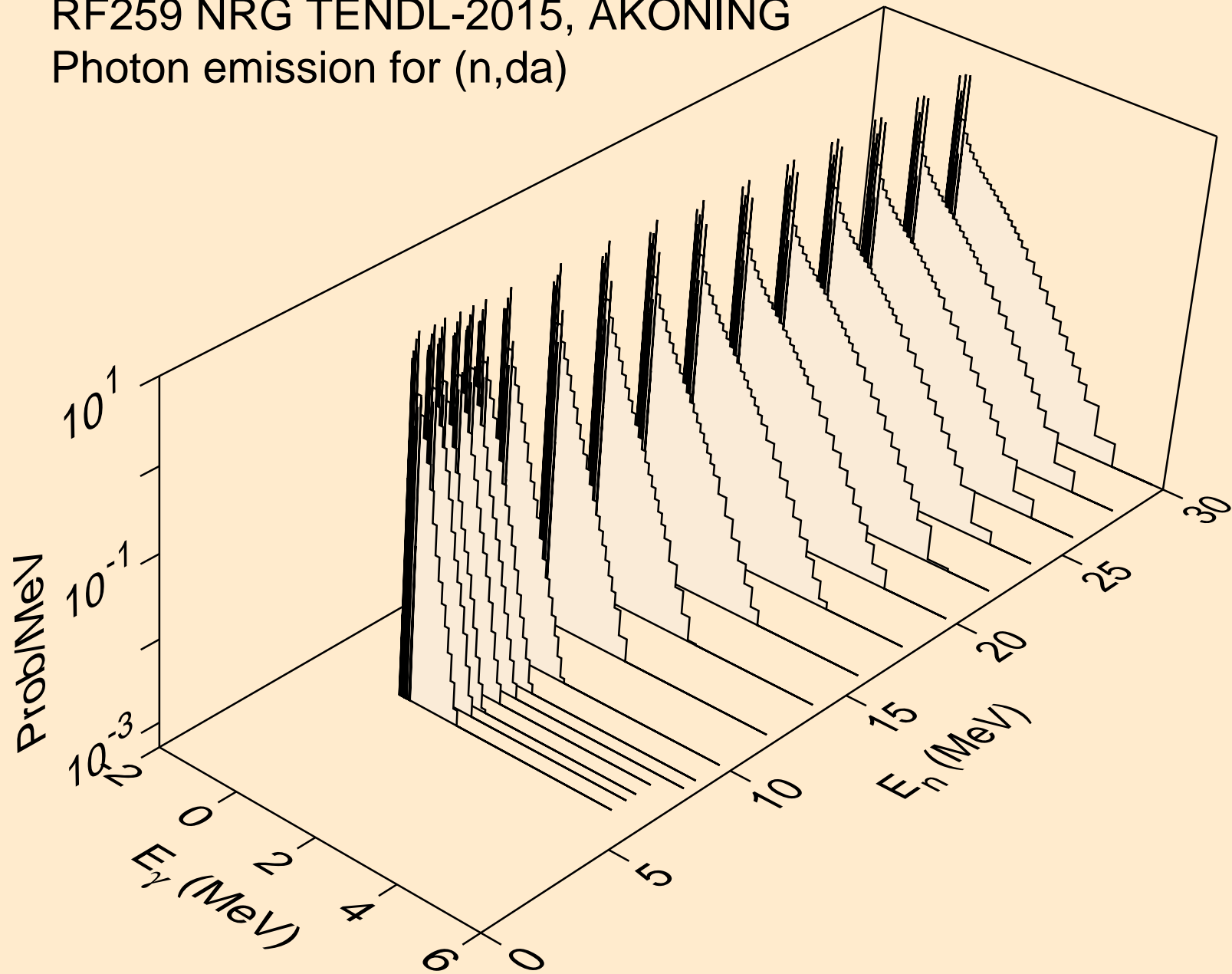

RF259 NRG TENDL-2015, AKONING  
thermal capture photon spectrum

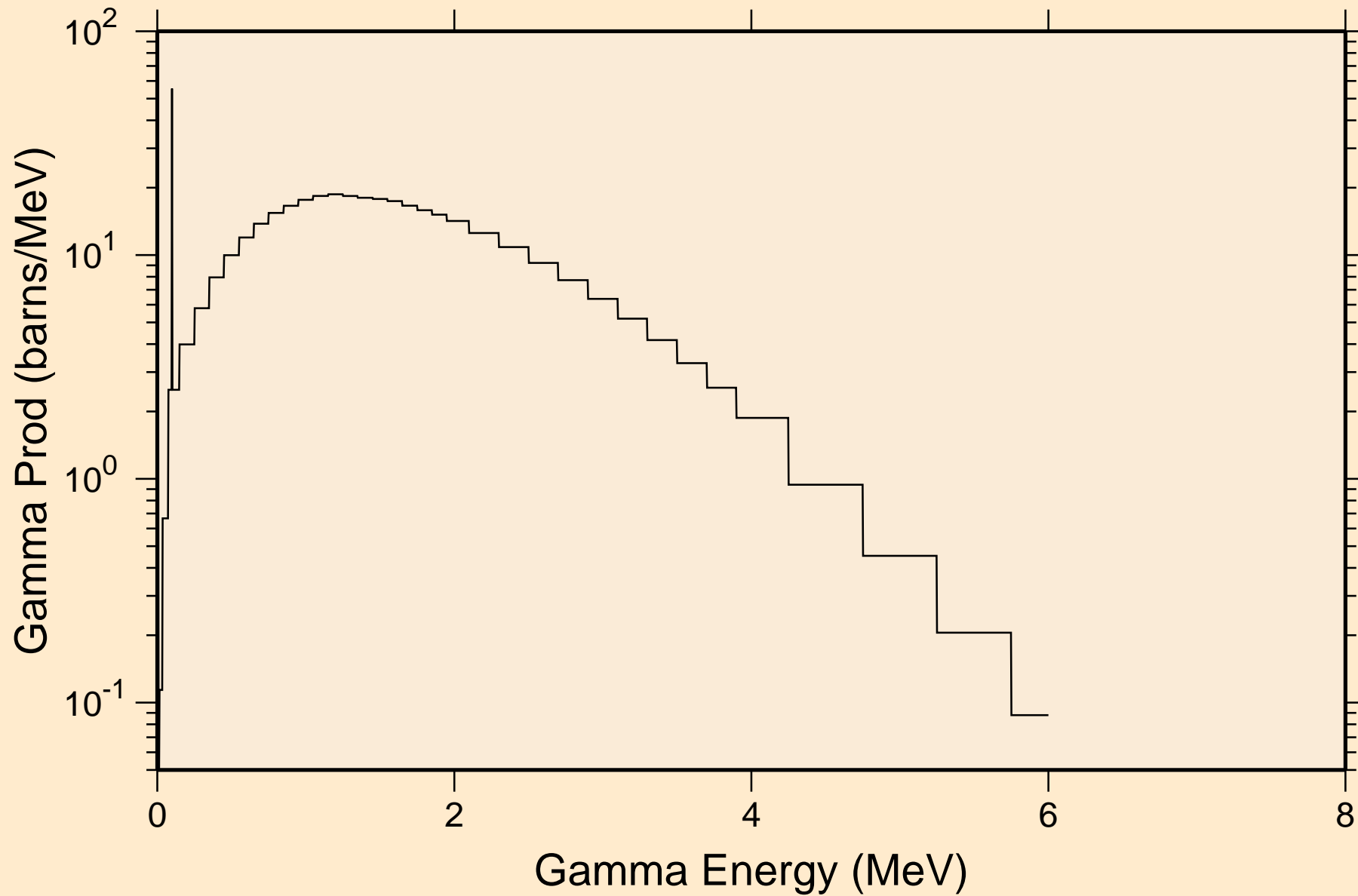

RF259 NRG TENDL-2015, AKONING  
14 MeV photon spectrum

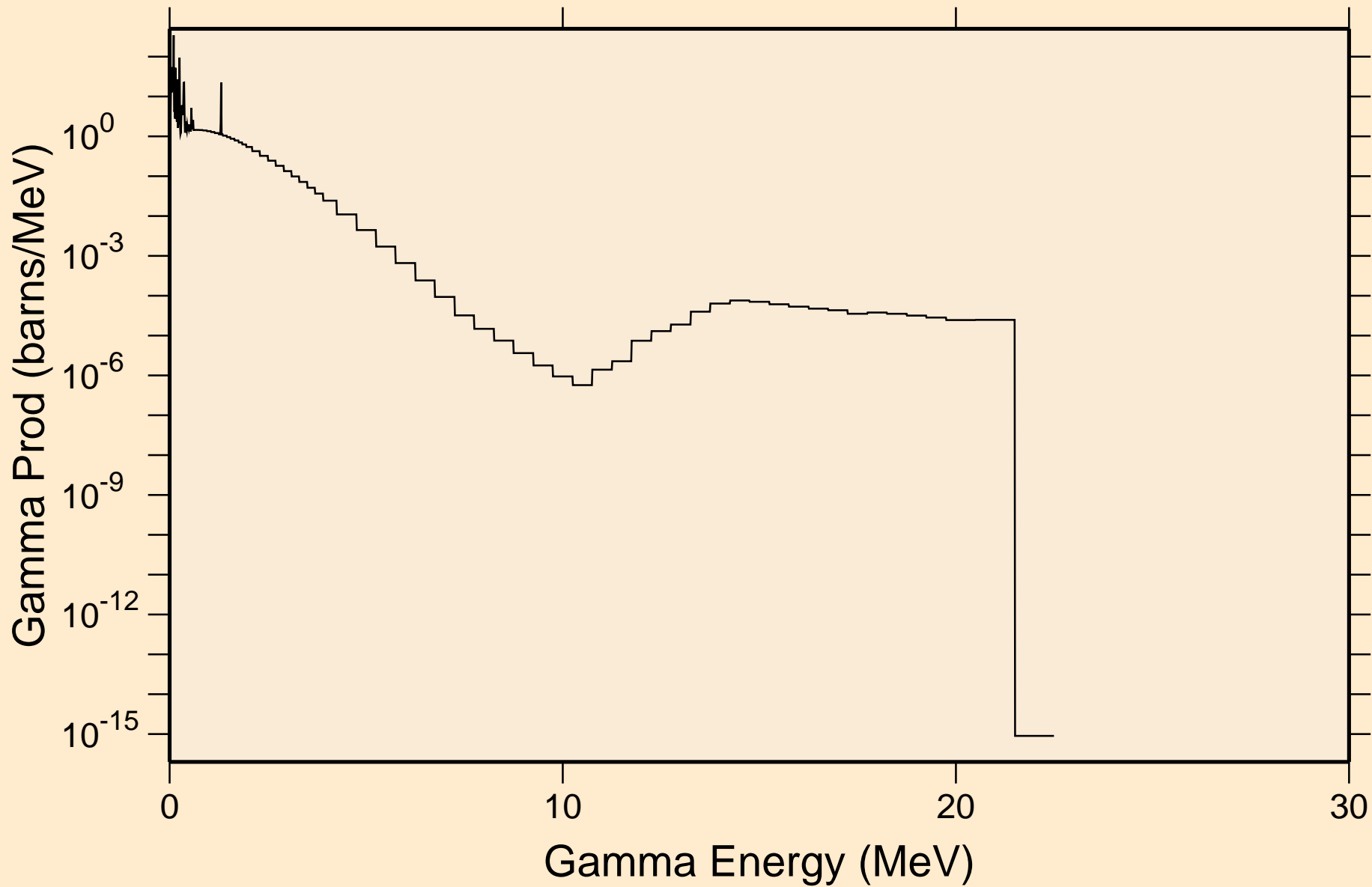



# RF259 NRG TENDL-2015, AKONING

## Particle heating contributions

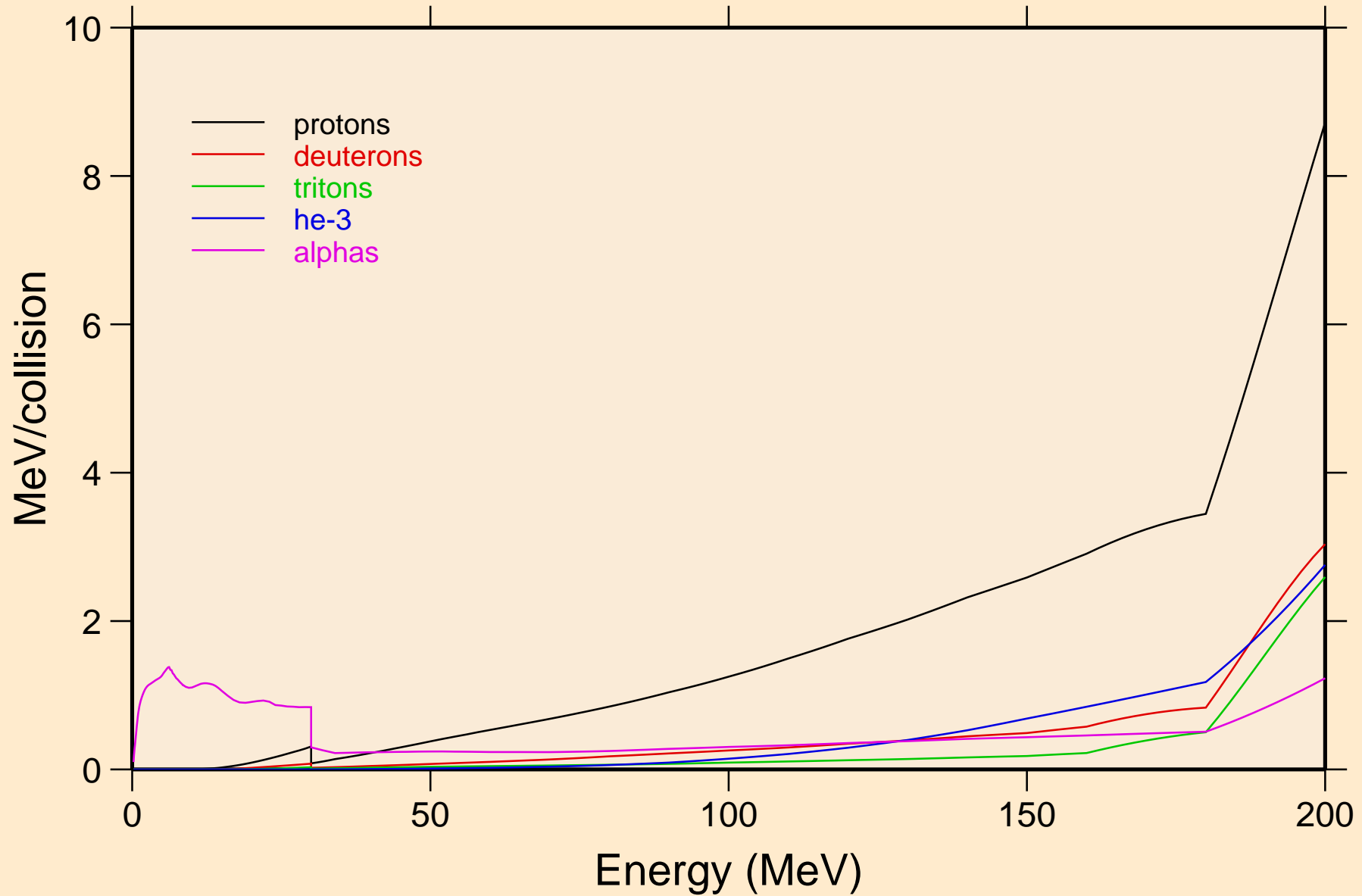

# RF259 NRG TENDL-2015, AKONING

## Recoil Heating

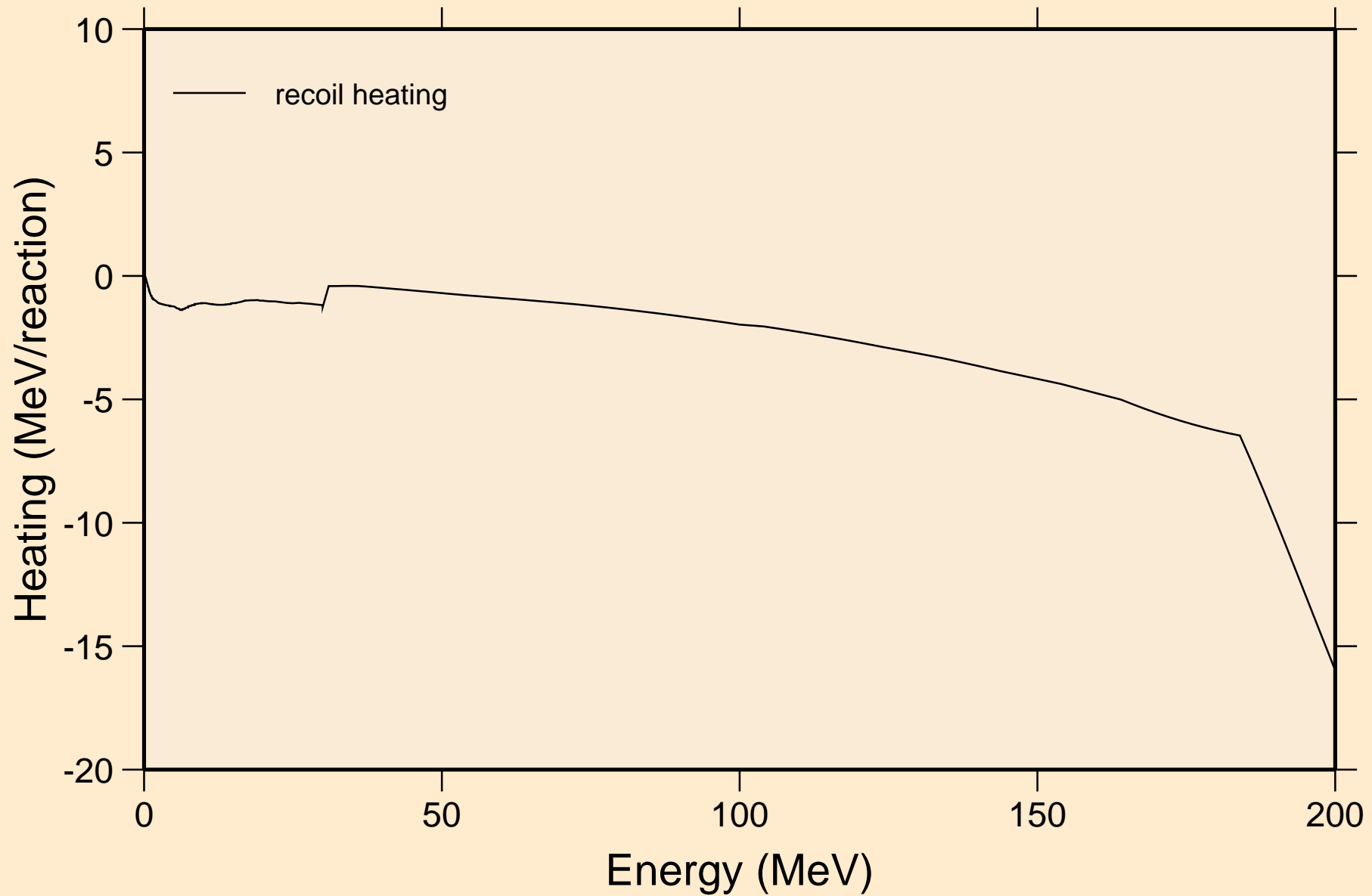

# RF259 NRG TENDL-2015, AKONING

## Particle production cross sections

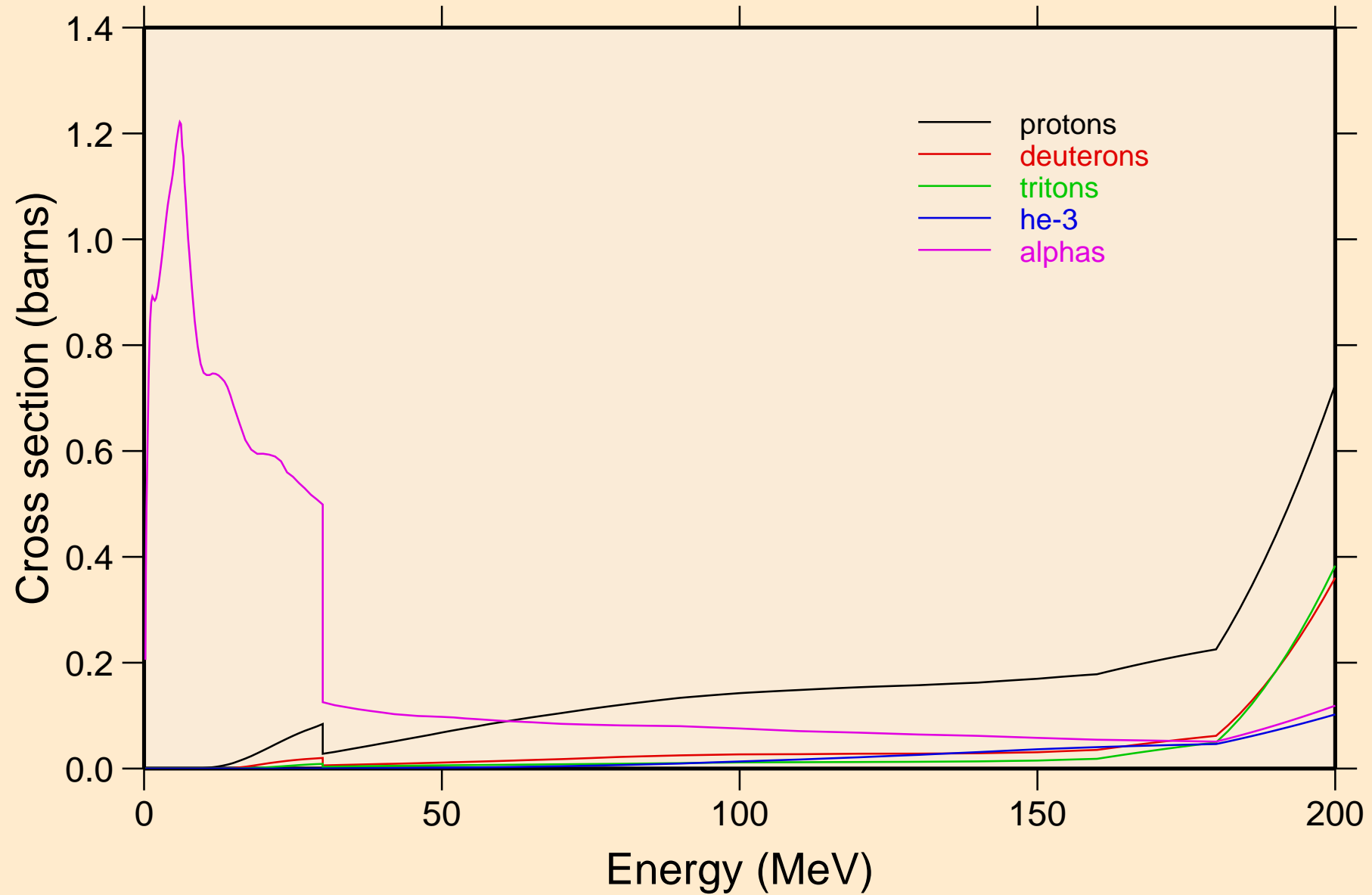

RF259 NRG TENDL-2015, AKONING  
protons from (n,x)

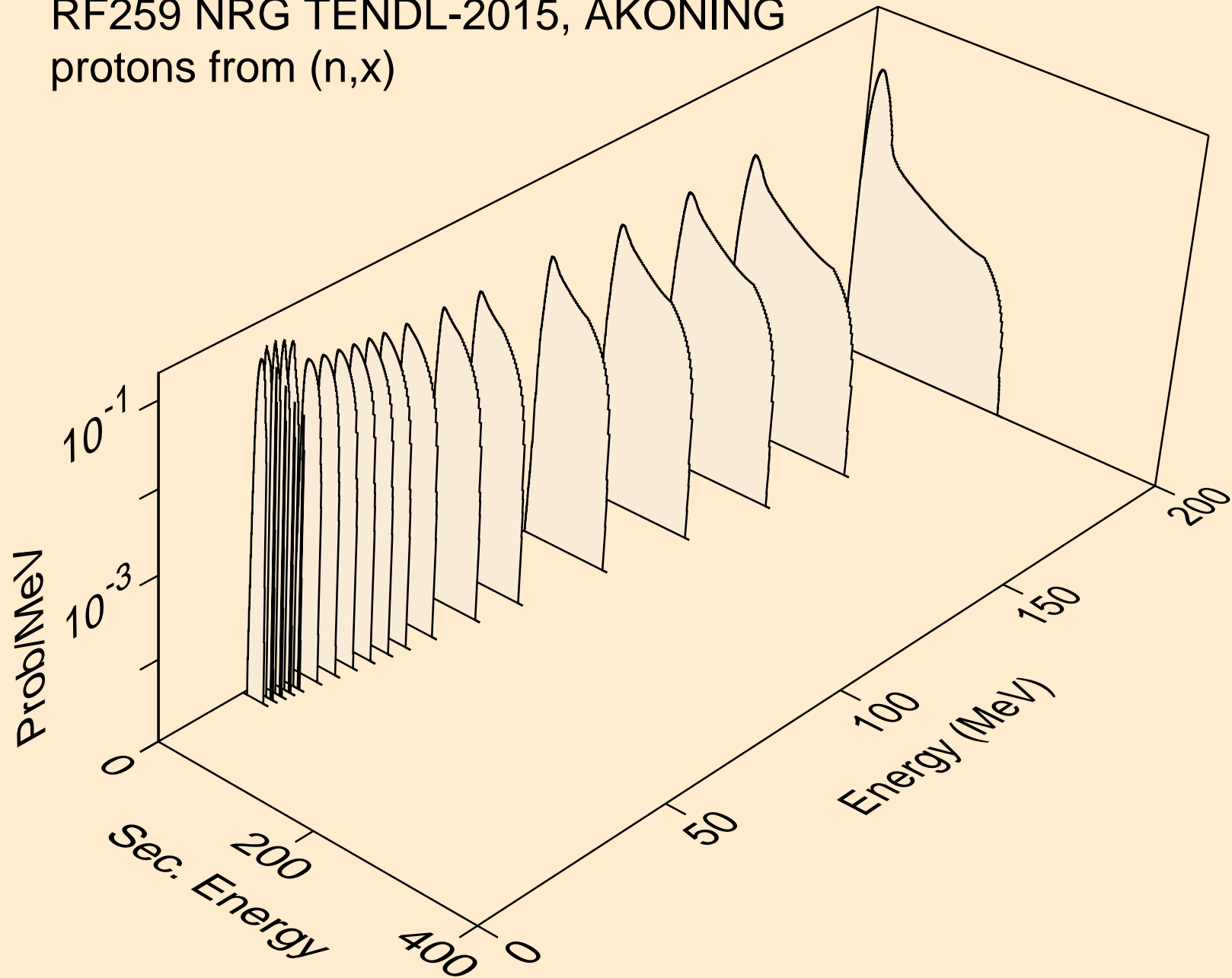

RF259 NRG TENDL-2015, AKONING  
protons from (n,n\*)p

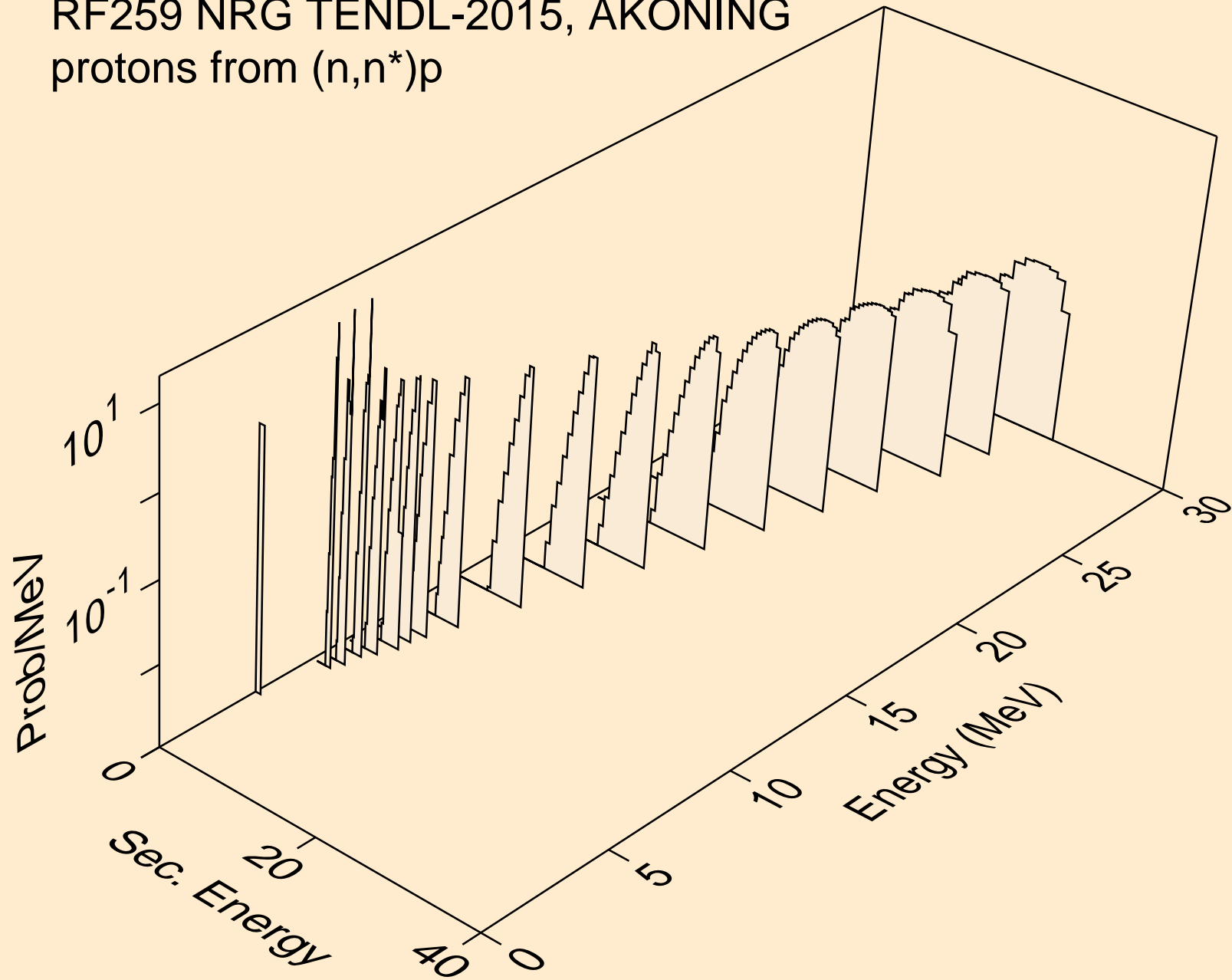

RF259 NRG TENDL-2015, AKONING  
protons from (n,2np)

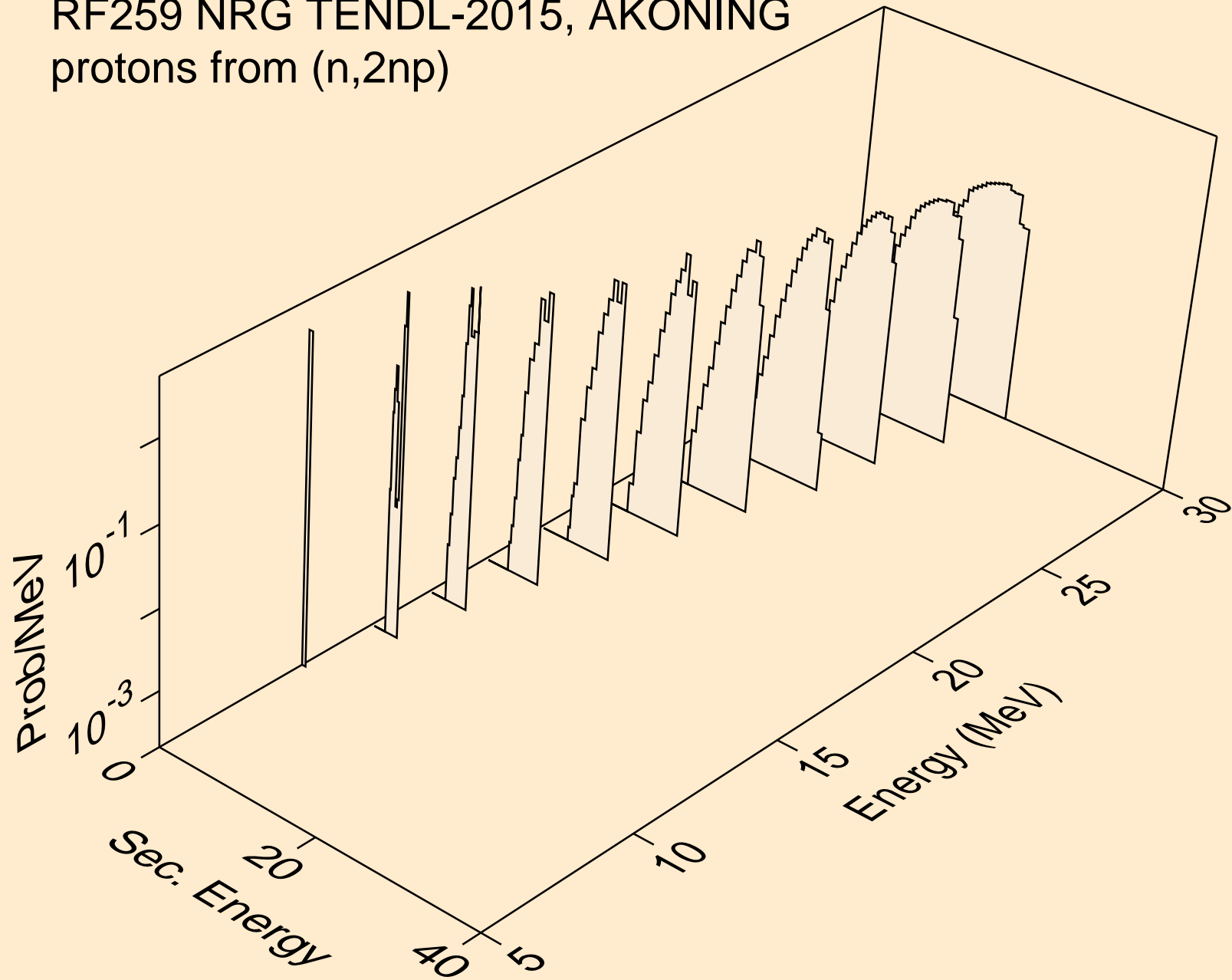

RF259 NRG TENDL-2015, AKONING  
protons from (n,3np)

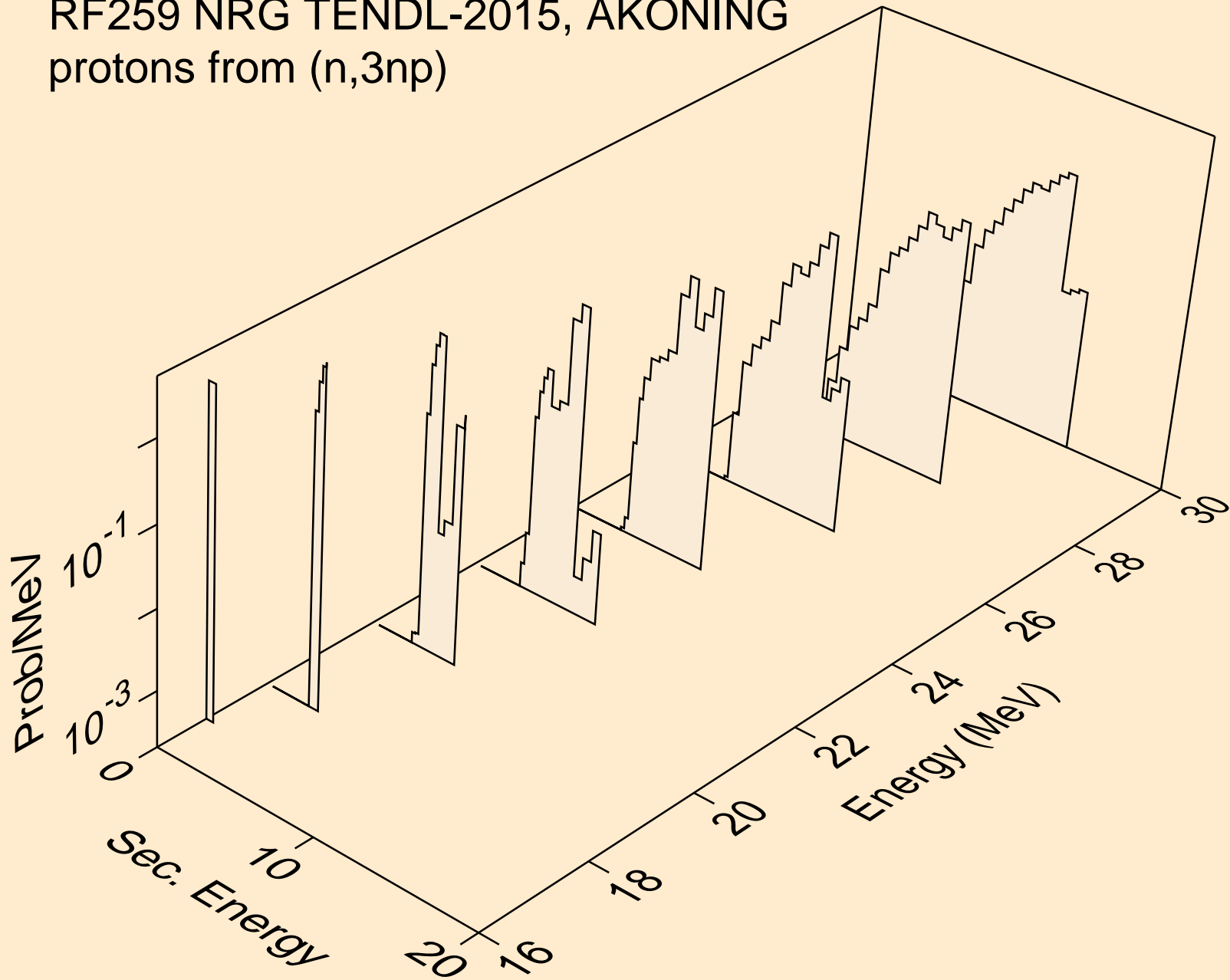

RF259 NRG TENDL-2015, AKONING  
protons from (n,2np)

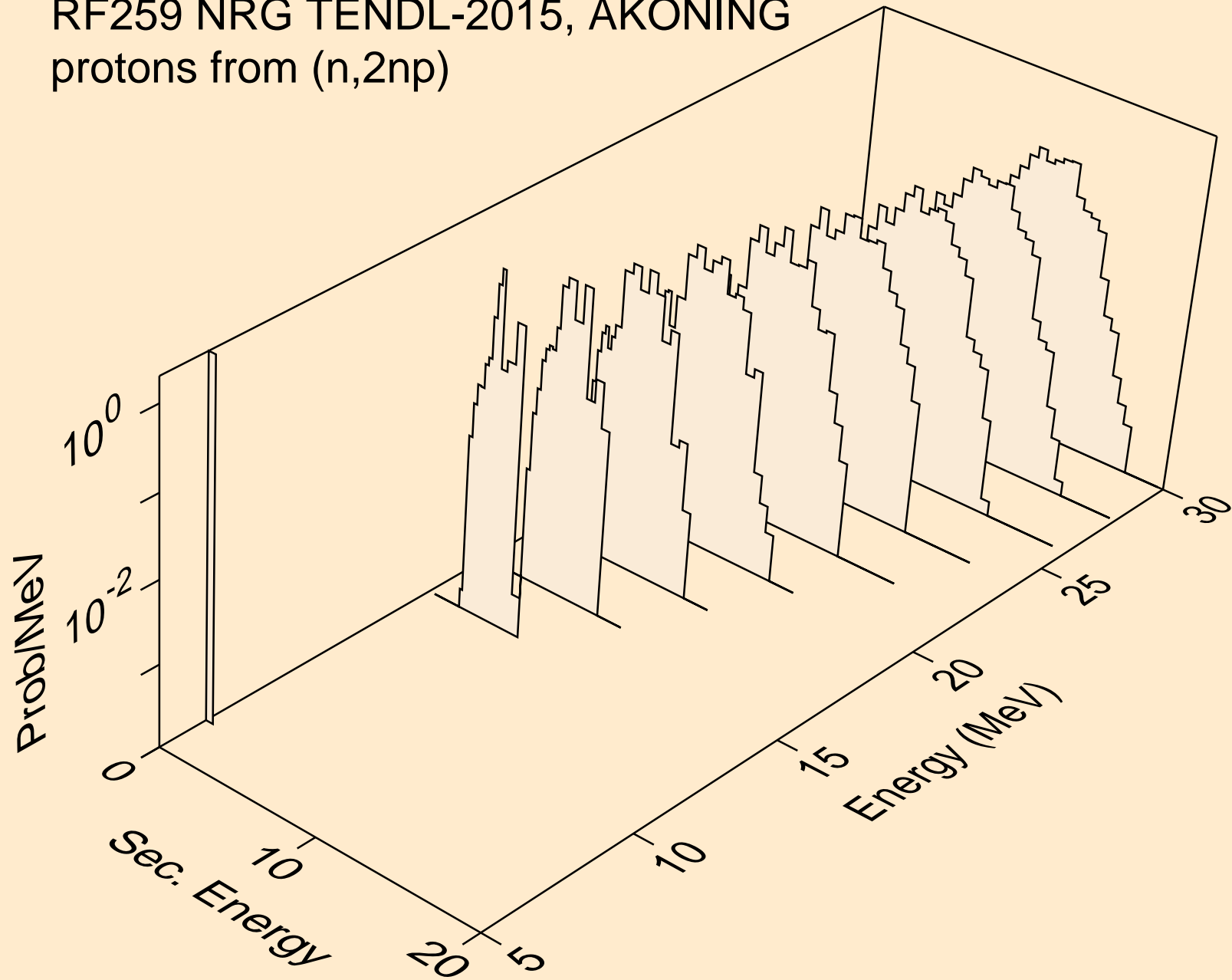



RF259 NRG TENDL-2015, AKONING  
protons from (n,npa)

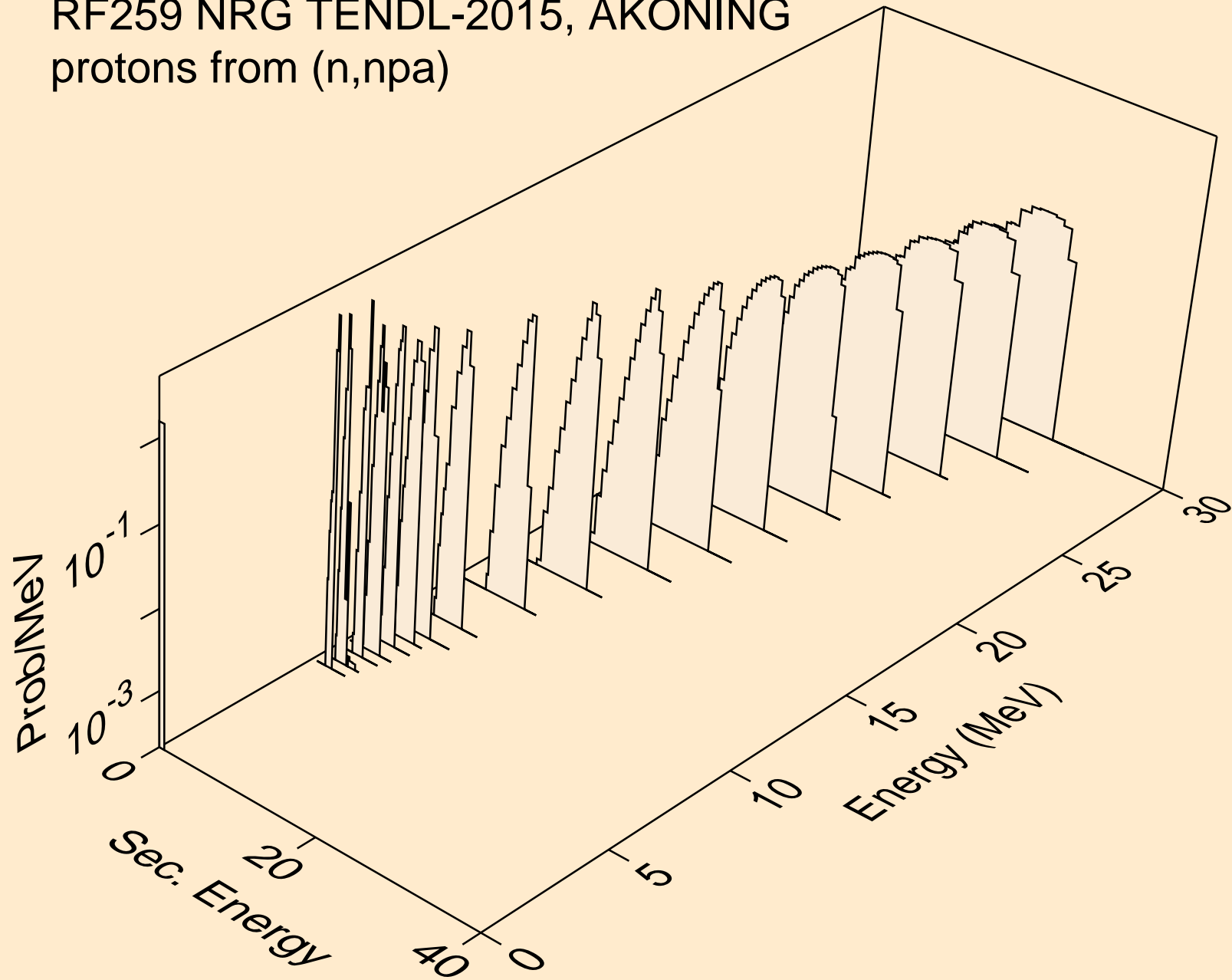

RF259 NRG TENDL-2015, AKONING  
protons from (n,p)

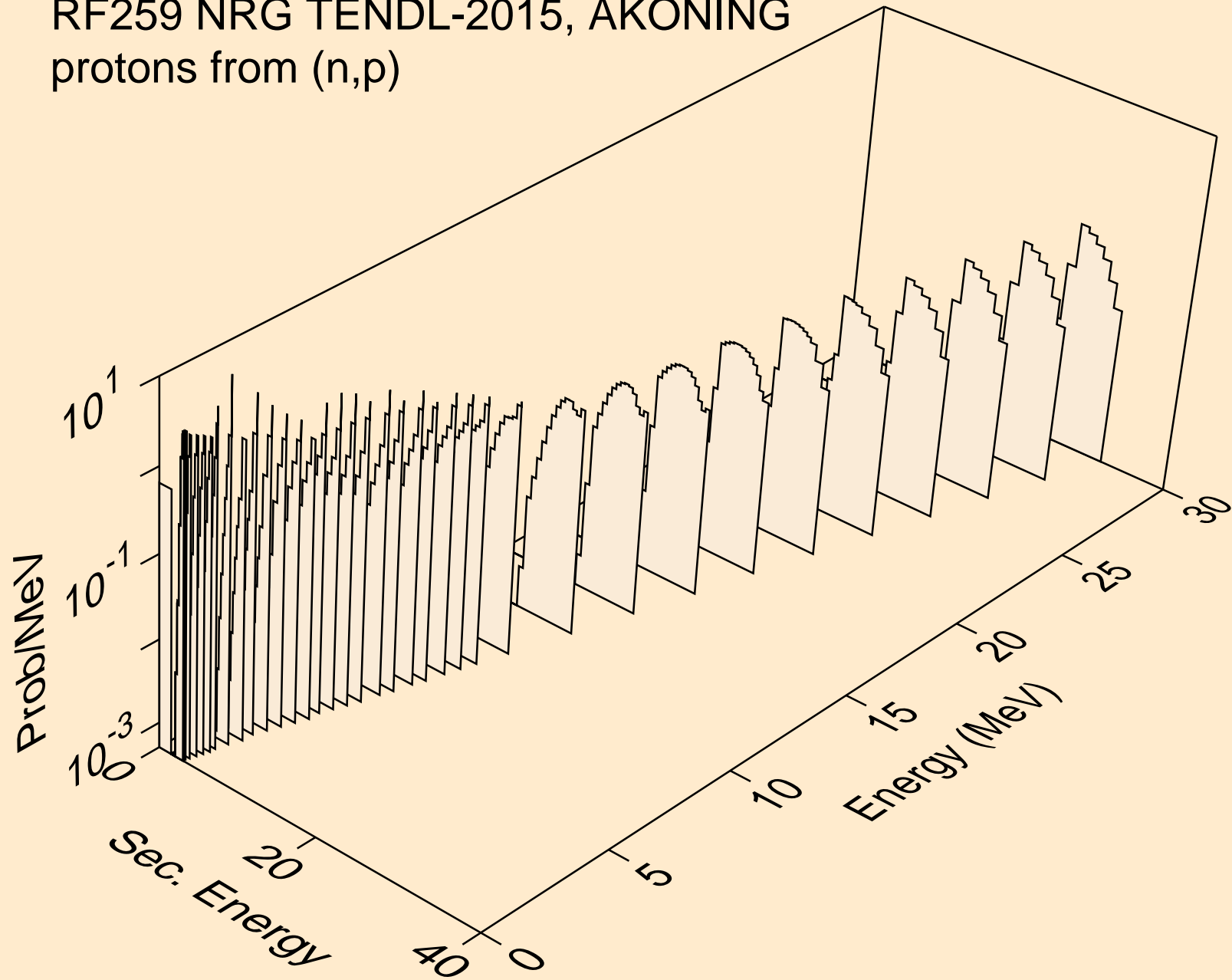

RF259 NRG TENDL-2015, AKONING  
protons from (n,2p)

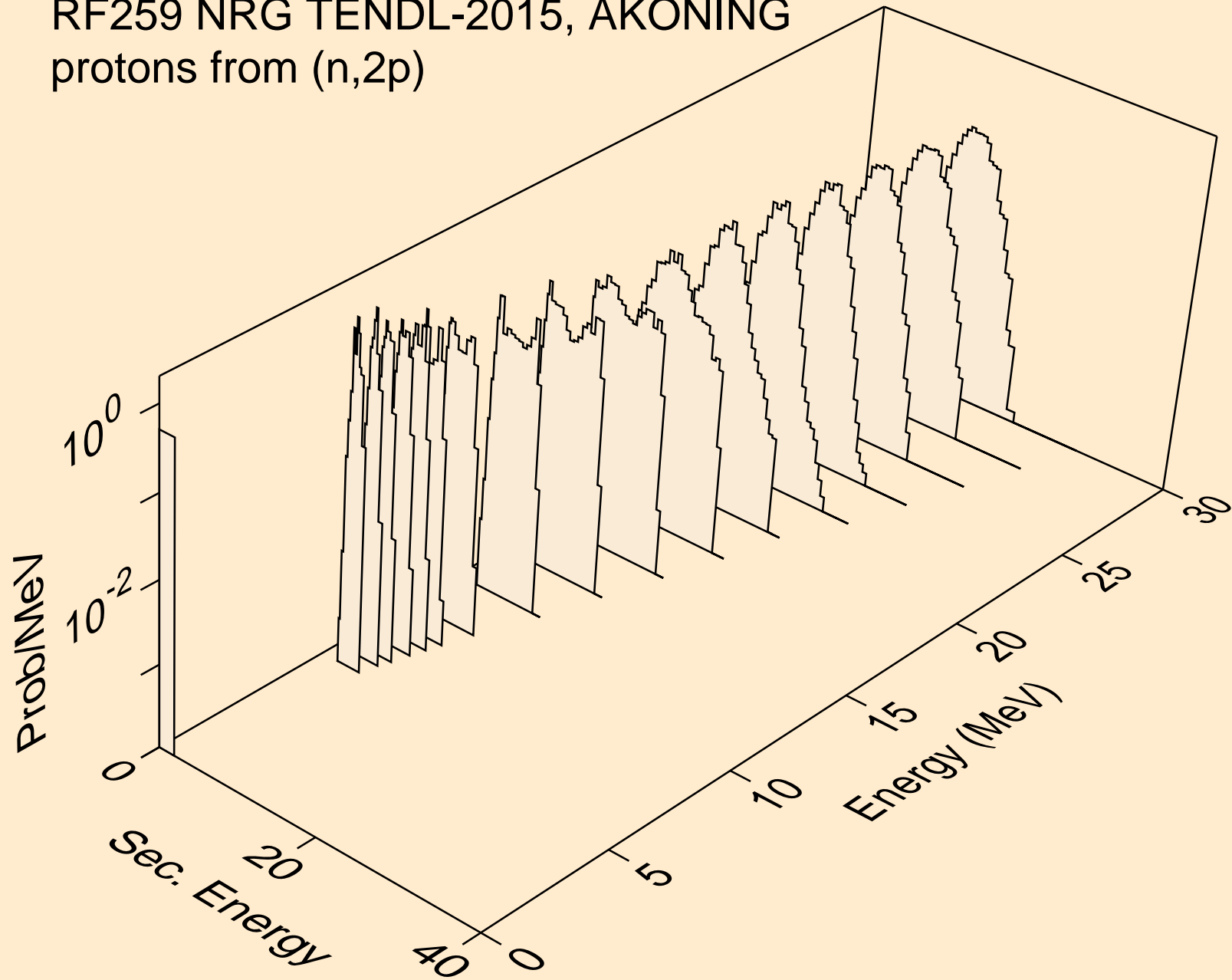

RF259 NRG TENDL-2015, AKONING  
protons from (n,pa)

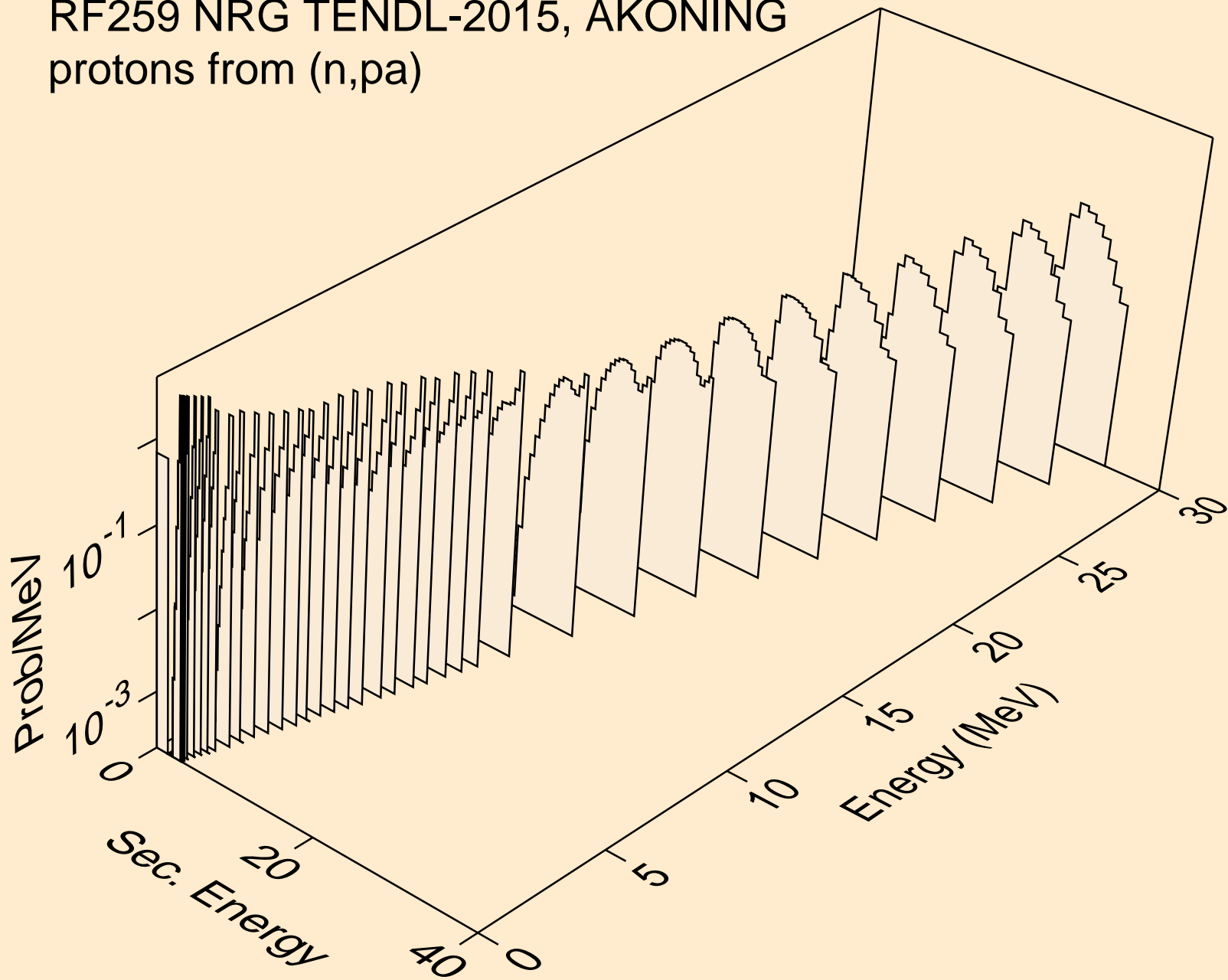

RF259 NRG TENDL-2015, AKONING  
protons from (n,pd)

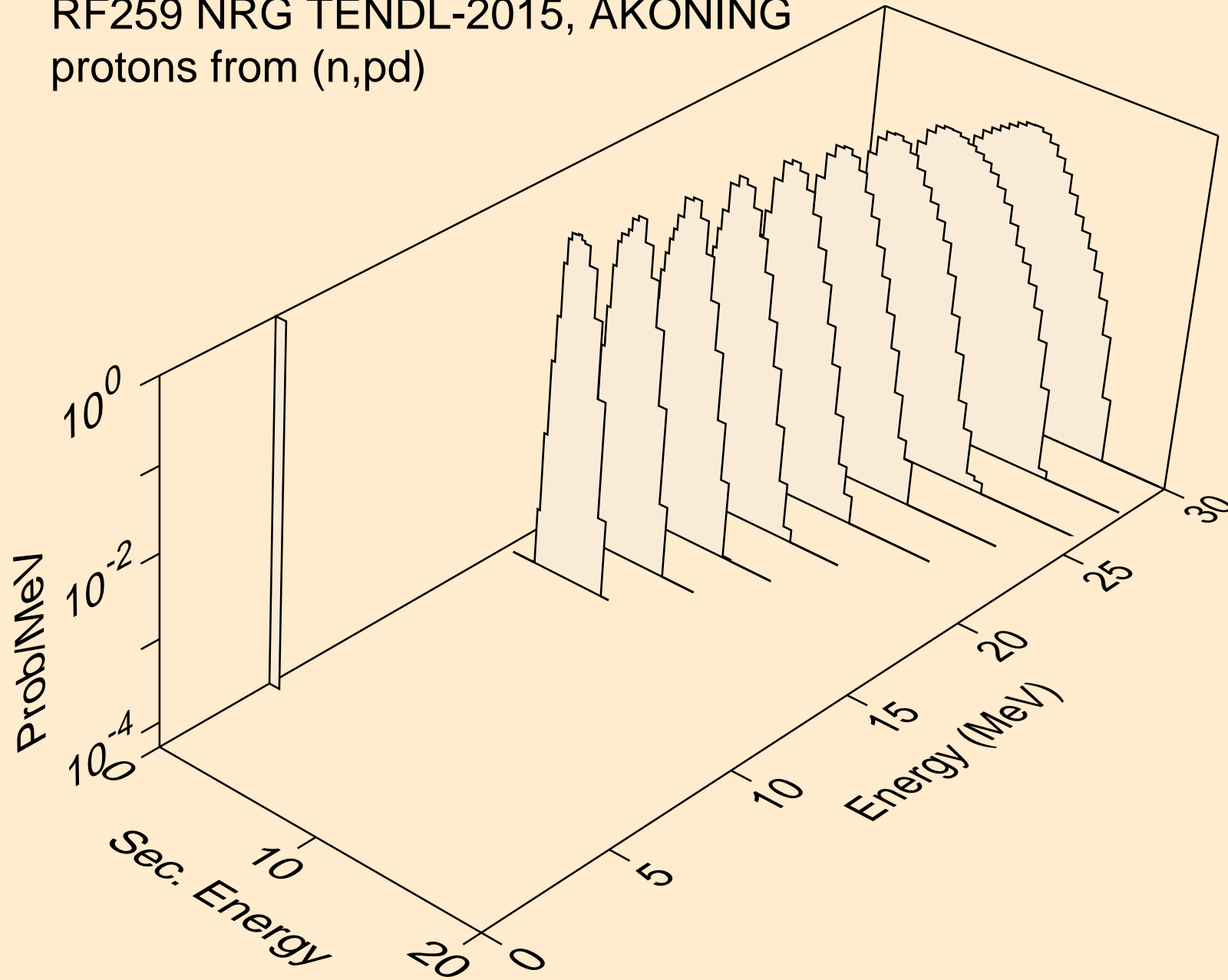

RF259 NRG TENDL-2015, AKONING  
deuterons from (n,x)

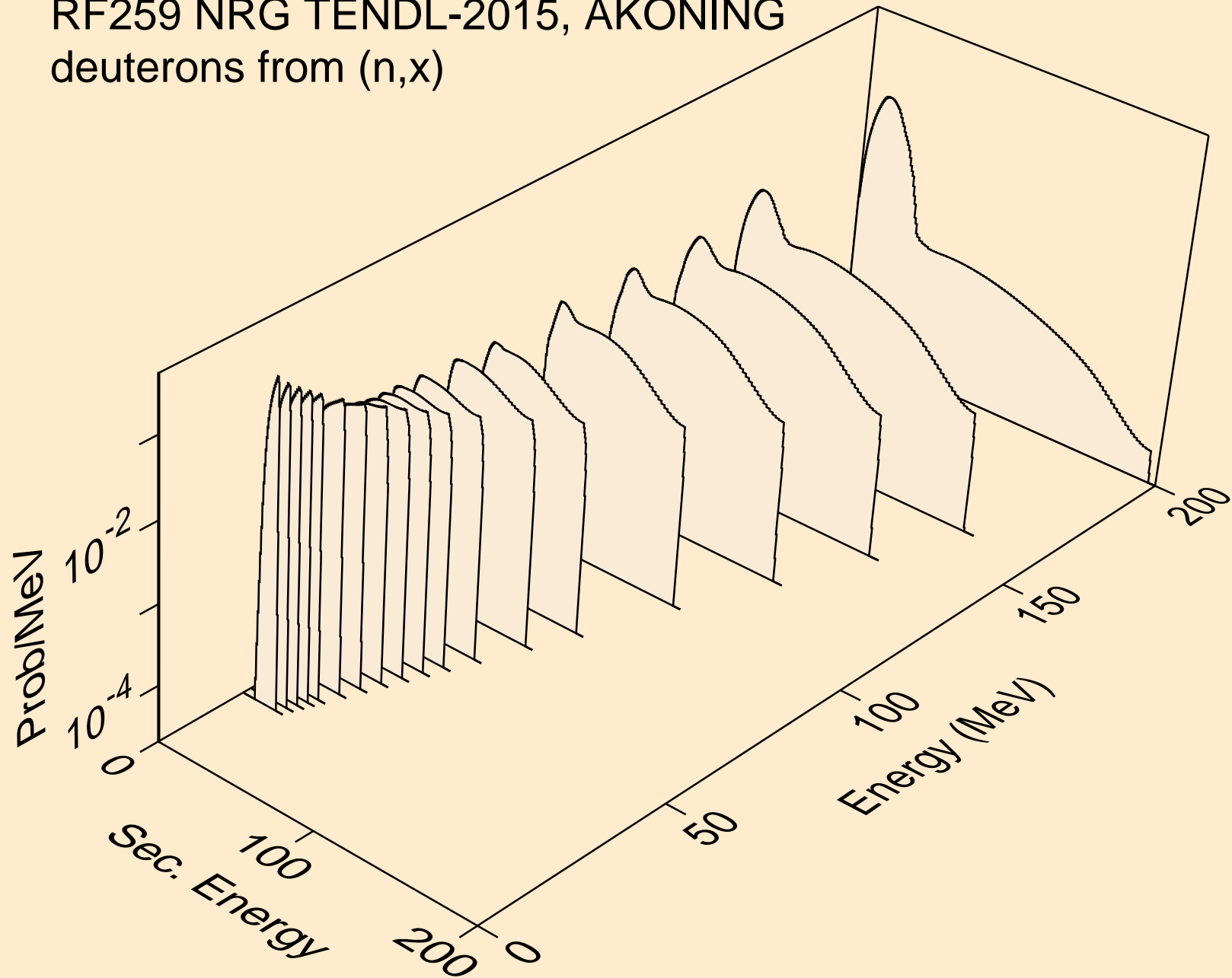

RF259 NRG TENDL-2015, AKONING  
deuterons from (n,2nd)

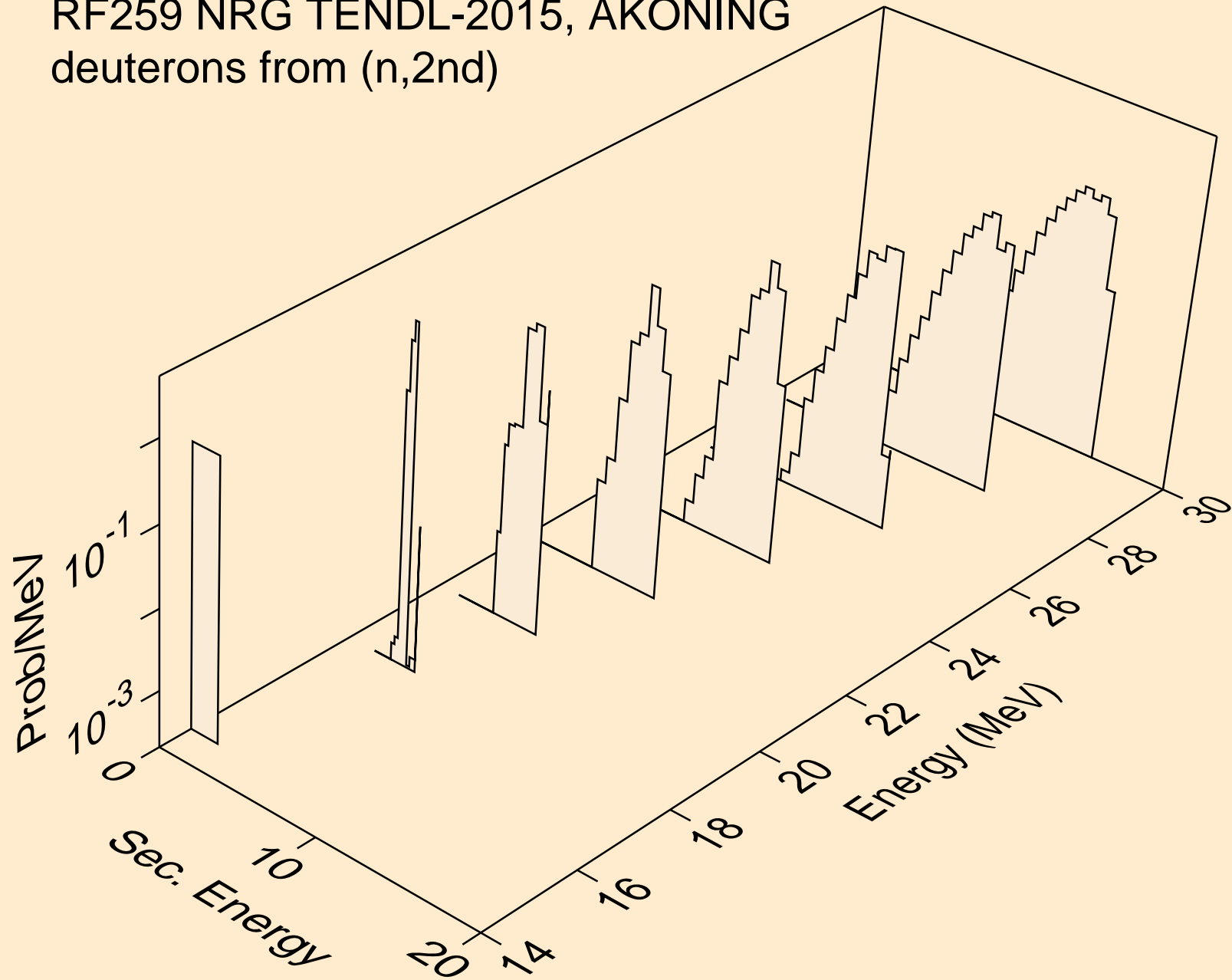

RF259 NRG TENDL-2015, AKONING  
deuterons from (n,n\*)d

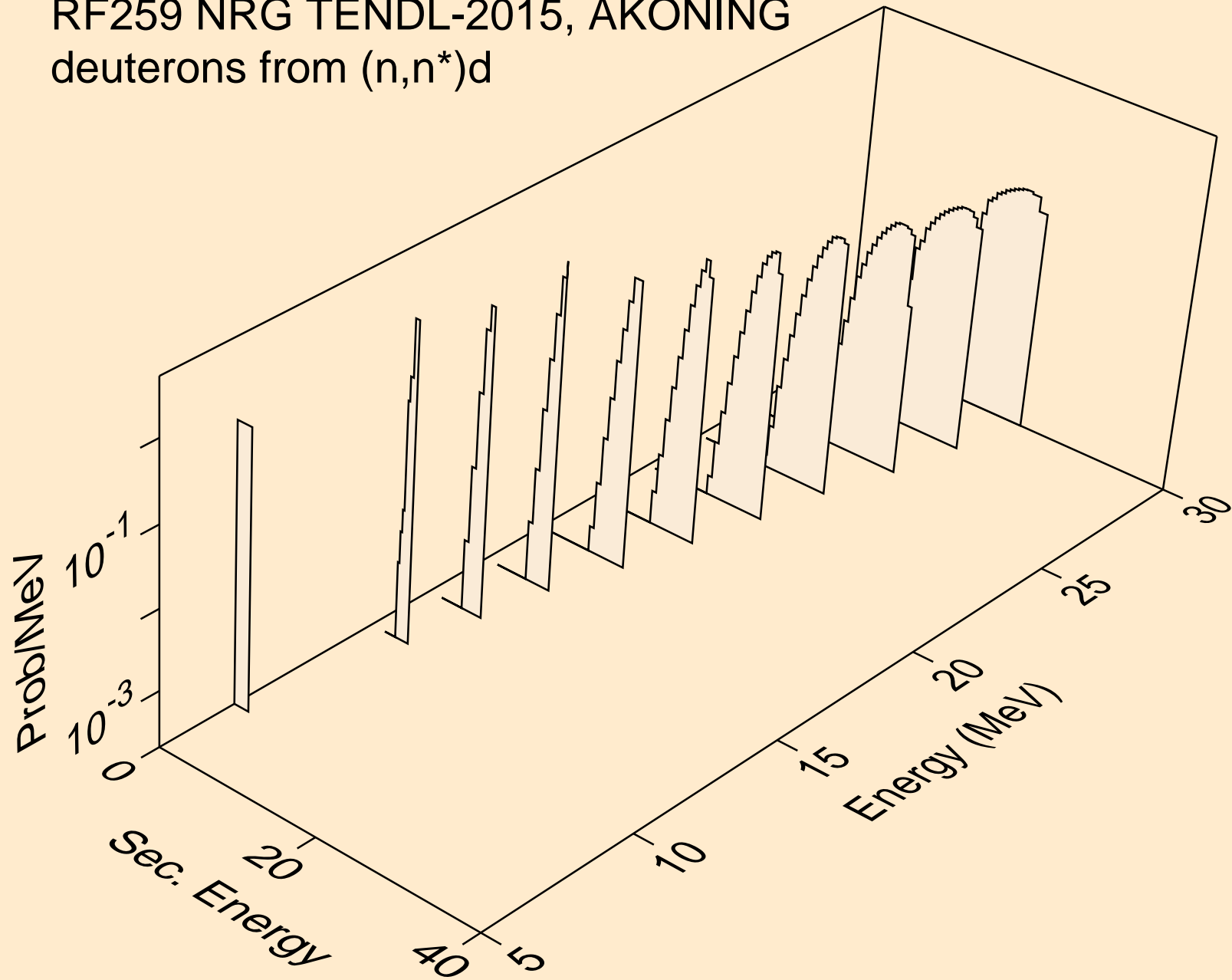



RF259 NRG TENDL-2015, AKONING  
deuterons from (n,n\*)d2a

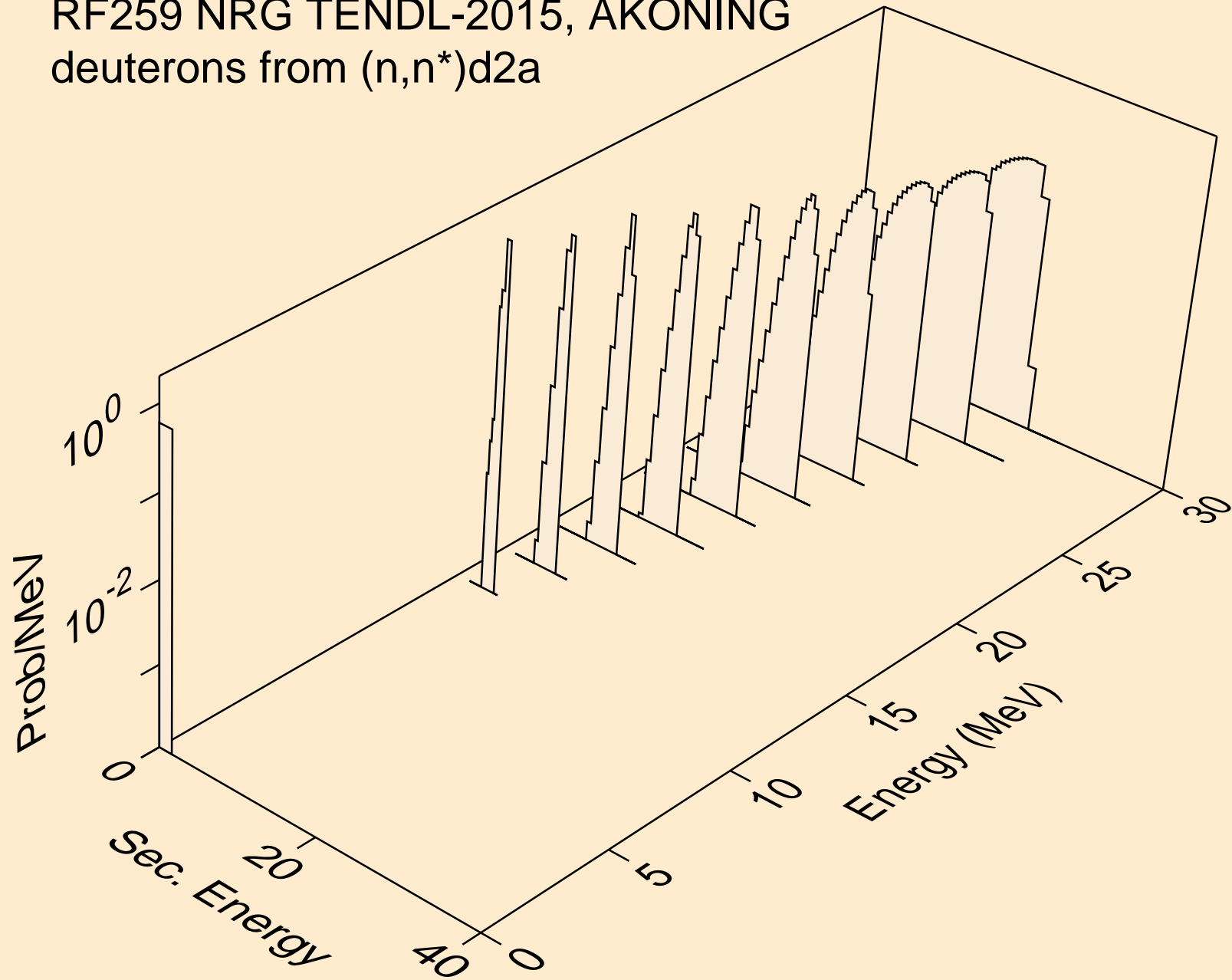

RF259 NRG TENDL-2015, AKONING  
deuterons from (n,d)

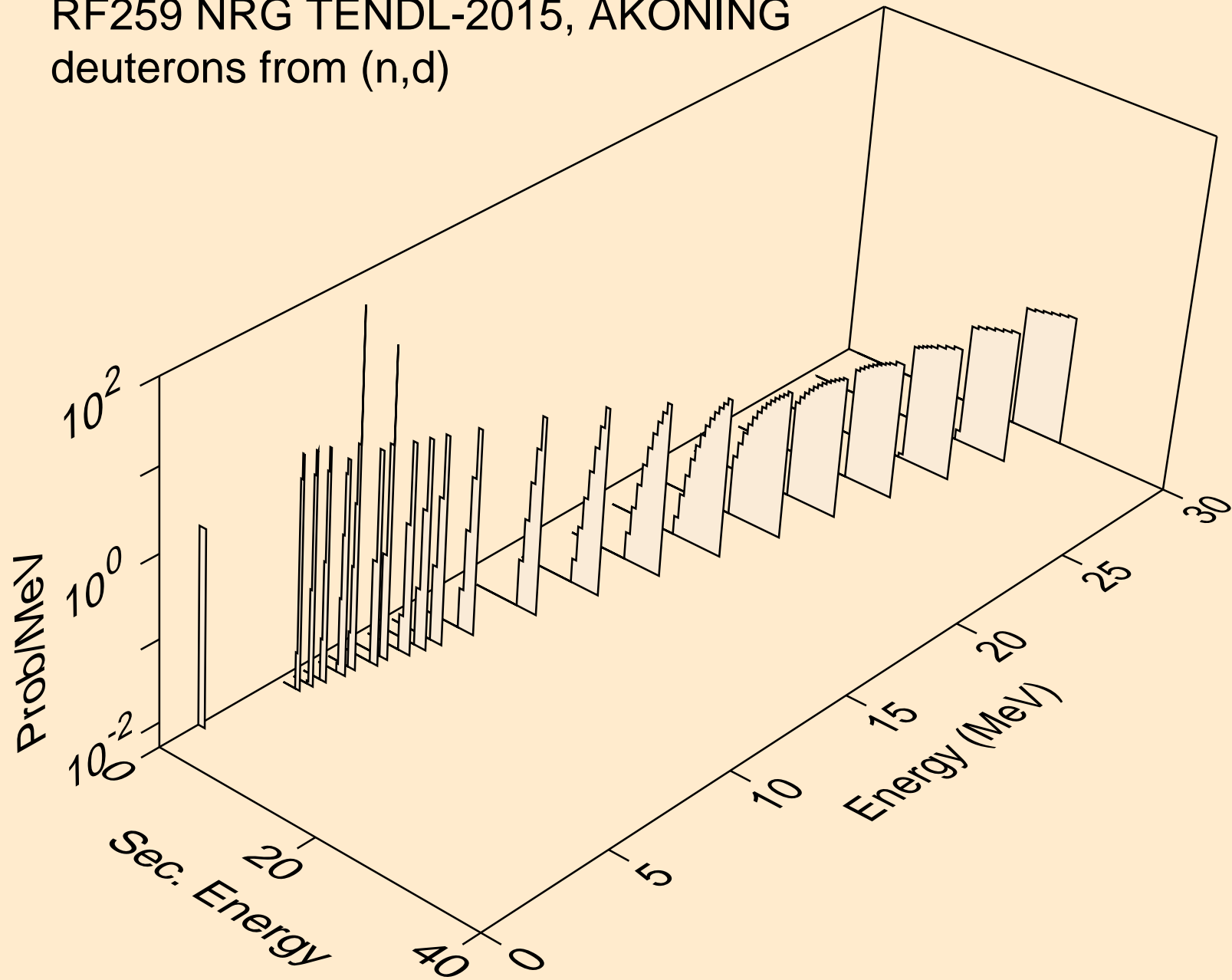

RF259 NRG TENDL-2015, AKONING  
deuterons from (n,d2a)

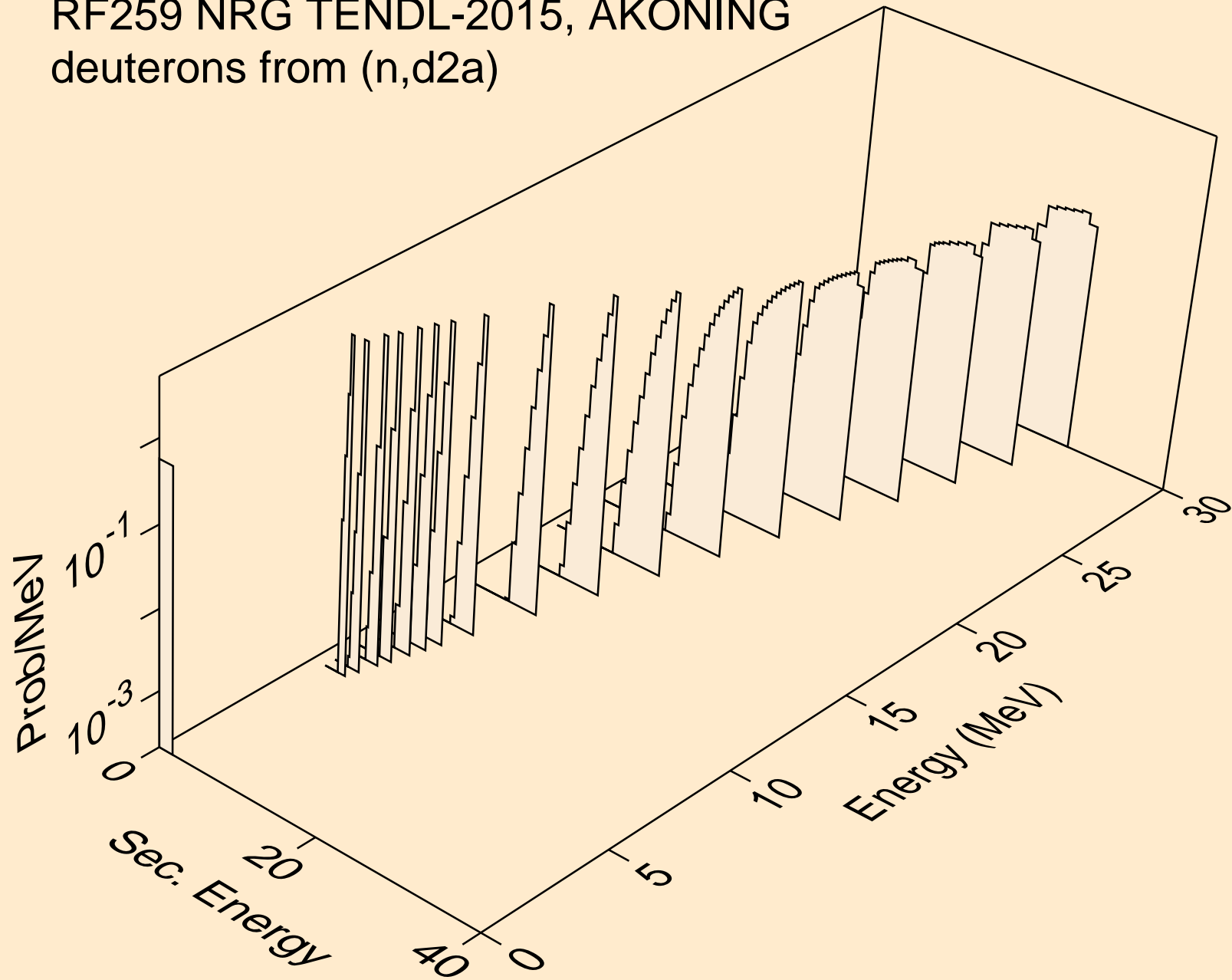

RF259 NRG TENDL-2015, AKONING  
deuterons from (n,pd)

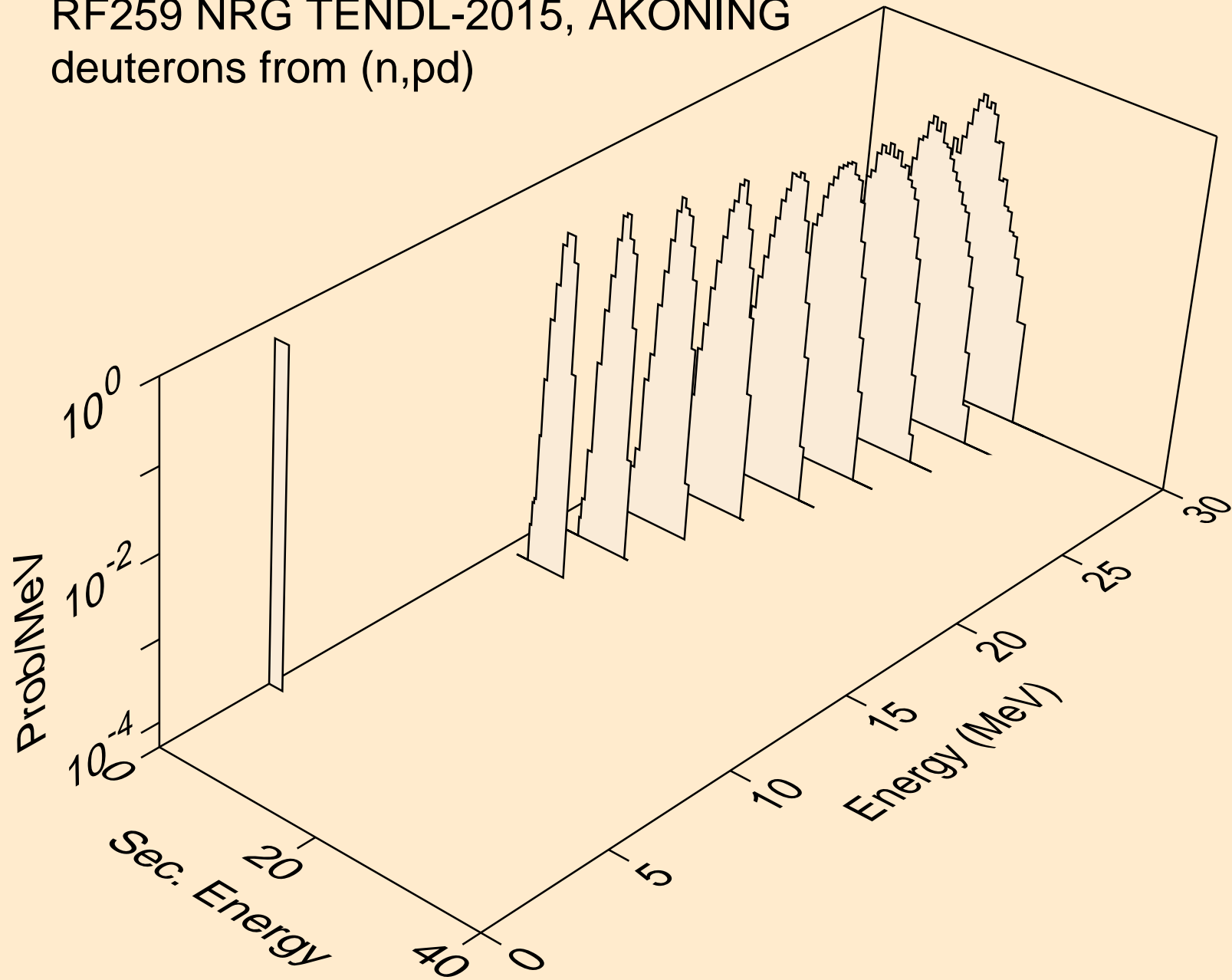

RF259 NRG TENDL-2015, AKONING  
deuterons from (n,da)

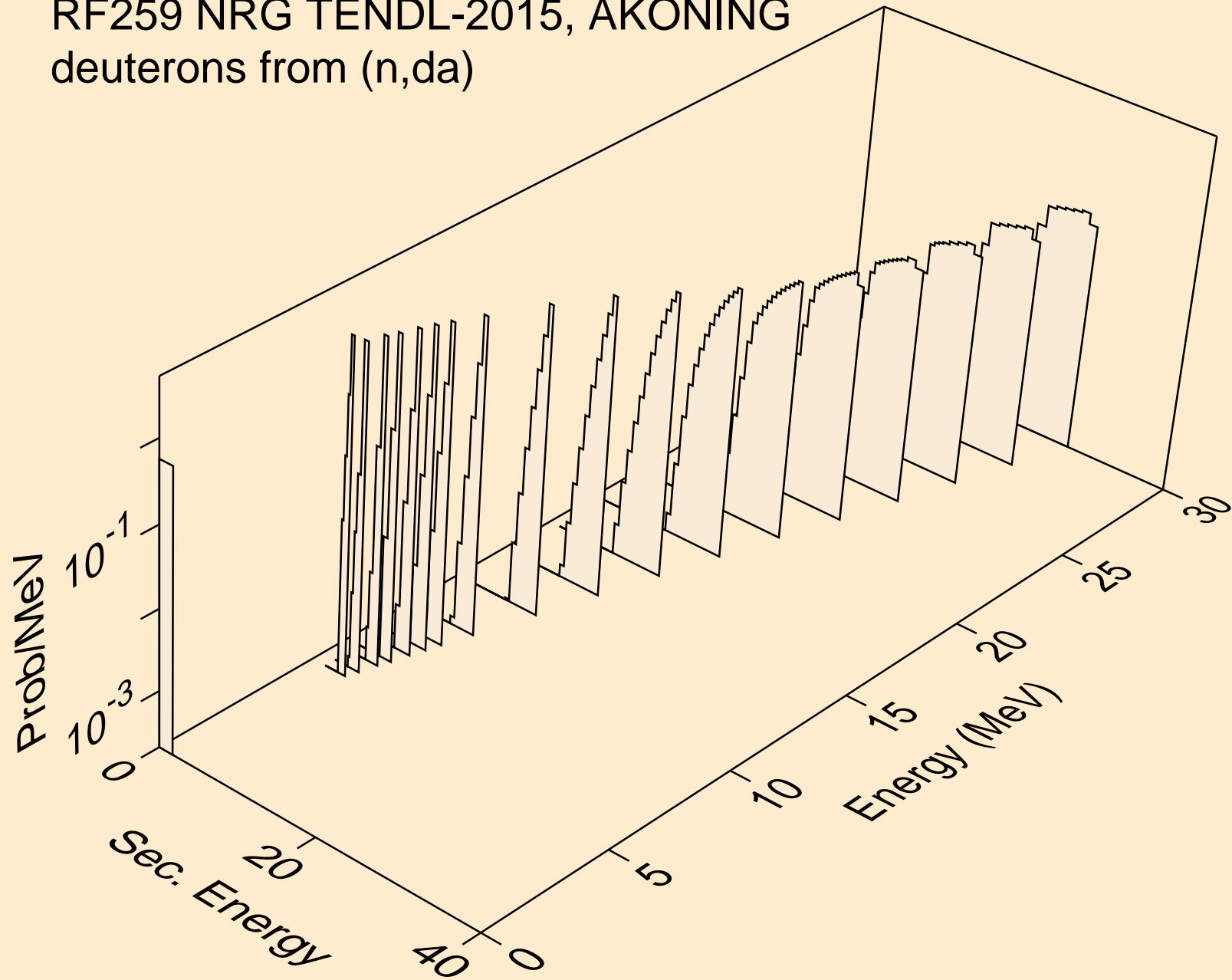

RF259 NRG TENDL-2015, AKONING  
tritons from (n,x)

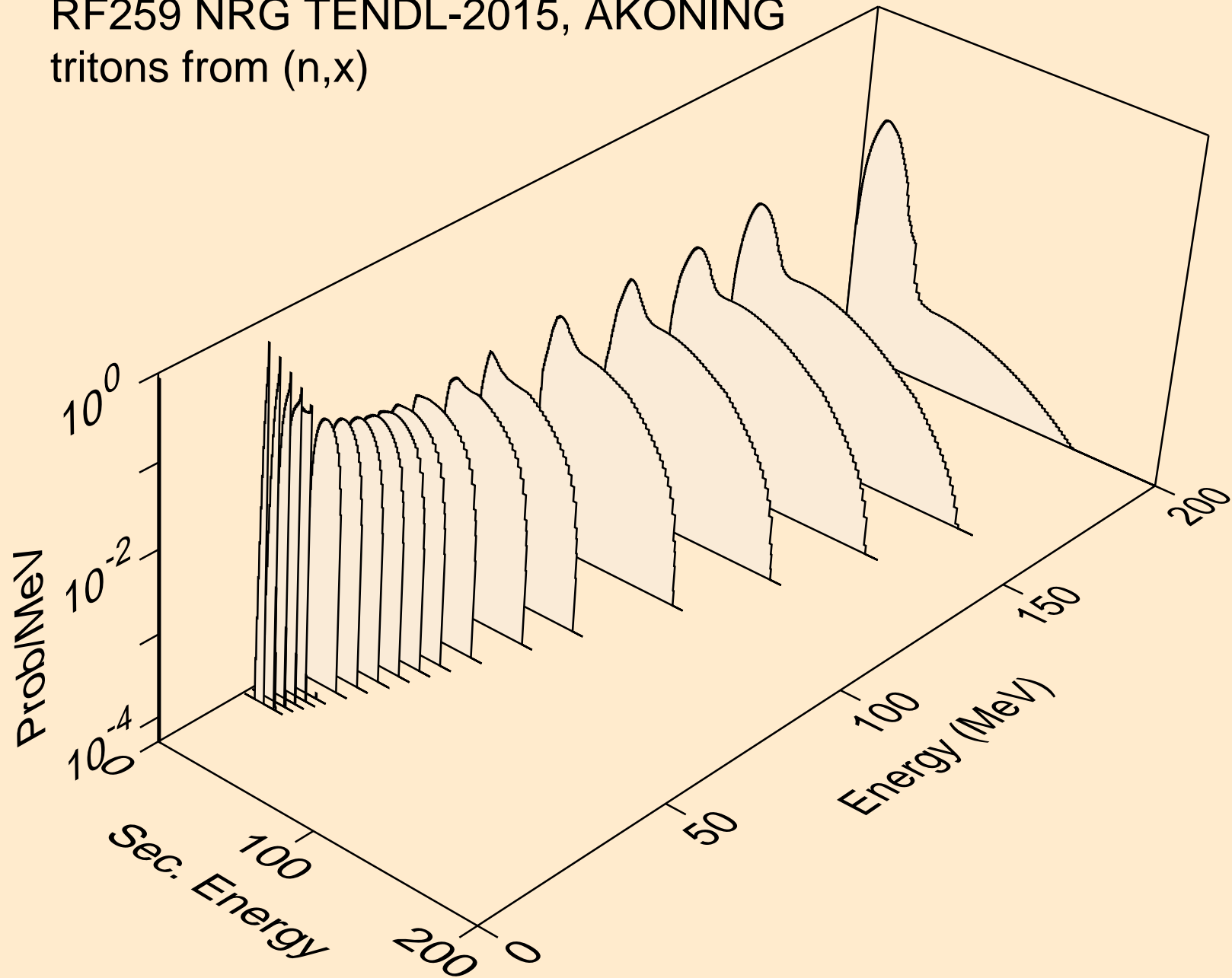

RF259 NRG TENDL-2015, AKONING  
tritons from (n,n\*)t

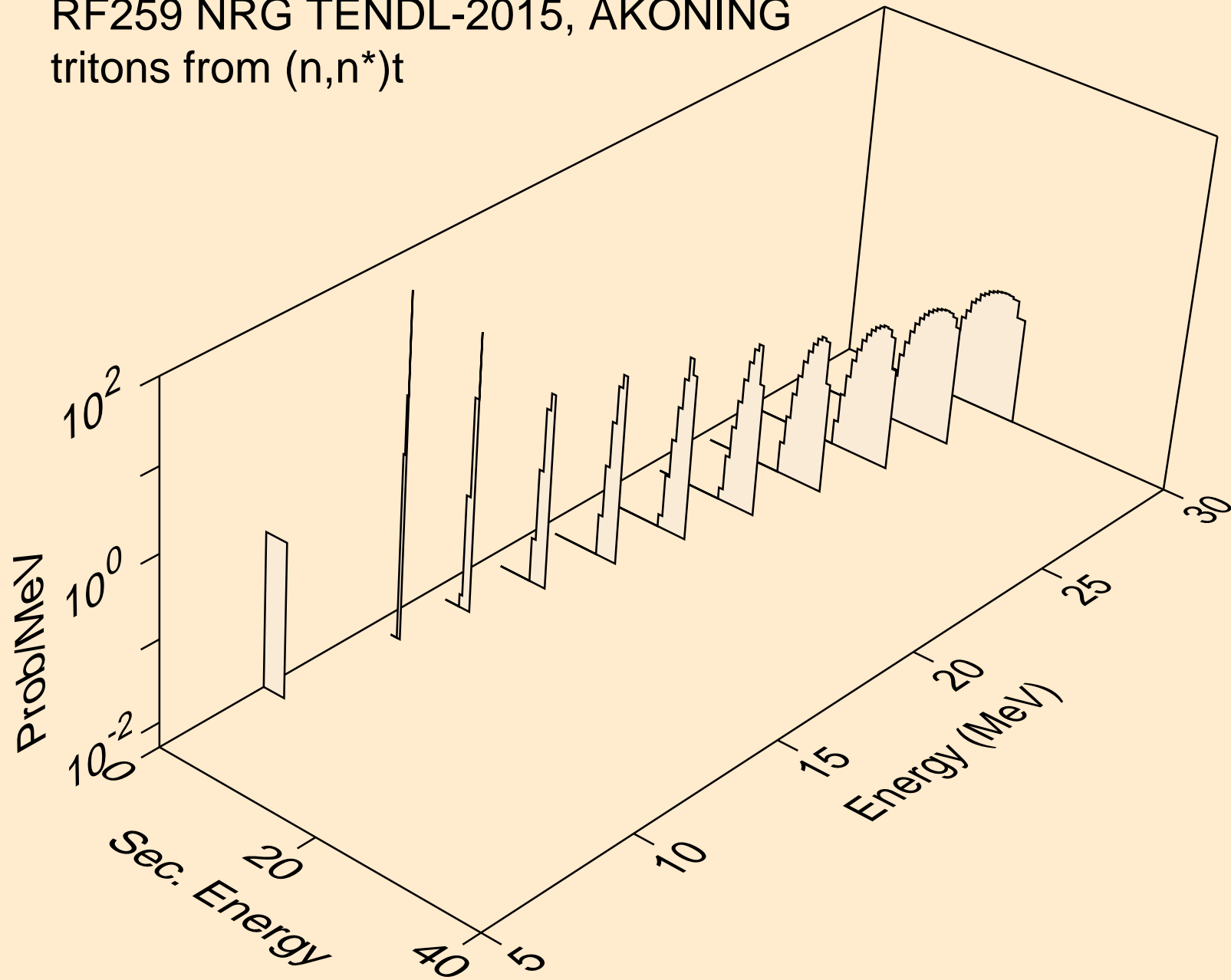

RF259 NRG TENDL-2015, AKONING  
tritons from (n,n\*)t2a

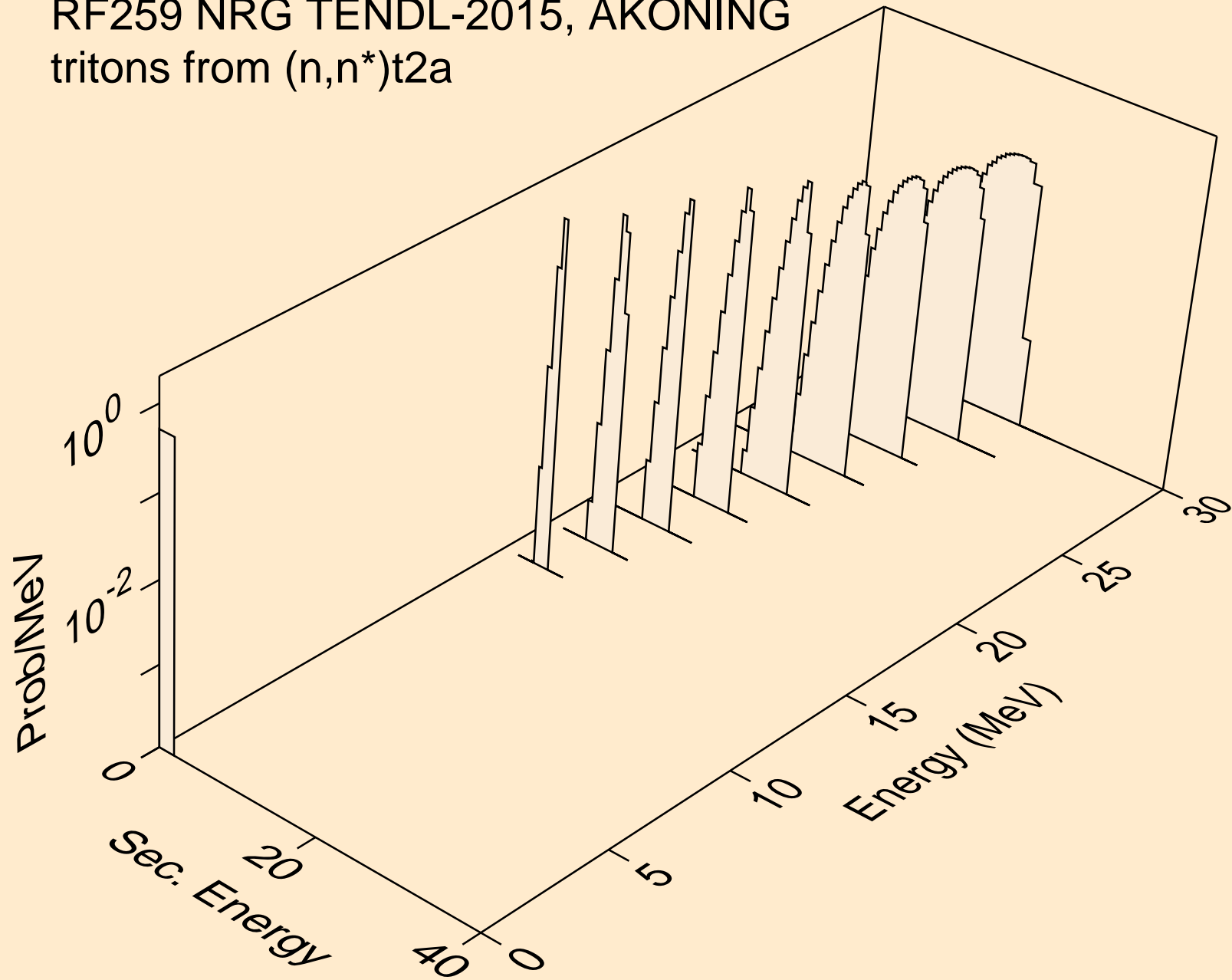



RF259 NRG TENDL-2015, AKONING  
tritons from (n,t)

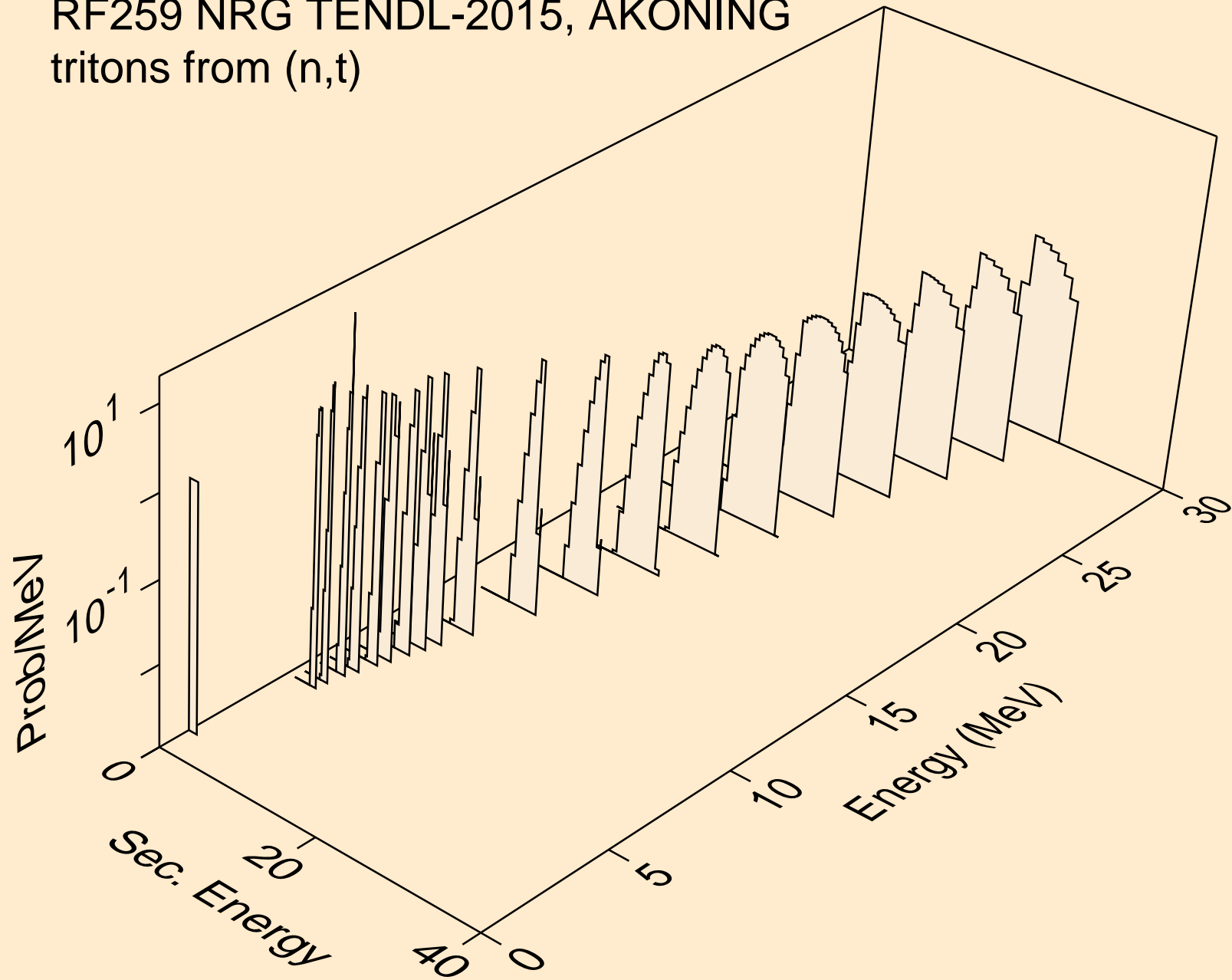

RF259 NRG TENDL-2015, AKONING  
tritons from (n,t2a)

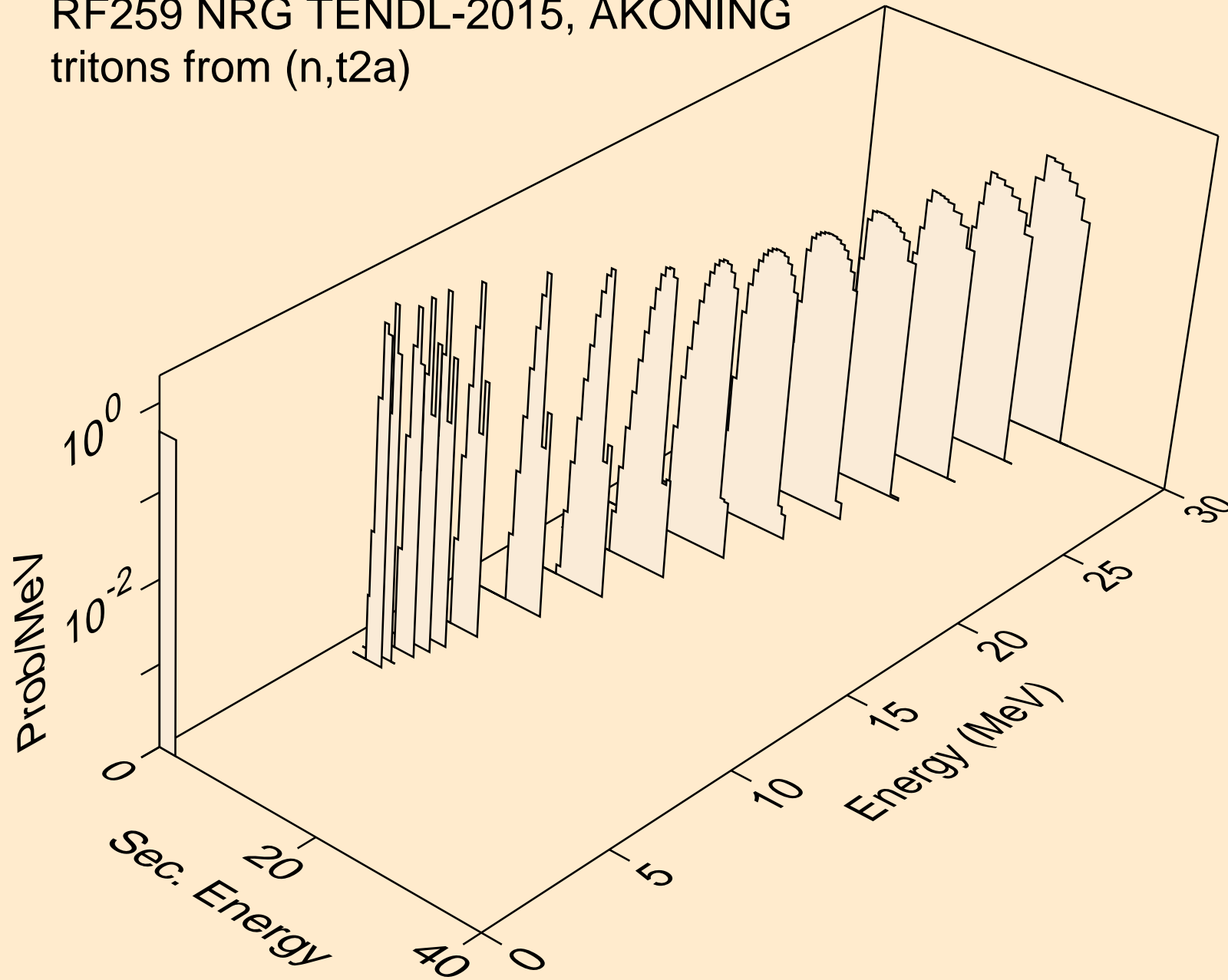

RF259 NRG TENDL-2015, AKONING  
he3s from (n,x)

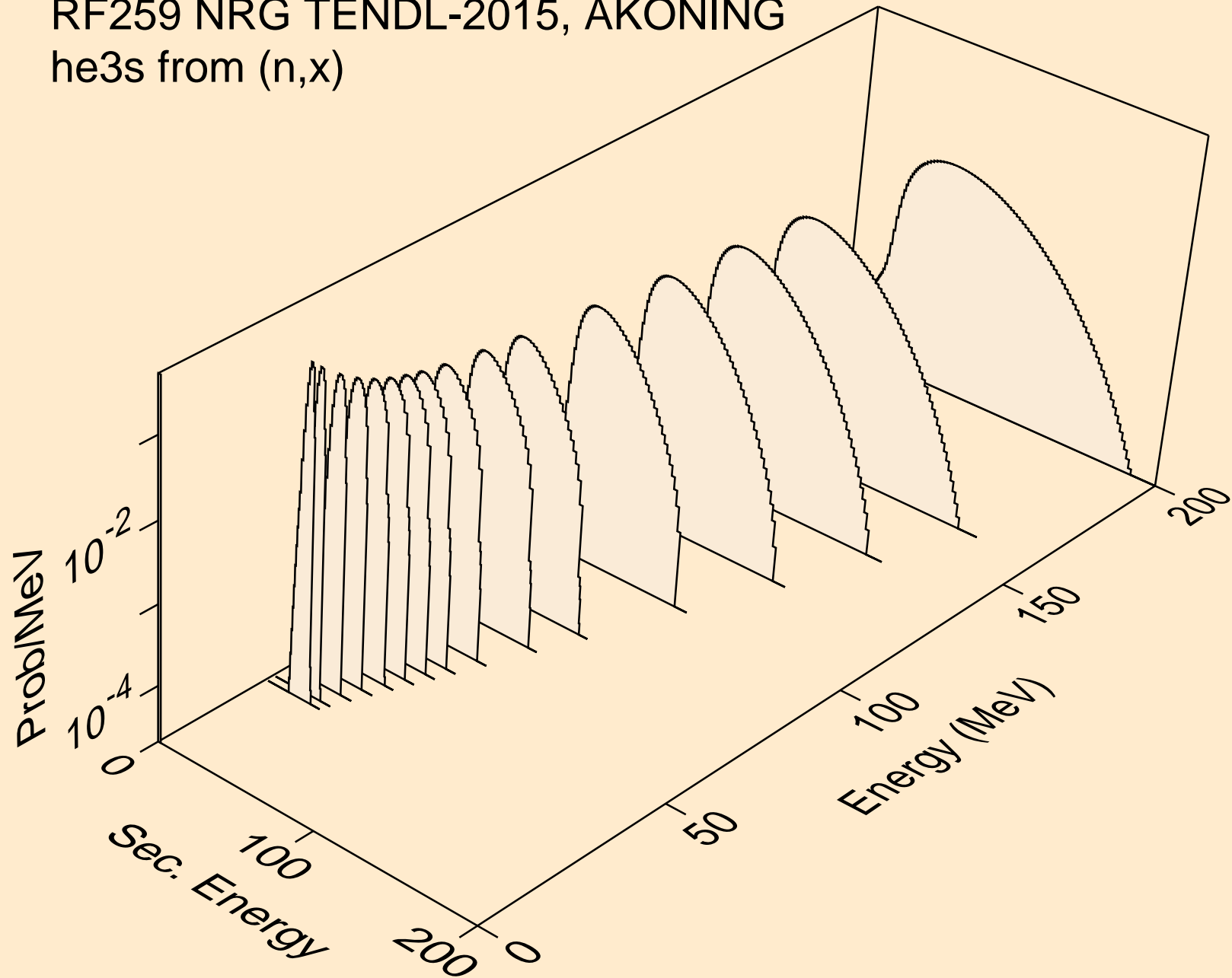

RF259 NRG TENDL-2015, AKONING  
he3s from (n,n\*)he3

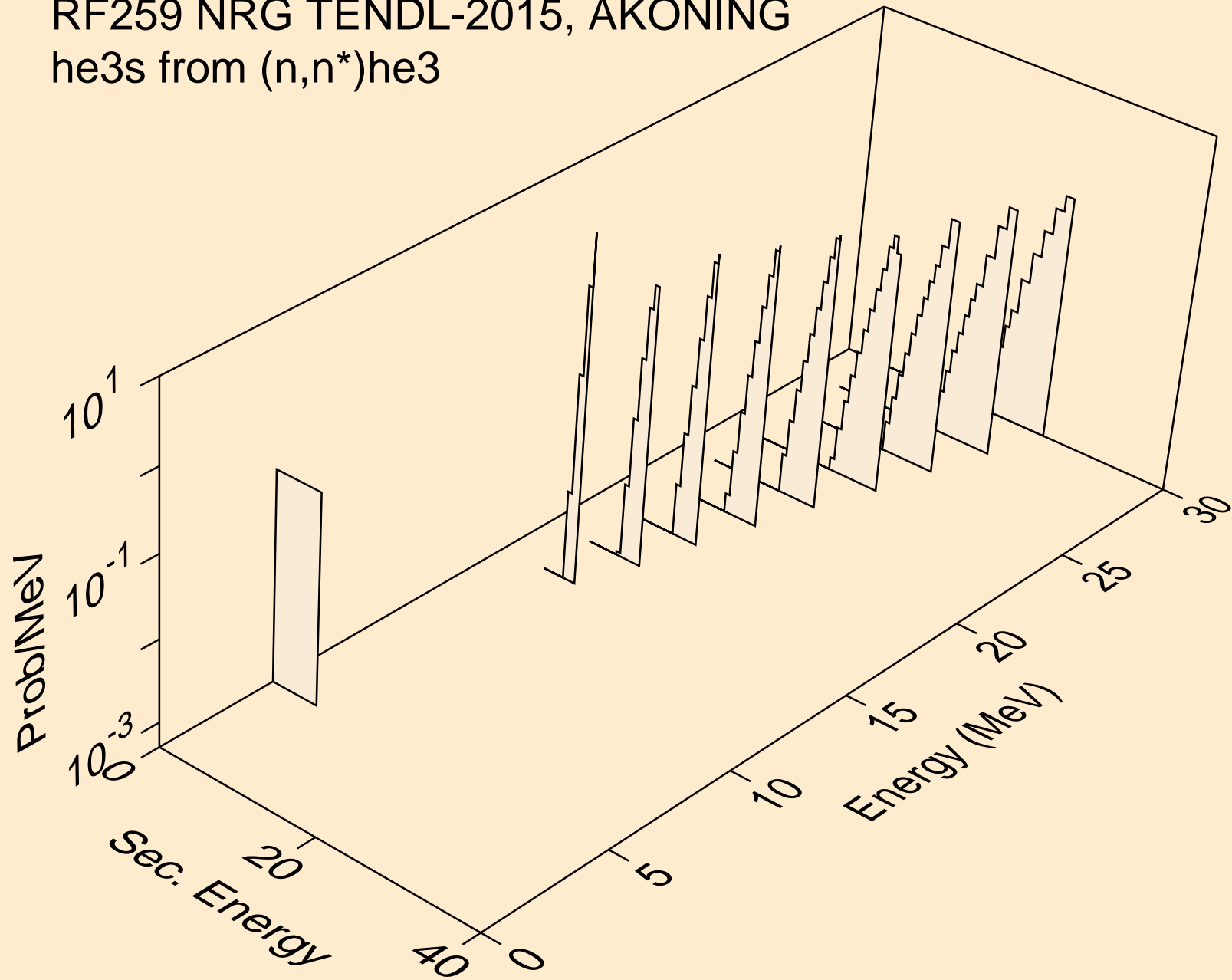

RF259 NRG TENDL-2015, AKONING  
he3s from (n,he3)

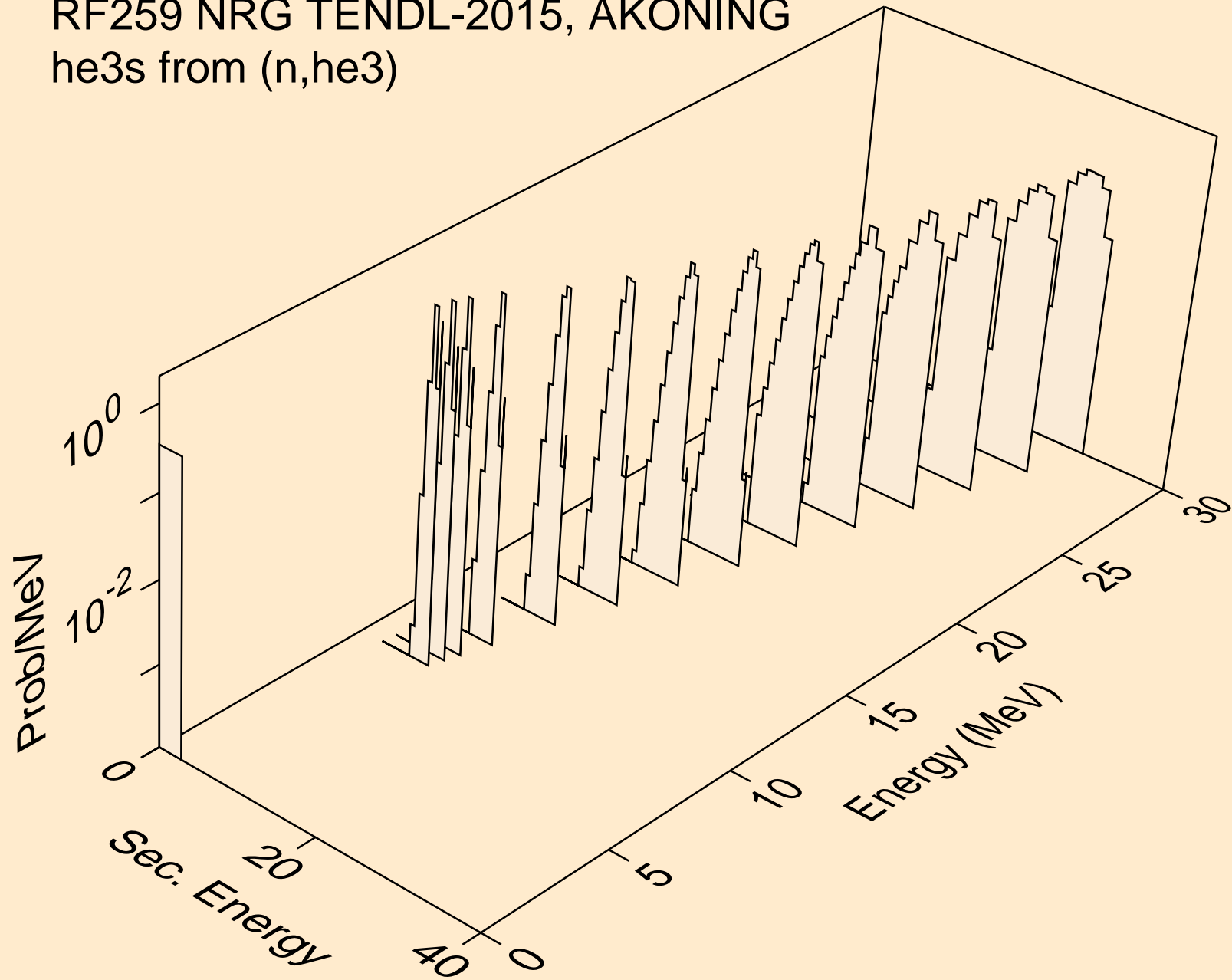

RF259 NRG TENDL-2015, AKONING  
alphas from (n,x)

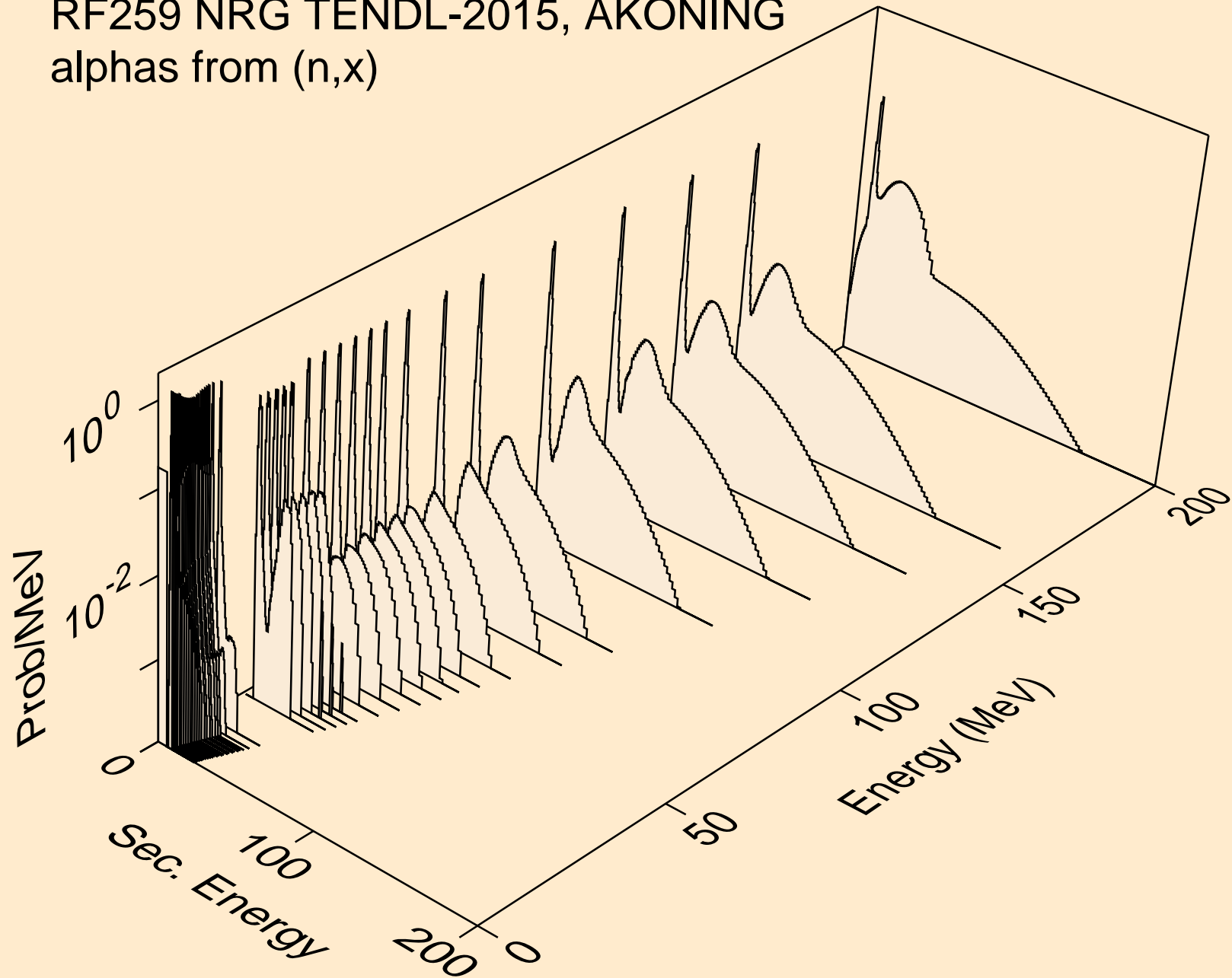

RF259 NRG TENDL-2015, AKONING  
alphas from (n,n\*)a

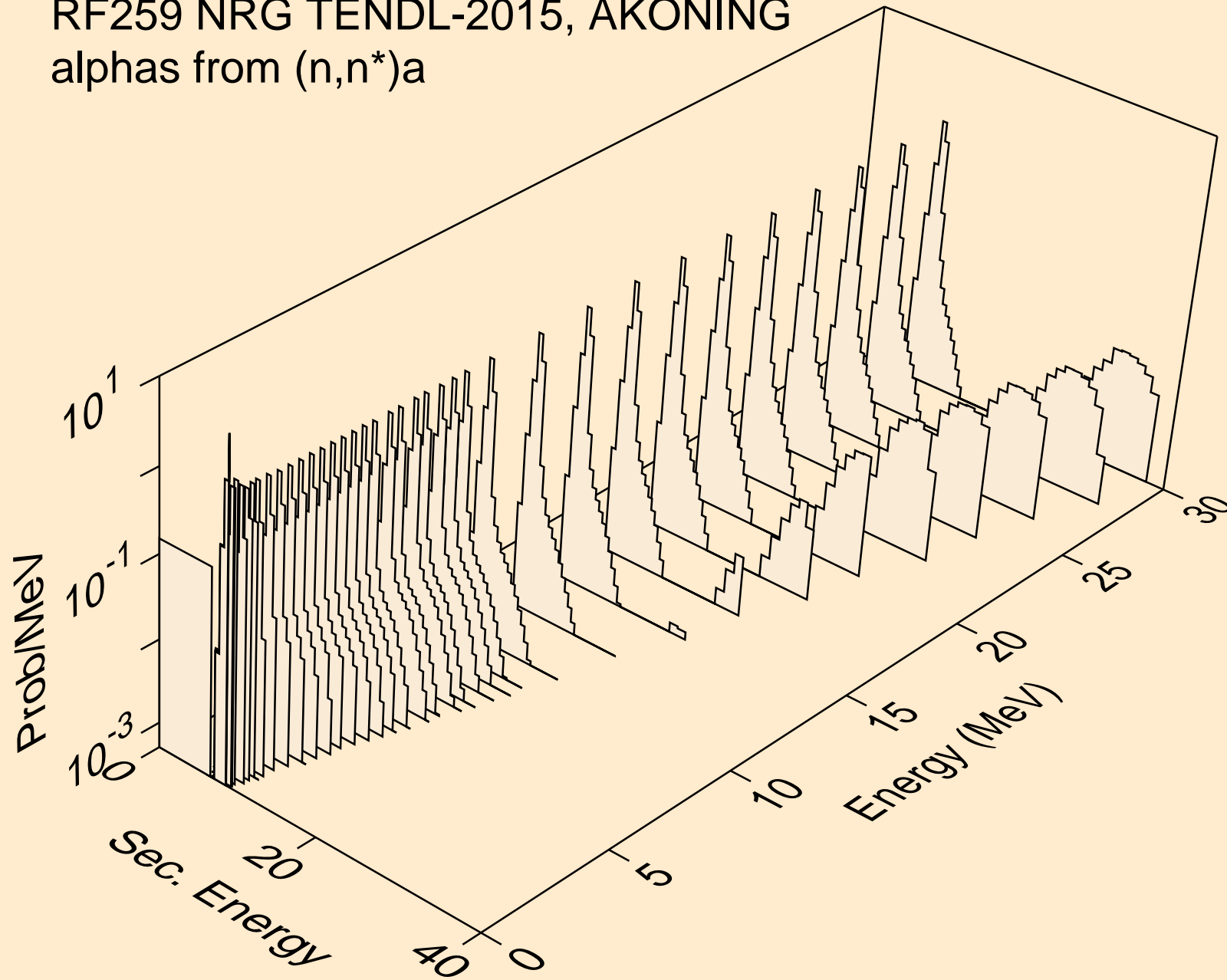

RF259 NRG TENDL-2015, AKONING  
alphas from (n,n\*)3a

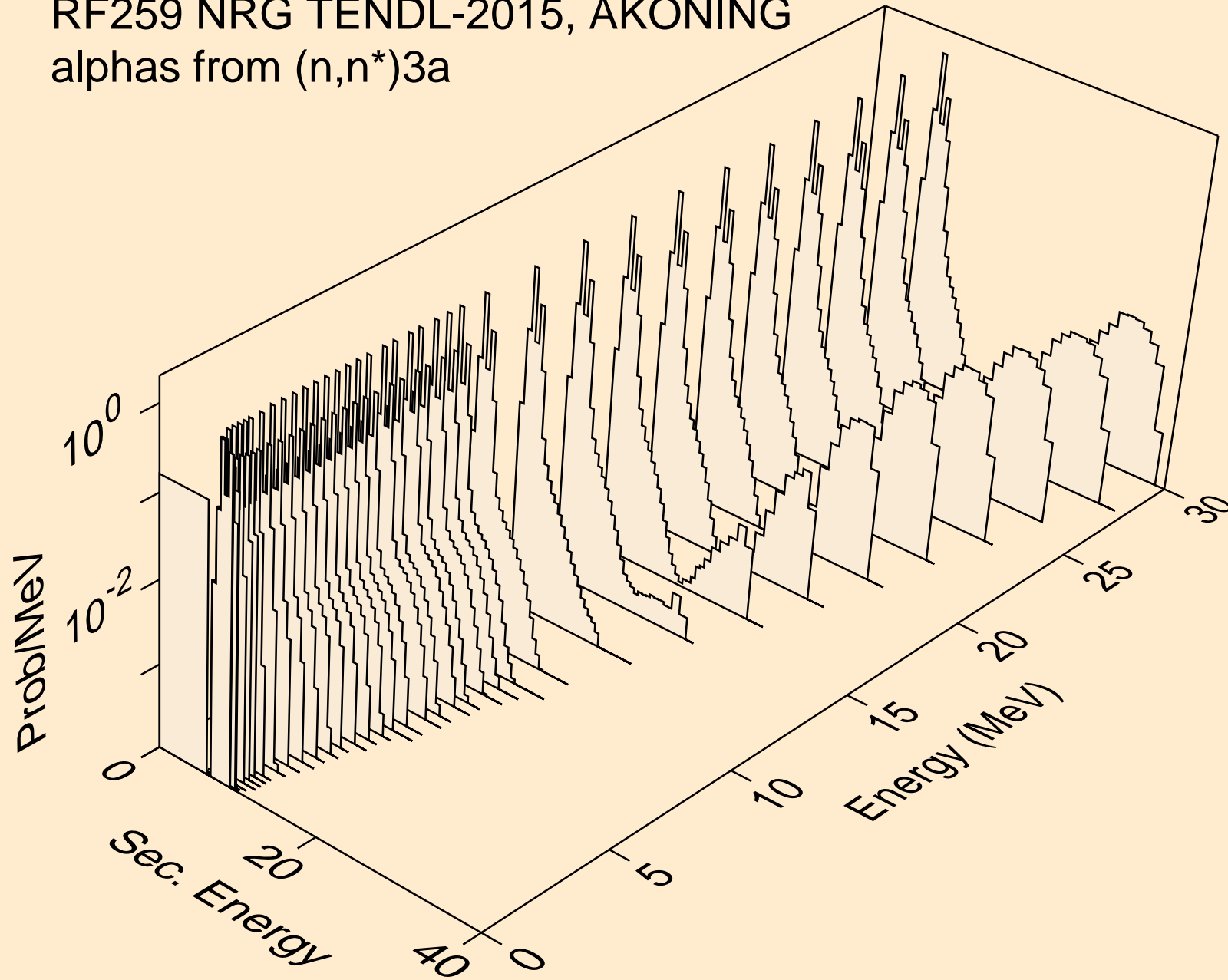



RF259 NRG TENDL-2015, AKONING  
alphas from (n,2n)a

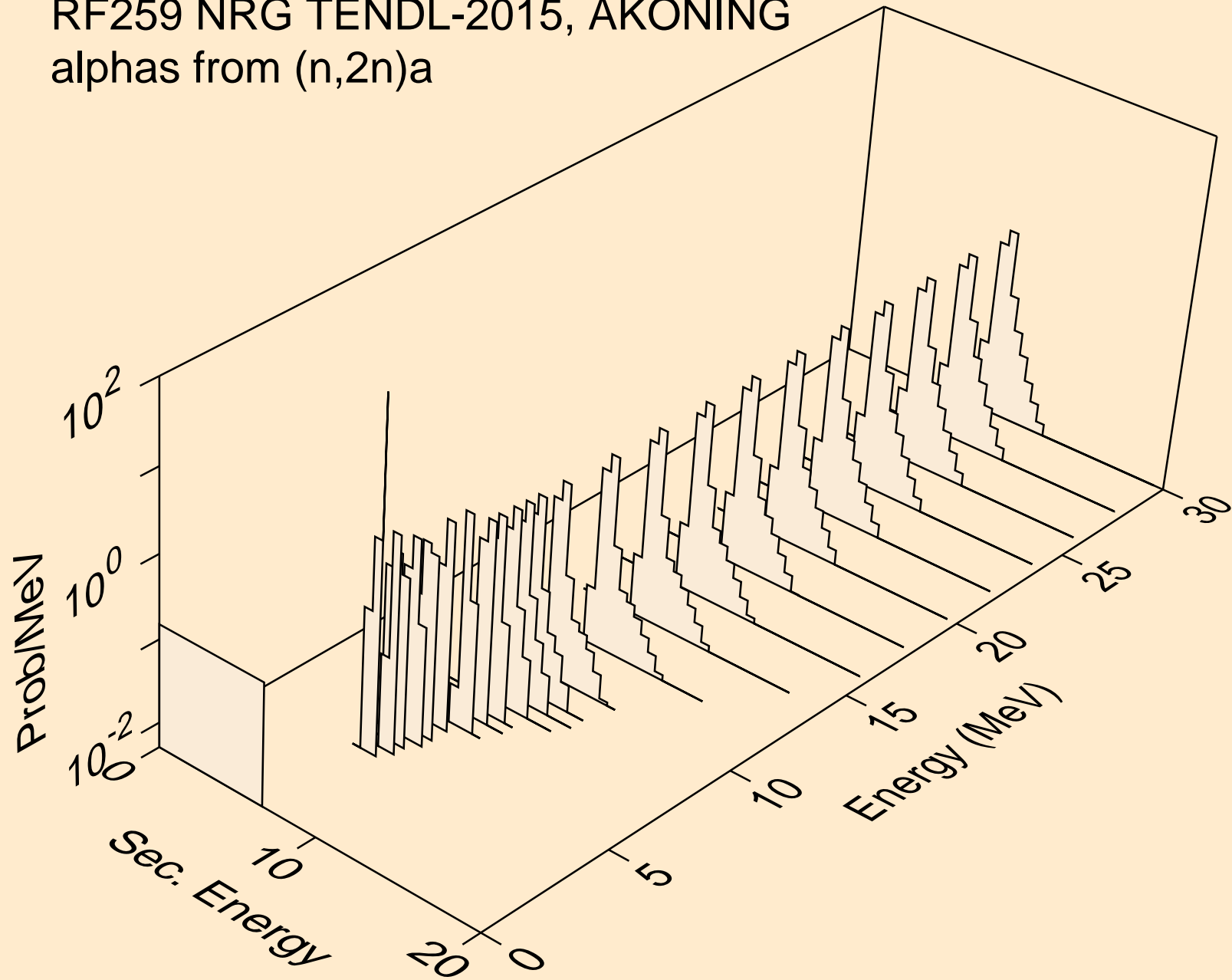

RF259 NRG TENDL-2015, AKONING  
alphas from (n,3n)a

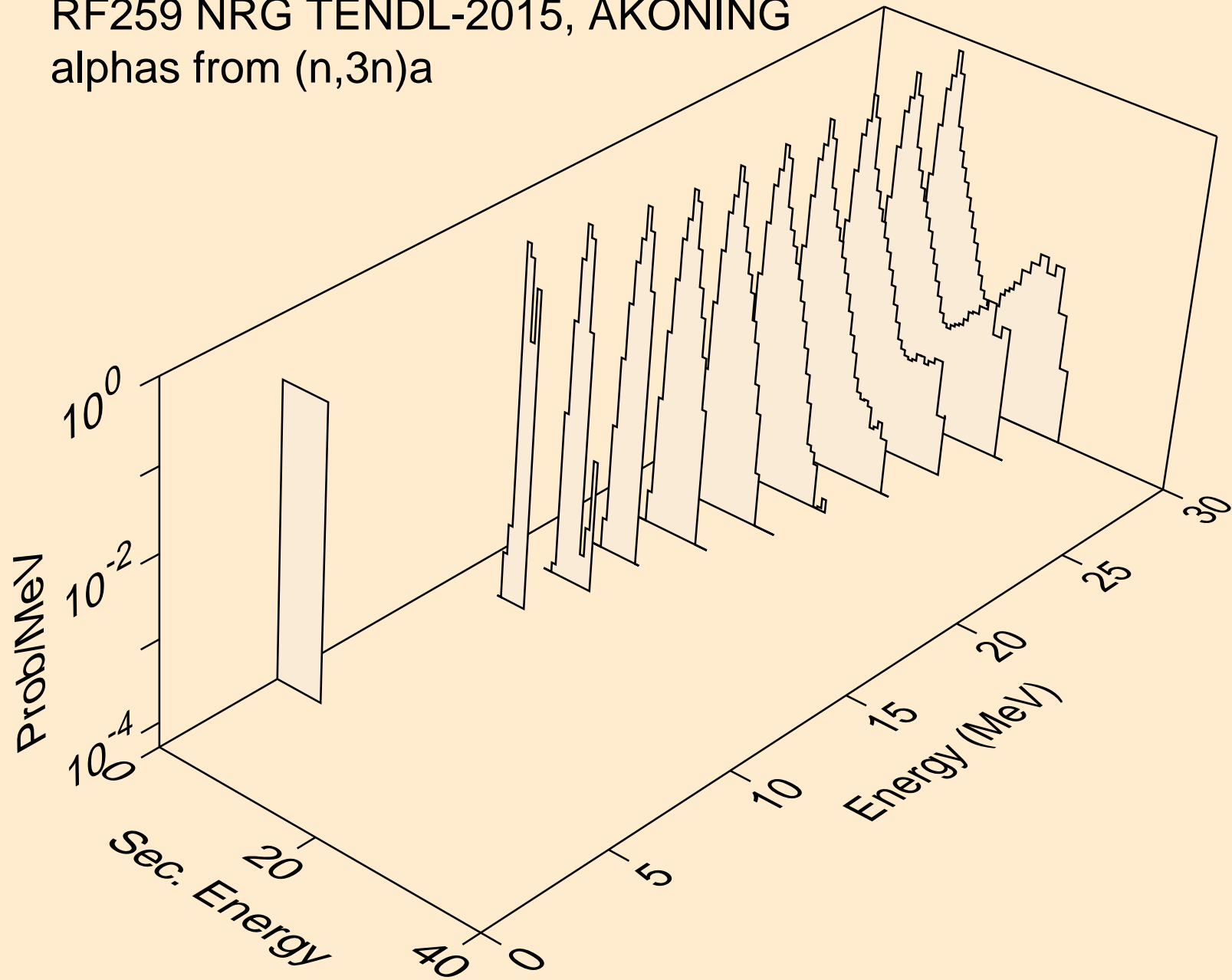

RF259 NRG TENDL-2015, AKONING  
alphas from (n,n\*)2a

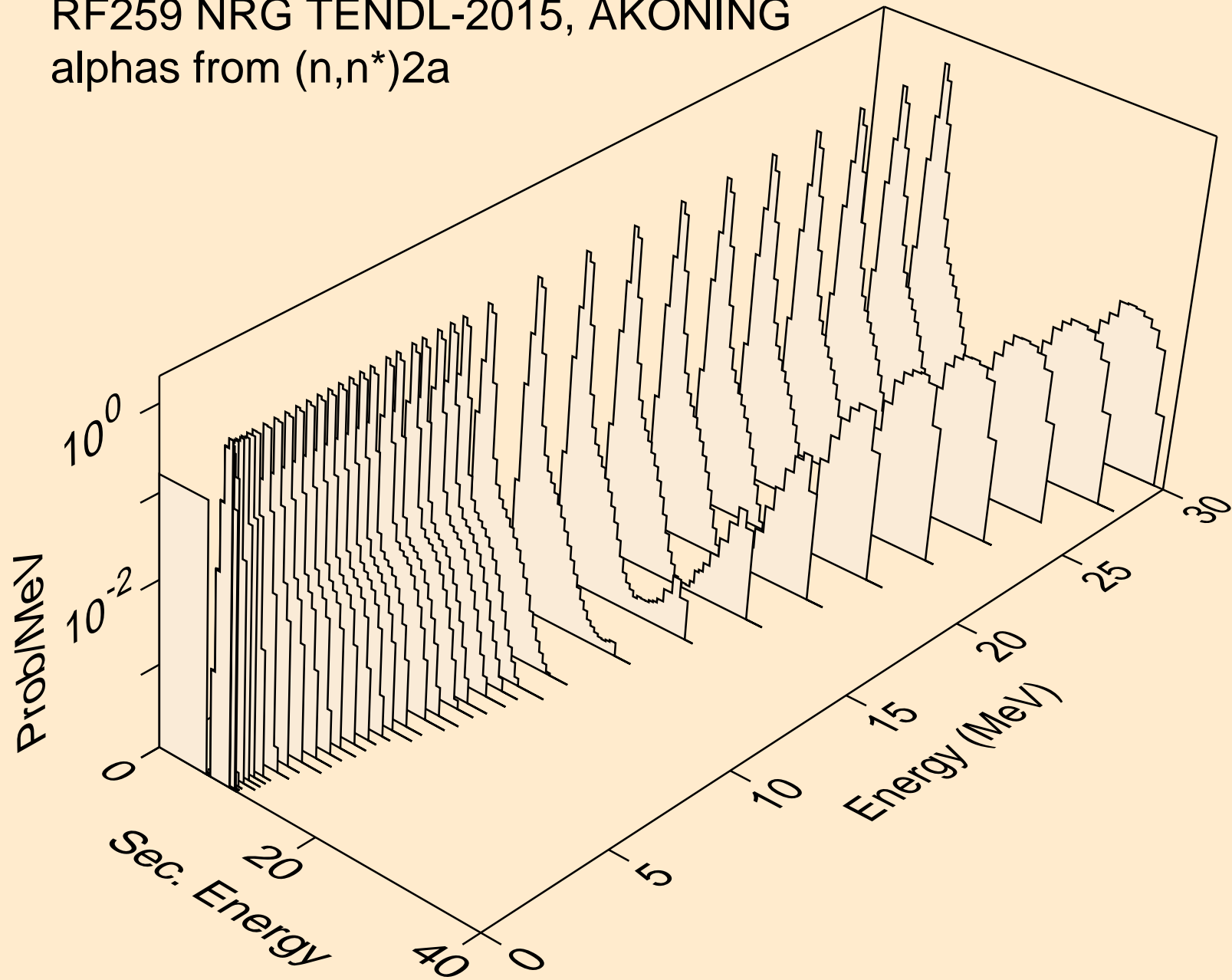

RF259 NRG TENDL-2015, AKONING  
alphas from (n,2n)2a

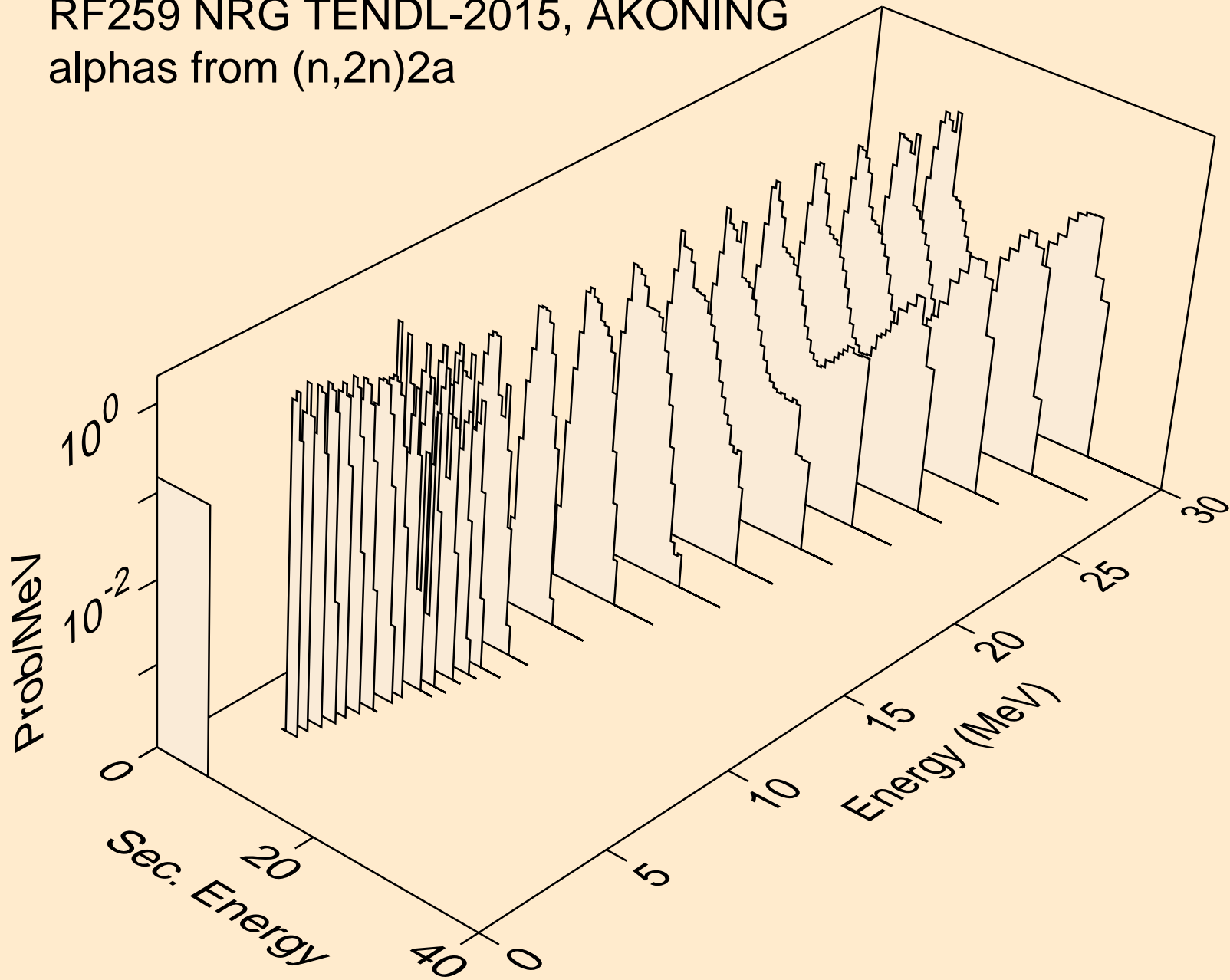

RF259 NRG TENDL-2015, AKONING  
alphas from (n,n\*)d2a

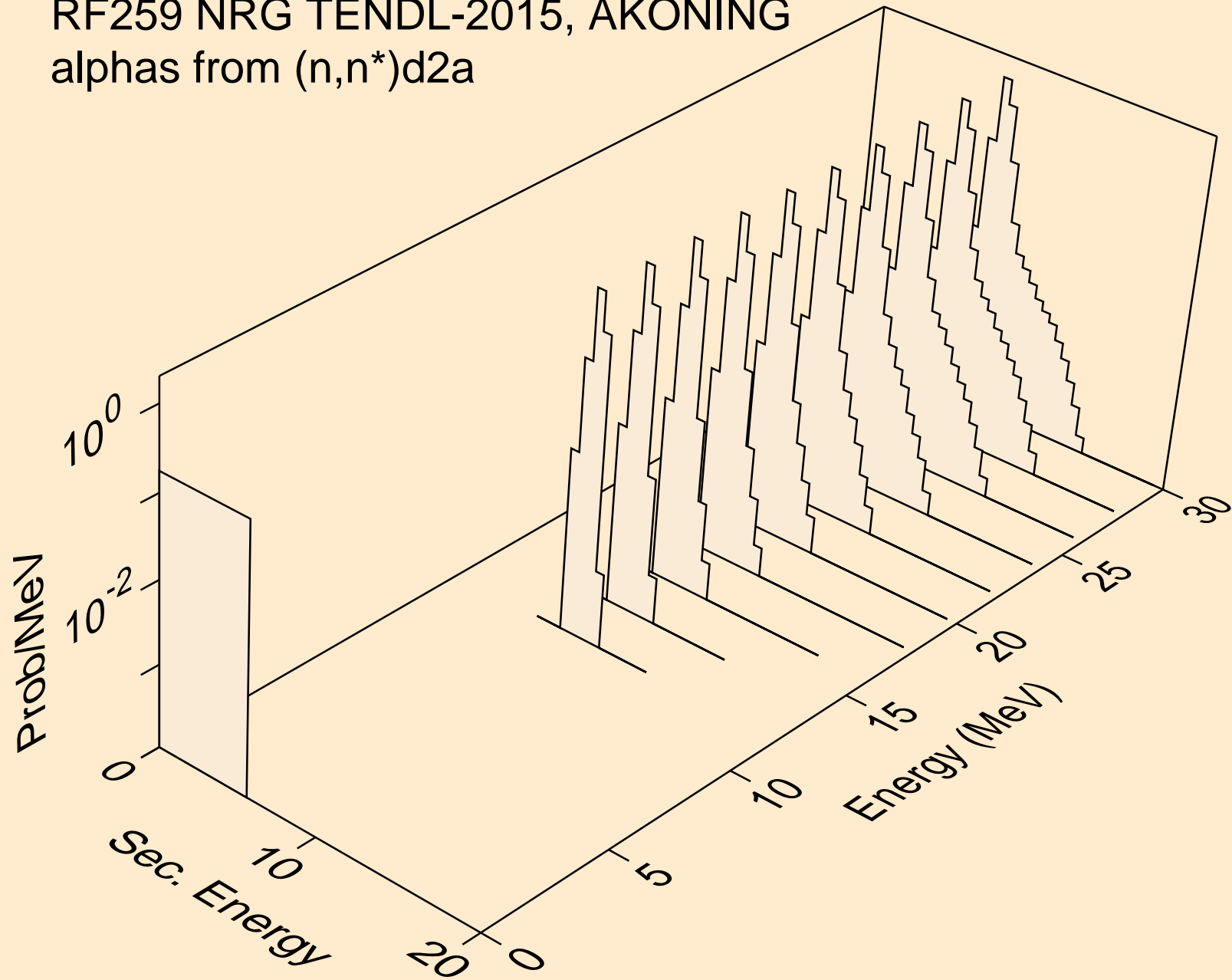

RF259 NRG TENDL-2015, AKONING  
alphas from (n,n\*)t2a

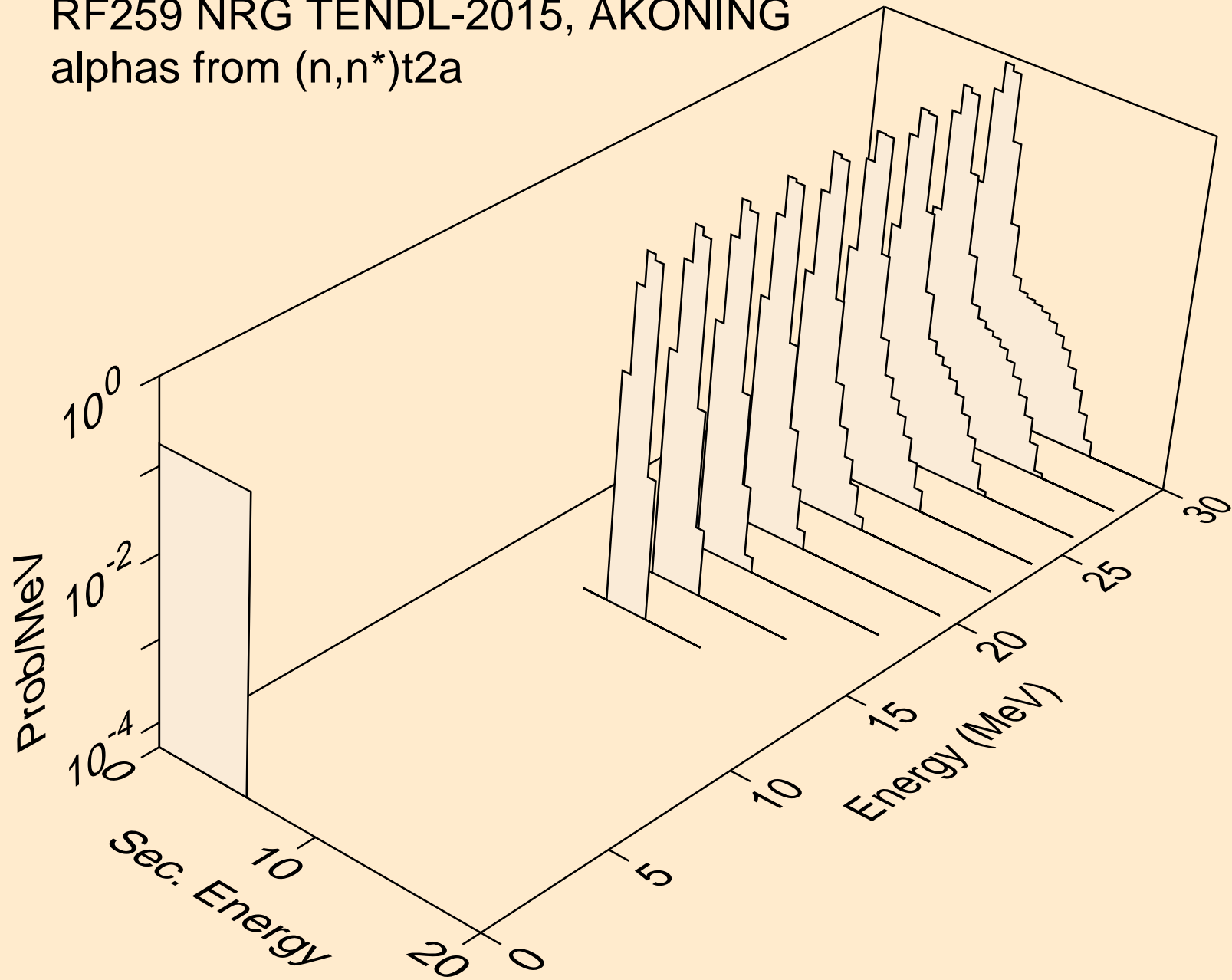

RF259 NRG TENDL-2015, AKONING  
alphas from (n,npa)

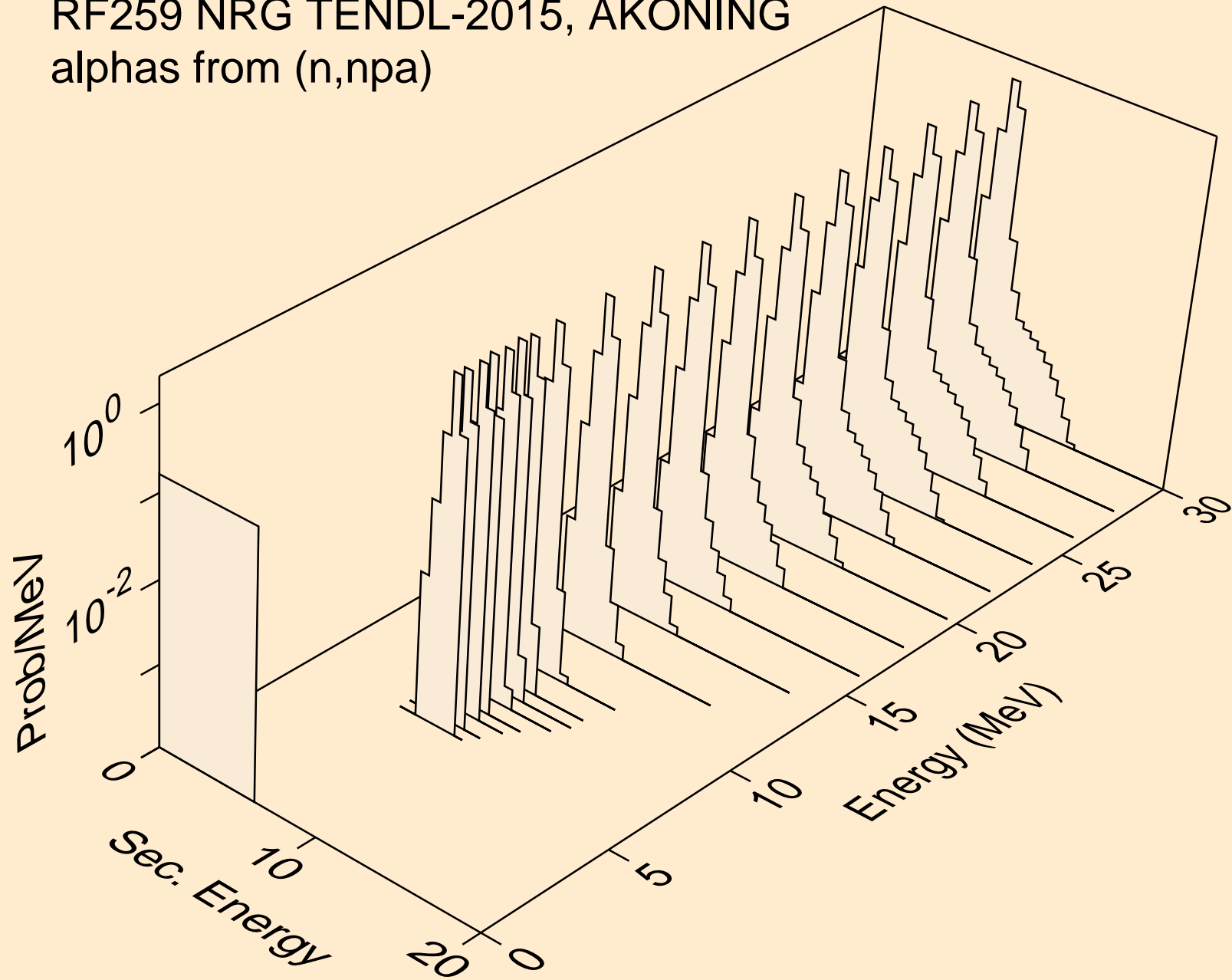

RF259 NRG TENDL-2015, AKONING  
alphas from (n,a)

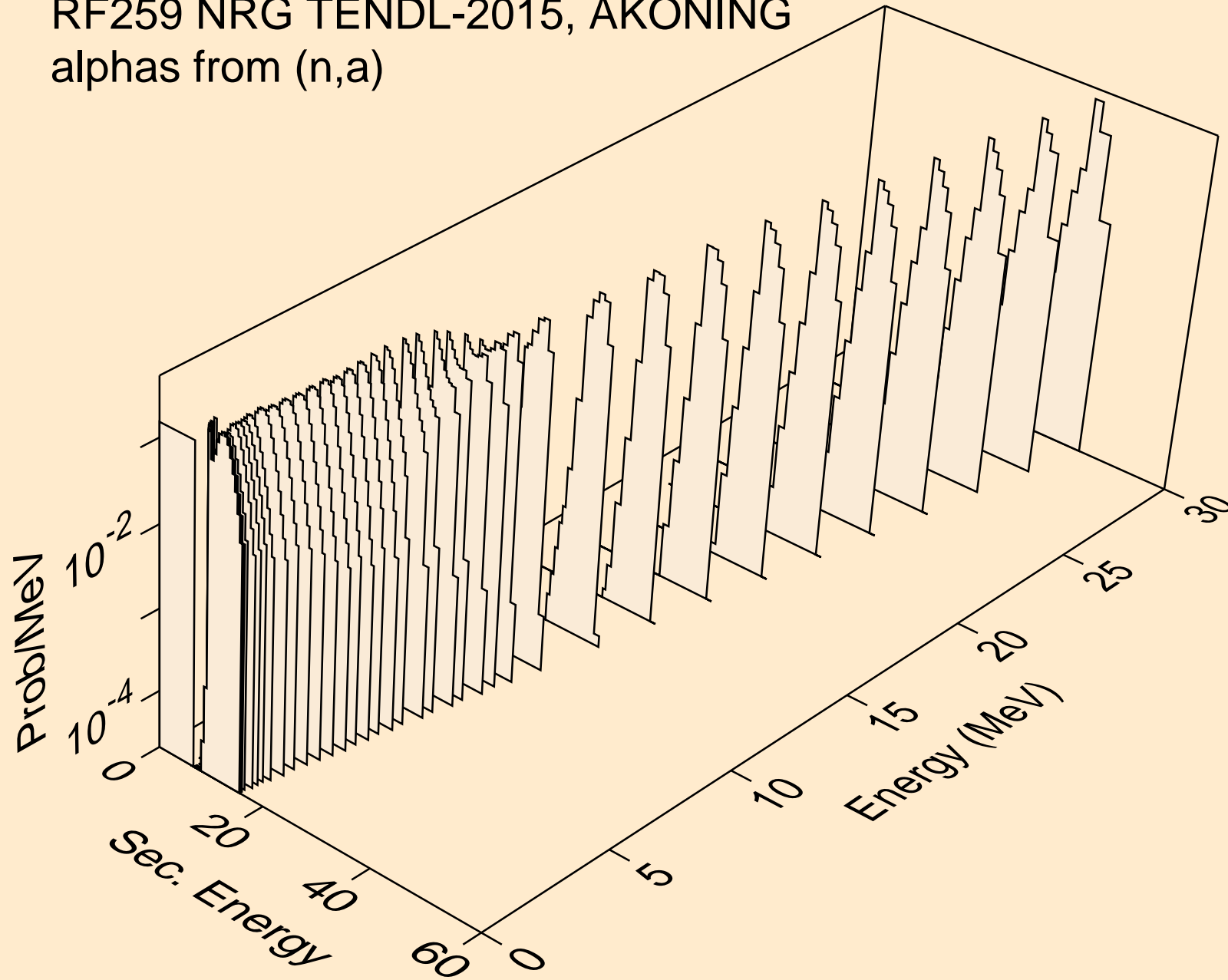



RF259 NRG TENDL-2015, AKONING  
alphas from (n,2a)

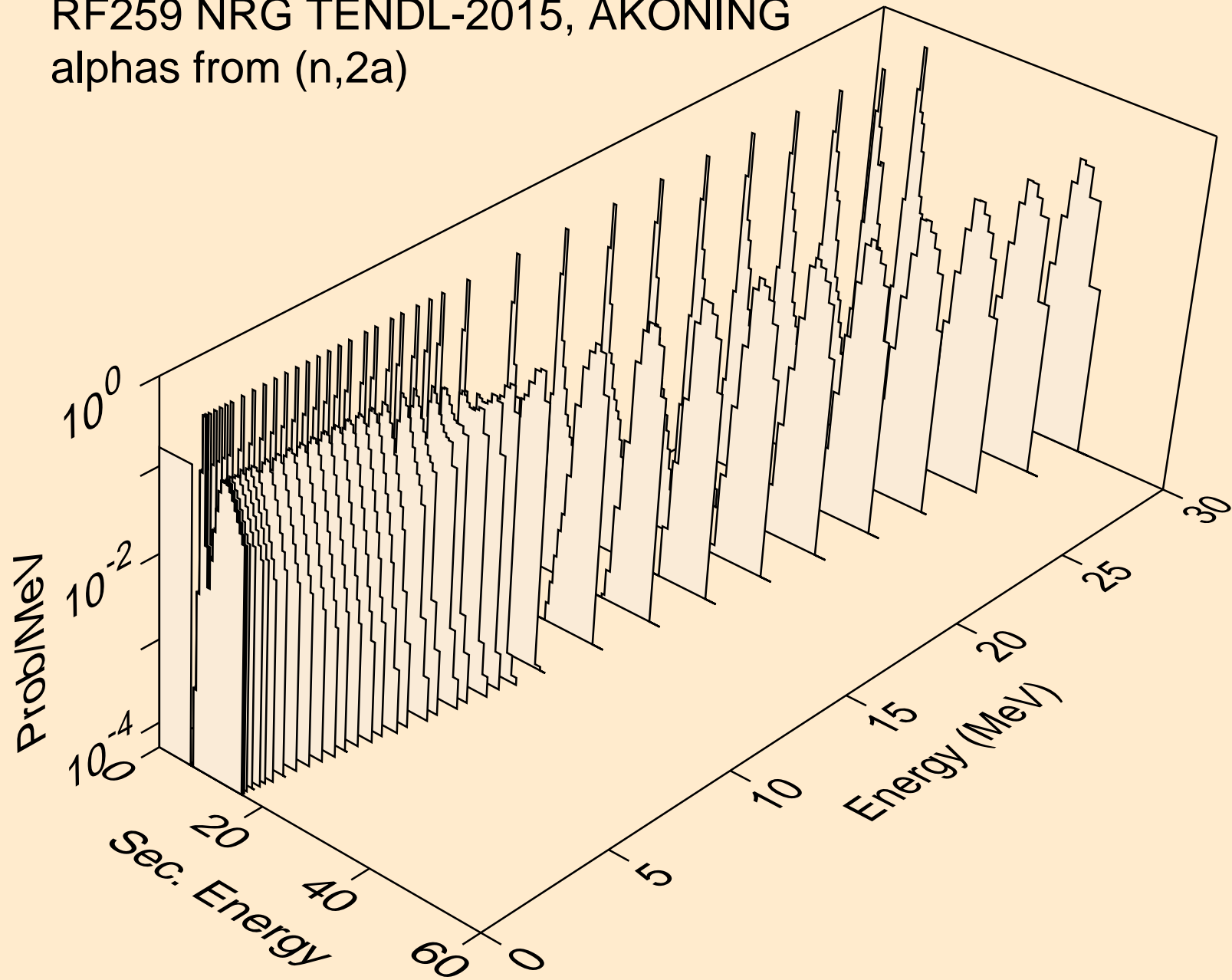

RF259 NRG TENDL-2015, AKONING  
alphas from (n,3a)

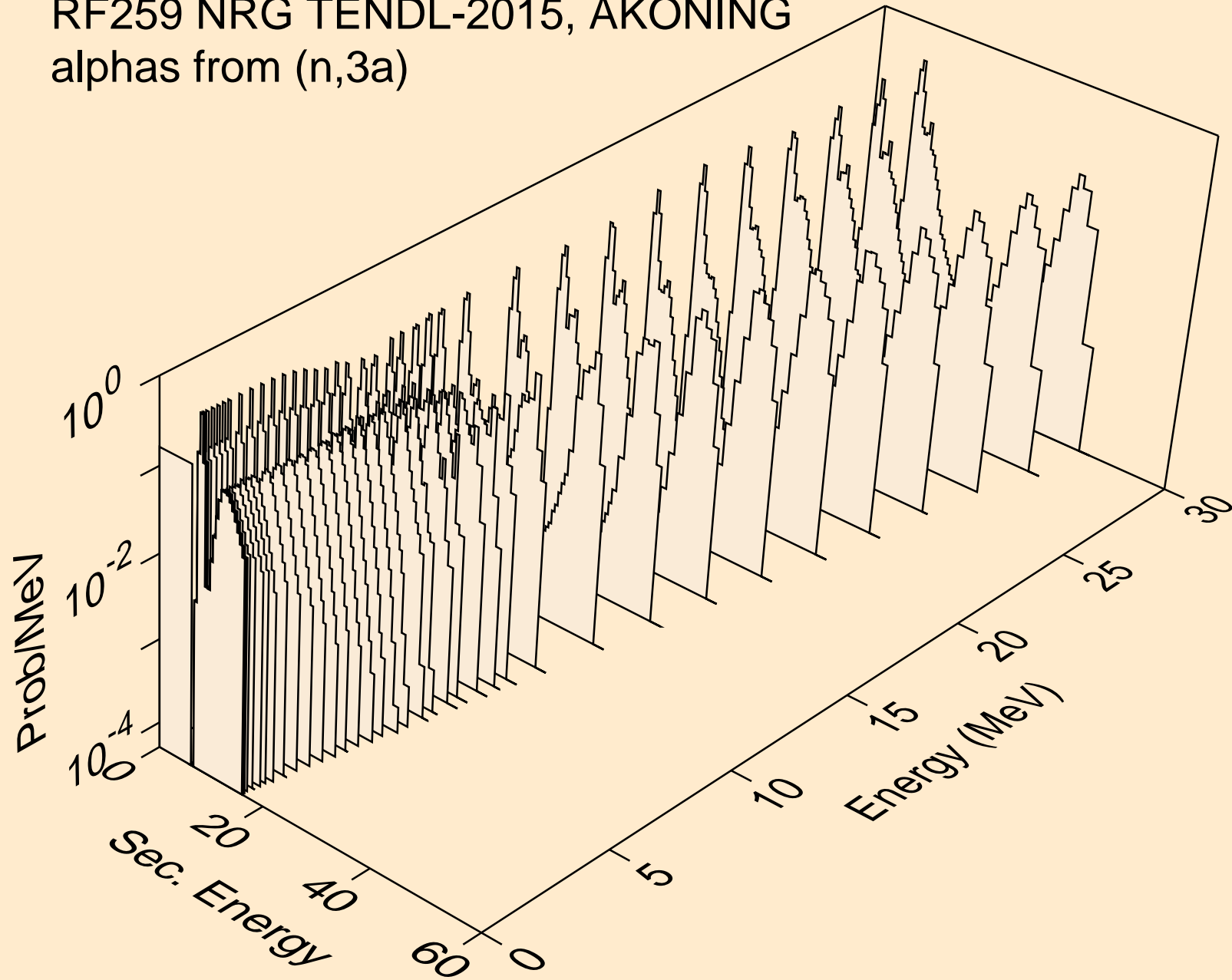

RF259 NRG TENDL-2015, AKONING  
alphas from (n,pa)

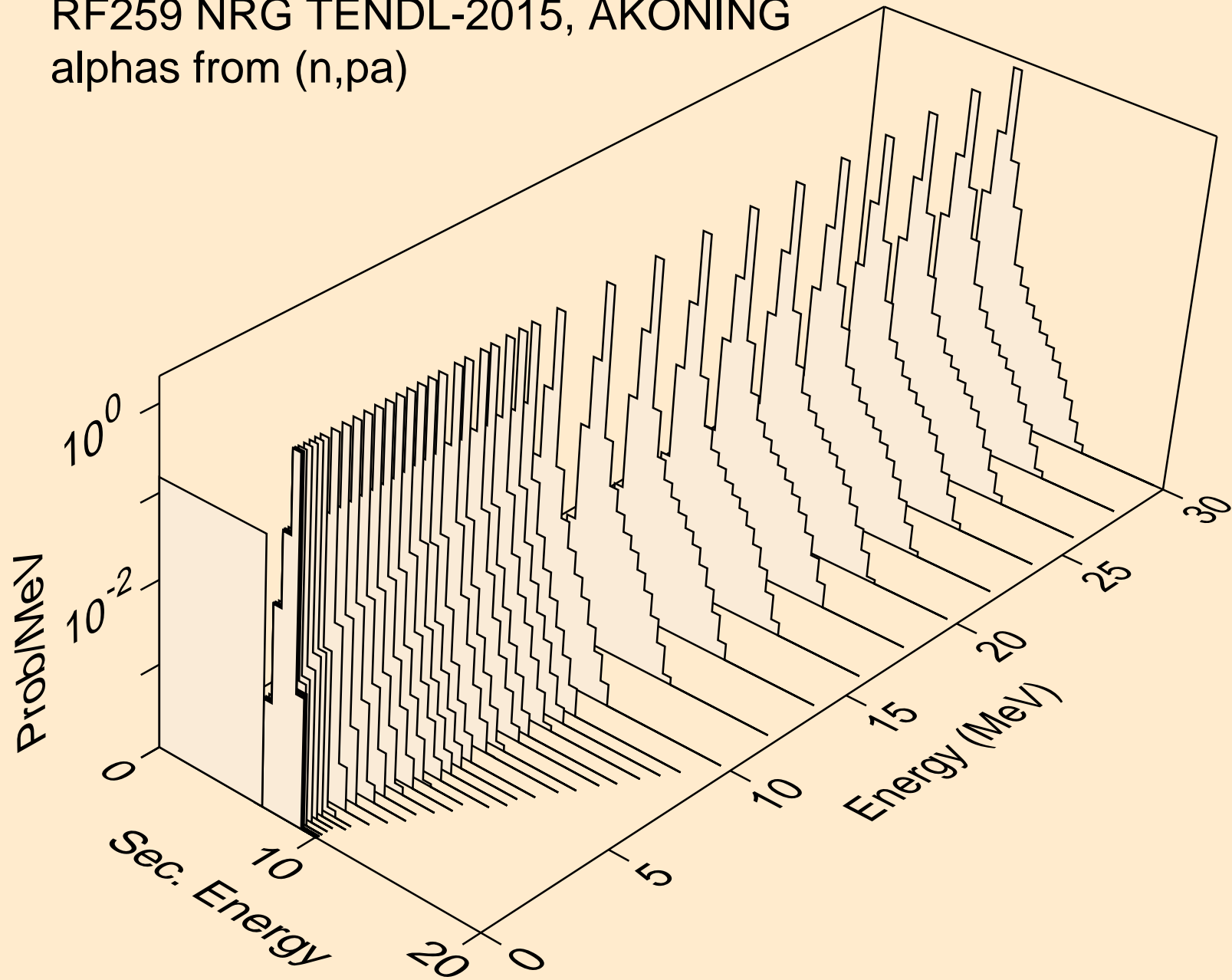

RF259 NRG TENDL-2015, AKONING  
alphas from (n,t2a)

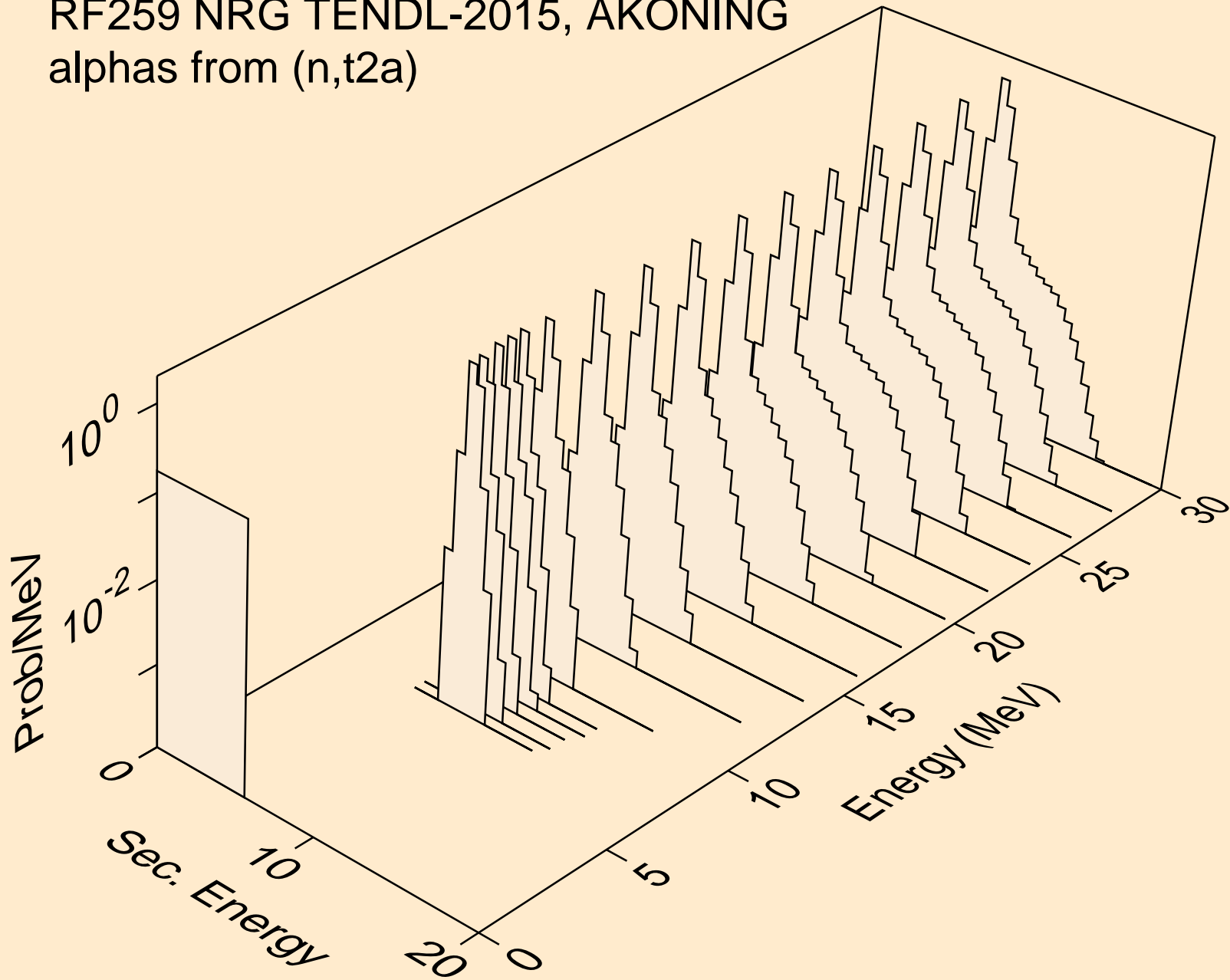

RF259 NRG TENDL-2015, AKONING  
alphas from (n,d2a)

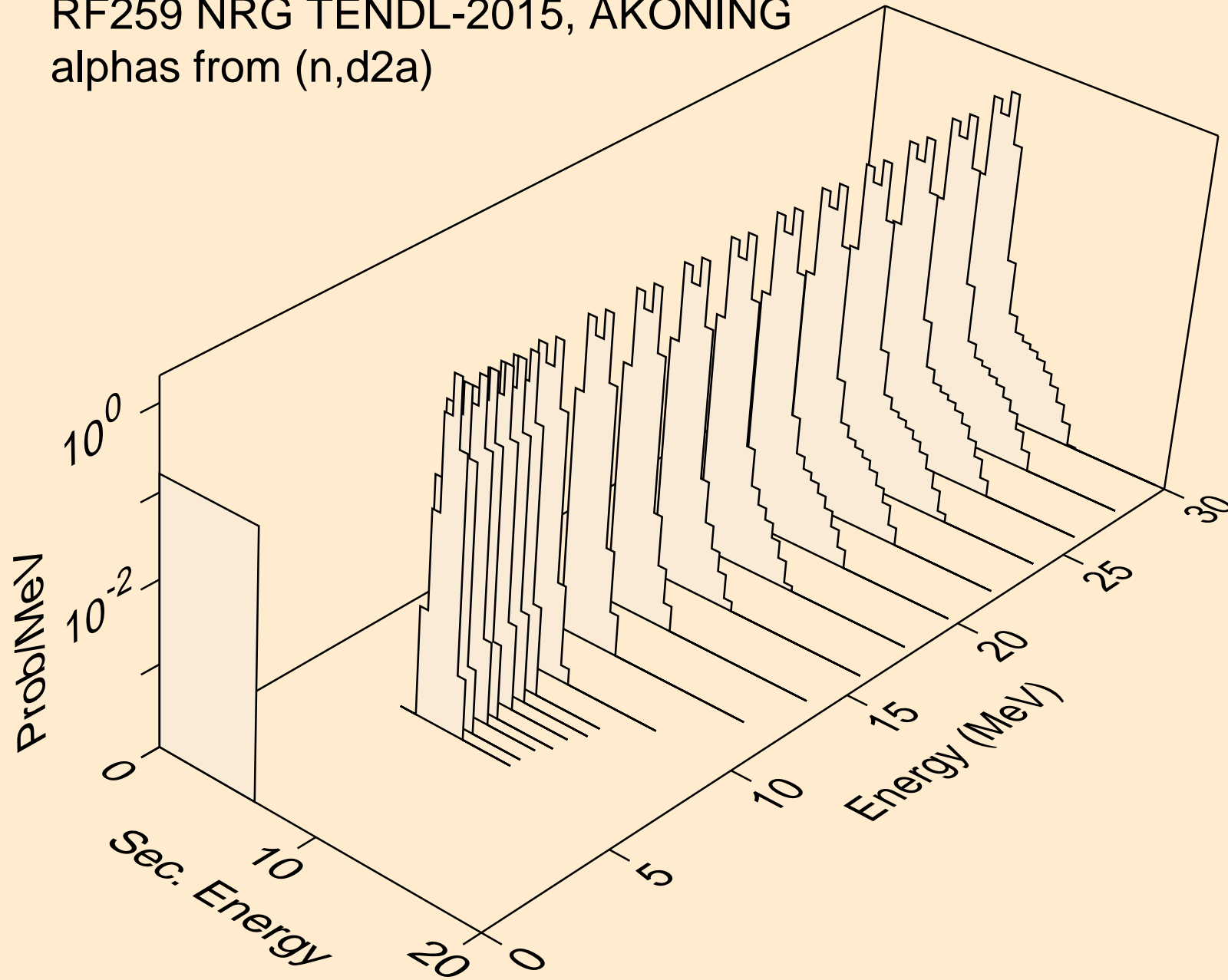

RF259 NRG TENDL-2015, AKONING  
alphas from (n,da)

