

# TA165 NRG TENDL-2015, AKONING

## Principal cross sections

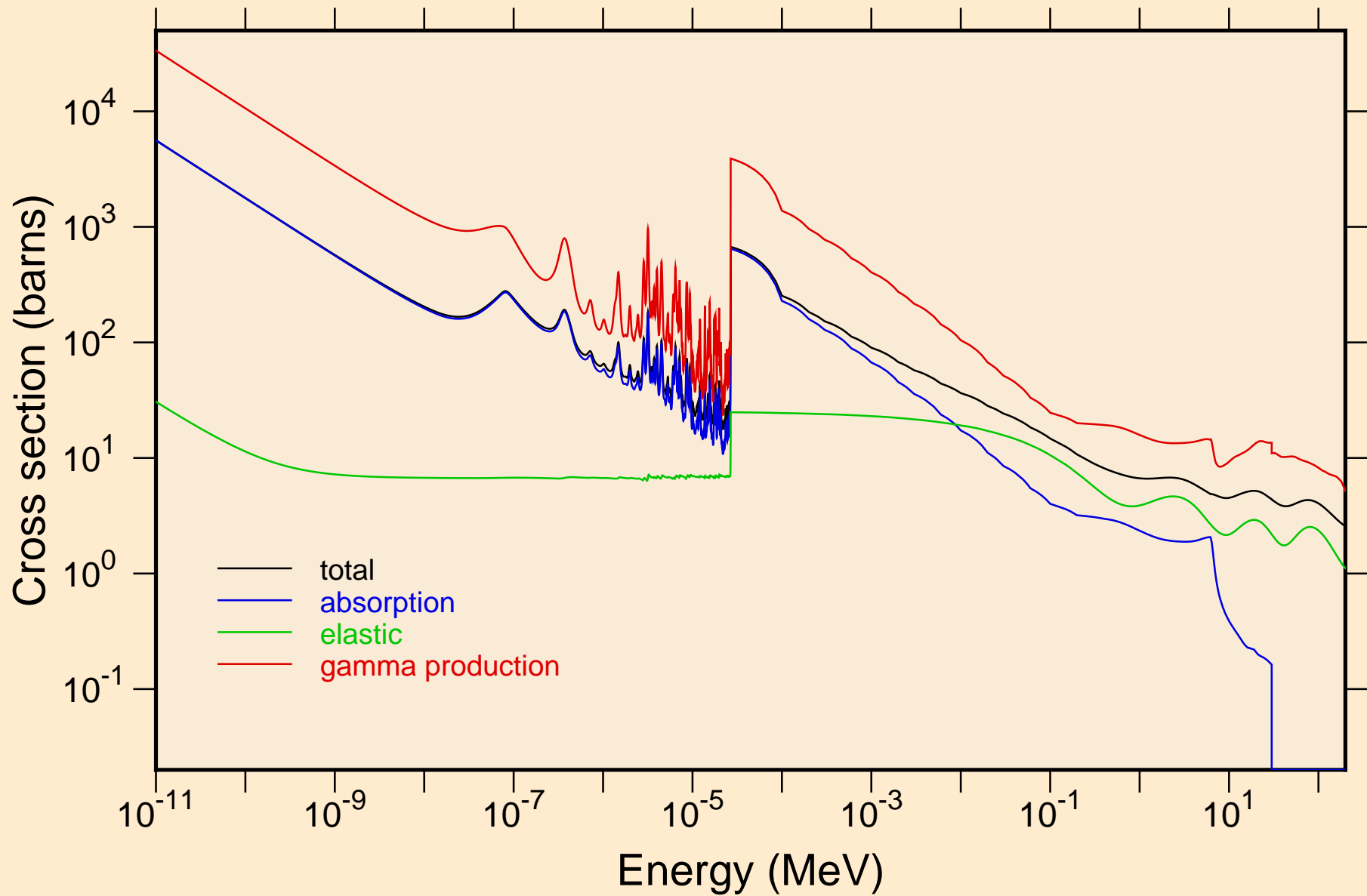

TA165 NRG TENDL-2015, AKONING  
resonance total cross section

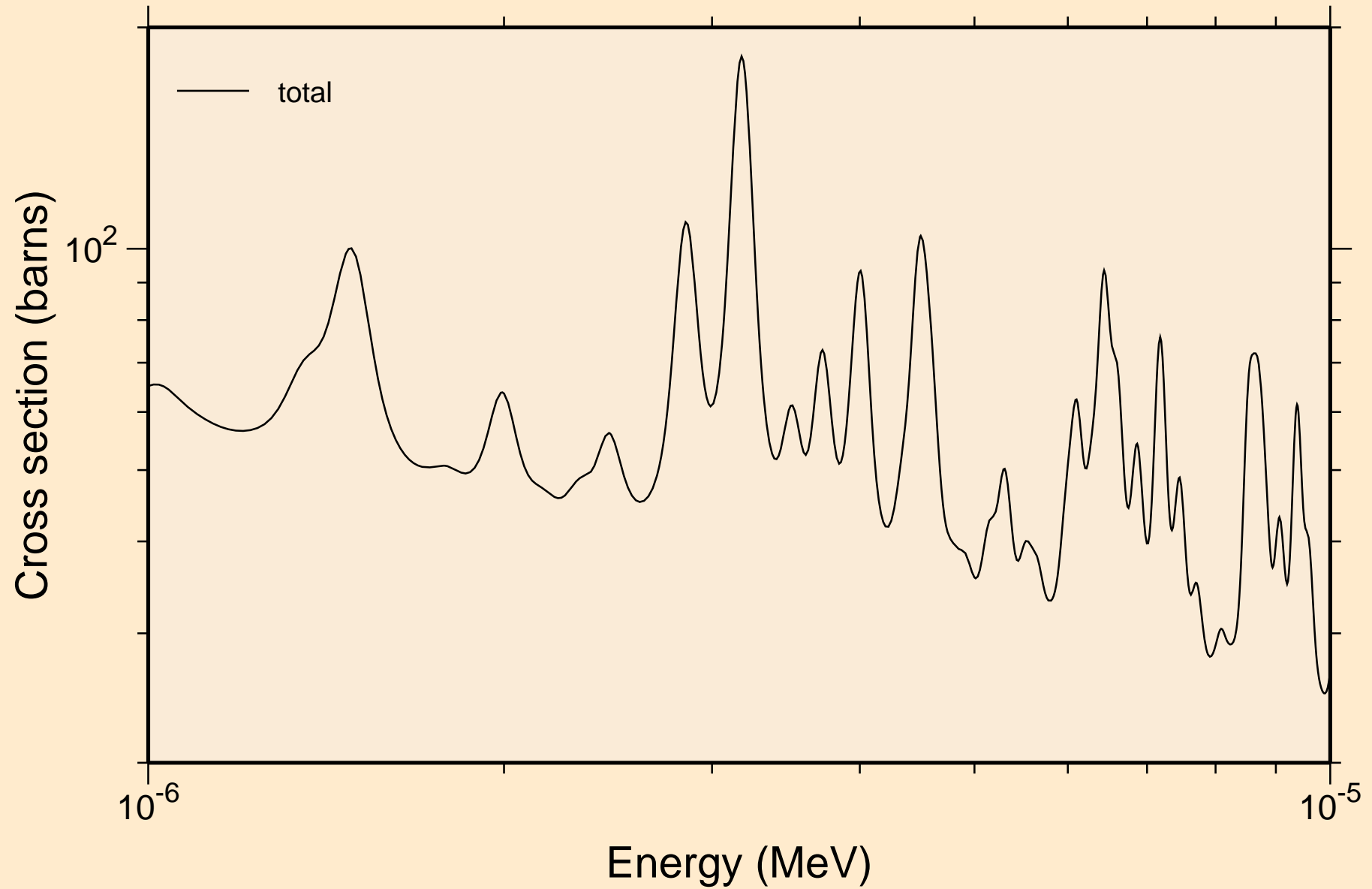

TA165 NRG TENDL-2015, AKONING  
resonance total cross section

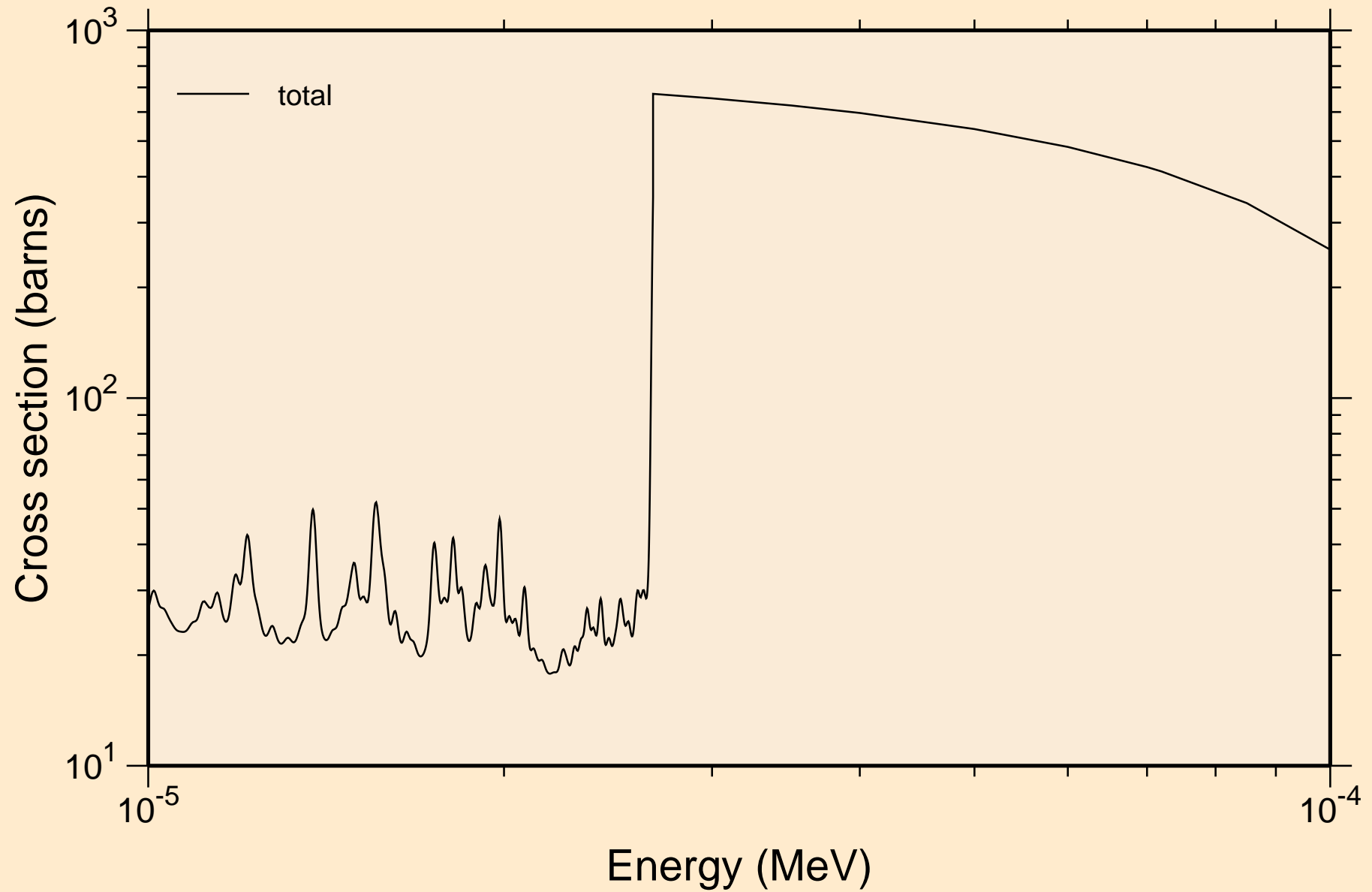

TA165 NRG TENDL-2015, AKONING  
resonance total cross section

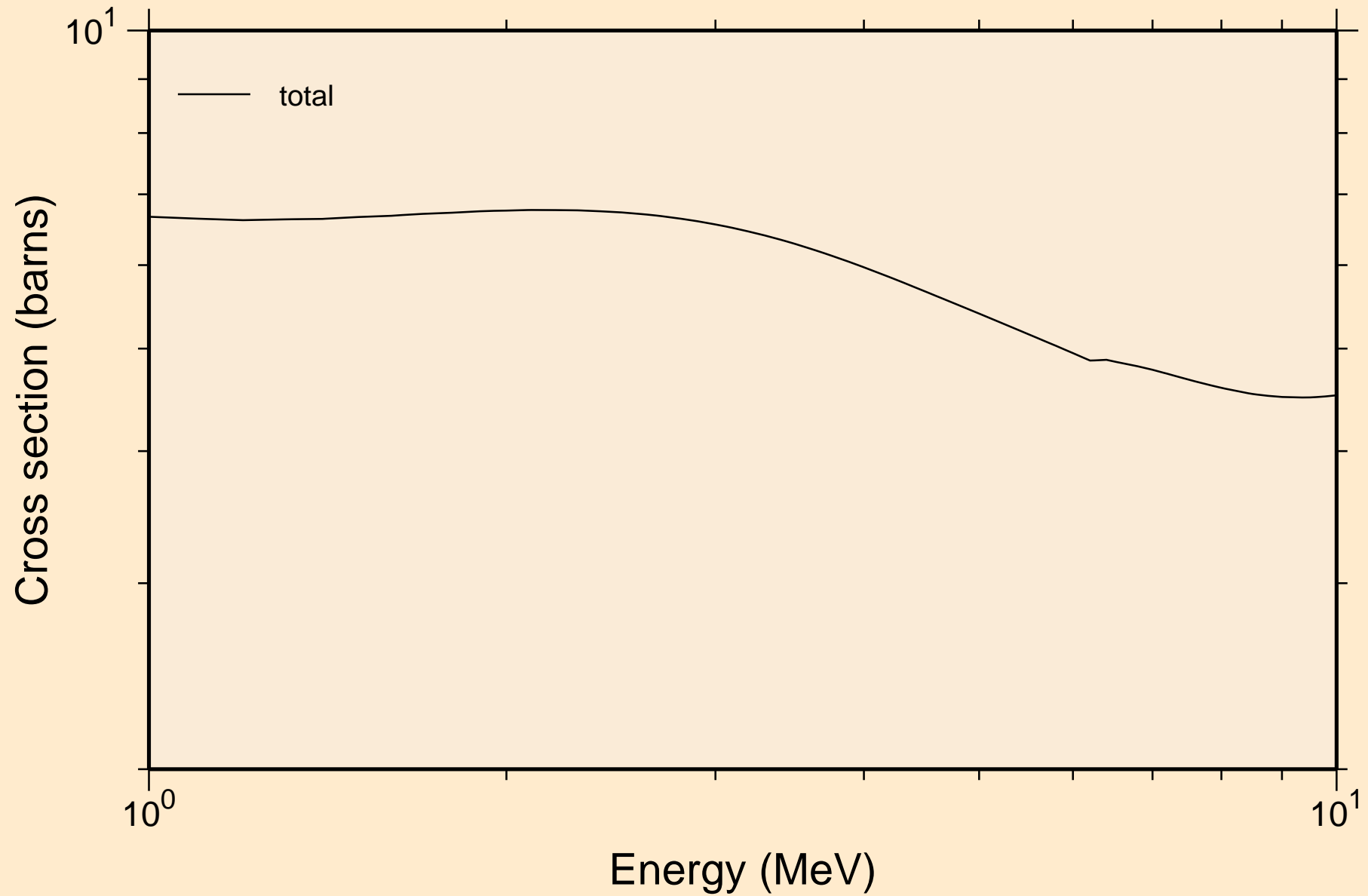

TA165 NRG TENDL-2015, AKONING  
resonance absorption cross sections

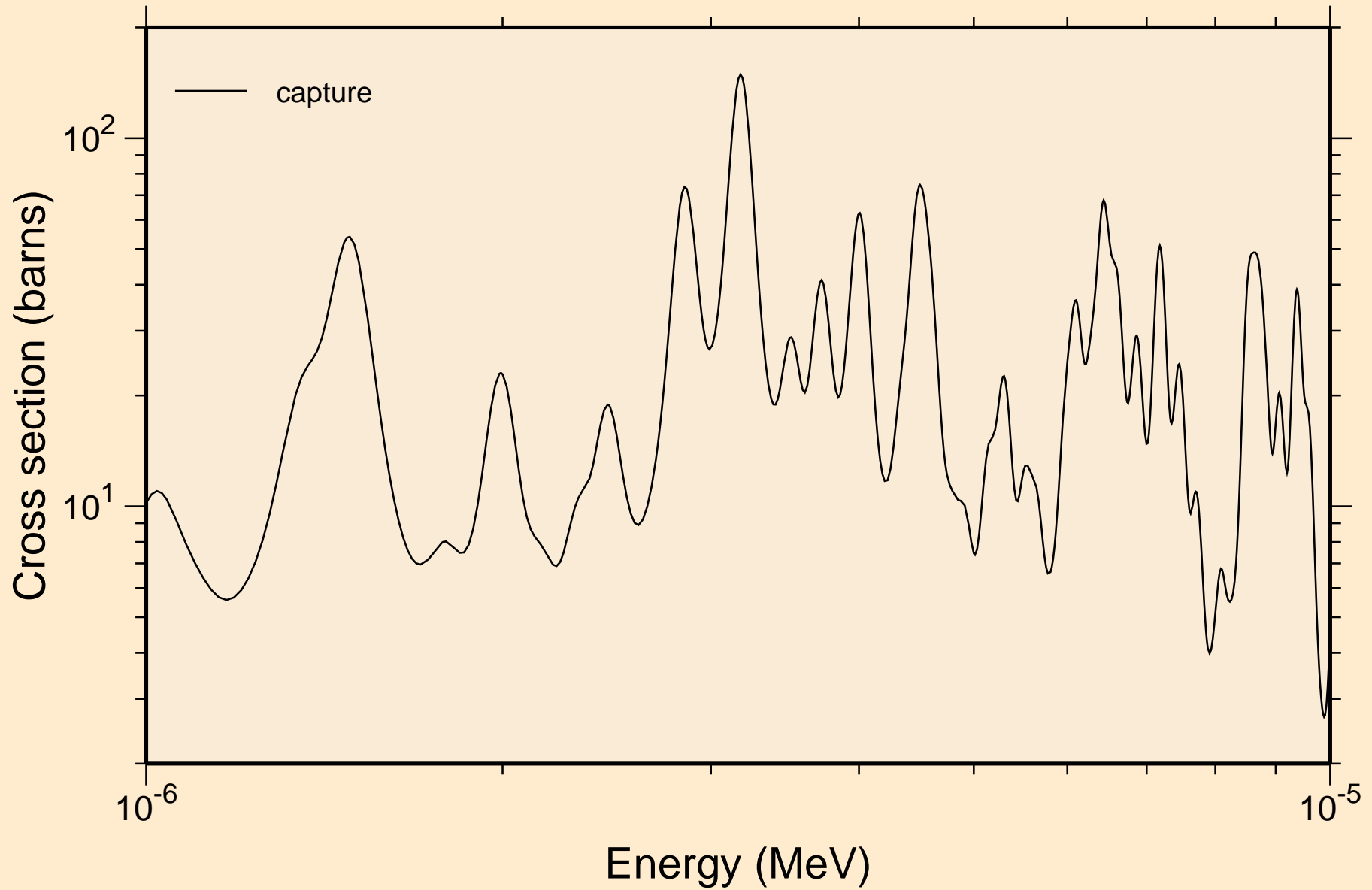

TA165 NRG TENDL-2015, AKONING  
resonance absorption cross sections

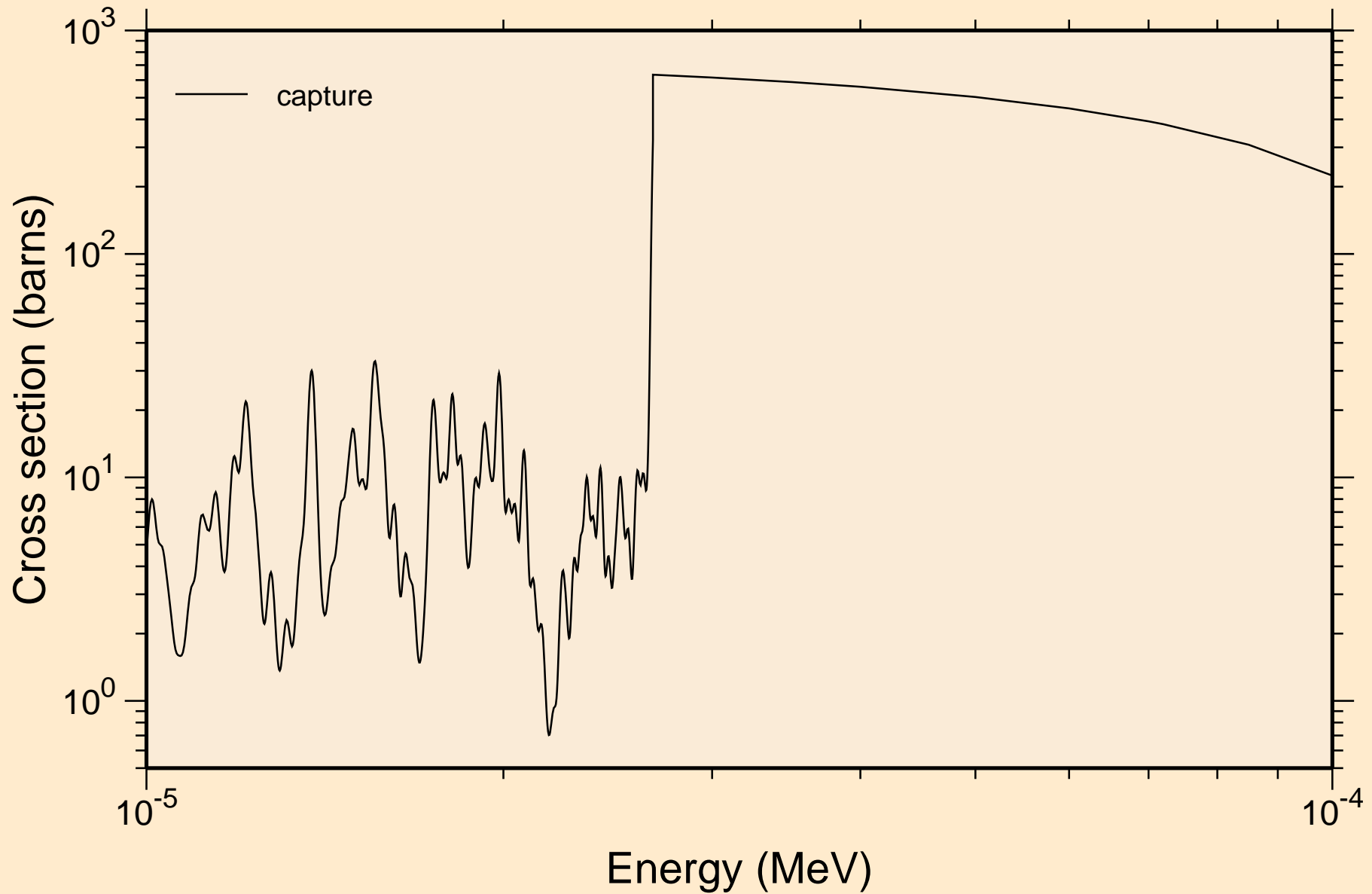

TA165 NRG TENDL-2015, AKONING  
resonance absorption cross sections

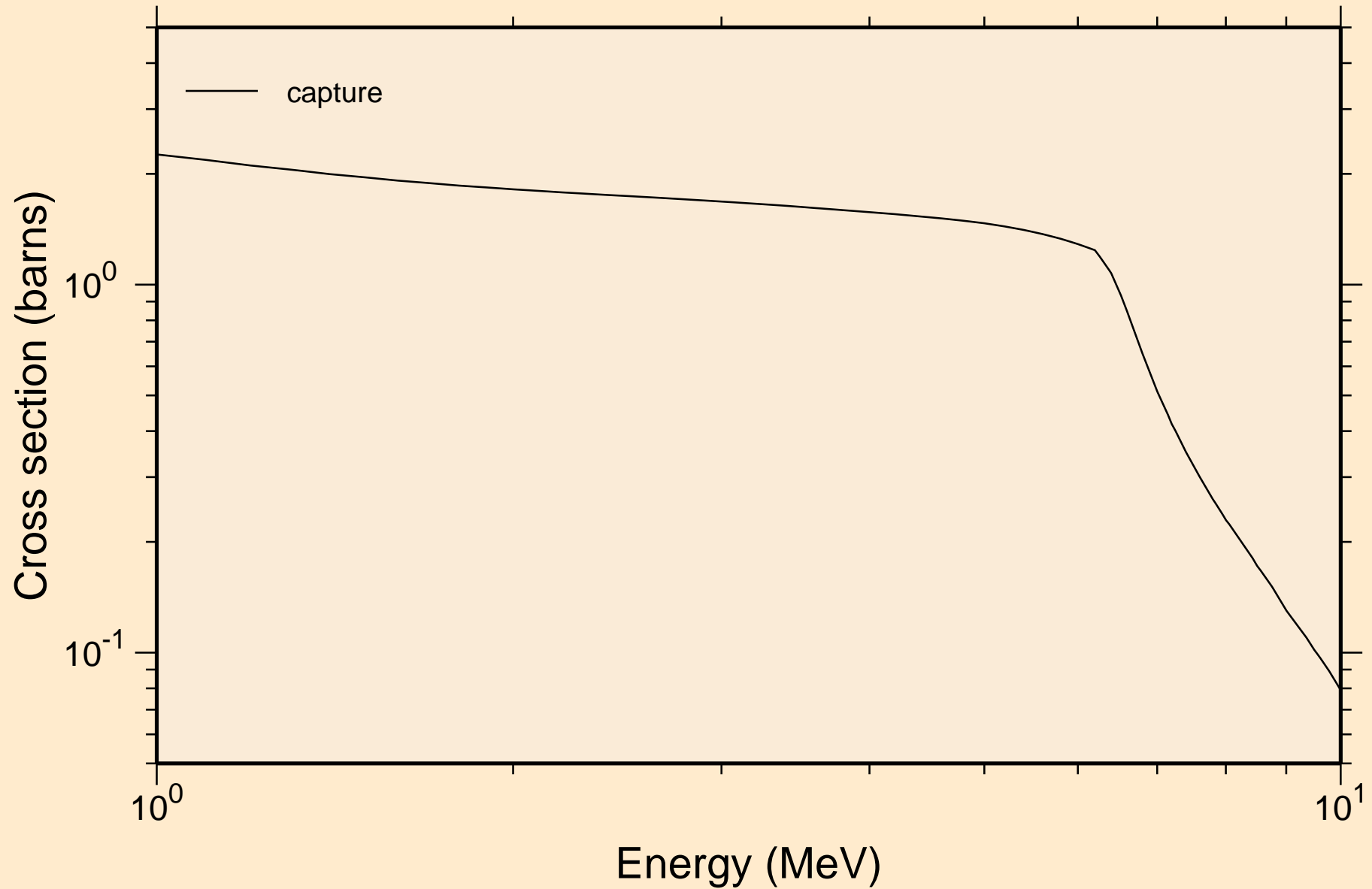

# TA165 NRG TENDL-2015, AKONING

## Non-threshold reactions

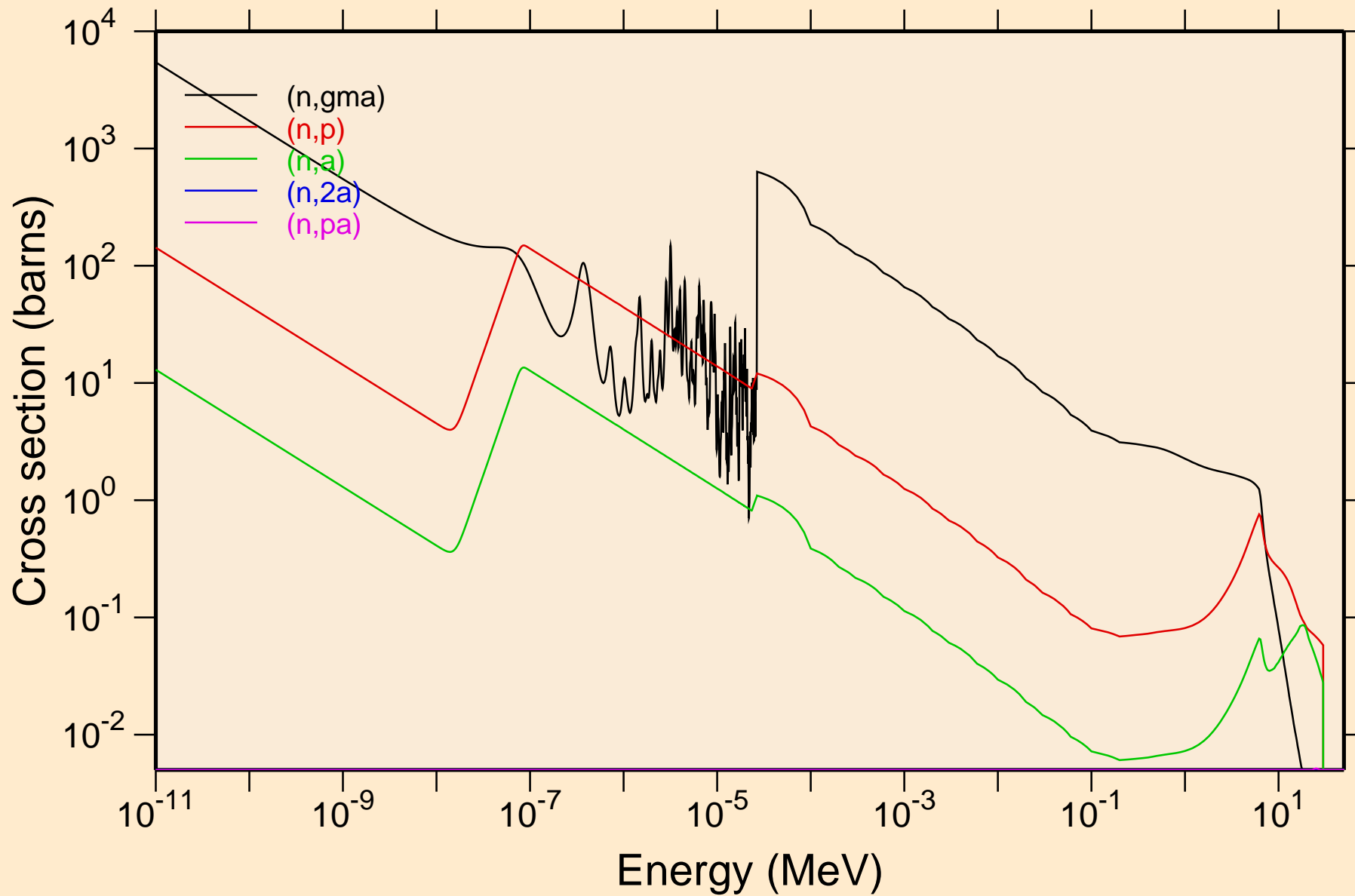



# TA165 NRG TENDL-2015, AKONING

## Principal cross sections

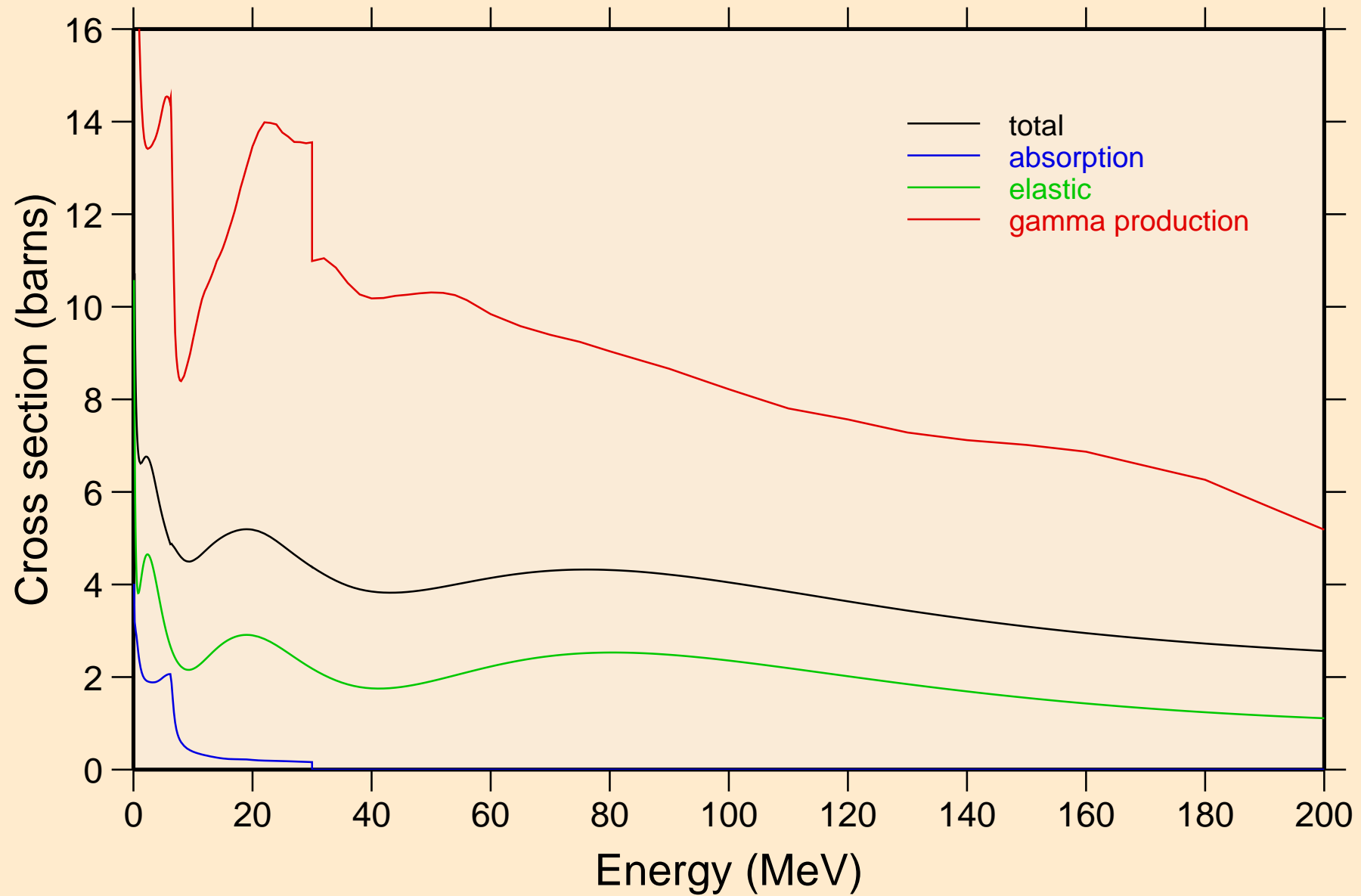

# TA165 NRG TENDL-2015, AKONING

## Non-threshold reactions

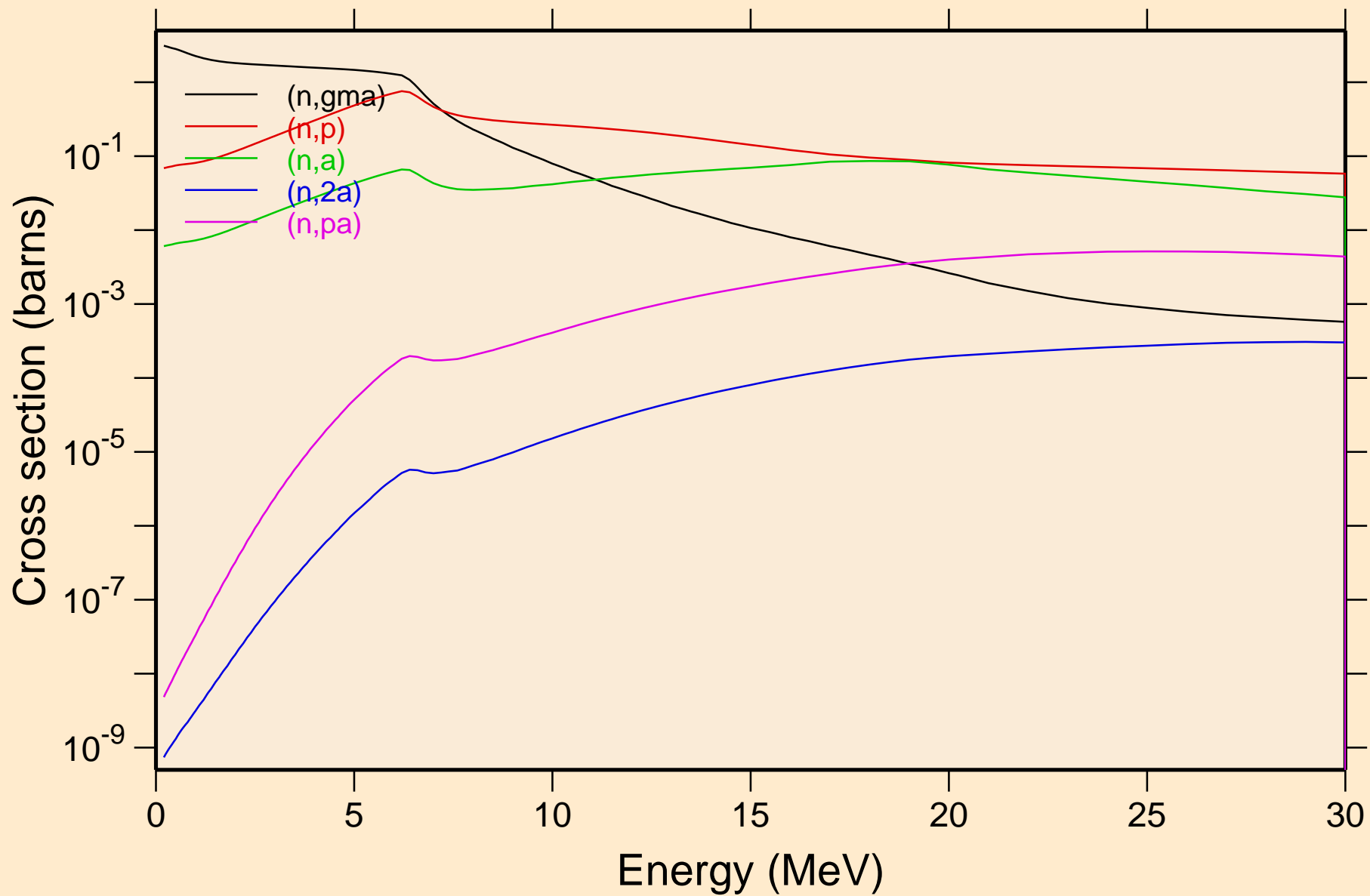

# TA165 NRG TENDL-2015, AKONING

## Inelastic levels

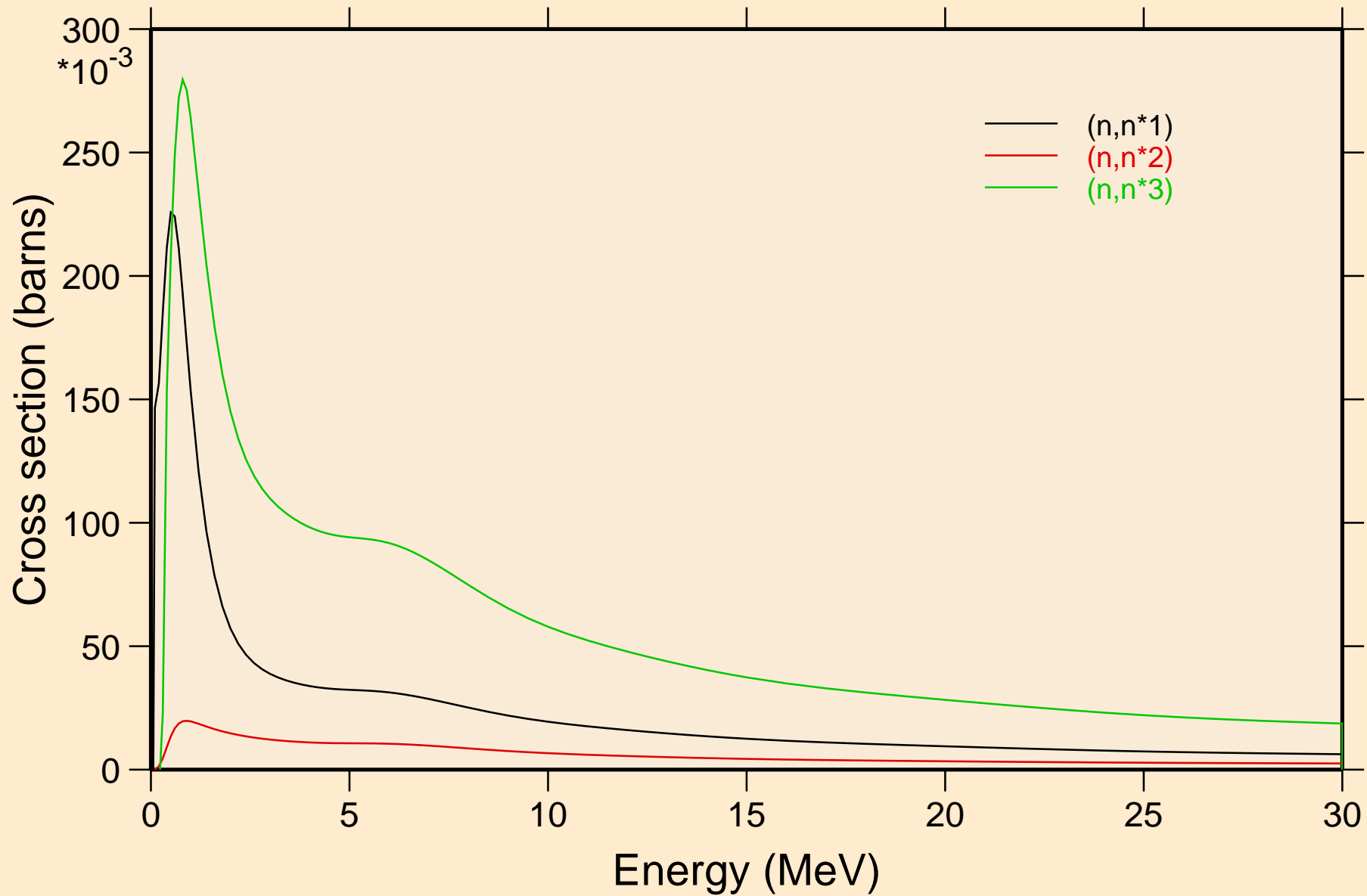

# TA165 NRG TENDL-2015, AKONING

## Threshold reactions

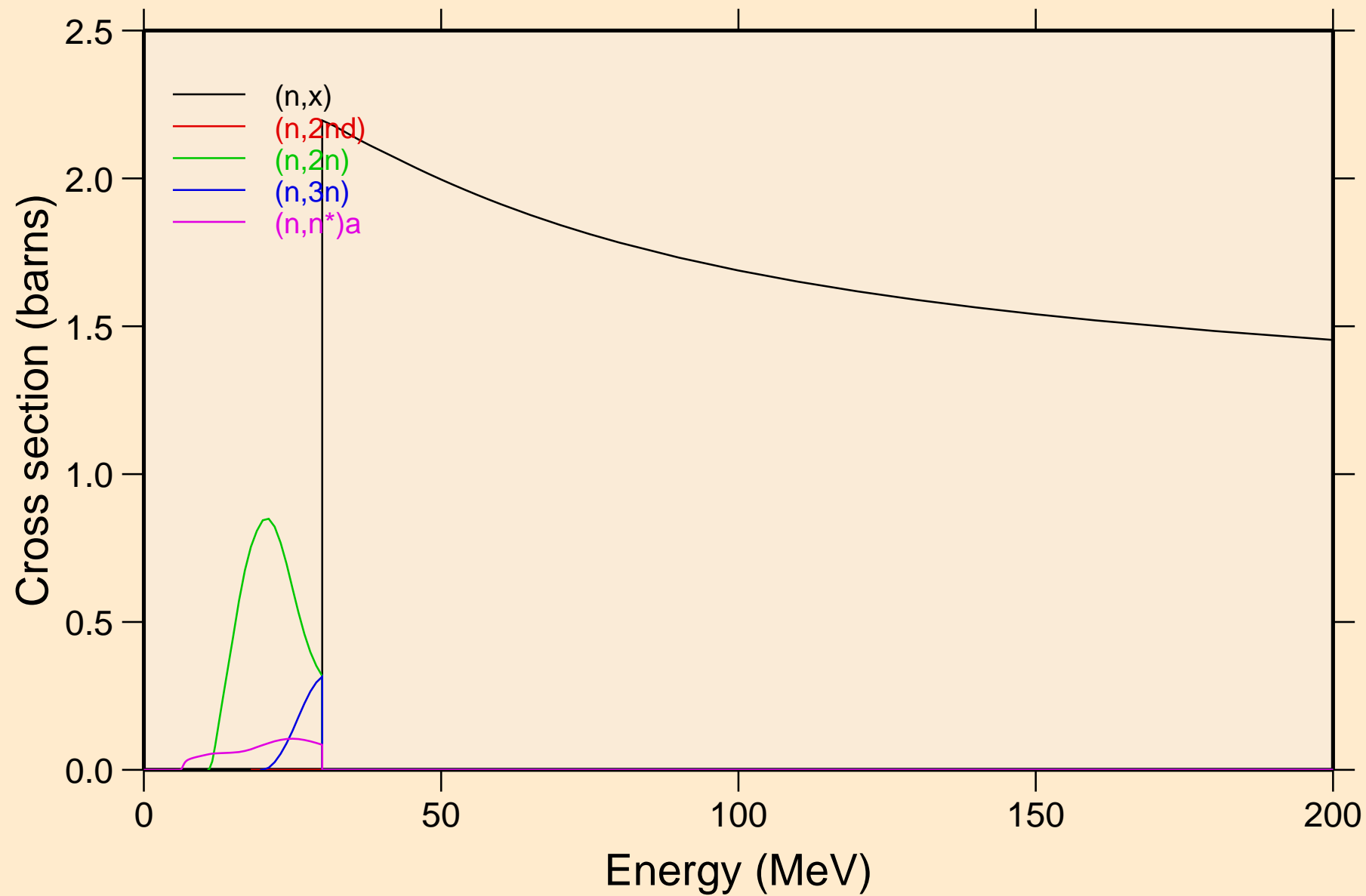

# TA165 NRG TENDL-2015, AKONING

## Threshold reactions

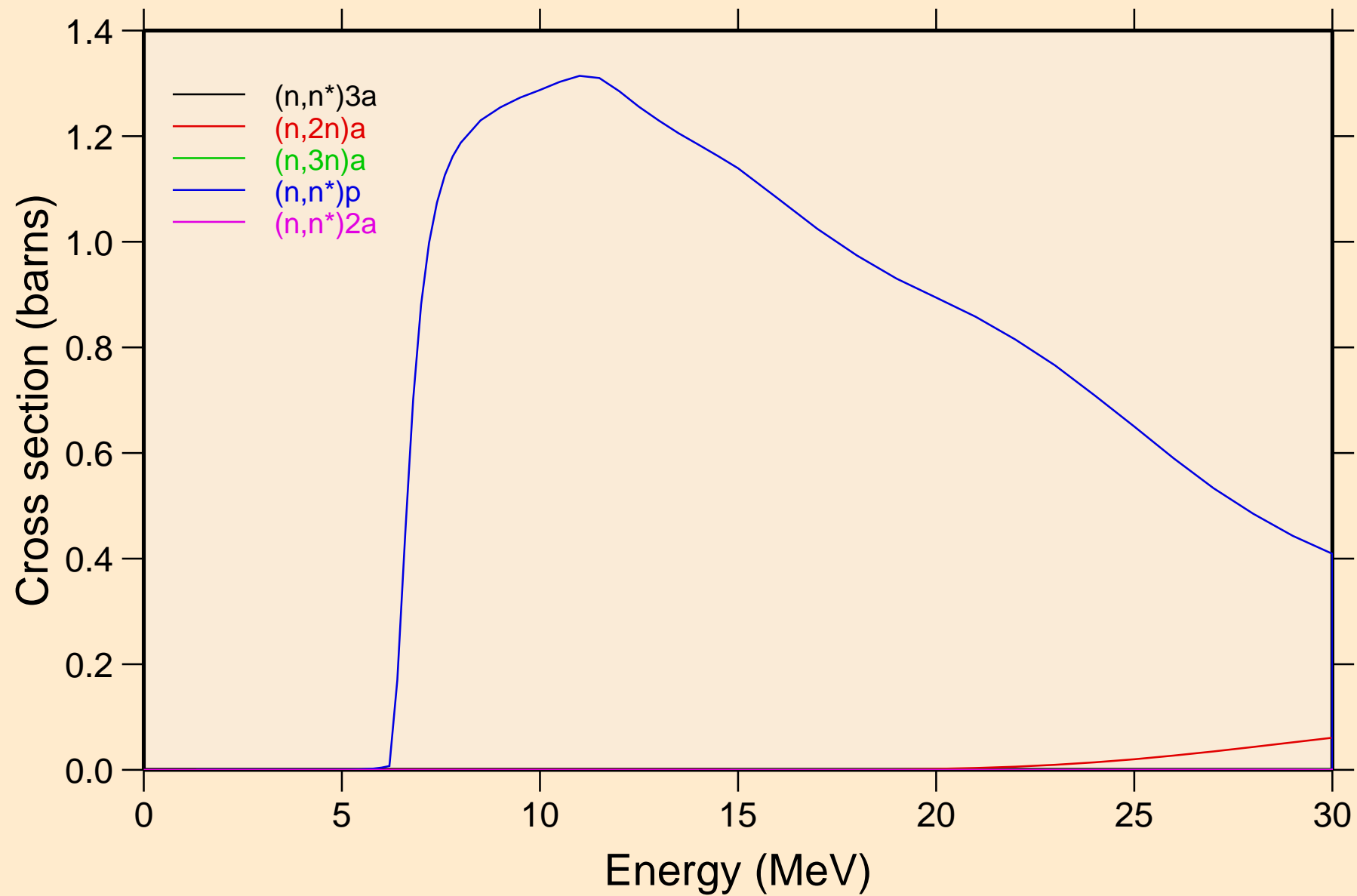

# TA165 NRG TENDL-2015, AKONING

## Threshold reactions

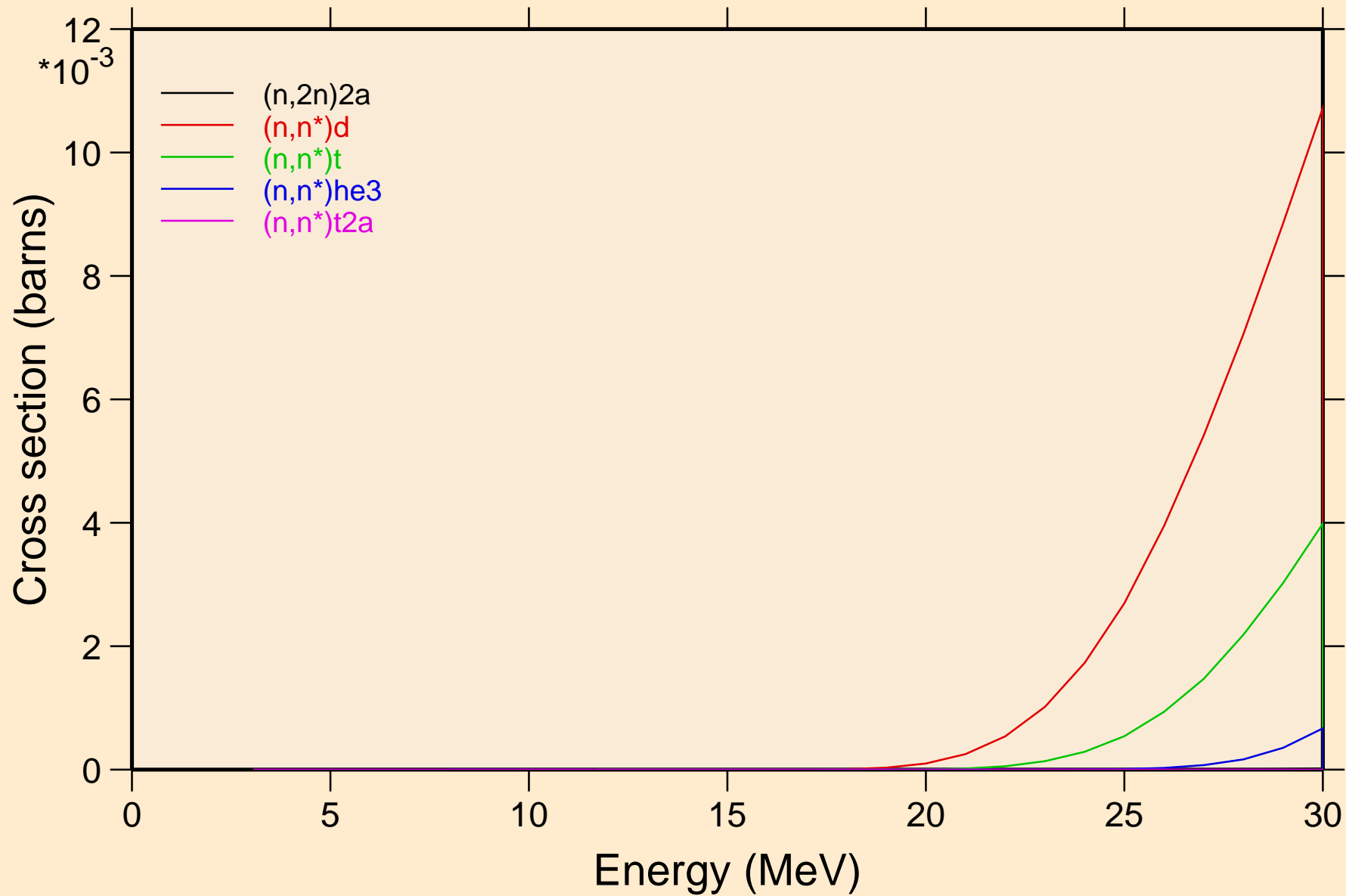

# TA165 NRG TENDL-2015, AKONING

## Threshold reactions

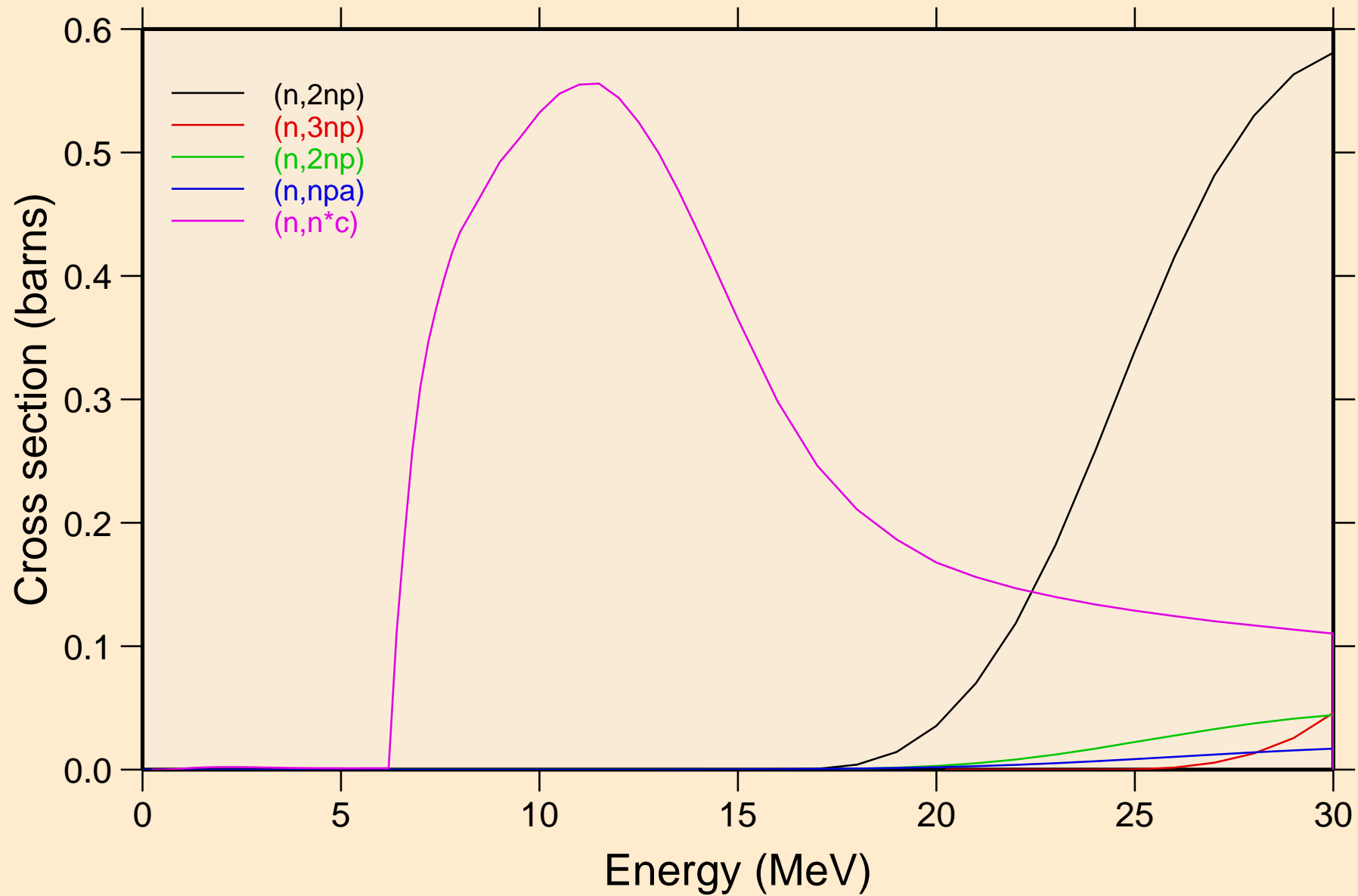

# TA165 NRG TENDL-2015, AKONING

## Threshold reactions

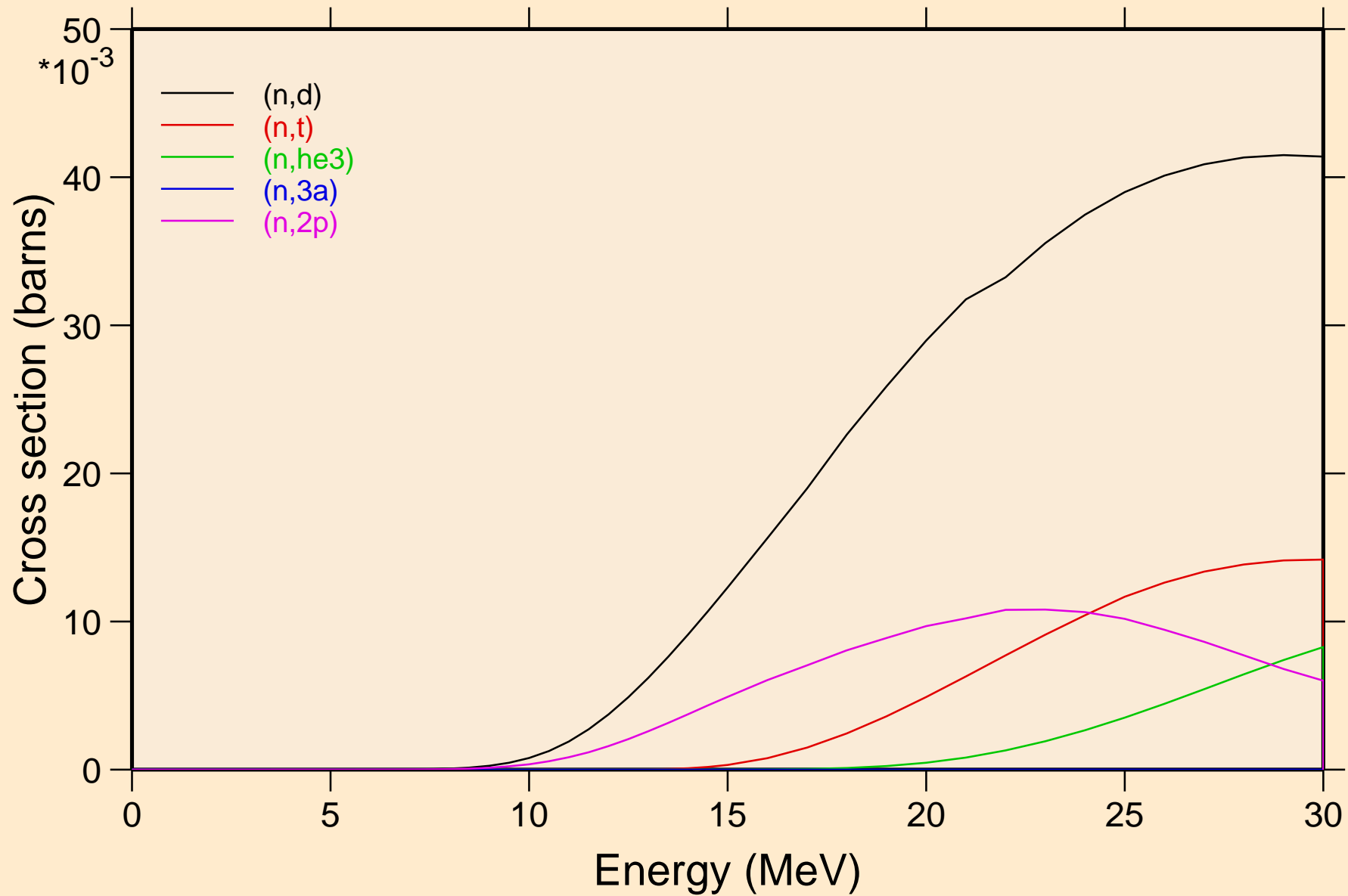



# TA165 NRG TENDL-2015, AKONING

## Threshold reactions

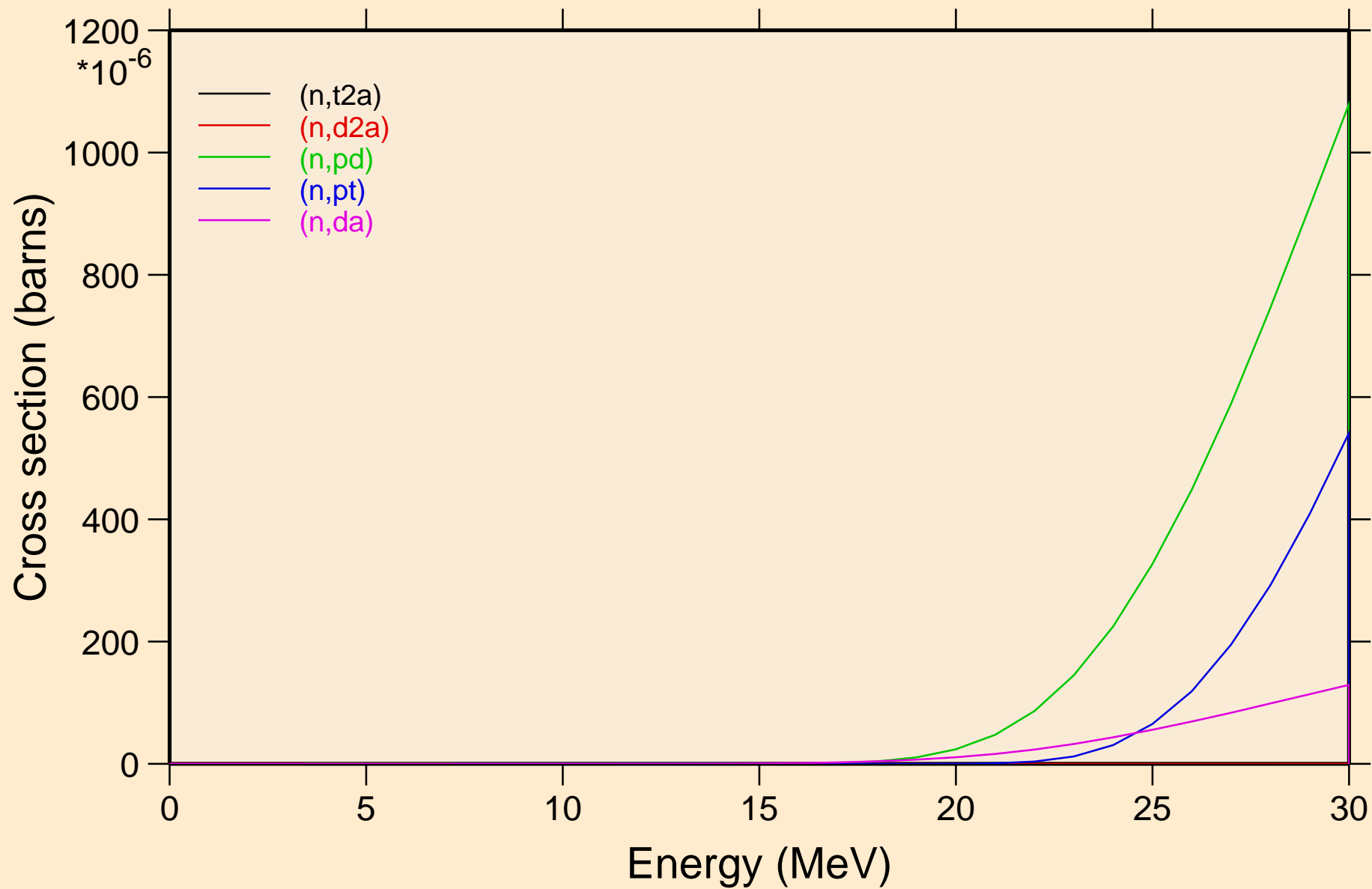

TA165 NRG TENDL-2015, AKONING  
angular distribution for elastic

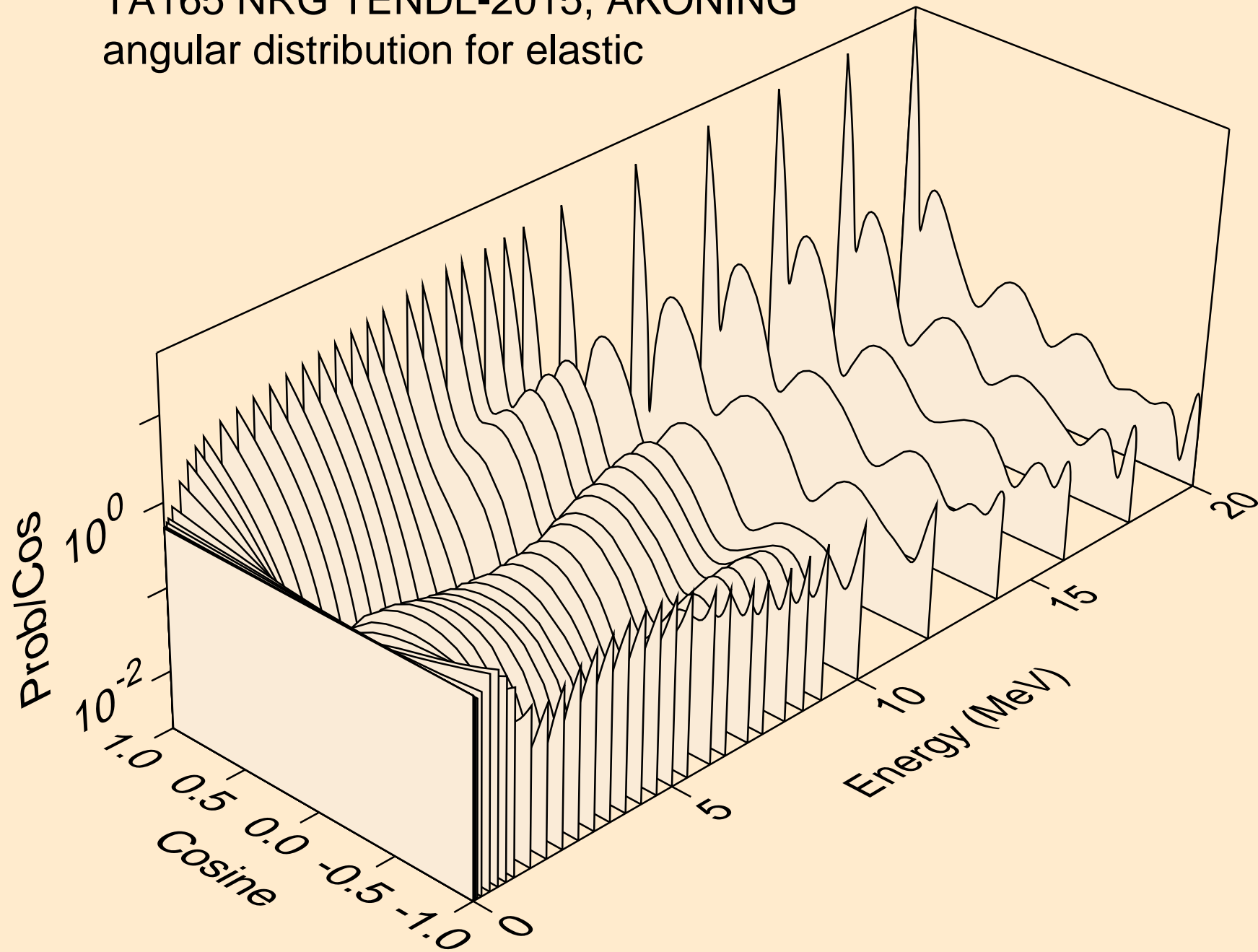

TA165 NRG TENDL-2015, AKONING  
angular distribution for elastic

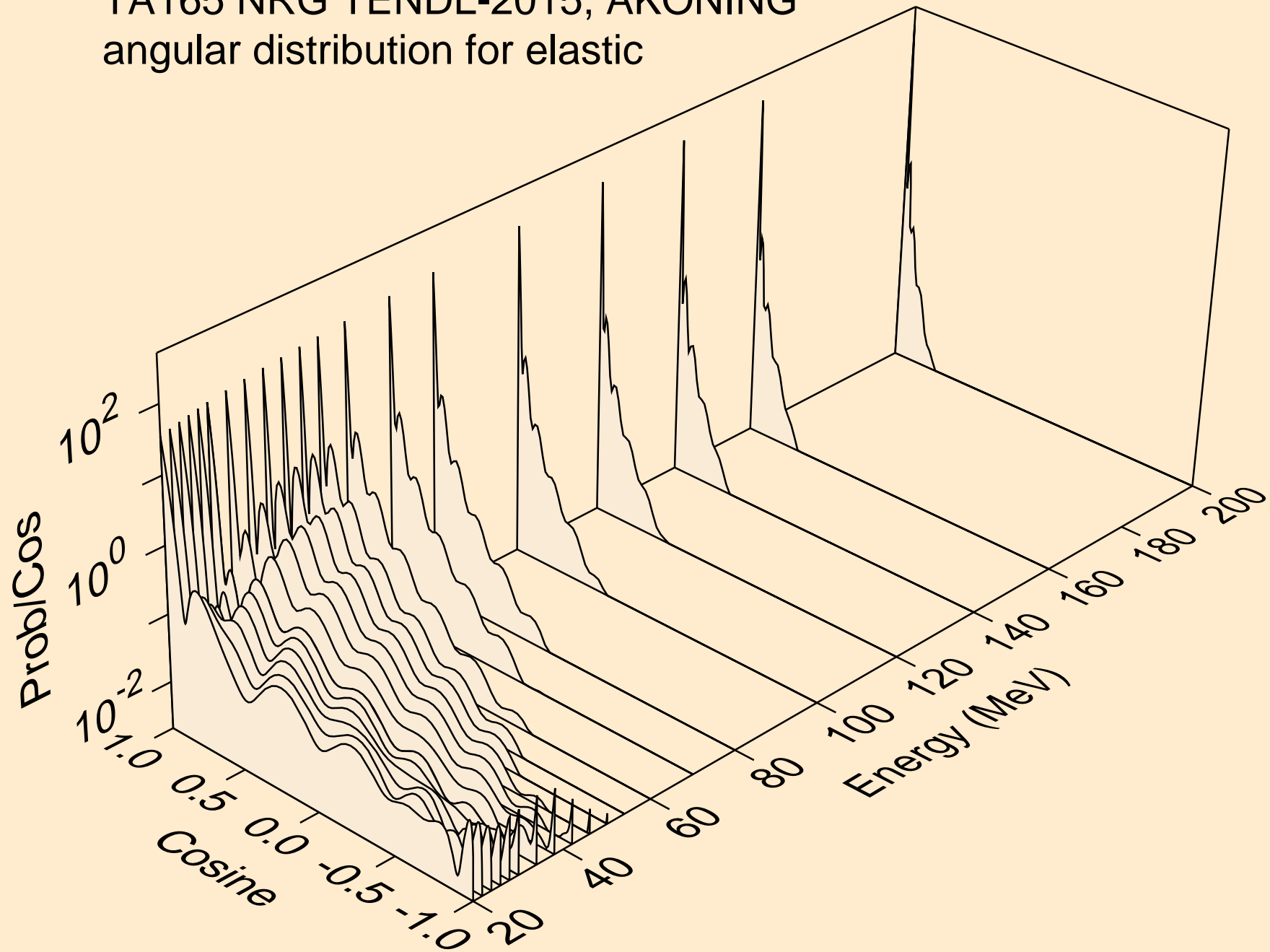

TA165 NRG TENDL-2015, AKONING  
angular distribution for (n,n\*1)

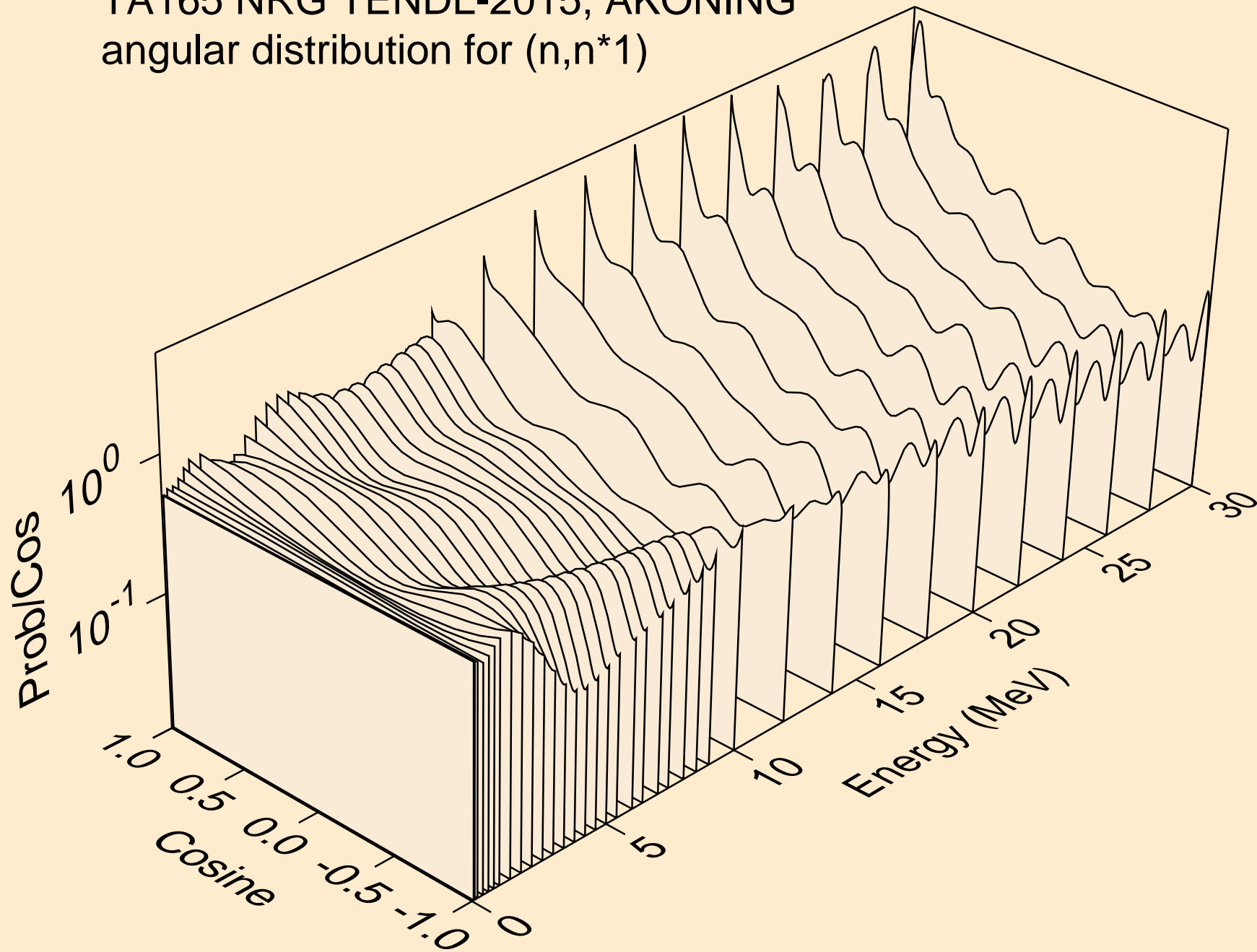

TA165 NRG TENDL-2015, AKONING  
angular distribution for (n,n\*2)

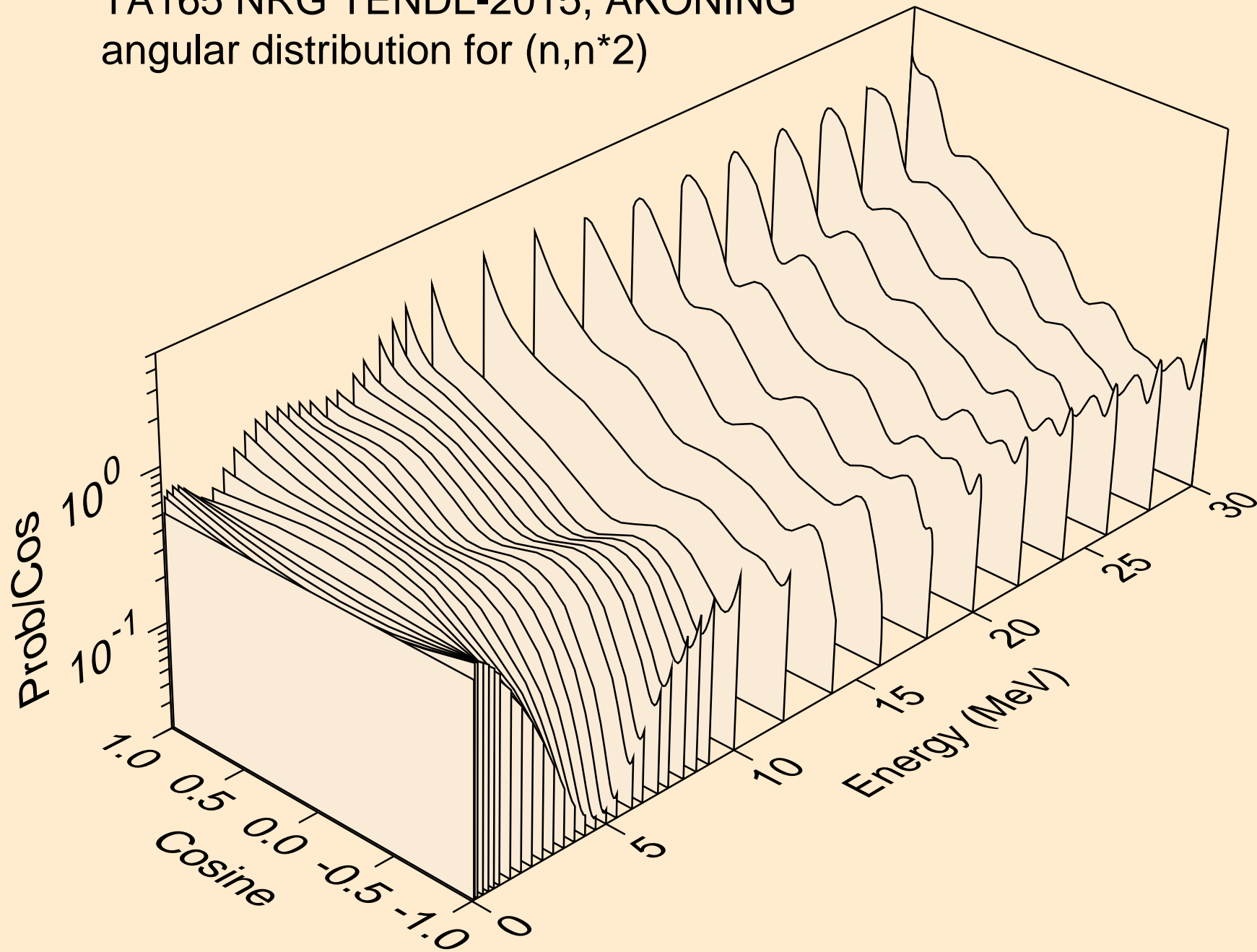

TA165 NRG TENDL-2015, AKONING  
angular distribution for (n,n\*3)

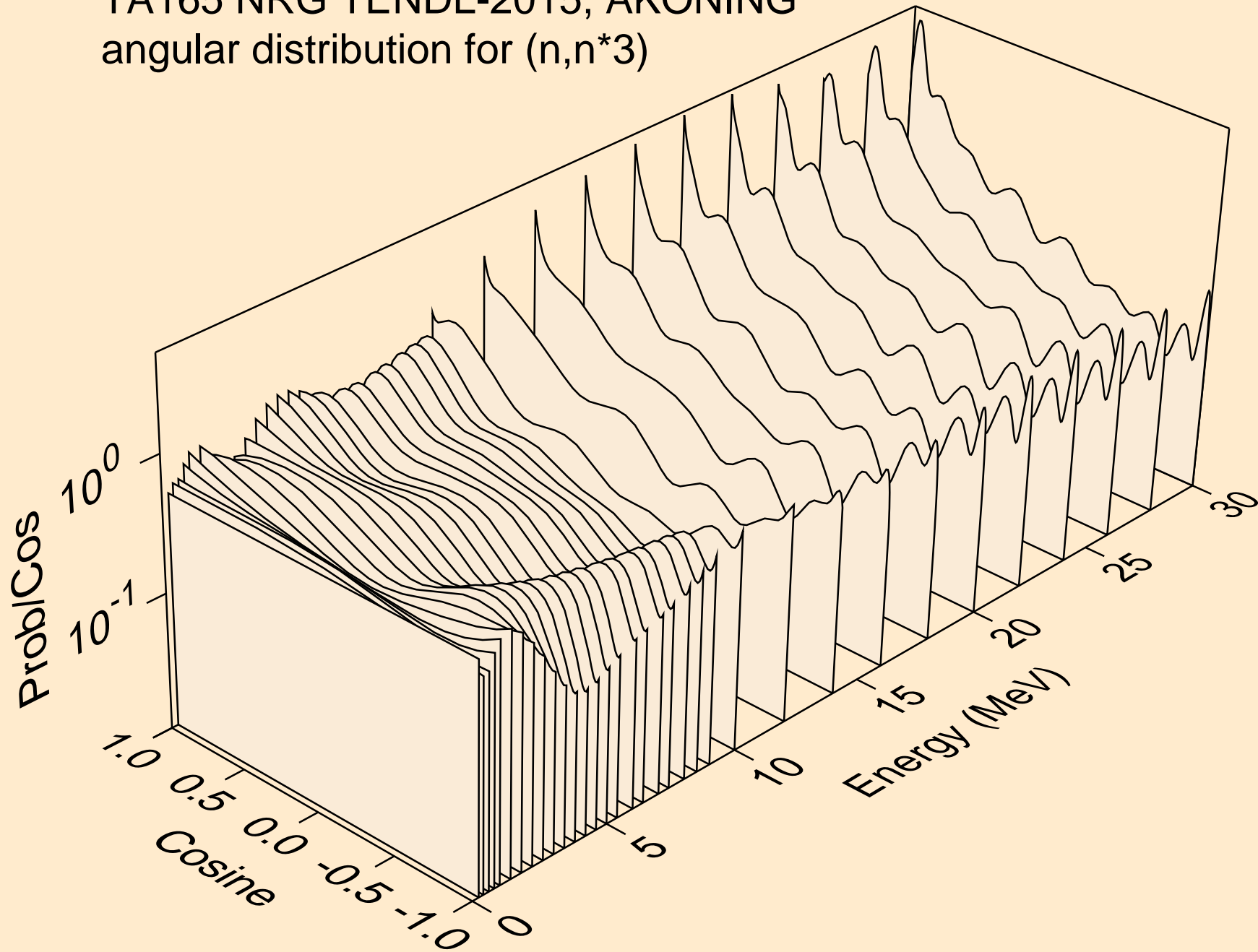

TA165 NRG TENDL-2015, AKONING  
Neutron emission for (n,x)

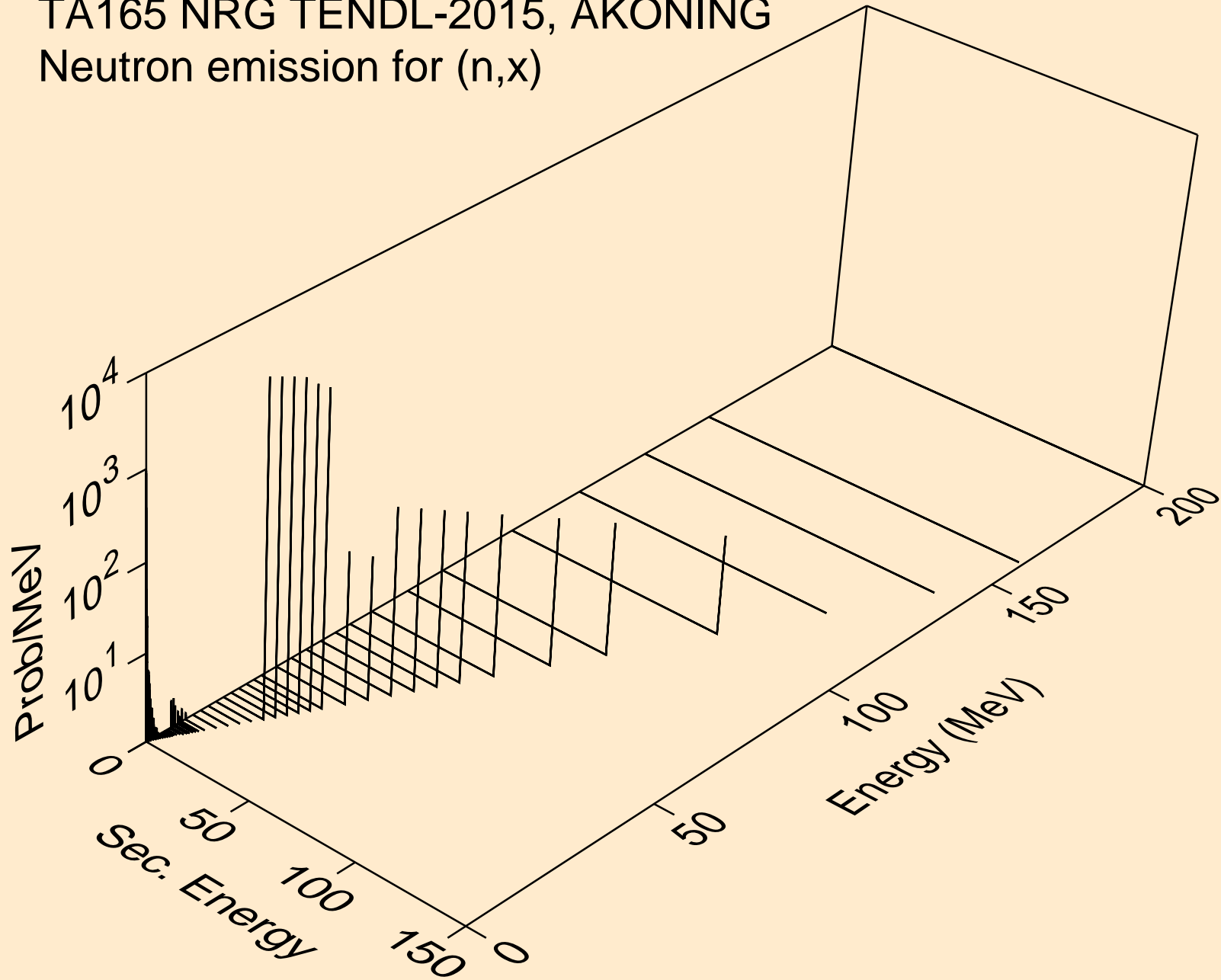

TA165 NRG TENDL-2015, AKONING  
Neutron emission for (n,2nd)

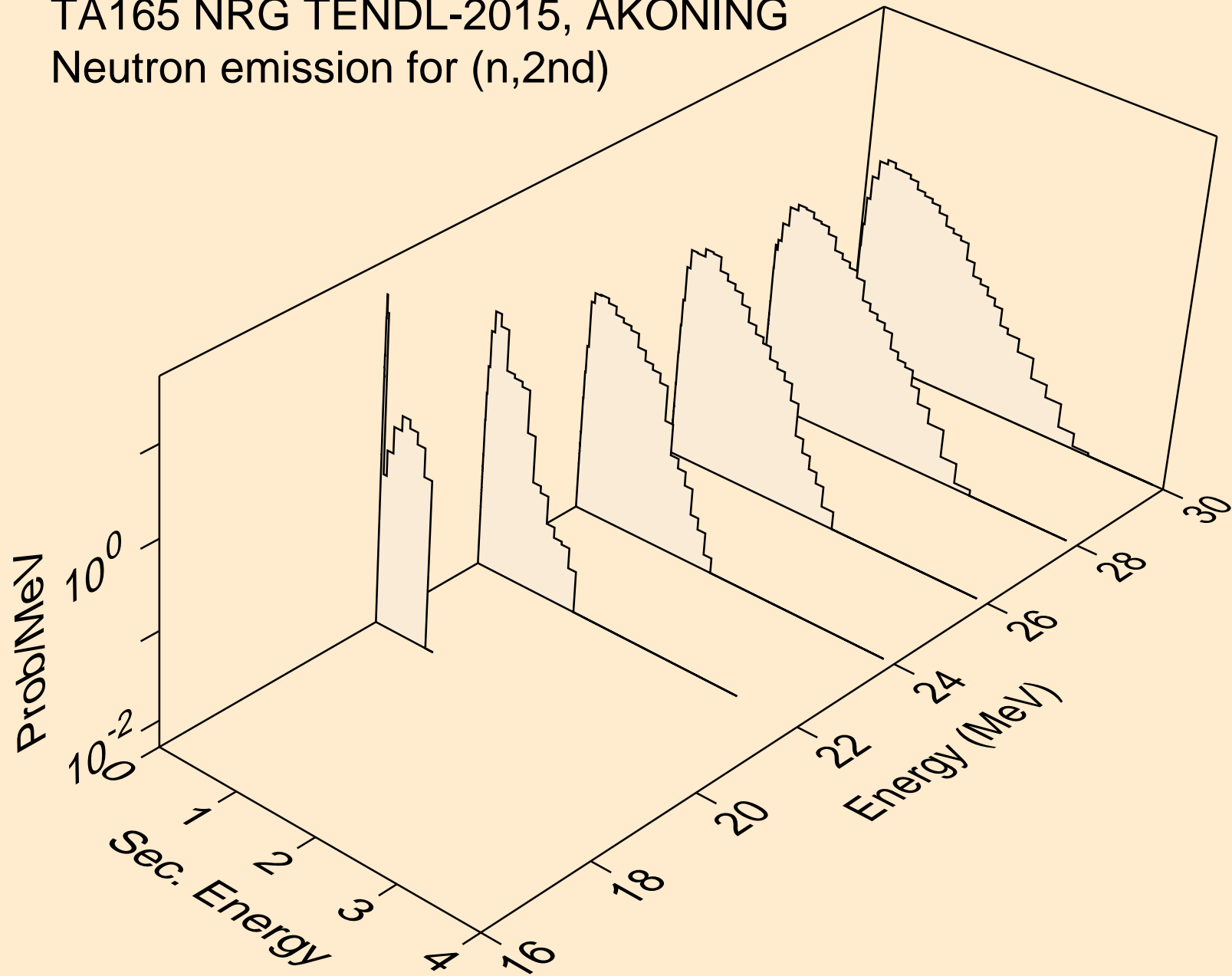



TA165 NRG TENDL-2015, AKONING  
Neutron emission for (n,2n)

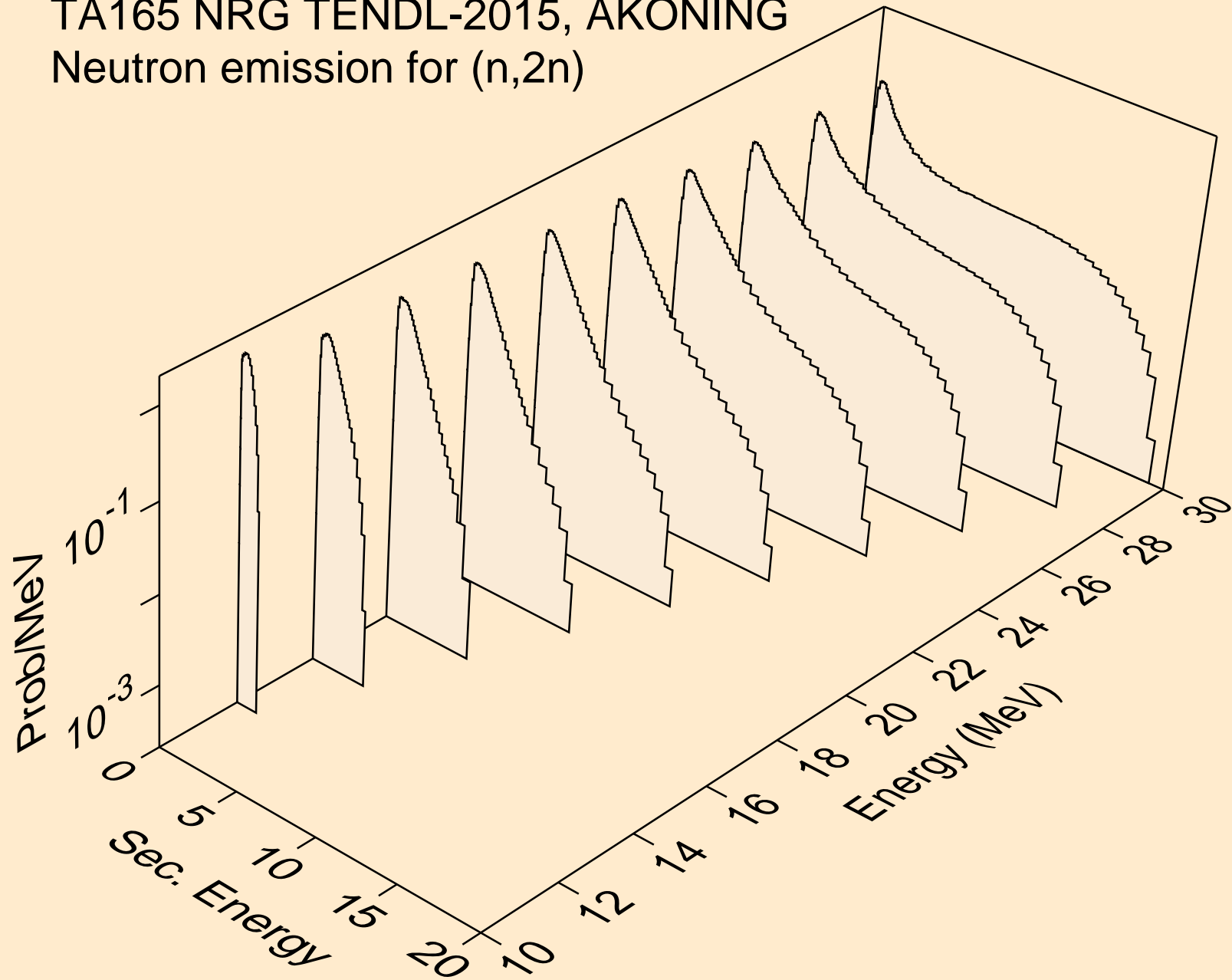

TA165 NRG TENDL-2015, AKONING  
Neutron emission for (n,3n)

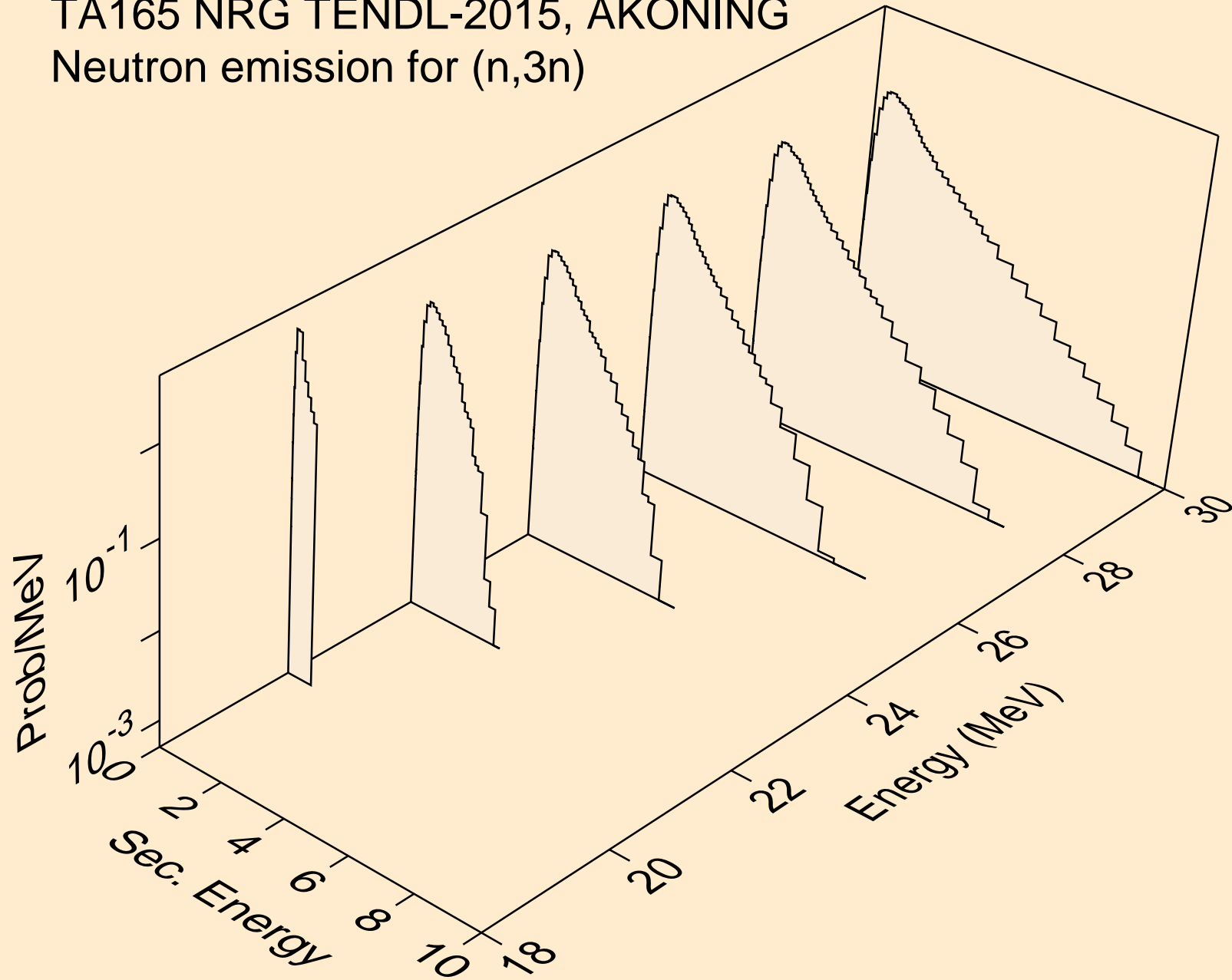

TA165 NRG TENDL-2015, AKONING  
Neutron emission for (n,n\*)a

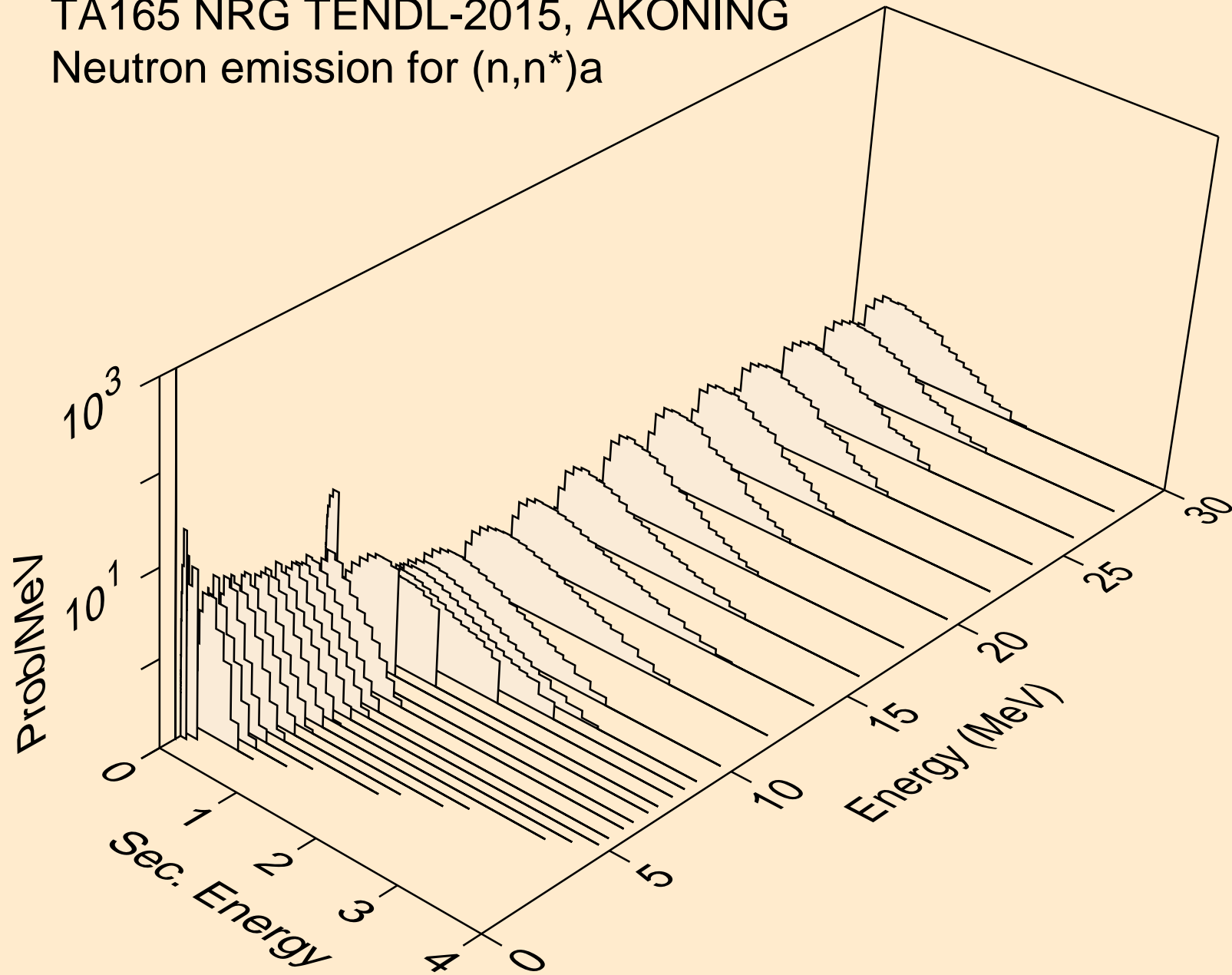

TA165 NRG TENDL-2015, AKONING  
Neutron emission for (n,n\*)3a

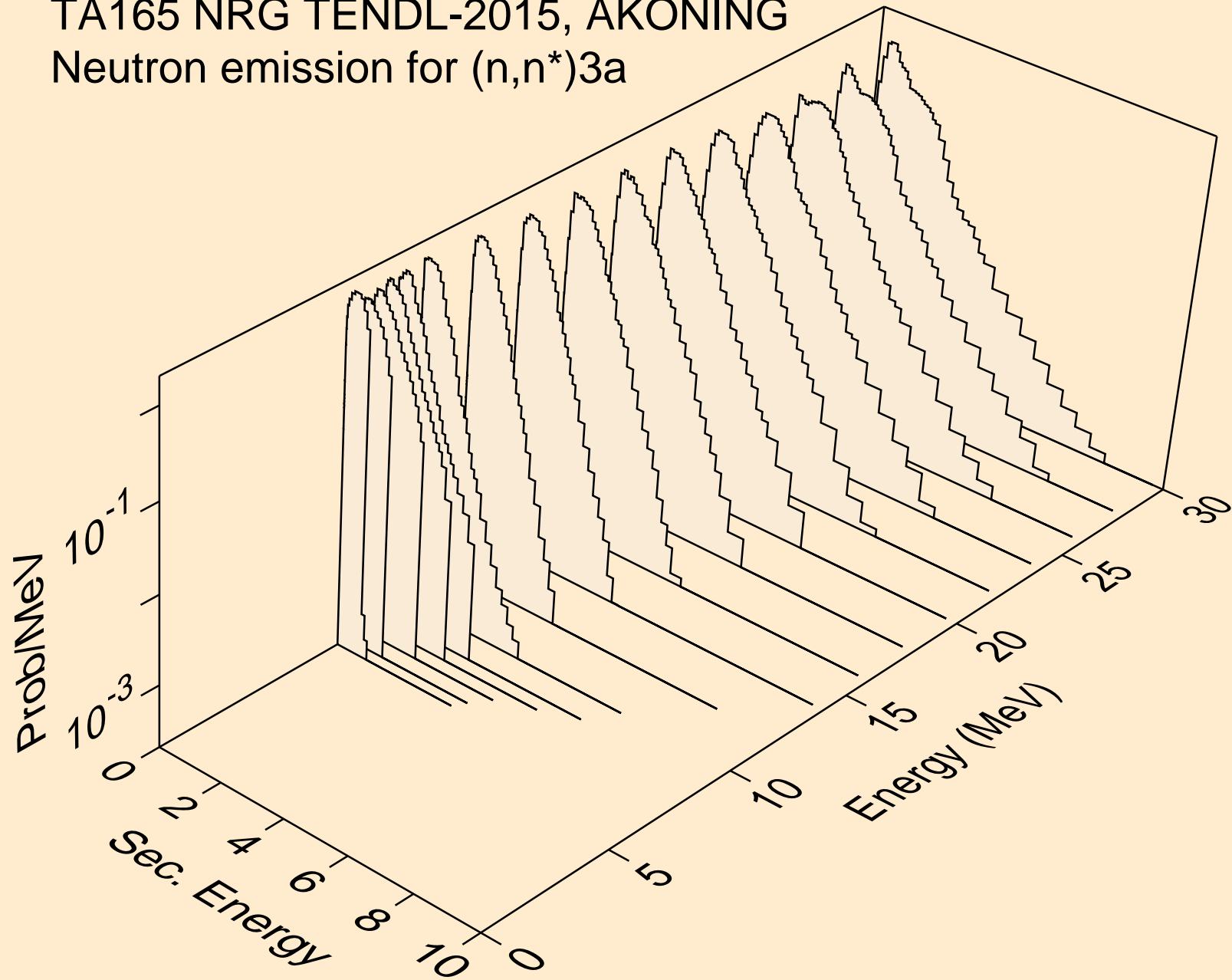

TA165 NRG TENDL-2015, AKONING  
Neutron emission for (n,2n)a

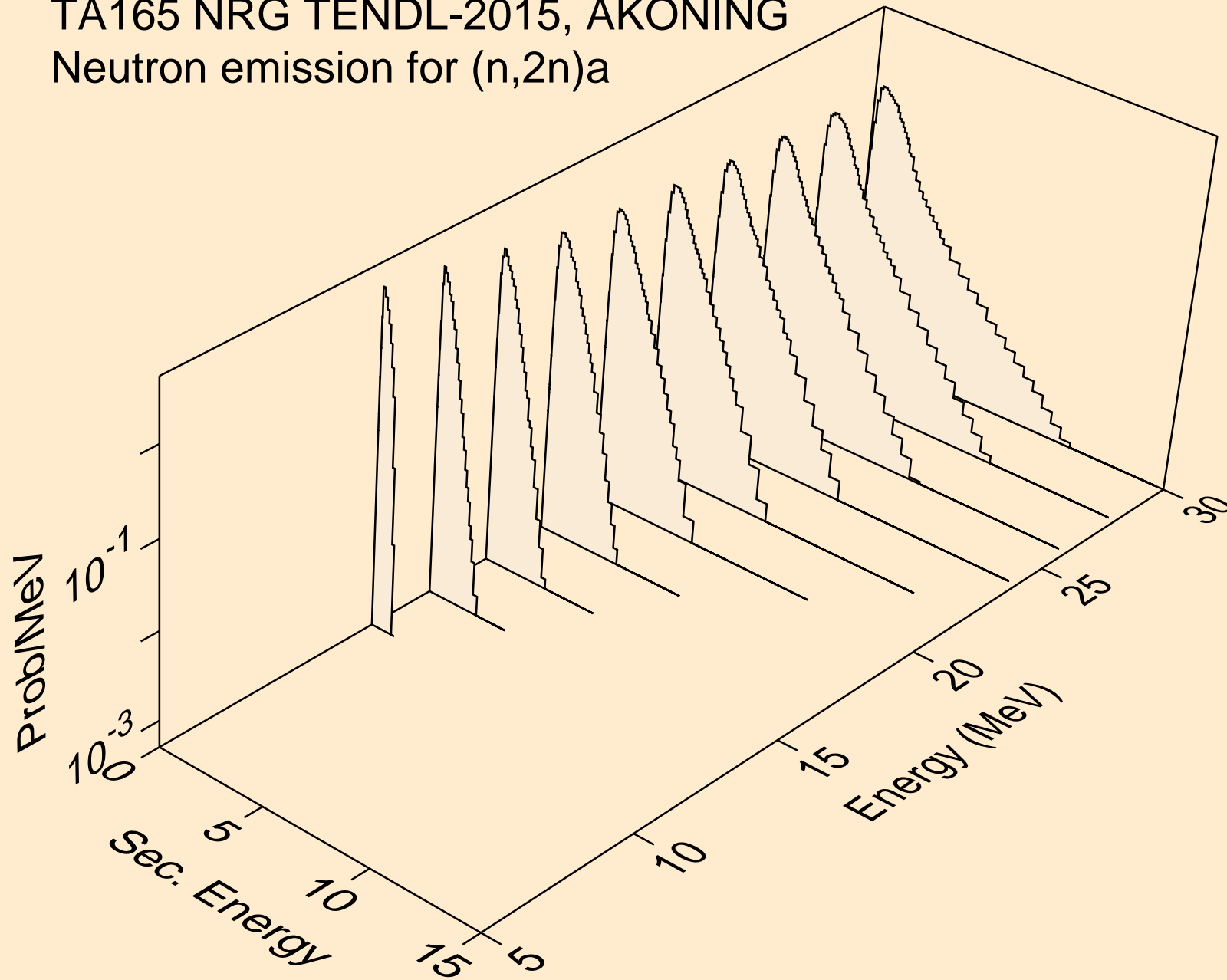

TA165 NRG TENDL-2015, AKONING  
Neutron emission for (n,3n)a

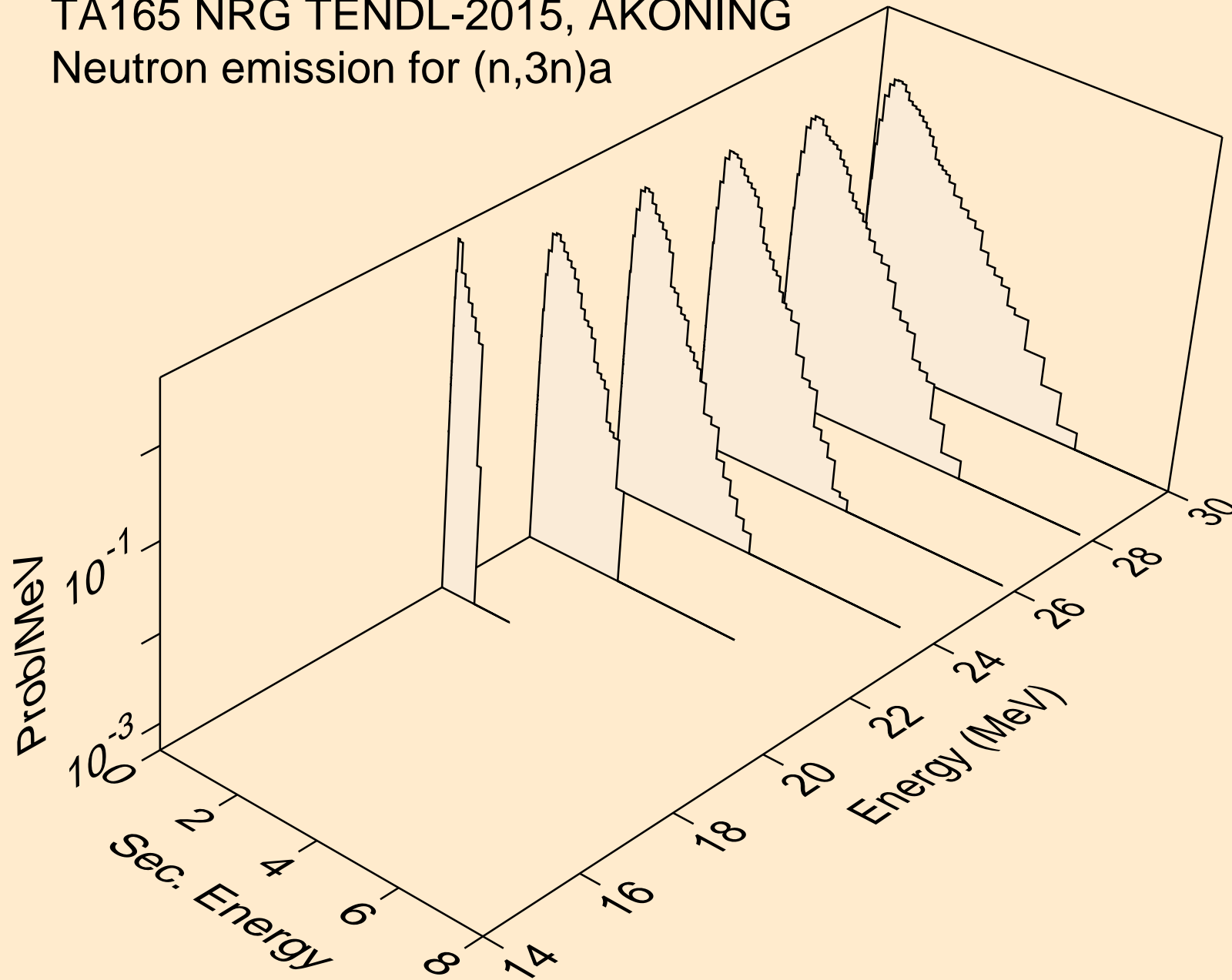

TA165 NRG TENDL-2015, AKONING  
Neutron emission for (n,n\*)p

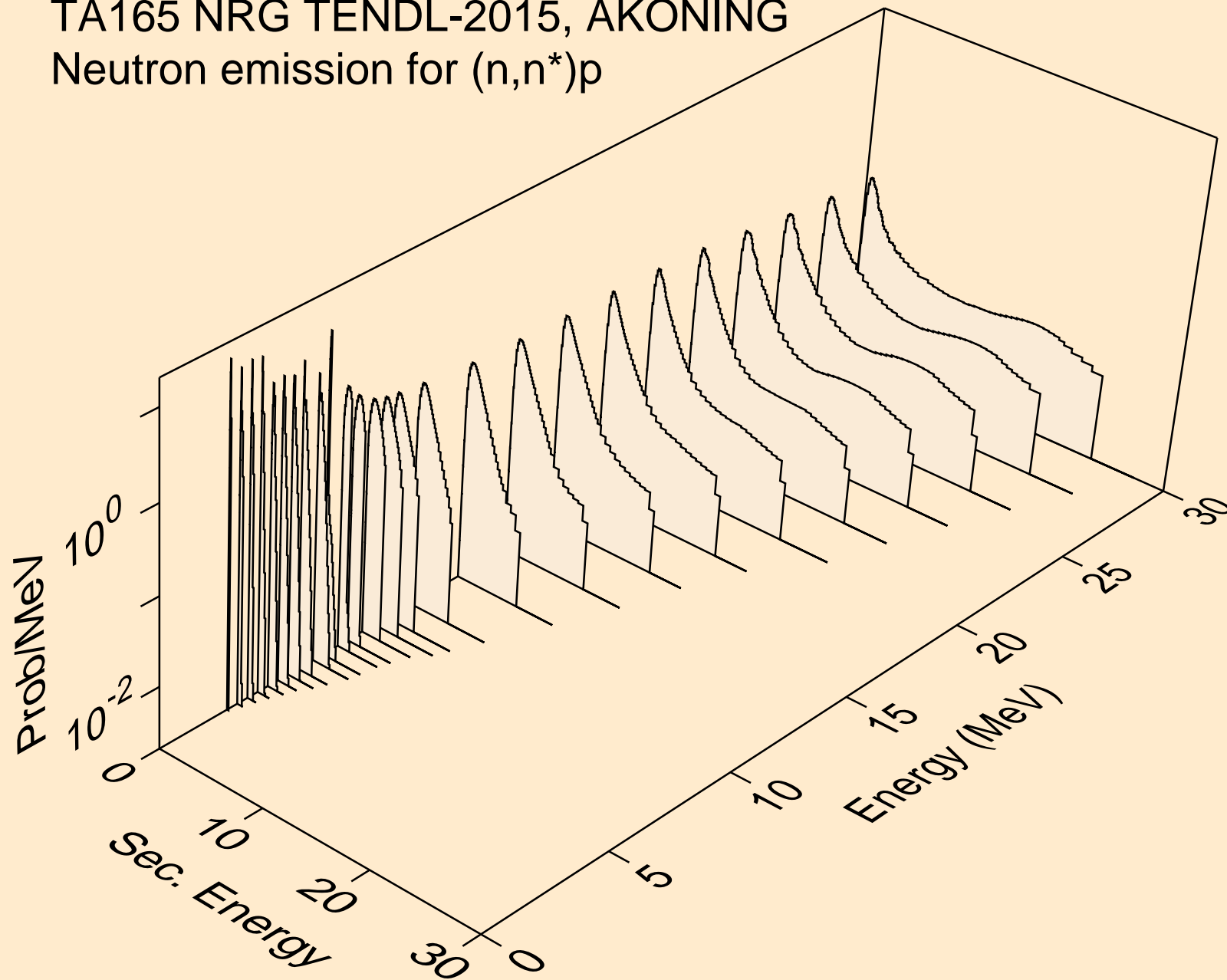

TA165 NRG TENDL-2015, AKONING  
Neutron emission for (n,n\*)2a

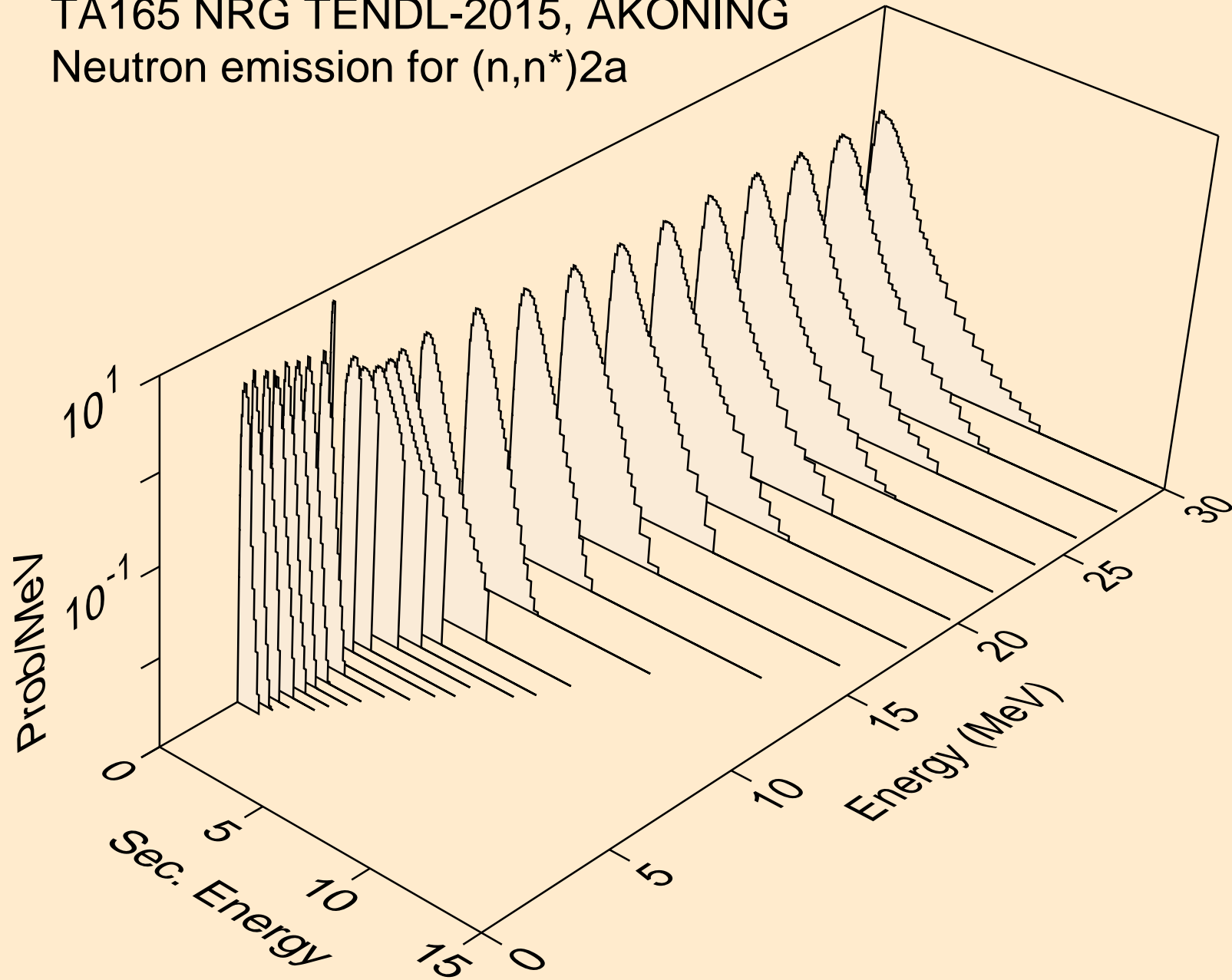



TA165 NRG TENDL-2015, AKONING  
Neutron emission for (n,2n)2a

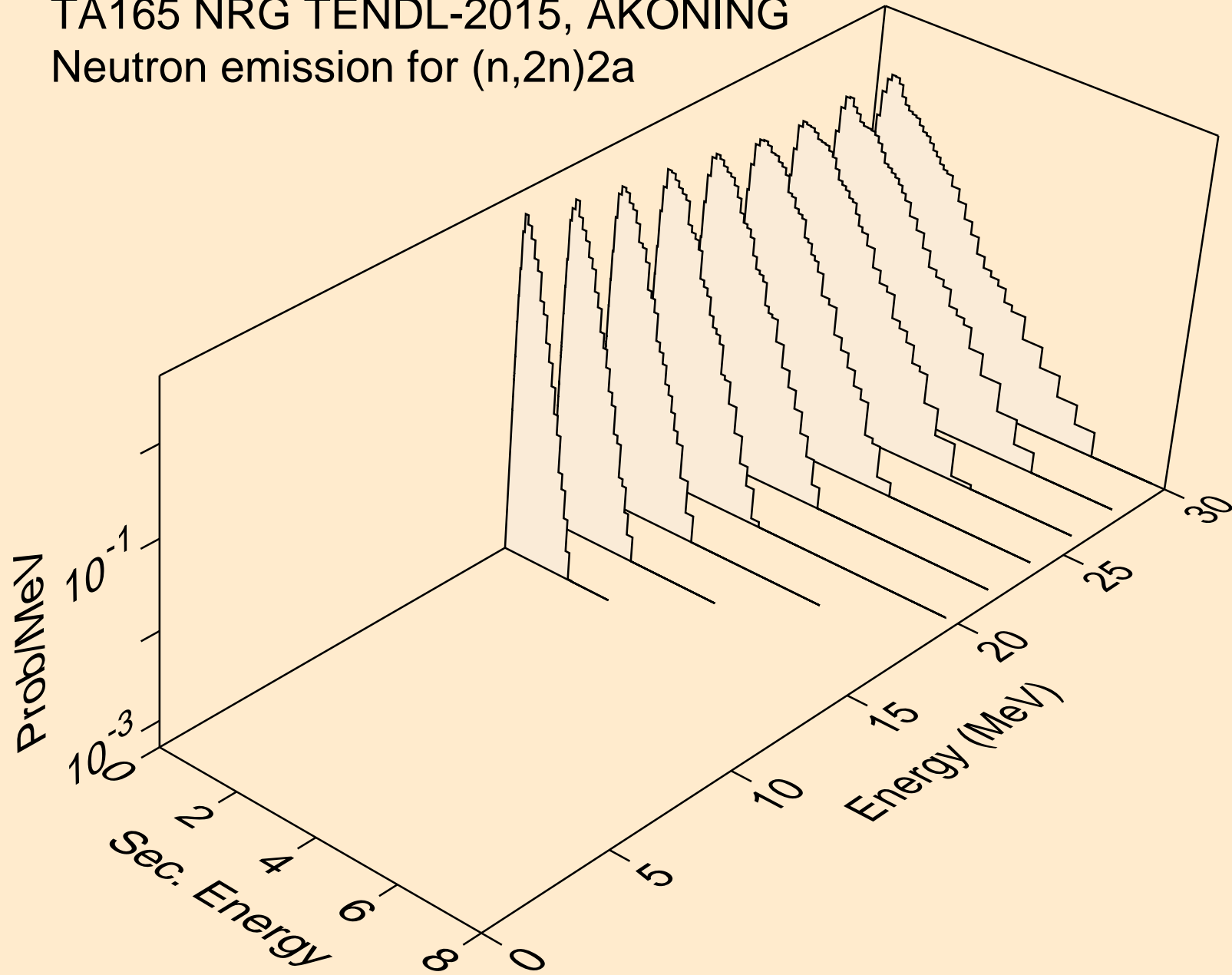

TA165 NRG TENDL-2015, AKONING  
Neutron emission for (n,n\*)d

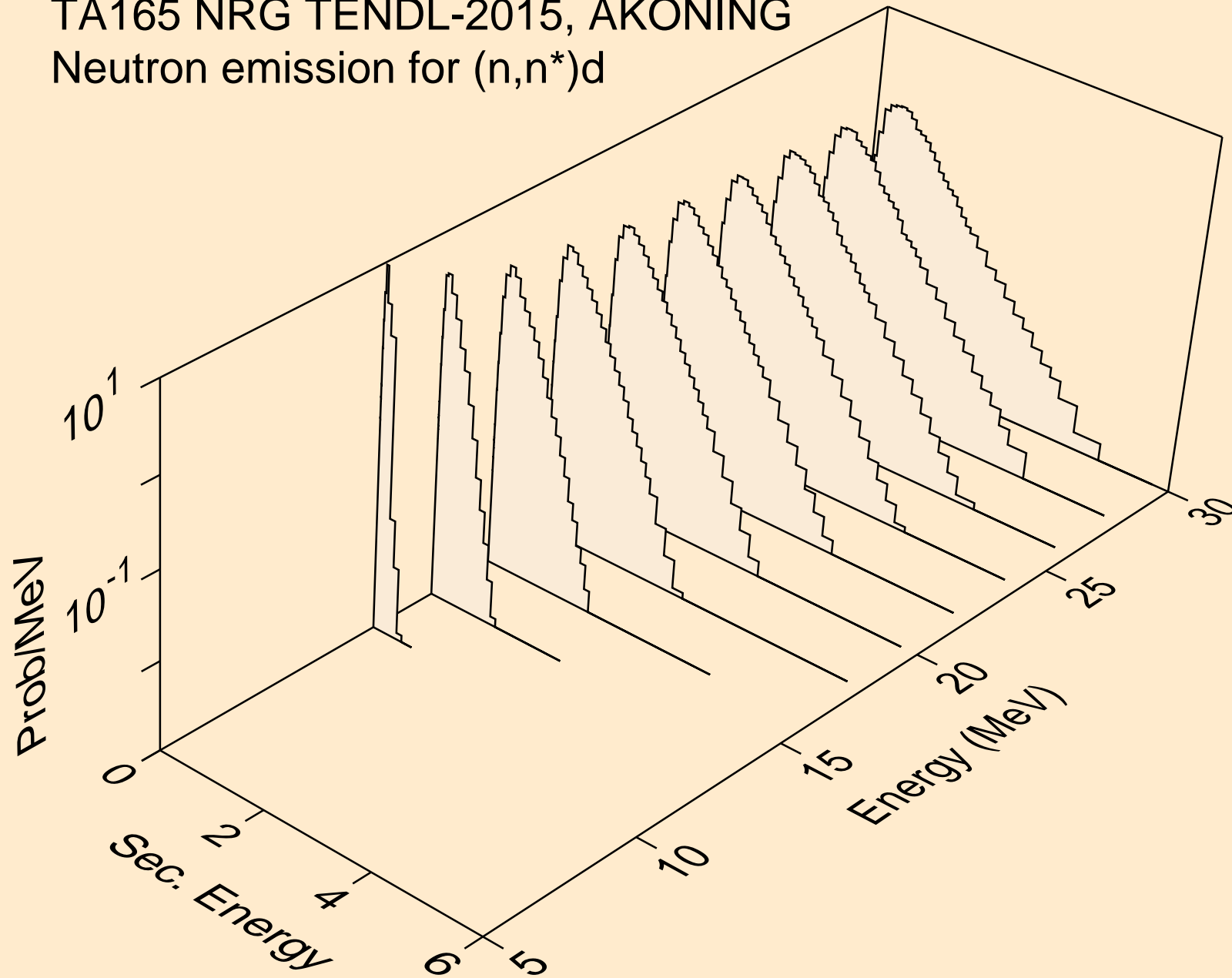

TA165 NRG TENDL-2015, AKONING  
Neutron emission for (n,n\*)t

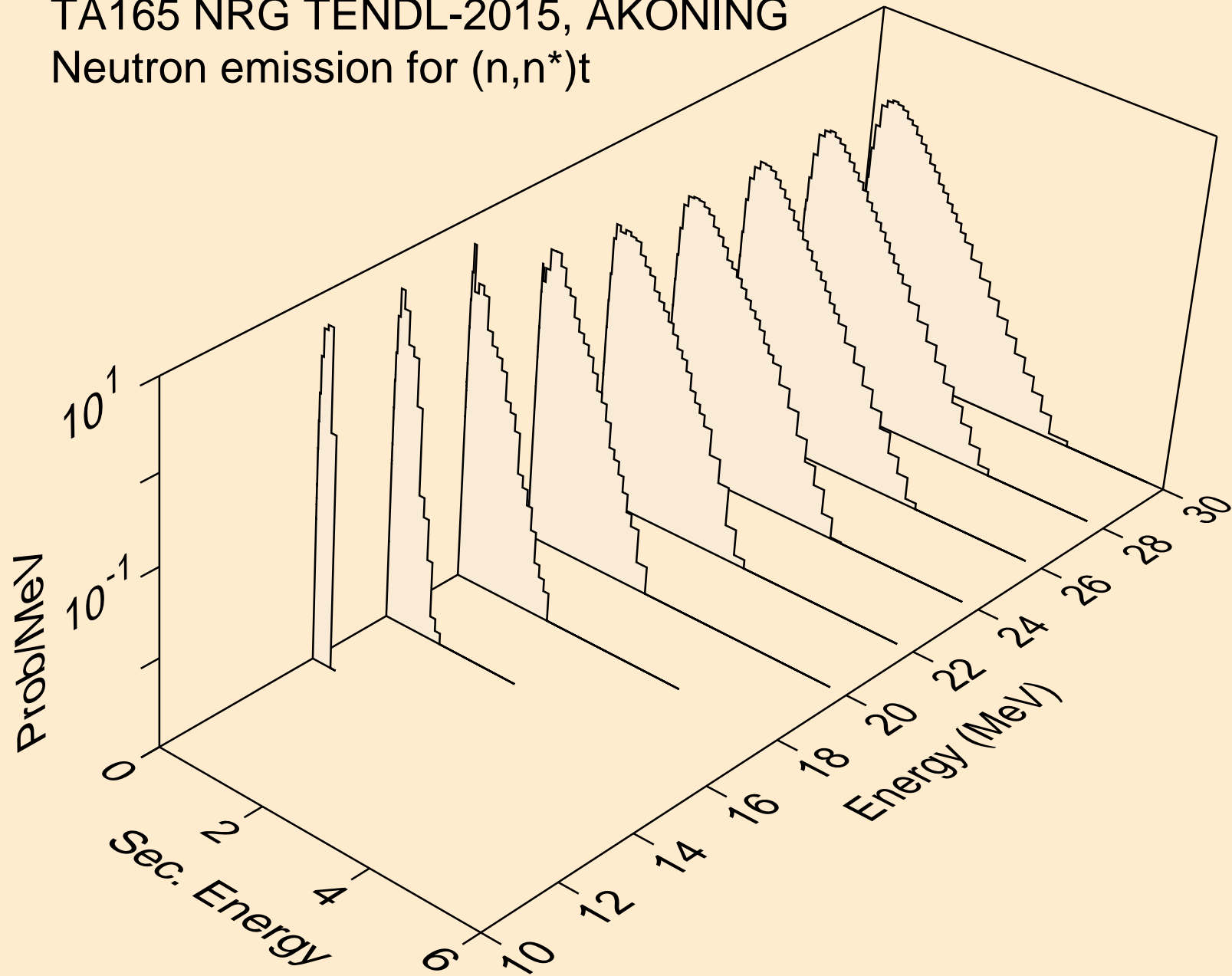

TA165 NRG TENDL-2015, AKONING  
Neutron emission for (n,n\*)he3

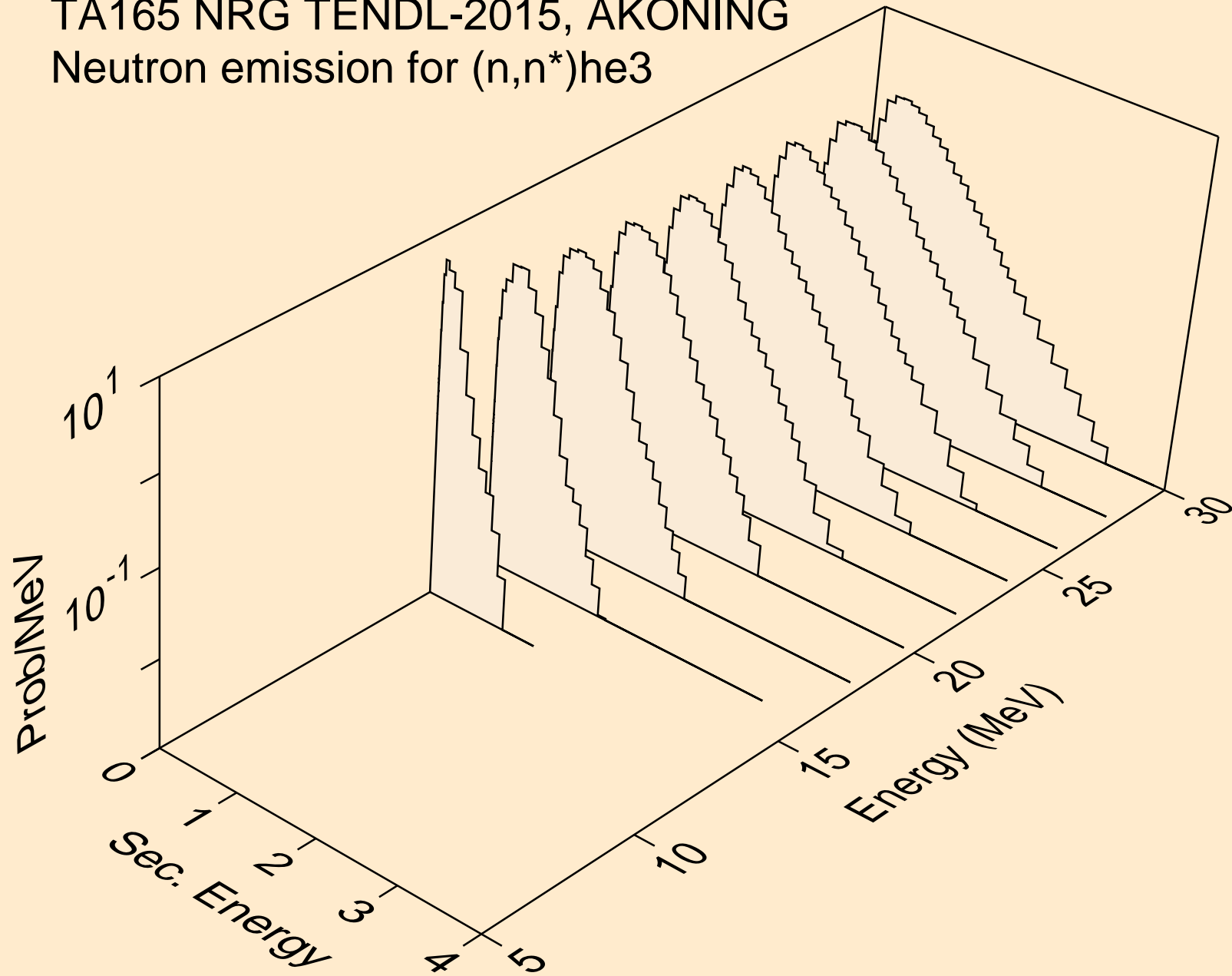

TA165 NRG TENDL-2015, AKONING  
Neutron emission for (n,n\*)t2a

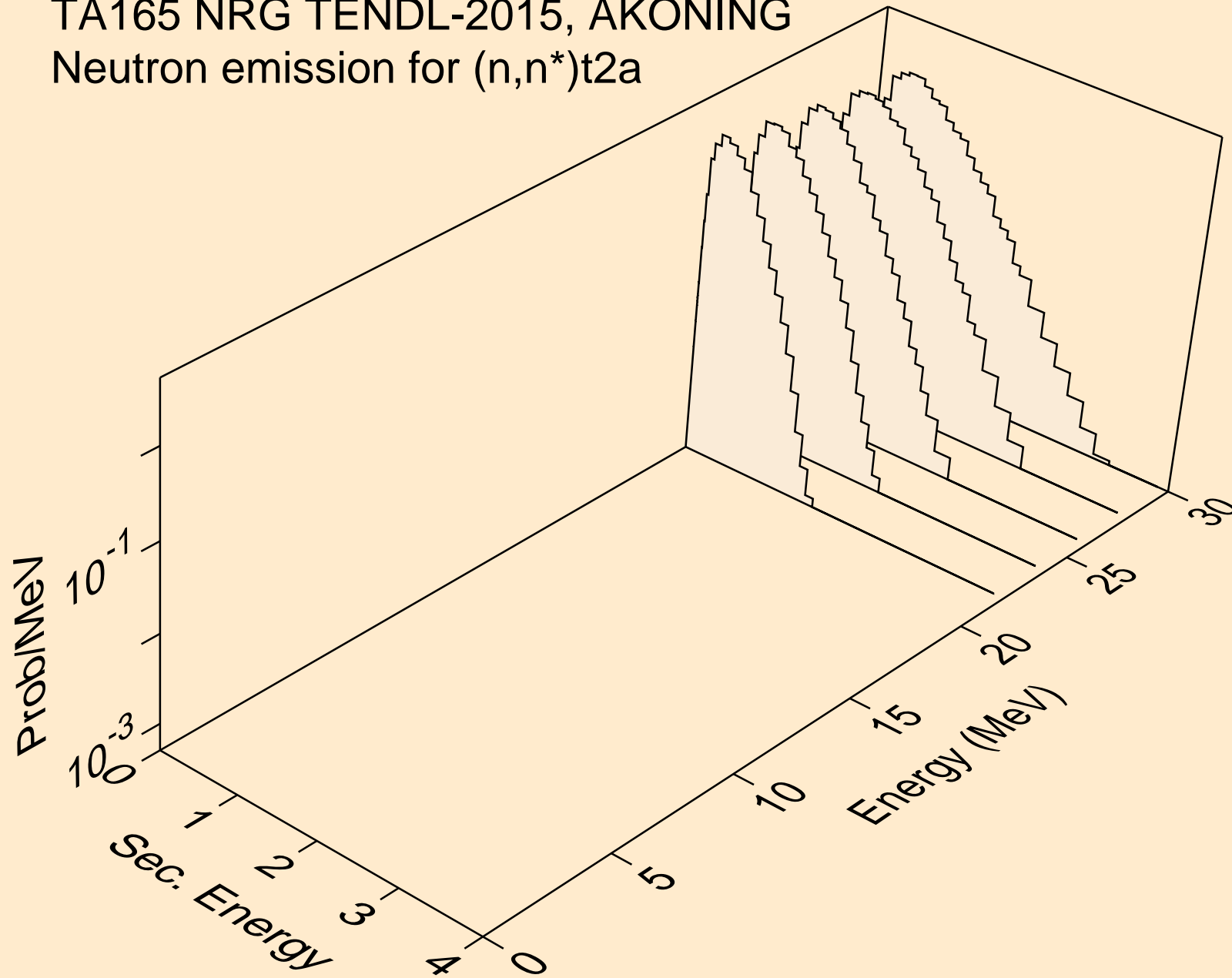

TA165 NRG TENDL-2015, AKONING  
Neutron emission for (n,2np)

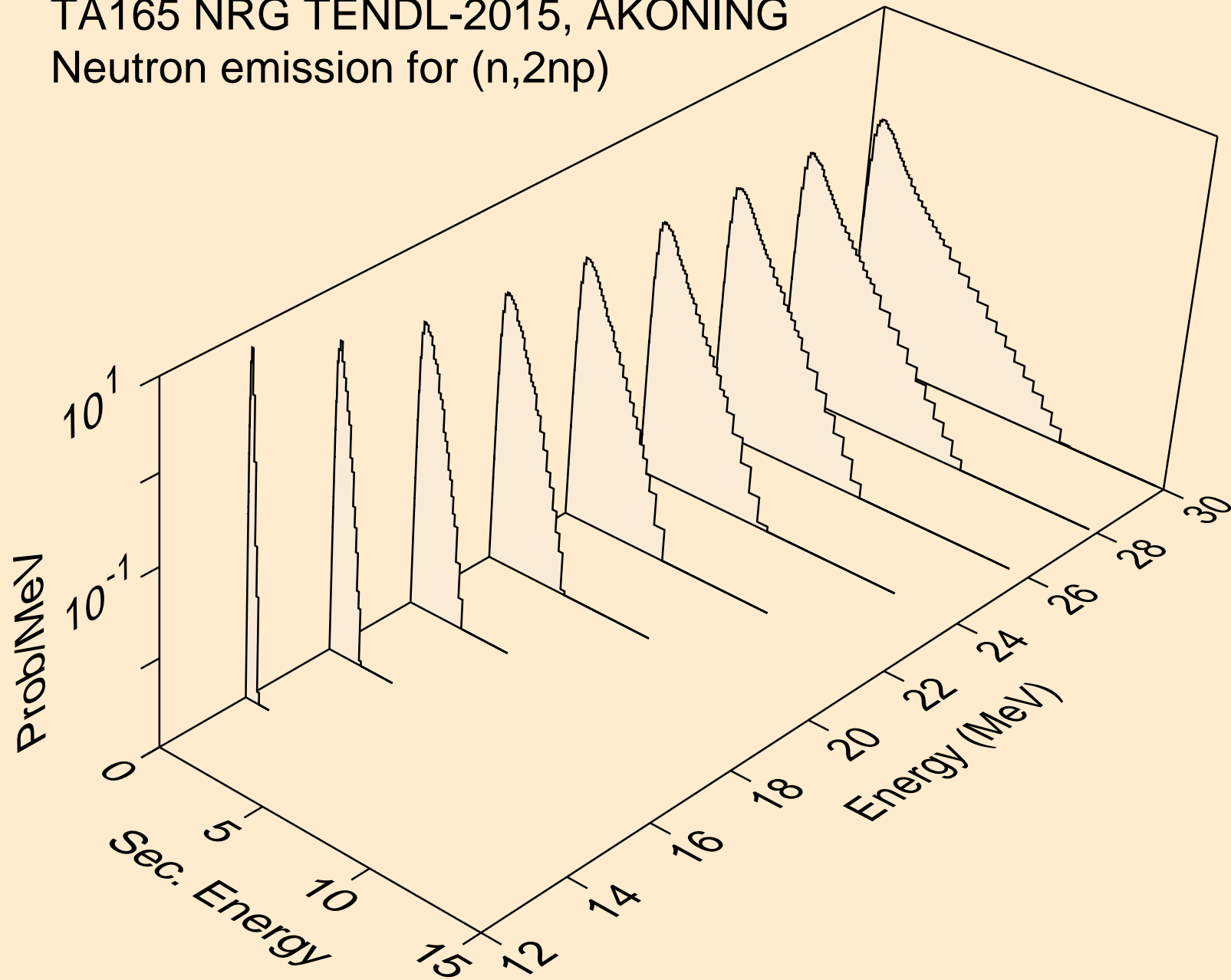

TA165 NRG TENDL-2015, AKONING  
Neutron emission for (n,3np)

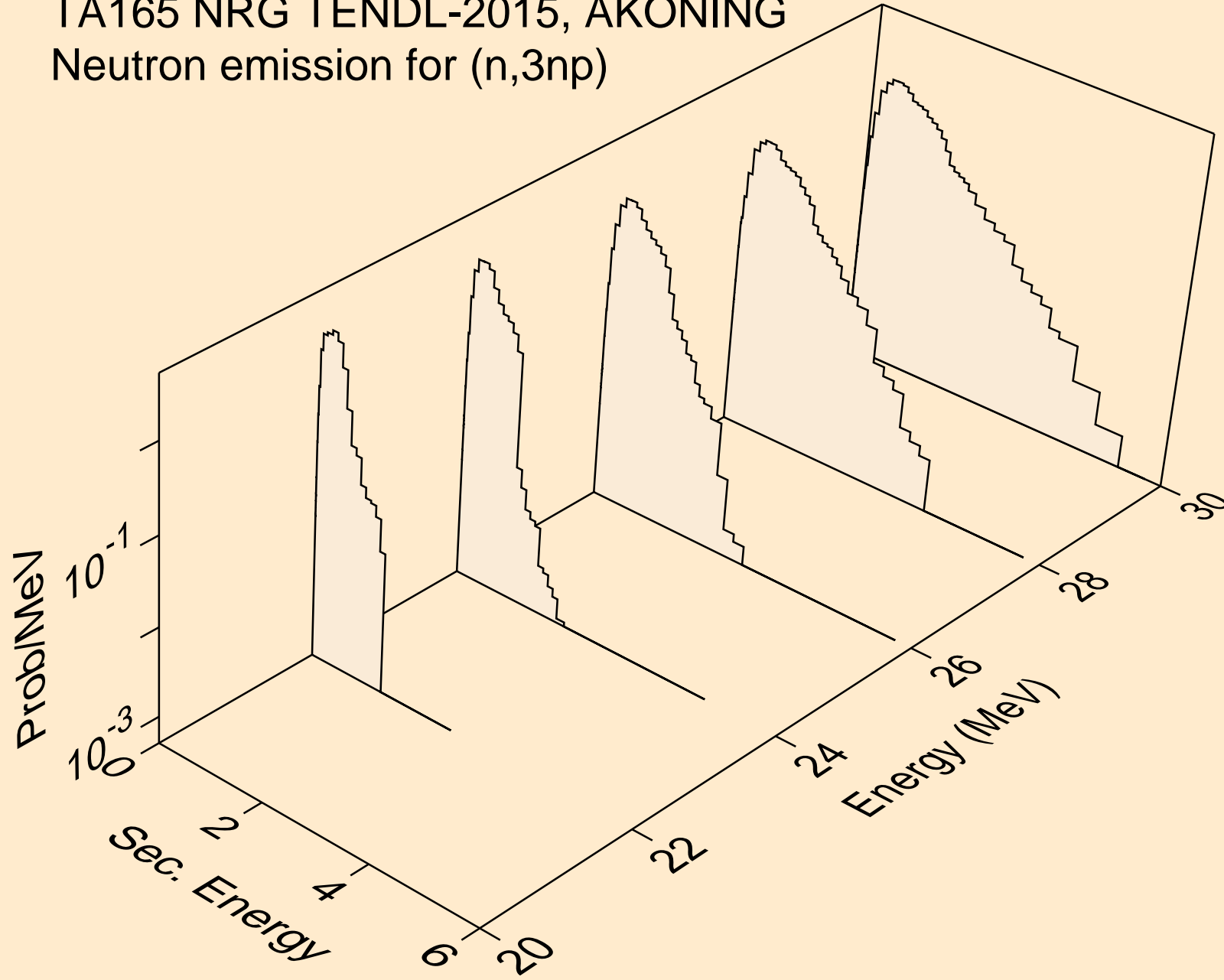

TA165 NRG TENDL-2015, AKONING  
Neutron emission for (n,2np)

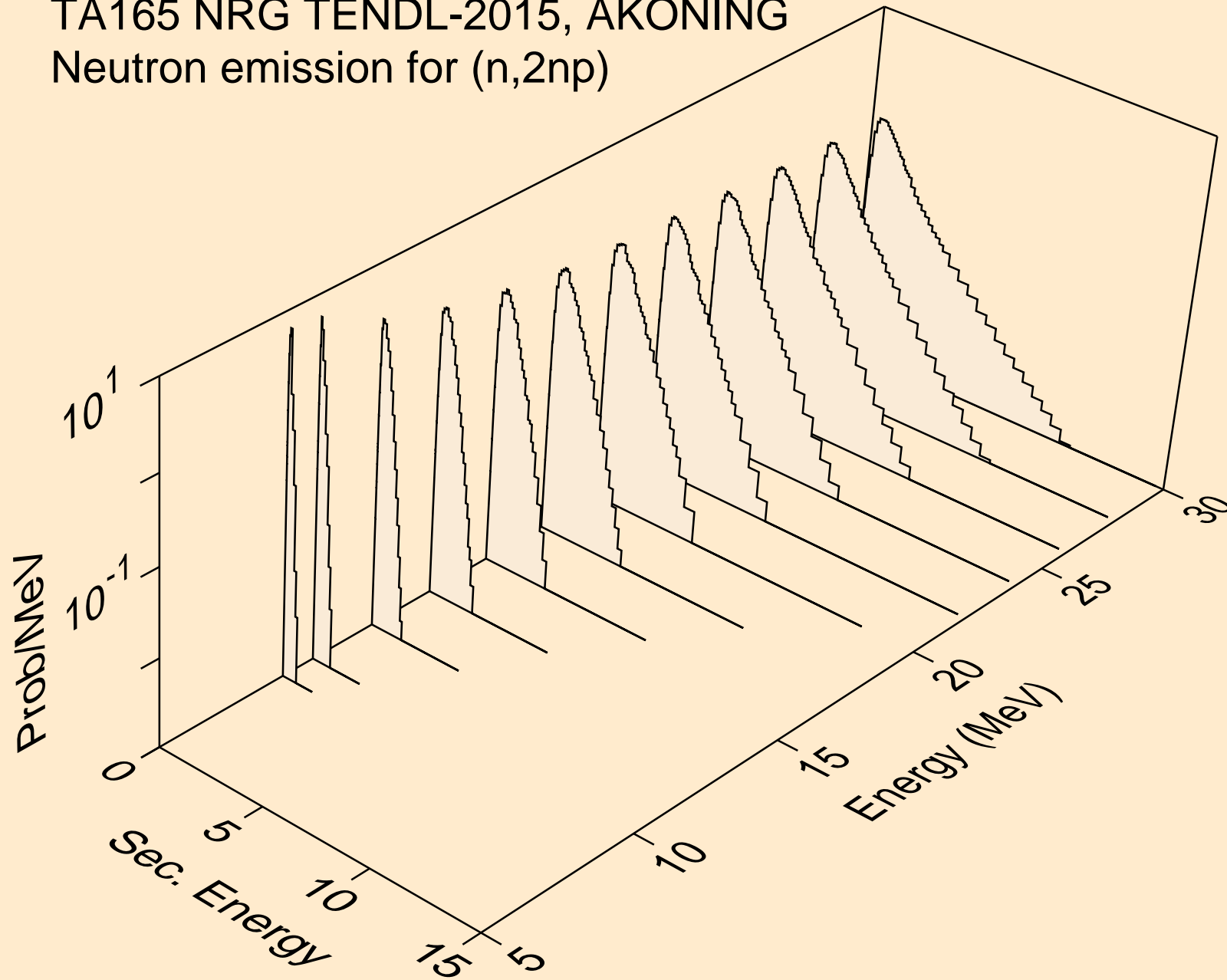



TA165 NRG TENDL-2015, AKONING  
Neutron emission for (n,npa)

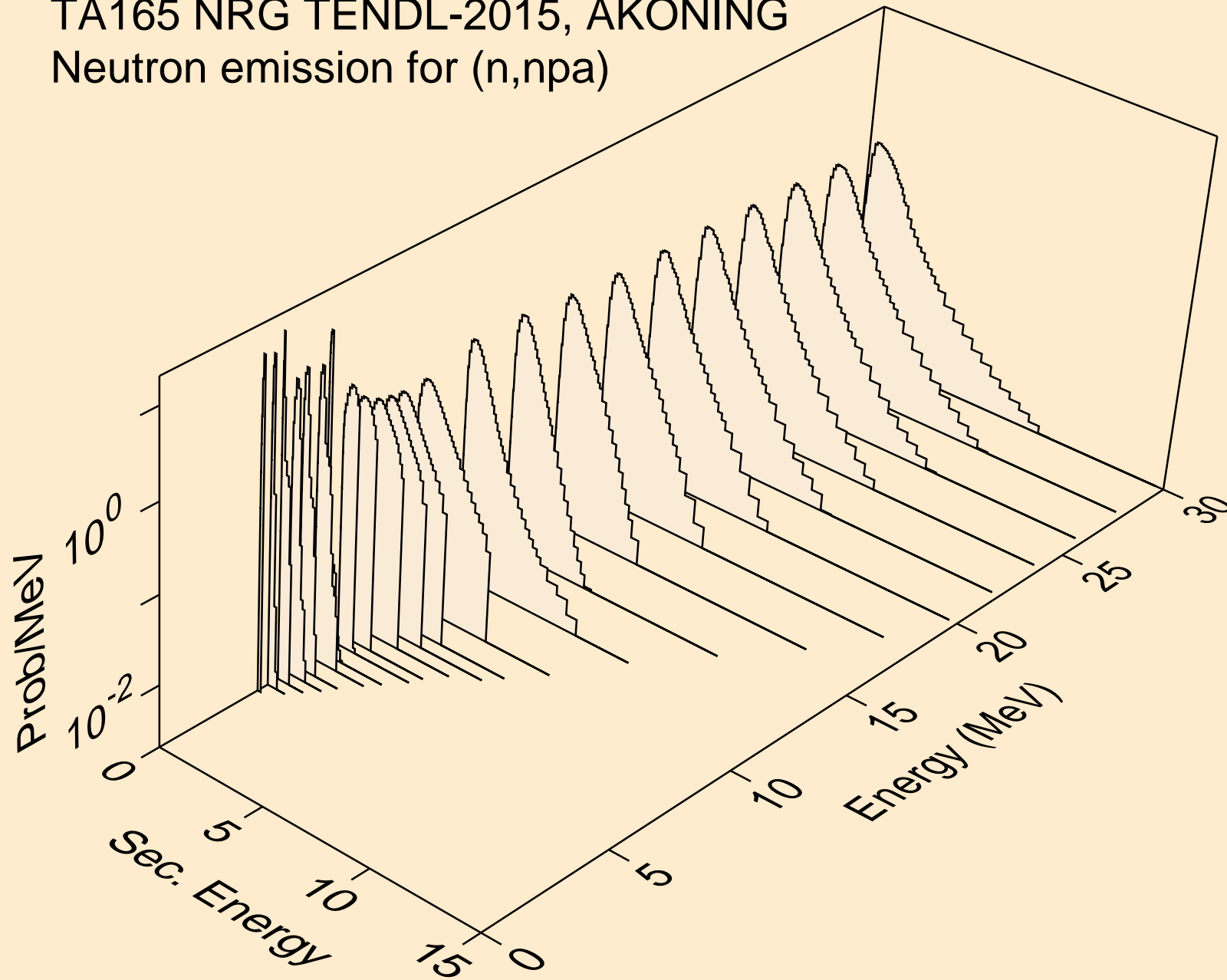

TA165 NRG TENDL-2015, AKONING  
Neutron emission for (n,n\*c)

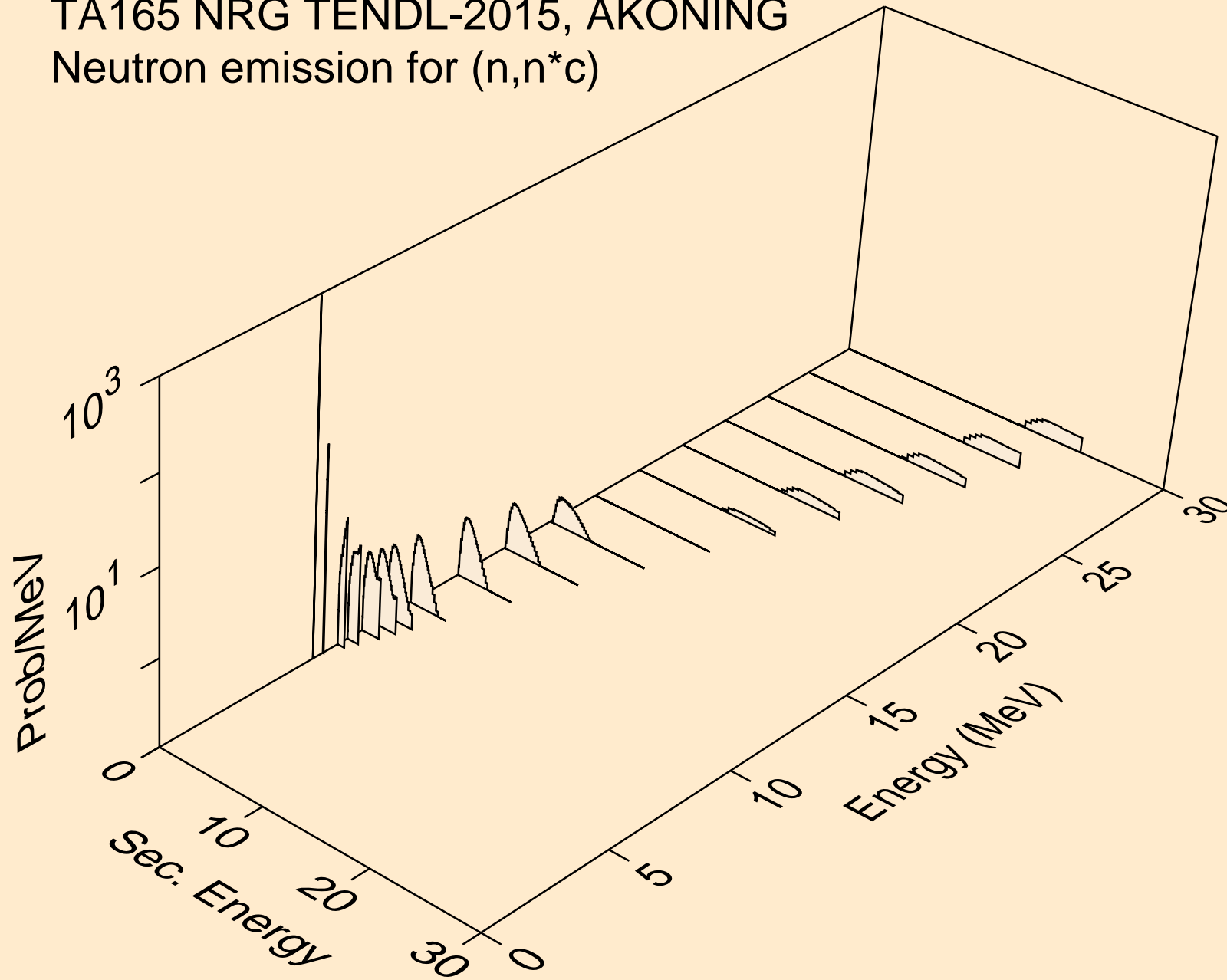

TA165 NRG TENDL-2015, AKONING  
Photon emission for (n,x)

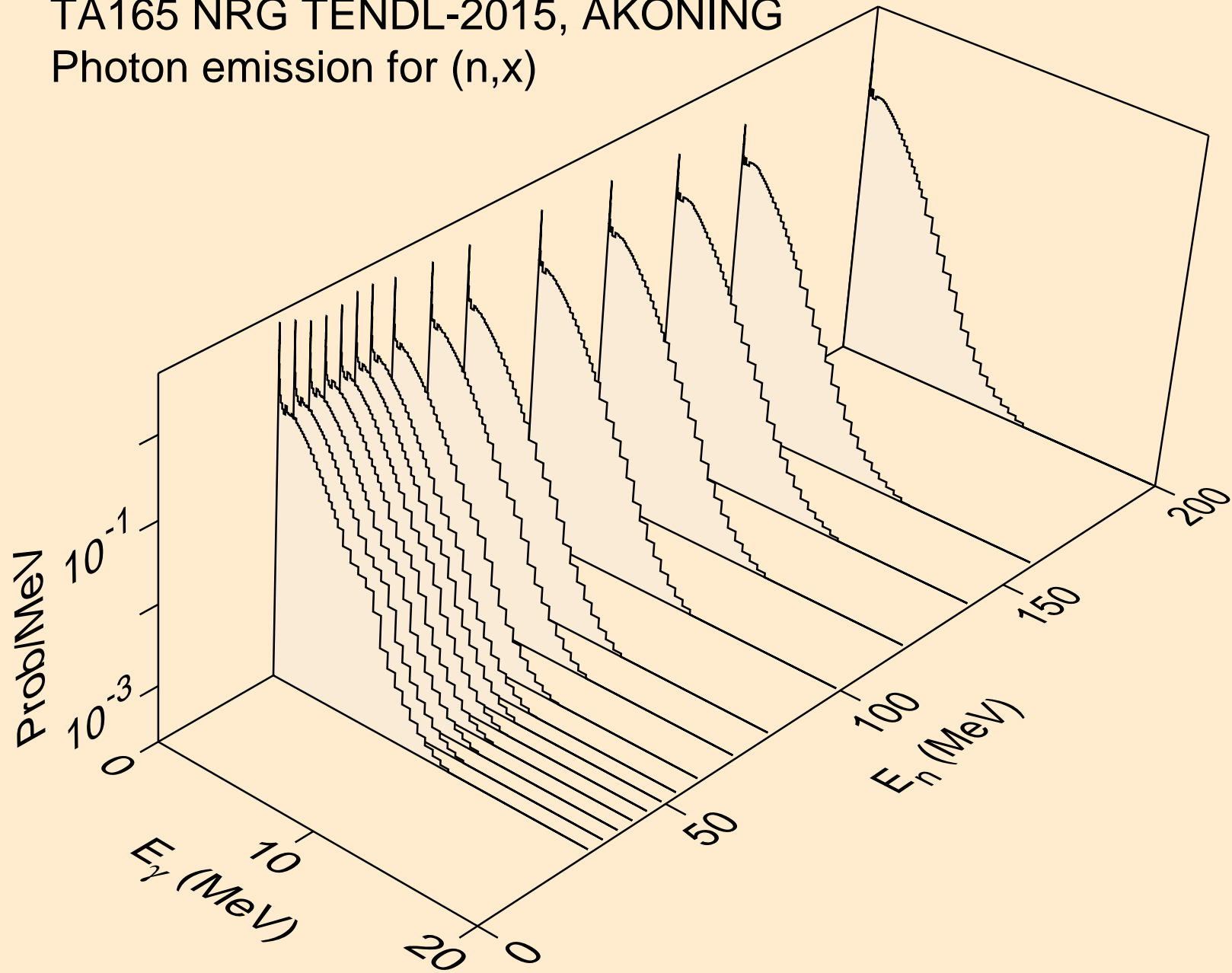

TA165 NRG TENDL-2015, AKONING  
Photon emission for (n,2nd)

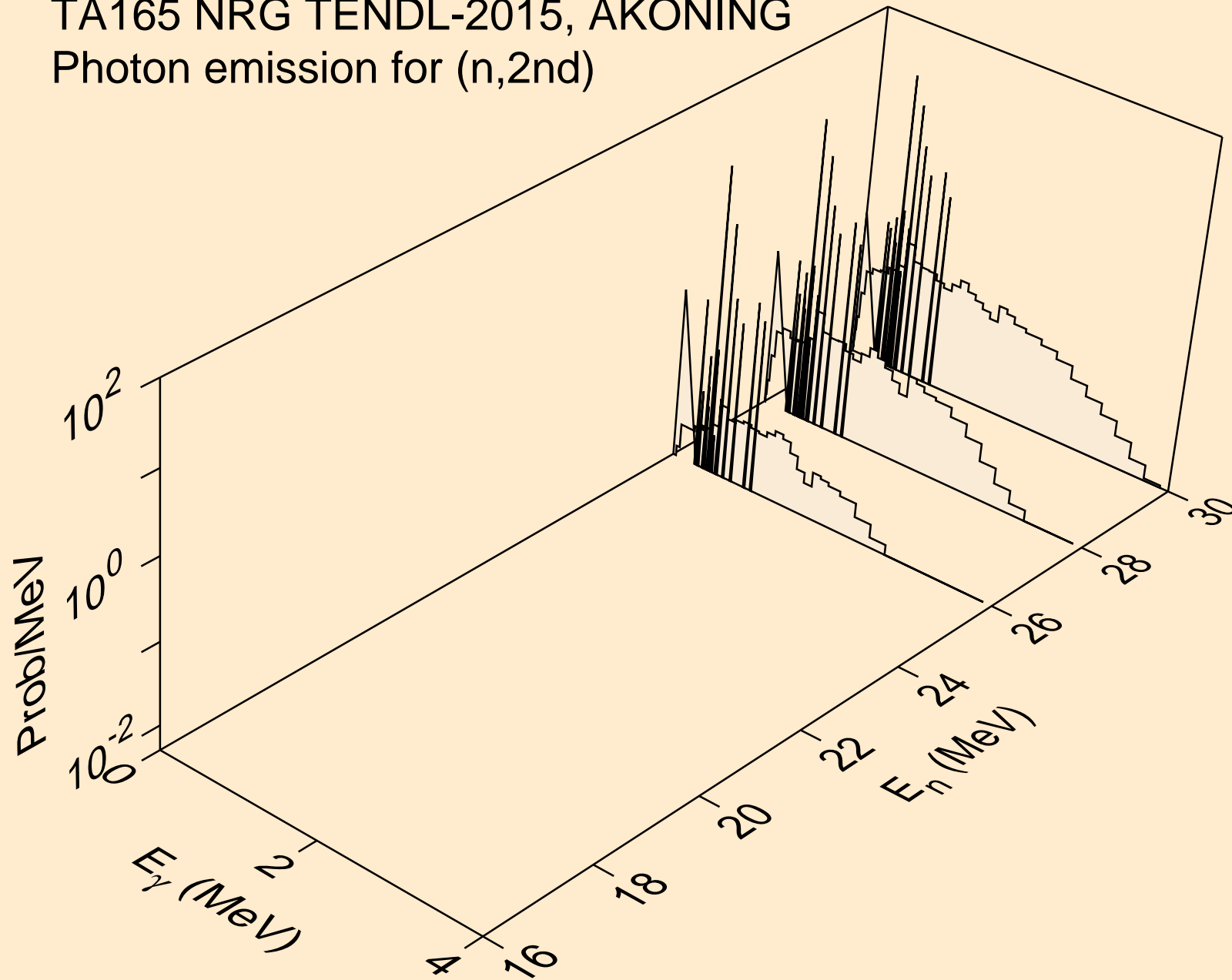

TA165 NRG TENDL-2015, AKONING  
Photon emission for (n,2n)

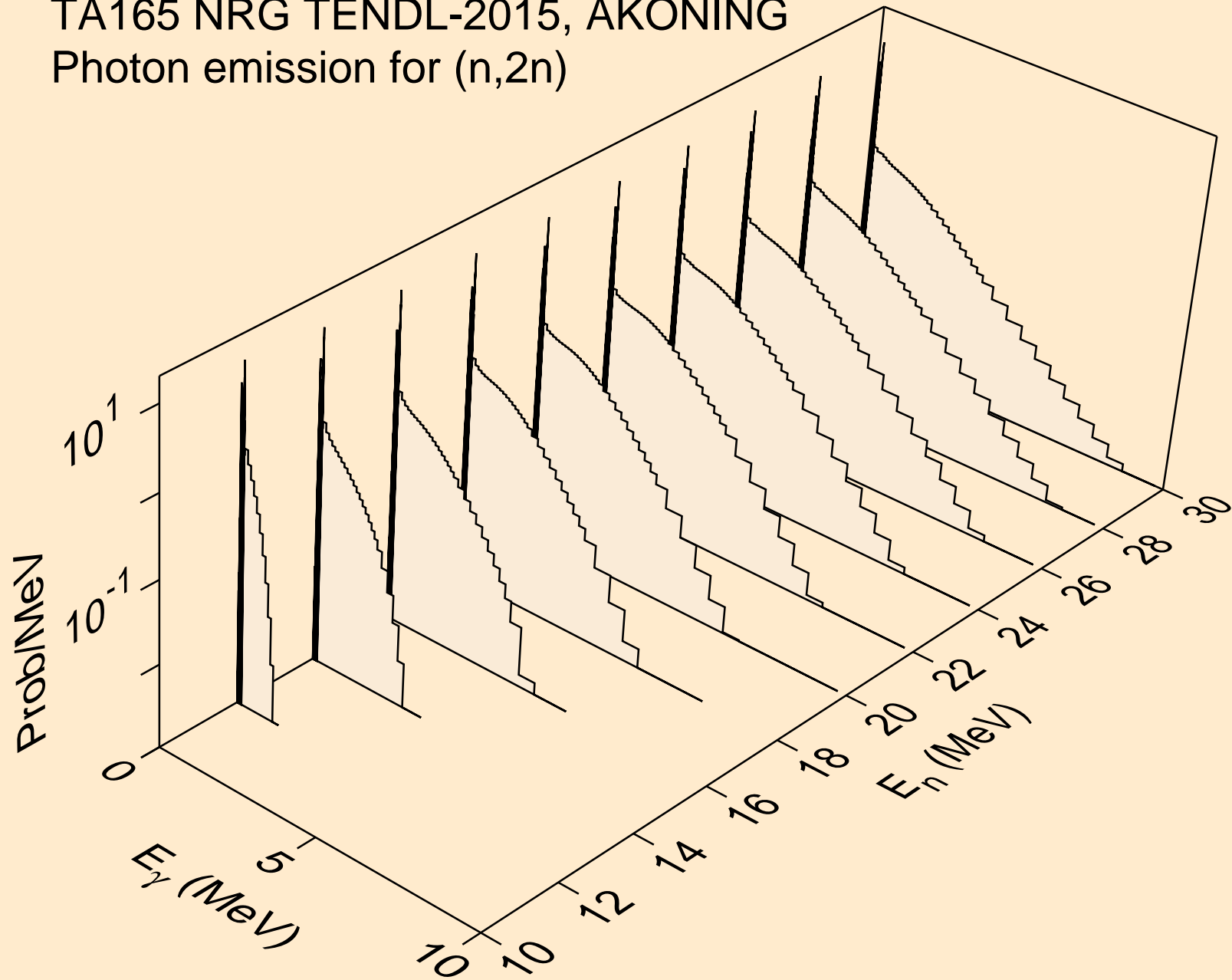

TA165 NRG TENDL-2015, AKONING  
Photon emission for (n,3n)

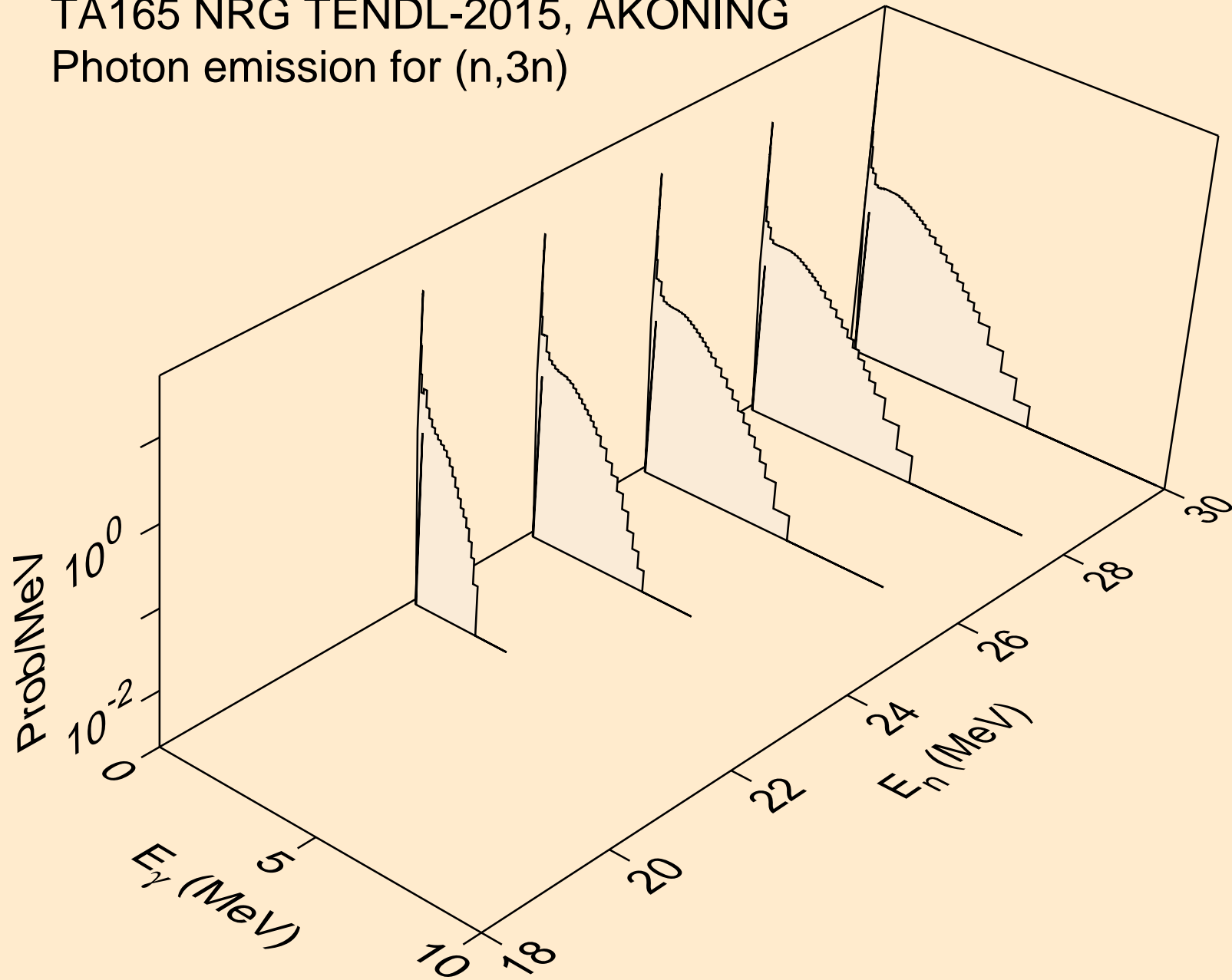

TA165 NRG TENDL-2015, AKONING  
Photon emission for (n,n\*)a

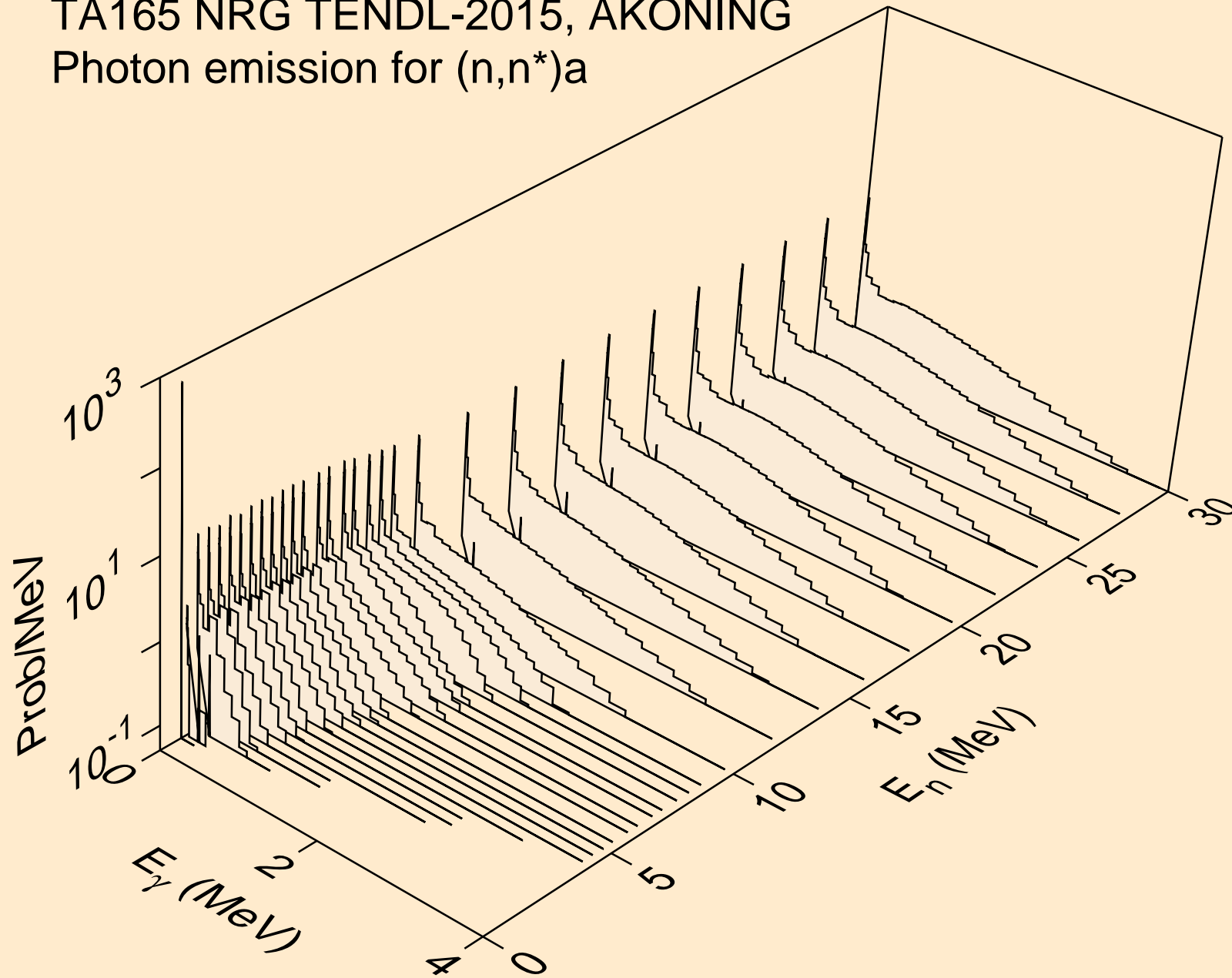

TA165 NRG TENDL-2015, AKONING  
Photon emission for (n,n\*)3a

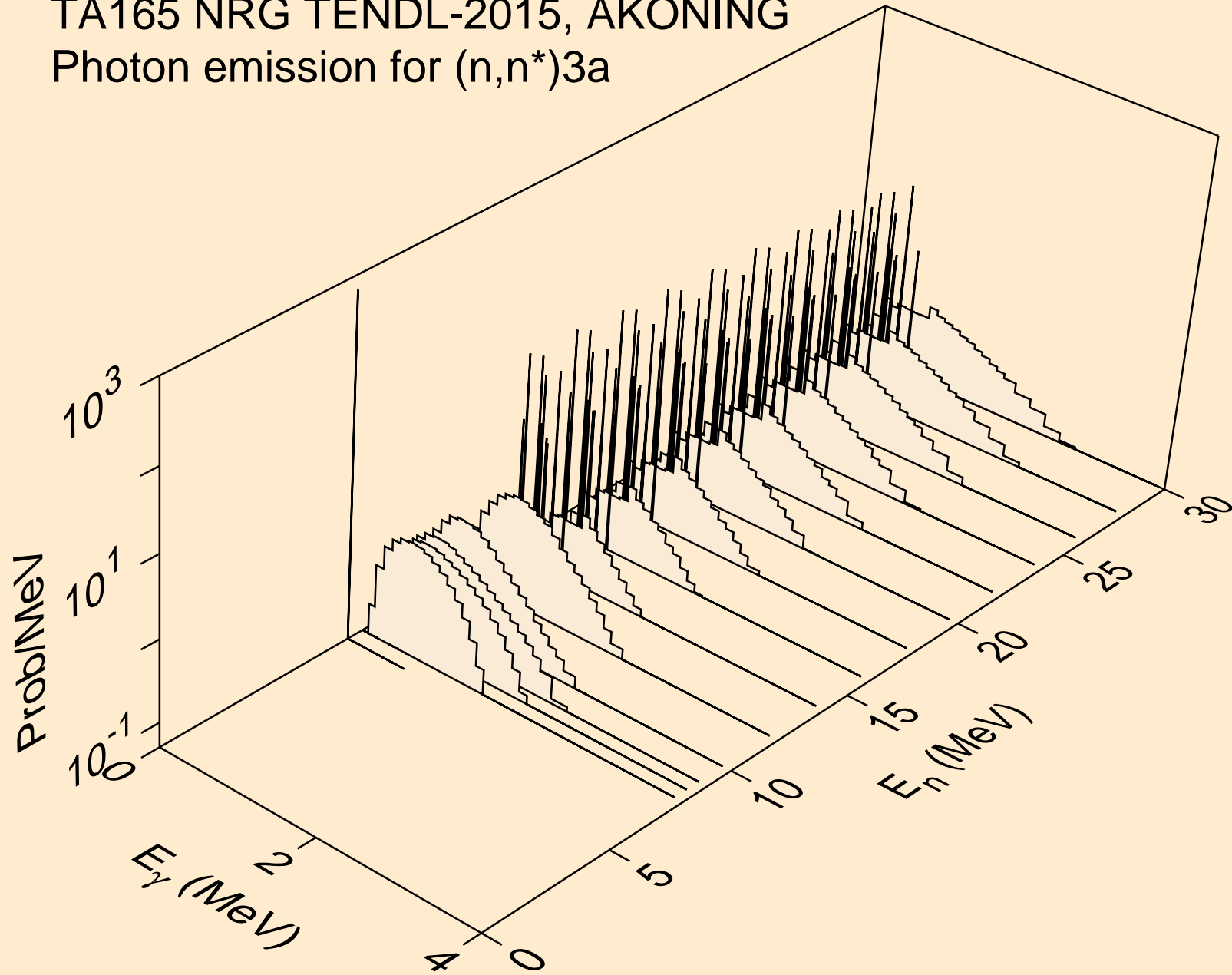



TA165 NRG TENDL-2015, AKONING  
Photon emission for (n,2n)a

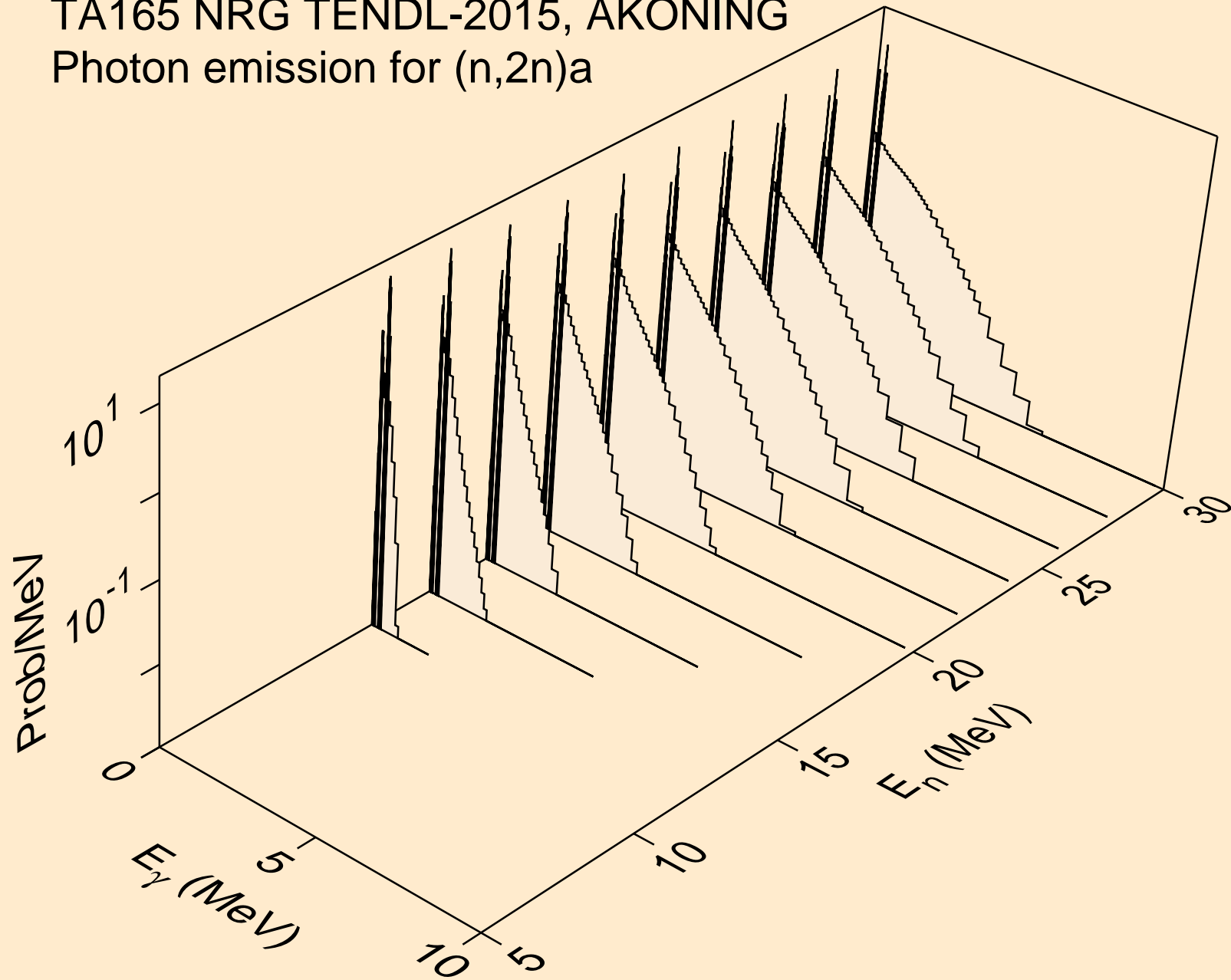

TA165 NRG TENDL-2015, AKONING  
Photon emission for (n,3n)a

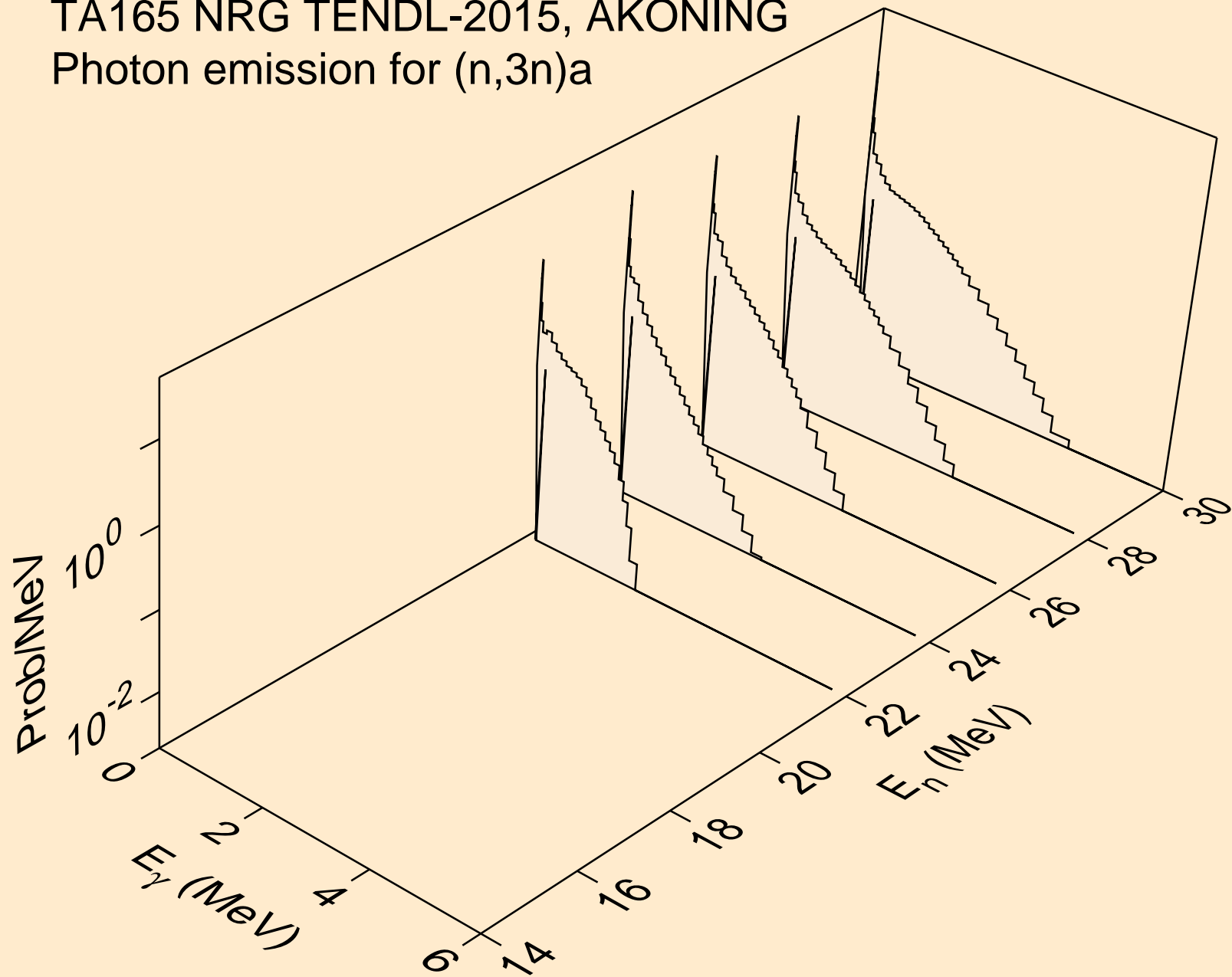

TA165 NRG TENDL-2015, AKONING  
Photon emission for (n,n\*)p

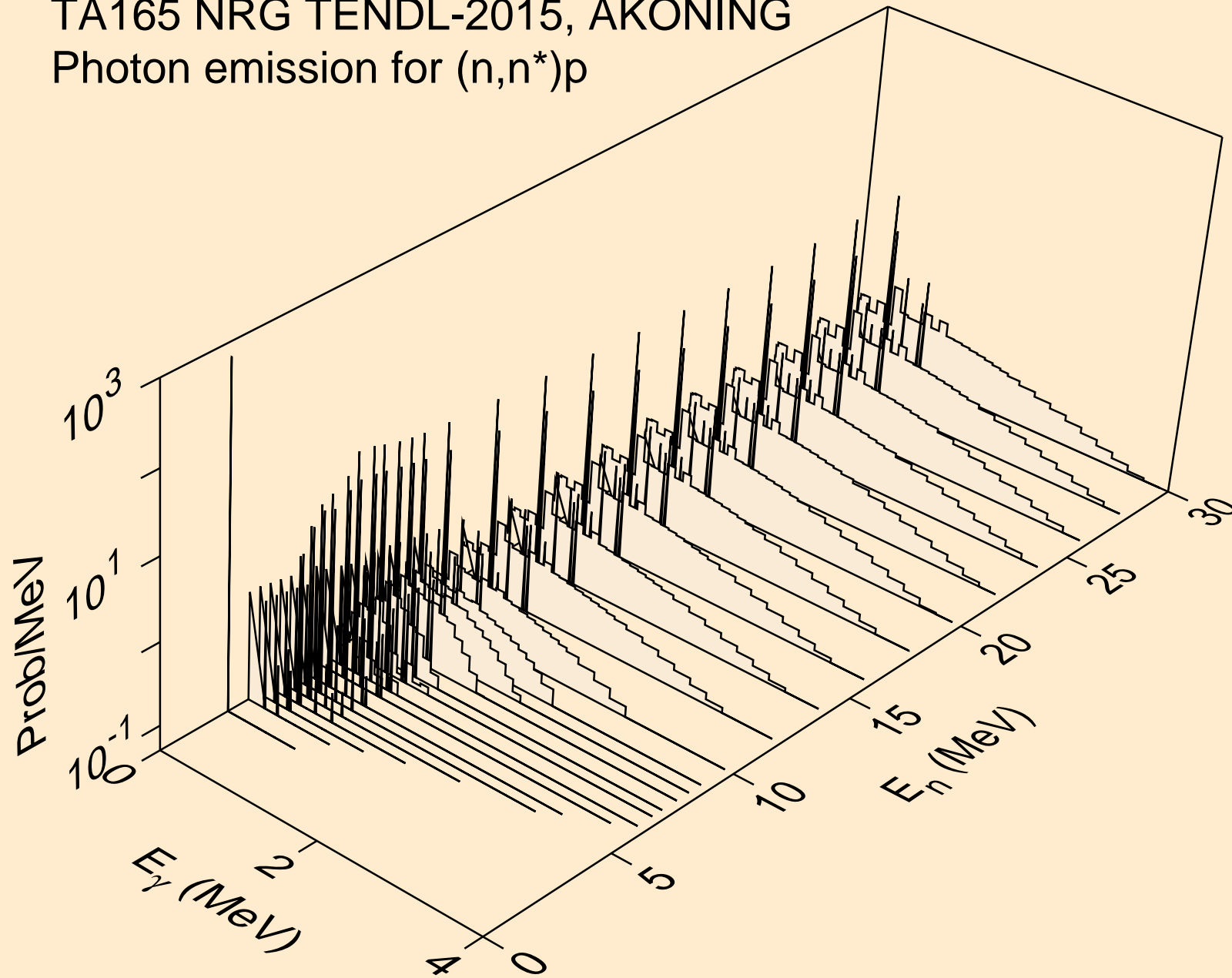

TA165 NRG TENDL-2015, AKONING  
Photon emission for (n,n\*)2a

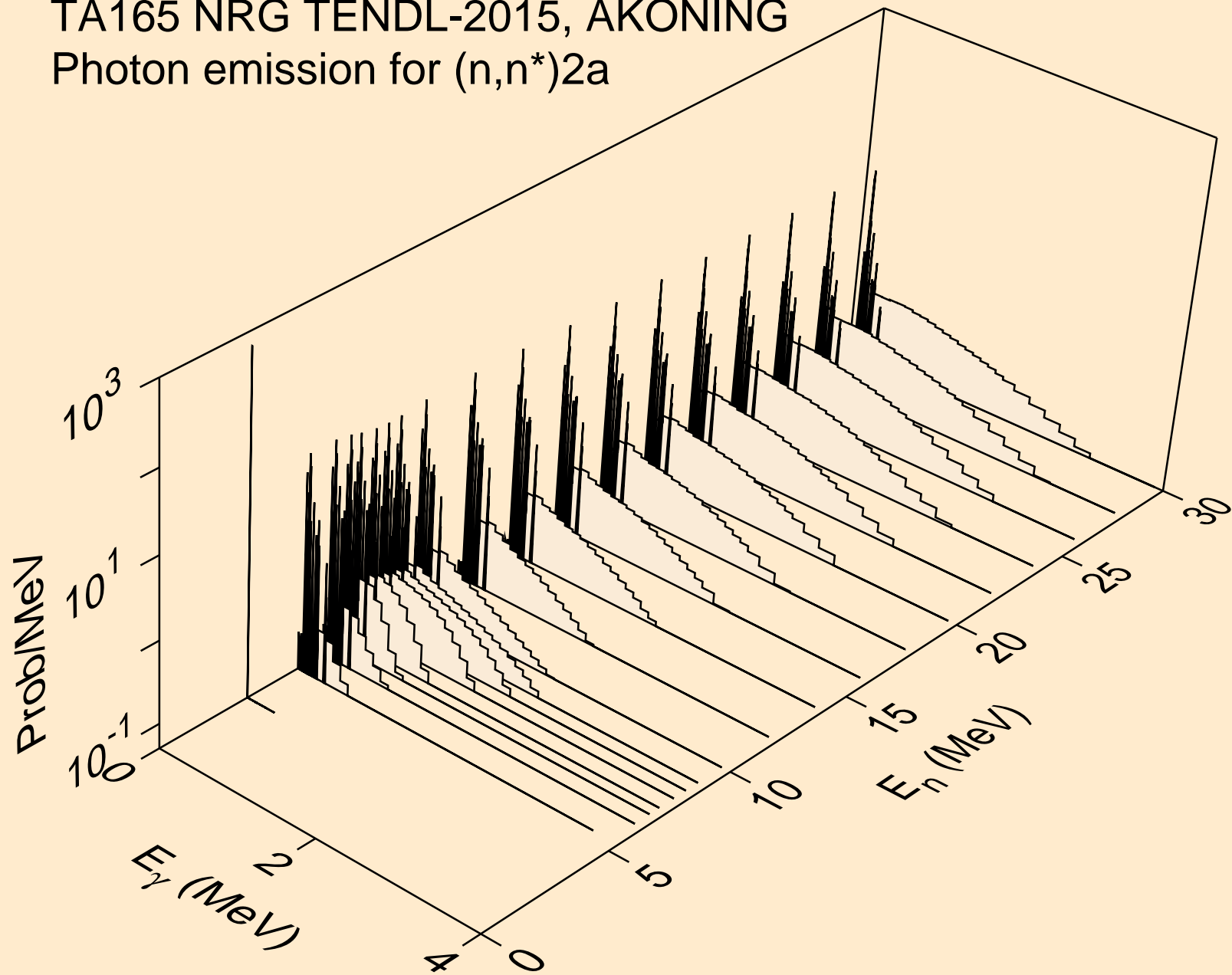

TA165 NRG TENDL-2015, AKONING  
Photon emission for (n,2n)2a

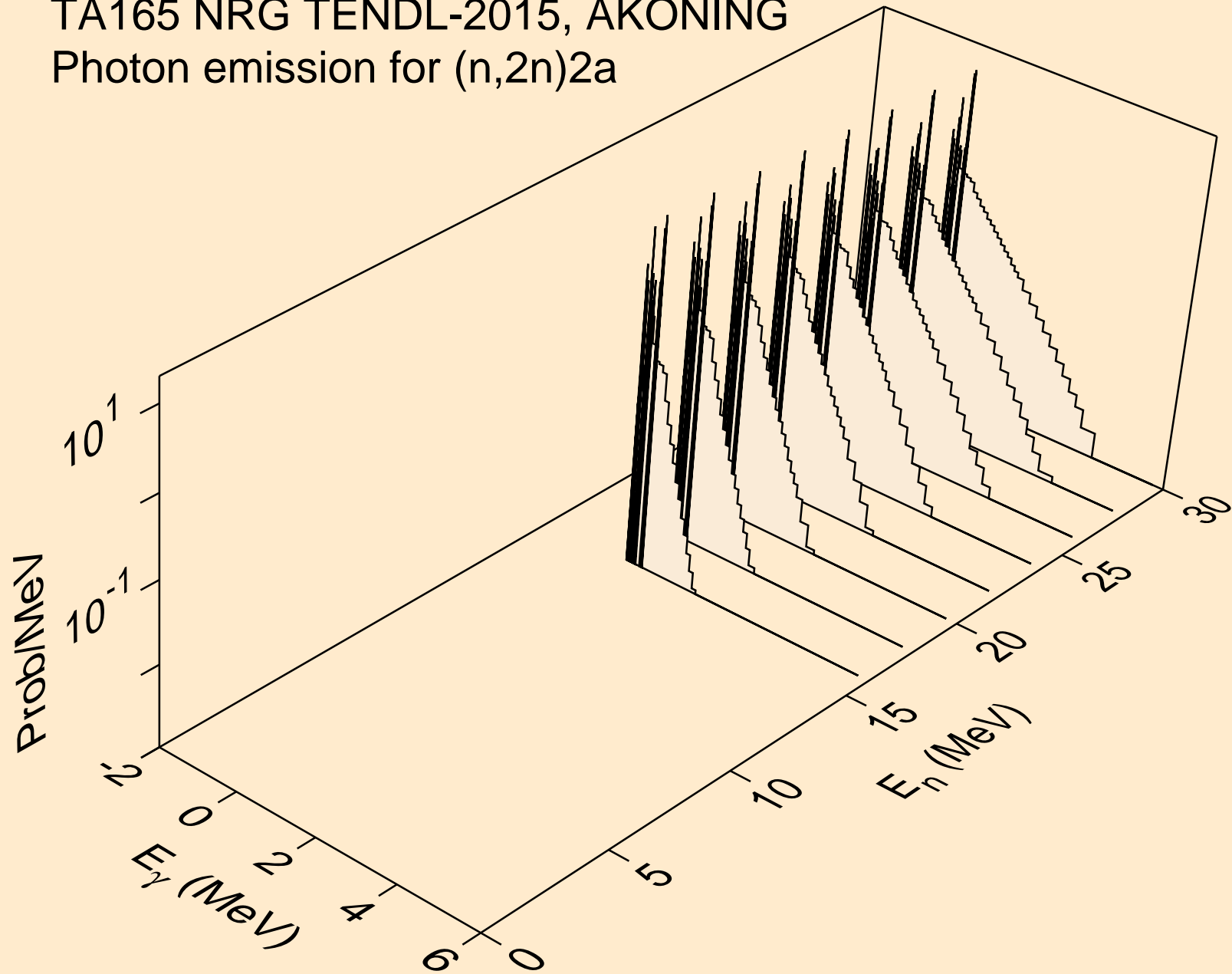

TA165 NRG TENDL-2015, AKONING  
Photon emission for (n,n\*)d

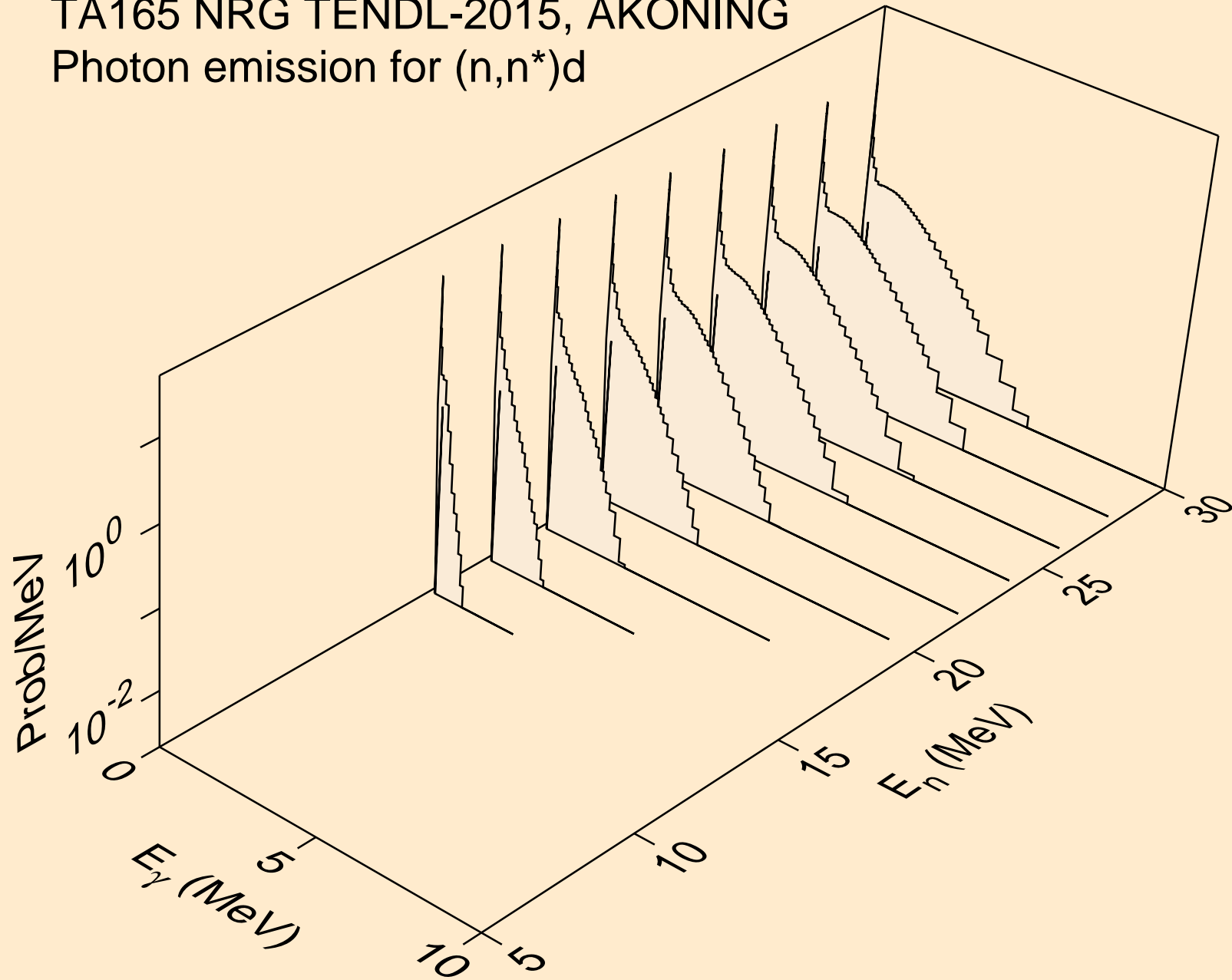

TA165 NRG TENDL-2015, AKONING  
Photon emission for (n,n\*)t

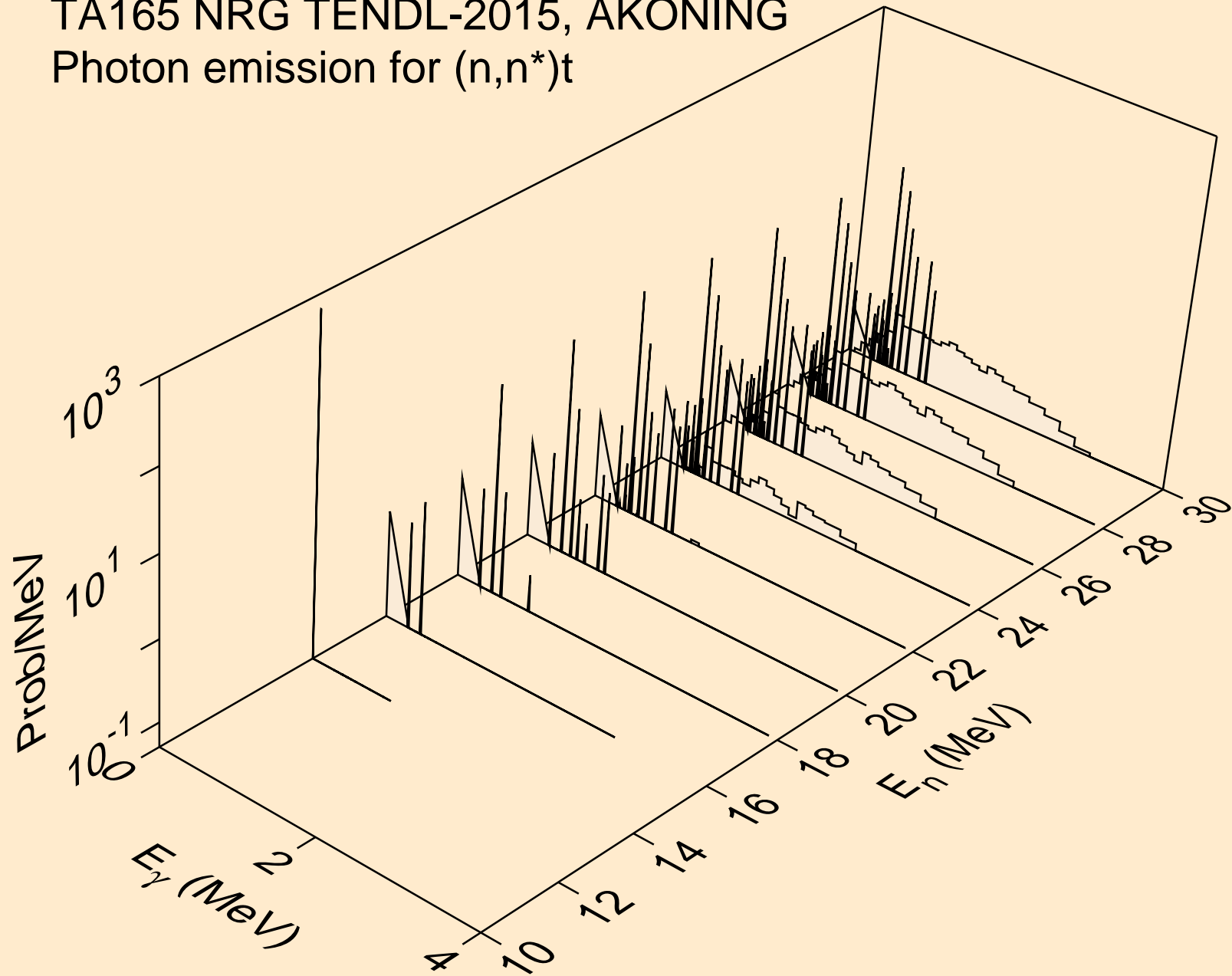

TA165 NRG TENDL-2015, AKONING  
Photon emission for (n,n\*)he3

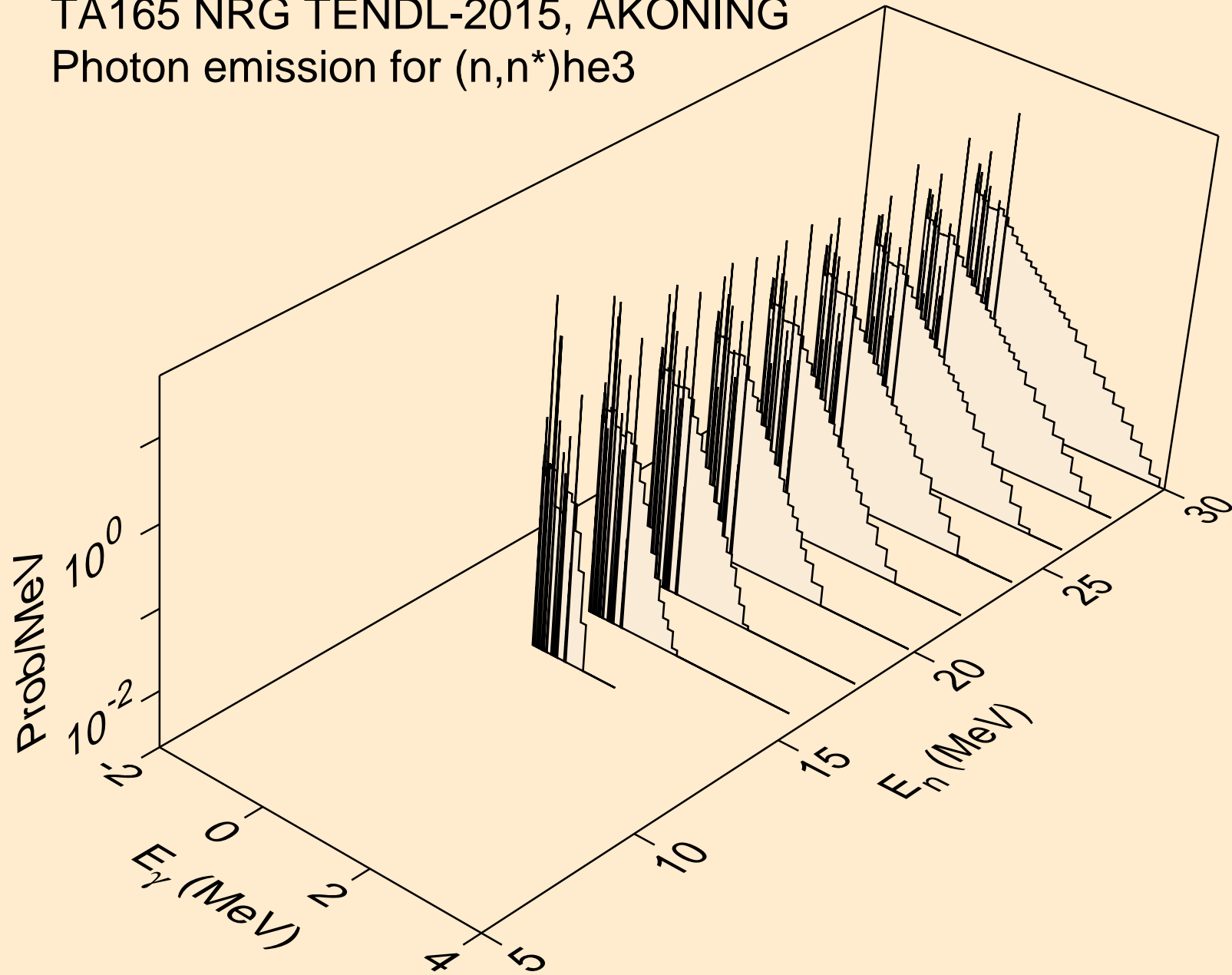



TA165 NRG TENDL-2015, AKONING  
Photon emission for (n,n\*)t2a

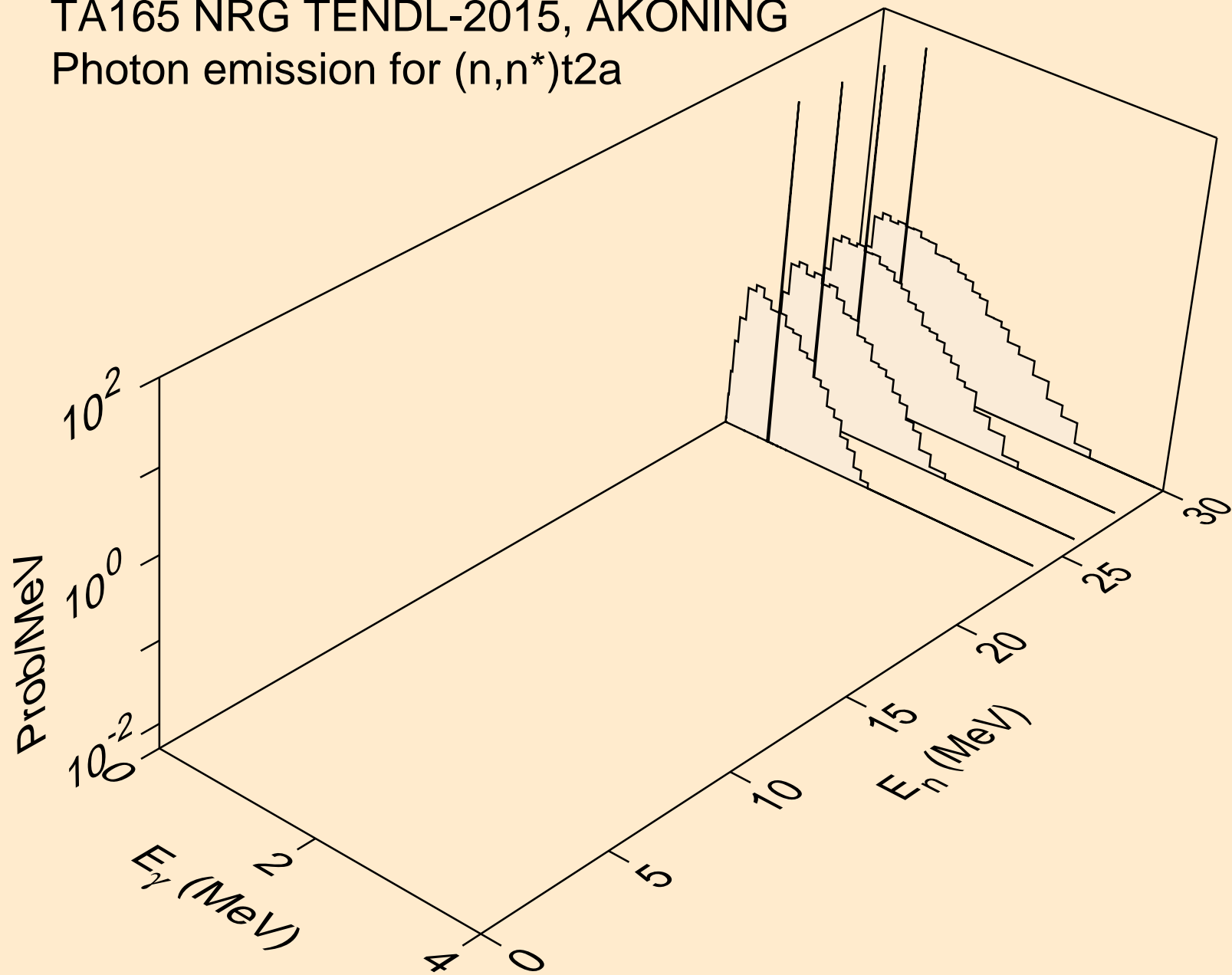

TA165 NRG TENDL-2015, AKONING  
Photon emission for (n,2np)

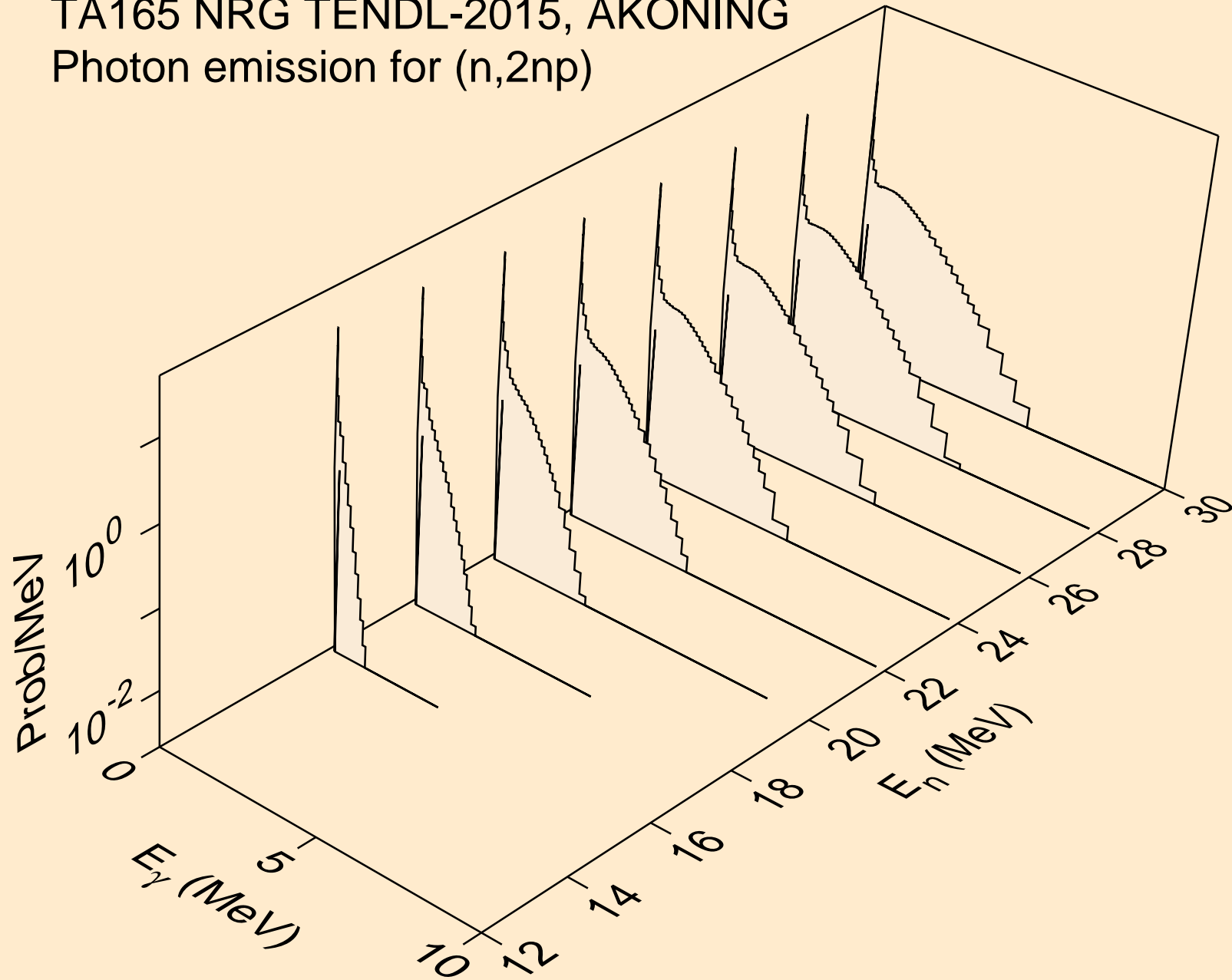

TA165 NRG TENDL-2015, AKONING  
Photon emission for (n,3np)

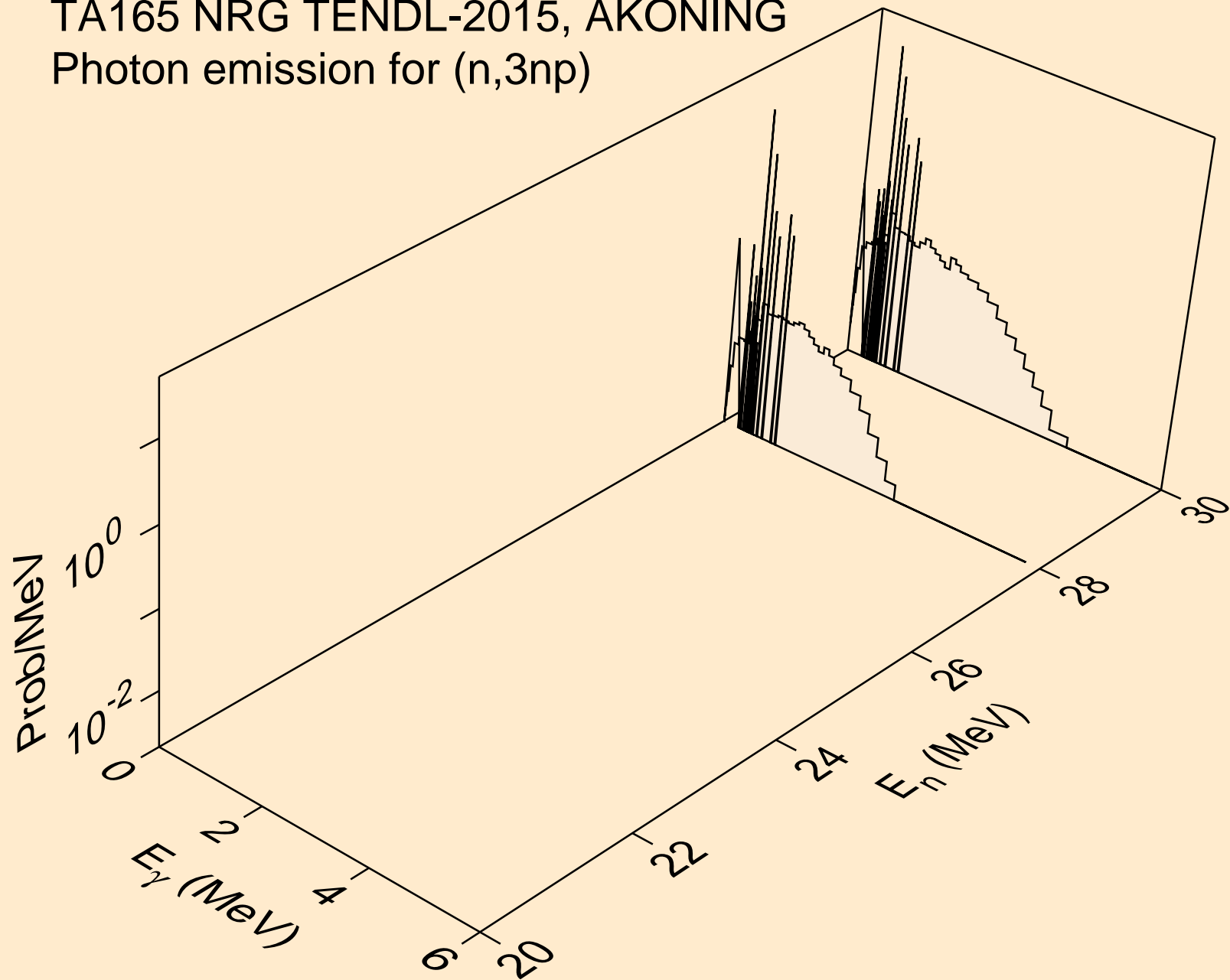

TA165 NRG TENDL-2015, AKONING  
Photon emission for (n,2np)

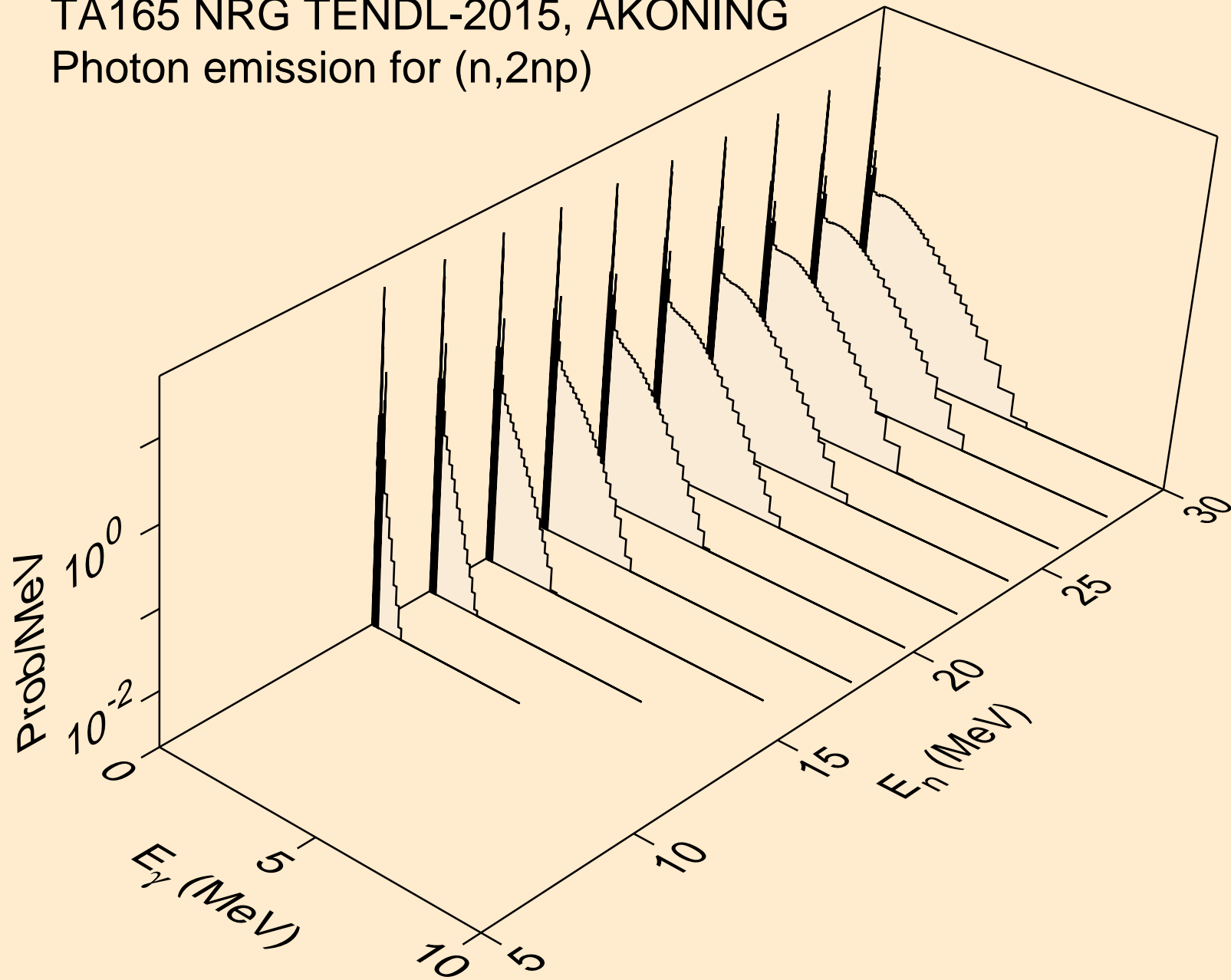

TA165 NRG TENDL-2015, AKONING  
Photon emission for (n,npa)

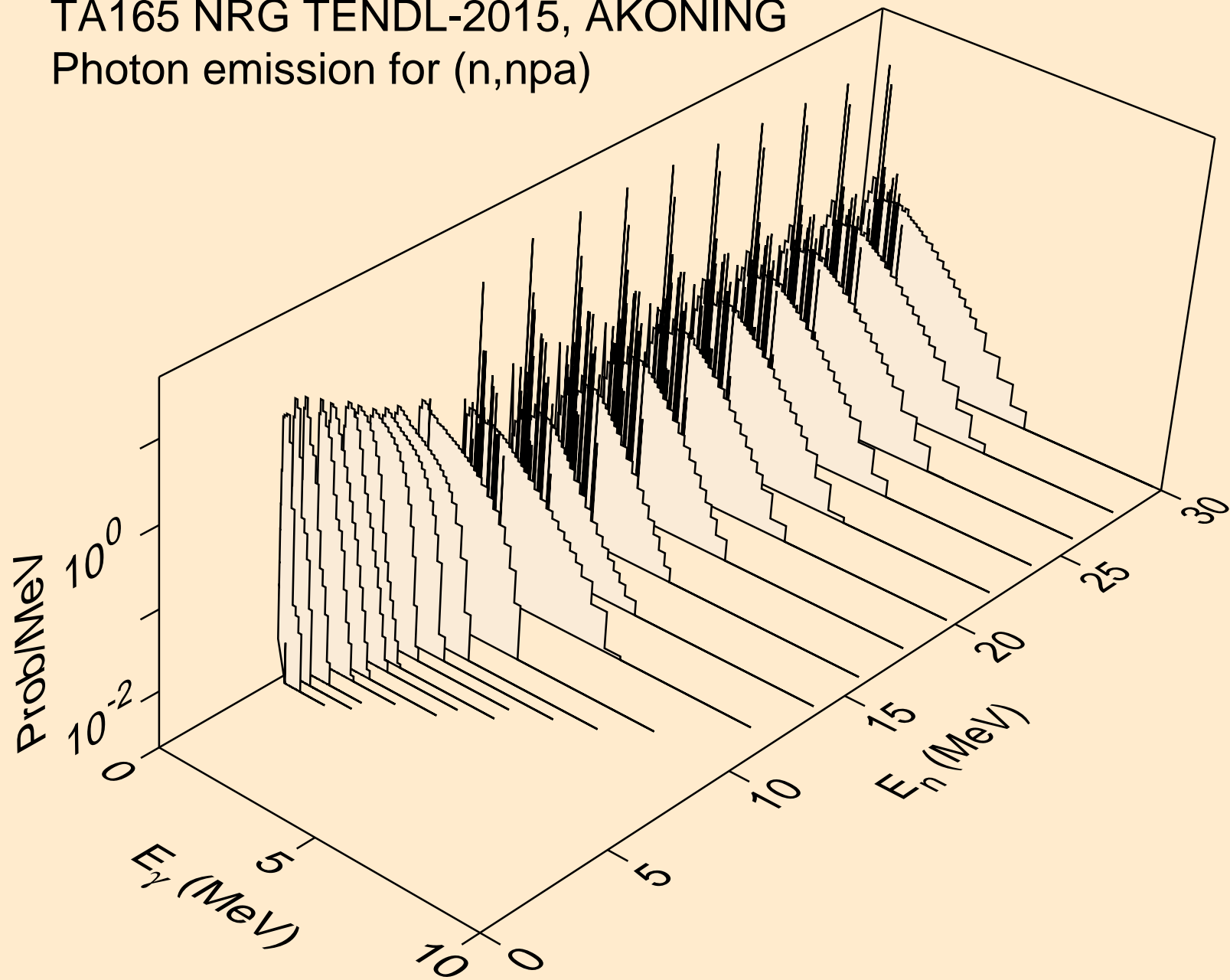

TA165 NRG TENDL-2015, AKONING  
Photon emission for (n,n\*c)

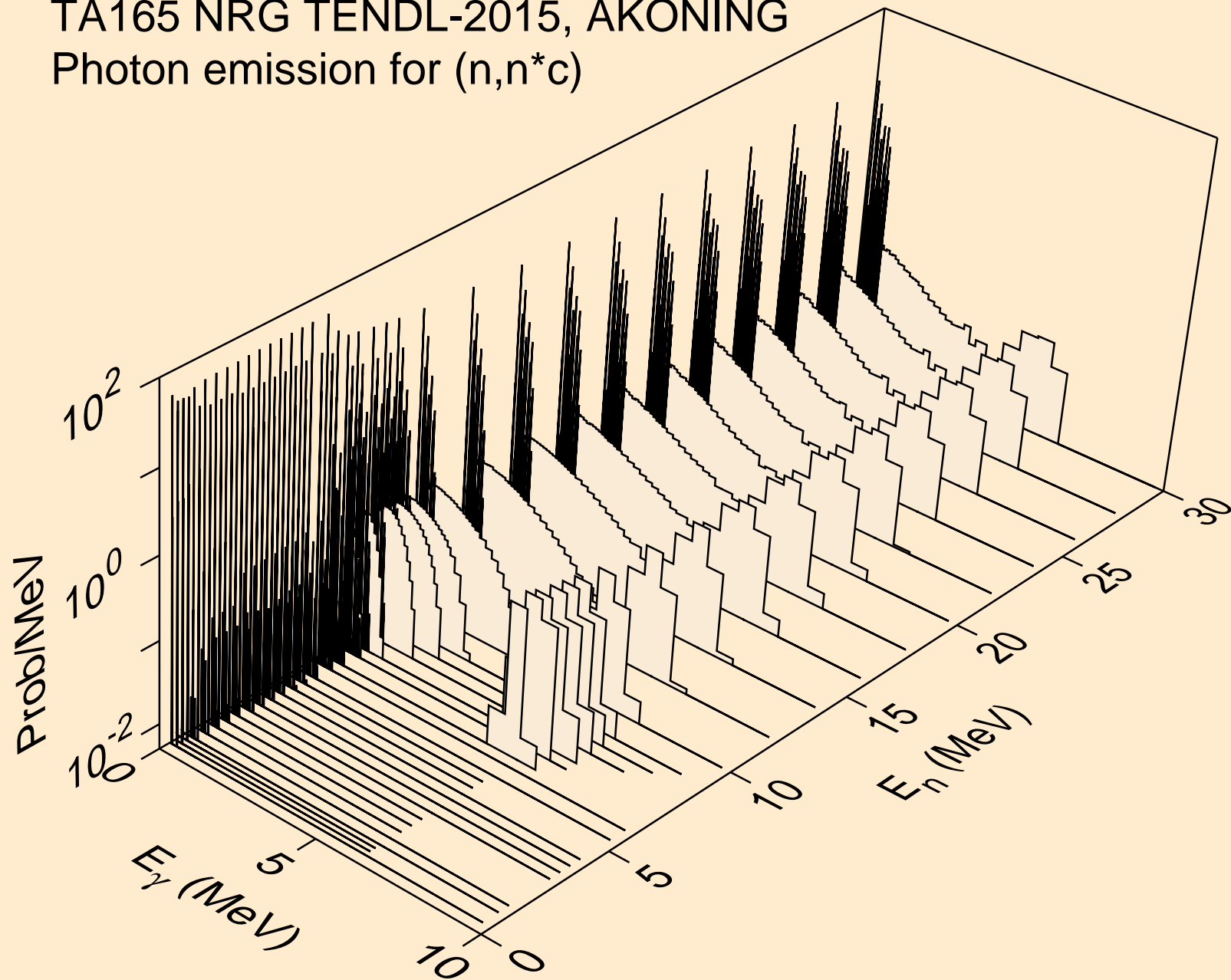

TA165 NRG TENDL-2015, AKONING  
Photon emission for (n,gma)

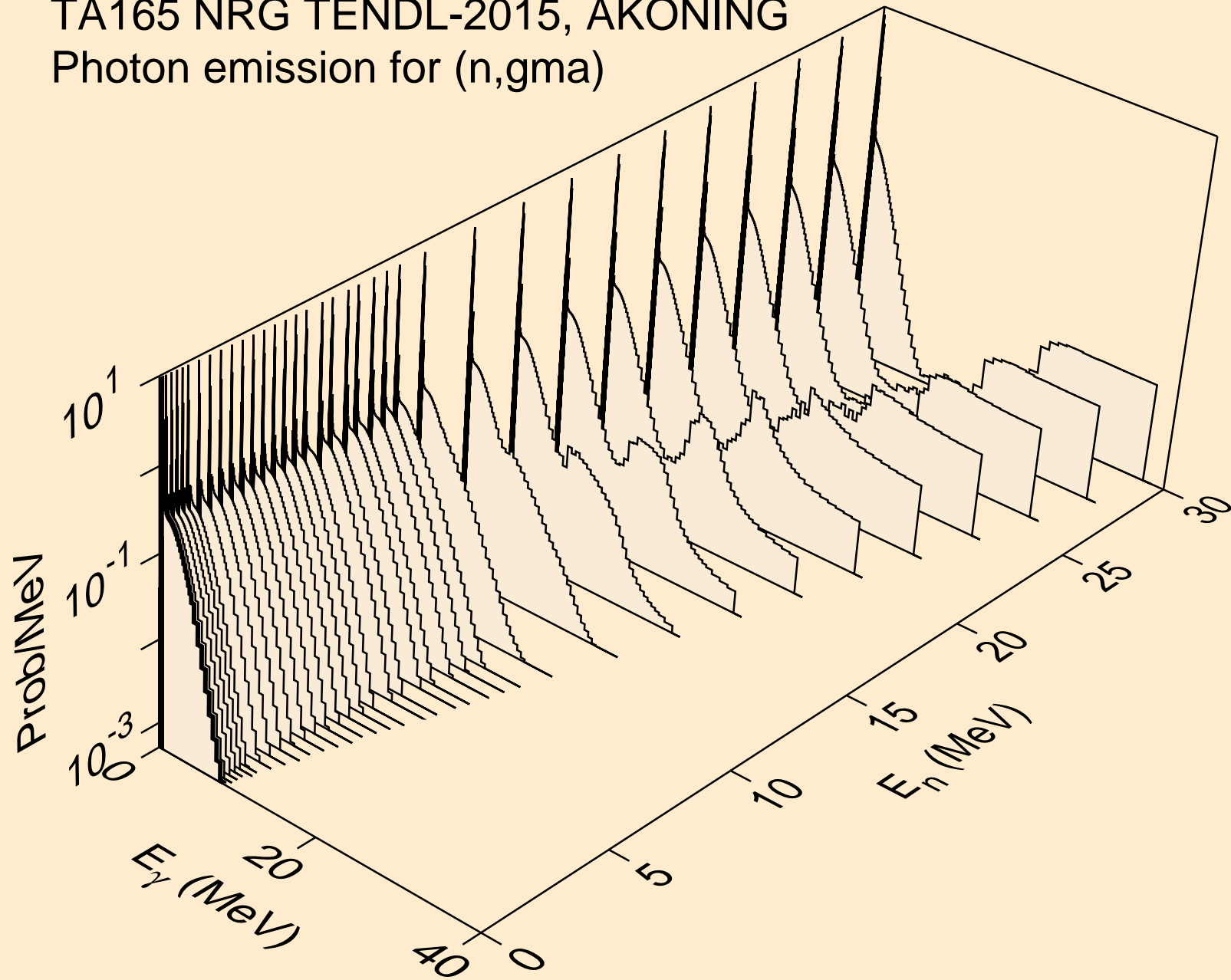

TA165 NRG TENDL-2015, AKONING  
Photon emission for (n,p)

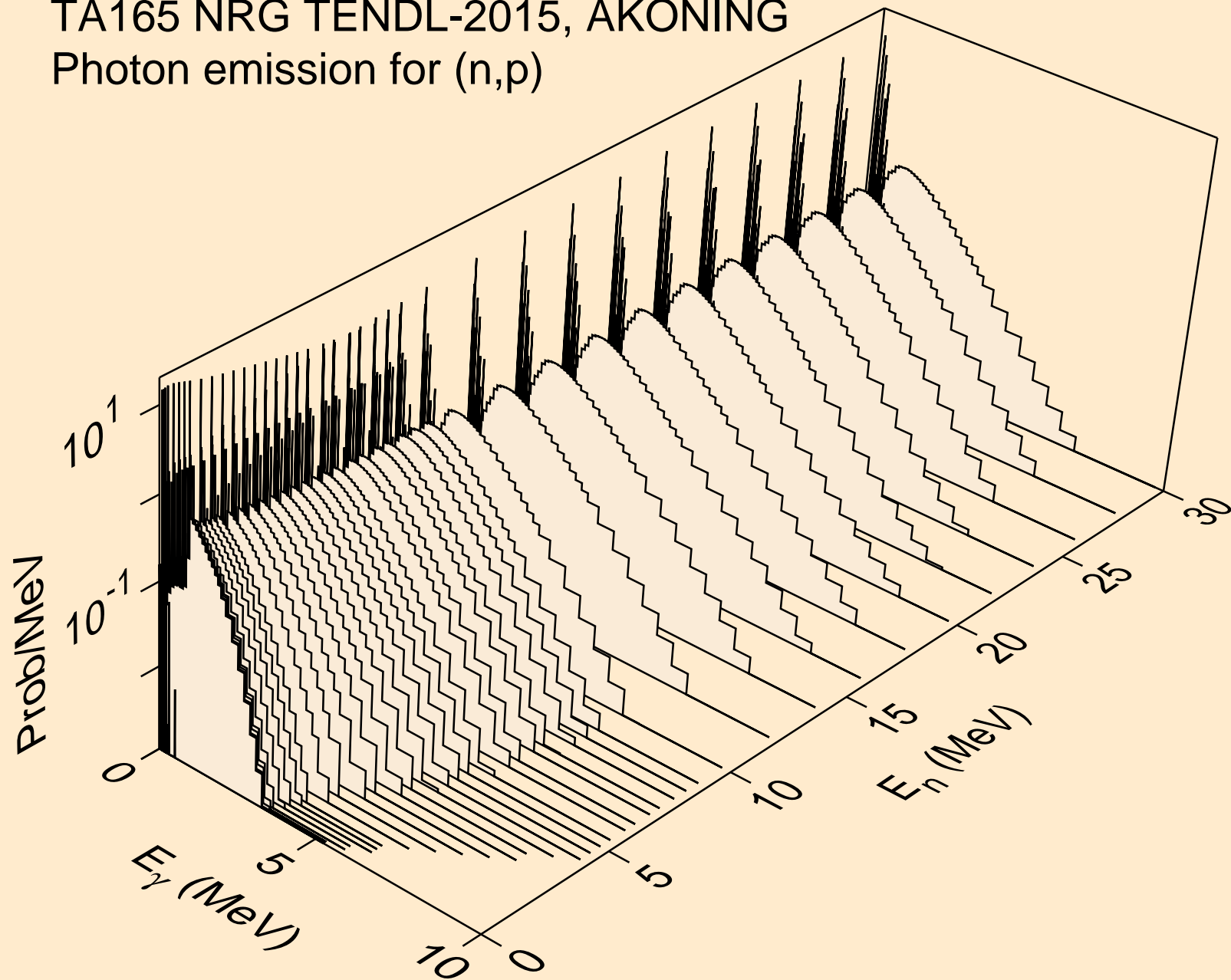



TA165 NRG TENDL-2015, AKONING  
Photon emission for (n,d)

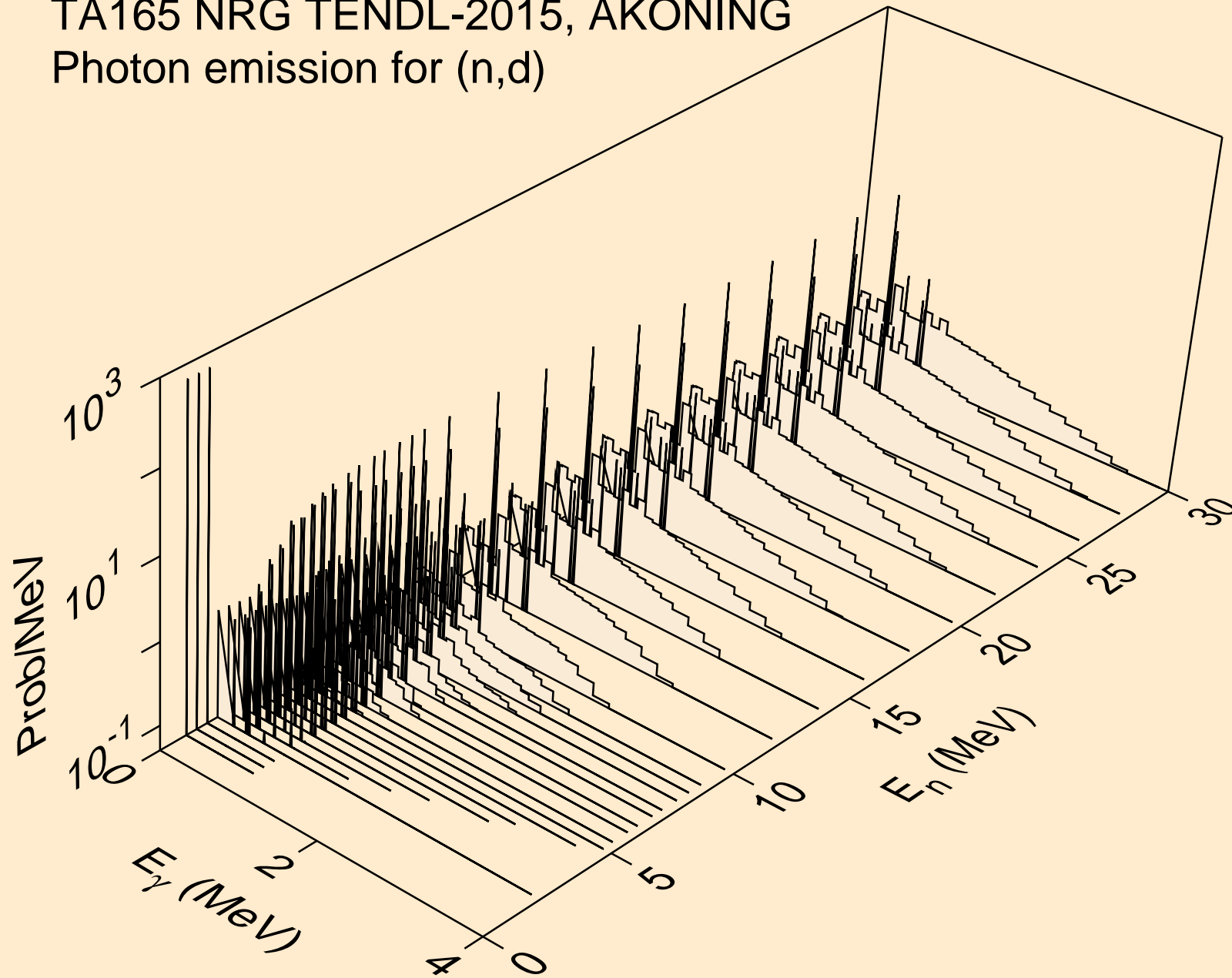

TA165 NRG TENDL-2015, AKONING  
Photon emission for (n,t)

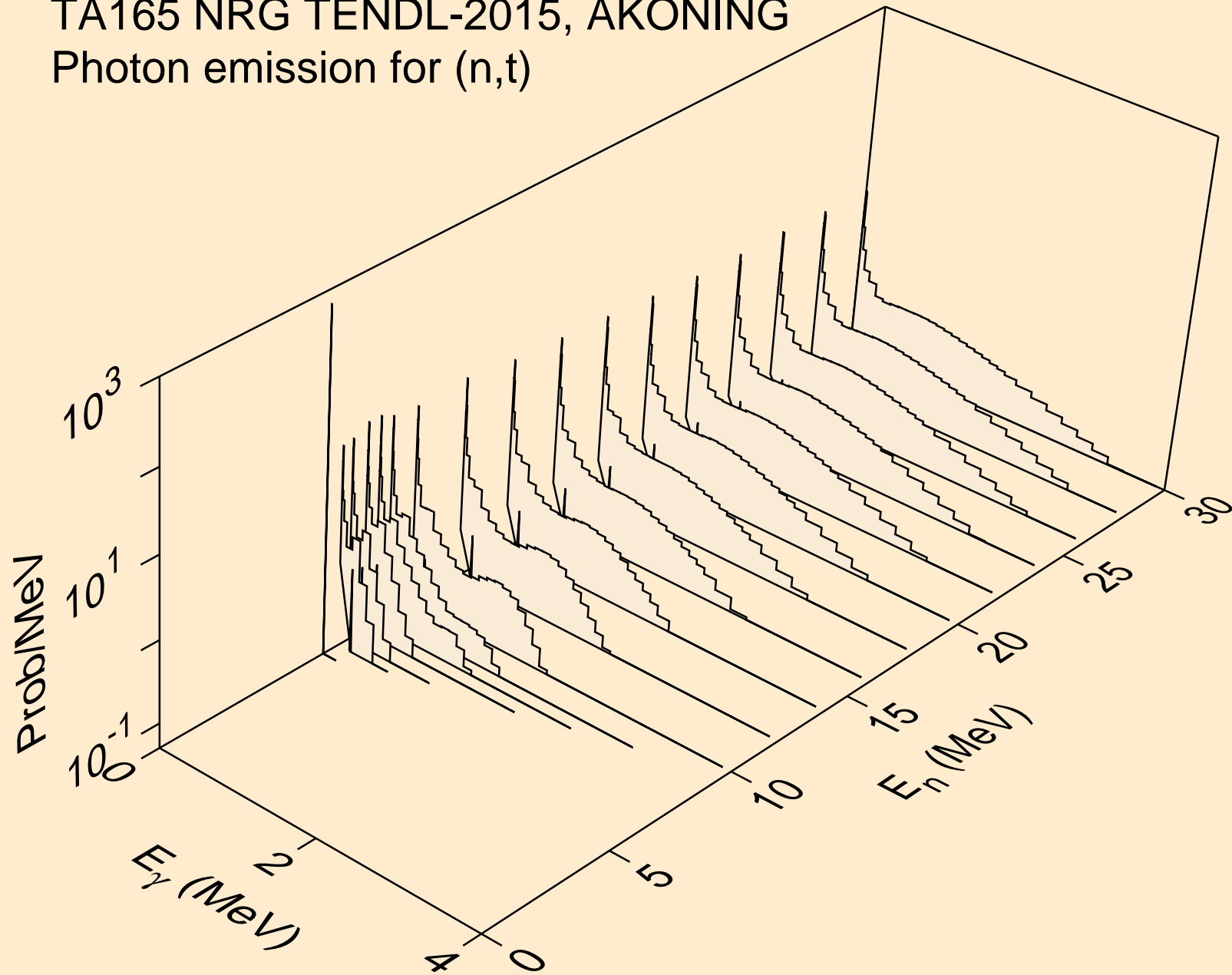

TA165 NRG TENDL-2015, AKONING  
Photon emission for (n,he3)

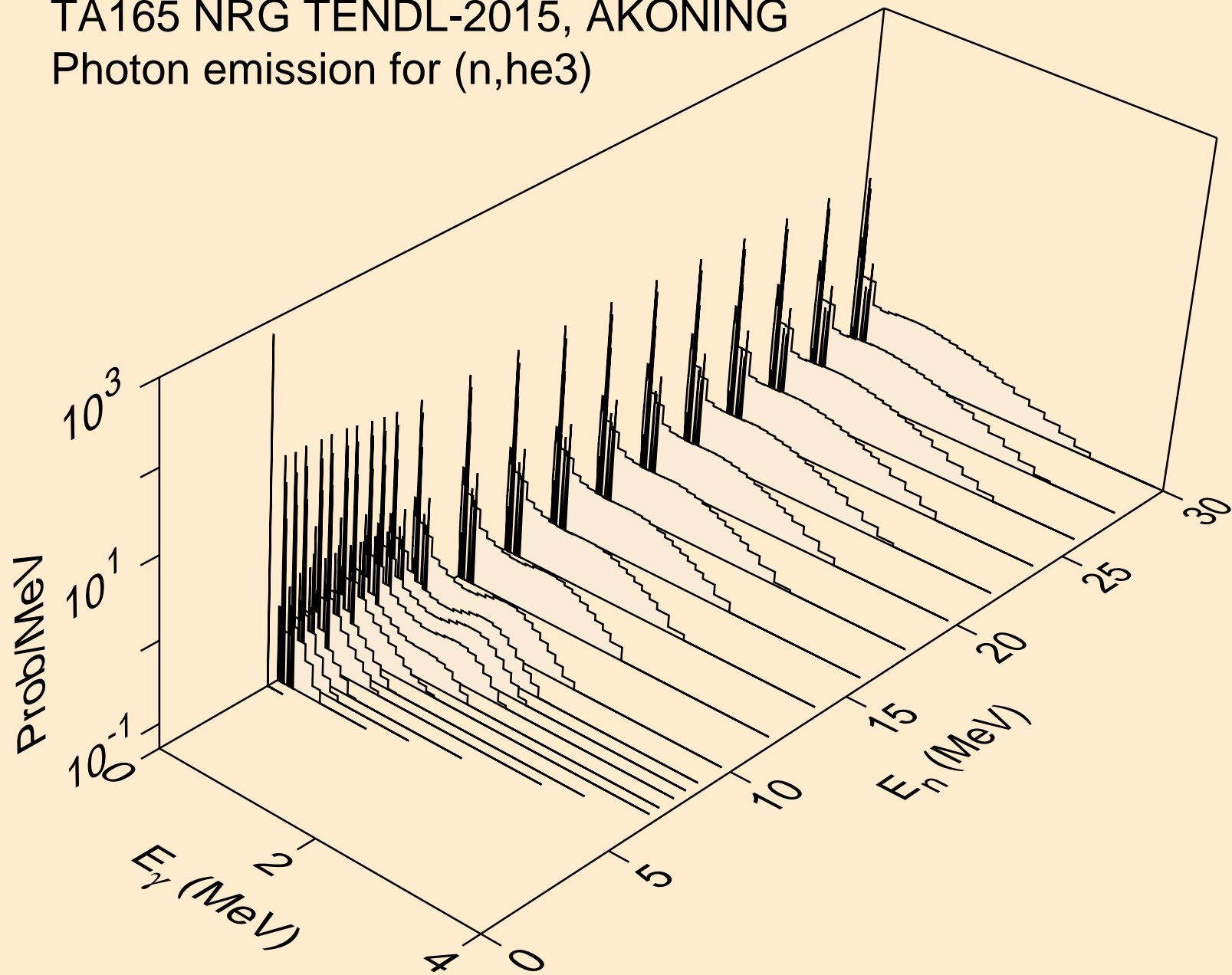

TA165 NRG TENDL-2015, AKONING  
Photon emission for (n,a)

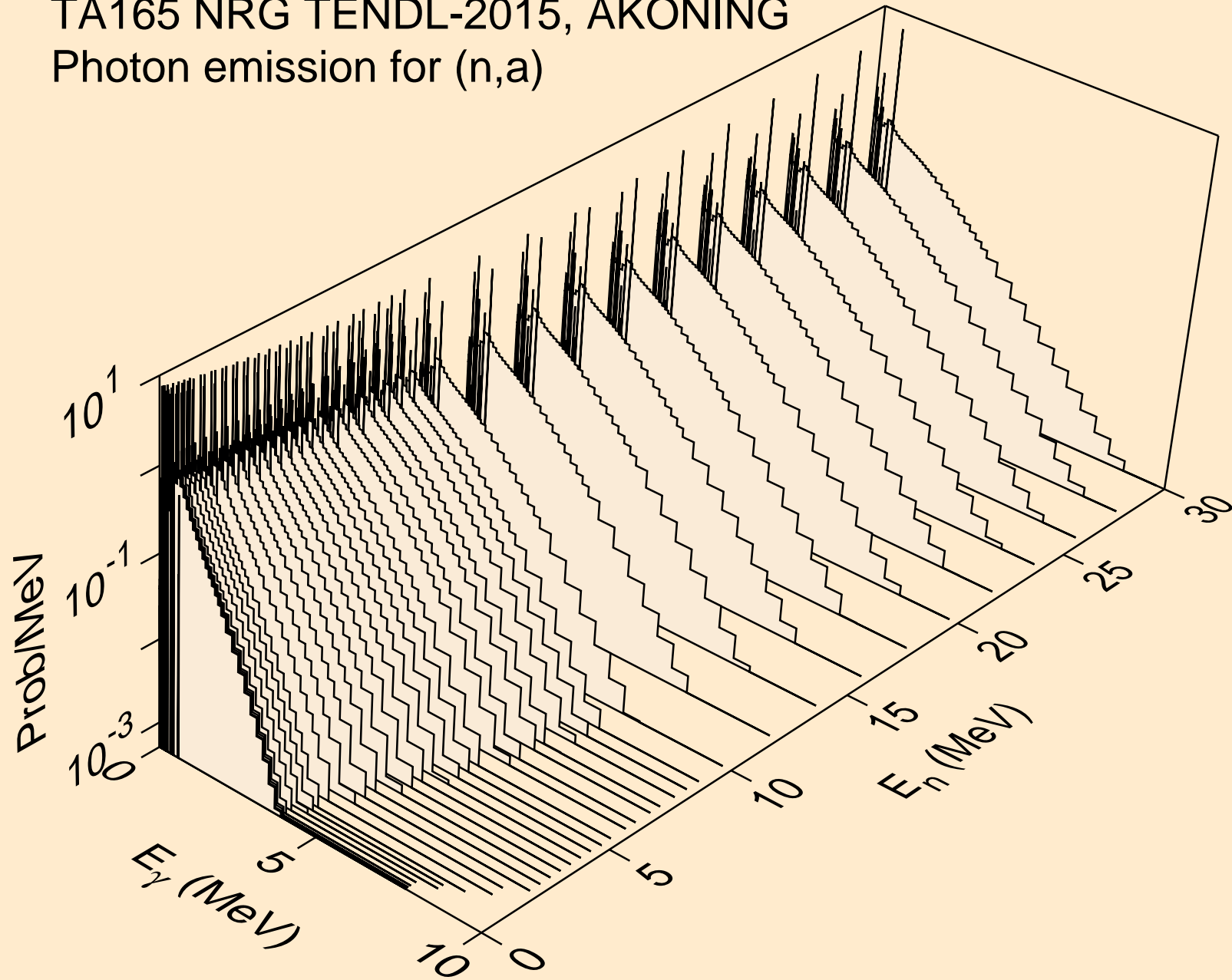

TA165 NRG TENDL-2015, AKONING  
Photon emission for (n,2a)

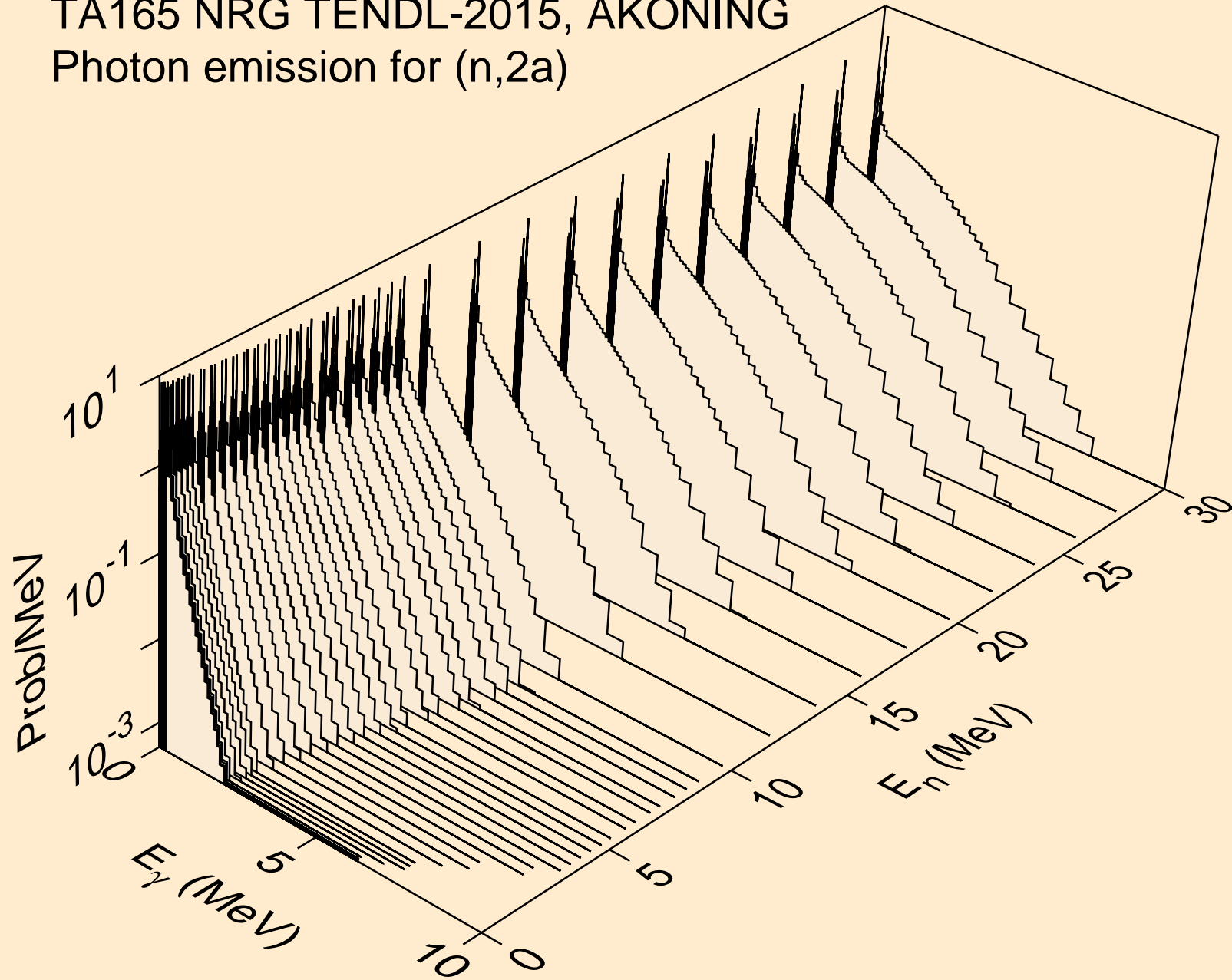

TA165 NRG TENDL-2015, AKONING  
Photon emission for (n,3a)

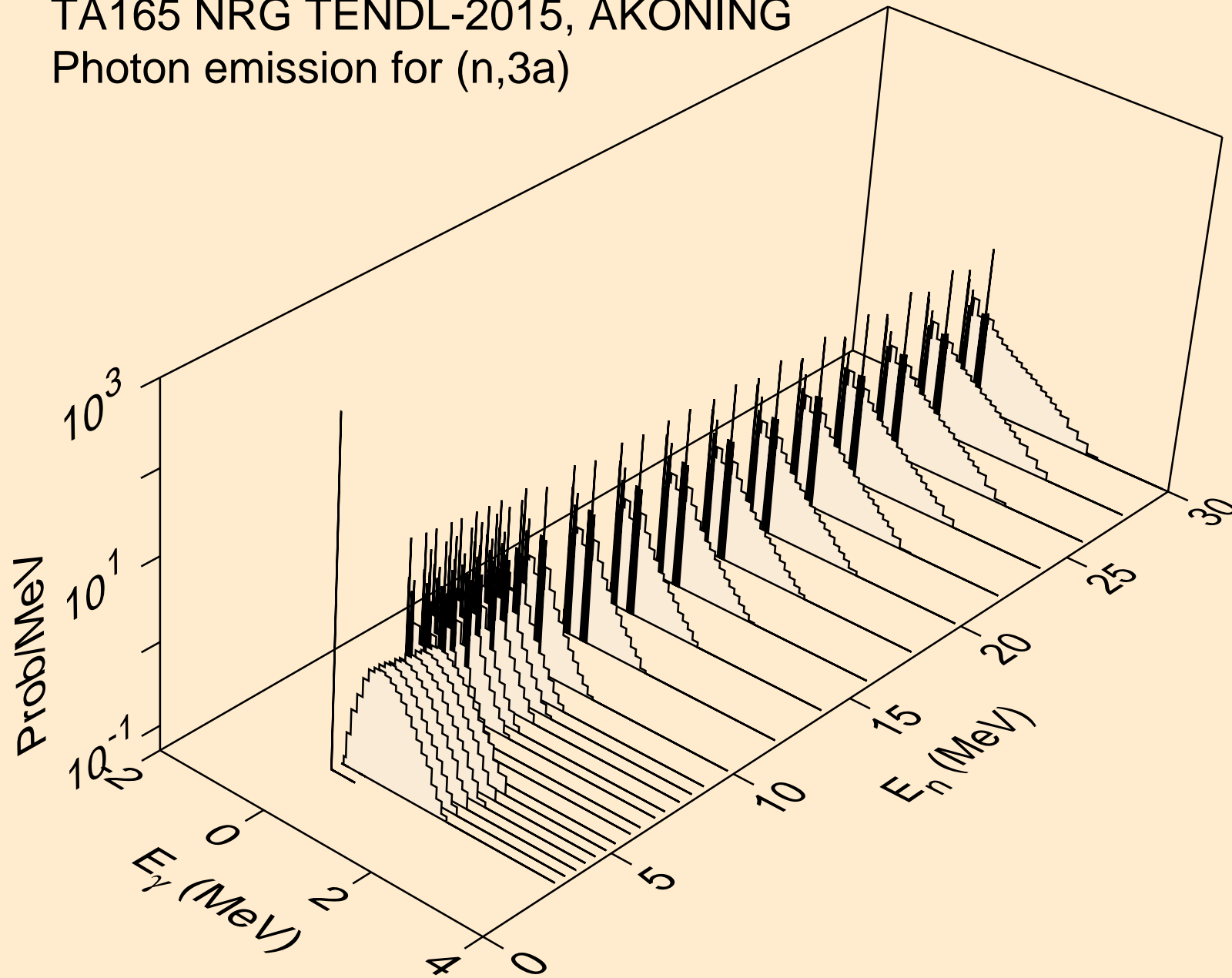

TA165 NRG TENDL-2015, AKONING  
Photon emission for (n,2p)

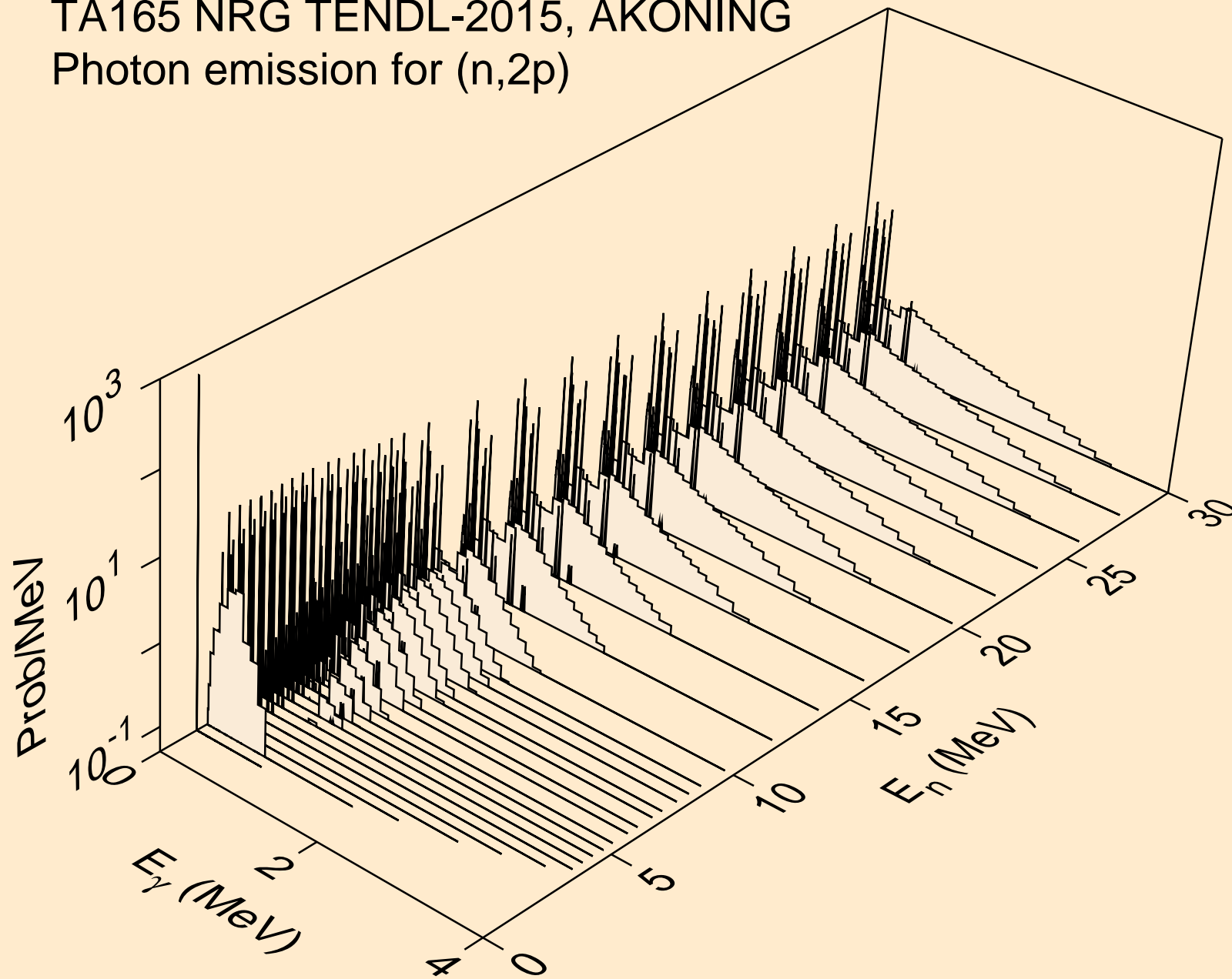

TA165 NRG TENDL-2015, AKONING  
Photon emission for (n,p $\alpha$ )

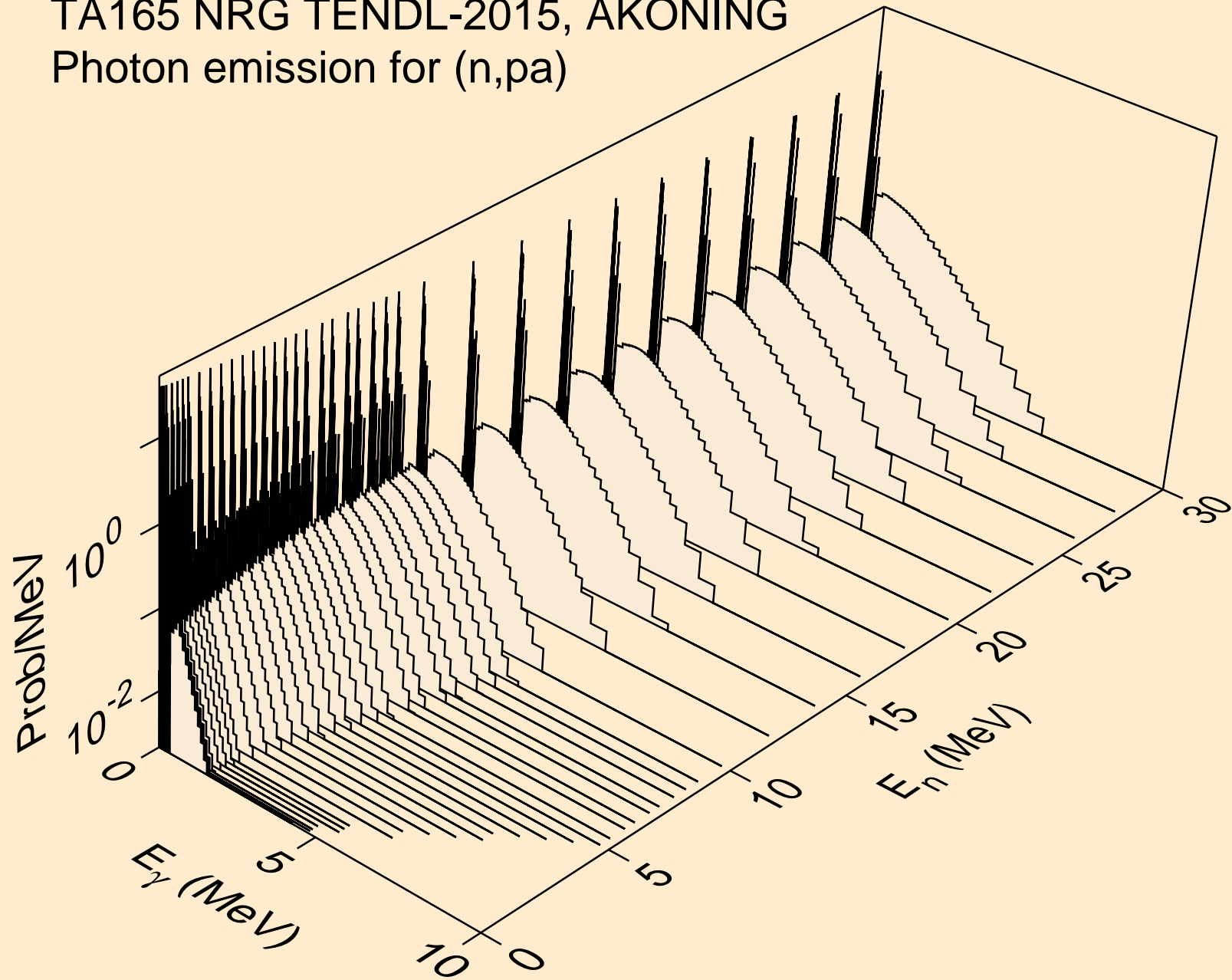



TA165 NRG TENDL-2015, AKONING  
Photon emission for (n,t2a)

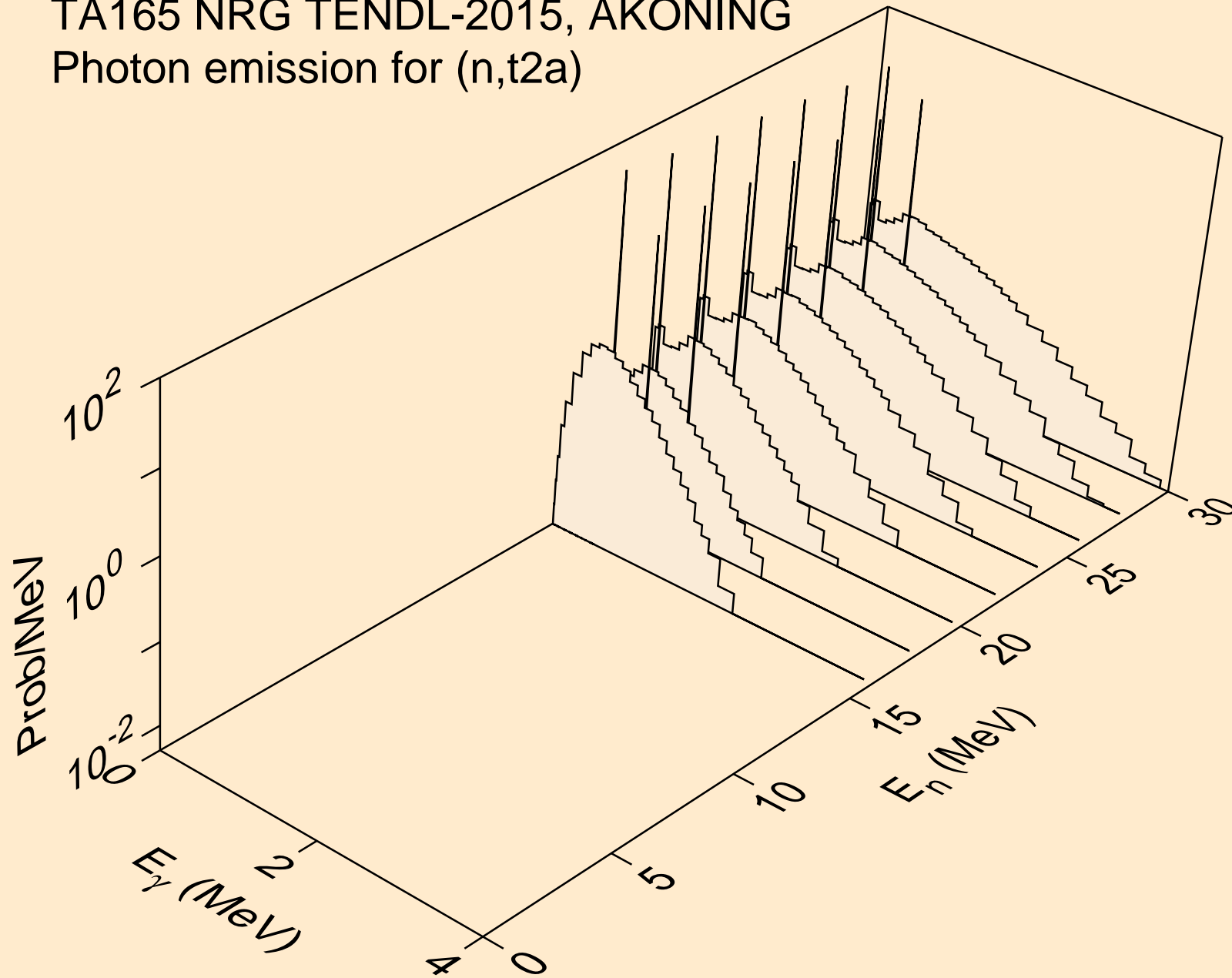

TA165 NRG TENDL-2015, AKONING  
Photon emission for (n,d2a)

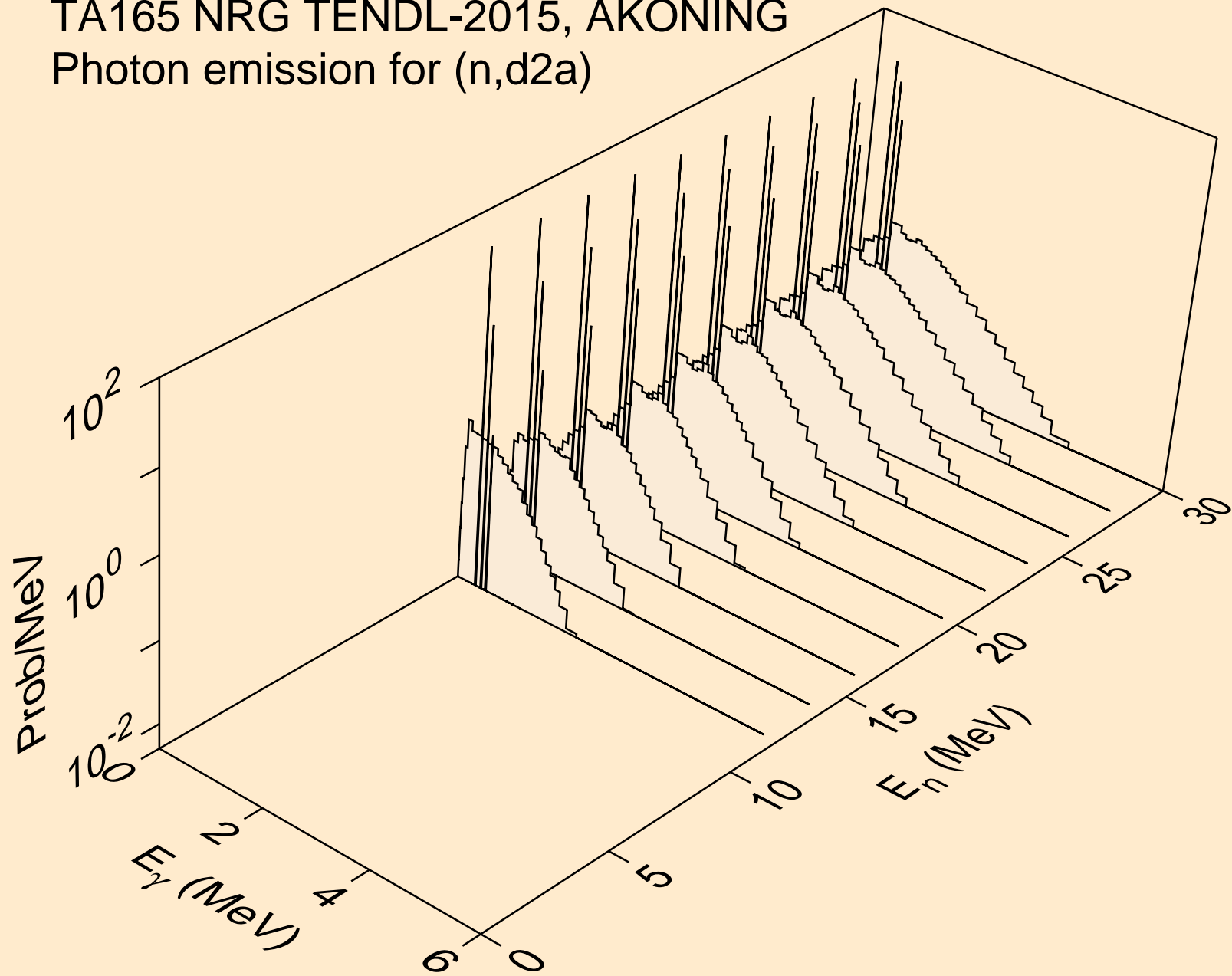

TA165 NRG TENDL-2015, AKONING  
Photon emission for (n,pd)

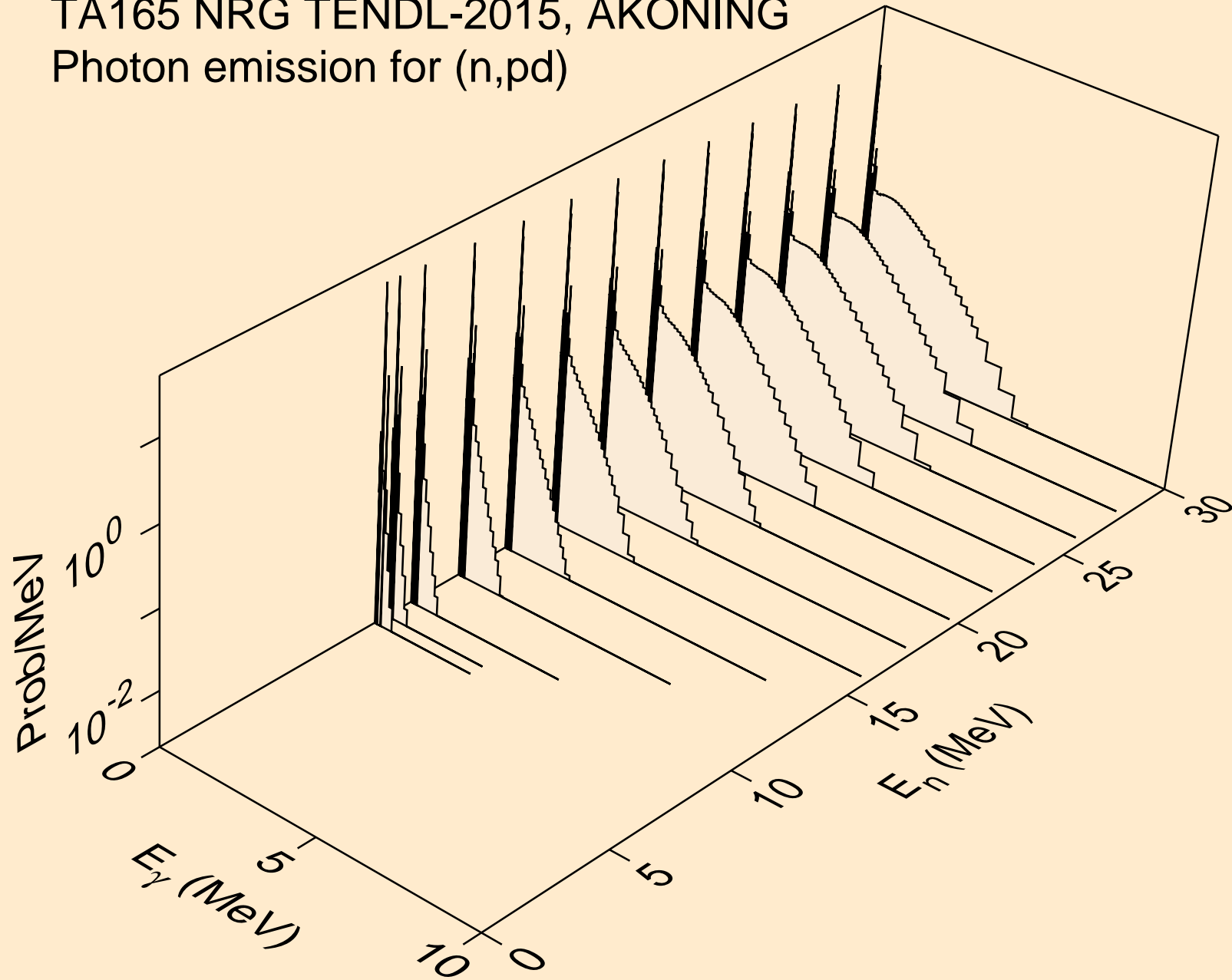

TA165 NRG TENDL-2015, AKONING  
Photon emission for (n,pt)

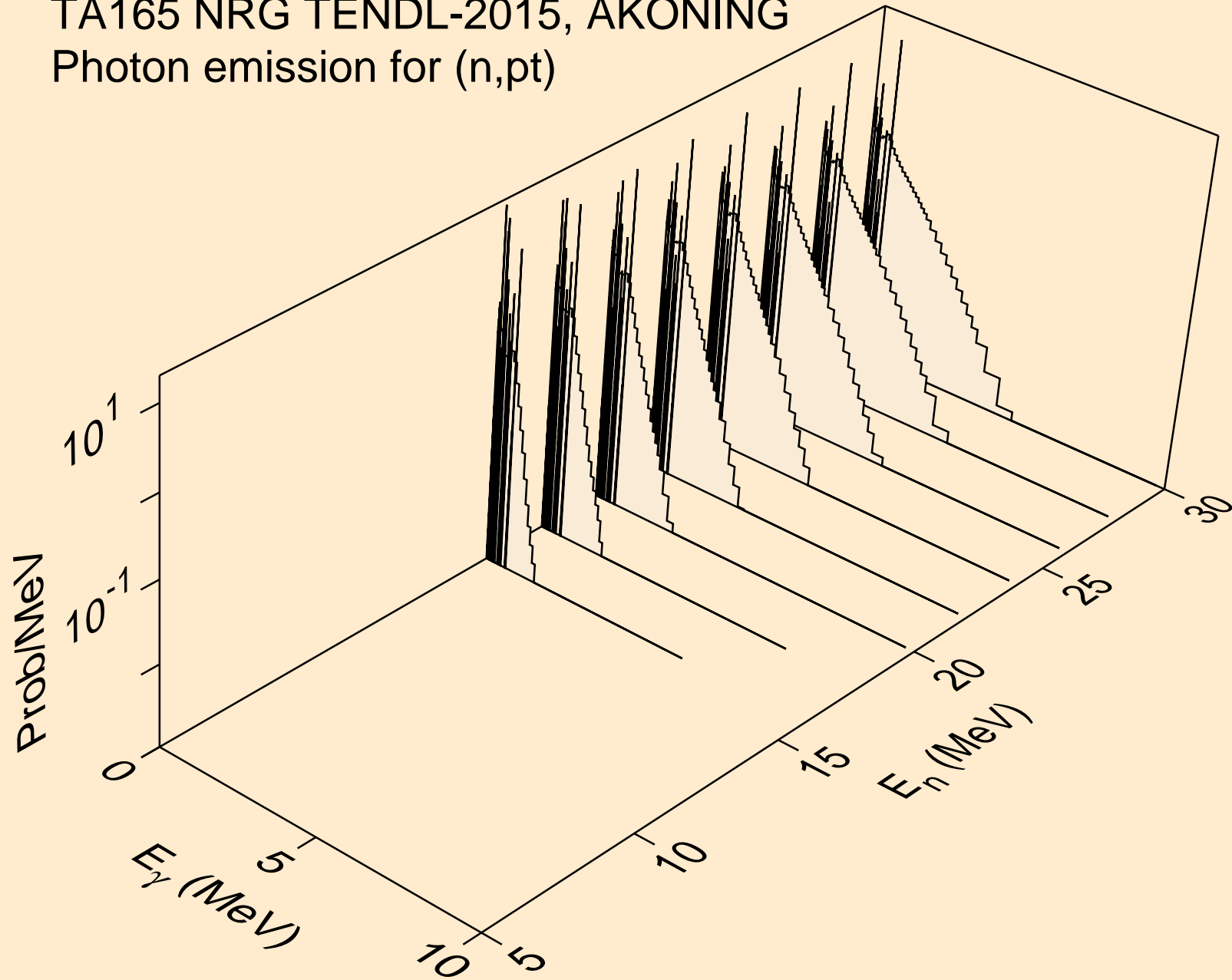

TA165 NRG TENDL-2015, AKONING  
Photon emission for (n,da)

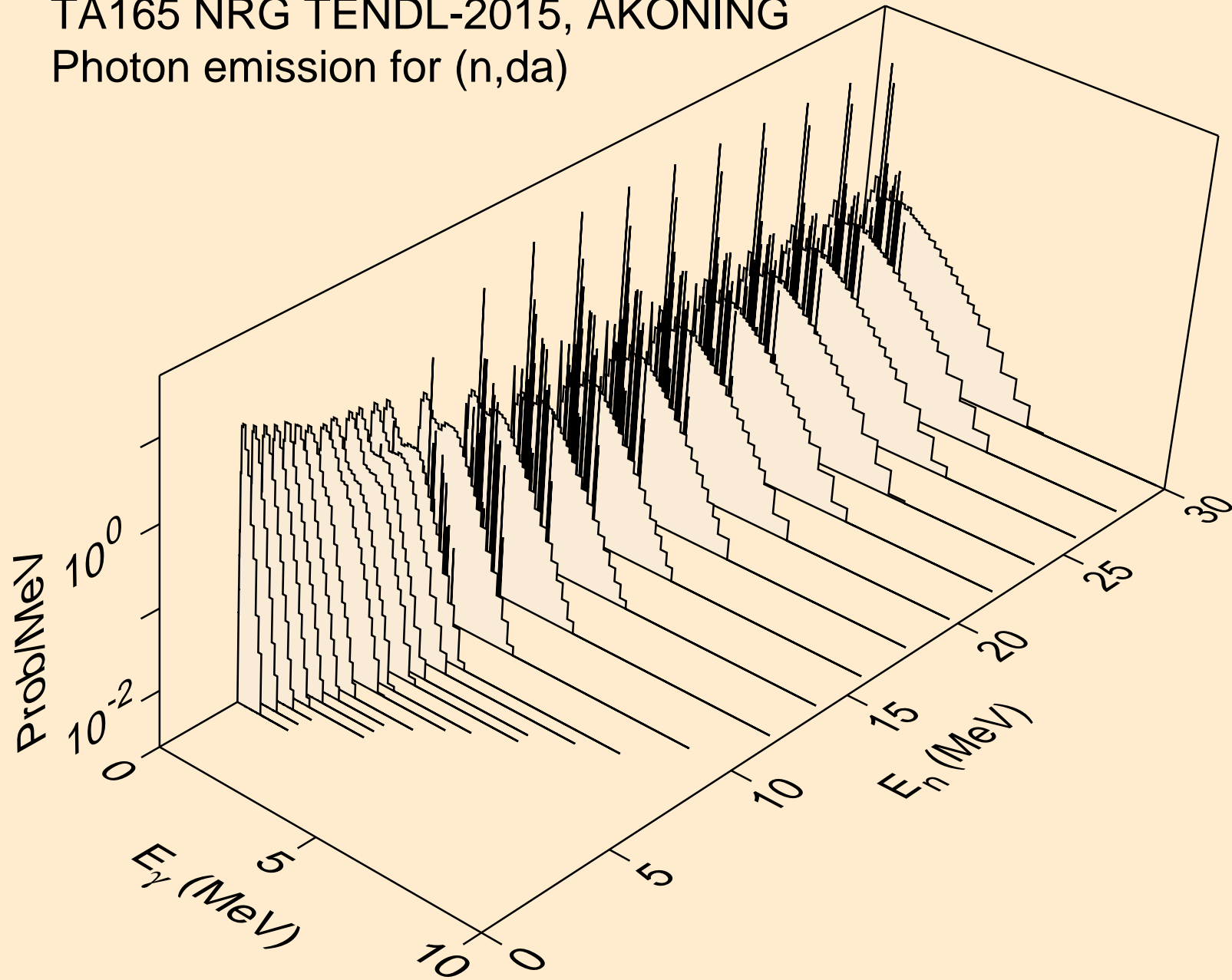

TA165 NRG TENDL-2015, AKONING  
thermal capture photon spectrum

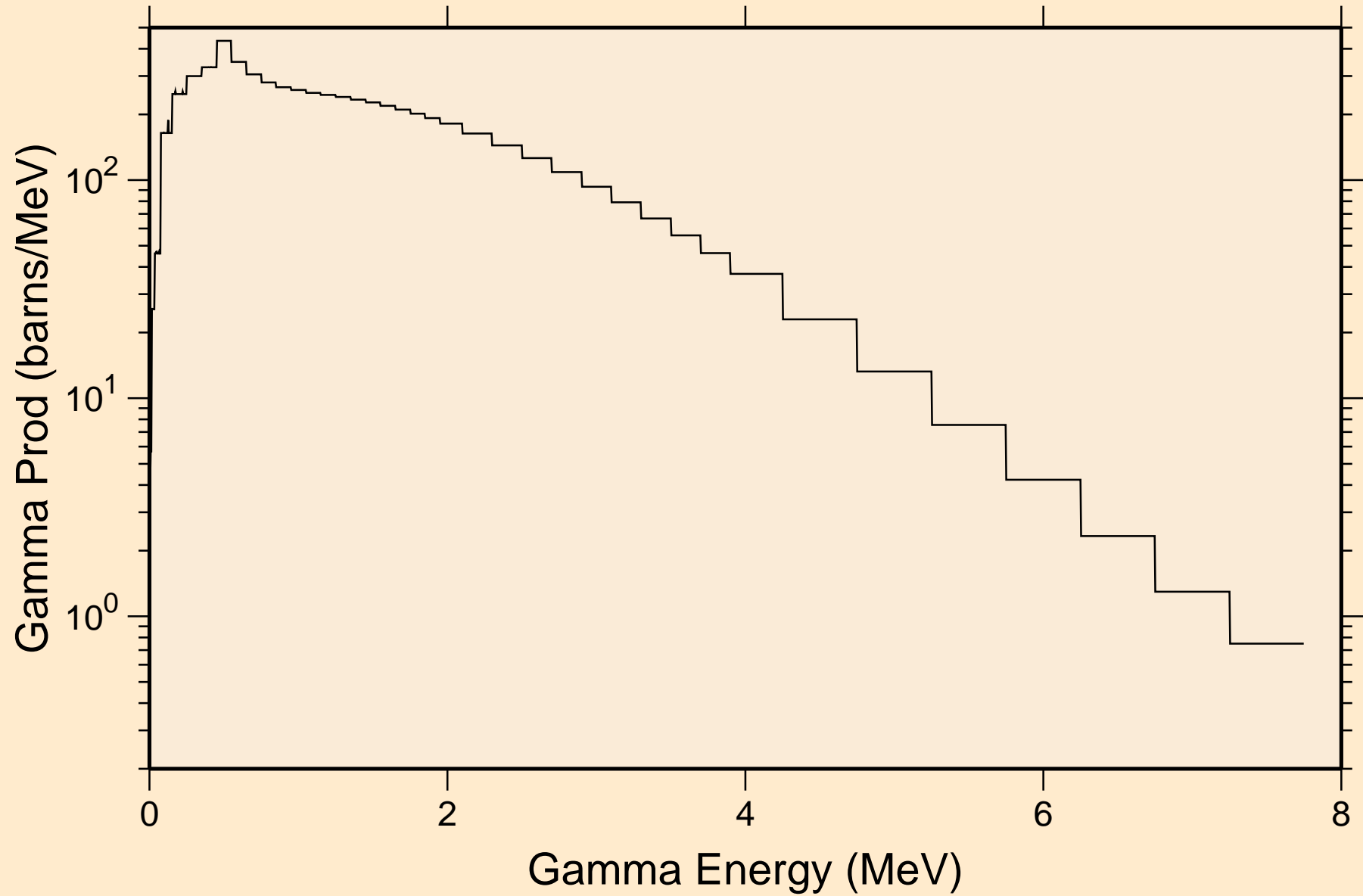

TA165 NRG TENDL-2015, AKONING  
14 MeV photon spectrum

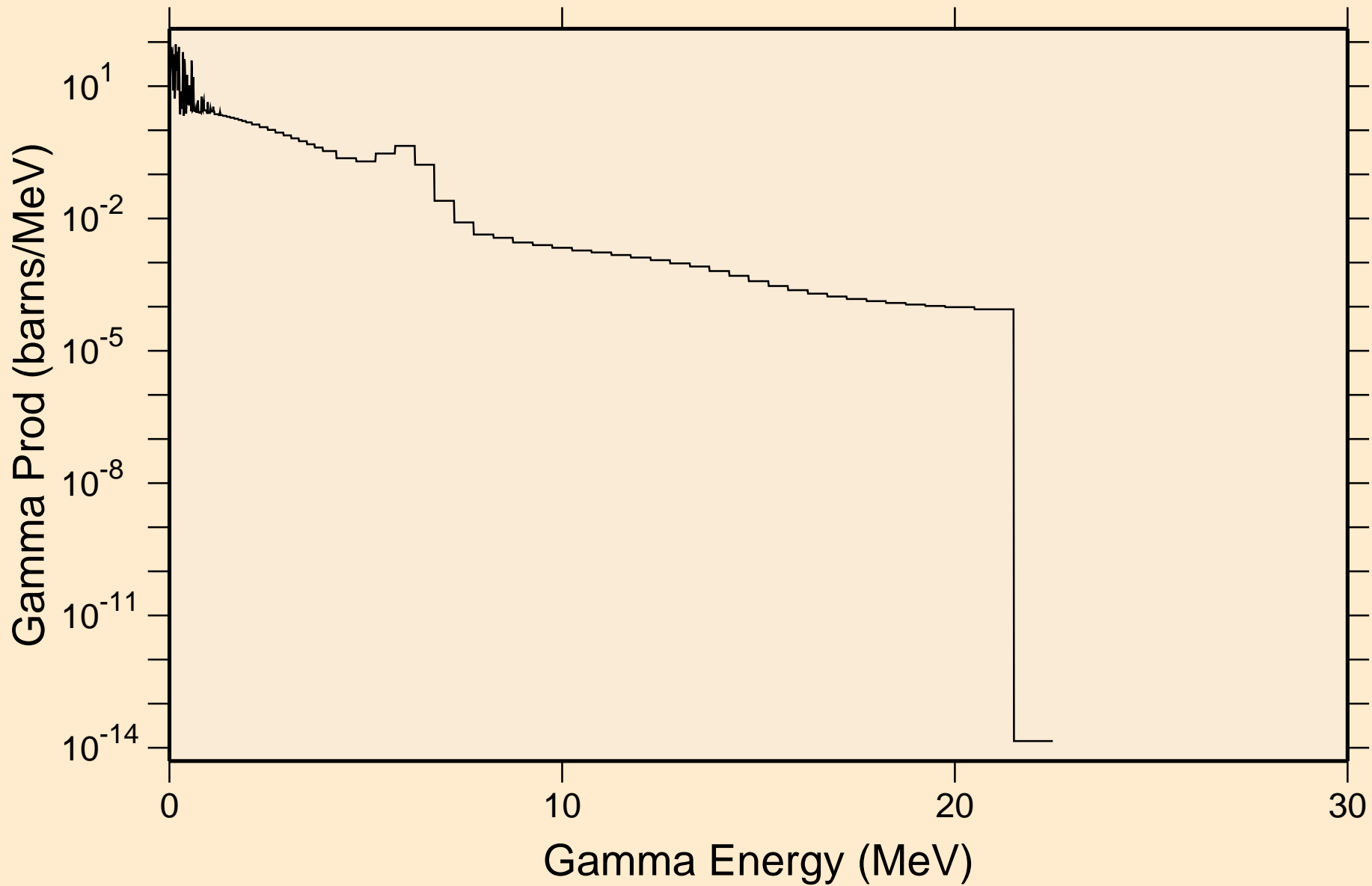

# TA165 NRG TENDL-2015, AKONING

## Particle heating contributions

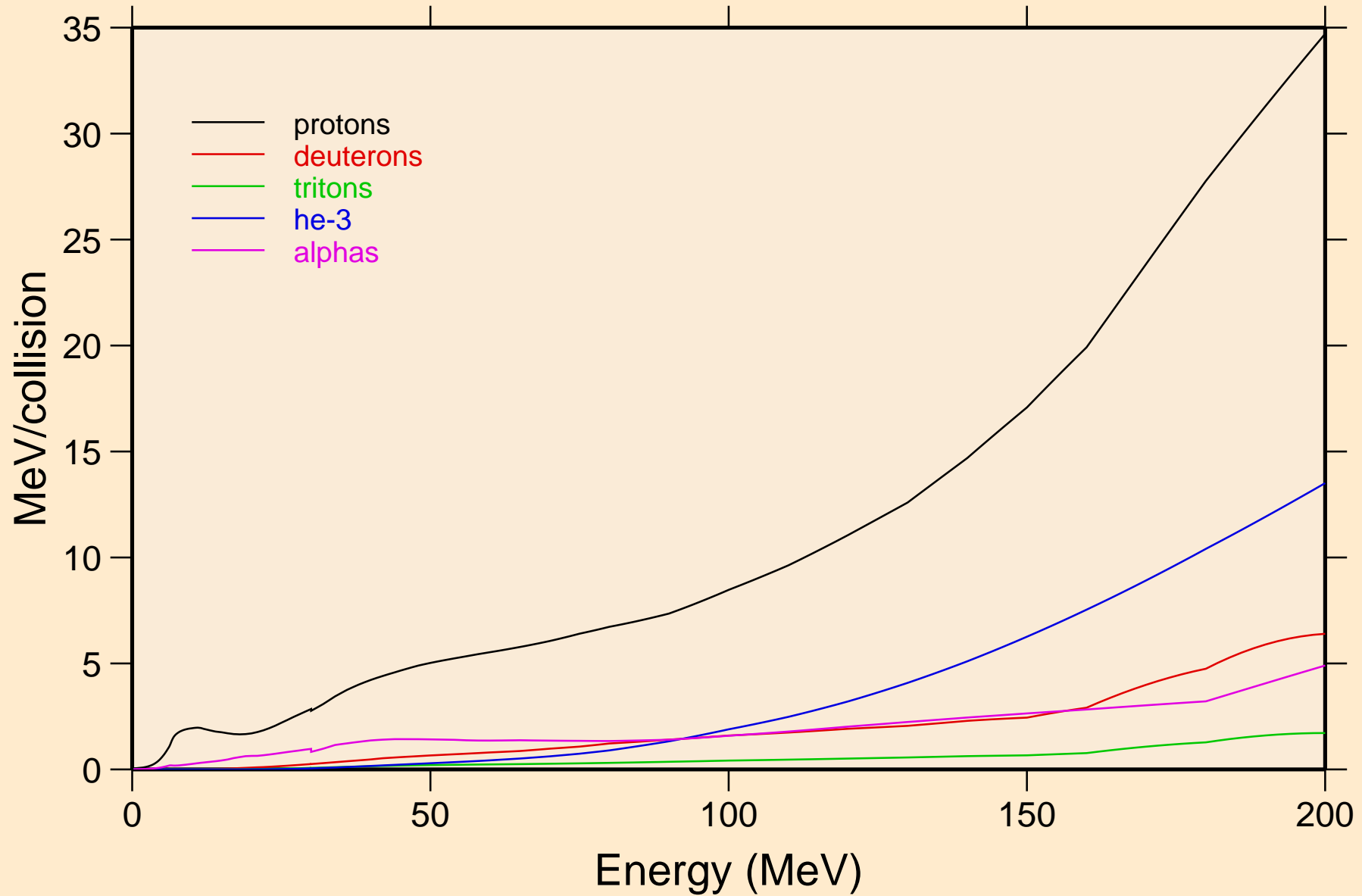



# TA165 NRG TENDL-2015, AKONING

## Recoil Heating

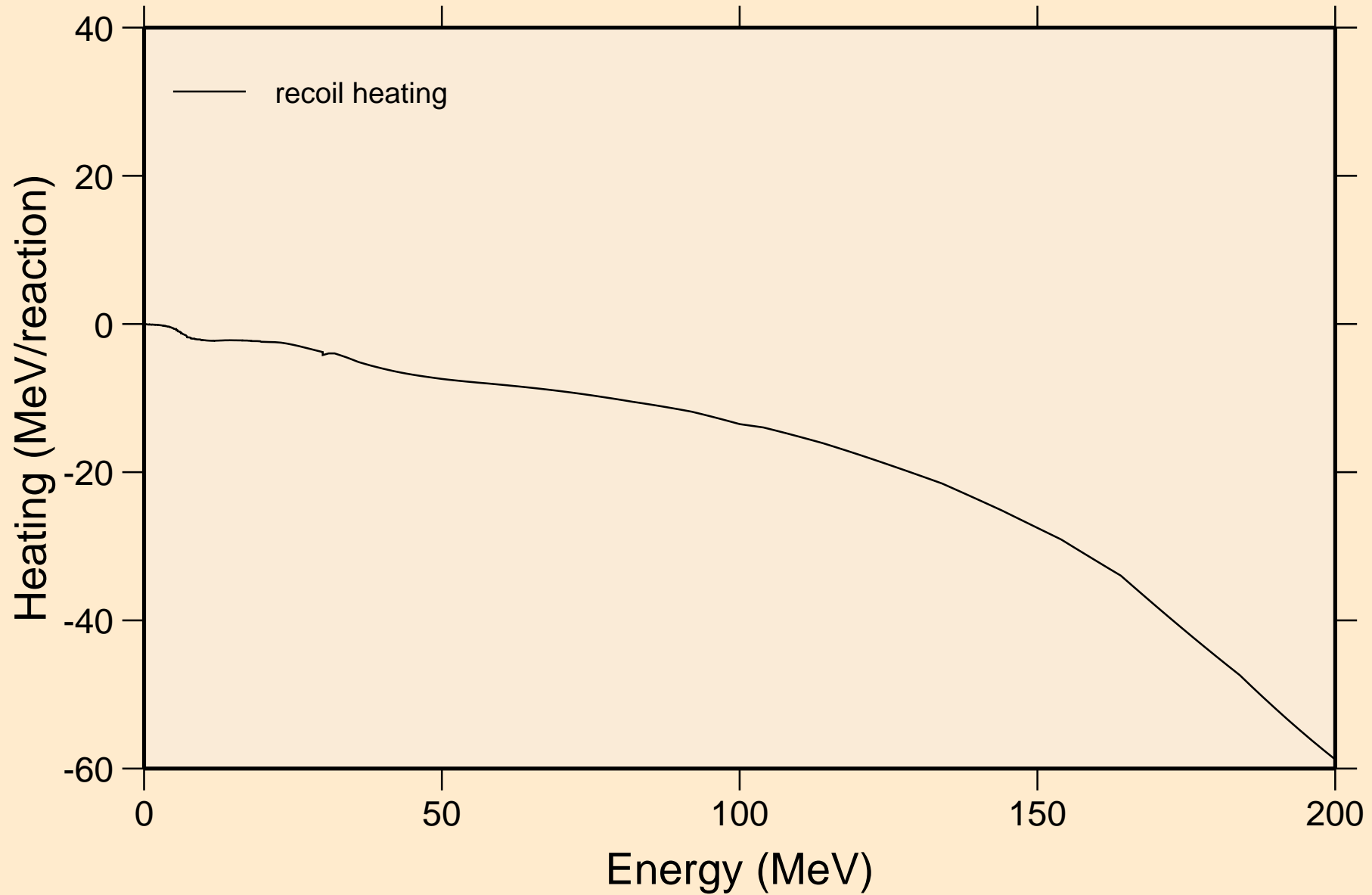

# TA165 NRG TENDL-2015, AKONING

## Particle production cross sections

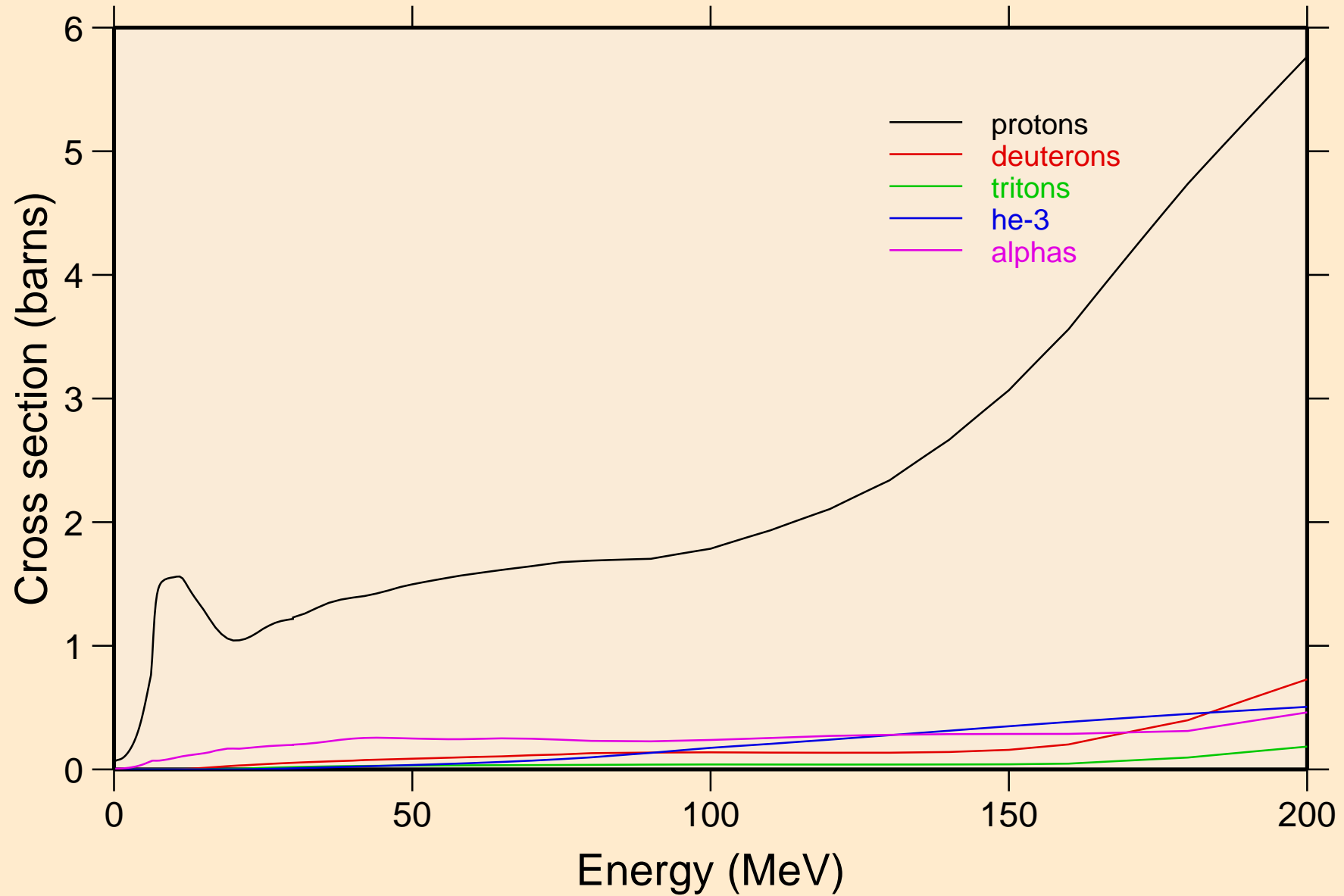

TA165 NRG TENDL-2015, AKONING  
protons from (n,x)

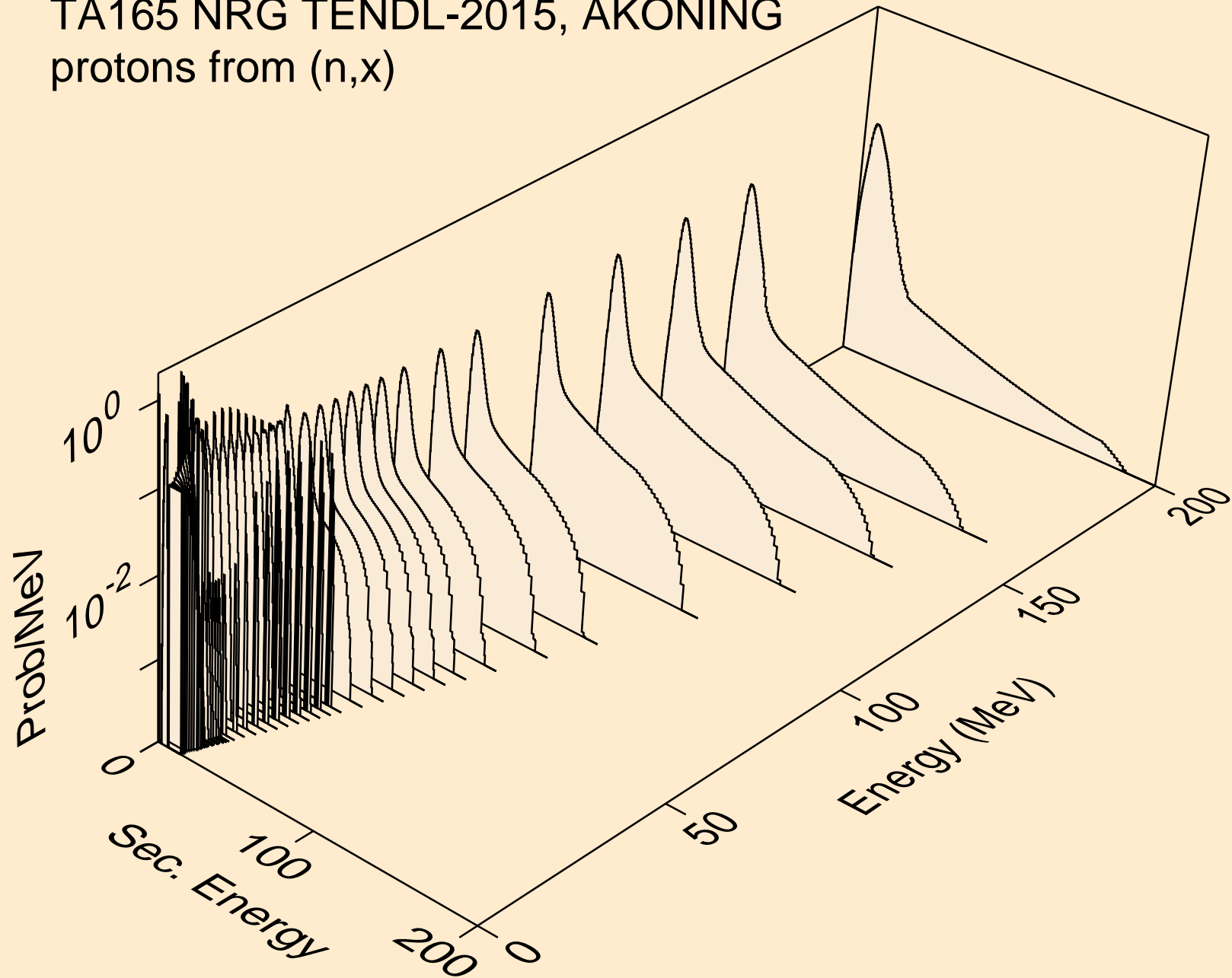

TA165 NRG TENDL-2015, AKONING  
protons from (n,n\*)p

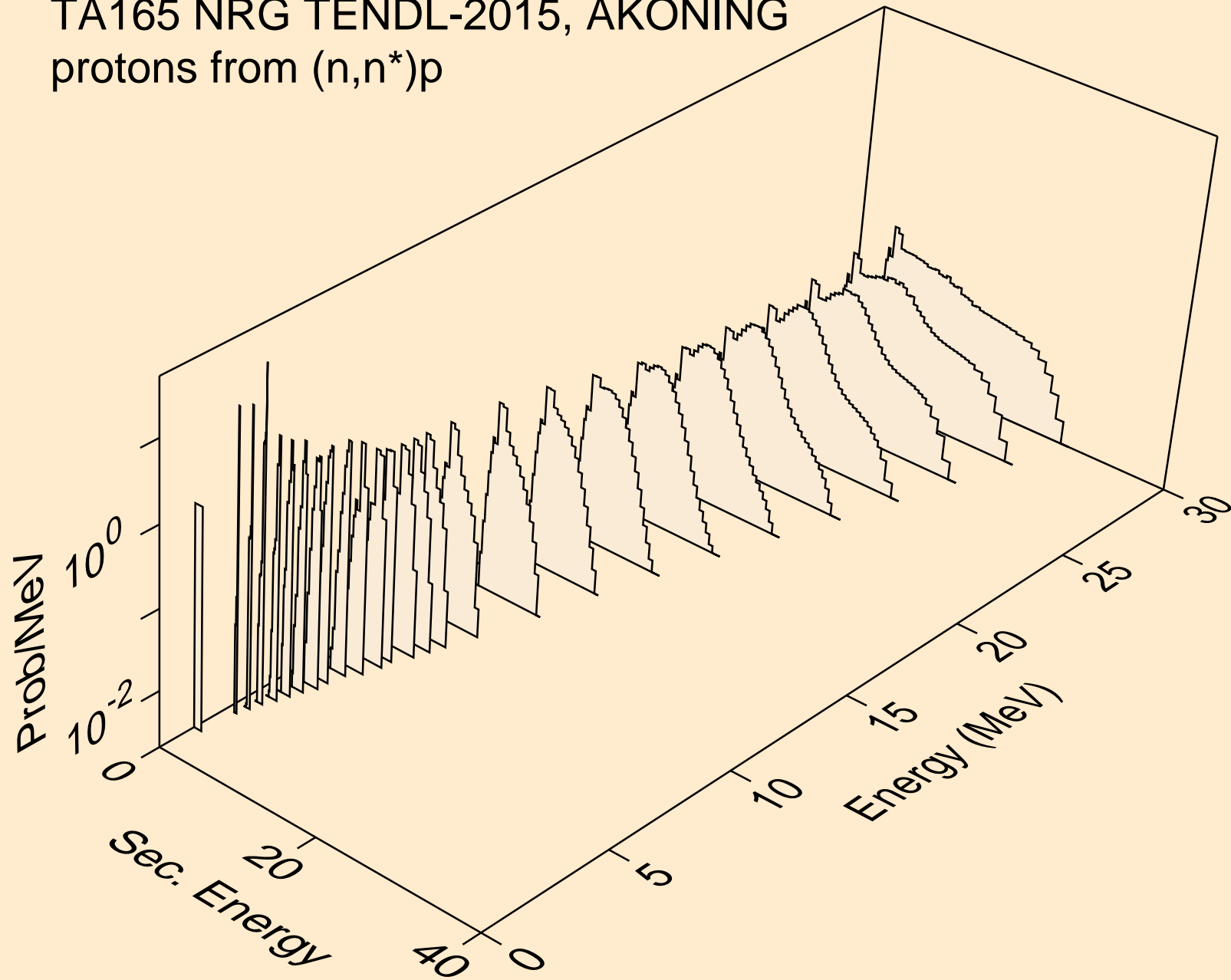

TA165 NRG TENDL-2015, AKONING  
protons from (n,2np)

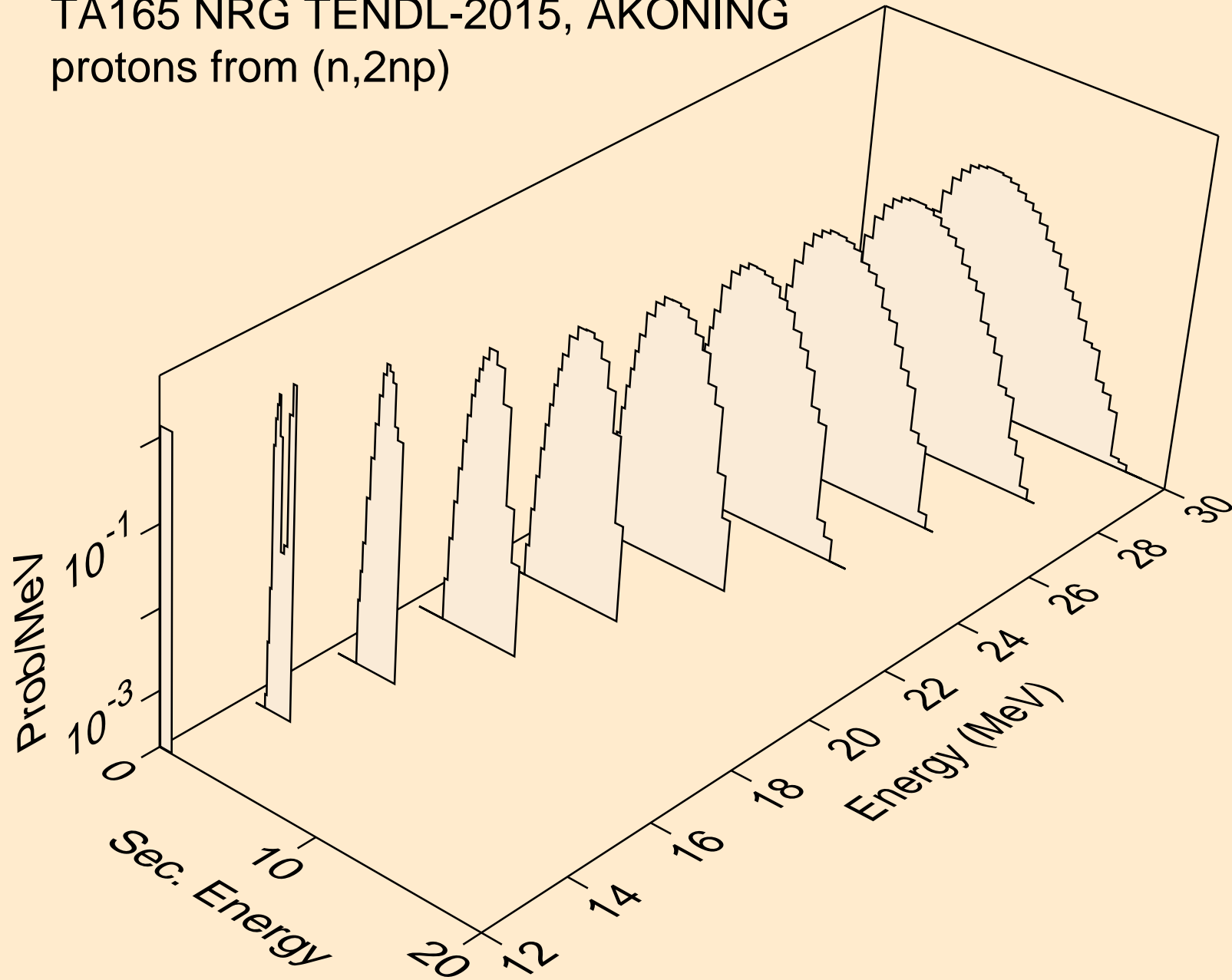

TA165 NRG TENDL-2015, AKONING  
protons from (n,3np)

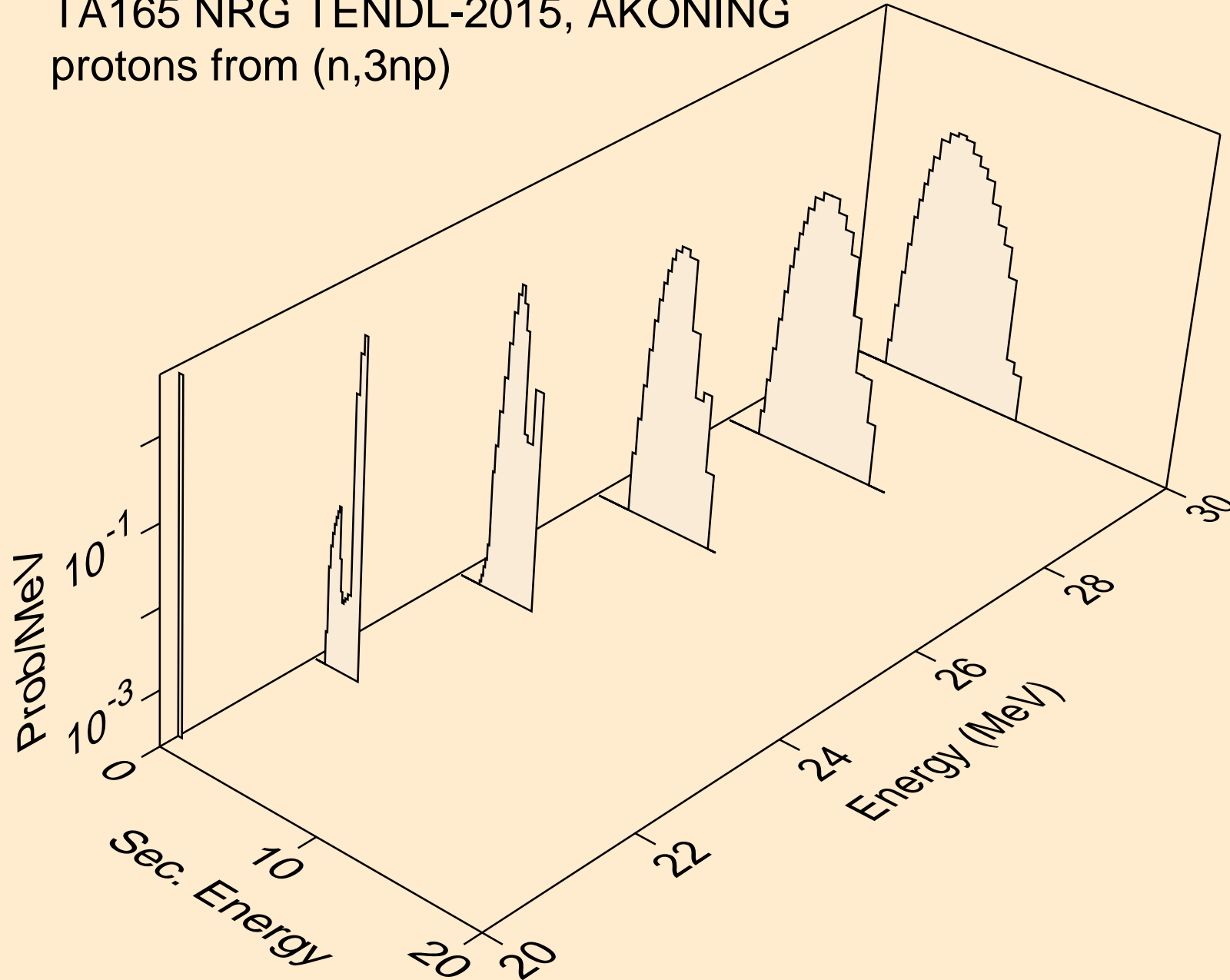

TA165 NRG TENDL-2015, AKONING  
protons from (n,2np)

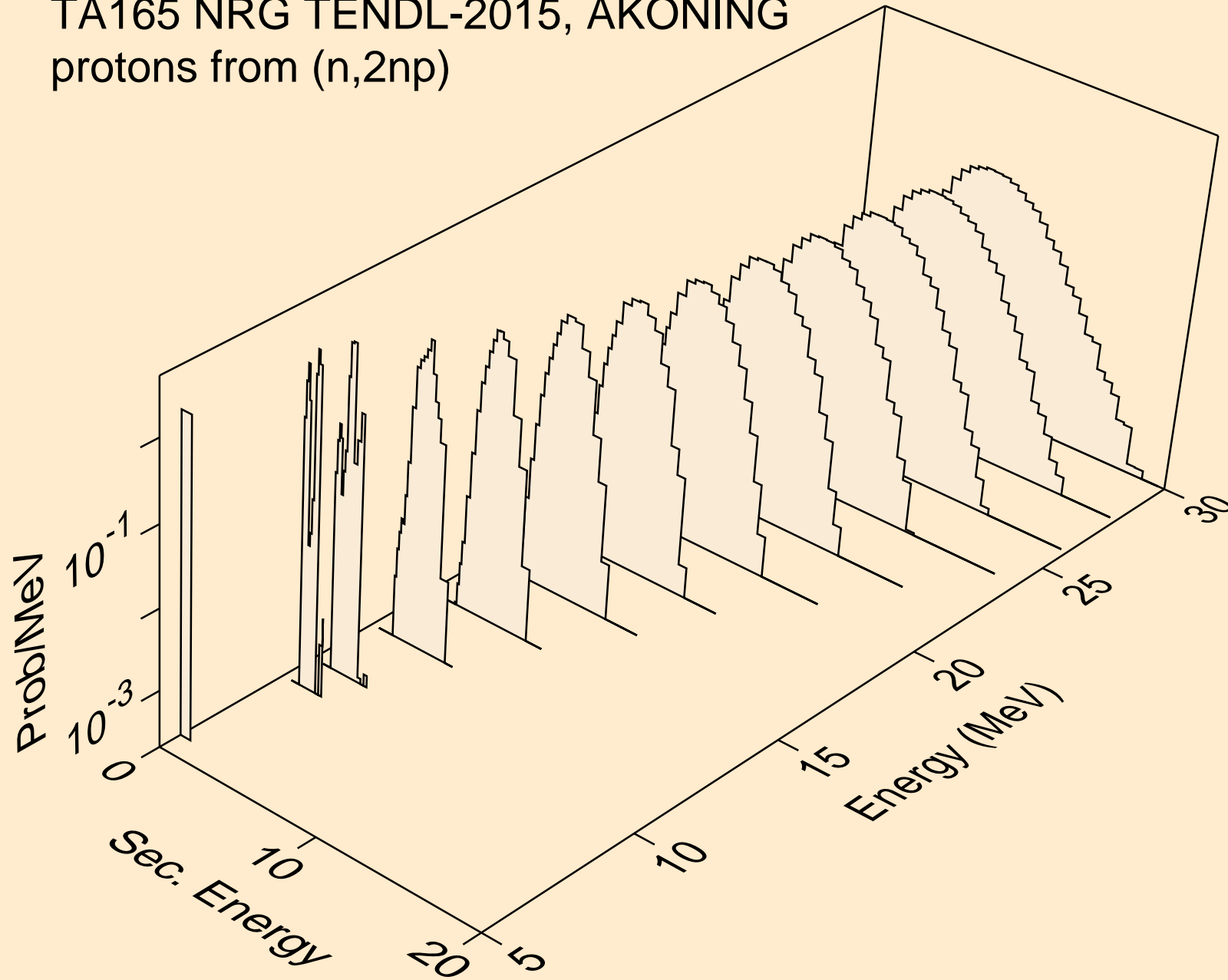

TA165 NRG TENDL-2015, AKONING  
protons from (n,npa)

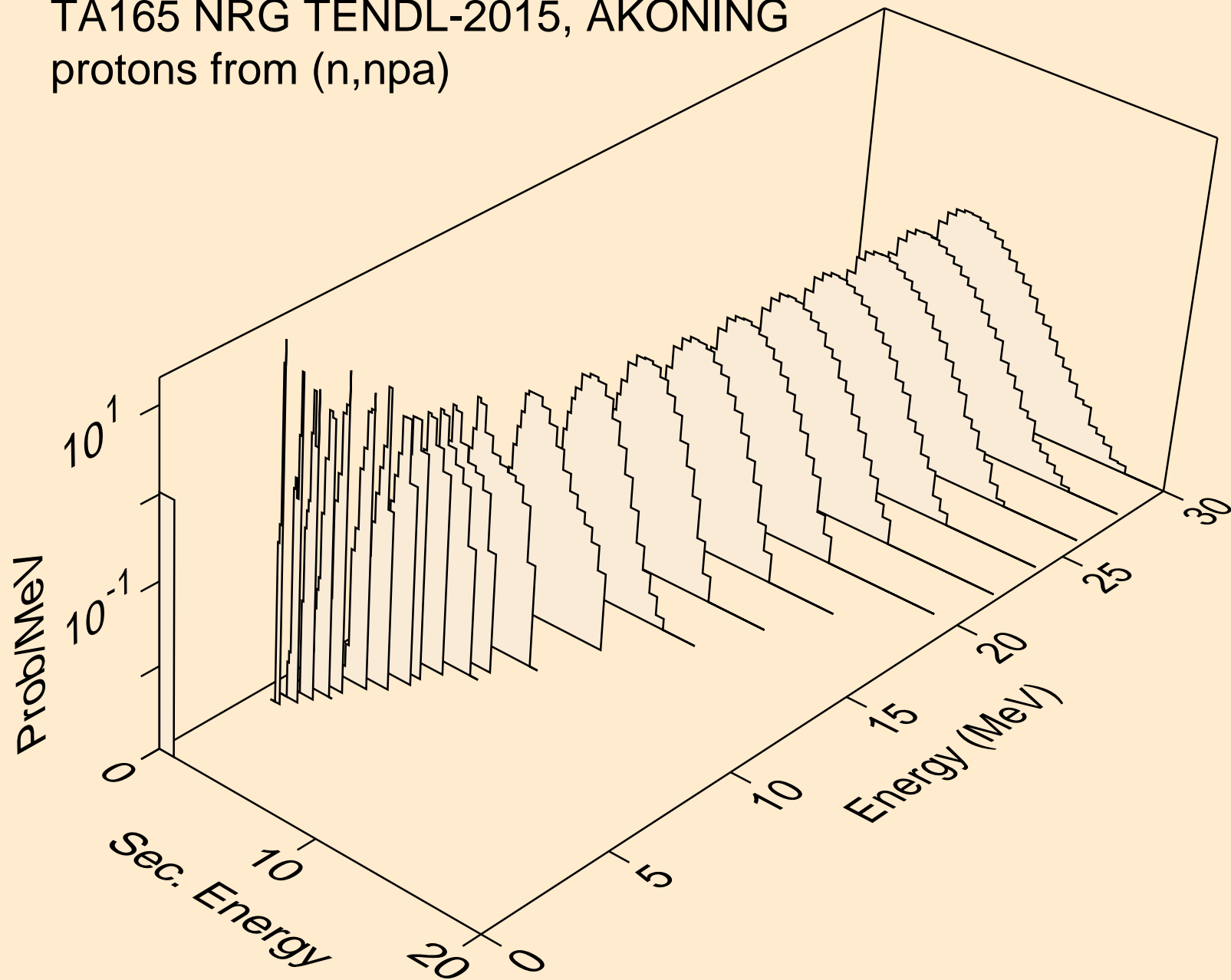



TA165 NRG TENDL-2015, AKONING  
protons from (n,p)

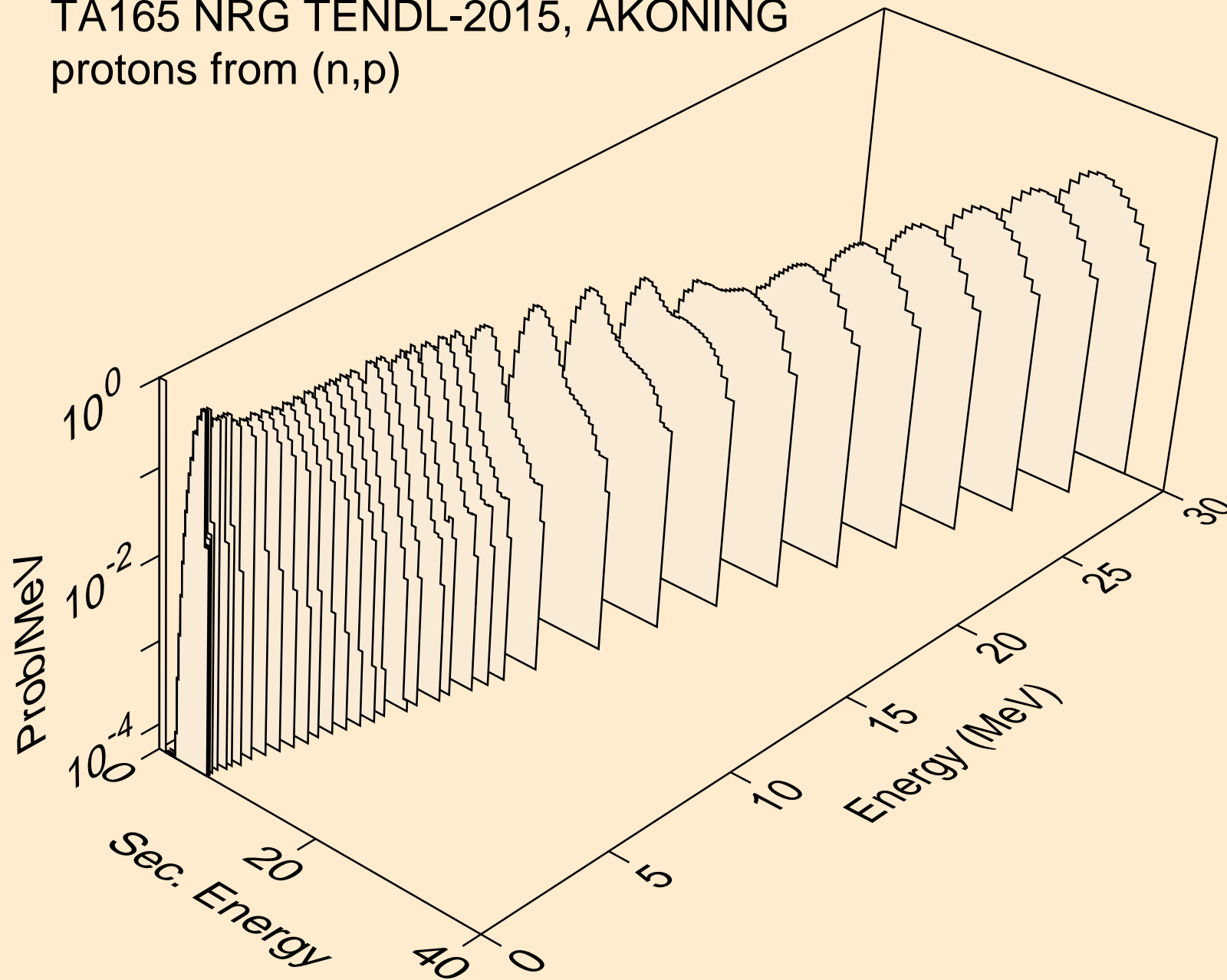

TA165 NRG TENDL-2015, AKONING  
protons from (n,2p)

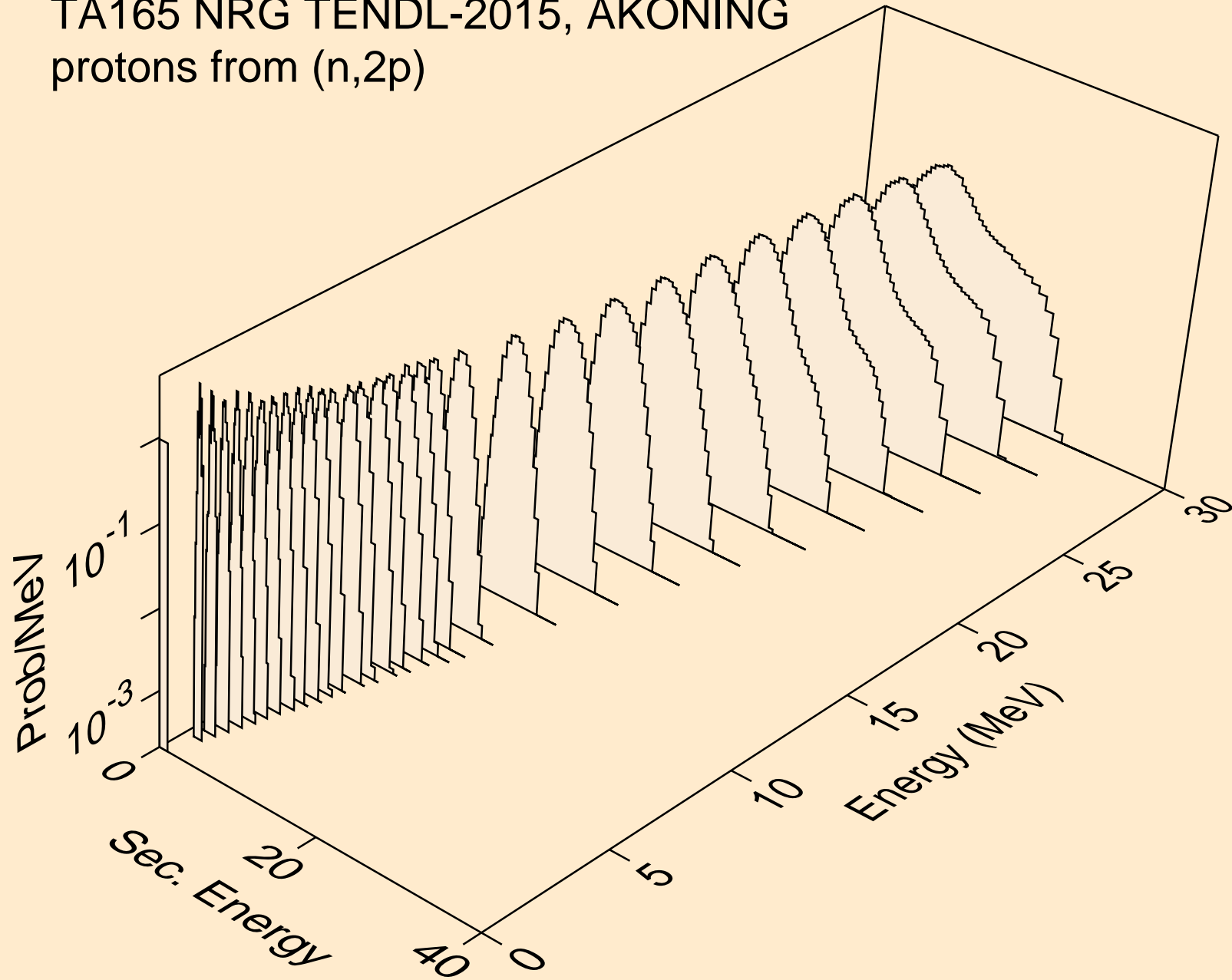

TA165 NRG TENDL-2015, AKONING  
protons from (n,pa)

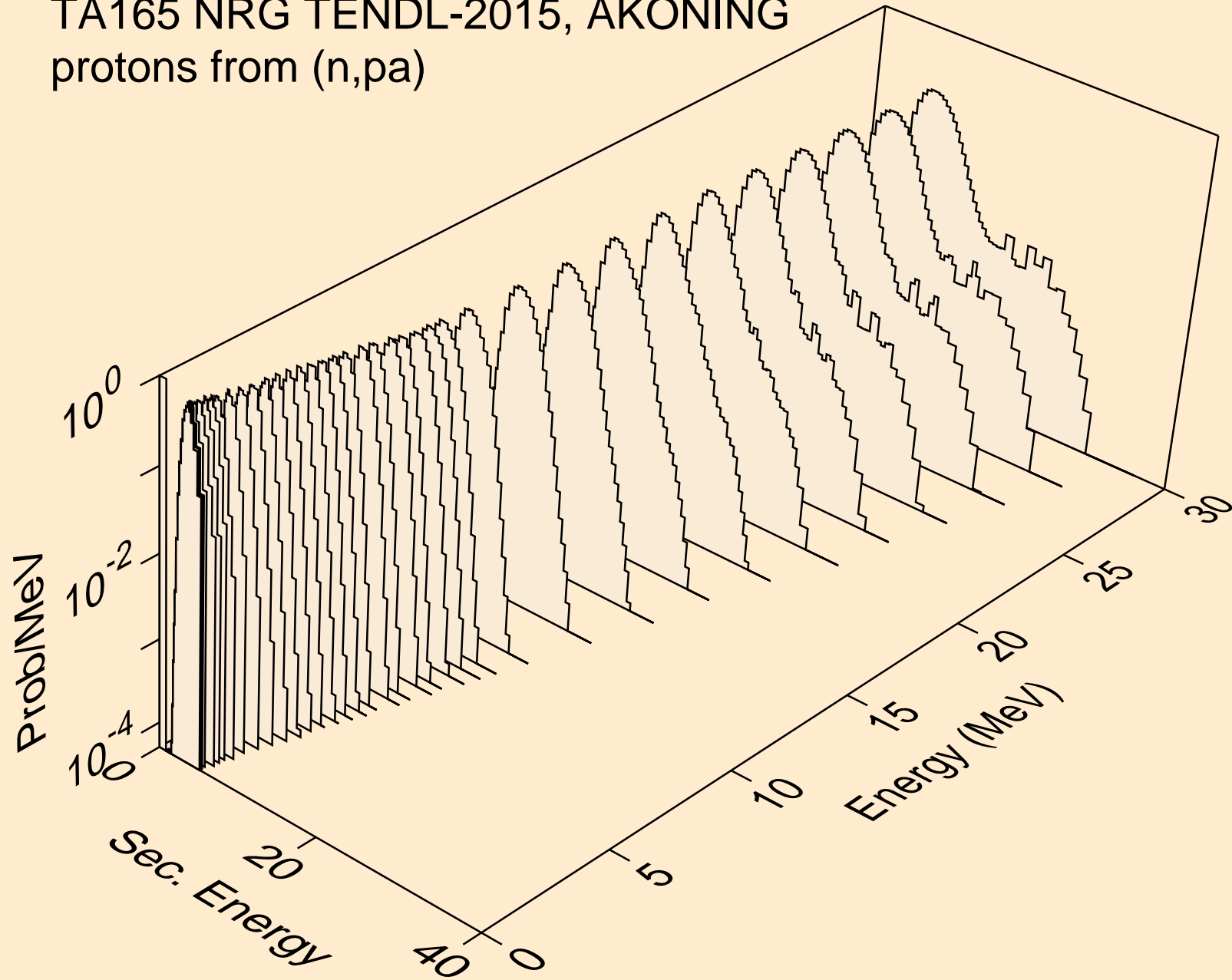

TA165 NRG TENDL-2015, AKONING  
protons from (n,pd)

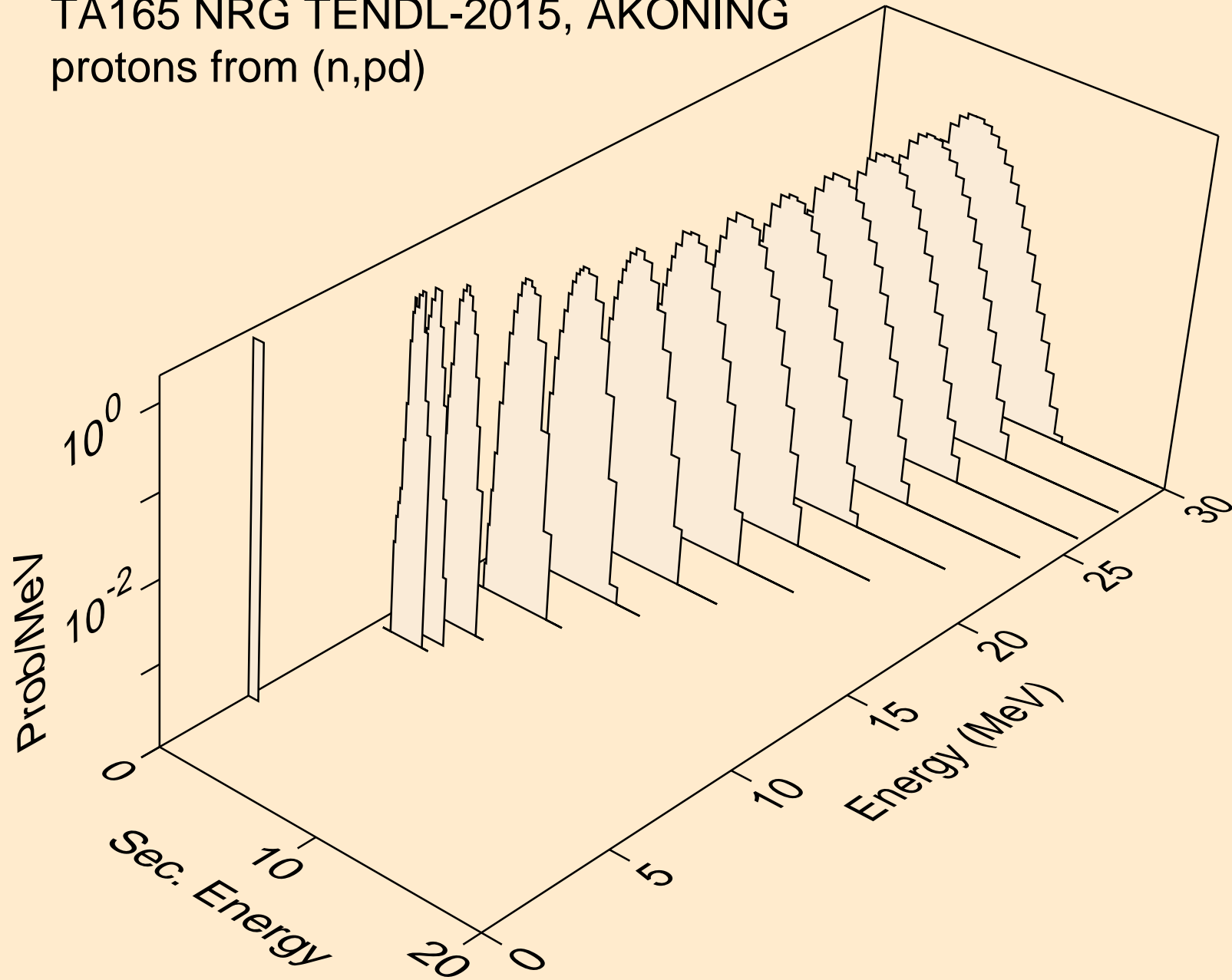

TA165 NRG TENDL-2015, AKONING  
protons from (n,pt)

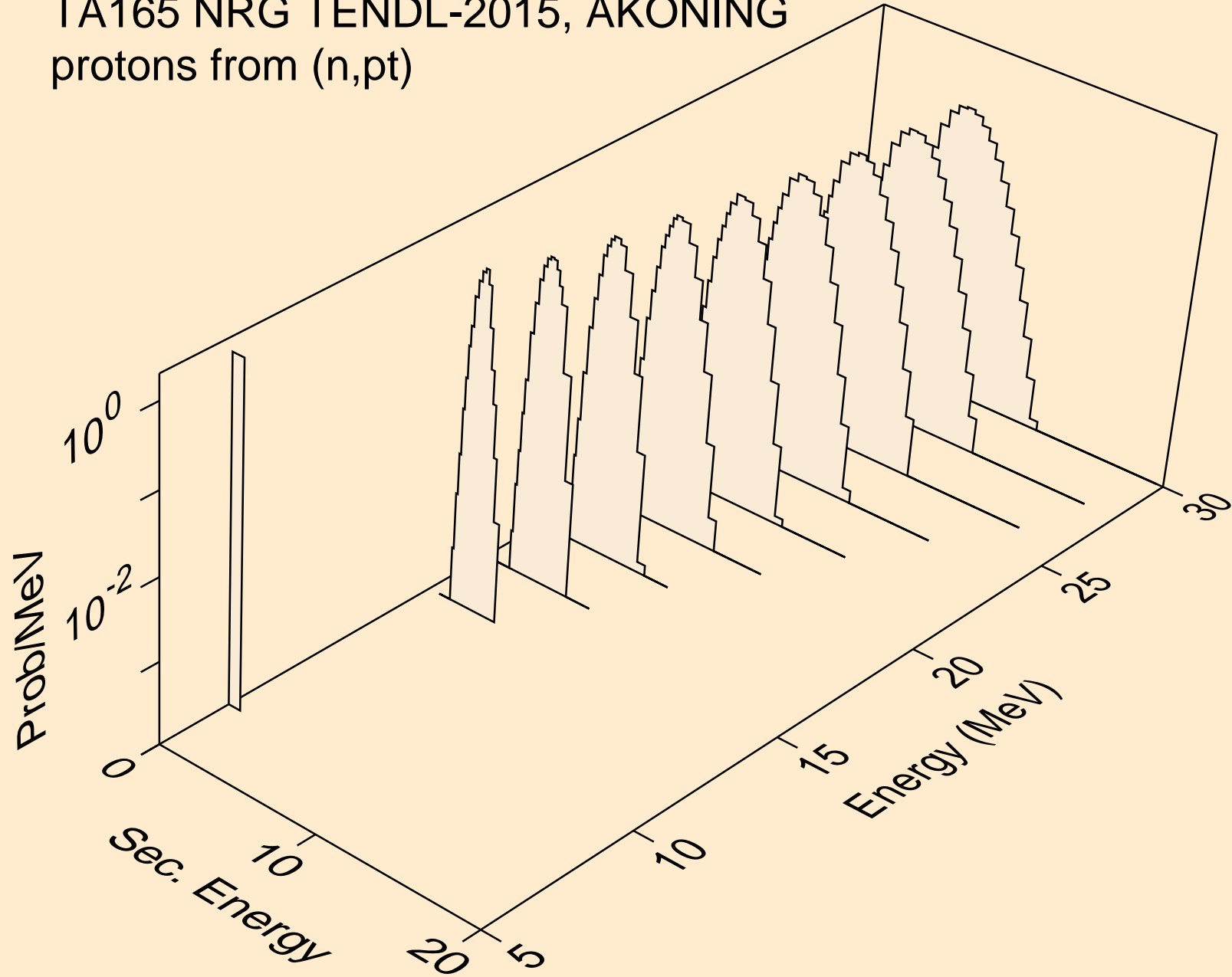

TA165 NRG TENDL-2015, AKONING  
deuterons from (n,x)

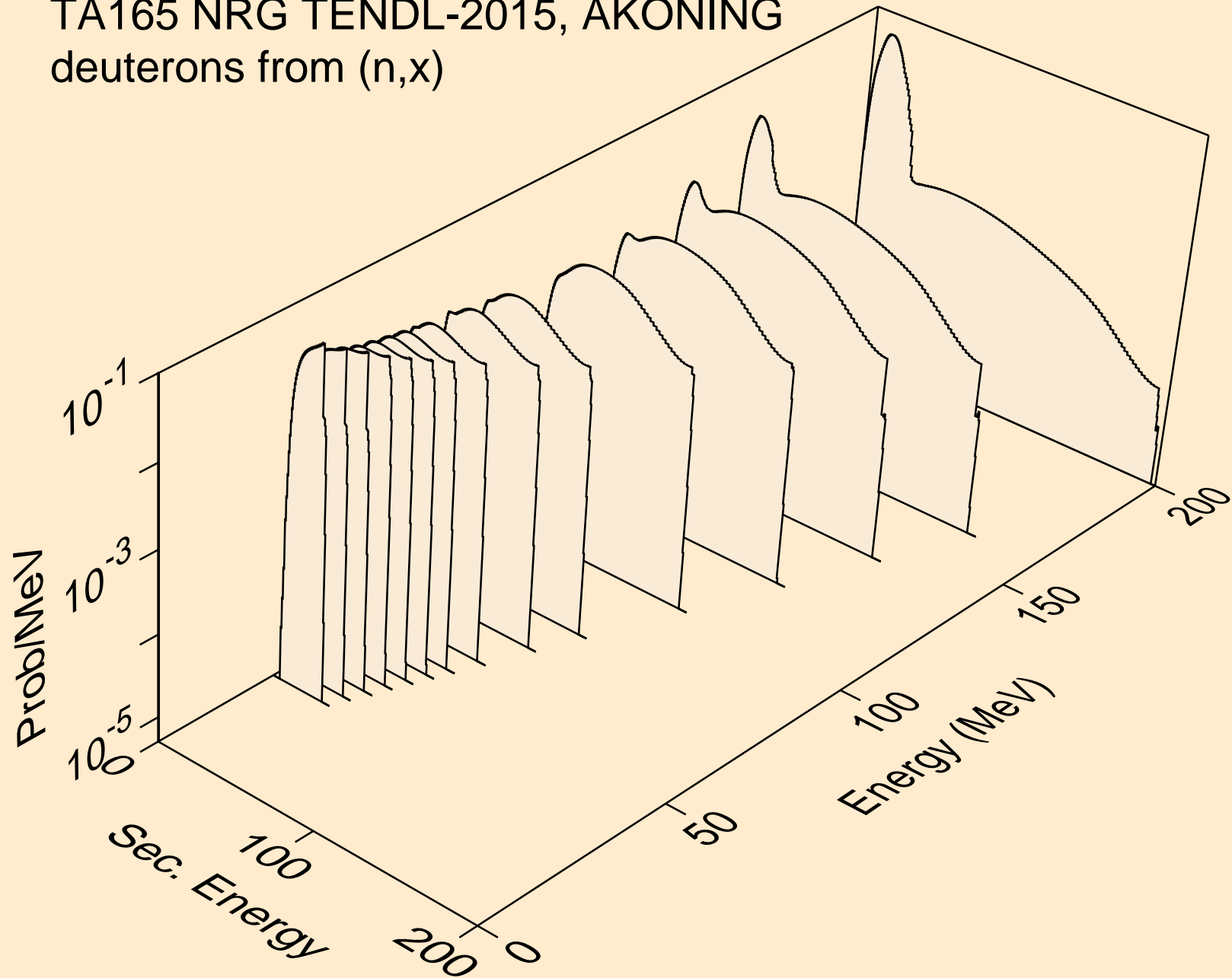

TA165 NRG TENDL-2015, AKONING  
deuterons from (n,2nd)

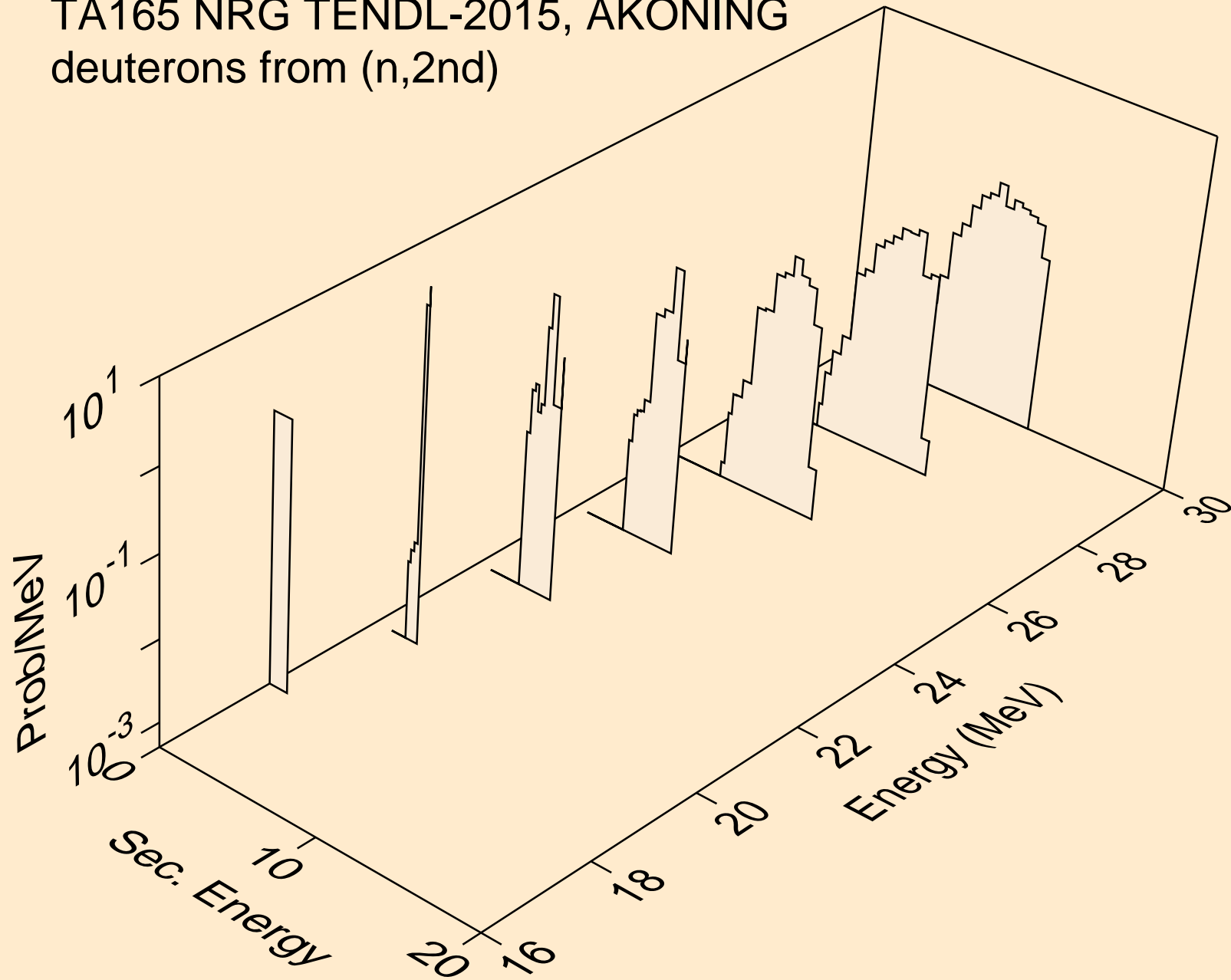

TA165 NRG TENDL-2015, AKONING  
deuterons from (n,n\*)d

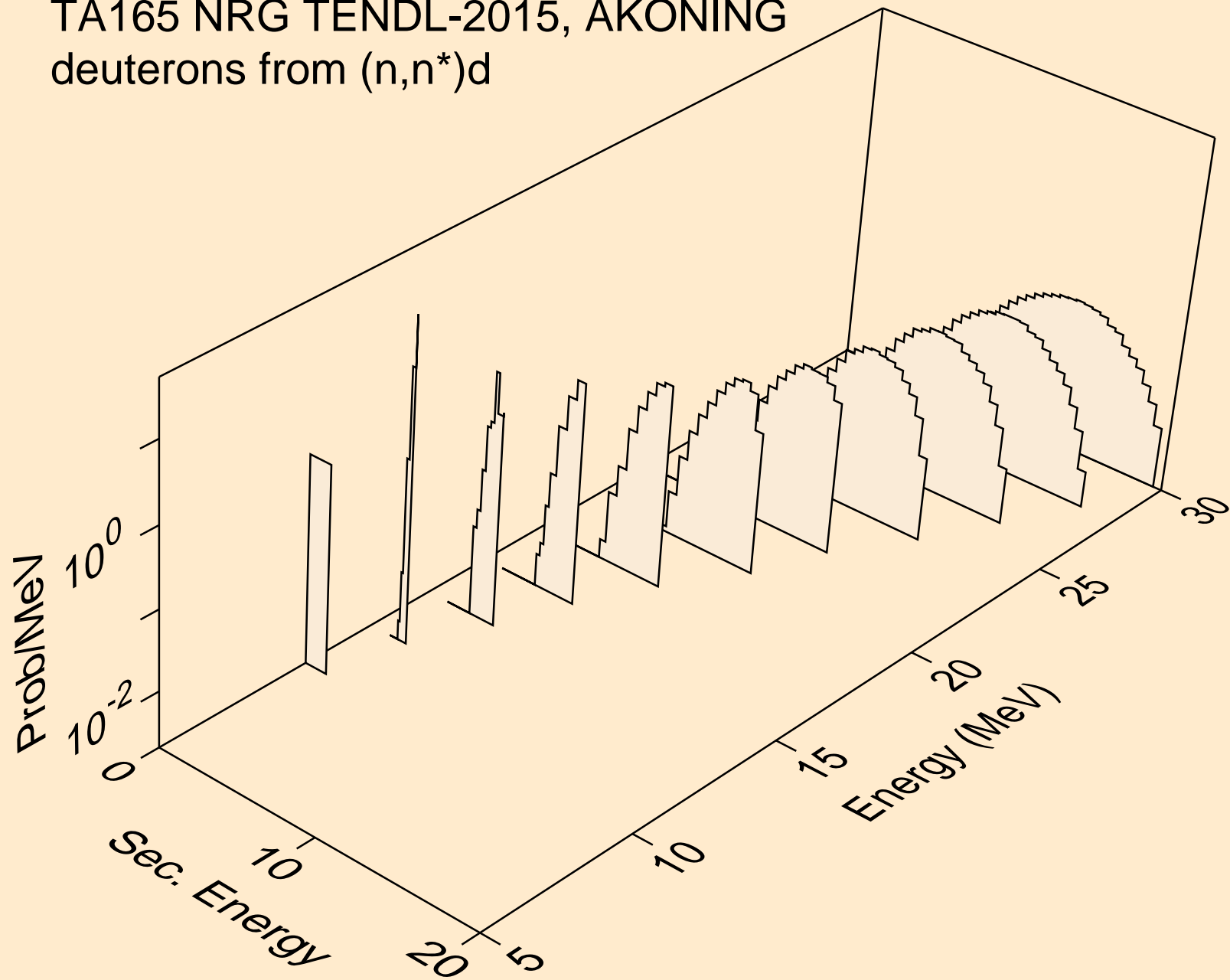



TA165 NRG TENDL-2015, AKONING  
deuterons from (n,d)

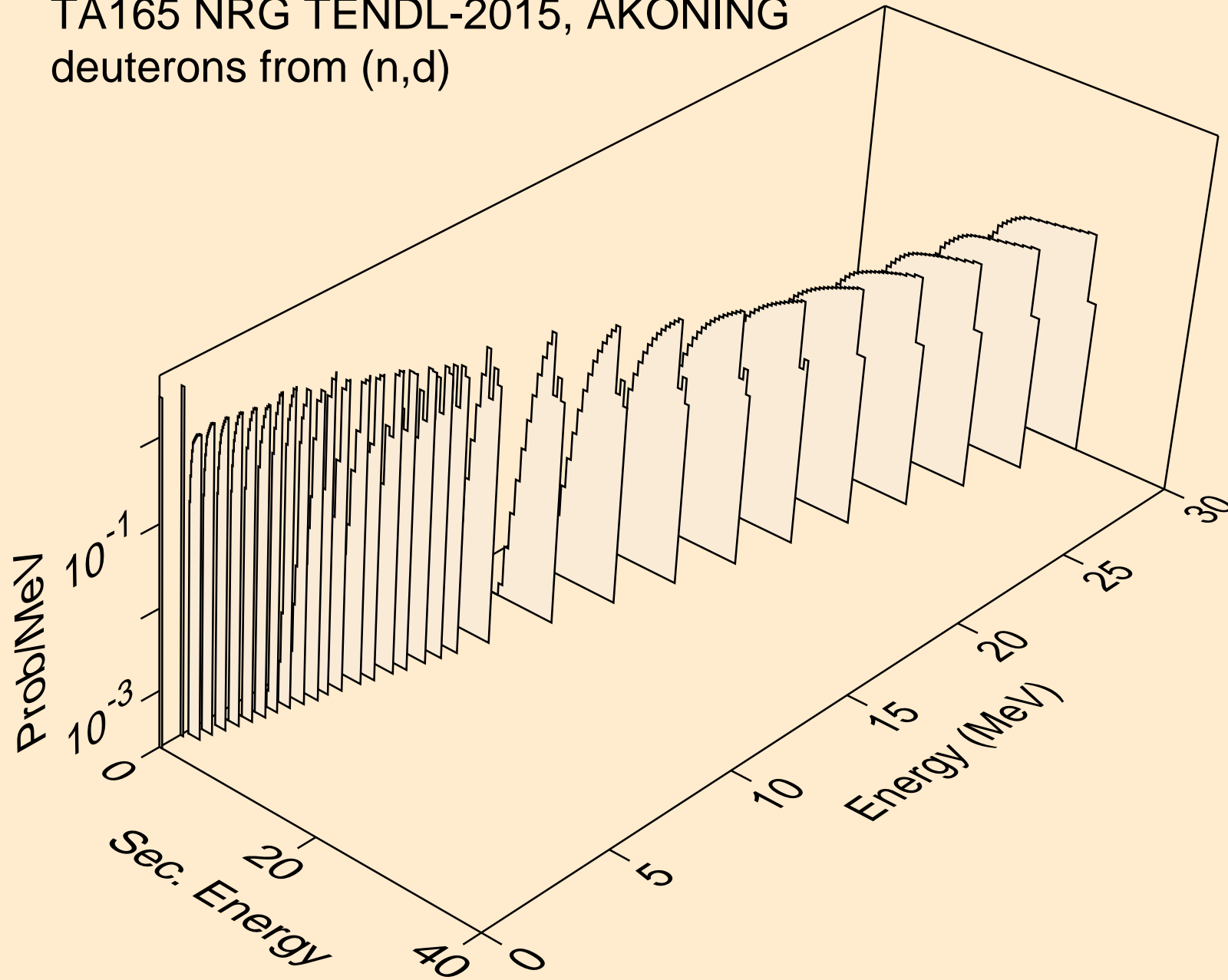

TA165 NRG TENDL-2015, AKONING  
deuterons from (n,d2a)

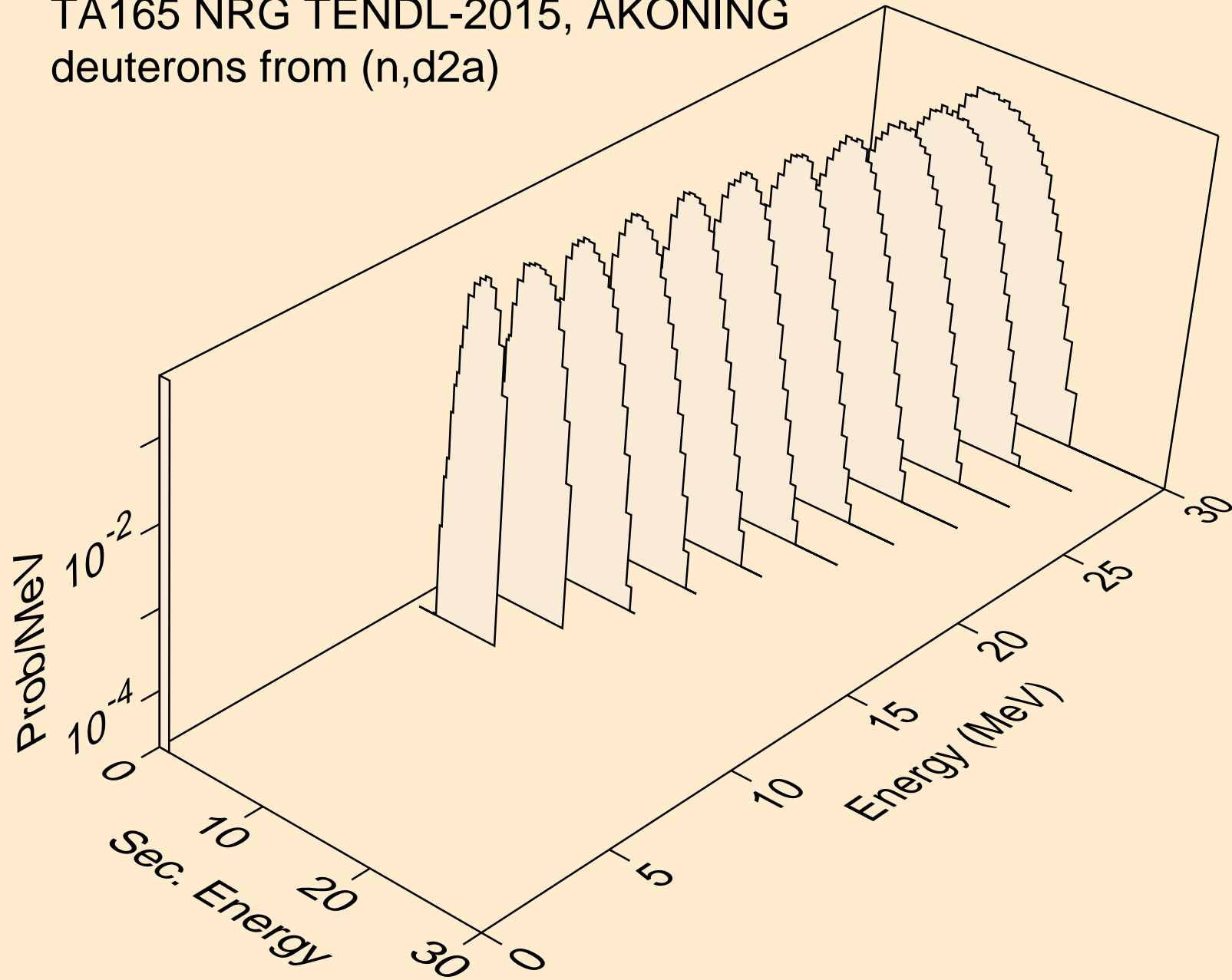

TA165 NRG TENDL-2015, AKONING  
deuterons from (n,pd)

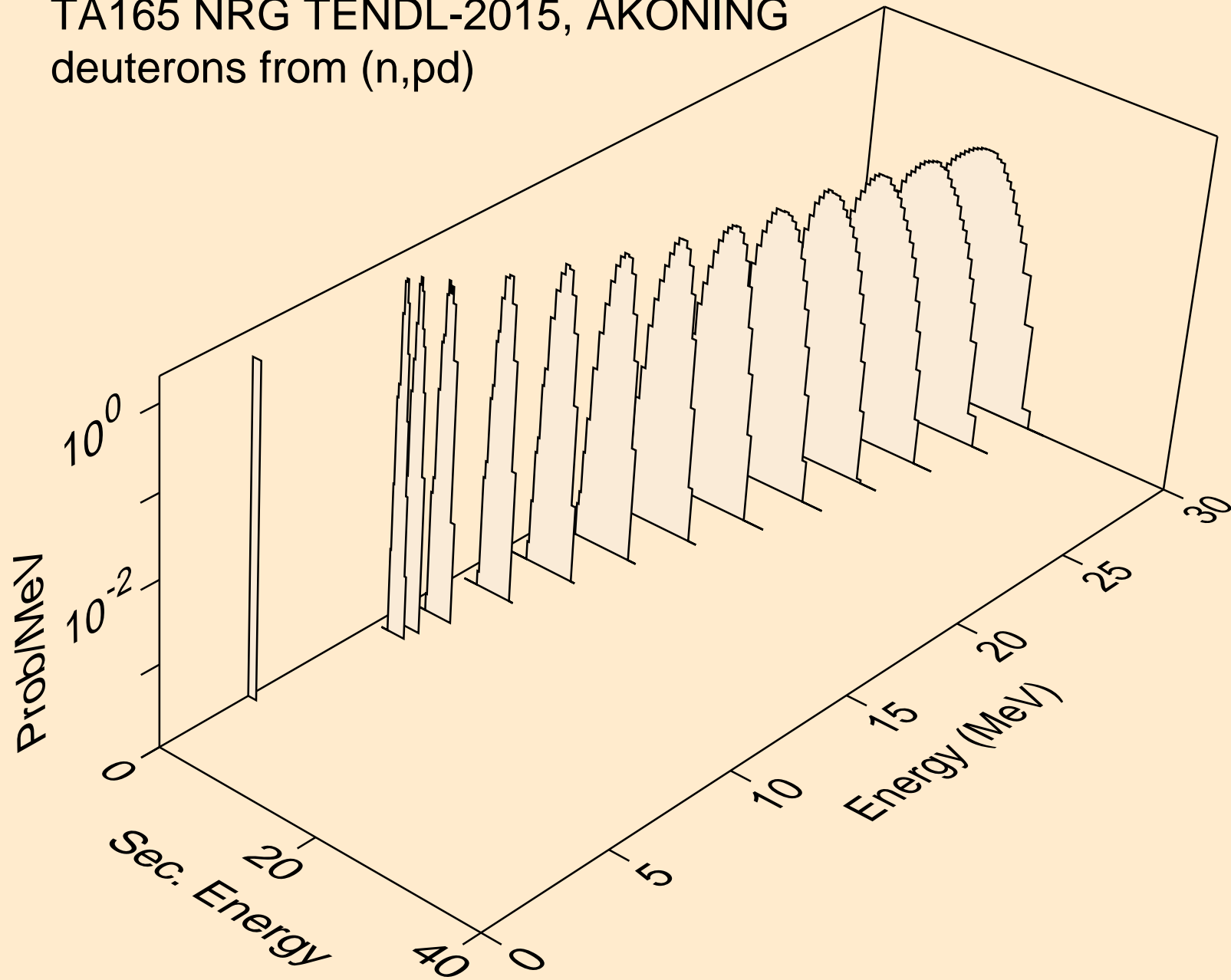

TA165 NRG TENDL-2015, AKONING  
deuterons from (n,da)

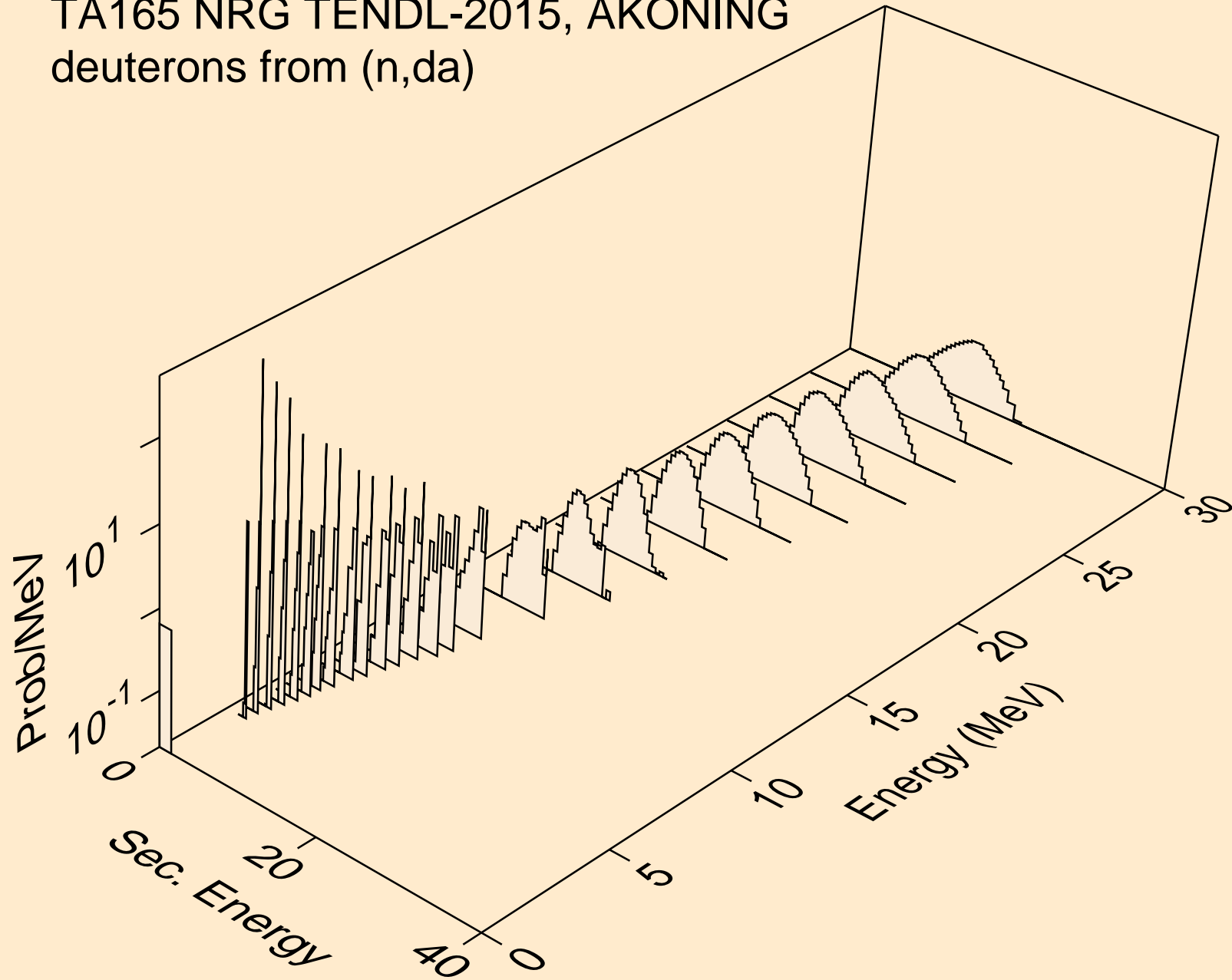

TA165 NRG TENDL-2015, AKONING  
tritons from (n,x)

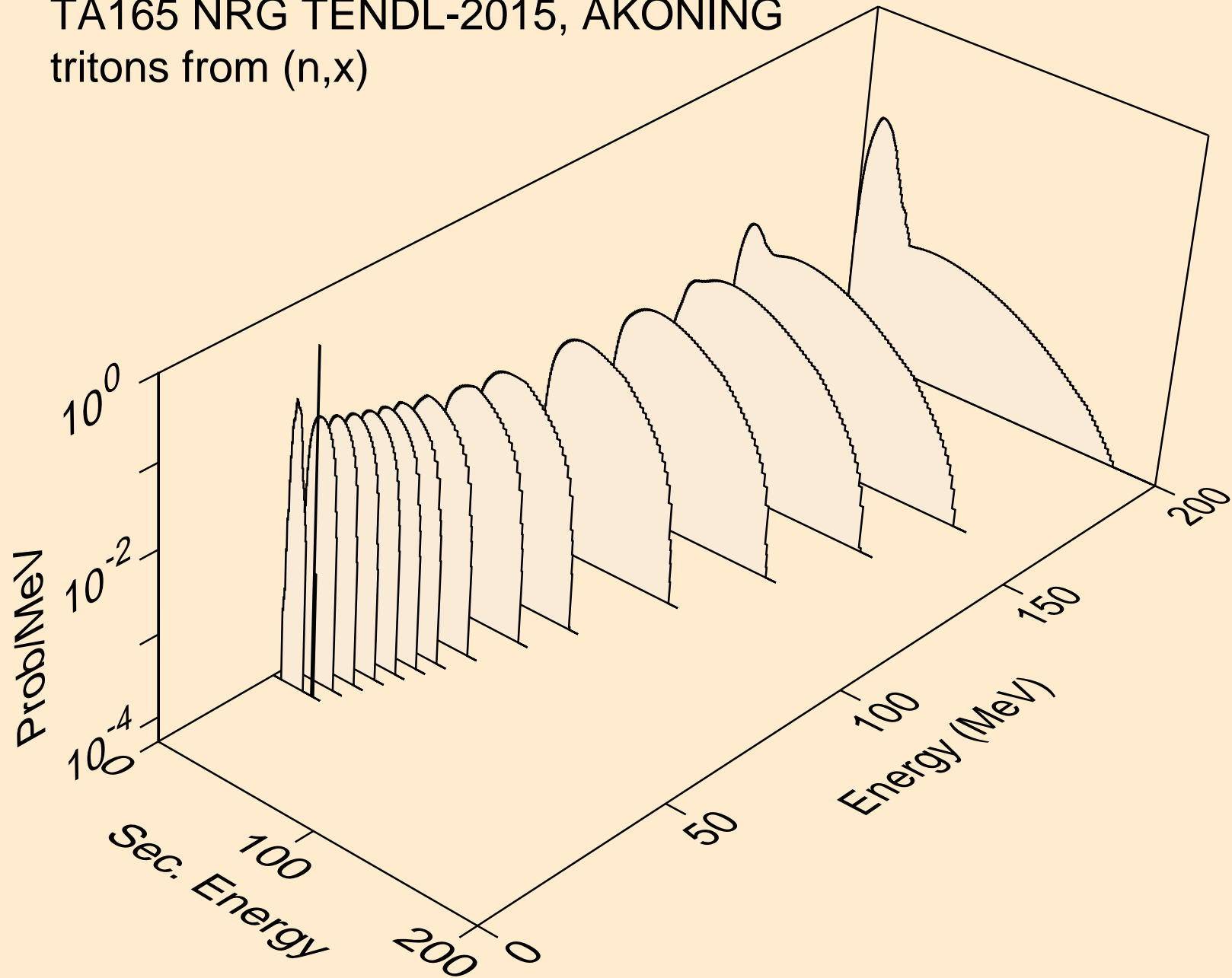

TA165 NRG TENDL-2015, AKONING  
tritons from (n,n\*)t

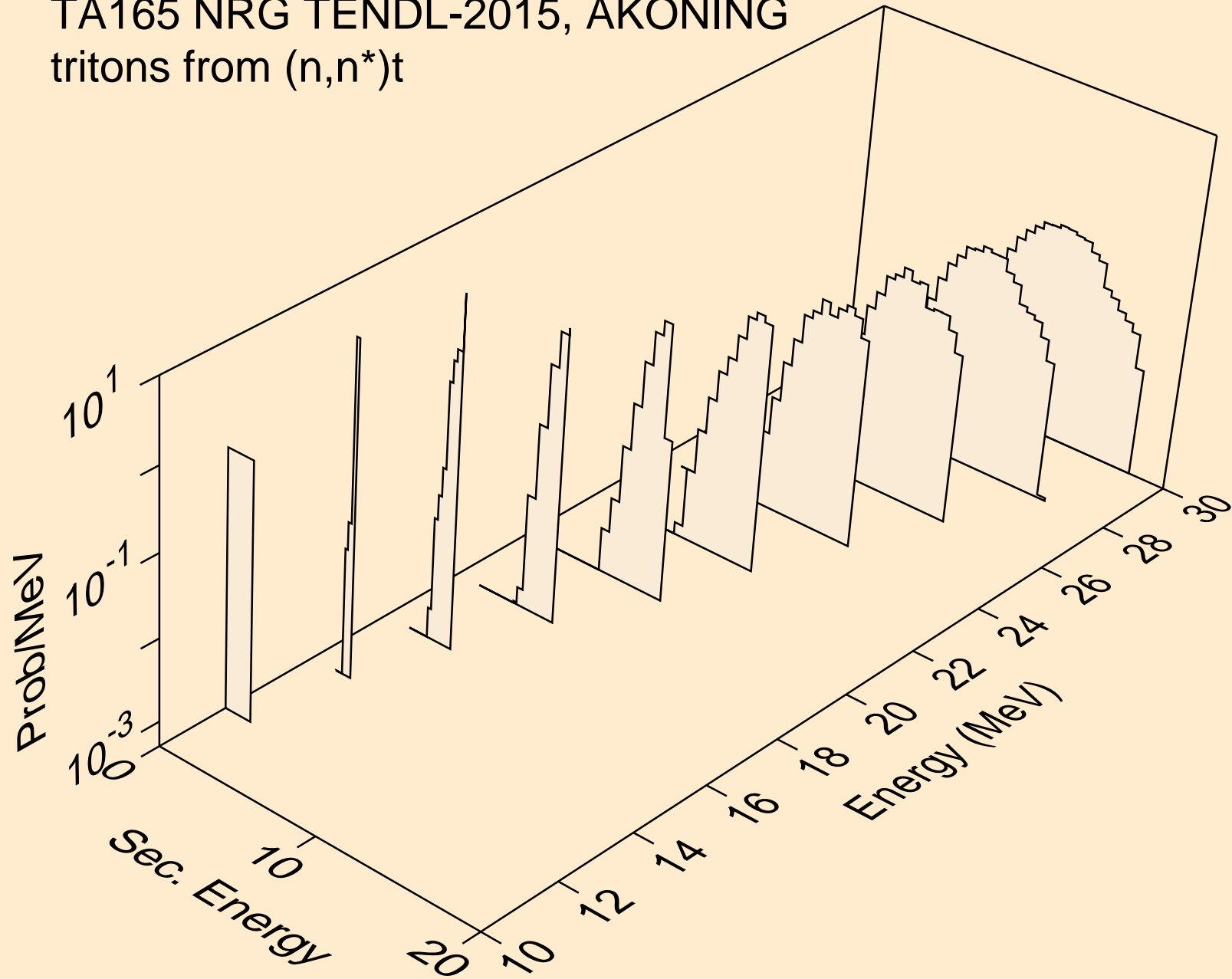

TA165 NRG TENDL-2015, AKONING  
tritons from (n,n\*)t2a

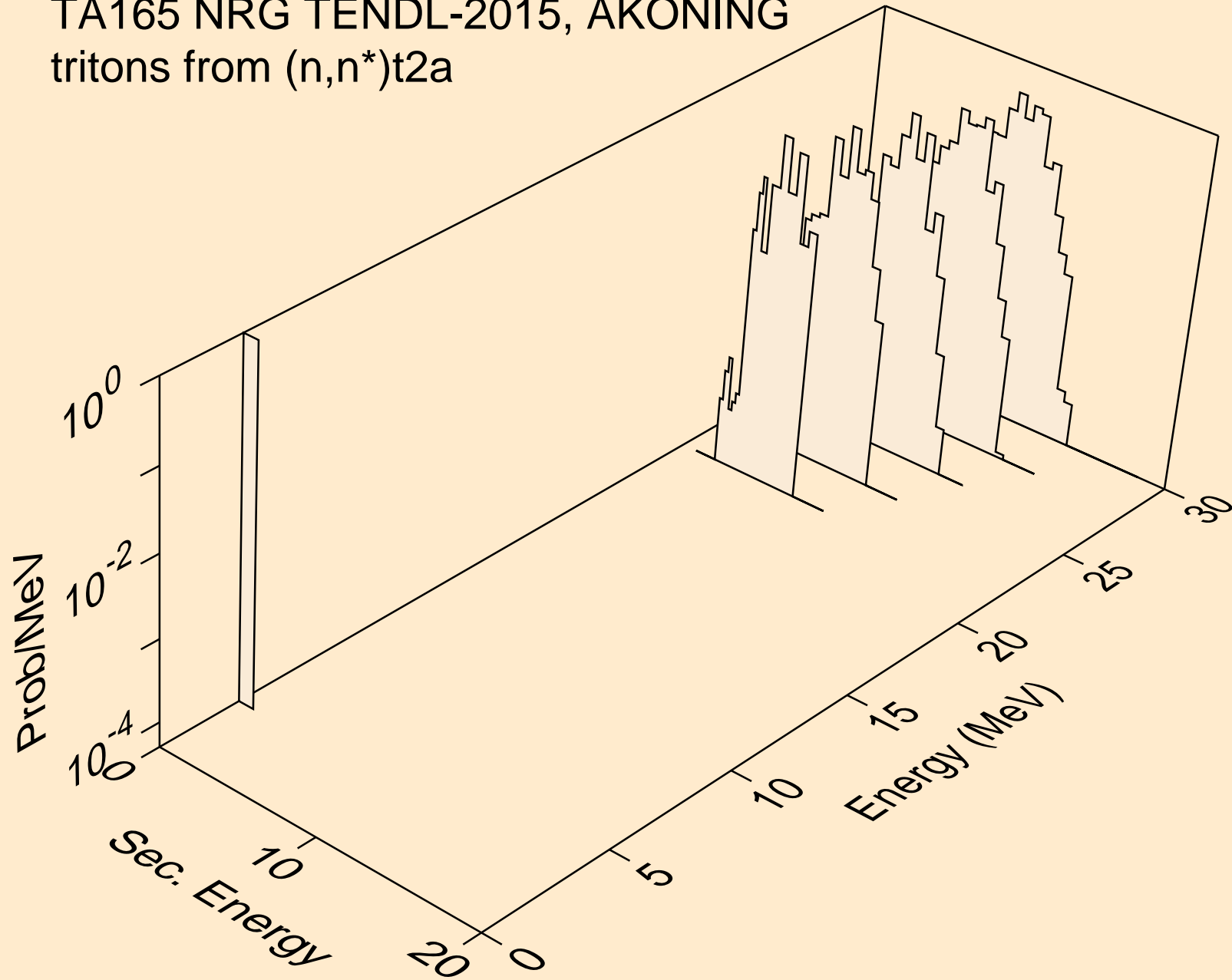

TA165 NRG TENDL-2015, AKONING  
tritons from (n,t)

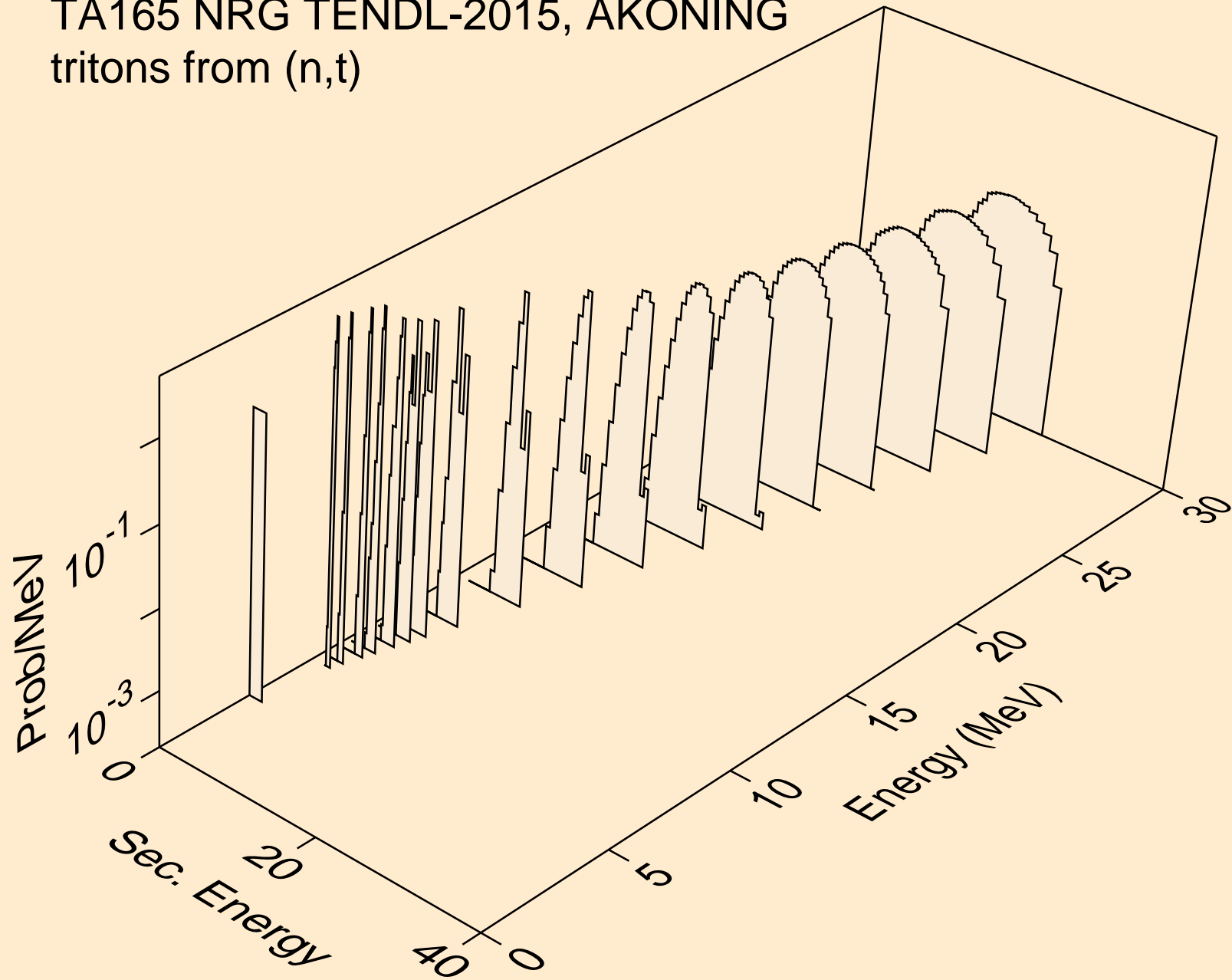



TA165 NRG TENDL-2015, AKONING  
tritons from (n,t2a)

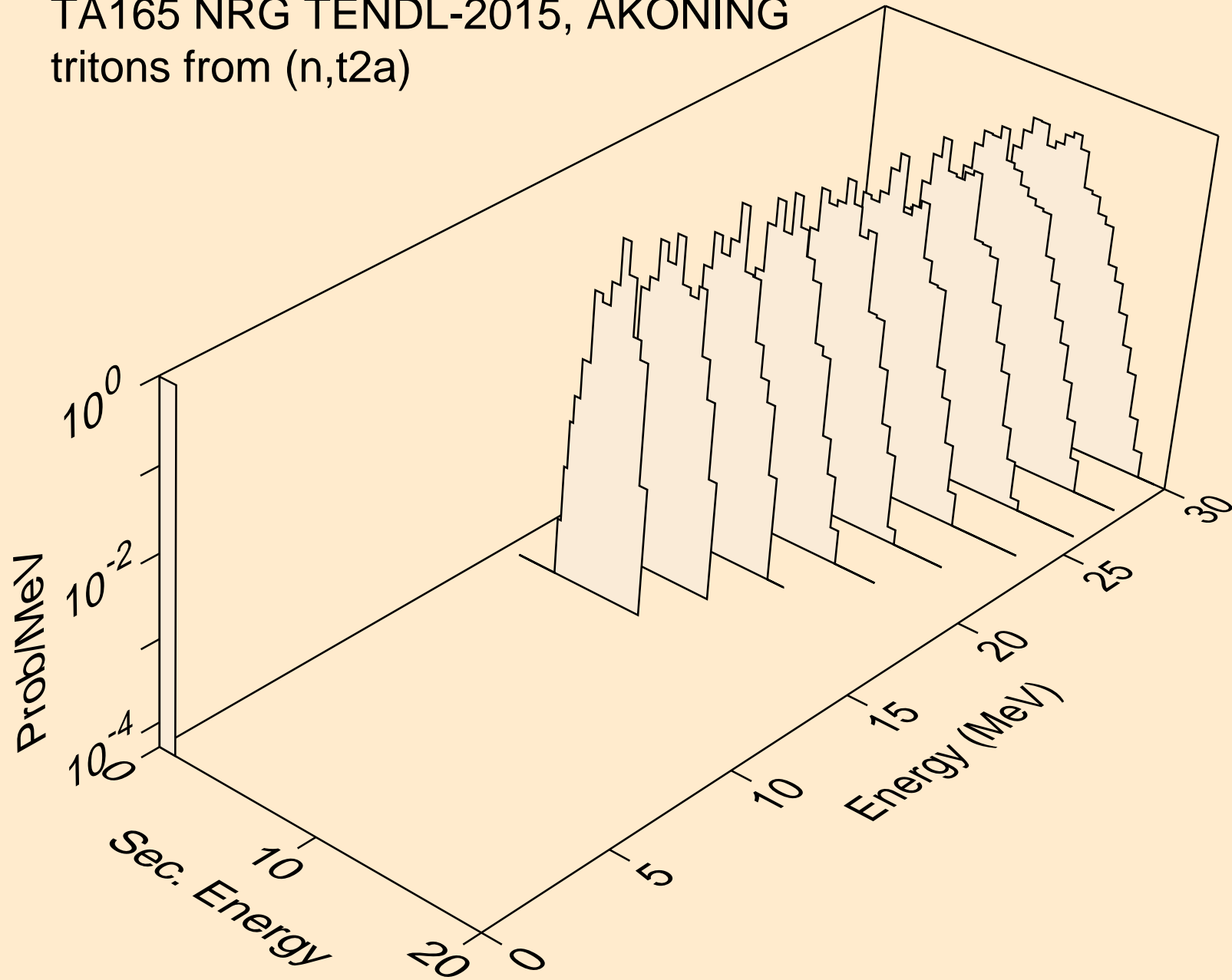

TA165 NRG TENDL-2015, AKONING  
tritons from (n,pt)

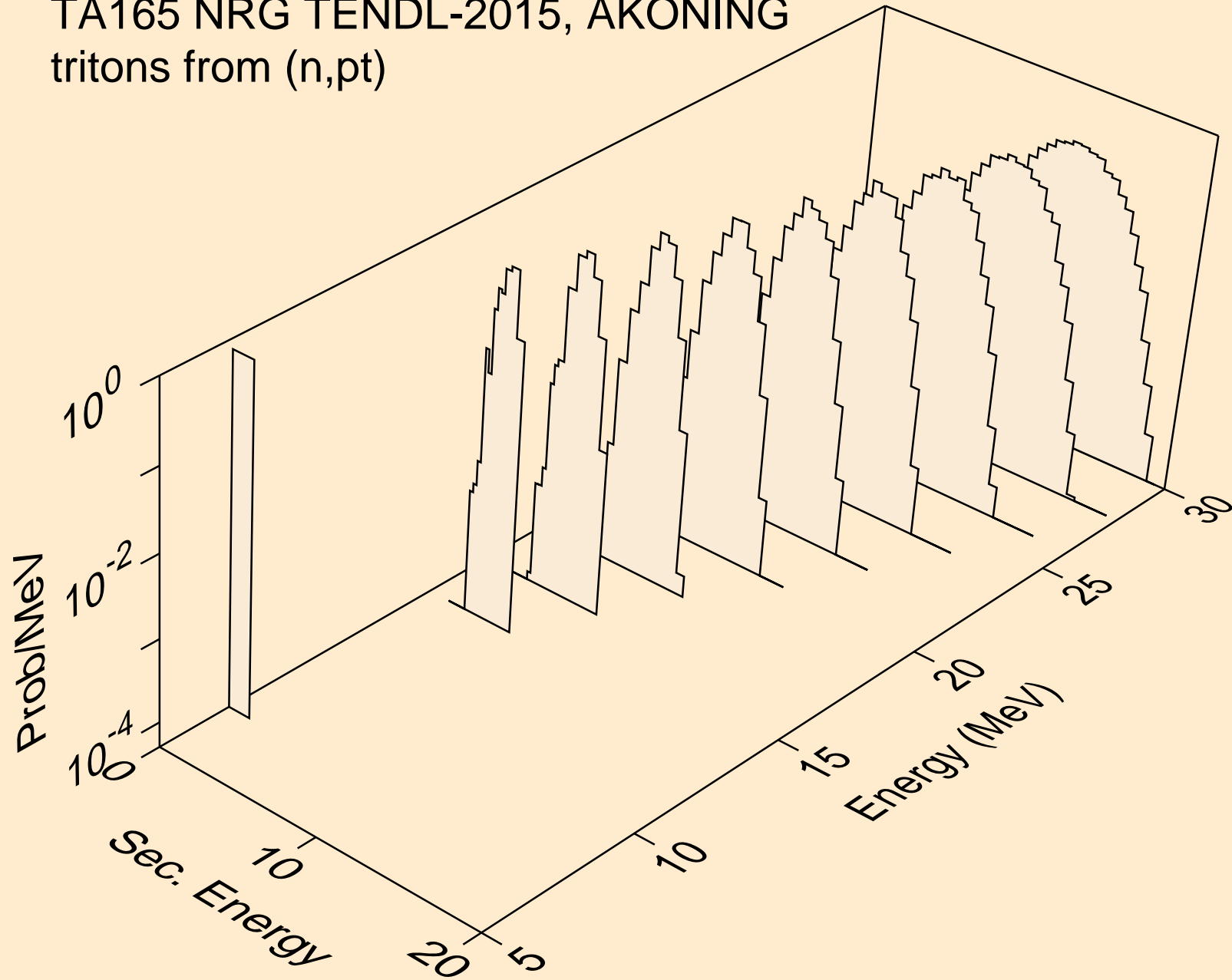

TA165 NRG TENDL-2015, AKONING  
he3s from (n,x)

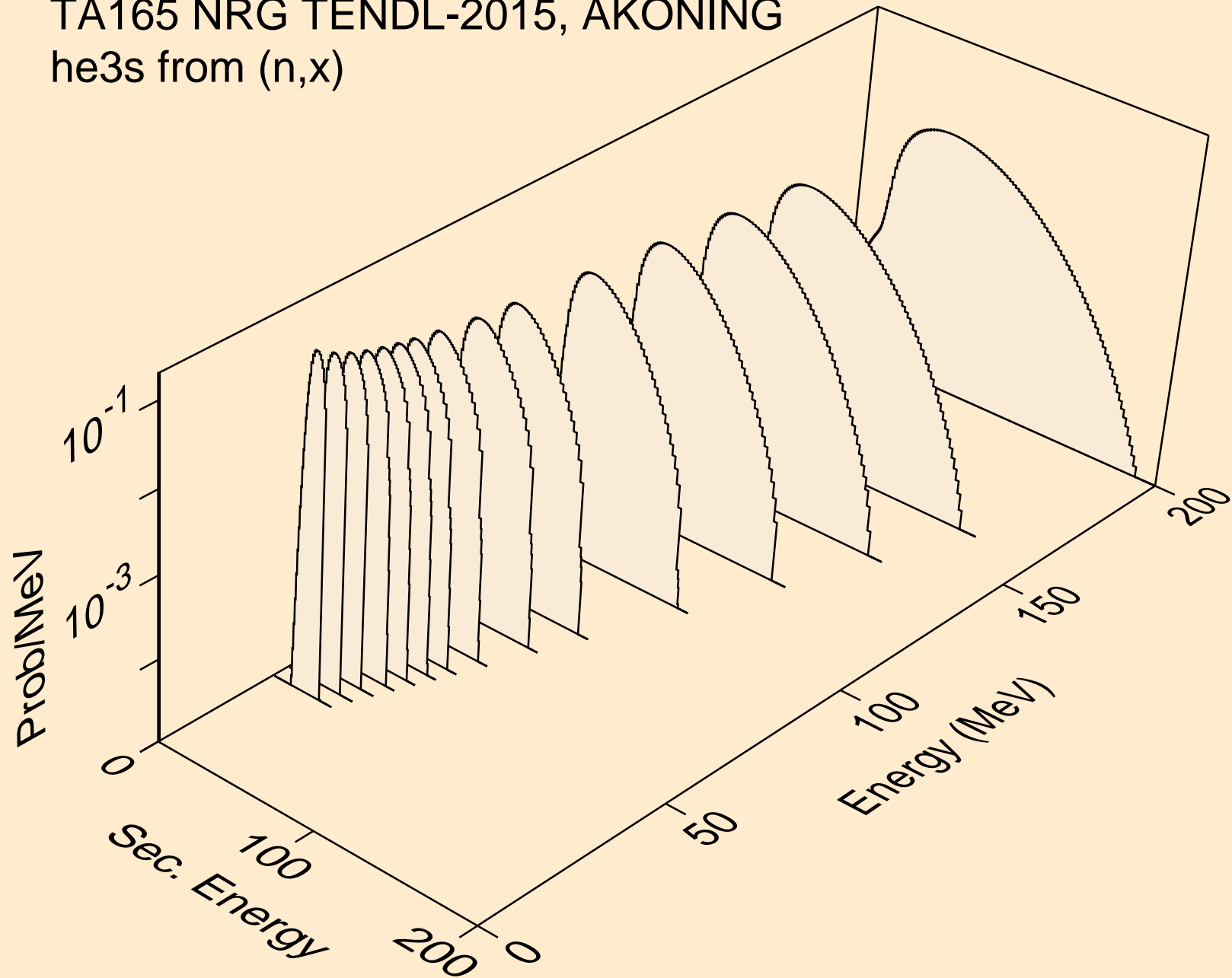

TA165 NRG TENDL-2015, AKONING  
he3s from (n,n\*)he3

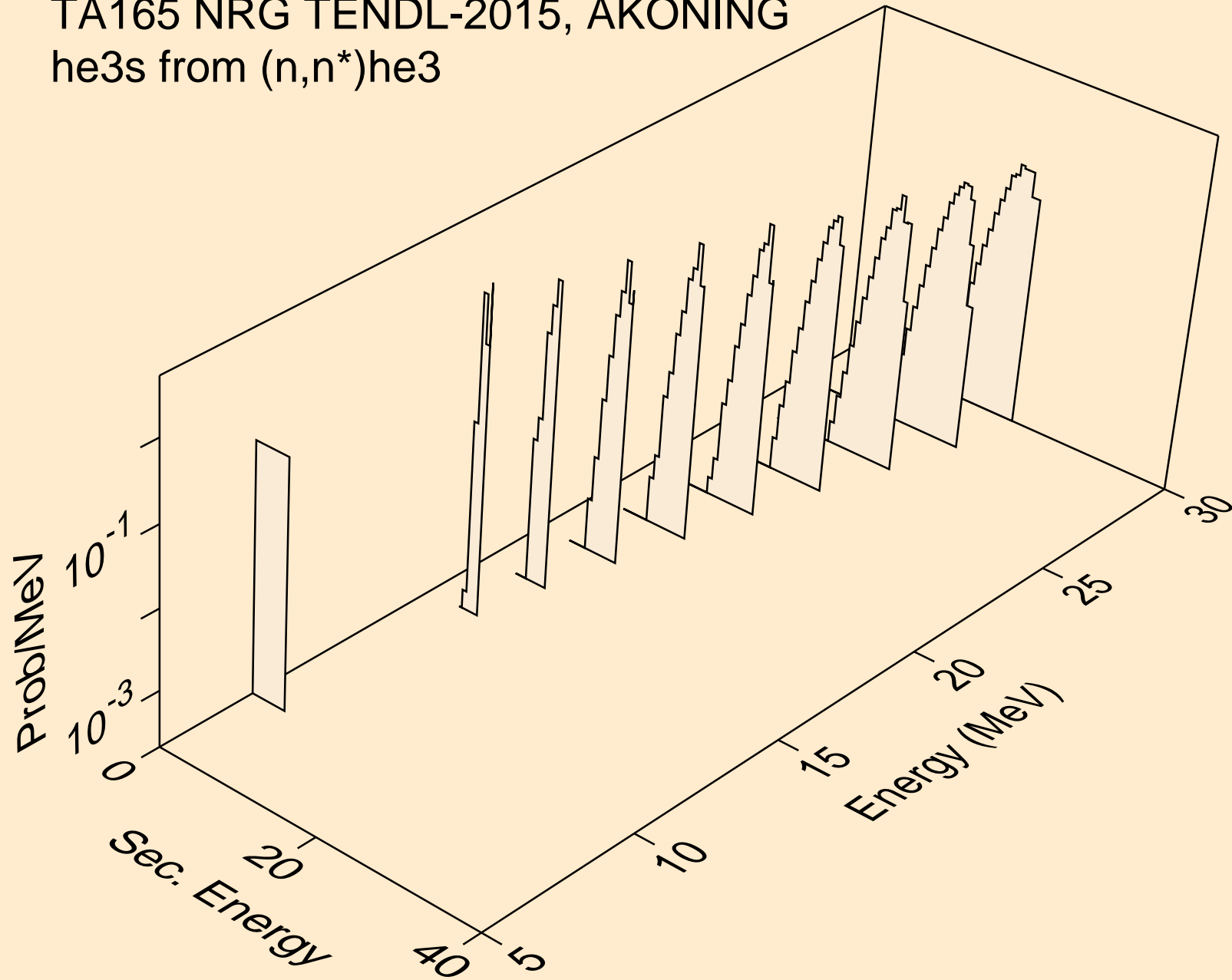

TA165 NRG TENDL-2015, AKONING  
he3s from (n,he3)

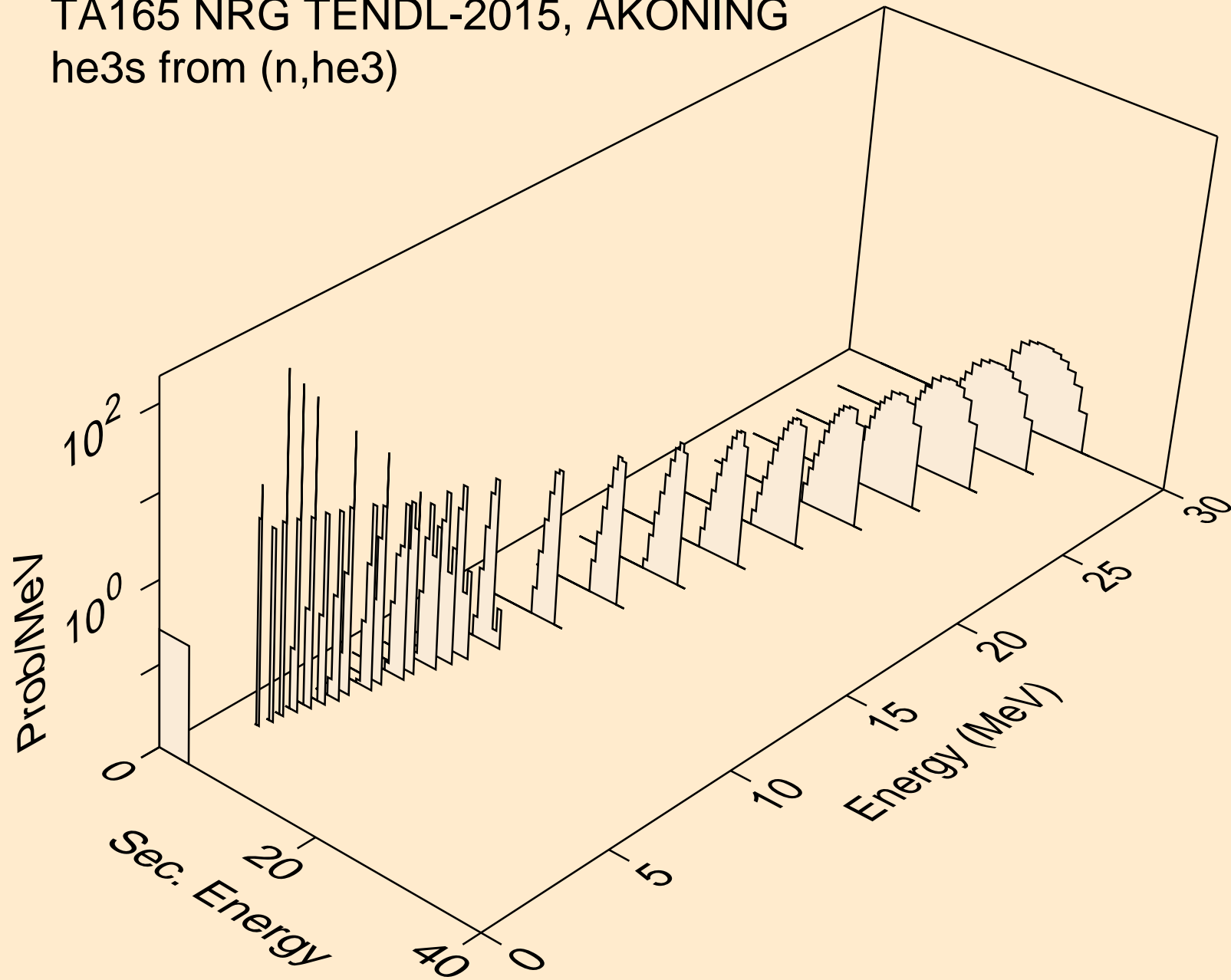

TA165 NRG TENDL-2015, AKONING  
alphas from (n,x)

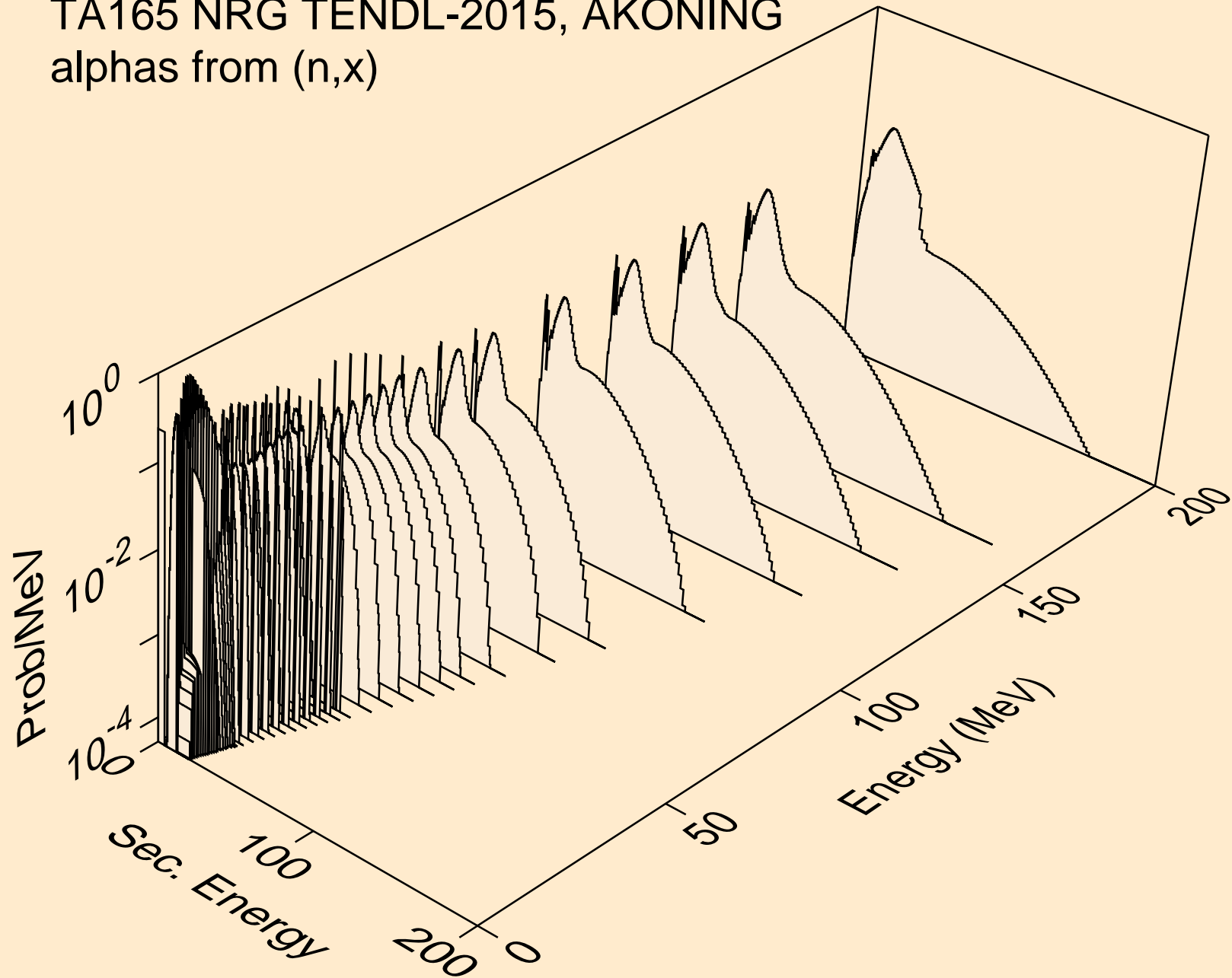

TA165 NRG TENDL-2015, AKONING  
alphas from (n,n\*)a

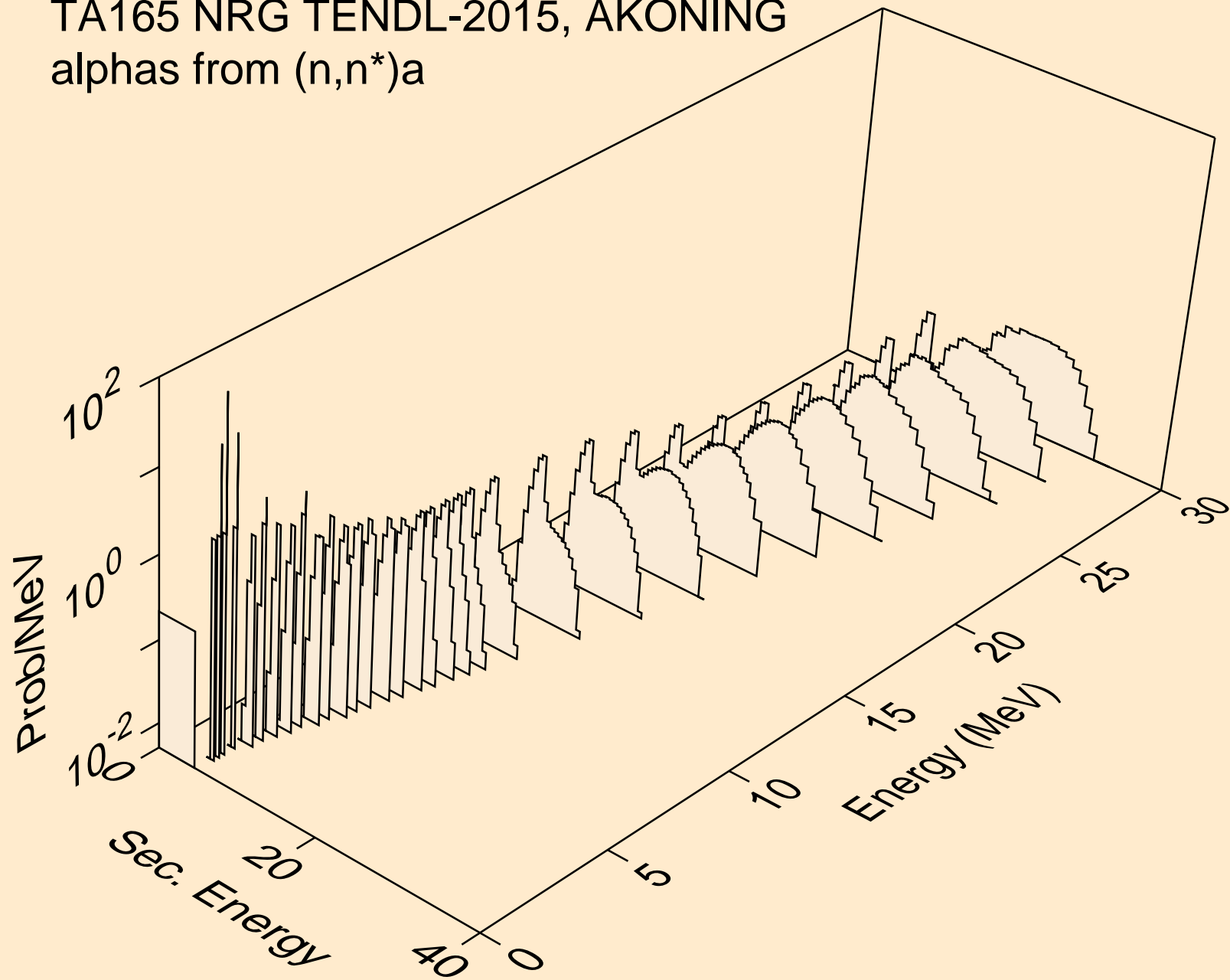

TA165 NRG TENDL-2015, AKONING  
alphas from (n,n\*)3a

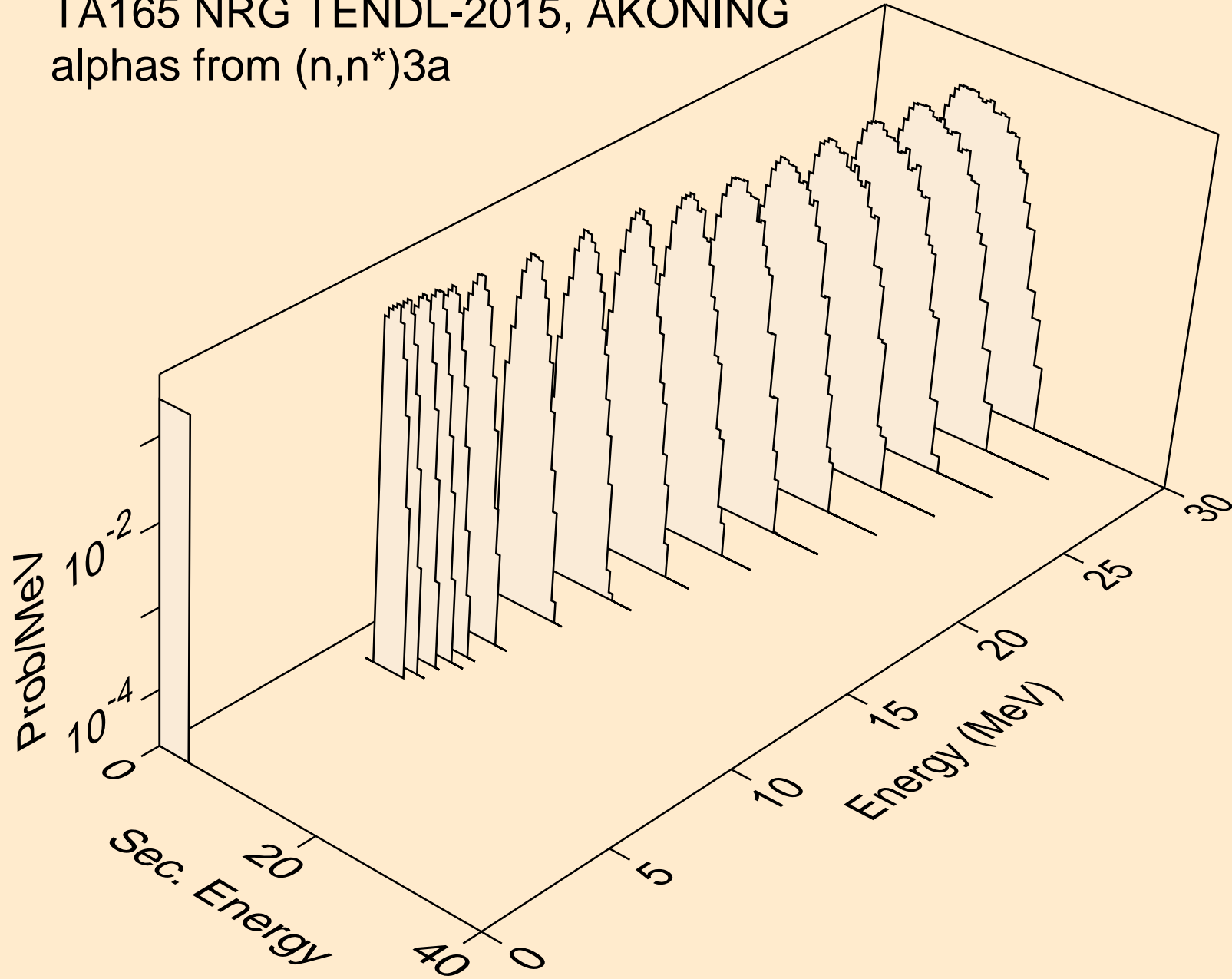



TA165 NRG TENDL-2015, AKONING  
alphas from (n,2n)a

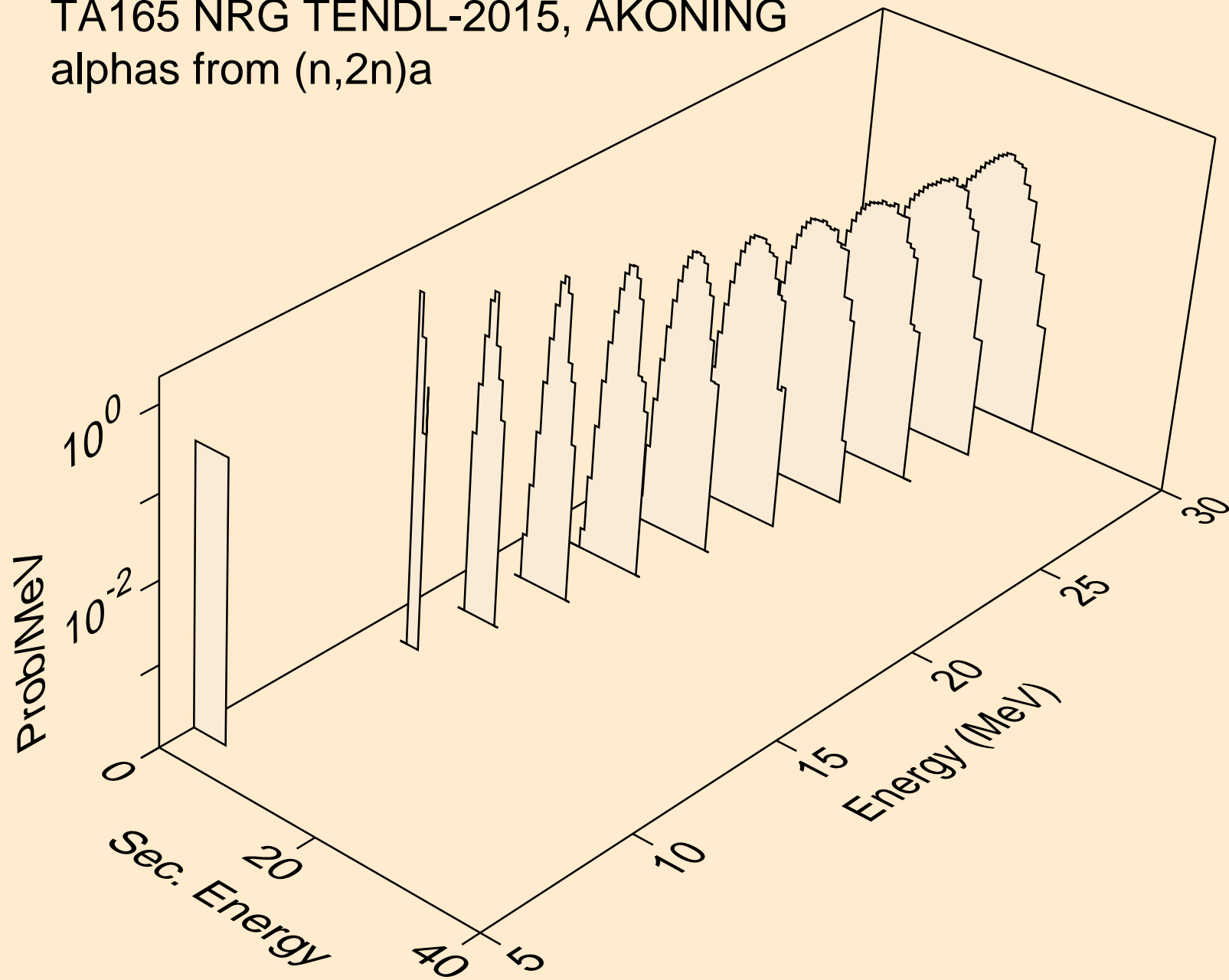

TA165 NRG TENDL-2015, AKONING  
alphas from (n,3n)a

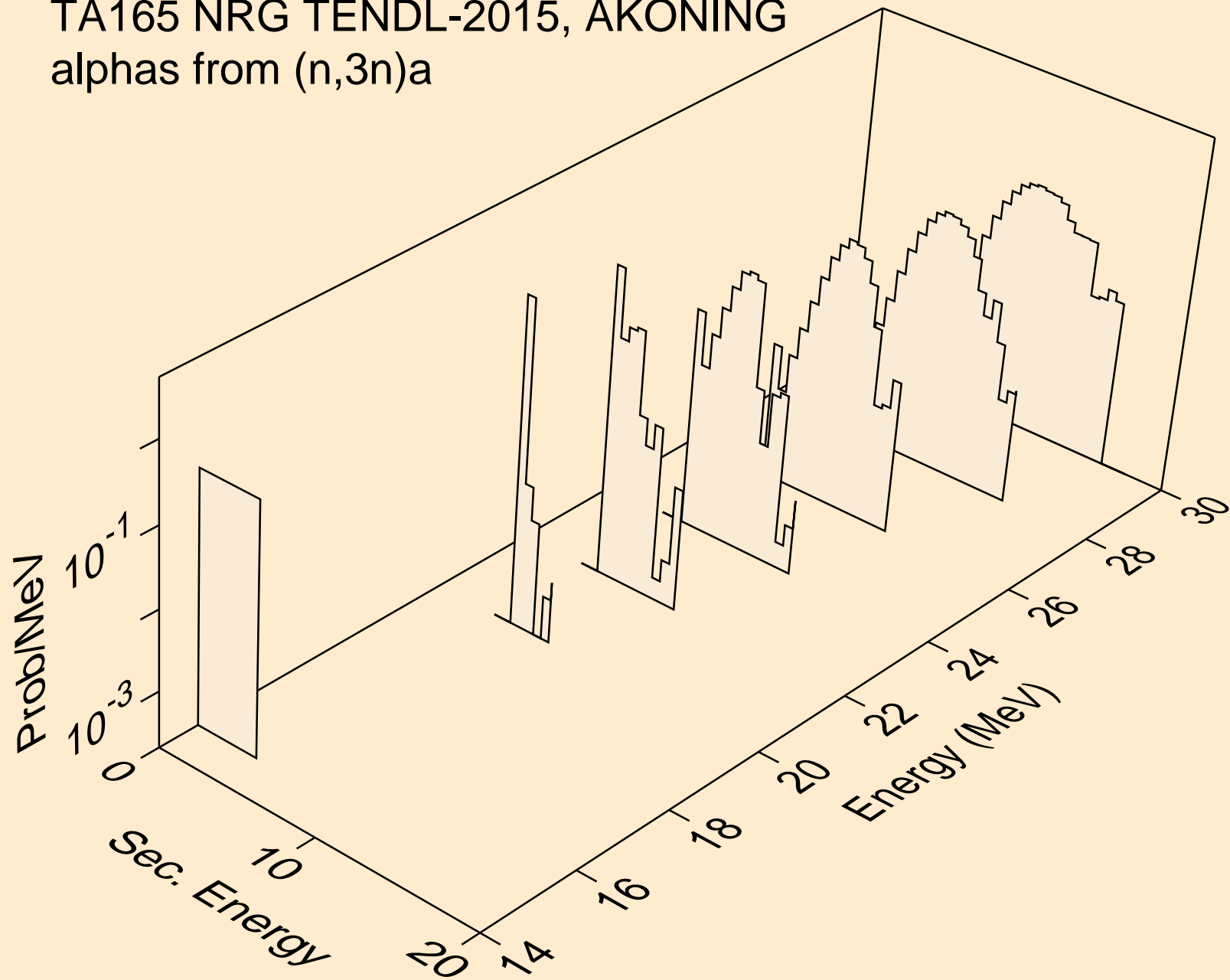

TA165 NRG TENDL-2015, AKONING  
alphas from (n,n\*)2a

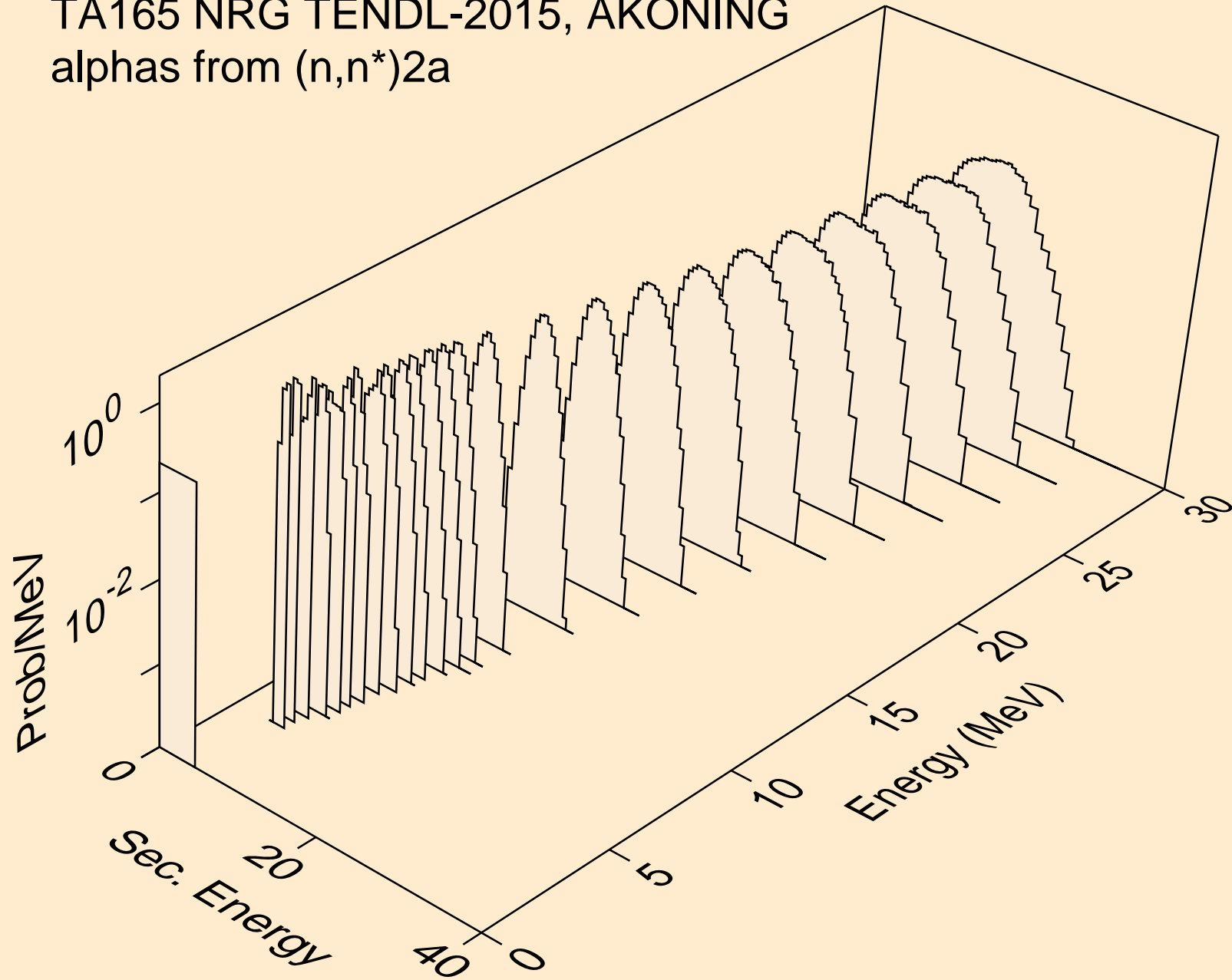

TA165 NRG TENDL-2015, AKONING  
alphas from (n,2n)2a

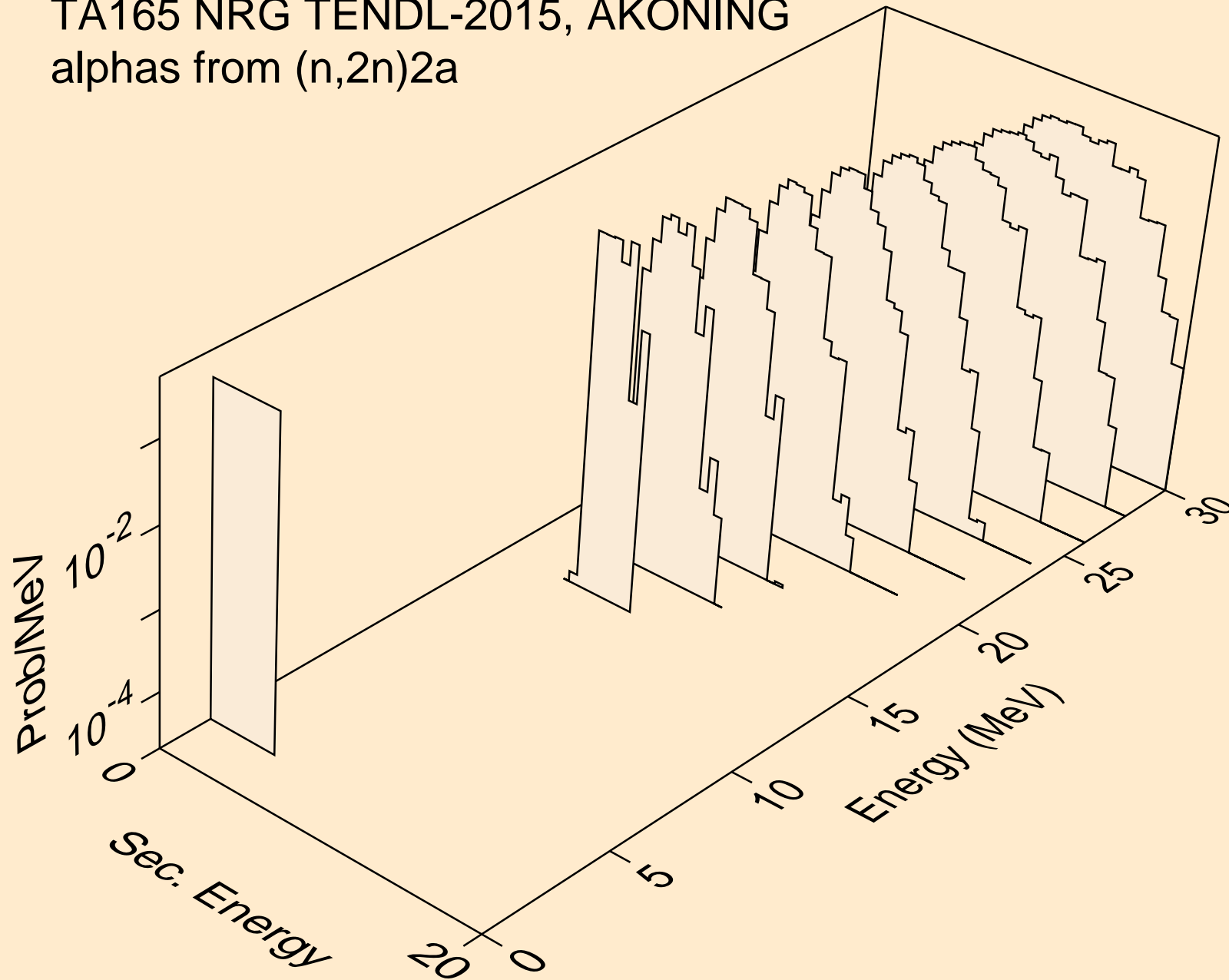

TA165 NRG TENDL-2015, AKONING  
alphas from (n,n\*)t2a

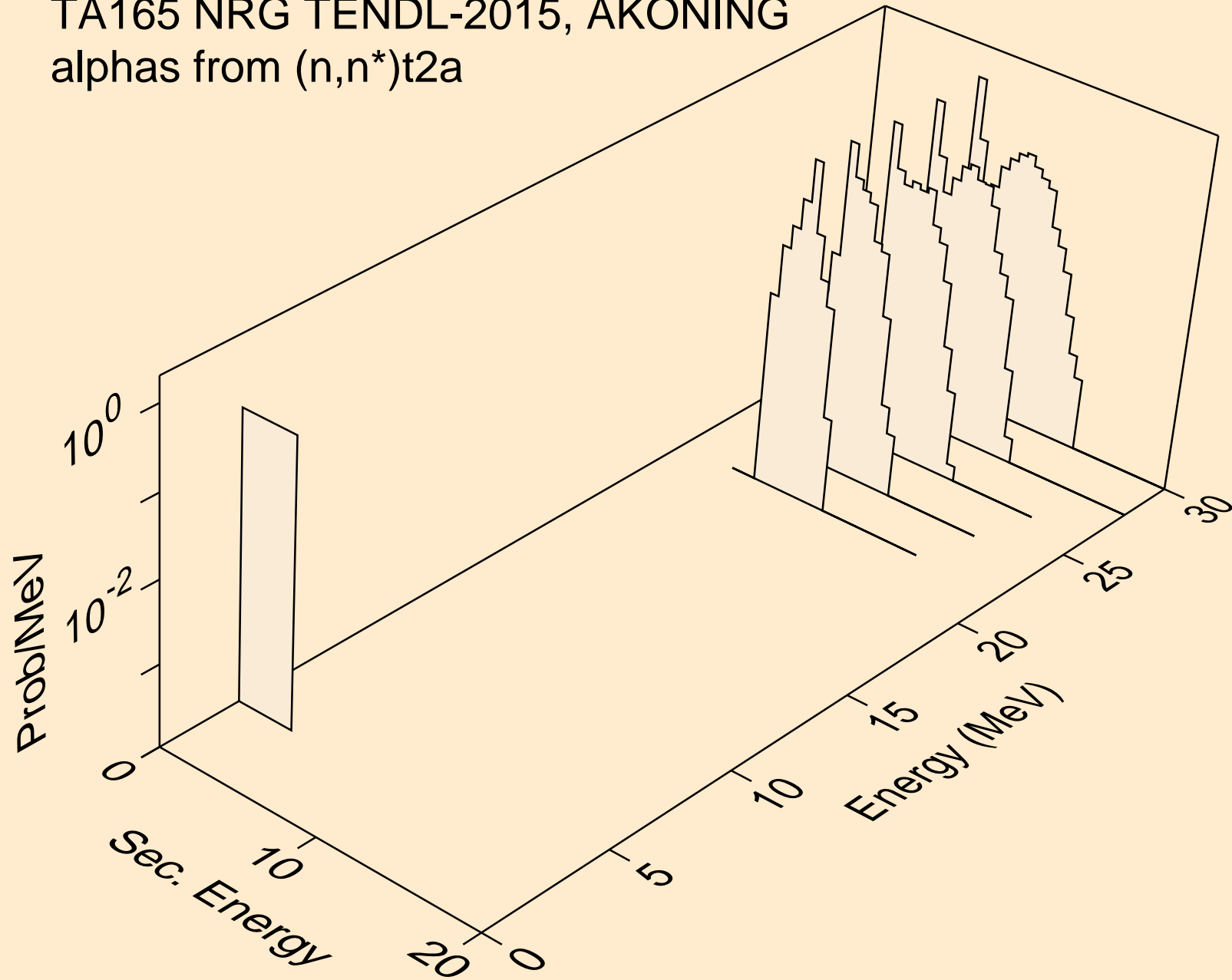

TA165 NRG TENDL-2015, AKONING  
alphas from (n,npa)

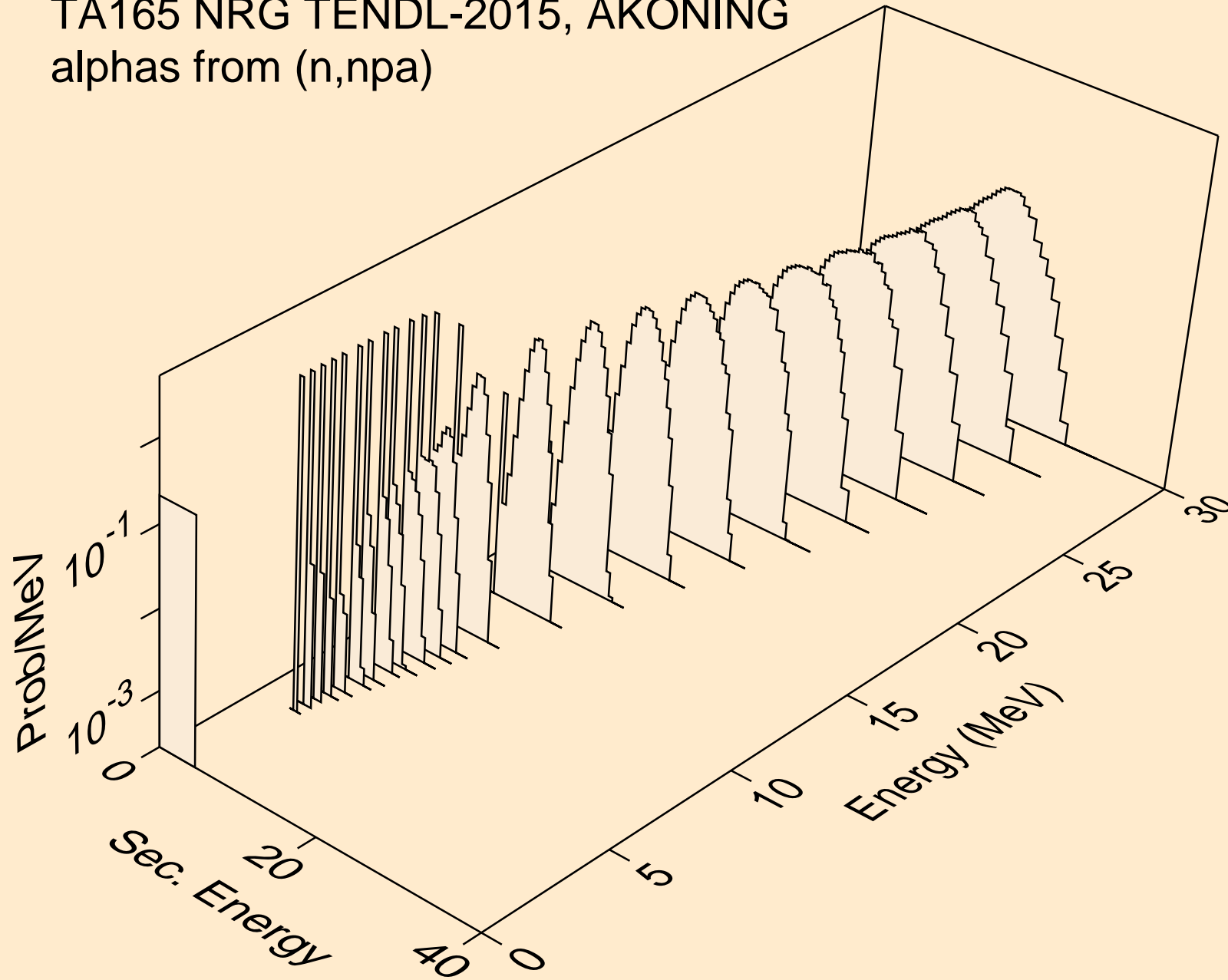

TA165 NRG TENDL-2015, AKONING  
alphas from (n,a)

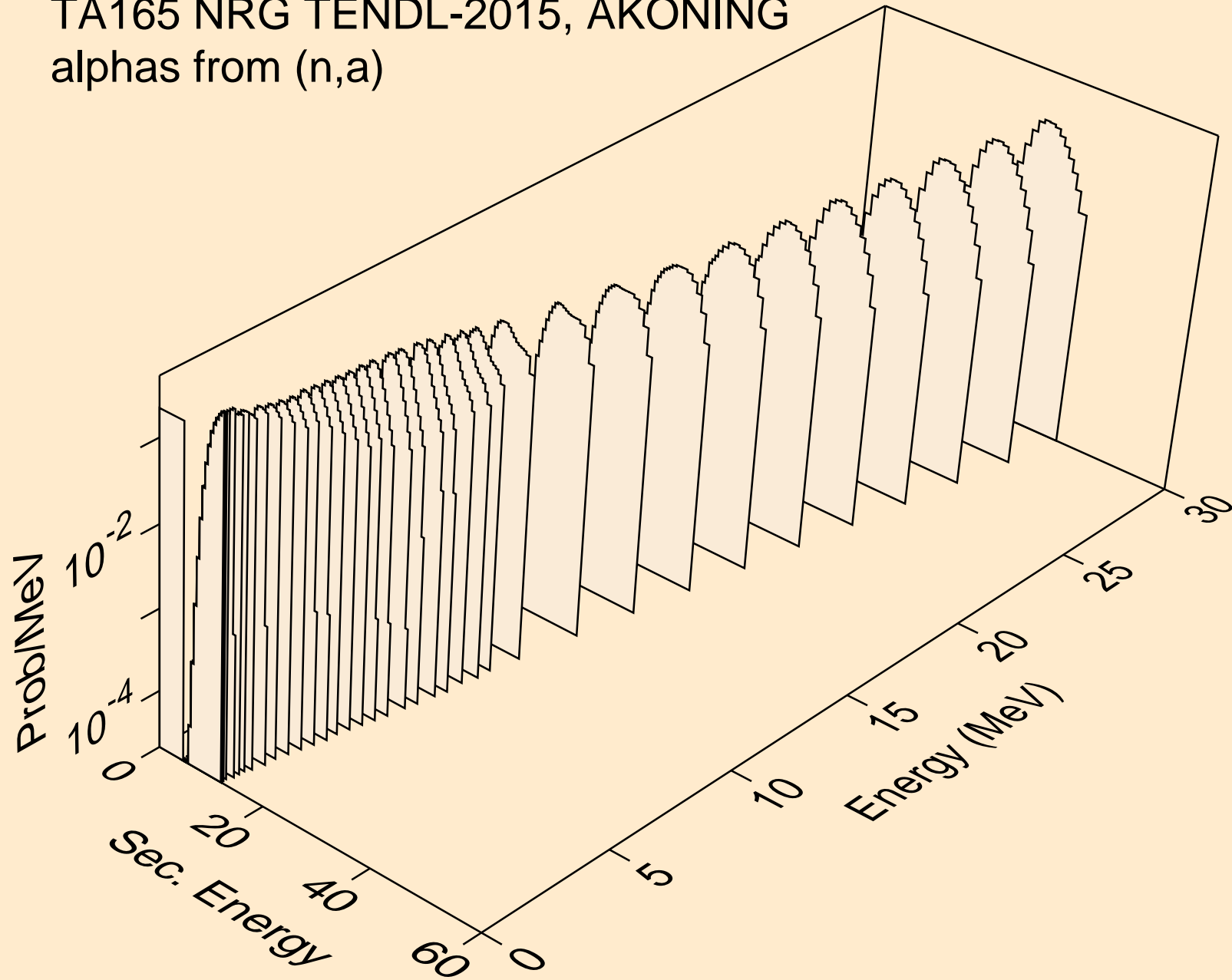

TA165 NRG TENDL-2015, AKONING  
alphas from (n,2a)

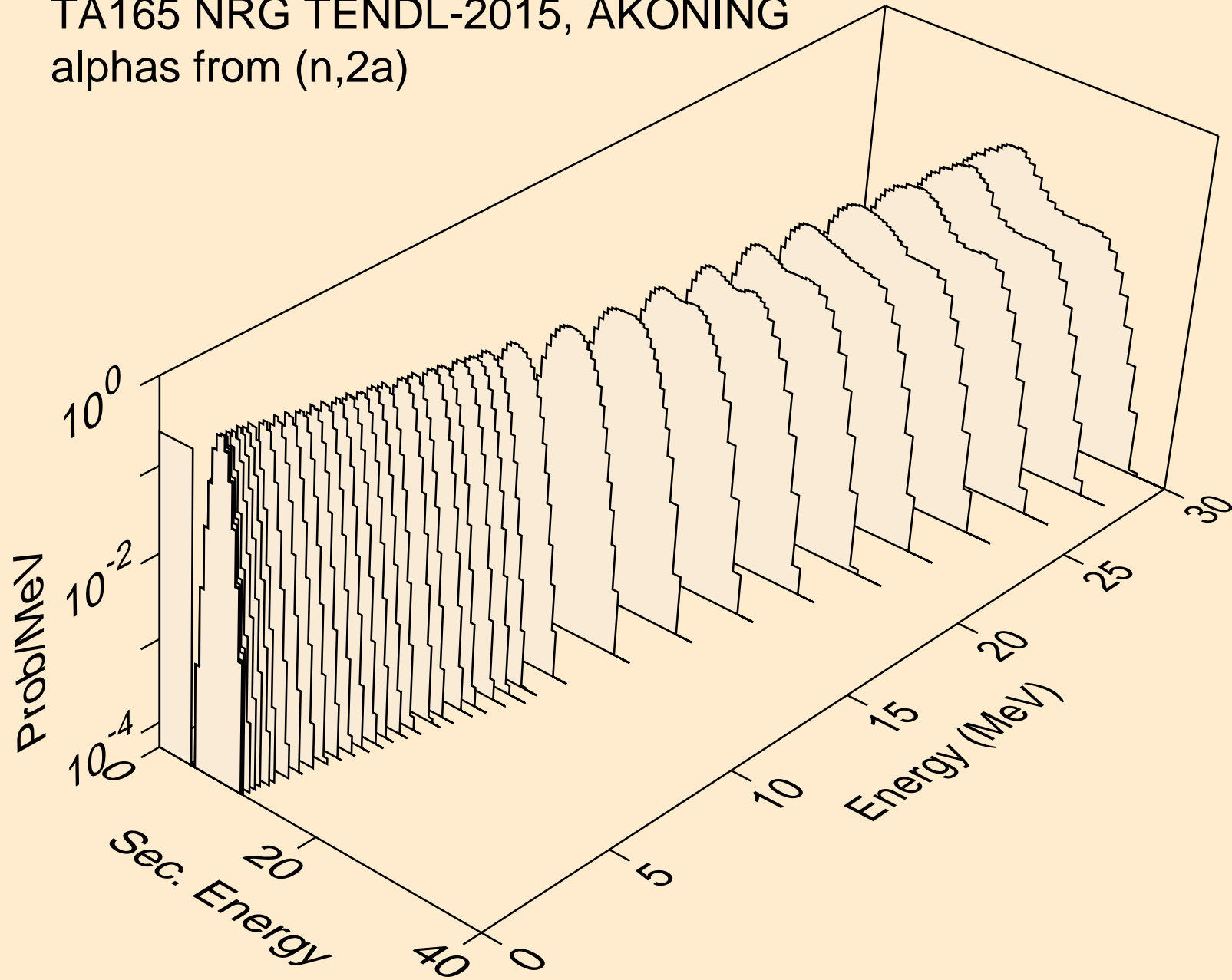



TA165 NRG TENDL-2015, AKONING  
alphas from (n,3a)

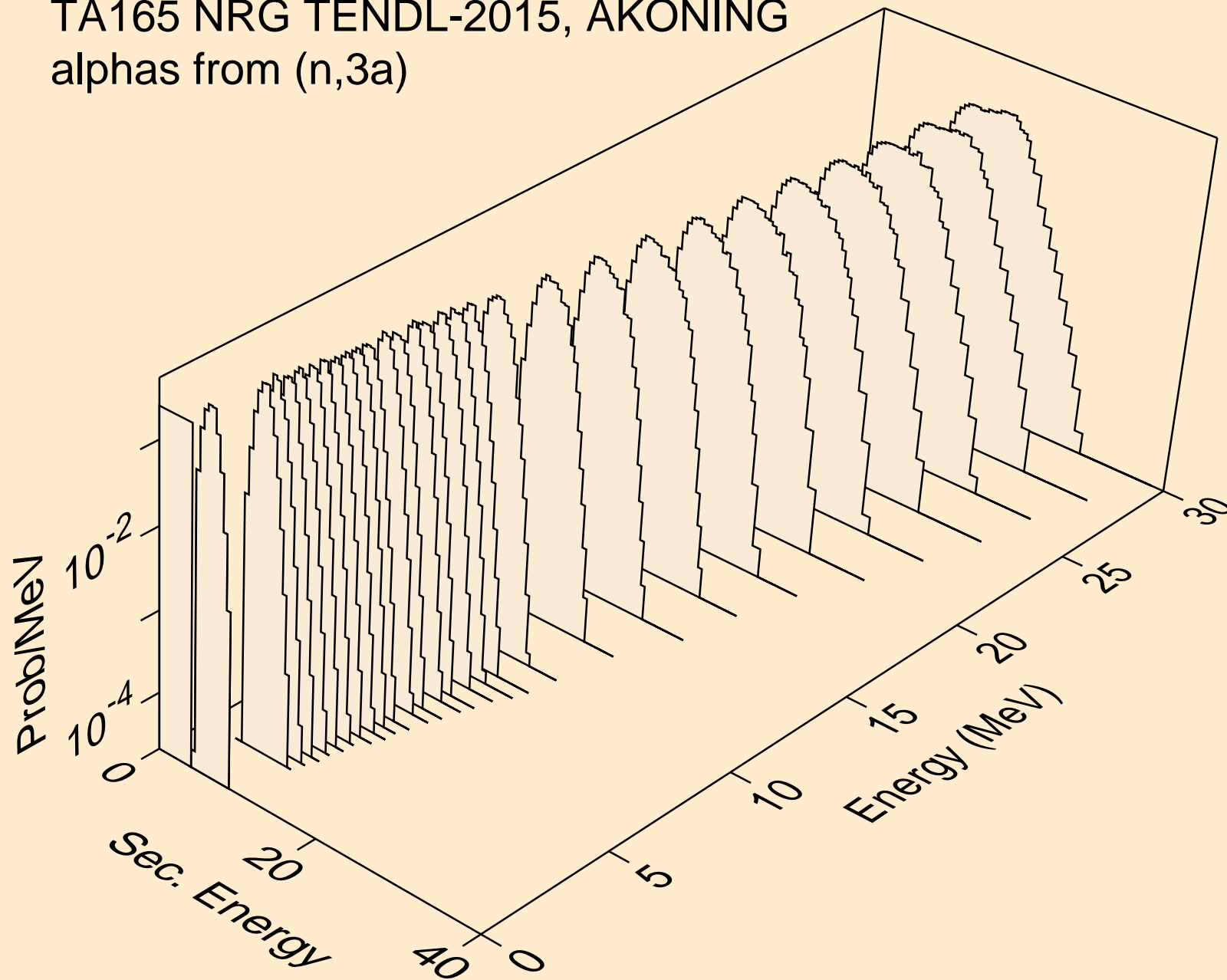

TA165 NRG TENDL-2015, AKONING  
alphas from (n,pa)

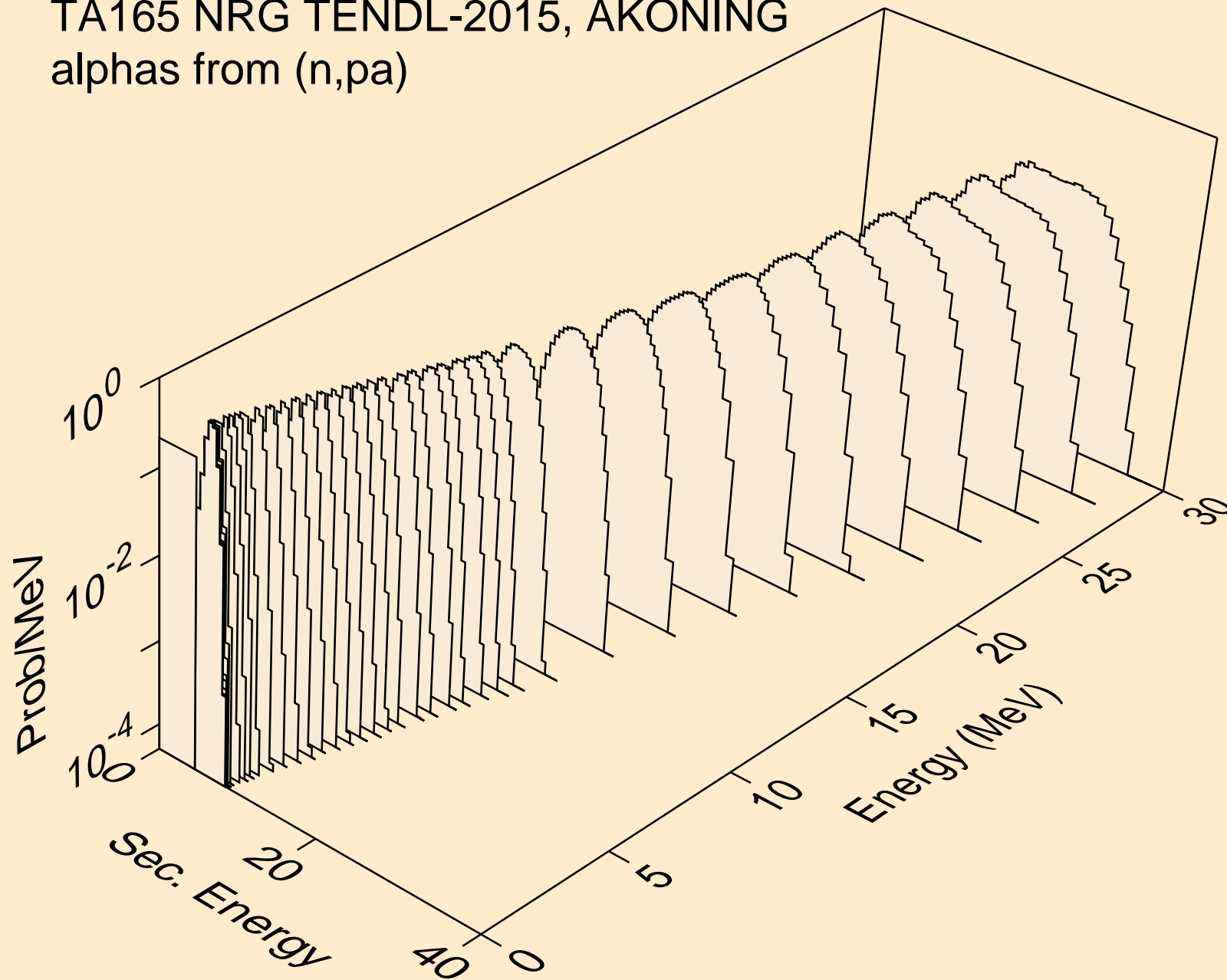

TA165 NRG TENDL-2015, AKONING  
alphas from (n,t2a)

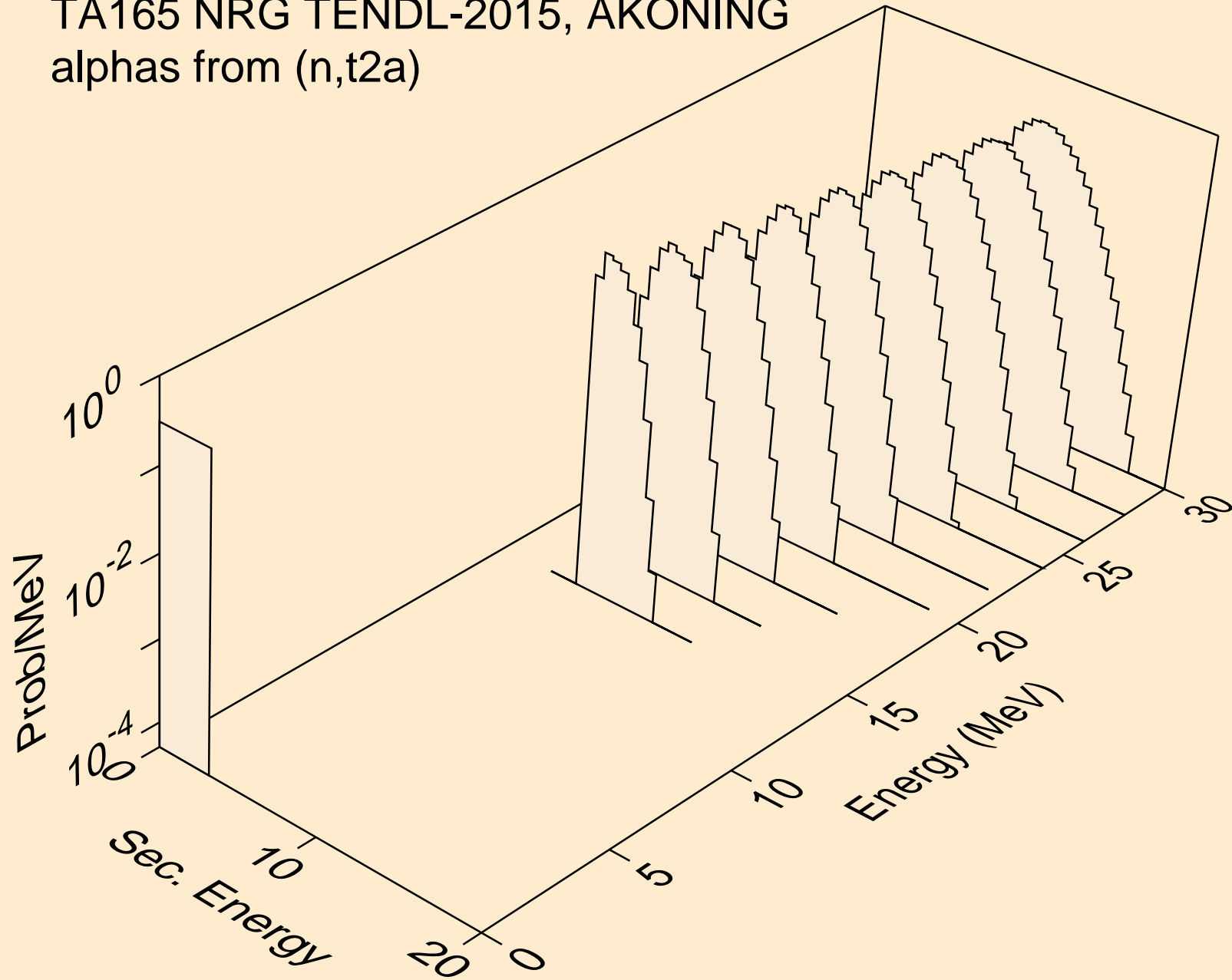

TA165 NRG TENDL-2015, AKONING  
alphas from (n,d2a)

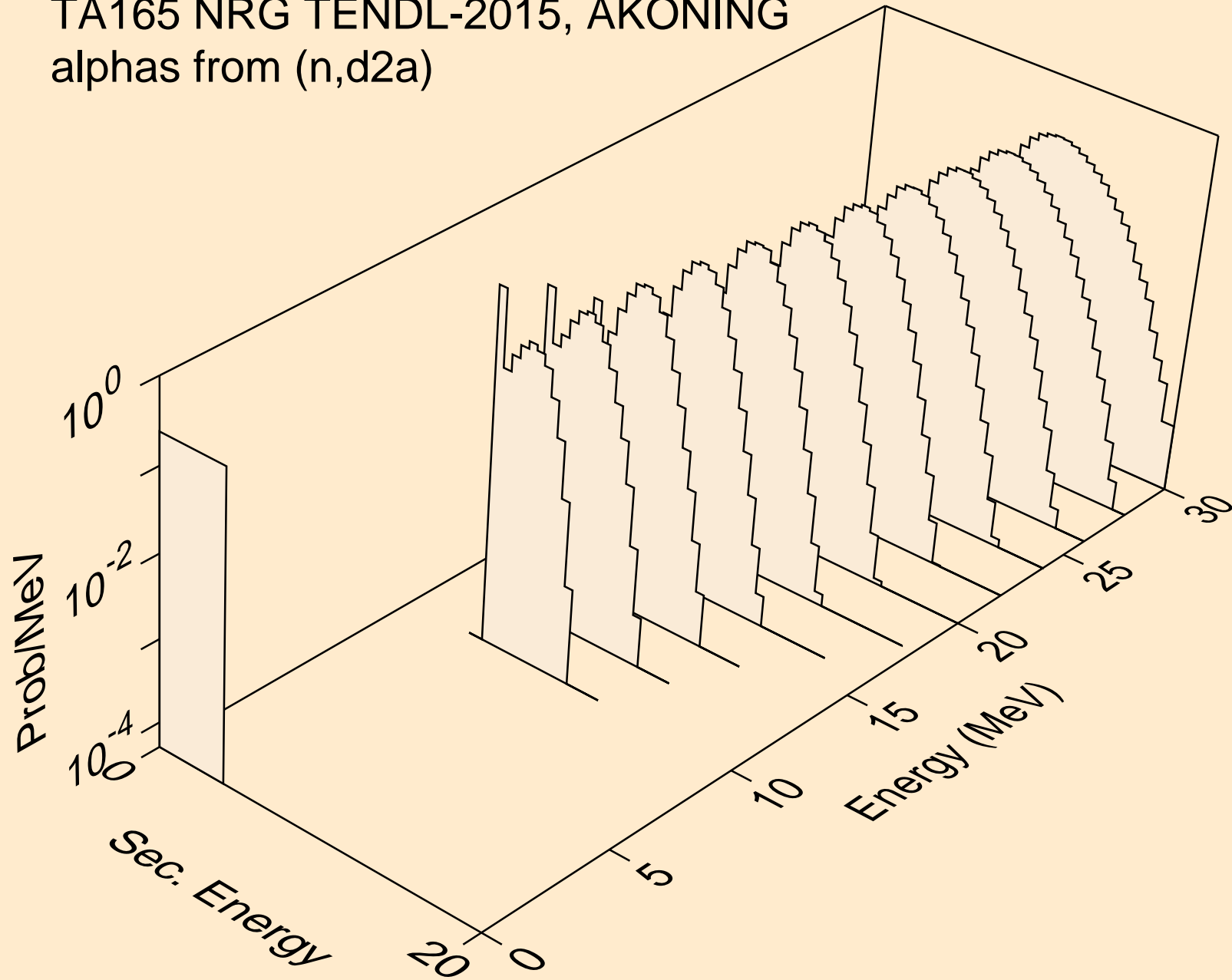

TA165 NRG TENDL-2015, AKONING  
alphas from (n,da)

