

# TA167 NRG TENDL-2015, AKONING

## Principal cross sections

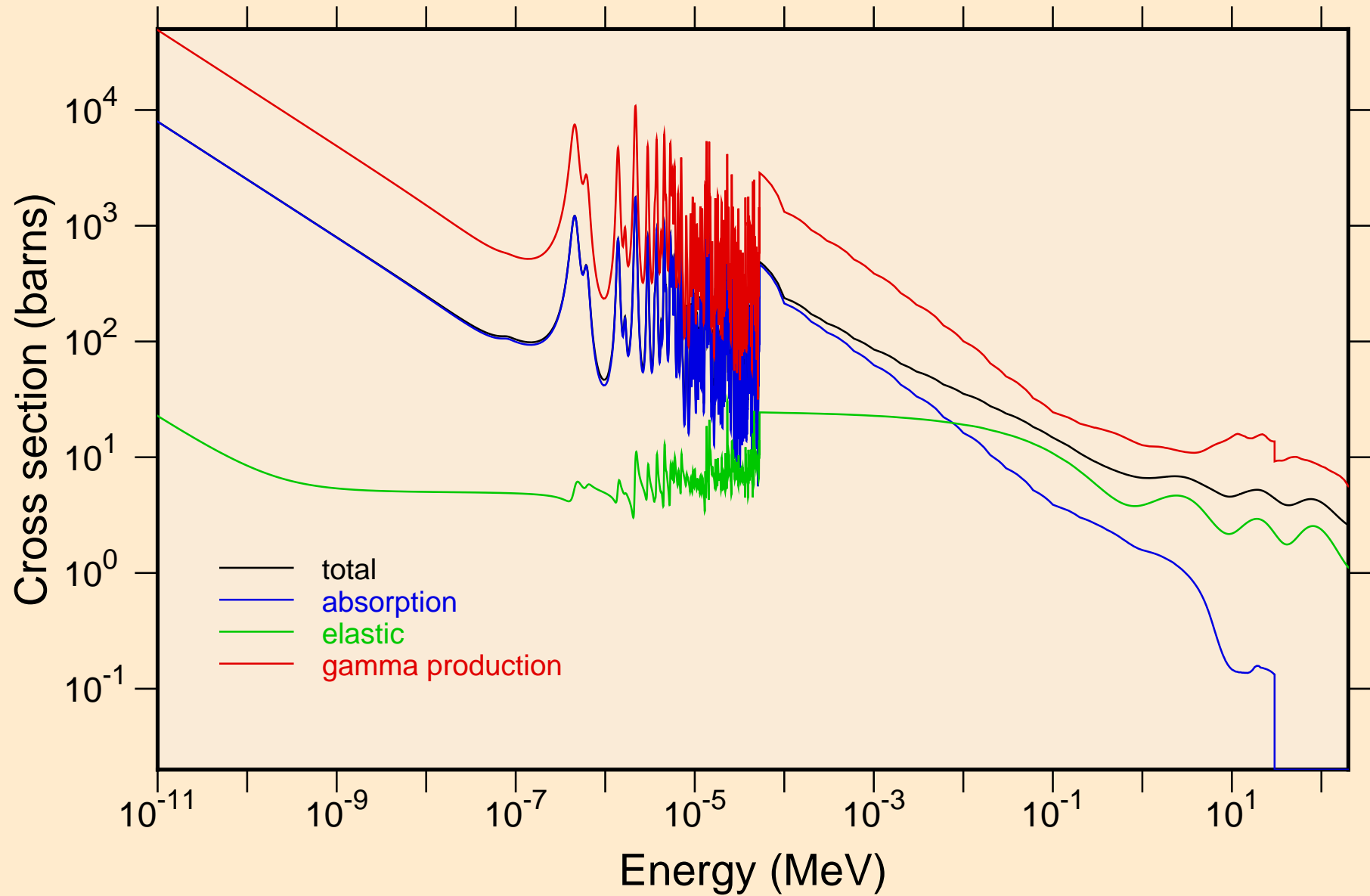

TA167 NRG TENDL-2015, AKONING  
resonance total cross section

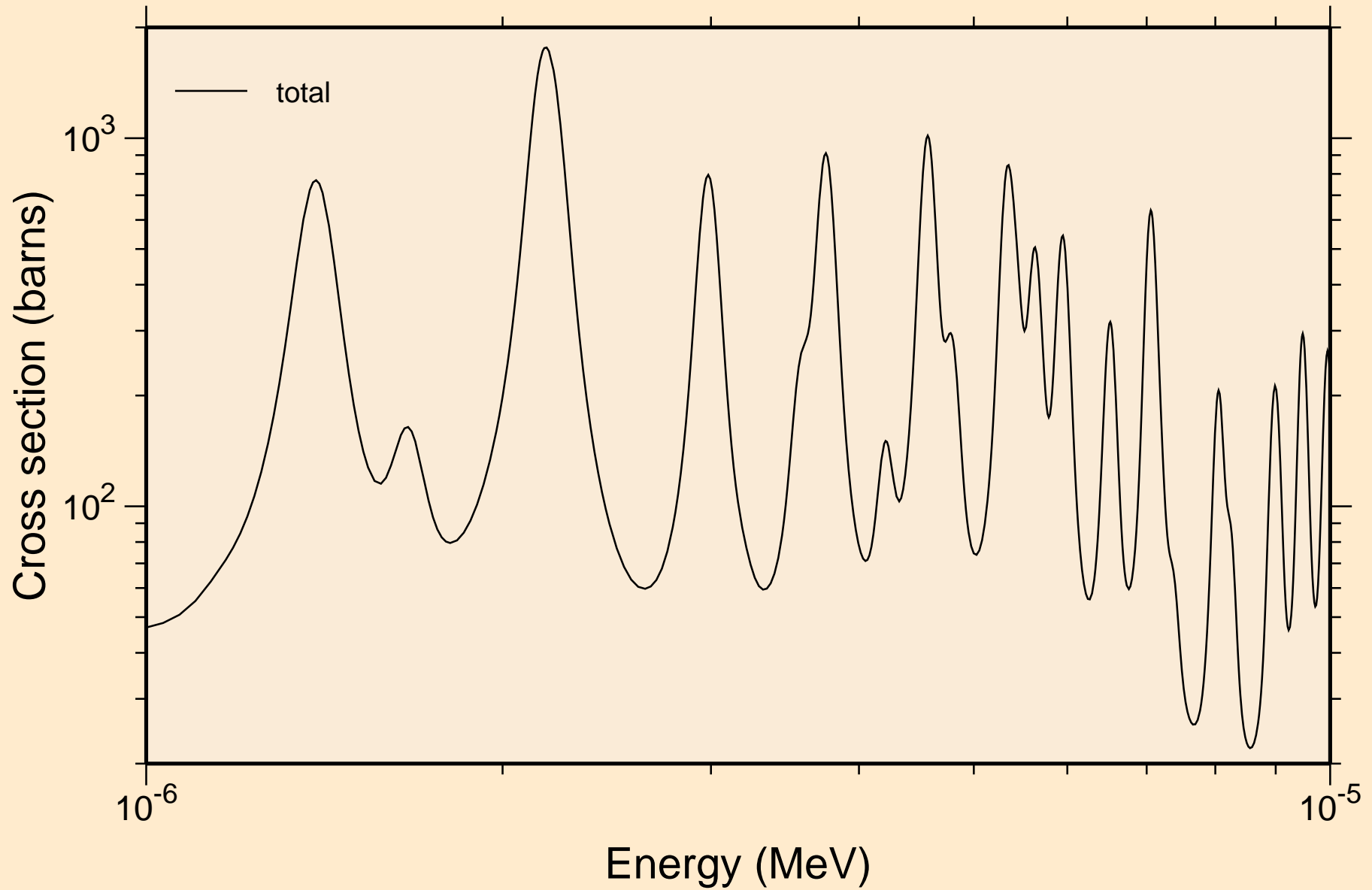

TA167 NRG TENDL-2015, AKONING  
resonance total cross section

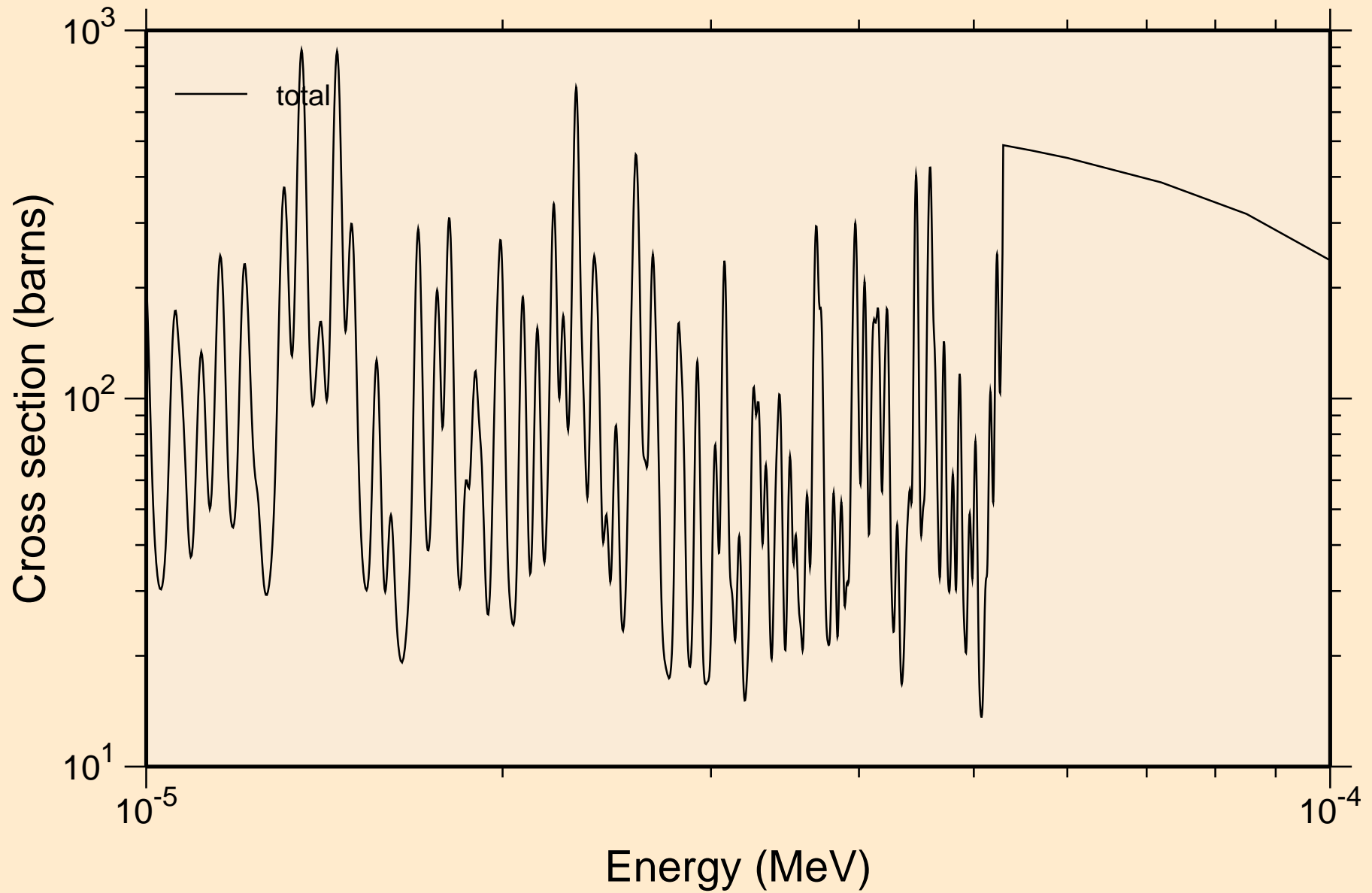

TA167 NRG TENDL-2015, AKONING  
resonance total cross section

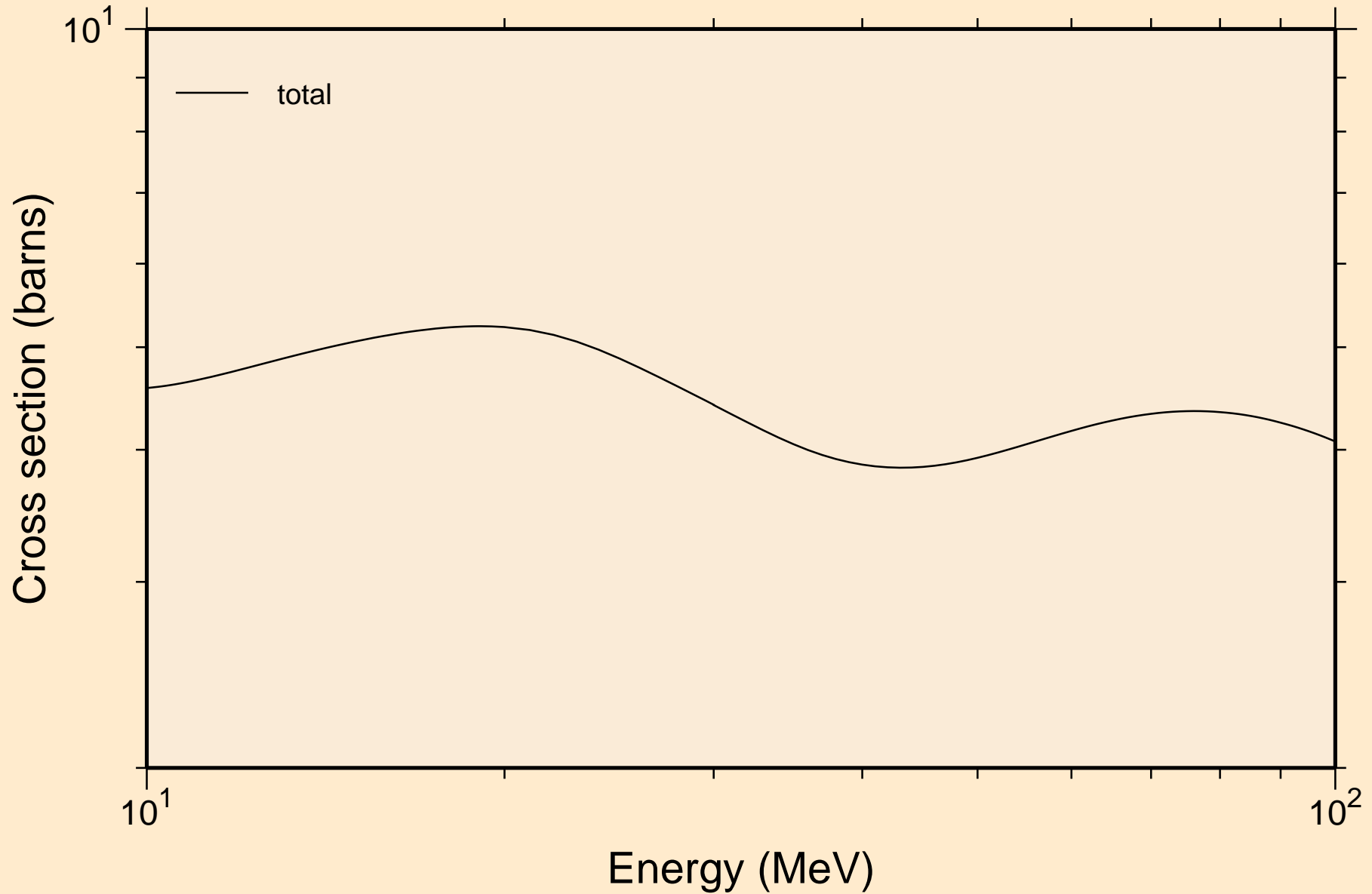

TA167 NRG TENDL-2015, AKONING  
resonance absorption cross sections

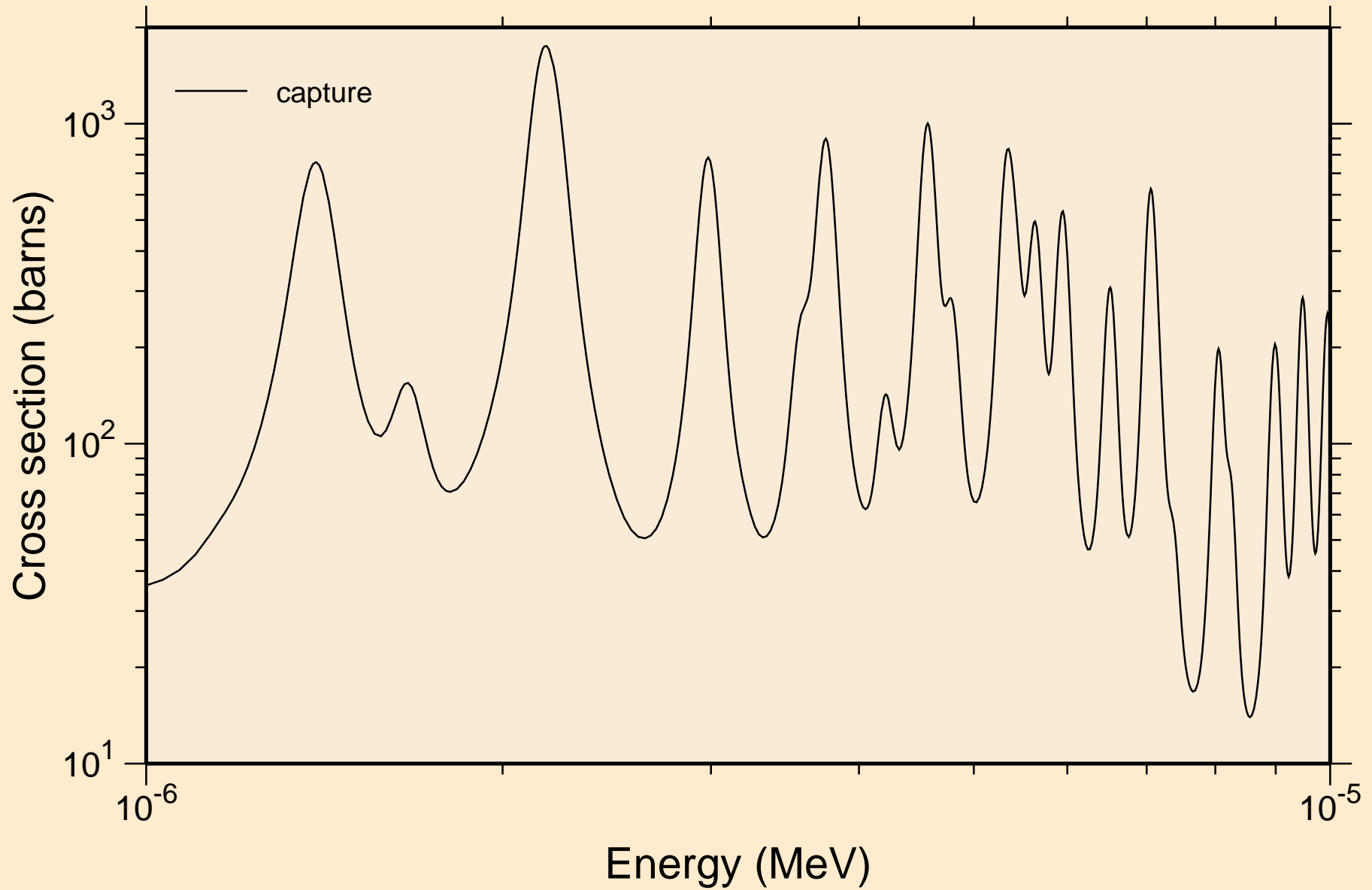

TA167 NRG TENDL-2015, AKONING  
resonance absorption cross sections

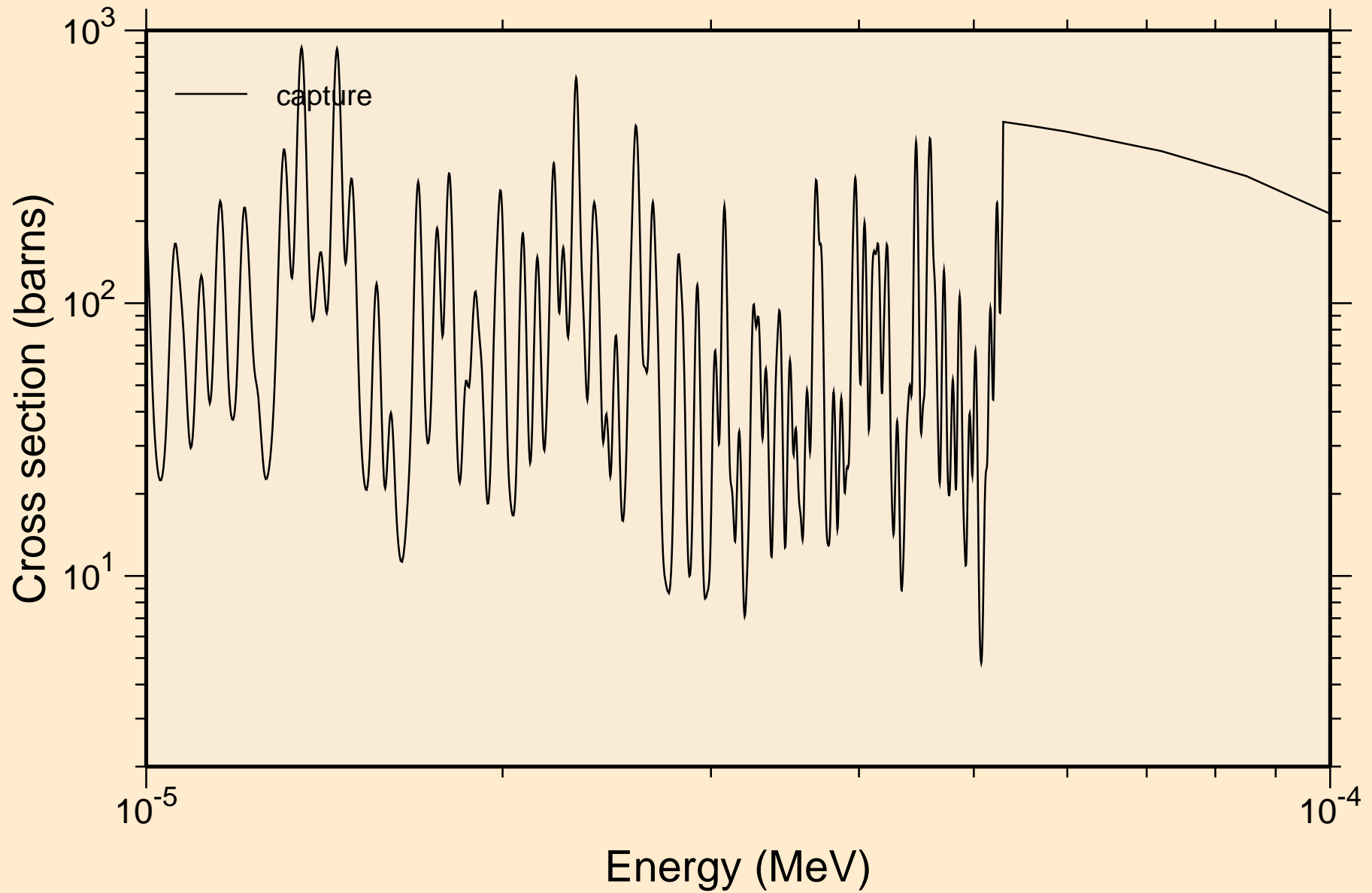

TA167 NRG TENDL-2015, AKONING  
resonance absorption cross sections

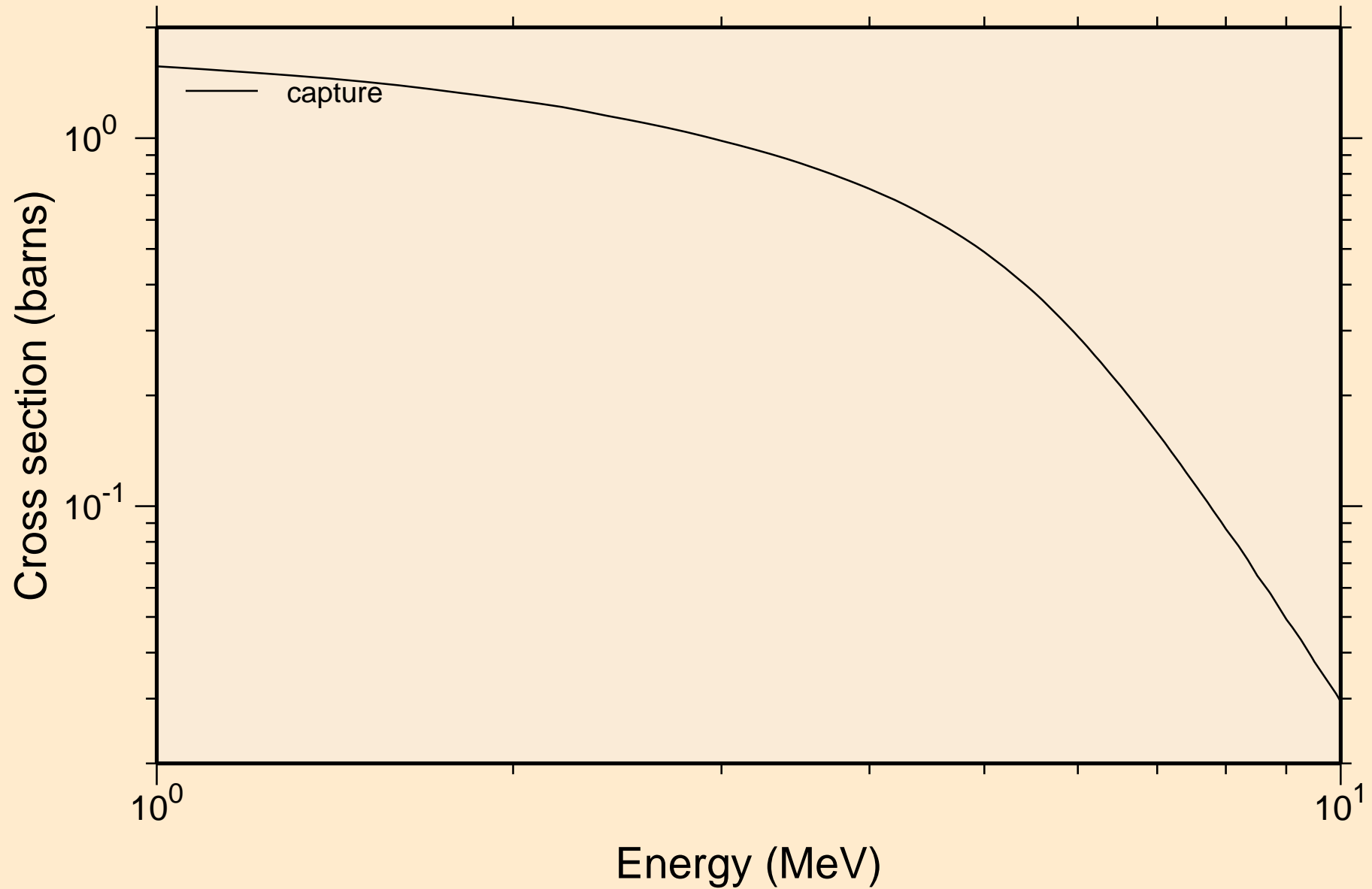

# TA167 NRG TENDL-2015, AKONING

## Non-threshold reactions

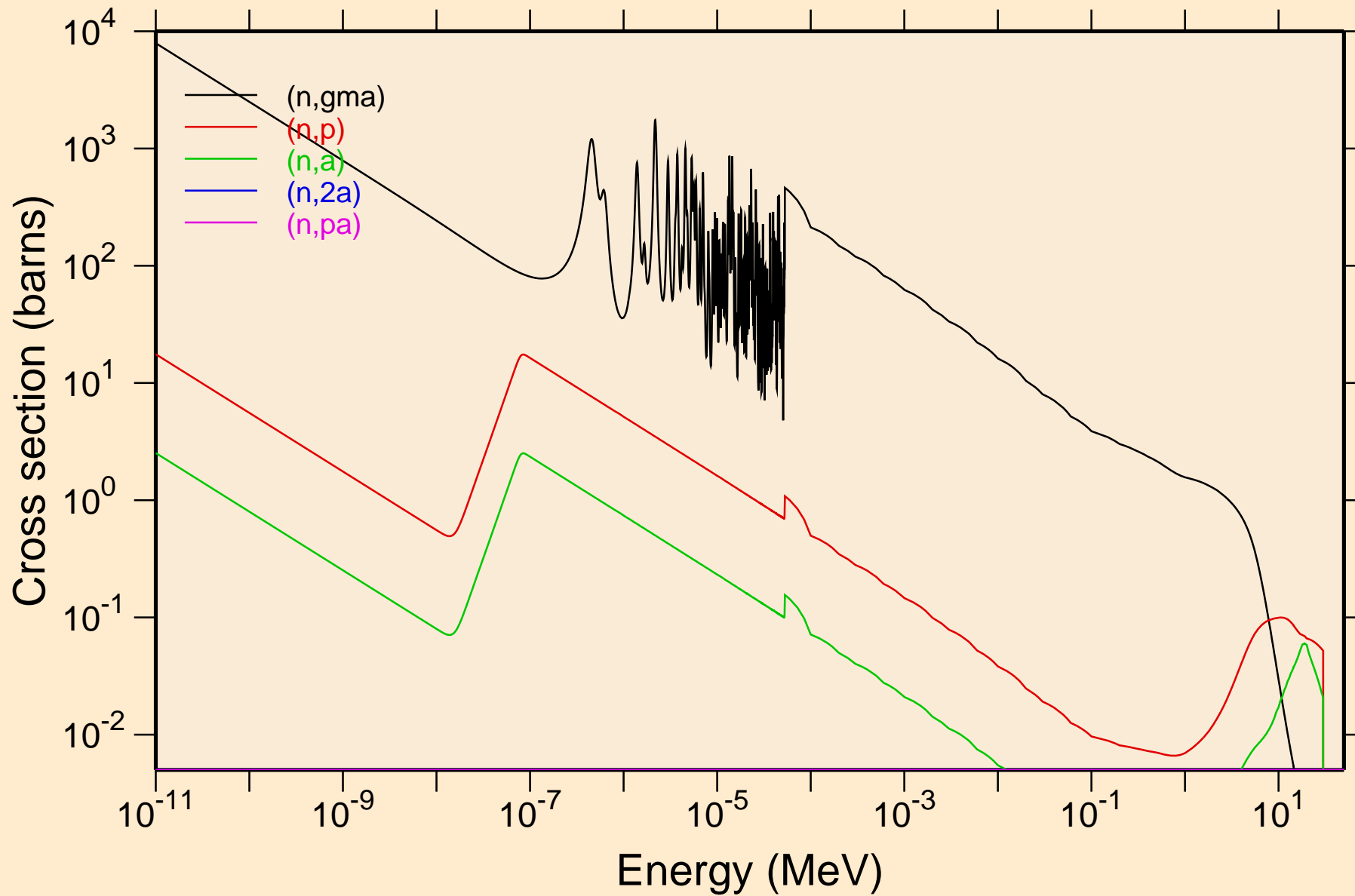



# TA167 NRG TENDL-2015, AKONING

## Principal cross sections

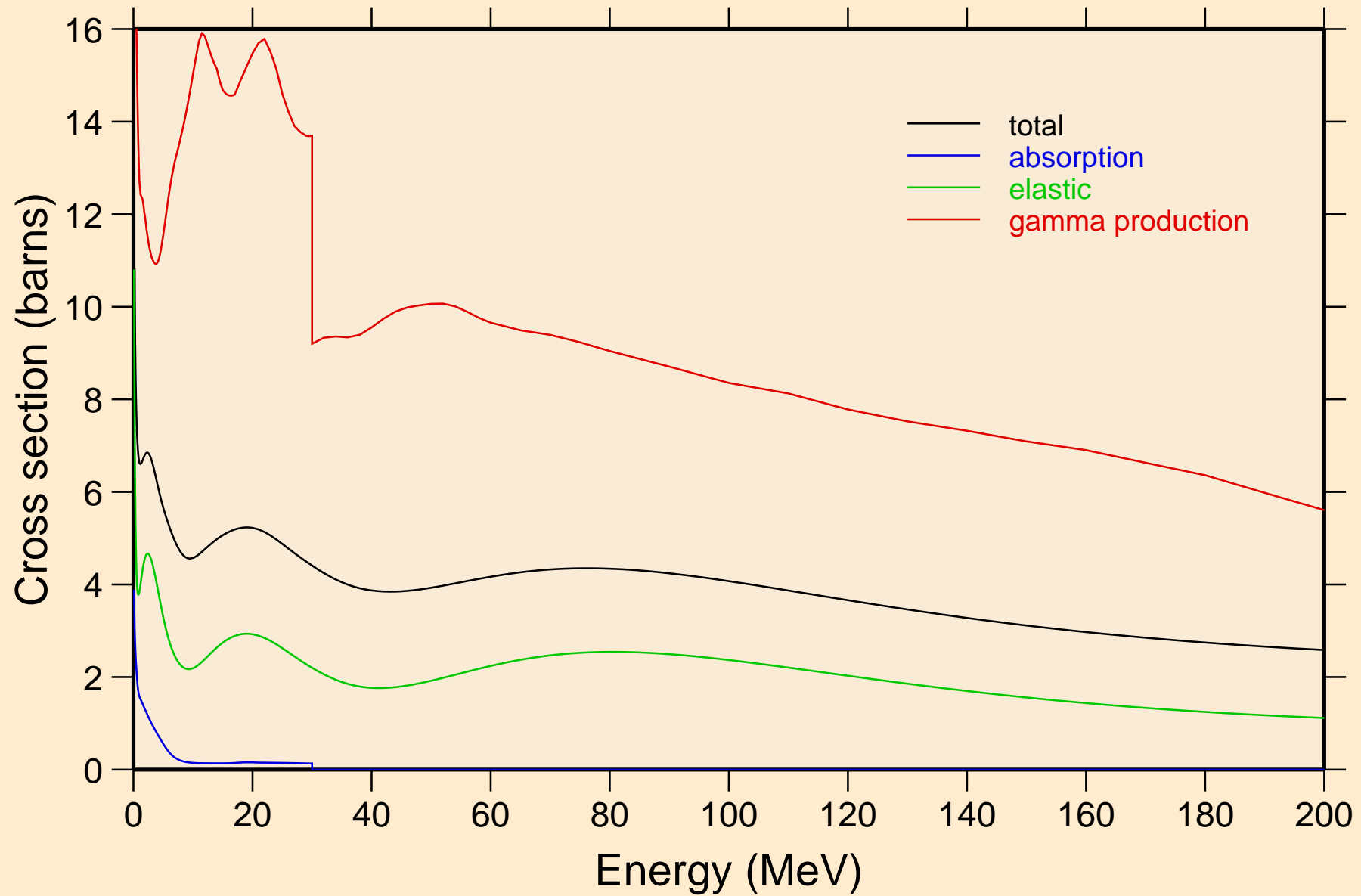

# TA167 NRG TENDL-2015, AKONING

## Non-threshold reactions

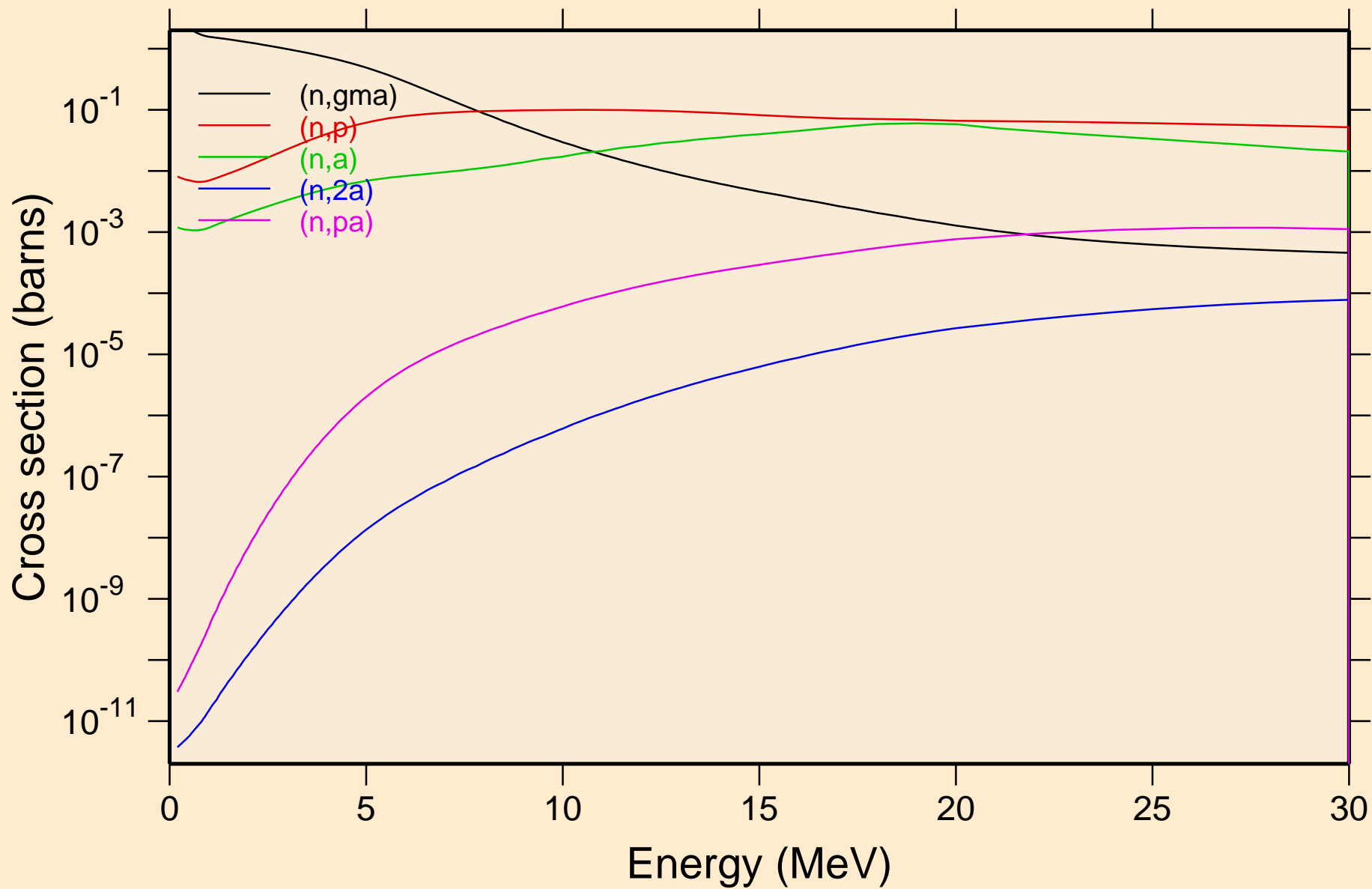

# TA167 NRG TENDL-2015, AKONING

## Inelastic levels

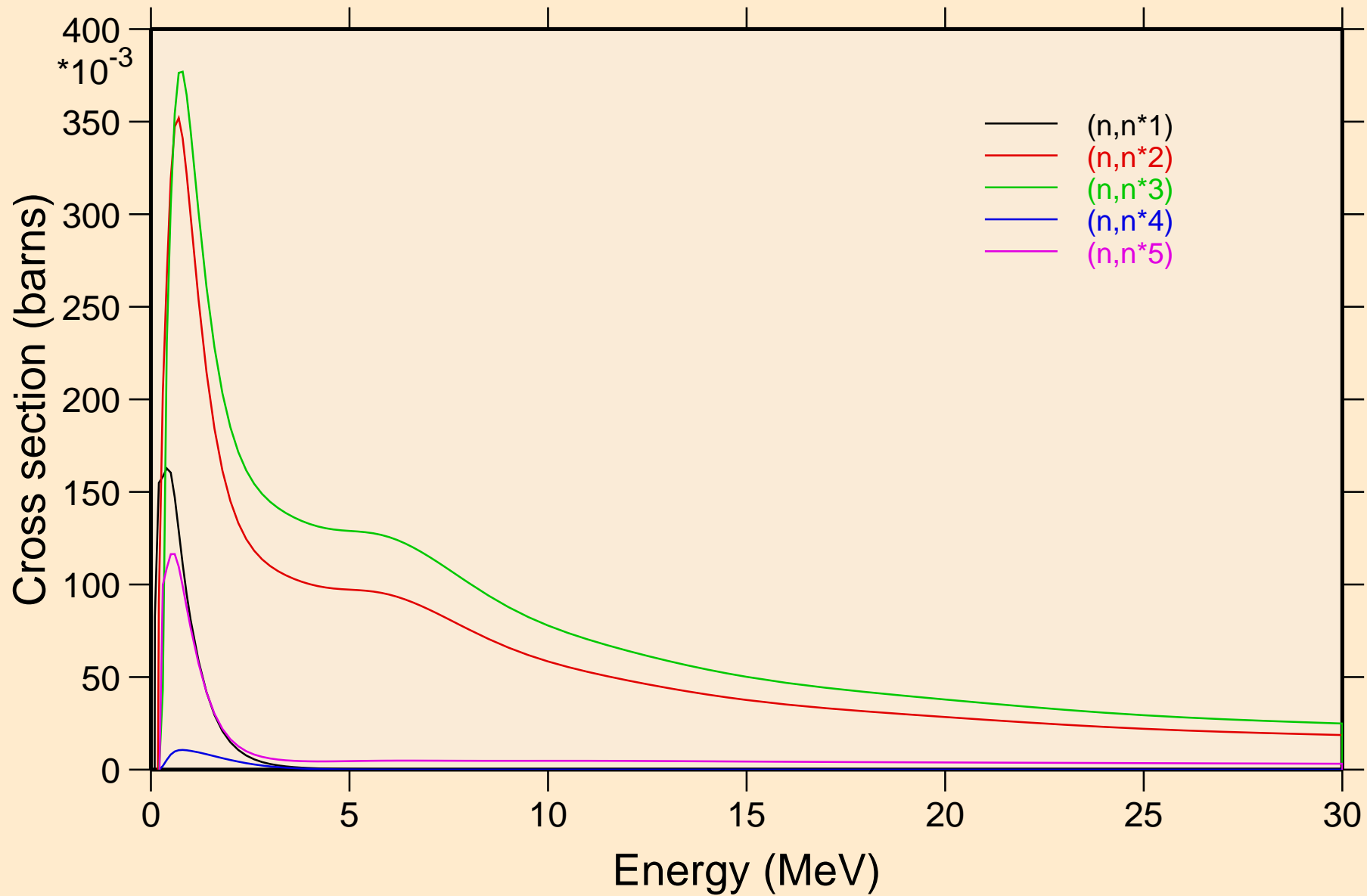

# TA167 NRG TENDL-2015, AKONING

## Inelastic levels

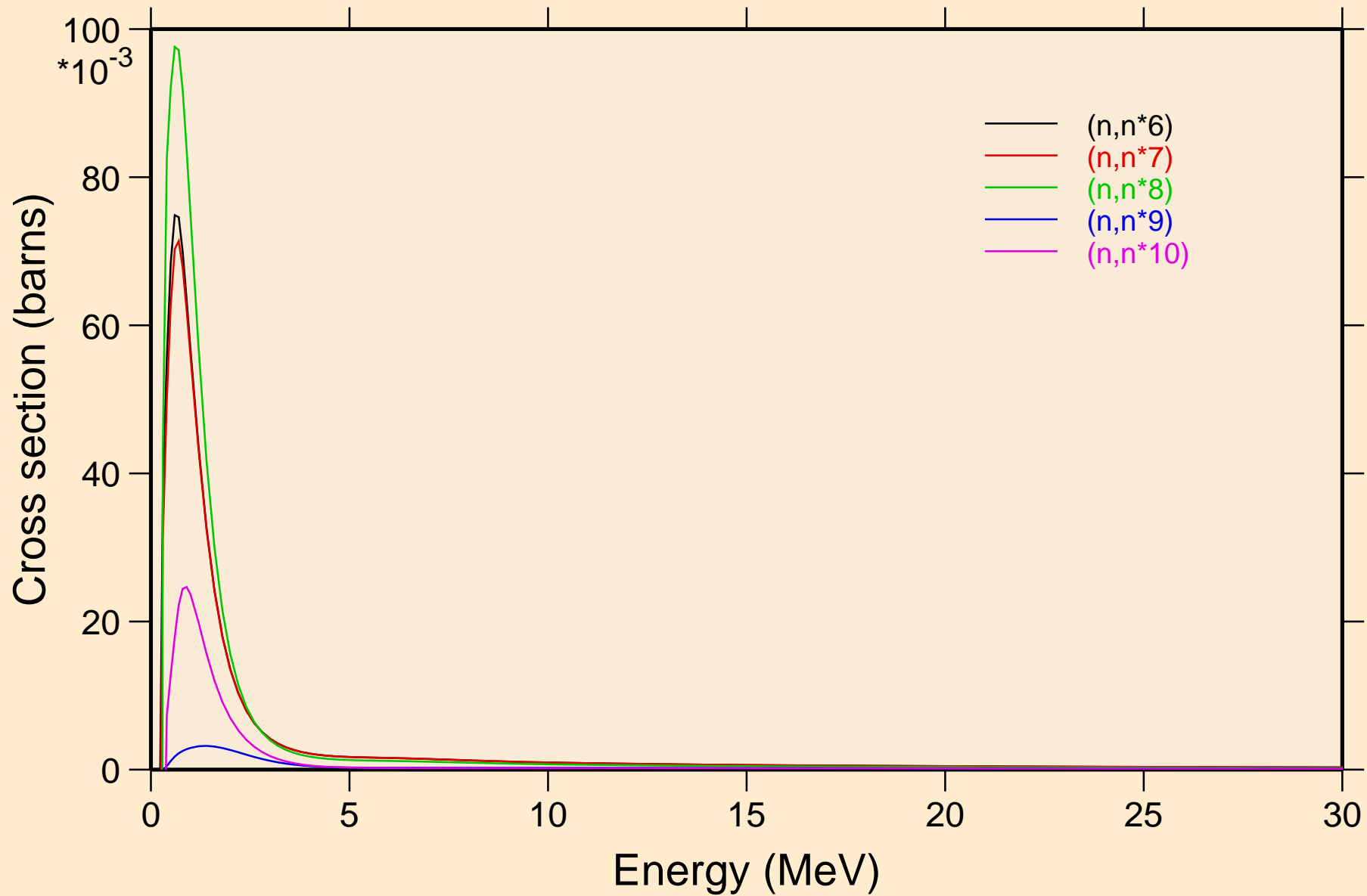

# TA167 NRG TENDL-2015, AKONING

## Inelastic levels

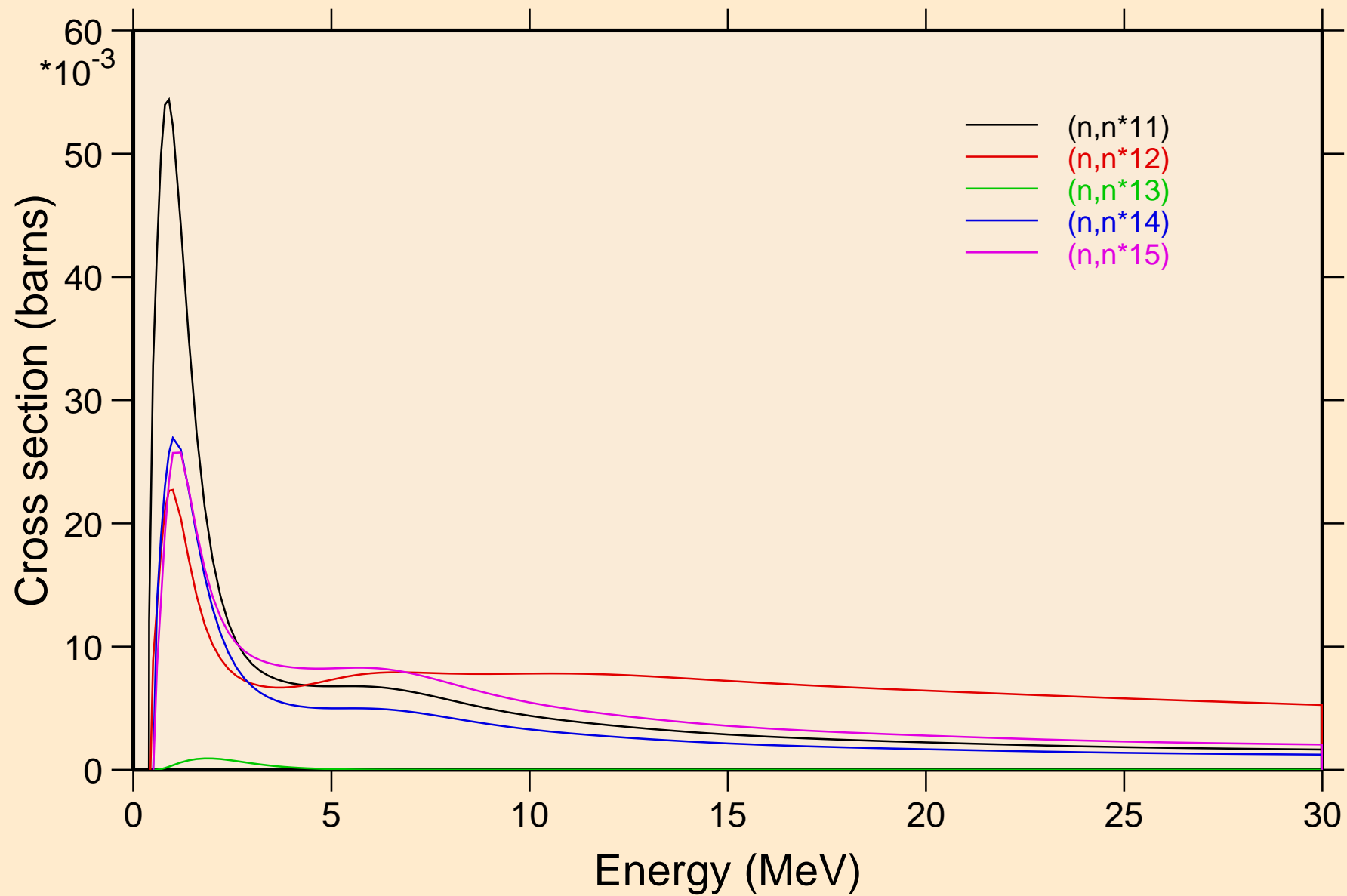

TA167 NRG TENDL-2015, AKONING  
Inelastic levels

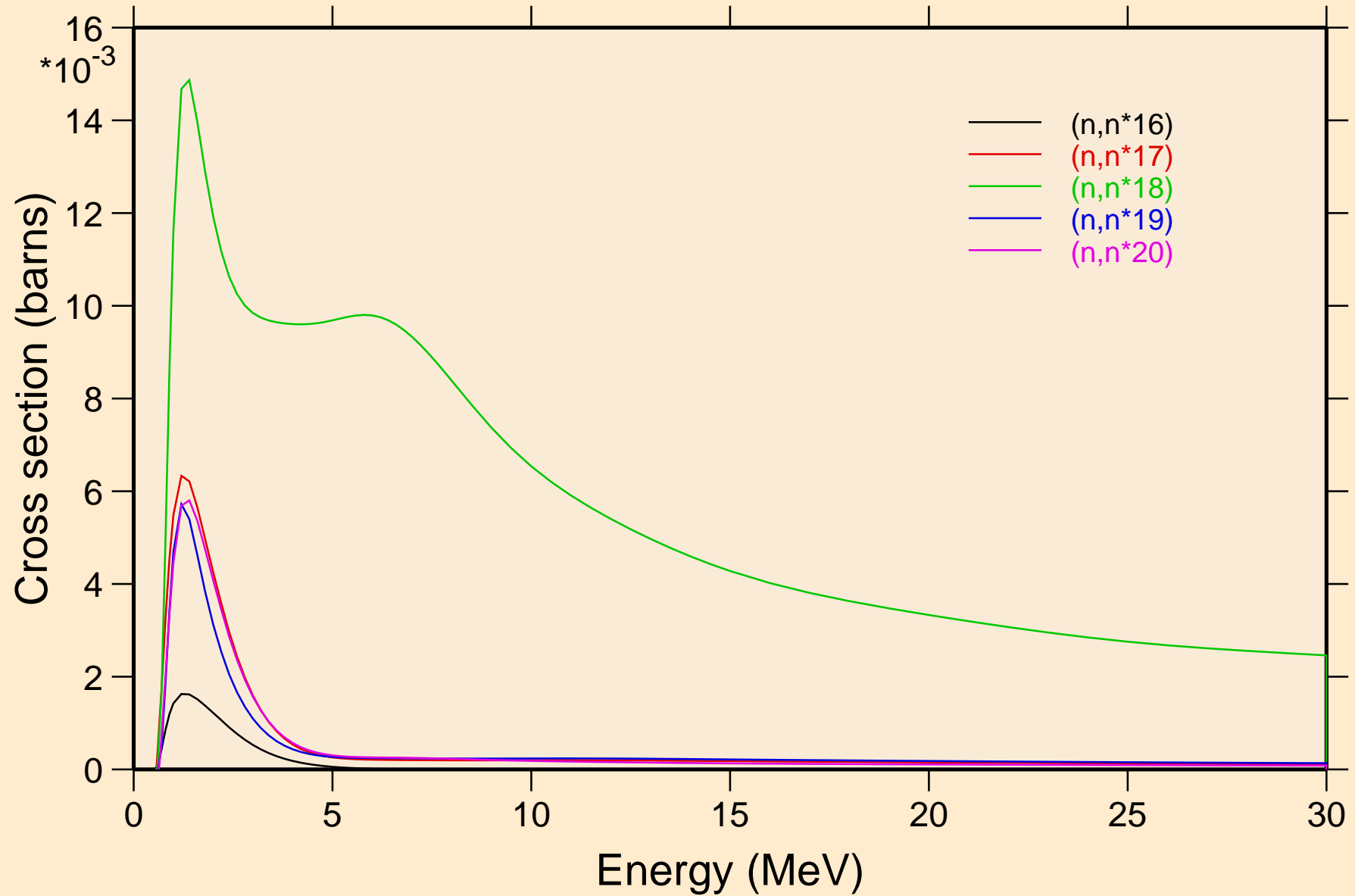

# TA167 NRG TENDL-2015, AKONING

## Inelastic levels

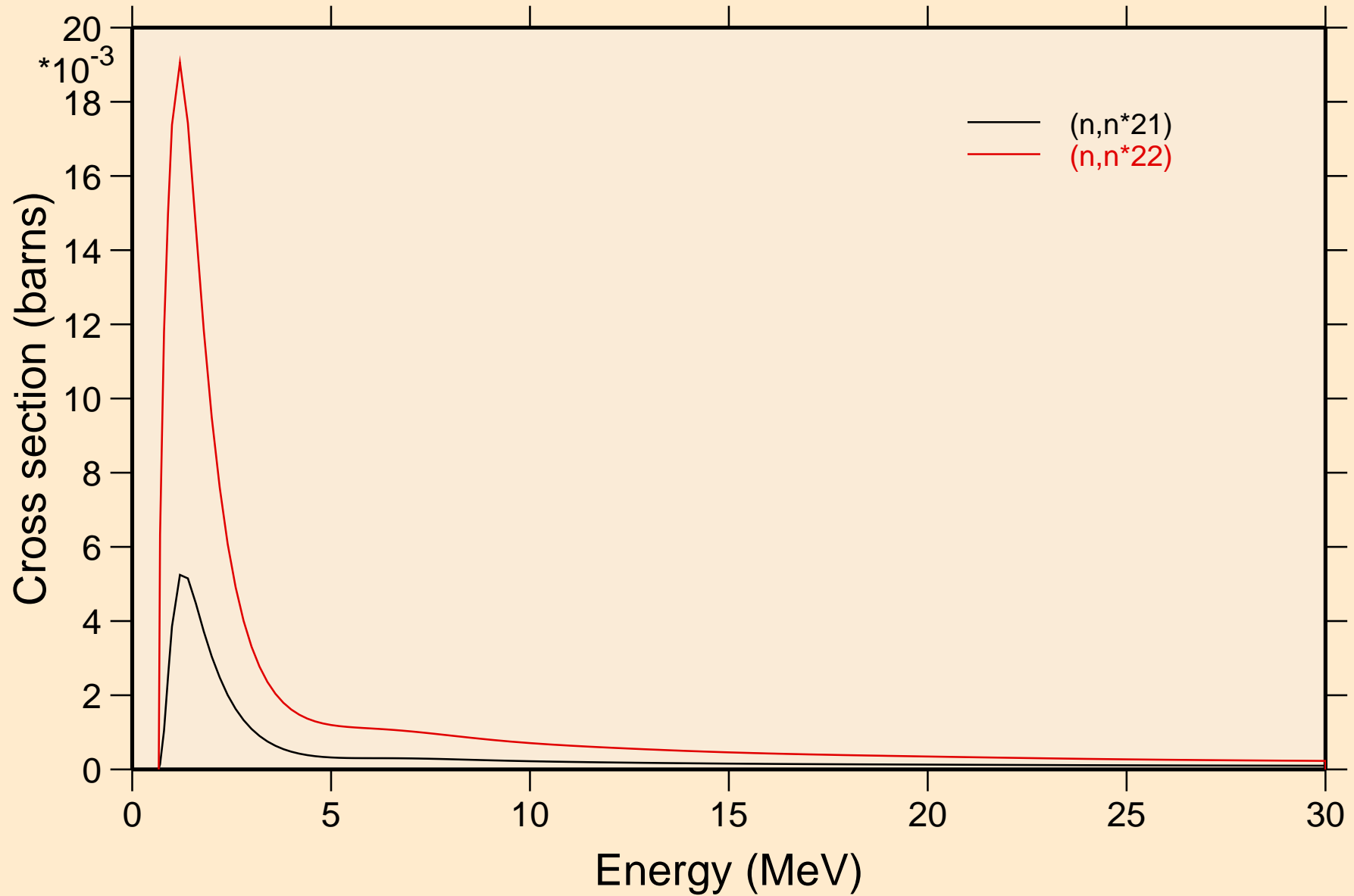

# TA167 NRG TENDL-2015, AKONING

## Threshold reactions

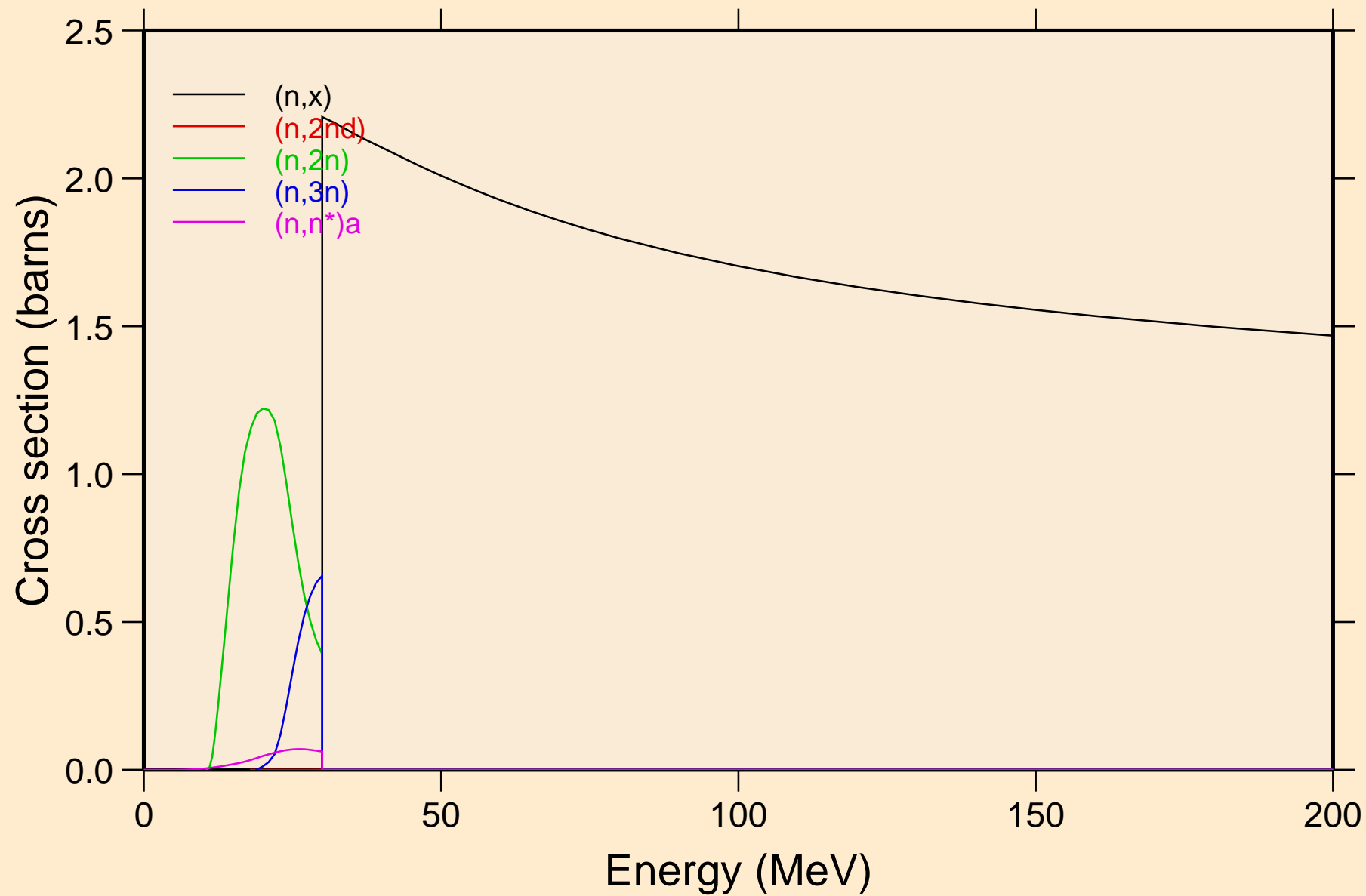



# TA167 NRG TENDL-2015, AKONING

## Threshold reactions

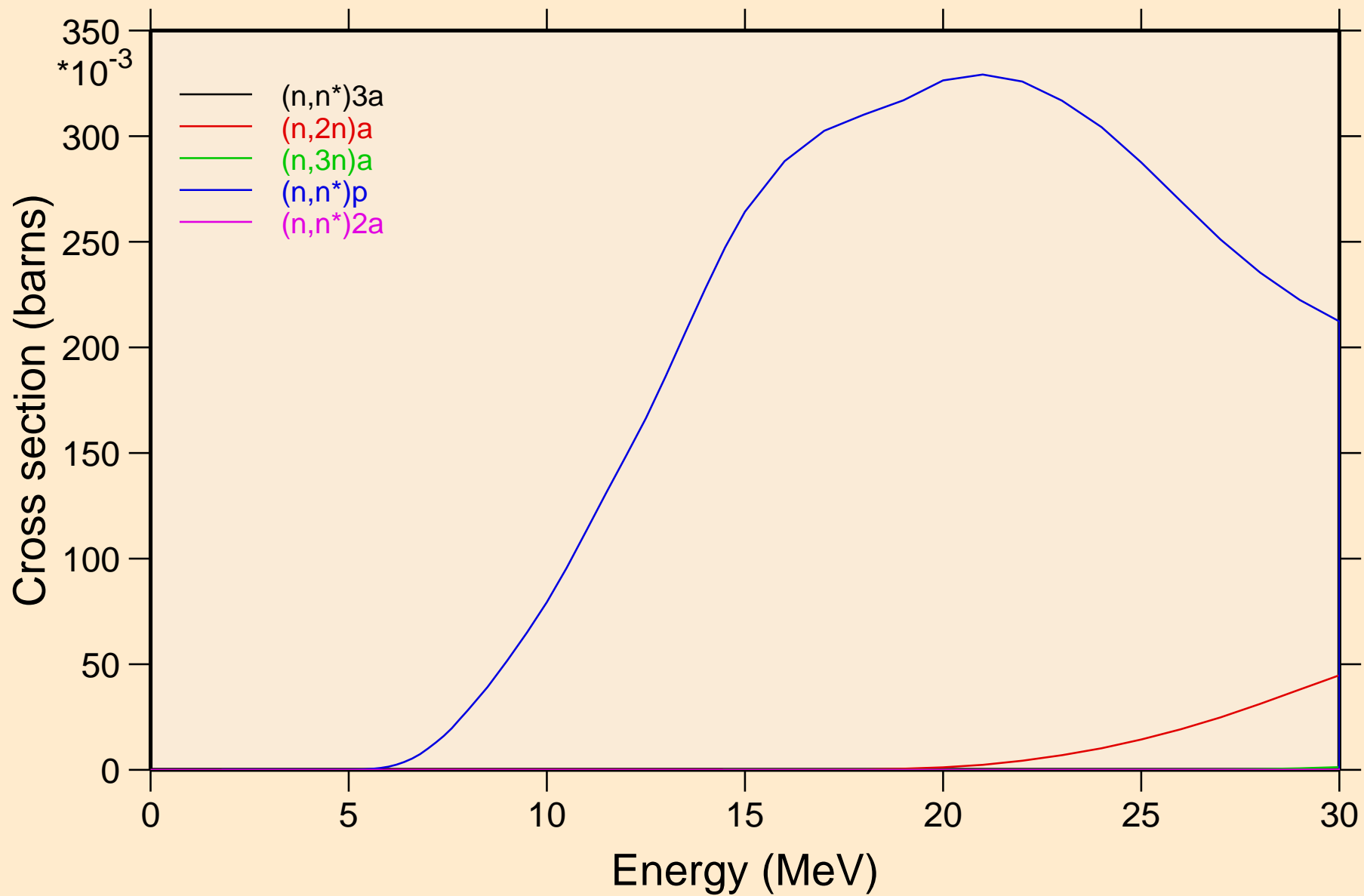

# TA167 NRG TENDL-2015, AKONING

## Threshold reactions

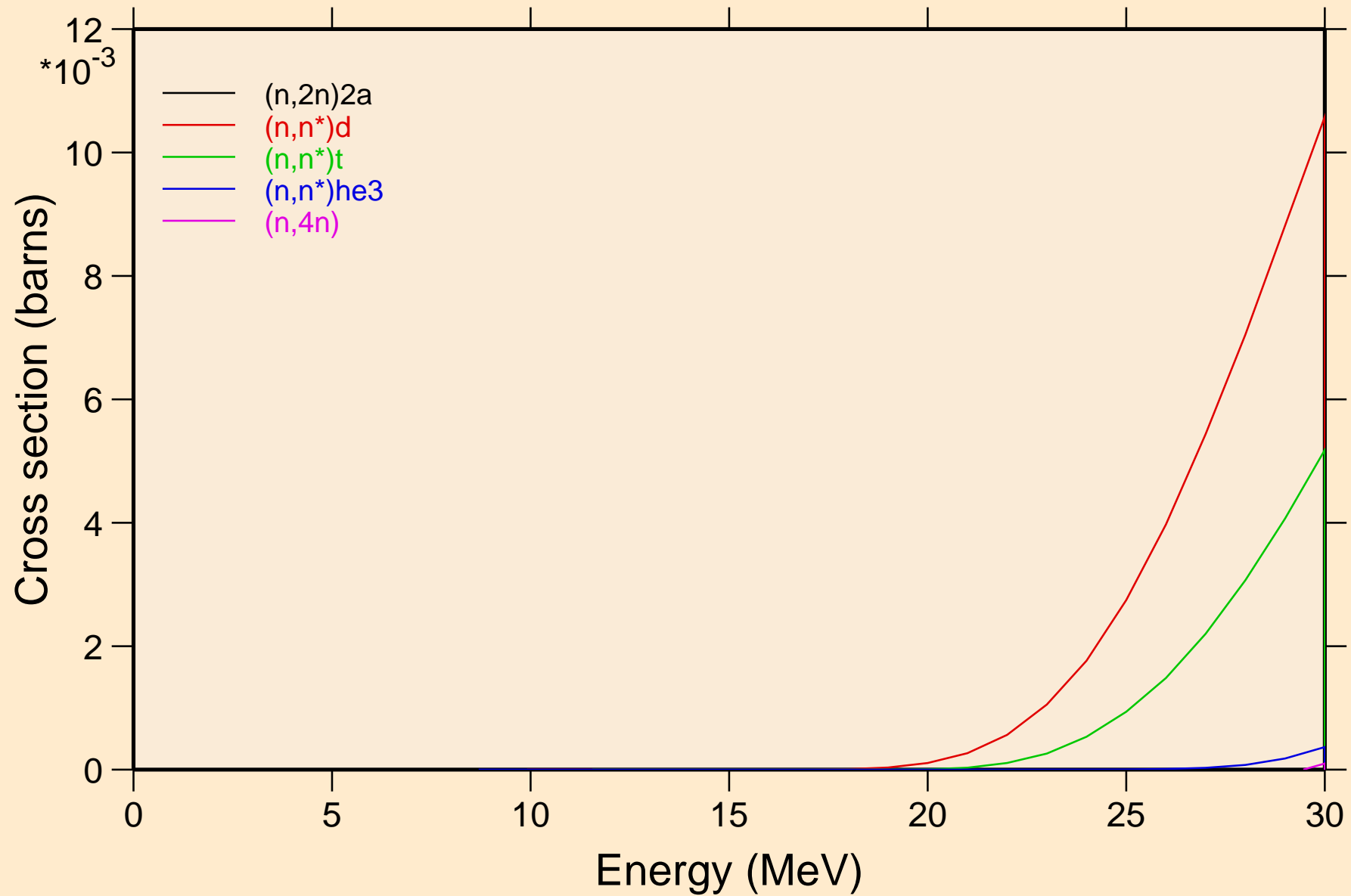

# TA167 NRG TENDL-2015, AKONING

## Threshold reactions

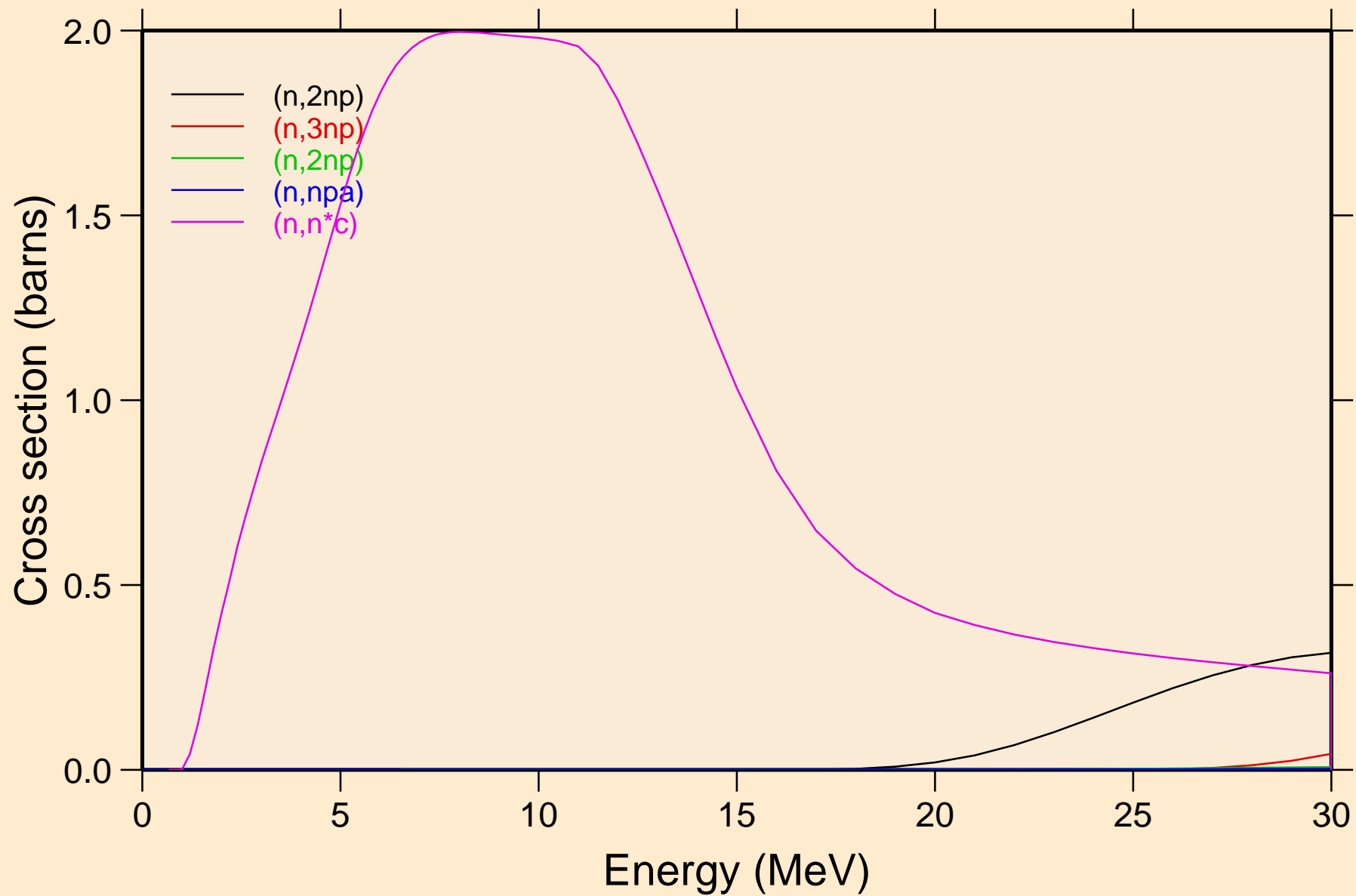

# TA167 NRG TENDL-2015, AKONING

## Threshold reactions

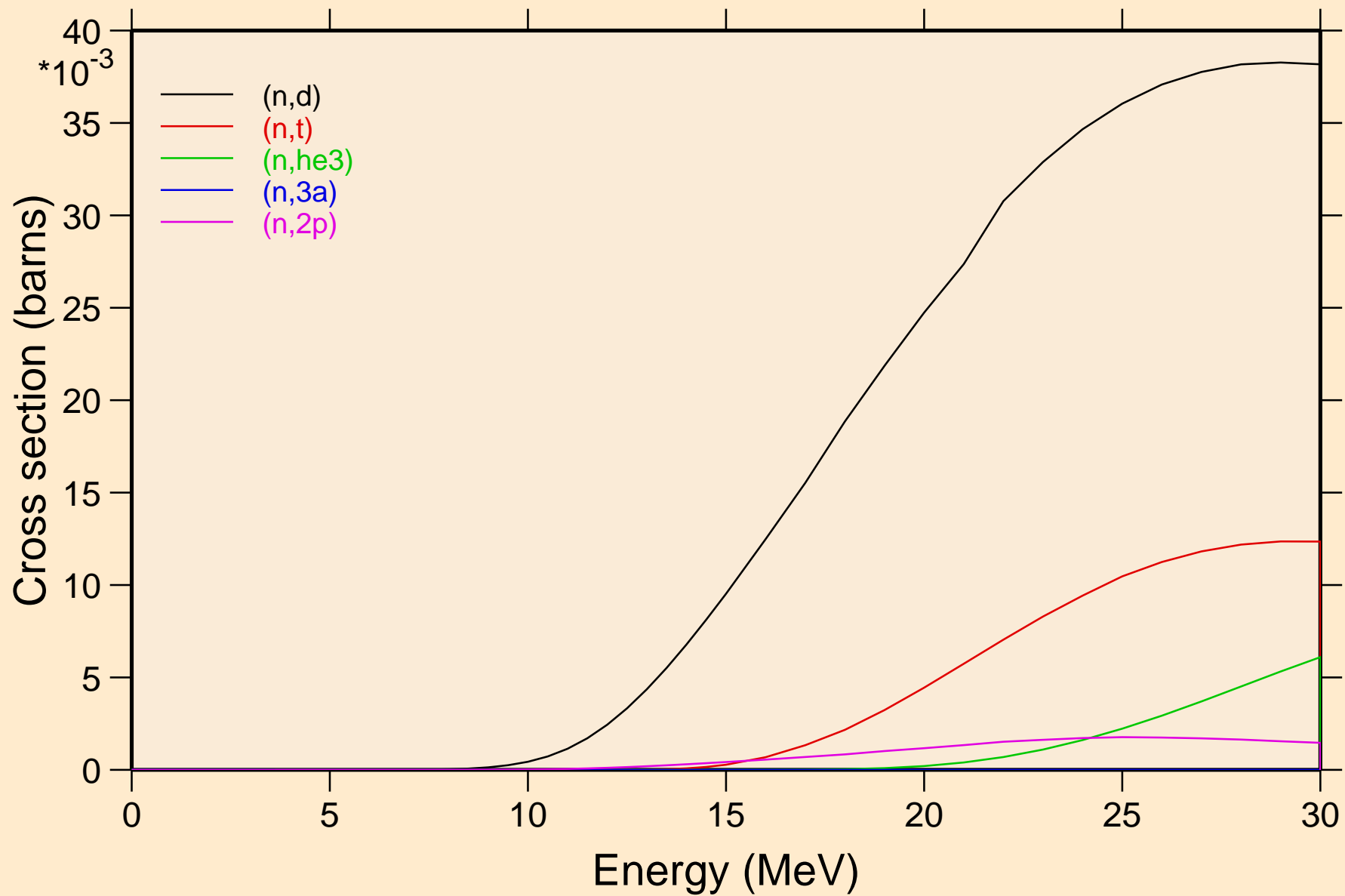

# TA167 NRG TENDL-2015, AKONING

## Threshold reactions

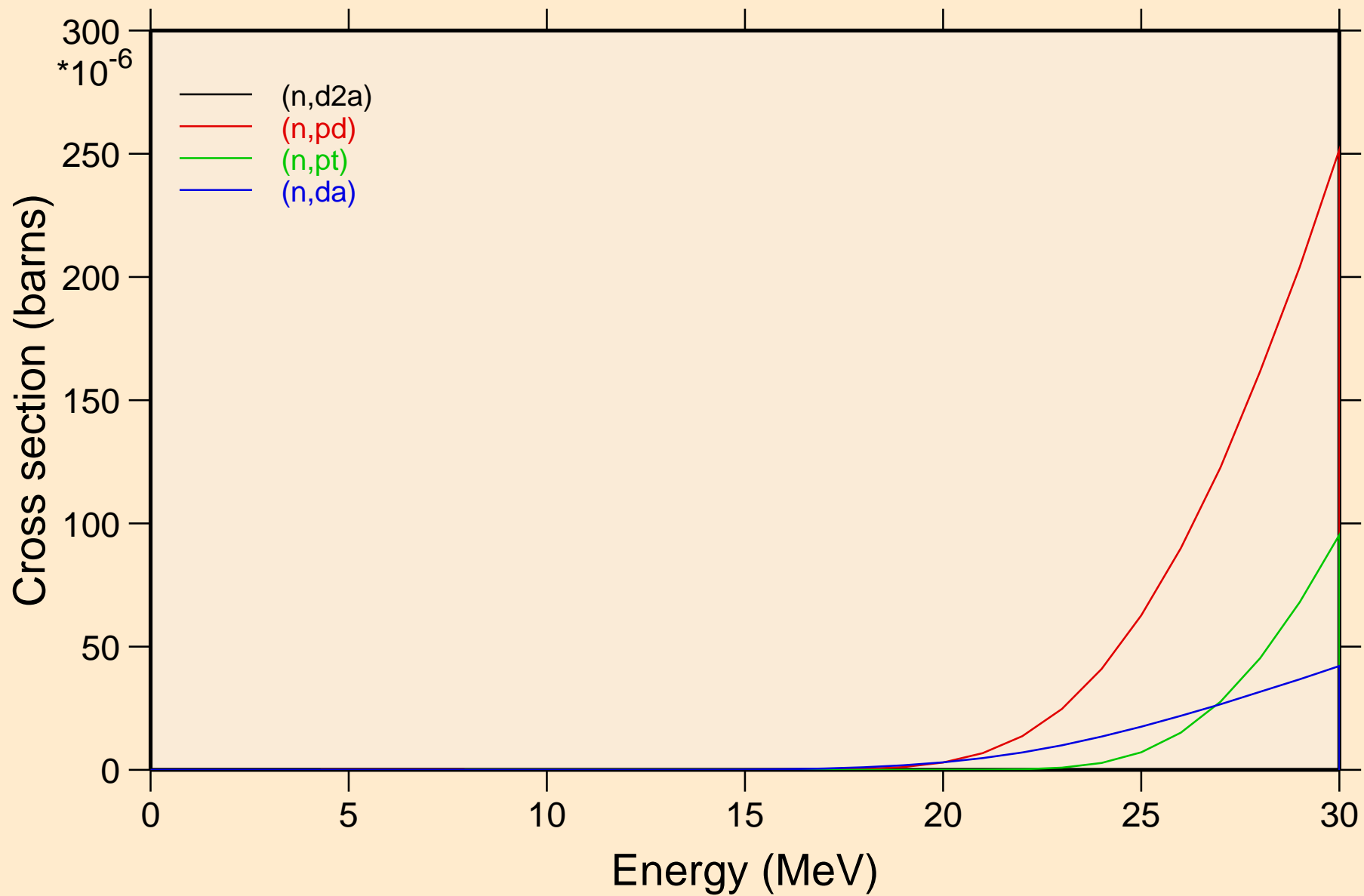

TA167 NRG TENDL-2015, AKONING  
angular distribution for elastic

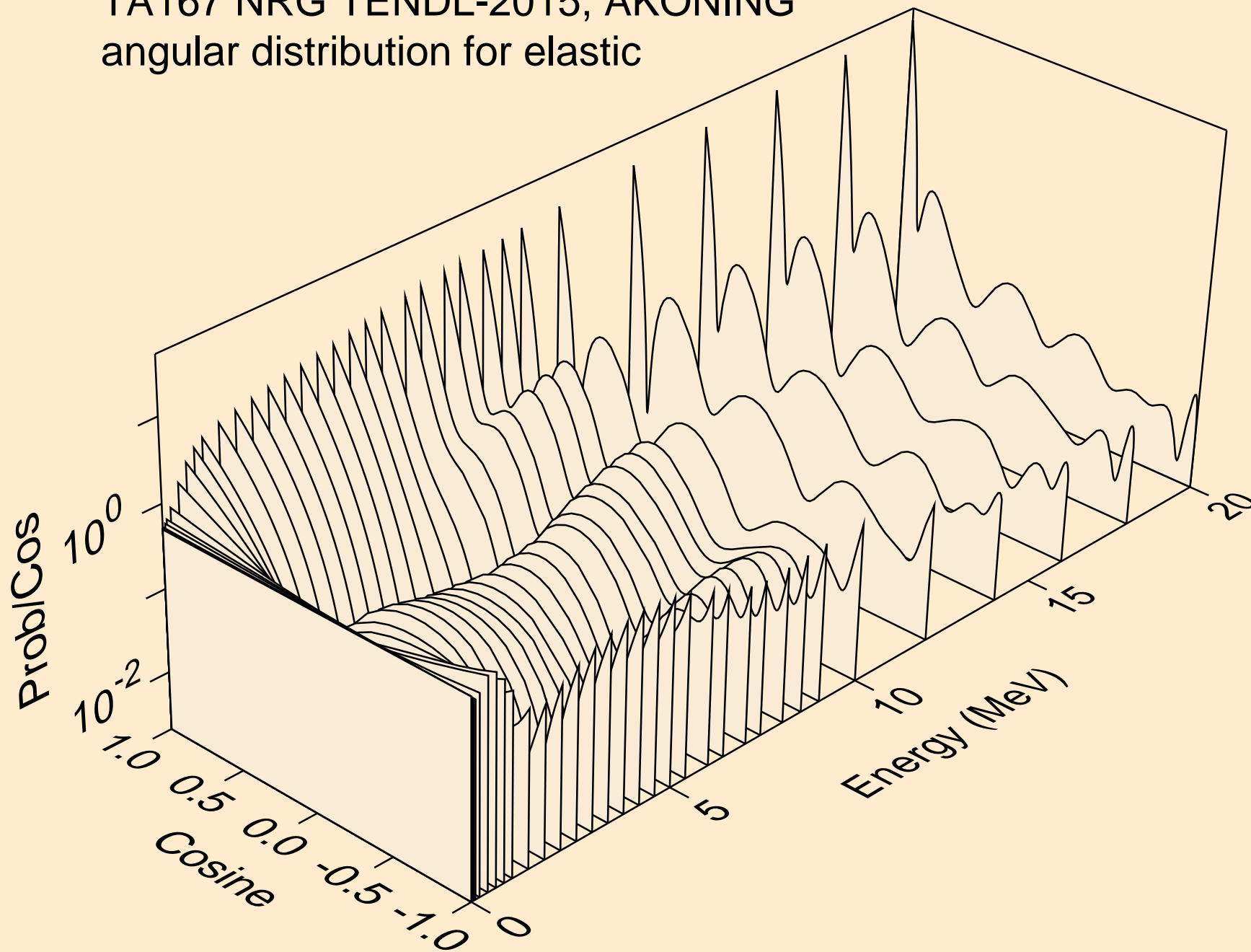

TA167 NRG TENDL-2015, AKONING  
angular distribution for elastic

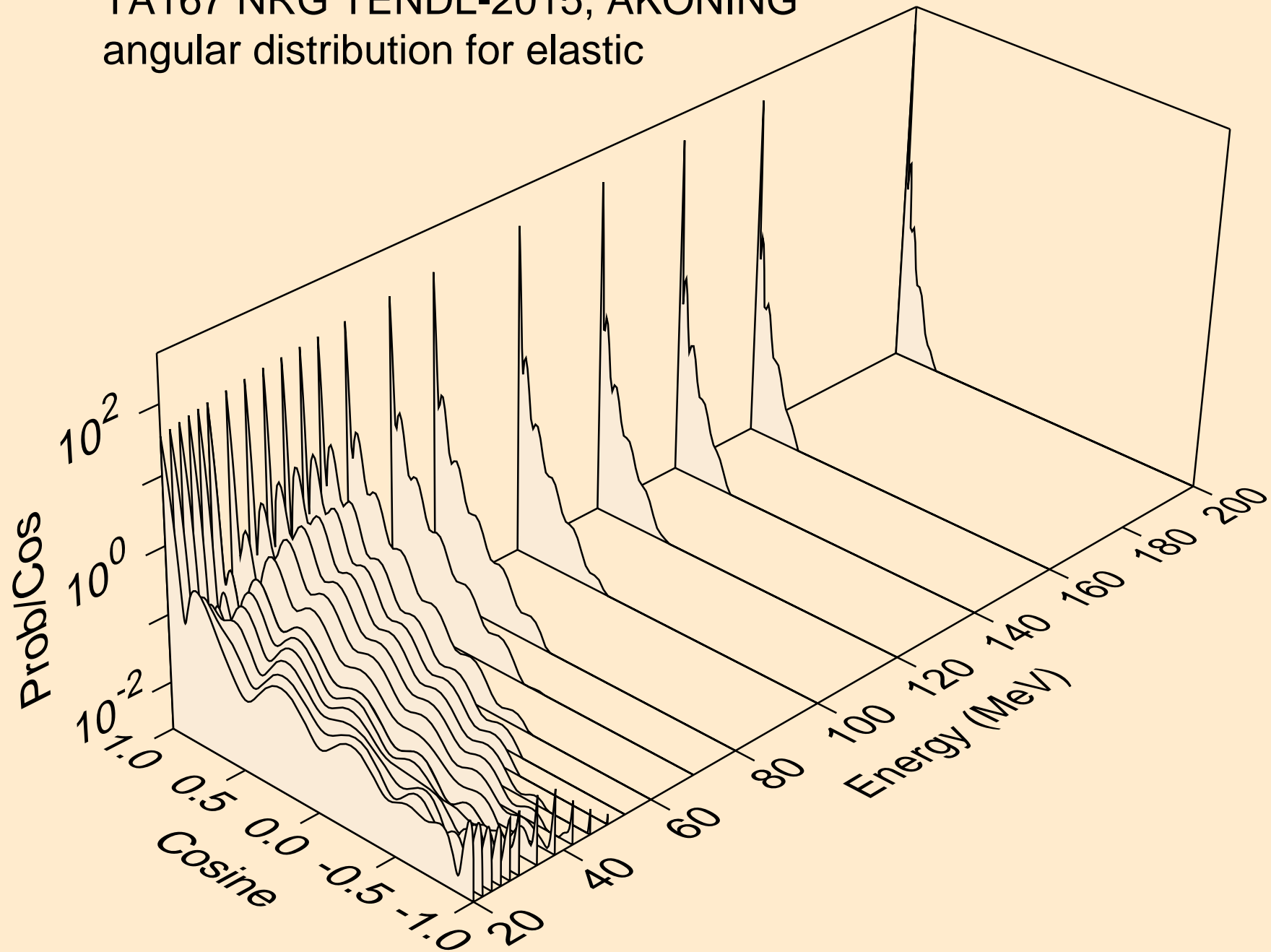

TA167 NRG TENDL-2015, AKONING  
angular distribution for (n,n\*1)

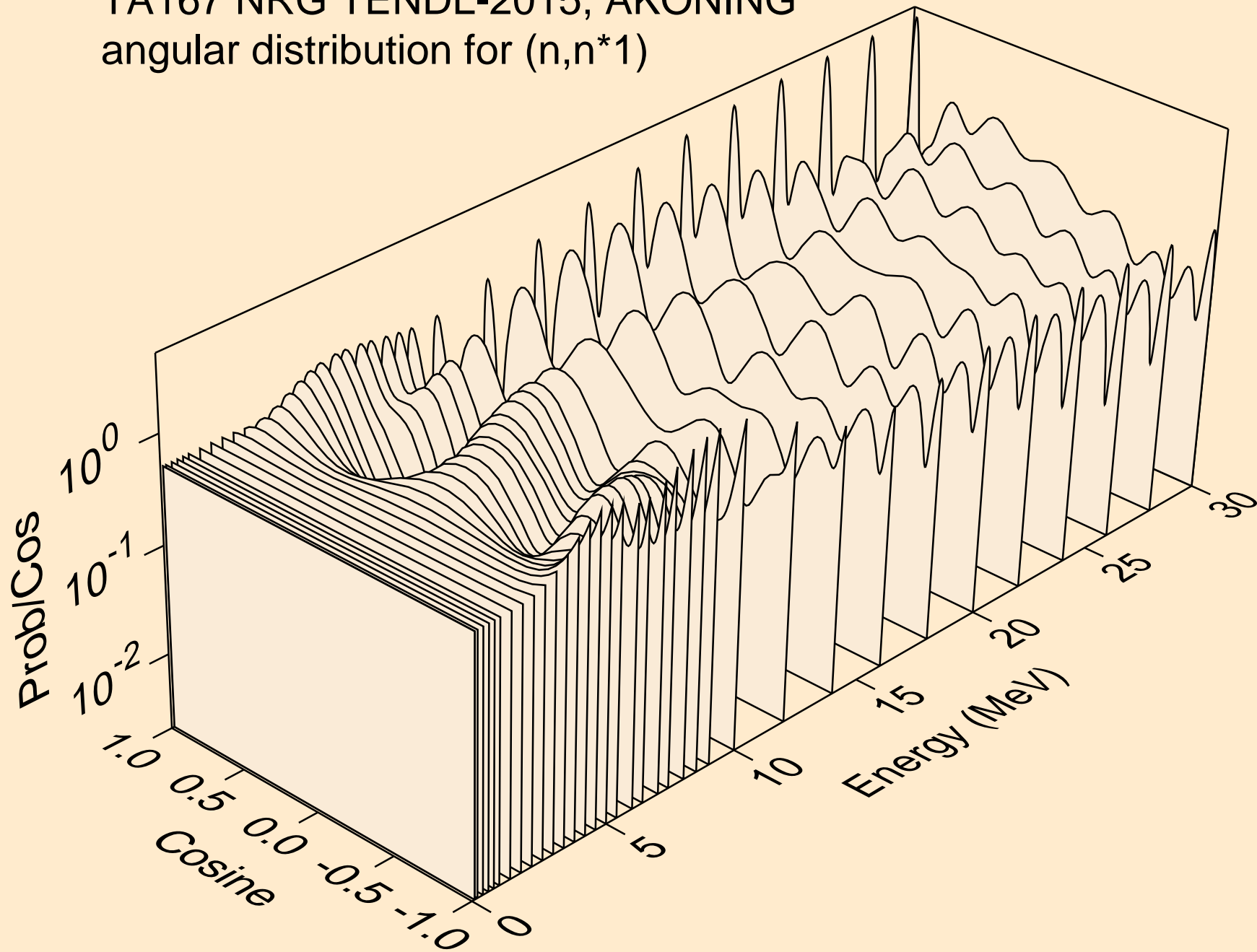



TA167 NRG TENDL-2015, AKONING  
angular distribution for (n,n\*2)

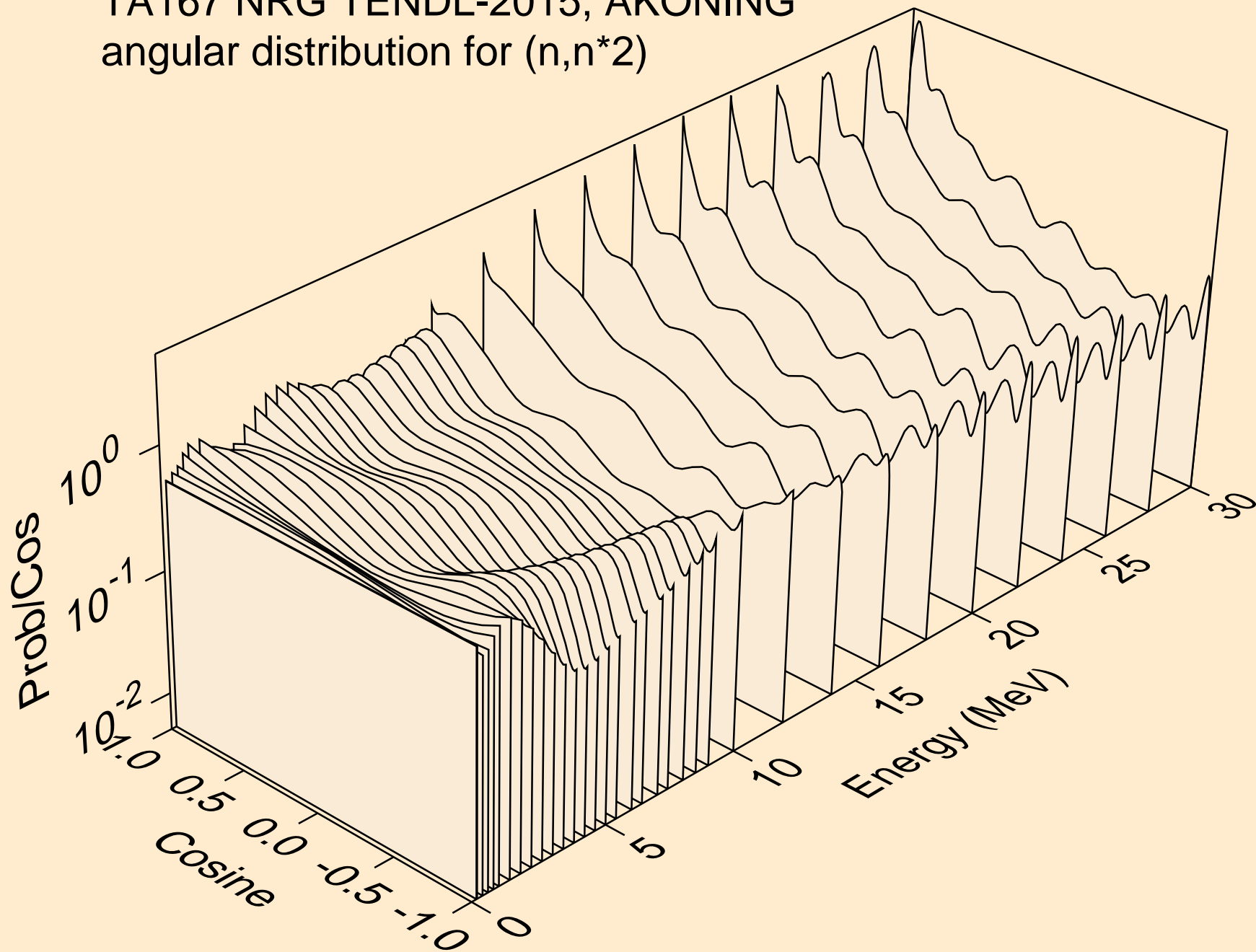

TA167 NRG TENDL-2015, AKONING  
angular distribution for (n,n\*3)

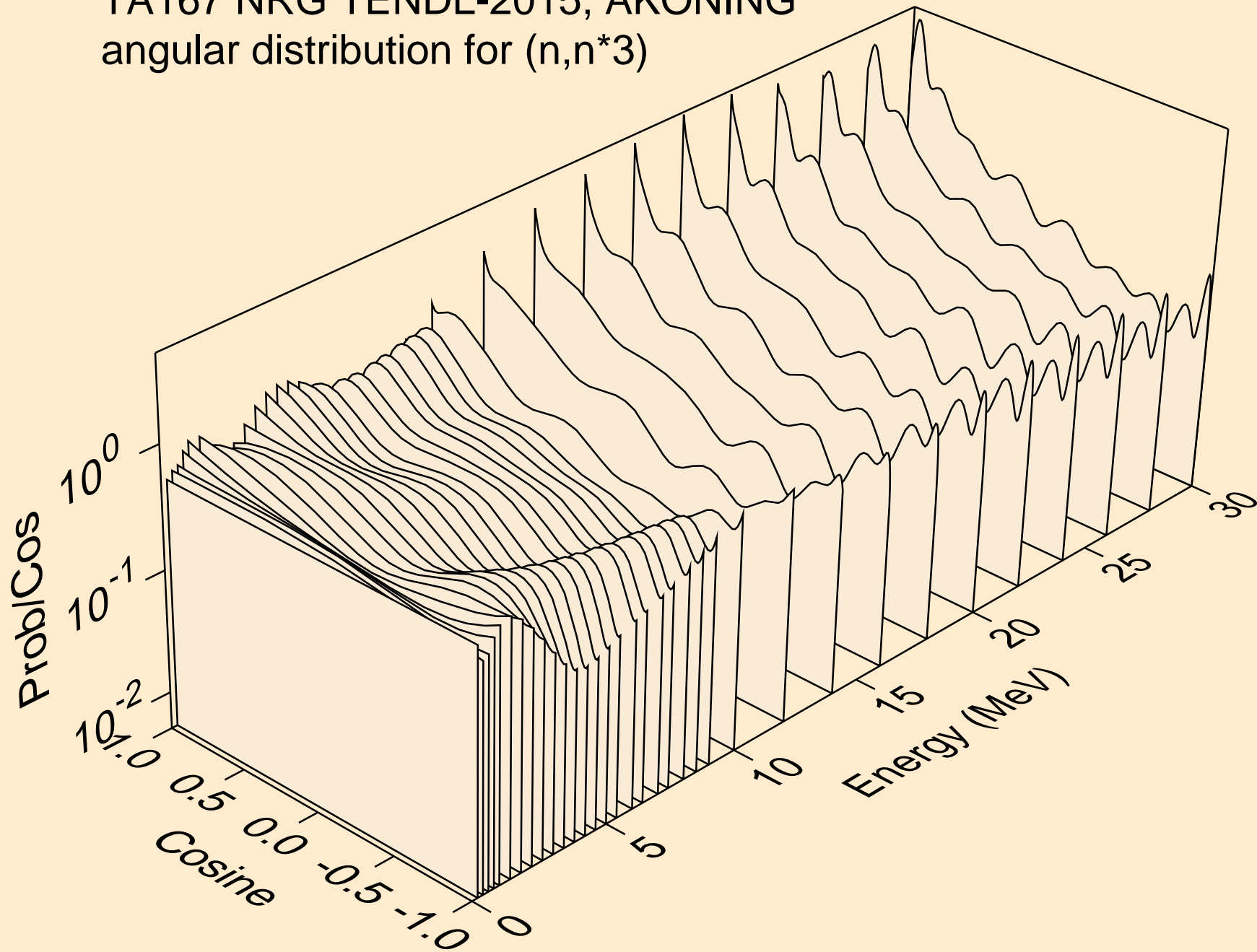

TA167 NRG TENDL-2015, AKONING  
angular distribution for (n,n\*4)

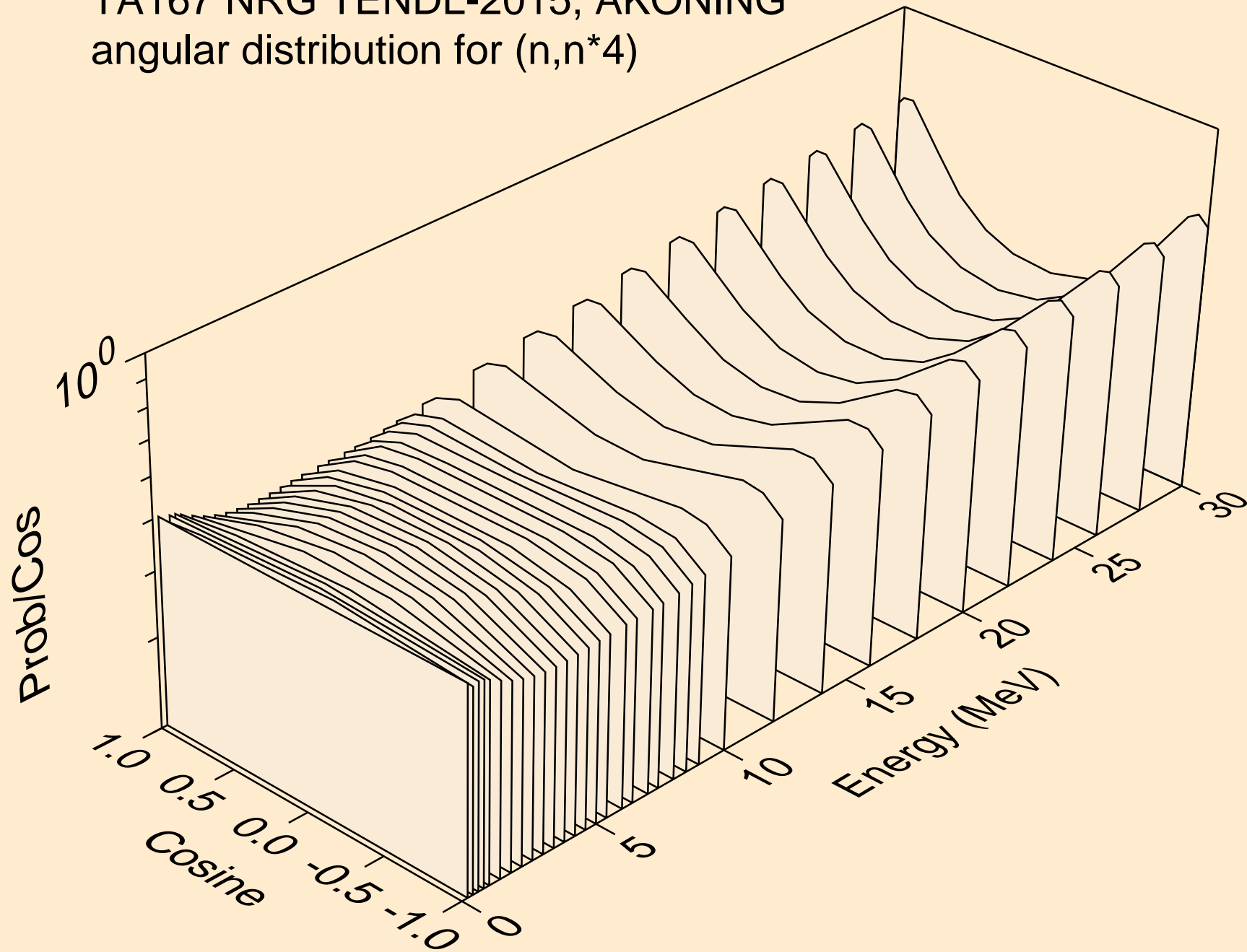

TA167 NRG TENDL-2015, AKONING  
angular distribution for (n,n\*5)

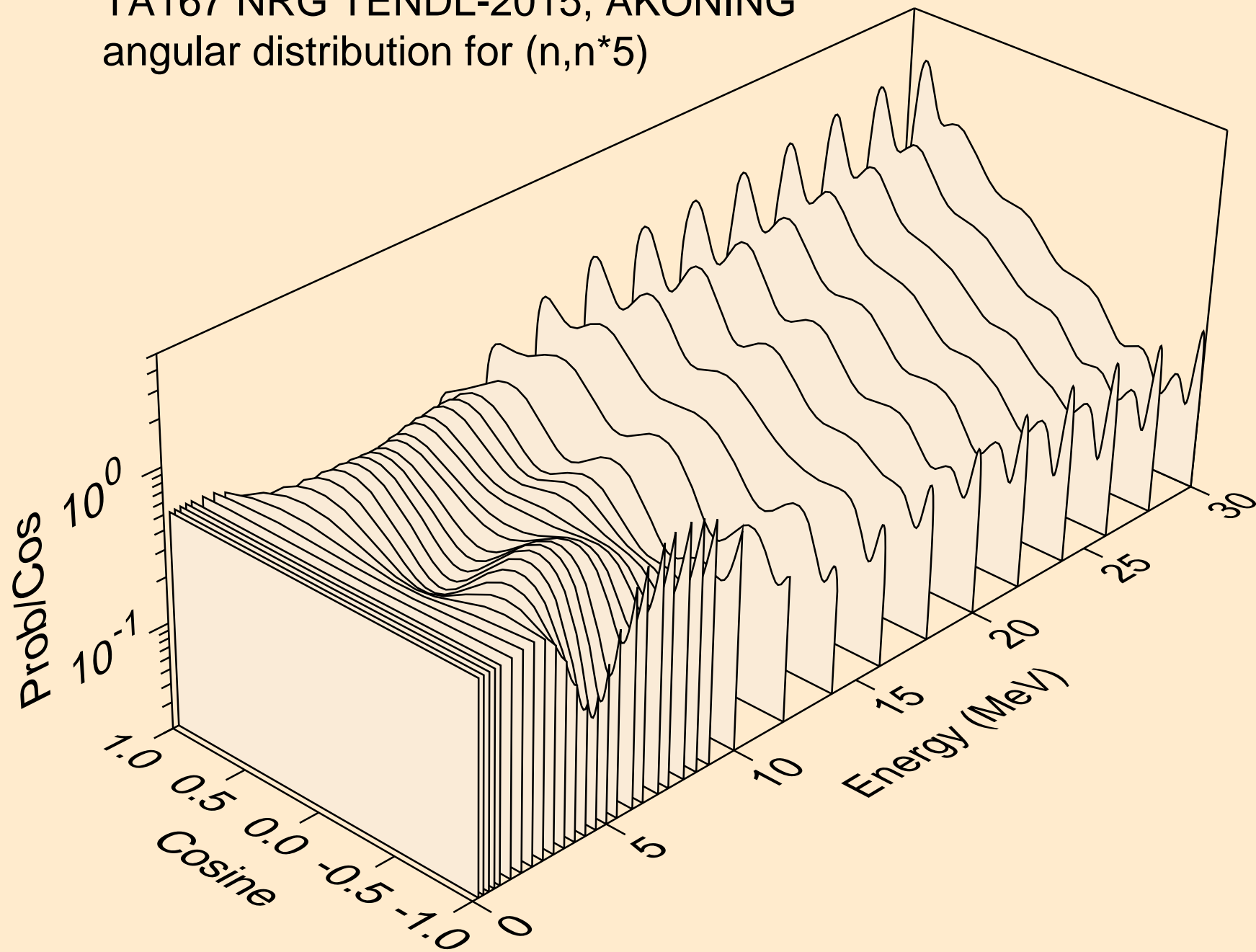

TA167 NRG TENDL-2015, AKONING  
angular distribution for (n,n\*6)

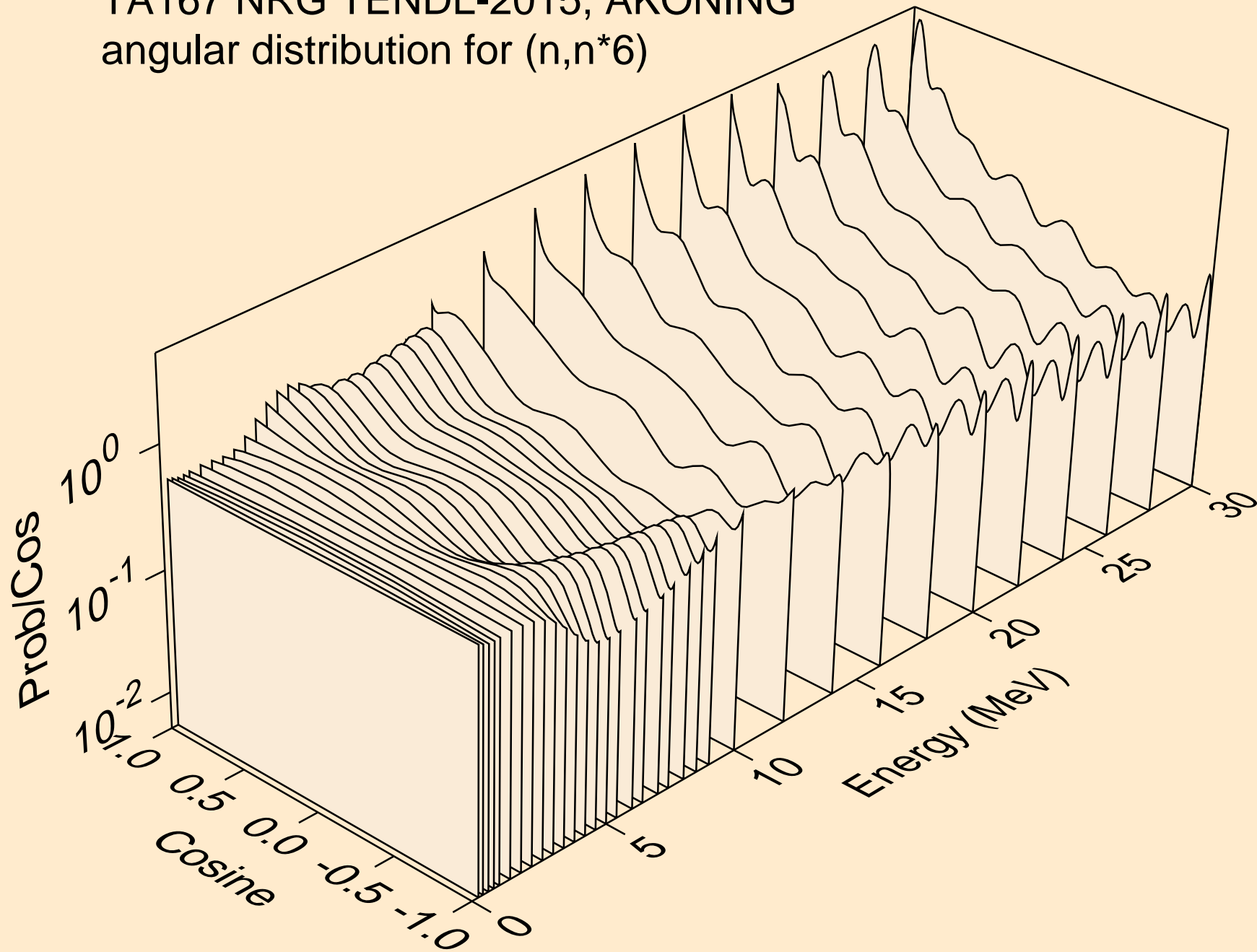

TA167 NRG TENDL-2015, AKONING  
angular distribution for (n,n\*7)

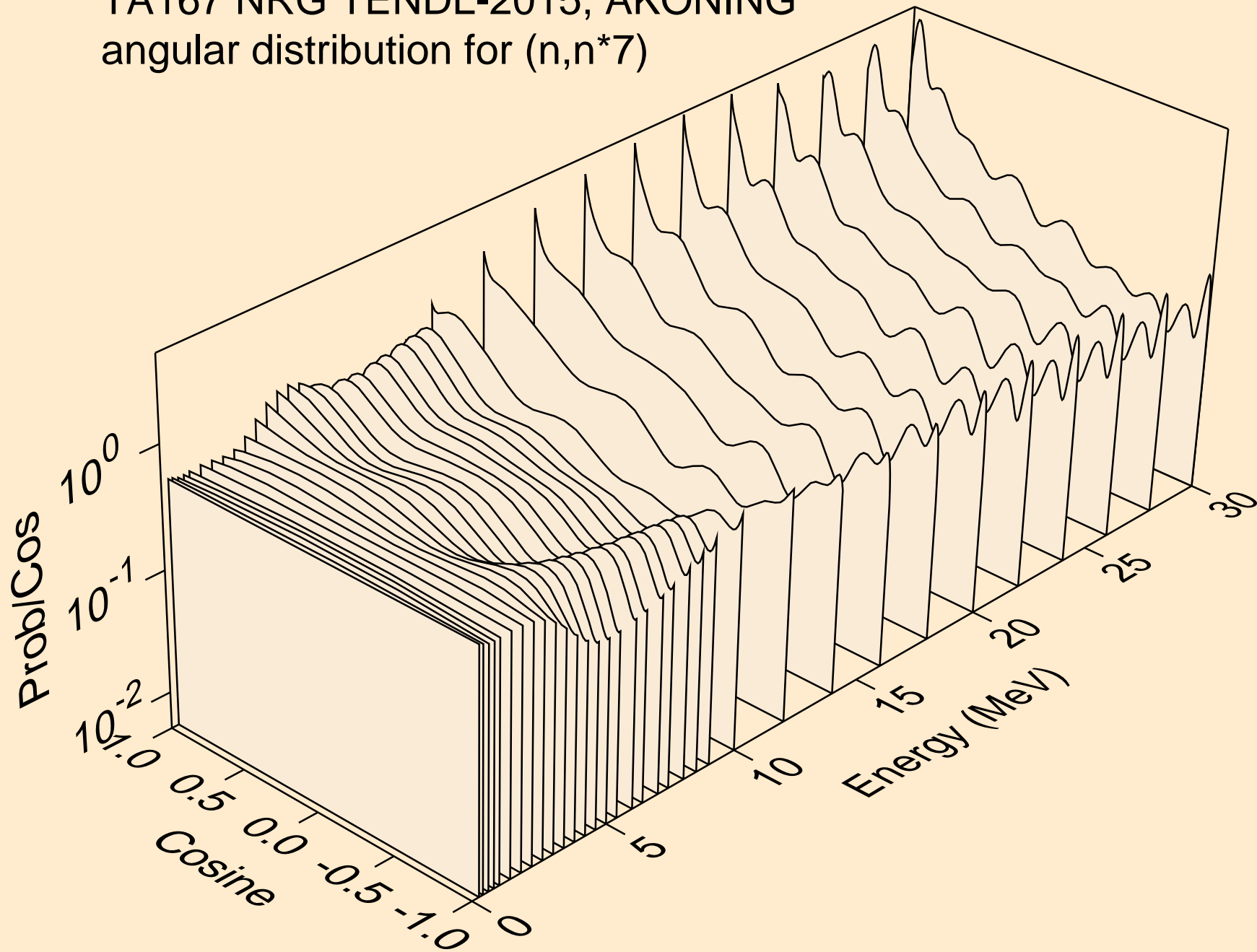

TA167 NRG TENDL-2015, AKONING  
angular distribution for (n,n\*8)

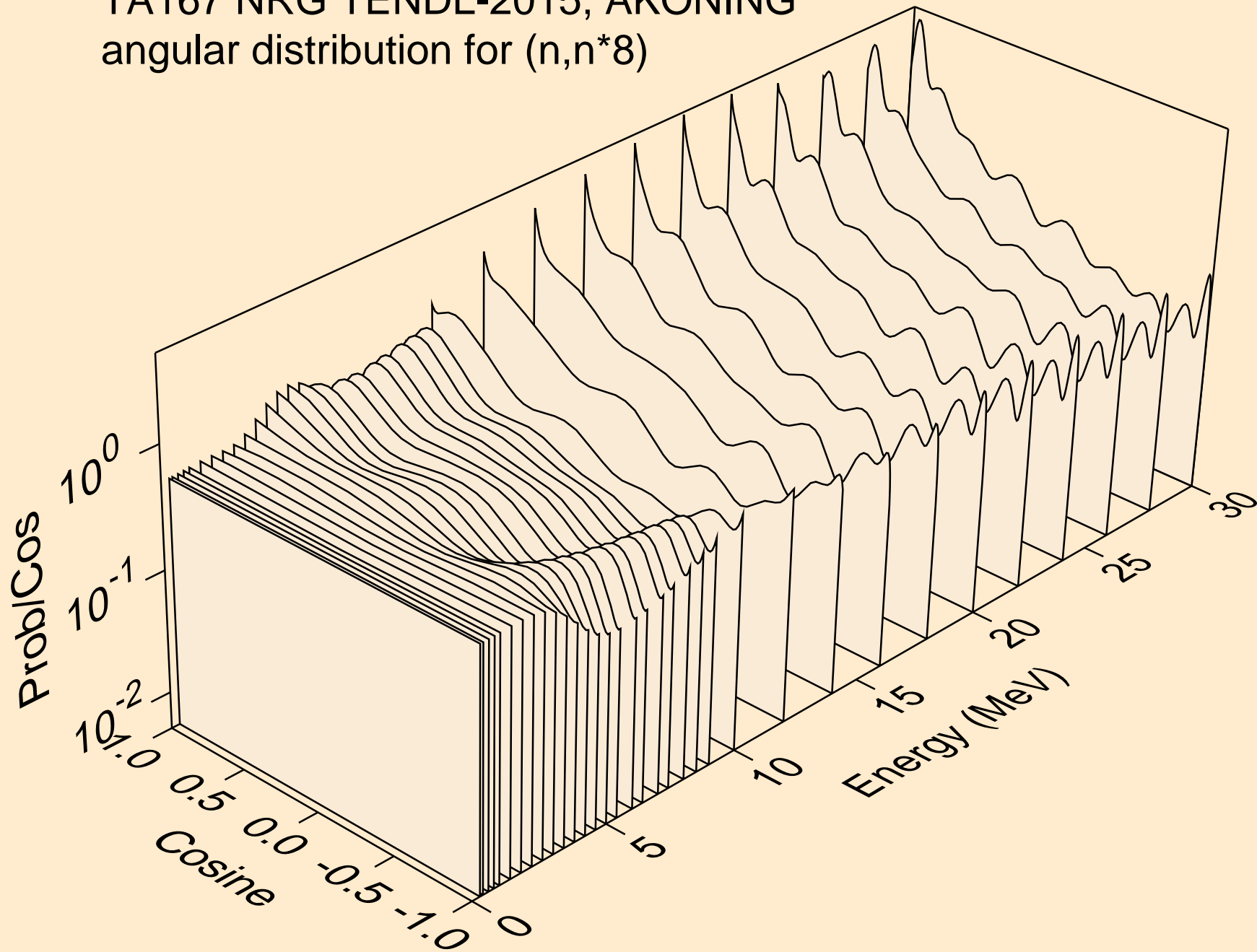

TA167 NRG TENDL-2015, AKONING  
angular distribution for (n,n\*9)

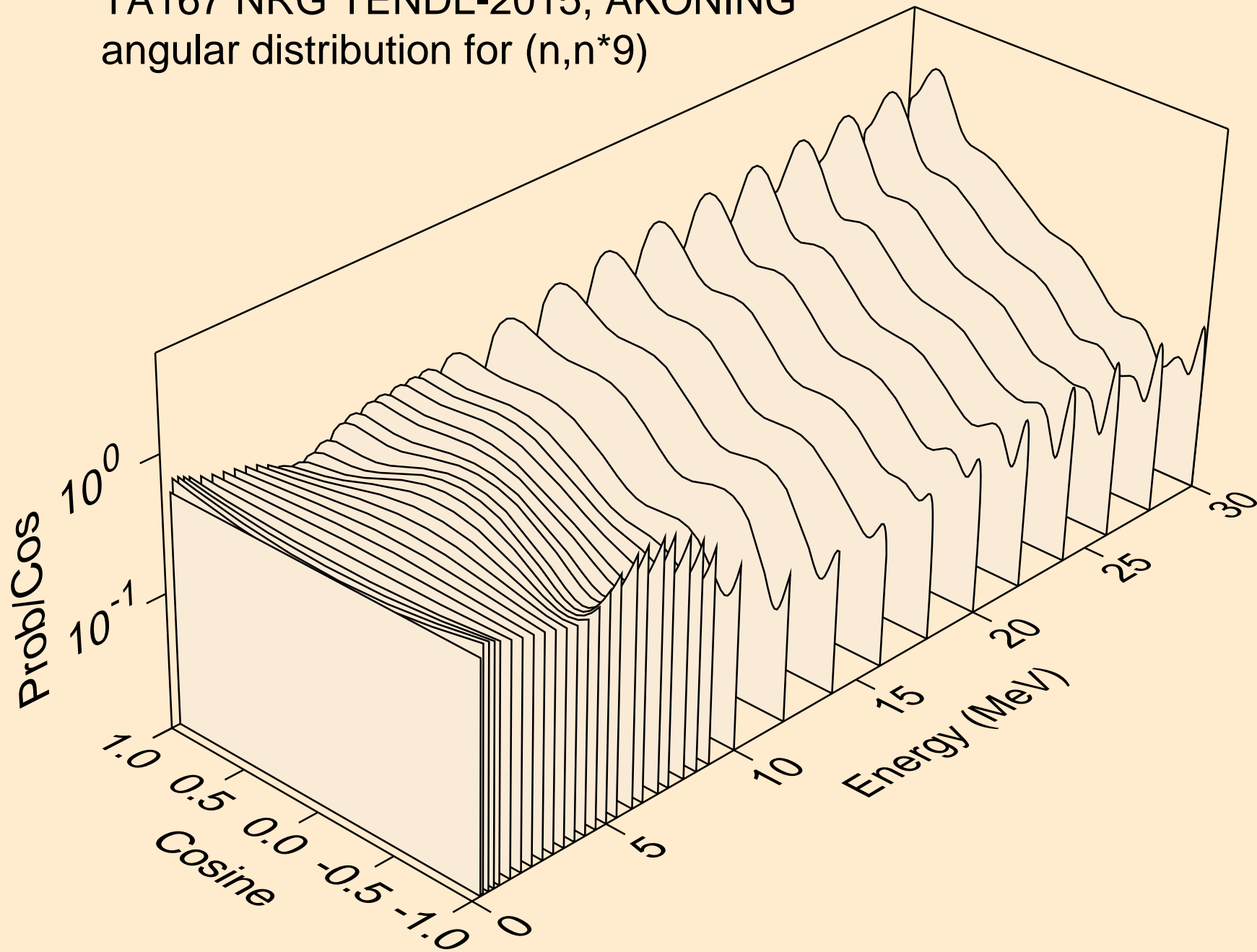



TA167 NRG TENDL-2015, AKONING  
angular distribution for (n,n\*10)

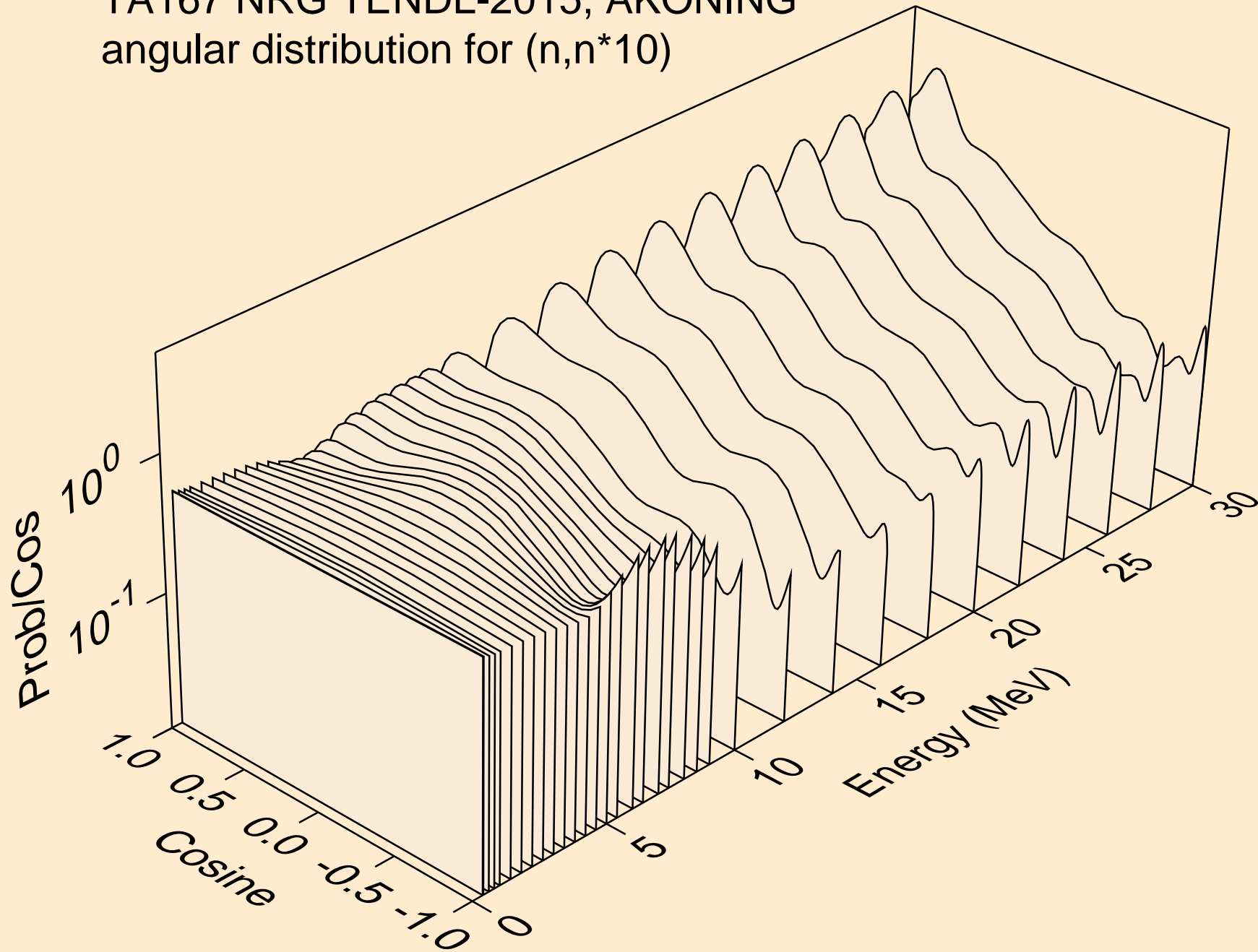

TA167 NRG TENDL-2015, AKONING  
angular distribution for (n,n\*11)

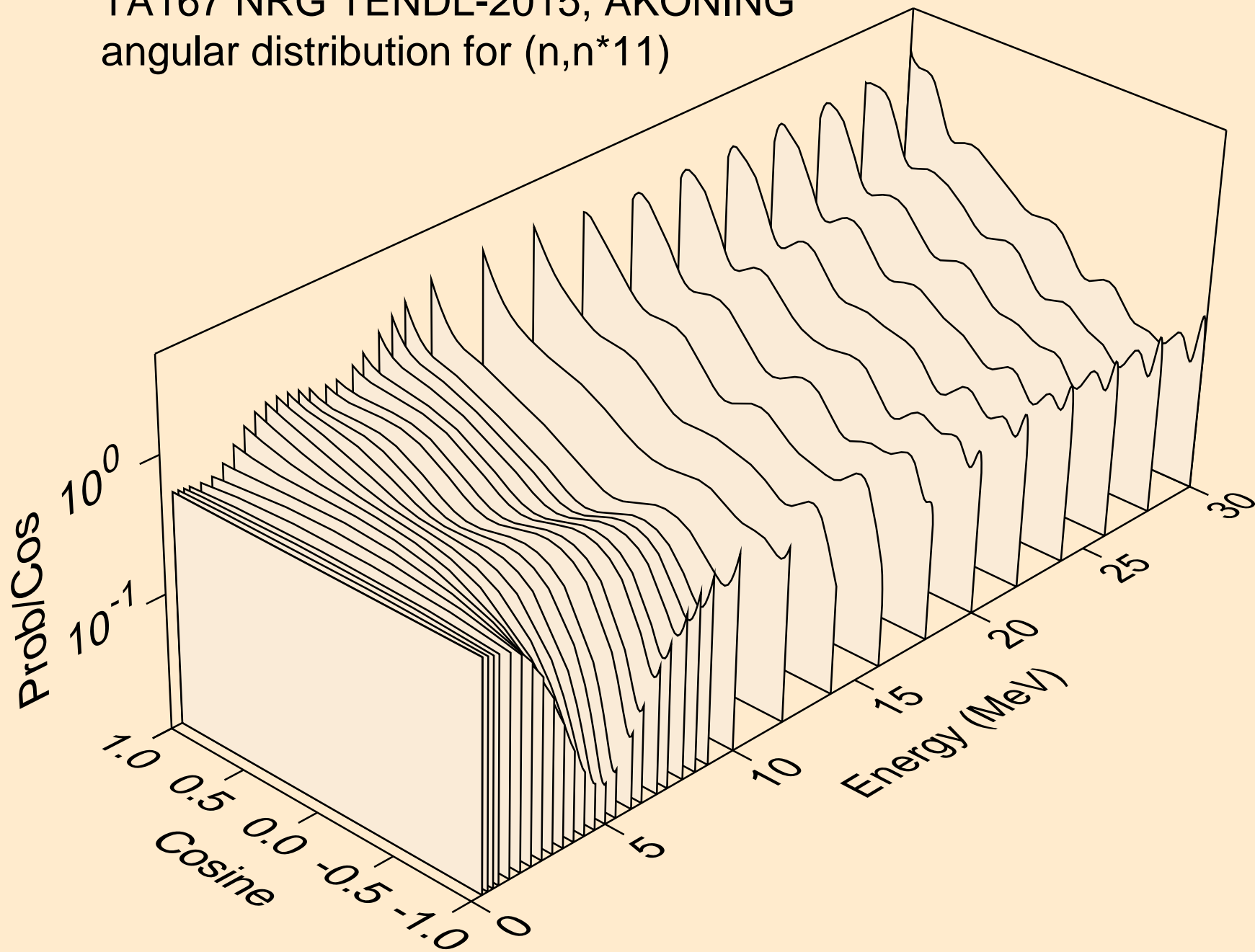

TA167 NRG TENDL-2015, AKONING  
angular distribution for (n,n\*12)

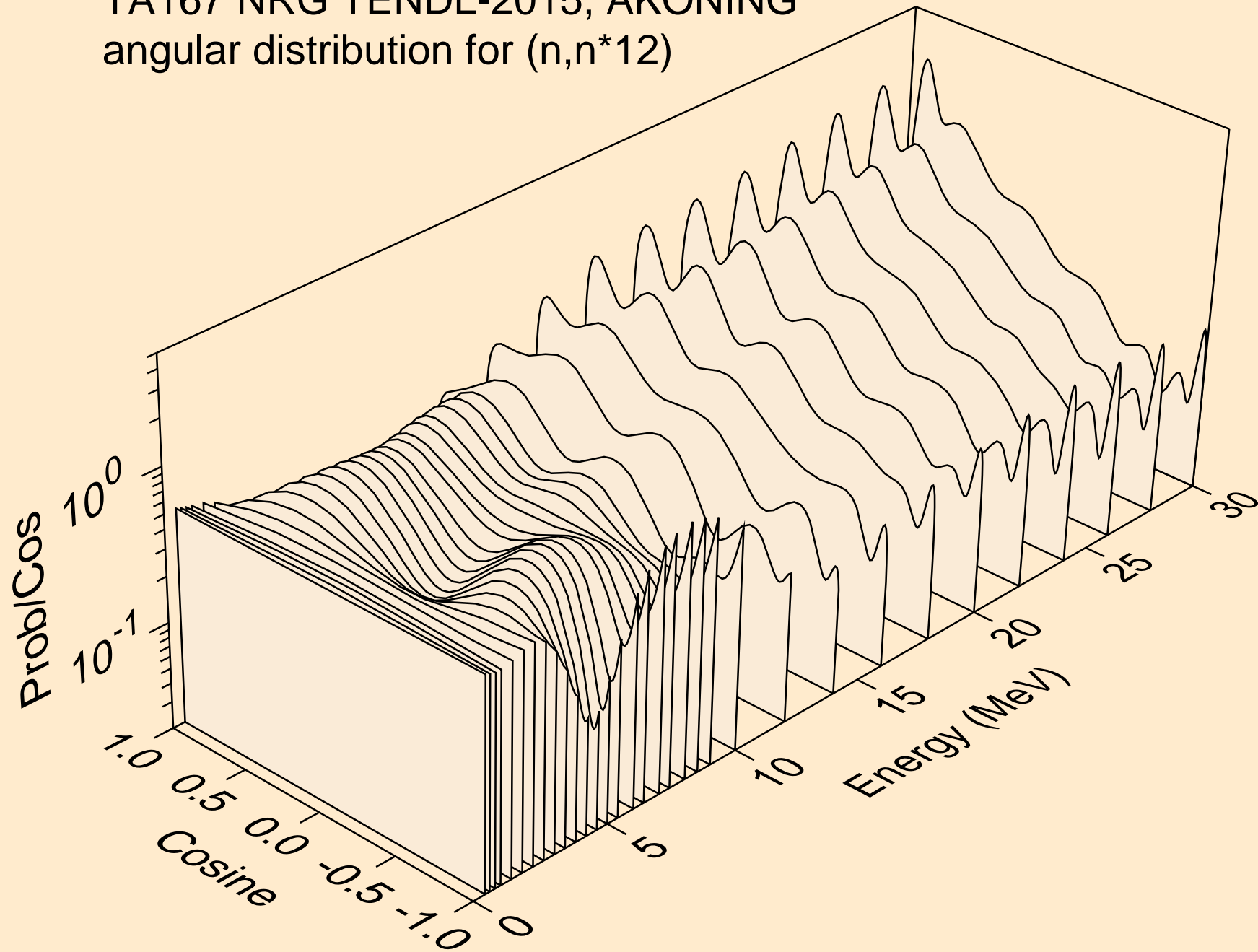

TA167 NRG TENDL-2015, AKONING  
angular distribution for (n,n\*13)

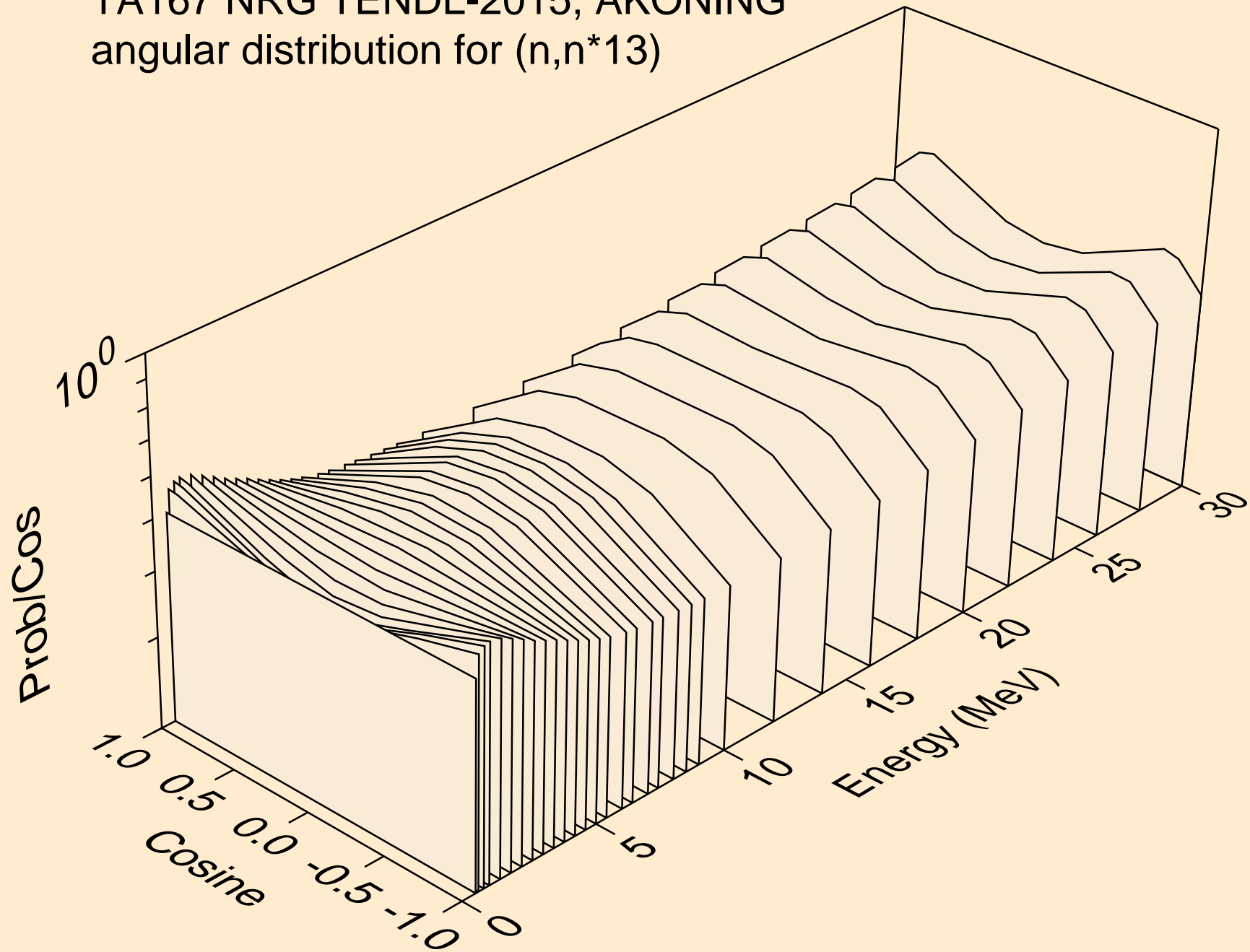

TA167 NRG TENDL-2015, AKONING  
angular distribution for (n,n\*14)

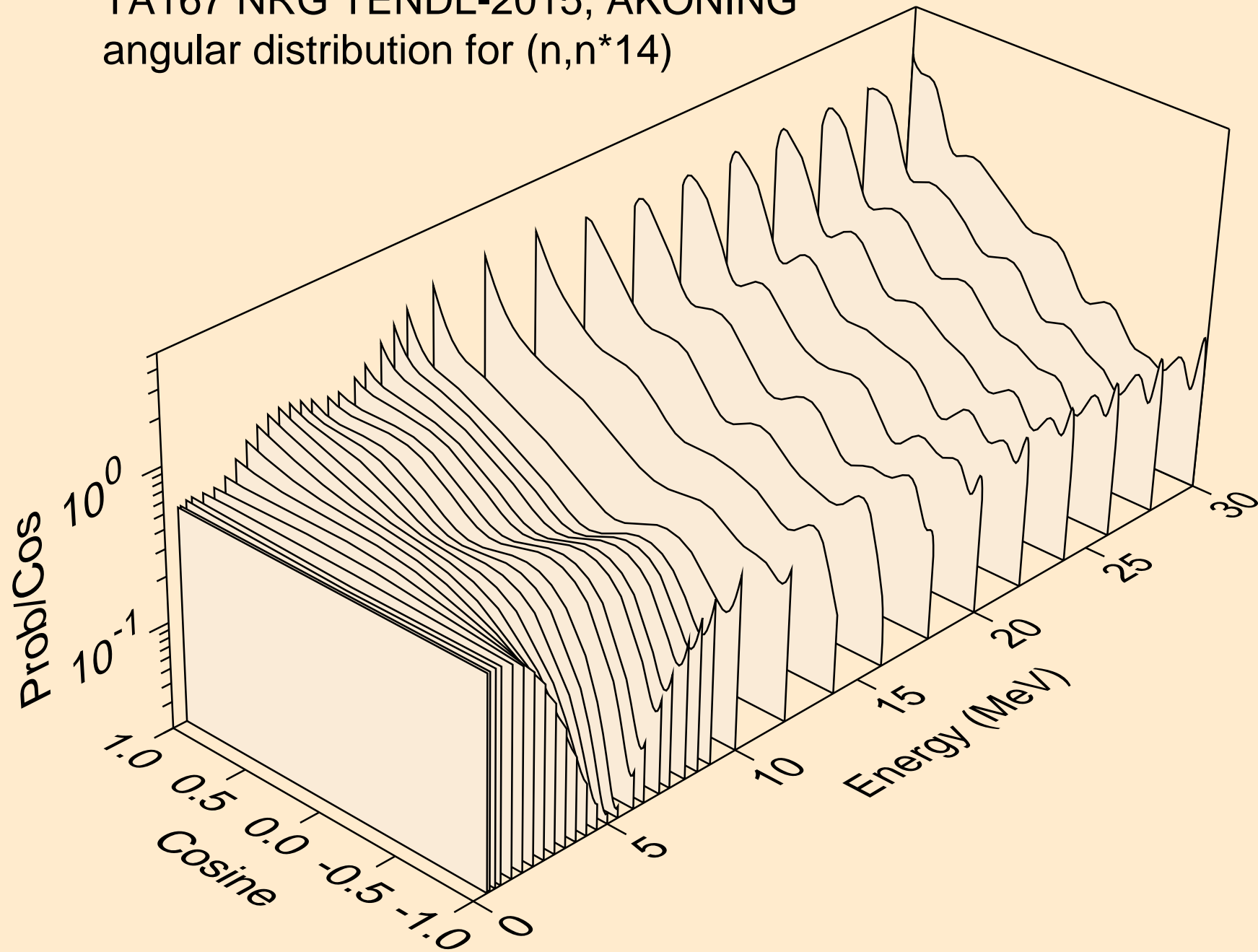

TA167 NRG TENDL-2015, AKONING  
angular distribution for (n,n\*15)

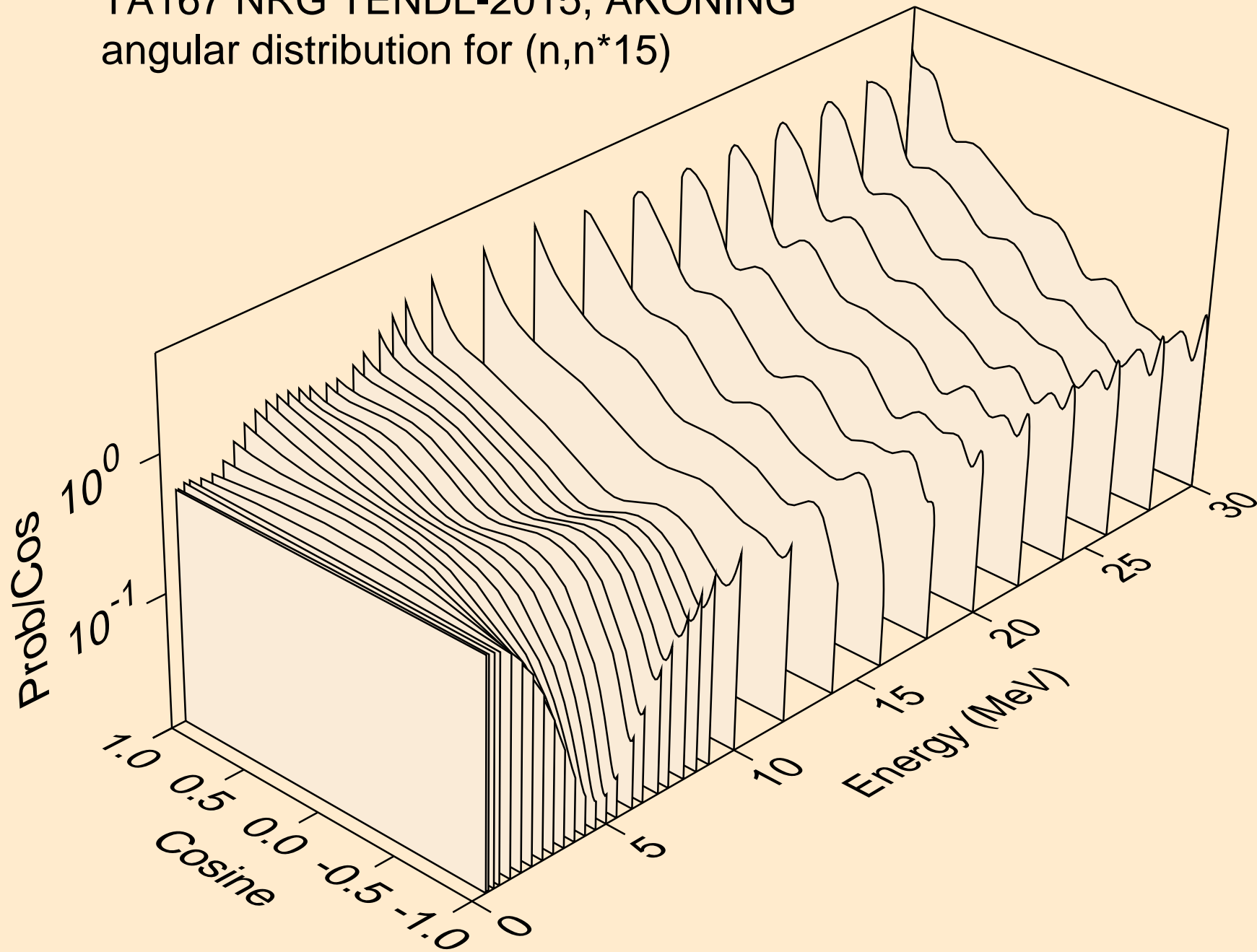

TA167 NRG TENDL-2015, AKONING  
angular distribution for (n,n\*16)

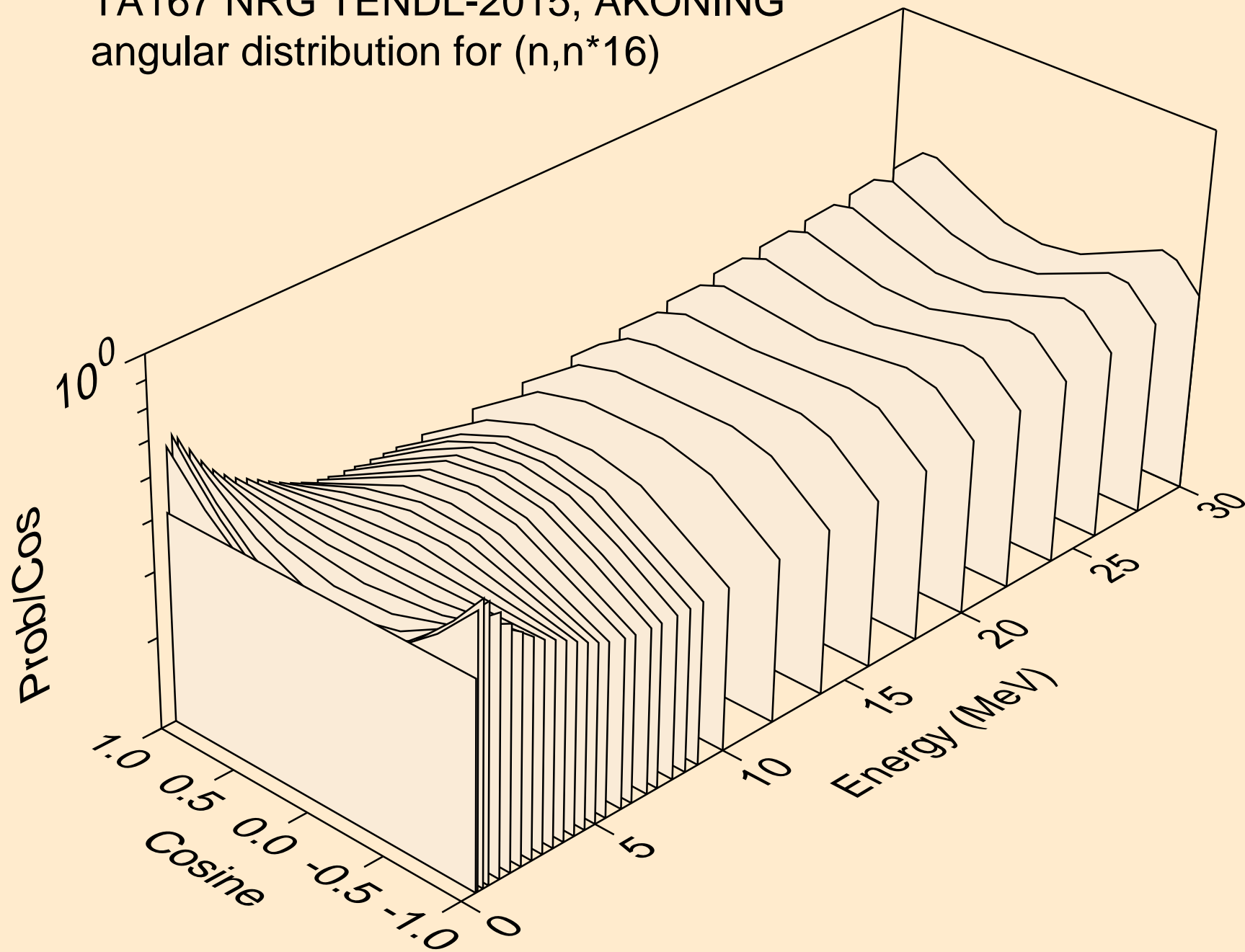

TA167 NRG TENDL-2015, AKONING  
angular distribution for (n,n\*17)

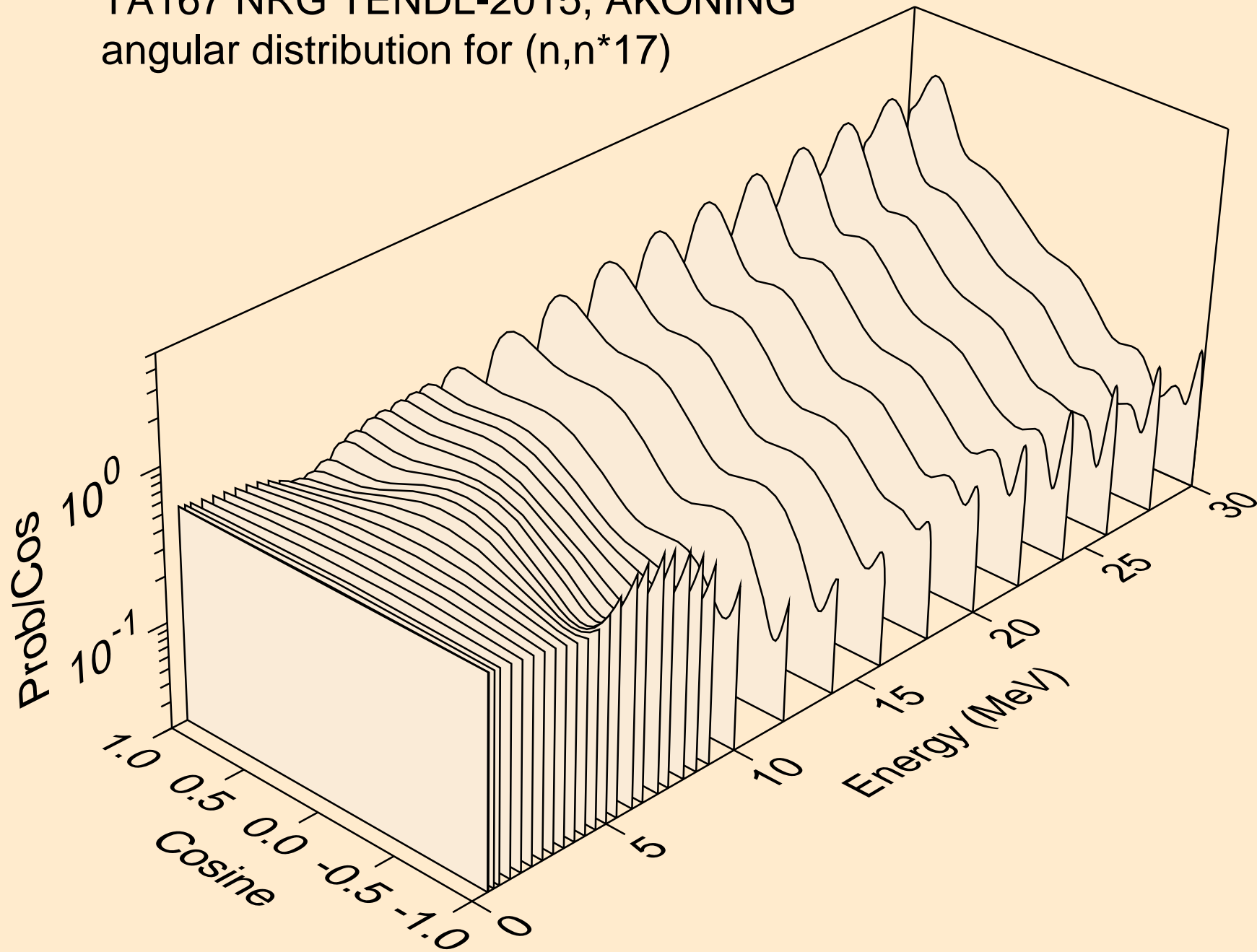



TA167 NRG TENDL-2015, AKONING  
angular distribution for (n,n\*18)

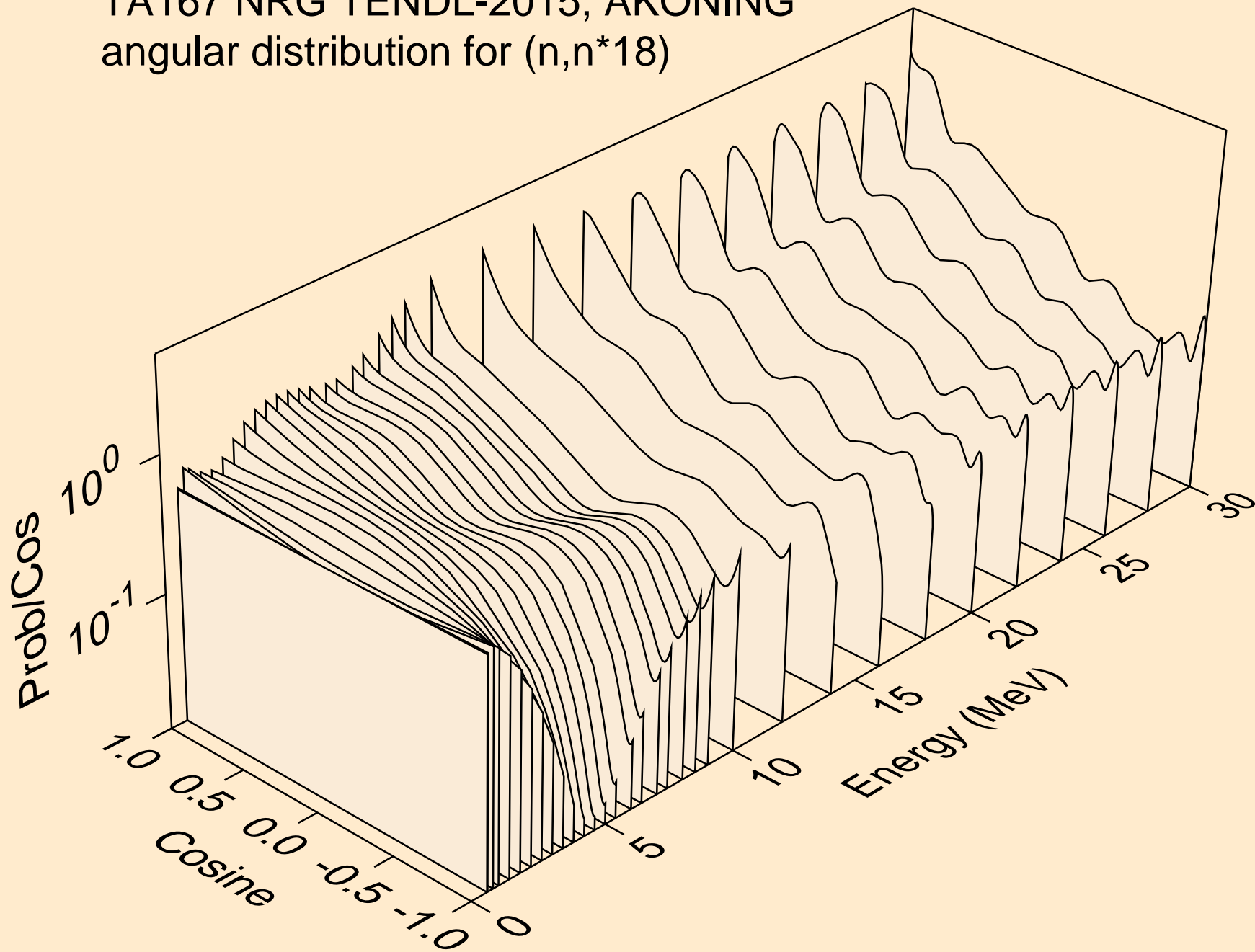

TA167 NRG TENDL-2015, AKONING  
angular distribution for (n,n\*19)

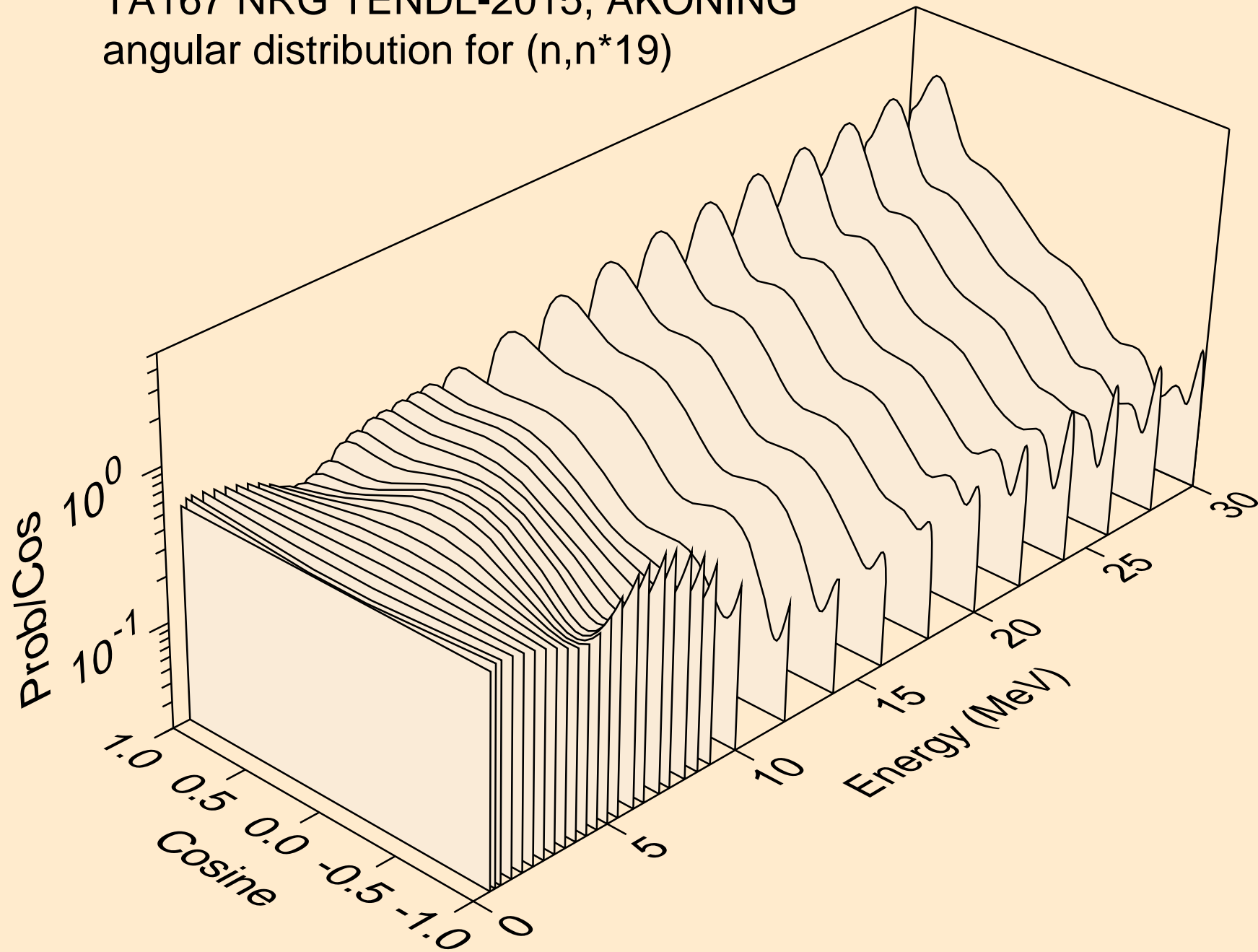

TA167 NRG TENDL-2015, AKONING  
angular distribution for (n,n\*20)

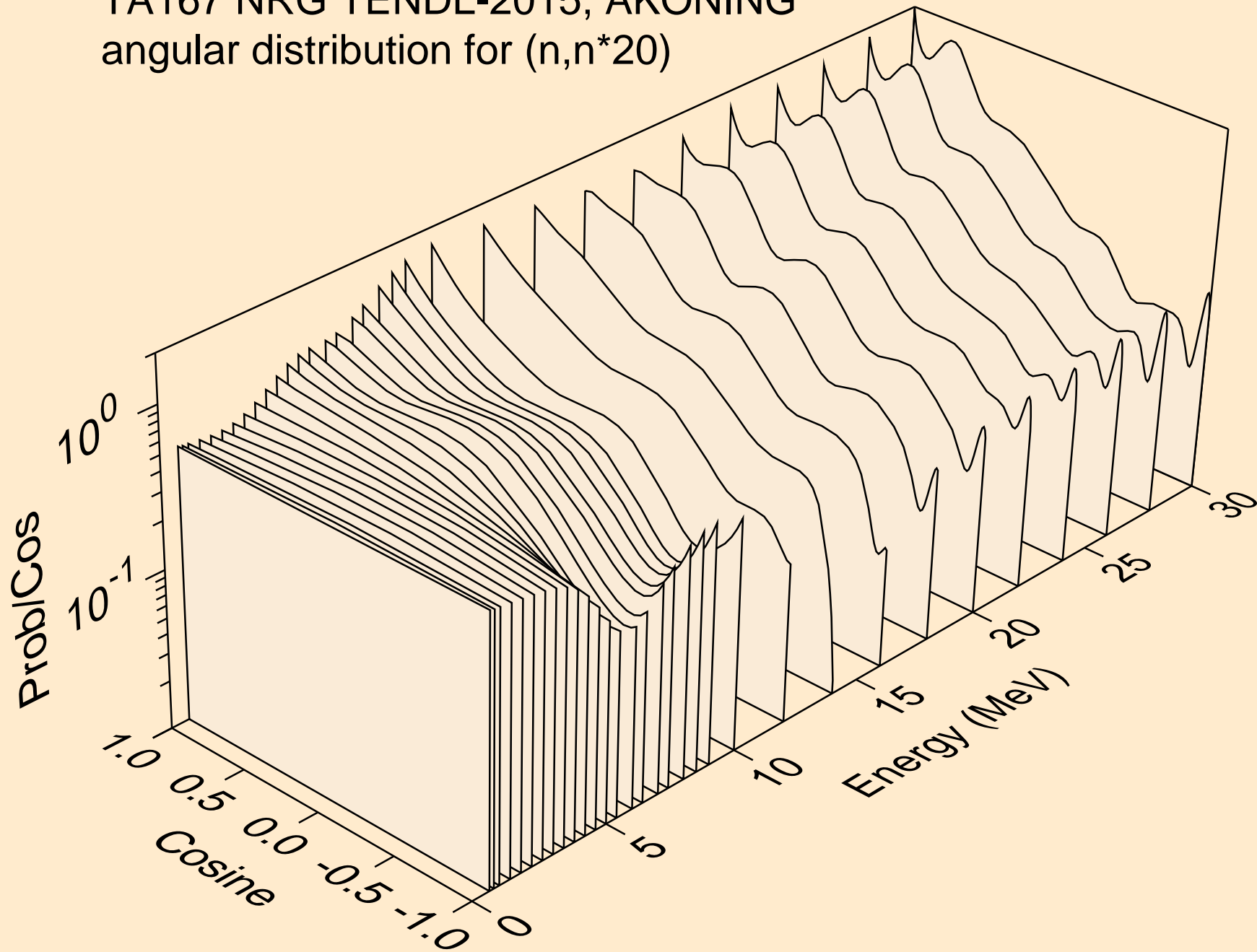

TA167 NRG TENDL-2015, AKONING  
angular distribution for (n,n\*21)

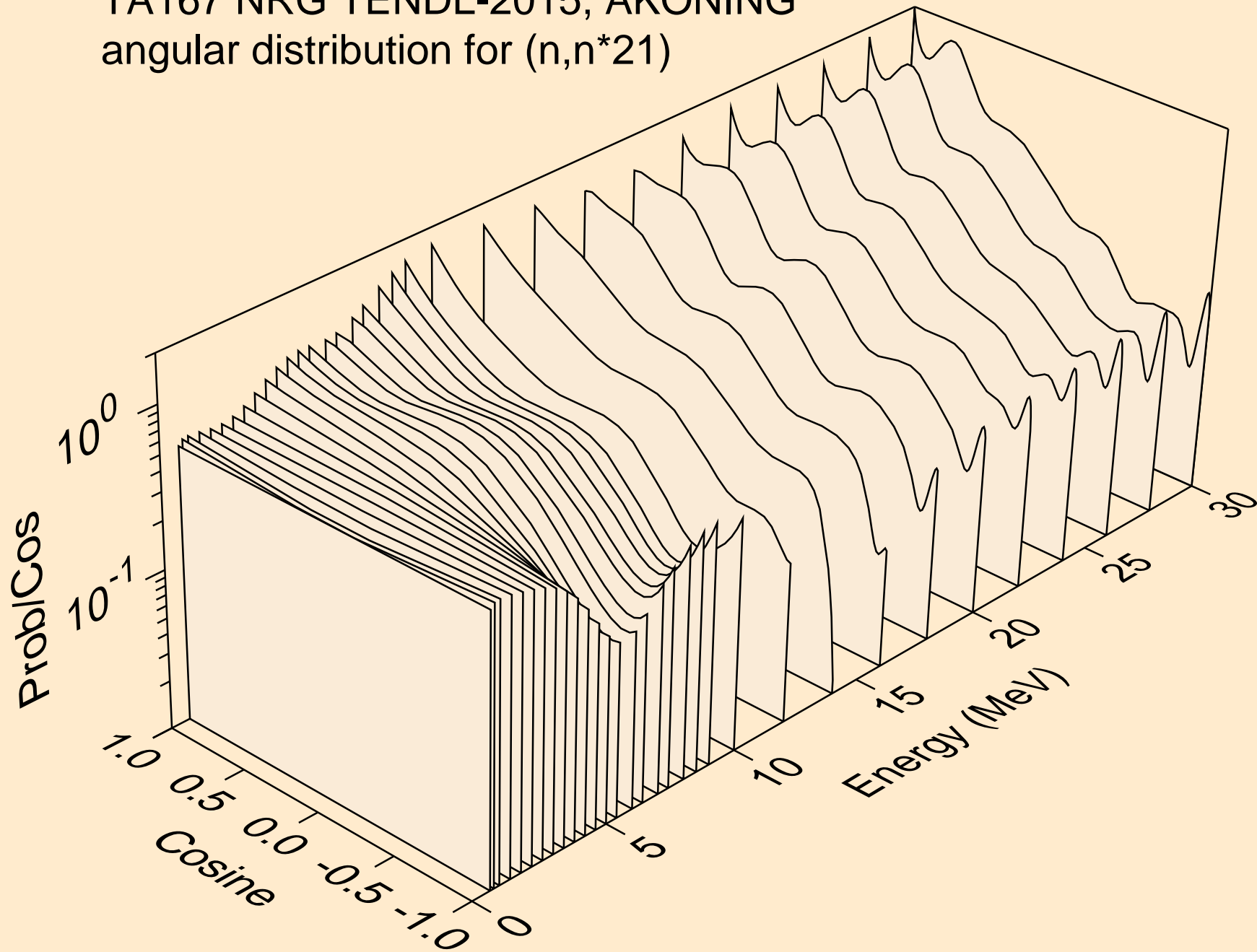

TA167 NRG TENDL-2015, AKONING  
angular distribution for (n,n\*22)

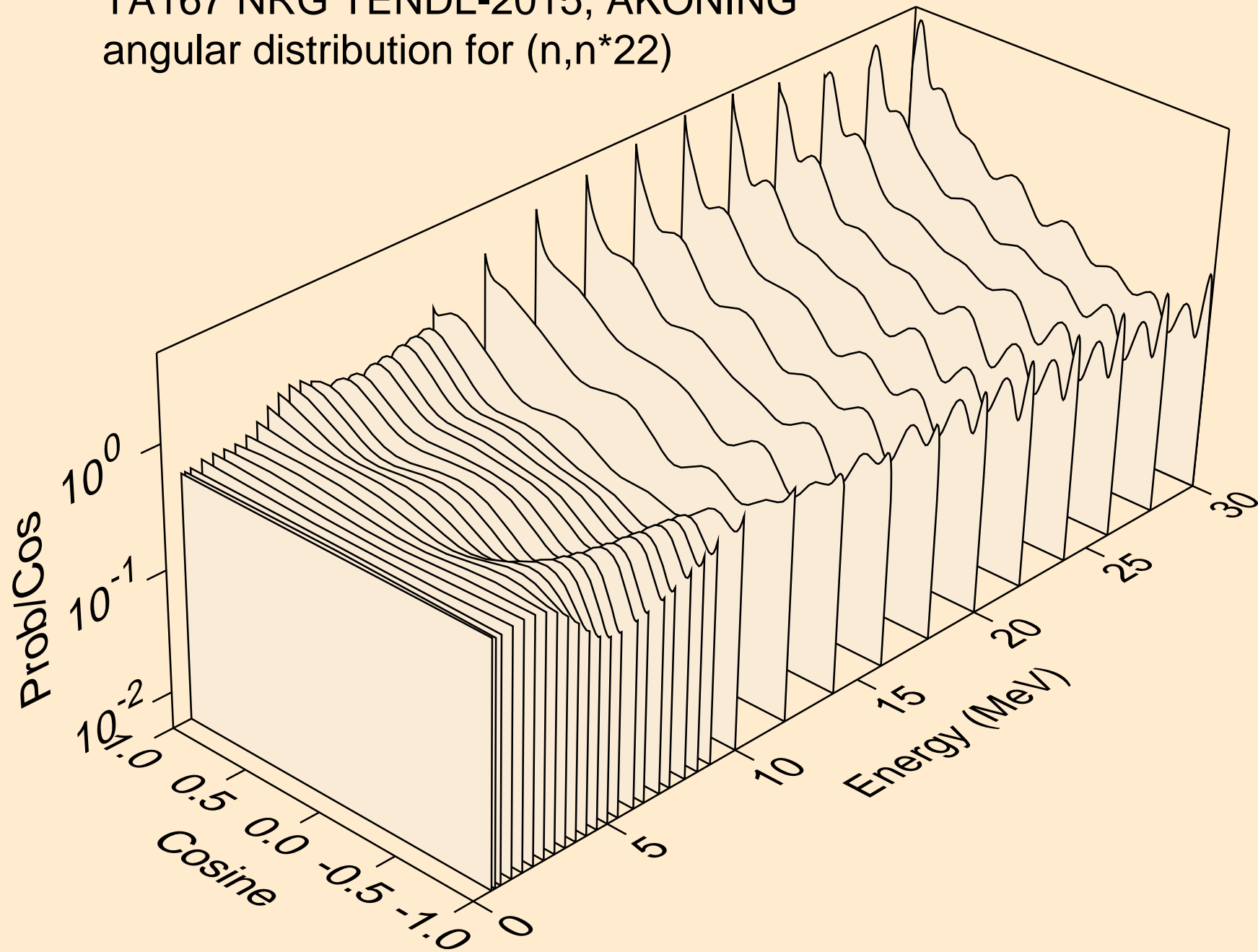

TA167 NRG TENDL-2015, AKONING  
Neutron emission for (n,x)

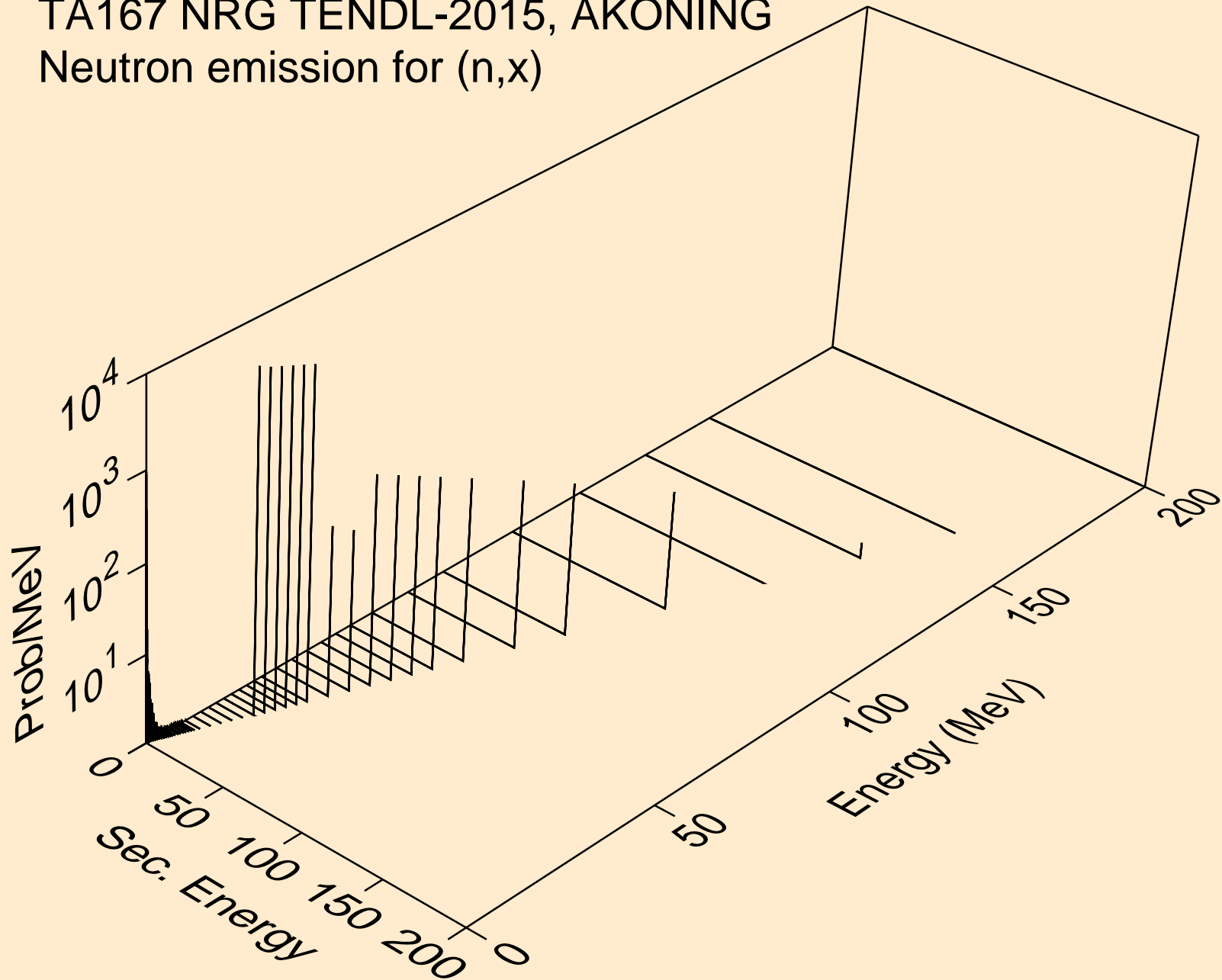

TA167 NRG TENDL-2015, AKONING  
Neutron emission for (n,2nd)

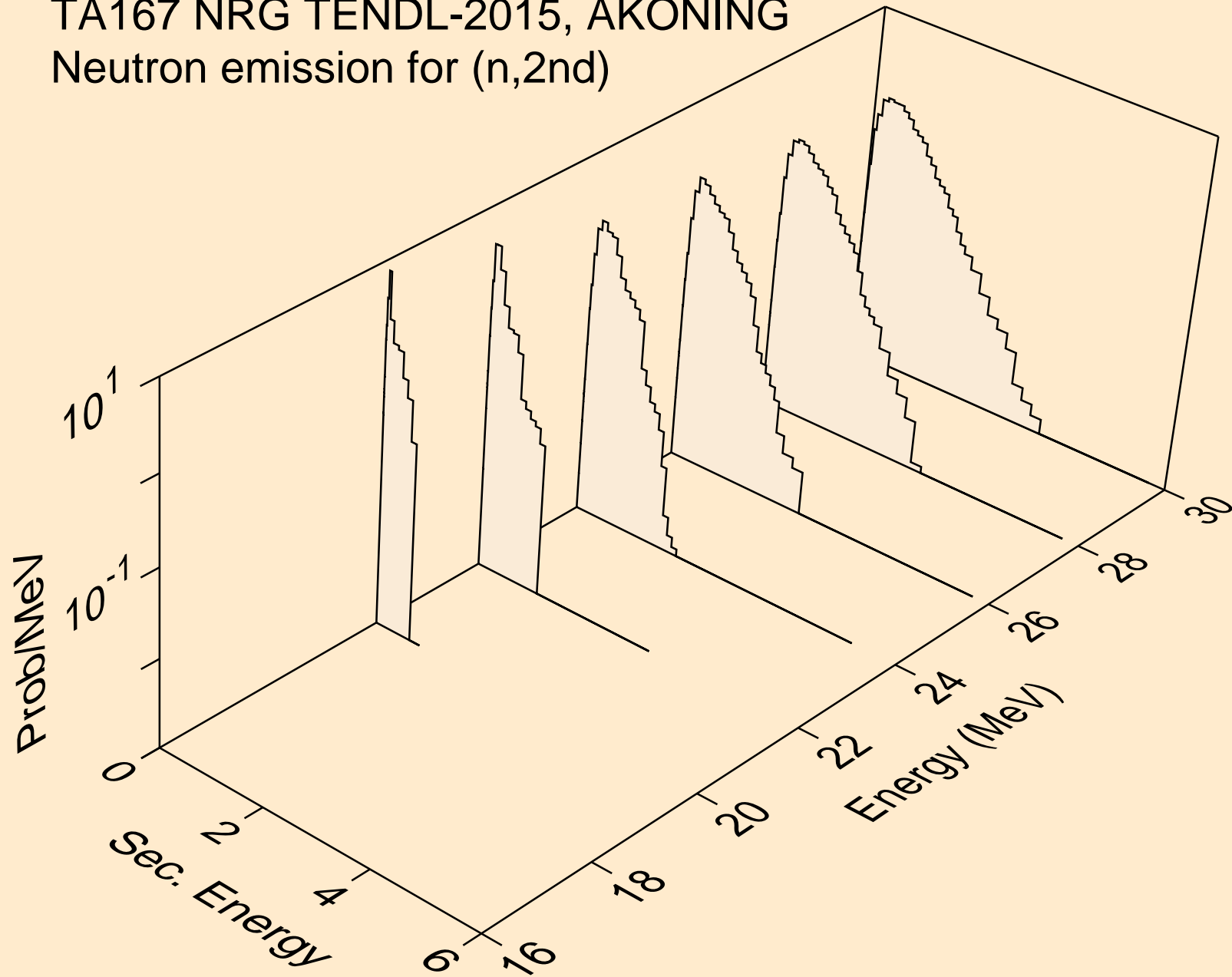

TA167 NRG TENDL-2015, AKONING  
Neutron emission for (n,2n)

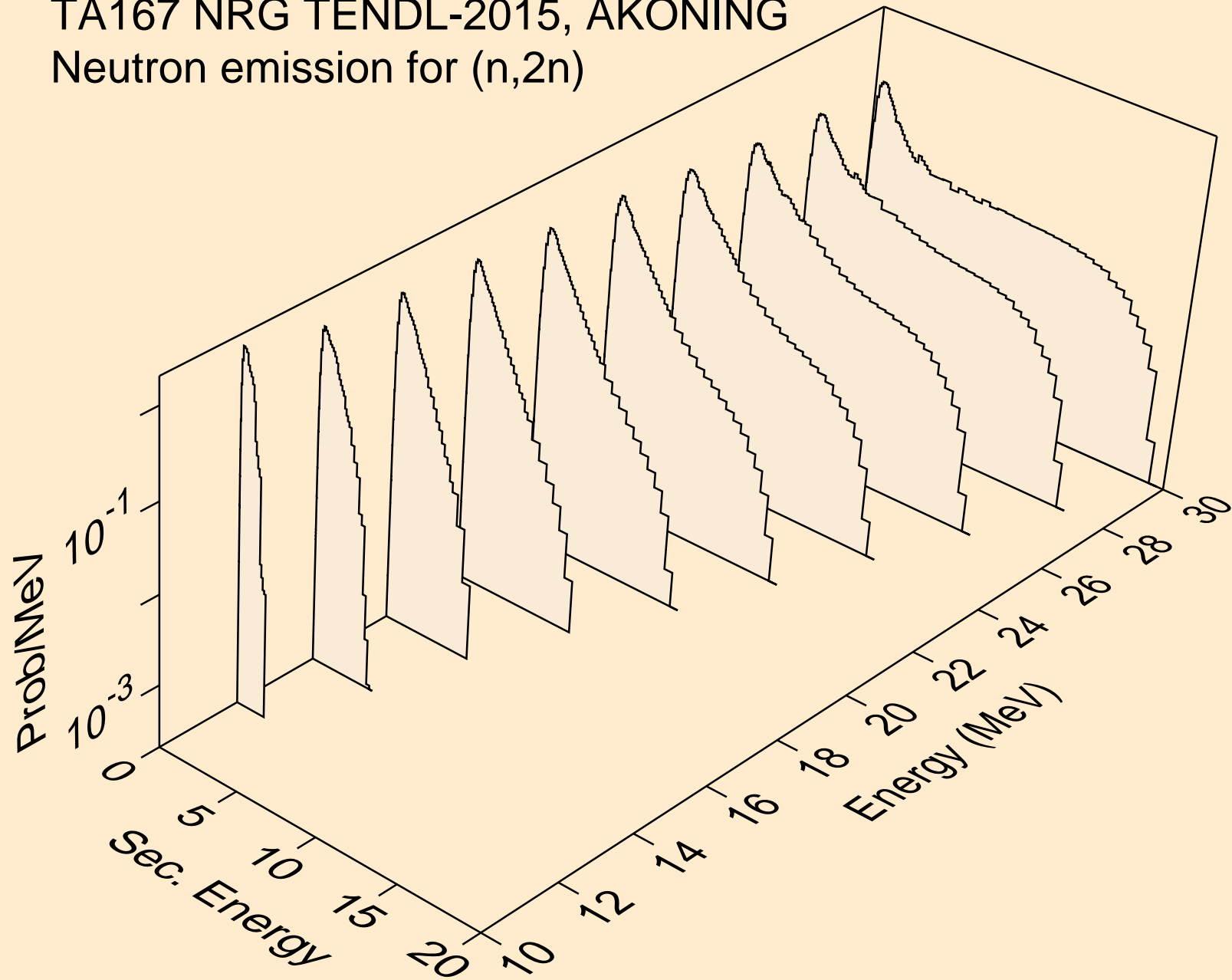



TA167 NRG TENDL-2015, AKONING  
Neutron emission for (n,3n)

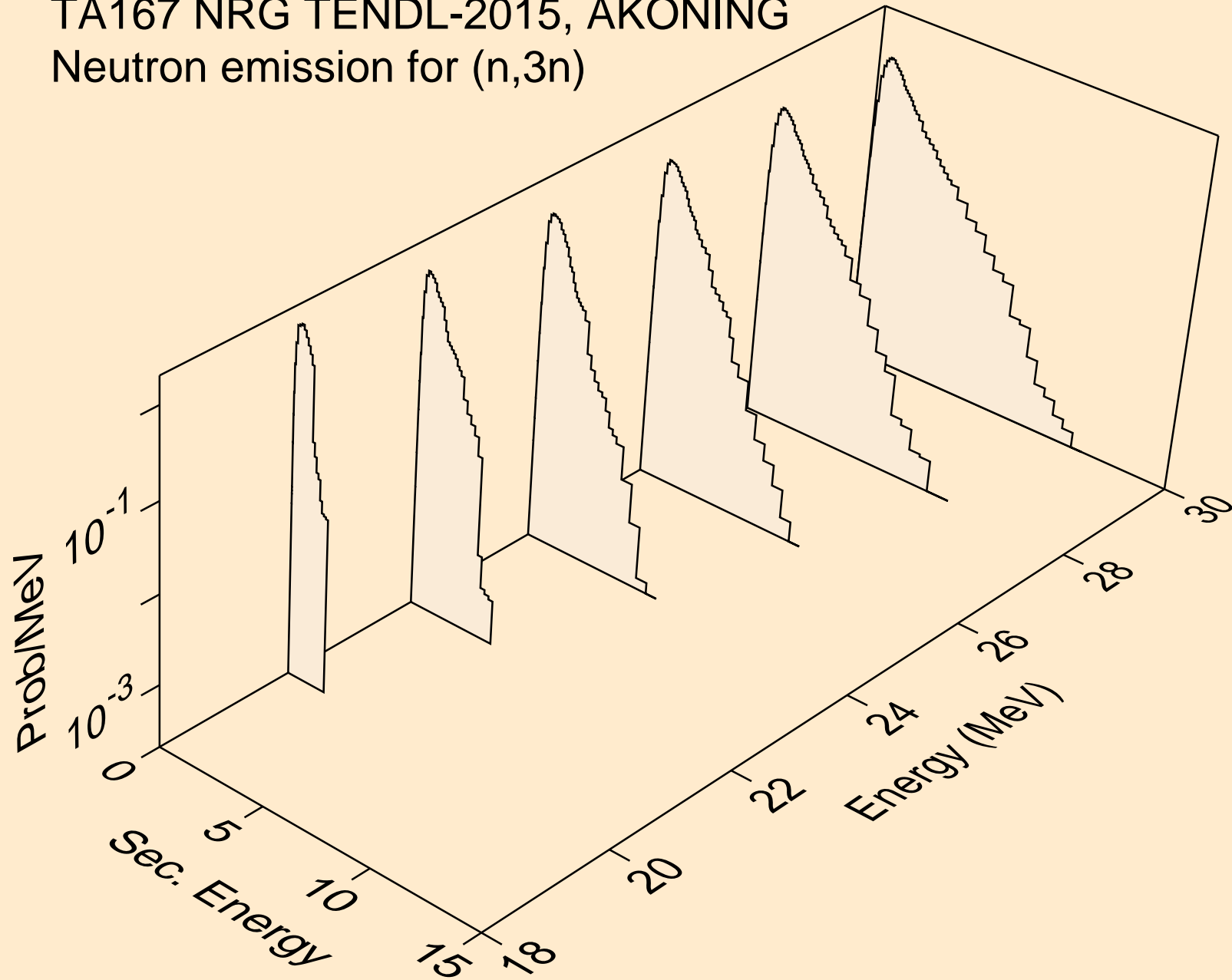

TA167 NRG TENDL-2015, AKONING  
Neutron emission for (n,n\*)a

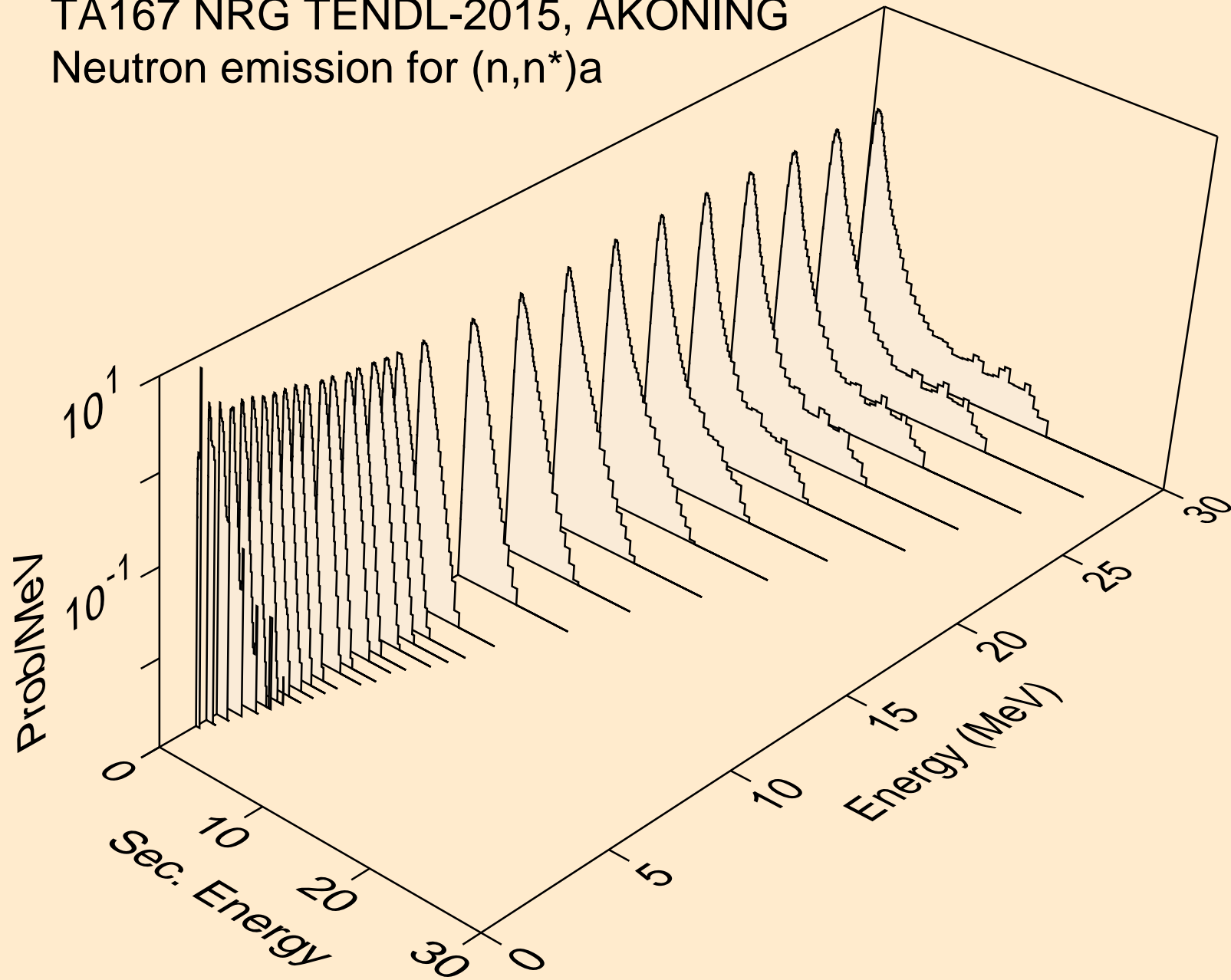

TA167 NRG TENDL-2015, AKONING  
Neutron emission for (n,n\*)3a

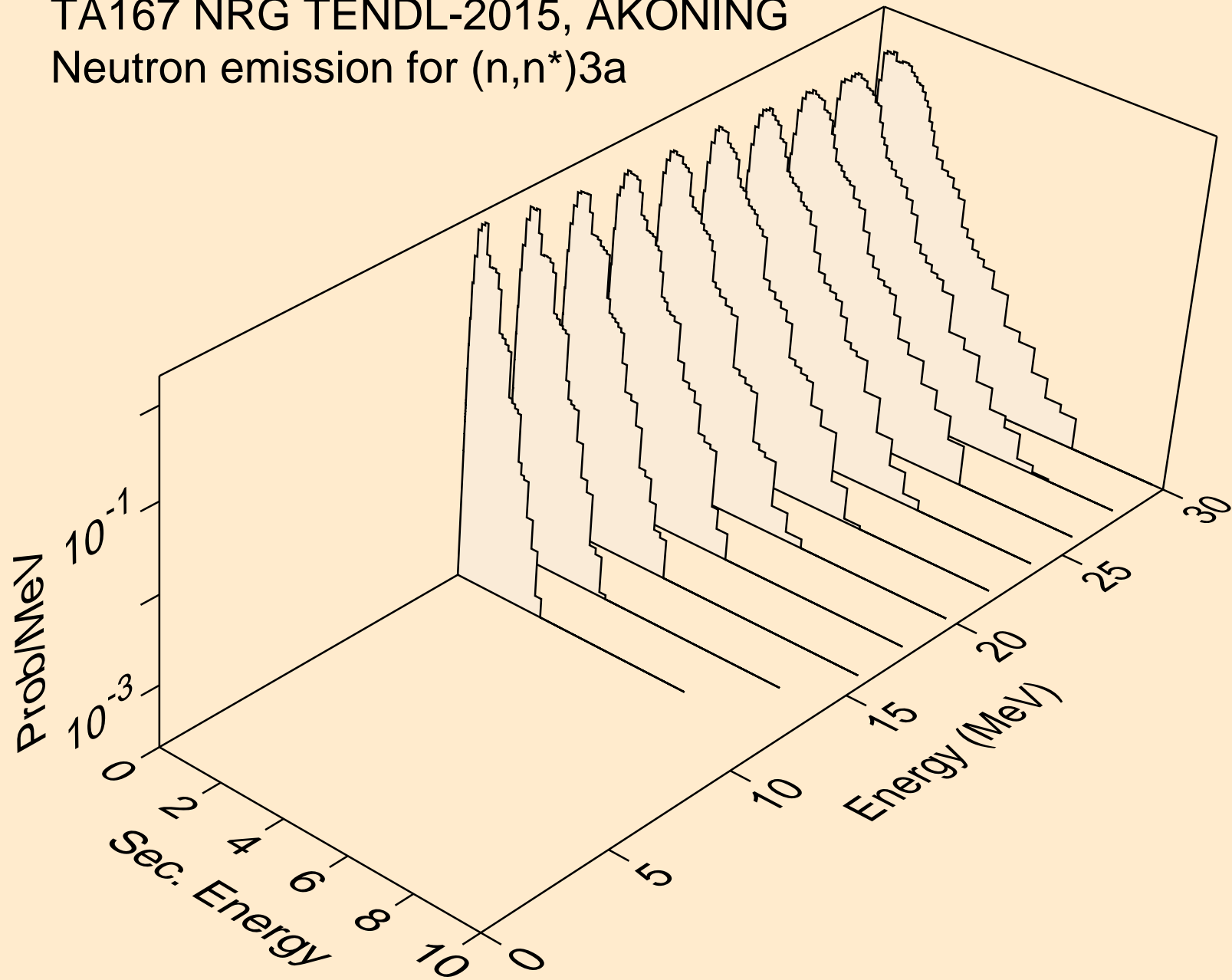

TA167 NRG TENDL-2015, AKONING  
Neutron emission for (n,2n)a

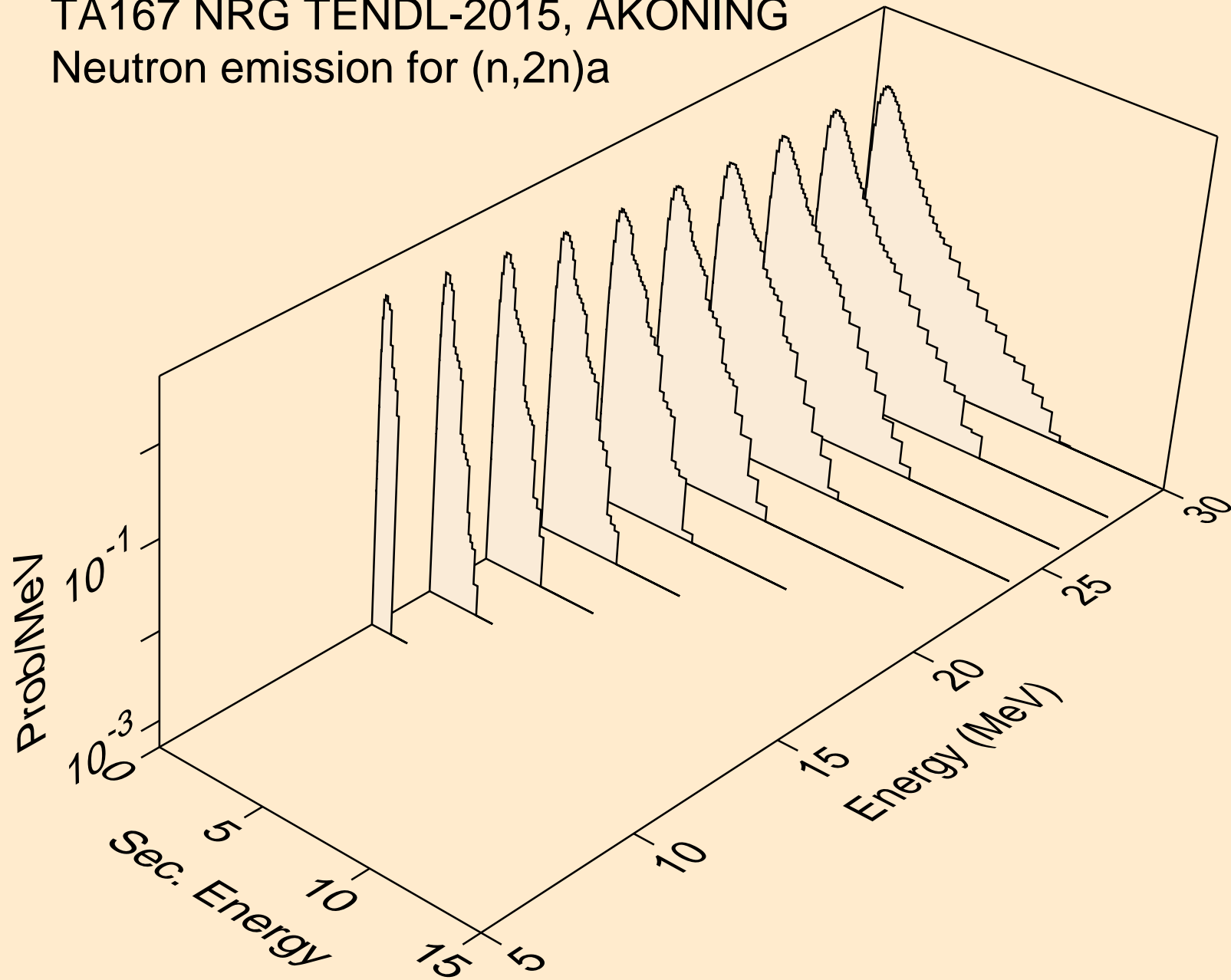

TA167 NRG TENDL-2015, AKONING  
Neutron emission for (n,3n)a

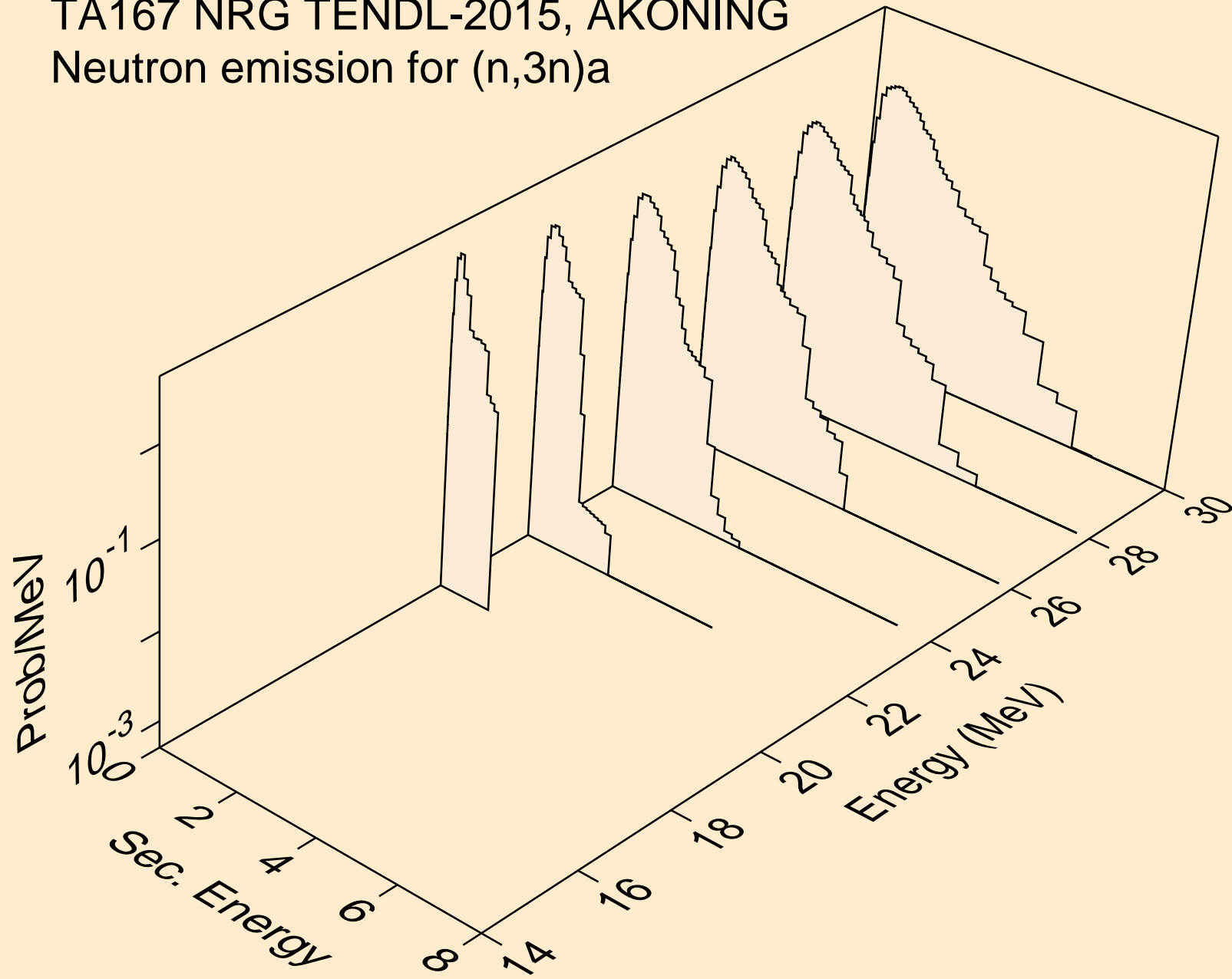

TA167 NRG TENDL-2015, AKONING  
Neutron emission for (n,n\*)p

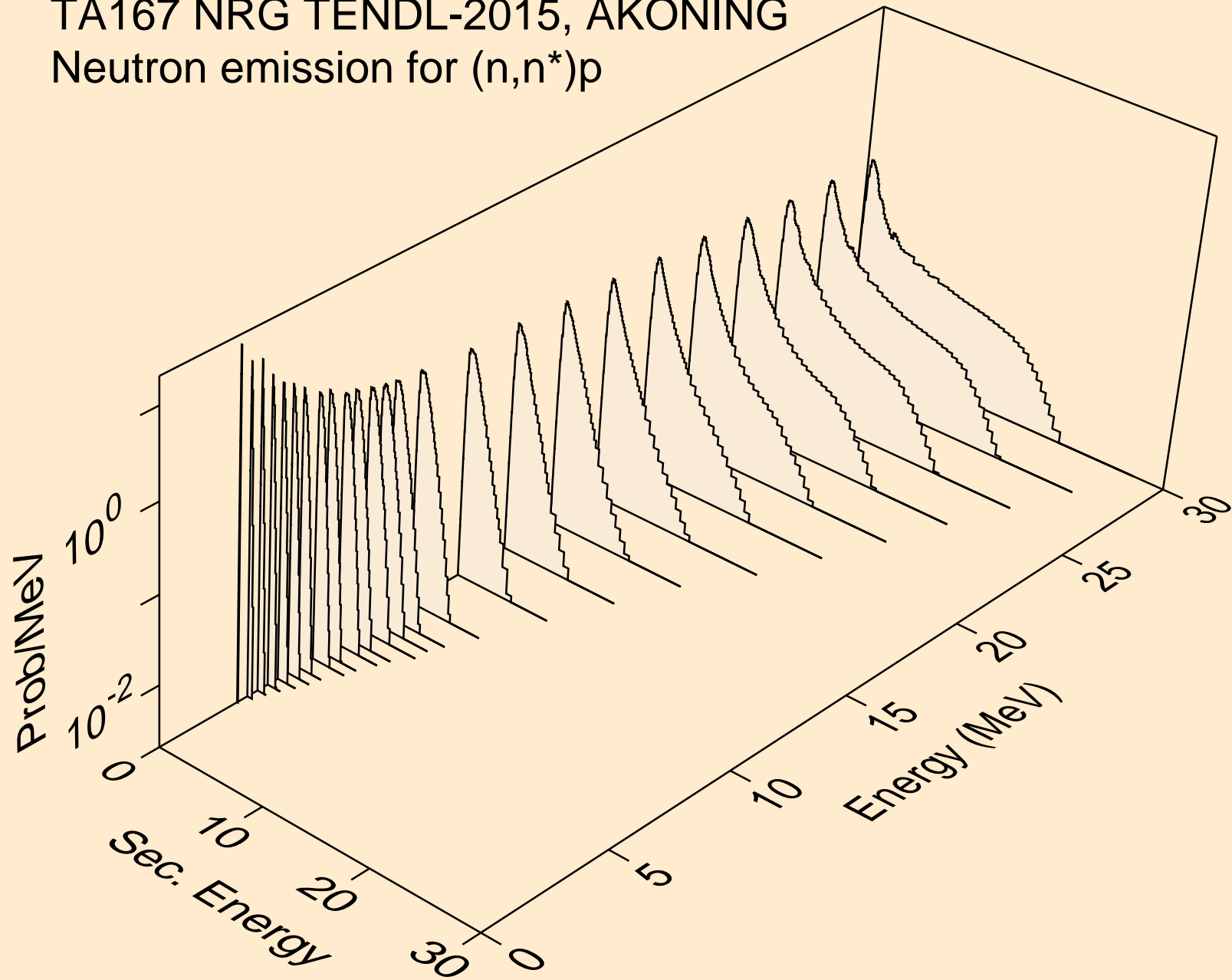

TA167 NRG TENDL-2015, AKONING  
Neutron emission for (n,n\*)2a

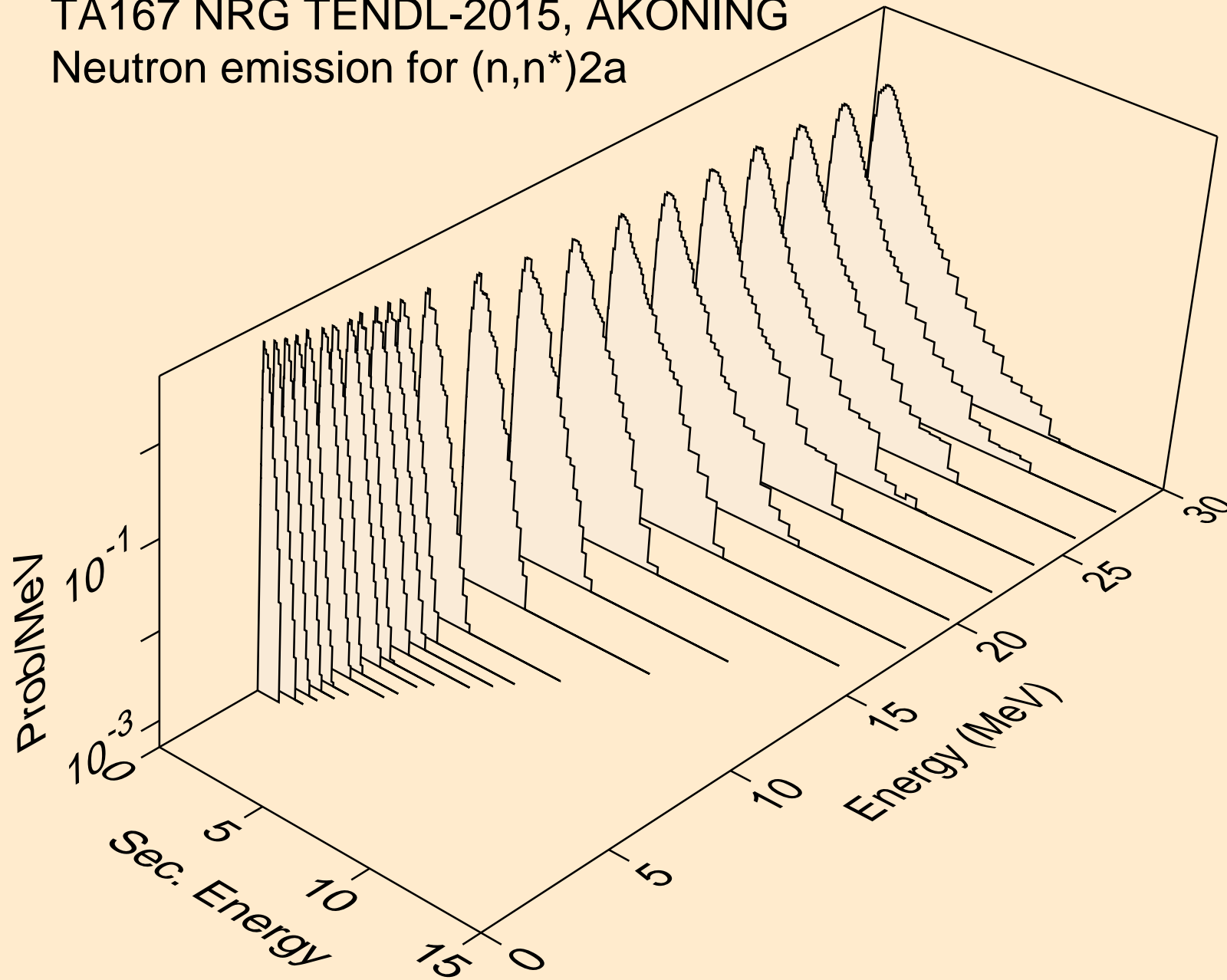

TA167 NRG TENDL-2015, AKONING  
Neutron emission for (n,2n)2a

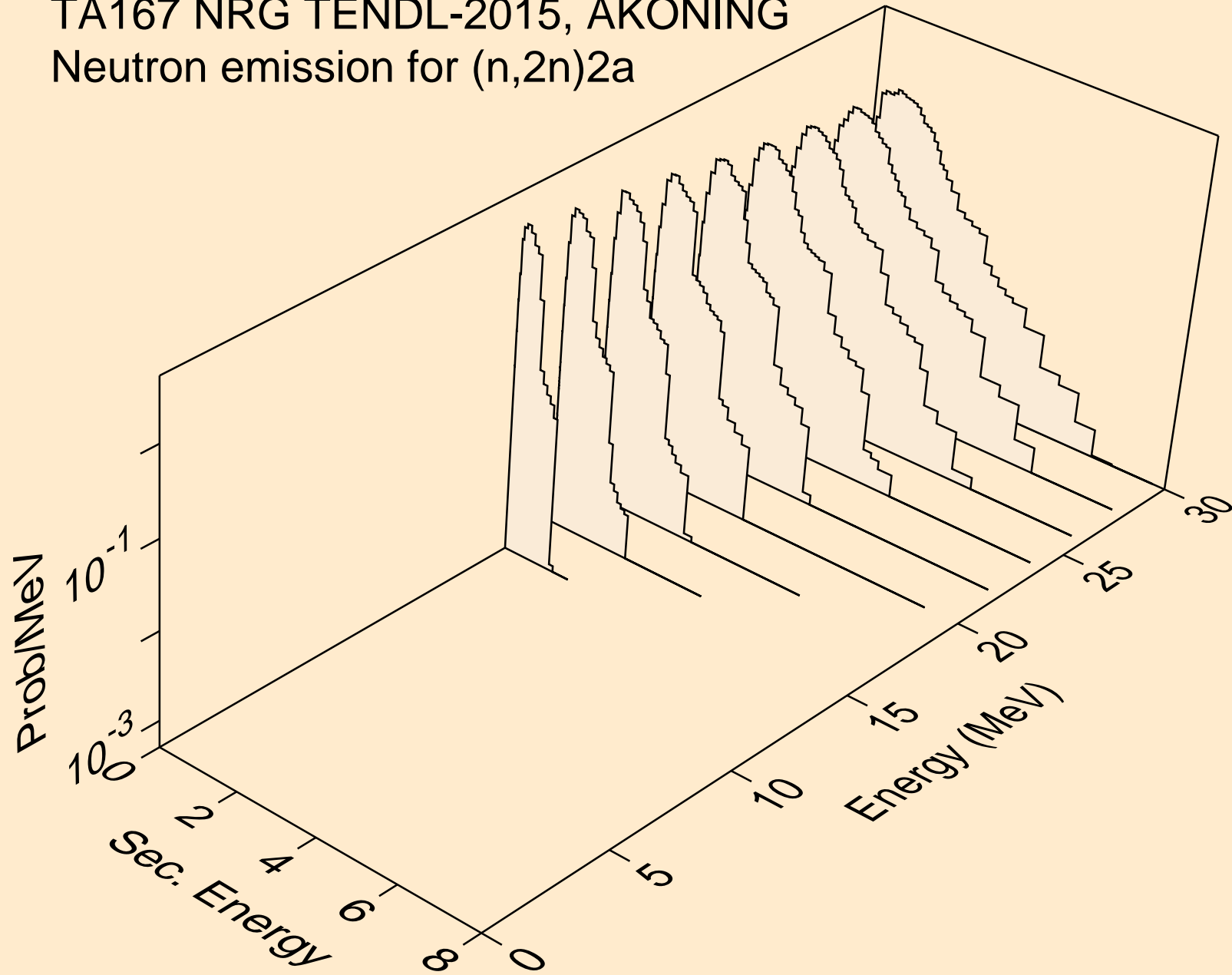



TA167 NRG TENDL-2015, AKONING  
Neutron emission for (n,n\*)d

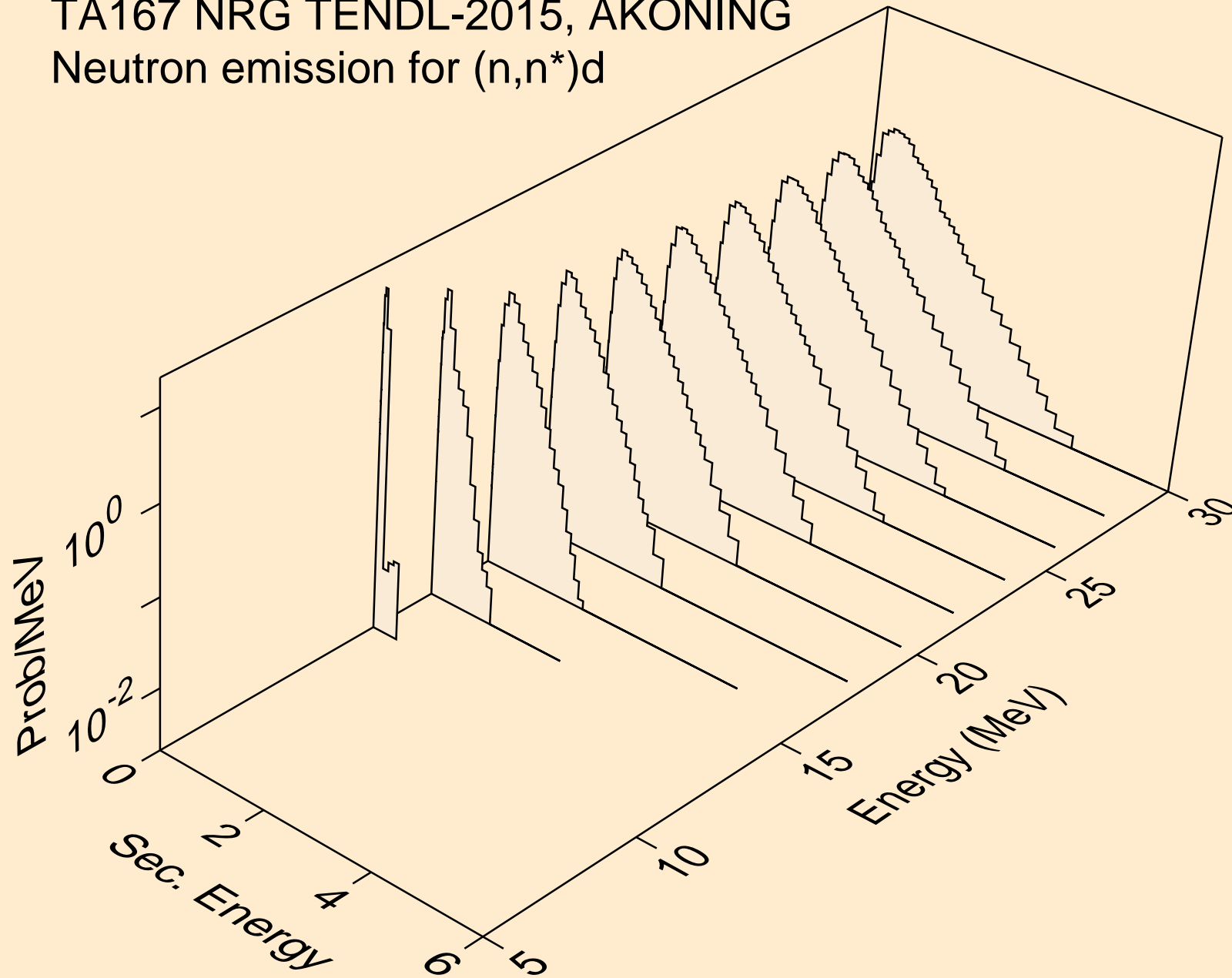

TA167 NRG TENDL-2015, AKONING  
Neutron emission for (n,n\*)t

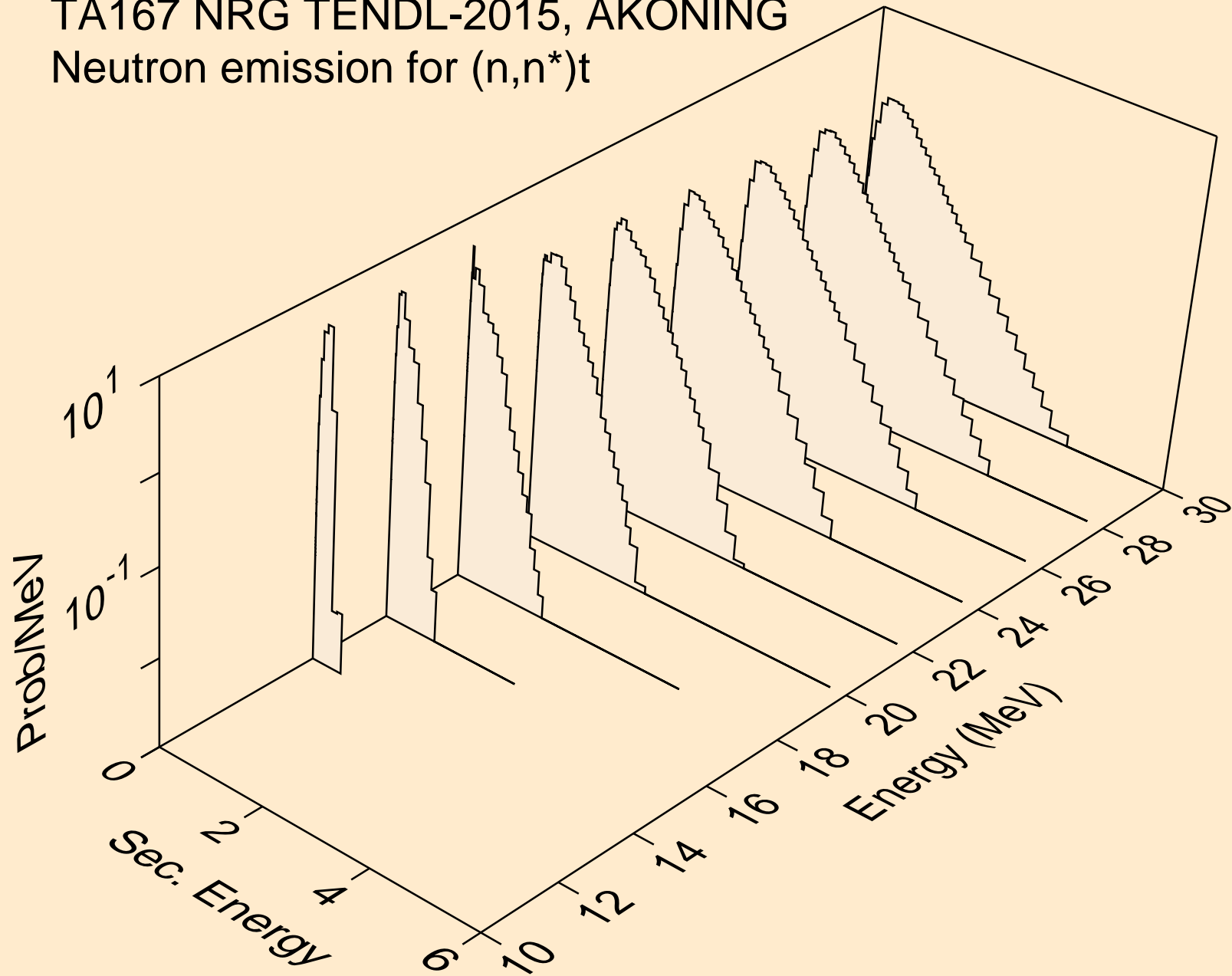

TA167 NRG TENDL-2015, AKONING  
Neutron emission for (n,n\*)he3

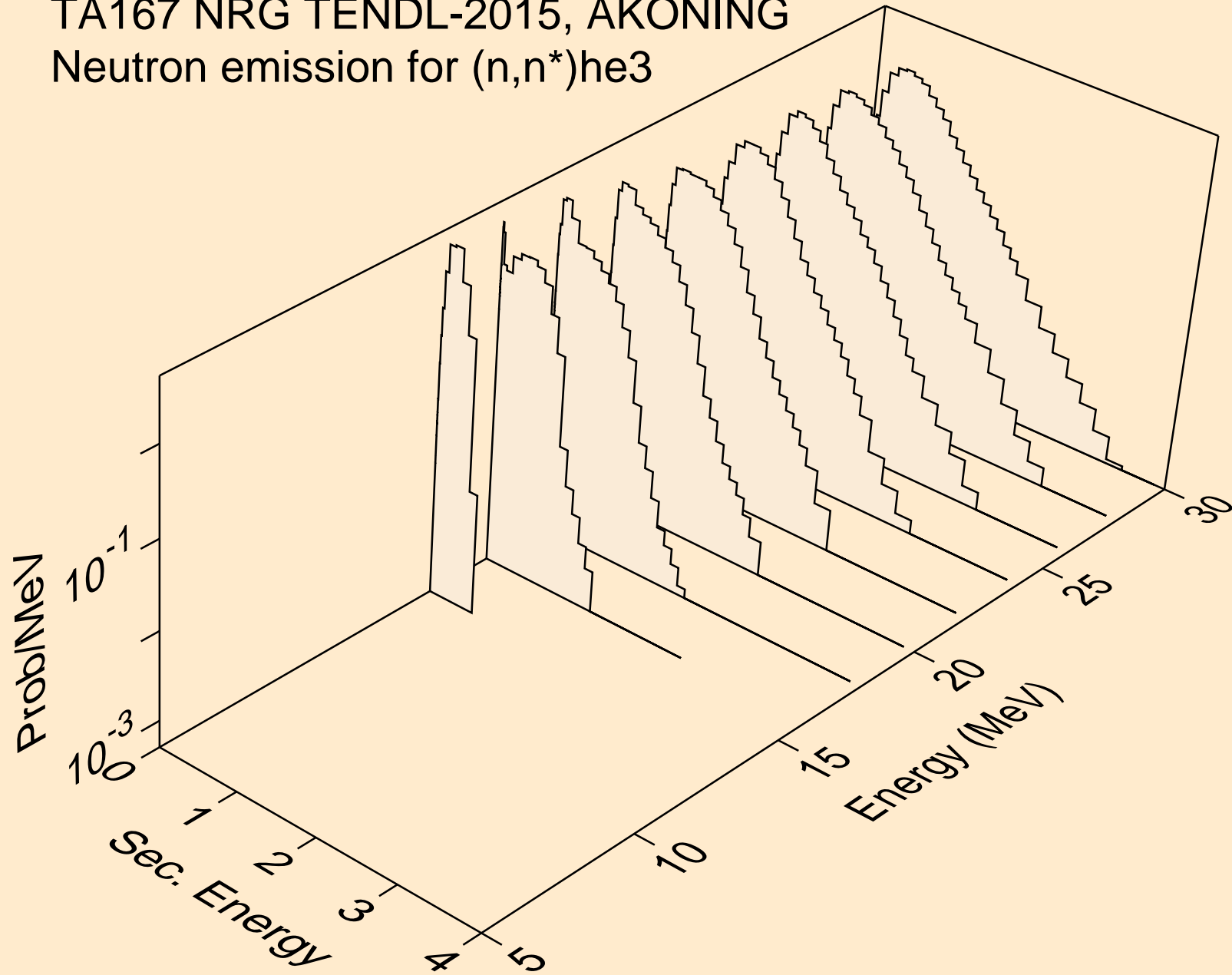

TA167 NRG TENDL-2015, AKONING  
Neutron emission for (n,4n)

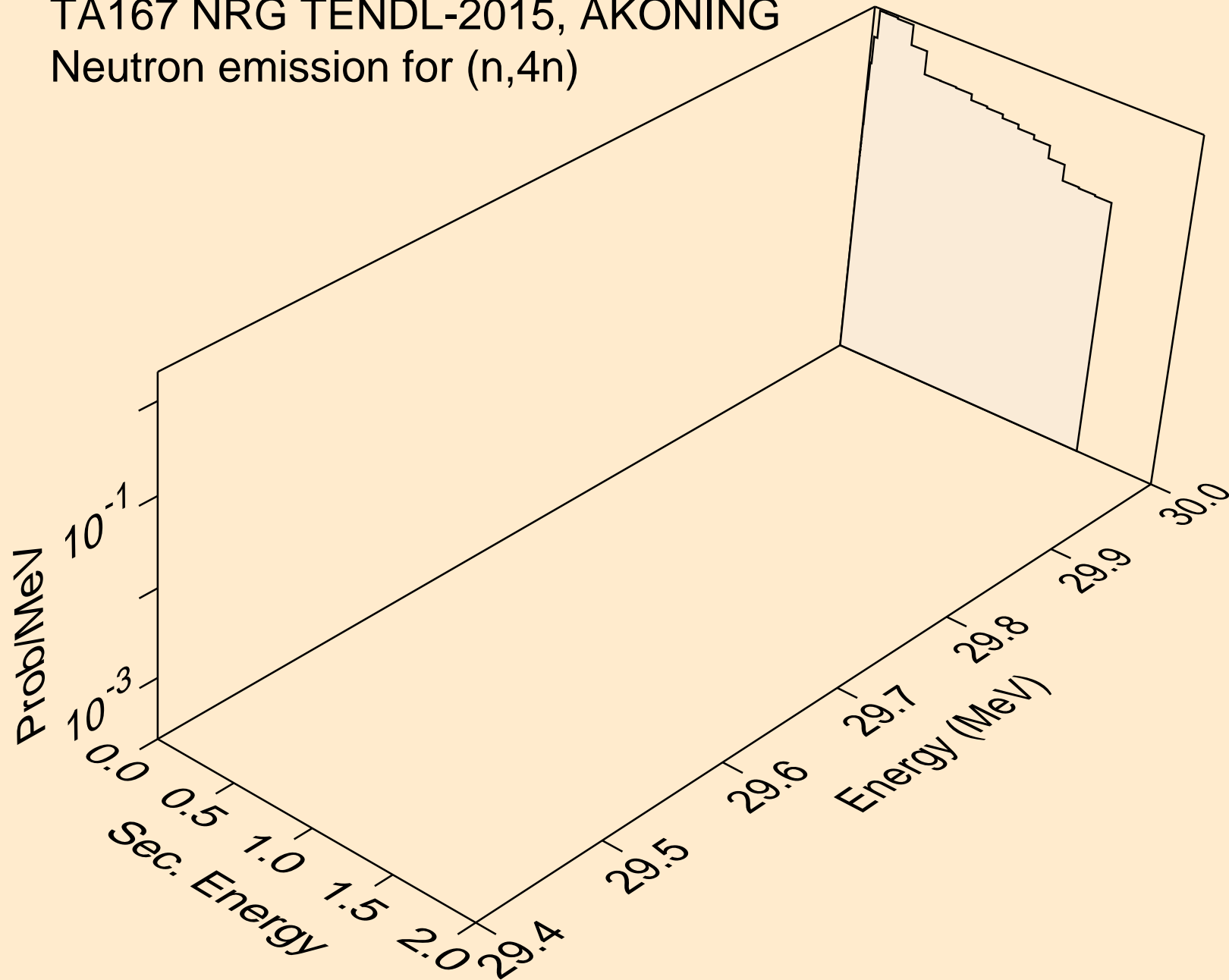

TA167 NRG TENDL-2015, AKONING  
Neutron emission for (n,2np)

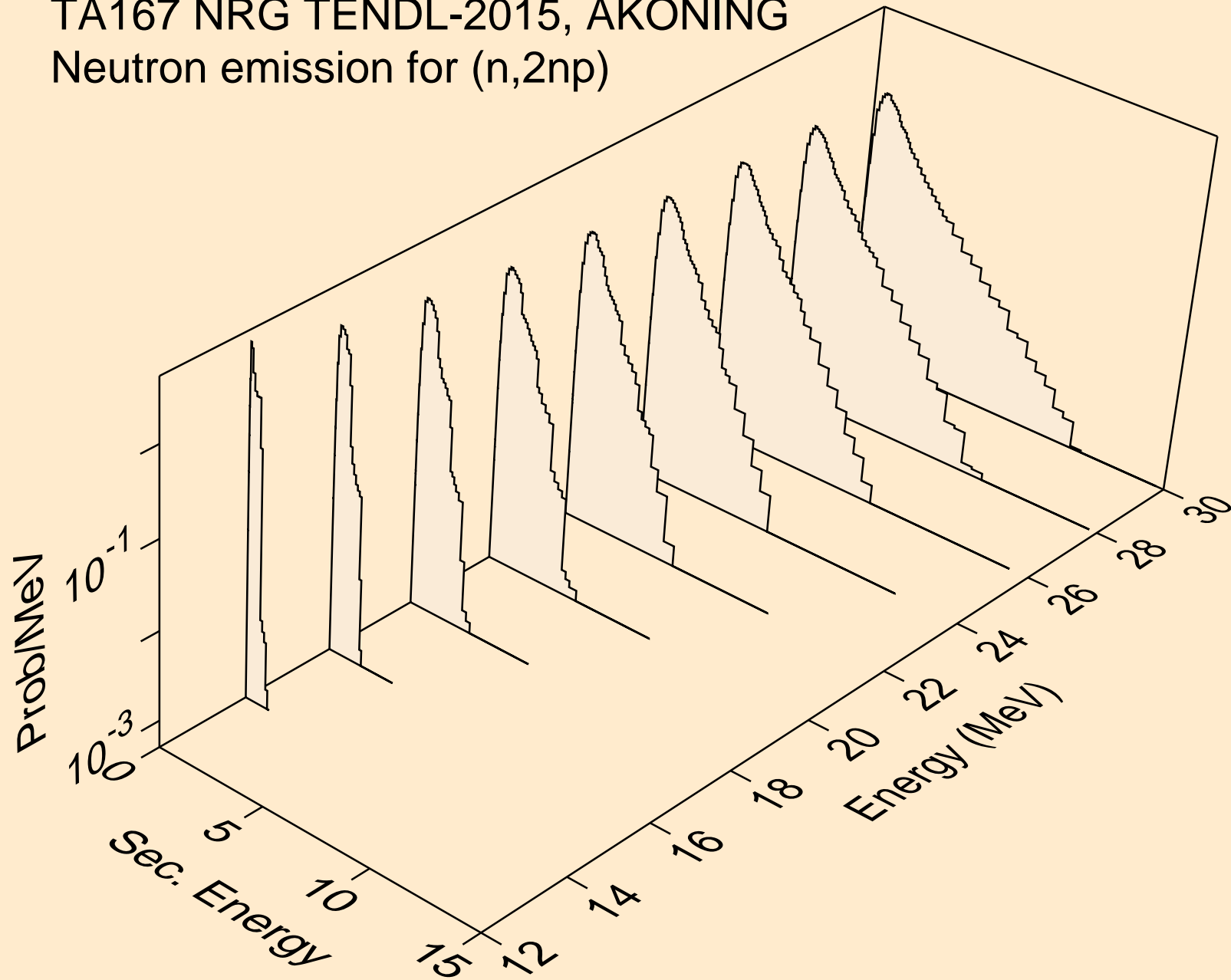

TA167 NRG TENDL-2015, AKONING  
Neutron emission for (n,3np)

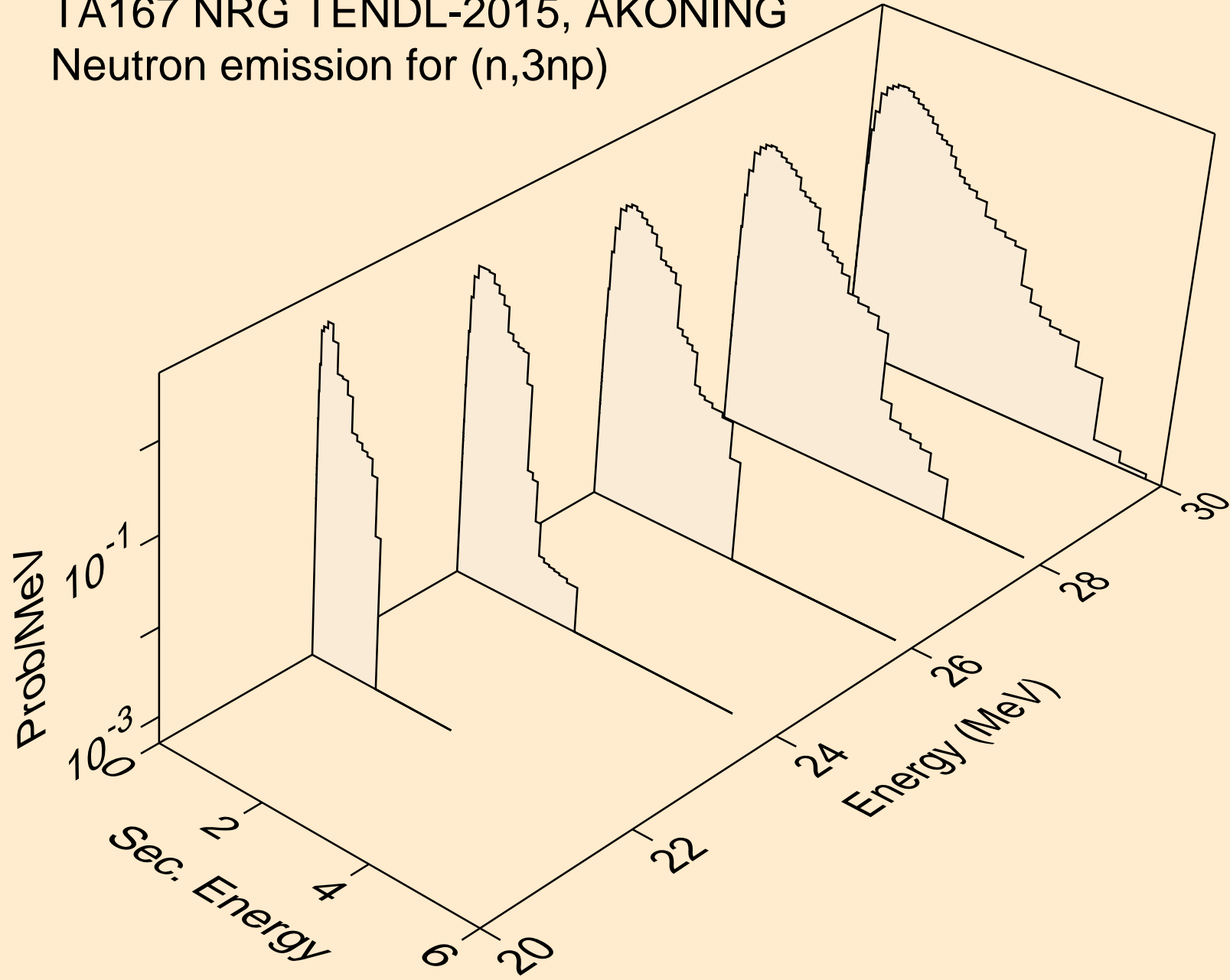

TA167 NRG TENDL-2015, AKONING  
Neutron emission for (n,2np)

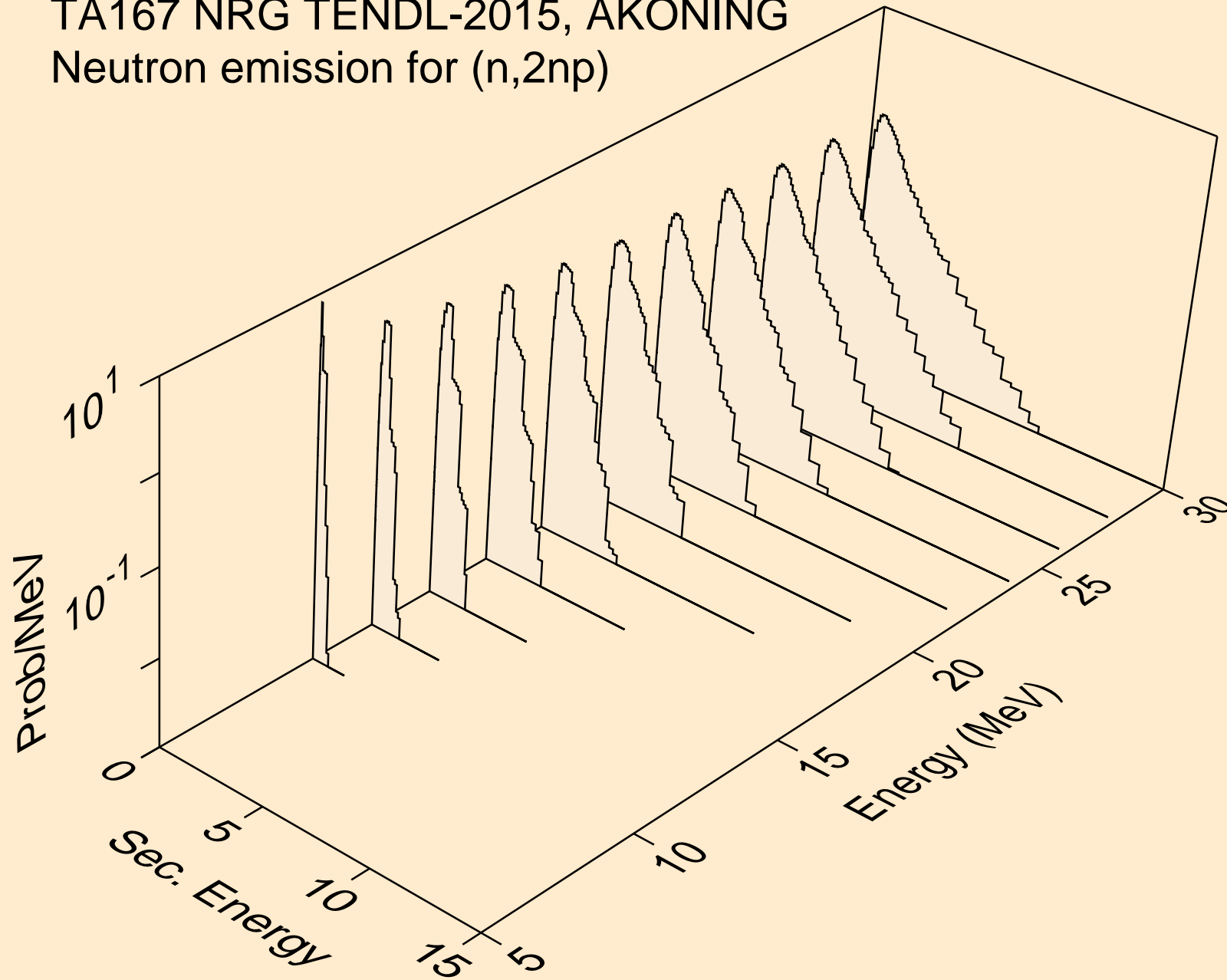

TA167 NRG TENDL-2015, AKONING  
Neutron emission for (n,npa)

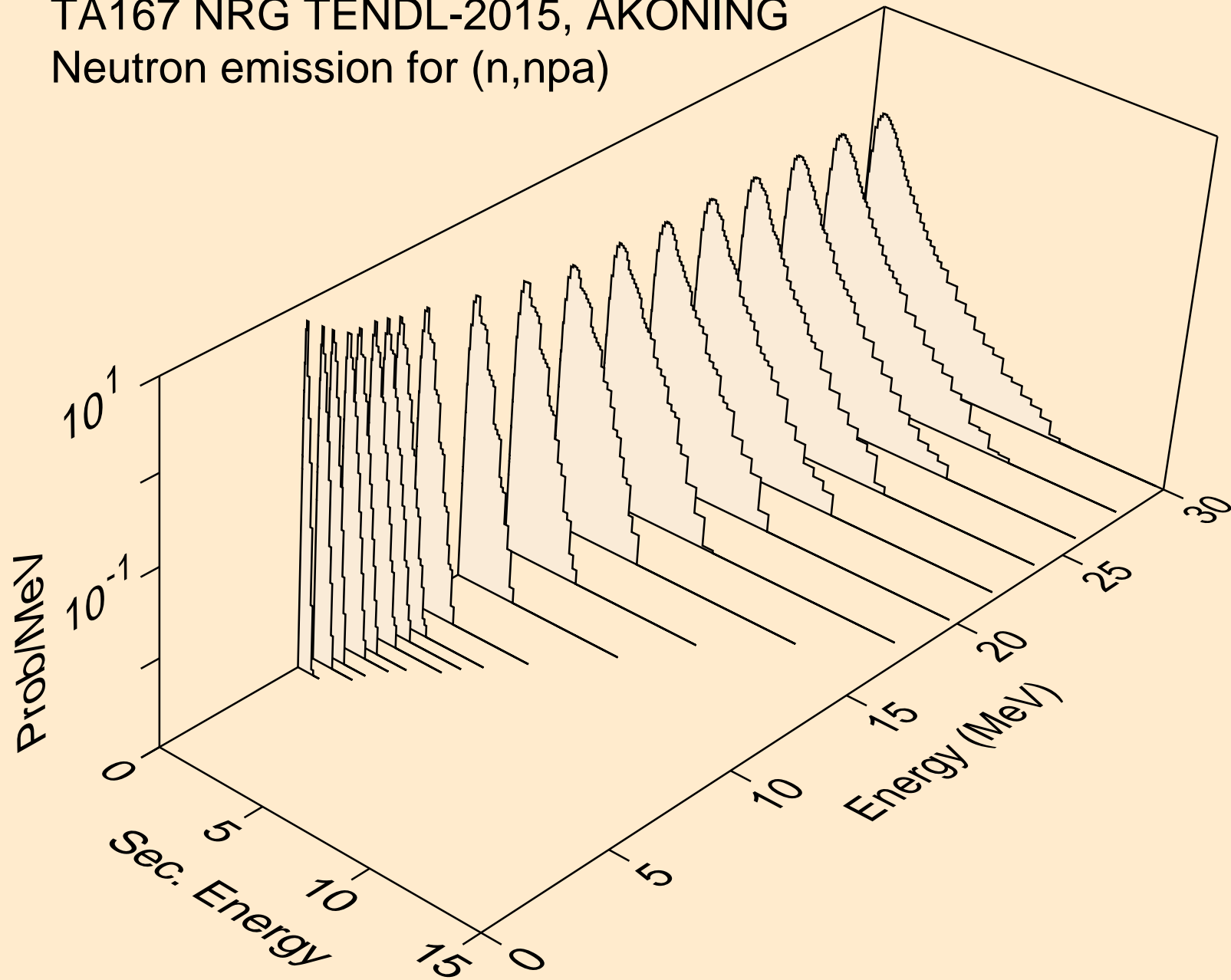



TA167 NRG TENDL-2015, AKONING  
Neutron emission for (n,n\*c)

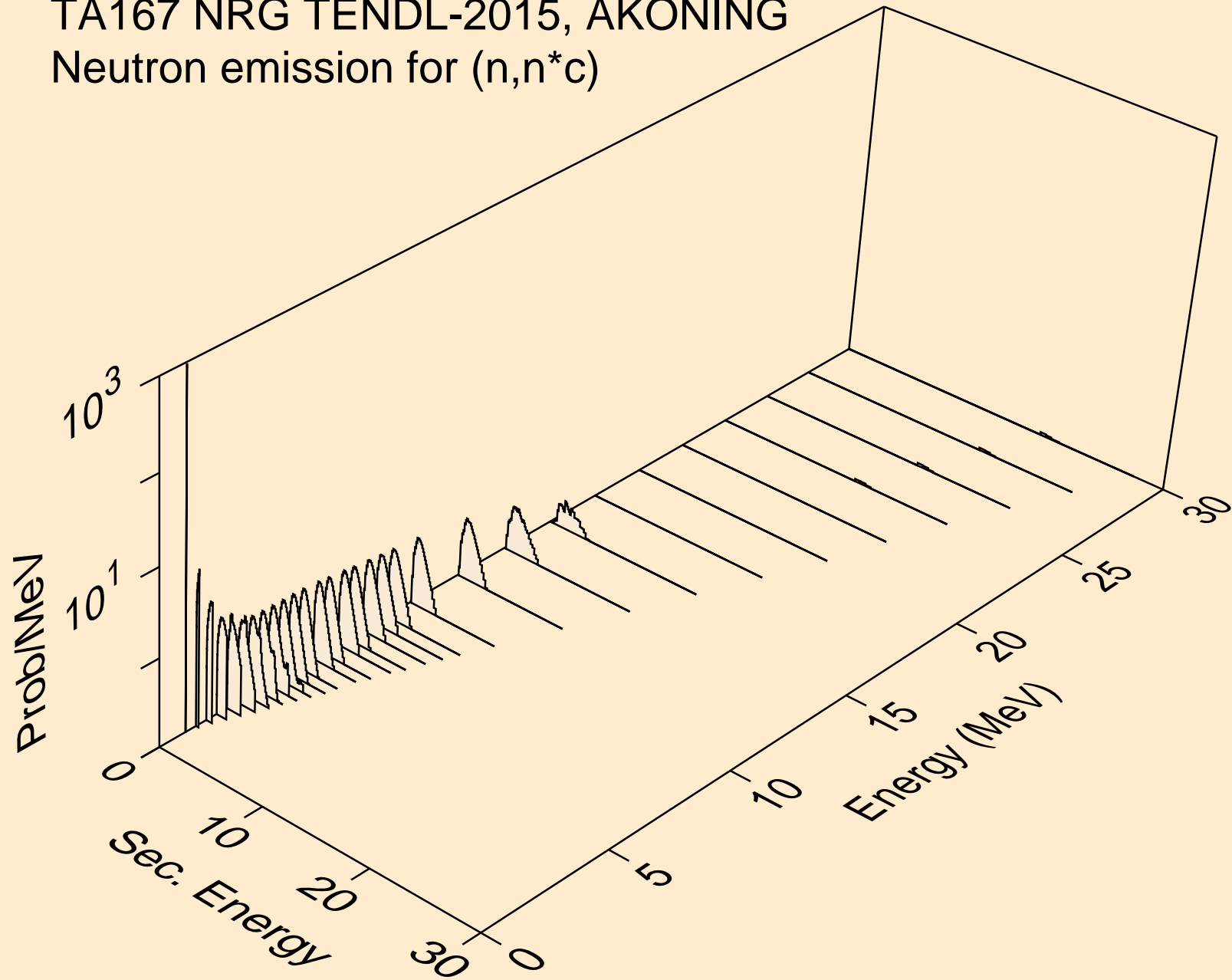

TA167 NRG TENDL-2015, AKONING  
Photon emission for (n,x)

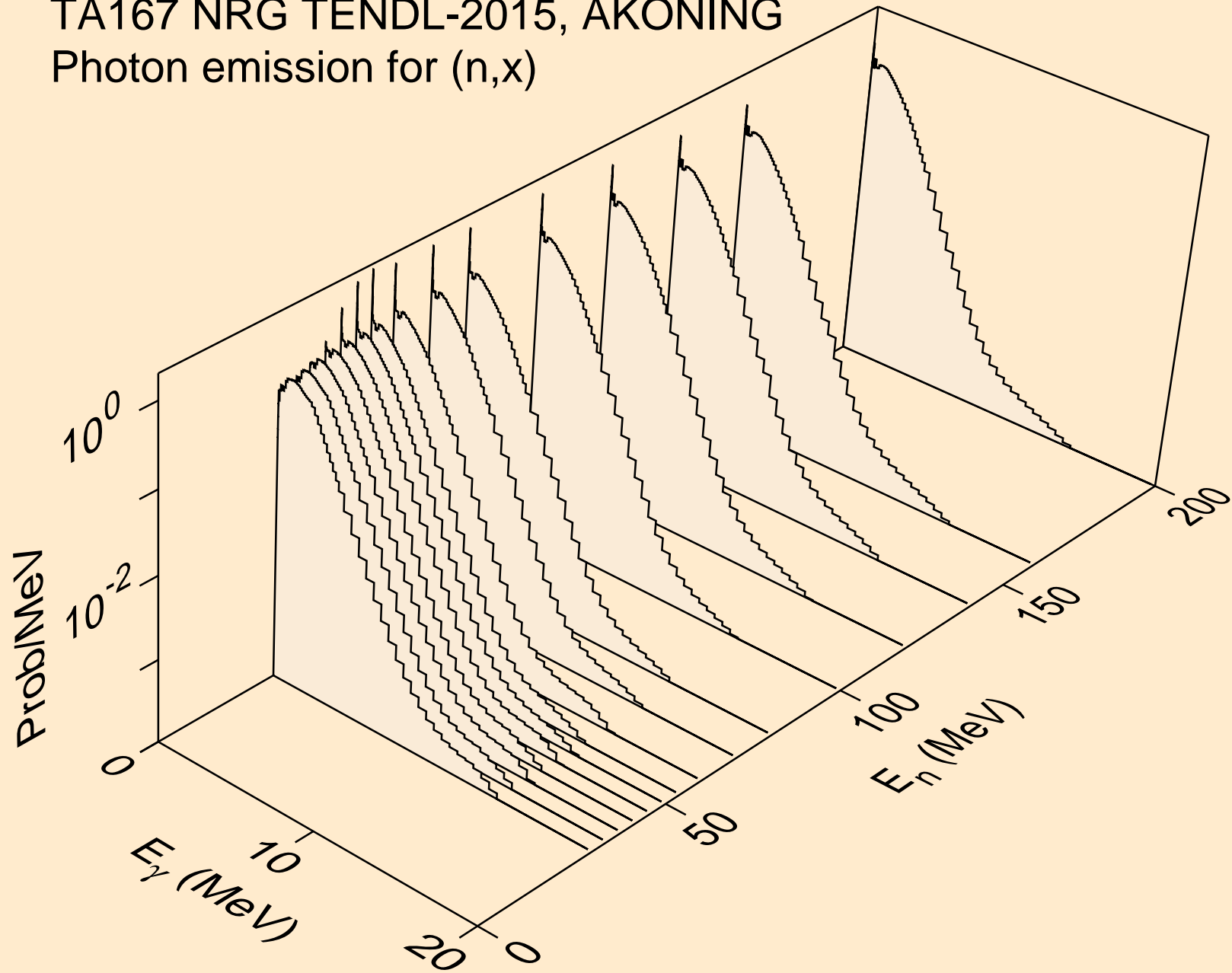

TA167 NRG TENDL-2015, AKONING  
Photon emission for (n,2nd)

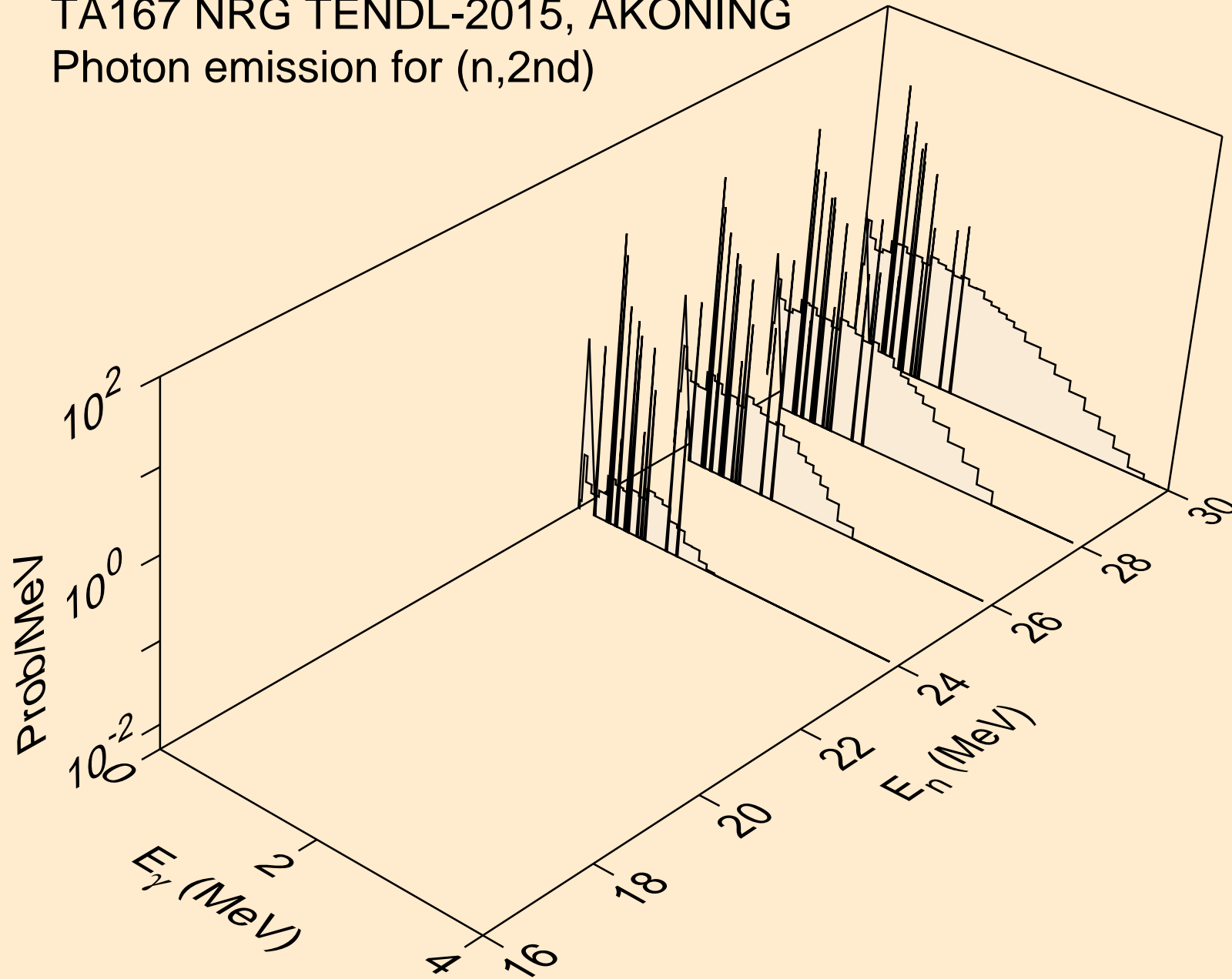

TA167 NRG TENDL-2015, AKONING  
Photon emission for (n,2n)

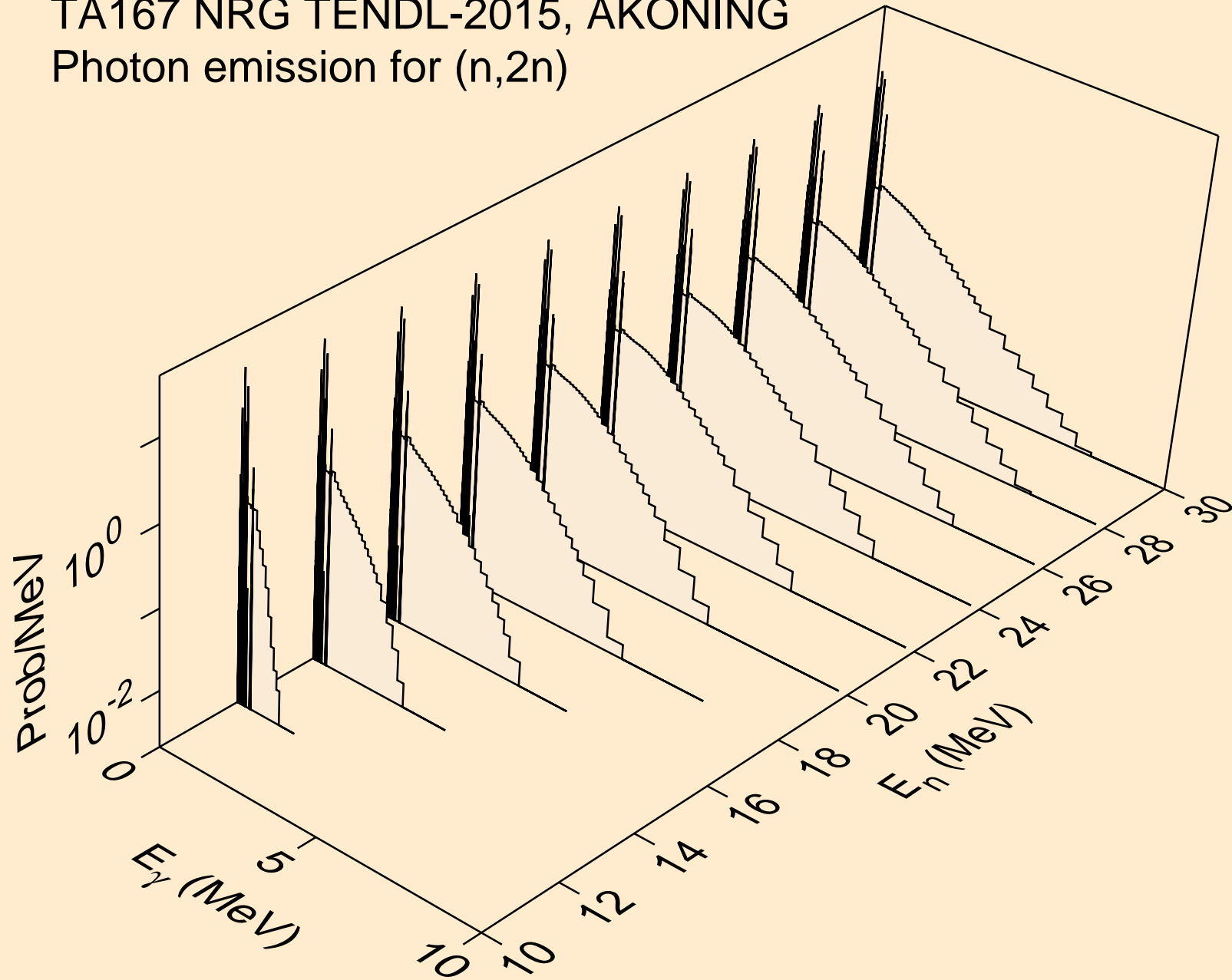

TA167 NRG TENDL-2015, AKONING  
Photon emission for (n,3n)

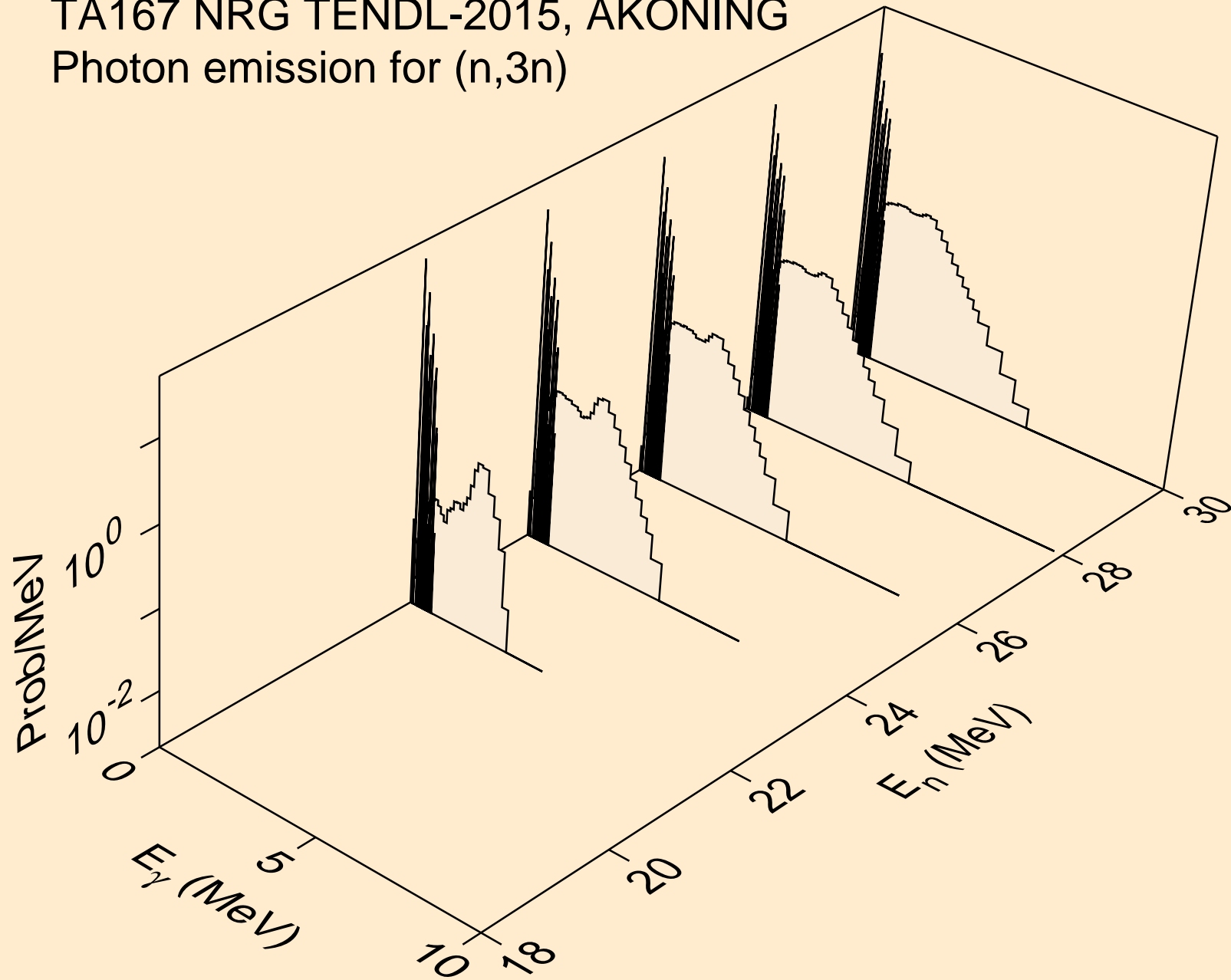

TA167 NRG TENDL-2015, AKONING  
Photon emission for (n,n\*)a

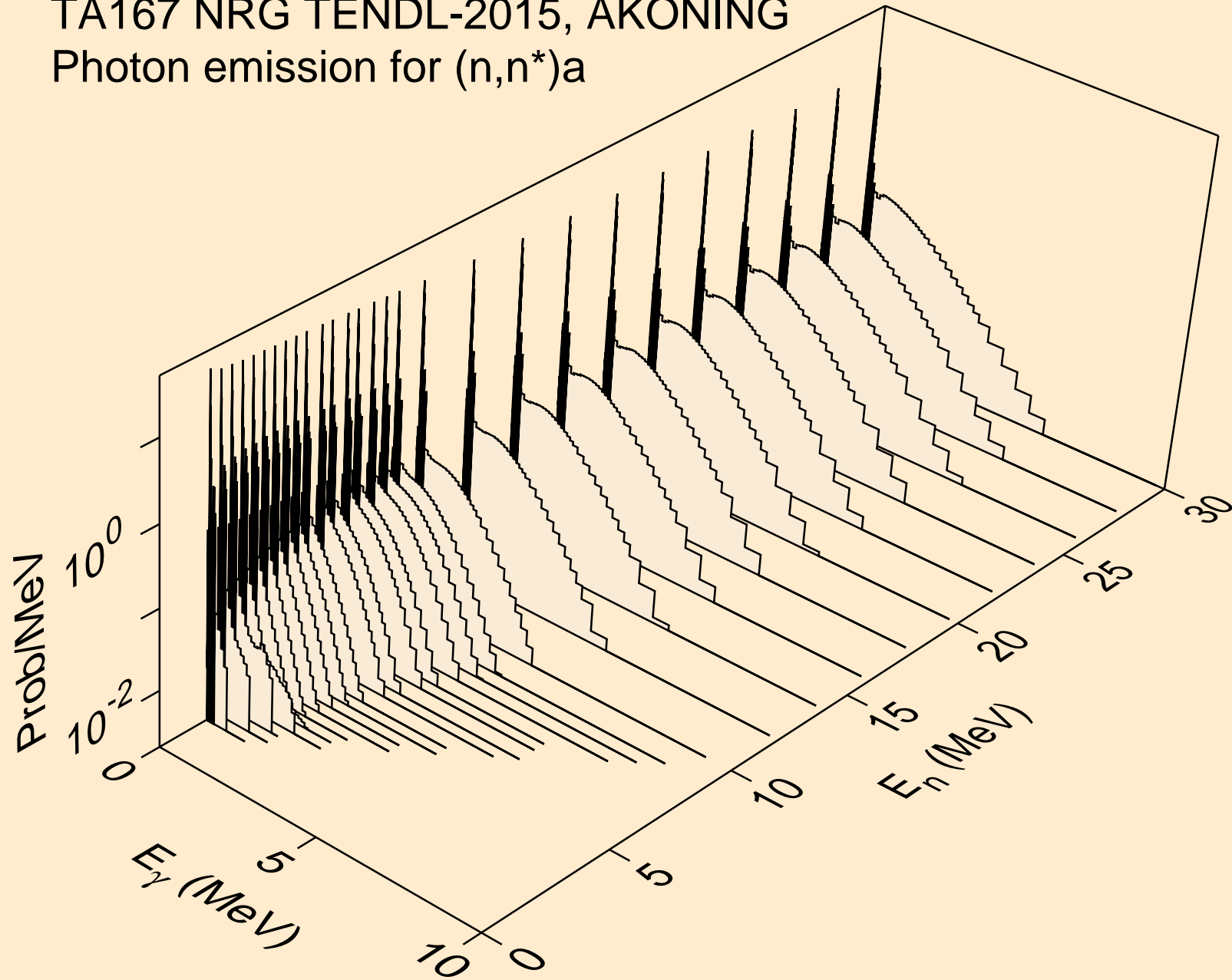

TA167 NRG TENDL-2015, AKONING  
Photon emission for (n,n\*)3a

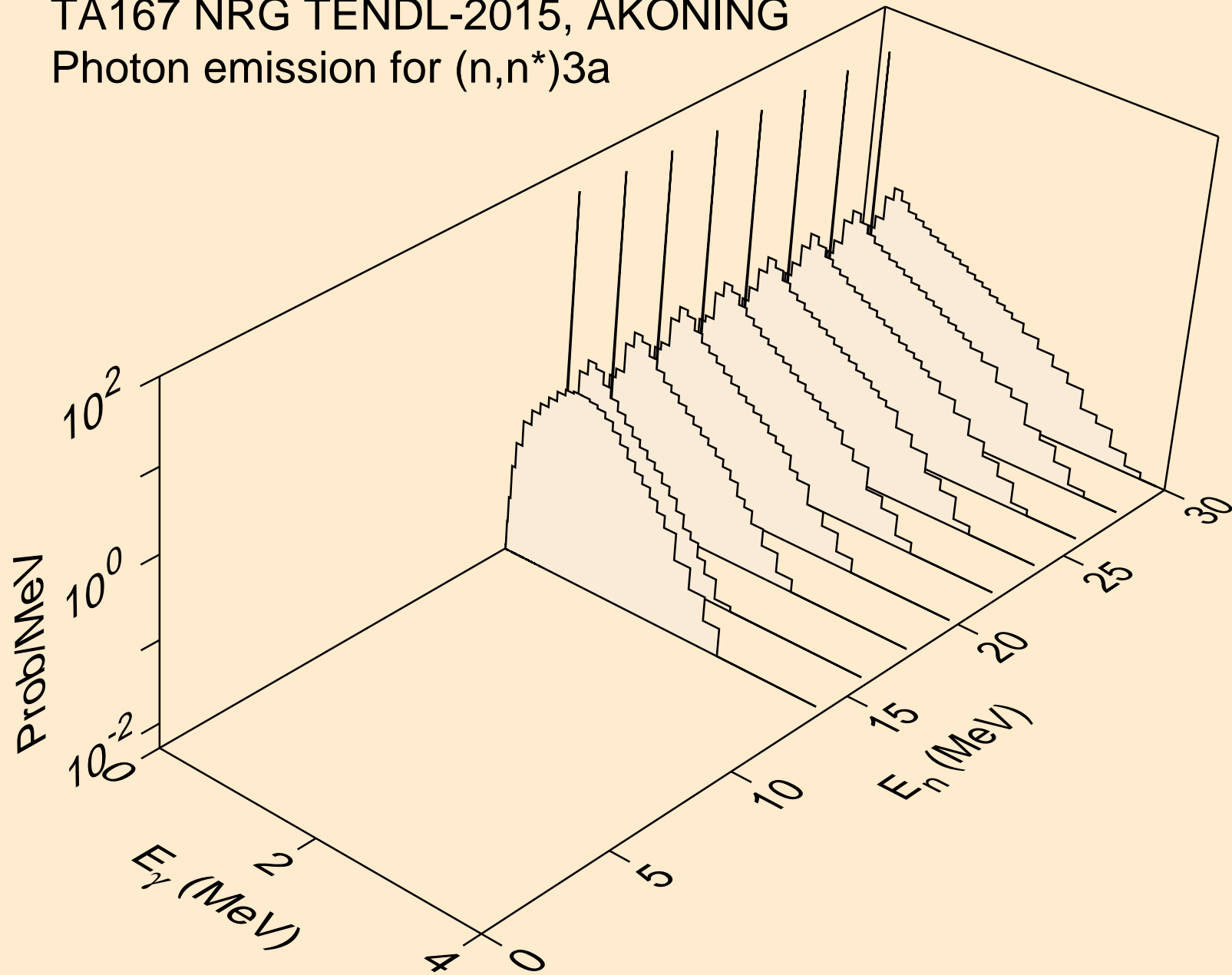

TA167 NRG TENDL-2015, AKONING  
Photon emission for (n,2n)a

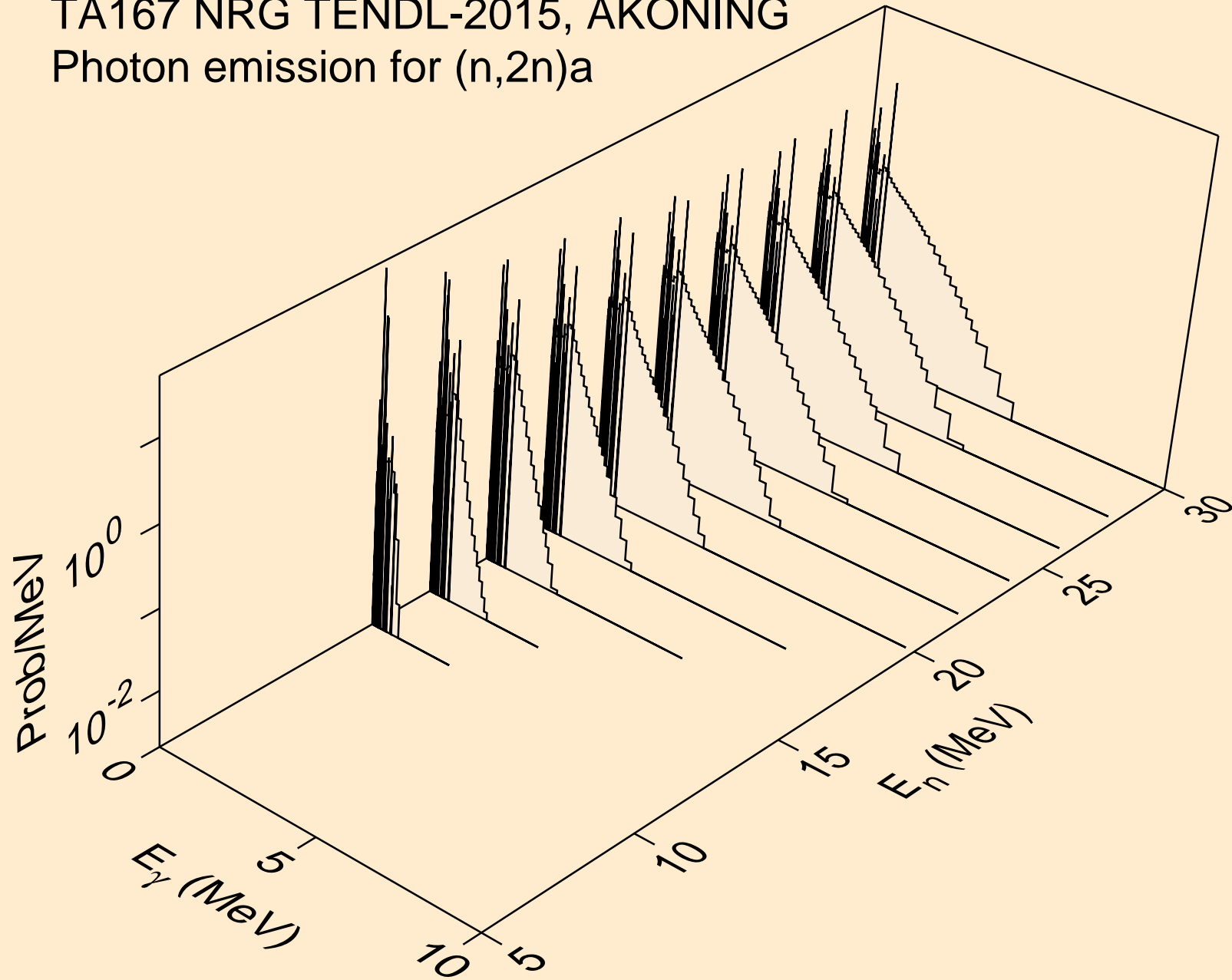



TA167 NRG TENDL-2015, AKONING  
Photon emission for (n,3n)a

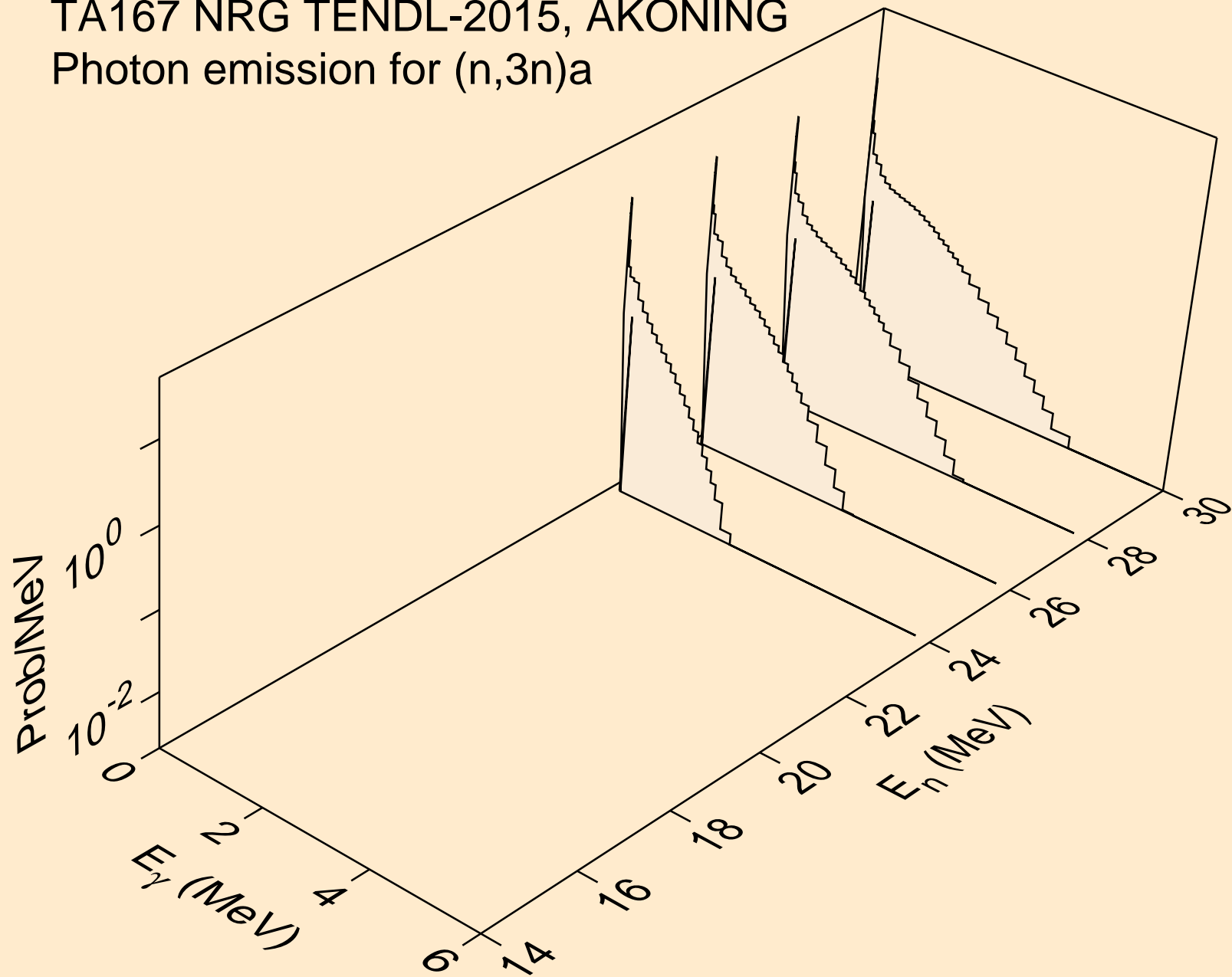

TA167 NRG TENDL-2015, AKONING  
Photon emission for (n,n\*)p

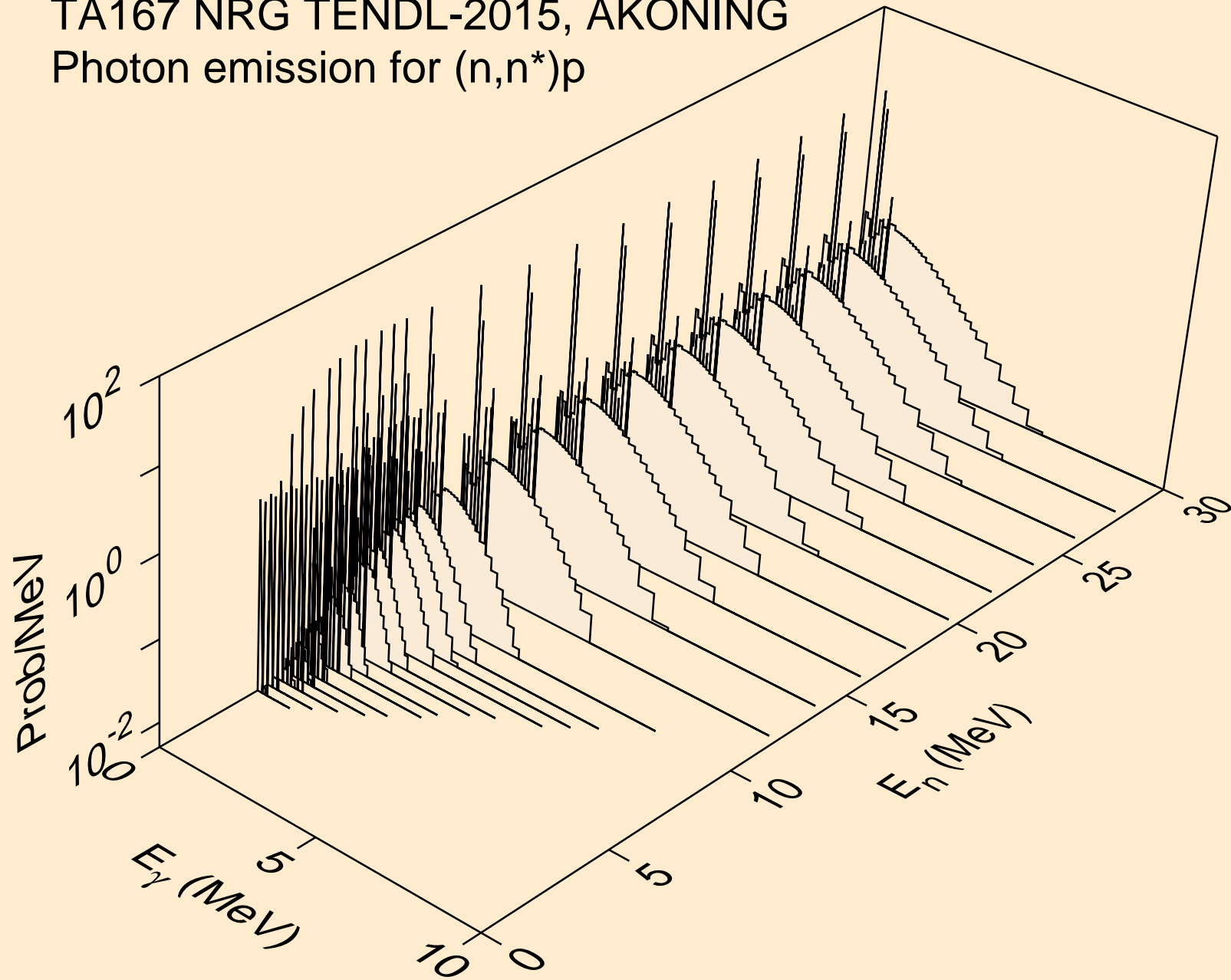

TA167 NRG TENDL-2015, AKONING  
Photon emission for (n,n\*)2a

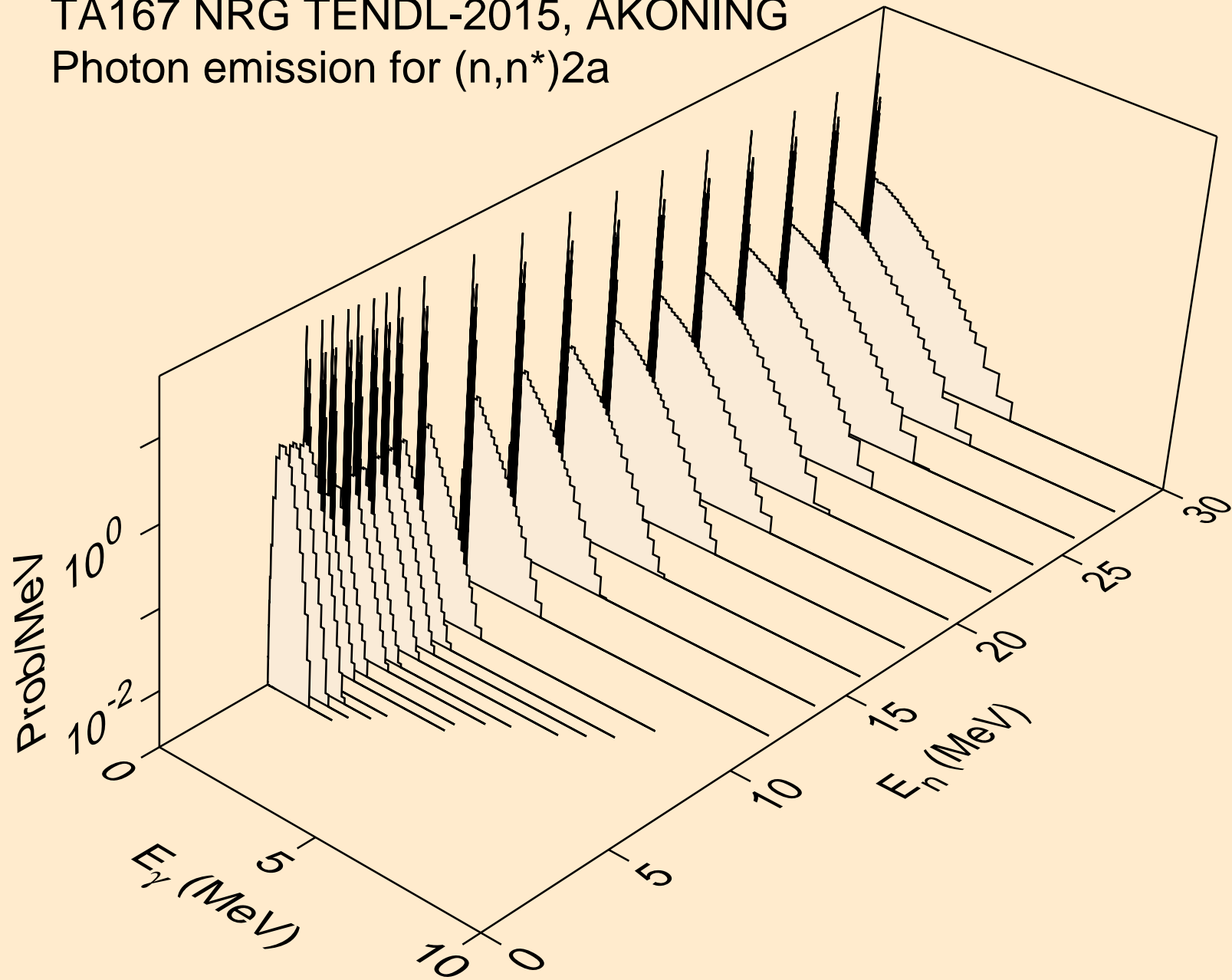

TA167 NRG TENDL-2015, AKONING  
Photon emission for (n,2n)2a

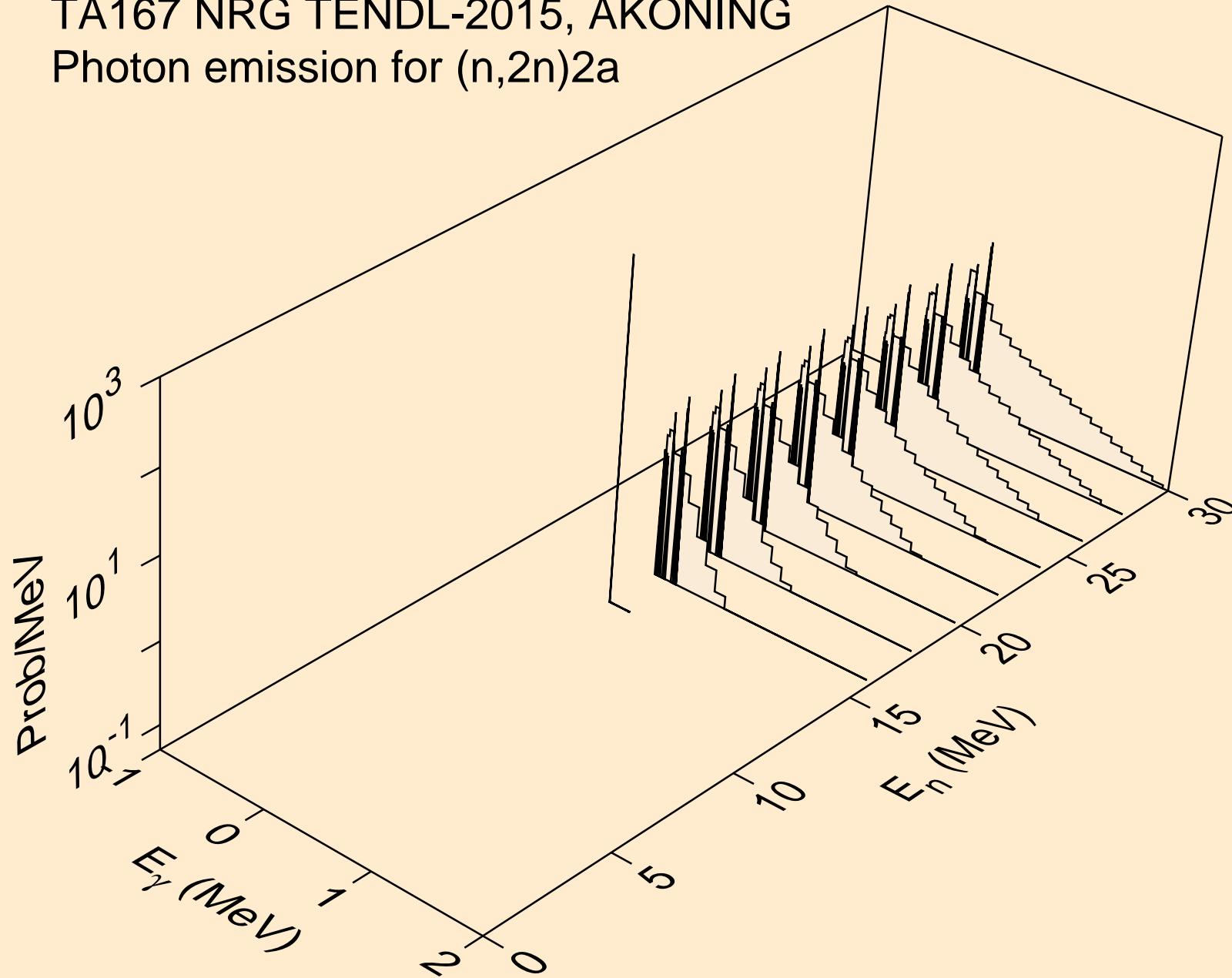

TA167 NRG TENDL-2015, AKONING  
Photon emission for (n,n\*)d

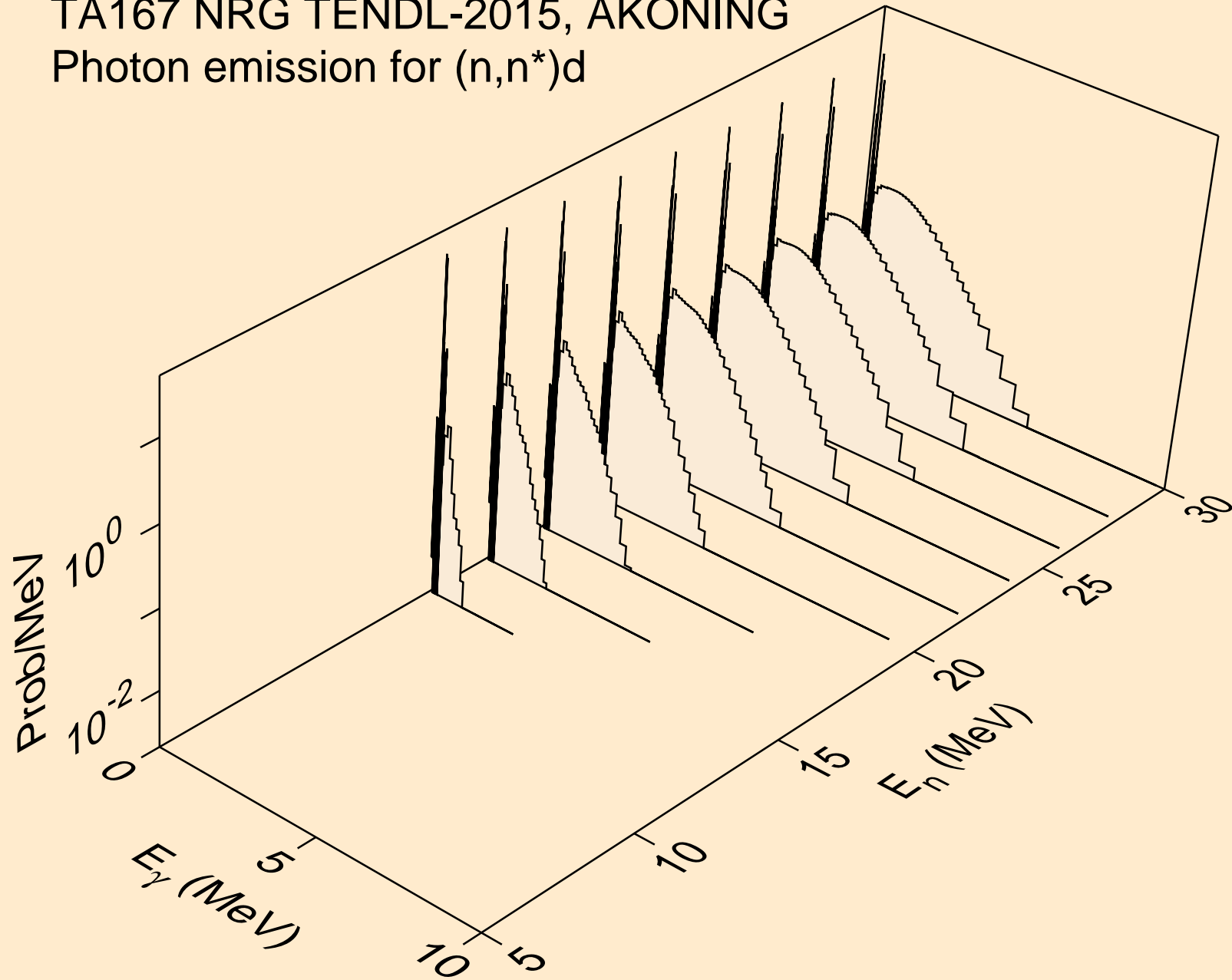

TA167 NRG TENDL-2015, AKONING  
Photon emission for (n,n\*)t

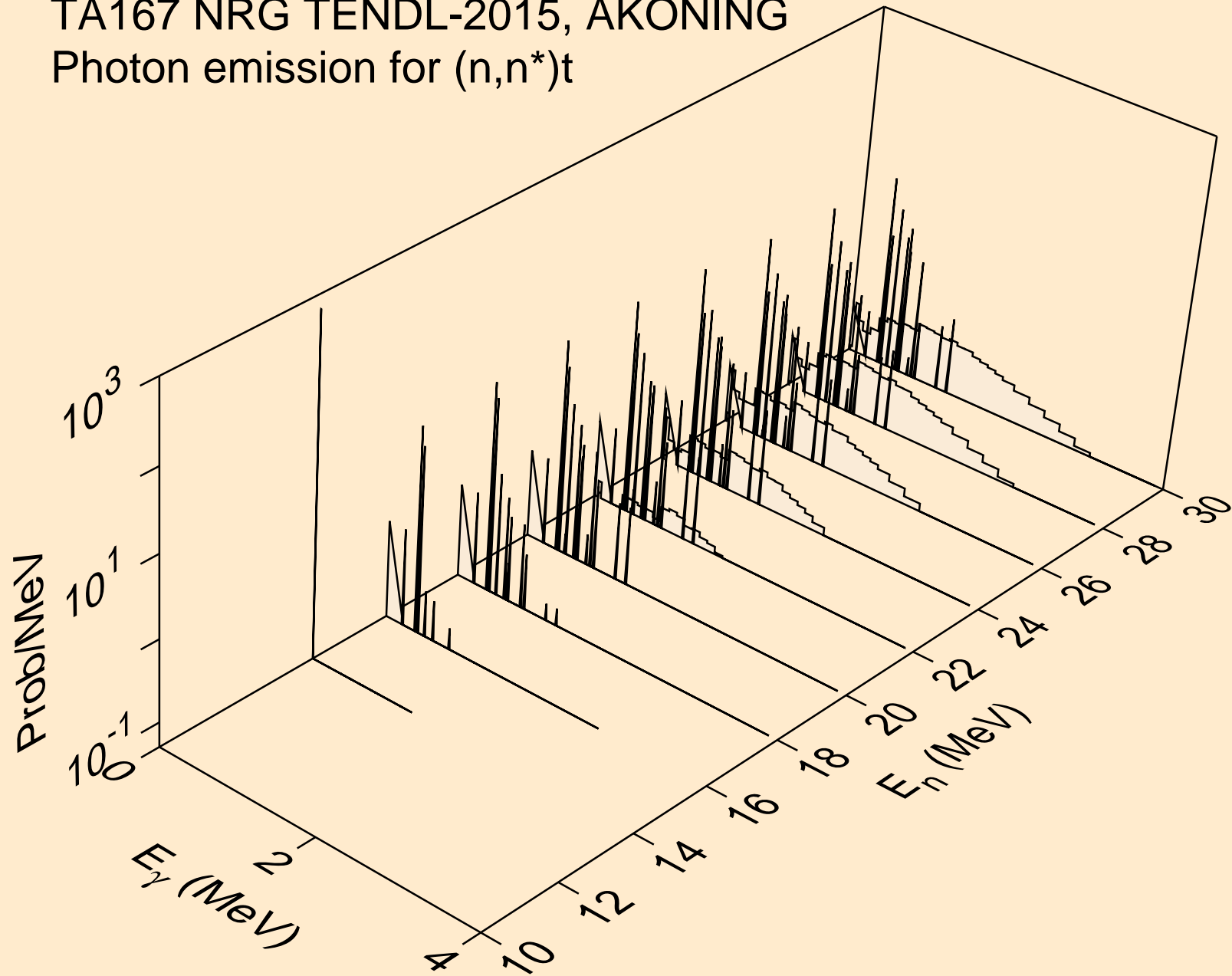

TA167 NRG TENDL-2015, AKONING  
Photon emission for (n,n\*)he3

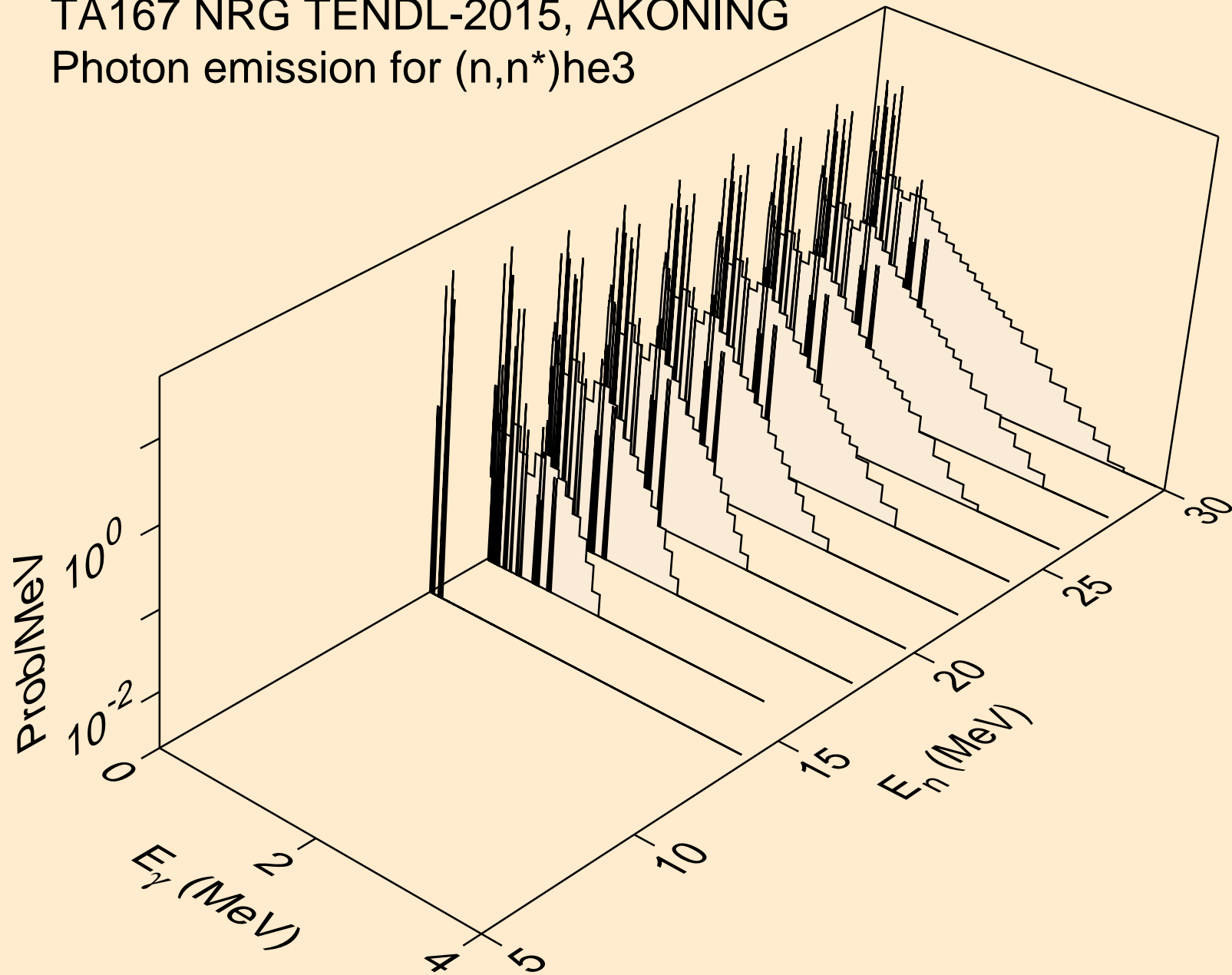

TA167 NRG TENDL-2015, AKONING  
Photon emission for (n,4n)

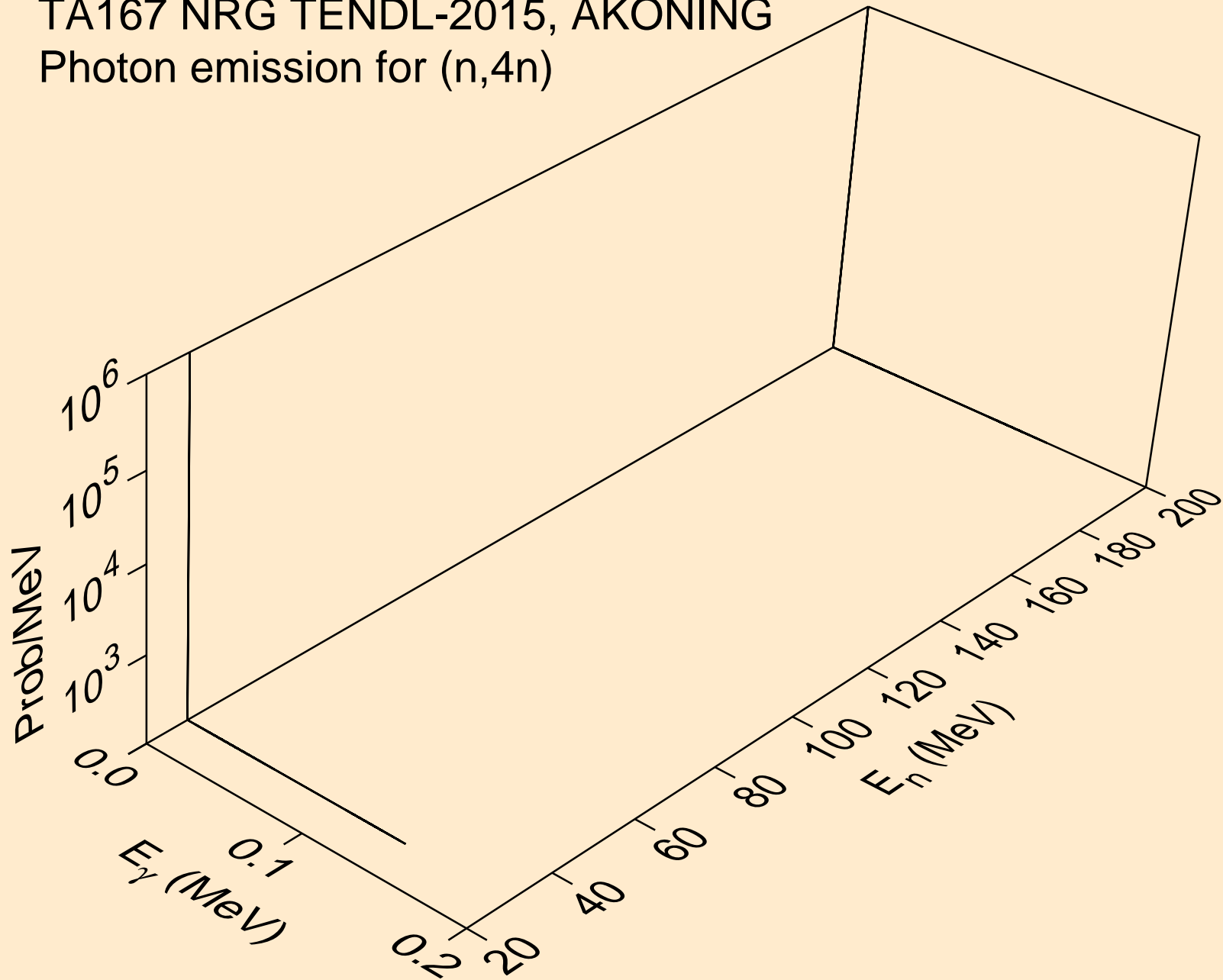



TA167 NRG TENDL-2015, AKONING  
Photon emission for (n,2np)

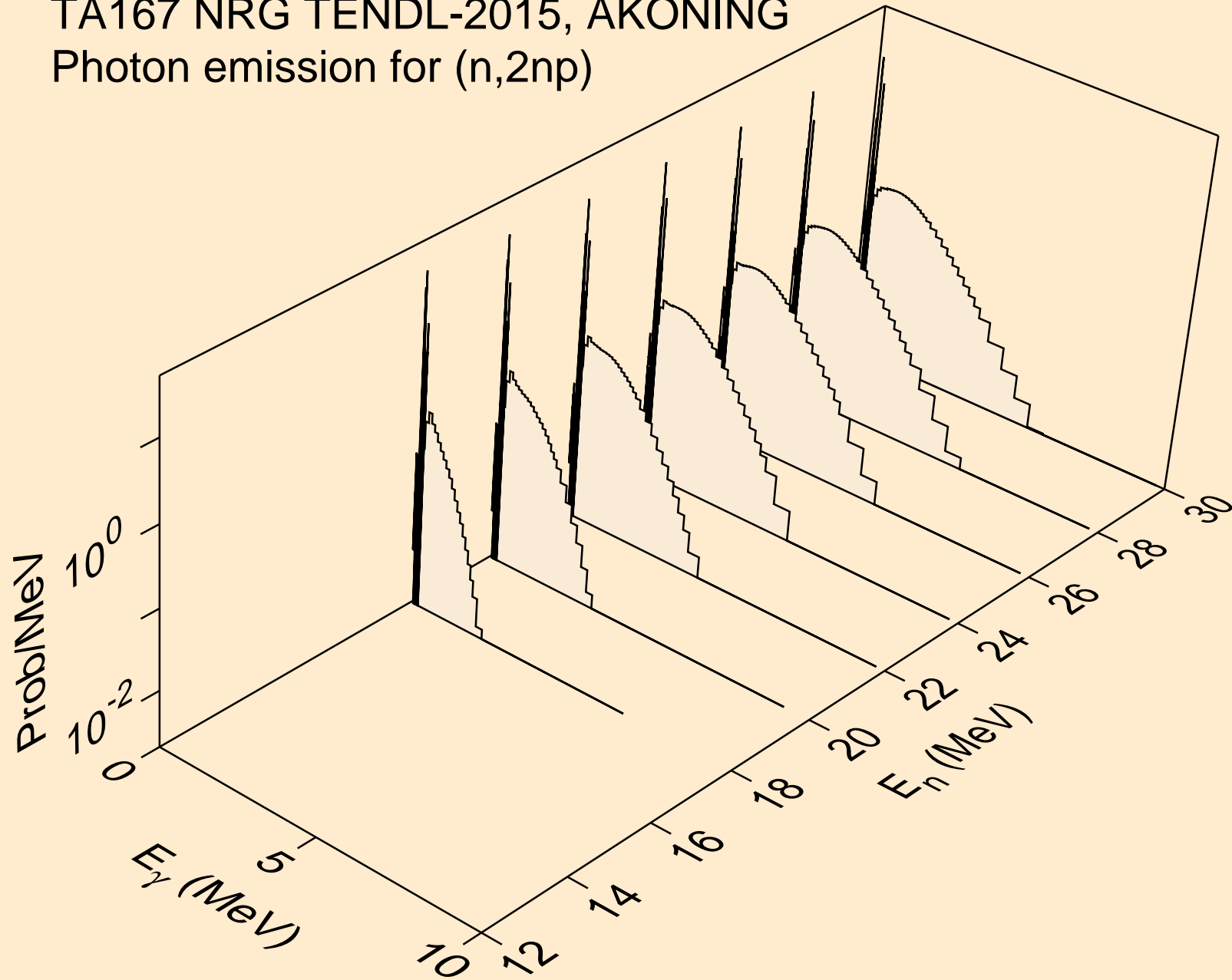

TA167 NRG TENDL-2015, AKONING  
Photon emission for (n,3np)

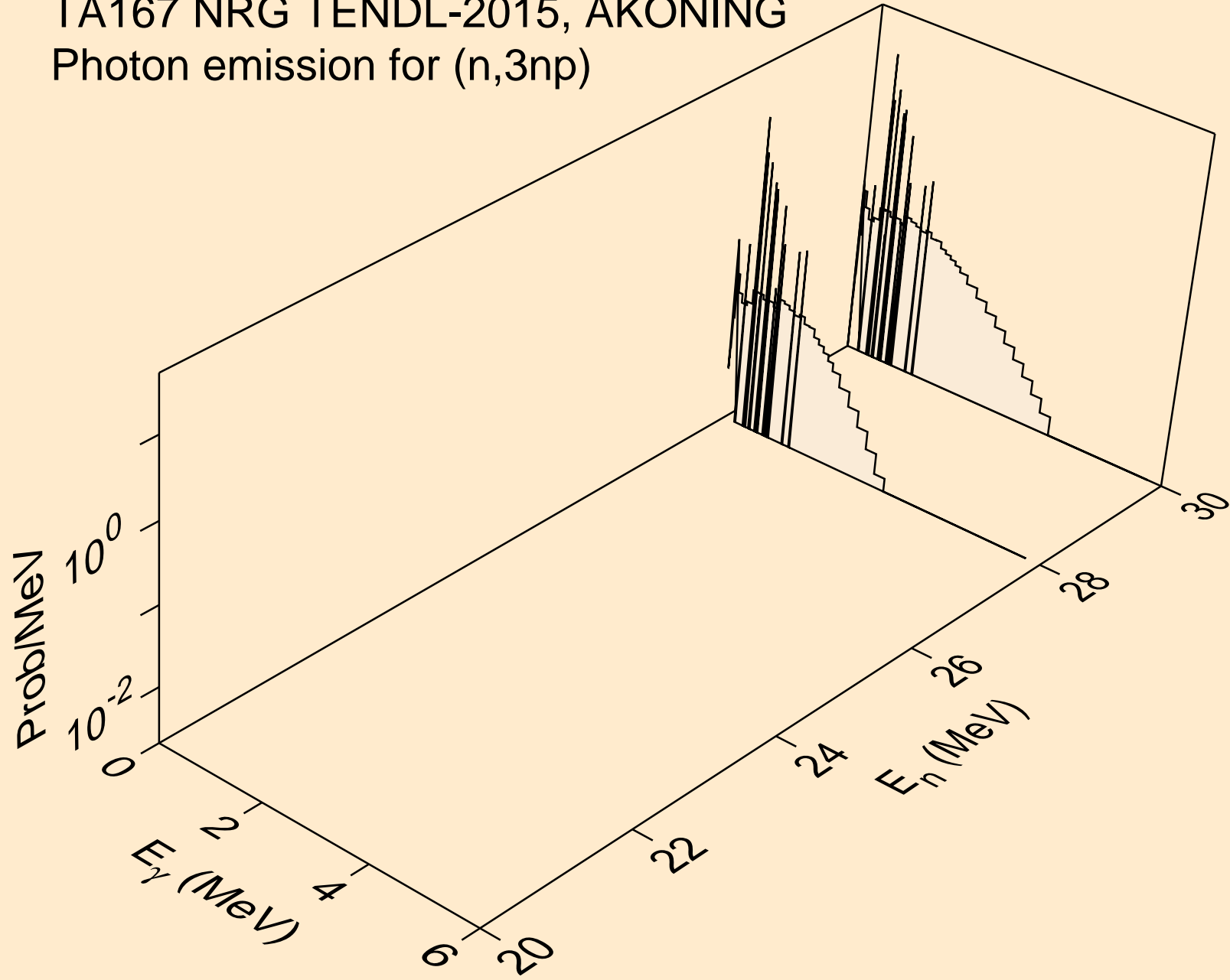

TA167 NRG TENDL-2015, AKONING  
Photon emission for (n,2np)

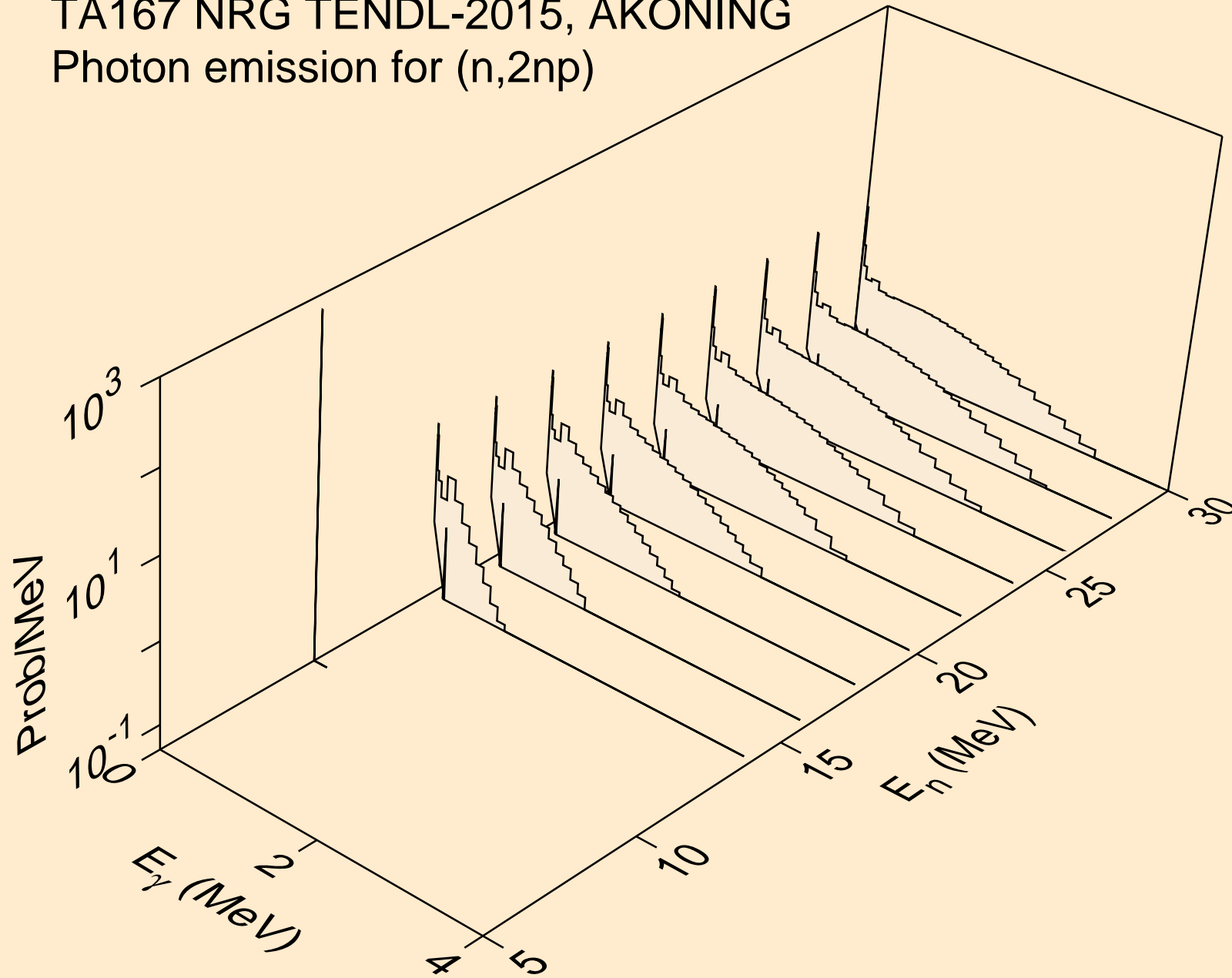

TA167 NRG TENDL-2015, AKONING  
Photon emission for (n,npa)

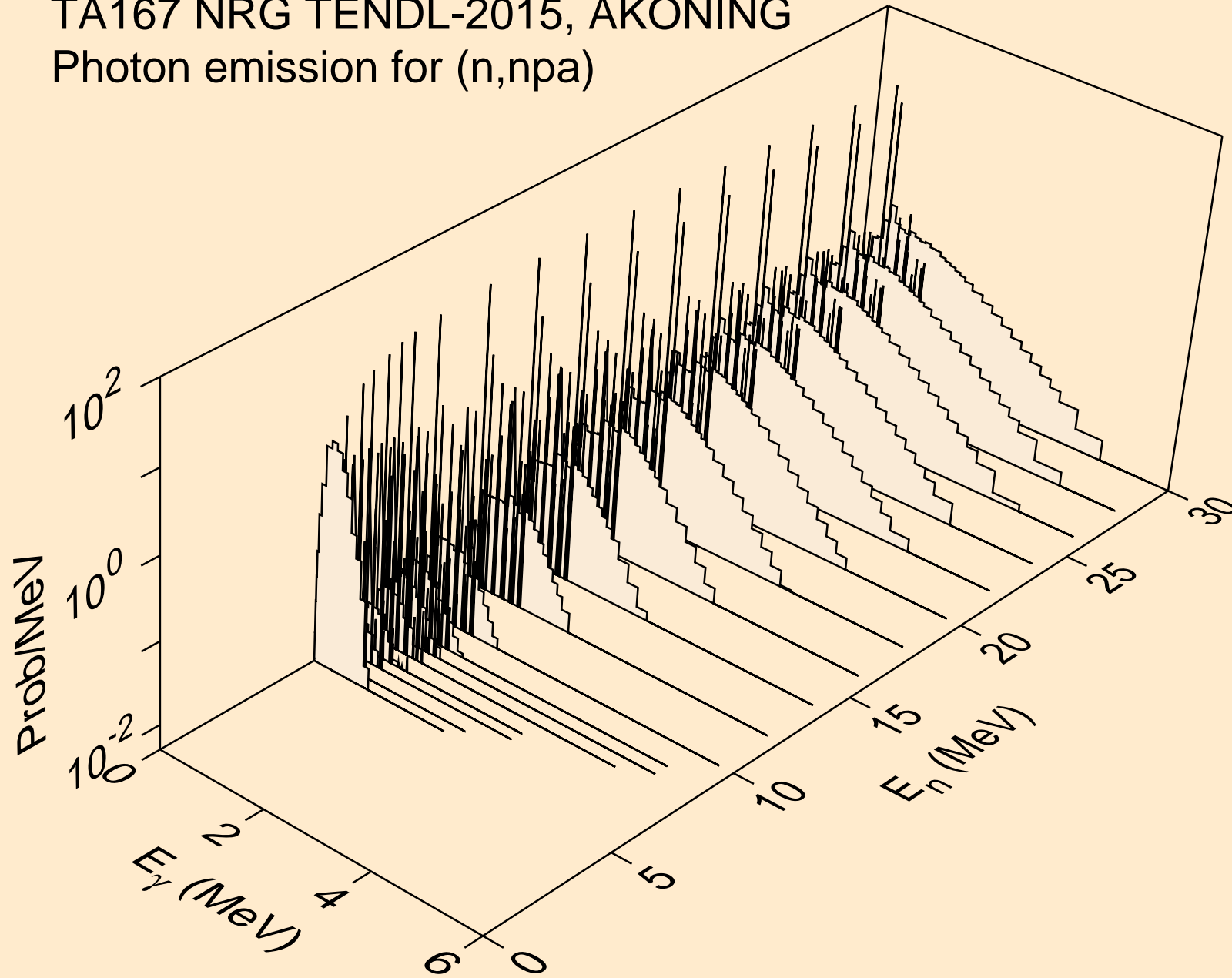

TA167 NRG TENDL-2015, AKONING  
Photon emission for (n,n\*c)

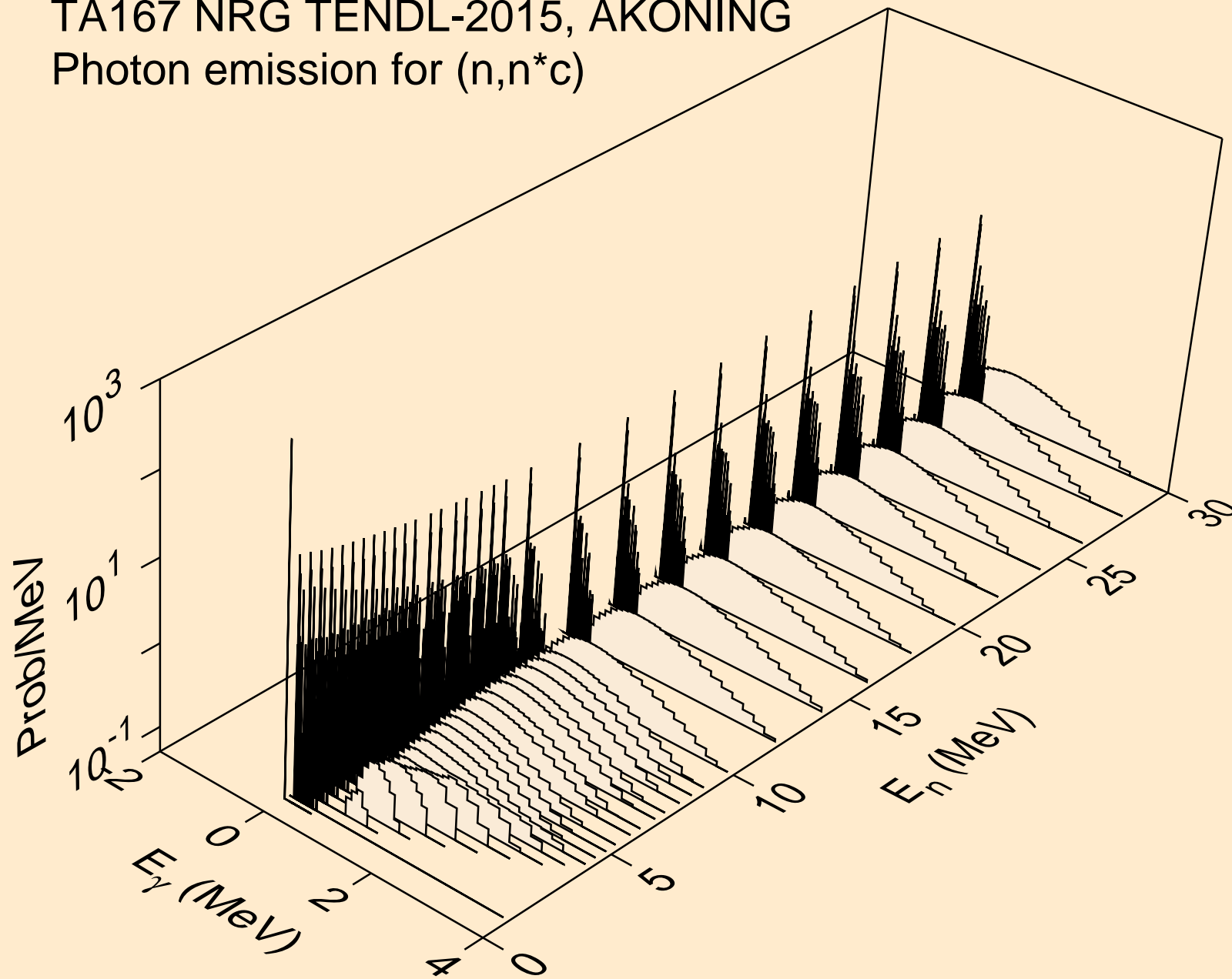

TA167 NRG TENDL-2015, AKONING  
Photon emission for (n,gma)

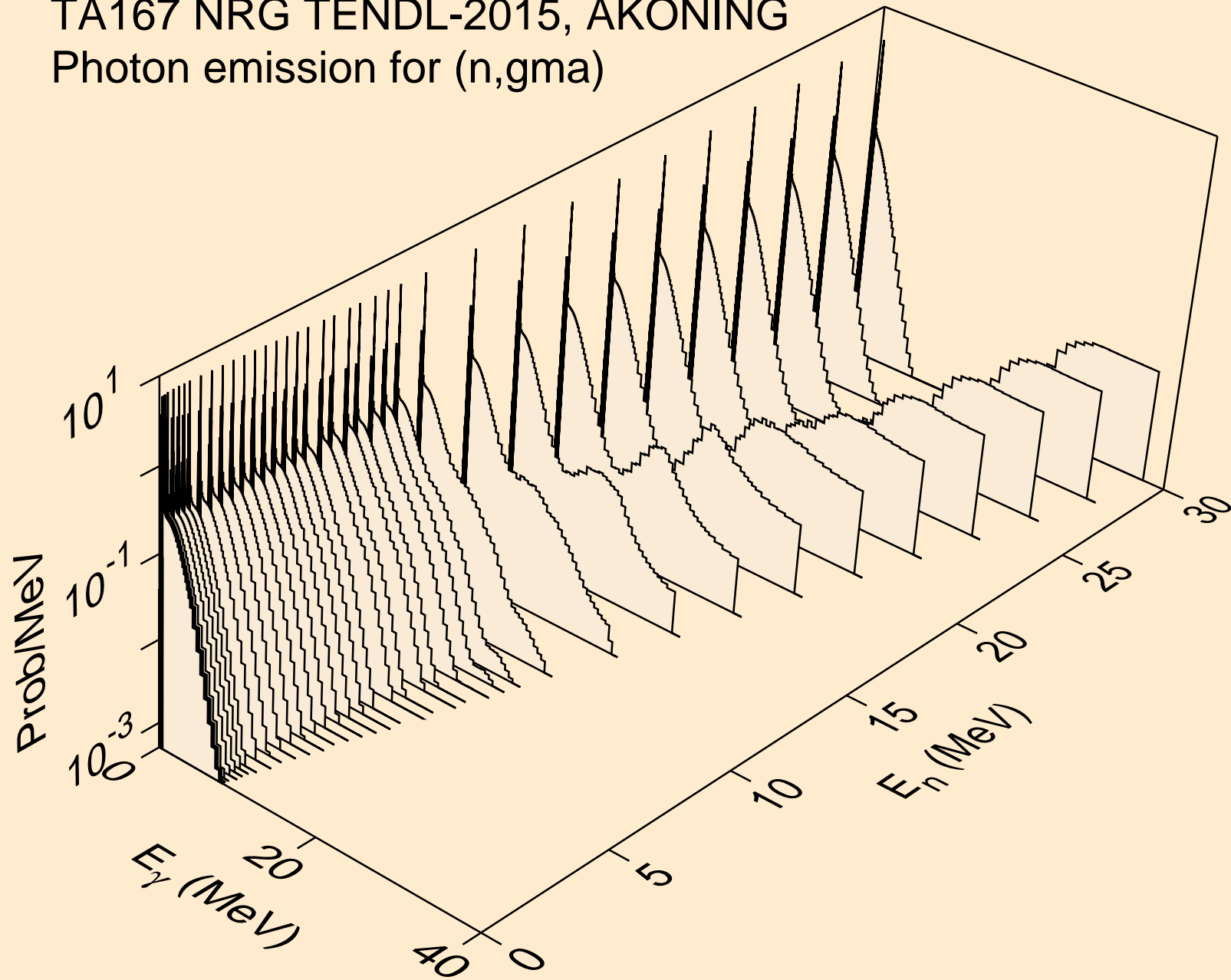

TA167 NRG TENDL-2015, AKONING  
Photon emission for (n,p)

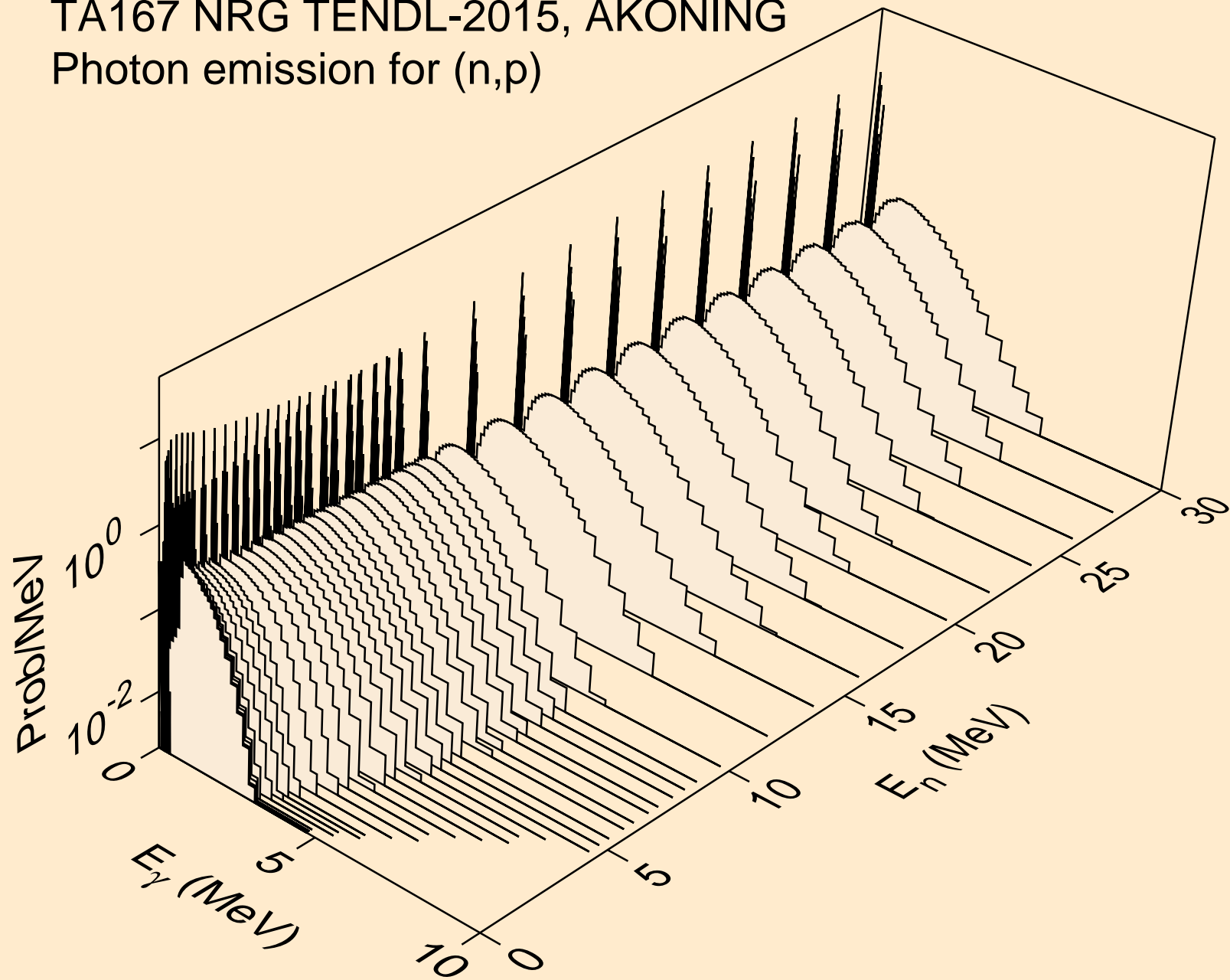

TA167 NRG TENDL-2015, AKONING  
Photon emission for (n,d)

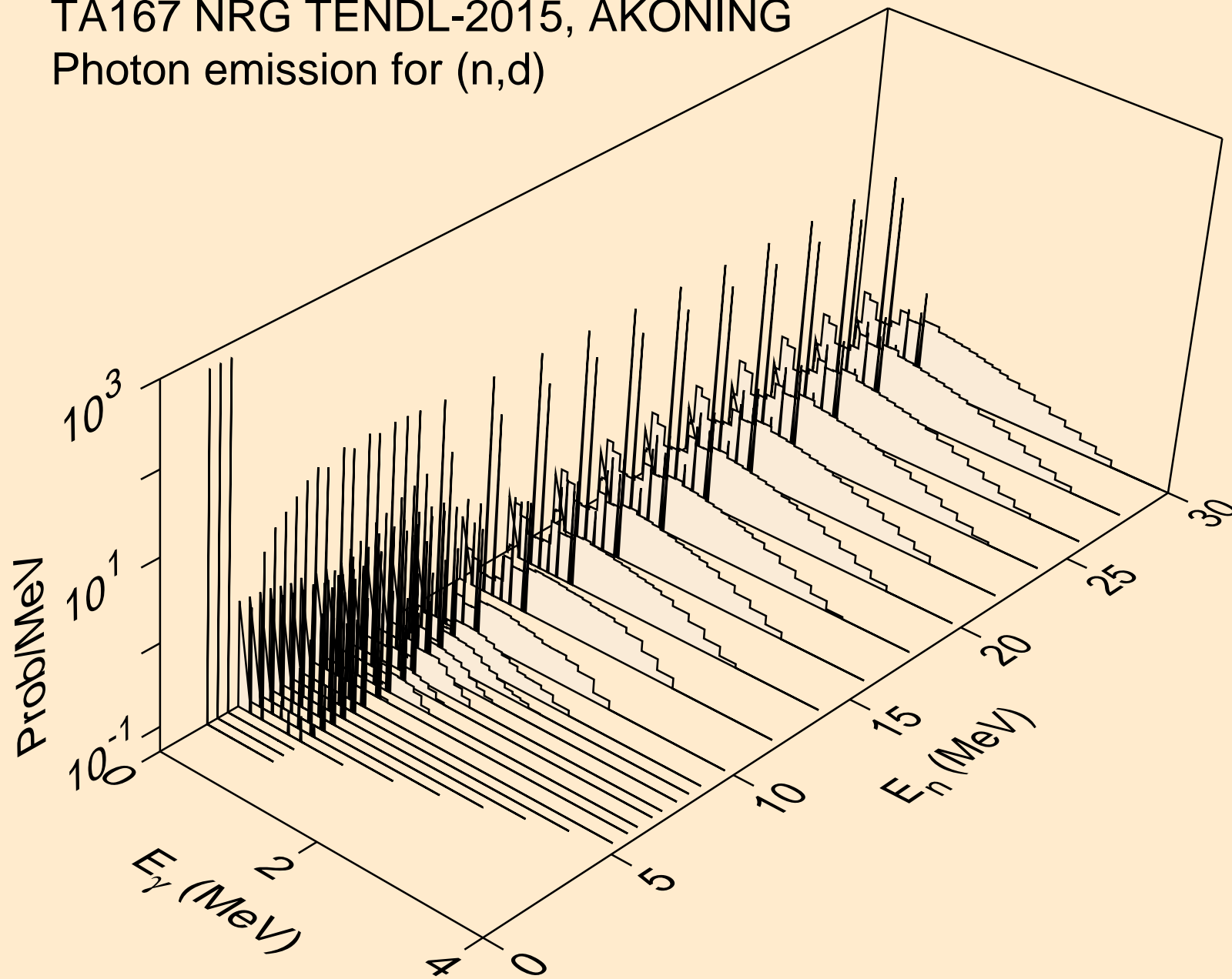



TA167 NRG TENDL-2015, AKONING  
Photon emission for (n,t)

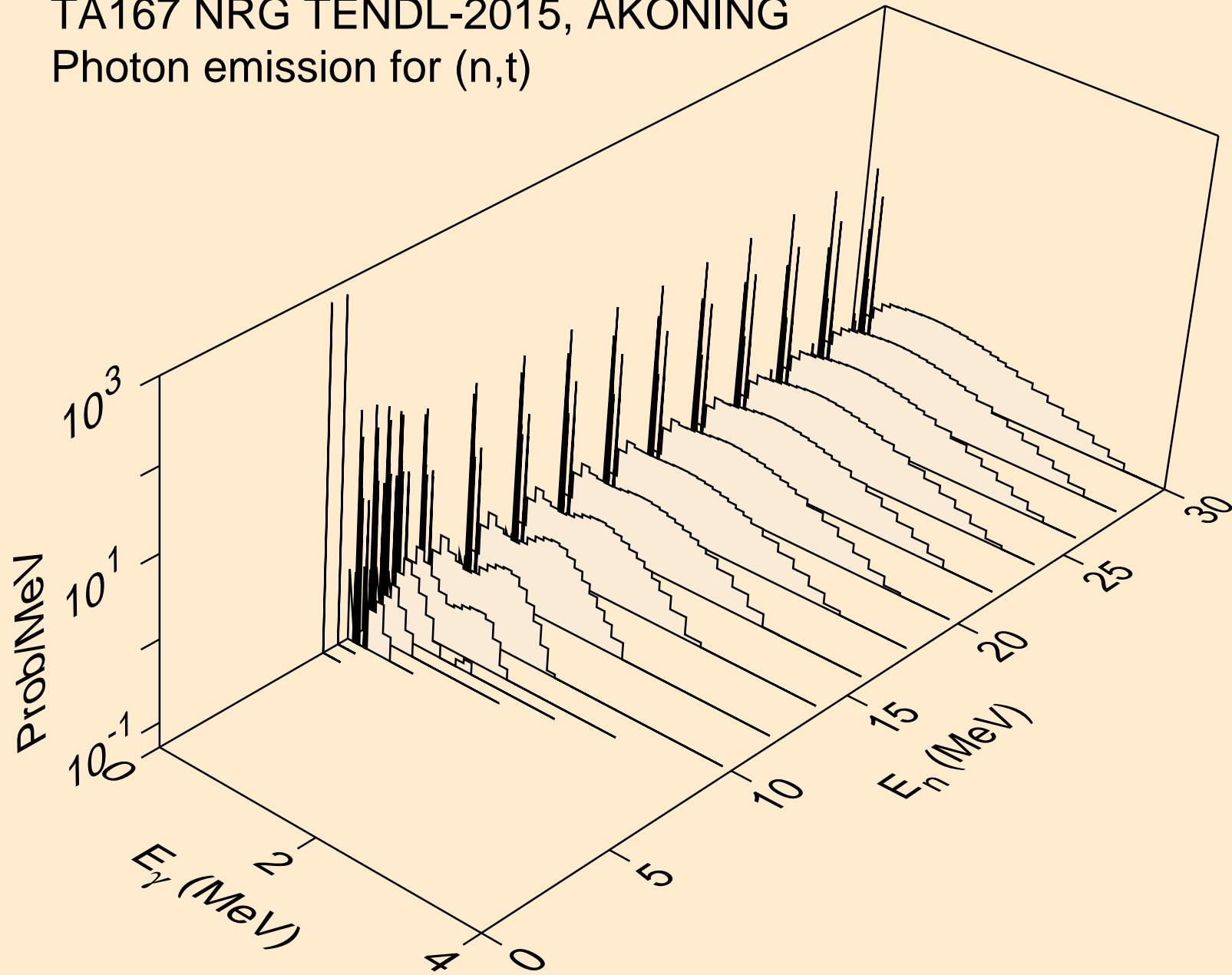

TA167 NRG TENDL-2015, AKONING  
Photon emission for (n,he3)

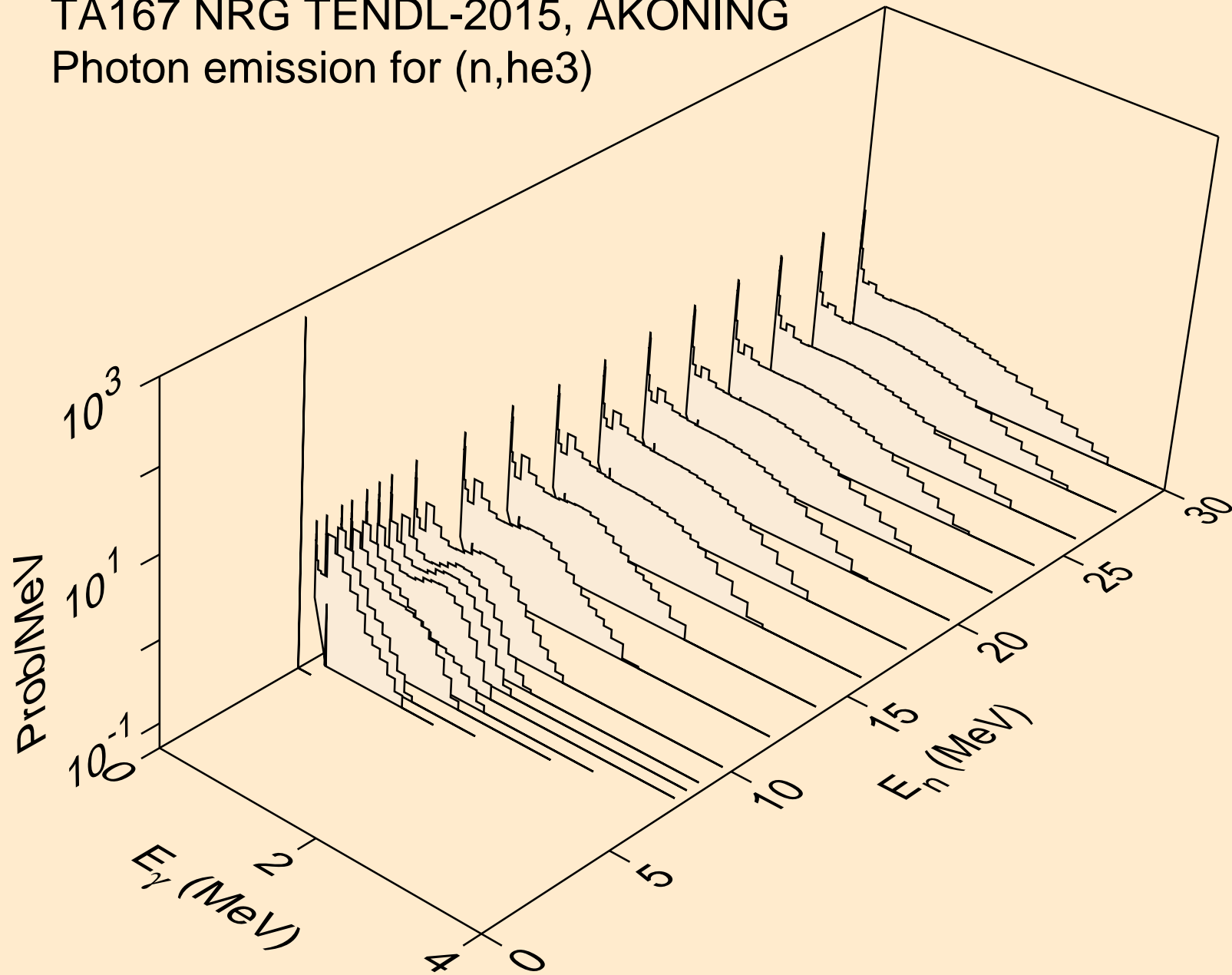

TA167 NRG TENDL-2015, AKONING  
Photon emission for (n,a)

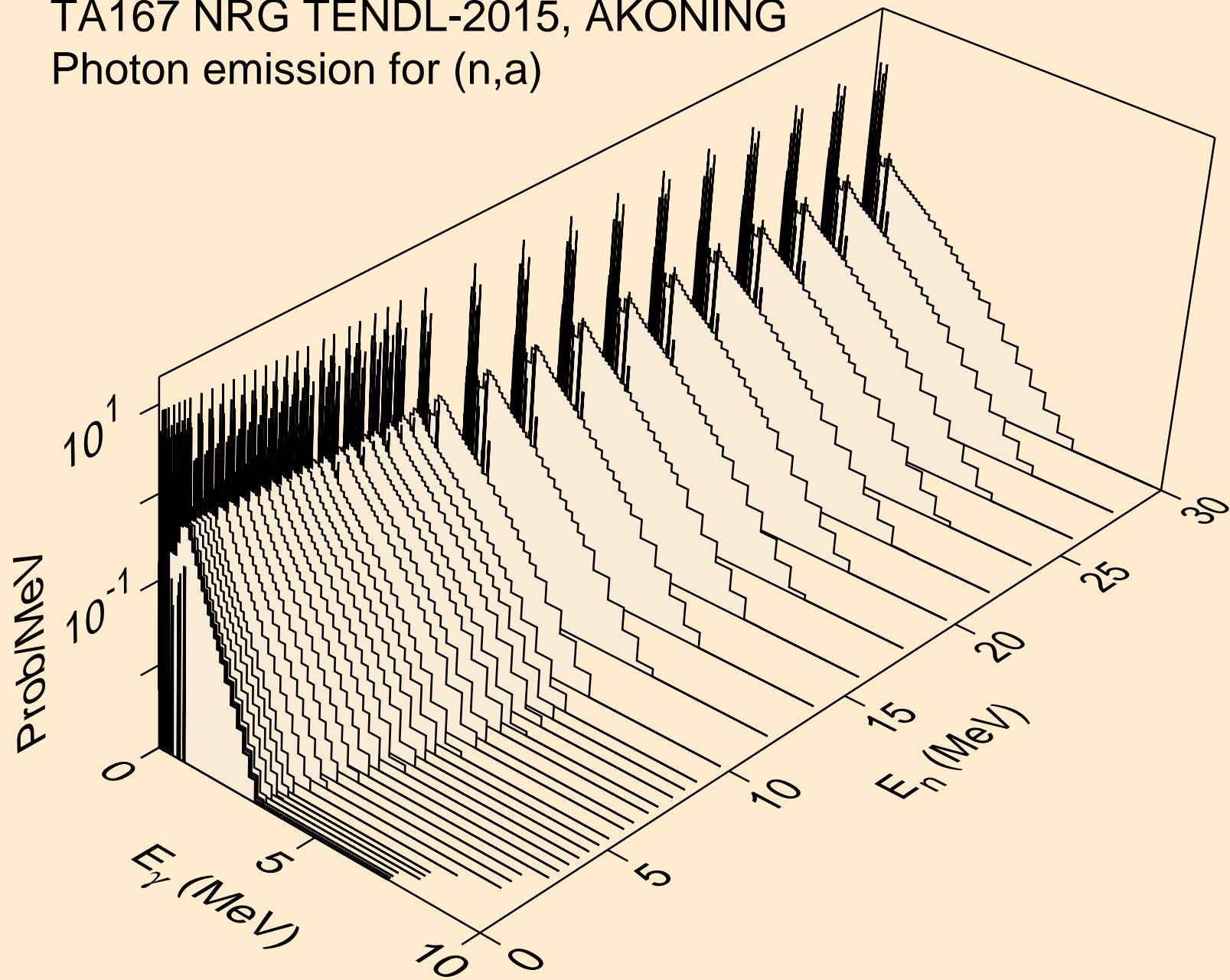

TA167 NRG TENDL-2015, AKONING  
Photon emission for (n,2a)

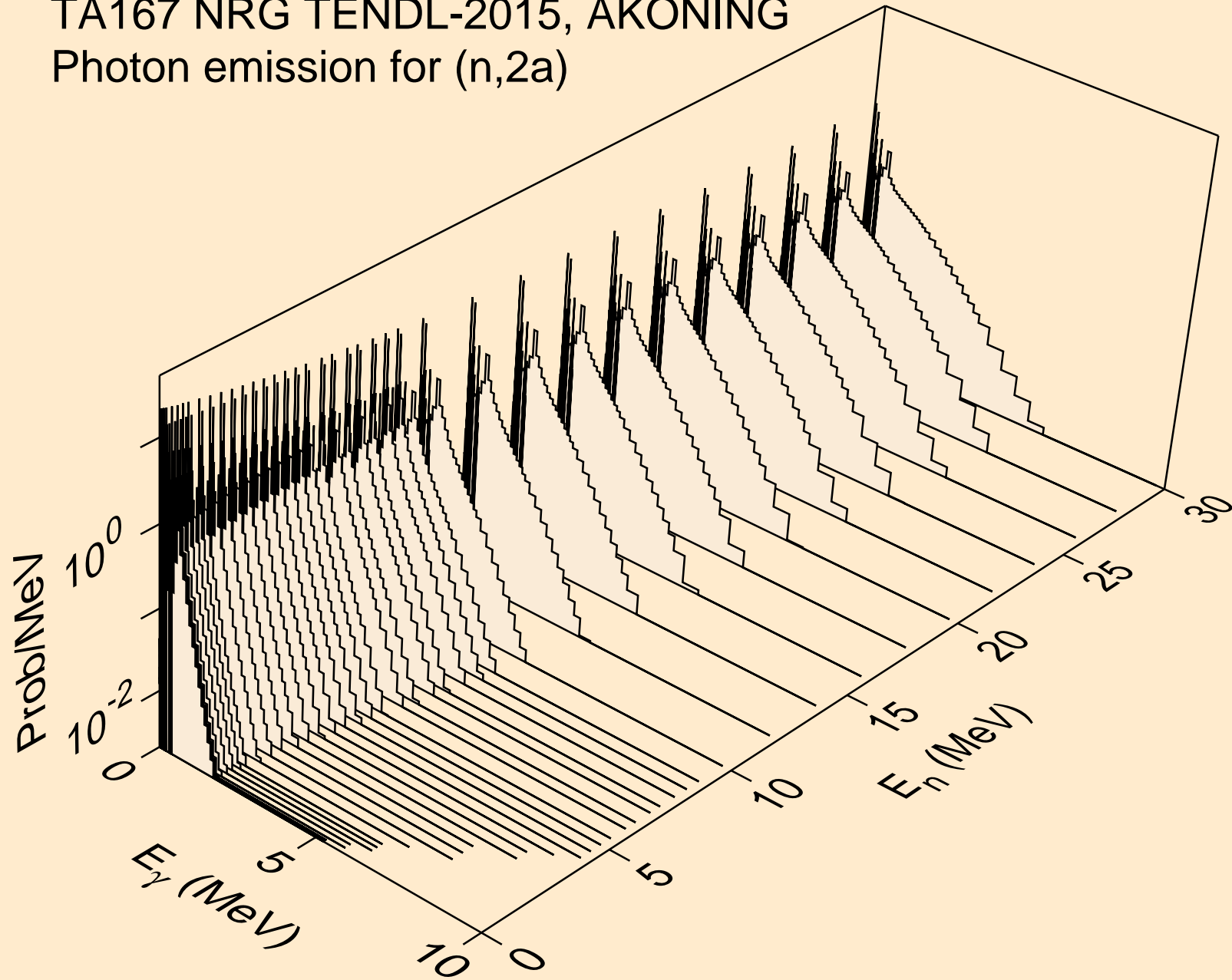

TA167 NRG TENDL-2015, AKONING  
Photon emission for (n,3a)

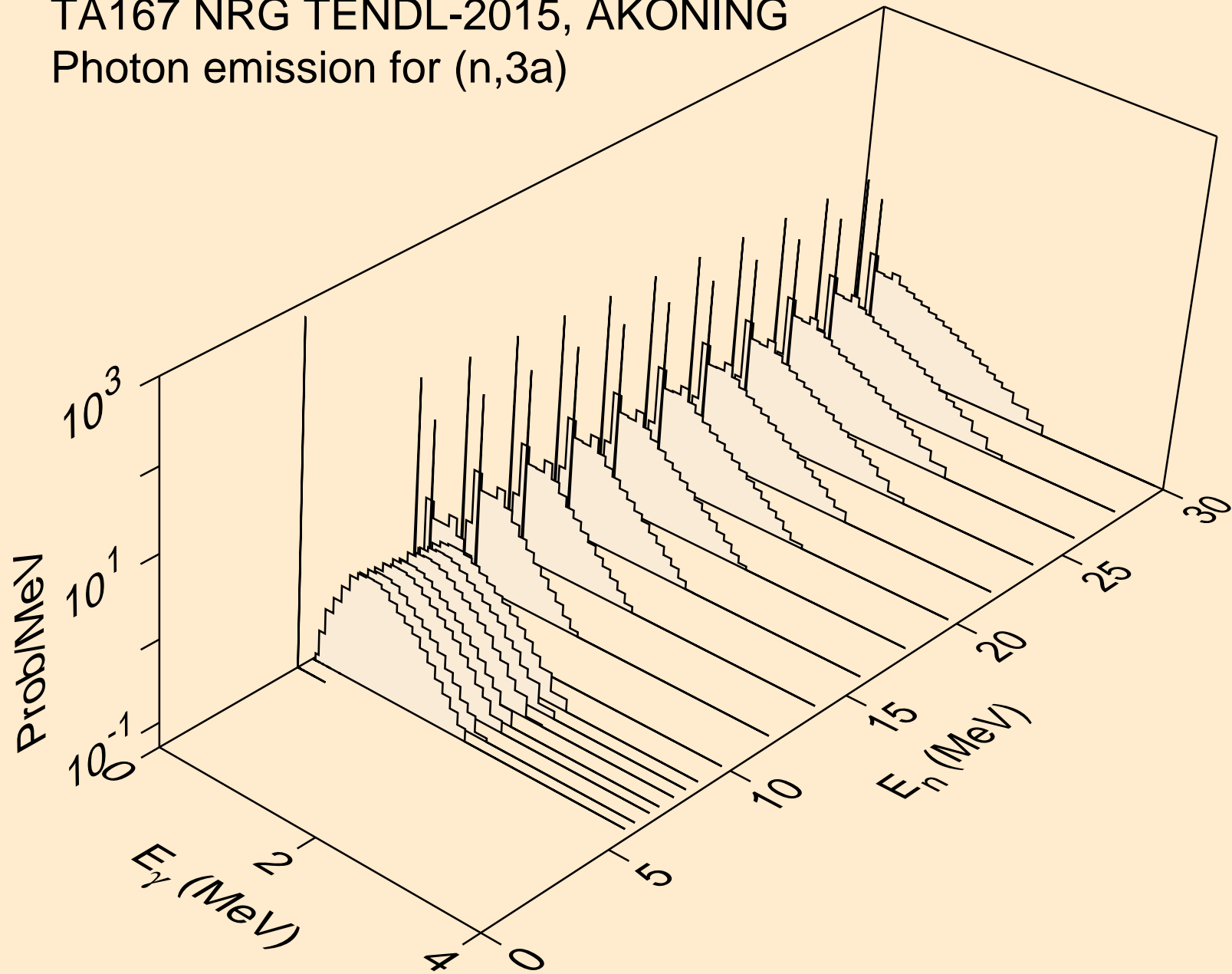

TA167 NRG TENDL-2015, AKONING  
Photon emission for (n,2p)

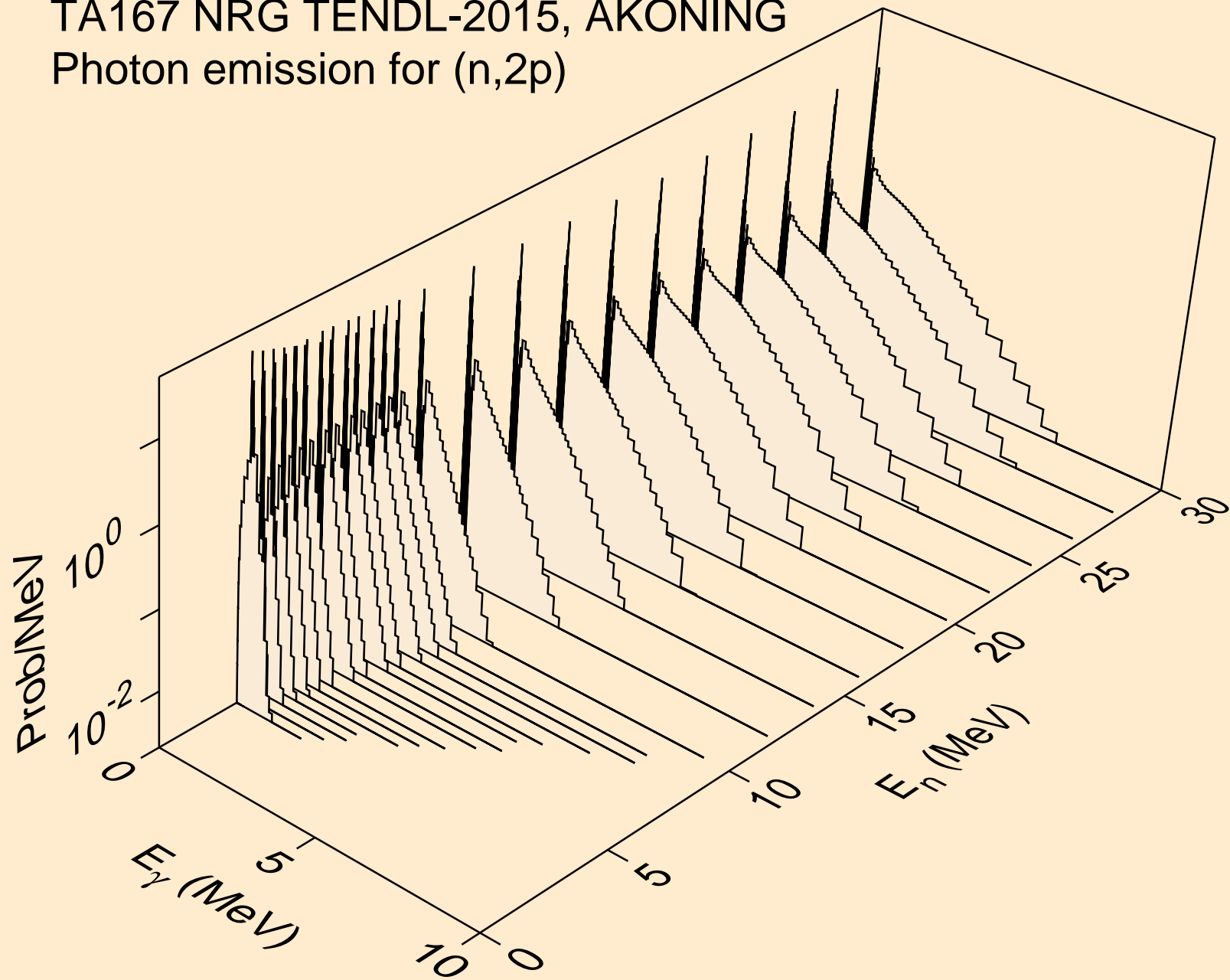

TA167 NRG TENDL-2015, AKONING  
Photon emission for (n,p $\alpha$ )

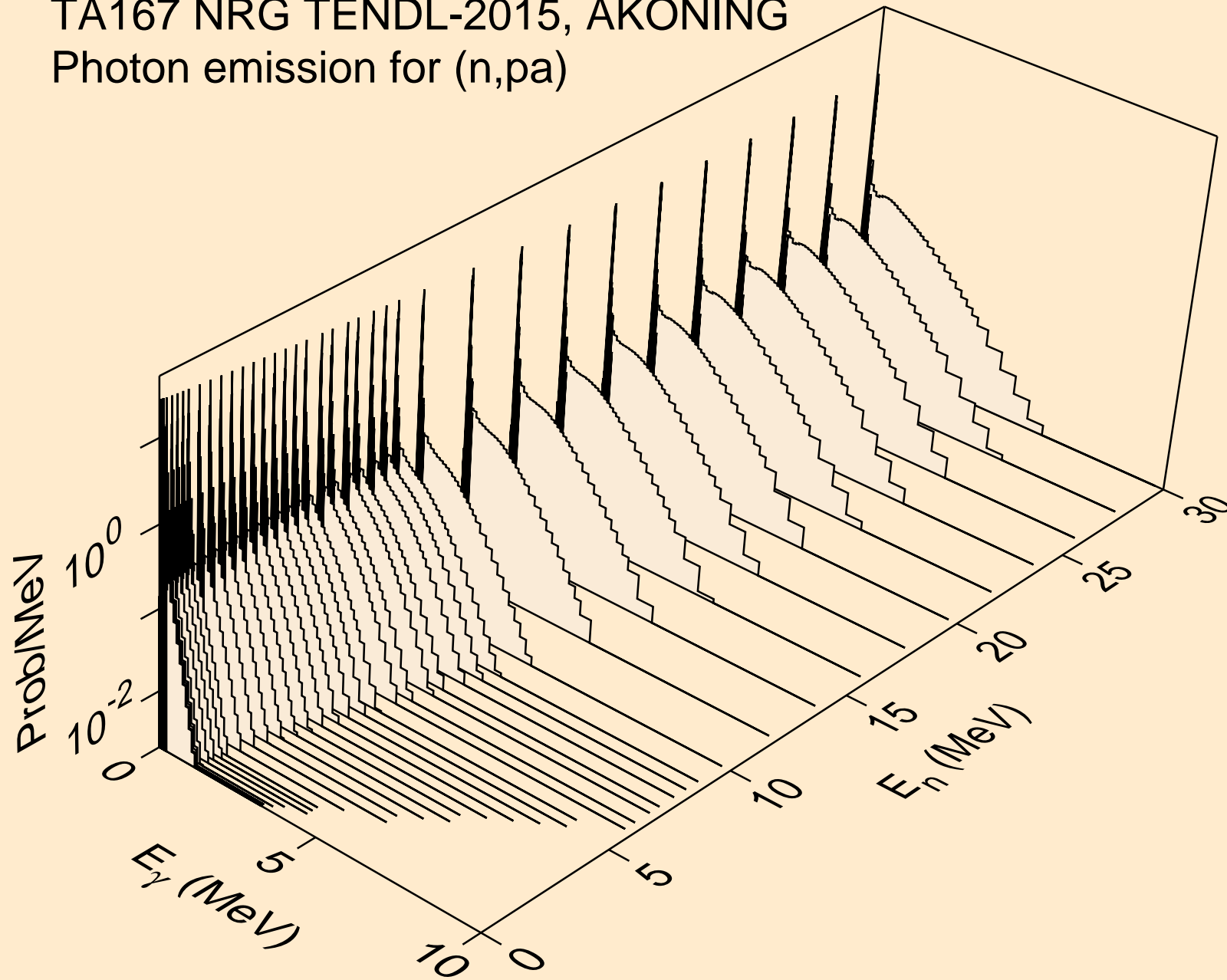

TA167 NRG TENDL-2015, AKONING  
Photon emission for (n,d2a)

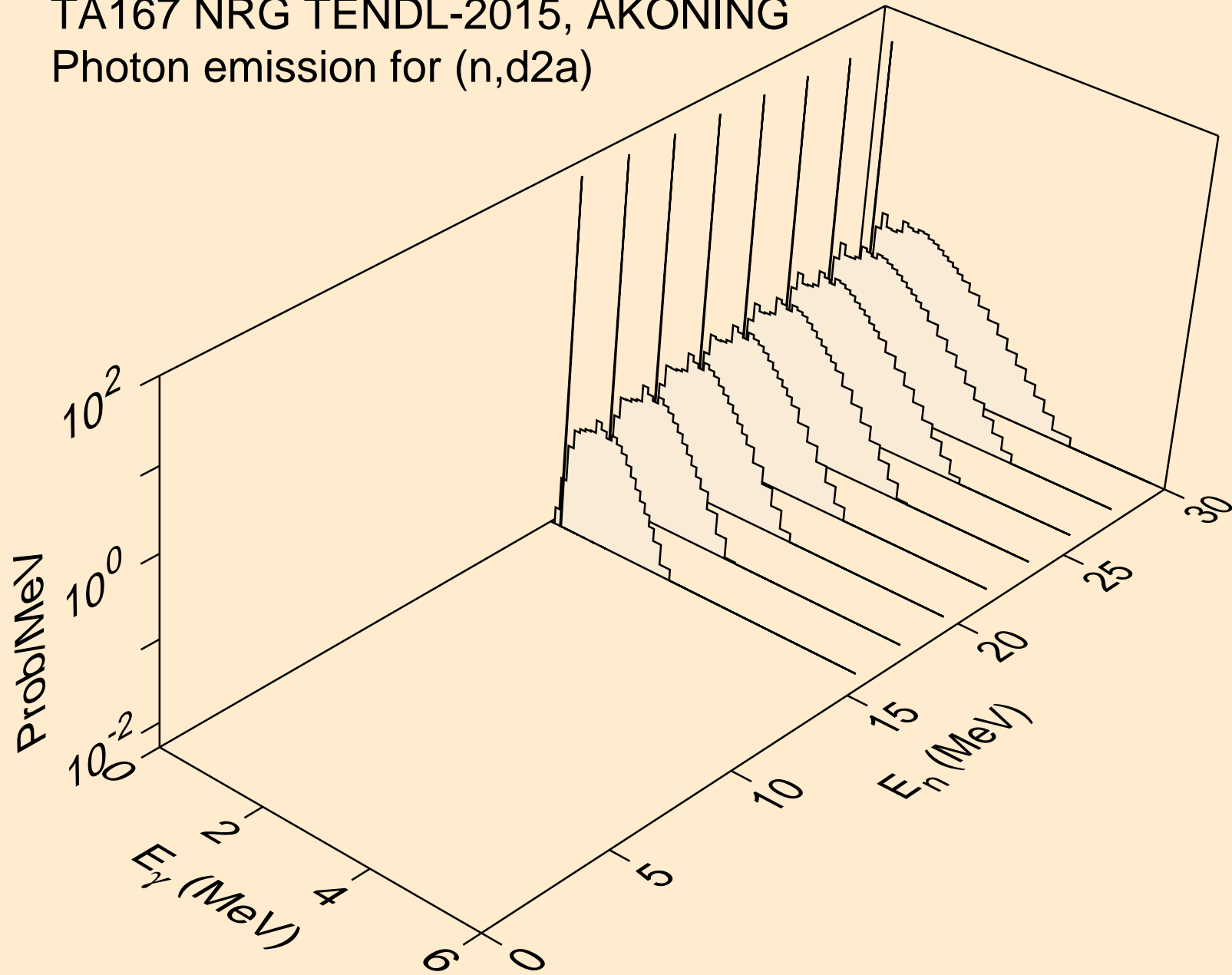



TA167 NRG TENDL-2015, AKONING  
Photon emission for (n,pd)

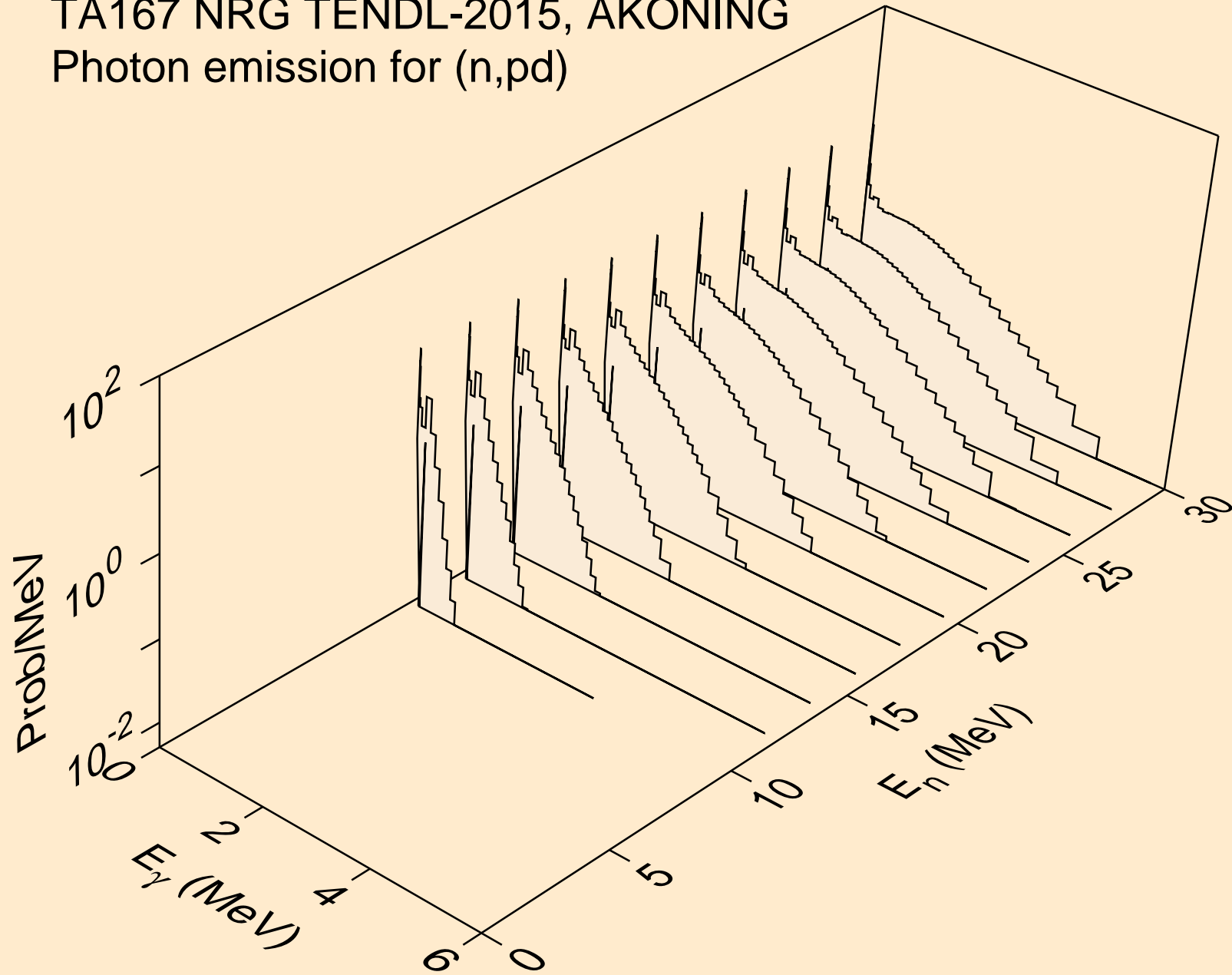

TA167 NRG TENDL-2015, AKONING  
Photon emission for (n,pt)

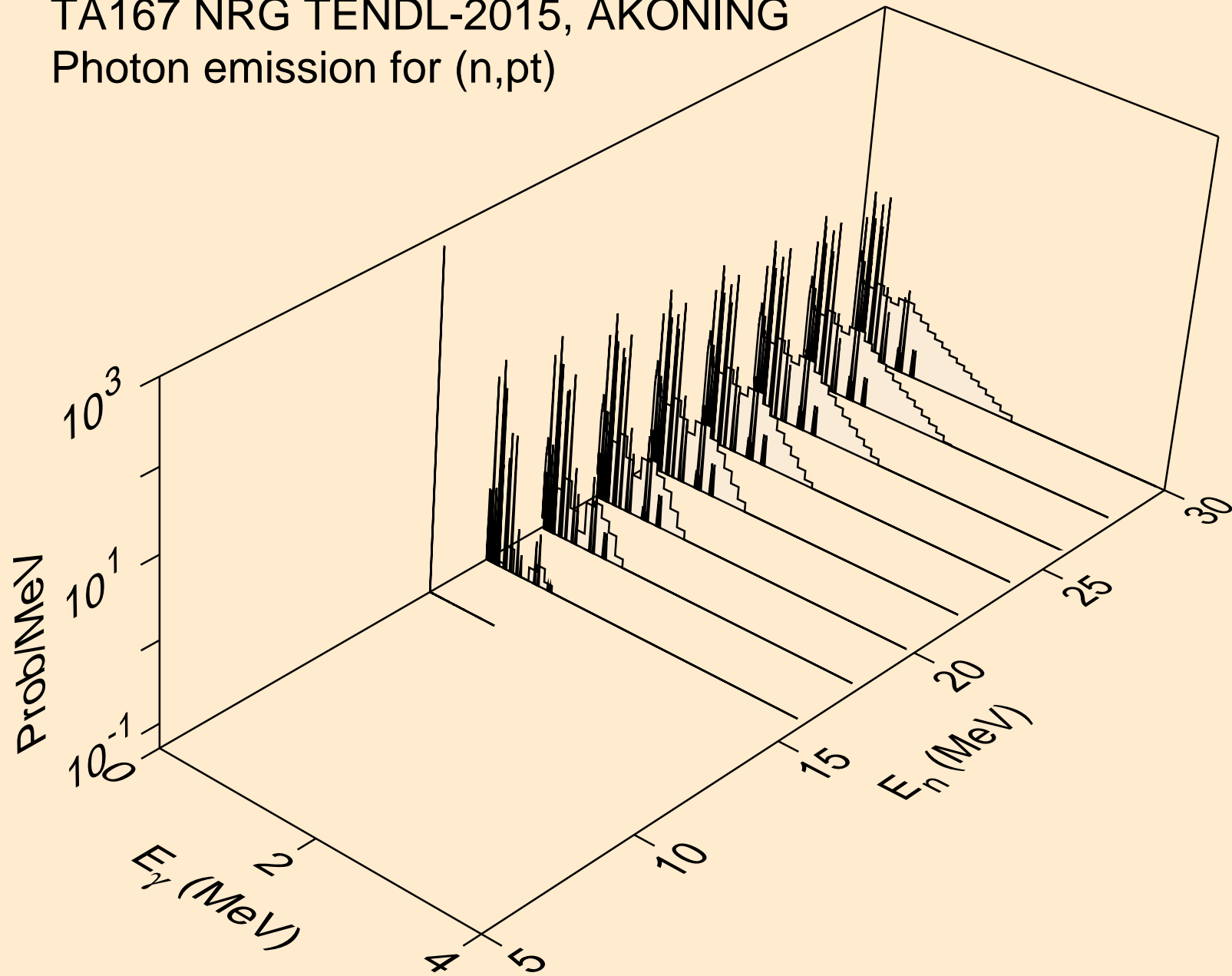

TA167 NRG TENDL-2015, AKONING  
Photon emission for (n,da)

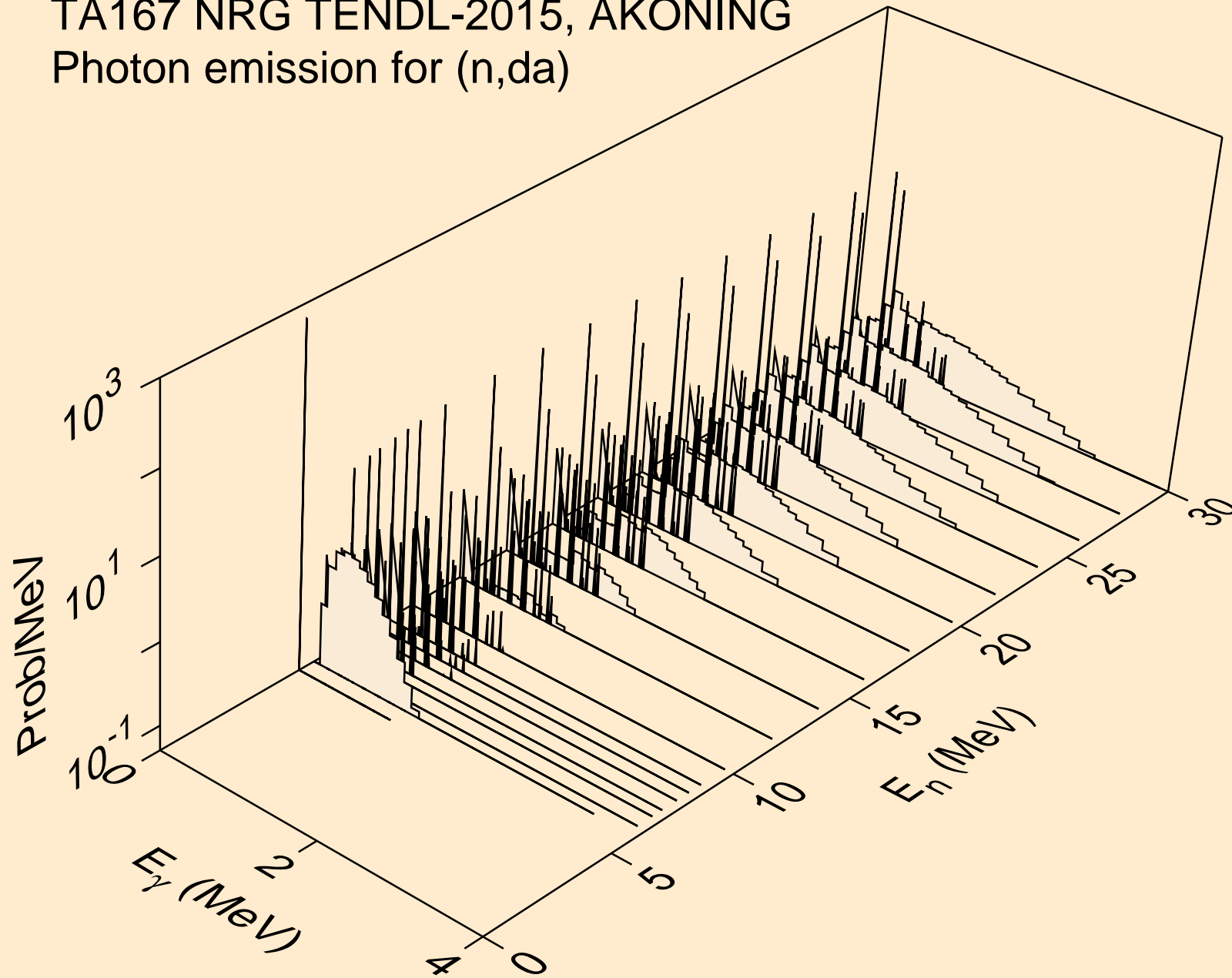

TA167 NRG TENDL-2015, AKONING  
thermal capture photon spectrum

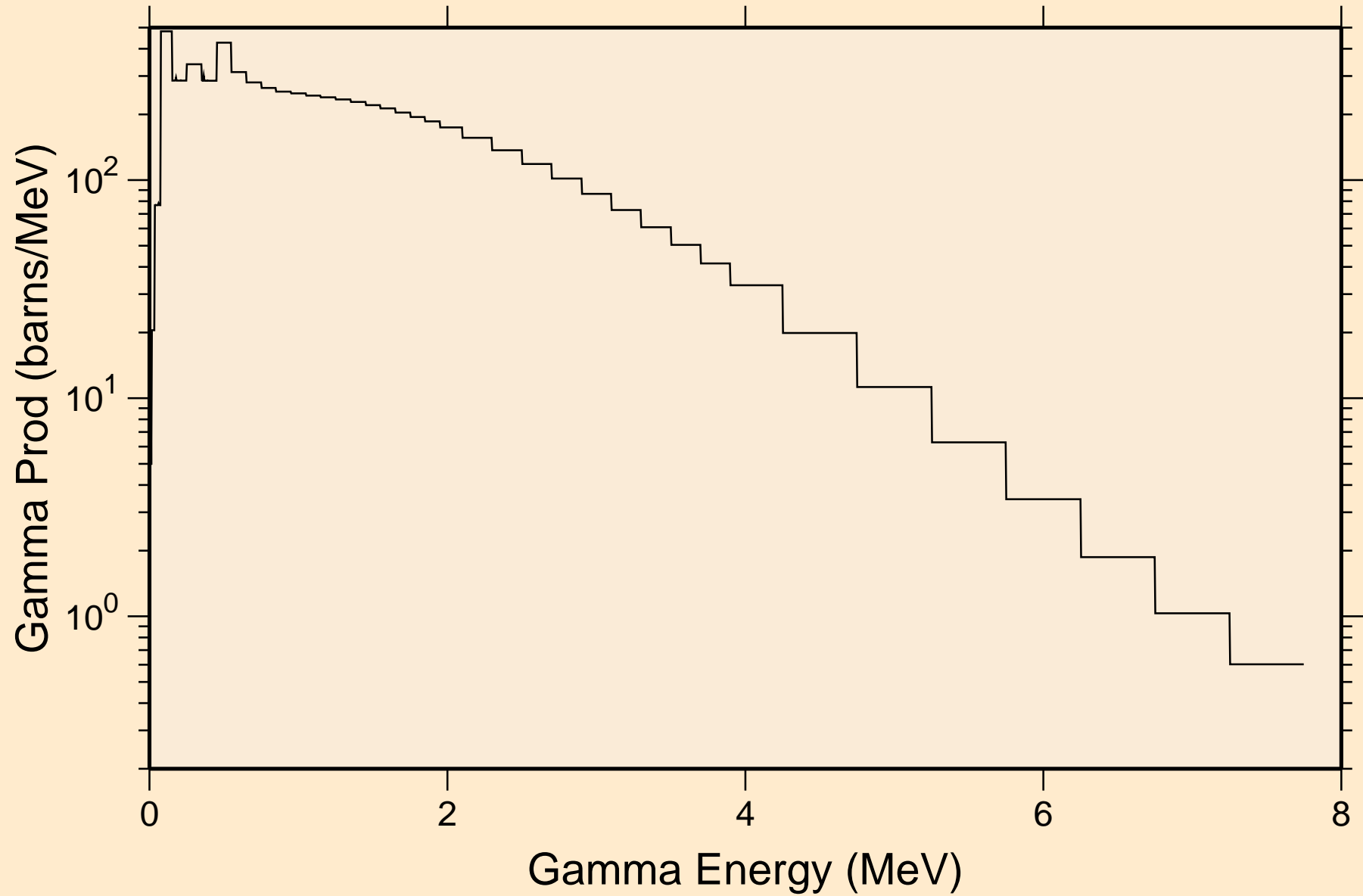

TA167 NRG TENDL-2015, AKONING  
14 MeV photon spectrum

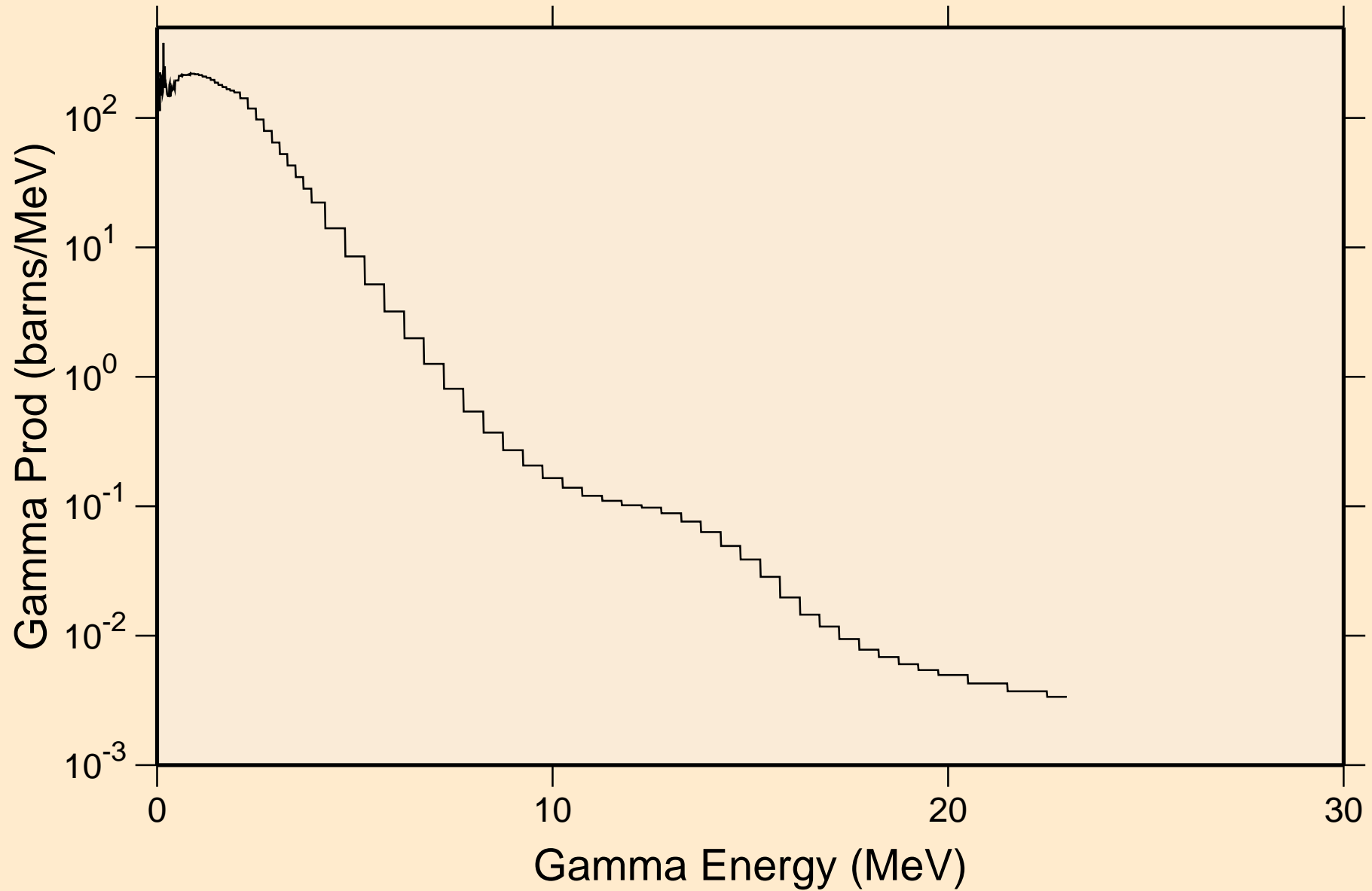

# TA167 NRG TENDL-2015, AKONING

## Particle heating contributions

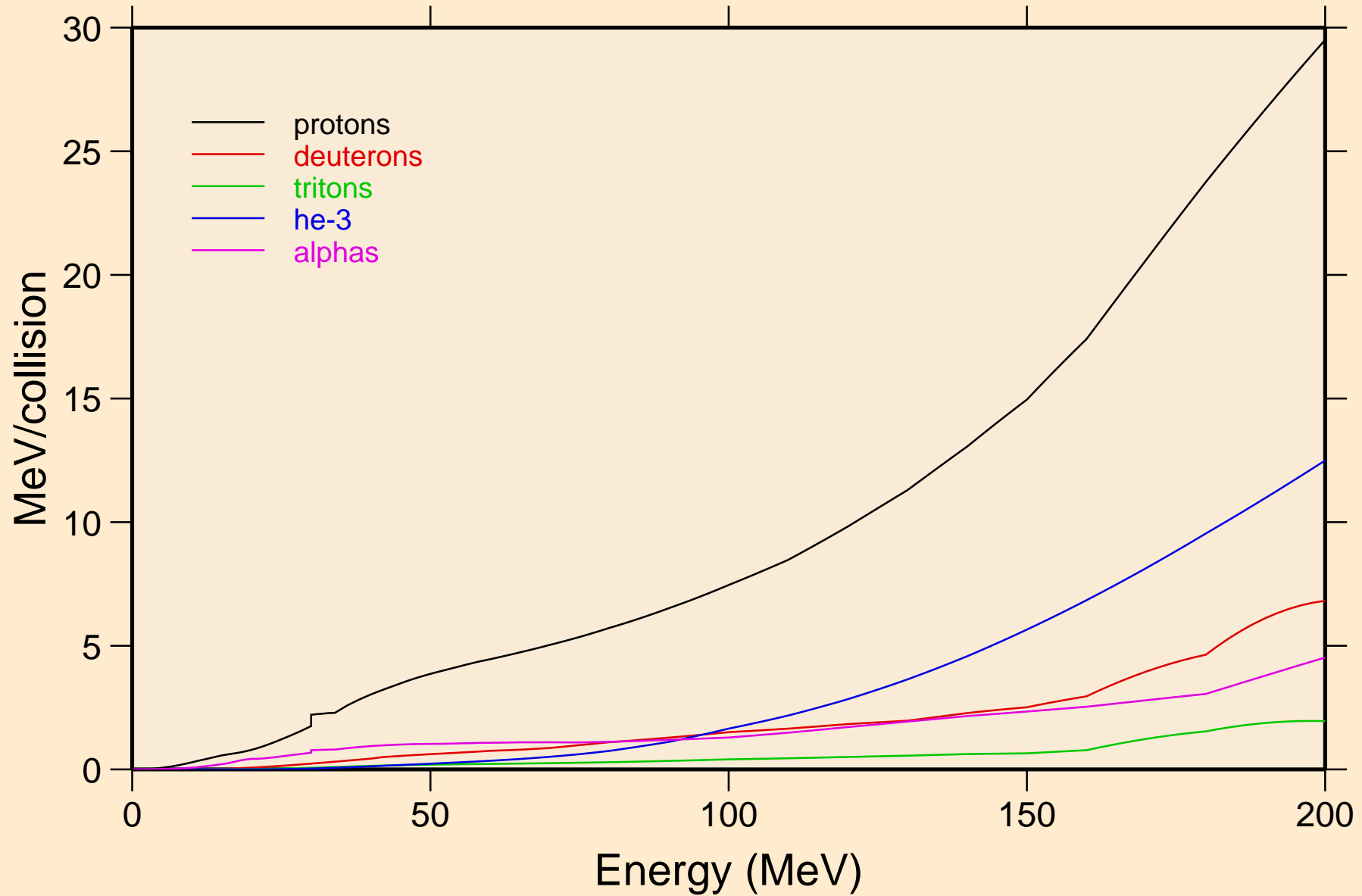

# TA167 NRG TENDL-2015, AKONING

## Recoil Heating

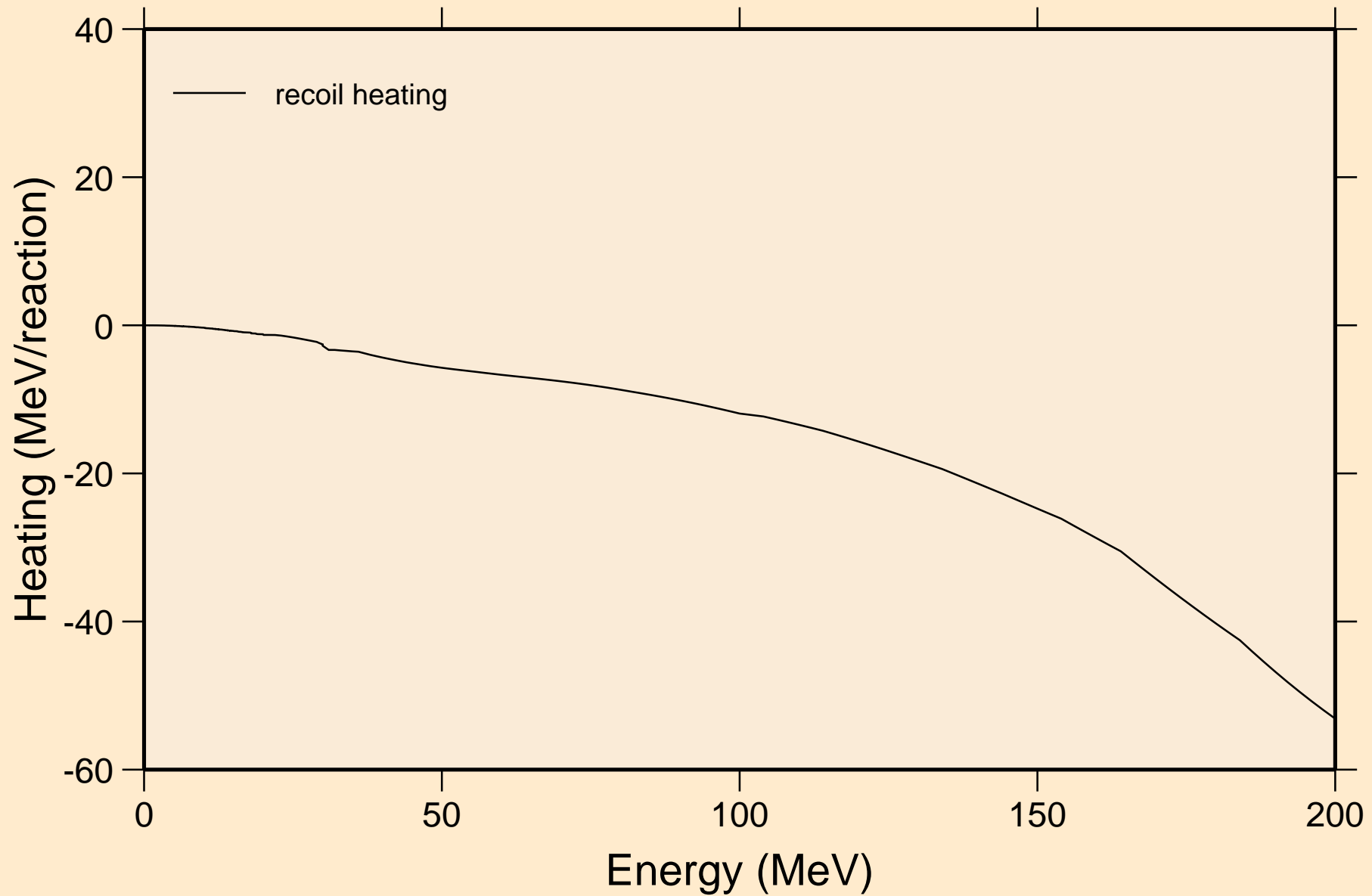

TA167 NRG TENDL-2015, AKONING  
Particle production cross sections

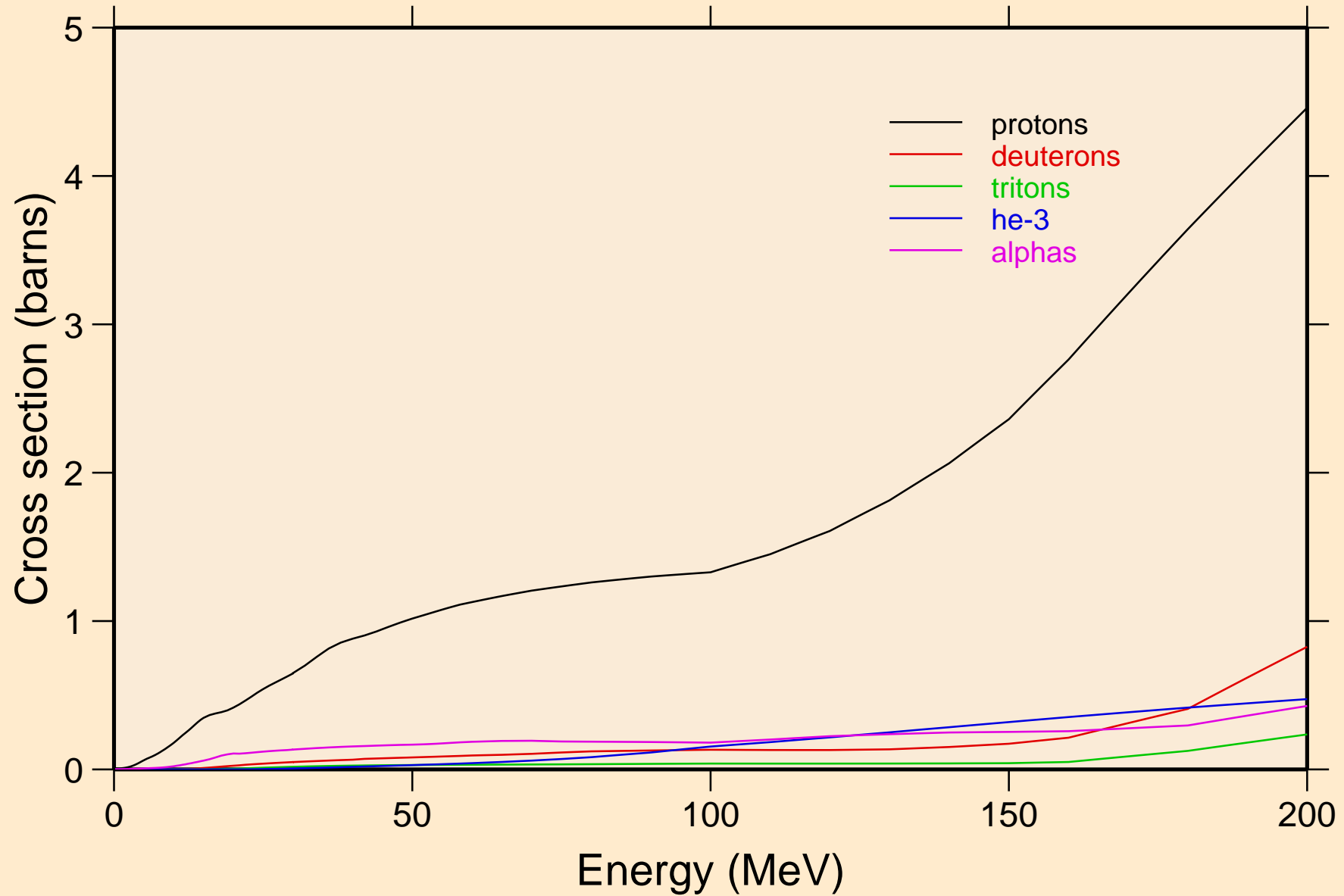



TA167 NRG TENDL-2015, AKONING  
protons from (n,x)

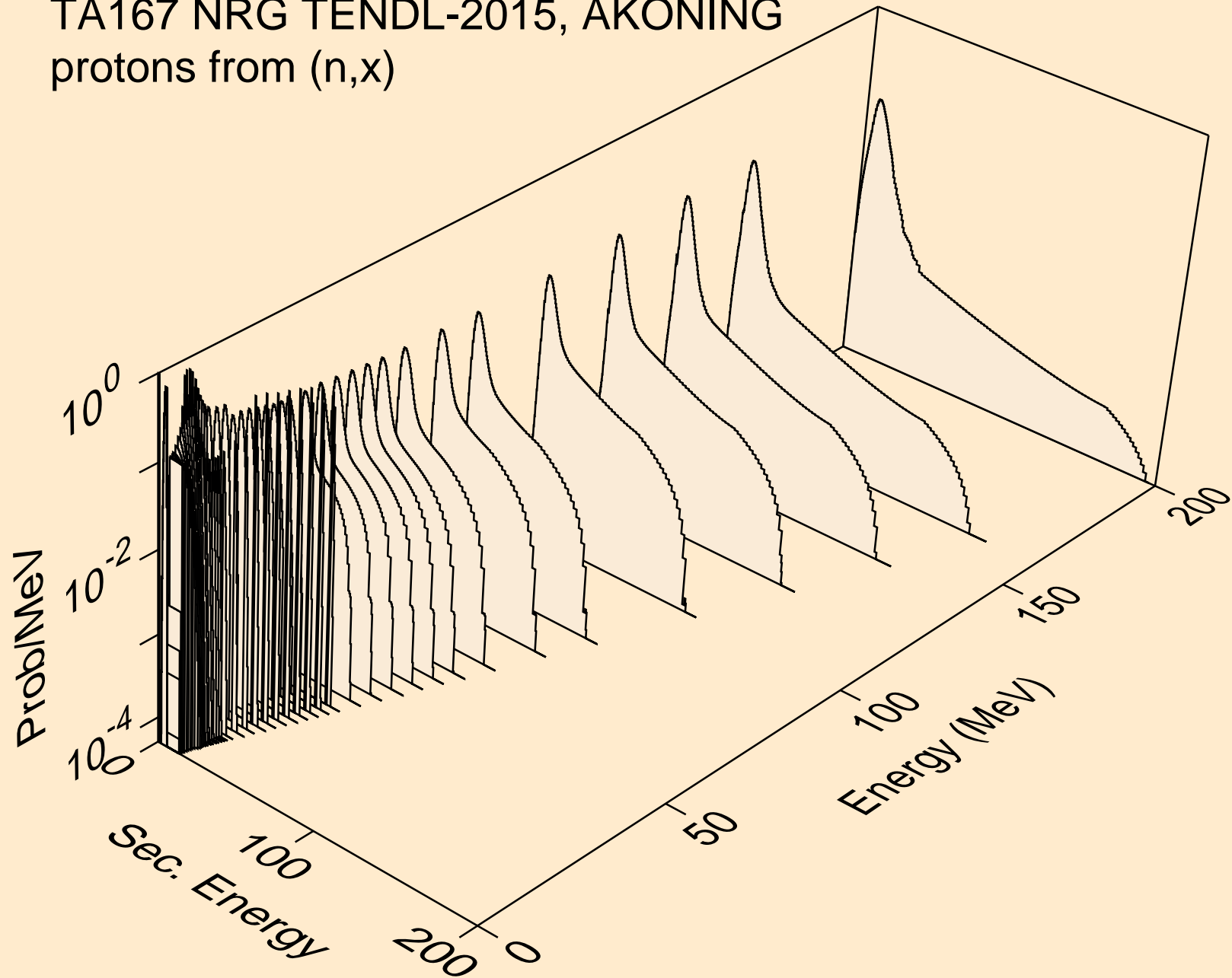

TA167 NRG TENDL-2015, AKONING  
protons from (n,n\*)p

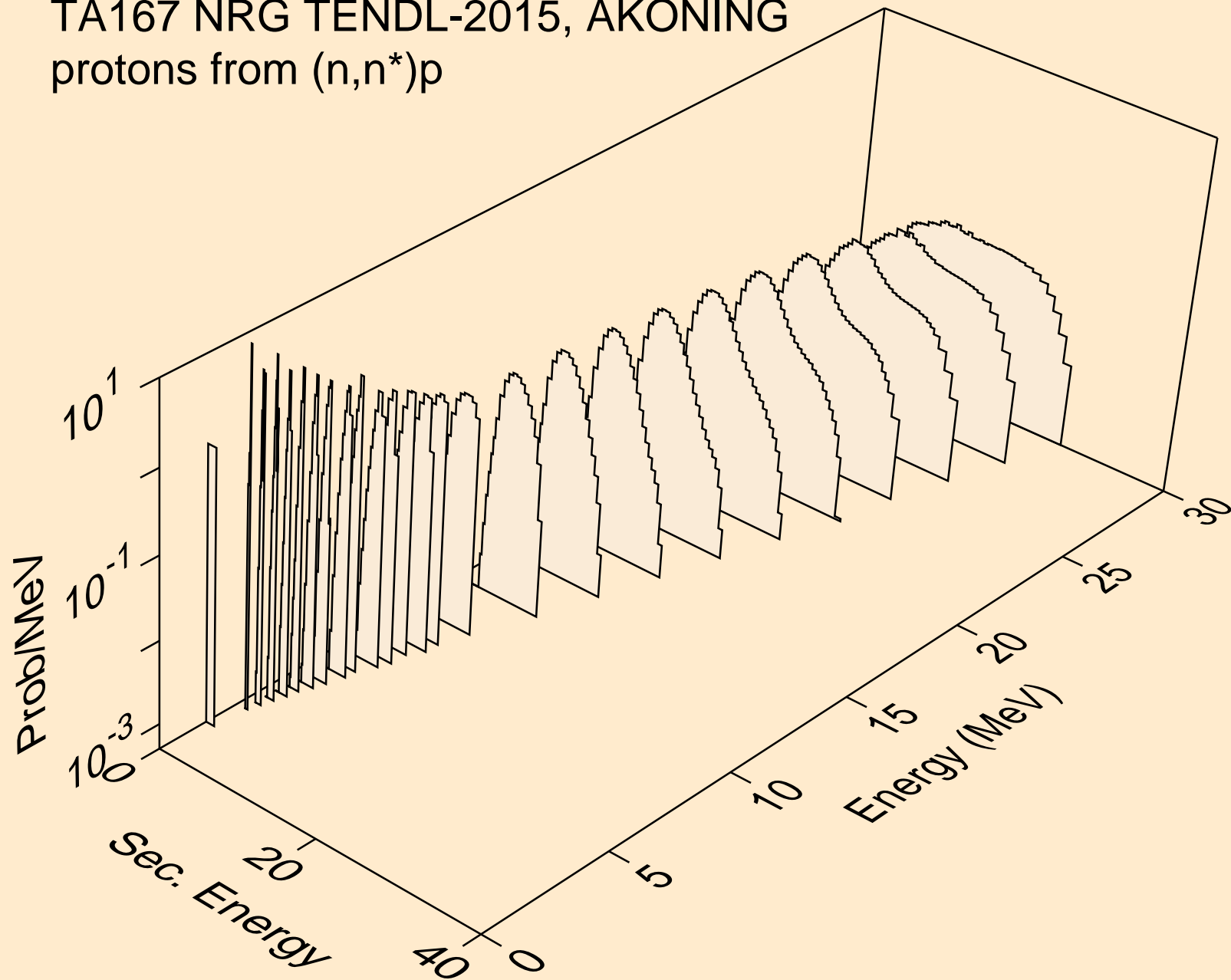

TA167 NRG TENDL-2015, AKONING  
protons from (n,2np)

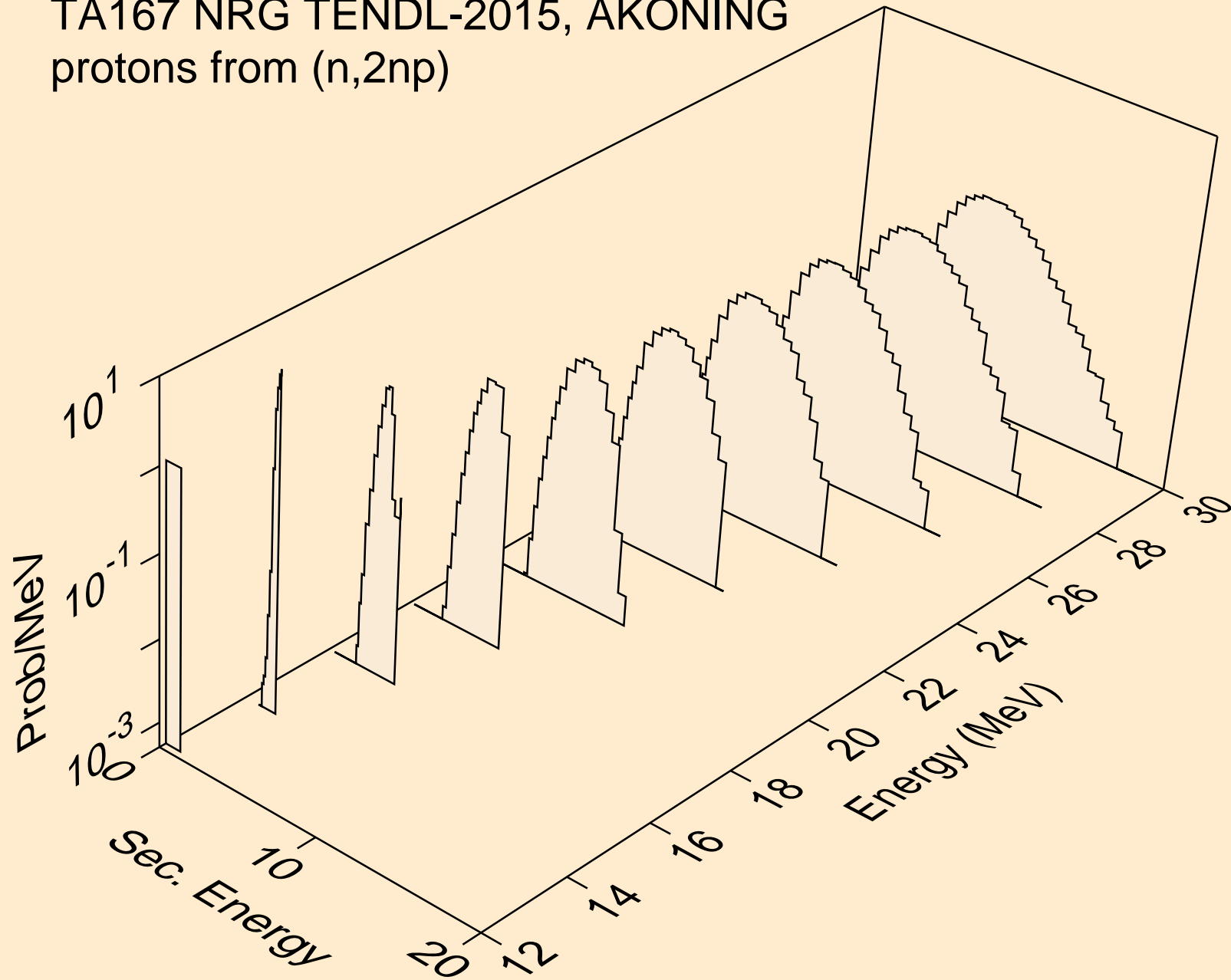

TA167 NRG TENDL-2015, AKONING  
protons from (n,3np)

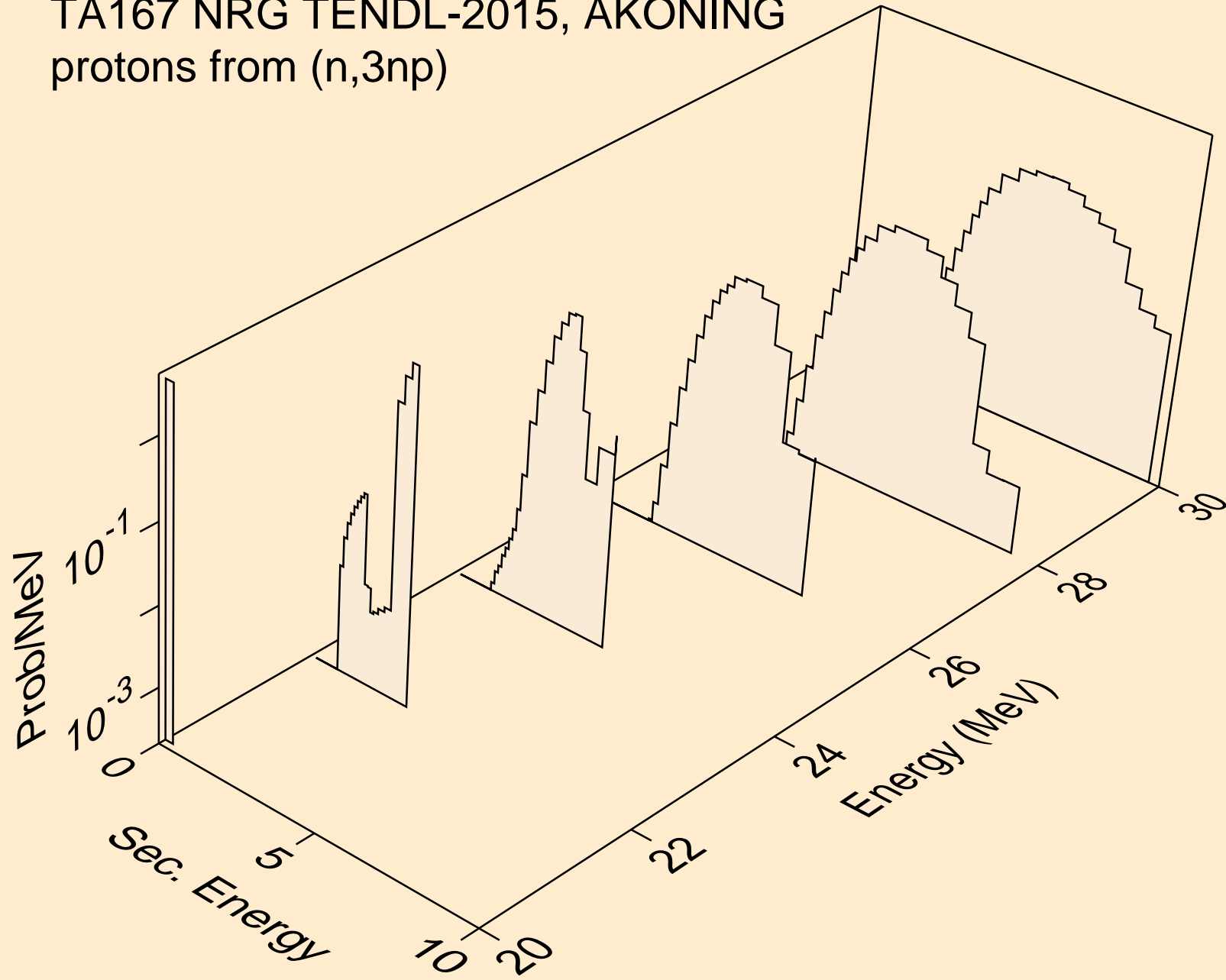

TA167 NRG TENDL-2015, AKONING  
protons from (n,2np)

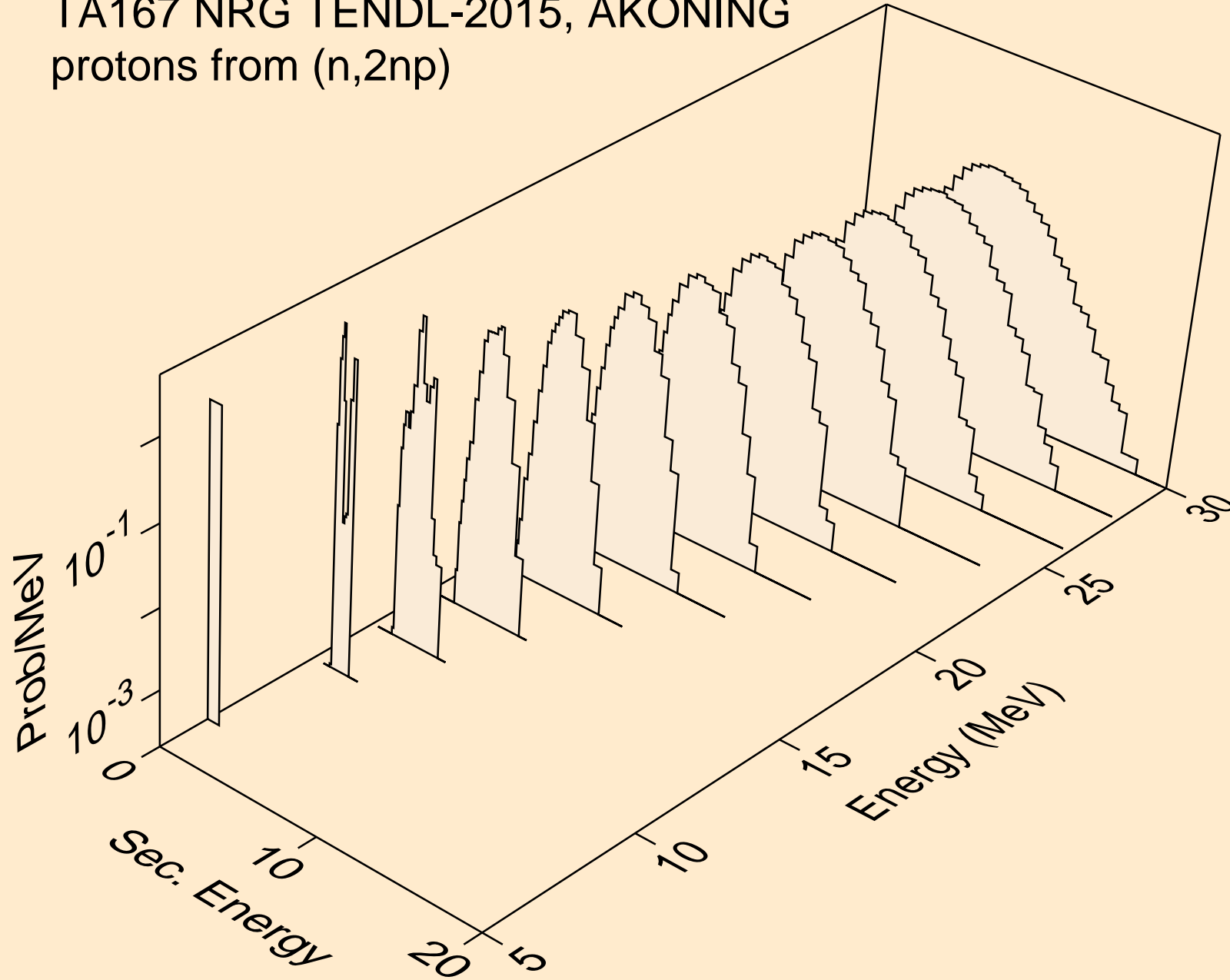

TA167 NRG TENDL-2015, AKONING  
protons from (n,npa)

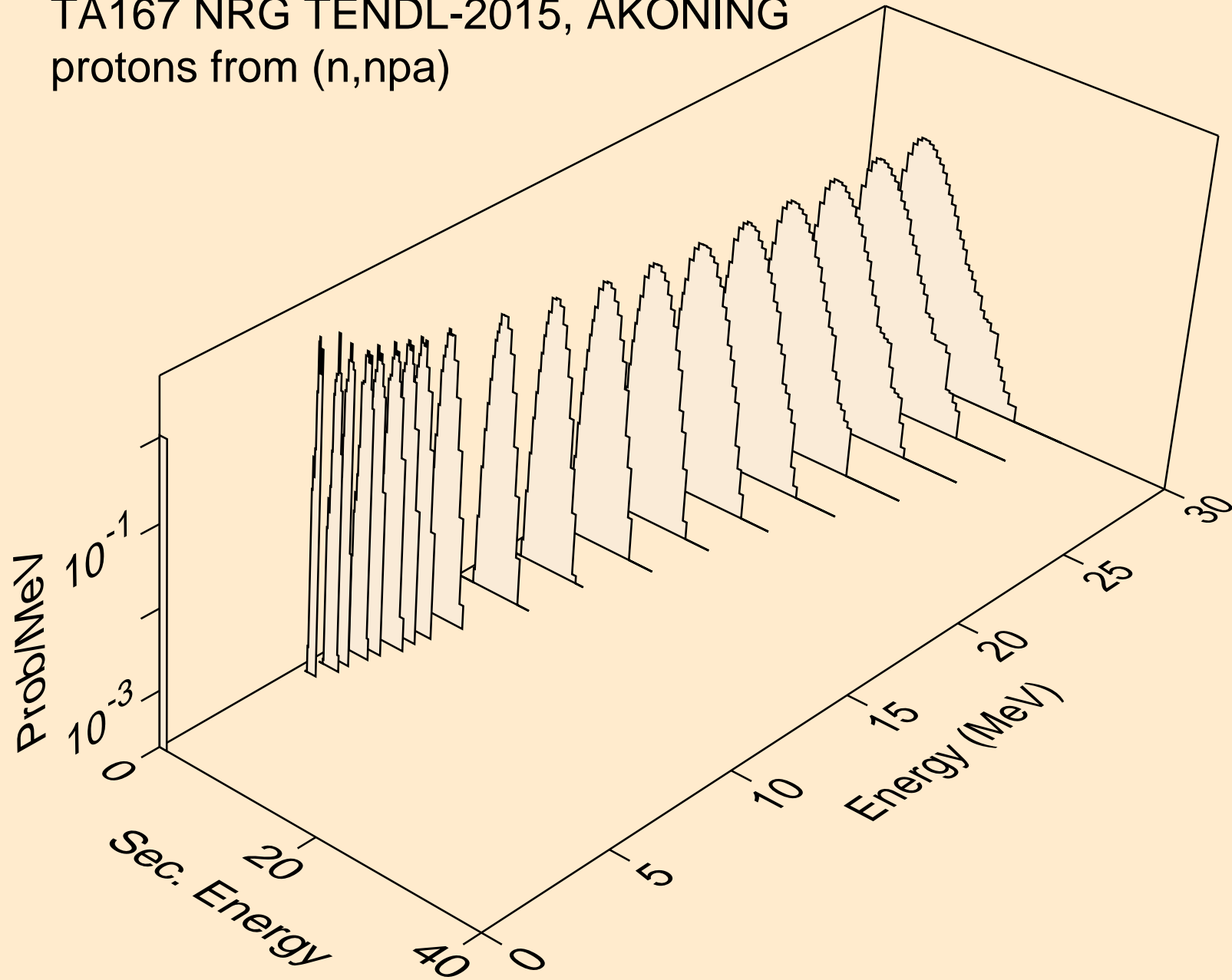

TA167 NRG TENDL-2015, AKONING  
protons from (n,p)

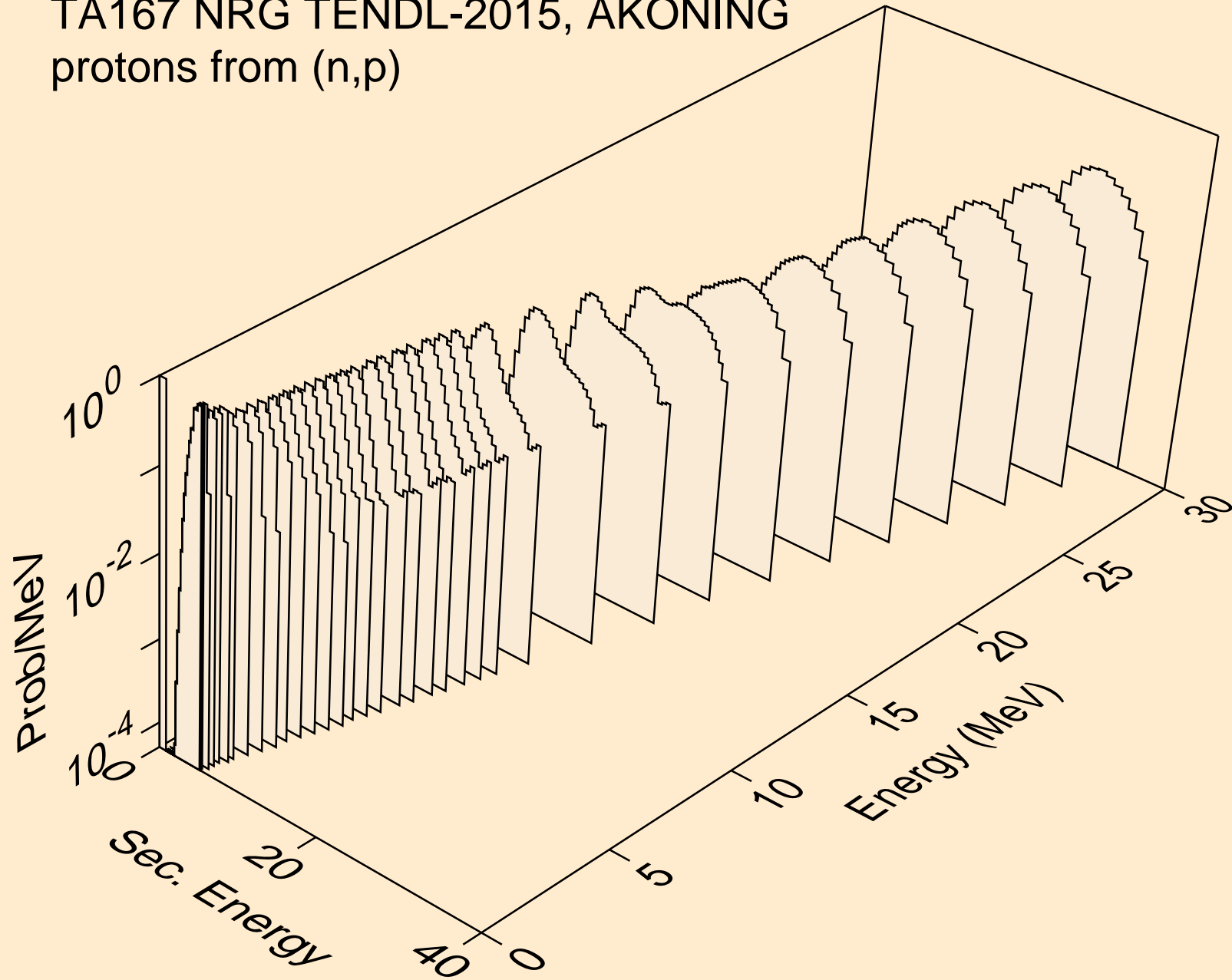

TA167 NRG TENDL-2015, AKONING  
protons from (n,2p)

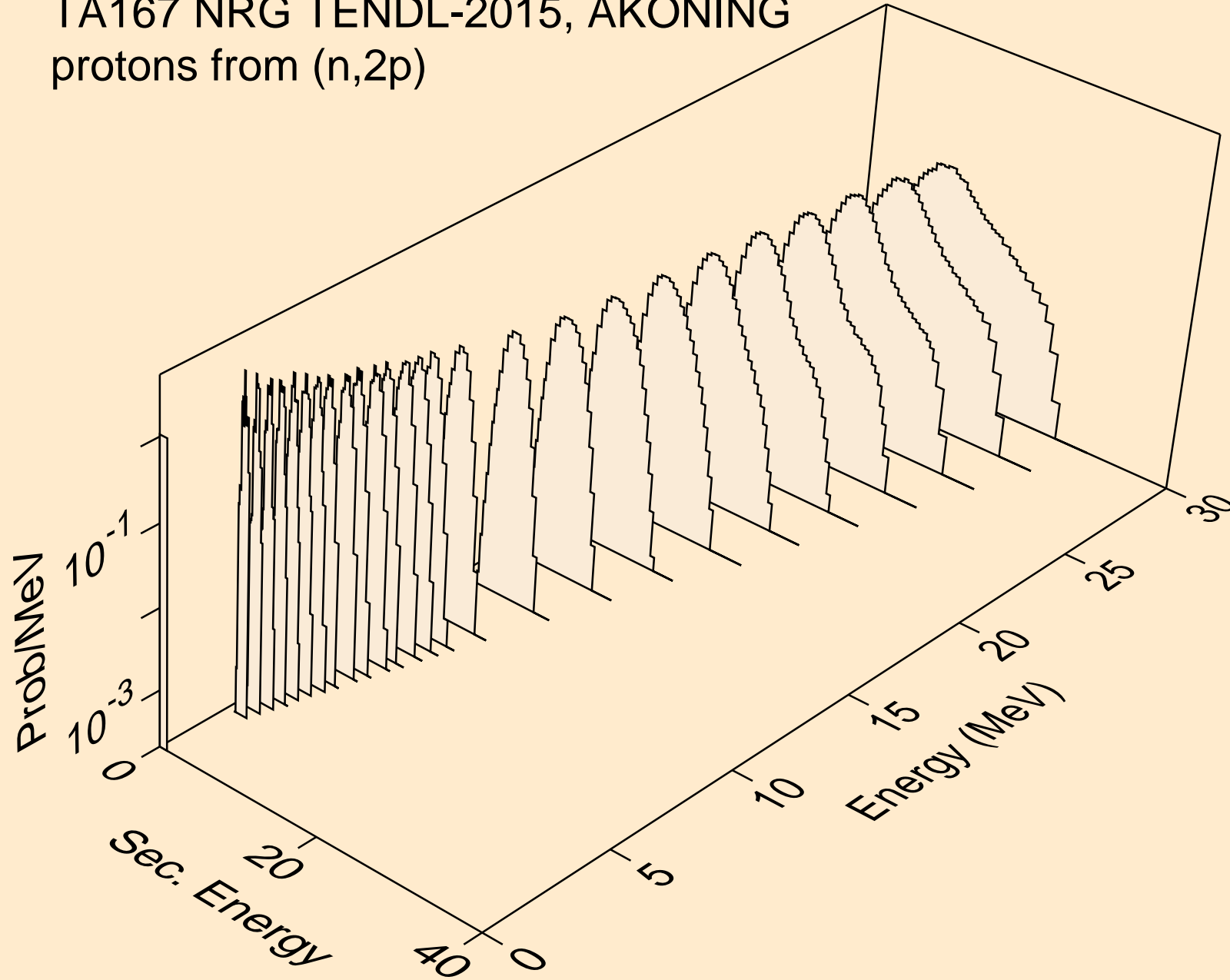



TA167 NRG TENDL-2015, AKONING  
protons from (n,pa)

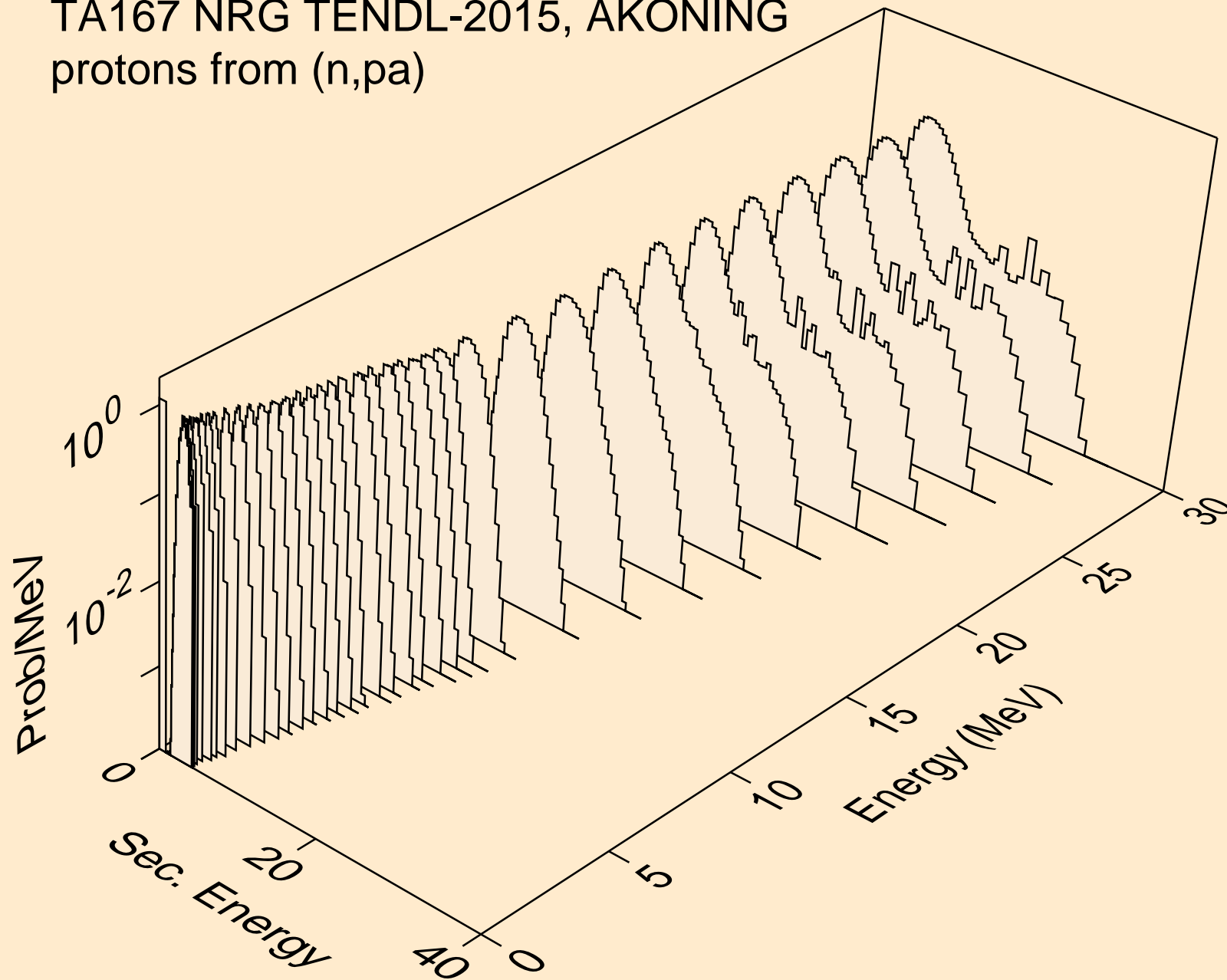

TA167 NRG TENDL-2015, AKONING  
protons from (n,pd)

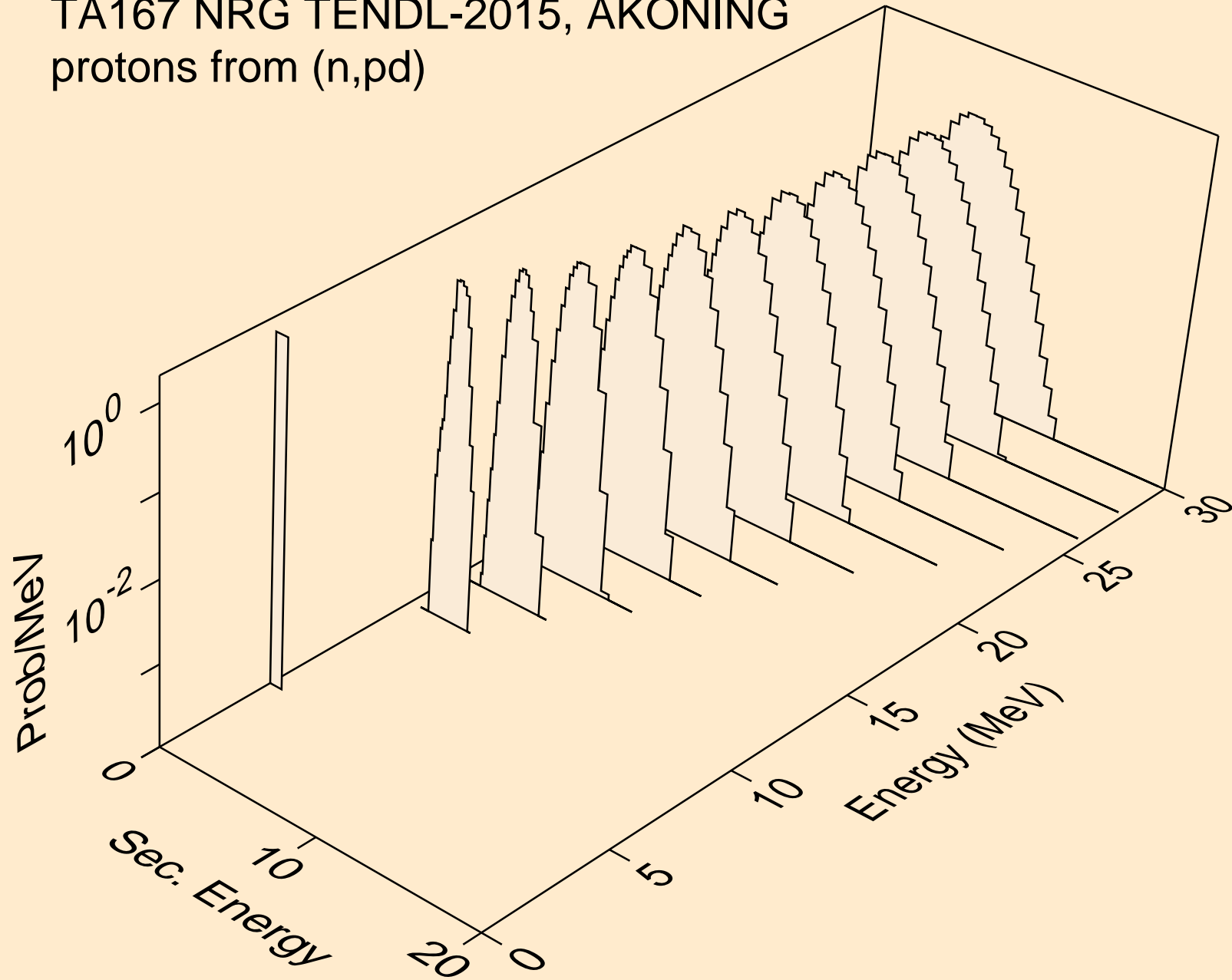

TA167 NRG TENDL-2015, AKONING  
protons from (n,pt)

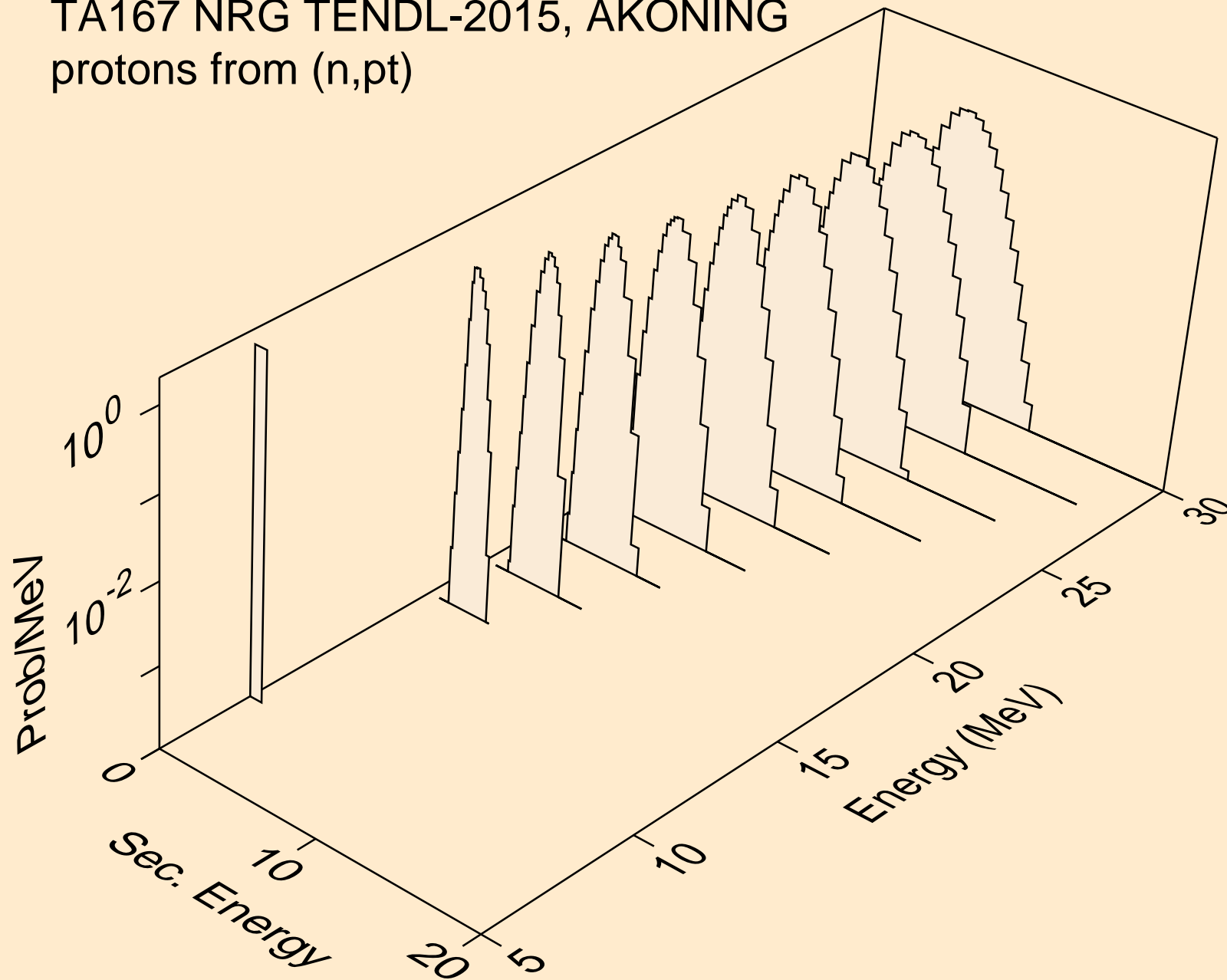

TA167 NRG TENDL-2015, AKONING  
deuterons from (n,x)

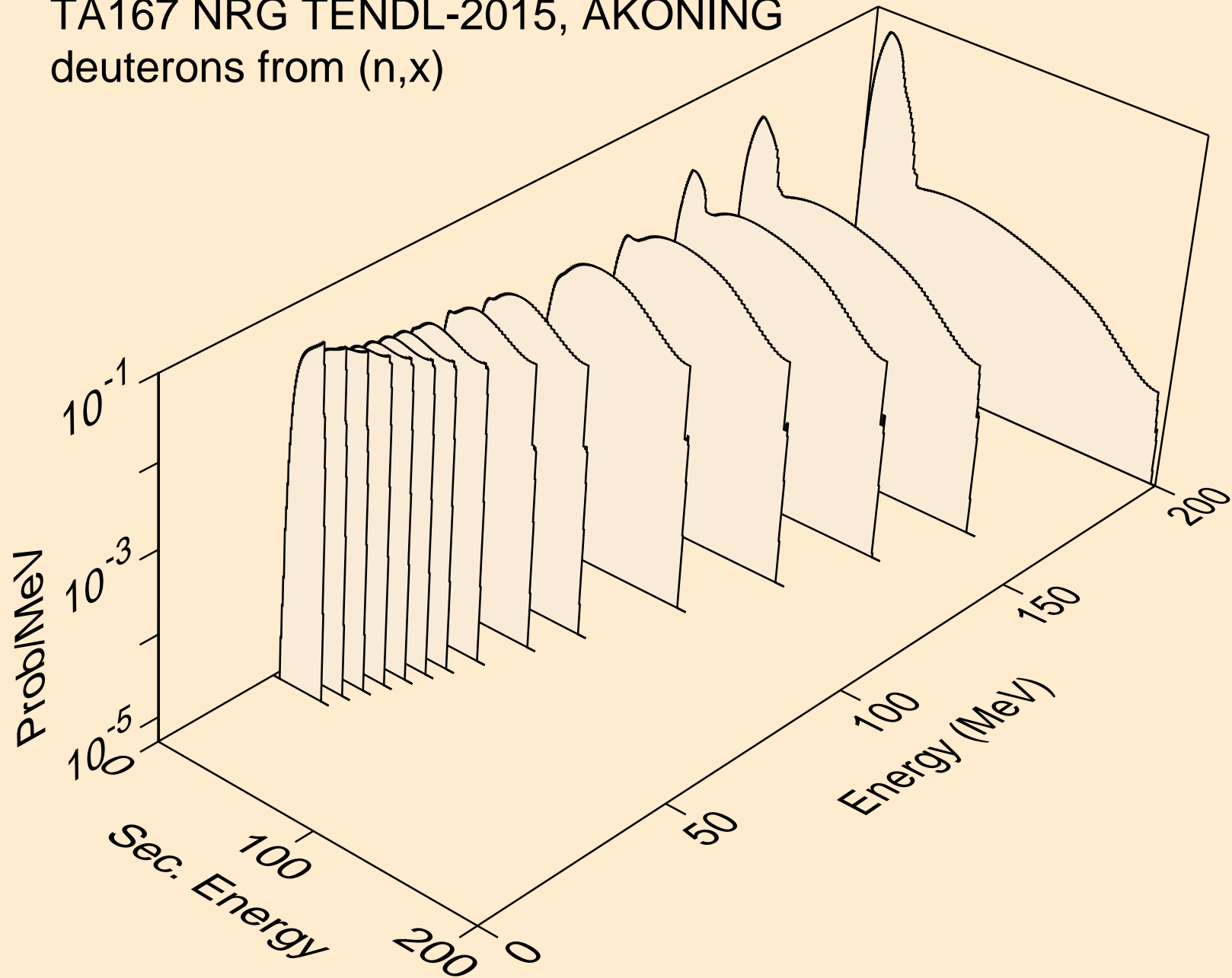

TA167 NRG TENDL-2015, AKONING  
deuterons from (n,2nd)

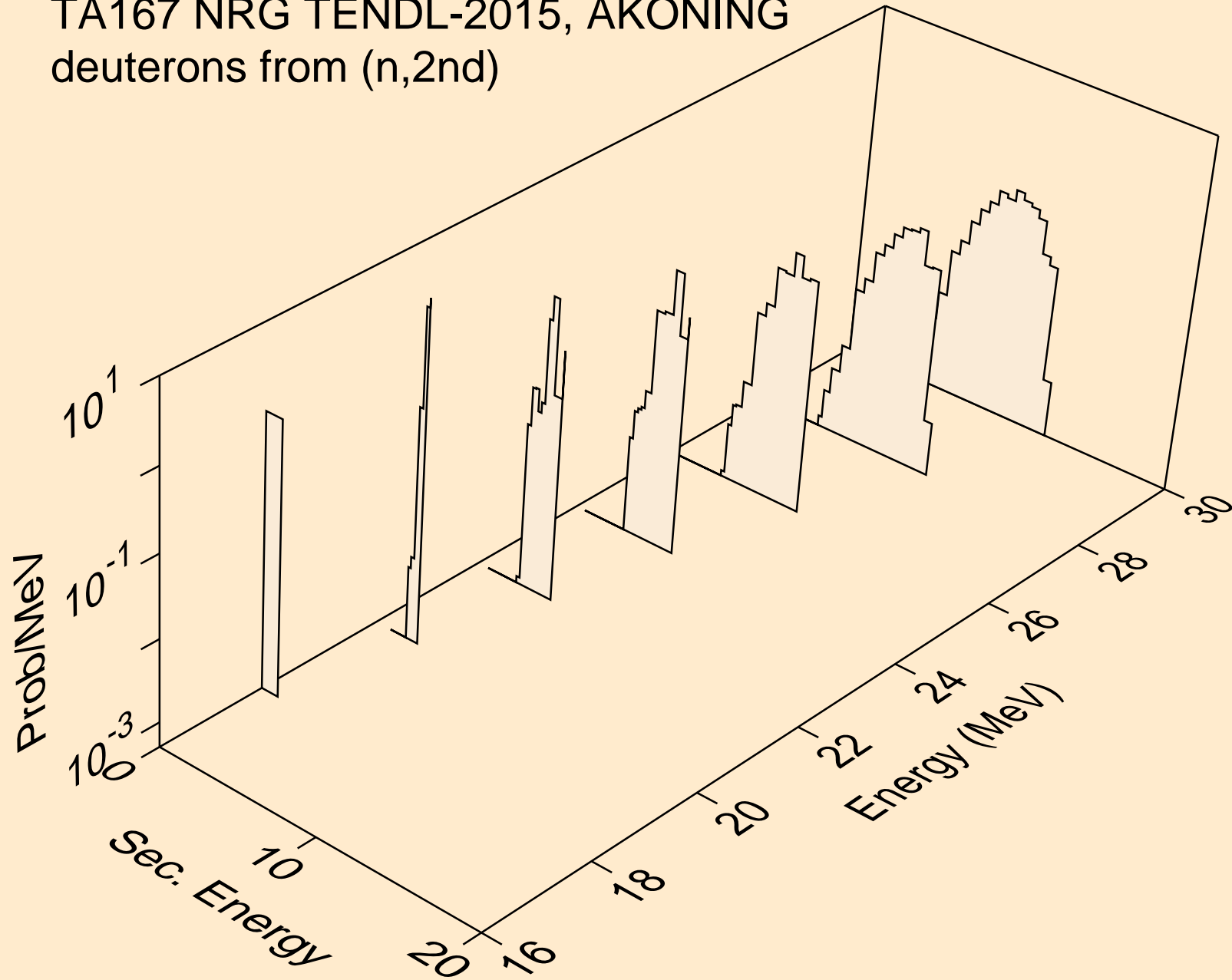

TA167 NRG TENDL-2015, AKONING  
deuterons from (n,n\*)d

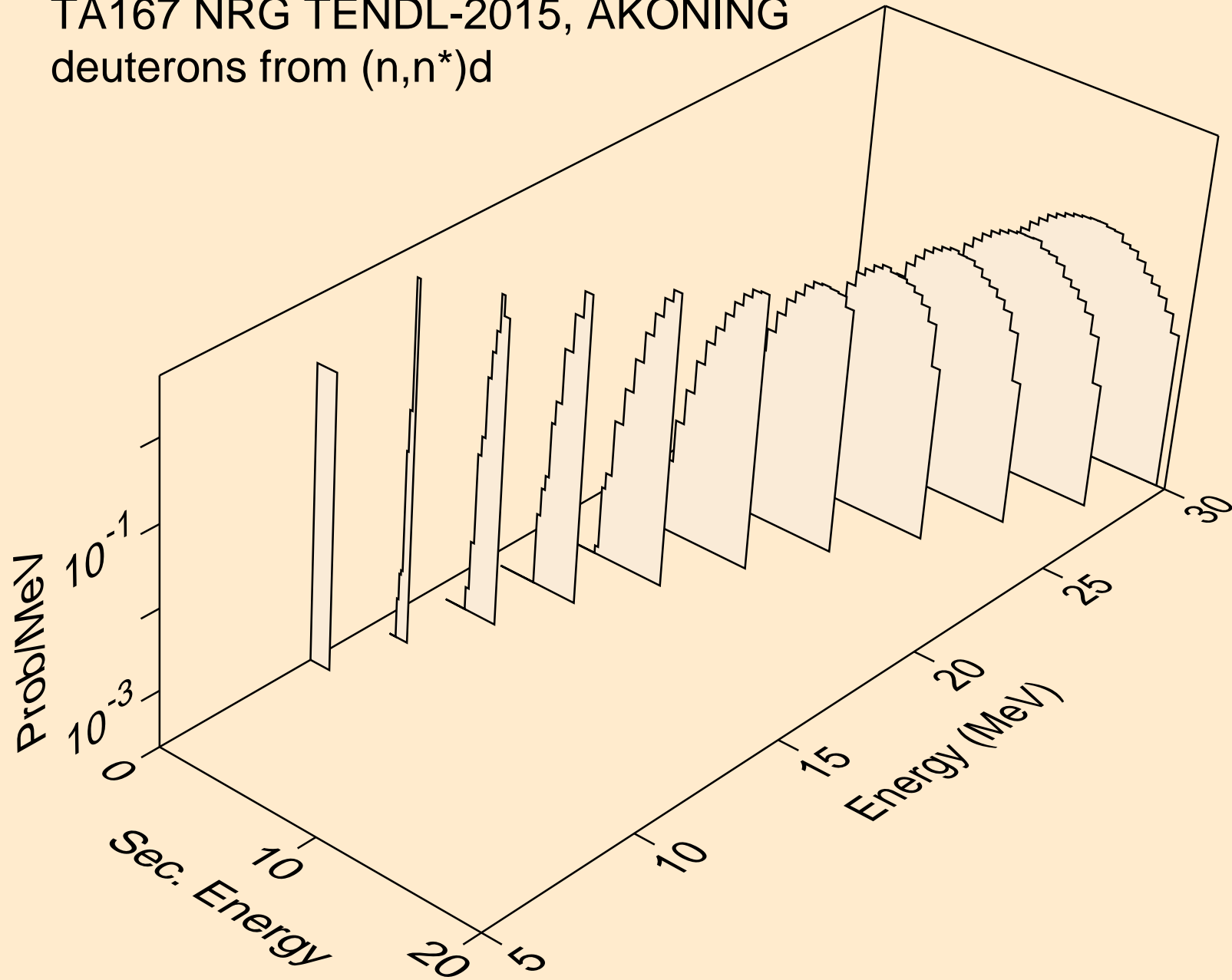

TA167 NRG TENDL-2015, AKONING  
deuterons from (n,d)

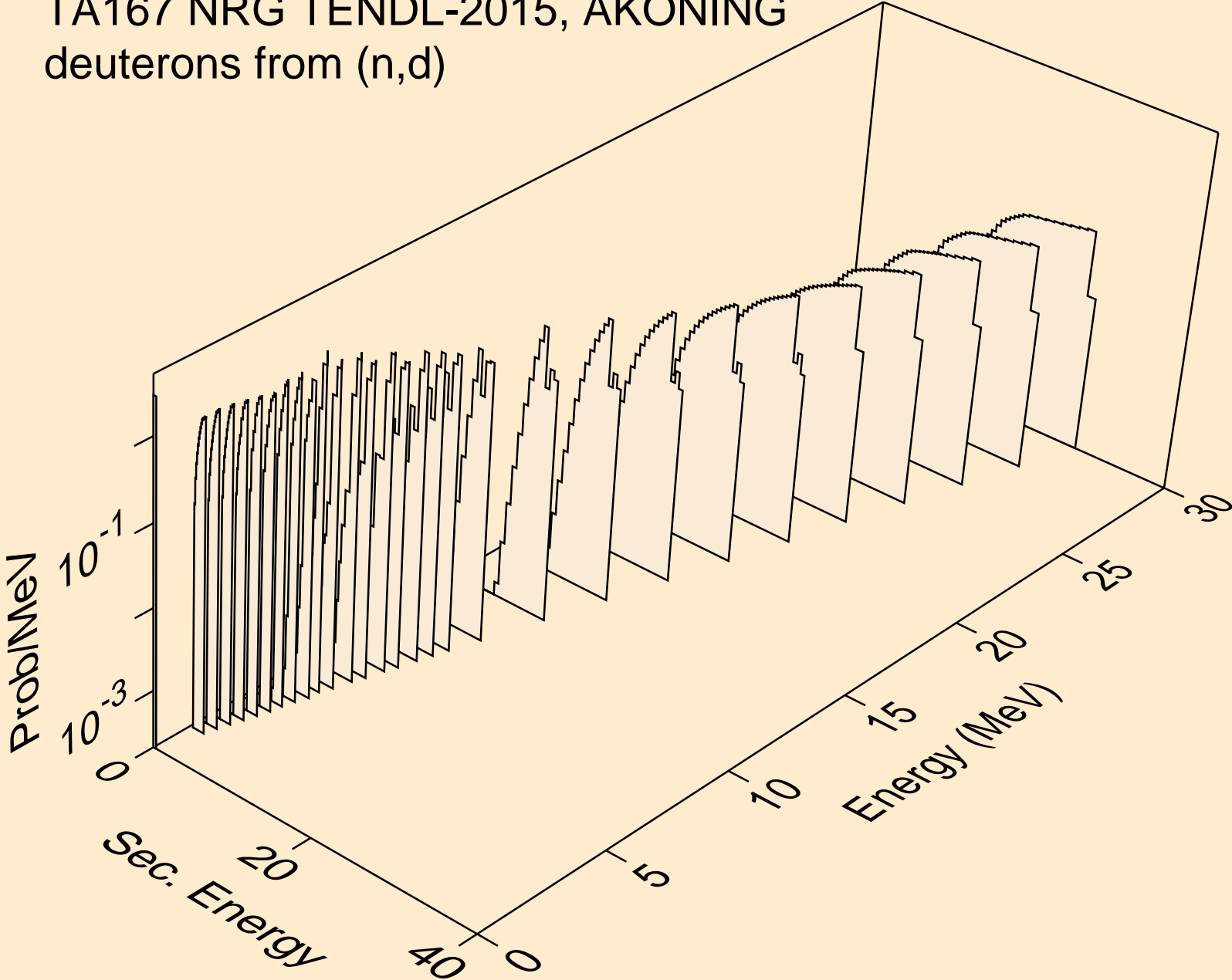

TA167 NRG TENDL-2015, AKONING  
deuterons from (n,d2a)

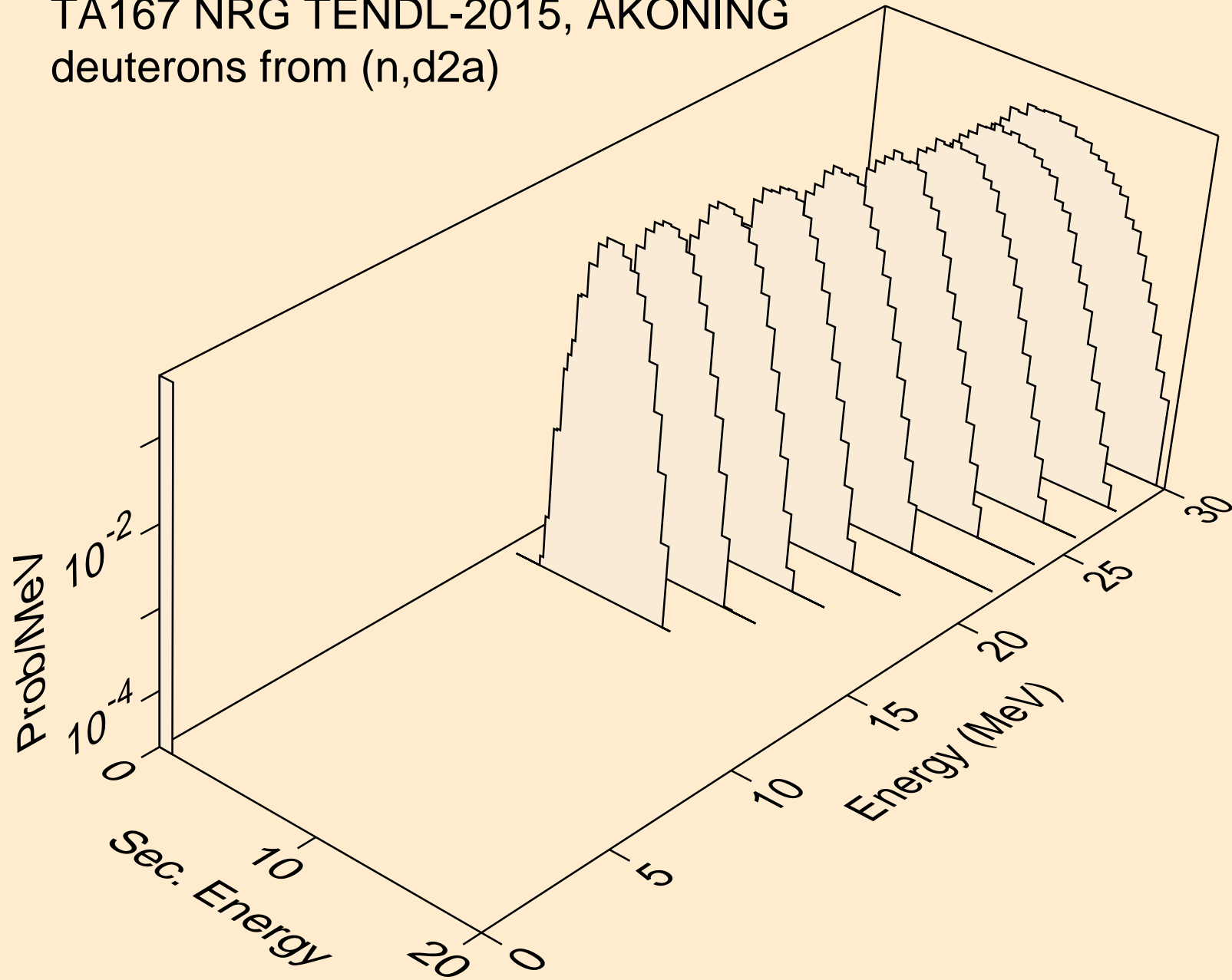



TA167 NRG TENDL-2015, AKONING  
deuterons from (n,pd)

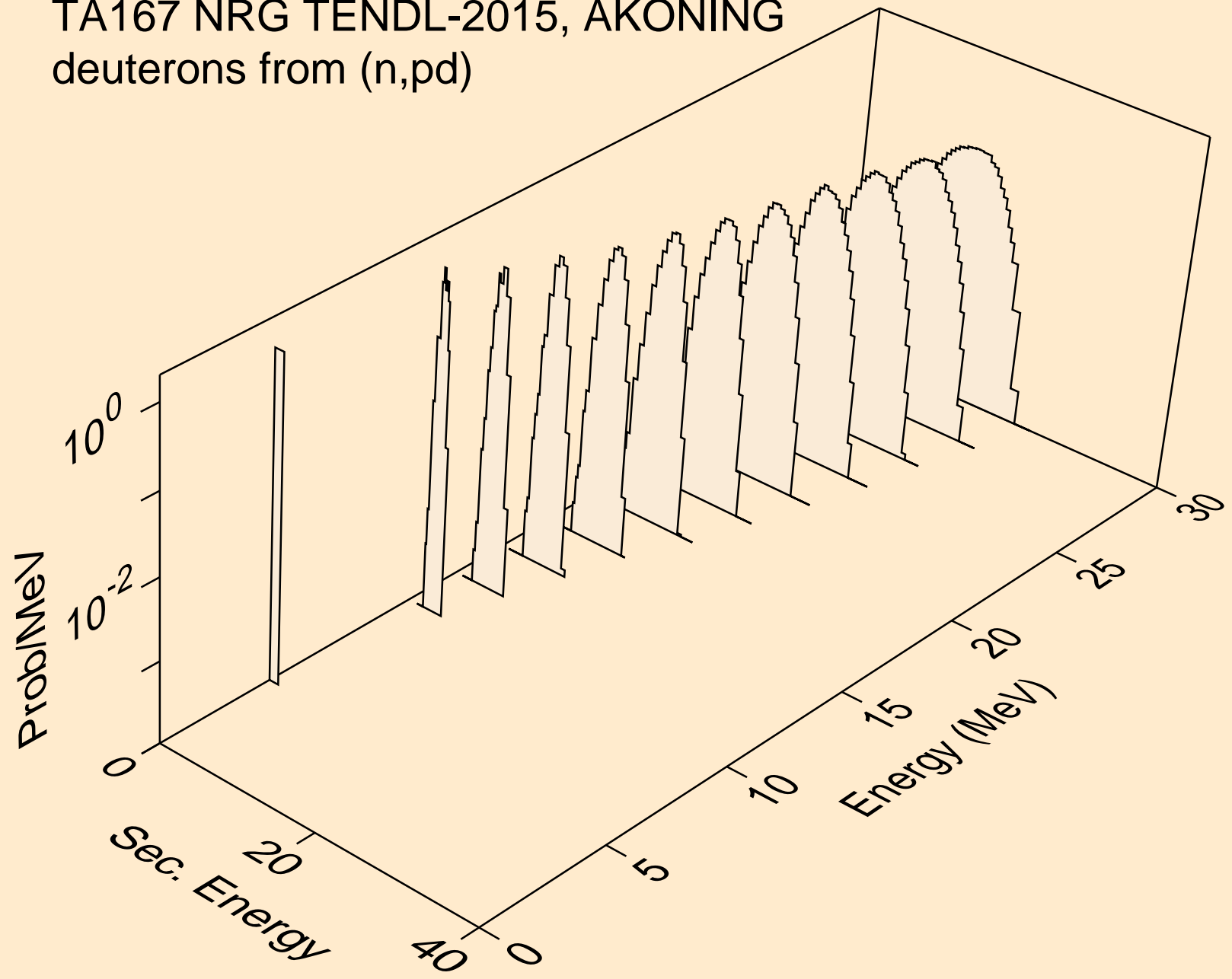

TA167 NRG TENDL-2015, AKONING  
deuterons from (n,da)

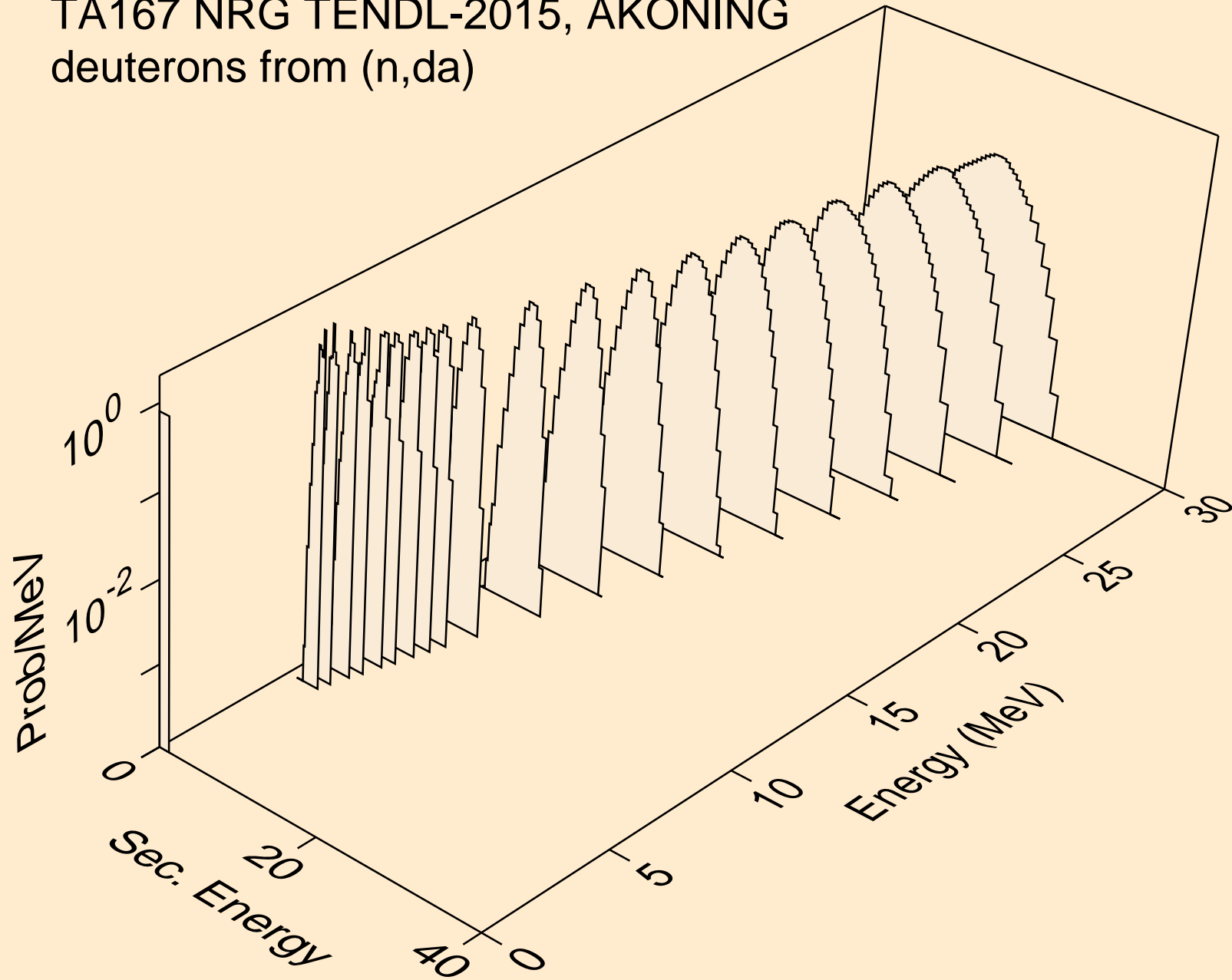

TA167 NRG TENDL-2015, AKONING  
tritons from (n,x)

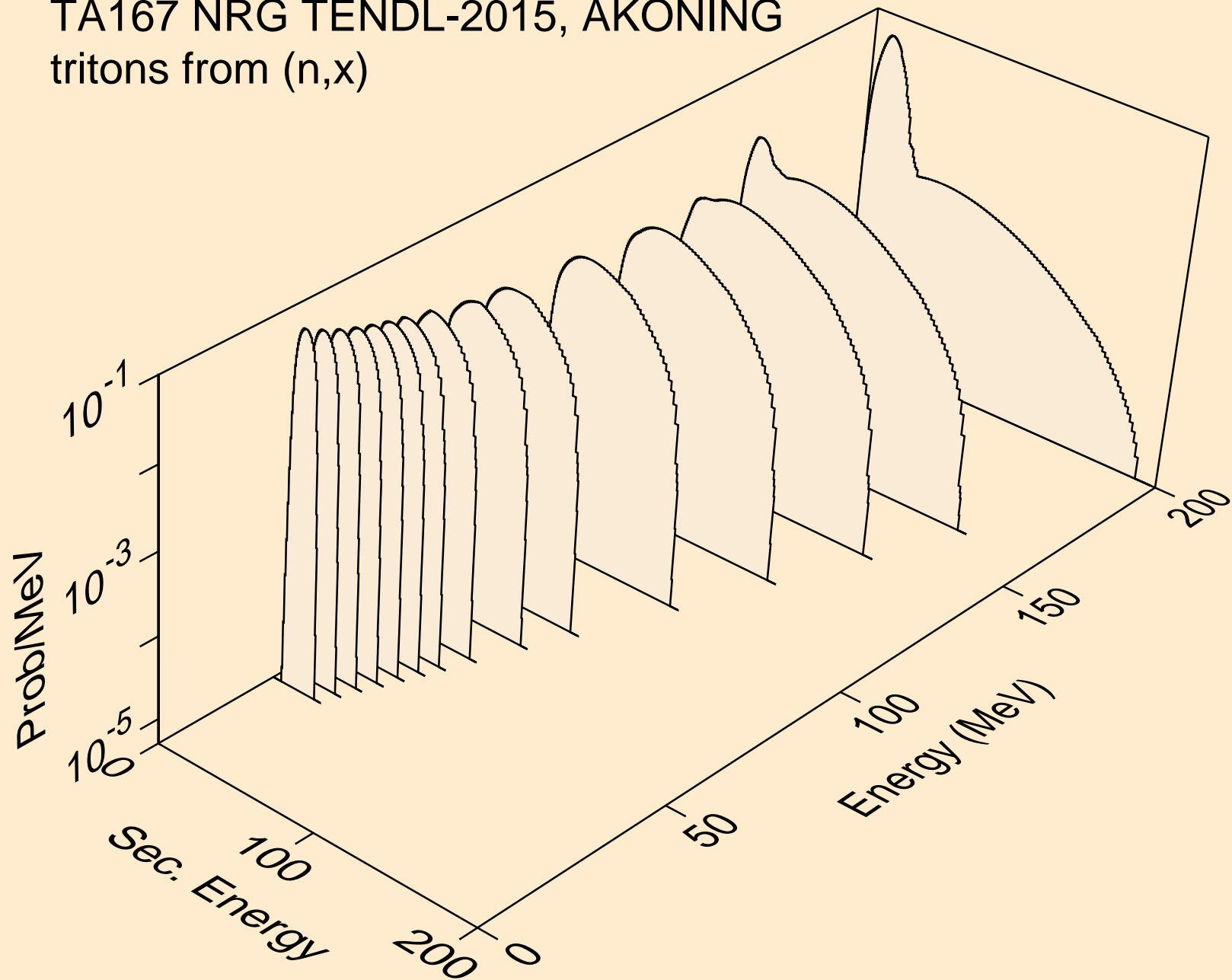

TA167 NRG TENDL-2015, AKONING  
tritons from (n,n\*)t

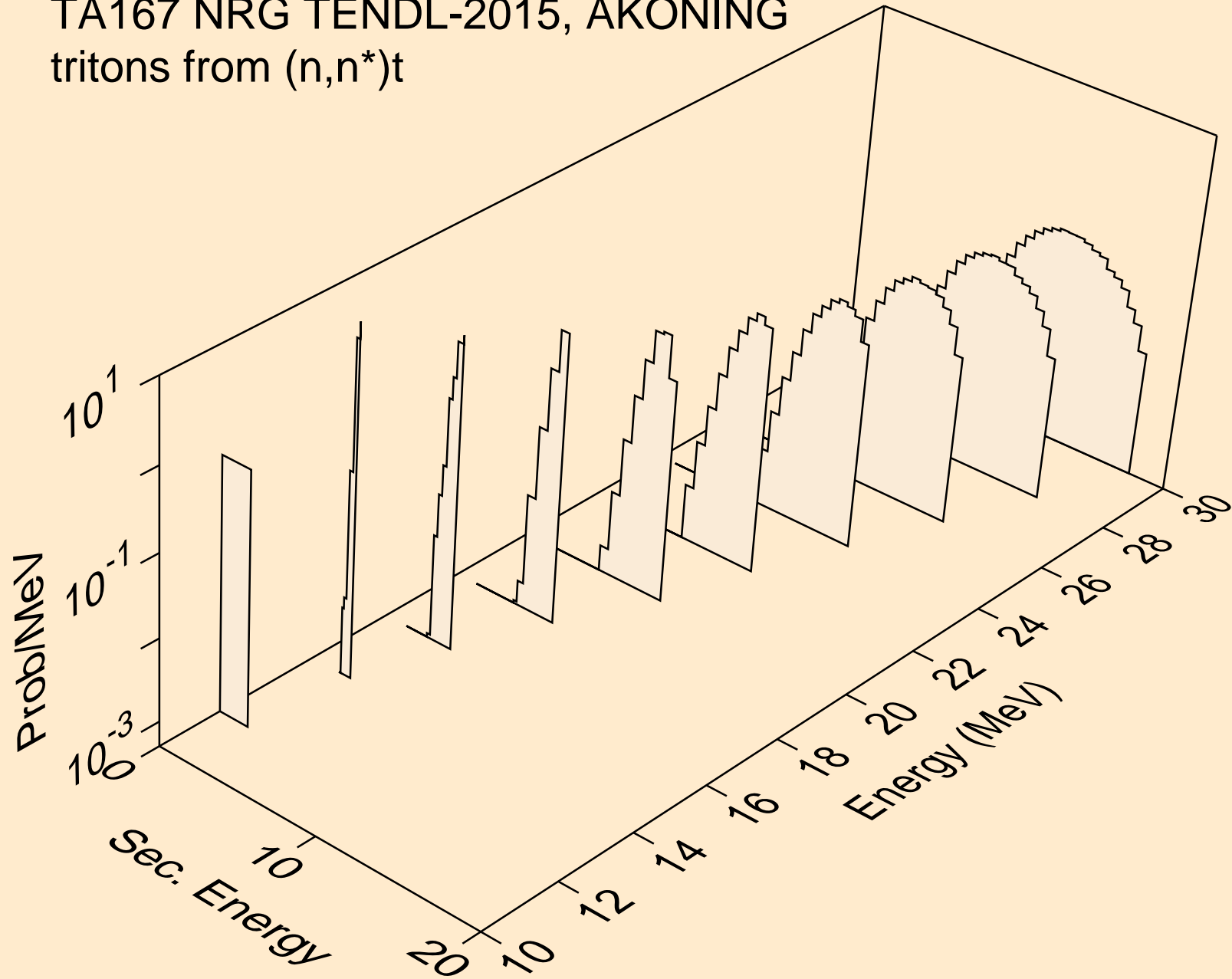

TA167 NRG TENDL-2015, AKONING  
tritons from (n,t)

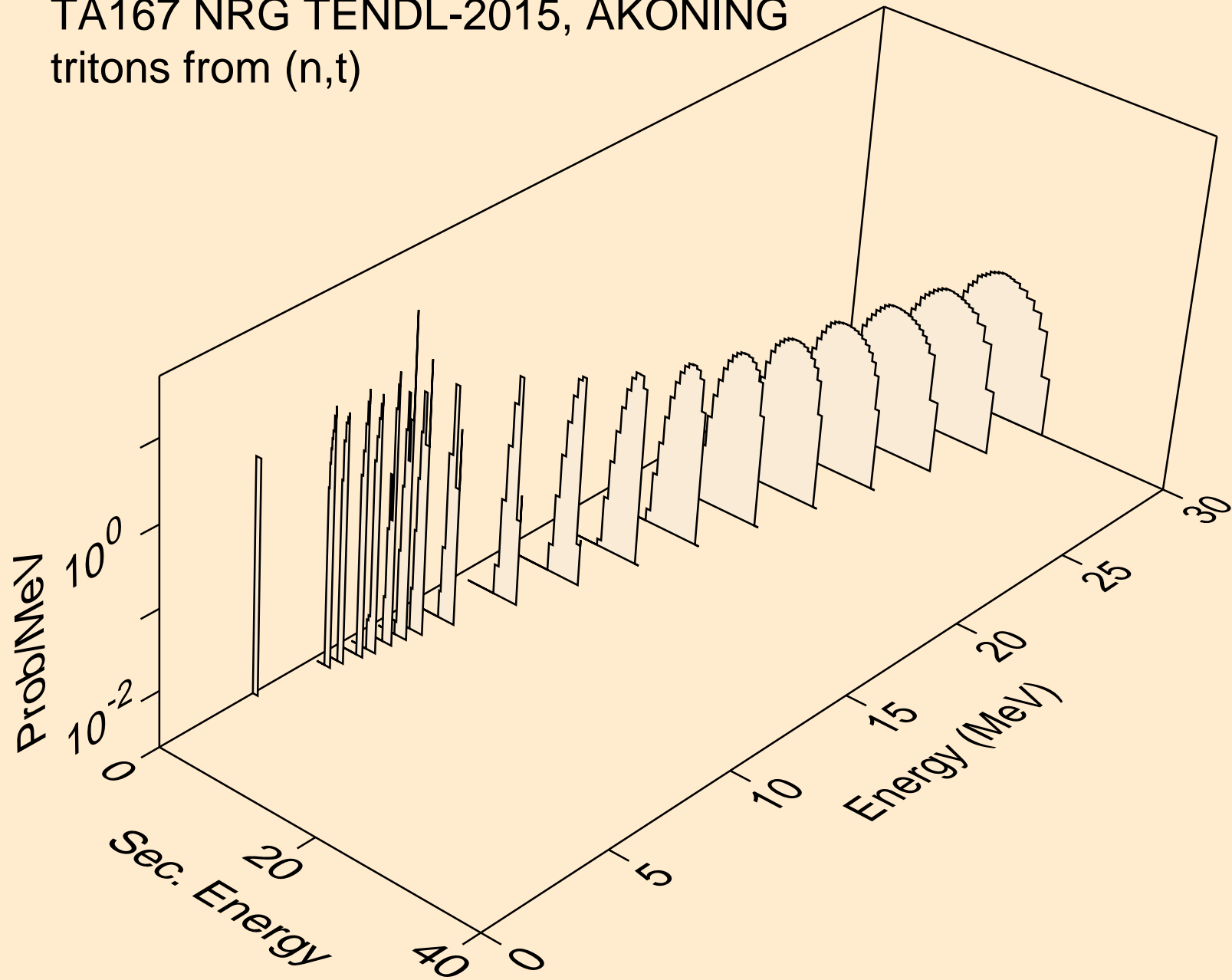

TA167 NRG TENDL-2015, AKONING  
tritons from (n,pt)

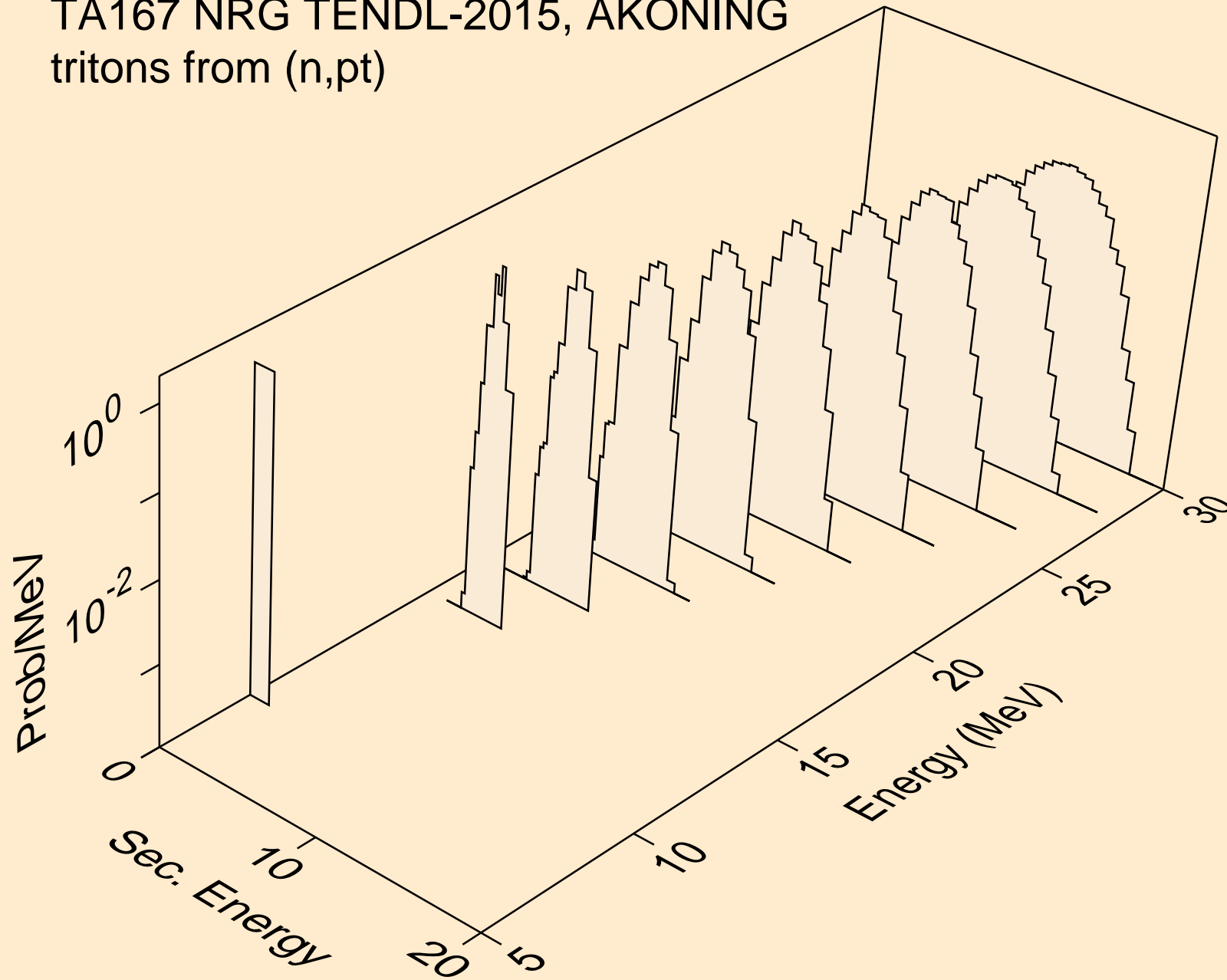

TA167 NRG TENDL-2015, AKONING  
he3s from (n,x)

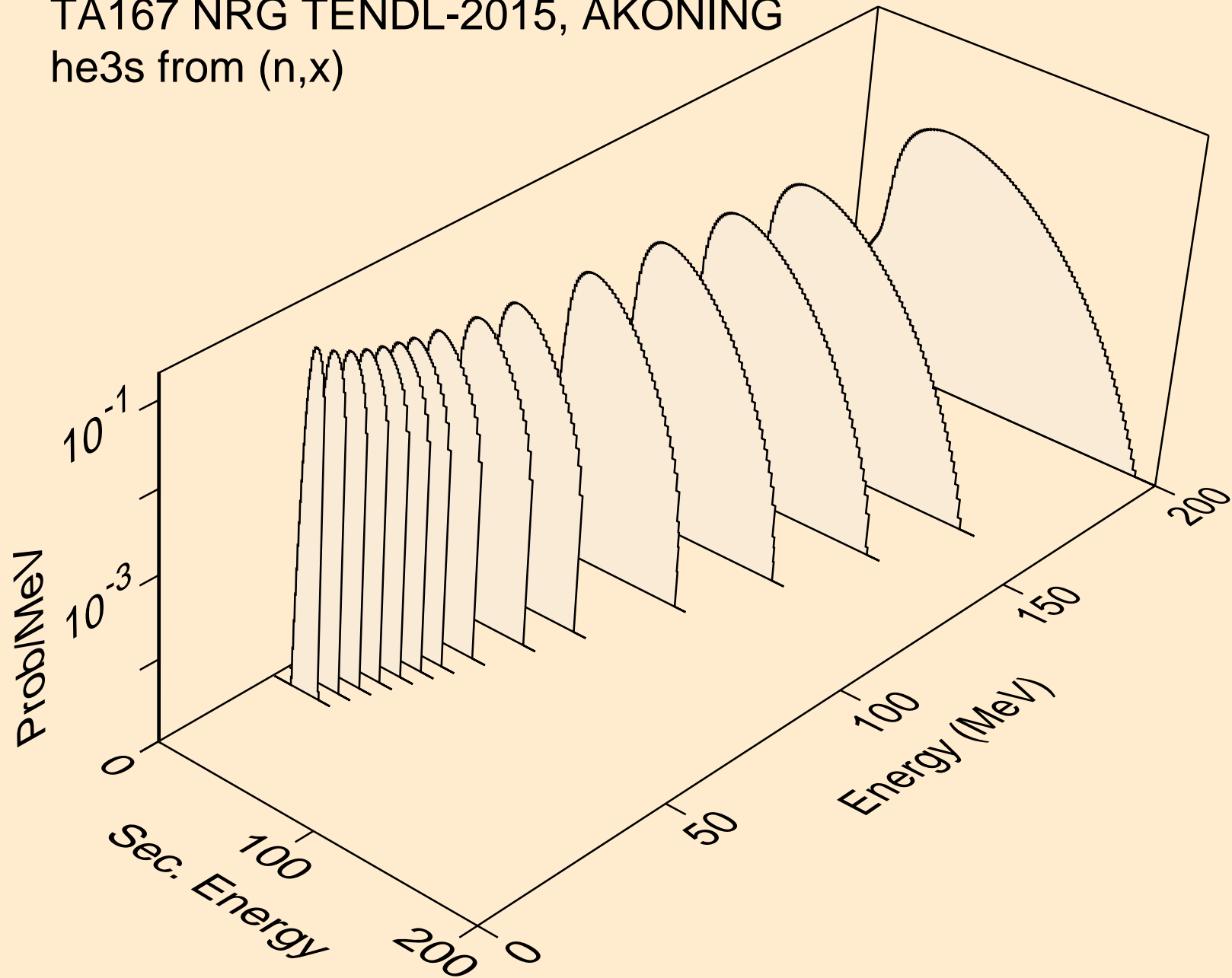

TA167 NRG TENDL-2015, AKONING  
he3s from (n,n\*)he3

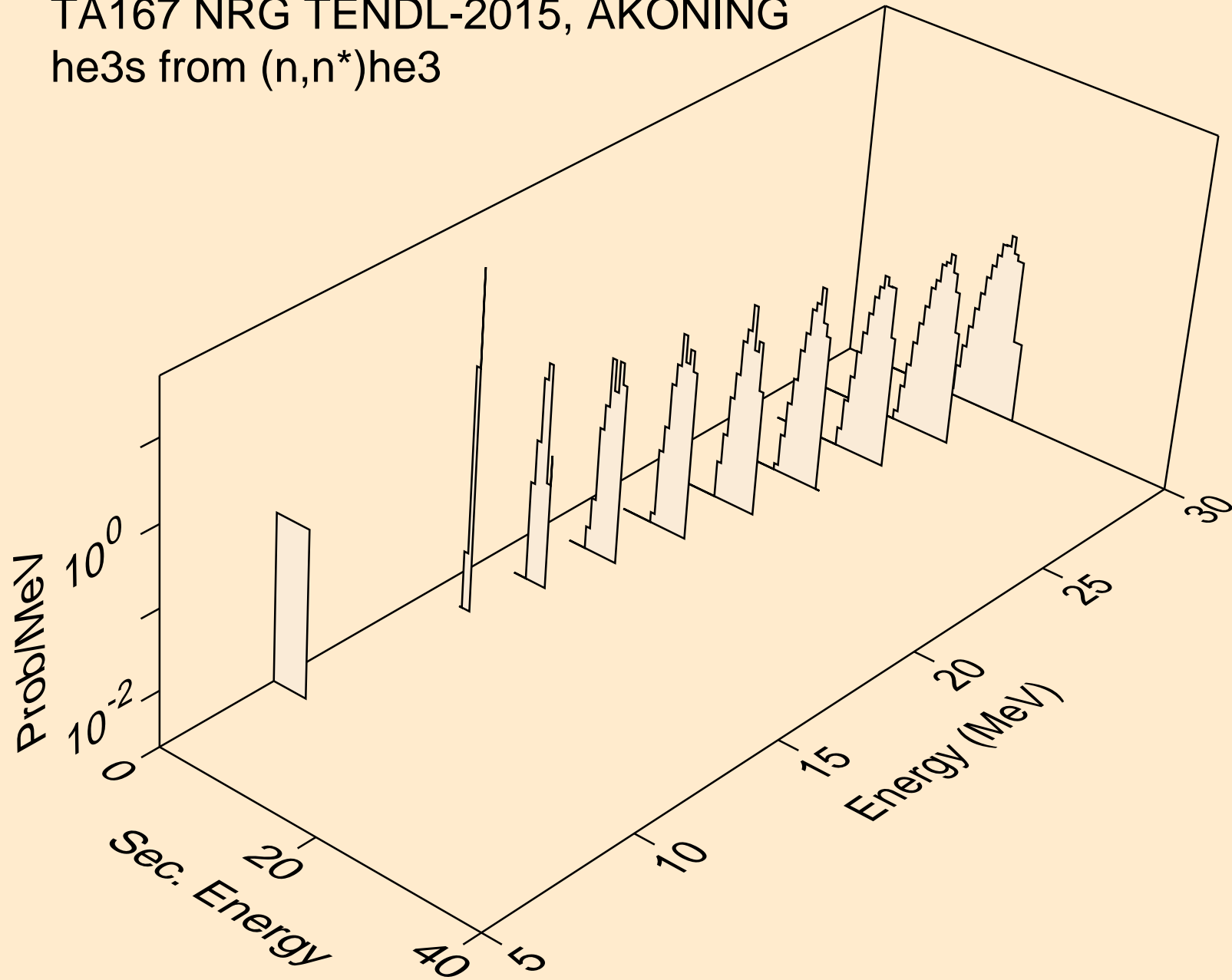



TA167 NRG TENDL-2015, AKONING  
he3s from (n,he3)

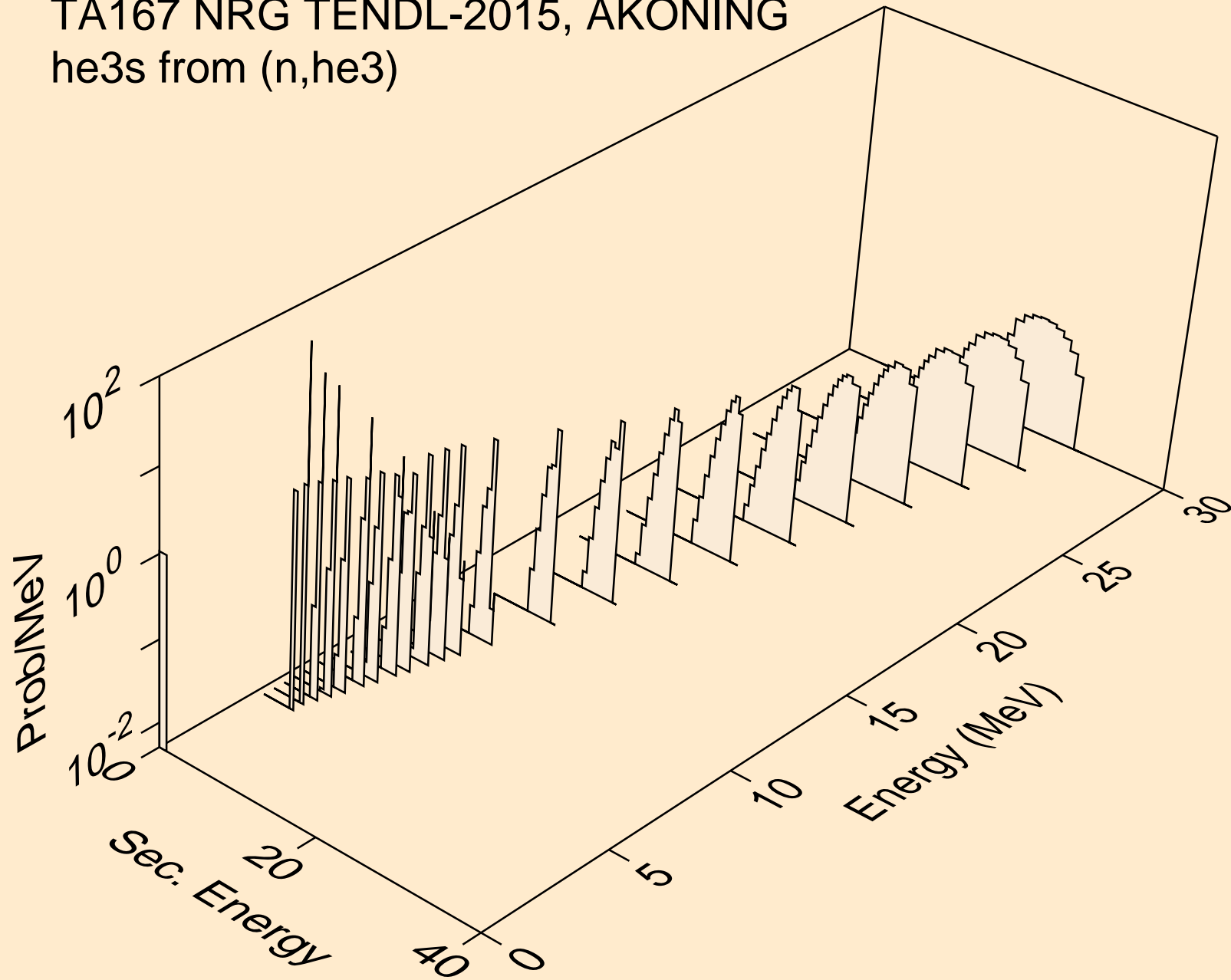

TA167 NRG TENDL-2015, AKONING  
alphas from (n,x)

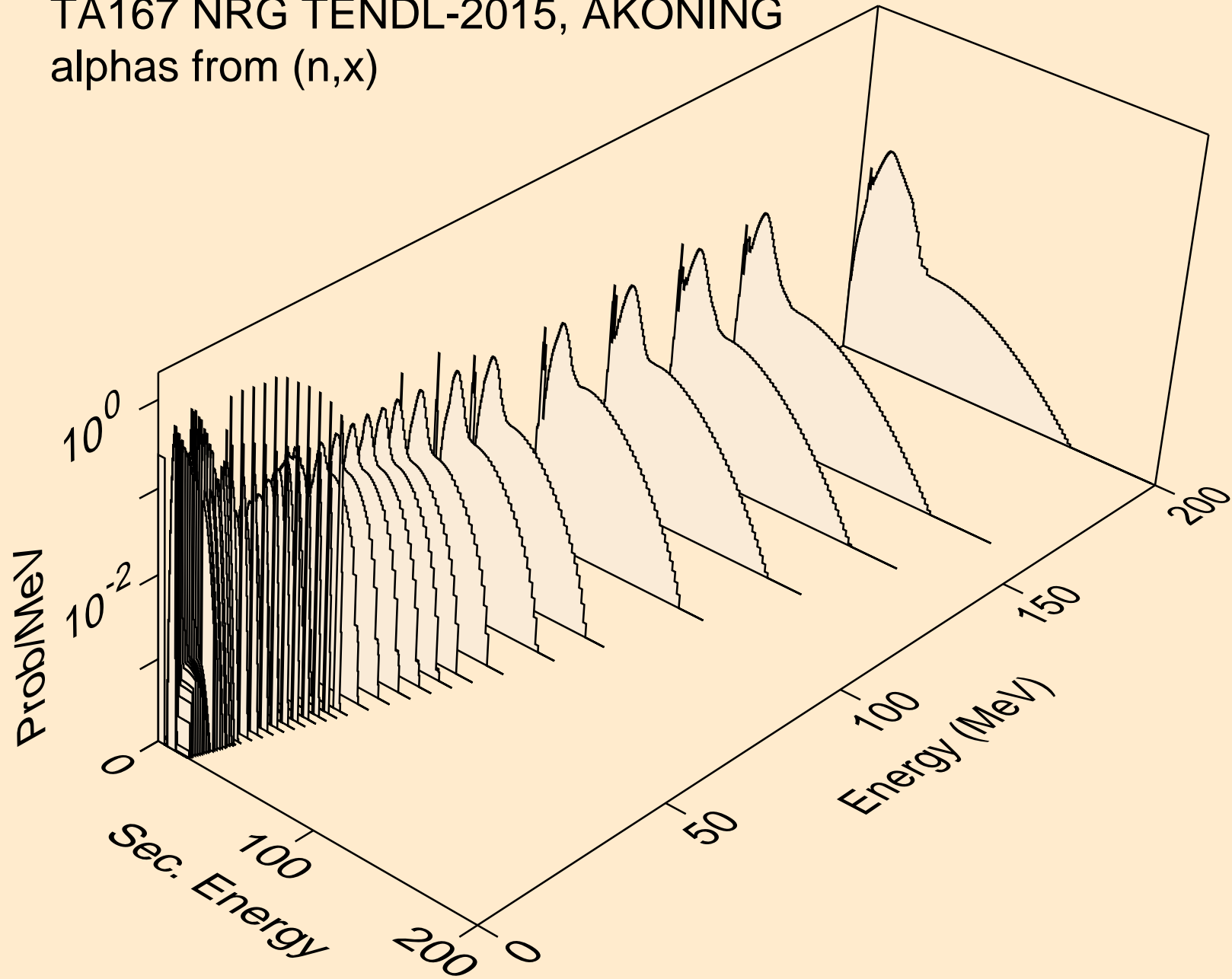

TA167 NRG TENDL-2015, AKONING  
alphas from (n,n\*)a

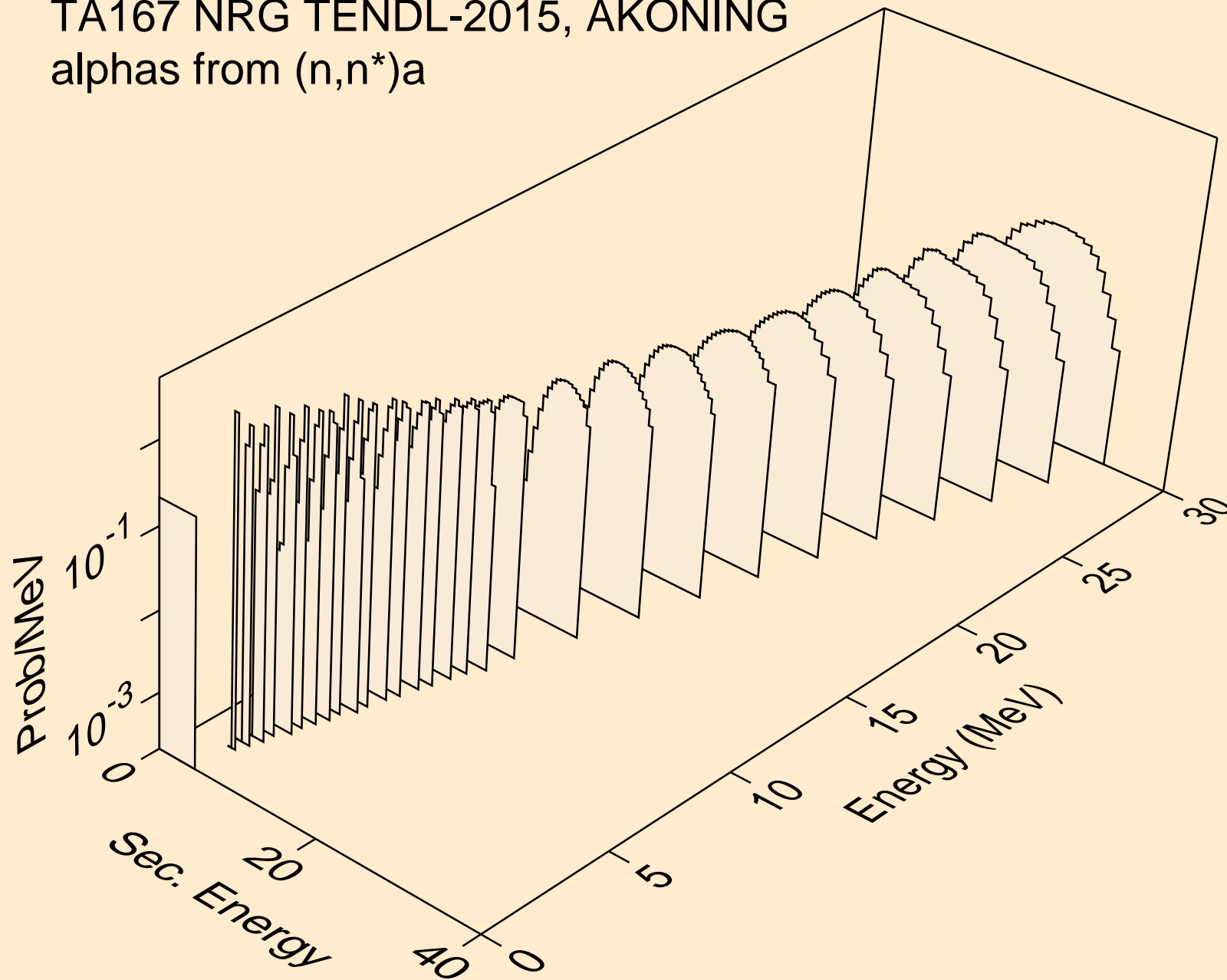

TA167 NRG TENDL-2015, AKONING  
alphas from (n,n\*)3a

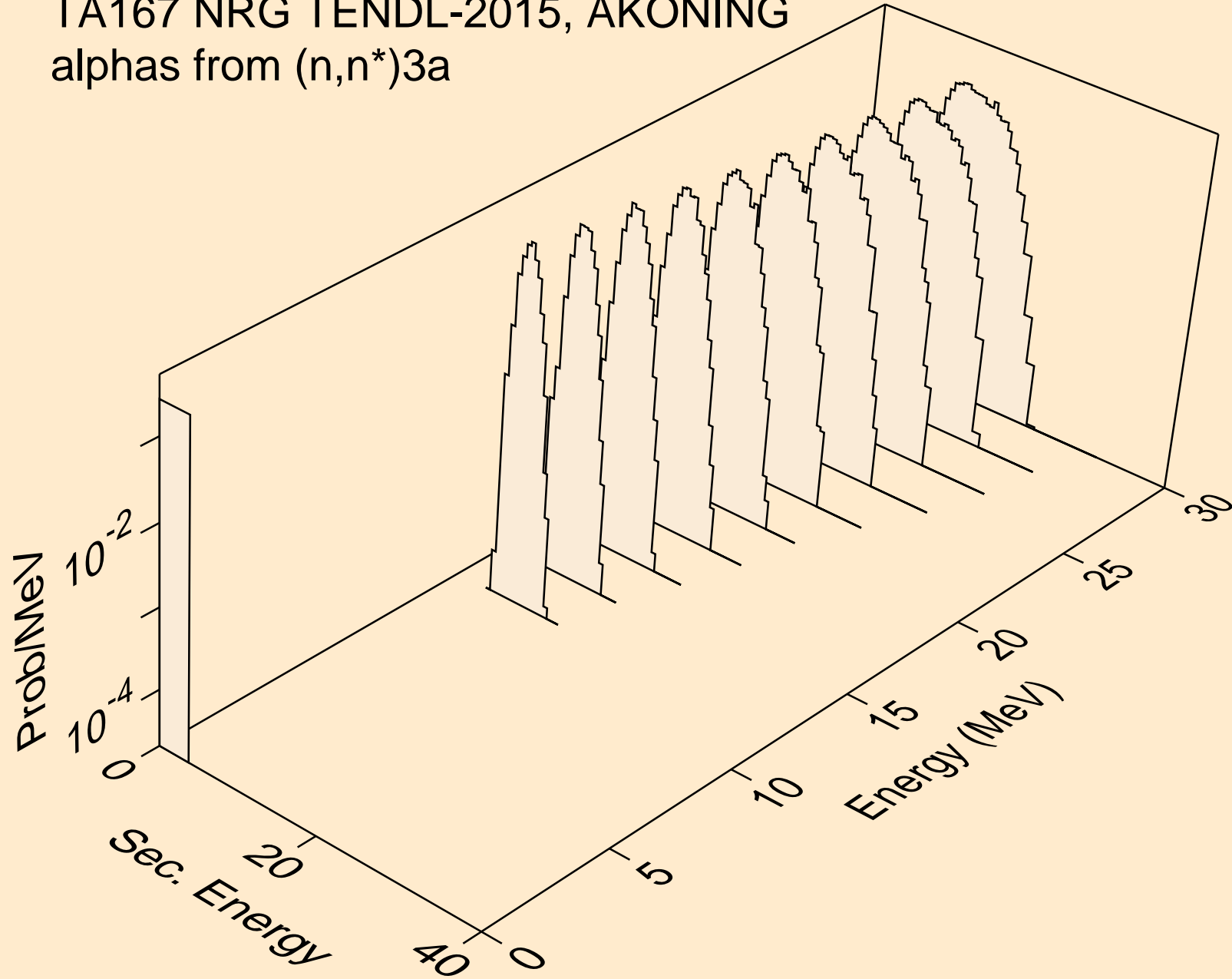

TA167 NRG TENDL-2015, AKONING  
alphas from (n,2n)a

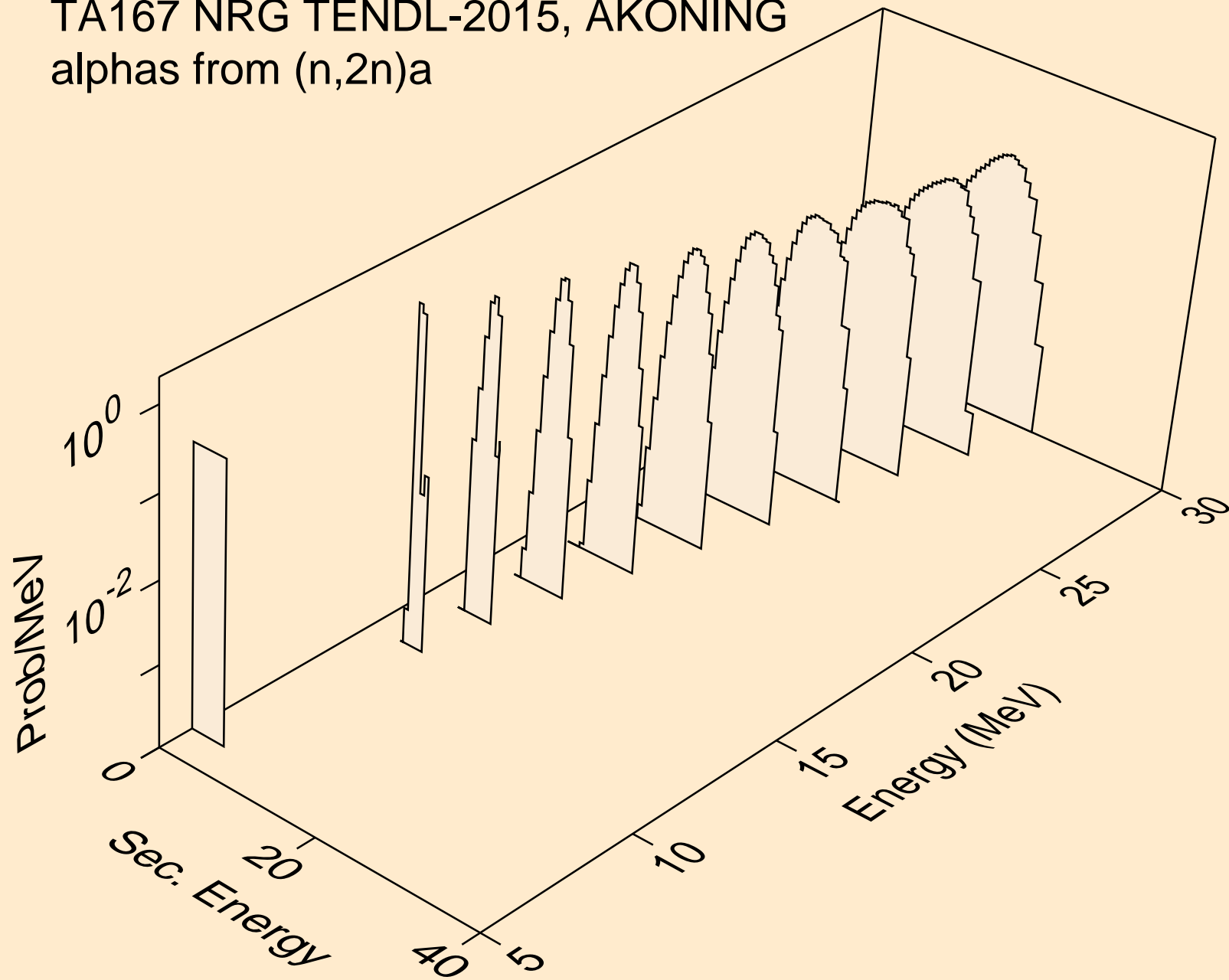

TA167 NRG TENDL-2015, AKONING  
alphas from (n,3n)a

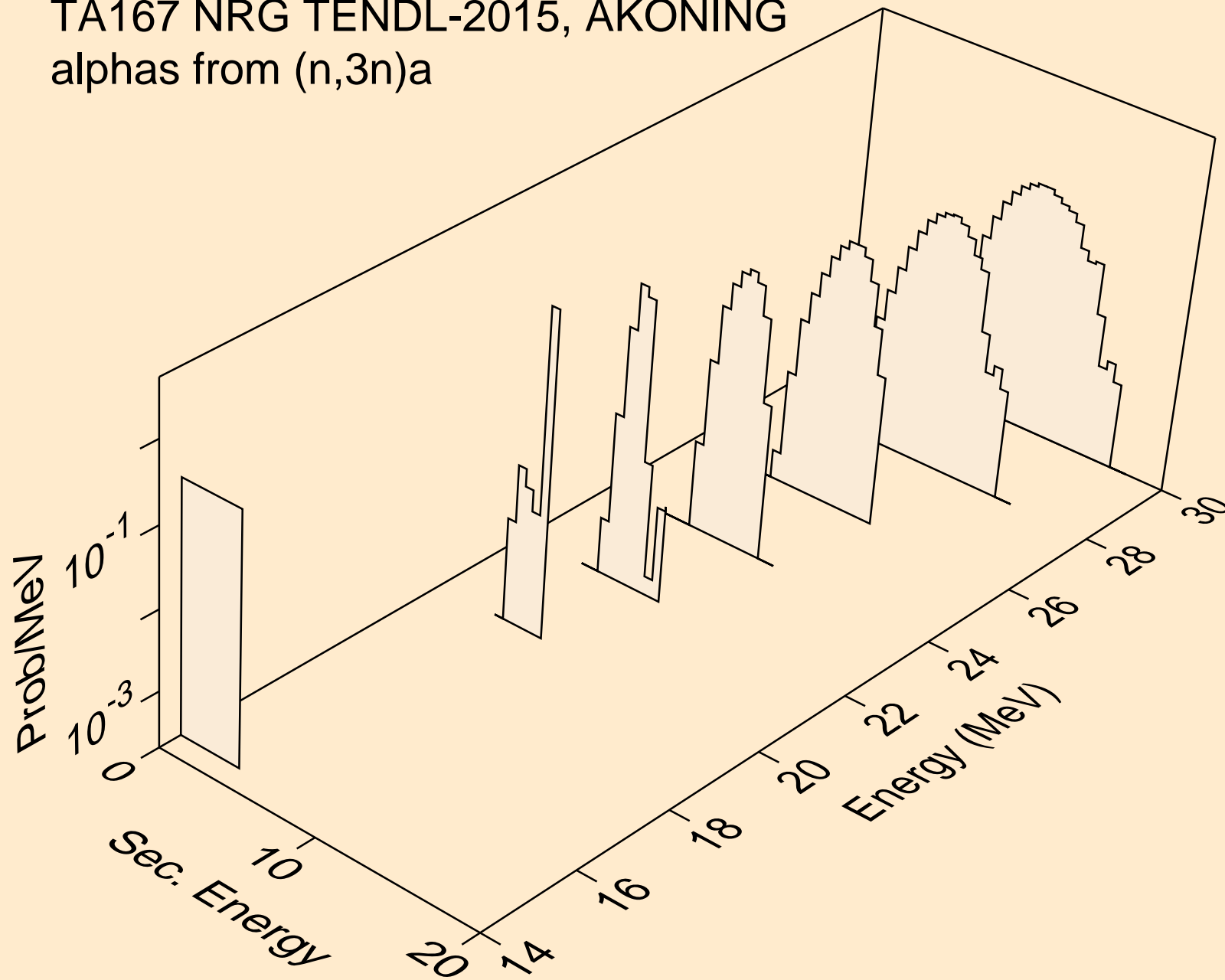

TA167 NRG TENDL-2015, AKONING  
alphas from (n,n\*)2a

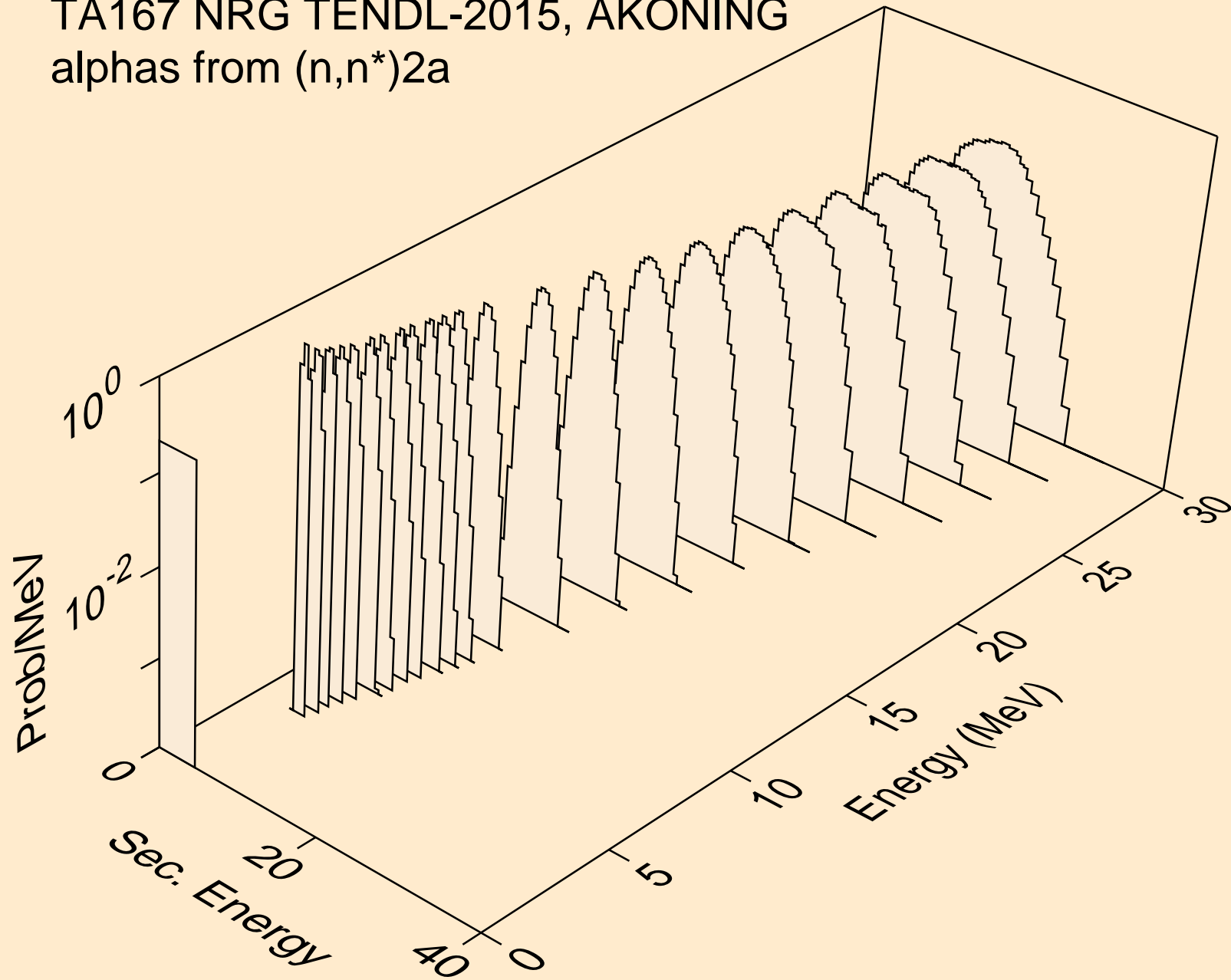

TA167 NRG TENDL-2015, AKONING  
alphas from (n,2n)2a

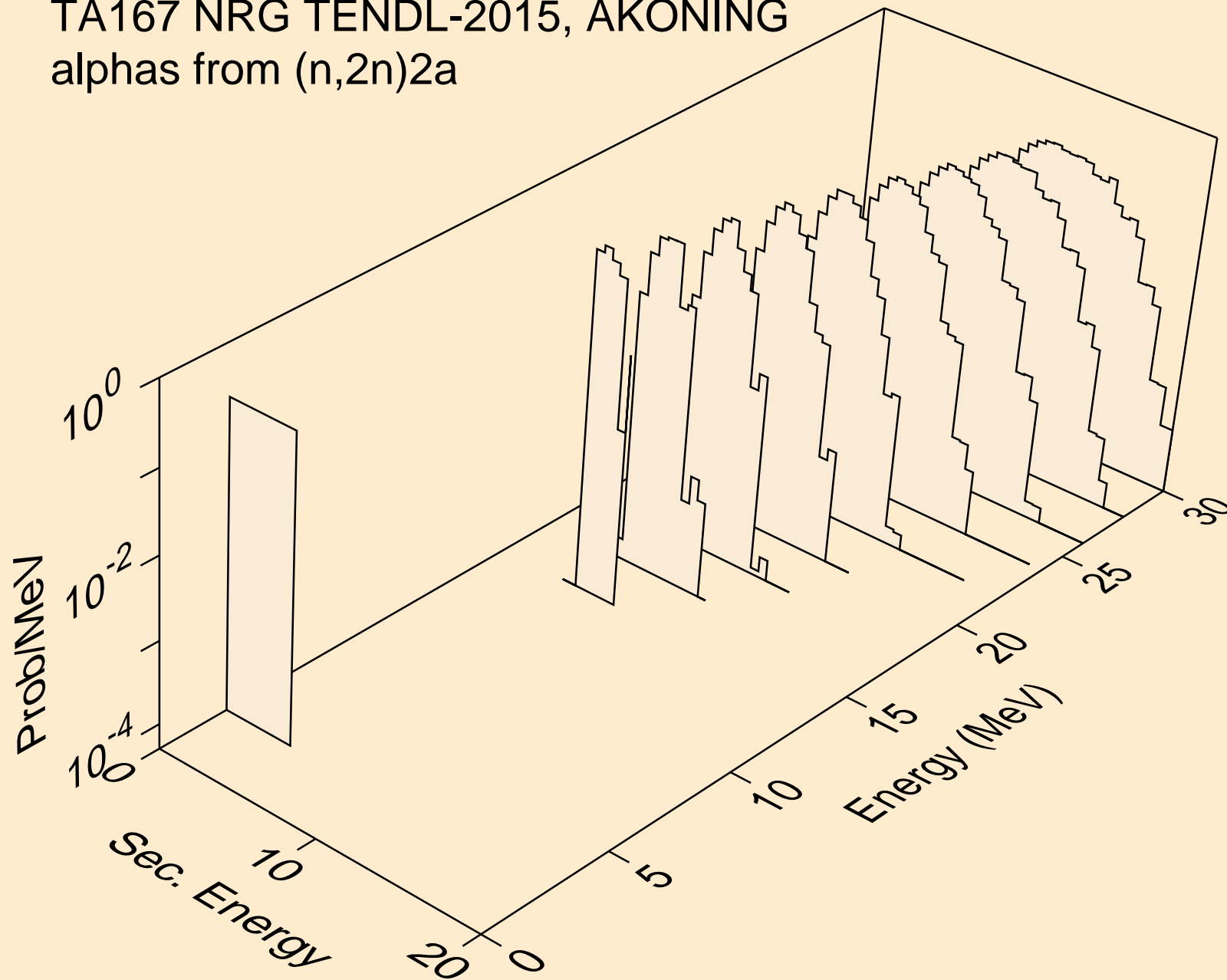



TA167 NRG TENDL-2015, AKONING  
alphas from (n,npa)

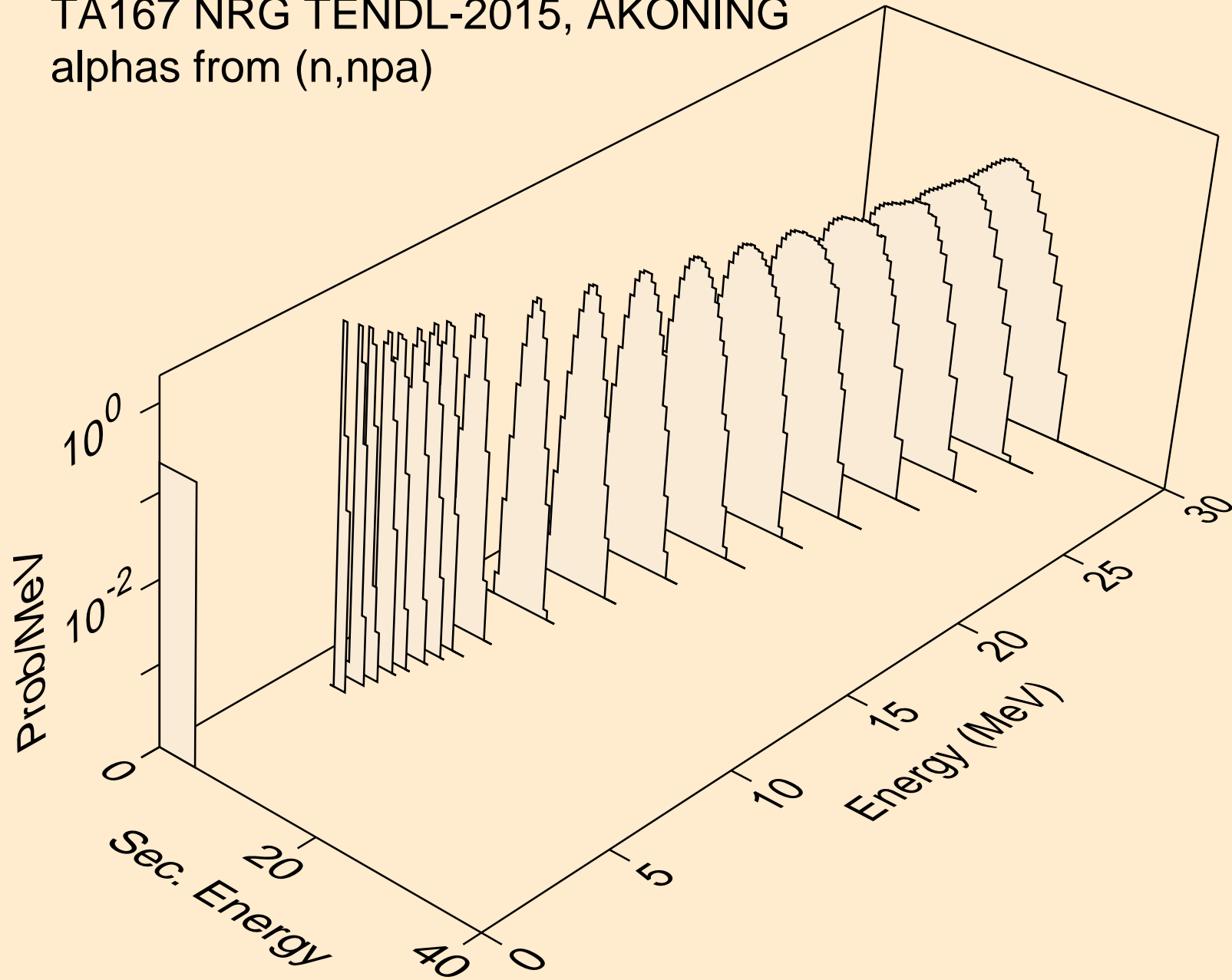

TA167 NRG TENDL-2015, AKONING  
alphas from (n,a)

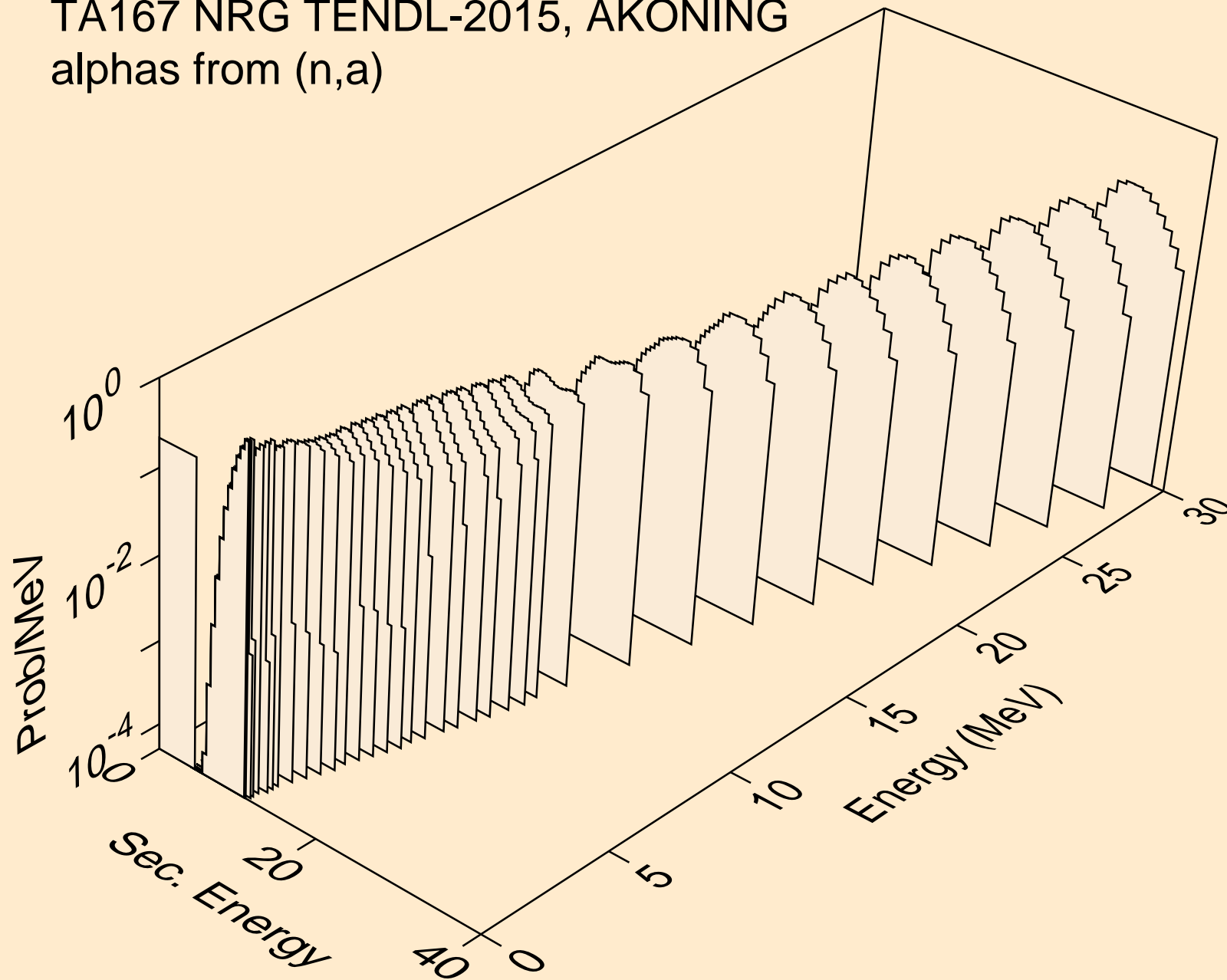

TA167 NRG TENDL-2015, AKONING  
alphas from (n,2a)

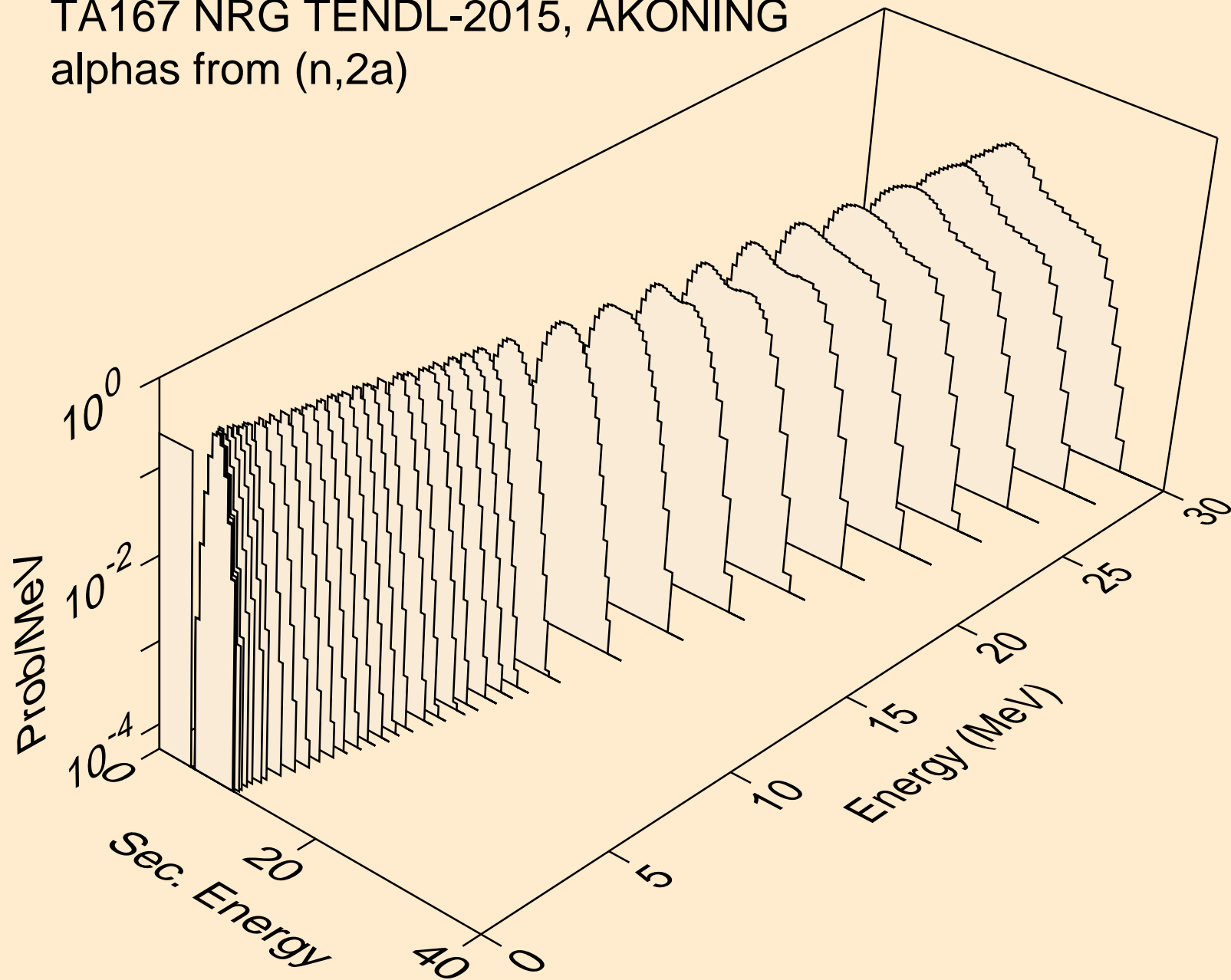

TA167 NRG TENDL-2015, AKONING  
alphas from (n,3a)

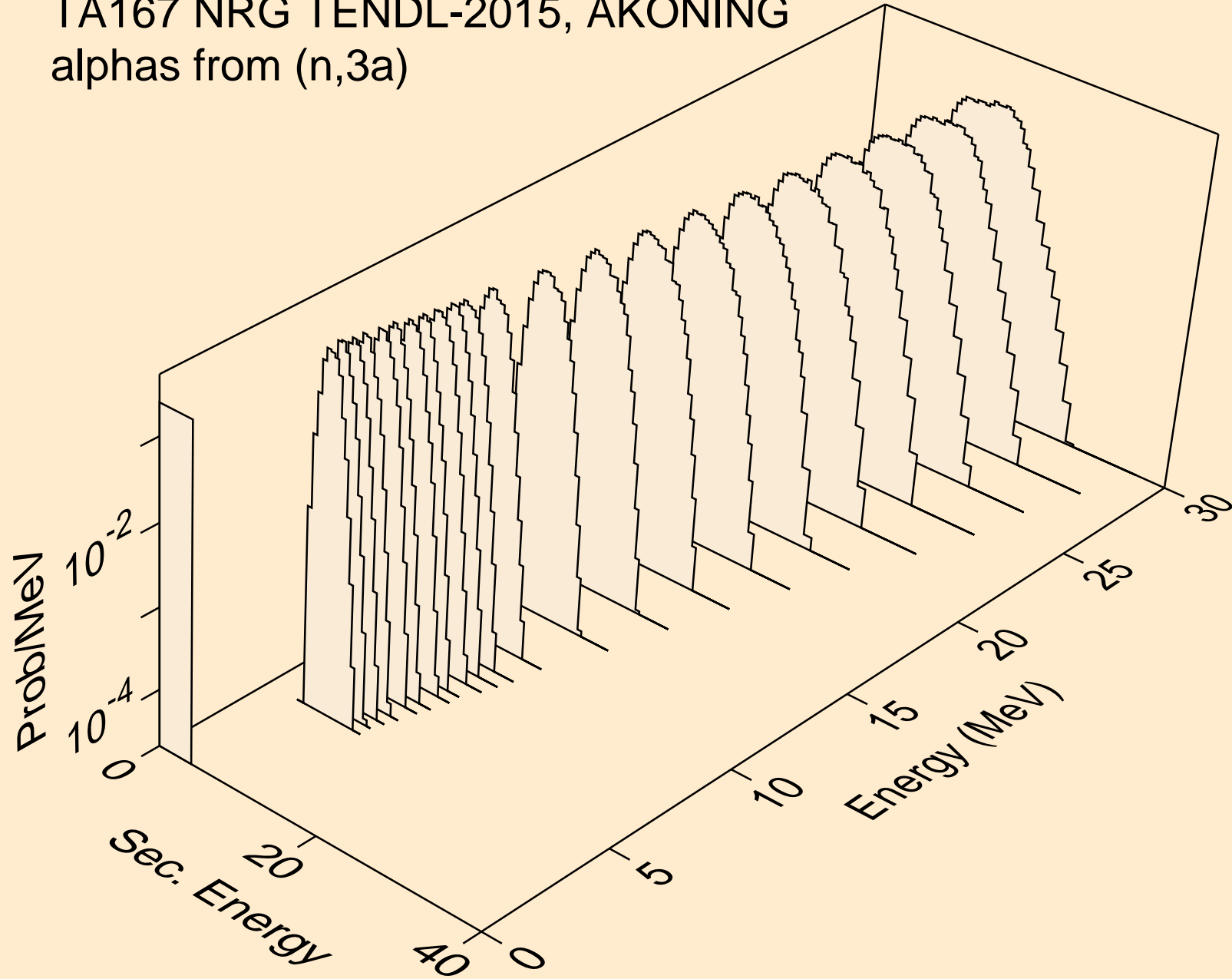

TA167 NRG TENDL-2015, AKONING  
alphas from (n,pa)

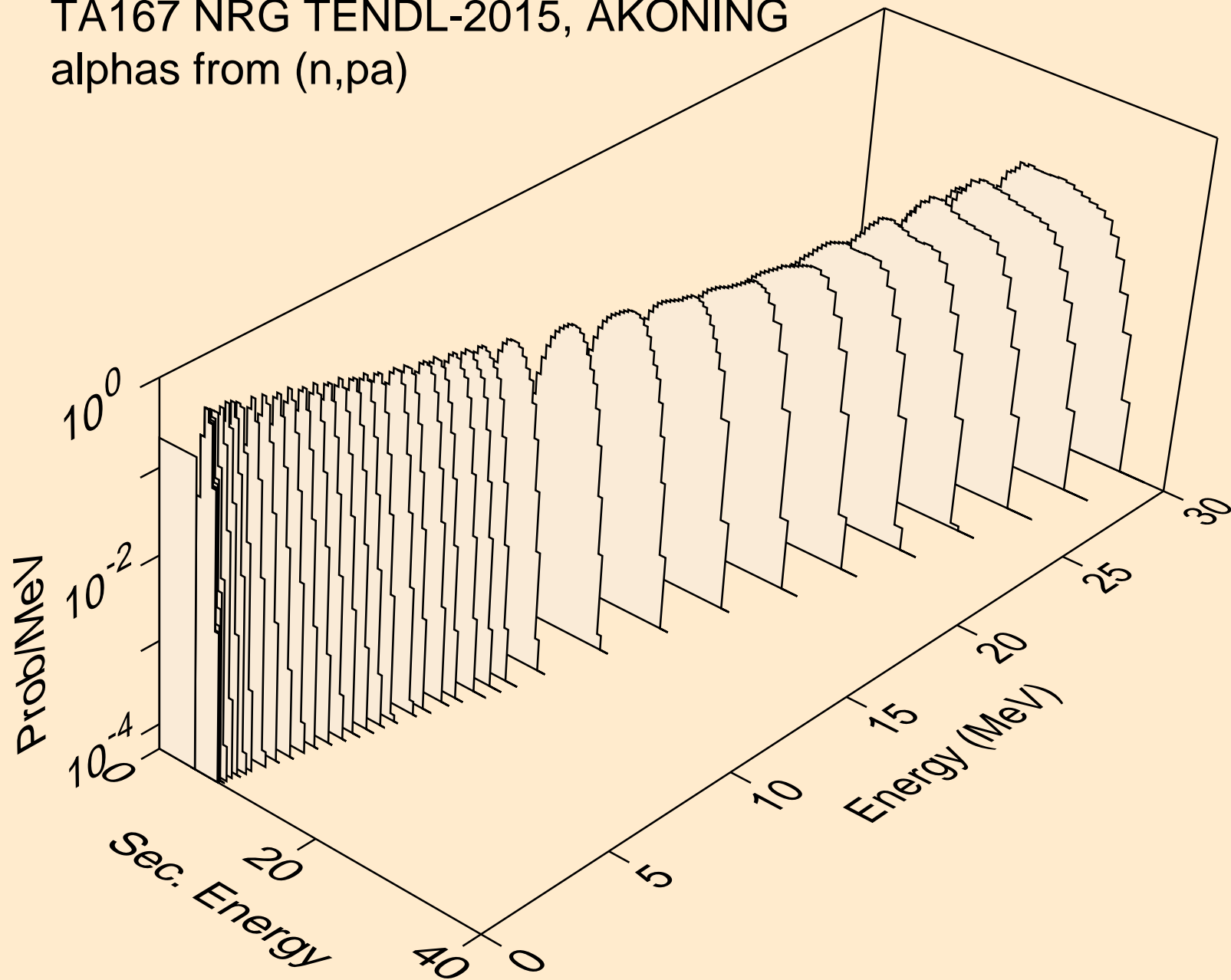

TA167 NRG TENDL-2015, AKONING  
alphas from (n,d2a)

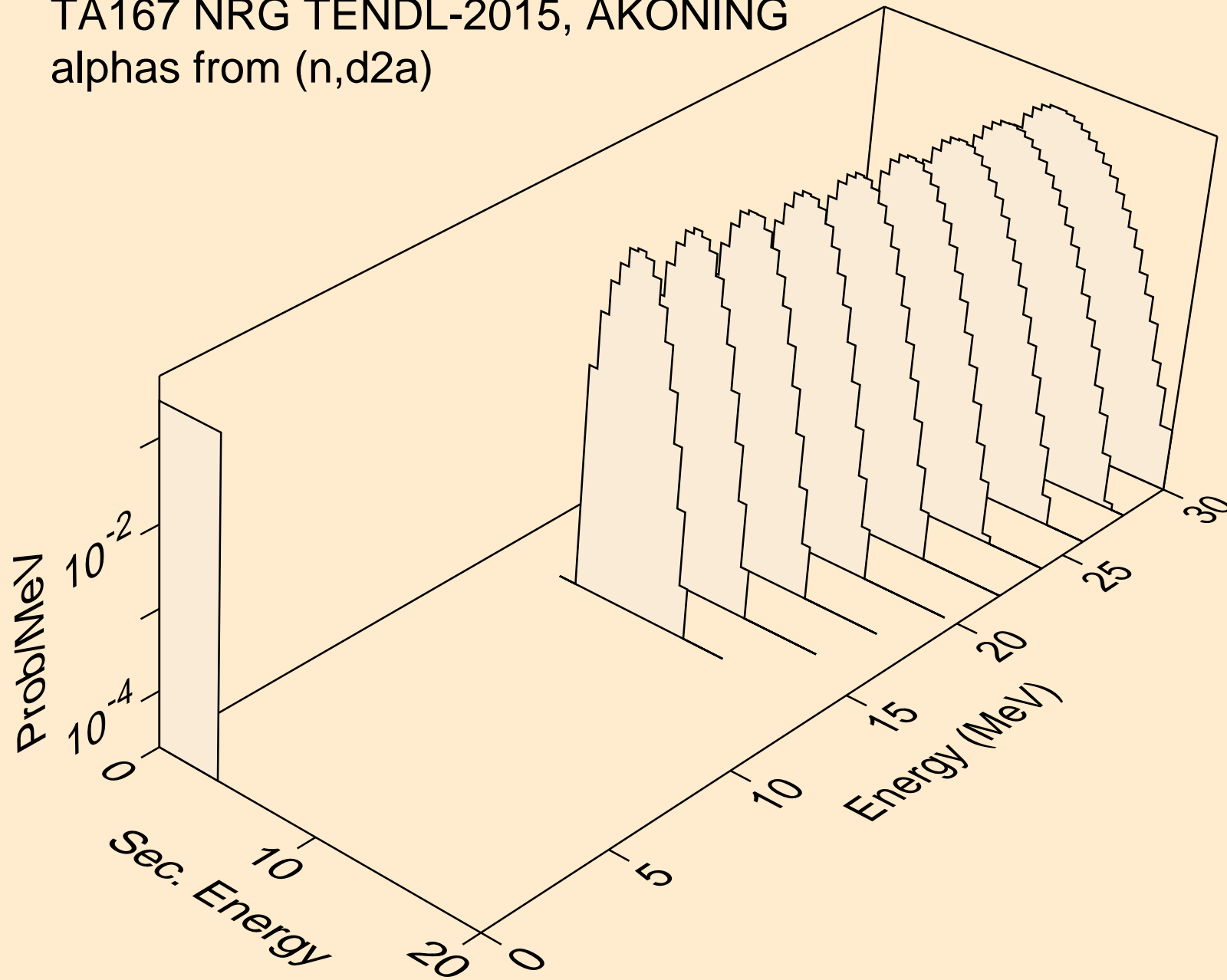

TA167 NRG TENDL-2015, AKONING  
alphas from (n,da)

