

# TE112 NRG TENDL-2015, AKONING

## Principal cross sections

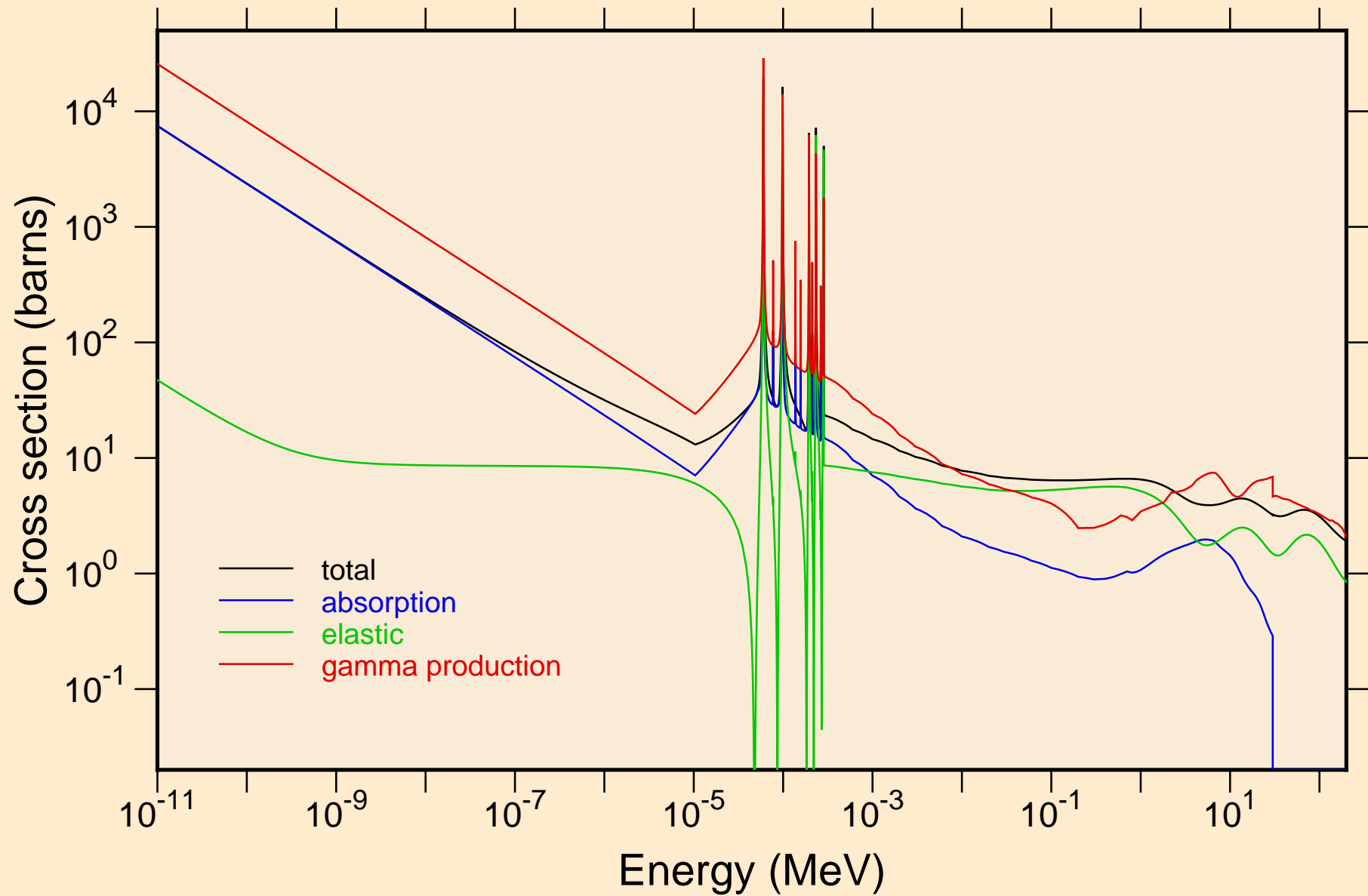

TE112 NRG TENDL-2015, AKONING  
resonance total cross section

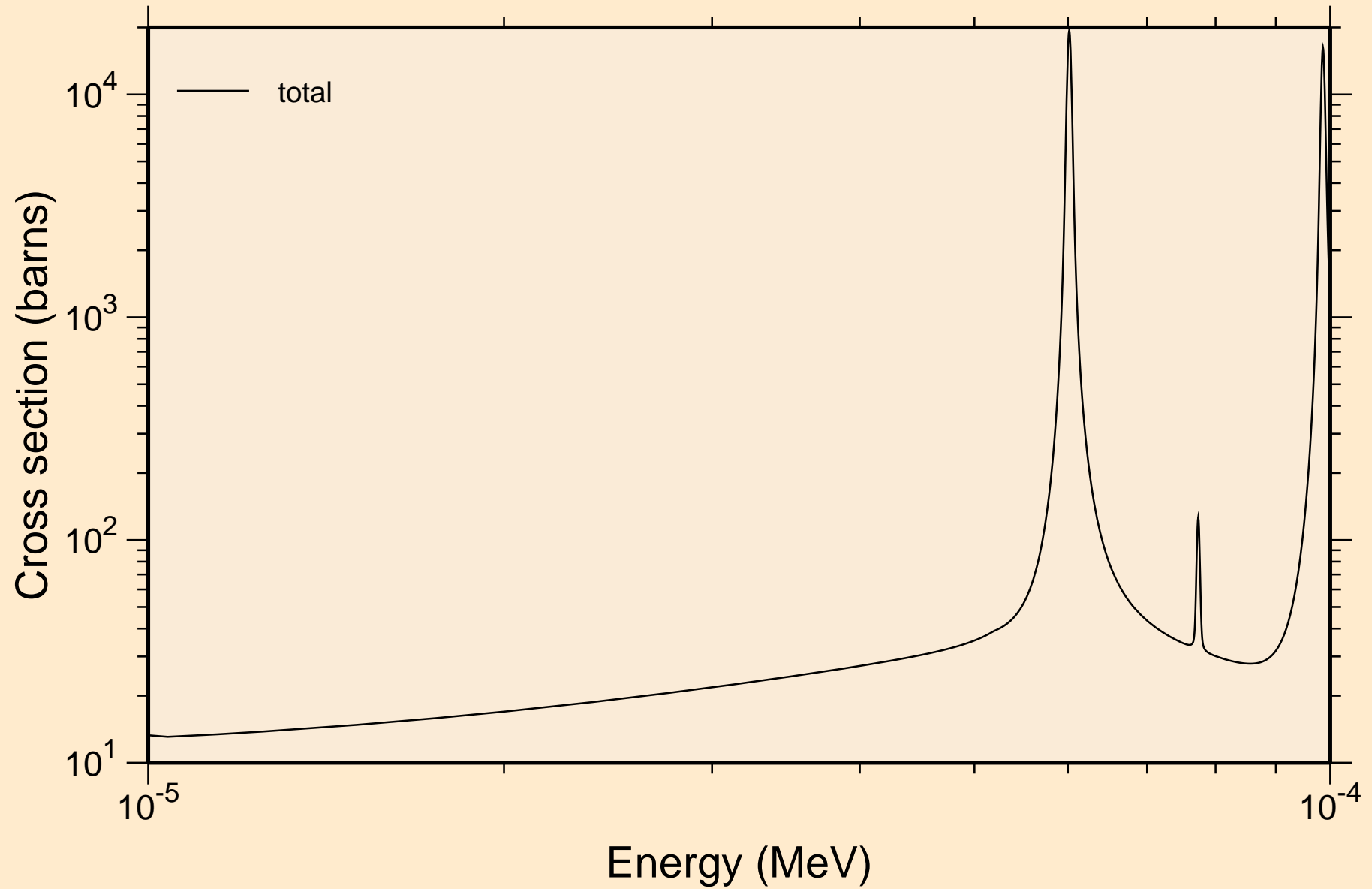

TE112 NRG TENDL-2015, AKONING  
resonance total cross section

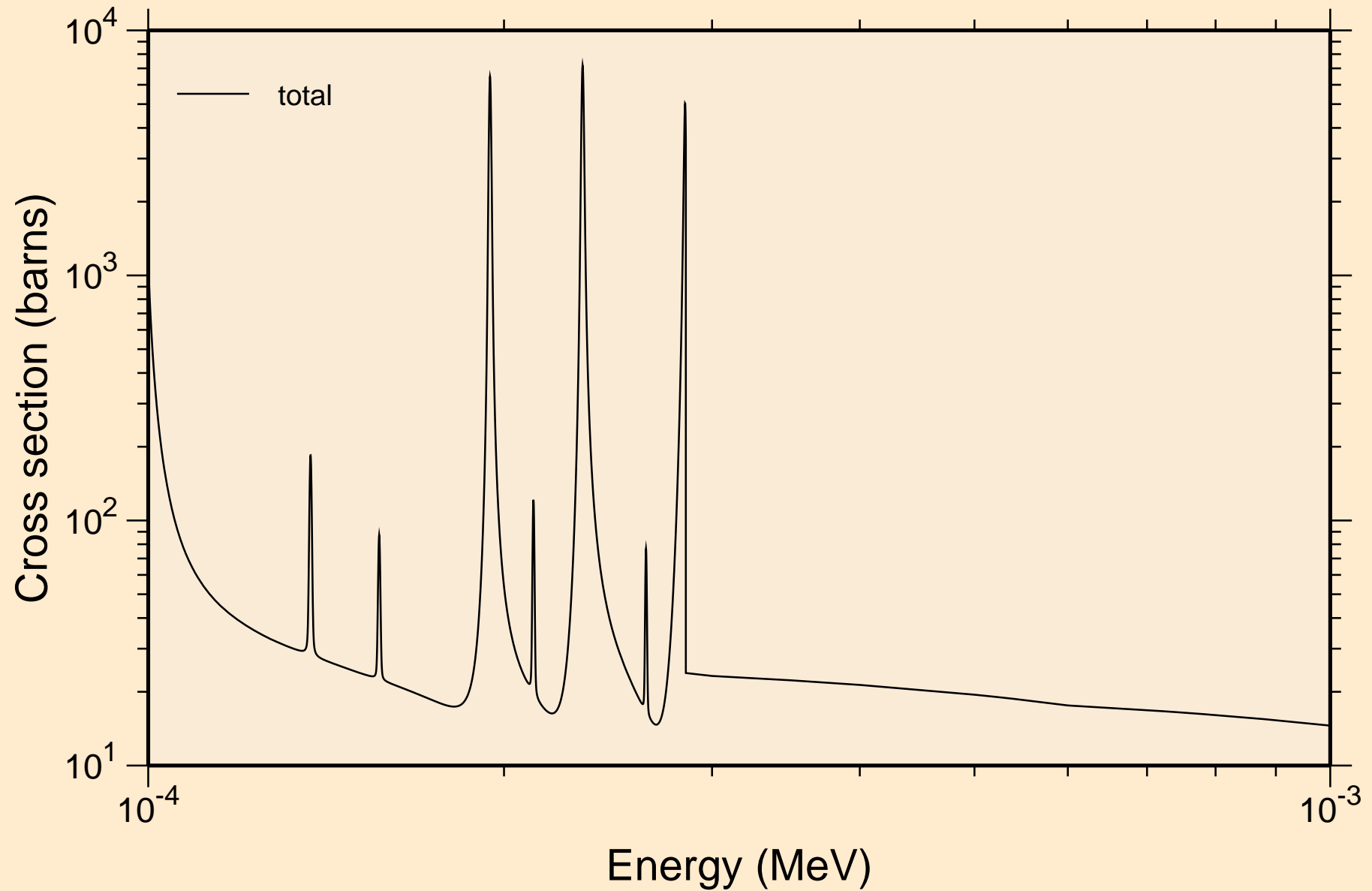

TE112 NRG TENDL-2015, AKONING  
resonance total cross section

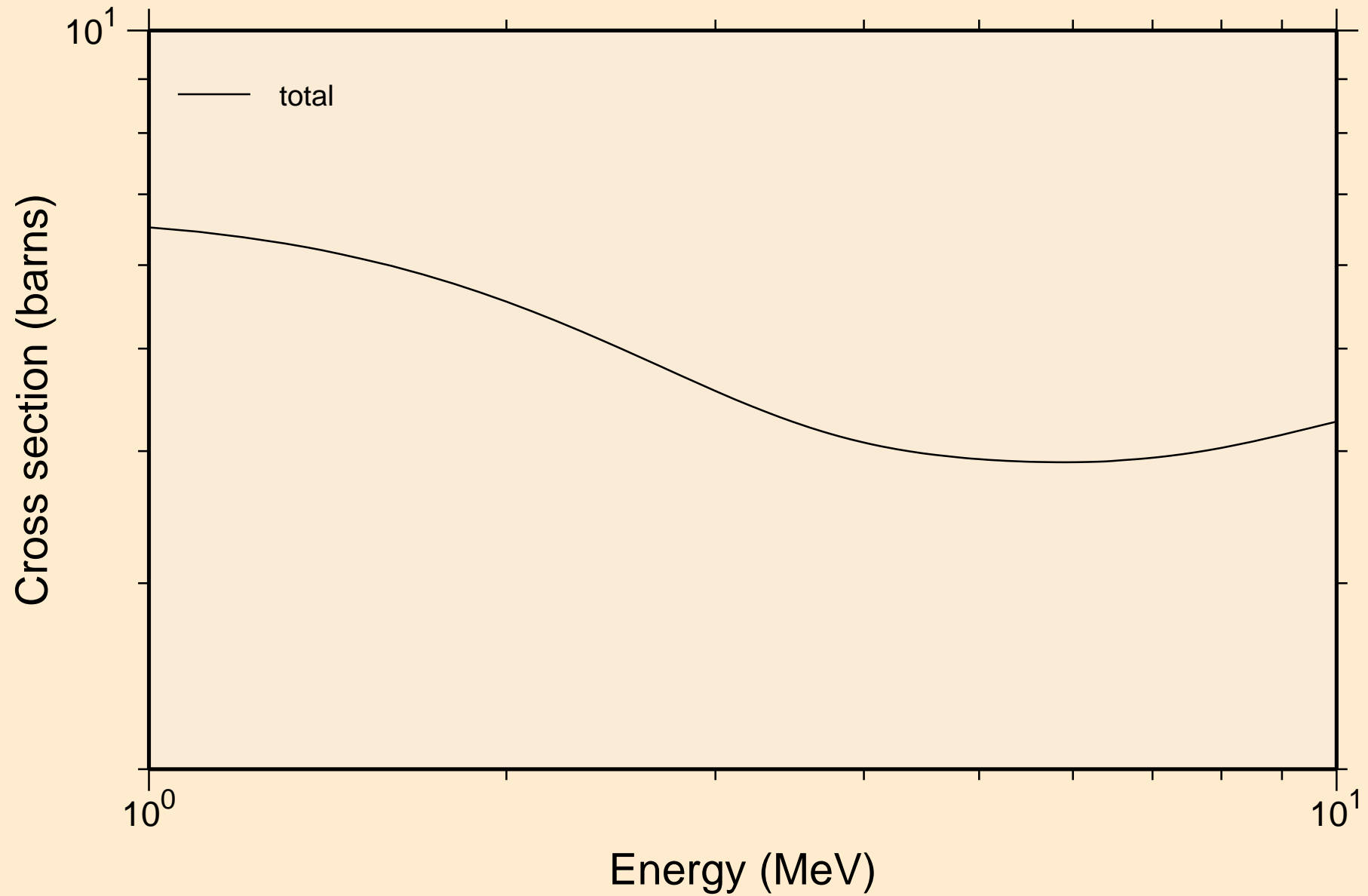

TE112 NRG TENDL-2015, AKONING  
resonance absorption cross sections

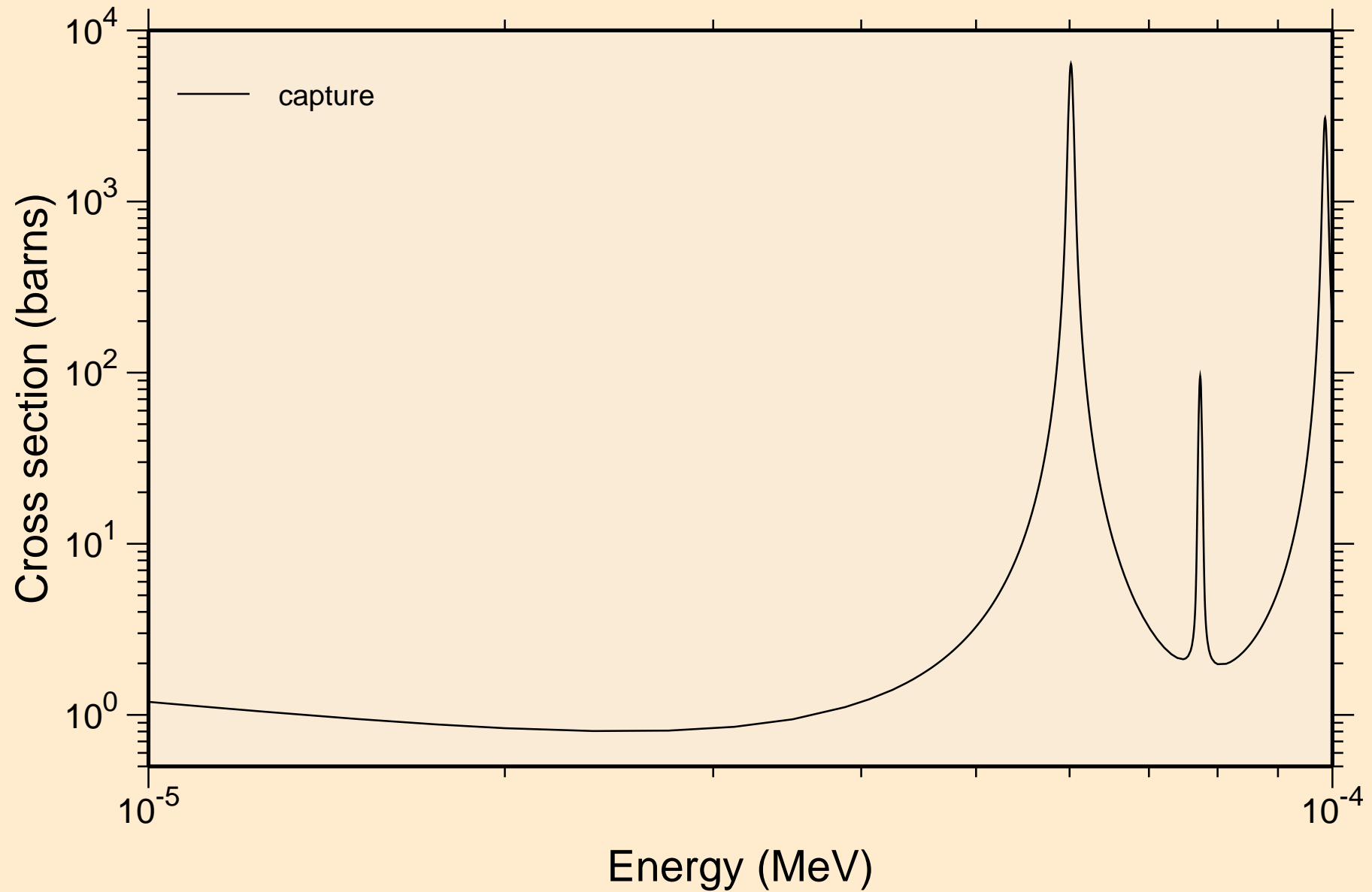

TE112 NRG TENDL-2015, AKONING  
resonance absorption cross sections

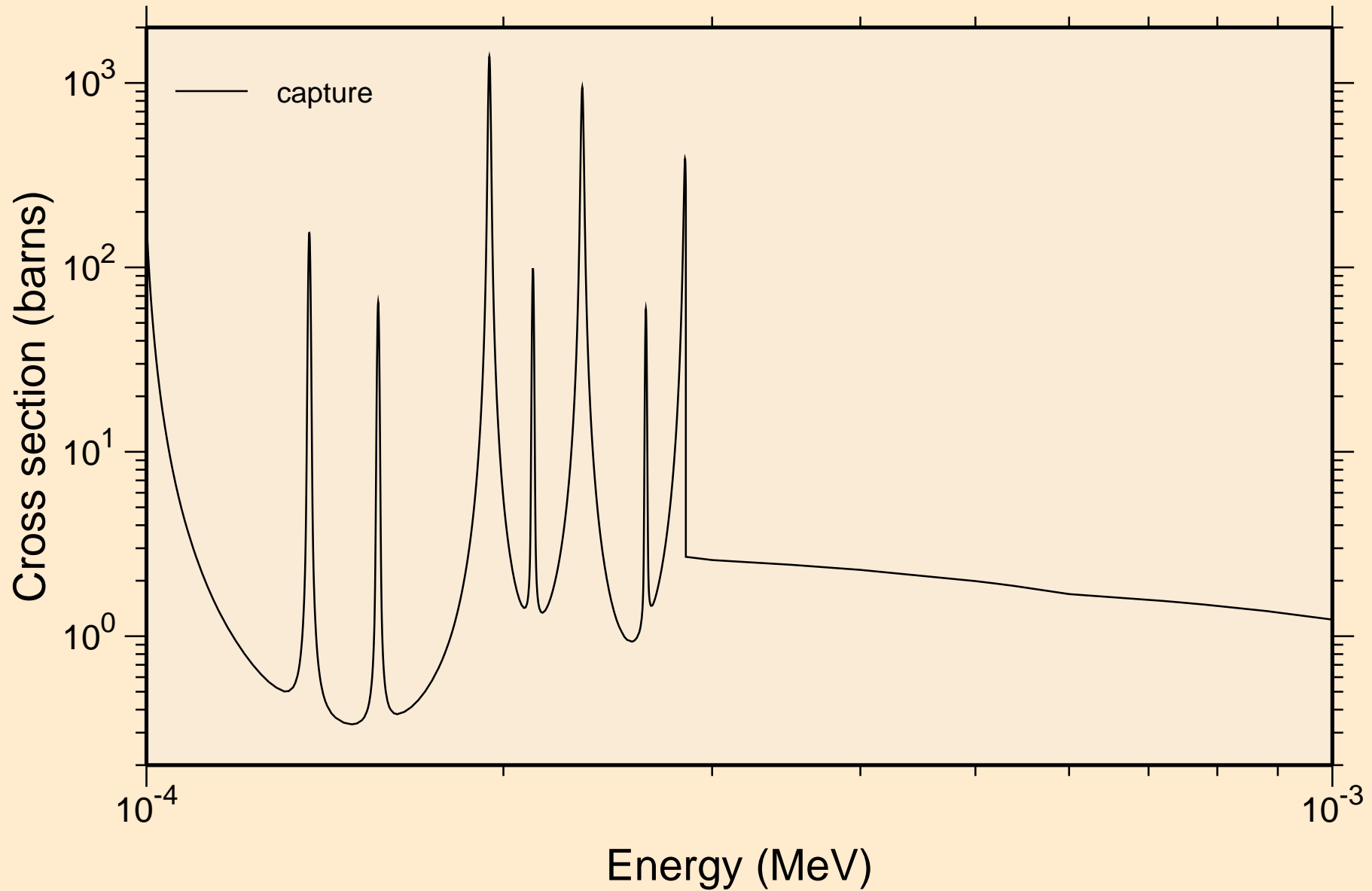

TE112 NRG TENDL-2015, AKONING  
resonance absorption cross sections

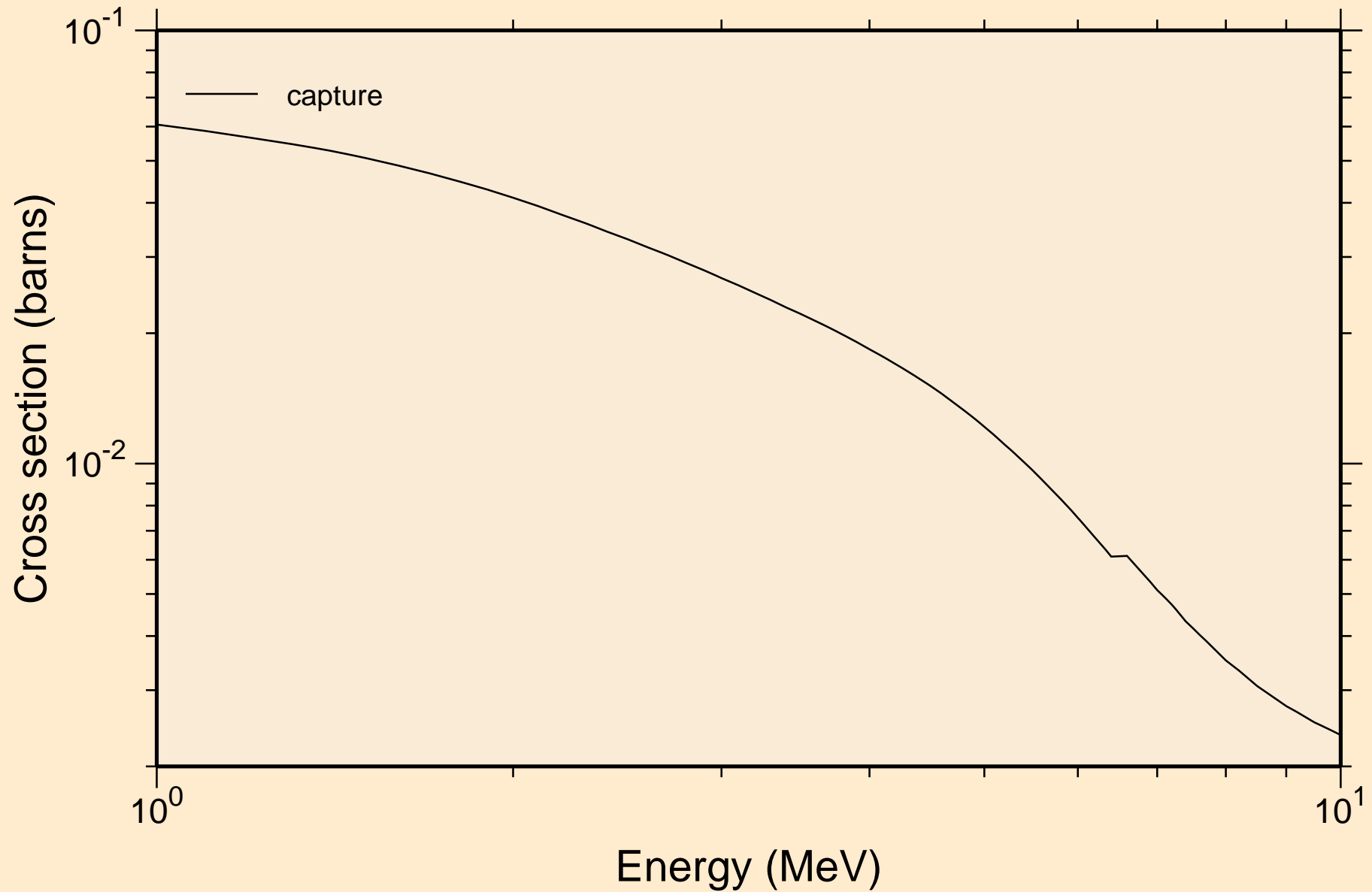

# TE112 NRG TENDL-2015, AKONING

## Non-threshold reactions

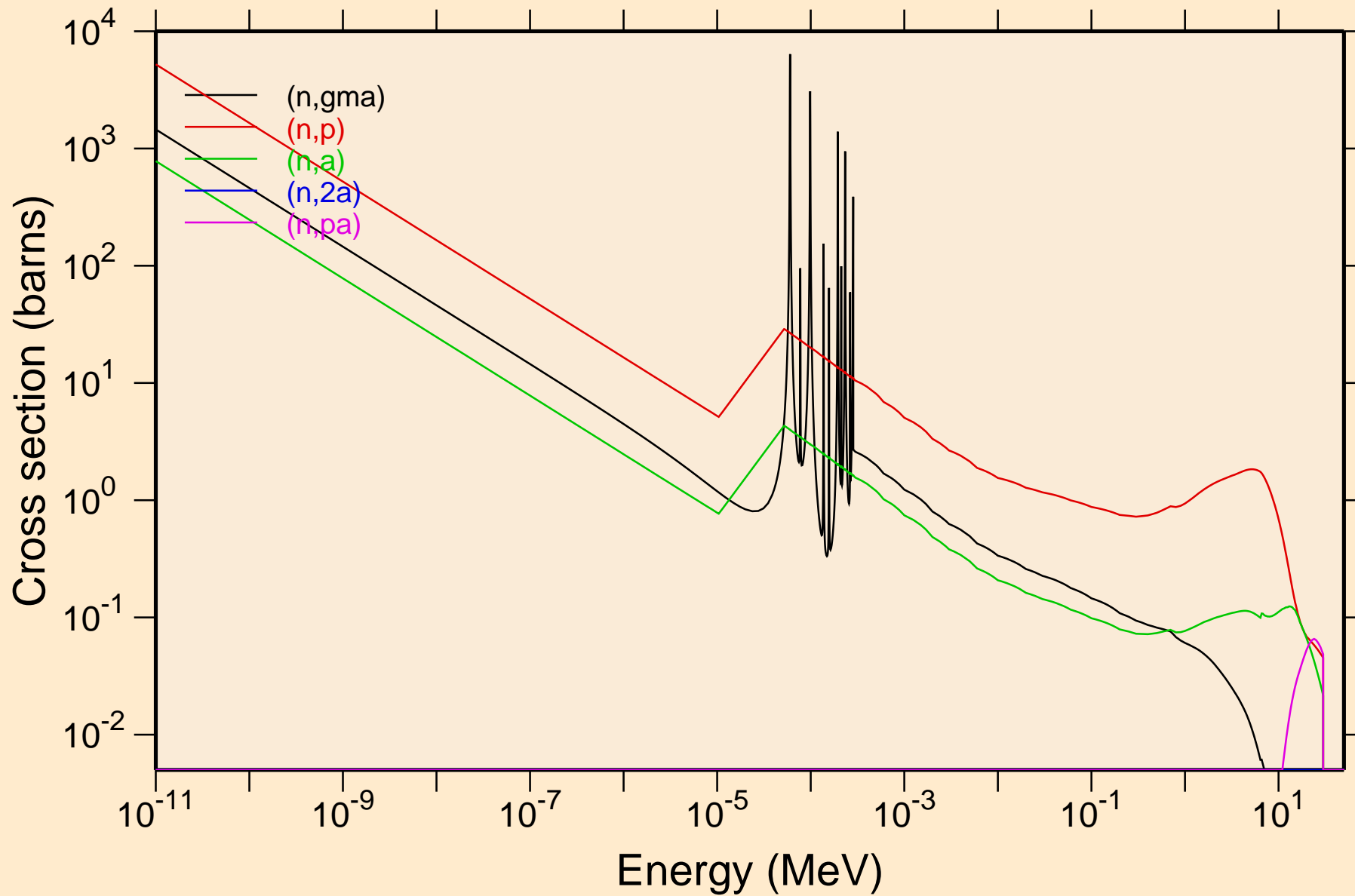



# TE112 NRG TENDL-2015, AKONING

## Principal cross sections

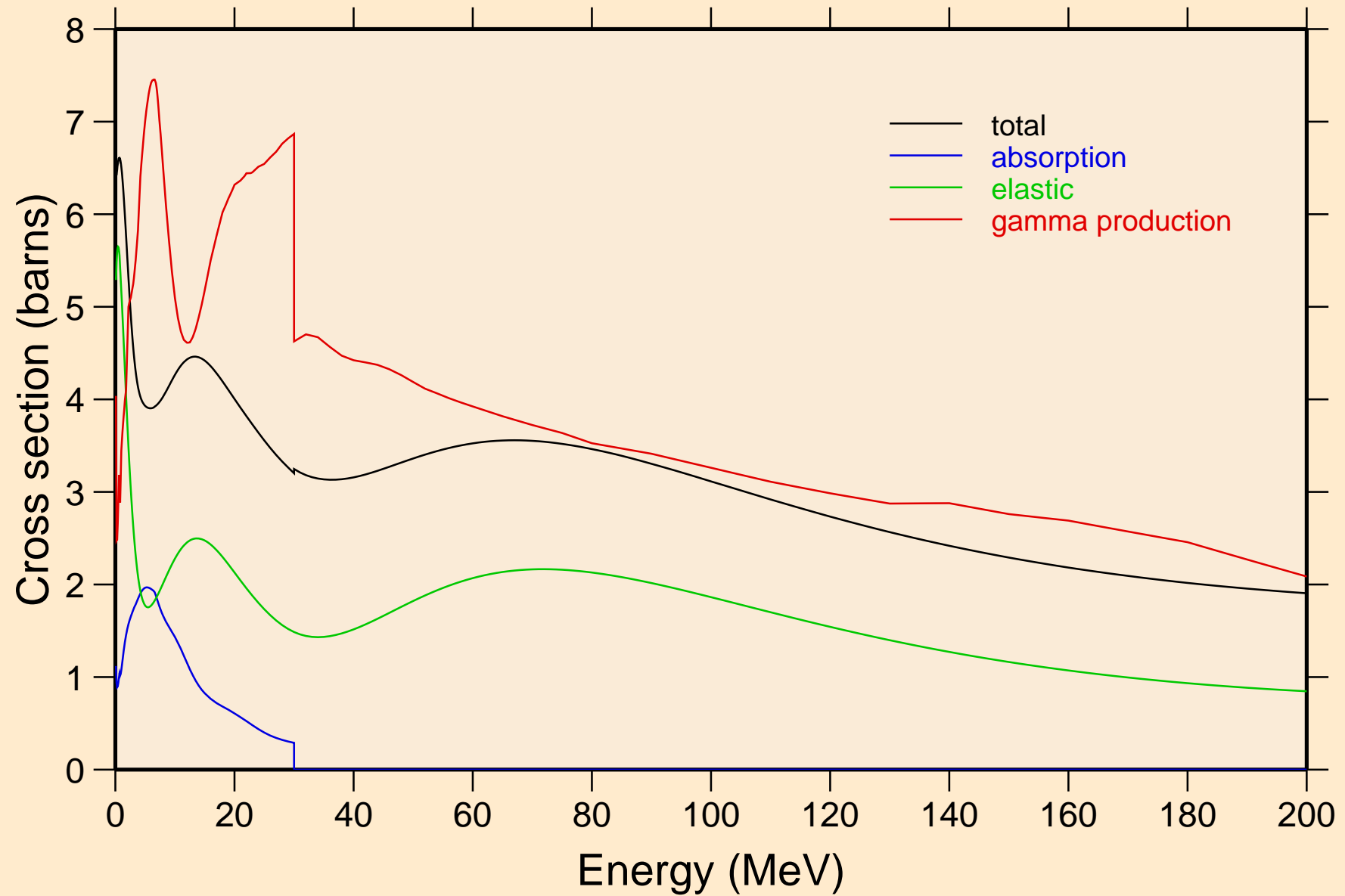

# TE112 NRG TENDL-2015, AKONING

## Non-threshold reactions

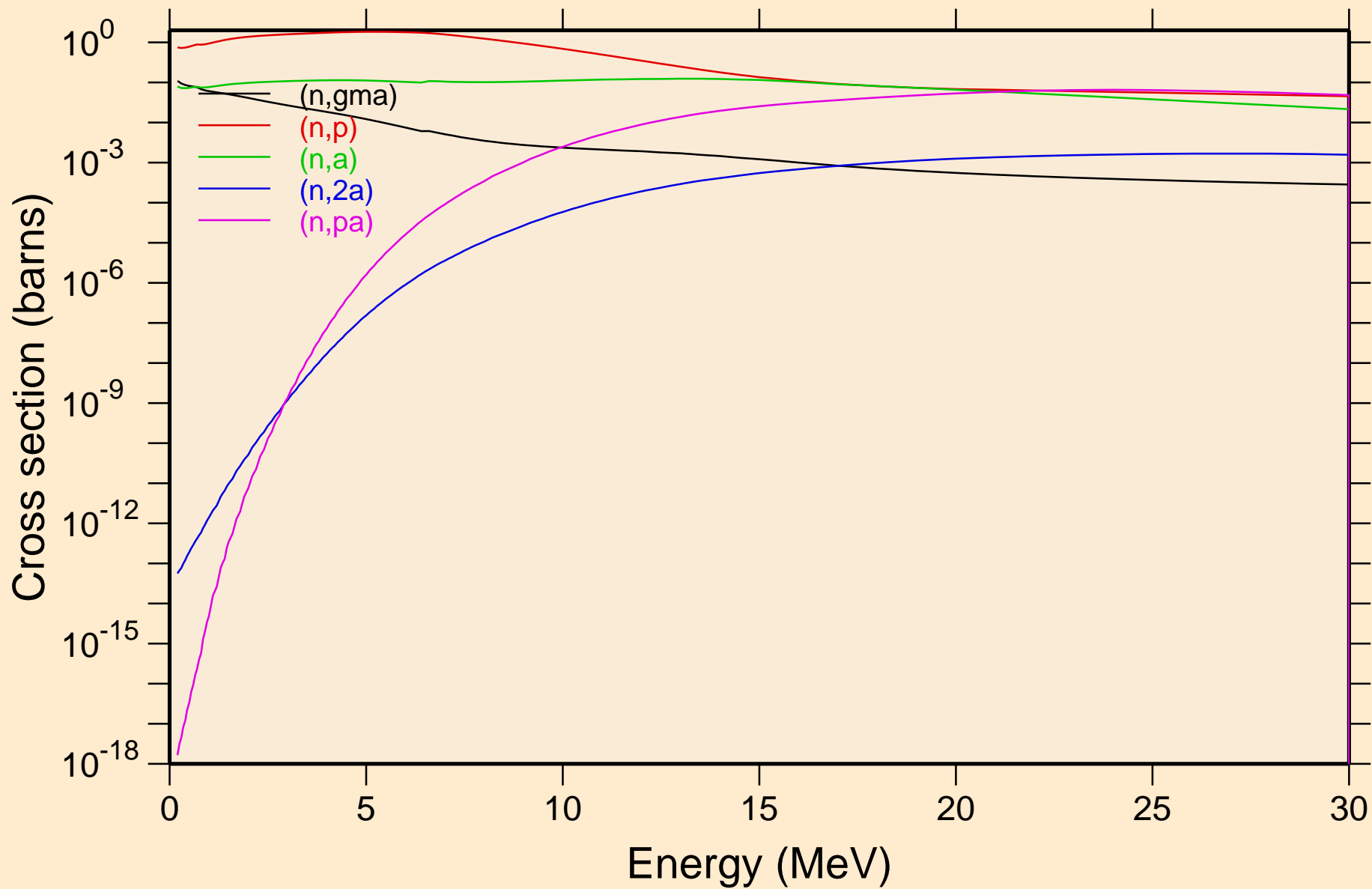

# TE112 NRG TENDL-2015, AKONING

## Inelastic levels

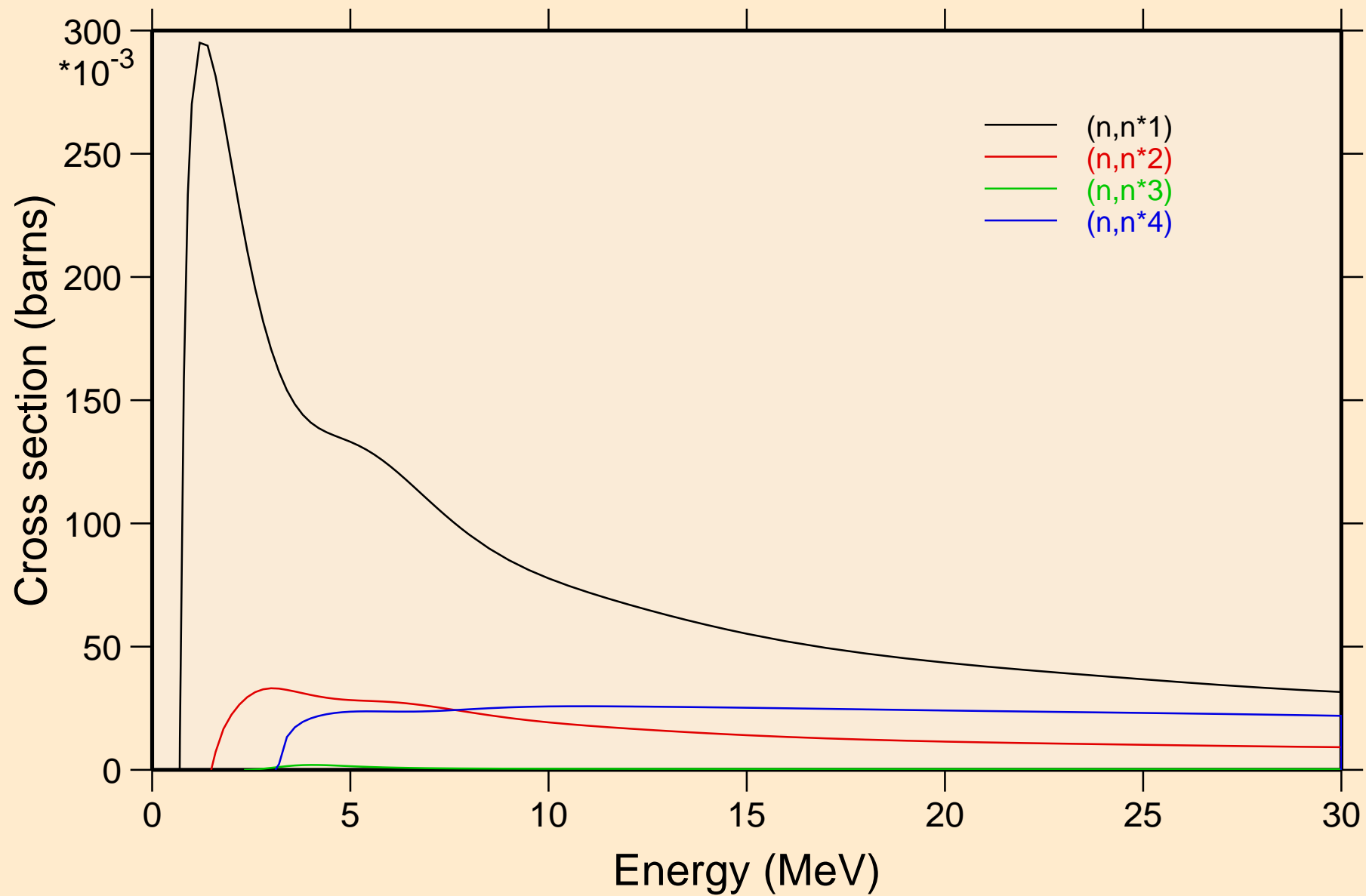

# TE112 NRG TENDL-2015, AKONING

## Threshold reactions

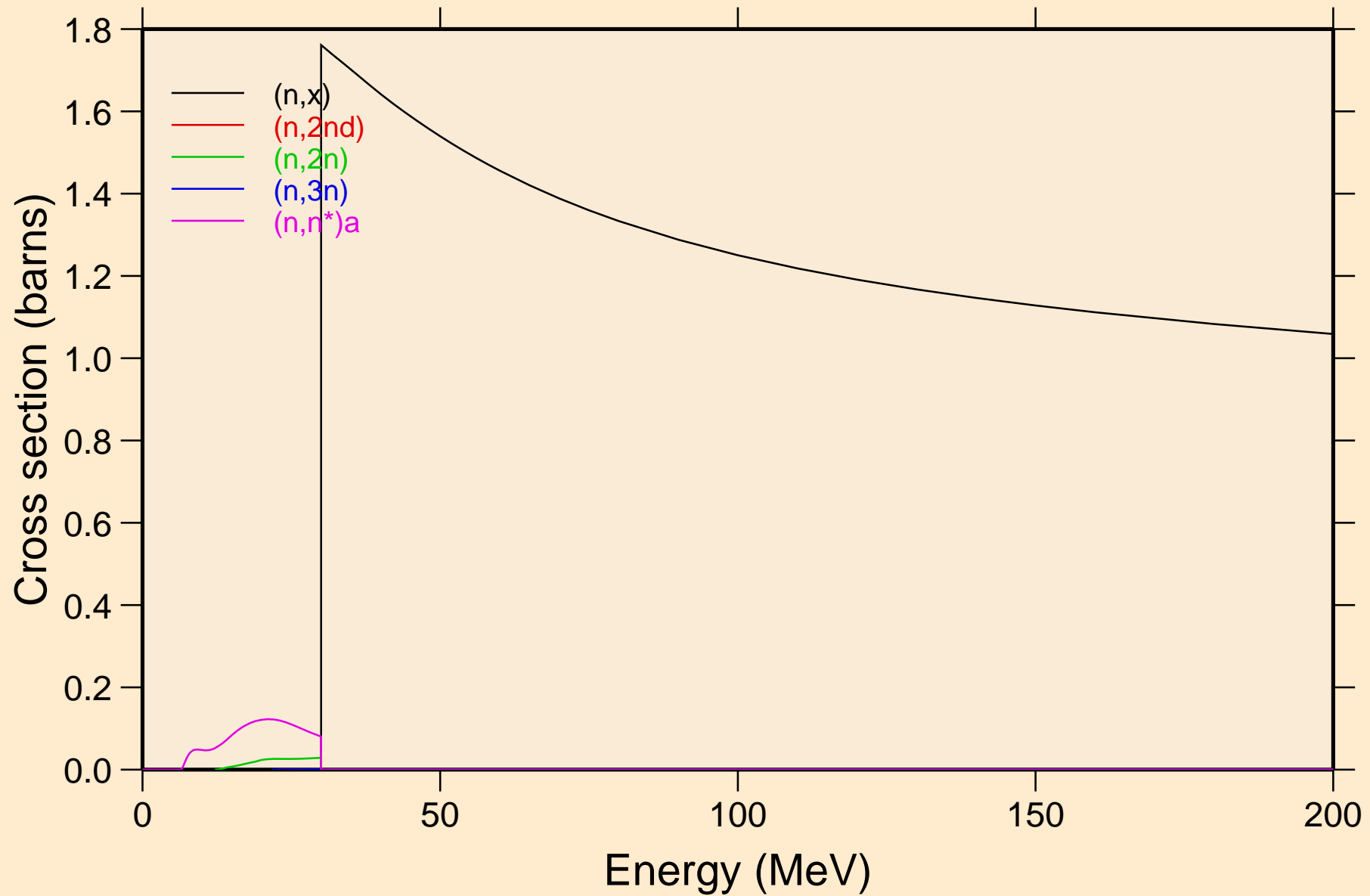

# TE112 NRG TENDL-2015, AKONING

## Threshold reactions

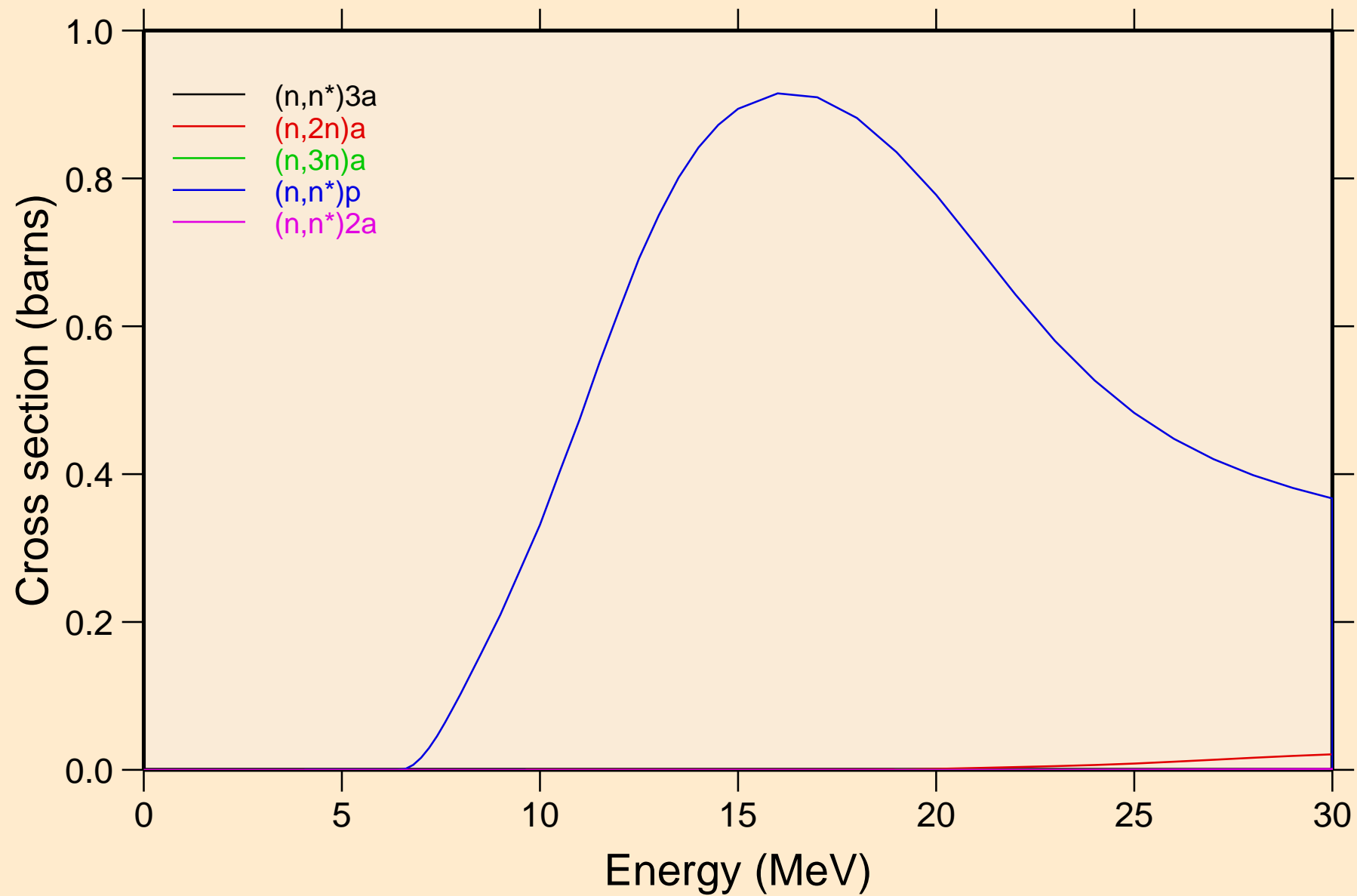

# TE112 NRG TENDL-2015, AKONING

## Threshold reactions

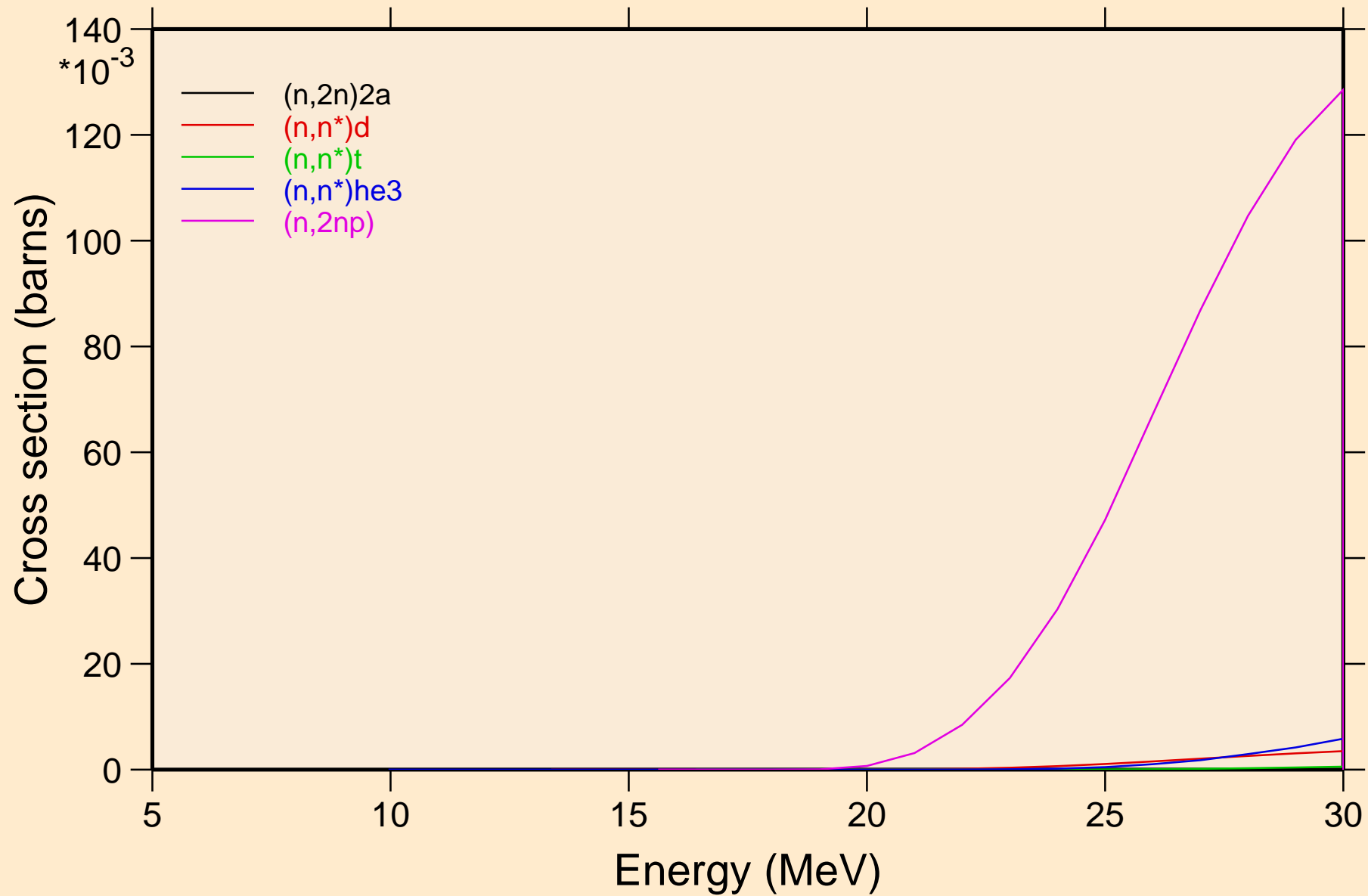

# TE112 NRG TENDL-2015, AKONING

## Threshold reactions

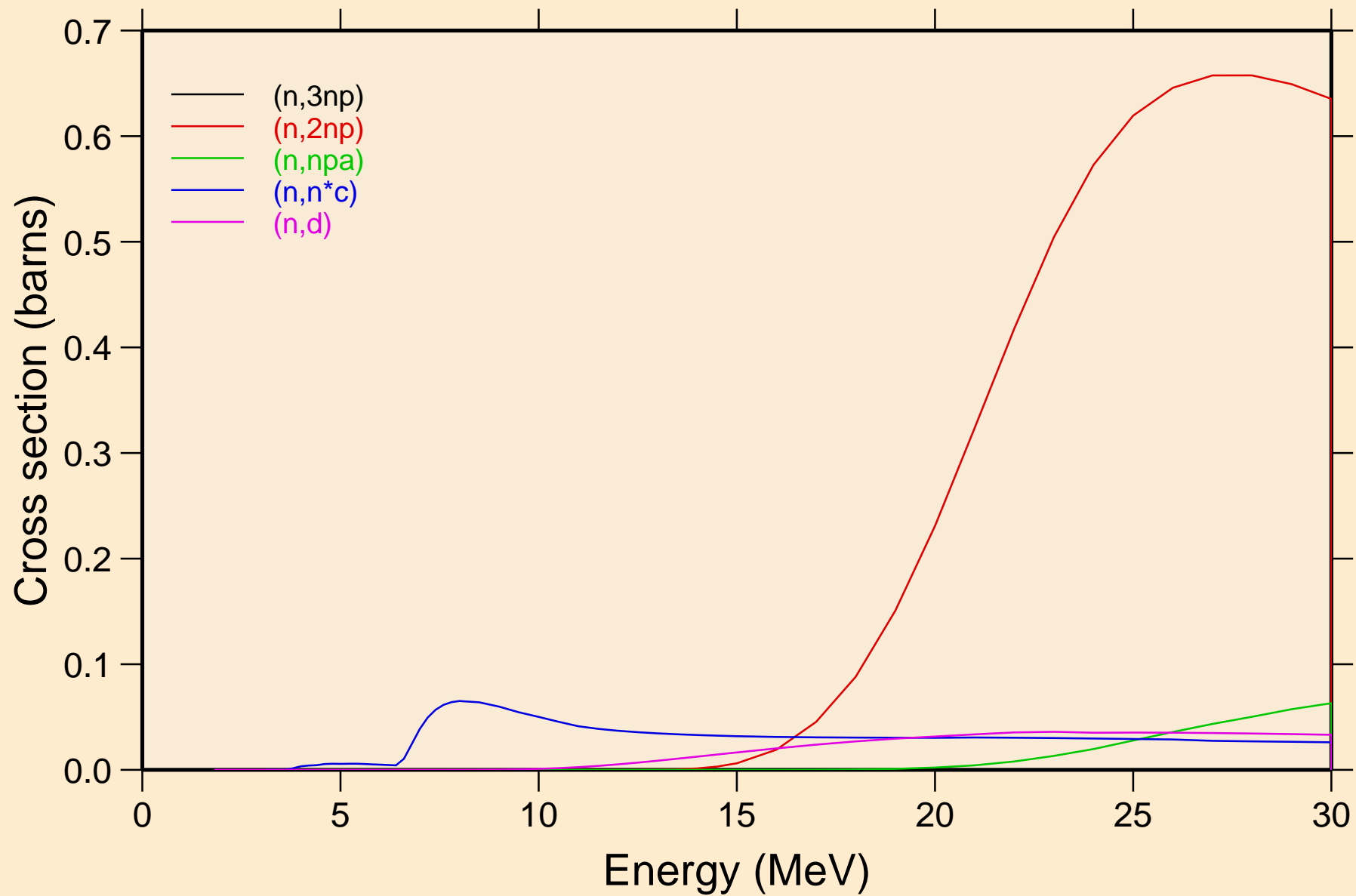

# TE112 NRG TENDL-2015, AKONING

## Threshold reactions

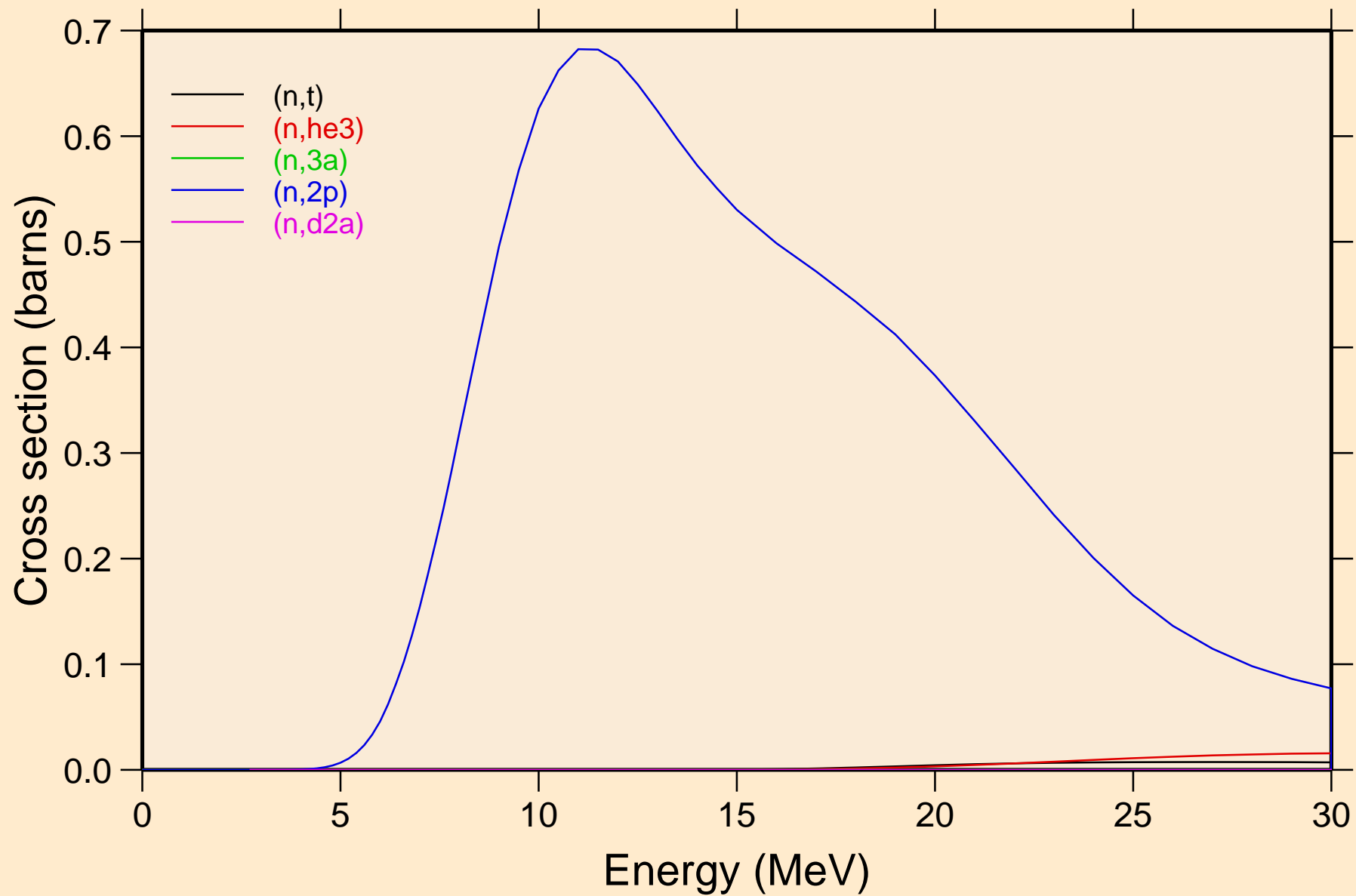



# TE112 NRG TENDL-2015, AKONING

## Threshold reactions

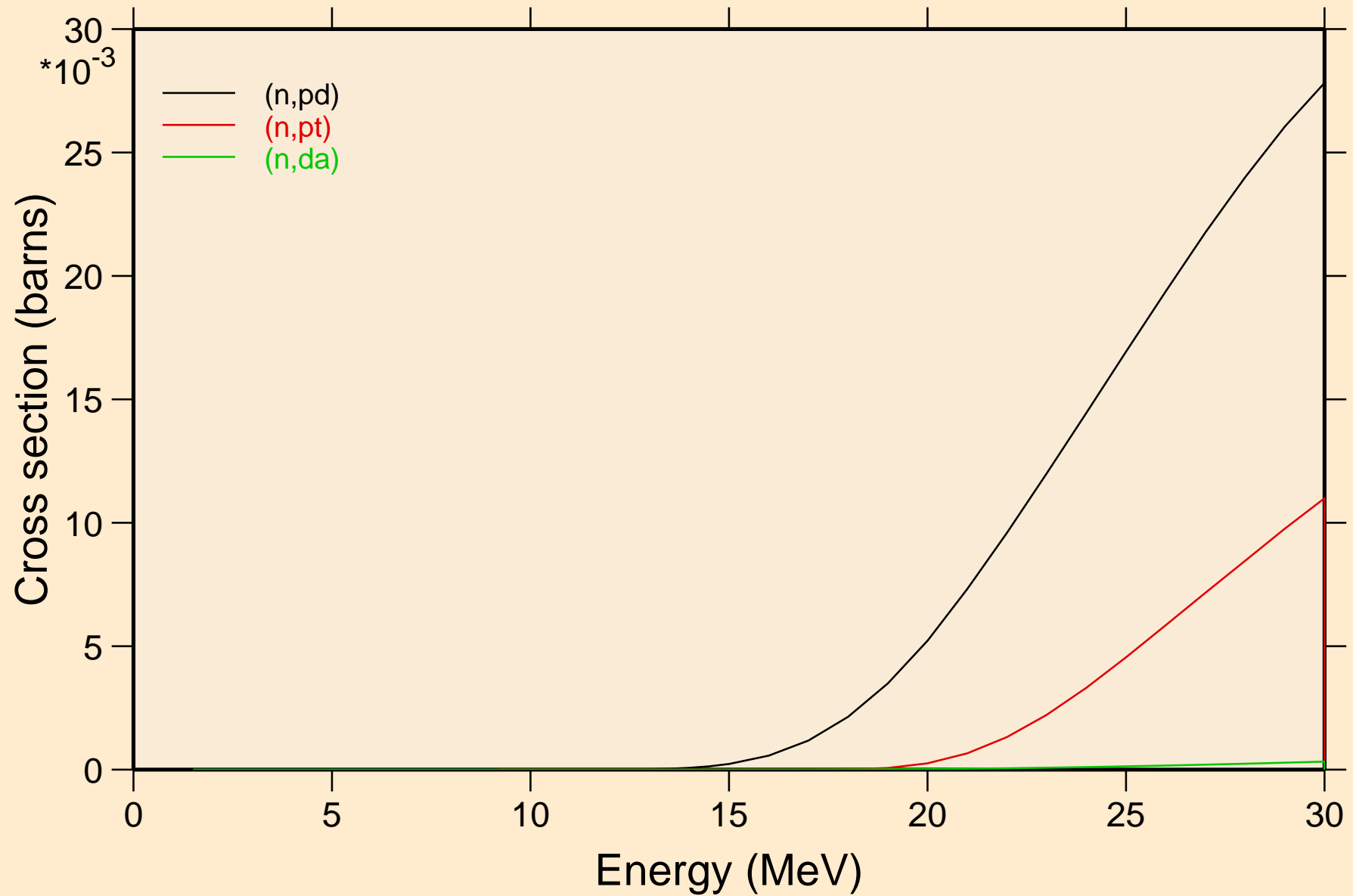

TE112 NRG TENDL-2015, AKONING  
angular distribution for elastic

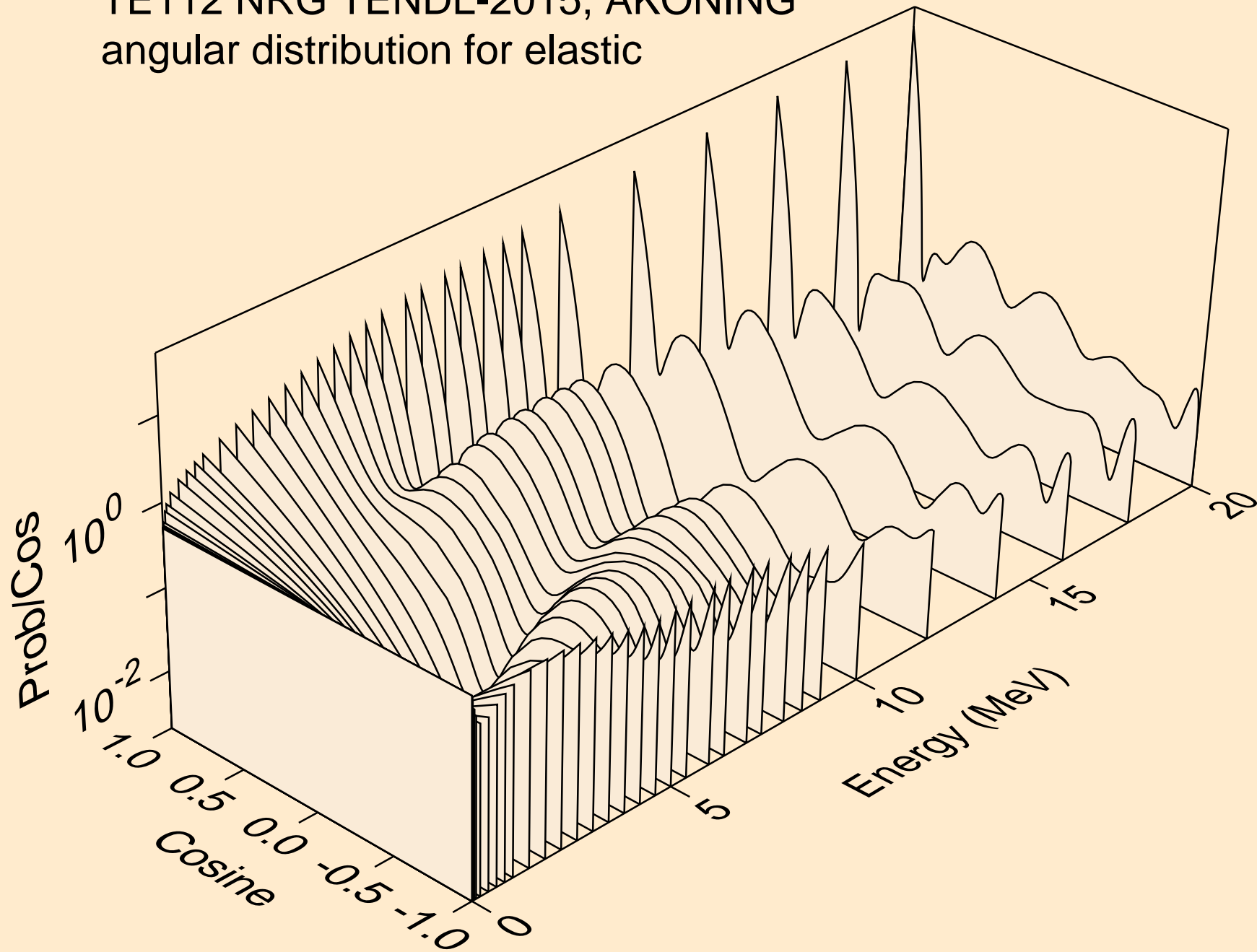

TE112 NRG TENDL-2015, AKONING  
angular distribution for elastic

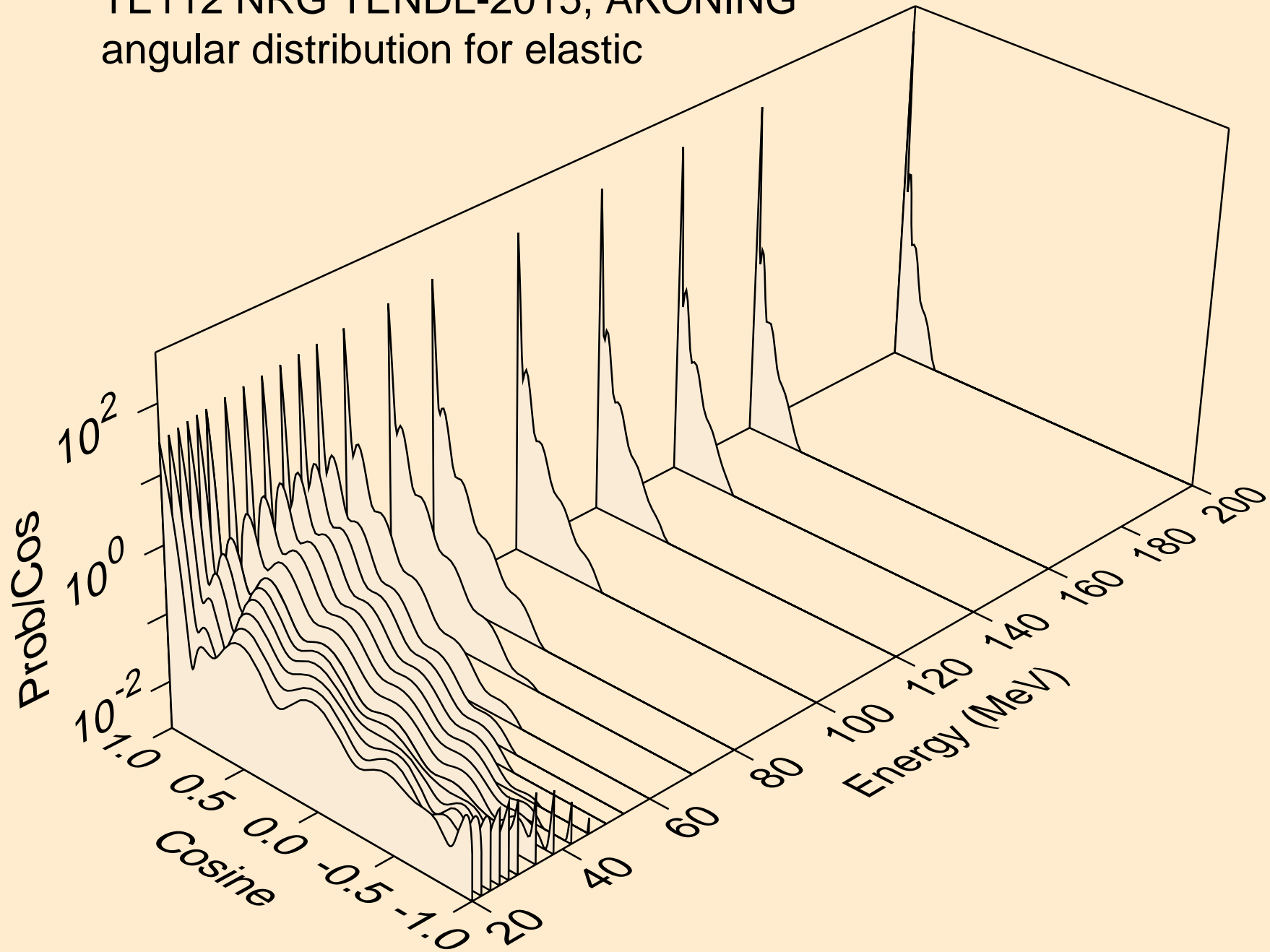

TE112 NRG TENDL-2015, AKONING  
angular distribution for (n,n\*1)

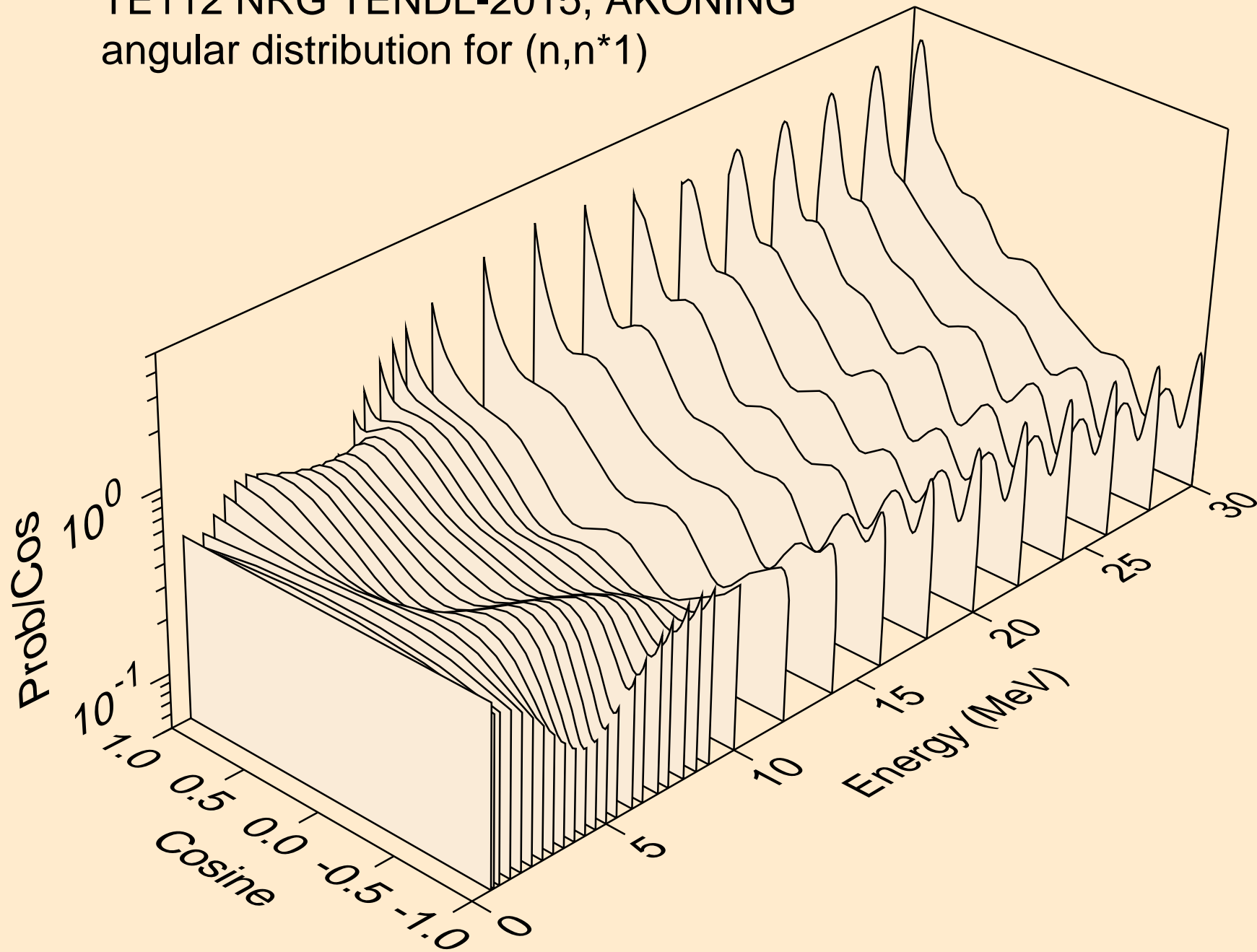

TE112 NRG TENDL-2015, AKONING  
angular distribution for (n,n\*2)

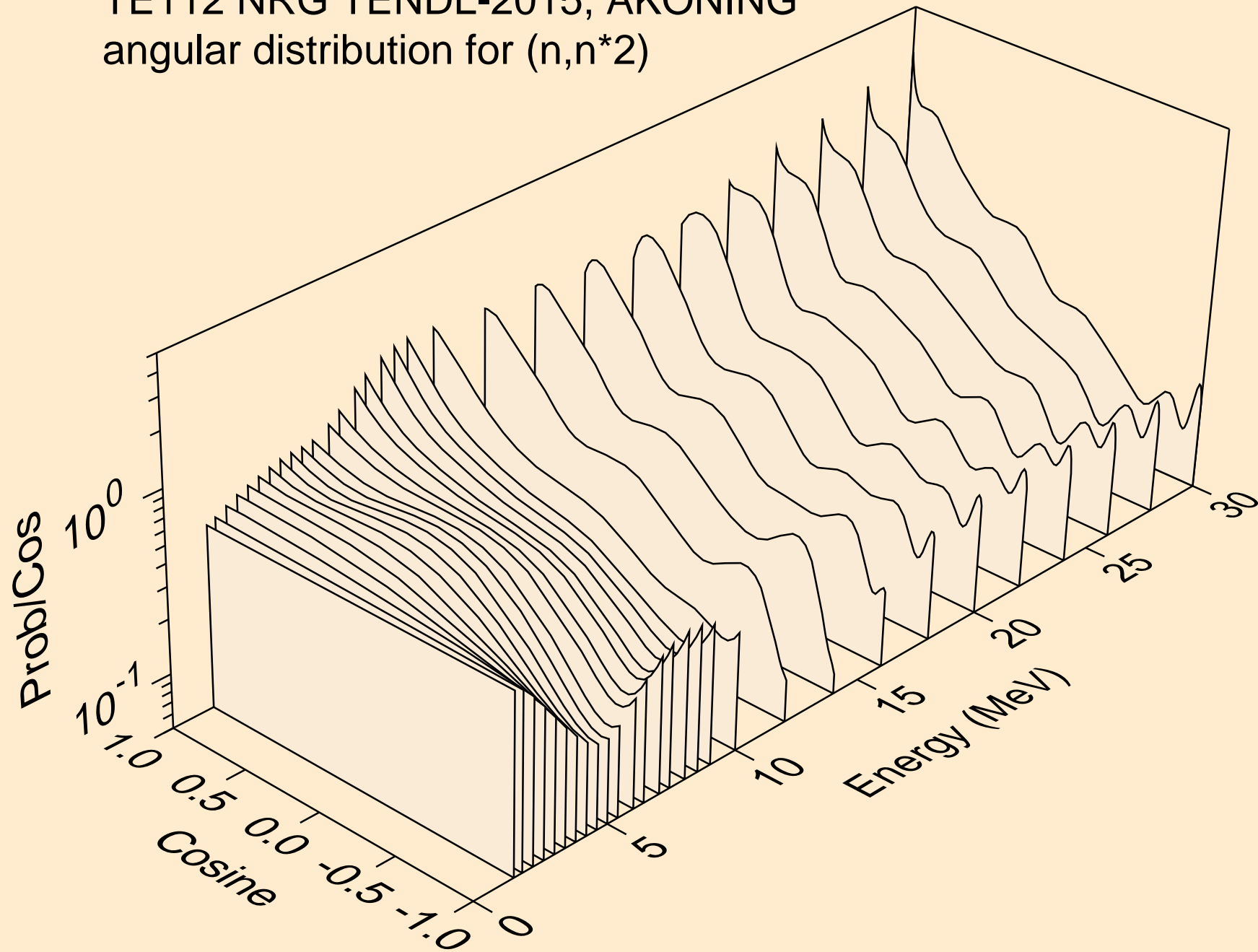

TE112 NRG TENDL-2015, AKONING  
angular distribution for (n,n\*3)

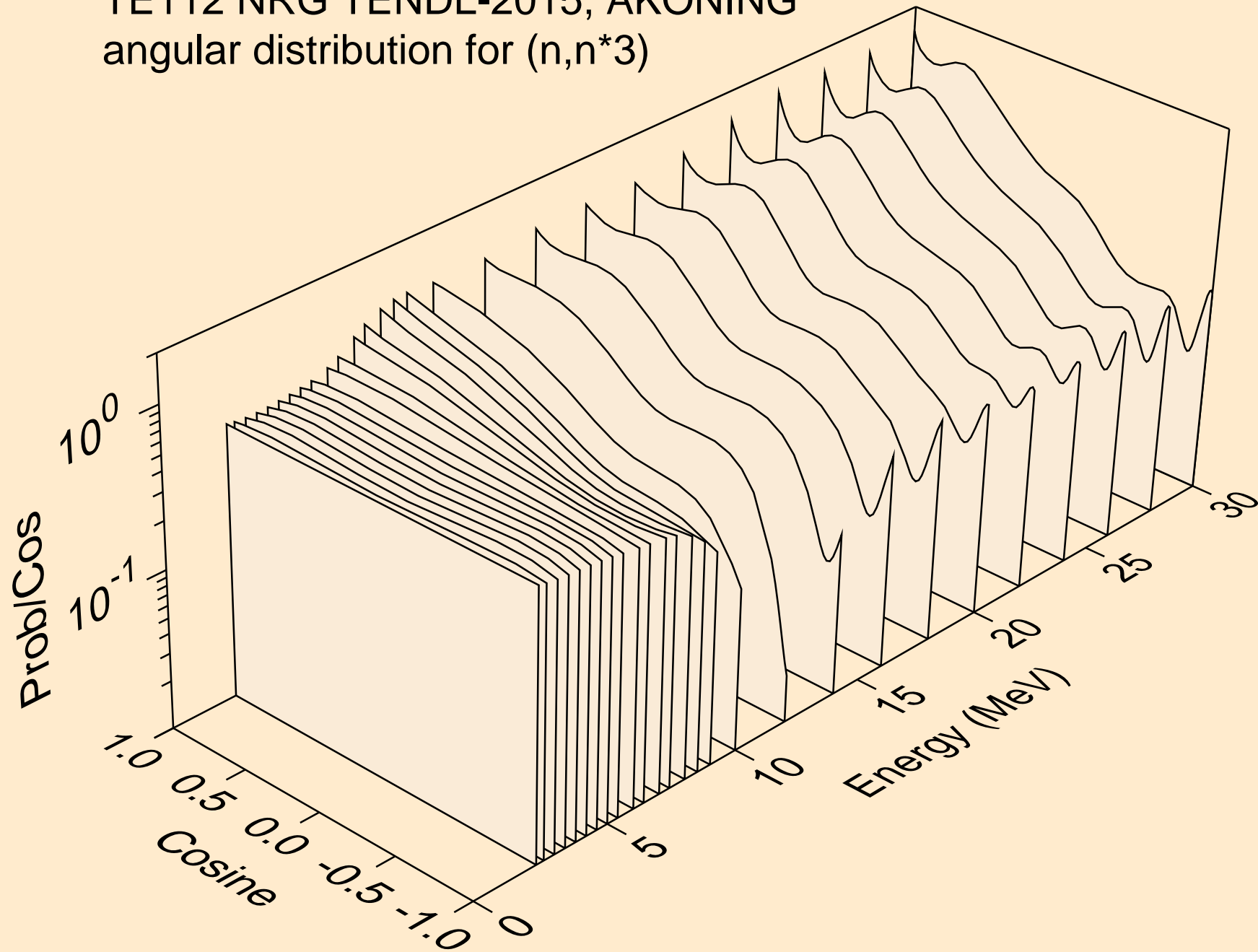

TE112 NRG TENDL-2015, AKONING  
angular distribution for (n,n\*4)

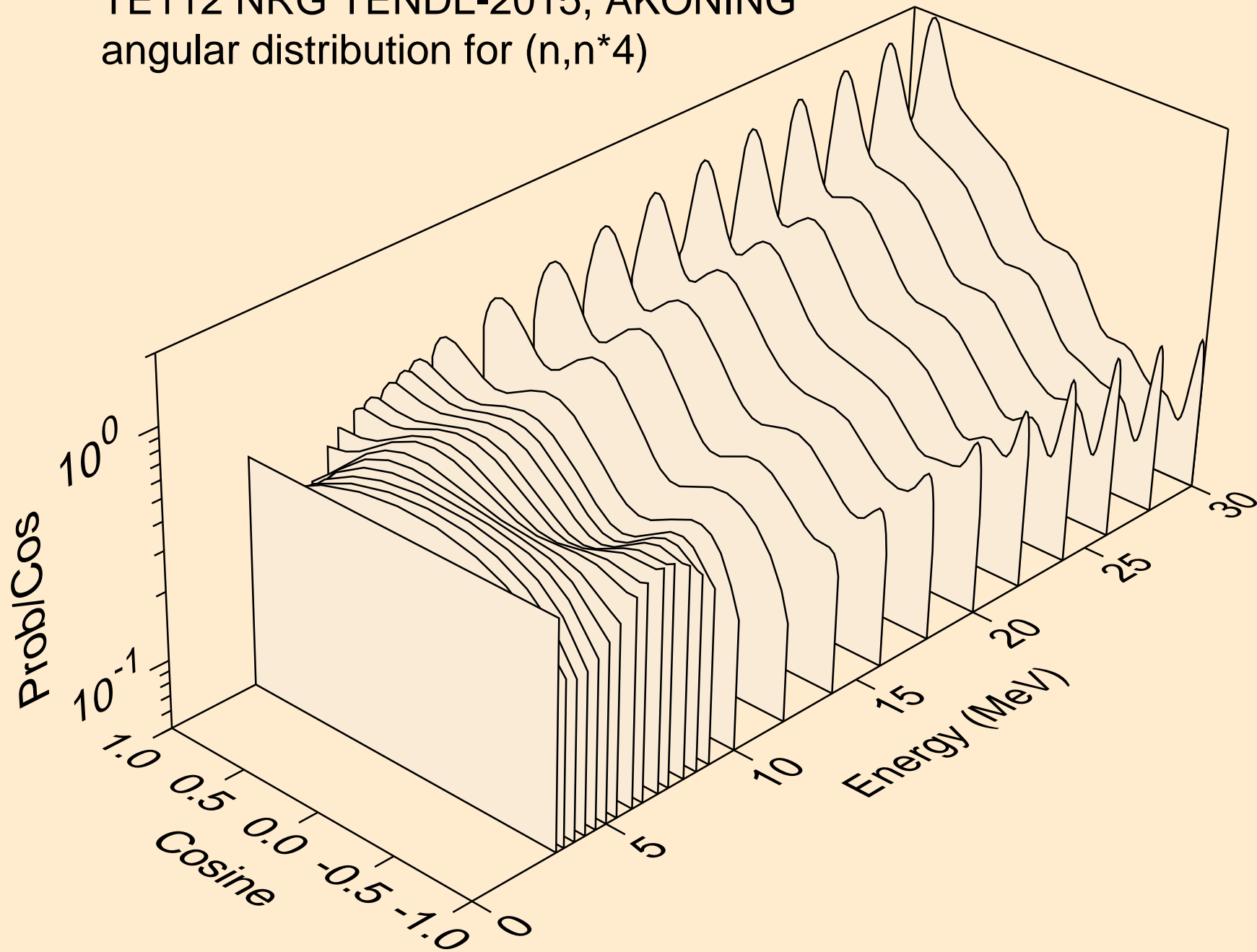

TE112 NRG TENDL-2015, AKONING  
Neutron emission for (n,x)

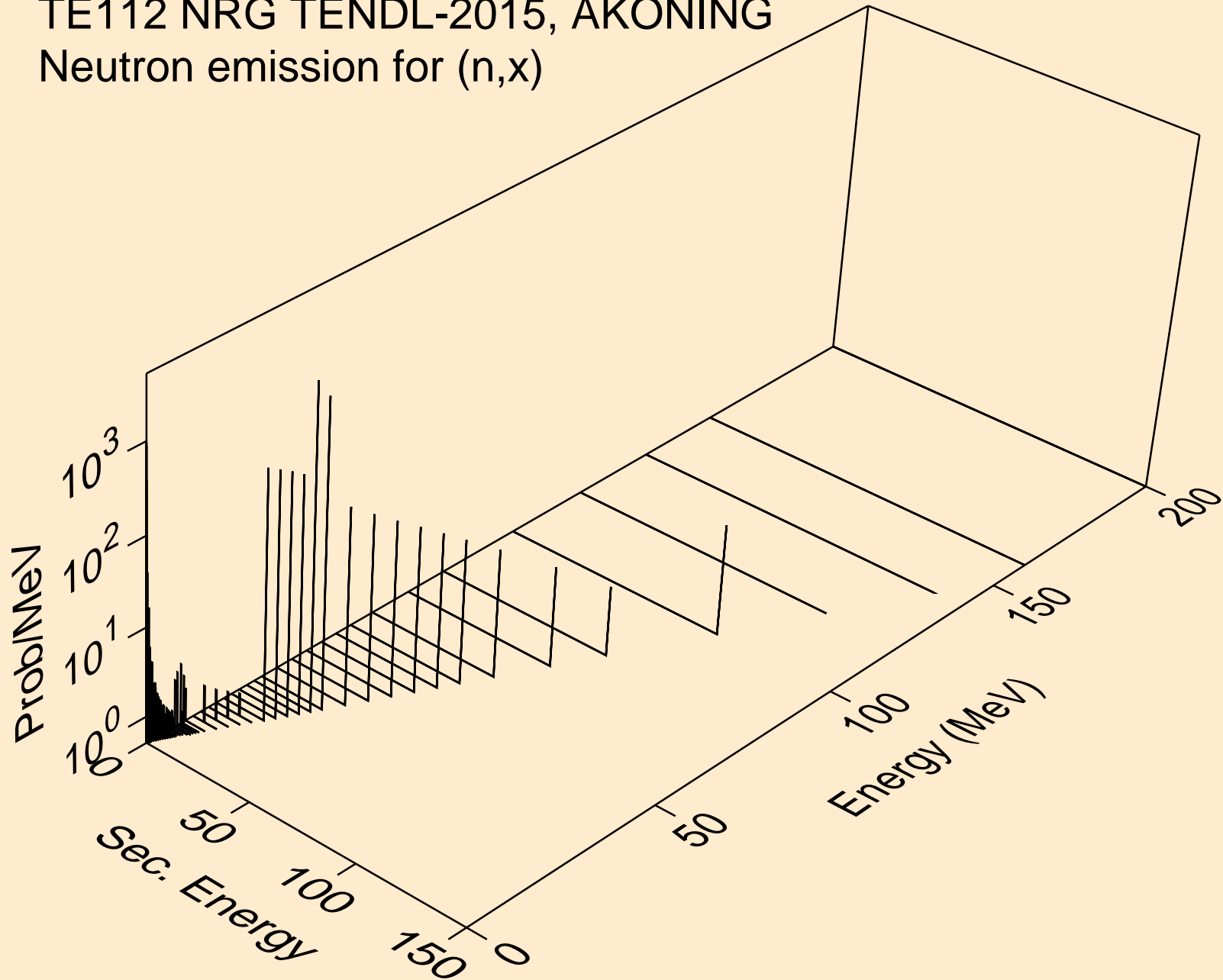



TE112 NRG TENDL-2015, AKONING  
Neutron emission for (n,2nd)

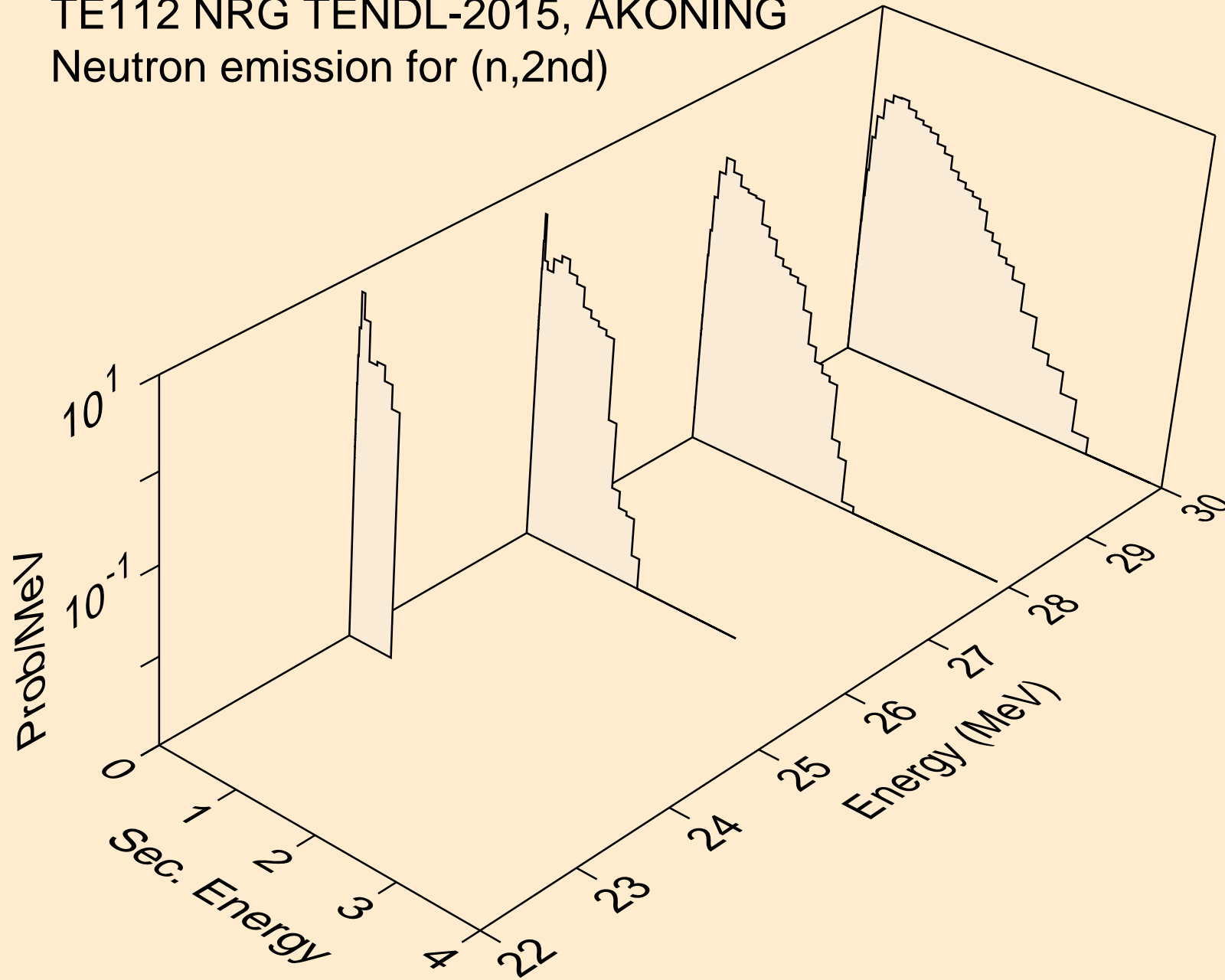

TE112 NRG TENDL-2015, AKONING  
Neutron emission for (n,2n)

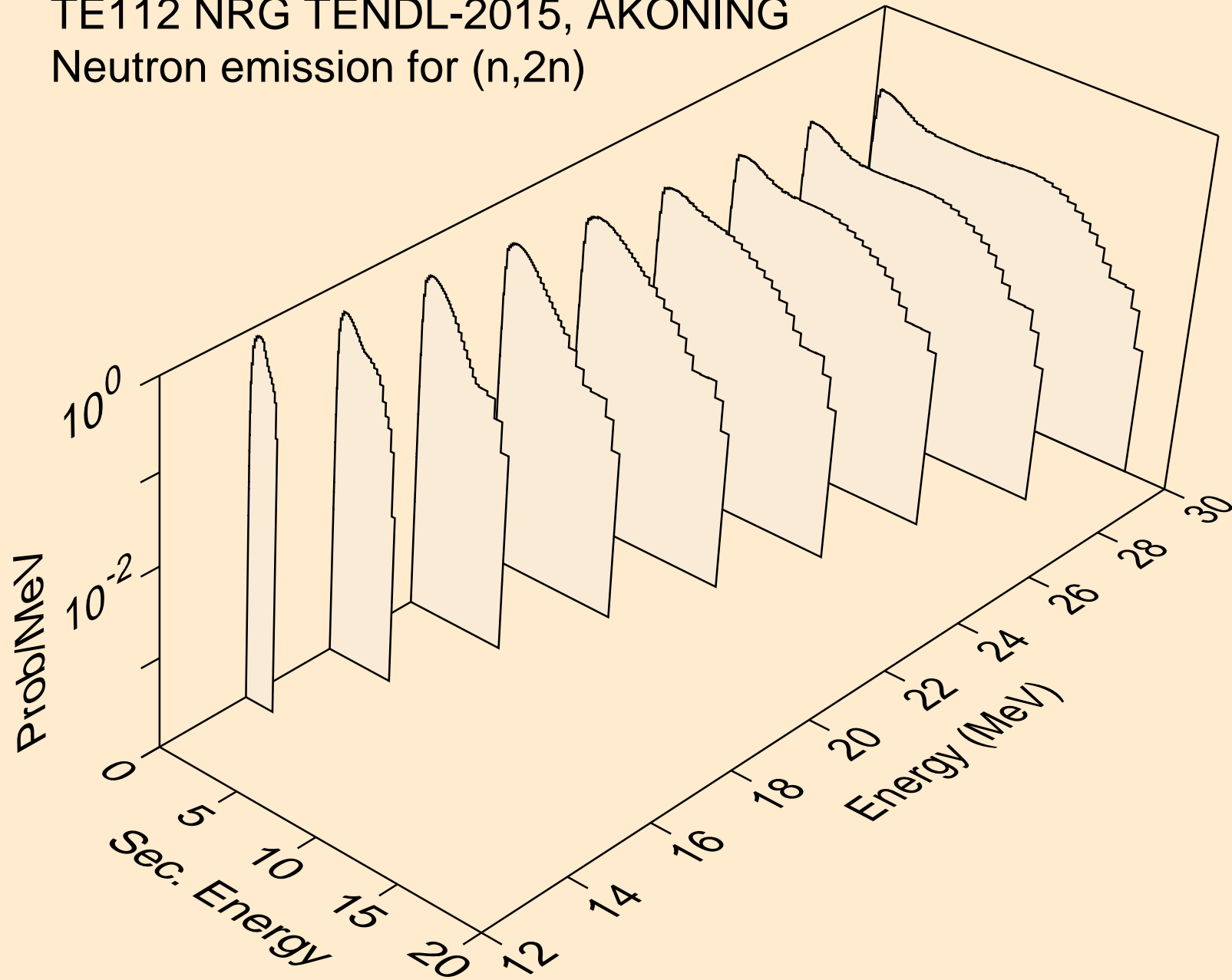

TE112 NRG TENDL-2015, AKONING  
Neutron emission for (n,3n)

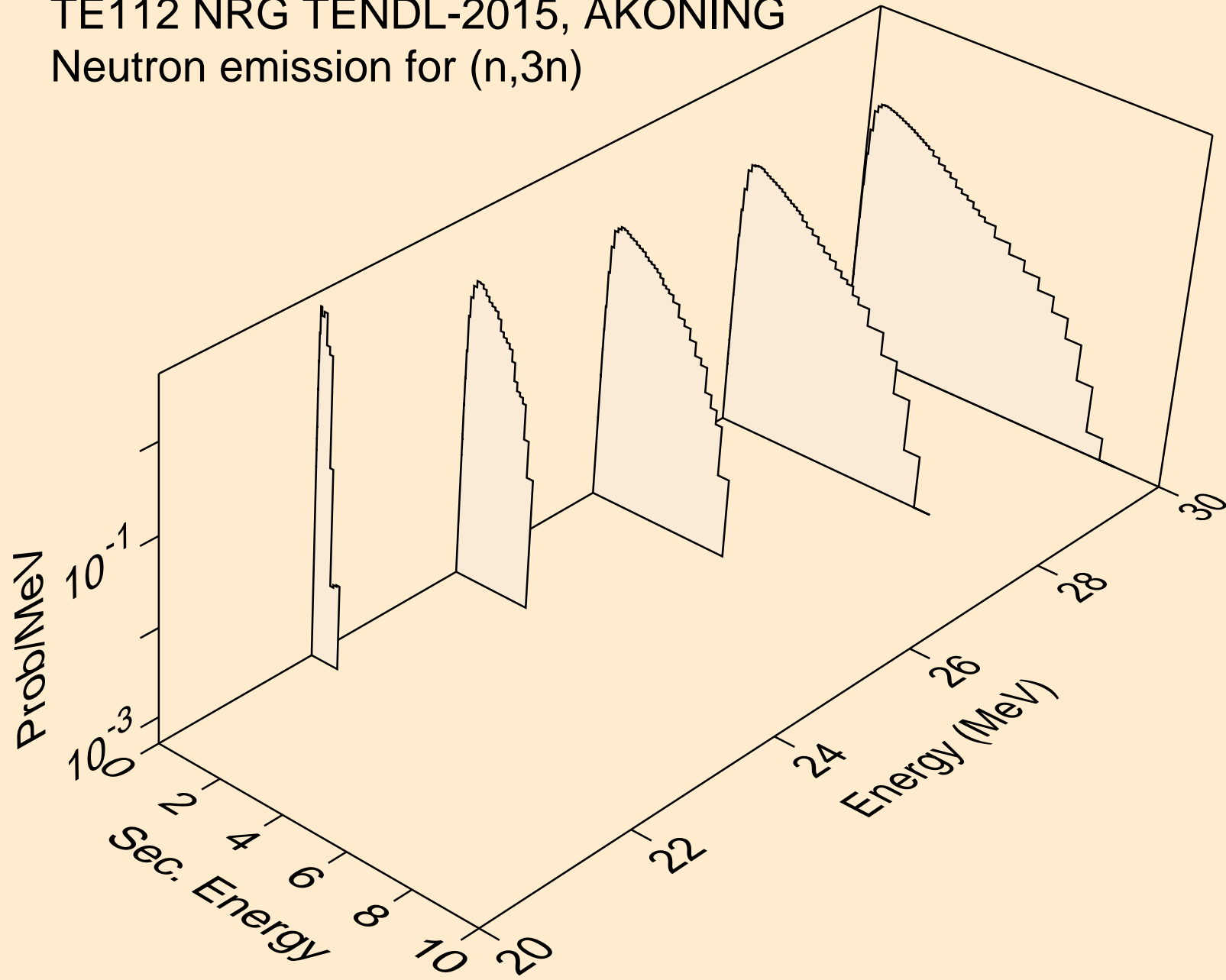

TE112 NRG TENDL-2015, AKONING  
Neutron emission for (n,n\*)a

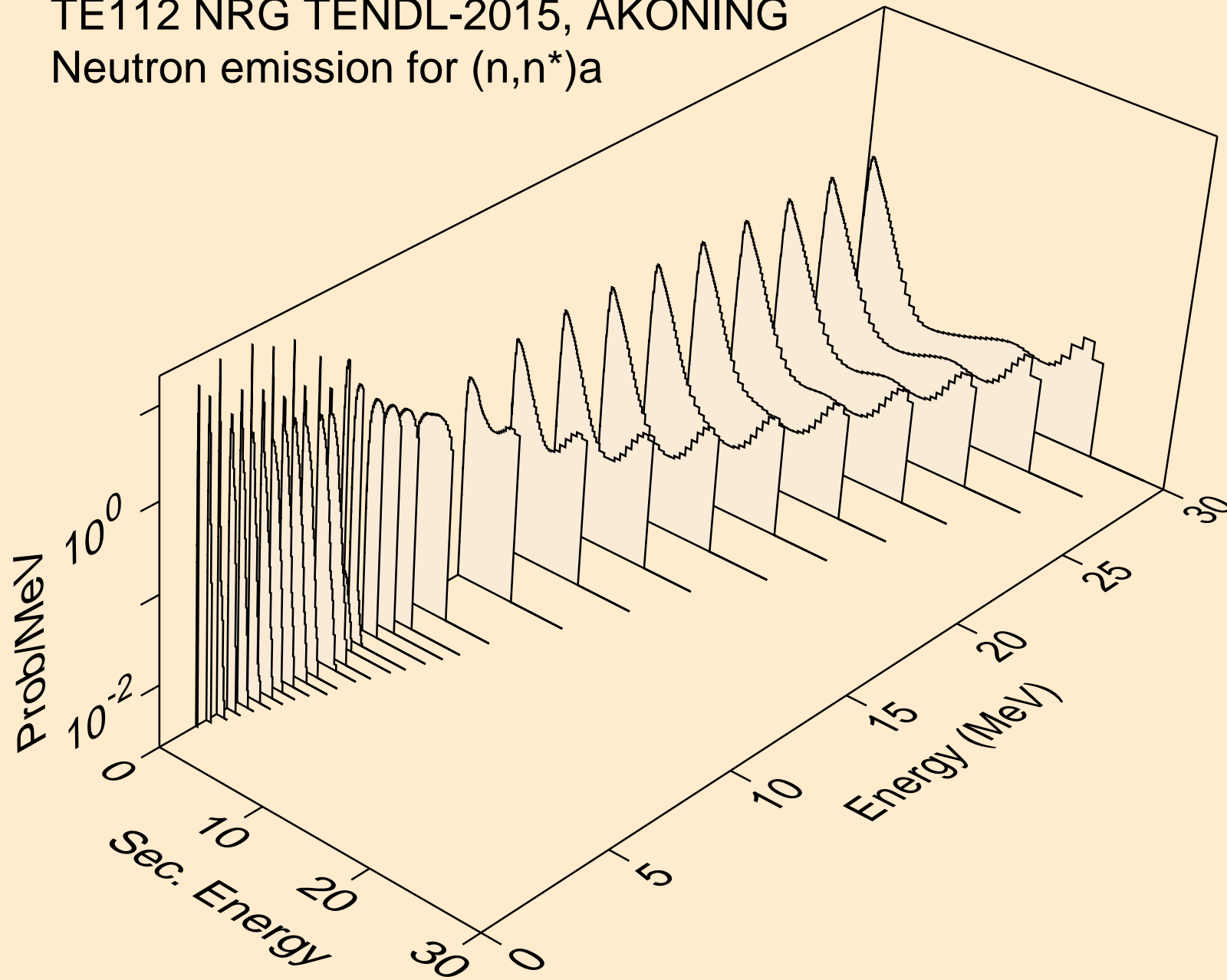

TE112 NRG TENDL-2015, AKONING  
Neutron emission for (n,n\*)3a

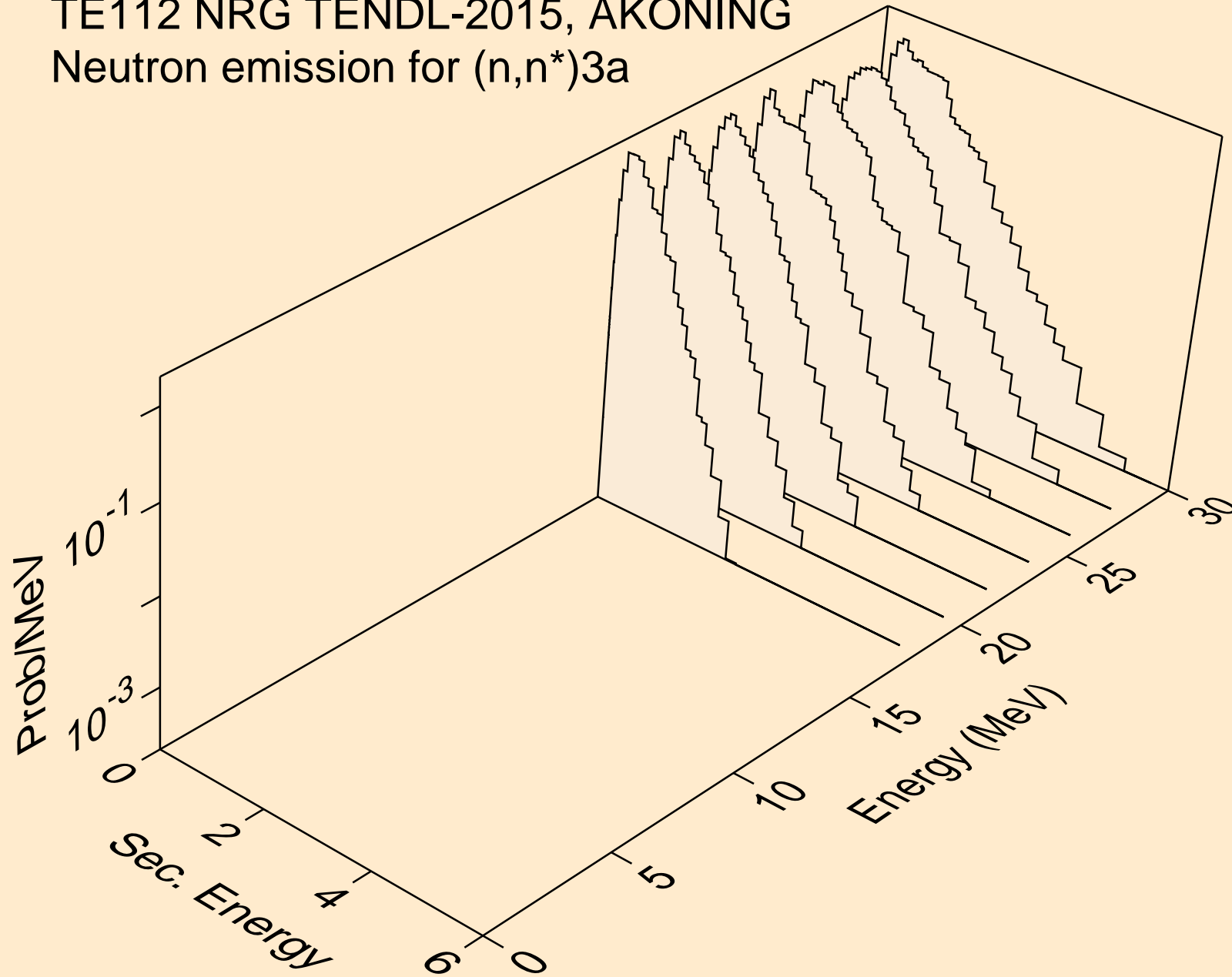

TE112 NRG TENDL-2015, AKONING  
Neutron emission for (n,2n)a

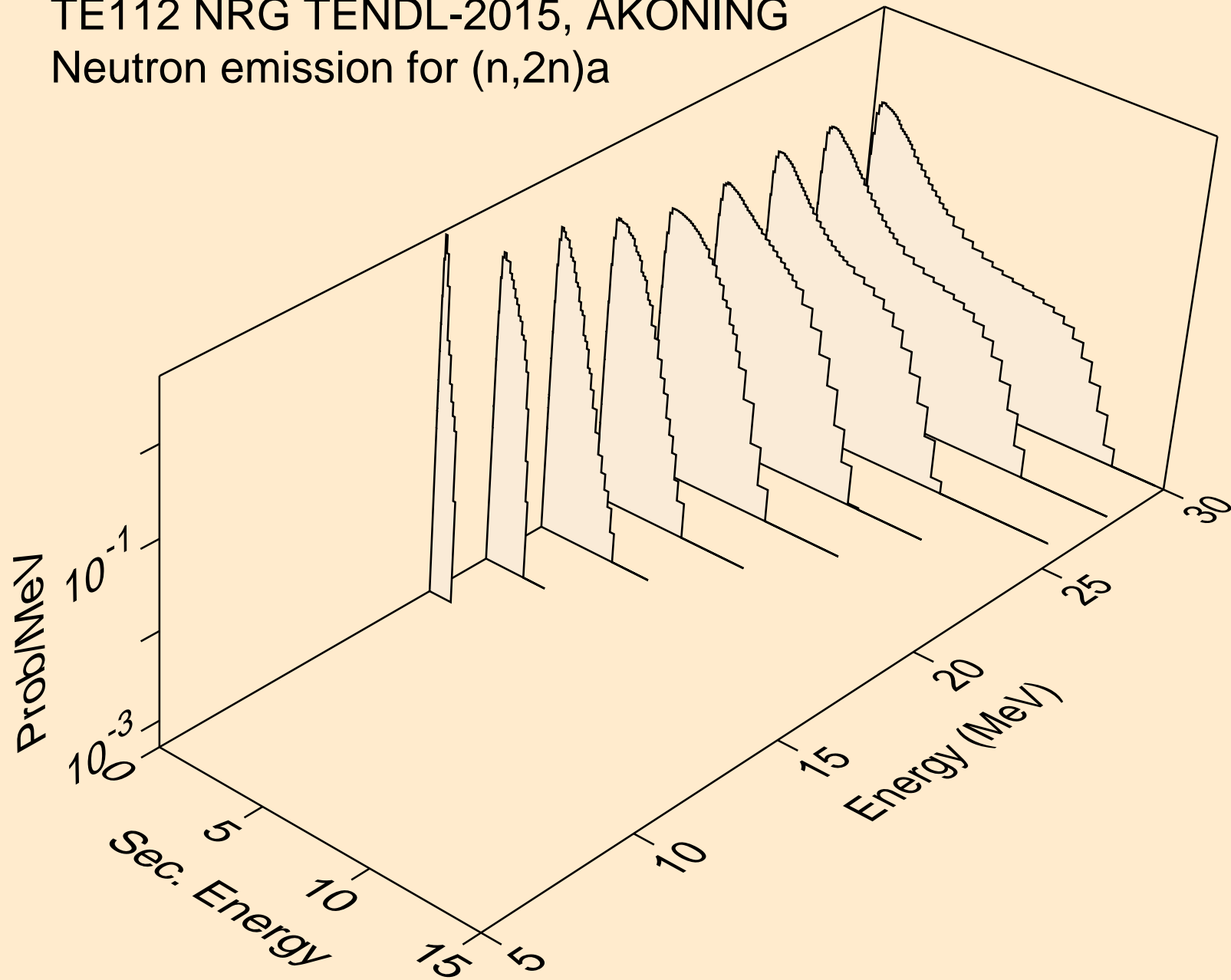

TE112 NRG TENDL-2015, AKONING  
Neutron emission for (n,3n)a

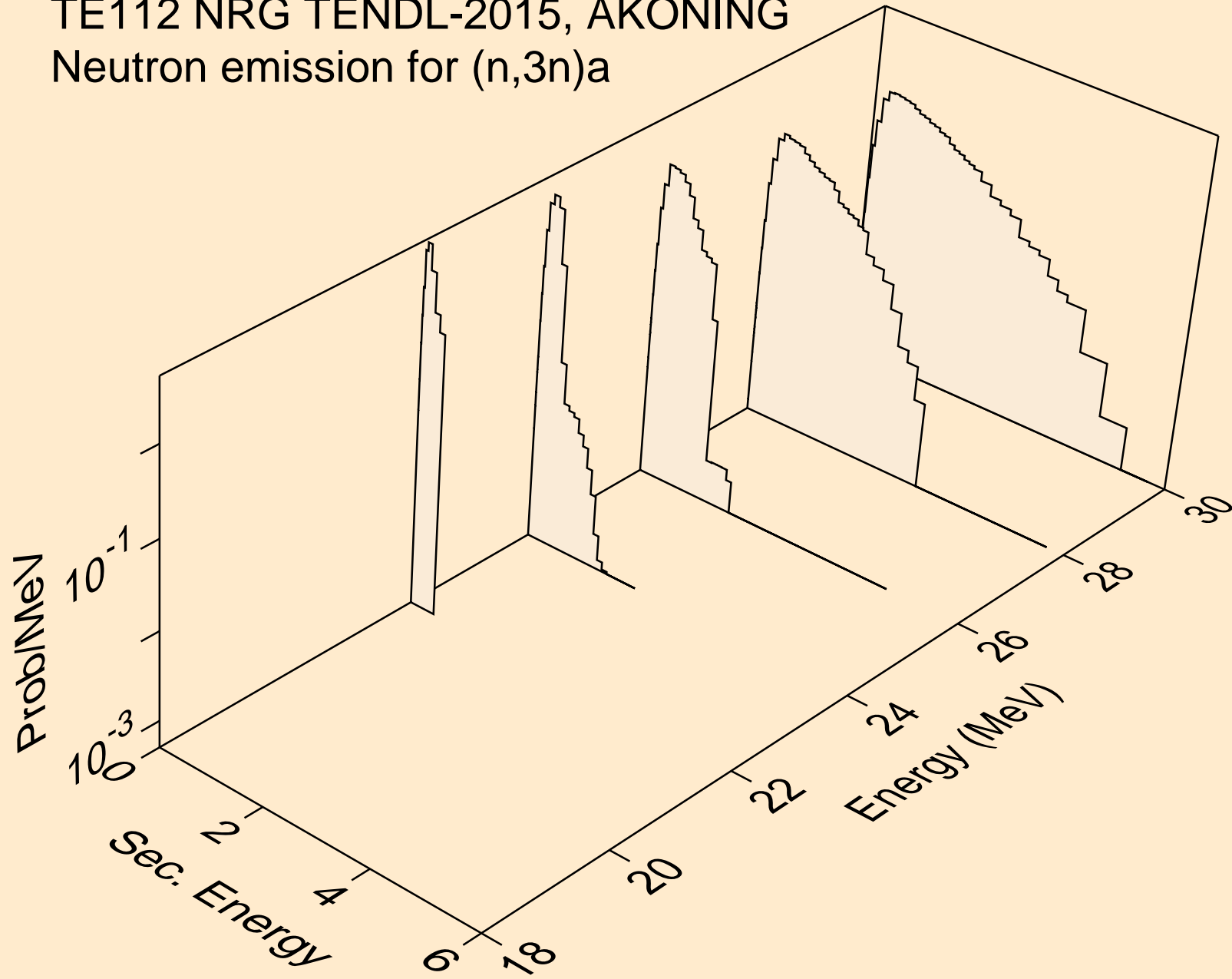

TE112 NRG TENDL-2015, AKONING  
Neutron emission for (n,n\*)p

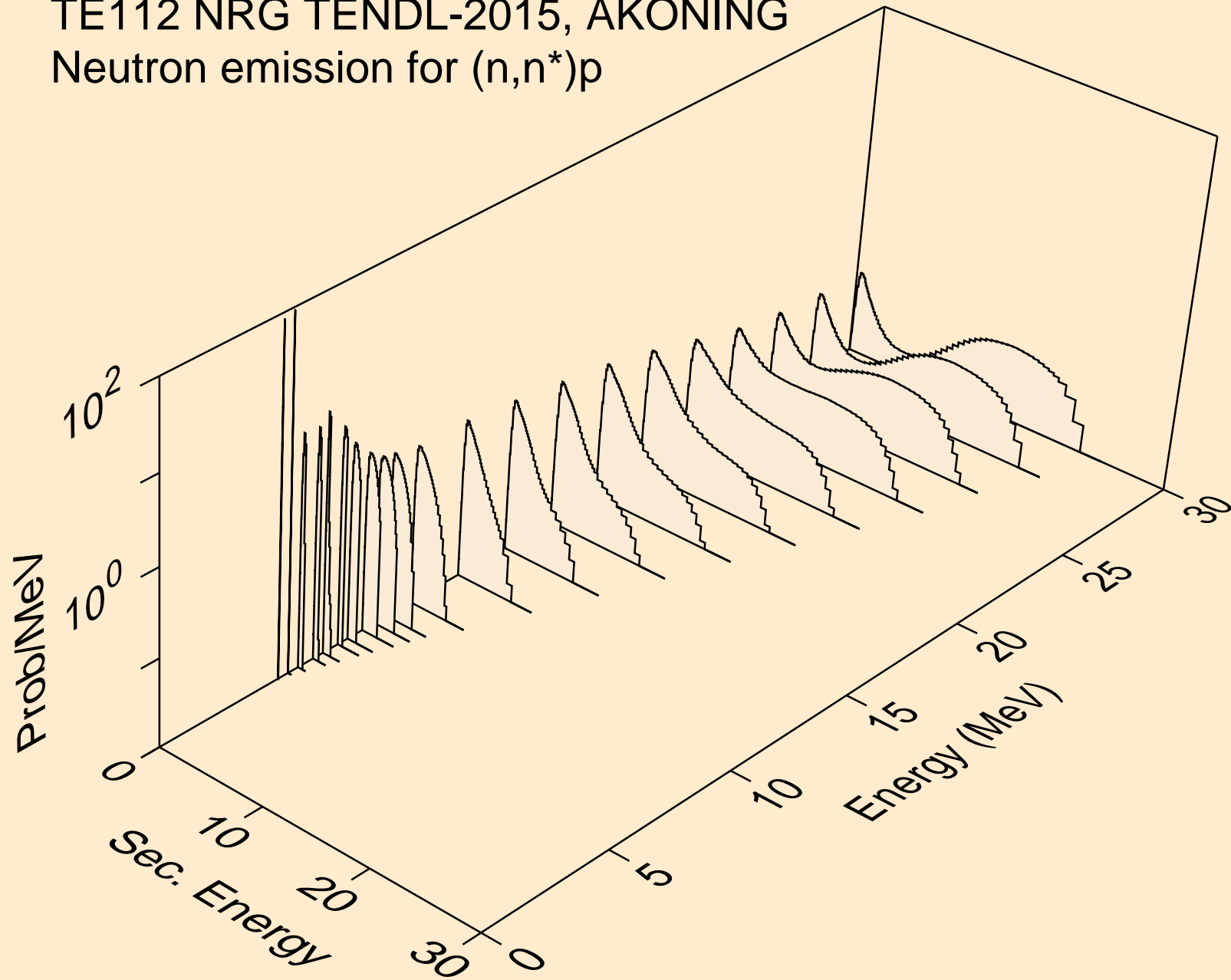



TE112 NRG TENDL-2015, AKONING  
Neutron emission for (n,n\*)2a

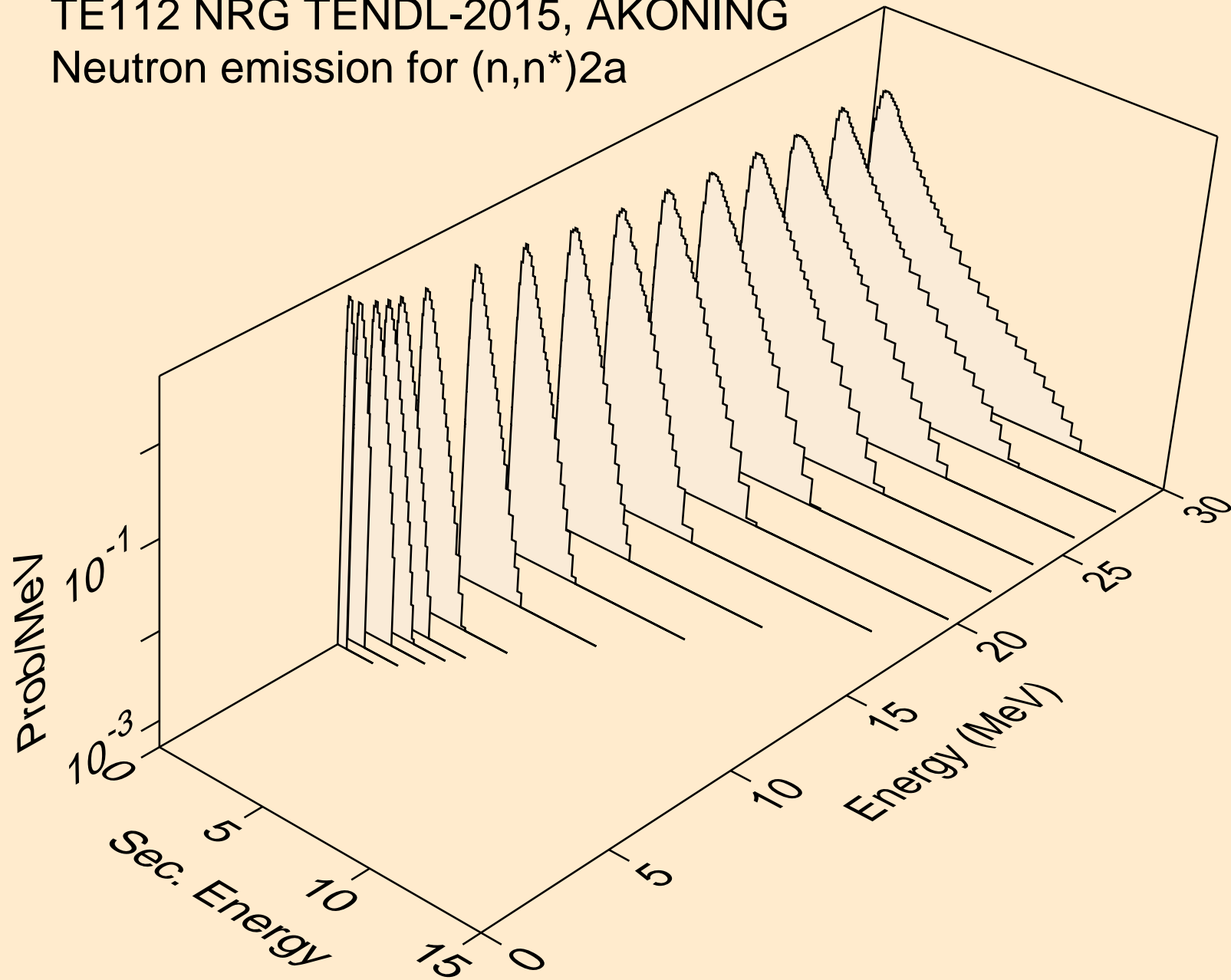

TE112 NRG TENDL-2015, AKONING  
Neutron emission for (n,2n)2a

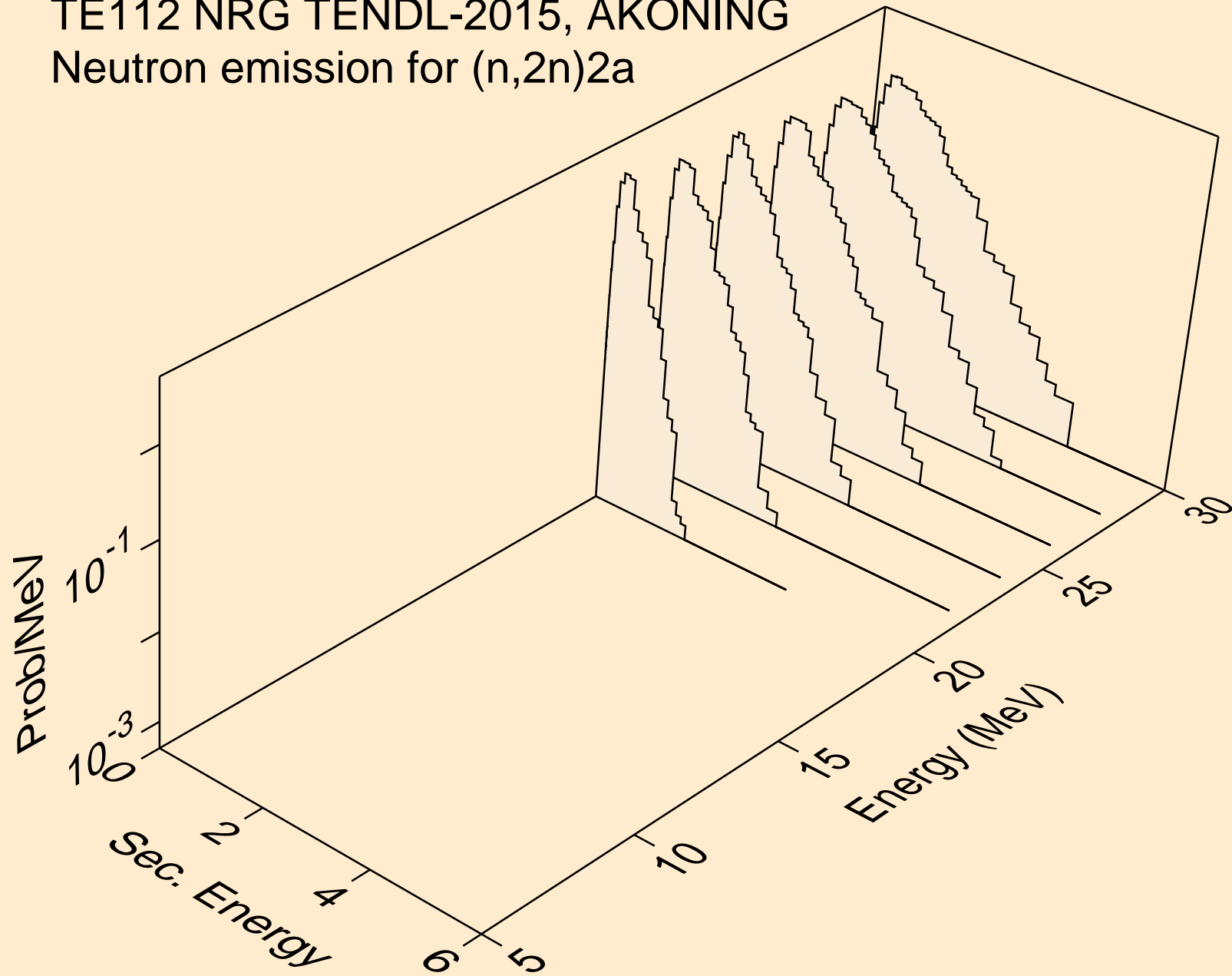

TE112 NRG TENDL-2015, AKONING  
Neutron emission for (n,n\*)d

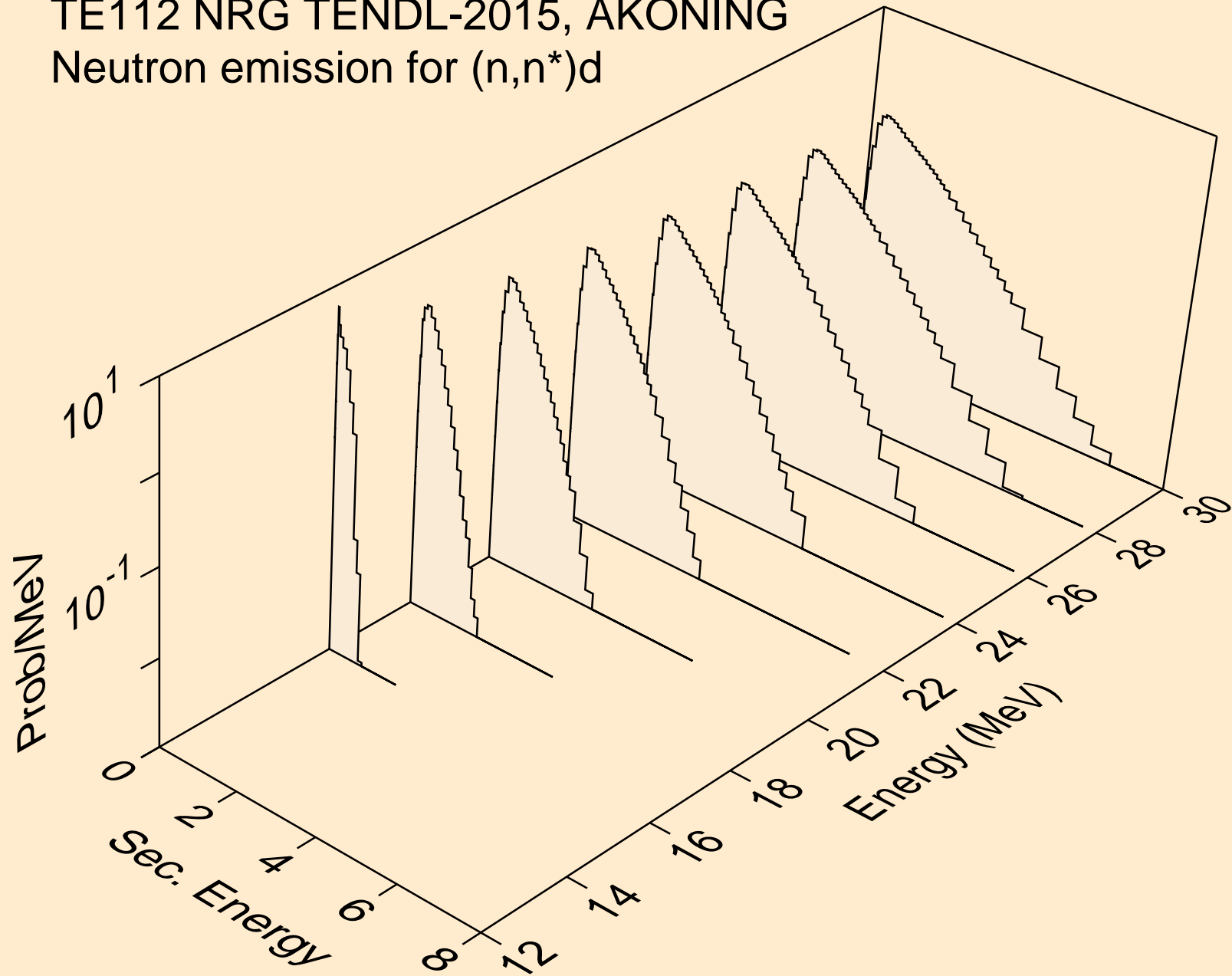

TE112 NRG TENDL-2015, AKONING  
Neutron emission for (n,n\*)t

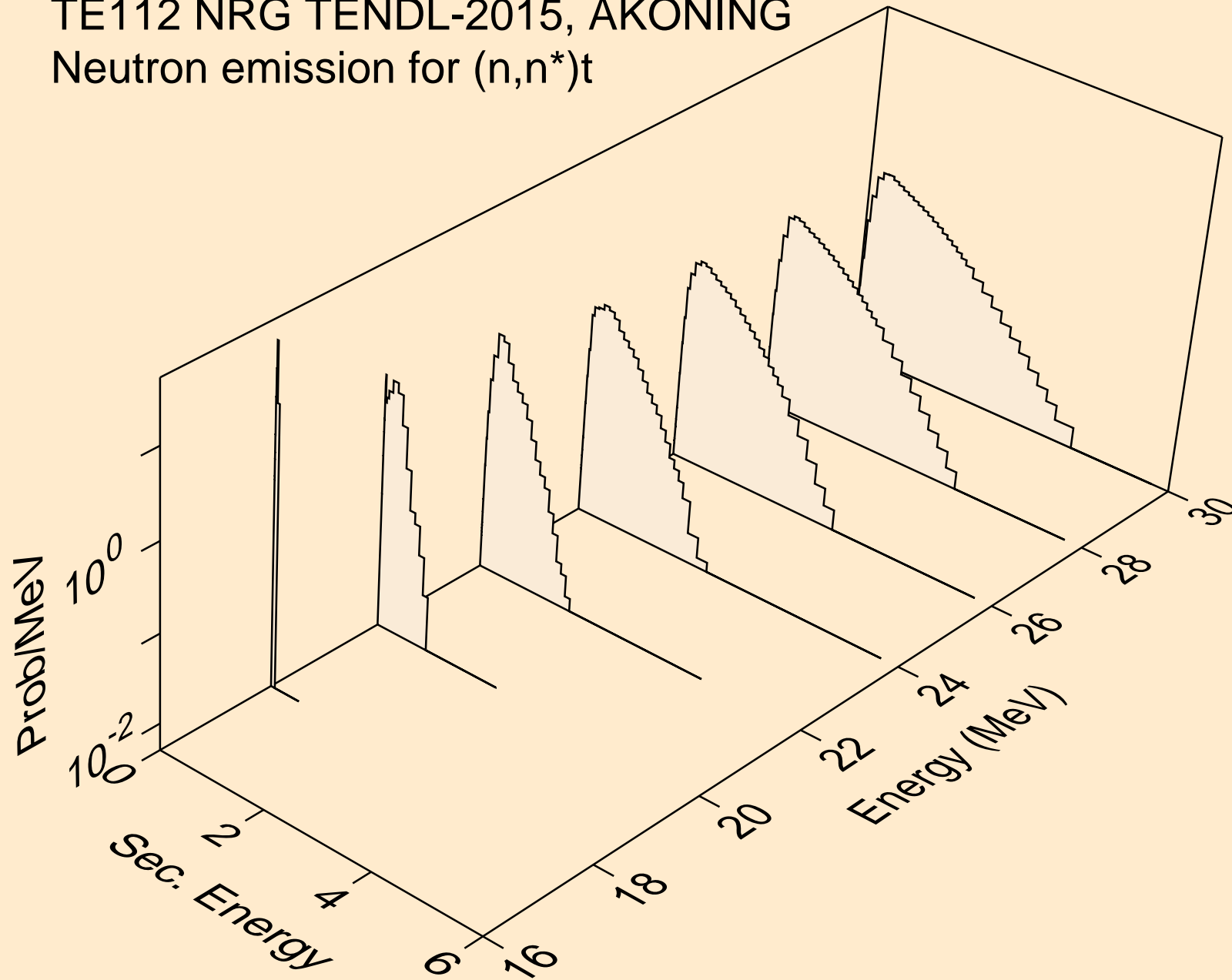

TE112 NRG TENDL-2015, AKONING  
Neutron emission for (n,n\*)he3

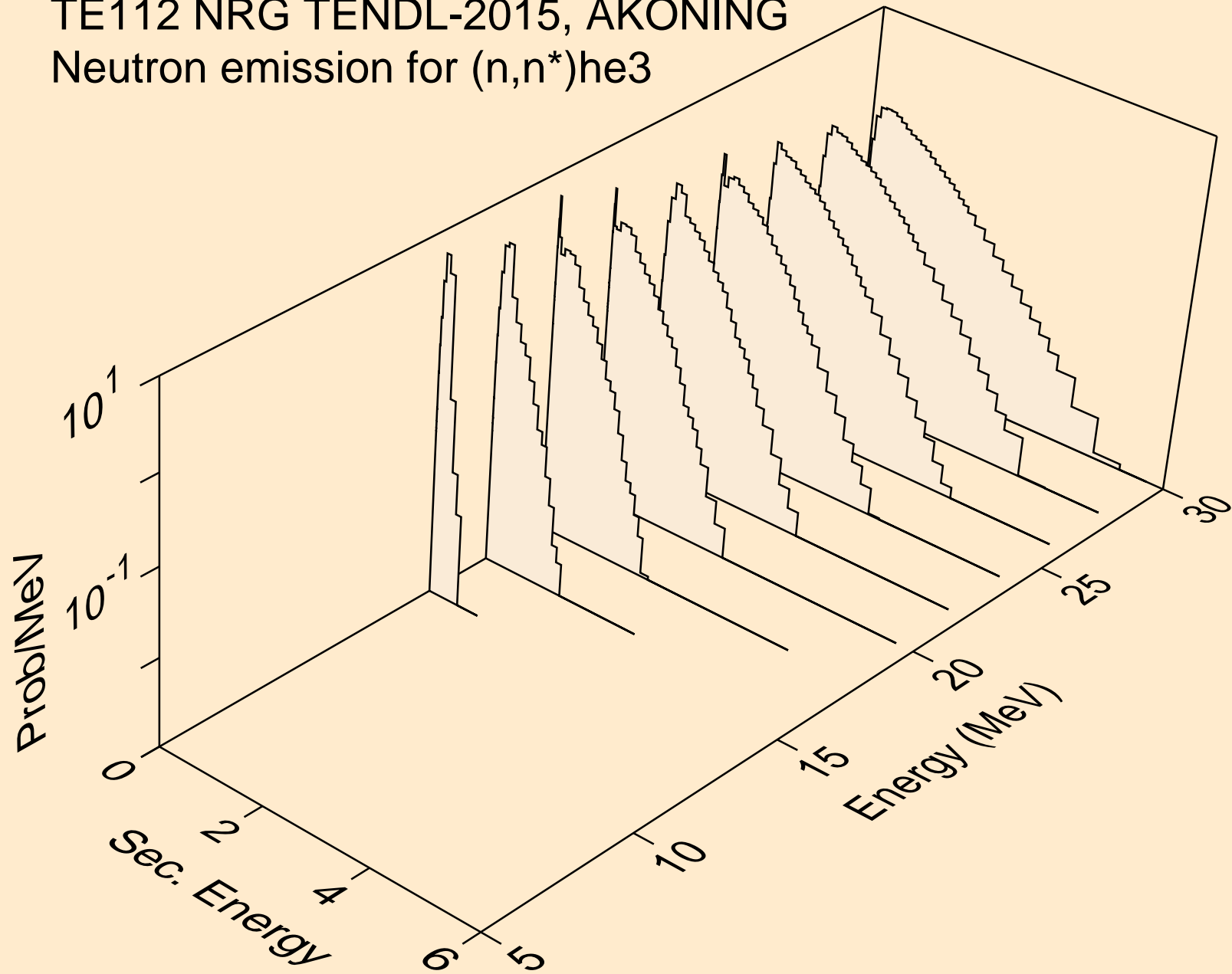

TE112 NRG TENDL-2015, AKONING  
Neutron emission for (n,2np)

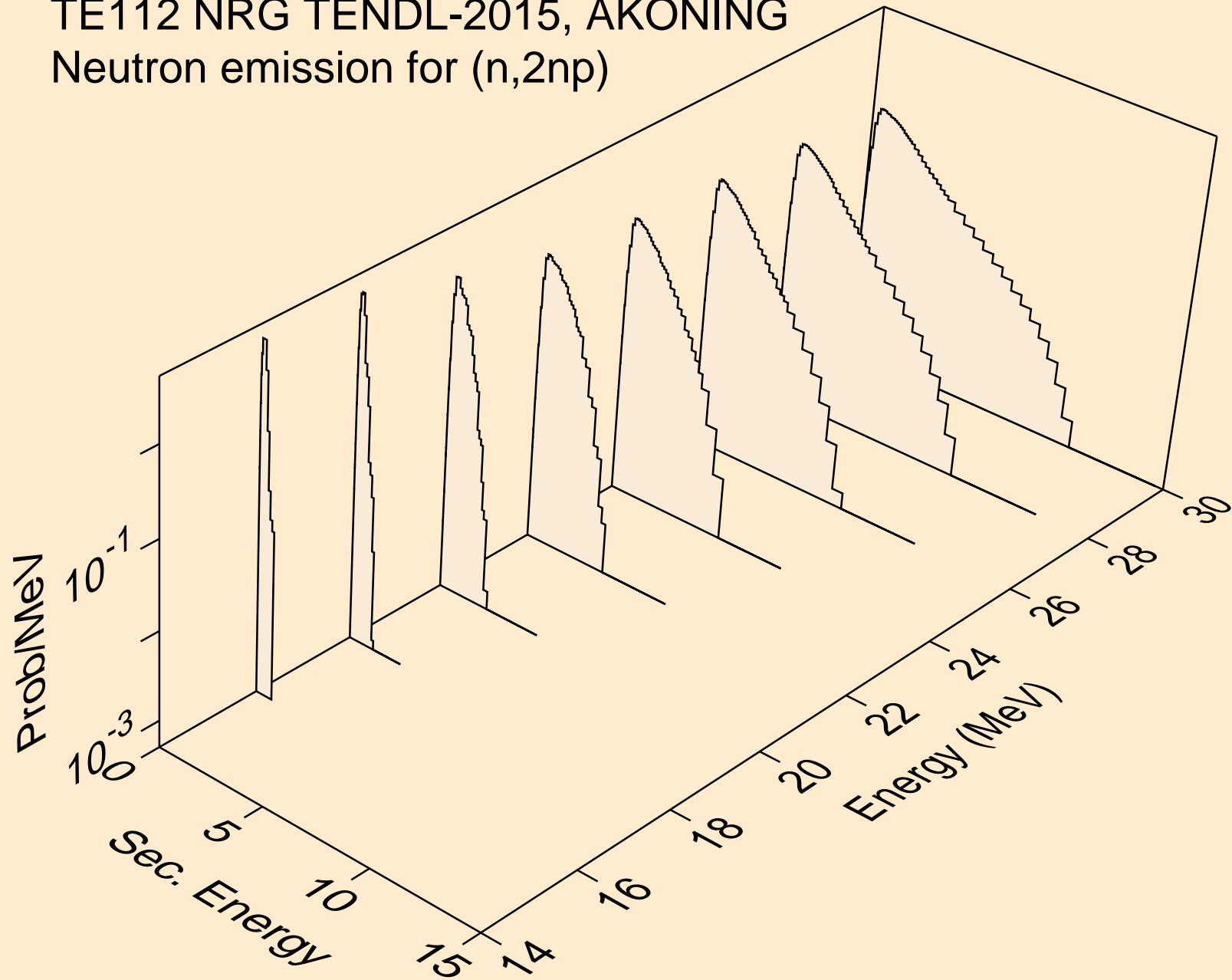

TE112 NRG TENDL-2015, AKONING  
Neutron emission for (n,3np)

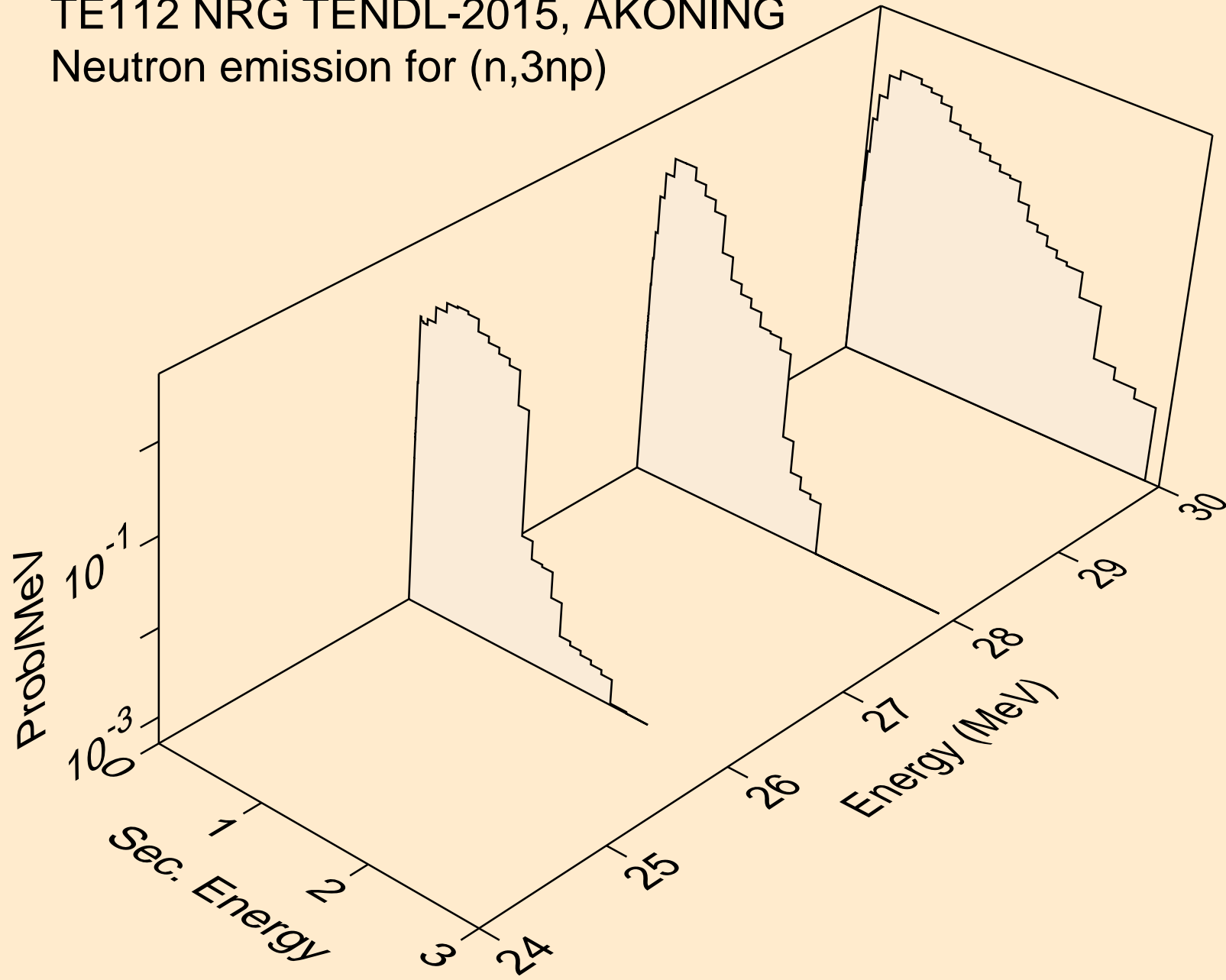

TE112 NRG TENDL-2015, AKONING  
Neutron emission for (n,2np)

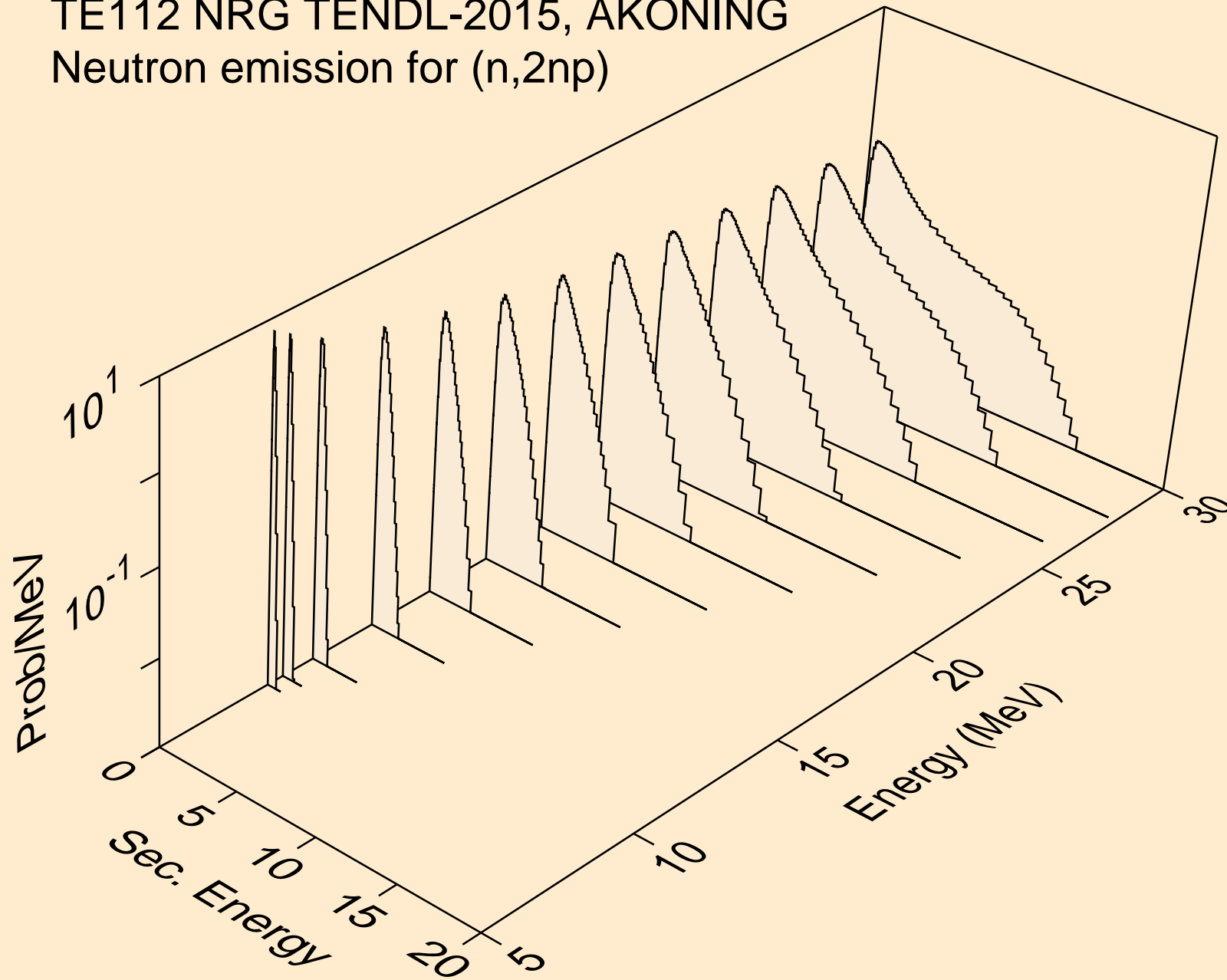



TE112 NRG TENDL-2015, AKONING  
Neutron emission for (n,npa)

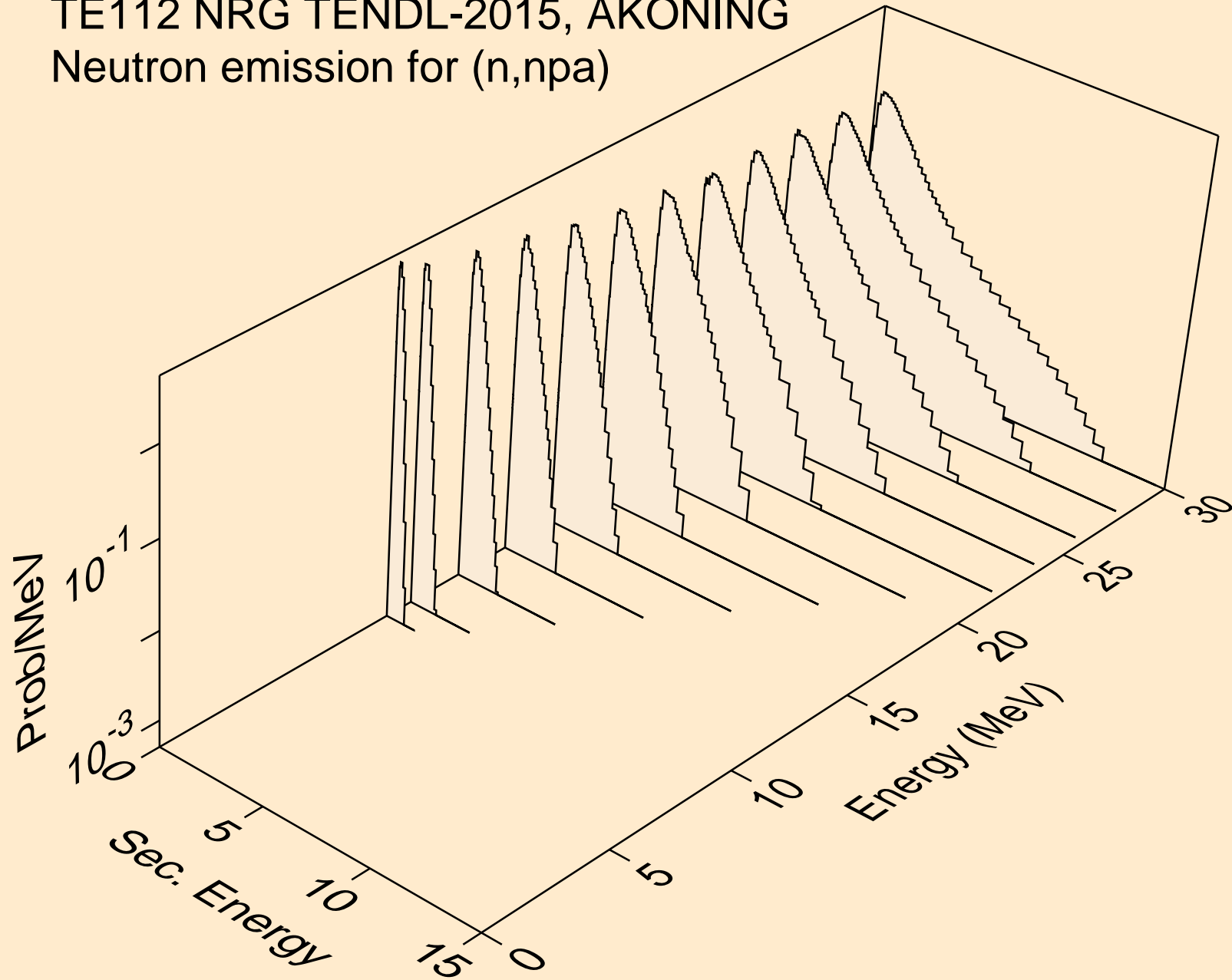

TE112 NRG TENDL-2015, AKONING  
Neutron emission for (n,n\*c)

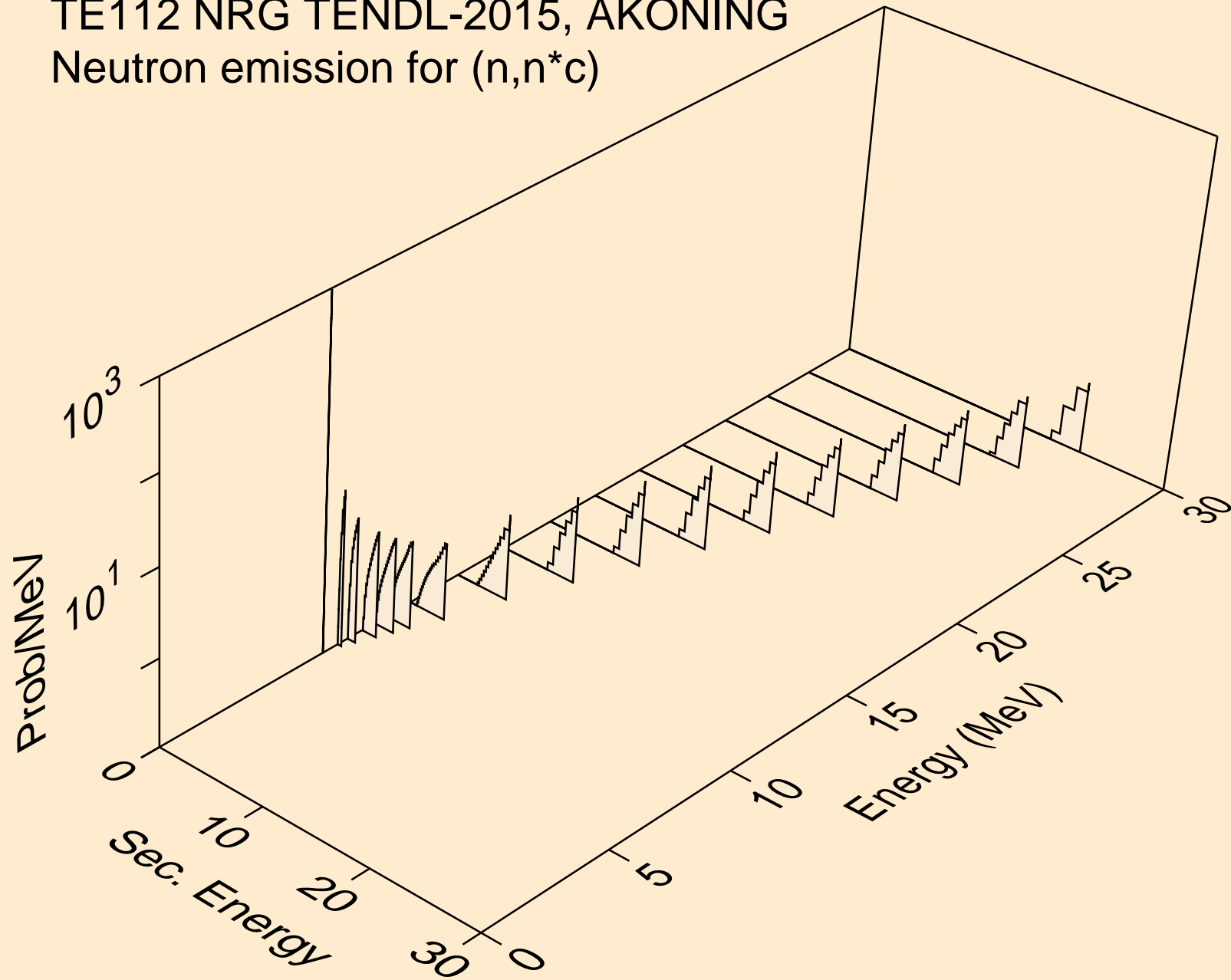

TE112 NRG TENDL-2015, AKONING  
Photon emission for (n,x)

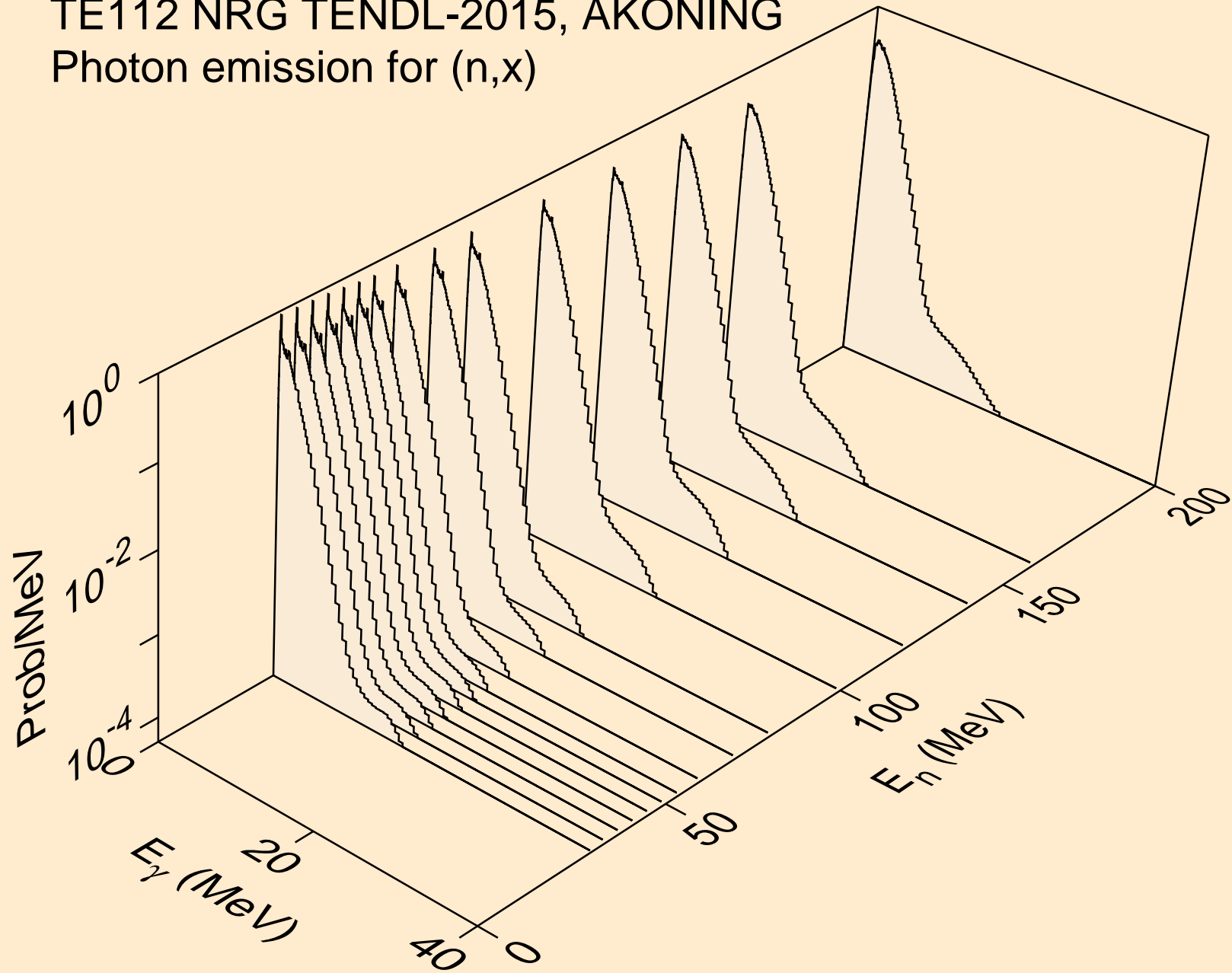

TE112 NRG TENDL-2015, AKONING  
Photon emission for (n,2nd)

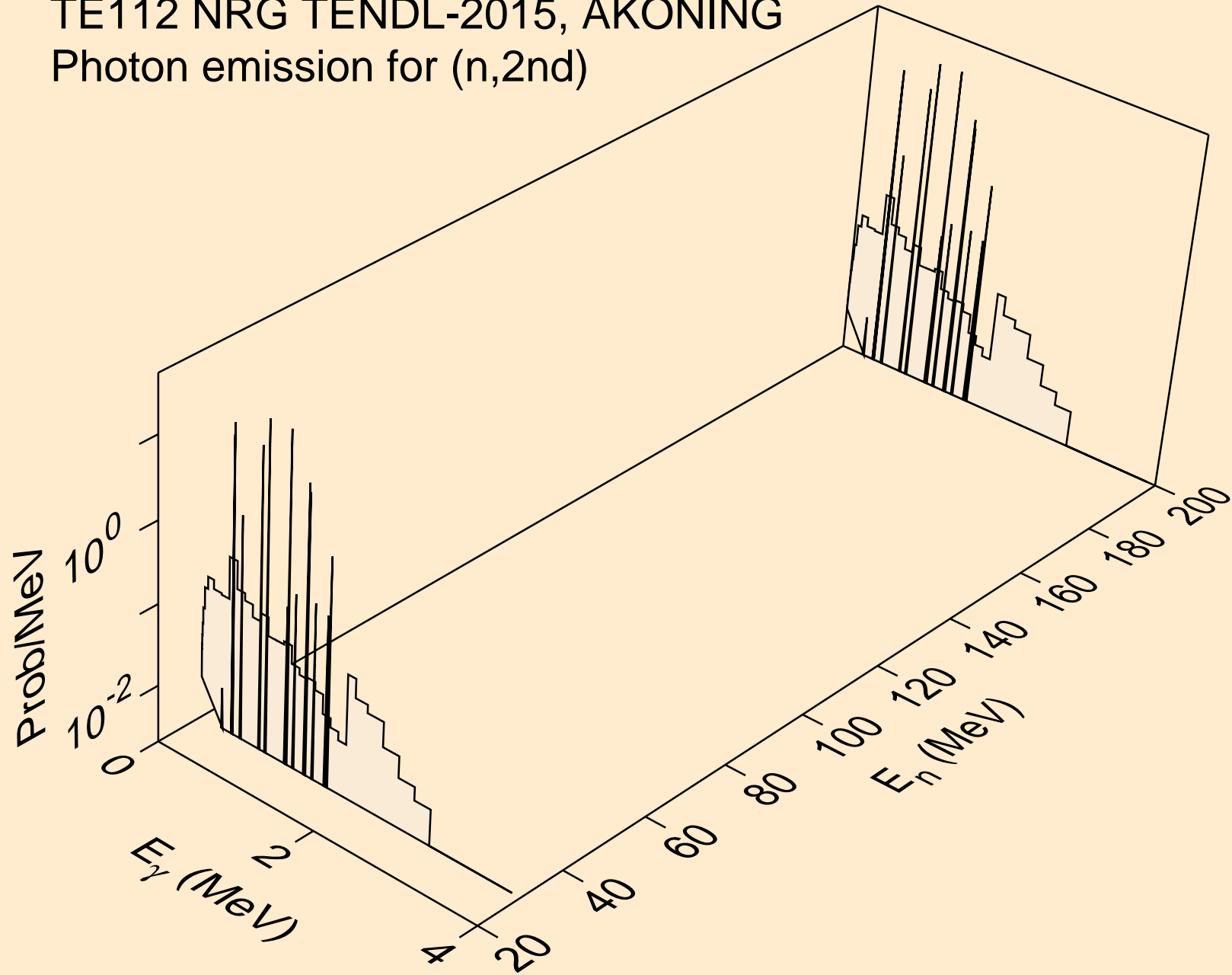

TE112 NRG TENDL-2015, AKONING  
Photon emission for (n,2n)

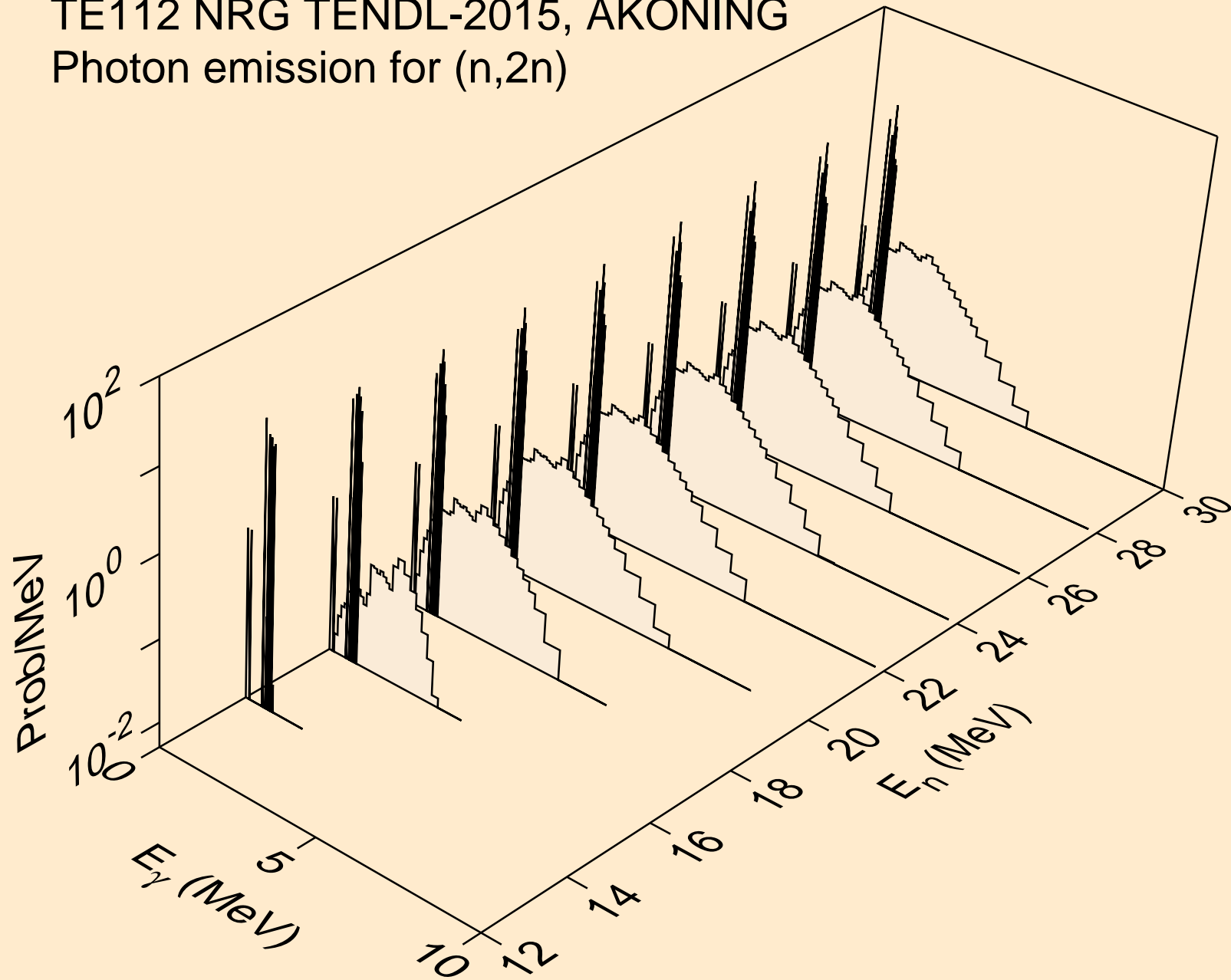

TE112 NRG TENDL-2015, AKONING  
Photon emission for (n,3n)

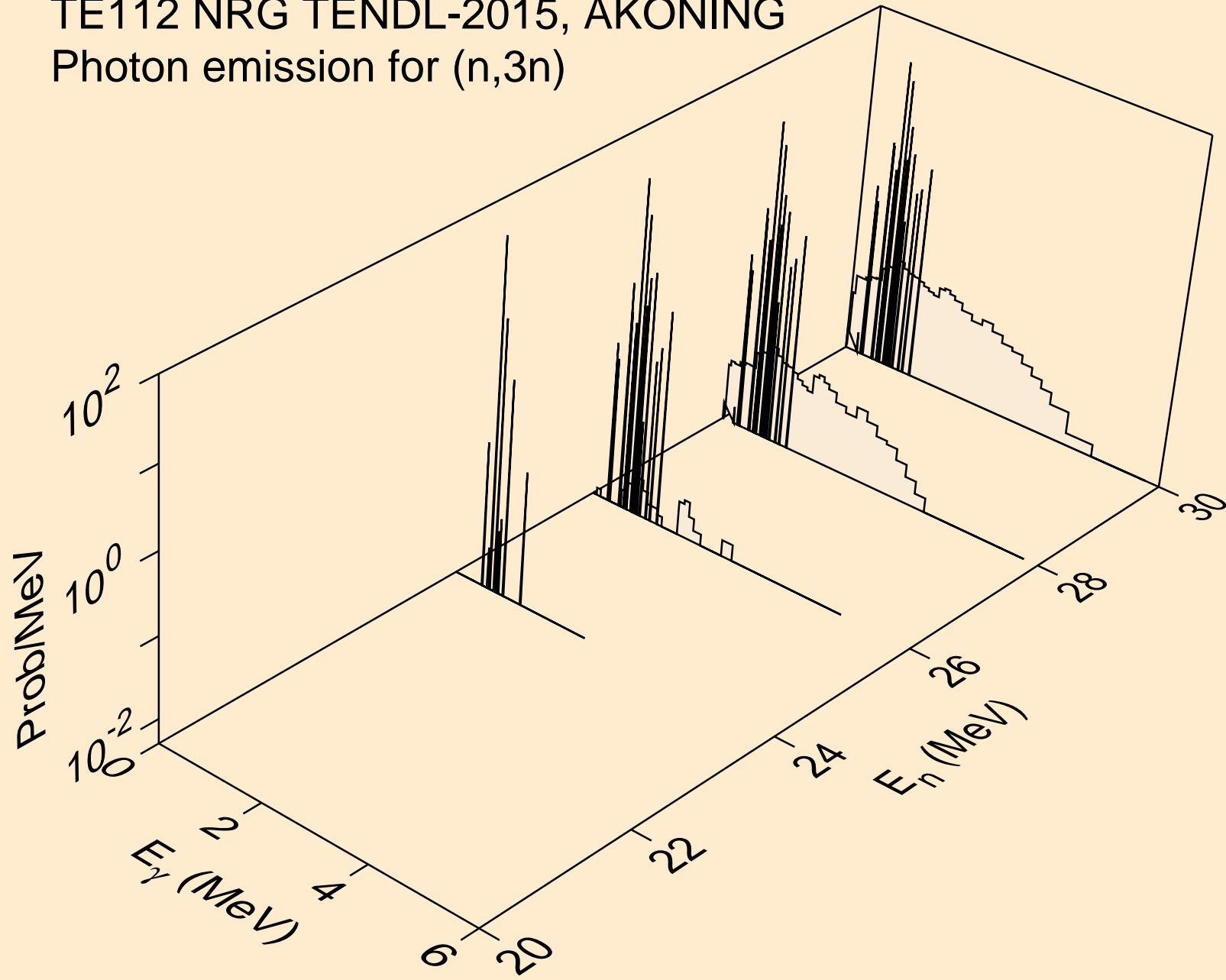

TE112 NRG TENDL-2015, AKONING  
Photon emission for (n,n\*)a

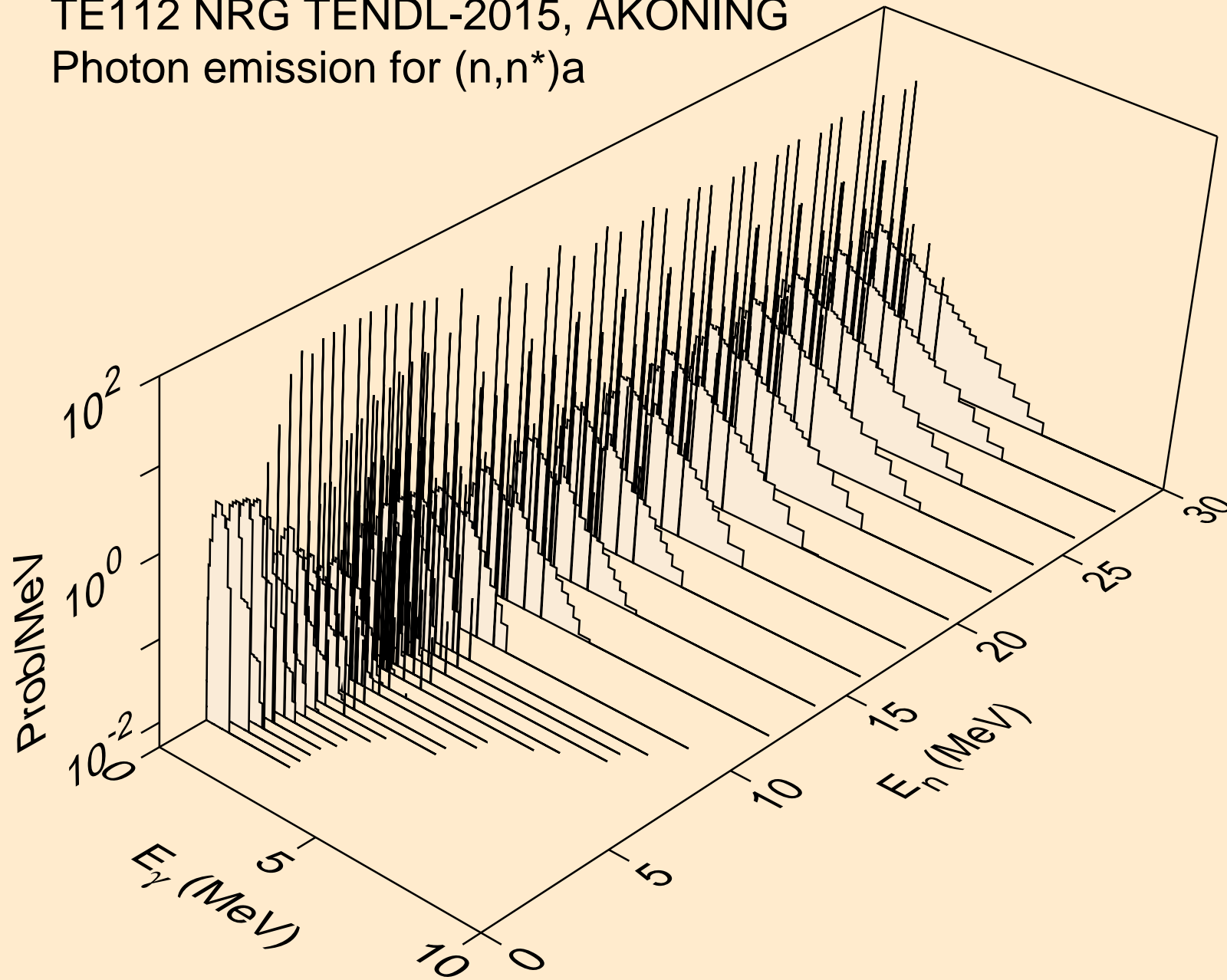

TE112 NRG TENDL-2015, AKONING  
Photon emission for (n,n\*)3a

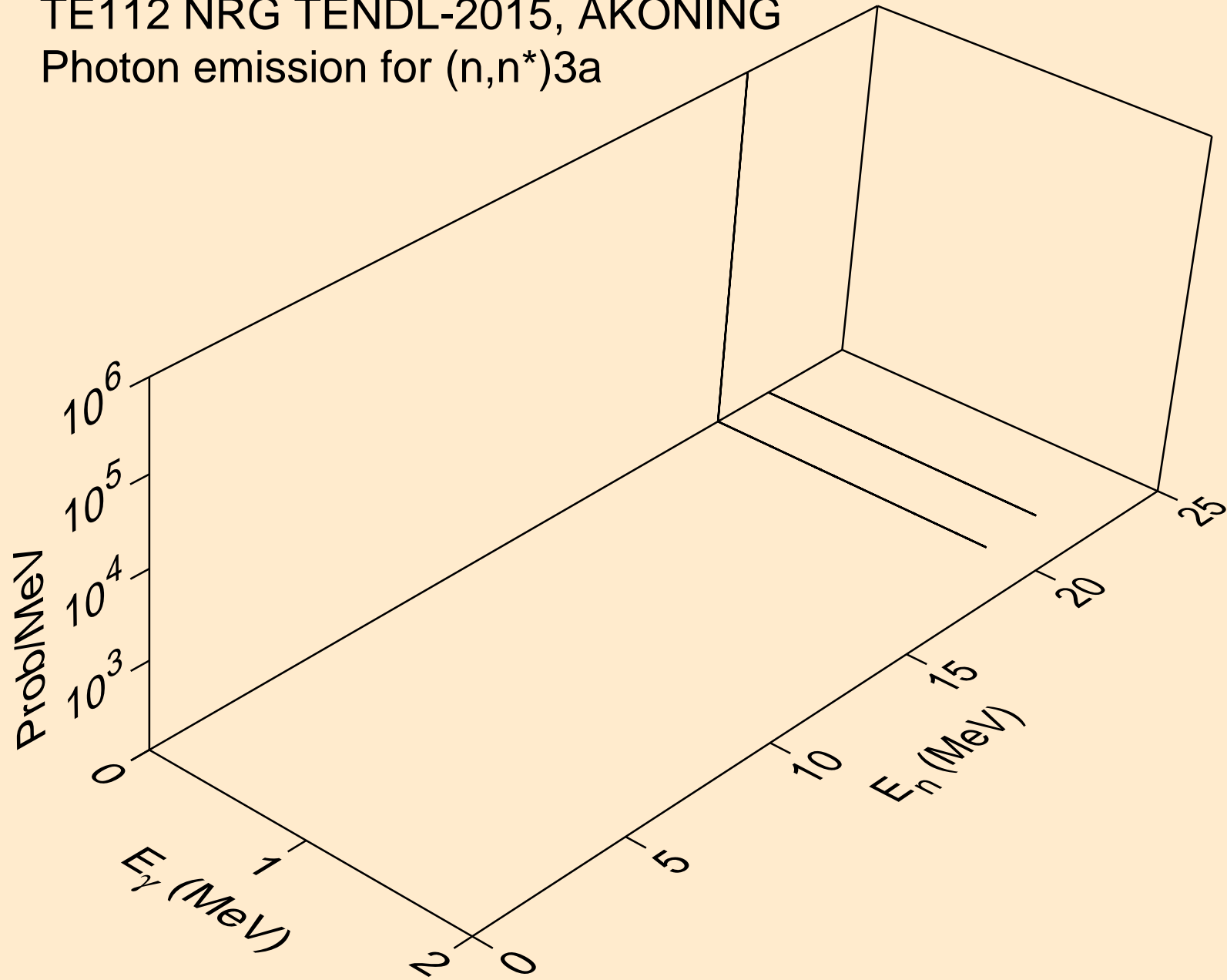



TE112 NRG TENDL-2015, AKONING  
Photon emission for (n,2n)a

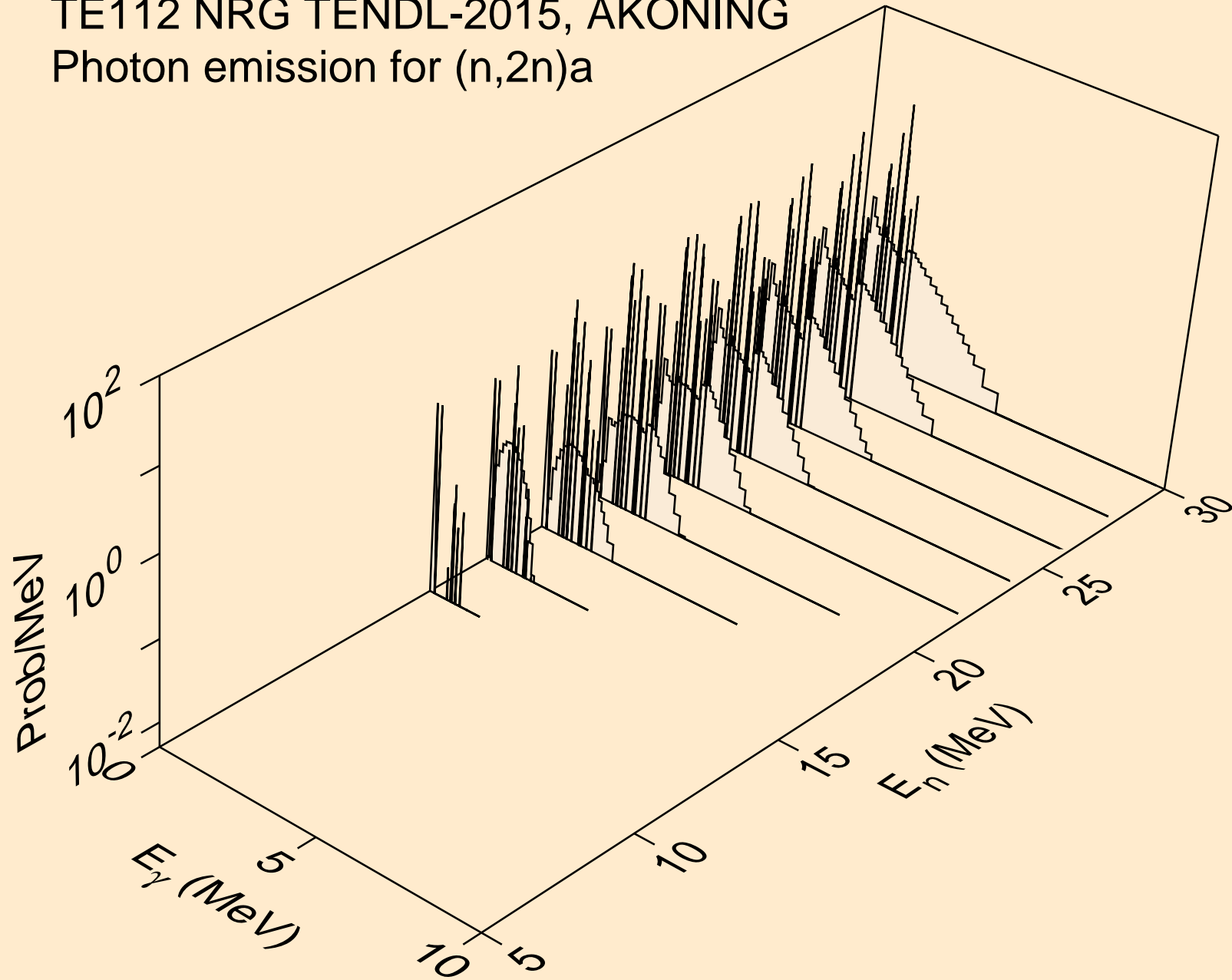

TE112 NRG TENDL-2015, AKONING  
Photon emission for (n,3n)a

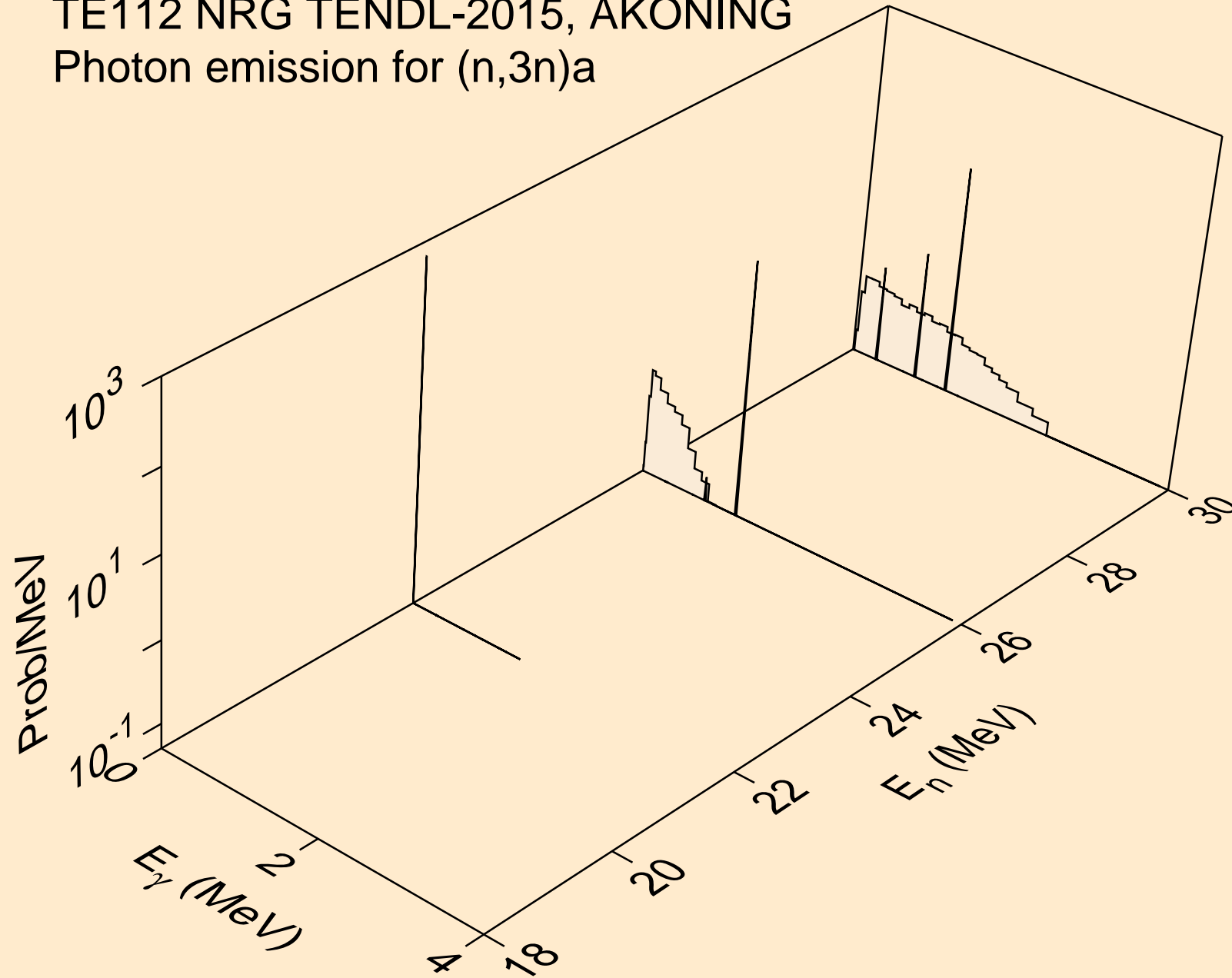

TE112 NRG TENDL-2015, AKONING  
Photon emission for (n,n\*)p

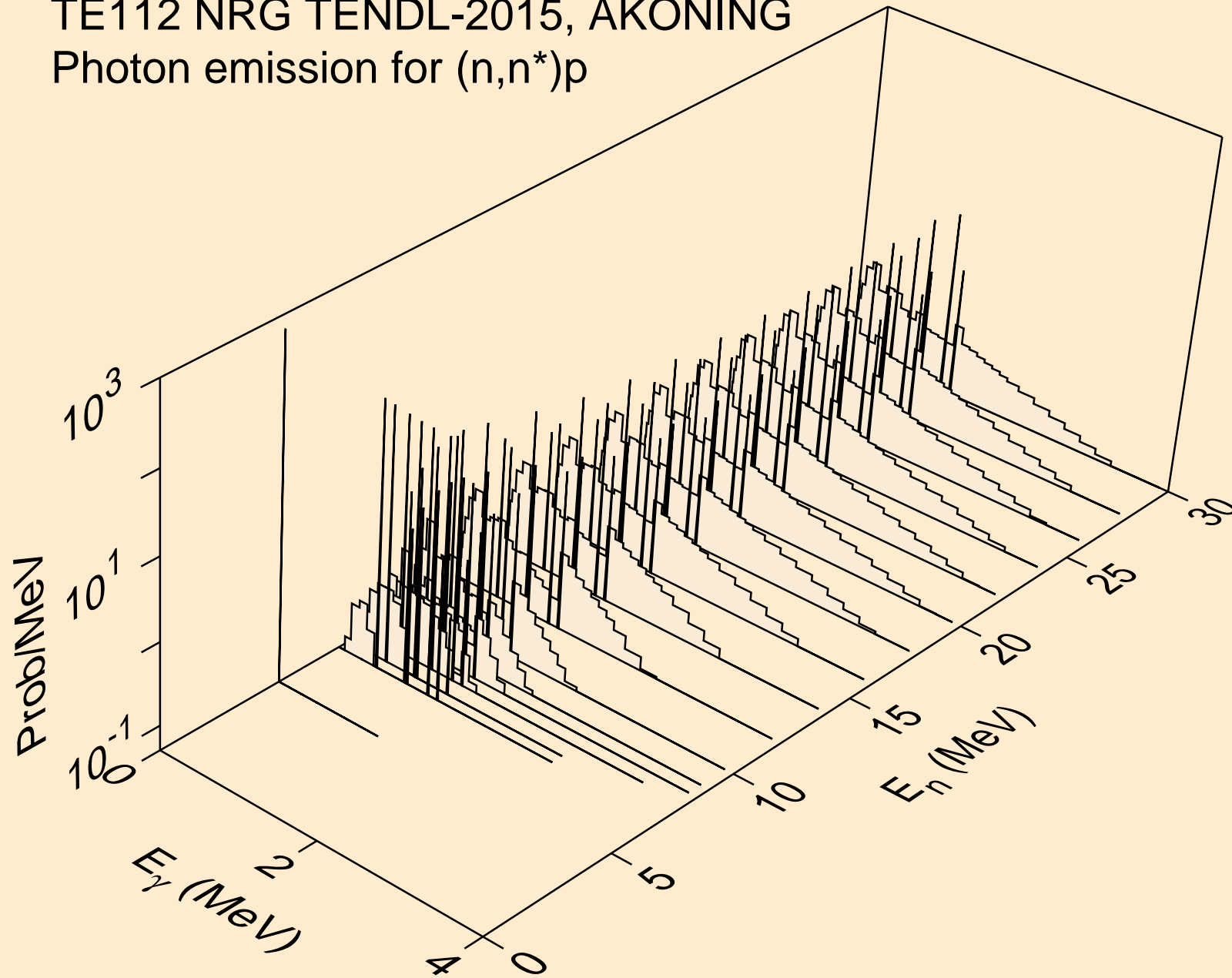

TE112 NRG TENDL-2015, AKONING  
Photon emission for (n,n\*)2a

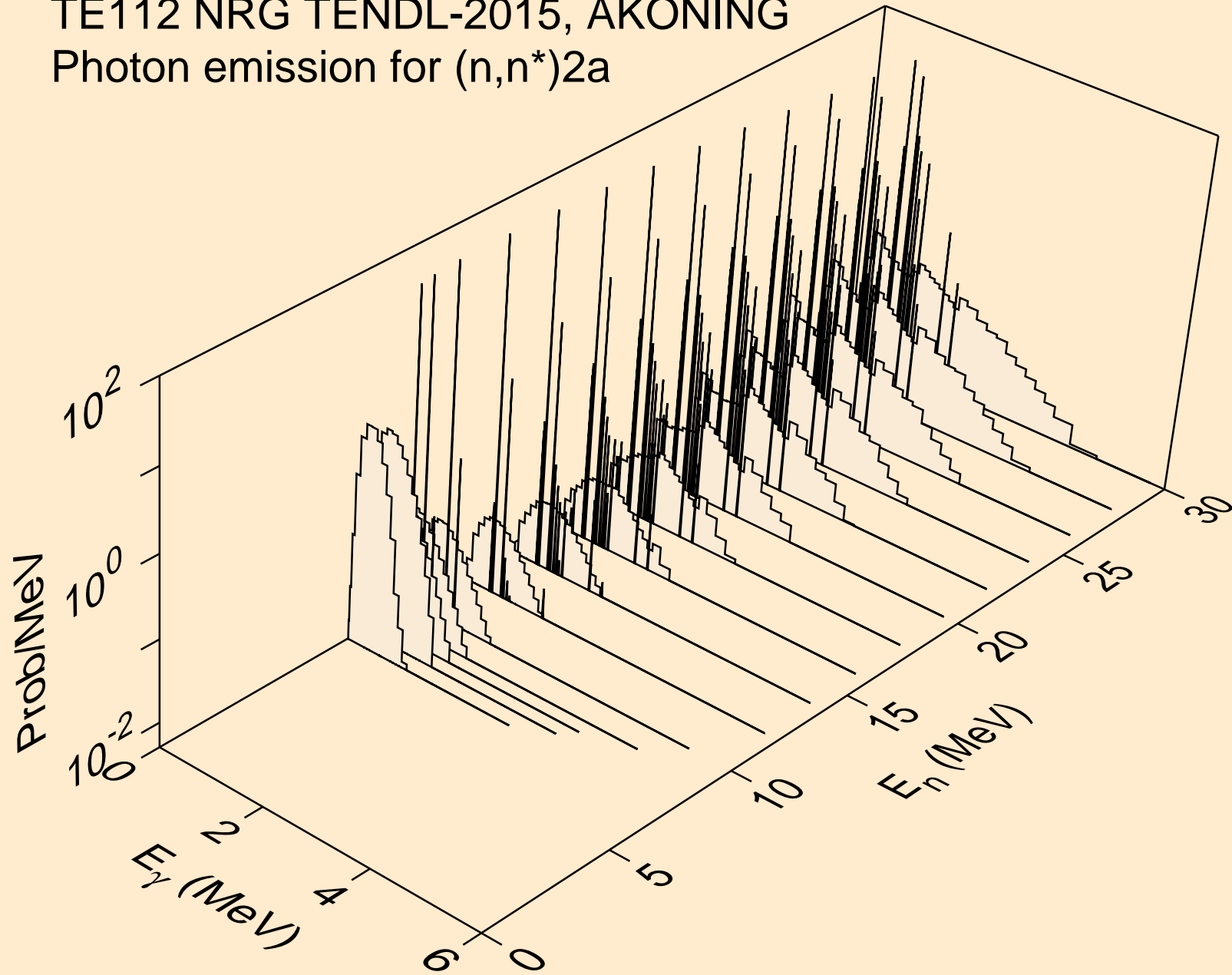

TE112 NRG TENDL-2015, AKONING  
Photon emission for (n,2n)2a

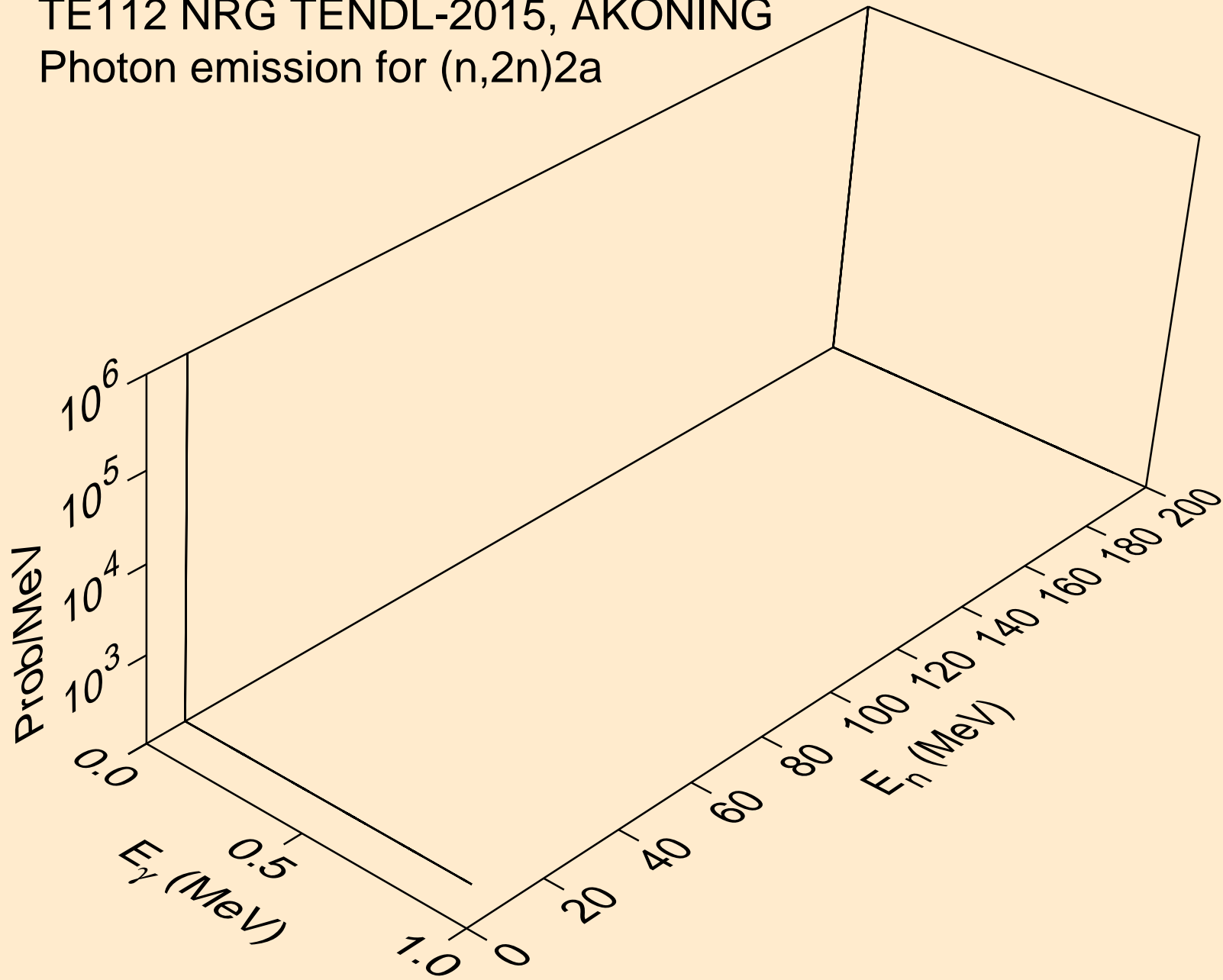

TE112 NRG TENDL-2015, AKONING  
Photon emission for (n,n\*)d

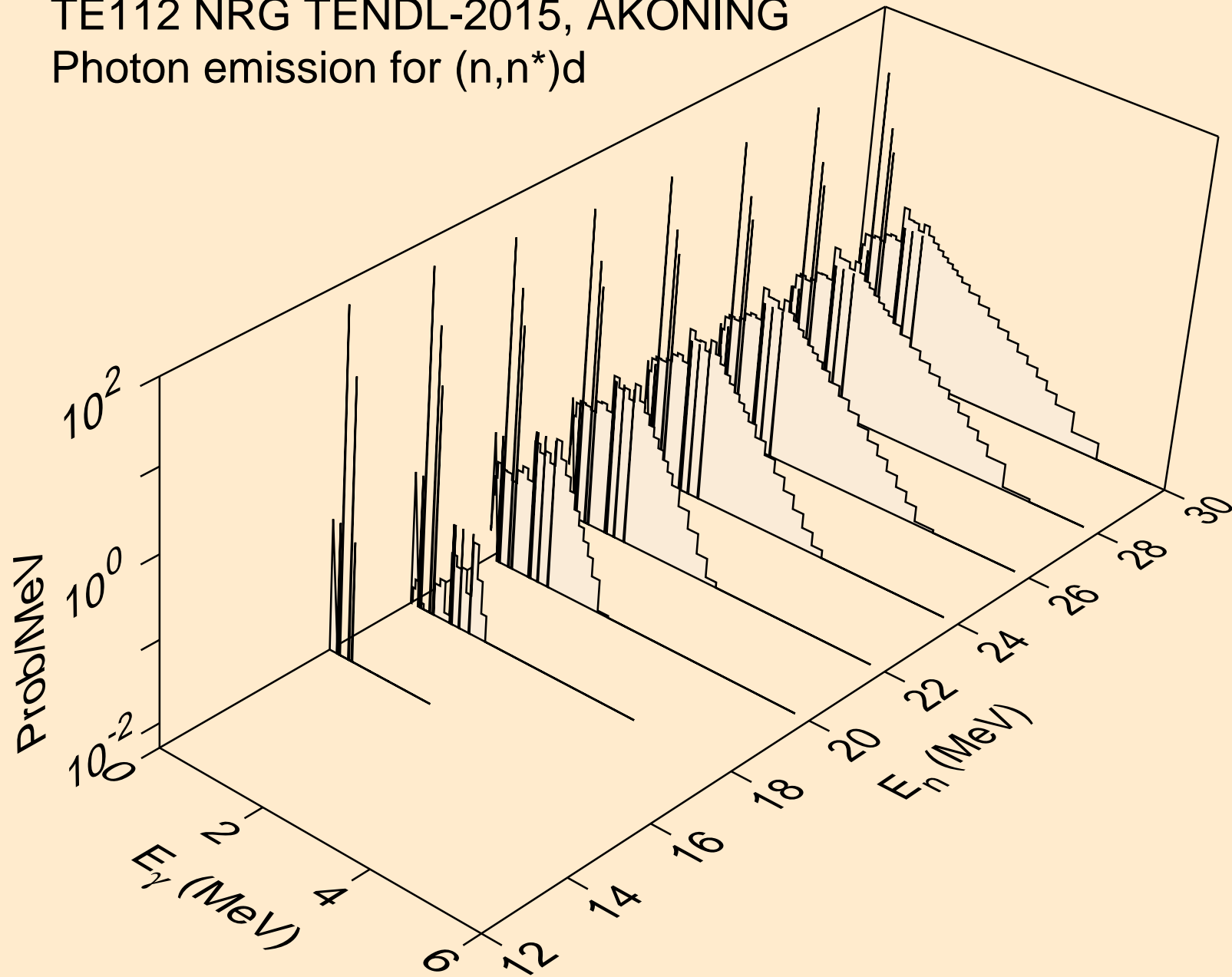

TE112 NRG TENDL-2015, AKONING  
Photon emission for (n,n\*)t

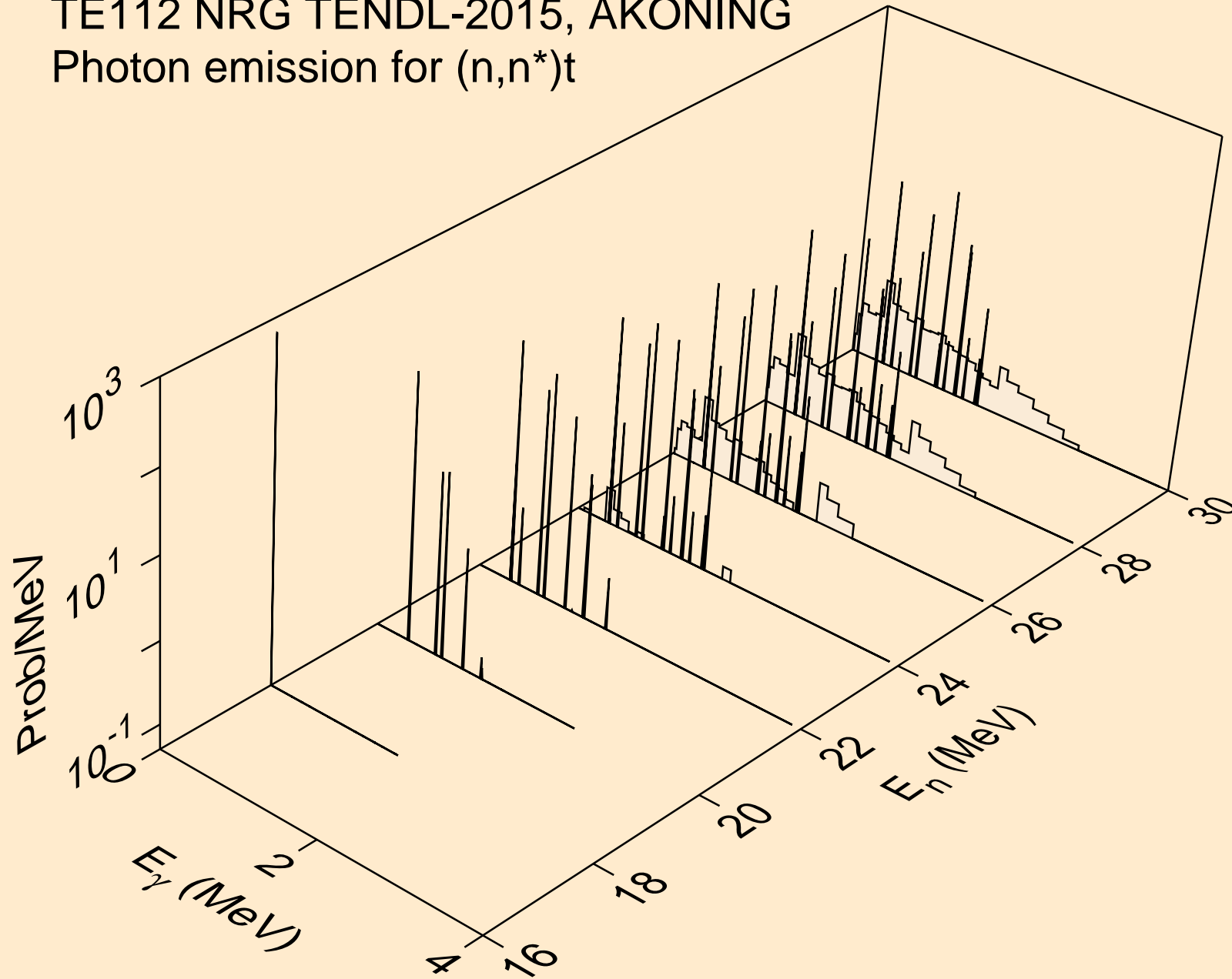

TE112 NRG TENDL-2015, AKONING  
Photon emission for (n,n\*)he3

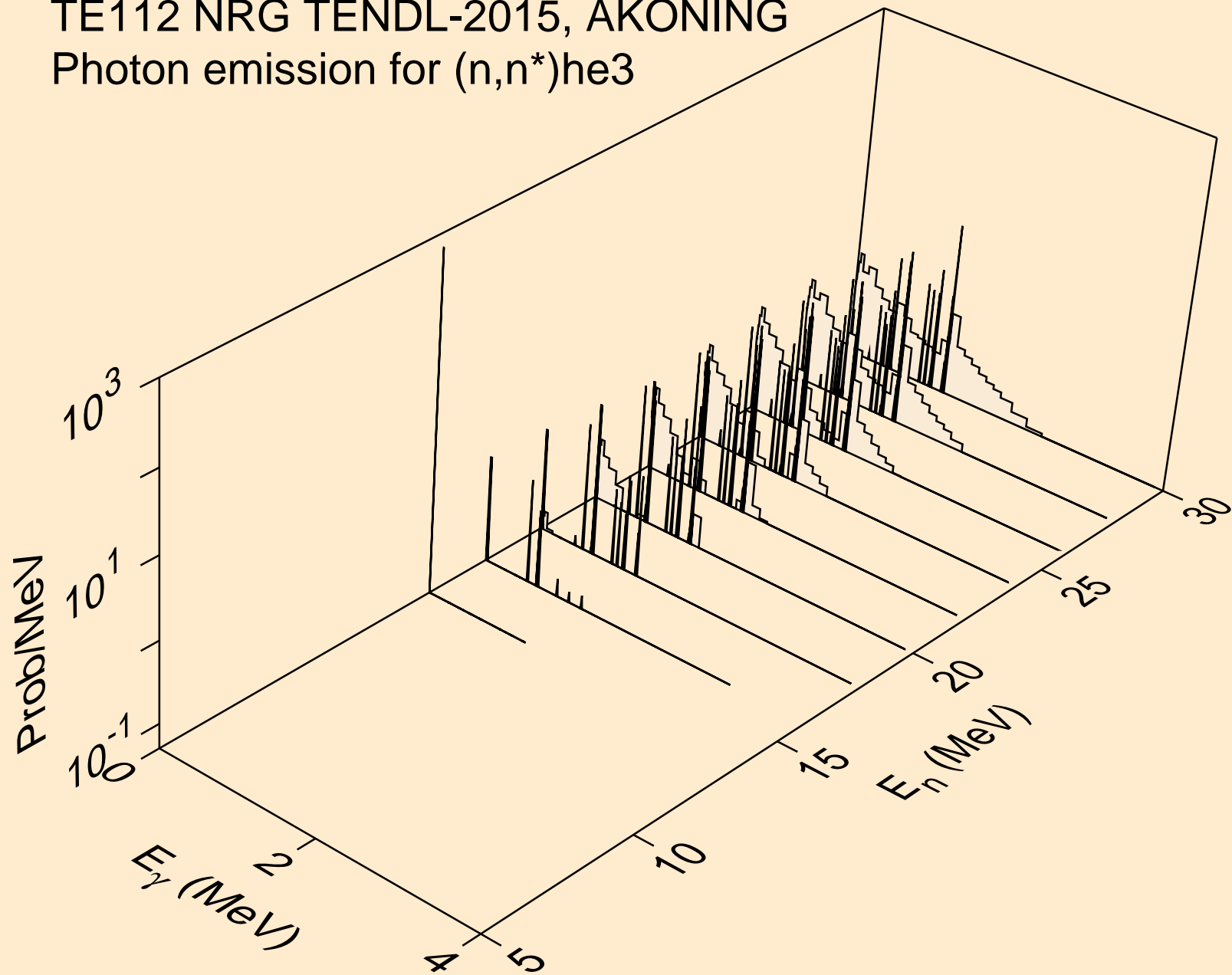



TE112 NRG TENDL-2015, AKONING  
Photon emission for (n,2np)

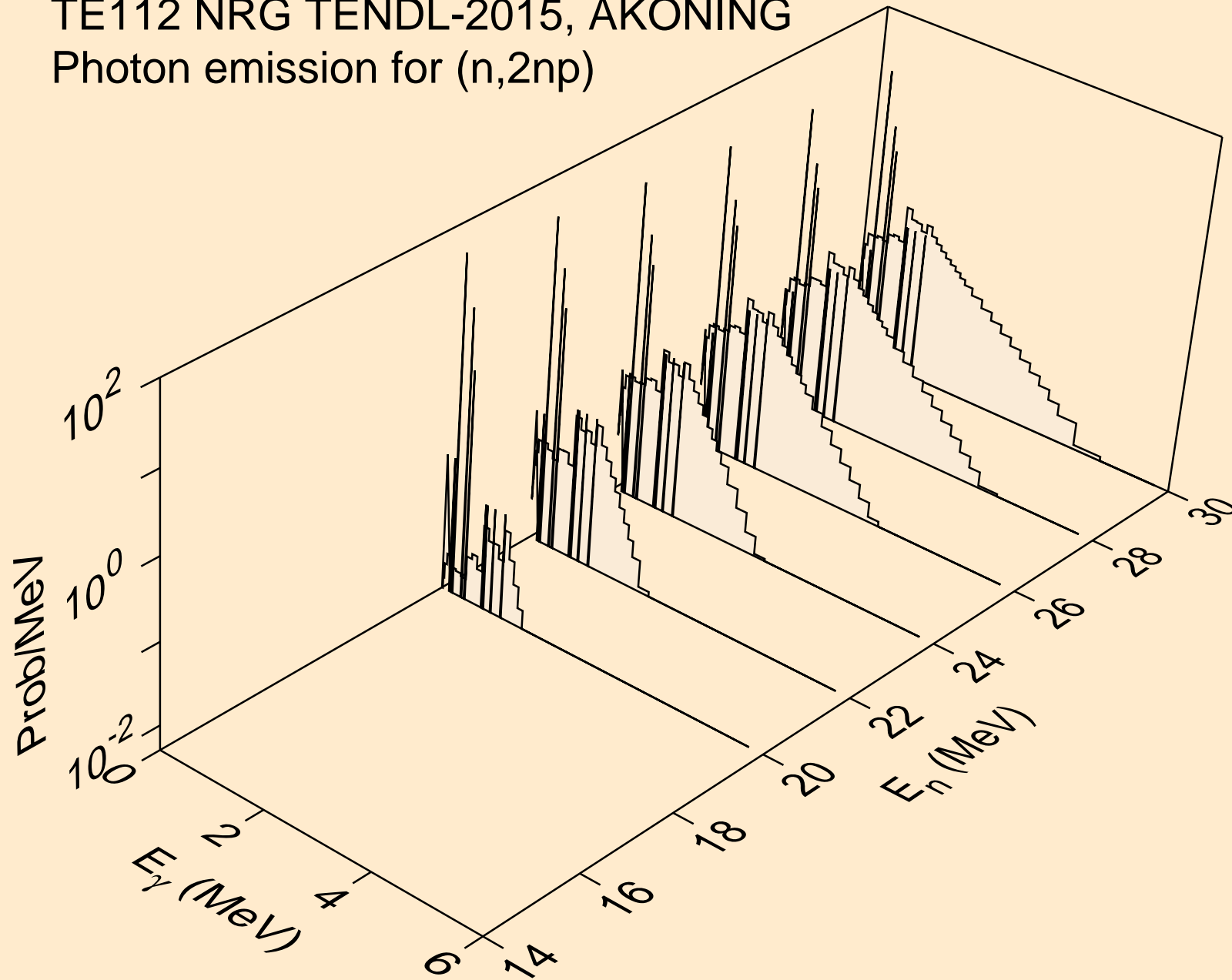

TE112 NRG TENDL-2015, AKONING  
Photon emission for (n,3np)

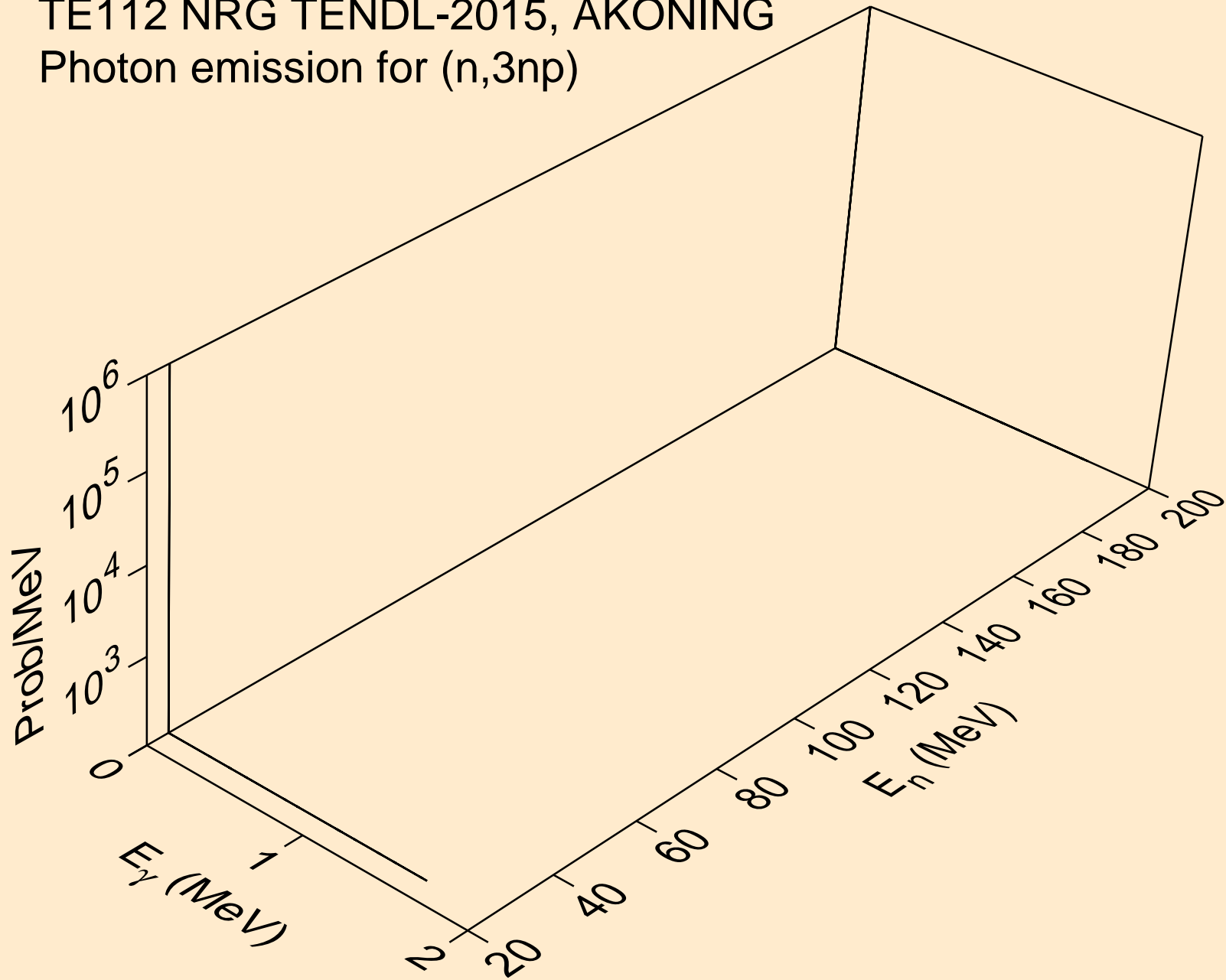

TE112 NRG TENDL-2015, AKONING  
Photon emission for (n,2np)

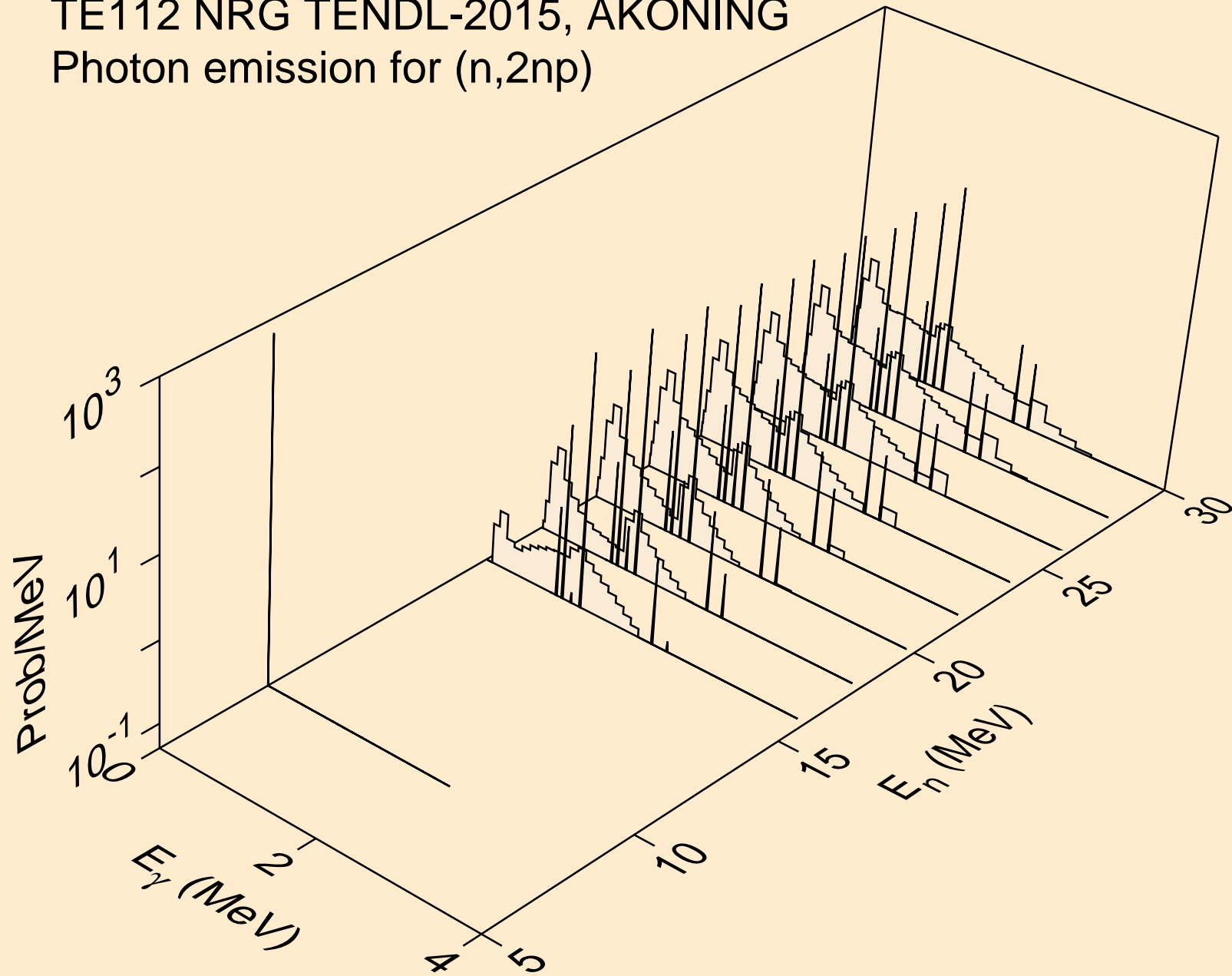

TE112 NRG TENDL-2015, AKONING  
Photon emission for (n,npa)

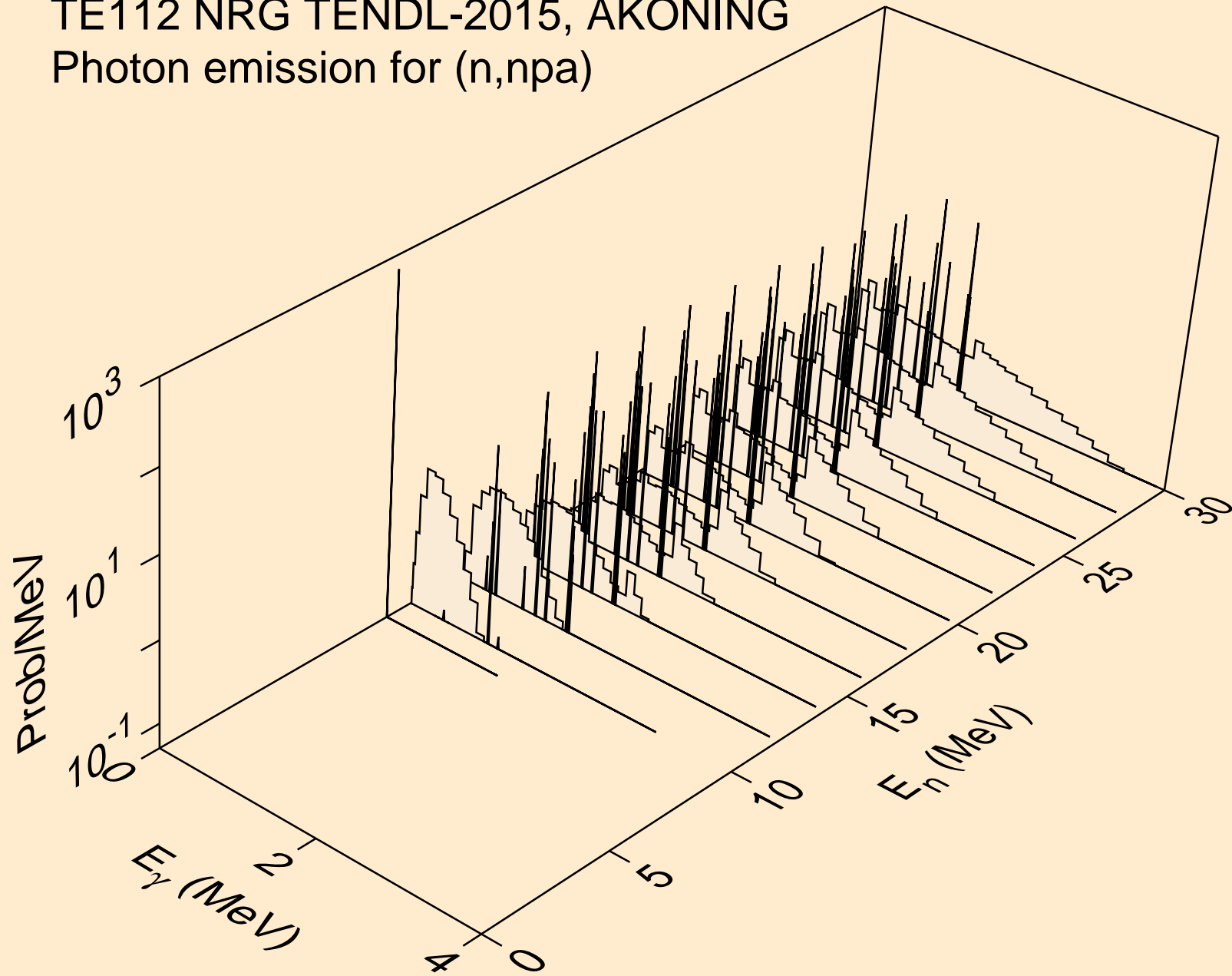

TE112 NRG TENDL-2015, AKONING  
Photon emission for (n,n\*c)

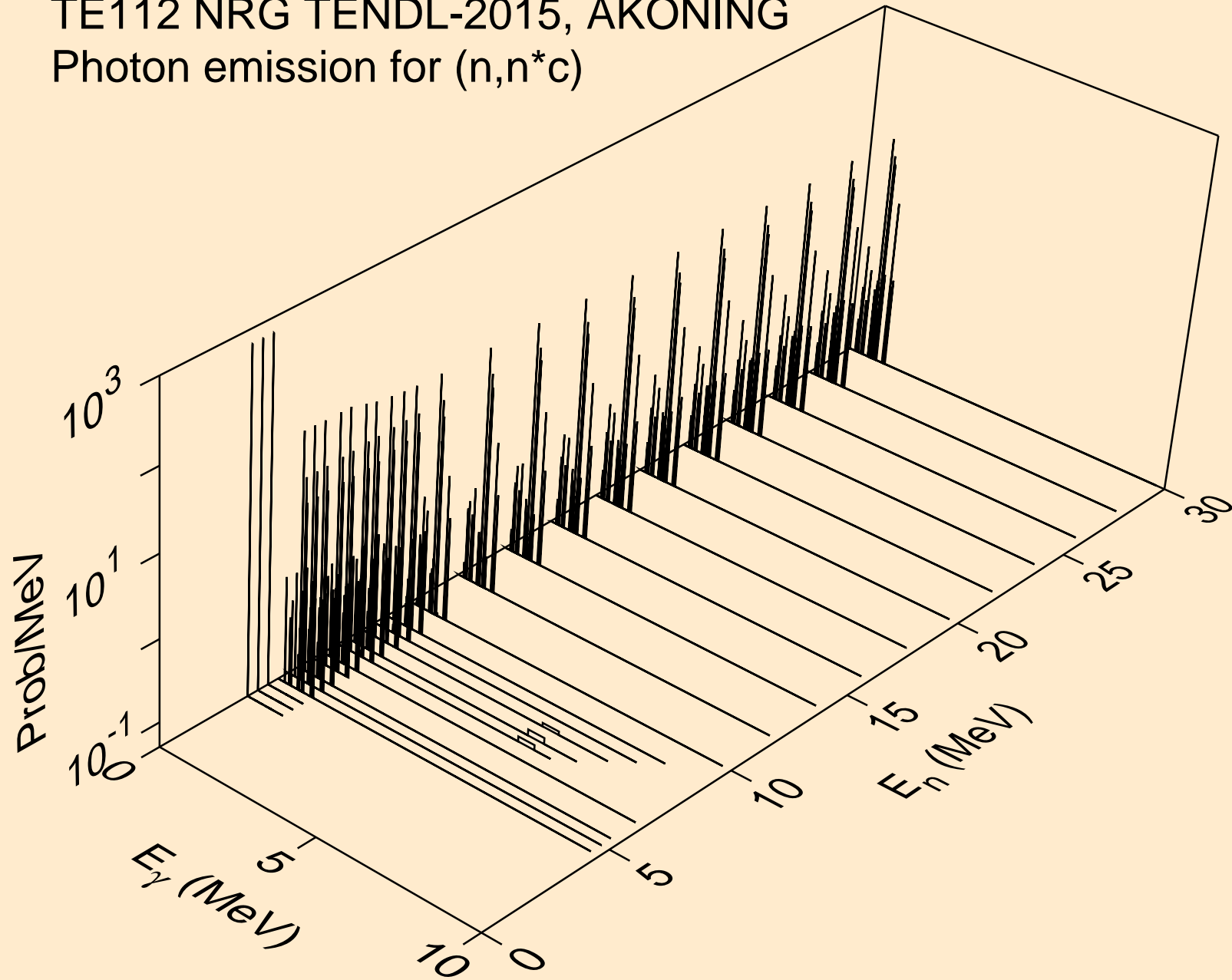

TE112 NRG TENDL-2015, AKONING  
Photon emission for (n,gma)

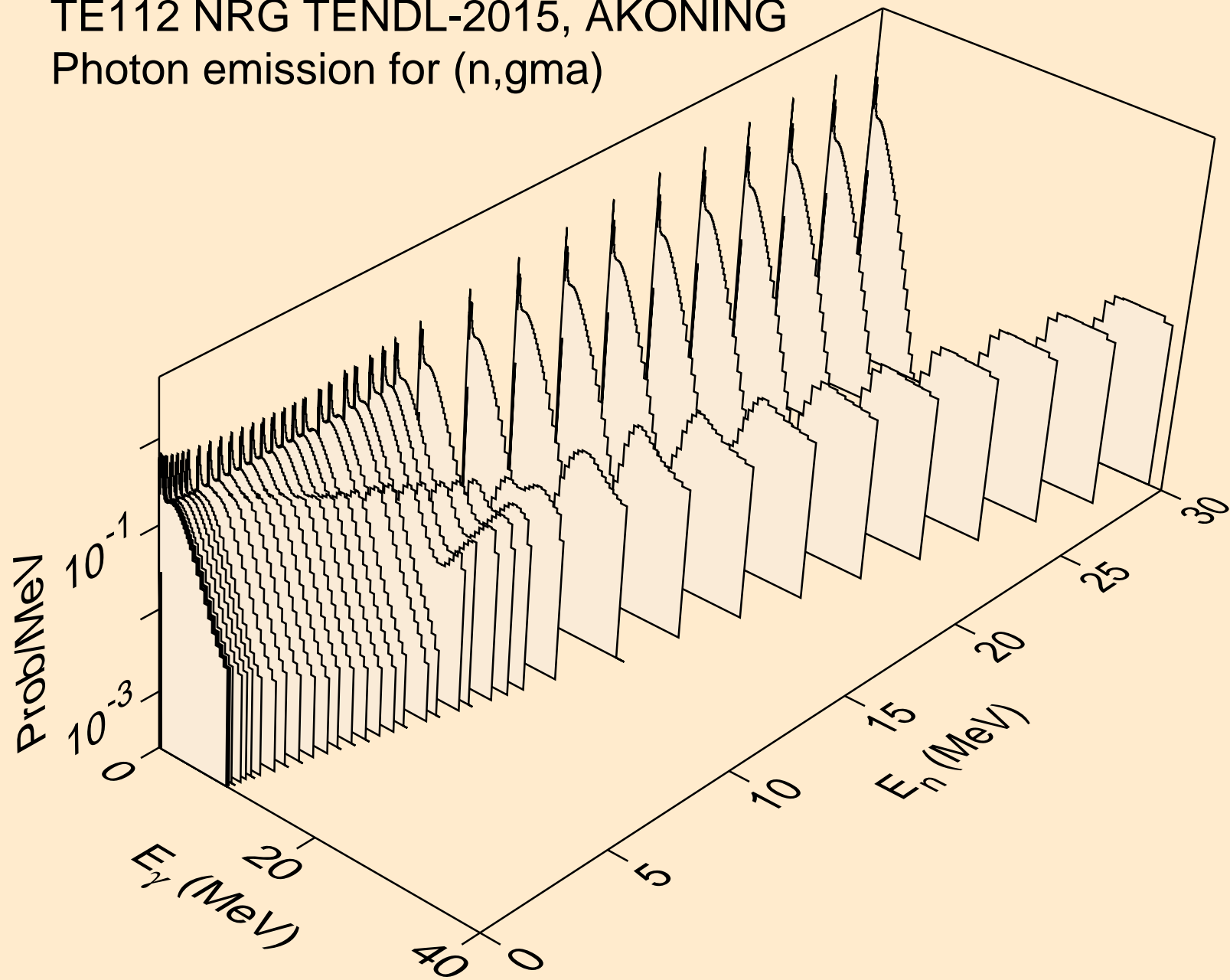

TE112 NRG TENDL-2015, AKONING  
Photon emission for (n,p)

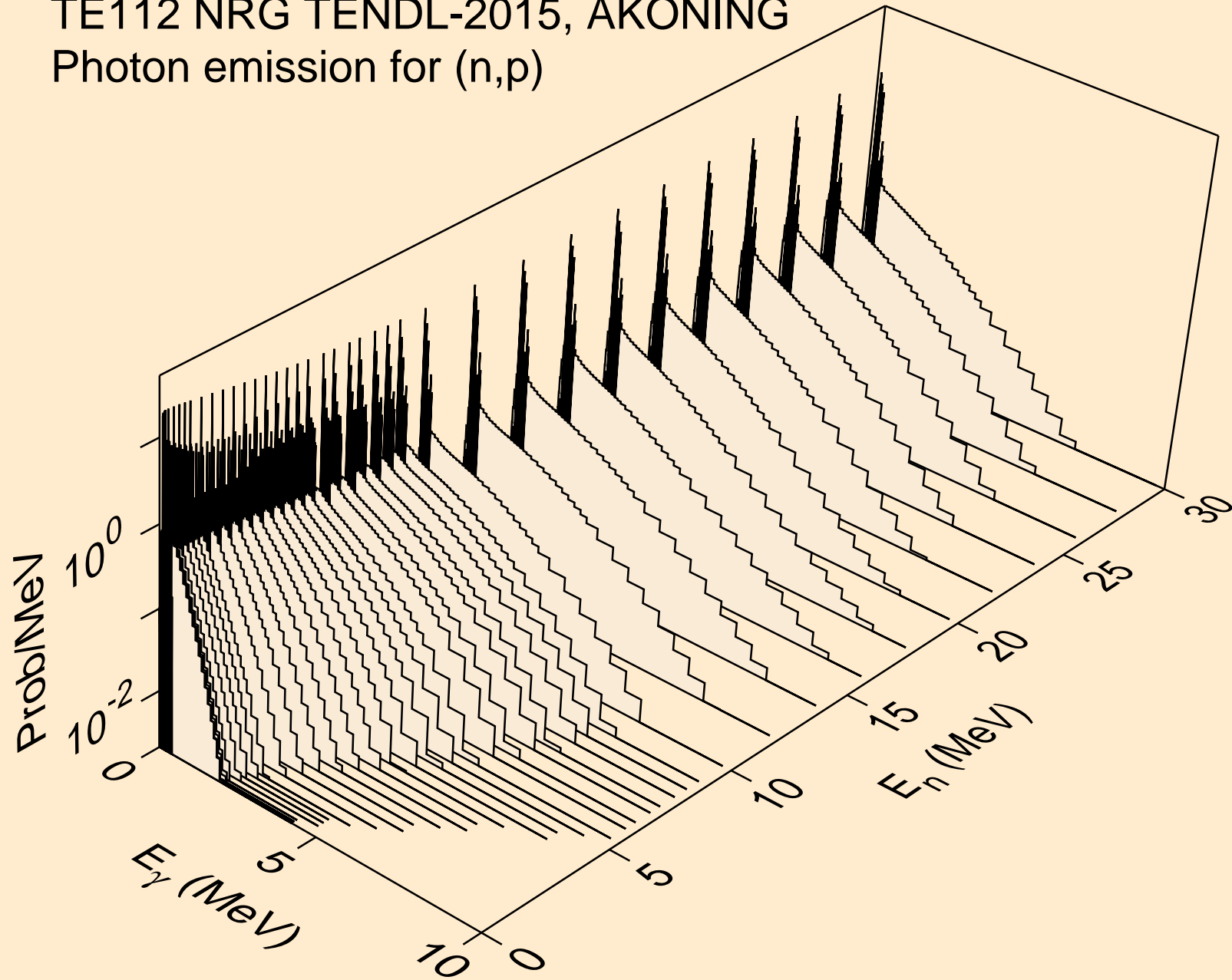

TE112 NRG TENDL-2015, AKONING  
Photon emission for (n,d)

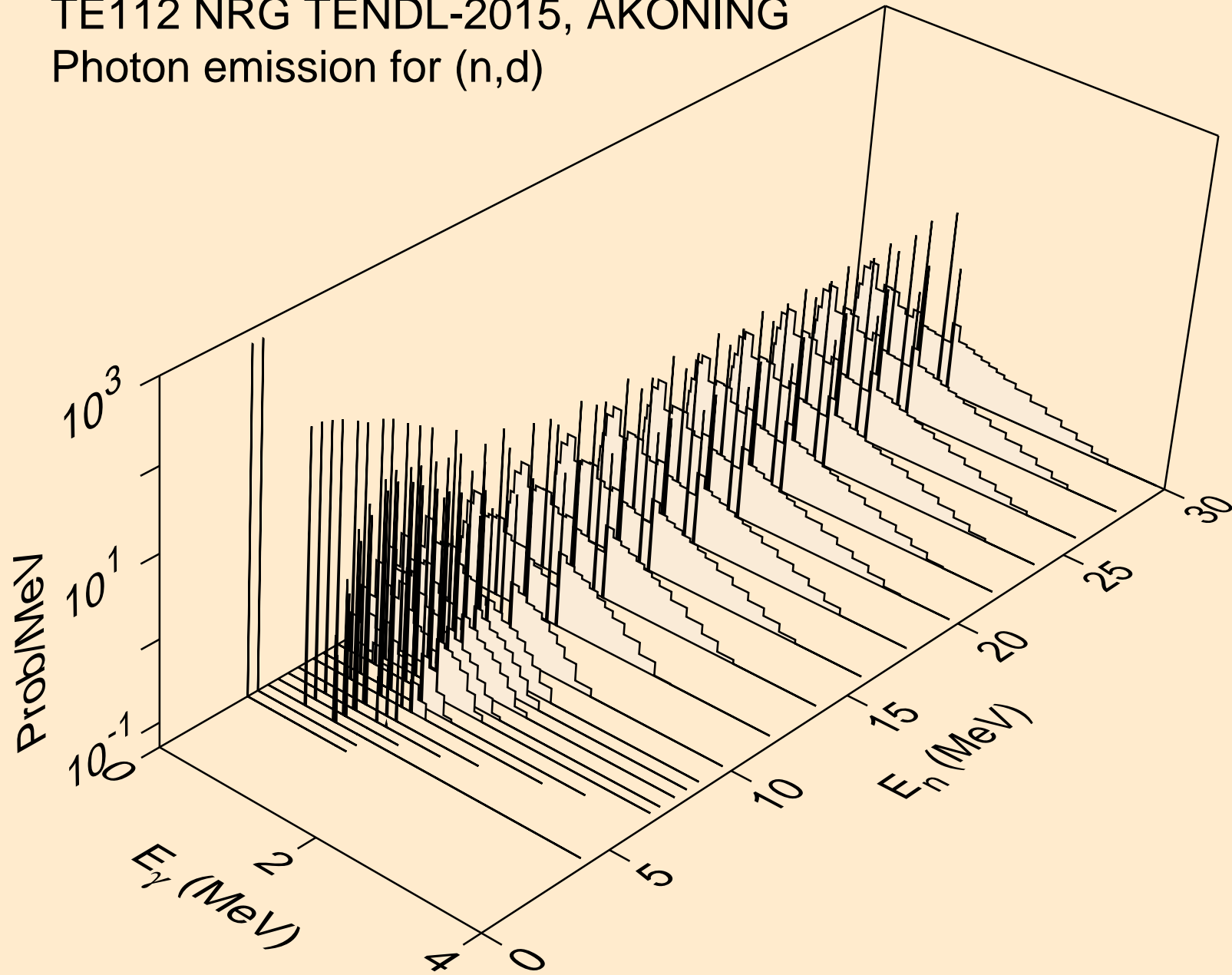



TE112 NRG TENDL-2015, AKONING  
Photon emission for (n,t)

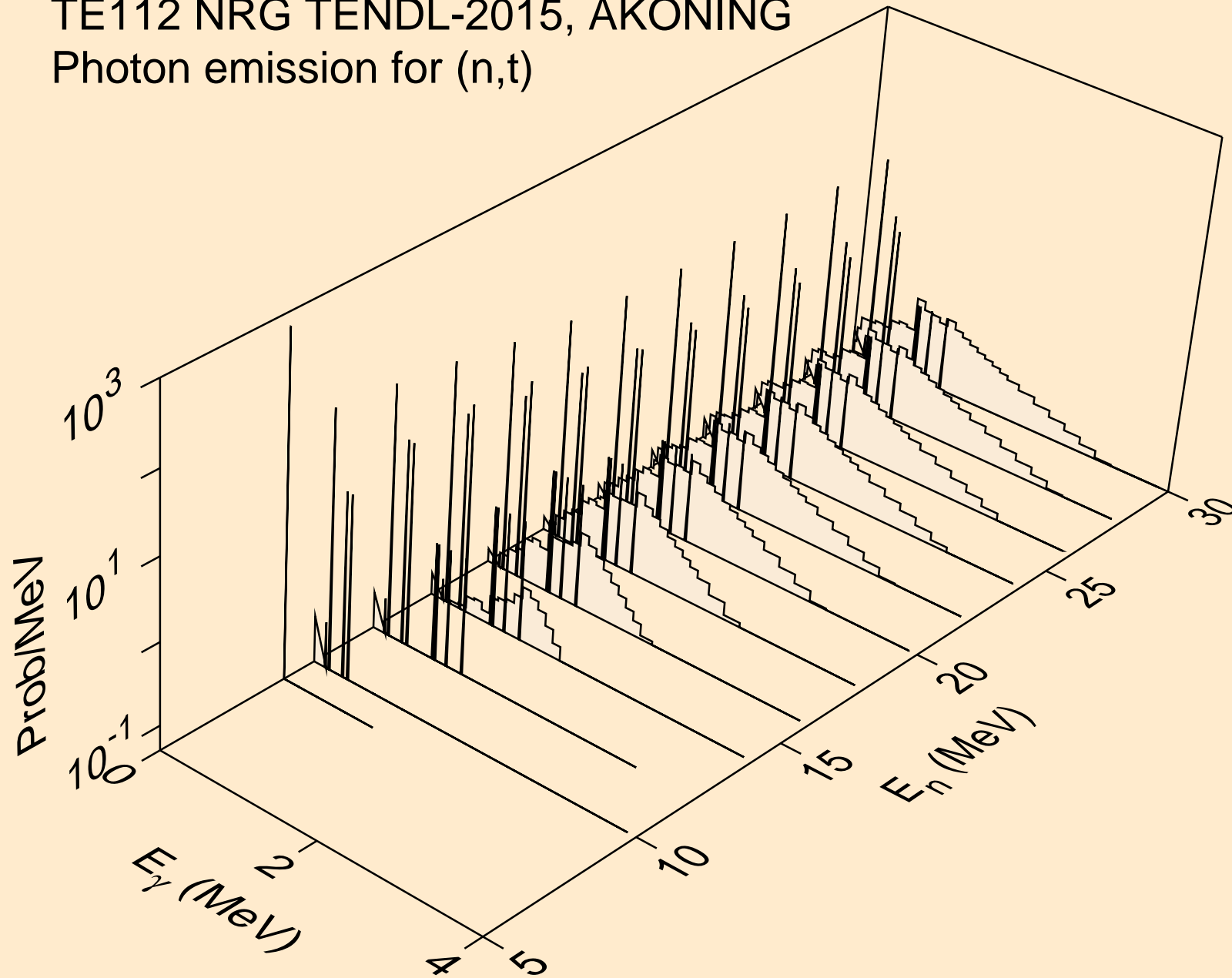

TE112 NRG TENDL-2015, AKONING  
Photon emission for (n,he3)

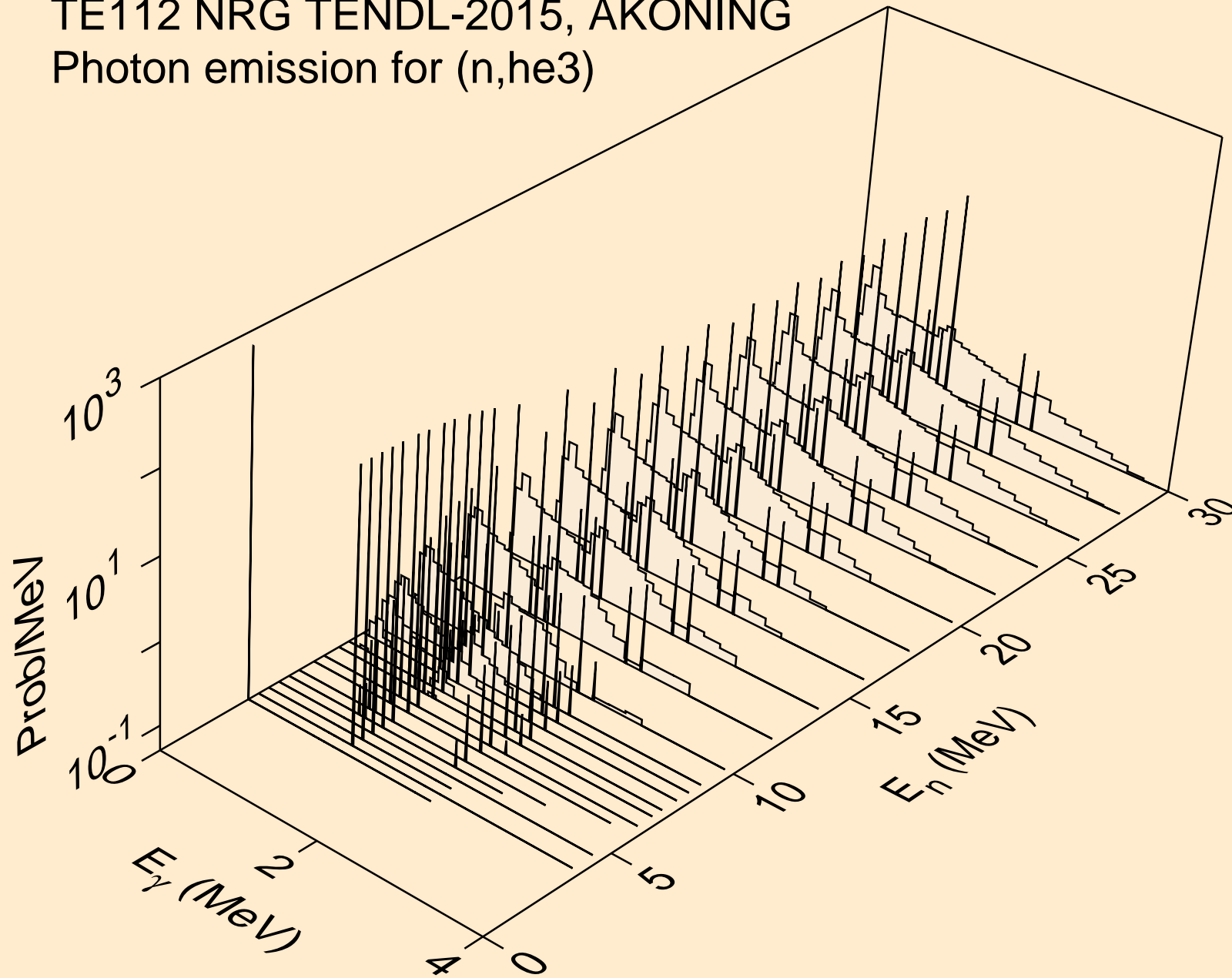

TE112 NRG TENDL-2015, AKONING  
Photon emission for (n,a)

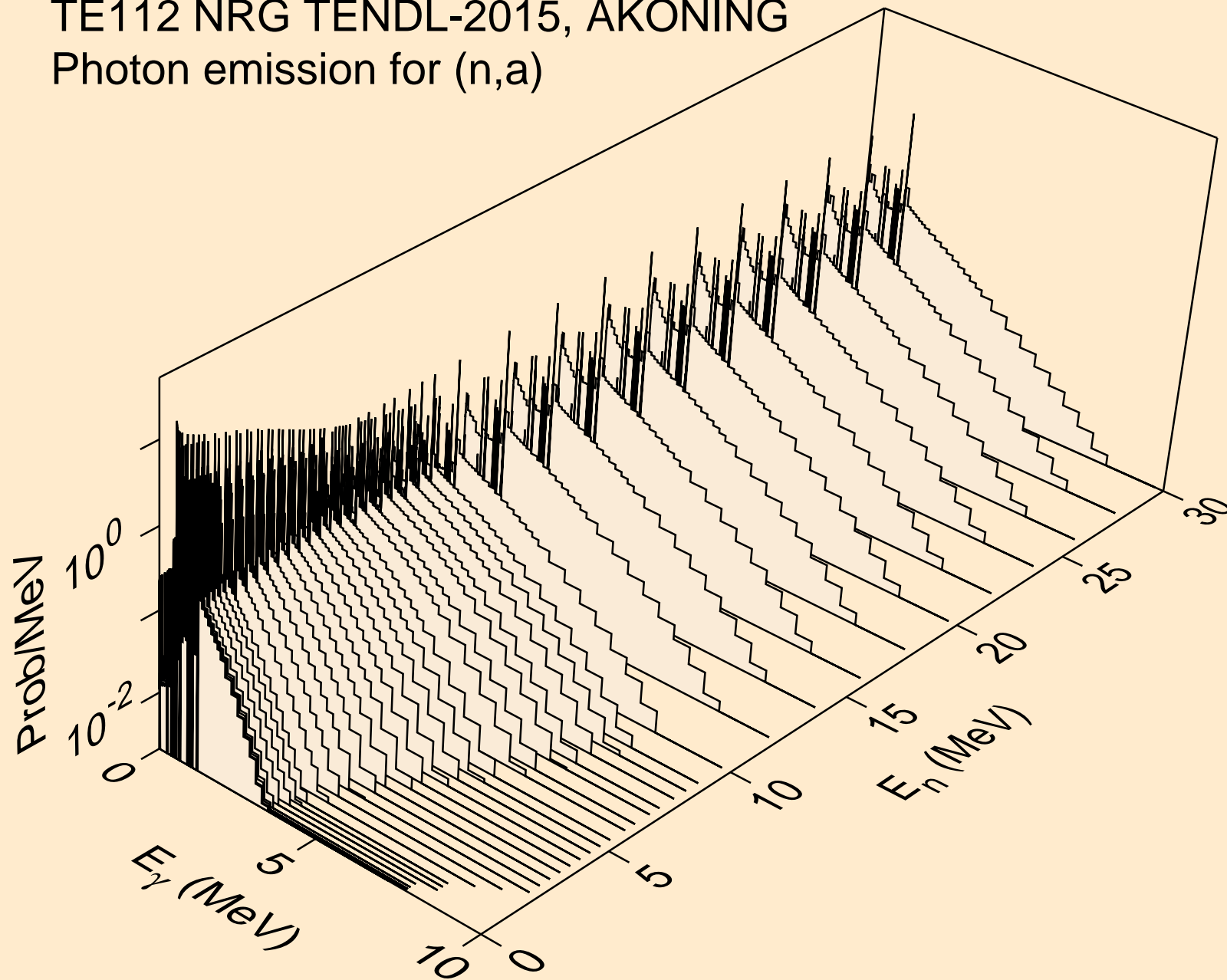

TE112 NRG TENDL-2015, AKONING  
Photon emission for (n,2a)

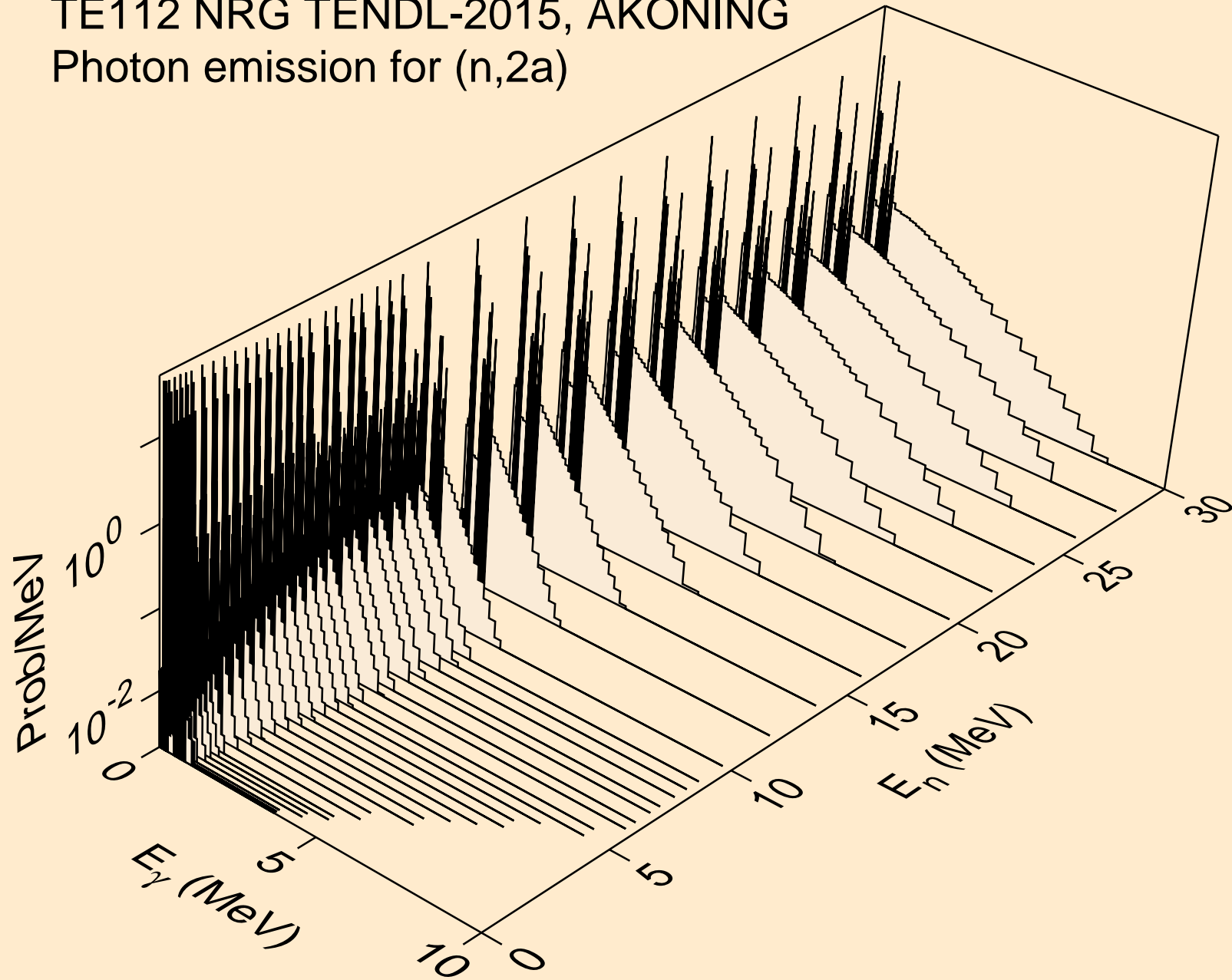

TE112 NRG TENDL-2015, AKONING  
Photon emission for (n,3a)

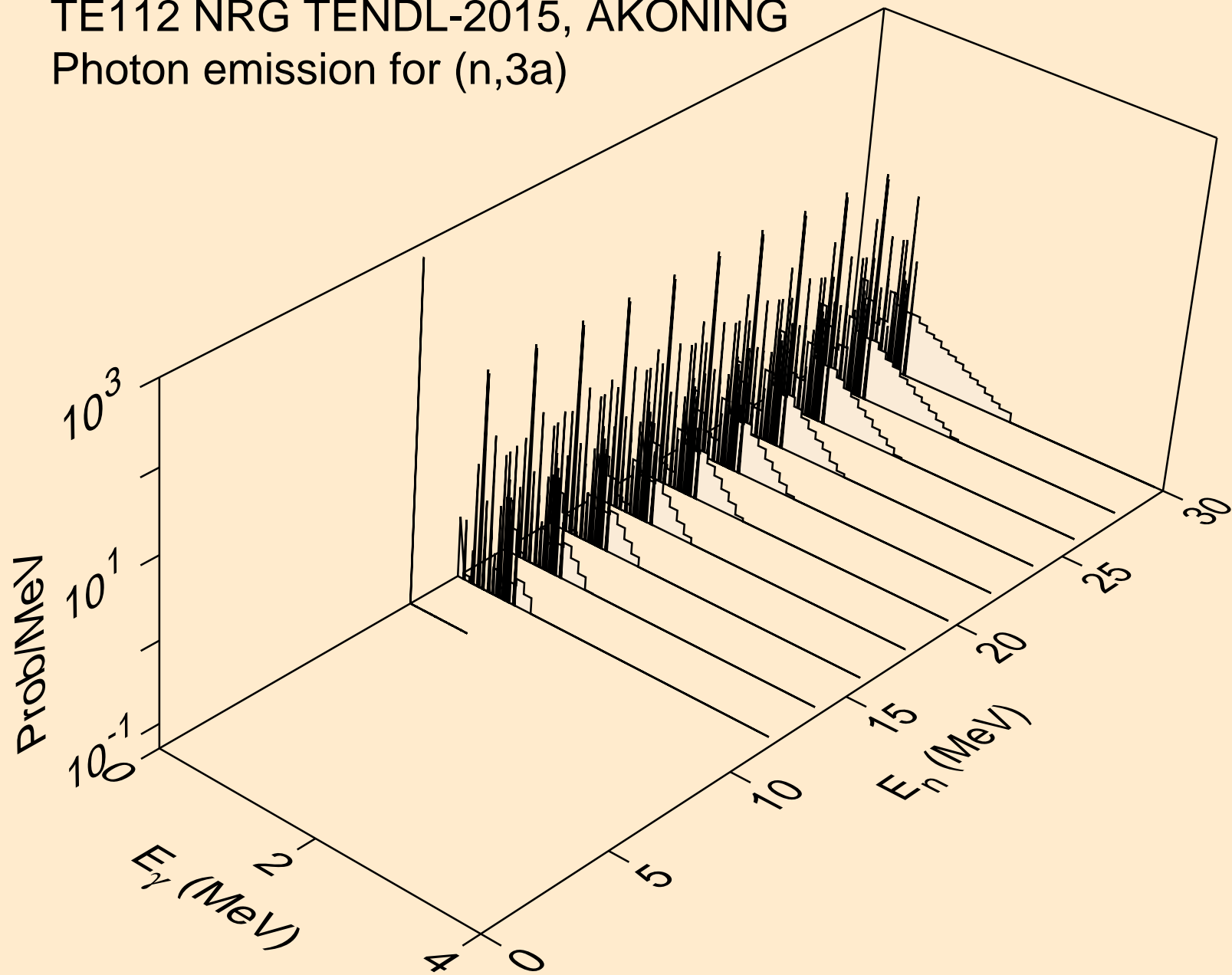

TE112 NRG TENDL-2015, AKONING  
Photon emission for (n,2p)

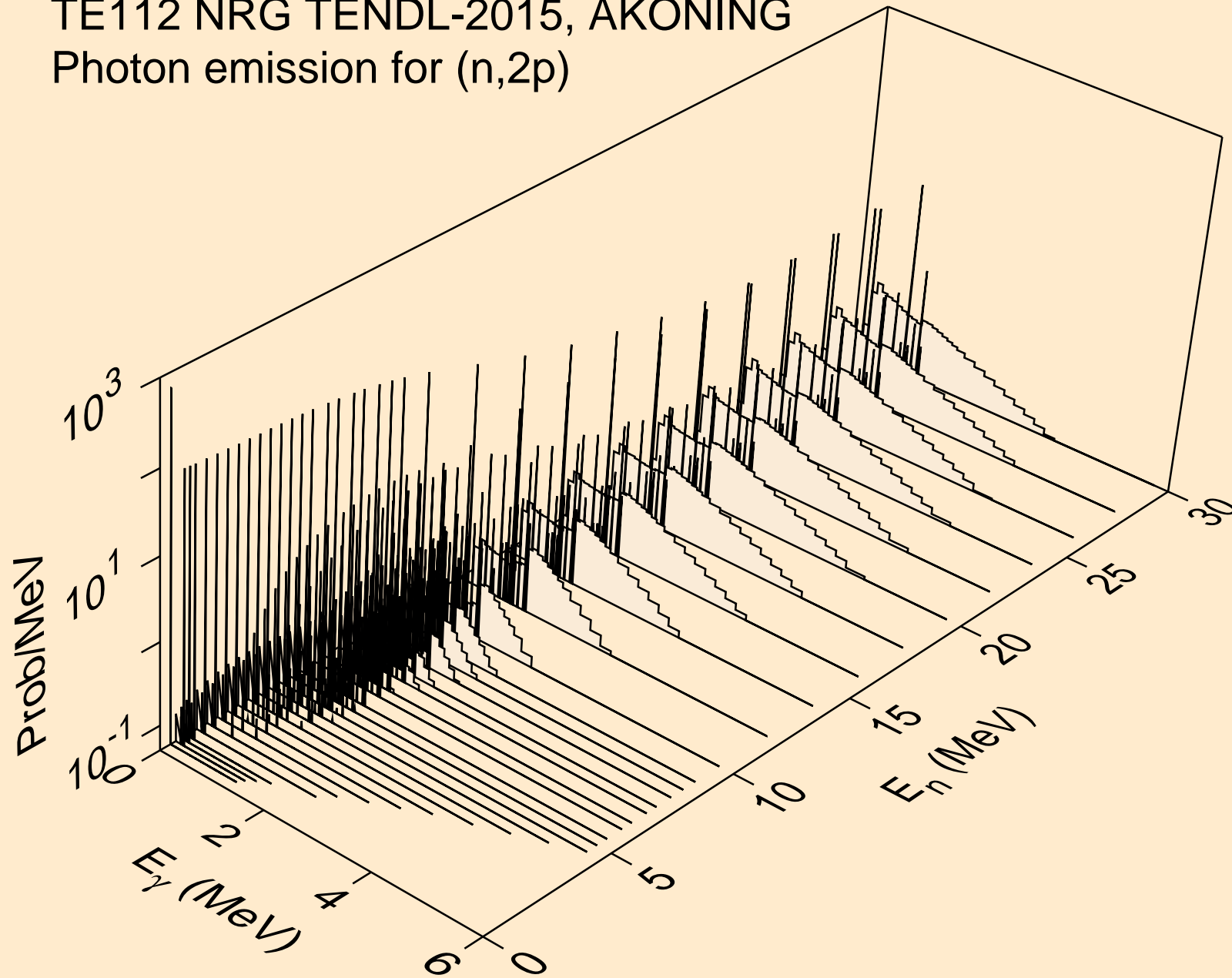

TE112 NRG TENDL-2015, AKONING  
Photon emission for (n,p $\alpha$ )

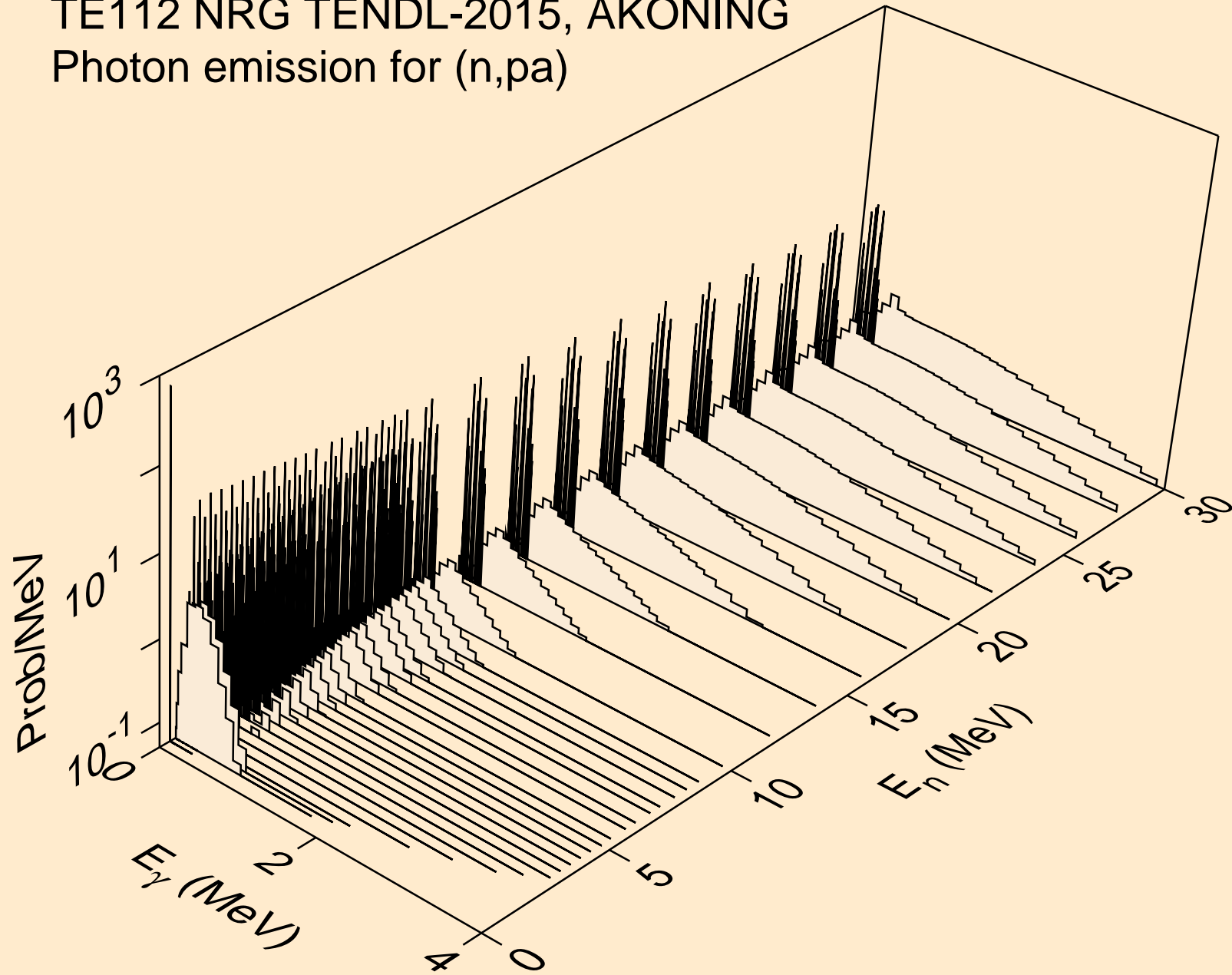

TE112 NRG TENDL-2015, AKONING  
Photon emission for (n,d2a)

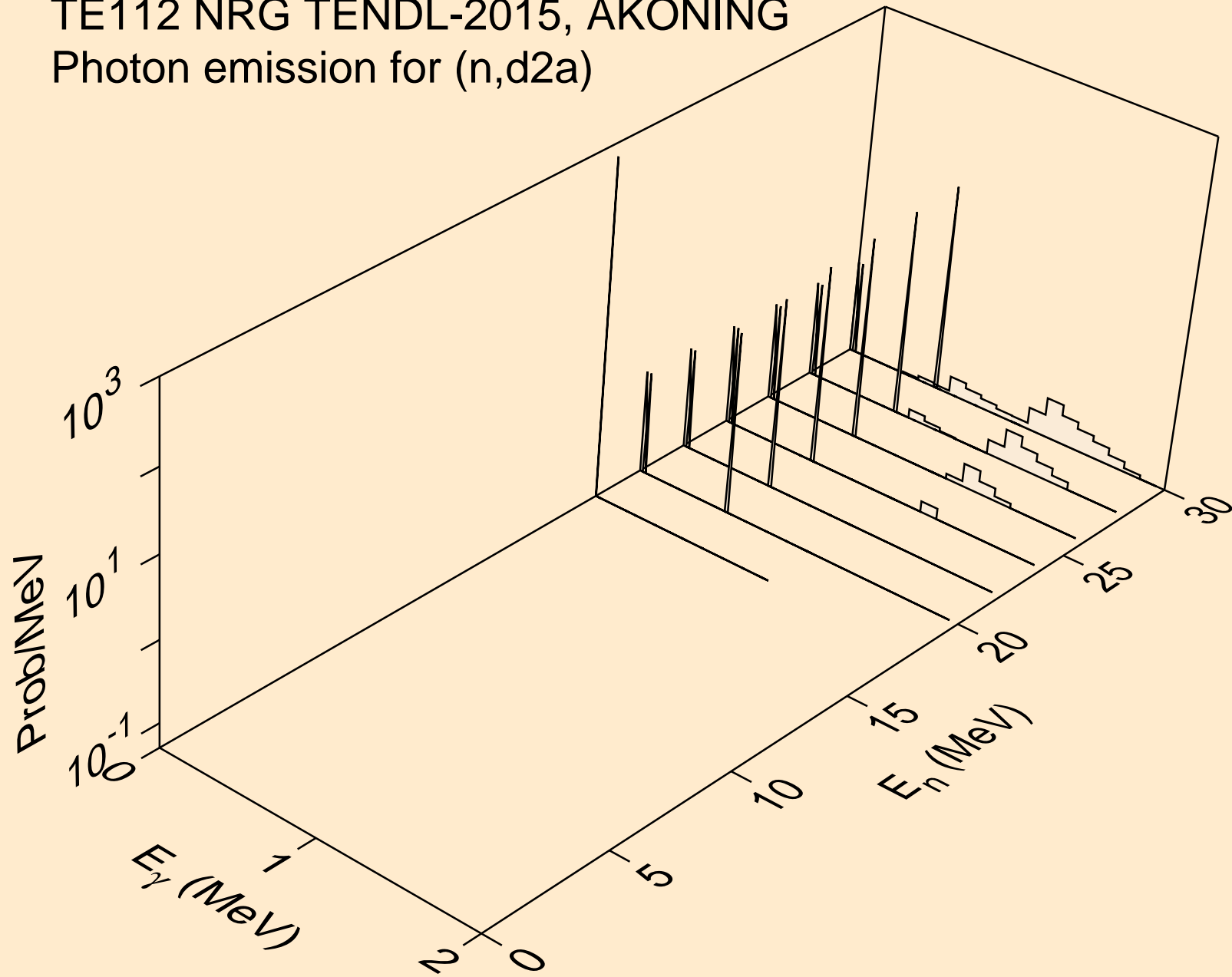



TE112 NRG TENDL-2015, AKONING  
Photon emission for (n,pd)

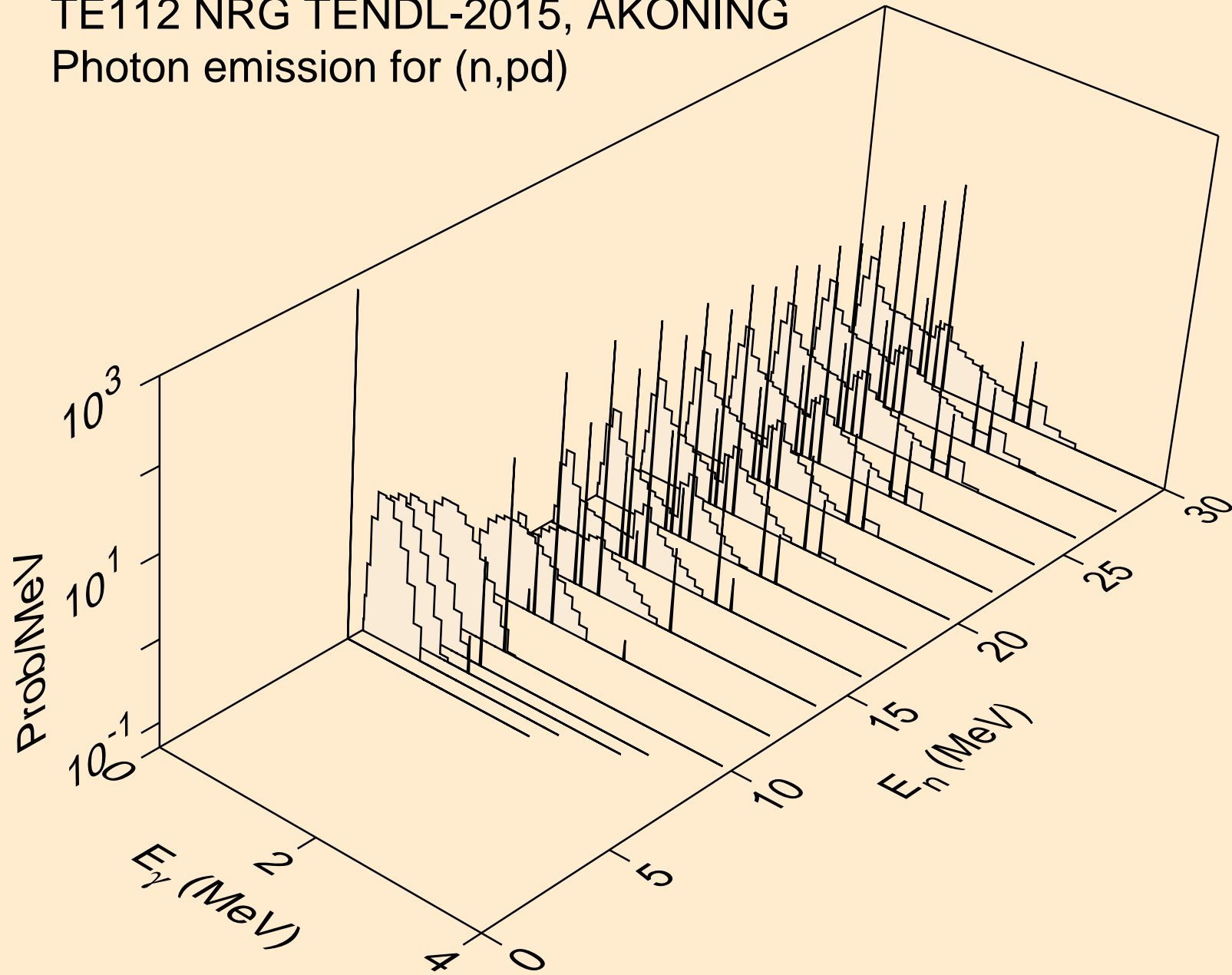

TE112 NRG TENDL-2015, AKONING  
Photon emission for (n,pt)

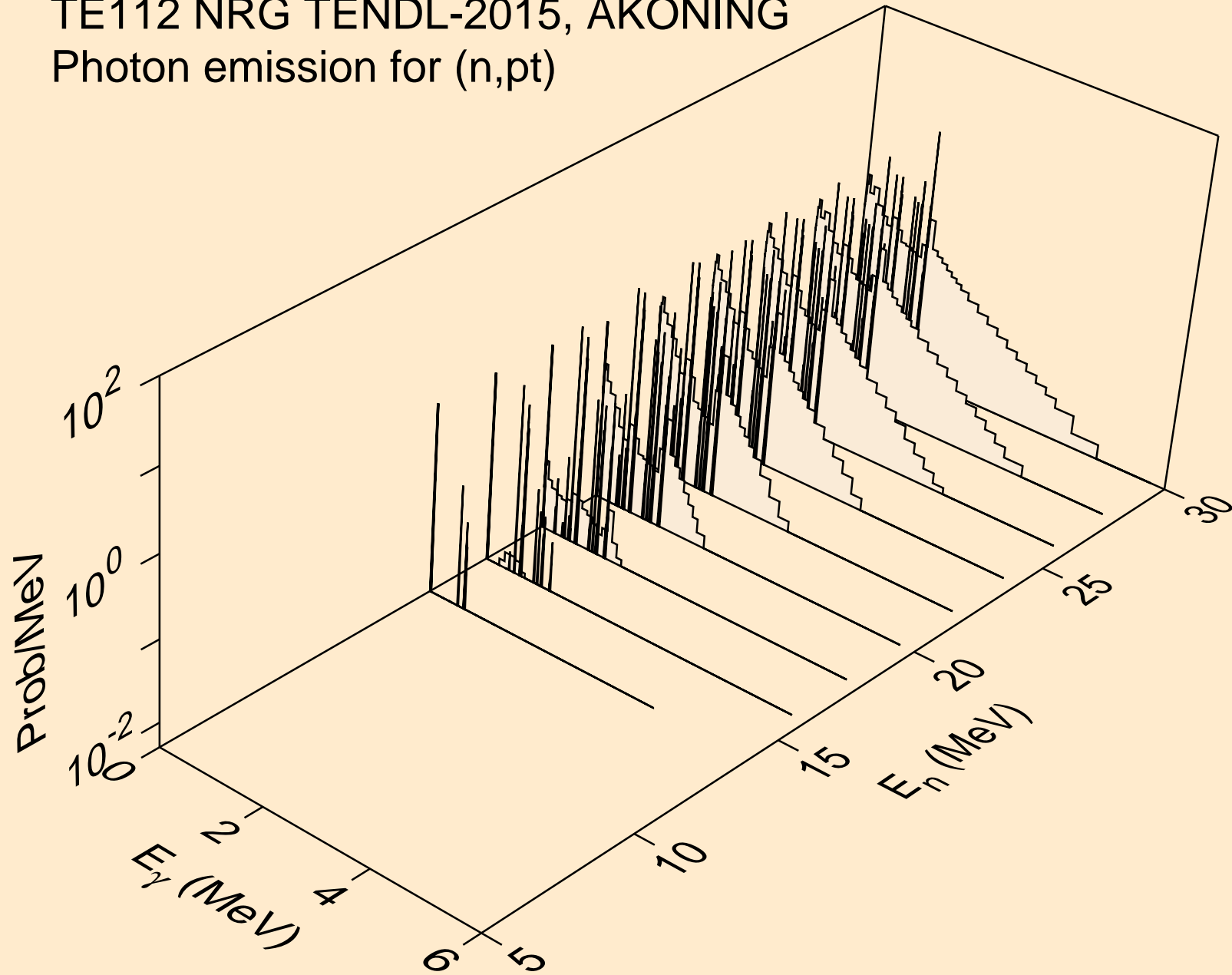

TE112 NRG TENDL-2015, AKONING  
Photon emission for (n,da)

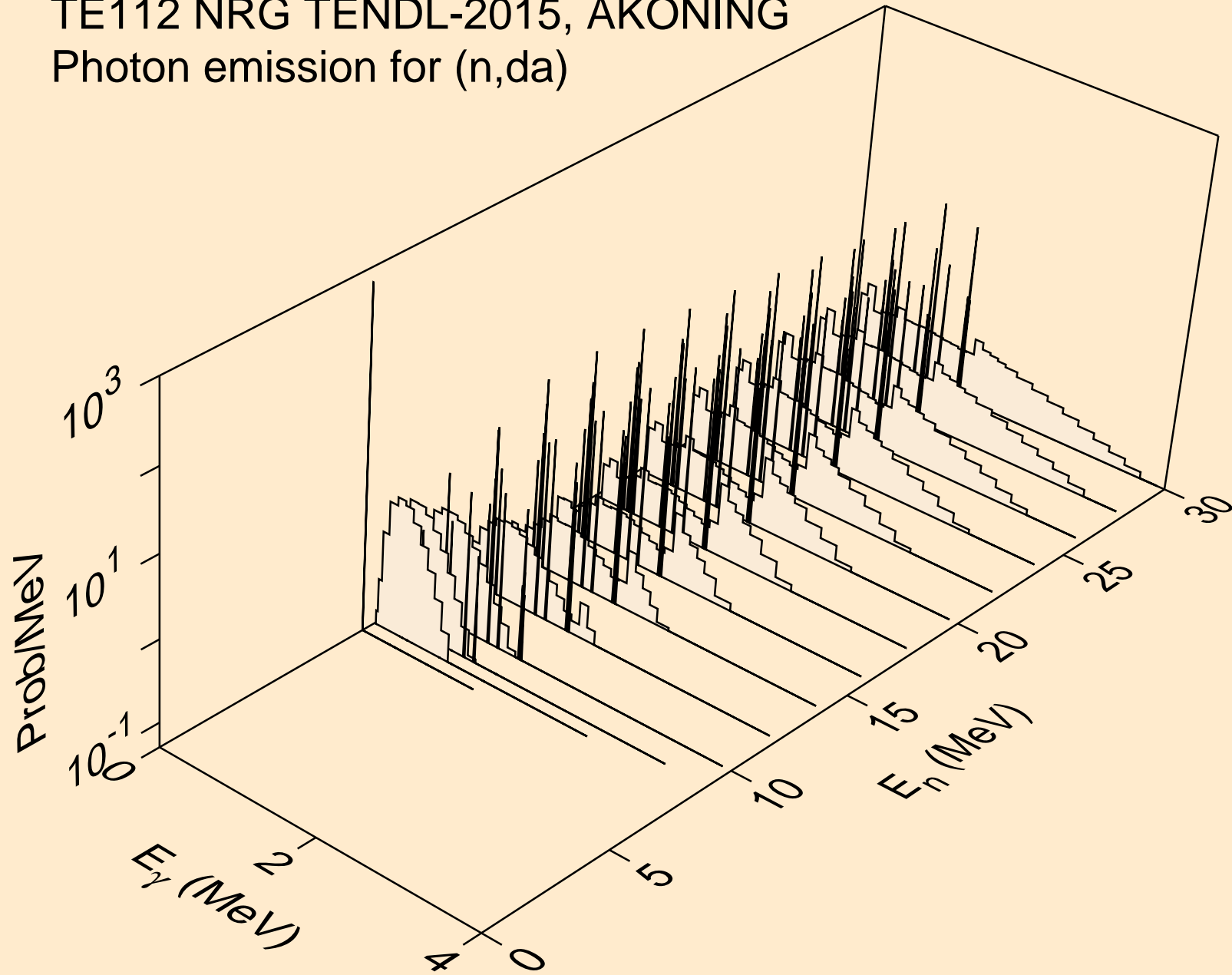

TE112 NRG TENDL-2015, AKONING  
thermal capture photon spectrum

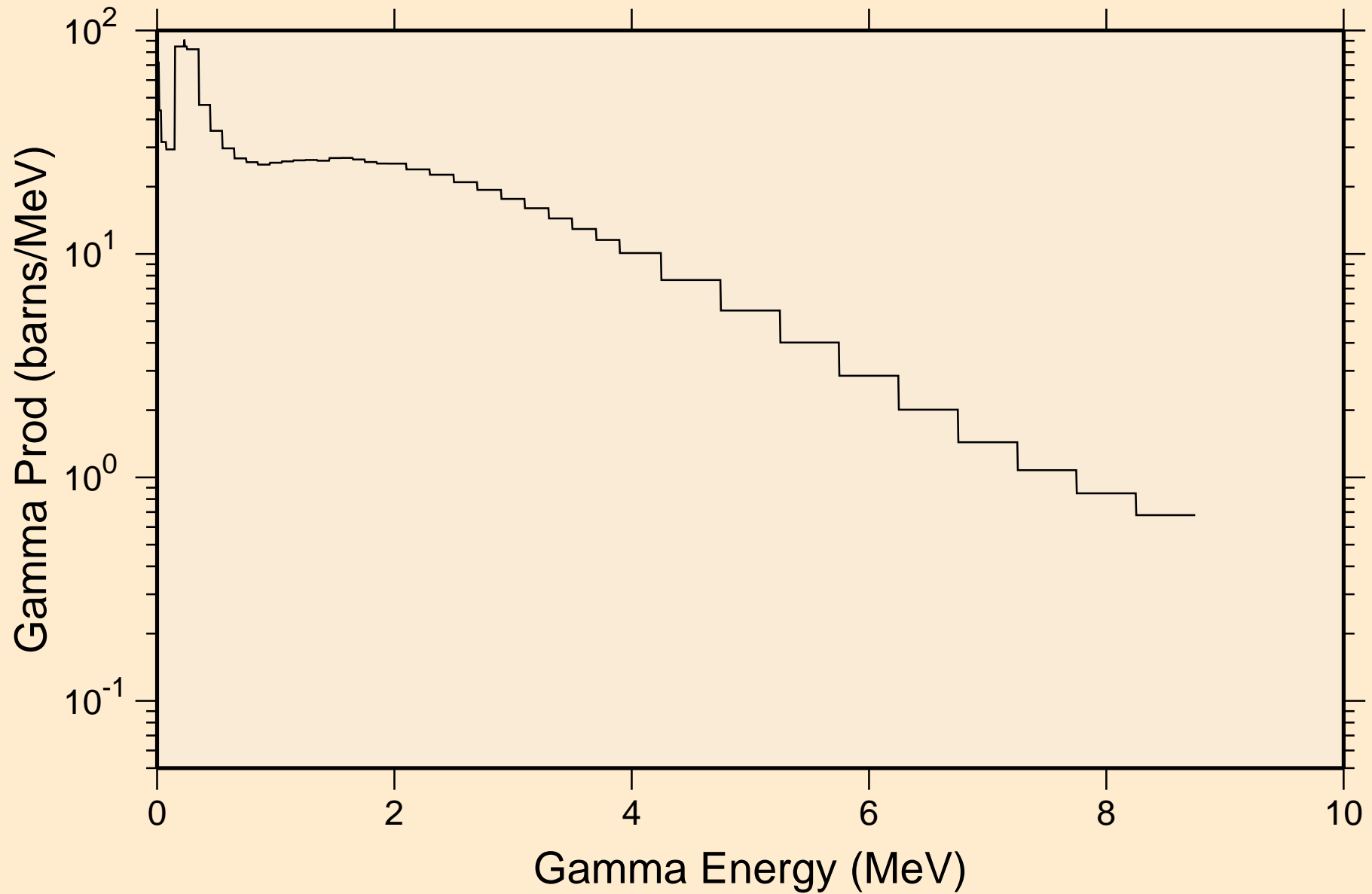

TE112 NRG TENDL-2015, AKONING  
14 MeV photon spectrum

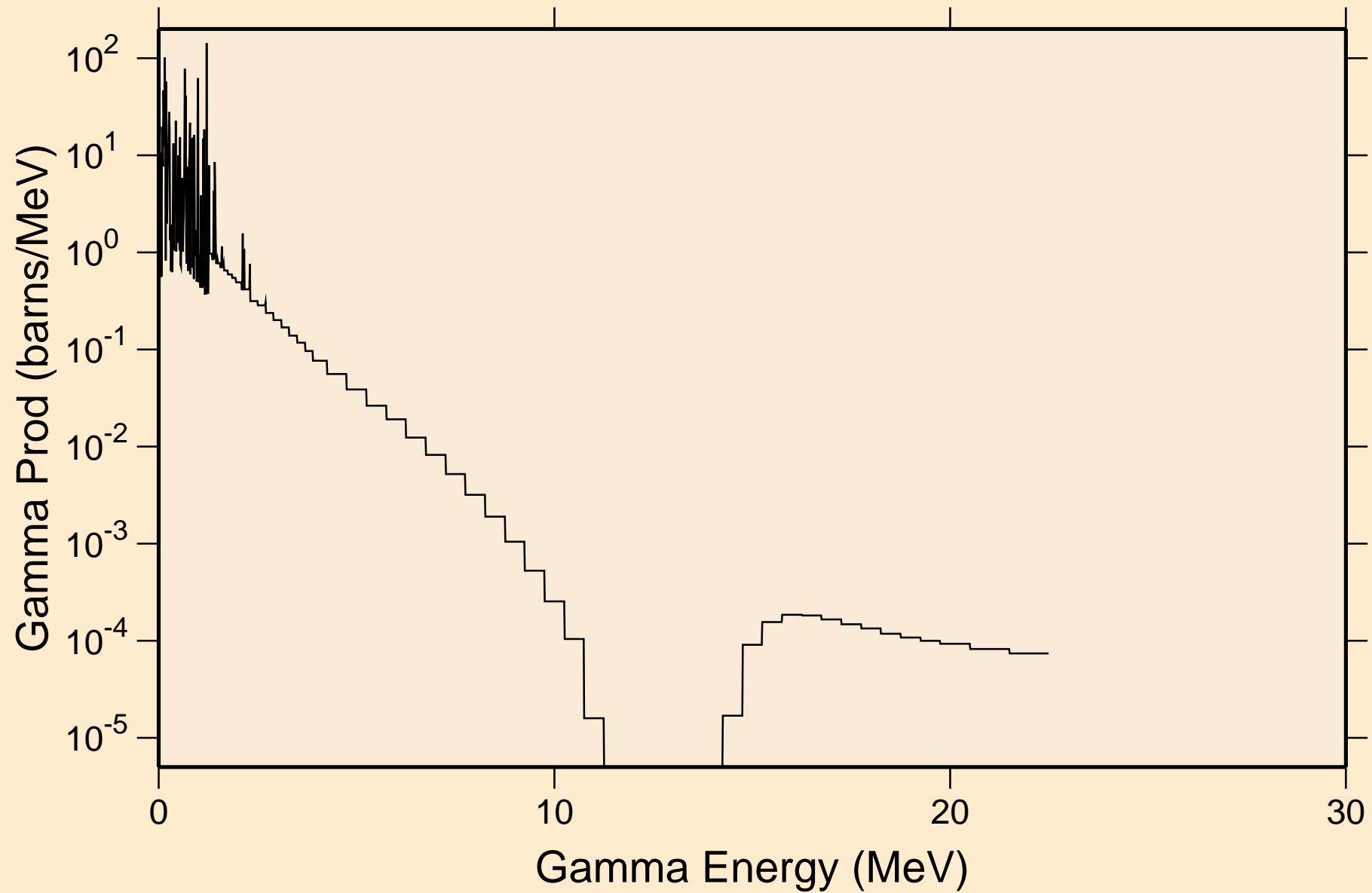

# TE112 NRG TENDL-2015, AKONING

## Particle heating contributions

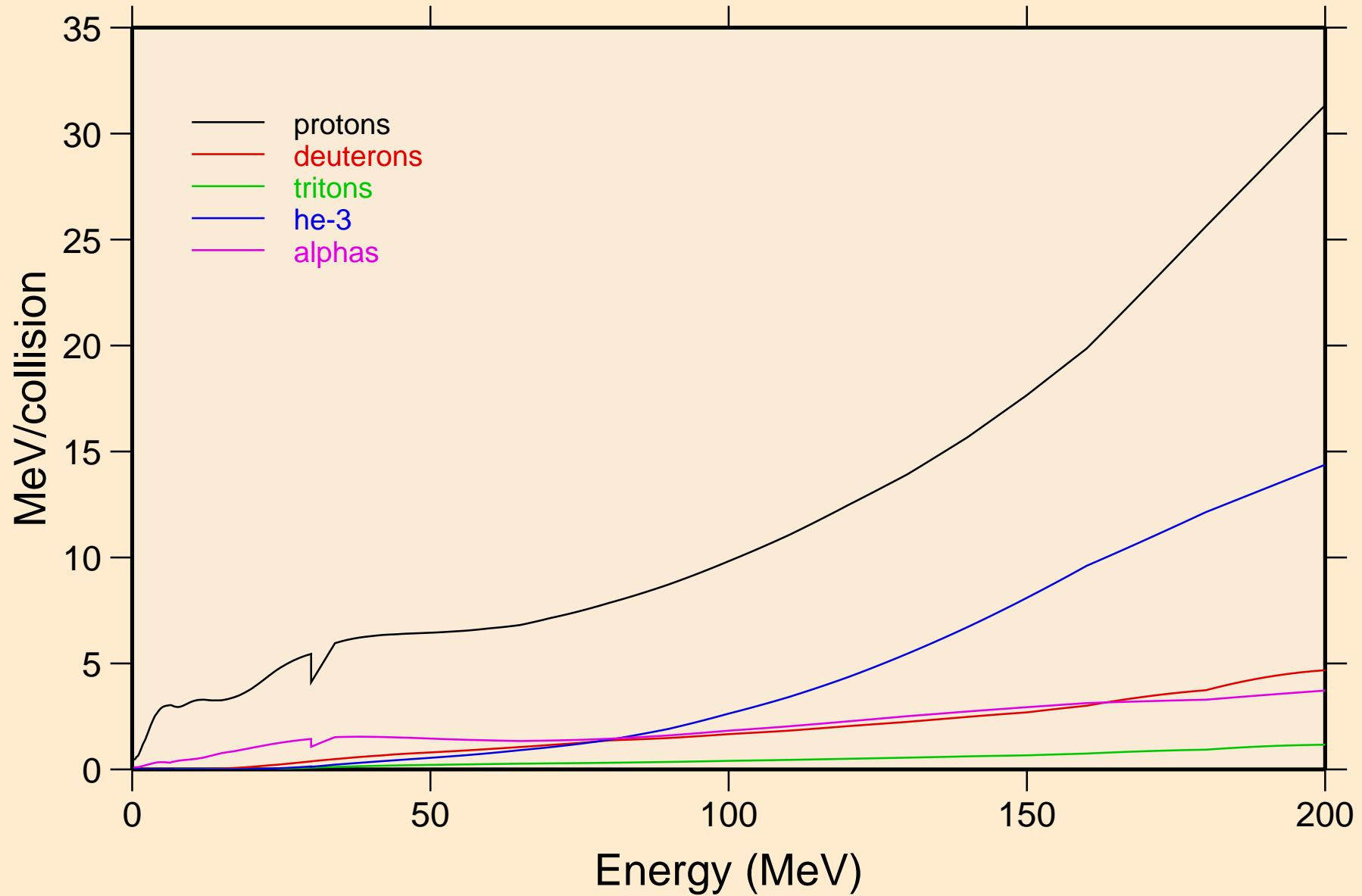

# TE112 NRG TENDL-2015, AKONING

## Recoil Heating

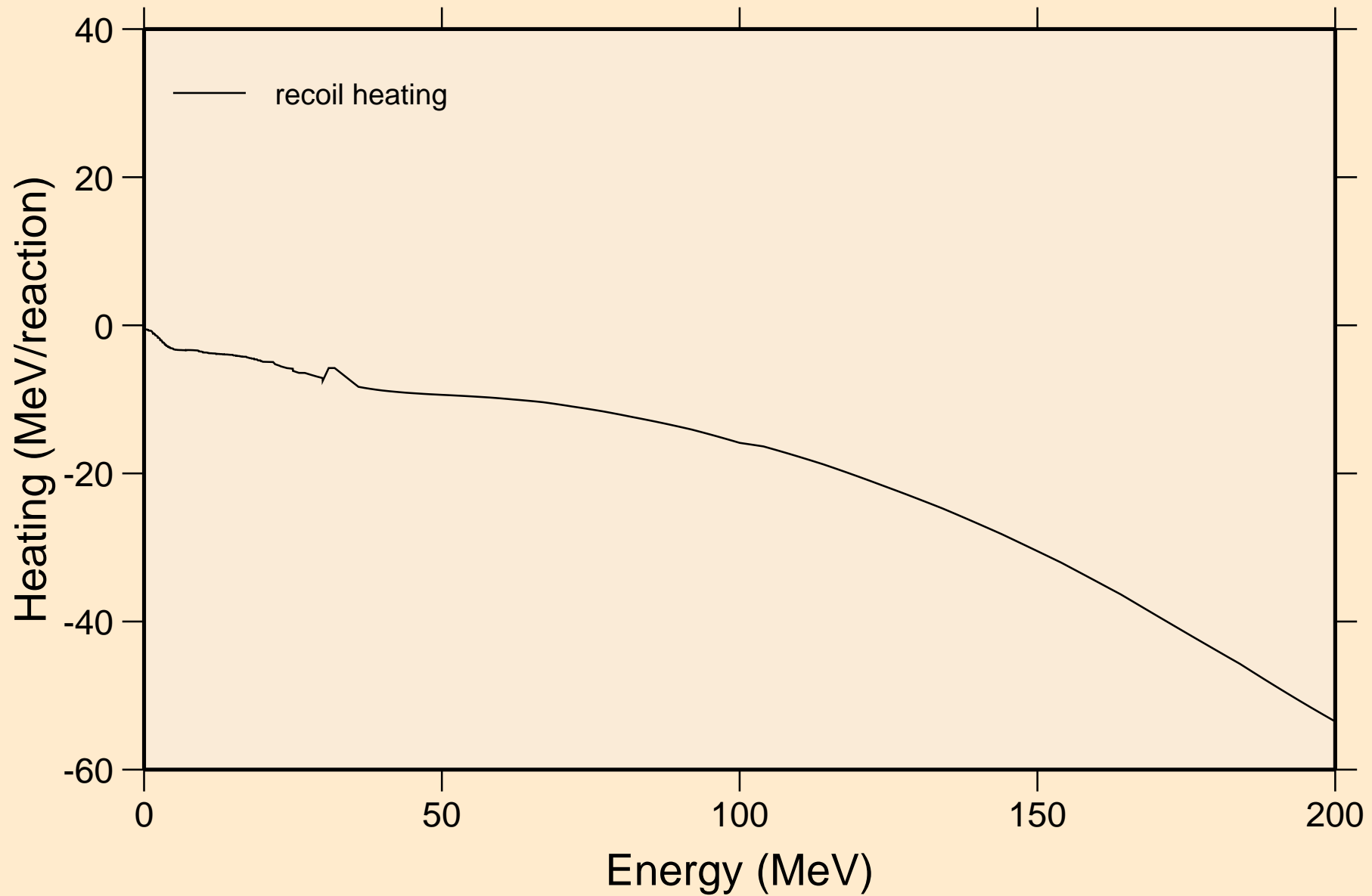

# TE112 NRG TENDL-2015, AKONING

## Particle production cross sections

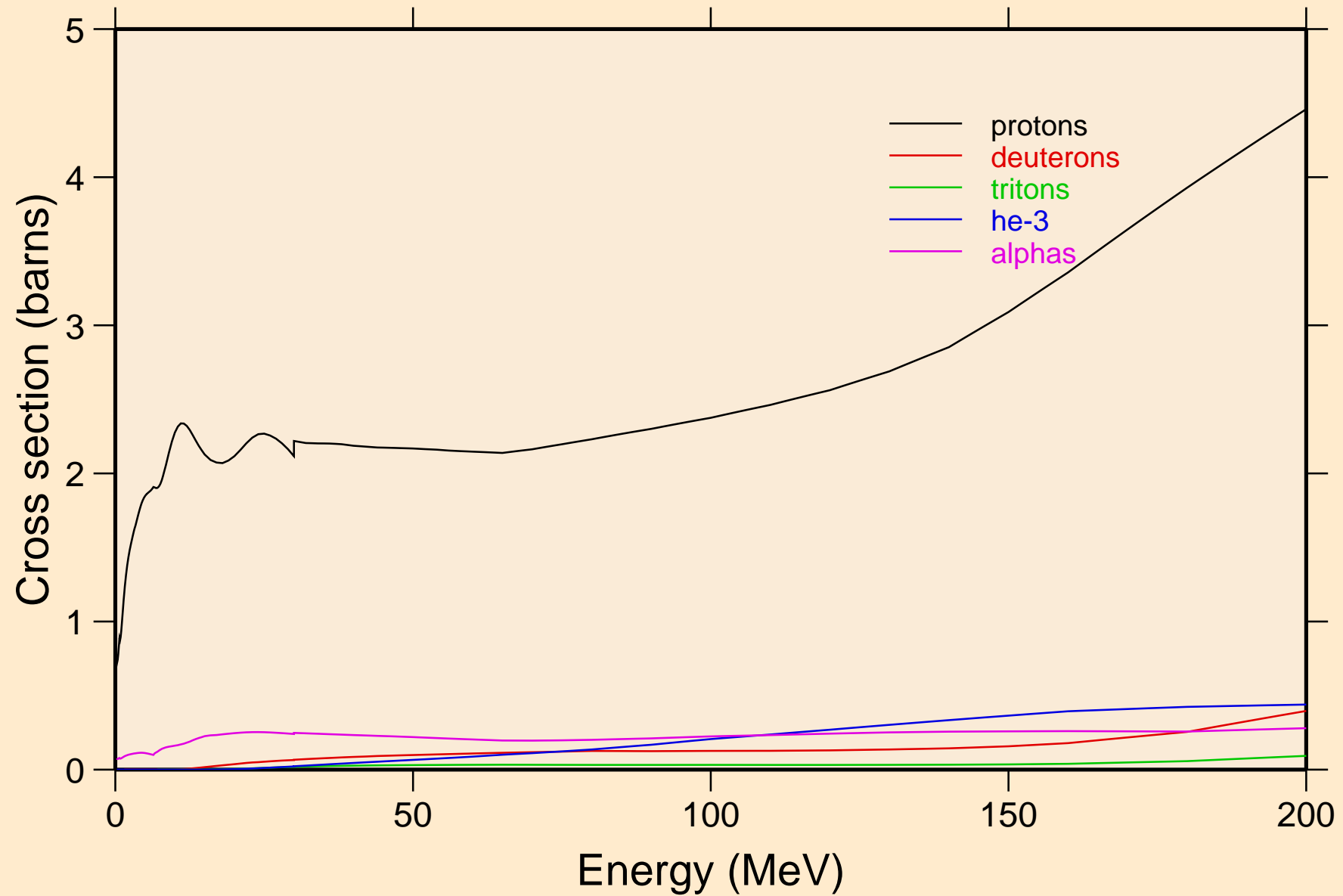



TE112 NRG TENDL-2015, AKONING  
protons from (n,x)

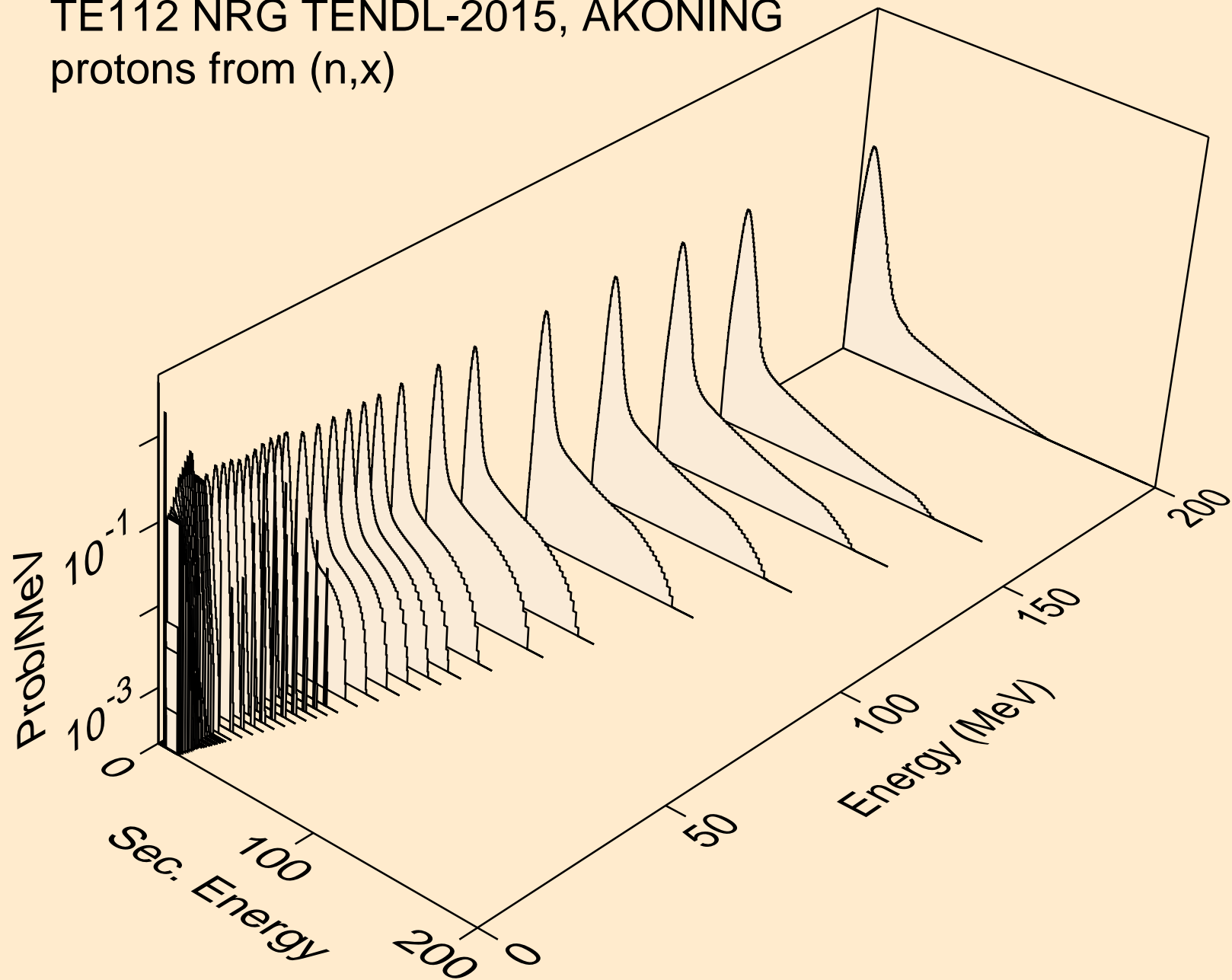

TE112 NRG TENDL-2015, AKONING  
protons from (n,n\*)p

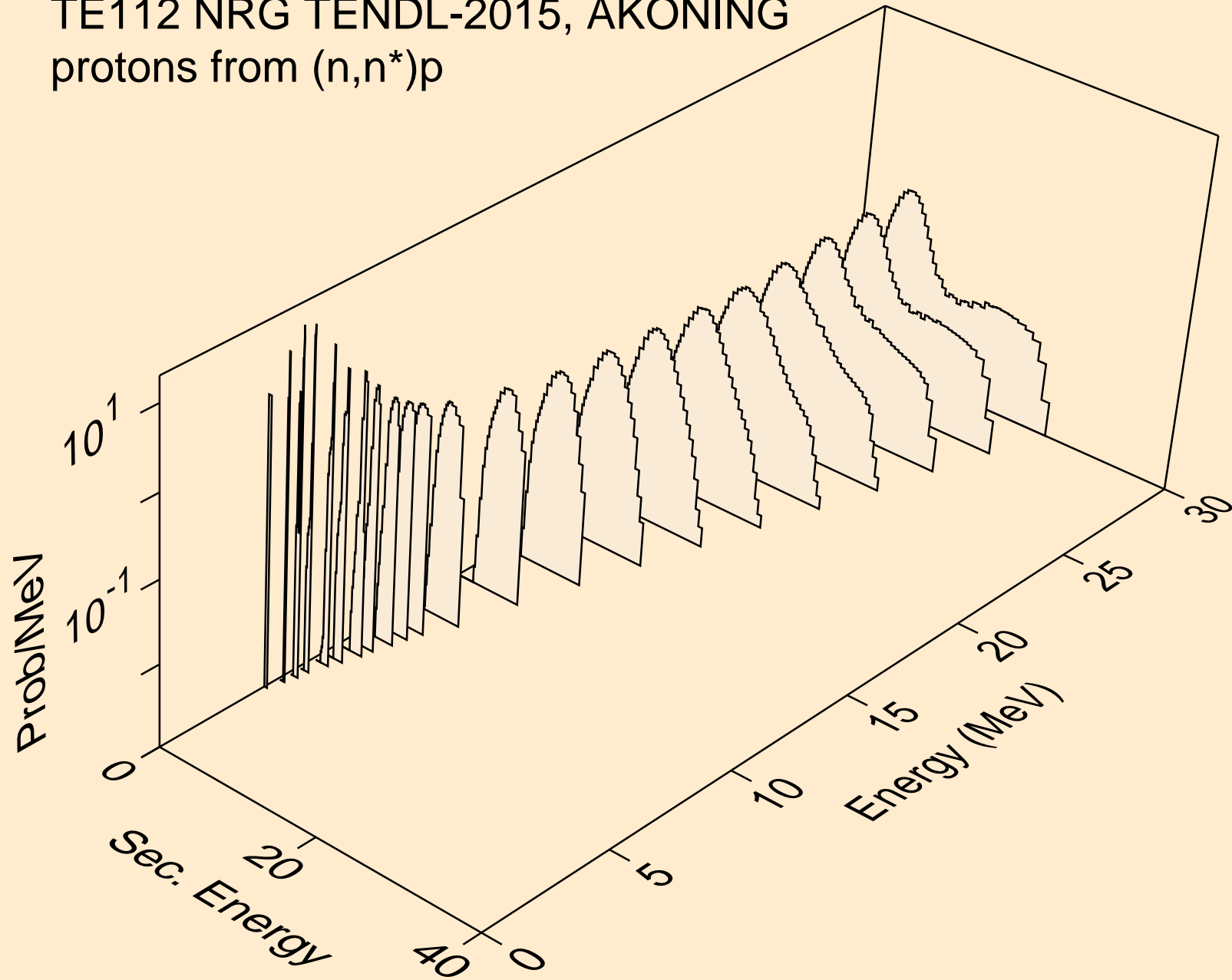

TE112 NRG TENDL-2015, AKONING  
protons from (n,2np)

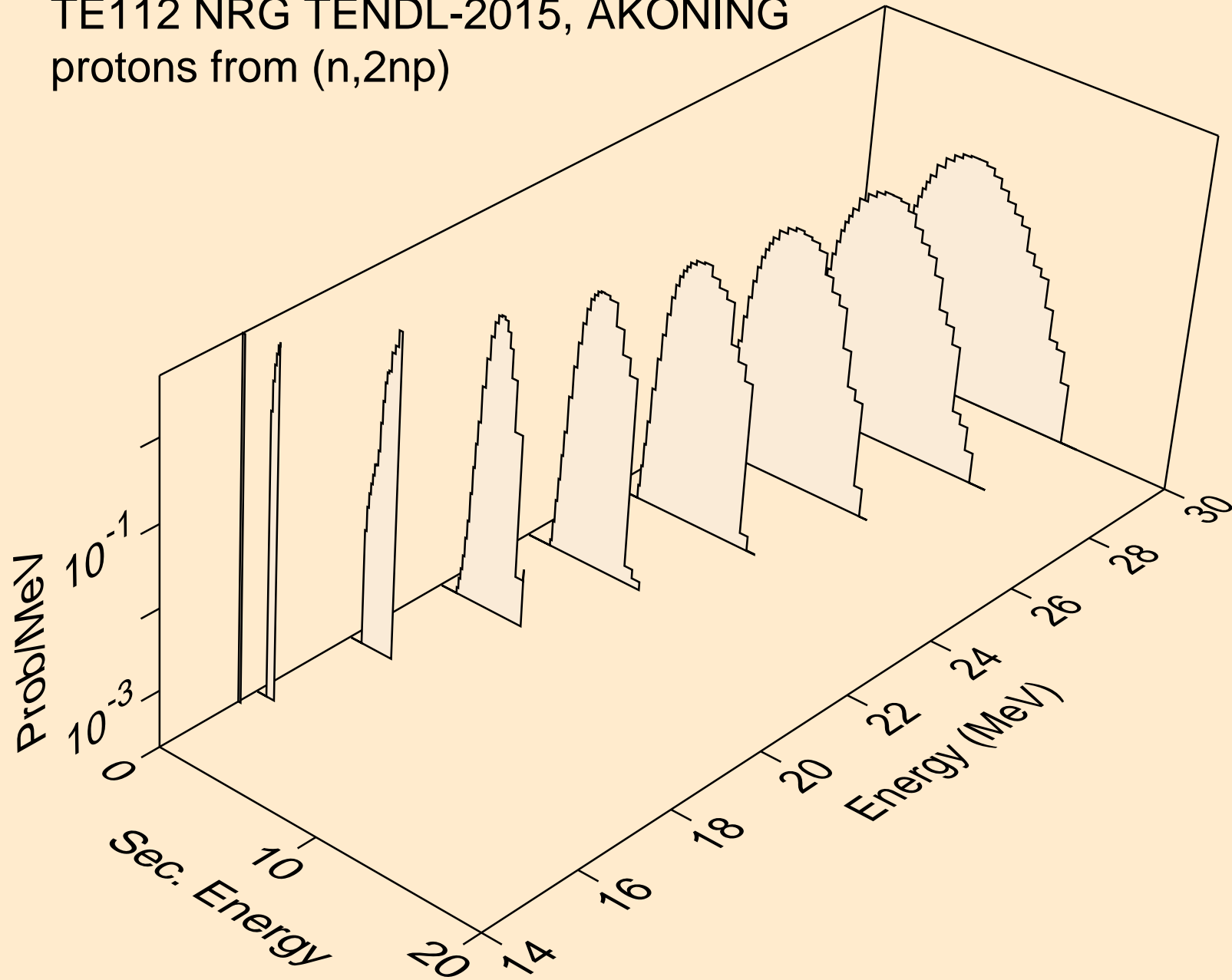

TE112 NRG TENDL-2015, AKONING  
protons from (n,3np)

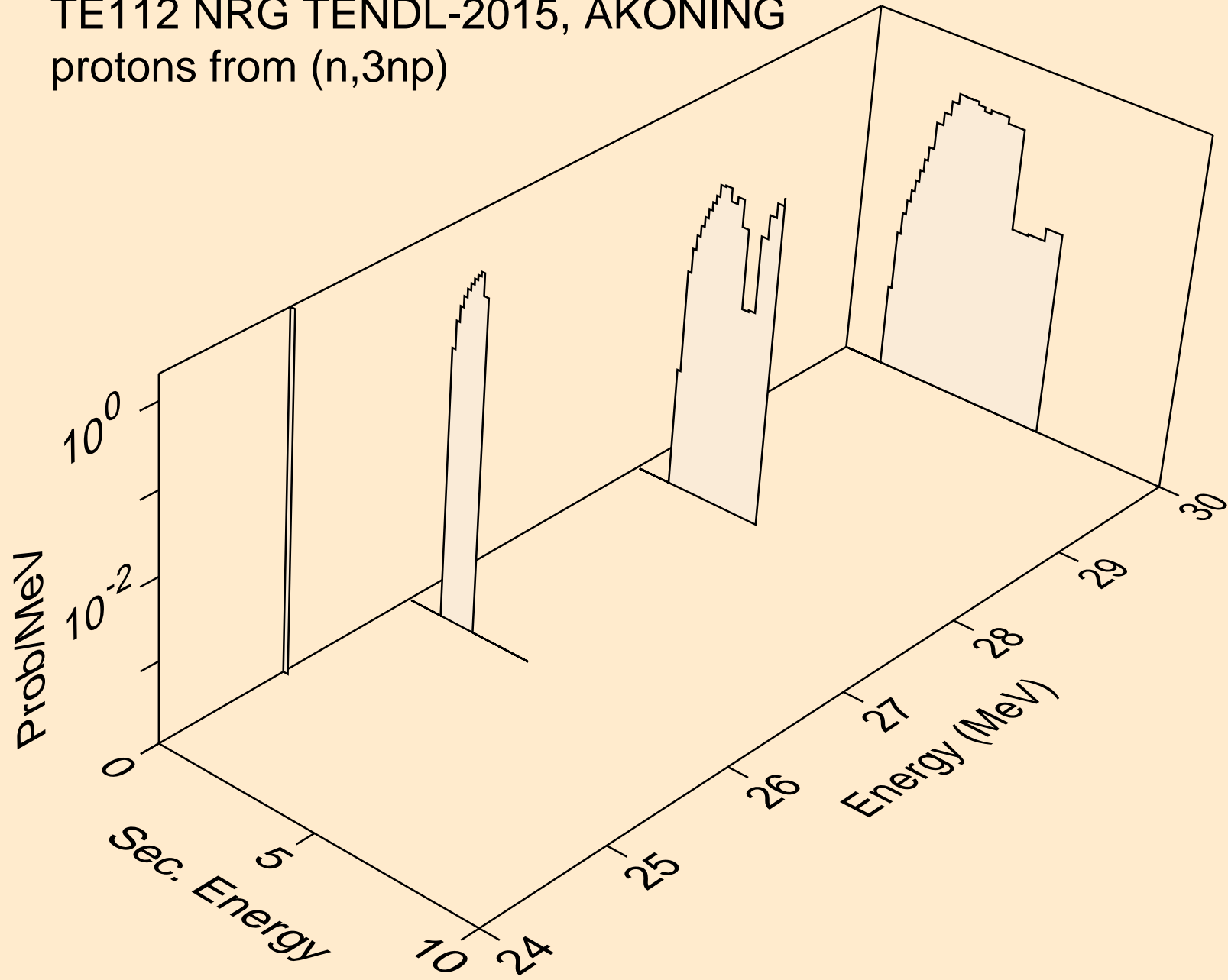

TE112 NRG TENDL-2015, AKONING  
protons from (n,2np)

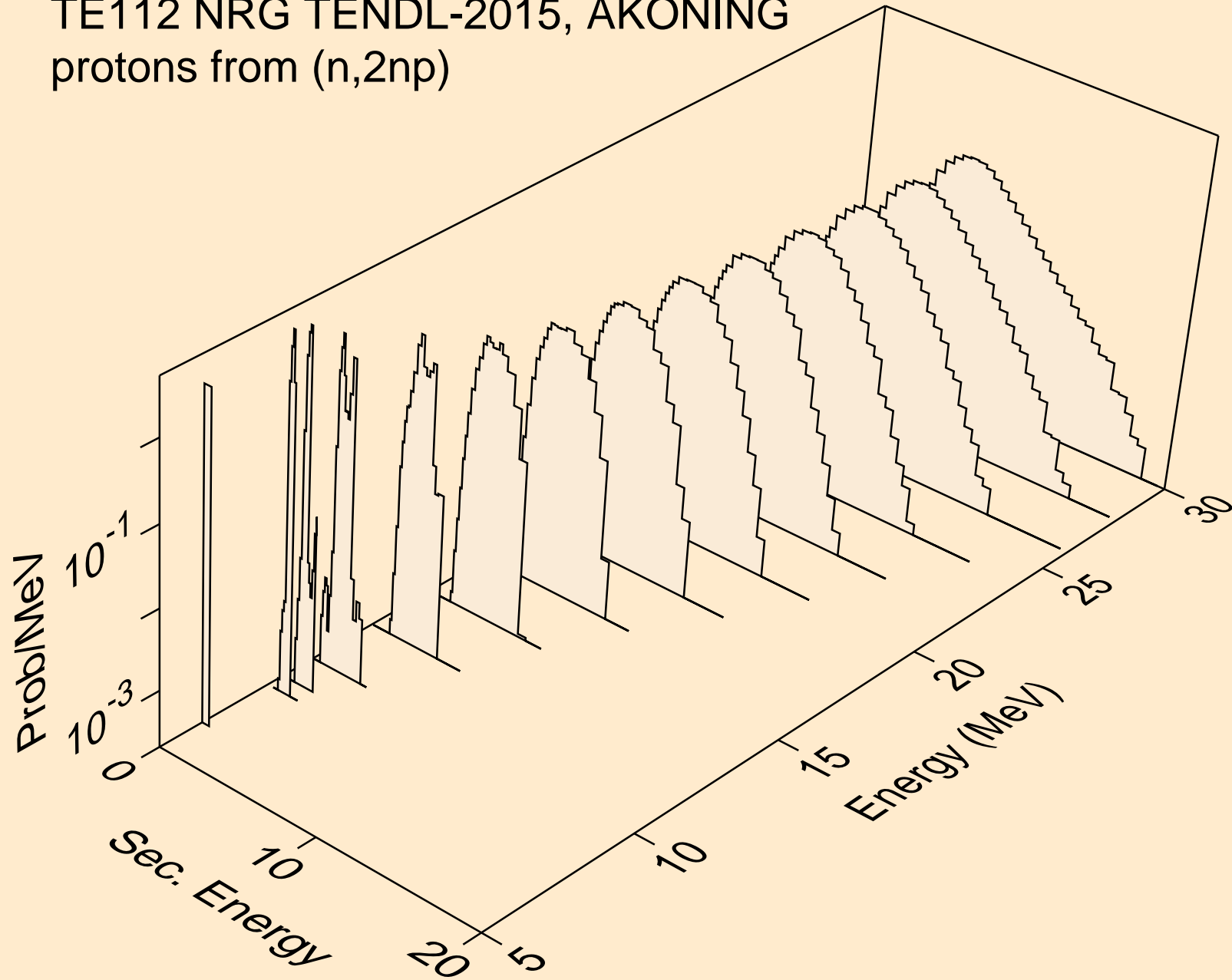

TE112 NRG TENDL-2015, AKONING  
protons from (n,npa)

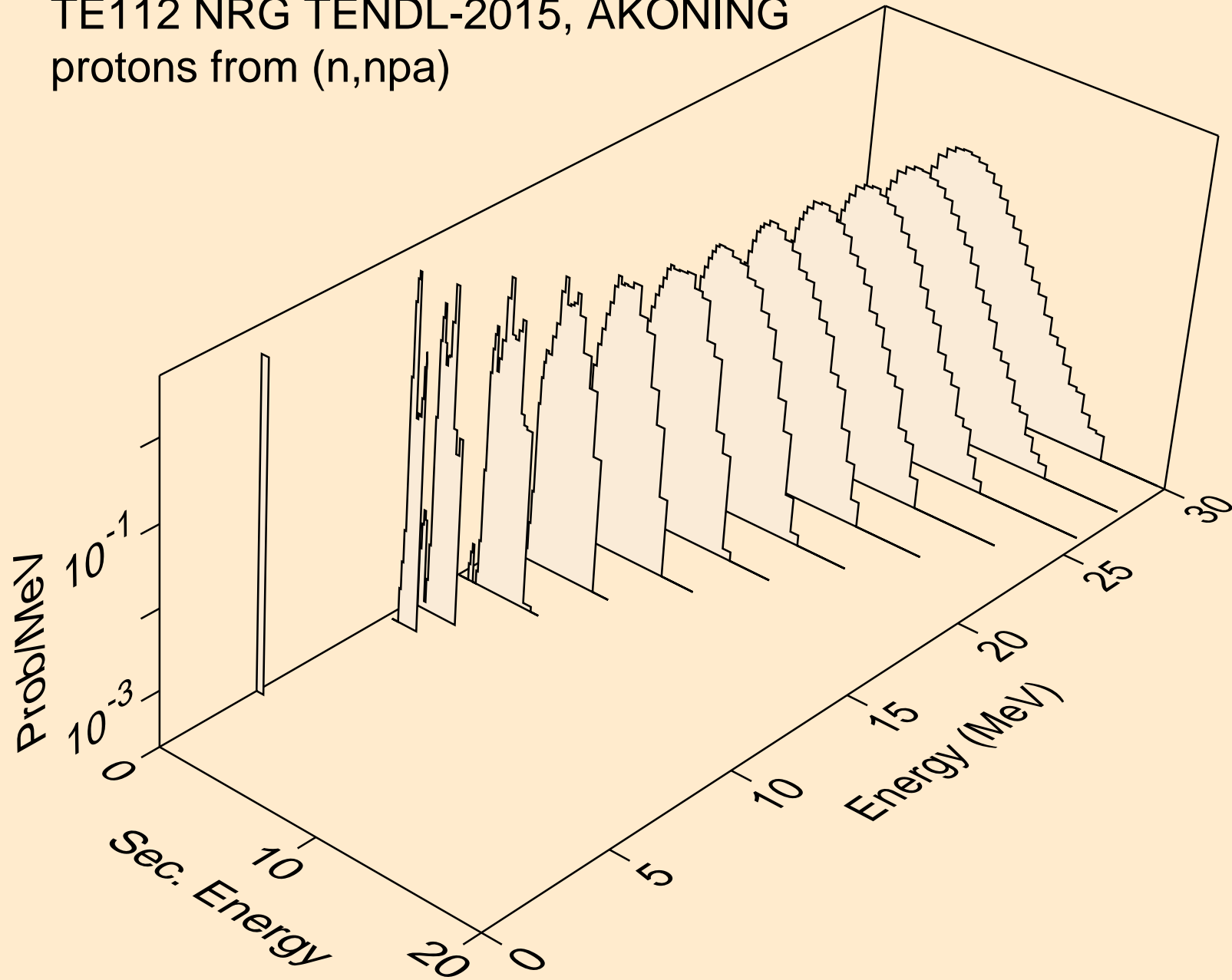

TE112 NRG TENDL-2015, AKONING  
protons from (n,p)

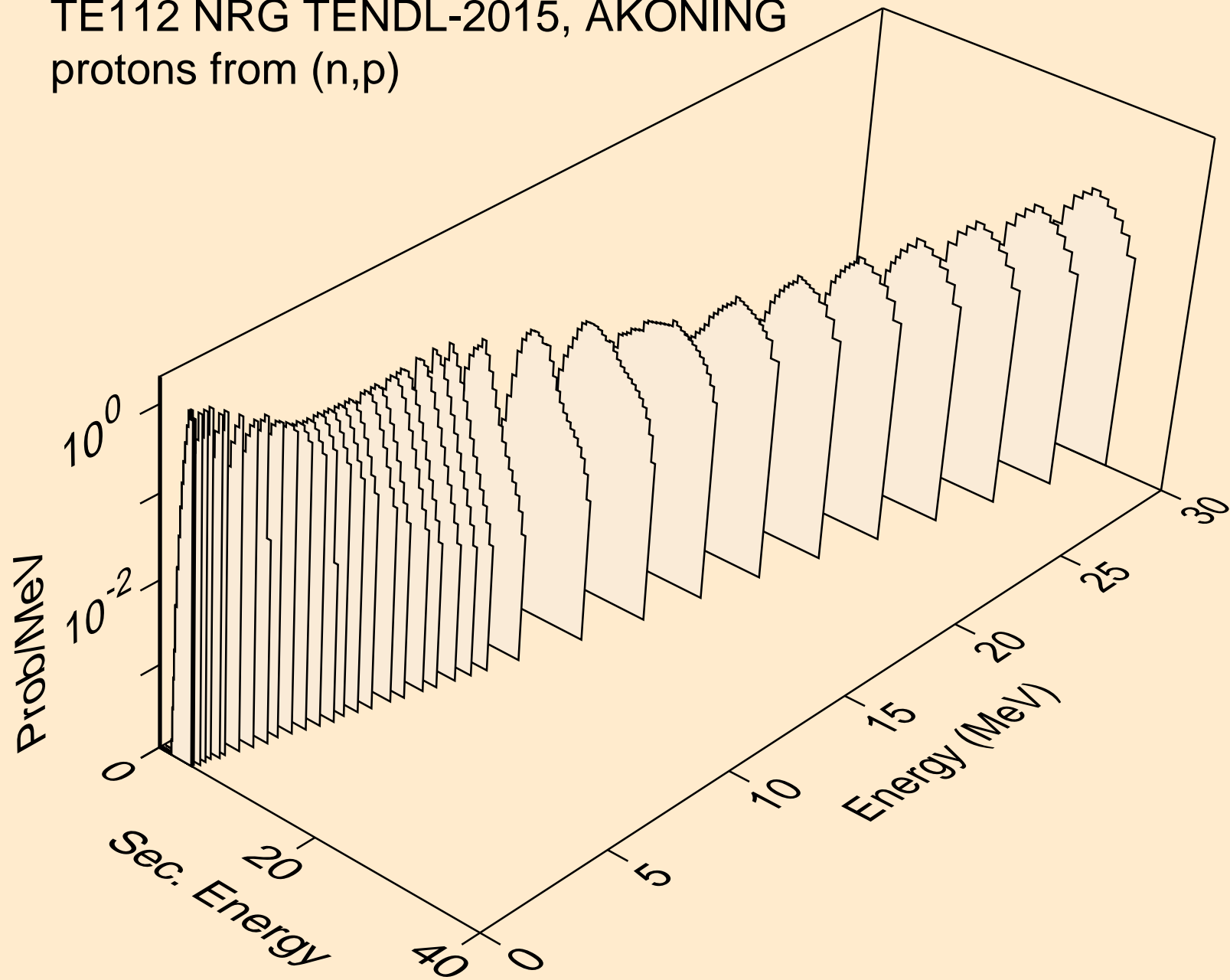

TE112 NRG TENDL-2015, AKONING  
protons from (n,2p)

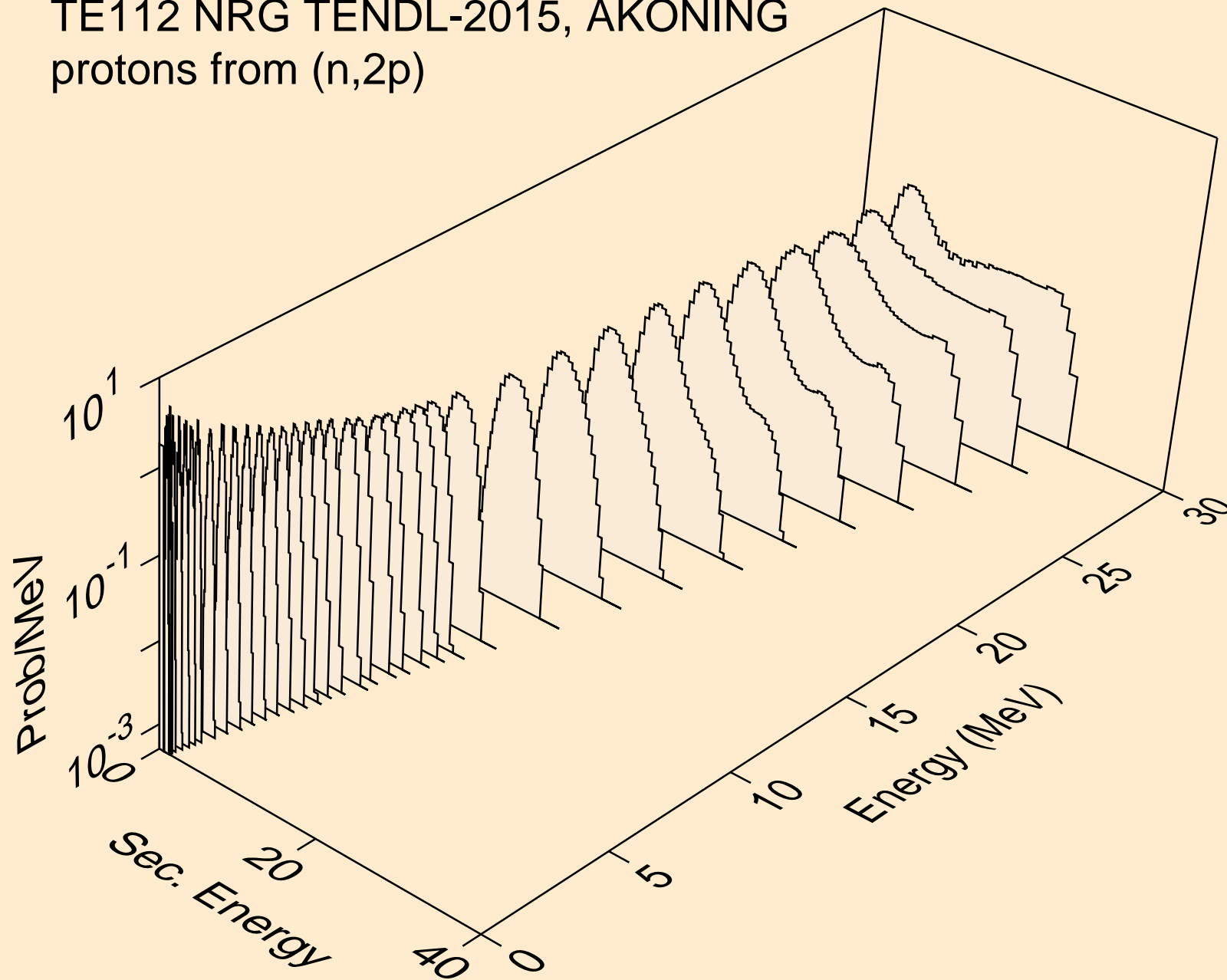



TE112 NRG TENDL-2015, AKONING  
protons from (n,pa)

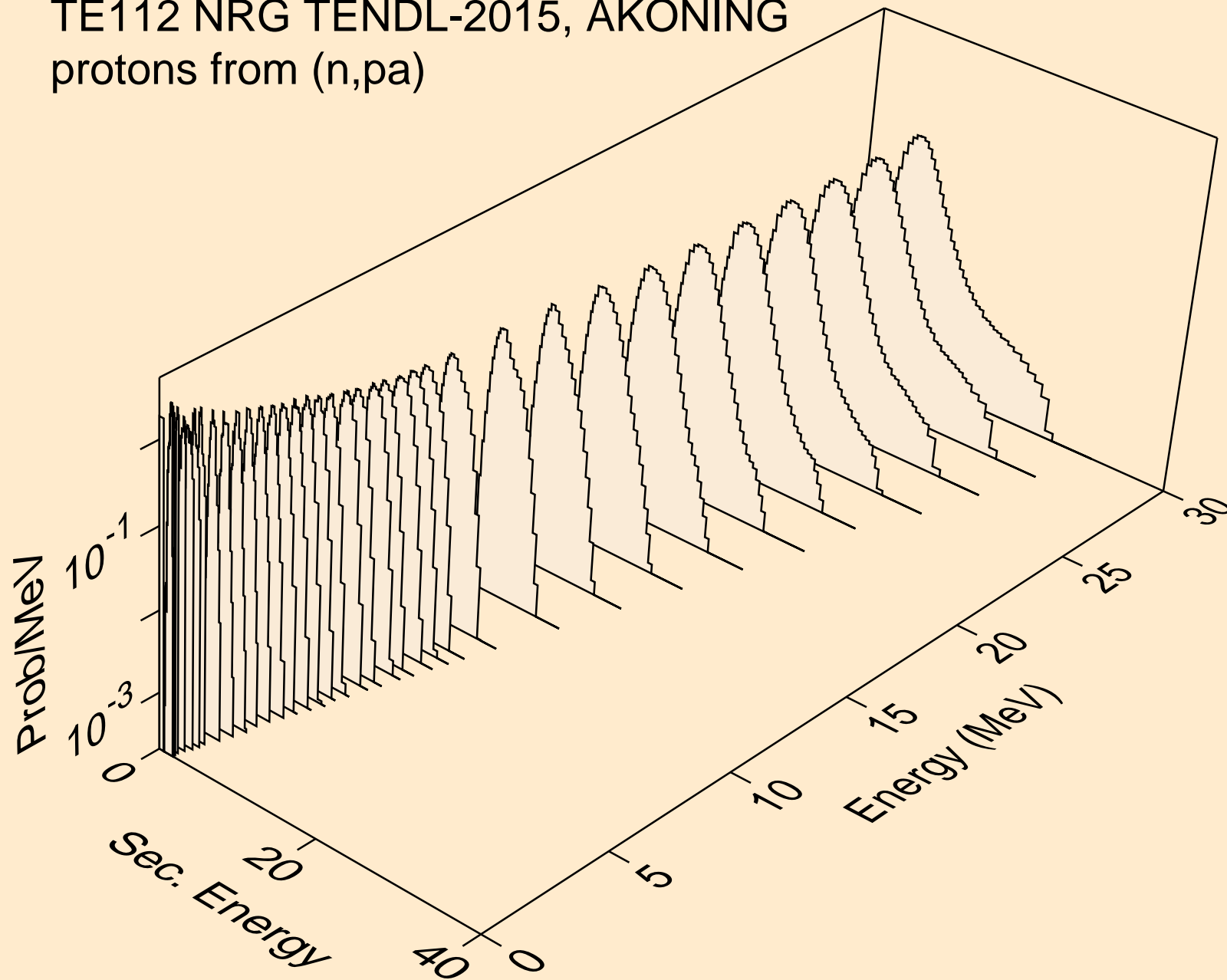

TE112 NRG TENDL-2015, AKONING  
protons from (n,pd)

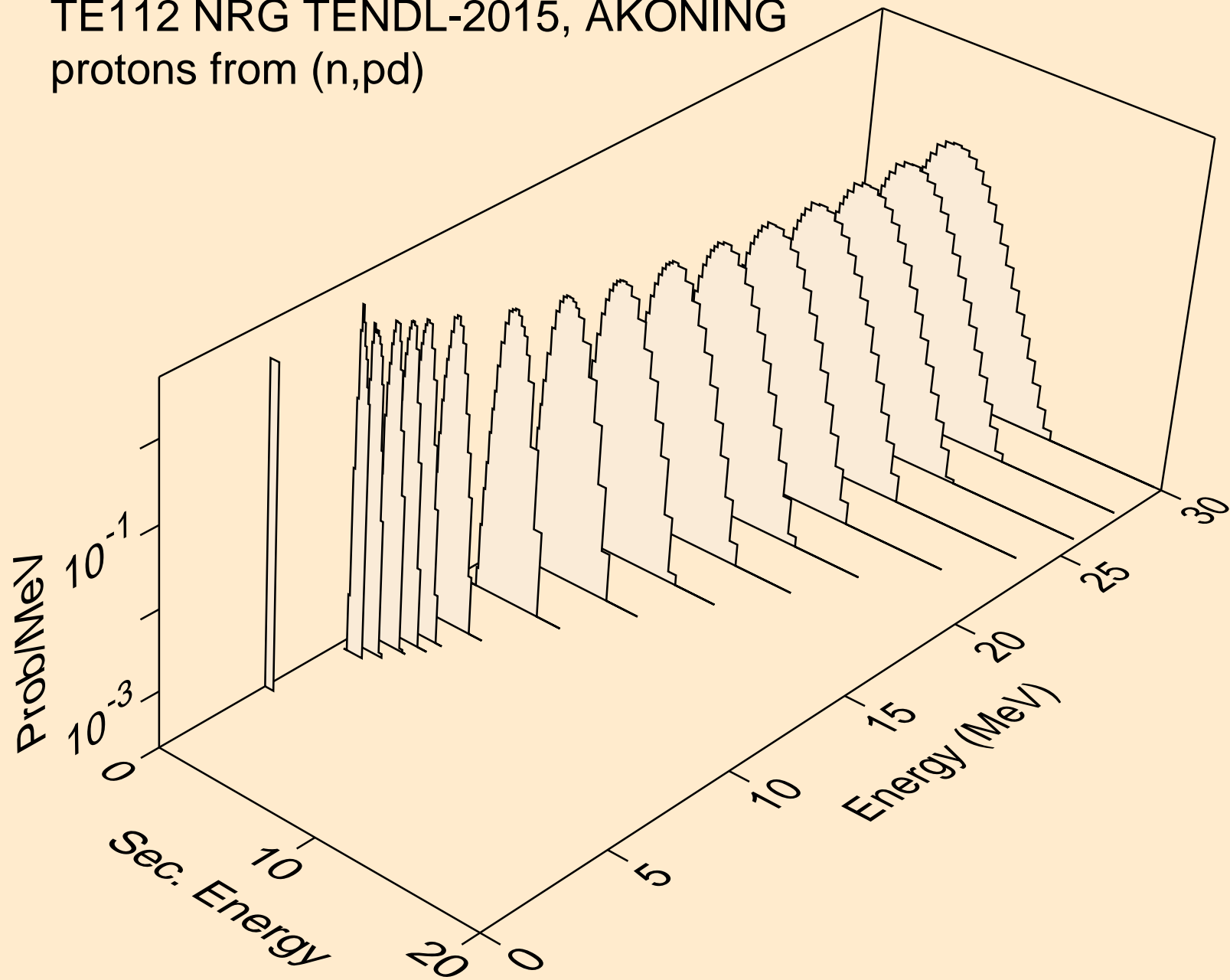

TE112 NRG TENDL-2015, AKONING  
protons from (n,pt)

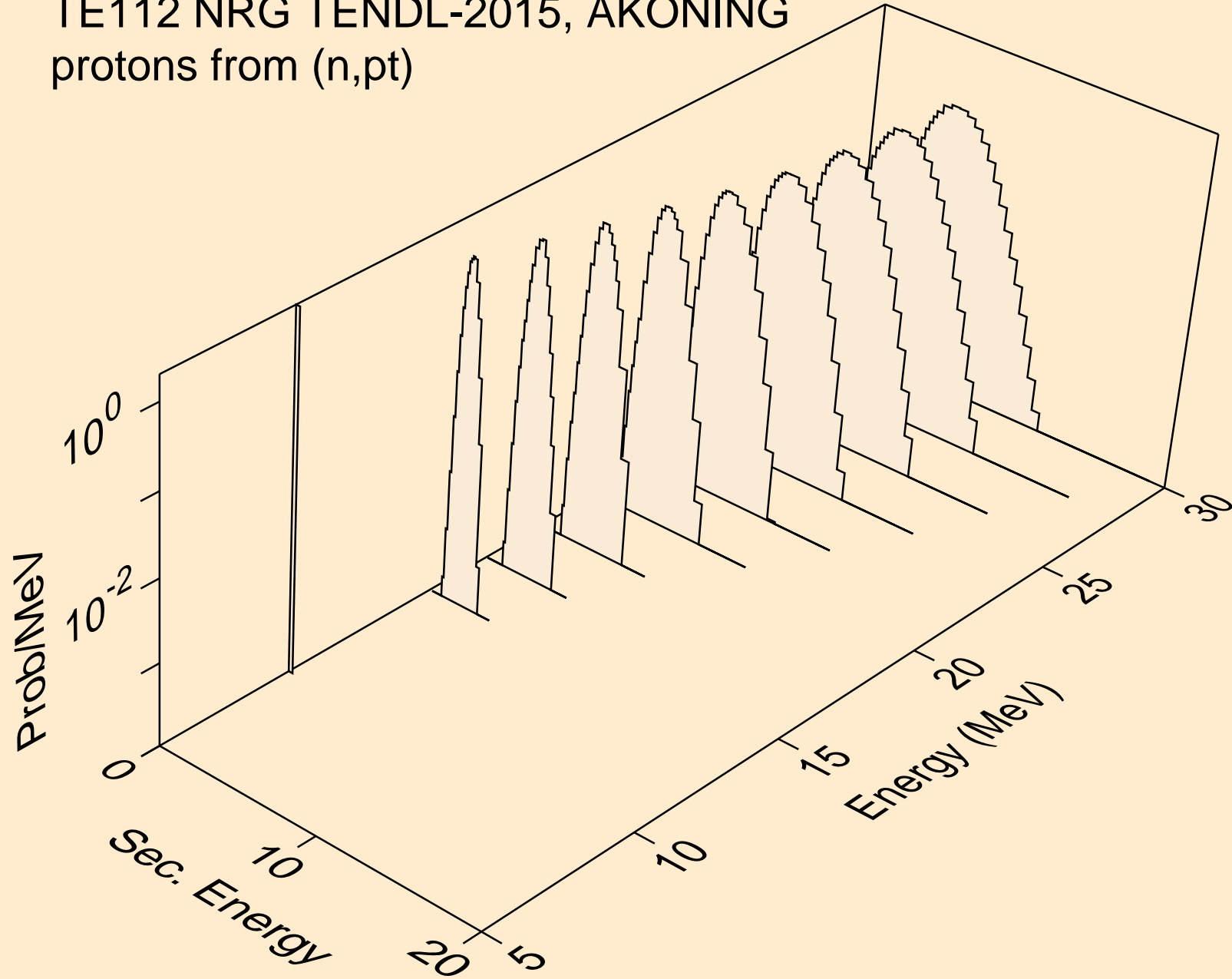

TE112 NRG TENDL-2015, AKONING  
deuterons from (n,x)

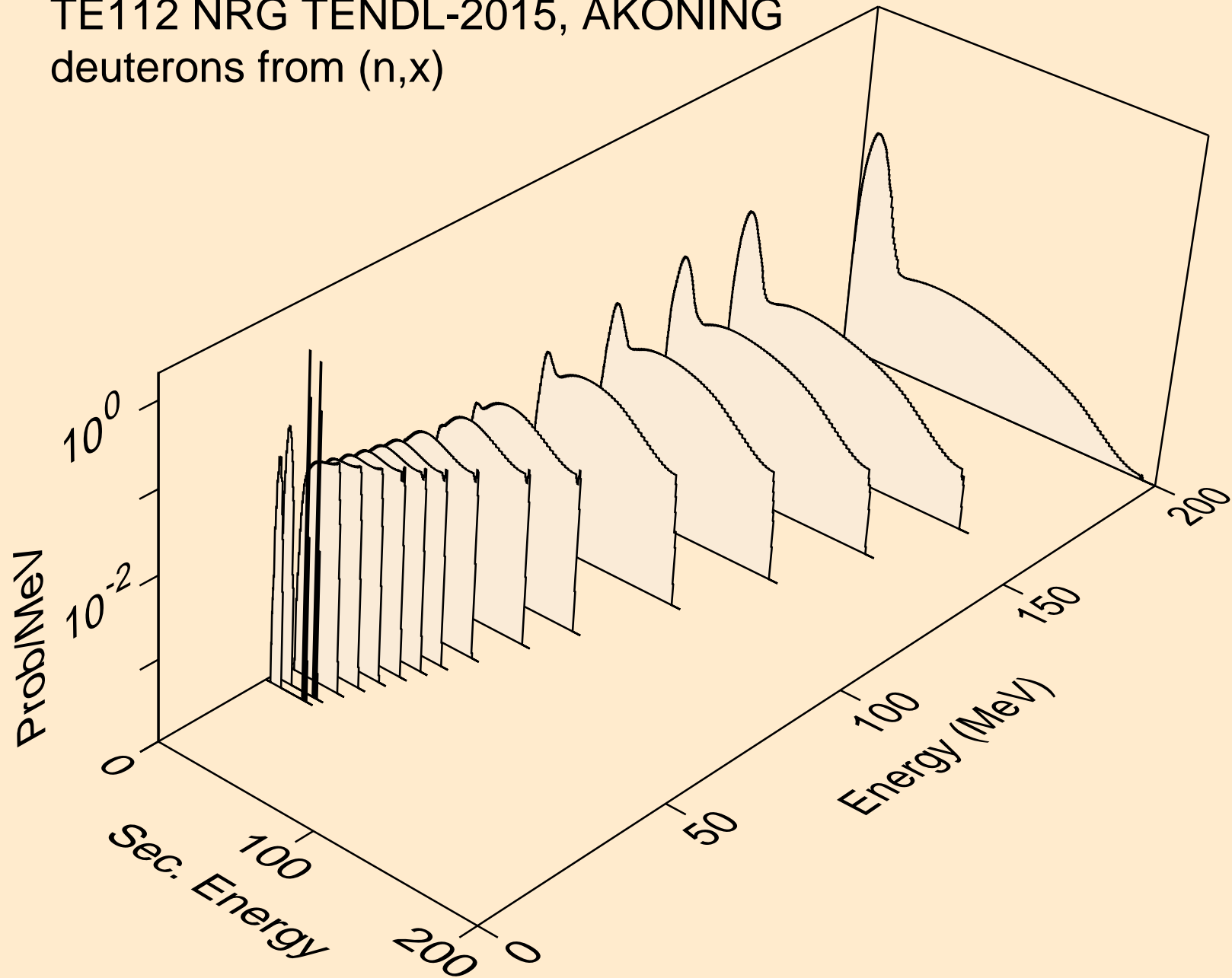

TE112 NRG TENDL-2015, AKONING  
deuterons from (n,2nd)

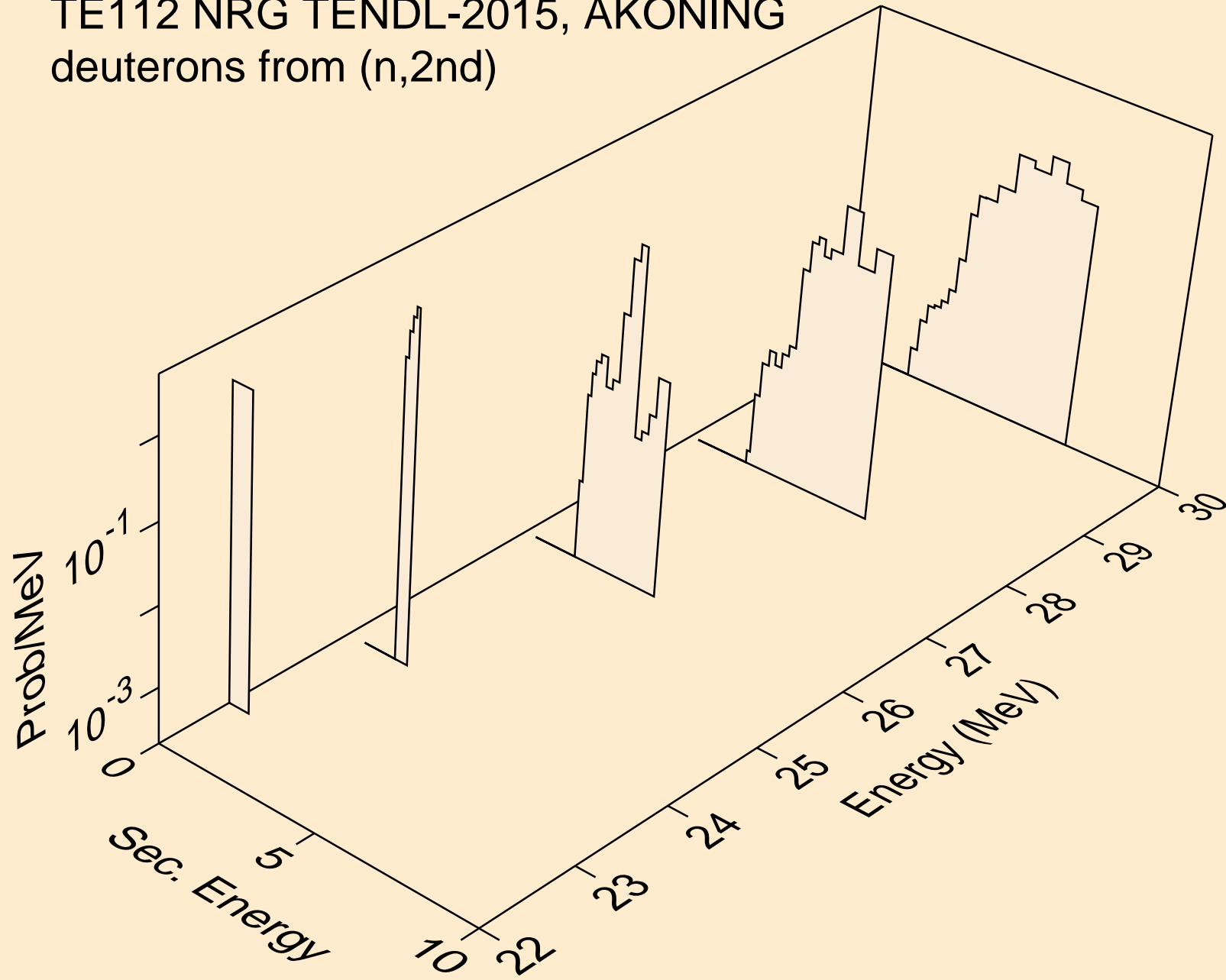

TE112 NRG TENDL-2015, AKONING  
deuterons from (n,n\*)d

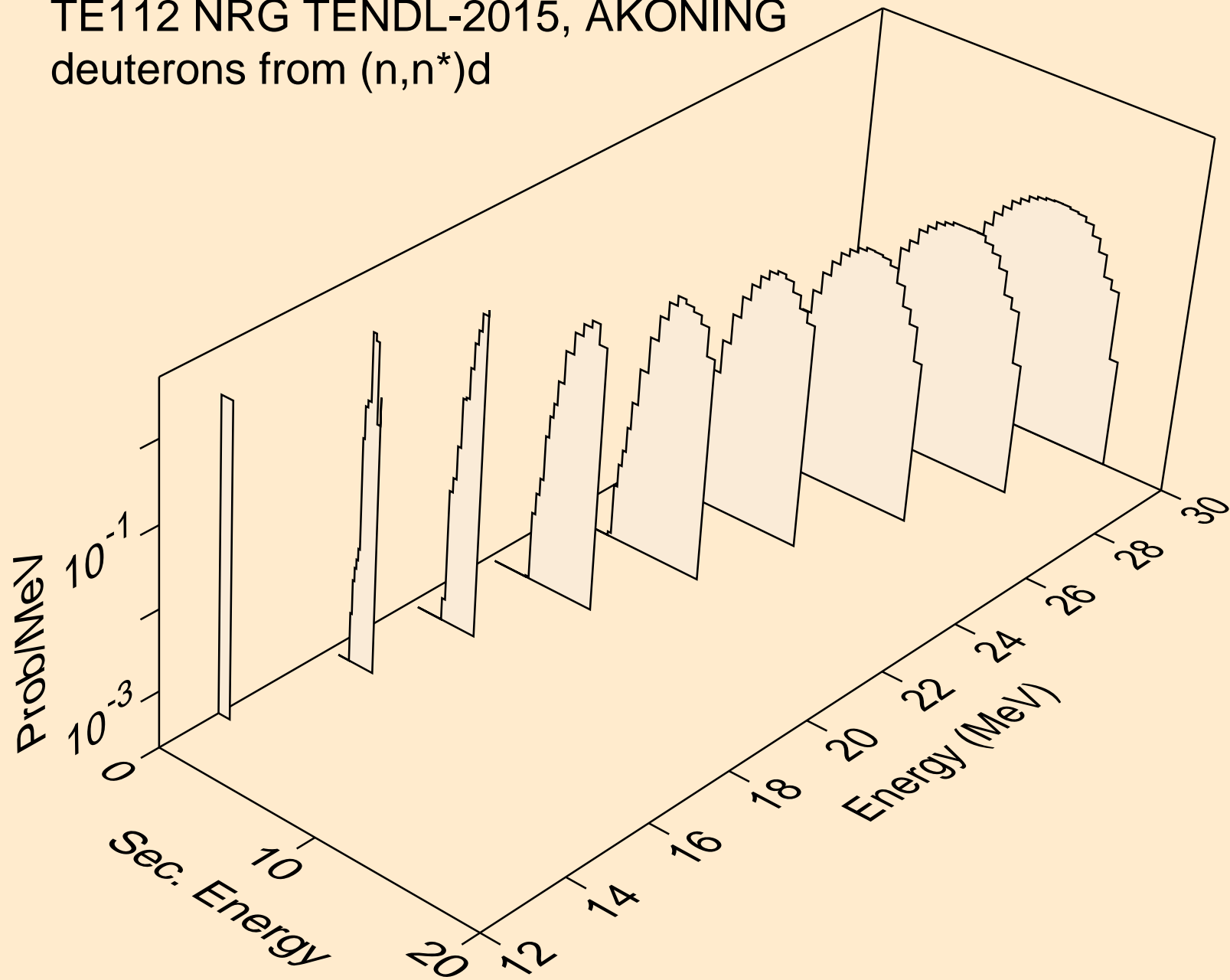

TE112 NRG TENDL-2015, AKONING  
deuterons from (n,d)

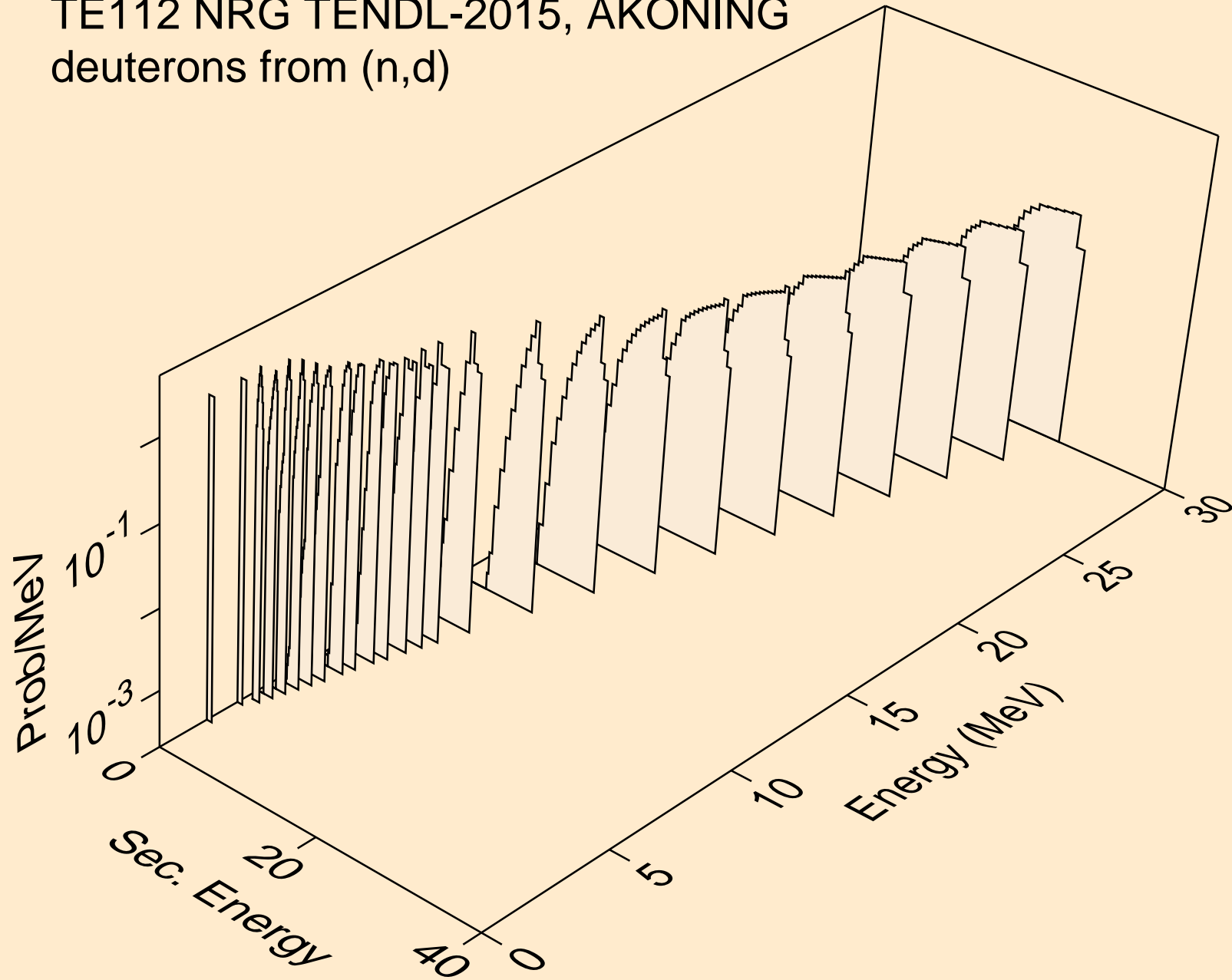

TE112 NRG TENDL-2015, AKONING  
deuterons from (n,d2a)

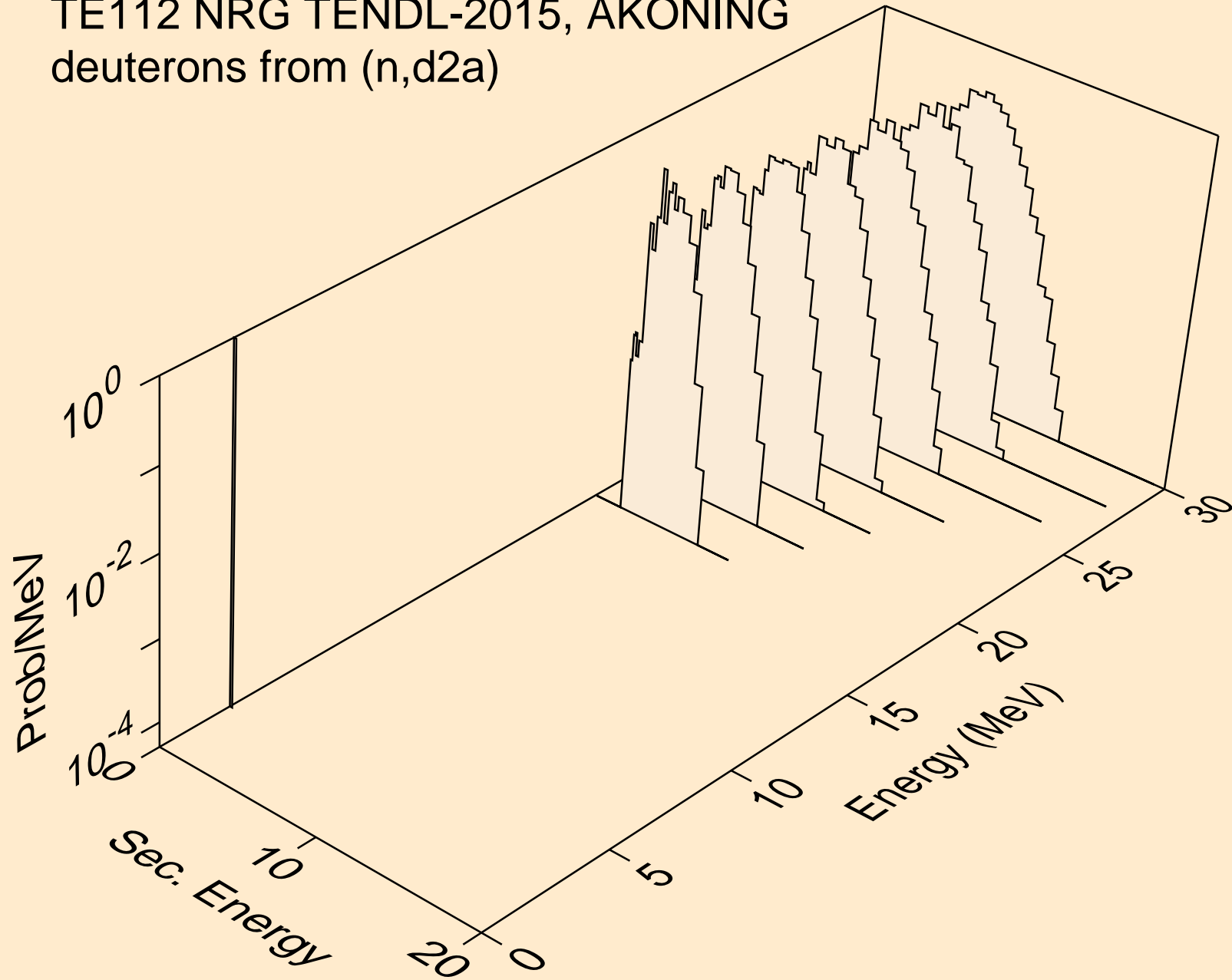



TE112 NRG TENDL-2015, AKONING  
deuterons from (n,pd)

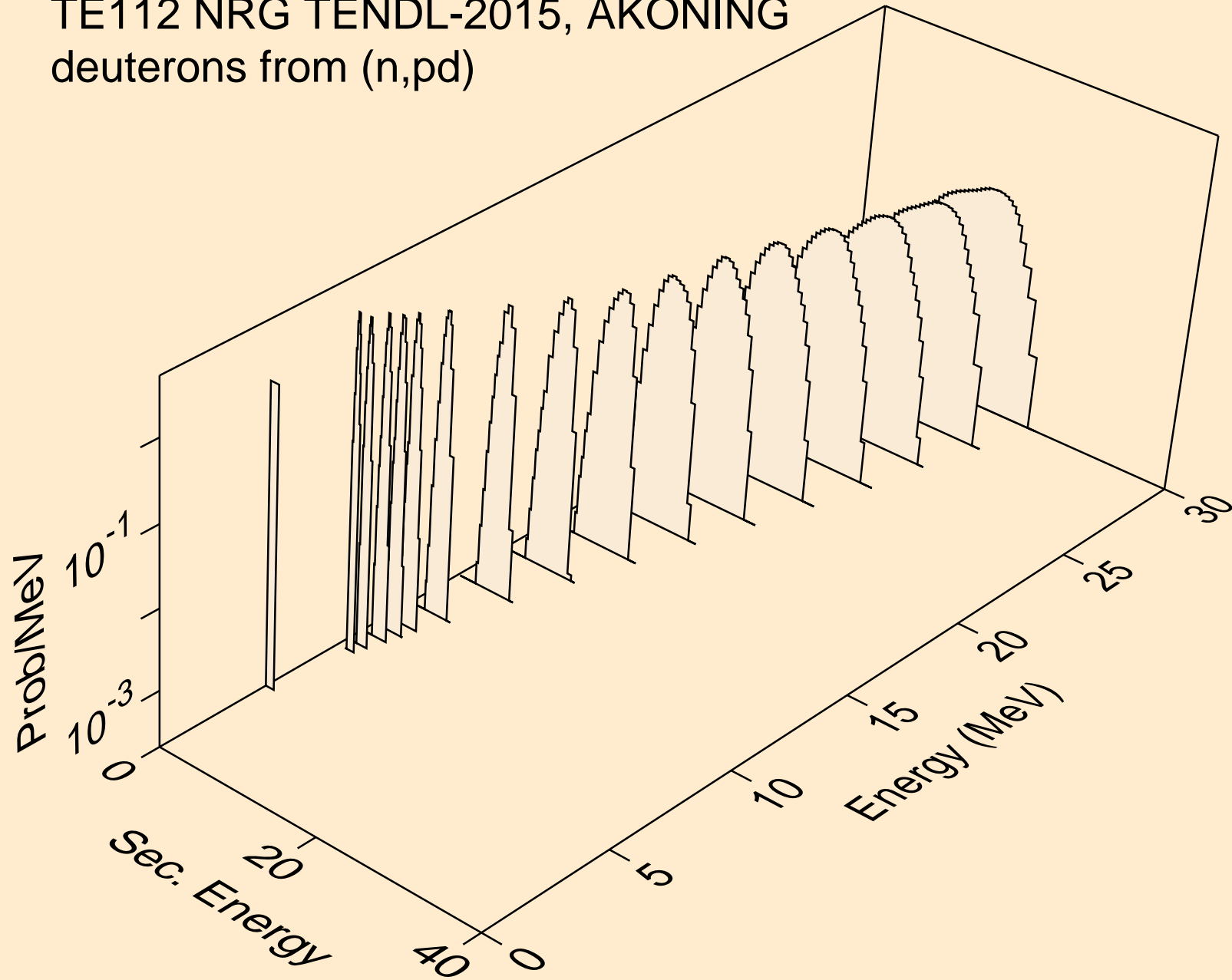

TE112 NRG TENDL-2015, AKONING  
deuterons from (n,da)

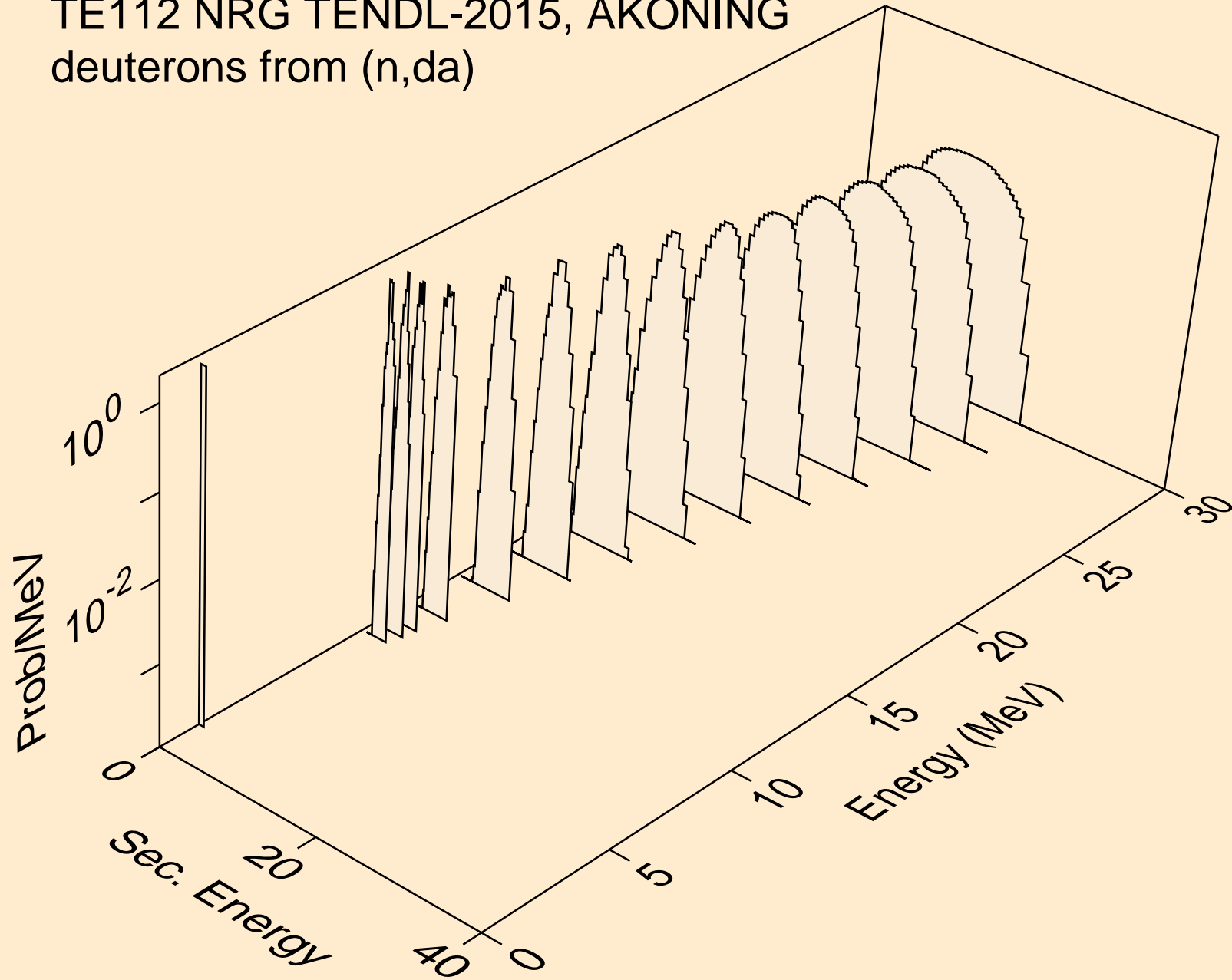

TE112 NRG TENDL-2015, AKONING  
tritons from (n,x)

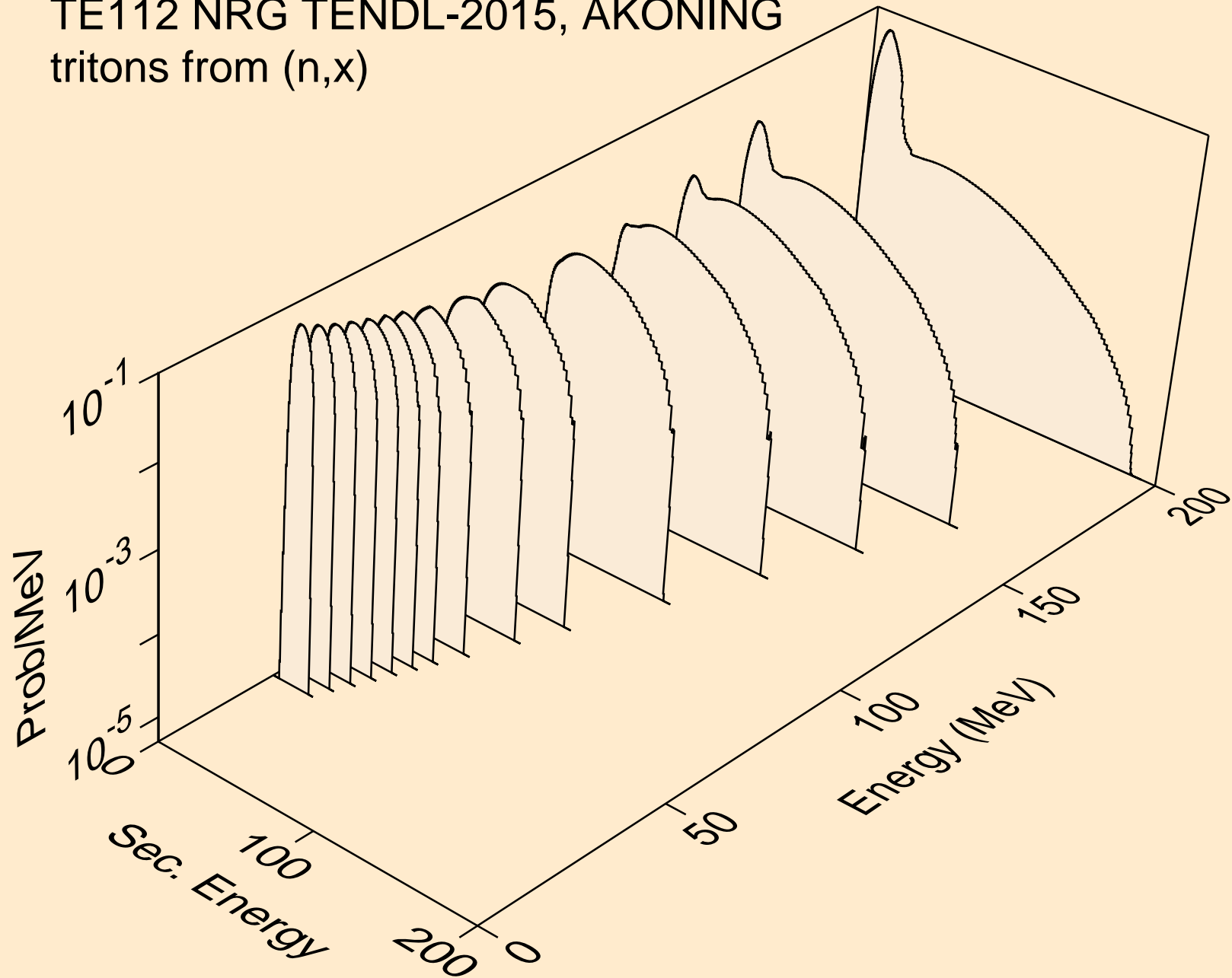

TE112 NRG TENDL-2015, AKONING  
tritons from (n,n\*)t

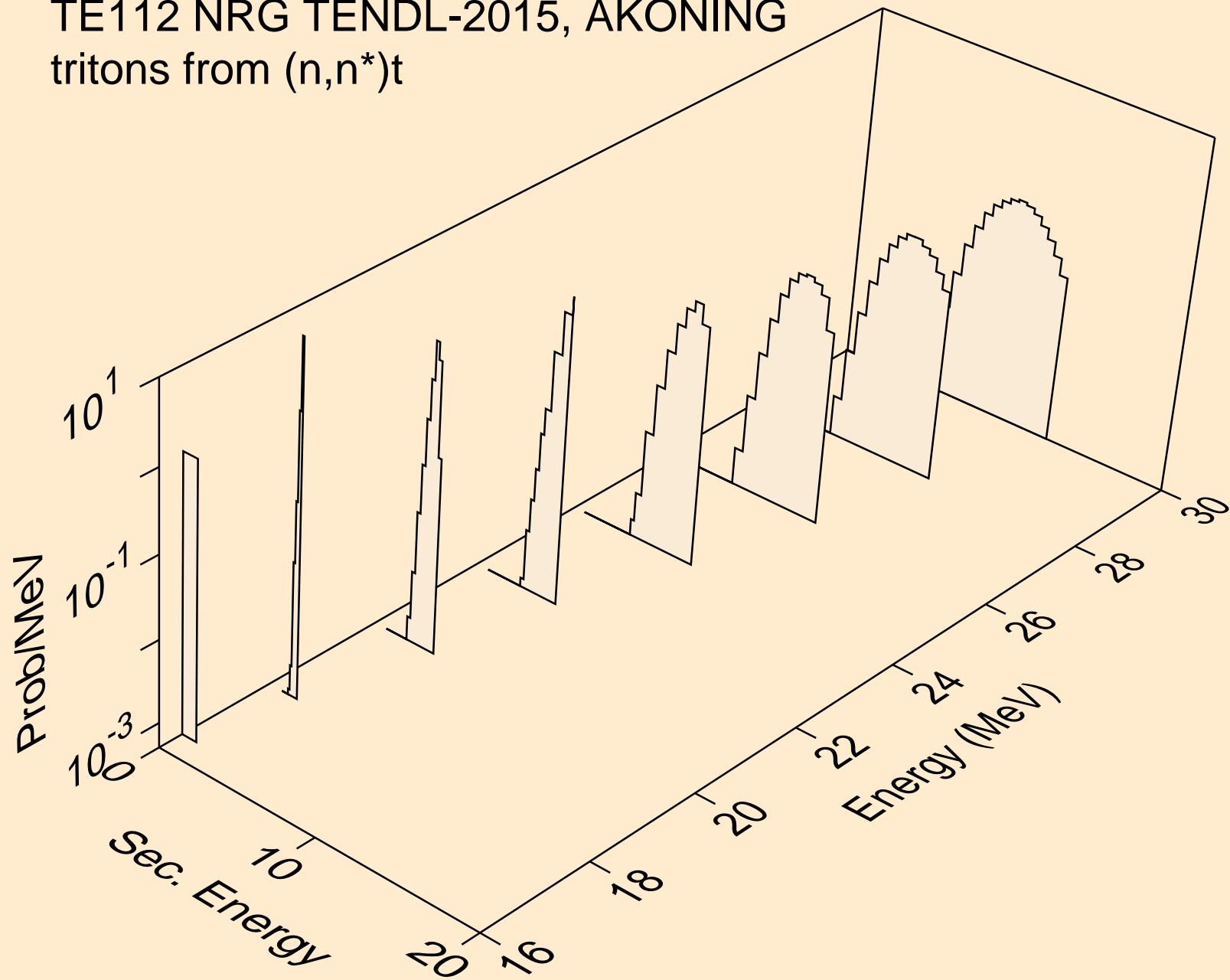

TE112 NRG TENDL-2015, AKONING  
tritons from (n,t)

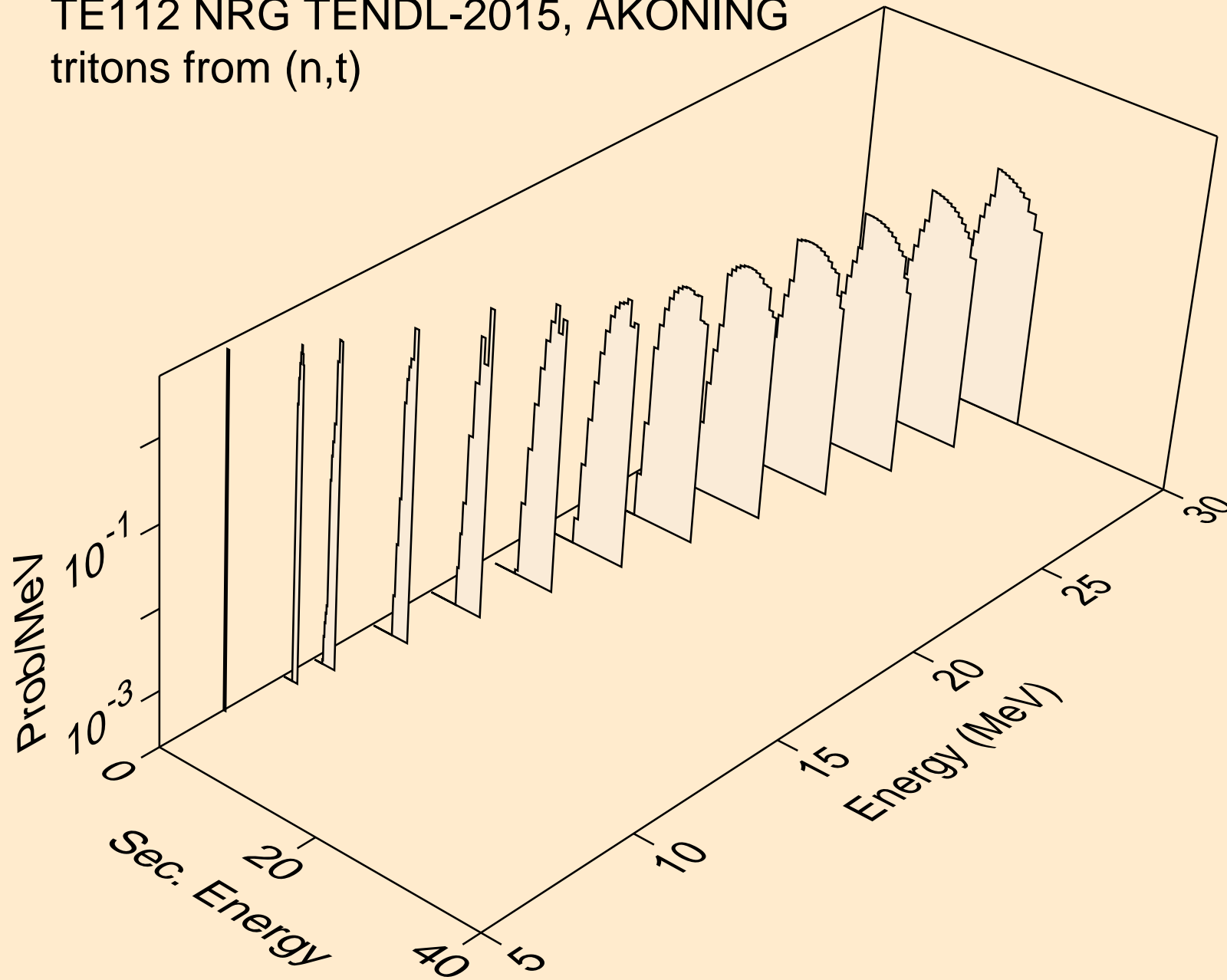

TE112 NRG TENDL-2015, AKONING  
tritons from (n,pt)

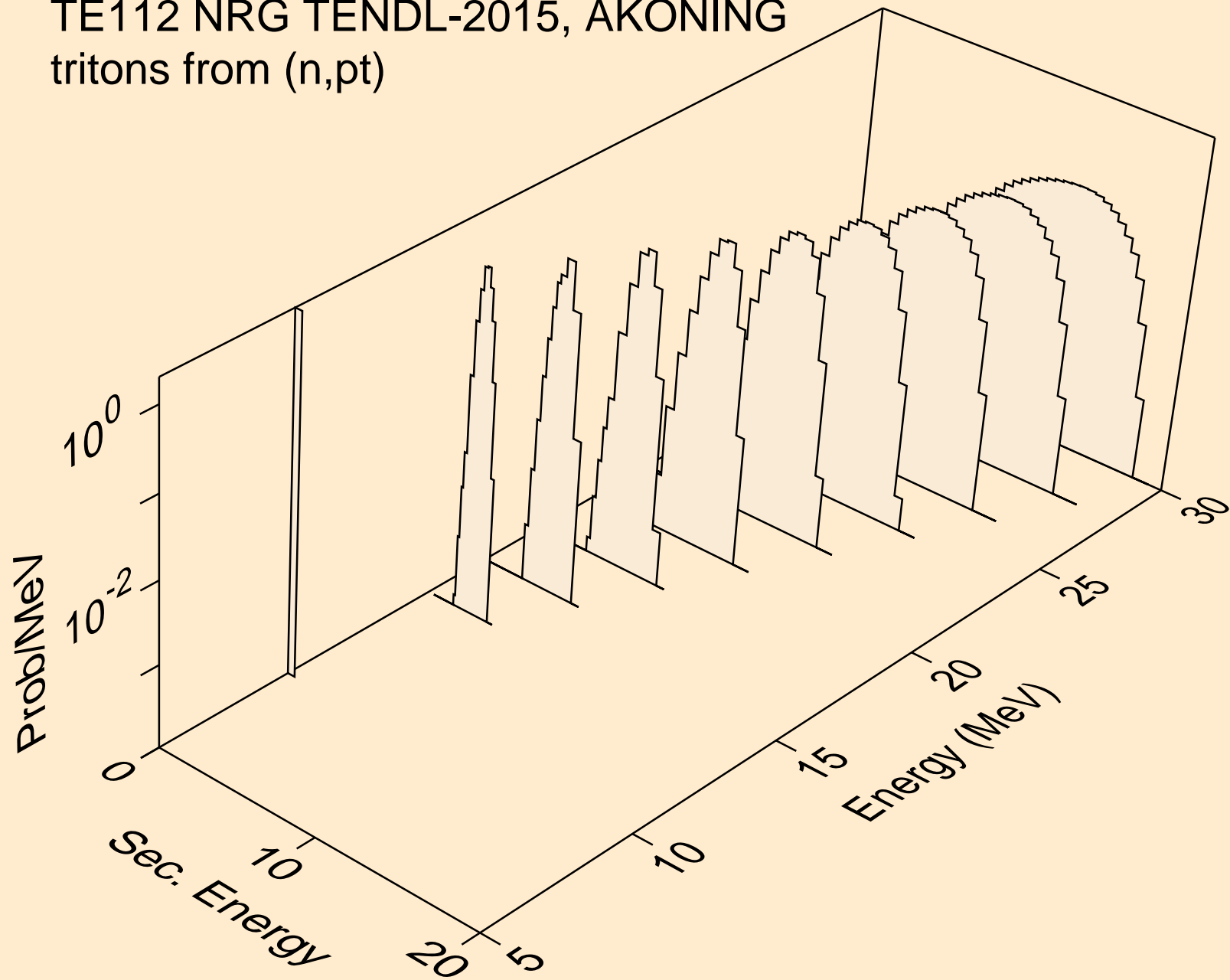

TE112 NRG TENDL-2015, AKONING  
he3s from (n,x)

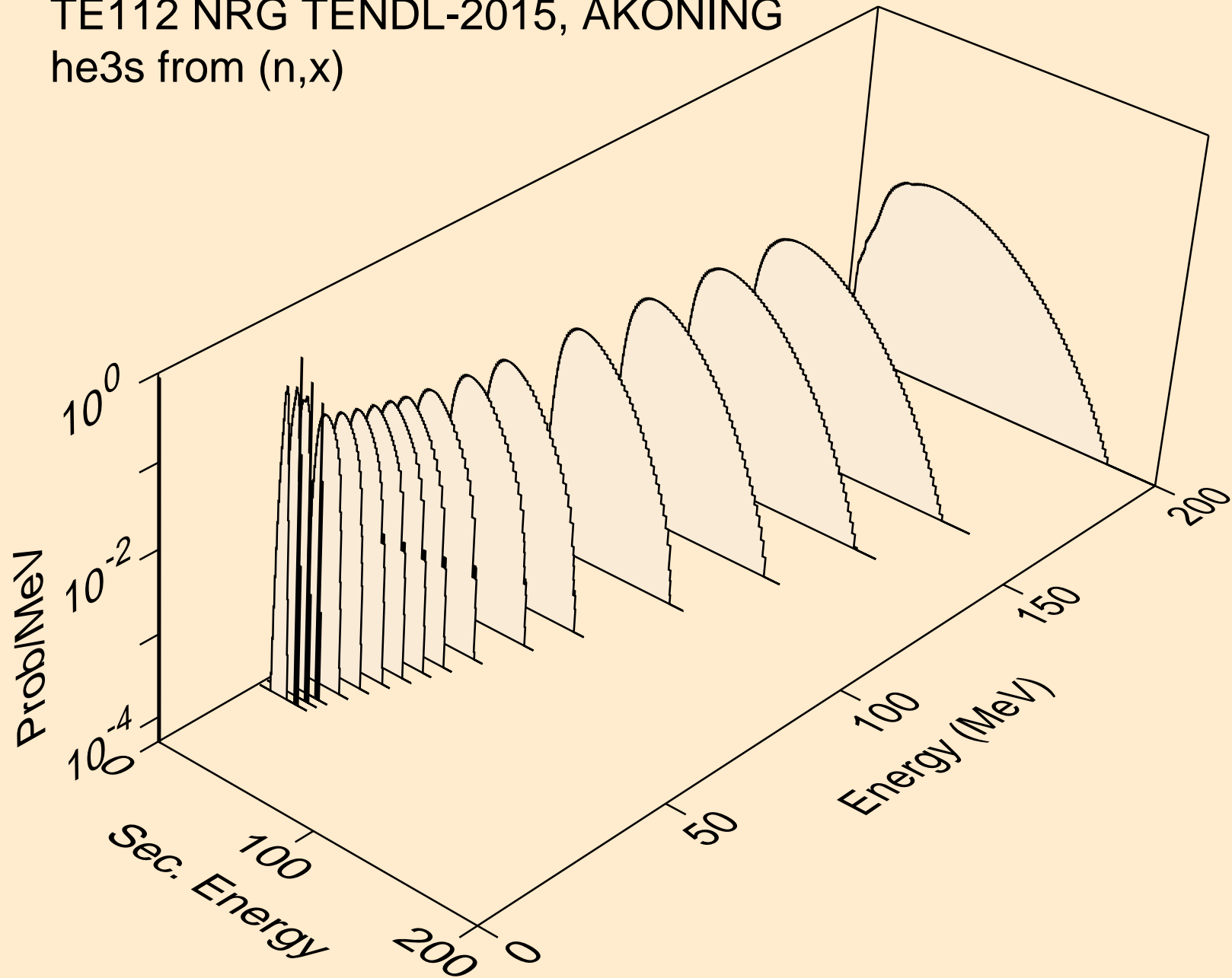

TE112 NRG TENDL-2015, AKONING  
he3s from (n,n\*)he3

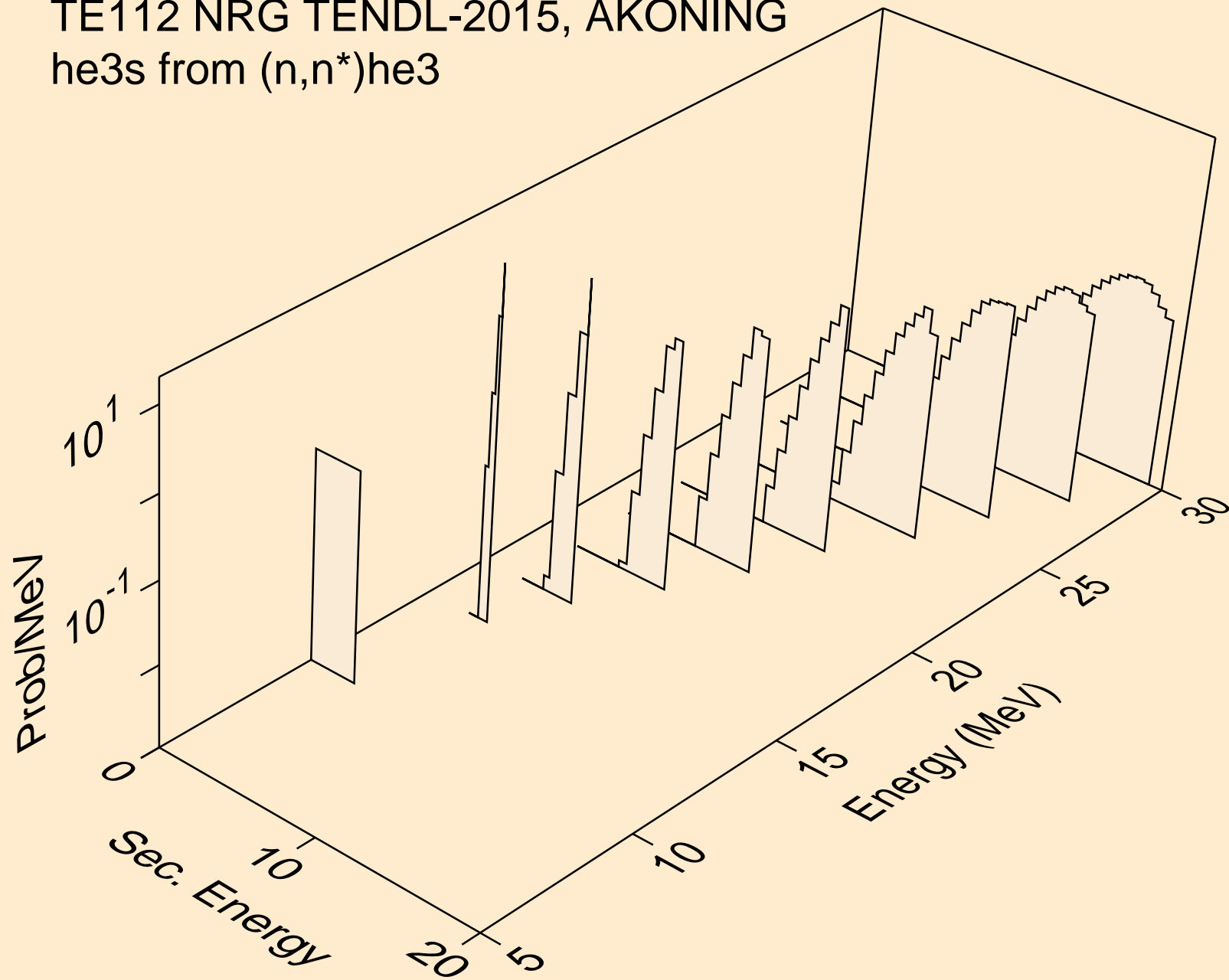



TE112 NRG TENDL-2015, AKONING  
he3s from (n,he3)

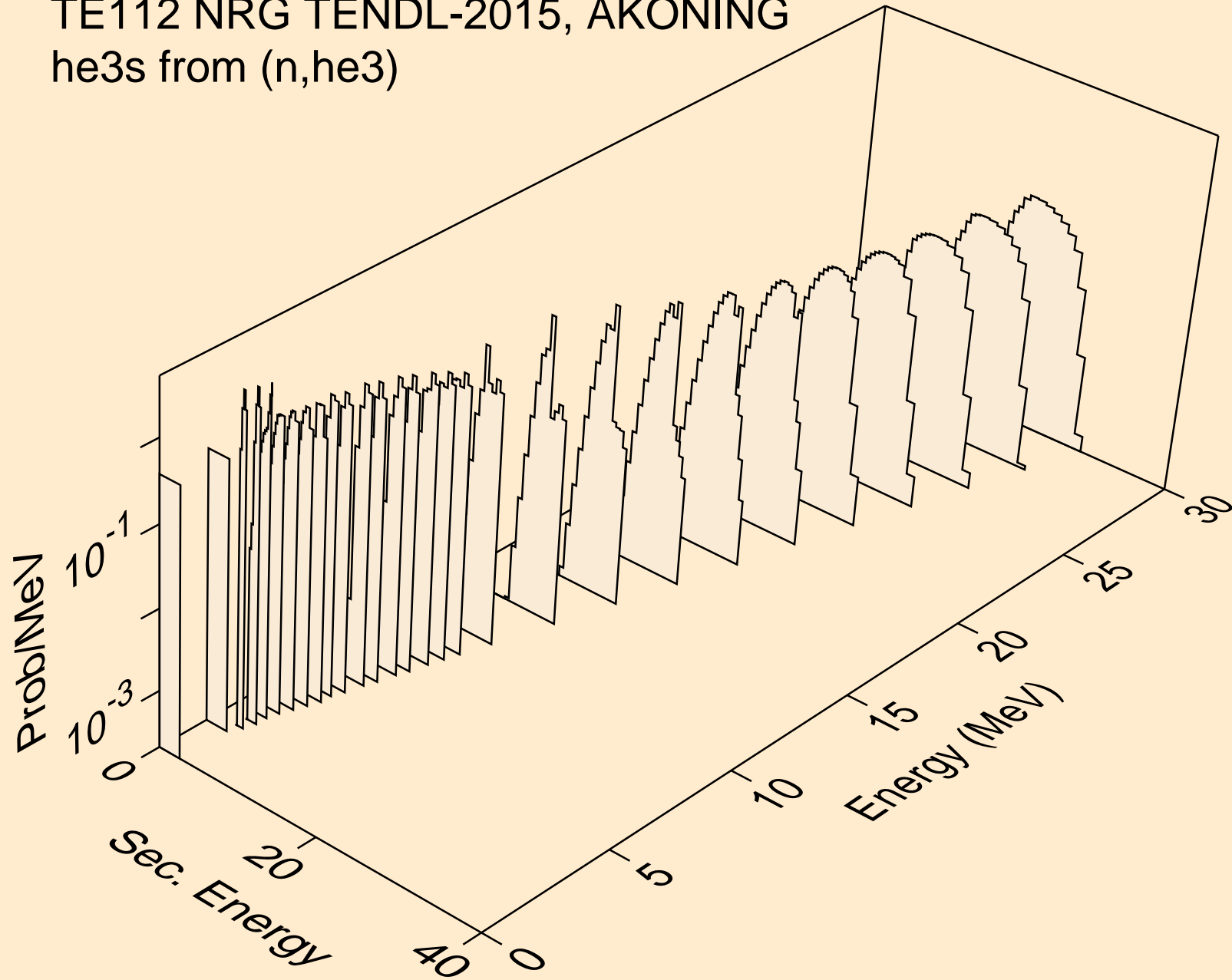

TE112 NRG TENDL-2015, AKONING  
alphas from (n,x)

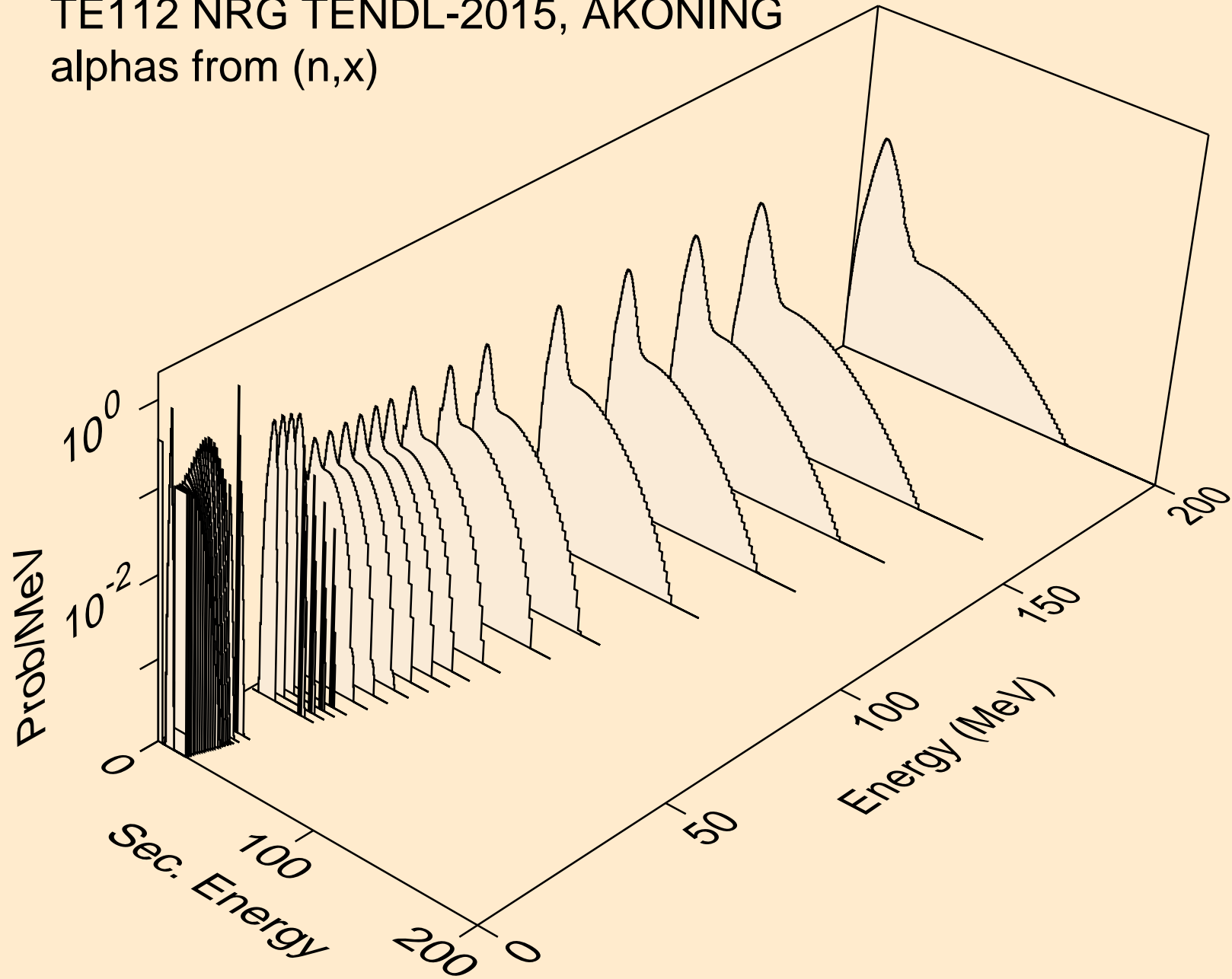

TE112 NRG TENDL-2015, AKONING  
alphas from (n,n\*)a

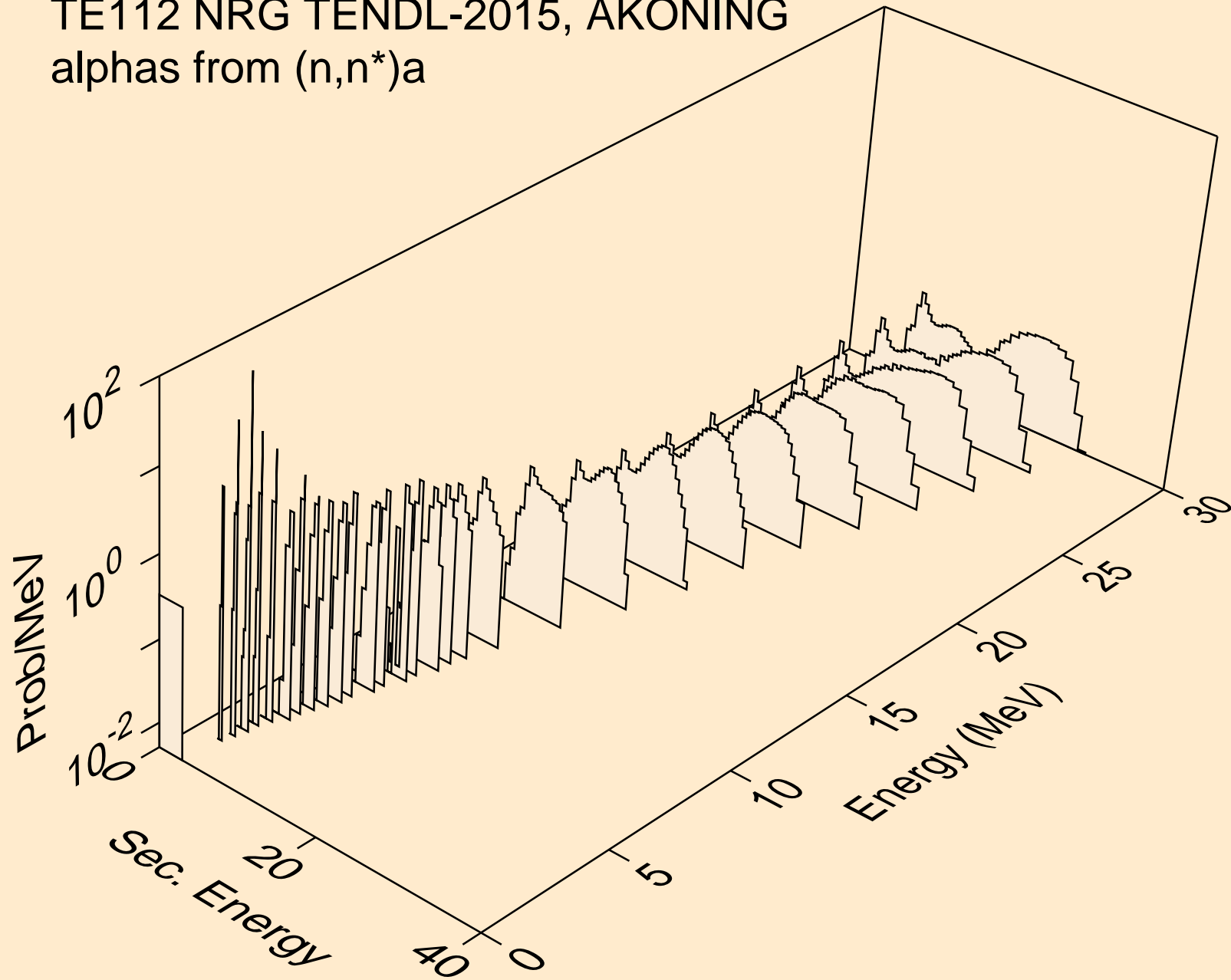

TE112 NRG TENDL-2015, AKONING  
alphas from (n,n\*)3a

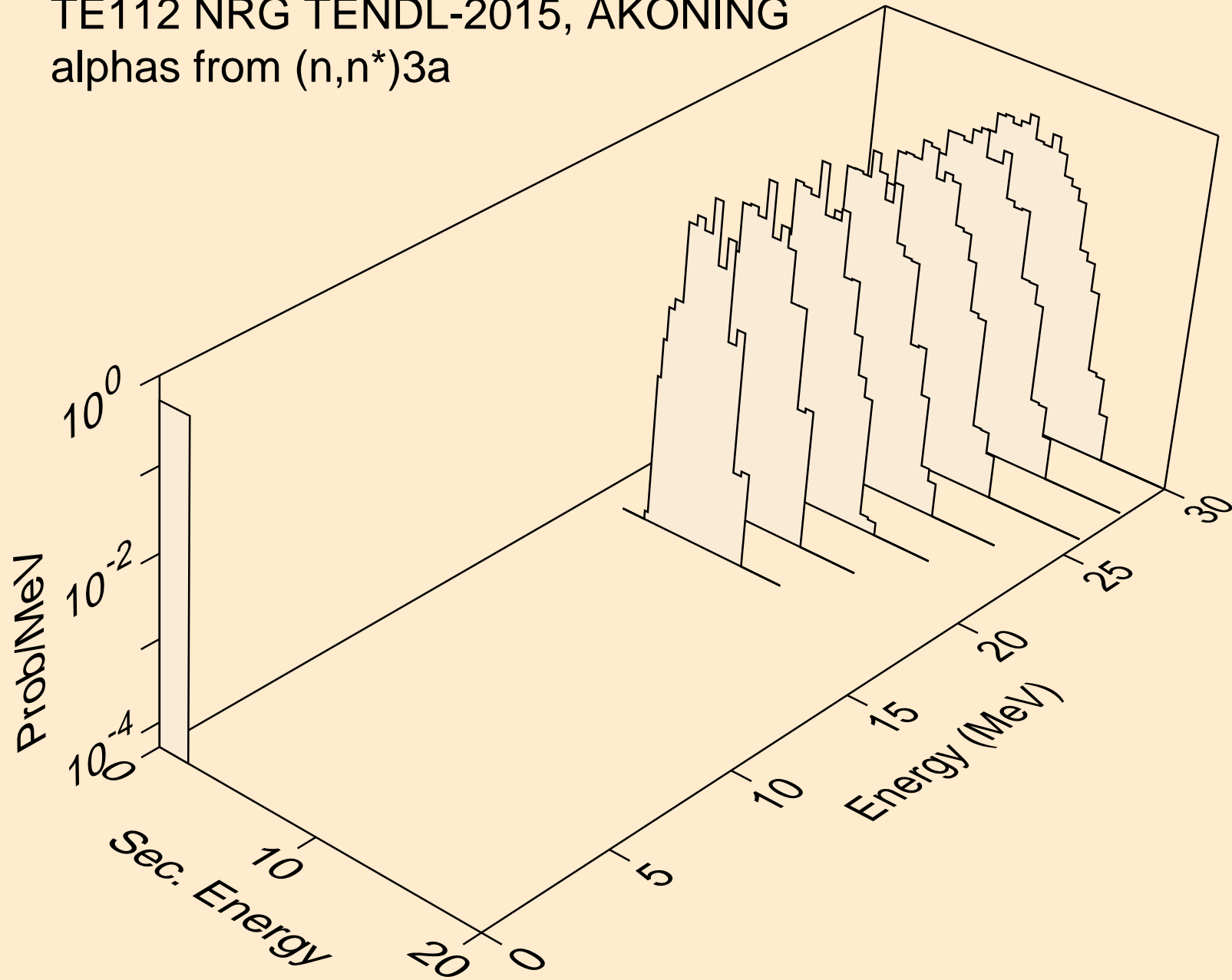

TE112 NRG TENDL-2015, AKONING  
alphas from (n,2n)a

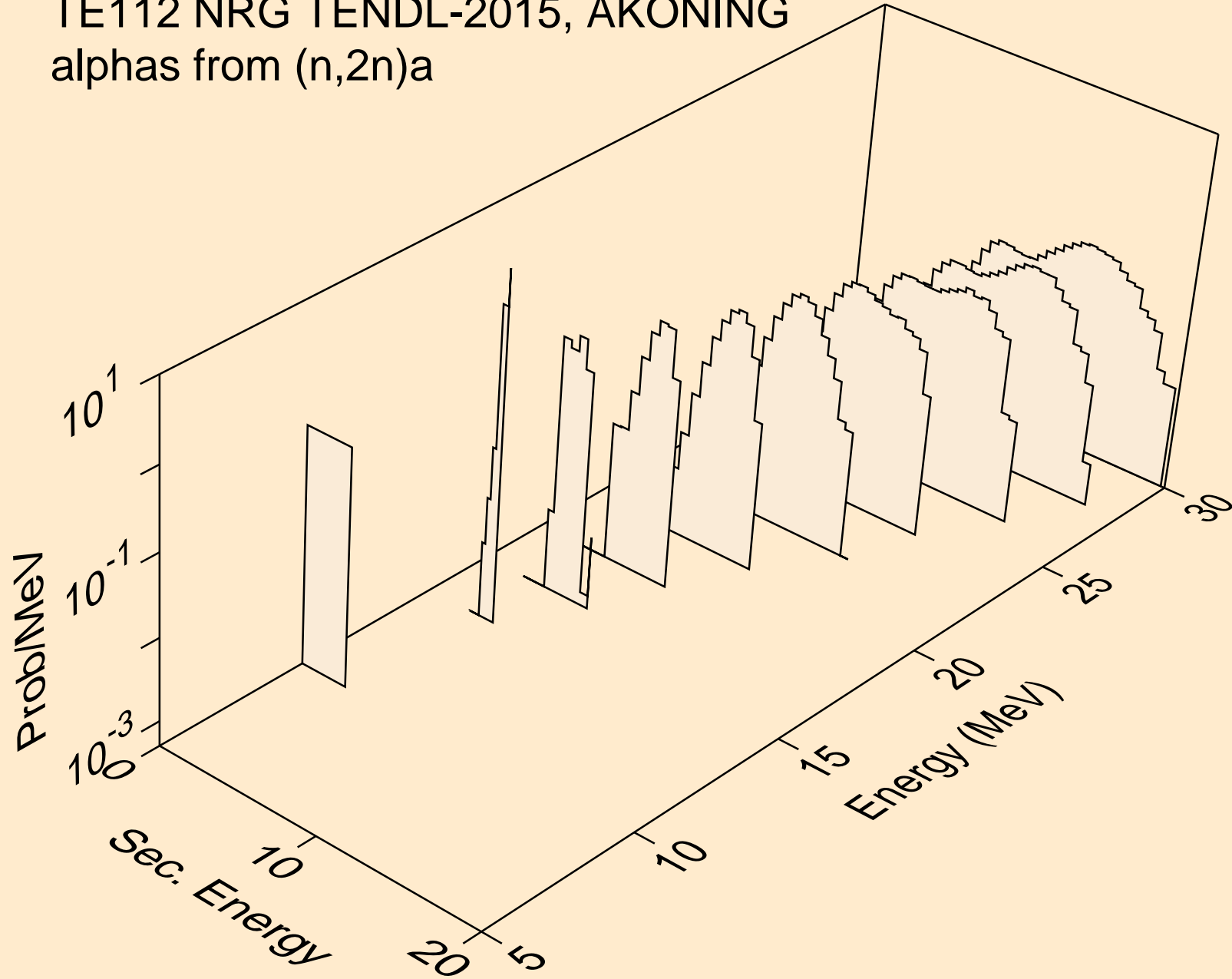

TE112 NRG TENDL-2015, AKONING  
alphas from (n,3n)a

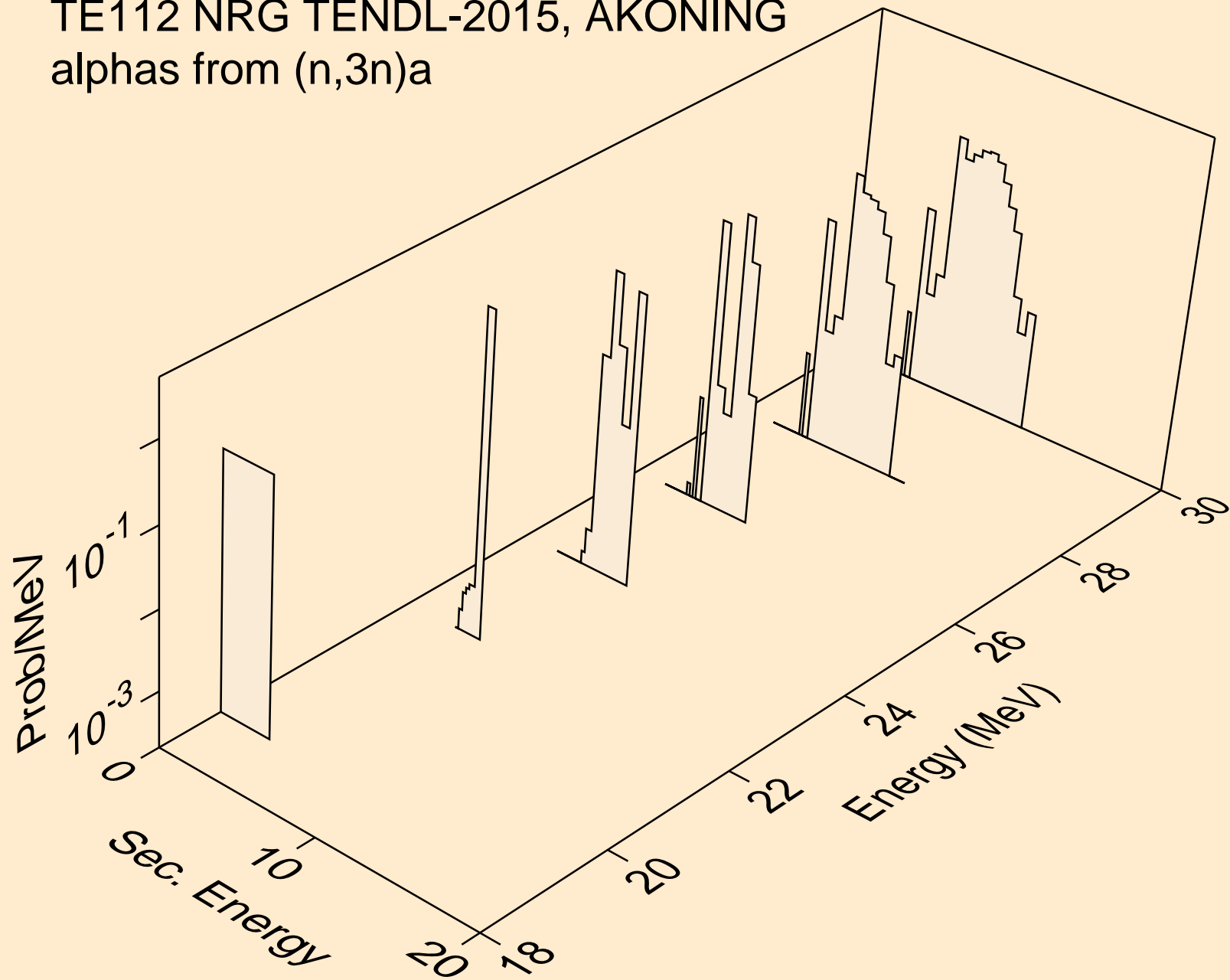

TE112 NRG TENDL-2015, AKONING  
alphas from (n,n\*)2a

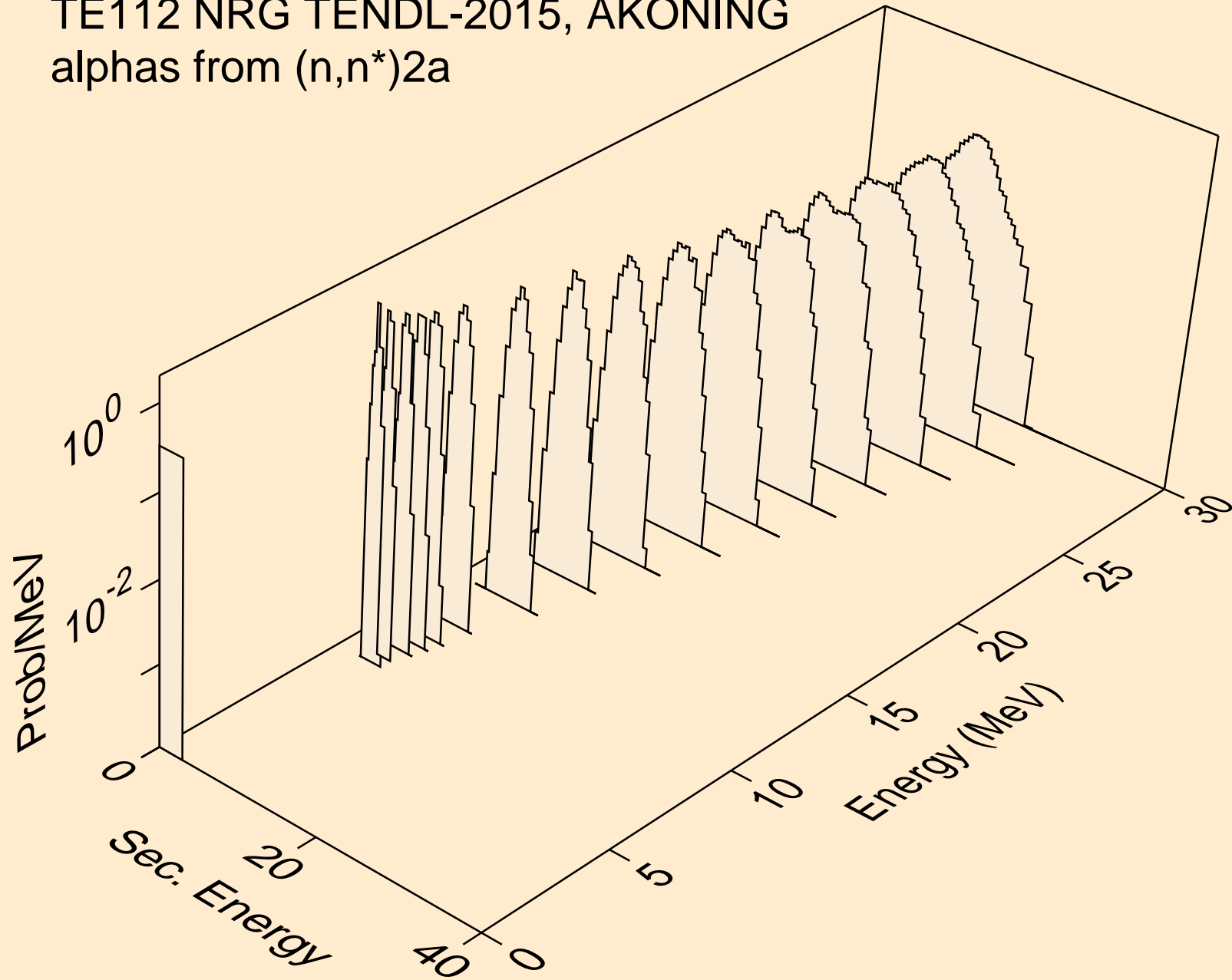

TE112 NRG TENDL-2015, AKONING  
alphas from (n,2n)2a

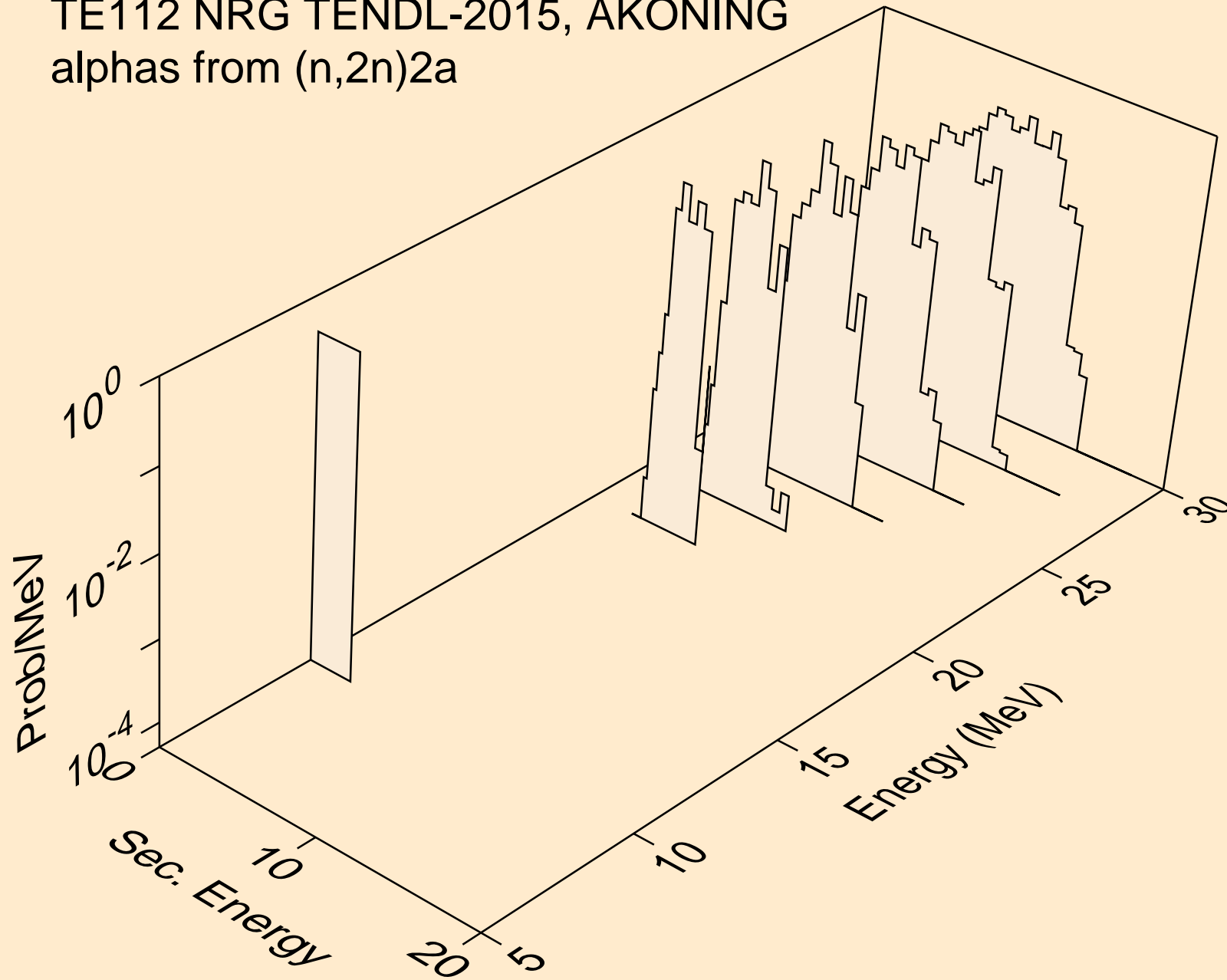



TE112 NRG TENDL-2015, AKONING  
alphas from (n,npa)

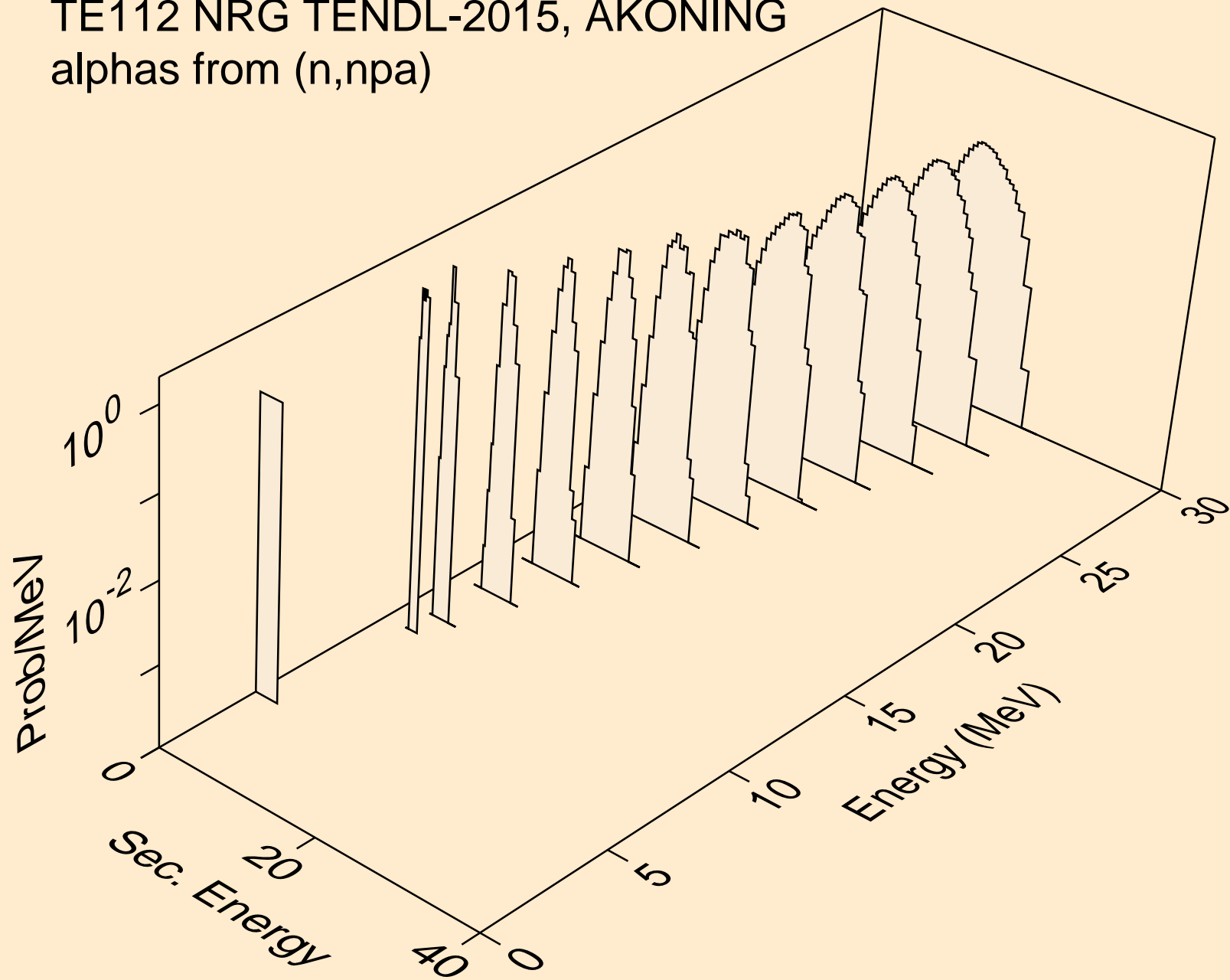

TE112 NRG TENDL-2015, AKONING  
alphas from (n,a)

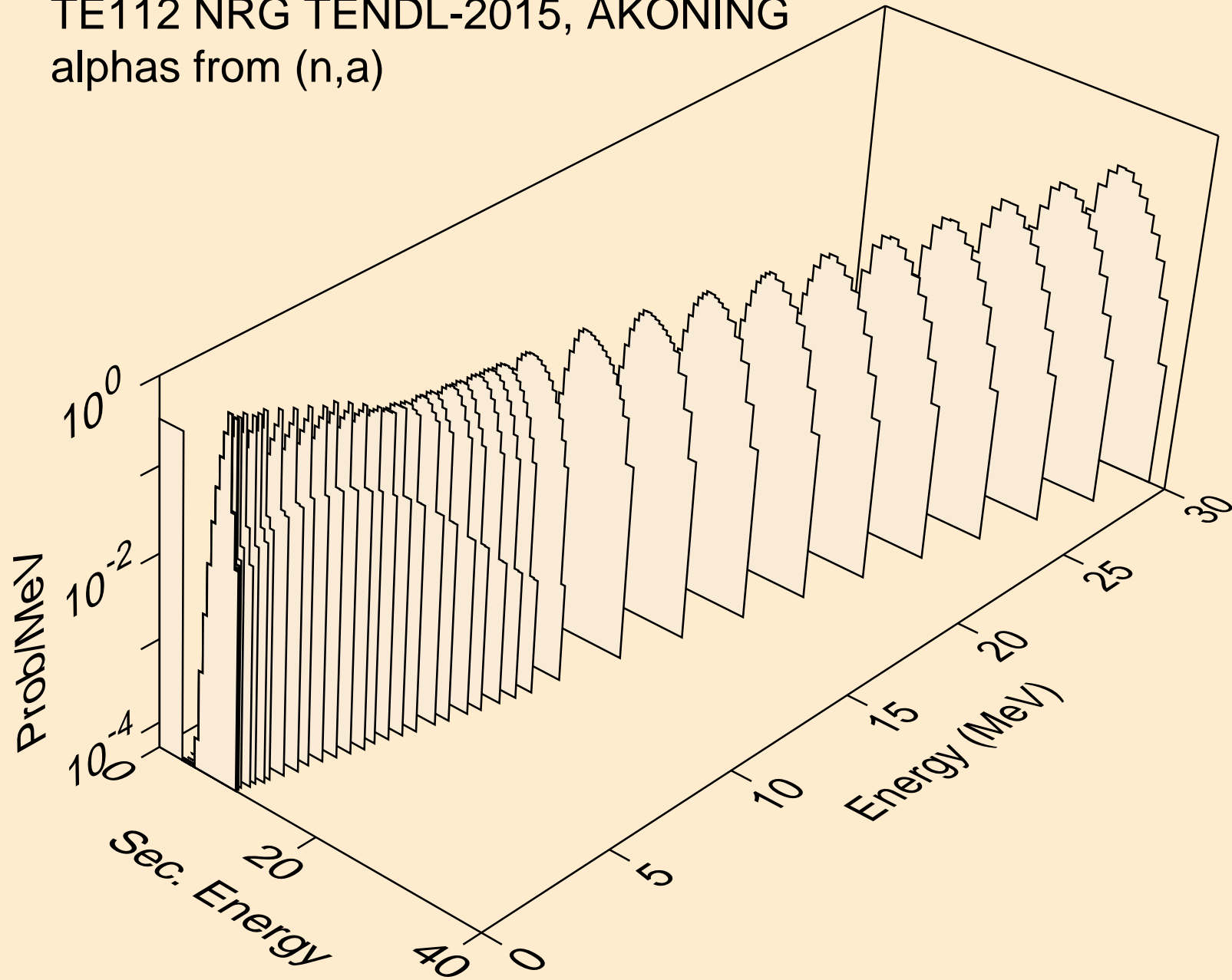

TE112 NRG TENDL-2015, AKONING  
alphas from (n,2a)

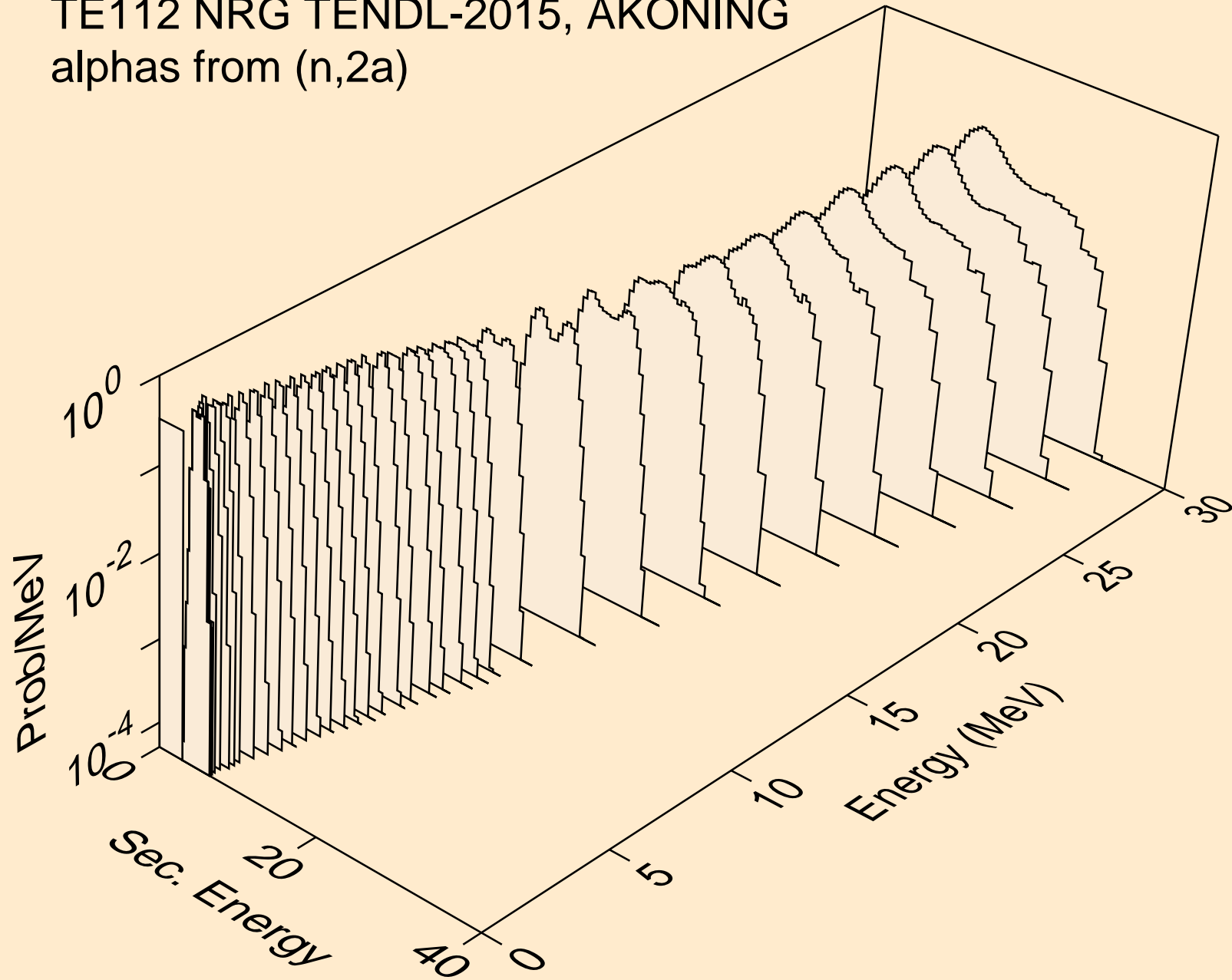

TE112 NRG TENDL-2015, AKONING  
alphas from (n,3a)

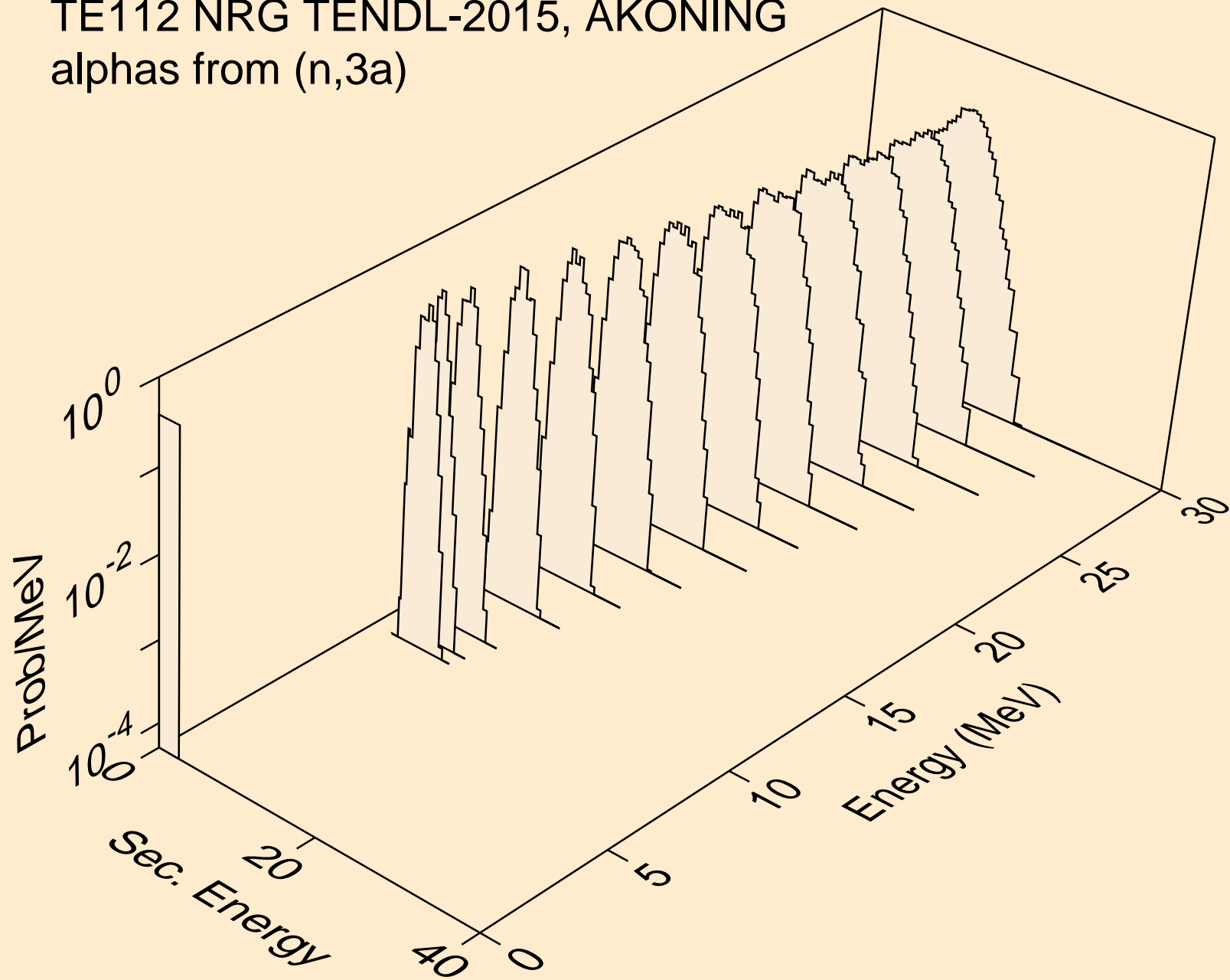

TE112 NRG TENDL-2015, AKONING  
alphas from (n,pa)

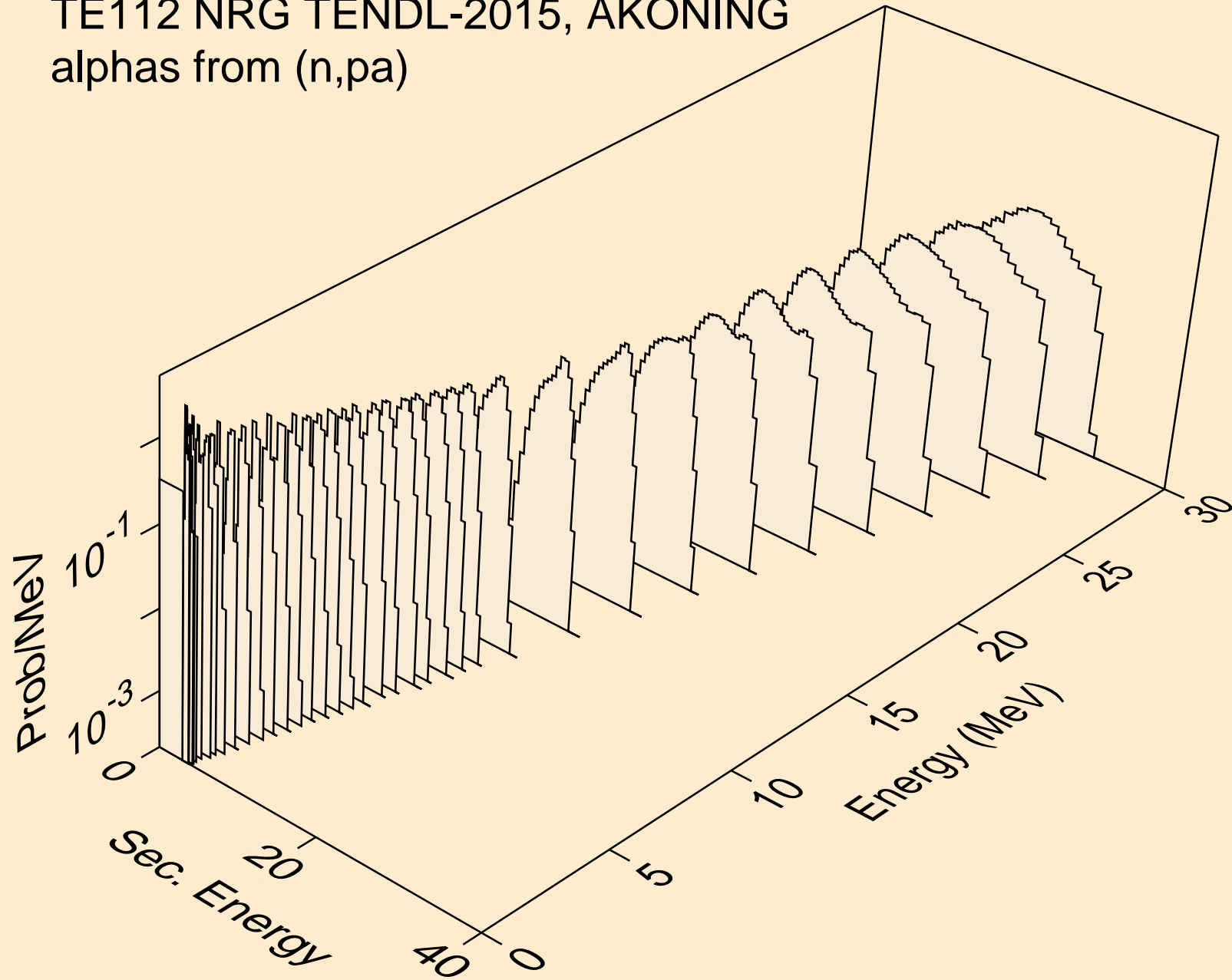

TE112 NRG TENDL-2015, AKONING  
alphas from (n,d2a)

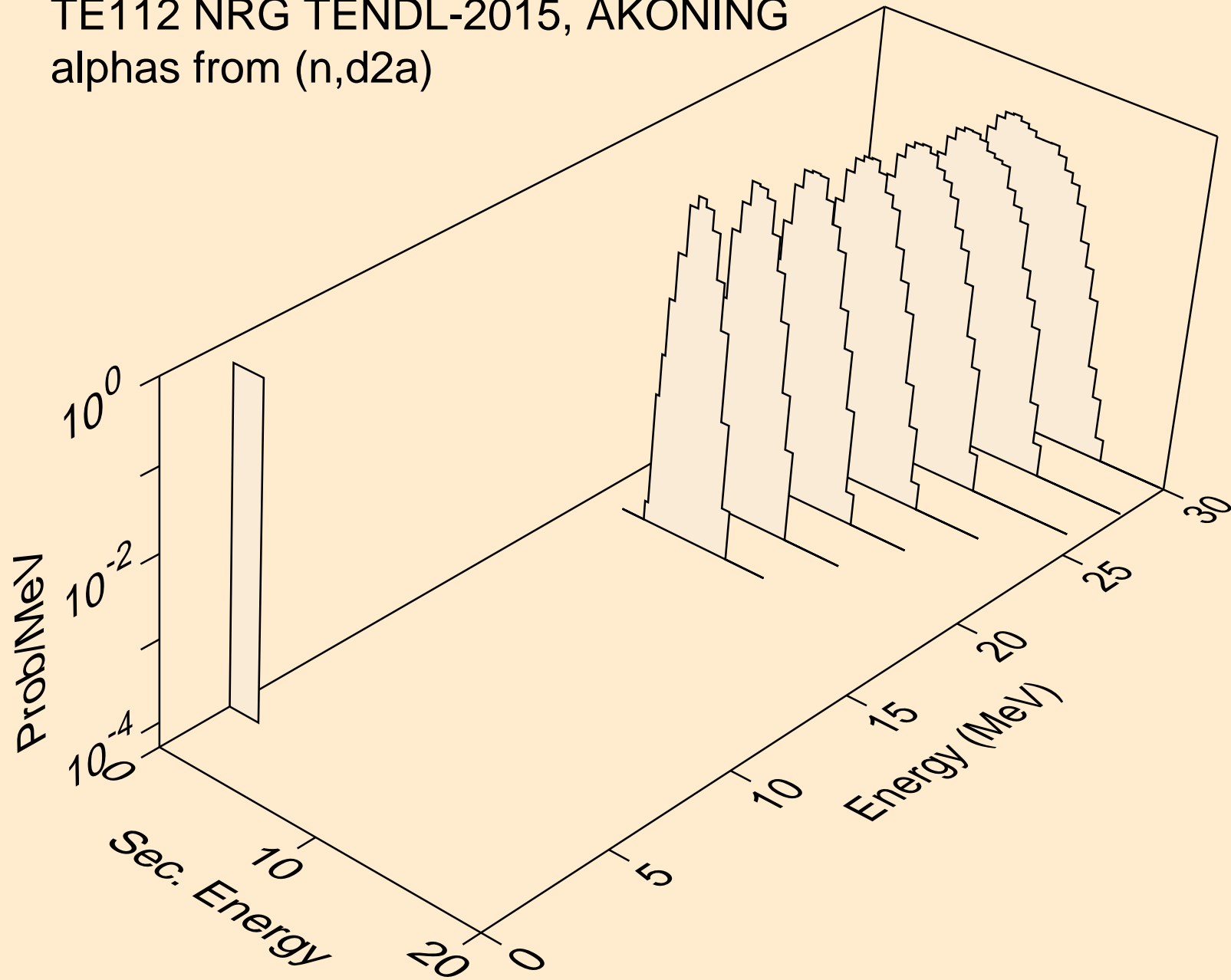

TE112 NRG TENDL-2015, AKONING  
alphas from (n,da)

