

# YB164 NRG TENDL-2015, AKONING

## Principal cross sections

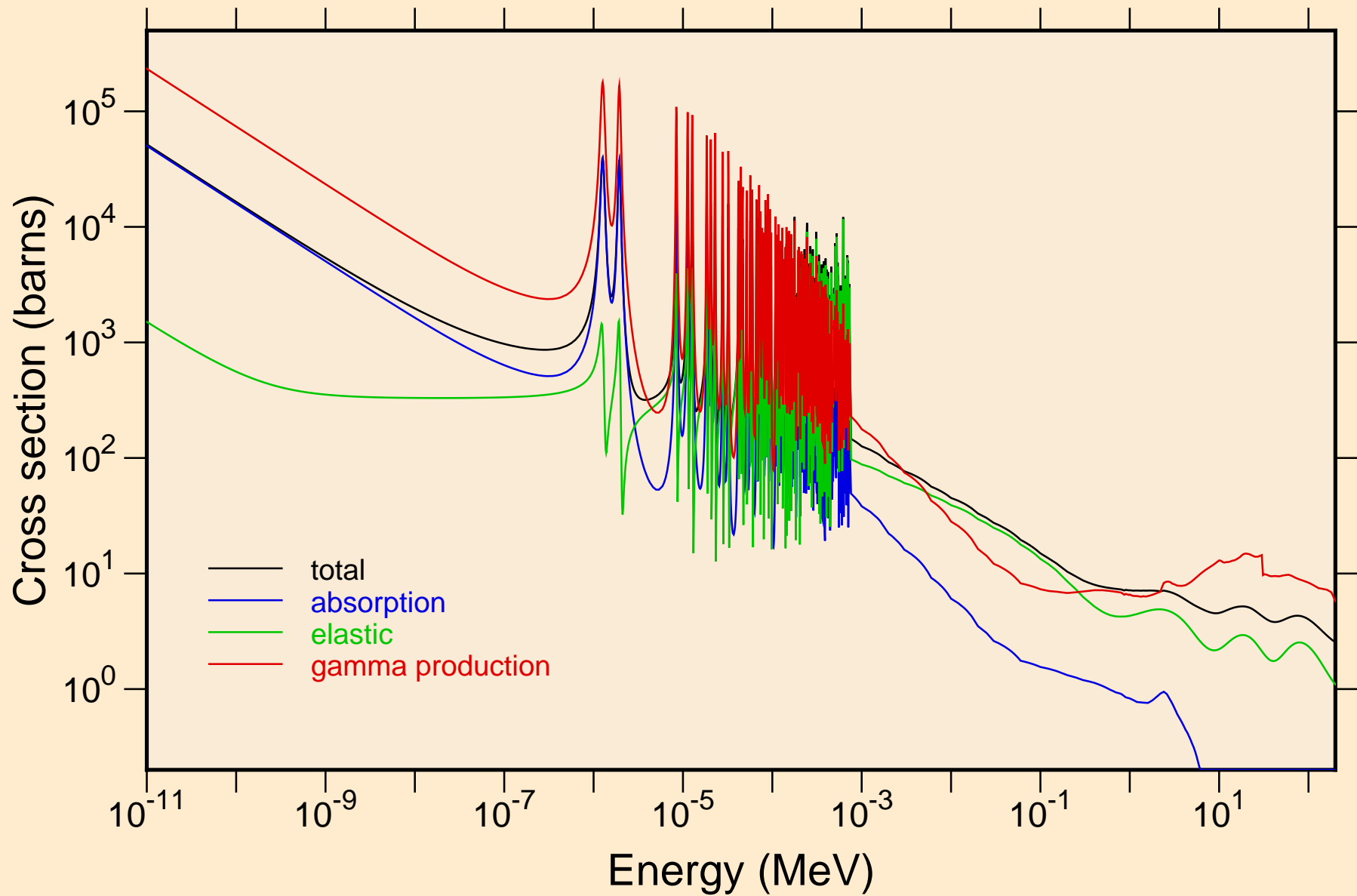

YB164 NRG TENDL-2015, AKONING  
resonance total cross section

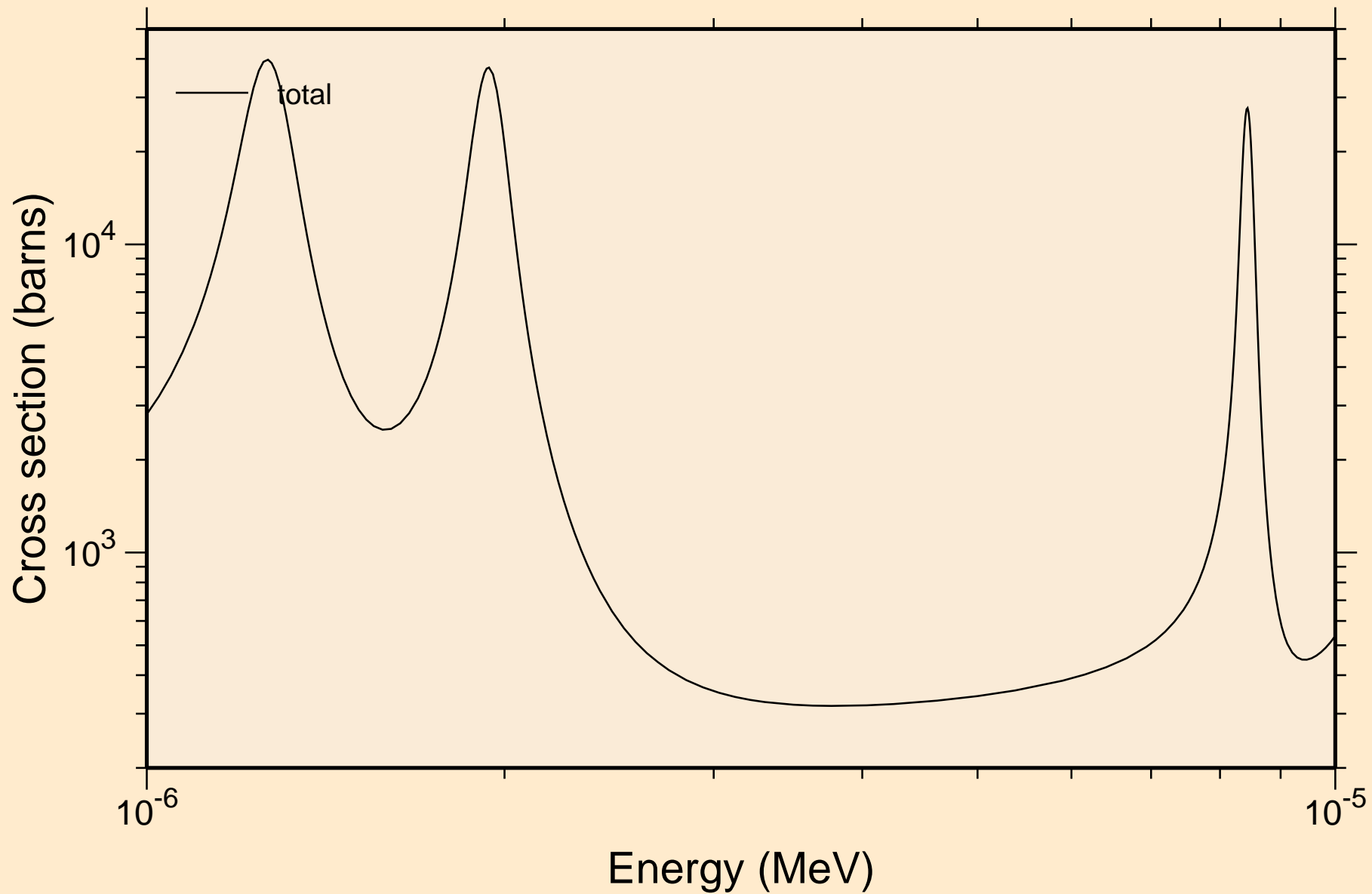

YB164 NRG TENDL-2015, AKONING  
resonance total cross section

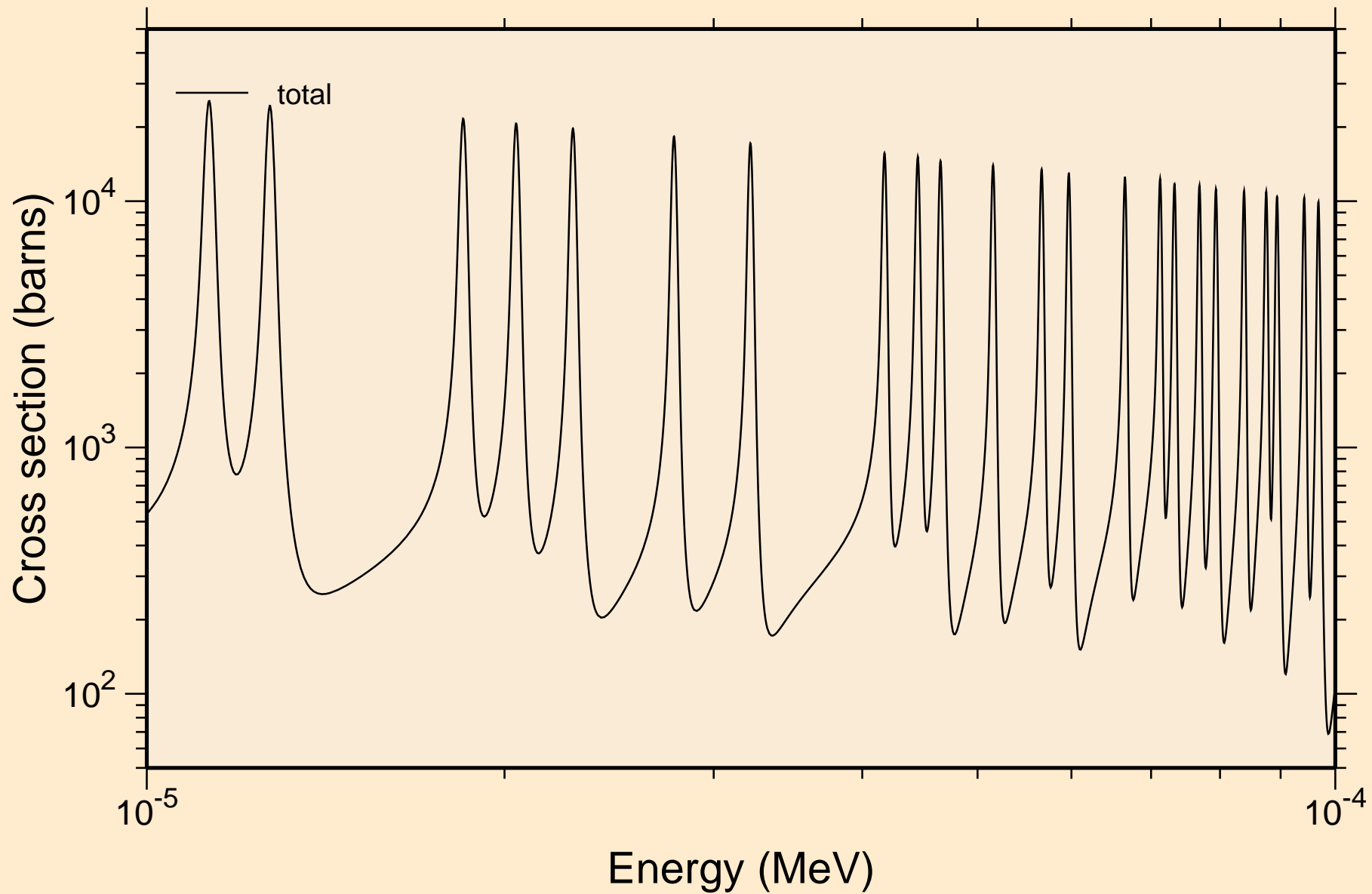

YB164 NRG TENDL-2015, AKONING  
resonance total cross section

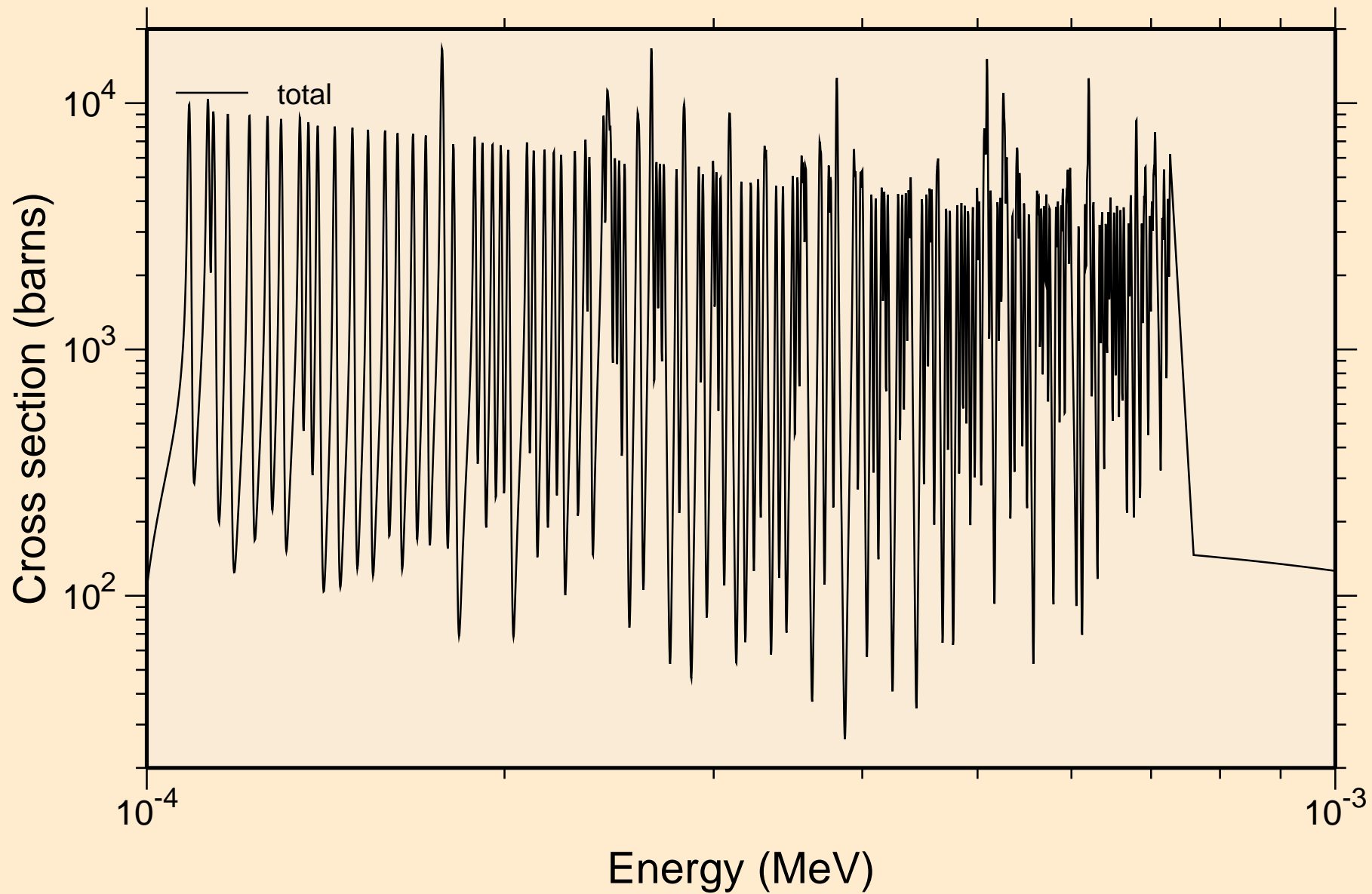

YB164 NRG TENDL-2015, AKONING  
resonance total cross section

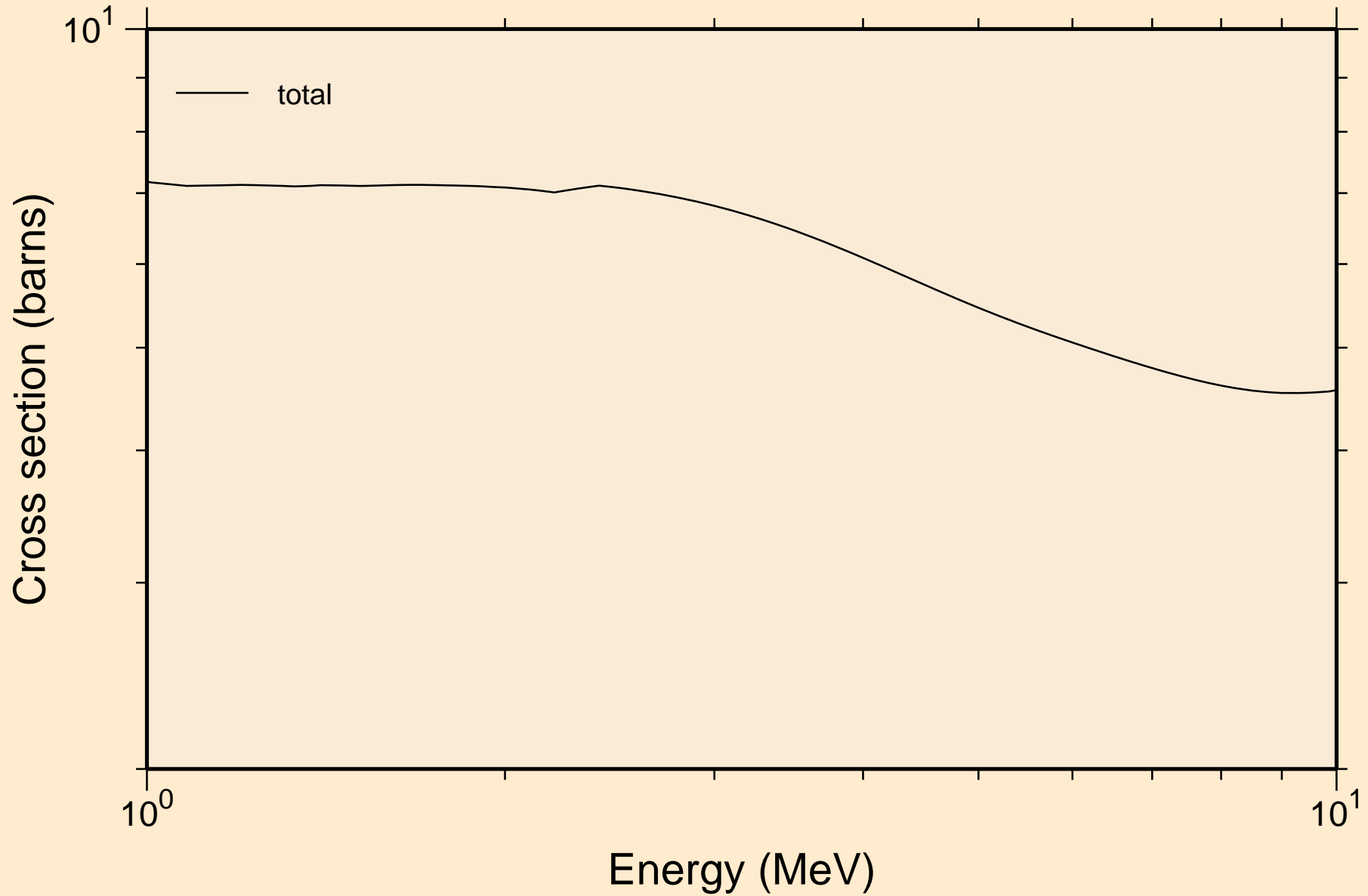

YB164 NRG TENDL-2015, AKONING  
resonance absorption cross sections

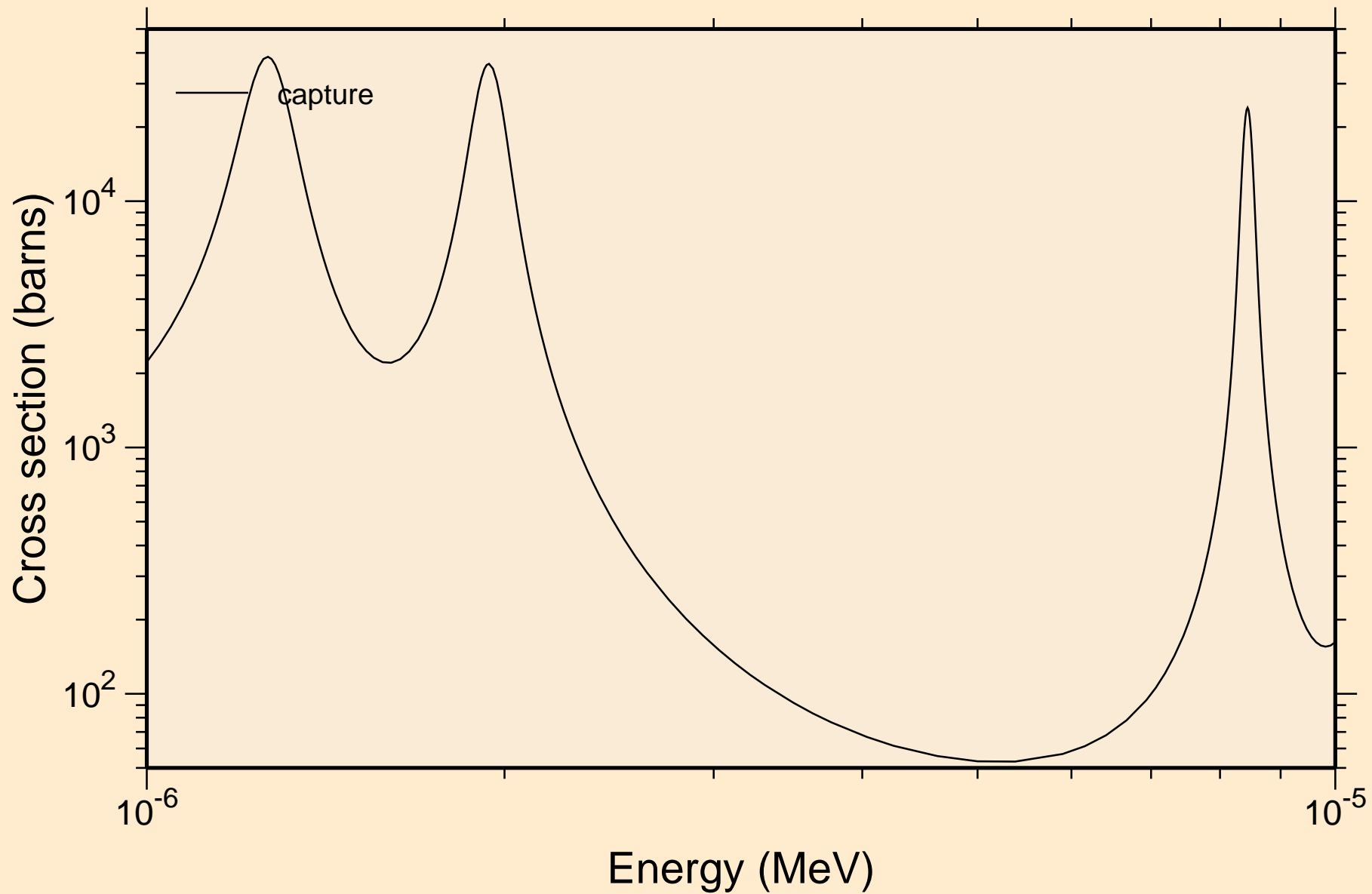

YB164 NRG TENDL-2015, AKONING  
resonance absorption cross sections

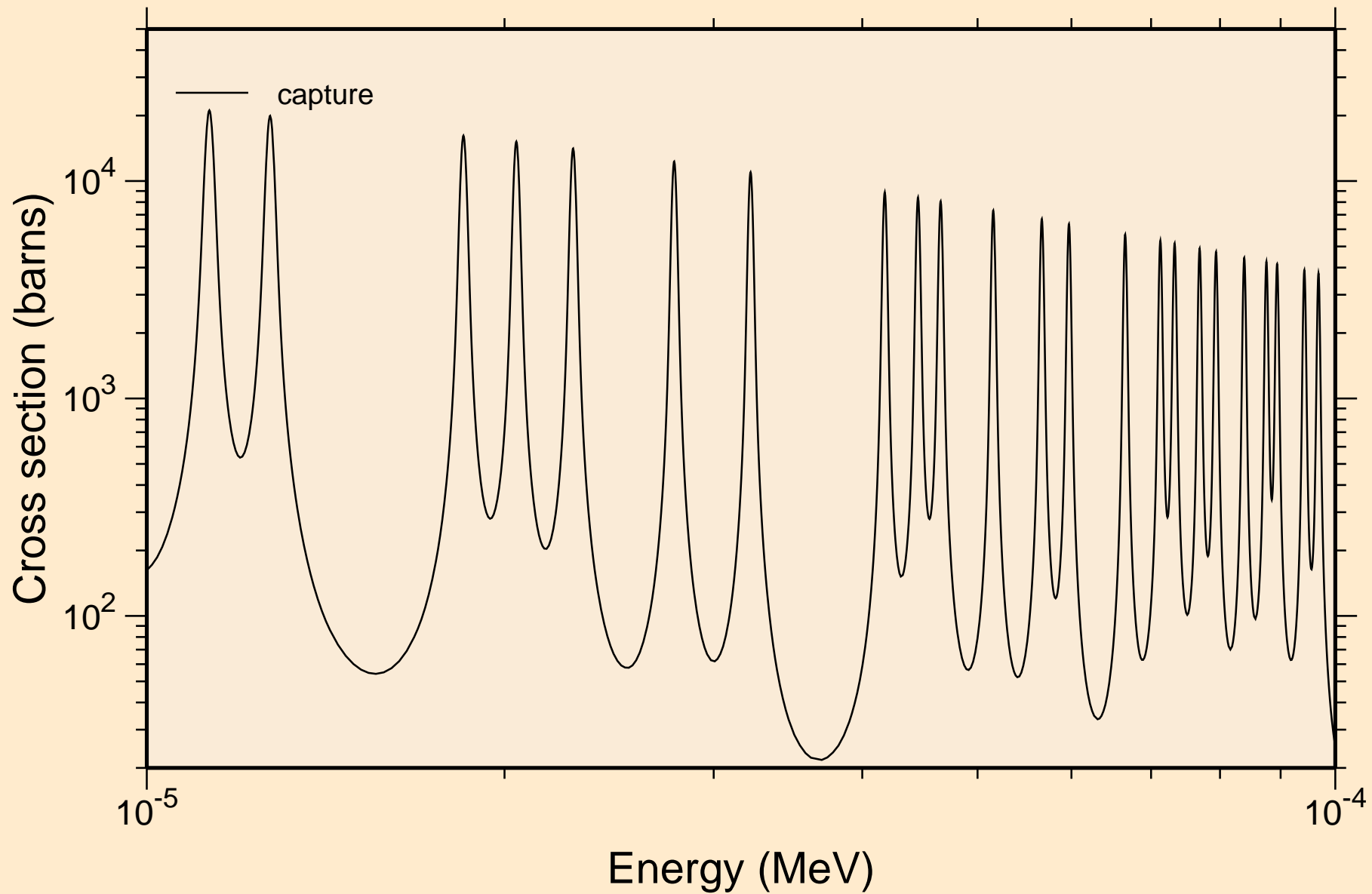

YB164 NRG TENDL-2015, AKONING  
resonance absorption cross sections

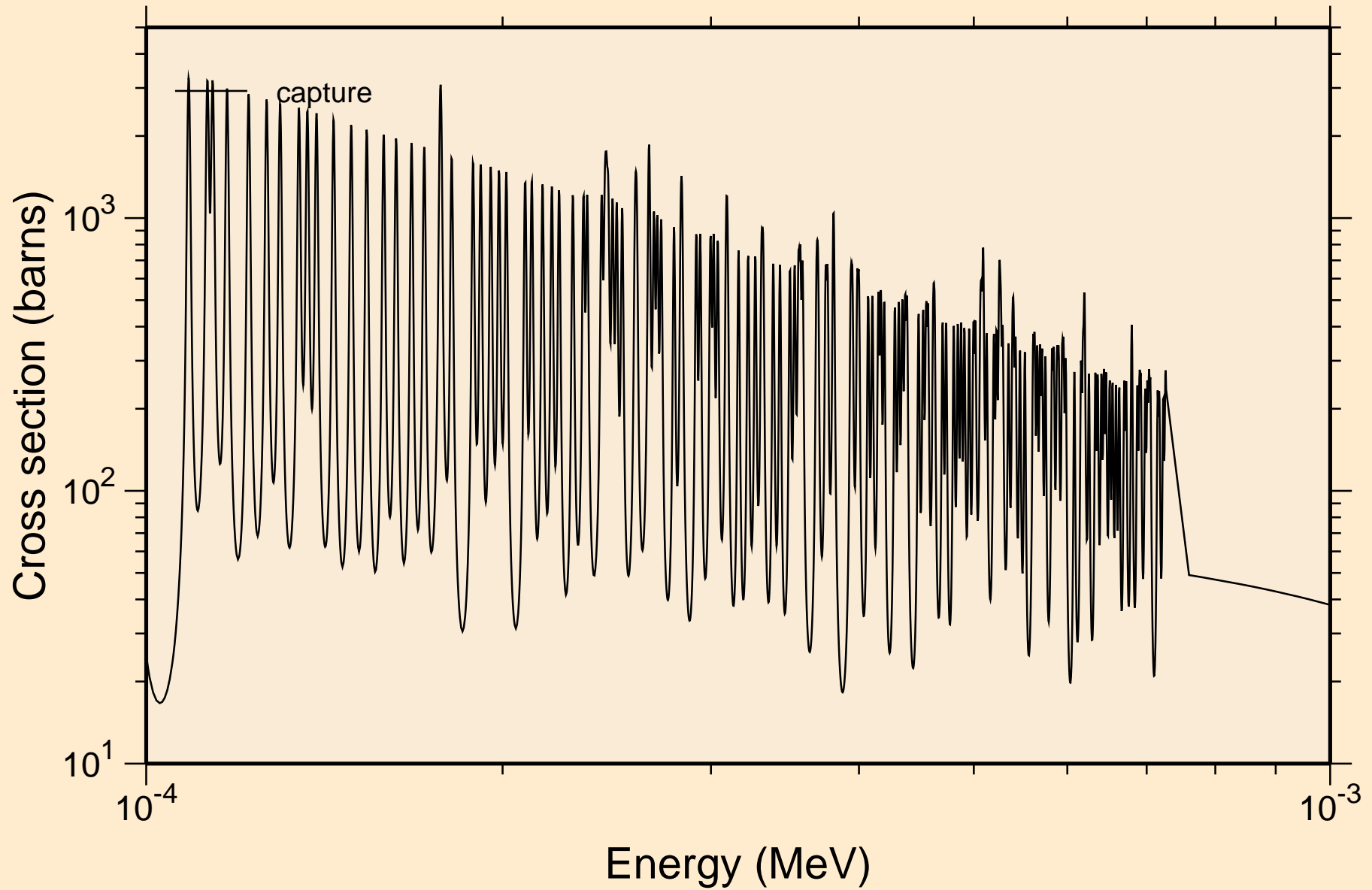



YB164 NRG TENDL-2015, AKONING  
resonance absorption cross sections

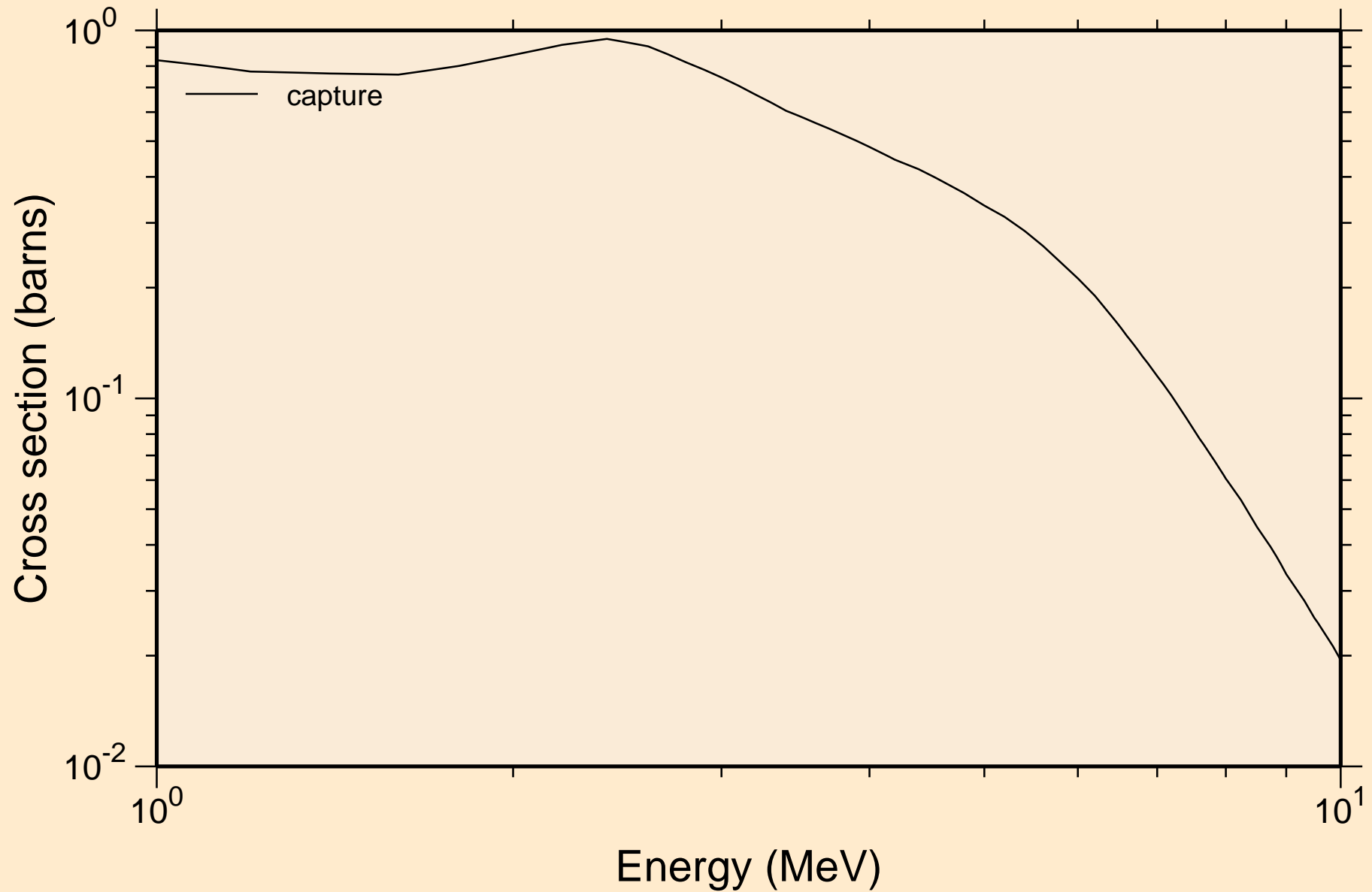

# YB164 NRG TENDL-2015, AKONING

## Non-threshold reactions

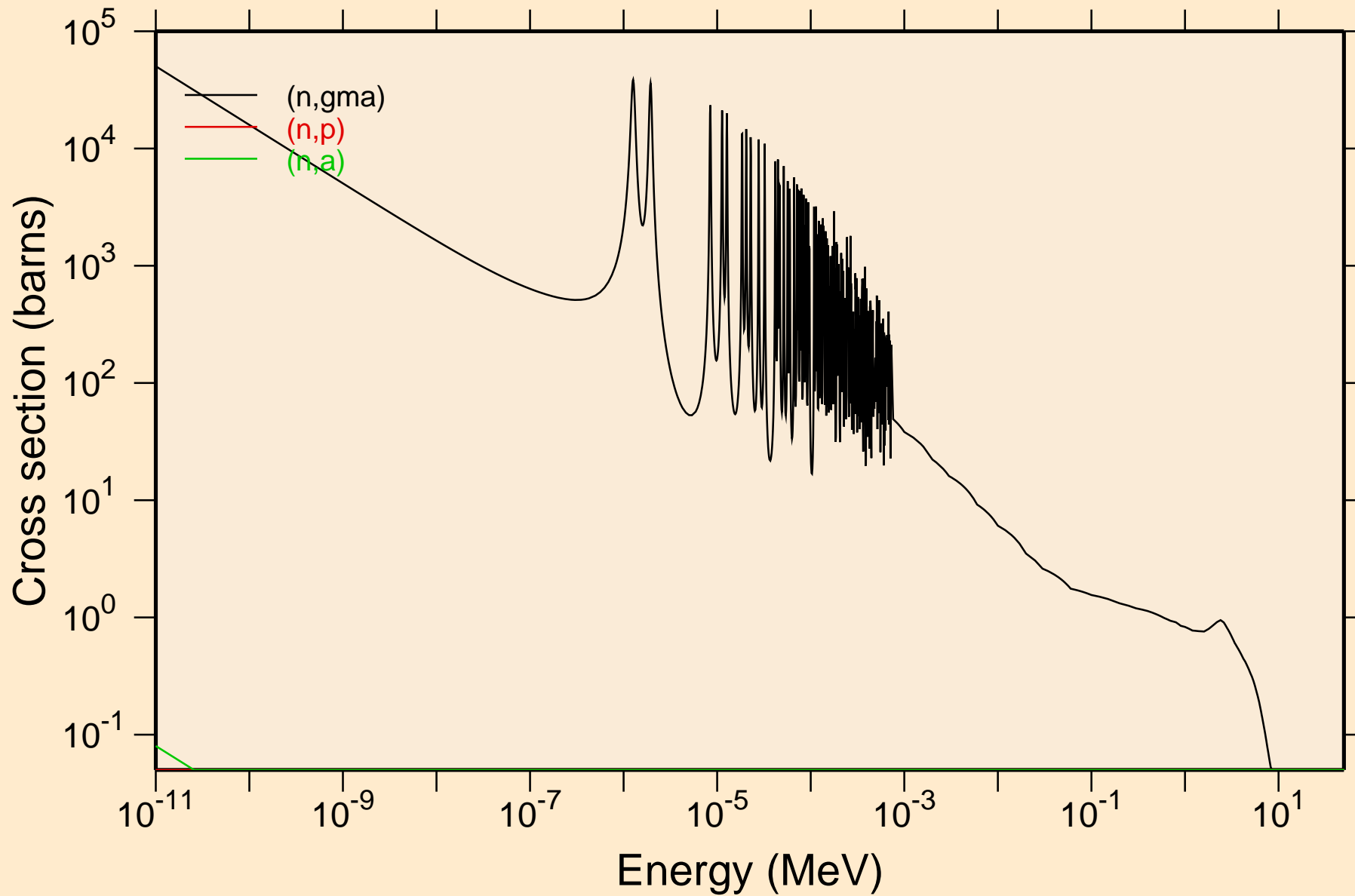

# YB164 NRG TENDL-2015, AKONING

## Principal cross sections

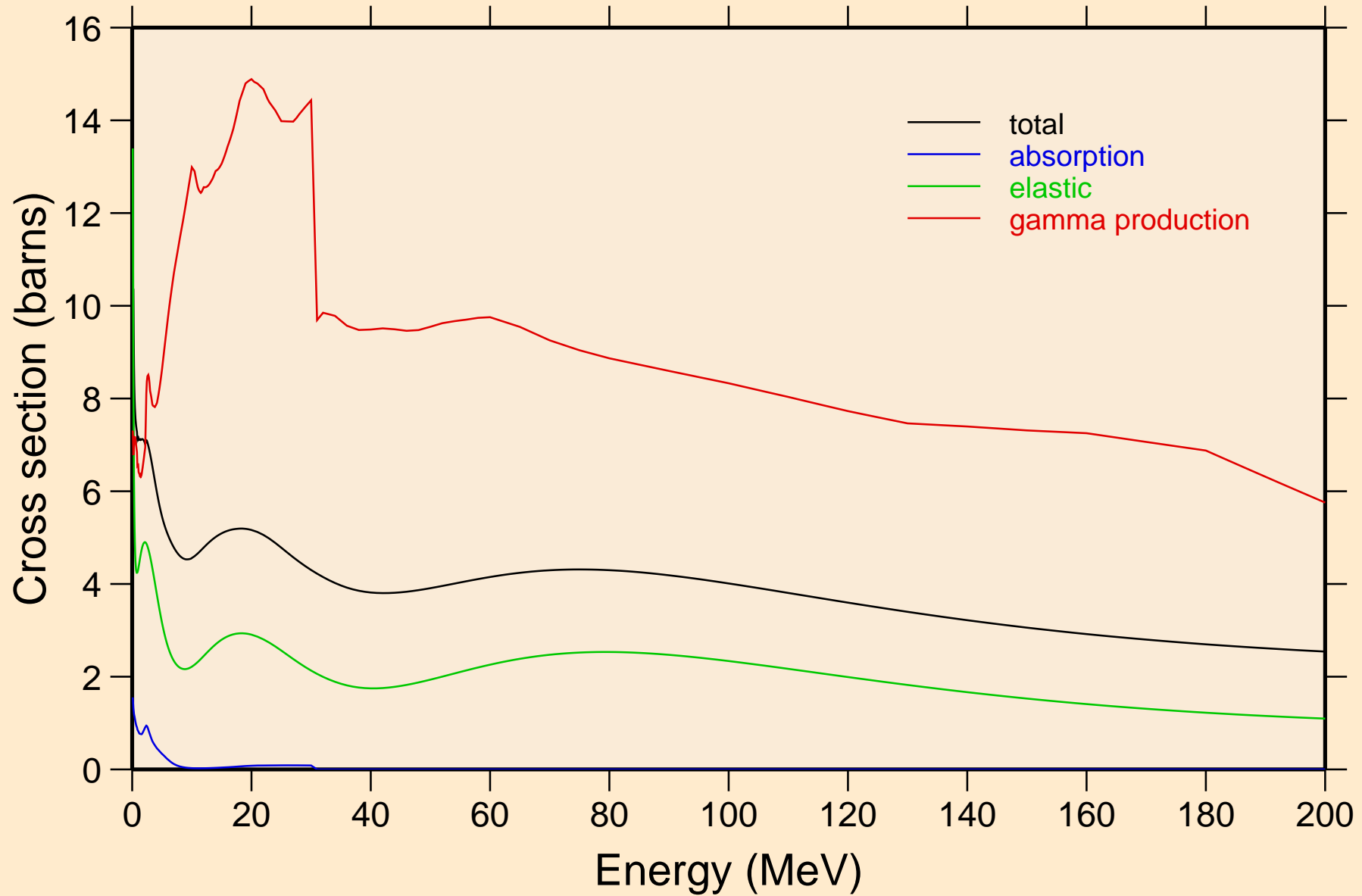

# YB164 NRG TENDL-2015, AKONING

## Non-threshold reactions

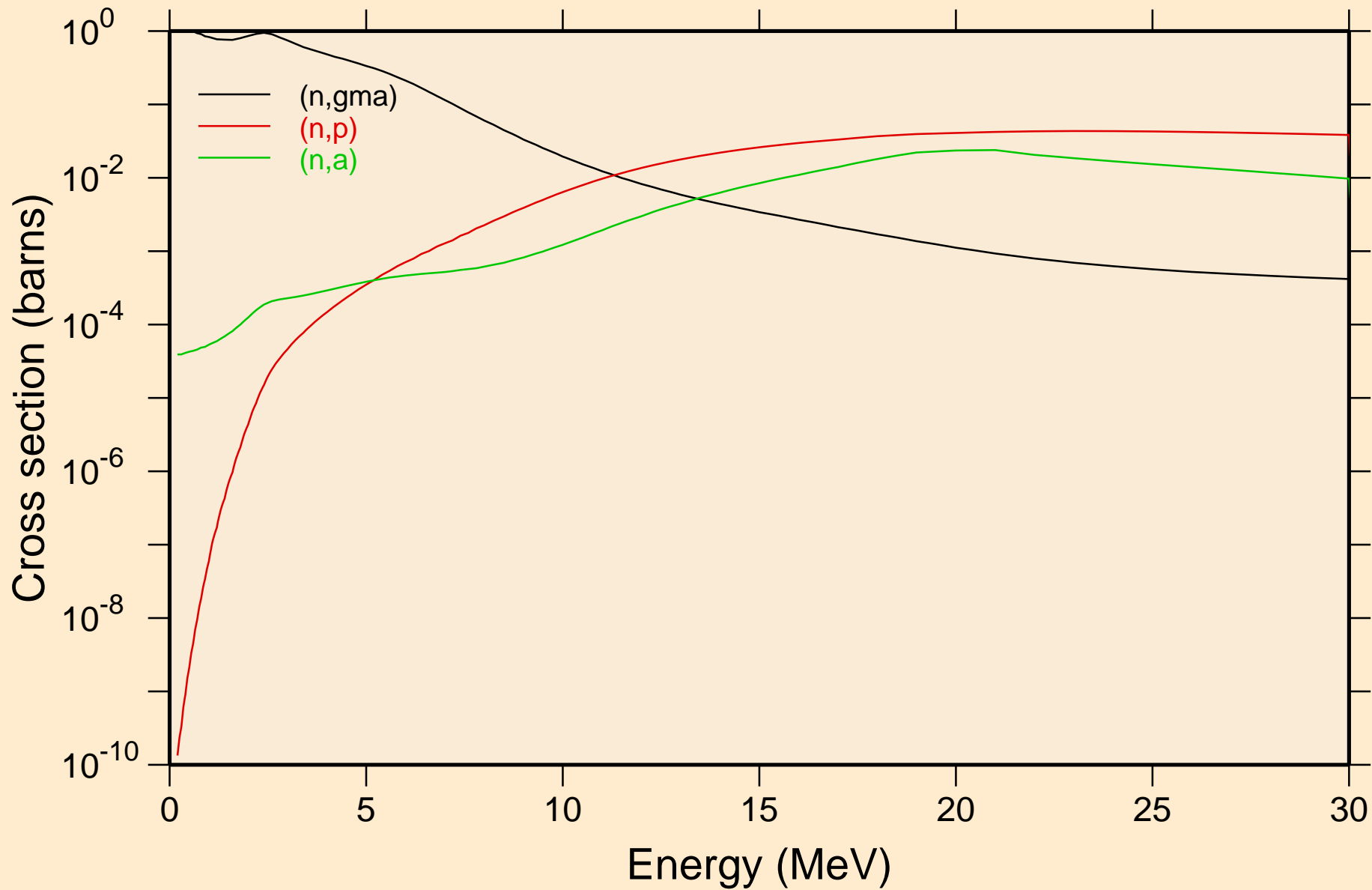

# YB164 NRG TENDL-2015, AKONING

## Inelastic levels

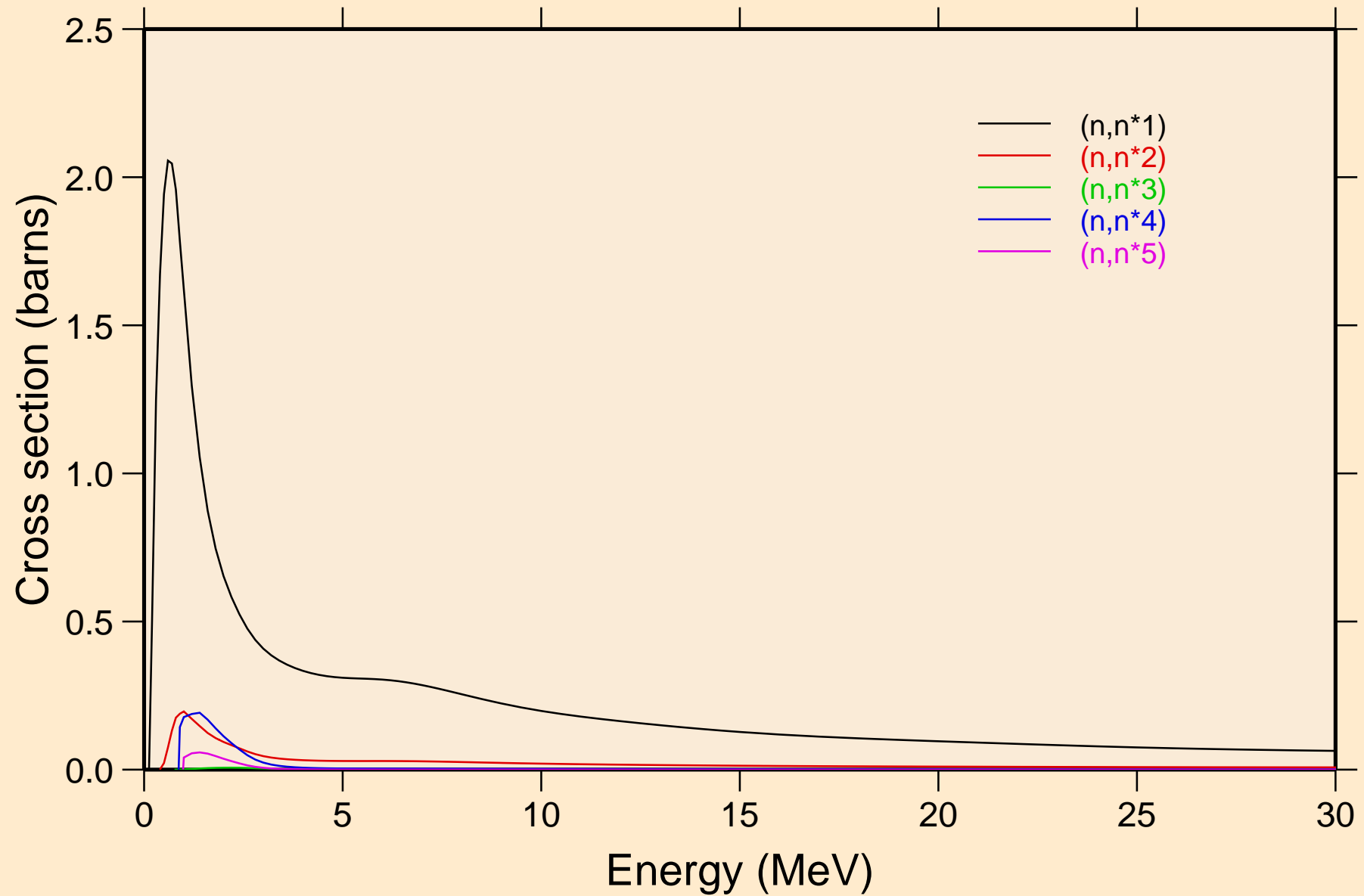

# YB164 NRG TENDL-2015, AKONING

## Inelastic levels

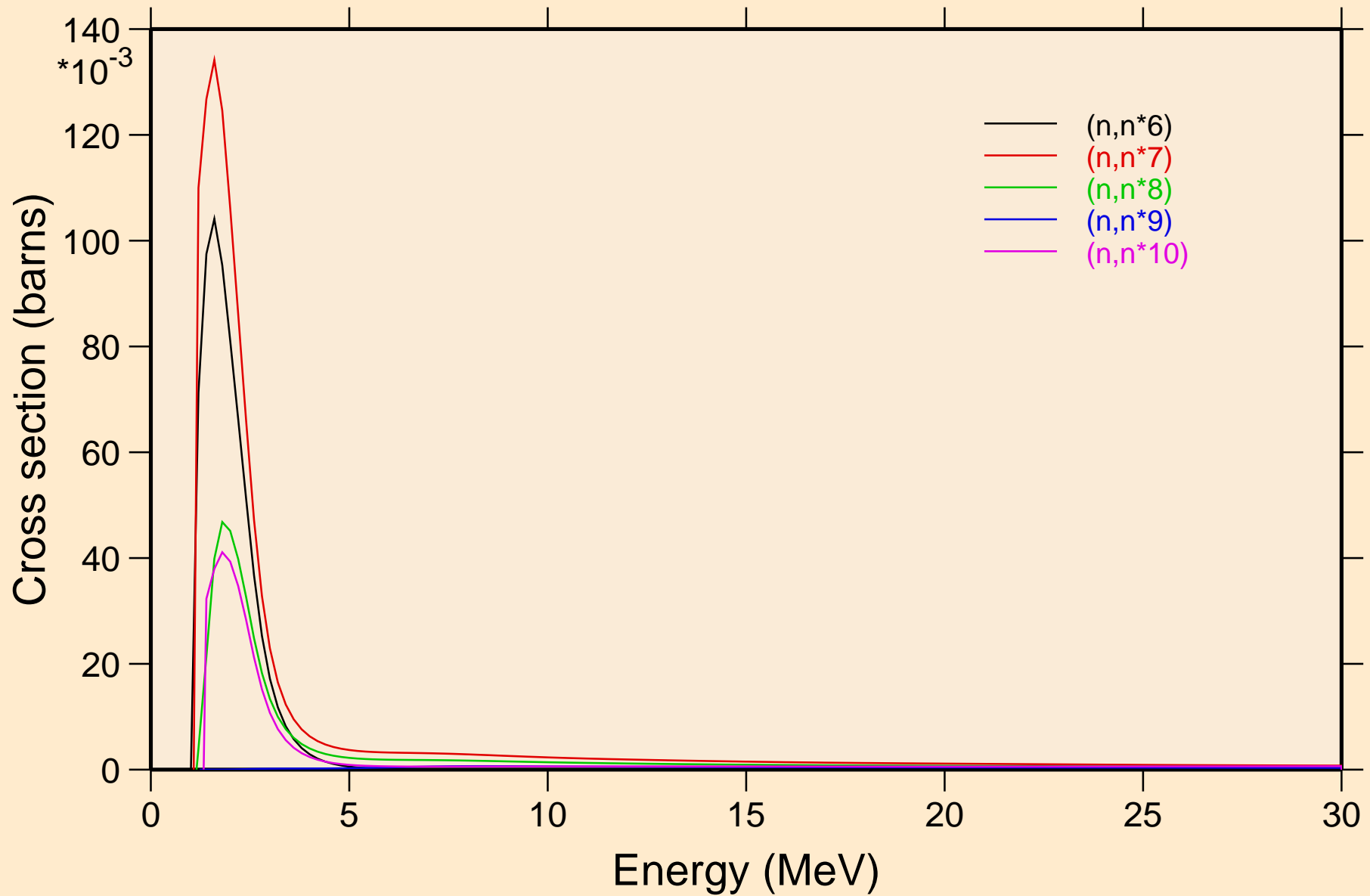

# YB164 NRG TENDL-2015, AKONING

## Inelastic levels

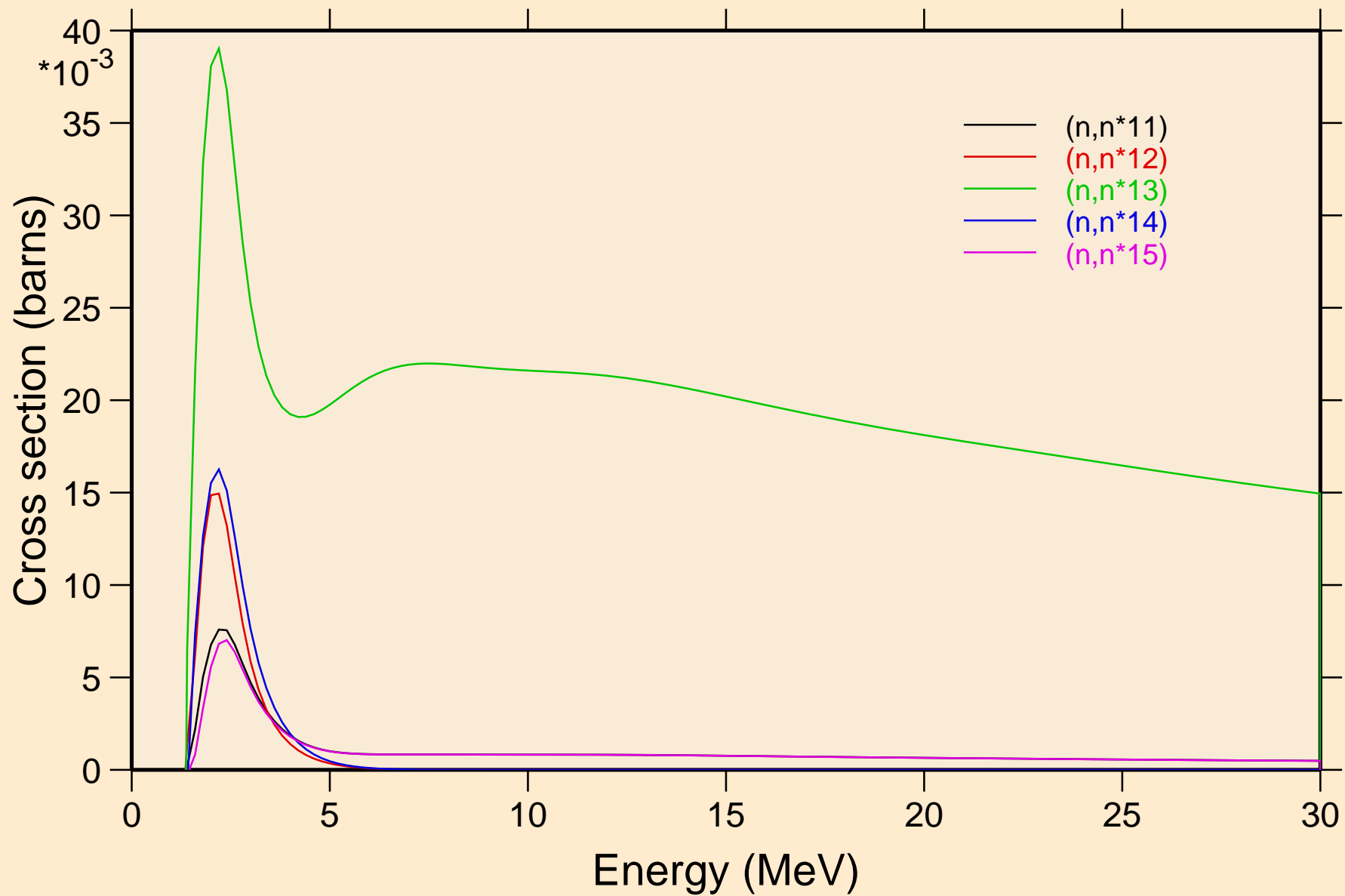

# YB164 NRG TENDL-2015, AKONING

## Inelastic levels

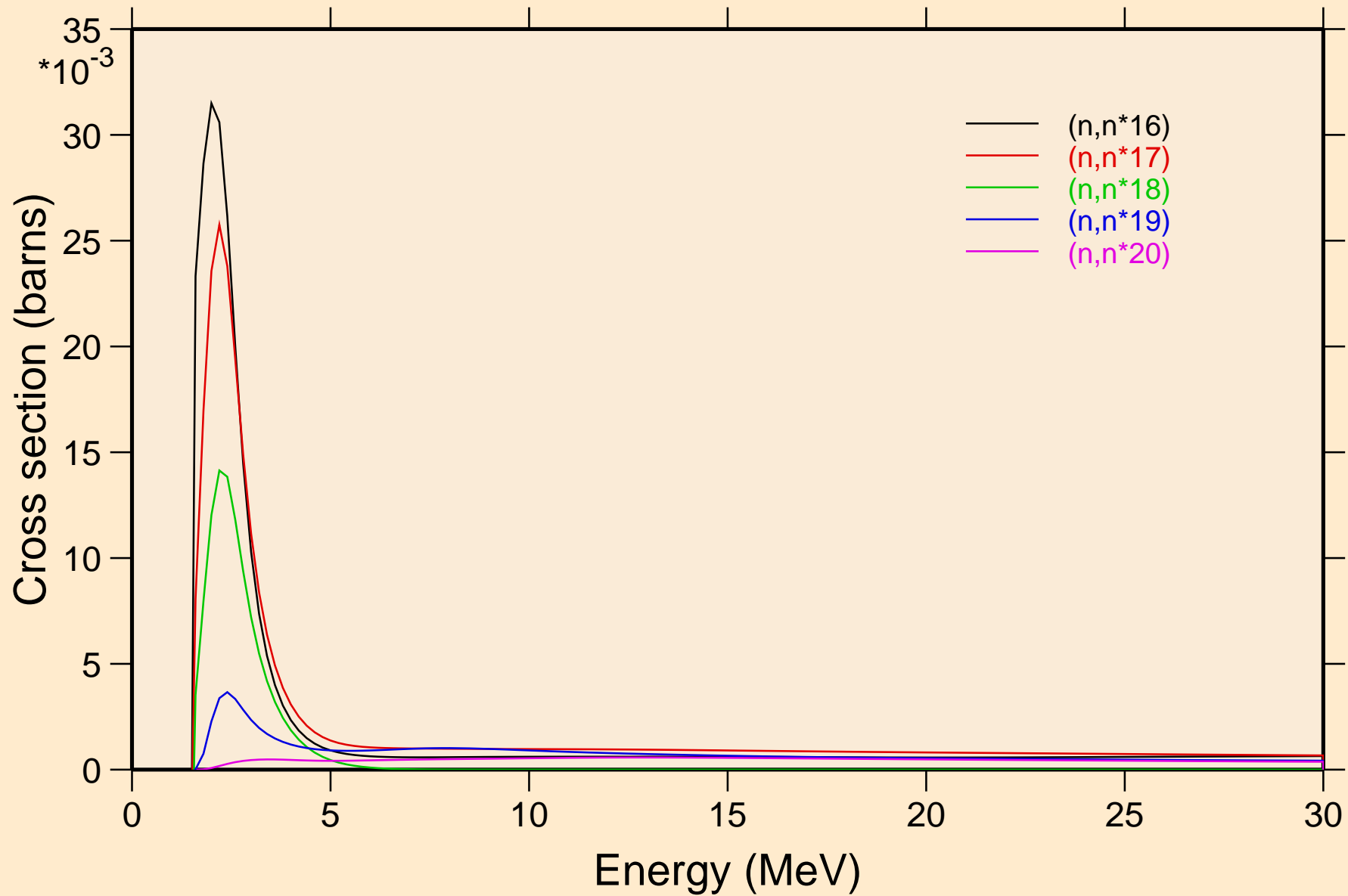



# YB164 NRG TENDL-2015, AKONING

## Inelastic levels

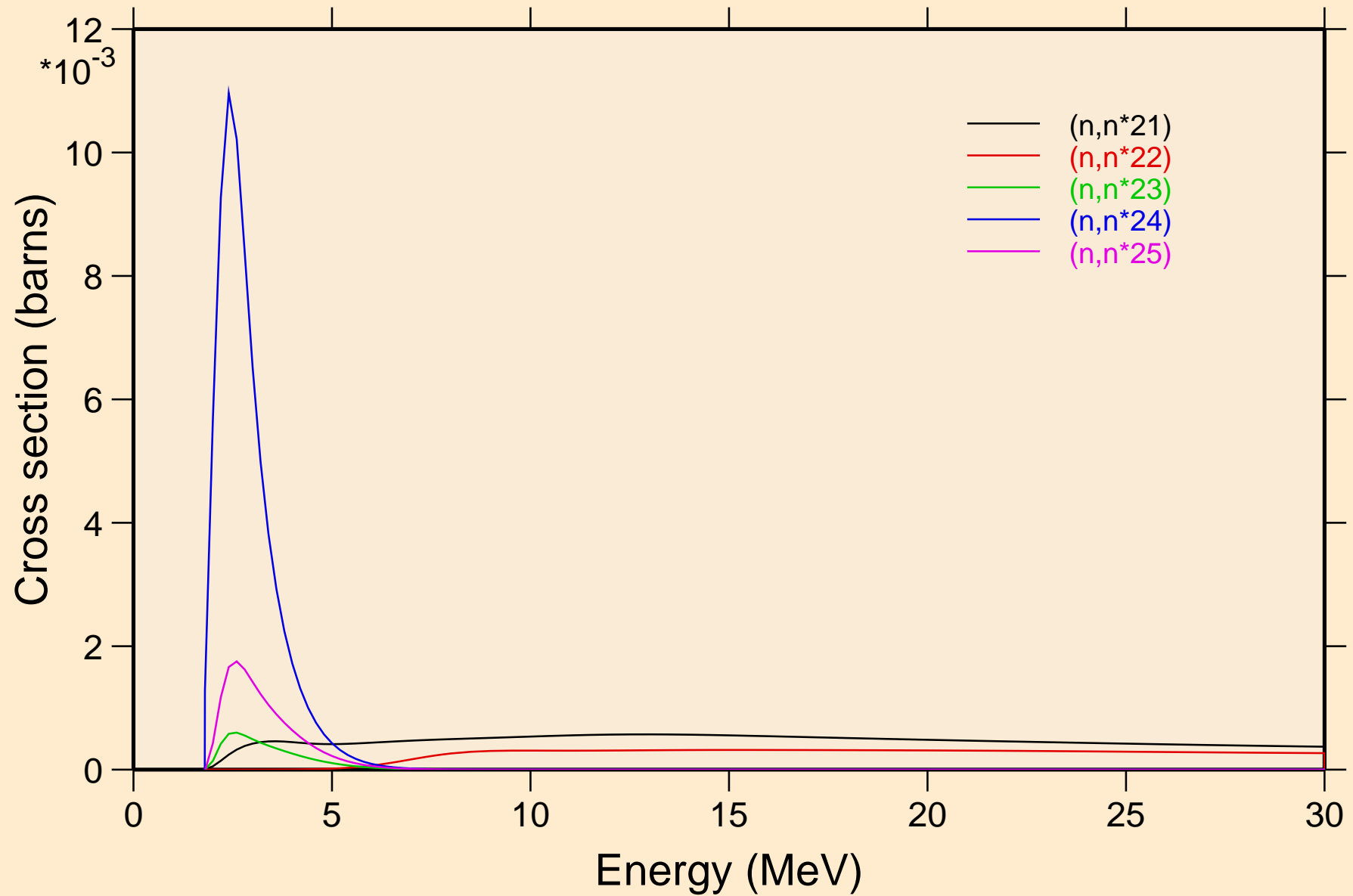

# YB164 NRG TENDL-2015, AKONING

## Inelastic levels

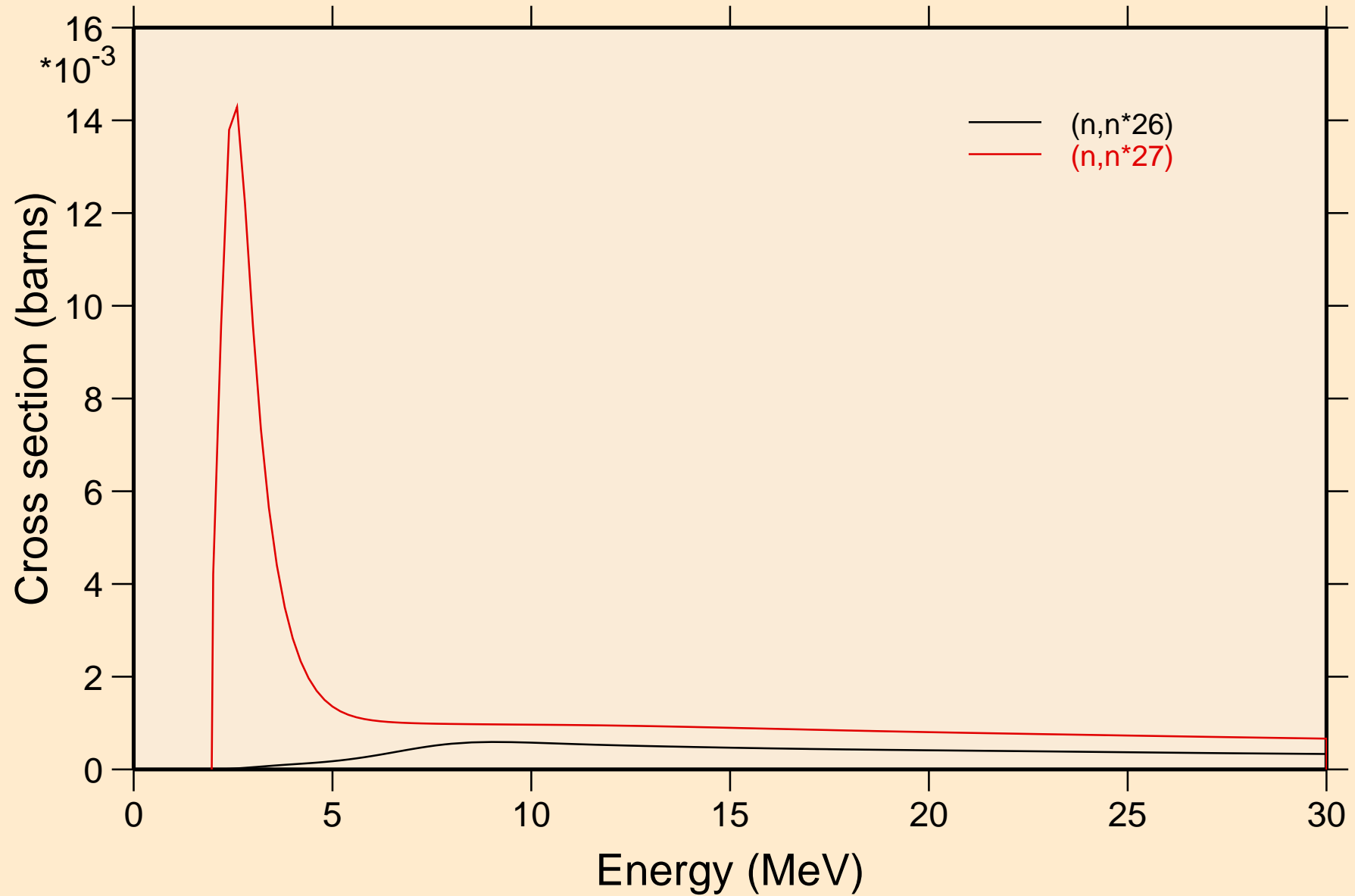

# YB164 NRG TENDL-2015, AKONING

## Threshold reactions

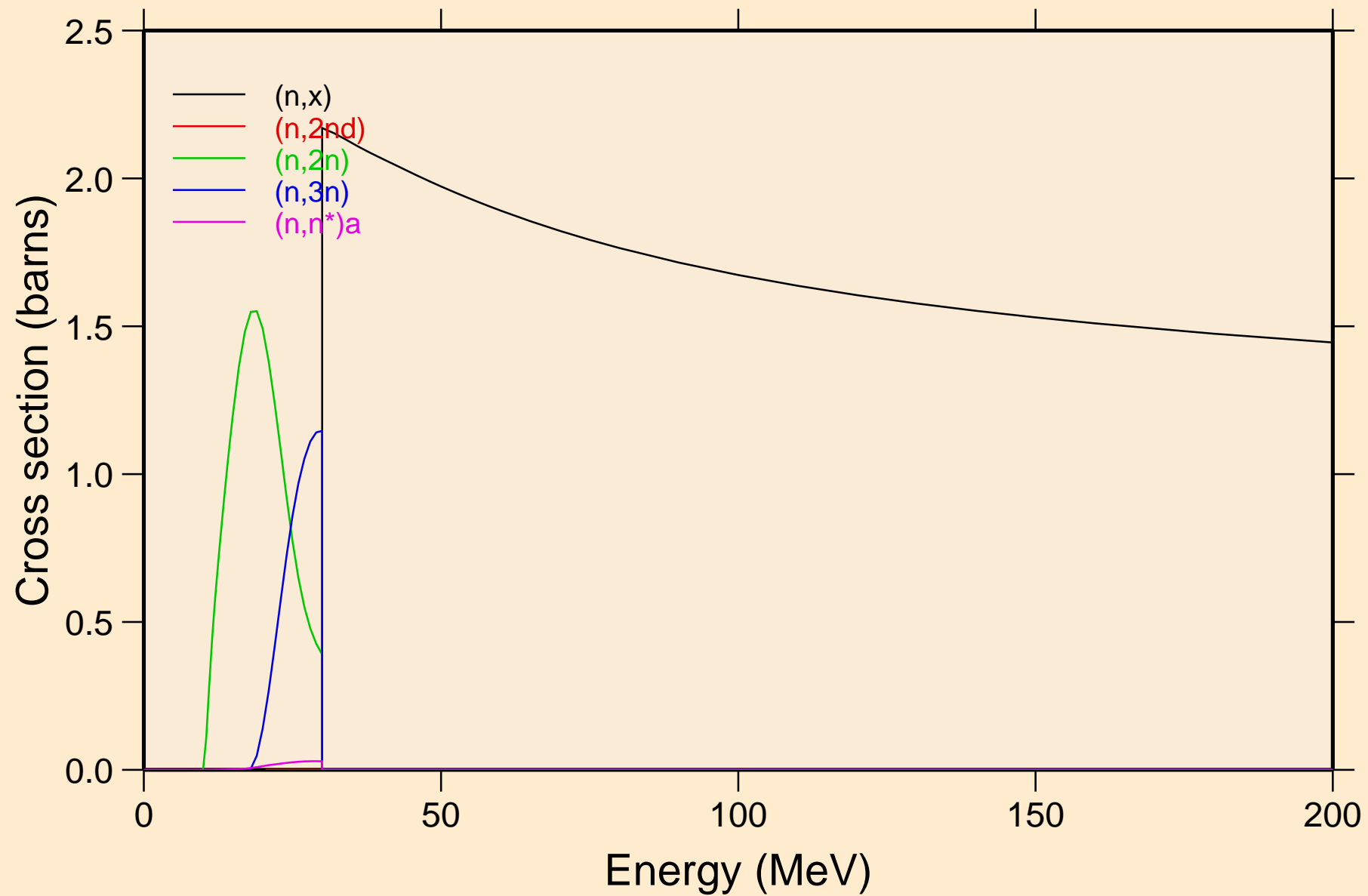

# YB164 NRG TENDL-2015, AKONING

## Threshold reactions

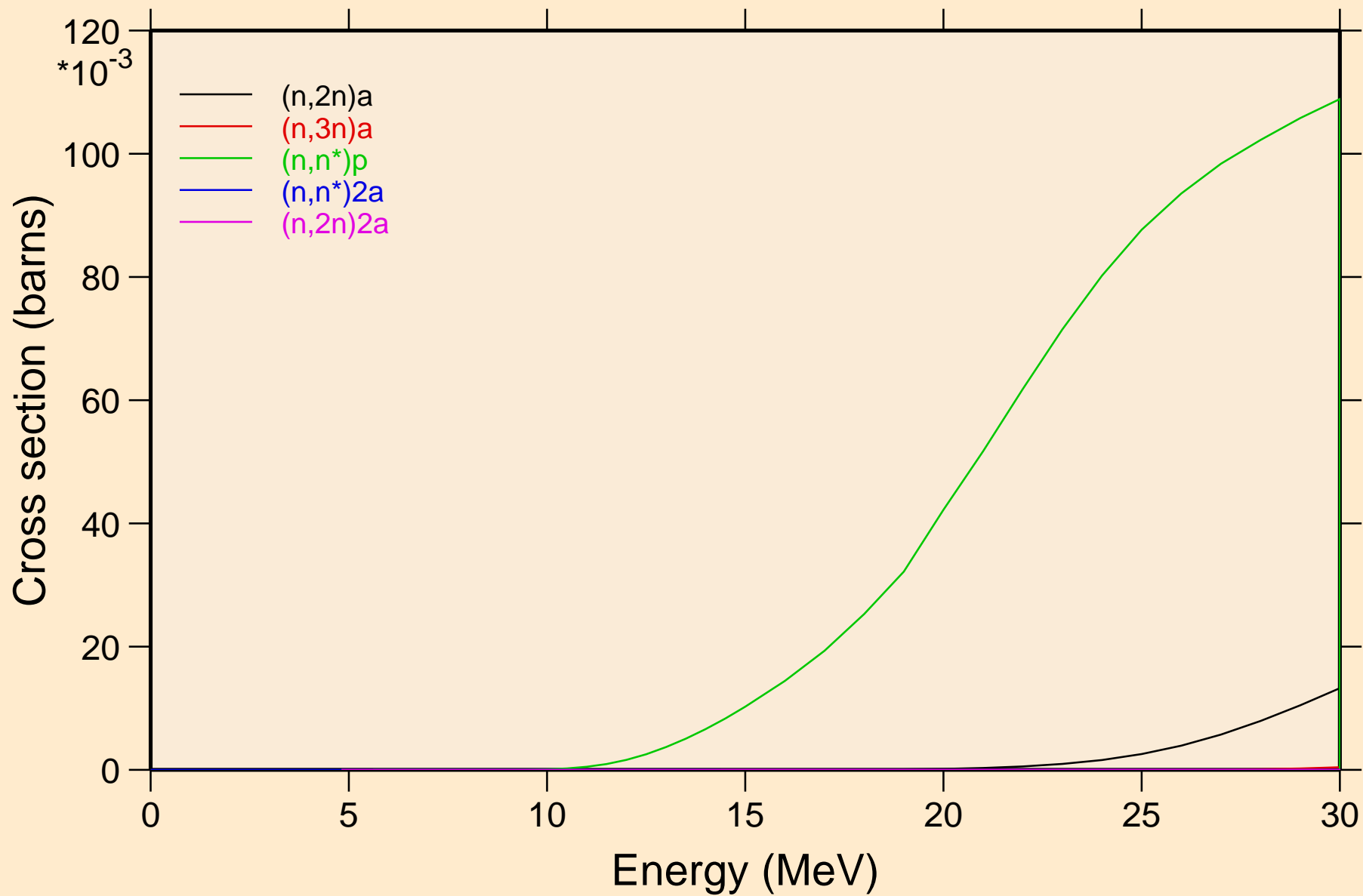

# YB164 NRG TENDL-2015, AKONING

## Threshold reactions

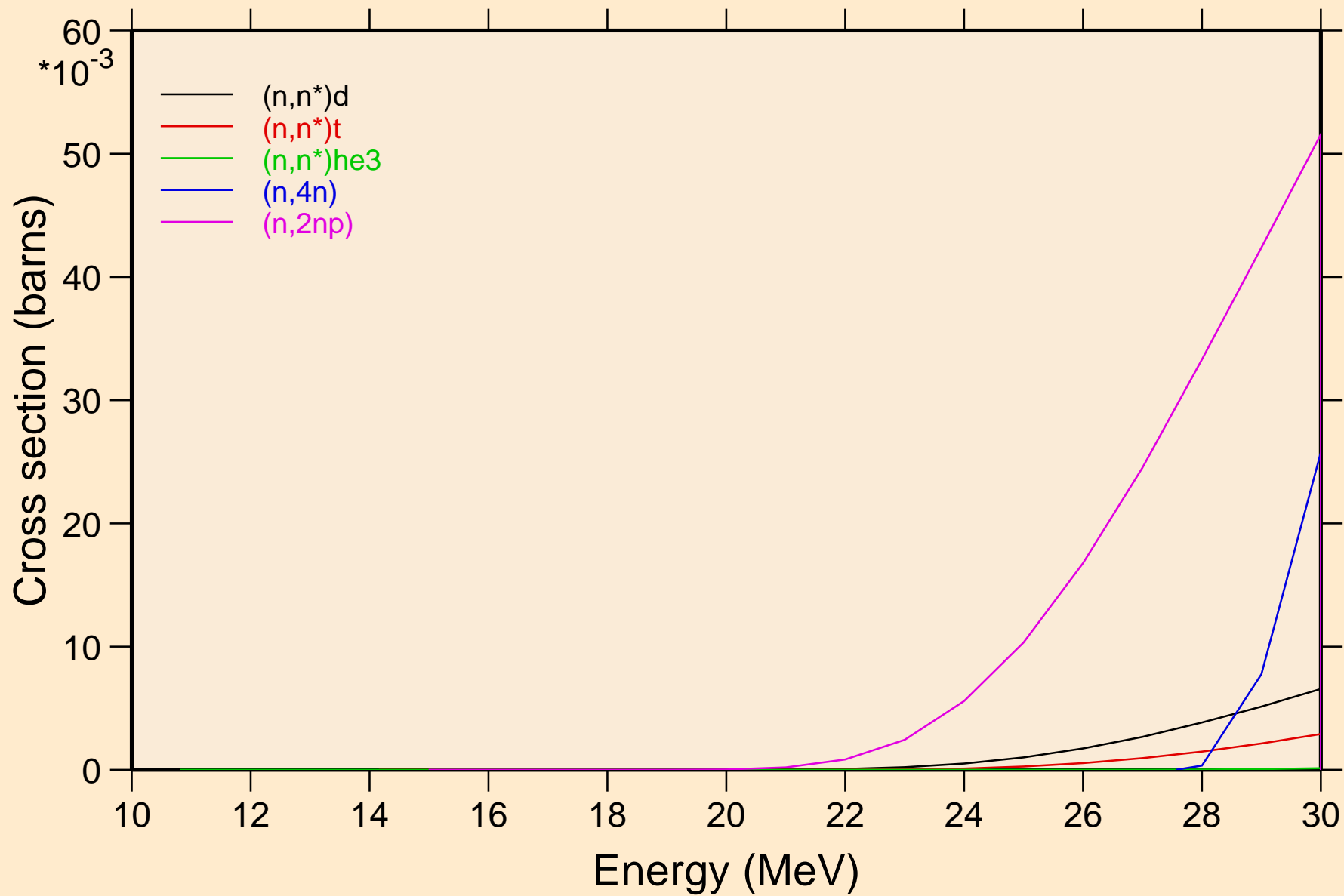

# YB164 NRG TENDL-2015, AKONING

## Threshold reactions

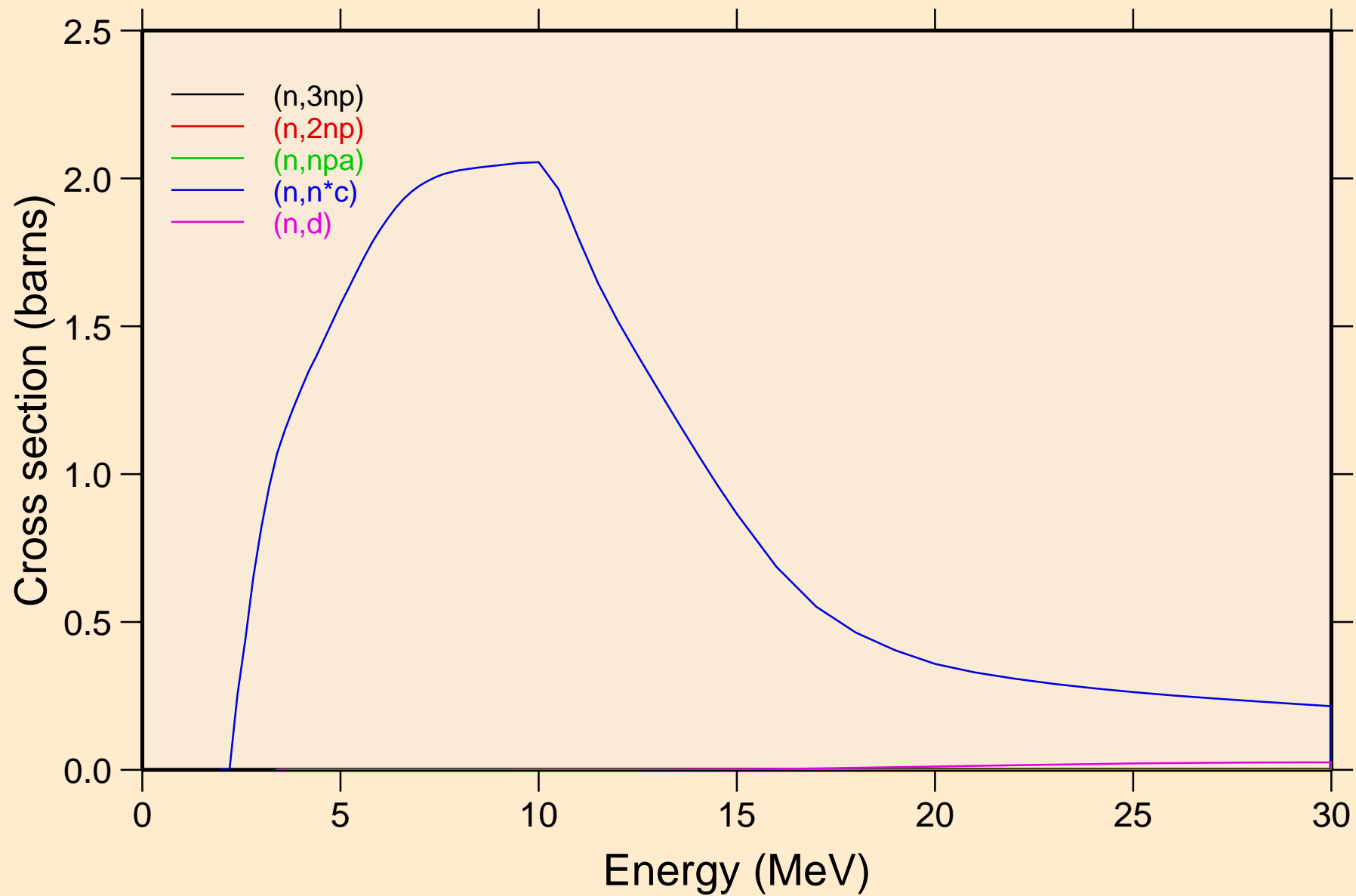

# YB164 NRG TENDL-2015, AKONING

## Threshold reactions

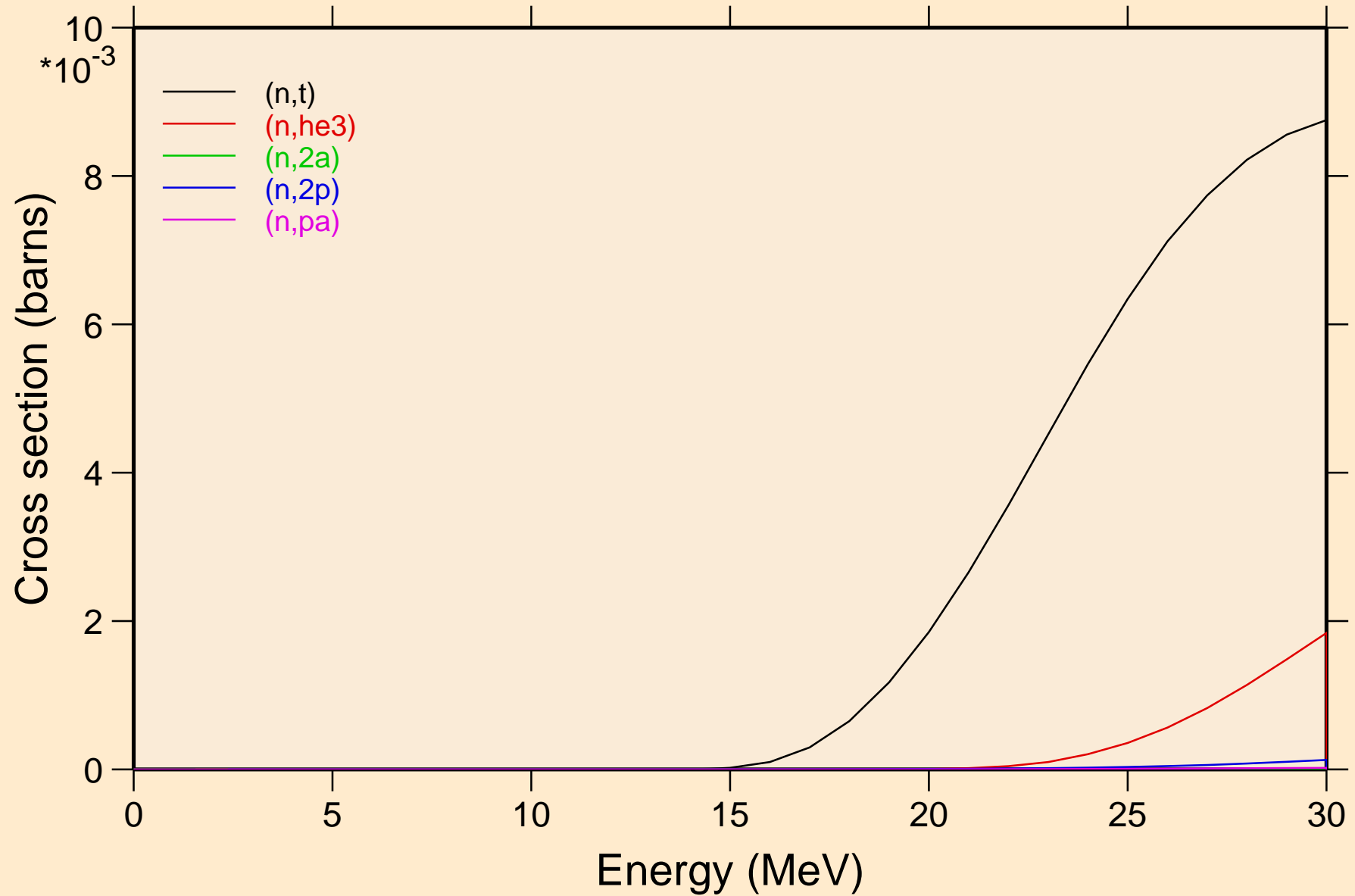

# YB164 NRG TENDL-2015, AKONING

## Threshold reactions

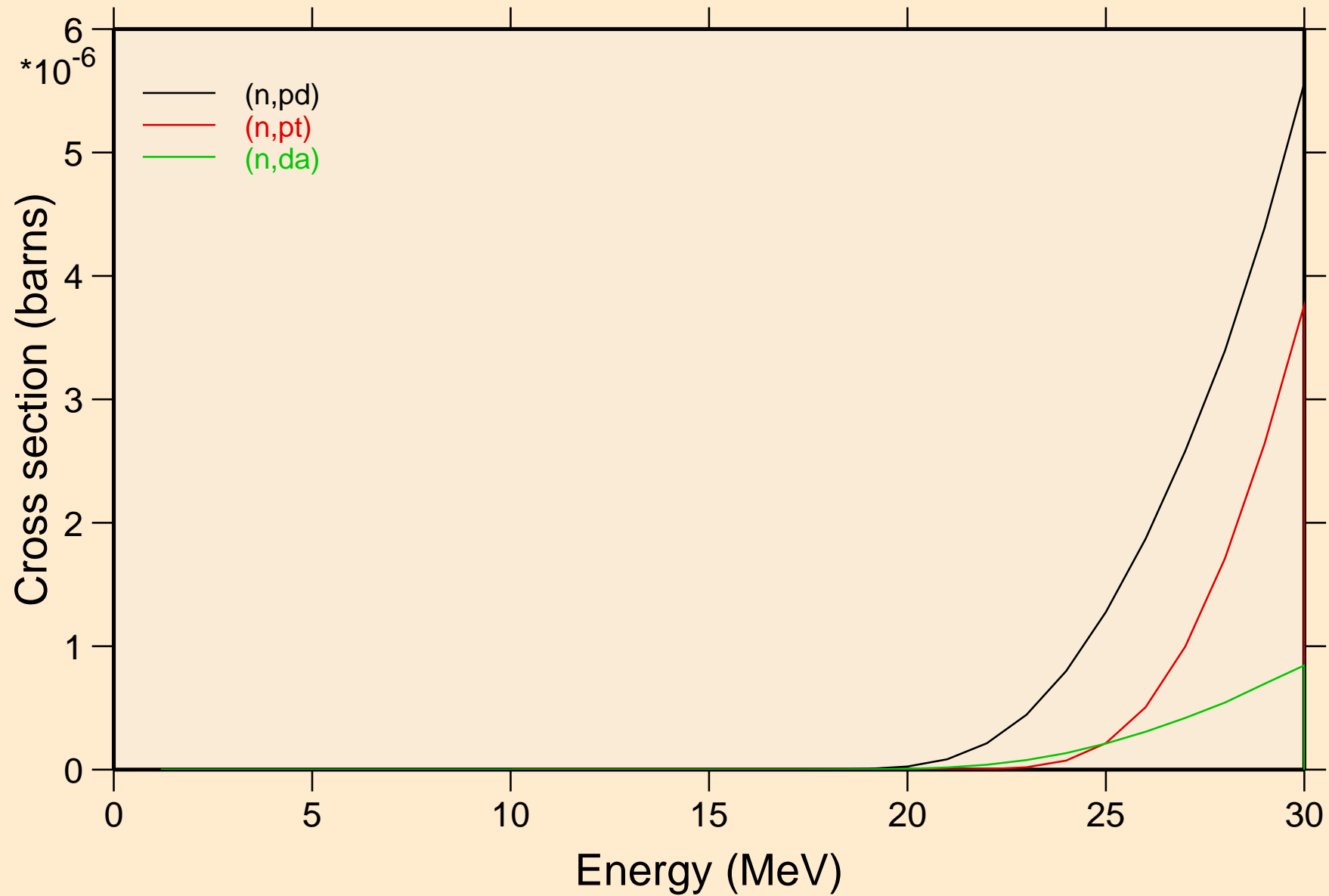



YB164 NRG TENDL-2015, AKONING  
angular distribution for elastic

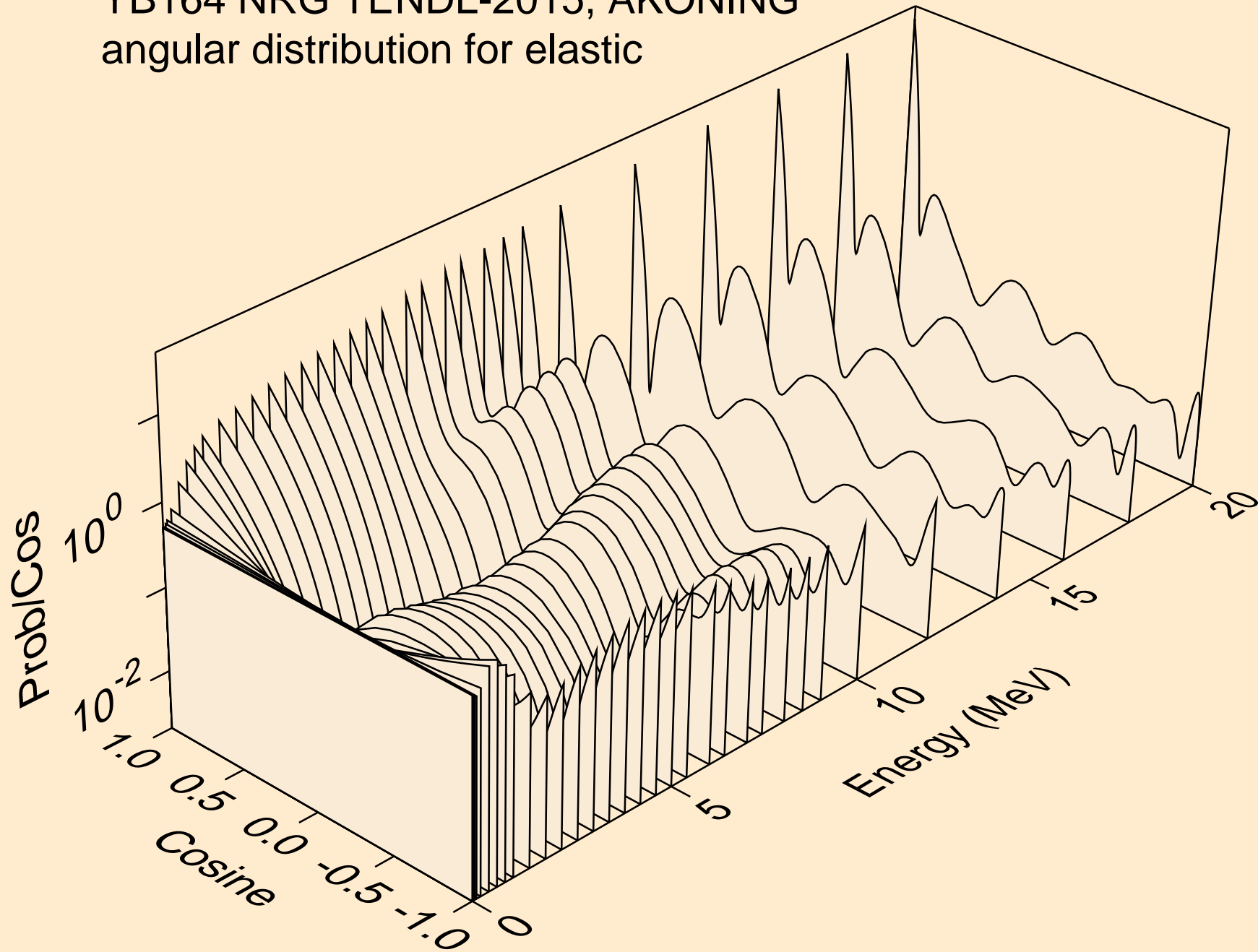

YB164 NRG TENDL-2015, AKONING  
angular distribution for elastic

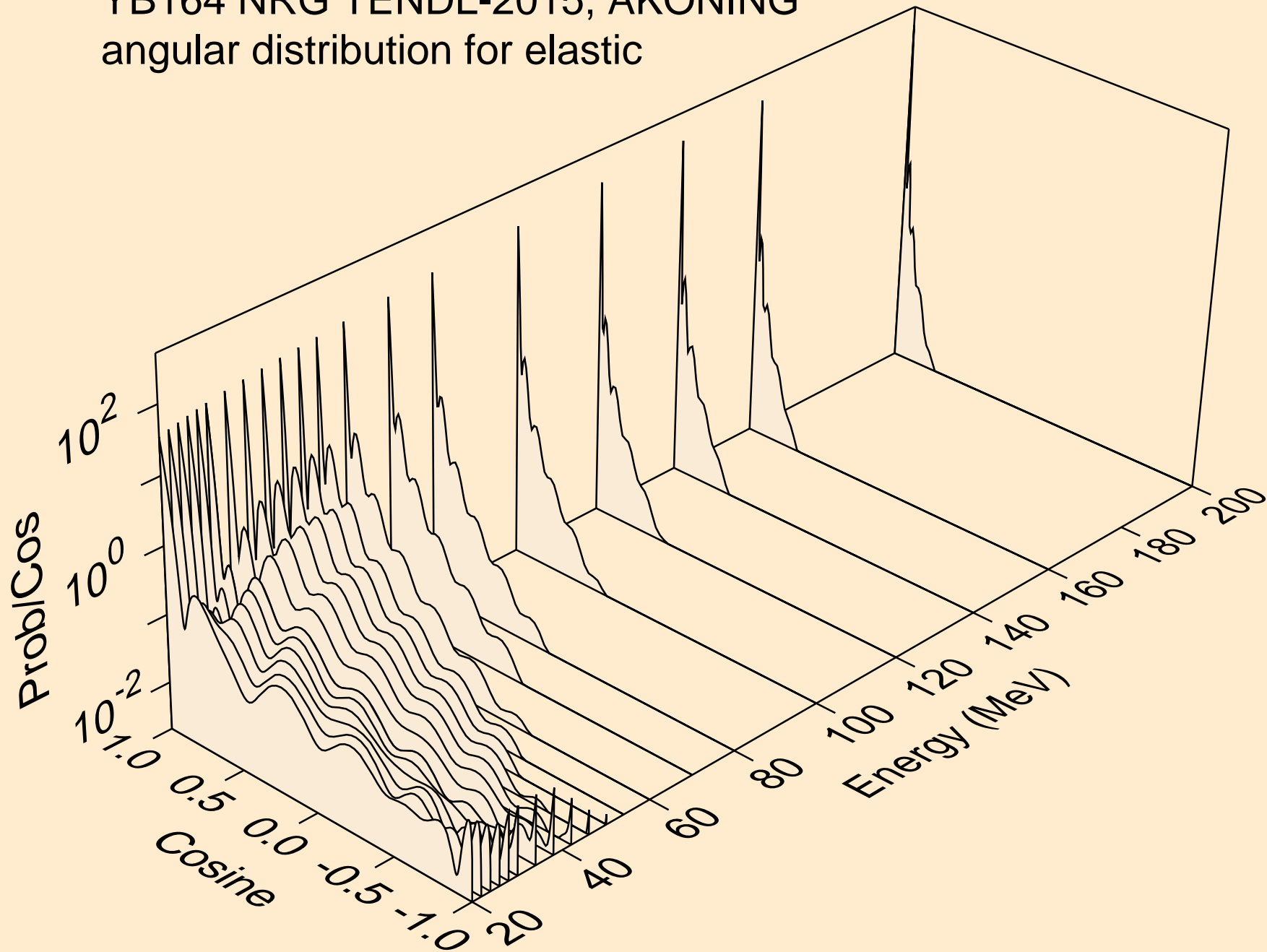

YB164 NRG TENDL-2015, AKONING  
angular distribution for (n,n\*1)

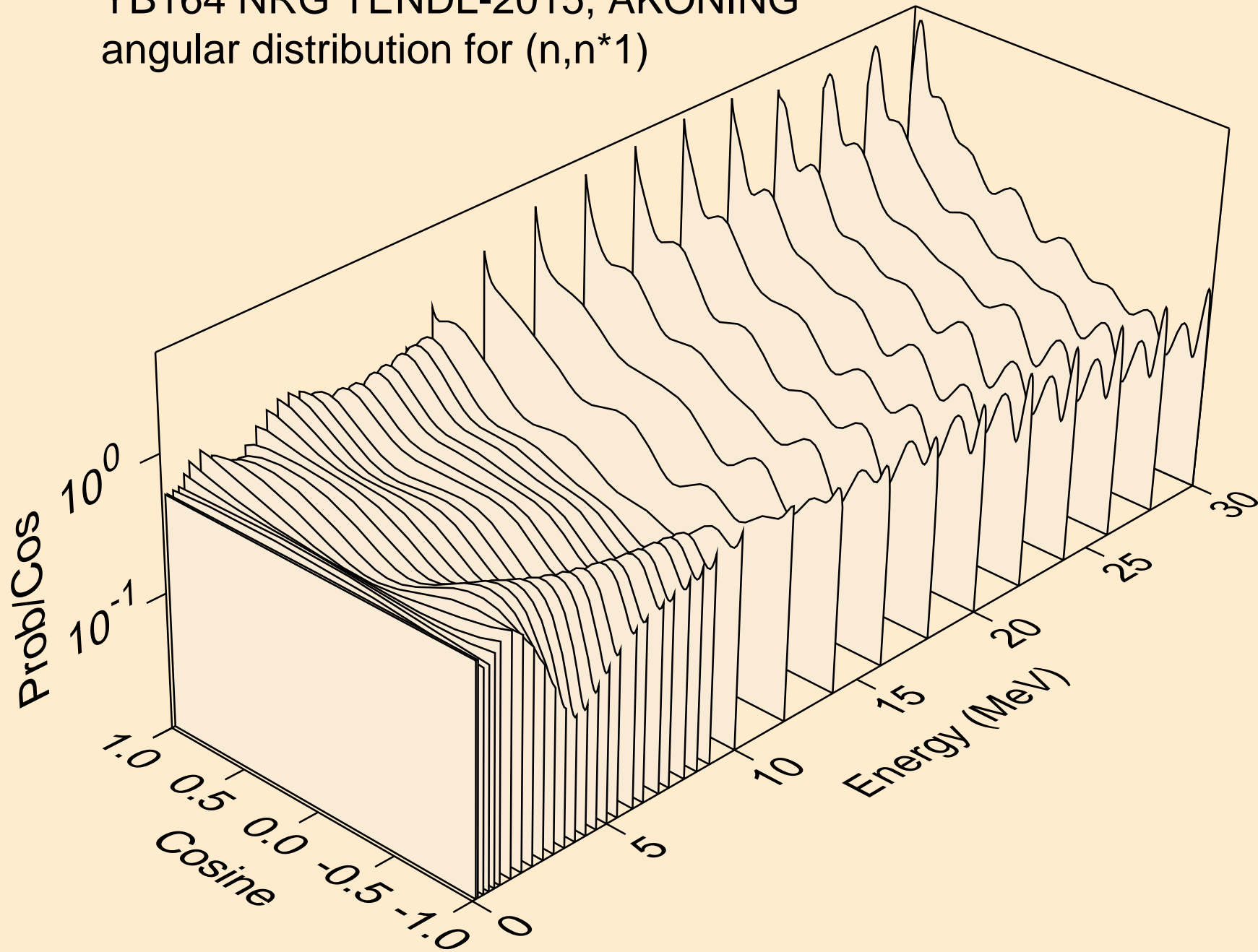

YB164 NRG TENDL-2015, AKONING  
angular distribution for (n,n\*2)

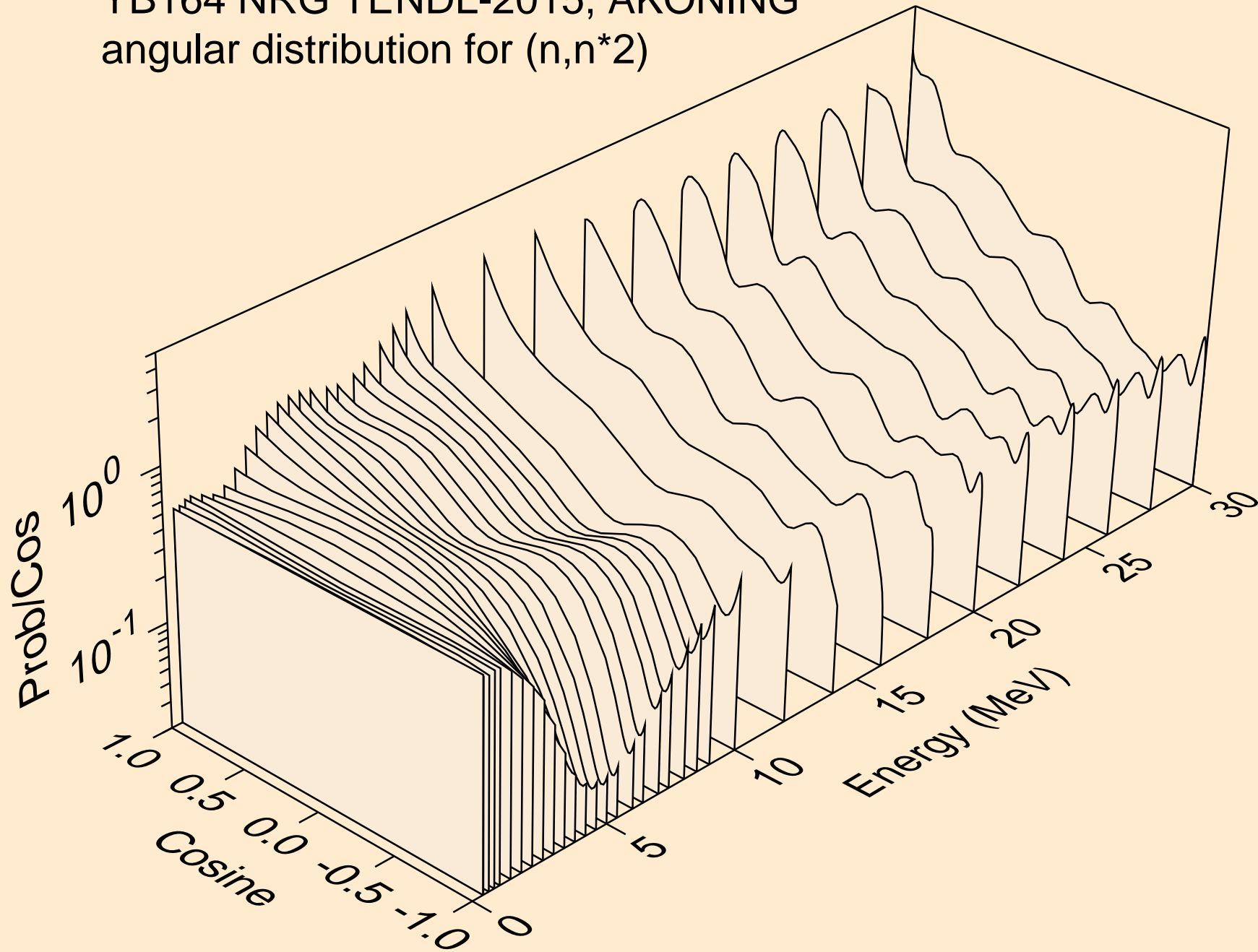

YB164 NRG TENDL-2015, AKONING  
angular distribution for (n,n\*3)

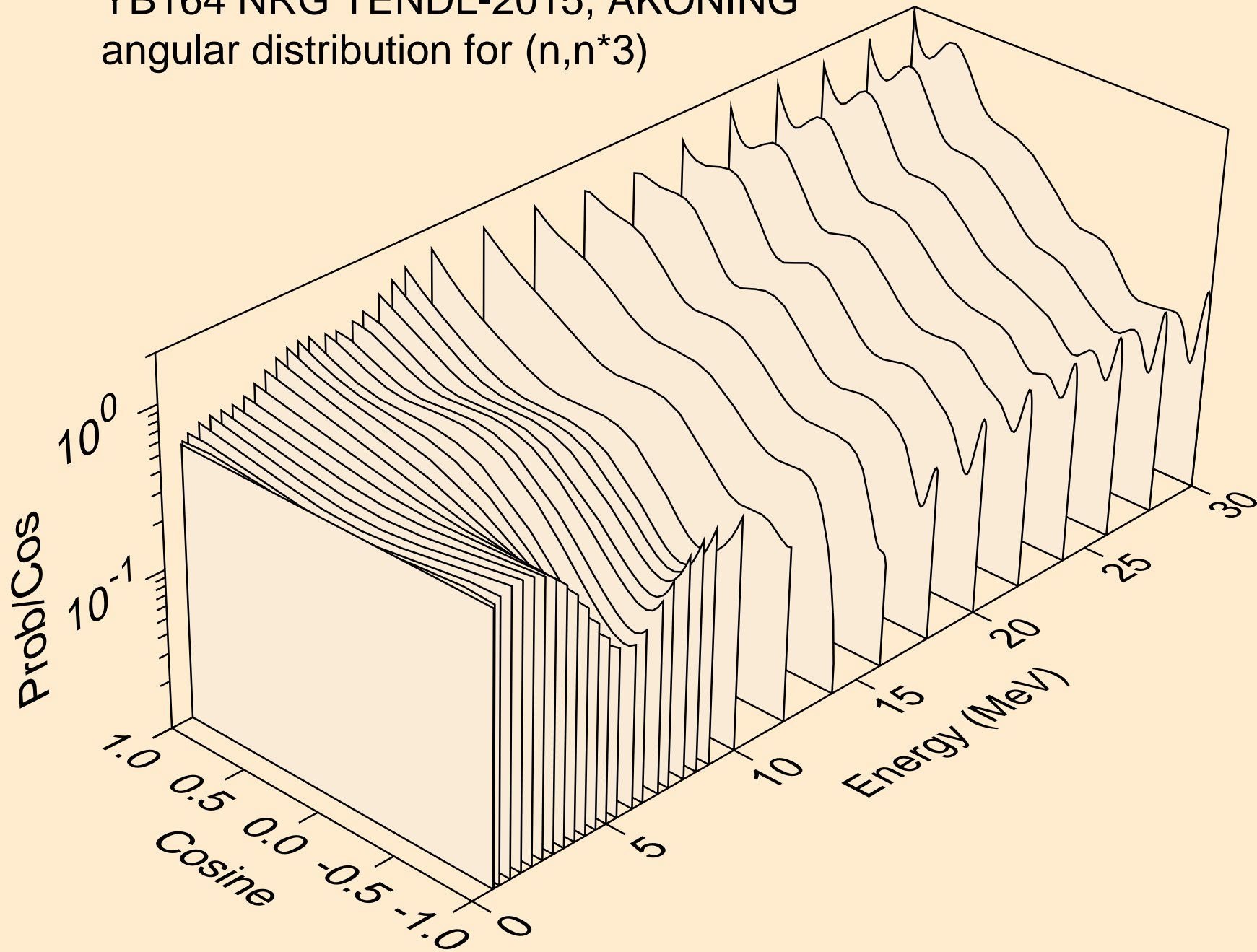

YB164 NRG TENDL-2015, AKONING  
angular distribution for (n,n\*4)

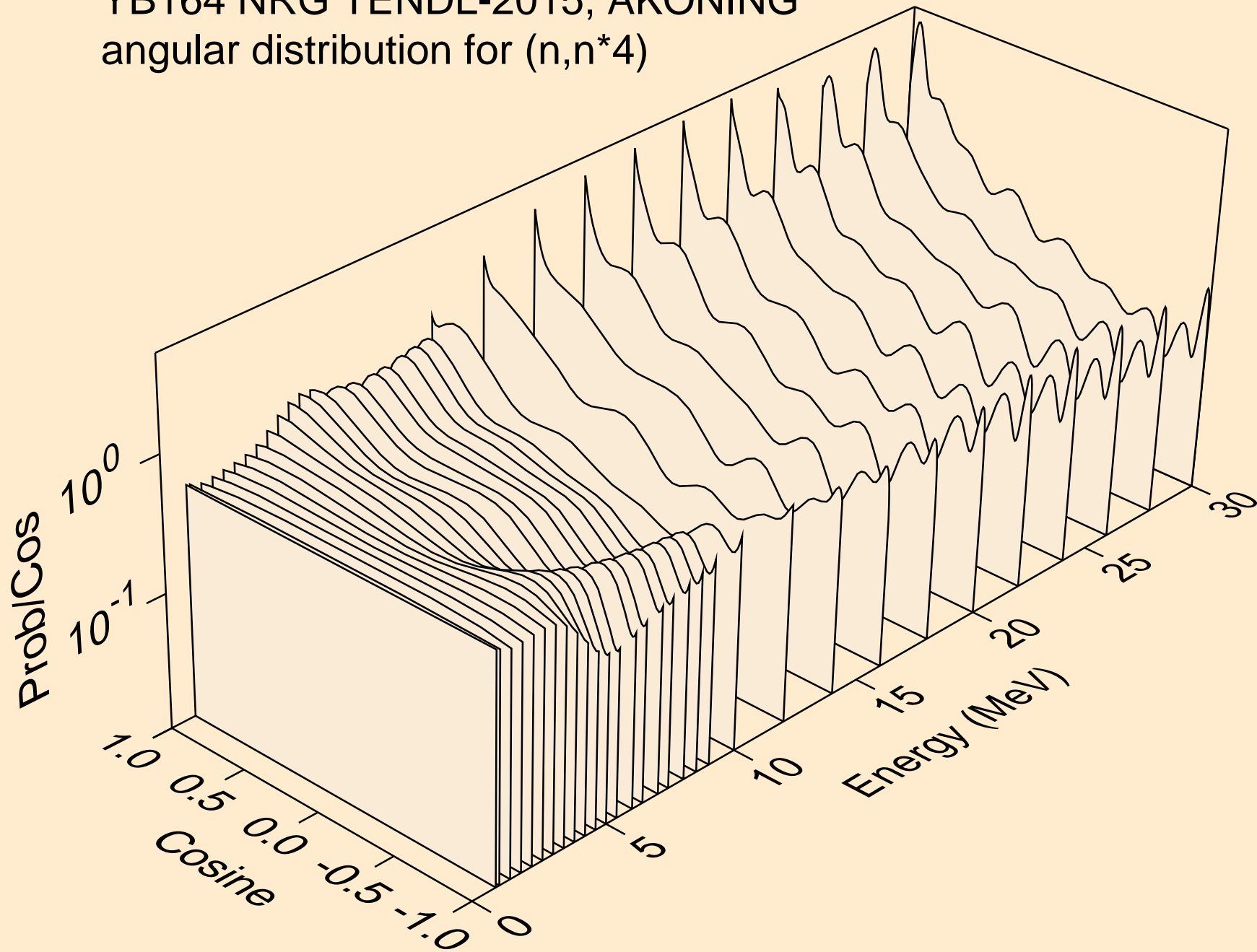

YB164 NRG TENDL-2015, AKONING  
angular distribution for (n,n\*5)

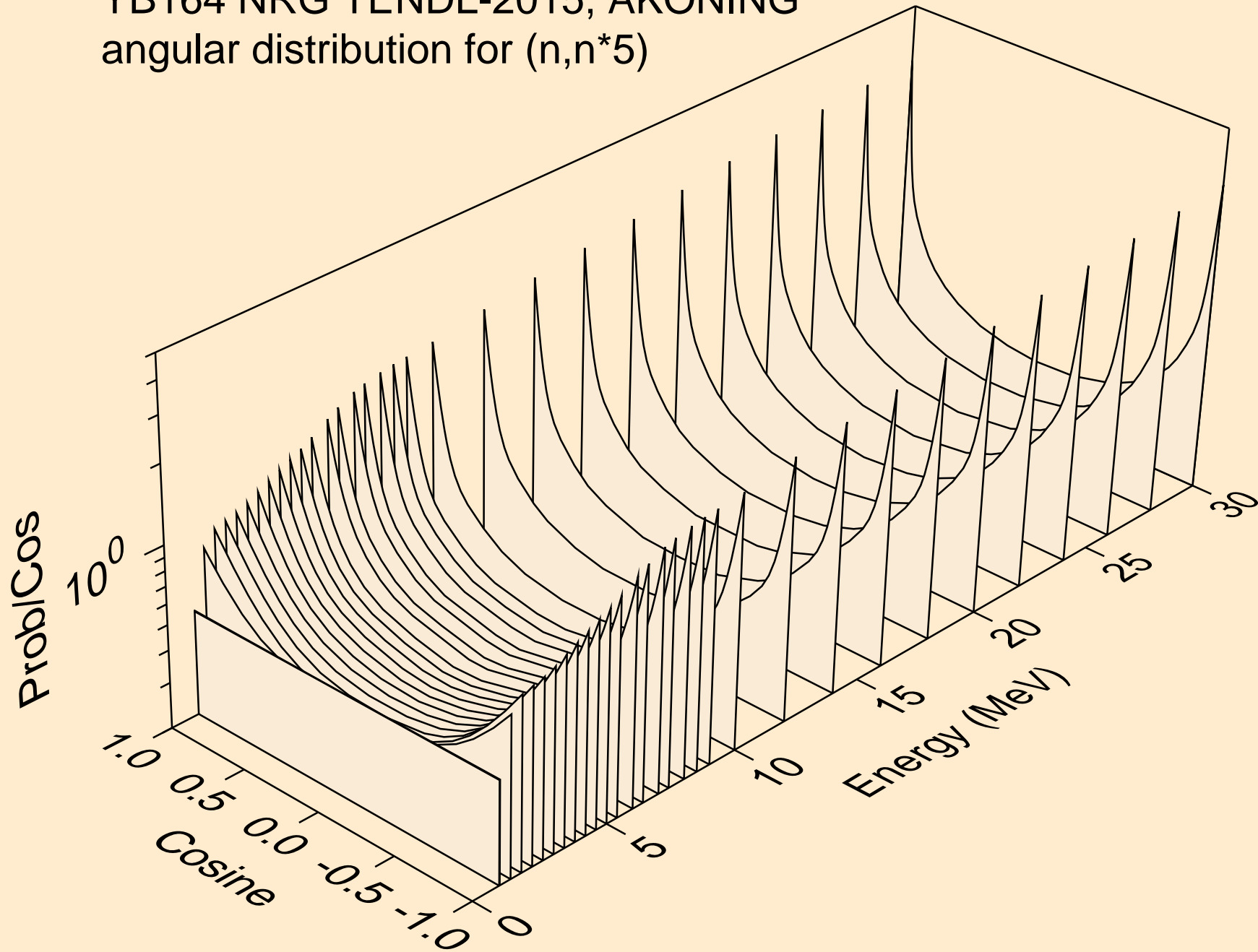

YB164 NRG TENDL-2015, AKONING  
angular distribution for (n,n\*6)

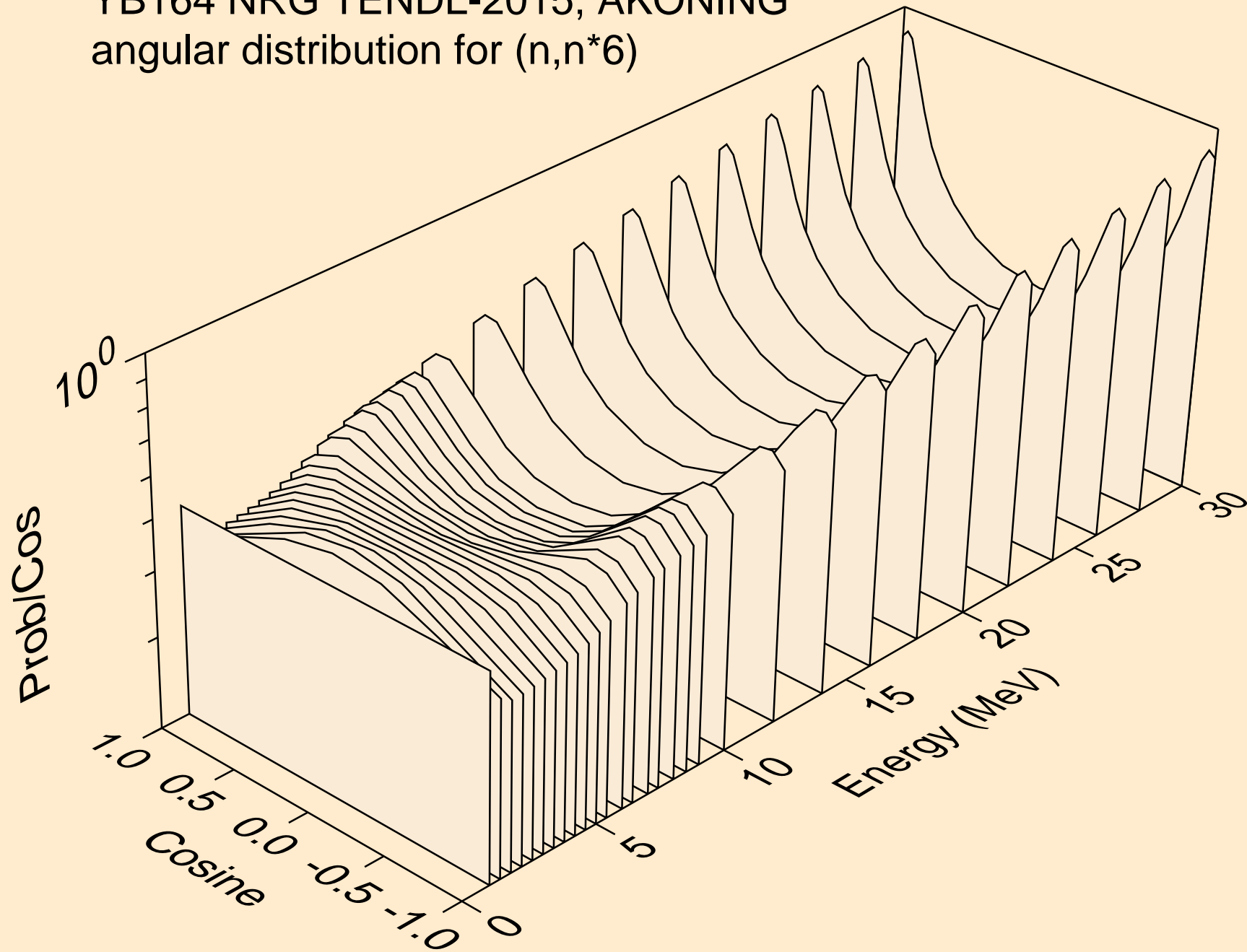



YB164 NRG TENDL-2015, AKONING  
angular distribution for (n,n\*7)

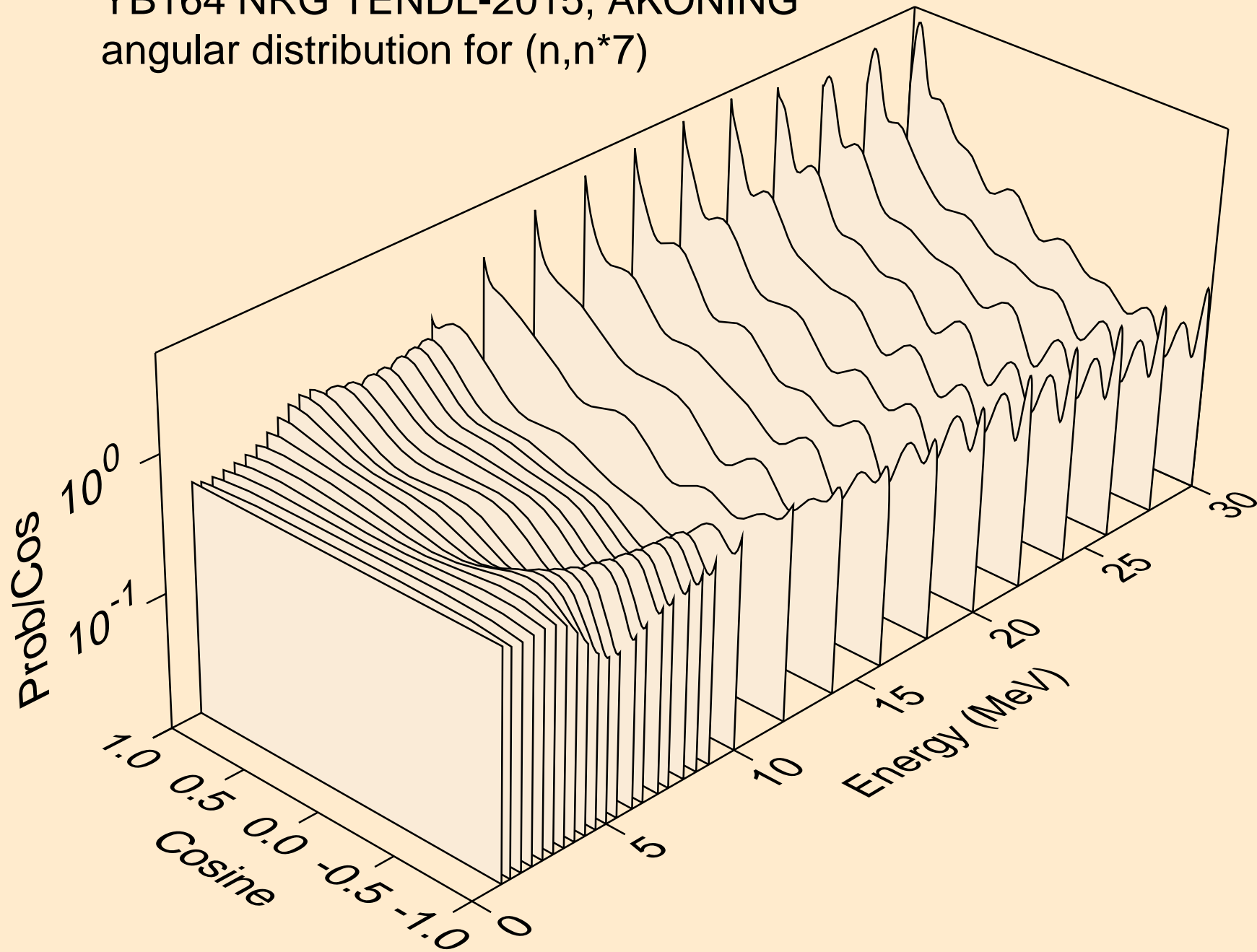

YB164 NRG TENDL-2015, AKONING  
angular distribution for (n,n\*8)

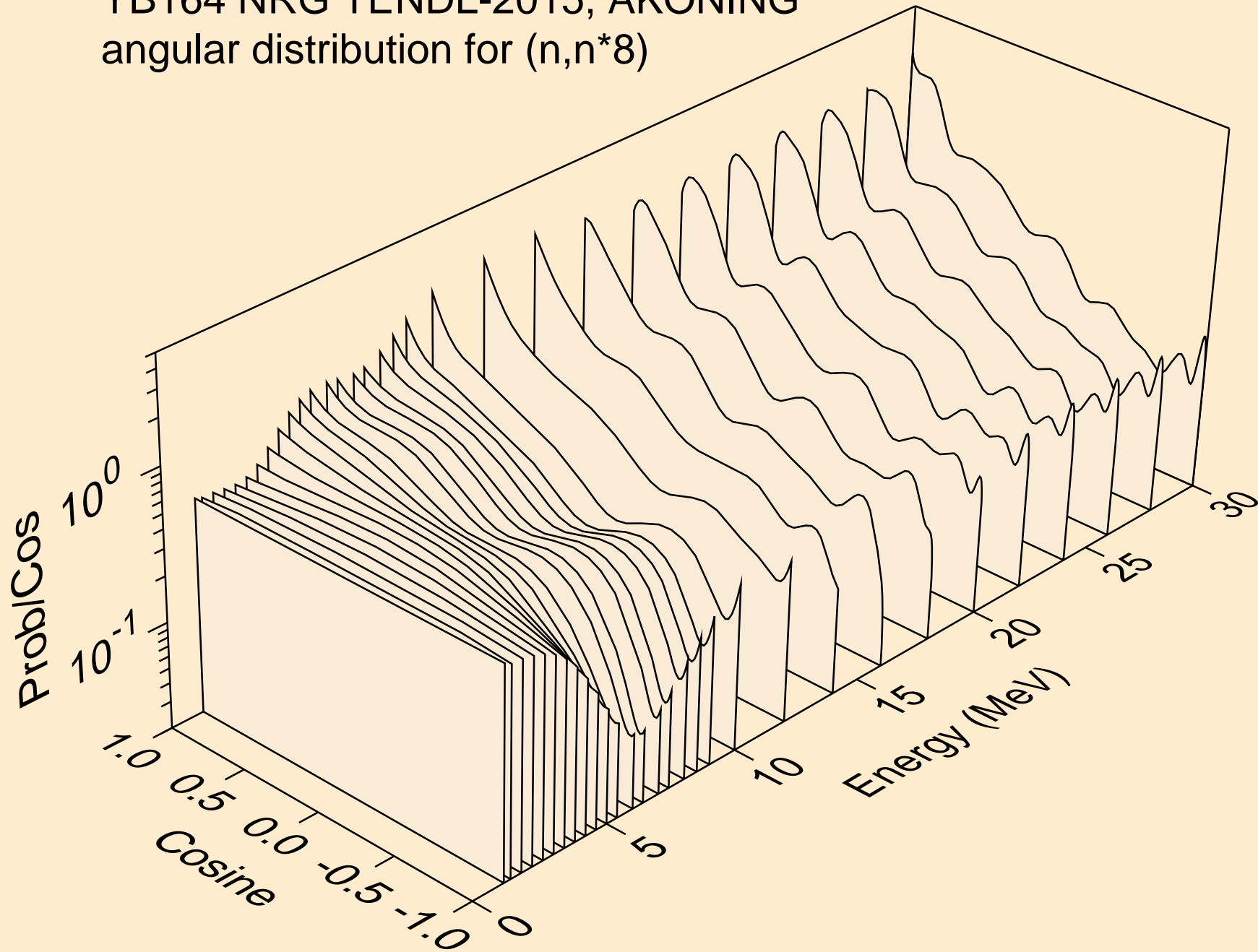

YB164 NRG TENDL-2015, AKONING  
angular distribution for (n,n\*9)

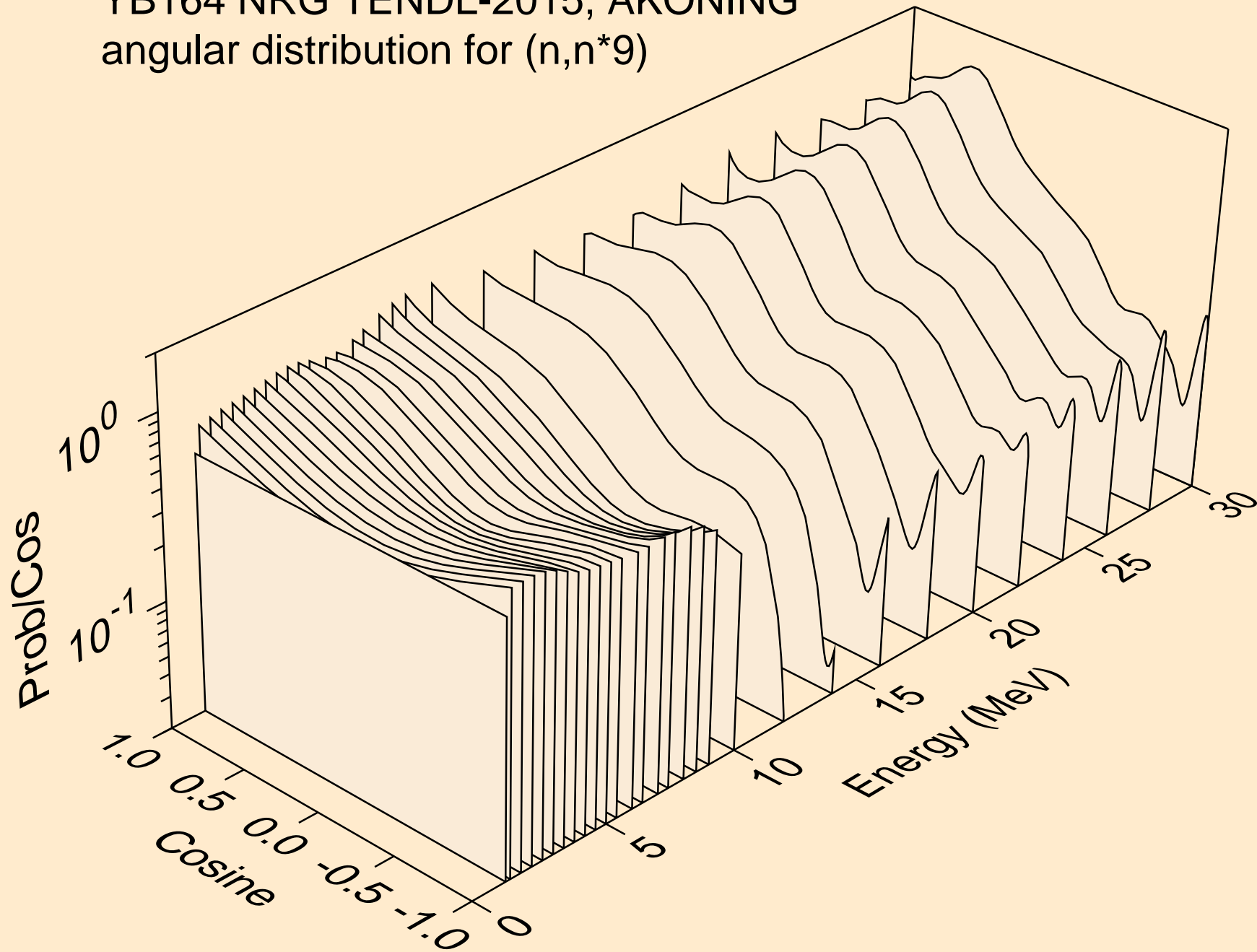

YB164 NRG TENDL-2015, AKONING  
angular distribution for (n,n\*10)

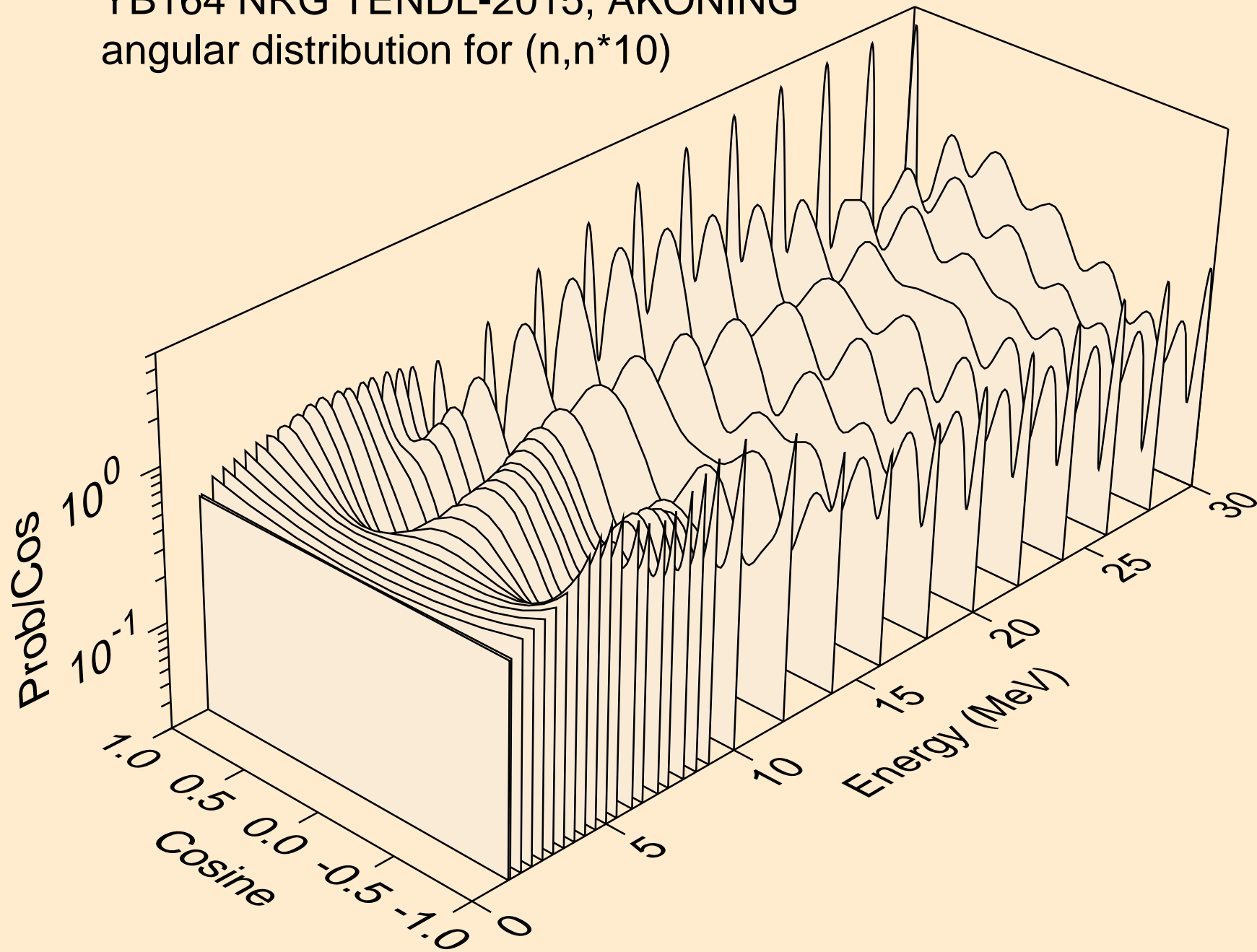

YB164 NRG TENDL-2015, AKONING  
angular distribution for (n,n\*11)

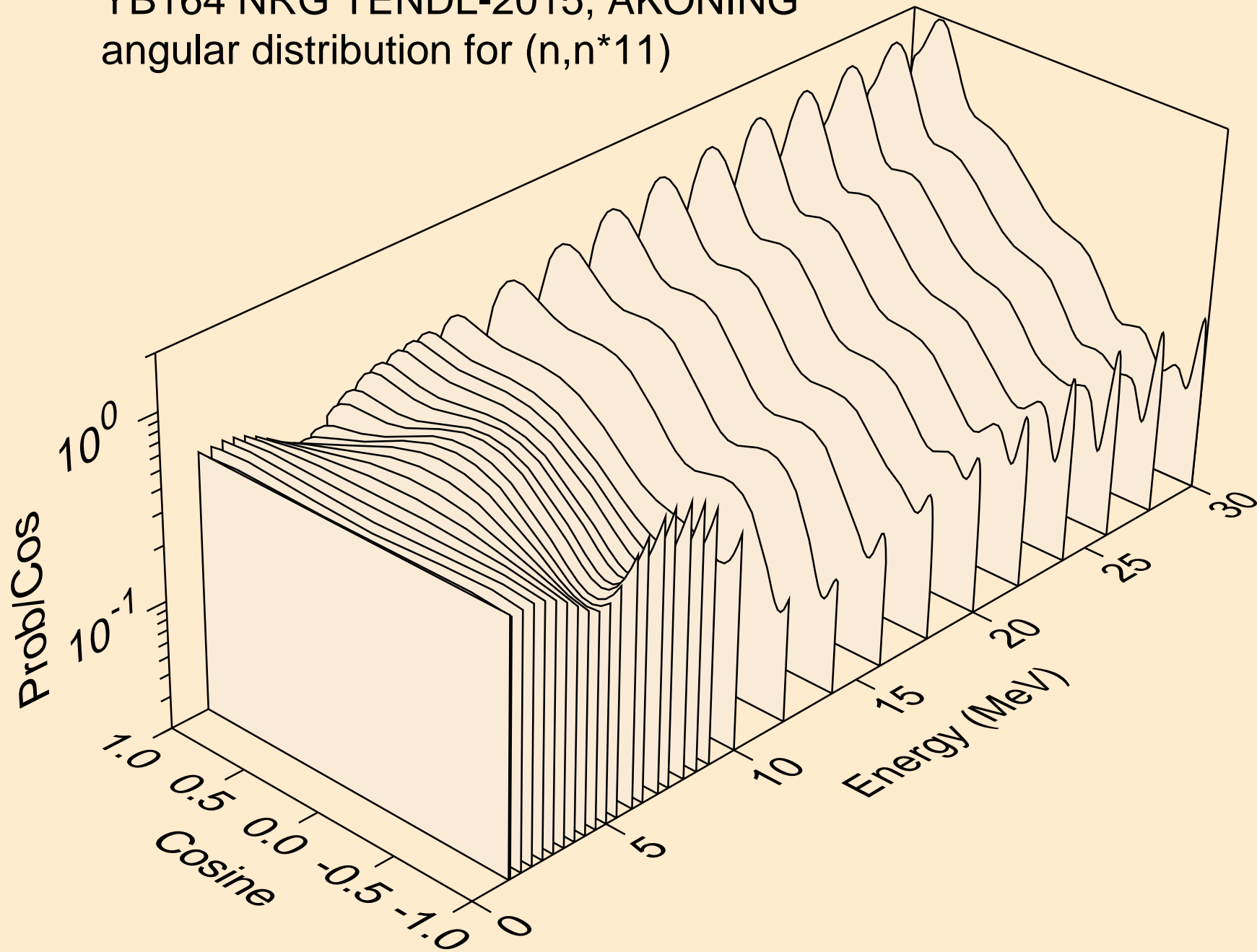

YB164 NRG TENDL-2015, AKONING  
angular distribution for (n,n\*12)

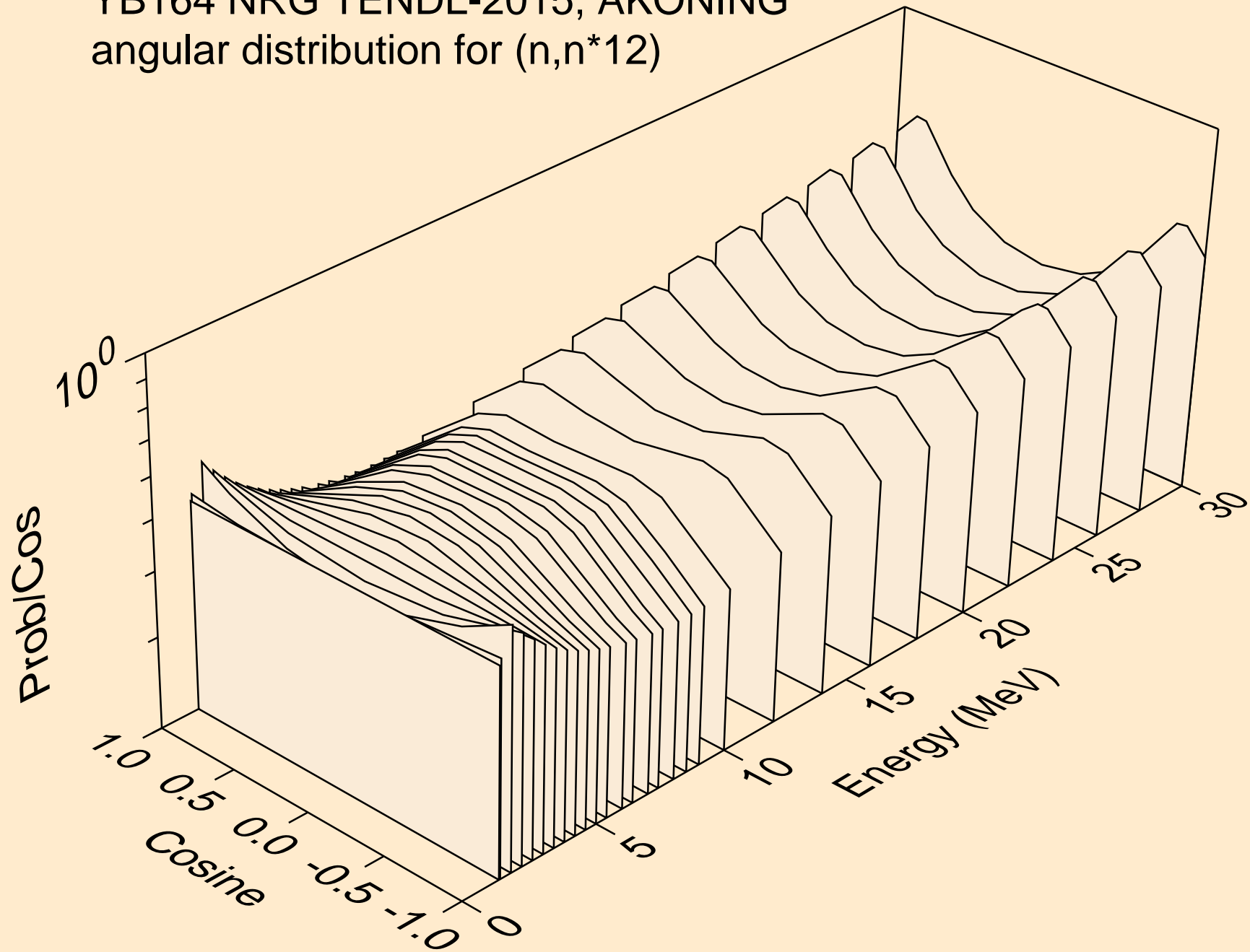

YB164 NRG TENDL-2015, AKONING  
angular distribution for (n,n\*13)

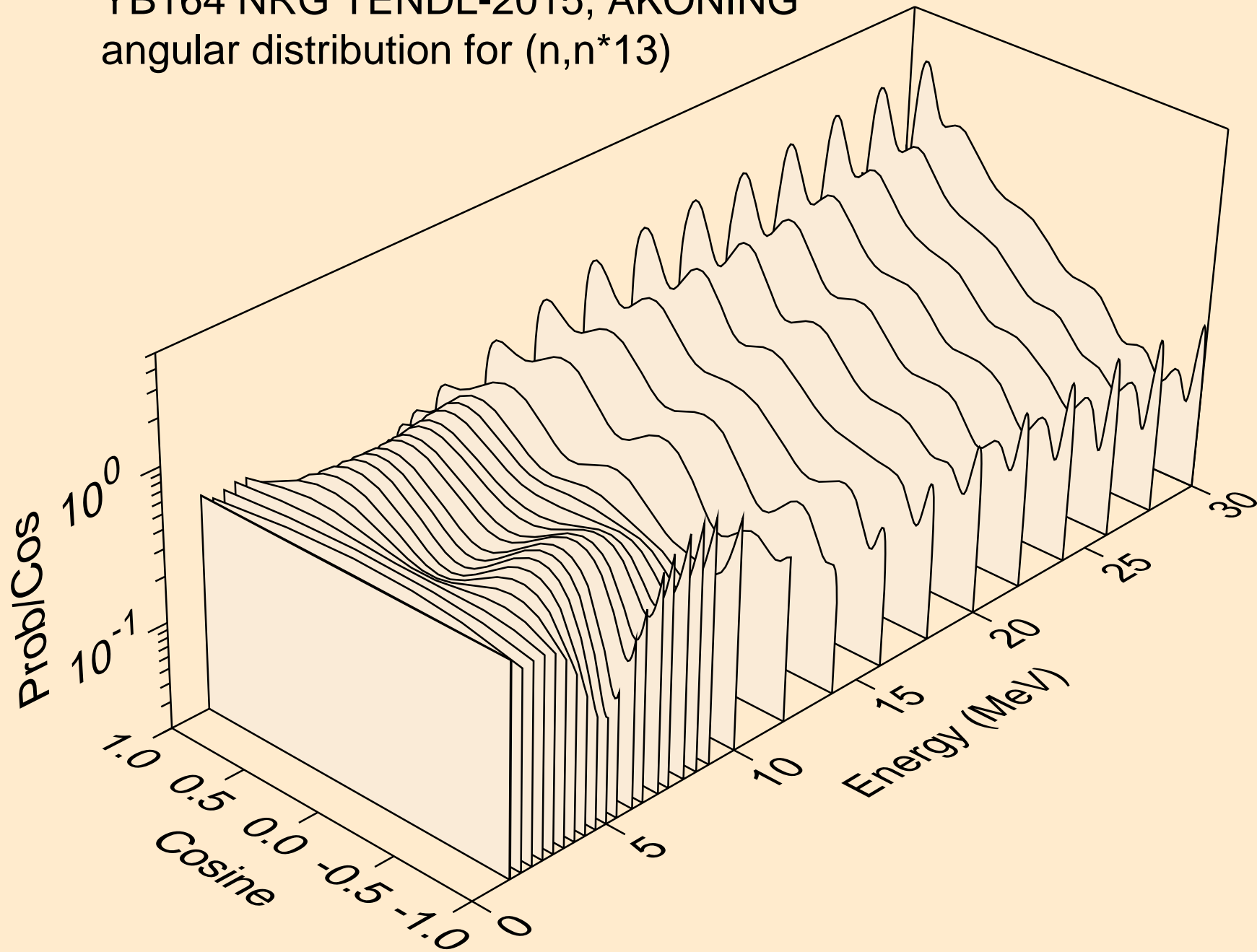

YB164 NRG TENDL-2015, AKONING  
angular distribution for (n,n\*14)

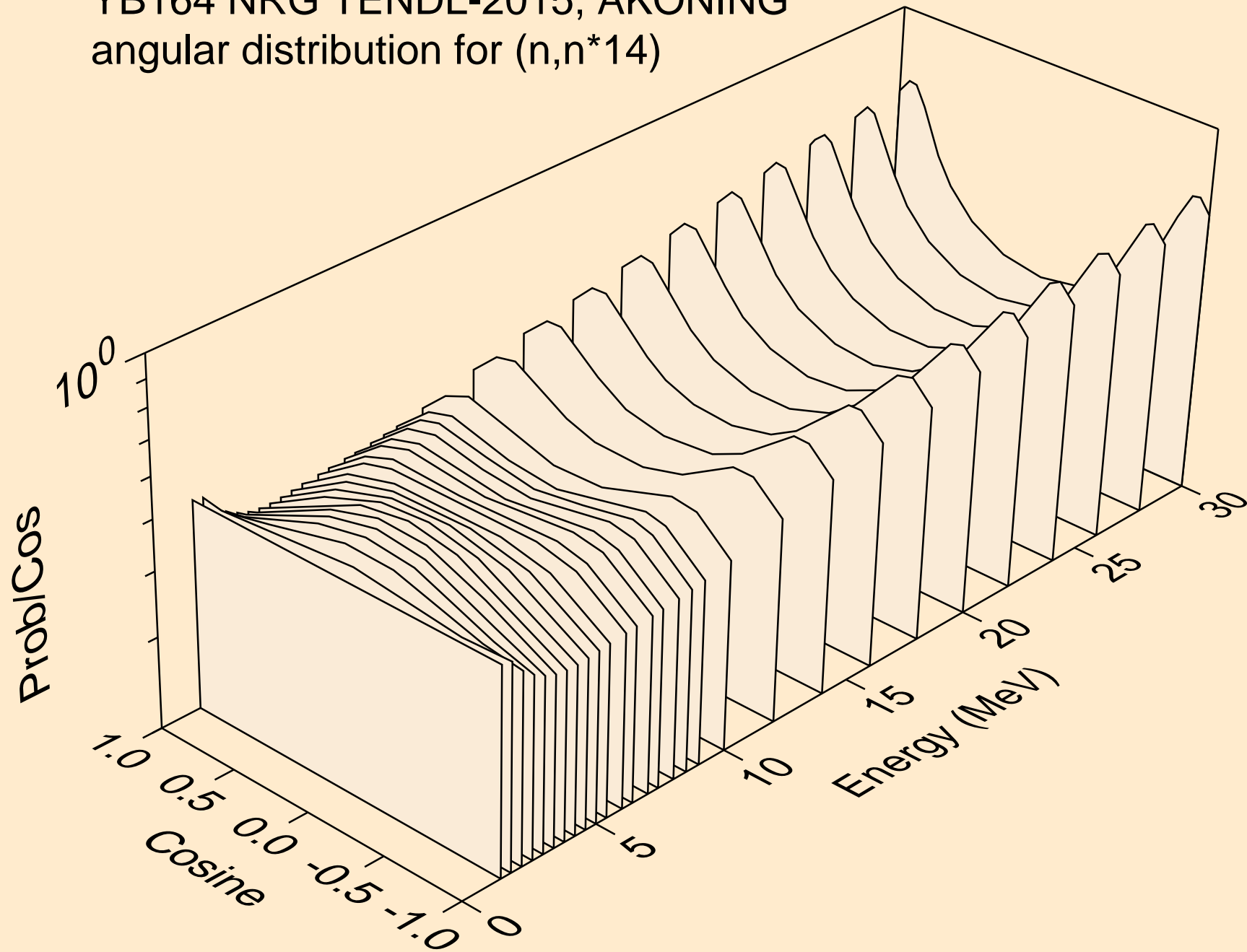



YB164 NRG TENDL-2015, AKONING  
angular distribution for (n,n\*15)

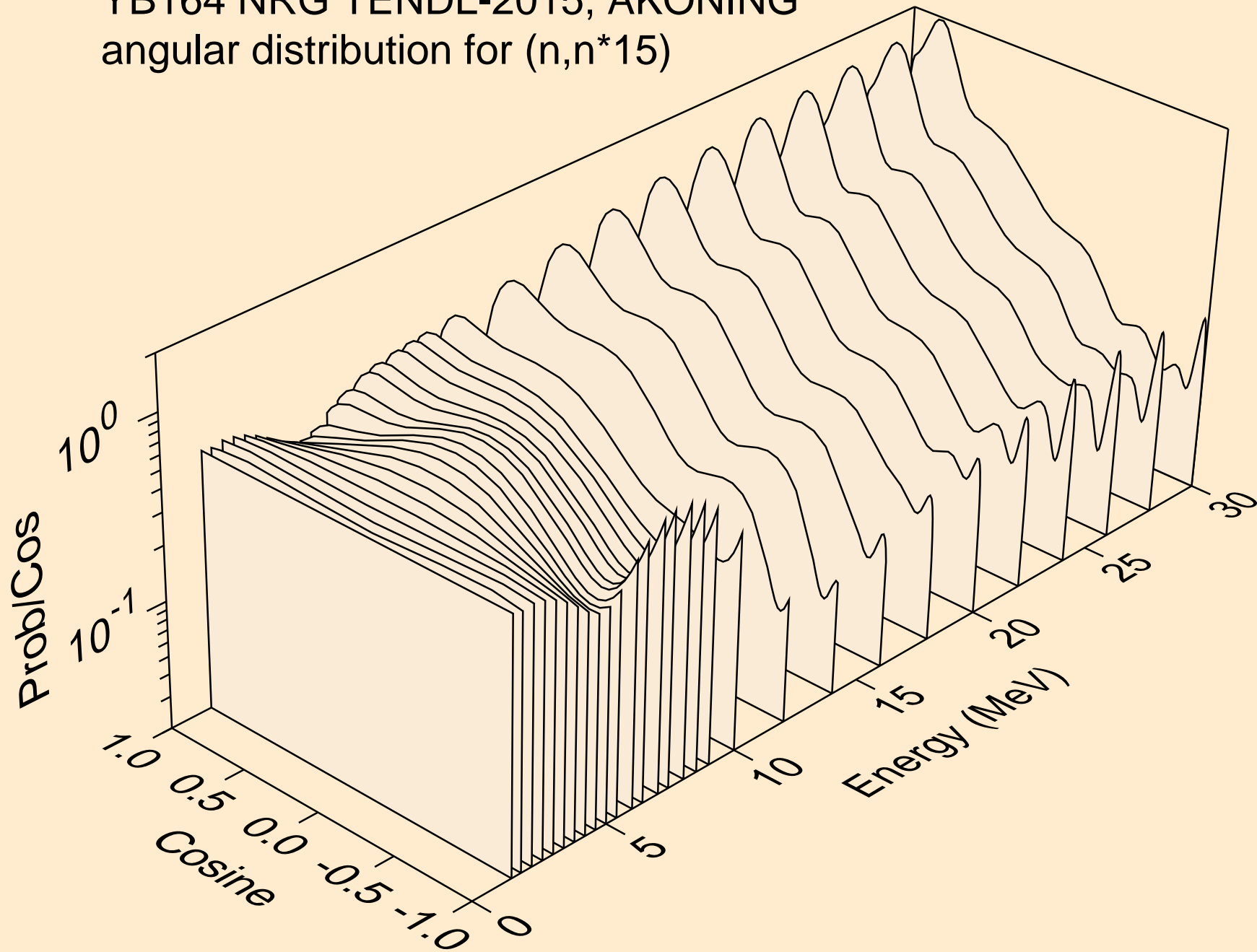

YB164 NRG TENDL-2015, AKONING  
angular distribution for (n,n\*16)

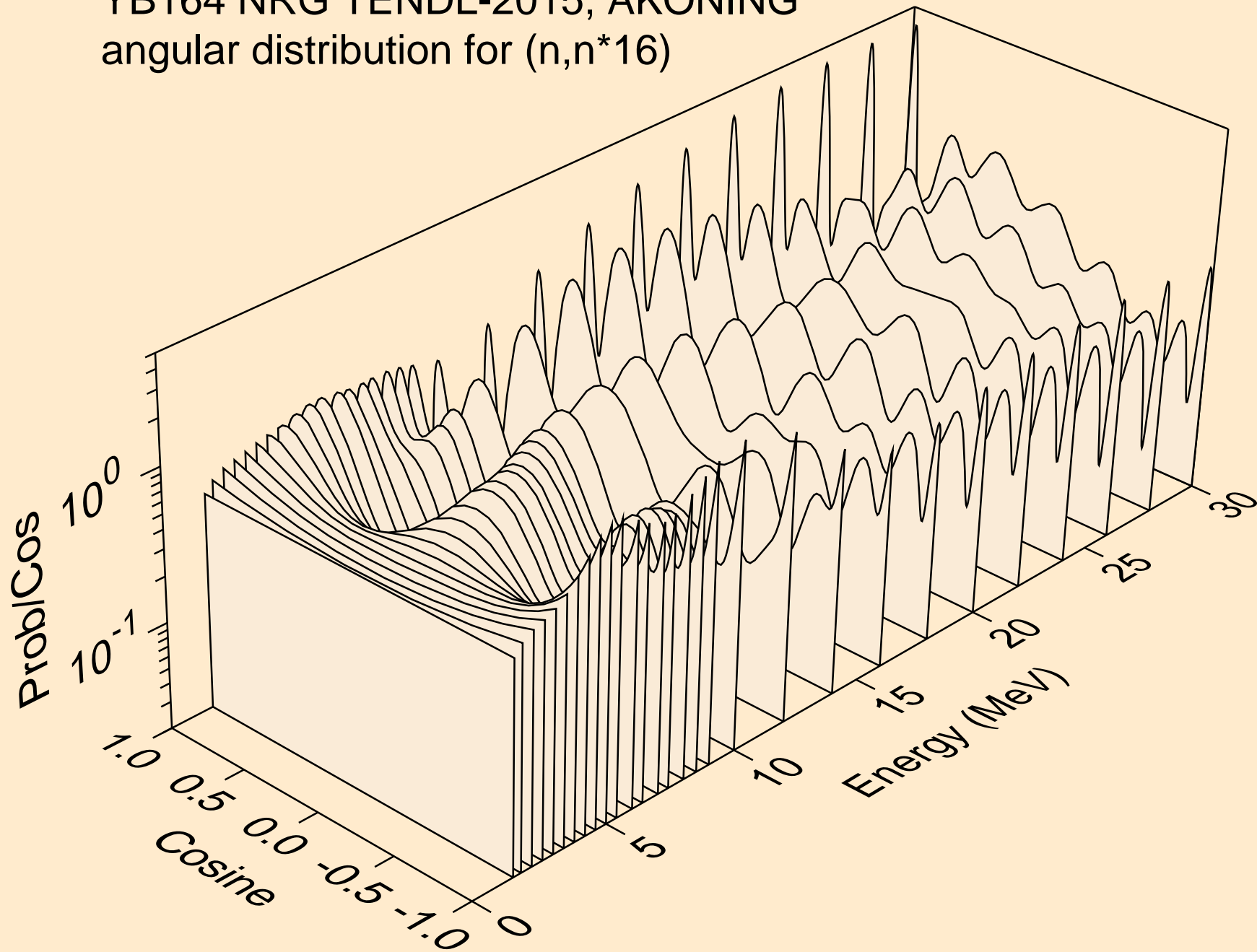

YB164 NRG TENDL-2015, AKONING  
angular distribution for (n,n\*17)

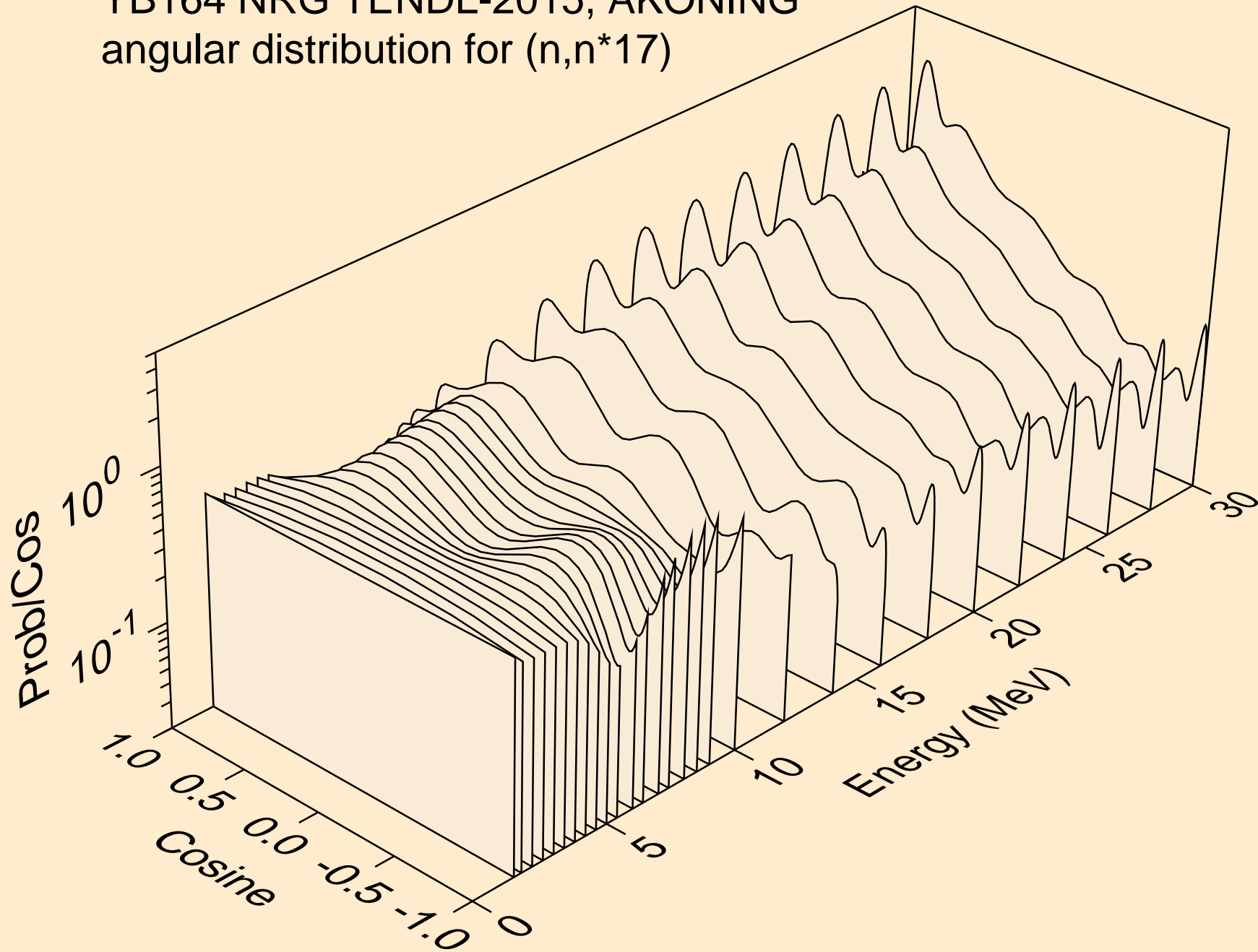

YB164 NRG TENDL-2015, AKONING  
angular distribution for (n,n\*18)

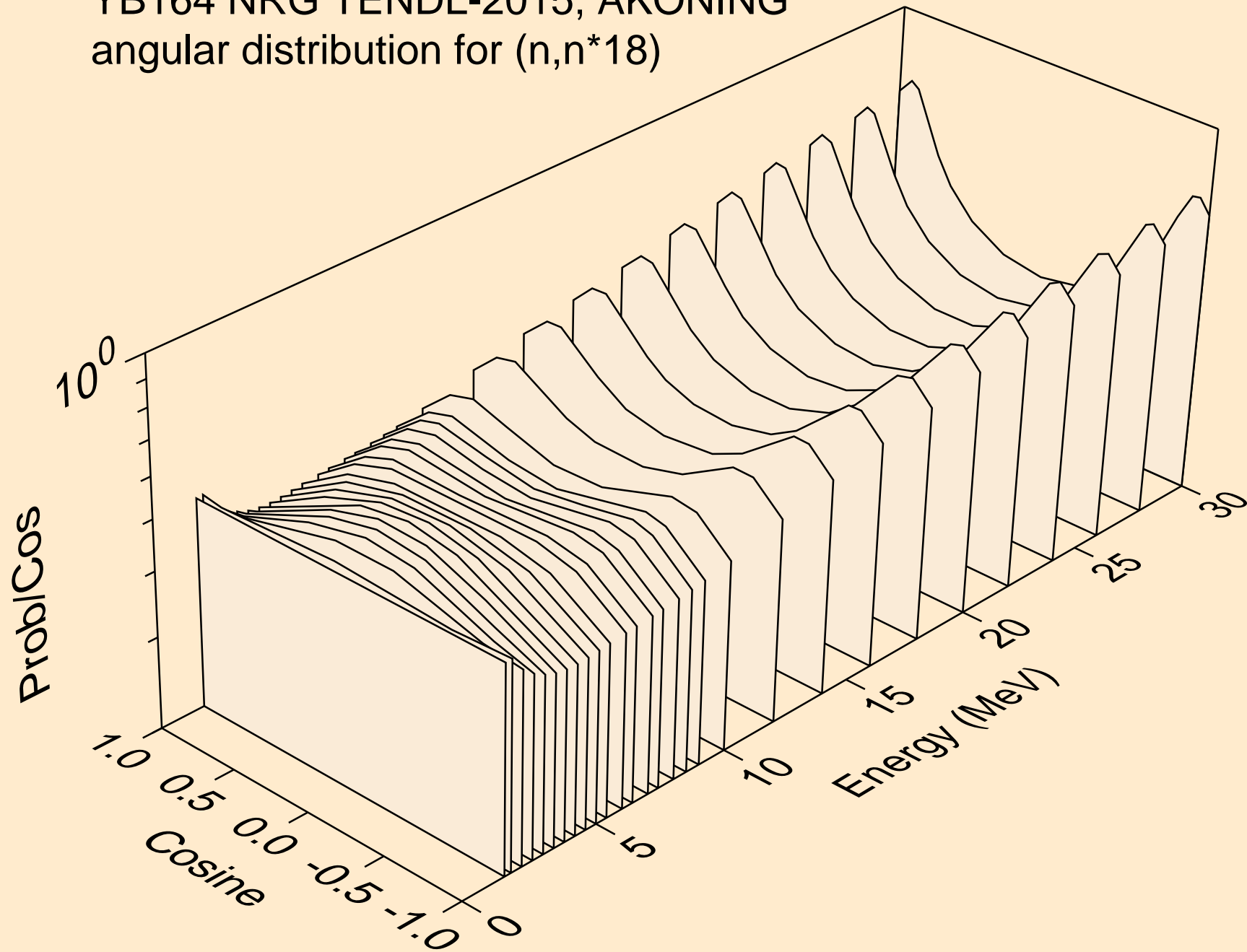

YB164 NRG TENDL-2015, AKONING  
angular distribution for (n,n\*19)

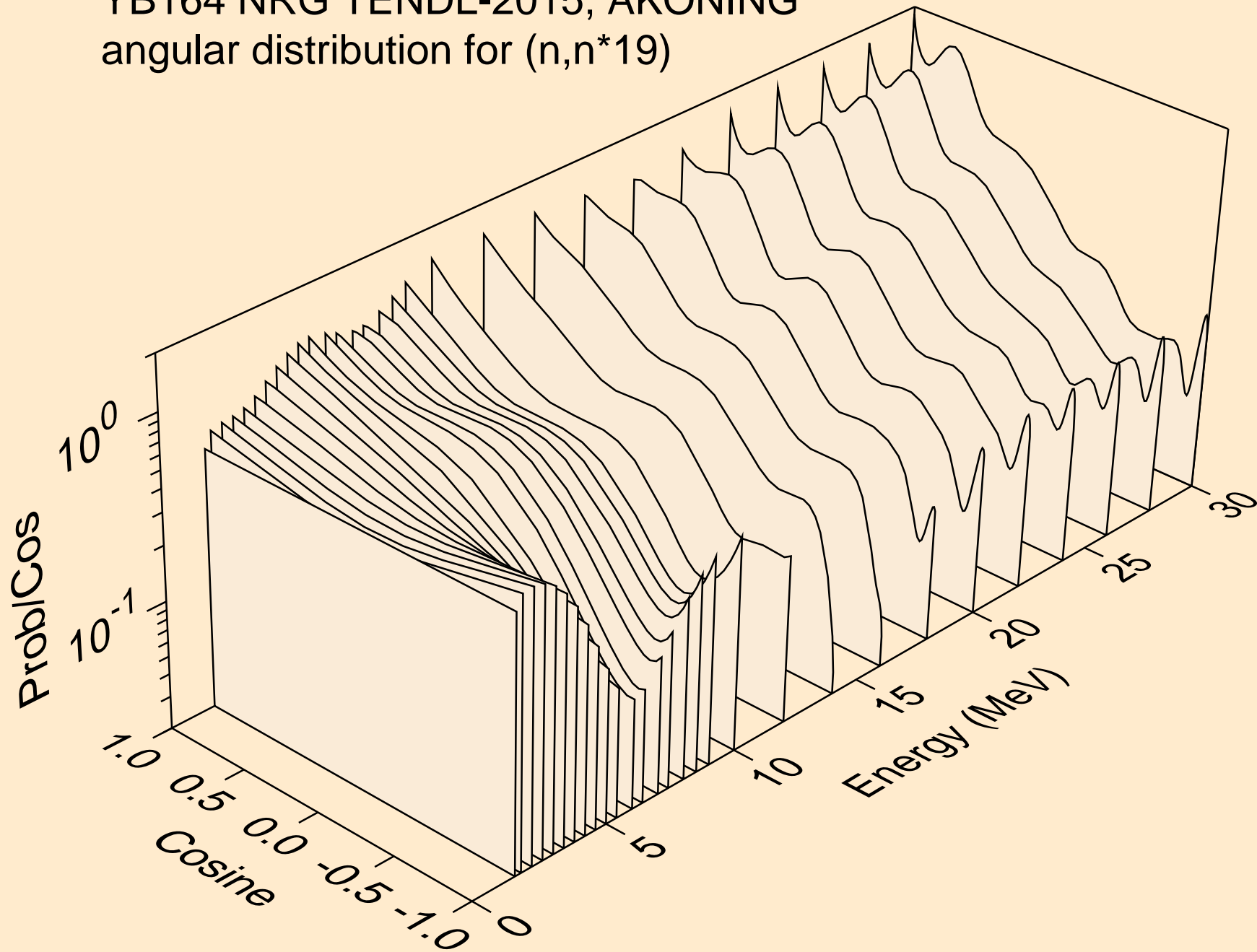

YB164 NRG TENDL-2015, AKONING  
angular distribution for (n,n\*20)

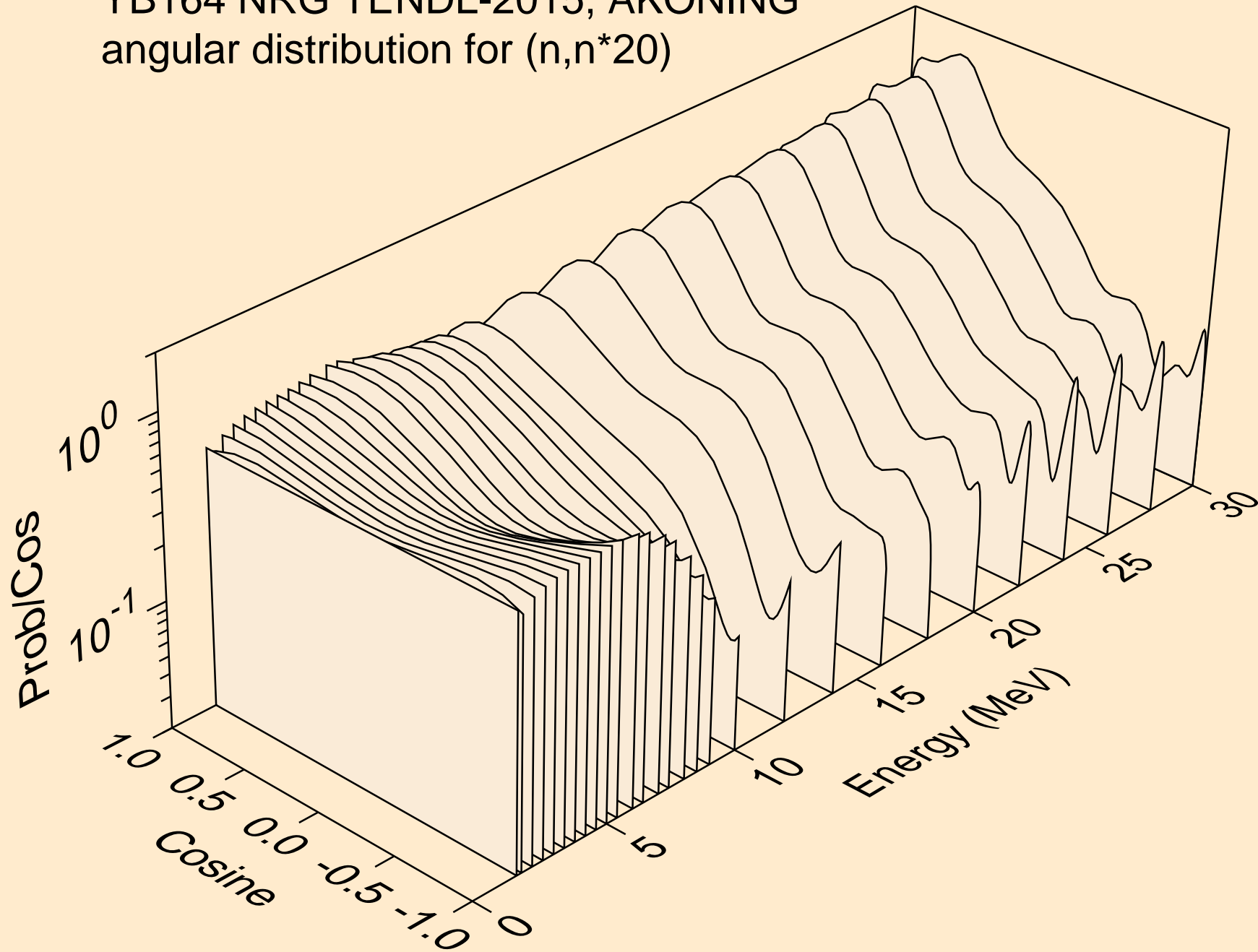

YB164 NRG TENDL-2015, AKONING  
angular distribution for (n,n\*21)

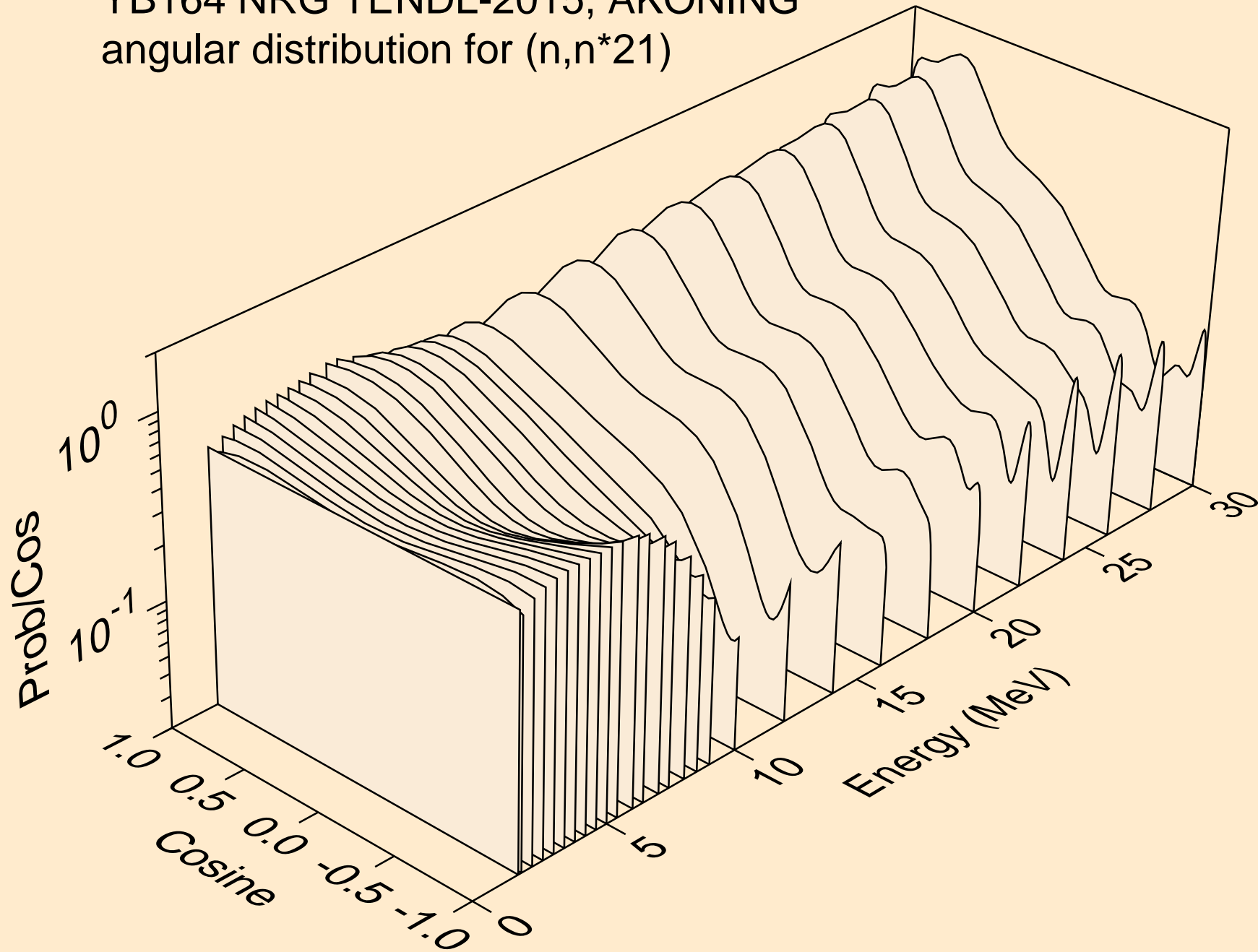

YB164 NRG TENDL-2015, AKONING  
angular distribution for (n,n\*22)

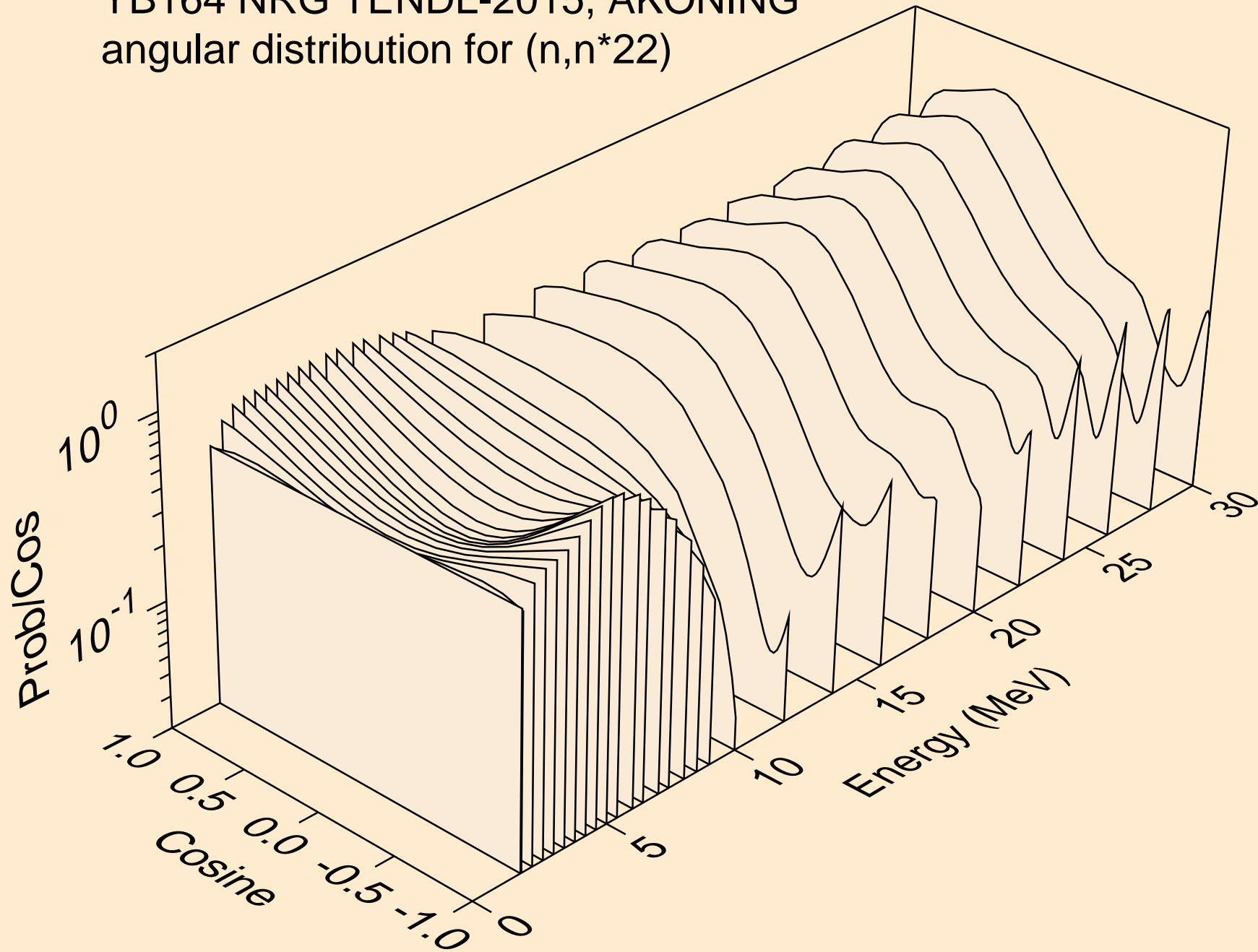



YB164 NRG TENDL-2015, AKONING  
angular distribution for (n,n\*23)

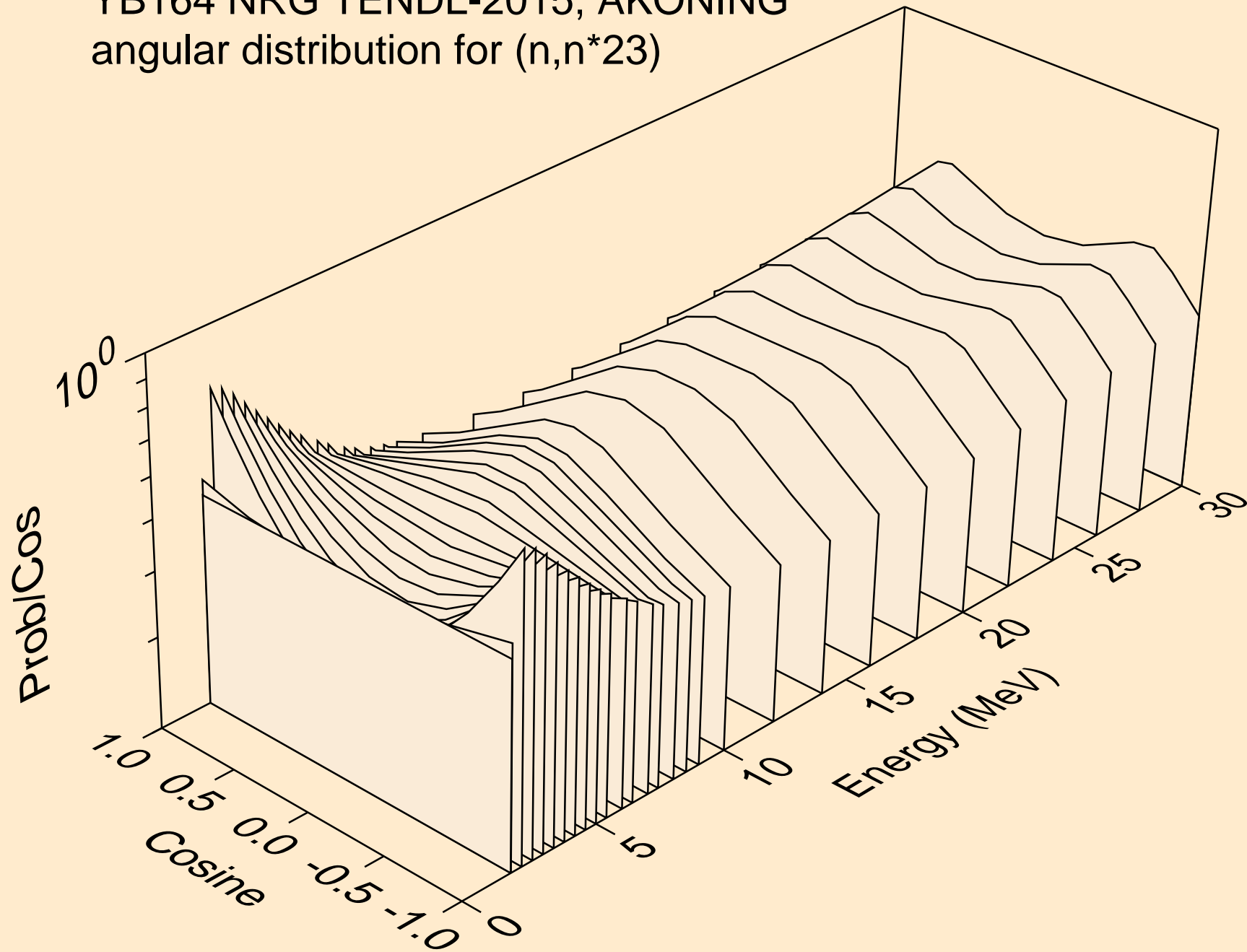

YB164 NRG TENDL-2015, AKONING  
angular distribution for (n,n\*24)

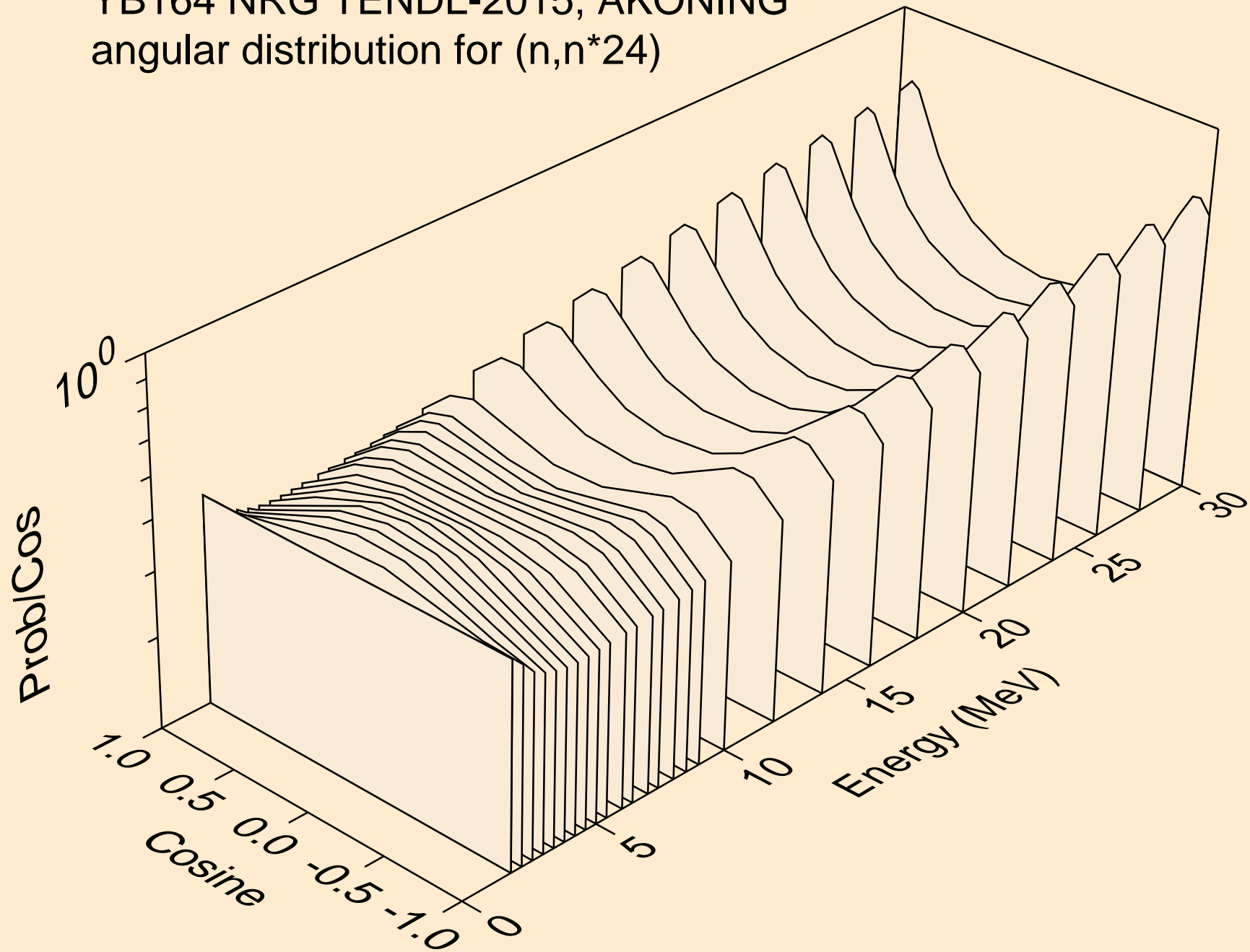

YB164 NRG TENDL-2015, AKONING  
angular distribution for (n,n\*25)

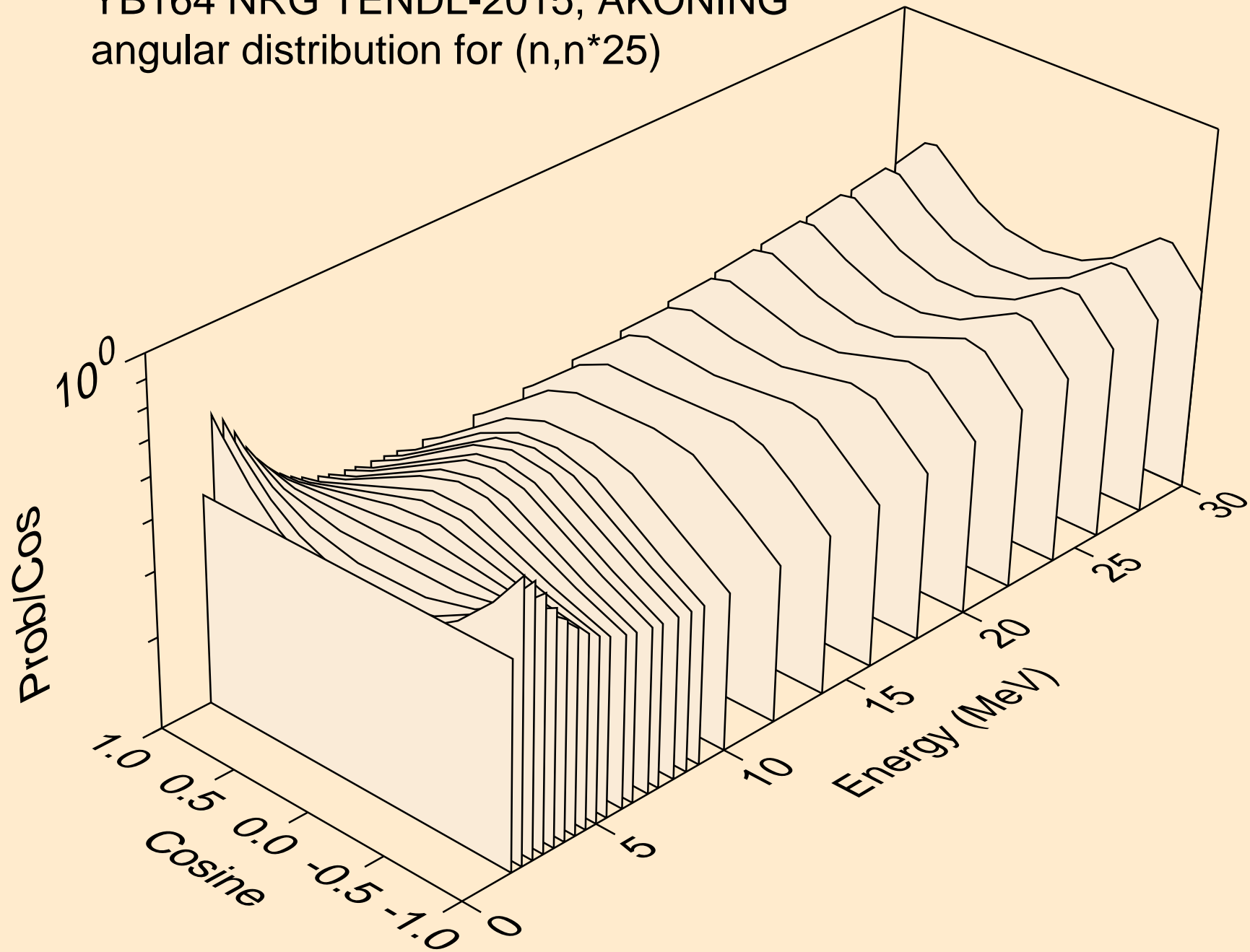

YB164 NRG TENDL-2015, AKONING  
angular distribution for (n,n\*26)

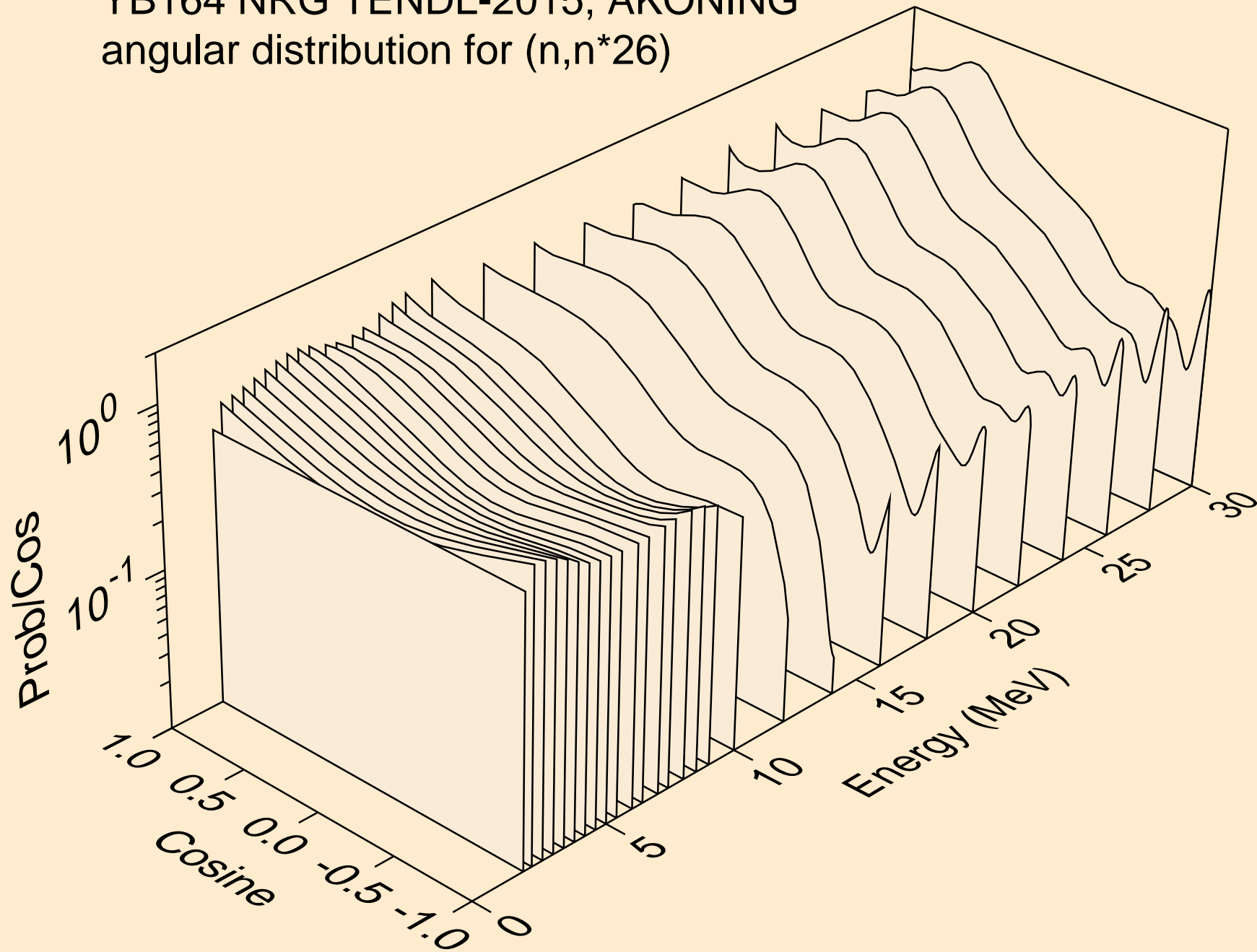

YB164 NRG TENDL-2015, AKONING  
angular distribution for (n,n\*27)

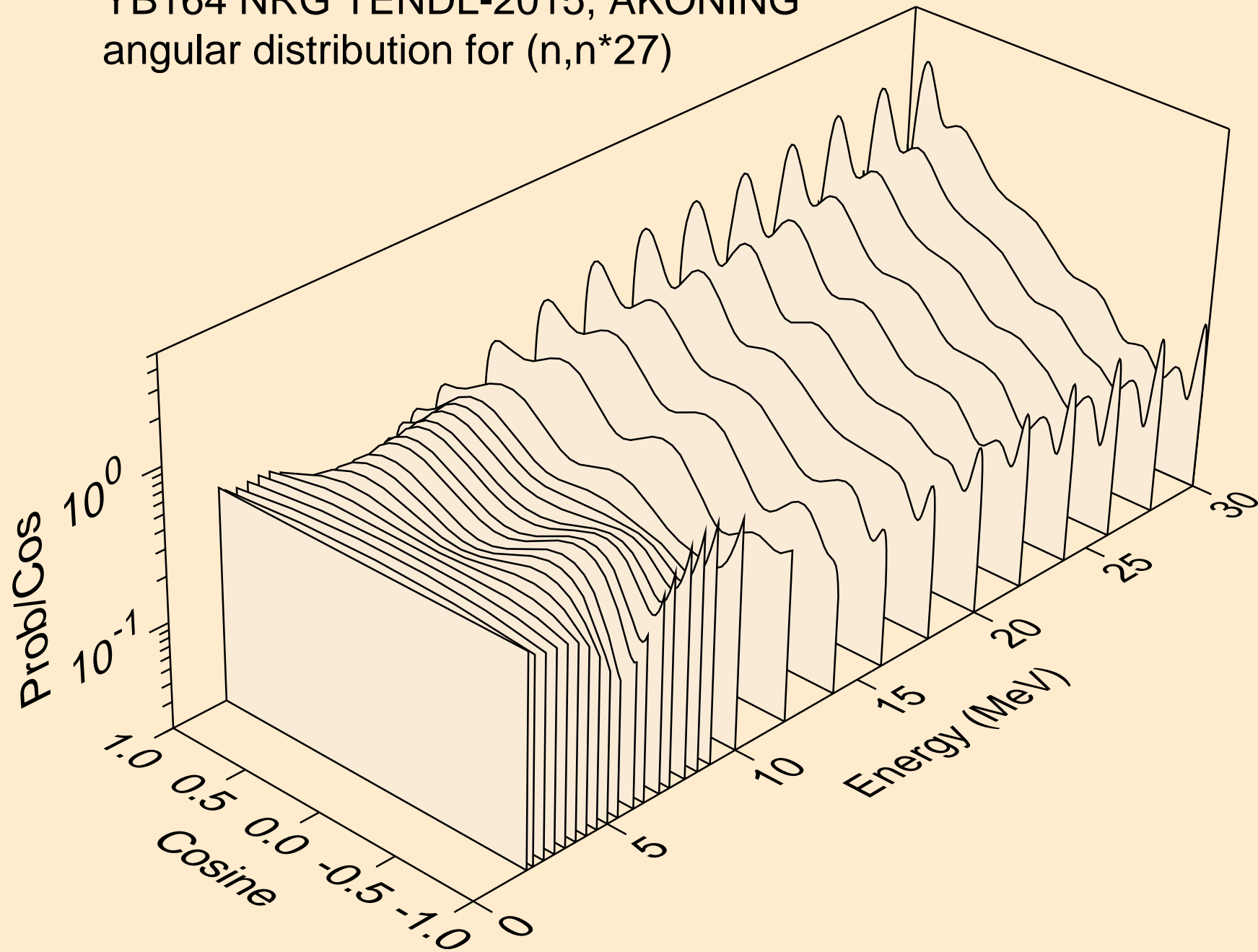

YB164 NRG TENDL-2015, AKONING  
Neutron emission for (n,x)

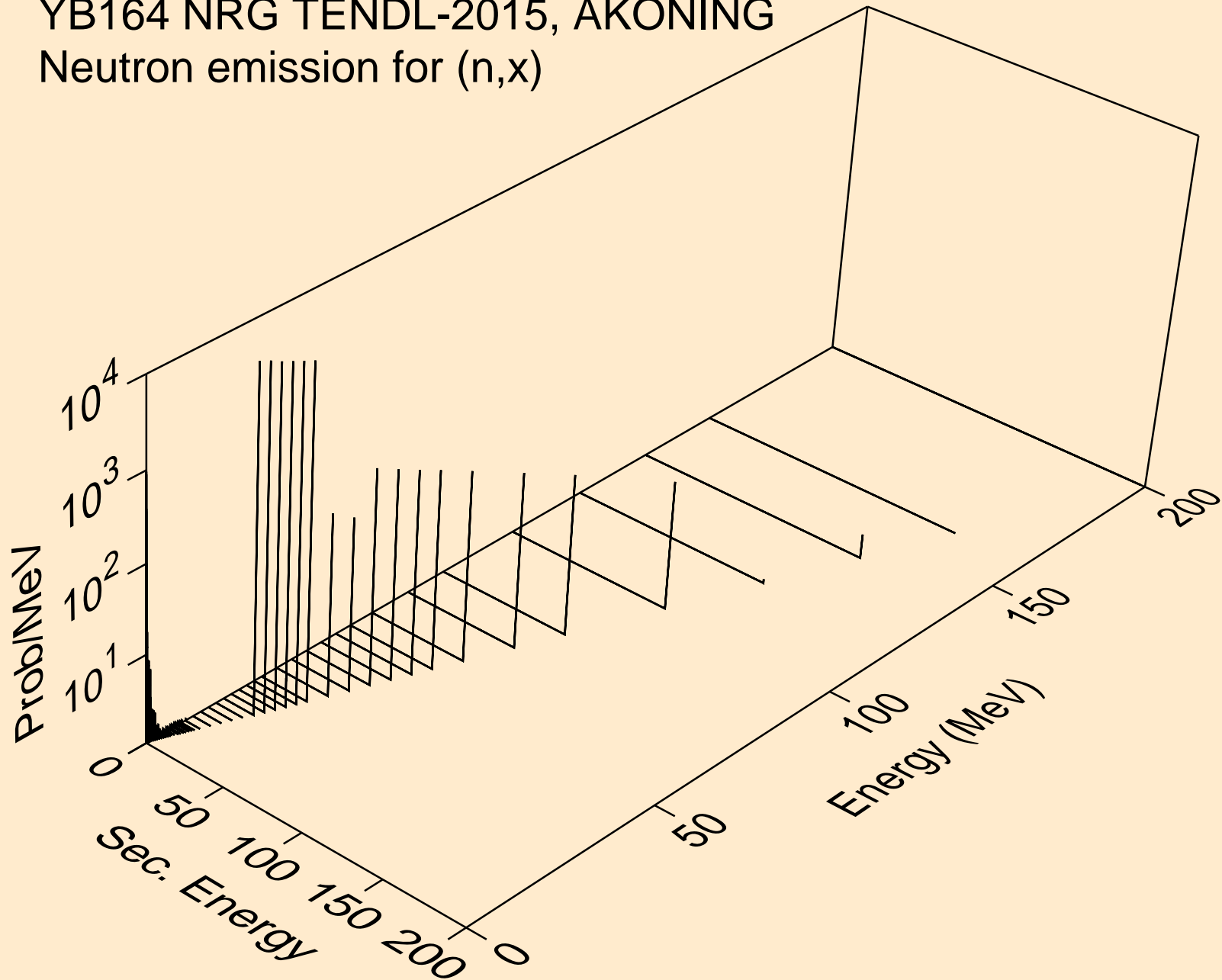

YB164 NRG TENDL-2015, AKONING  
Neutron emission for (n,2nd)

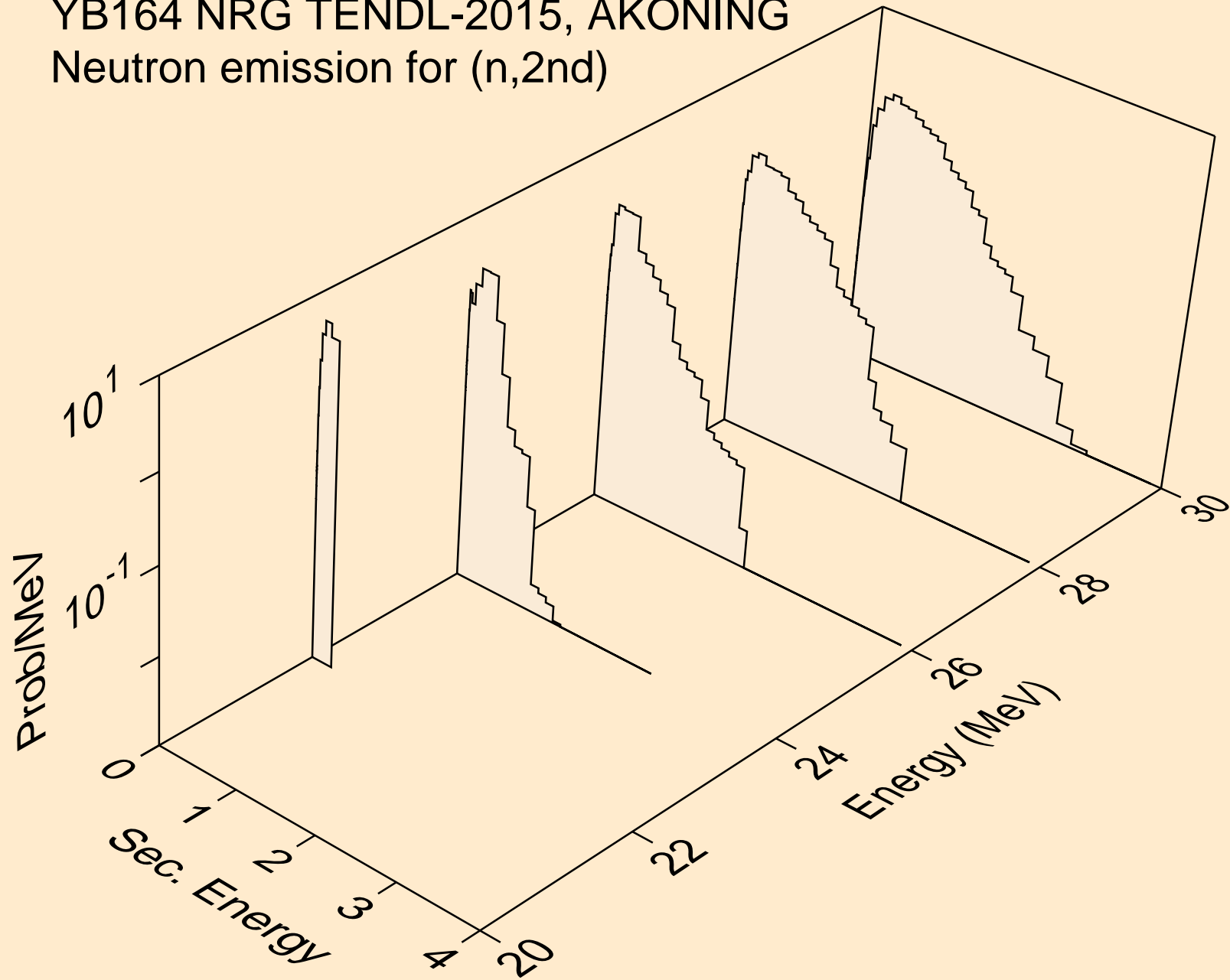

YB164 NRG TENDL-2015, AKONING  
Neutron emission for (n,2n)

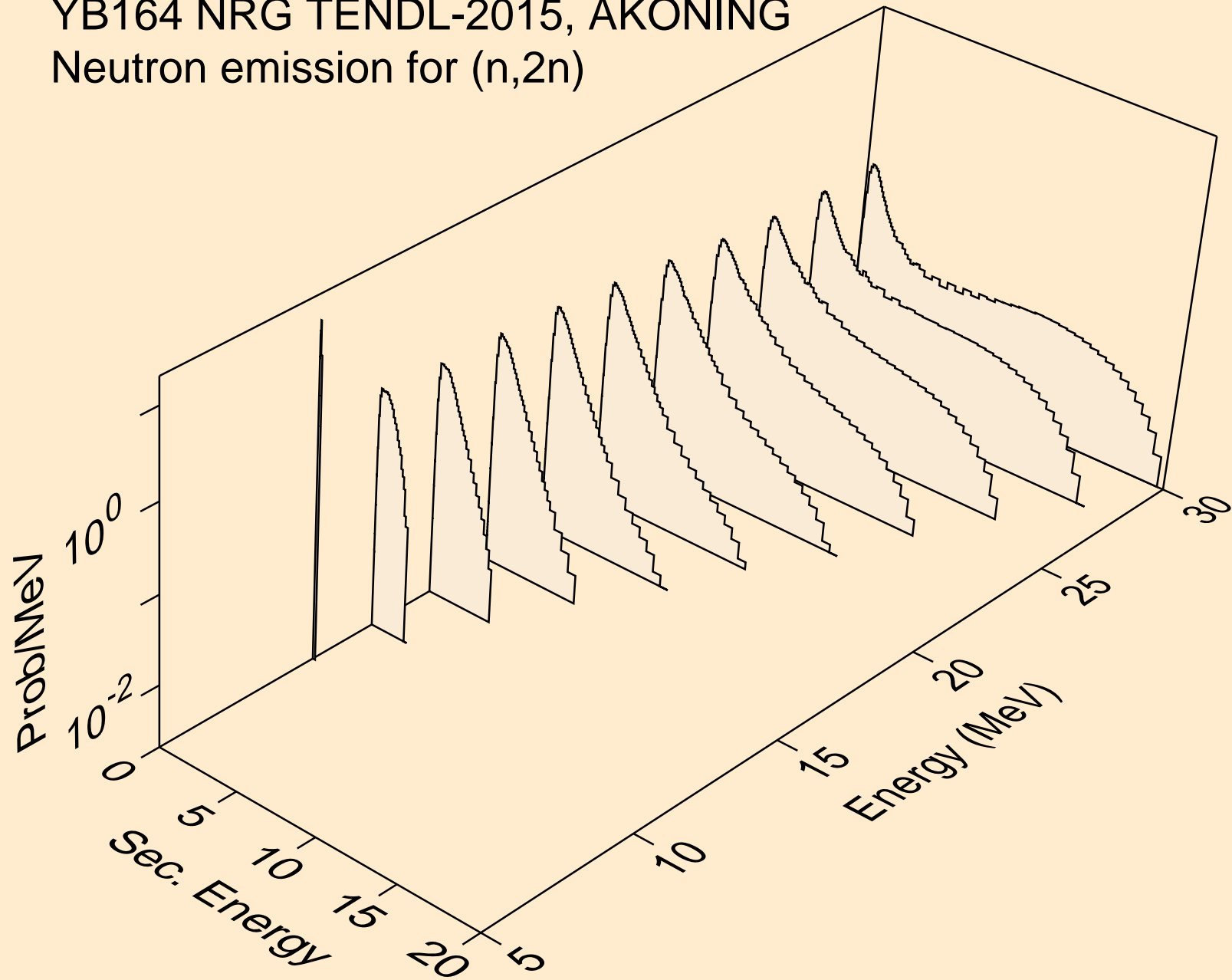



YB164 NRG TENDL-2015, AKONING  
Neutron emission for (n,3n)

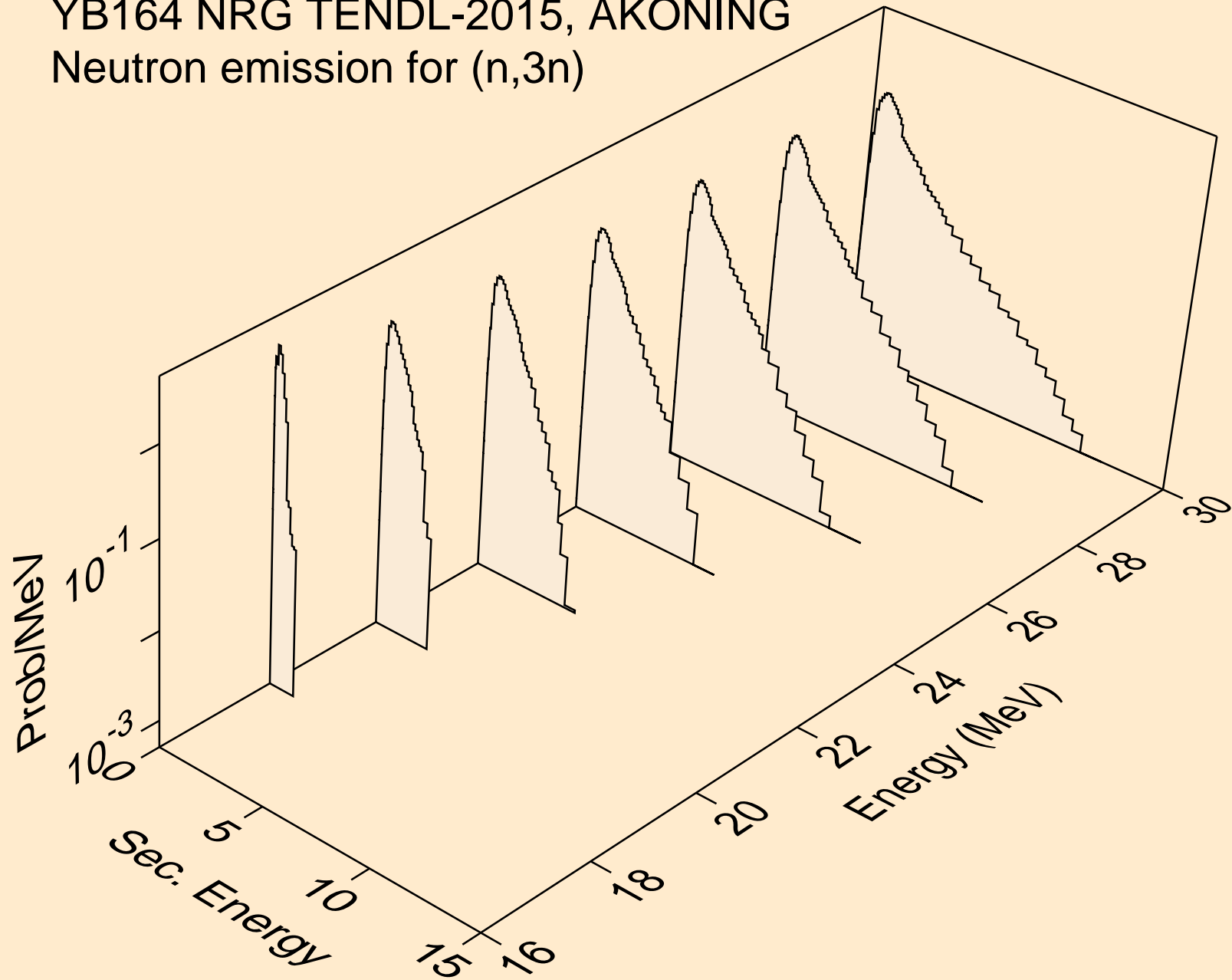

YB164 NRG TENDL-2015, AKONING  
Neutron emission for (n,n\*)a

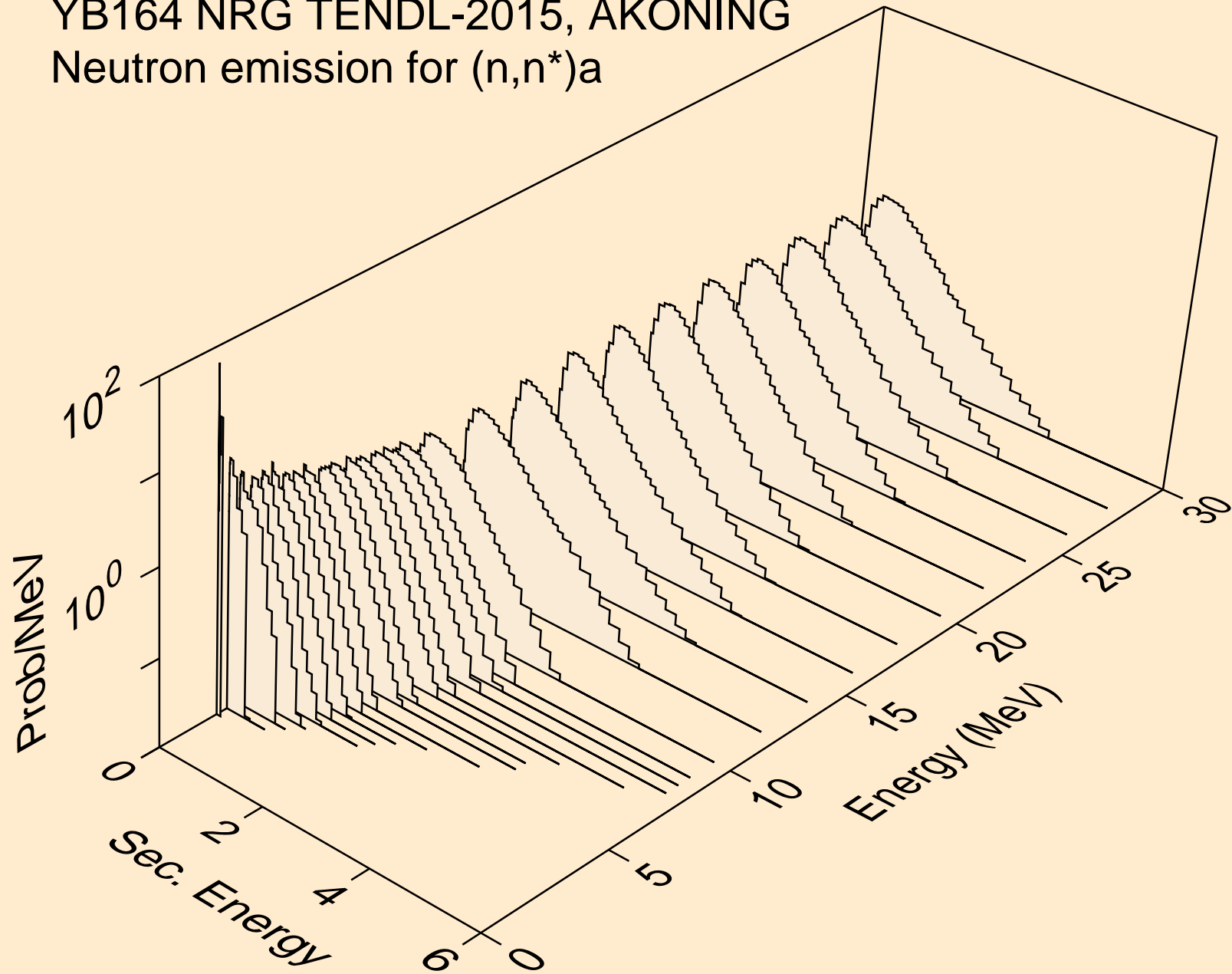

YB164 NRG TENDL-2015, AKONING  
Neutron emission for (n,2n)a

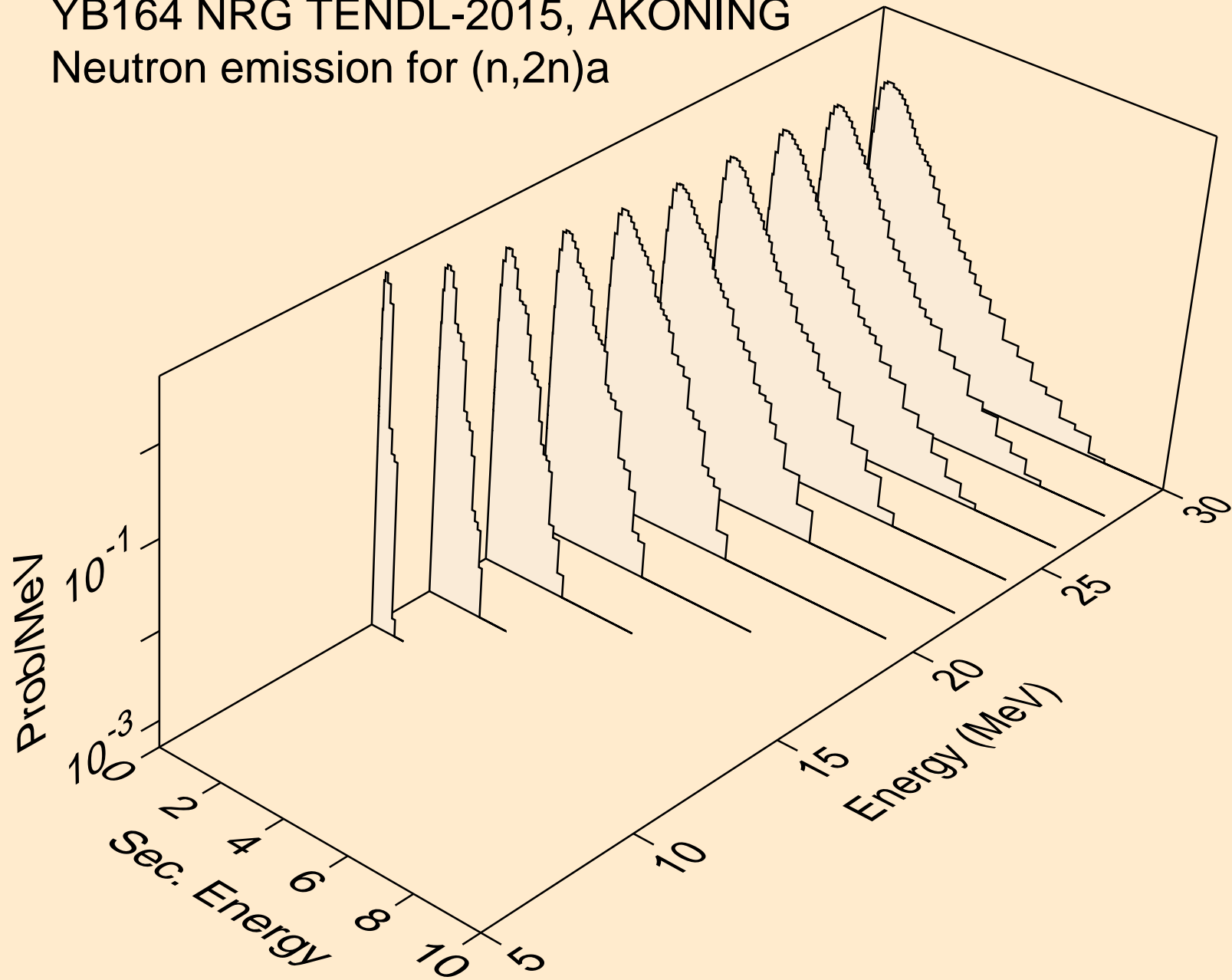

YB164 NRG TENDL-2015, AKONING  
Neutron emission for (n,3n)a

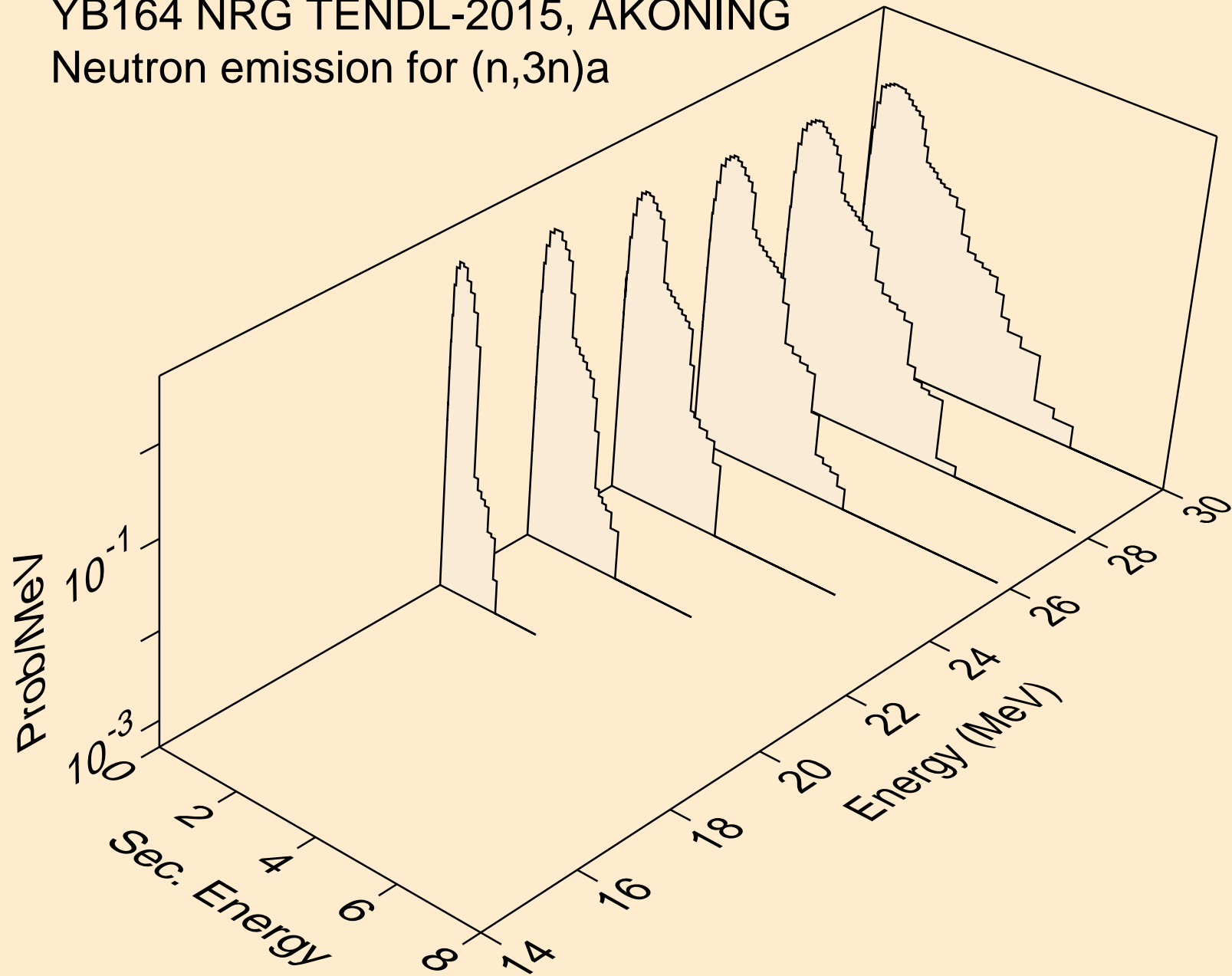

YB164 NRG TENDL-2015, AKONING  
Neutron emission for (n,n\*)p

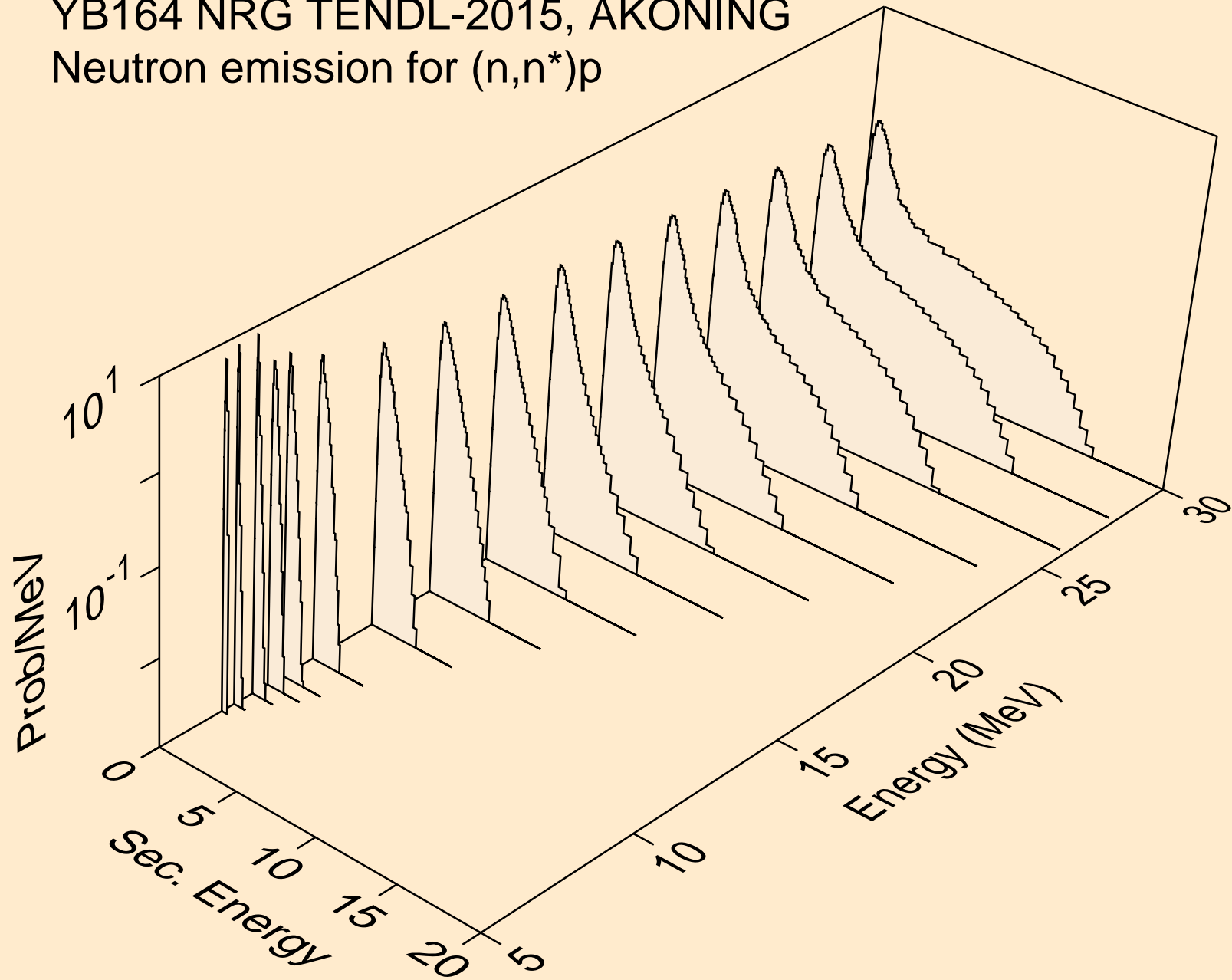

YB164 NRG TENDL-2015, AKONING  
Neutron emission for (n,n\*)2a

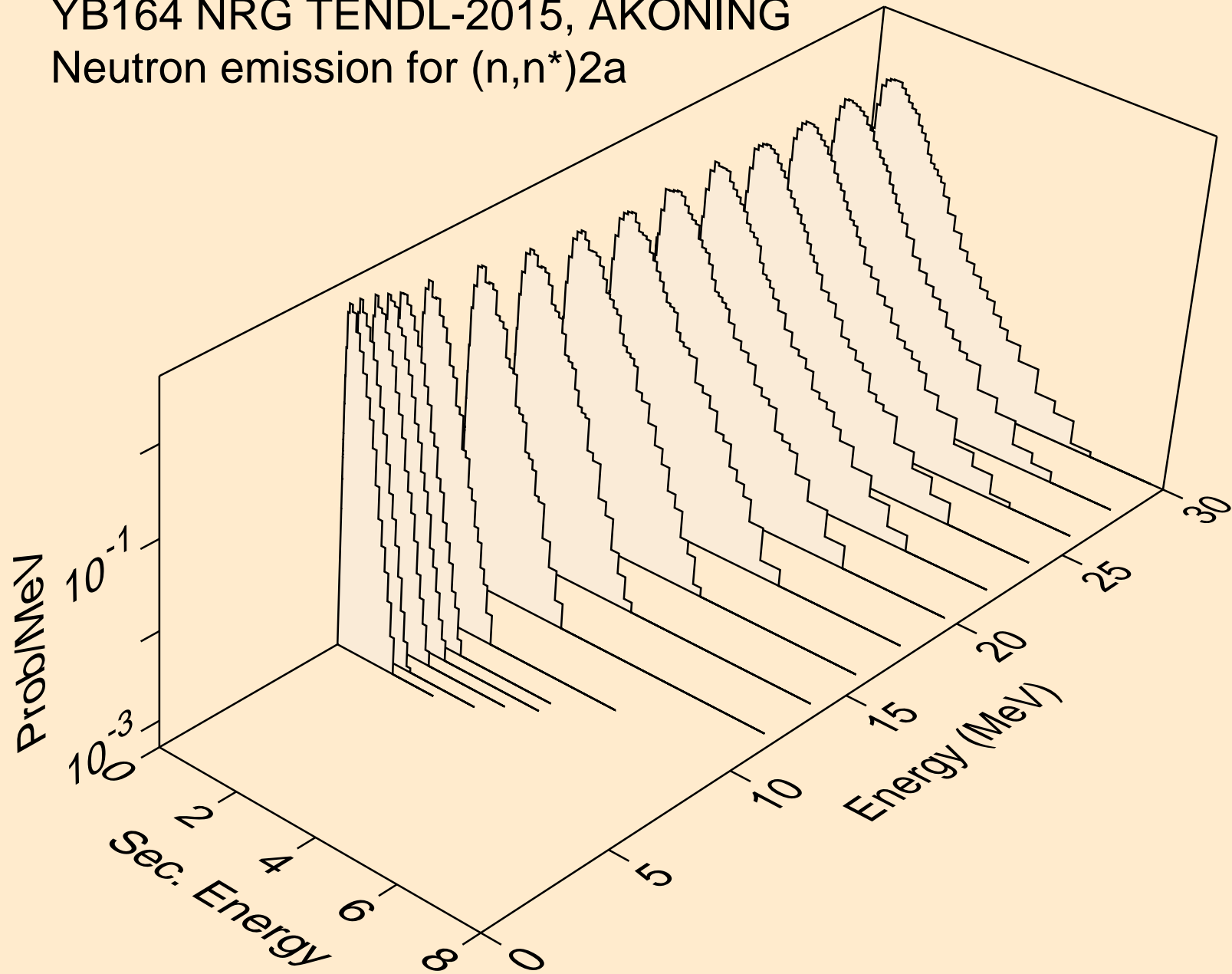

YB164 NRG TENDL-2015, AKONING  
Neutron emission for (n,2n)2a

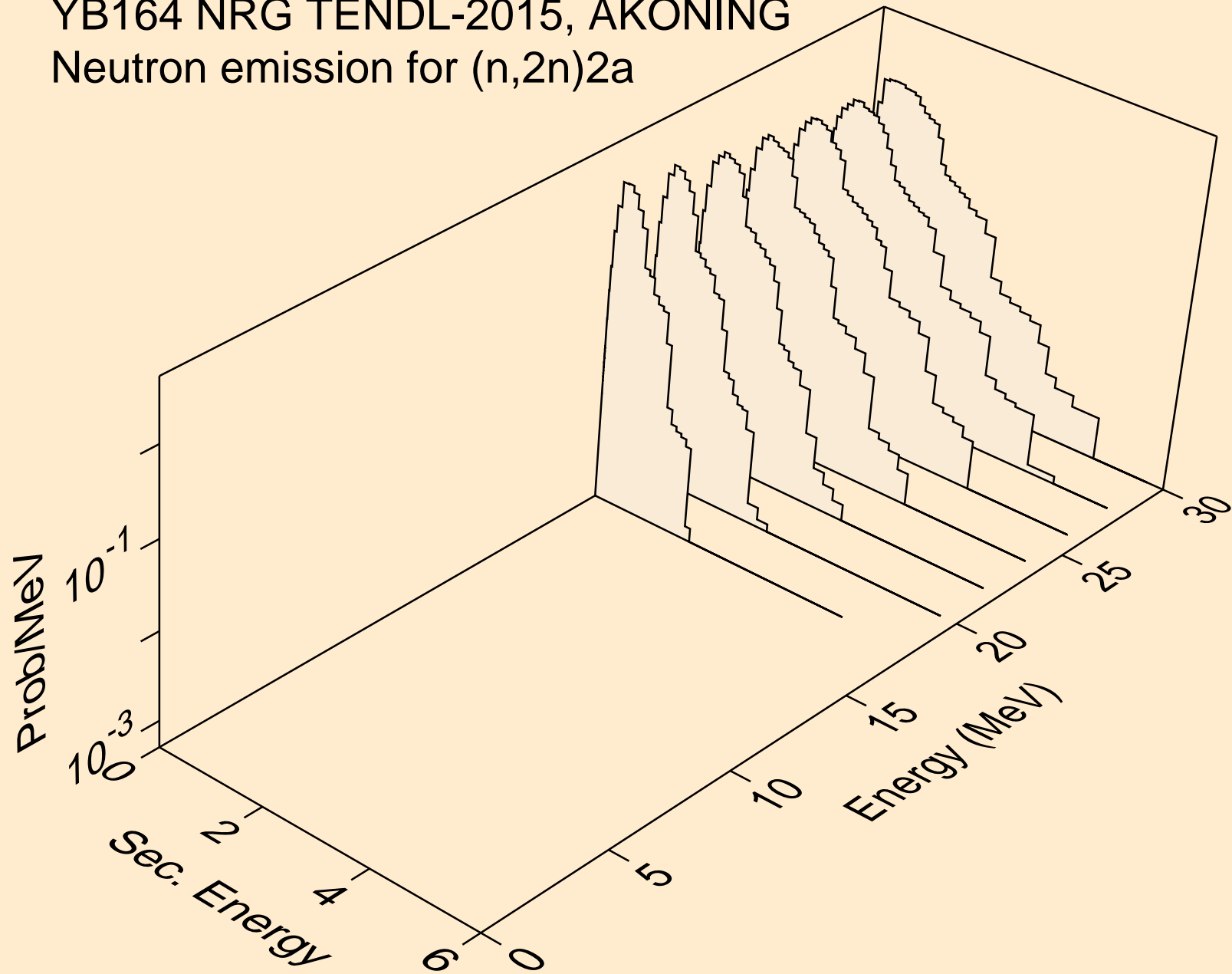

YB164 NRG TENDL-2015, AKONING  
Neutron emission for (n,n\*)d

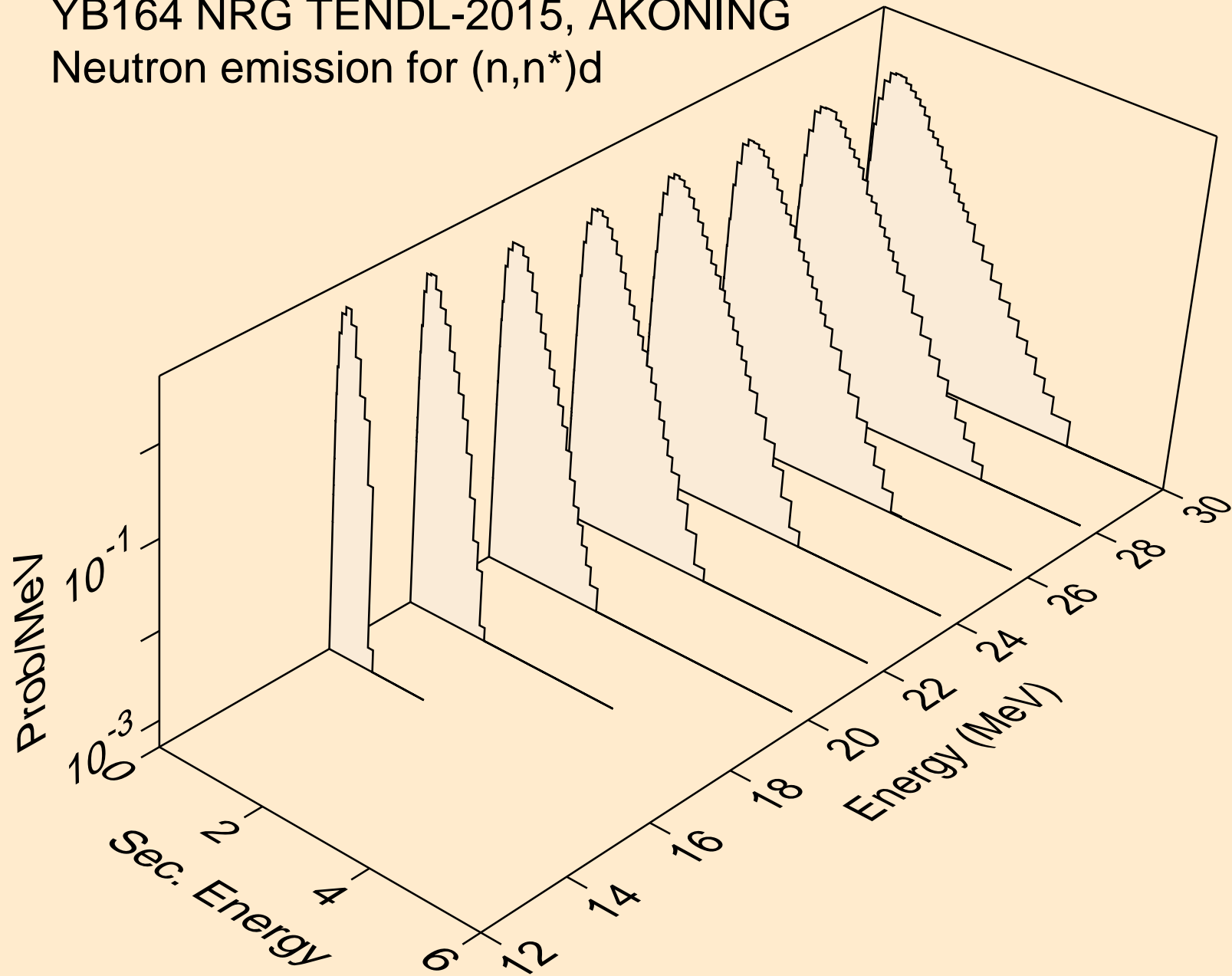



YB164 NRG TENDL-2015, AKONING  
Neutron emission for (n,n\*)t

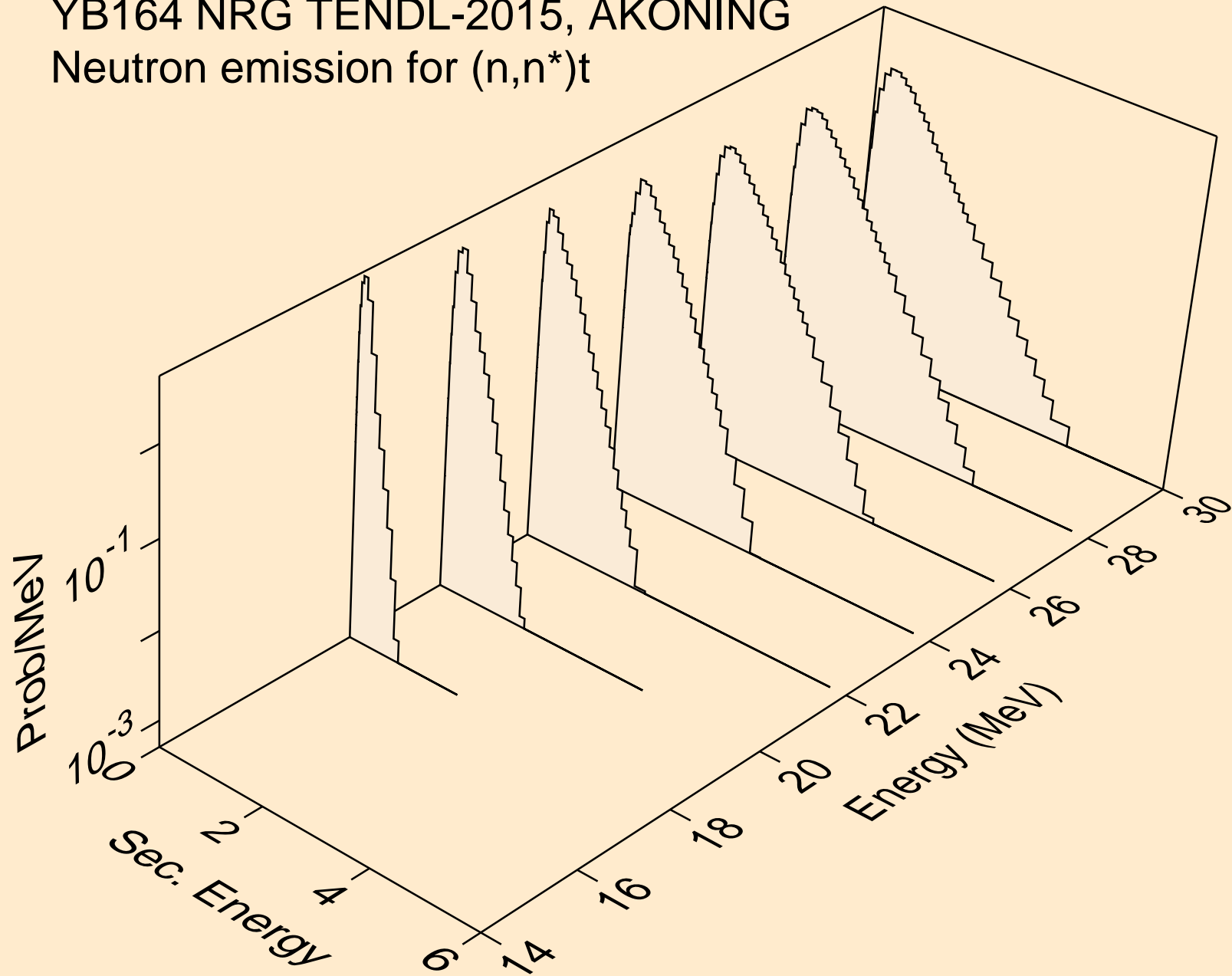

YB164 NRG TENDL-2015, AKONING  
Neutron emission for (n,n\*)he3

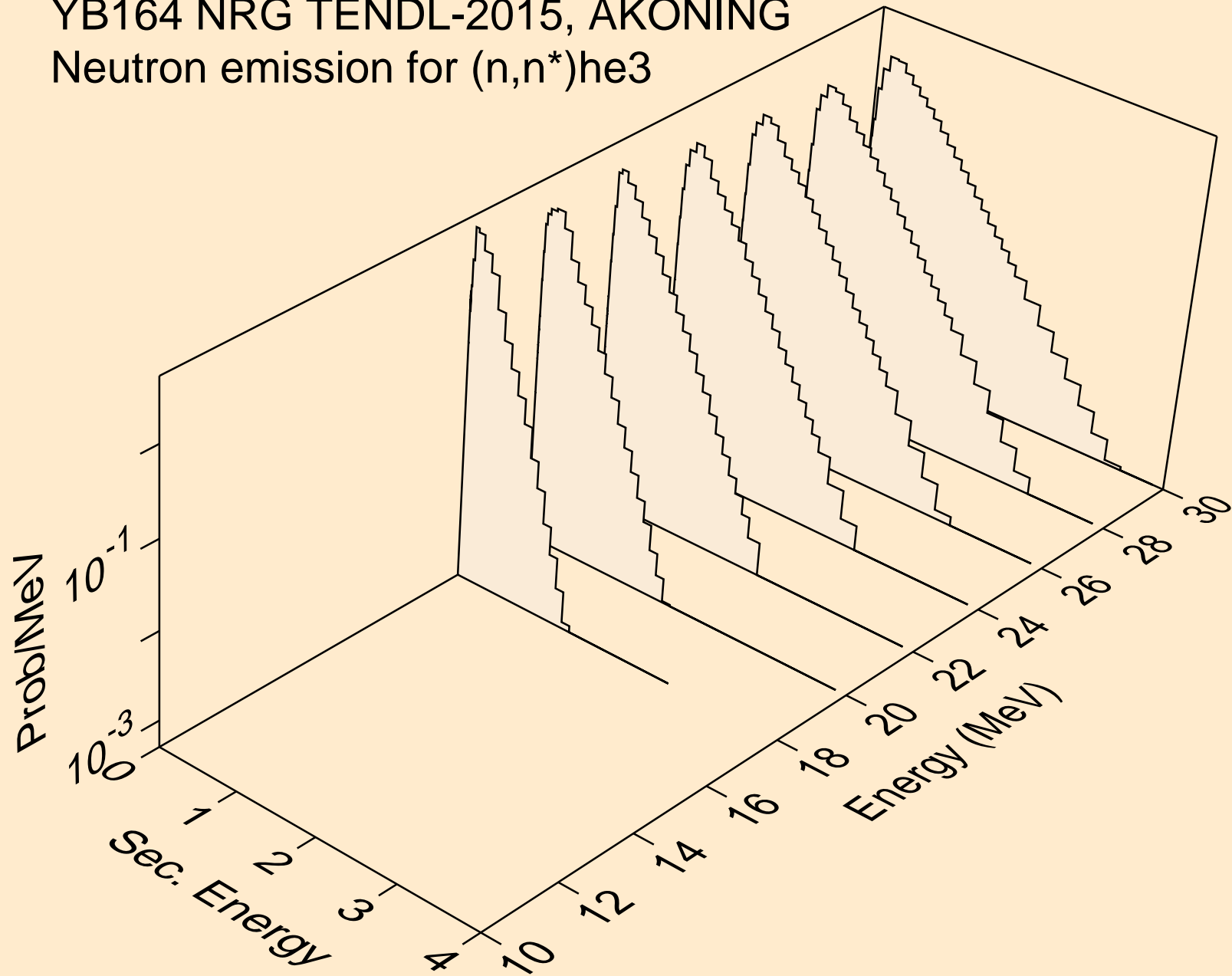

YB164 NRG TENDL-2015, AKONING  
Neutron emission for (n,4n)

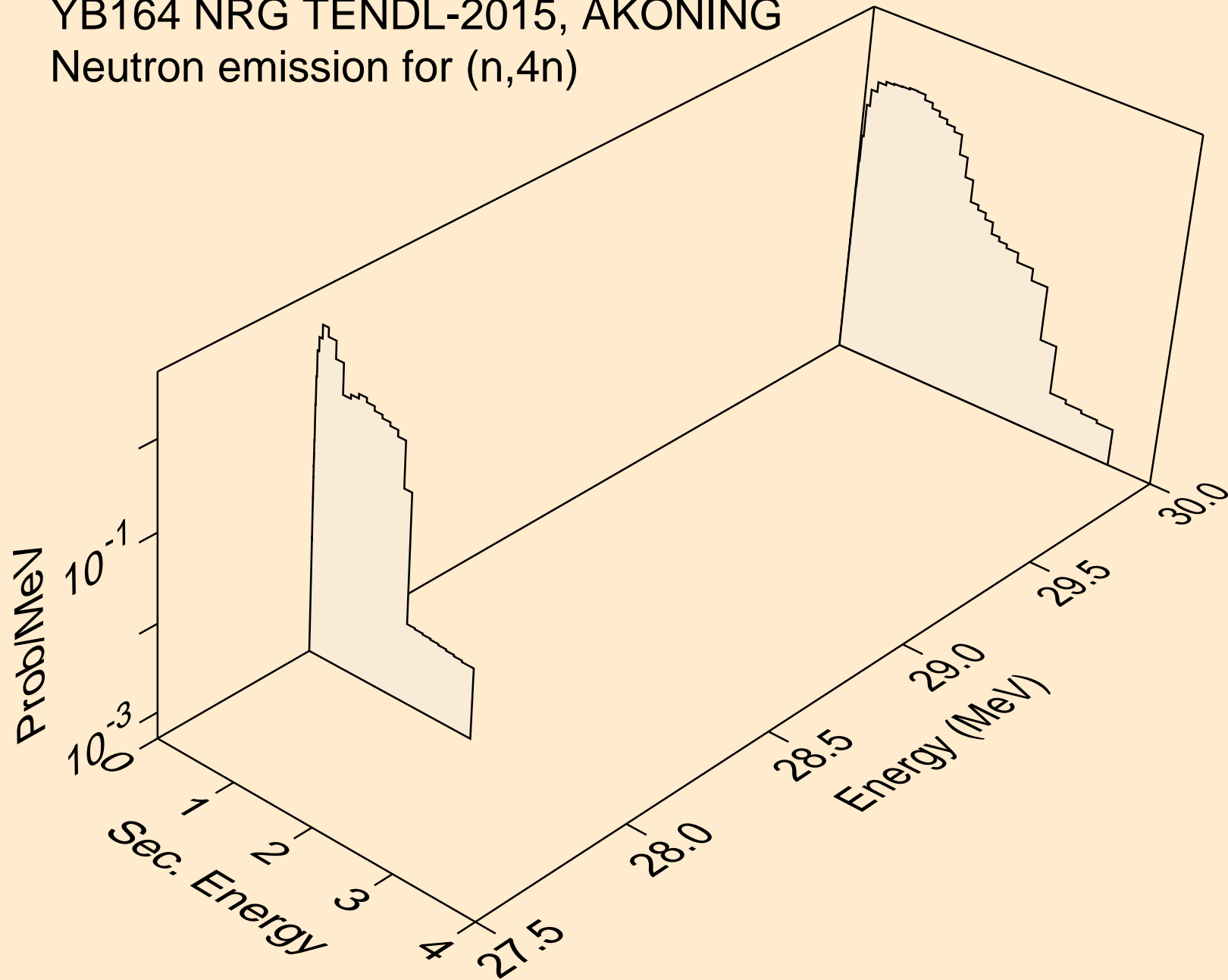

YB164 NRG TENDL-2015, AKONING  
Neutron emission for (n,2np)

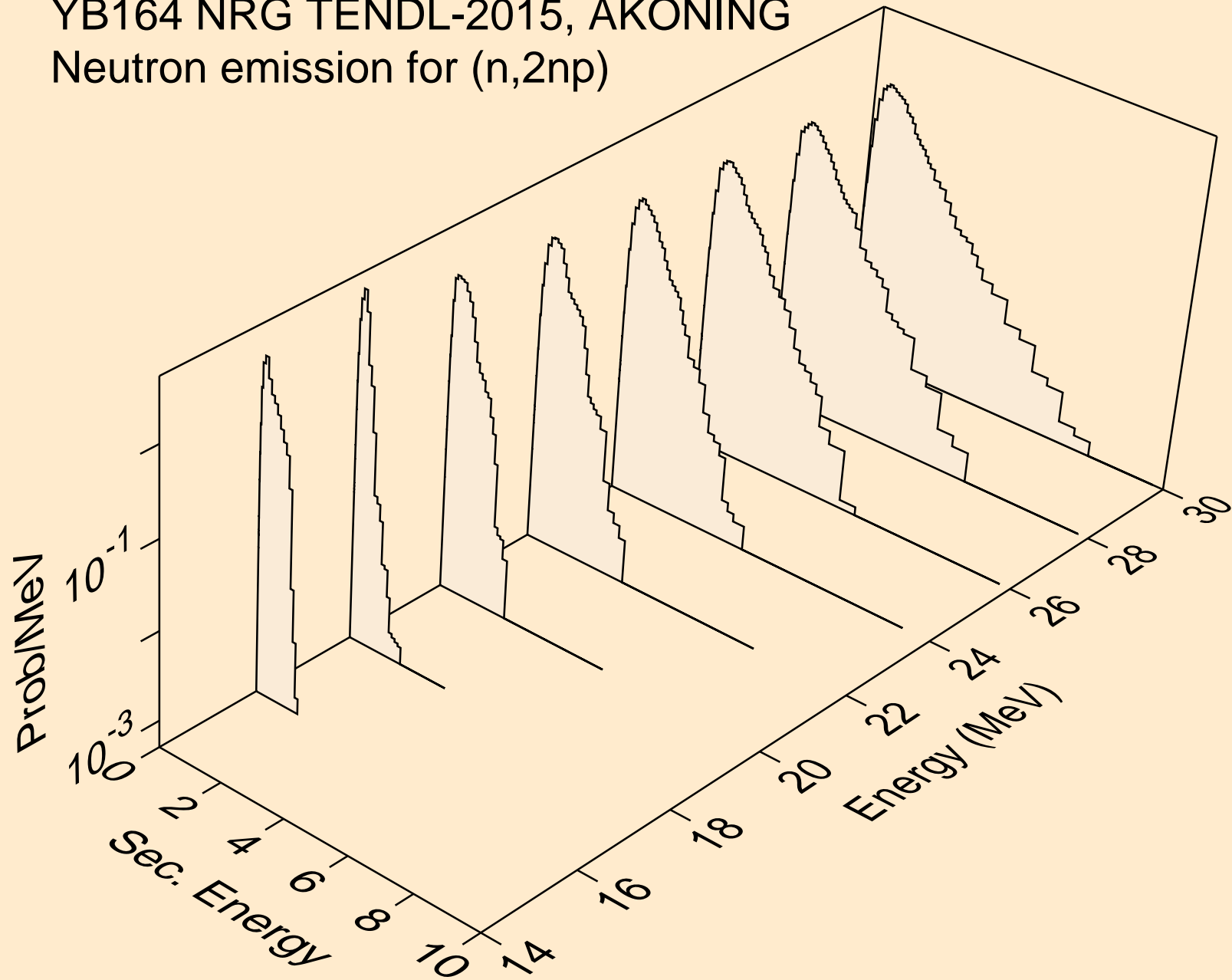

YB164 NRG TENDL-2015, AKONING  
Neutron emission for (n,3np)

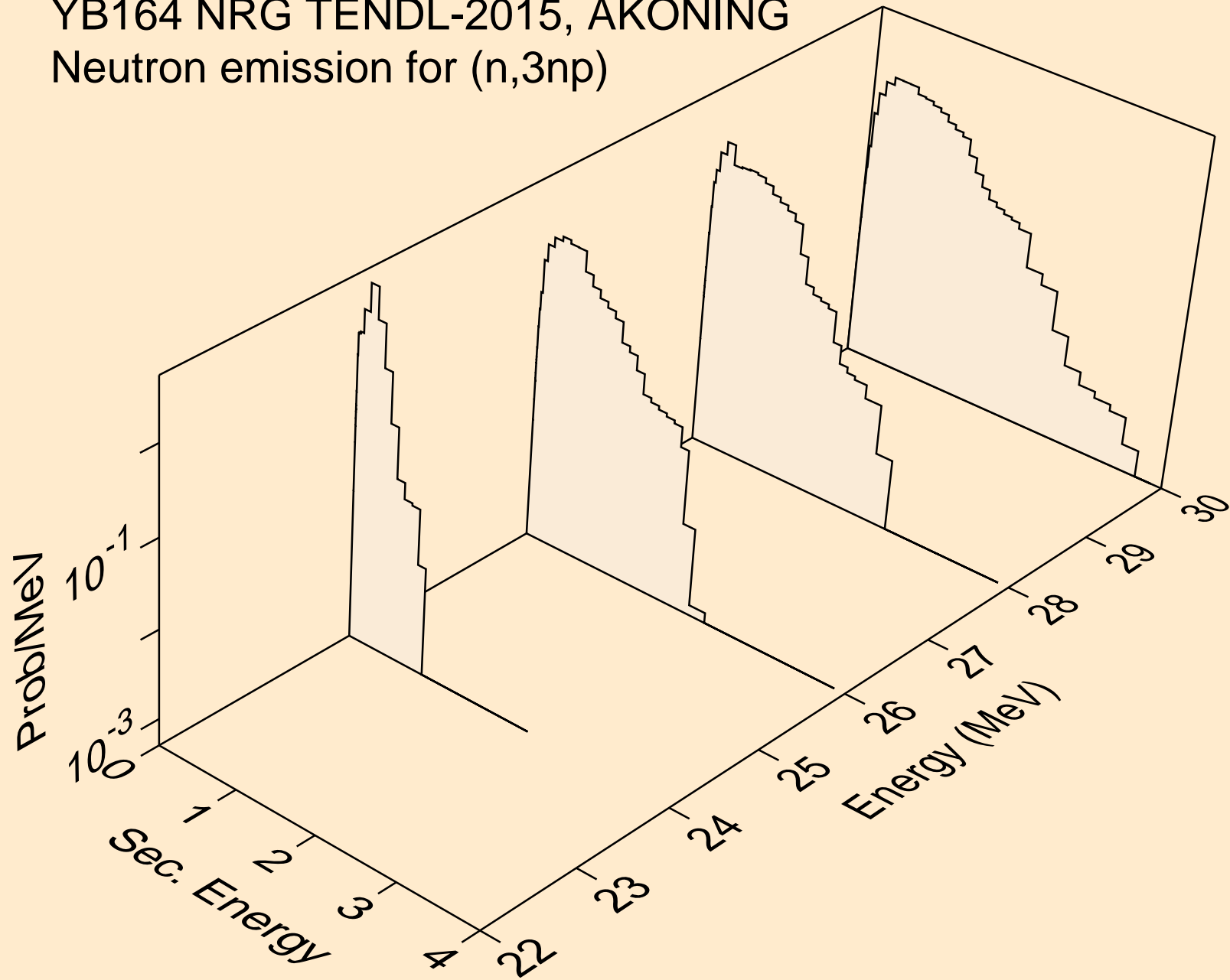

YB164 NRG TENDL-2015, AKONING  
Neutron emission for (n,2np)

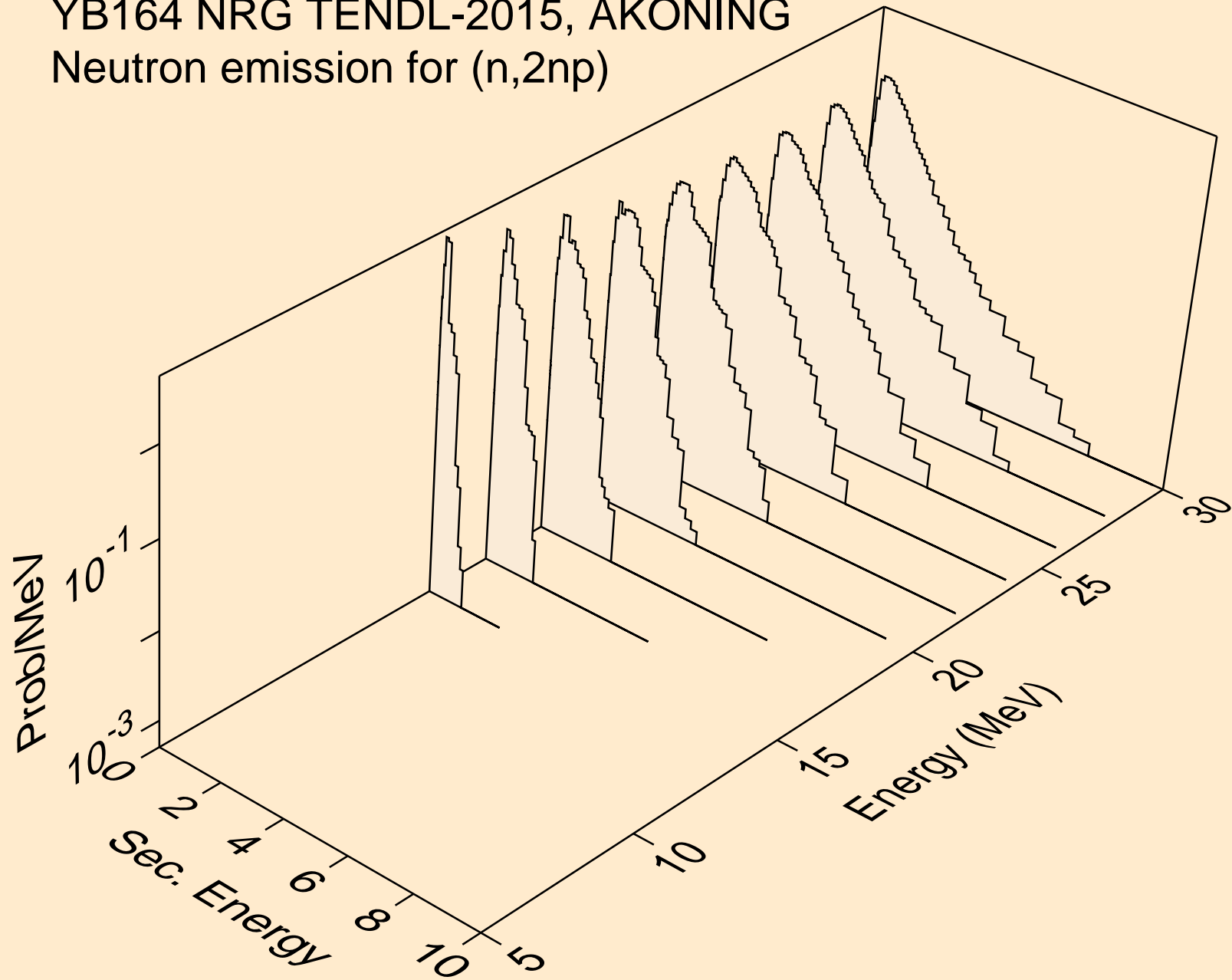

YB164 NRG TENDL-2015, AKONING  
Neutron emission for (n,npa)

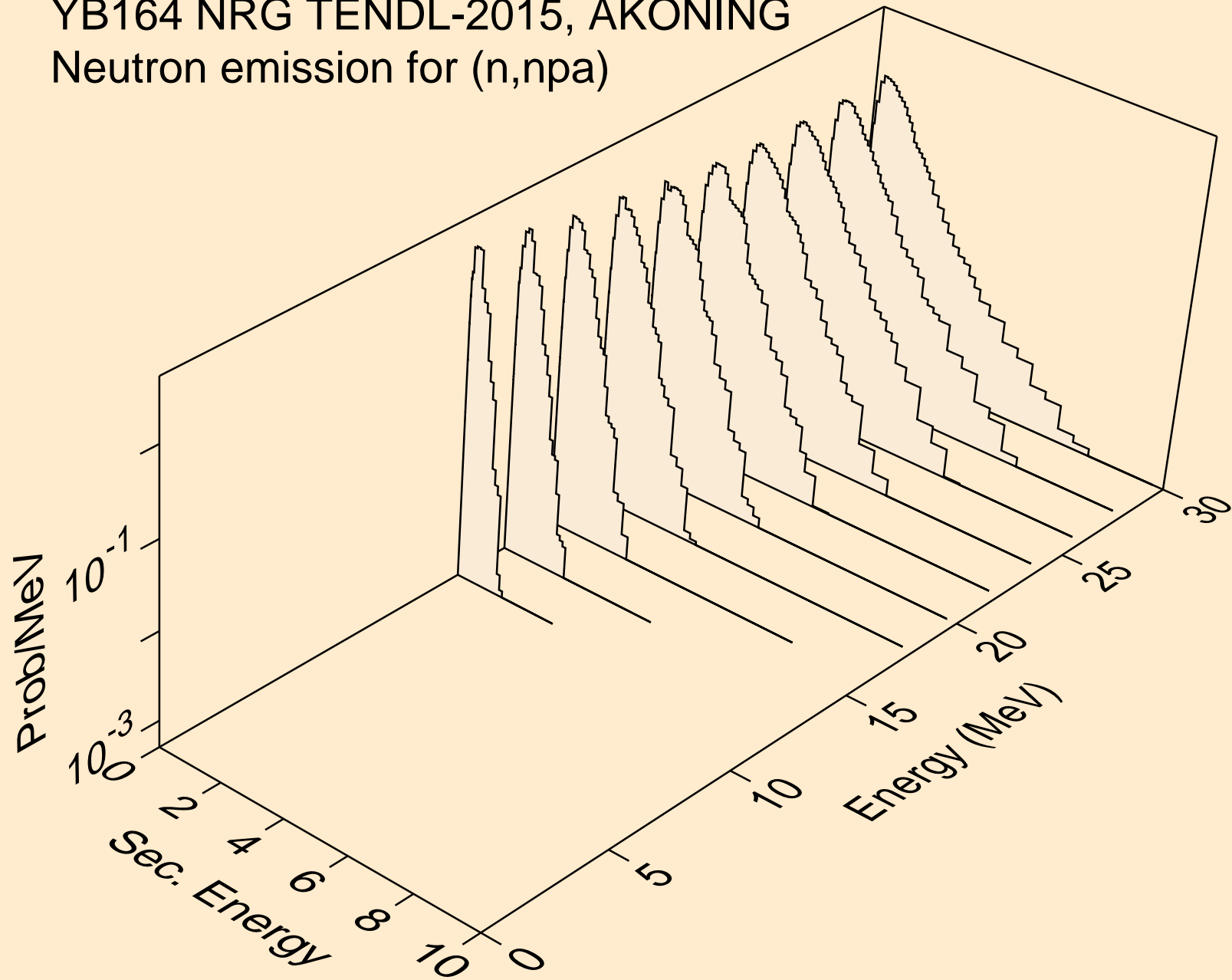

YB164 NRG TENDL-2015, AKONING  
Neutron emission for (n,n\*c)

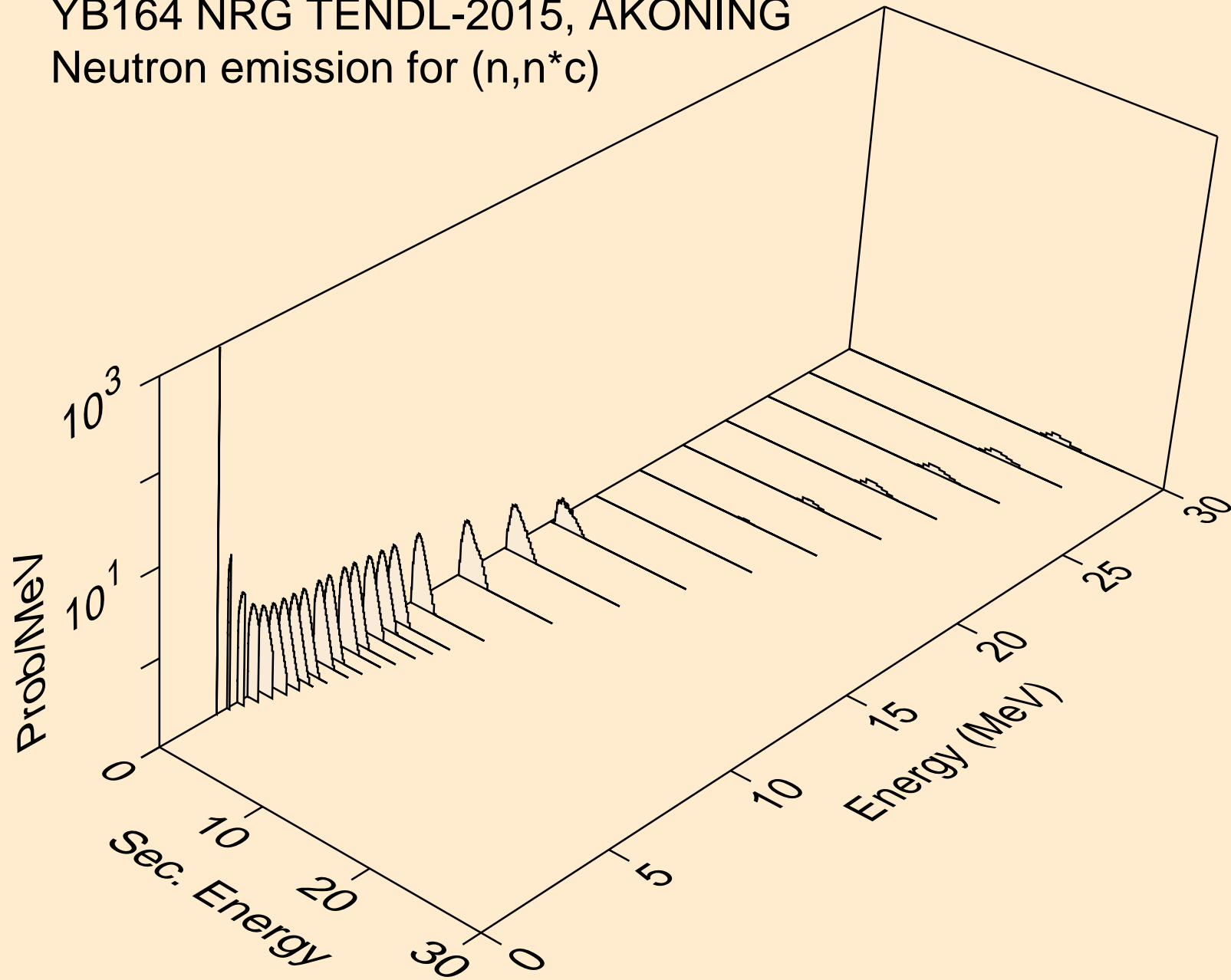



YB164 NRG TENDL-2015, AKONING  
Photon emission for (n,x)

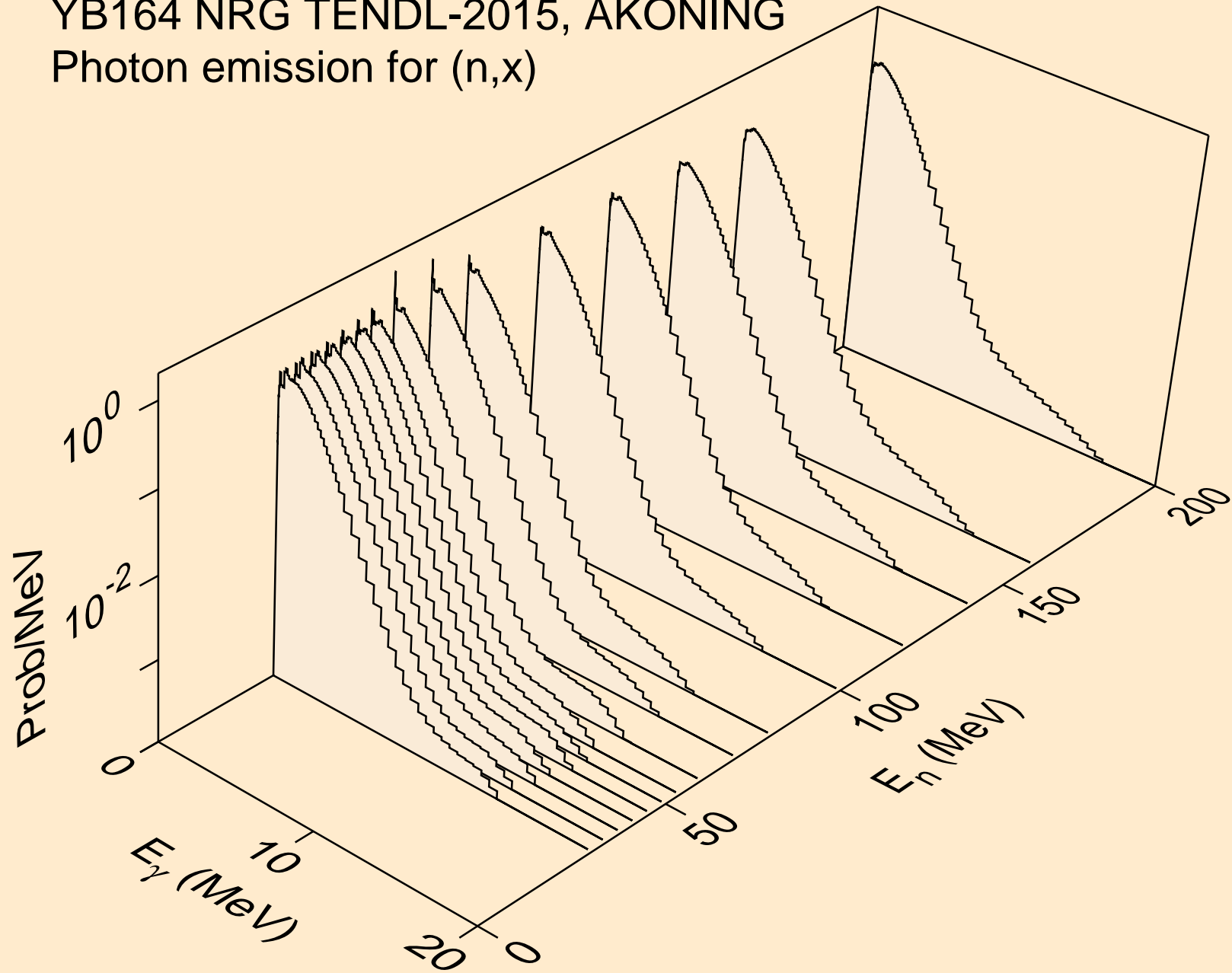

YB164 NRG TENDL-2015, AKONING  
Photon emission for (n,2nd)

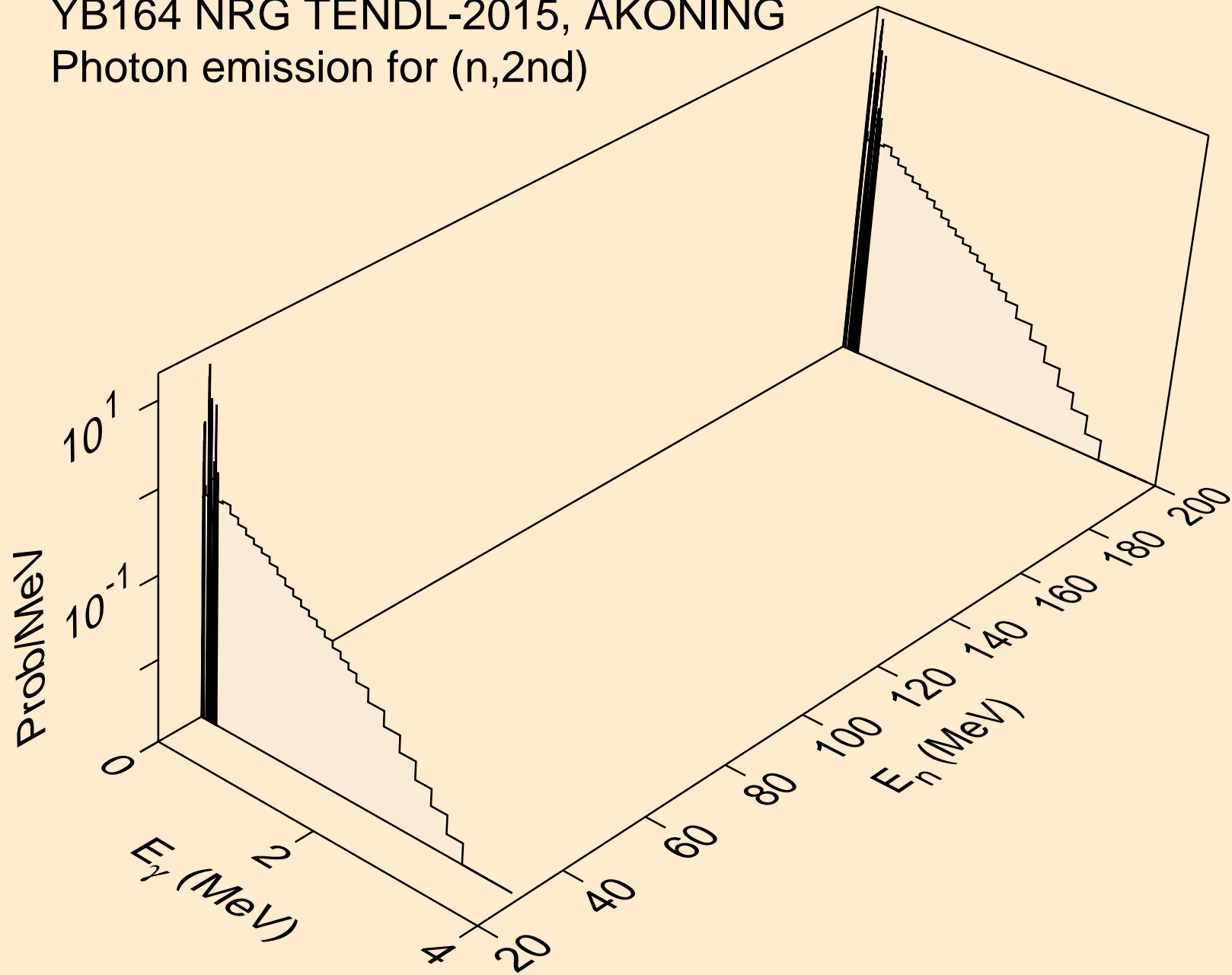

YB164 NRG TENDL-2015, AKONING  
Photon emission for (n,2n)

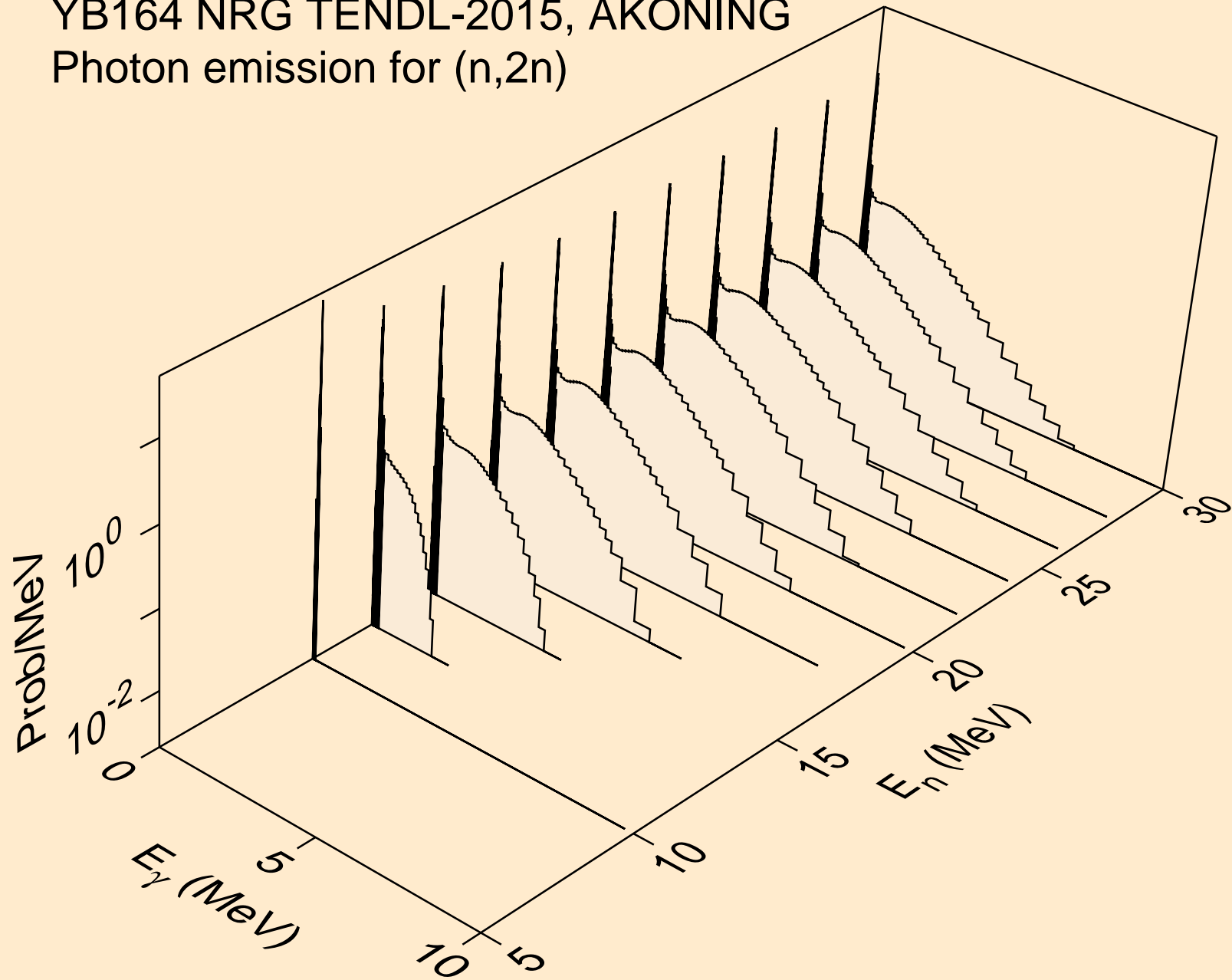

YB164 NRG TENDL-2015, AKONING  
Photon emission for (n,3n)

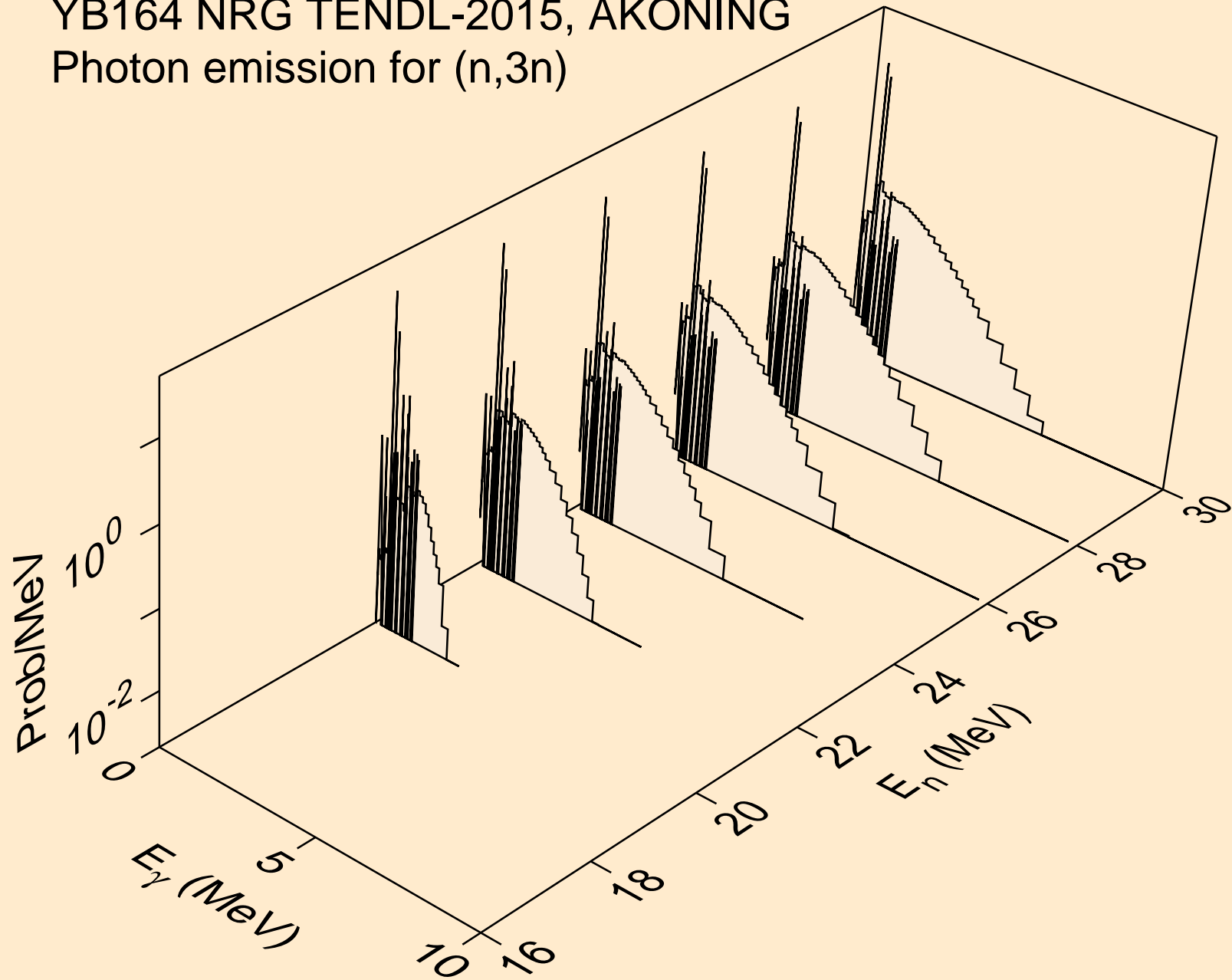

YB164 NRG TENDL-2015, AKONING  
Photon emission for (n,n\*)a

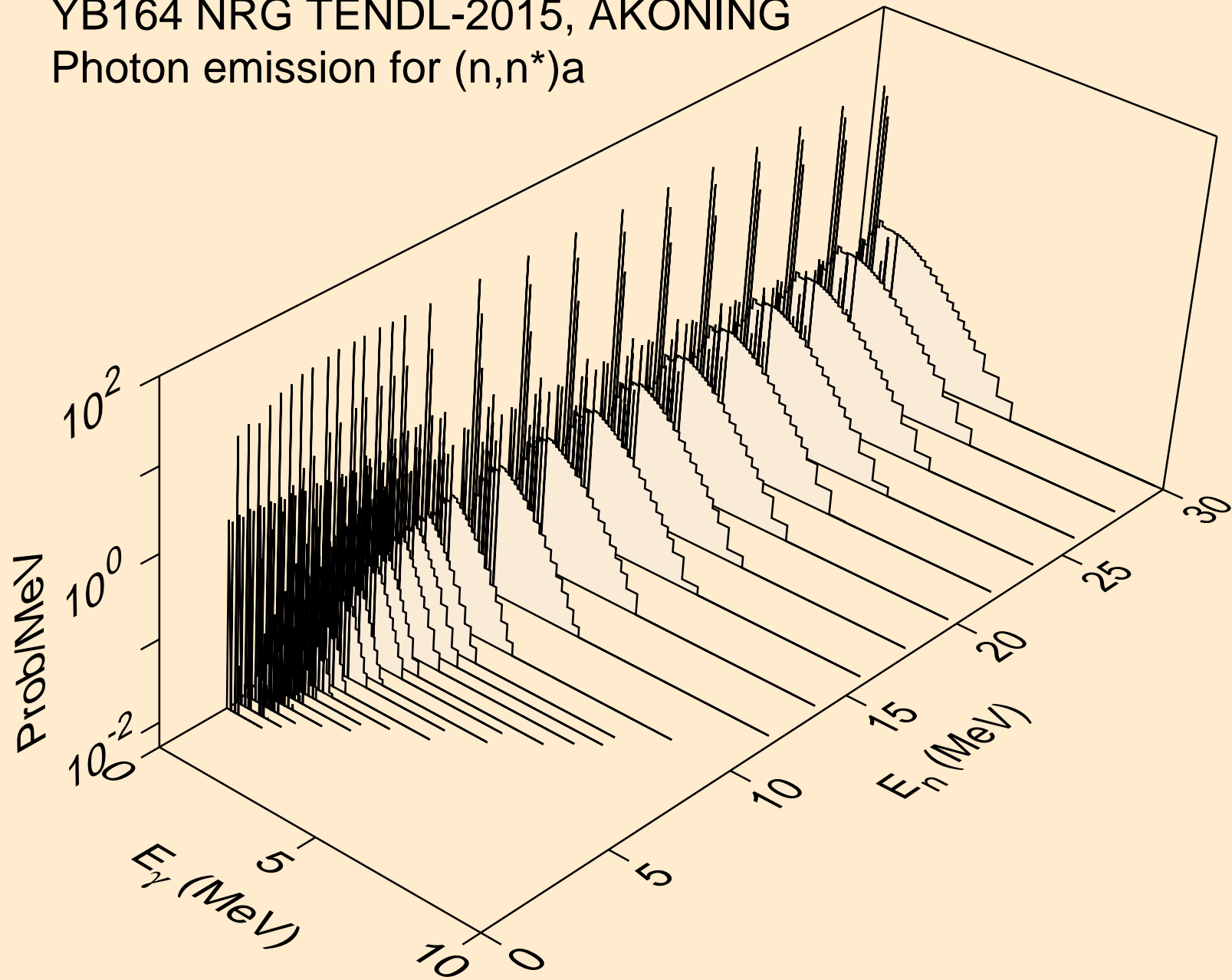

YB164 NRG TENDL-2015, AKONING  
Photon emission for (n,2n) $\alpha$

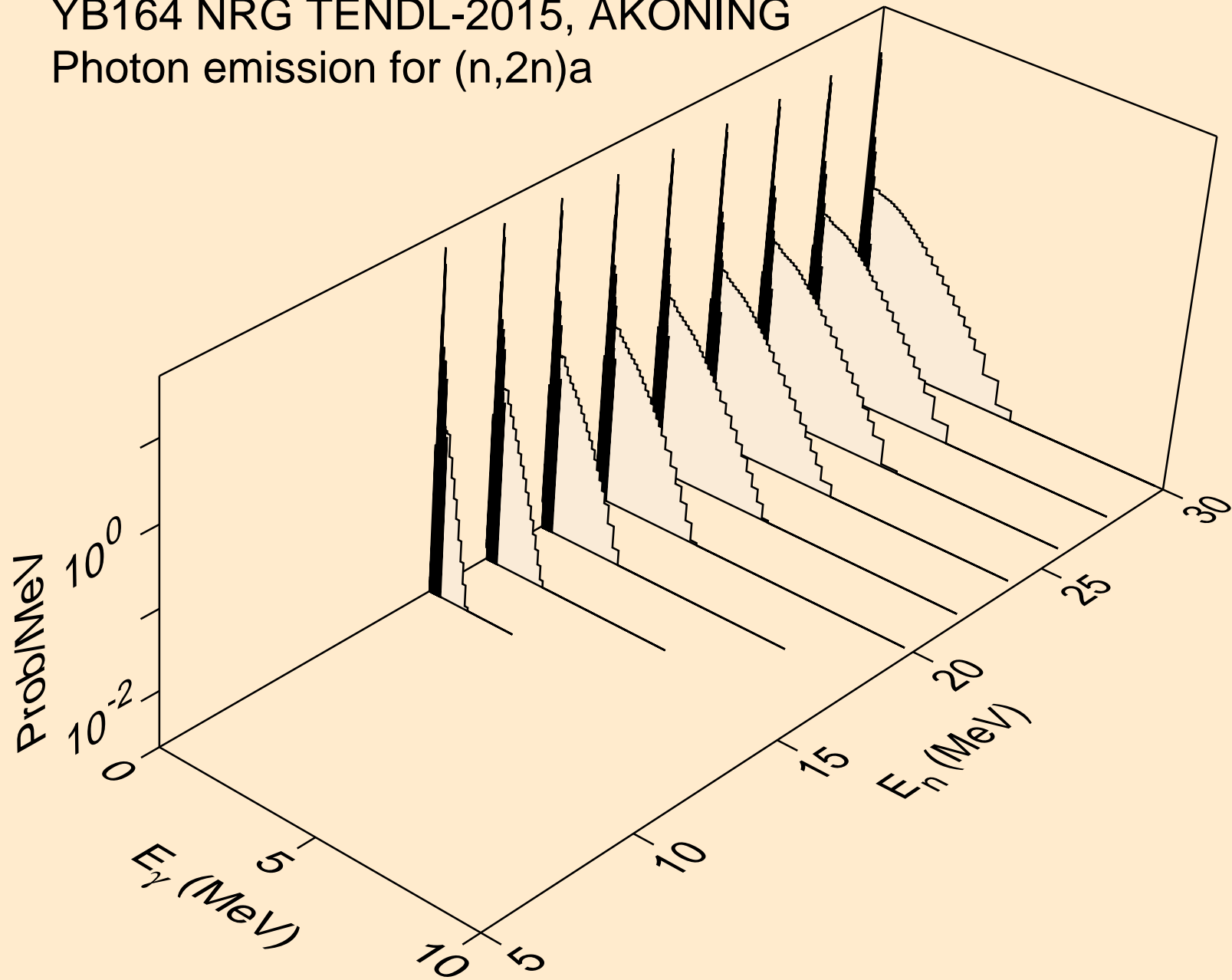

YB164 NRG TENDL-2015, AKONING  
Photon emission for (n,3n)a

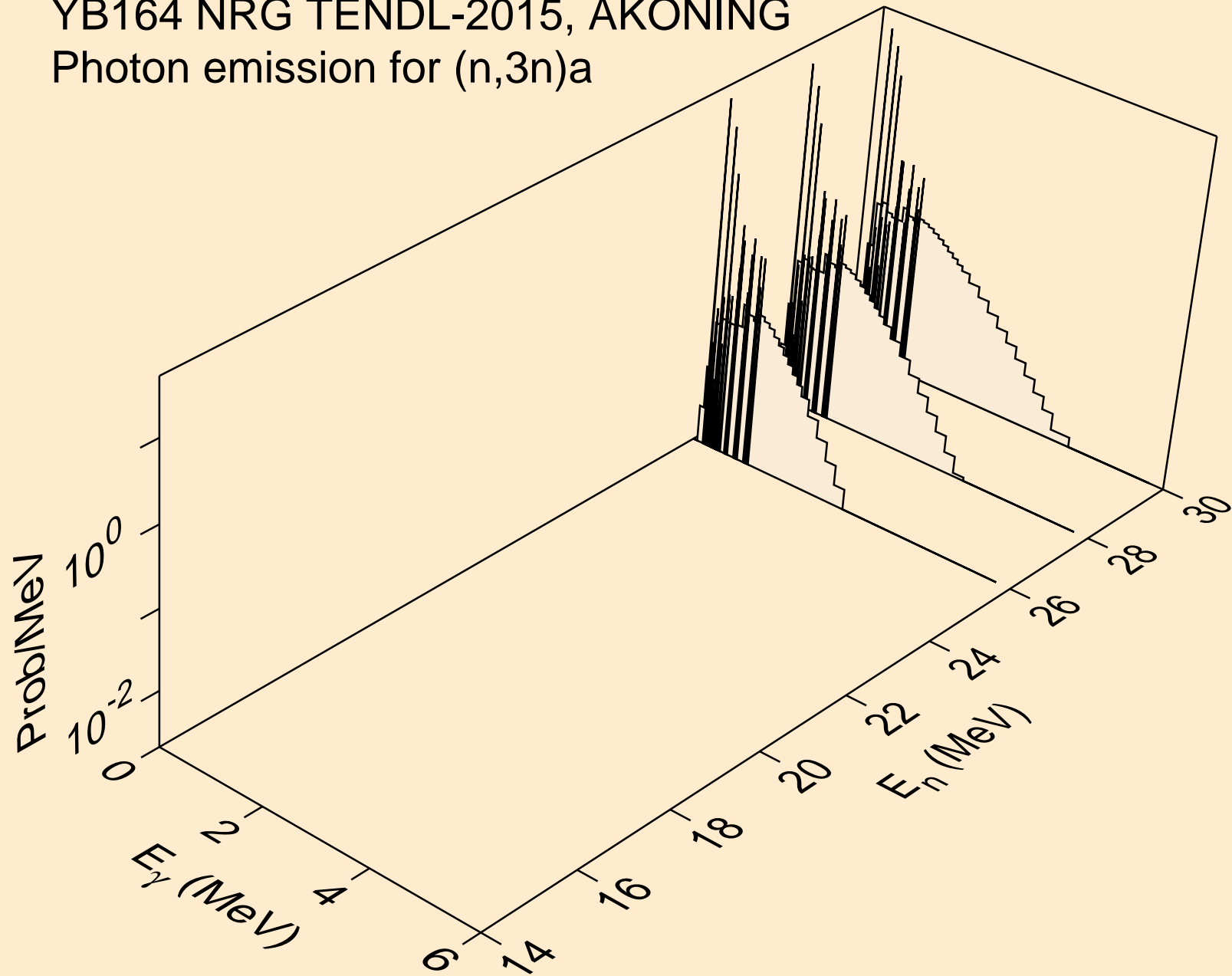

YB164 NRG TENDL-2015, AKONING  
Photon emission for (n,n\*)p

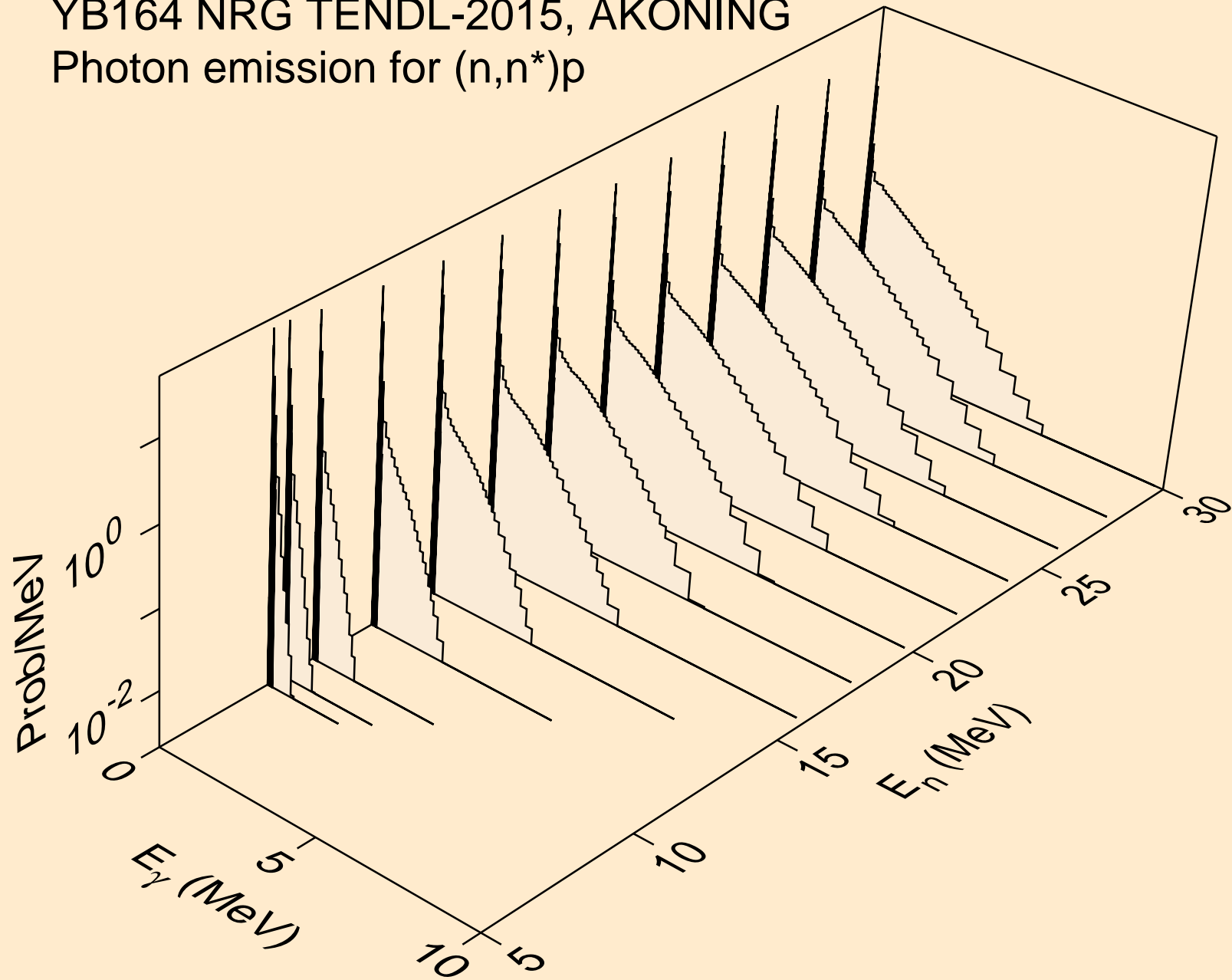



YB164 NRG TENDL-2015, AKONING  
Photon emission for (n,n\*)2a

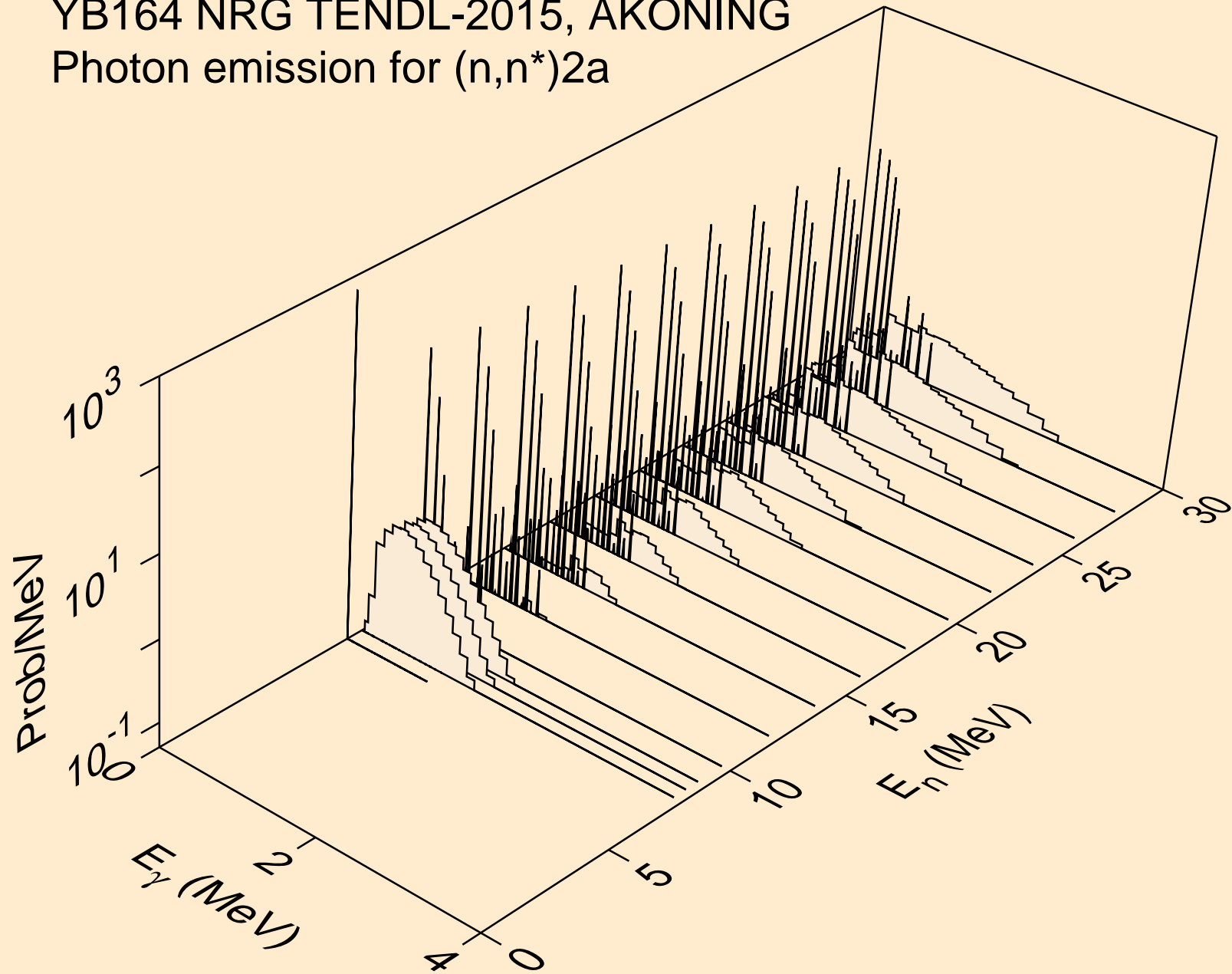

YB164 NRG TENDL-2015, AKONING  
Photon emission for (n,2n)2a

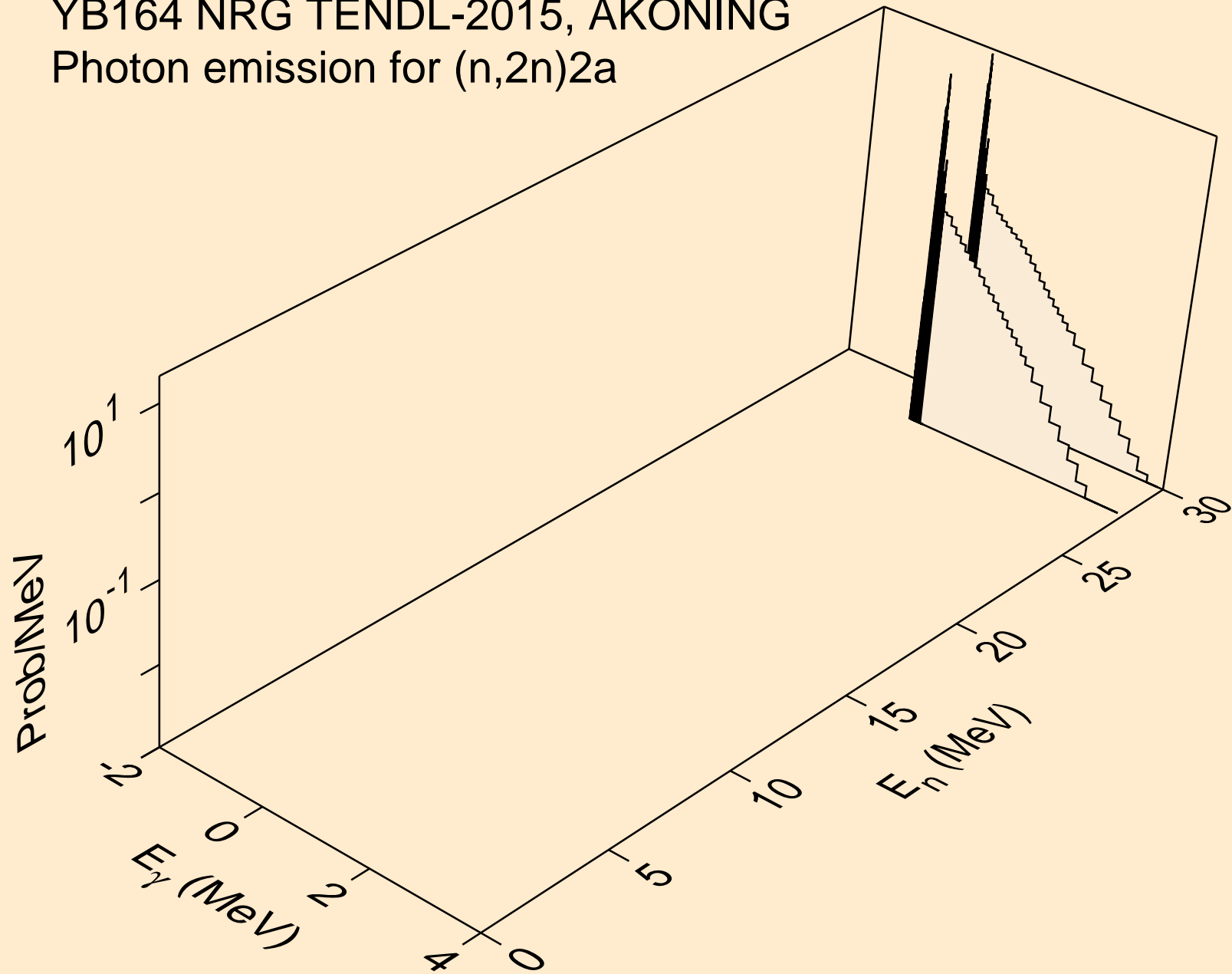

YB164 NRG TENDL-2015, AKONING  
Photon emission for (n,n\*)d

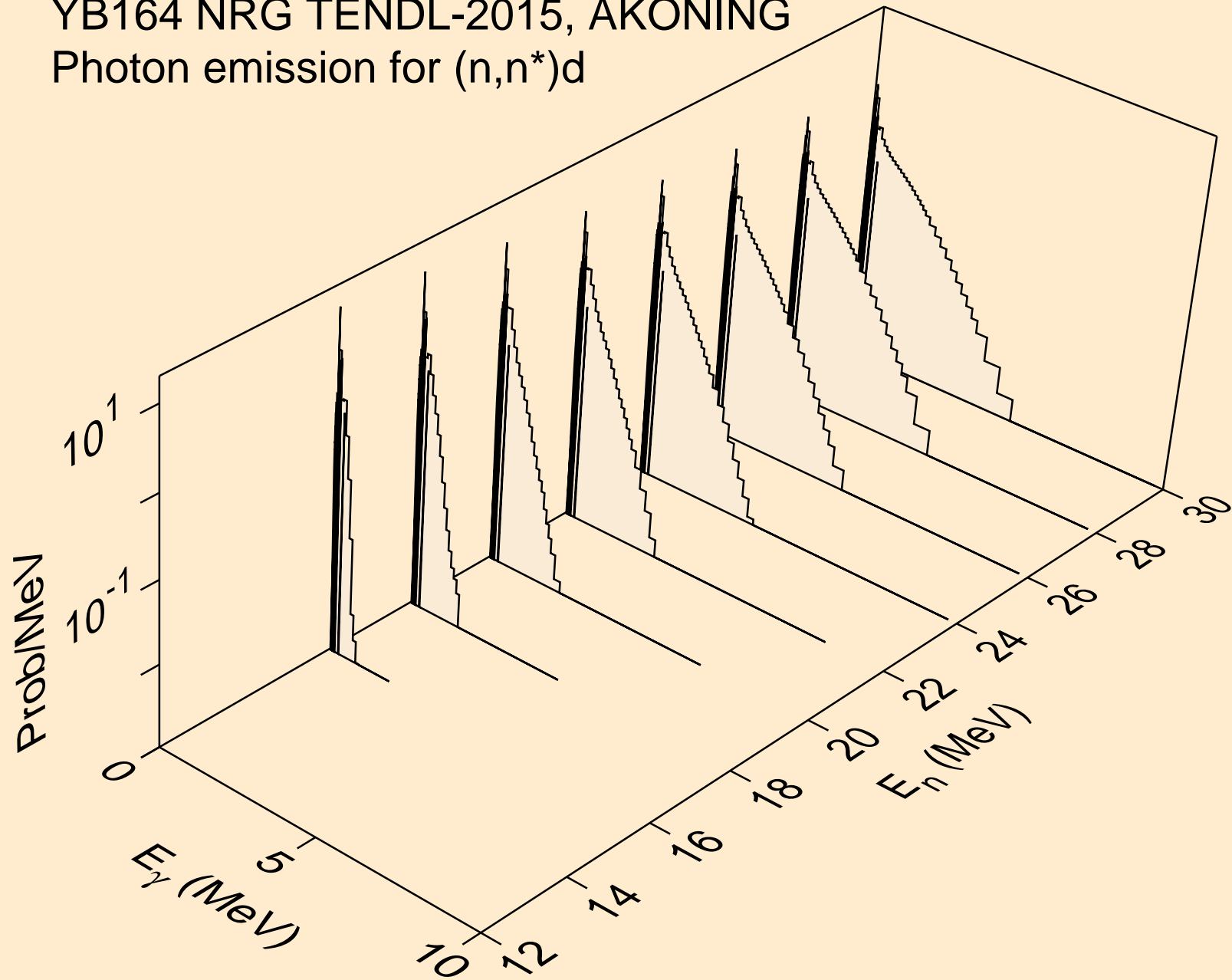

YB164 NRG TENDL-2015, AKONING  
Photon emission for (n,n\*)t

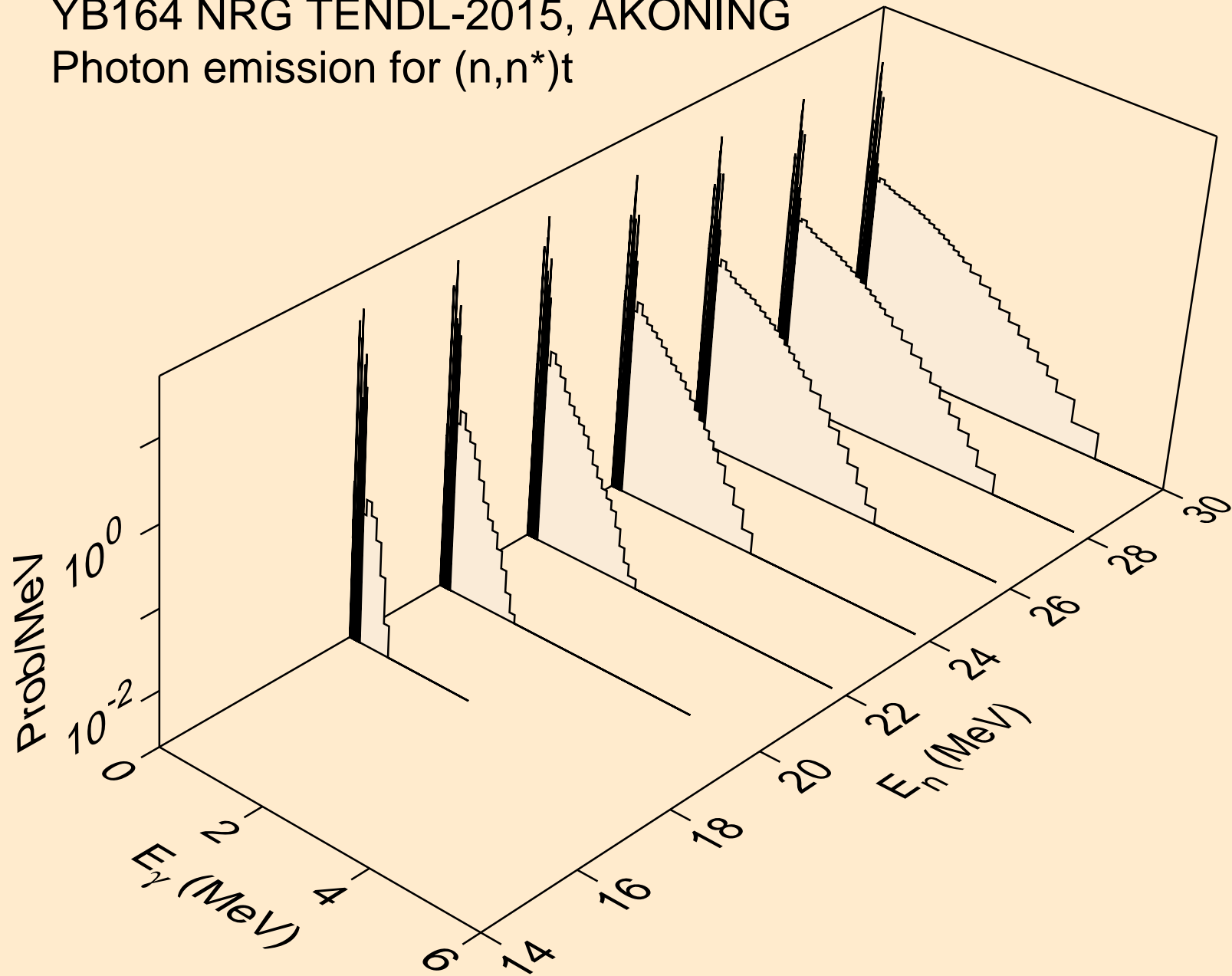

YB164 NRG TENDL-2015, AKONING  
Photon emission for (n,n\*)he3

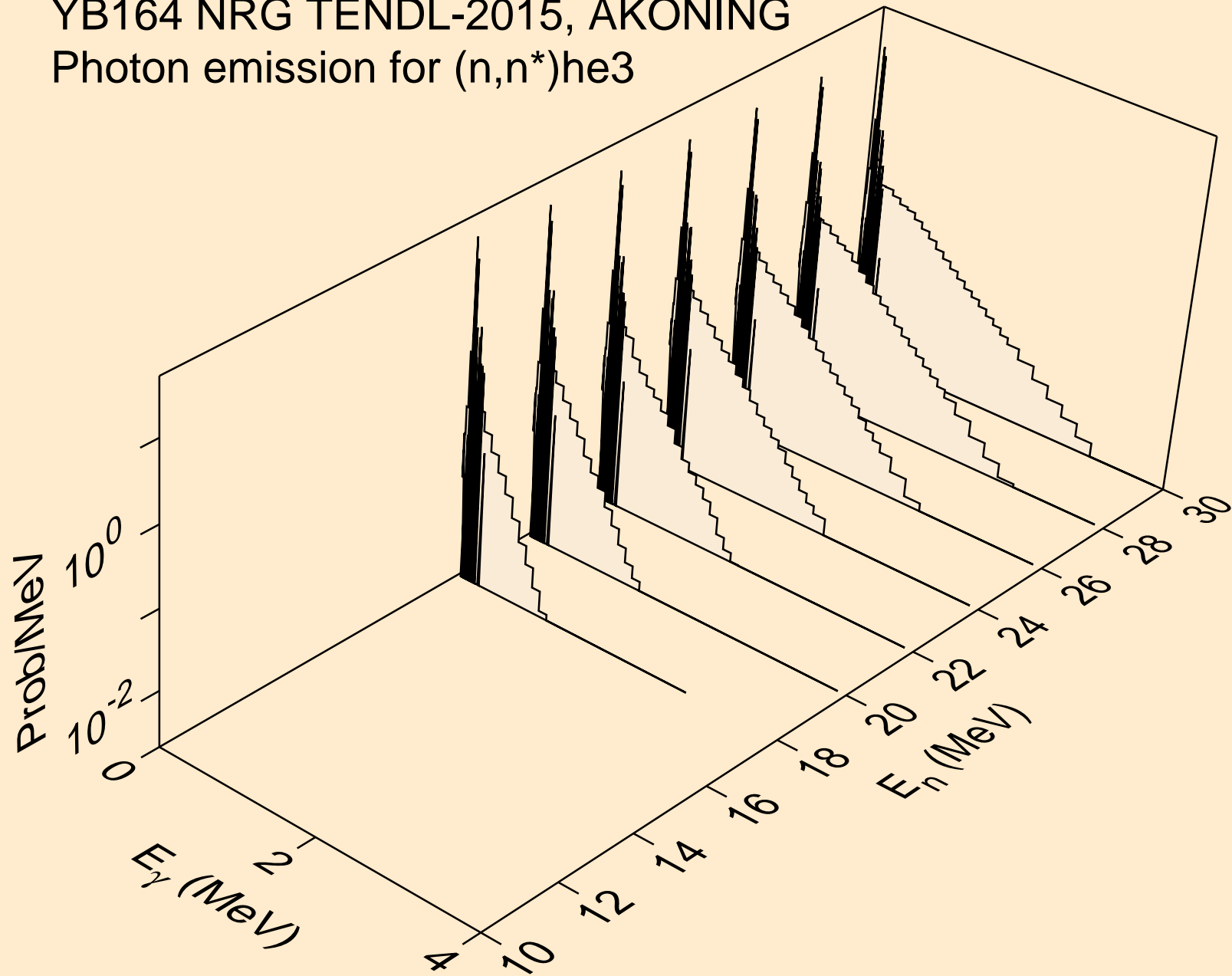

YB164 NRG TENDL-2015, AKONING  
Photon emission for (n,4n)

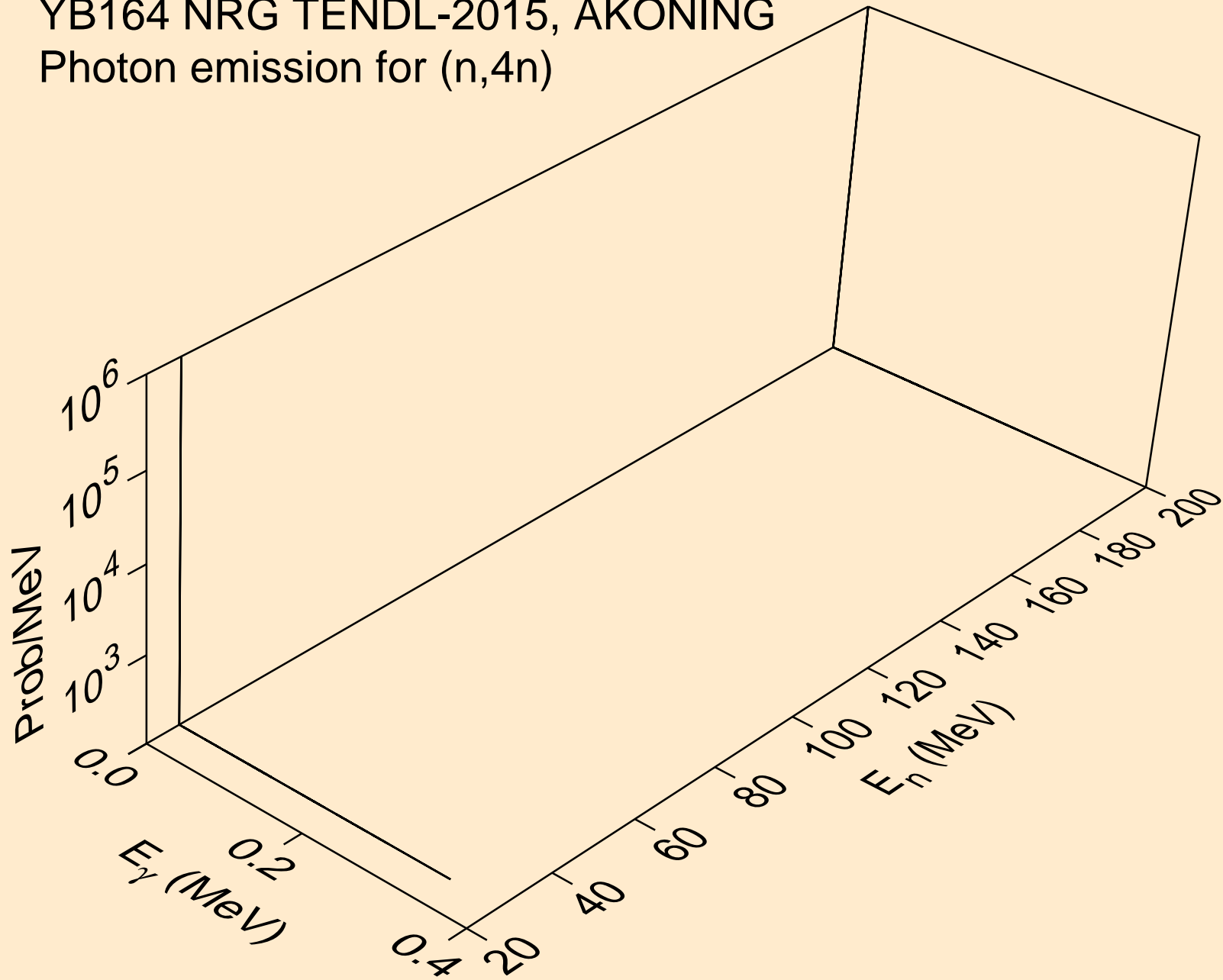

YB164 NRG TENDL-2015, AKONING  
Photon emission for (n,2np)

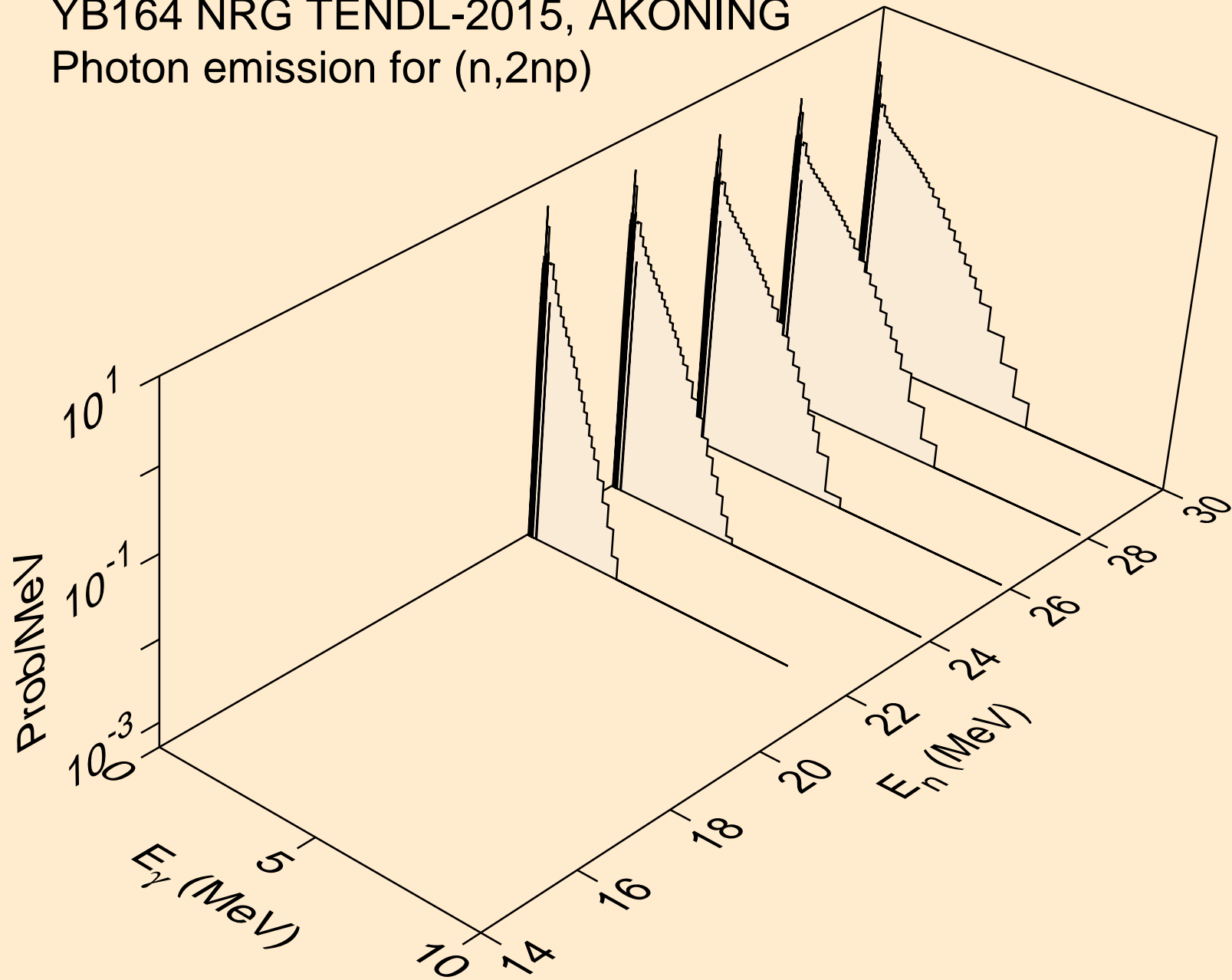

YB164 NRG TENDL-2015, AKONING  
Photon emission for (n,3np)

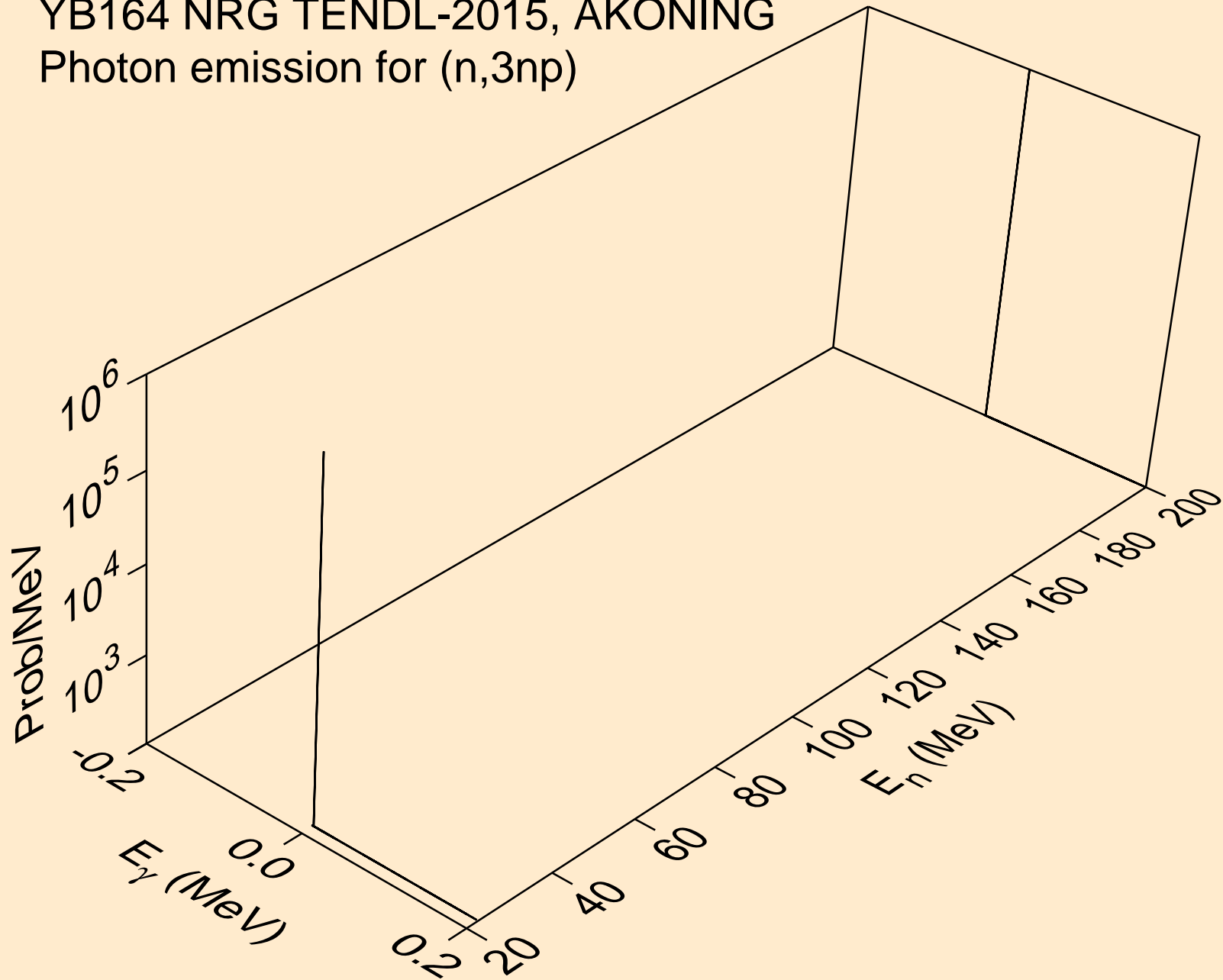



YB164 NRG TENDL-2015, AKONING  
Photon emission for (n,2np)

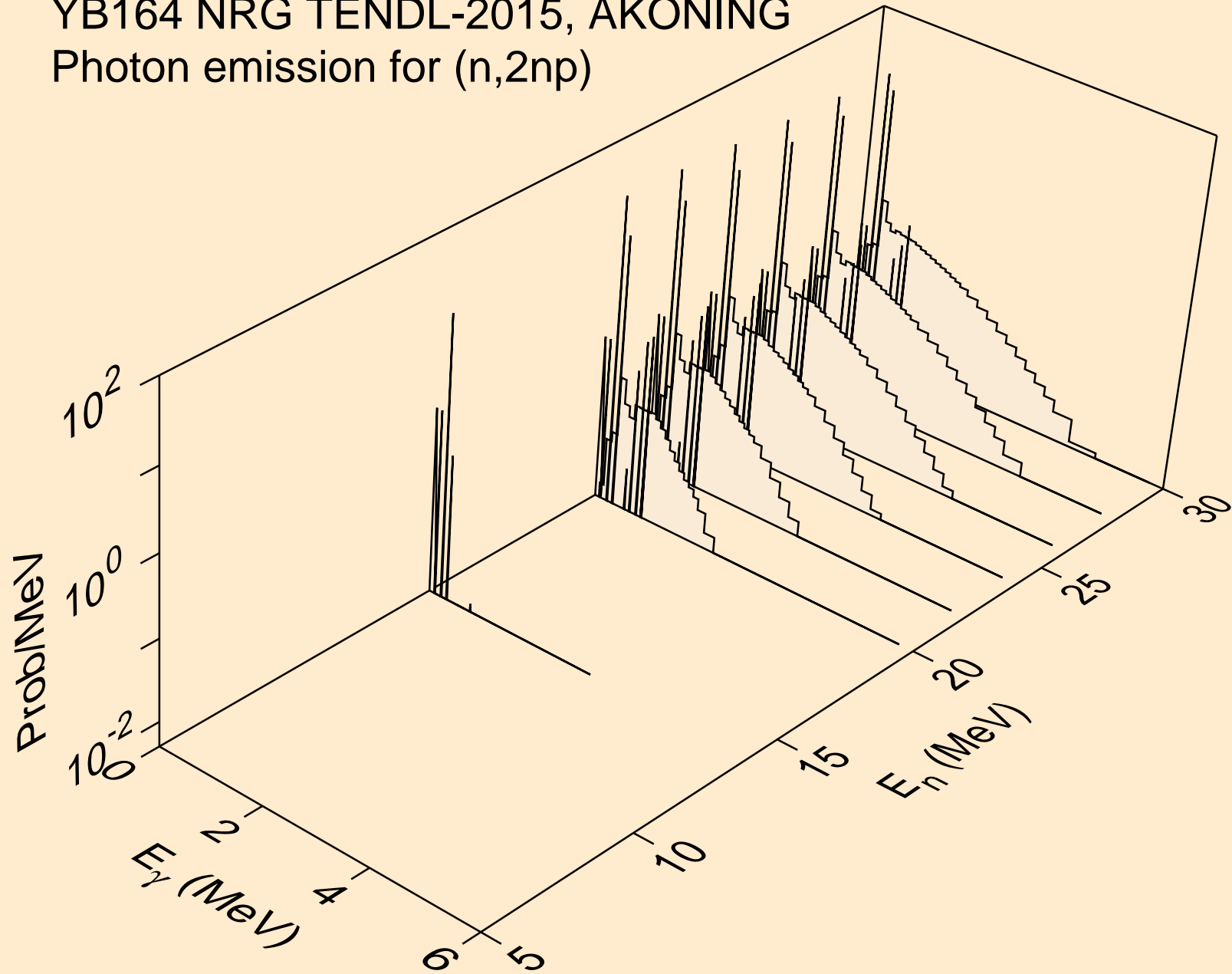

YB164 NRG TENDL-2015, AKONING  
Photon emission for (n,npa)

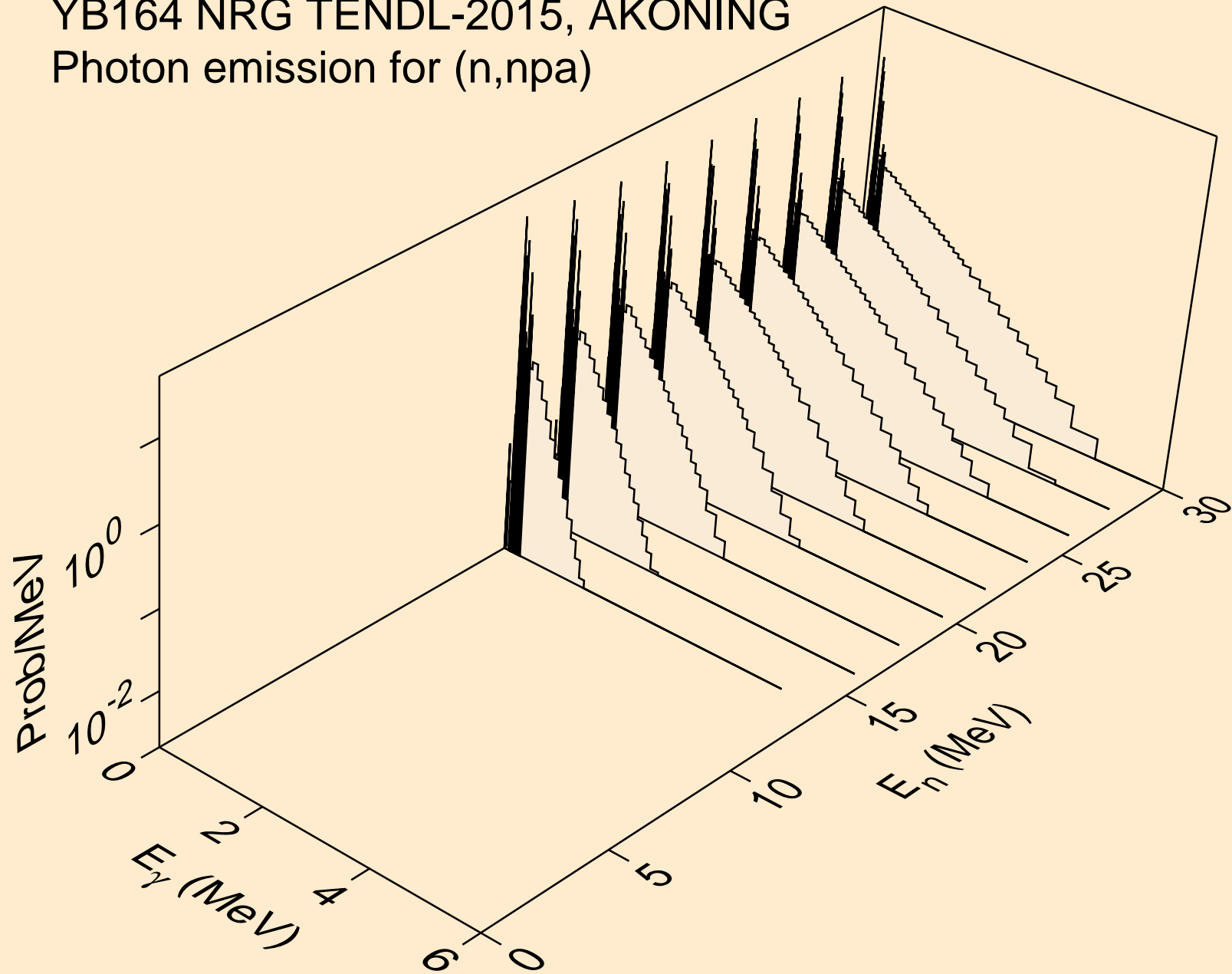

YB164 NRG TENDL-2015, AKONING  
Photon emission for (n,n\*c)

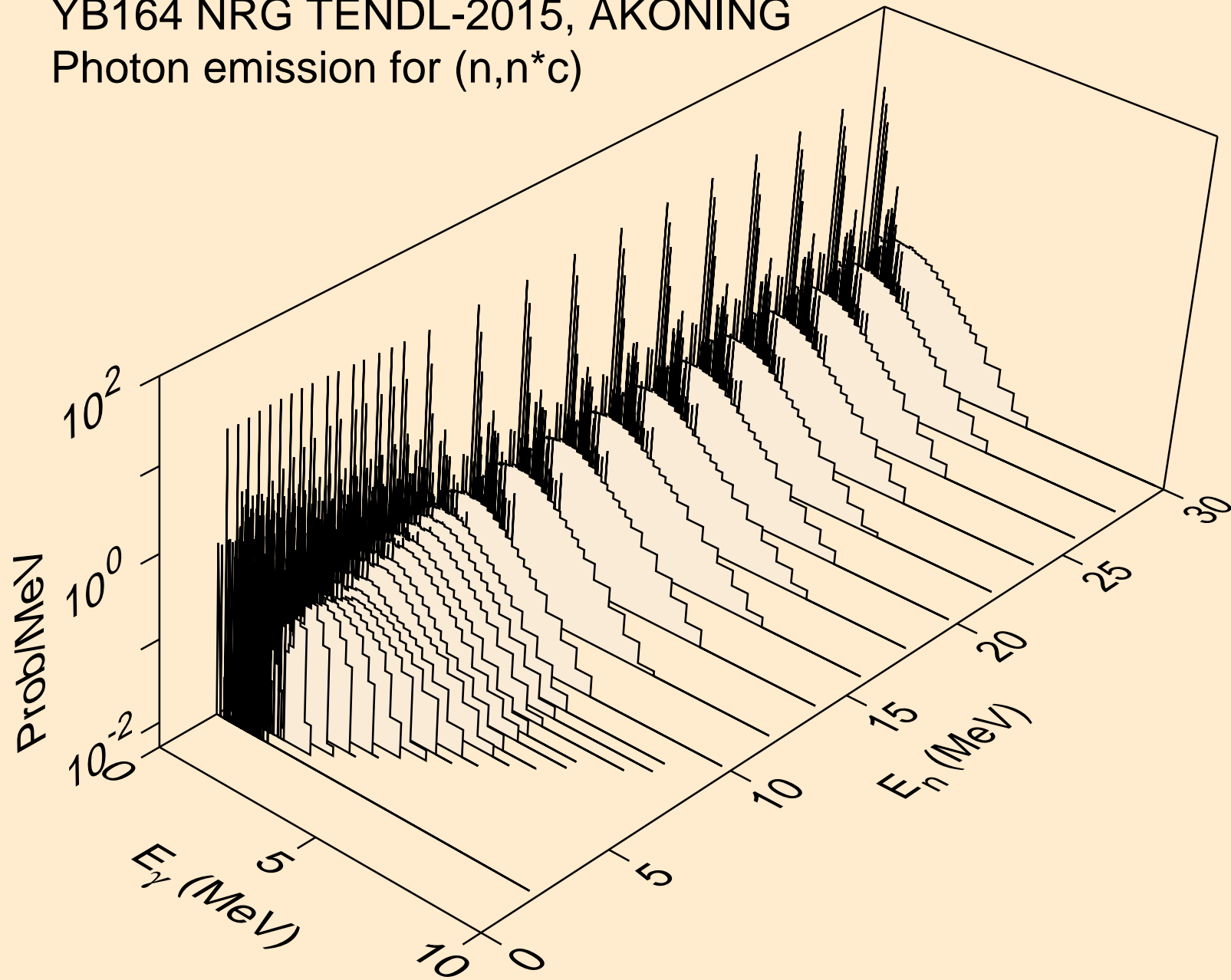

YB164 NRG TENDL-2015, AKONING  
Photon emission for (n,gma)

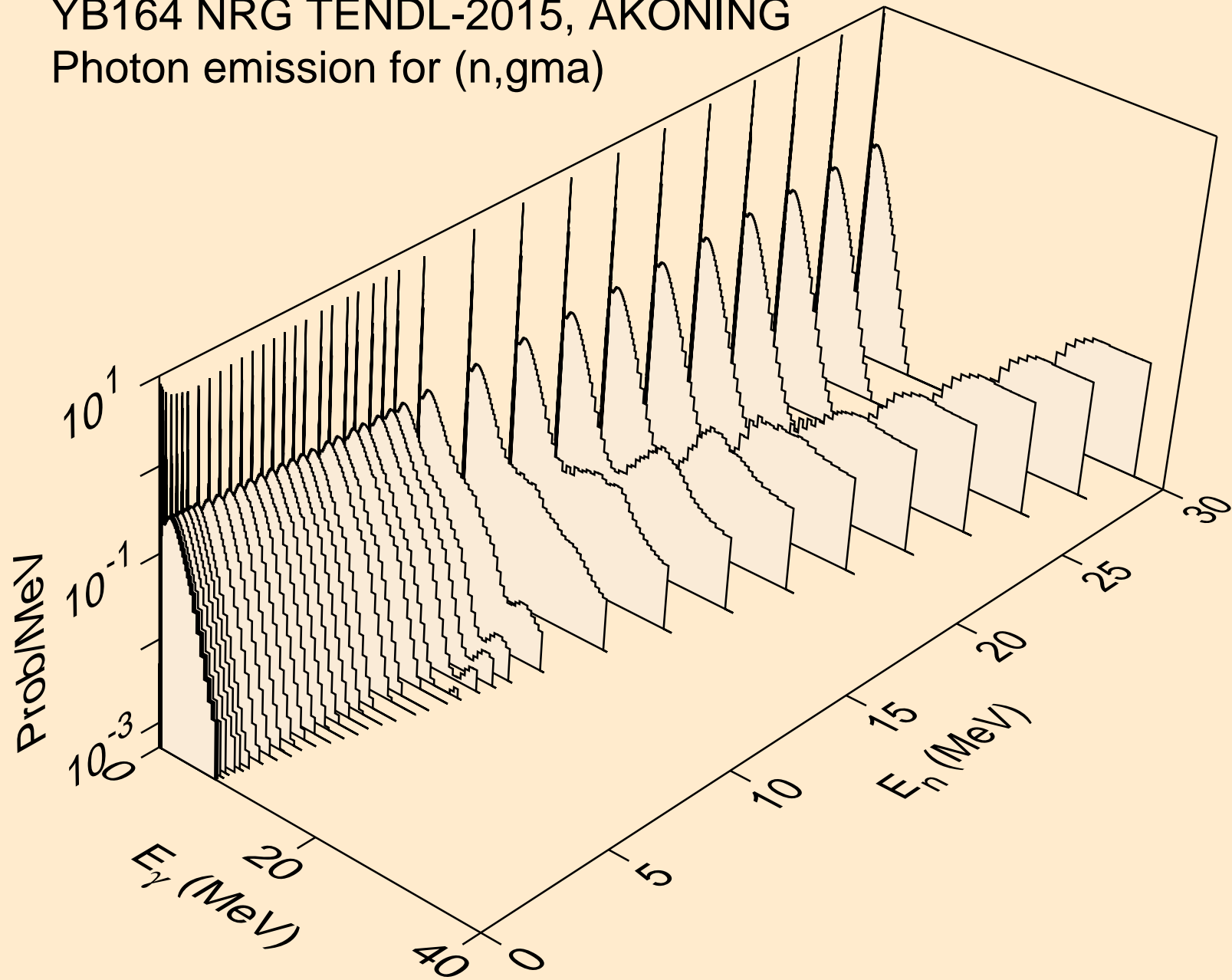

YB164 NRG TENDL-2015, AKONING  
Photon emission for (n,p)

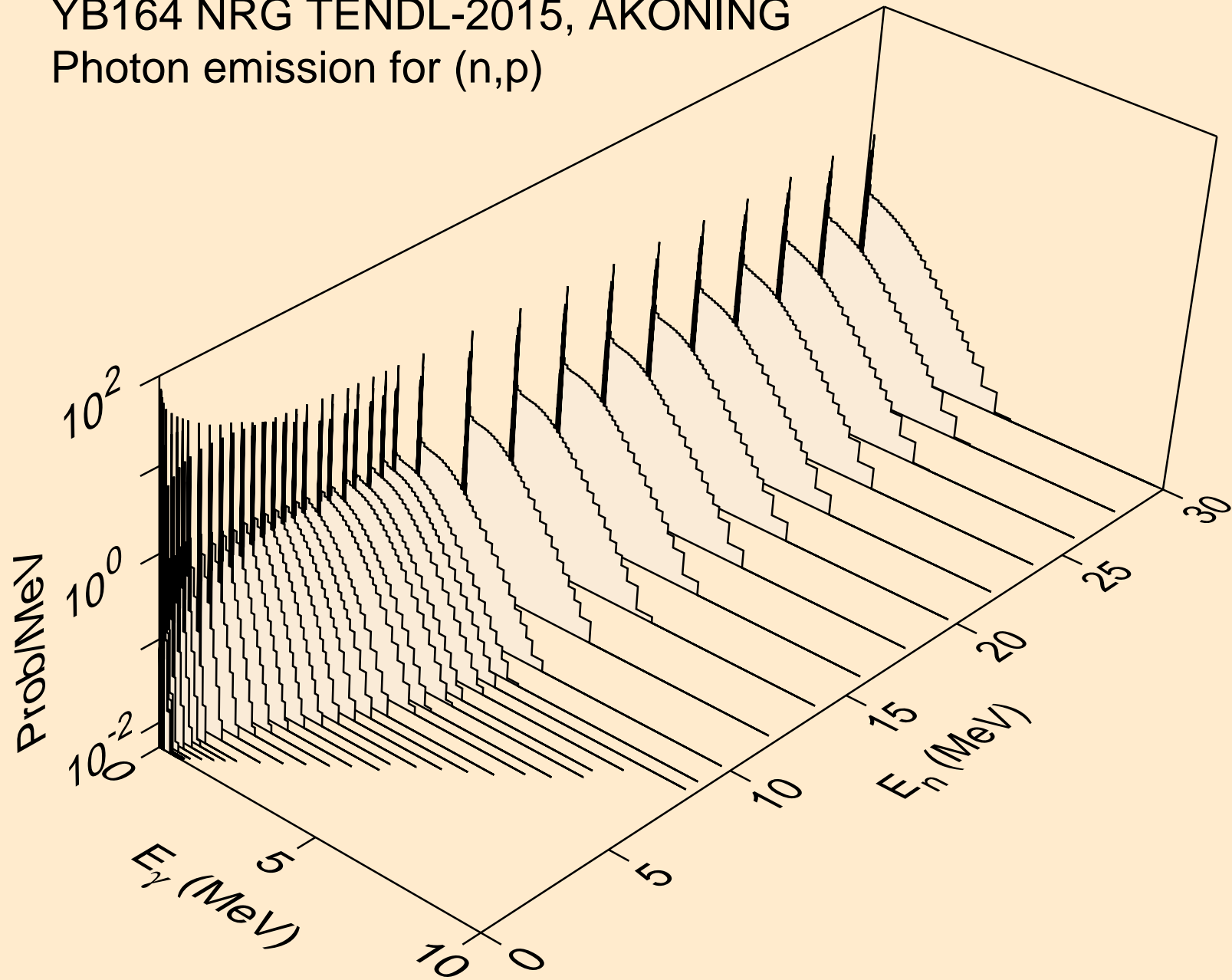

YB164 NRG TENDL-2015, AKONING  
Photon emission for (n,d)

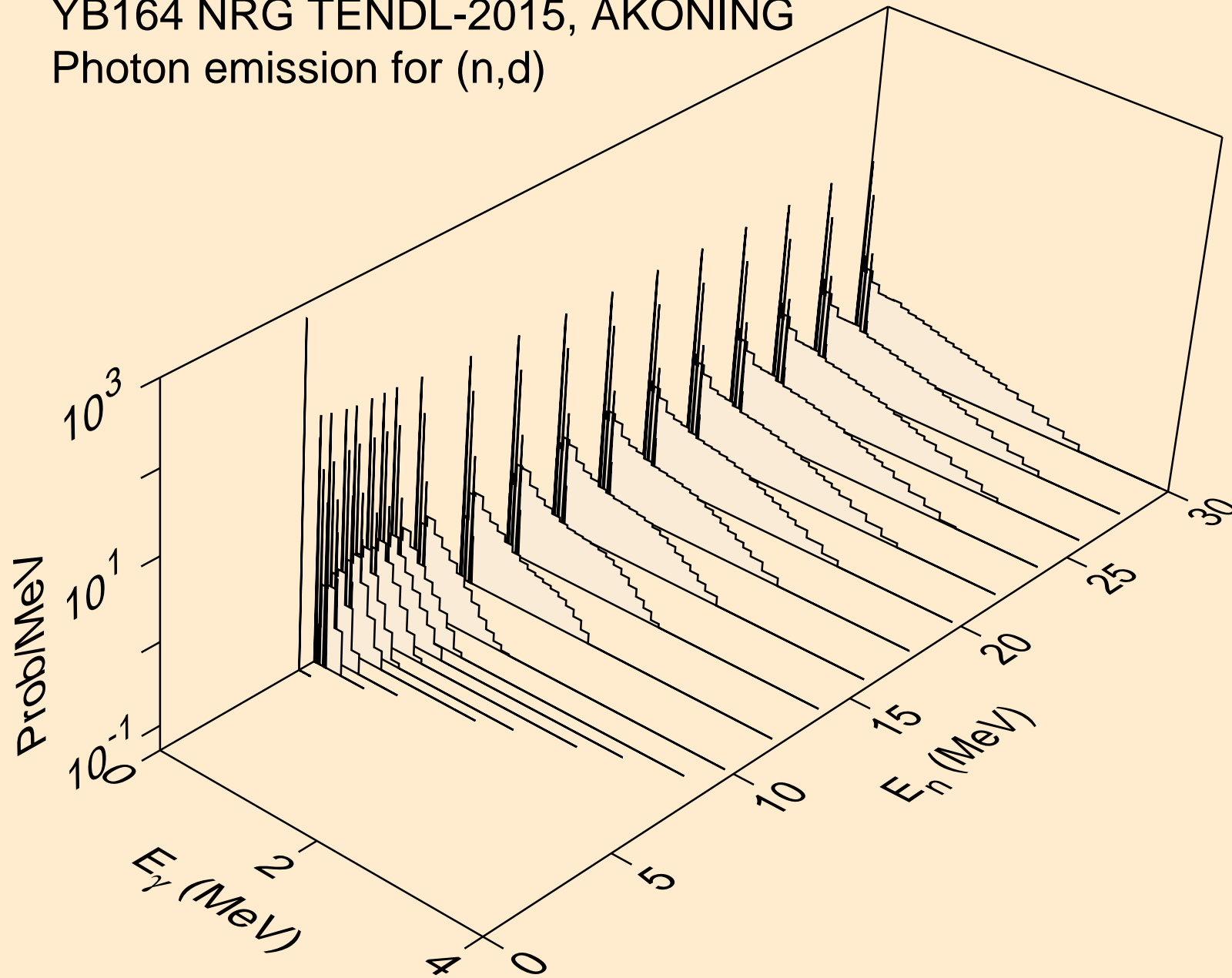

YB164 NRG TENDL-2015, AKONING  
Photon emission for (n,t)

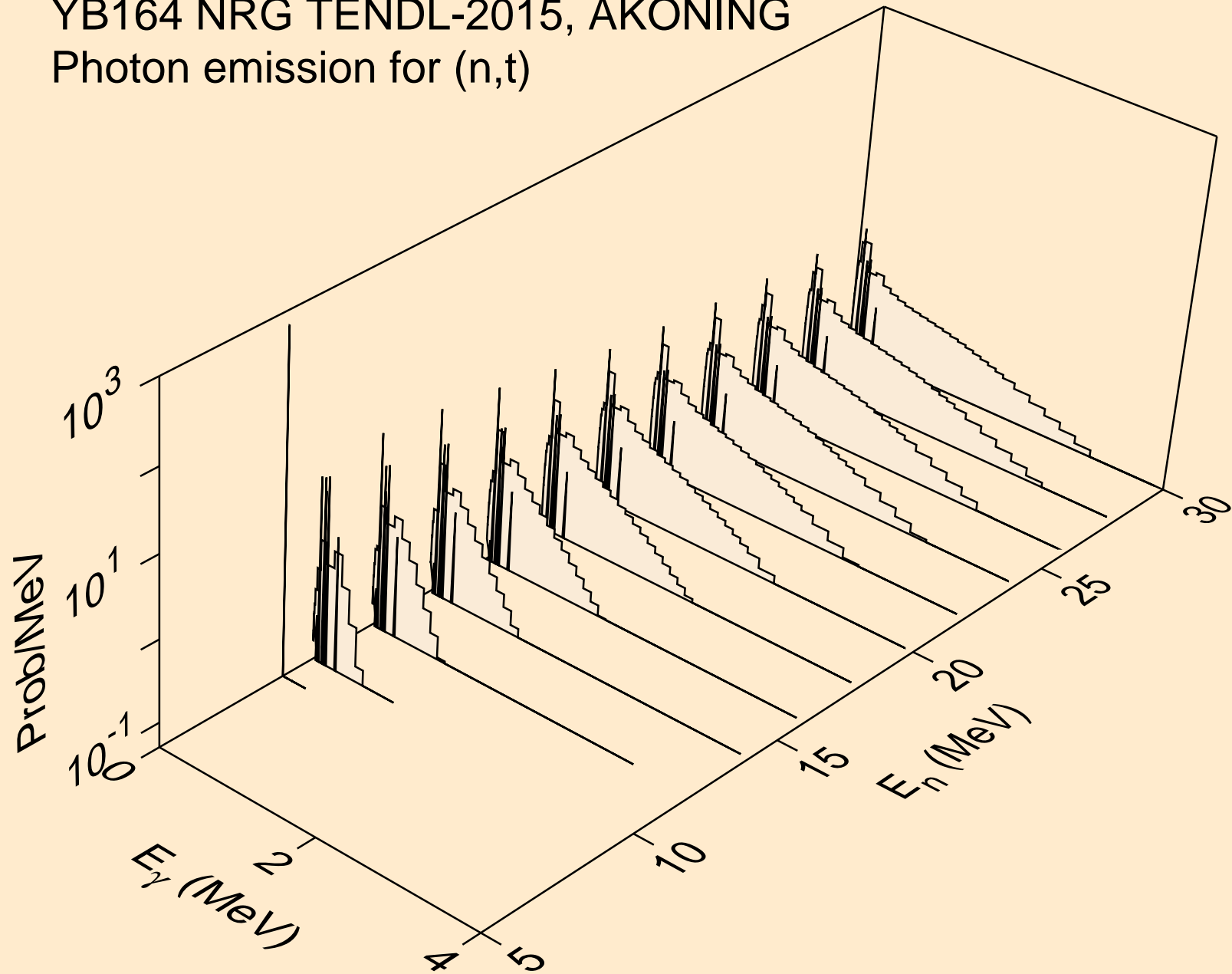

YB164 NRG TENDL-2015, AKONING  
Photon emission for (n,he3)

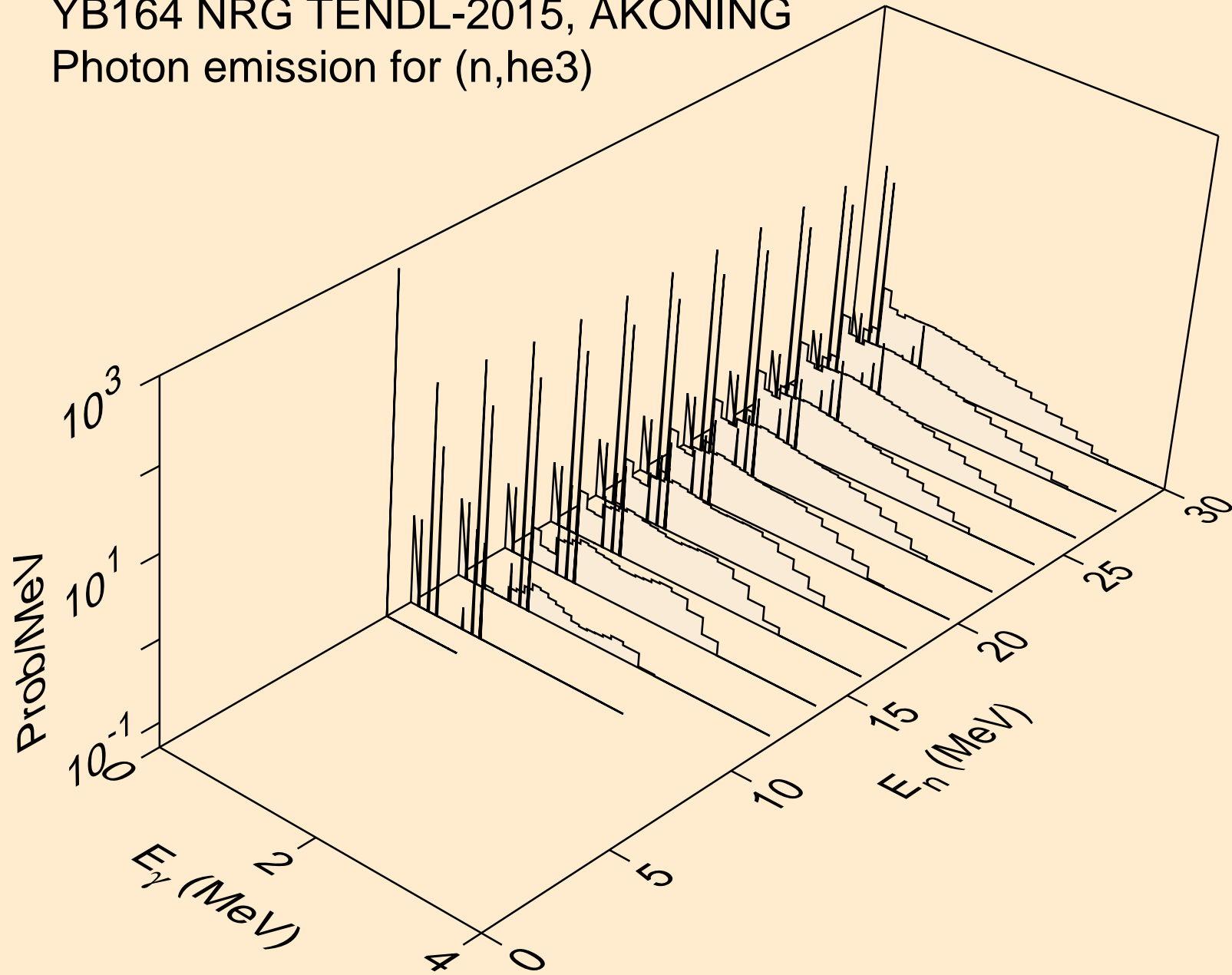



YB164 NRG TENDL-2015, AKONING  
Photon emission for (n,a)

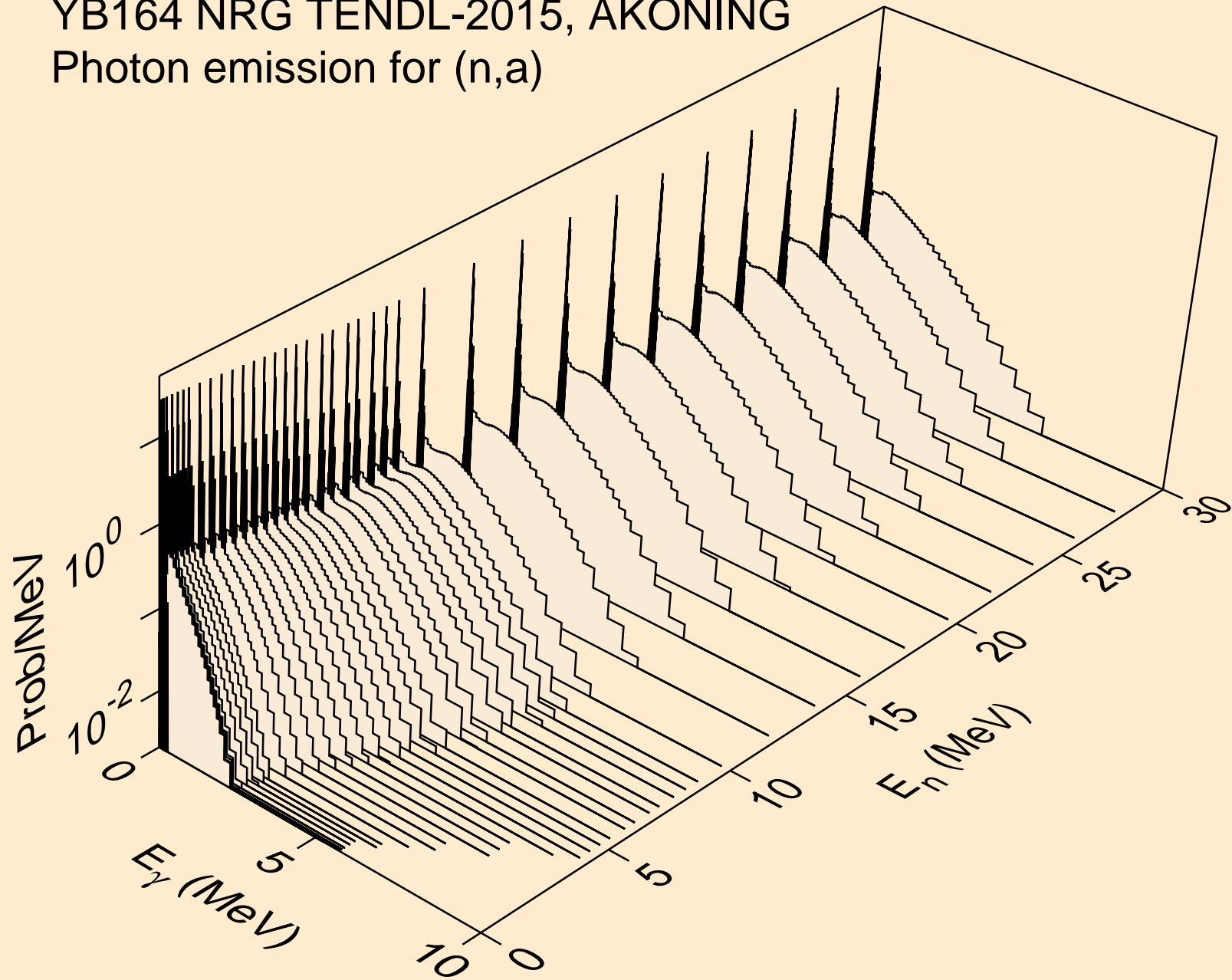

YB164 NRG TENDL-2015, AKONING  
Photon emission for (n,2a)

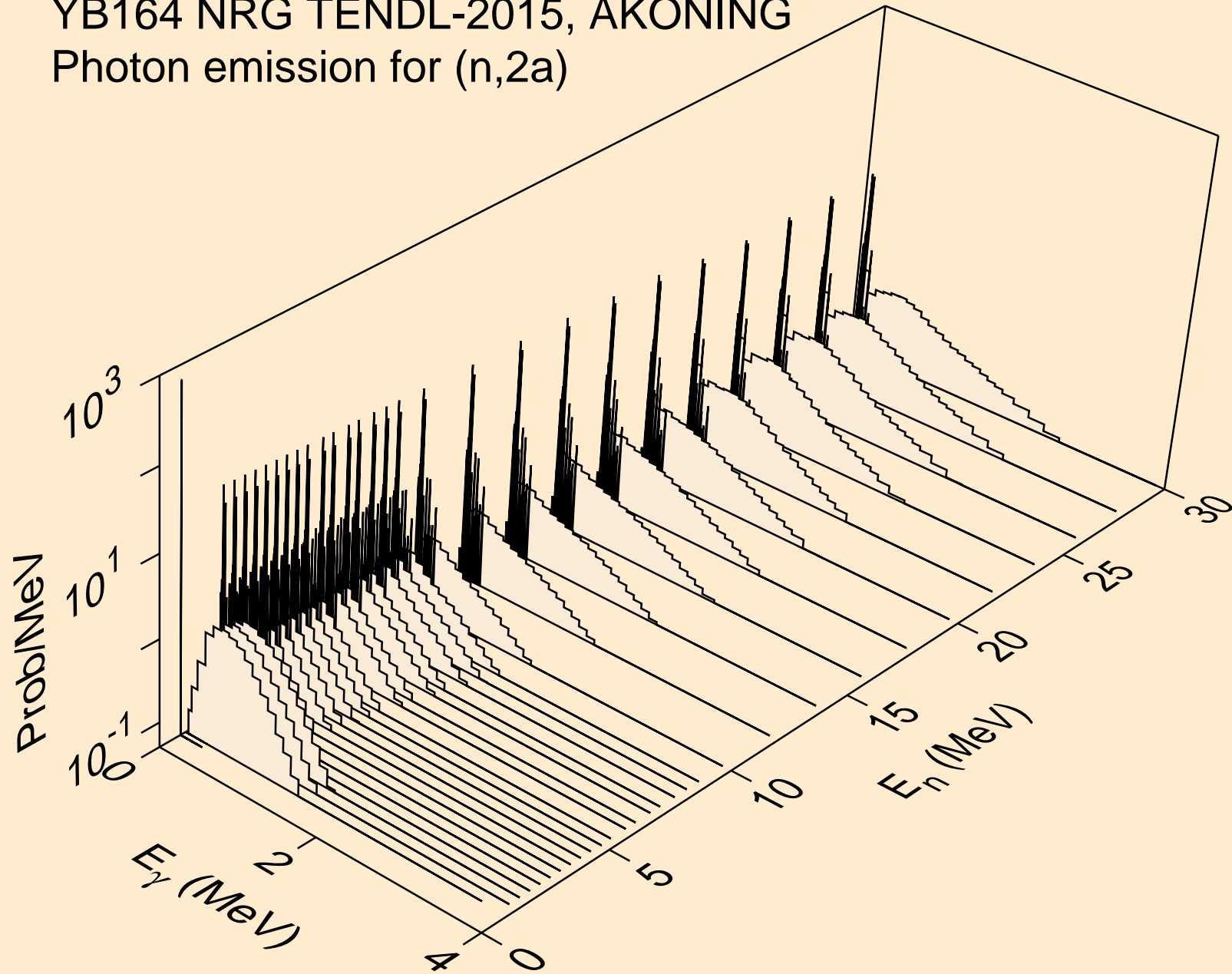

YB164 NRG TENDL-2015, AKONING  
Photon emission for (n,2p)

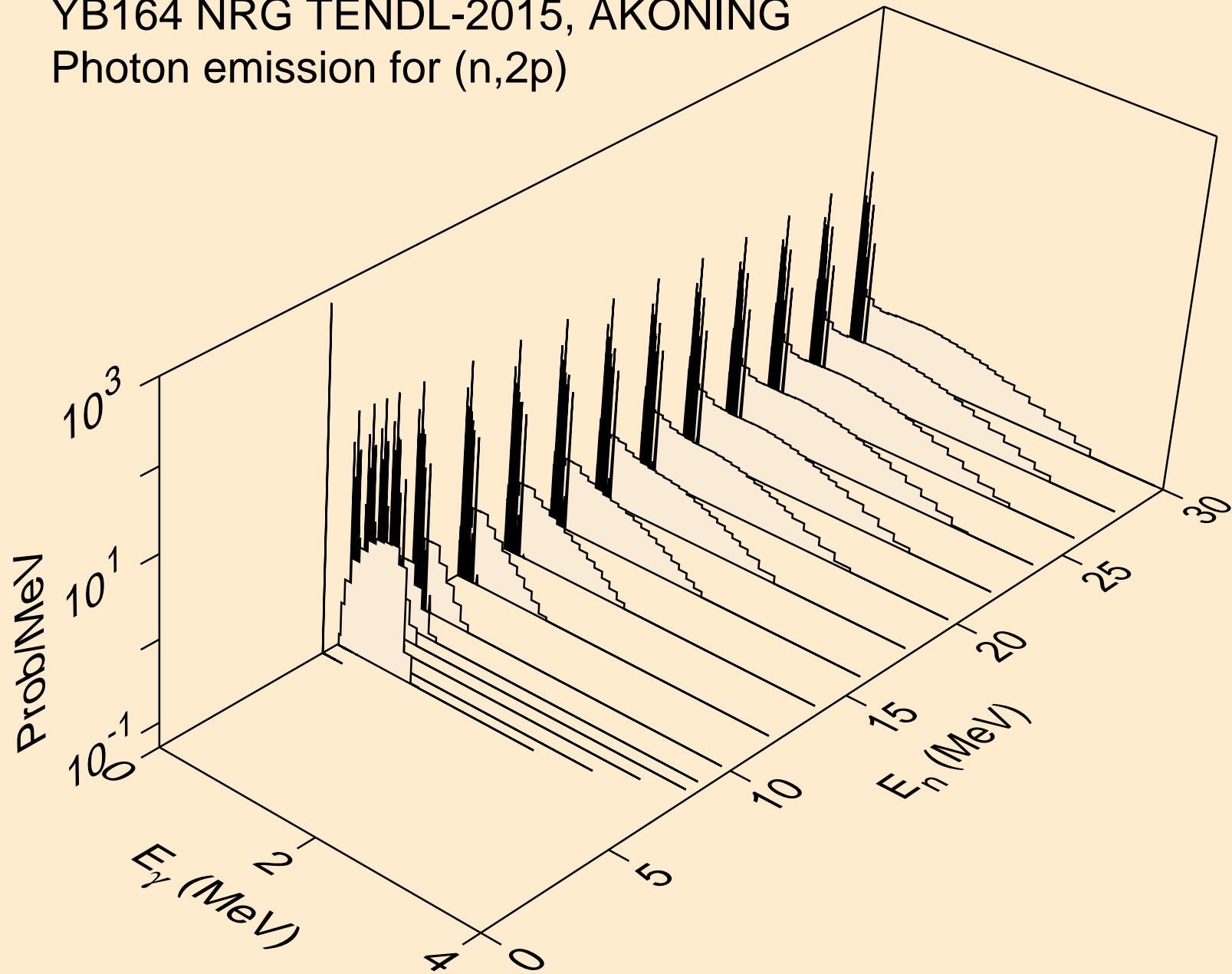

YB164 NRG TENDL-2015, AKONING  
Photon emission for (n,p $\alpha$ )

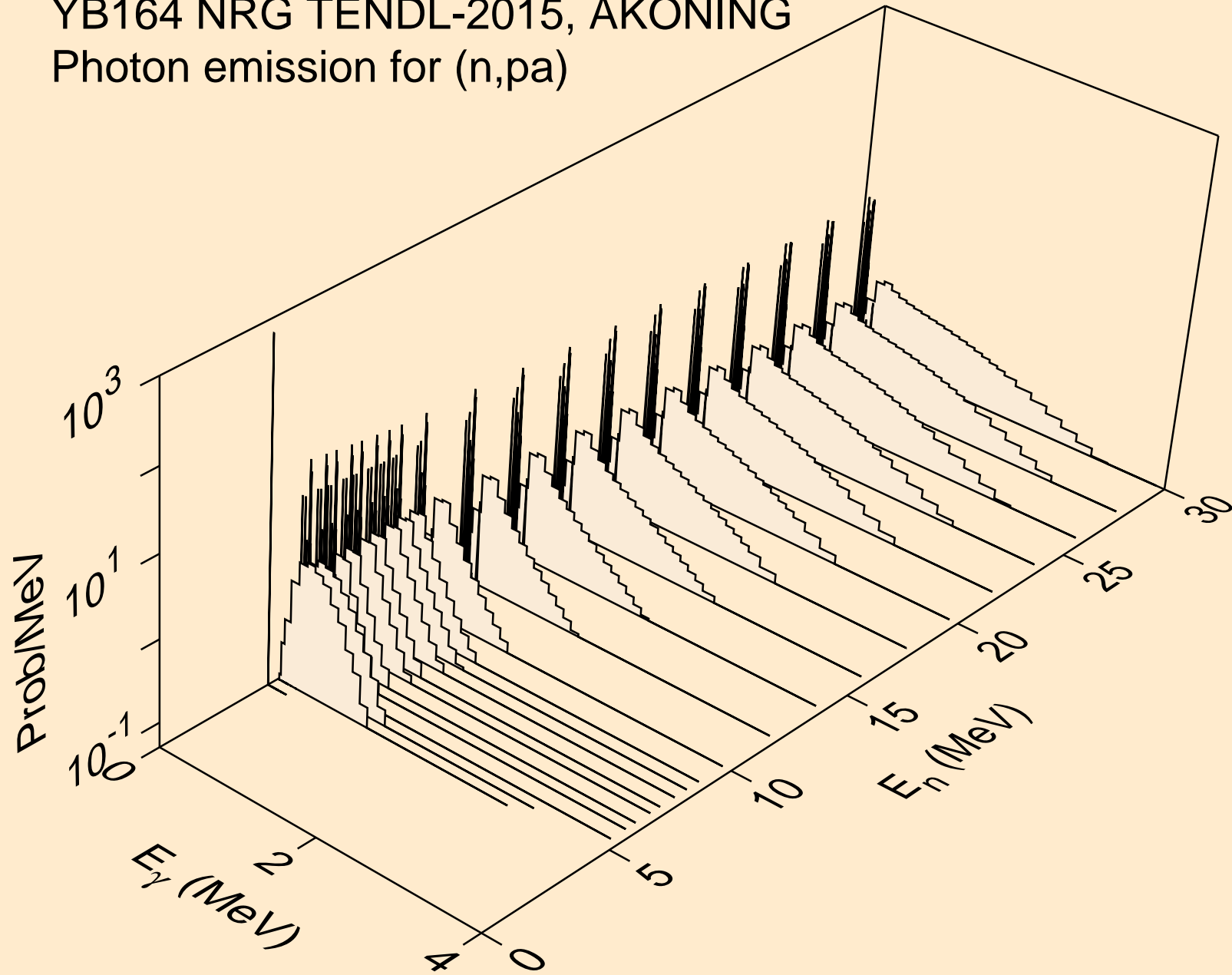

YB164 NRG TENDL-2015, AKONING  
Photon emission for (n,pd)

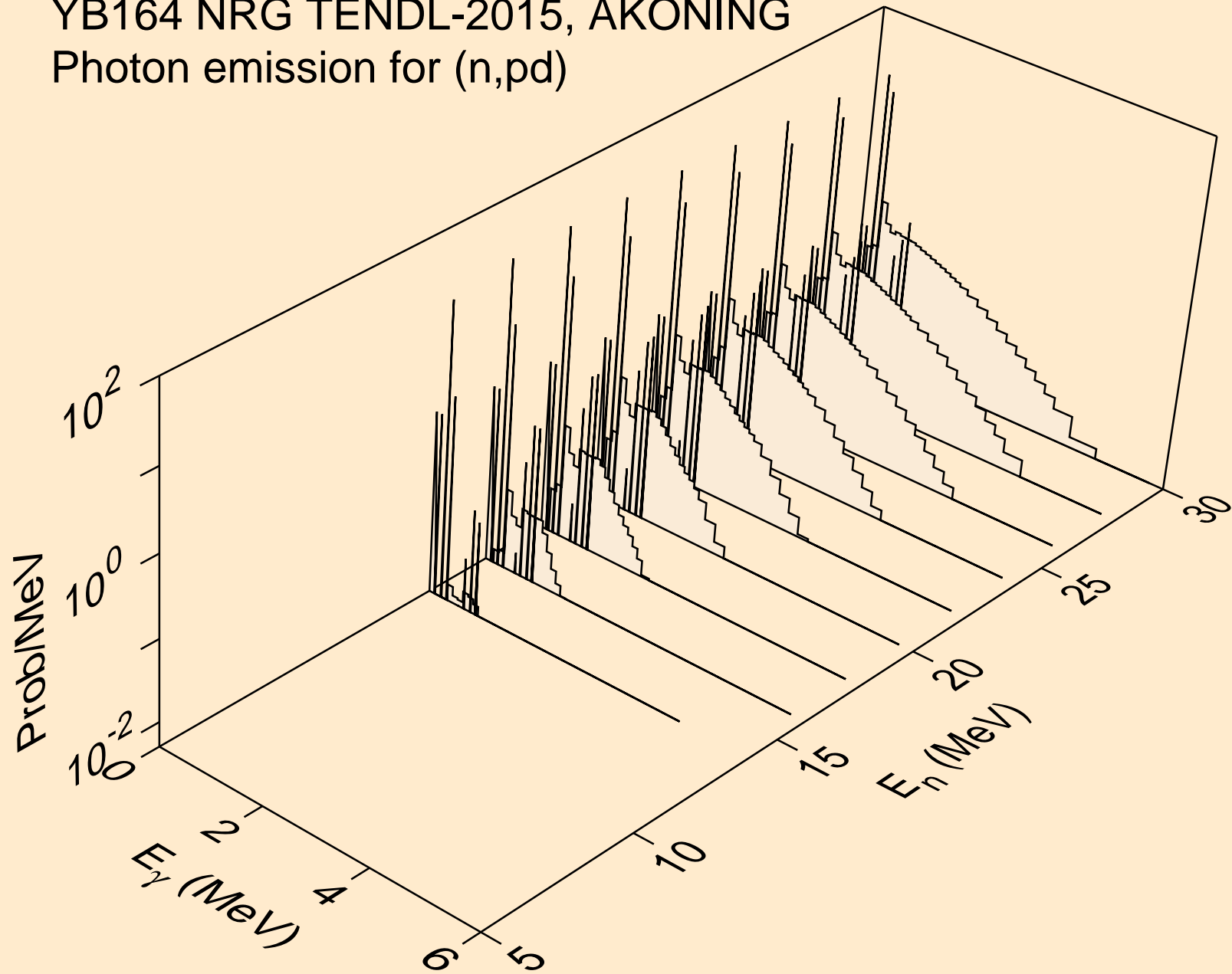

YB164 NRG TENDL-2015, AKONING  
Photon emission for (n,pt)

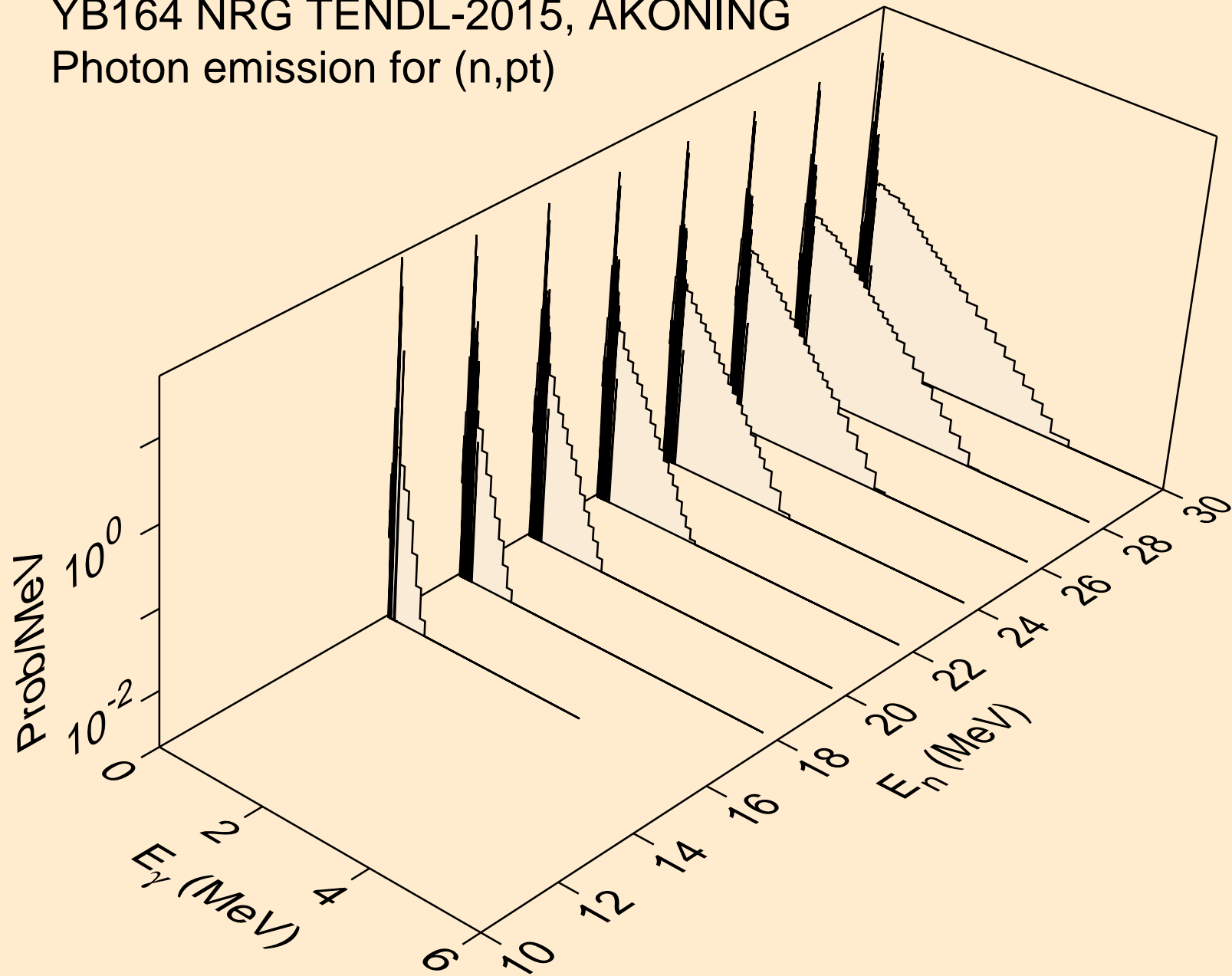

YB164 NRG TENDL-2015, AKONING  
Photon emission for (n,da)

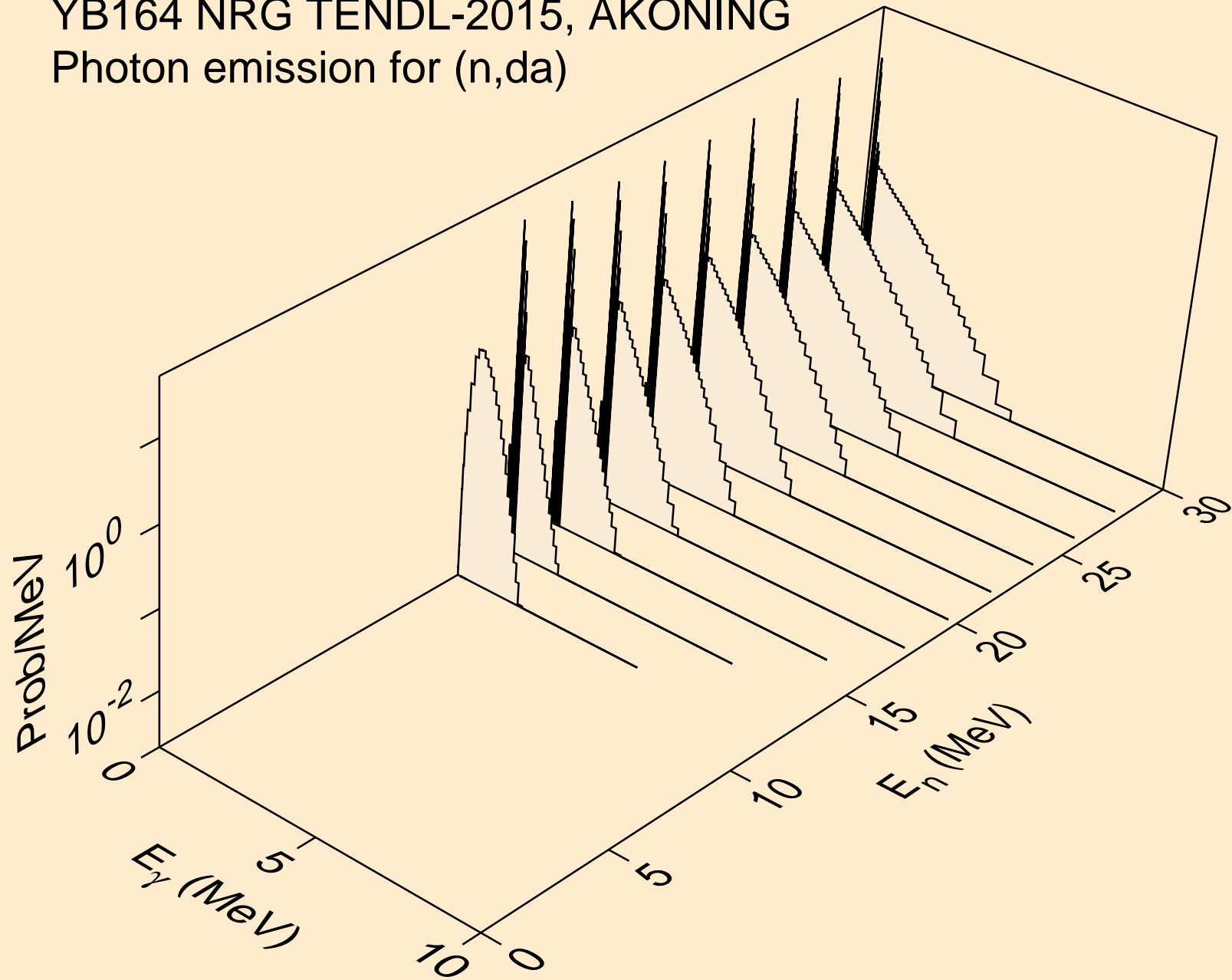

YB164 NRG TENDL-2015, AKONING  
thermal capture photon spectrum

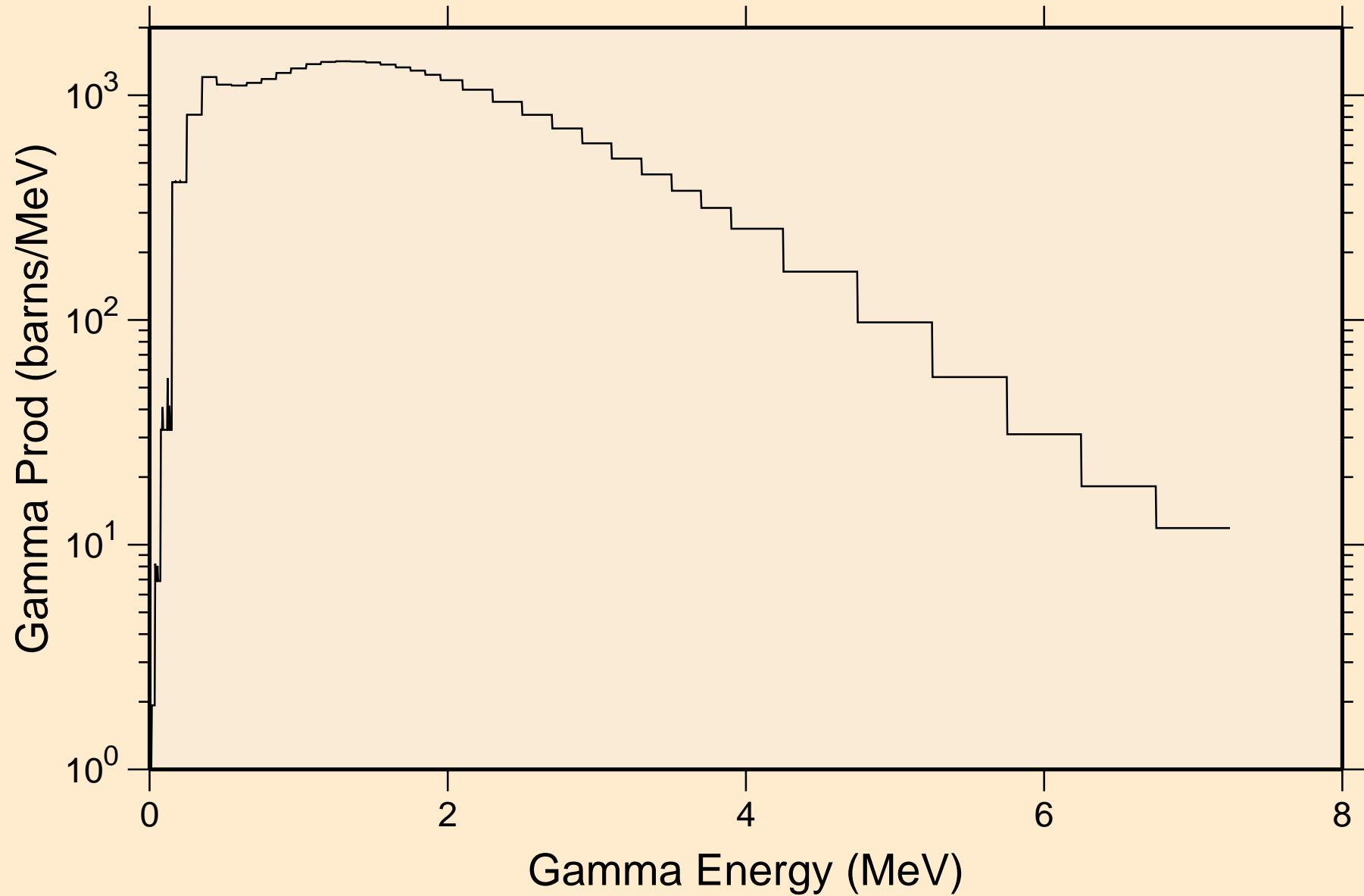



YB164 NRG TENDL-2015, AKONING  
14 MeV photon spectrum

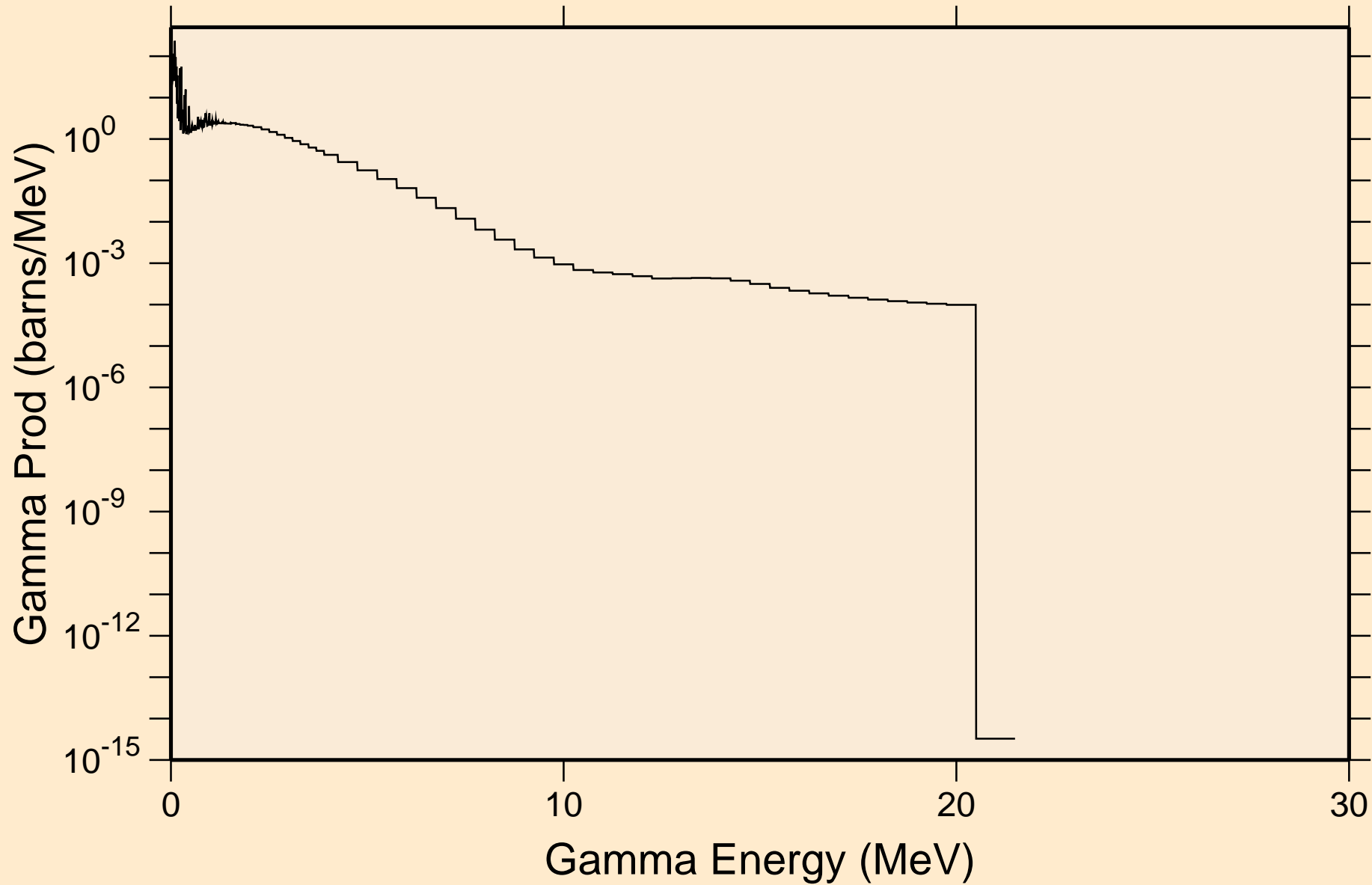

# YB164 NRG TENDL-2015, AKONING

## Particle heating contributions

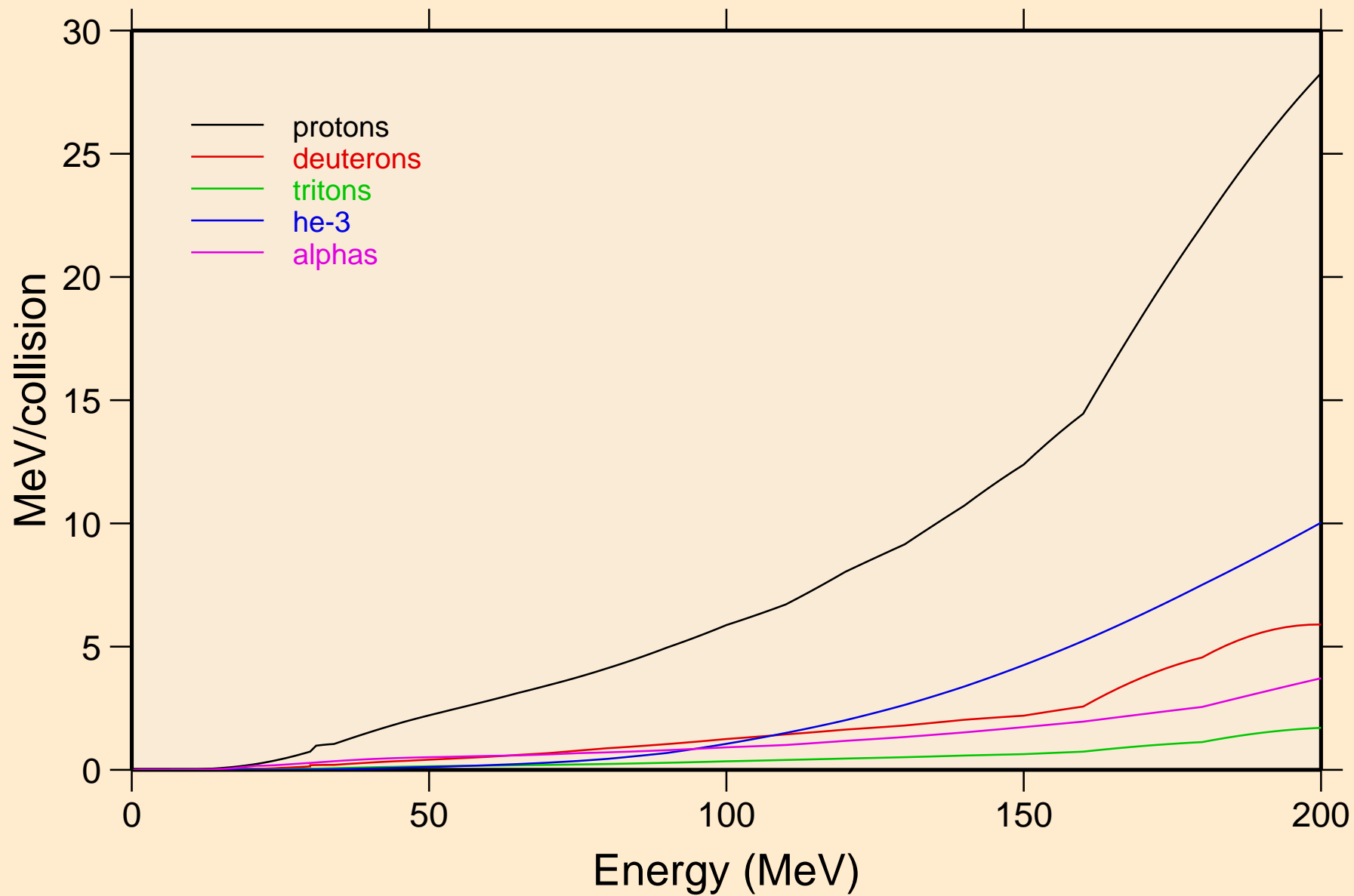

# YB164 NRG TENDL-2015, AKONING

## Recoil Heating

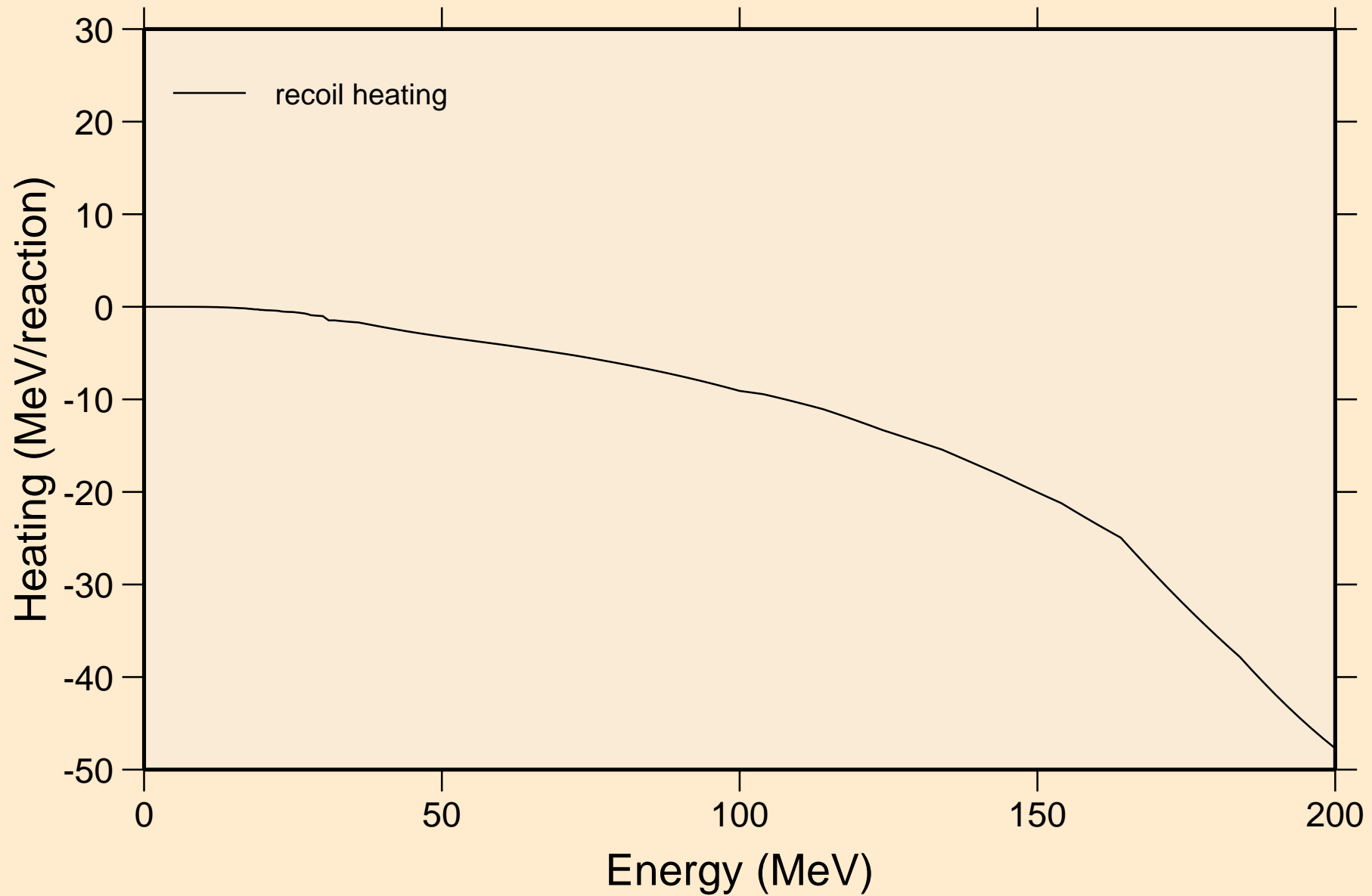

# YB164 NRG TENDL-2015, AKONING

## Particle production cross sections

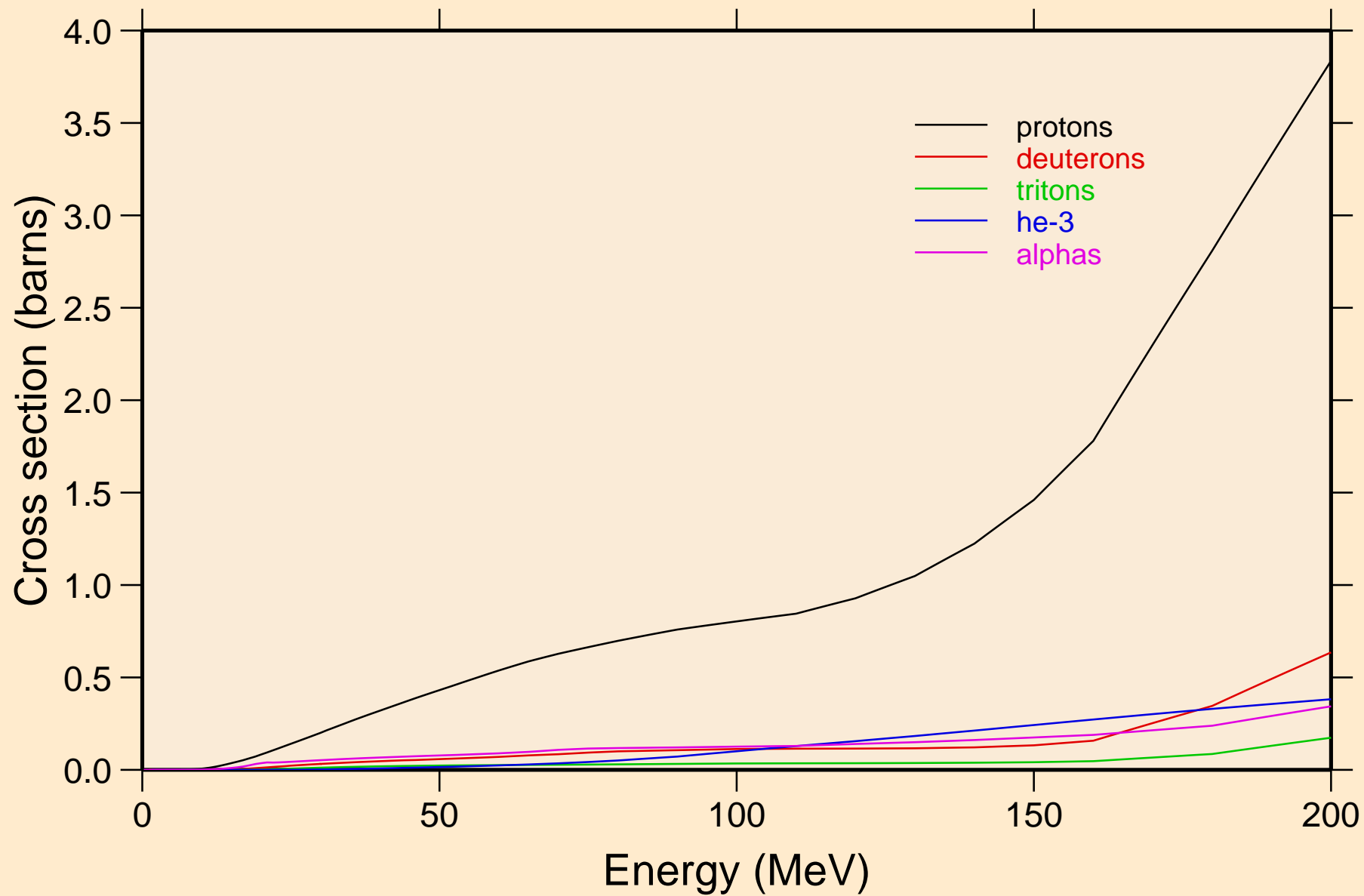

YB164 NRG TENDL-2015, AKONING  
protons from (n,x)

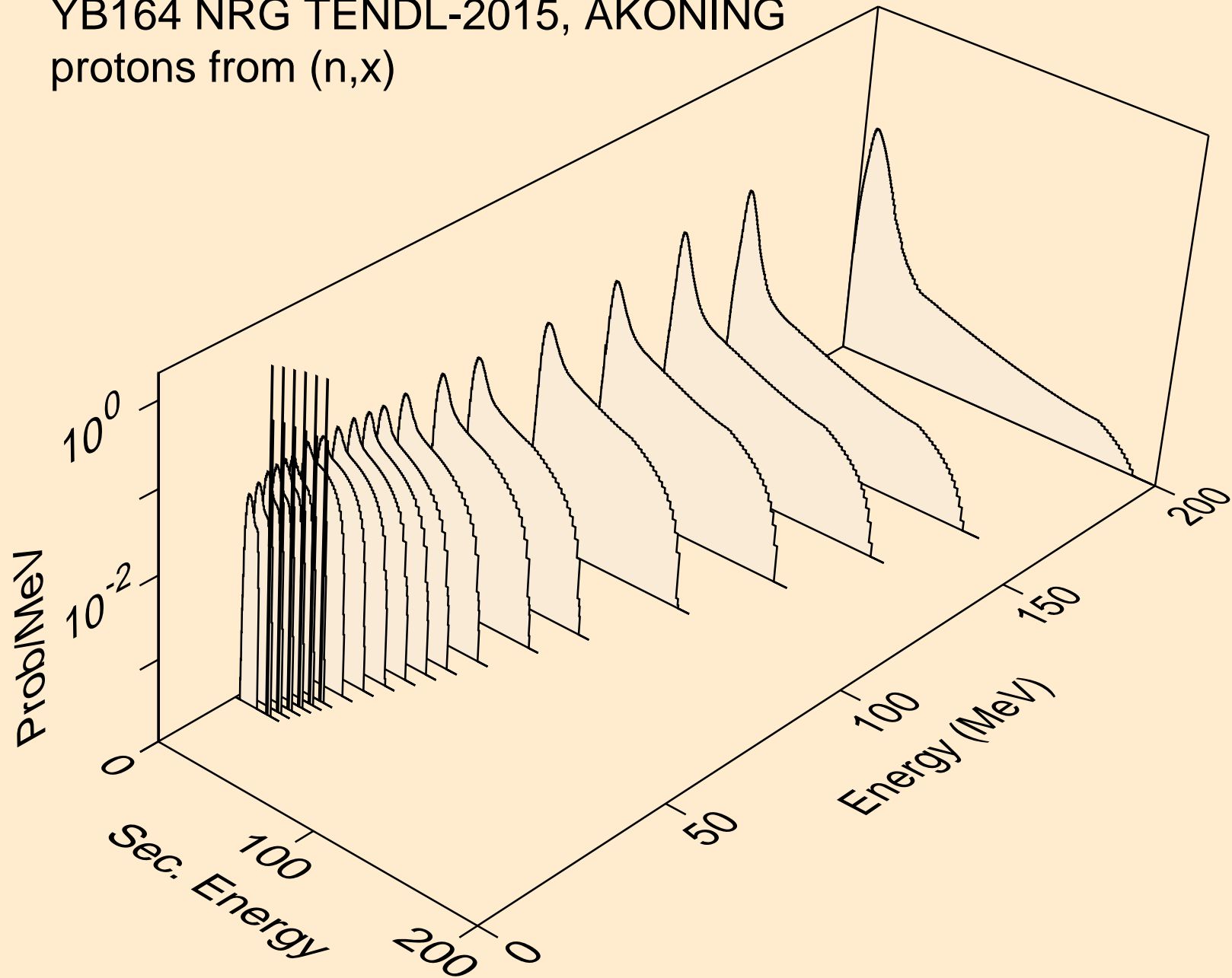

YB164 NRG TENDL-2015, AKONING  
protons from (n,n\*)p

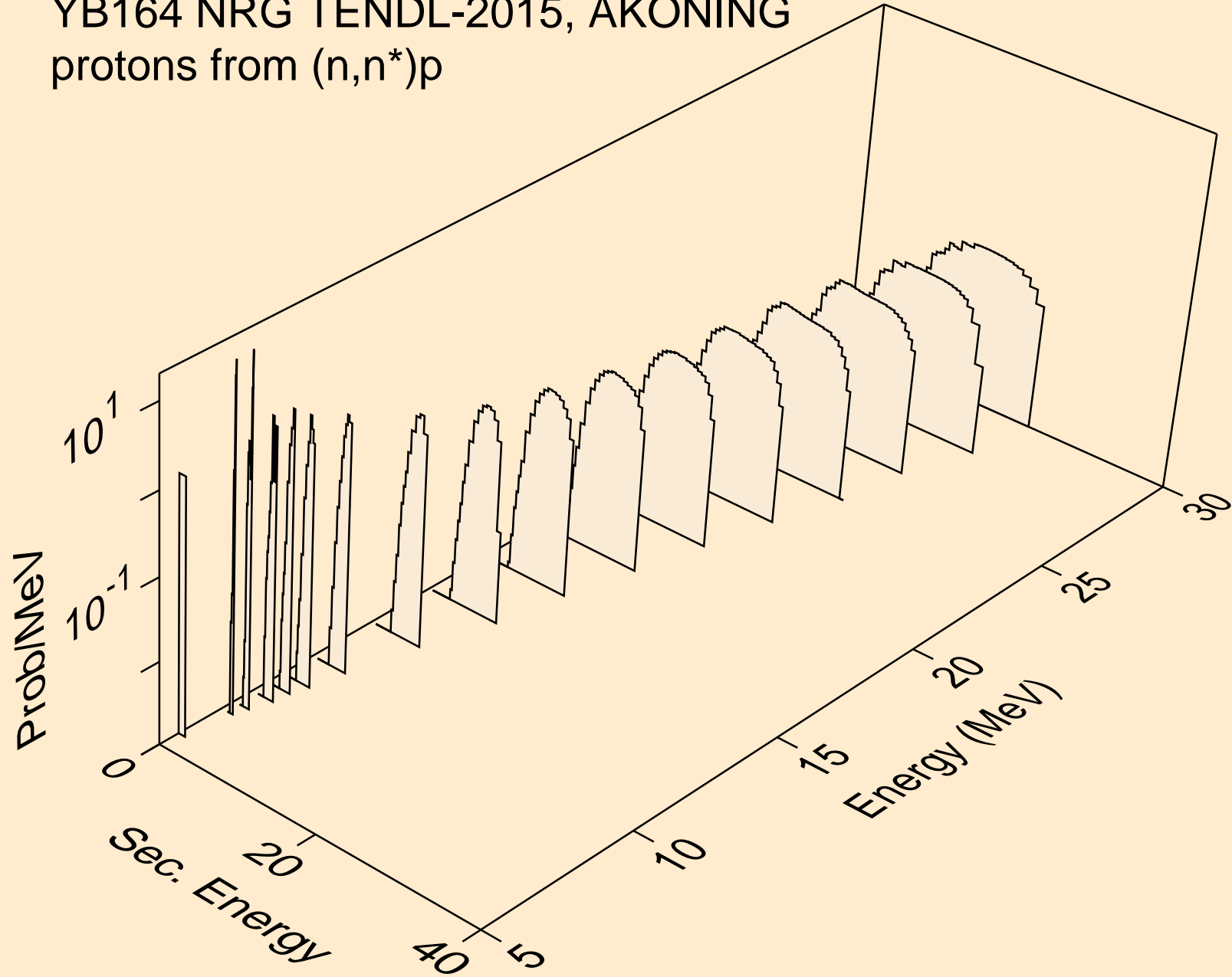

YB164 NRG TENDL-2015, AKONING  
protons from (n,2np)

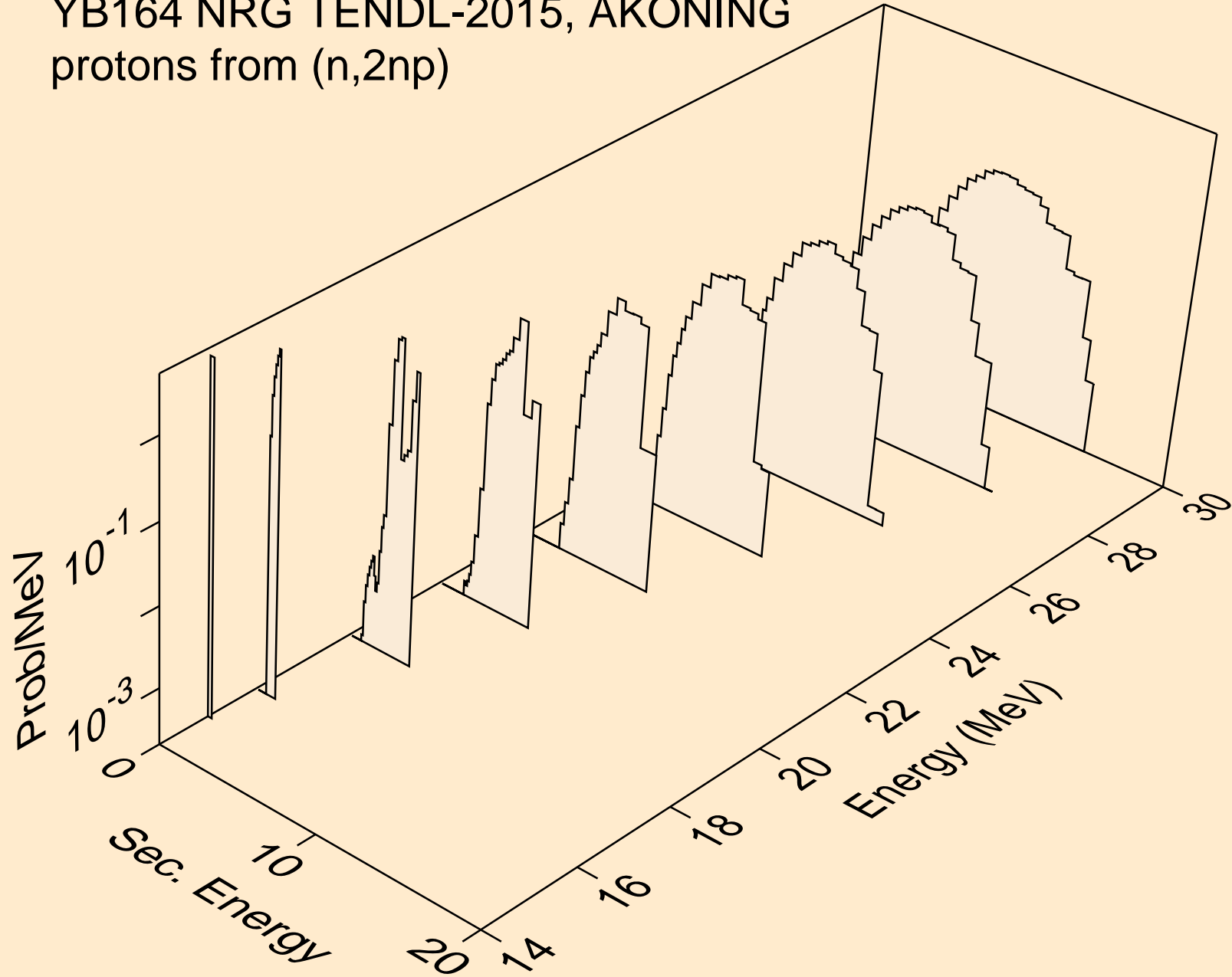

YB164 NRG TENDL-2015, AKONING  
protons from (n,3np)

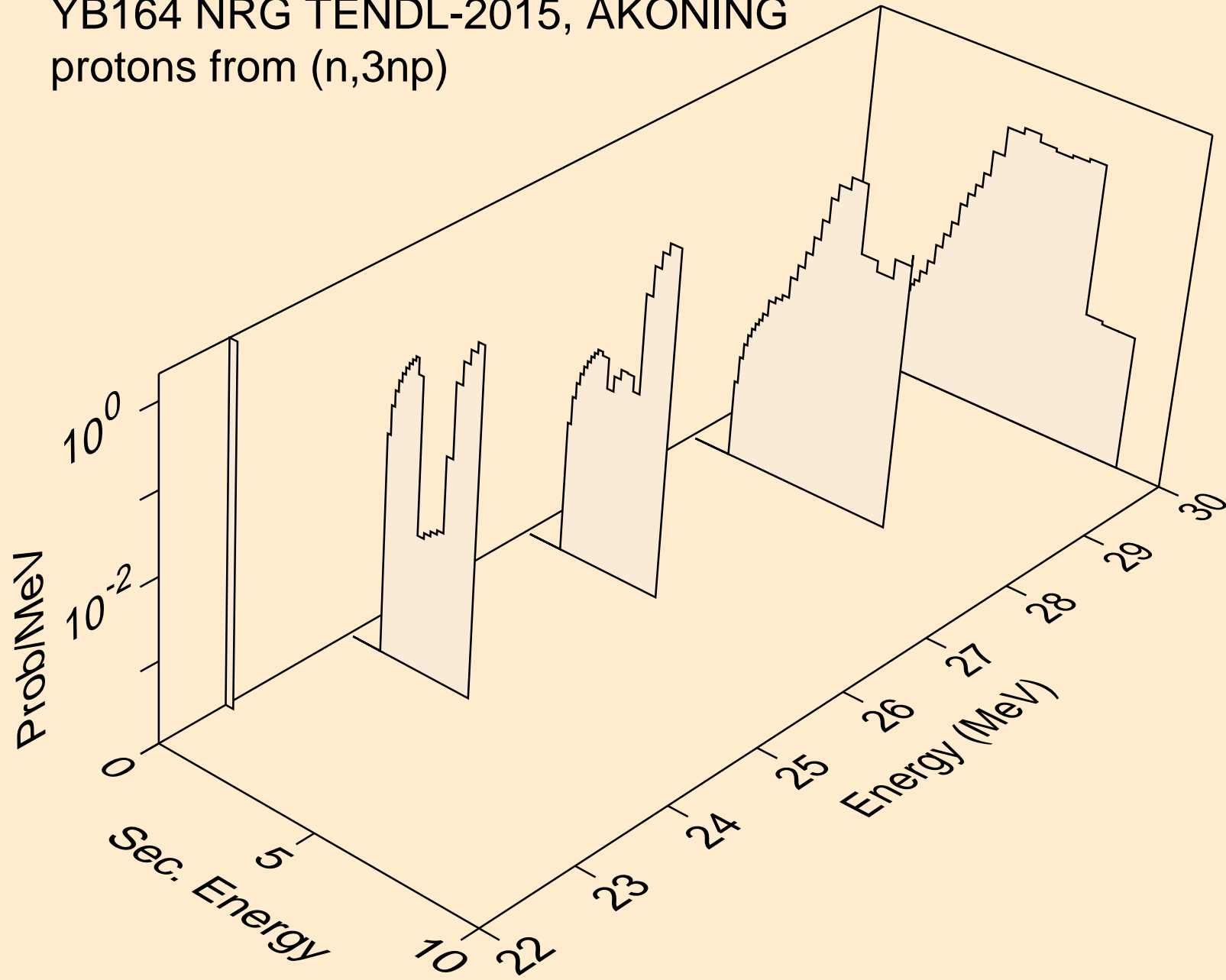



YB164 NRG TENDL-2015, AKONING  
protons from (n,2np)

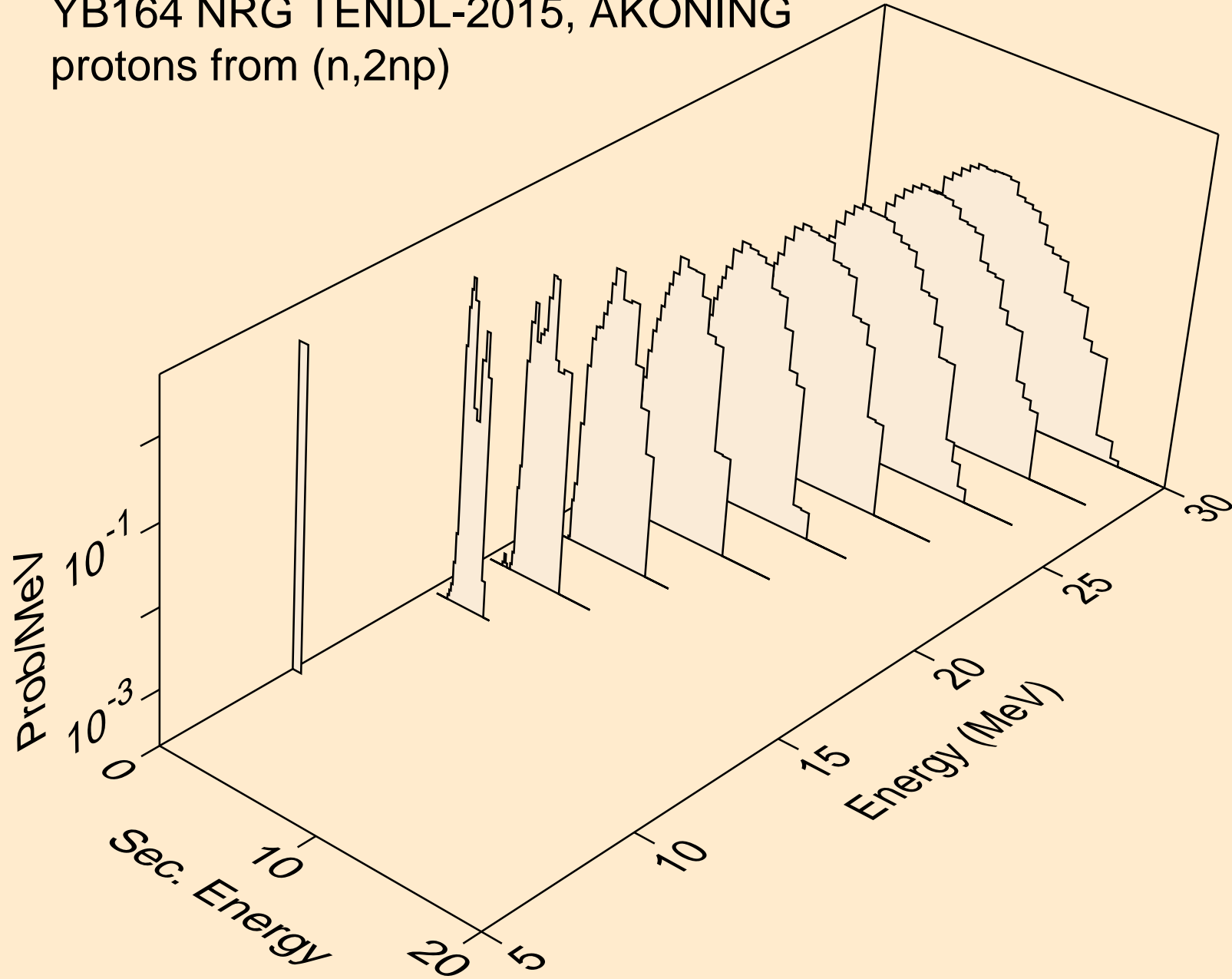

YB164 NRG TENDL-2015, AKONING  
protons from (n,npa)

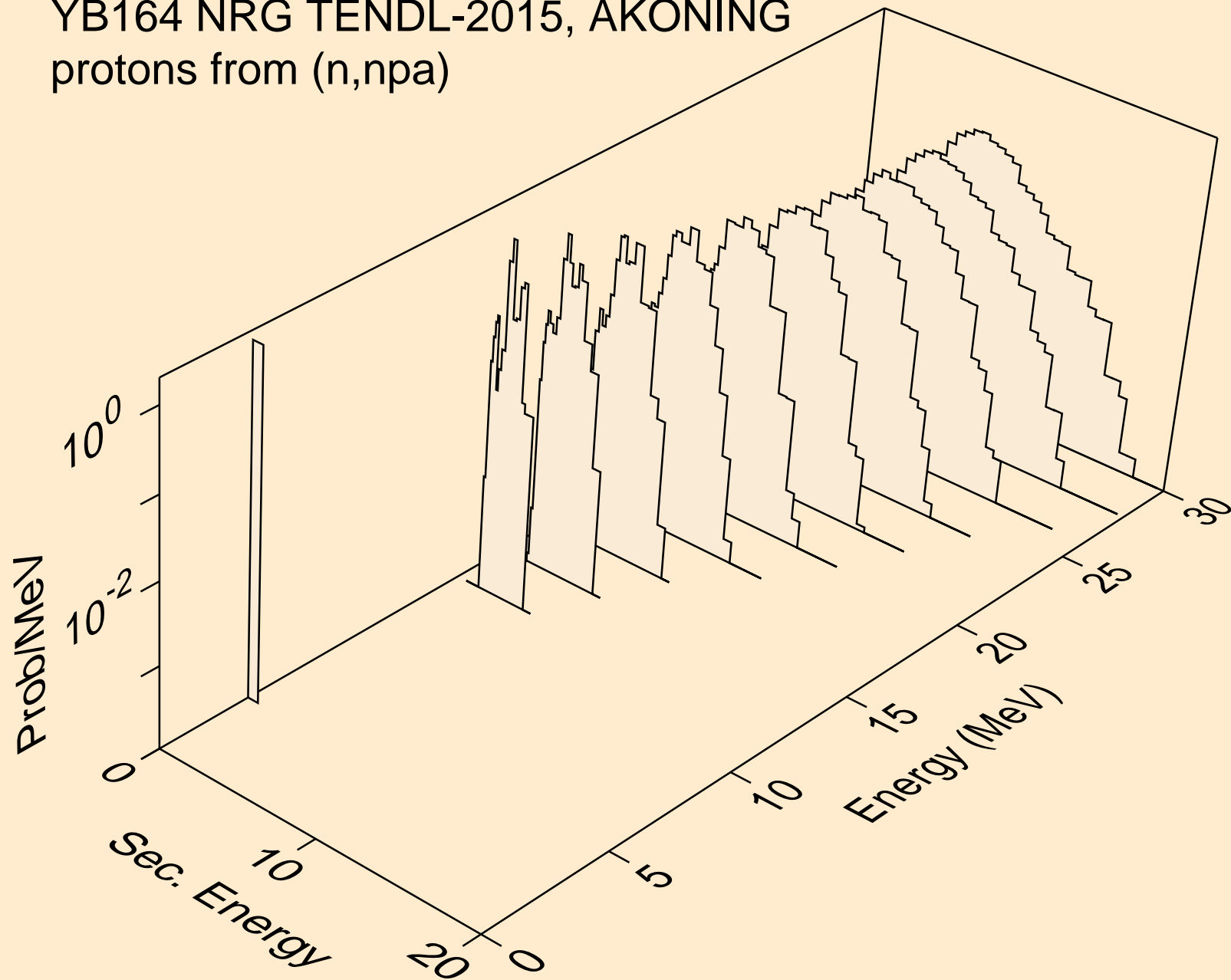

YB164 NRG TENDL-2015, AKONING  
protons from (n,p)

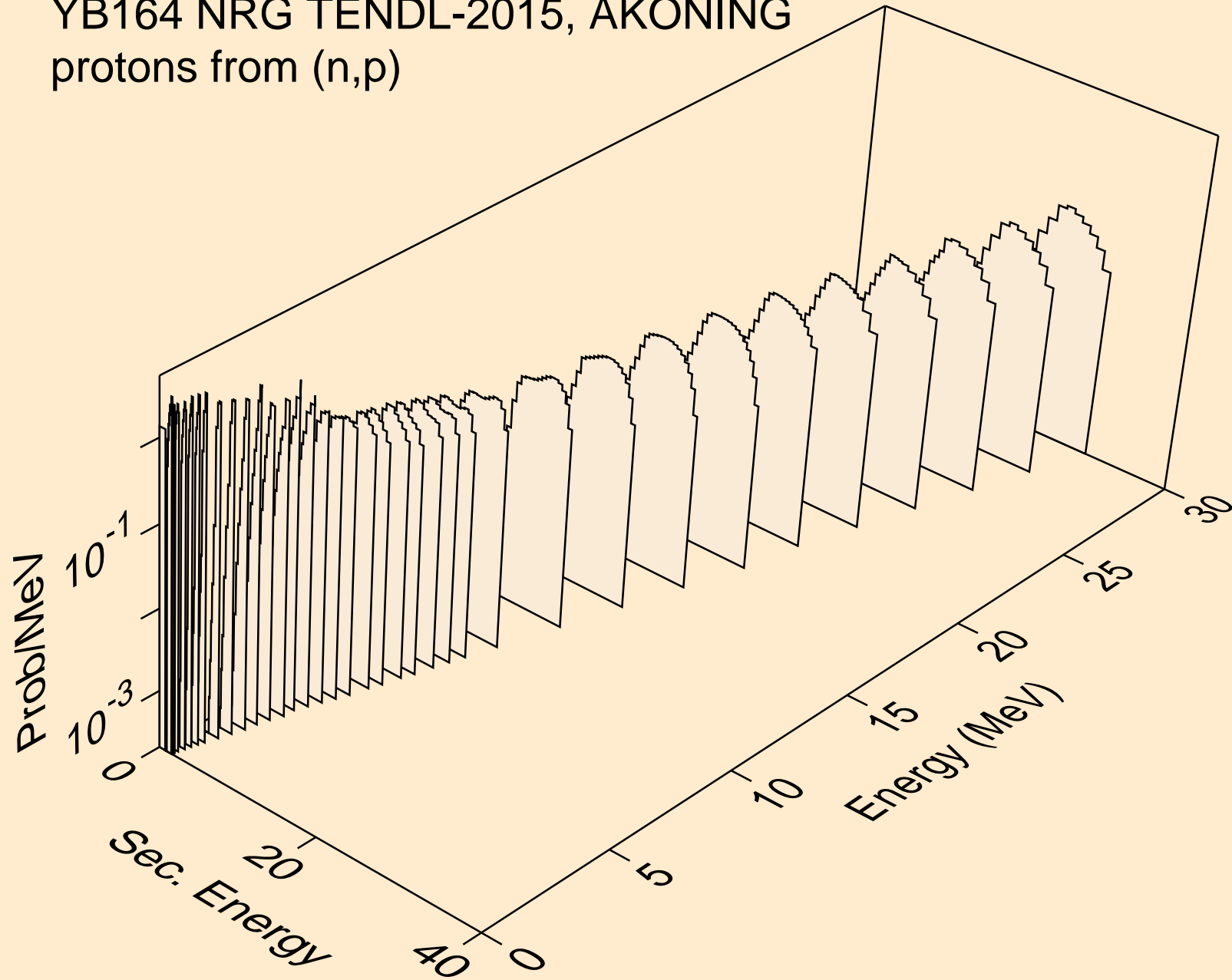

YB164 NRG TENDL-2015, AKONING  
protons from (n,2p)

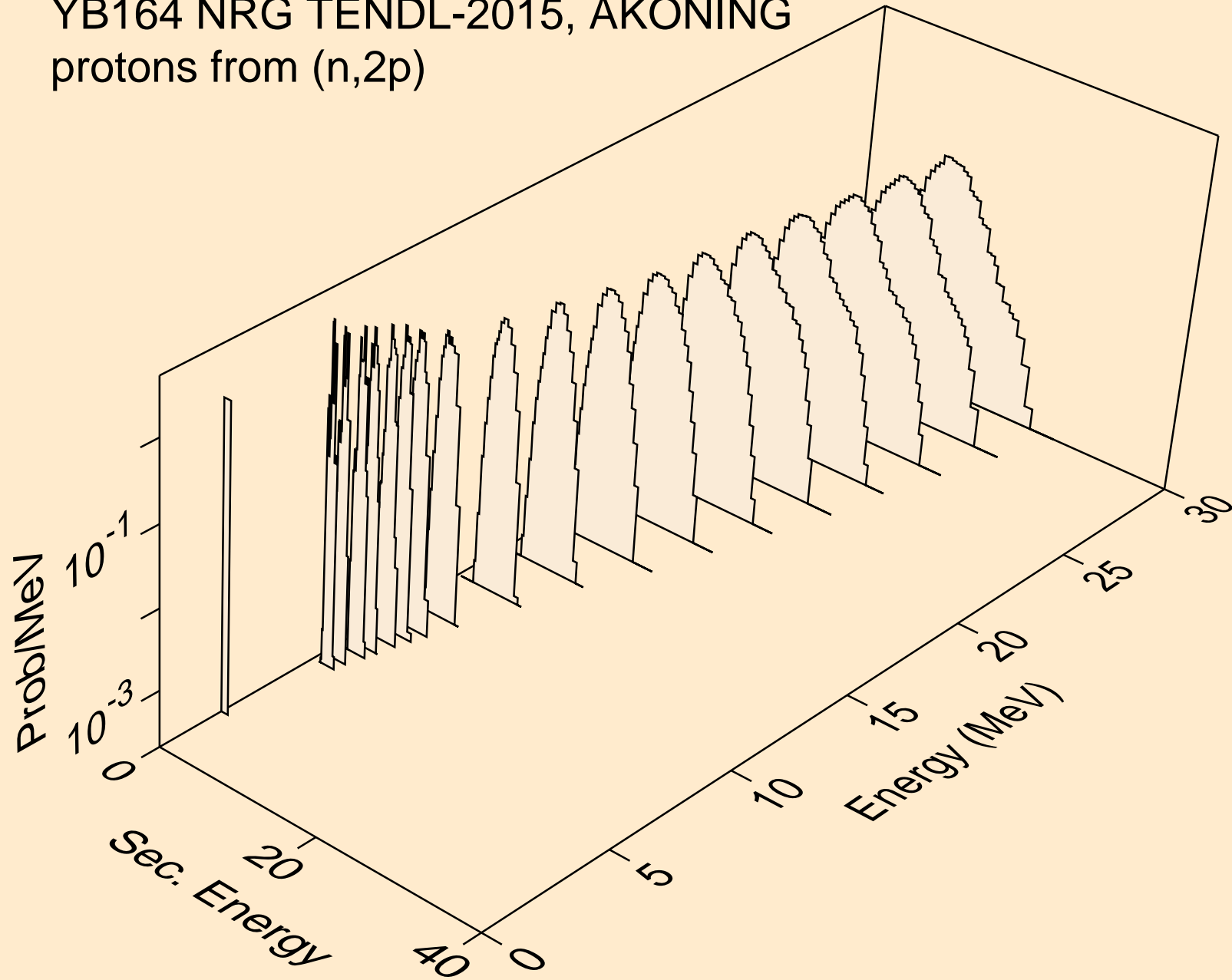

YB164 NRG TENDL-2015, AKONING  
protons from (n,pa)

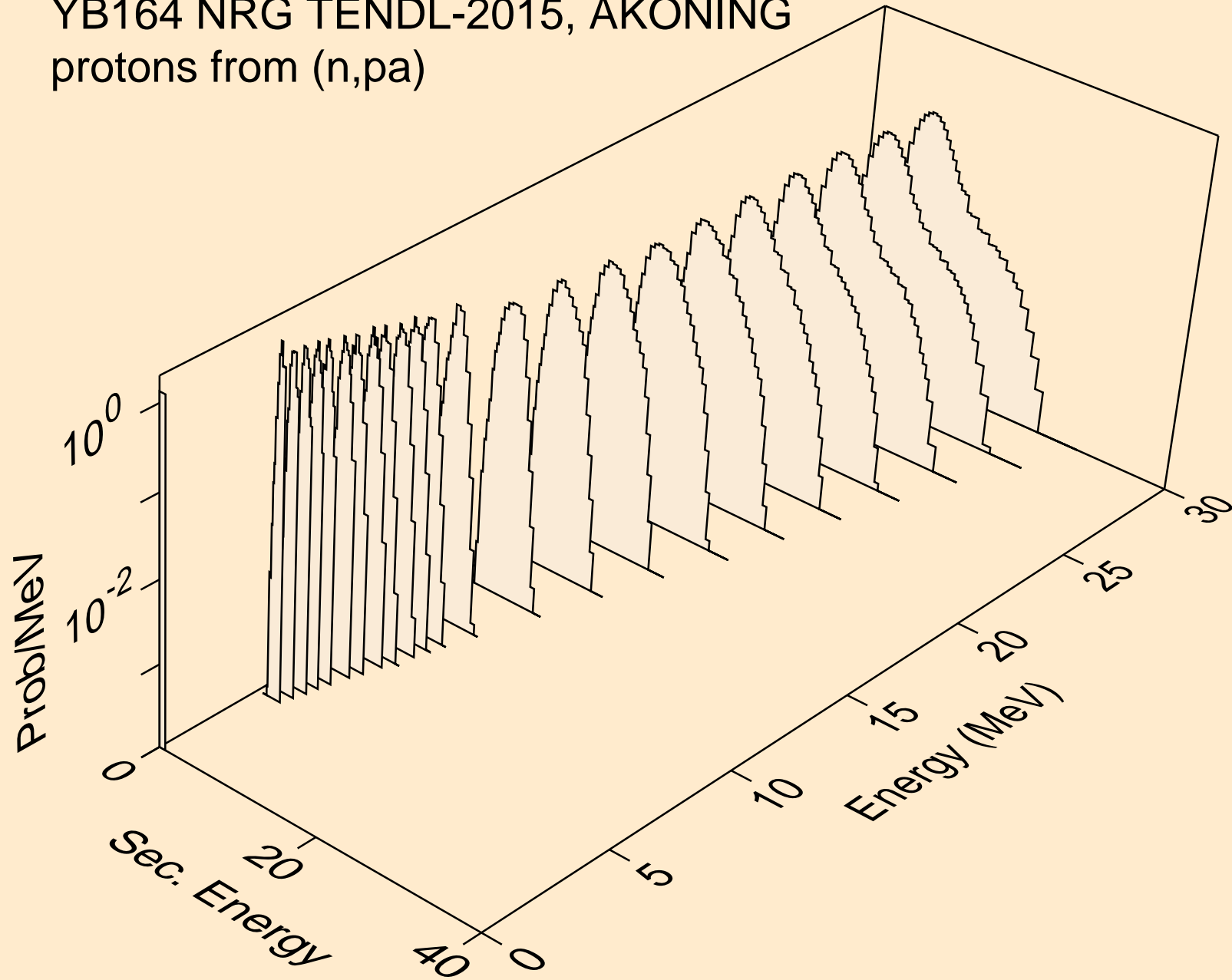

YB164 NRG TENDL-2015, AKONING  
protons from (n,pd)

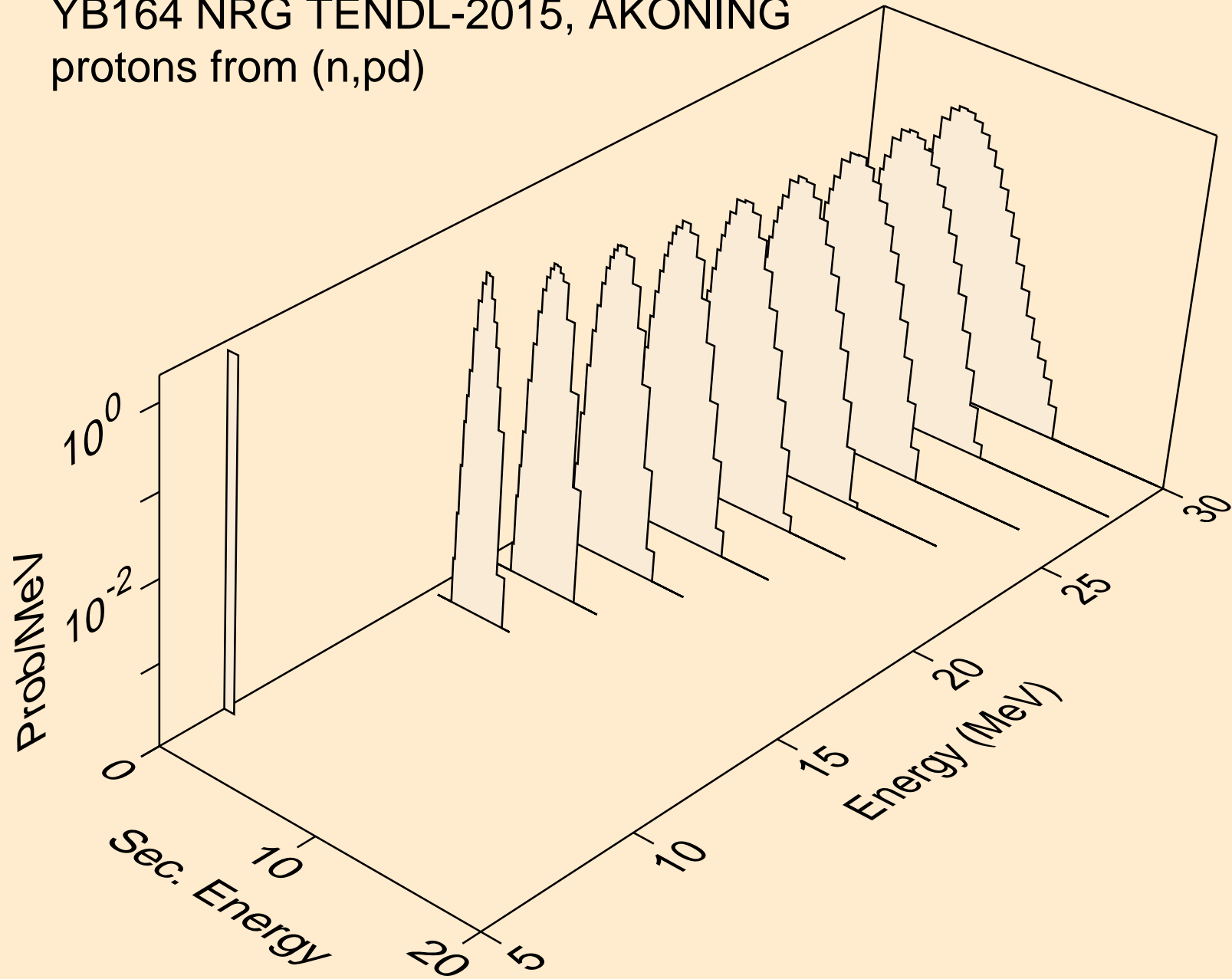

YB164 NRG TENDL-2015, AKONING  
protons from (n,pt)

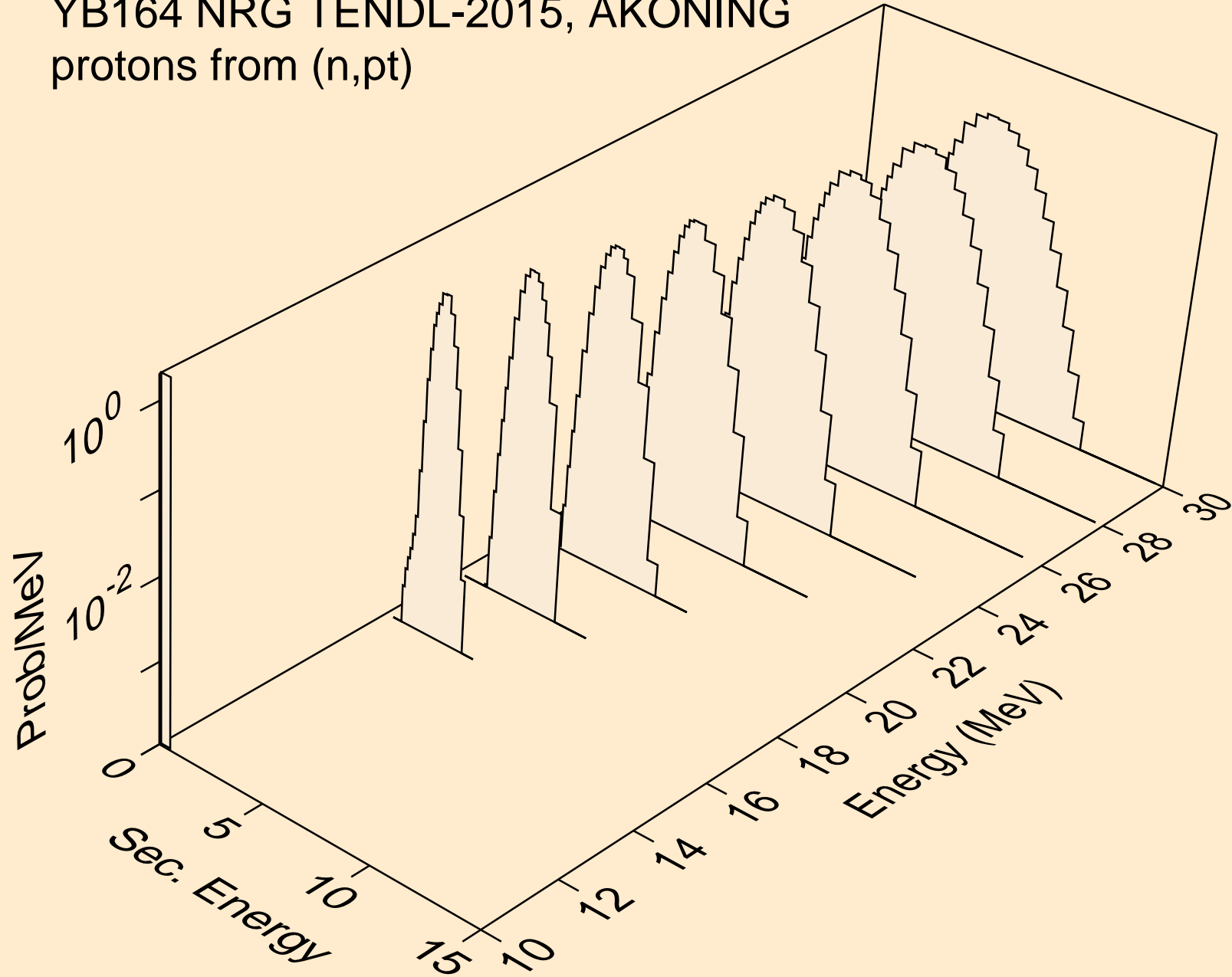

YB164 NRG TENDL-2015, AKONING  
deuterons from (n,x)

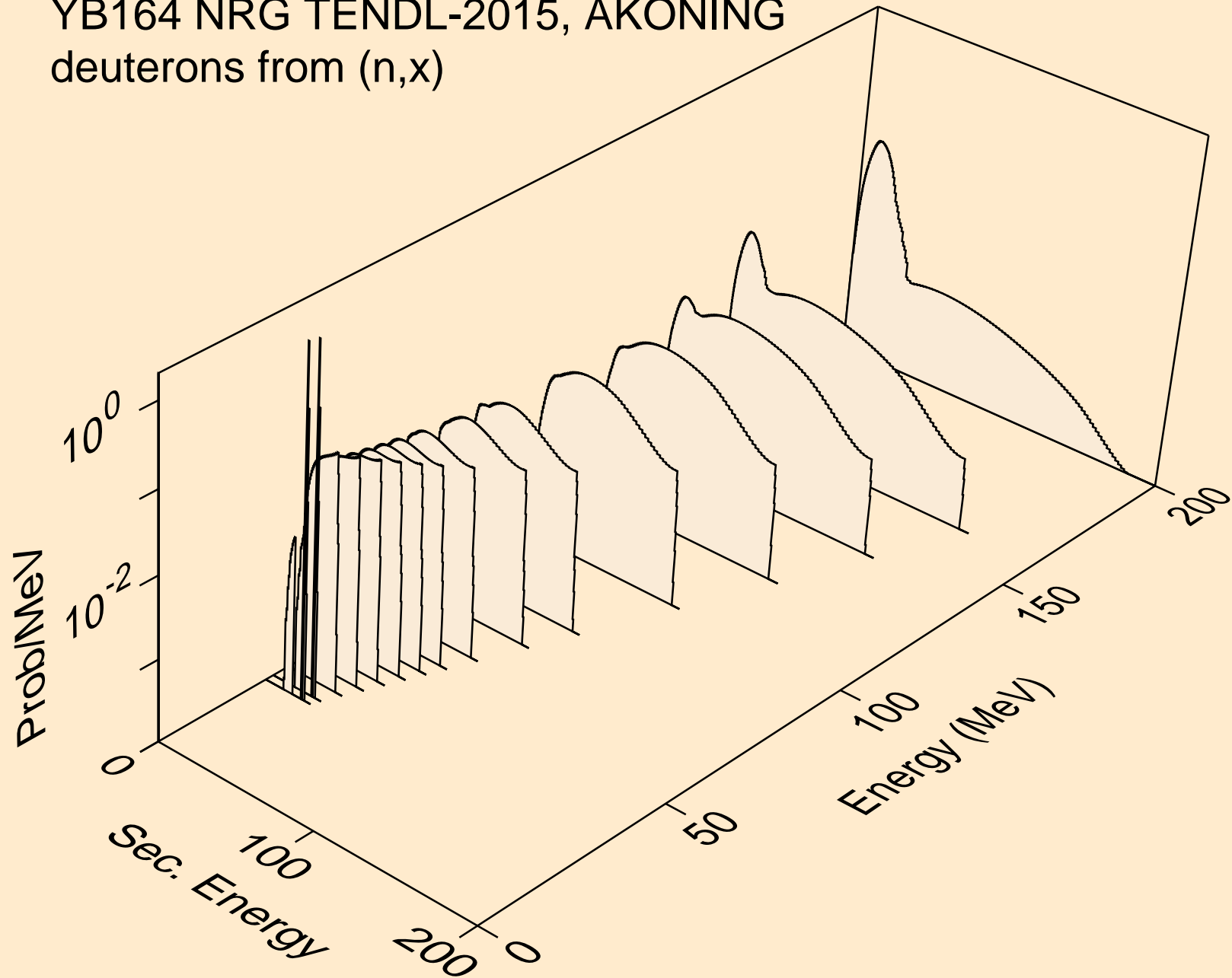



YB164 NRG TENDL-2015, AKONING  
deuterons from (n,2nd)

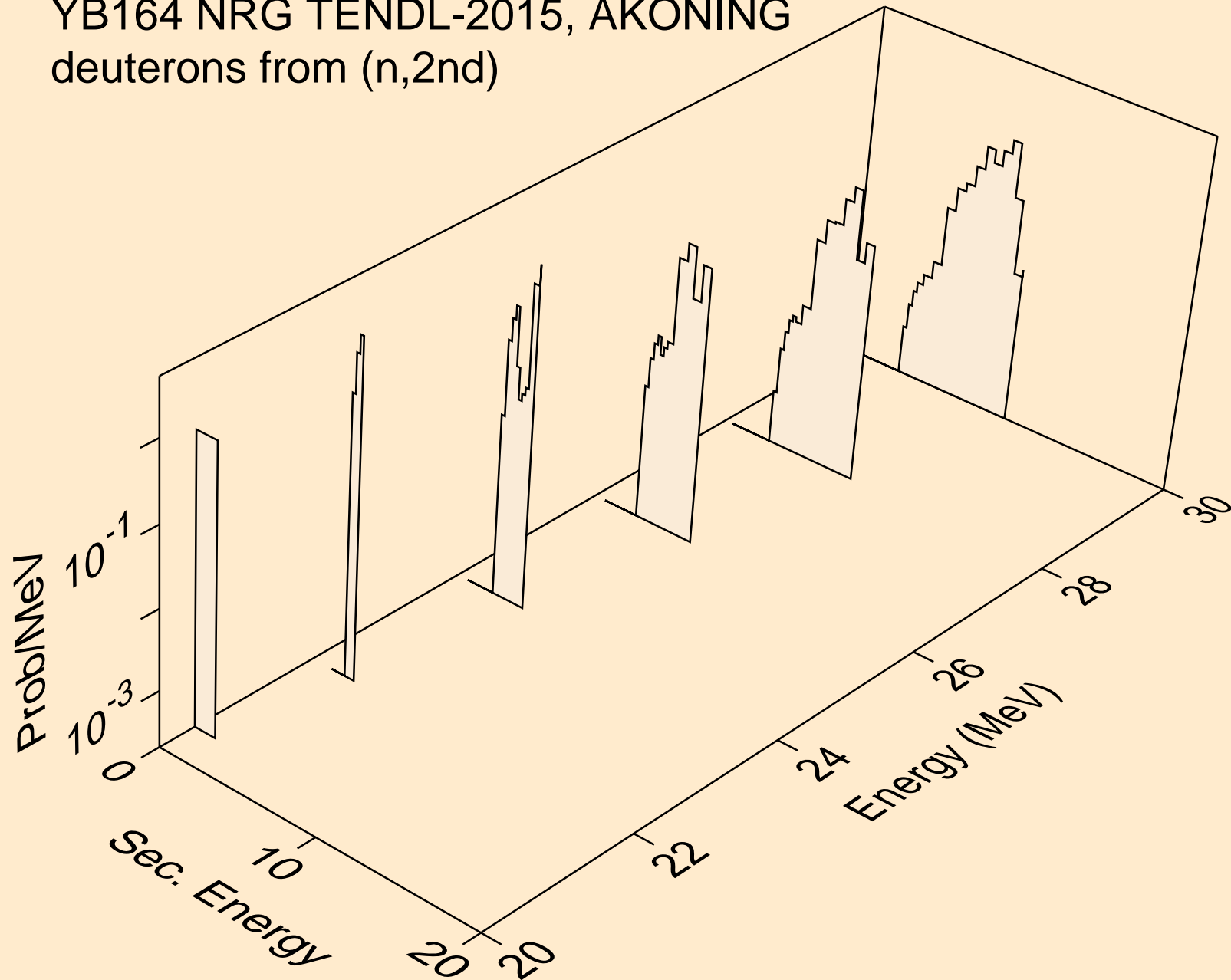

YB164 NRG TENDL-2015, AKONING  
deuterons from (n,n\*)d

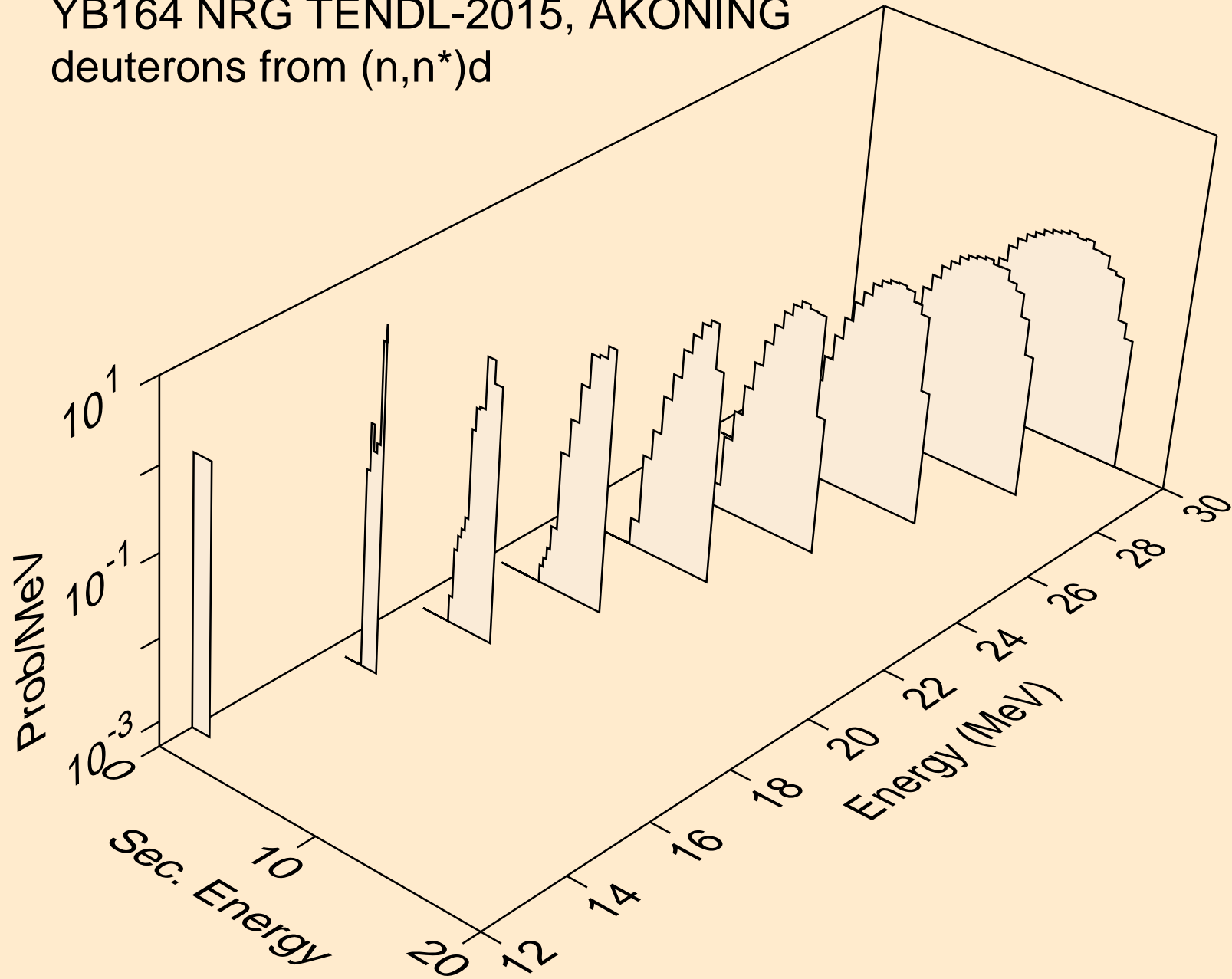

YB164 NRG TENDL-2015, AKONING  
deuterons from (n,d)

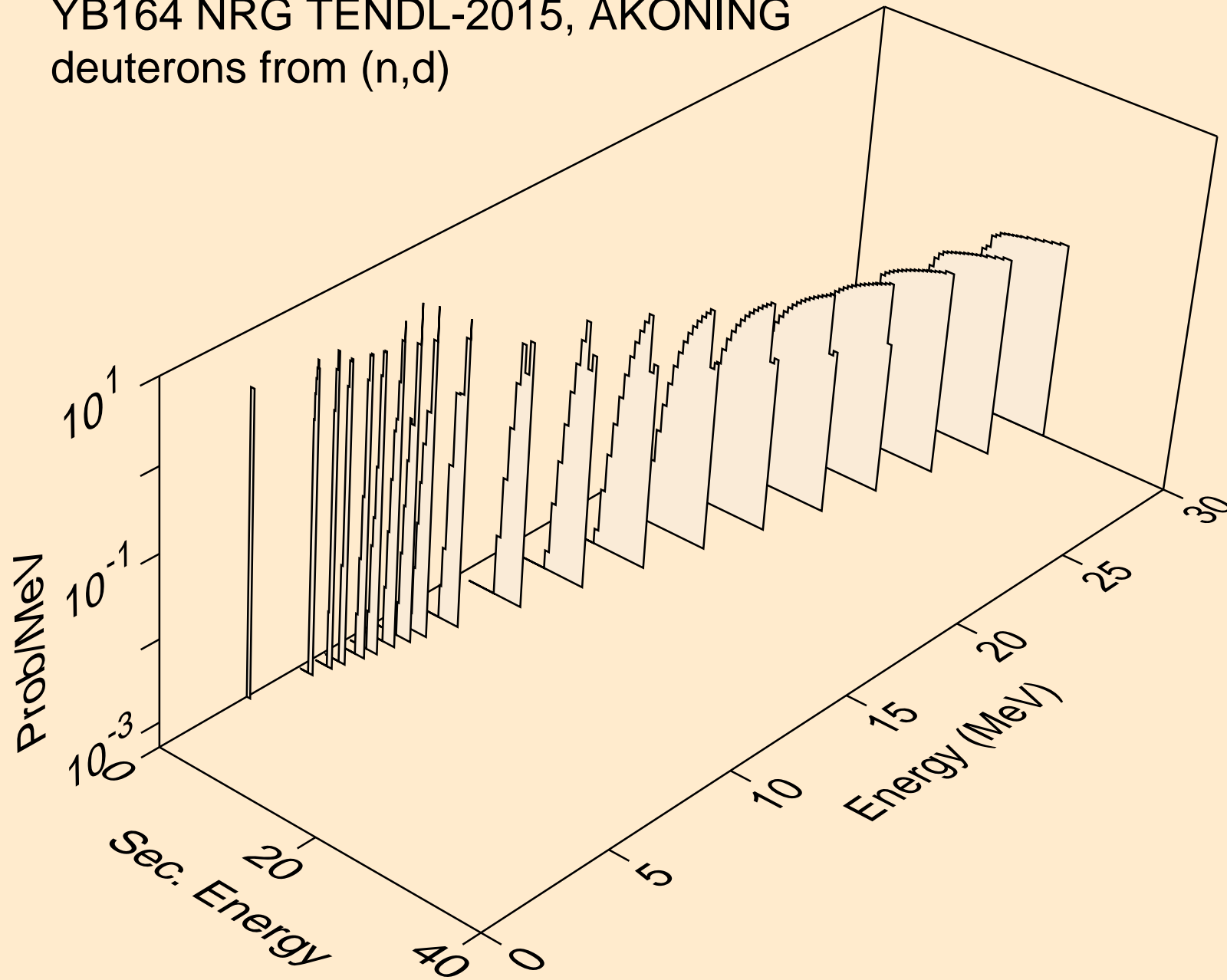

YB164 NRG TENDL-2015, AKONING  
deuterons from (n,pd)

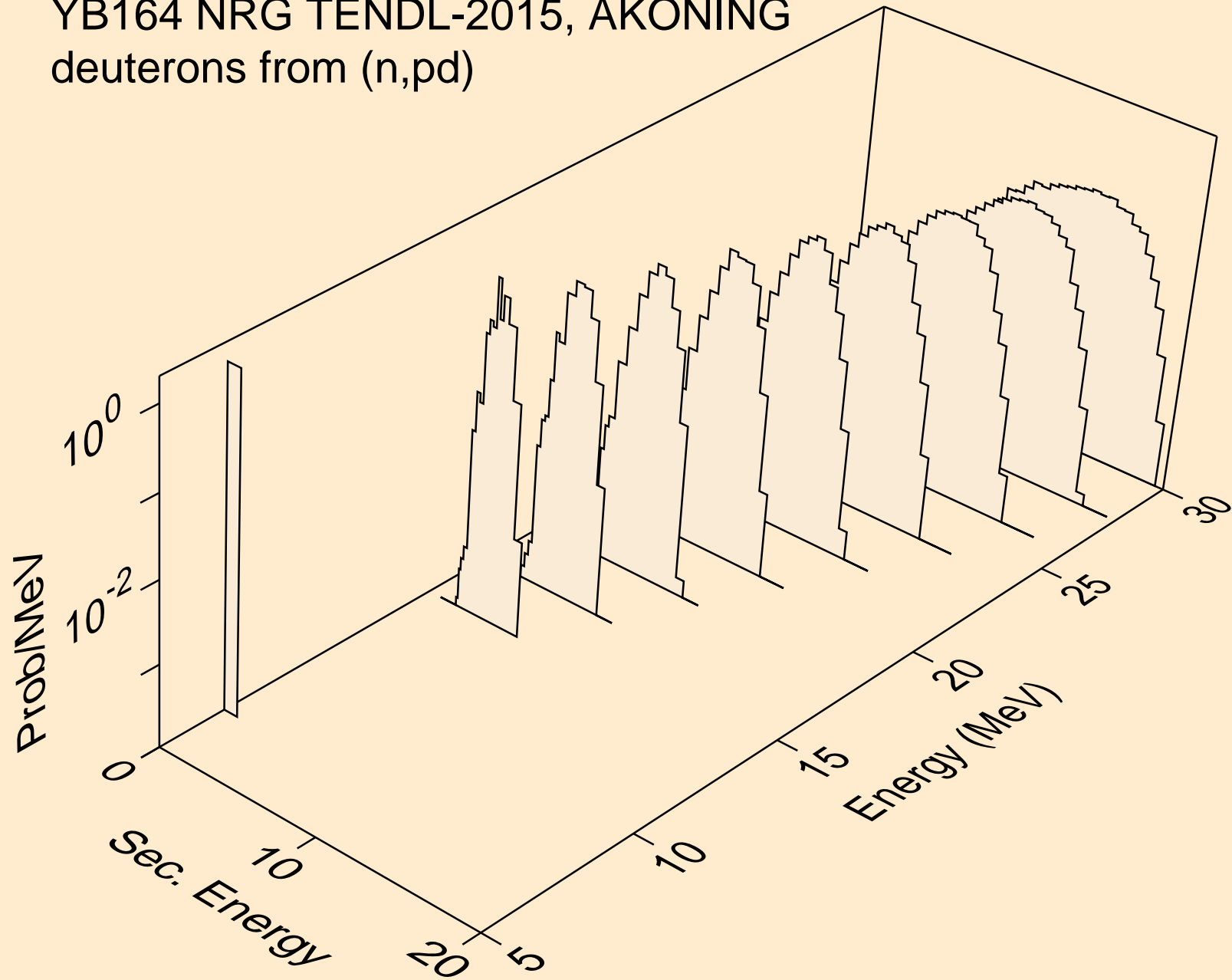

YB164 NRG TENDL-2015, AKONING  
deuterons from (n,da)

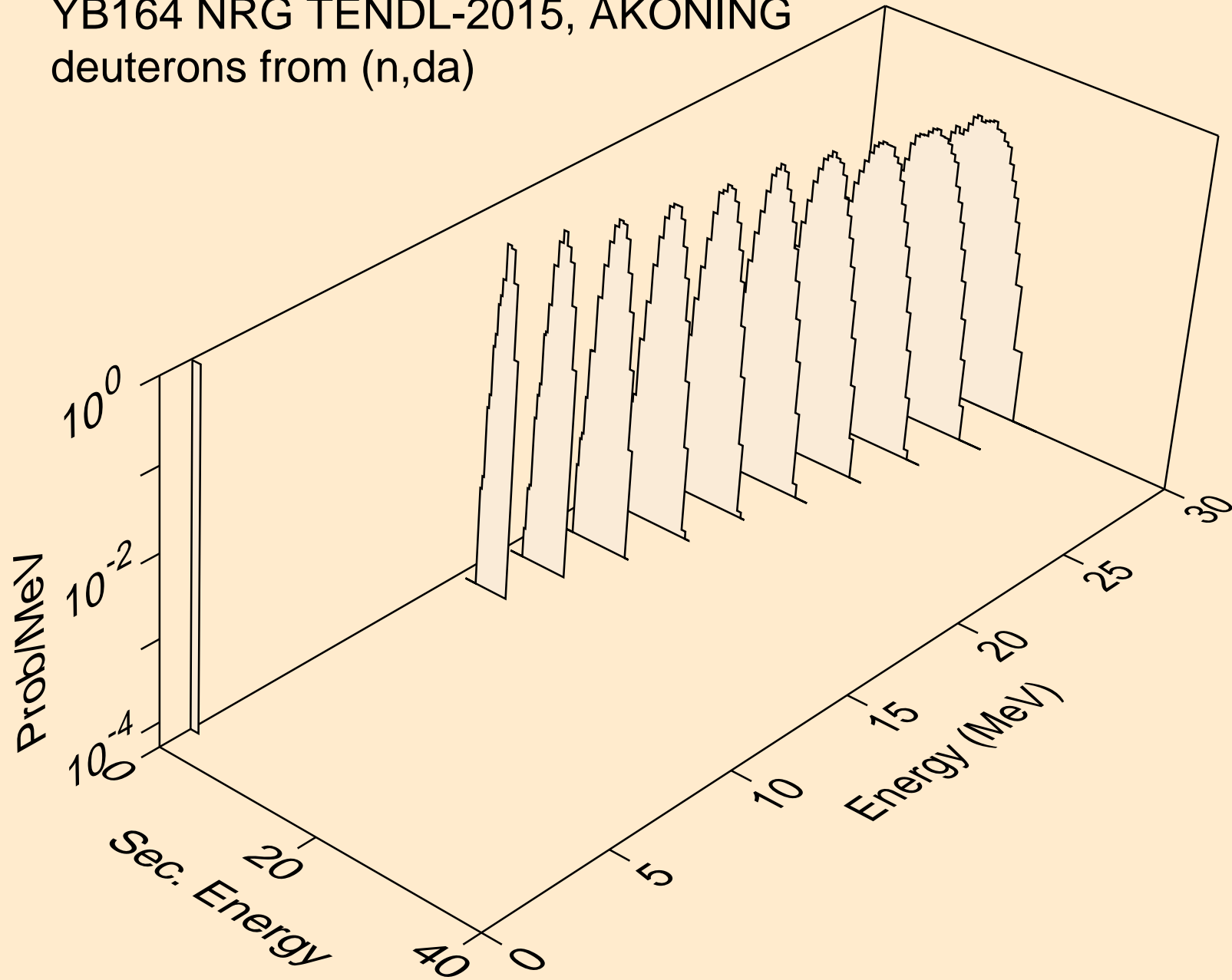

YB164 NRG TENDL-2015, AKONING  
tritons from (n,x)

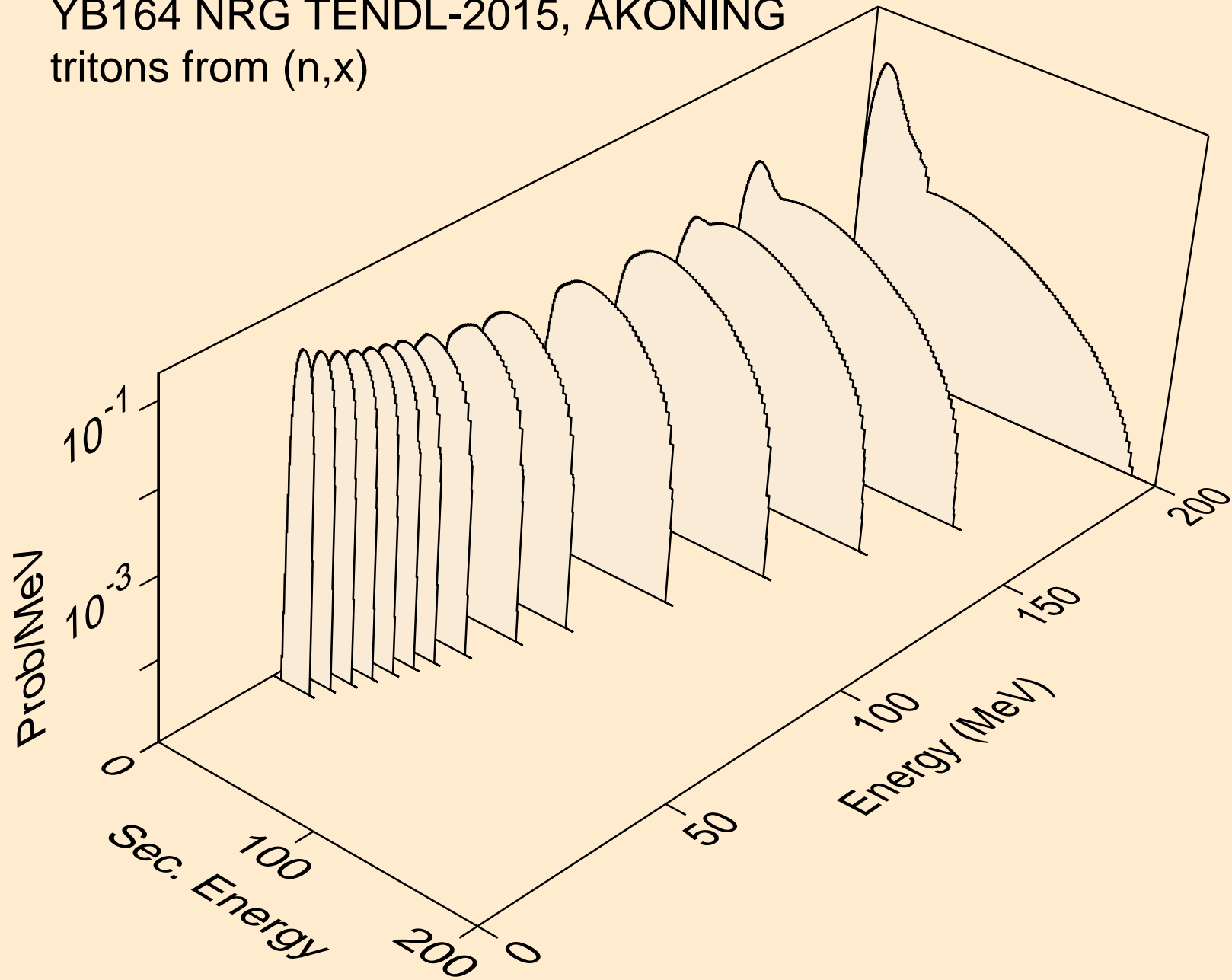

YB164 NRG TENDL-2015, AKONING  
tritons from (n,n\*)t

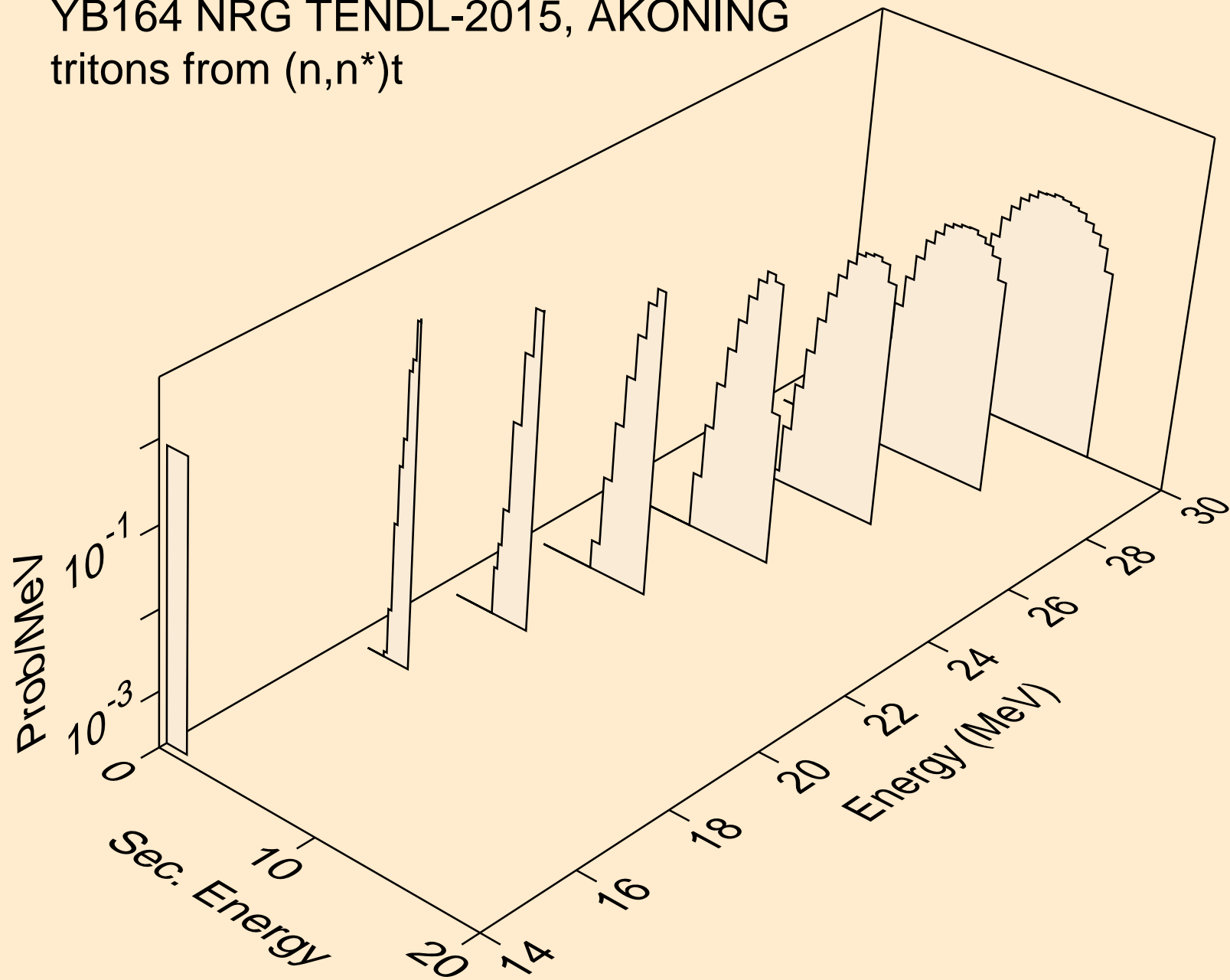

YB164 NRG TENDL-2015, AKONING  
tritons from (n,t)

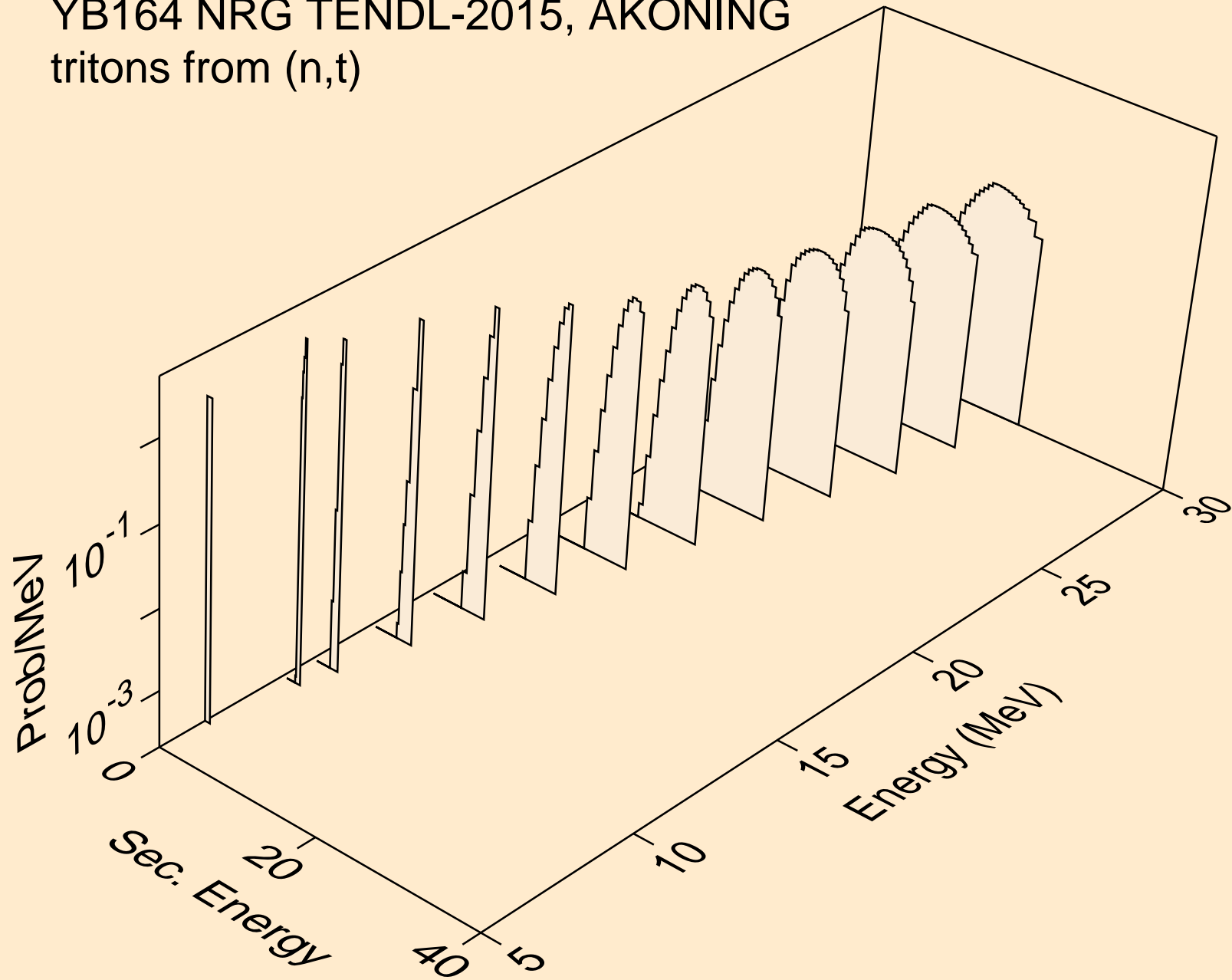



YB164 NRG TENDL-2015, AKONING  
tritons from (n,pt)

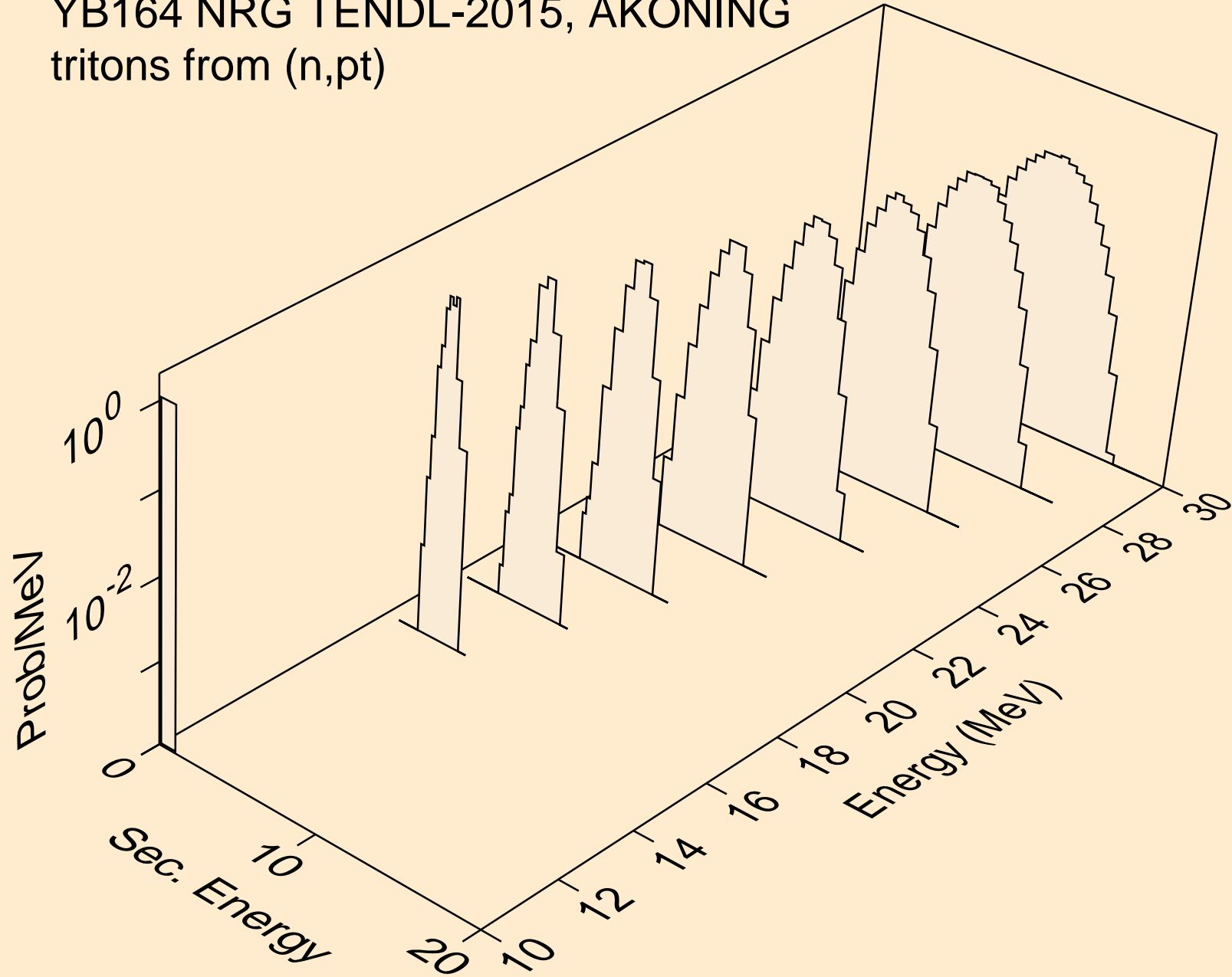

YB164 NRG TENDL-2015, AKONING  
he3s from (n,x)

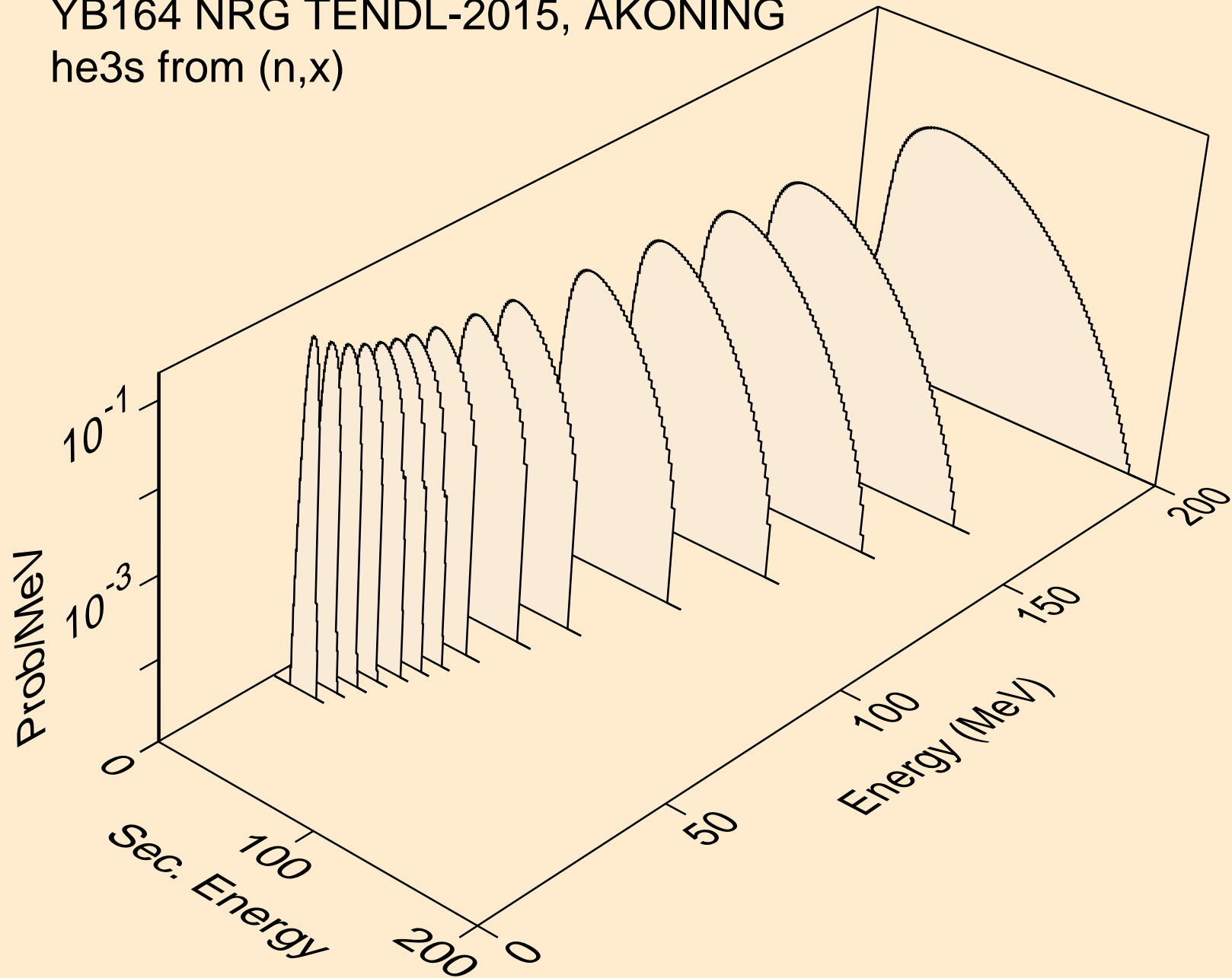

YB164 NRG TENDL-2015, AKONING  
he3s from (n,n\*)he3

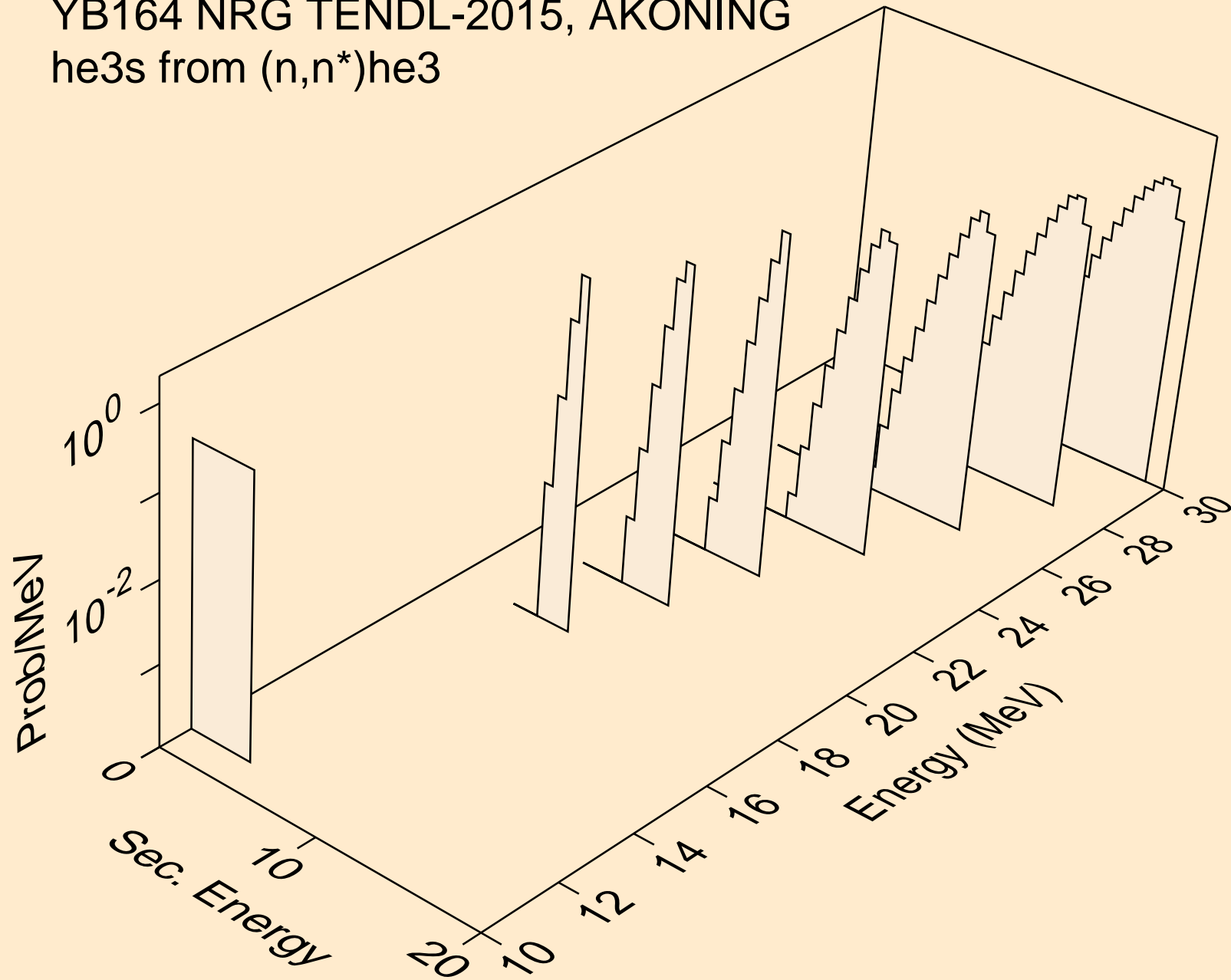

YB164 NRG TENDL-2015, AKONING  
he3s from (n,he3)

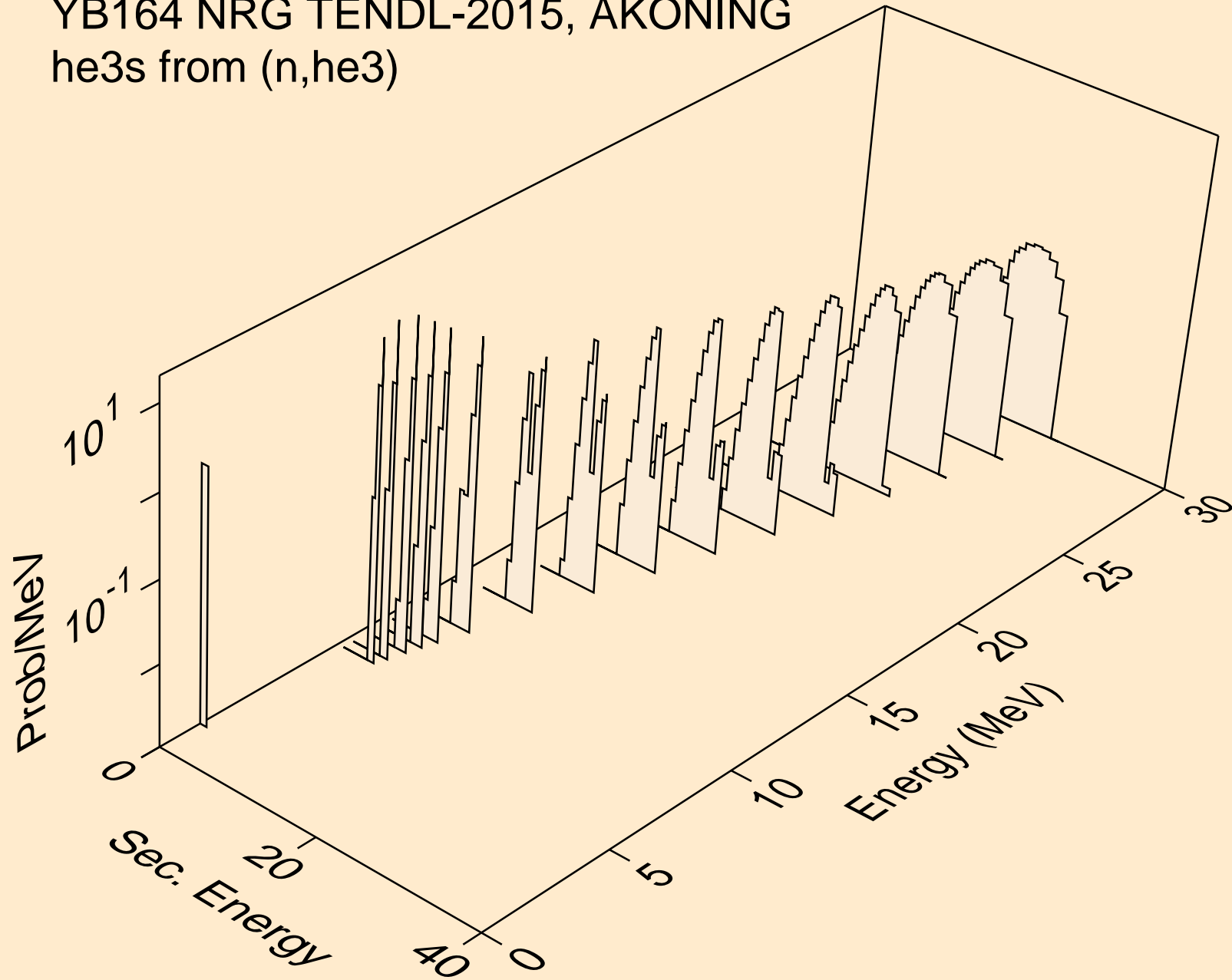

YB164 NRG TENDL-2015, AKONING  
alphas from (n,x)

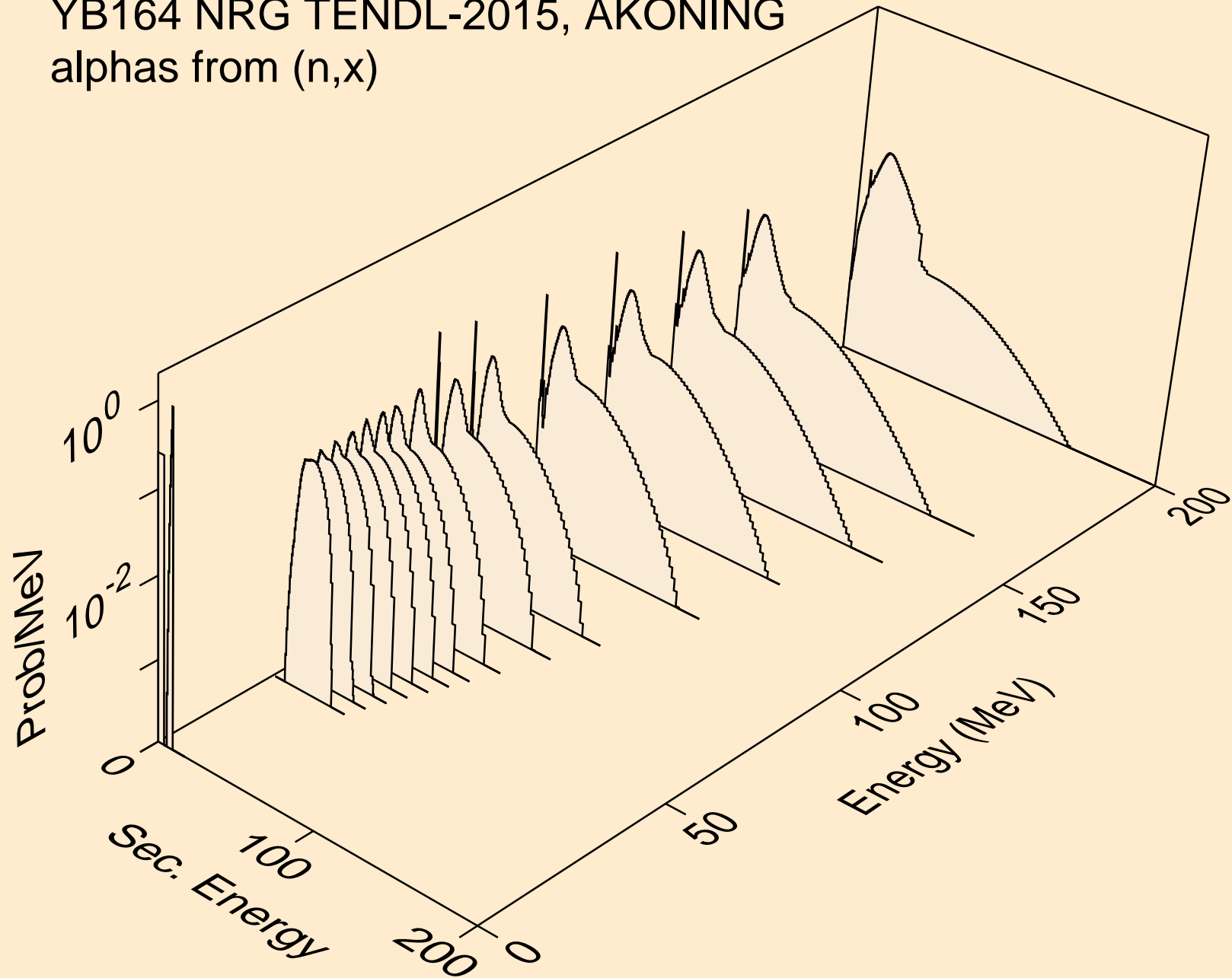

YB164 NRG TENDL-2015, AKONING  
alphas from (n,n\*)a

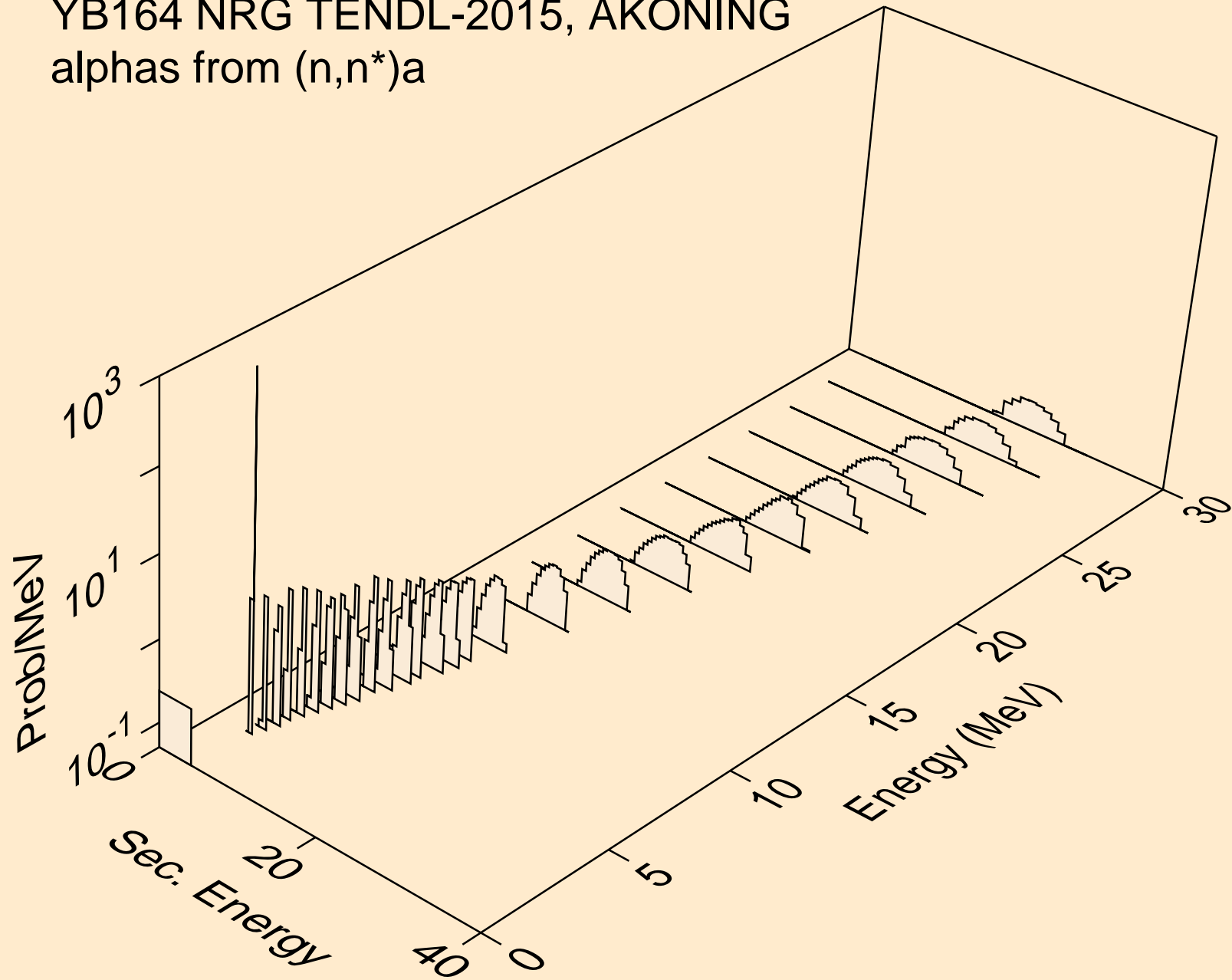

YB164 NRG TENDL-2015, AKONING  
alphas from (n,2n)a

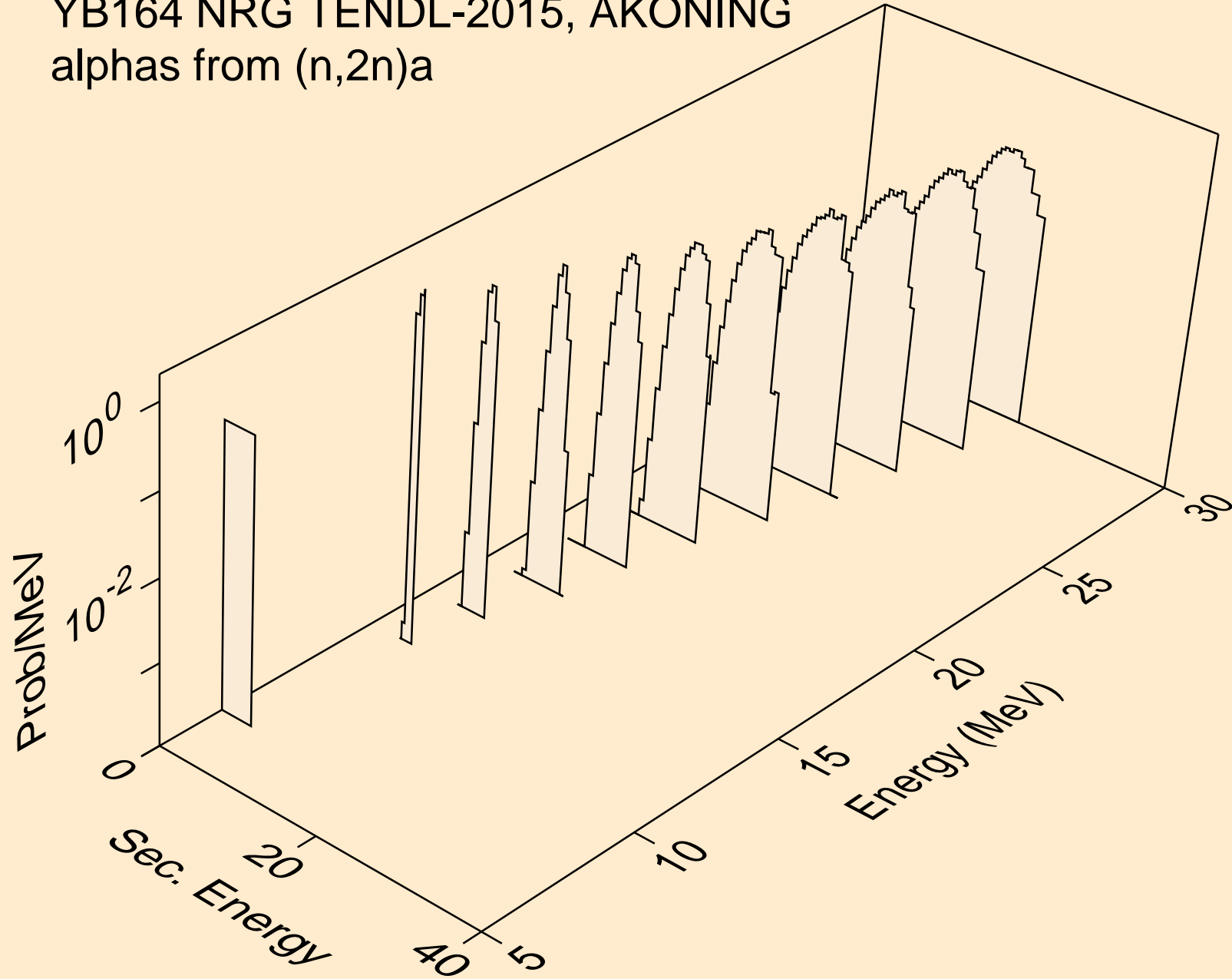

YB164 NRG TENDL-2015, AKONING  
alphas from (n,3n)a

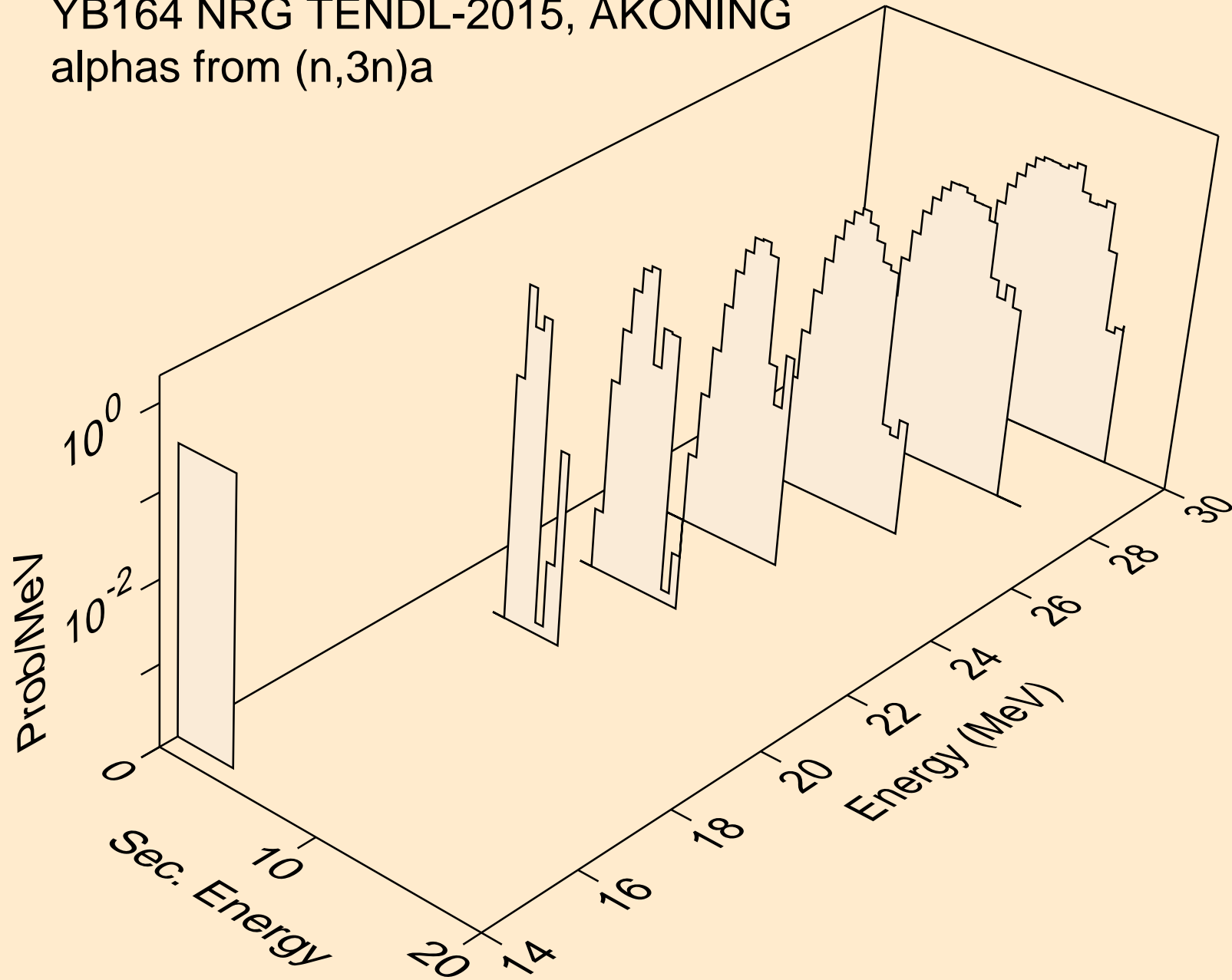



YB164 NRG TENDL-2015, AKONING  
alphas from (n,n\*)2a

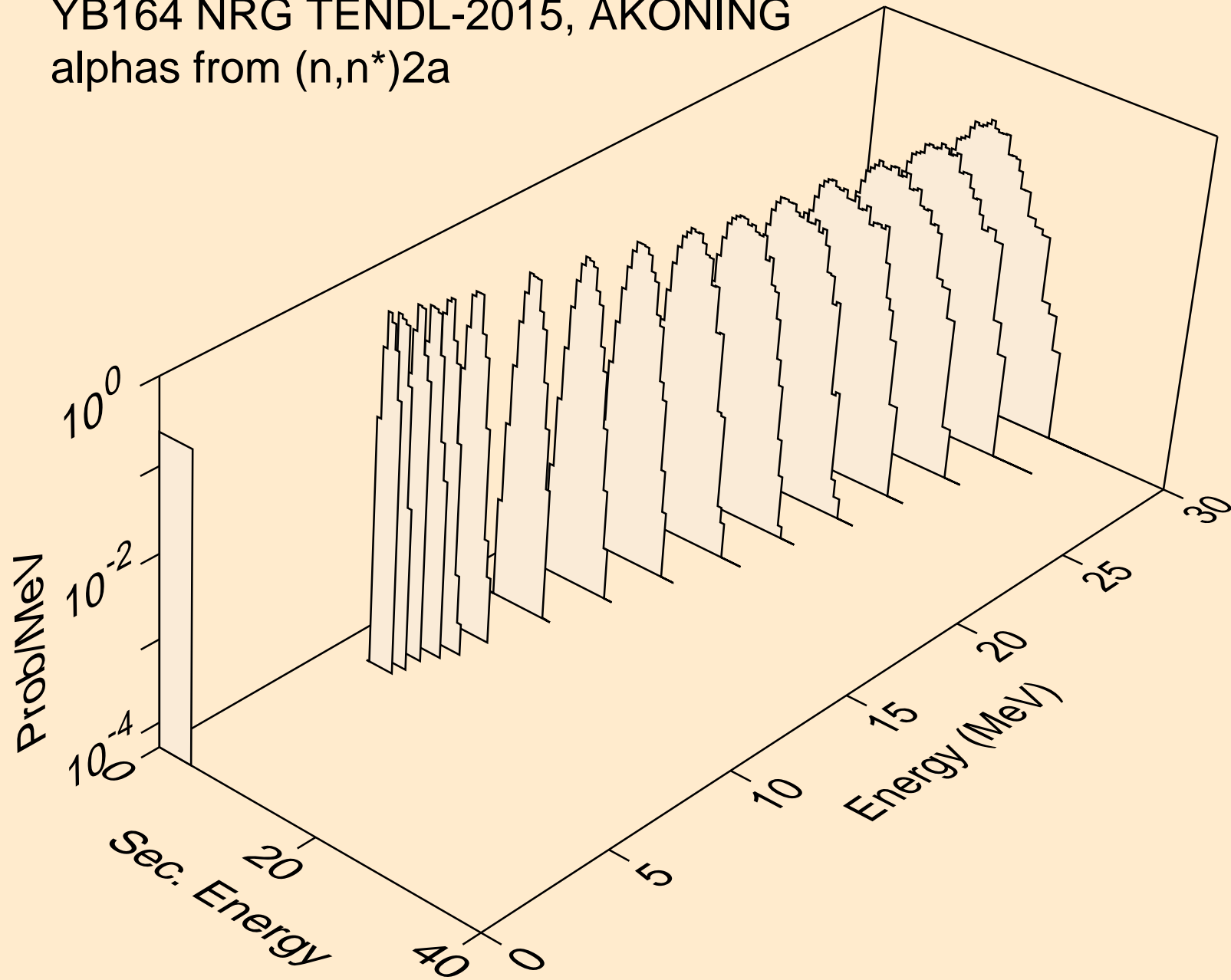

YB164 NRG TENDL-2015, AKONING  
alphas from (n,2n)2a

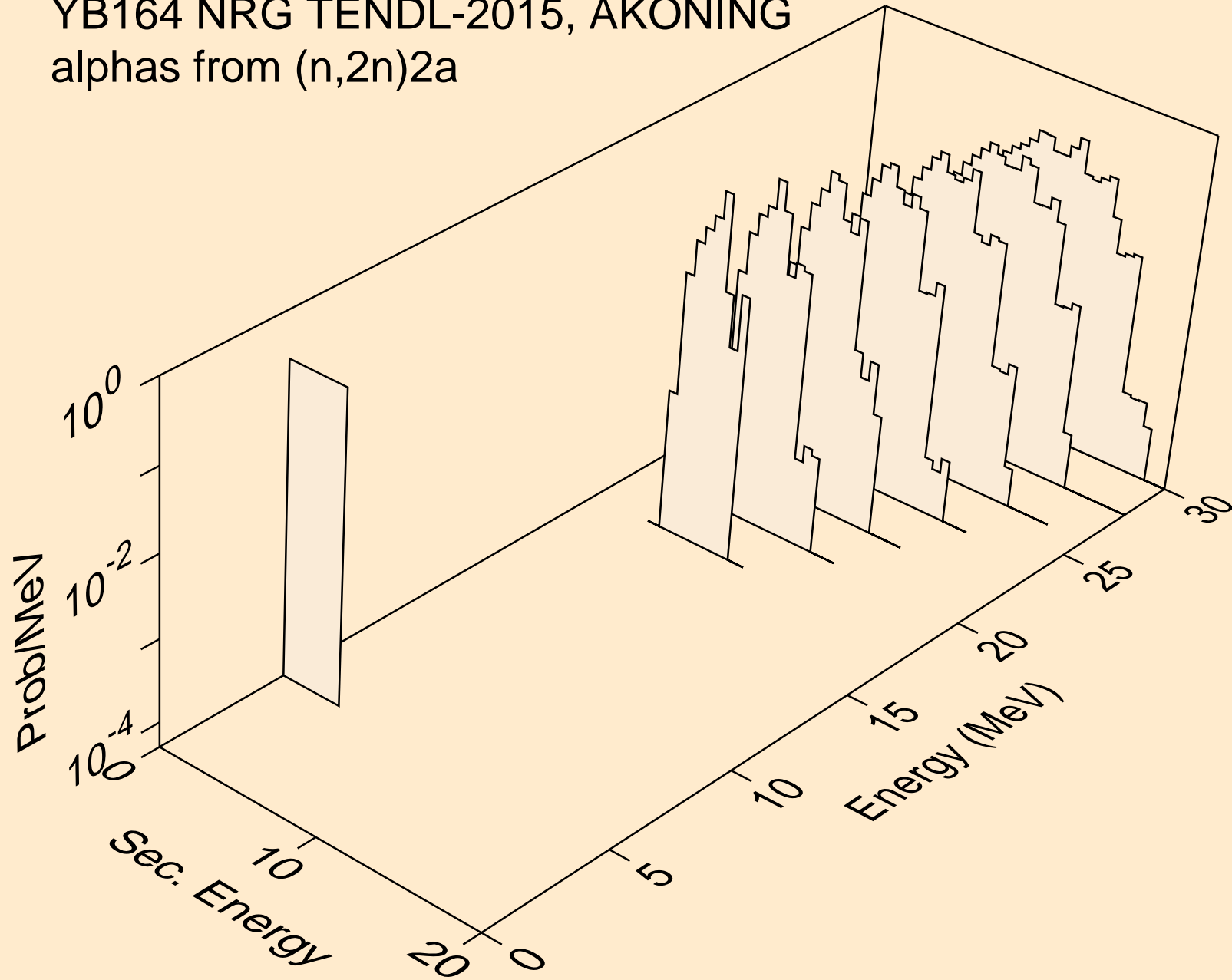

YB164 NRG TENDL-2015, AKONING  
alphas from (n,npa)

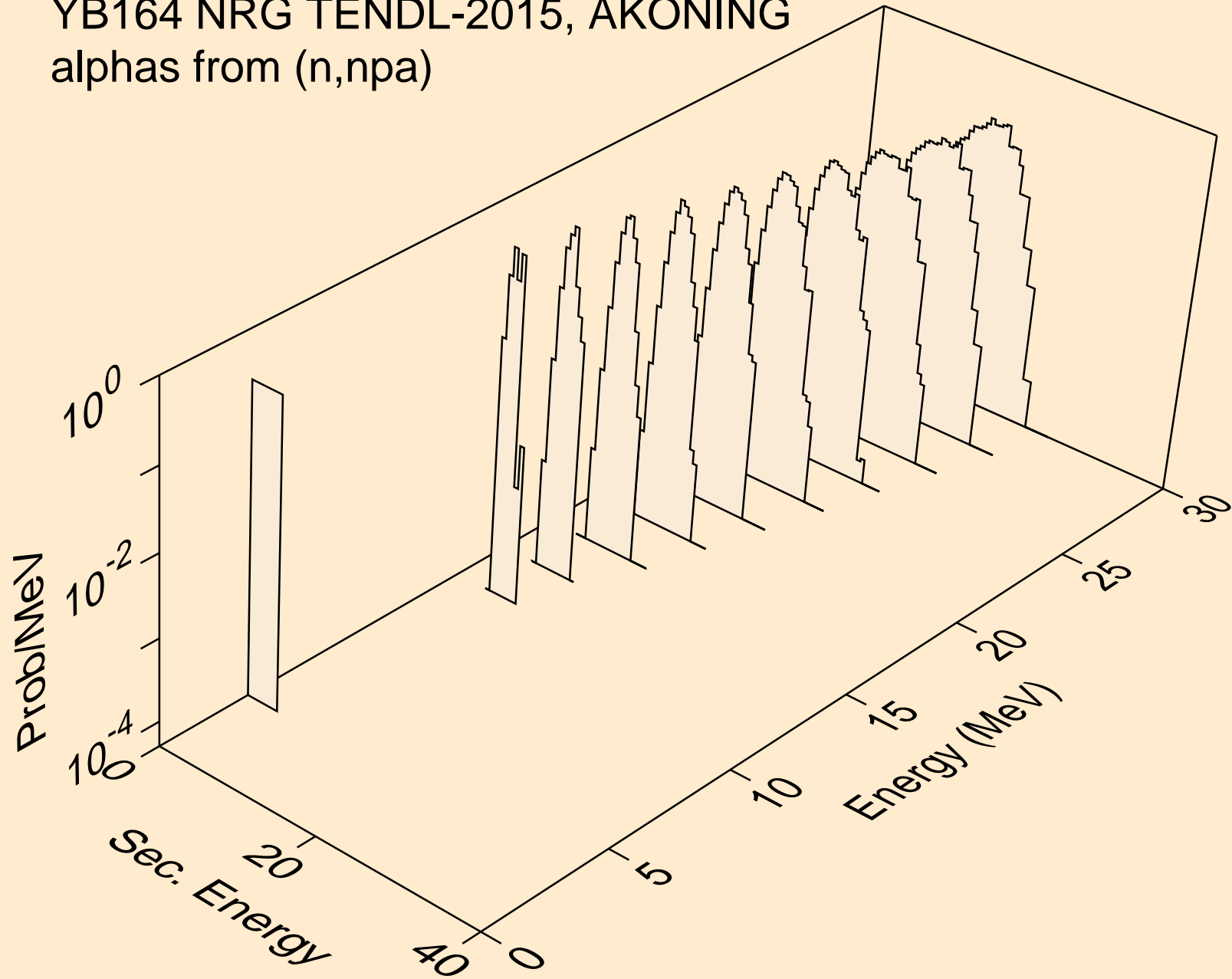

YB164 NRG TENDL-2015, AKONING  
alphas from (n,a)

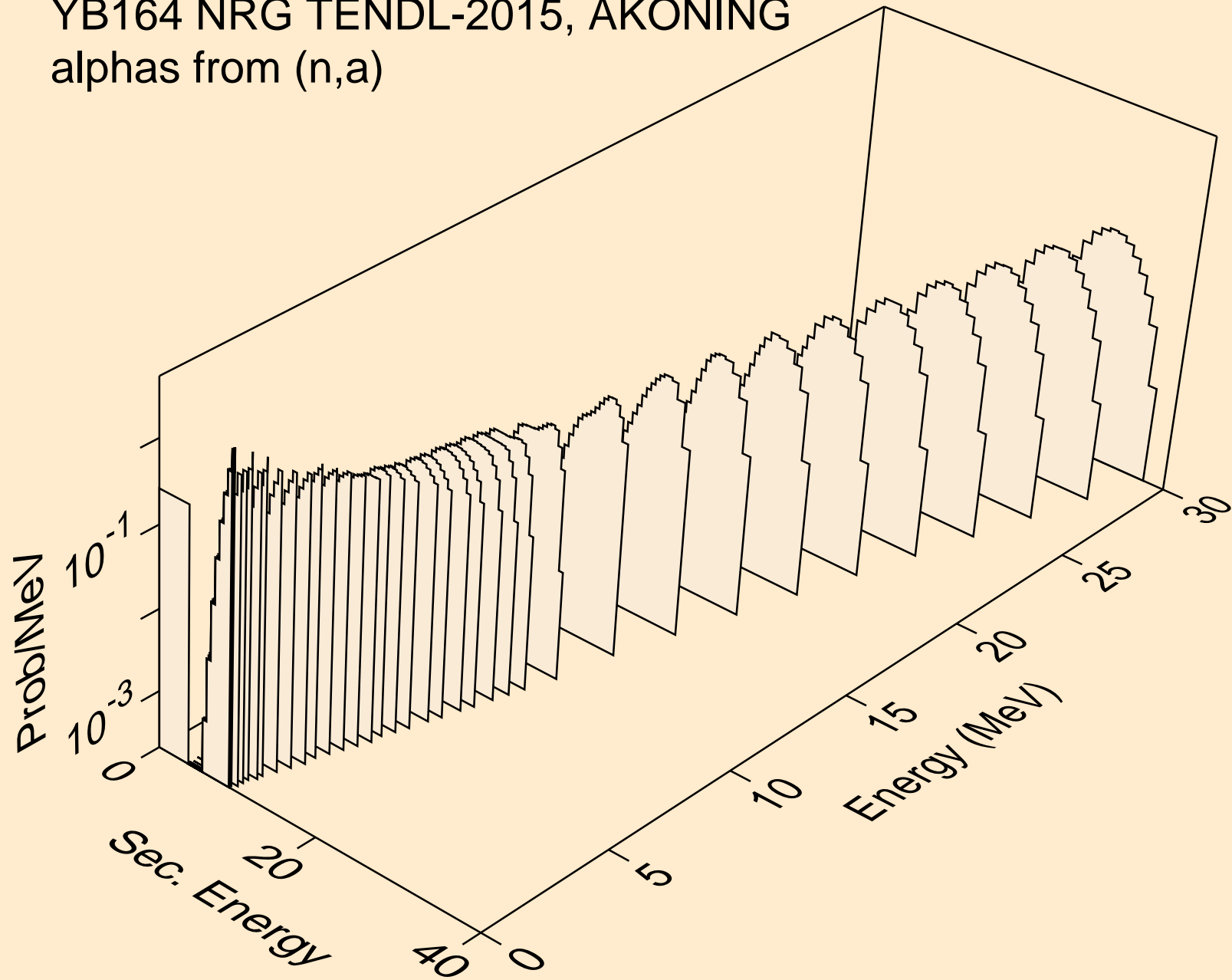

YB164 NRG TENDL-2015, AKONING  
alphas from (n,2a)

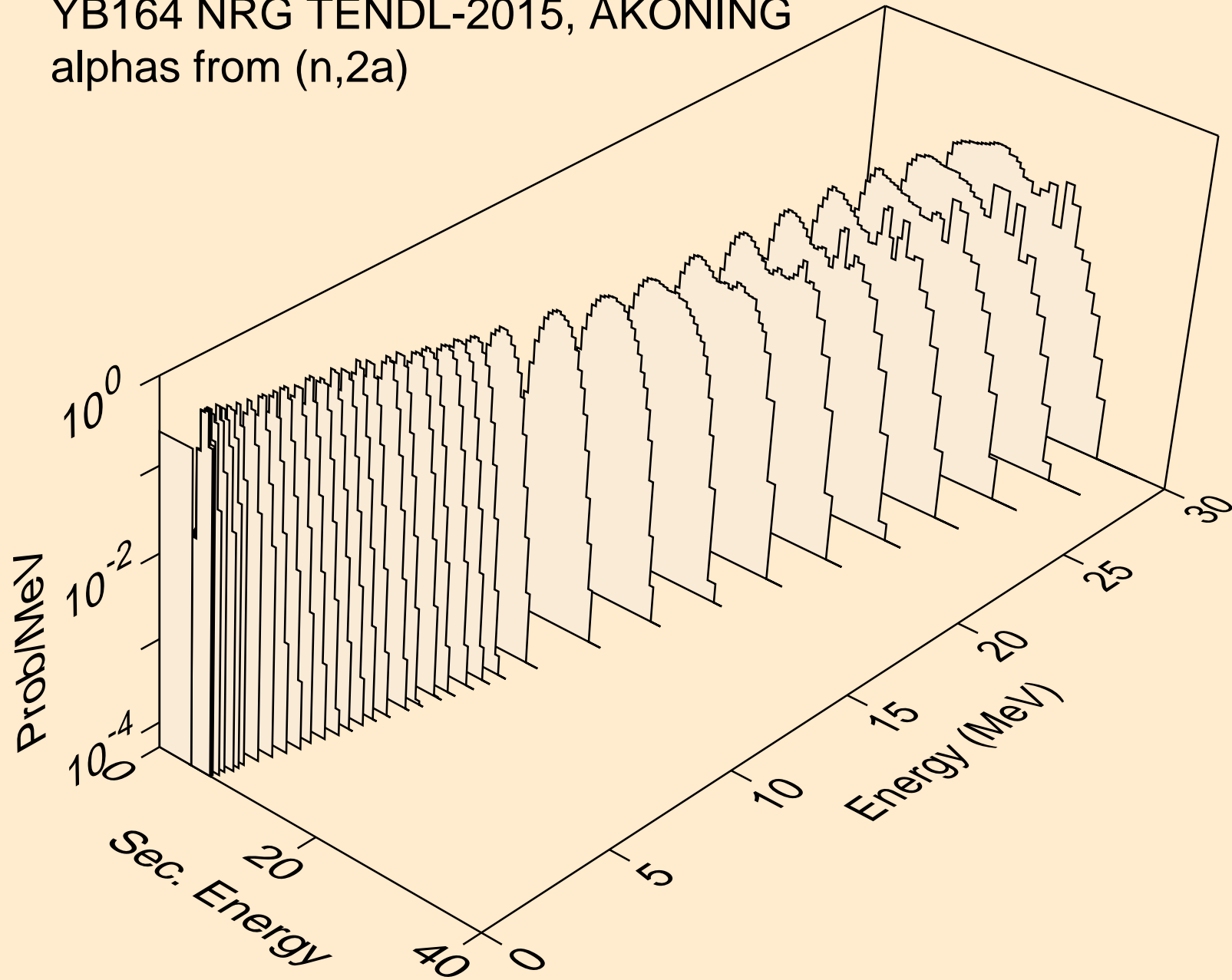

YB164 NRG TENDL-2015, AKONING  
alphas from (n,pa)

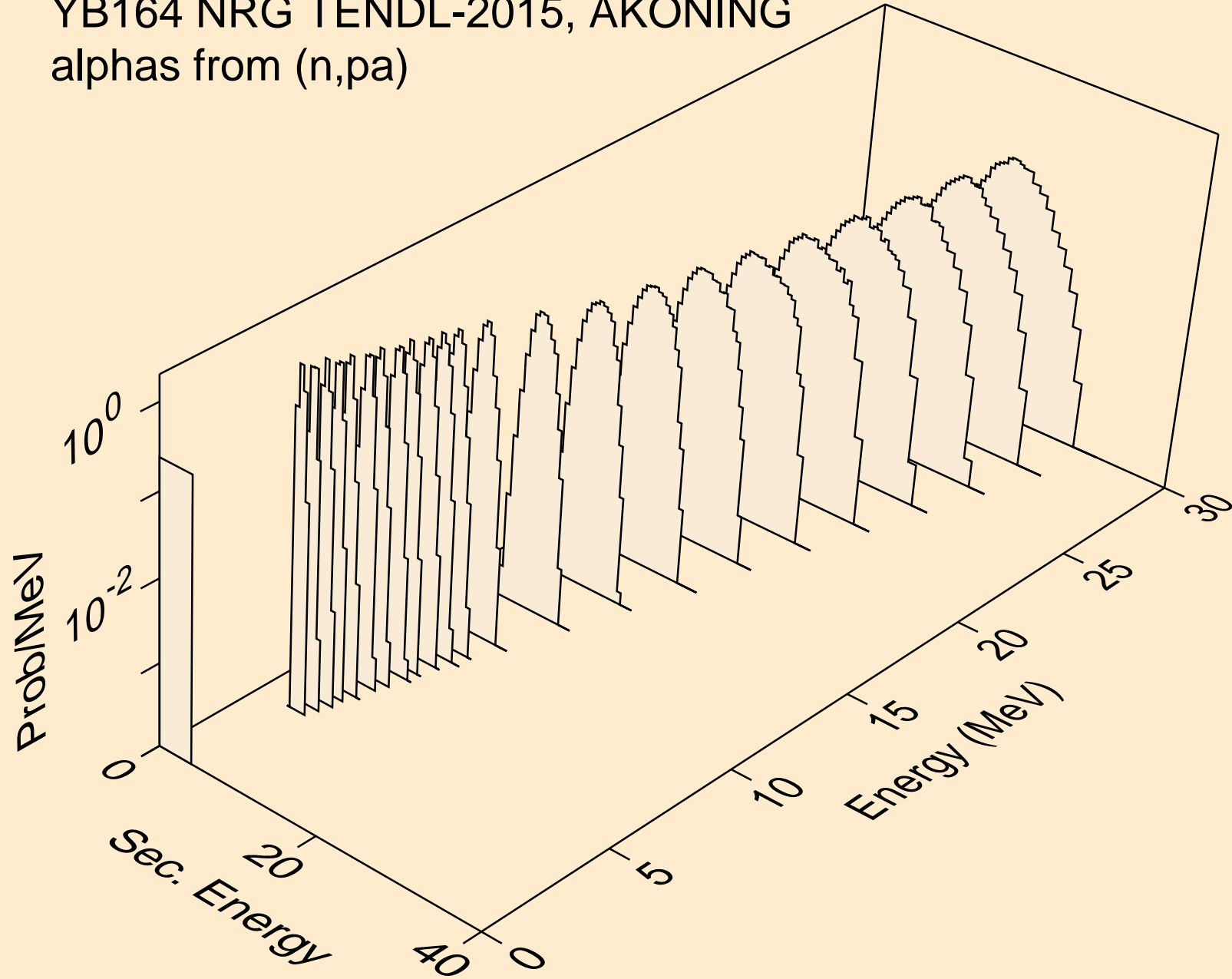

YB164 NRG TENDL-2015, AKONING  
alphas from (n,da)

