

AR047 NEUTRON ACER TENDL-2019 LIBRARY; T=293.16K
Principal cross sections

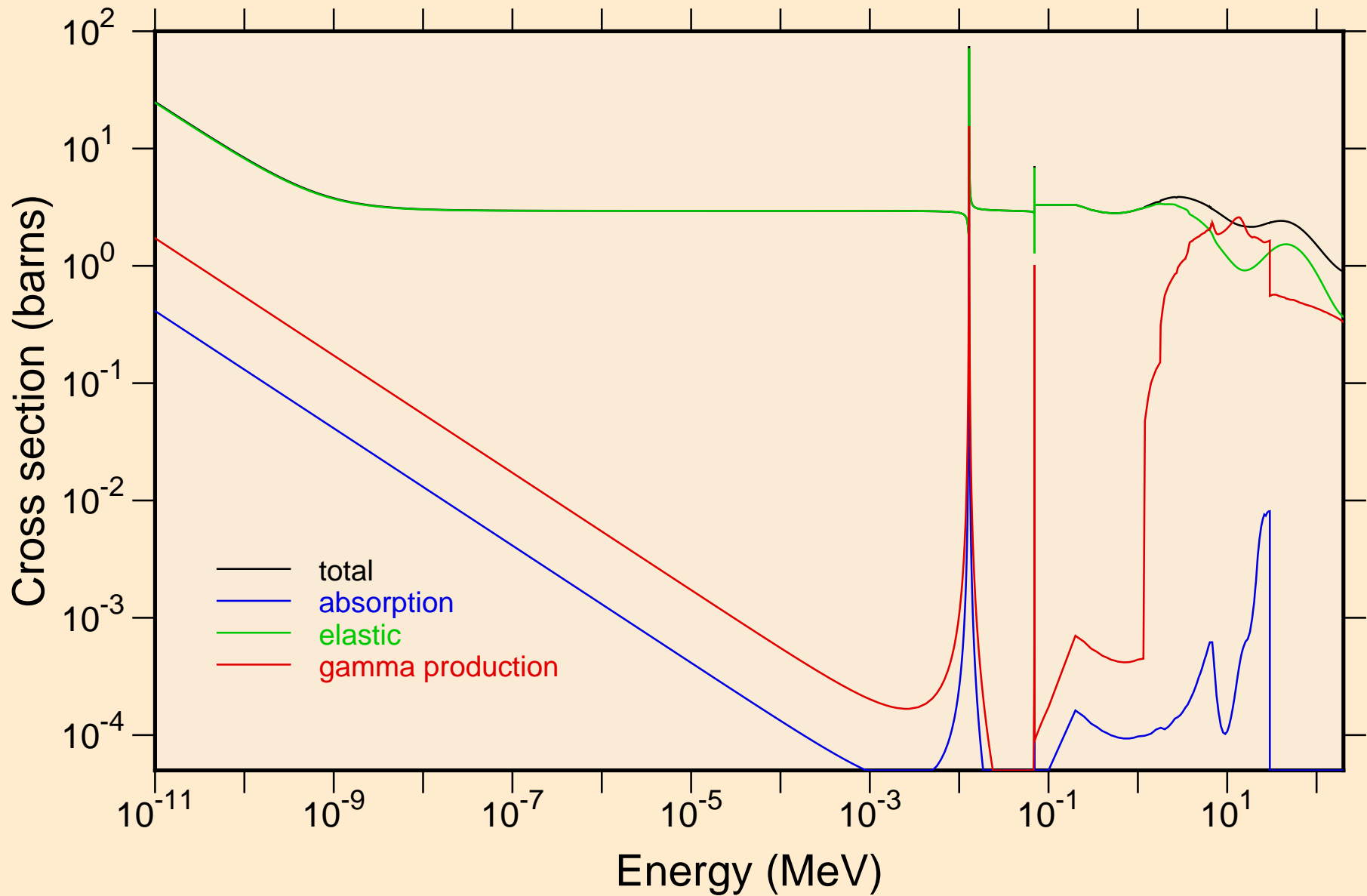

AR047 NEUTRON ACER TENDL-2019 LIBRARY; T=293.16K
Heating

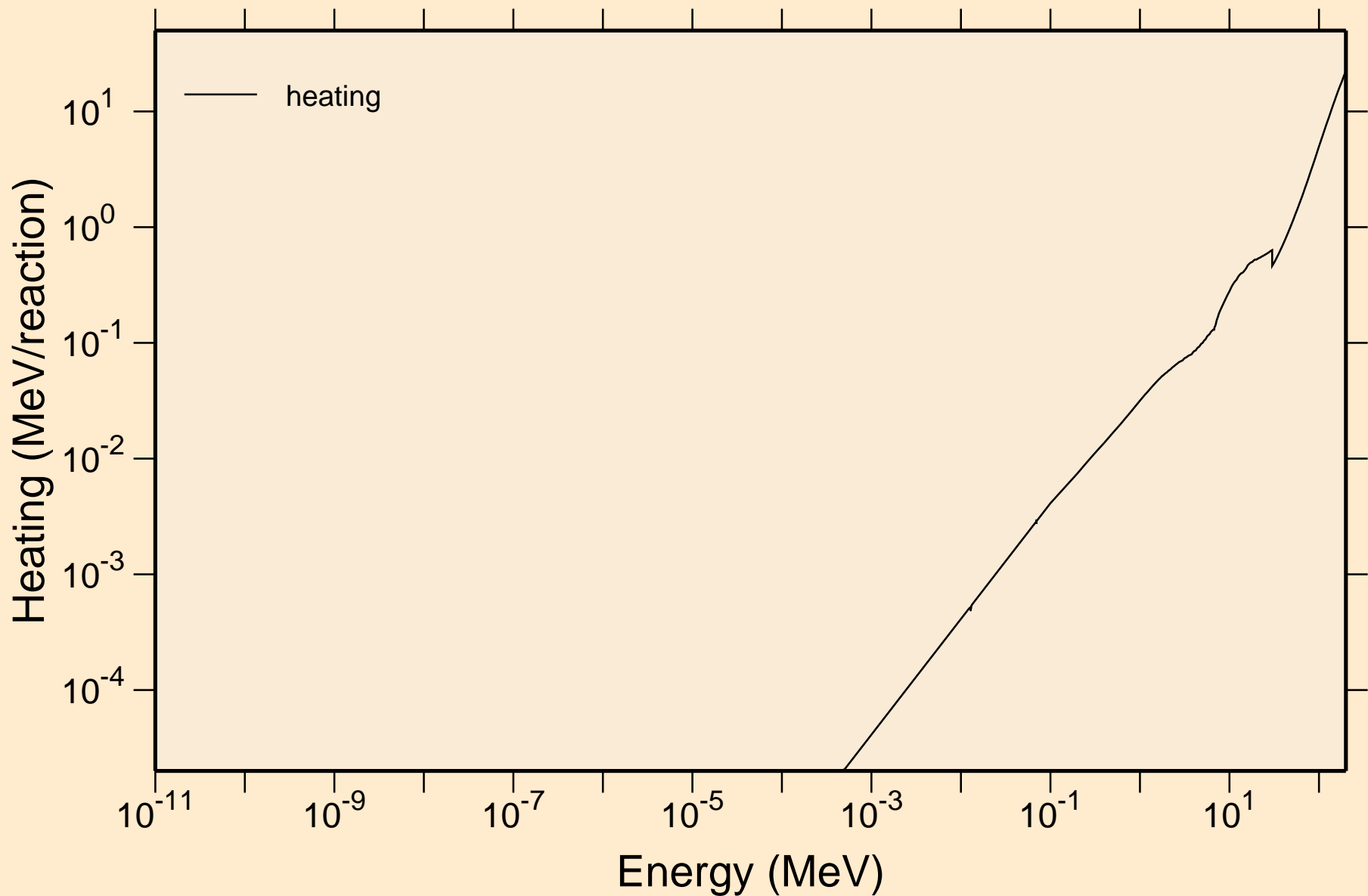

AR047 NEUTRON ACER TENDL-2019 LIBRARY; T=293.16K Damage

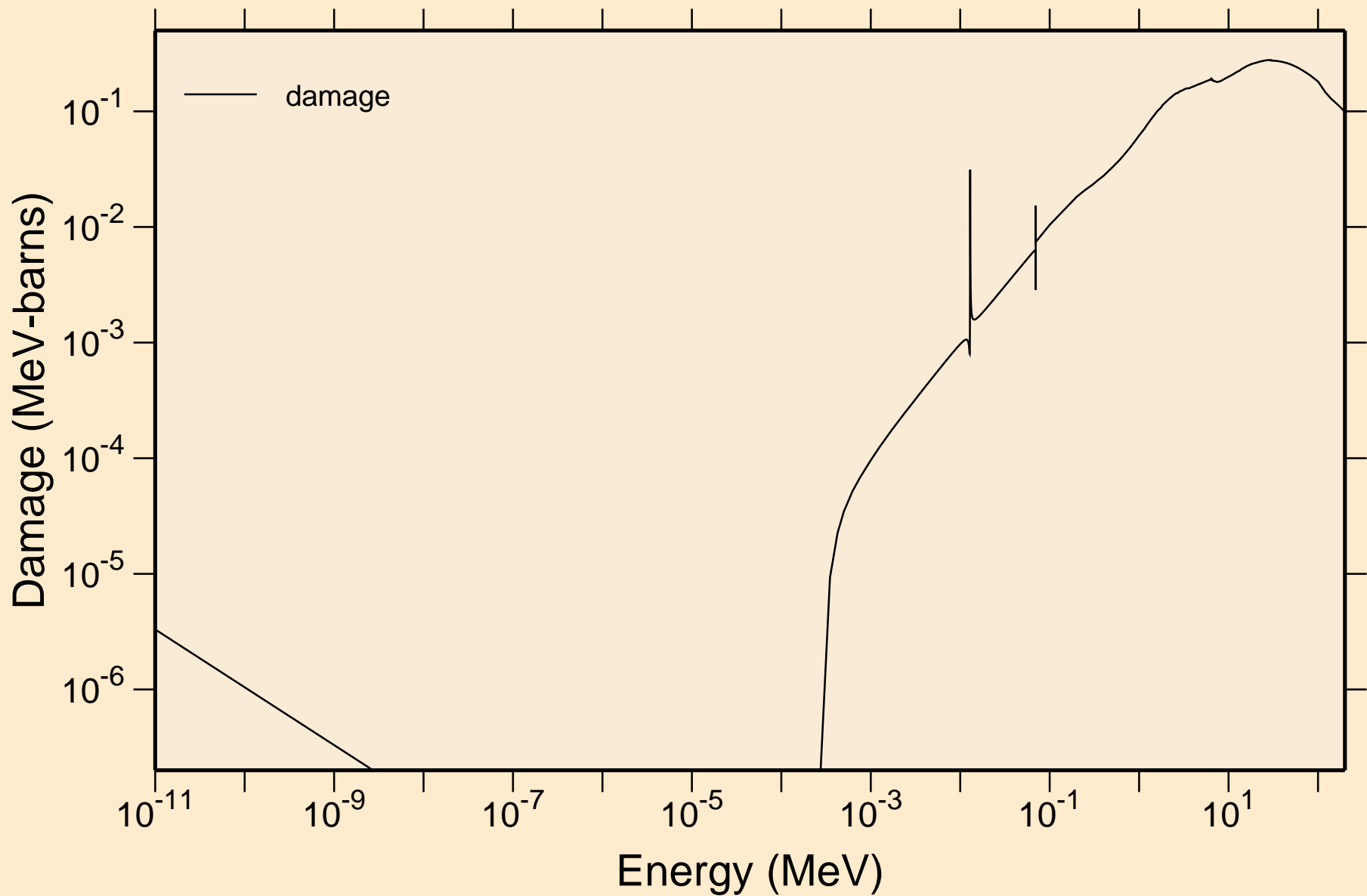

AR047 NEUTRON ACER TENDL-2019 LIBRARY; T=293.16K
Non-threshold reactions

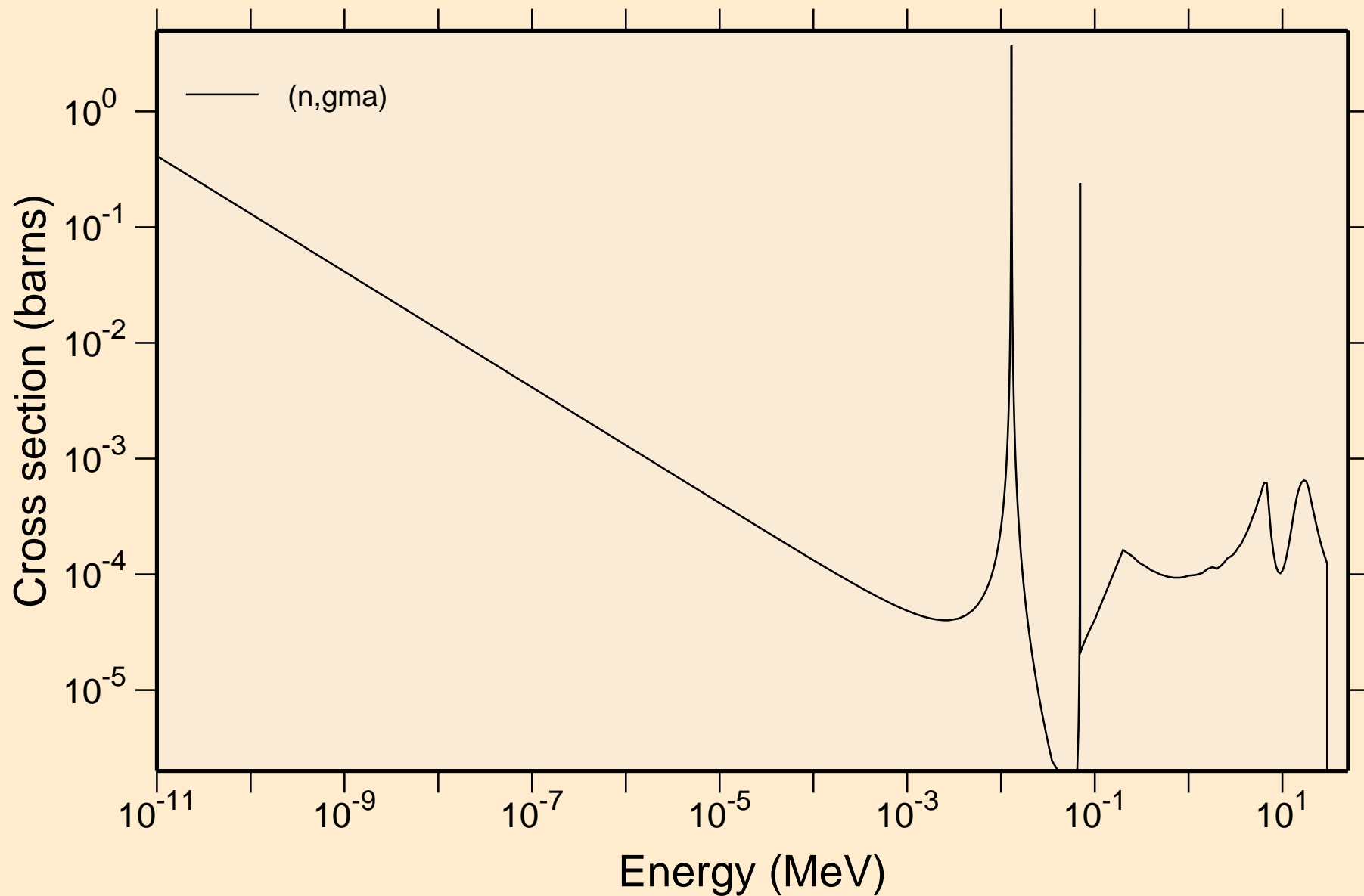

AR047 NEUTRON ACER TENDL-2019 LIBRARY; T=293.16K
Principal cross sections

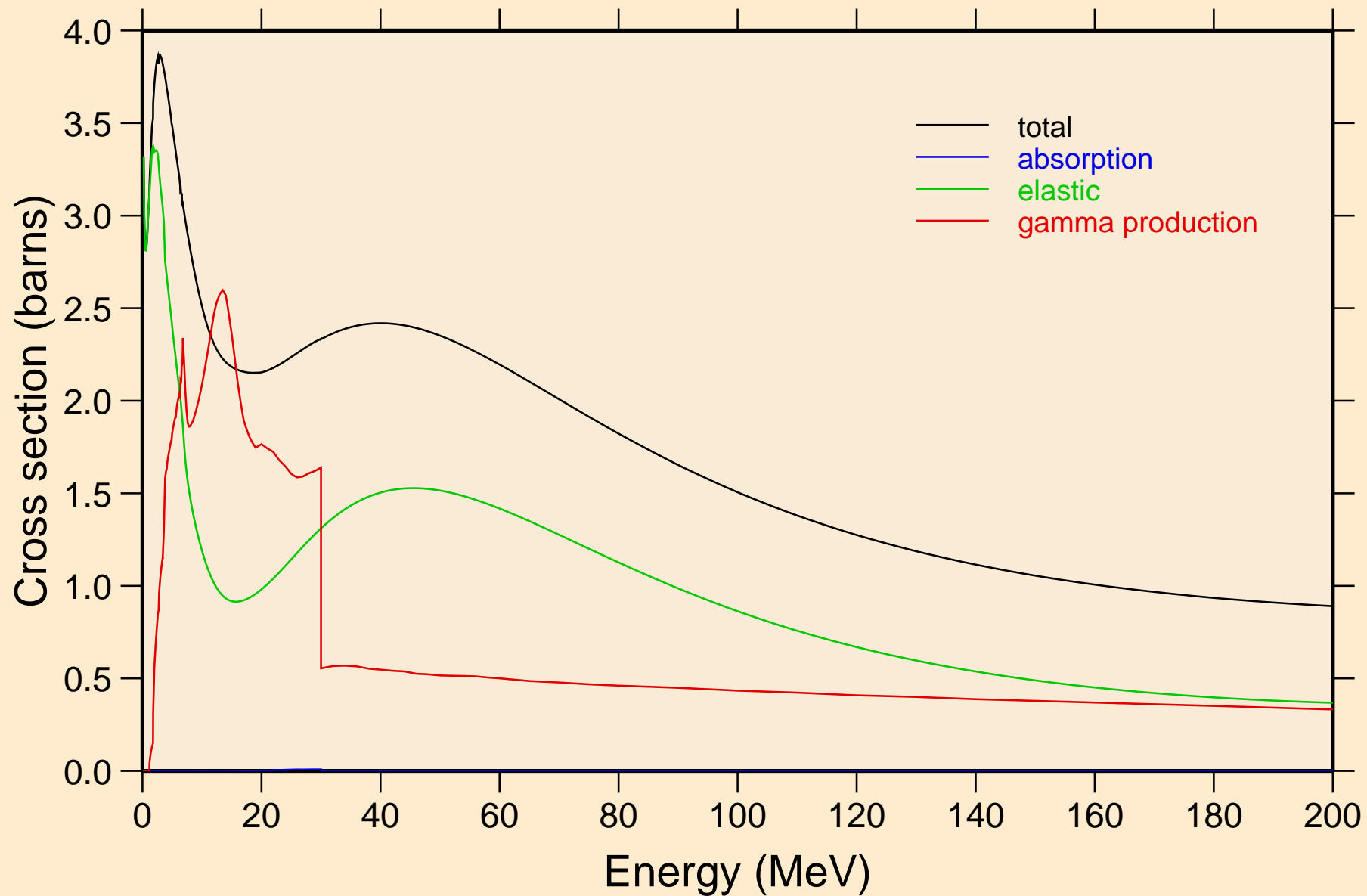

AR047 NEUTRON ACER TENDL-2019 LIBRARY; T=293.16K
Heating

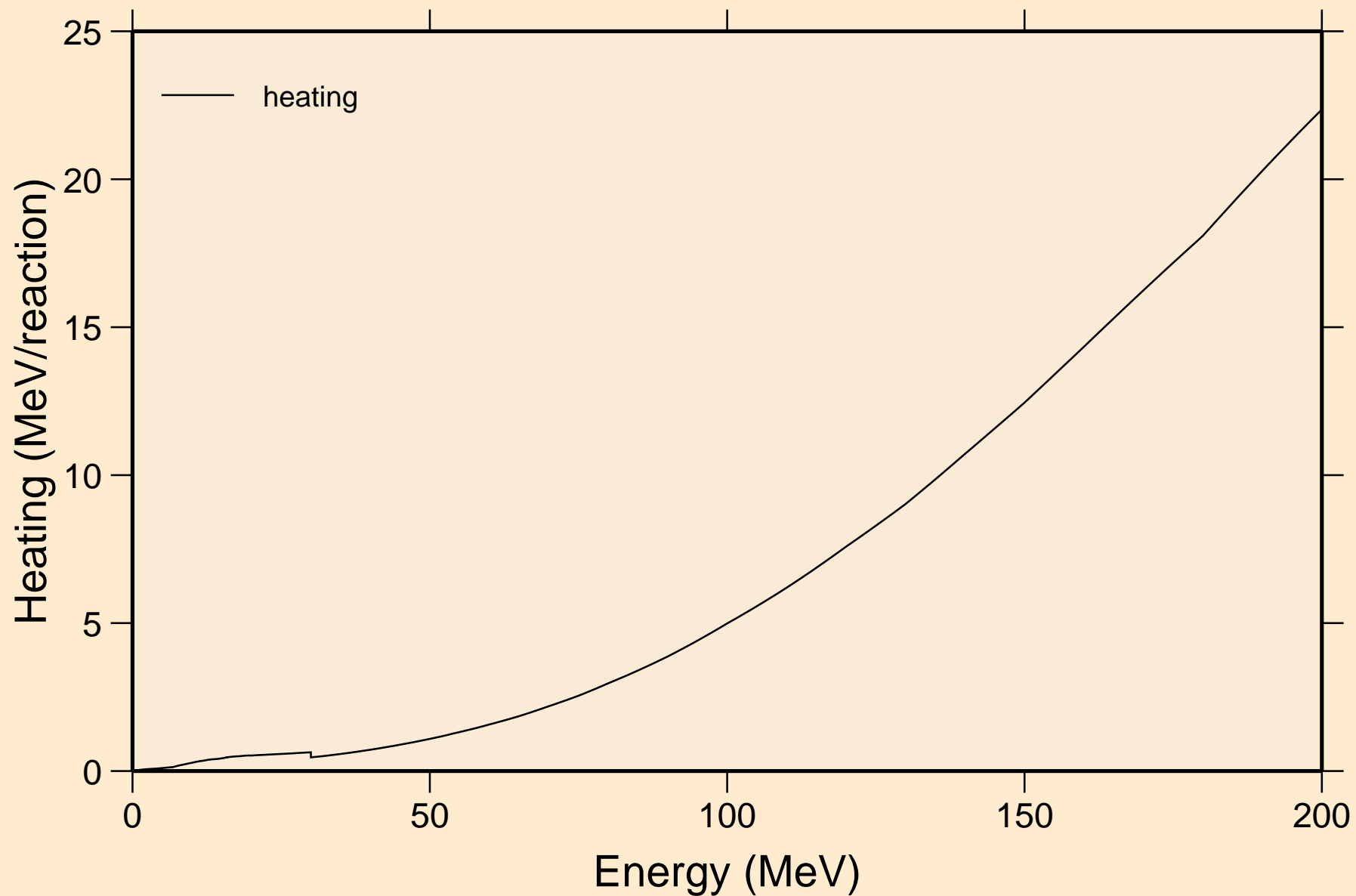

AR047 NEUTRON ACER TENDL-2019 LIBRARY; T=293.16K
Damage

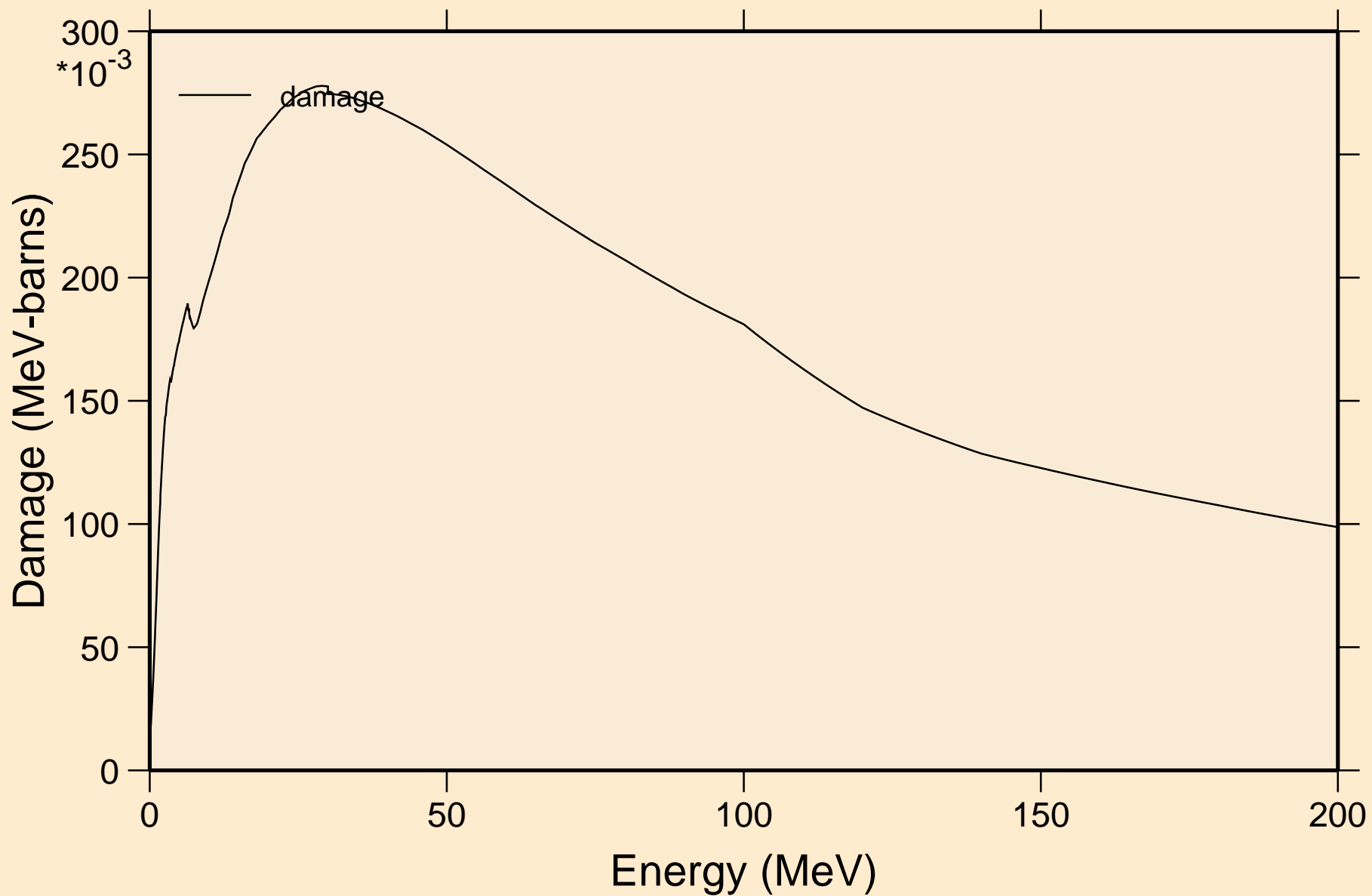

AR047 NEUTRON ACER TENDL-2019 LIBRARY; T=293.16K
Non-threshold reactions

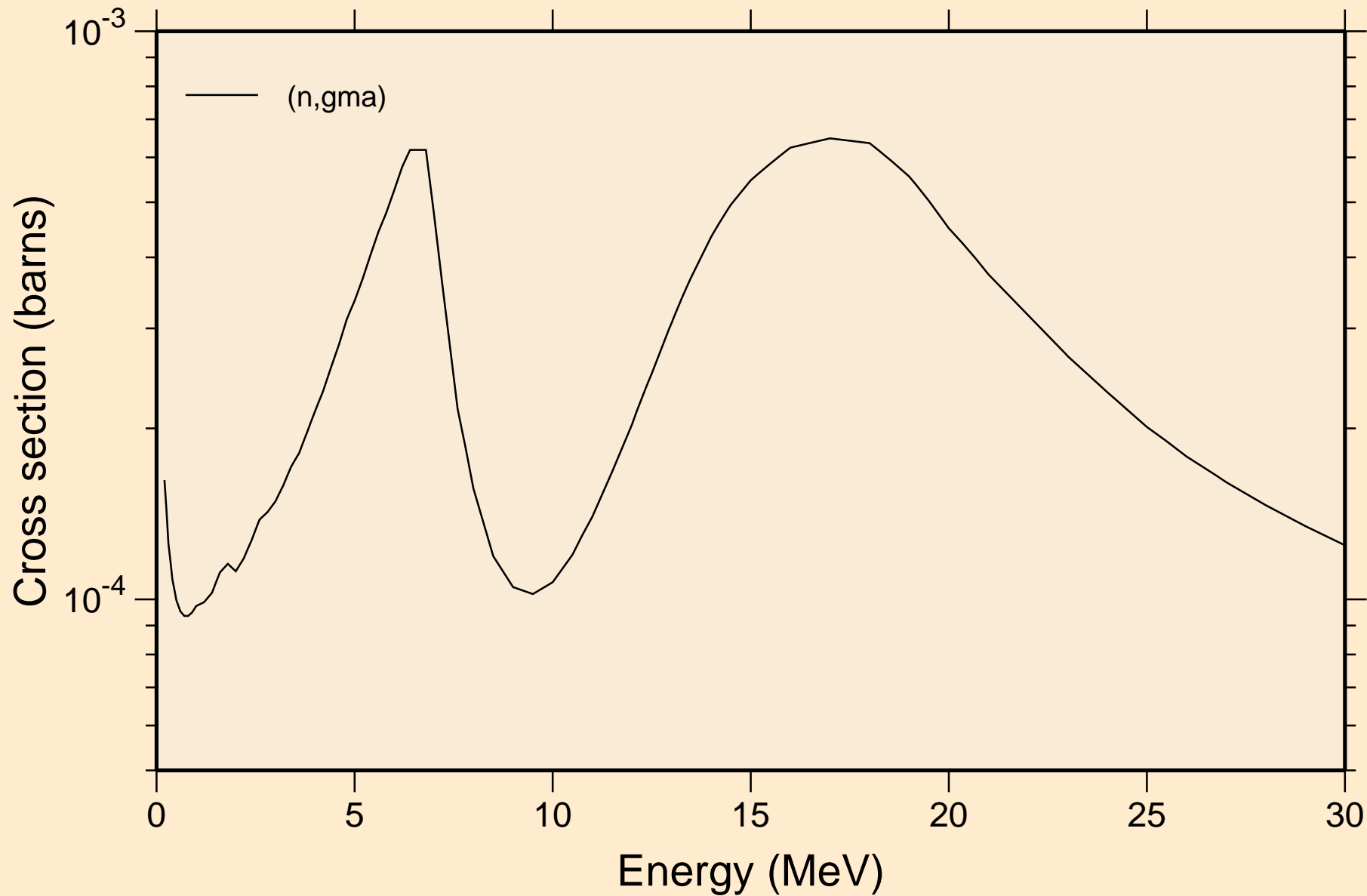

AR047 NEUTRON ACER TENDL-2019 LIBRARY; T=293.16K
Inelastic levels

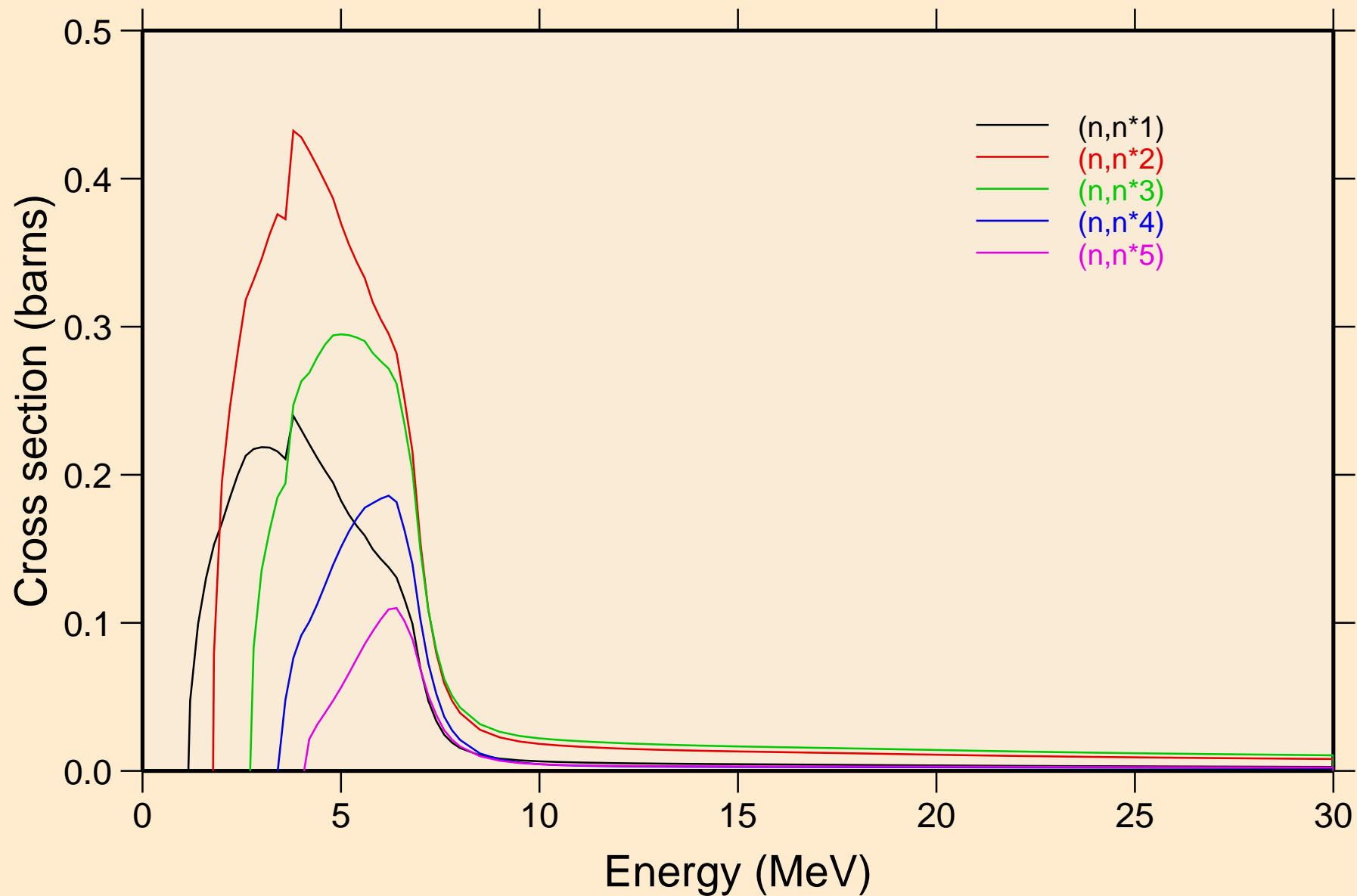

AR047 NEUTRON ACER TENDL-2019 LIBRARY; T=293.16K
Inelastic levels

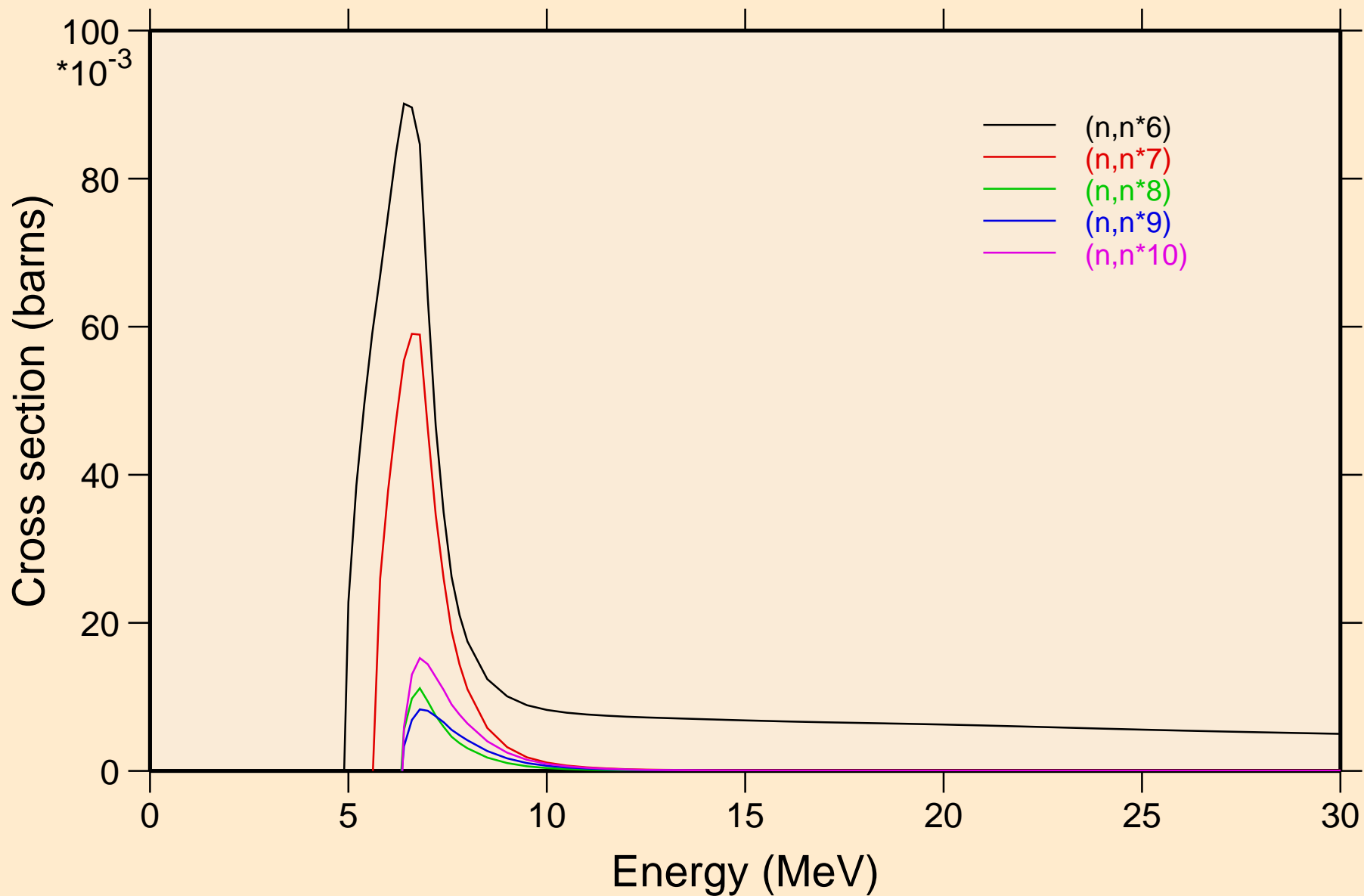

AR047 NEUTRON ACER TENDL-2019 LIBRARY; T=293.16K
Inelastic levels

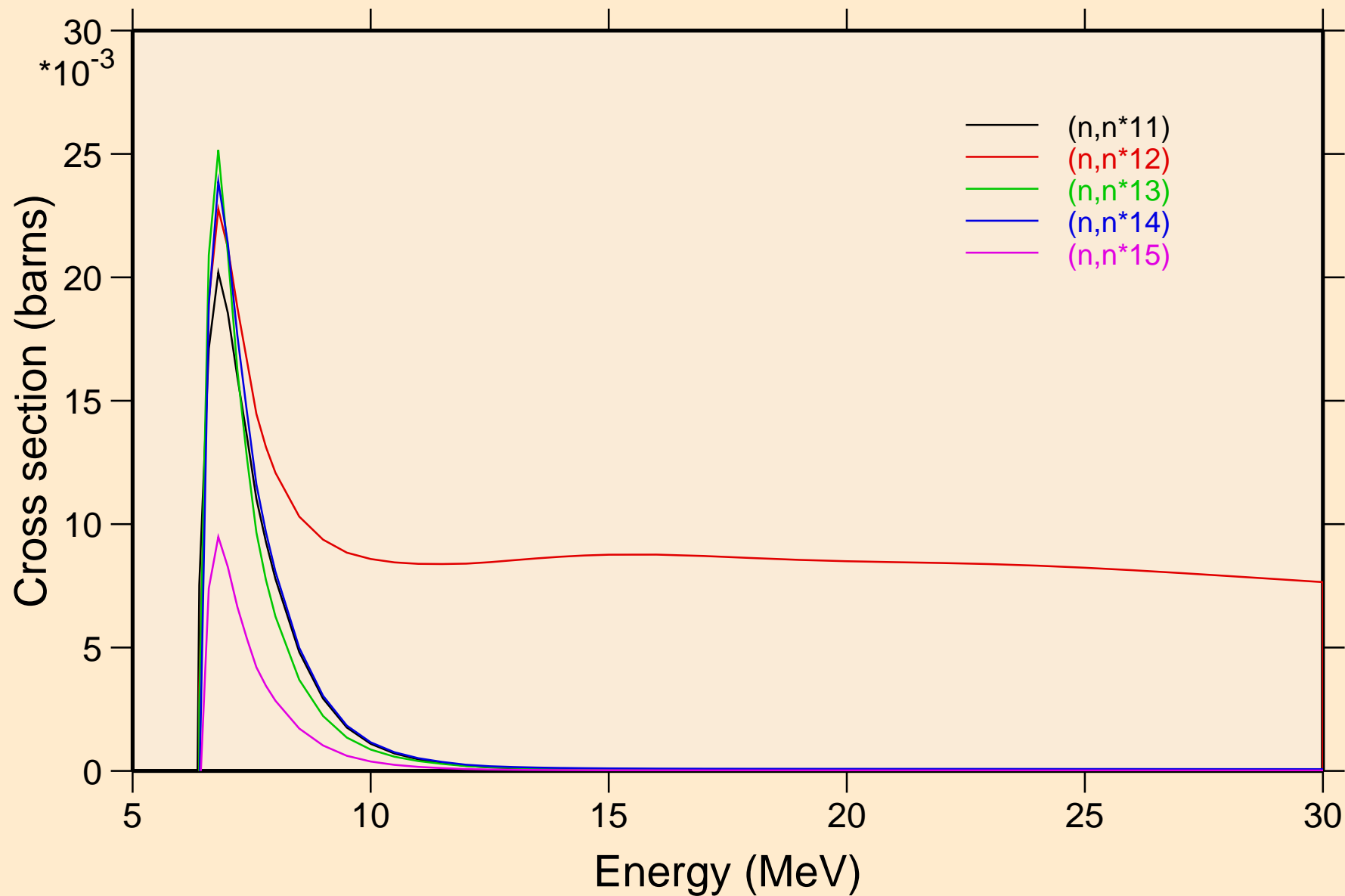

AR047 NEUTRON ACER TENDL-2019 LIBRARY; T=293.16K
Inelastic levels

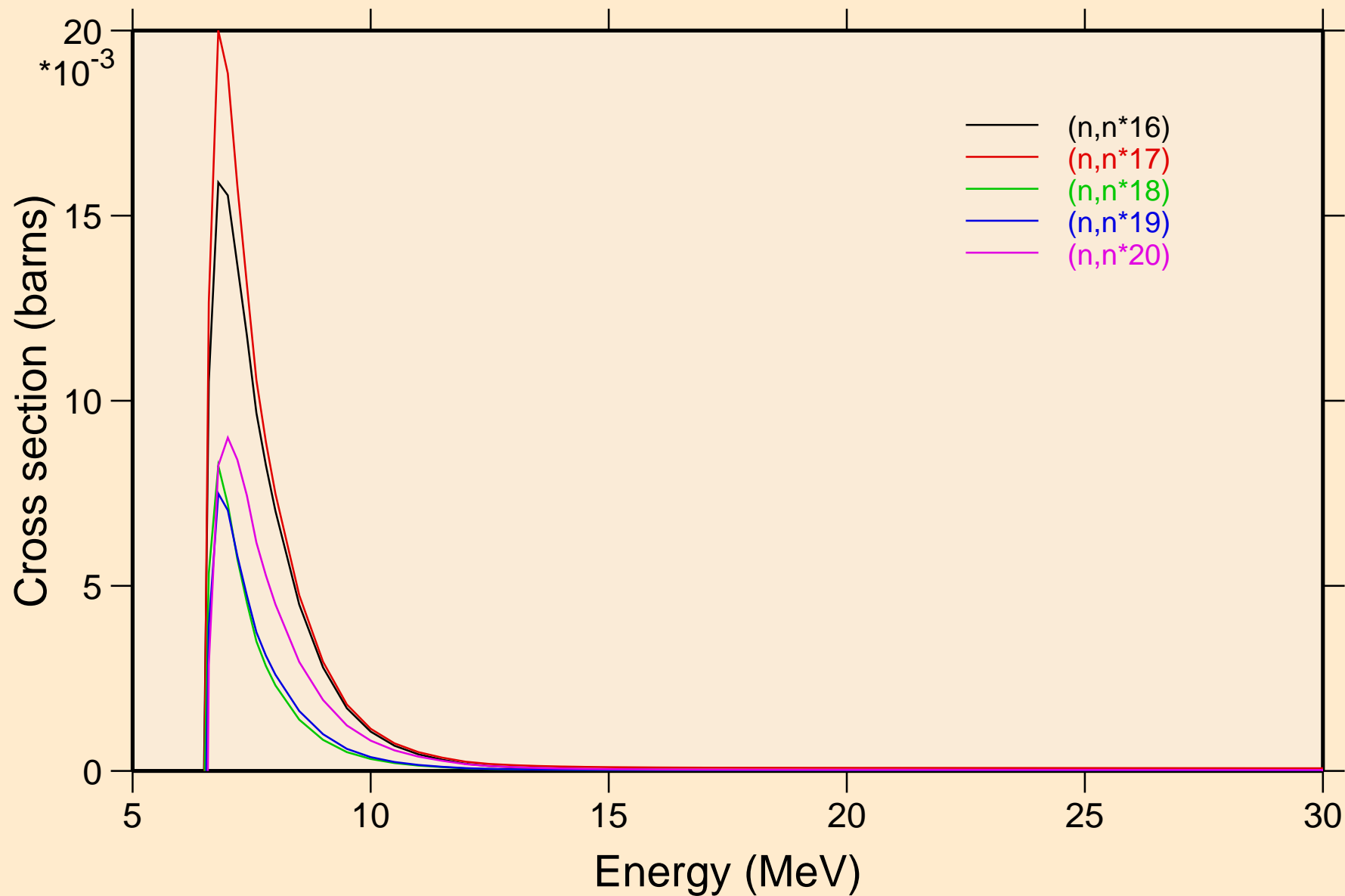

AR047 NEUTRON ACER TENDL-2019 LIBRARY; T=293.16K
Inelastic levels

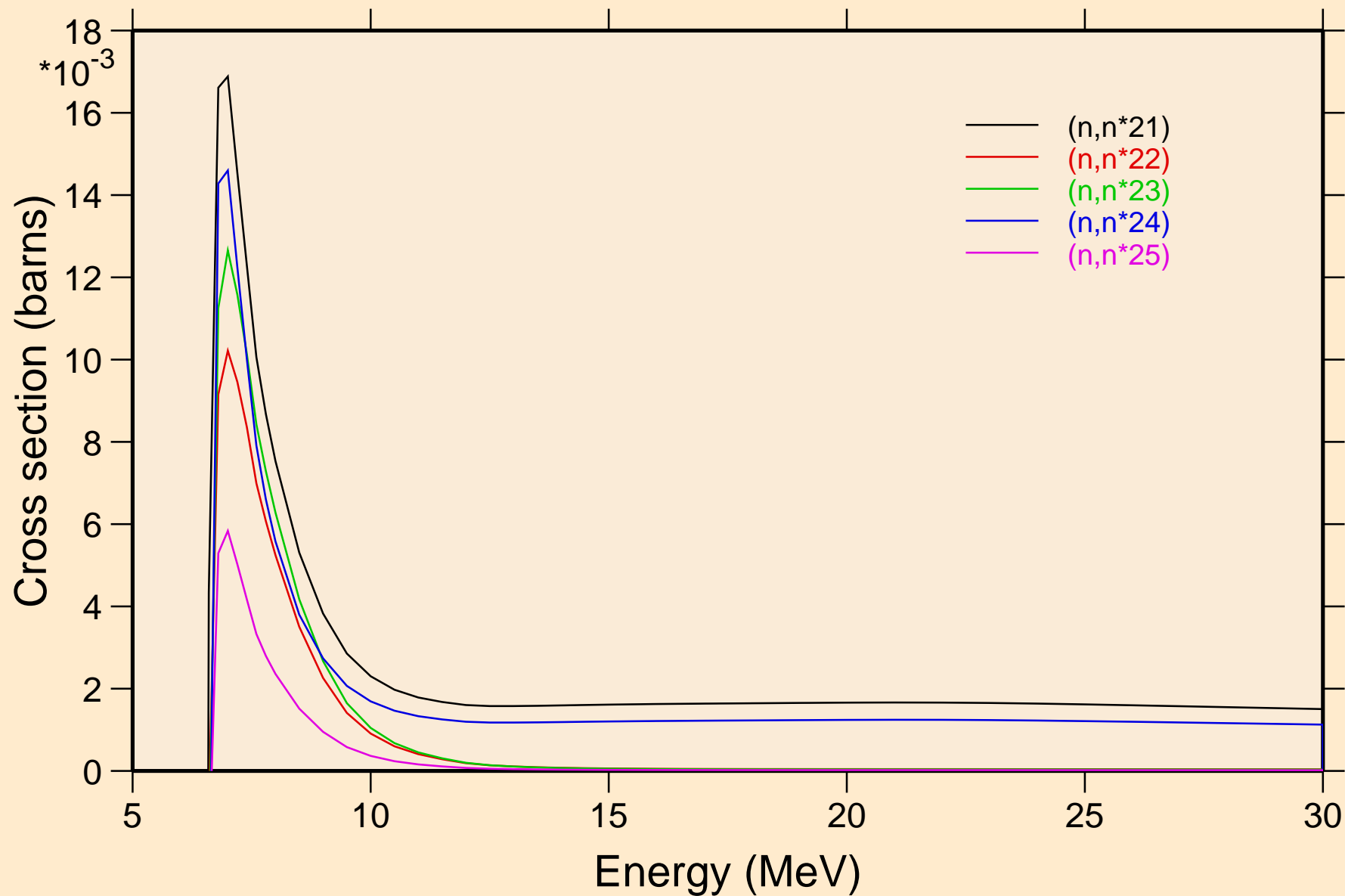

AR047 NEUTRON ACER TENDL-2019 LIBRARY; T=293.16K
Inelastic levels

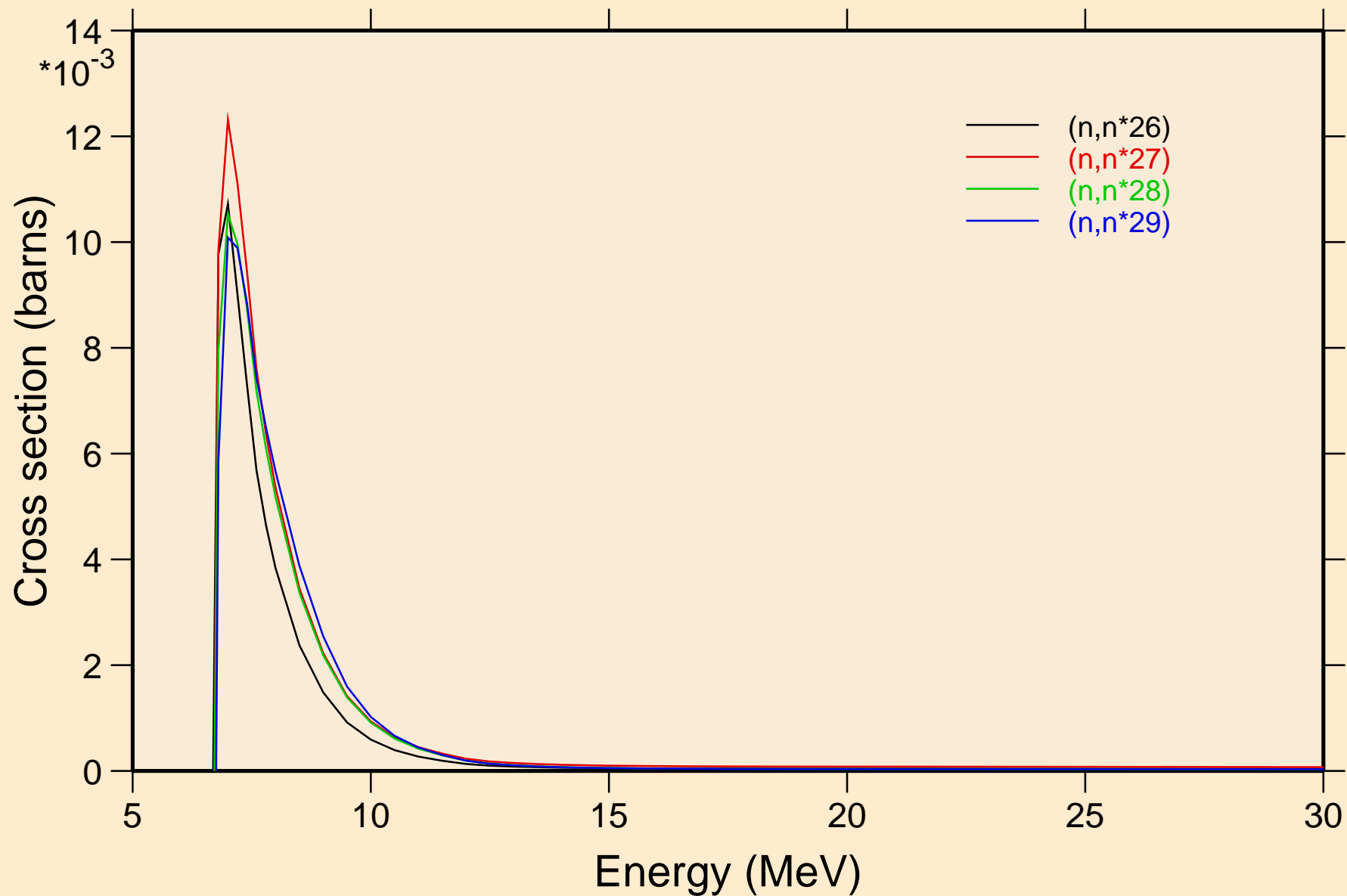

AR047 NEUTRON ACER TENDL-2019 LIBRARY; T=293.16K
Threshold reactions

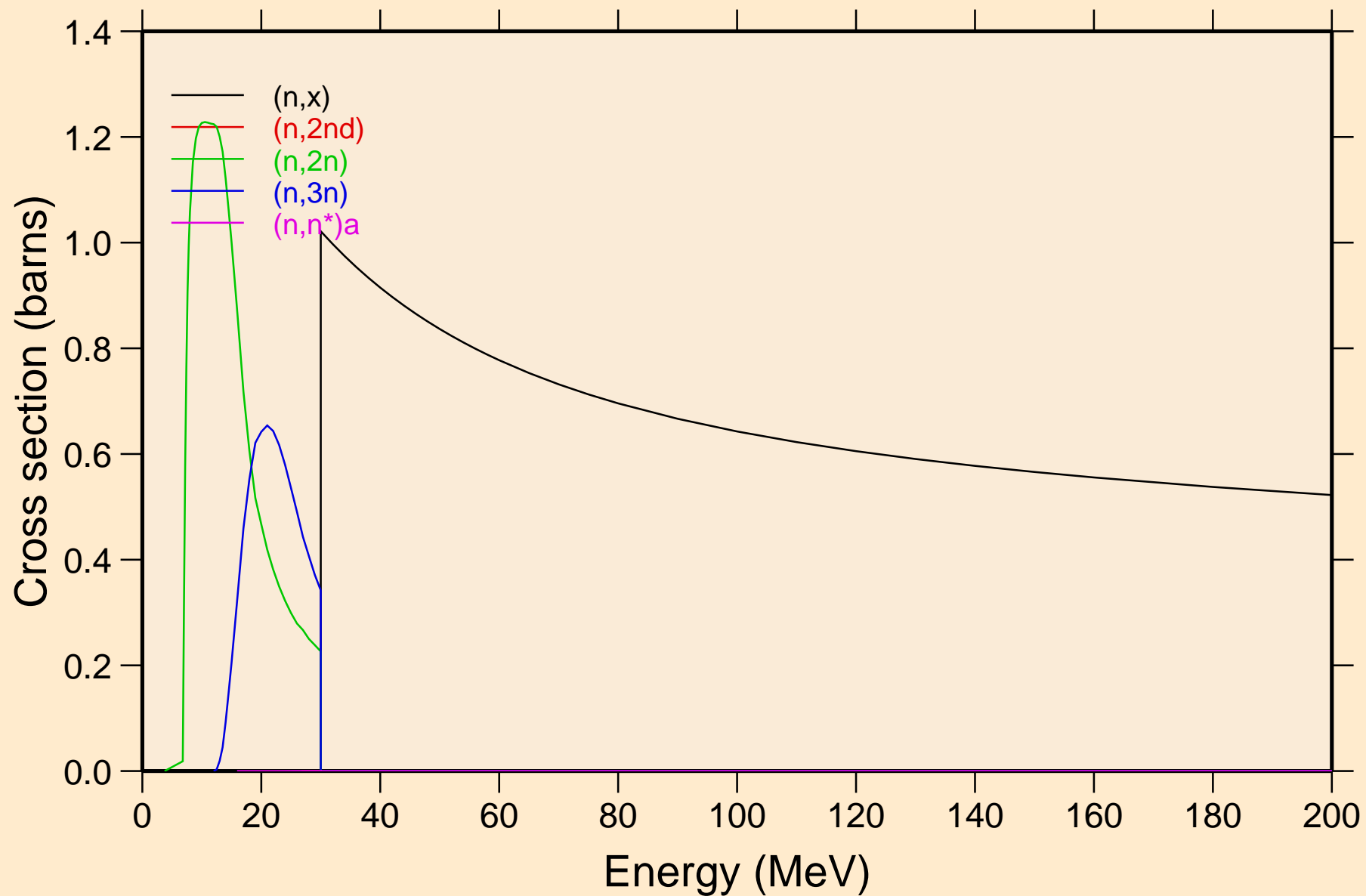

AR047 NEUTRON ACER TENDL-2019 LIBRARY; T=293.16K
Threshold reactions

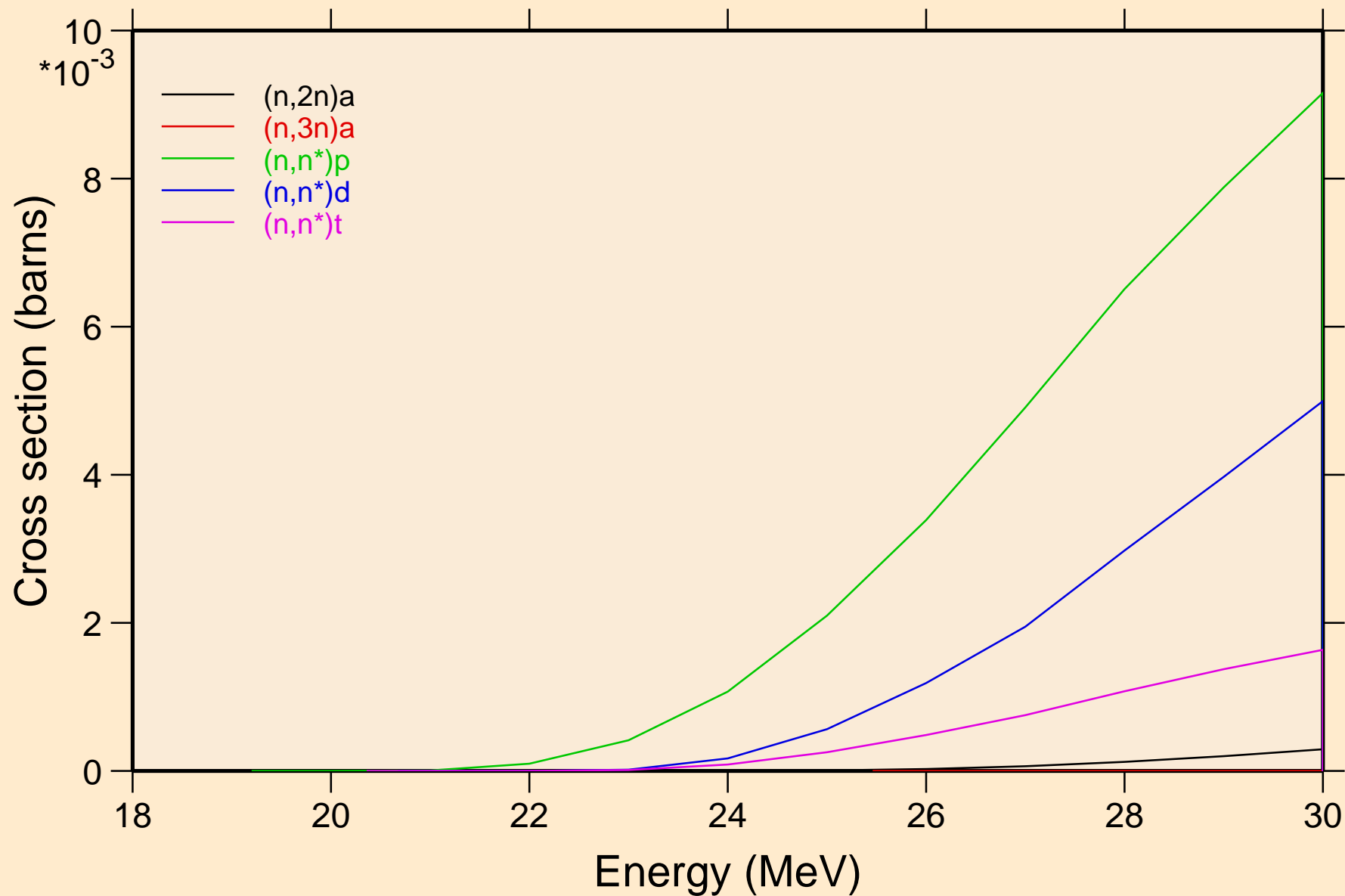

AR047 NEUTRON ACER TENDL-2019 LIBRARY; T=293.16K
Threshold reactions

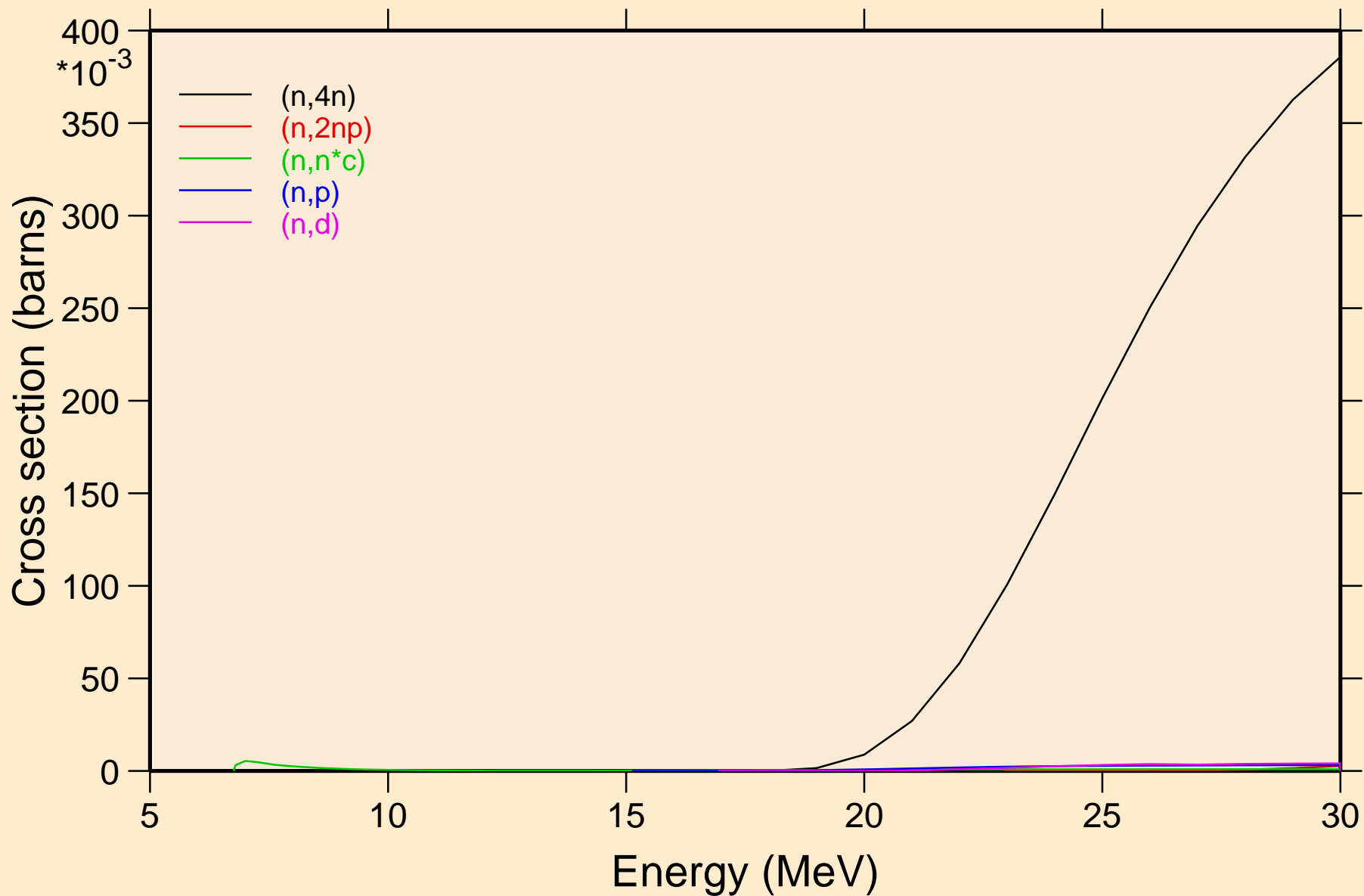

AR047 NEUTRON ACER TENDL-2019 LIBRARY; T=293.16K
Threshold reactions

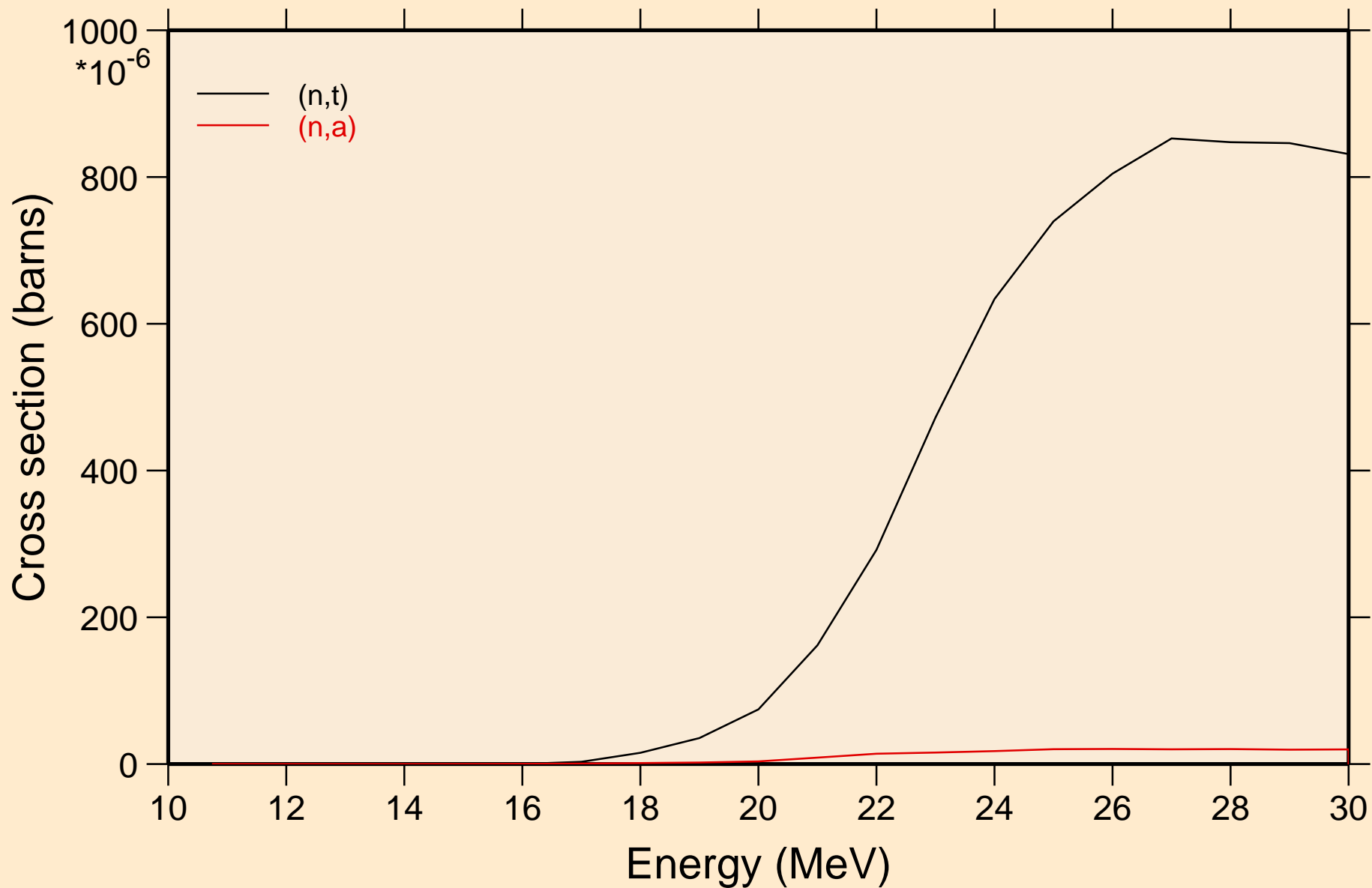

AR047 NEUTRON ACER TENDL-2019 LIBRARY; T=293.16K
Threshold reactions

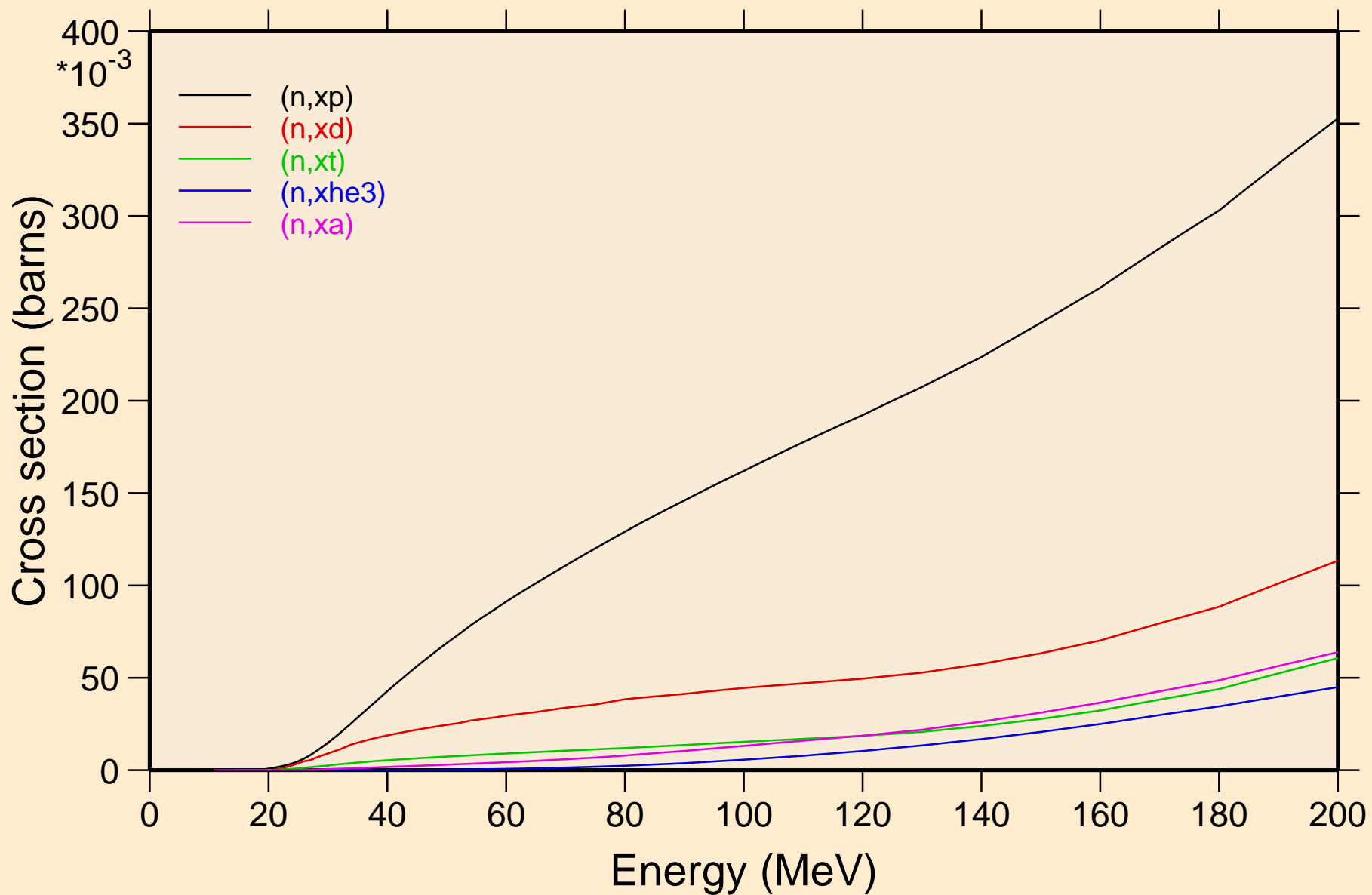

AR047 NEUTRON ACER TENDL-2019 LIBRARY; T=293.16K
angular distribution for elastic

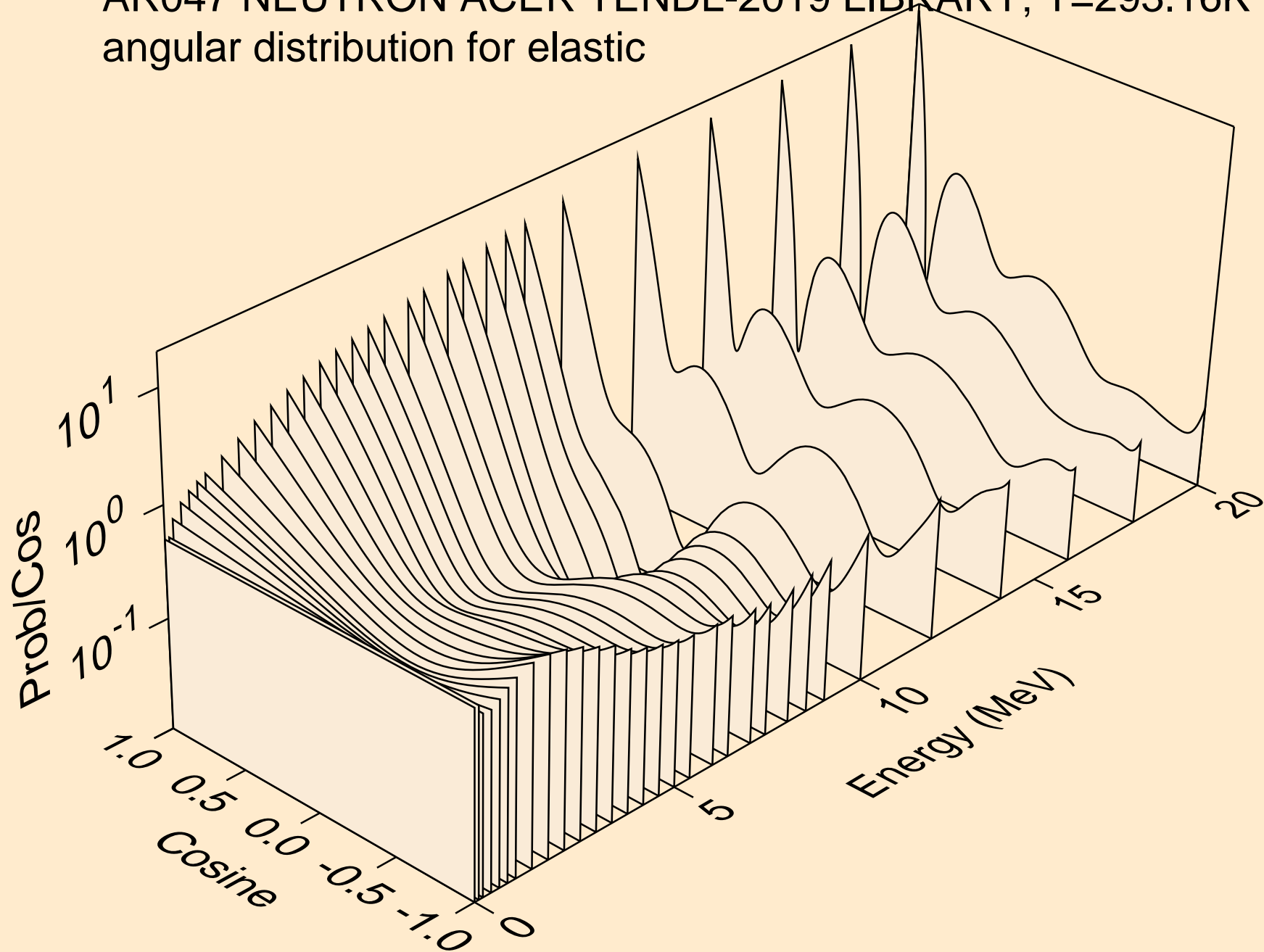

AR047 NEUTRON ACER TENDL-2019 LIBRARY; T=293.16K
angular distribution for elastic

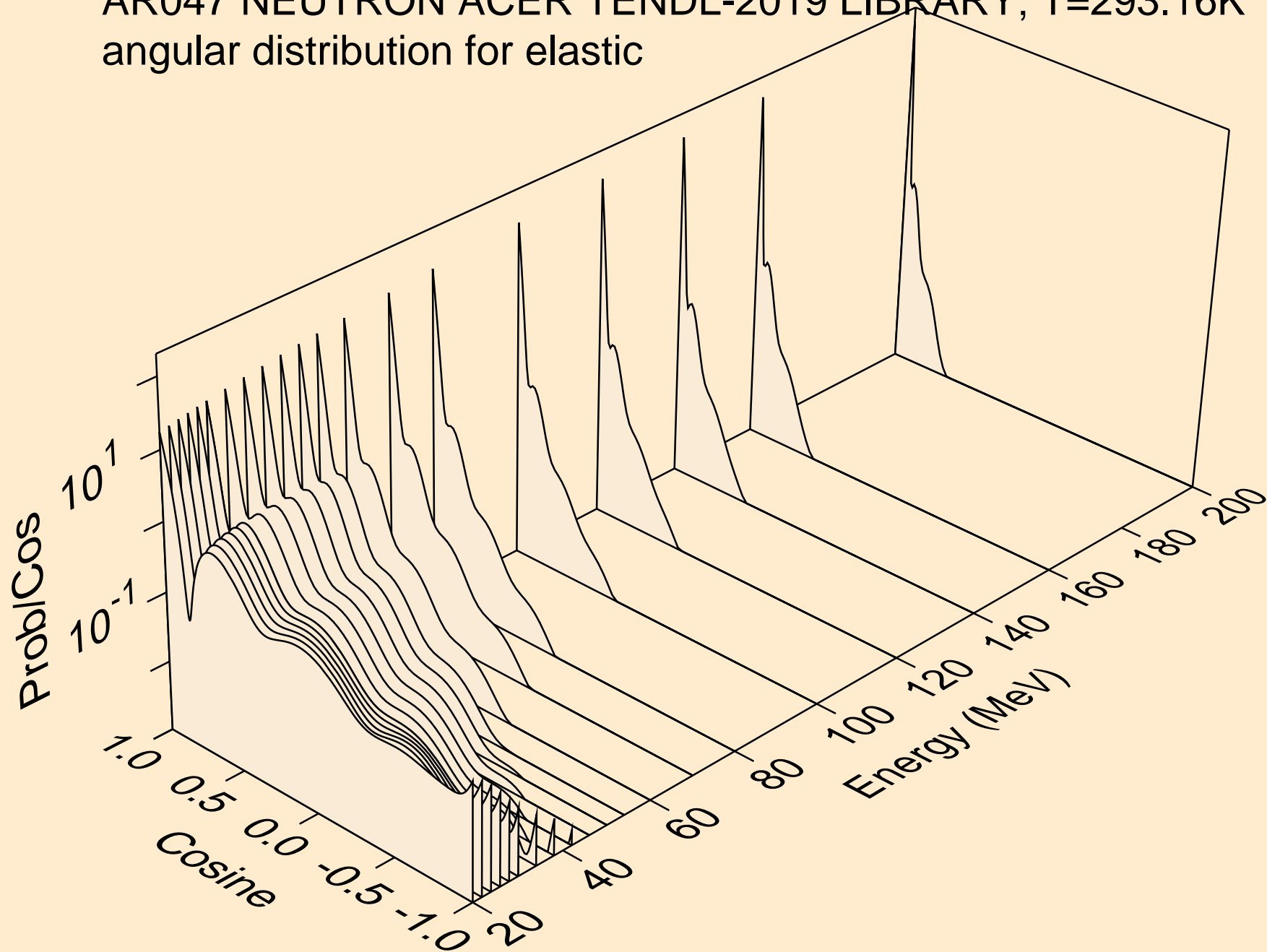

AR047 NEUTRON ACER TENDL-2019 LIBRARY; T=293.16K
angular distribution for (n,n*1)

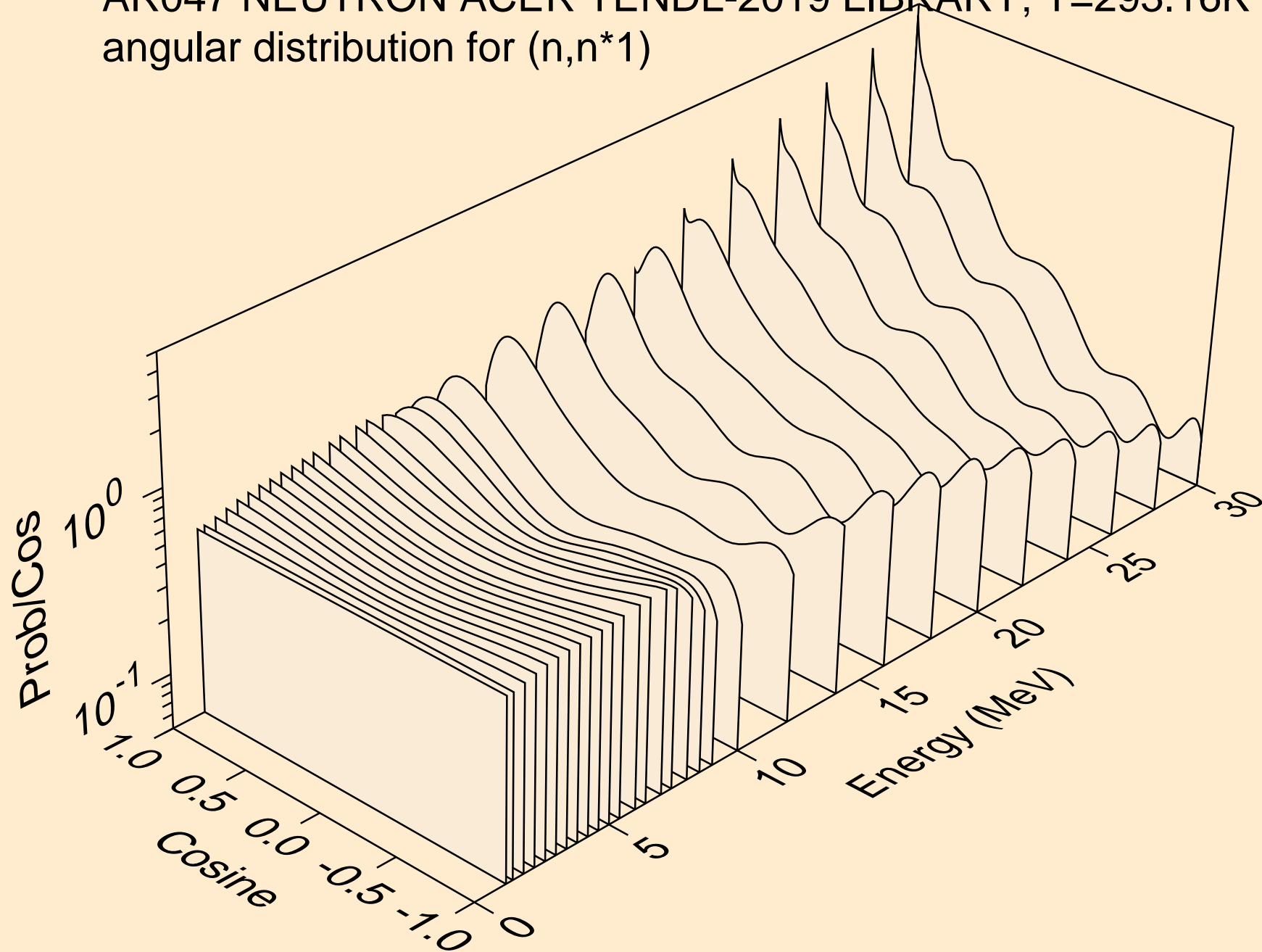

AR047 NEUTRON ACER TENDL-2019 LIBRARY; T=293.16K
angular distribution for (n,n*2)

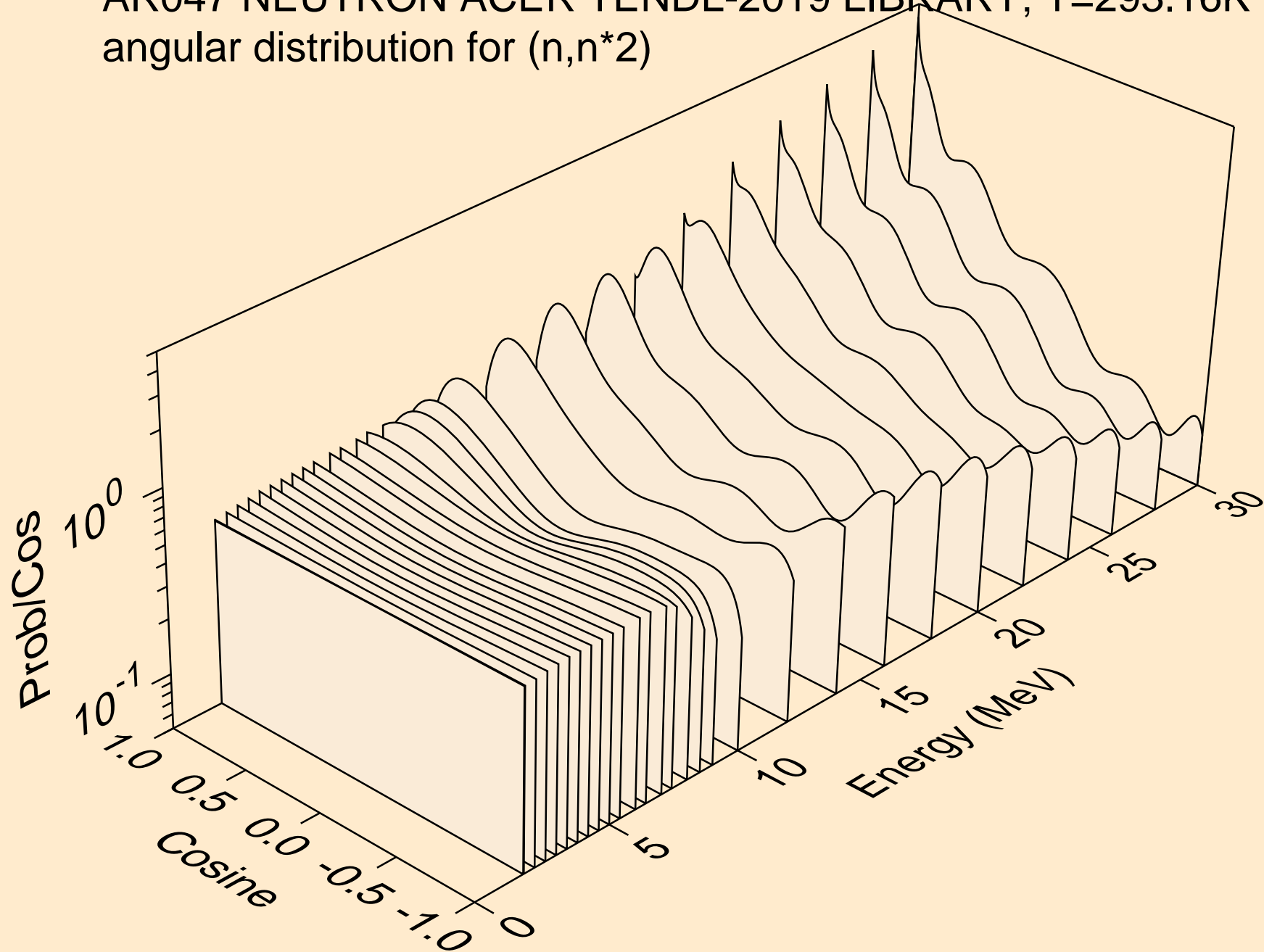

AR047 NEUTRON ACER TENDL-2019 LIBRARY; T=293.16K
angular distribution for (n,n*3)

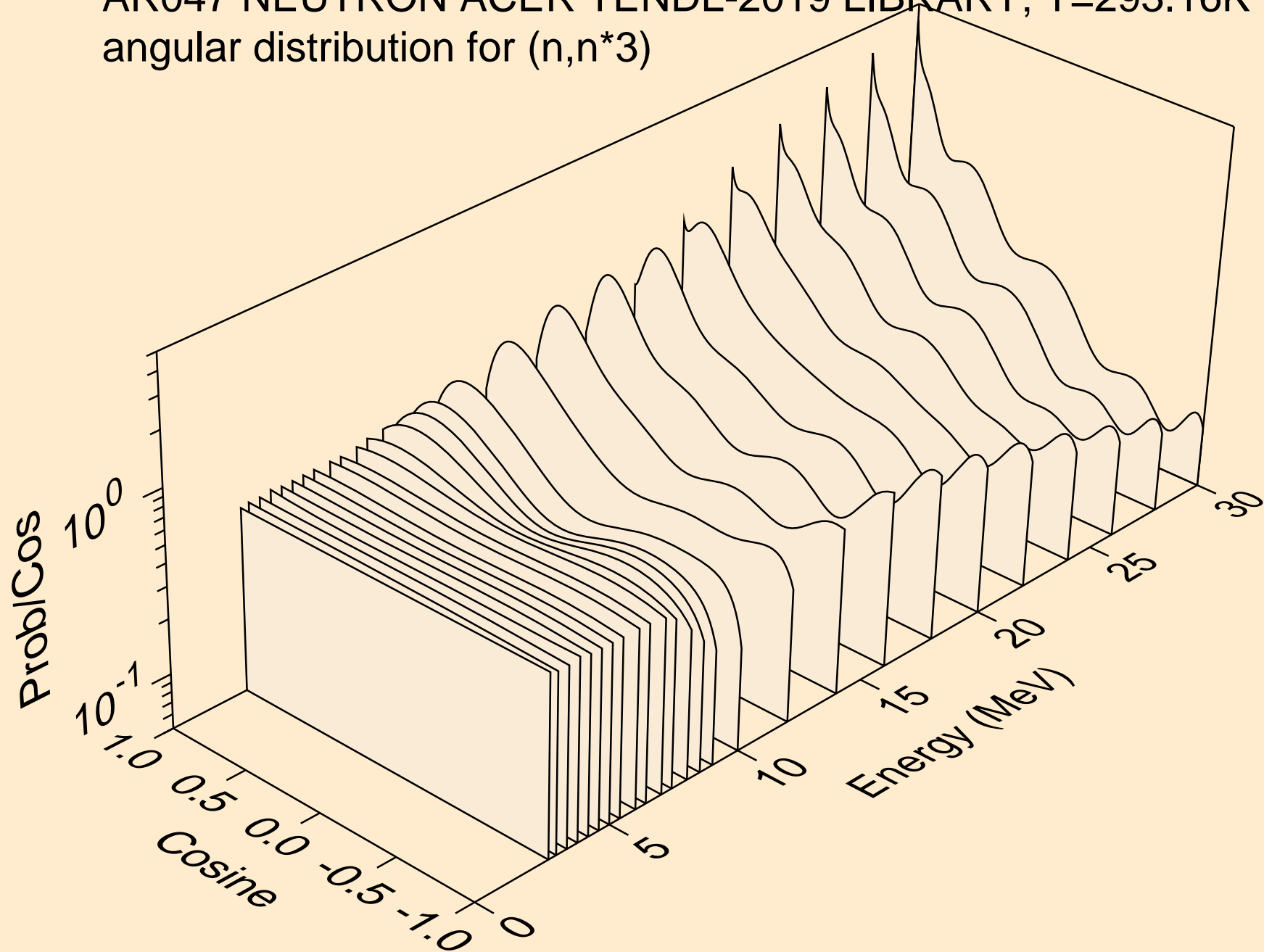

AR047 NEUTRON ACER TENDL-2019 LIBRARY; T=293.16K
angular distribution for (n,n*4)

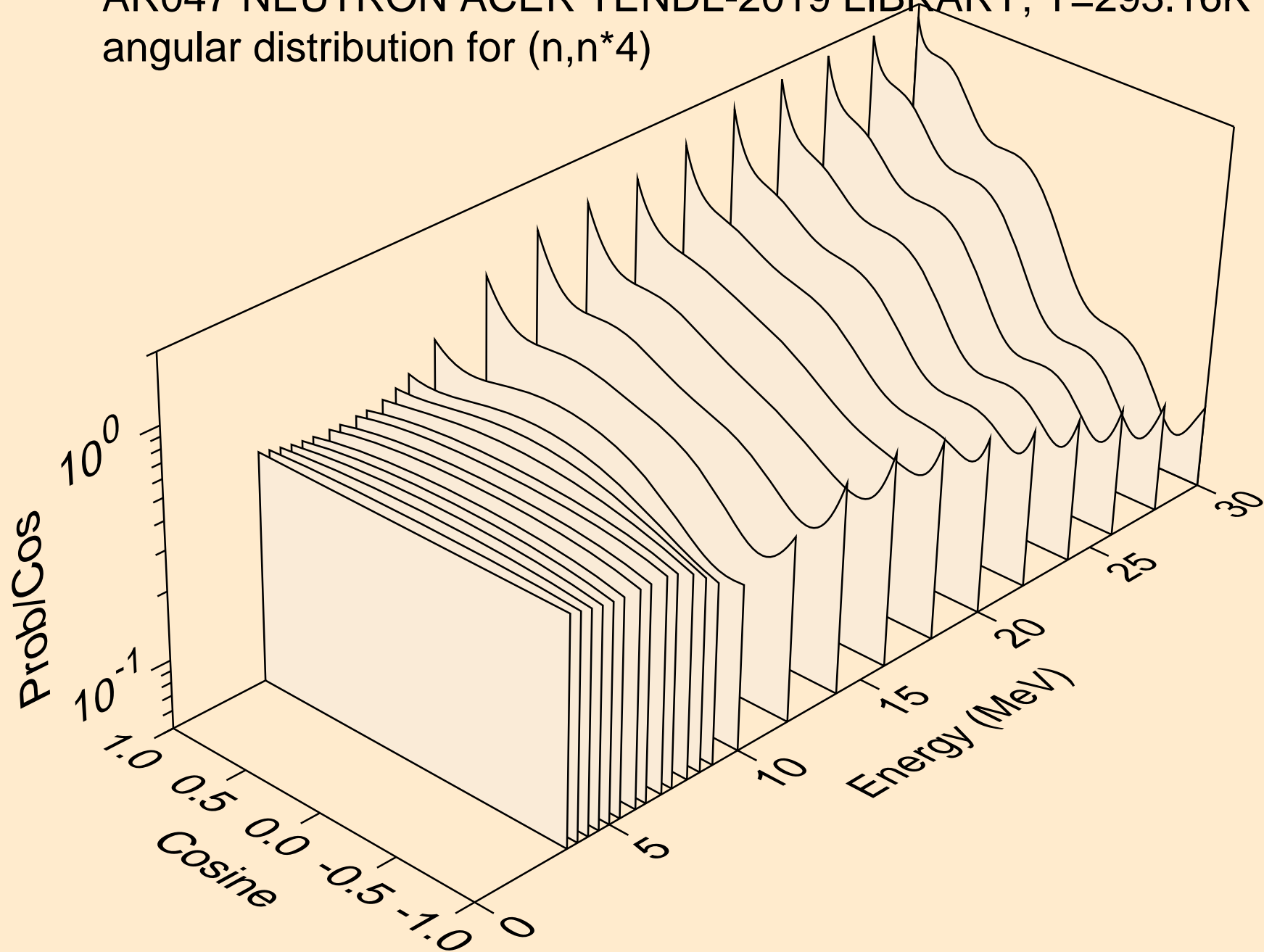

AR047 NEUTRON ACER TENDL-2019 LIBRARY; T=293.16K
angular distribution for (n,n*5)

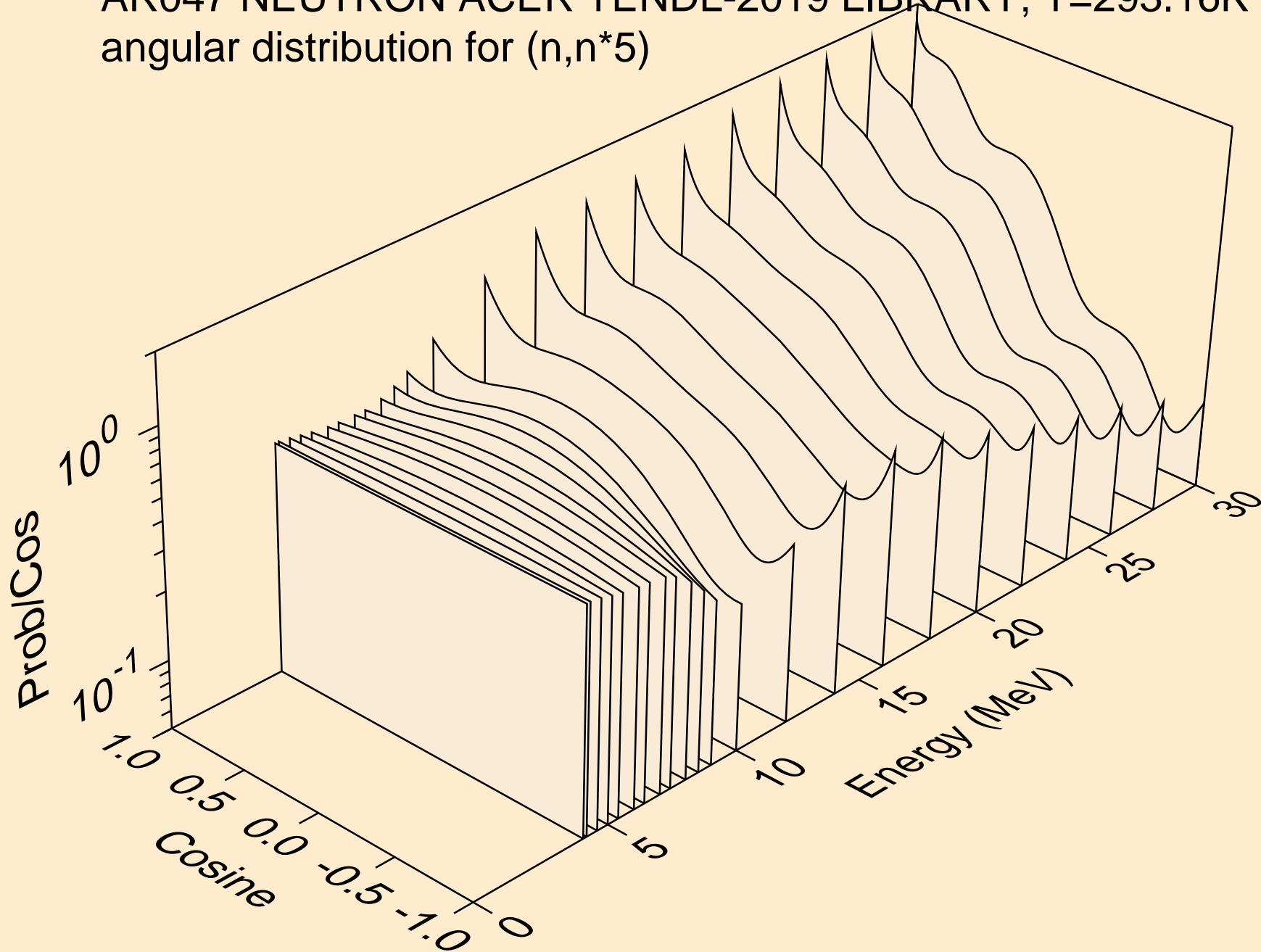

AR047 NEUTRON ACER TENDL-2019 LIBRARY; T=293.16K
angular distribution for (n,n*6)

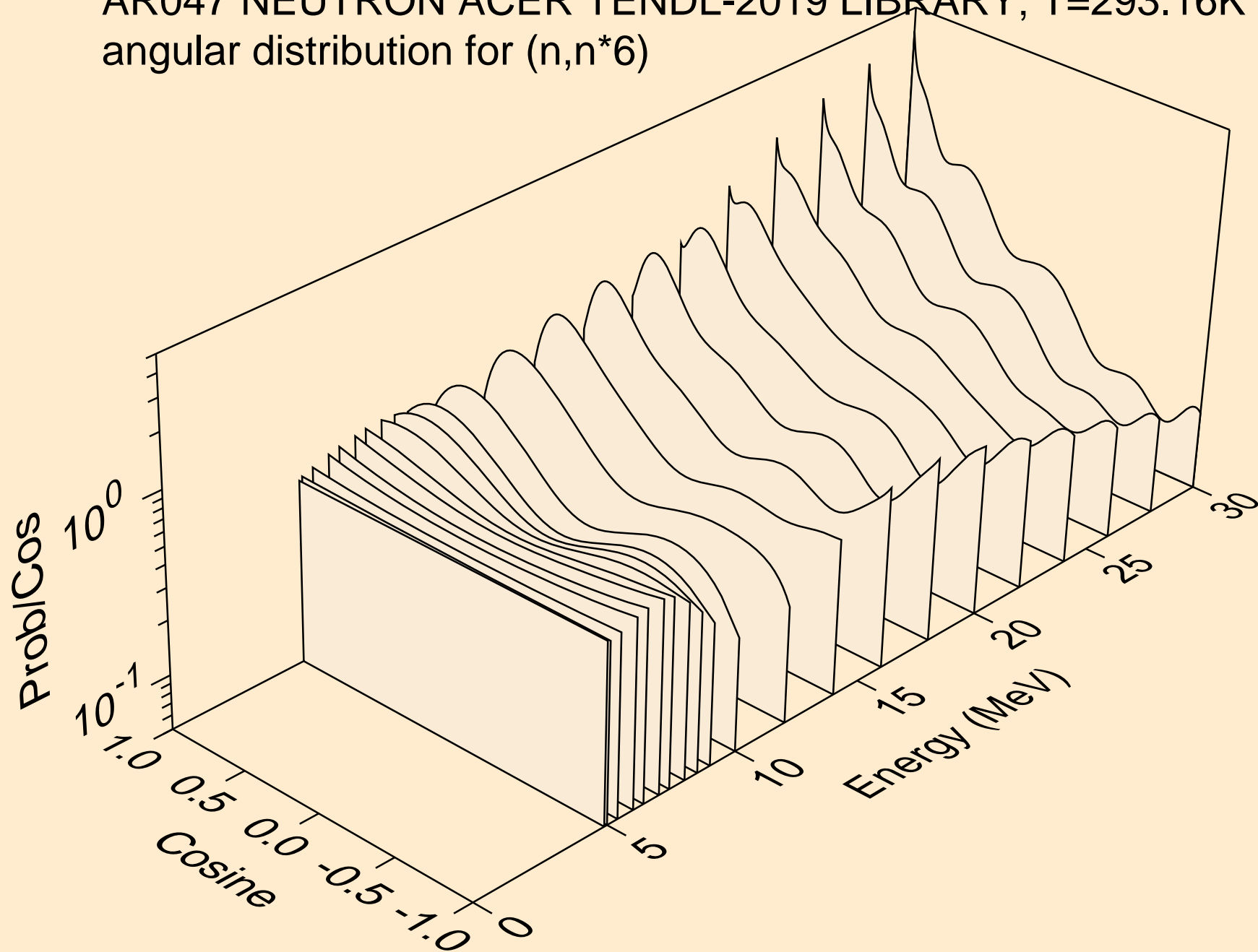

AR047 NEUTRON ACER TENDL-2019 LIBRARY; T=293.16K
angular distribution for (n,n*7)

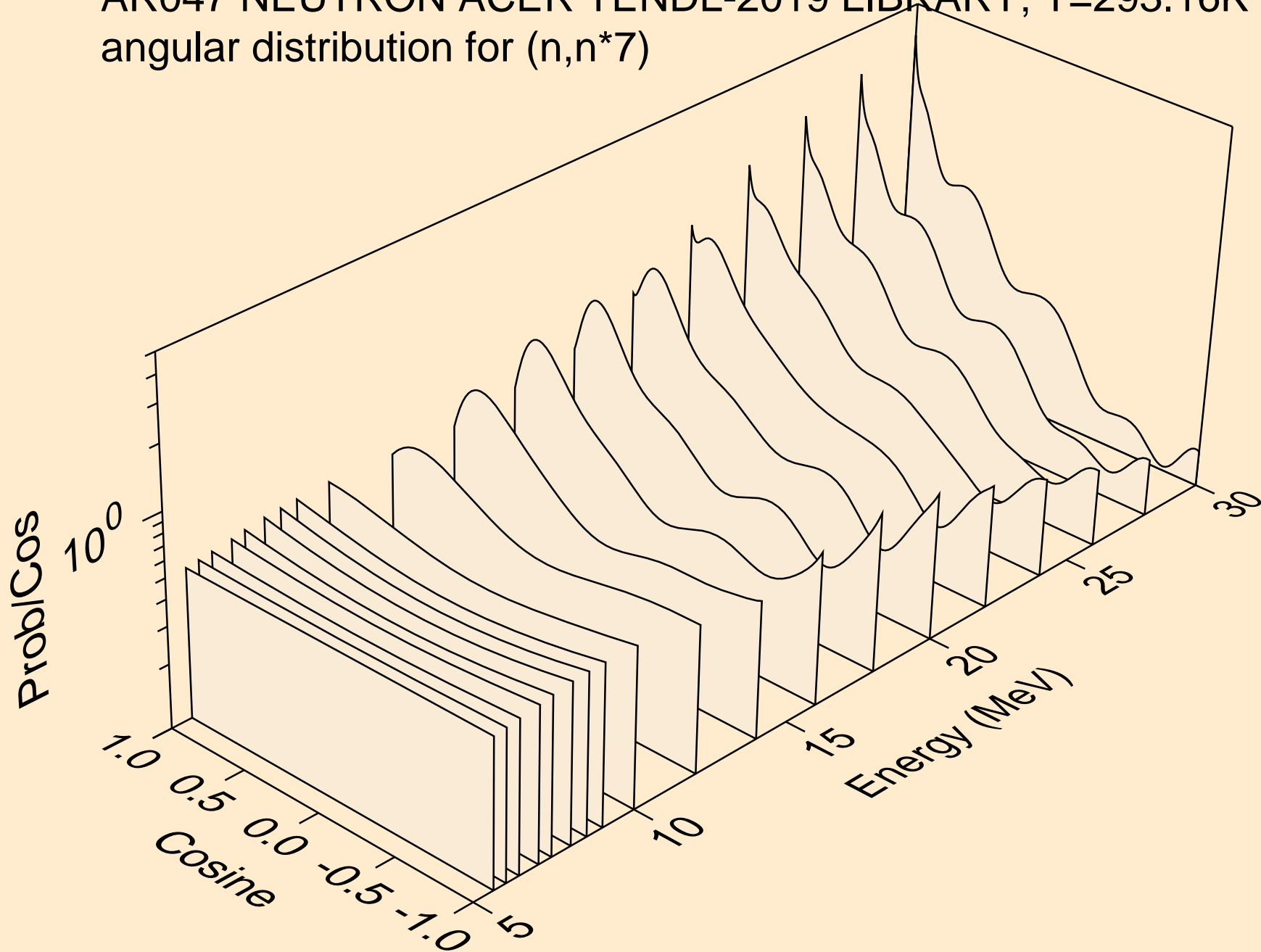

AR047 NEUTRON ACER TENDL-2019 LIBRARY; T=293.16K
angular distribution for (n,n*8)

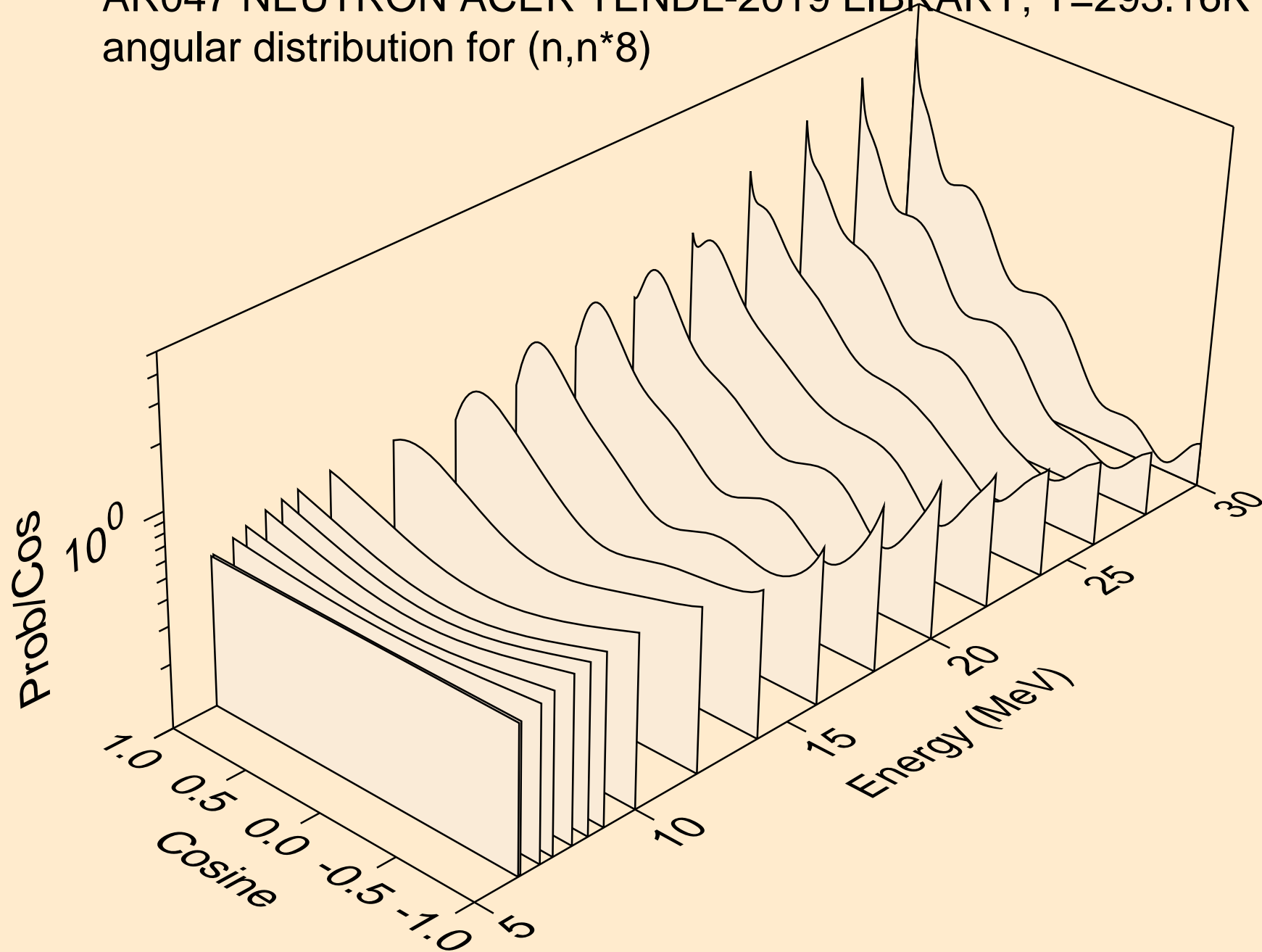

AR047 NEUTRON ACER TENDL-2019 LIBRARY; T=293.16K
angular distribution for (n,n*9)

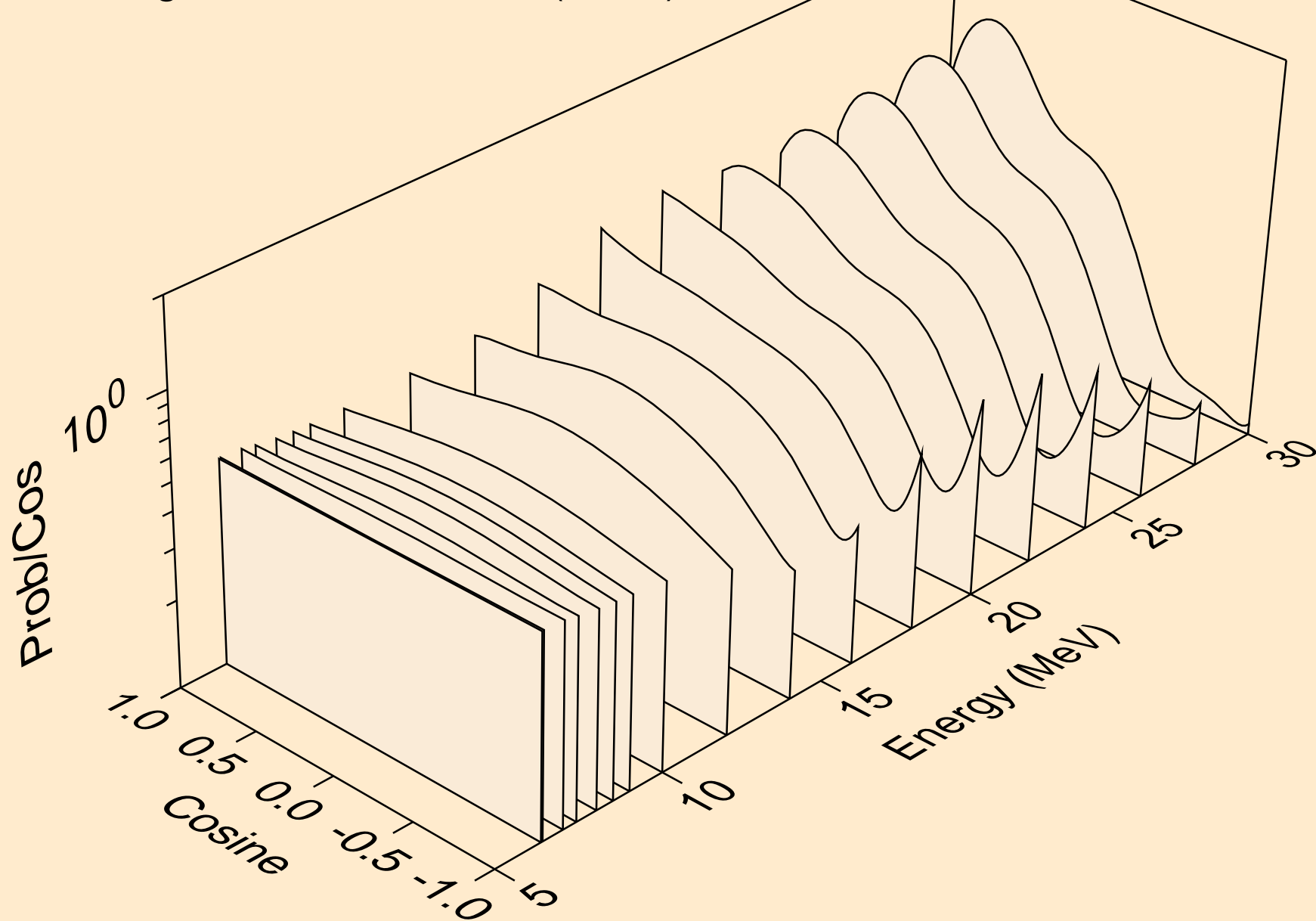

AR047 NEUTRON ACER TENDL-2019 LIBRARY; T=293.16K
angular distribution for (n,n*10)

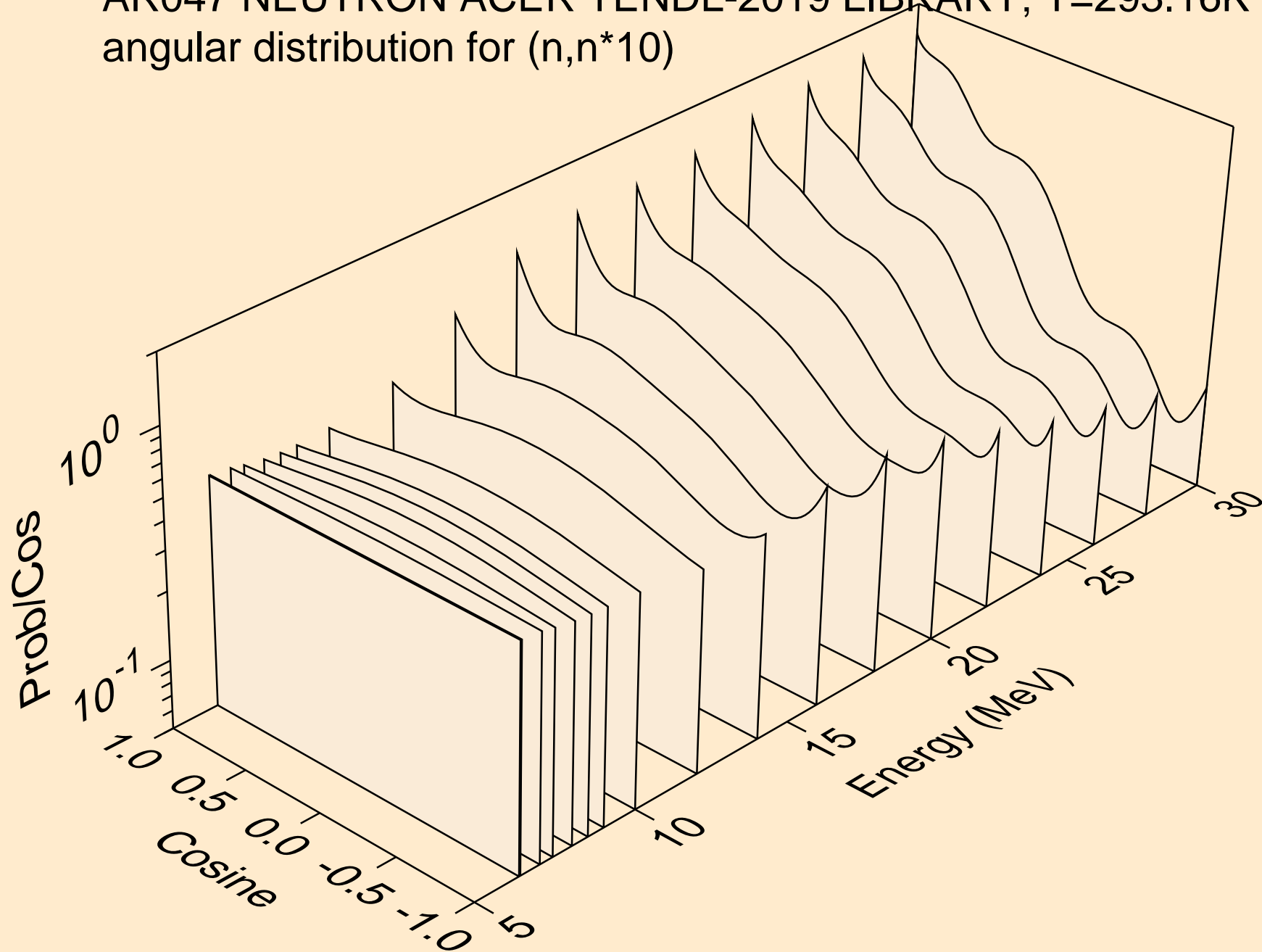

AR047 NEUTRON ACER TENDL-2019 LIBRARY; T=293.16K
angular distribution for (n,n*11)

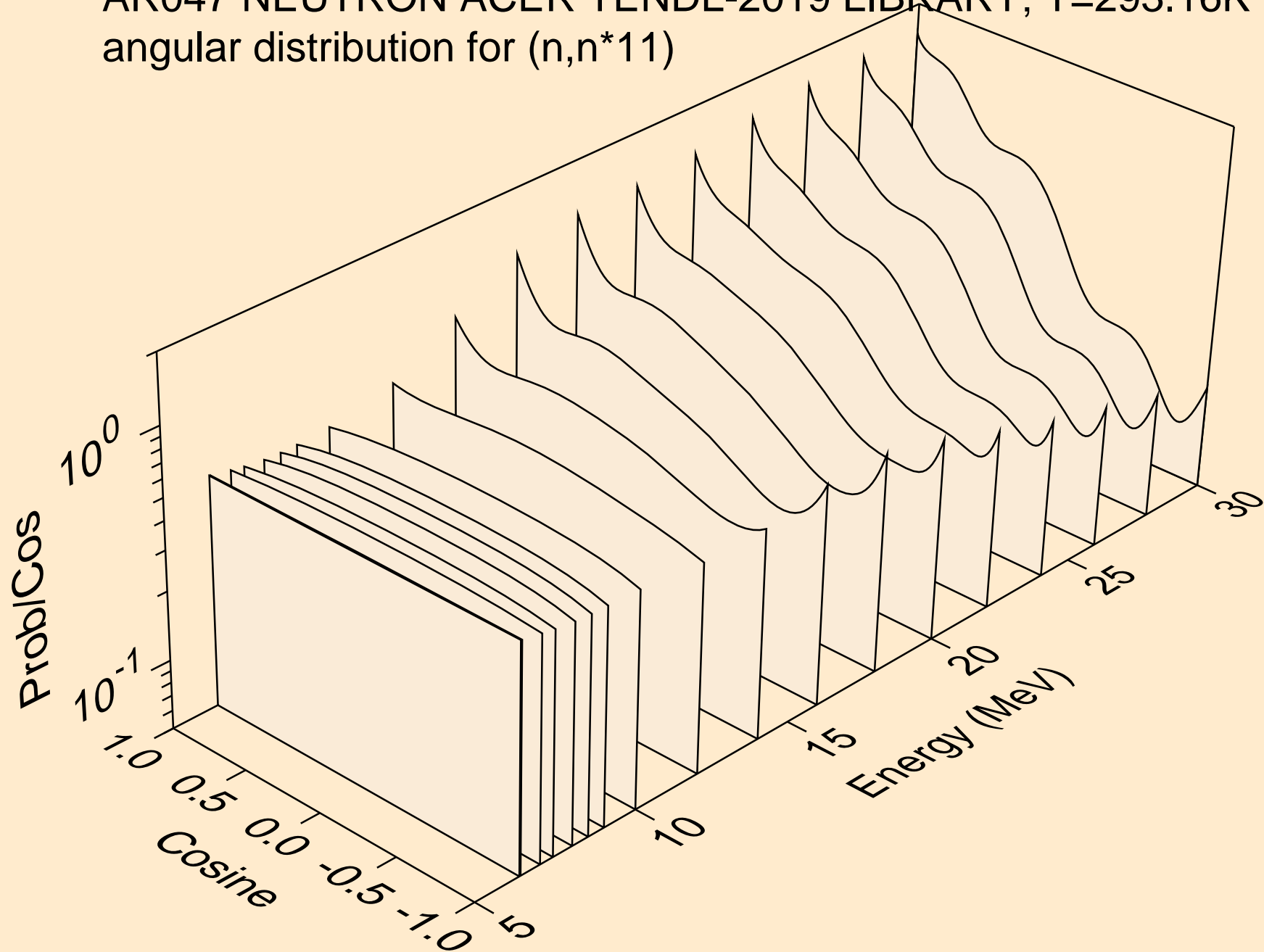

AR047 NEUTRON ACER TENDL-2019 LIBRARY; T=293.16K
angular distribution for (n,n*12)

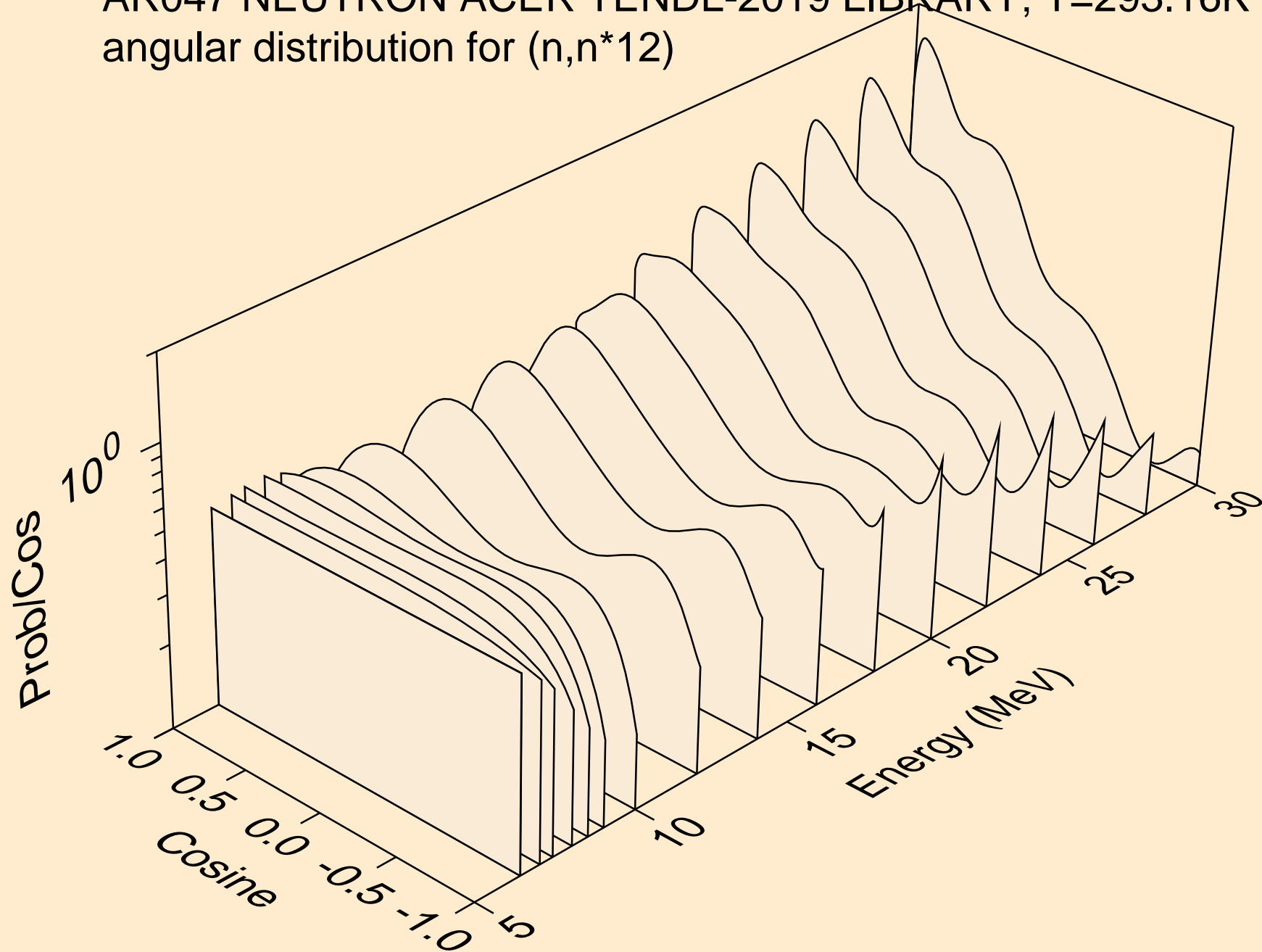

AR047 NEUTRON ACER TENDL-2019 LIBRARY; T=293.16K
angular distribution for (n,n*13)

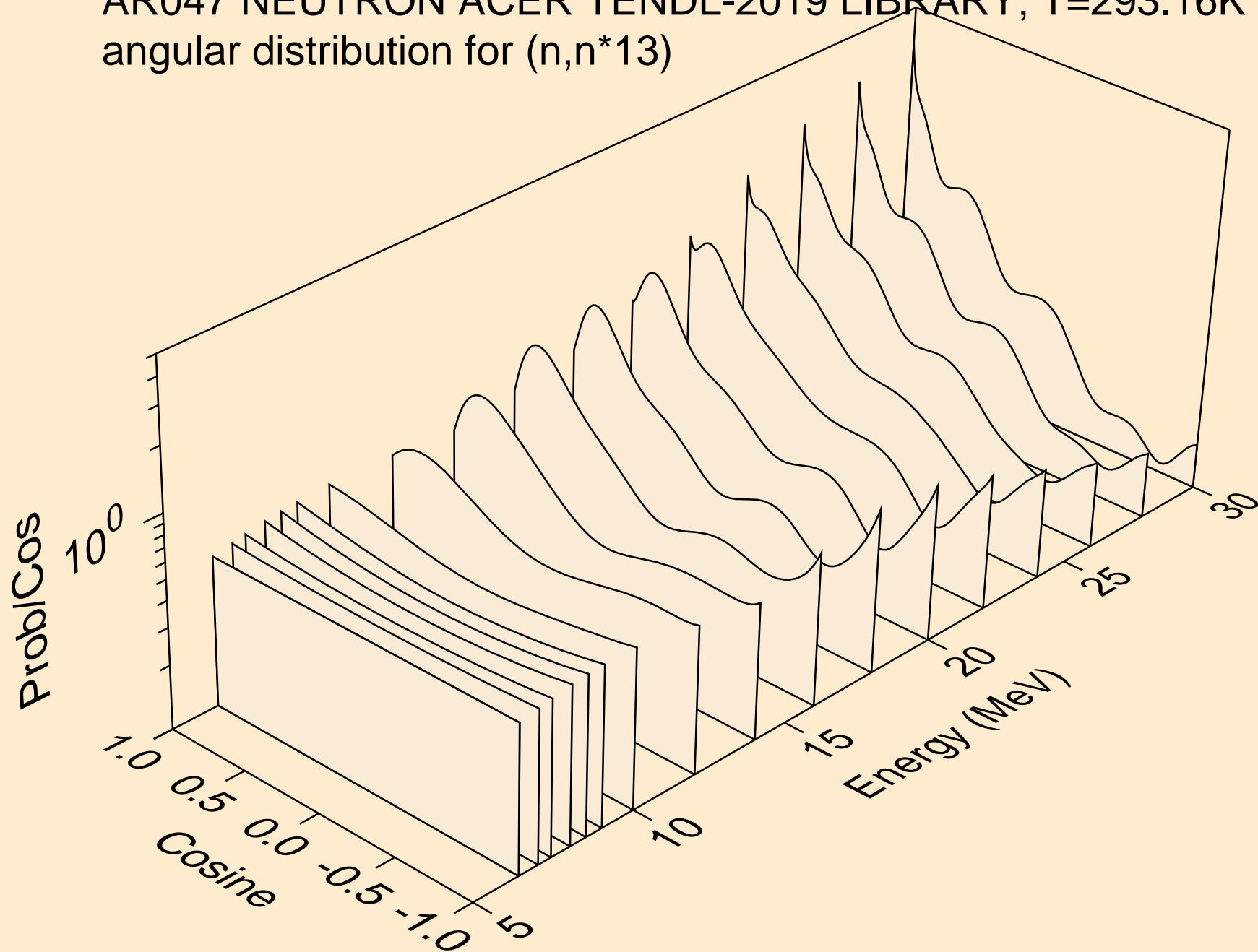

AR047 NEUTRON ACER TENDL-2019 LIBRARY; T=293.16K
angular distribution for (n,n*14)

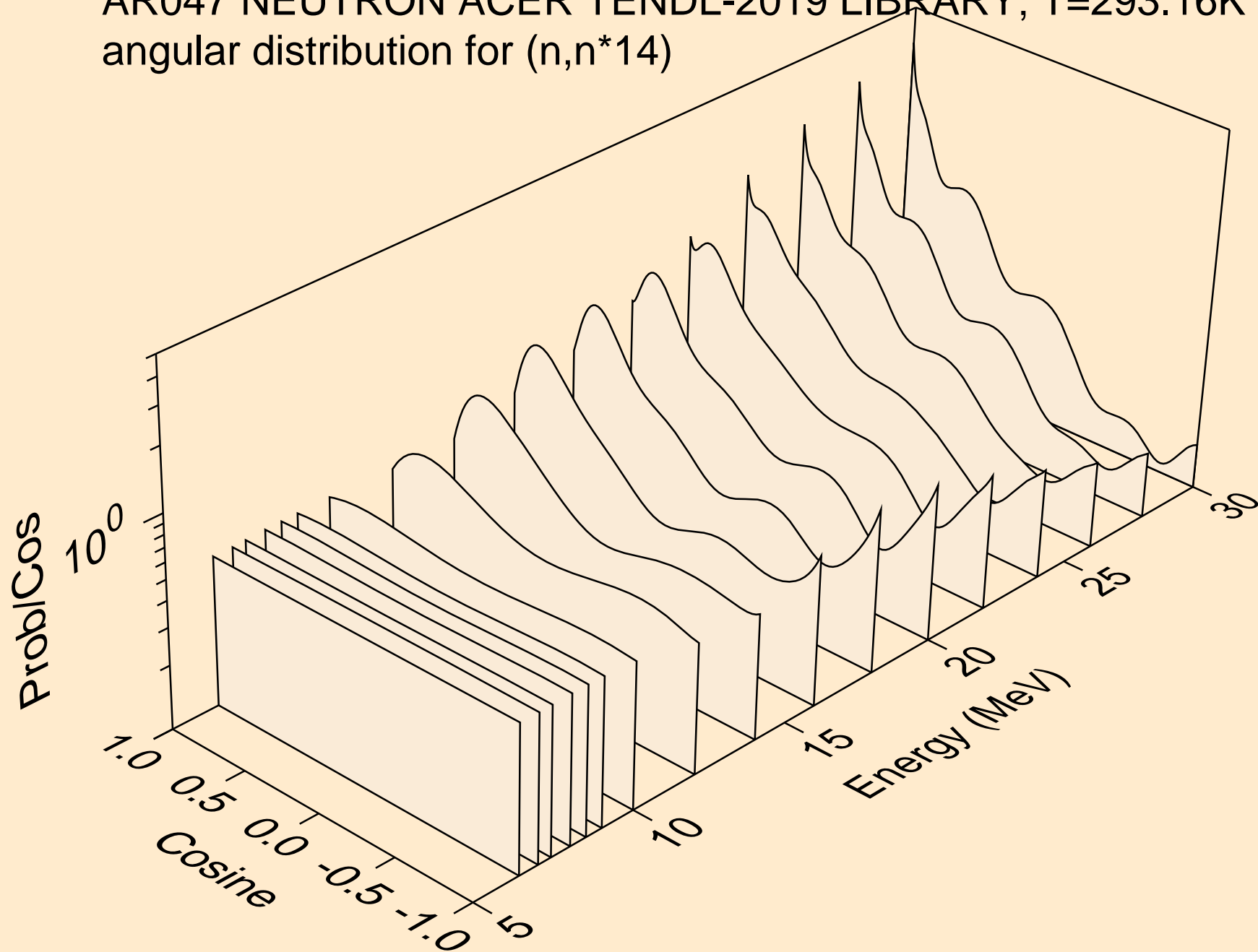

AR047 NEUTRON ACER TENDL-2019 LIBRARY; T=293.16K
angular distribution for (n,n*15)

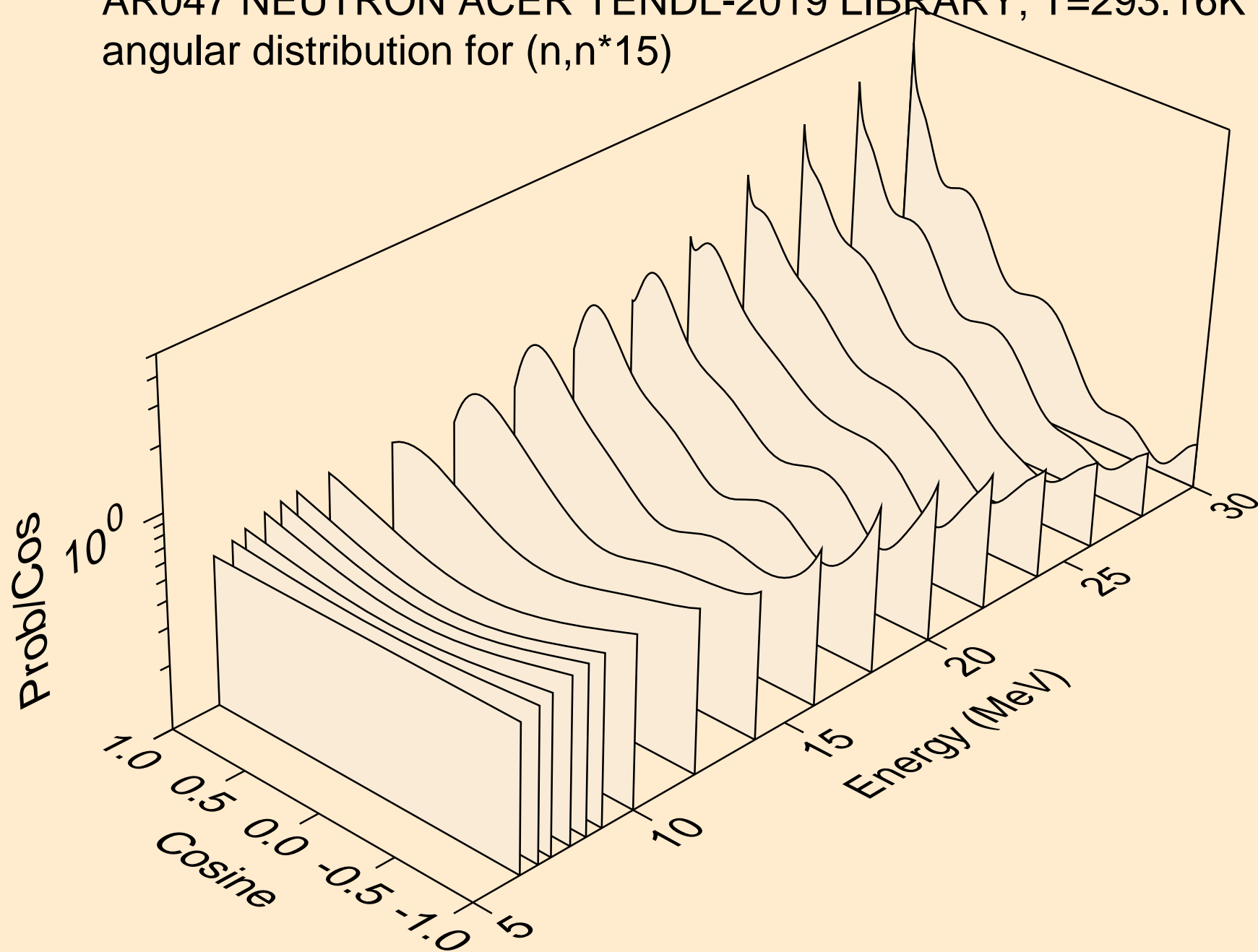

AR047 NEUTRON ACER TENDL-2019 LIBRARY; T=293.16K
angular distribution for (n,n*16)

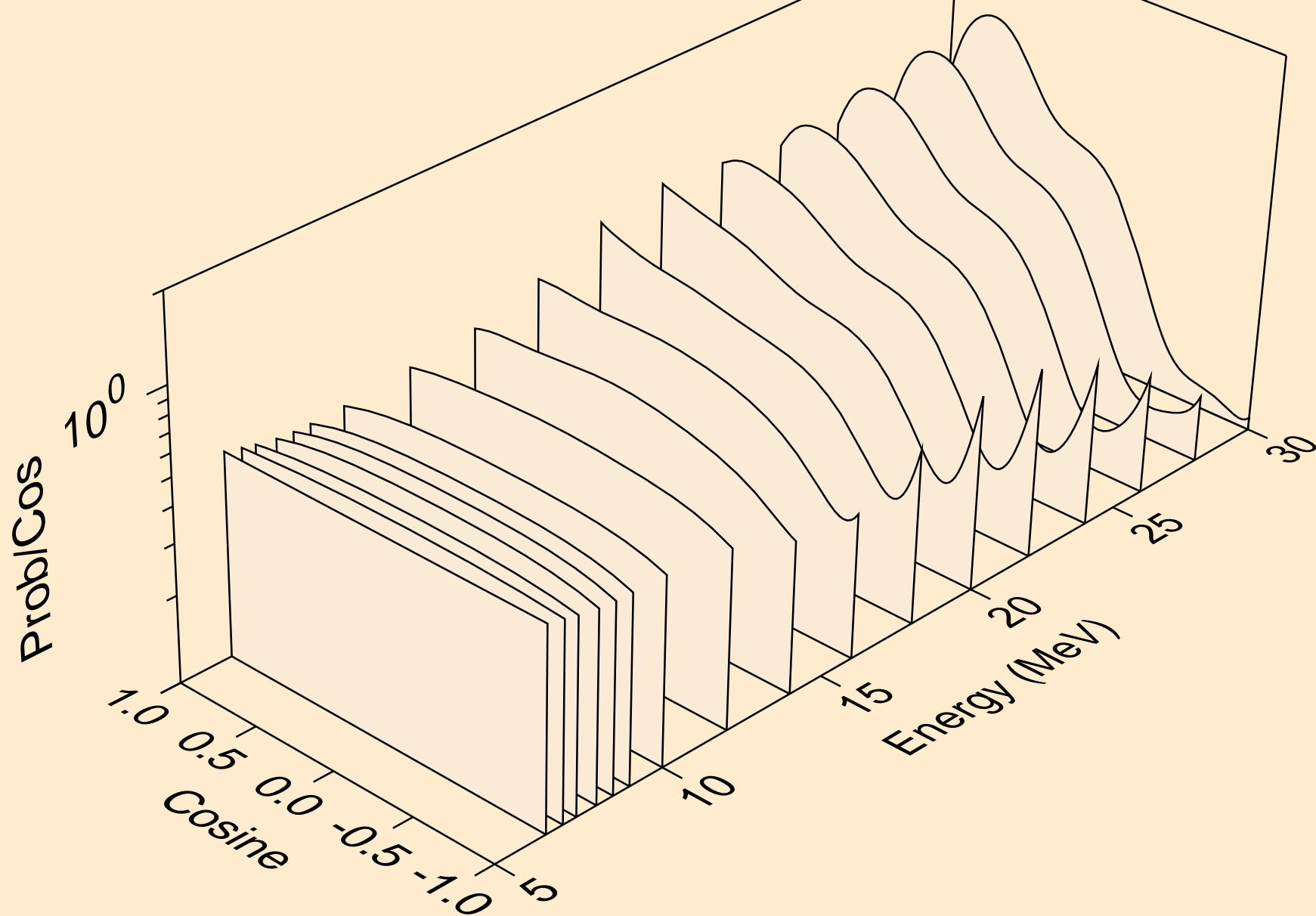

AR047 NEUTRON ACER TENDL-2019 LIBRARY; T=293.16K
angular distribution for (n,n*17)

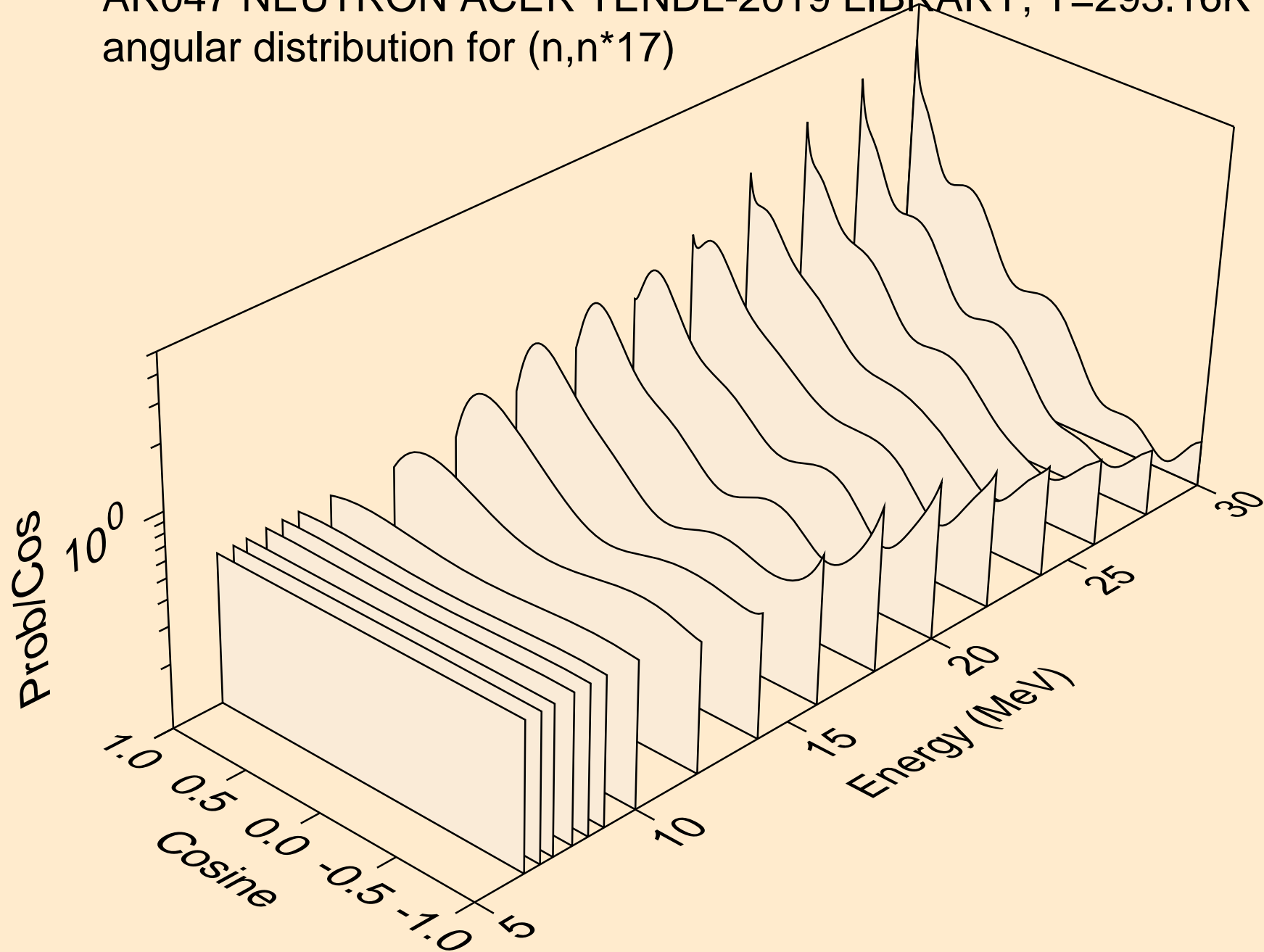

AR047 NEUTRON ACER TENDL-2019 LIBRARY; T=293.16K
angular distribution for (n,n*18)

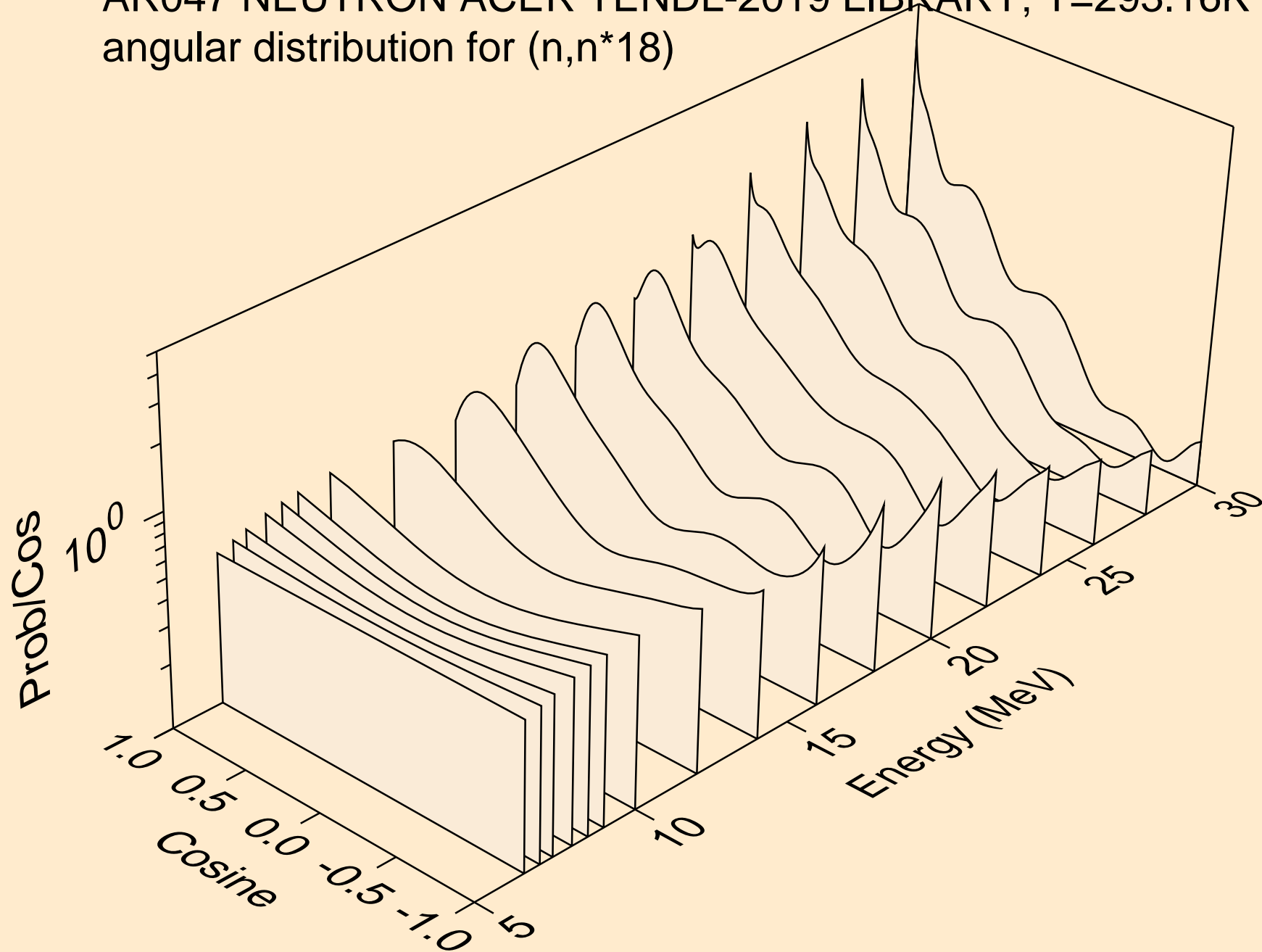

AR047 NEUTRON ACER TENDL-2019 LIBRARY; T=293.16K
angular distribution for (n,n*19)

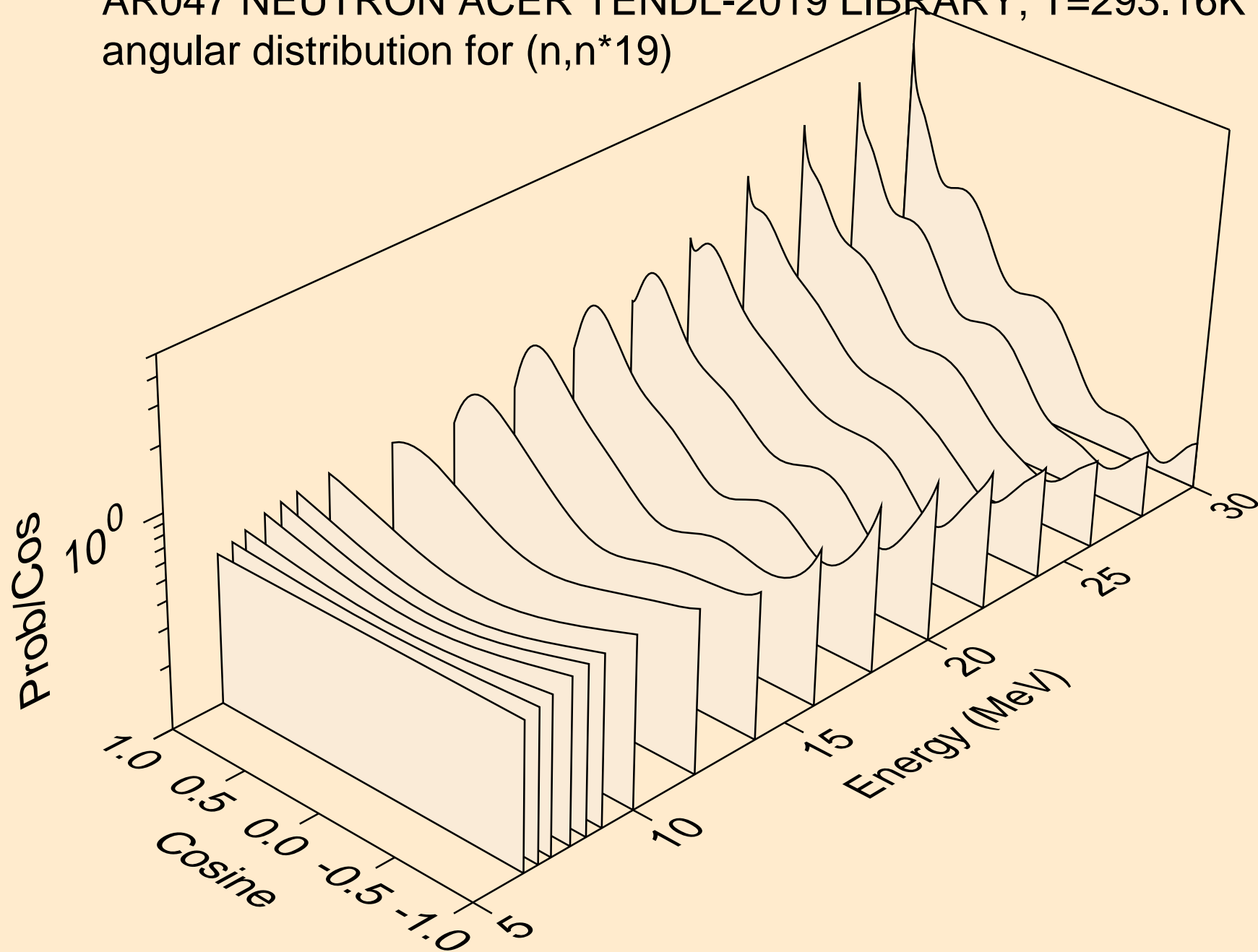

AR047 NEUTRON ACER TENDL-2019 LIBRARY; T=293.16K
angular distribution for (n,n*20)

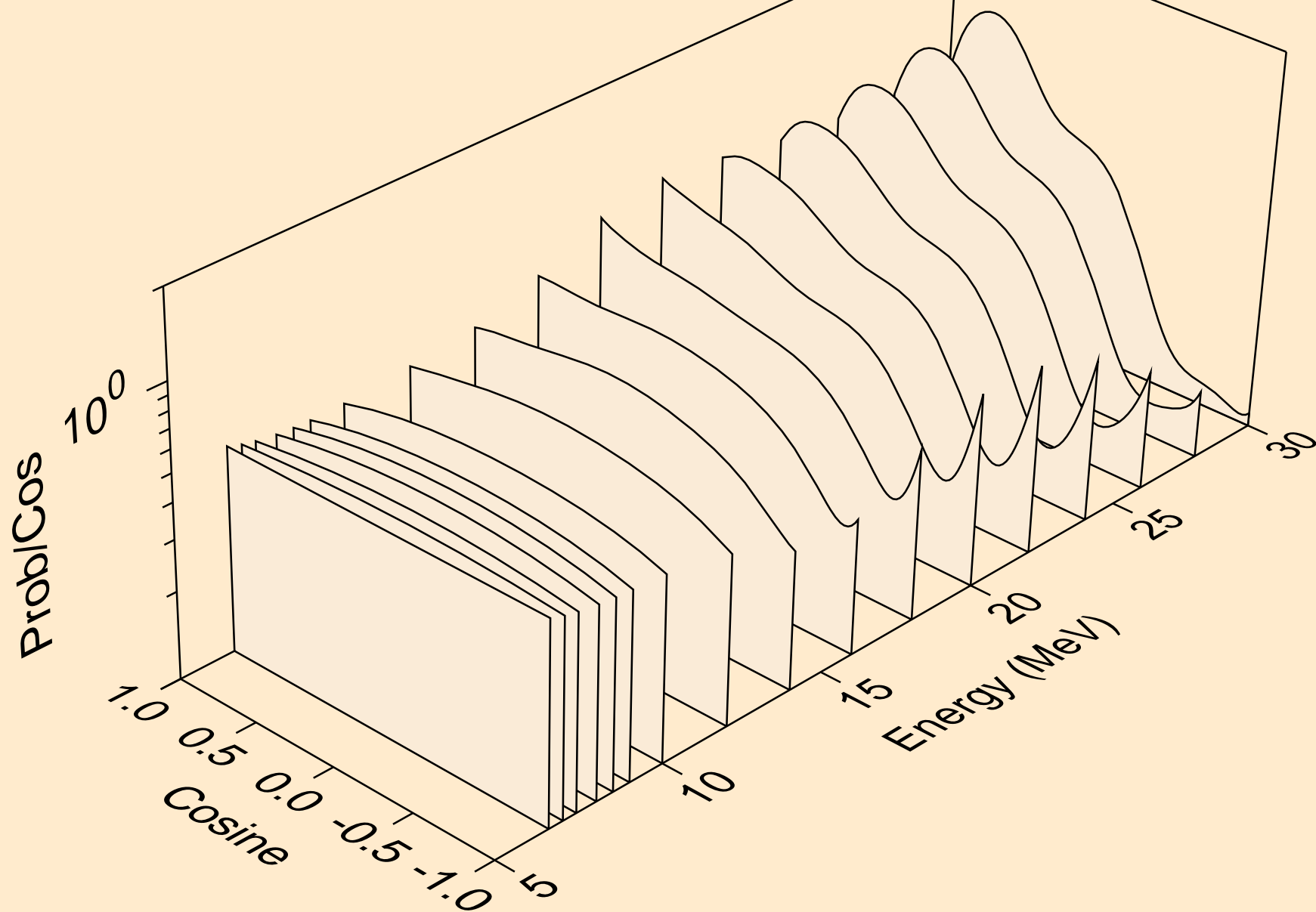

AR047 NEUTRON ACER TENDL-2019 LIBRARY; T=293.16K
angular distribution for (n,n*21)

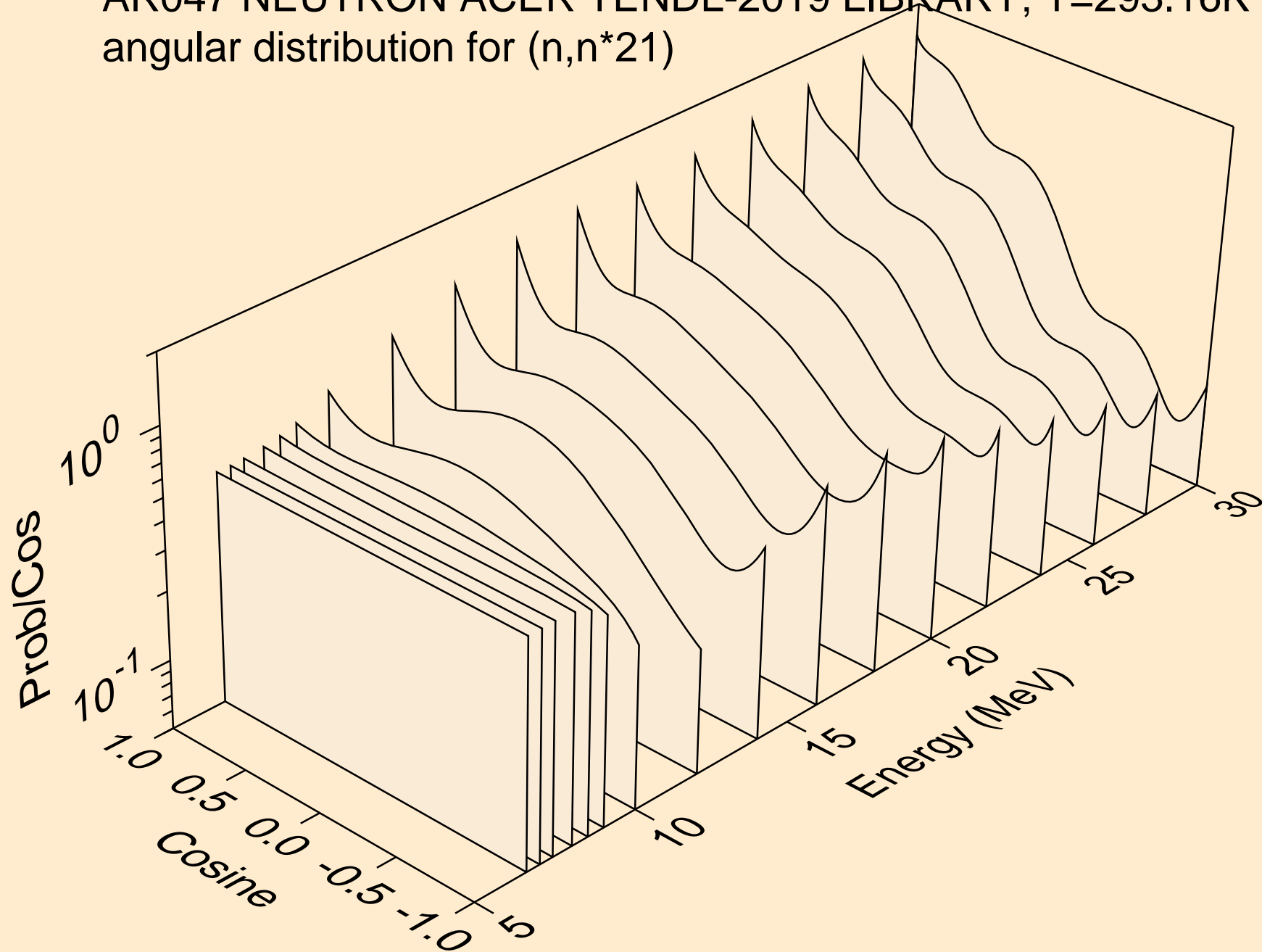

AR047 NEUTRON ACER TENDL-2019 LIBRARY; T=293.16K
angular distribution for (n,n*22)

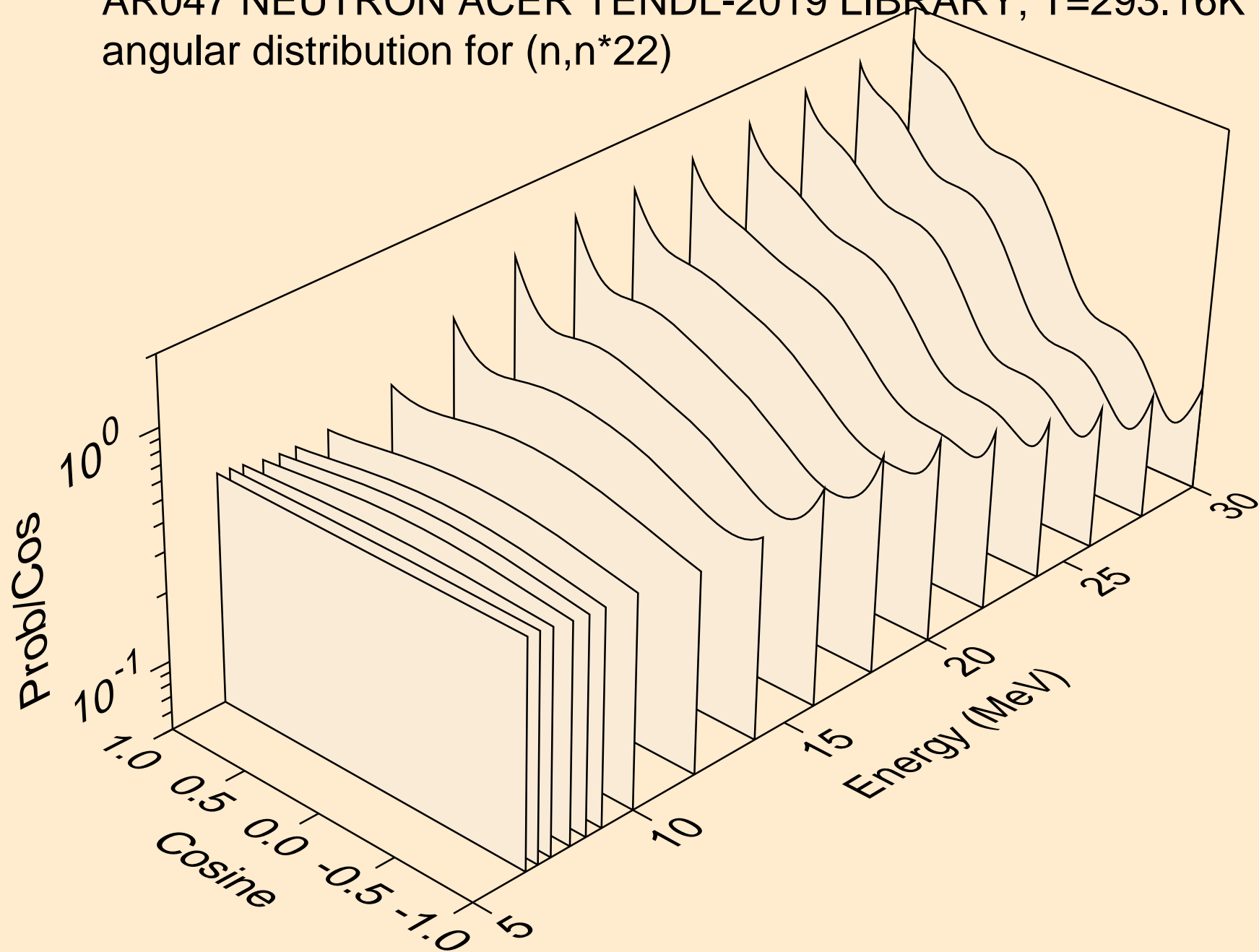

AR047 NEUTRON ACER TENDL-2019 LIBRARY; T=293.16K
angular distribution for (n,n*23)

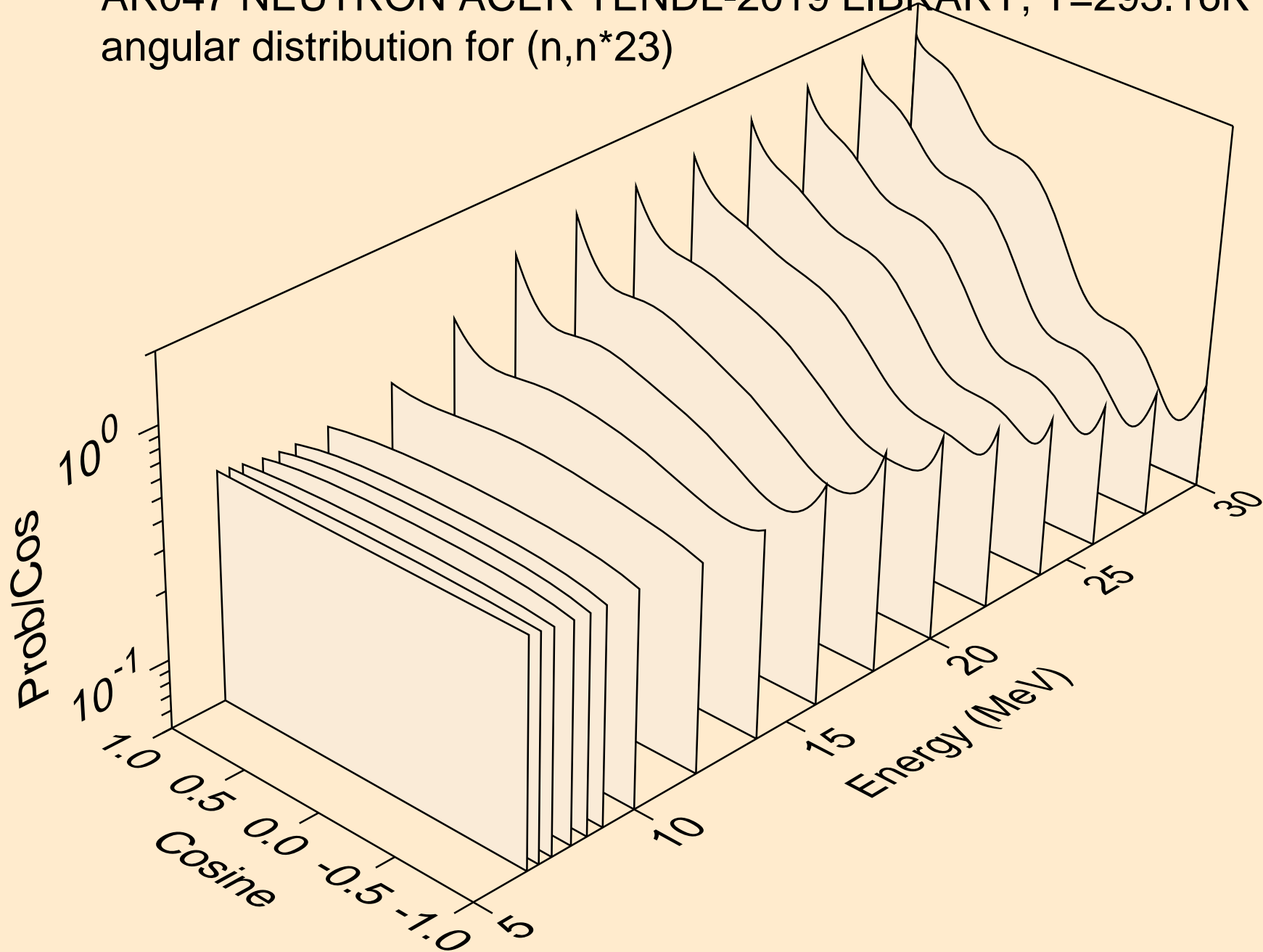

AR047 NEUTRON ACER TENDL-2019 LIBRARY; T=293.16K
angular distribution for (n,n*24)

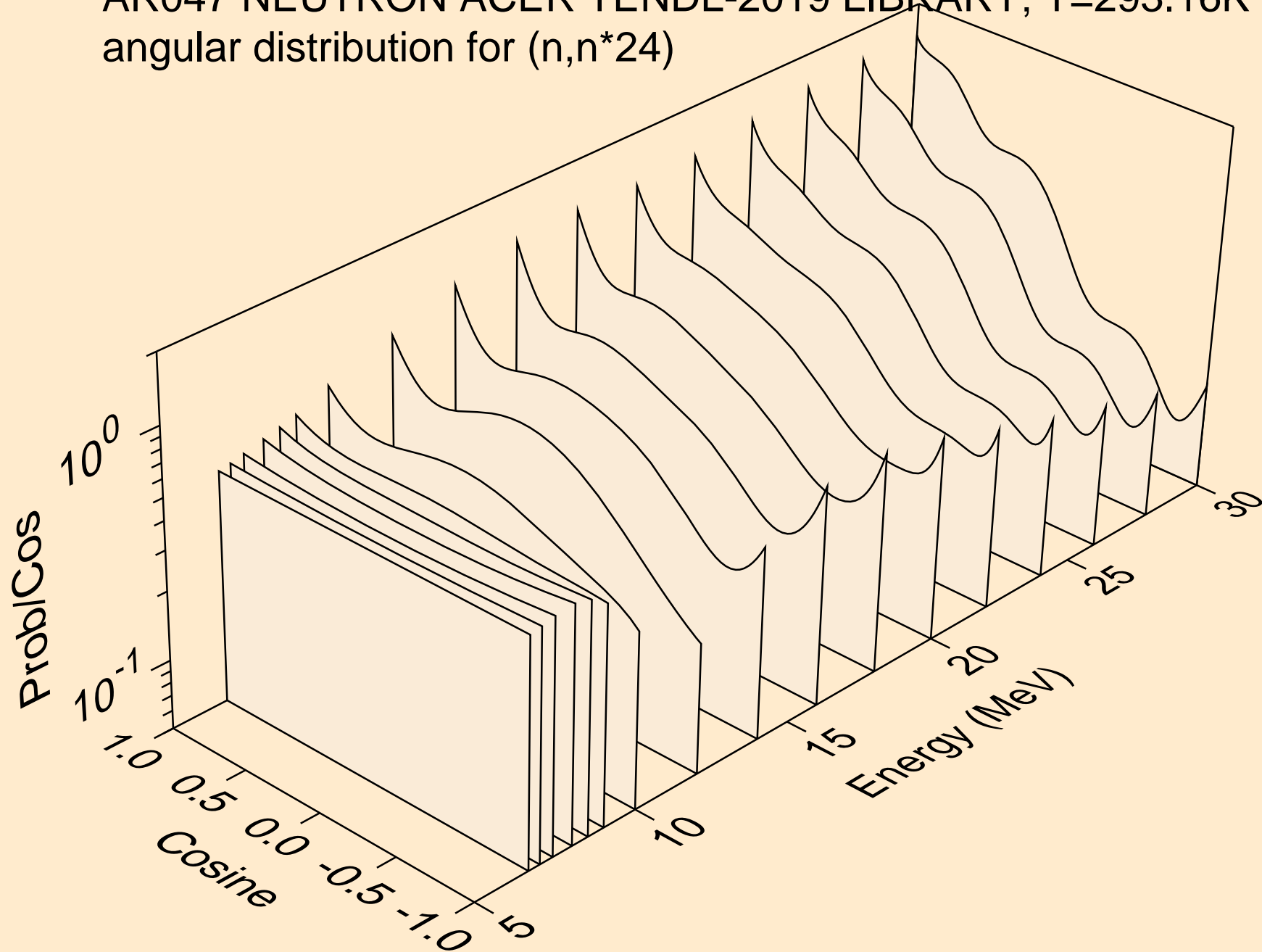

AR047 NEUTRON ACER TENDL-2019 LIBRARY; T=293.16K
angular distribution for (n,n*25)

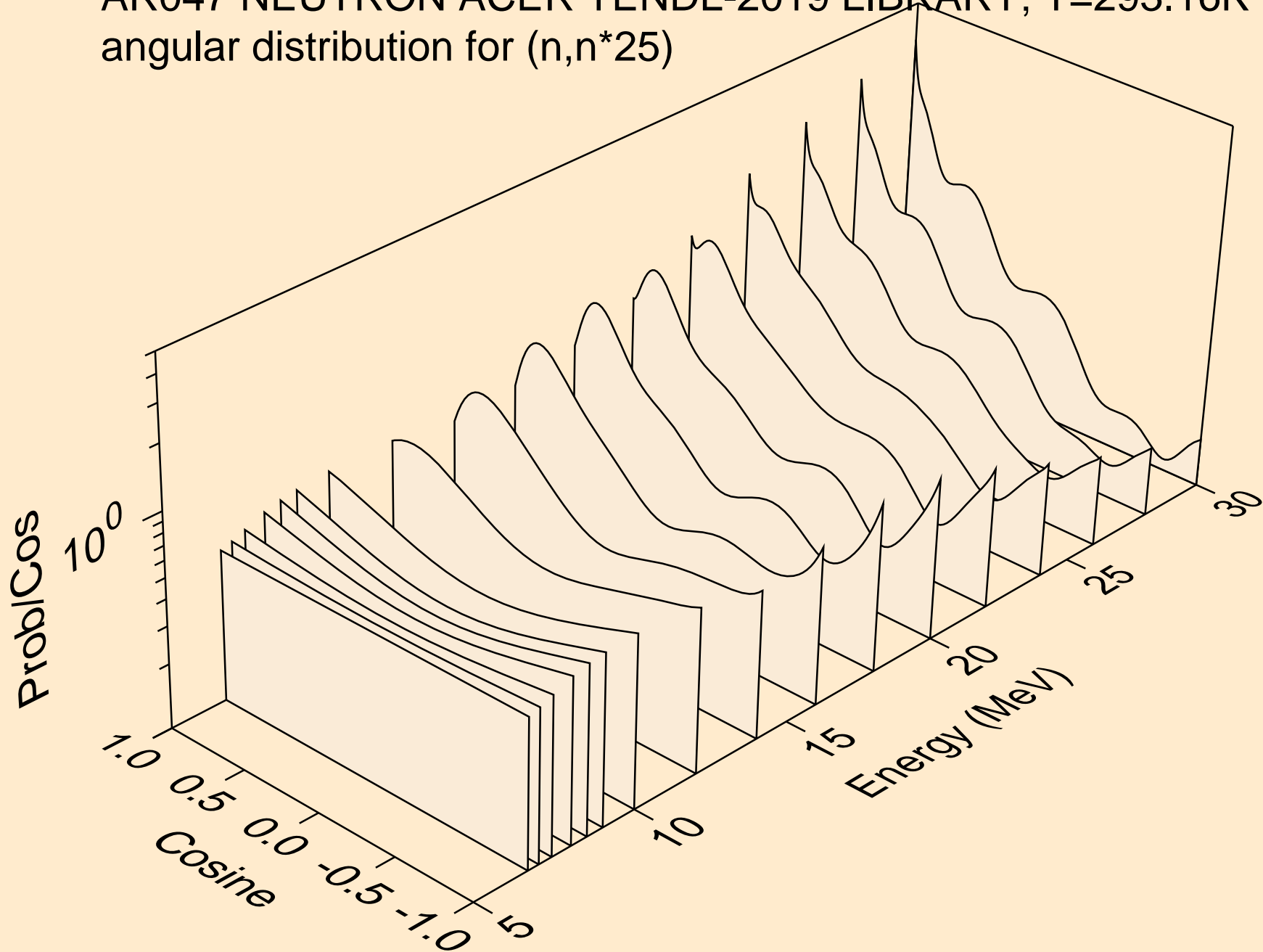

AR047 NEUTRON ACER TENDL-2019 LIBRARY; T=293.16K
angular distribution for (n,n*26)

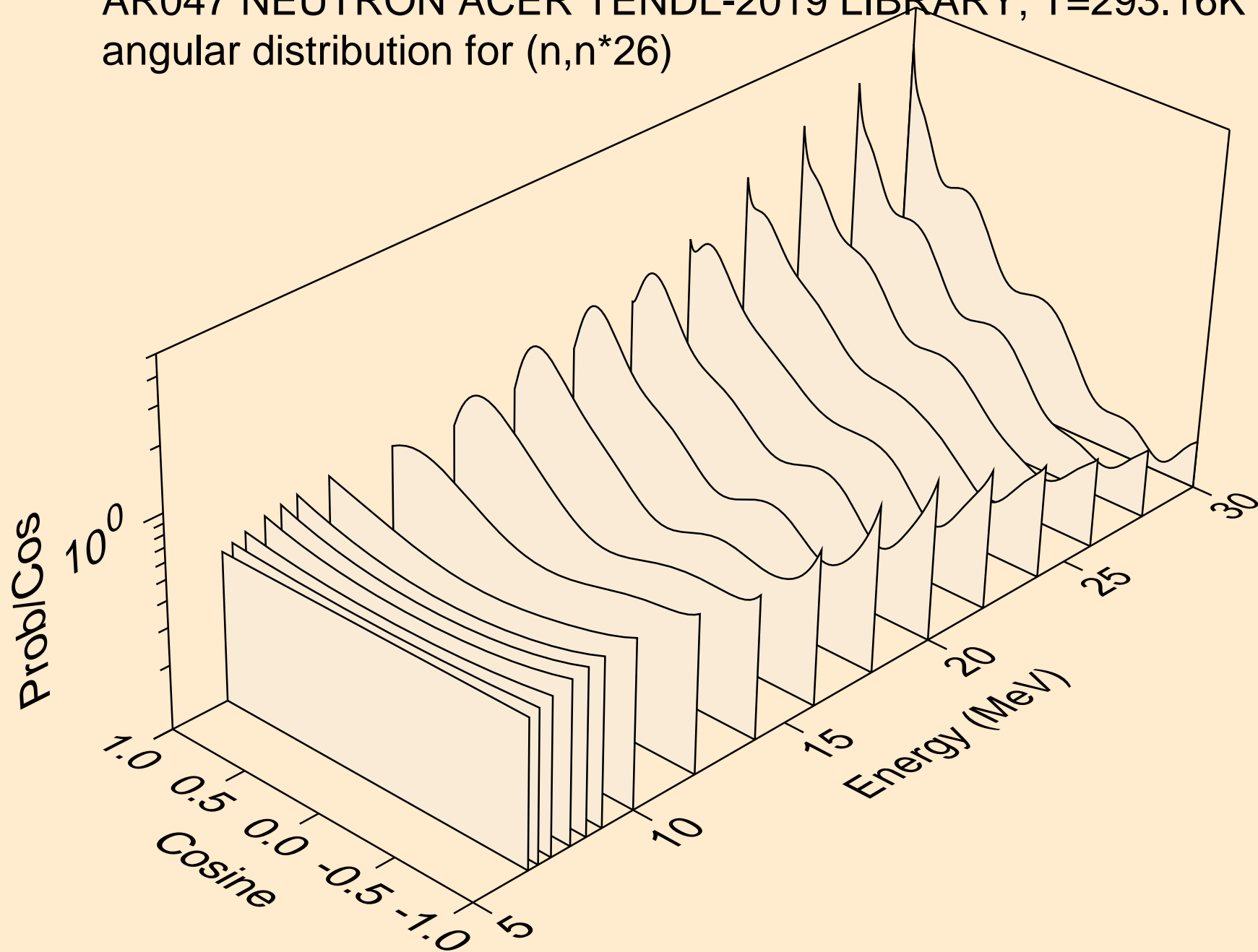

AR047 NEUTRON ACER TENDL-2019 LIBRARY; T=293.16K
angular distribution for (n,n*27)

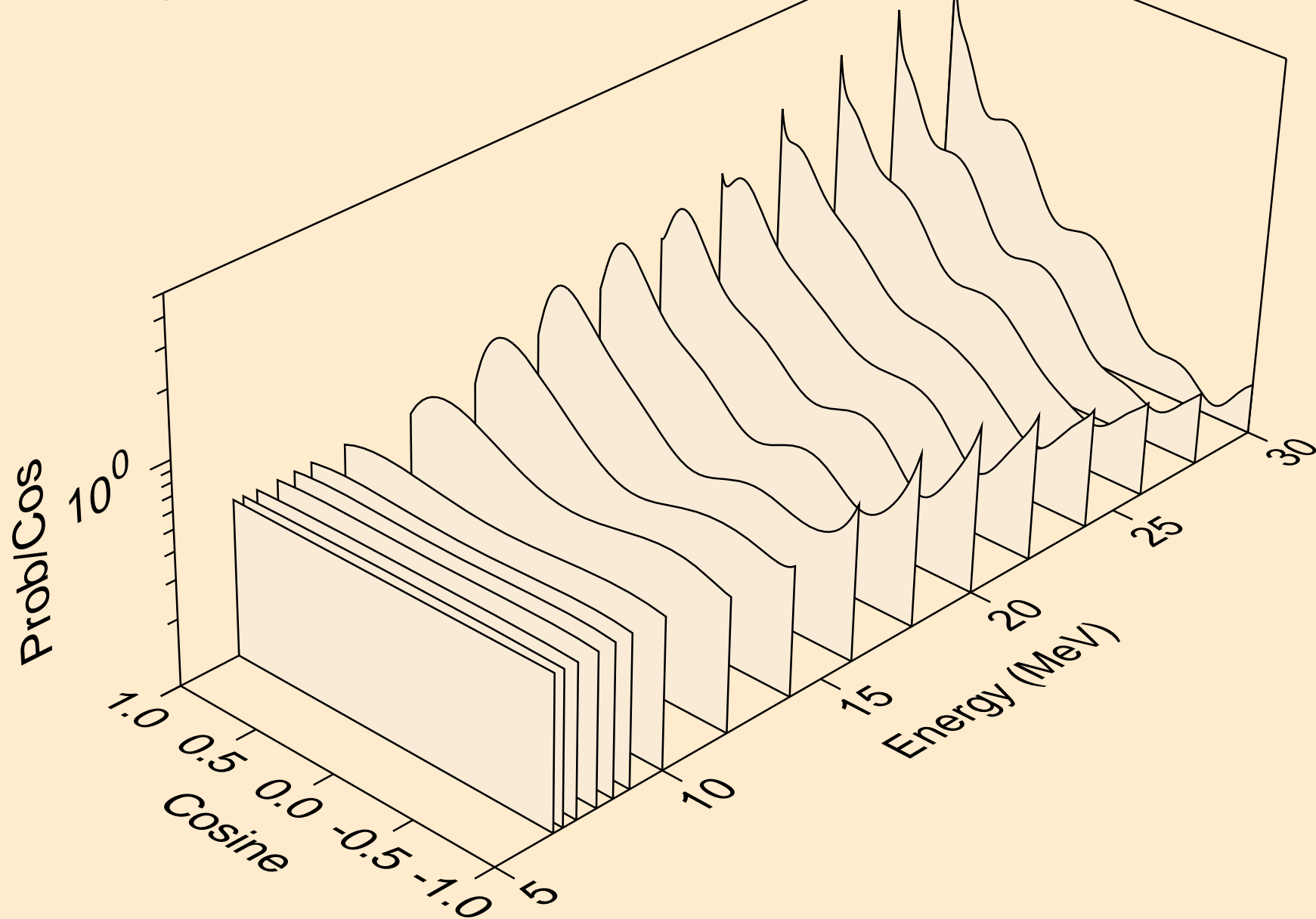

AR047 NEUTRON ACER TENDL-2019 LIBRARY; T=293.16K
angular distribution for (n,n*28)

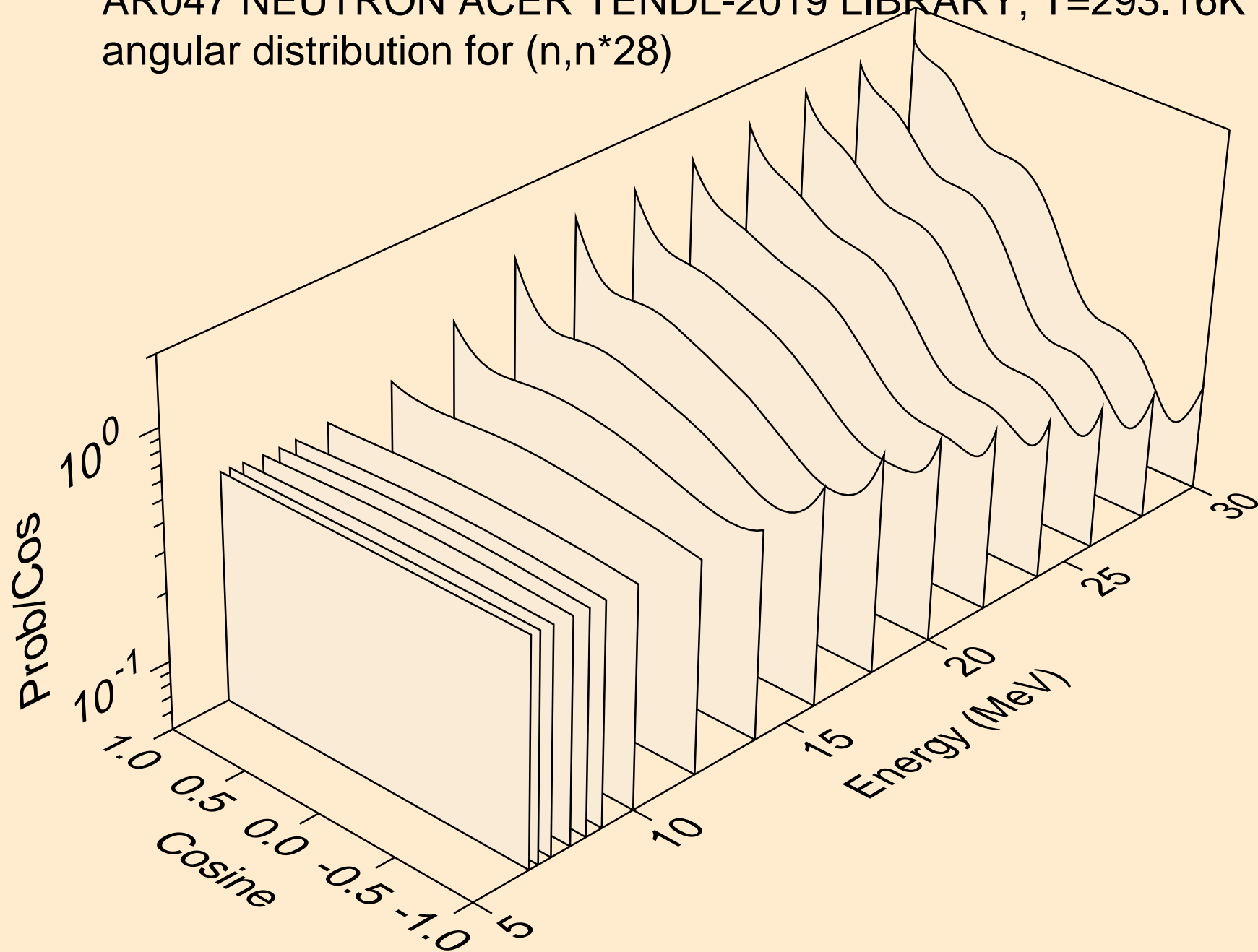

AR047 NEUTRON ACER TENDL-2019 LIBRARY; T=293.16K
angular distribution for (n,n*29)

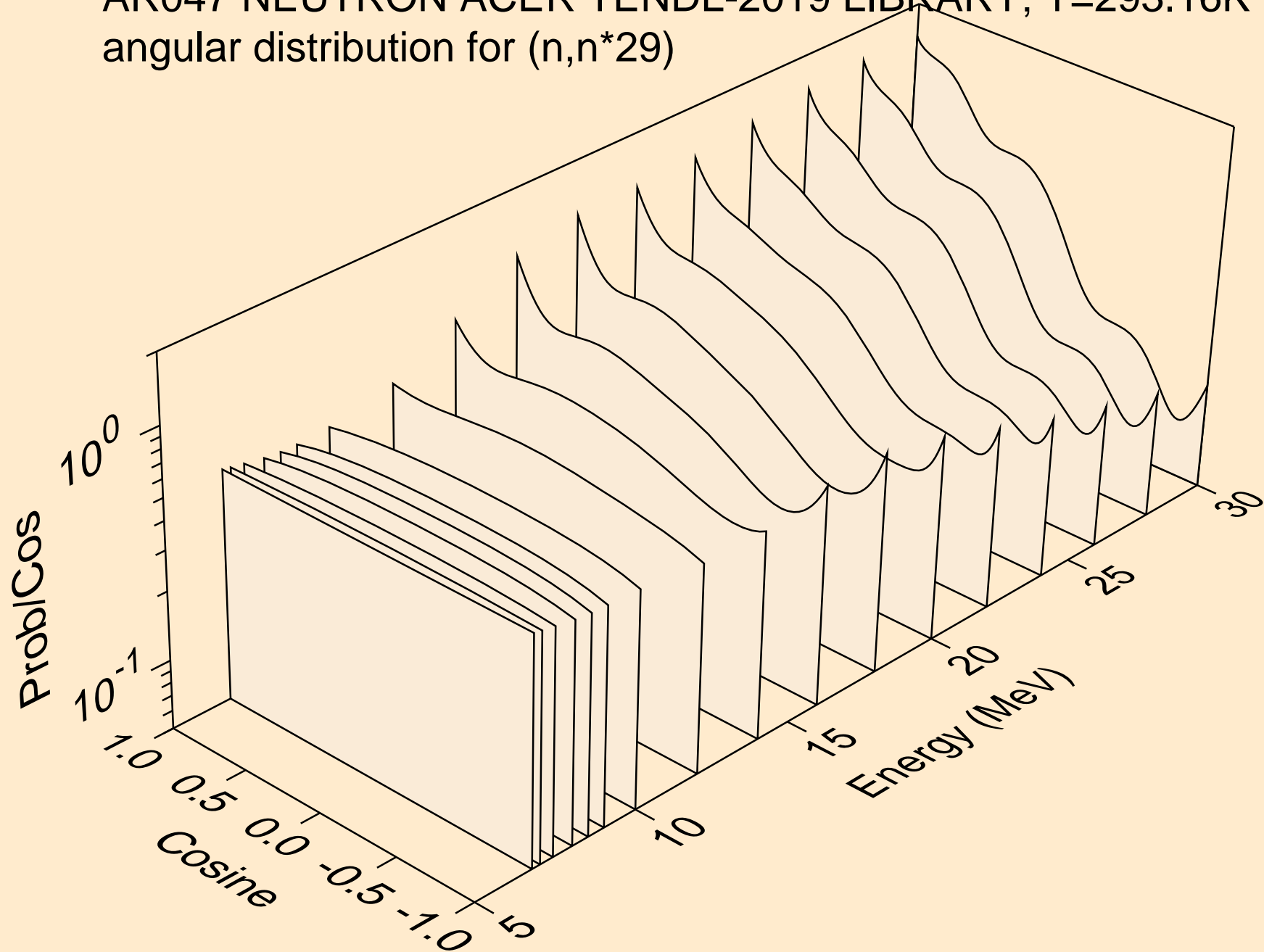

AR047 NEUTRON ACER TENDL-2019 LIBRARY; T=293.16K
Neutron emission for (n,x)

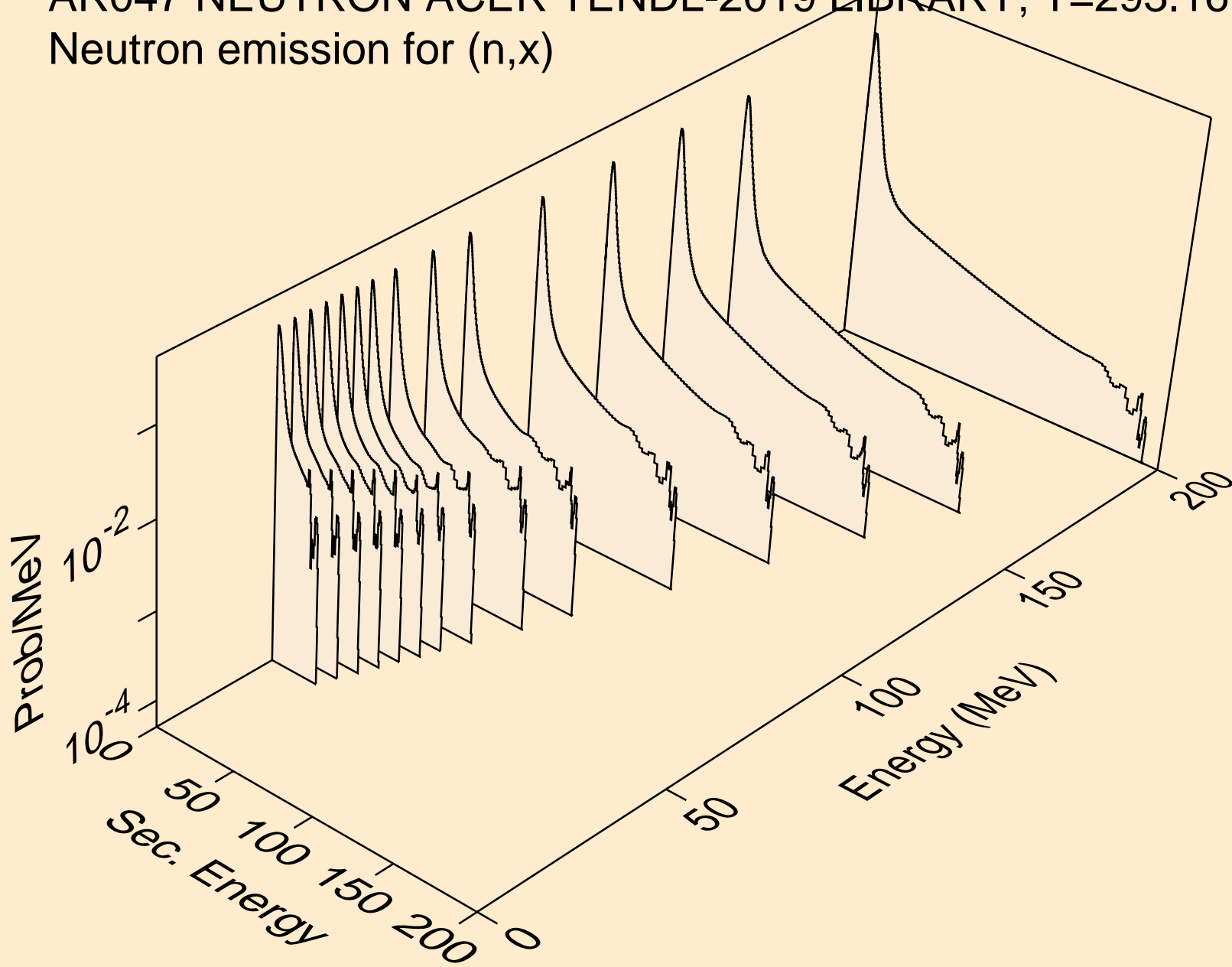

AR047 NEUTRON ACER TENDL-2019 LIBRARY; T=293.16K
Neutron emission for (n,2nd)

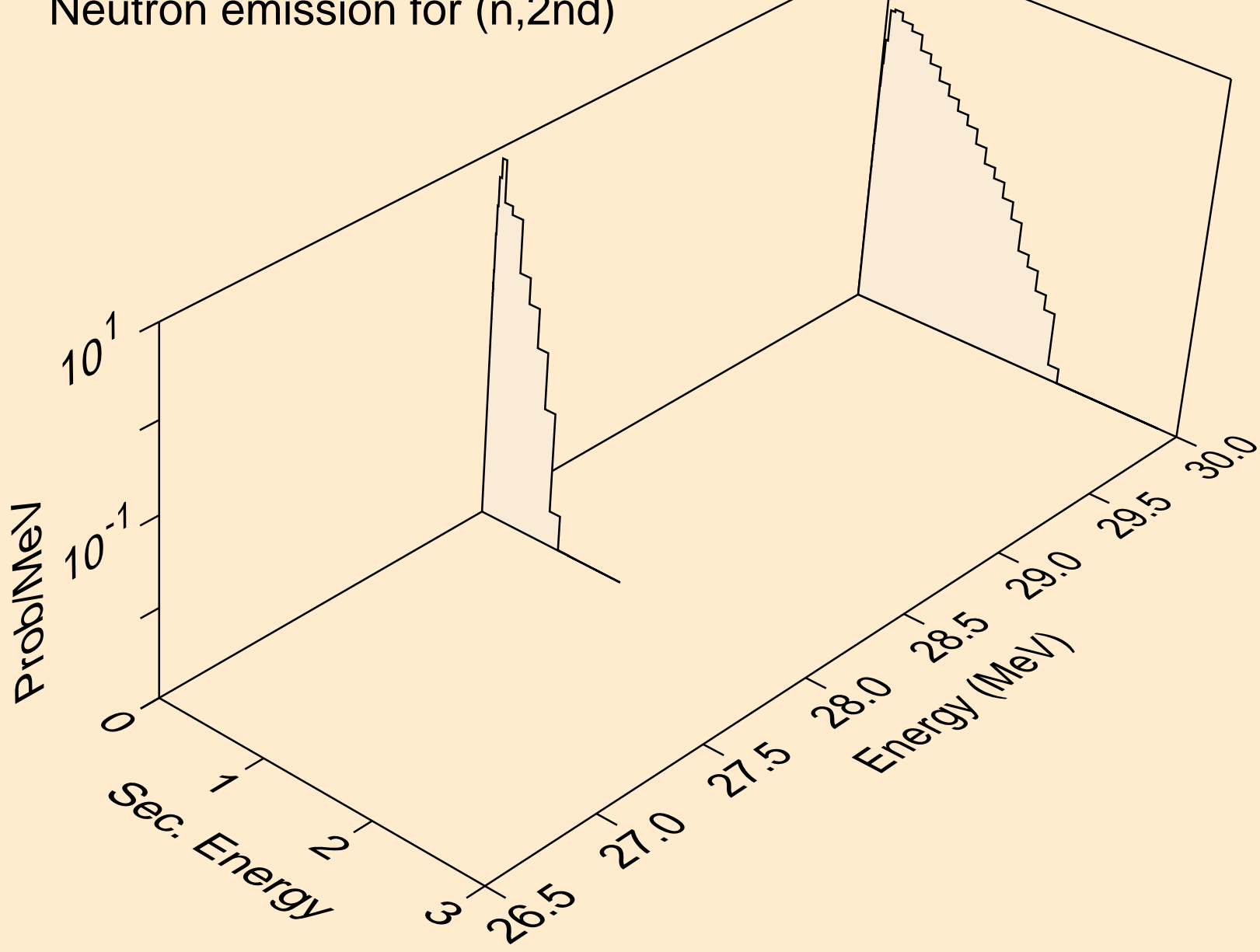

AR047 NEUTRON ACER TENDL-2019 LIBRARY; T=293.16K
Neutron emission for (n,2n)

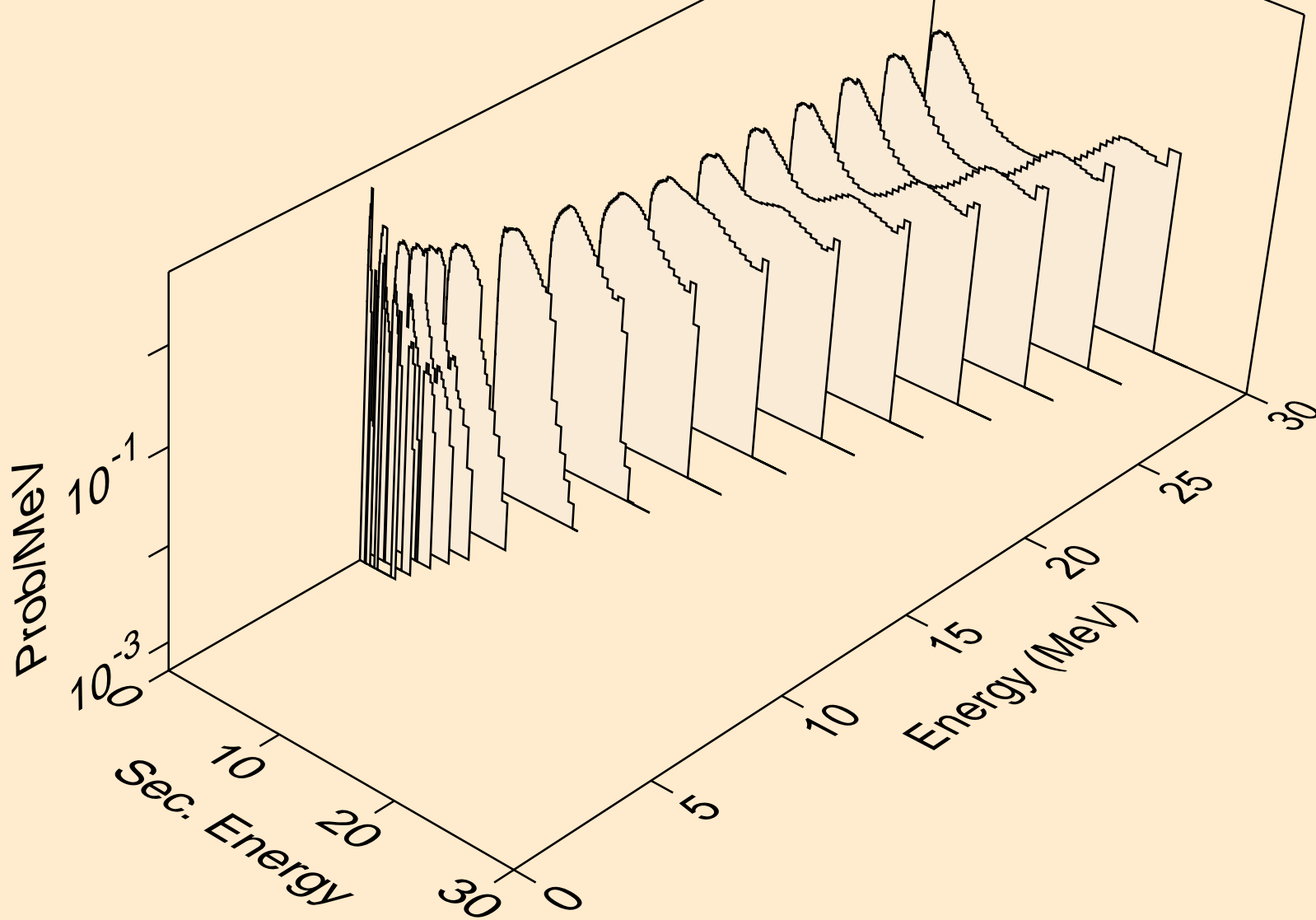

AR047 NEUTRON ACER TENDL-2019 LIBRARY; T=293.16K
Neutron emission for (n,3n)

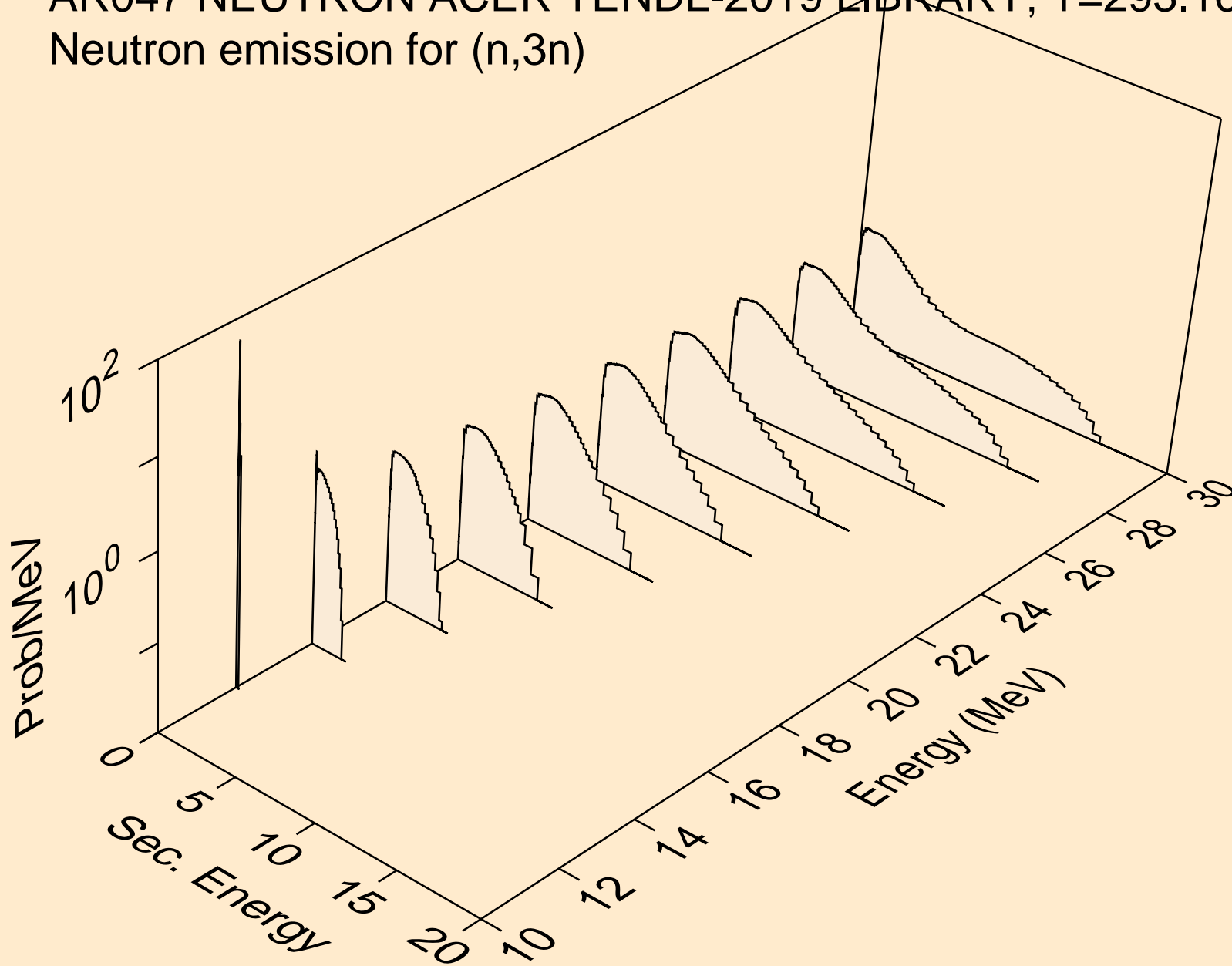

AR047 NEUTRON ACER TENDL-2019 LIBRARY; T=293.16K
Neutron emission for (n,n*)a

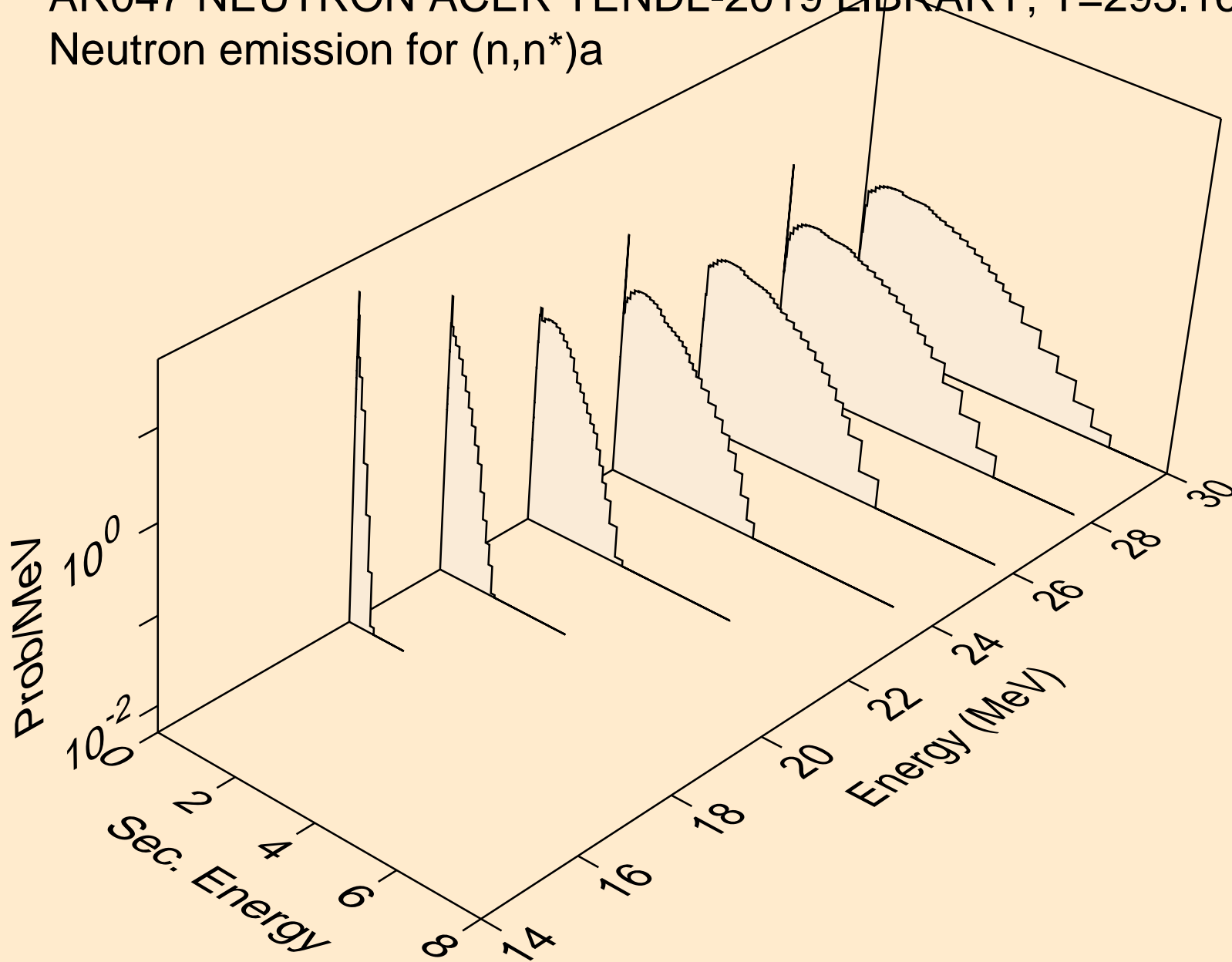

AR047 NEUTRON ACER TENDL-2019 LIBRARY; T=293.16K
Neutron emission for (n,2n)a

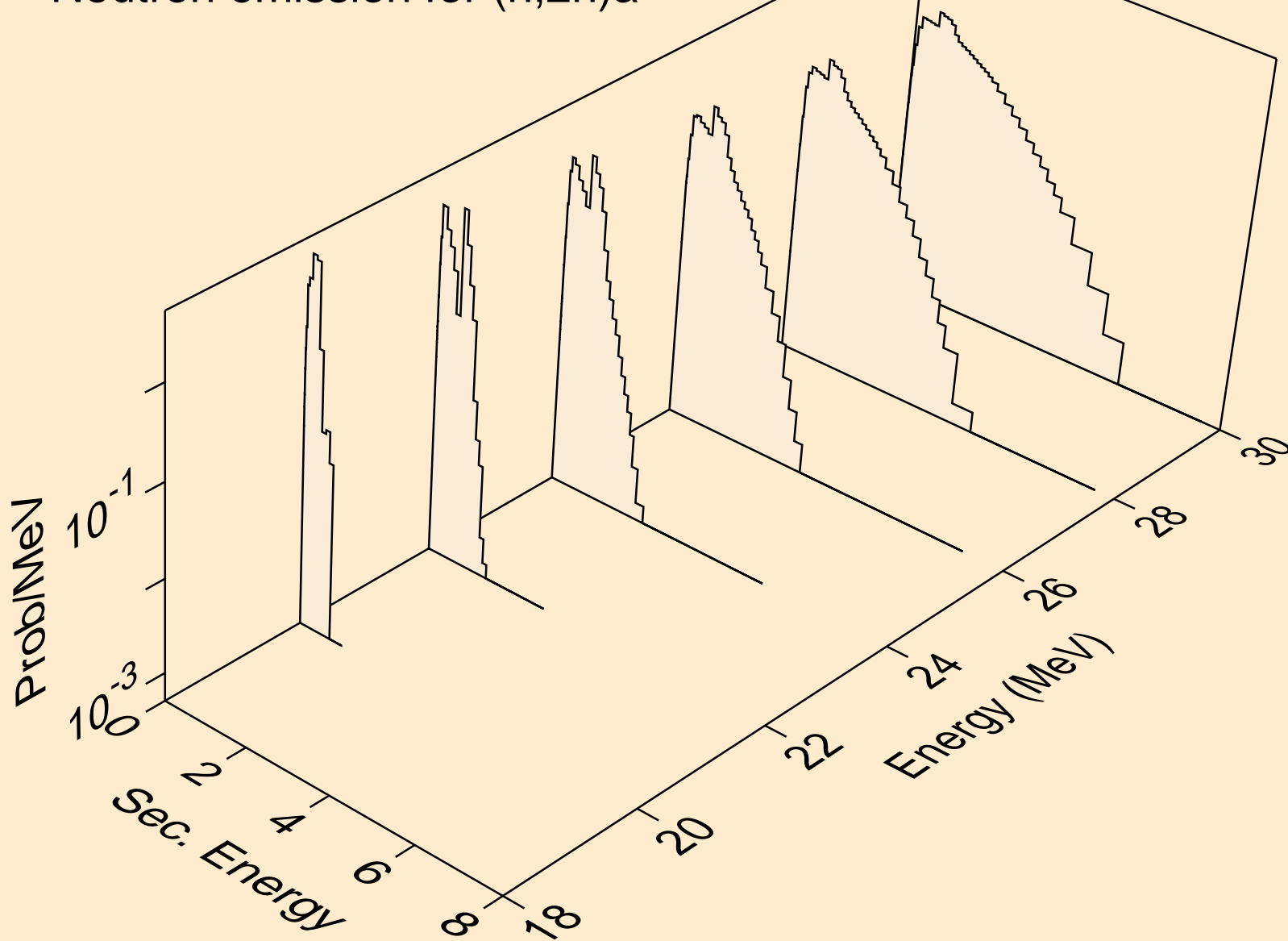

AR047 NEUTRON ACER TENDL-2019 LIBRARY; T=293.16K
Neutron emission for (n,3n)a

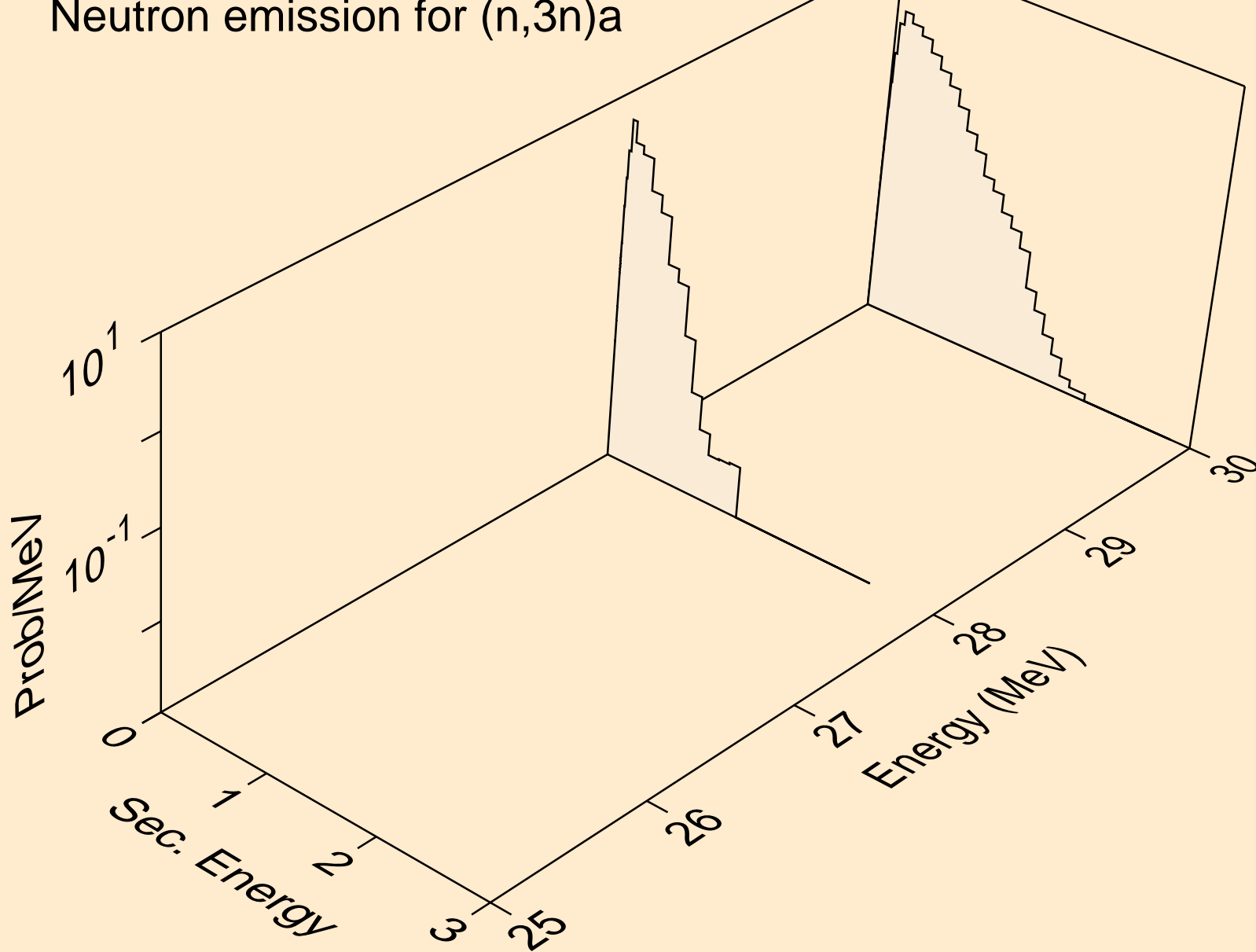

AR047 NEUTRON ACER TENDL-2019 LIBRARY; T=293.16K
Neutron emission for (n,n*)p

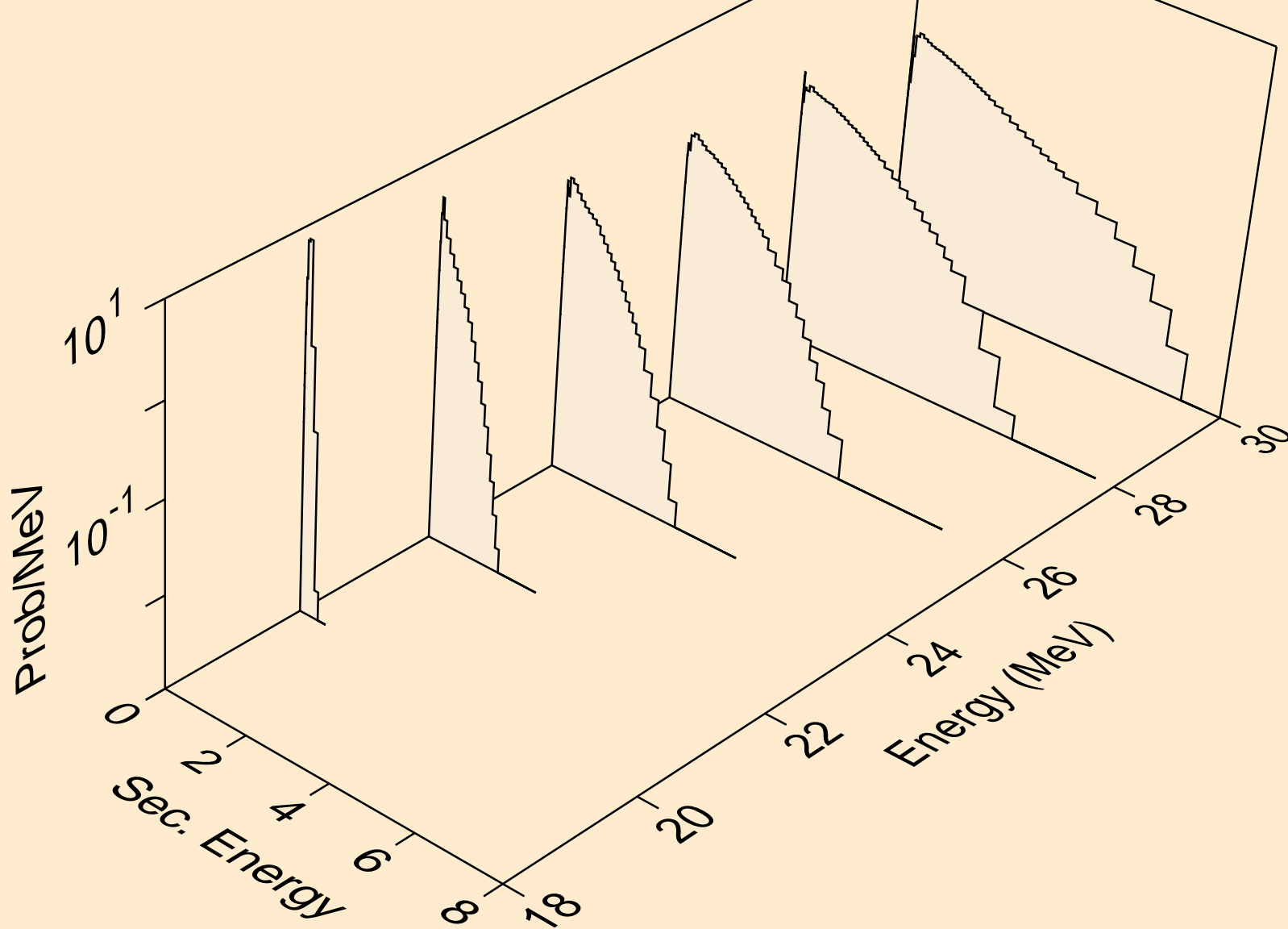

AR047 NEUTRON ACER TENDL-2019 LIBRARY; T=293.16K
Neutron emission for (n,n*)d

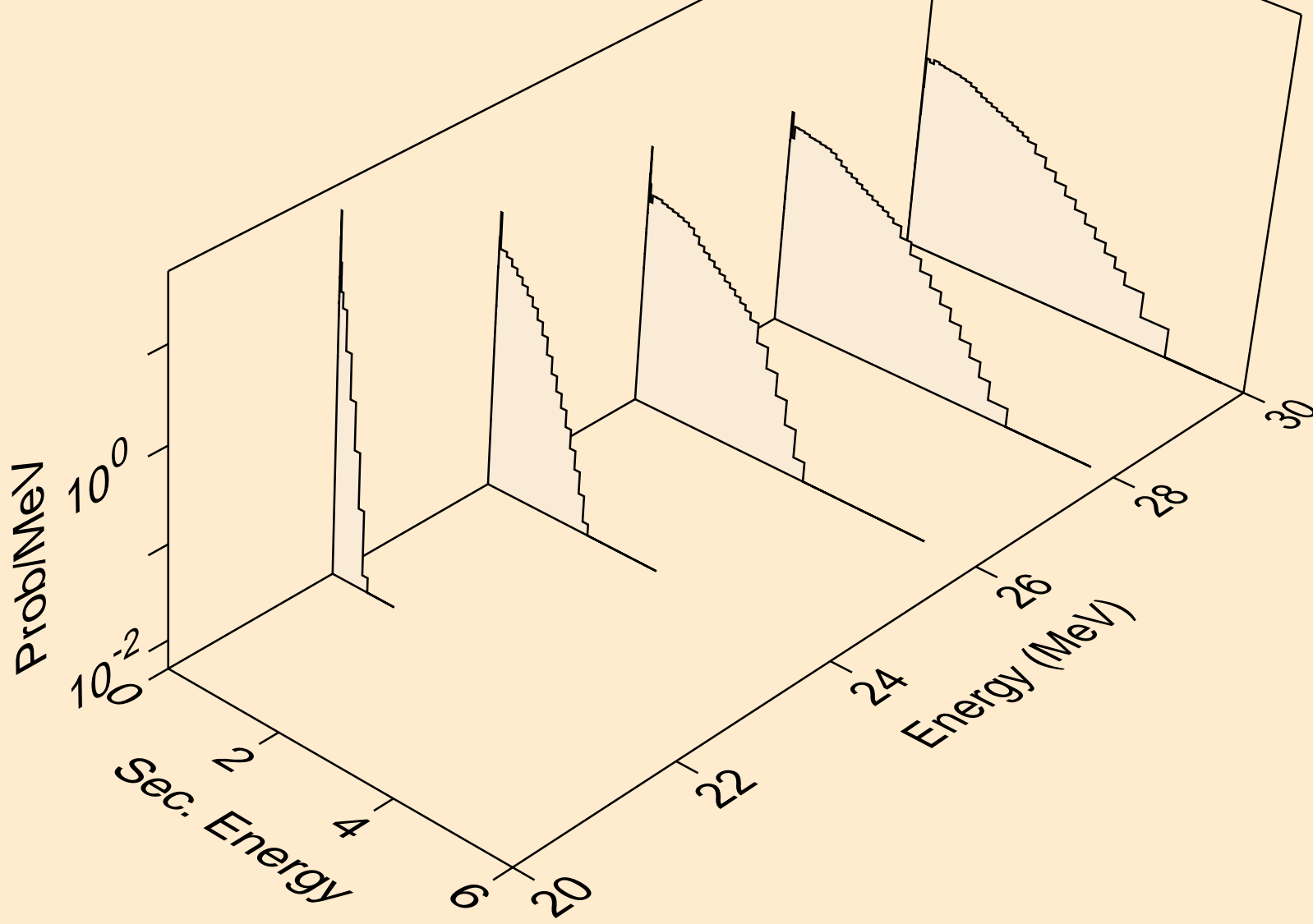

AR047 NEUTRON ACER TENDL-2019 LIBRARY; T=293.16K
Neutron emission for (n,n*)t

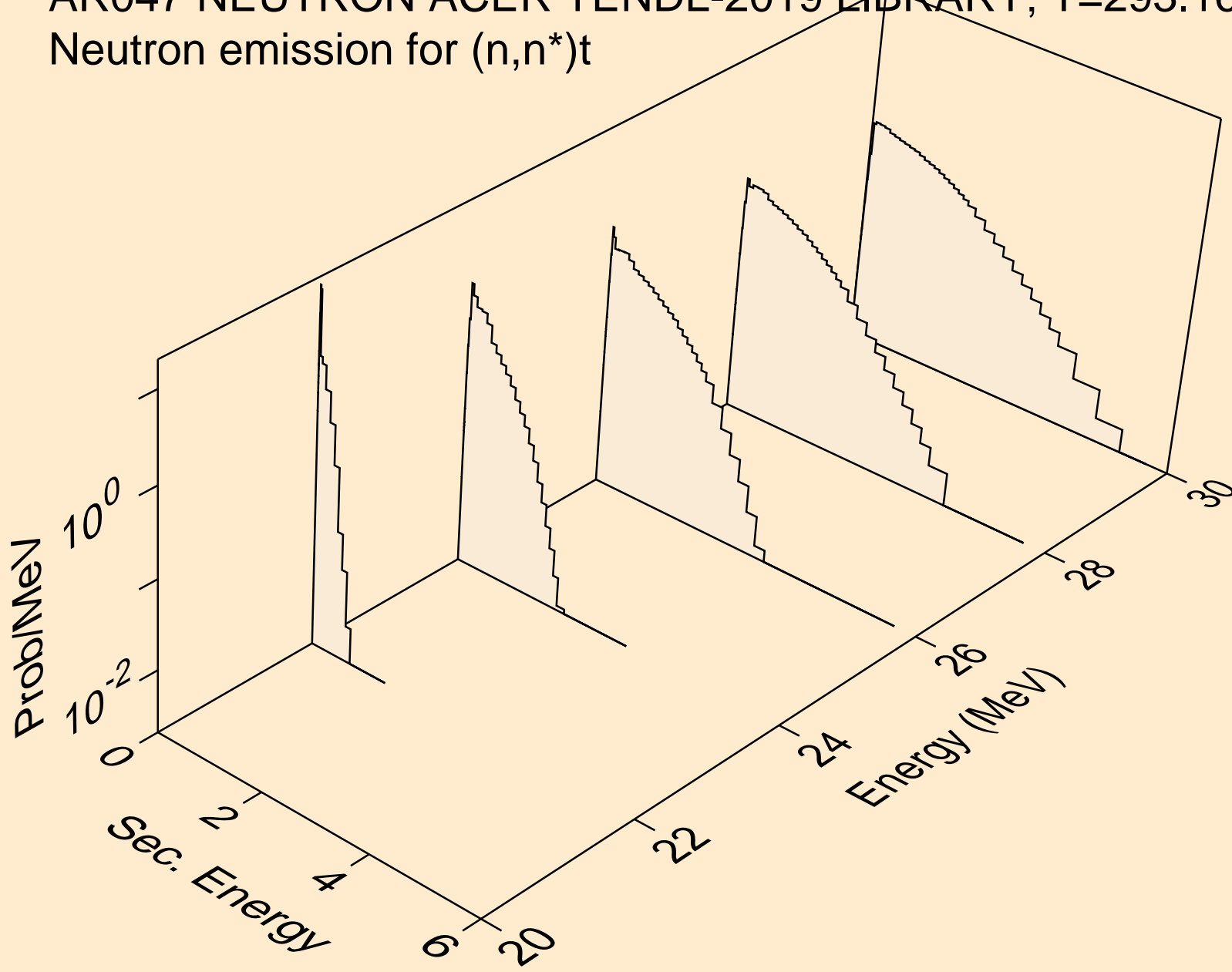

AR047 NEUTRON ACER TENDL-2019 LIBRARY; T=293.16K
Neutron emission for (n,4n)

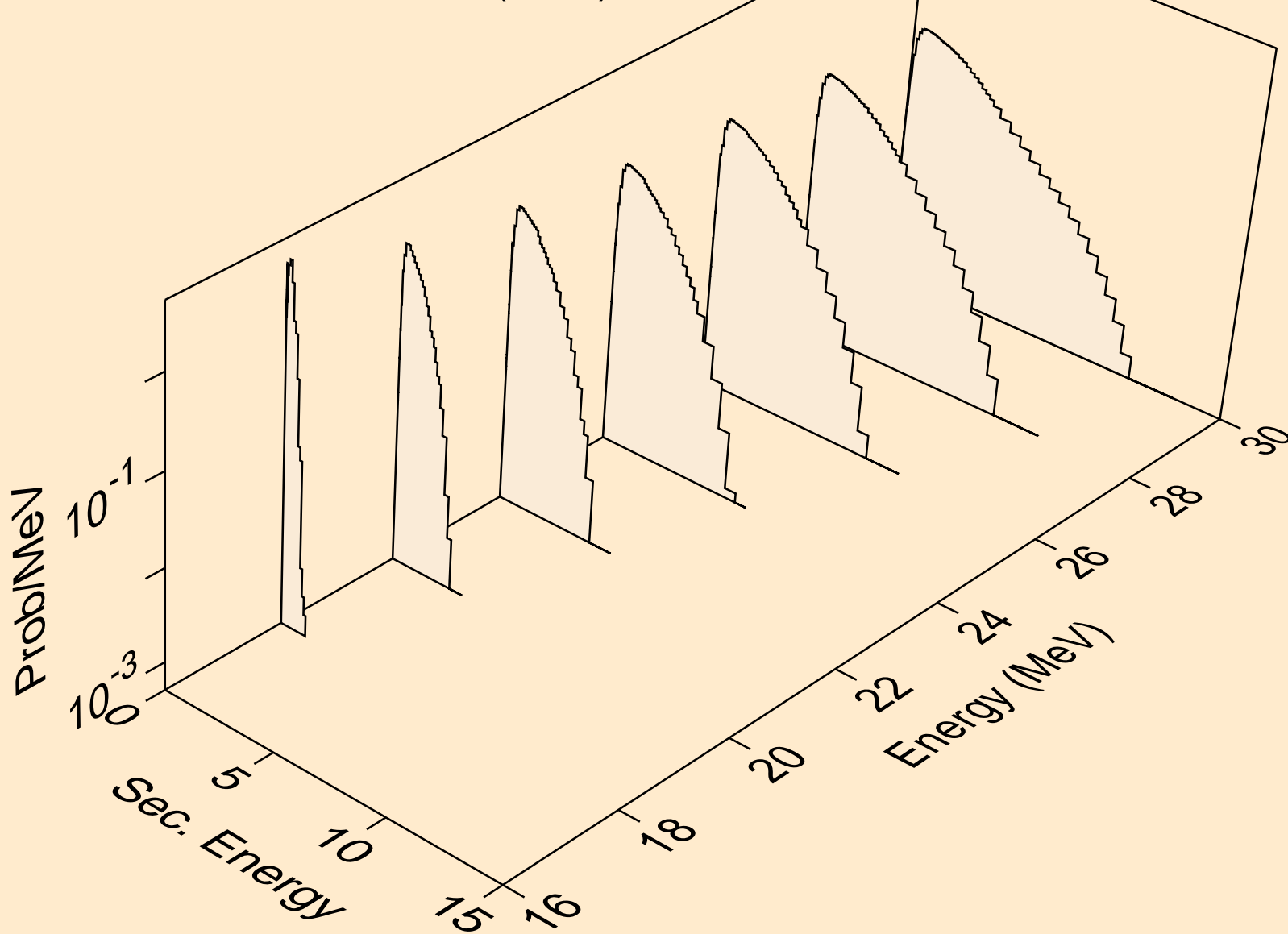

AR047 NEUTRON ACER TENDL-2019 LIBRARY; T=293.16K
Neutron emission for (n,2np)

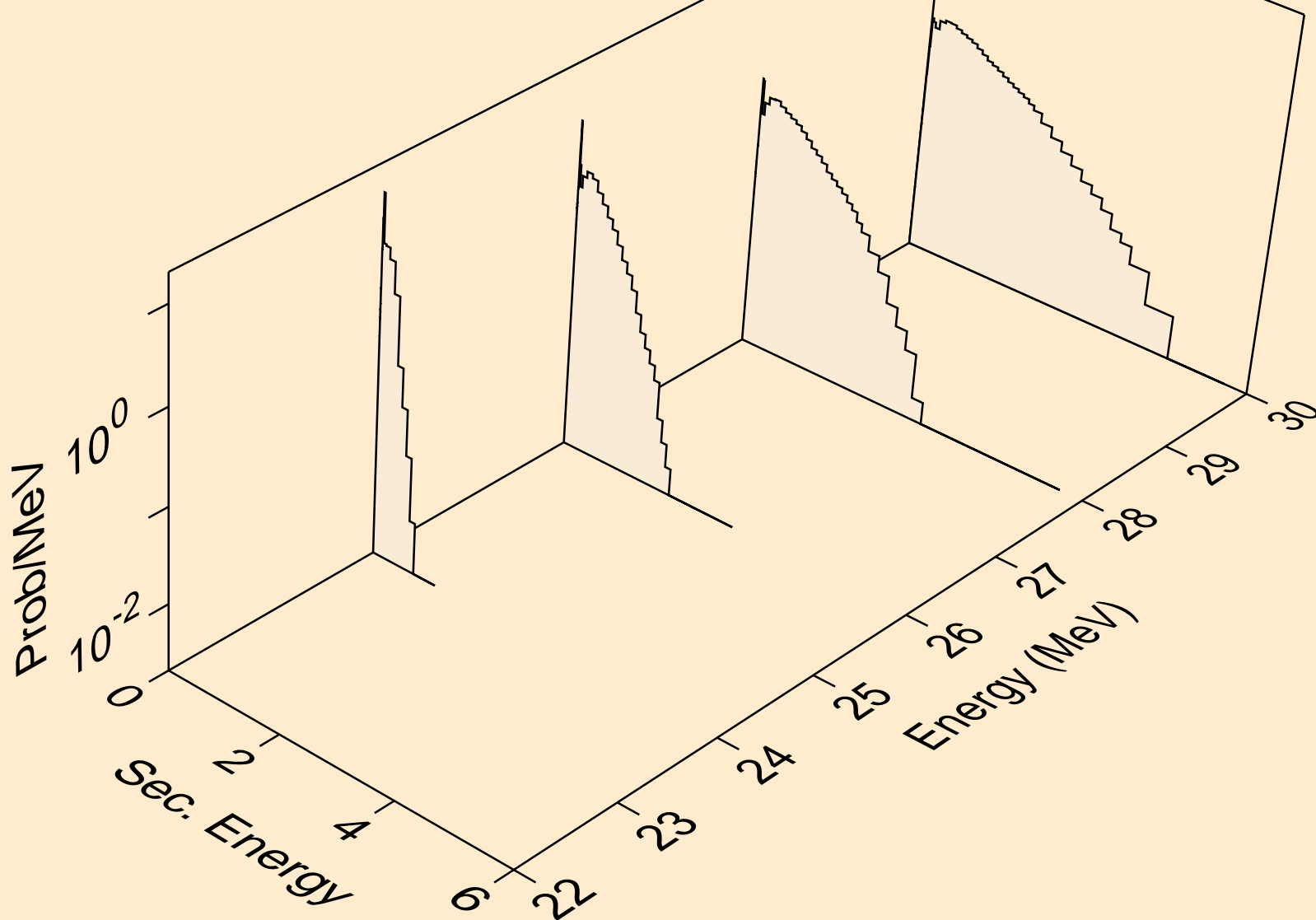

AR047 NEUTRON ACER TENDL-2019 LIBRARY; T=293.16K
Neutron emission for (n,n*c)

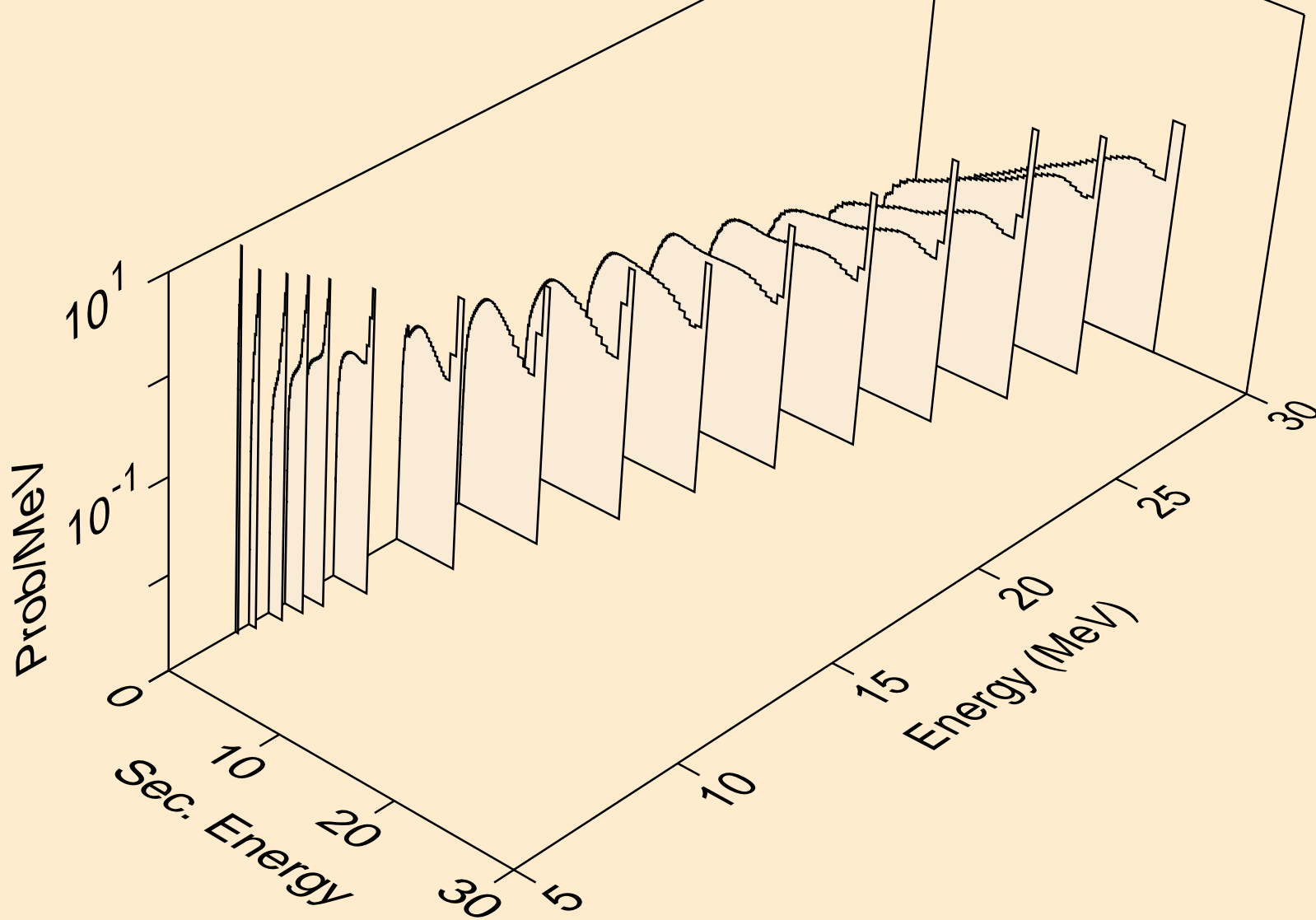

AR047 NEUTRON ACER TENDL-2019 LIBRARY; T=293.16K
Photon emission for (n,x)

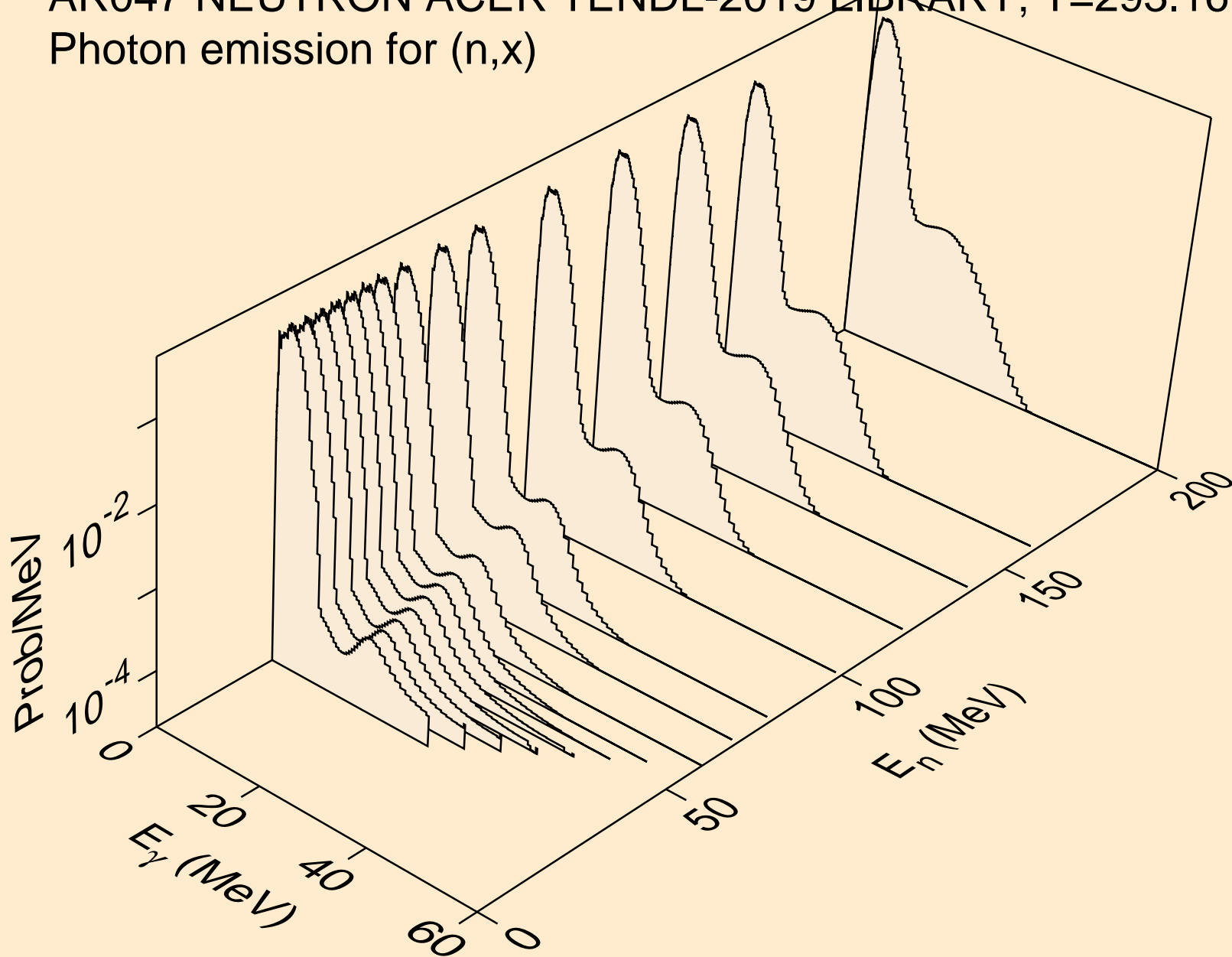

AR047 NEUTRON ACER TENDL-2019 LIBRARY; T=293.16K
Photon emission for (n,2nd)

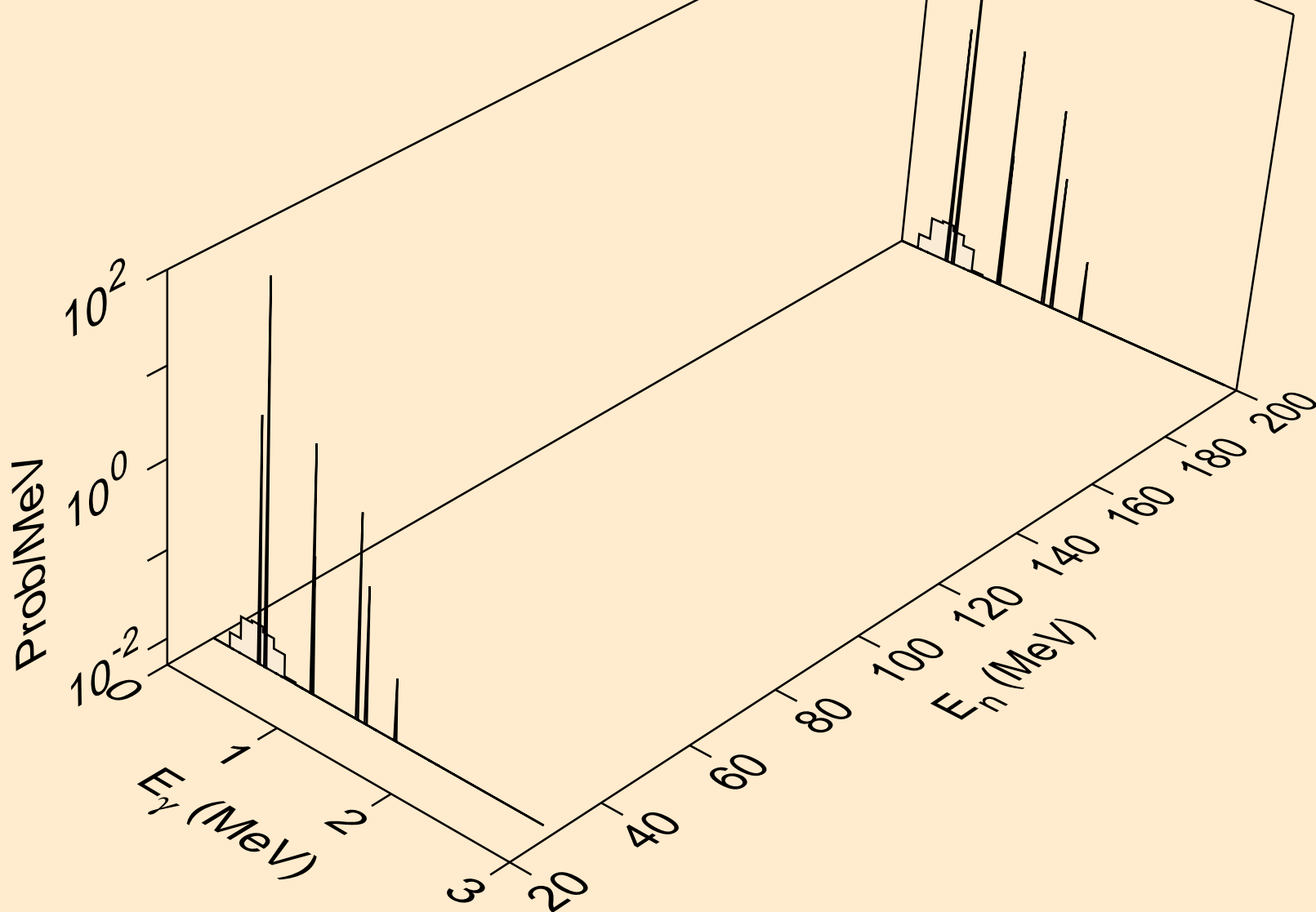

AR047 NEUTRON ACER TENDL-2019 LIBRARY; T=293.16K
Photon emission for (n,2n)

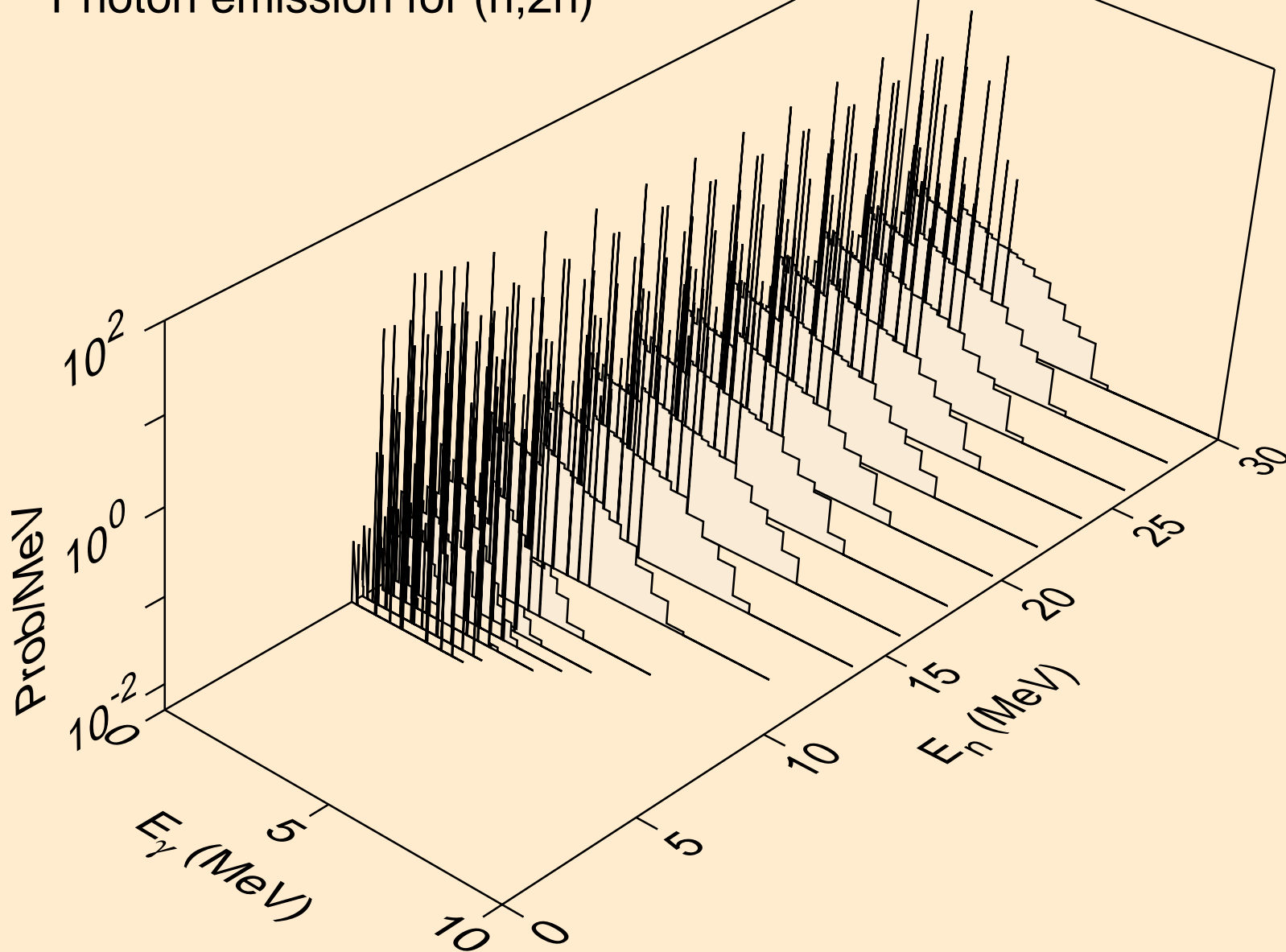

AR047 NEUTRON ACER TENDL-2019 LIBRARY; T=293.16K
Photon emission for (n,3n)

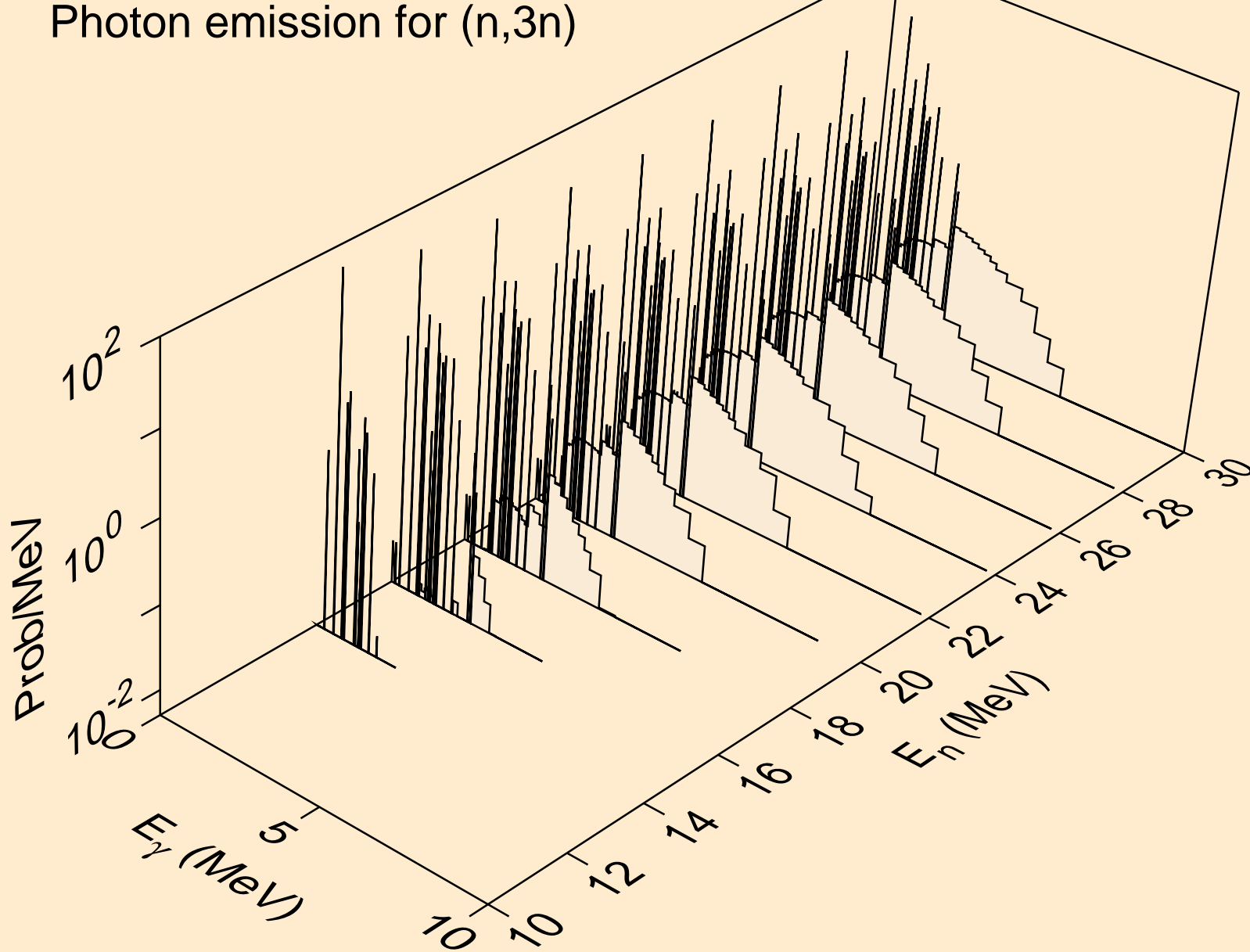

AR047 NEUTRON ACER TENDL-2019 LIBRARY; T=293.16K
Photon emission for (n,n*)a

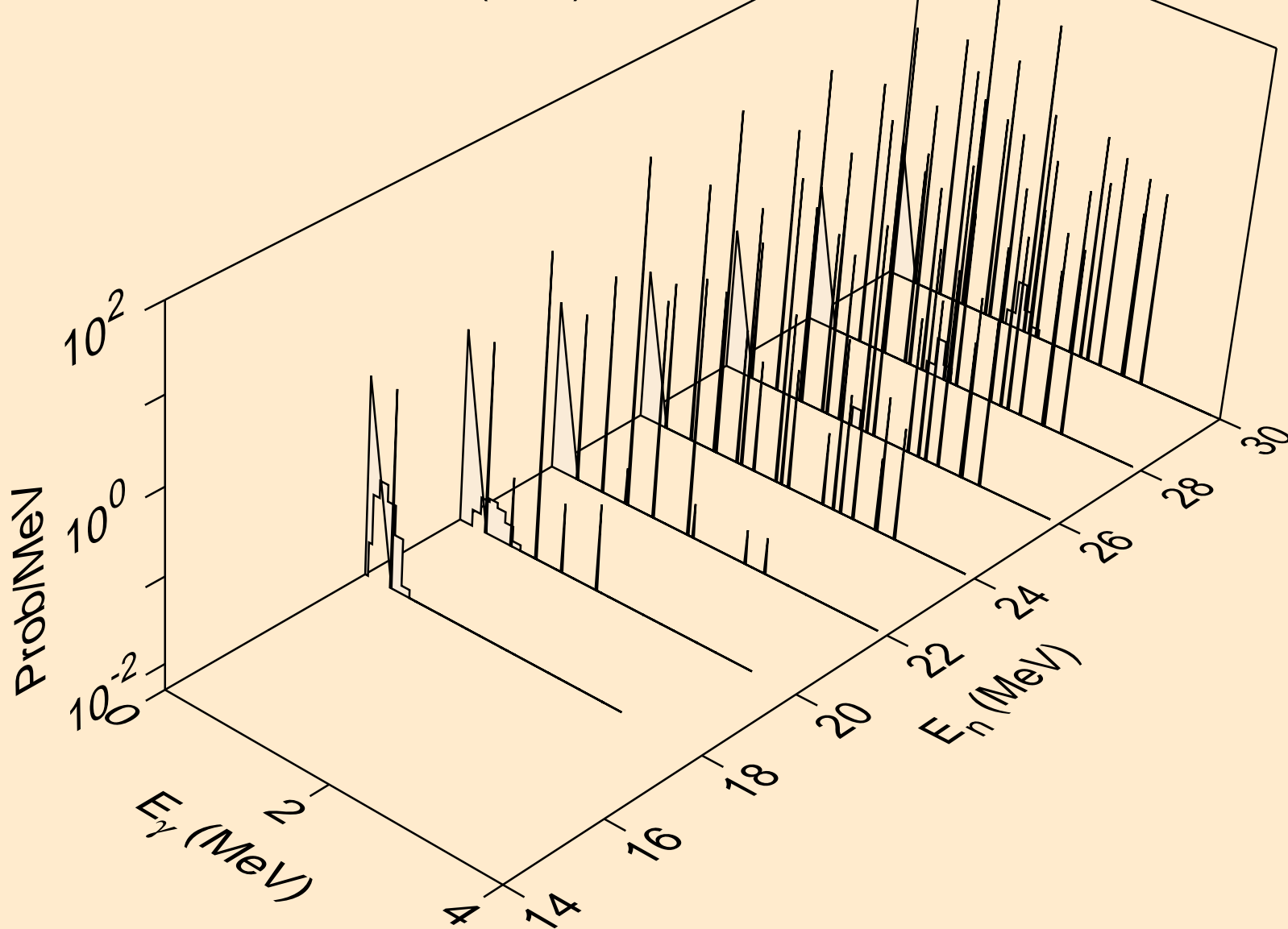

AR047 NEUTRON ACER TENDL-2019 LIBRARY; T=293.16K
Photon emission for (n,2n)a

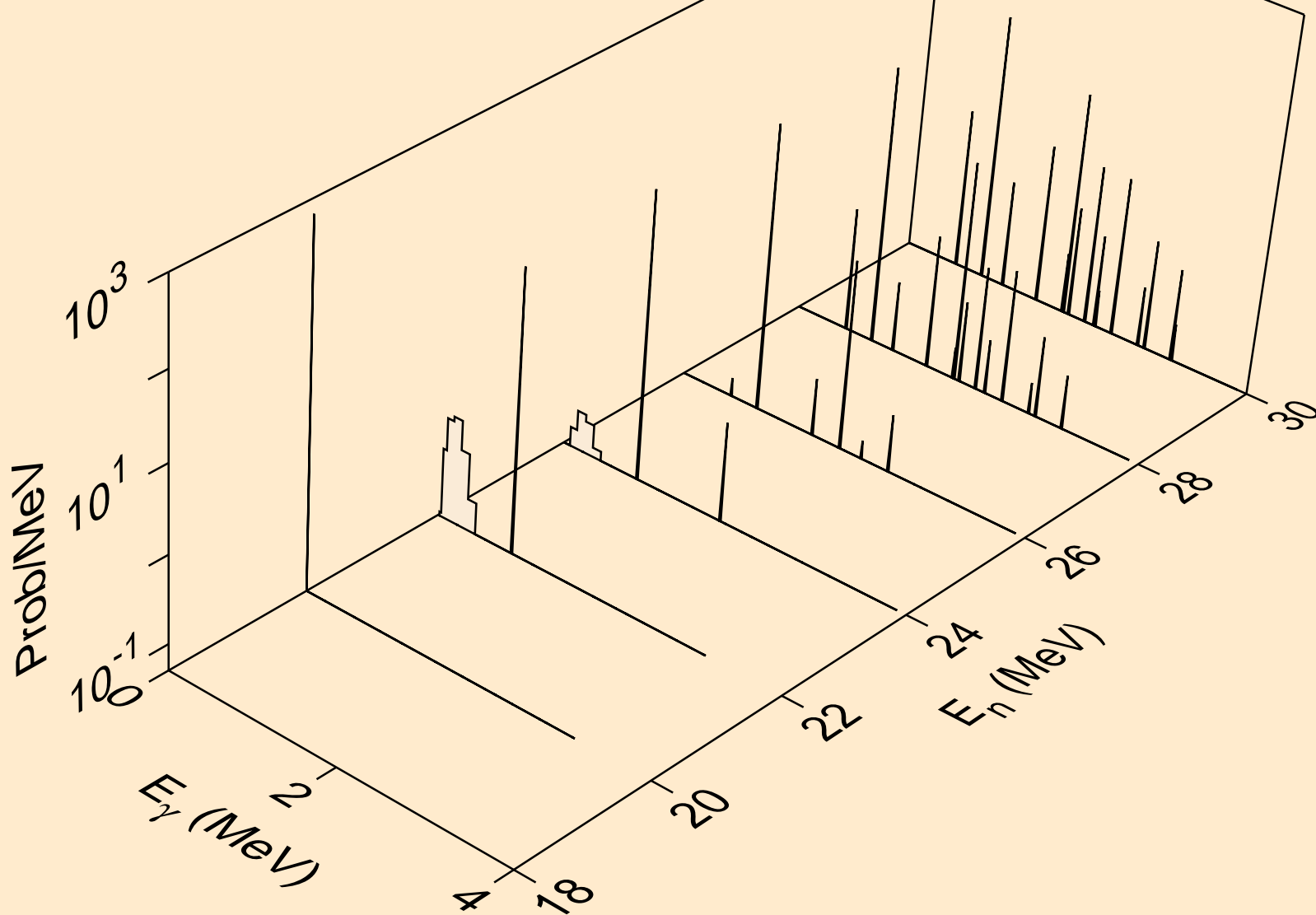

AR047 NEUTRON ACER TENDL-2019 LIBRARY; T=293.16K
Photon emission for (n,3n)a

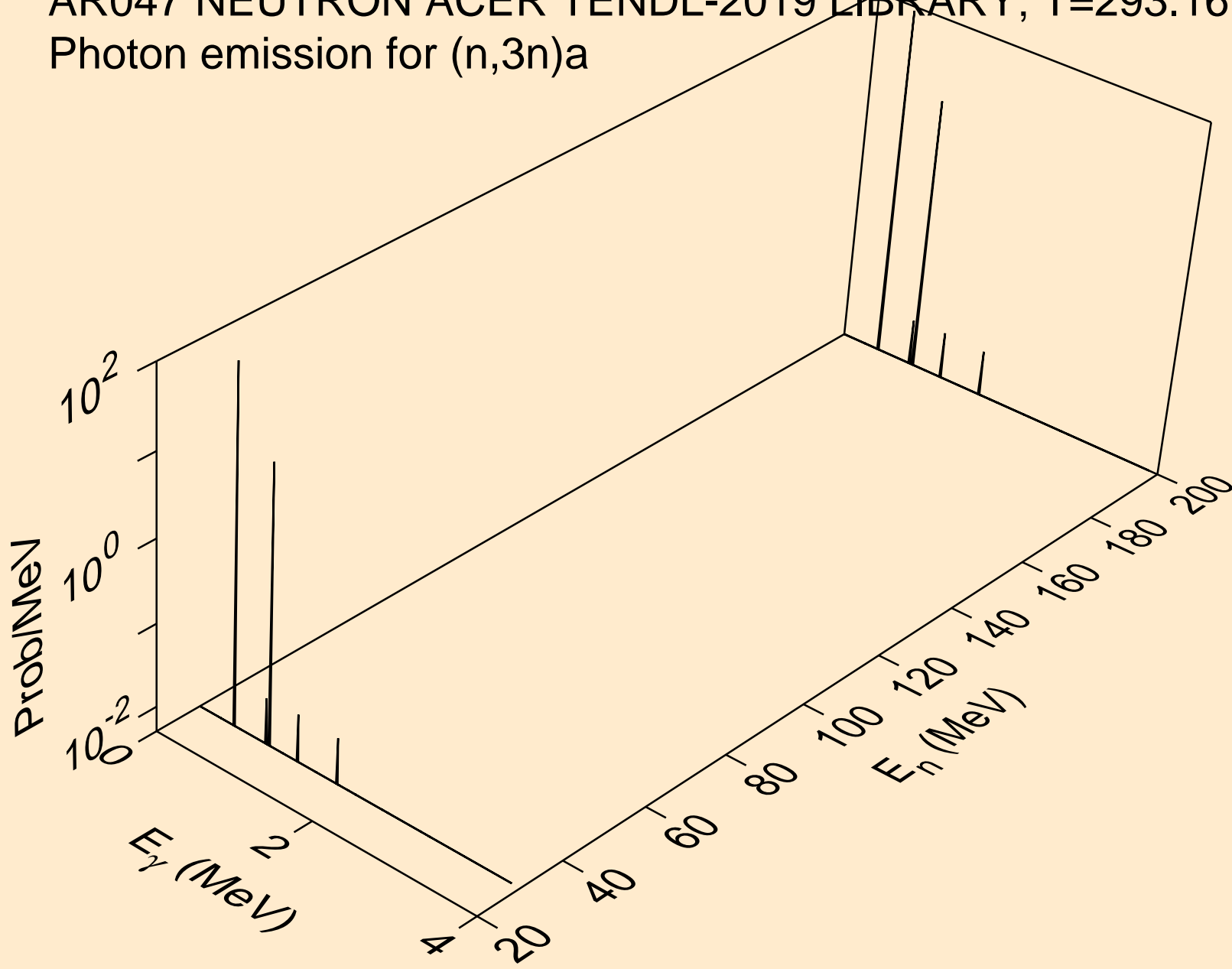

AR047 NEUTRON ACER TENDL-2019 LIBRARY; T=293.16K
Photon emission for (n,n*)p

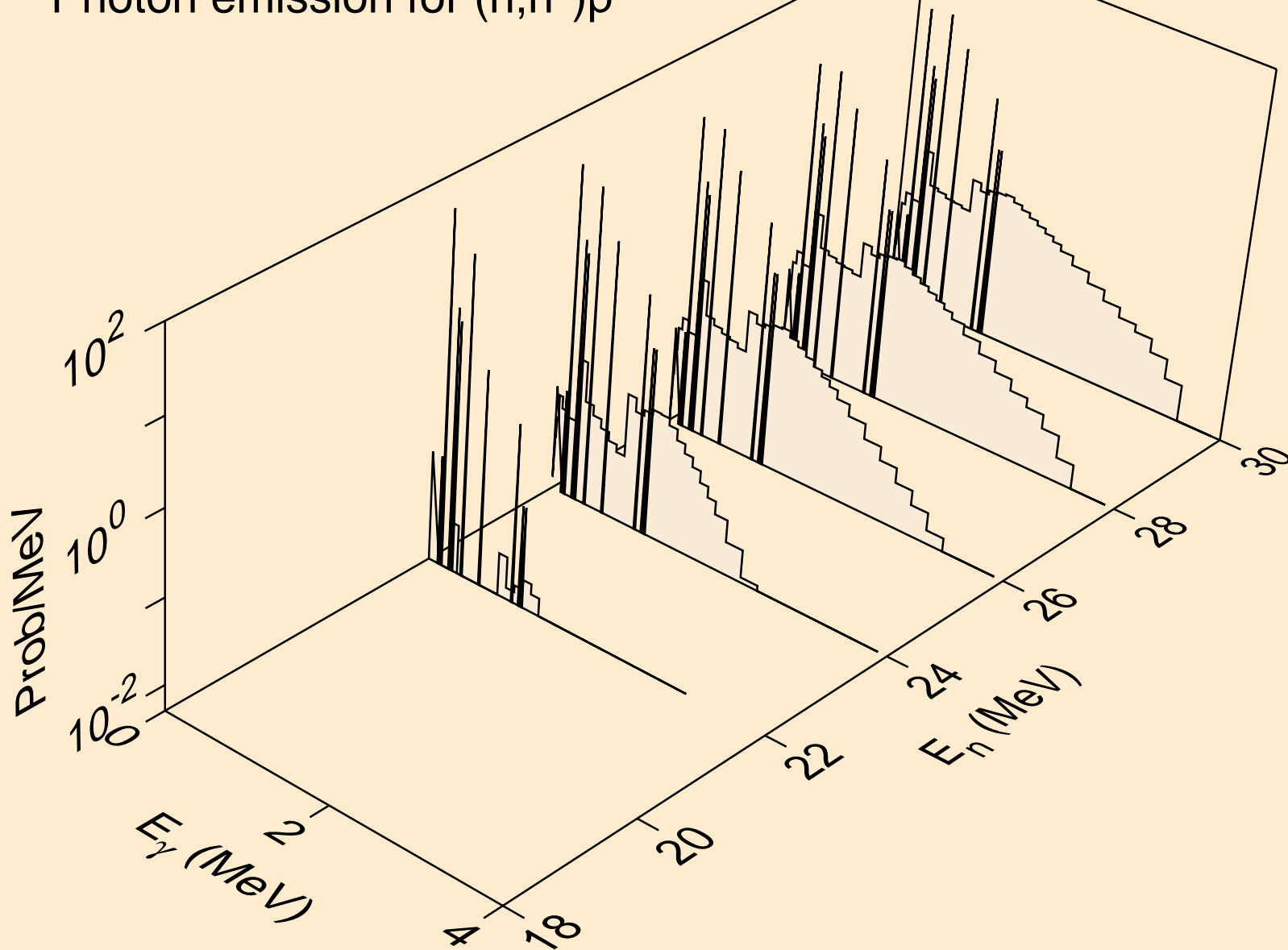

AR047 NEUTRON ACER TENDL-2019 LIBRARY; T=293.16K
Photon emission for (n,n*)d

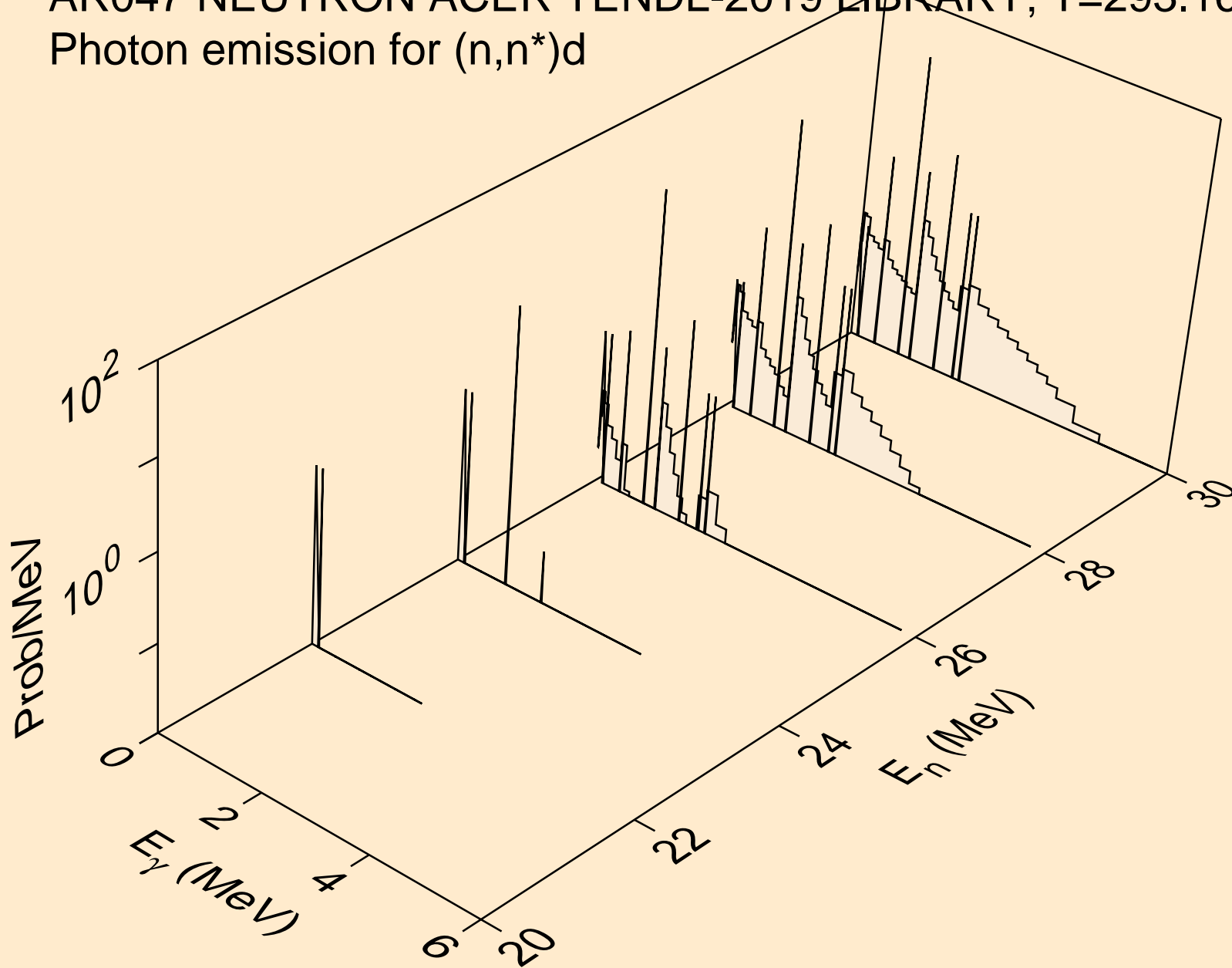

AR047 NEUTRON ACER TENDL-2019 LIBRARY; T=293.16K
Photon emission for (n,n*)t

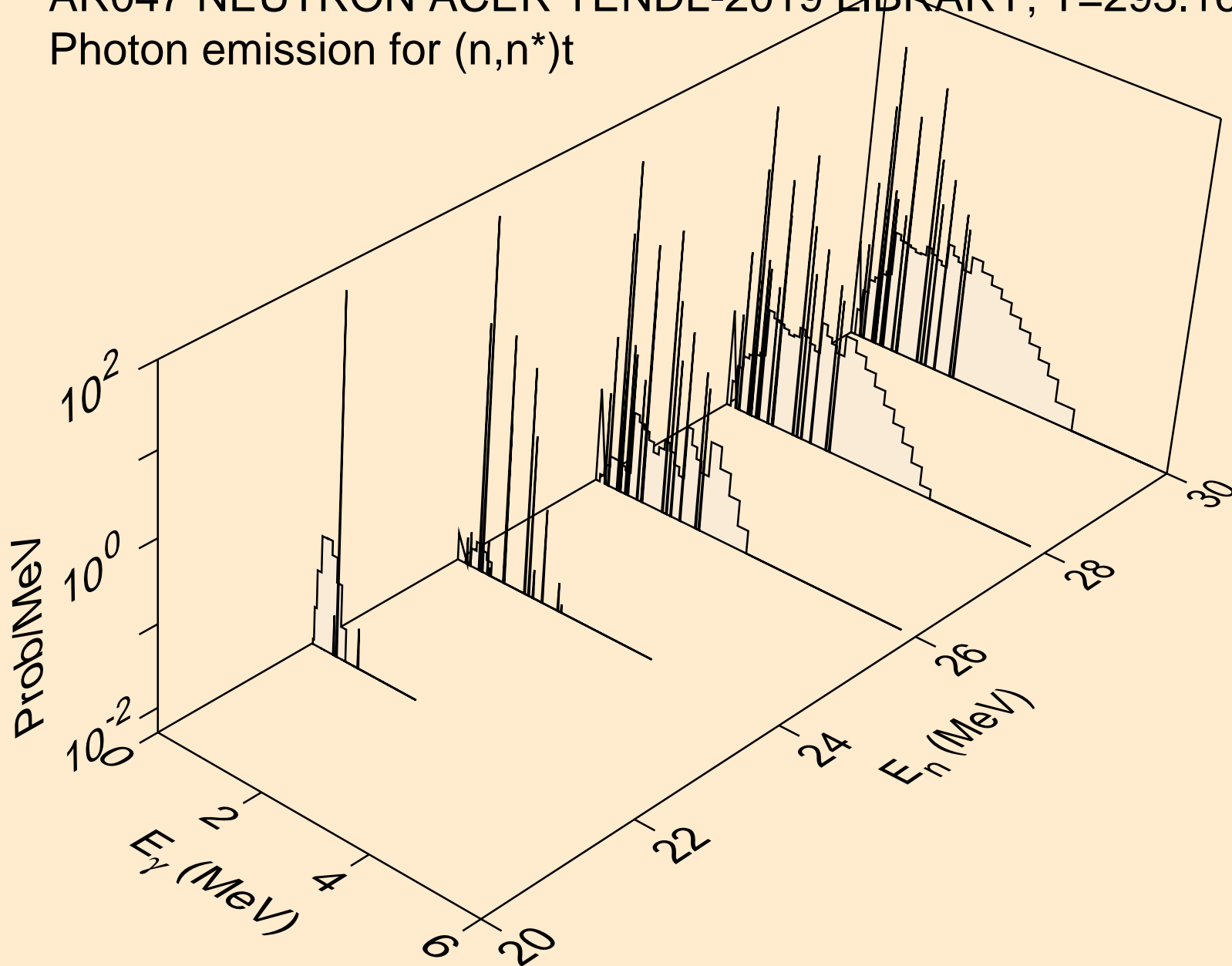

AR047 NEUTRON ACER TENDL-2019 LIBRARY; T=293.16K
Photon emission for (n,4n)

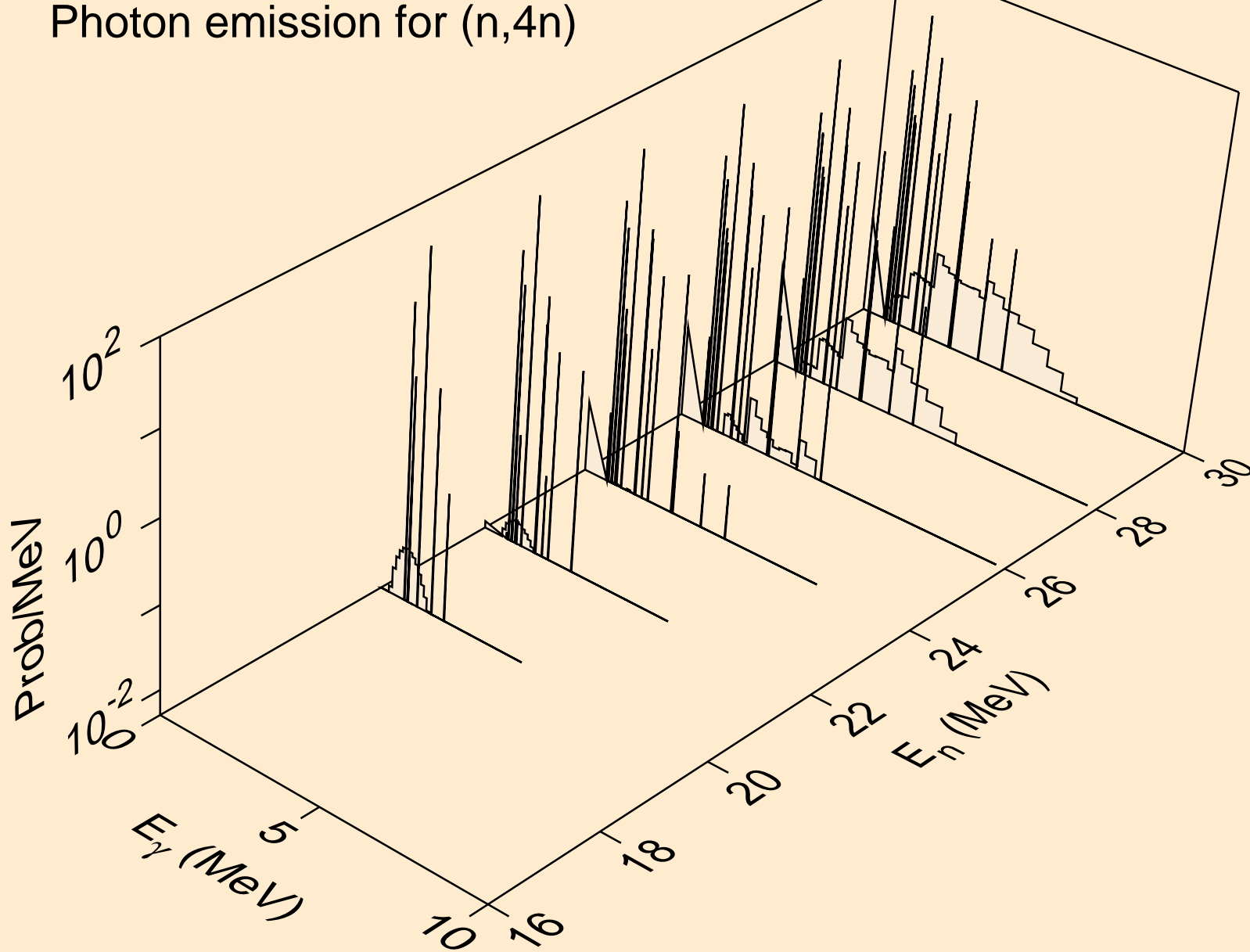

AR047 NEUTRON ACER TENDL-2019 LIBRARY; T=293.16K
Photon emission for (n,2np)

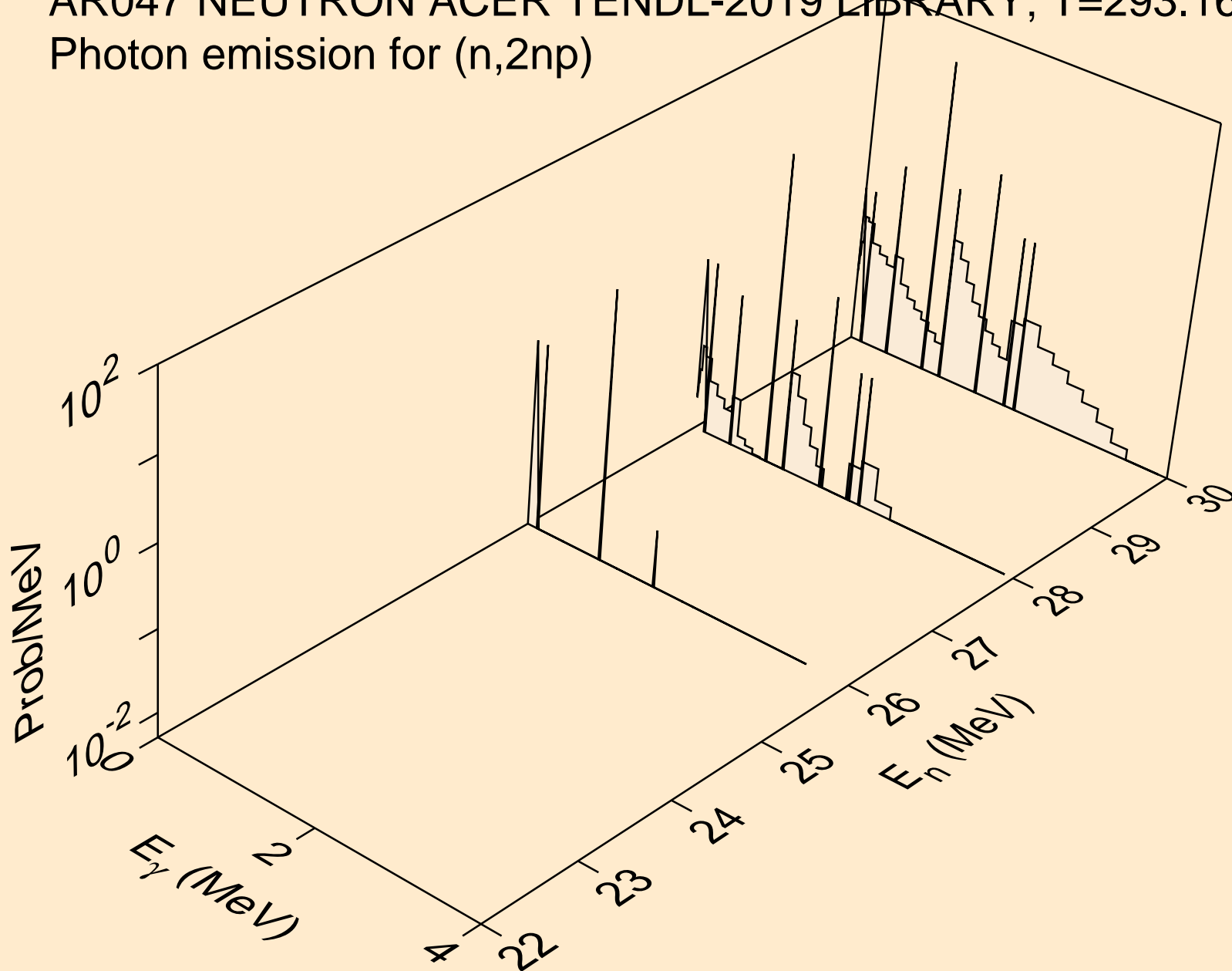

AR047 NEUTRON ACER TENDL-2019 LIBRARY; T=293.16K
Photon emission for (n,n*c)

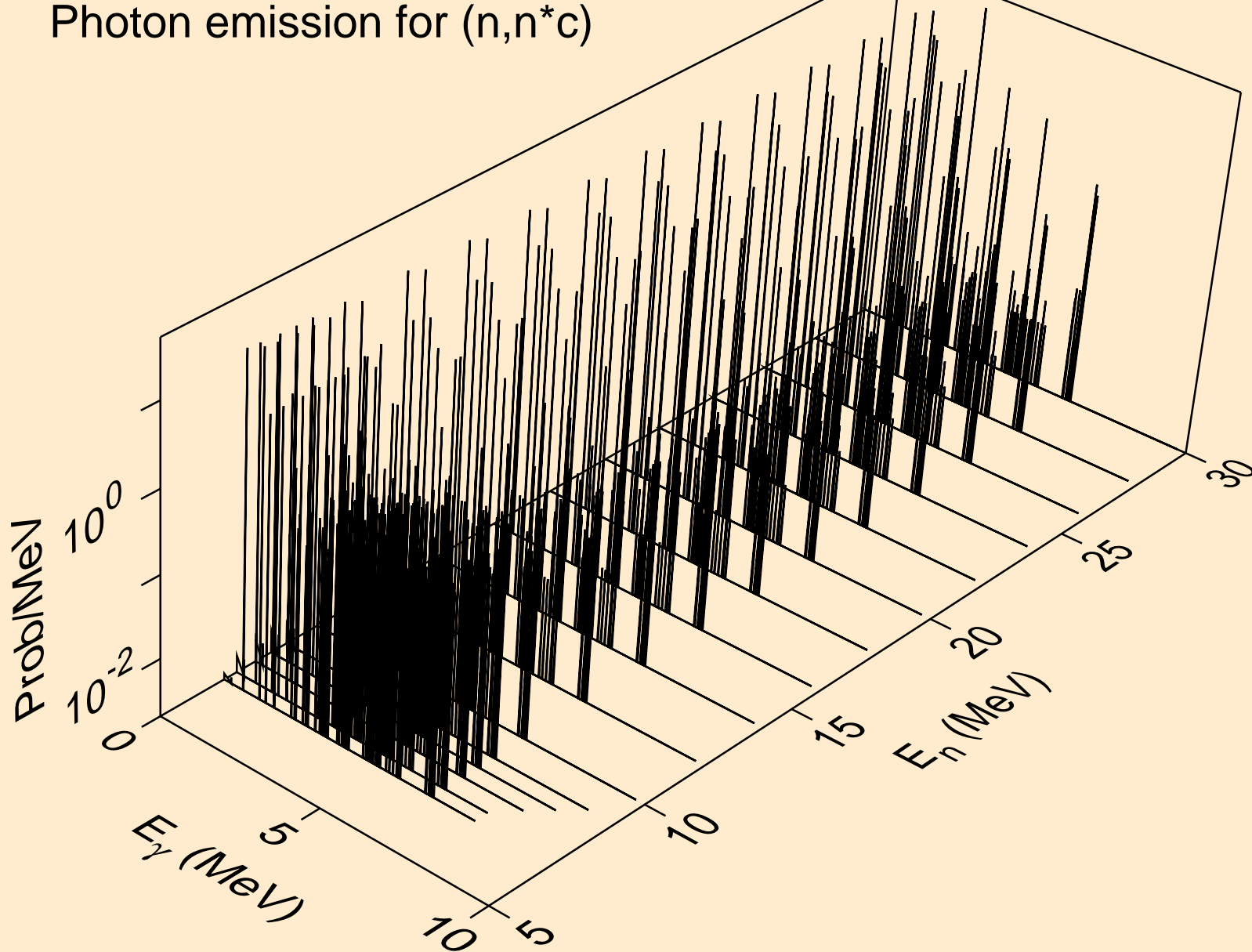

AR047 NEUTRON ACER TENDL-2019 LIBRARY; T=293.16K
Photon emission for (n,gma)

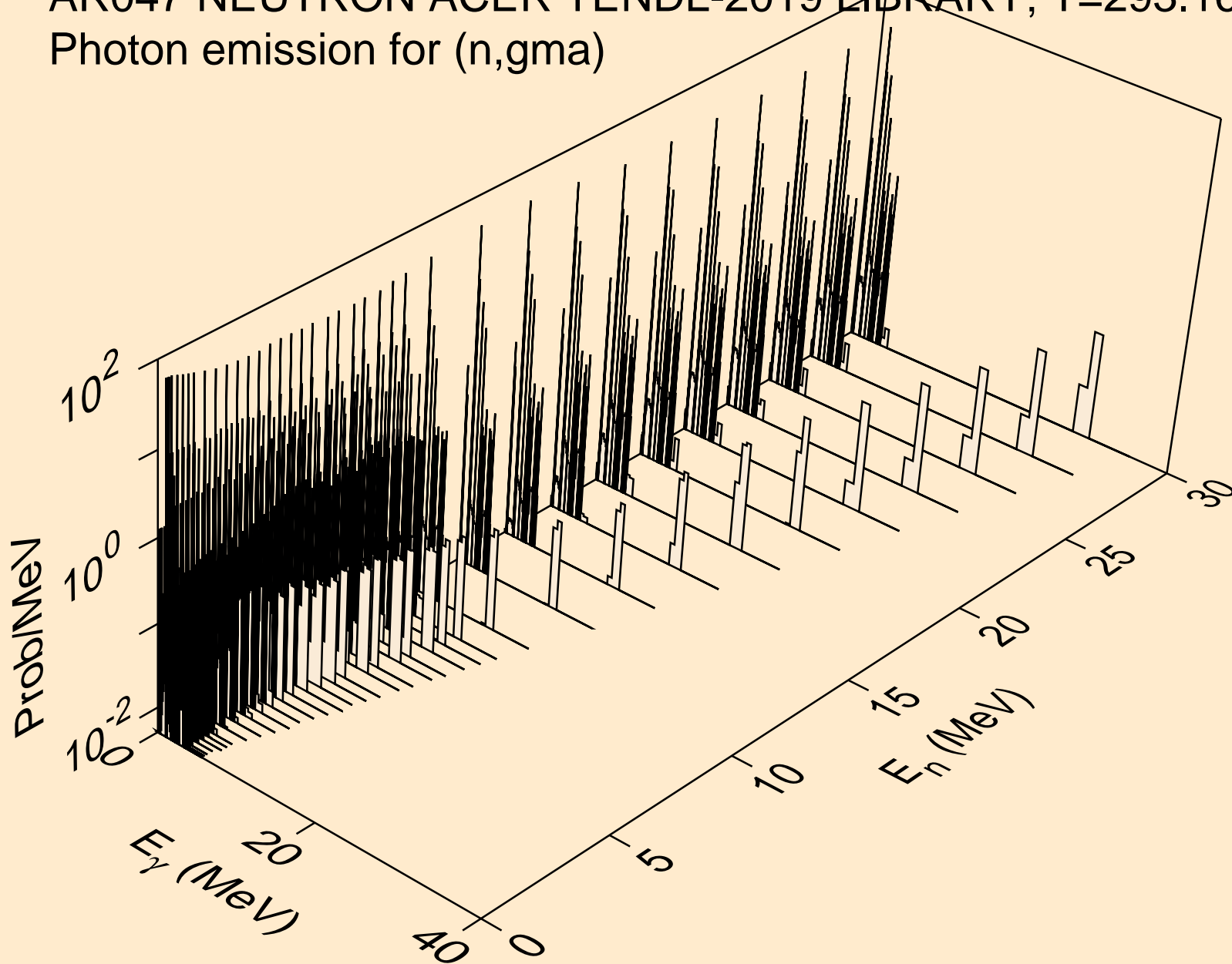

AR047 NEUTRON ACER TENDL-2019 LIBRARY; T=293.16K
Photon emission for (n,p)

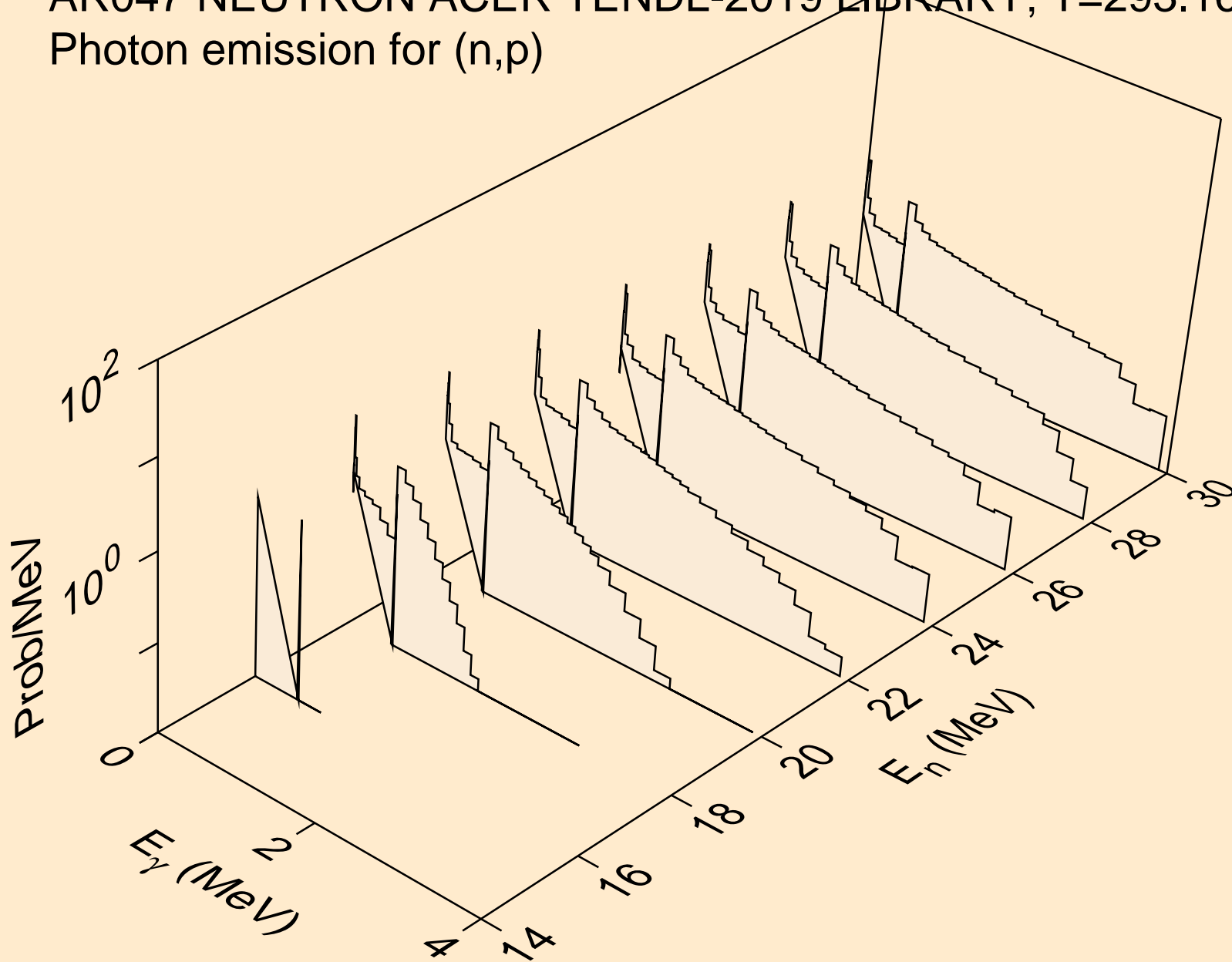

AR047 NEUTRON ACER TENDL-2019 LIBRARY; T=293.16K
Photon emission for (n,d)

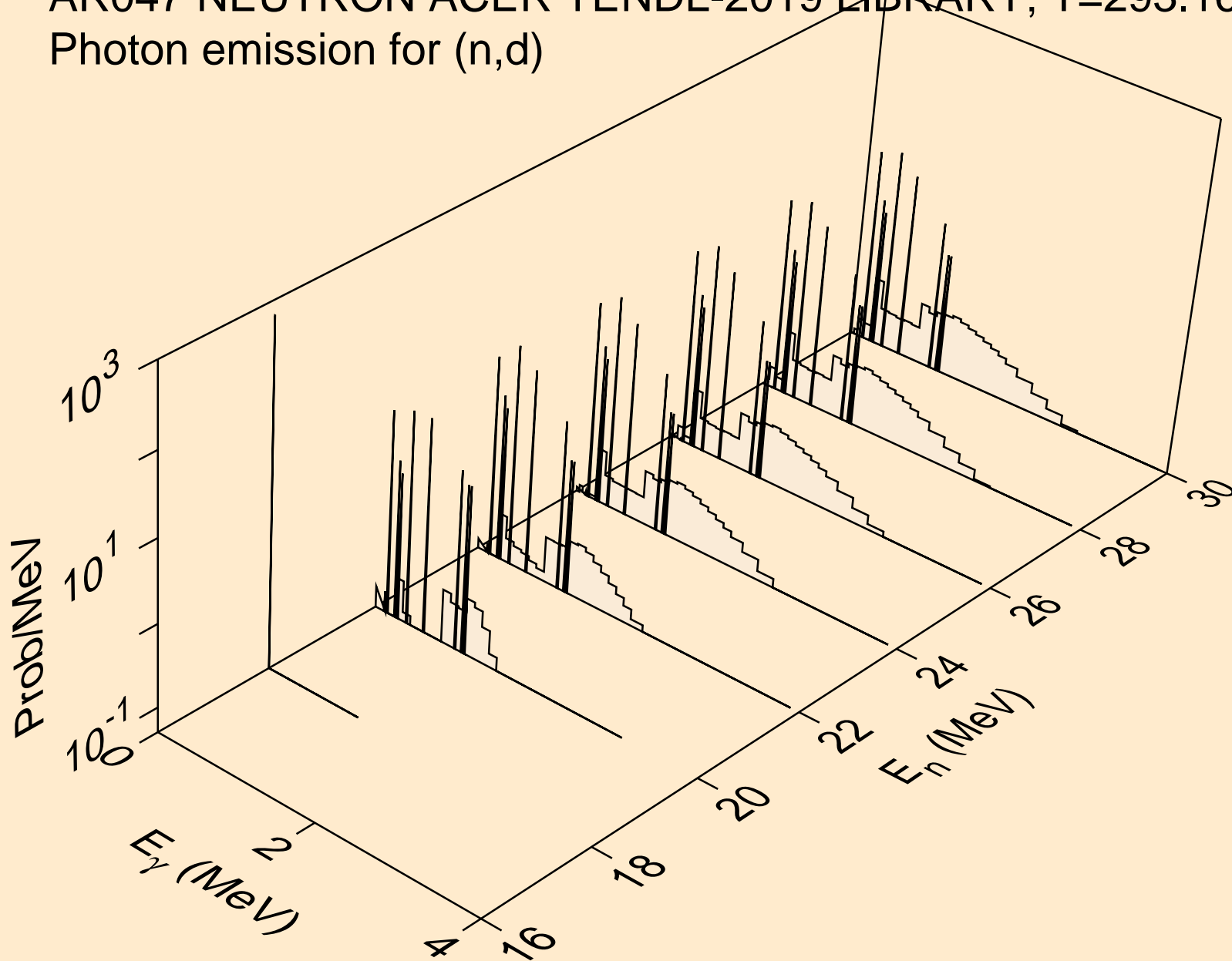

AR047 NEUTRON ACER TENDL-2019 LIBRARY; T=293.16K
Photon emission for (n,t)

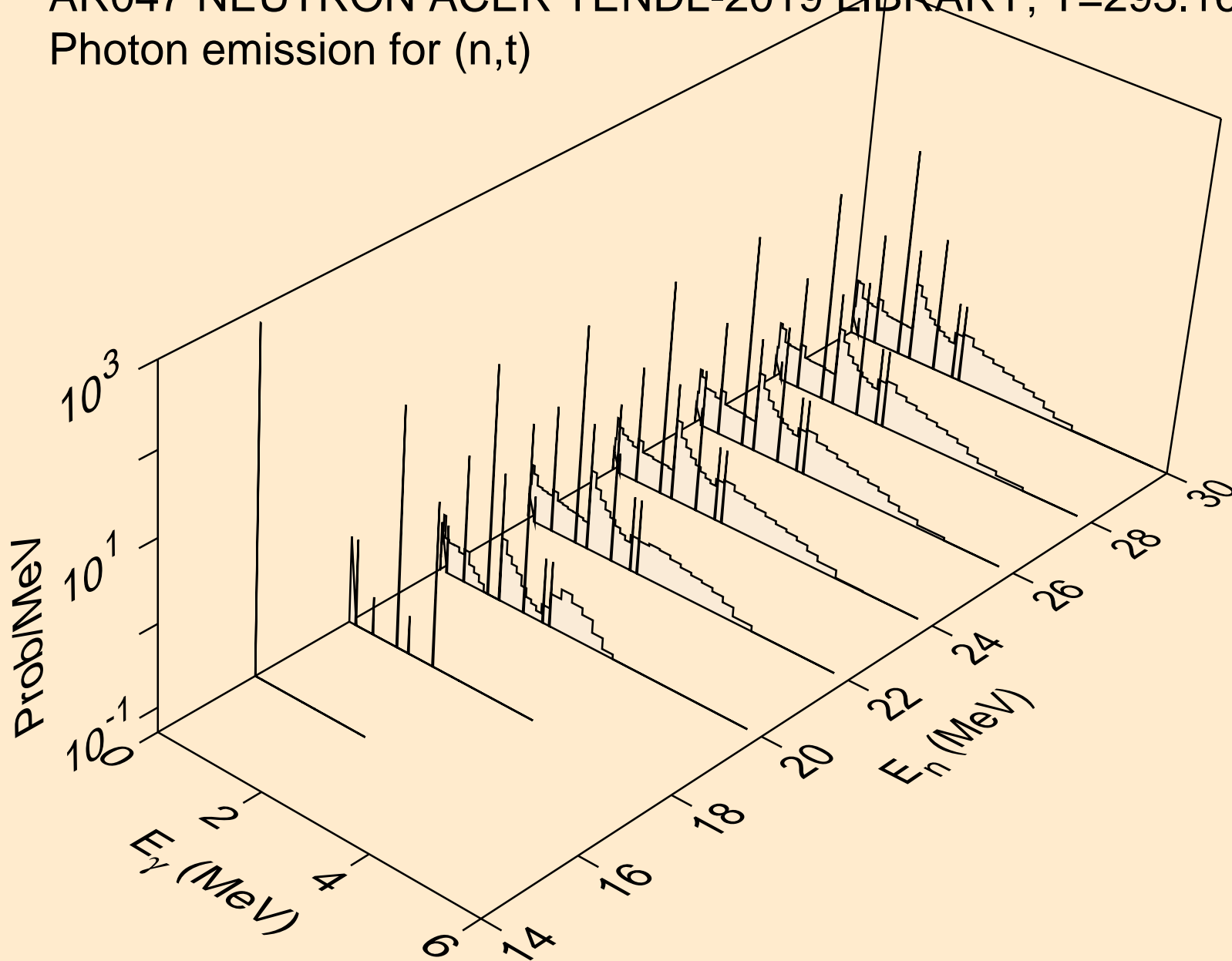

AR047 NEUTRON ACER TENDL-2019 LIBRARY; T=293.16K
Photon emission for (n,a)

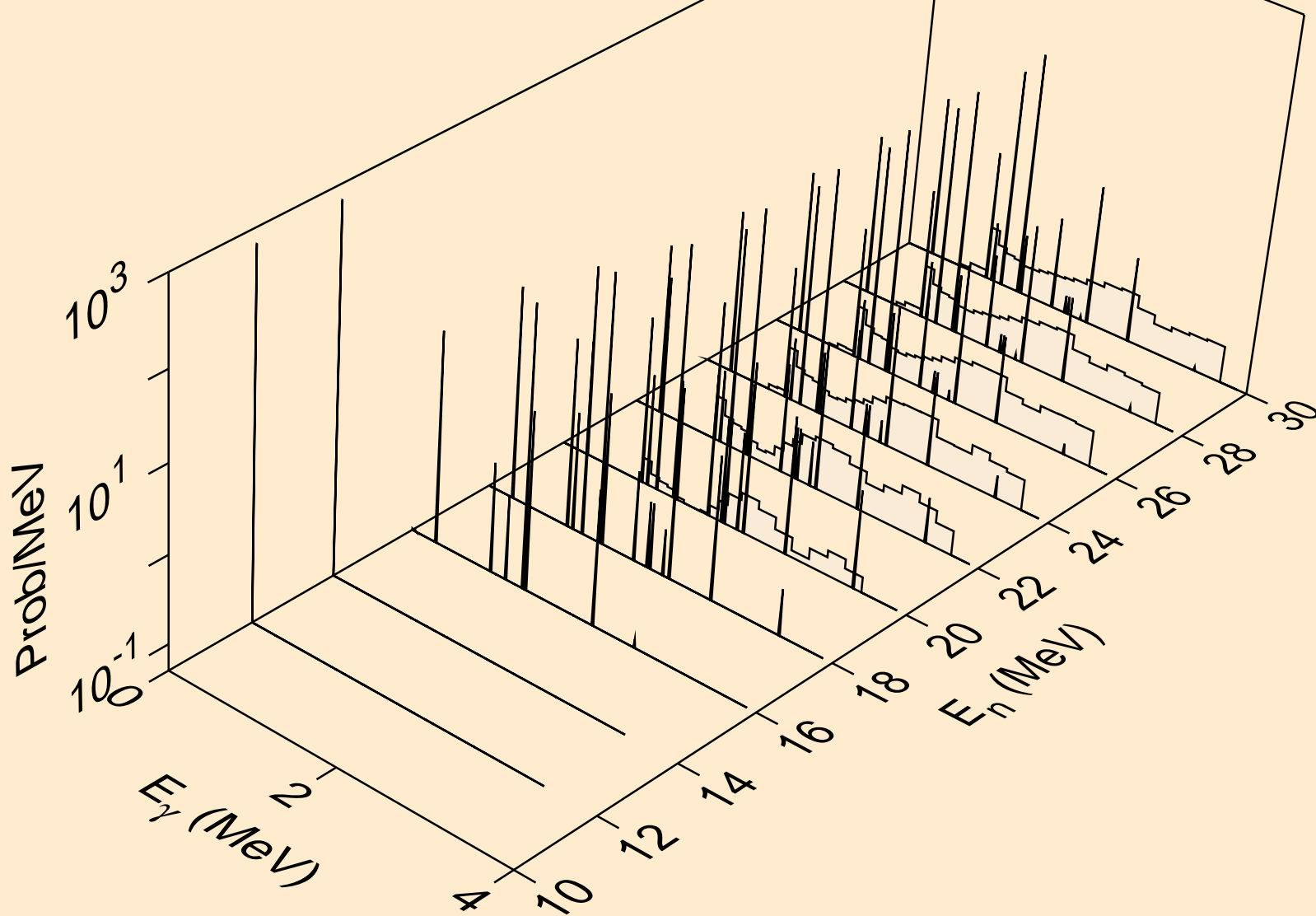

AR047 NEUTRON ACER TENDL-2019 LIBRARY; T=293.16K
thermal capture photon spectrum

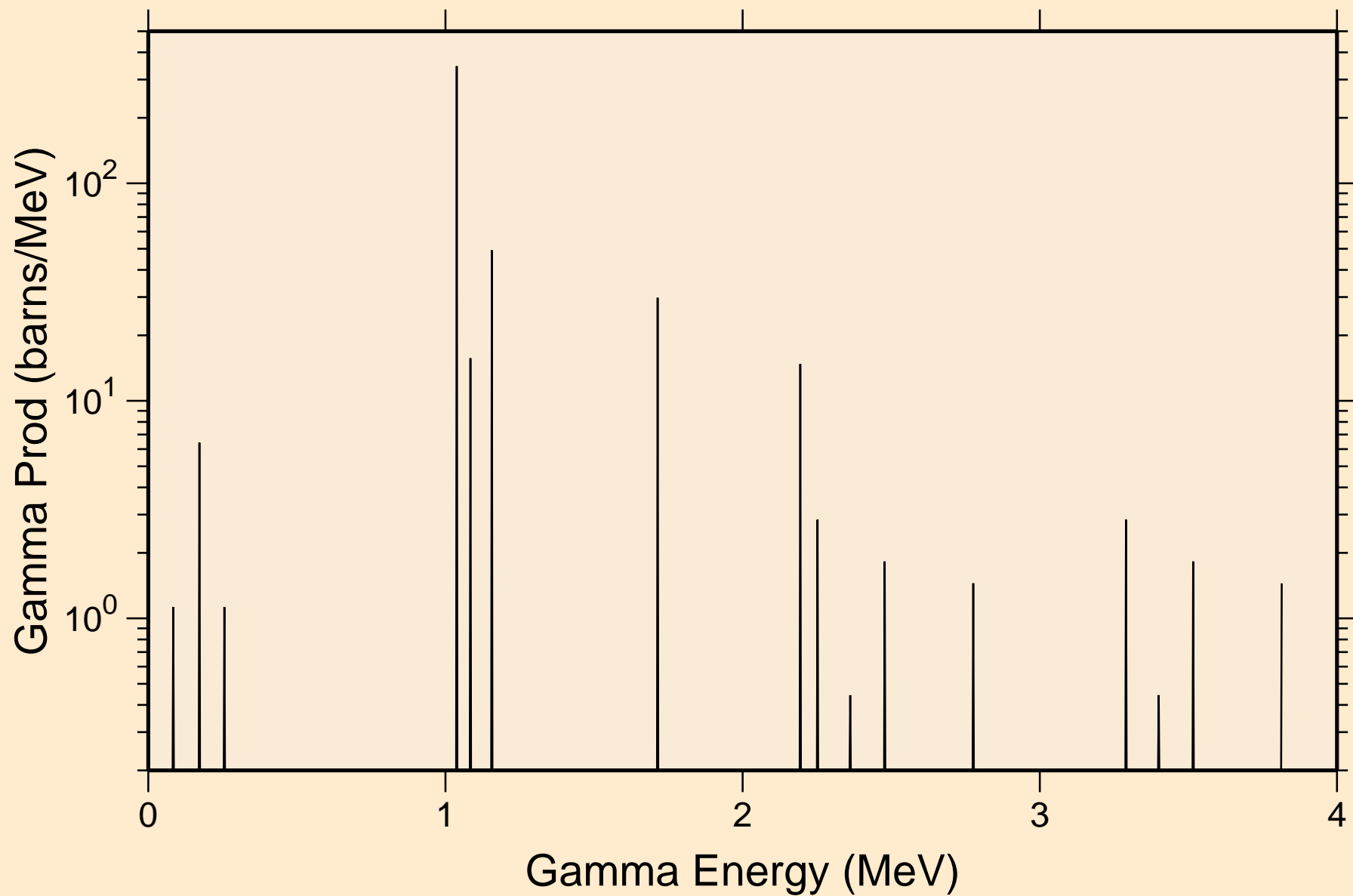

AR047 NEUTRON ACER TENDL-2019 LIBRARY; T=293.16K
14 MeV photon spectrum

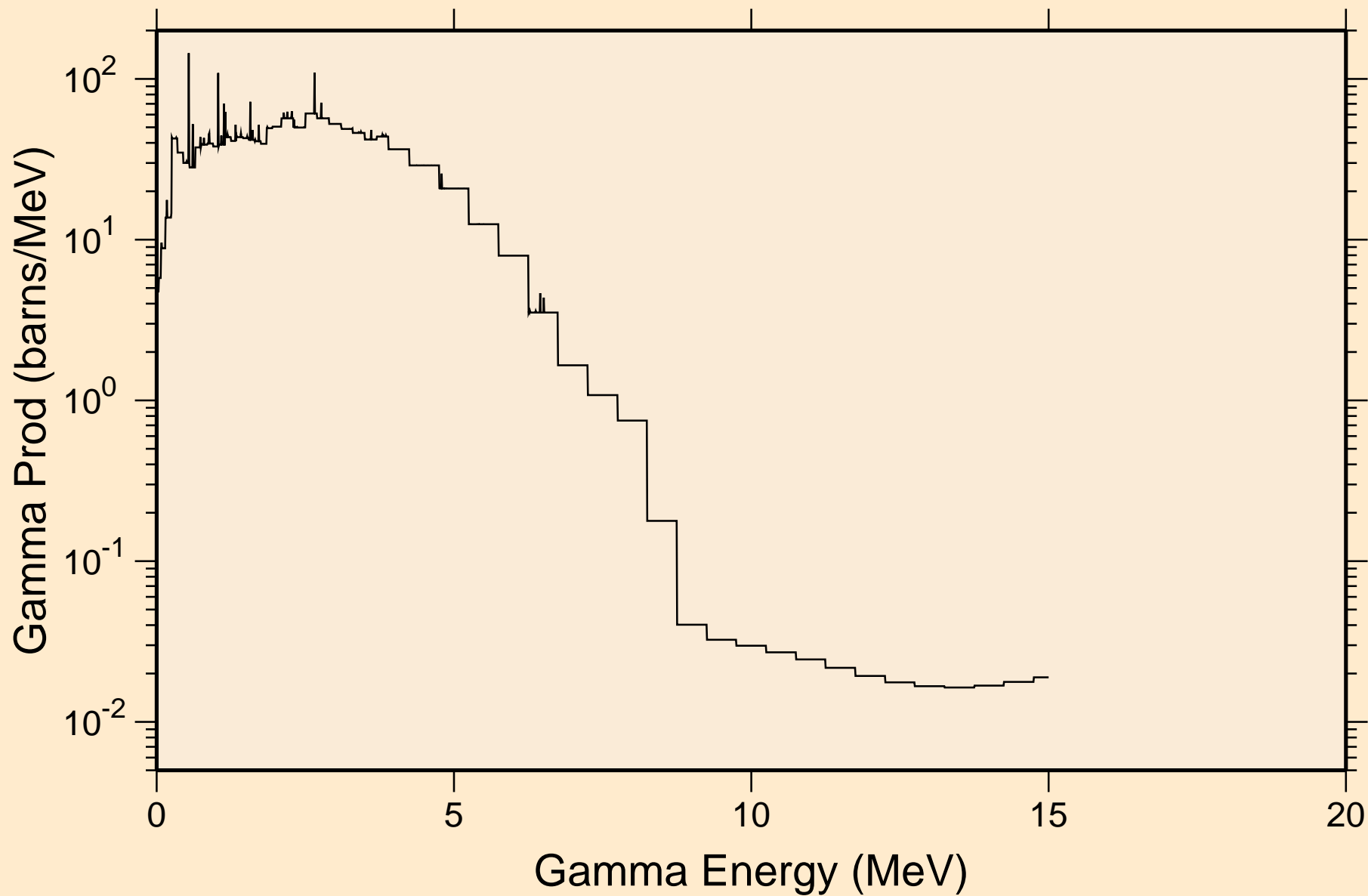

AR047 NEUTRON ACER TENDL-2019 LIBRARY; T=293.16K
Particle heating contributions

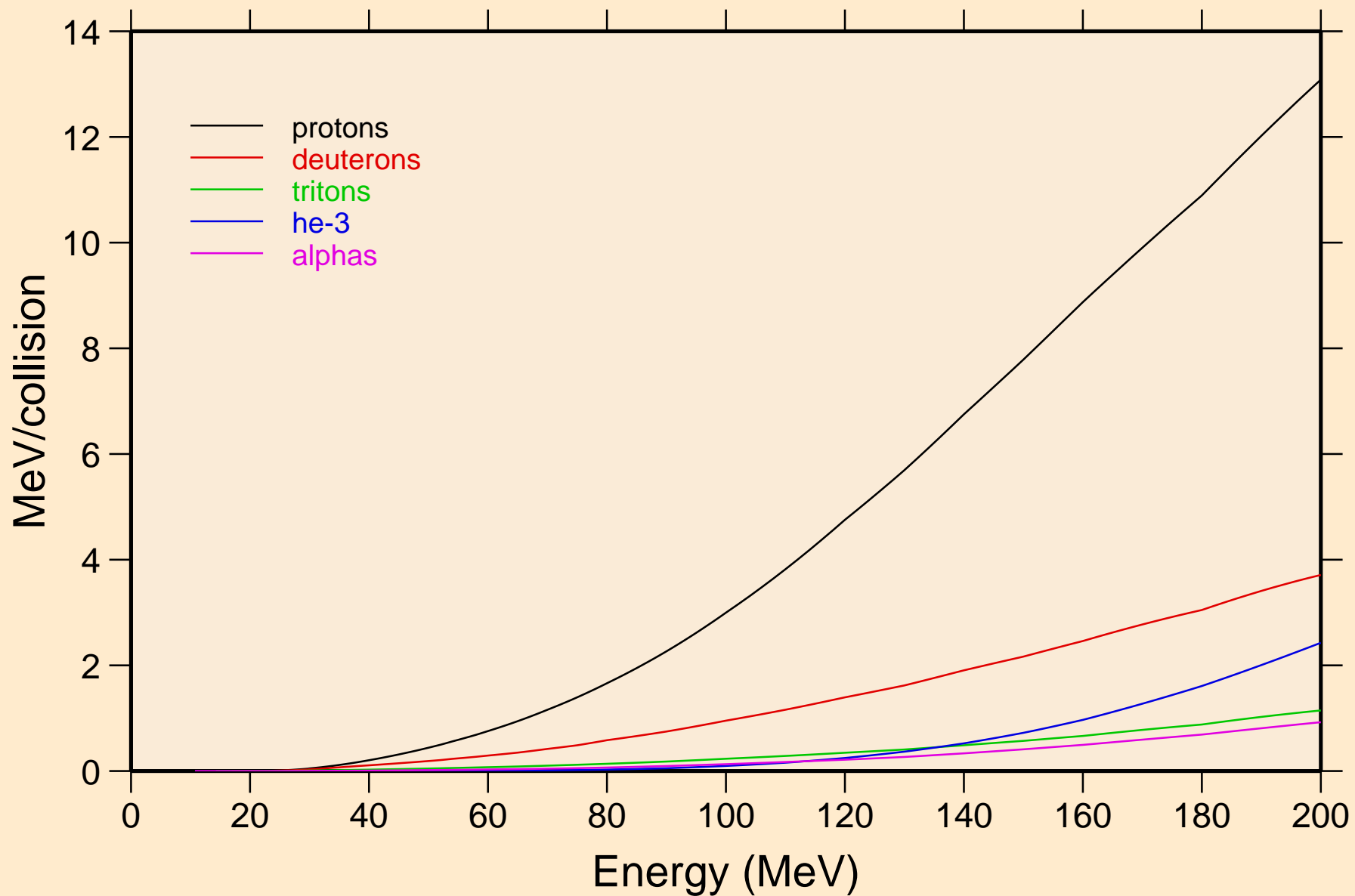

AR047 NEUTRON ACER TENDL-2019 LIBRARY; T=293.16K
Recoil Heating

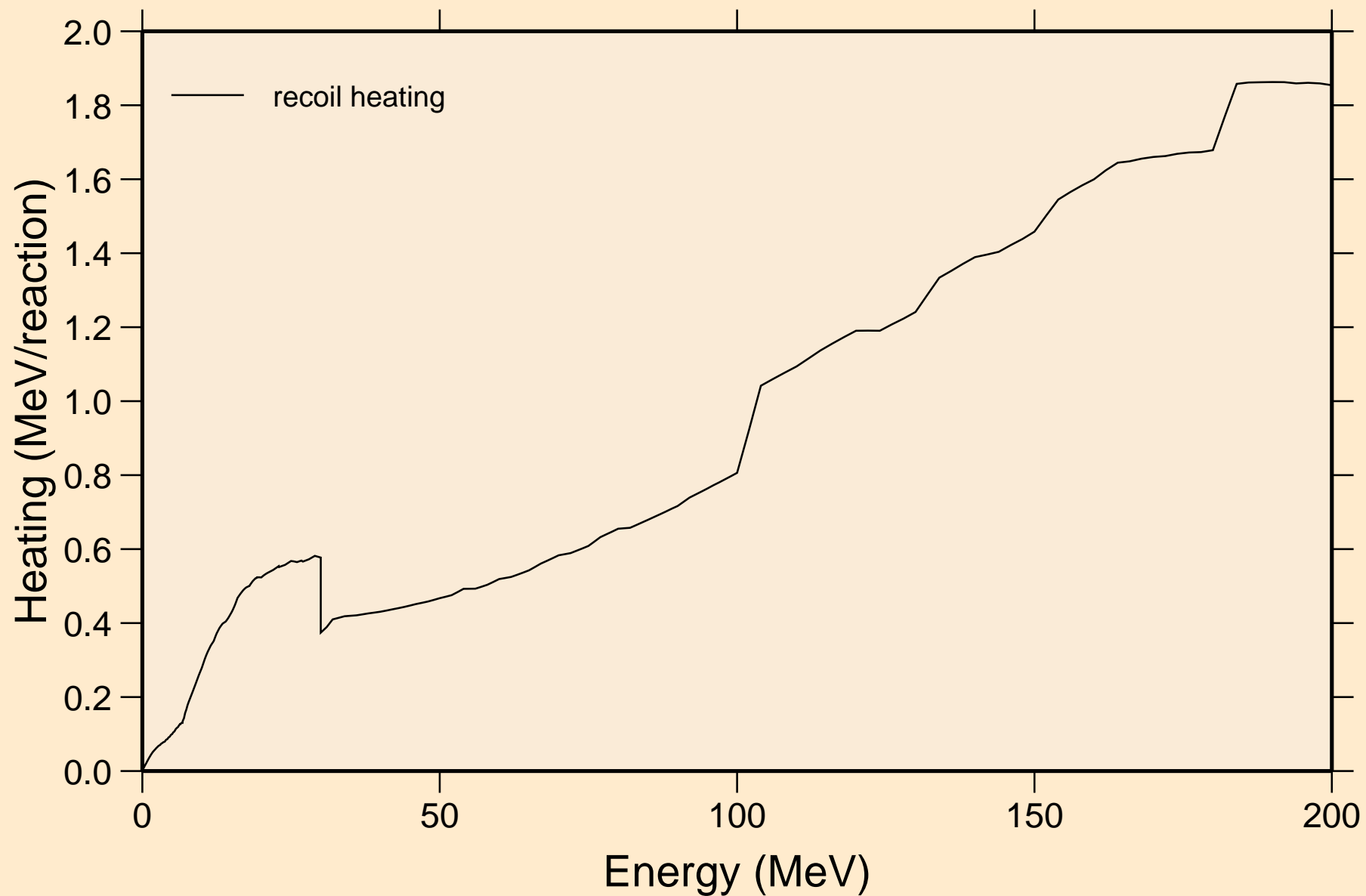

AR047 NEUTRON ACER TENDL-2019 LIBRARY; T=293.16K

Particle production cross sections

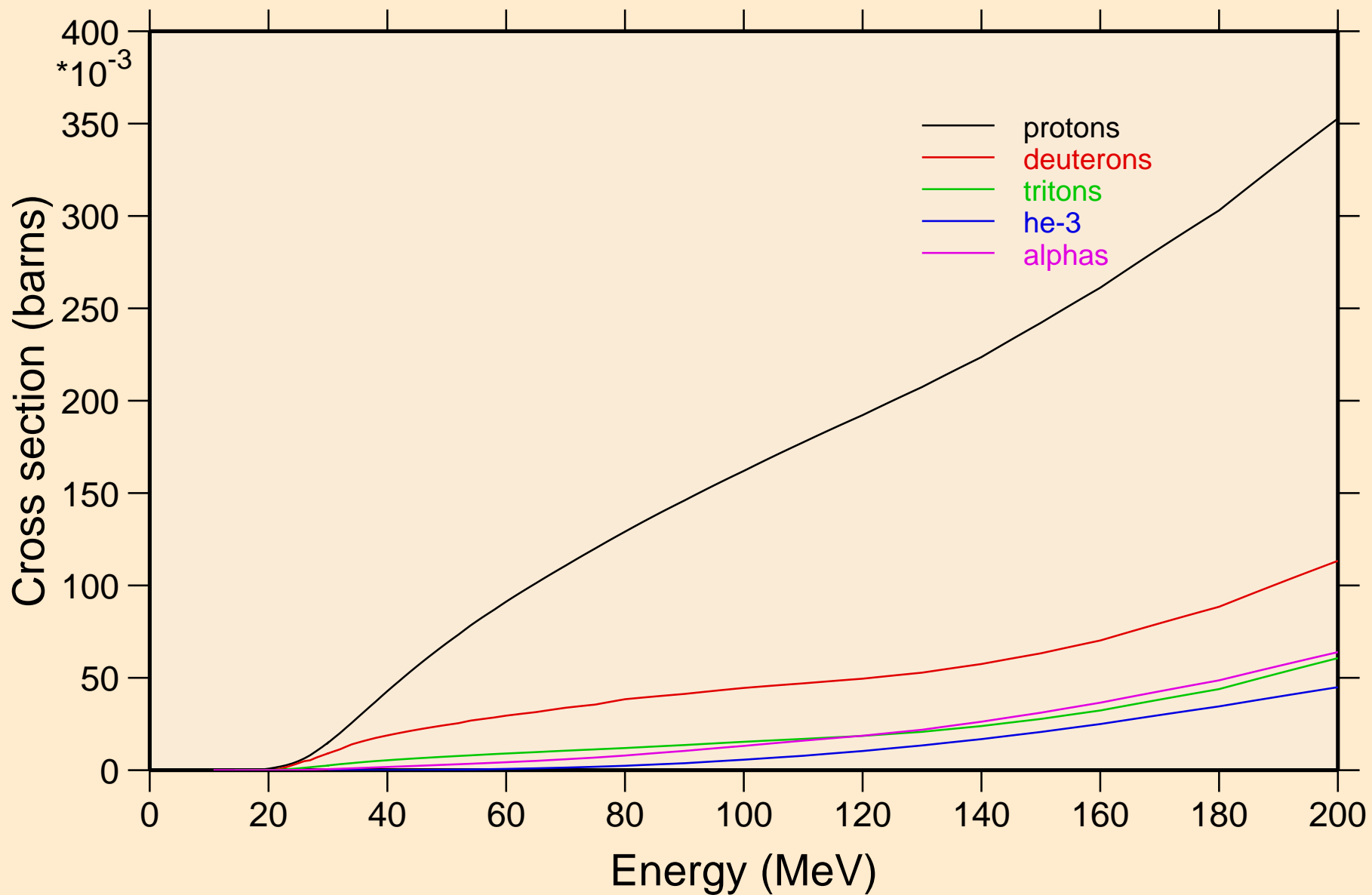

AR047 NEUTRON ACER TENDL-2019 LIBRARY; T=293.16K
protons from (n,x)

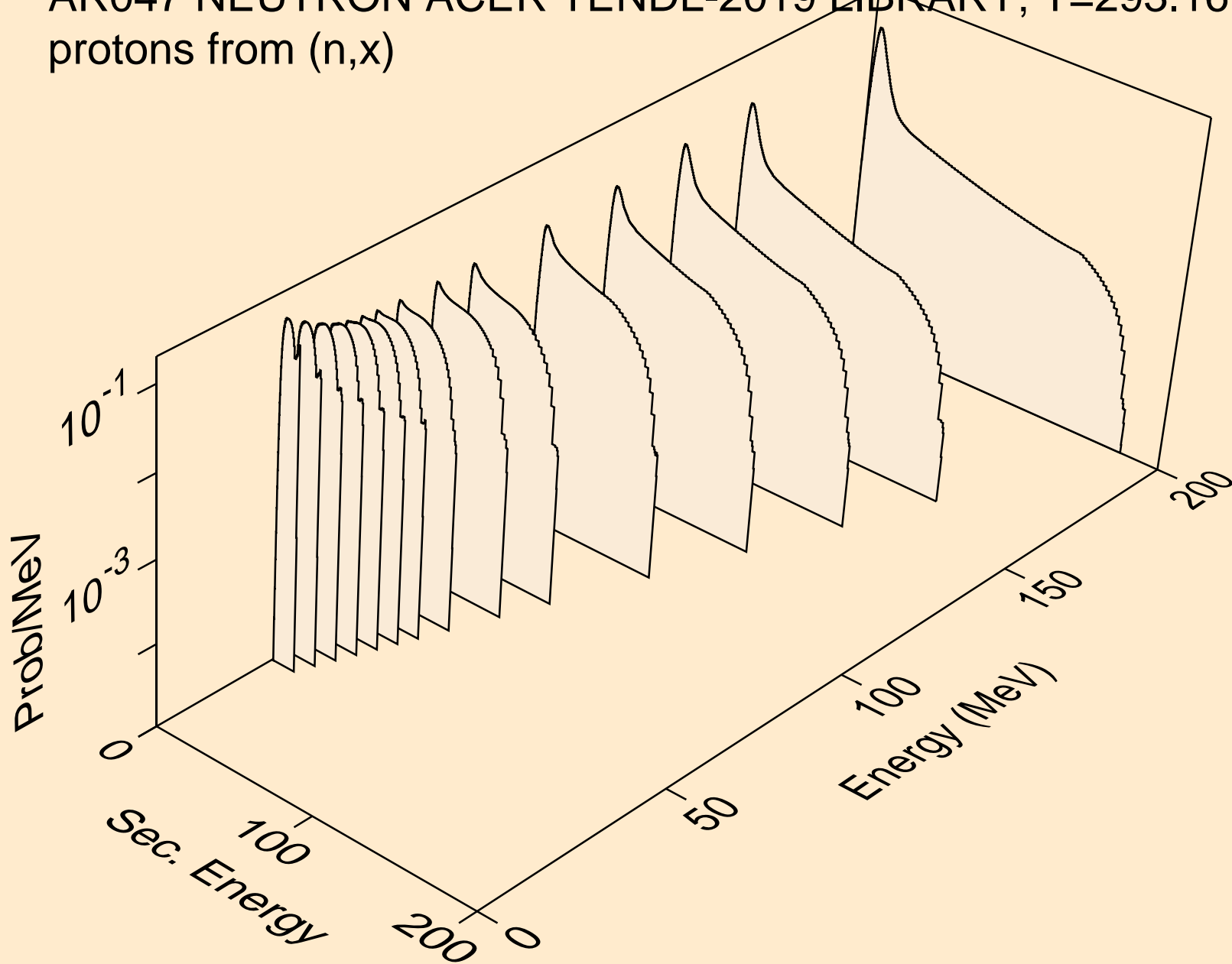

AR047 NEUTRON ACER TENDL-2019 LIBRARY; T=293.16K
protons from (n,n*)p

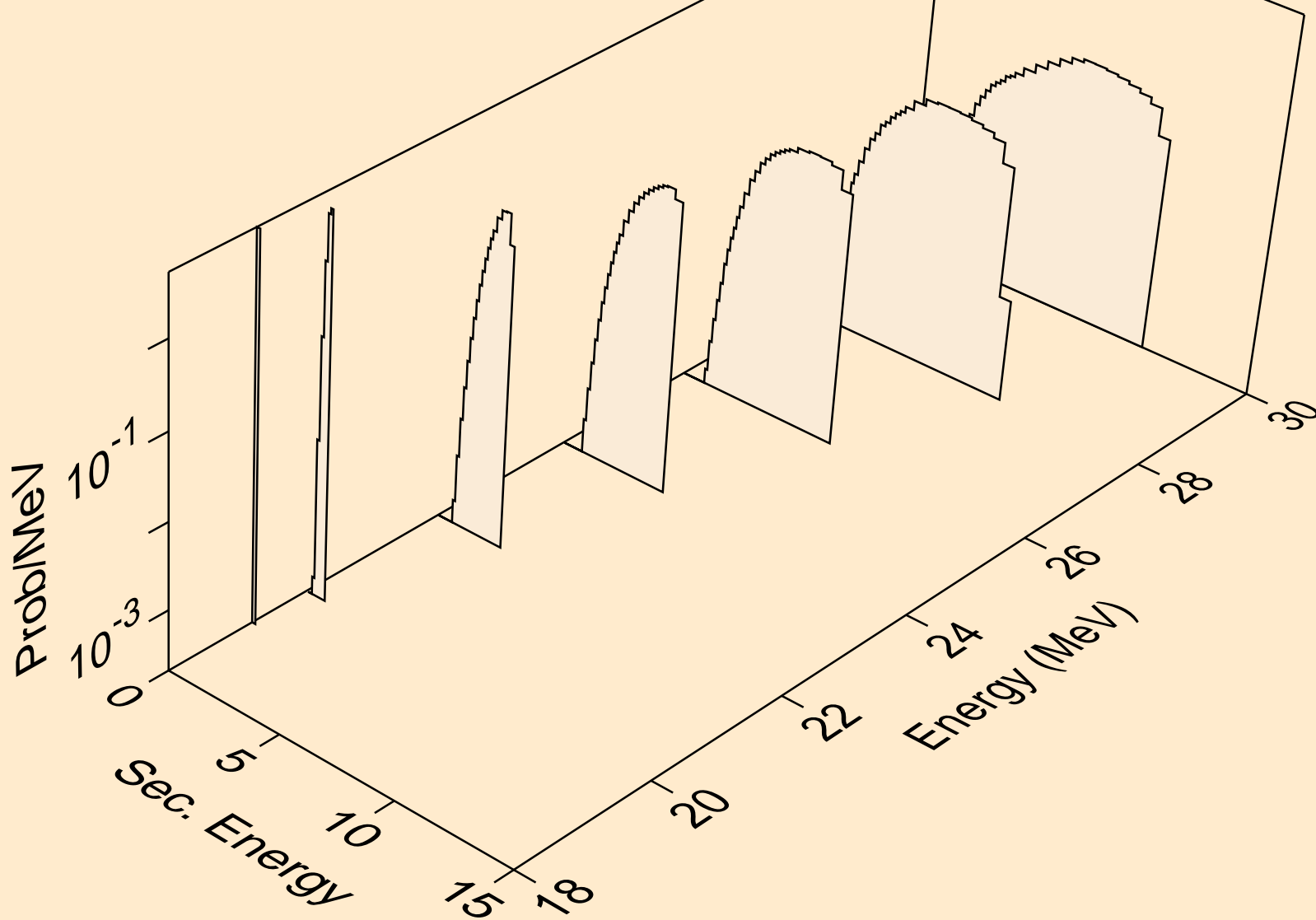

AR047 NEUTRON ACER TENDL-2019 LIBRARY; T=293.16K
protons from (n,2np)

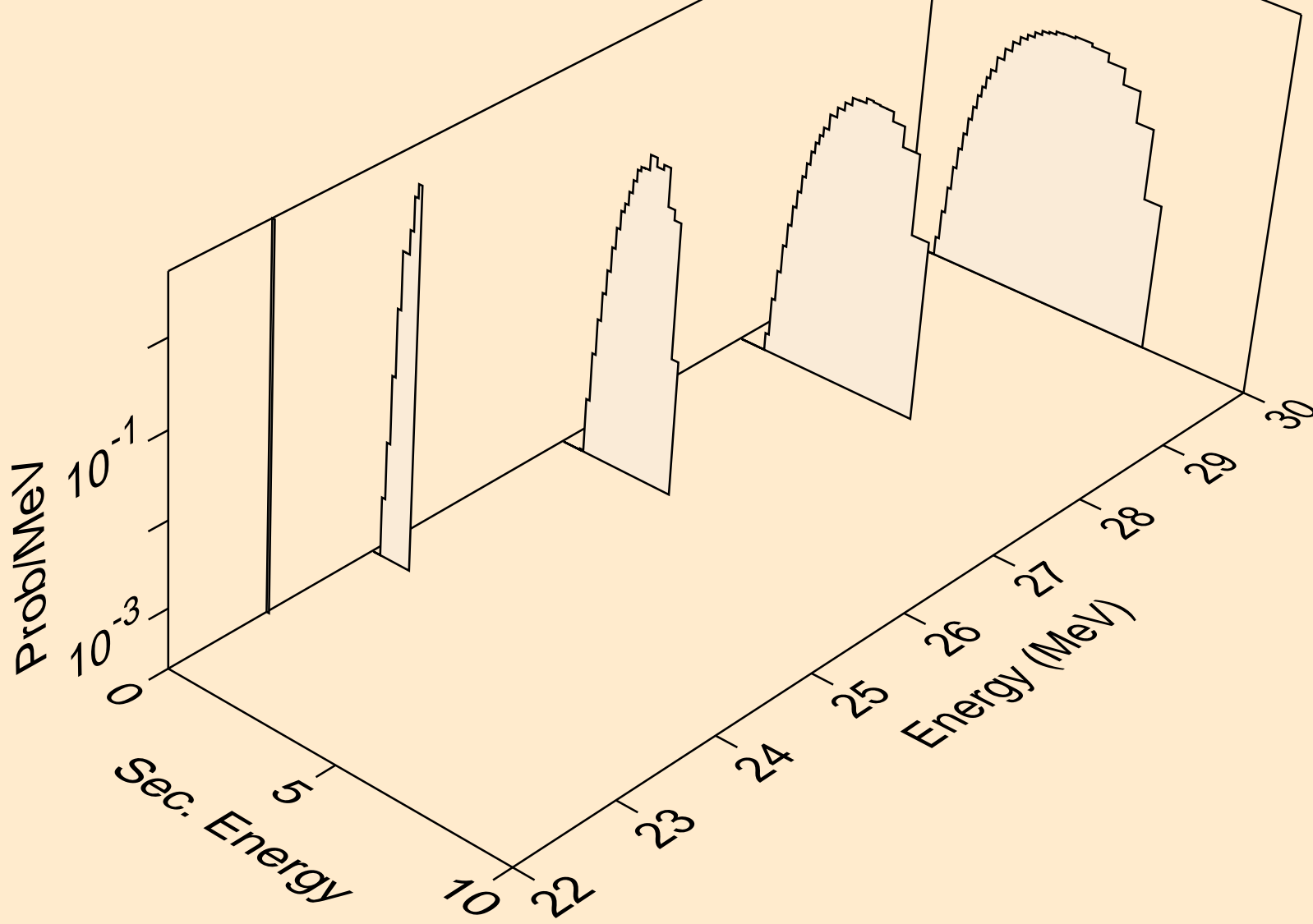

AR047 NEUTRON ACER TENDL-2019 LIBRARY; T=293.16K
protons from (n,p)

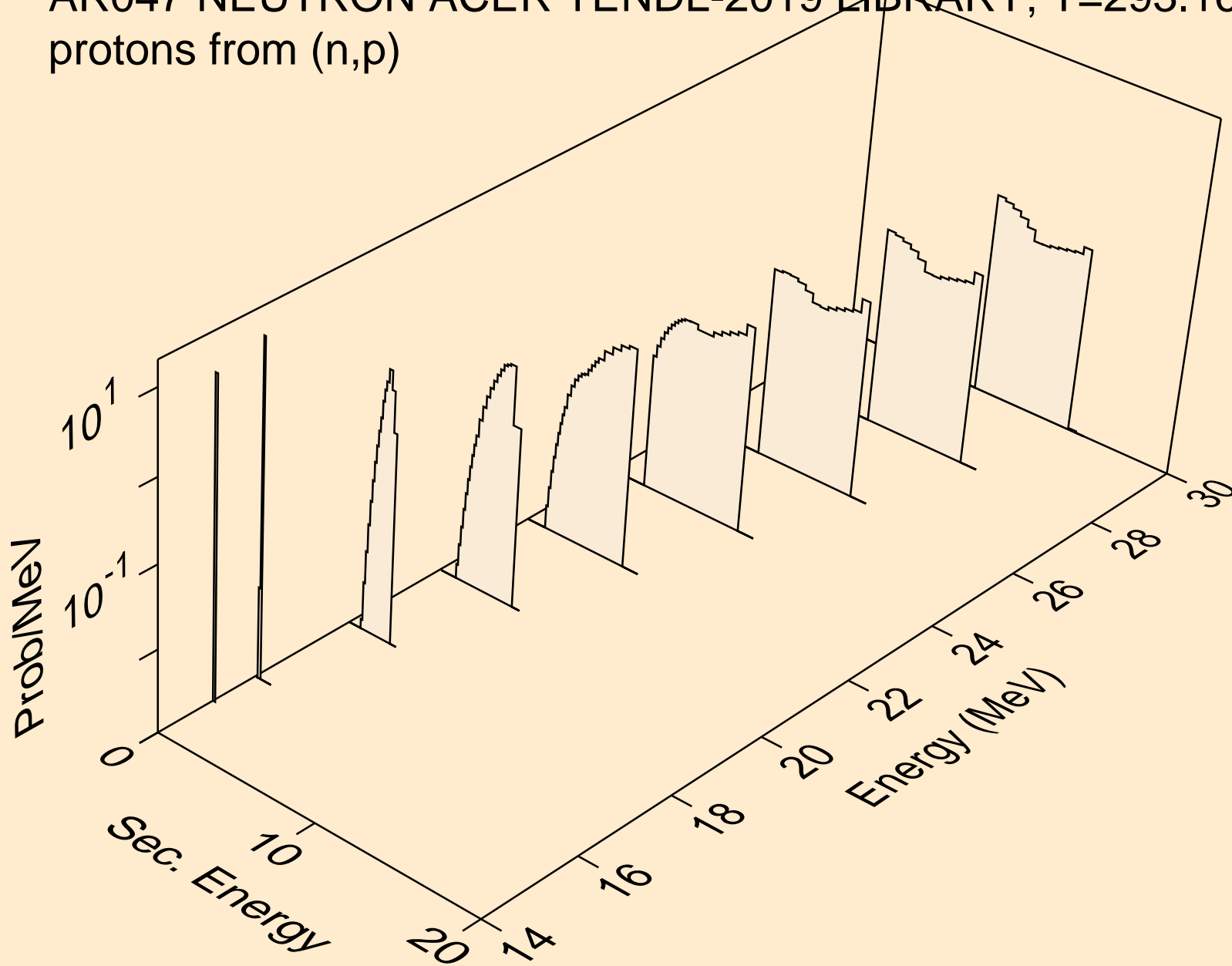

AR047 NEUTRON ACER TENDL-2019 LIBRARY; T=293.16K
deuterons from (n,x)

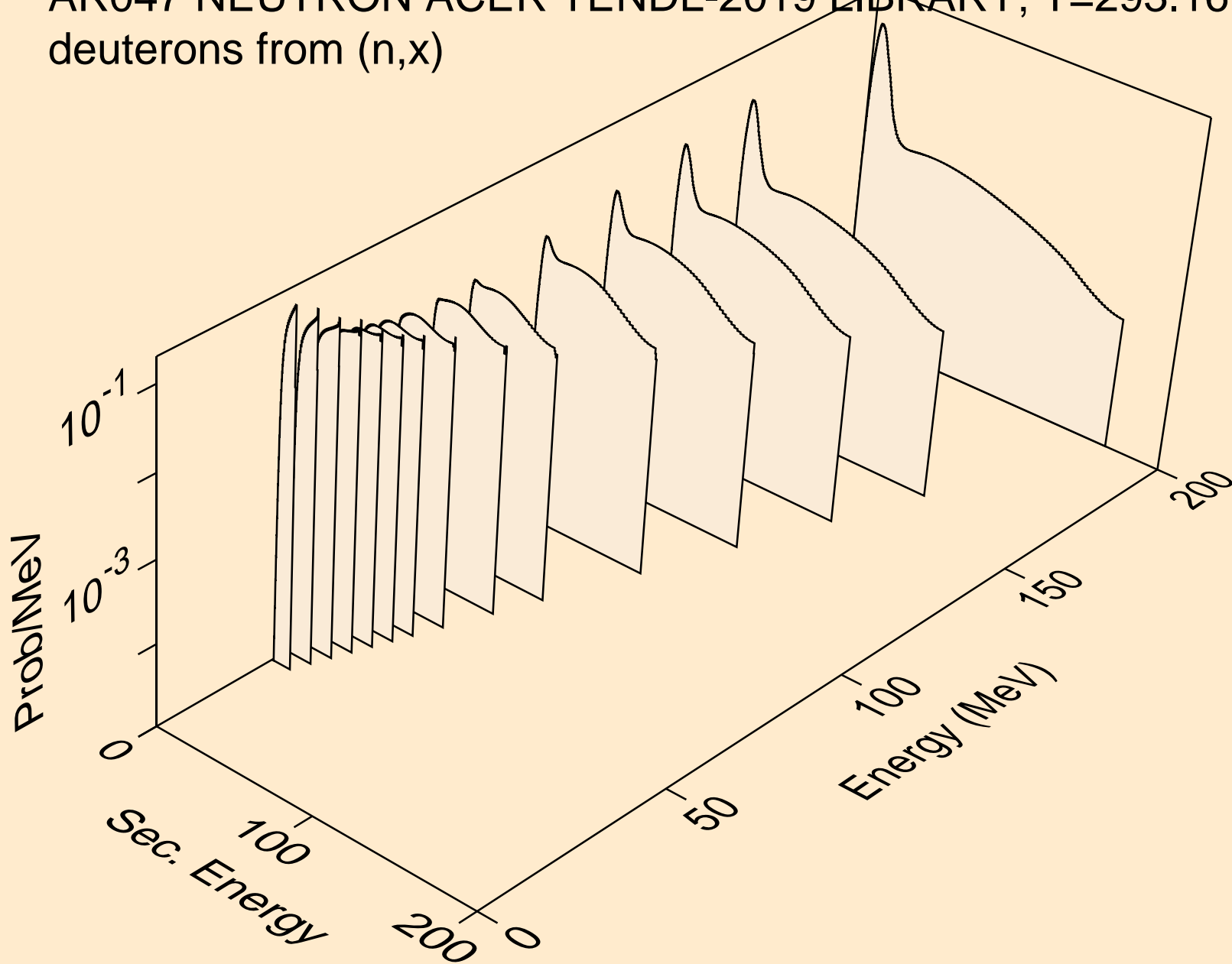

AR047 NEUTRON ACER TENDL-2019 LIBRARY; T=293.16K
deuterons from (n,2nd)

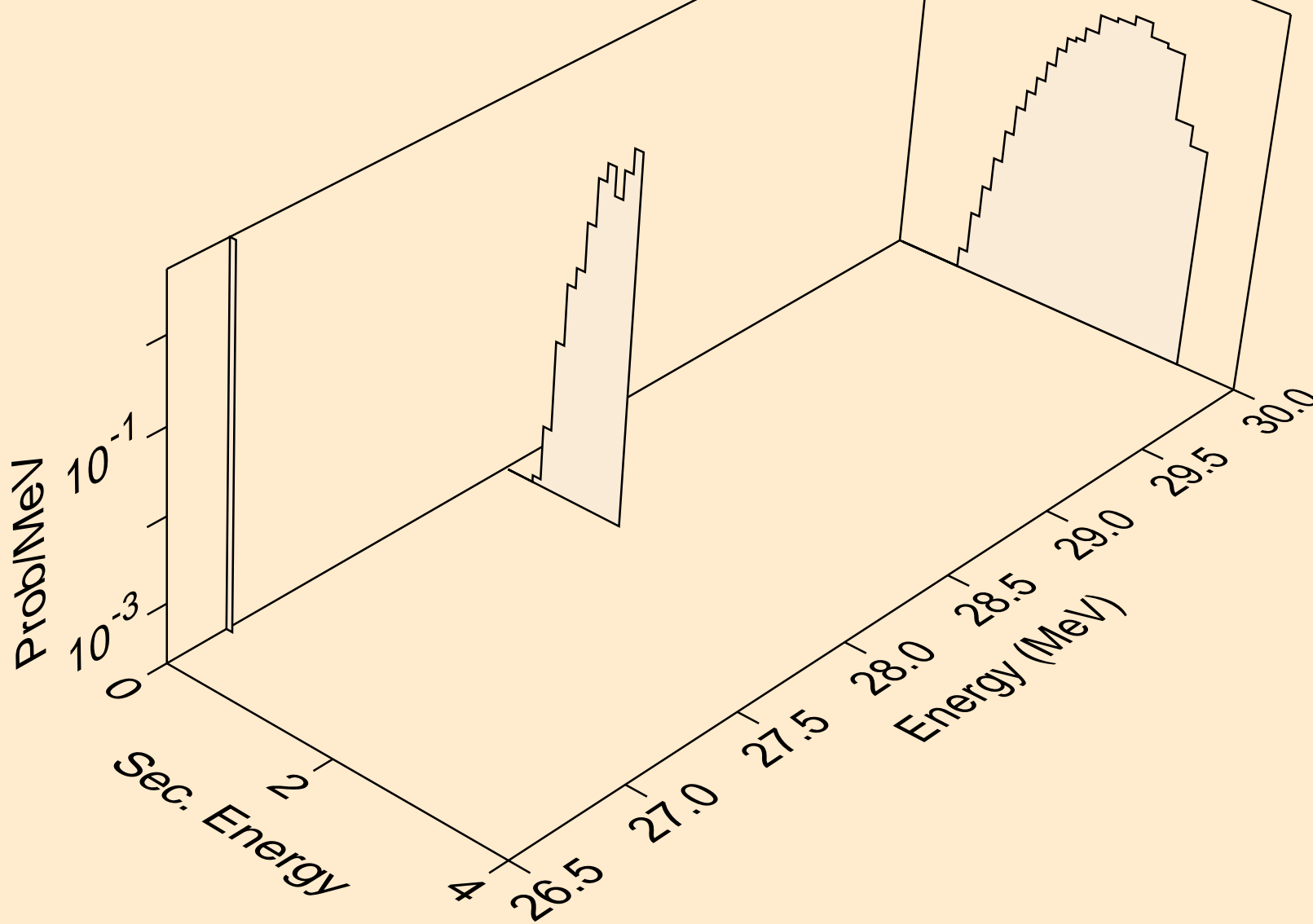

AR047 NEUTRON ACER TENDL-2019 LIBRARY; T=293.16K
deuterons from (n,n*)d

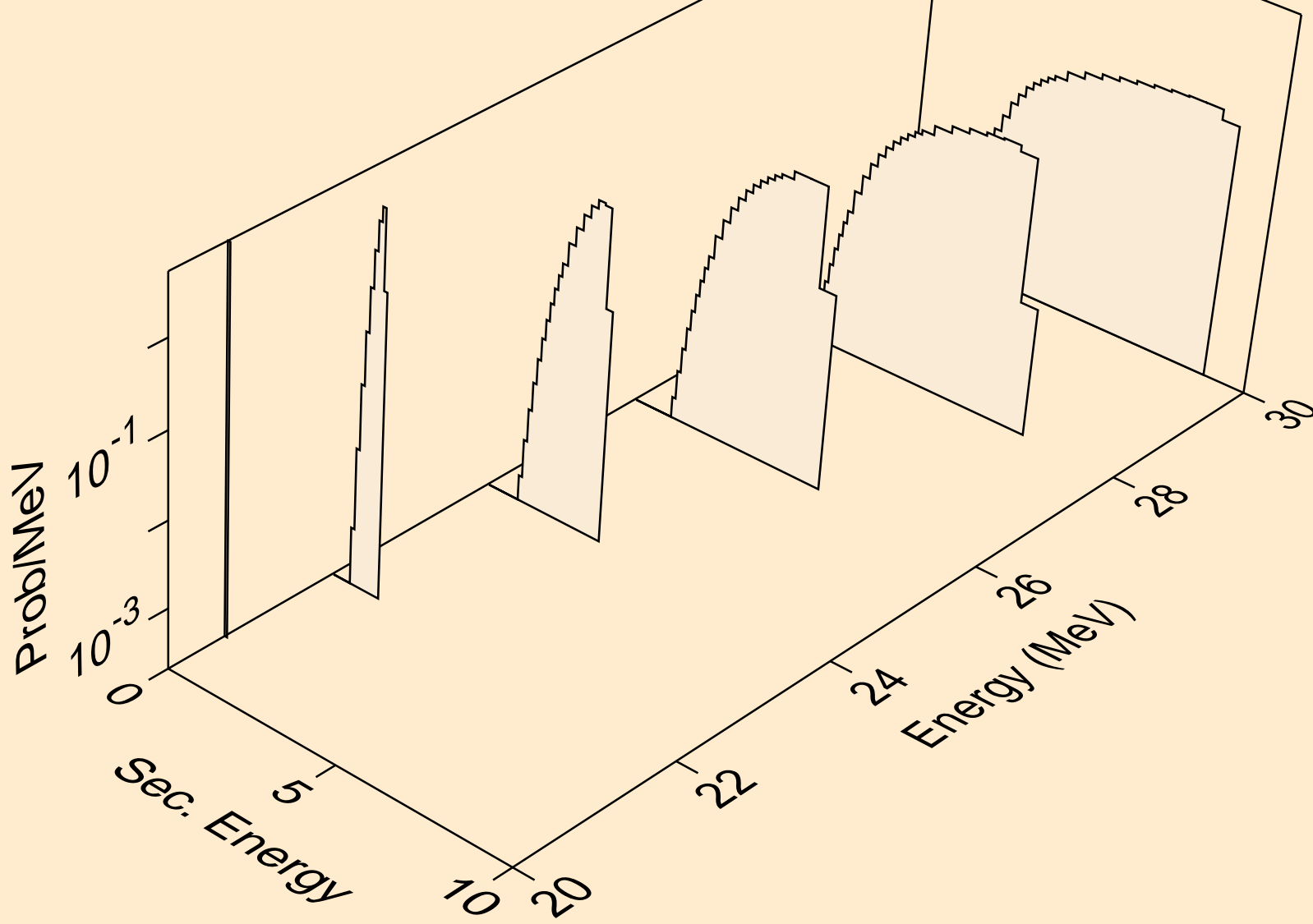

AR047 NEUTRON ACER TENDL-2019 LIBRARY; T=293.16K
deuterons from (n,d)

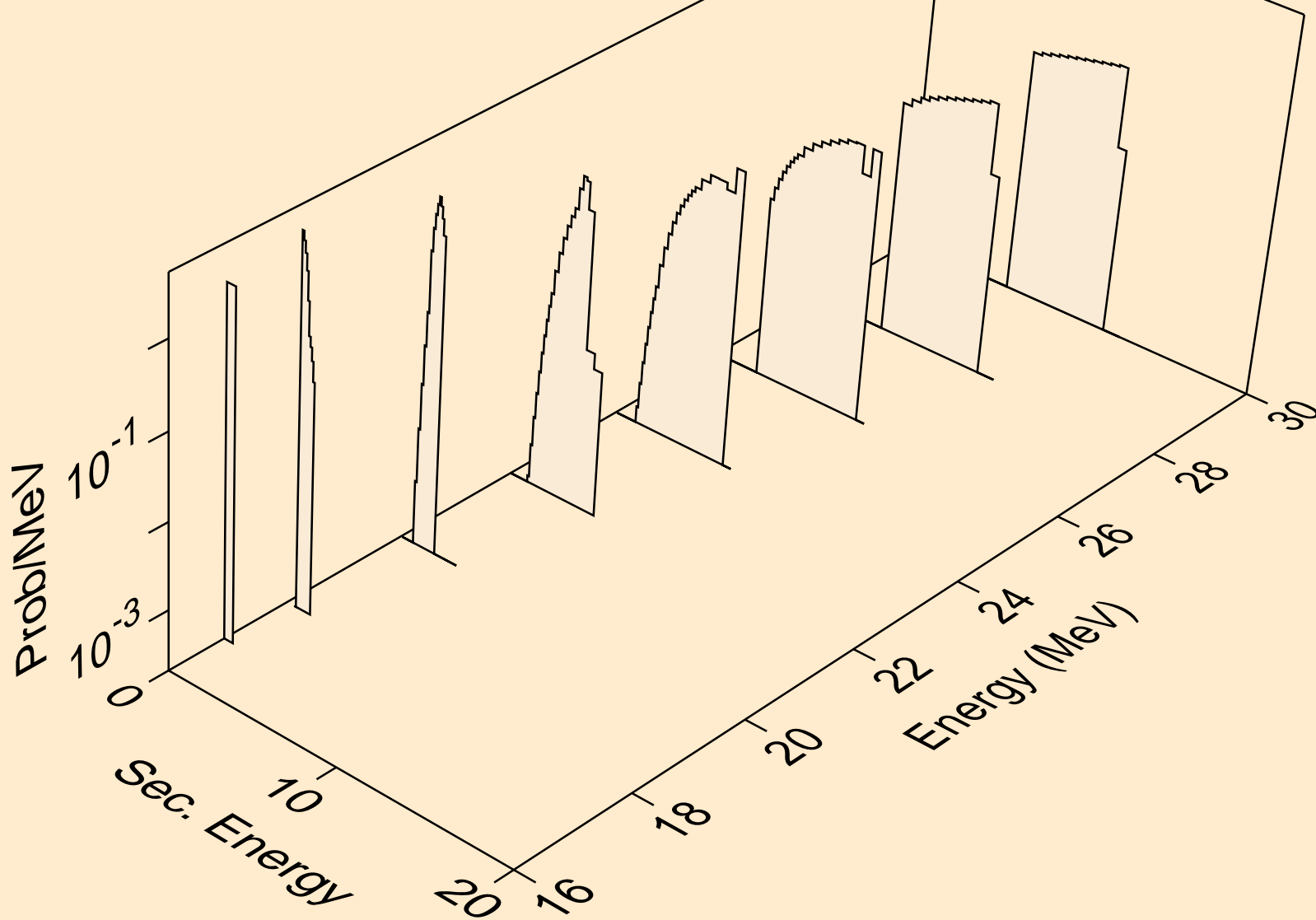

AR047 NEUTRON ACER TENDL-2019 LIBRARY; T=293.16K
tritons from (n,x)

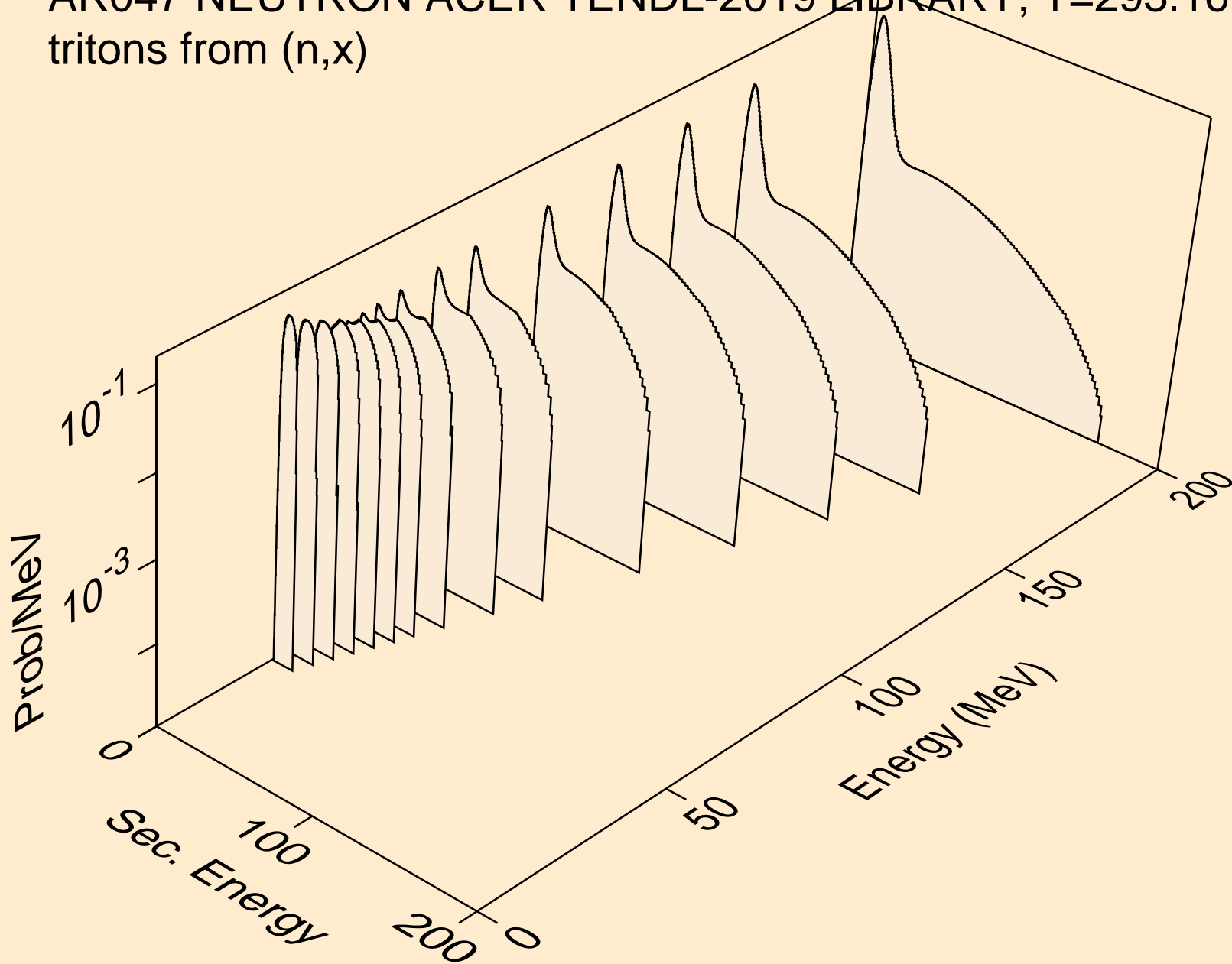

AR047 NEUTRON ACER TENDL-2019 LIBRARY; T=293.16K
tritons from (n,n*)t

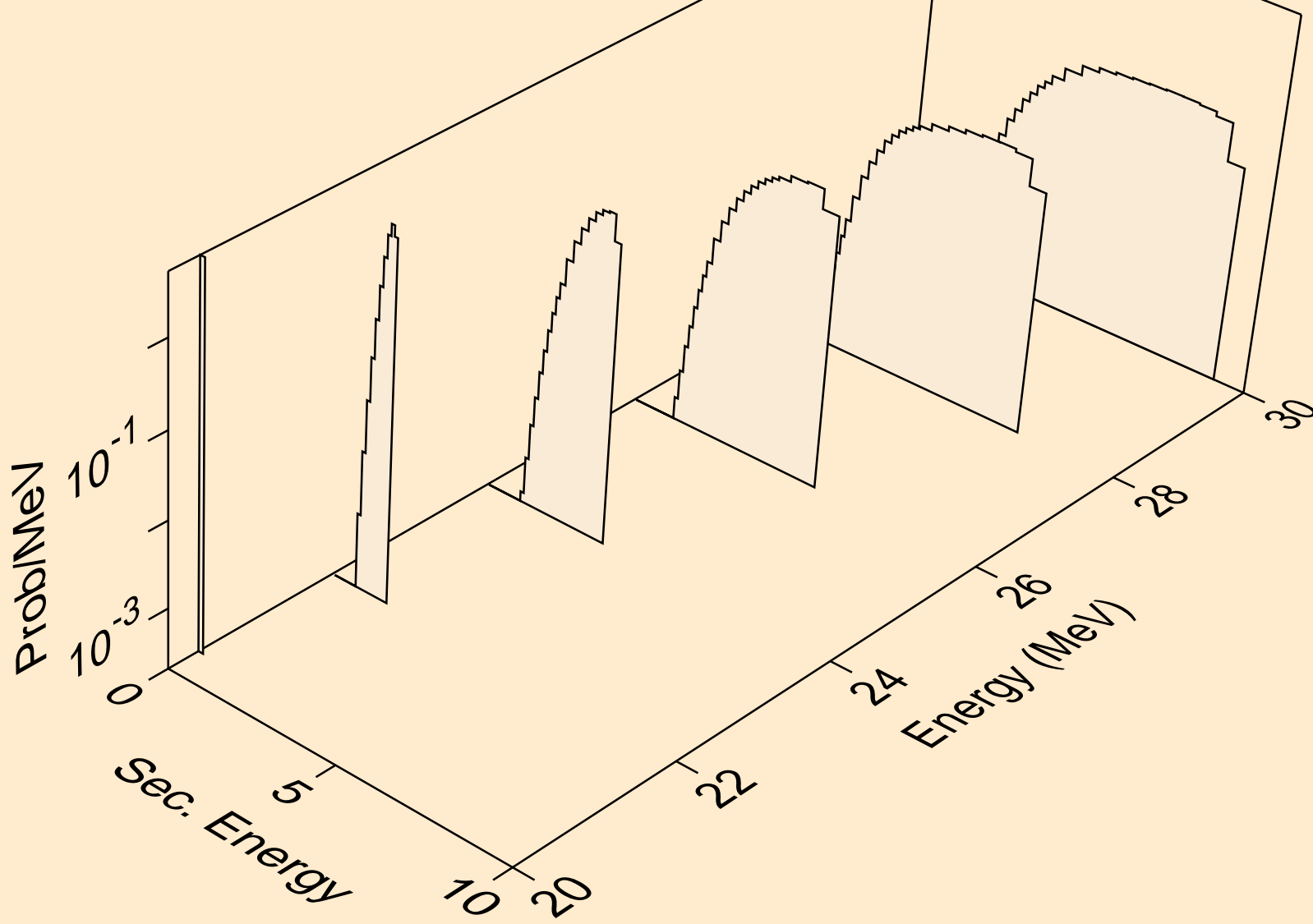

AR047 NEUTRON ACER TENDL-2019 LIBRARY; T=293.16K
tritons from (n,t)

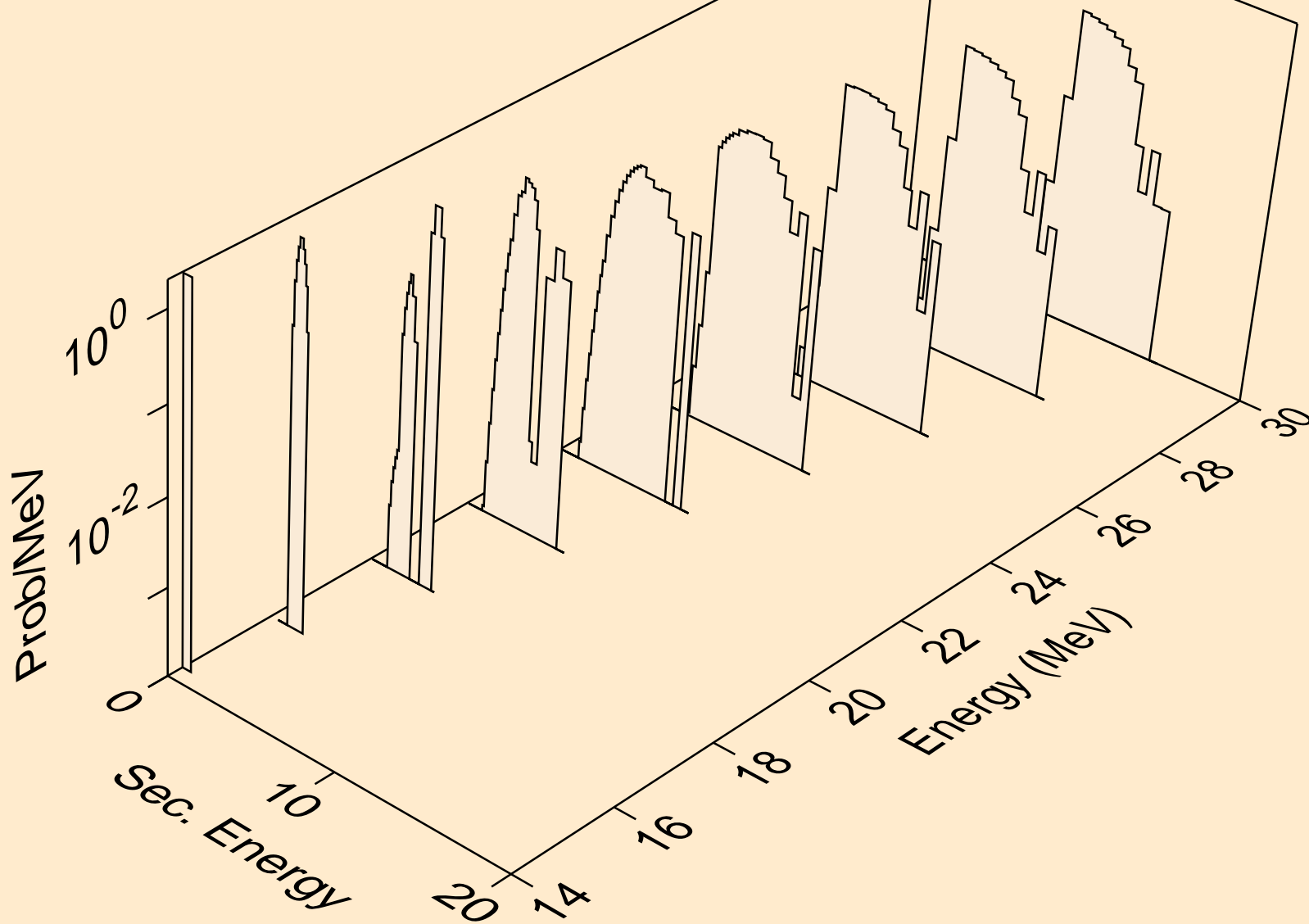

AR047 NEUTRON ACER TENDL-2019 LIBRARY; T=293.16K
he3s from (n,x)

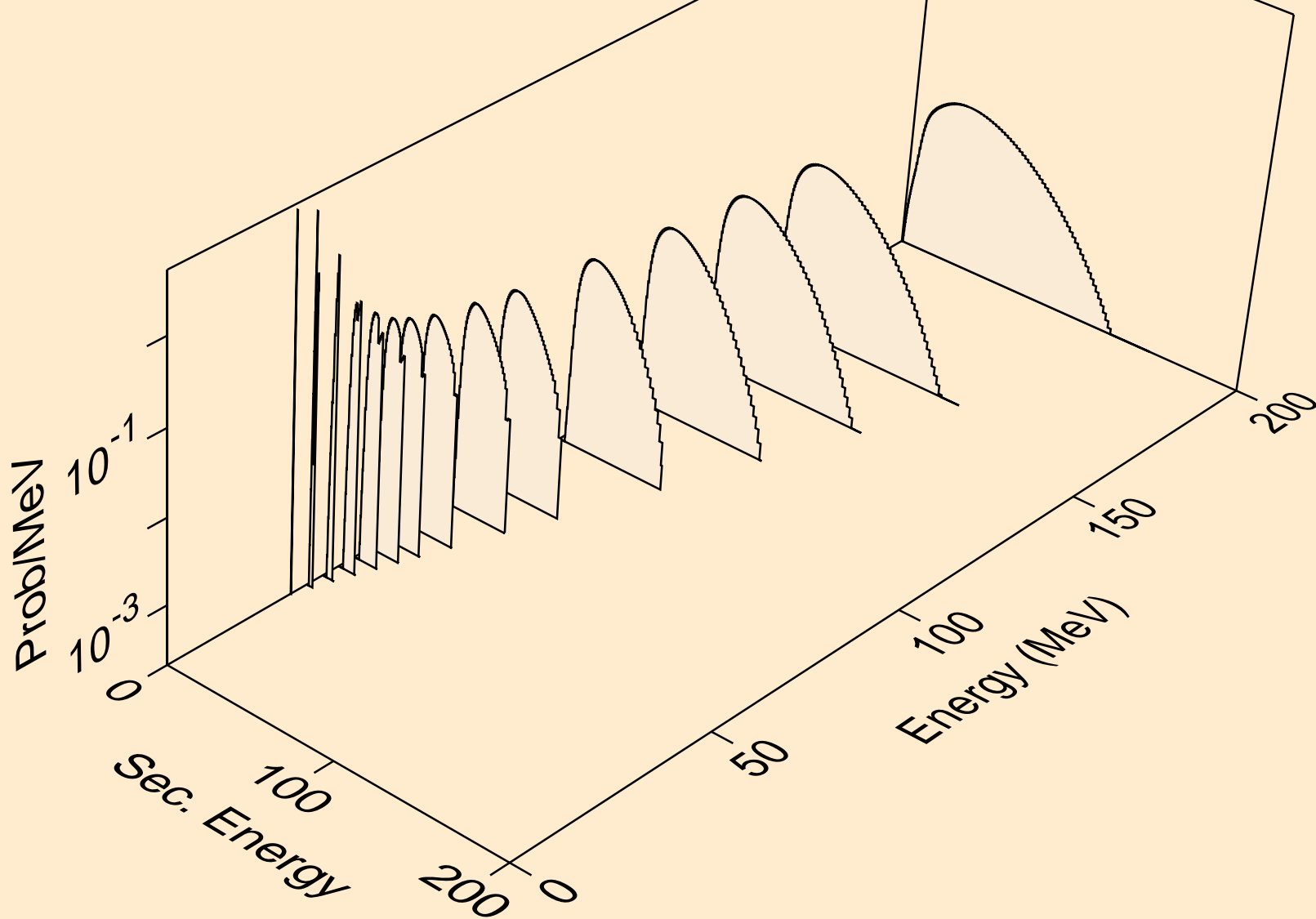

AR047 NEUTRON ACER TENDL-2019 LIBRARY; T=293.16K
alphas from (n,x)

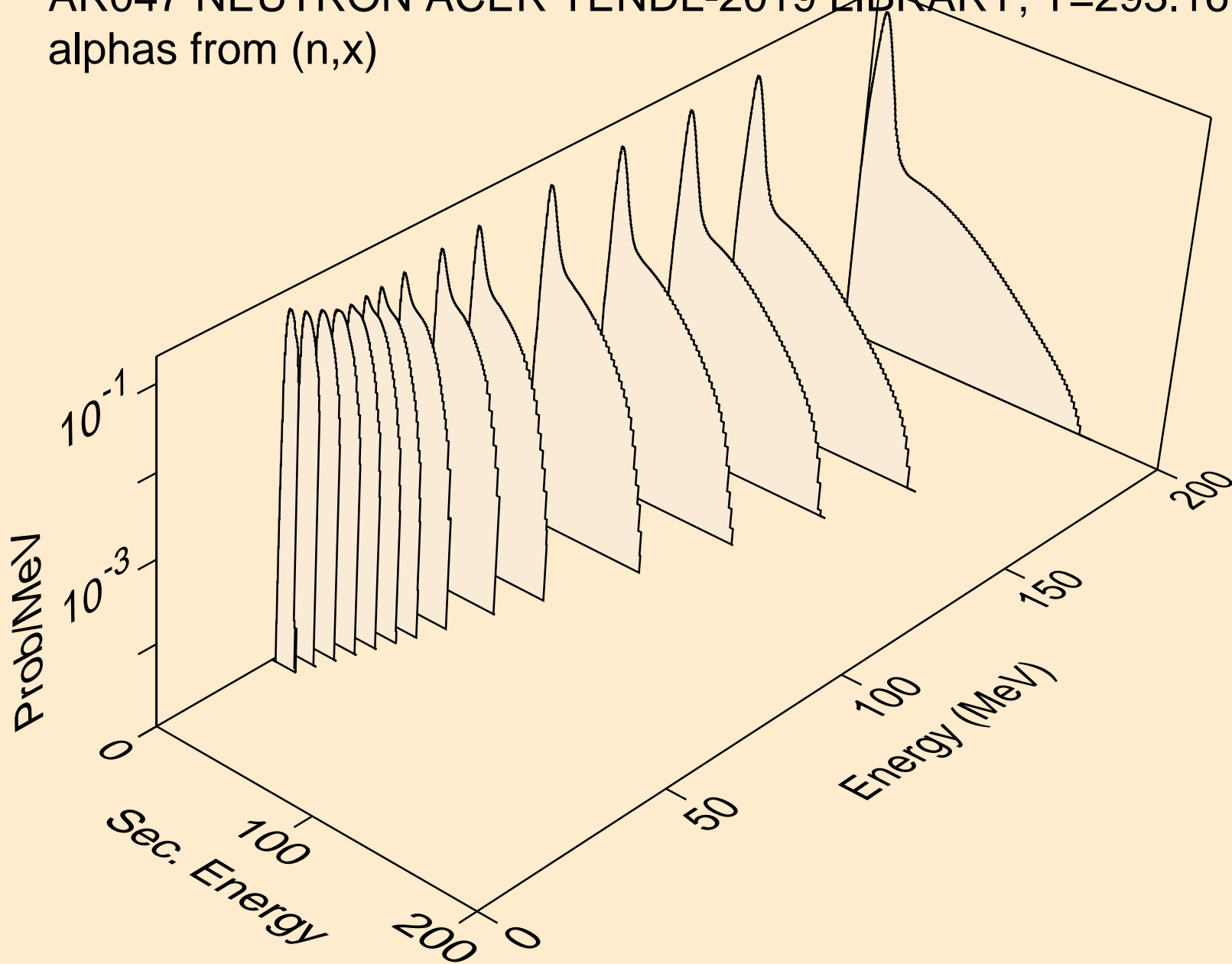

AR047 NEUTRON ACER TENDL-2019 LIBRARY; T=293.16K
alphas from (n,n*)a

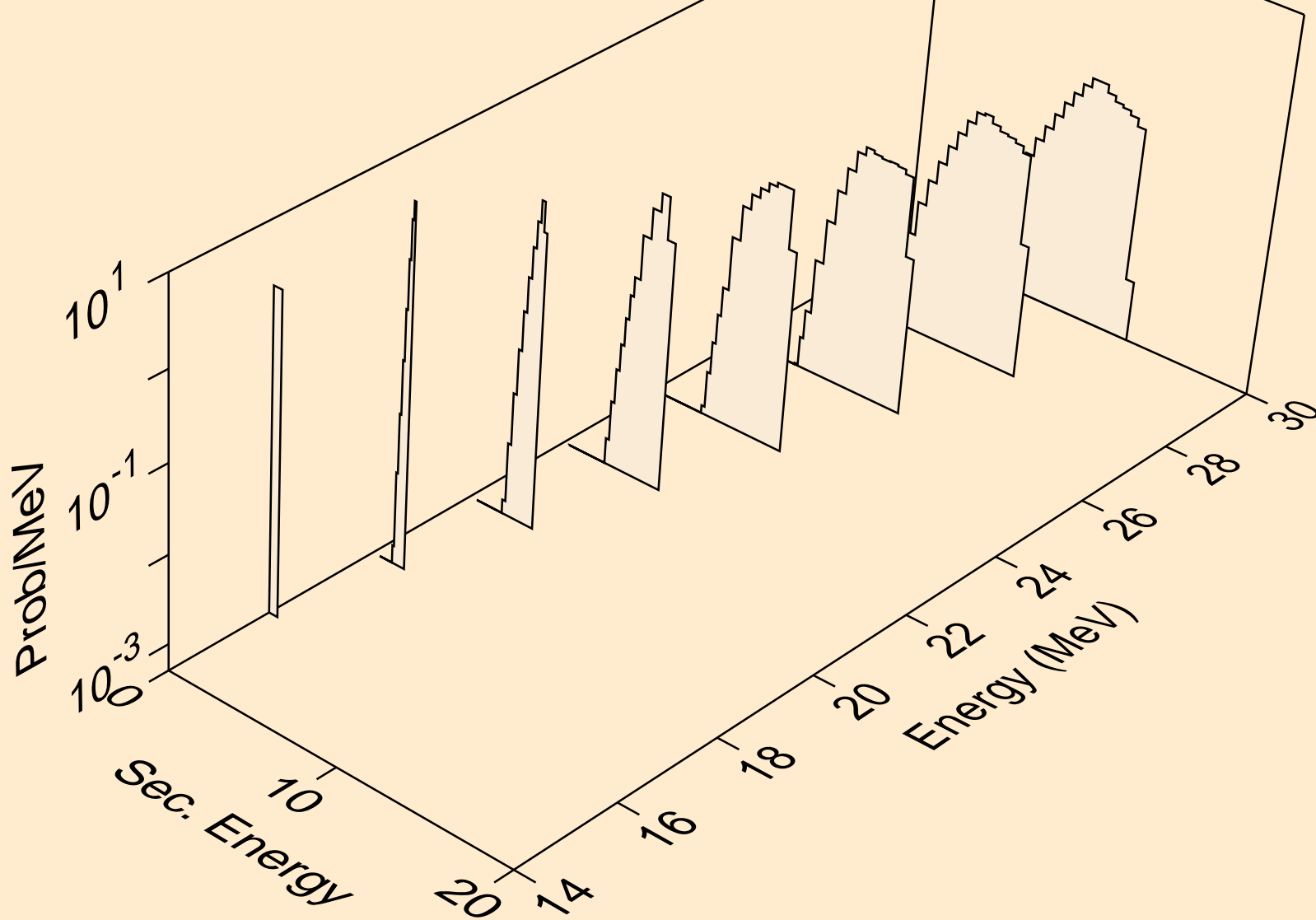

AR047 NEUTRON ACER TENDL-2019 LIBRARY; T=293.16K
alphas from (n,2n)a

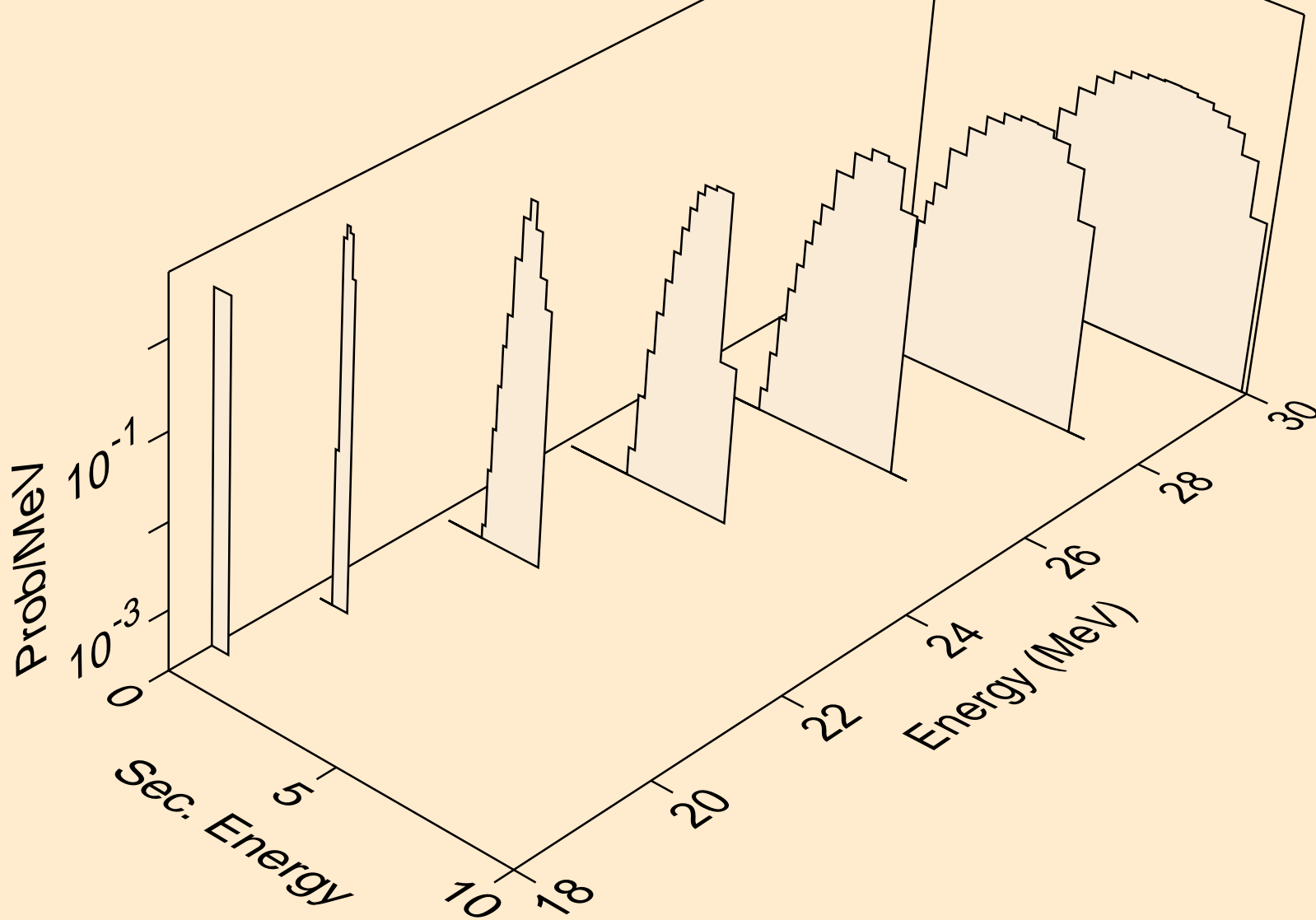

AR047 NEUTRON ACER TENDL-2019 LIBRARY; T=293.16K
alphas from (n,3n)a

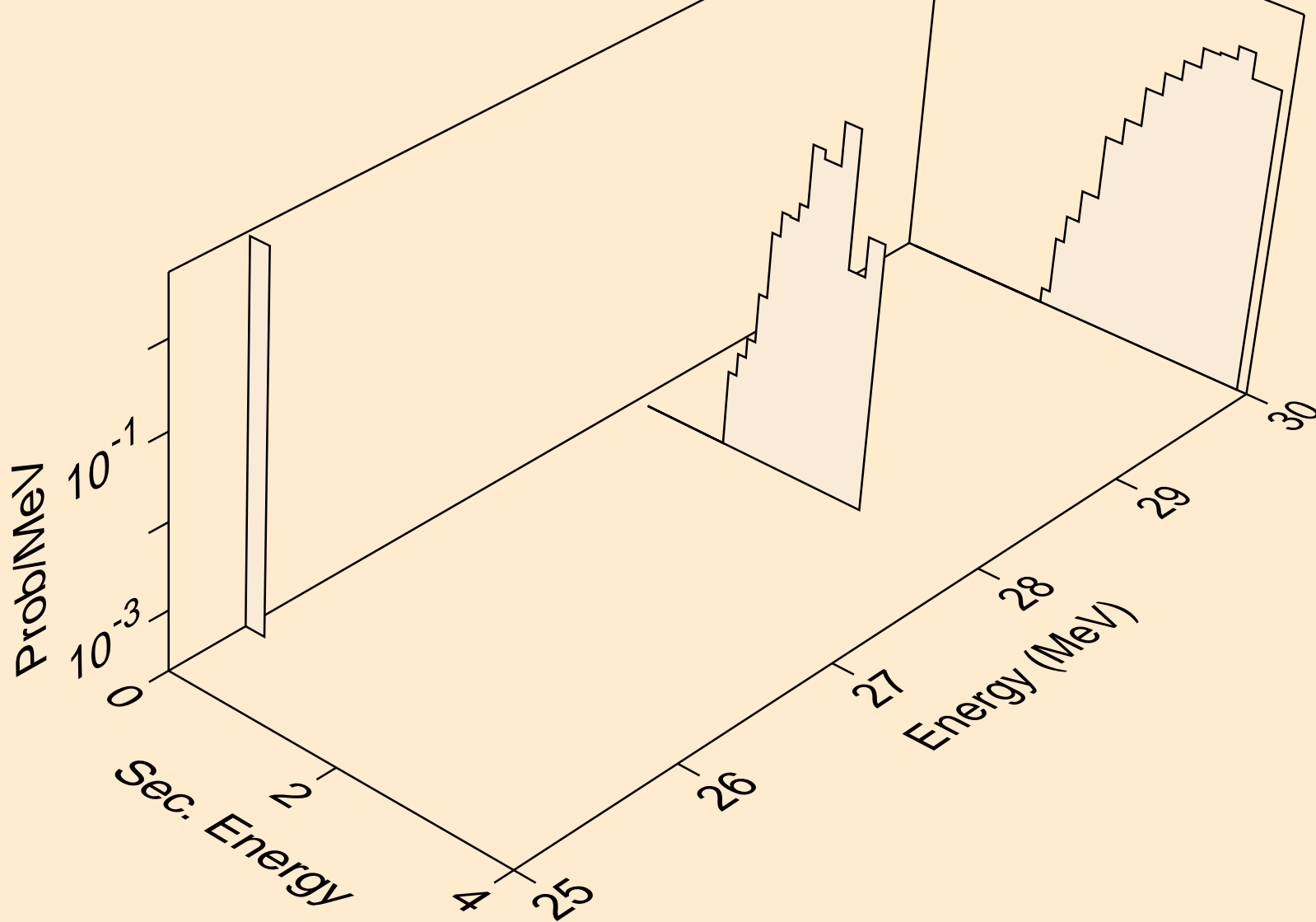

AR047 NEUTRON ACER TENDL-2019 LIBRARY; T=293.16K
alphas from (n,a)

