

BH264 NEUTRON ACER TENDL-2019 LIBRARY; T=293.16K
Principal cross sections

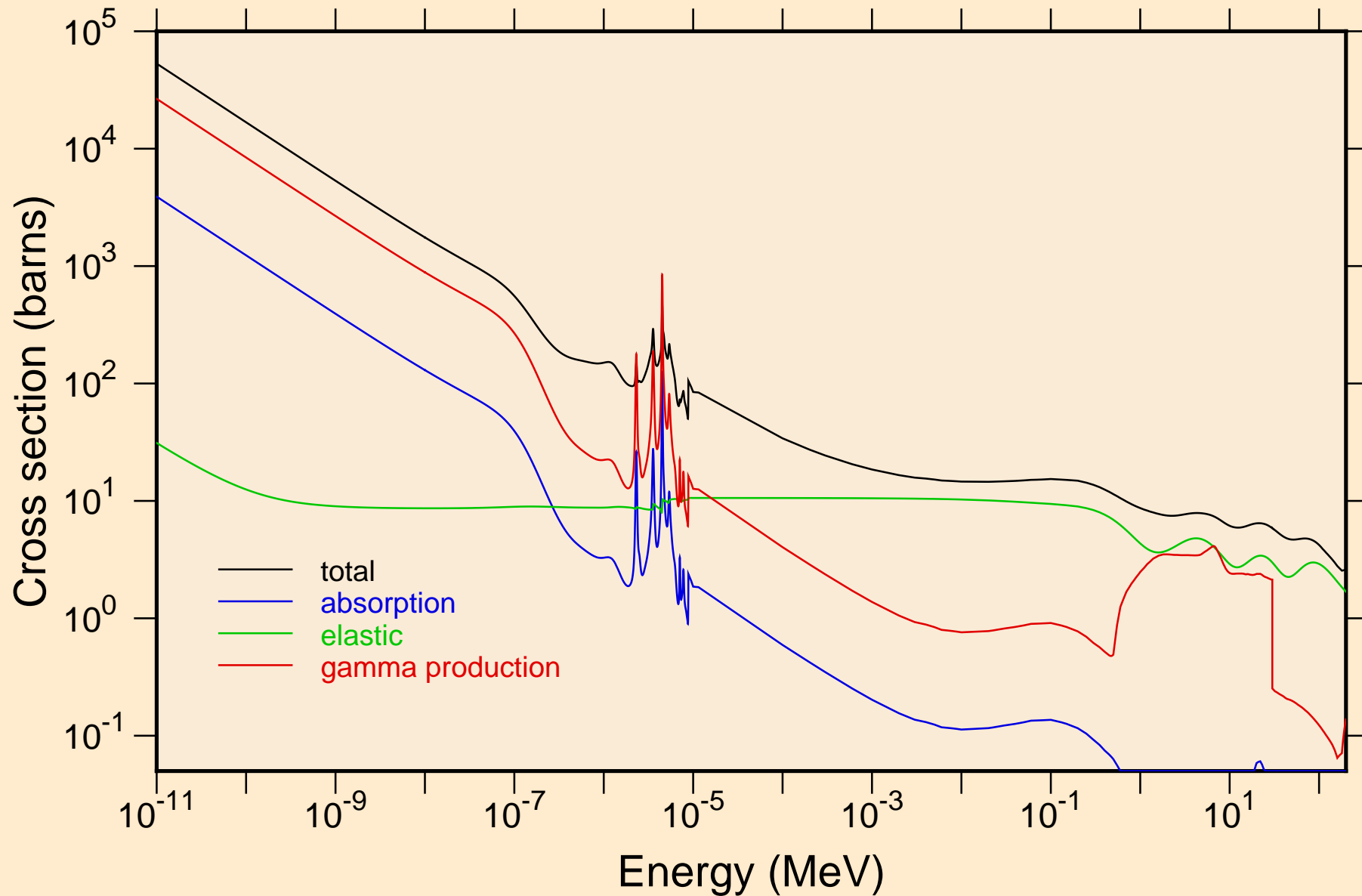

BH264 NEUTRON ACER TENDL-2019 LIBRARY; T=293.16K
resonance total cross section

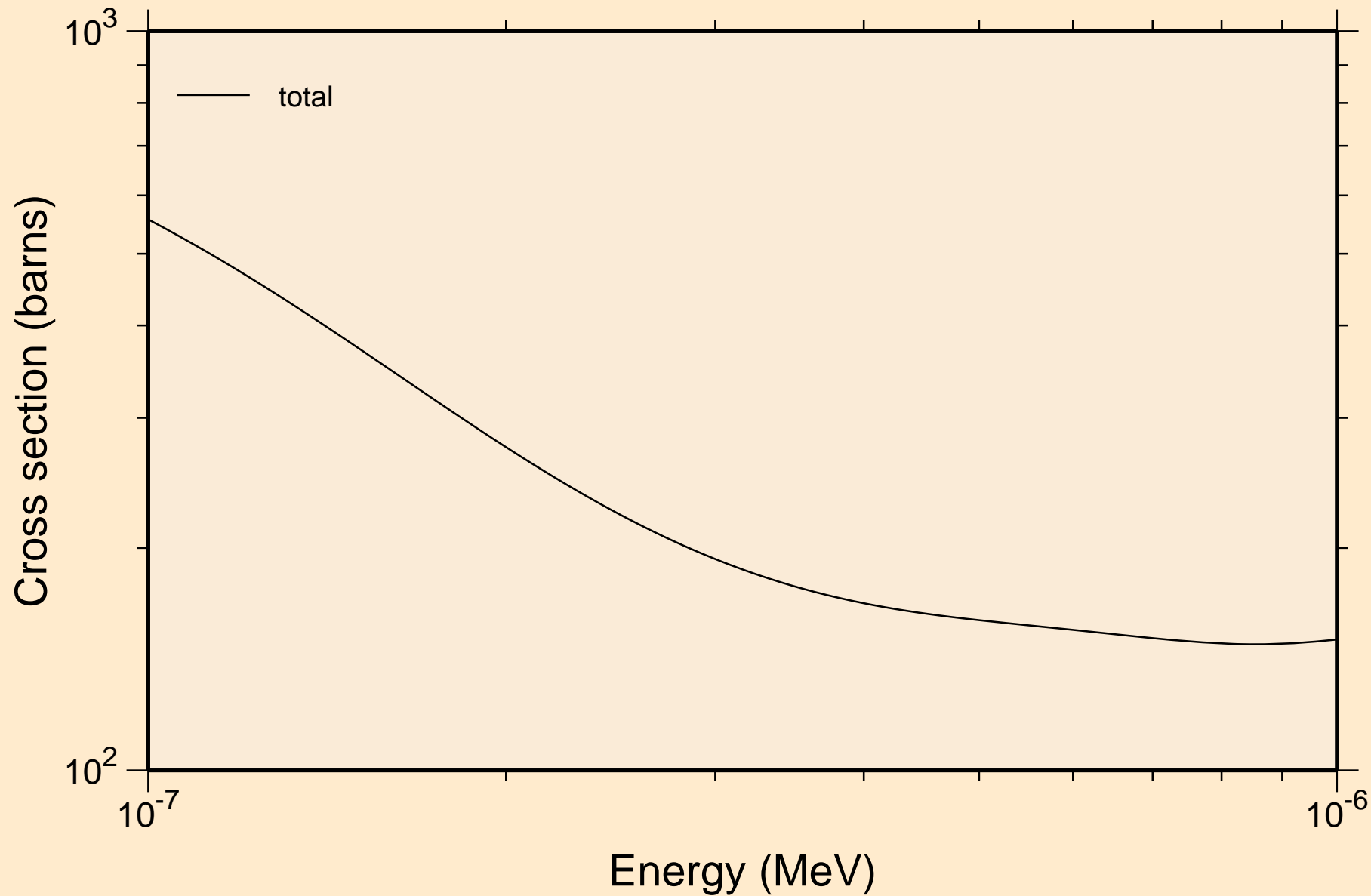

BH264 NEUTRON ACER TENDL-2019 LIBRARY; T=293.16K
resonance total cross section

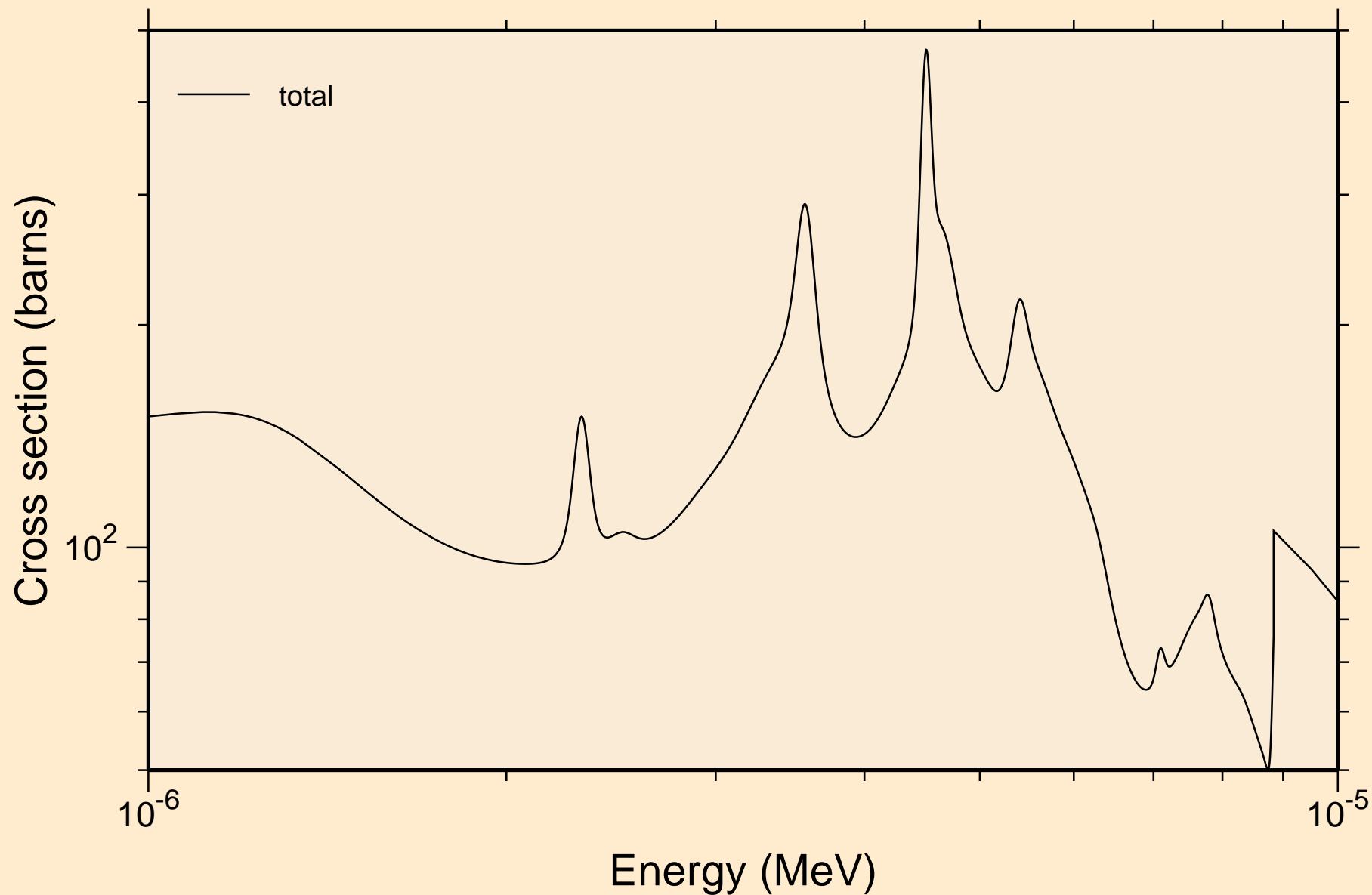

BH264 NEUTRON ACER TENDL-2019 LIBRARY; T=293.16K
resonance total cross section

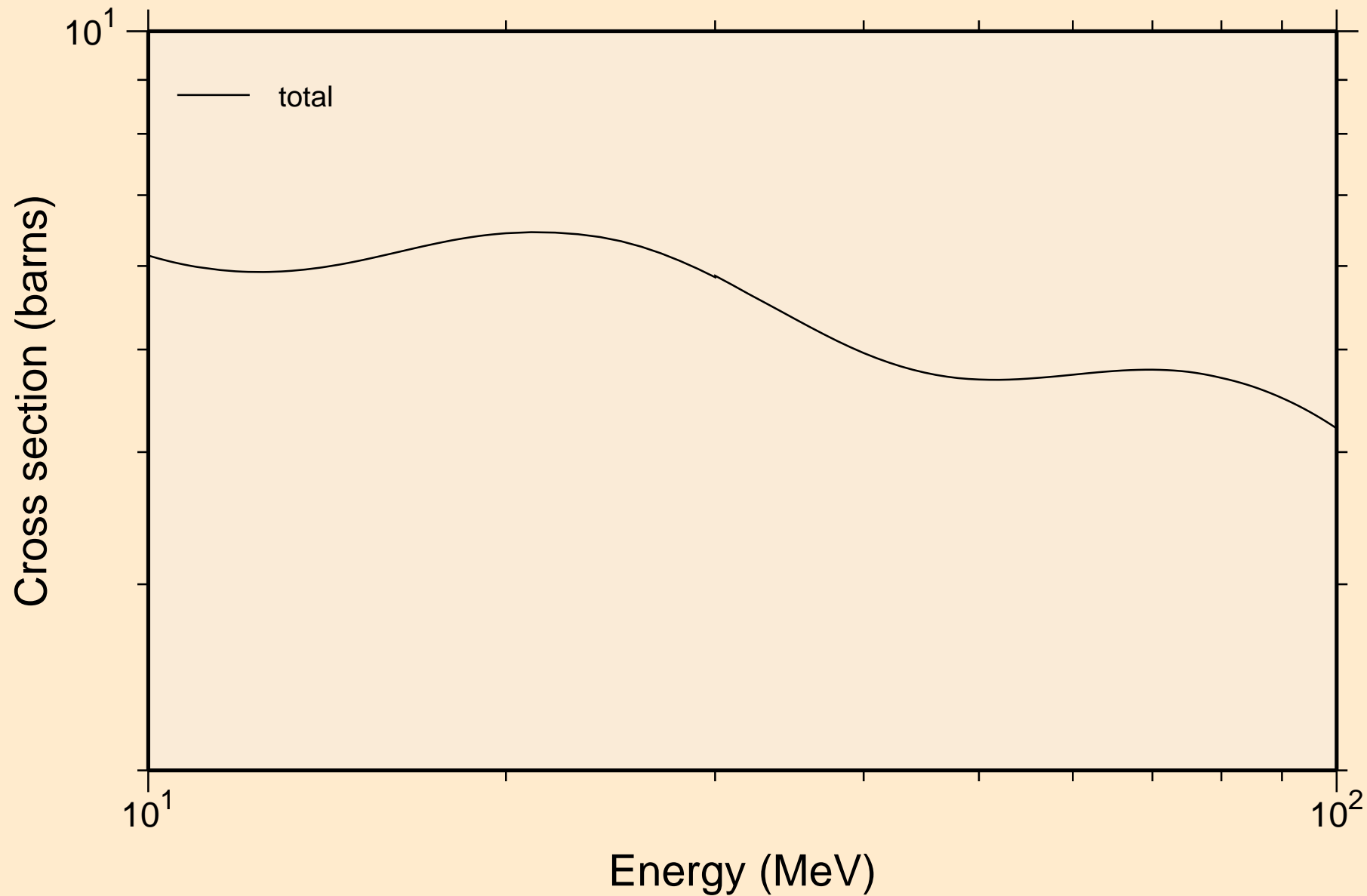

BH264 NEUTRON ACER TENDL-2019 LIBRARY; T=293.16K
resonance absorption cross sections

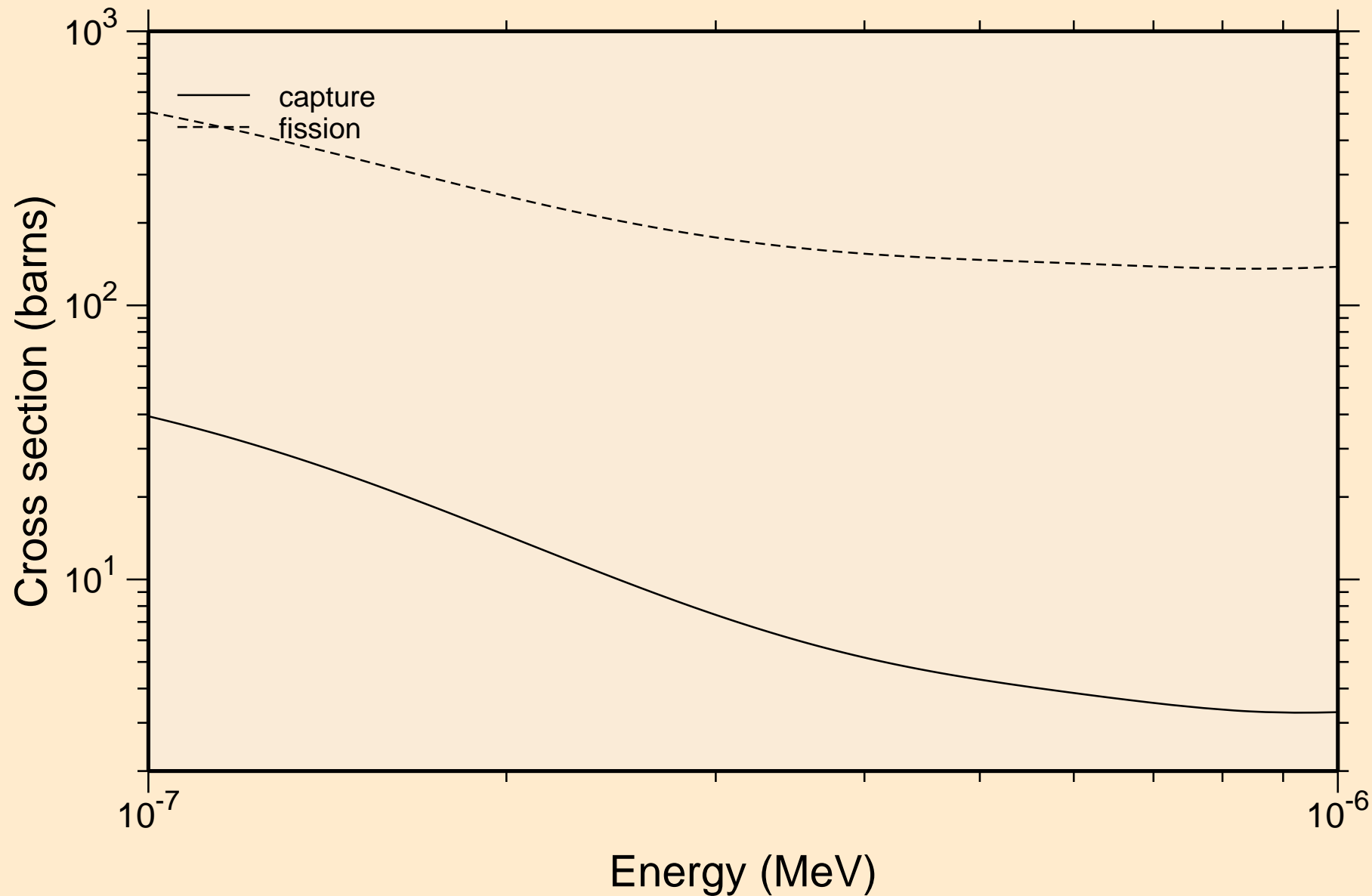

BH264 NEUTRON ACER TENDL-2019 LIBRARY; T=293.16K
resonance absorption cross sections

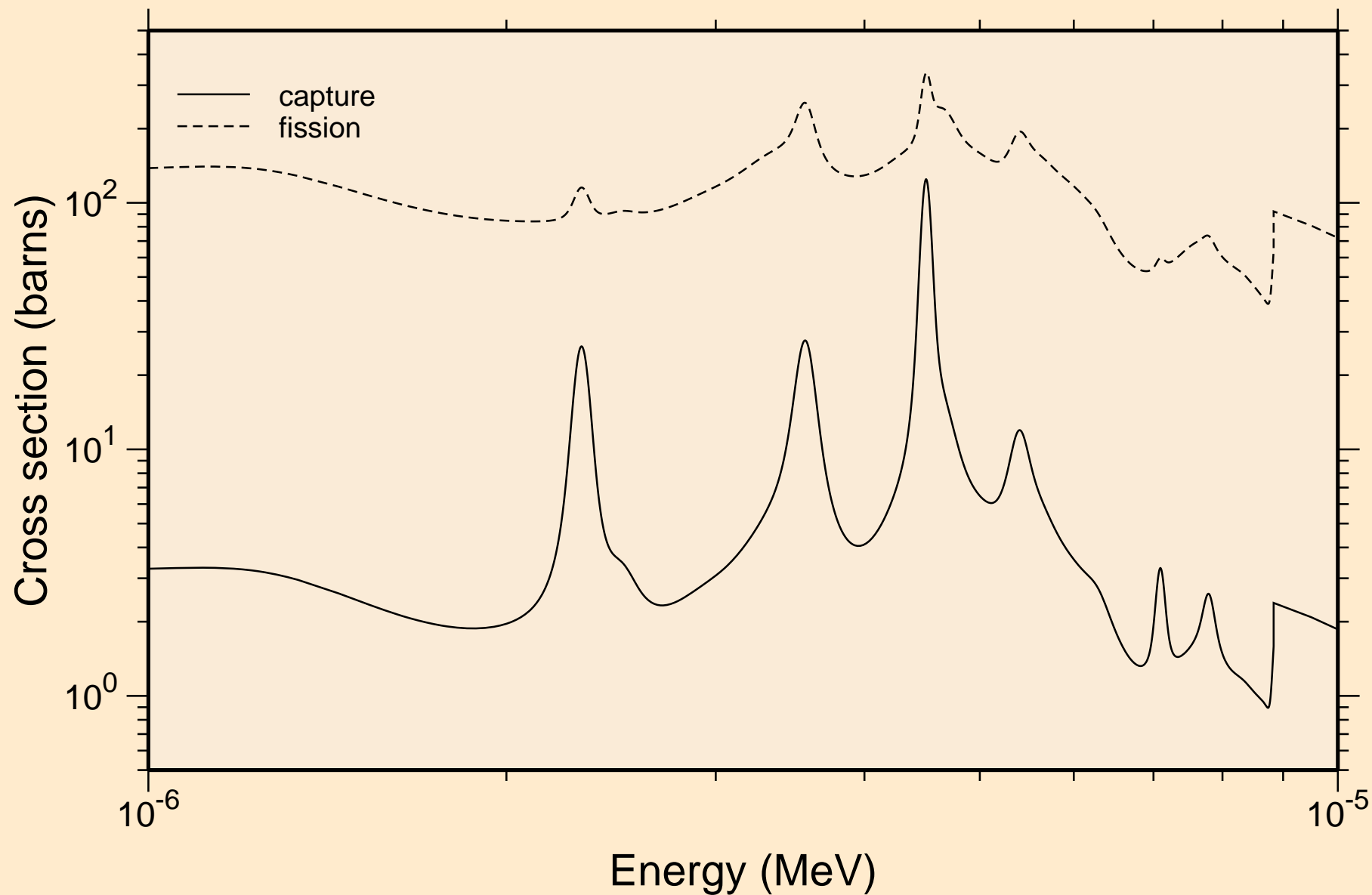

BH264 NEUTRON ACER TENDL-2019 LIBRARY; T=293.16K
resonance absorption cross sections

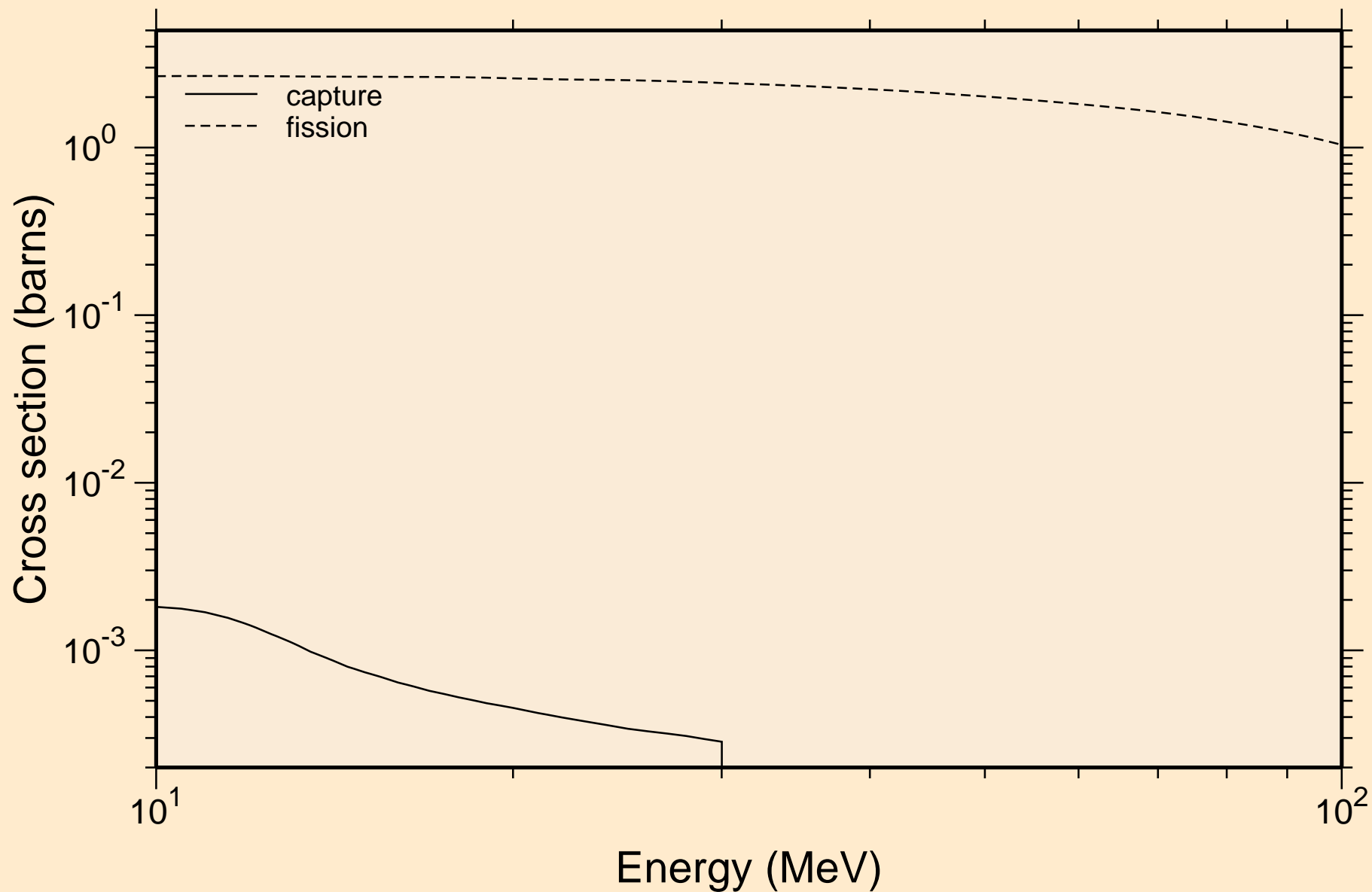

BH264 NEUTRON ACER TENDL-2019 LIBRARY; T=293.16K
Heating

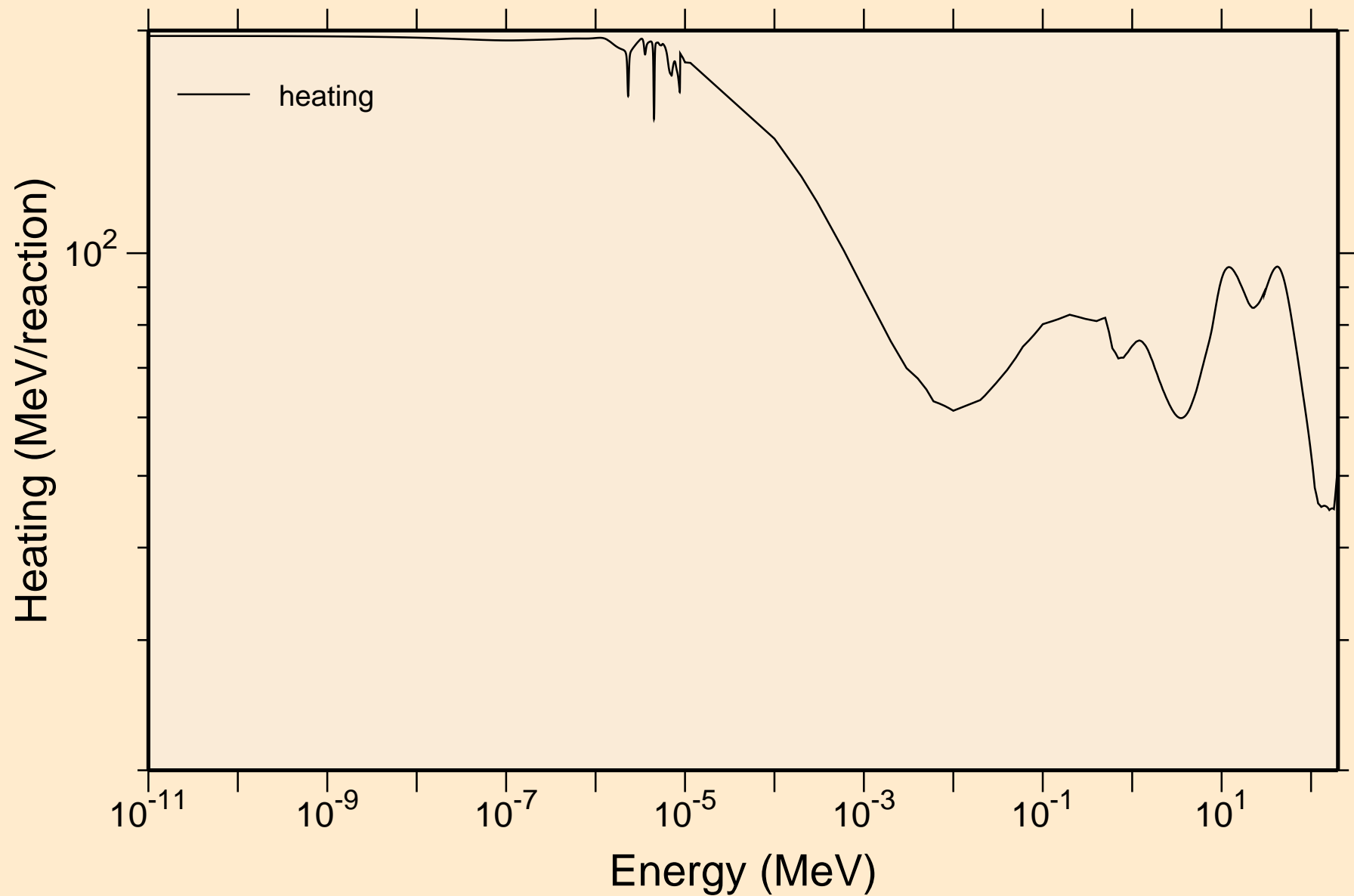

BH264 NEUTRON ACER TENDL-2019 LIBRARY; T=293.16K
Damage

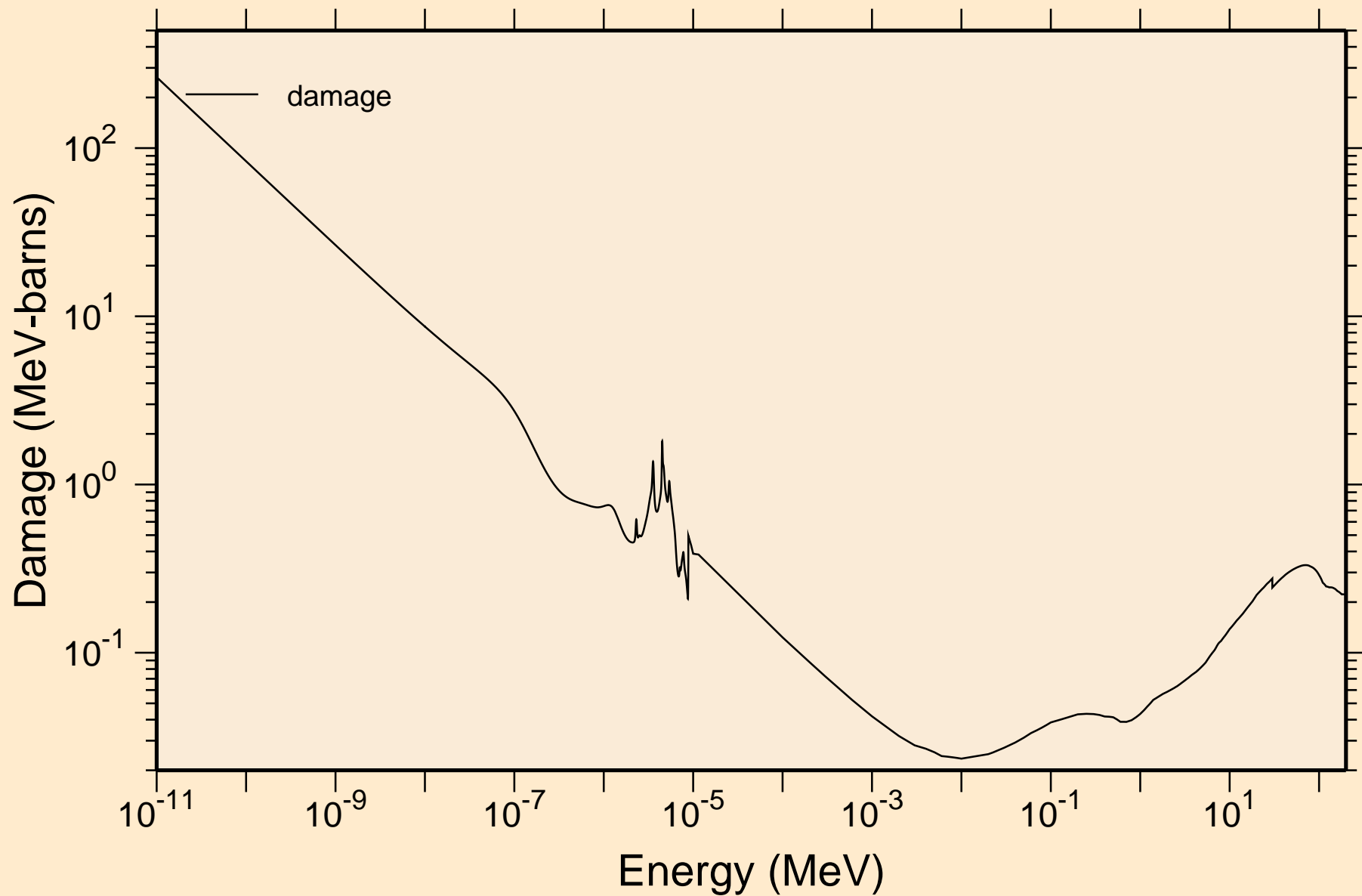

BH264 NEUTRON ACER TENDL-2019 LIBRARY; T=293.16K

Non-threshold reactions

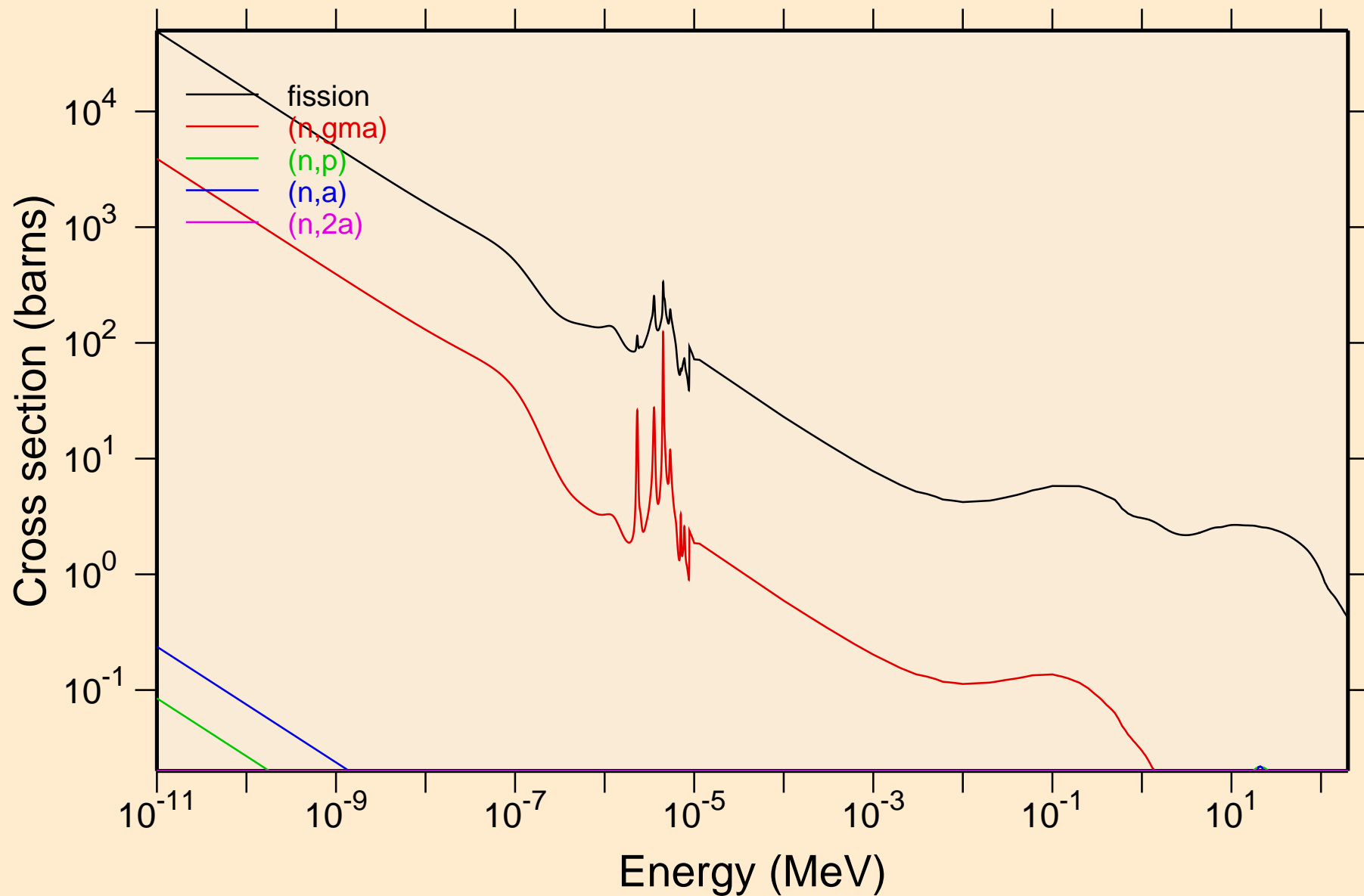

BH264 NEUTRON ACER TENDL-2019 LIBRARY; T=293.16K
Non-threshold reactions

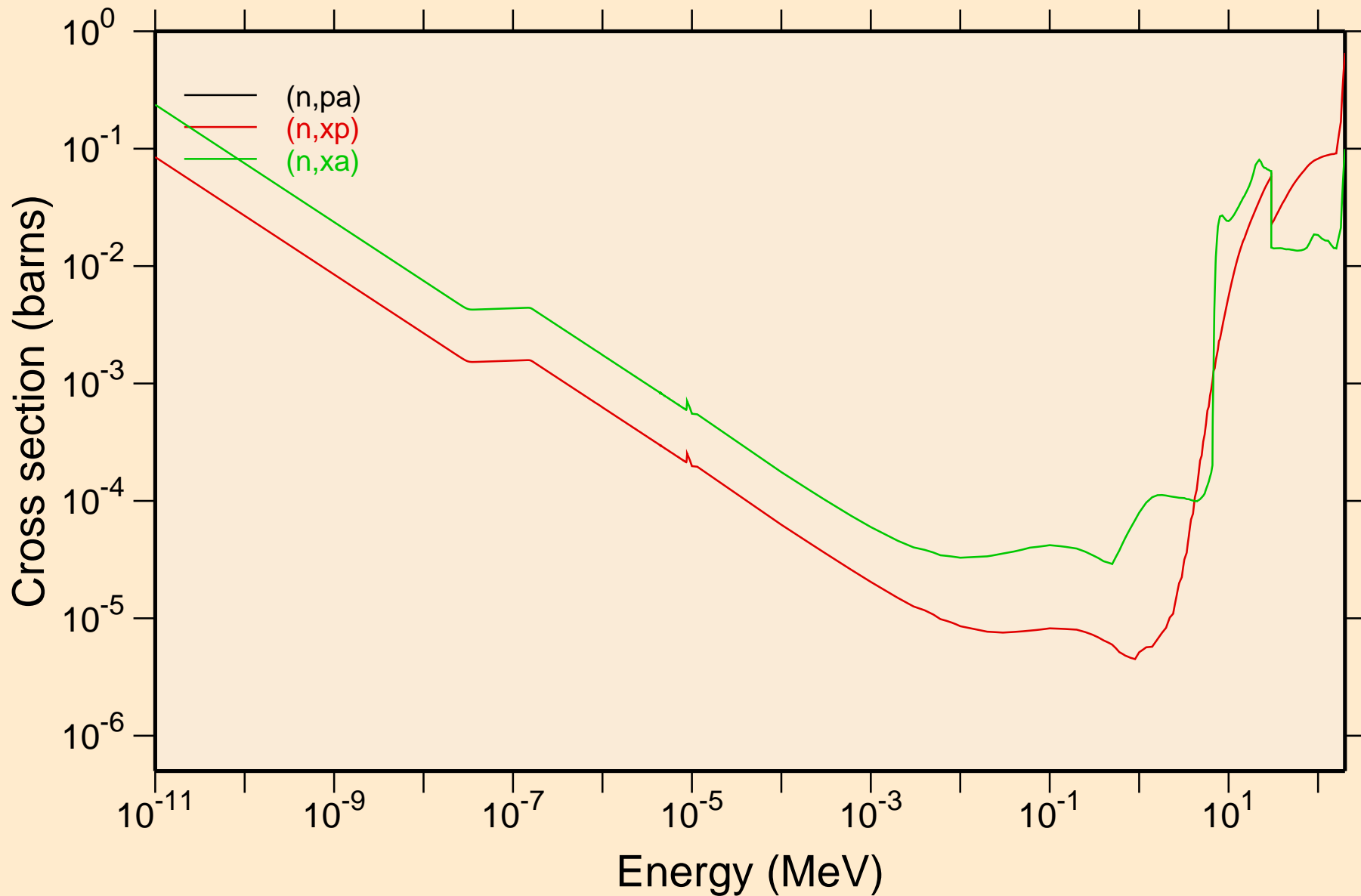

BH264 NEUTRON ACER TENDL-2019 LIBRARY; T=293.16K
Principal cross sections

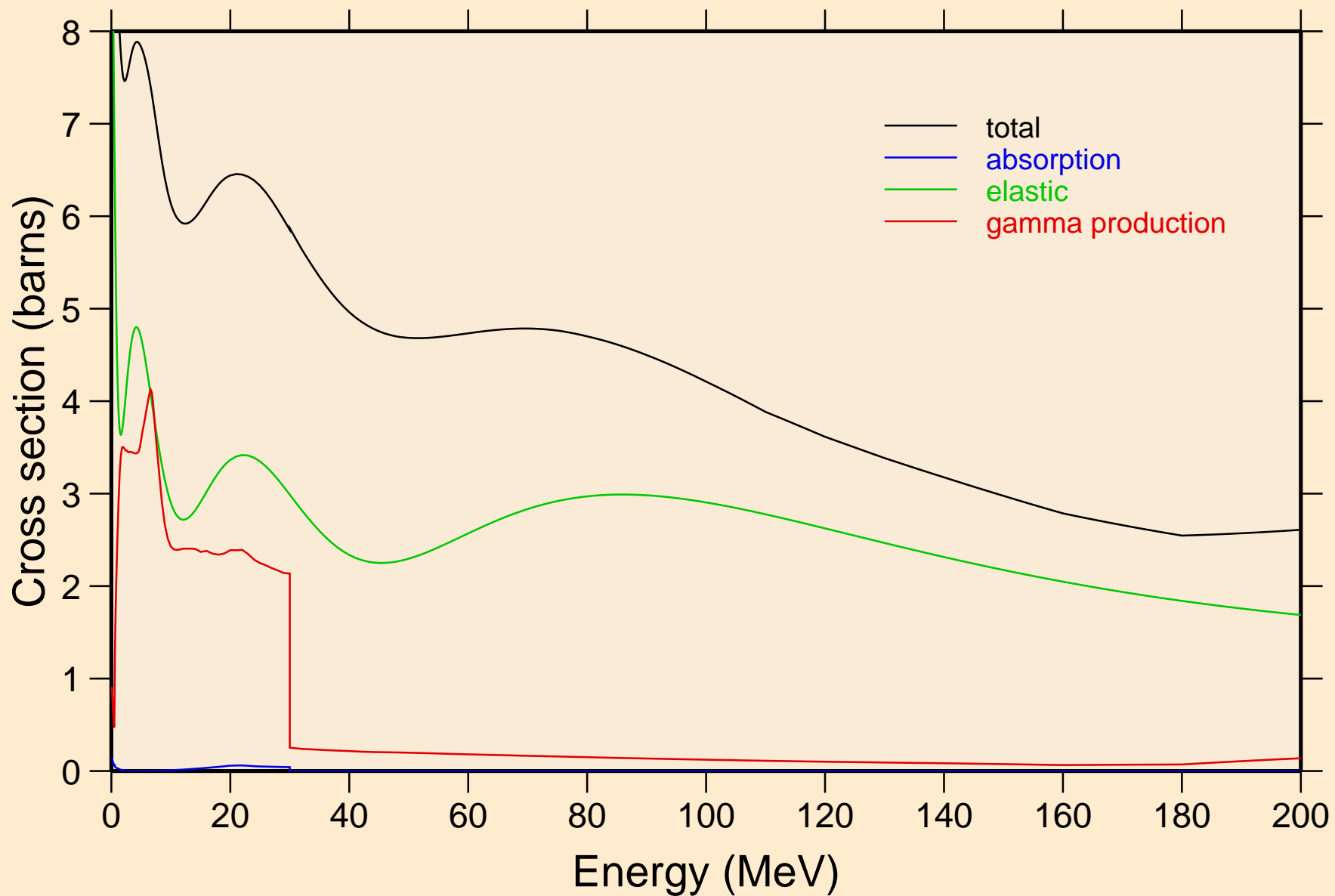

BH264 NEUTRON ACER TENDL-2019 LIBRARY; T=293.16K
Heating

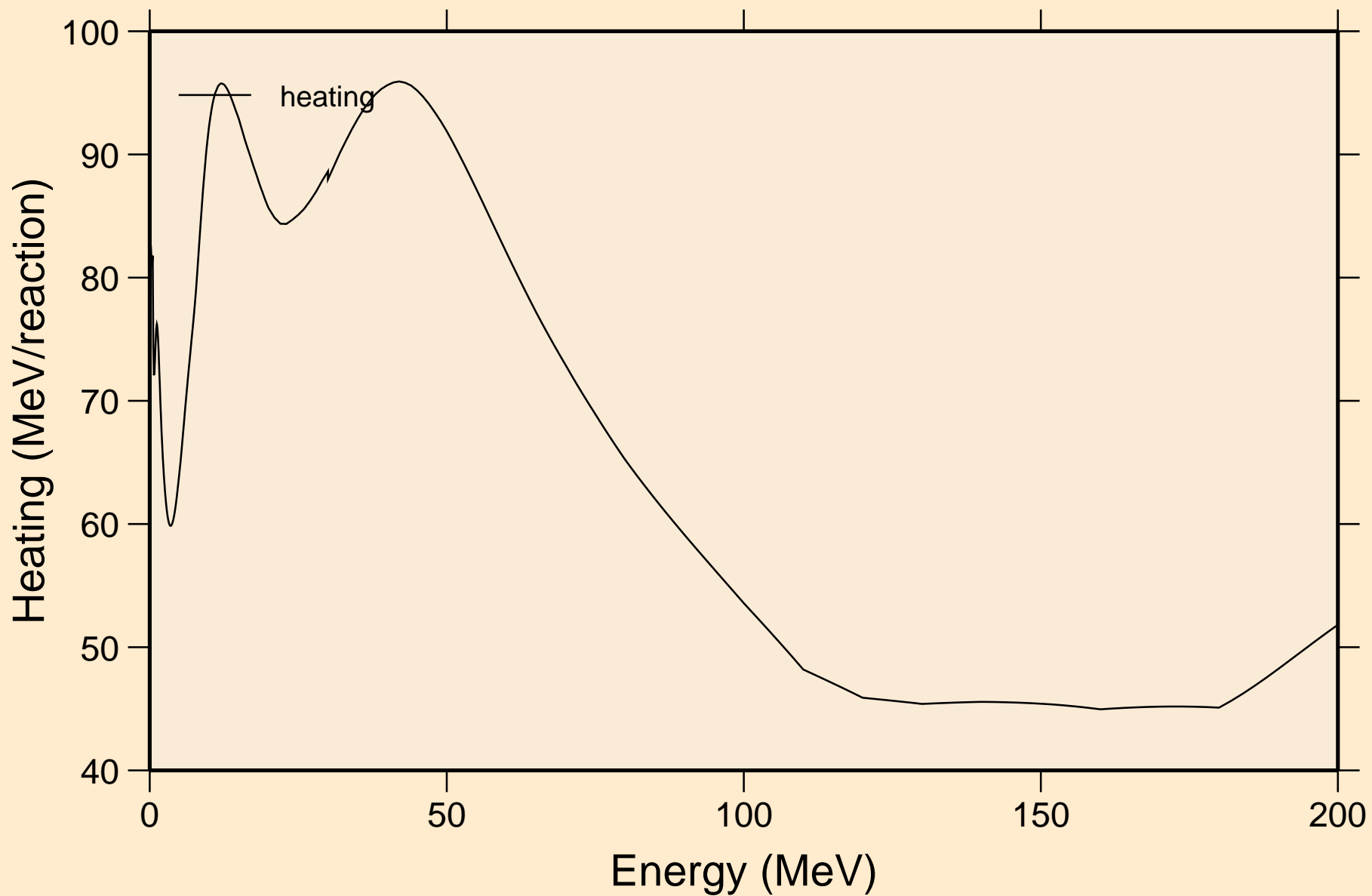

BH264 NEUTRON ACER TENDL-2019 LIBRARY; T=293.16K
Damage

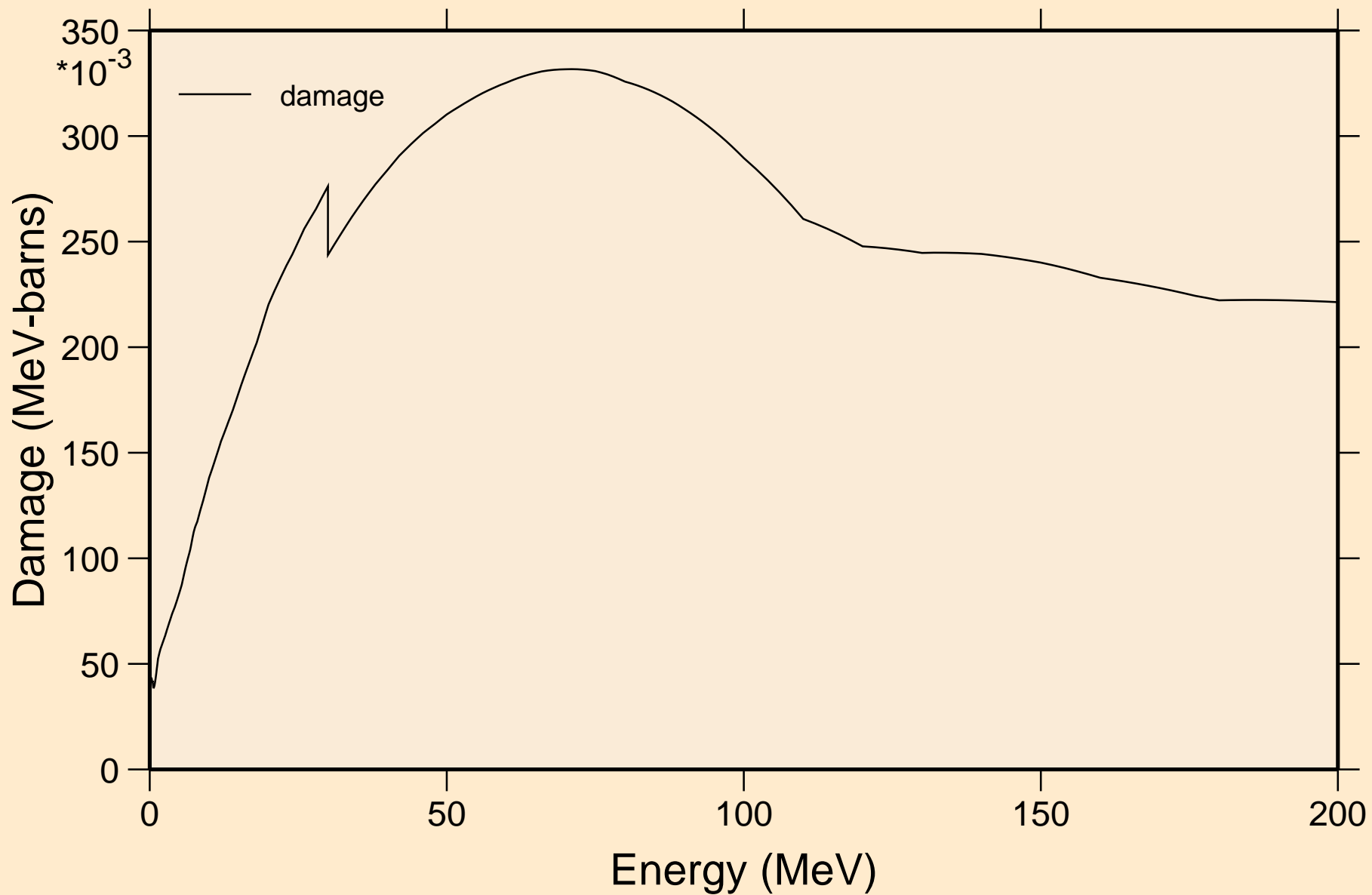

BH264 NEUTRON ACER TENDL-2019 LIBRARY; T=293.16K
Non-threshold reactions

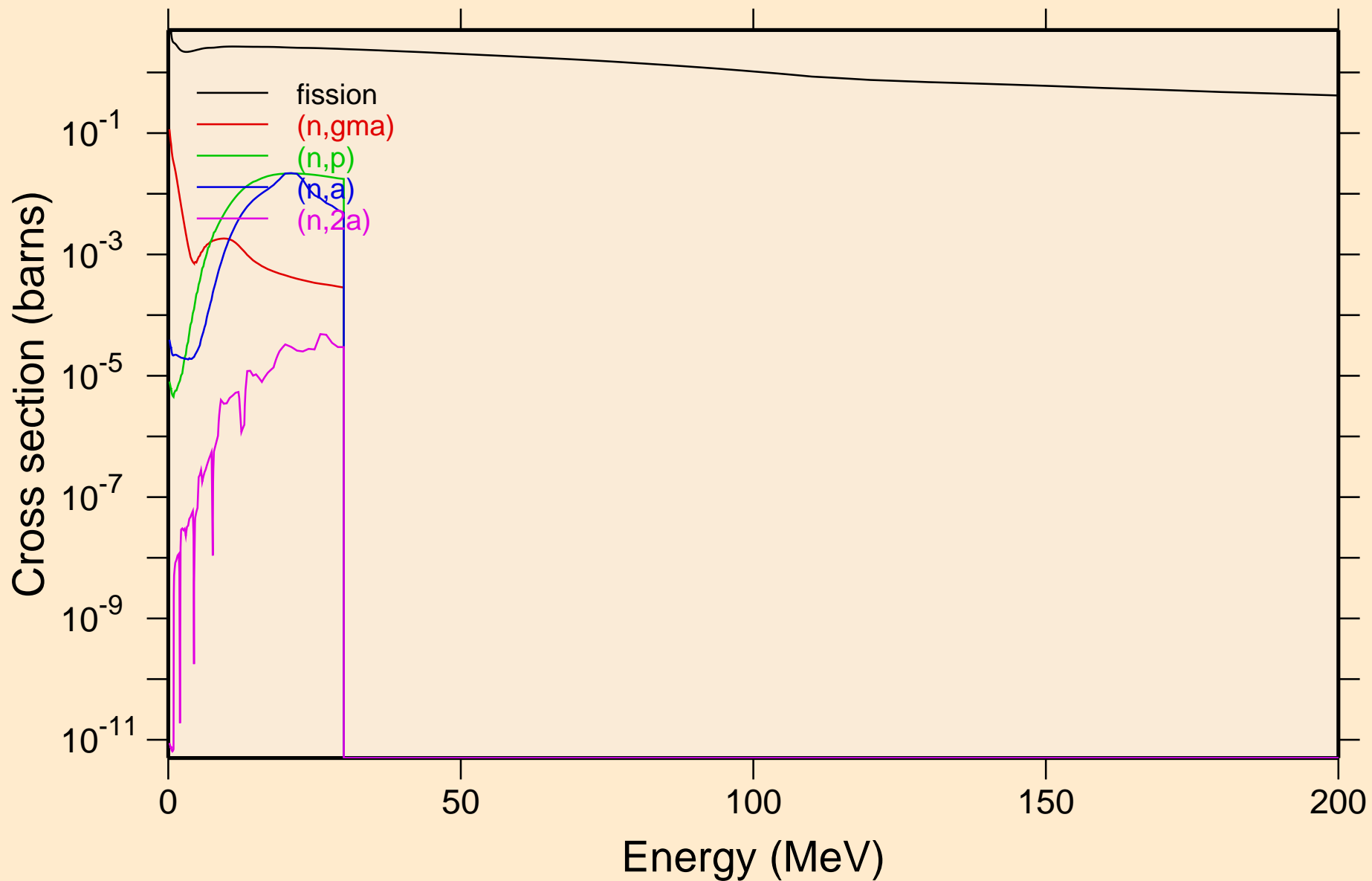

BH264 NEUTRON ACER TENDL-2019 LIBRARY; T=293.16K
Non-threshold reactions

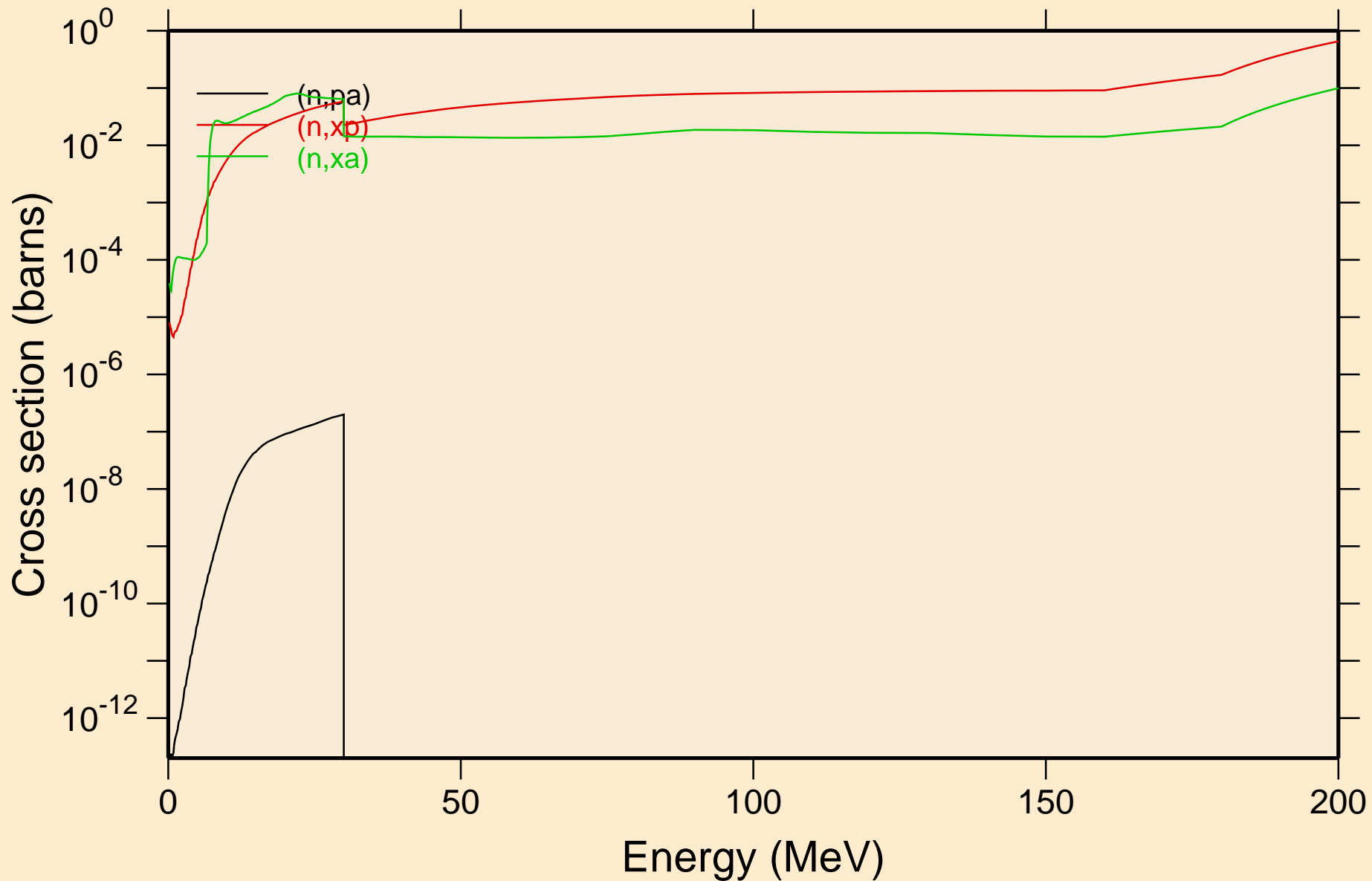

BH264 NEUTRON ACER TENDL-2019 LIBRARY; T=293.16K
Inelastic levels

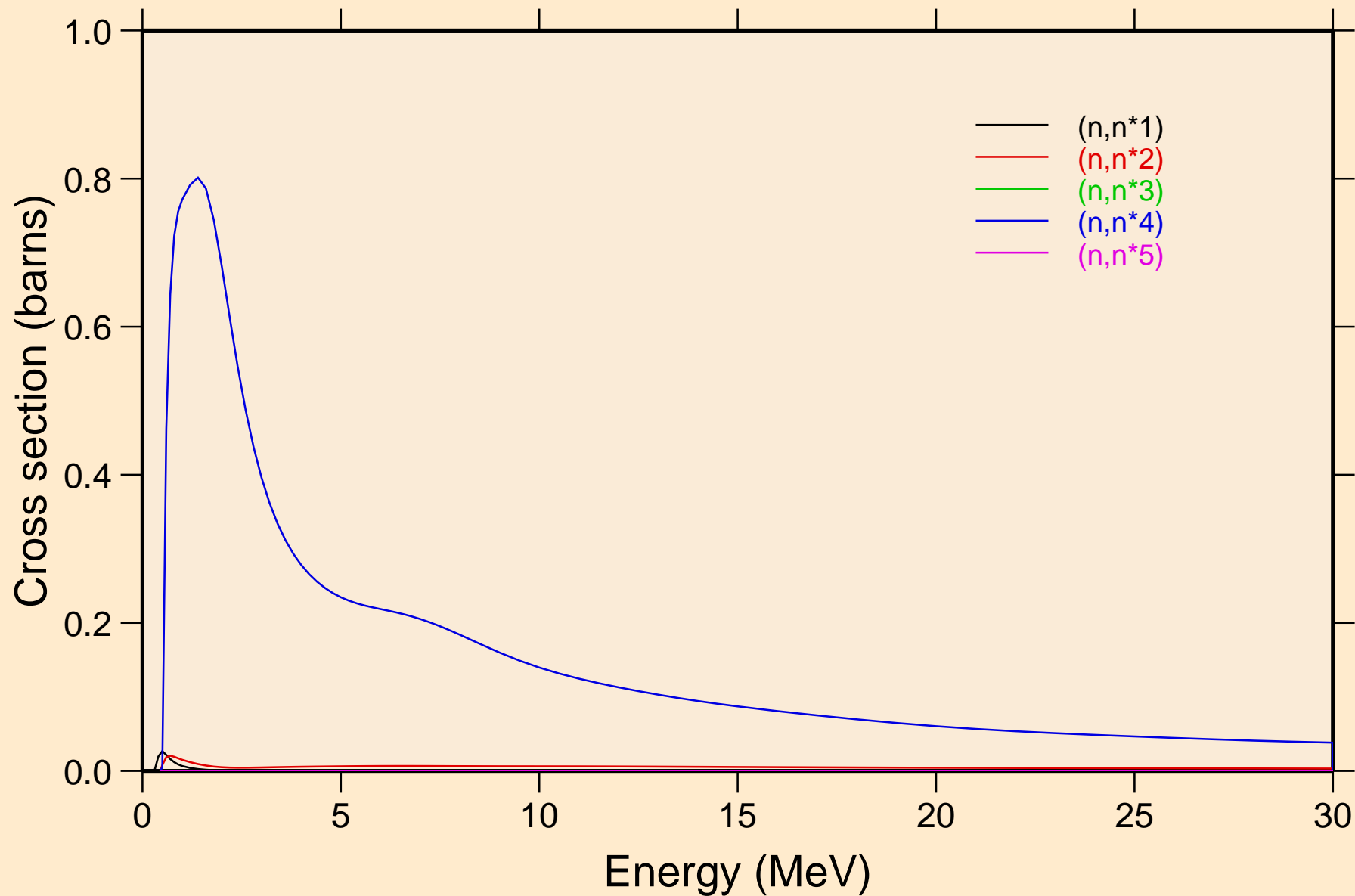

BH264 NEUTRON ACER TENDL-2019 LIBRARY; T=293.16K
Inelastic levels

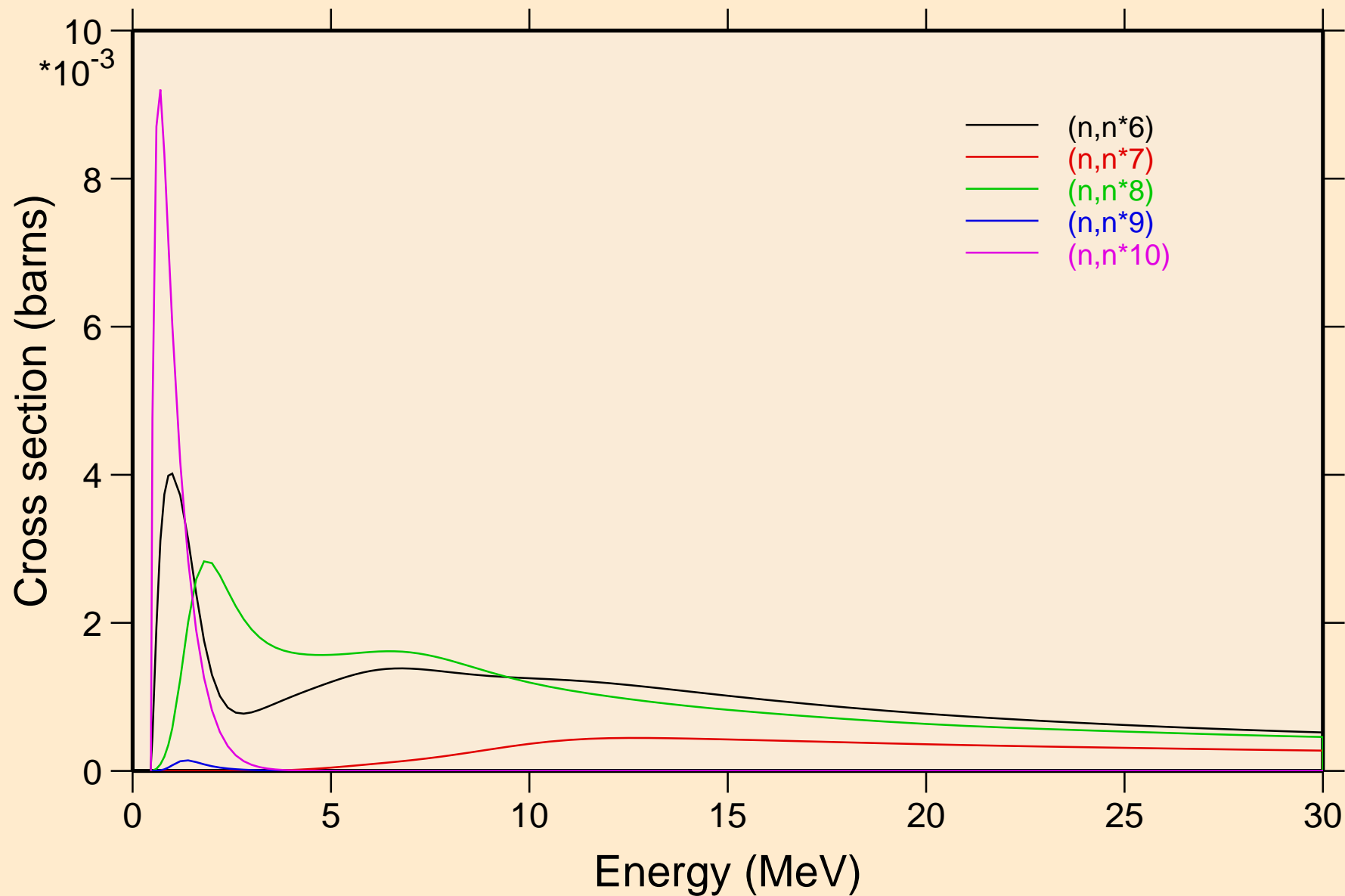

BH264 NEUTRON ACER TENDL-2019 LIBRARY; T=293.16K
Inelastic levels

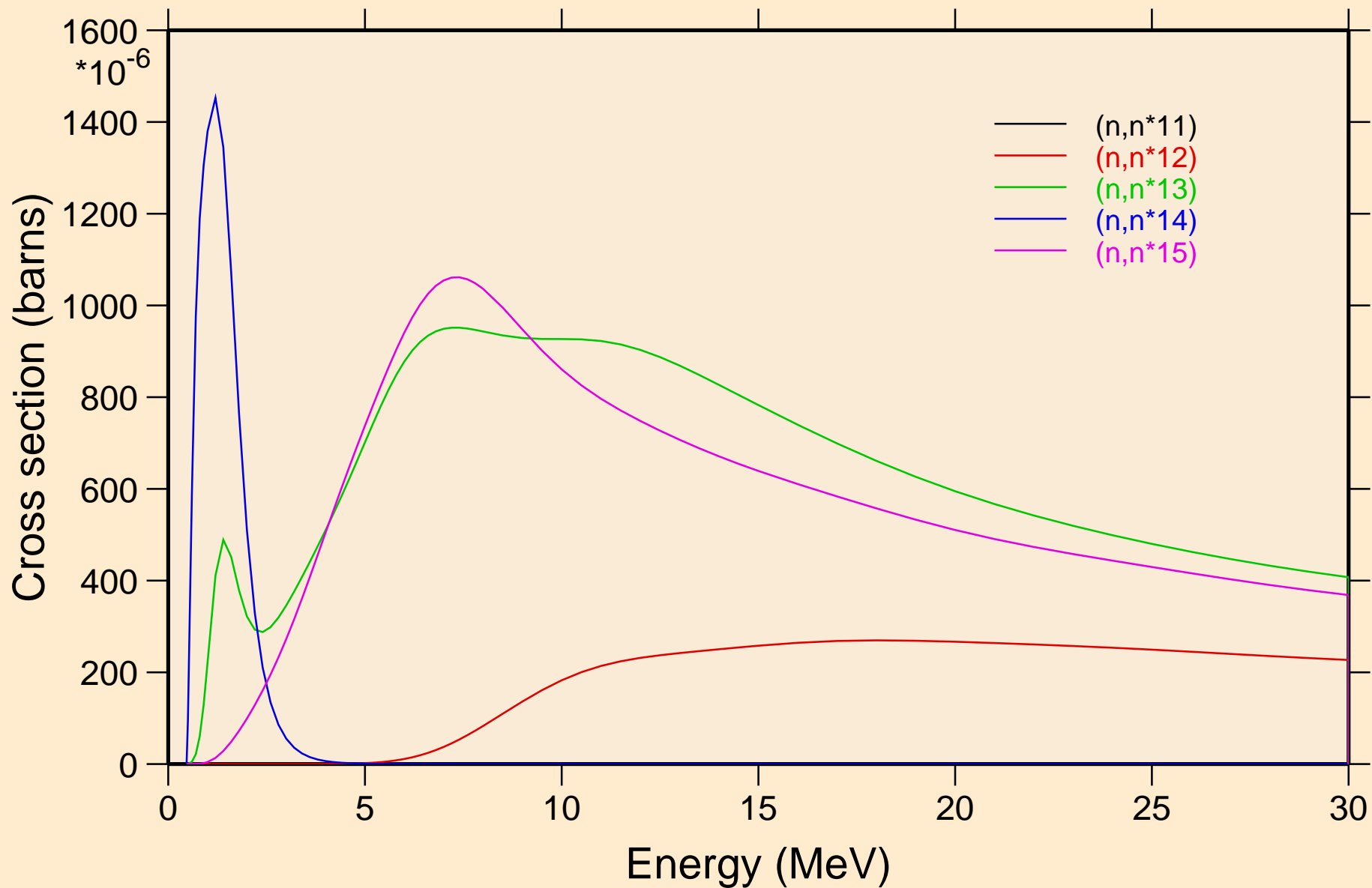

BH264 NEUTRON ACER TENDL-2019 LIBRARY; T=293.16K
Inelastic levels

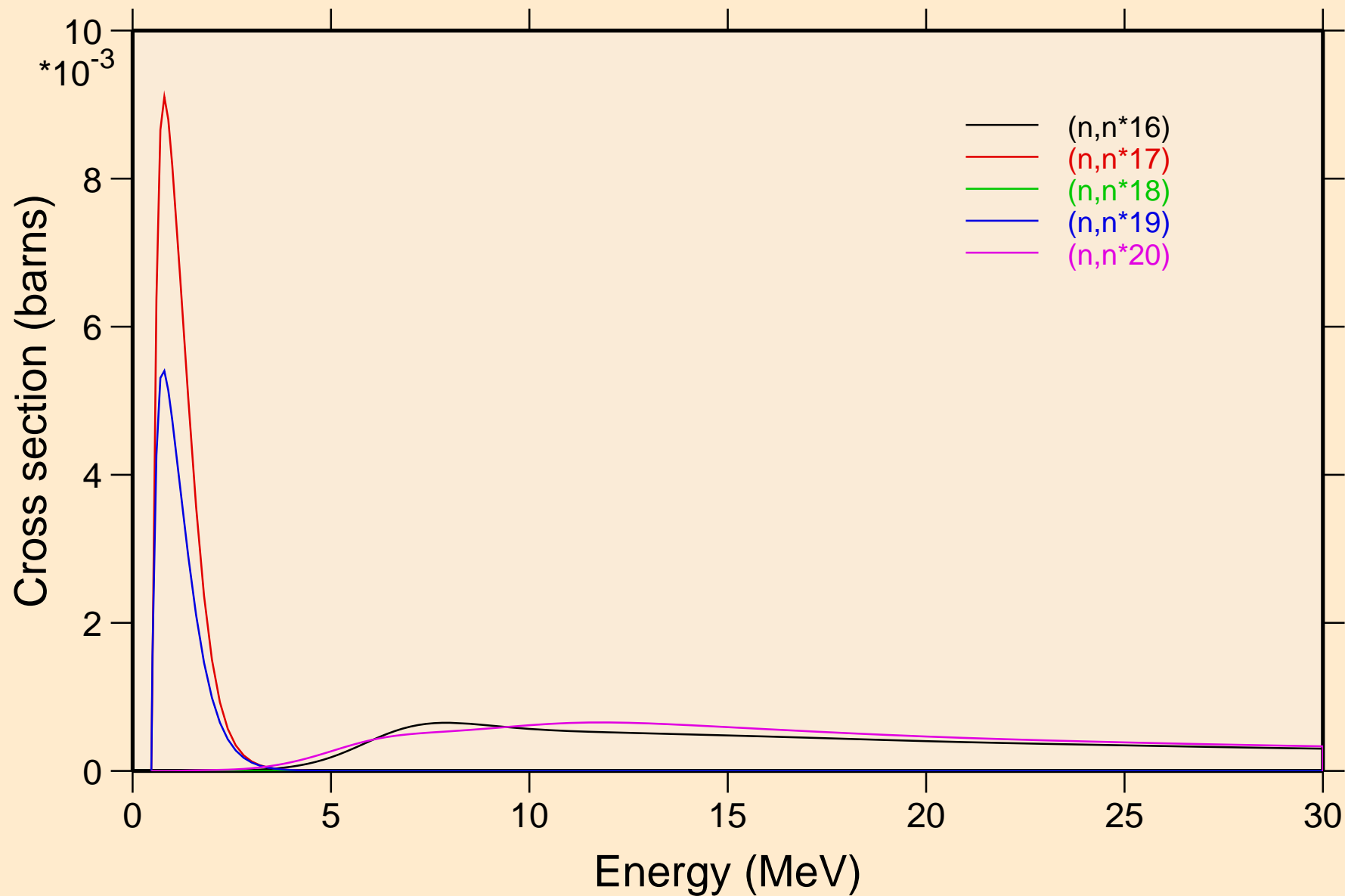

BH264 NEUTRON ACER TENDL-2019 LIBRARY; T=293.16K
Inelastic levels

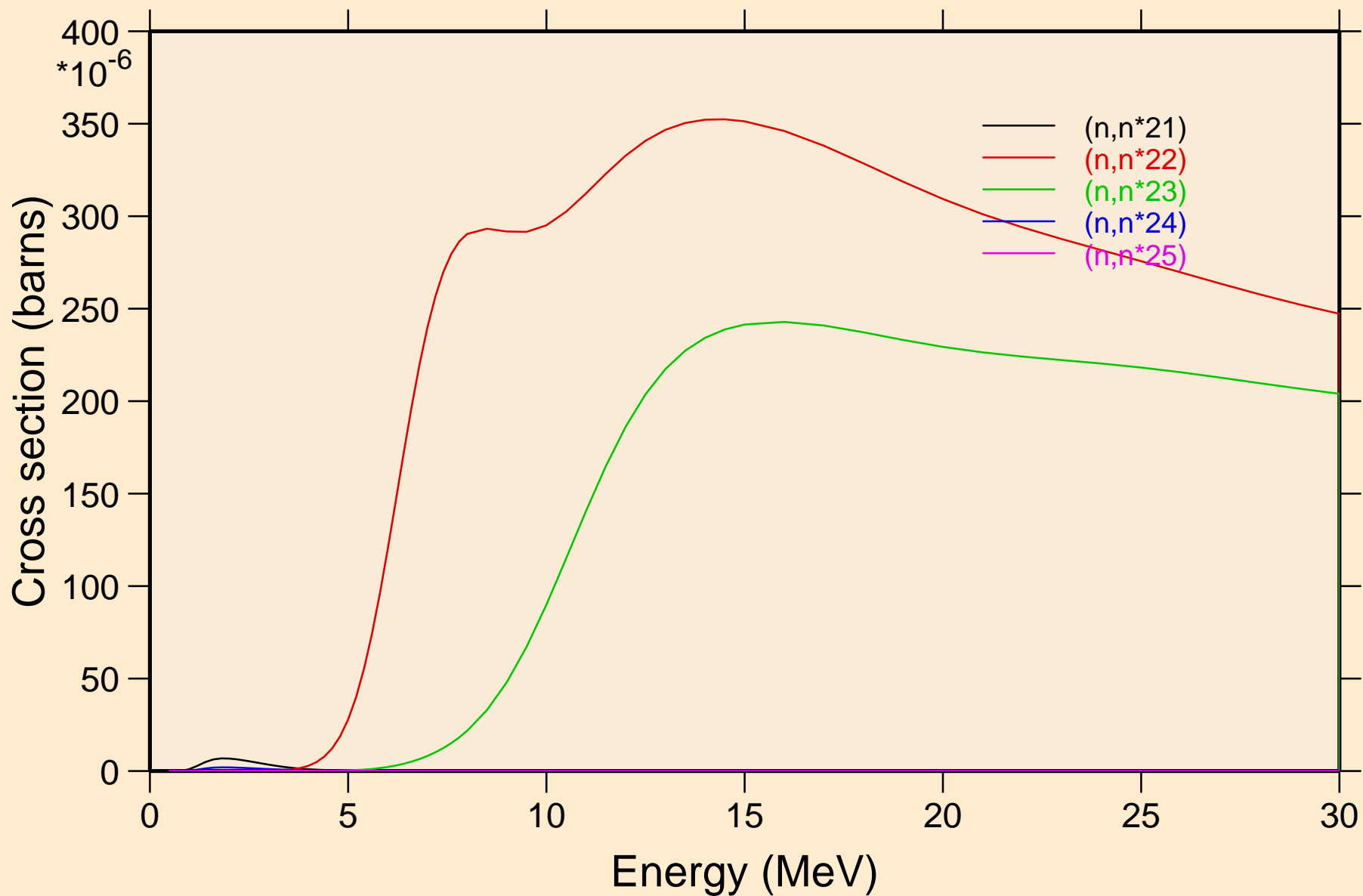

BH264 NEUTRON ACER TENDL-2019 LIBRARY; T=293.16K
Inelastic levels

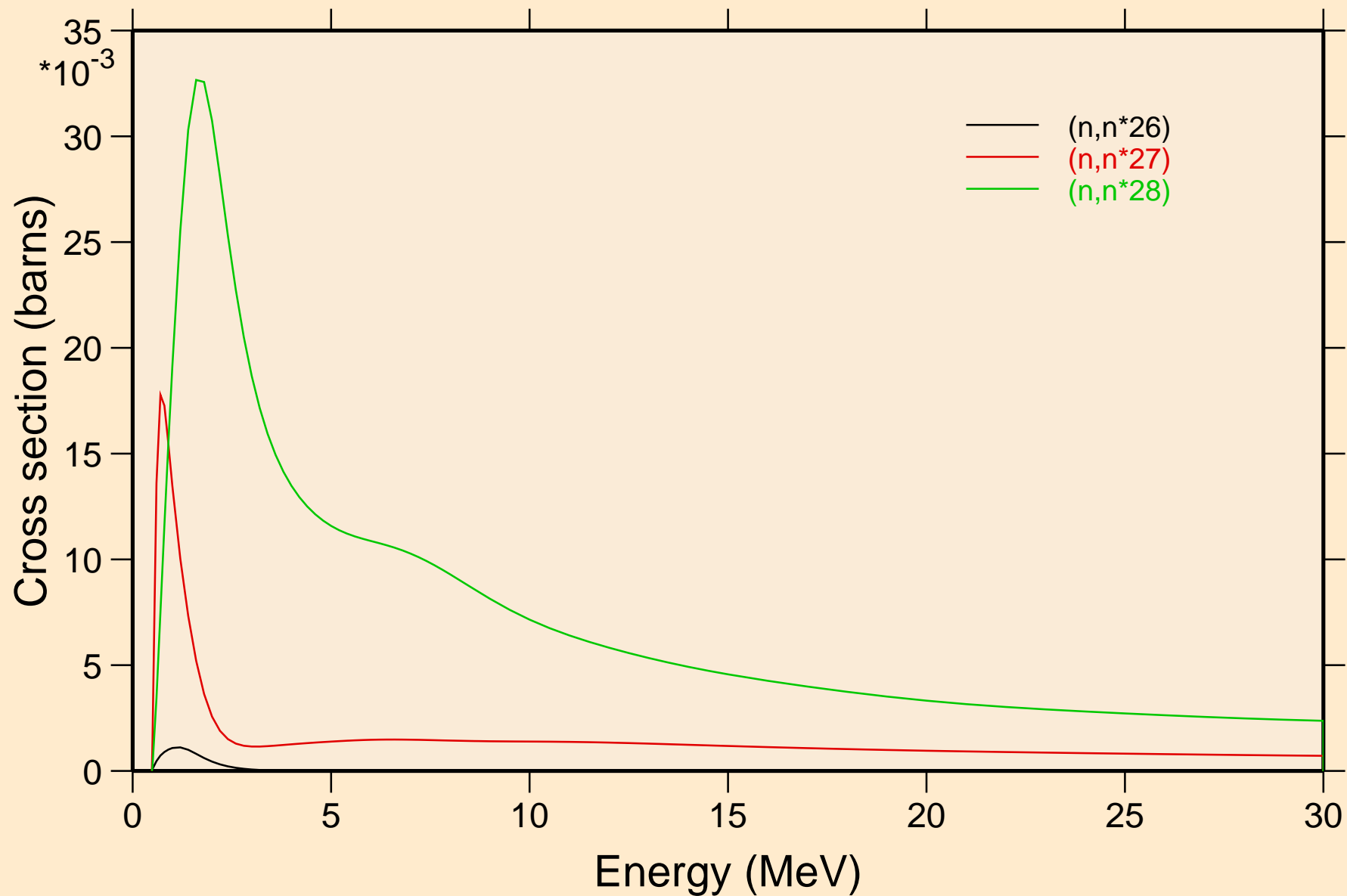

BH264 NEUTRON ACER TENDL-2019 LIBRARY; T=293.16K
Threshold reactions

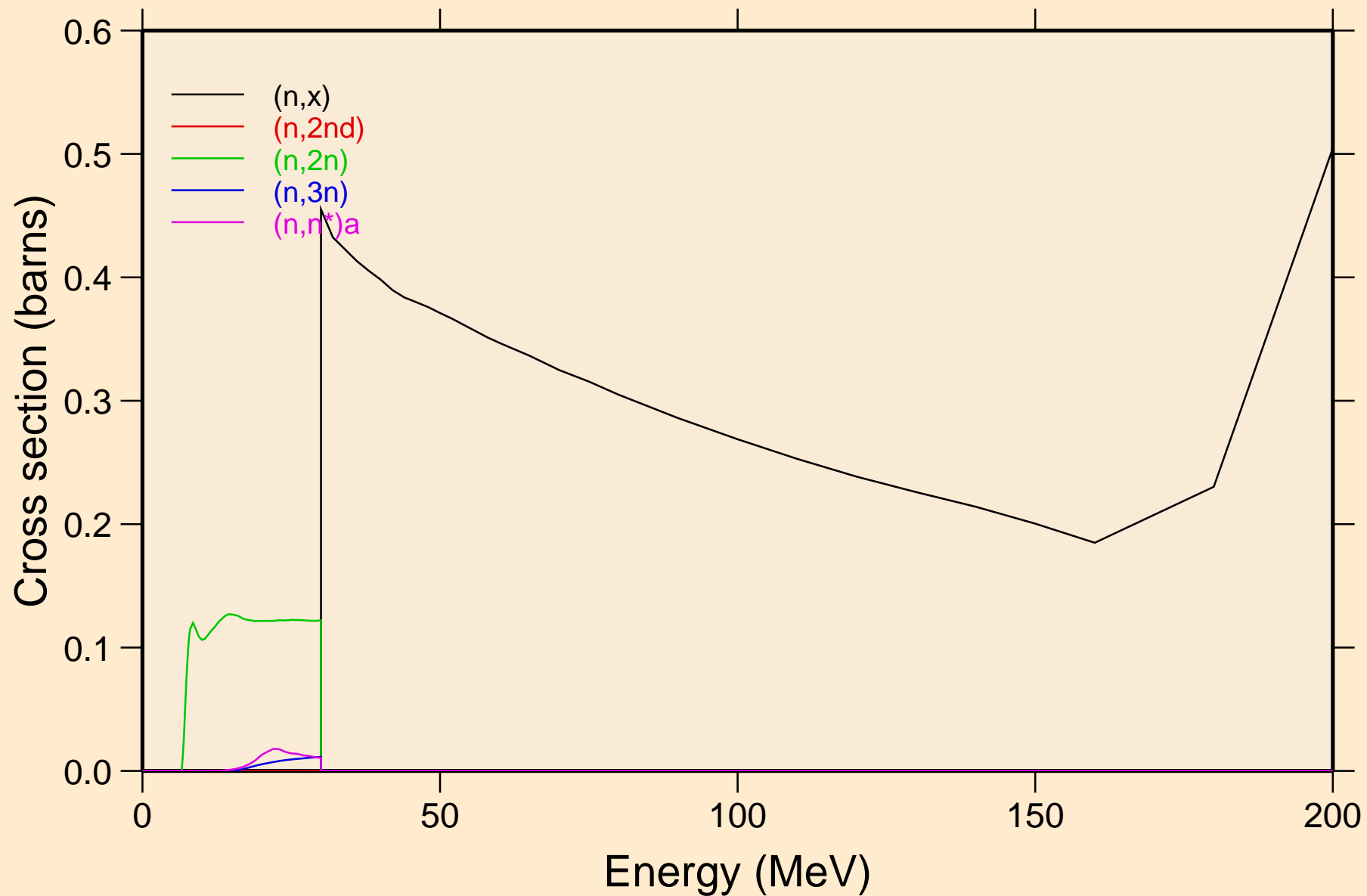

BH264 NEUTRON ACER TENDL-2019 LIBRARY; T=293.16K
Threshold reactions

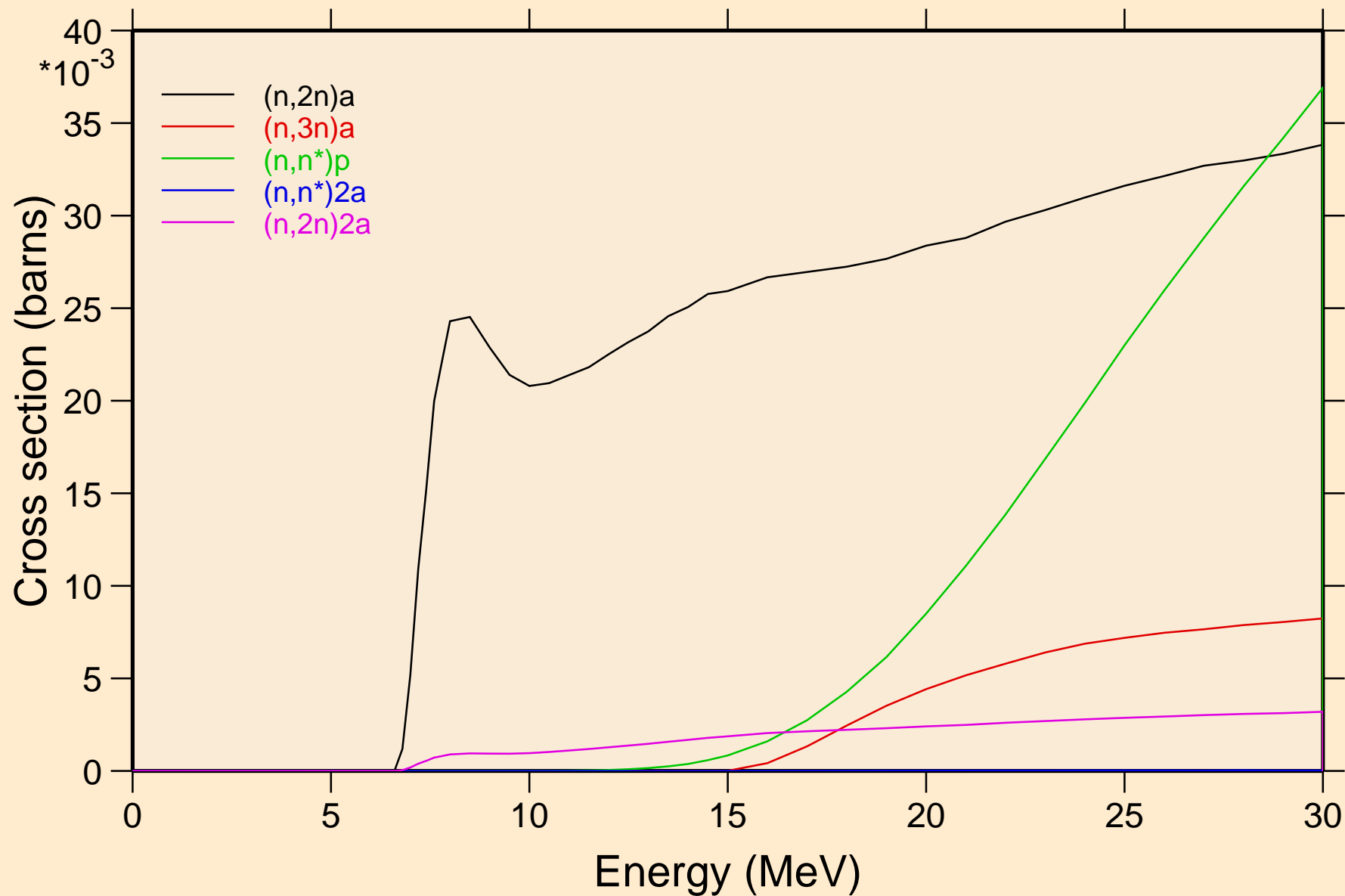

BH264 NEUTRON ACER TENDL-2019 LIBRARY; T=293.16K
Threshold reactions

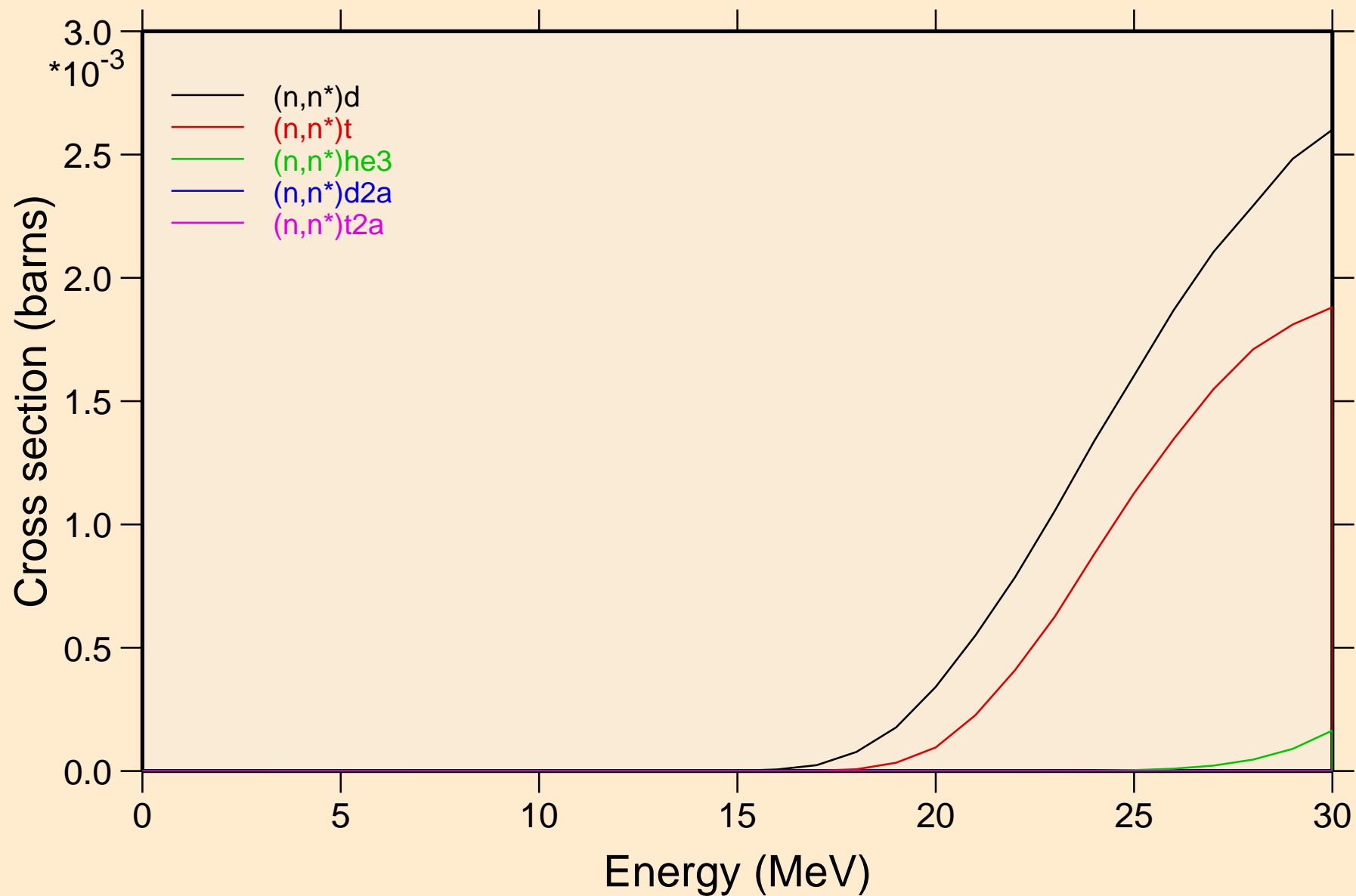

BH264 NEUTRON ACER TENDL-2019 LIBRARY; T=293.16K
Threshold reactions

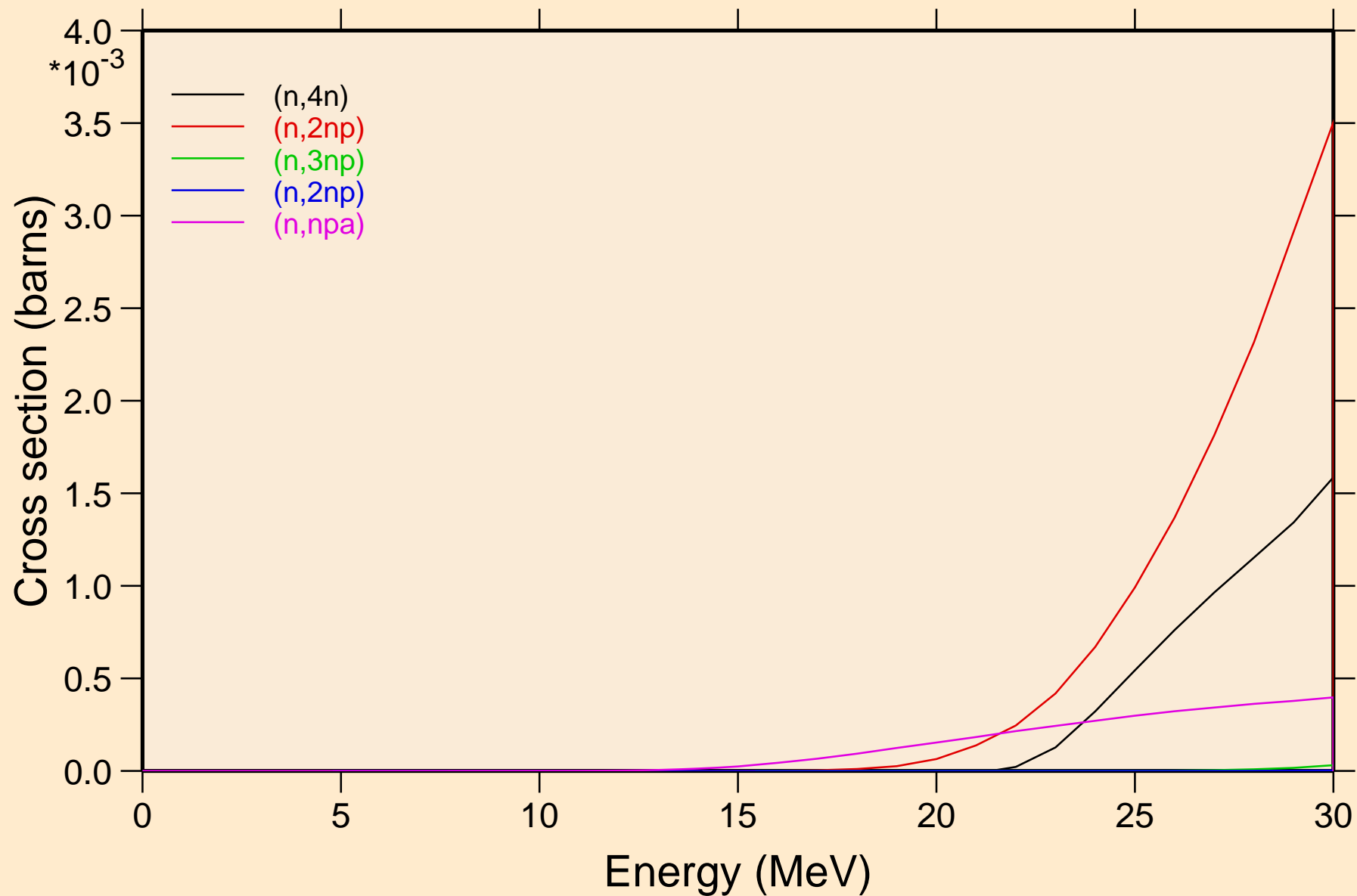

BH264 NEUTRON ACER TENDL-2019 LIBRARY; T=293.16K
Threshold reactions

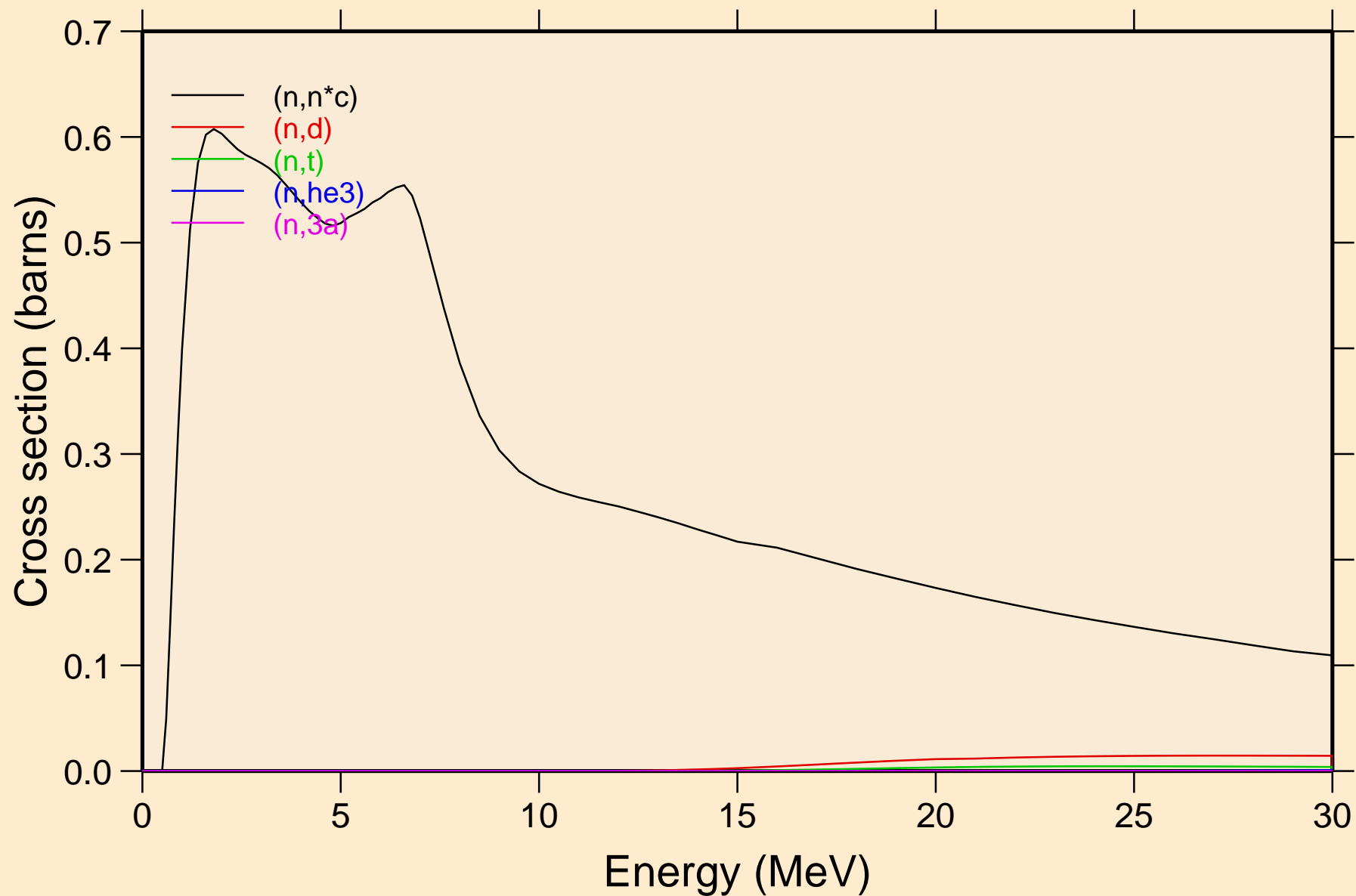

BH264 NEUTRON ACER TENDL-2019 LIBRARY; T=293.16K
Threshold reactions

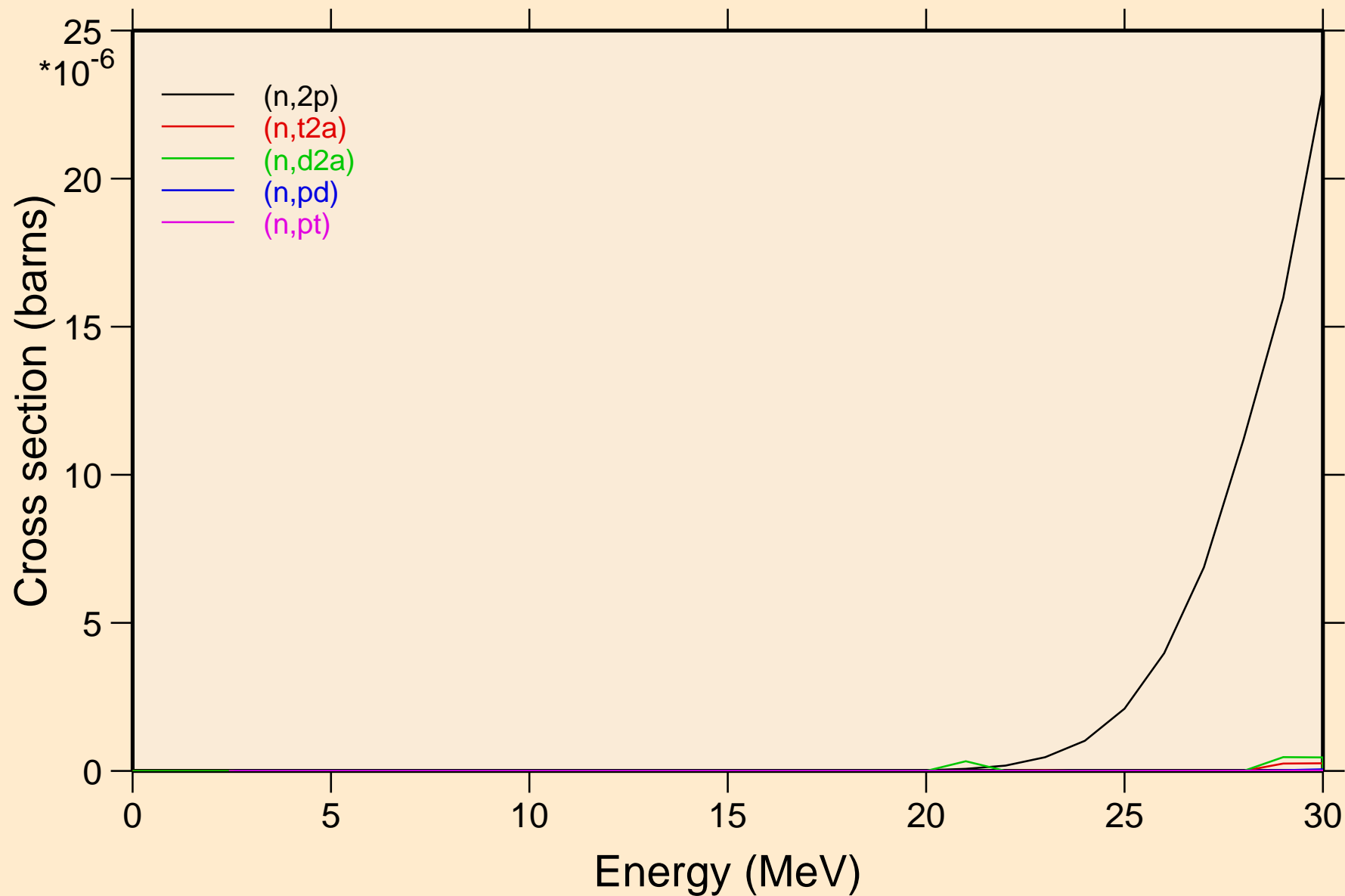

BH264 NEUTRON ACER TENDL-2019 LIBRARY; T=293.16K
Threshold reactions

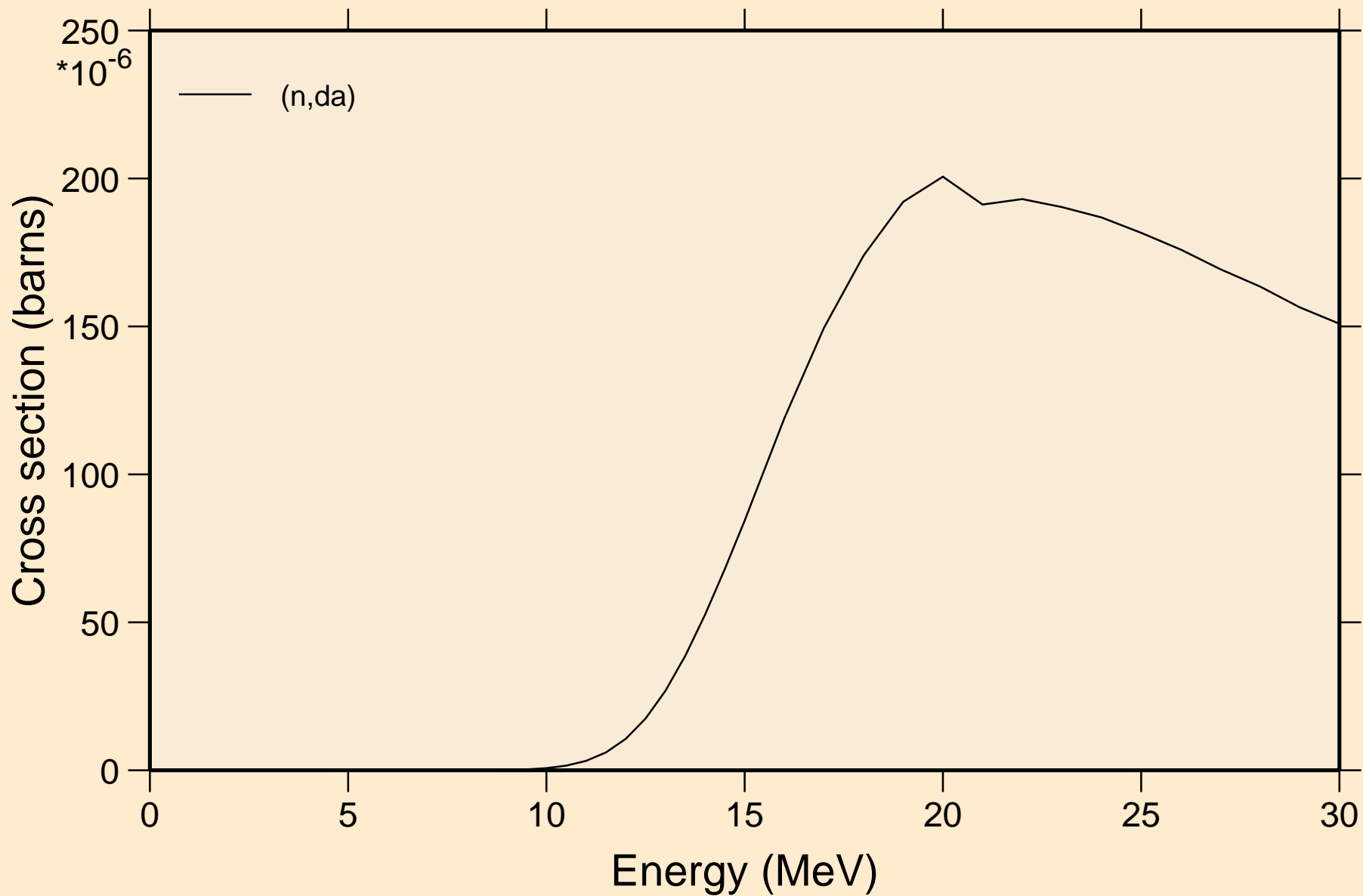

BH264 NEUTRON ACER TENDL-2019 LIBRARY; T=293.16K
Threshold reactions

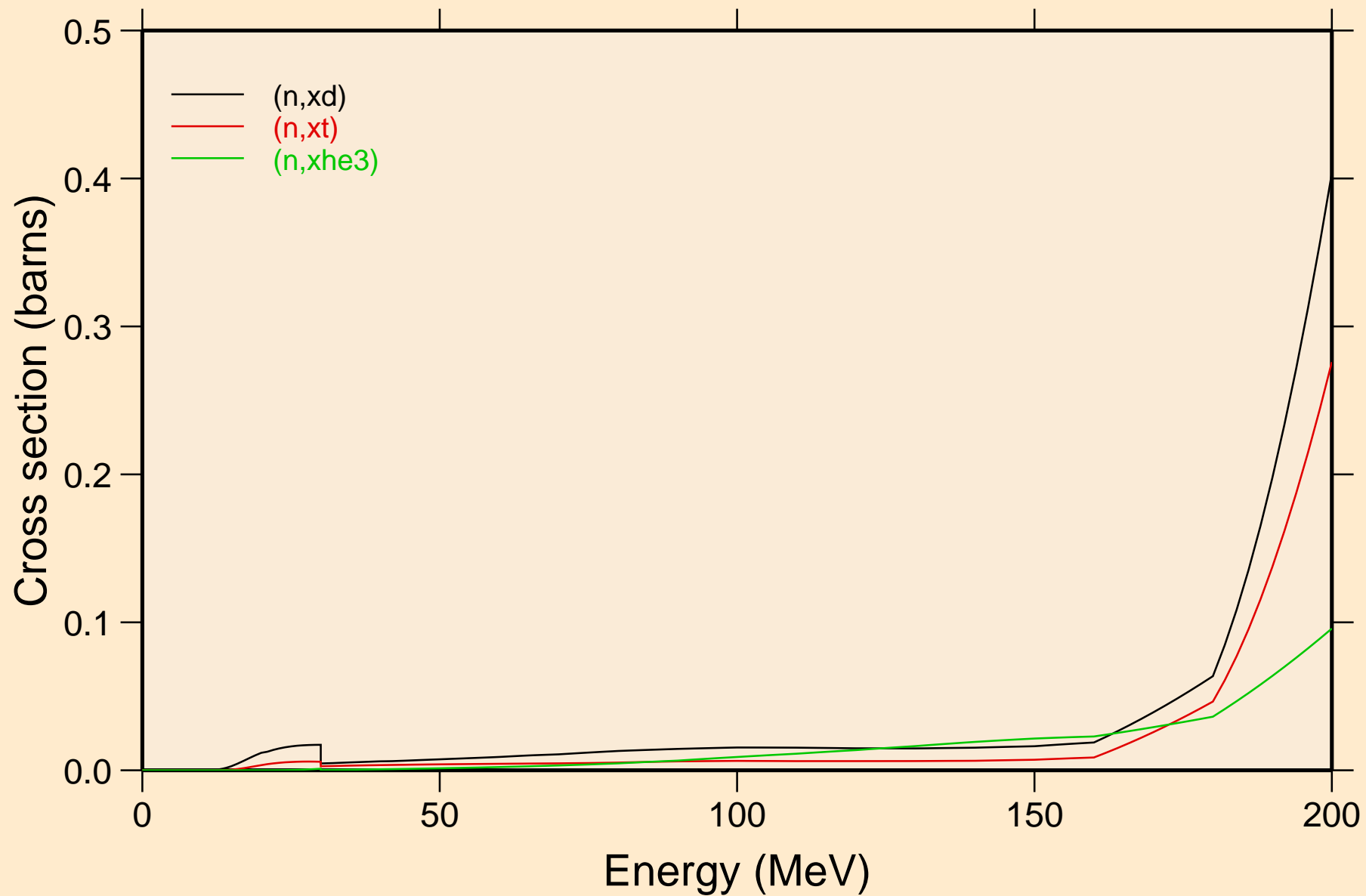

BH264 NEUTRON ACER TENDL-2019 LIBRARY; T=293.16K
angular distribution for elastic

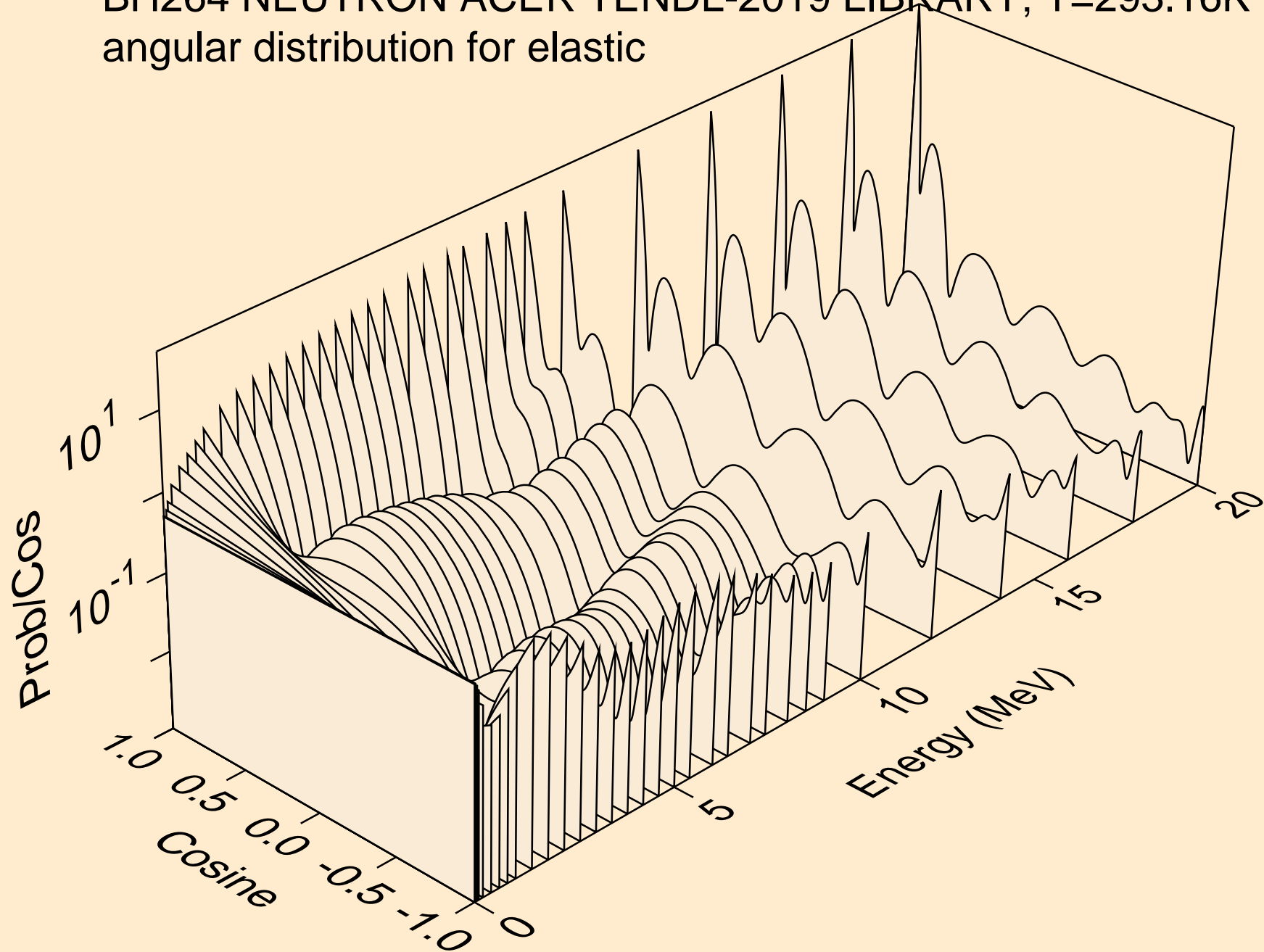

BH264 NEUTRON ACER TENDL-2019 LIBRARY; T=293.16K
angular distribution for elastic

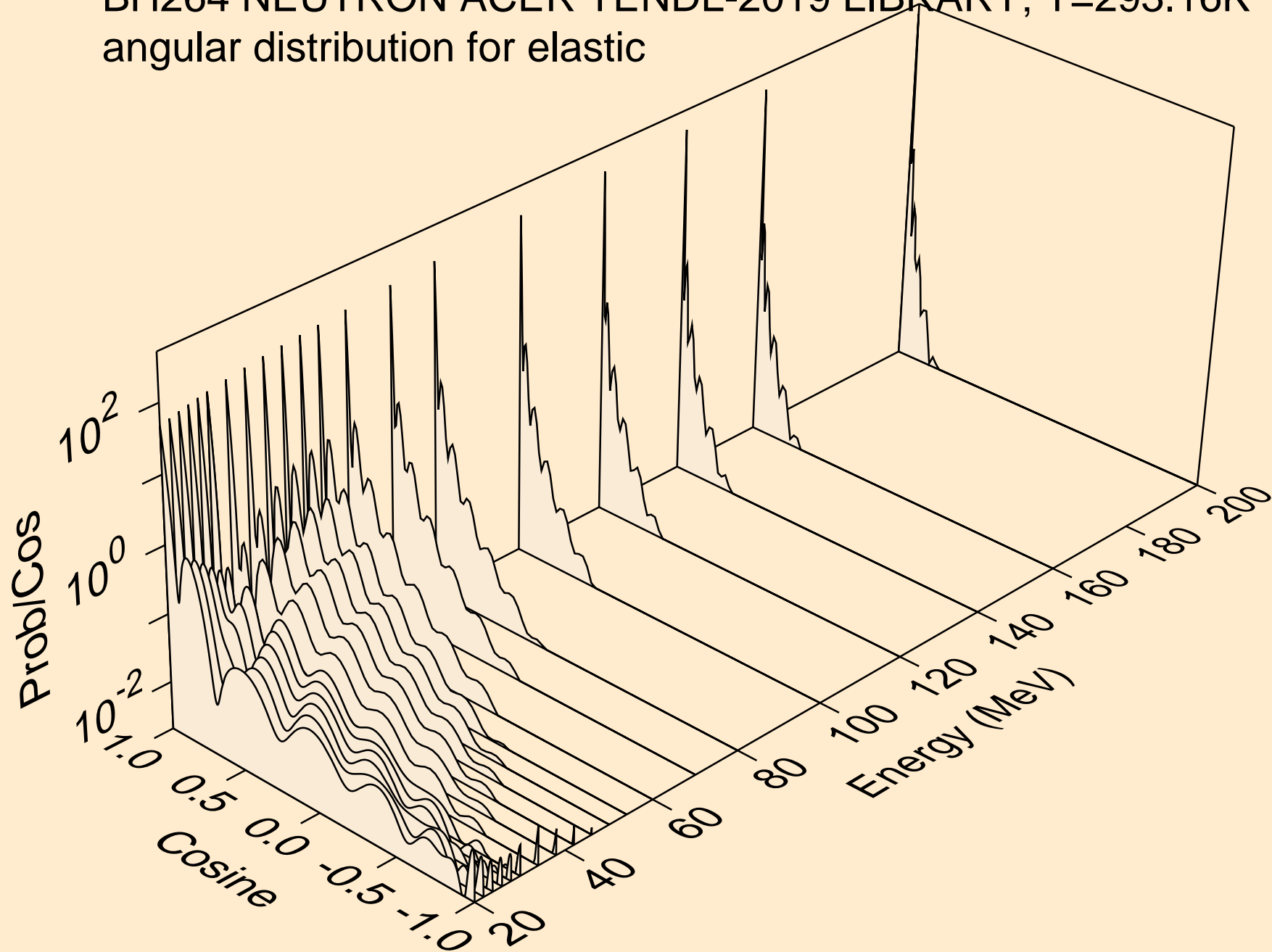

BH264 NEUTRON ACER TENDL-2019 LIBRARY; T=293.16K
angular distribution for (n,n*1)

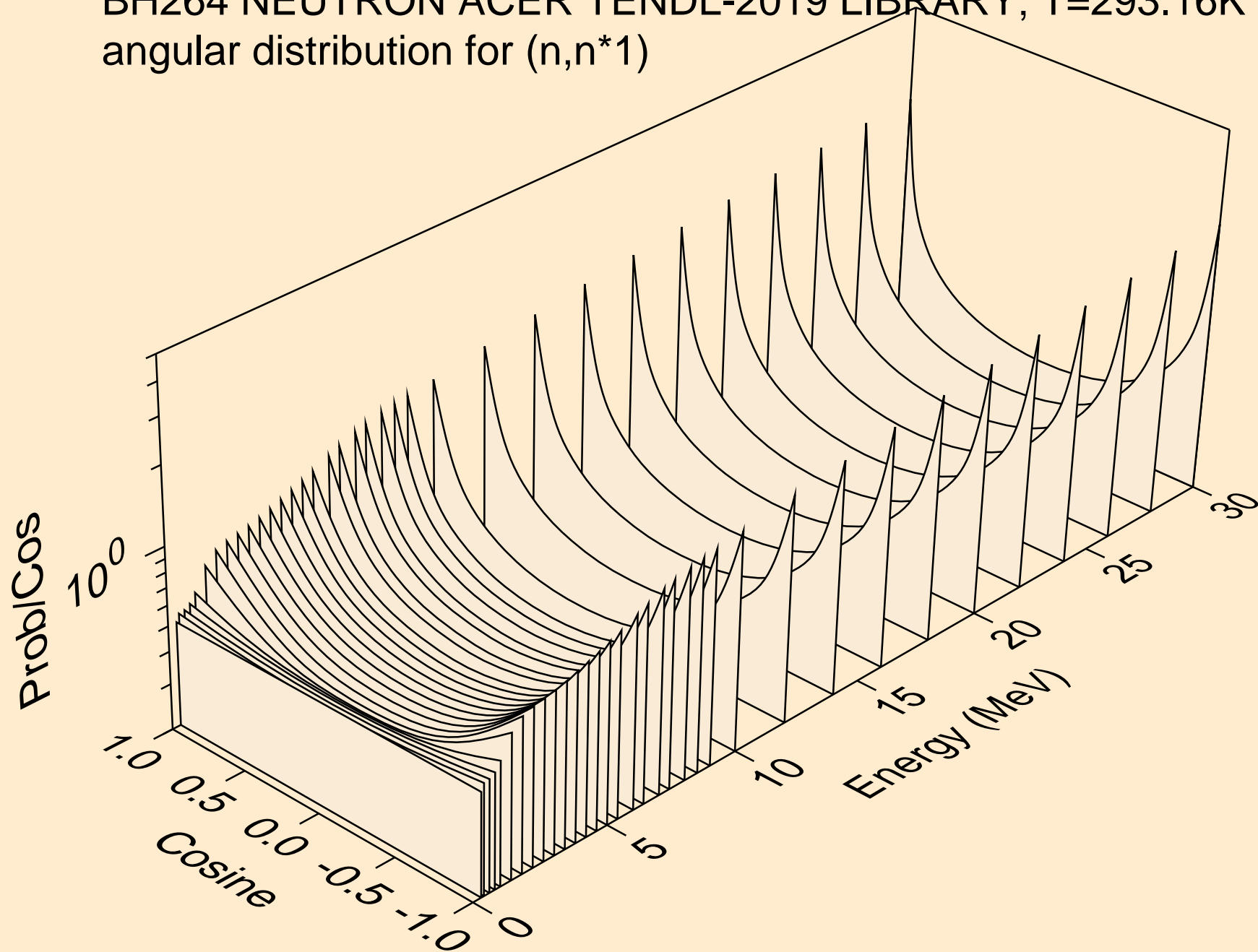

BH264 NEUTRON ACER TENDL-2019 LIBRARY; T=293.16K
angular distribution for (n,n*2)

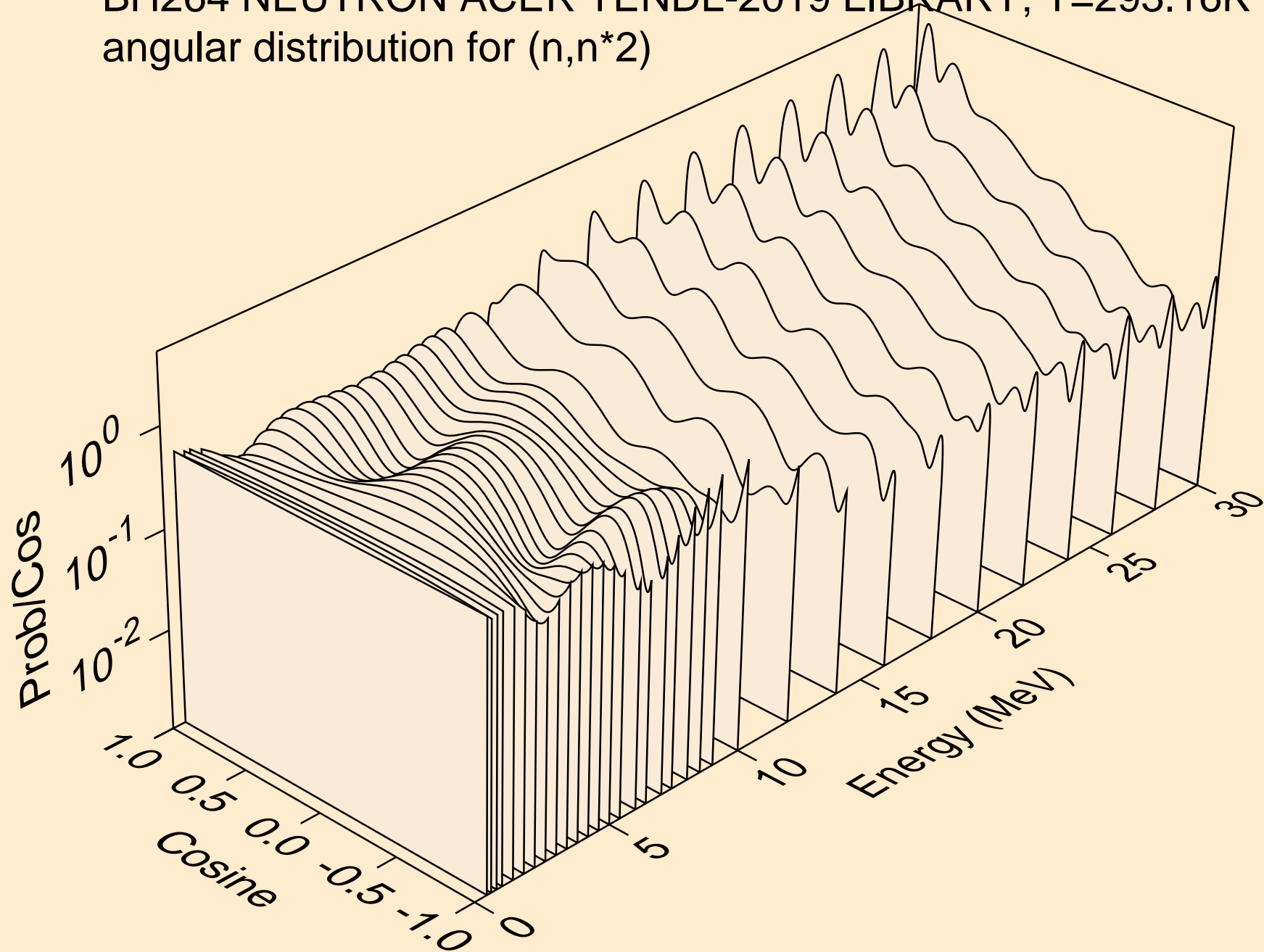

BH264 NEUTRON ACER TENDL-2019 LIBRARY; T=293.16K
angular distribution for (n,n*3)

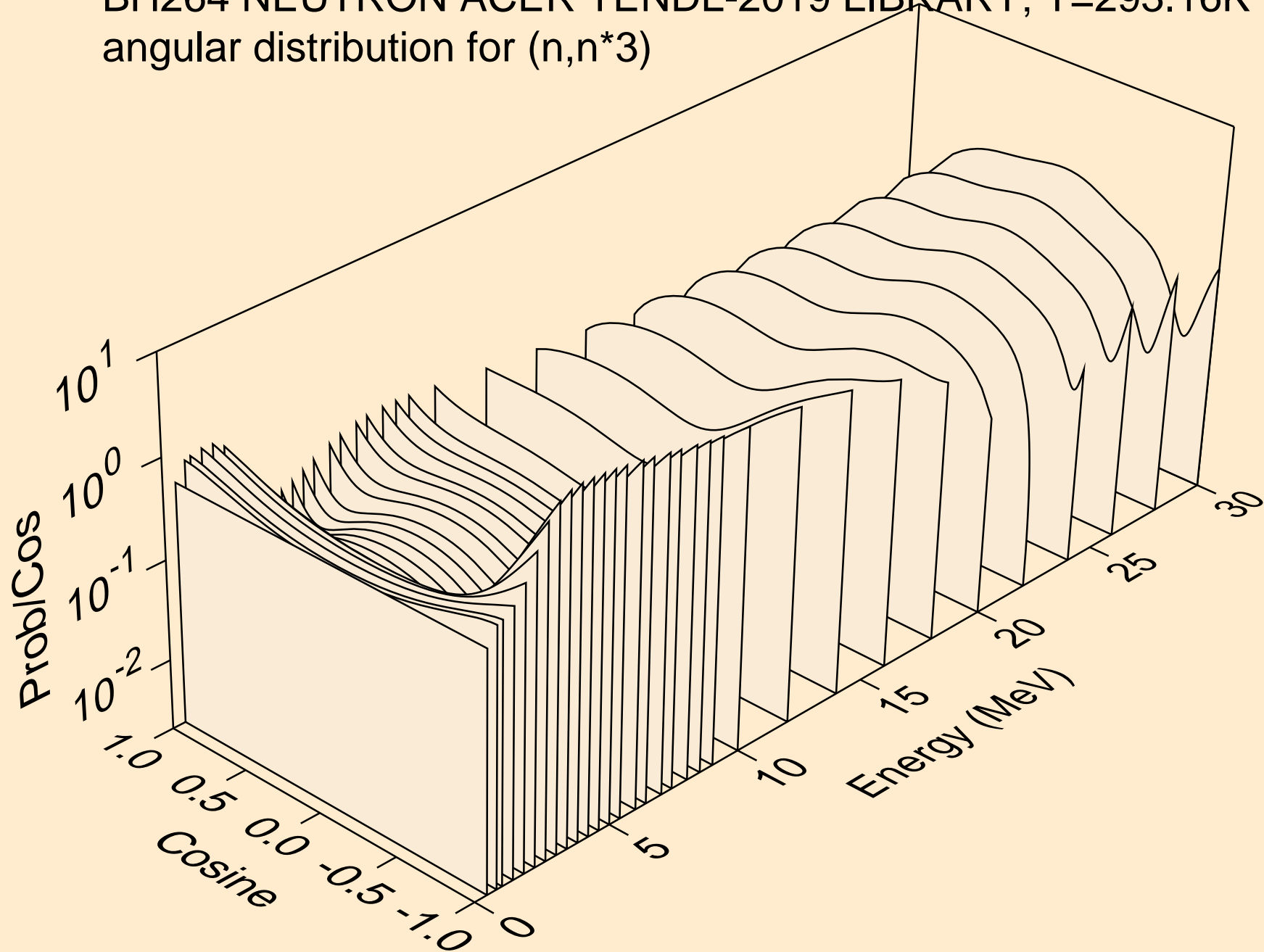

BH264 NEUTRON ACER TENDL-2019 LIBRARY; T=293.16K
angular distribution for (n,n*4)

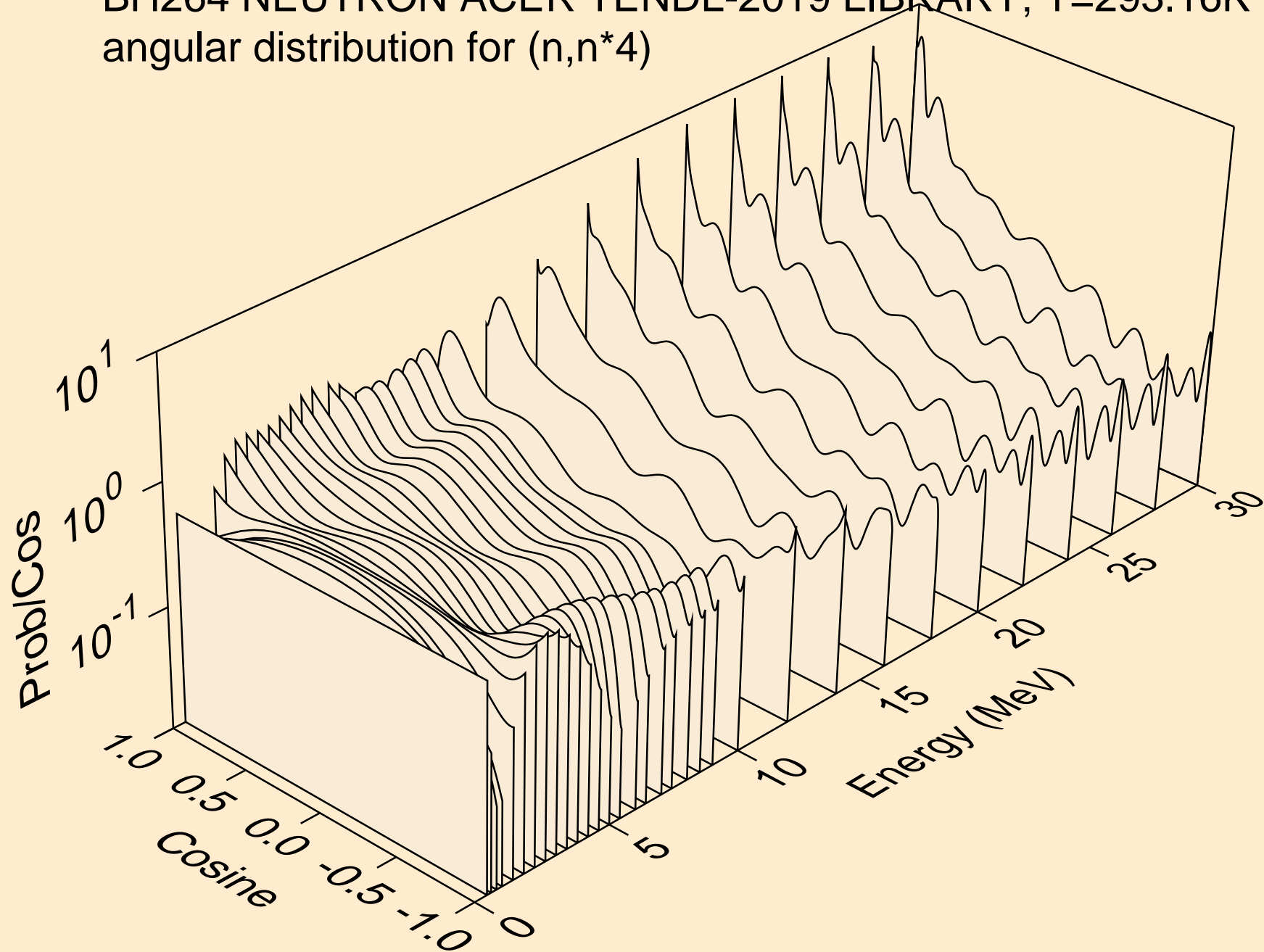

BH264 NEUTRON ACER TENDL-2019 LIBRARY; T=293.16K
angular distribution for (n,n*5)

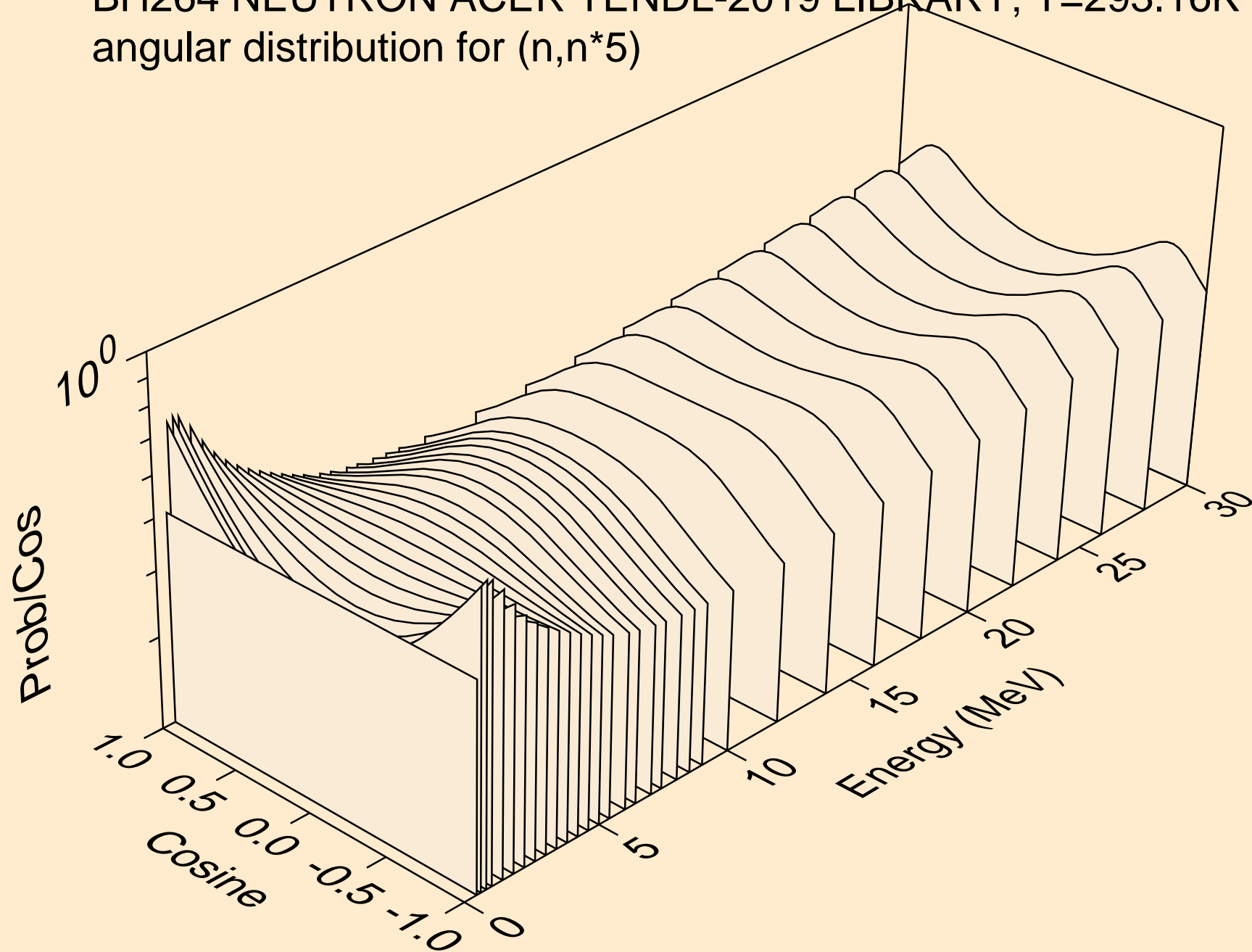

BH264 NEUTRON ACER TENDL-2019 LIBRARY; T=293.16K
angular distribution for (n,n*6)

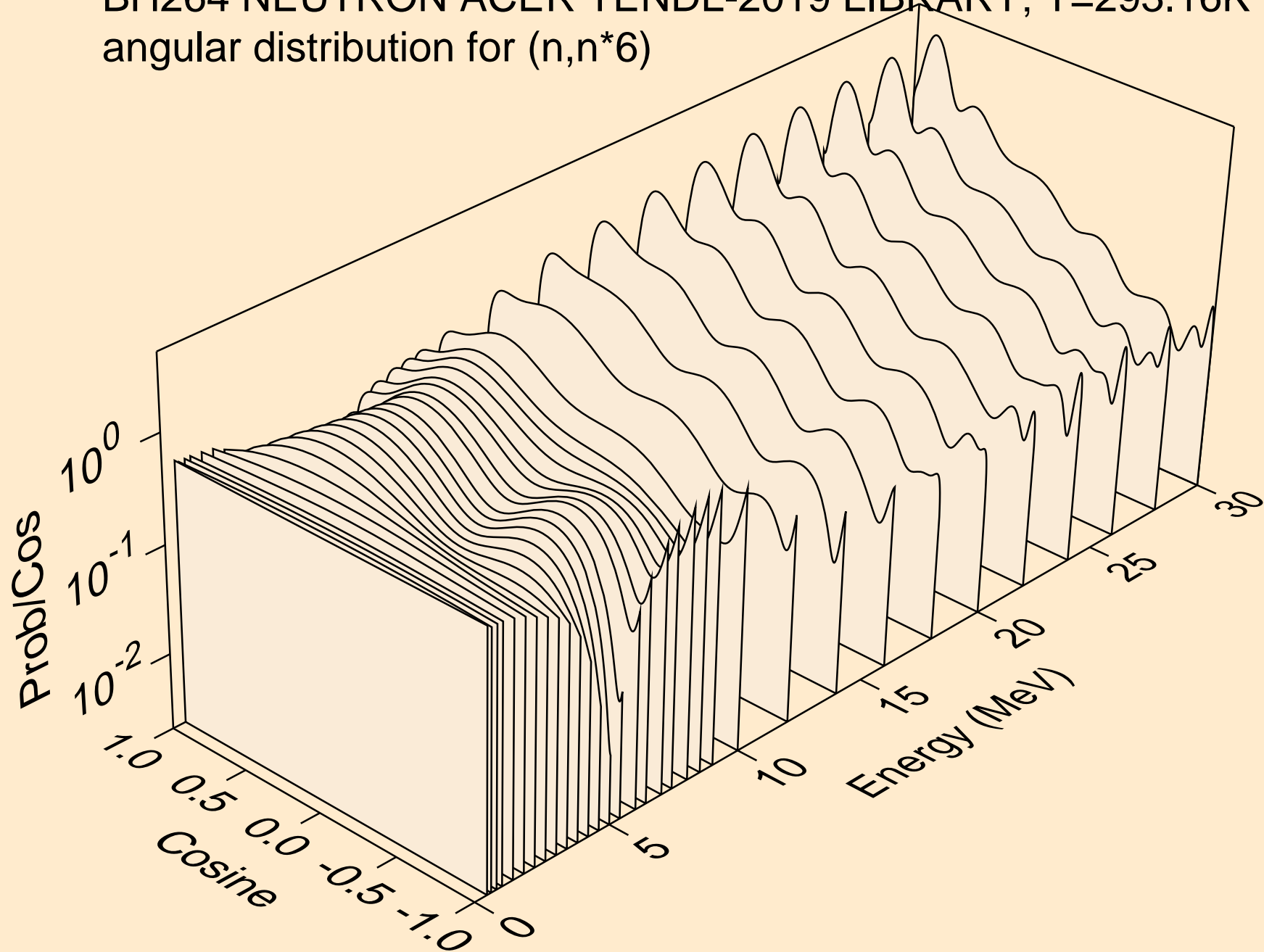

BH264 NEUTRON ACER TENDL-2019 LIBRARY; T=293.16K
angular distribution for (n,n*7)

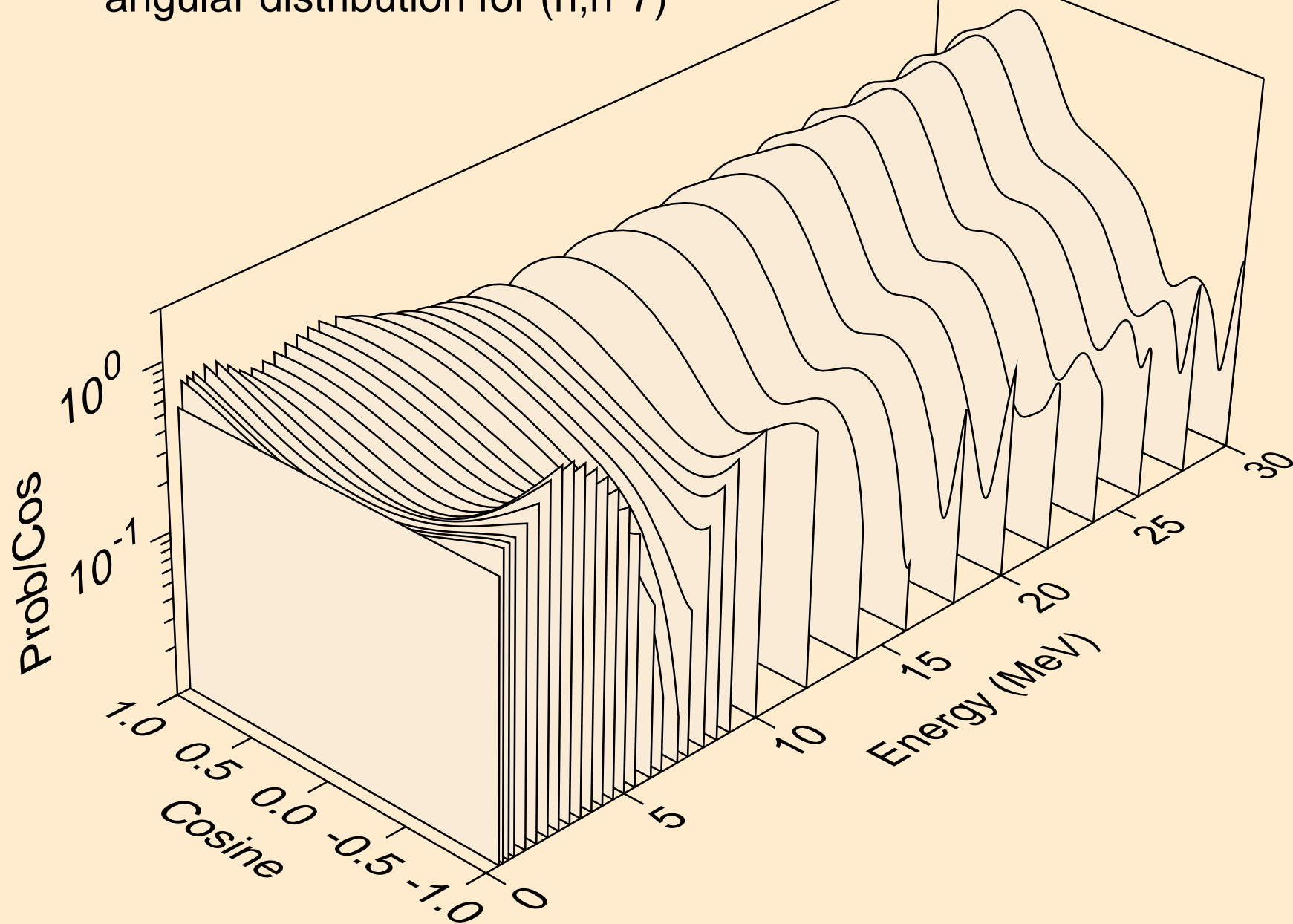

BH264 NEUTRON ACER TENDL-2019 LIBRARY; T=293.16K
angular distribution for (n,n*8)

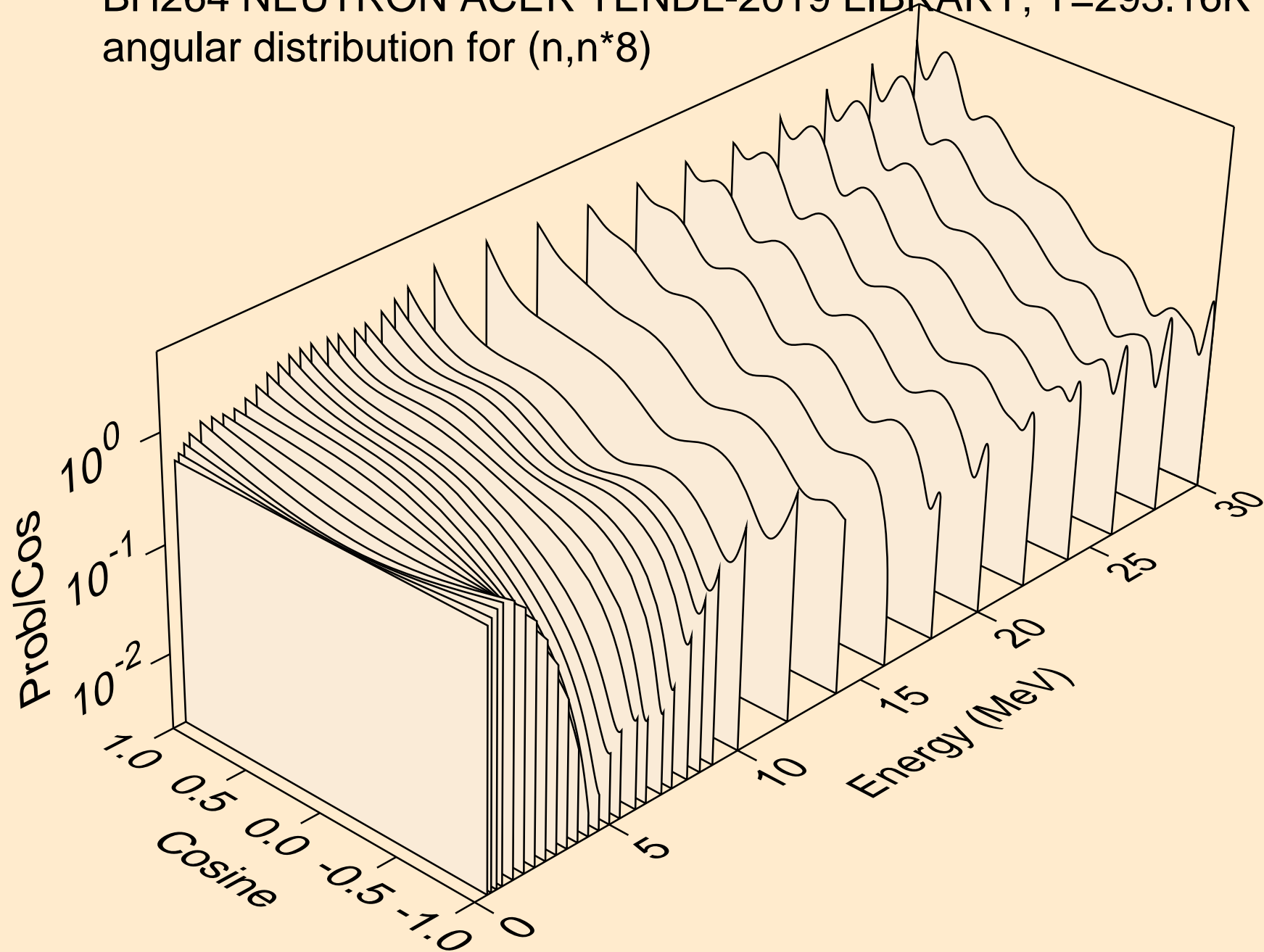

BH264 NEUTRON ACER TENDL-2019 LIBRARY; T=293.16K
angular distribution for (n,n*9)

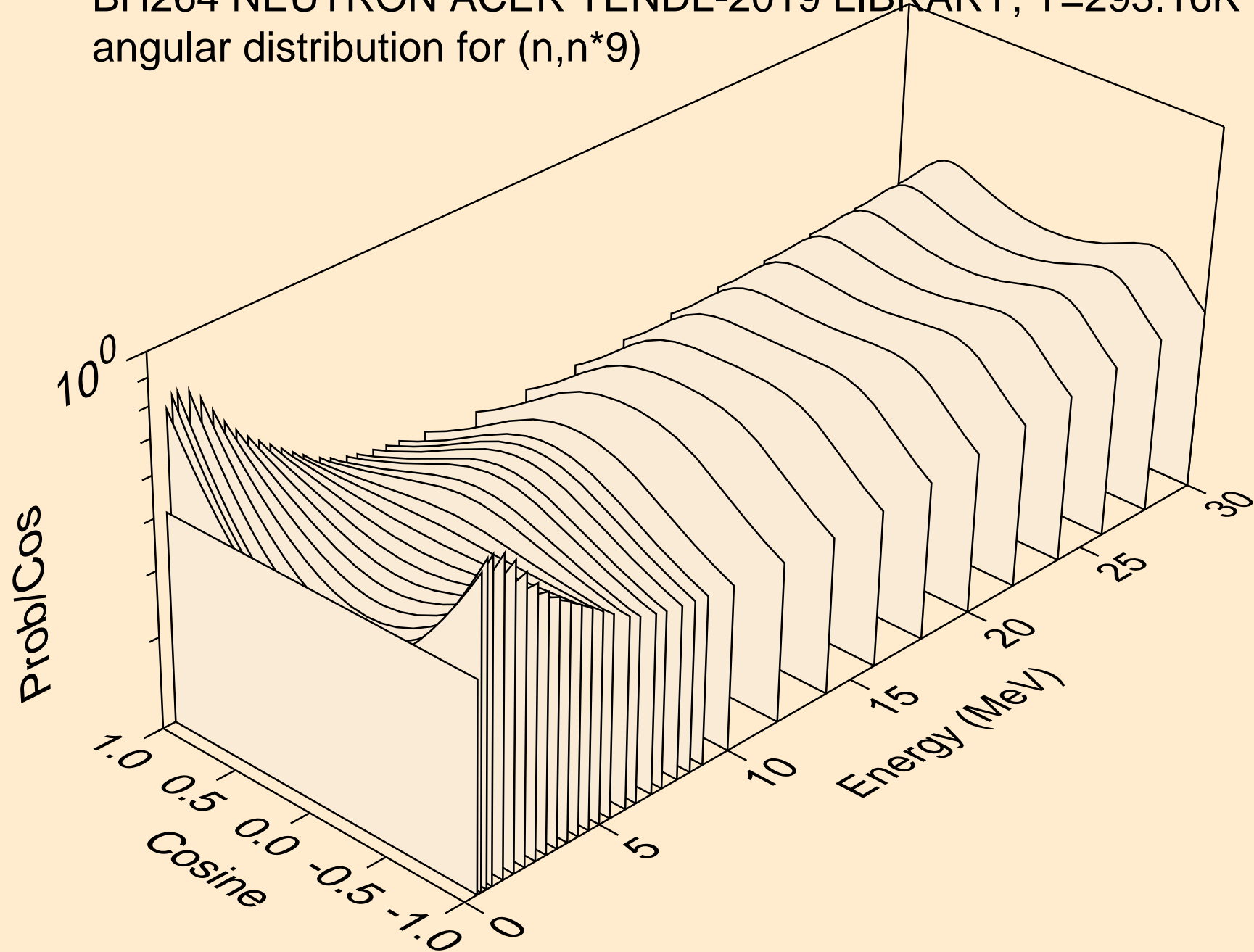

BH264 NEUTRON ACER TENDL-2019 LIBRARY; T=293.16K
angular distribution for (n,n*10)

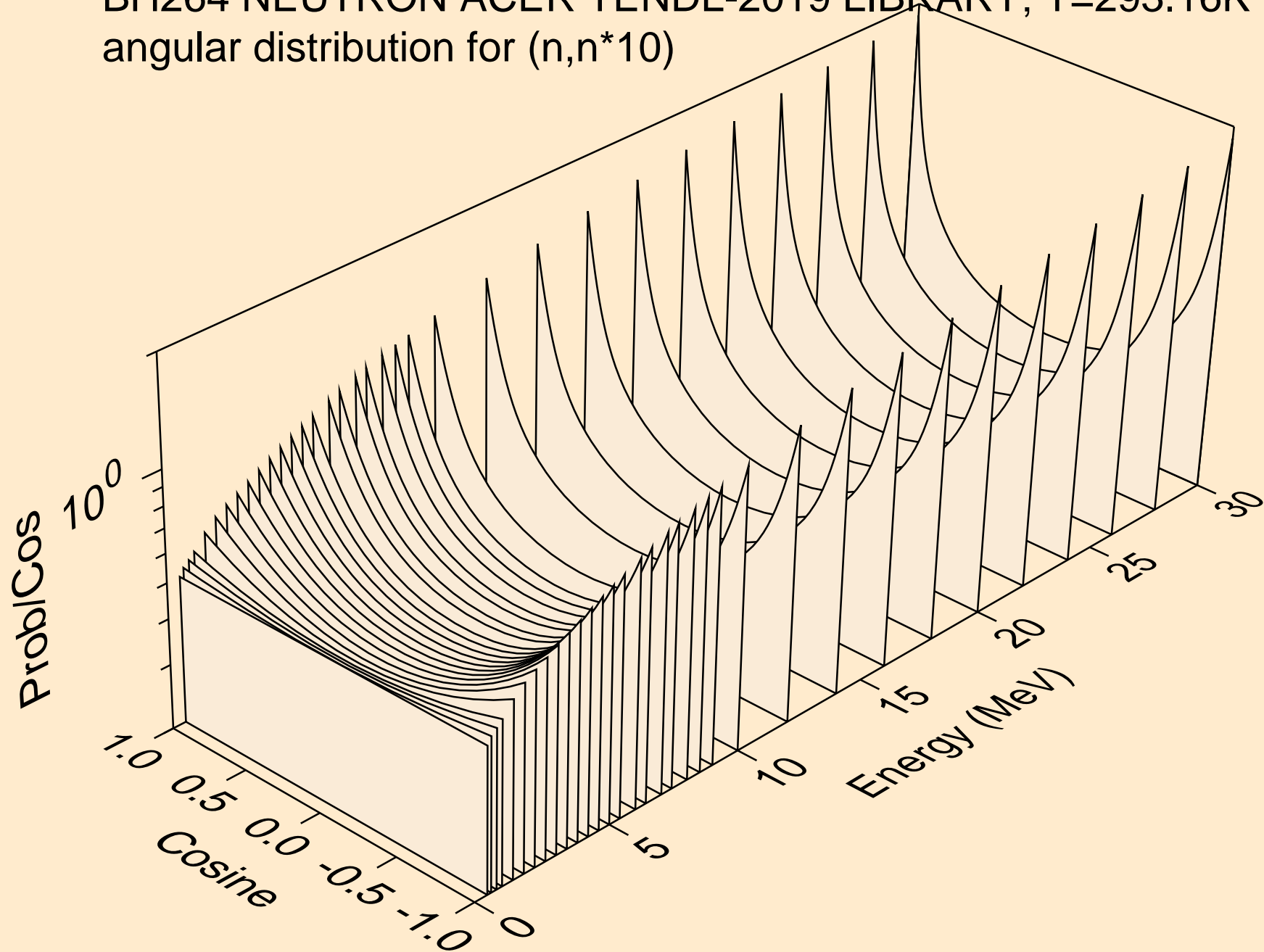

BH264 NEUTRON ACER TENDL-2019 LIBRARY; T=293.16K
angular distribution for (n,n*11)

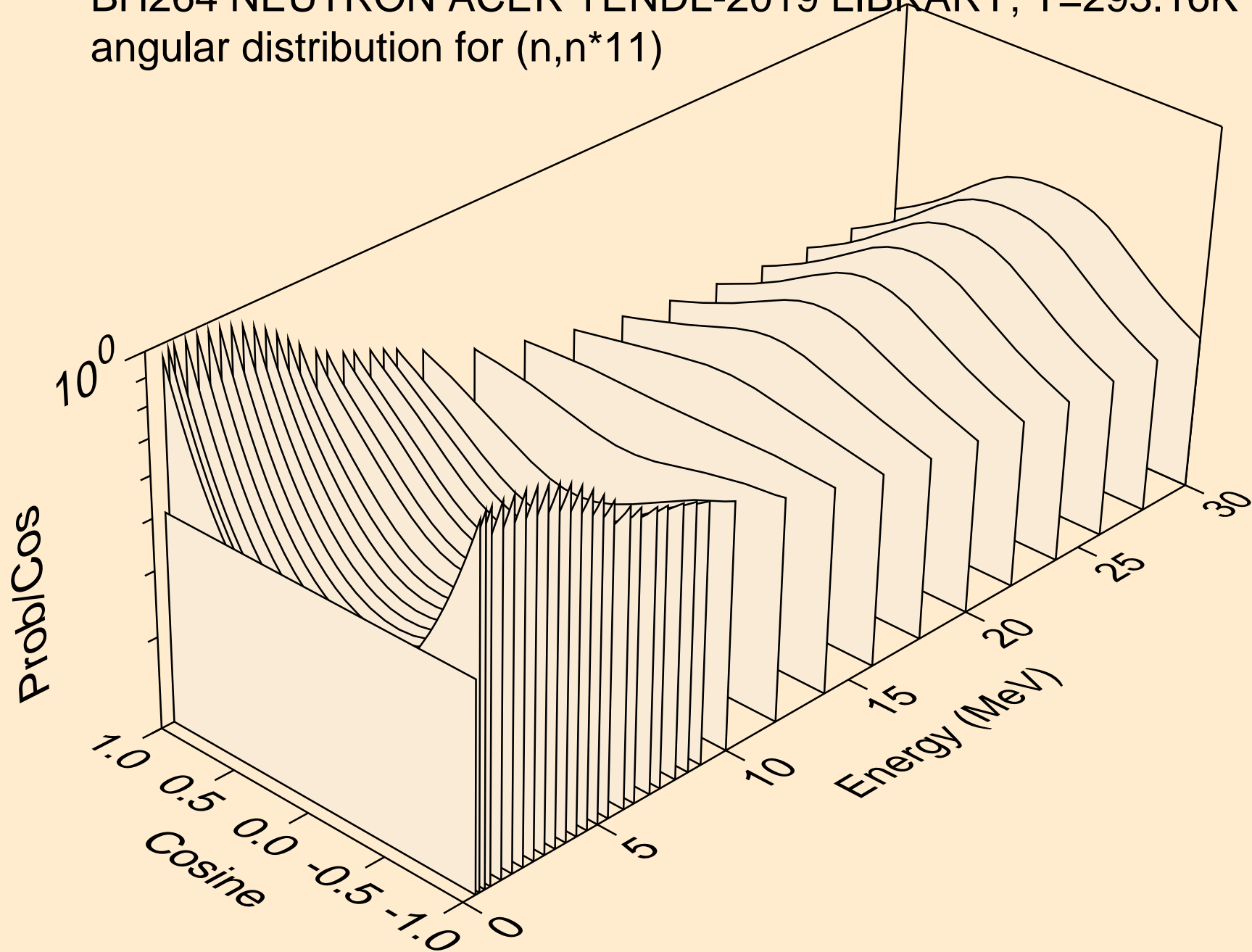

BH264 NEUTRON ACER TENDL-2019 LIBRARY; T=293.16K
angular distribution for (n,n*12)

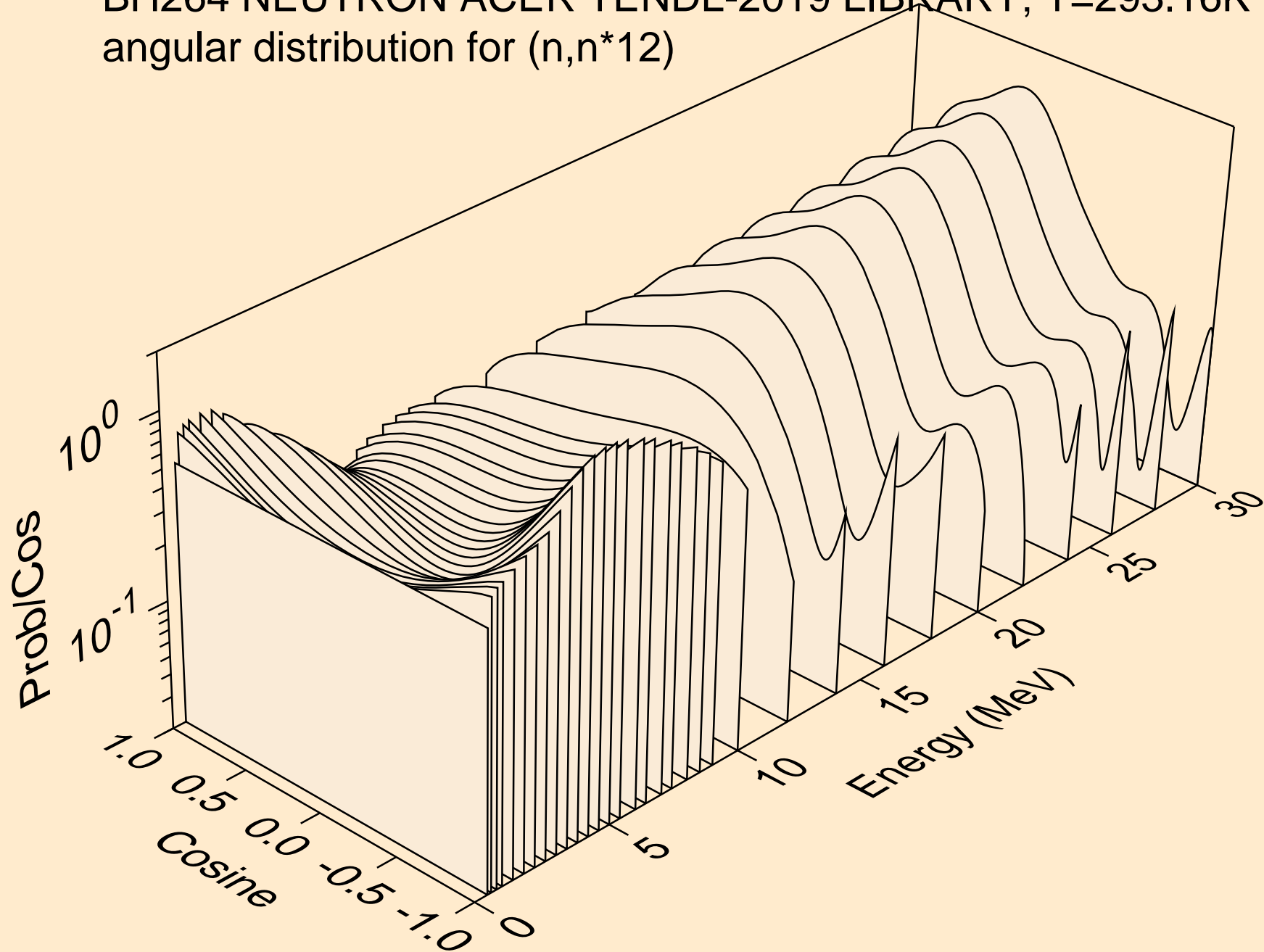

BH264 NEUTRON ACER TENDL-2019 LIBRARY; T=293.16K
angular distribution for (n,n*13)

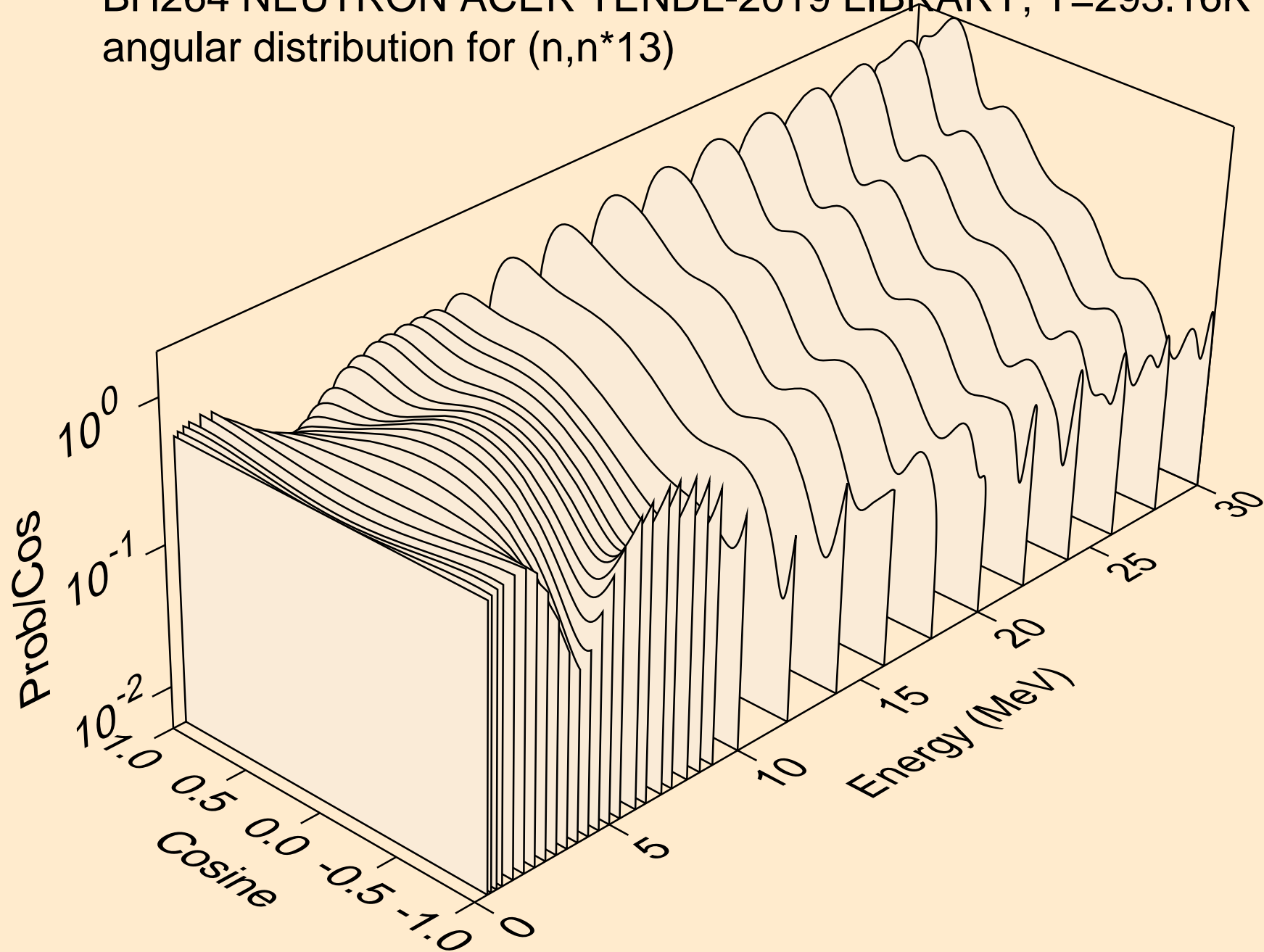

BH264 NEUTRON ACER TENDL-2019 LIBRARY; T=293.16K
angular distribution for (n,n*14)

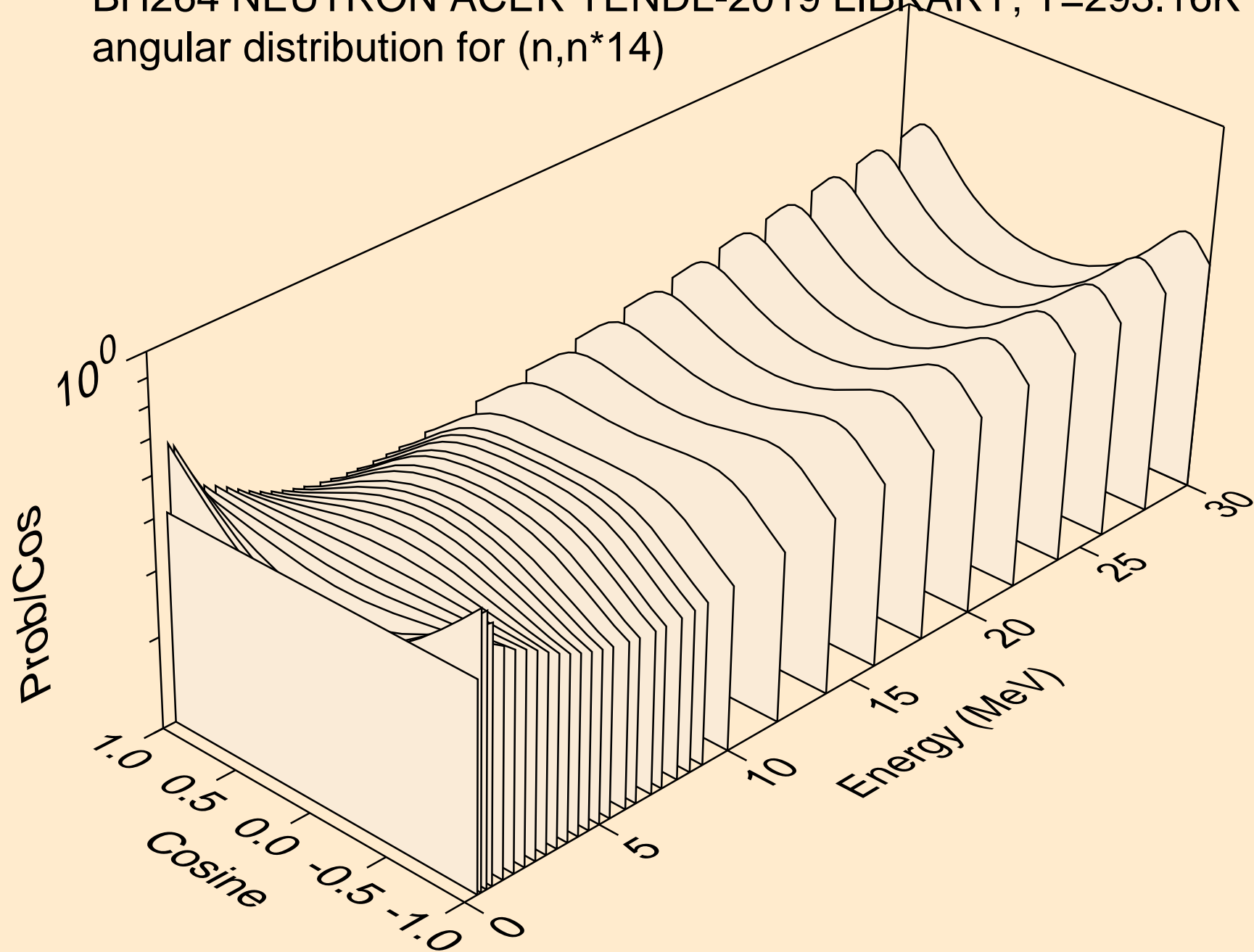

BH264 NEUTRON ACER TENDL-2019 LIBRARY; T=293.16K
angular distribution for (n,n*15)

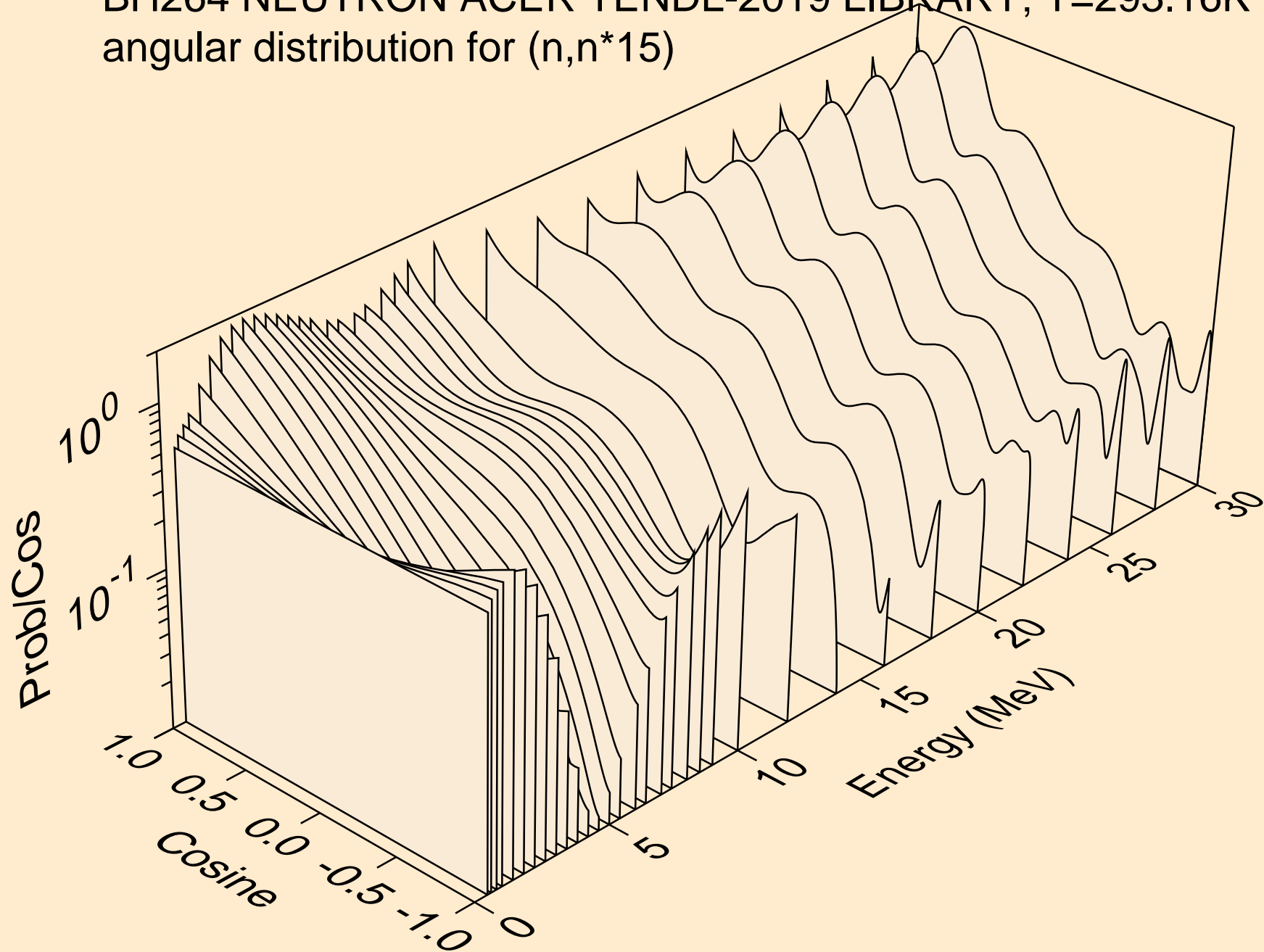

BH264 NEUTRON ACER TENDL-2019 LIBRARY; T=293.16K
angular distribution for (n,n*16)

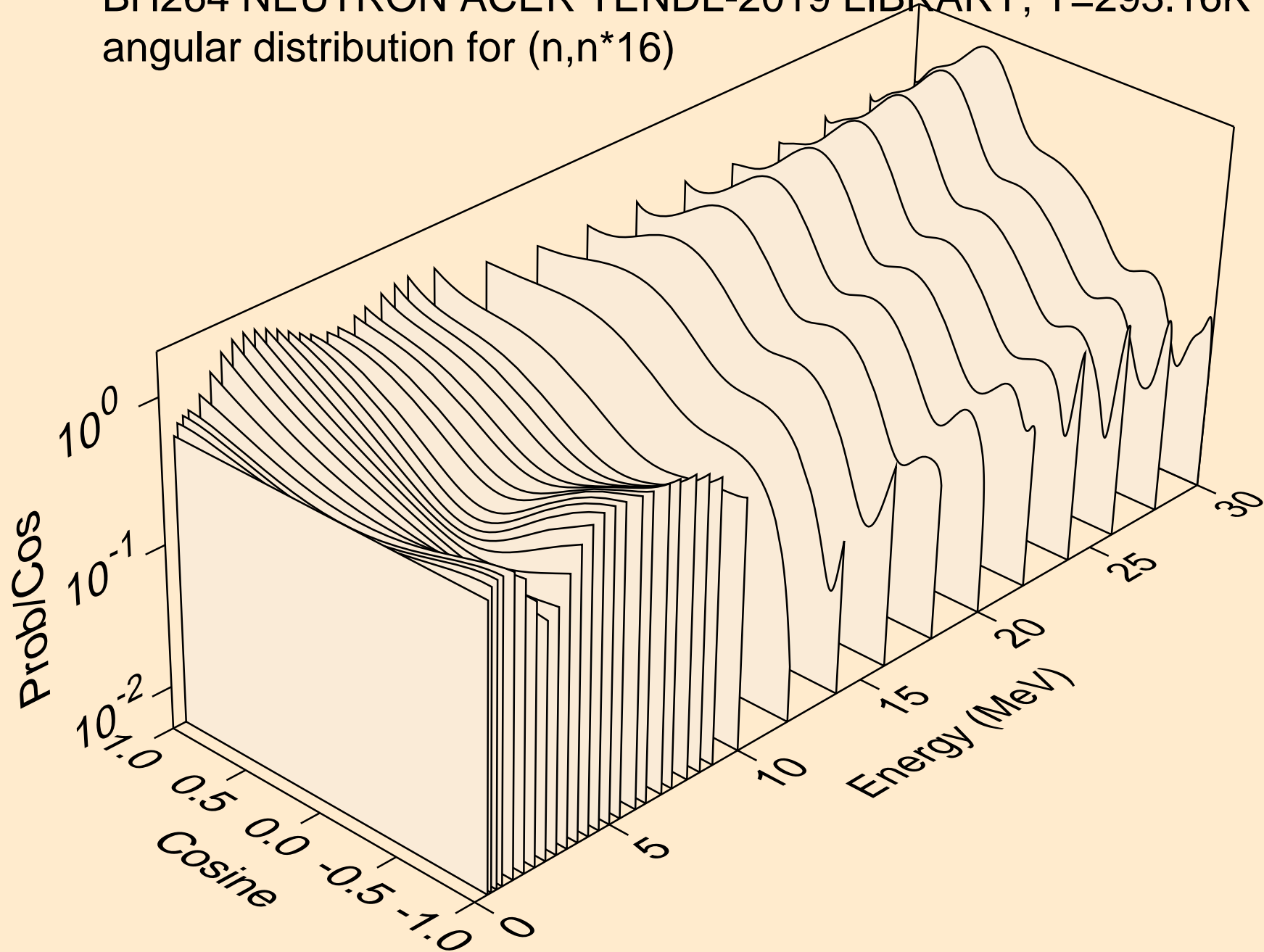

BH264 NEUTRON ACER TENDL-2019 LIBRARY; T=293.16K
angular distribution for (n,n*17)

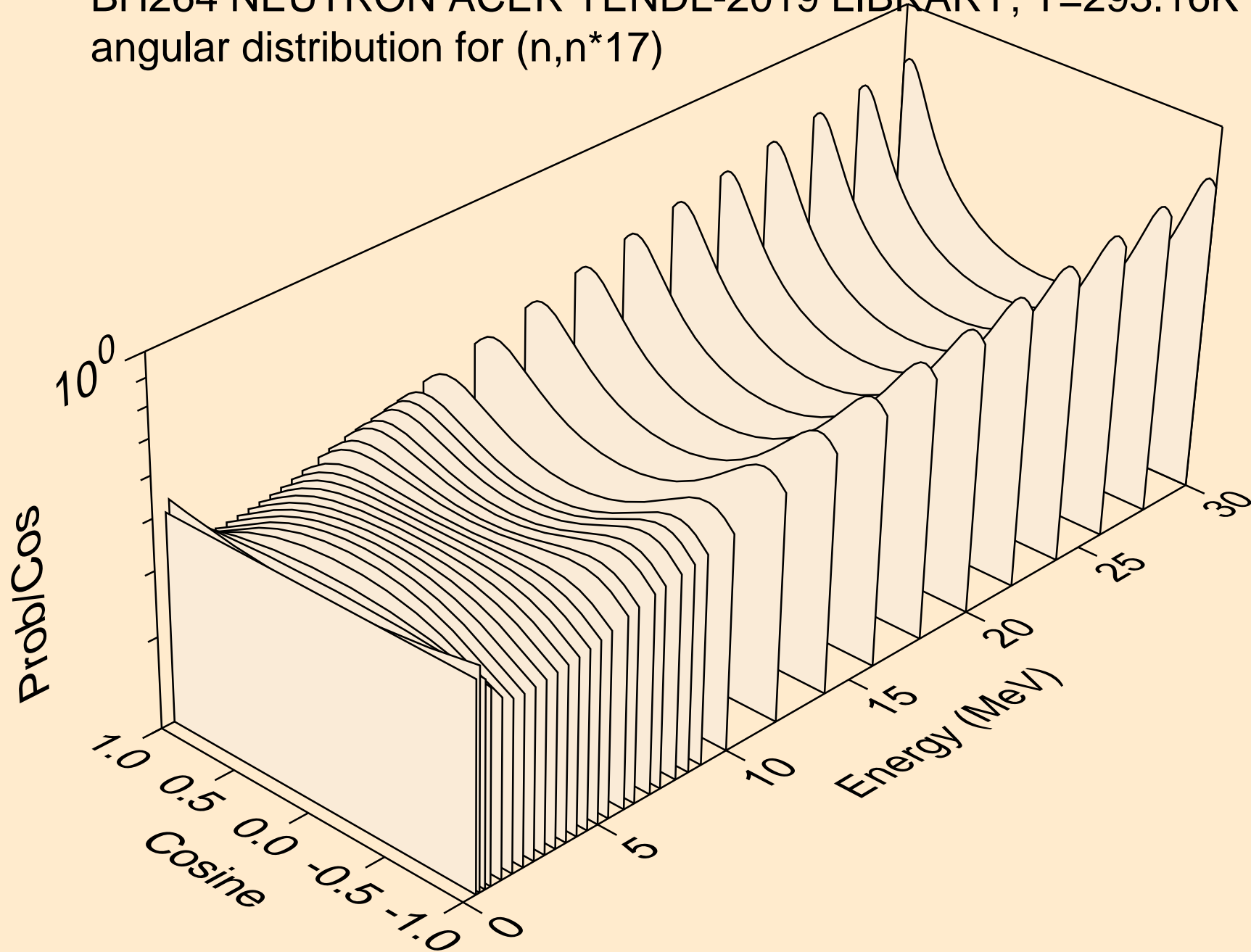

BH264 NEUTRON ACER TENDL-2019 LIBRARY; T=293.16K
angular distribution for (n,n*18)

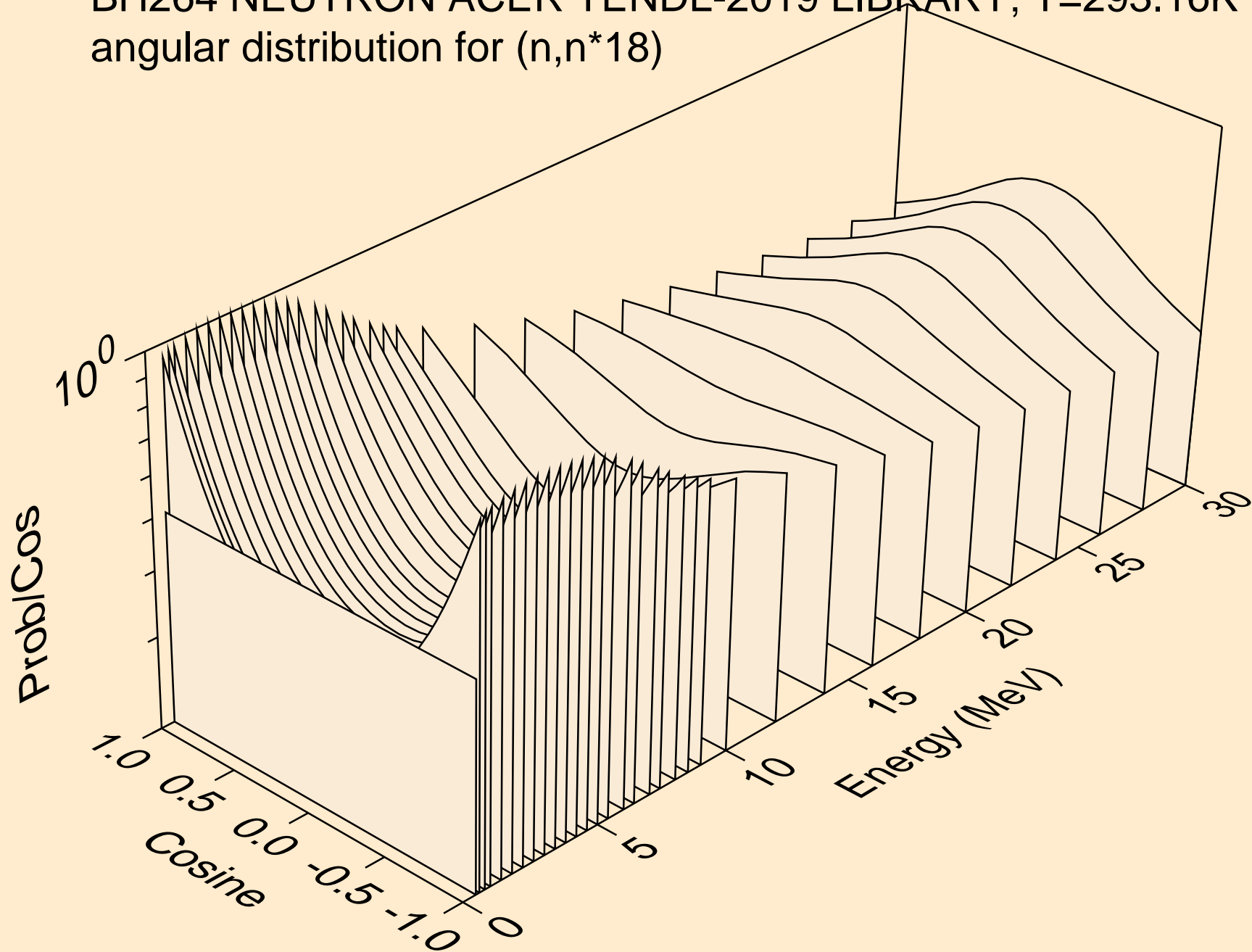

BH264 NEUTRON ACER TENDL-2019 LIBRARY; T=293.16K
angular distribution for (n,n*19)

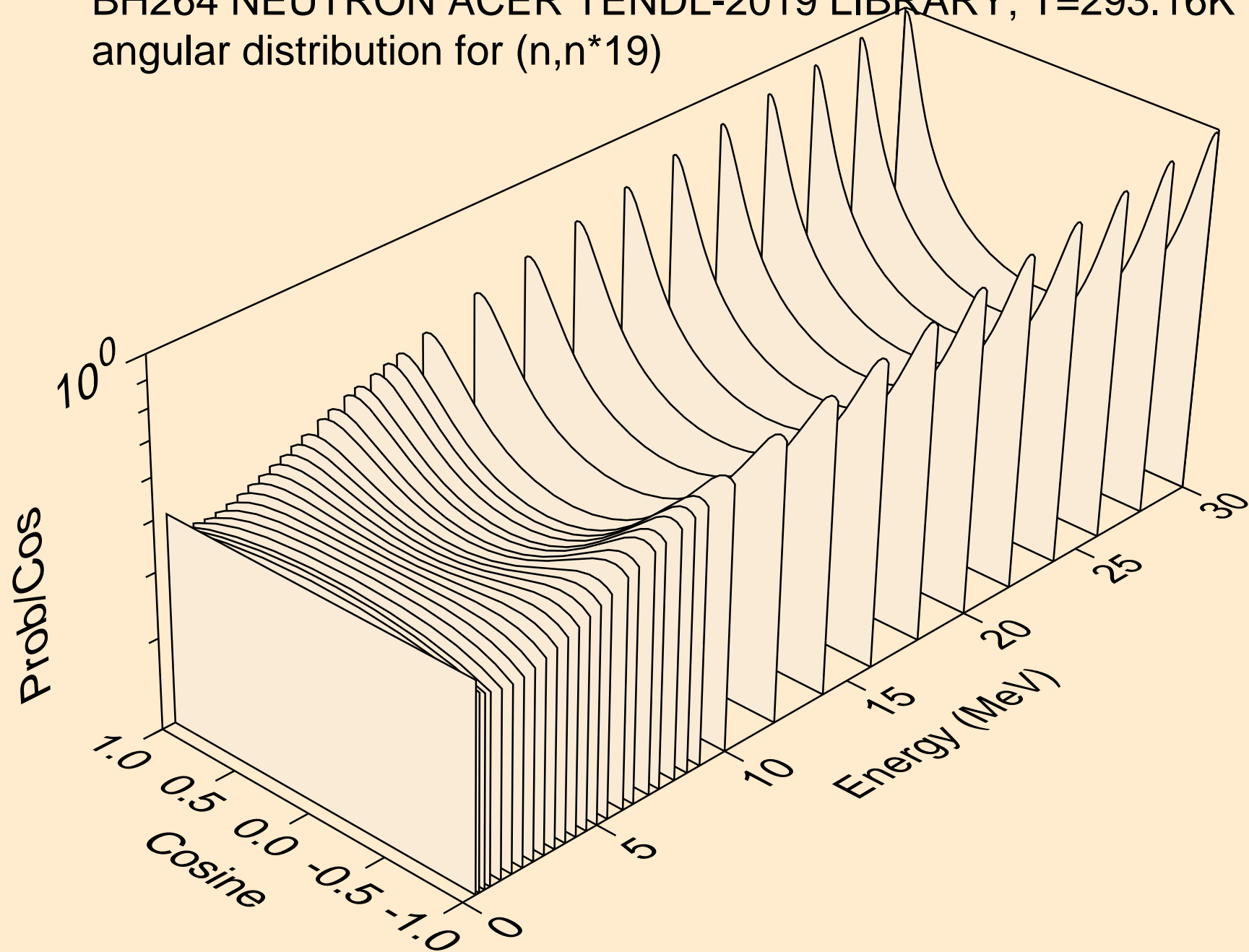

BH264 NEUTRON ACER TENDL-2019 LIBRARY; T=293.16K
angular distribution for (n,n*20)

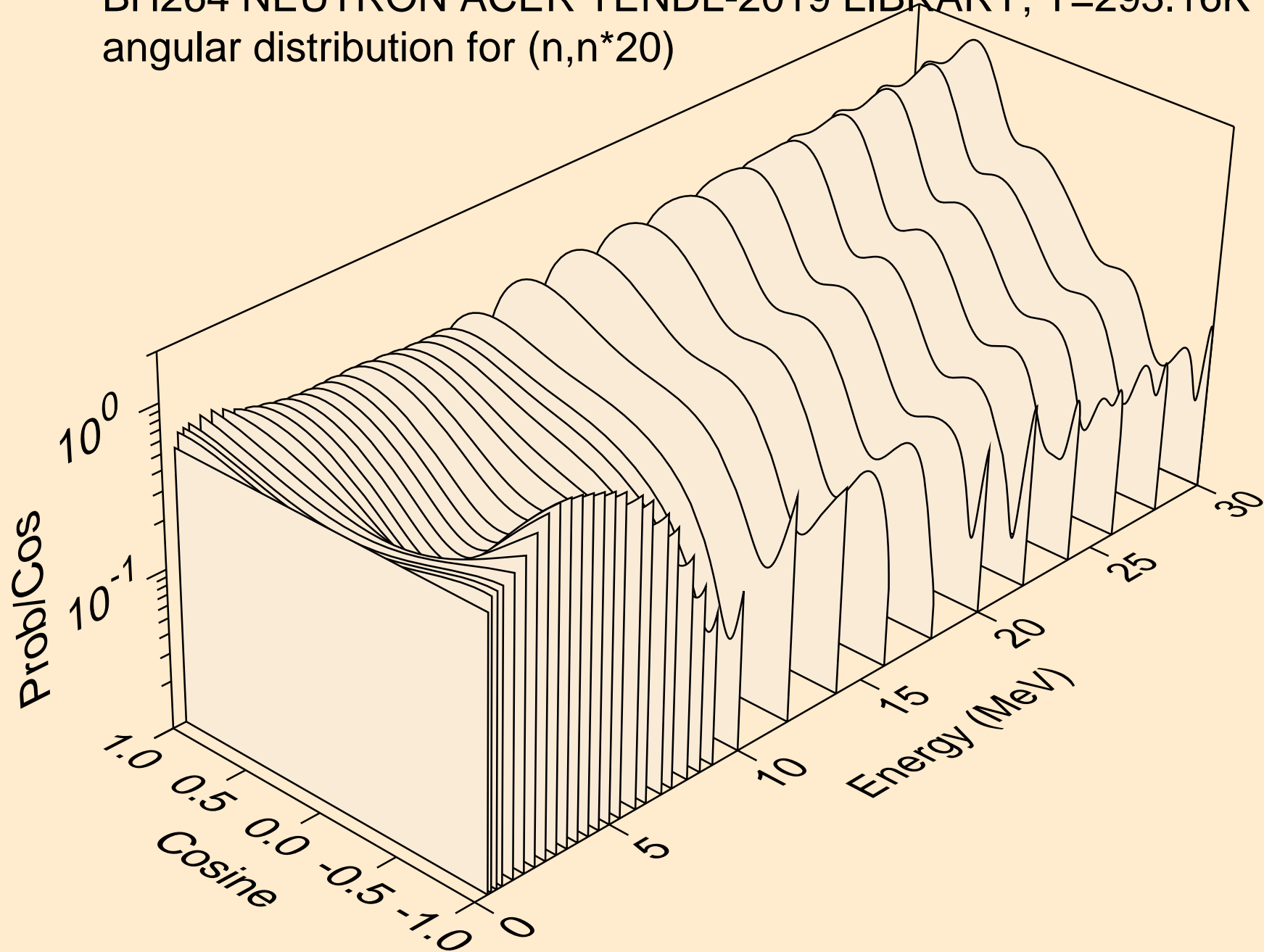

BH264 NEUTRON ACER TENDL-2019 LIBRARY; T=293.16K
angular distribution for (n,n*21)

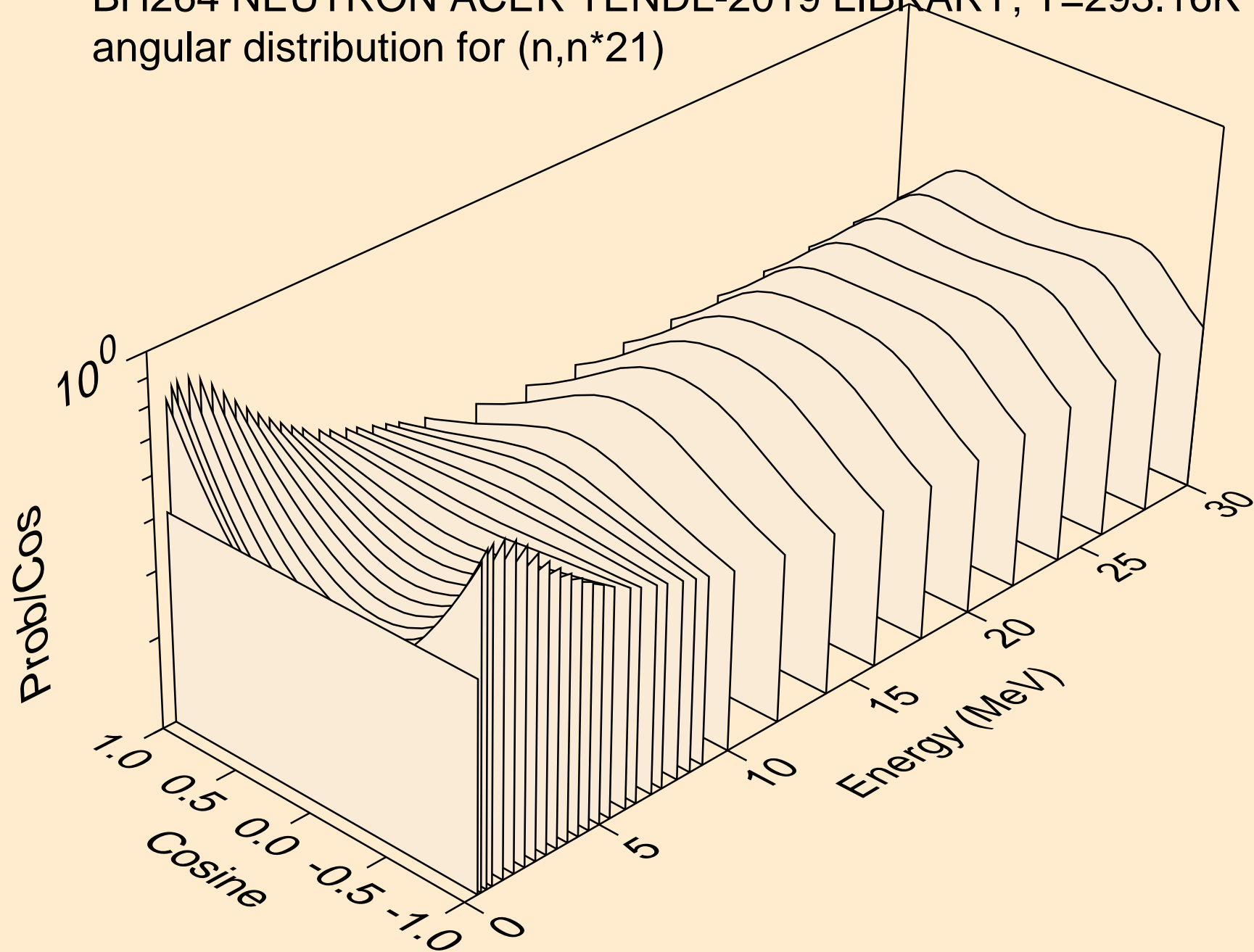

BH264 NEUTRON ACER TENDL-2019 LIBRARY; T=293.16K
angular distribution for (n,n*22)

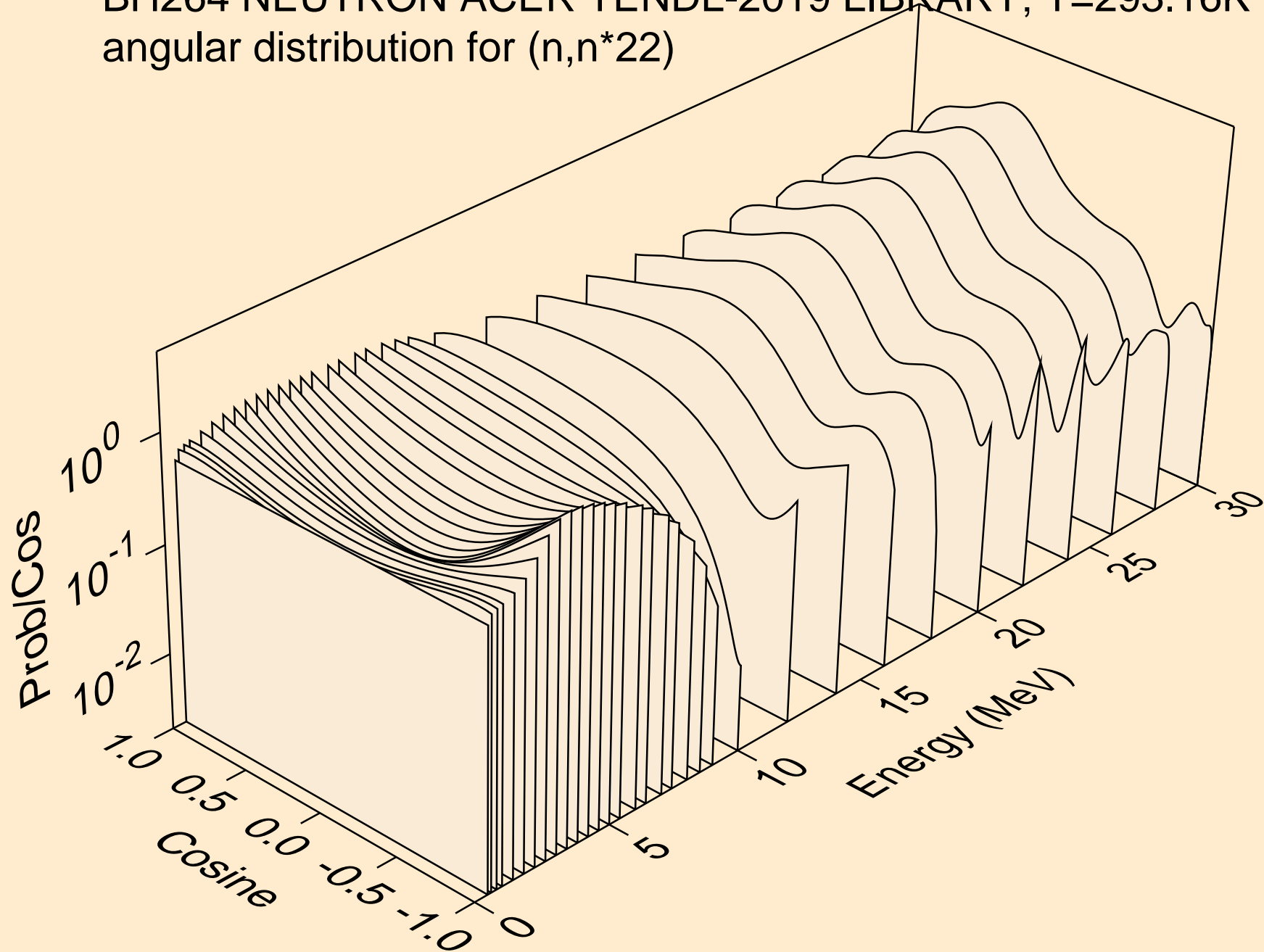

BH264 NEUTRON ACER TENDL-2019 LIBRARY; T=293.16K
angular distribution for (n,n*23)

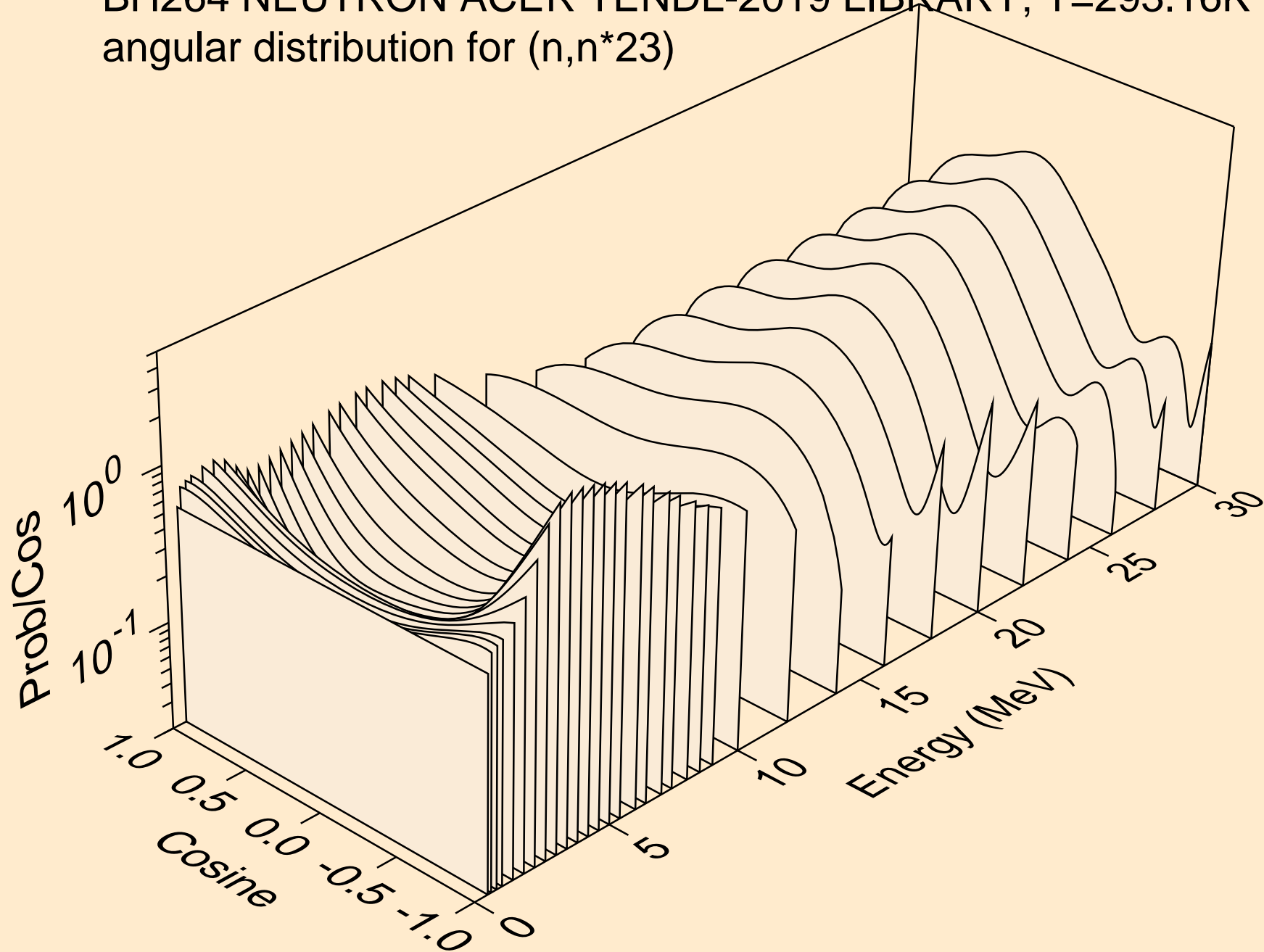

BH264 NEUTRON ACER TENDL-2019 LIBRARY; T=293.16K
angular distribution for (n,n*24)

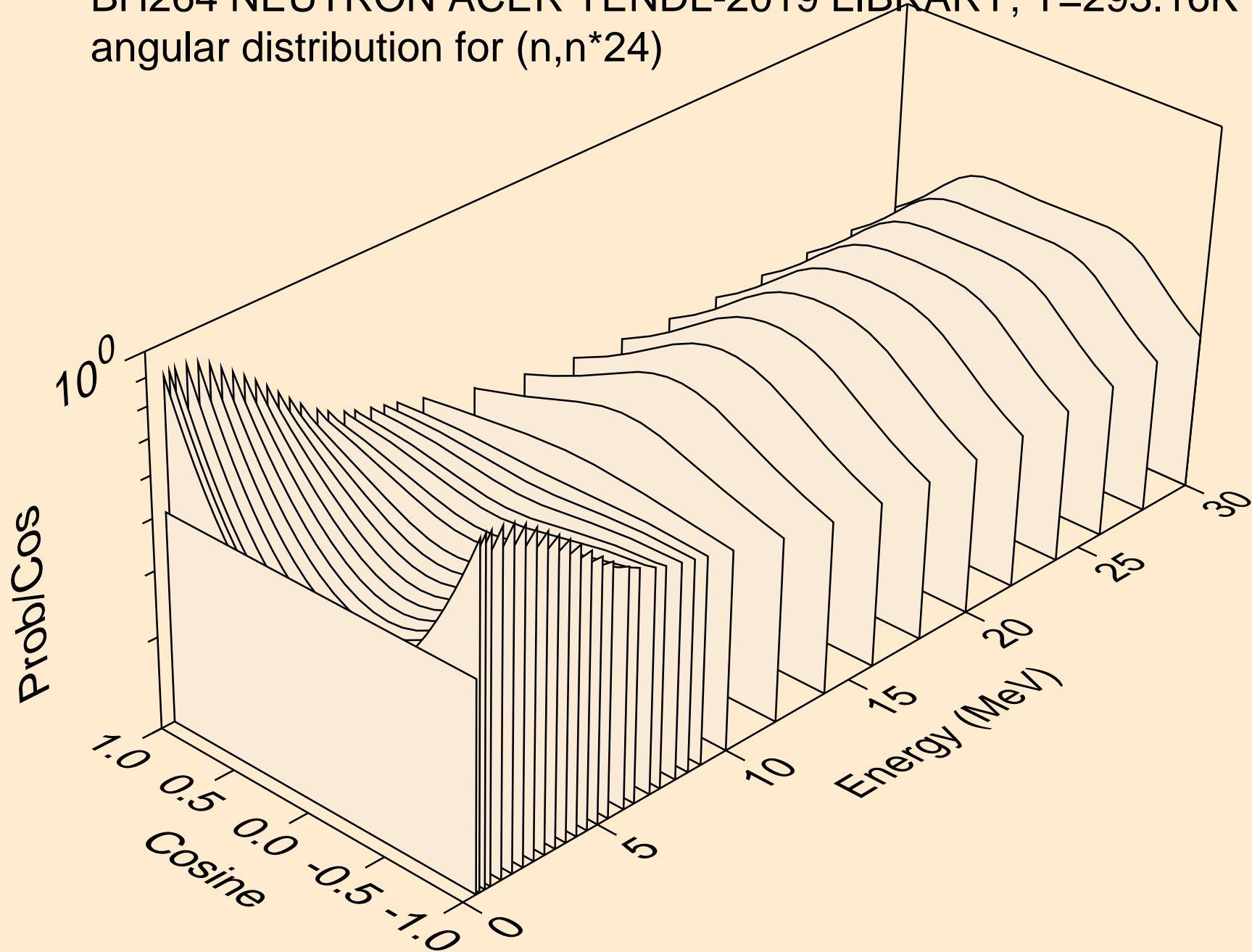

BH264 NEUTRON ACER TENDL-2019 LIBRARY; T=293.16K
angular distribution for (n,n*25)

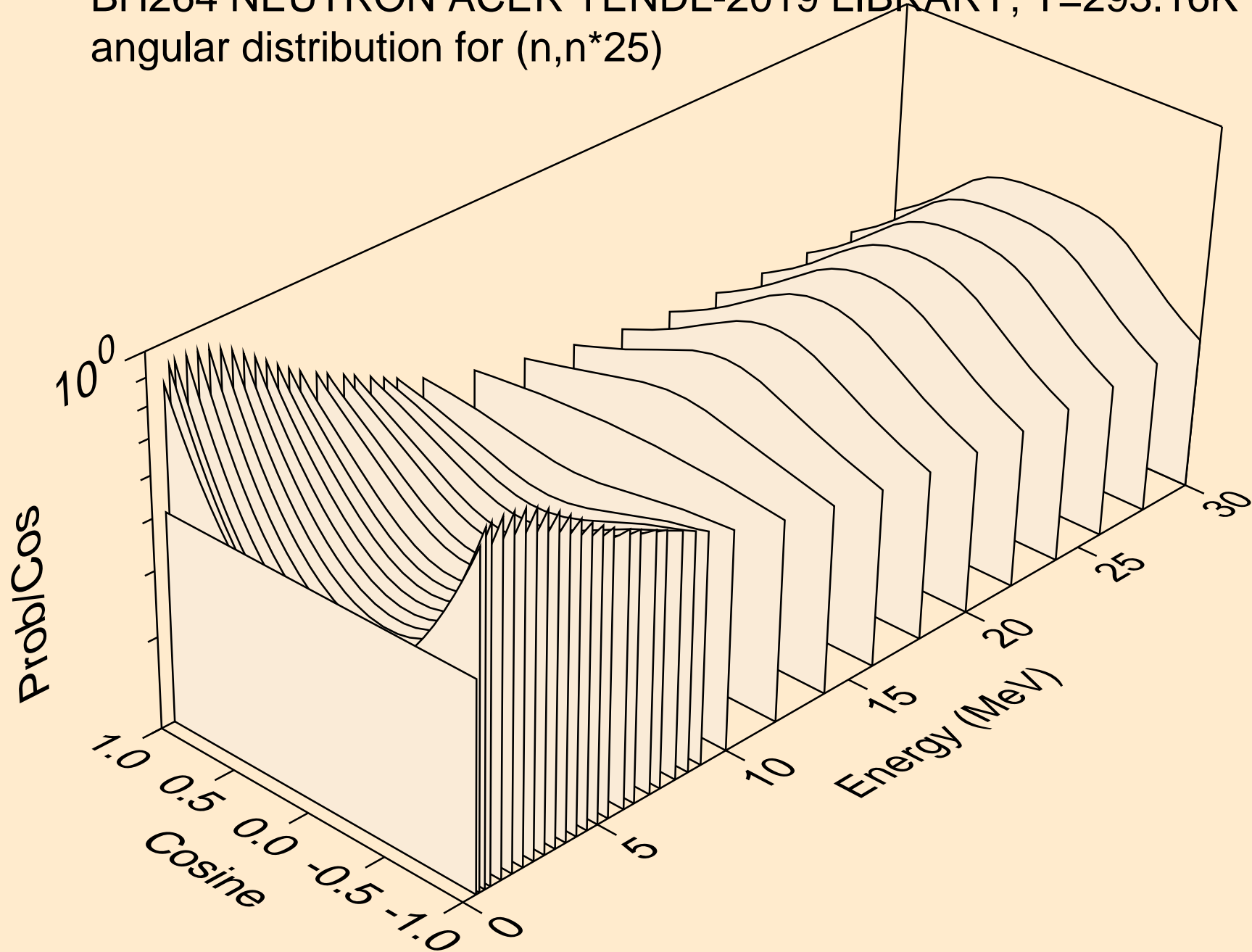

BH264 NEUTRON ACER TENDL-2019 LIBRARY; T=293.16K
angular distribution for (n,n*26)

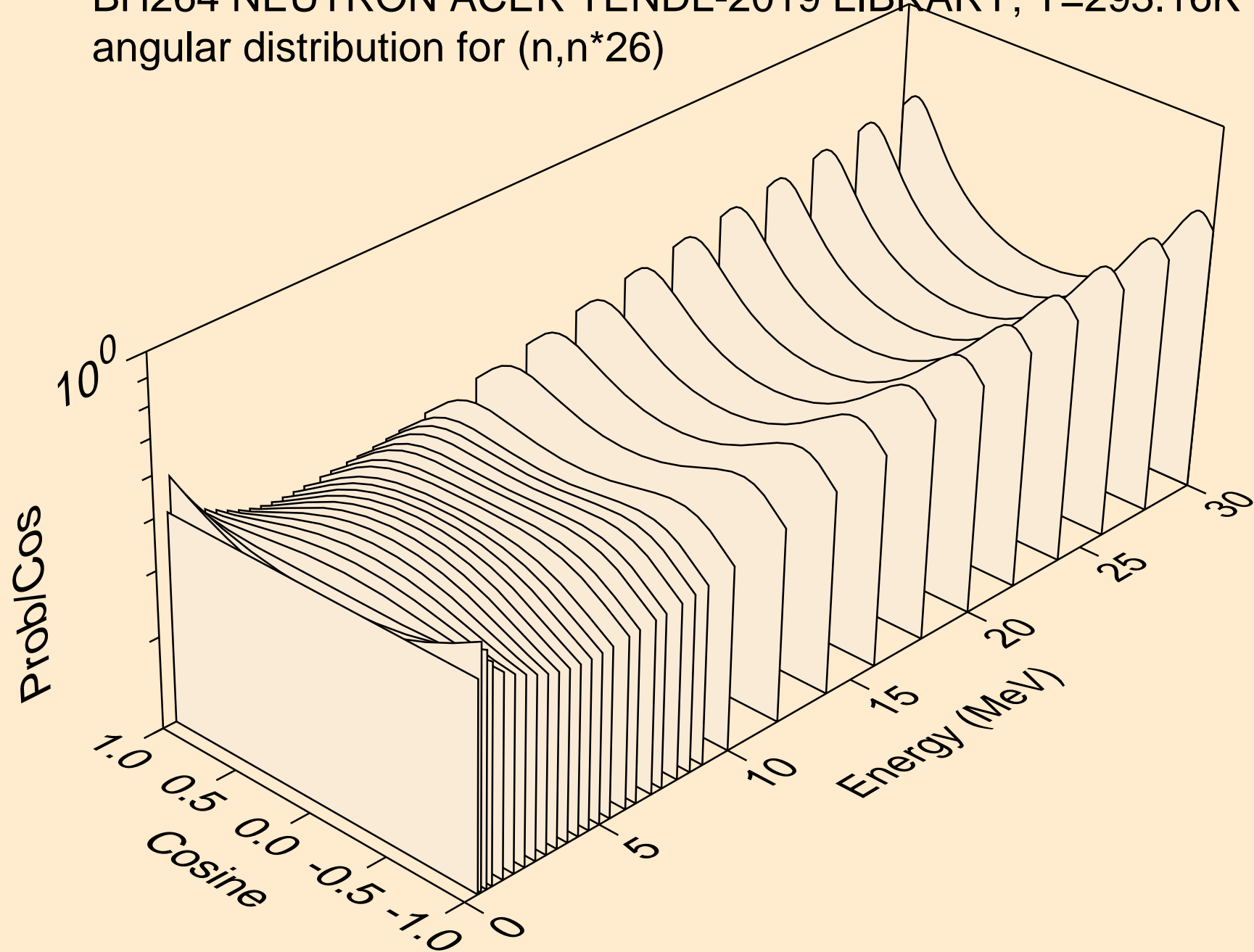

BH264 NEUTRON ACER TENDL-2019 LIBRARY; T=293.16K
angular distribution for (n,n*27)

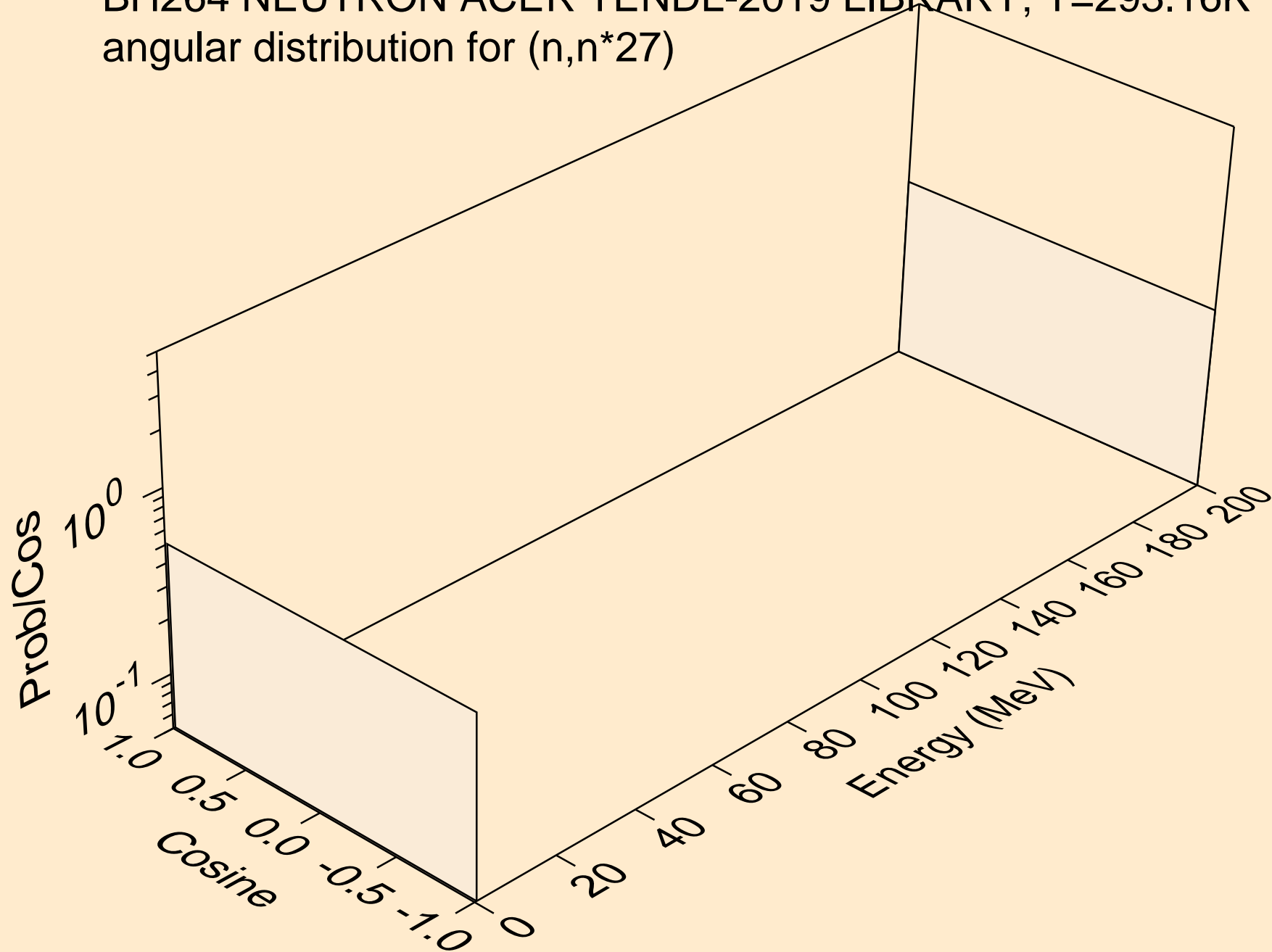

BH264 NEUTRON ACER TENDL-2019 LIBRARY; T=293.16K
angular distribution for (n,n*28)

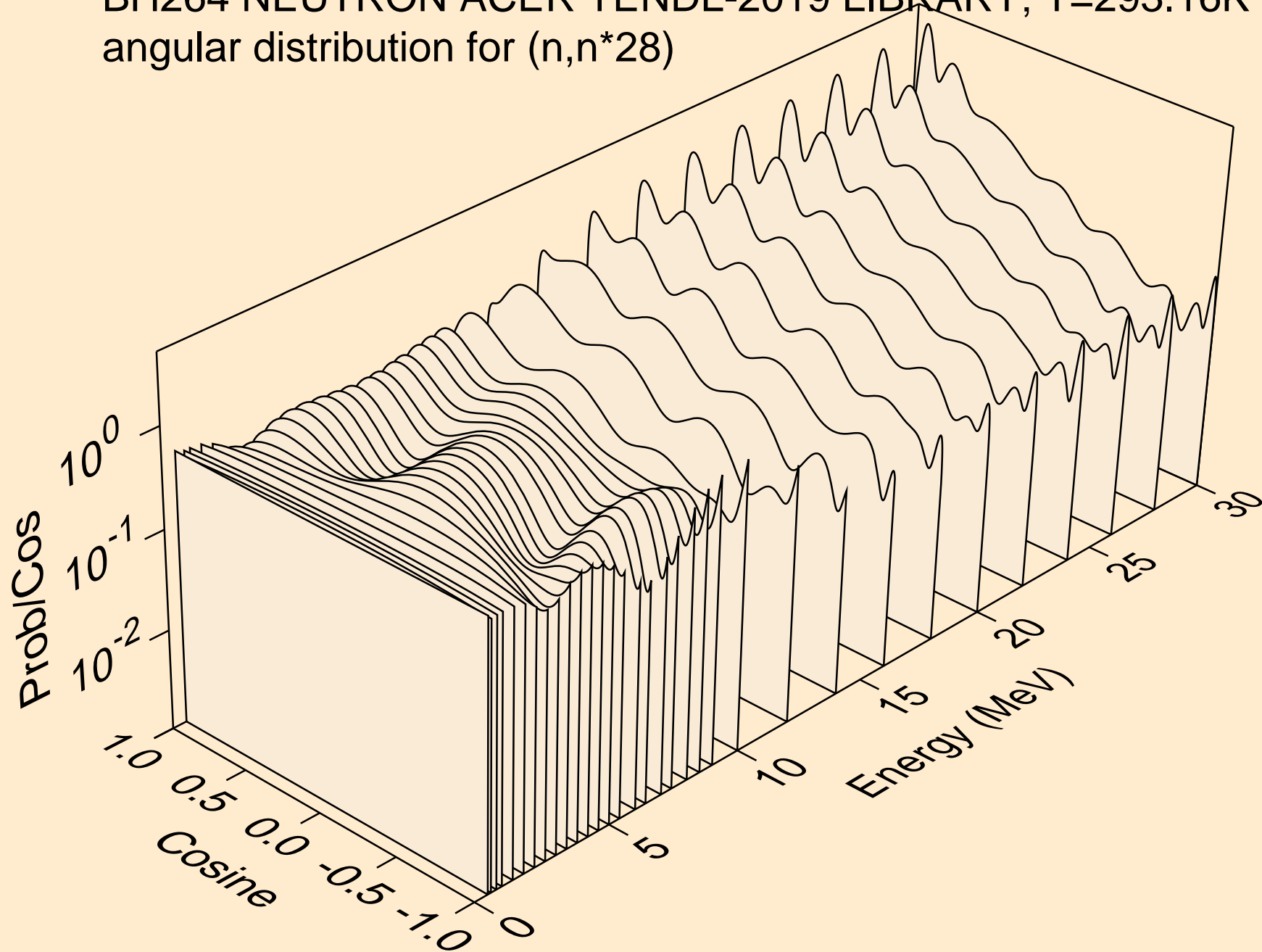

BH264 NEUTRON ACER TENDL-2019 LIBRARY; T=293.16K
Total fission nubar

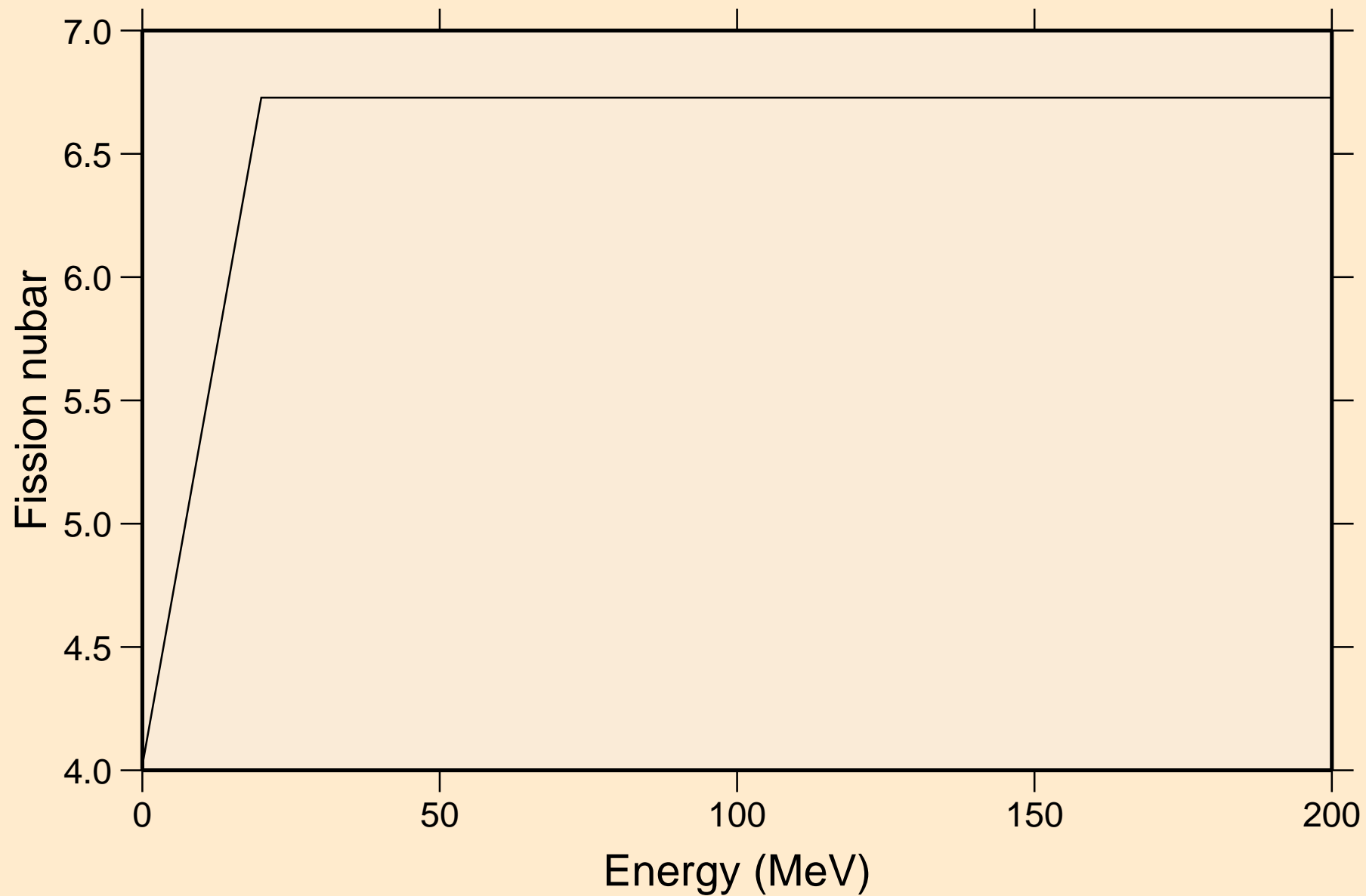

BH264 NEUTRON ACER TENDL-2019 LIBRARY; T=293.16K
Neutron emission for (n,x)

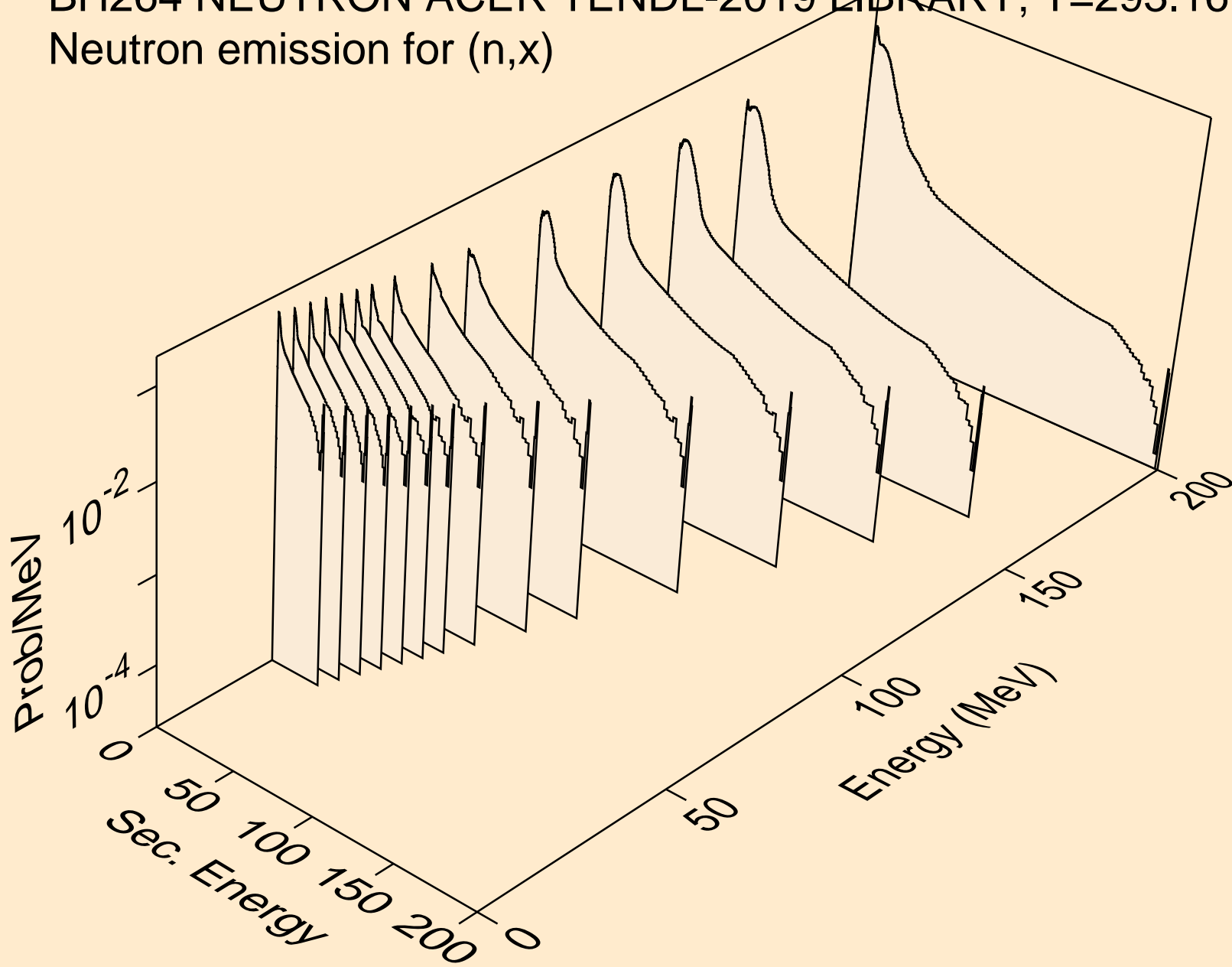

BH264 NEUTRON ACER TENDL-2019 LIBRARY; T=293.16K
Neutron emission for (n,2nd)

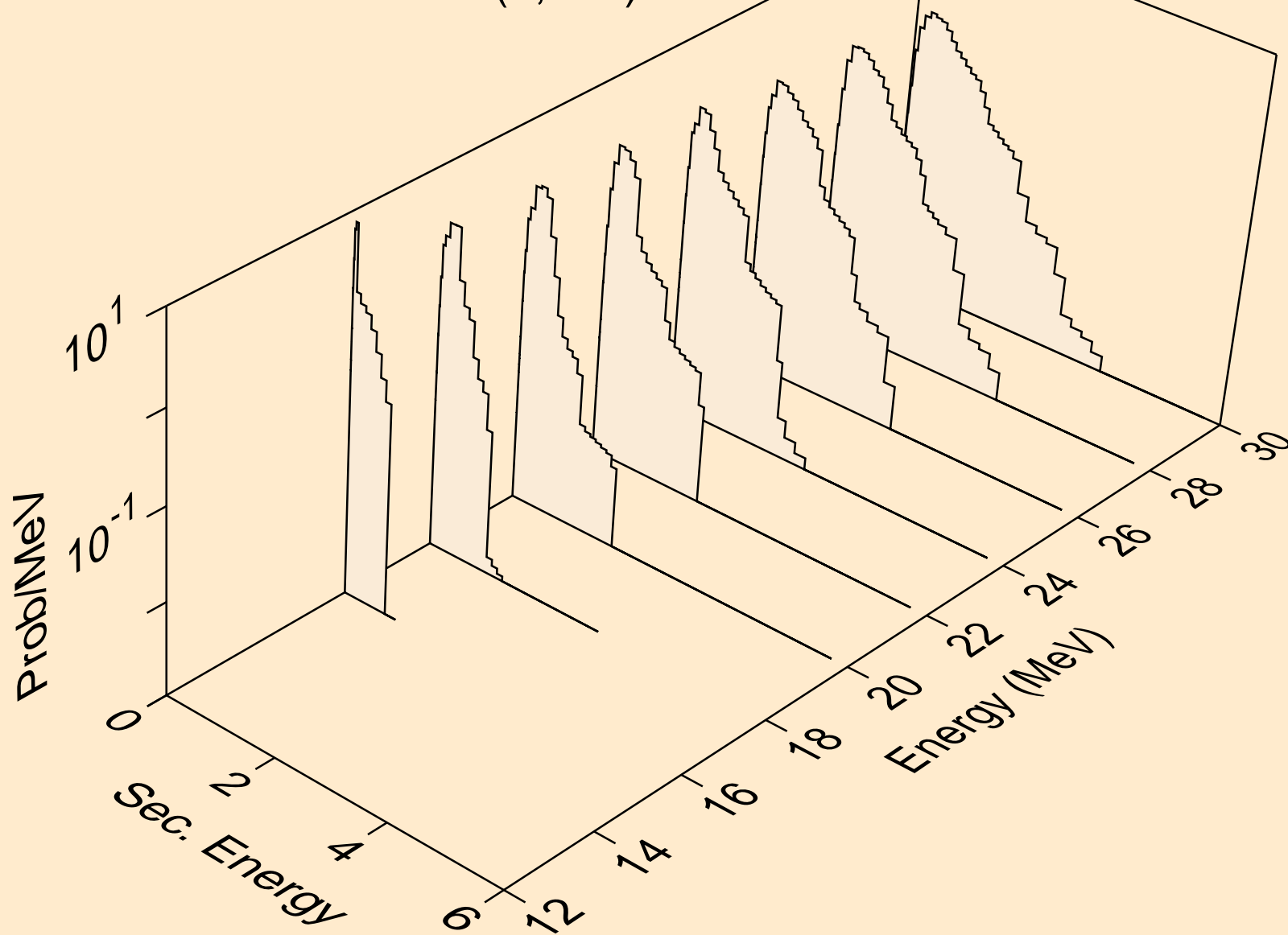

BH264 NEUTRON ACER TENDL-2019 LIBRARY; T=293.16K
Neutron emission for (n,2n)

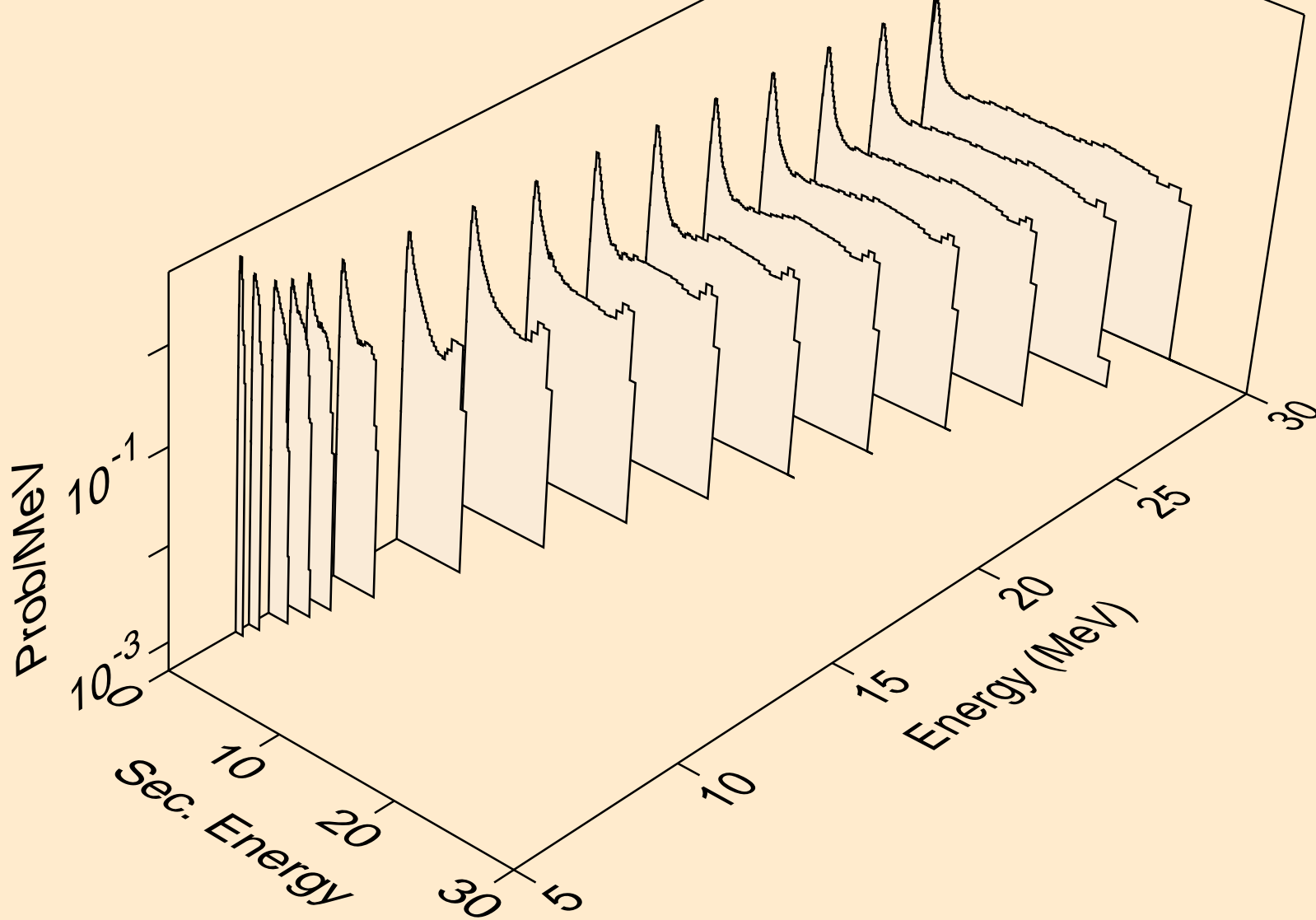

BH264 NEUTRON ACER TENDL-2019 LIBRARY; T=293.16K
Neutron emission for (n,3n)

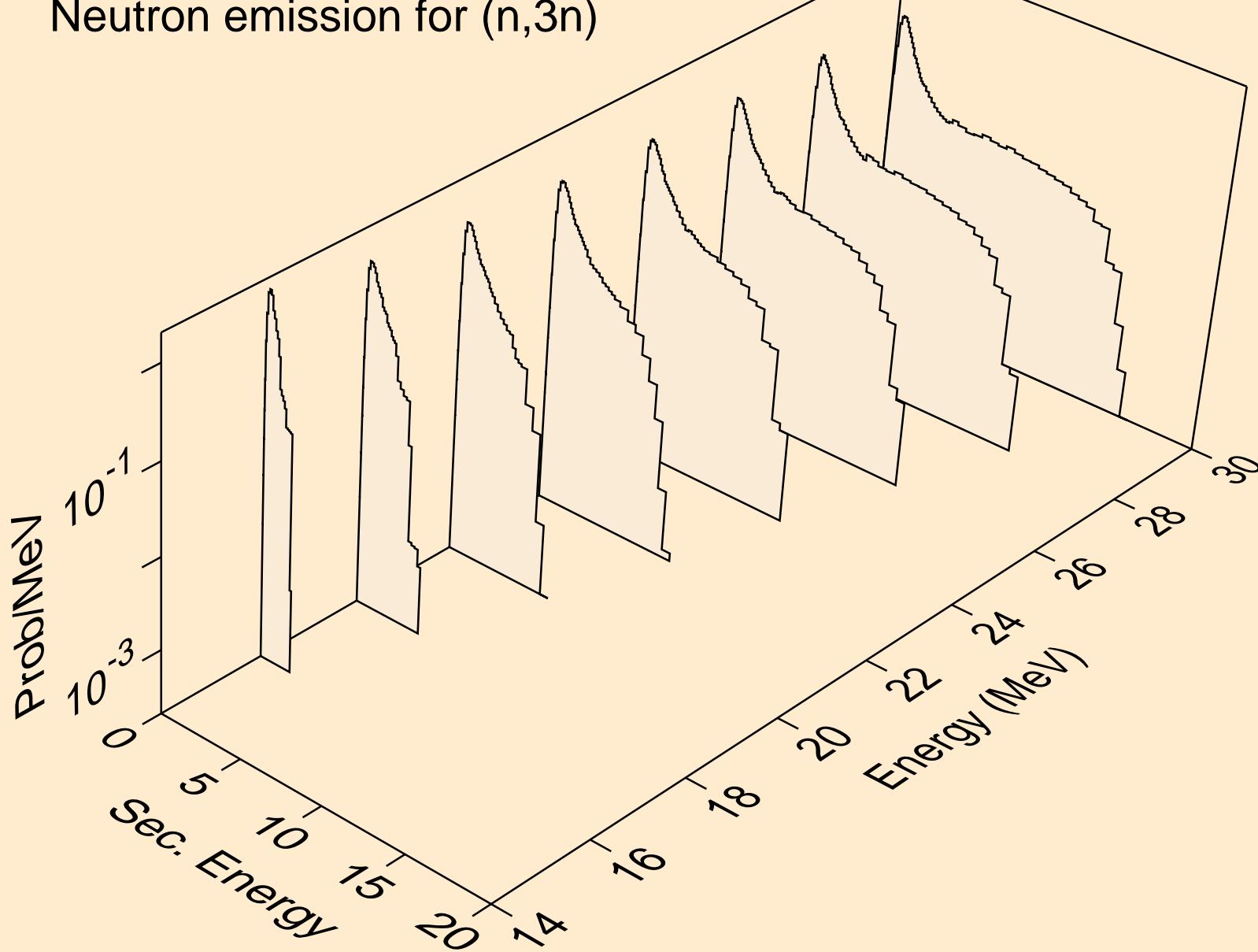

BH264 NEUTRON ACER TENDL-2019 LIBRARY; T=293.16K
Neutron emission for fission

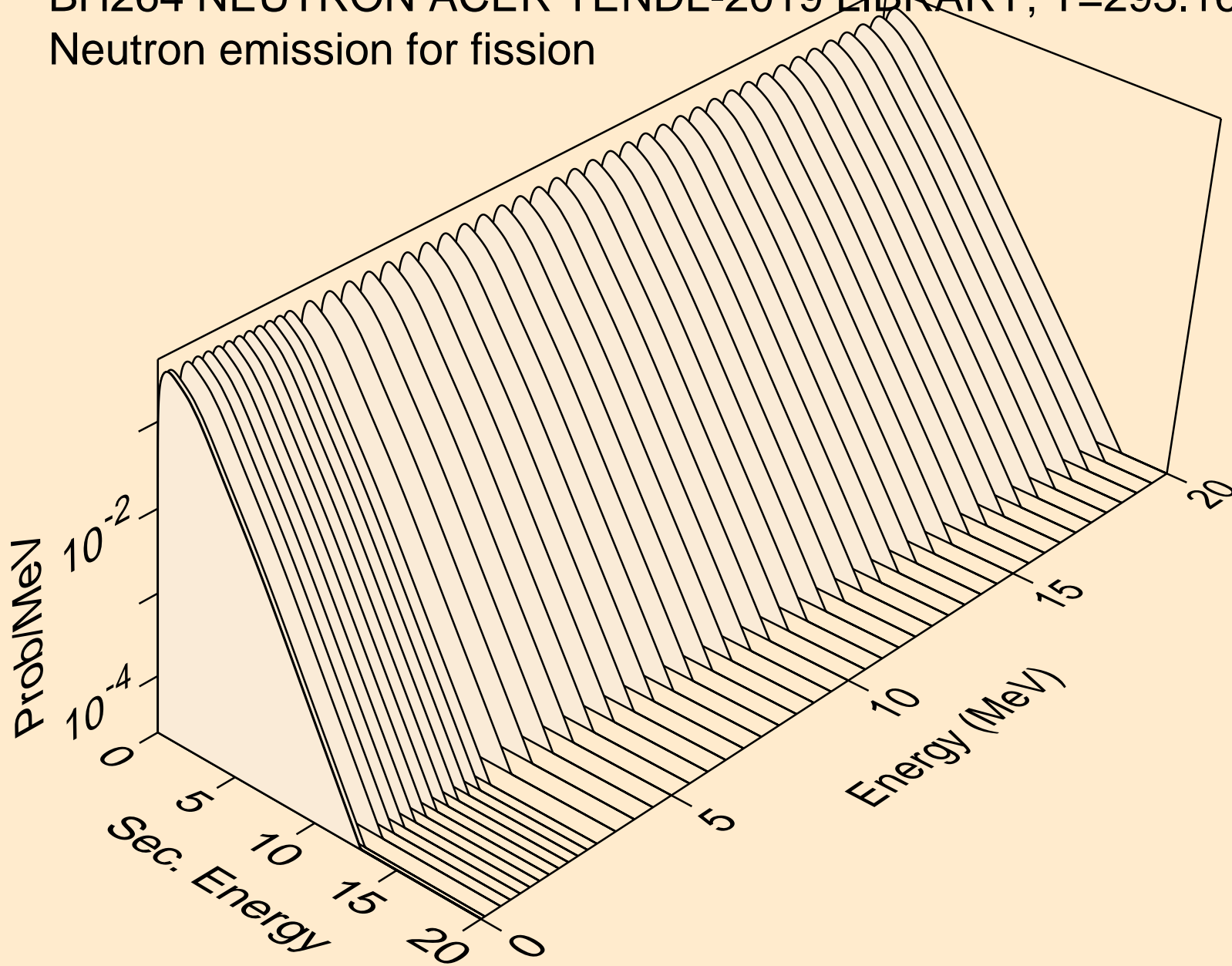

BH264 NEUTRON ACER TENDL-2019 LIBRARY; T=293.16K
Neutron emission for (n,n*)a

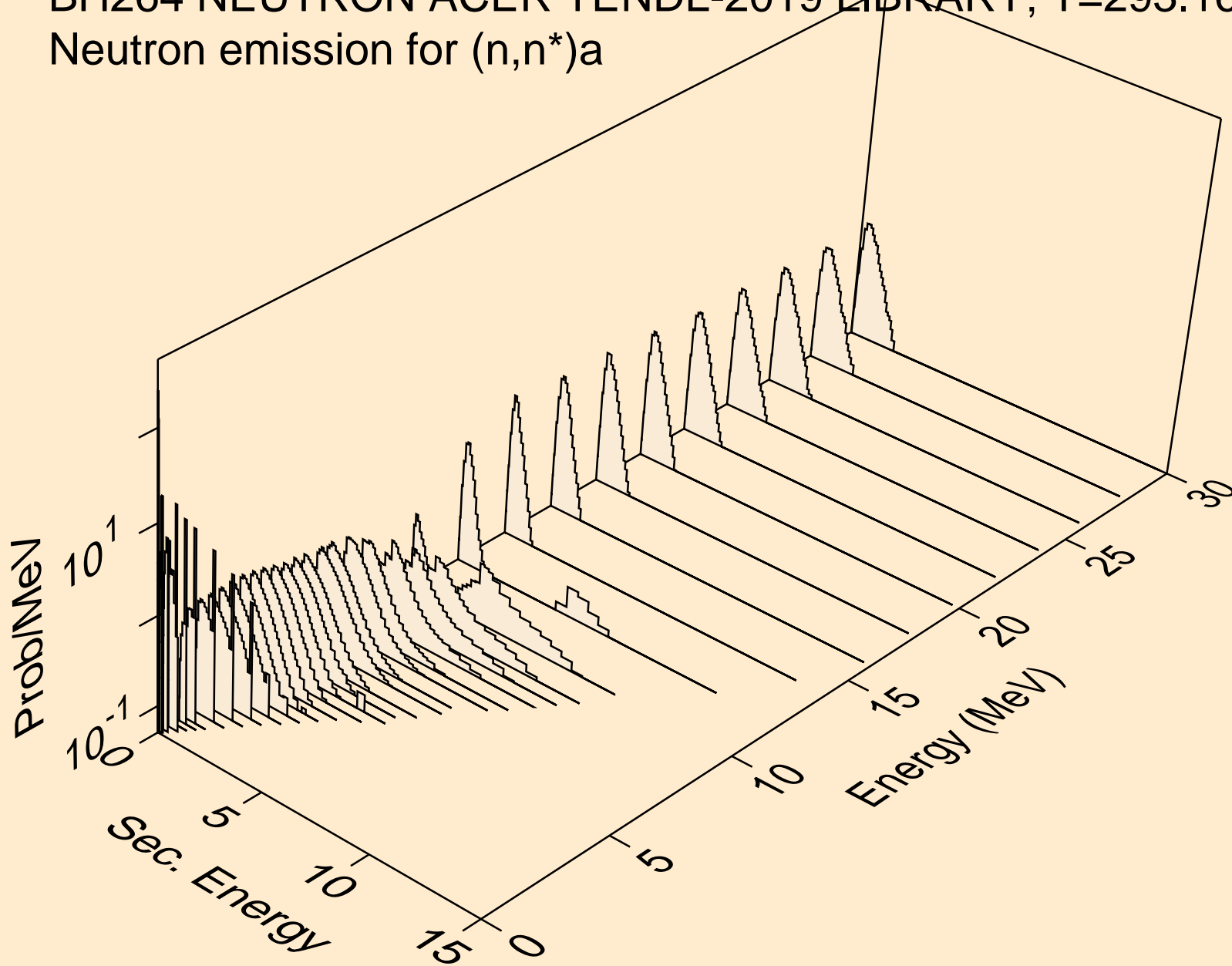

BH264 NEUTRON ACER TENDL-2019 LIBRARY; T=293.16K
Neutron emission for (n,2n)a

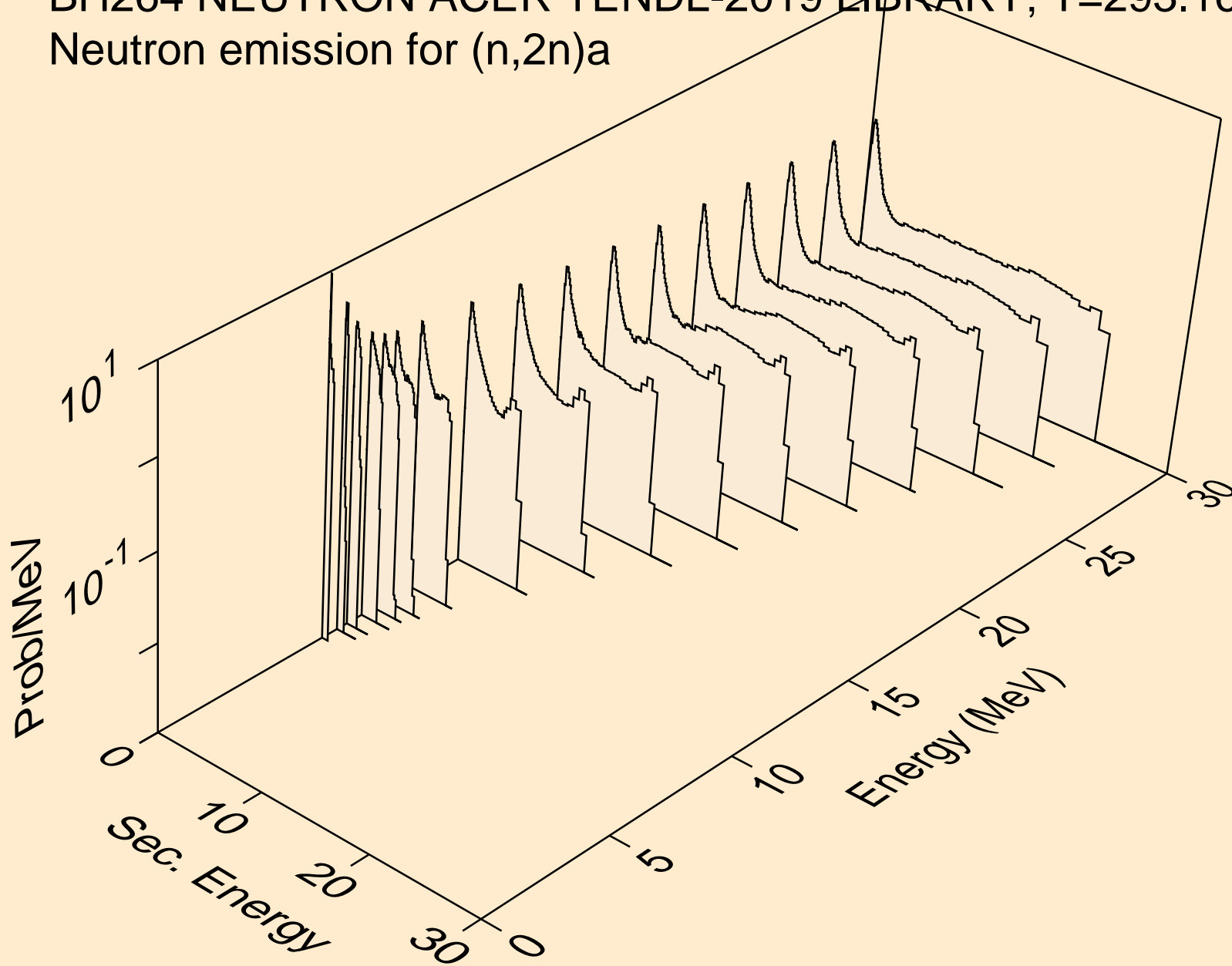

BH264 NEUTRON ACER TENDL-2019 LIBRARY; T=293.16K
Neutron emission for (n,3n)a

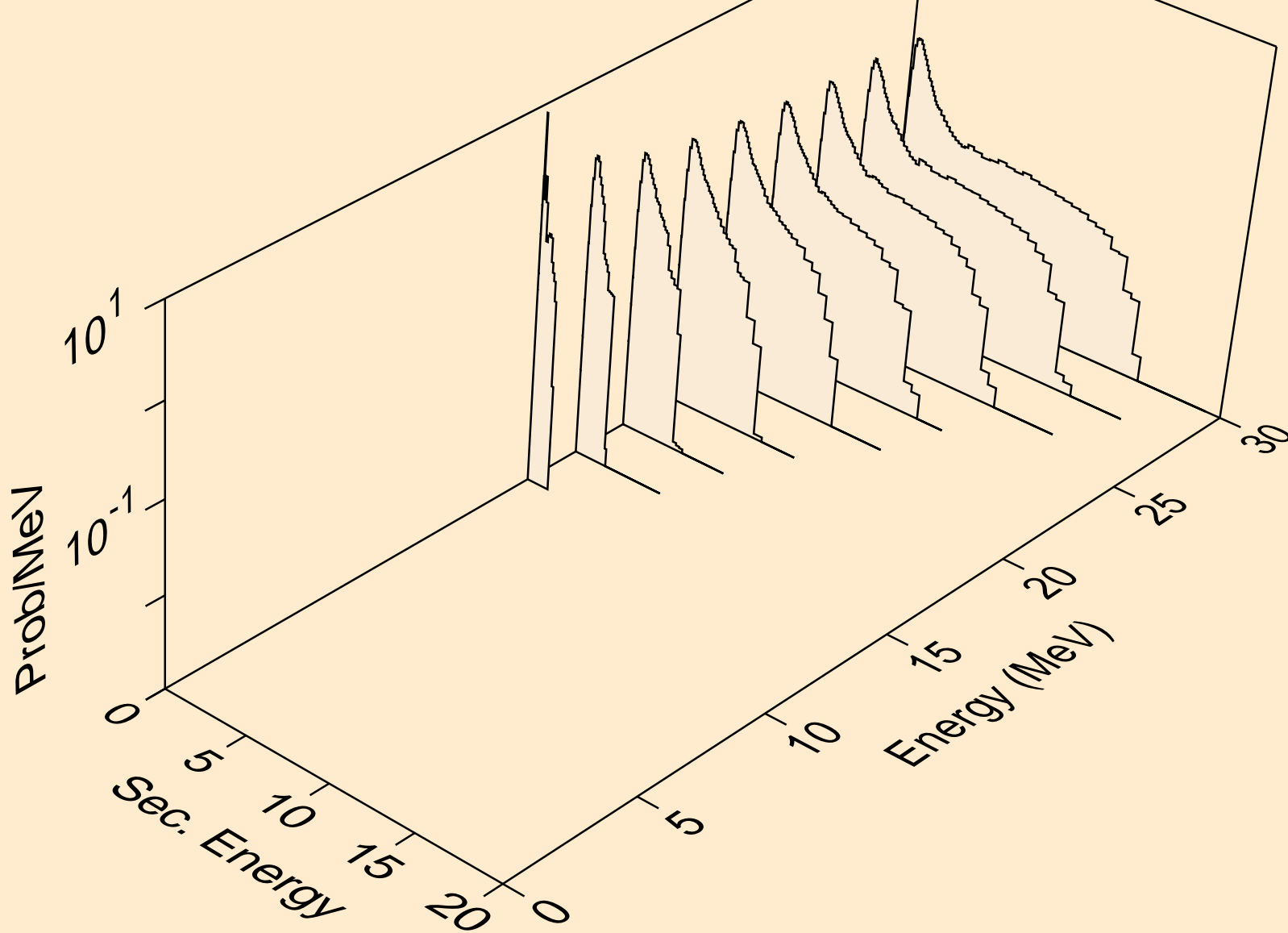

BH264 NEUTRON ACER TENDL-2019 LIBRARY; T=293.16K
Neutron emission for (n,n*)p

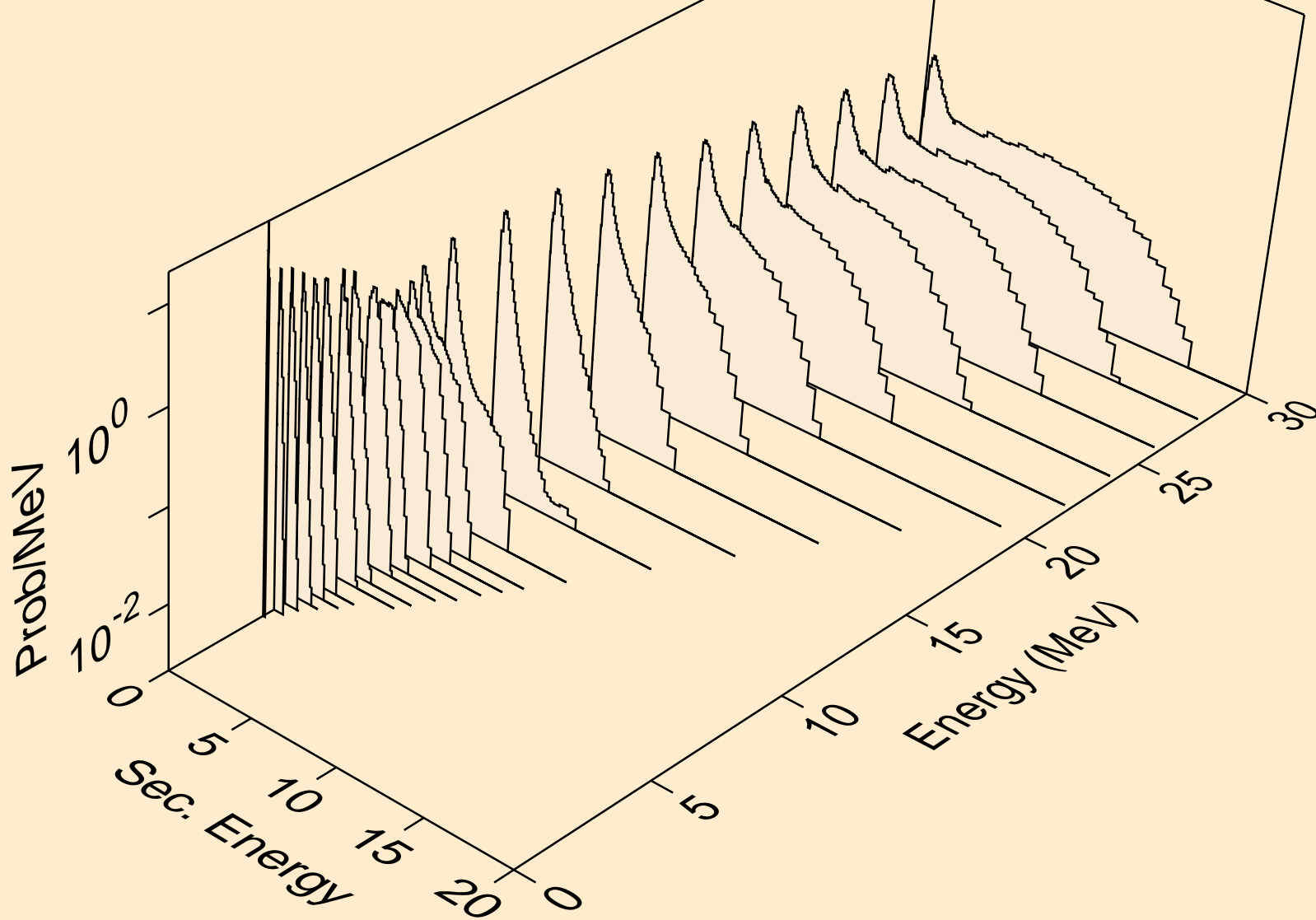

BH264 NEUTRON ACER TENDL-2019 LIBRARY; T=293.16K
Neutron emission for (n,n*)2a

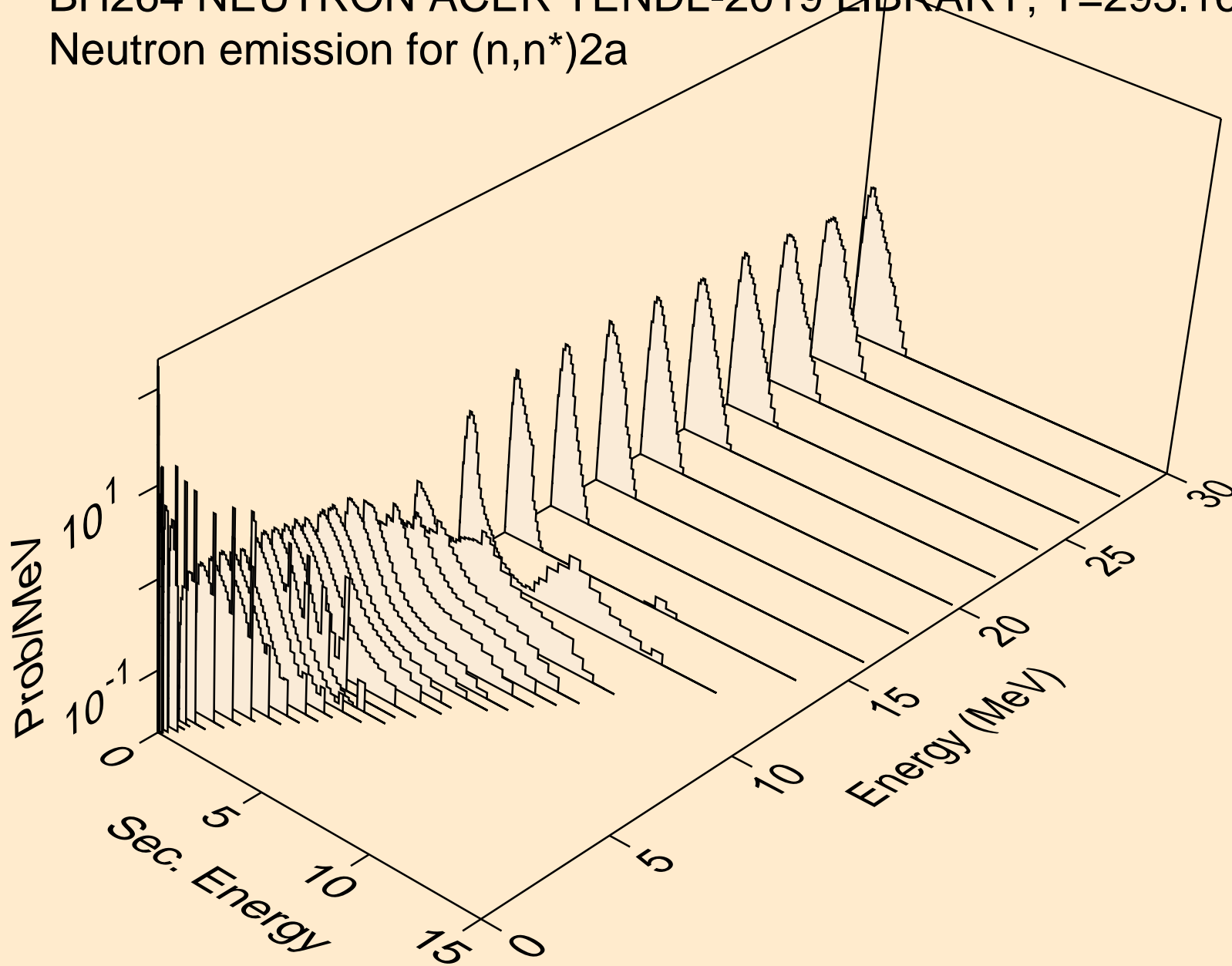

BH264 NEUTRON ACER TENDL-2019 LIBRARY; T=293.16K
Neutron emission for (n,2n)2a

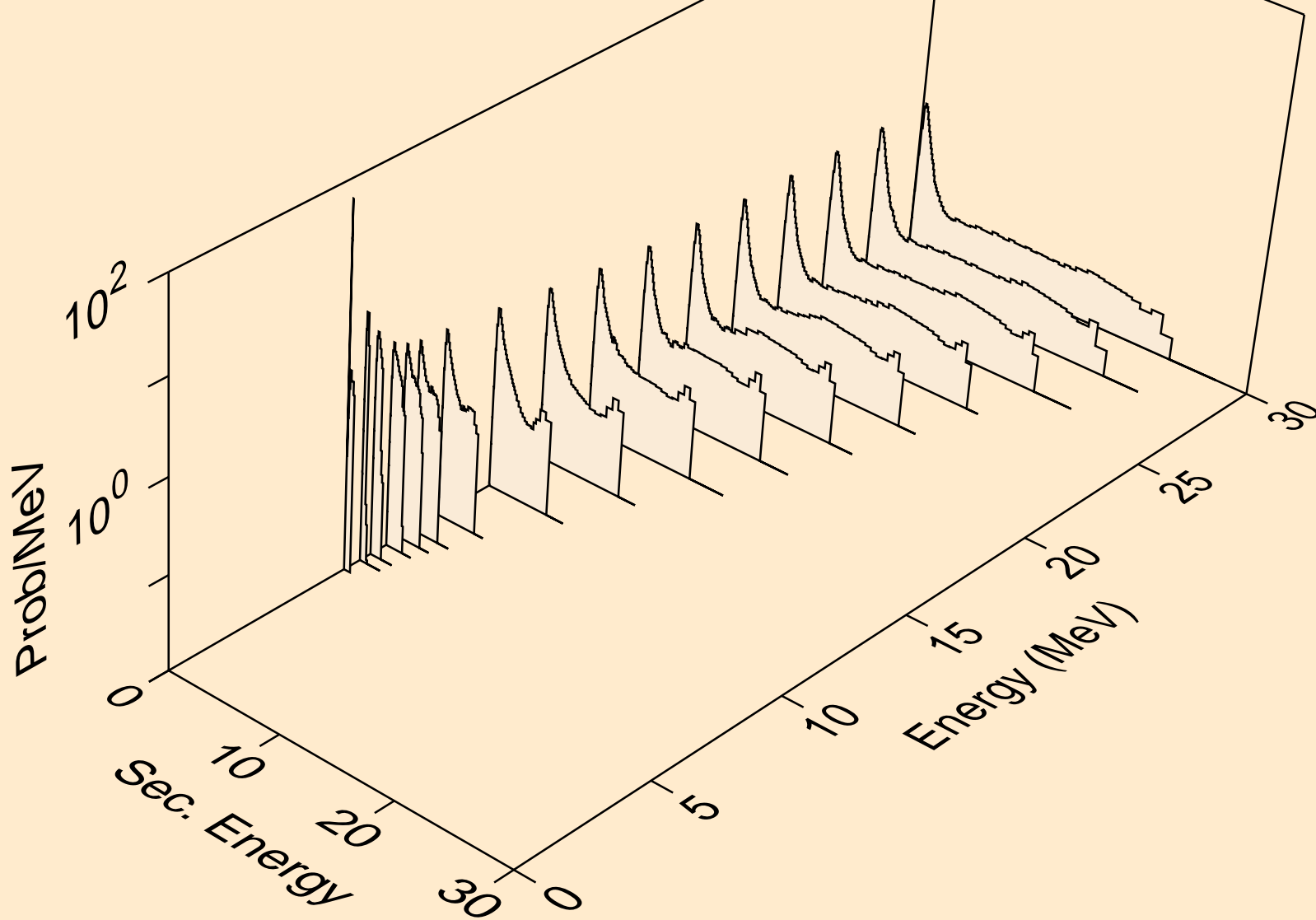

BH264 NEUTRON ACER TENDL-2019 LIBRARY; T=293.16K
Neutron emission for (n,n*)d

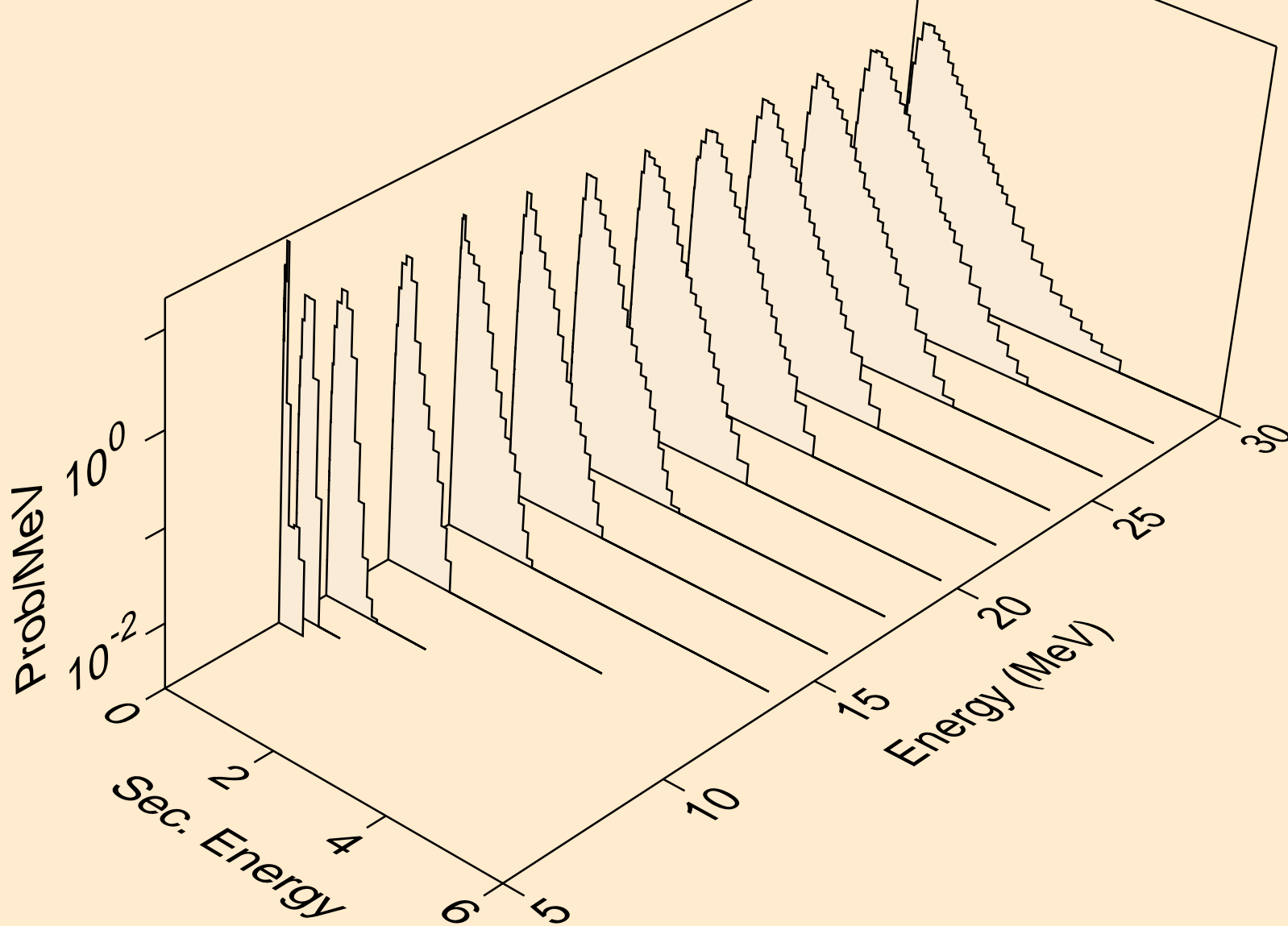

BH264 NEUTRON ACER TENDL-2019 LIBRARY; T=293.16K
Neutron emission for (n,n*)t

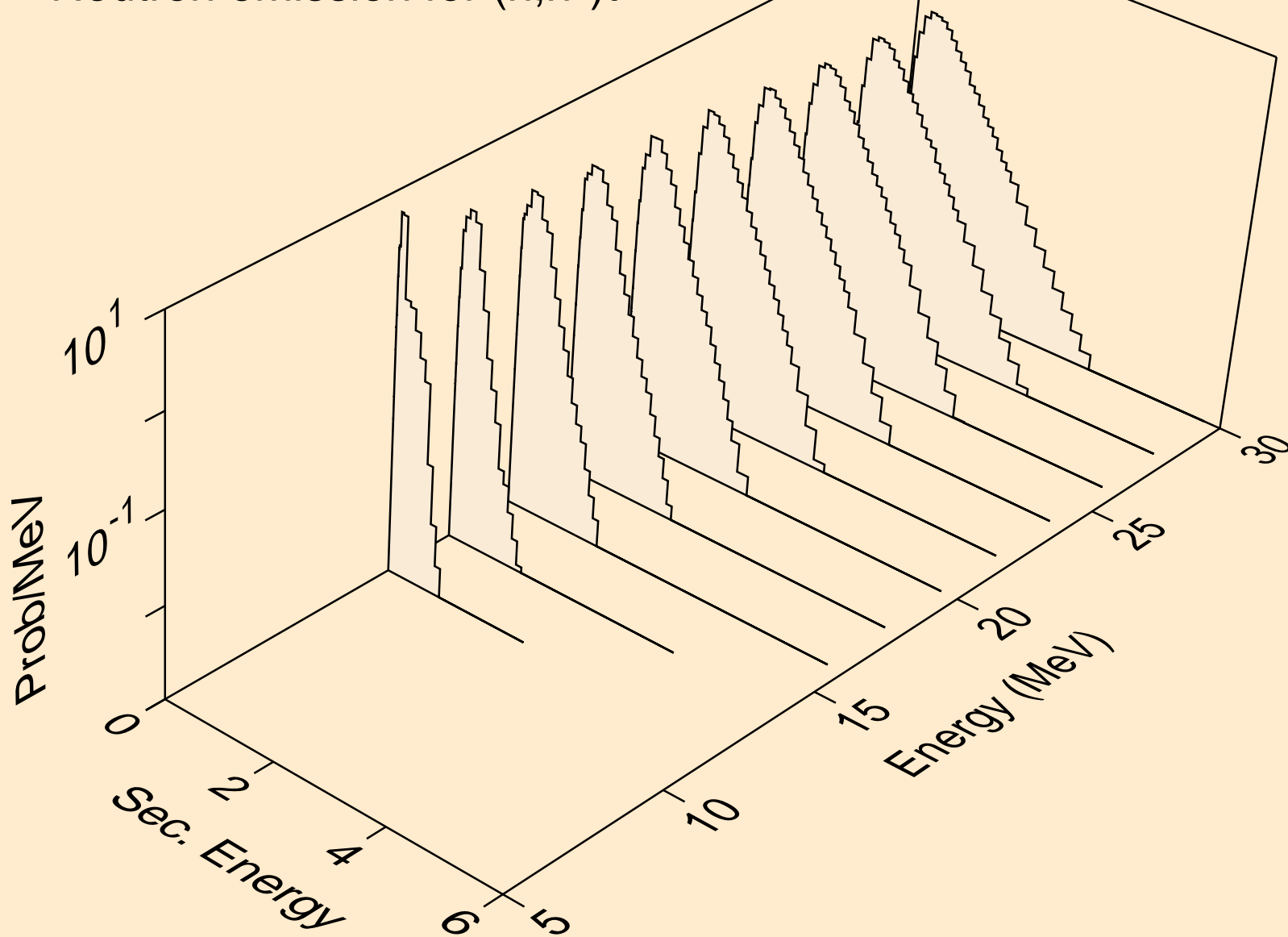

BH264 NEUTRON ACER TENDL-2019 LIBRARY; T=293.16K
Neutron emission for (n,n*)he3

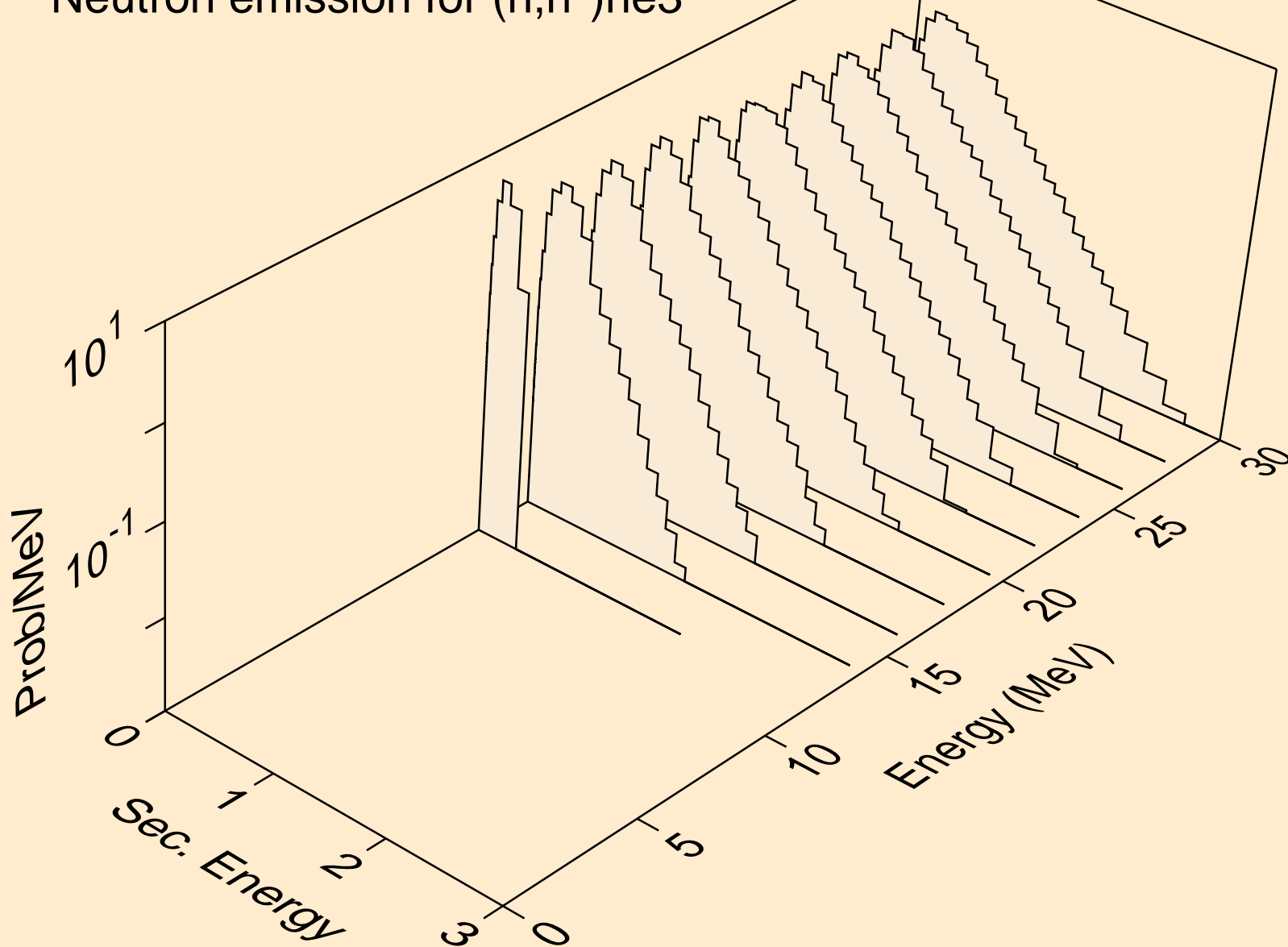

BH264 NEUTRON ACER TENDL-2019 LIBRARY; T=293.16K
Neutron emission for (n,n*)d2a

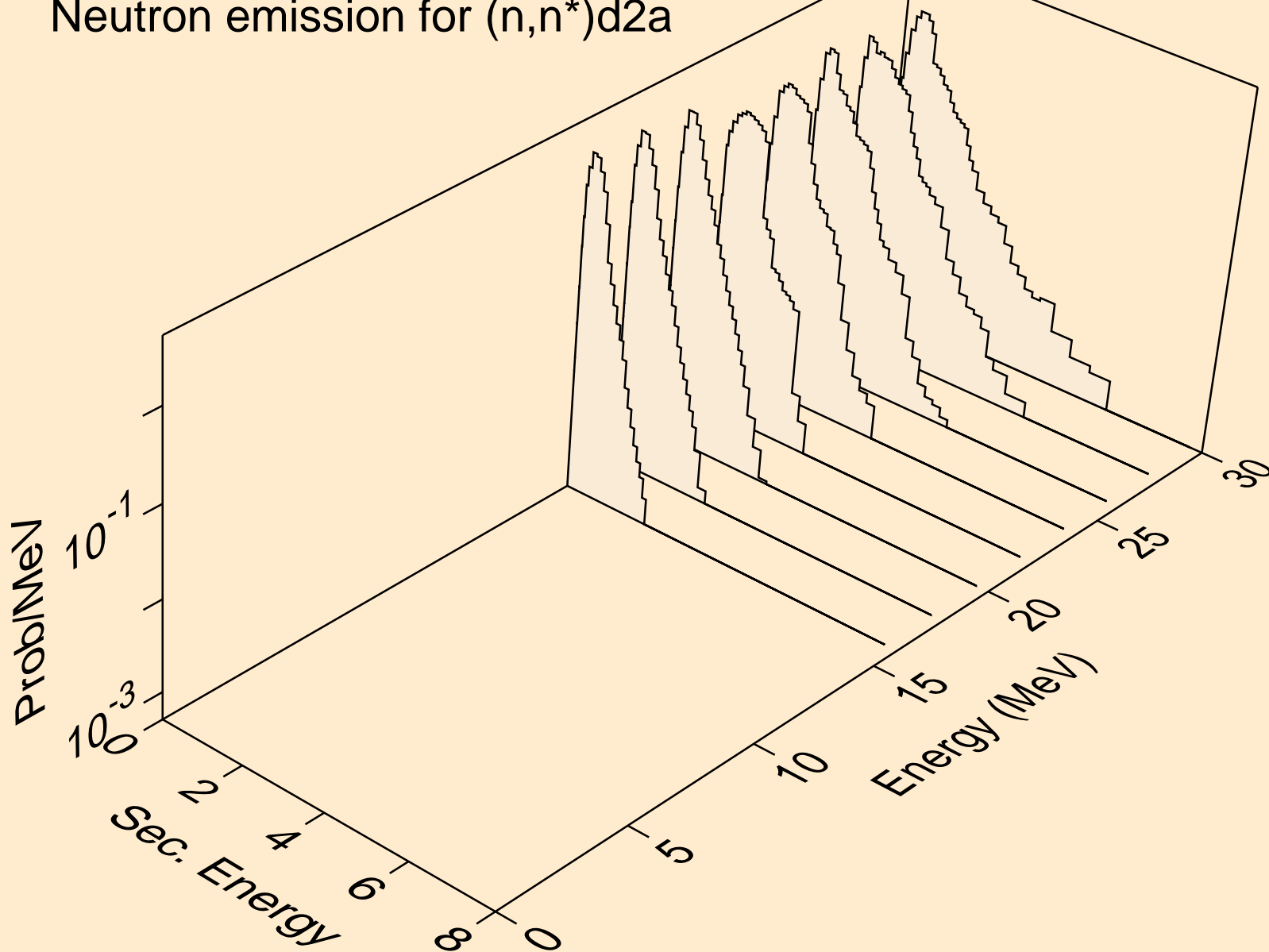

BH264 NEUTRON ACER TENDL-2019 LIBRARY; T=293.16K
Neutron emission for (n,n*)t2a

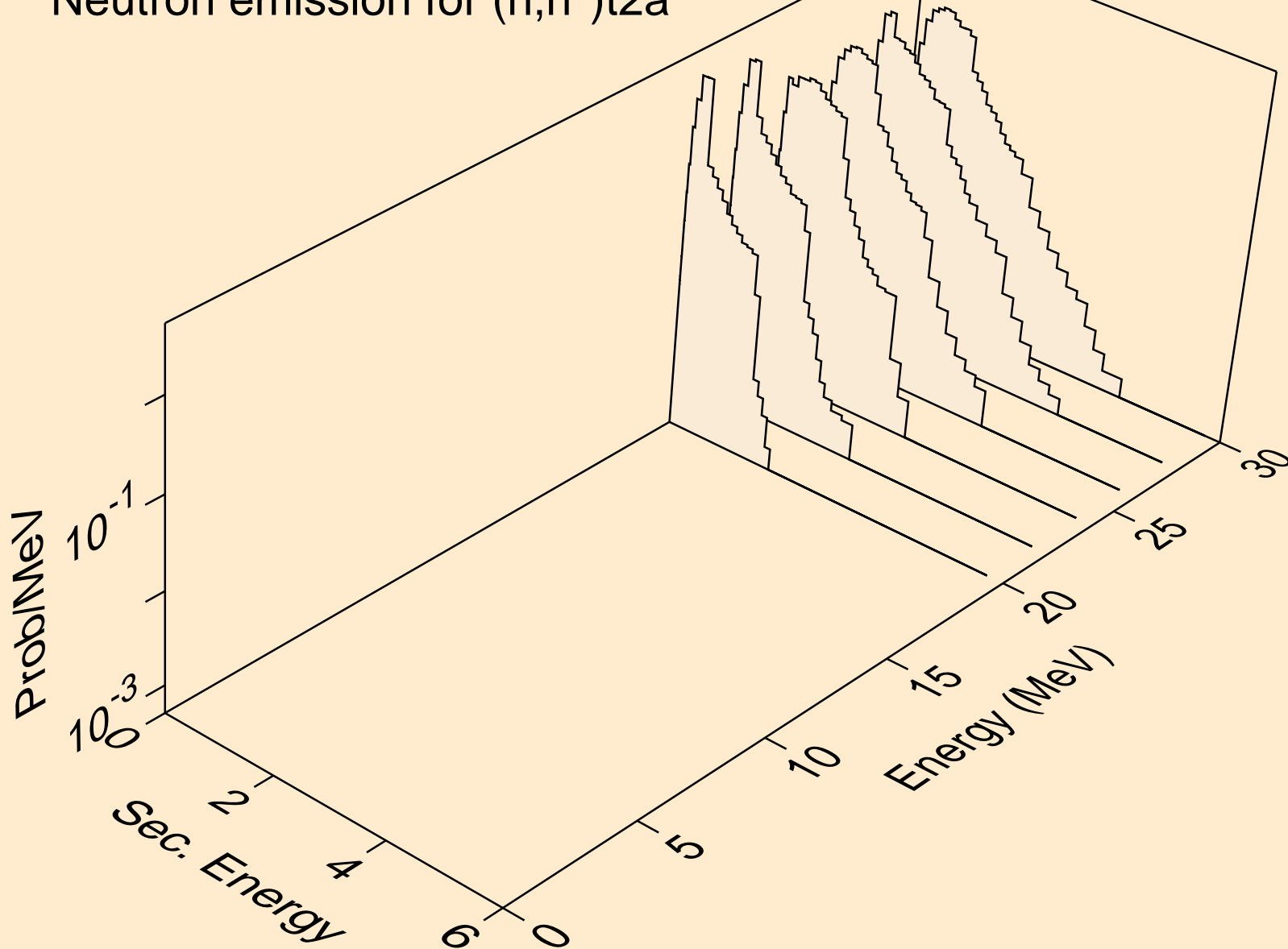

BH264 NEUTRON ACER TENDL-2019 LIBRARY; T=293.16K
Neutron emission for (n,4n)

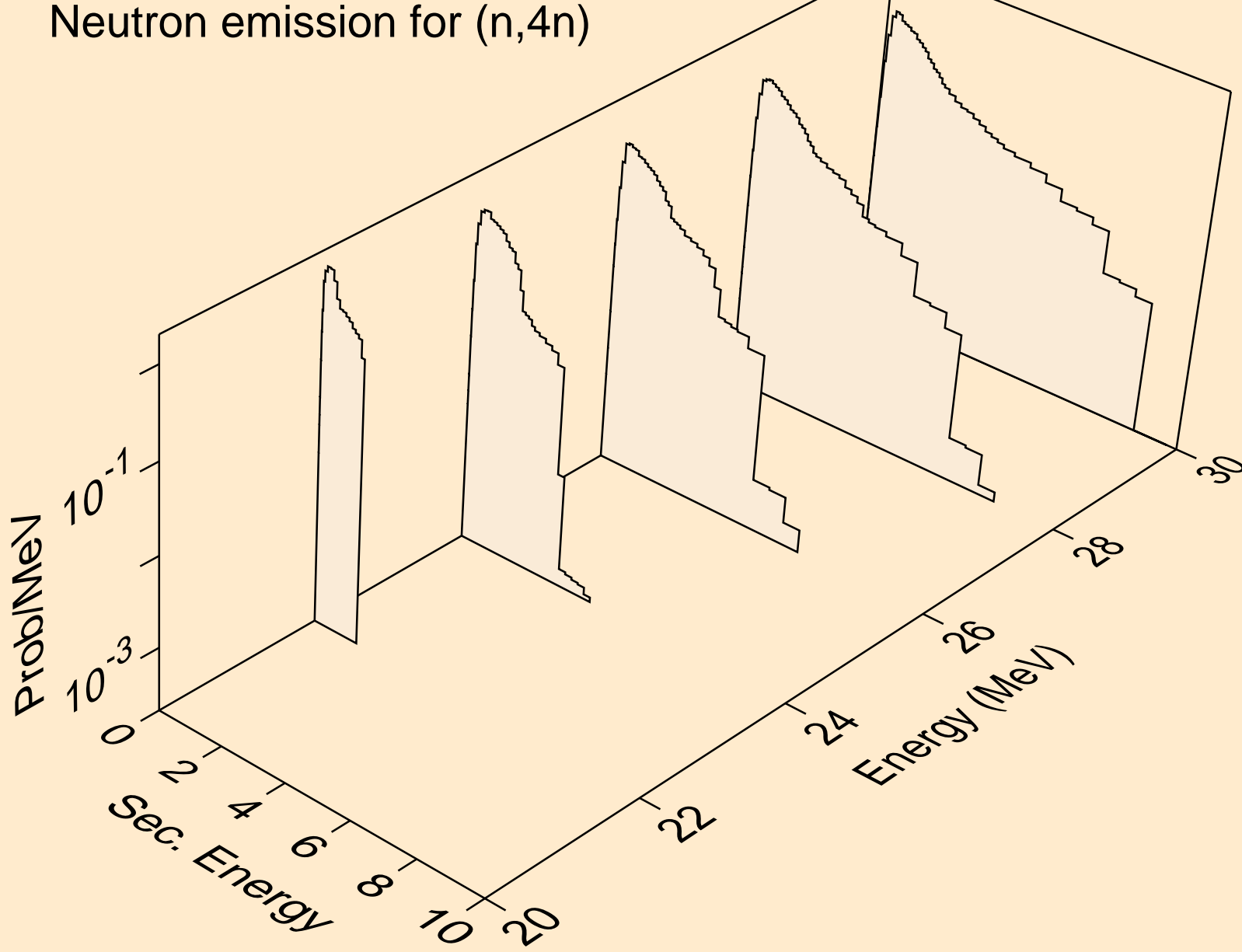

BH264 NEUTRON ACER TENDL-2019 LIBRARY; T=293.16K
Neutron emission for (n,2np)

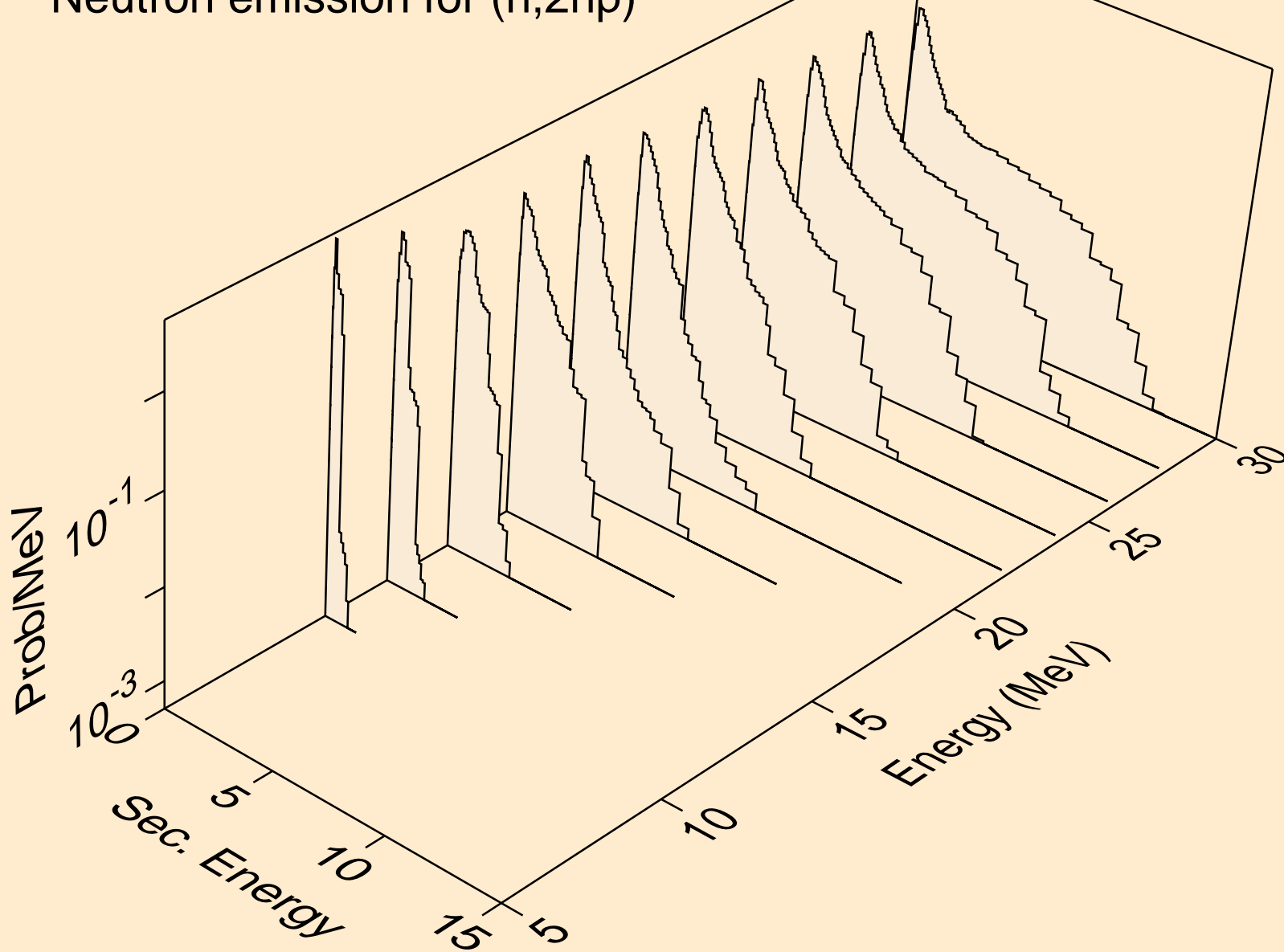

BH264 NEUTRON ACER TENDL-2019 LIBRARY; T=293.16K
Neutron emission for (n,3np)

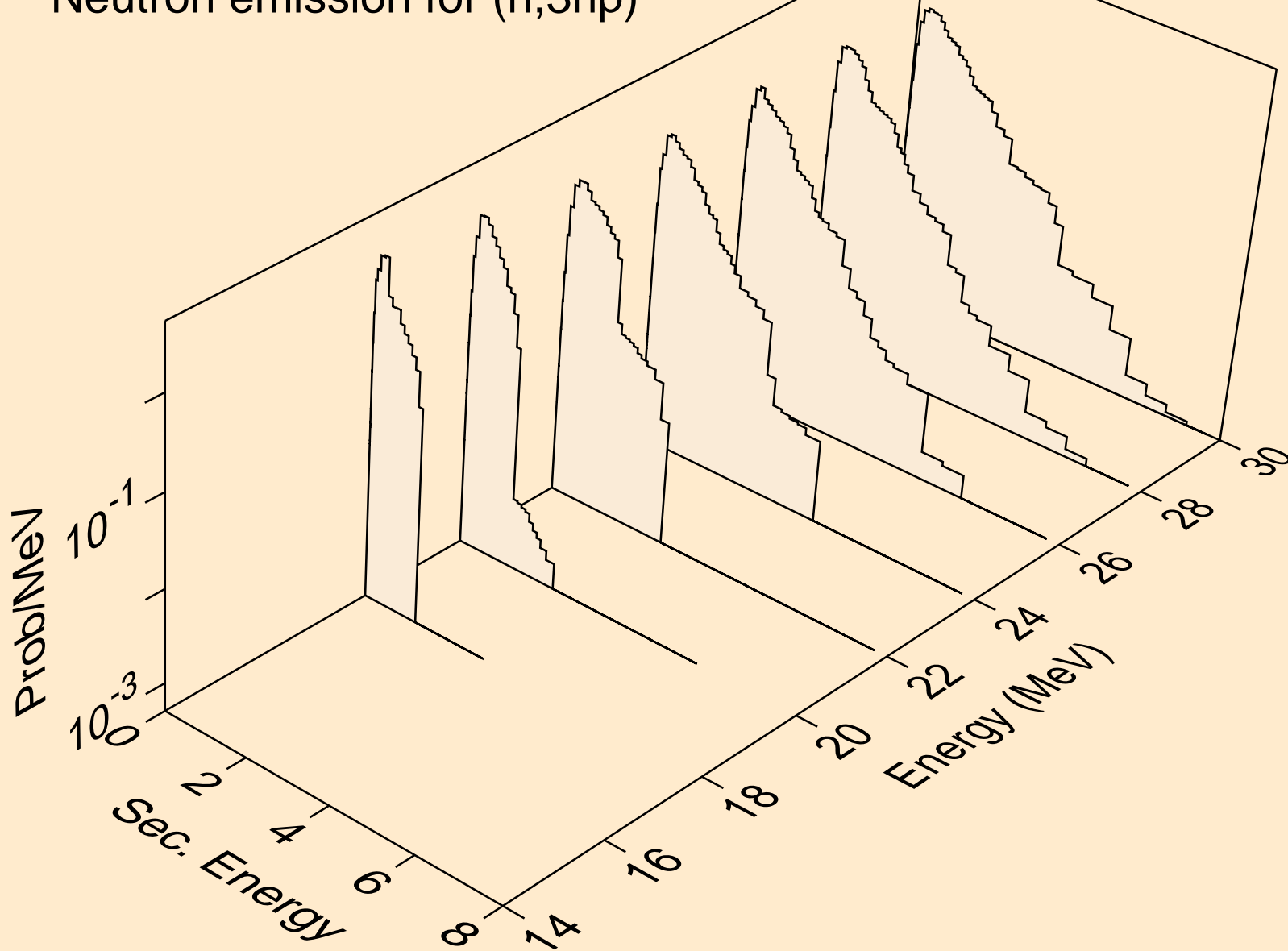

BH264 NEUTRON ACER TENDL-2019 LIBRARY; T=293.16K
Neutron emission for (n,2np)

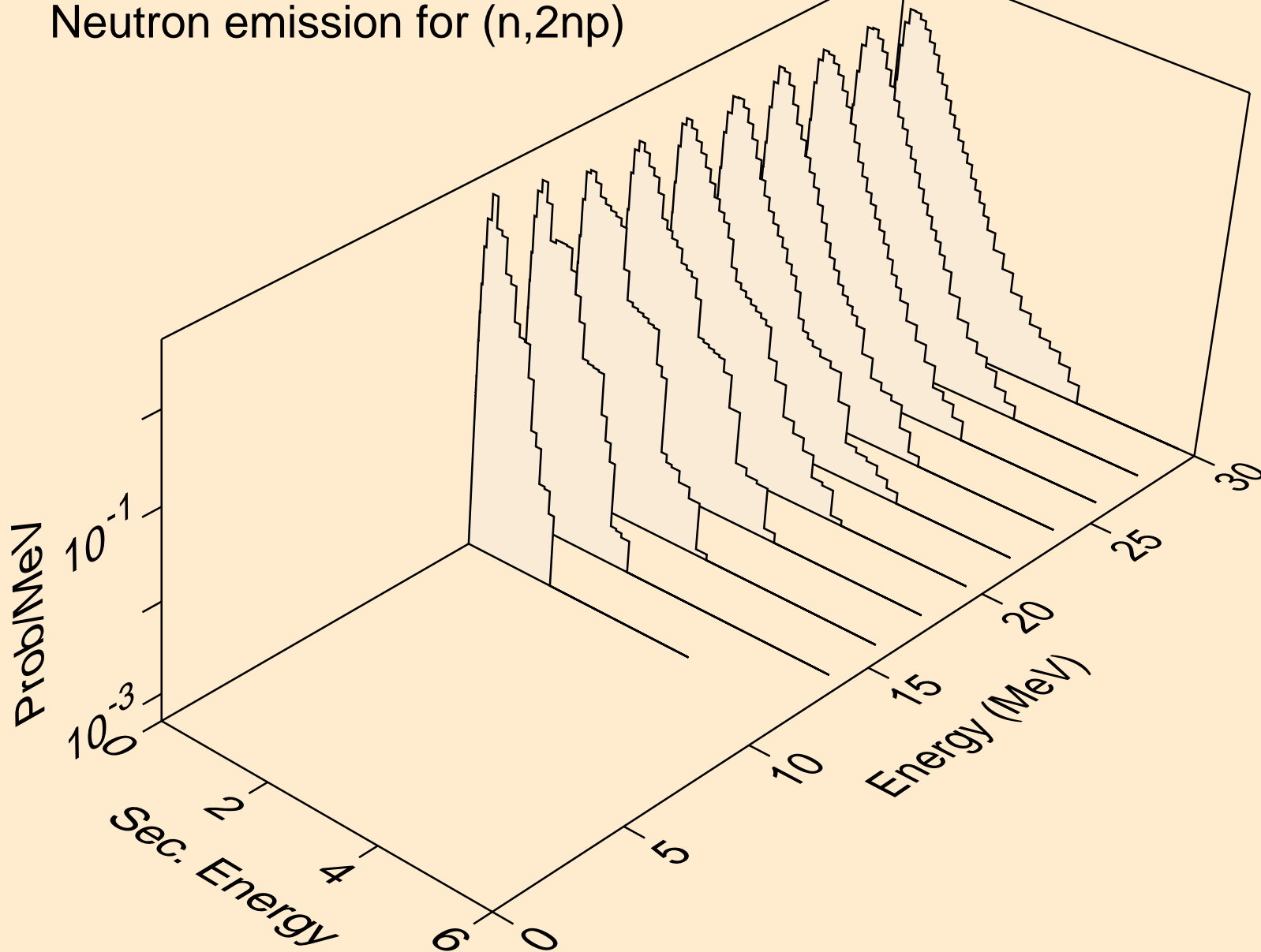

BH264 NEUTRON ACER TENDL-2019 LIBRARY; T=293.16K
Neutron emission for (n,npa)

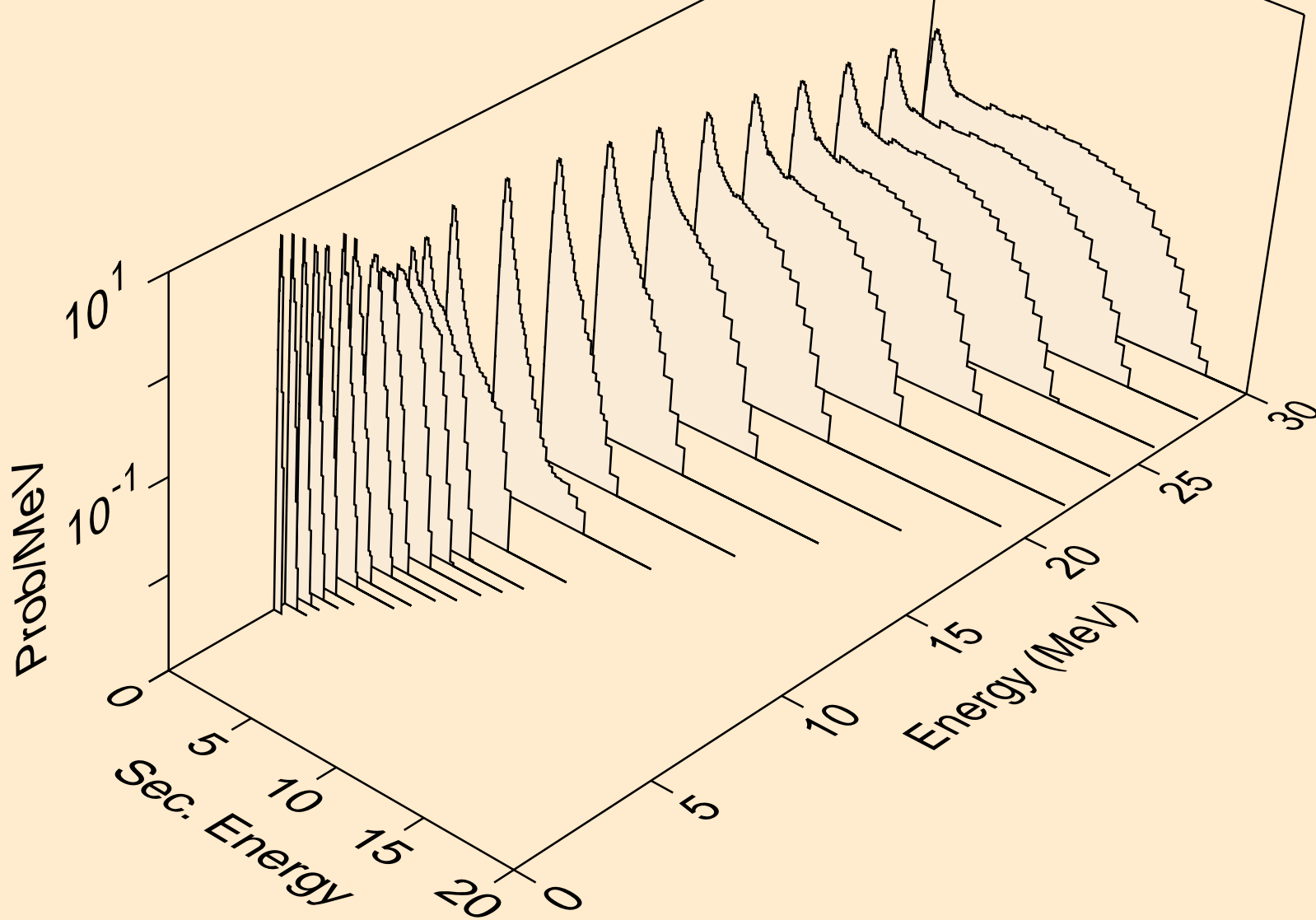

BH264 NEUTRON ACER TENDL-2019 LIBRARY; T=293.16K
Neutron emission for (n,n*c)

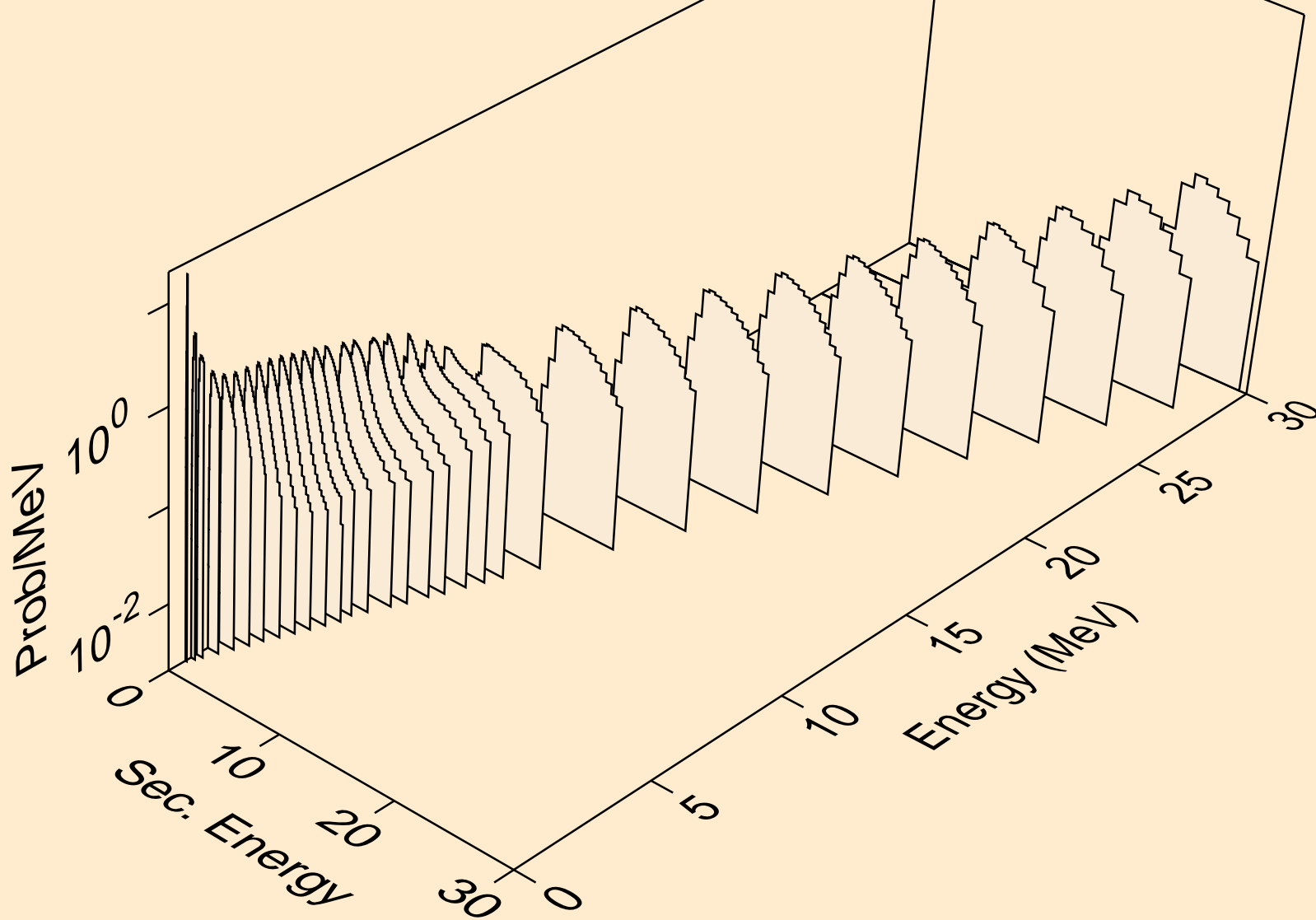

BH264 NEUTRON ACER TENDL-2019 LIBRARY; T=293.16K

Delayed nubar

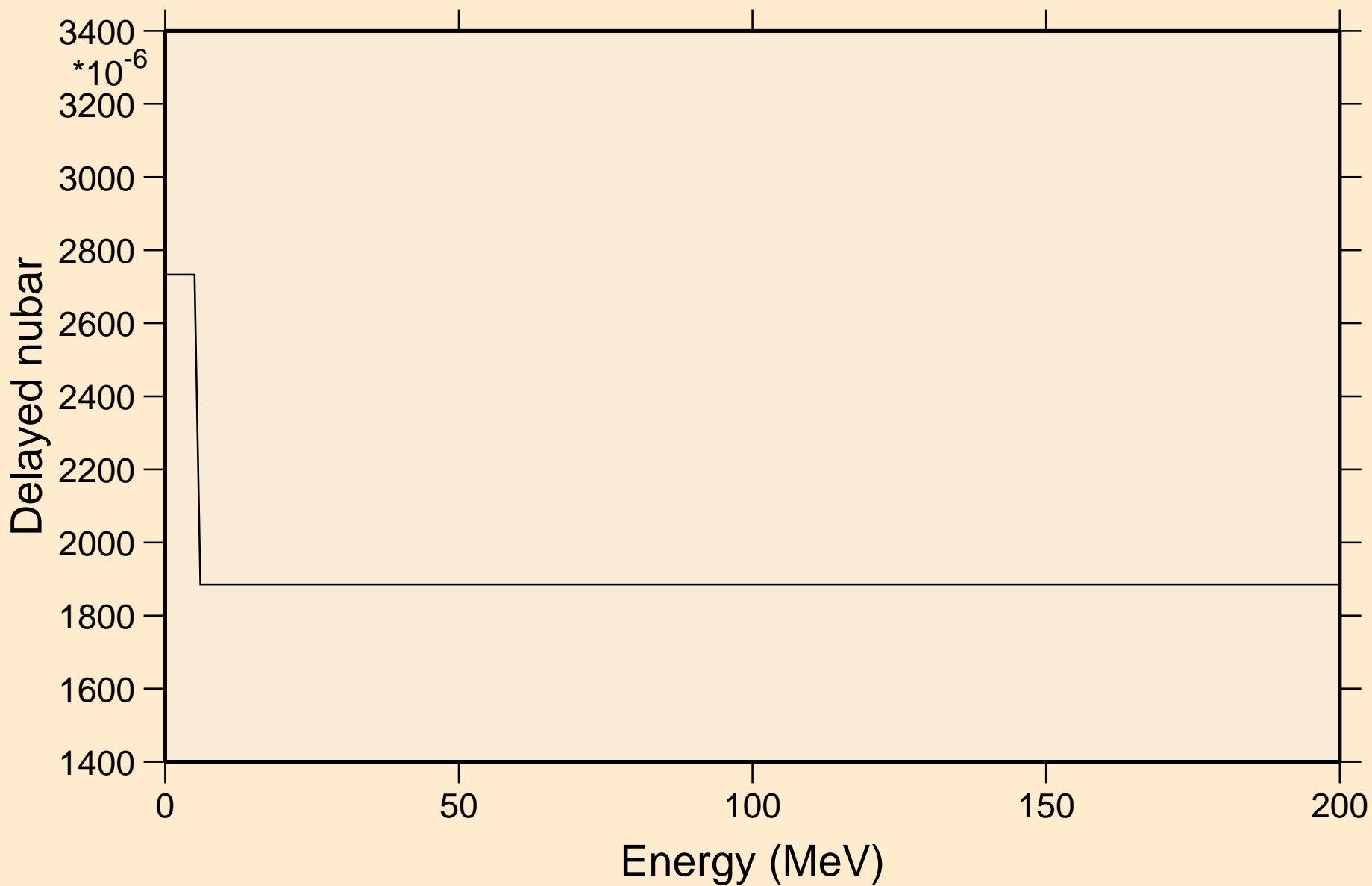

BH264 NEUTRON ACER TENDL-2019 LIBRARY; T=293.16K
Delayed neutron spectra

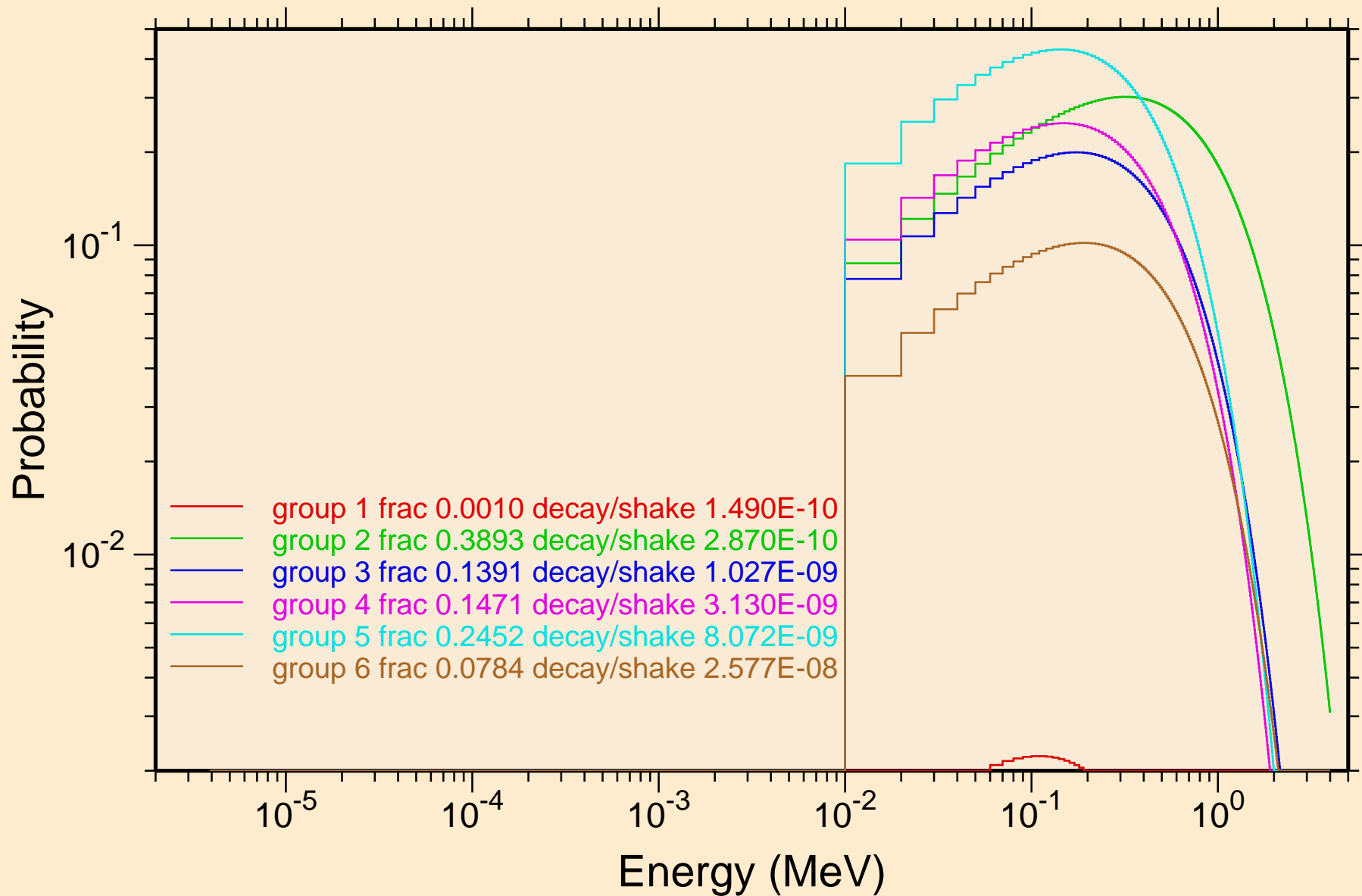

BH264 NEUTRON ACER TENDL-2019 LIBRARY; T=293.16K
Photon emission for (n,x)

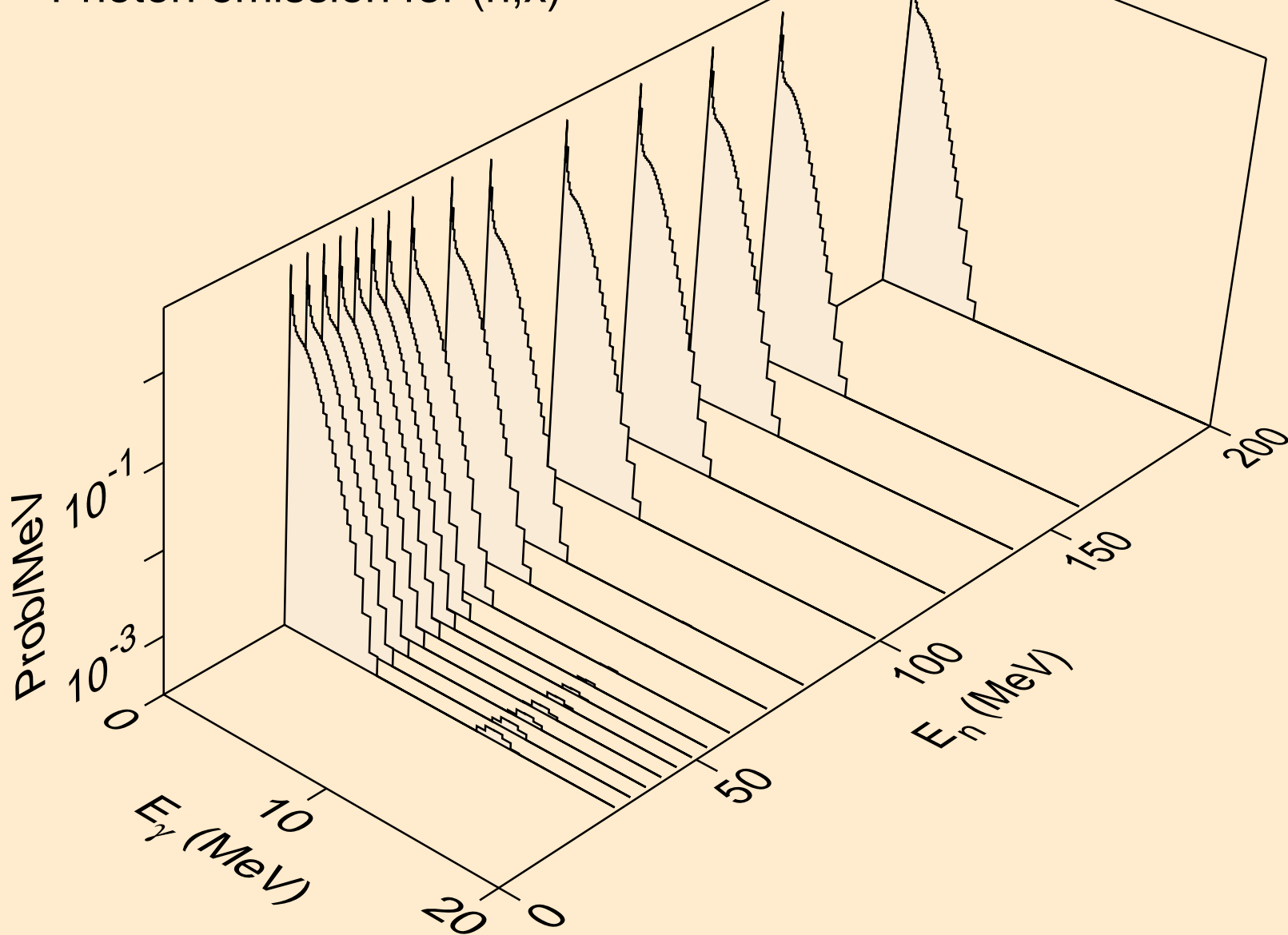

BH264 NEUTRON ACER TENDL-2019 LIBRARY; T=293.16K
Photon emission for (n,2nd)

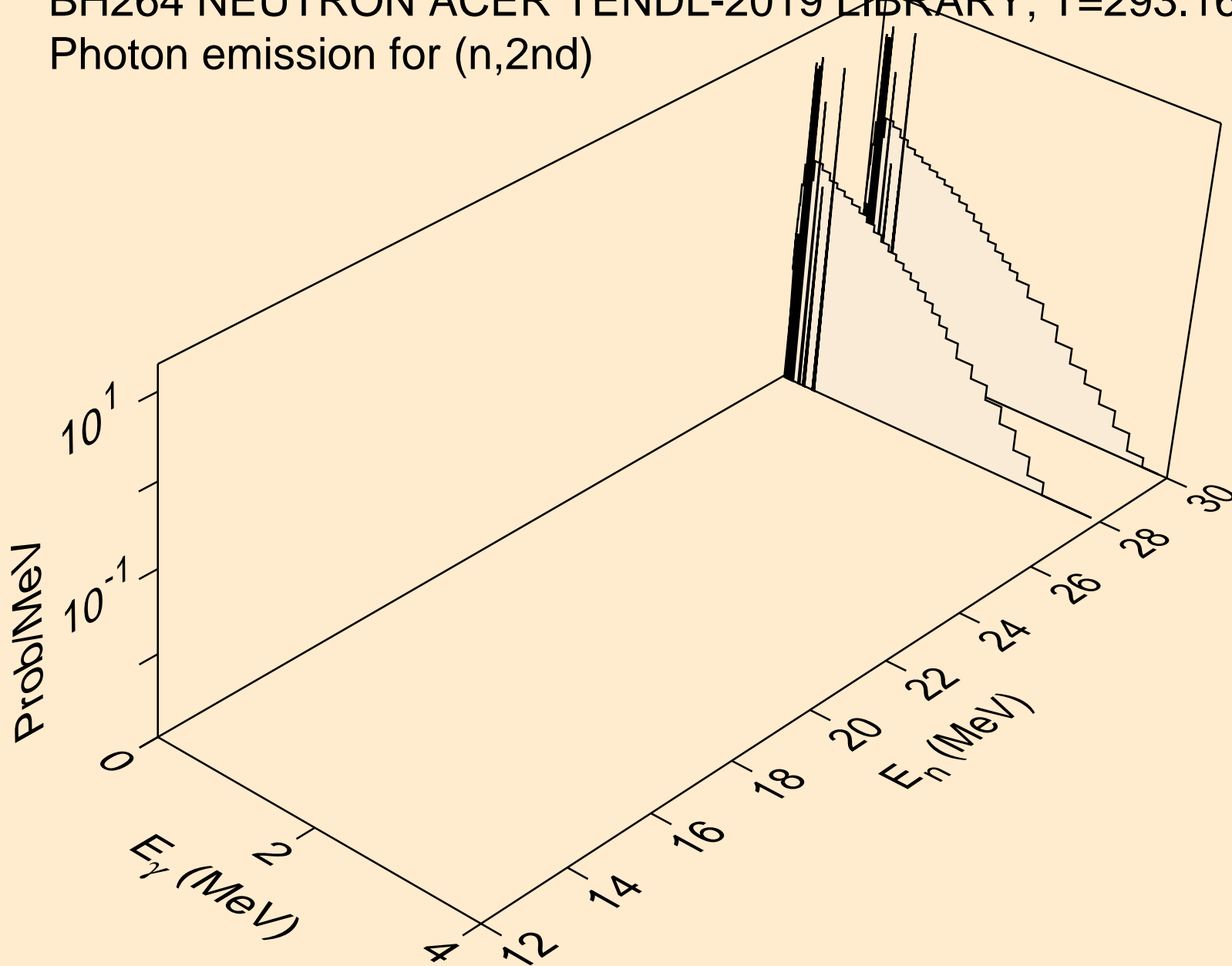

BH264 NEUTRON ACER TENDL-2019 LIBRARY; T=293.16K
Photon emission for (n,2n)

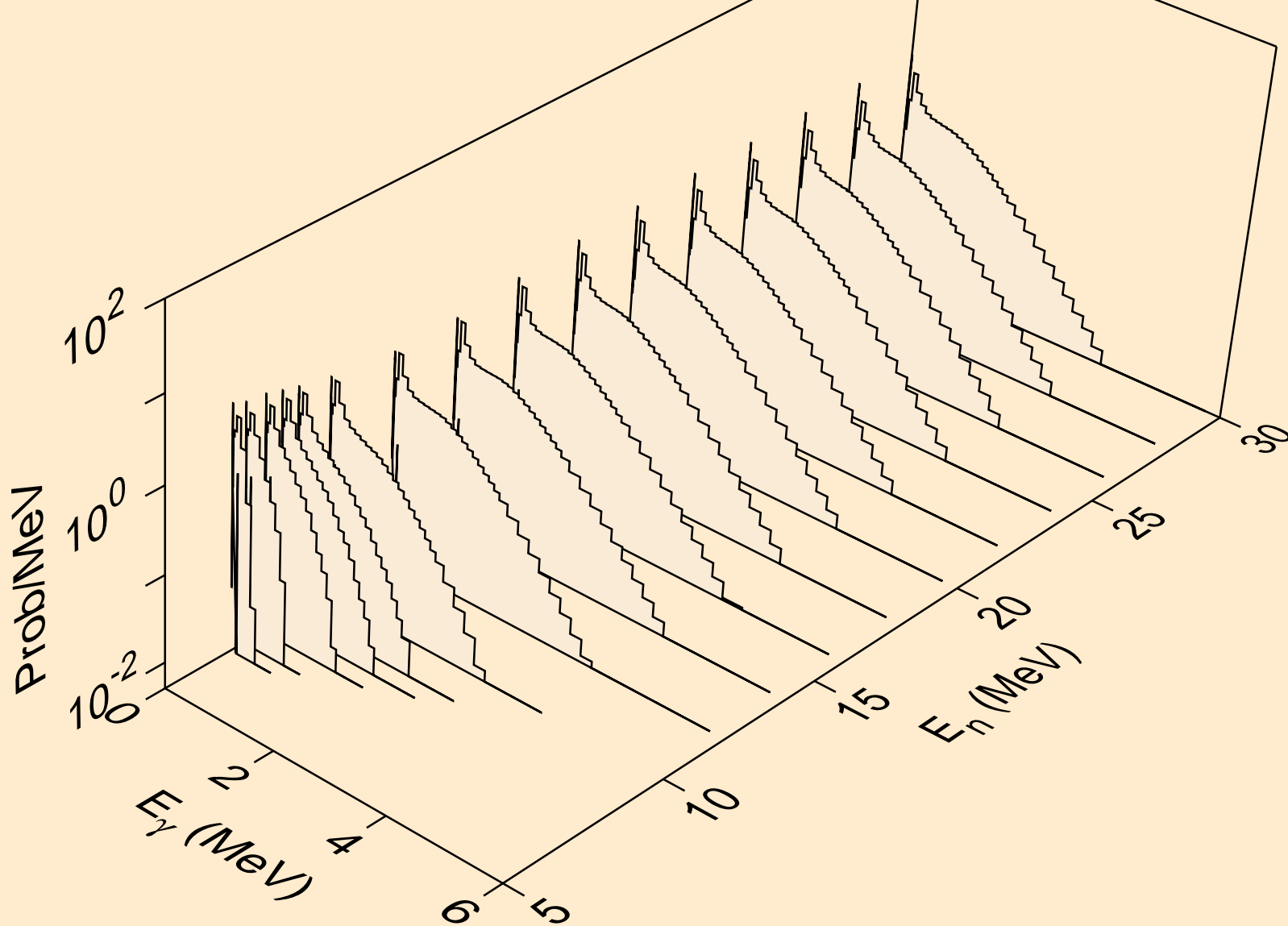

BH264 NEUTRON ACER TENDL-2019 LIBRARY; T=293.16K
Photon emission for (n,3n)

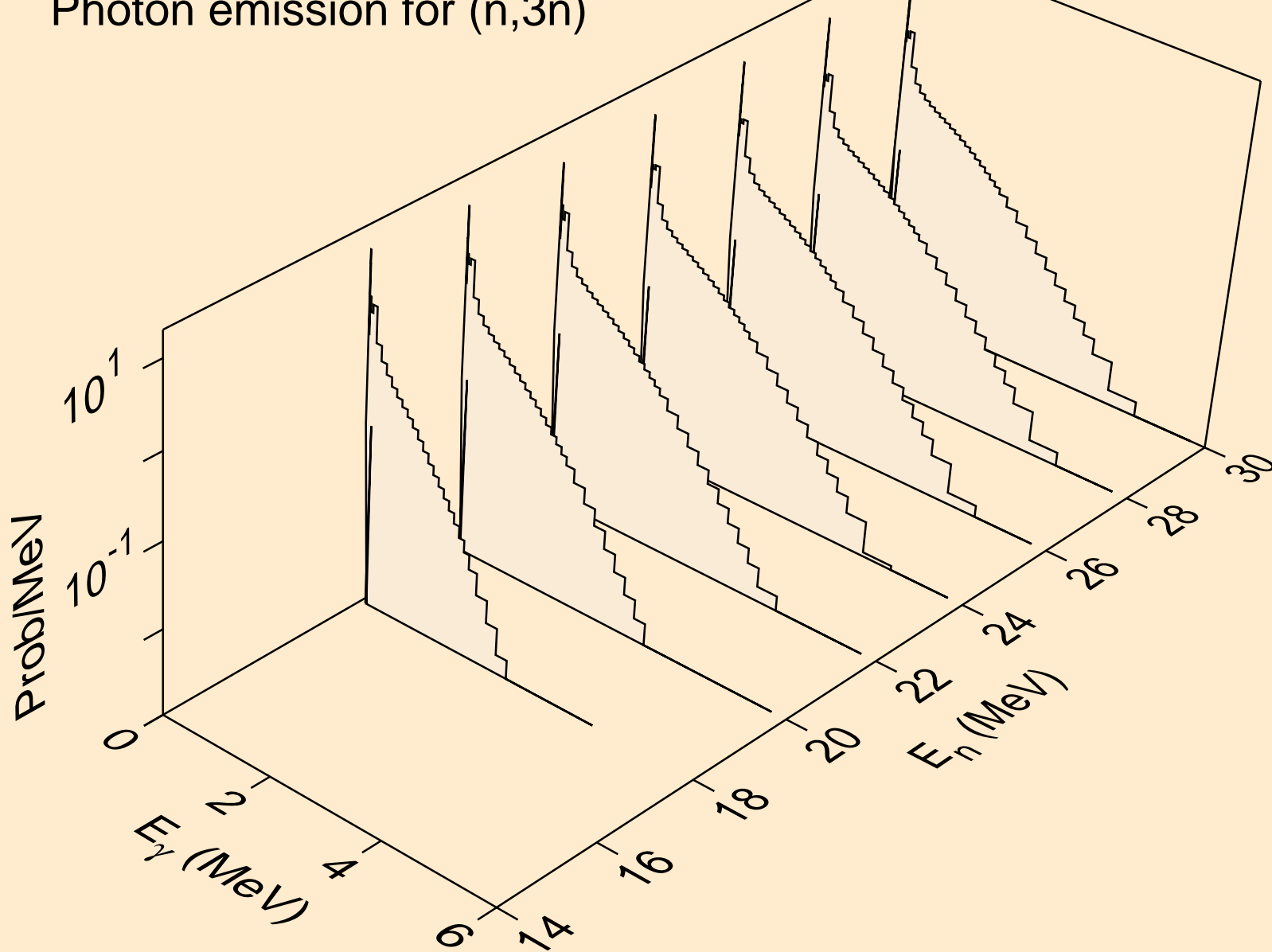

BH264 NEUTRON ACER TENDL-2019 LIBRARY; T=293.16K
Photon emission for (n,n*)a

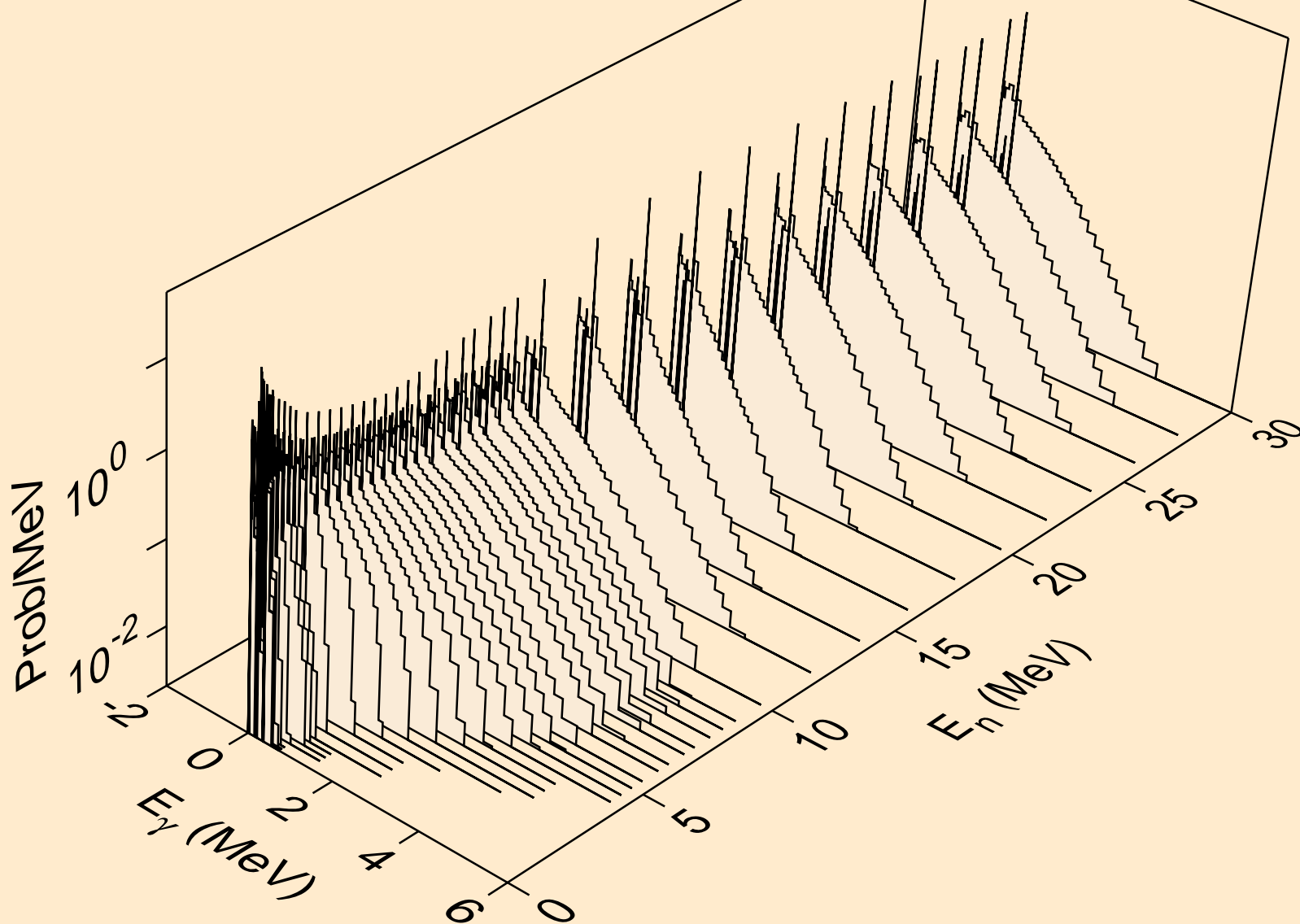

BH264 NEUTRON ACER TENDL-2019 LIBRARY; T=293.16K
Photon emission for (n,2n)a

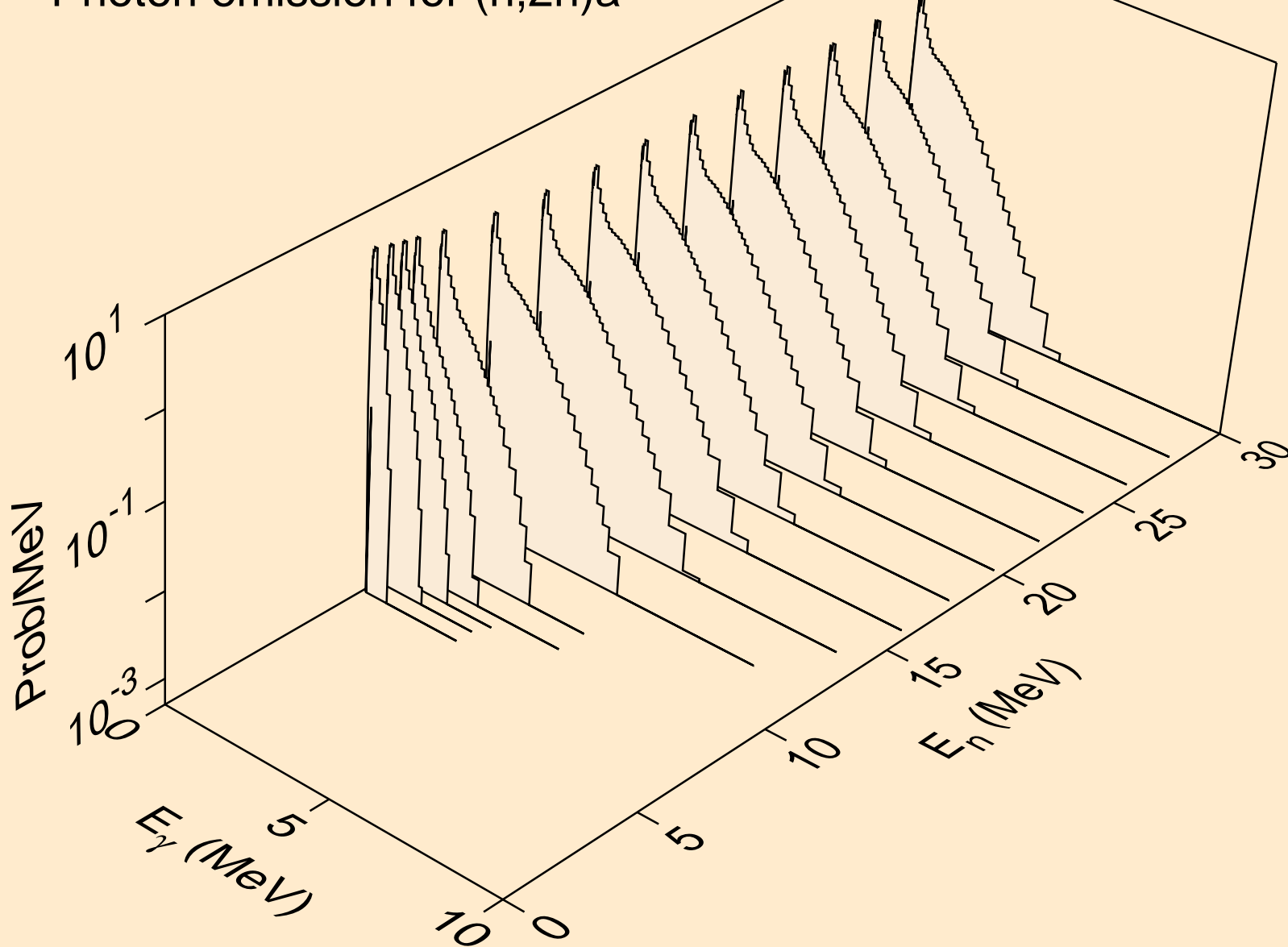

BH264 NEUTRON ACER TENDL-2019 LIBRARY; T=293.16K
Photon emission for (n,3n)a

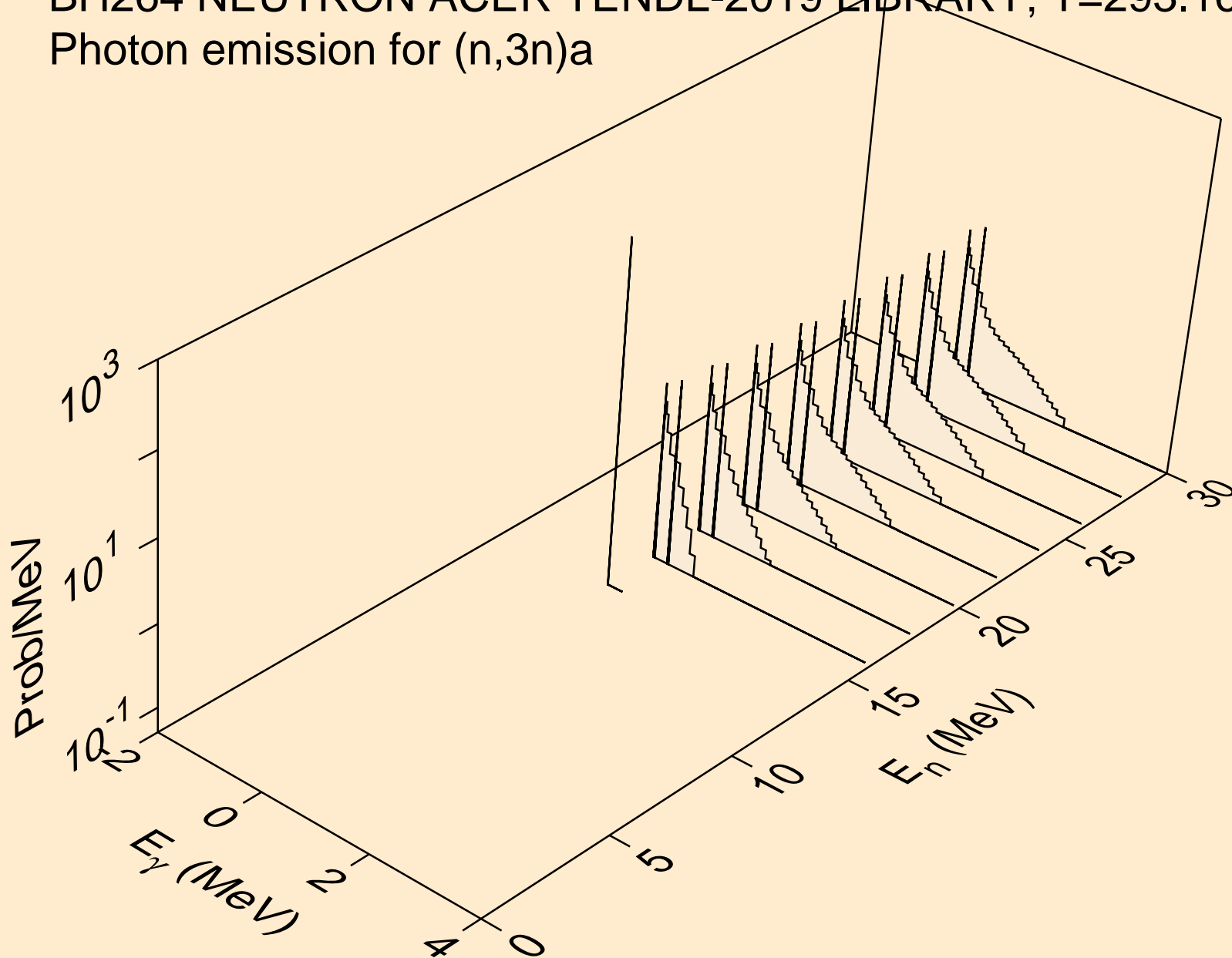

BH264 NEUTRON ACER TENDL-2019 LIBRARY; T=293.16K
Photon emission for (n,n*)p

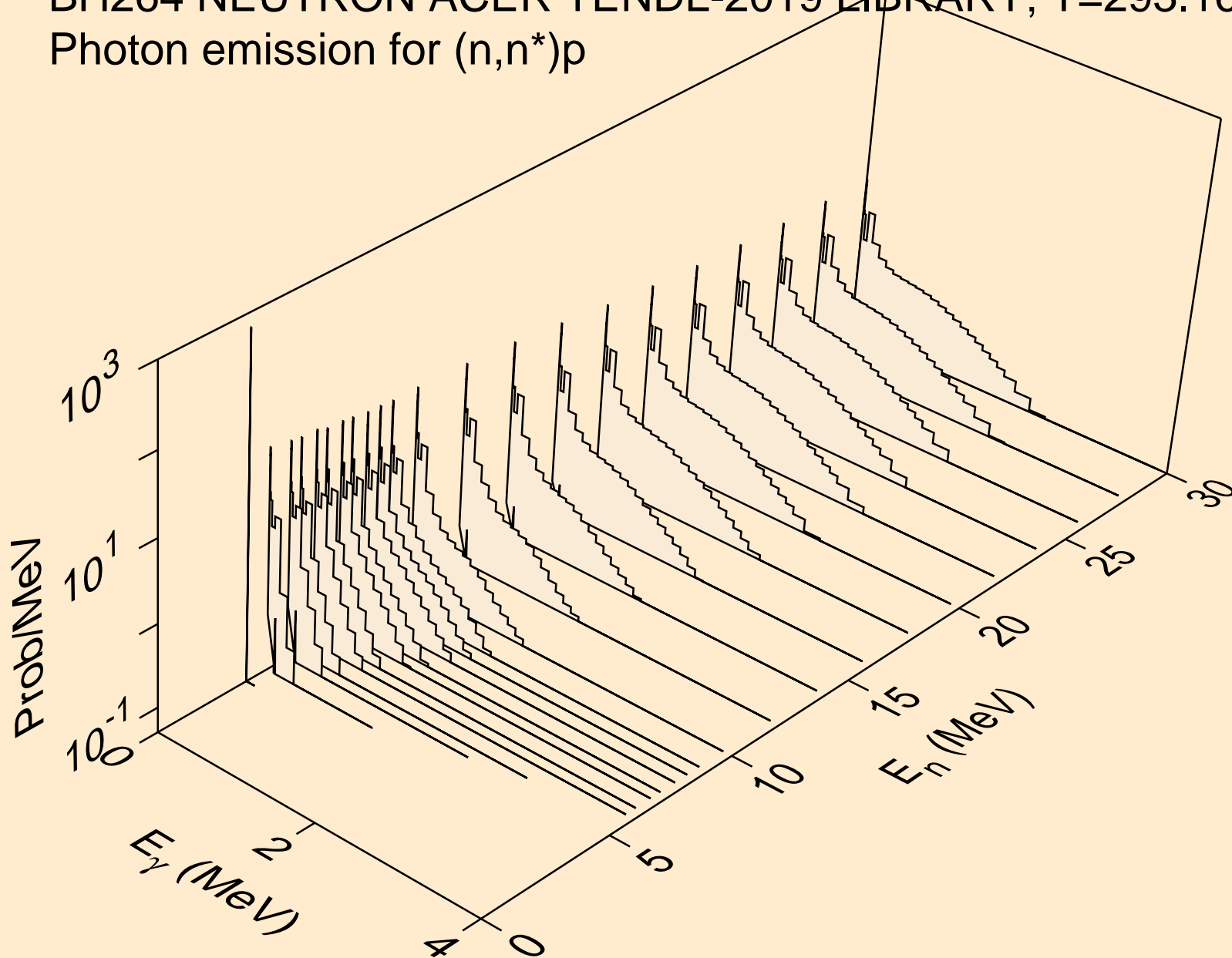

BH264 NEUTRON ACER TENDL-2019 LIBRARY; T=293.16K
Photon emission for (n,n*)2a

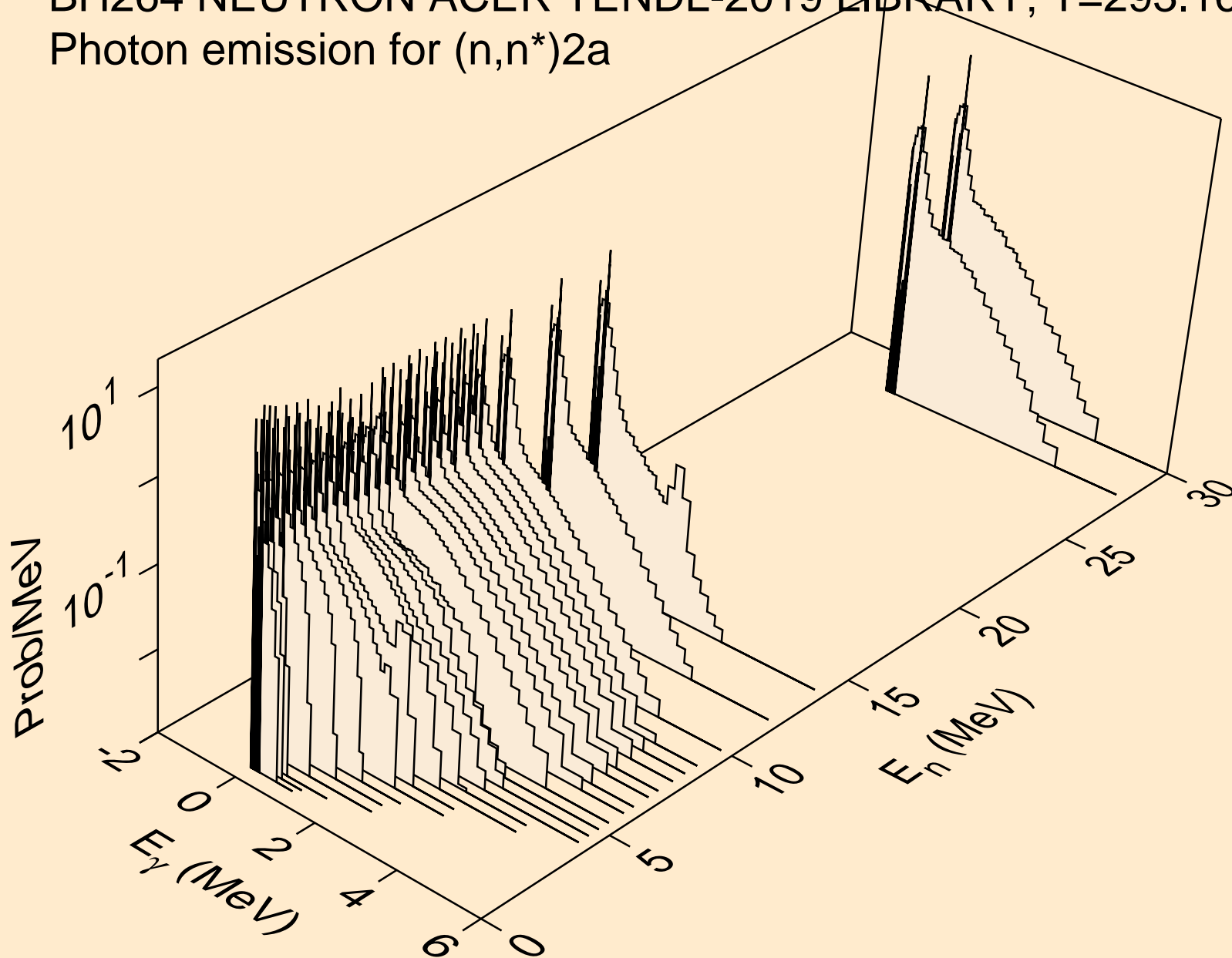

BH264 NEUTRON ACER TENDL-2019 LIBRARY; T=293.16K
Photon emission for (n,2n)2a

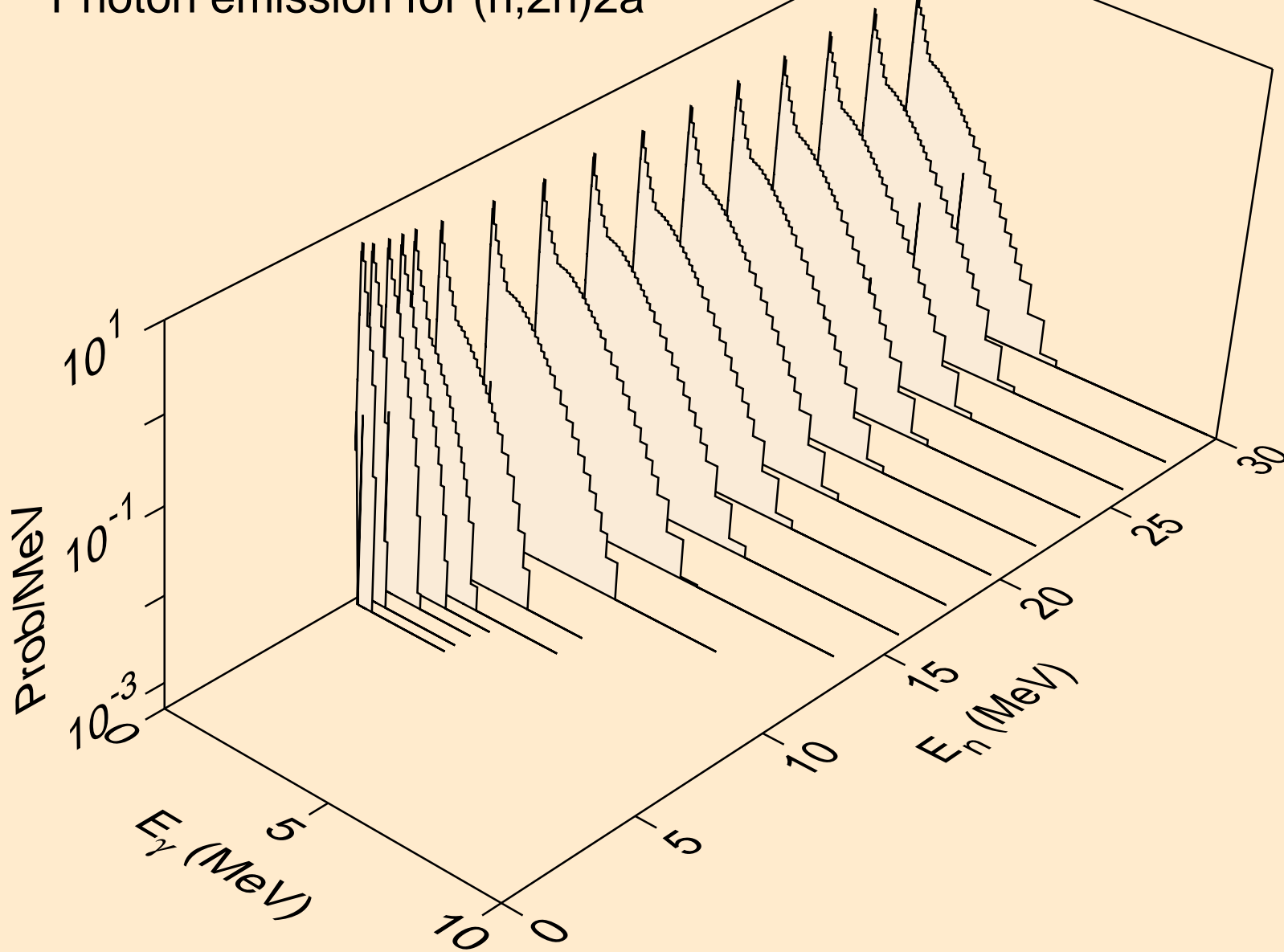

BH264 NEUTRON ACER TENDL-2019 LIBRARY; T=293.16K
Photon emission for (n,n*)d

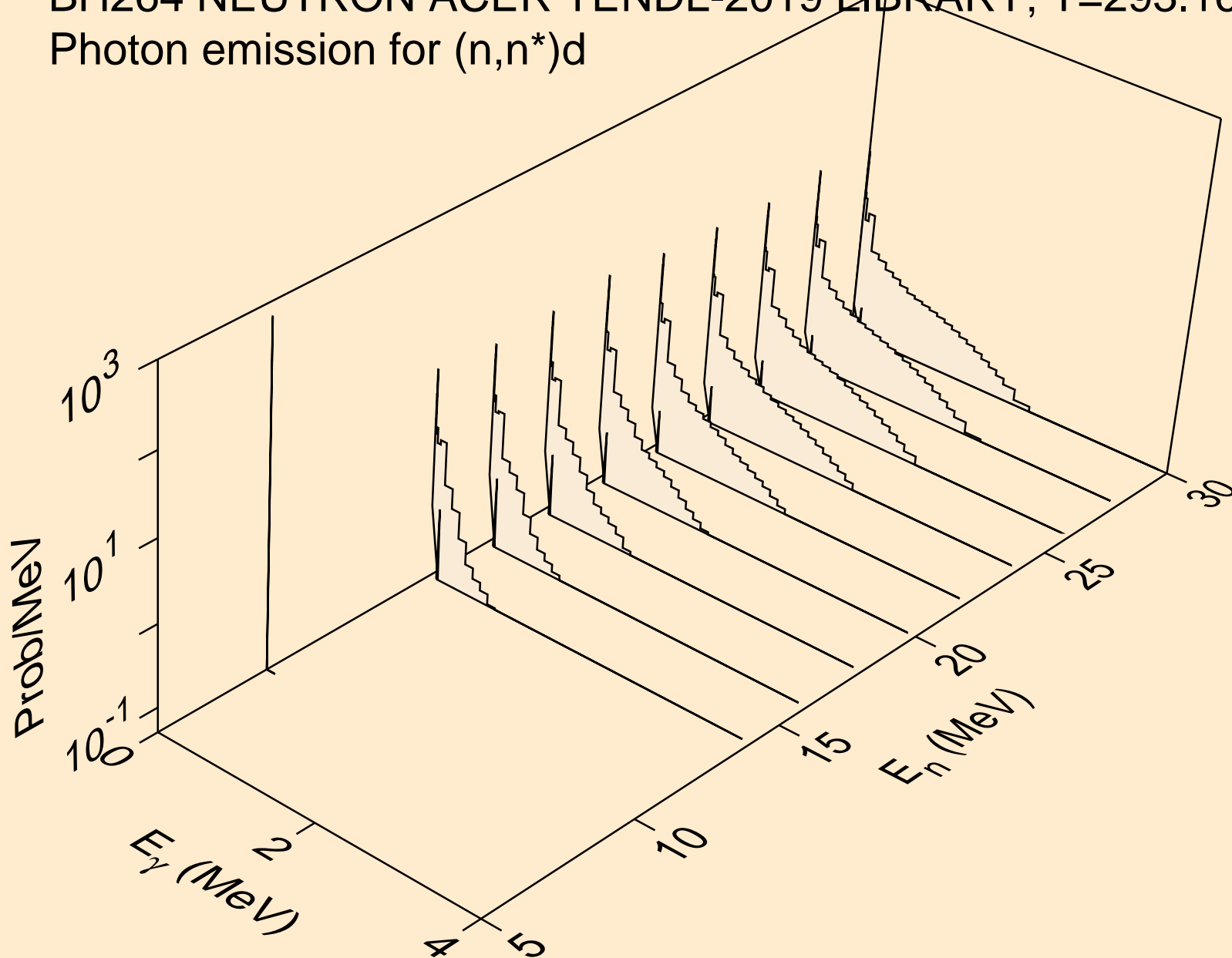

BH264 NEUTRON ACER TENDL-2019 LIBRARY; T=293.16K
Photon emission for (n,n*)t

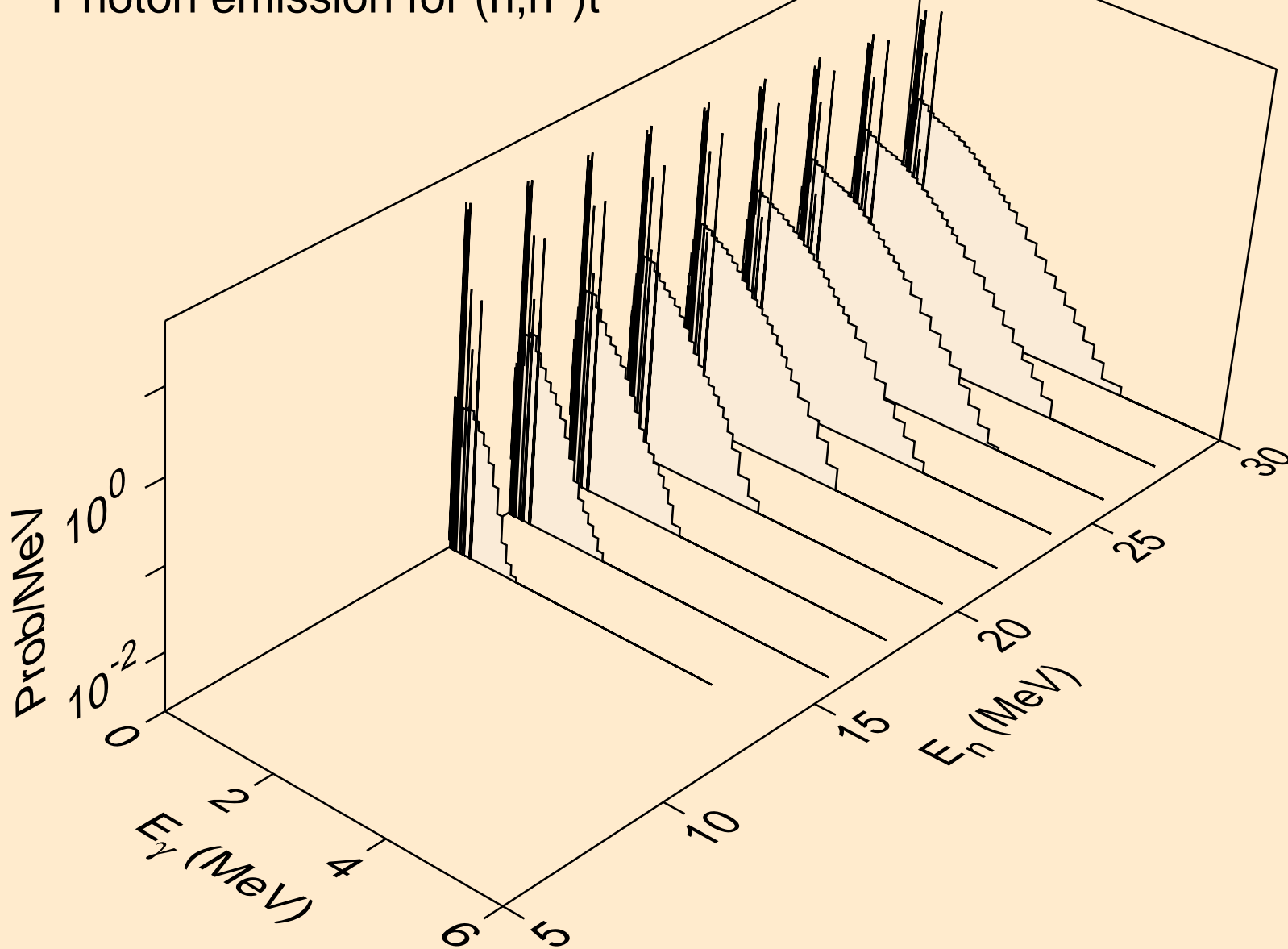

BH264 NEUTRON ACER TENDL-2019 LIBRARY; T=293.16K
Photon emission for (n,n*)he3

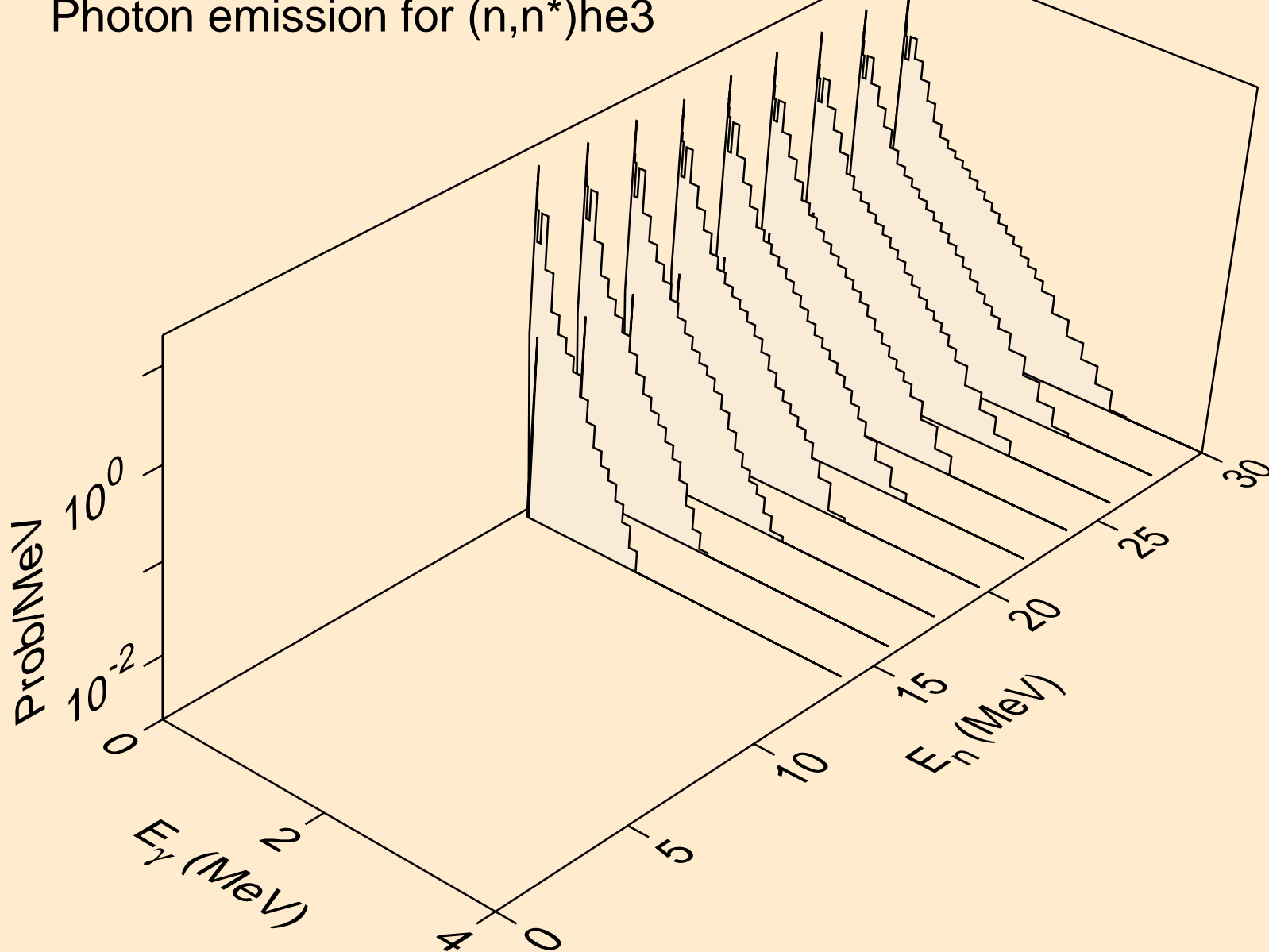

BH264 NEUTRON ACER TENDL-2019 LIBRARY; T=293.16K
Photon emission for (n,n*)d2a

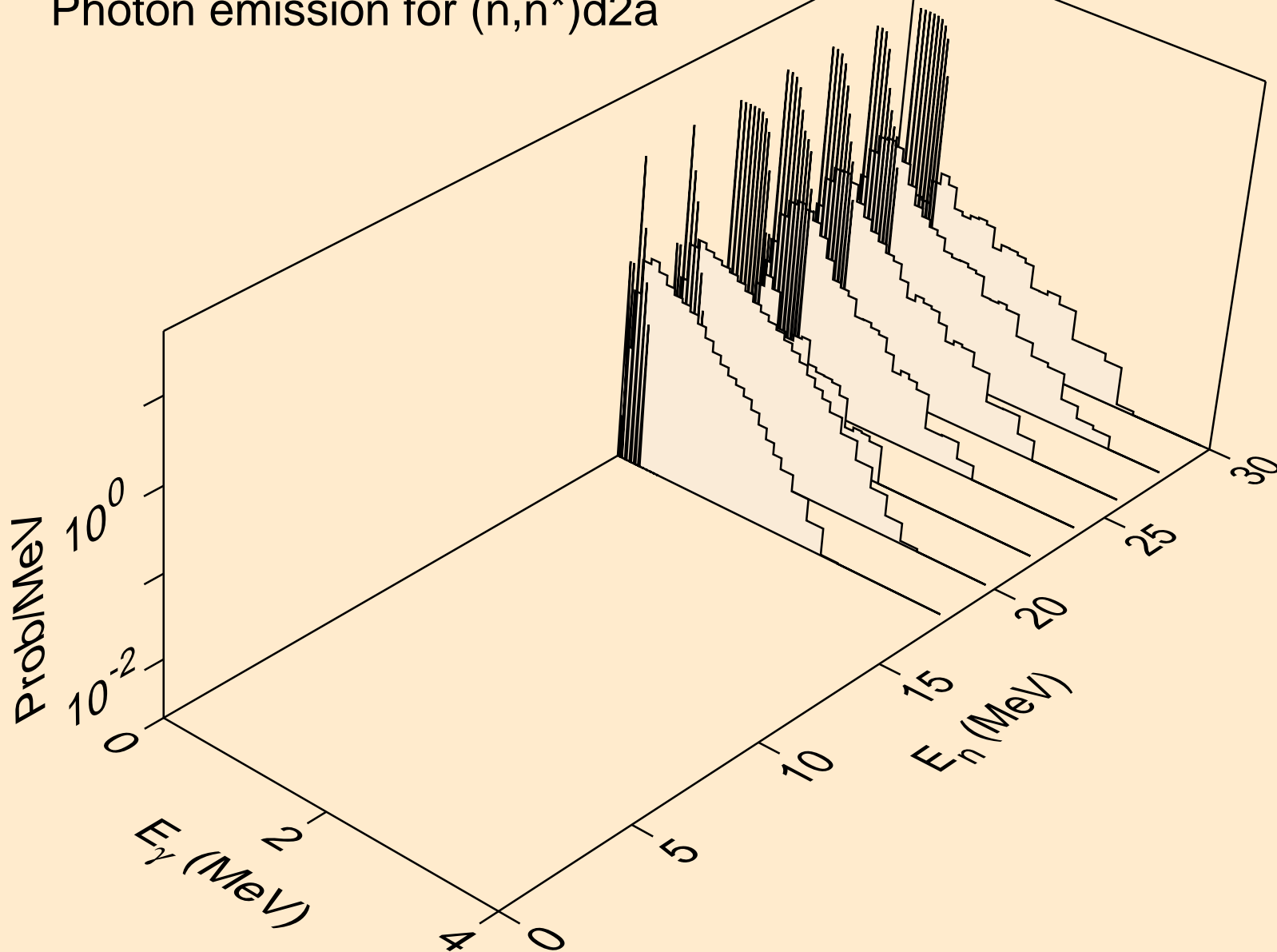

BH264 NEUTRON ACER TENDL-2019 LIBRARY; T=293.16K
Photon emission for (n,n*)t2a

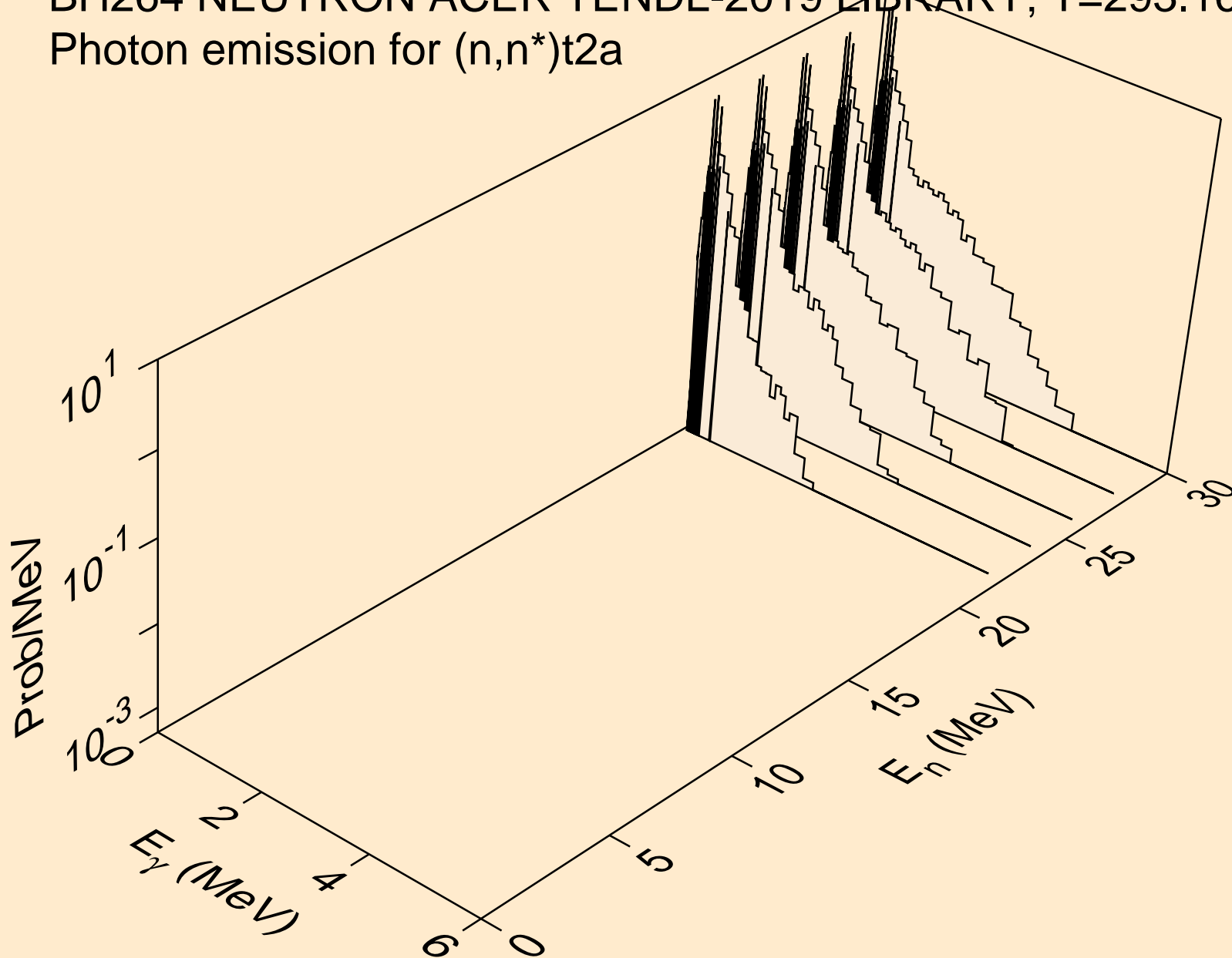

BH264 NEUTRON ACER TENDL-2019 LIBRARY; T=293.16K
Photon emission for (n,4n)

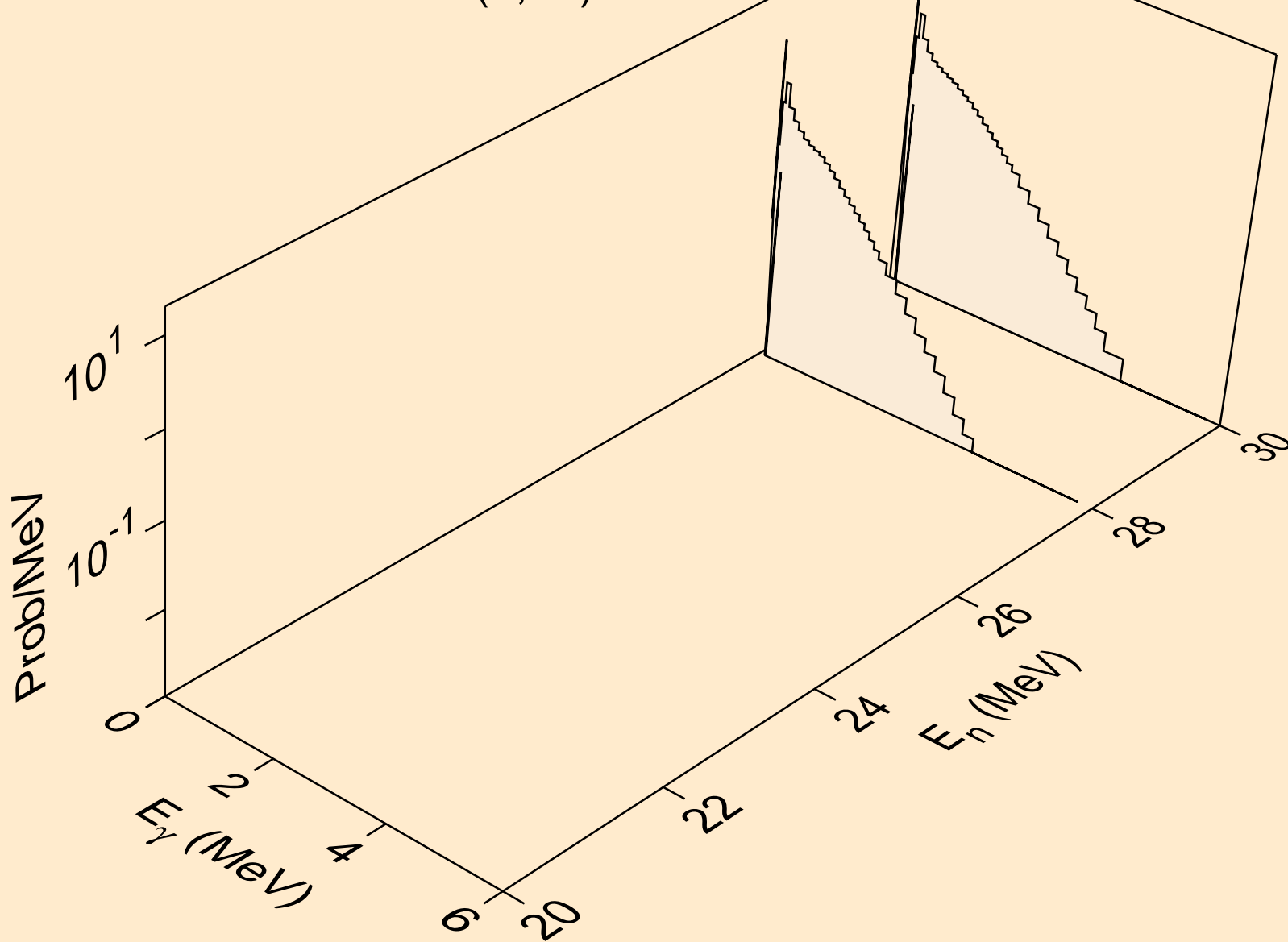

BH264 NEUTRON ACER TENDL-2019 LIBRARY; T=293.16K
Photon emission for (n,2np)

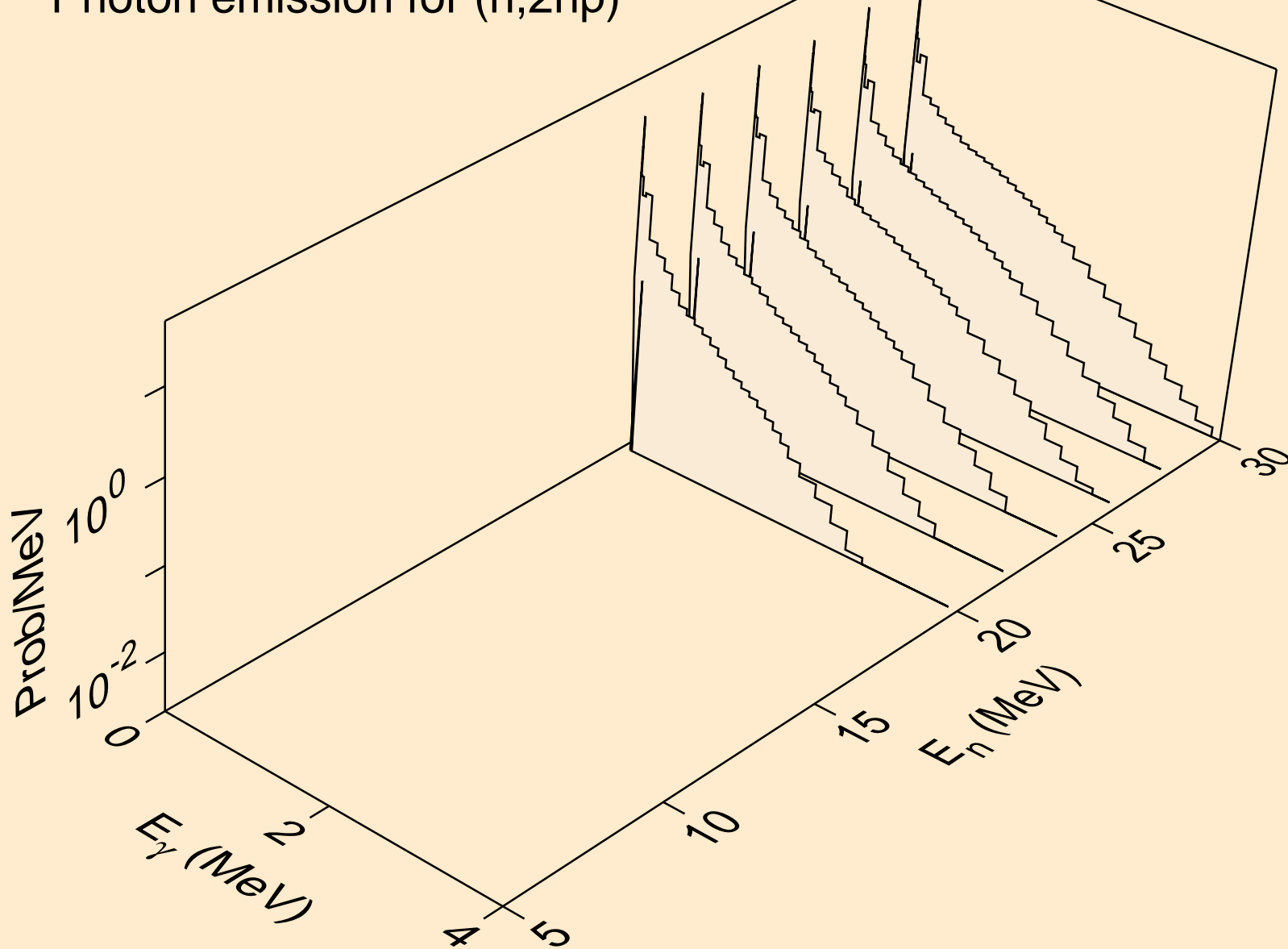

BH264 NEUTRON ACER TENDL-2019 LIBRARY; T=293.16K
Photon emission for (n,3np)

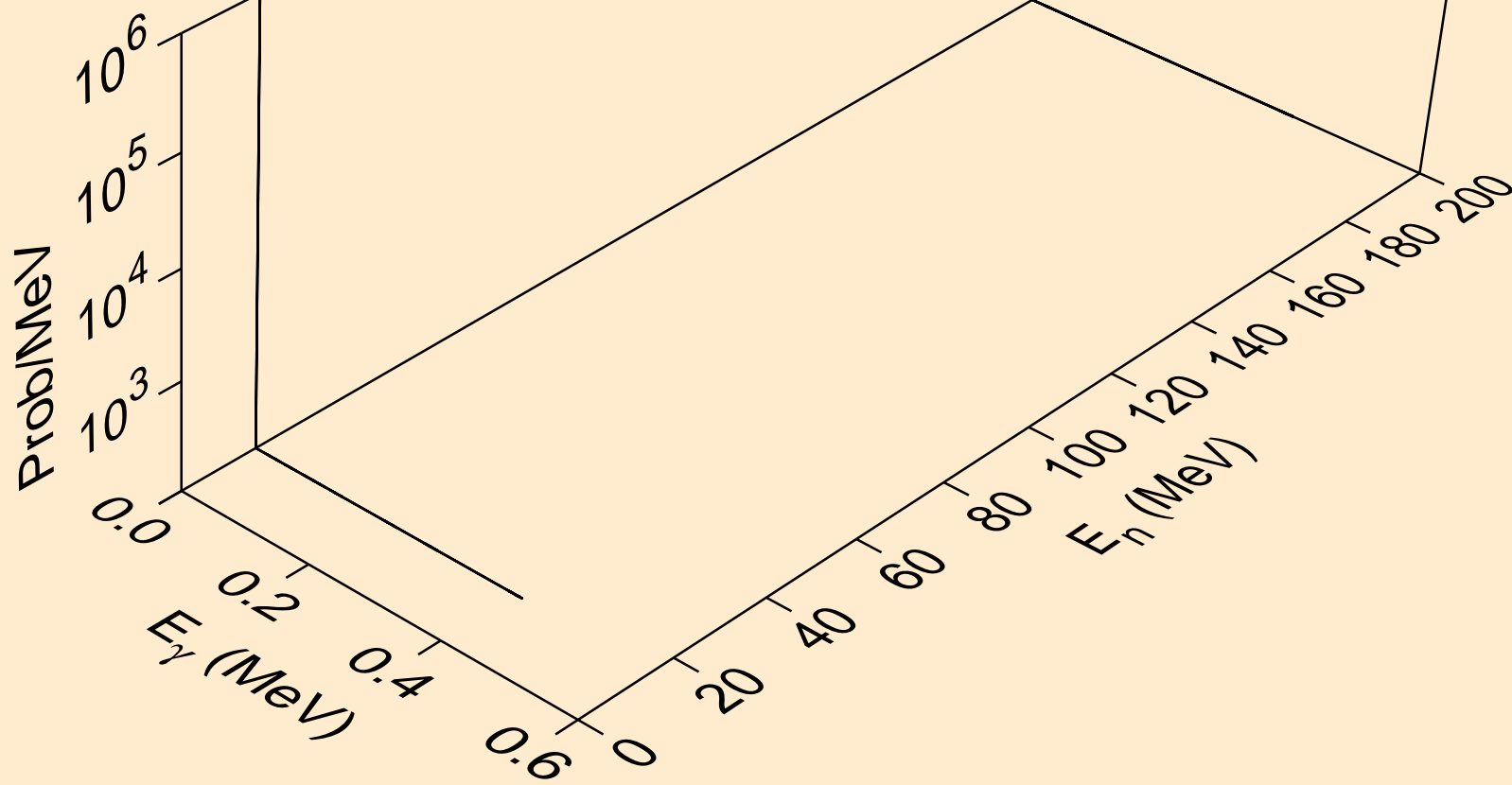

BH264 NEUTRON ACER TENDL-2019 LIBRARY; T=293.16K
Photon emission for (n,2np)

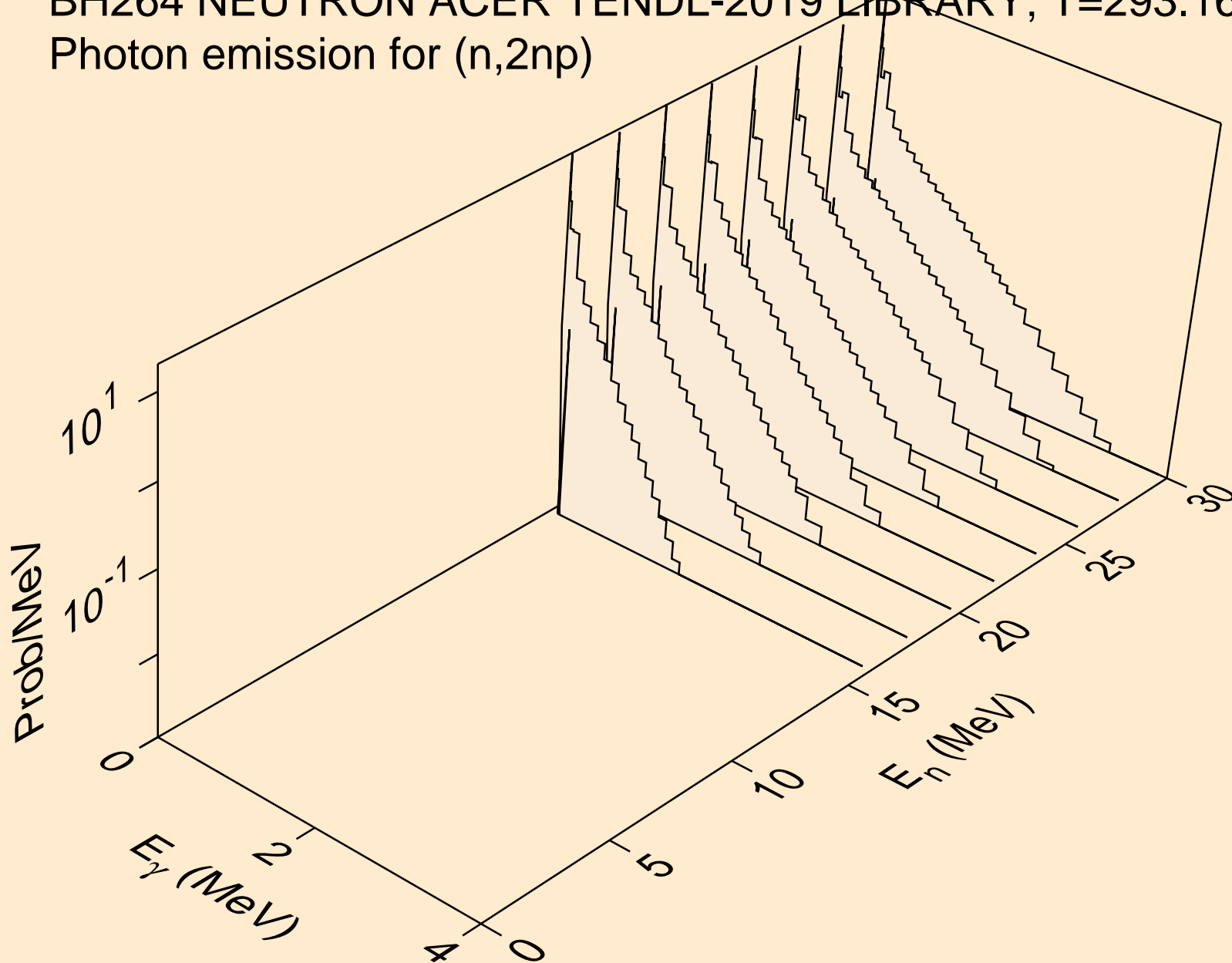

BH264 NEUTRON ACER TENDL-2019 LIBRARY; T=293.16K
Photon emission for (n,npa)

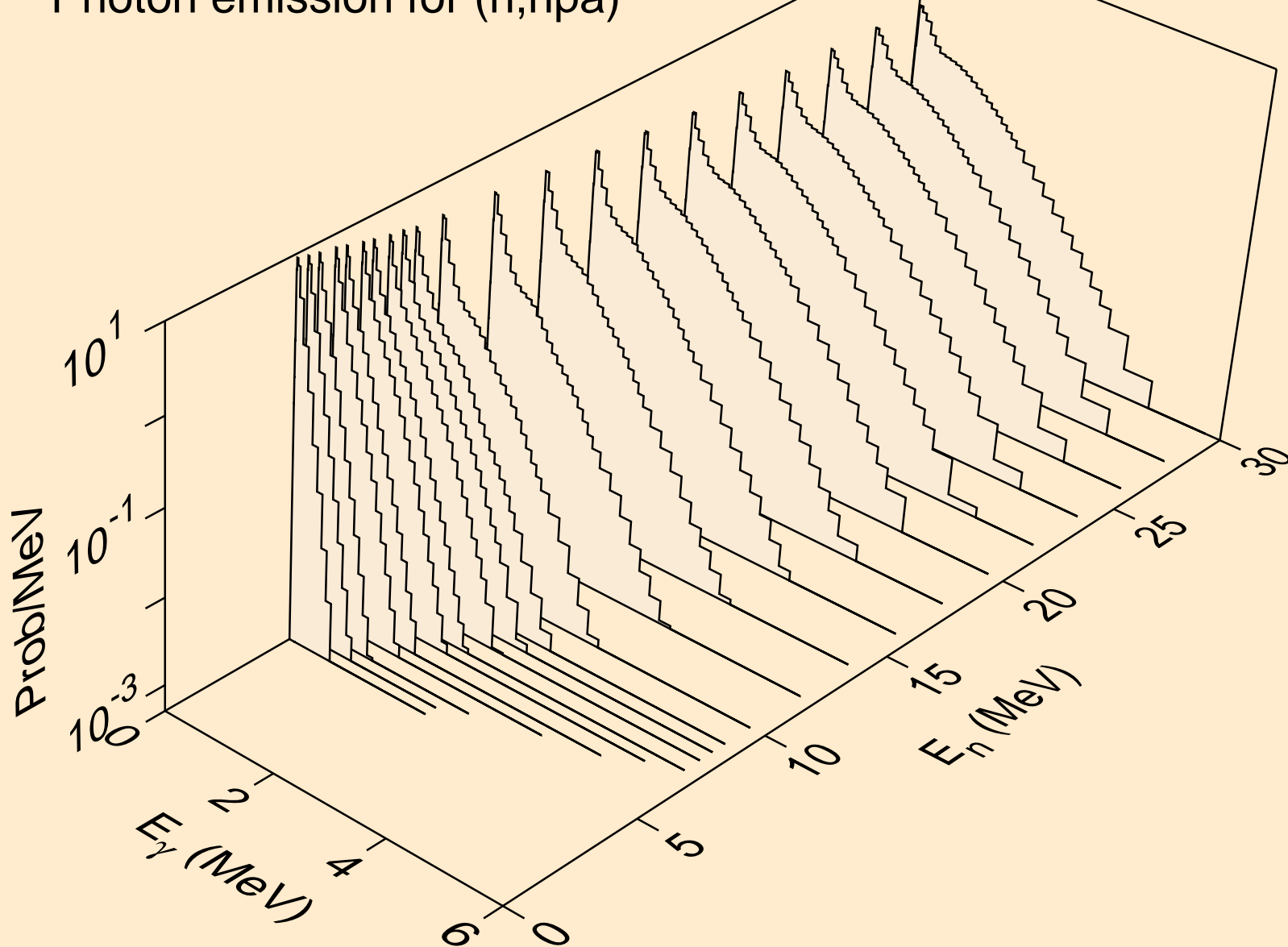

BH264 NEUTRON ACER TENDL-2019 LIBRARY; T=293.16K
Photon emission for (n,n*c)

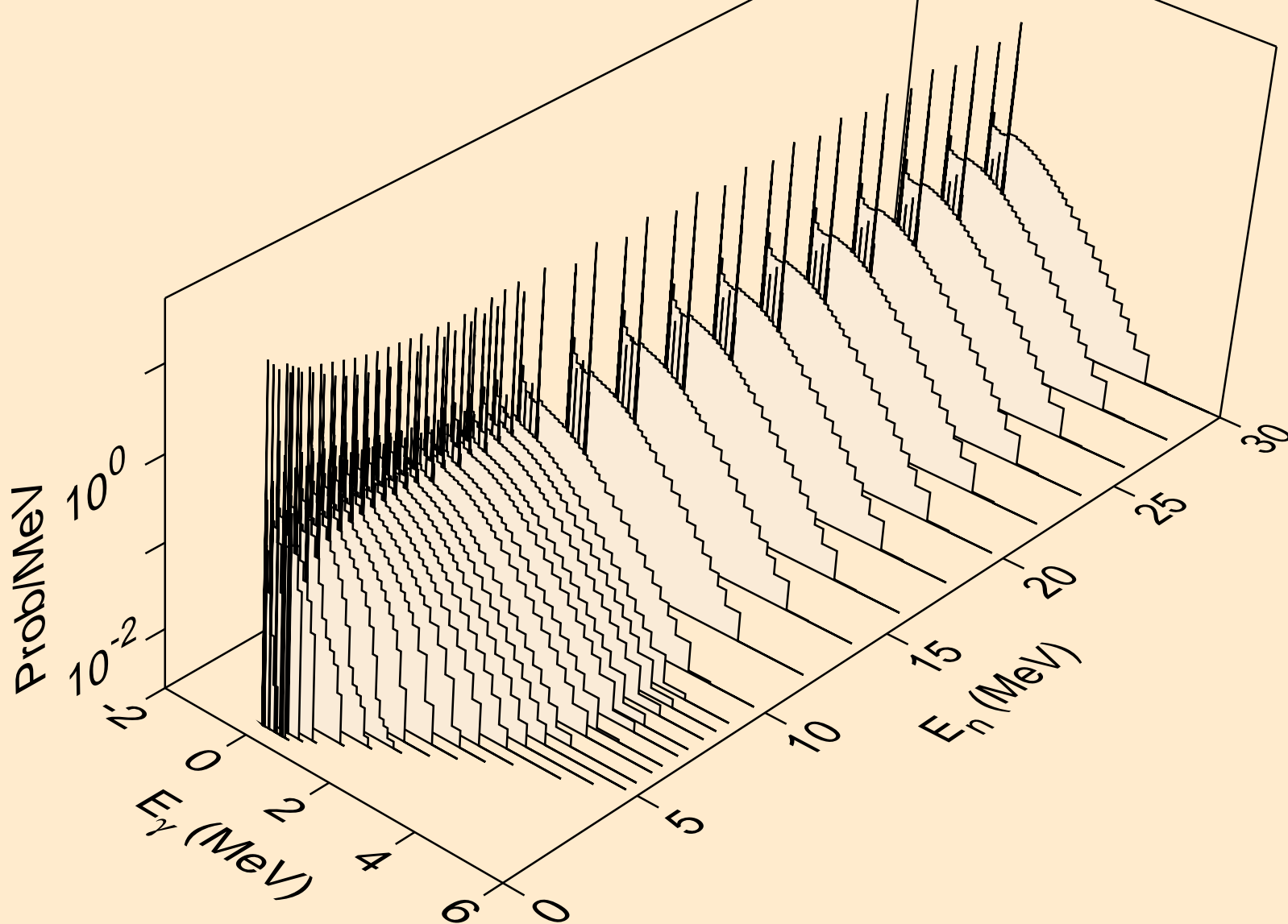

BH264 NEUTRON ACER TENDL-2019 LIBRARY; T=293.16K
Photon emission for (n,gma)

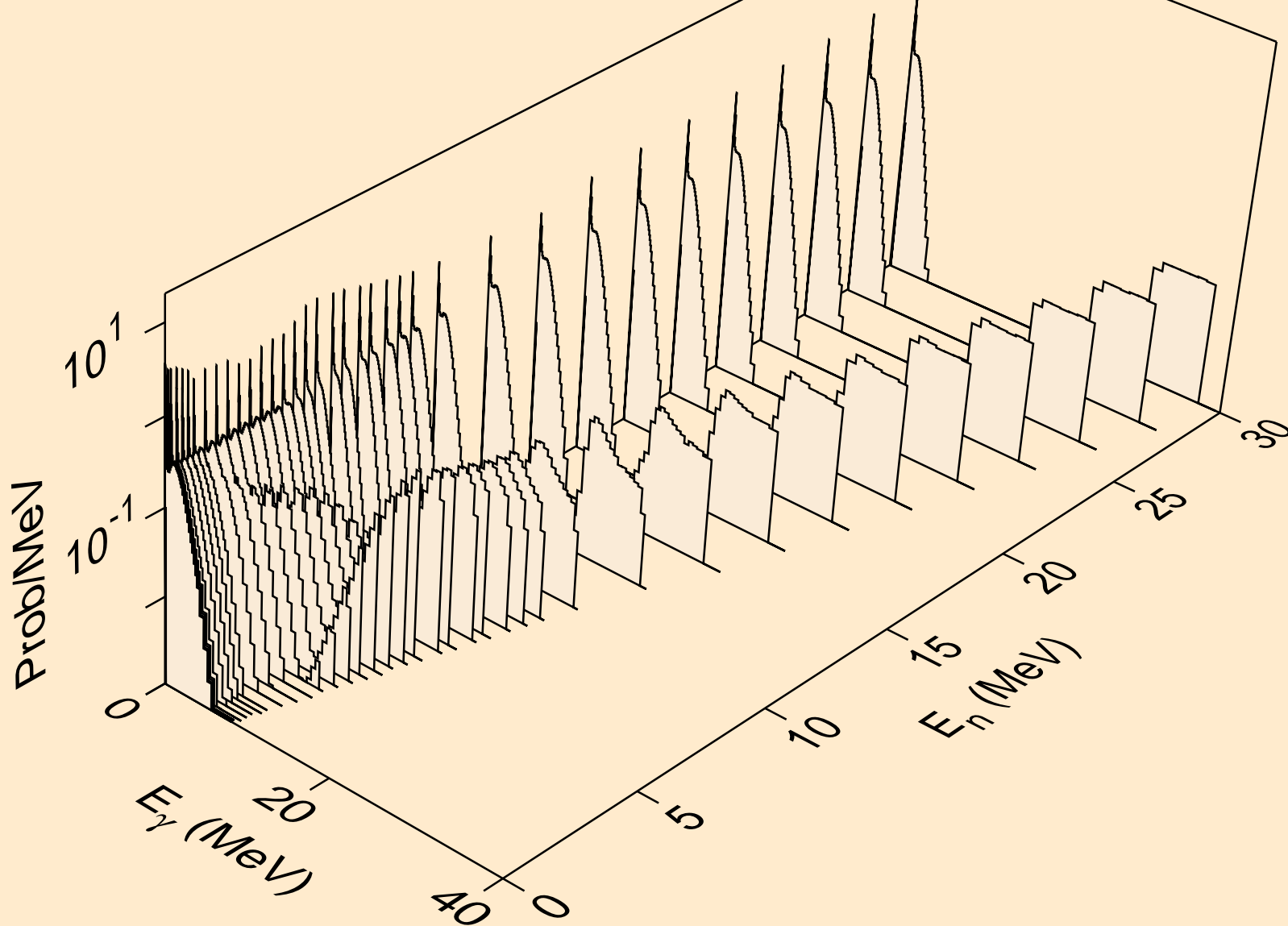

BH264 NEUTRON ACER TENDL-2019 LIBRARY; T=293.16K
Photon emission for (n,p)

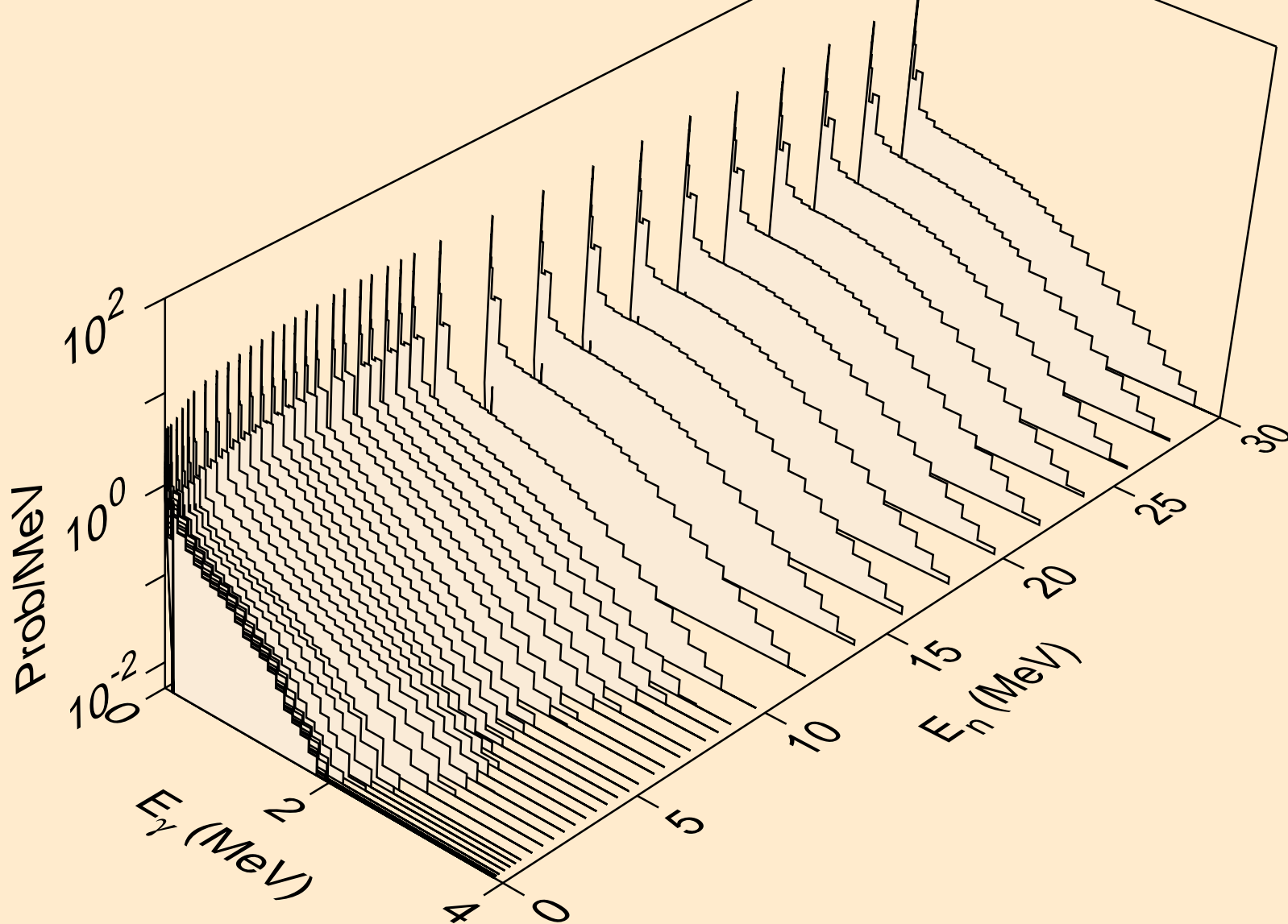

BH264 NEUTRON ACER TENDL-2019 LIBRARY; T=293.16K
Photon emission for (n,d)

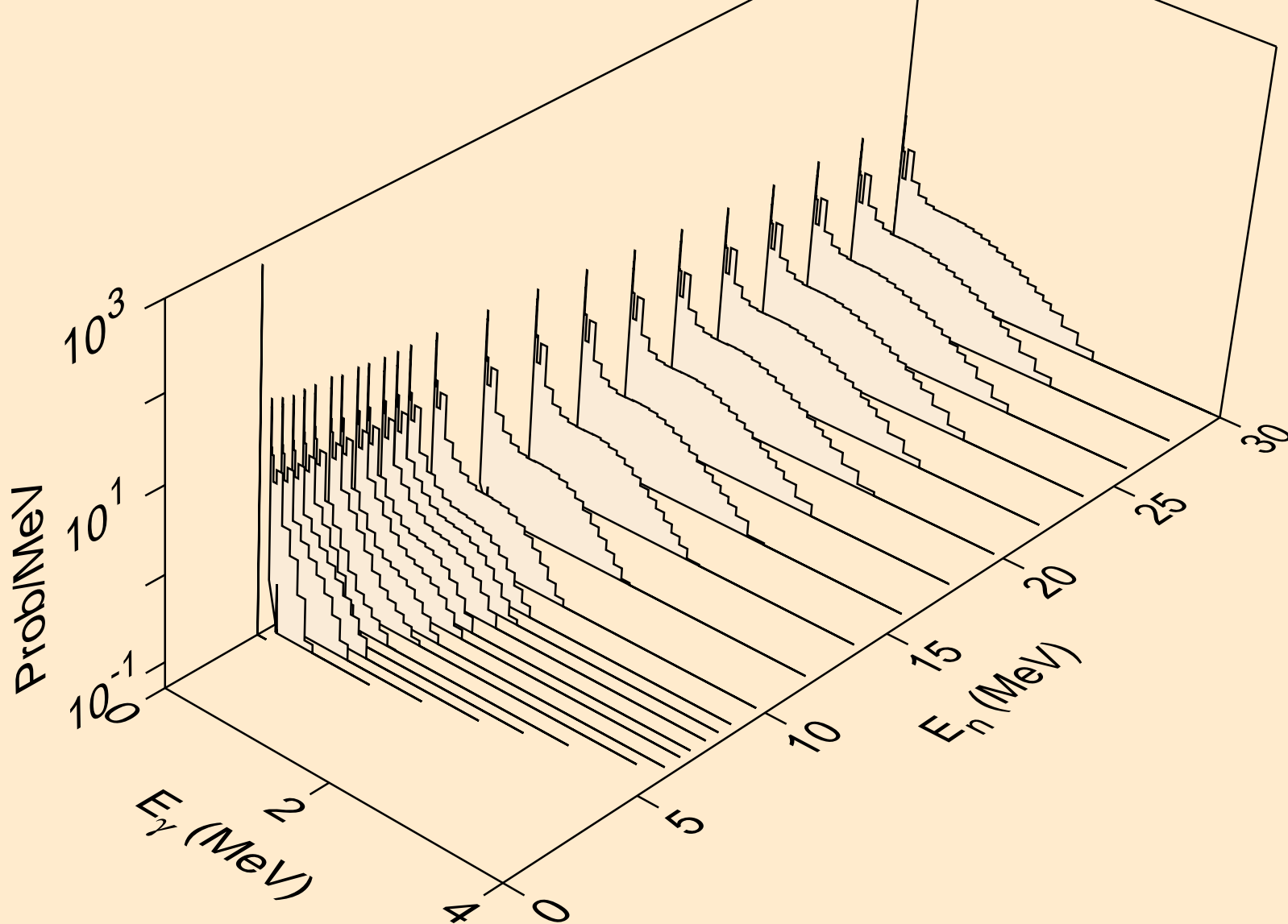

BH264 NEUTRON ACER TENDL-2019 LIBRARY; T=293.16K
Photon emission for (n,t)

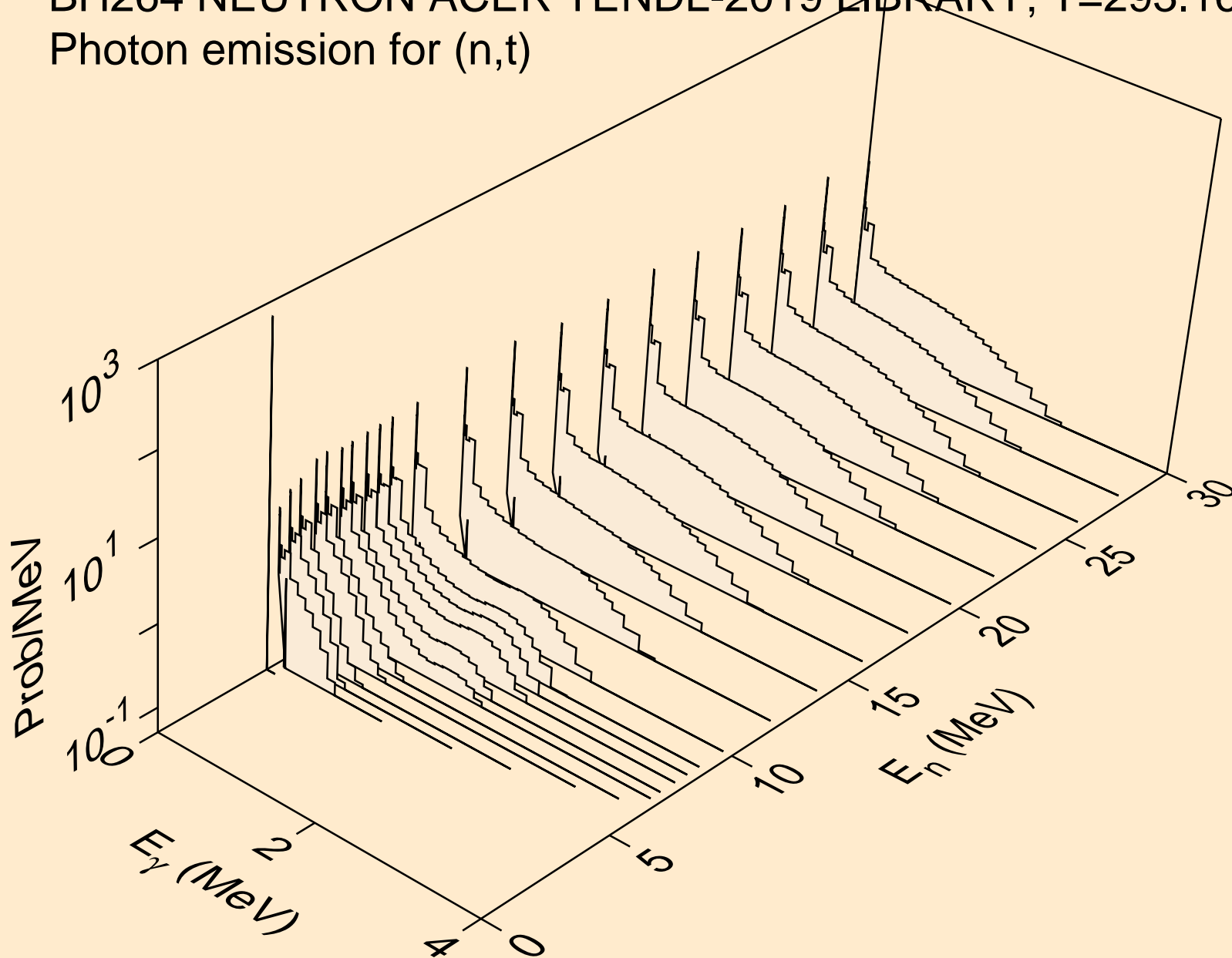

BH264 NEUTRON ACER TENDL-2019 LIBRARY; T=293.16K
Photon emission for (n,he3)

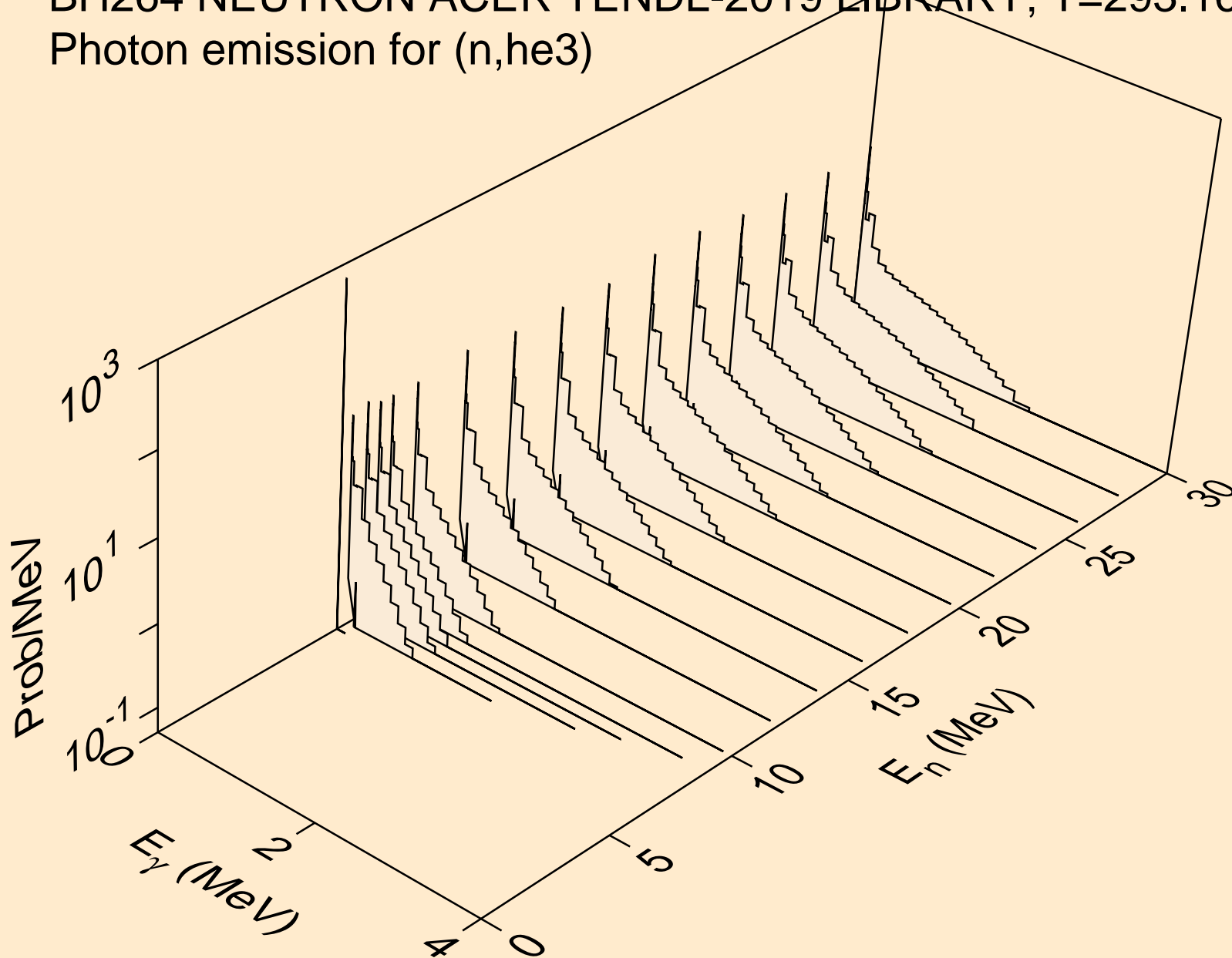

BH264 NEUTRON ACER TENDL-2019 LIBRARY; T=293.16K
Photon emission for (n,a)

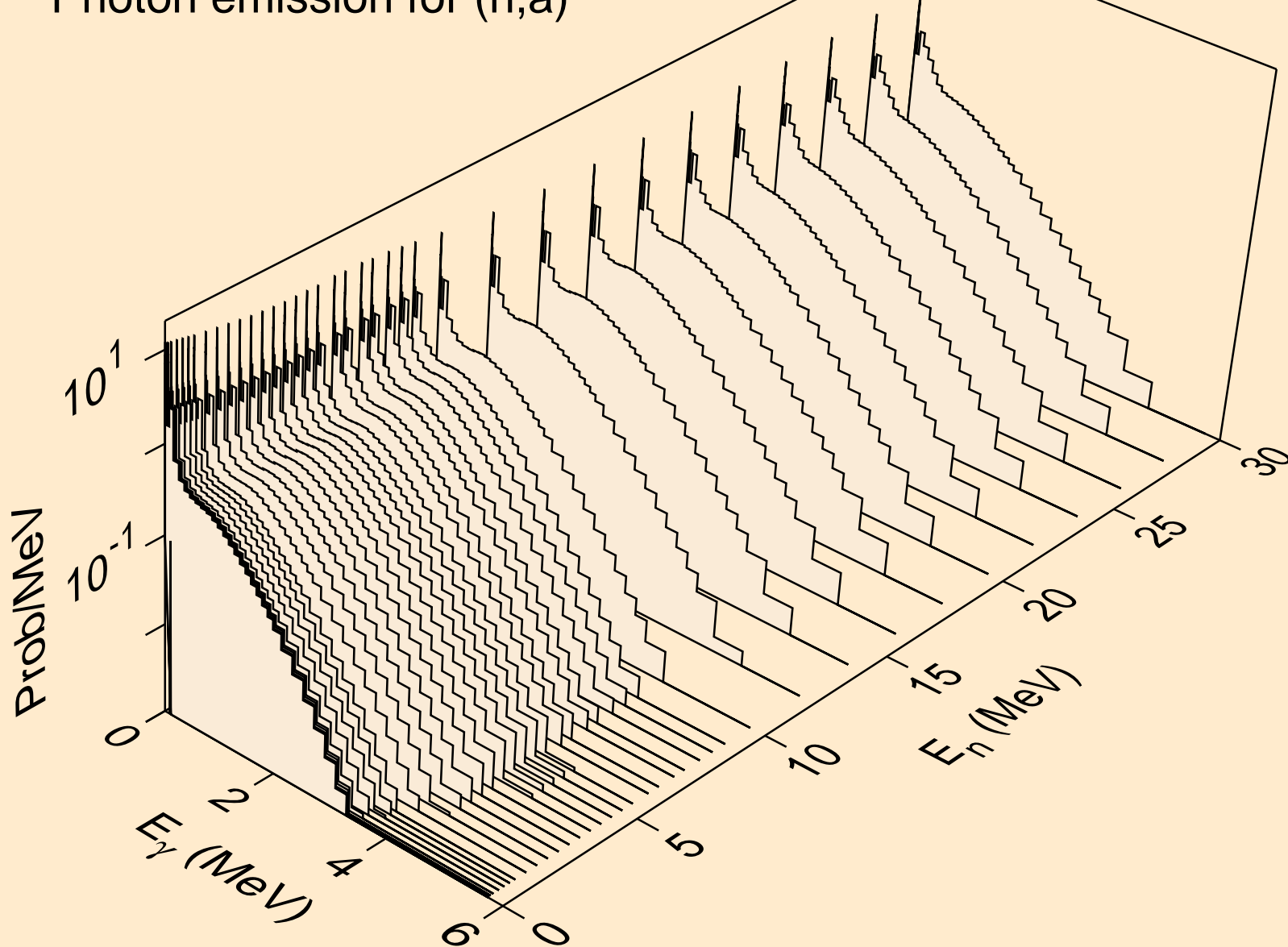

BH264 NEUTRON ACER TENDL-2019 LIBRARY; T=293.16K
Photon emission for (n,2a)

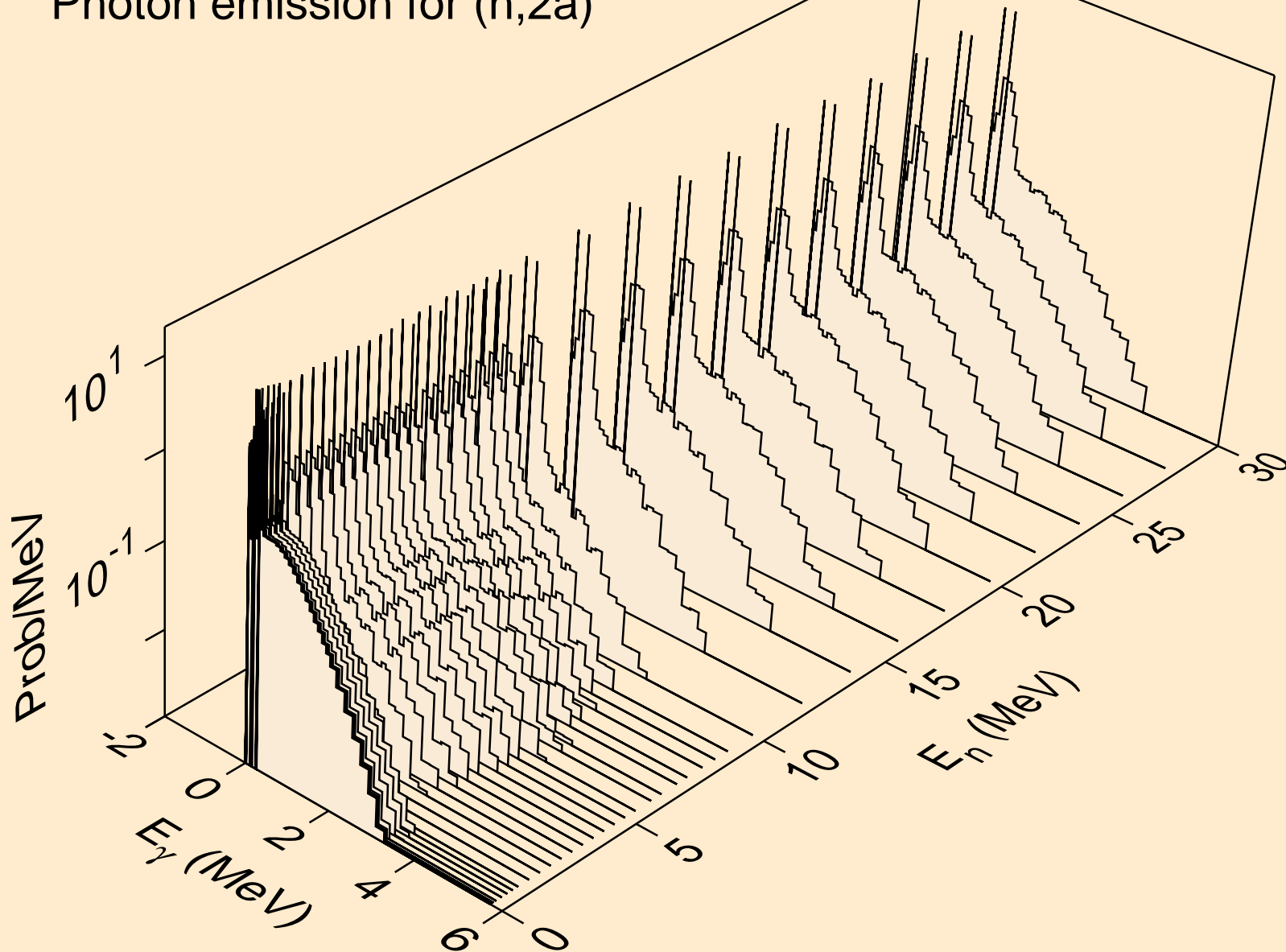

BH264 NEUTRON ACER TENDL-2019 LIBRARY; T=293.16K
Photon emission for (n,3a)

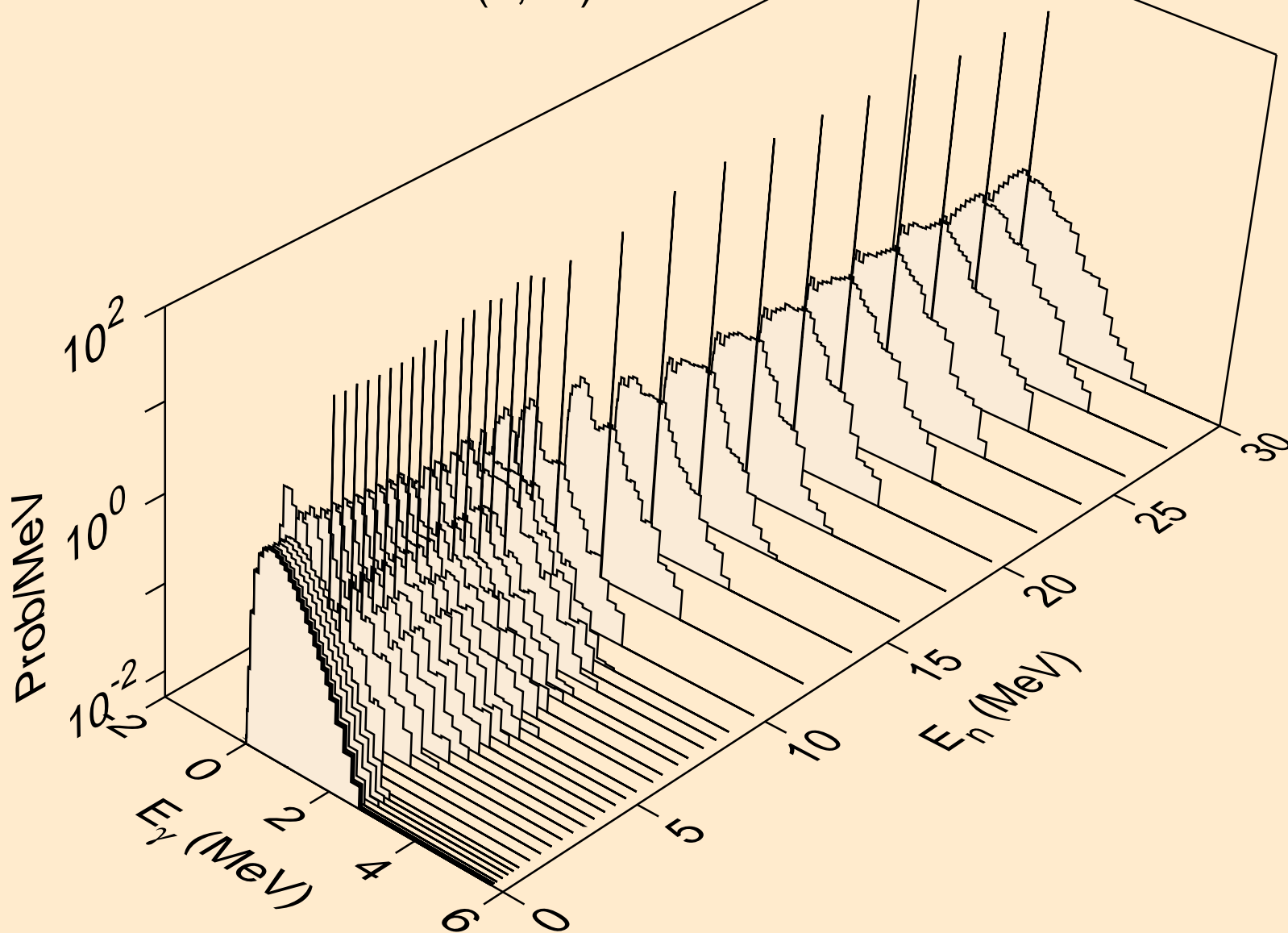

BH264 NEUTRON ACER TENDL-2019 LIBRARY; T=293.16K
Photon emission for (n,2p)

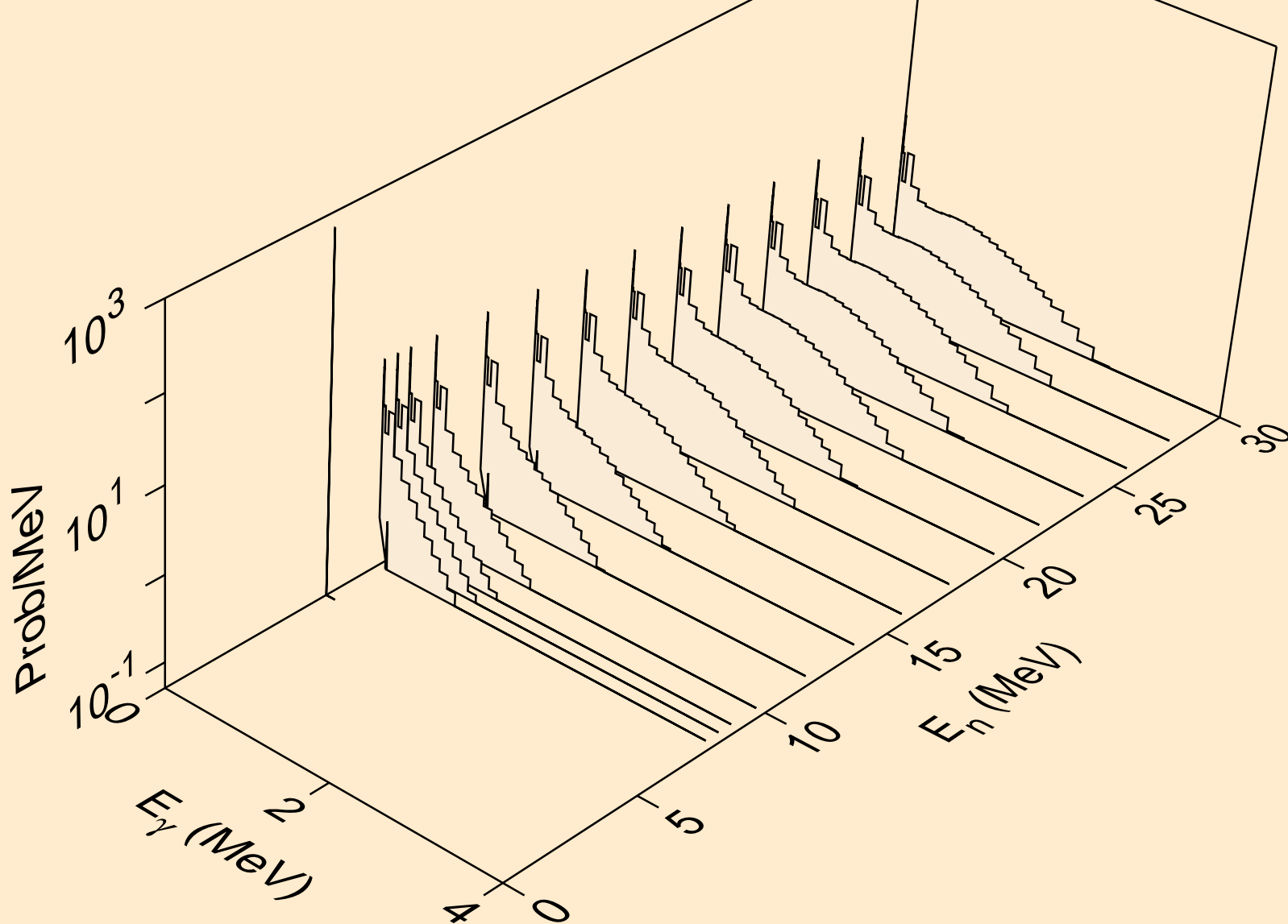

BH264 NEUTRON ACER TENDL-2019 LIBRARY; T=293.16K
Photon emission for (n,p)

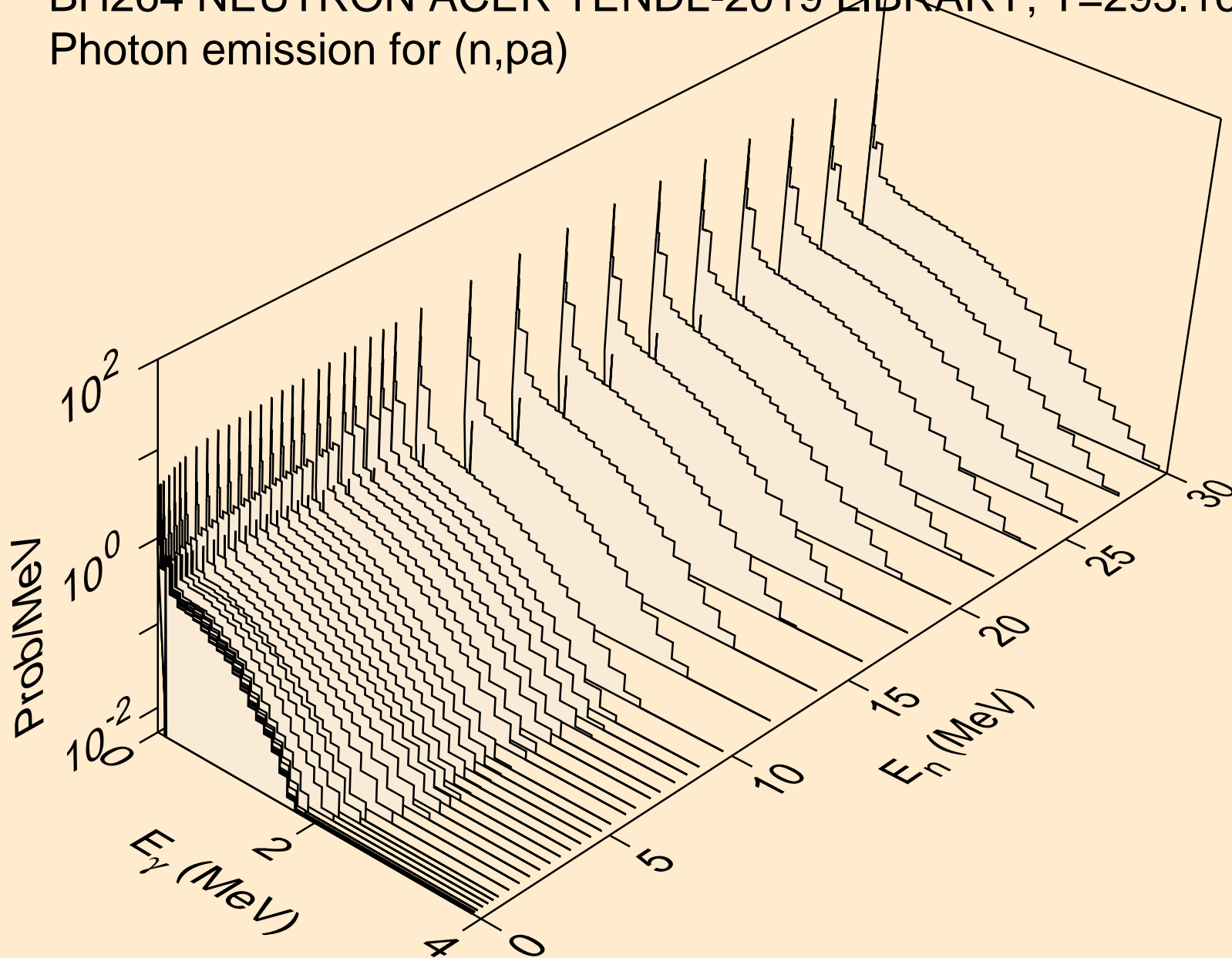

BH264 NEUTRON ACER TENDL-2019 LIBRARY; T=293.16K
Photon emission for (n,t2a)

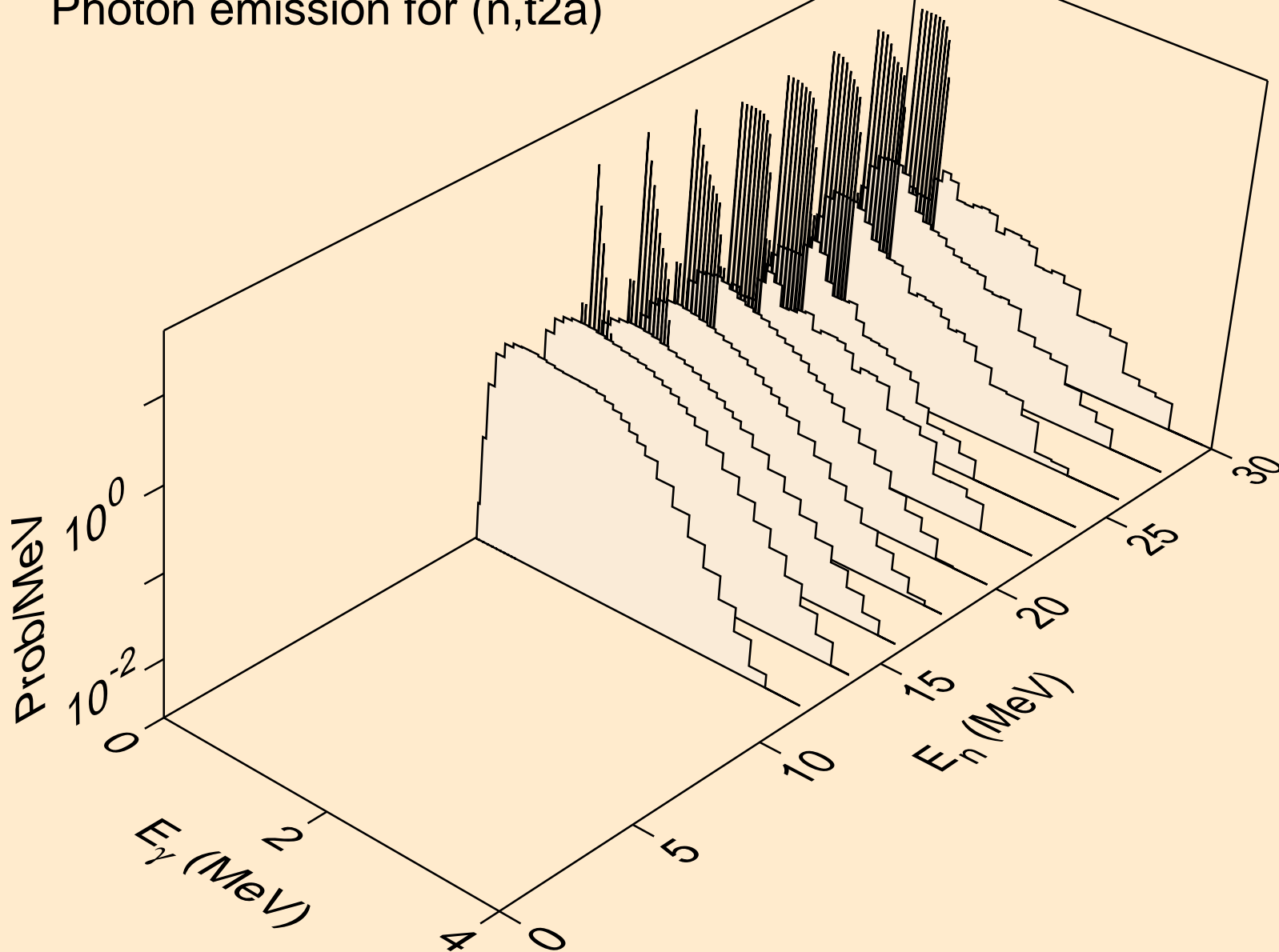

BH264 NEUTRON ACER TENDL-2019 LIBRARY; T=293.16K
Photon emission for (n,d2a)

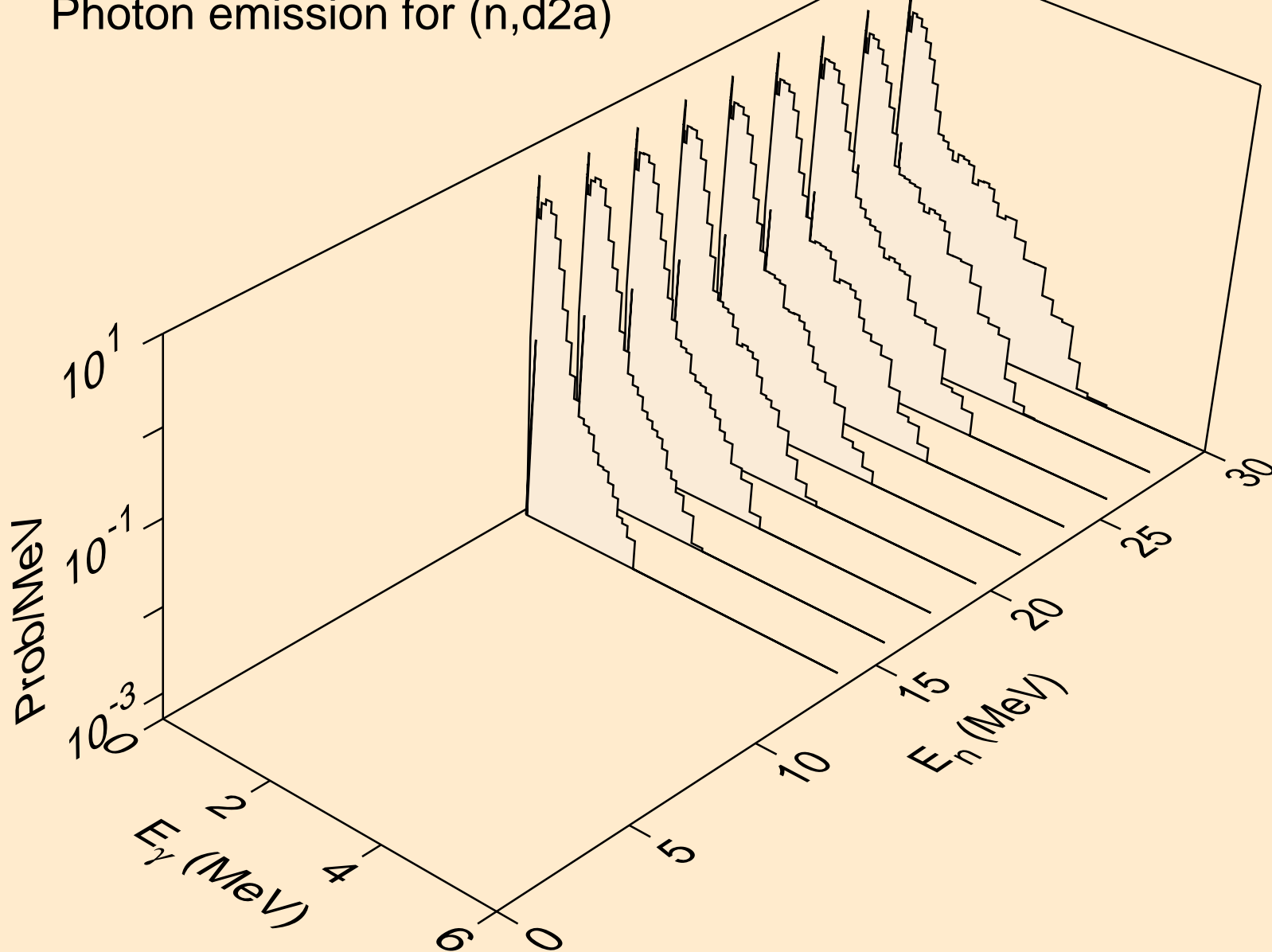

BH264 NEUTRON ACER TENDL-2019 LIBRARY; T=293.16K
Photon emission for (n,pd)

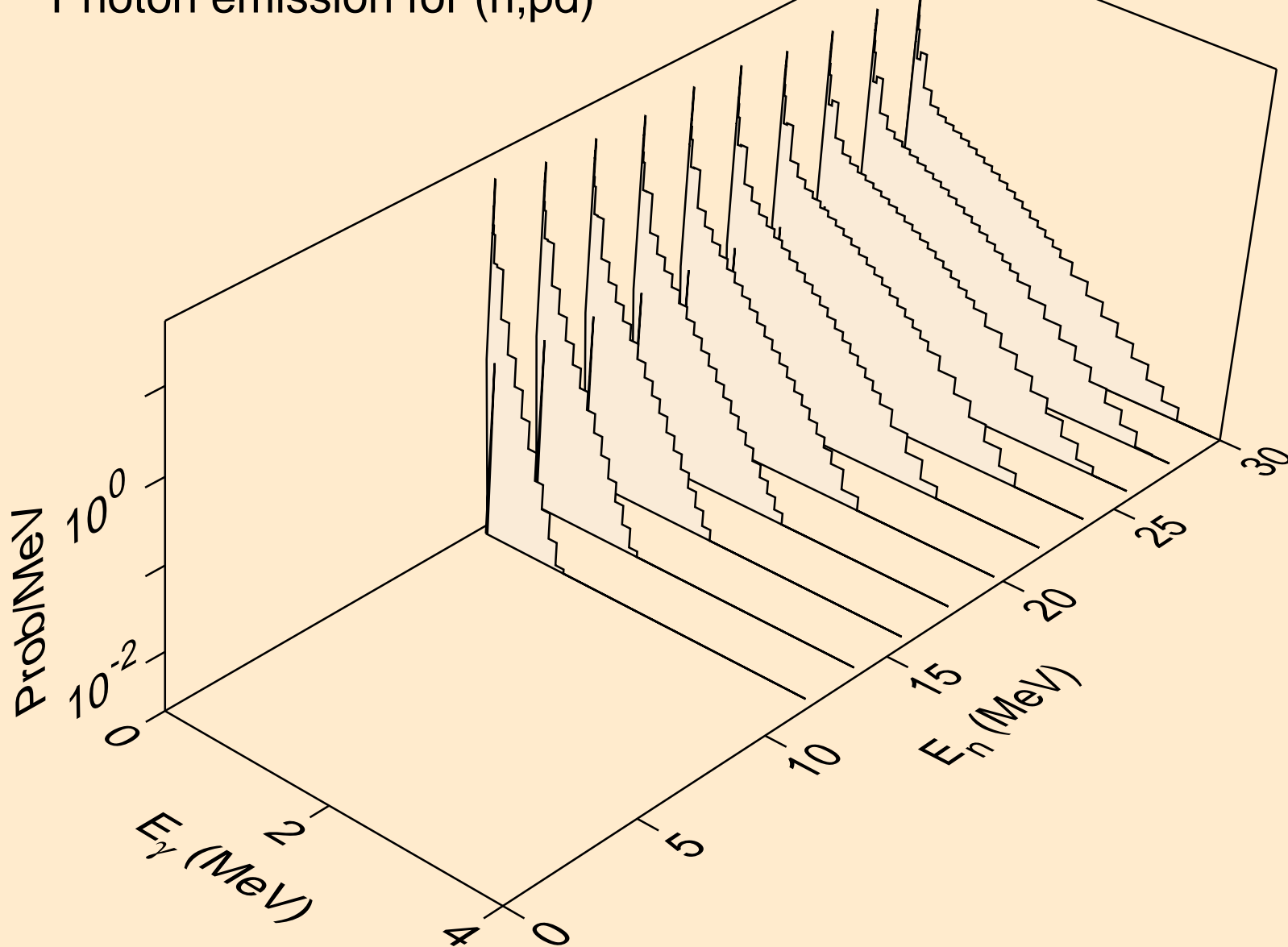

BH264 NEUTRON ACER TENDL-2019 LIBRARY; T=293.16K
Photon emission for (n,pt)

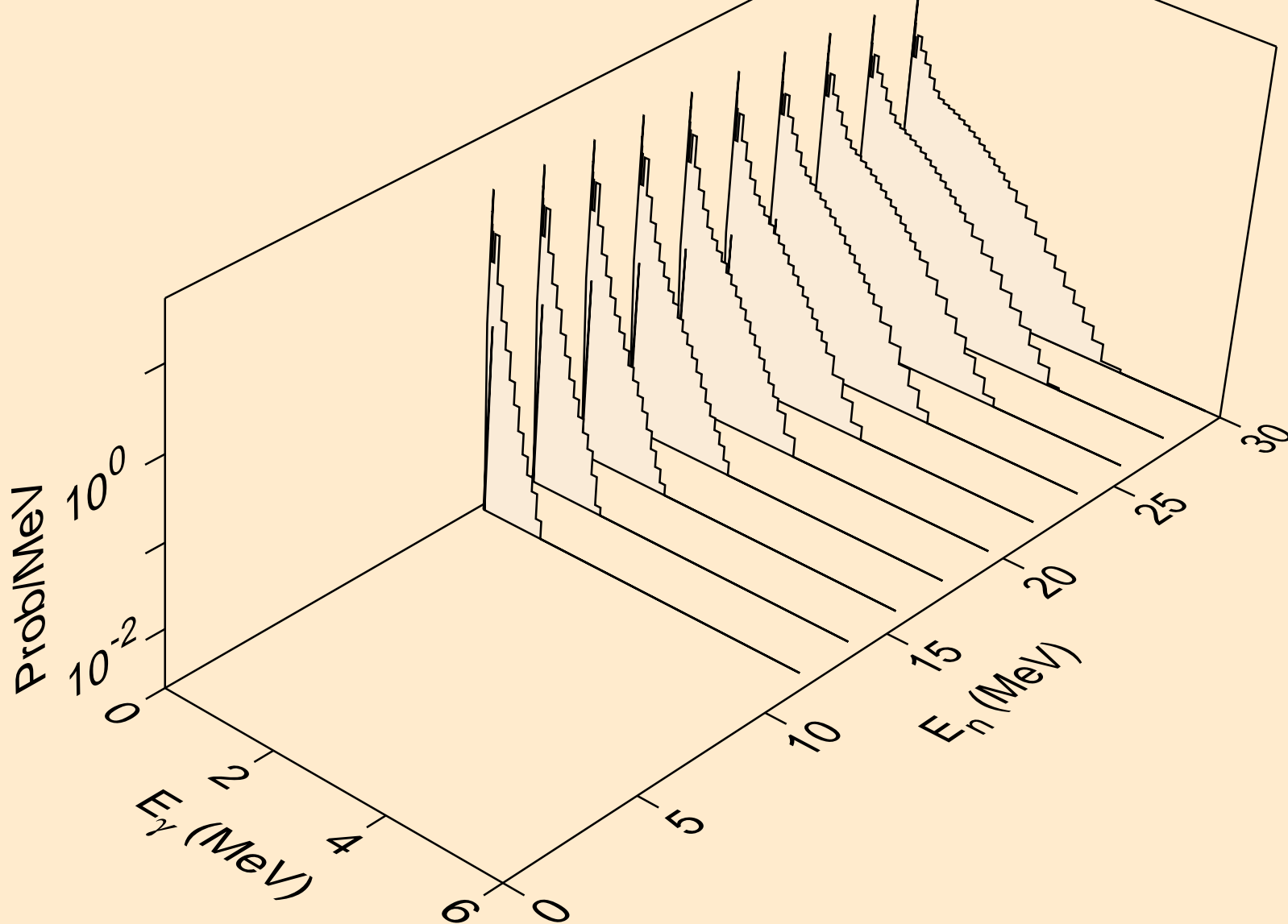

BH264 NEUTRON ACER TENDL-2019 LIBRARY; T=293.16K
Photon emission for (n,da)

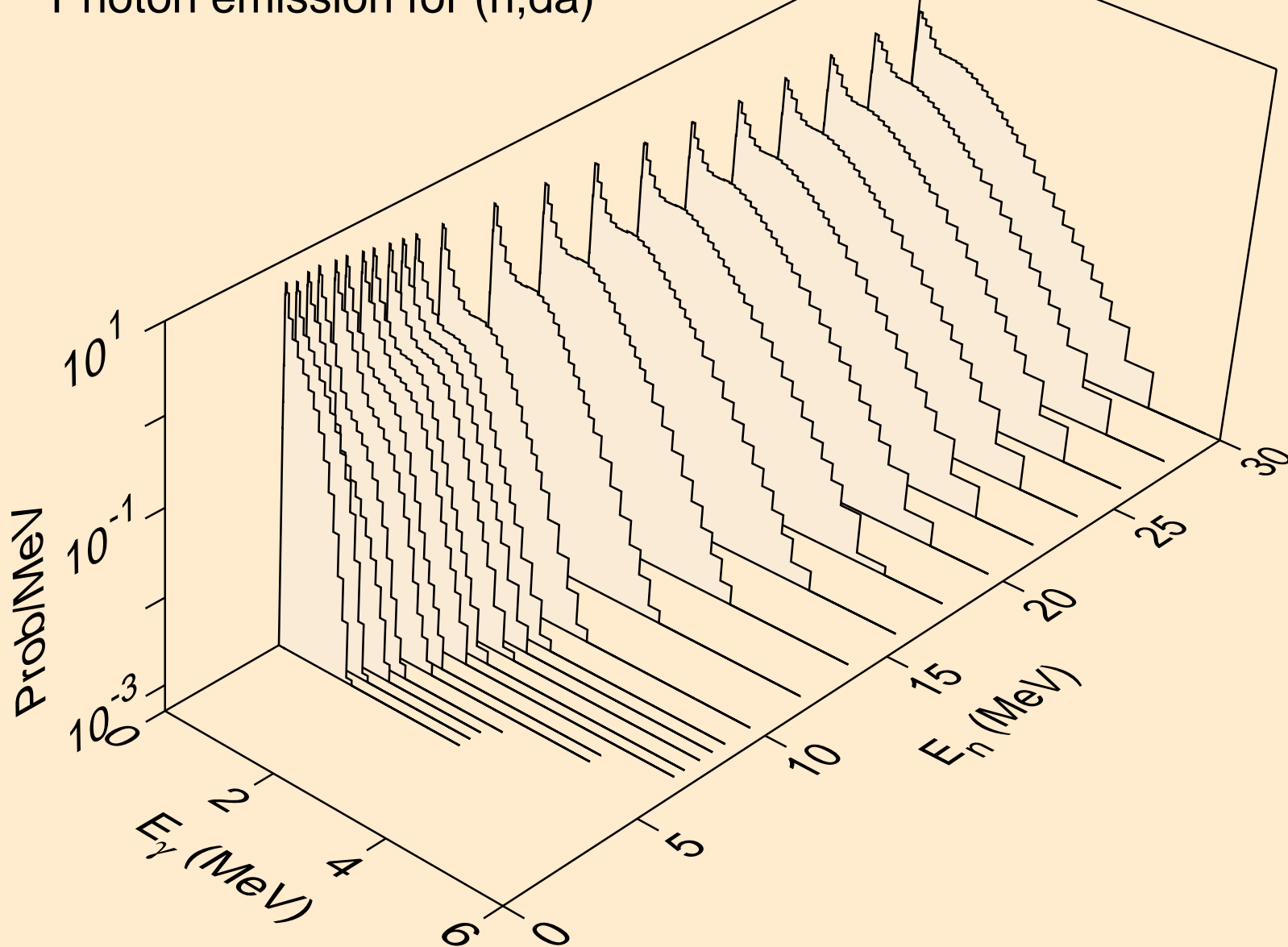

BH264 NEUTRON ACER TENDL-2019 LIBRARY; T=293.16K
thermal capture photon spectrum

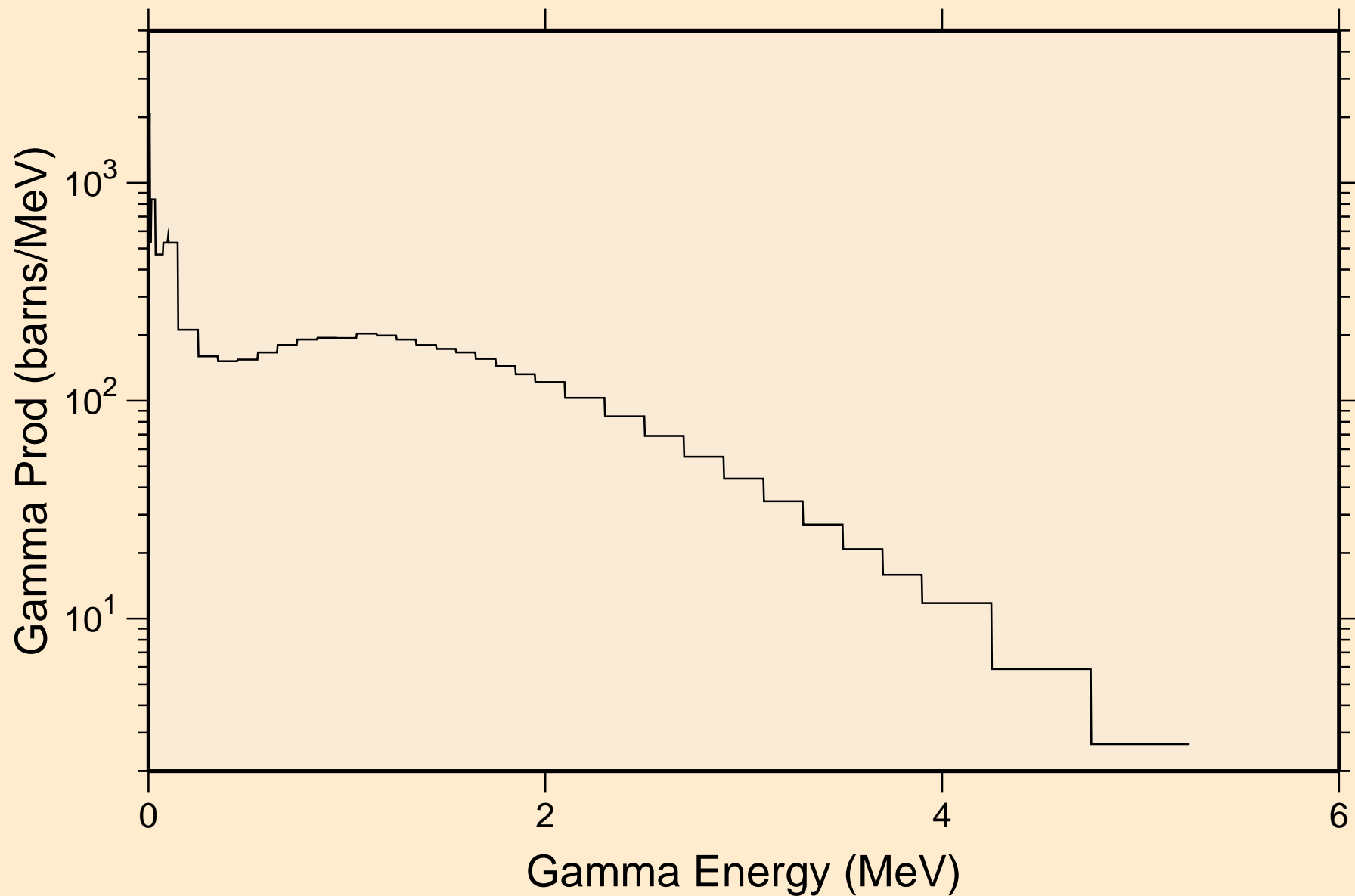

BH264 NEUTRON ACER TENDL-2019 LIBRARY; T=293.16K
14 MeV photon spectrum

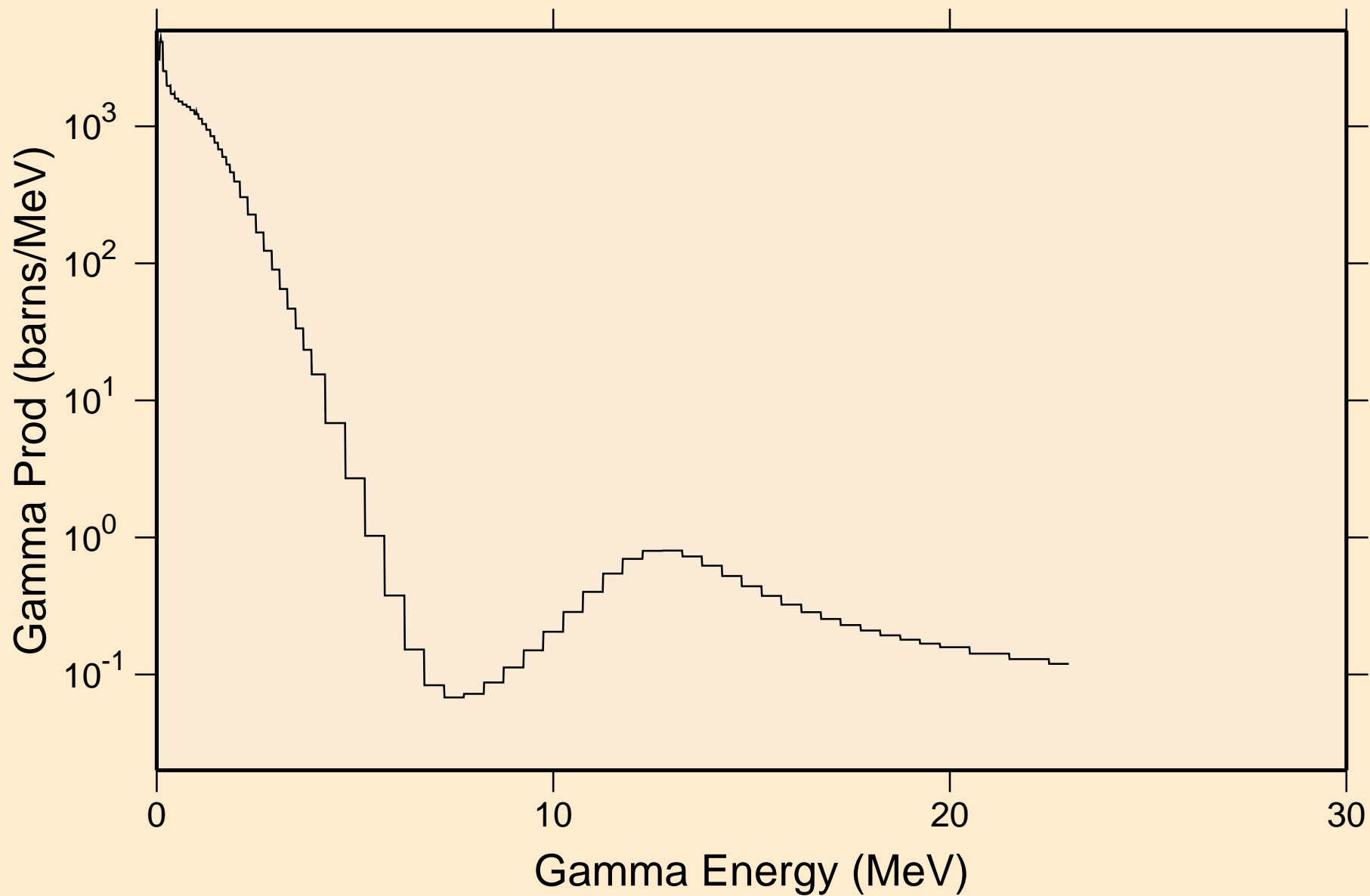

BH264 NEUTRON ACER TENDL-2019 LIBRARY; T=293.16K

Particle heating contributions

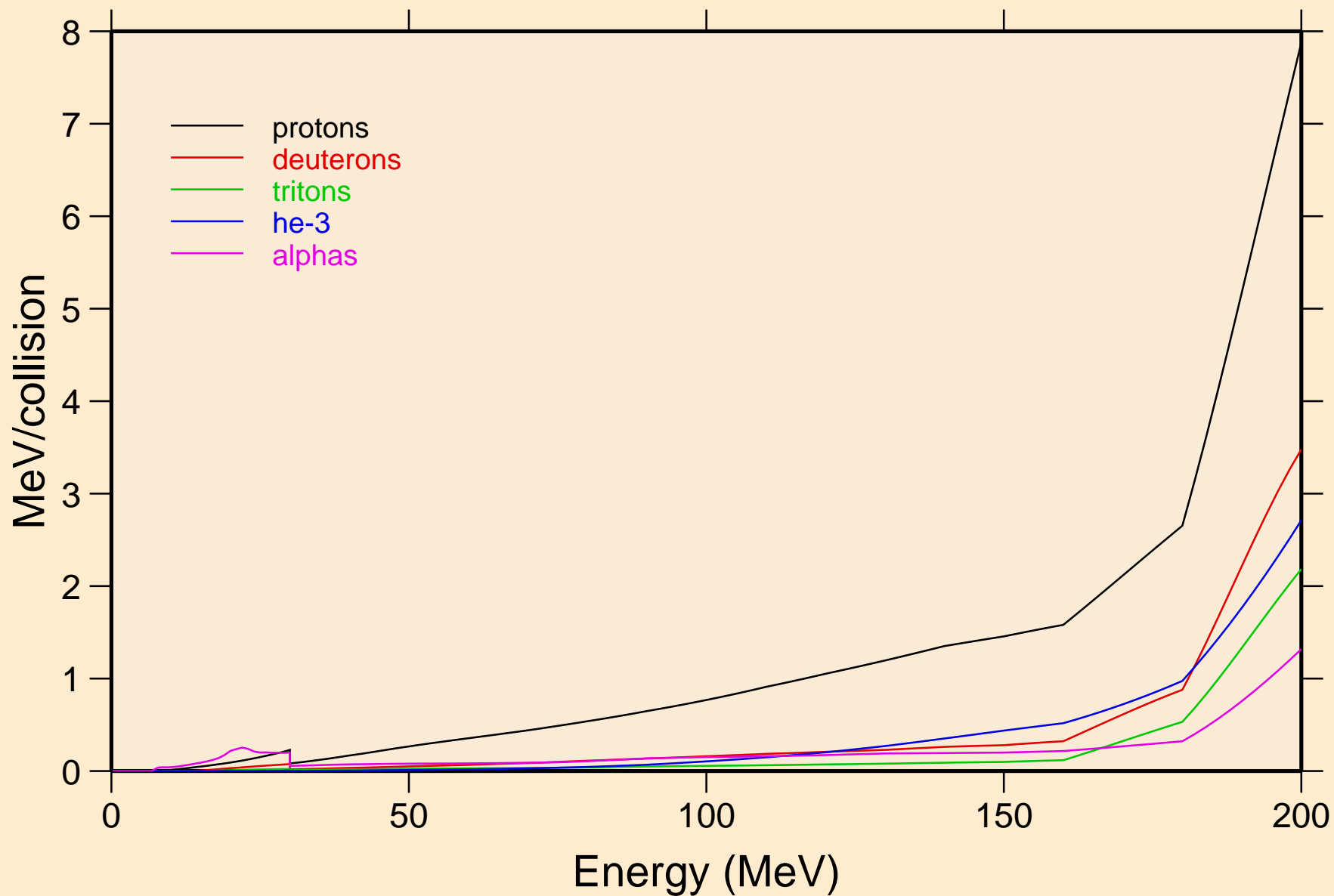

BH264 NEUTRON ACER TENDL-2019 LIBRARY; T=293.16K
Recoil Heating

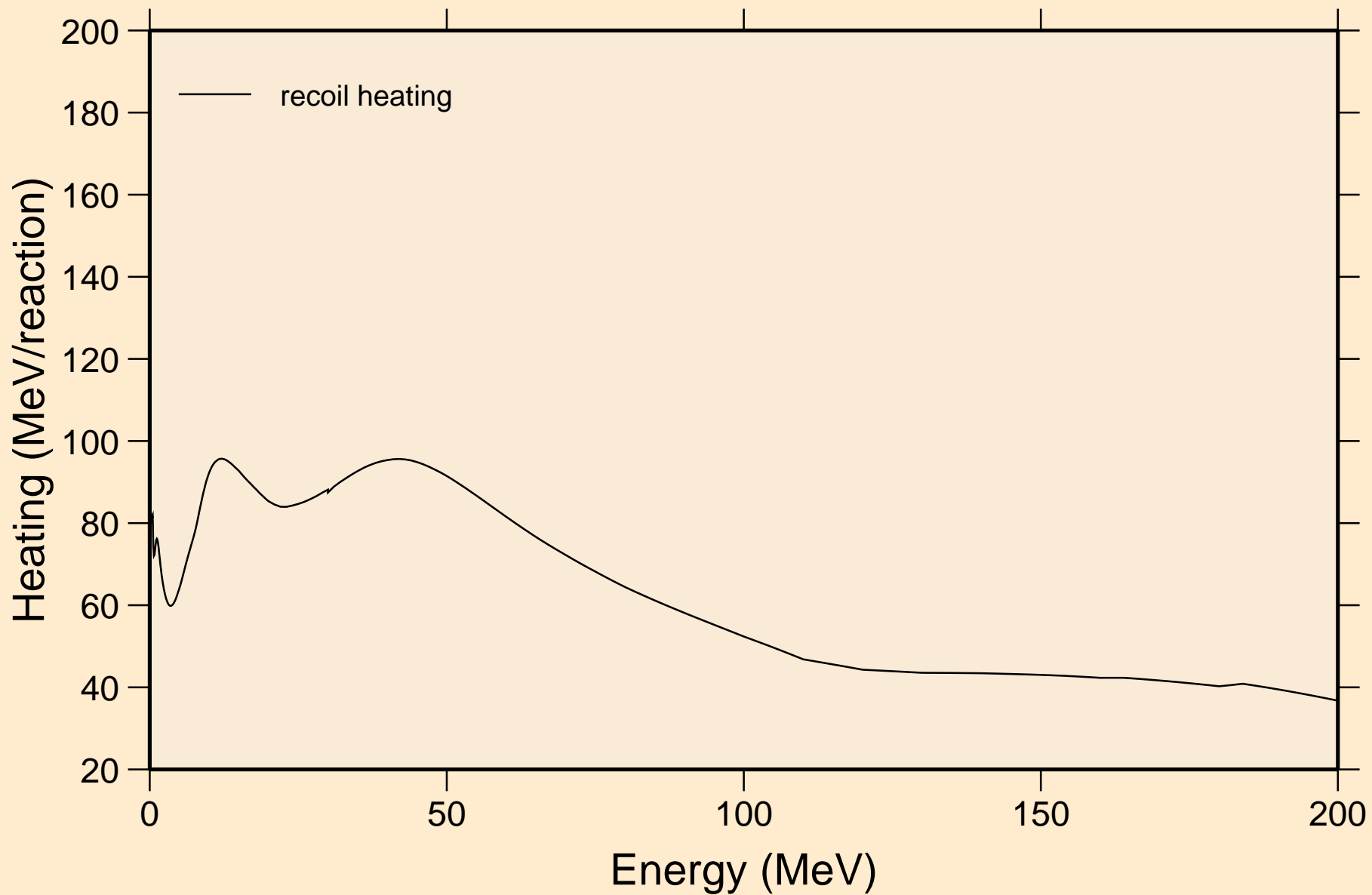

BH264 NEUTRON ACER TENDL-2019 LIBRARY; T=293.16K
Particle production cross sections

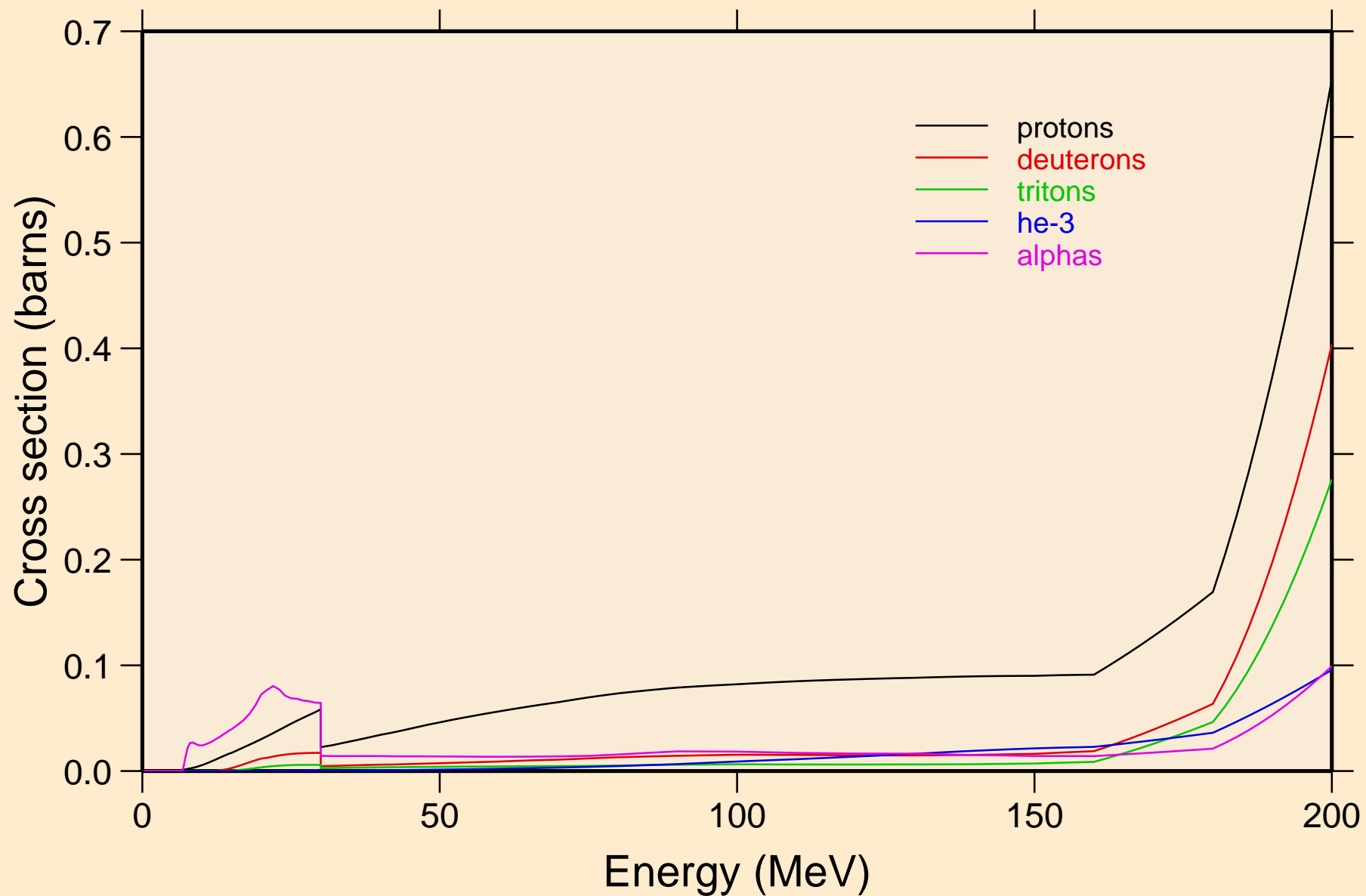

BH264 NEUTRON ACER TENDL-2019 LIBRARY; T=293.16K
protons from (n,x)

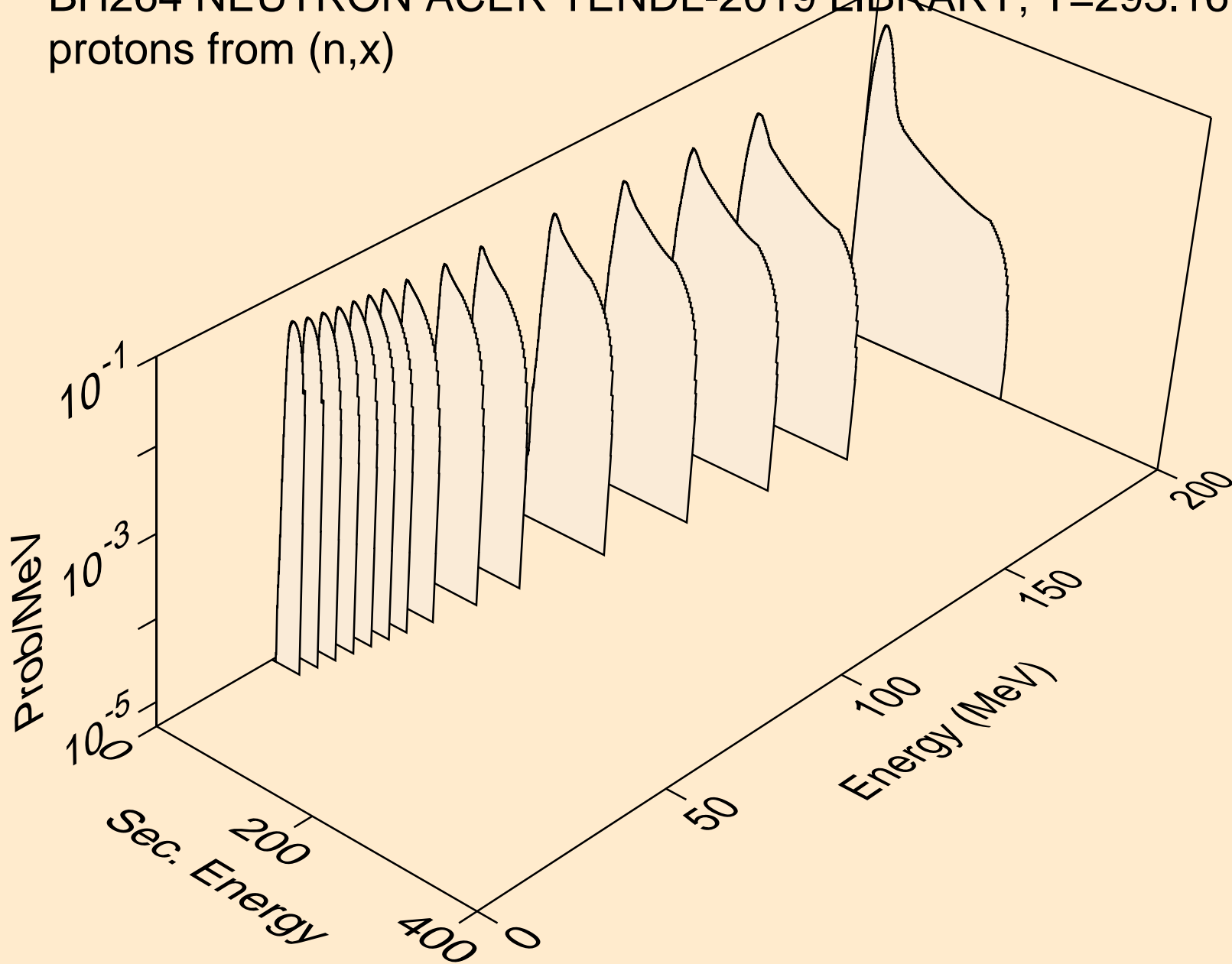

BH264 NEUTRON ACER TENDL-2019 LIBRARY; T=293.16K
protons from (n,n*)p

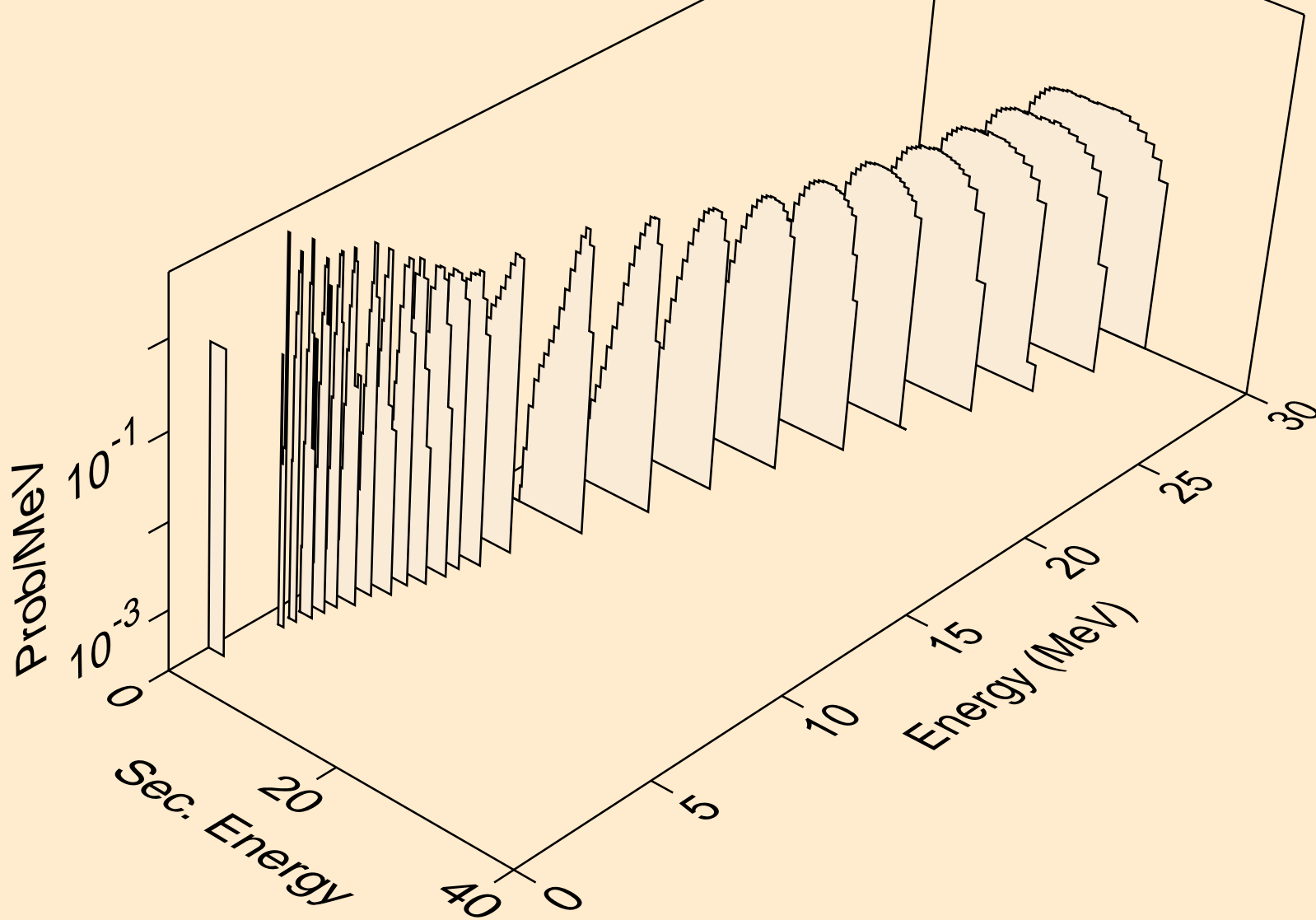

BH264 NEUTRON ACER TENDL-2019 LIBRARY; T=293.16K
protons from (n,2np)

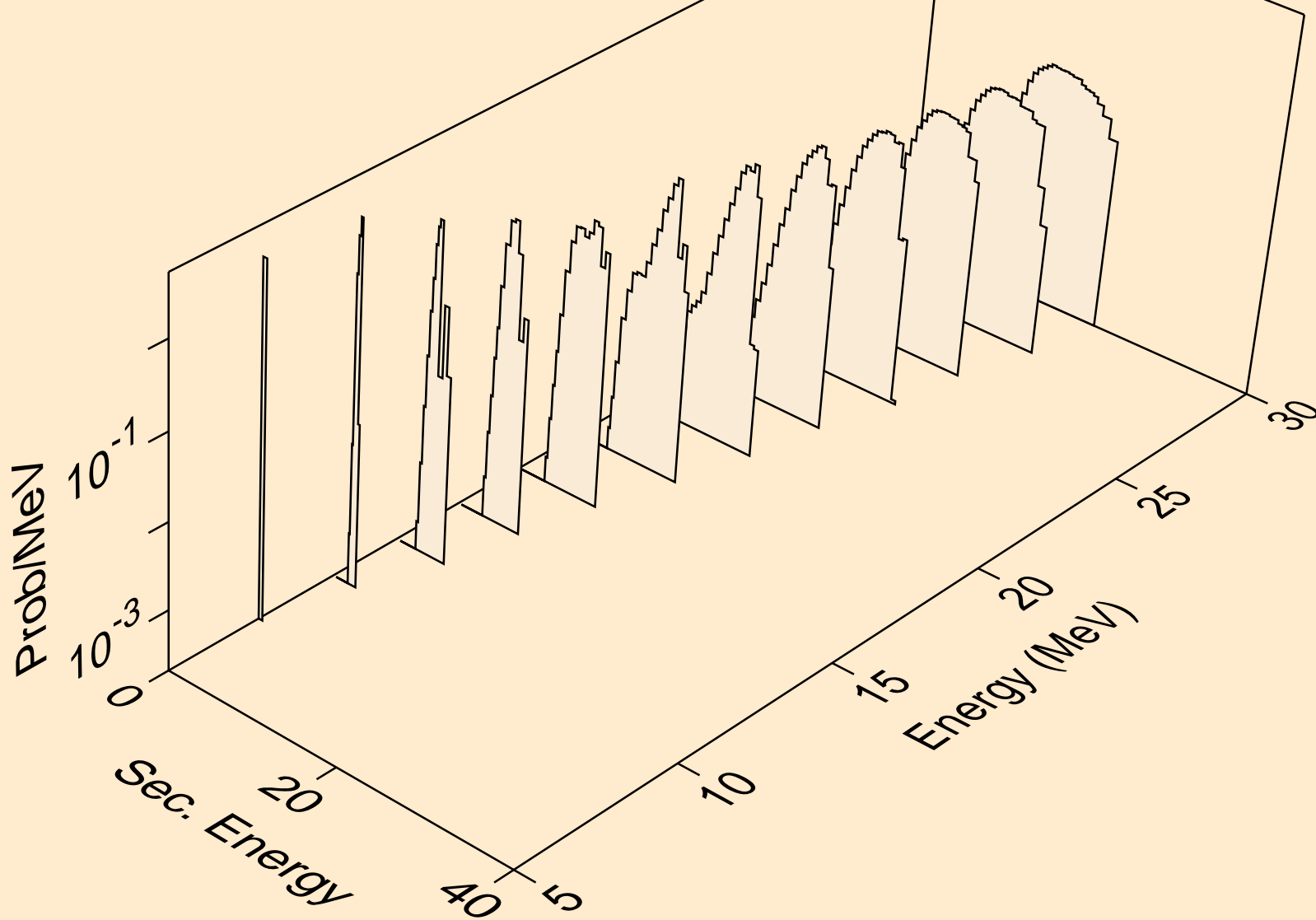

BH264 NEUTRON ACER TENDL-2019 LIBRARY; T=293.16K
protons from (n,3np)

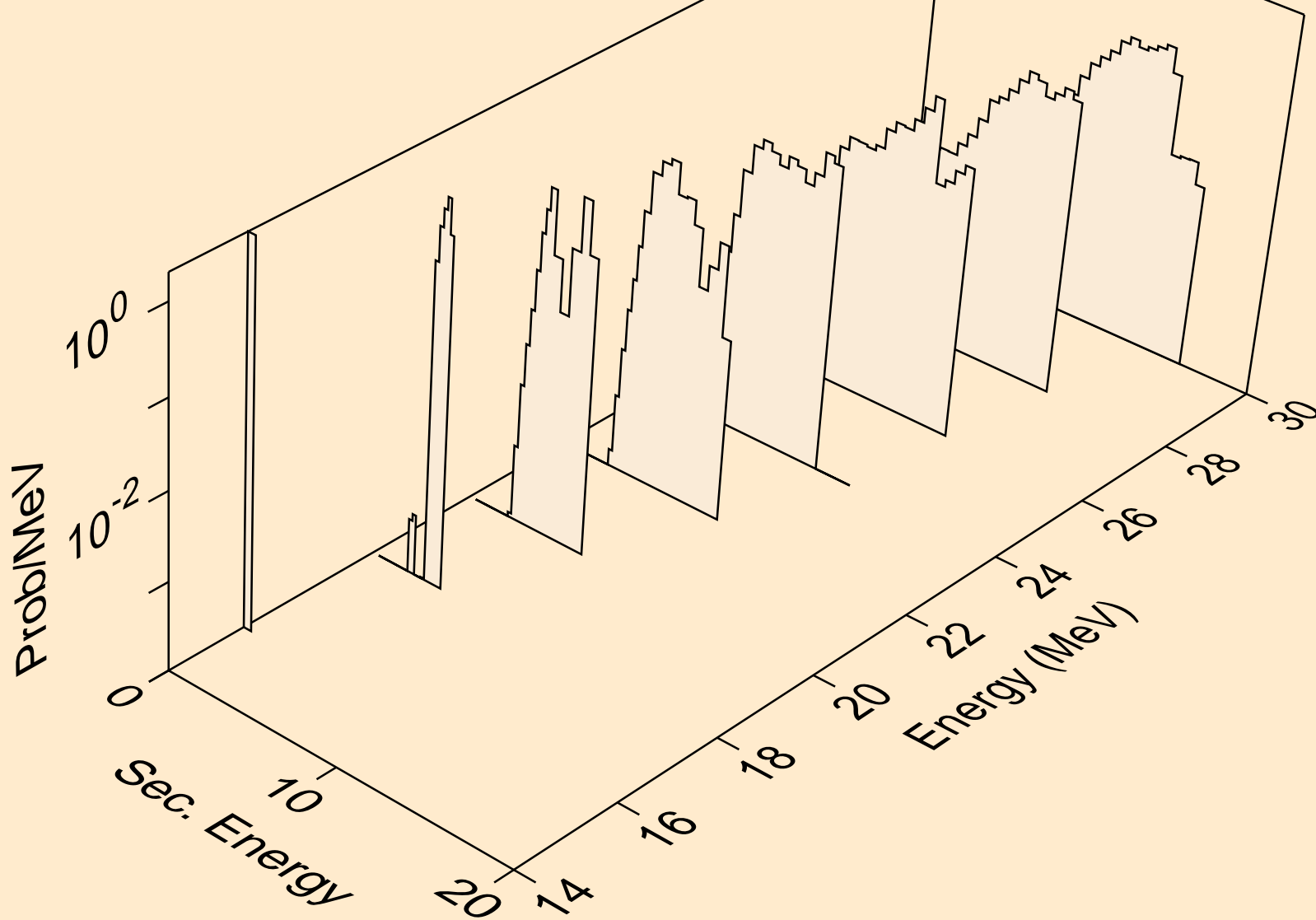

BH264 NEUTRON ACER TENDL-2019 LIBRARY; T=293.16K
protons from (n,2np)

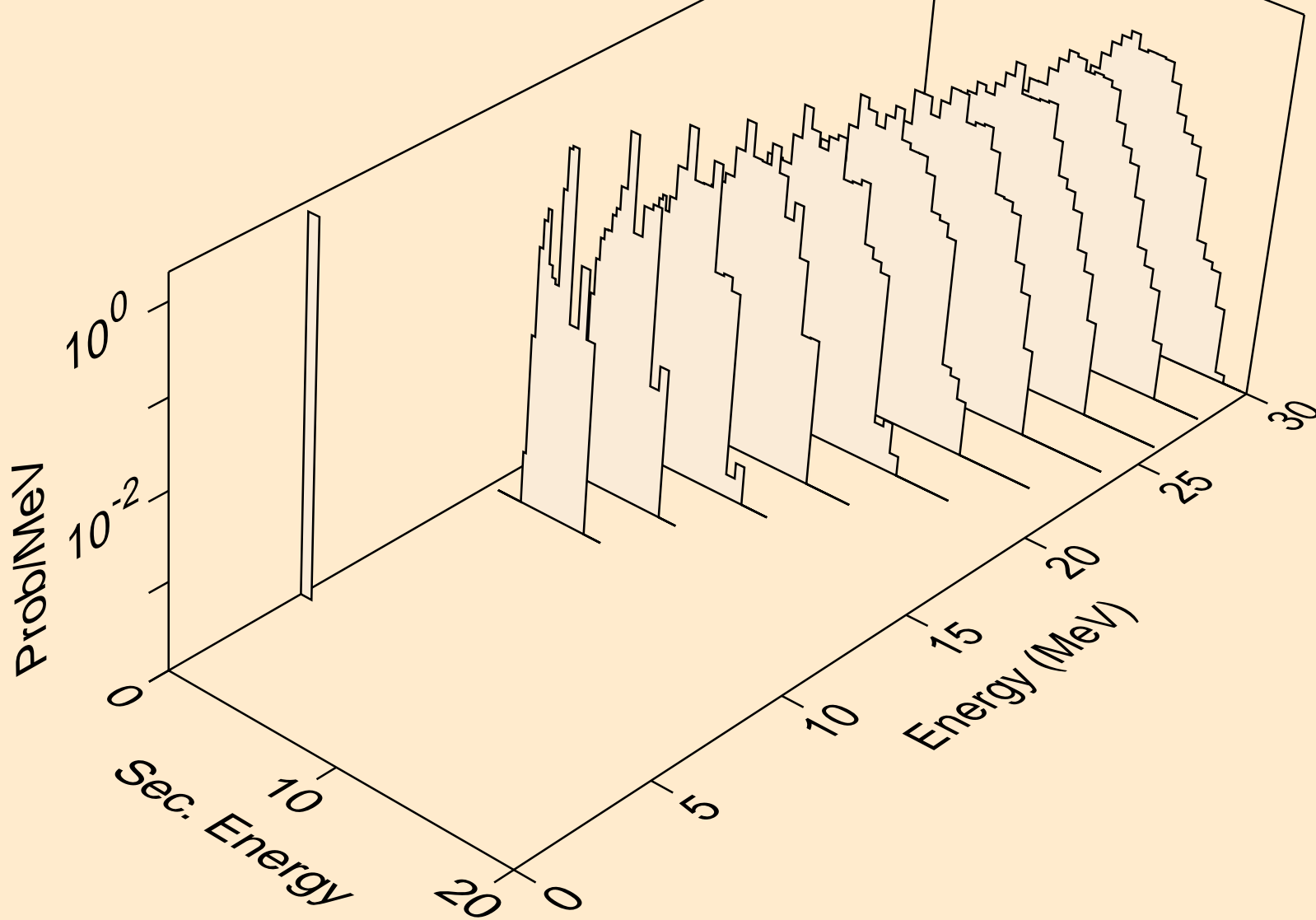

BH264 NEUTRON ACER TENDL-2019 LIBRARY; T=293.16K
protons from (n,npa)

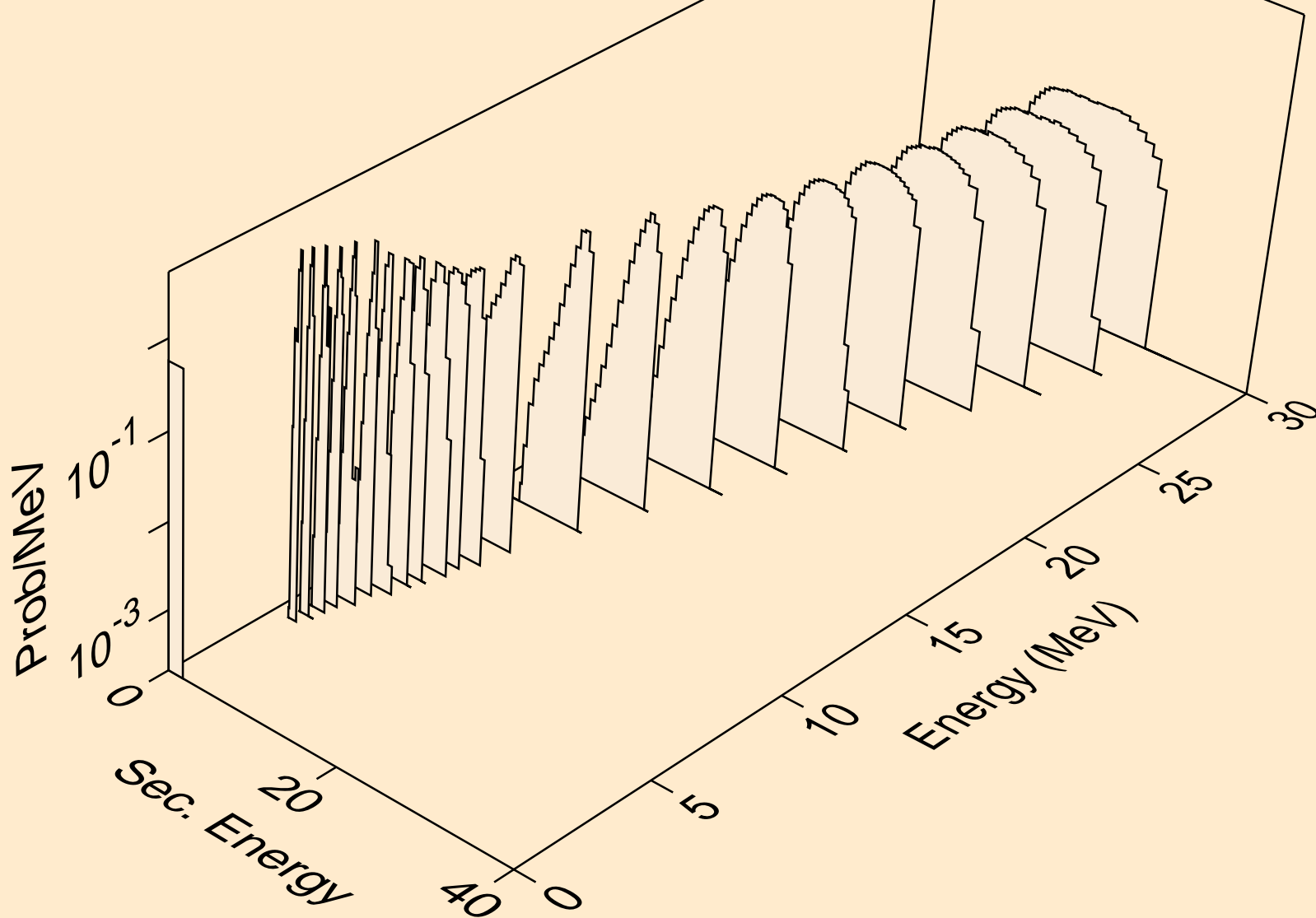

BH264 NEUTRON ACER TENDL-2019 LIBRARY; T=293.16K
protons from (n,p)

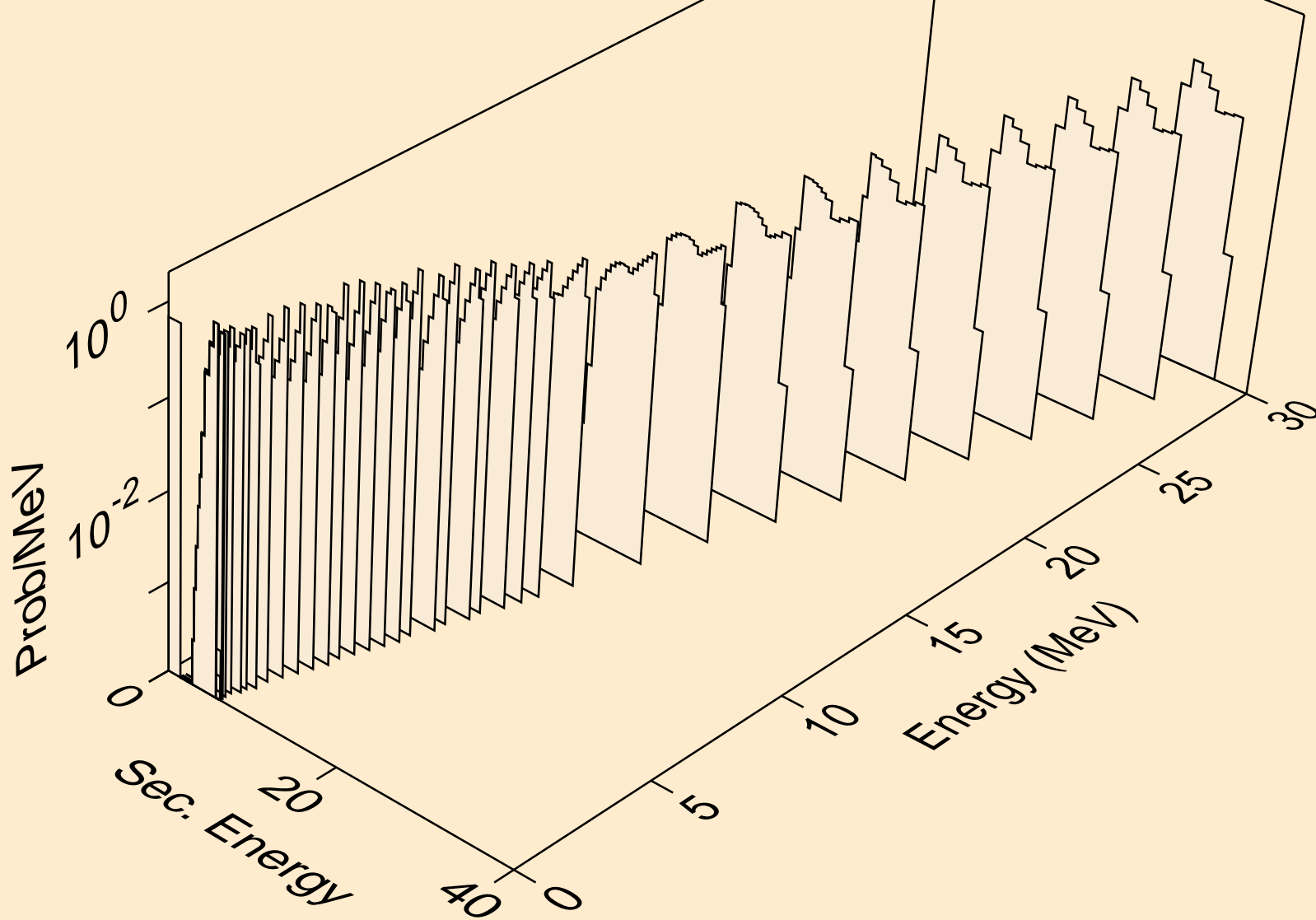

BH264 NEUTRON ACER TENDL-2019 LIBRARY; T=293.16K
protons from (n,2p)

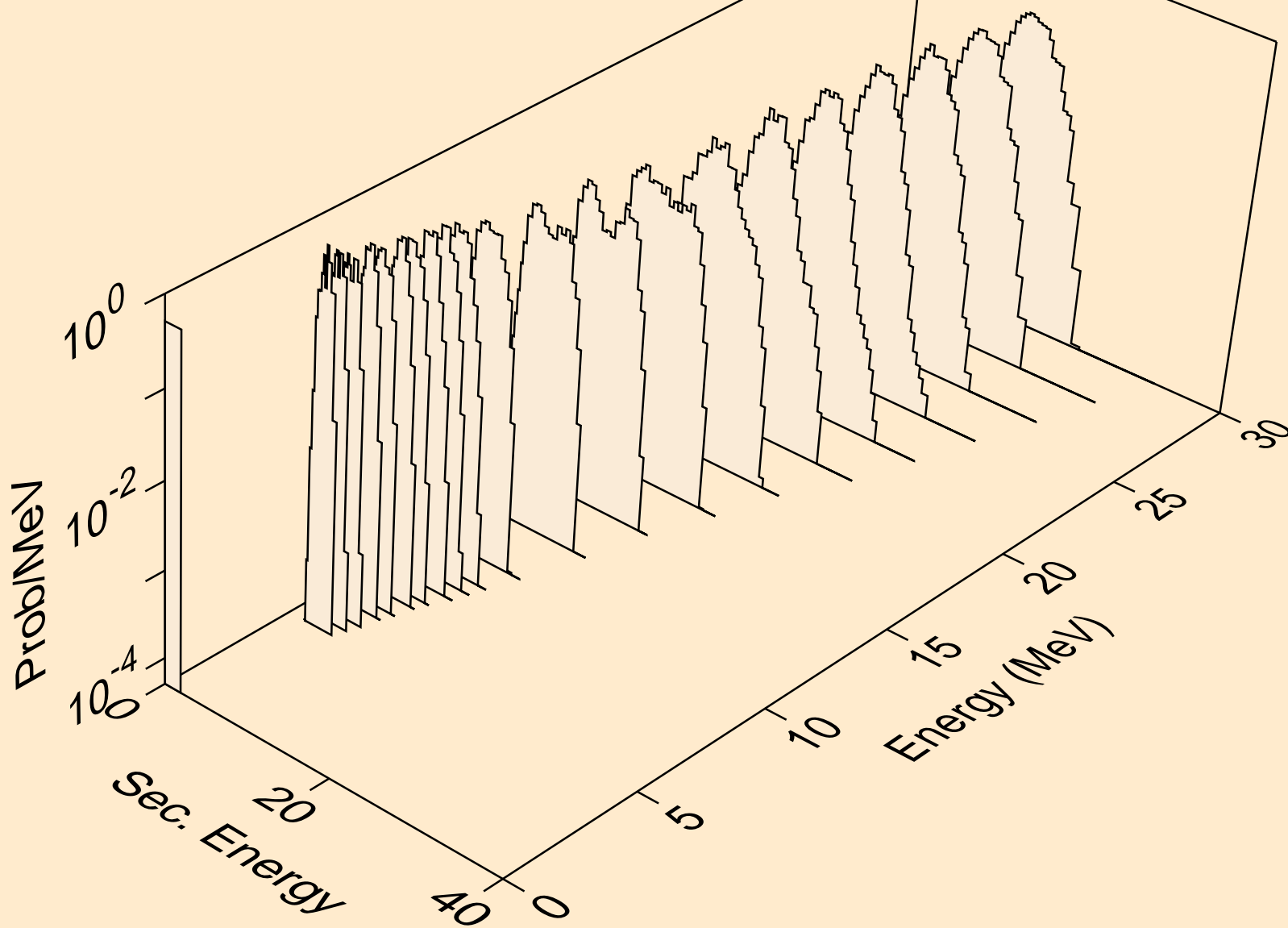

BH264 NEUTRON ACER TENDL-2019 LIBRARY; T=293.16K
protons from (n,p)

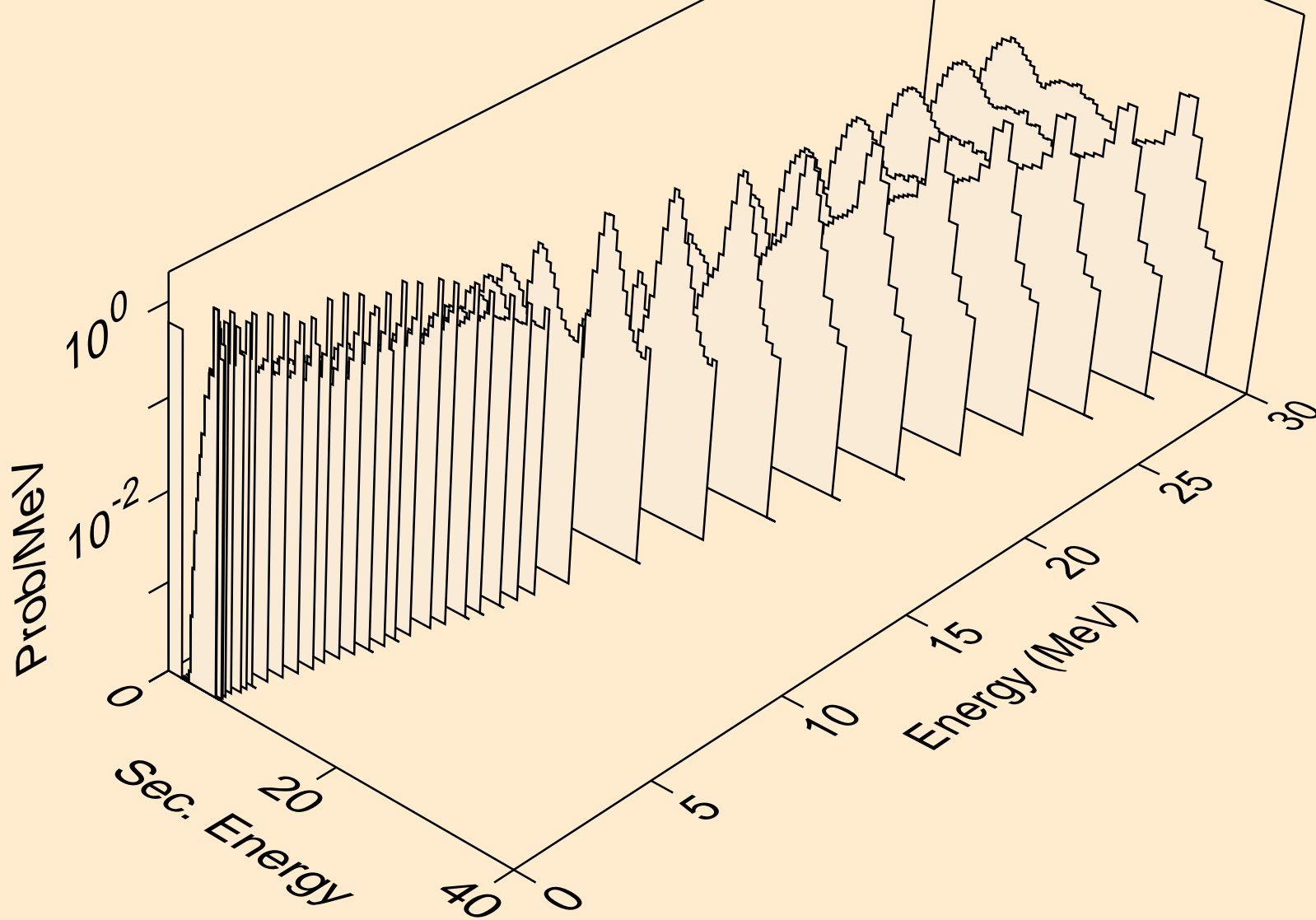

BH264 NEUTRON ACER TENDL-2019 LIBRARY; T=293.16K
protons from (n,pd)

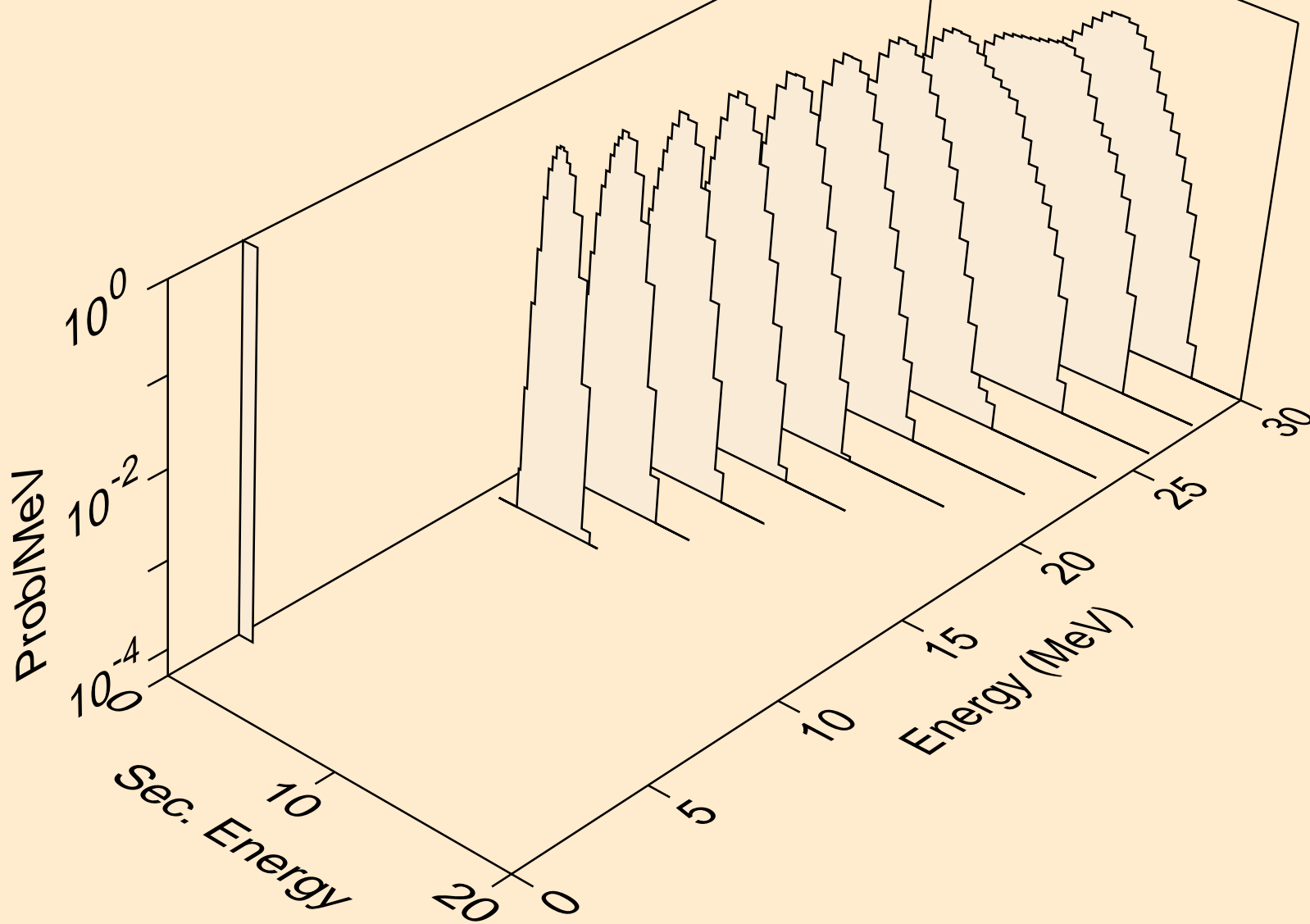

BH264 NEUTRON ACER TENDL-2019 LIBRARY; T=293.16K
protons from (n,pt)

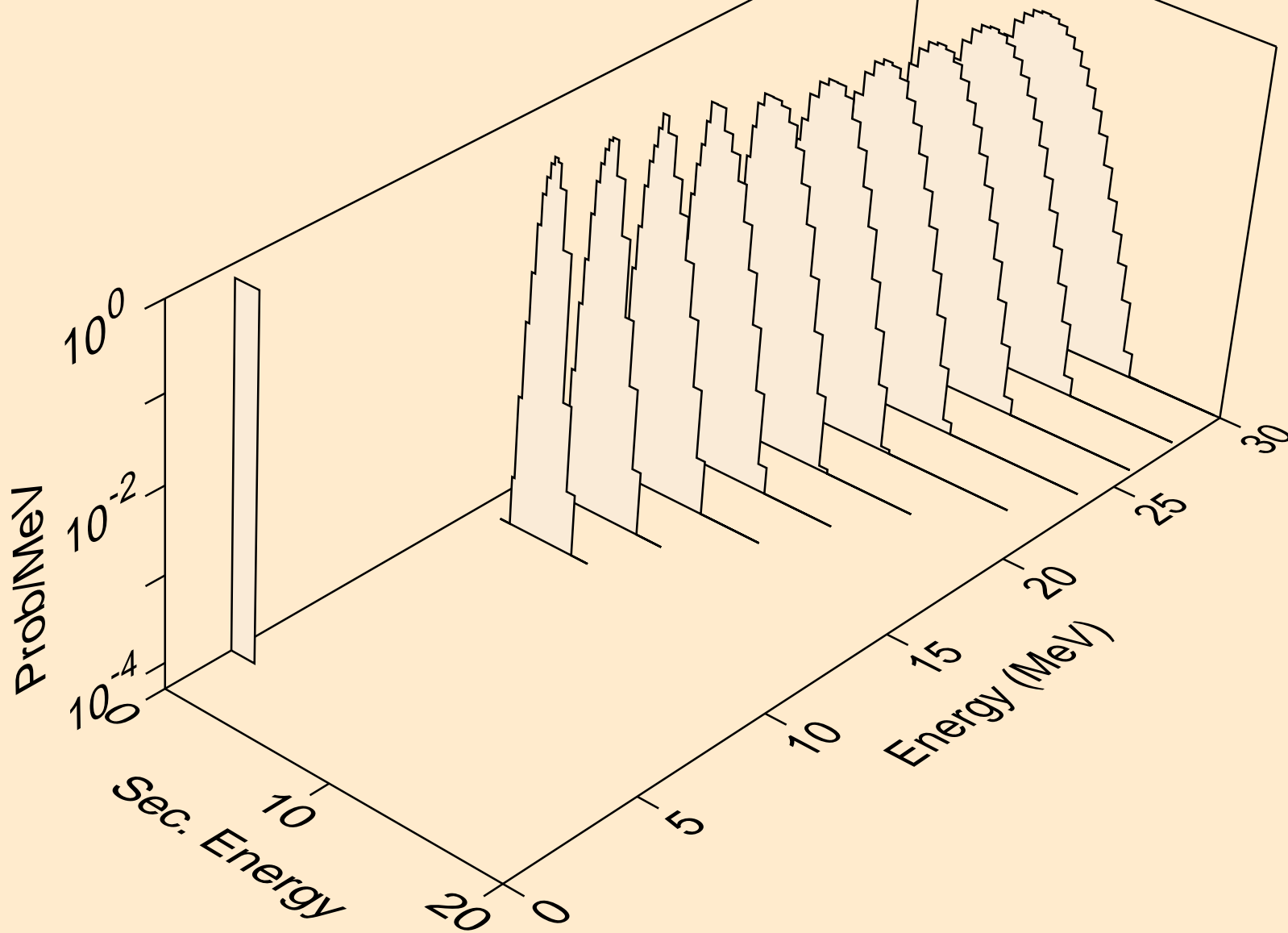

BH264 NEUTRON ACER TENDL-2019 LIBRARY; T=293.16K
deuterons from (n,x)

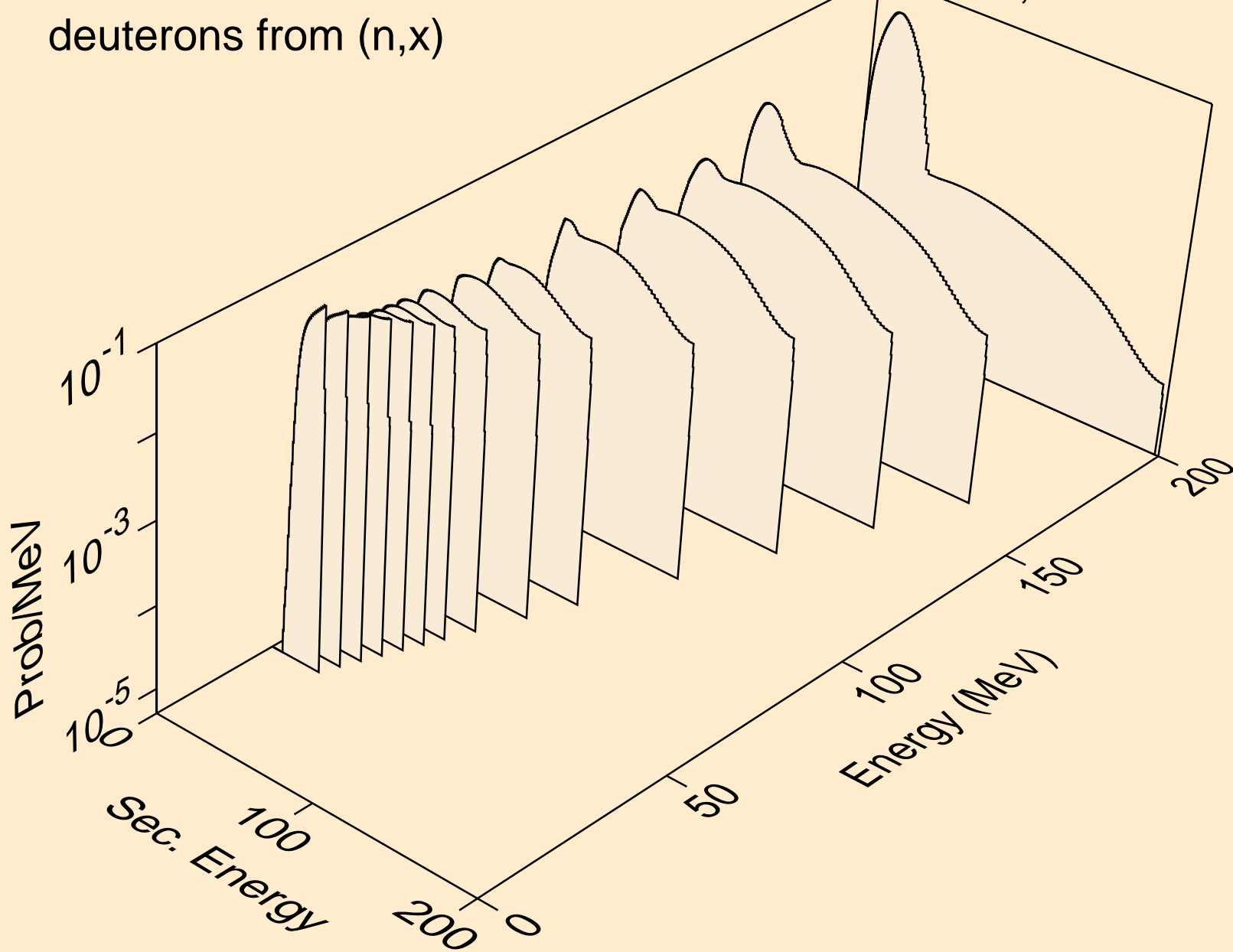

BH264 NEUTRON ACER TENDL-2019 LIBRARY; T=293.16K
deuterons from (n,2nd)

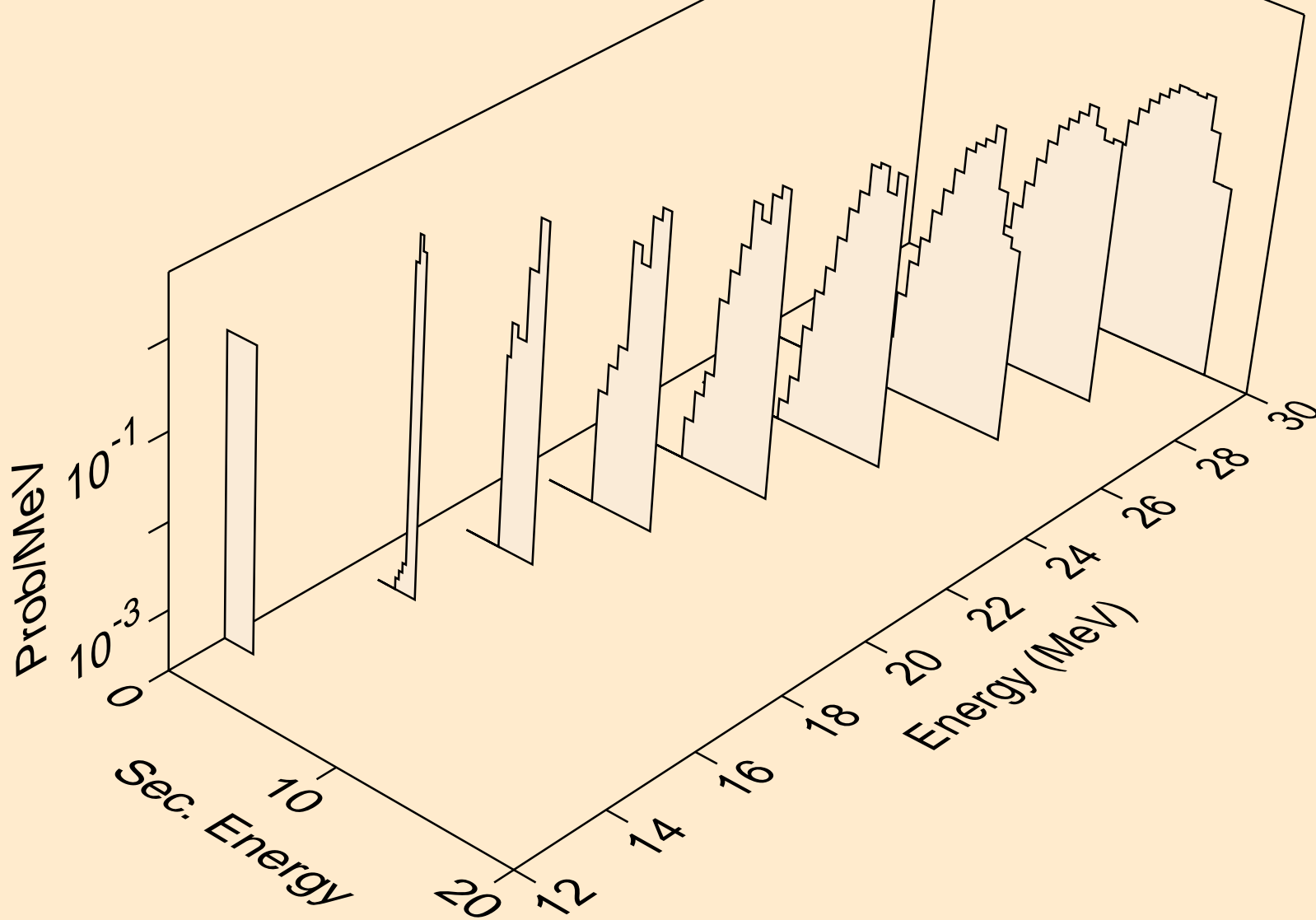

BH264 NEUTRON ACER TENDL-2019 LIBRARY; T=293.16K
deuterons from (n,n*)d

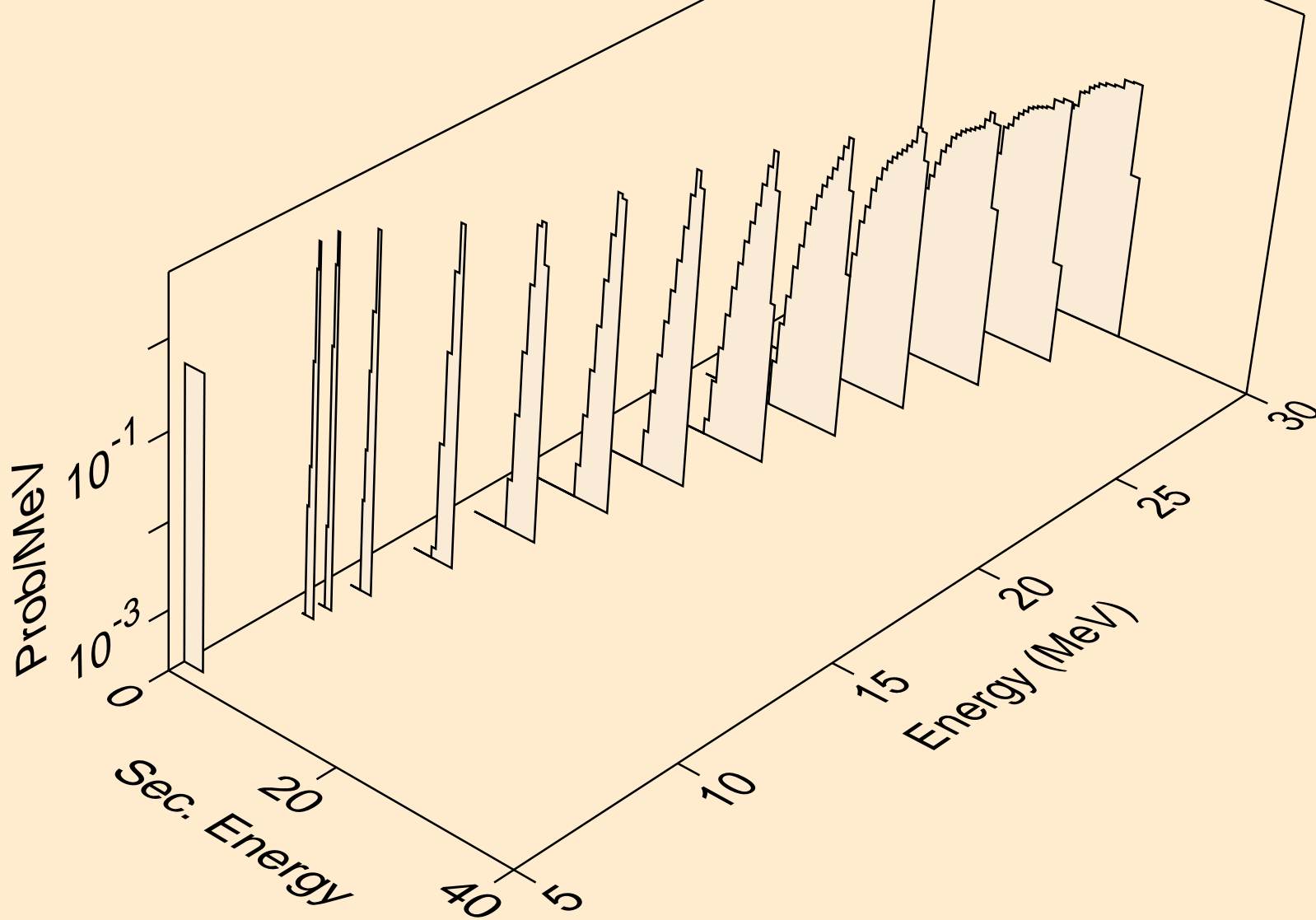

BH264 NEUTRON ACER TENDL-2019 LIBRARY; T=293.16K
deuterons from (n,n*)d2a

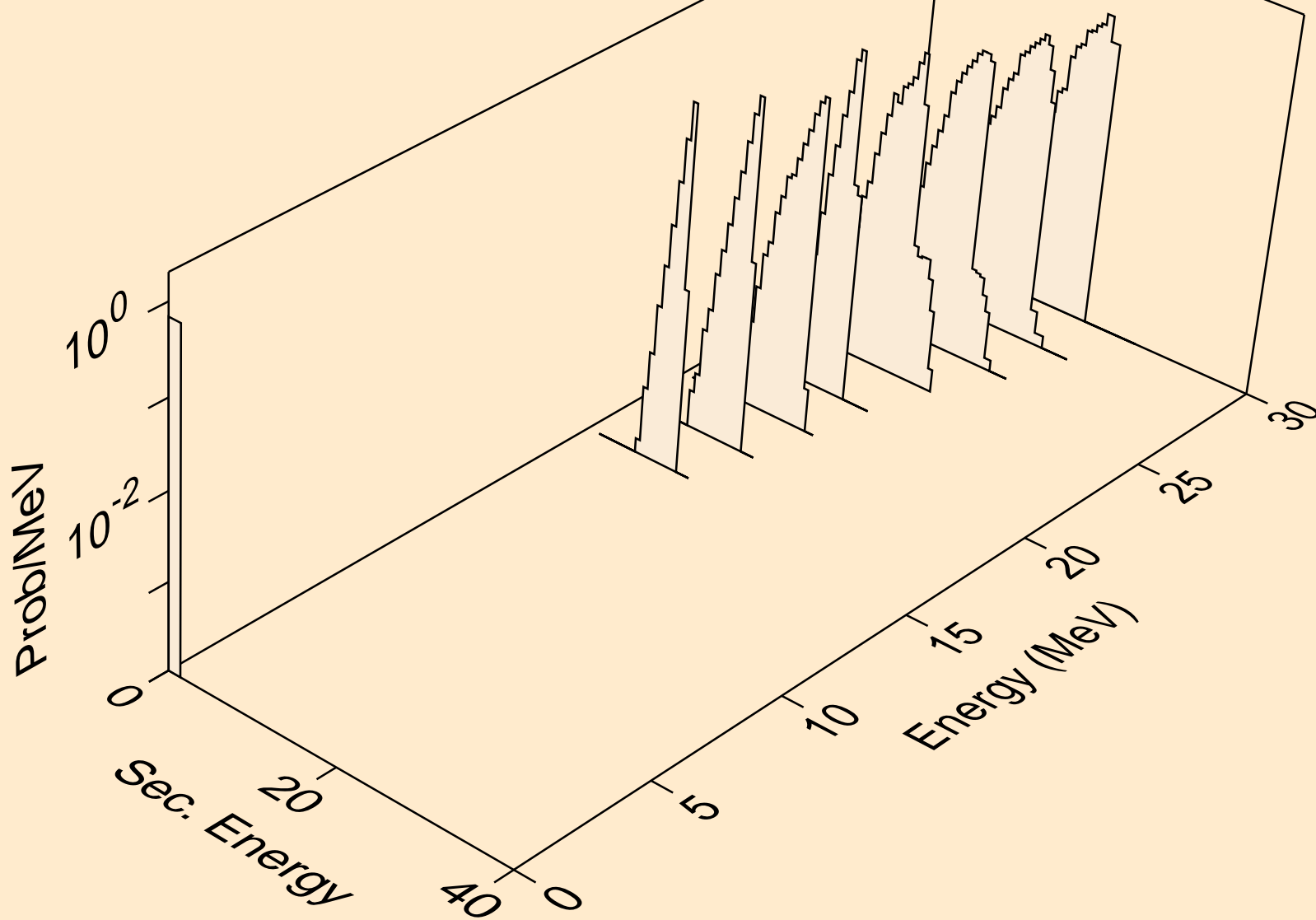

BH264 NEUTRON ACER TENDL-2019 LIBRARY; T=293.16K
deuterons from (n,d)

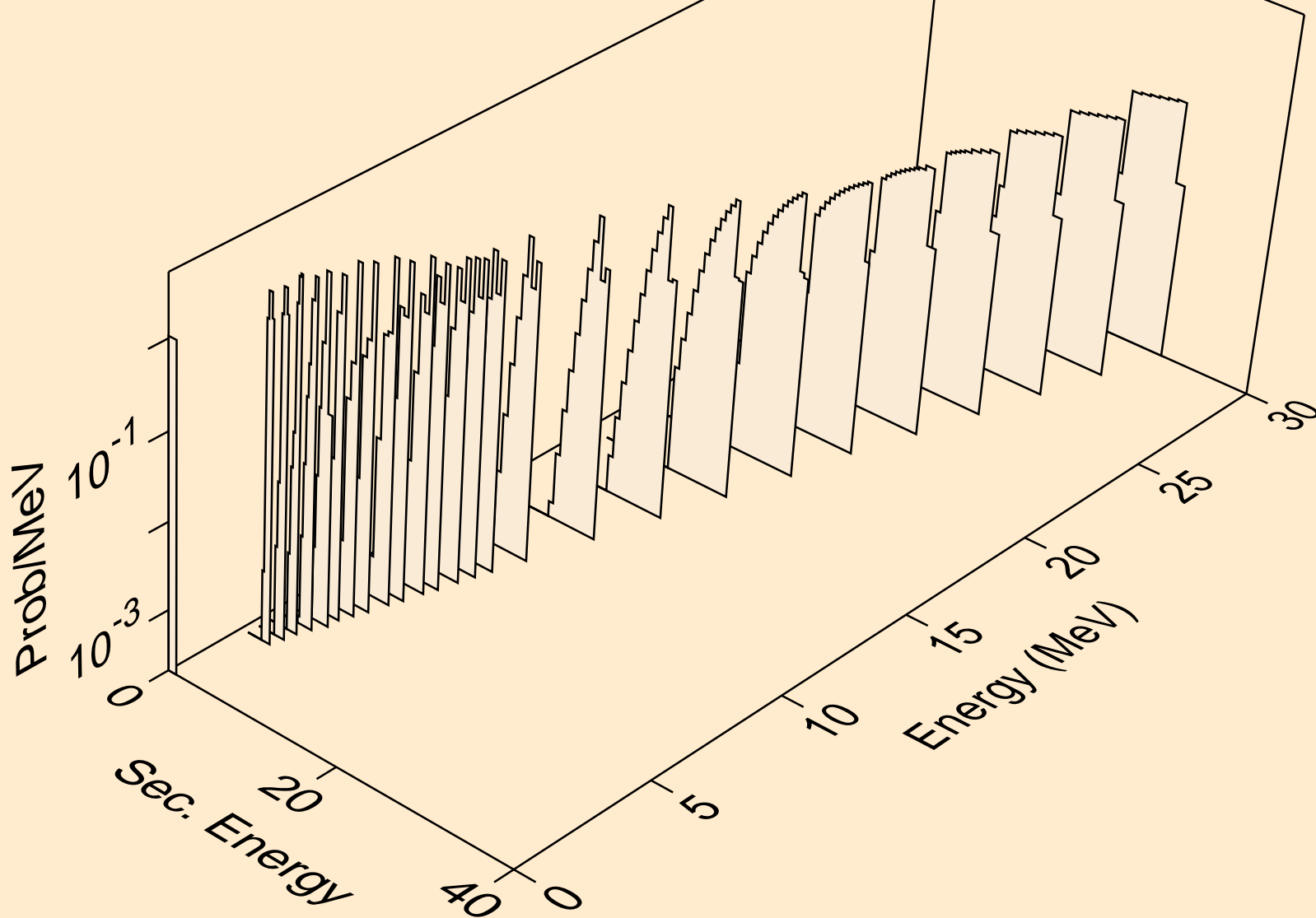

BH264 NEUTRON ACER TENDL-2019 LIBRARY; T=293.16K
deuterons from (n,d2a)

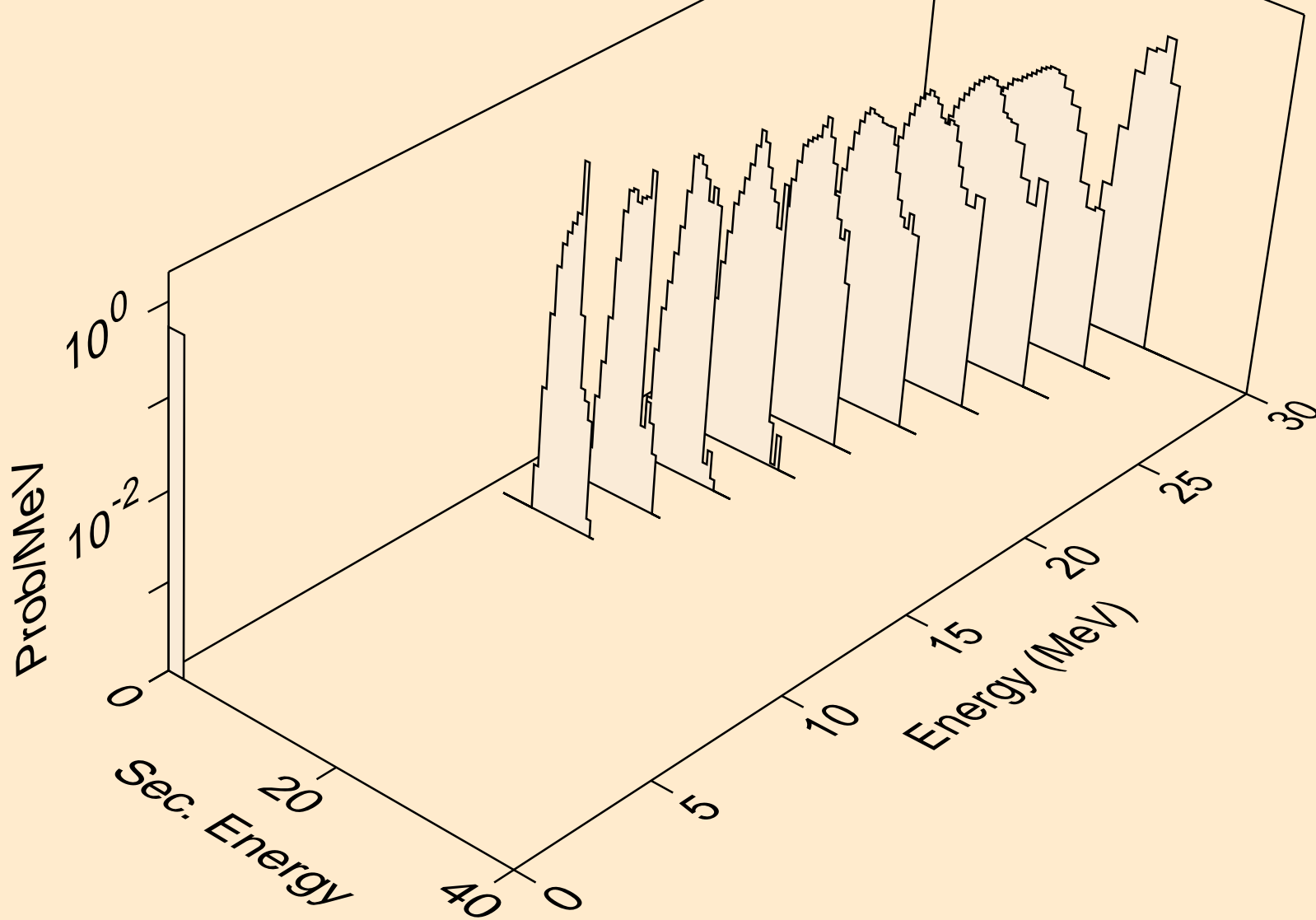

BH264 NEUTRON ACER TENDL-2019 LIBRARY; T=293.16K
deuterons from (n,pd)

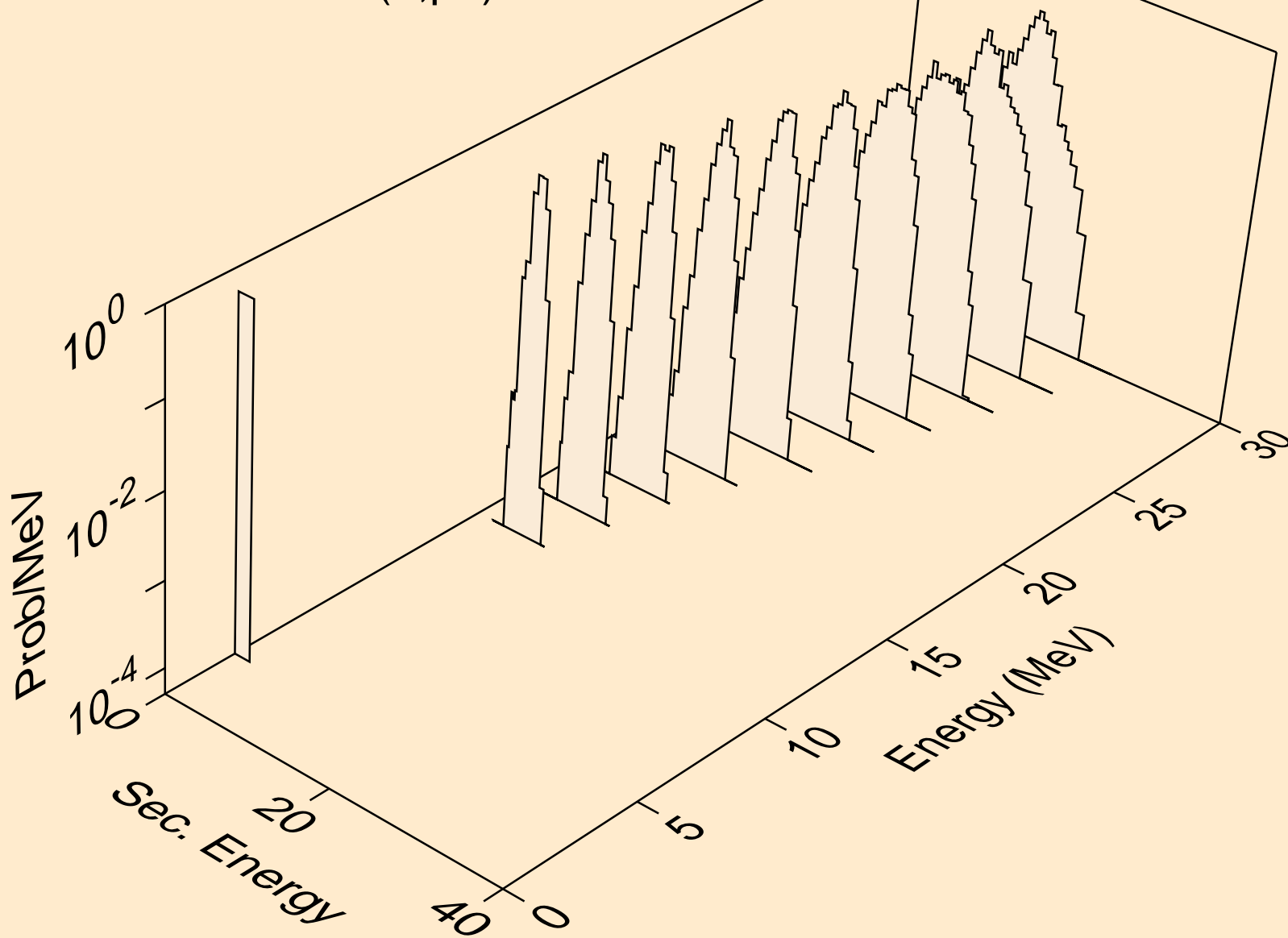

BH264 NEUTRON ACER TENDL-2019 LIBRARY; T=293.16K
deuterons from (n,da)

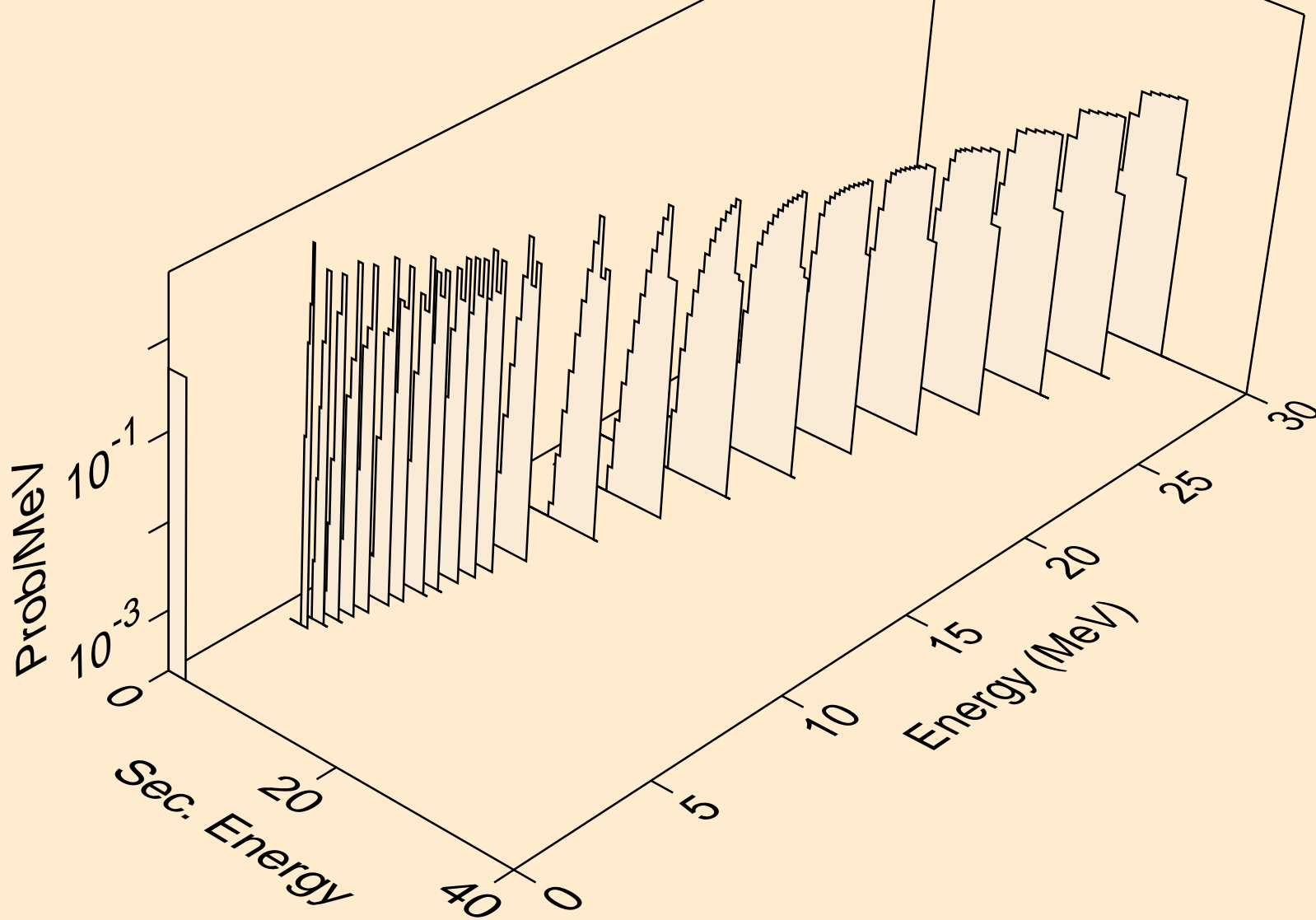

BH264 NEUTRON ACER TENDL-2019 LIBRARY; T=293.16K
tritons from (n,x)

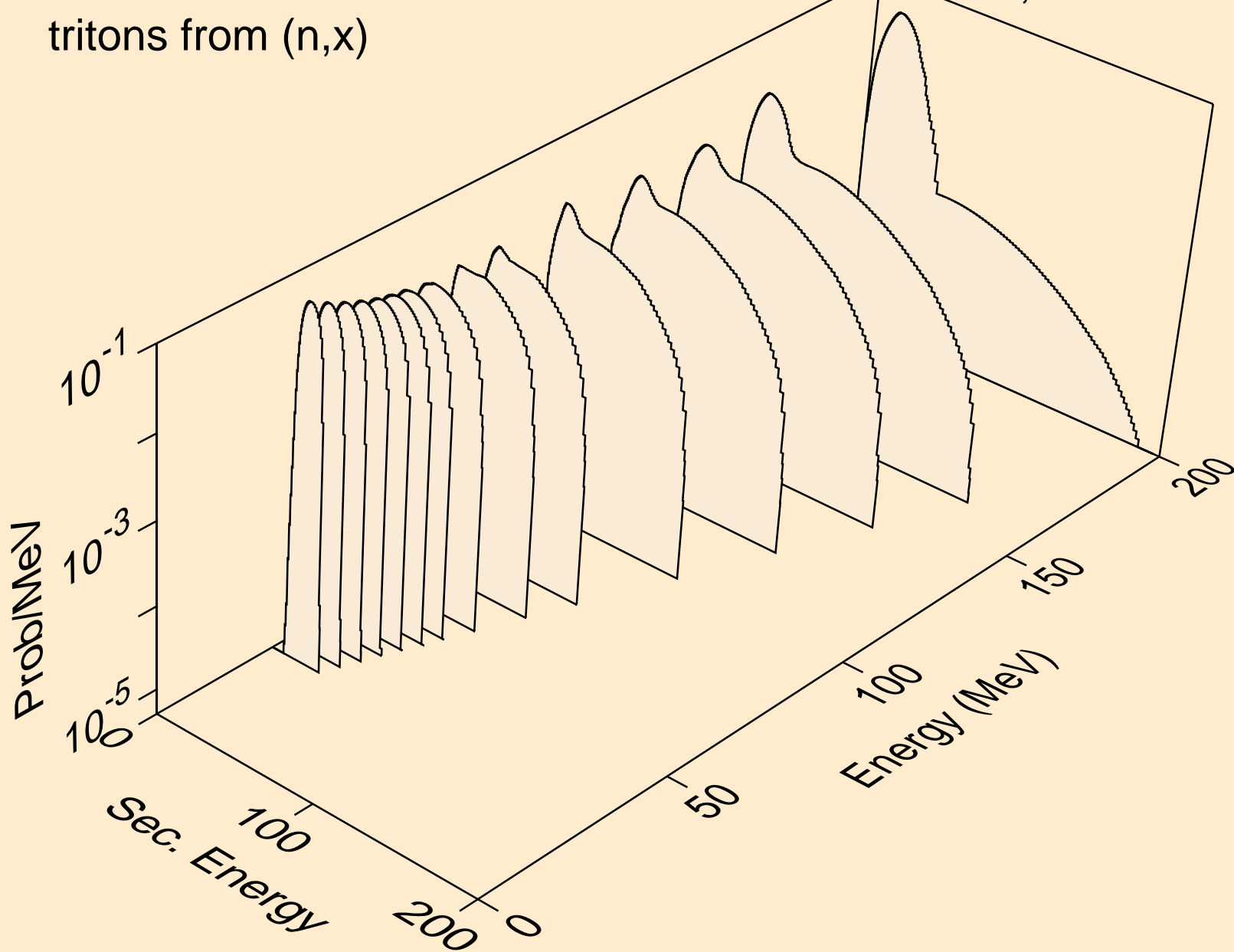

BH264 NEUTRON ACER TENDL-2019 LIBRARY; T=293.16K
tritons from (n,n*)t

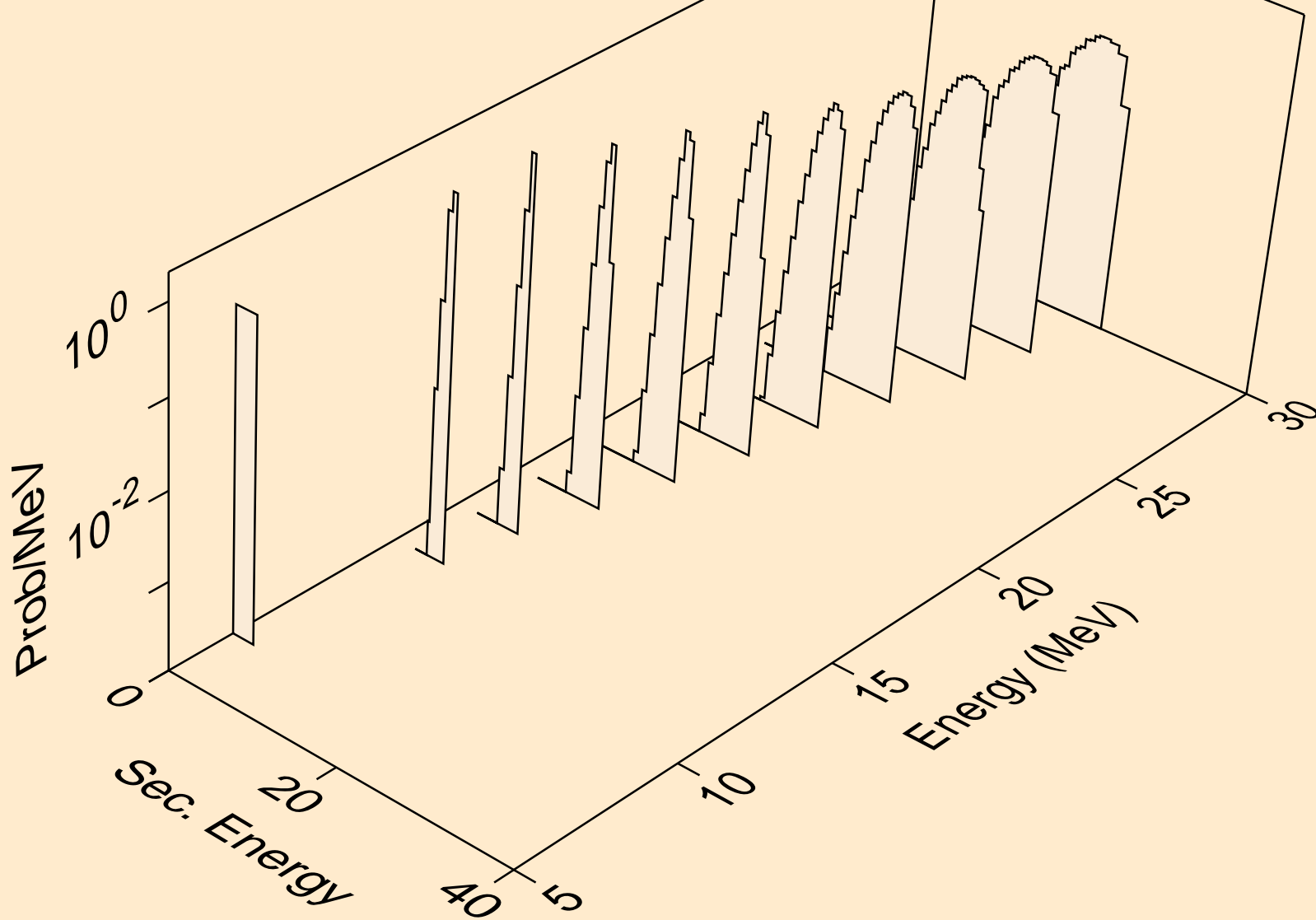

BH264 NEUTRON ACER TENDL-2019 LIBRARY; T=293.16K
tritons from (n,n*)t2a

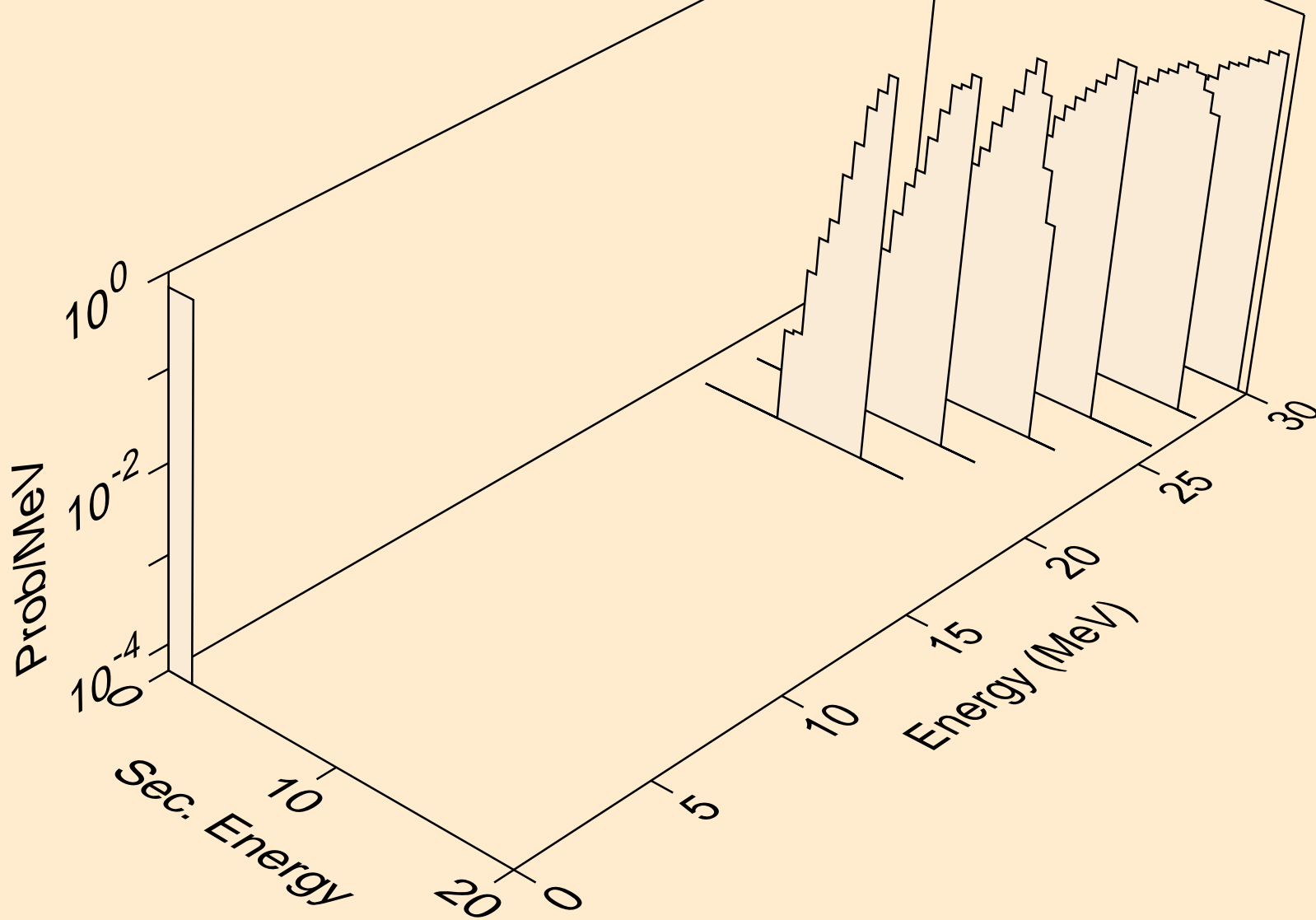

BH264 NEUTRON ACER TENDL-2019 LIBRARY; T=293.16K
tritons from (n,t)

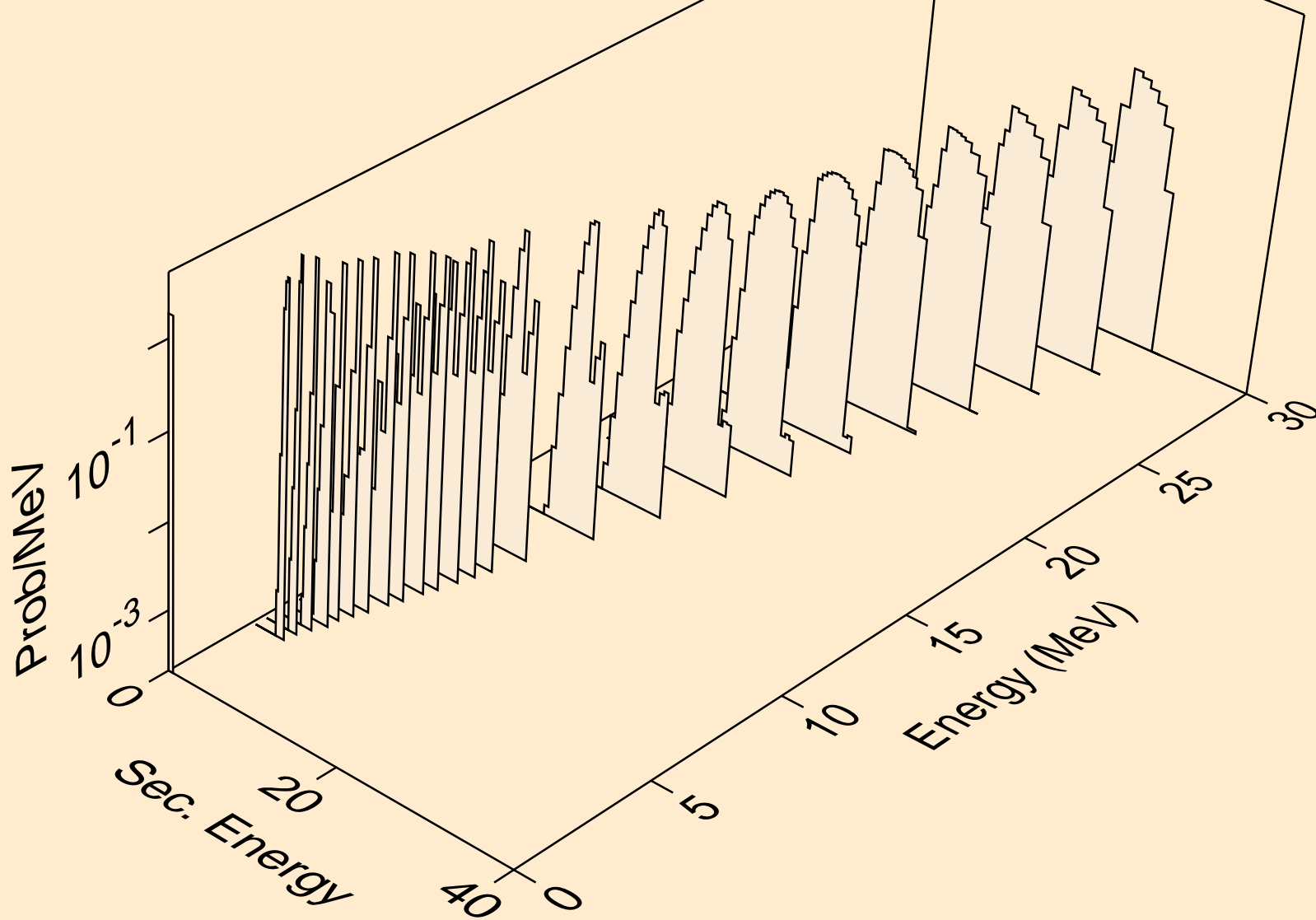

BH264 NEUTRON ACER TENDL-2019 LIBRARY; T=293.16K
tritons from (n,t2a)

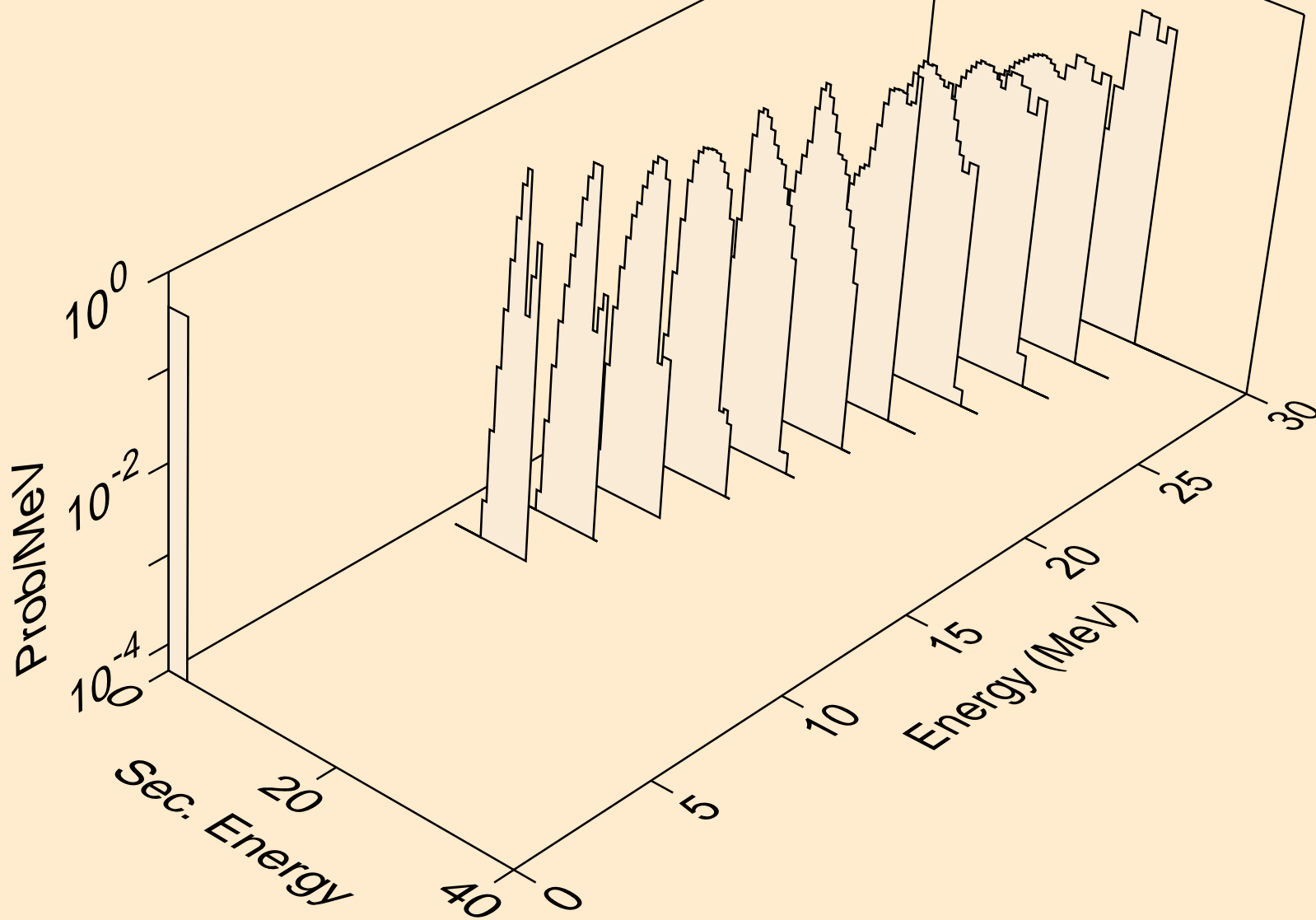

BH264 NEUTRON ACER TENDL-2019 LIBRARY; T=293.16K
tritons from (n,pt)

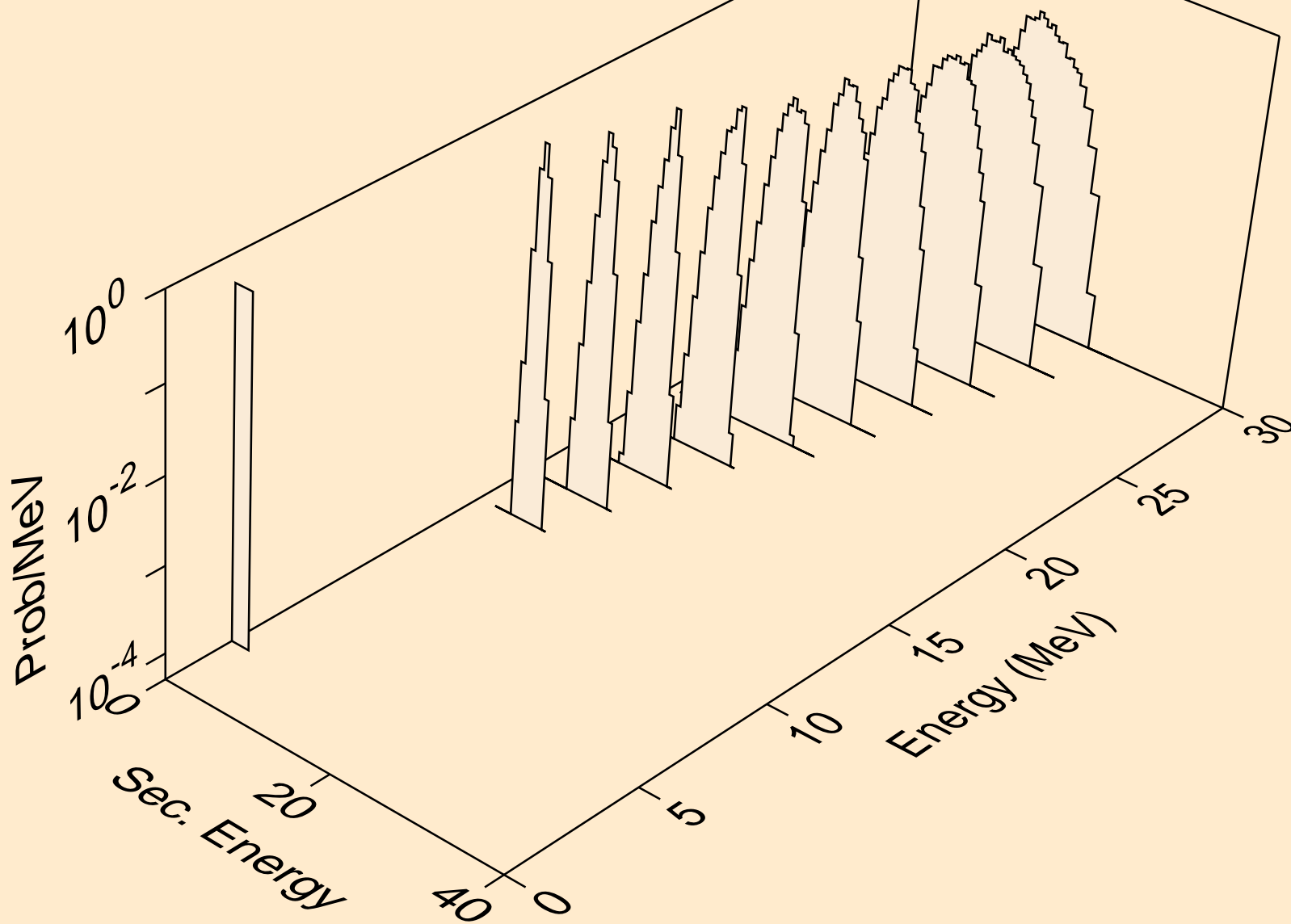

BH264 NEUTRON ACER TENDL-2019 LIBRARY; T=293.16K
he3s from (n,x)

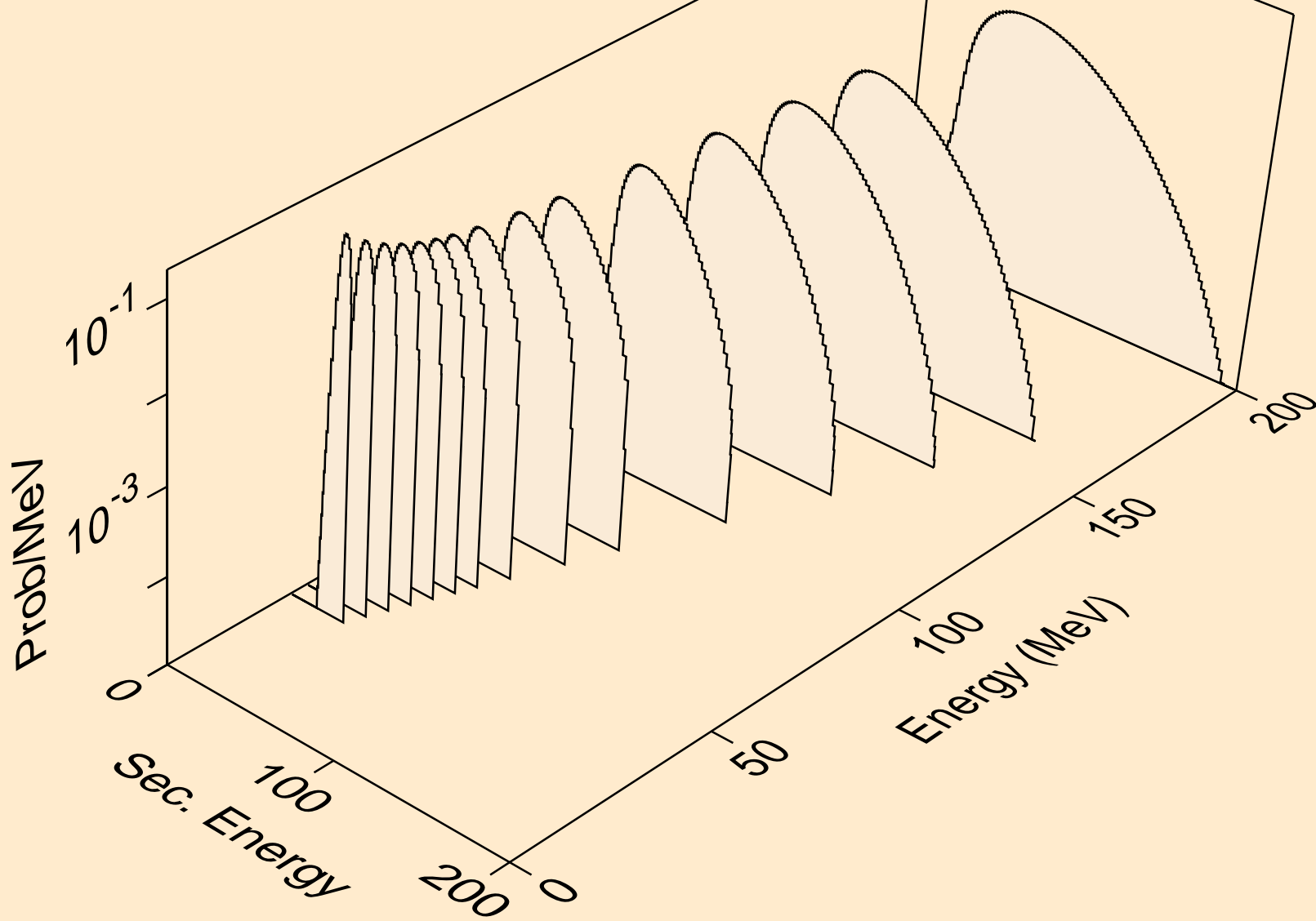

BH264 NEUTRON ACER TENDL-2019 LIBRARY; T=293.16K
he3s from (n,n*)he3

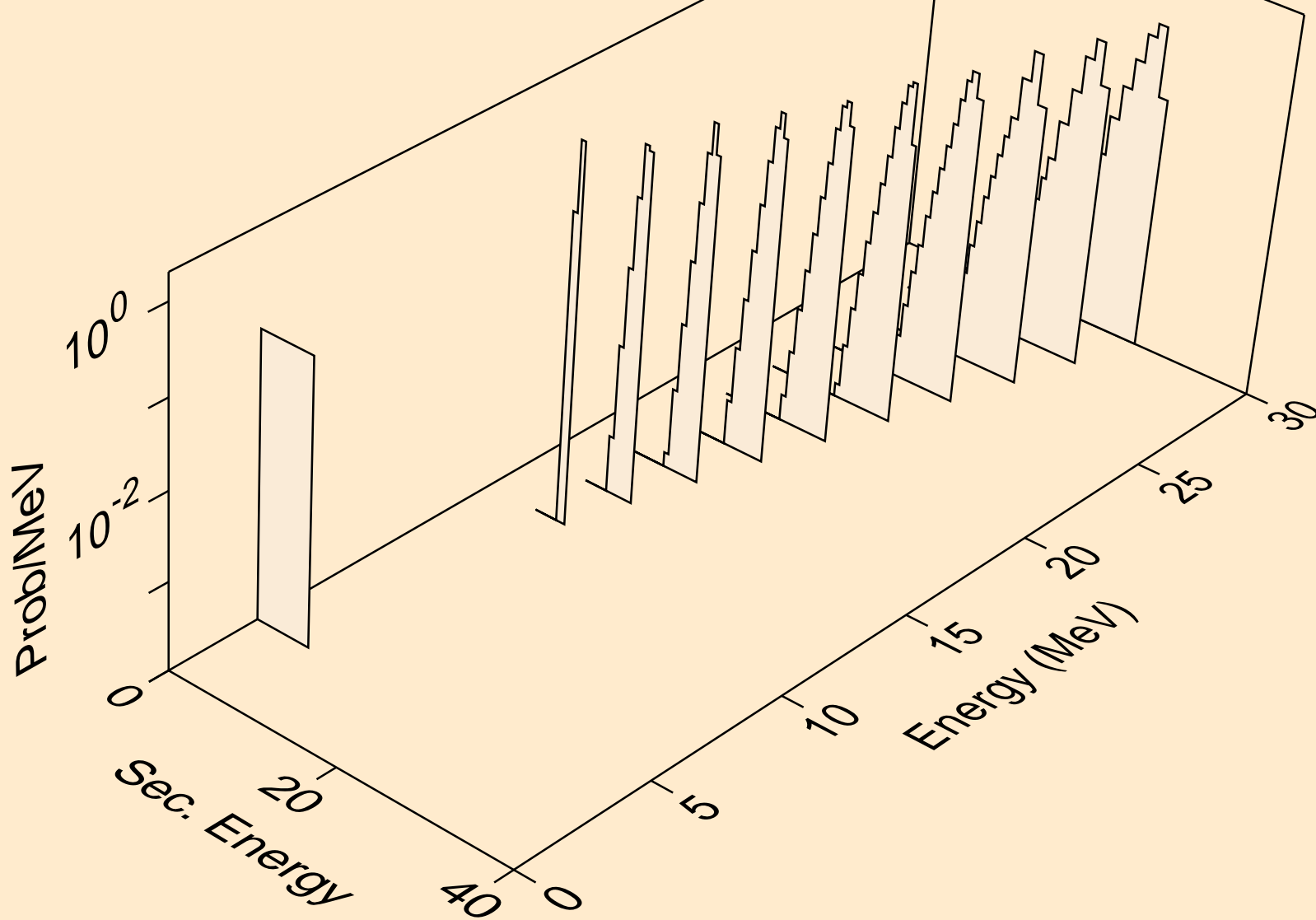

BH264 NEUTRON ACER TENDL-2019 LIBRARY; T=293.16K
he3s from (n,he3)

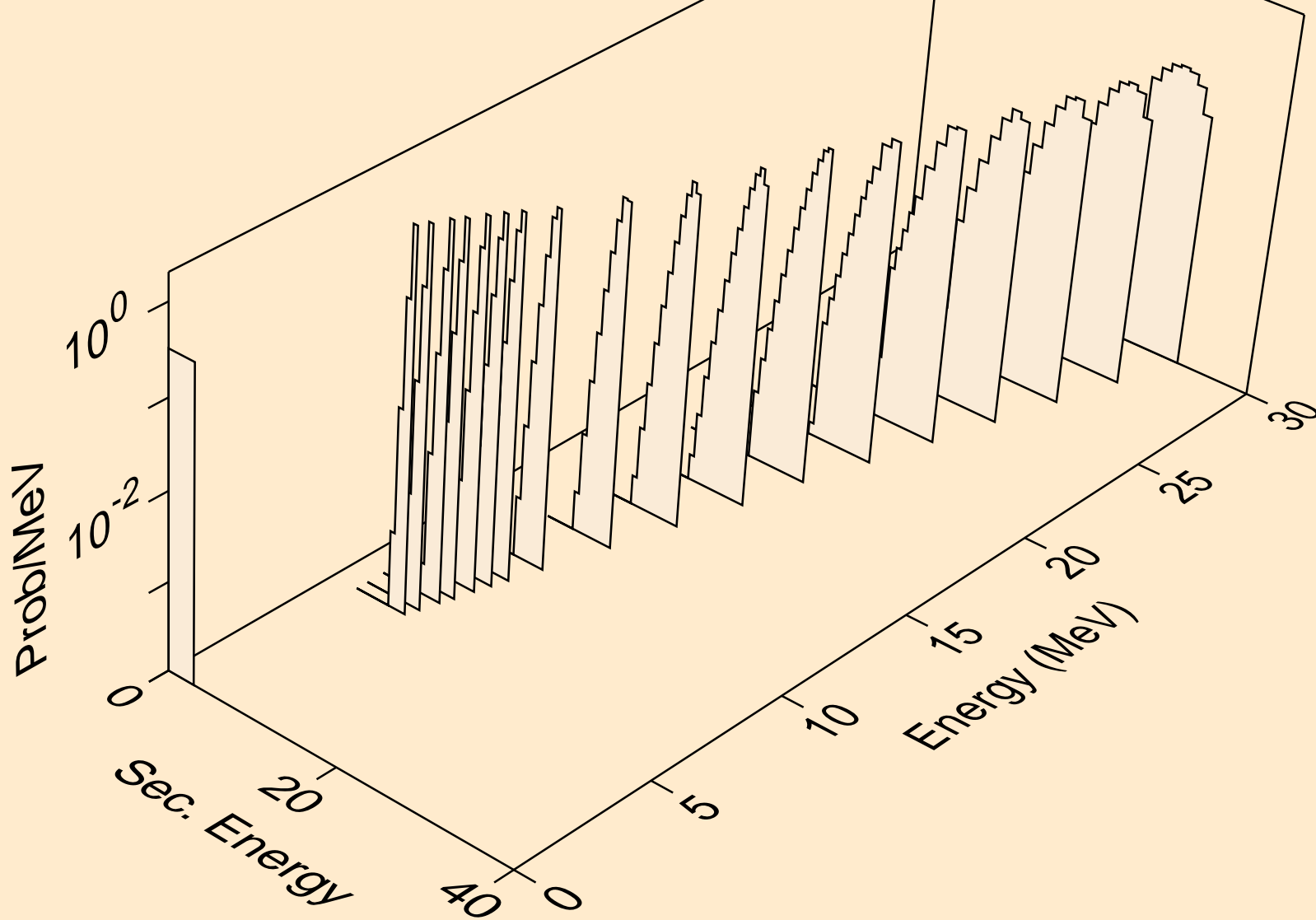

BH264 NEUTRON ACER TENDL-2019 LIBRARY; T=293.16K
alphas from (n,x)

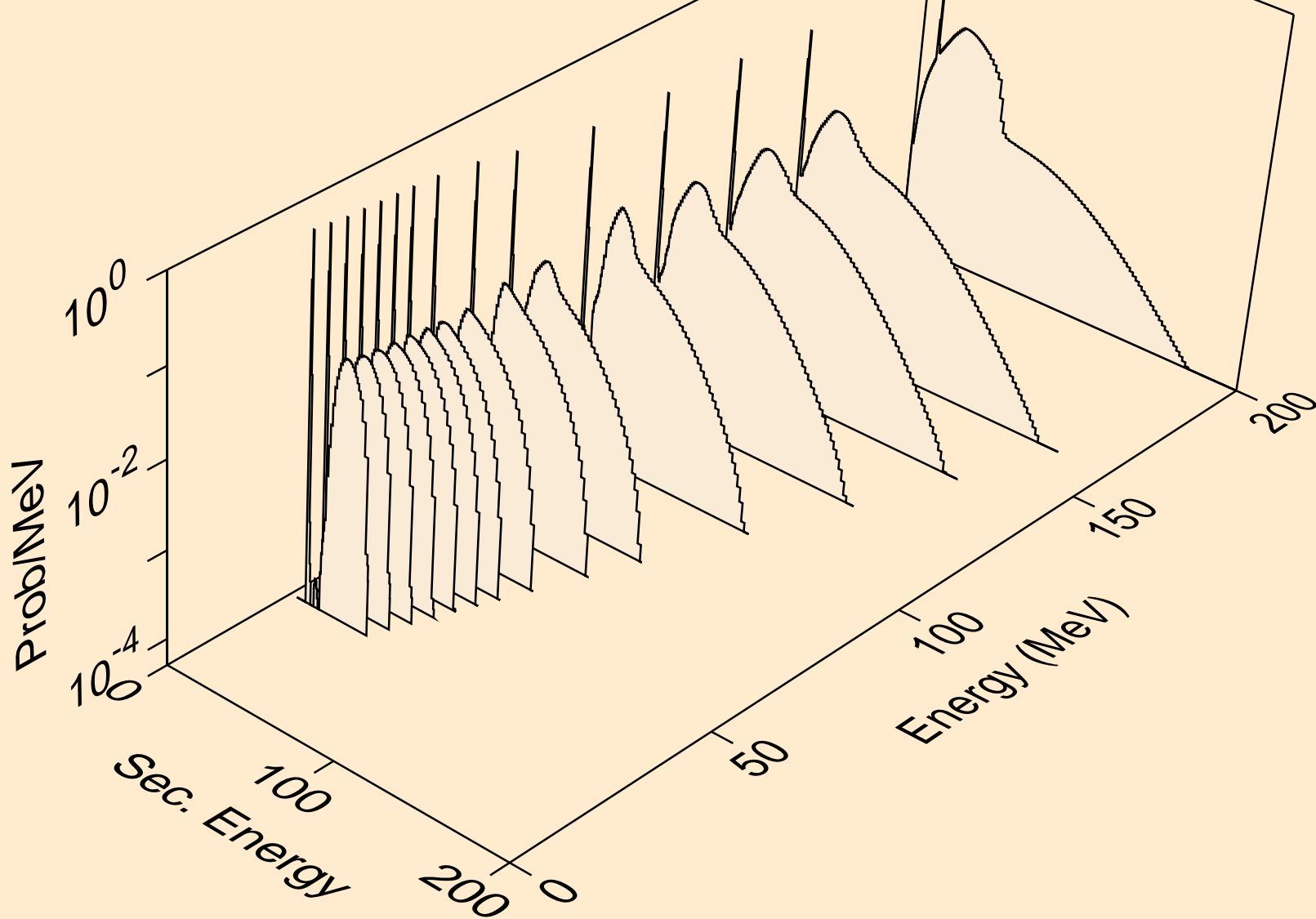

BH264 NEUTRON ACER TENDL-2019 LIBRARY; T=293.16K
alphas from (n,n*)a

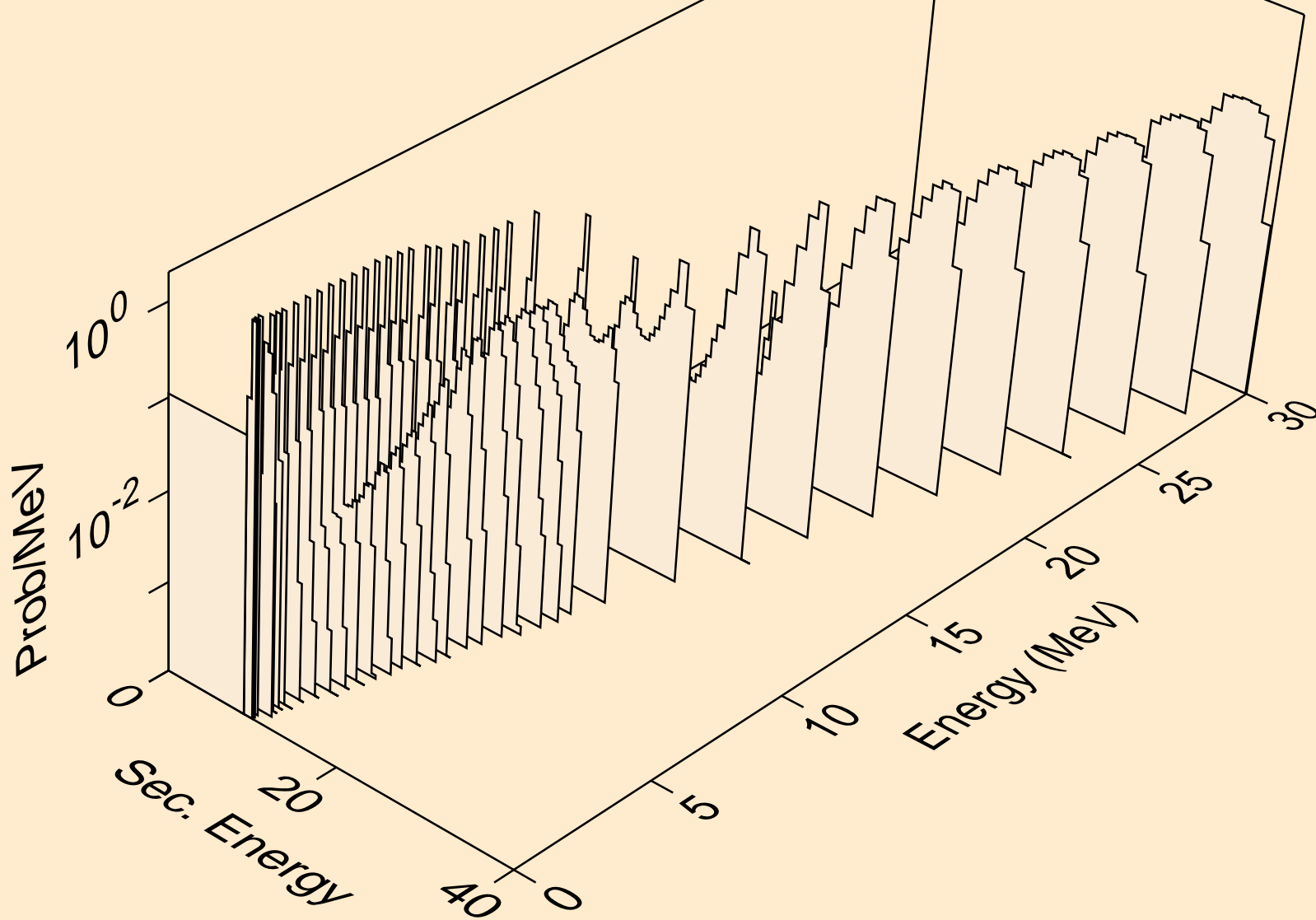

BH264 NEUTRON ACER TENDL-2019 LIBRARY; T=293.16K
alphas from (n,2n)a

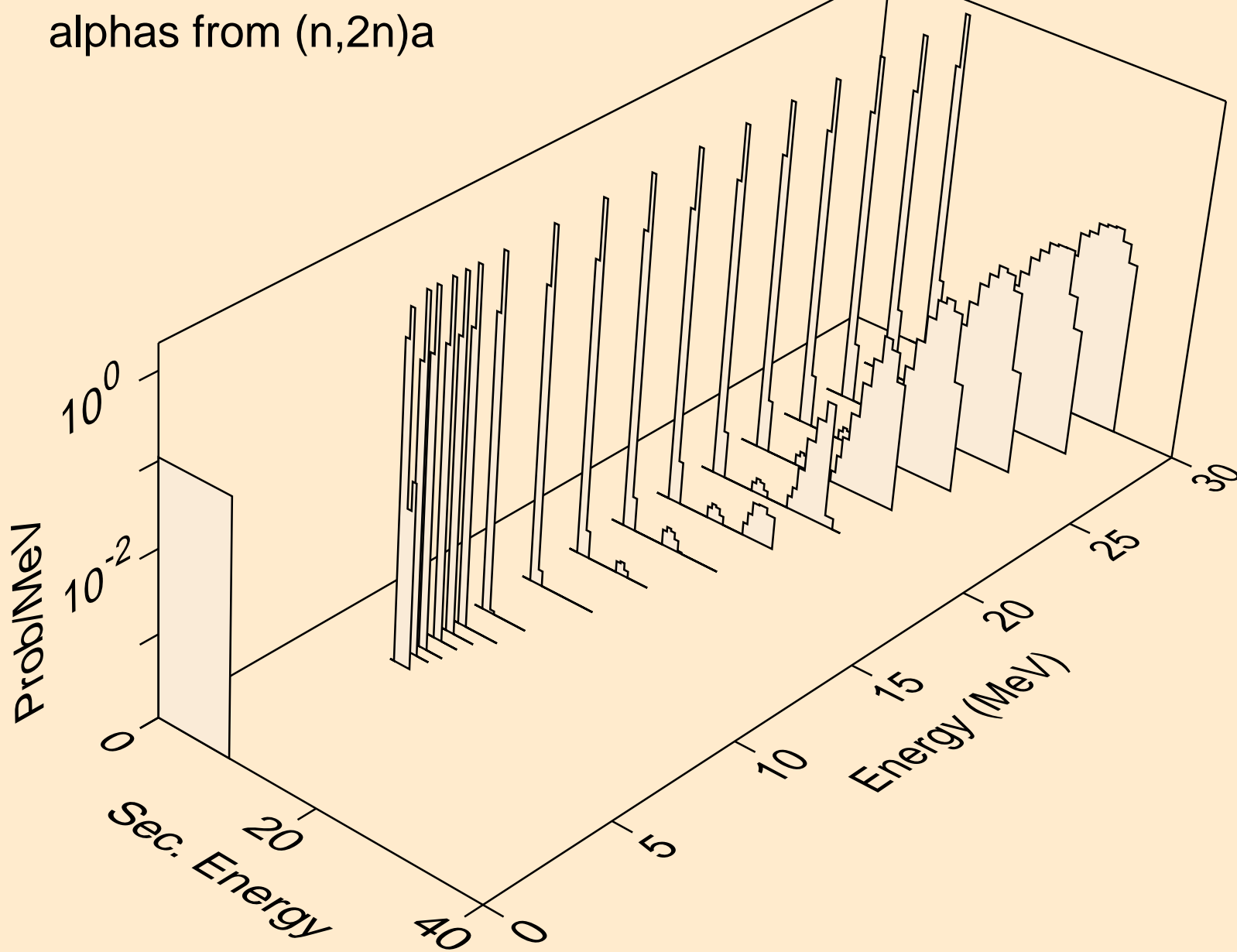

BH264 NEUTRON ACER TENDL-2019 LIBRARY; T=293.16K
alphas from (n,3n)a

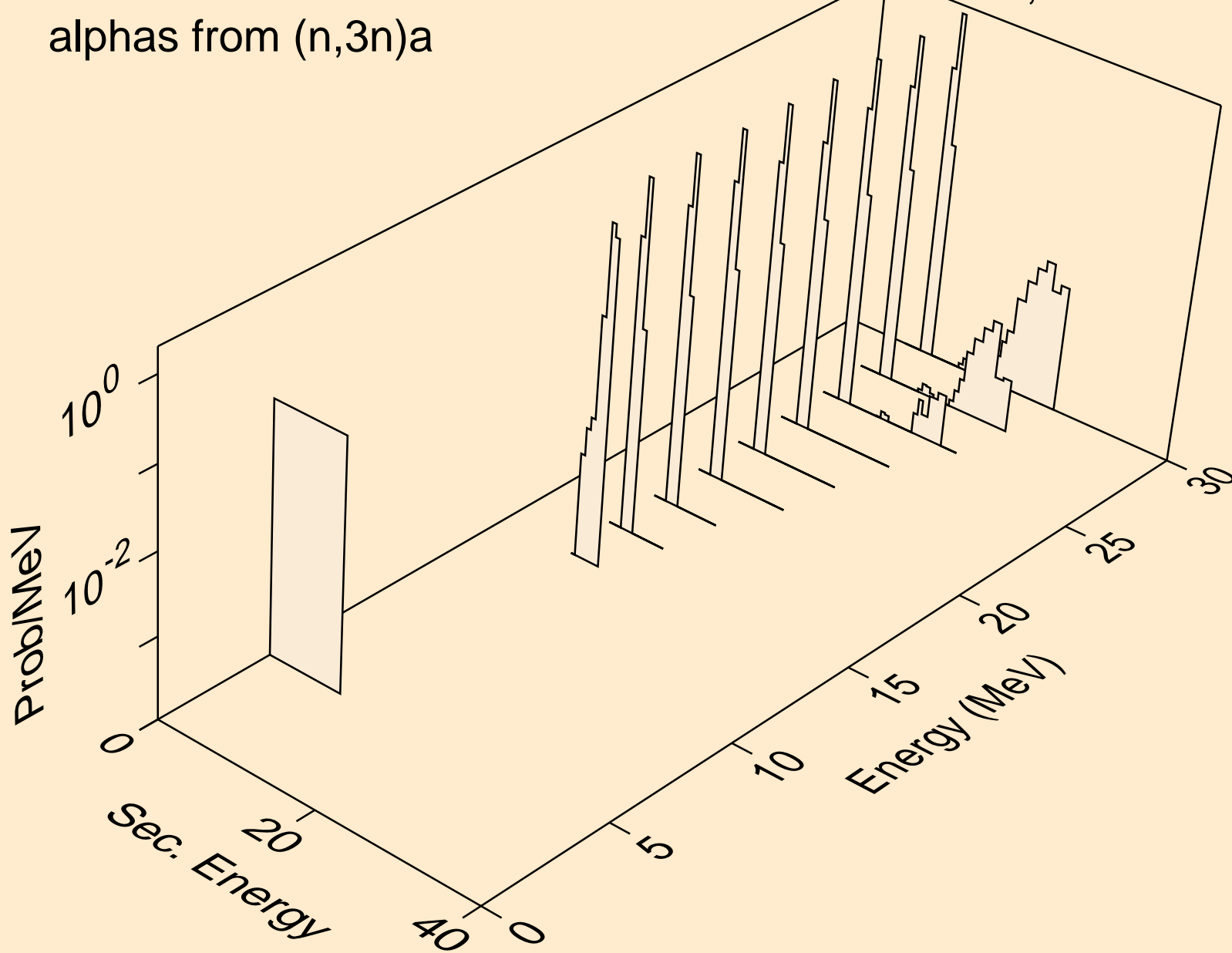

BH264 NEUTRON ACER TENDL-2019 LIBRARY; T=293.16K
alphas from (n,n*)2a

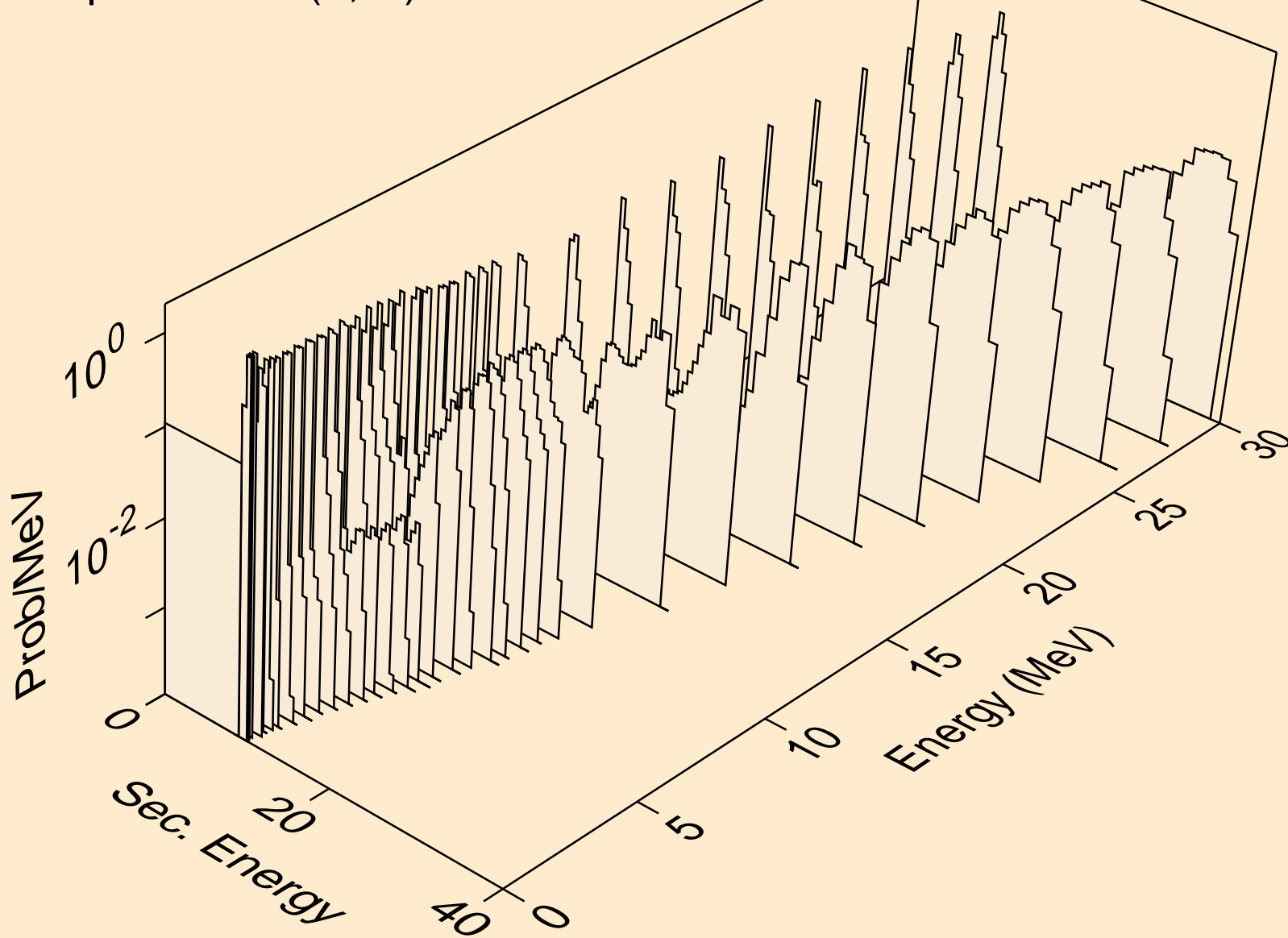

BH264 NEUTRON ACER TENDL-2019 LIBRARY; T=293.16K
alphas from (n,2n)2a

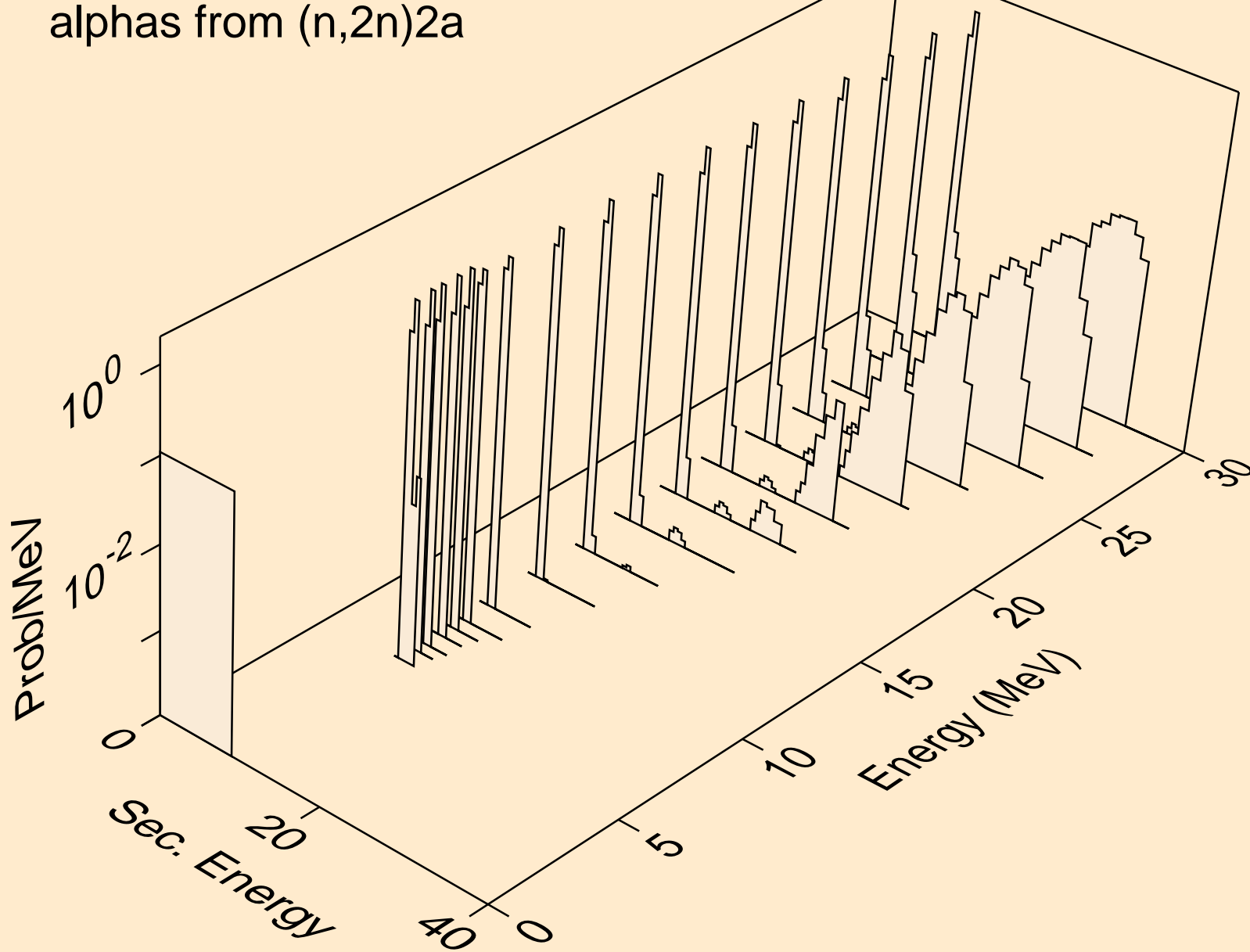

BH264 NEUTRON ACER TENDL-2019 LIBRARY; T=293.16K
alphas from (n,n*)d2a

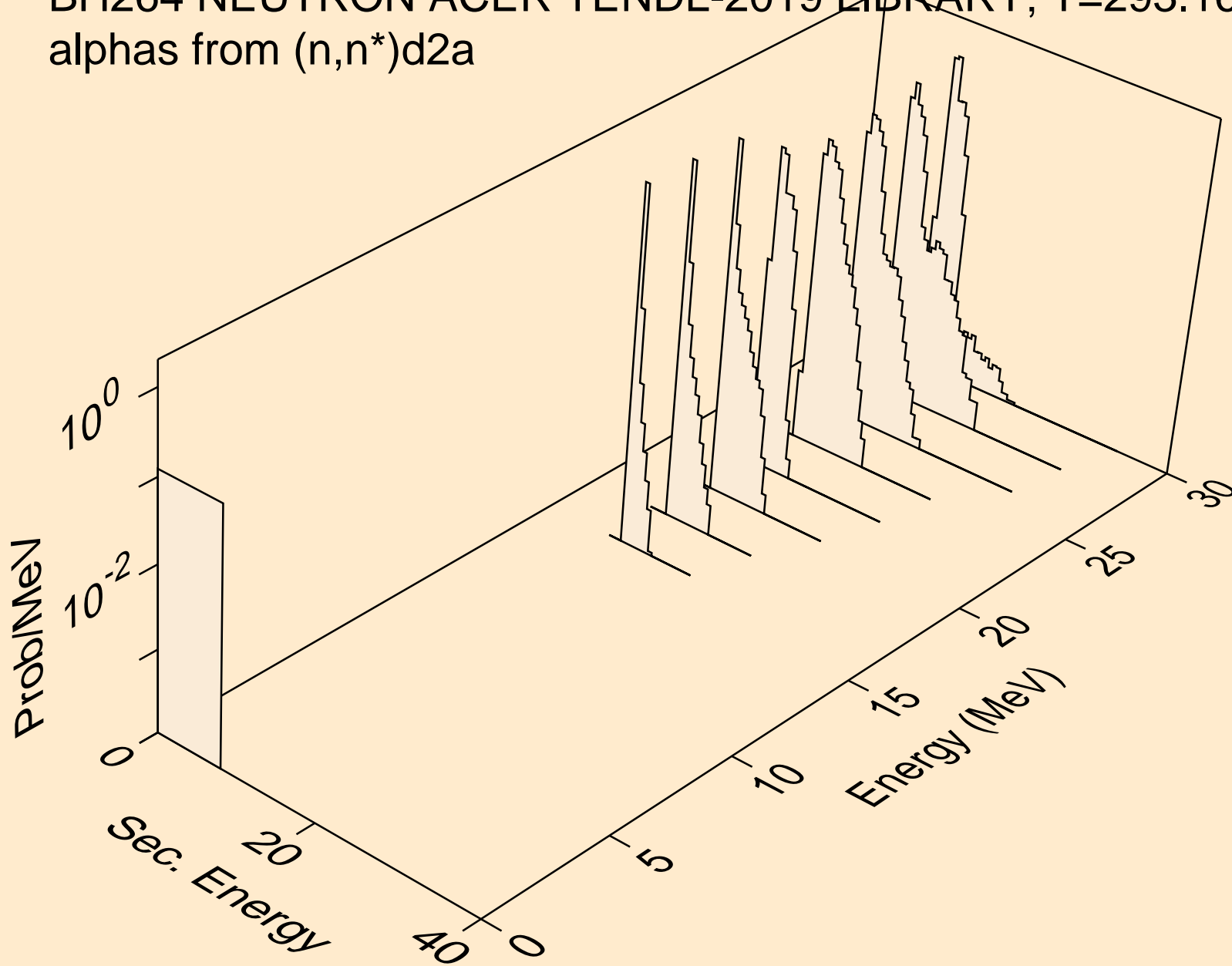

BH264 NEUTRON ACER TENDL-2019 LIBRARY; T=293.16K
alphas from (n,n*)t2a

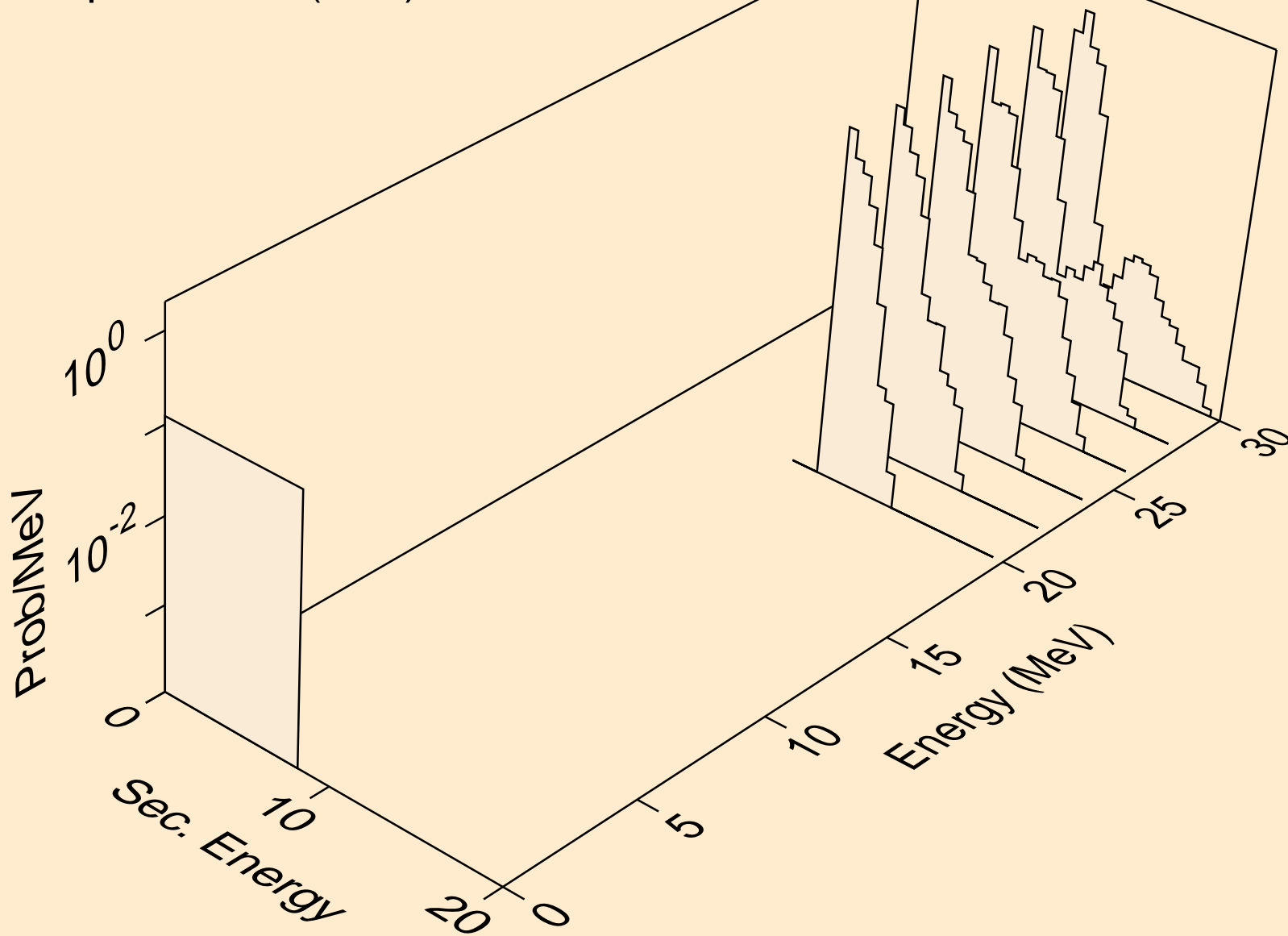

BH264 NEUTRON ACER TENDL-2019 LIBRARY; T=293.16K
alphas from (n,npa)

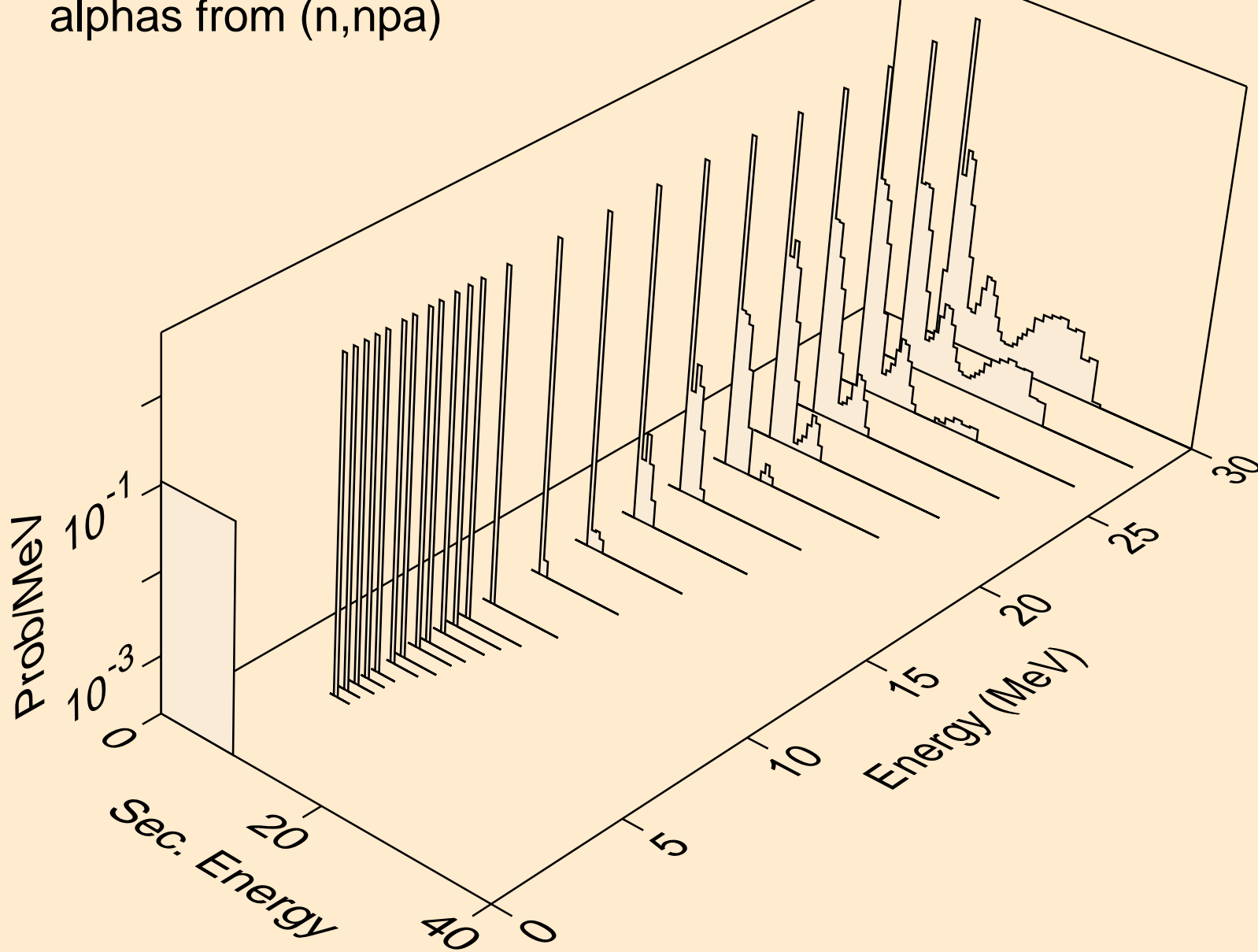

BH264 NEUTRON ACER TENDL-2019 LIBRARY; T=293.16K
alphas from (n,a)

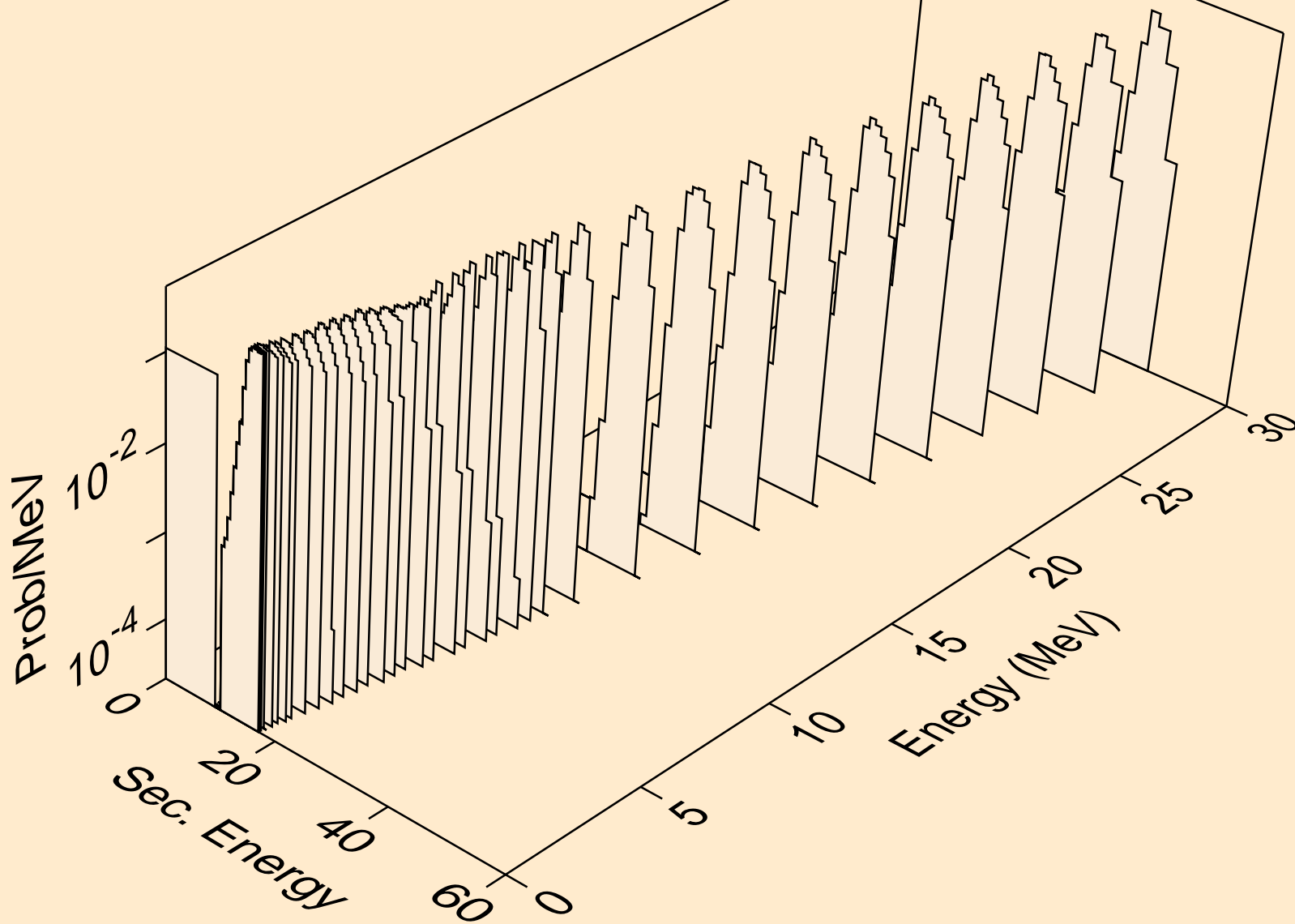

BH264 NEUTRON ACER TENDL-2019 LIBRARY; T=293.16K
alphas from (n,2a)

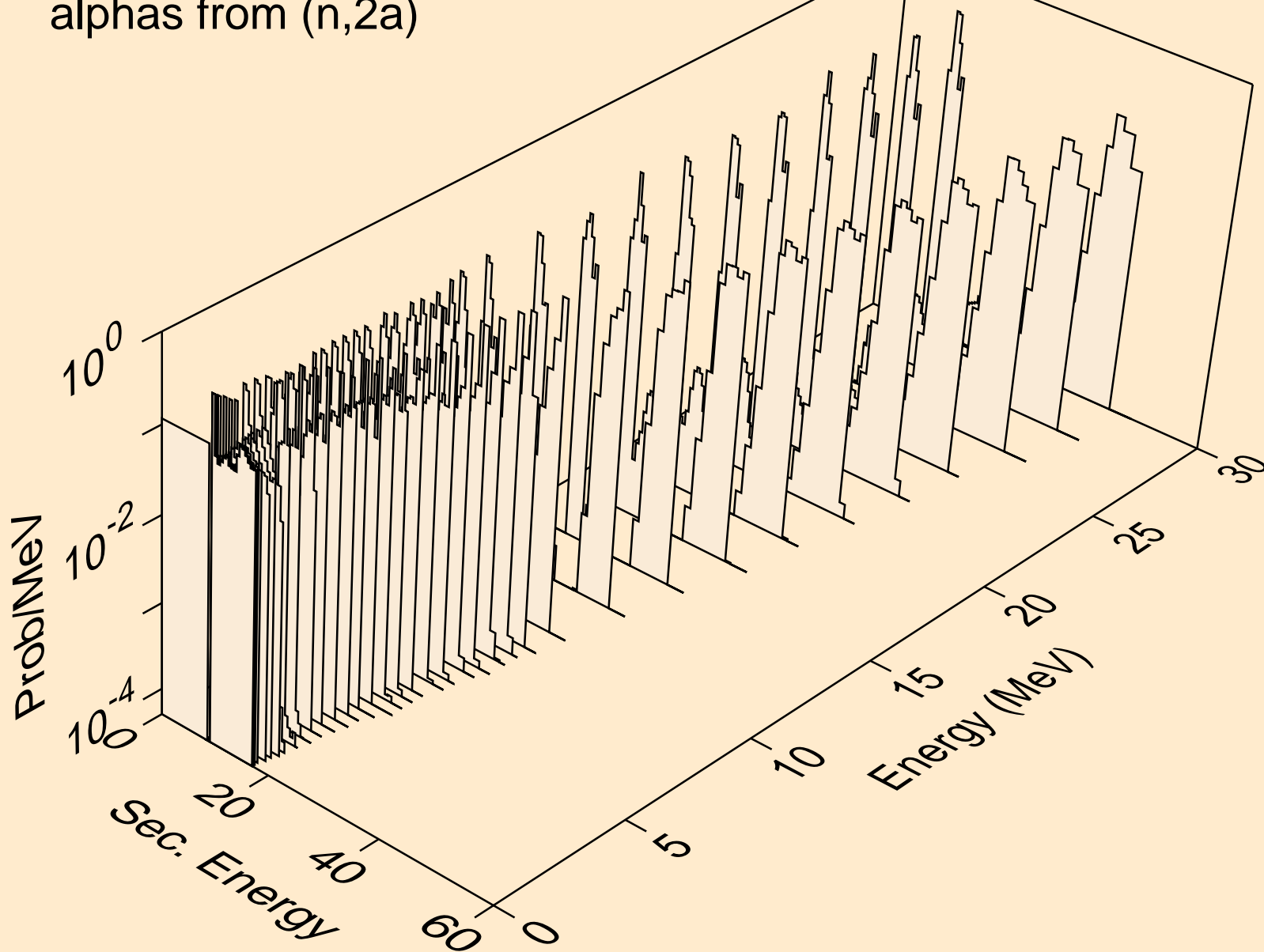

BH264 NEUTRON ACER TENDL-2019 LIBRARY; T=293.16K
alphas from (n,3a)

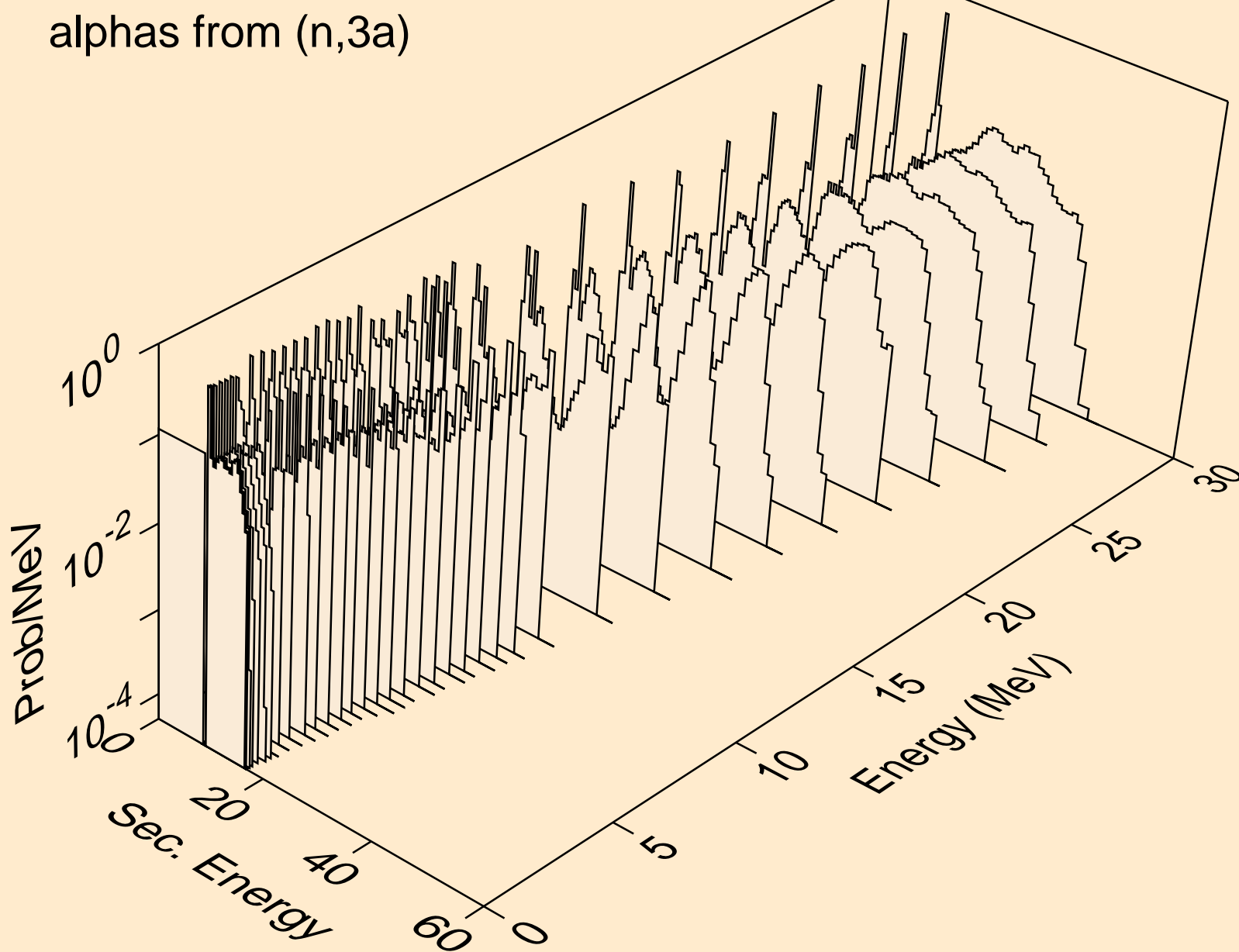

BH264 NEUTRON ACER TENDL-2019 LIBRARY; T=293.16K
alphas from (n,pa)

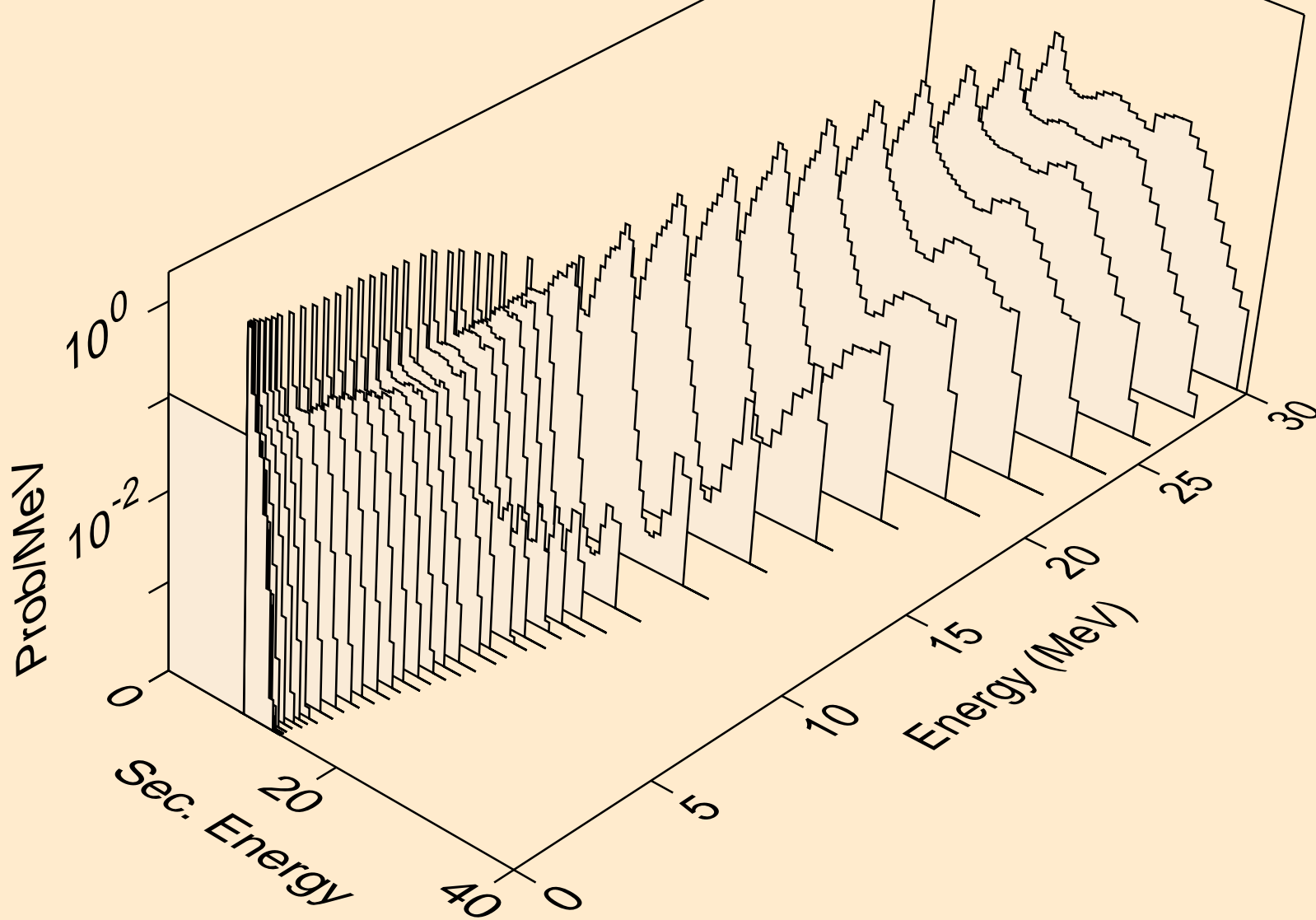

BH264 NEUTRON ACER TENDL-2019 LIBRARY; T=293.16K
alphas from (n,t2a)

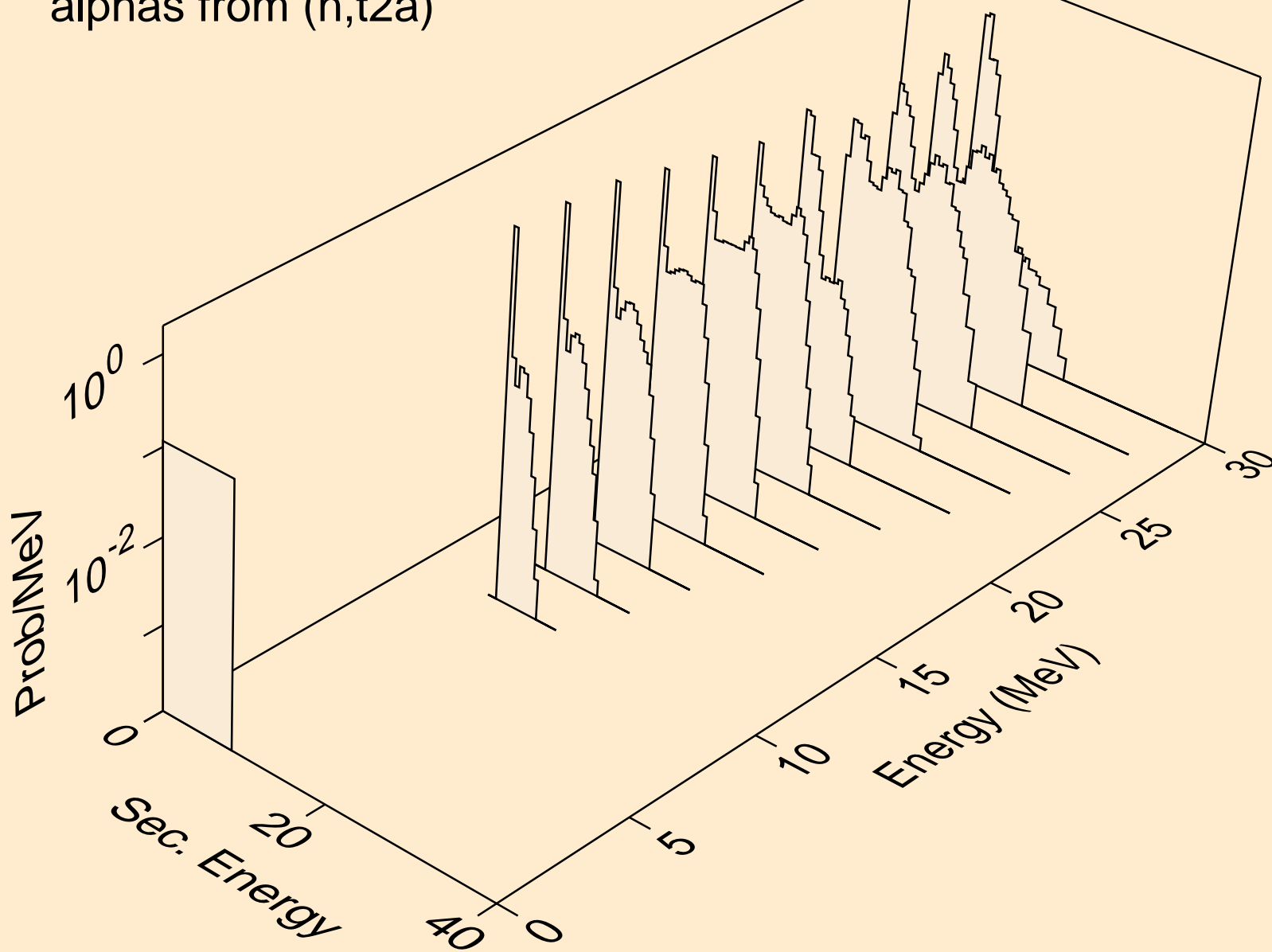

BH264 NEUTRON ACER TENDL-2019 LIBRARY; T=293.16K
alphas from (n,d2a)

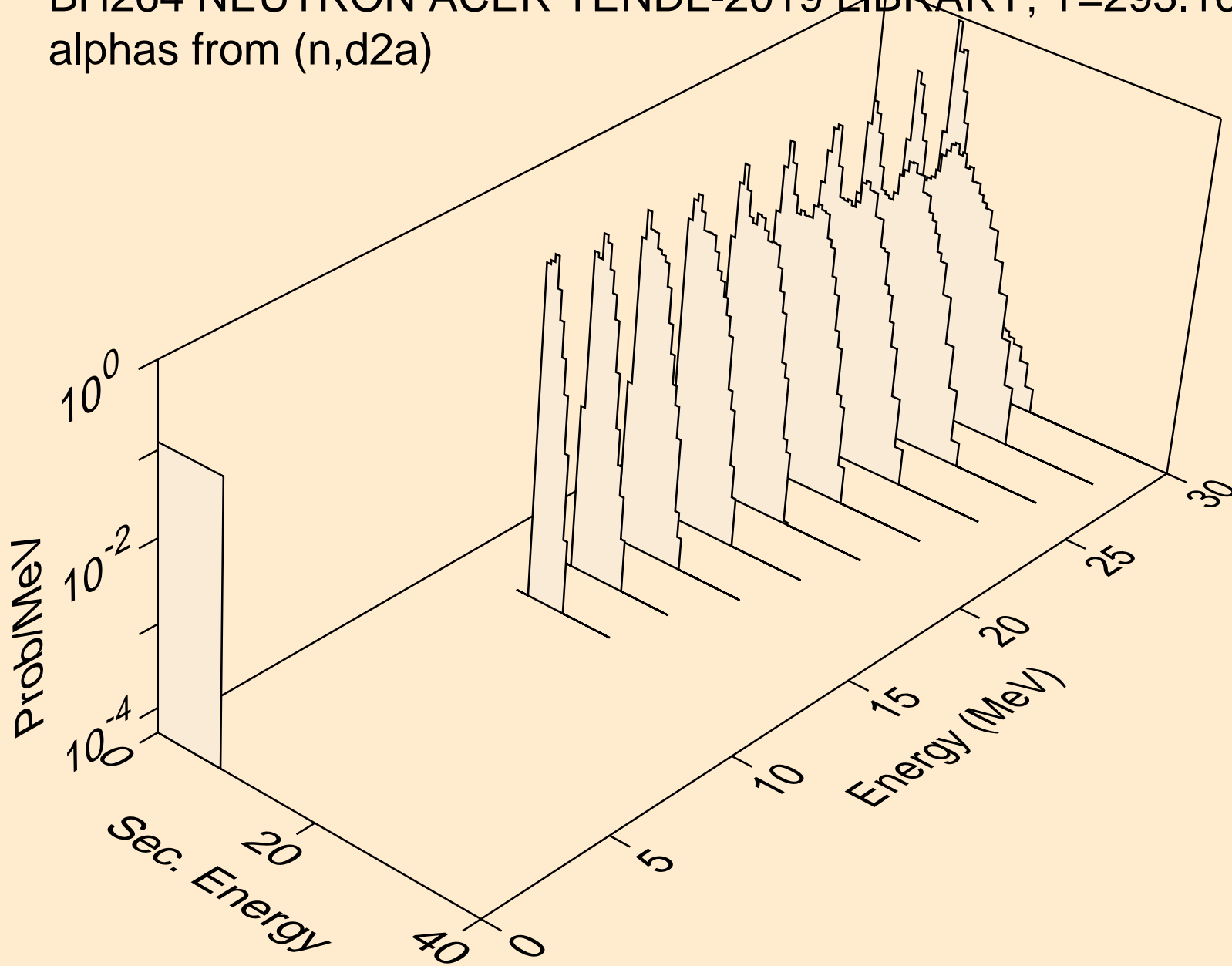

BH264 NEUTRON ACER TENDL-2019 LIBRARY; T=293.16K
alphas from (n,da)

