

FR206M NEUTRON ACER TENDL-2019 LIBRARY; T=293.16K  
Principal cross sections

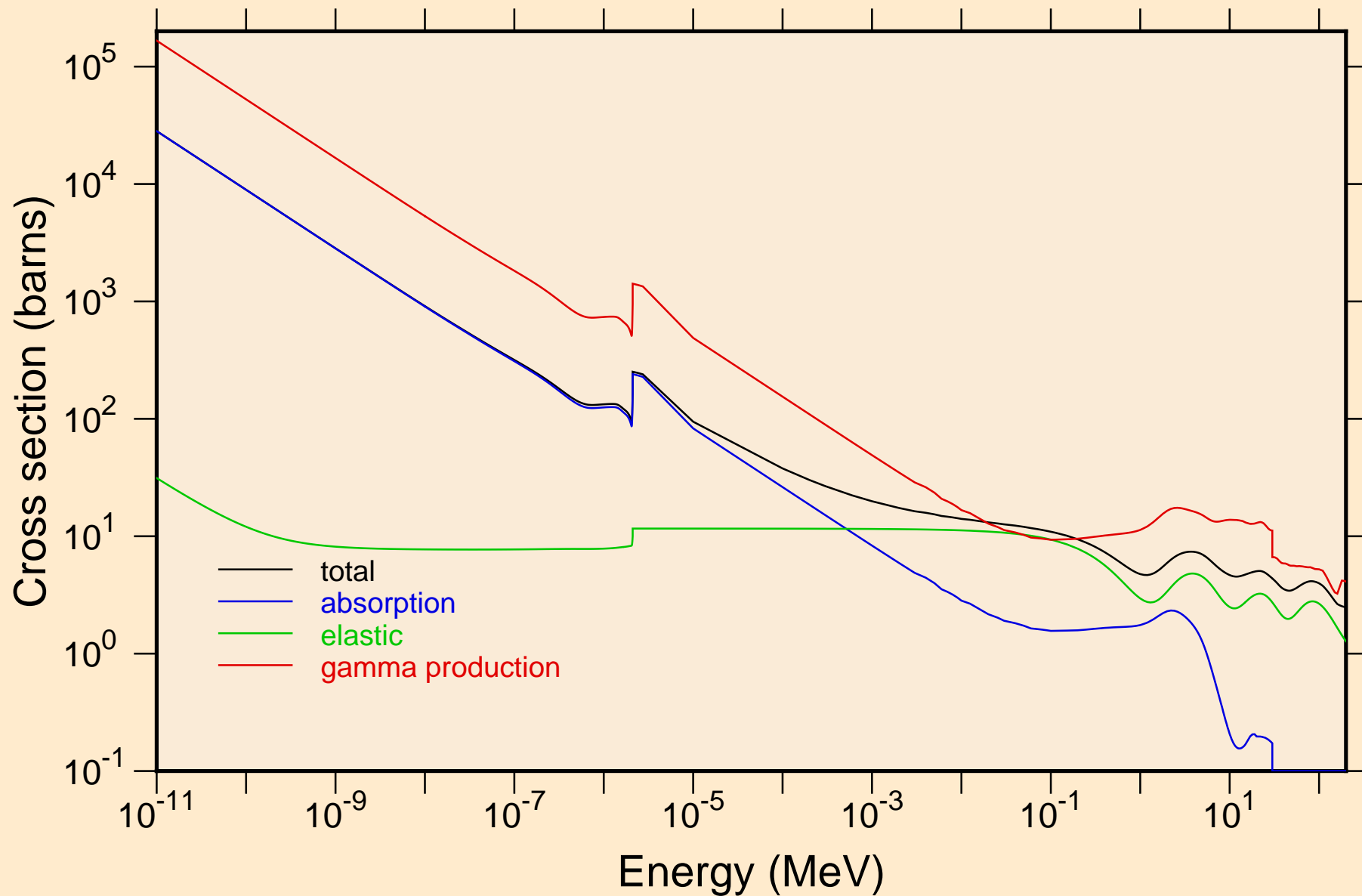

FR206M NEUTRON ACER TENDL-2019 LIBRARY; T=293.16K  
Heating

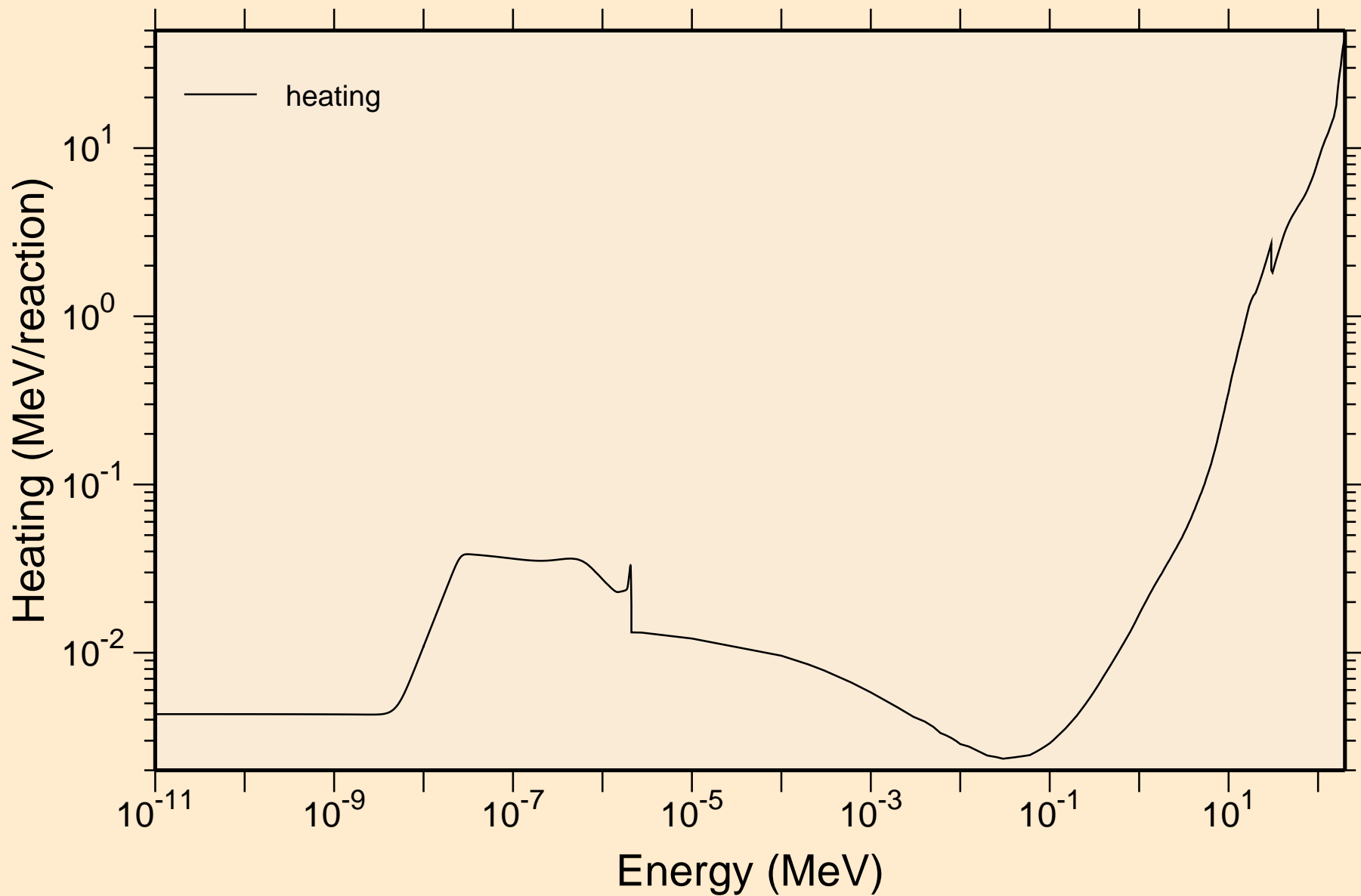

FR206M NEUTRON ACER TENDL-2019 LIBRARY; T=293.16K  
Damage

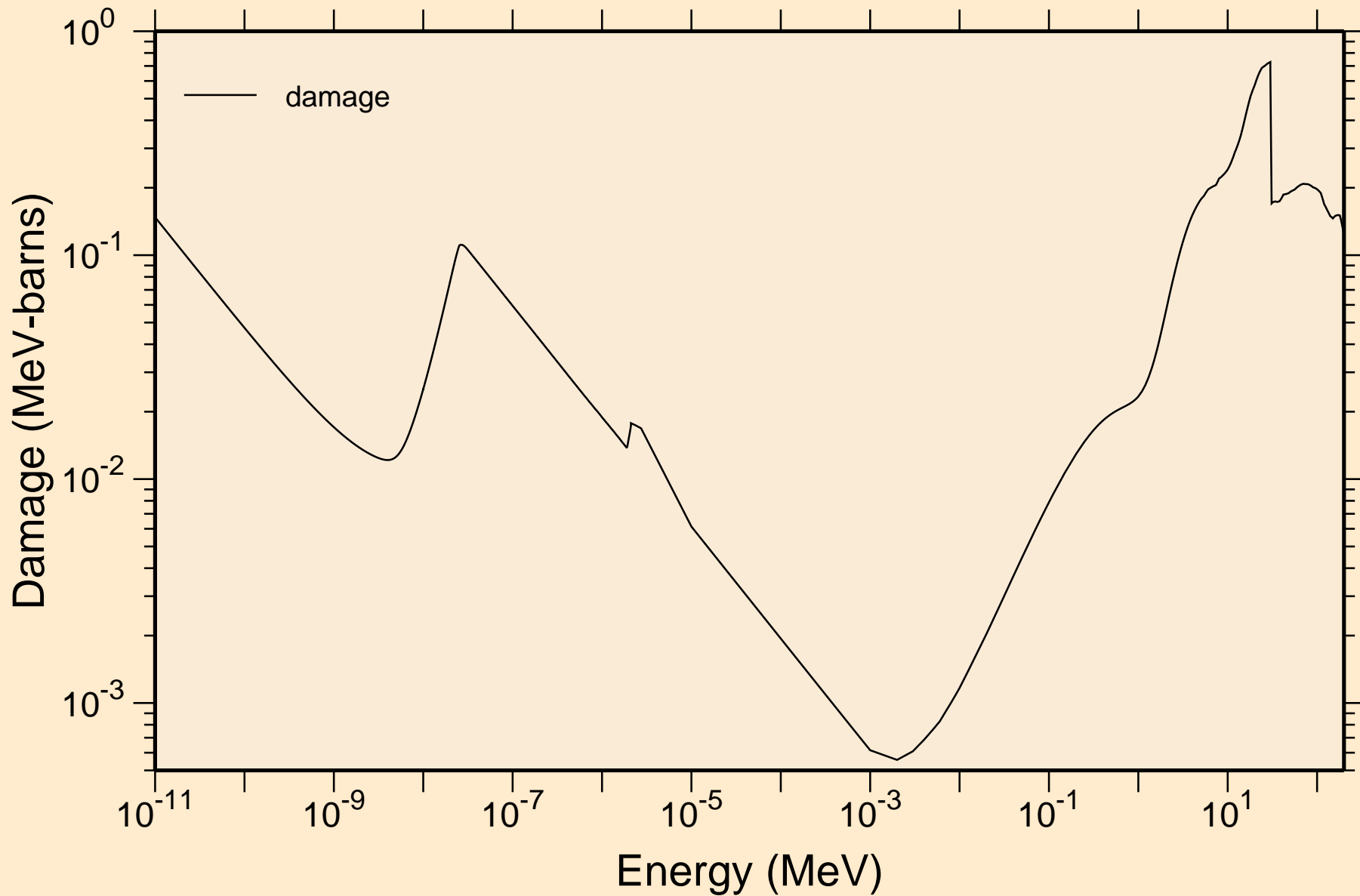

FR206M NEUTRON ACER TENDL-2019 LIBRARY; T=293.16K  
Non-threshold reactions

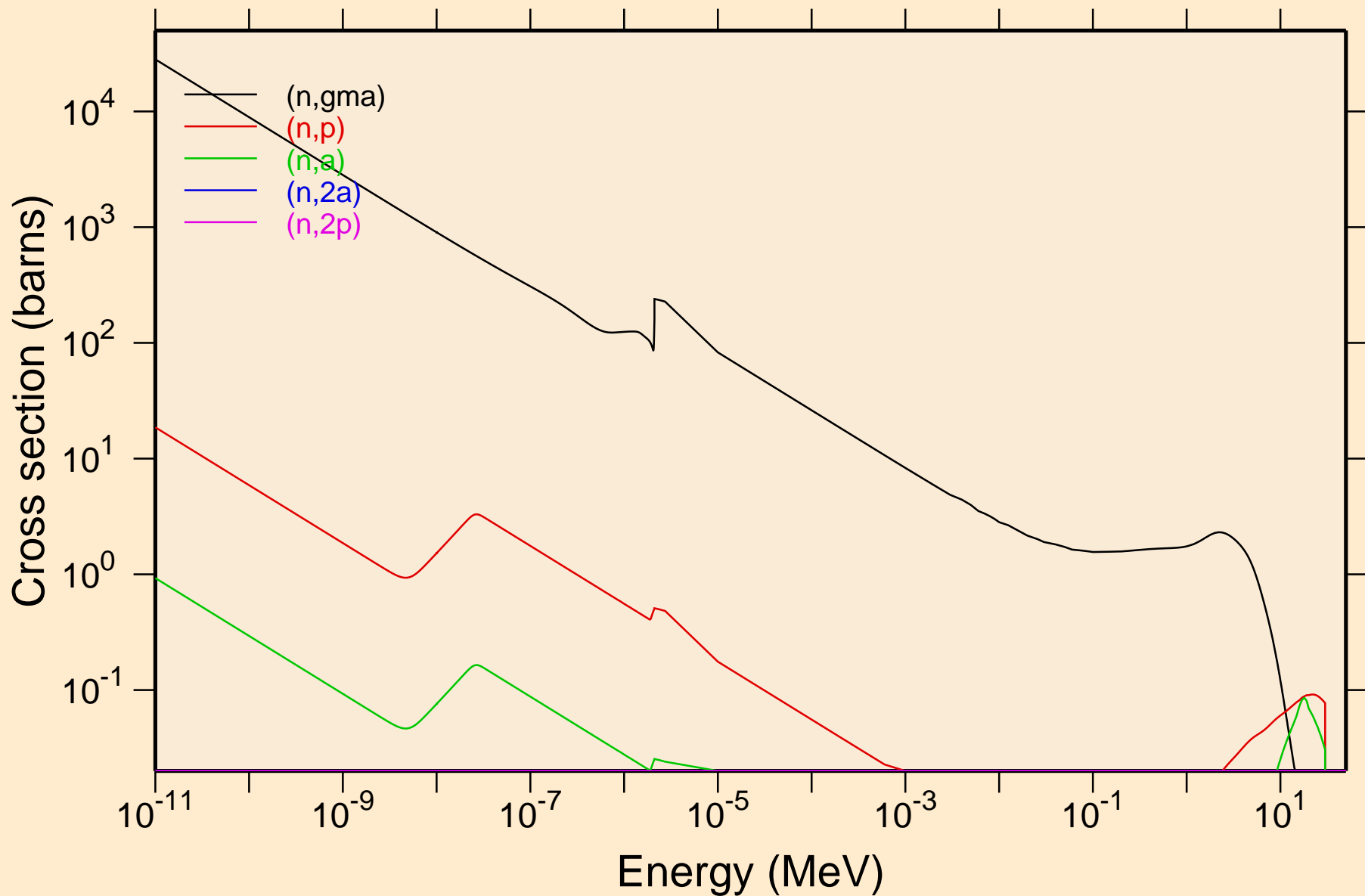

FR206M NEUTRON ACER TENDL-2019 LIBRARY; T=293.16K  
Non-threshold reactions

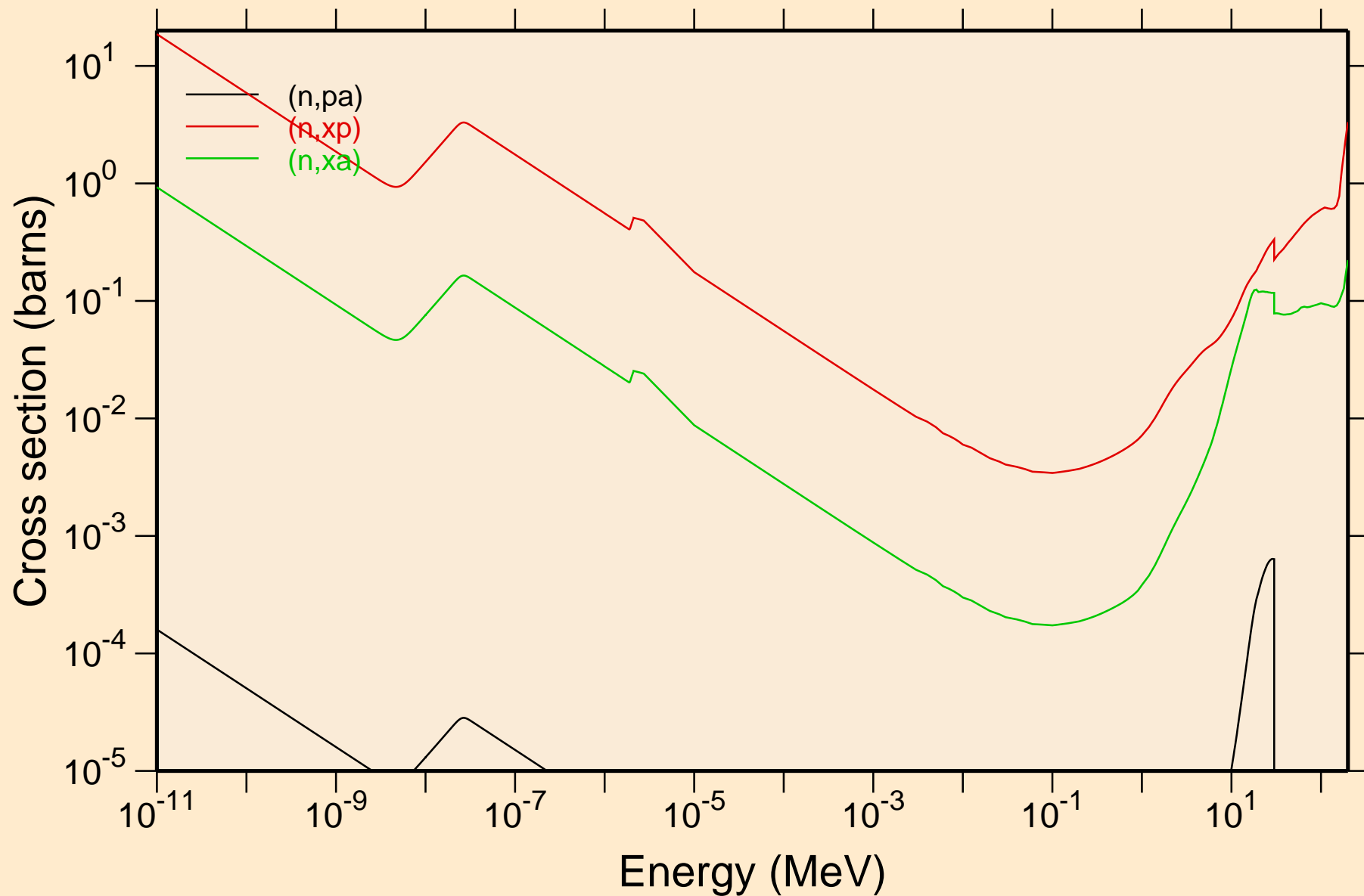

FR206M NEUTRON ACER TENDL-2019 LIBRARY; T=293.16K  
Principal cross sections

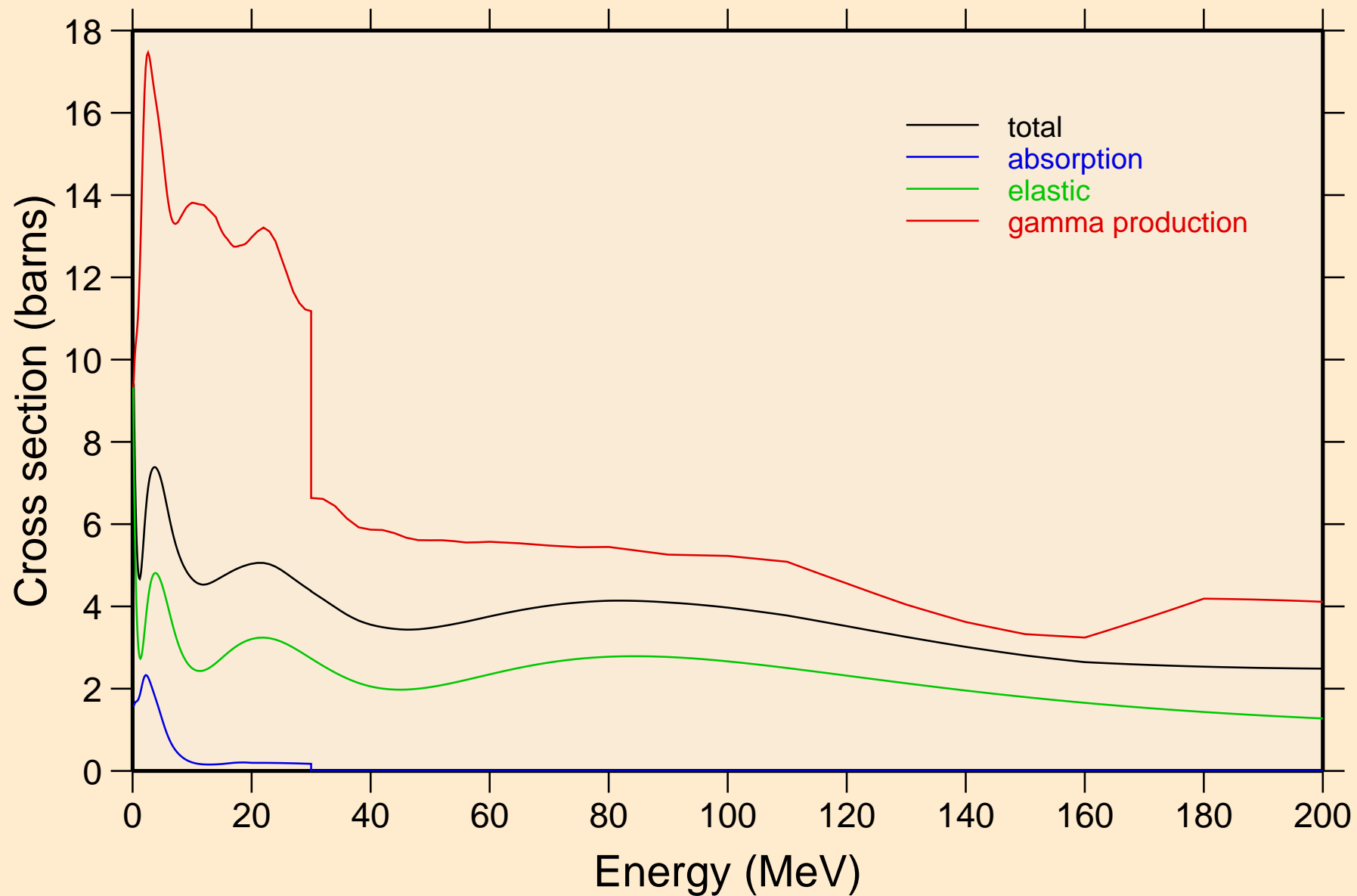

FR206M NEUTRON ACER TENDL-2019 LIBRARY; T=293.16K  
Heating

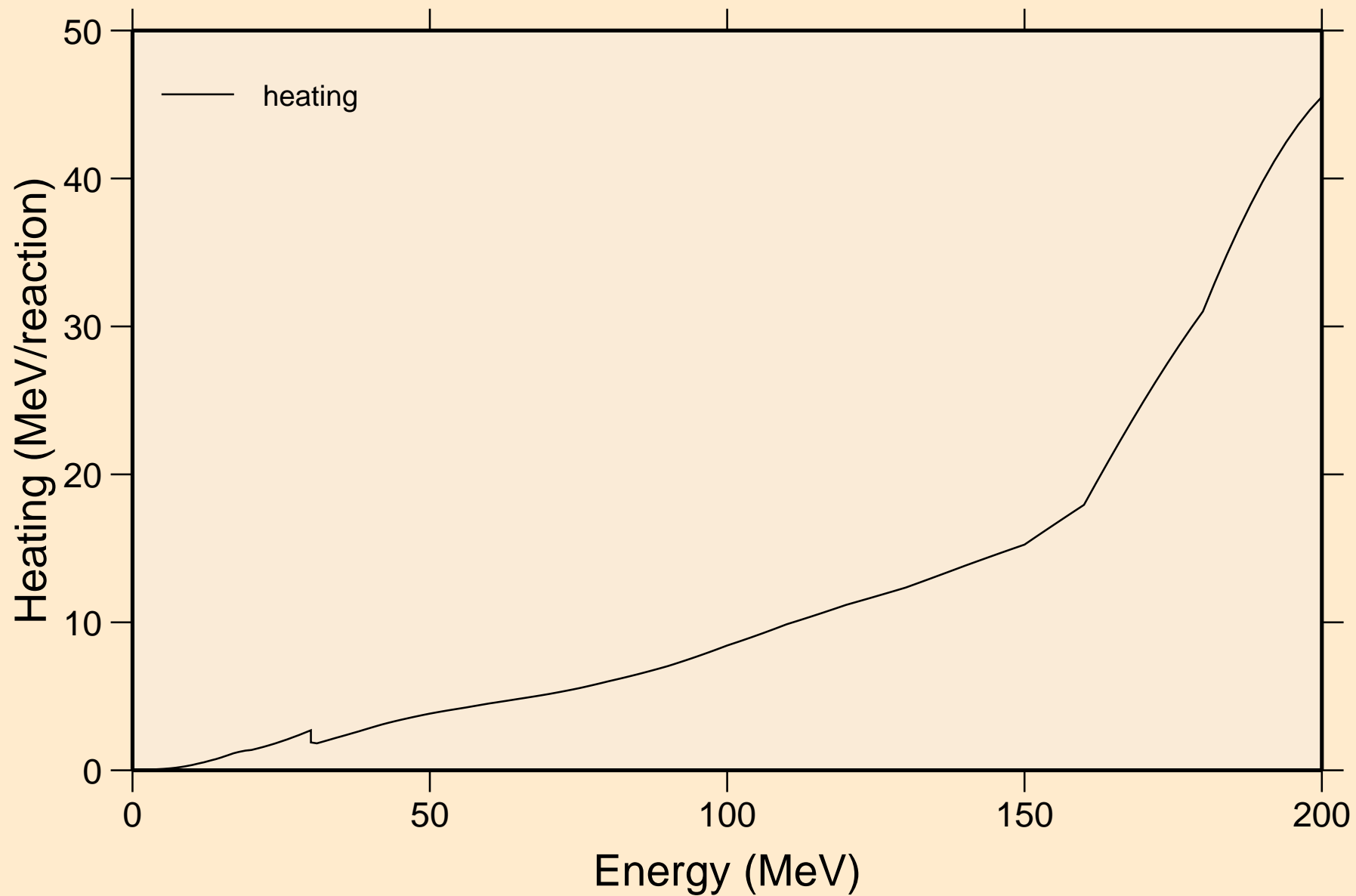

FR206M NEUTRON ACER TENDL-2019 LIBRARY; T=293.16K  
Damage

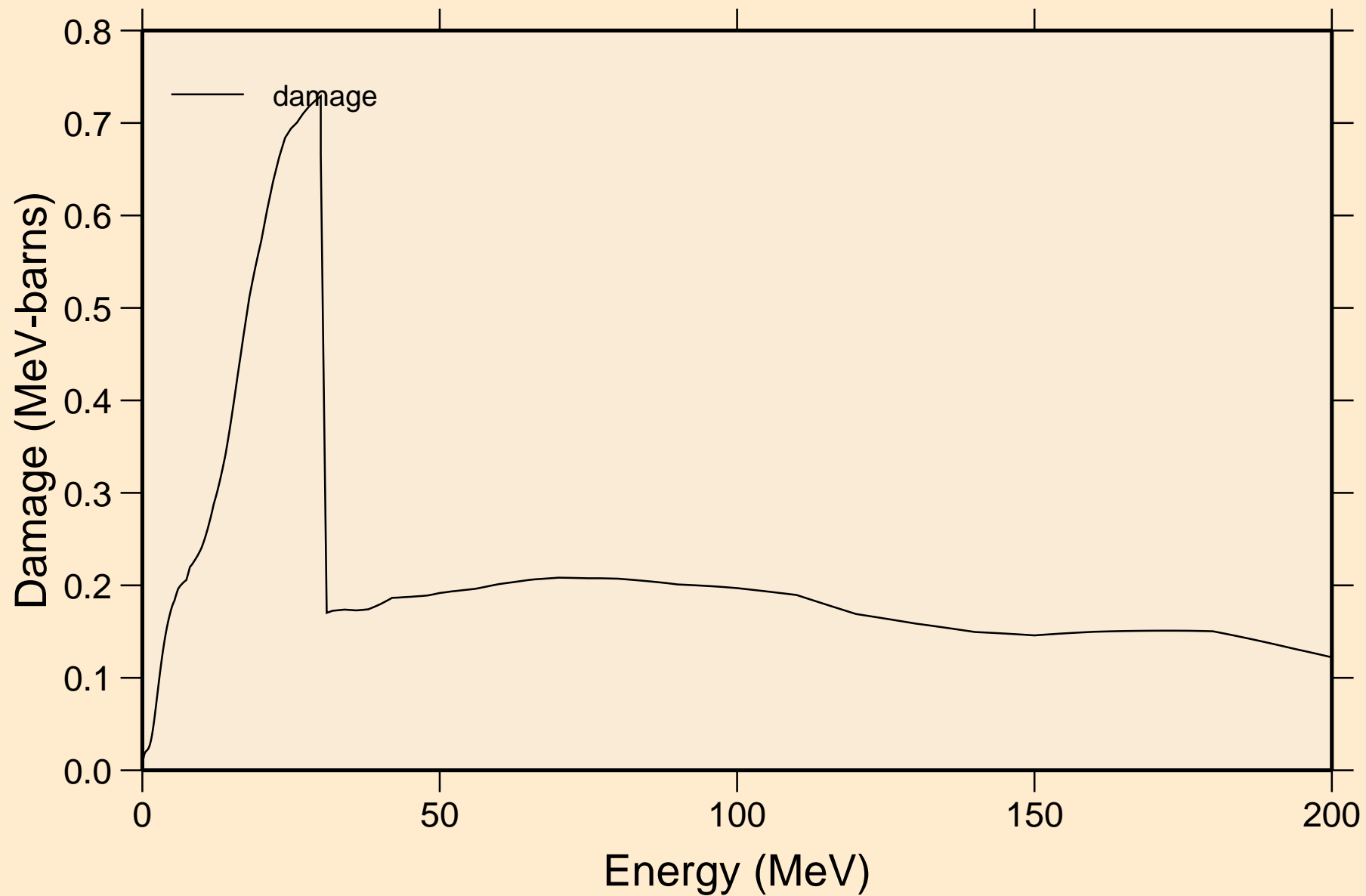



FR206M NEUTRON ACER TENDL-2019 LIBRARY; T=293.16K  
Non-threshold reactions

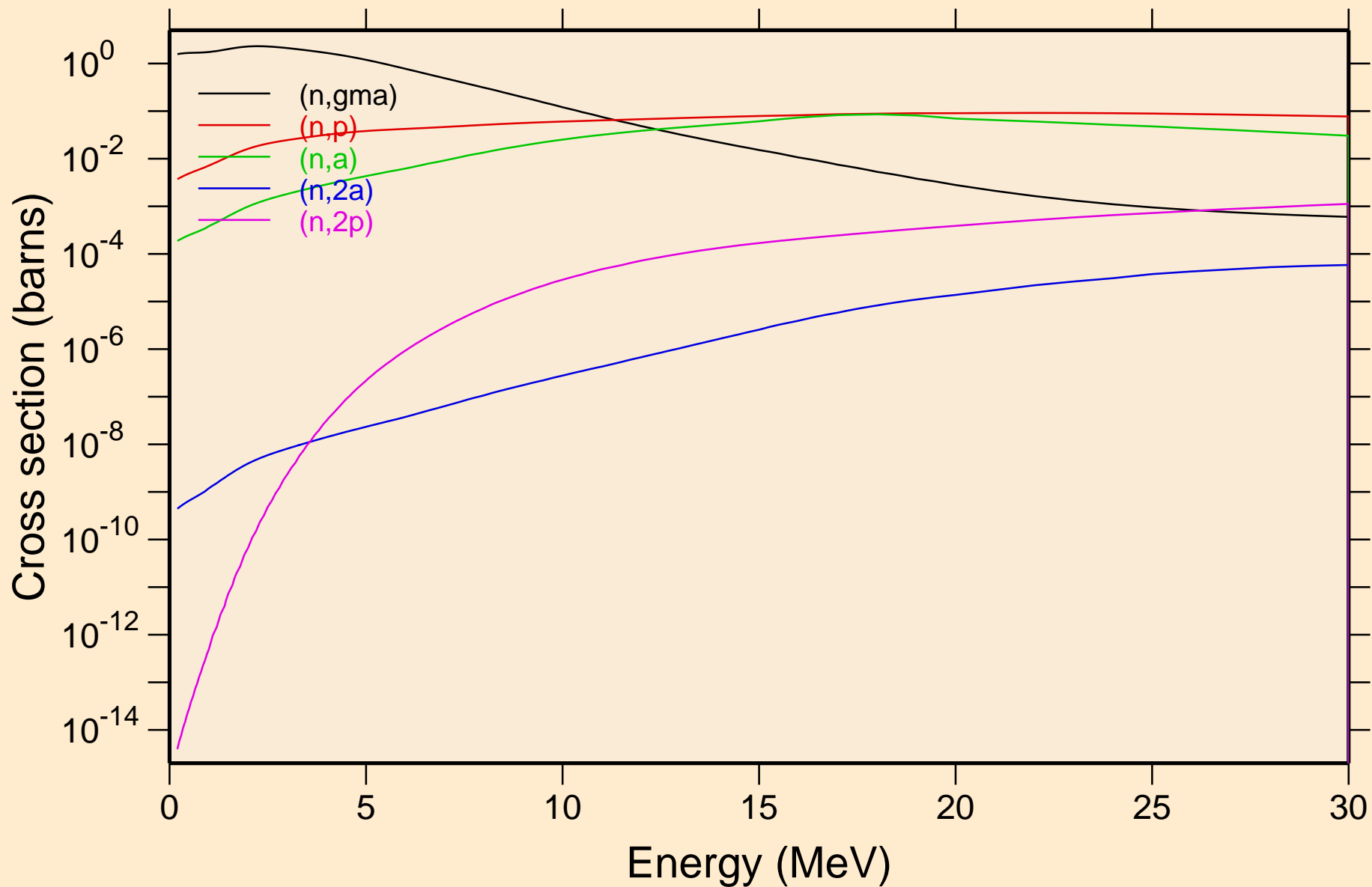

FR206M NEUTRON ACER TENDL-2019 LIBRARY; T=293.16K  
Non-threshold reactions

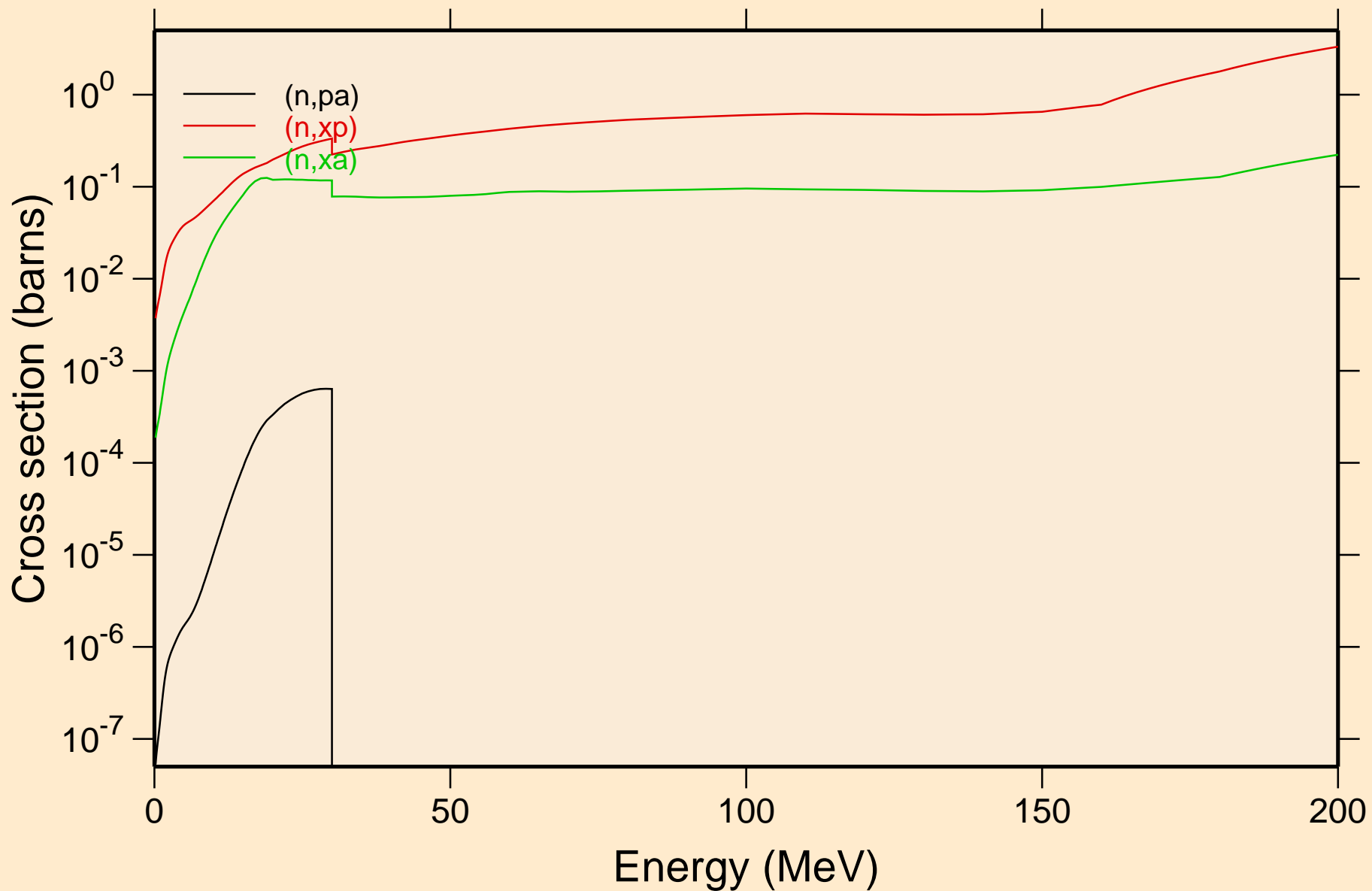

FR206M NEUTRON ACER TENDL-2019 LIBRARY; T=293.16K  
Inelastic levels

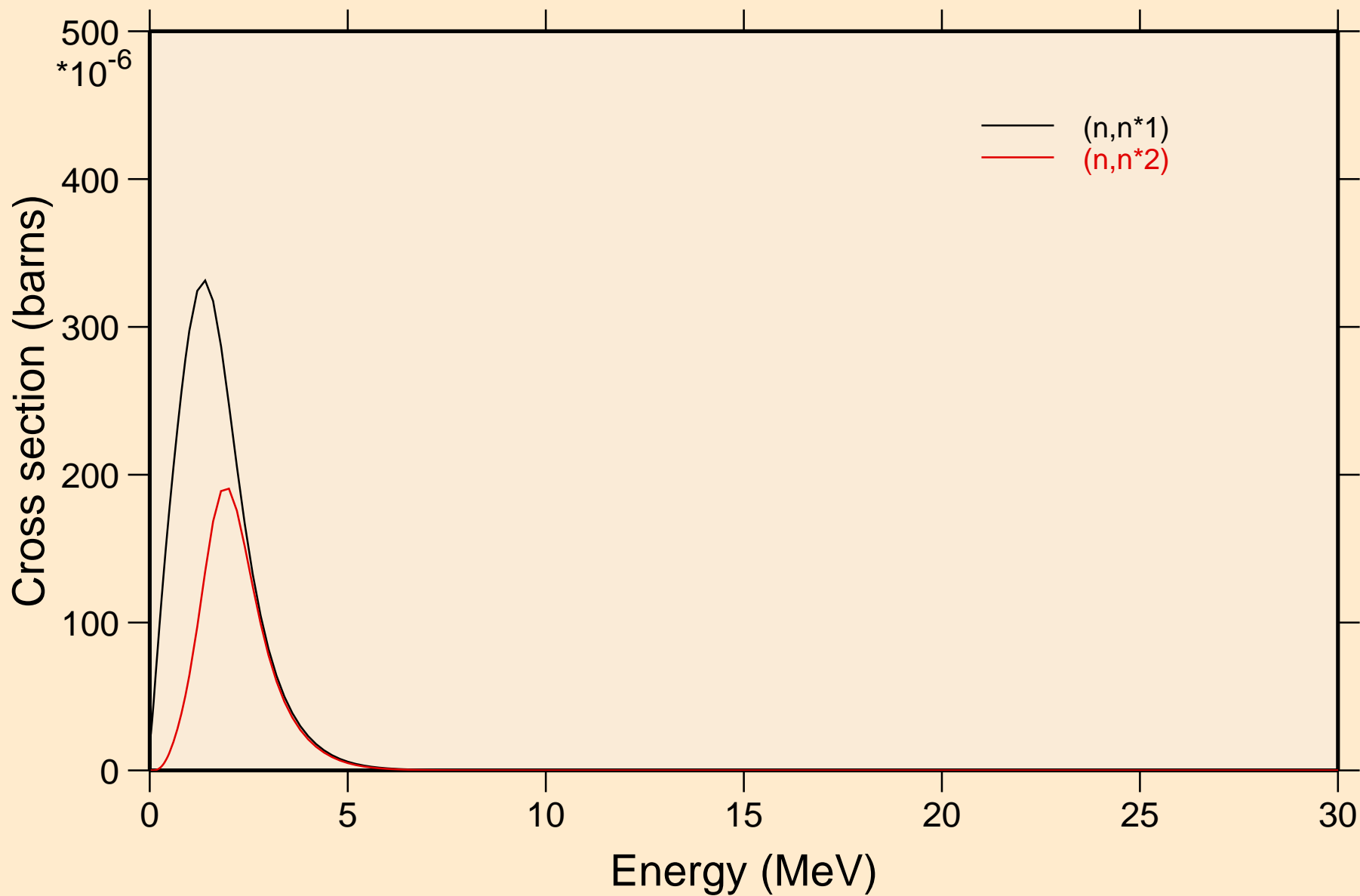

FR206M NEUTRON ACER TENDL-2019 LIBRARY; T=293.16K  
Threshold reactions

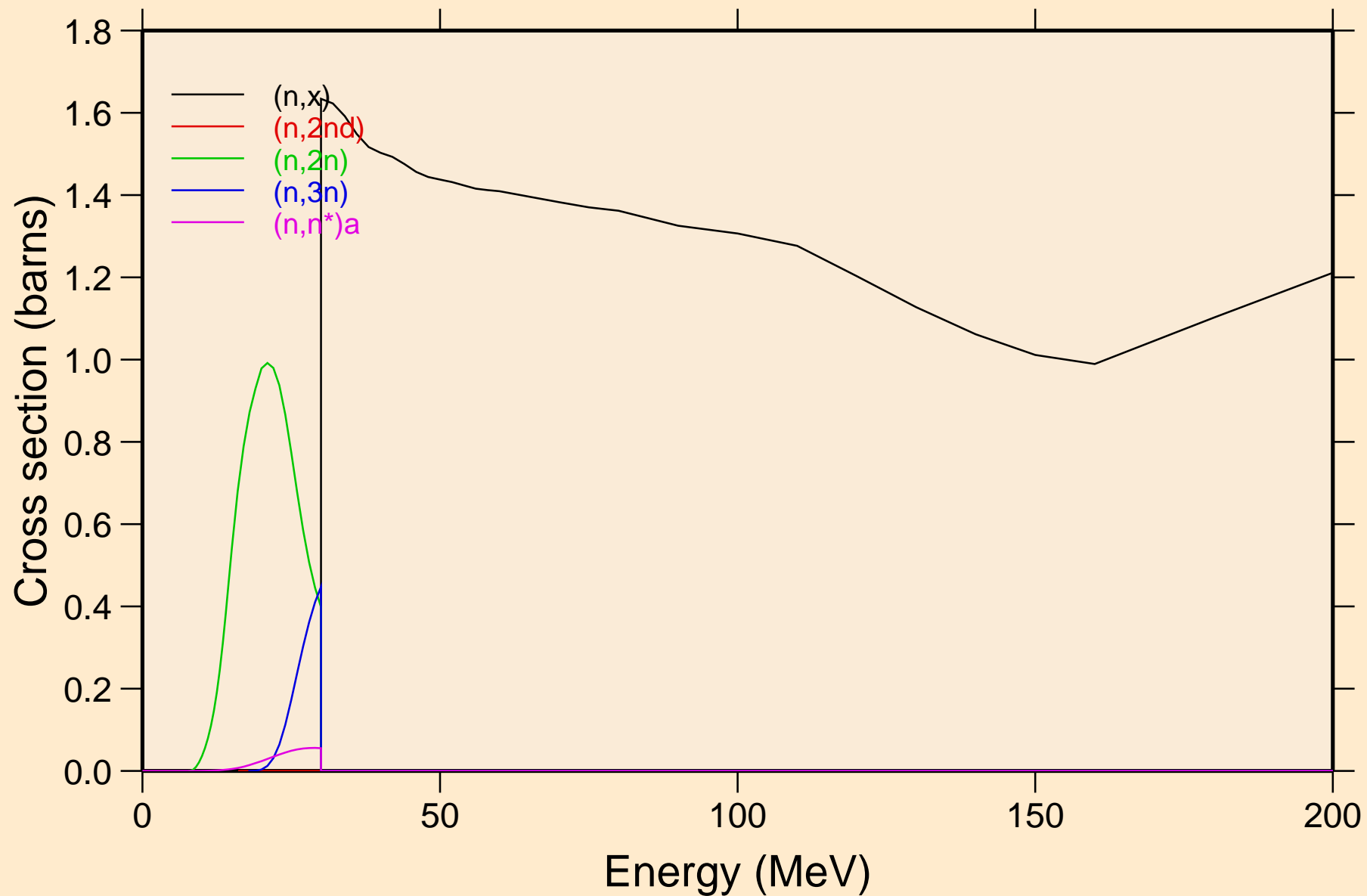

FR206M NEUTRON ACER TENDL-2019 LIBRARY; T=293.16K  
Threshold reactions

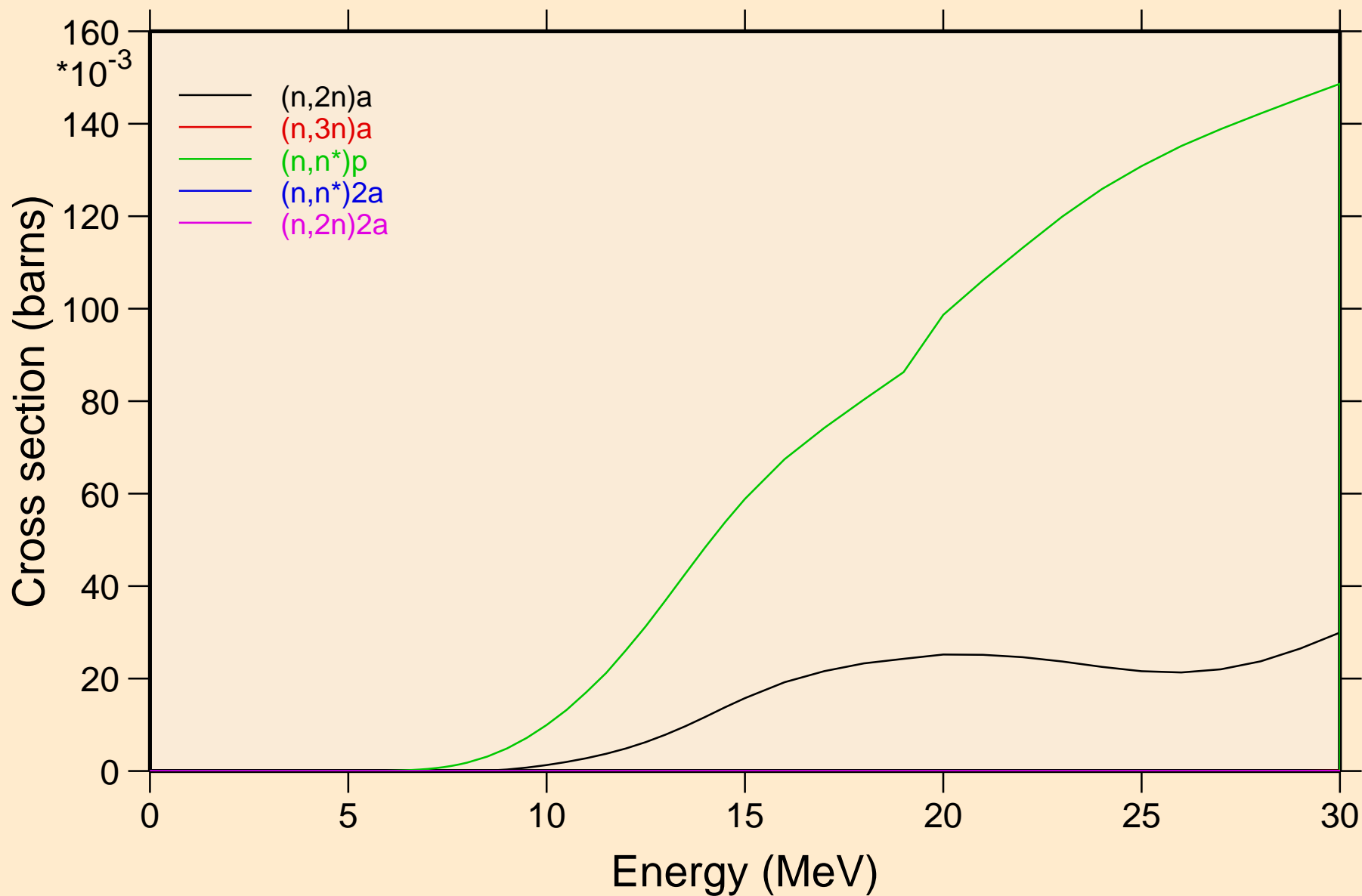

FR206M NEUTRON ACER TENDL-2019 LIBRARY; T=293.16K  
Threshold reactions

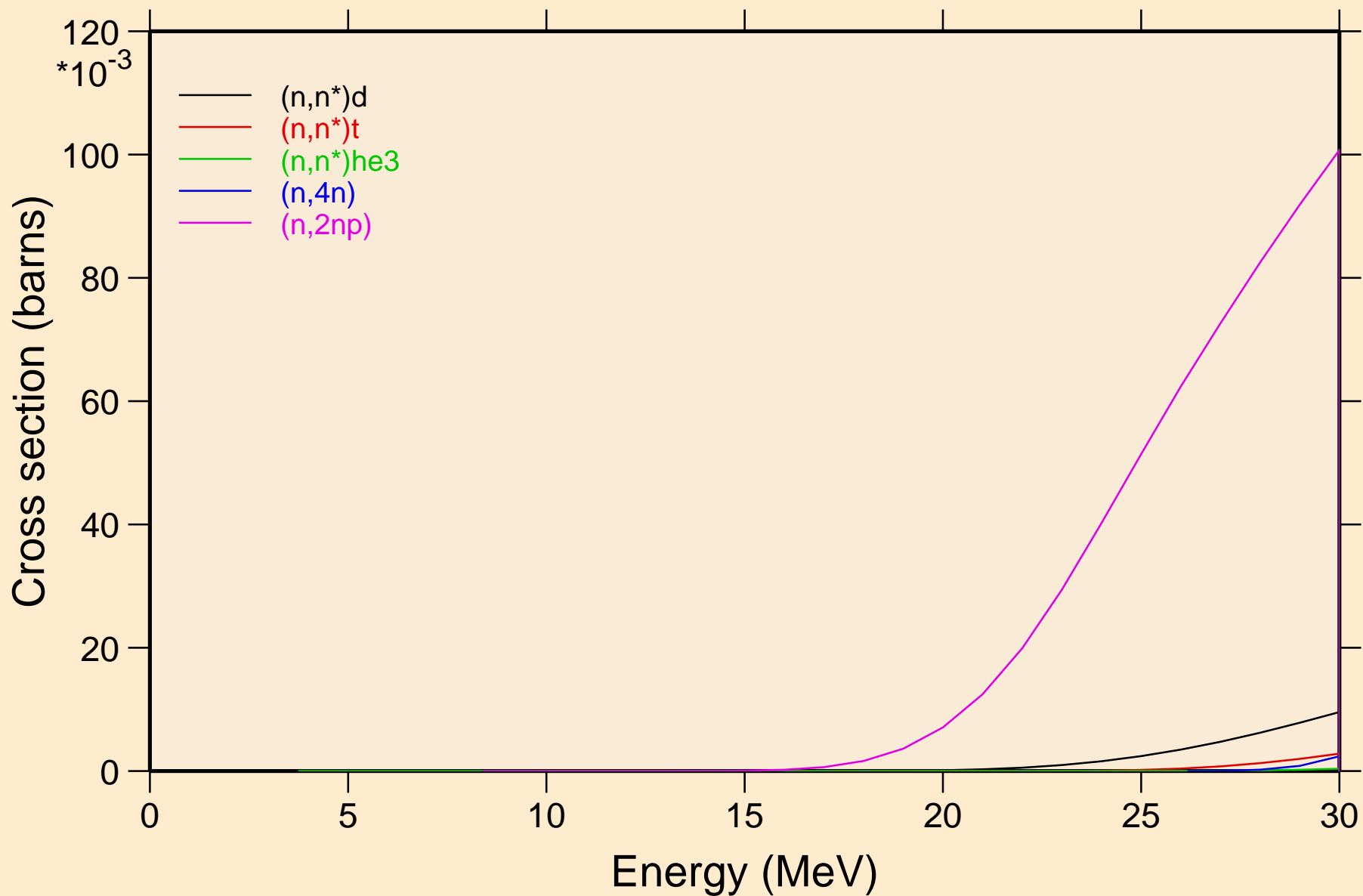

FR206M NEUTRON ACER TENDL-2019 LIBRARY; T=293.16K  
Threshold reactions

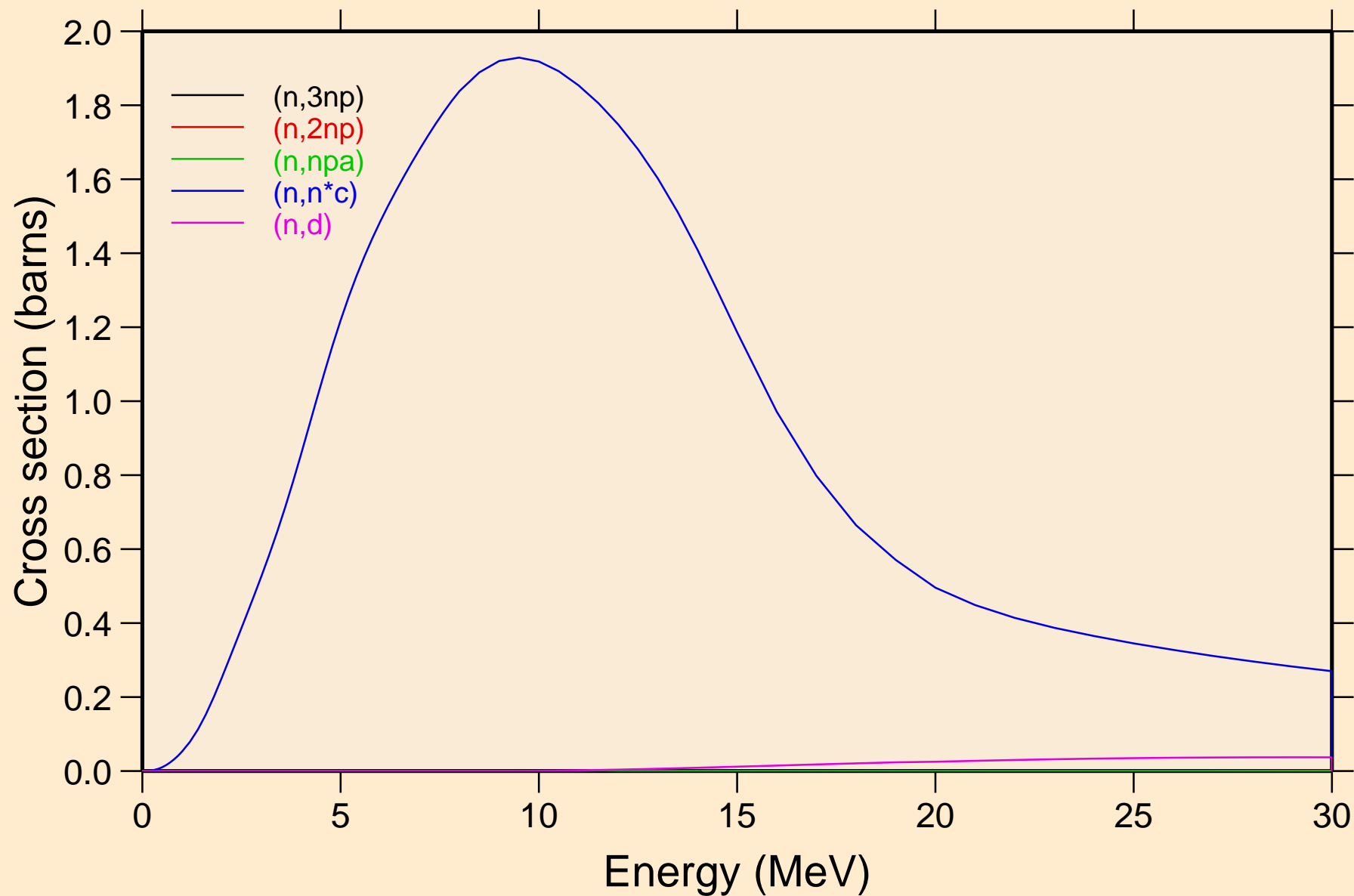

FR206M NEUTRON ACER TENDL-2019 LIBRARY; T=293.16K  
Threshold reactions

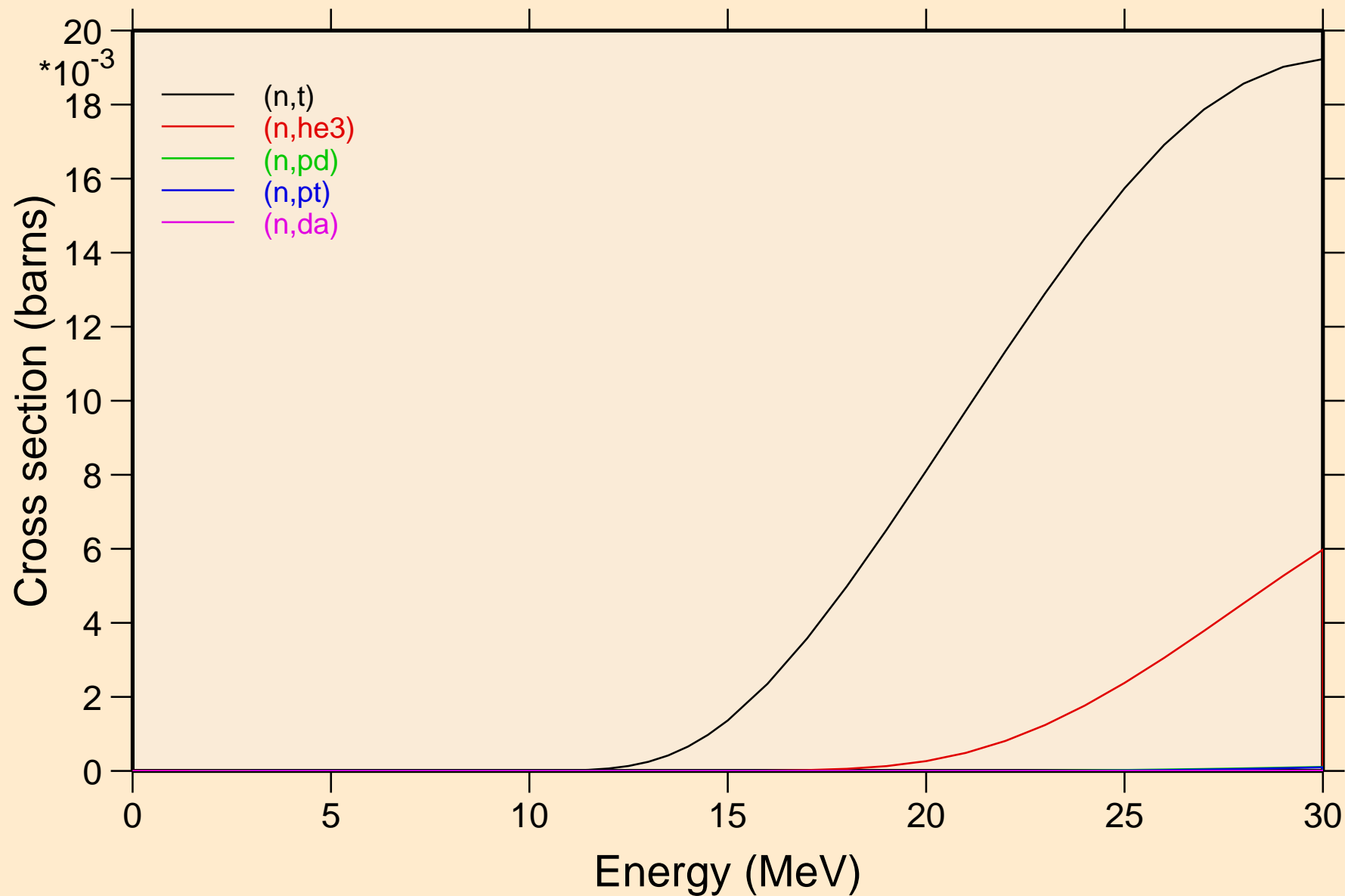



FR206M NEUTRON ACER TENDL-2019 LIBRARY; T=293.16K  
Threshold reactions

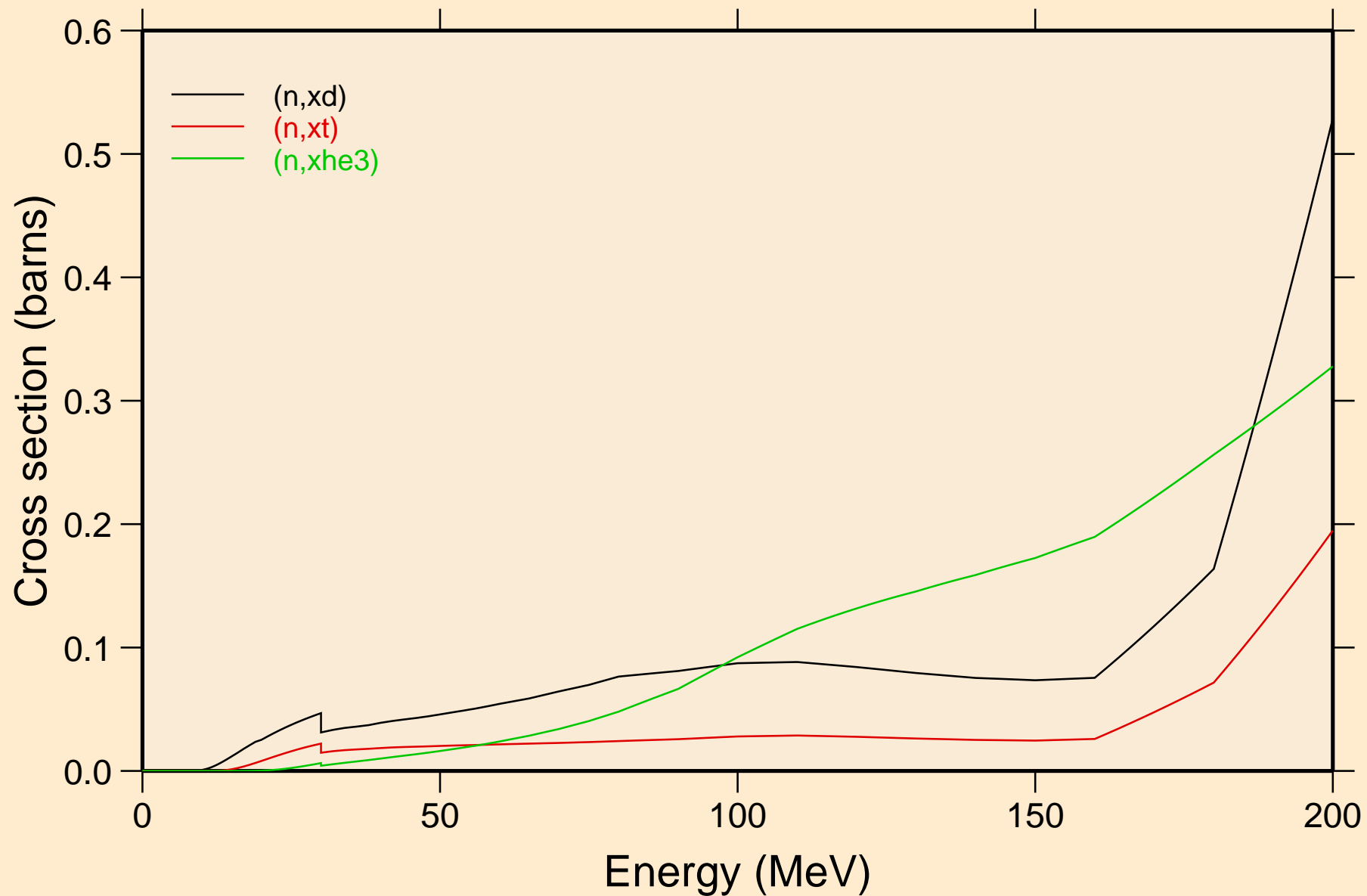

FR206M NEUTRON ACER TENDL-2019 LIBRARY; T=293.16K  
angular distribution for elastic

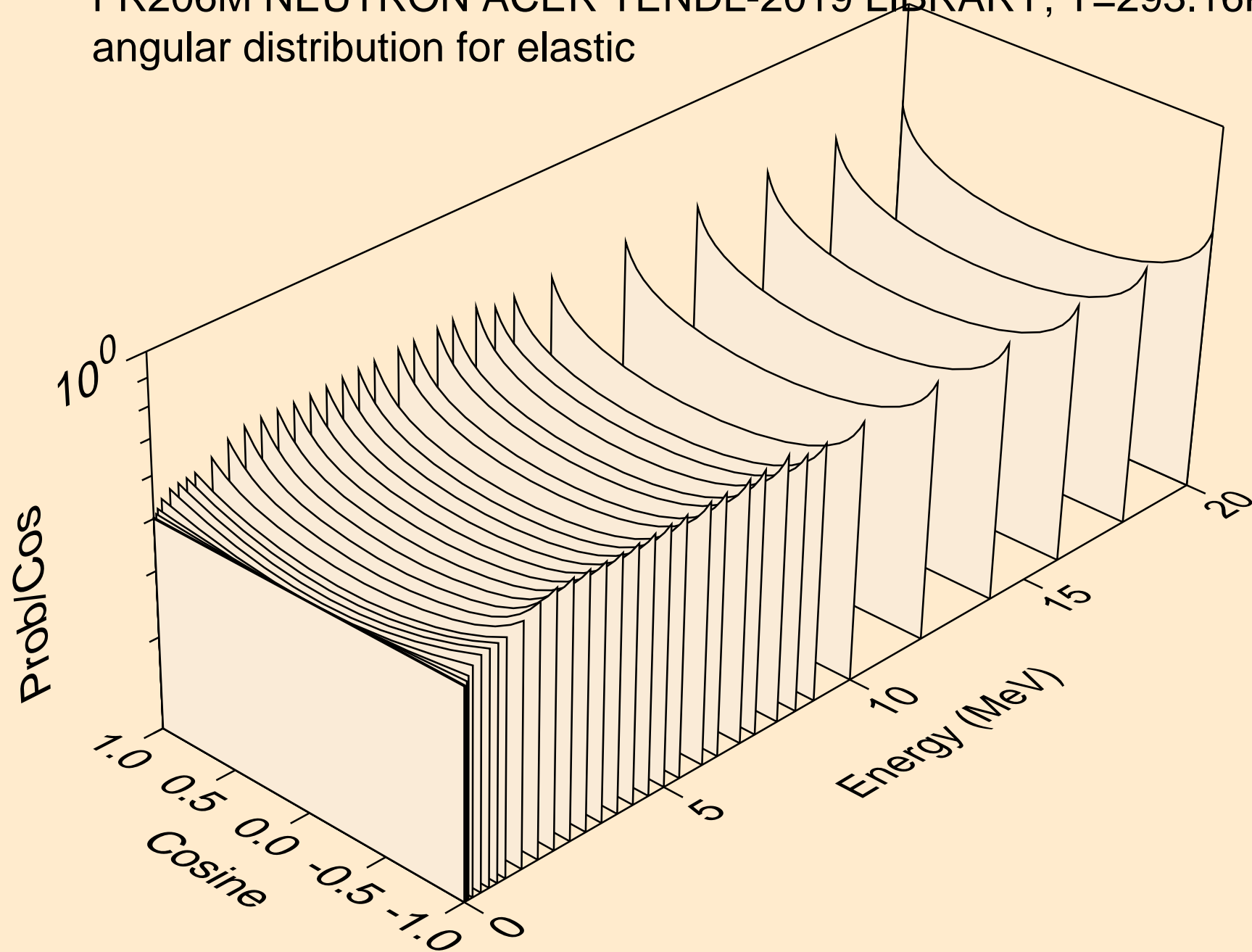

FR206M NEUTRON ACER TENDL-2019 LIBRARY; T=293.16K  
angular distribution for elastic

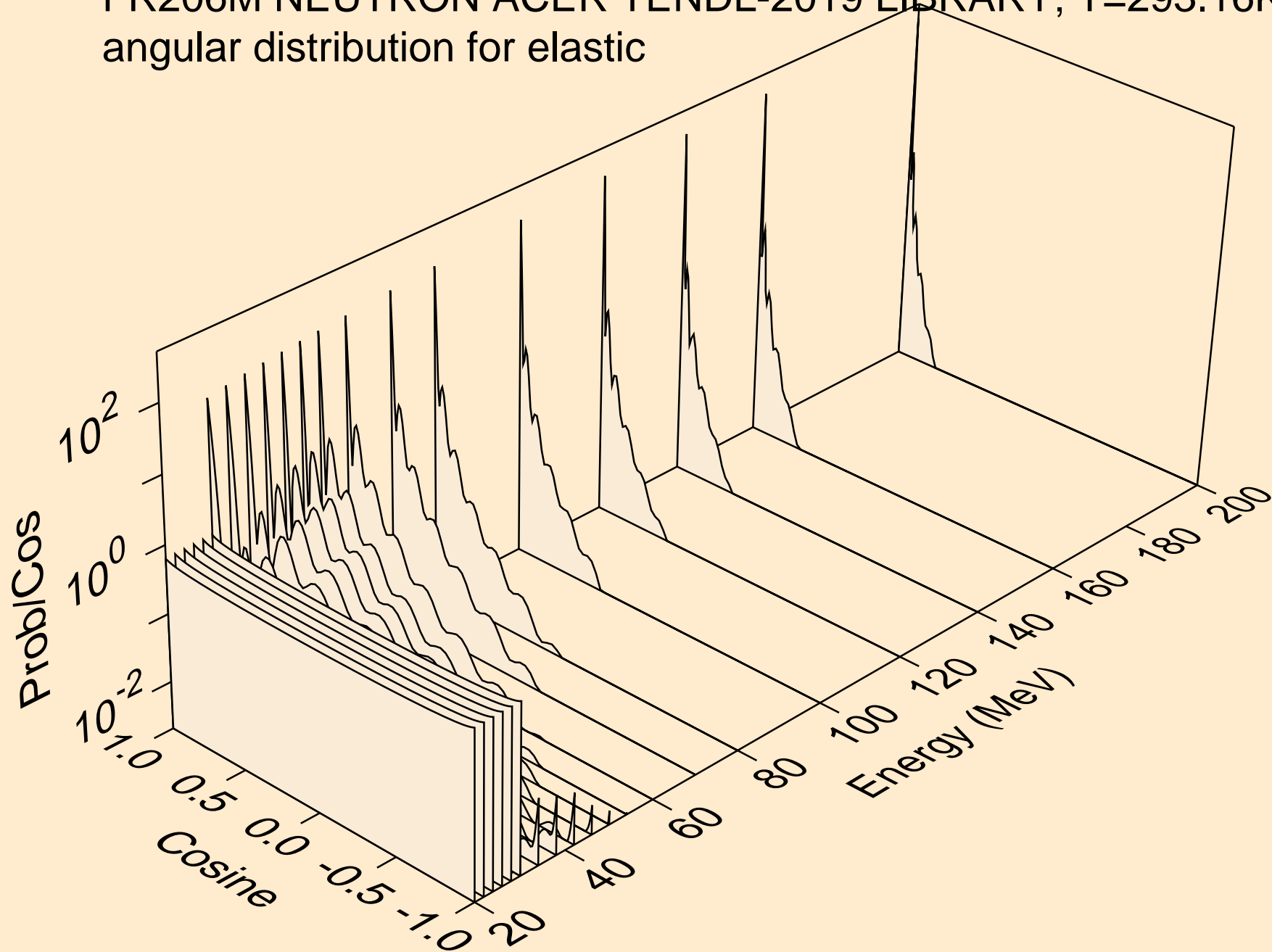

FR206M NEUTRON ACER TENDL-2019 LIBRARY; T=293.16K  
angular distribution for (n,n\*1)

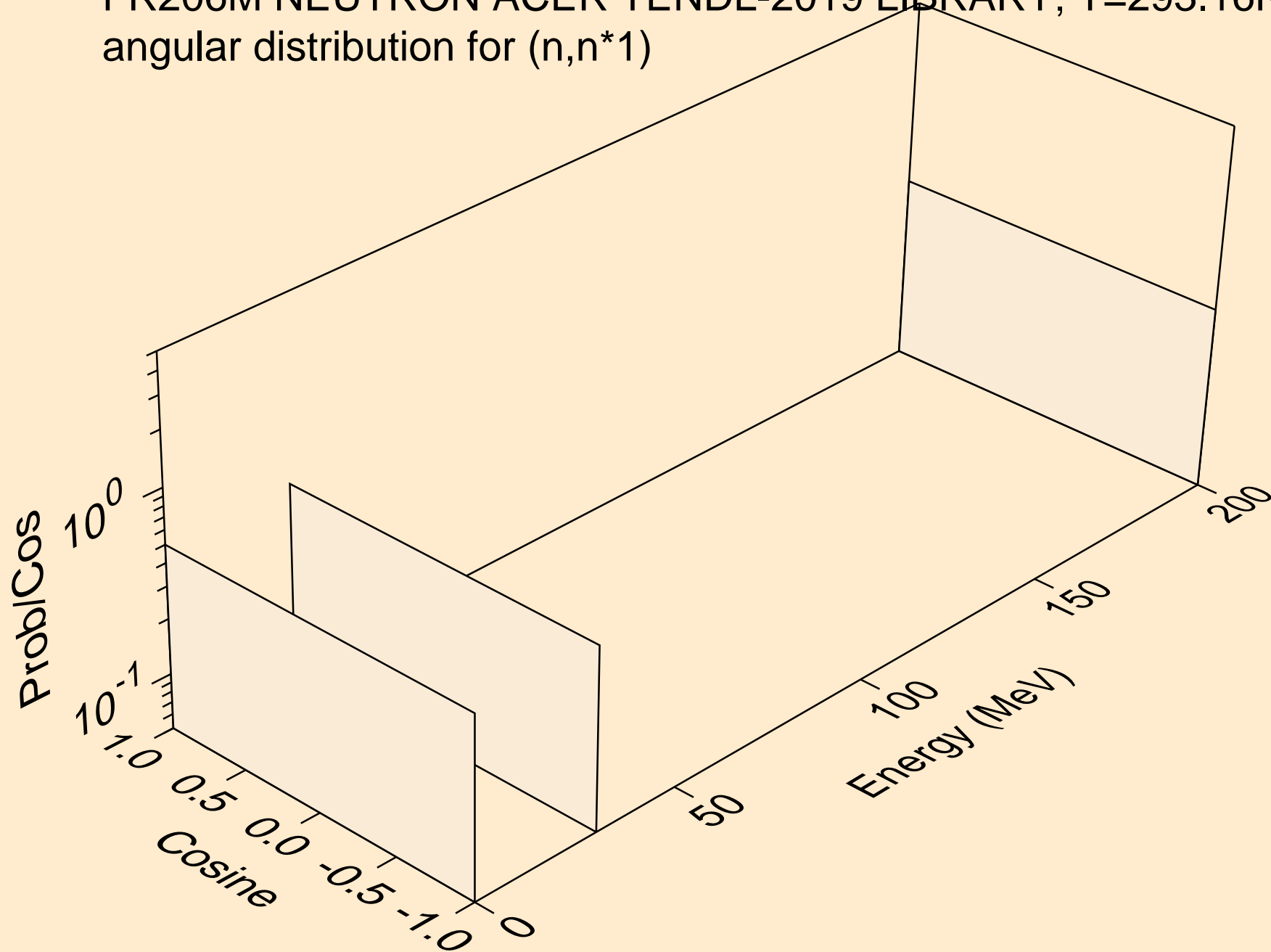

FR206M NEUTRON ACER TENDL-2019 LIBRARY; T=293.16K  
angular distribution for (n,n\*2)

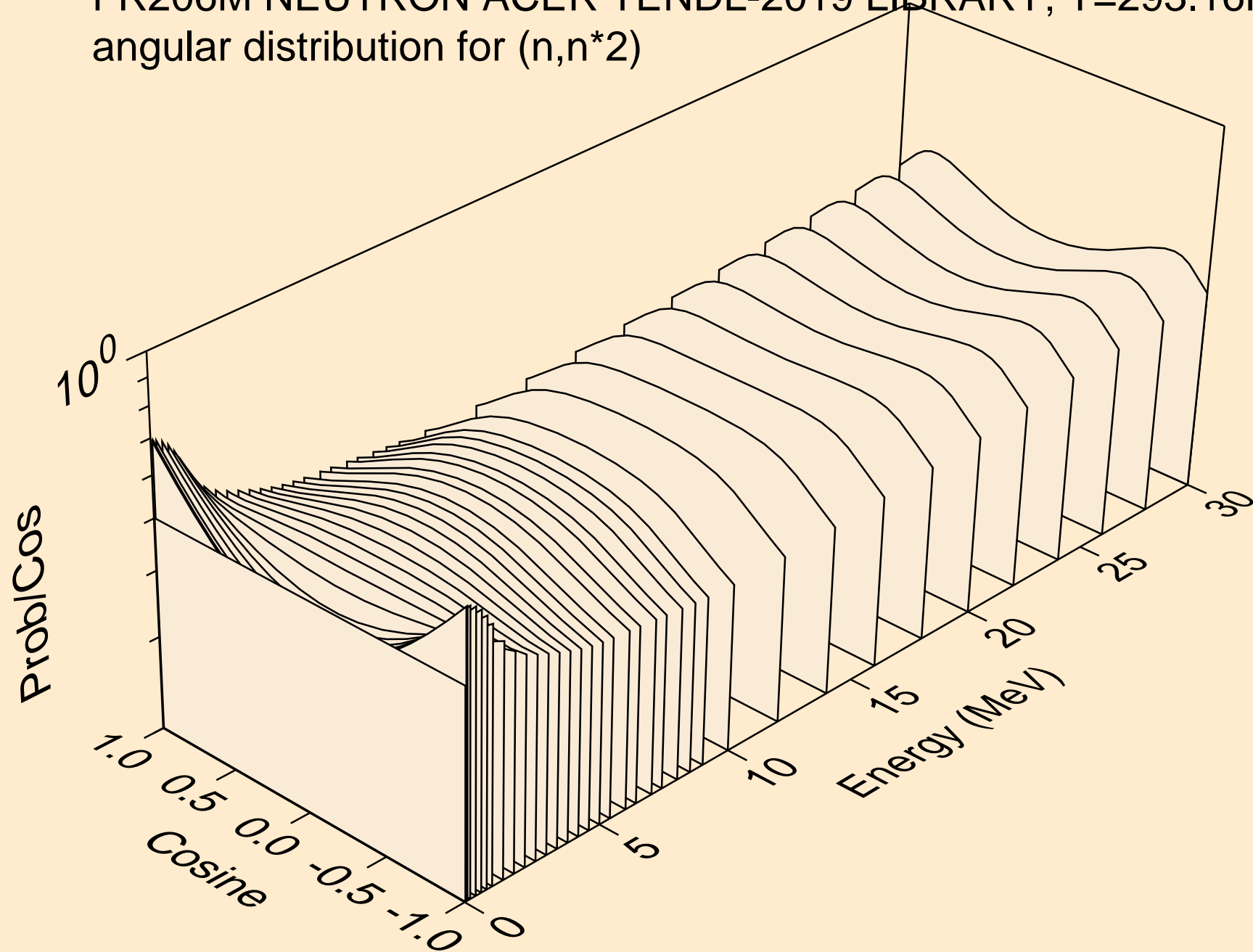

FR206M NEUTRON ACER TENDL-2019 LIBRARY; T=293.16K  
Neutron emission for (n,x)

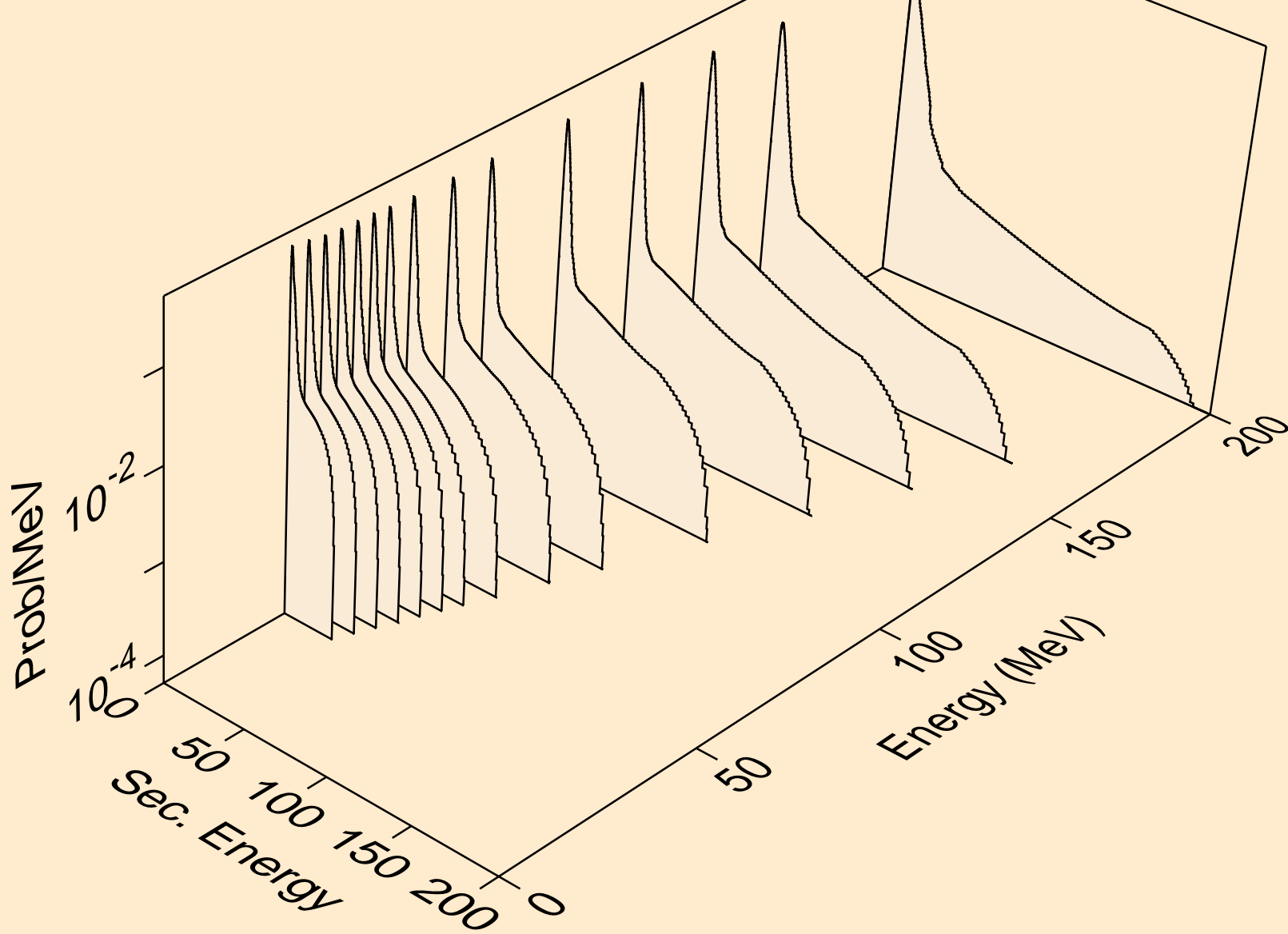

FR206M NEUTRON ACER TENDL-2019 LIBRARY; T=293.16K  
Neutron emission for (n,2nd)

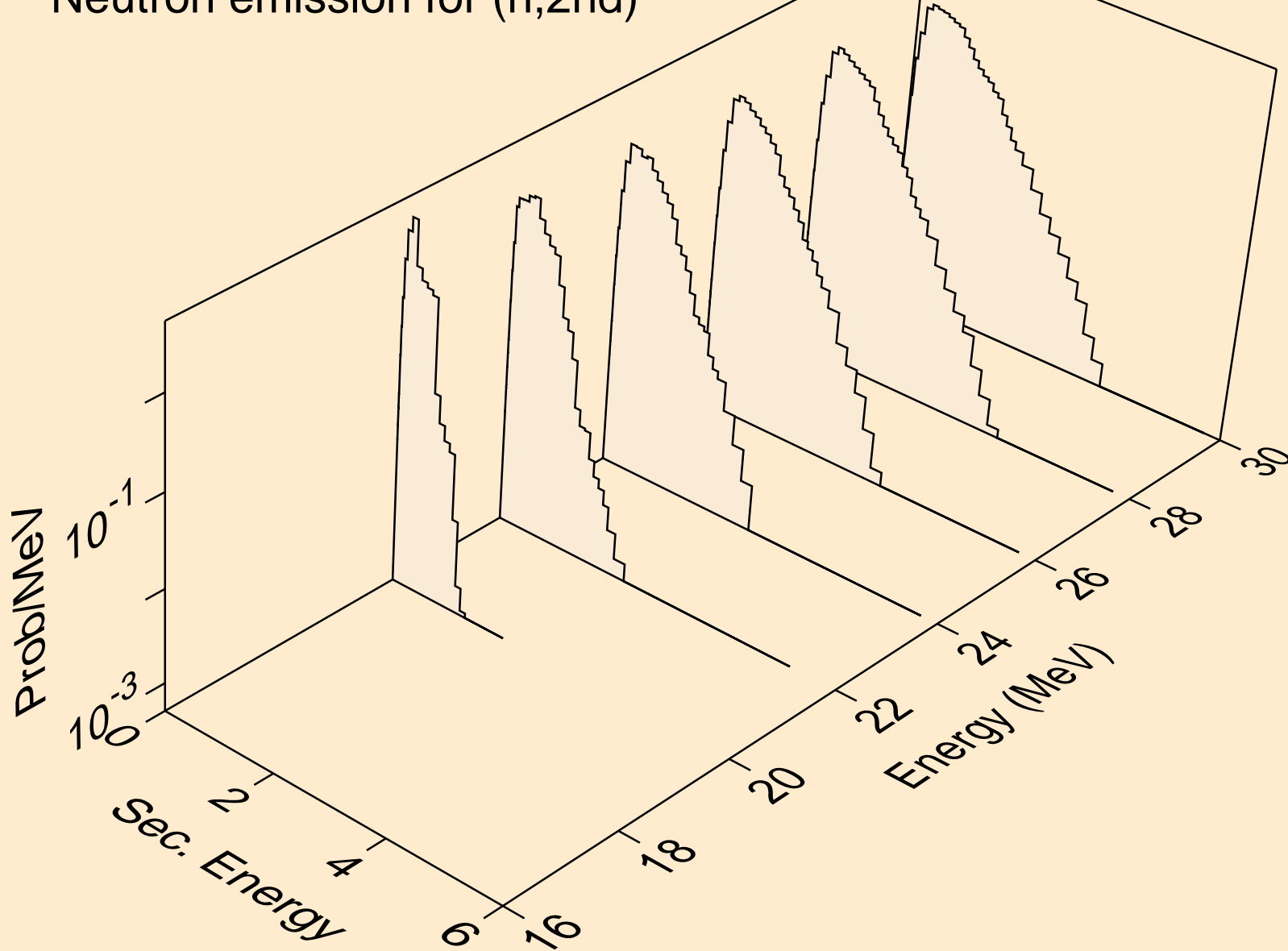

FR206M NEUTRON ACER TENDL-2019 LIBRARY; T=293.16K  
Neutron emission for (n,2n)

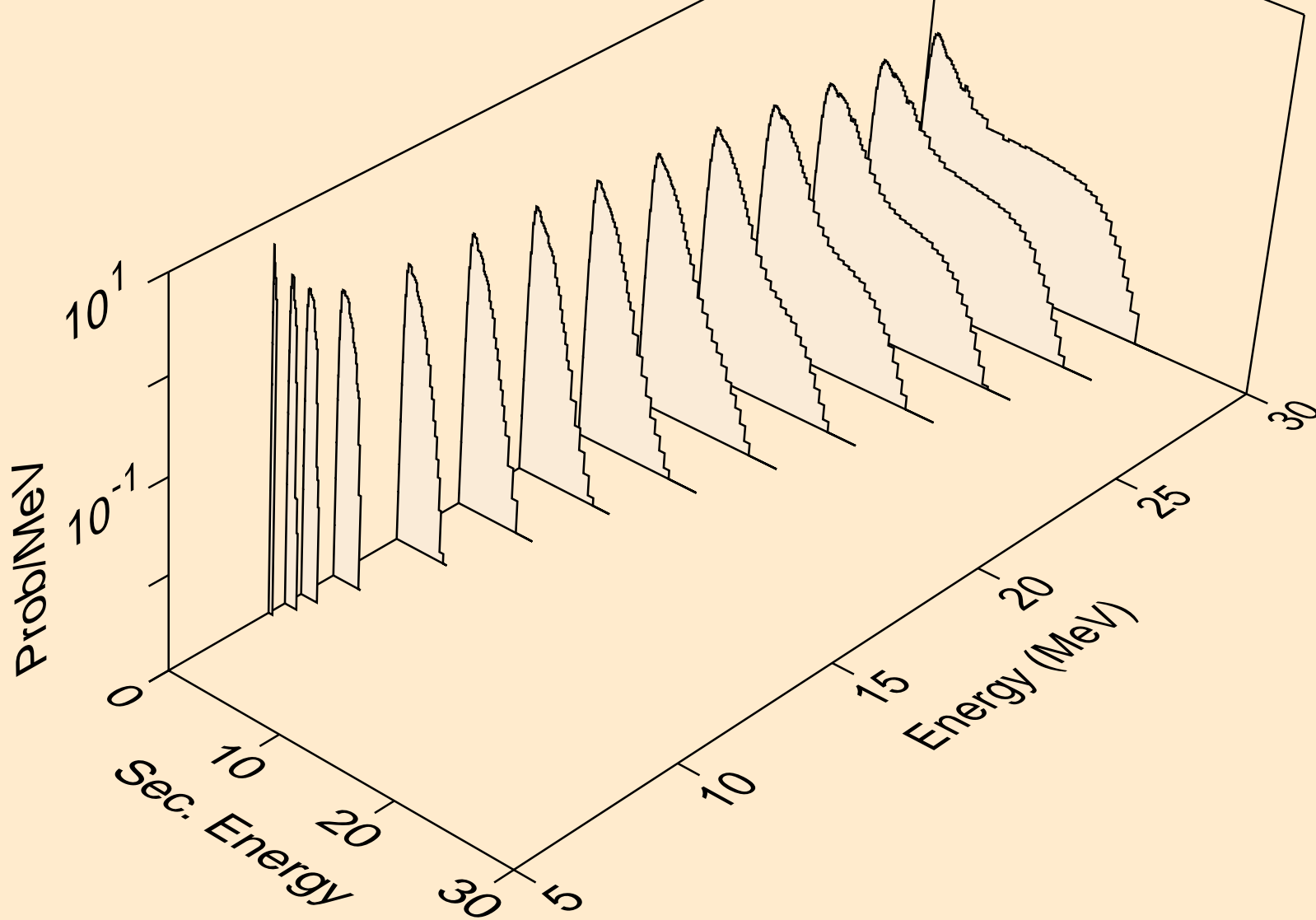



FR206M NEUTRON ACER TENDL-2019 LIBRARY; T=293.16K  
Neutron emission for (n,3n)

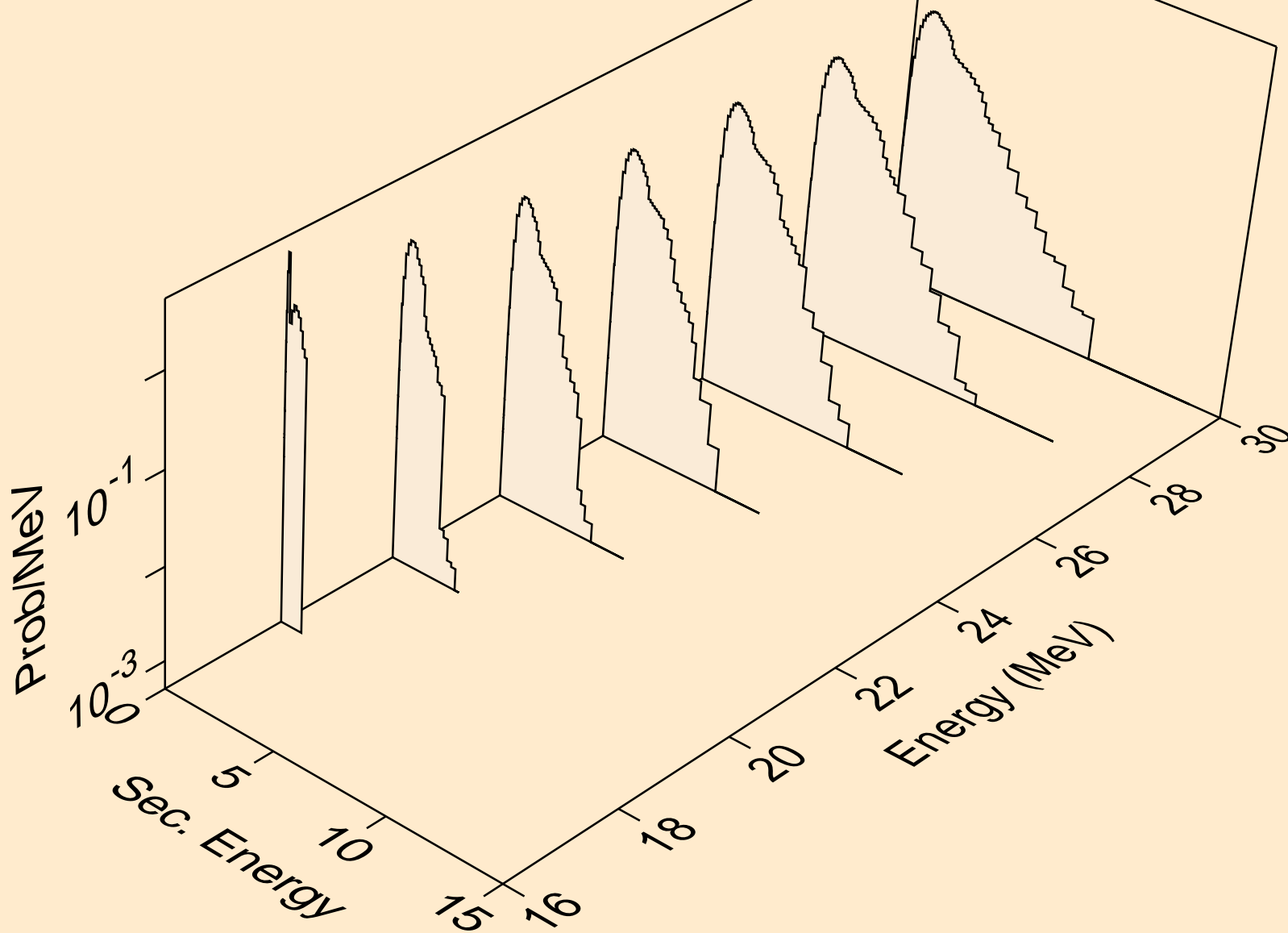

FR206M NEUTRON ACER TENDL-2019 LIBRARY; T=293.16K  
Neutron emission for (n,n\*)a

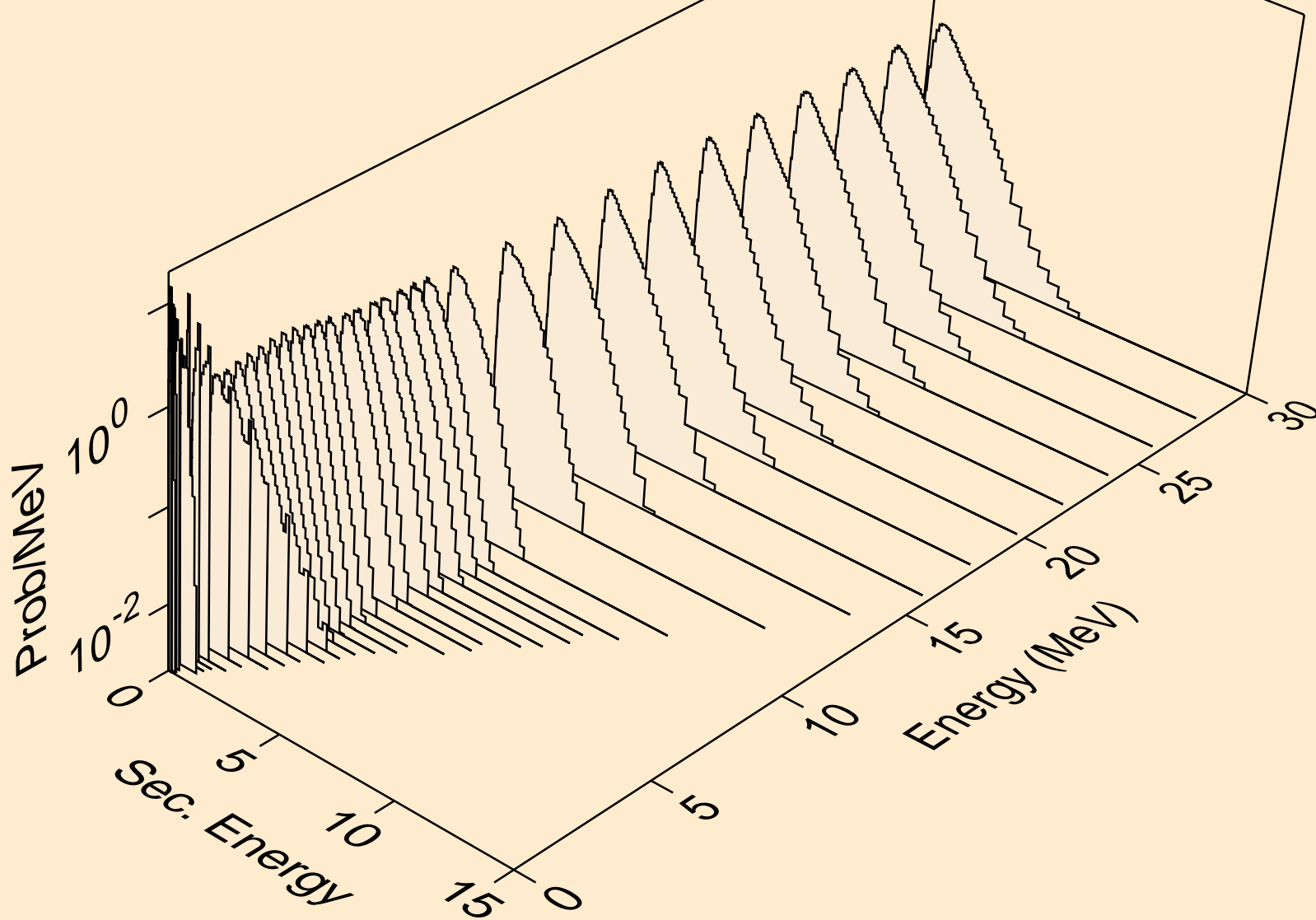

FR206M NEUTRON ACER TENDL-2019 LIBRARY; T=293.16K  
Neutron emission for (n,2n)a

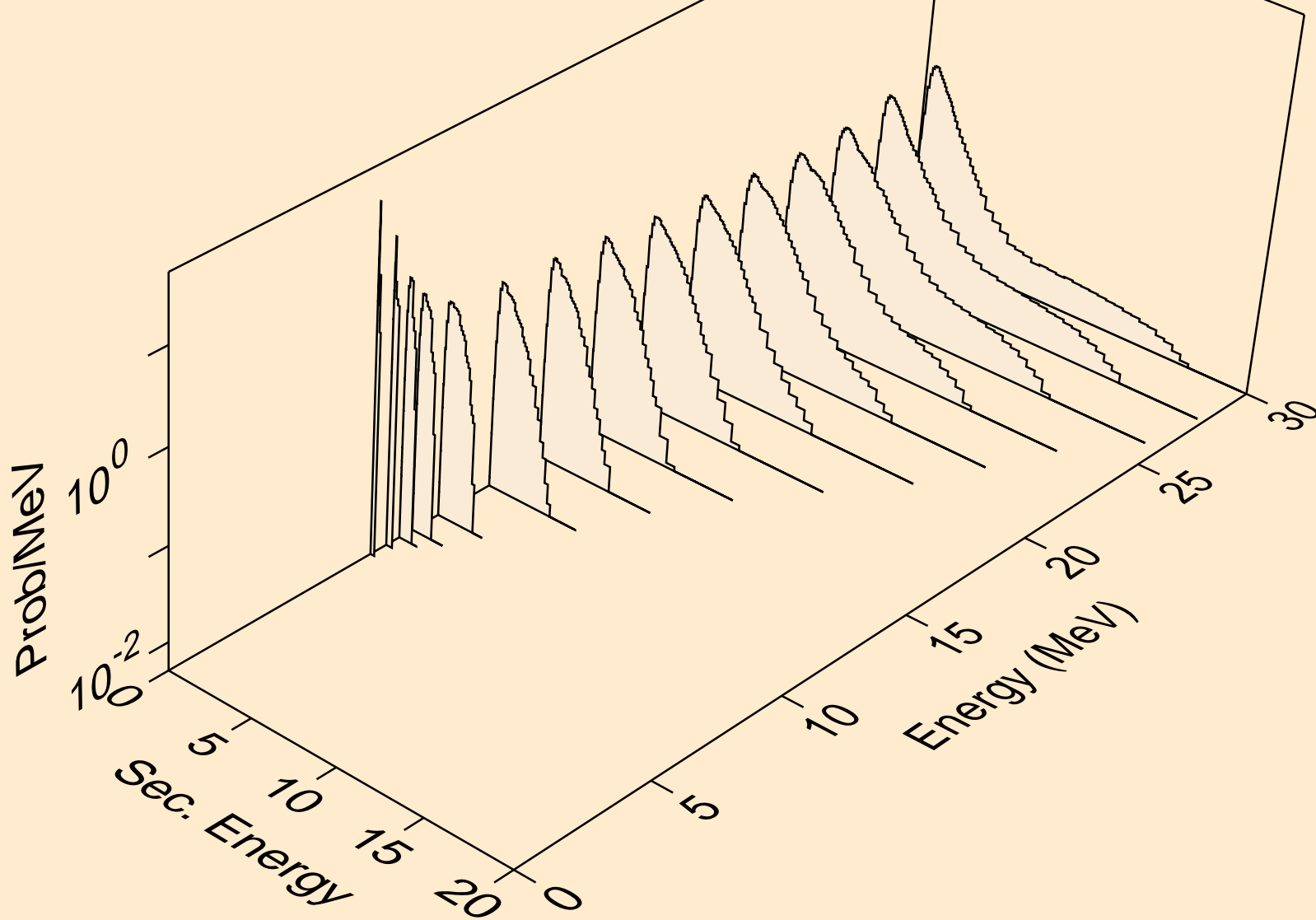

FR206M NEUTRON ACER TENDL-2019 LIBRARY; T=293.16K  
Neutron emission for (n,3n)a

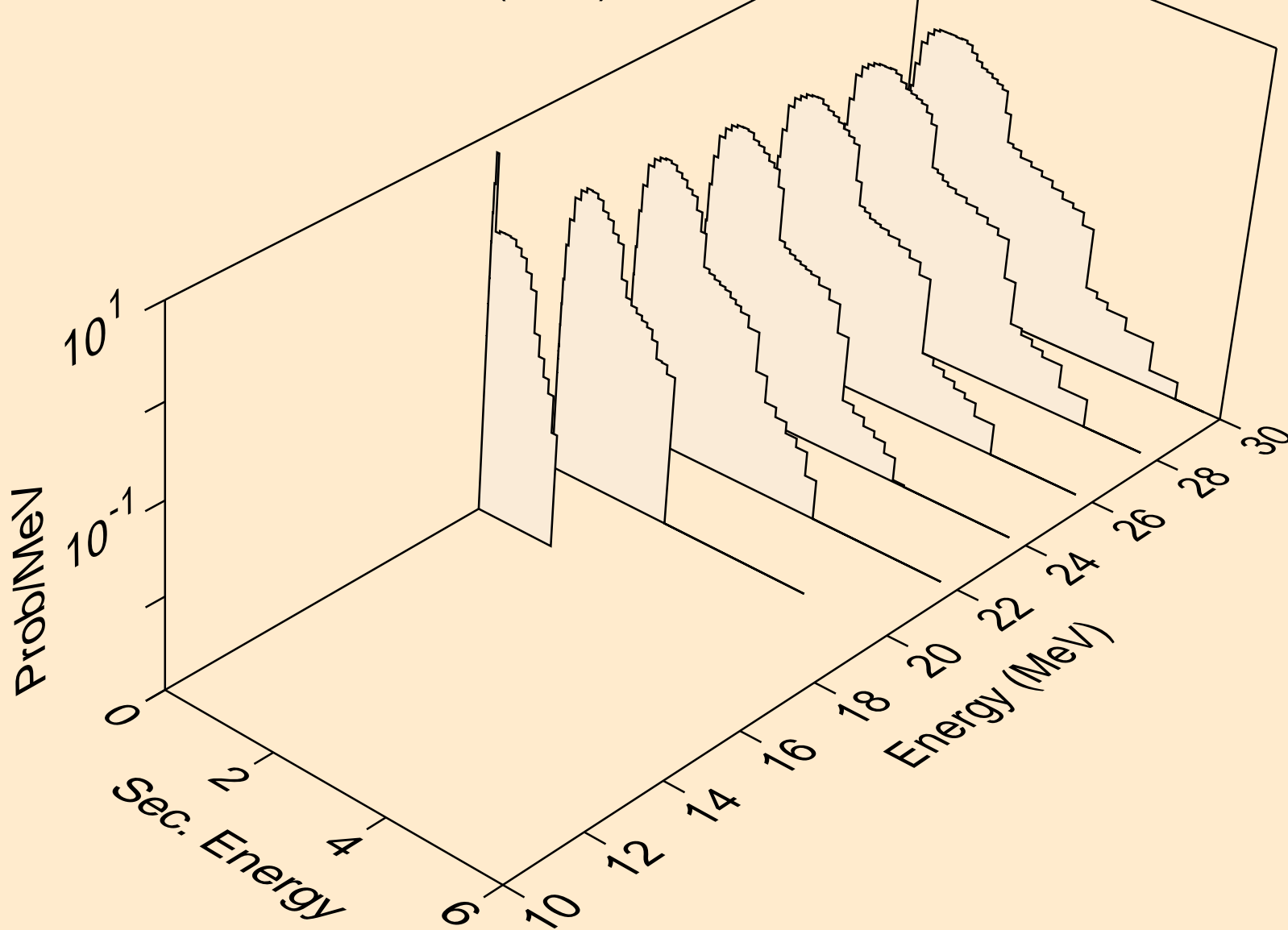

FR206M NEUTRON ACER TENDL-2019 LIBRARY; T=293.16K  
Neutron emission for (n,n\*)p

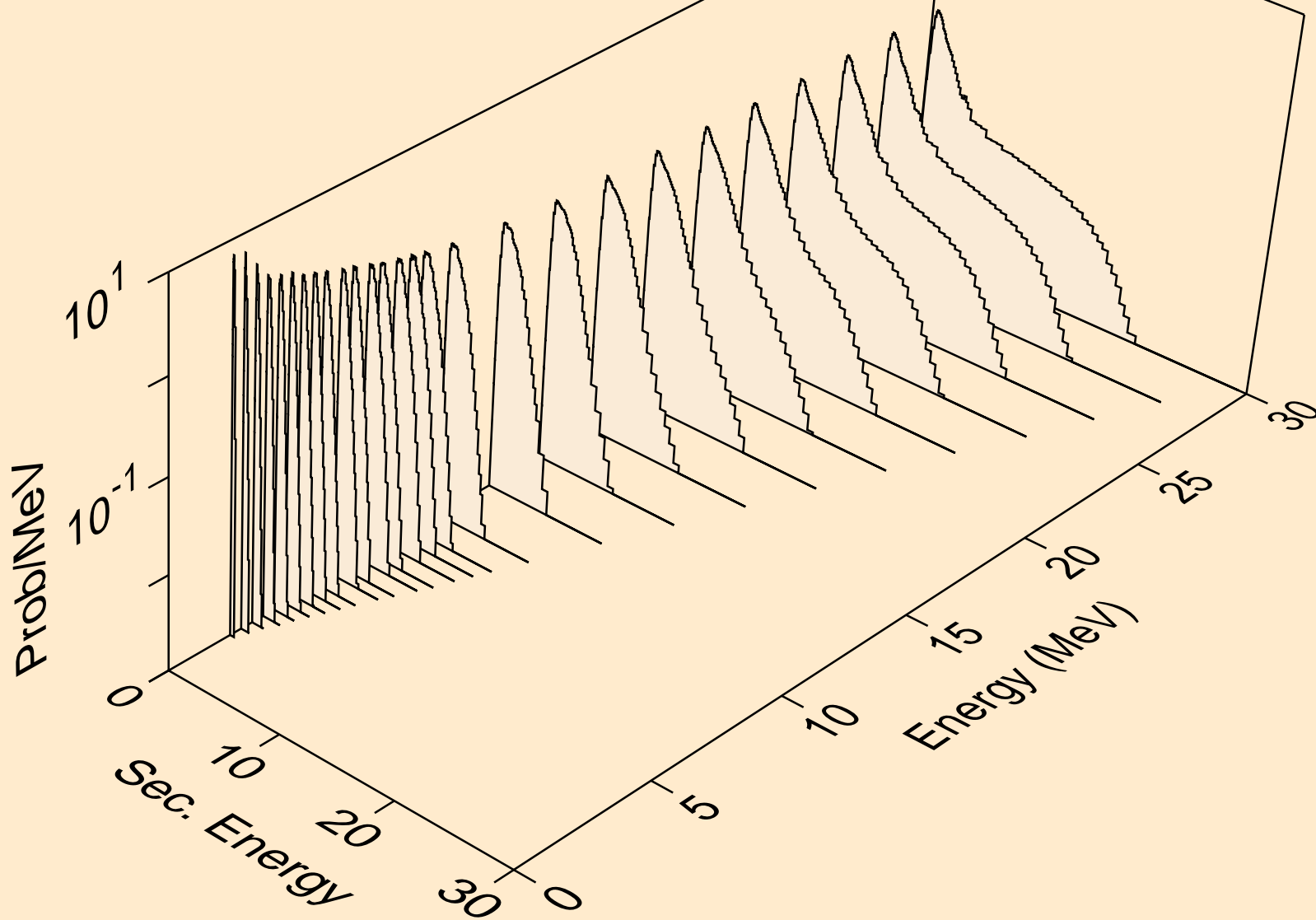

FR206M NEUTRON ACER TENDL-2019 LIBRARY; T=293.16K  
Neutron emission for (n,n\*)2a

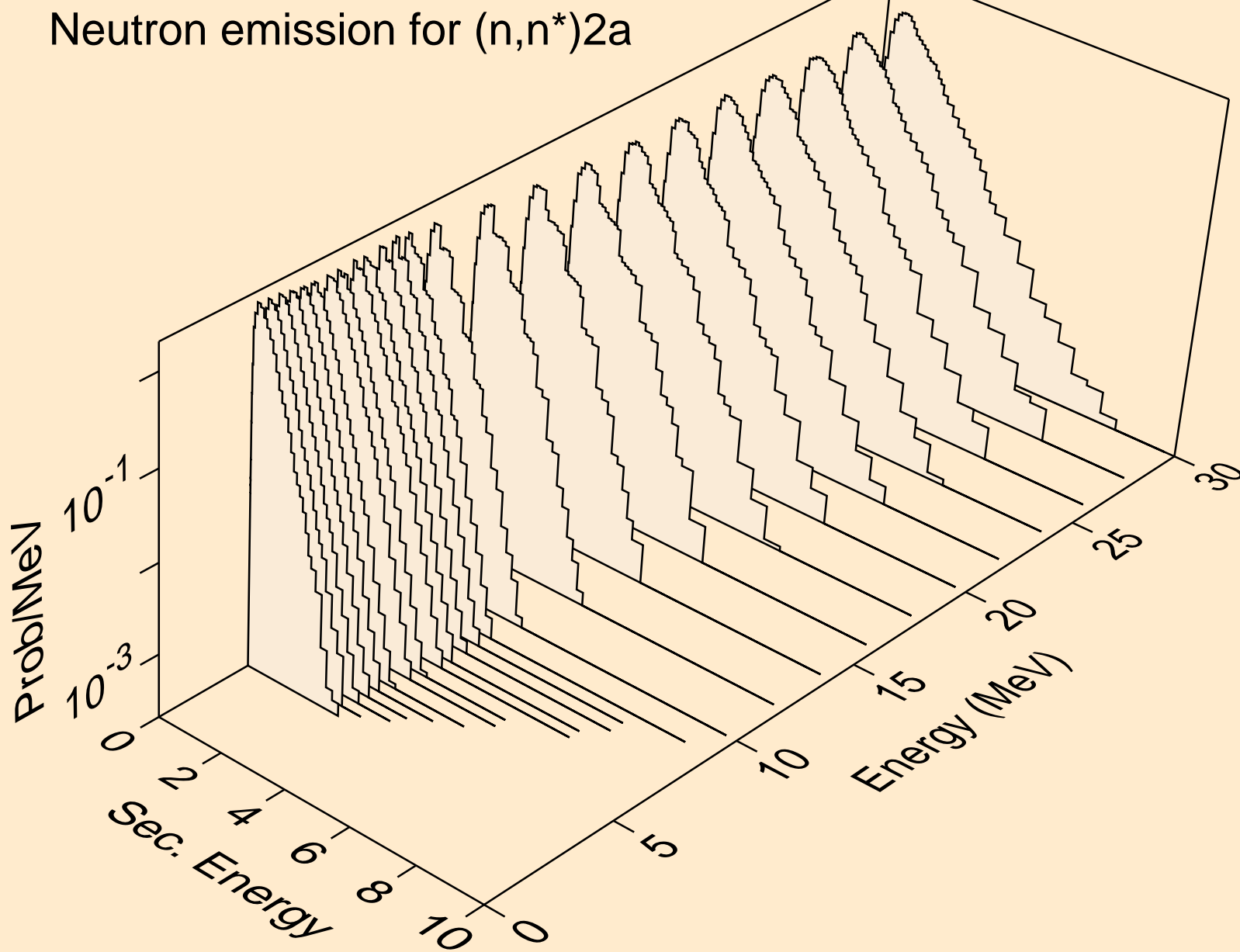

FR206M NEUTRON ACER TENDL-2019 LIBRARY; T=293.16K  
Neutron emission for (n,2n)2a

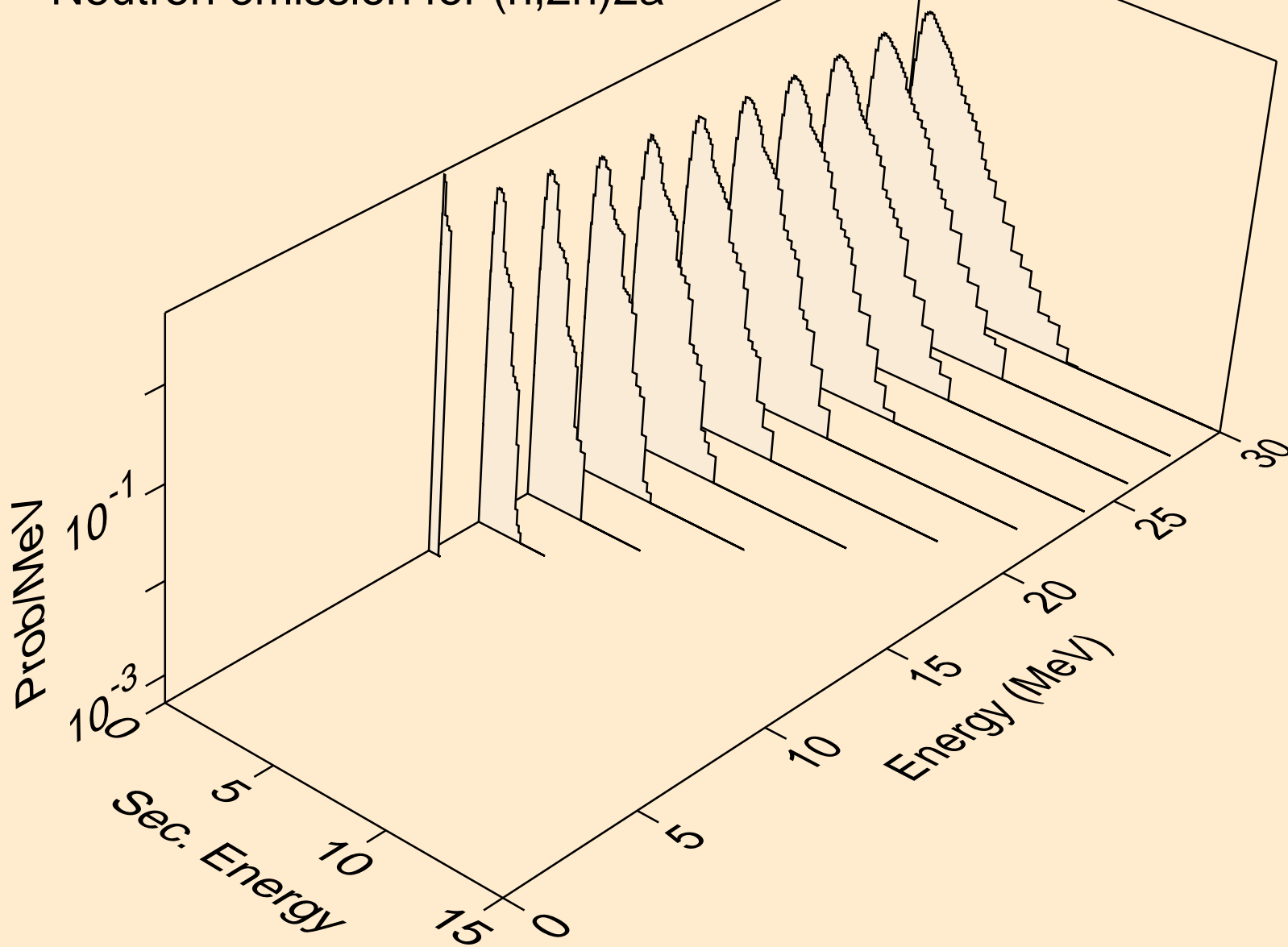

FR206M NEUTRON ACER TENDL-2019 LIBRARY; T=293.16K  
Neutron emission for (n,n\*)d

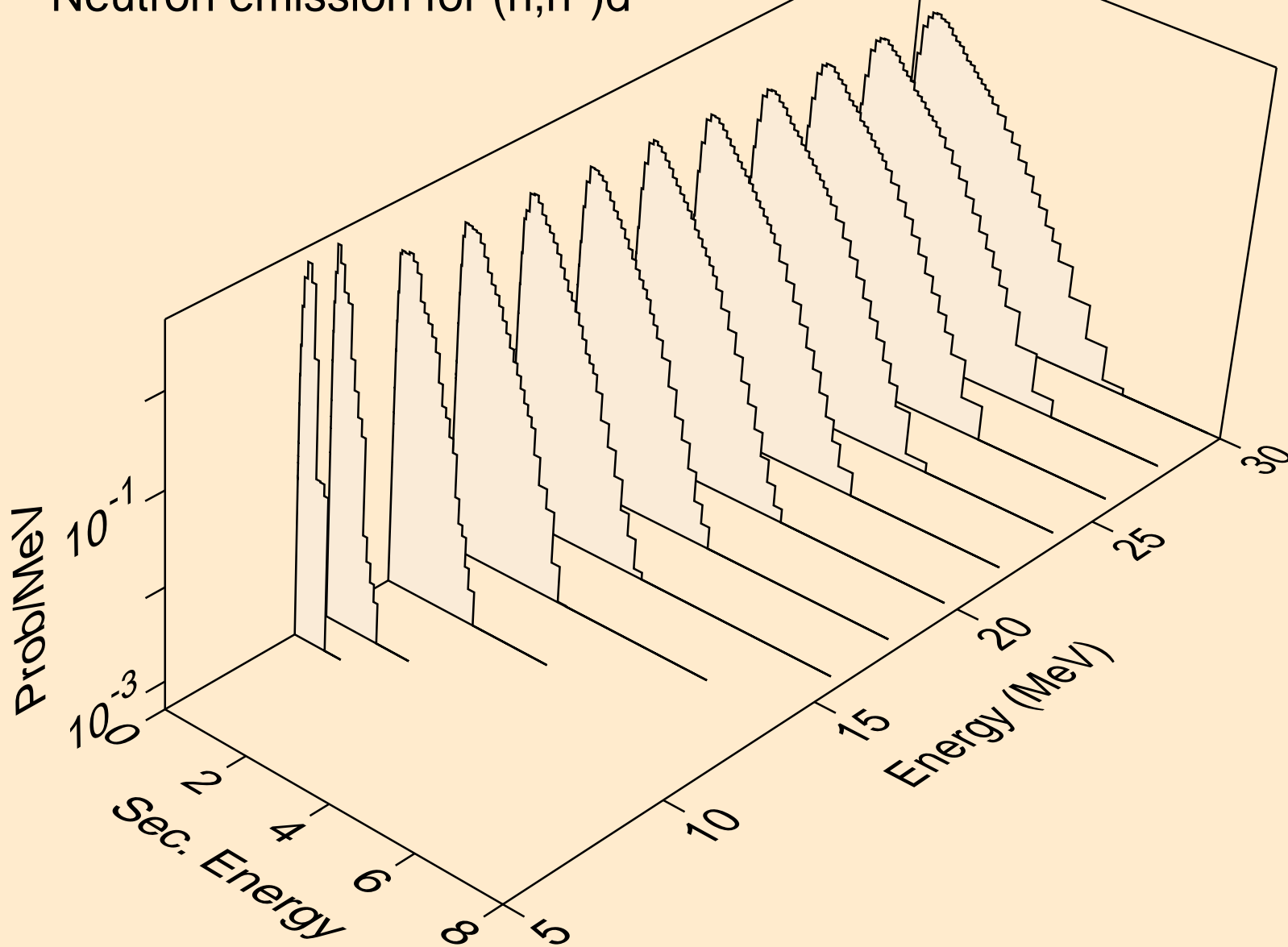



FR206M NEUTRON ACER TENDL-2019 LIBRARY; T=293.16K  
Neutron emission for (n,n\*)t

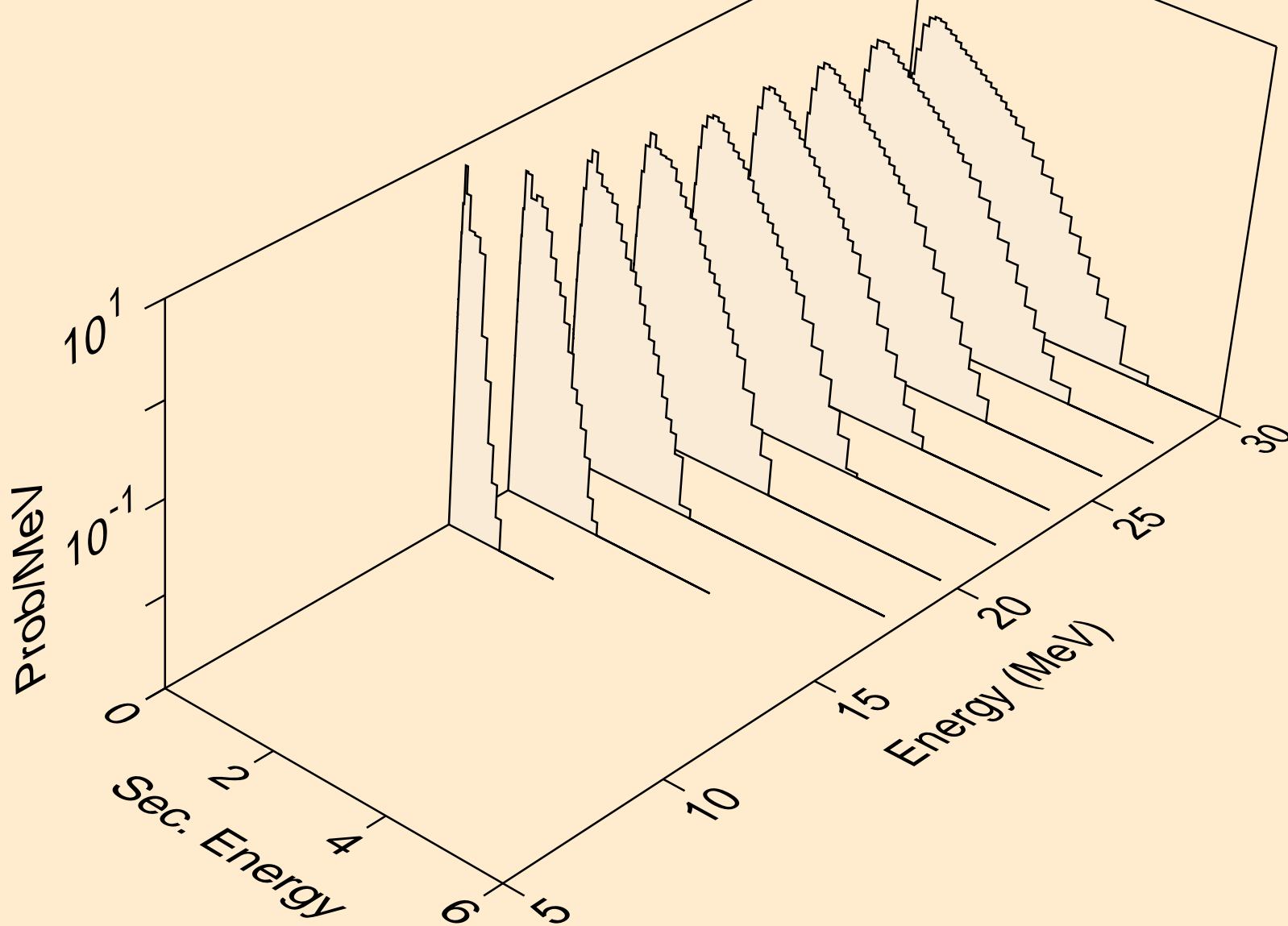

FR206M NEUTRON ACER TENDL-2019 LIBRARY; T=293.16K  
Neutron emission for (n,n\*)he3

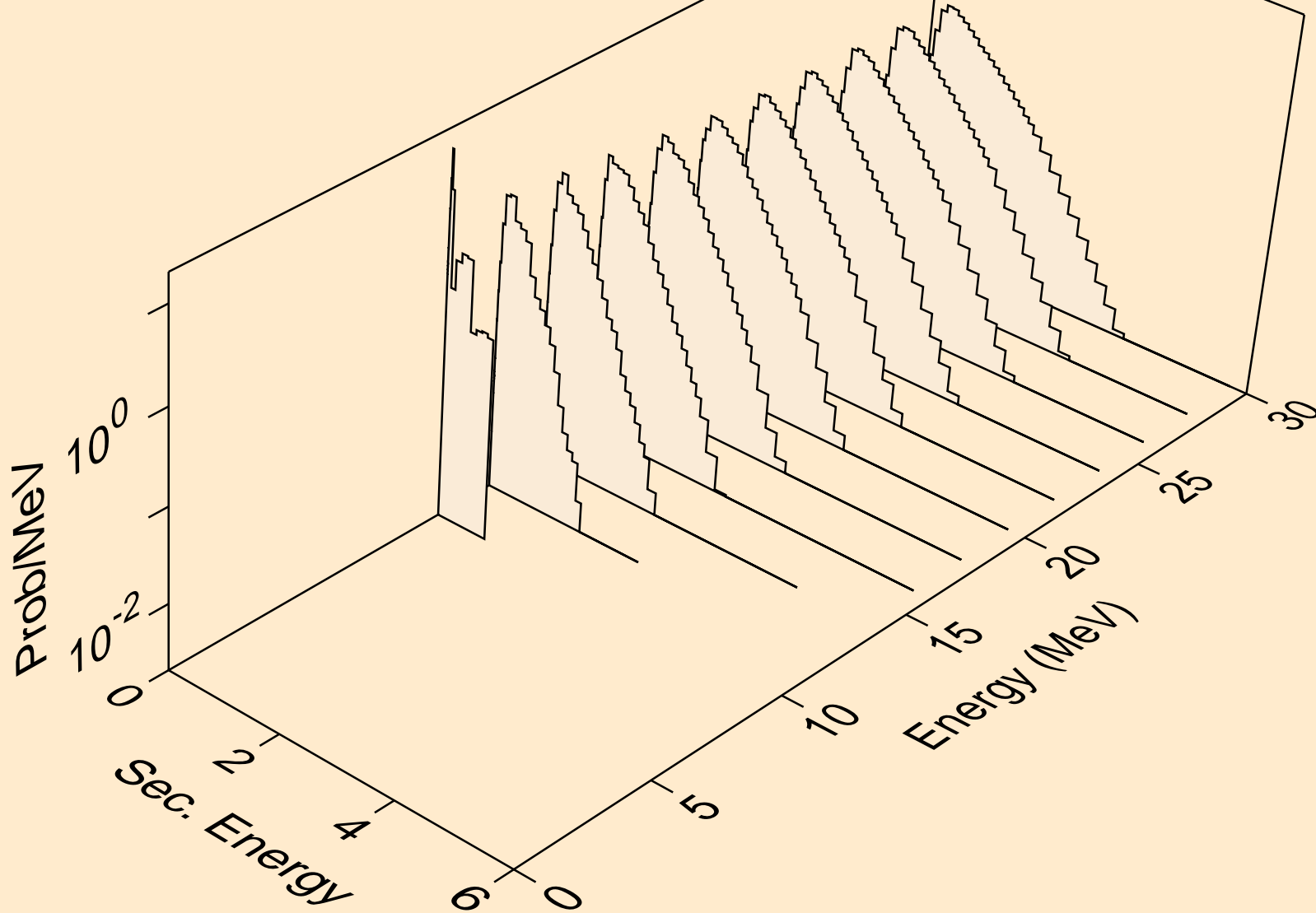

FR206M NEUTRON ACER TENDL-2019 LIBRARY; T=293.16K  
Neutron emission for (n,4n)

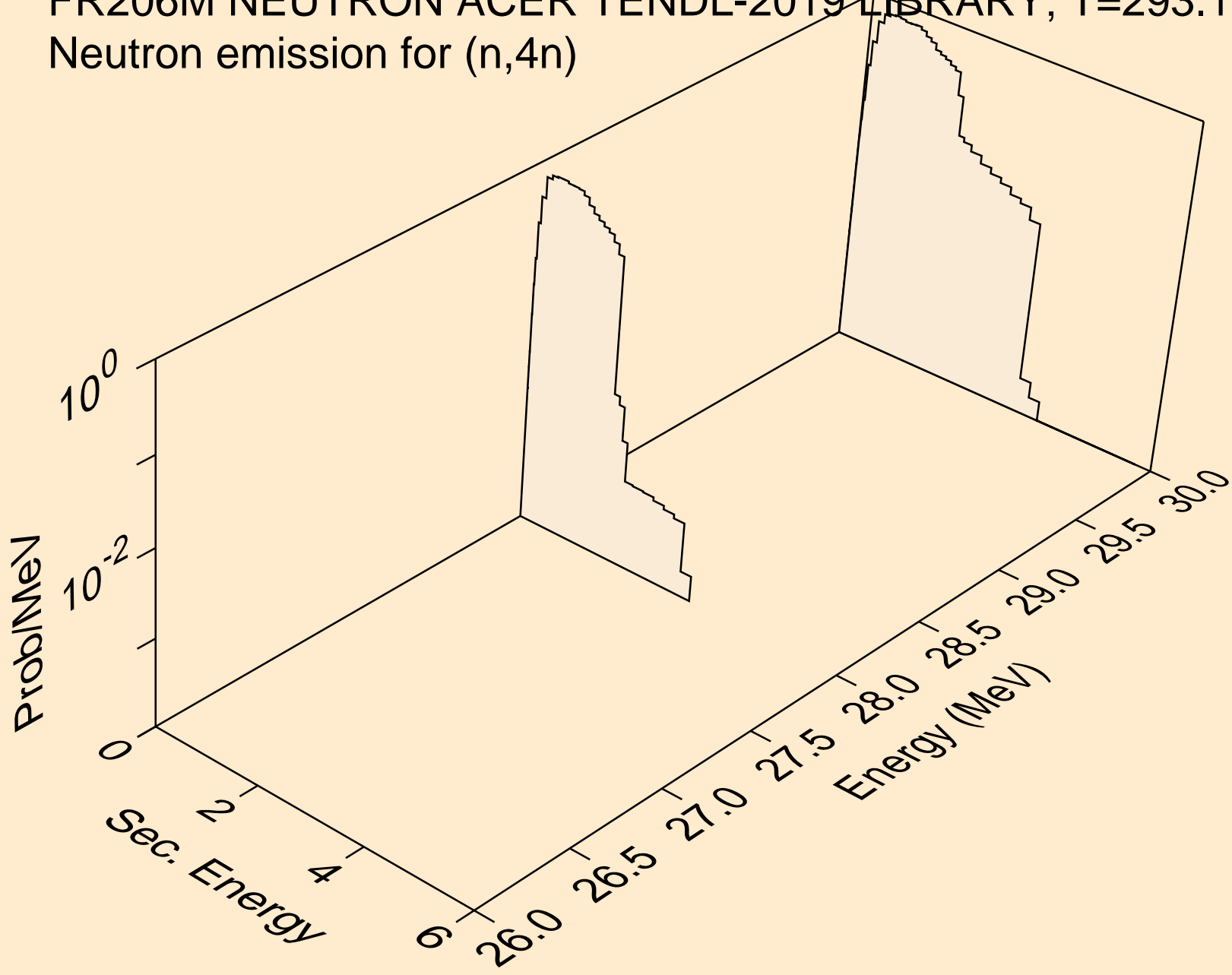

FR206M NEUTRON ACER TENDL-2019 LIBRARY; T=293.16K  
Neutron emission for (n,2np)

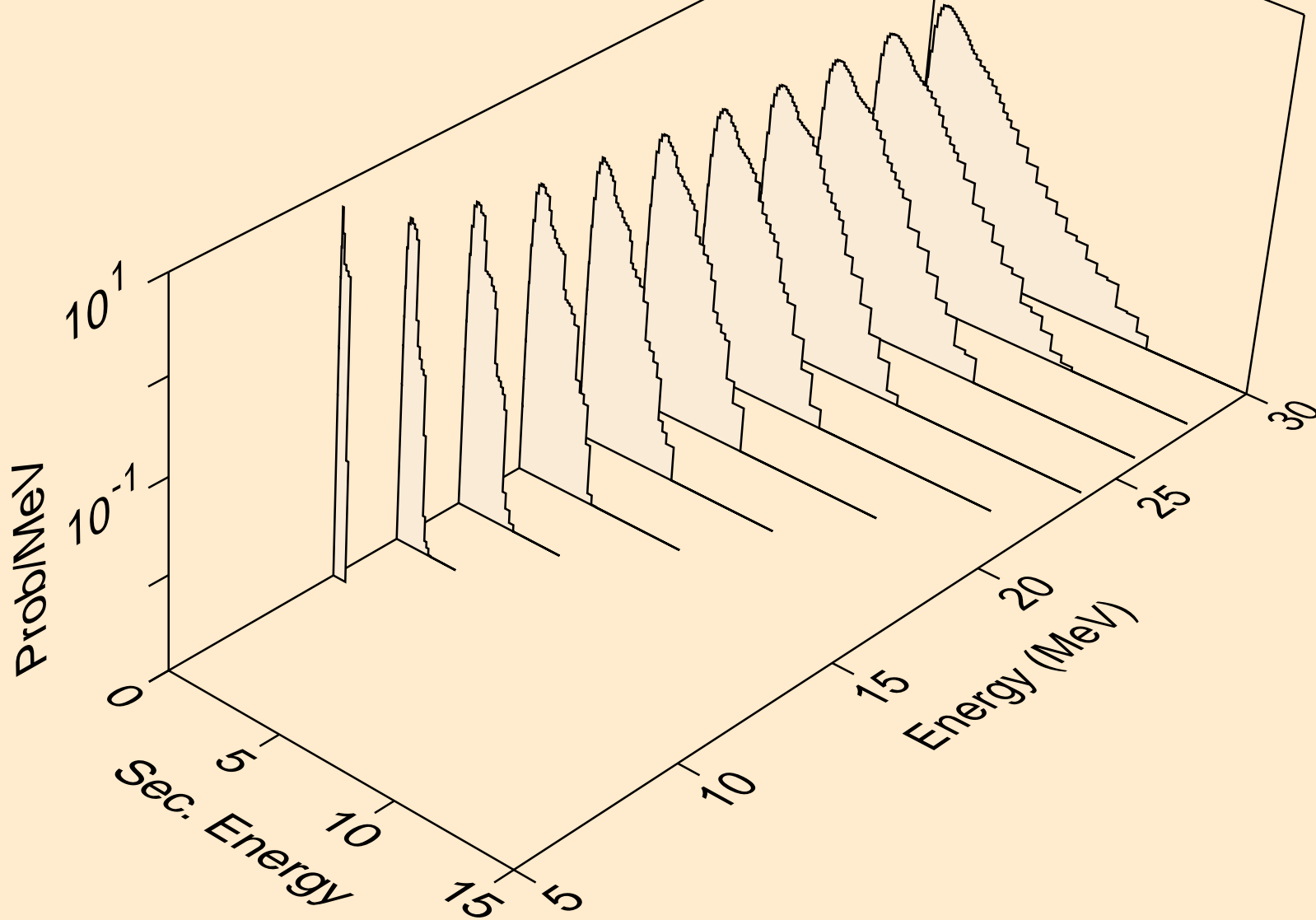

FR206M NEUTRON ACER TENDL-2019 LIBRARY; T=293.16K  
Neutron emission for (n,3np)

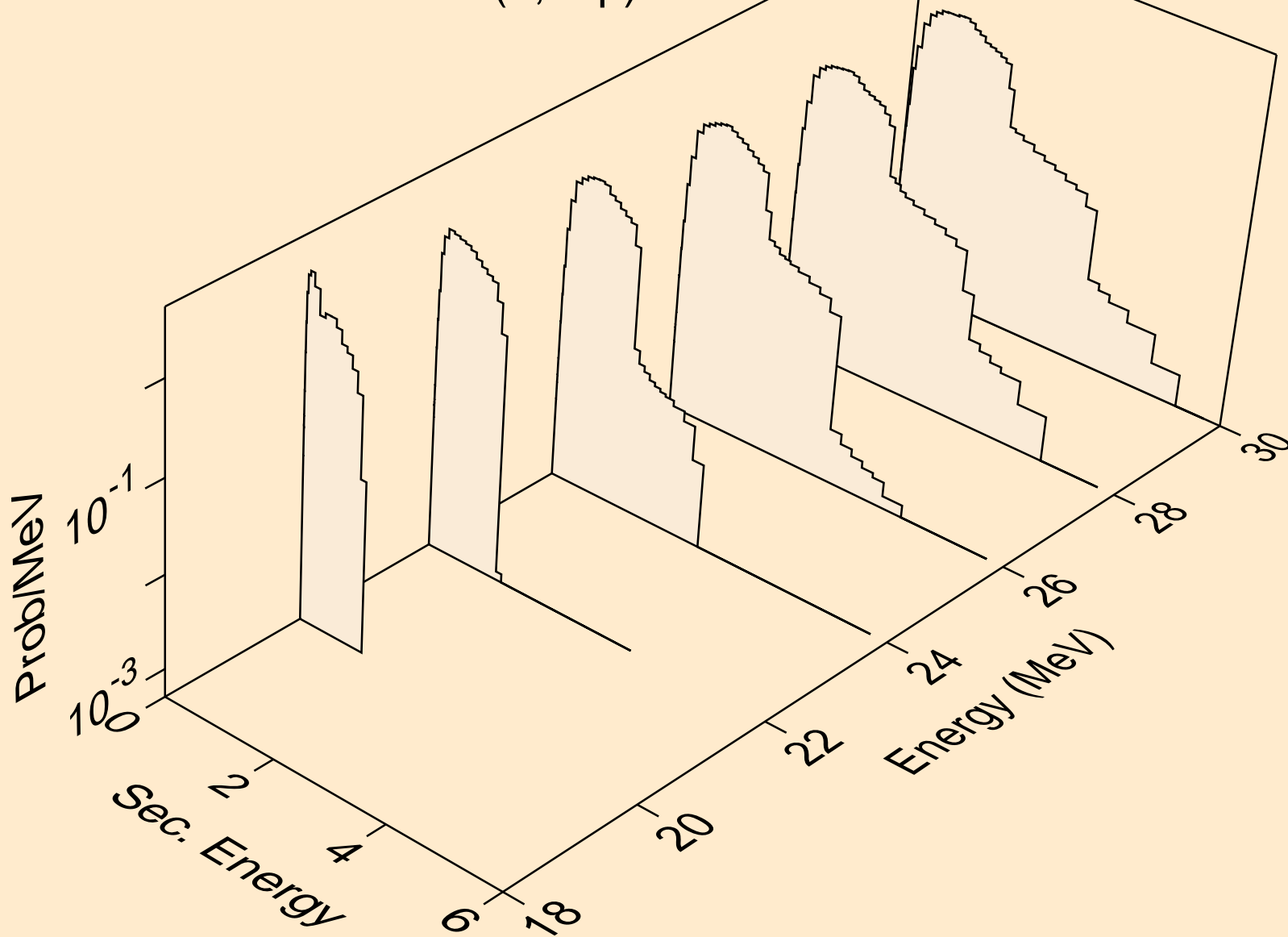

FR206M NEUTRON ACER TENDL-2019 LIBRARY; T=293.16K  
Neutron emission for (n,2np)

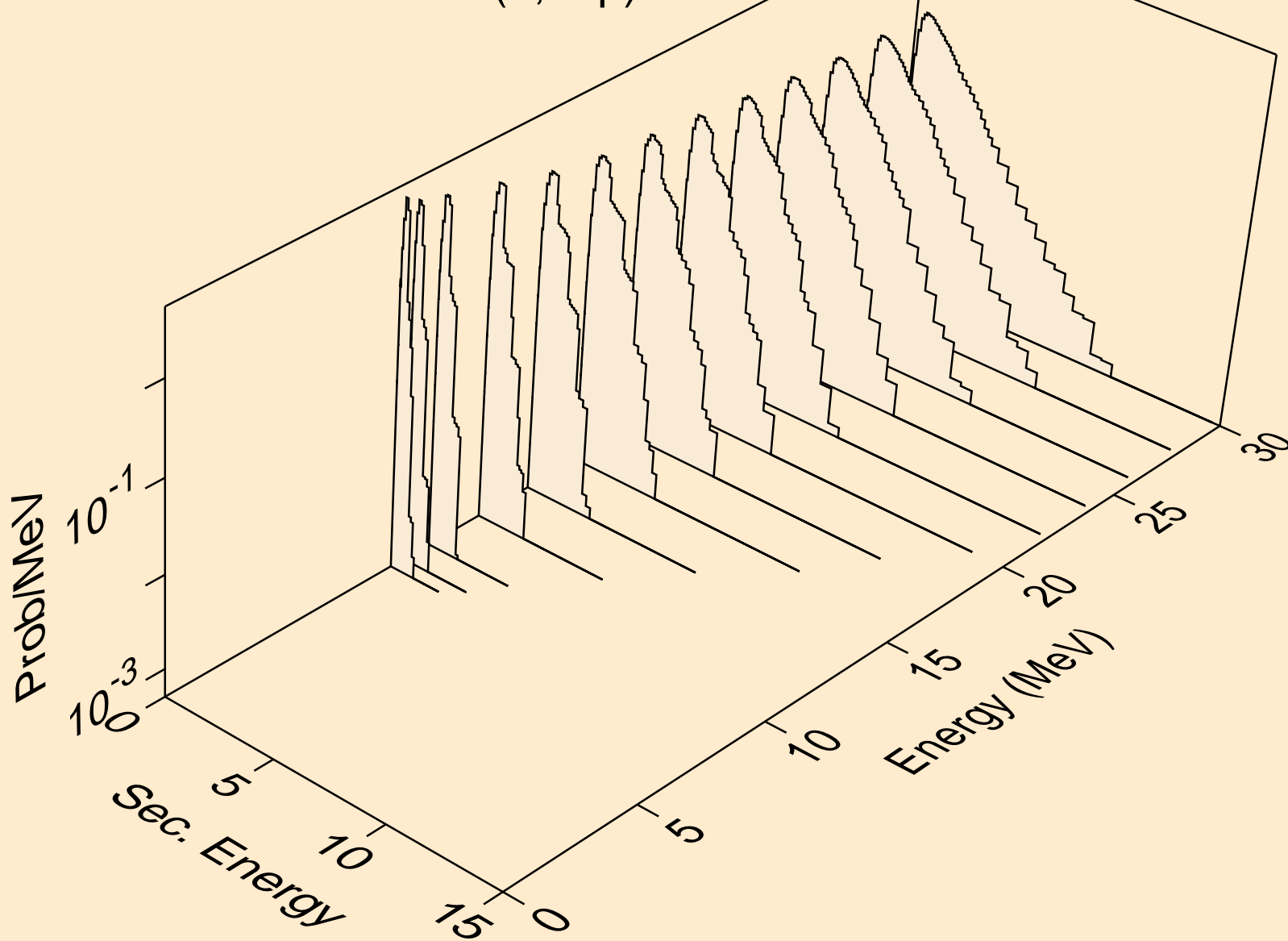

FR206M NEUTRON ACER TENDL-2019 LIBRARY; T=293.16K  
Neutron emission for (n,npa)

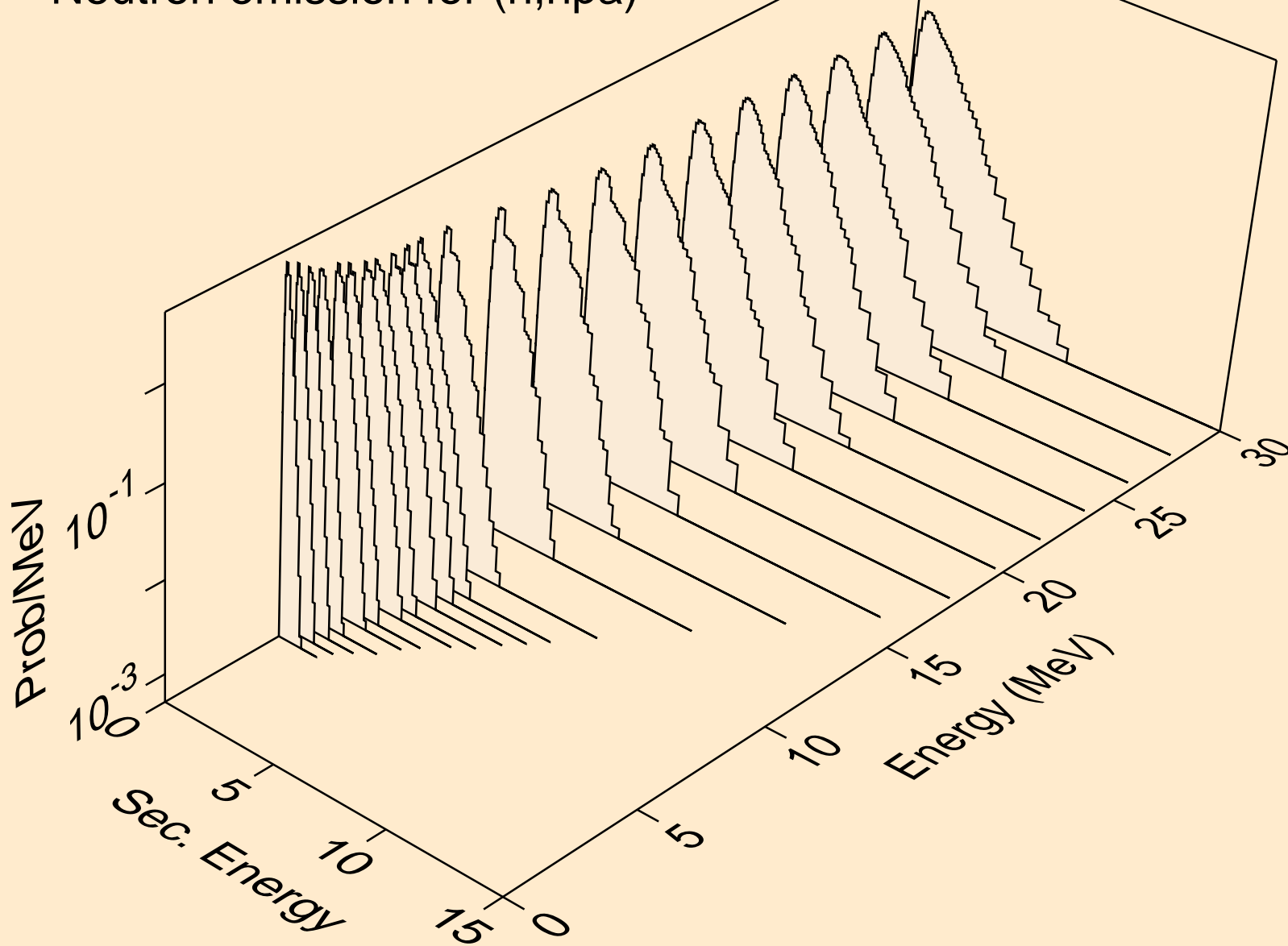

FR206M NEUTRON ACER TENDL-2019 LIBRARY; T=293.16K  
Neutron emission for (n,n\*c)

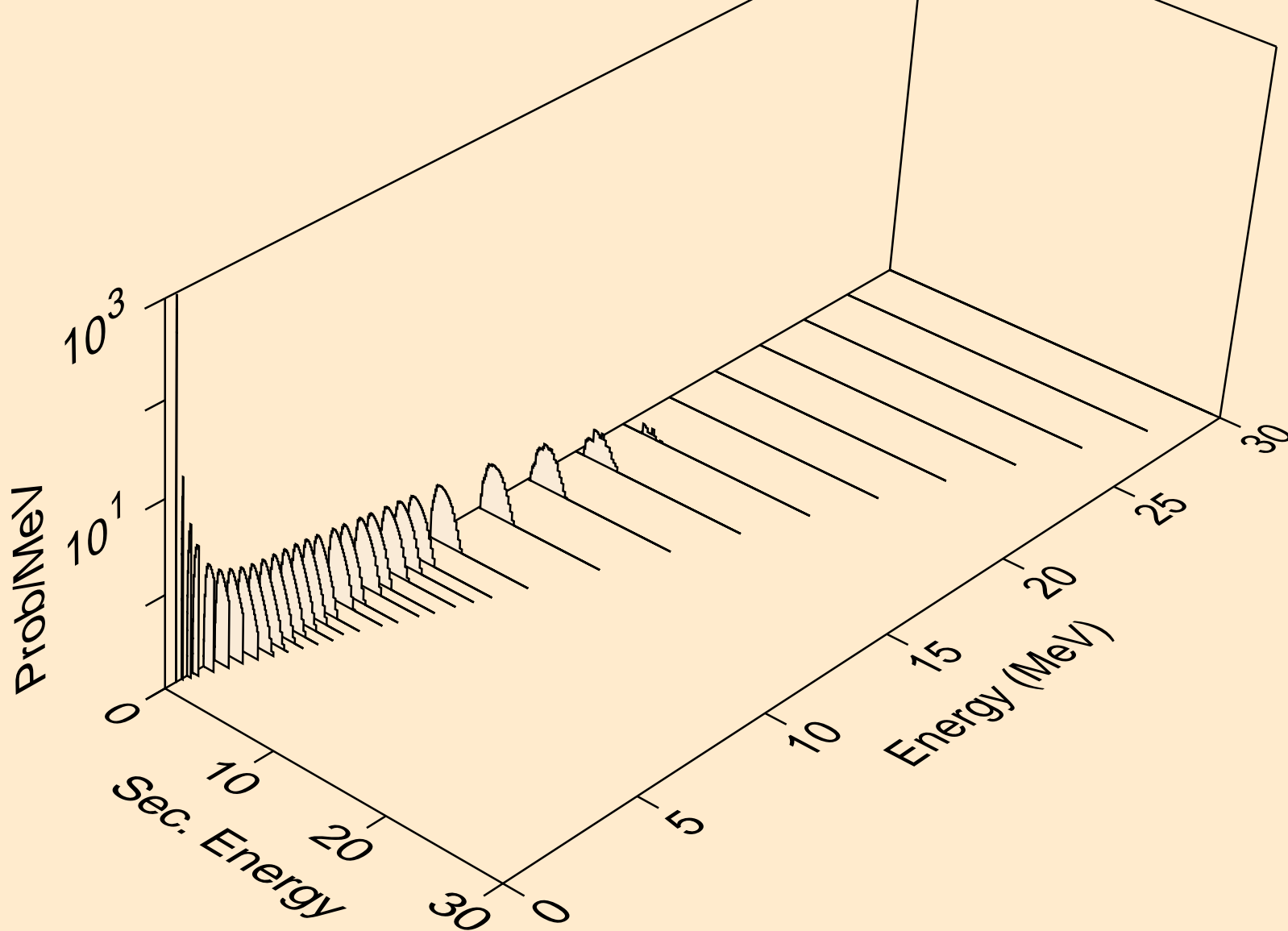



FR206M NEUTRON ACER TENDL-2019 LIBRARY; T=293.16K  
Photon emission for (n,x)

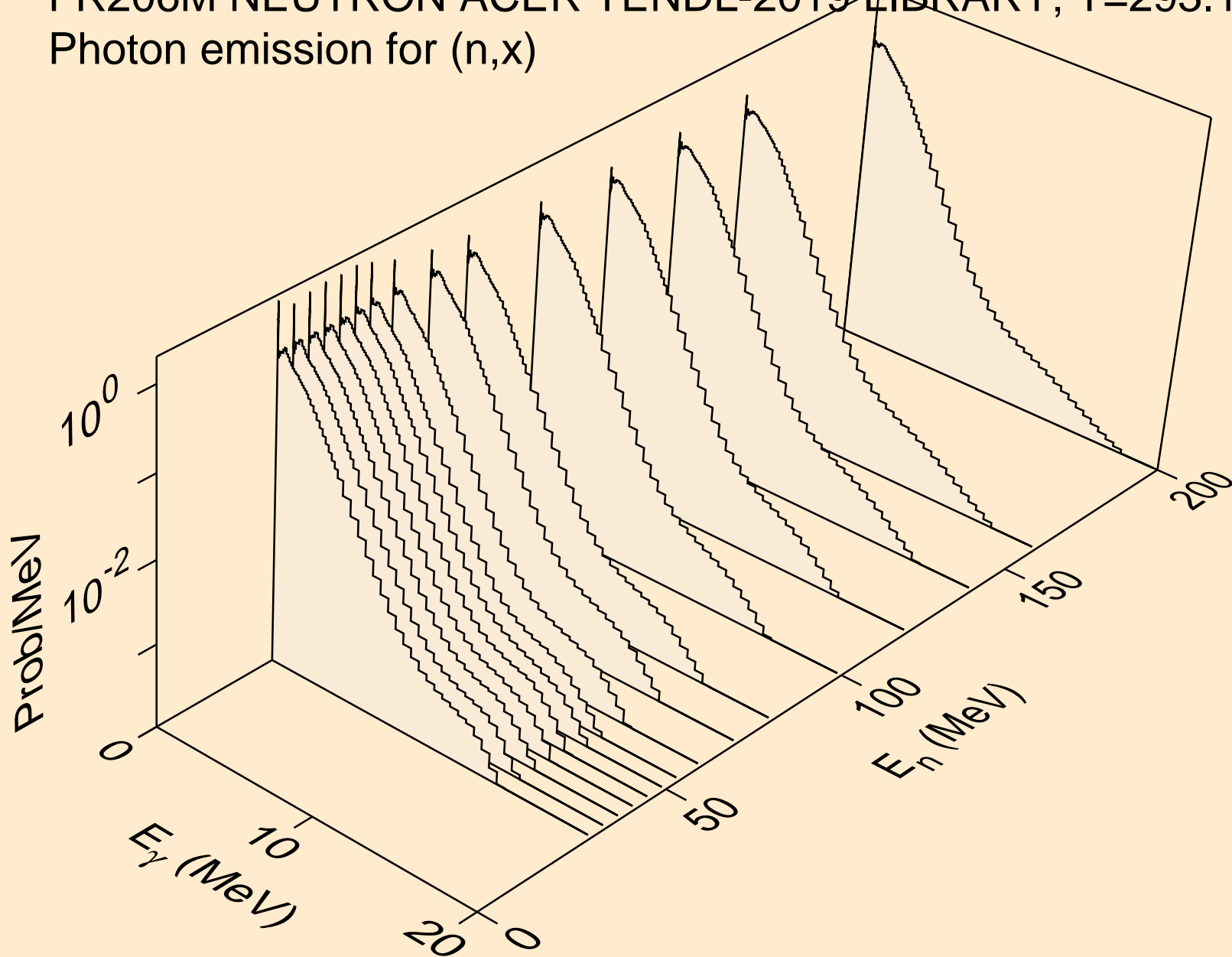

FR206M NEUTRON ACER TENDL-2019 LIBRARY; T=293.16K  
Photon emission for (n,2nd)

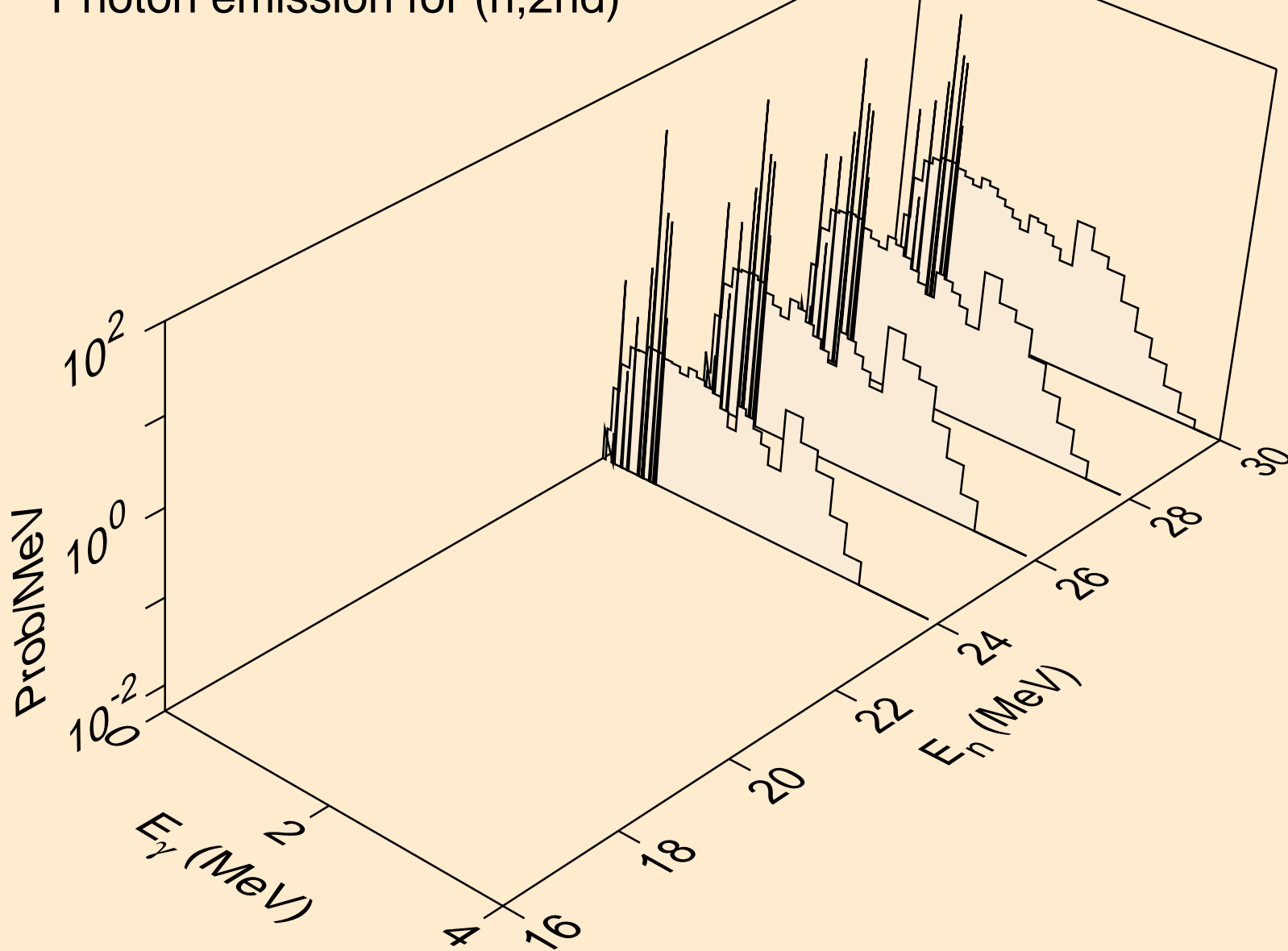

FR206M NEUTRON ACER TENDL-2019 LIBRARY; T=293.16K  
Photon emission for (n,2n)

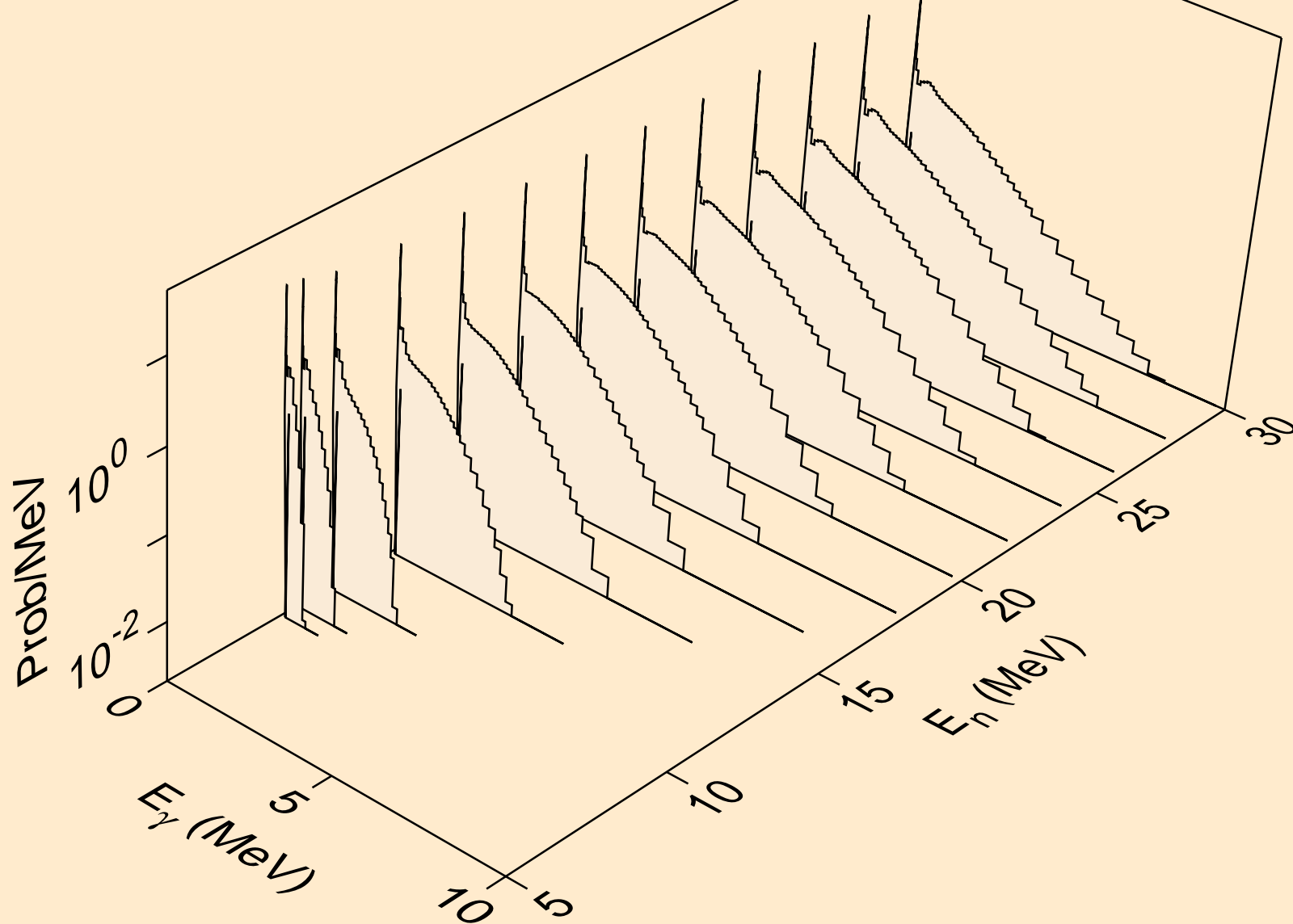

FR206M NEUTRON ACER TENDL-2019 LIBRARY; T=293.16K  
Photon emission for (n,3n)

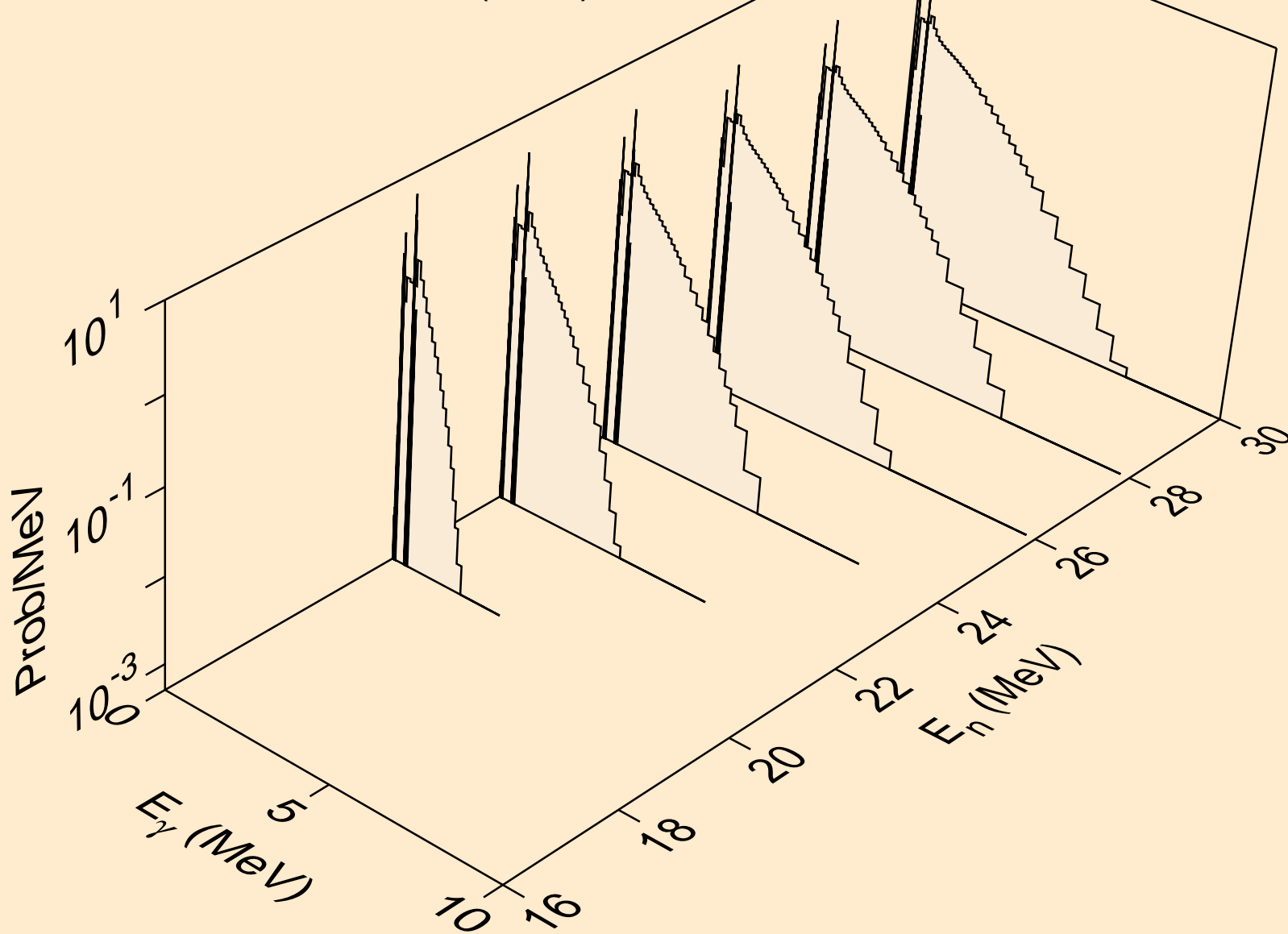

FR206M NEUTRON ACER TENDL-2019 LIBRARY; T=293.16K  
Photon emission for (n,n\*)a

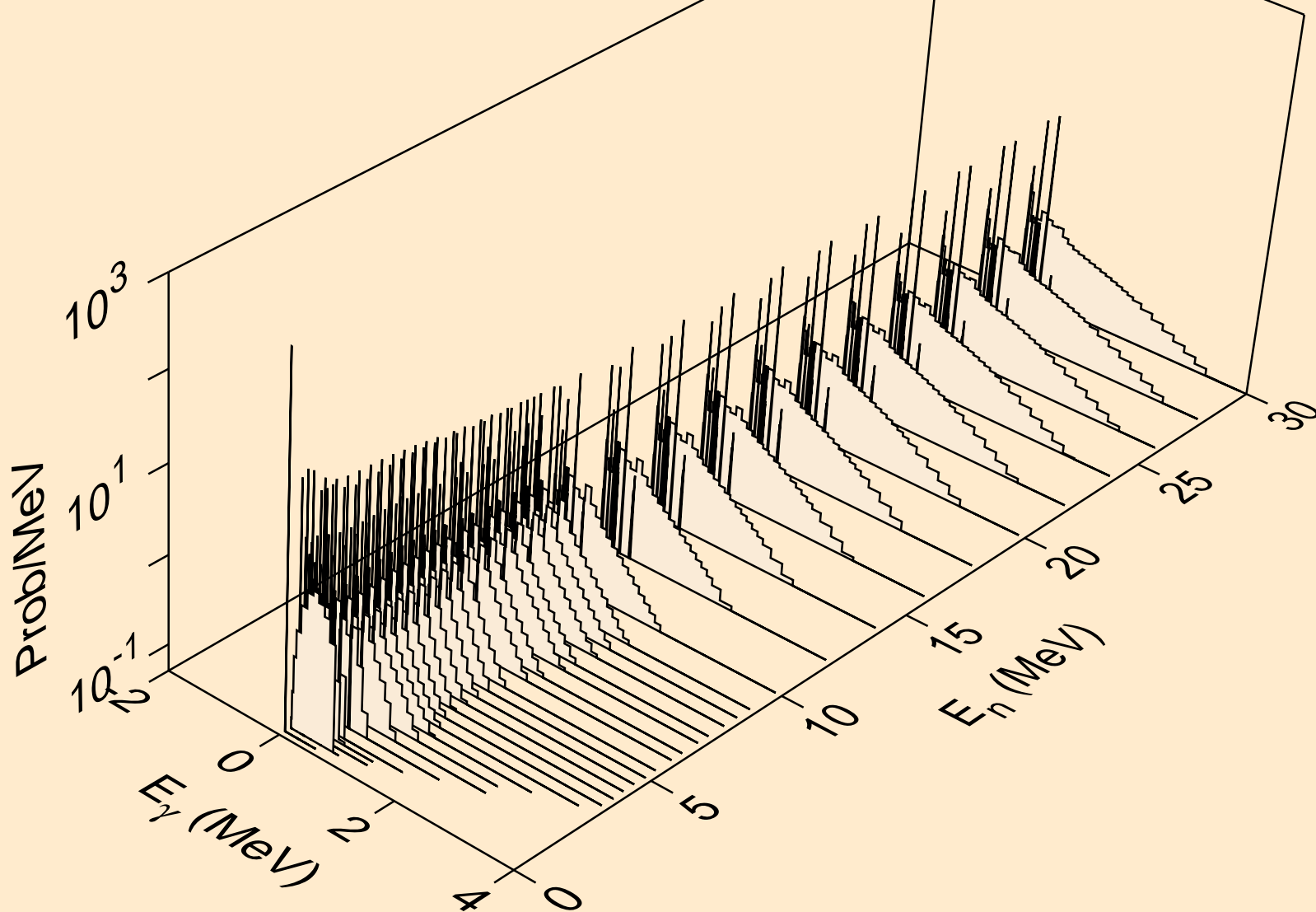

FR206M NEUTRON ACER TENDL-2019 LIBRARY; T=293.16K  
Photon emission for (n,2n)a

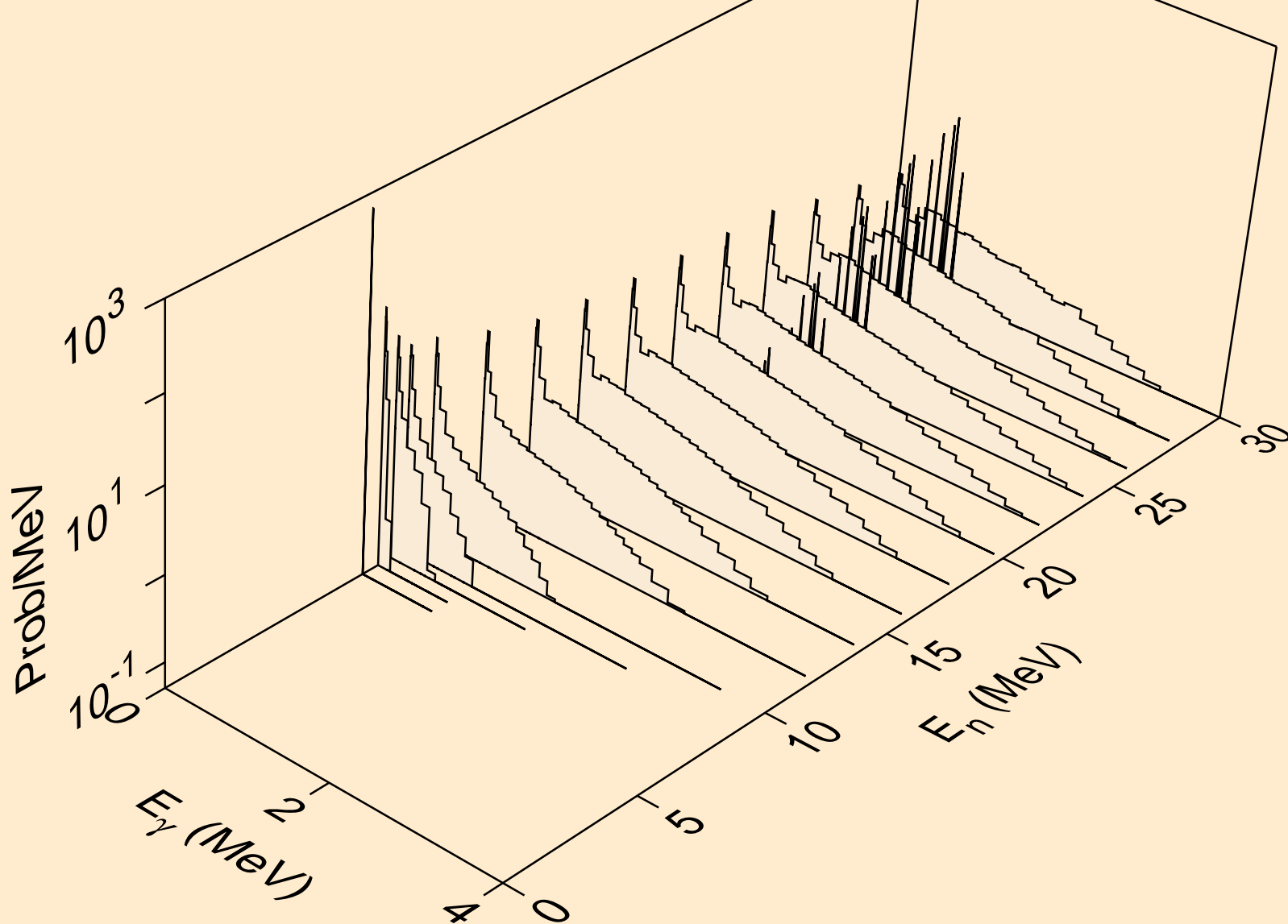

FR206M NEUTRON ACER TENDL-2019 LIBRARY; T=293.16K  
Photon emission for (n,3n)a

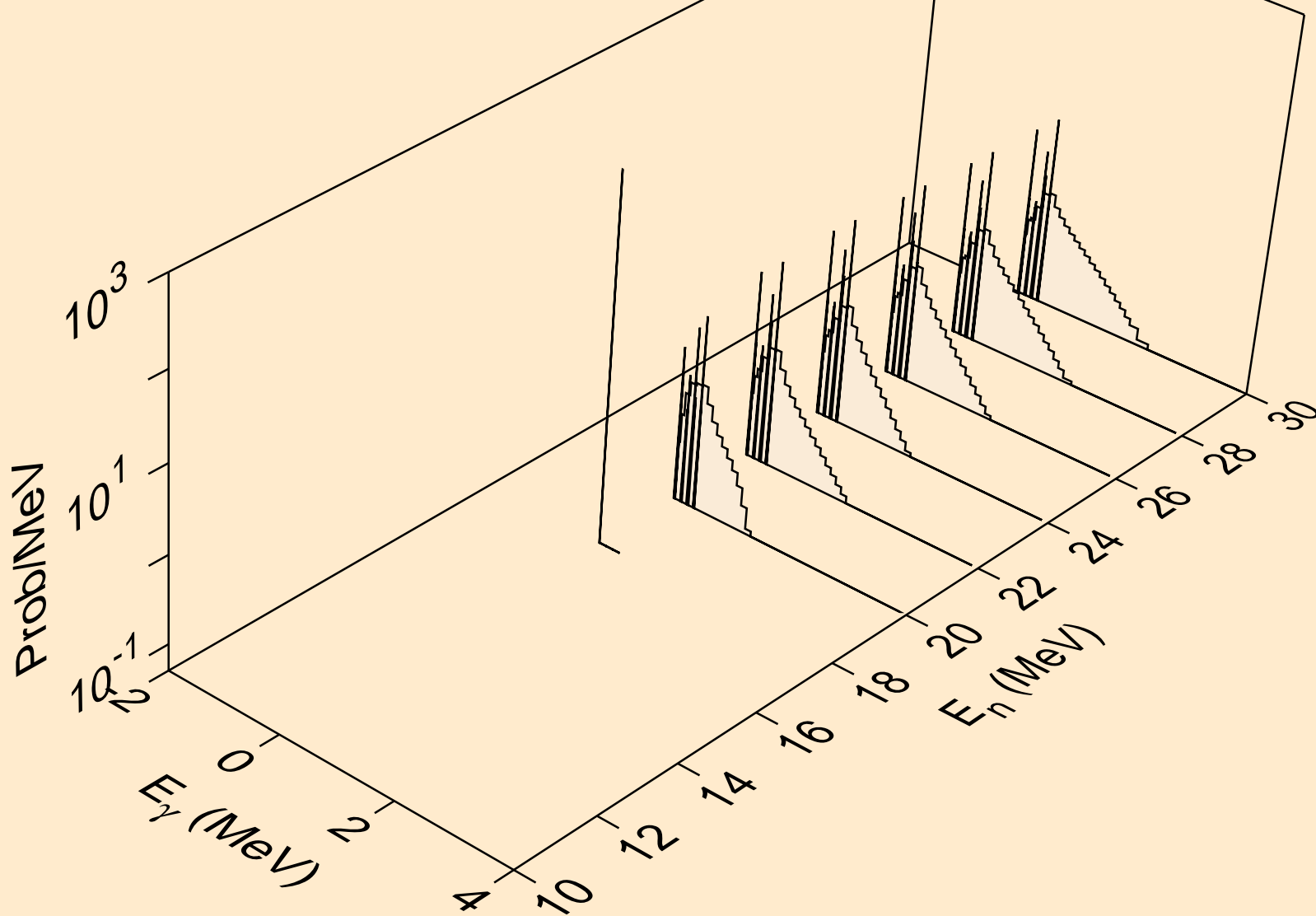

FR206M NEUTRON ACER TENDL-2019 LIBRARY; T=293.16K  
Photon emission for (n,n\*)p

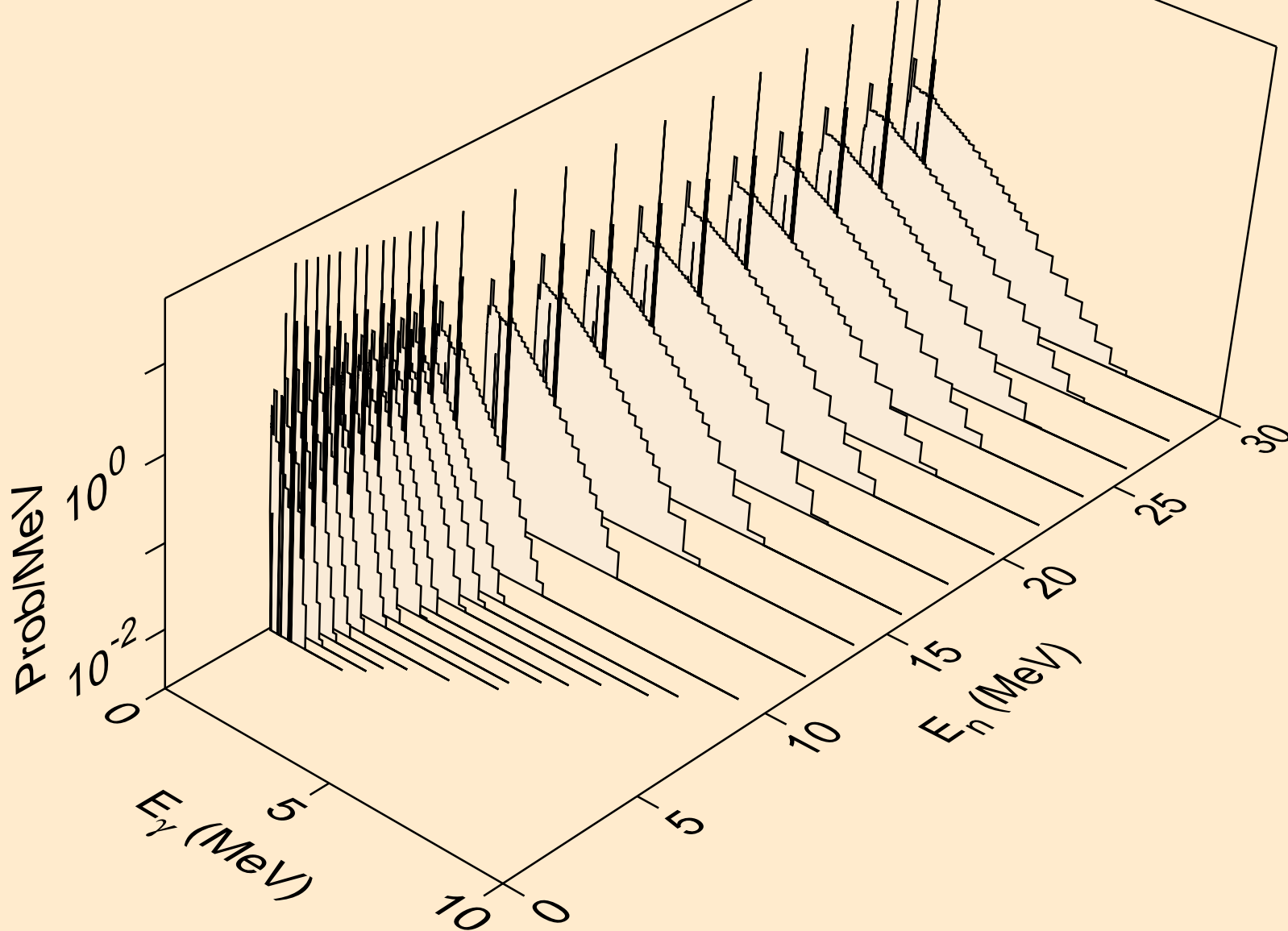



FR206M NEUTRON ACER TENDL-2019 LIBRARY; T=293.16K  
Photon emission for (n,n\*)2a

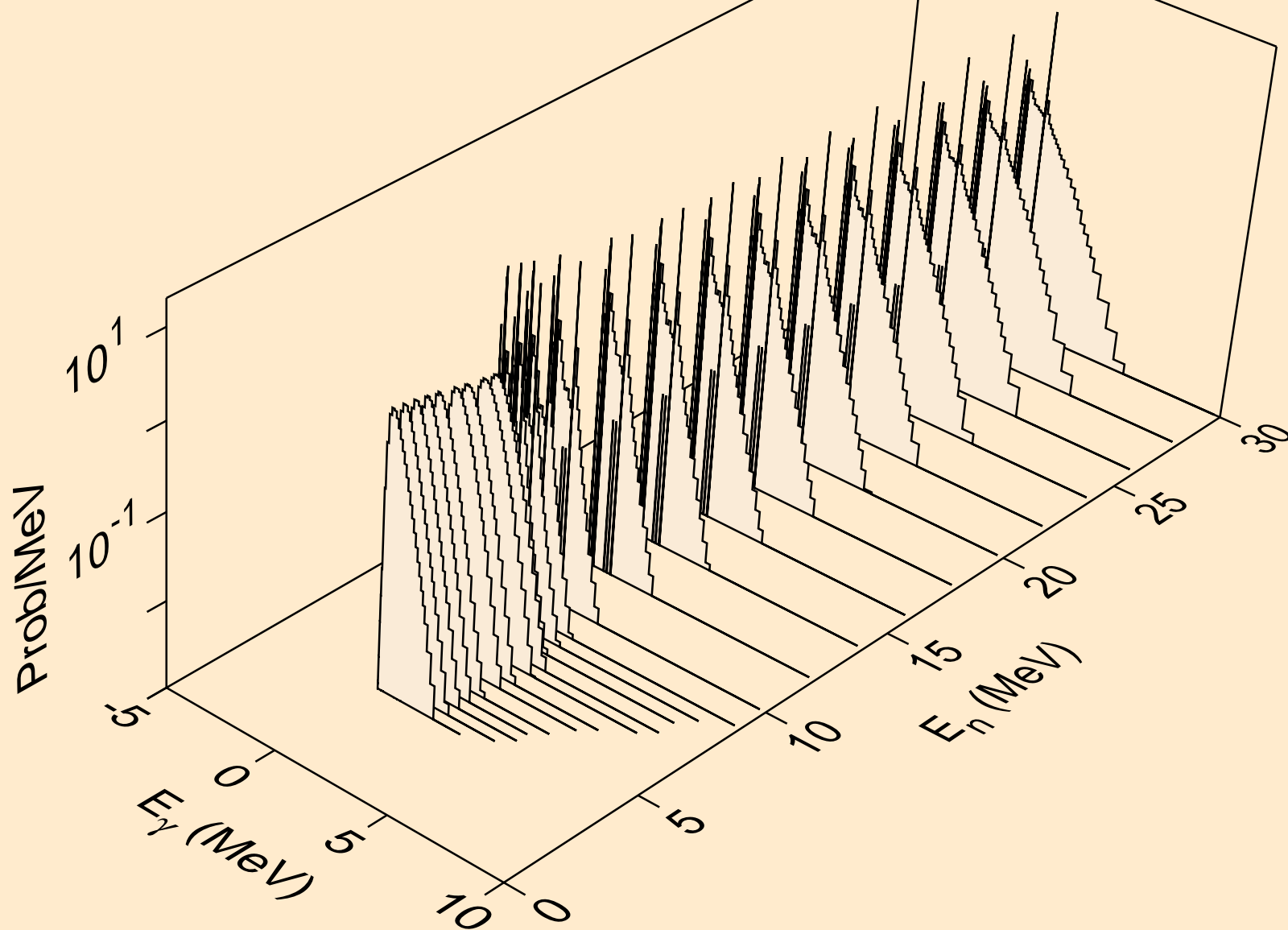

FR206M NEUTRON ACER TENDL-2019 LIBRARY; T=293.16K  
Photon emission for (n,2n)2a

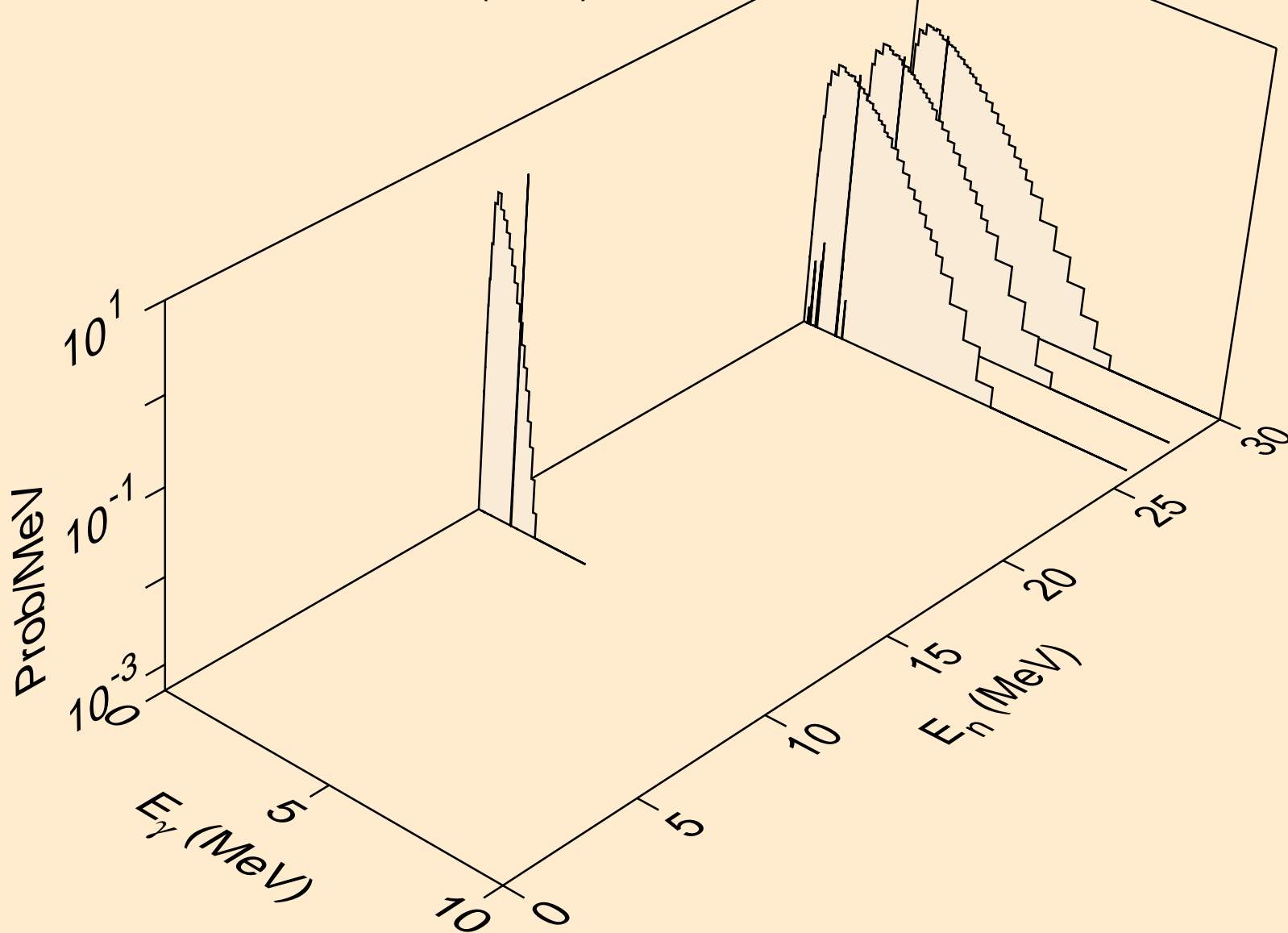

FR206M NEUTRON ACER TENDL-2019 LIBRARY; T=293.16K  
Photon emission for (n,n\*)d

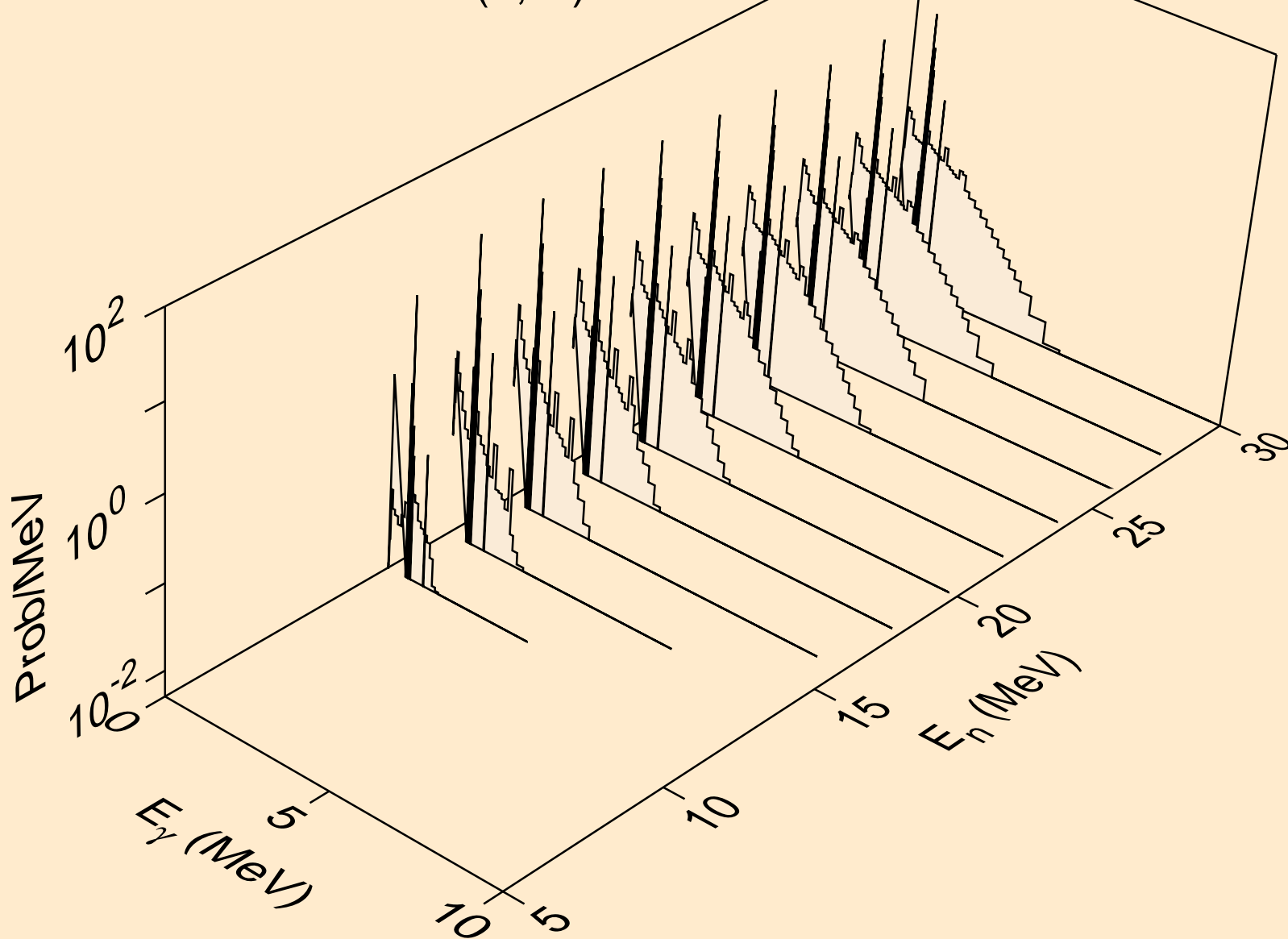

FR206M NEUTRON ACER TENDL-2019 LIBRARY; T=293.16K  
Photon emission for (n,n\*)t

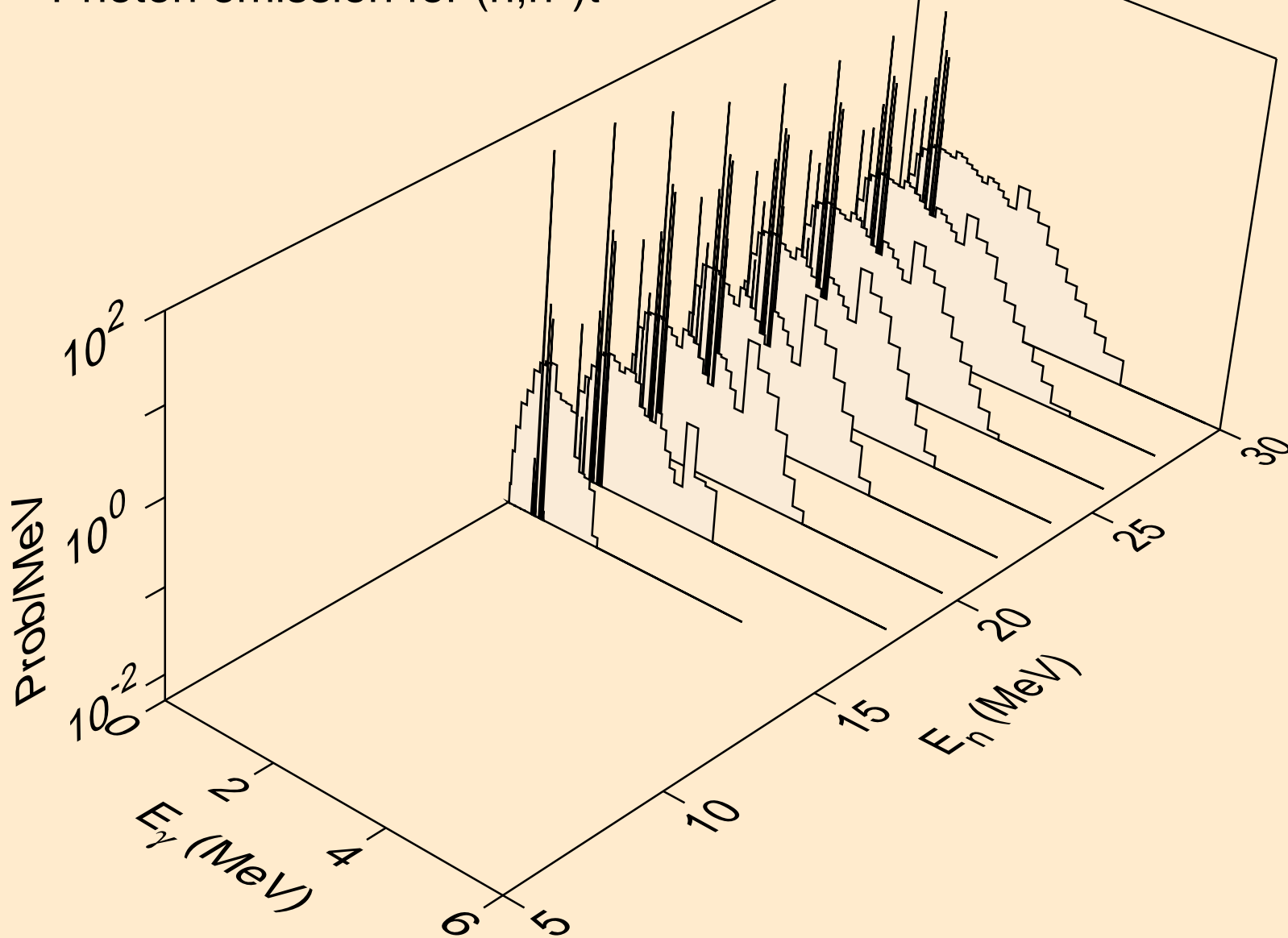

FR206M NEUTRON ACER TENDL-2019 LIBRARY; T=293.16K  
Photon emission for (n,n\*)he3

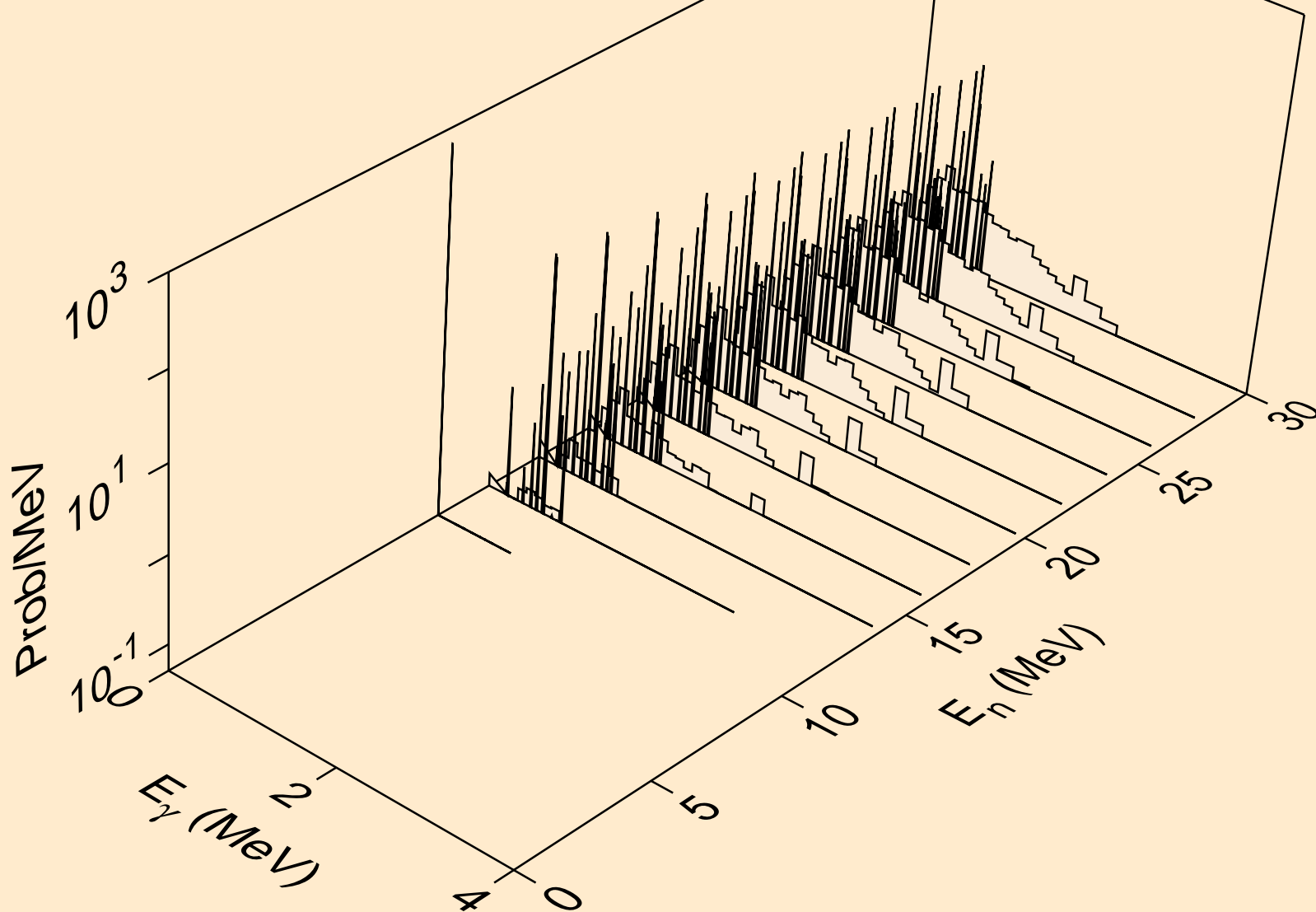

FR206M NEUTRON ACER TENDL-2019 LIBRARY; T=293.16K  
Photon emission for (n,4n)

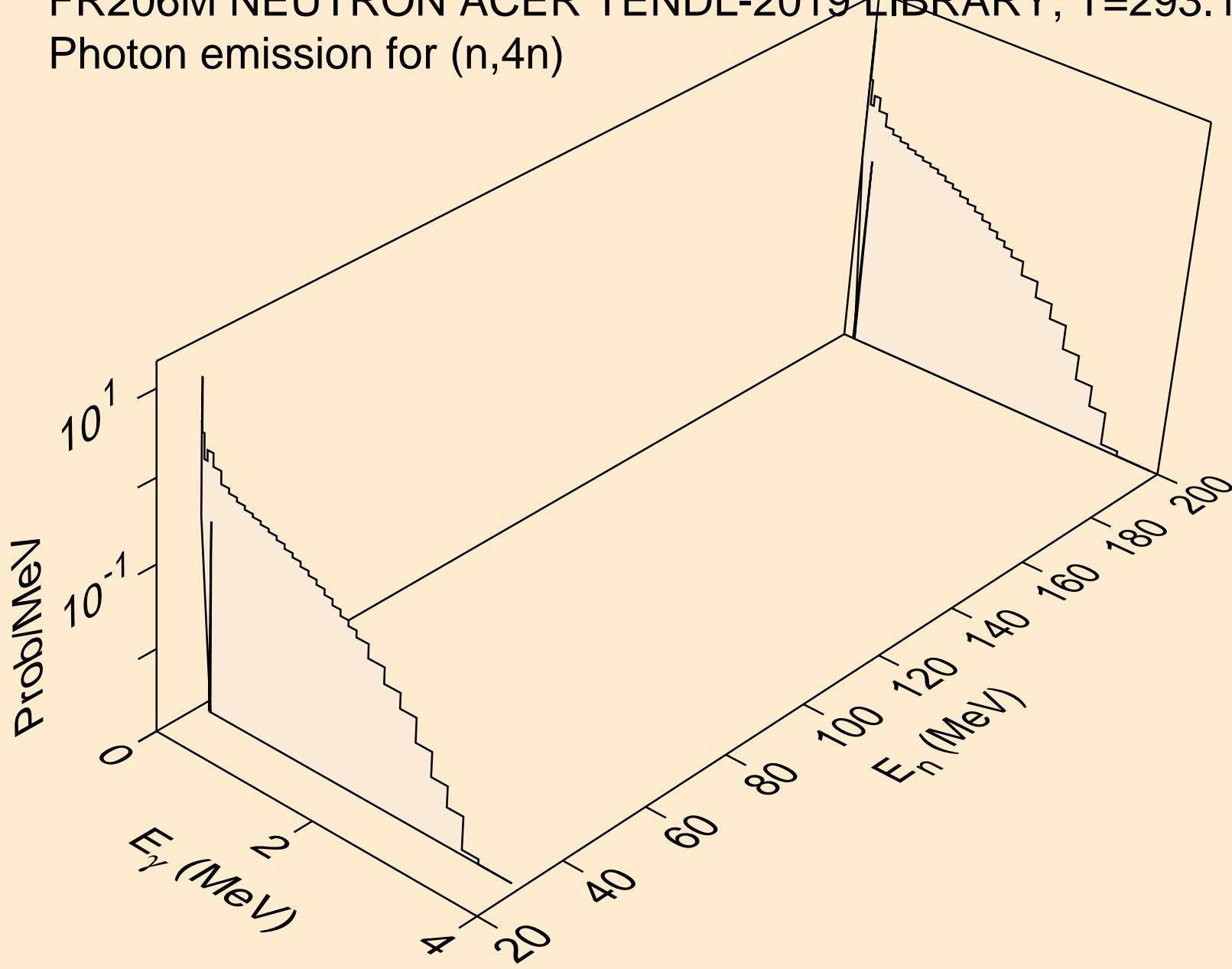

FR206M NEUTRON ACER TENDL-2019 LIBRARY; T=293.16K  
Photon emission for (n,2np)

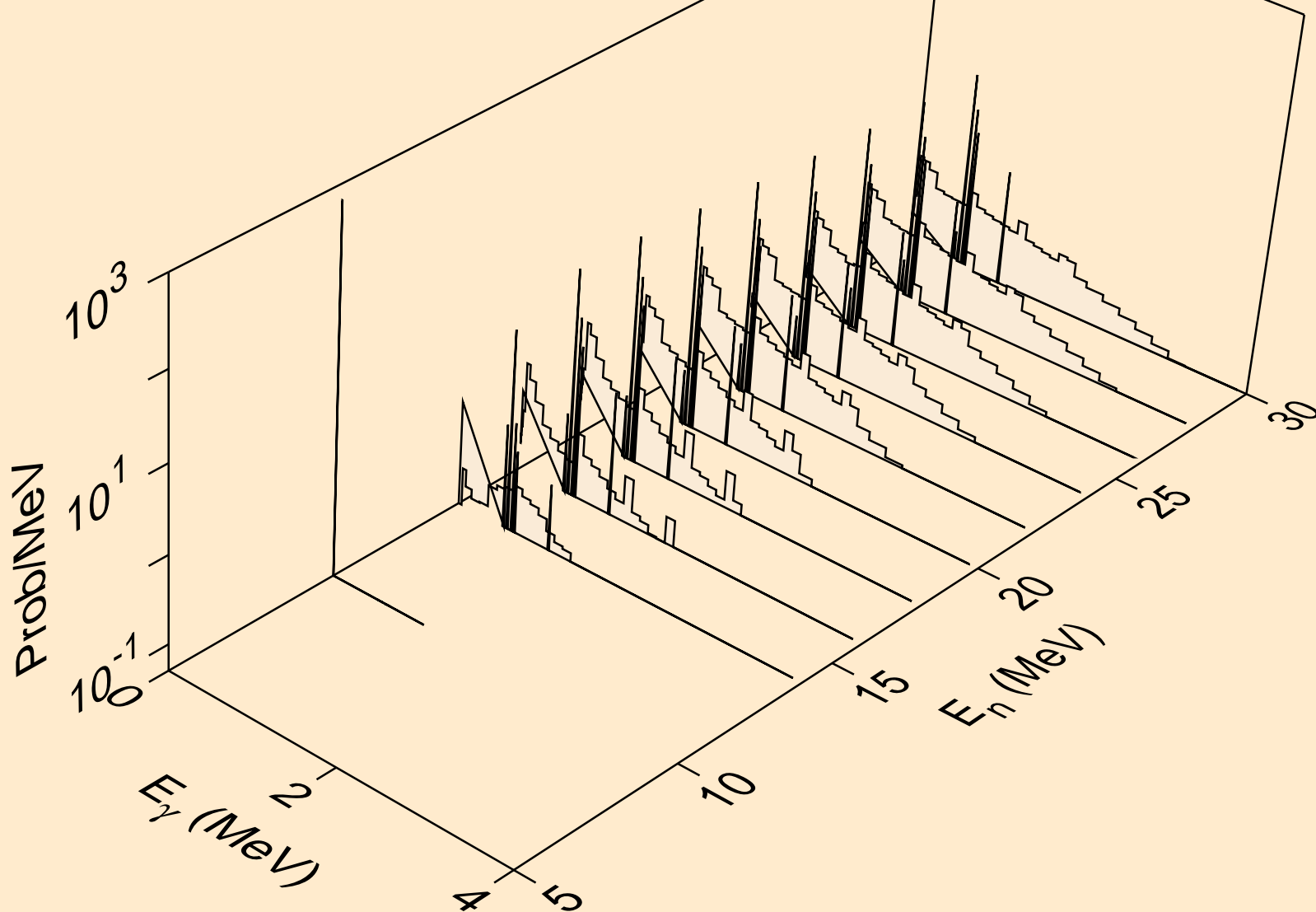

FR206M NEUTRON ACER TENDL-2019 LIBRARY; T=293.16K  
Photon emission for (n,3np)

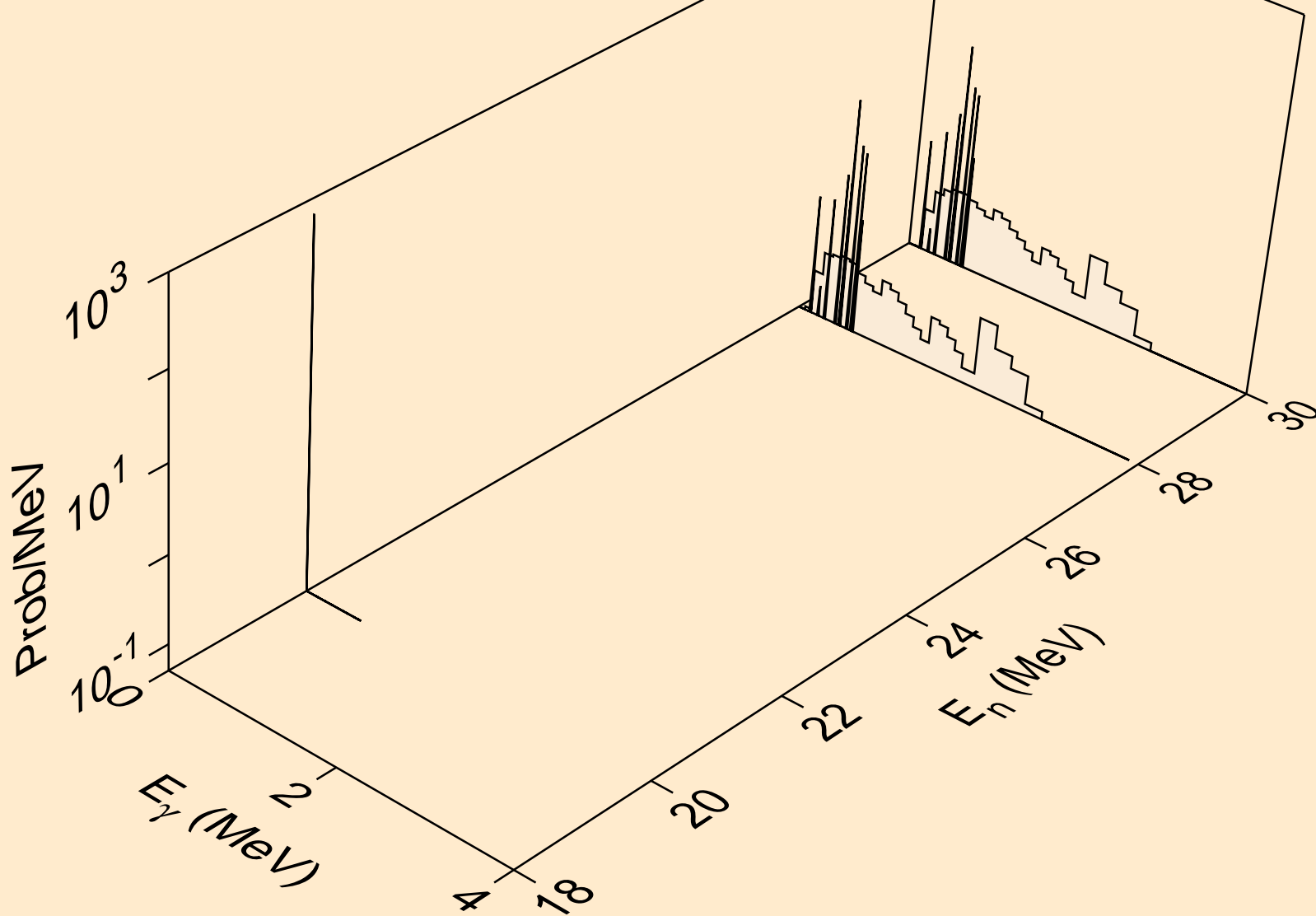



FR206M NEUTRON ACER TENDL-2019 LIBRARY; T=293.16K  
Photon emission for (n,2np)

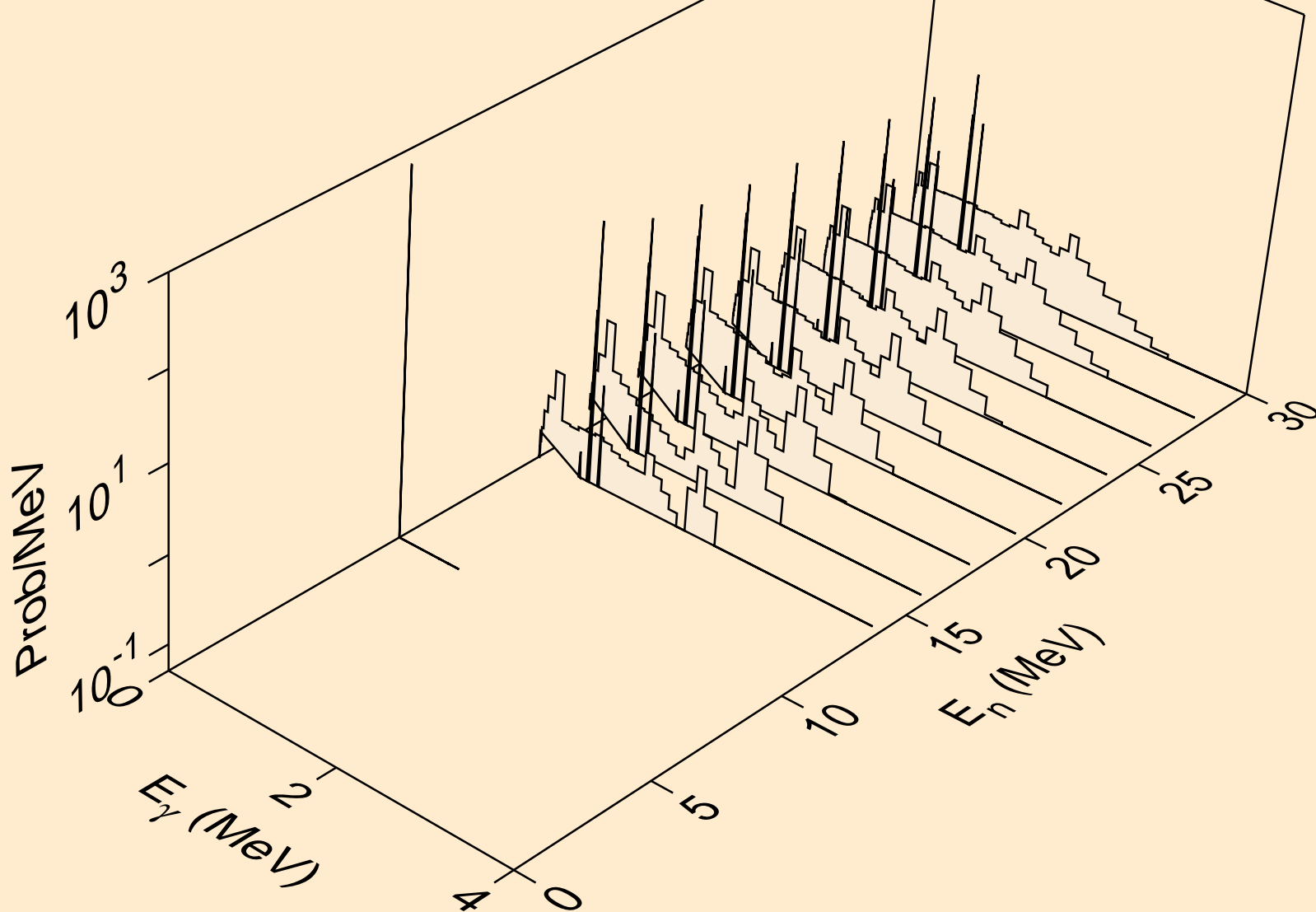

FR206M NEUTRON ACER TENDL-2019 LIBRARY; T=293.16K  
Photon emission for (n,npa)

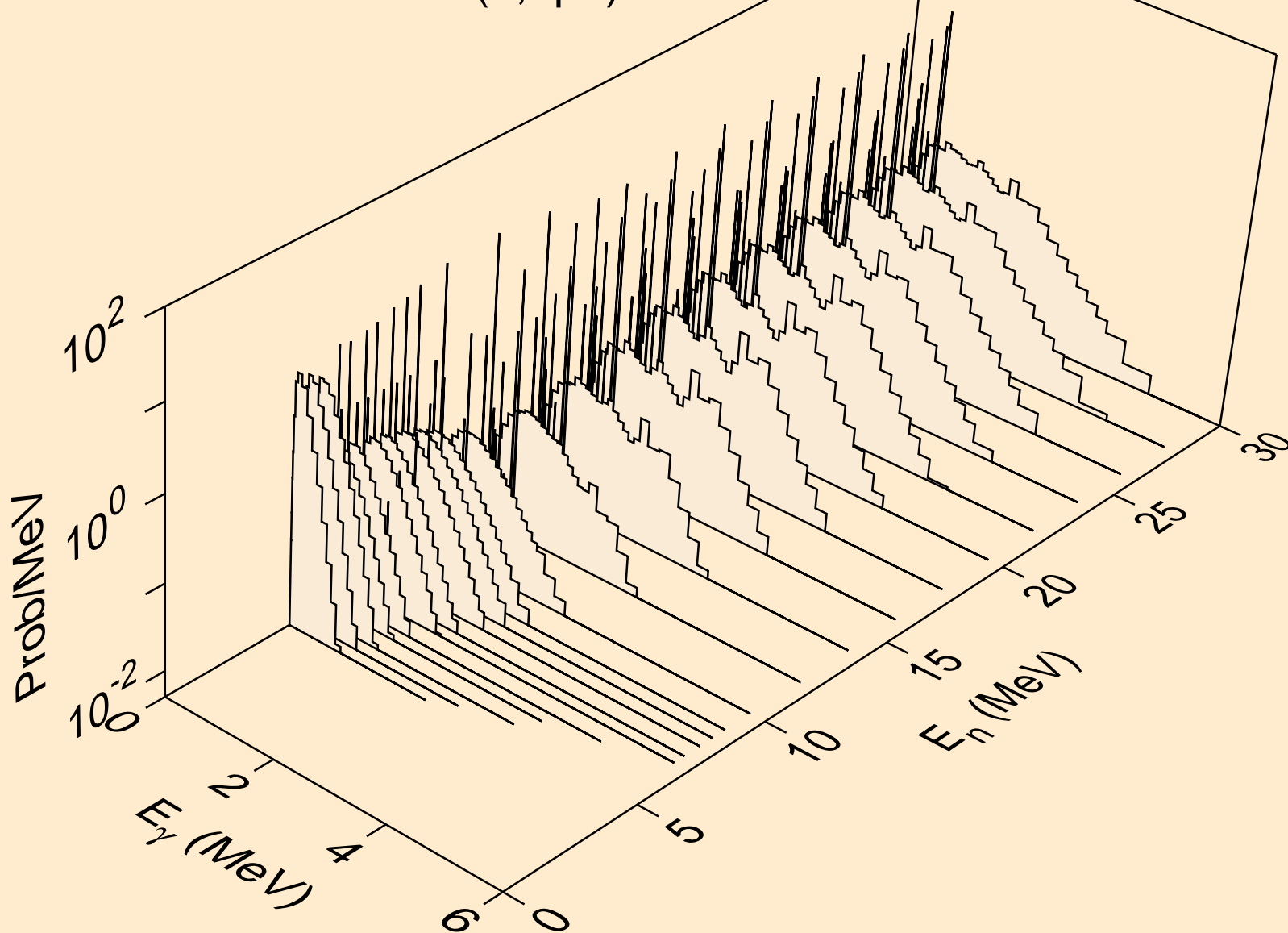

FR206M NEUTRON ACER TENDL-2019 LIBRARY; T=293.16K  
Photon emission for (n,n\*2)

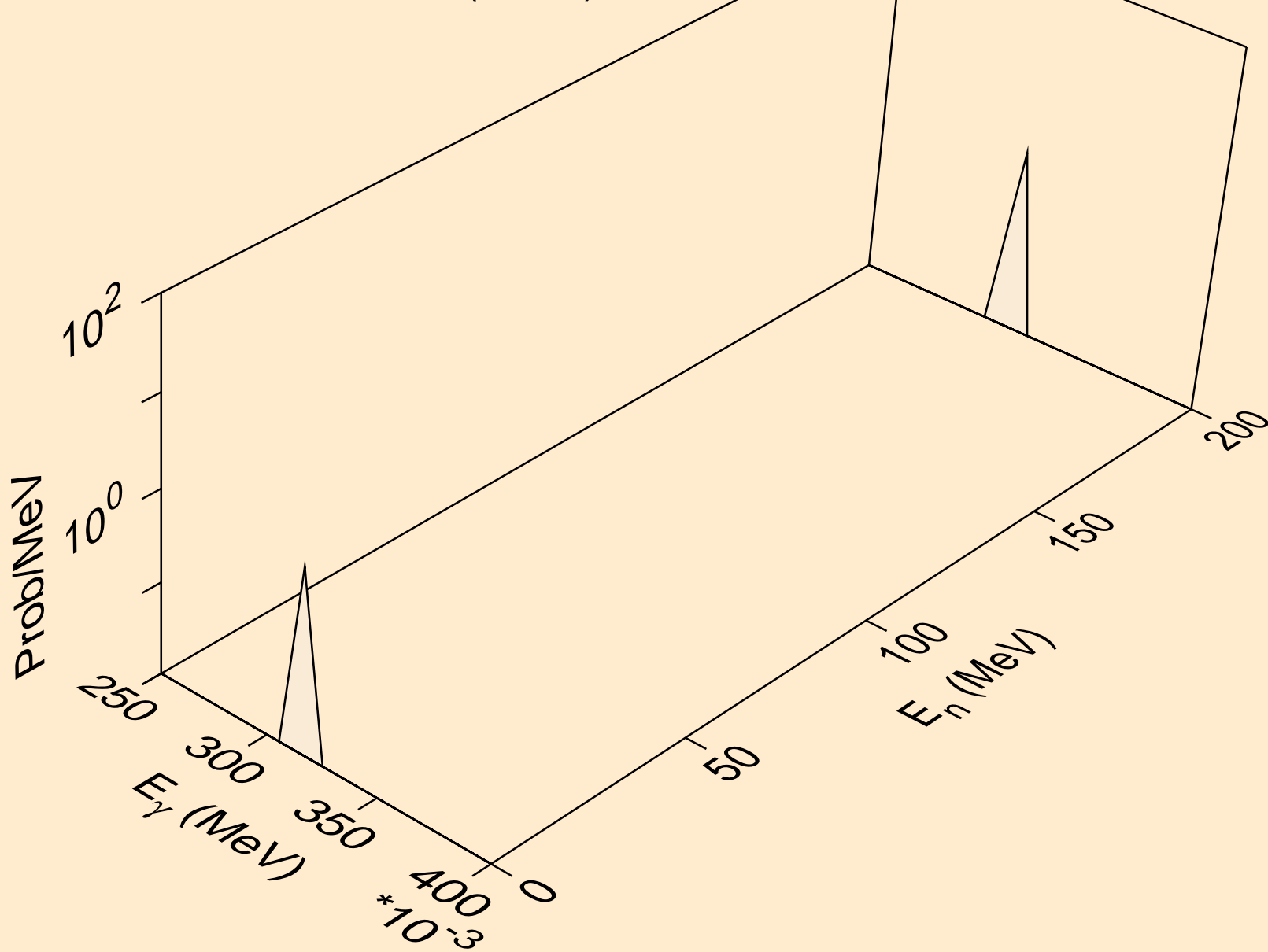

FR206M NEUTRON ACER TENDL-2019 LIBRARY; T=293.16K  
Photon emission for (n,n\*c)

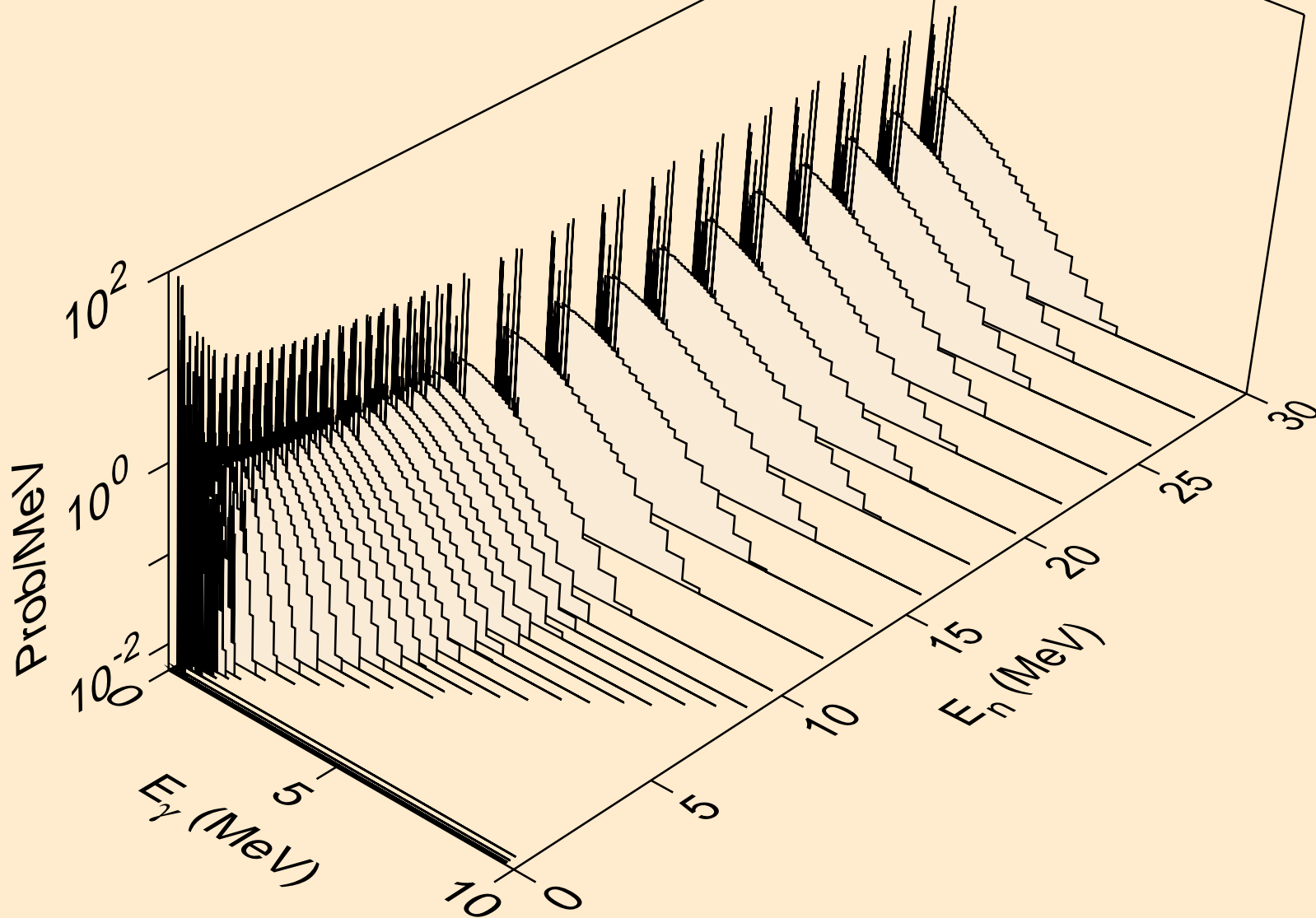

FR206M NEUTRON ACER TENDL-2019 LIBRARY; T=293.16K  
Photon emission for (n,gma)

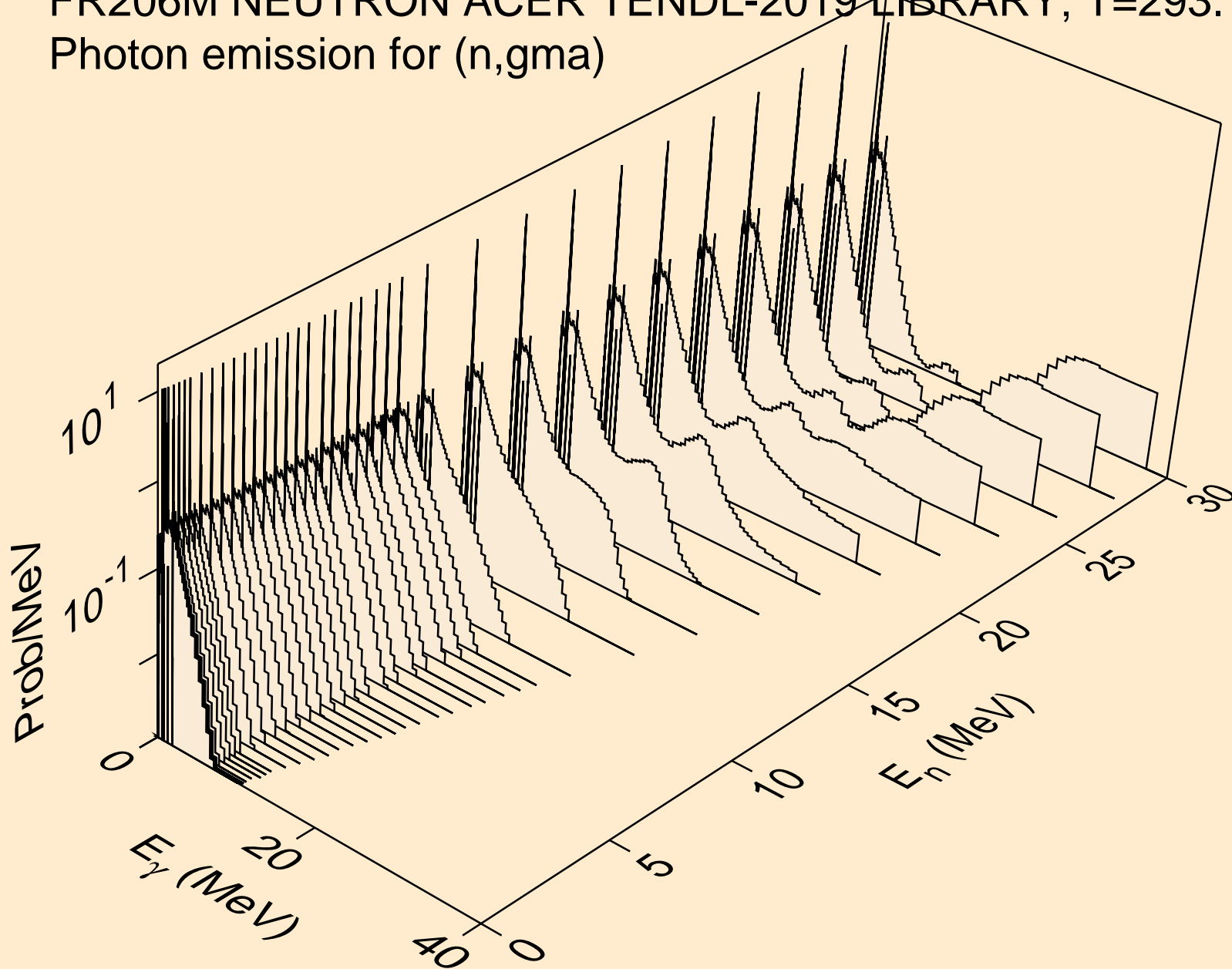

FR206M NEUTRON ACER TENDL-2019 LIBRARY; T=293.16K  
Photon emission for (n,p)

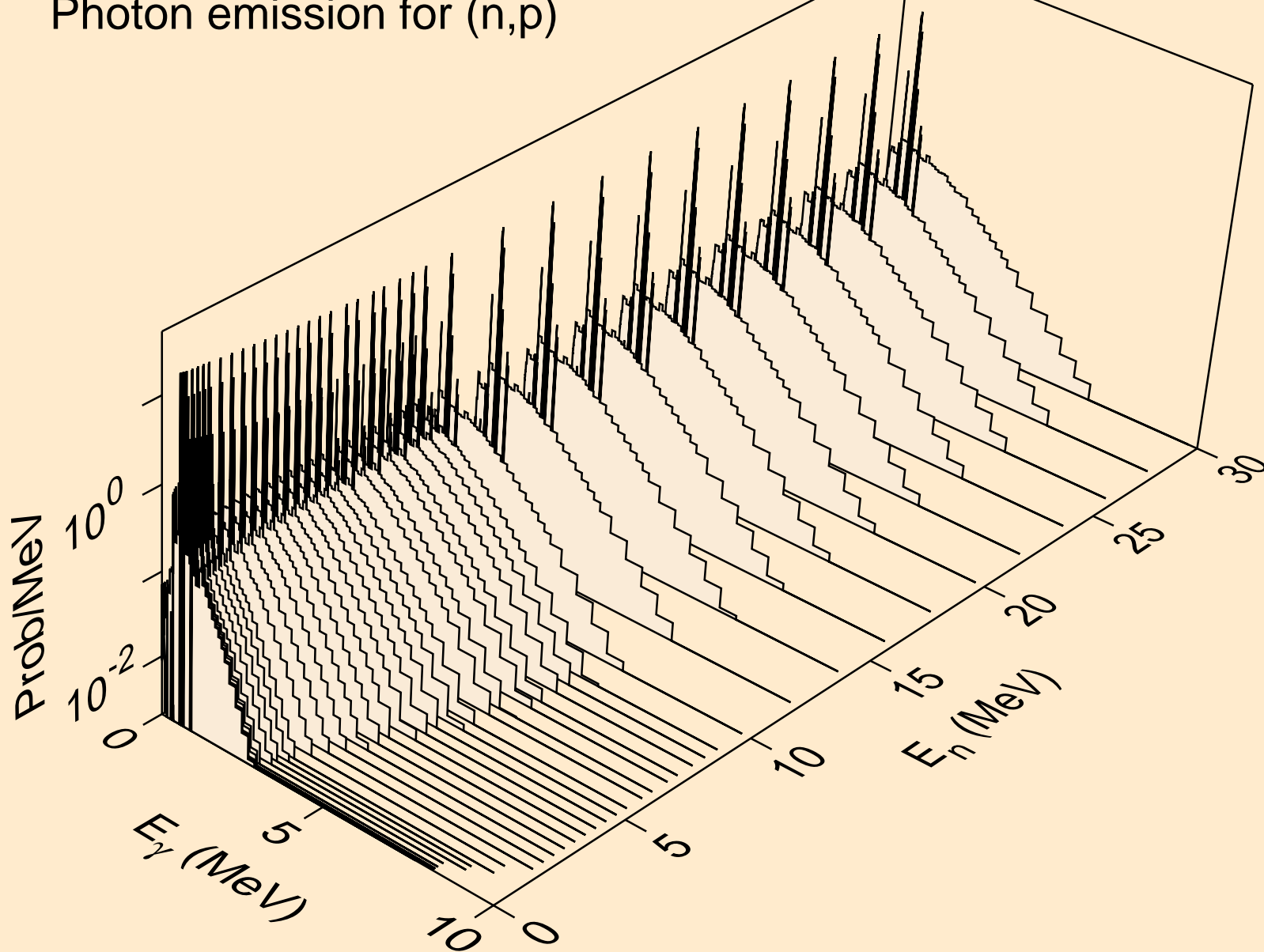

FR206M NEUTRON ACER TENDL-2019 LIBRARY; T=293.16K  
Photon emission for (n,d)

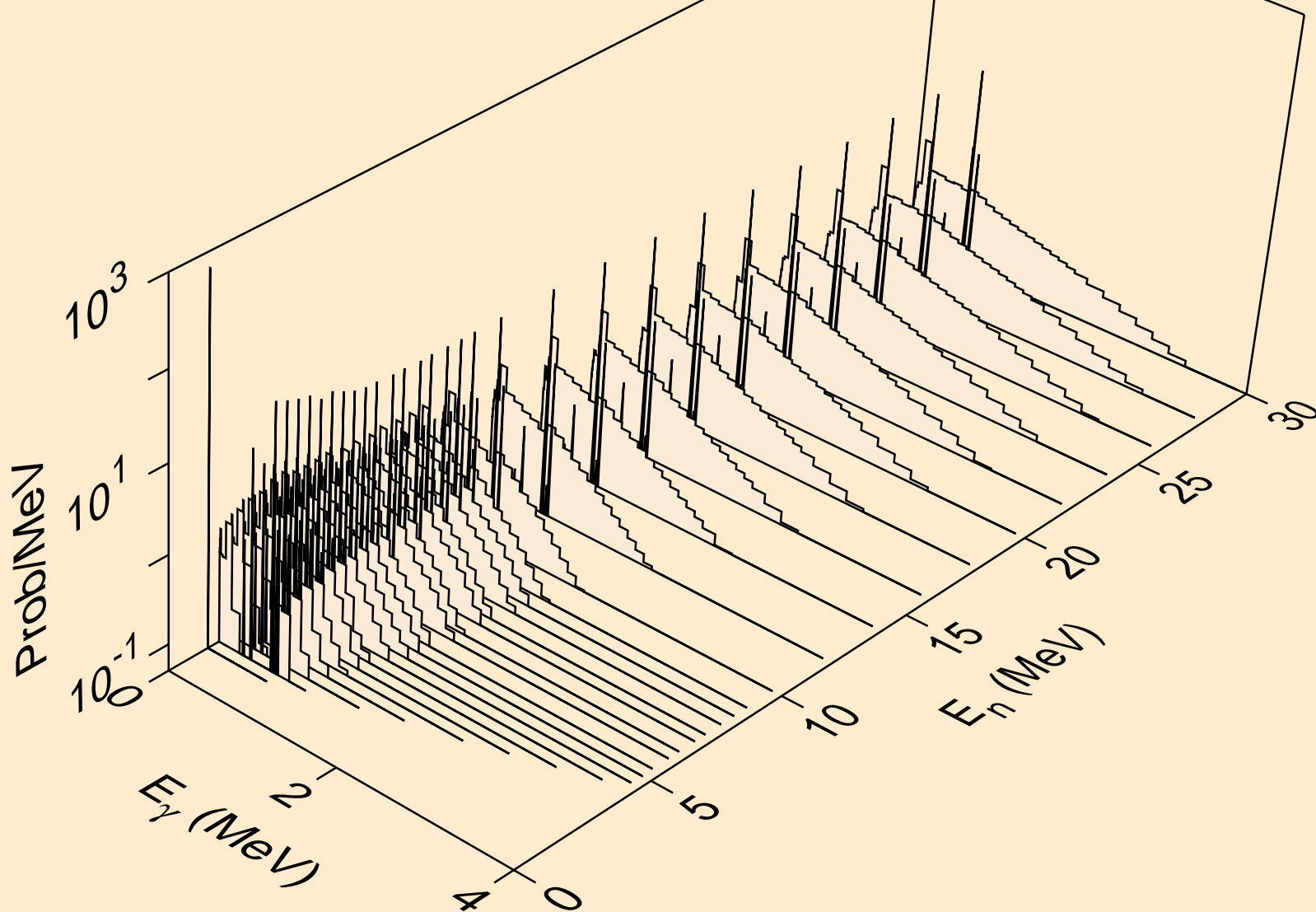

FR206M NEUTRON ACER TENDL-2019 LIBRARY; T=293.16K  
Photon emission for (n,t)

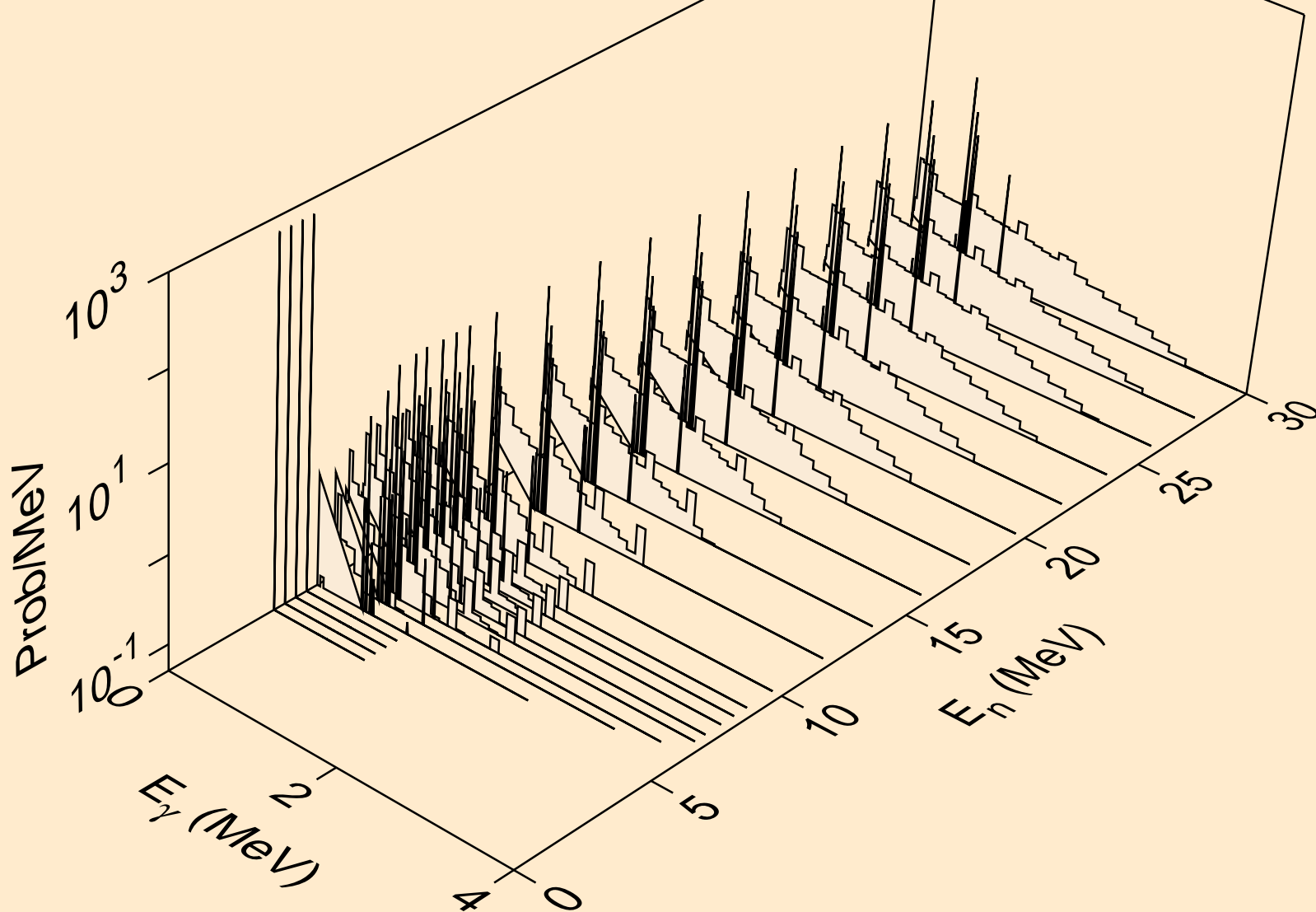



FR206M NEUTRON ACER TENDL-2019 LIBRARY; T=293.16K  
Photon emission for (n,he3)

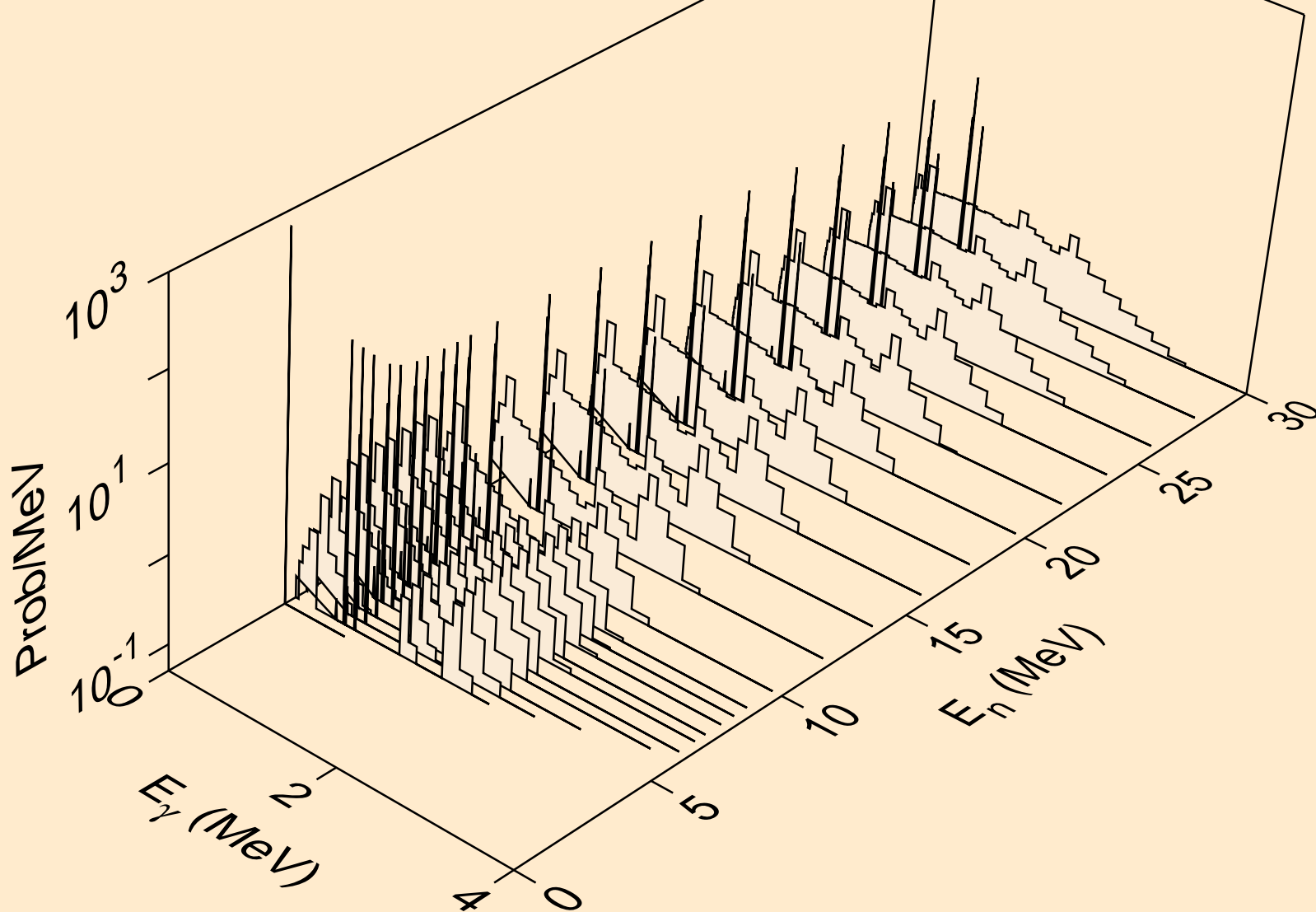

FR206M NEUTRON ACER TENDL-2019 LIBRARY; T=293.16K  
Photon emission for (n,a)

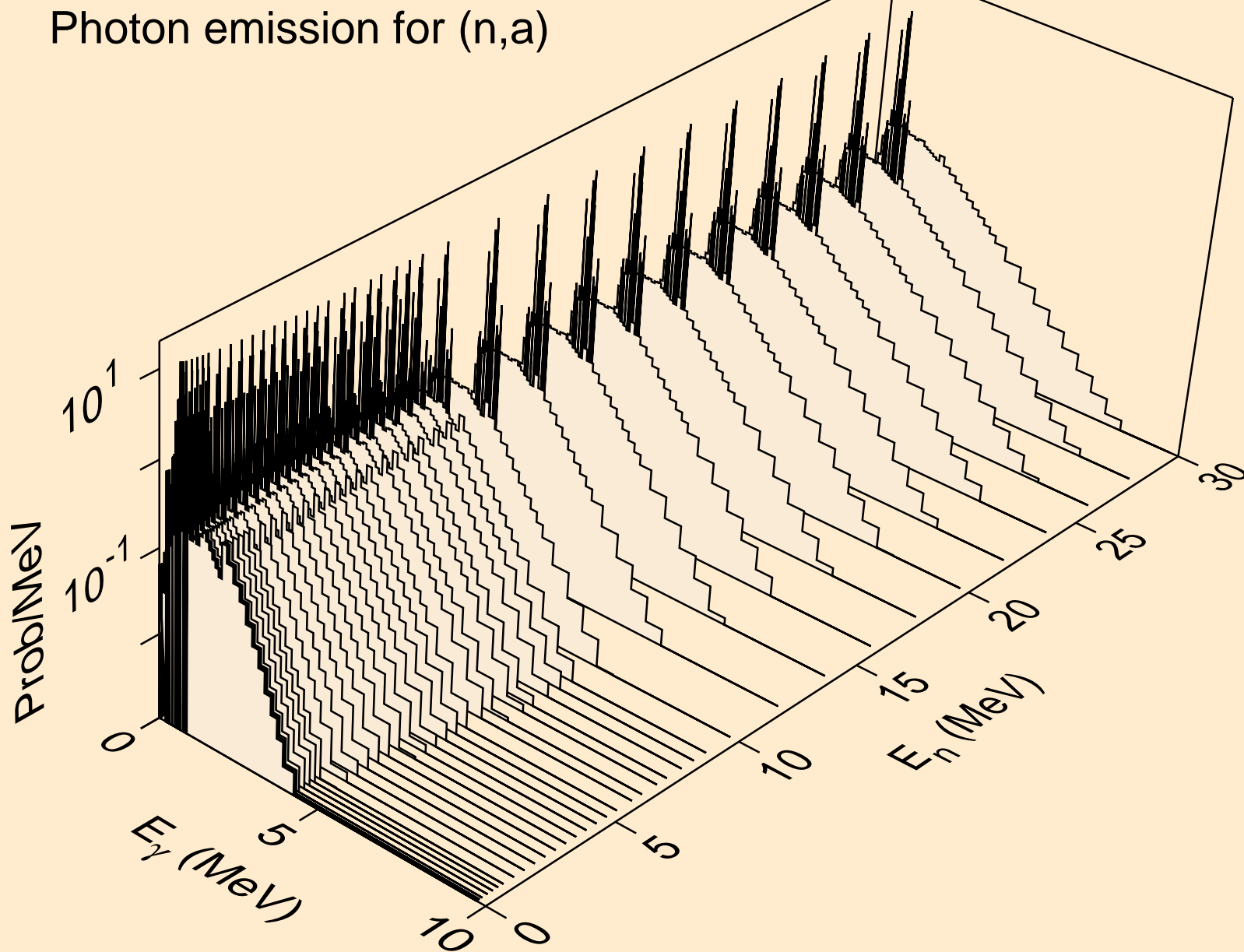

FR206M NEUTRON ACER TENDL-2019 LIBRARY; T=293.16K  
Photon emission for (n,2a)

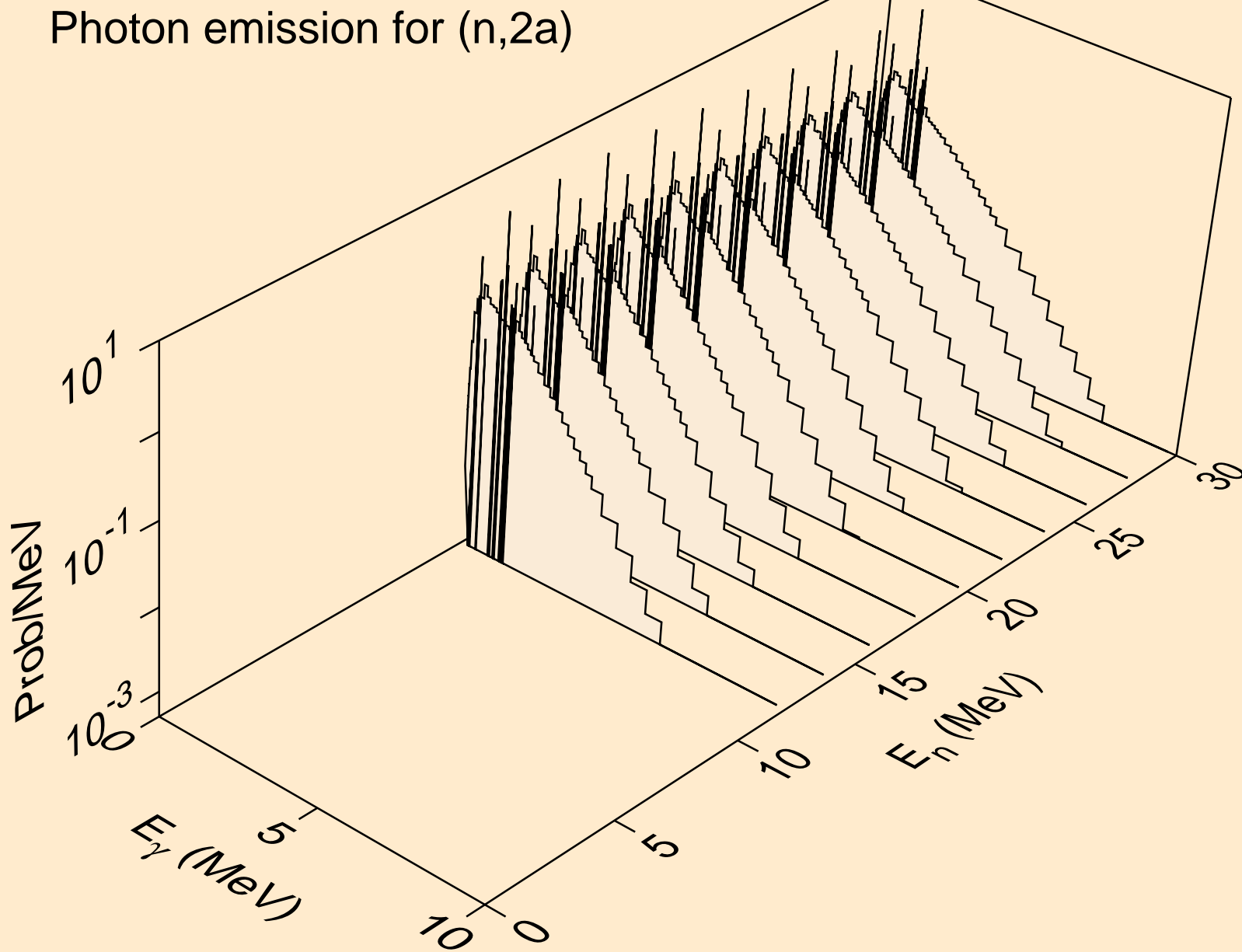

FR206M NEUTRON ACER TENDL-2019 LIBRARY; T=293.16K  
Photon emission for (n,2p)

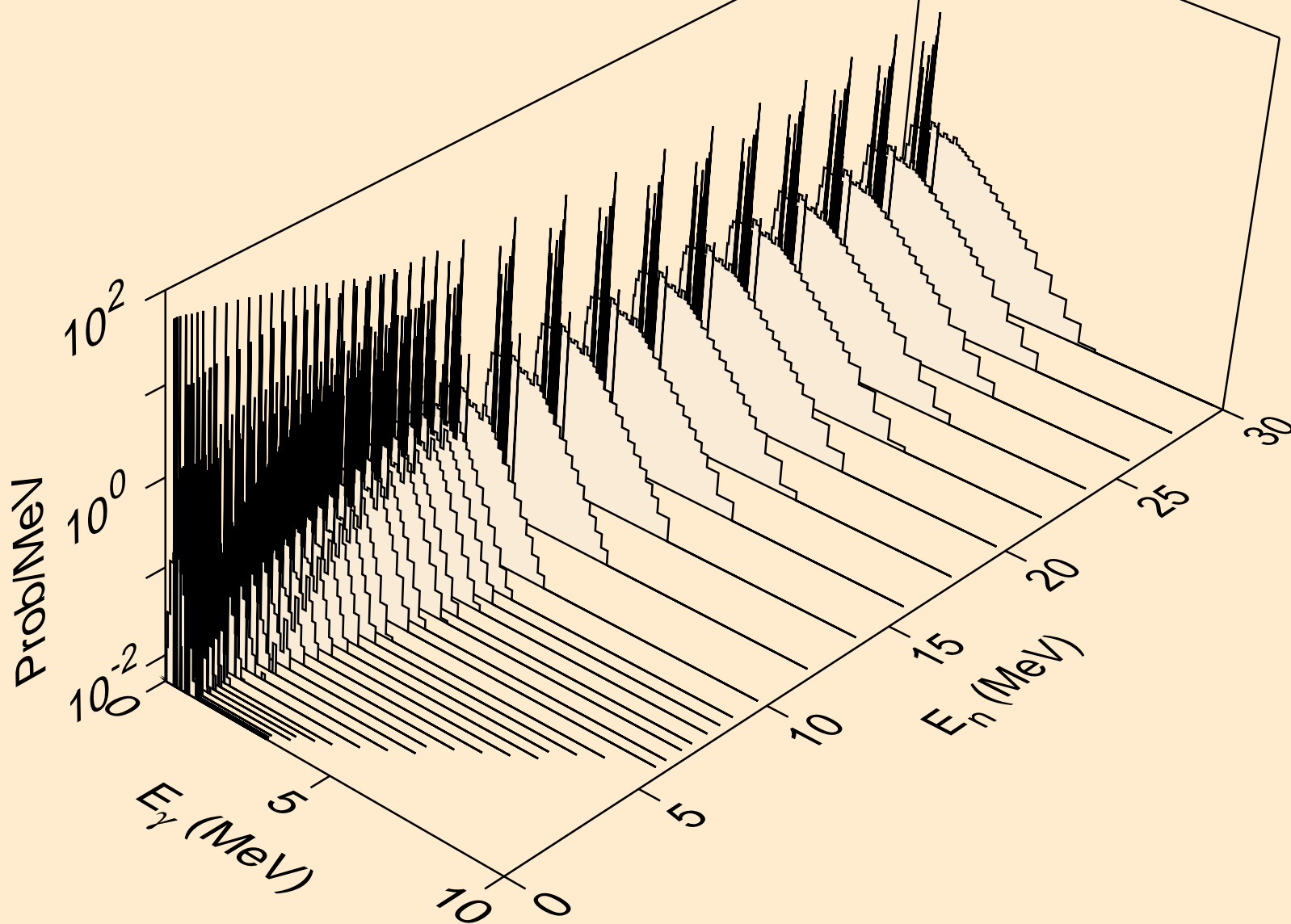

FR206M NEUTRON ACER TENDL-2019 LIBRARY; T=293.16K  
Photon emission for (n,p $\alpha$ )

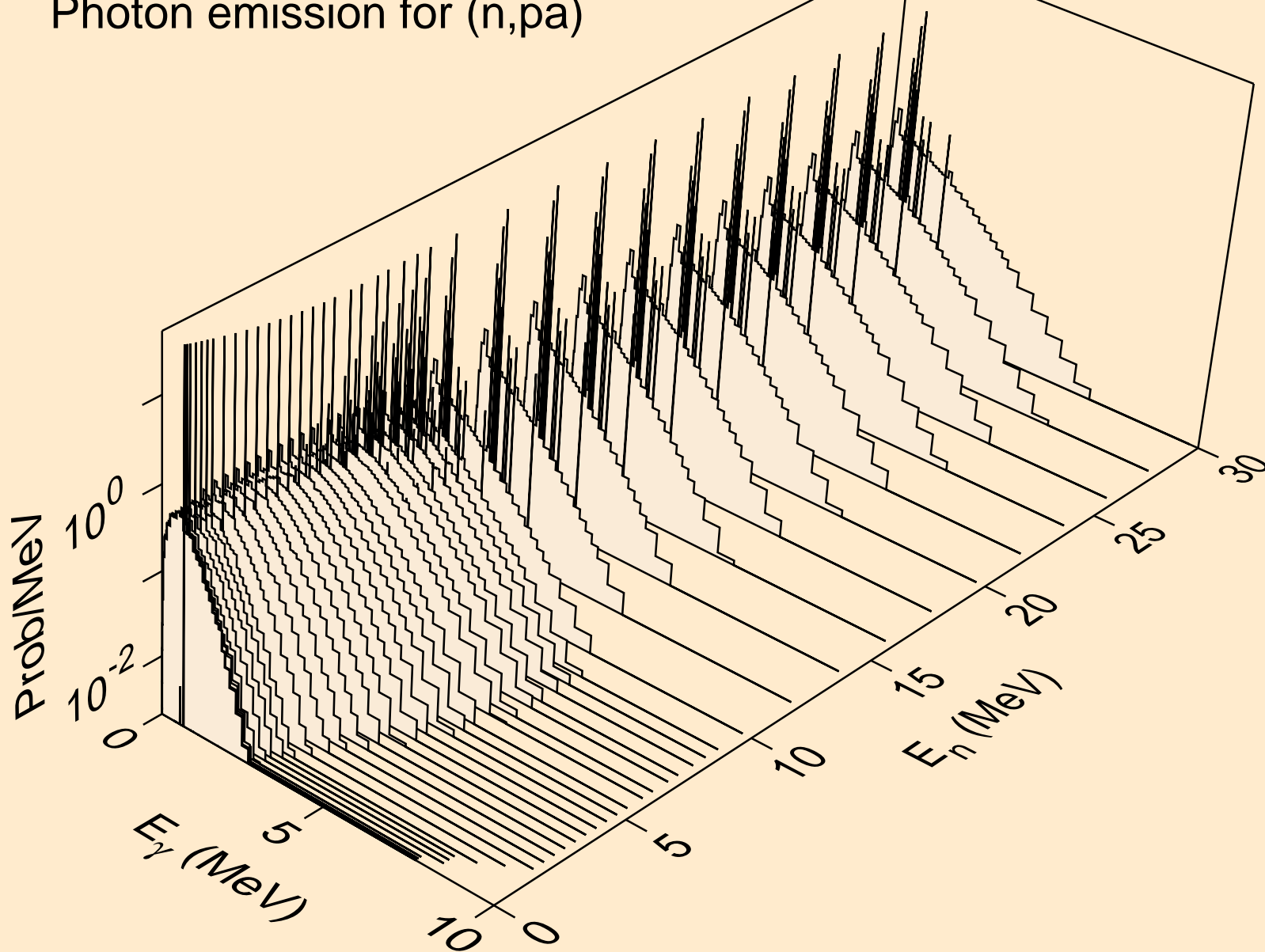

FR206M NEUTRON ACER TENDL-2019 LIBRARY; T=293.16K  
Photon emission for (n,pd)

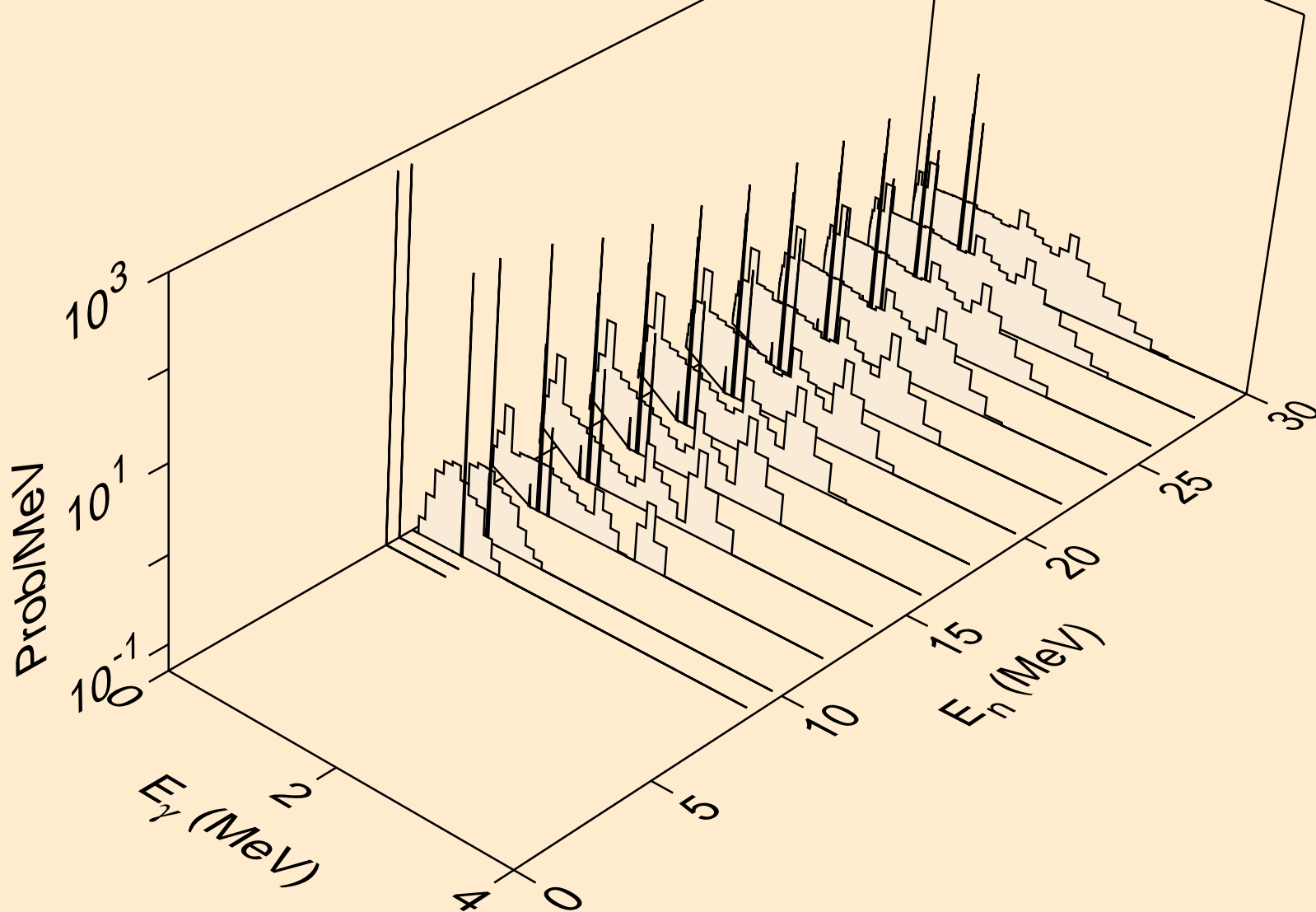

FR206M NEUTRON ACER TENDL-2019 LIBRARY; T=293.16K  
Photon emission for (n,pt)

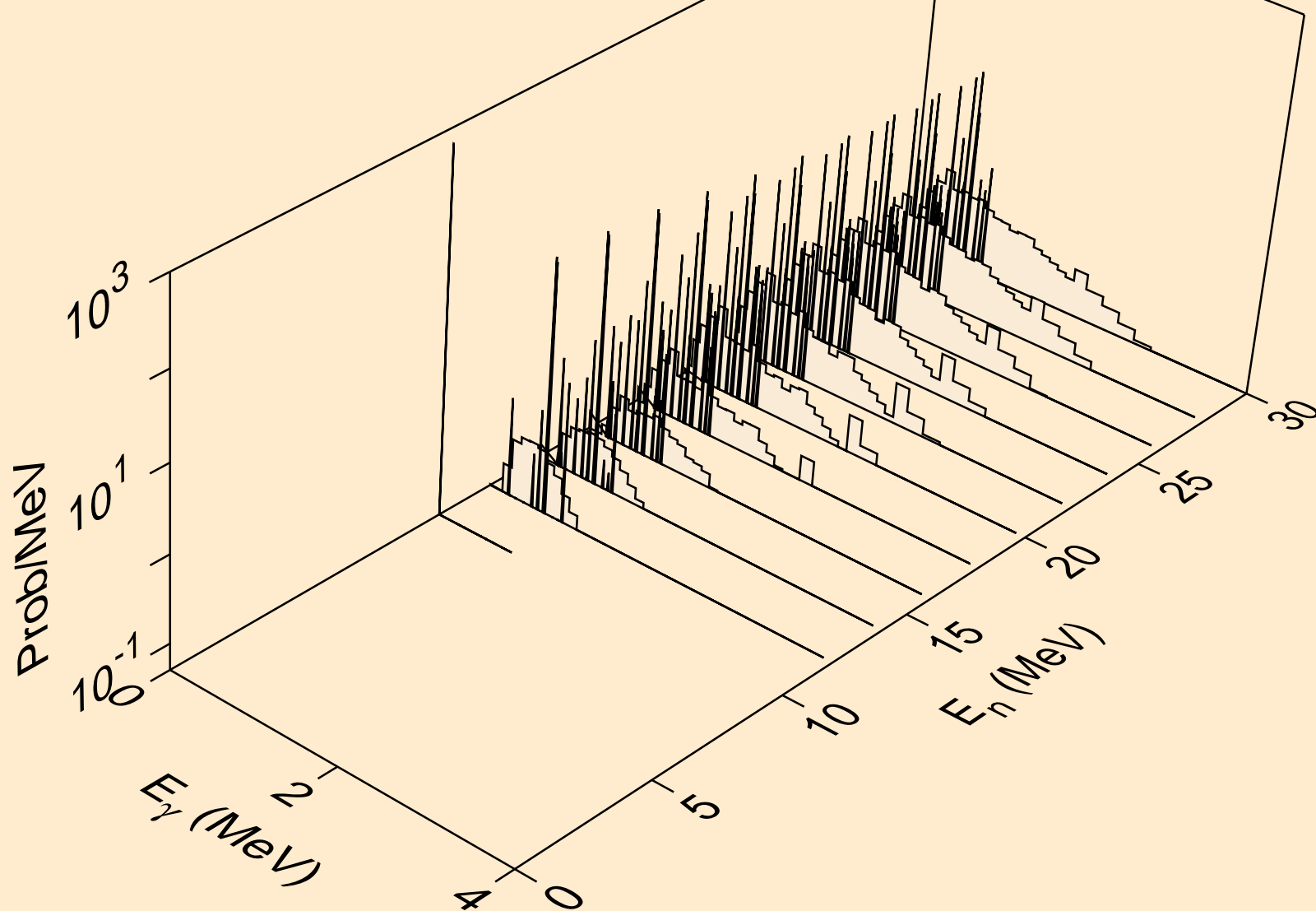

FR206M NEUTRON ACER TENDL-2019 LIBRARY; T=293.16K  
Photon emission for (n,da)

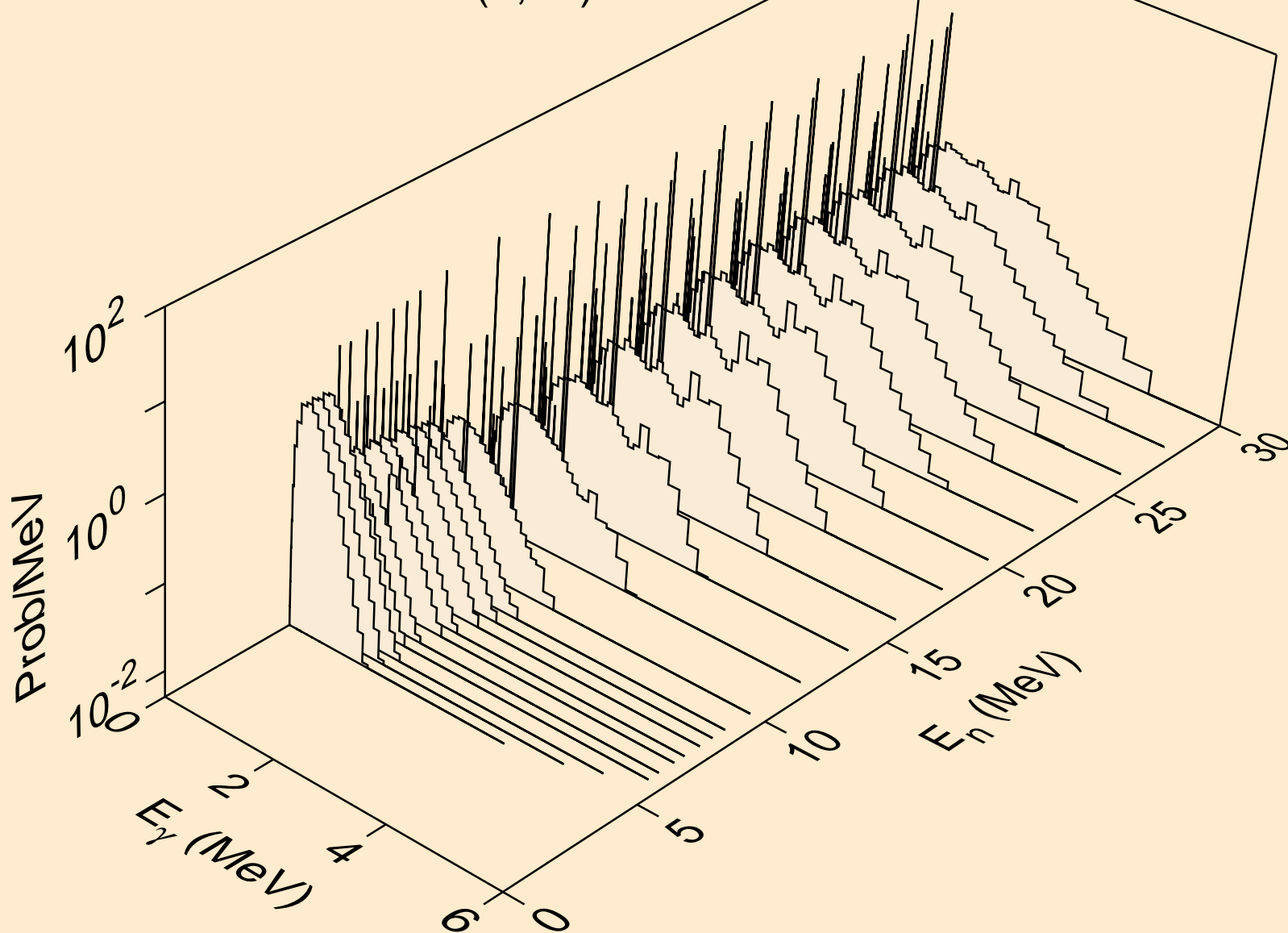



FR206M NEUTRON ACER TENDL-2019 LIBRARY; T=293.16K  
thermal capture photon spectrum

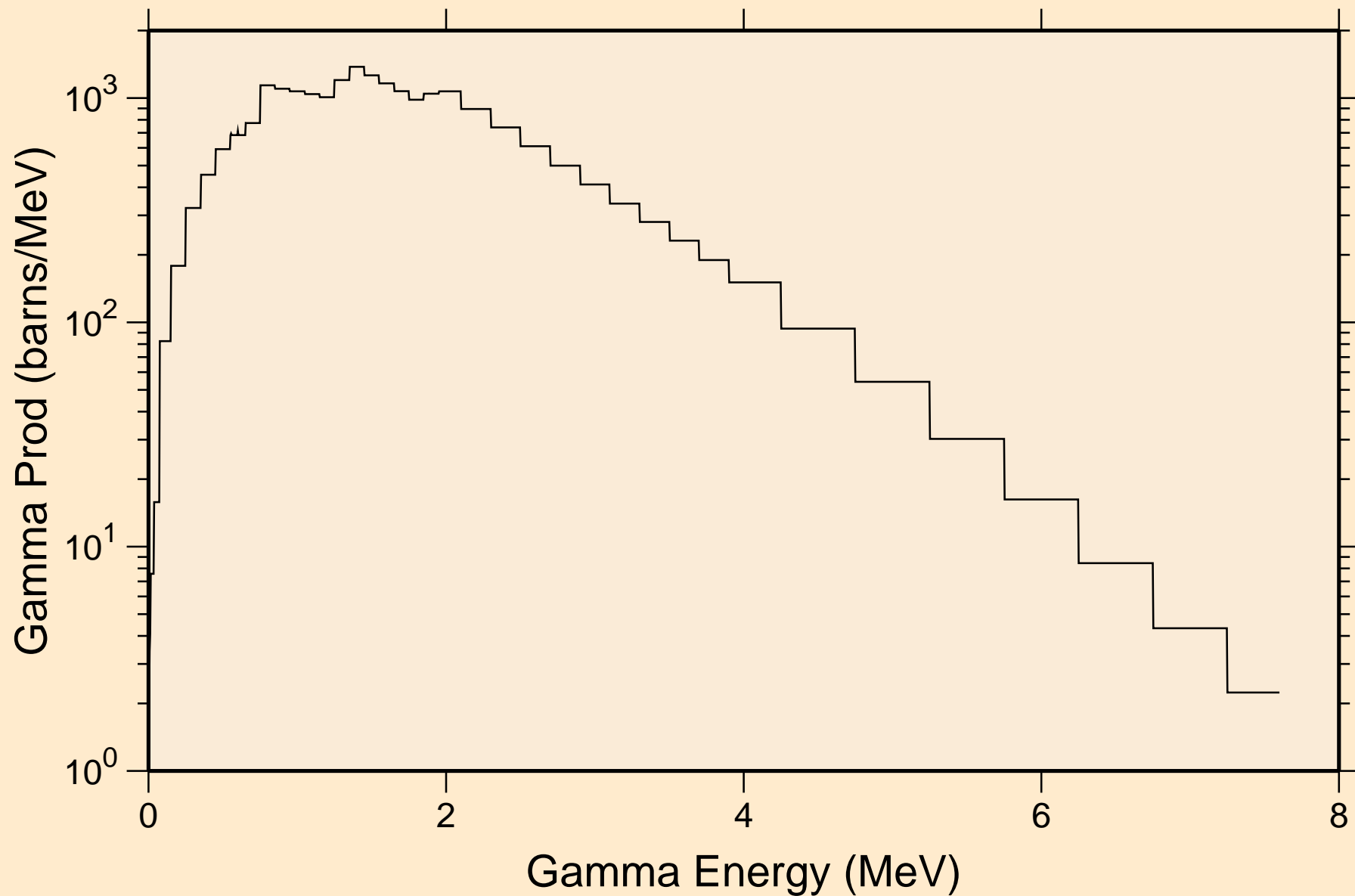

FR206M NEUTRON ACER TENDL-2019 LIBRARY; T=293.16K  
14 MeV photon spectrum

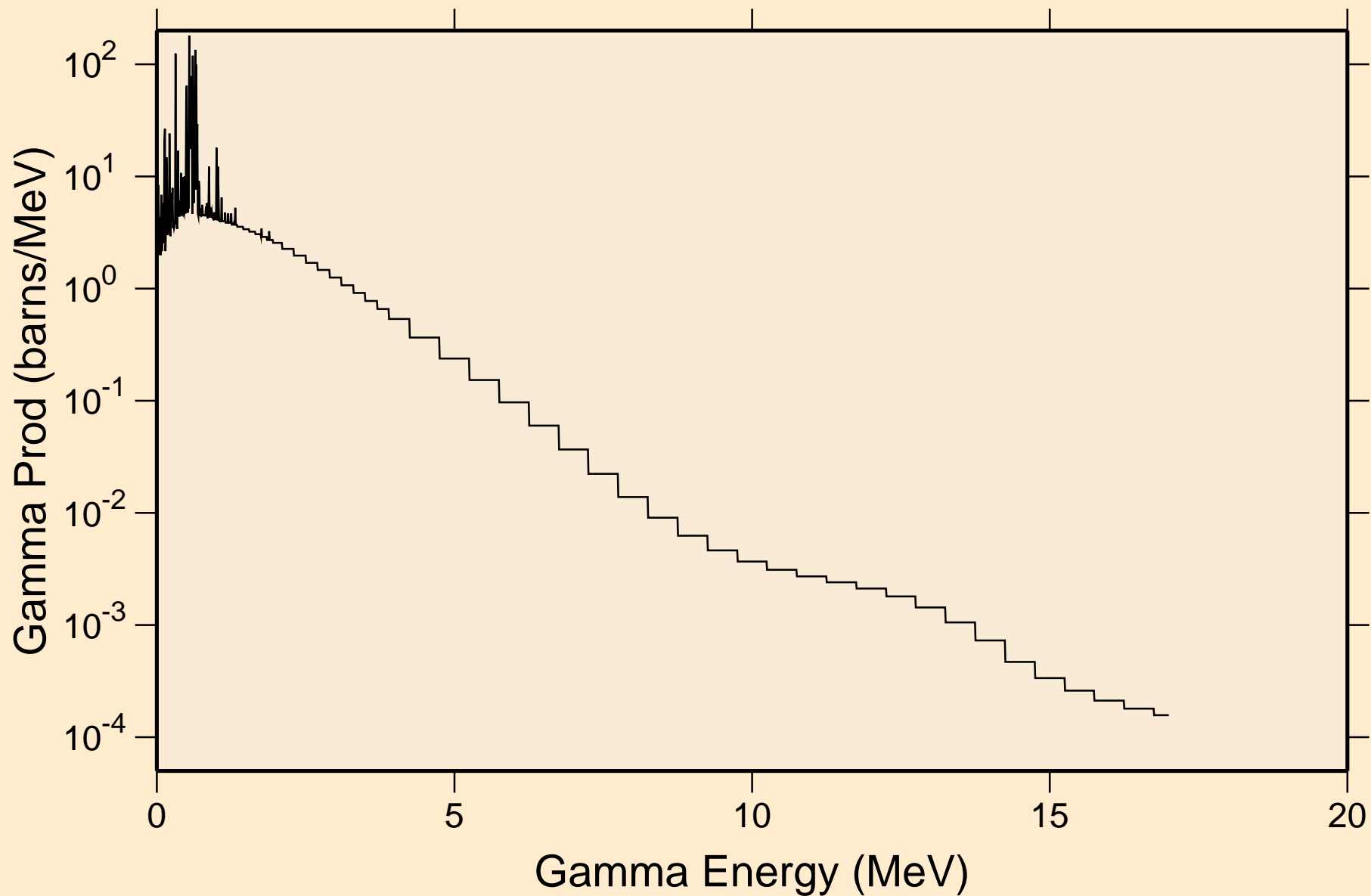

FR206M NEUTRON ACER TENDL-2019 LIBRARY; T=293.16K  
Particle heating contributions

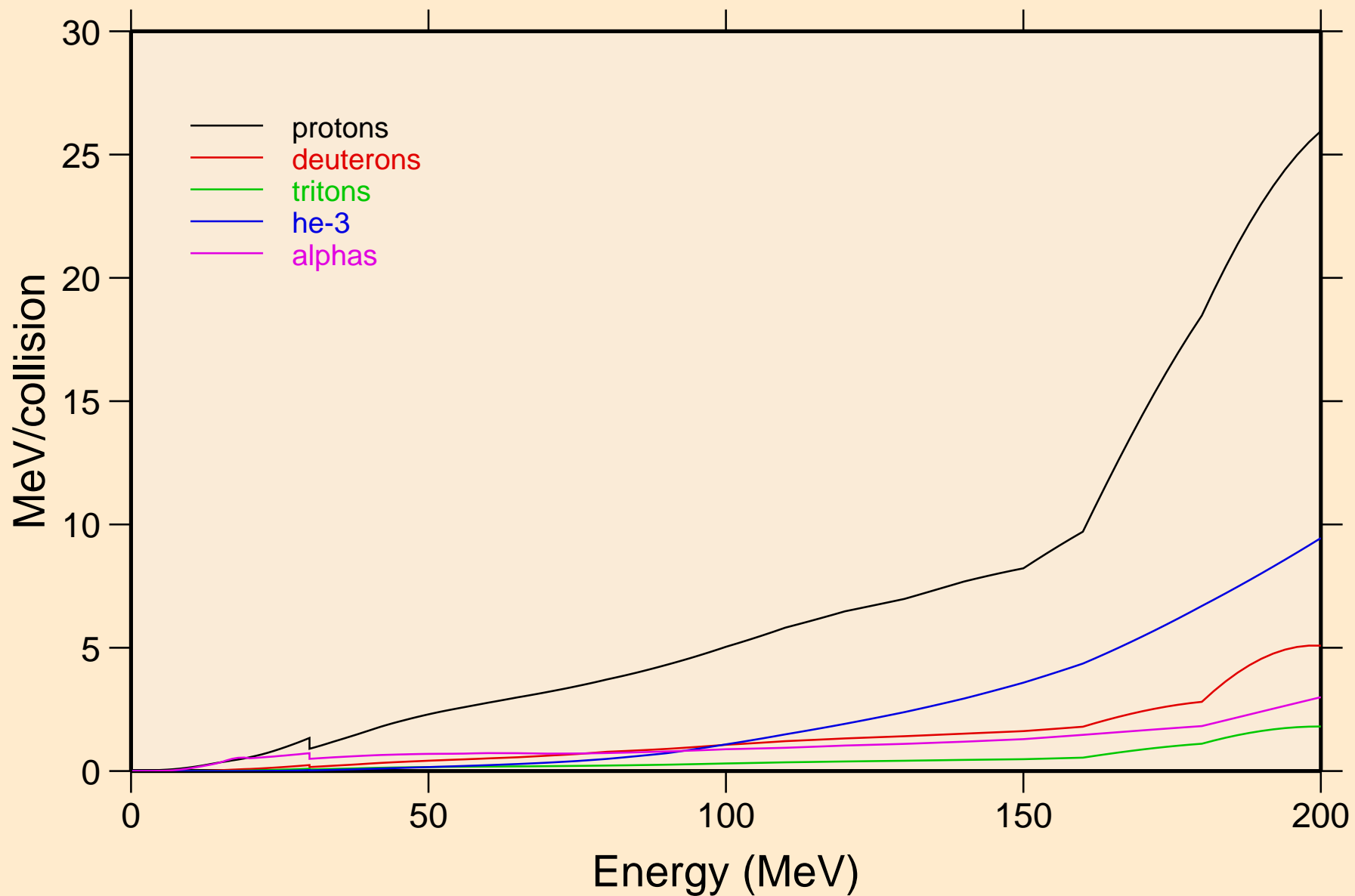

FR206M NEUTRON ACER TENDL-2019 LIBRARY; T=293.16K  
Recoil Heating

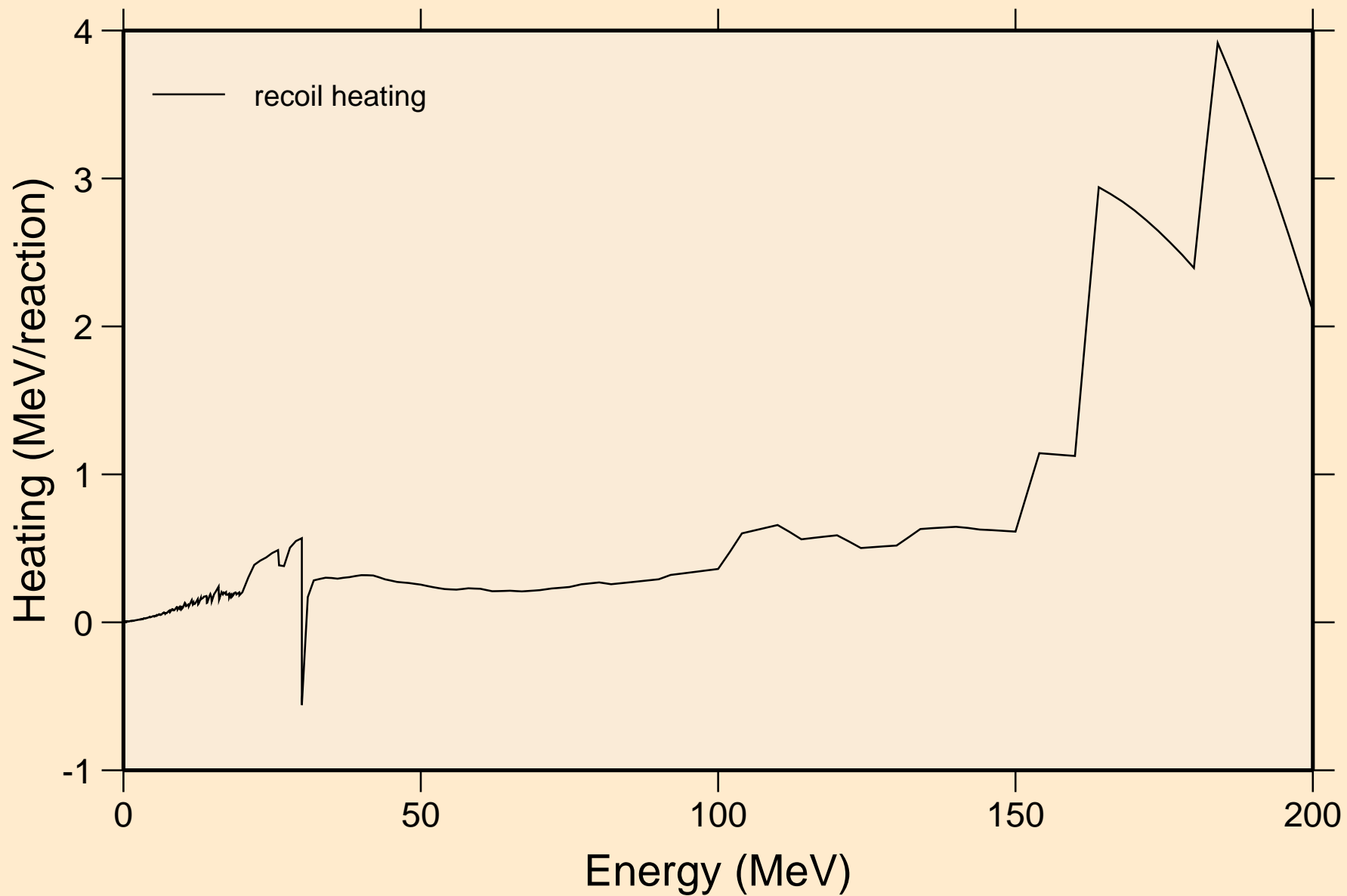

FR206M NEUTRON ACER TENDL-2019 LIBRARY; T=293.16K  
Particle production cross sections

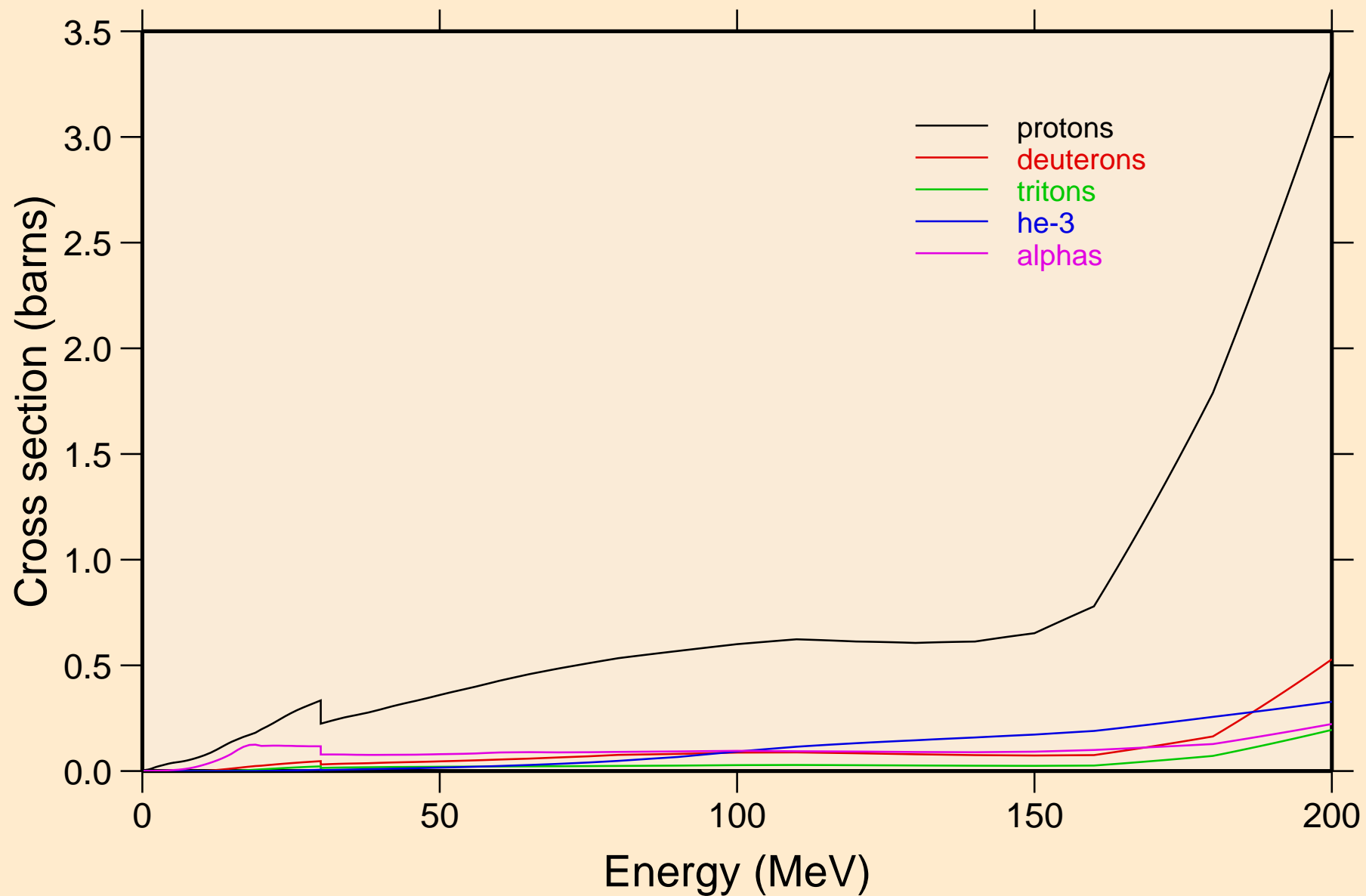

FR206M NEUTRON ACER TENDL-2019 LIBRARY; T=293.16K  
protons from (n,x)

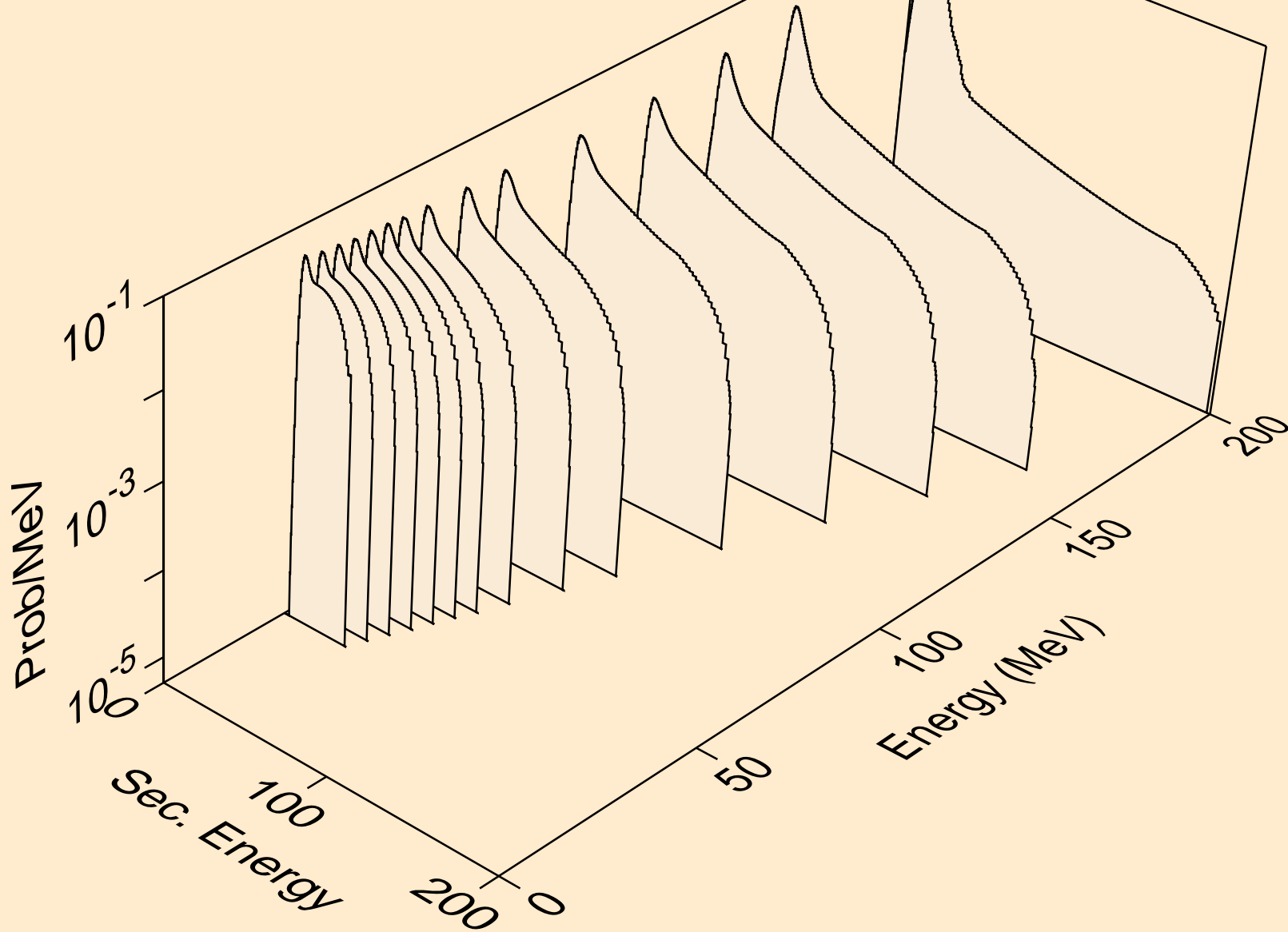

FR206M NEUTRON ACER TENDL-2019 LIBRARY; T=293.16K  
protons from (n,n\*)p

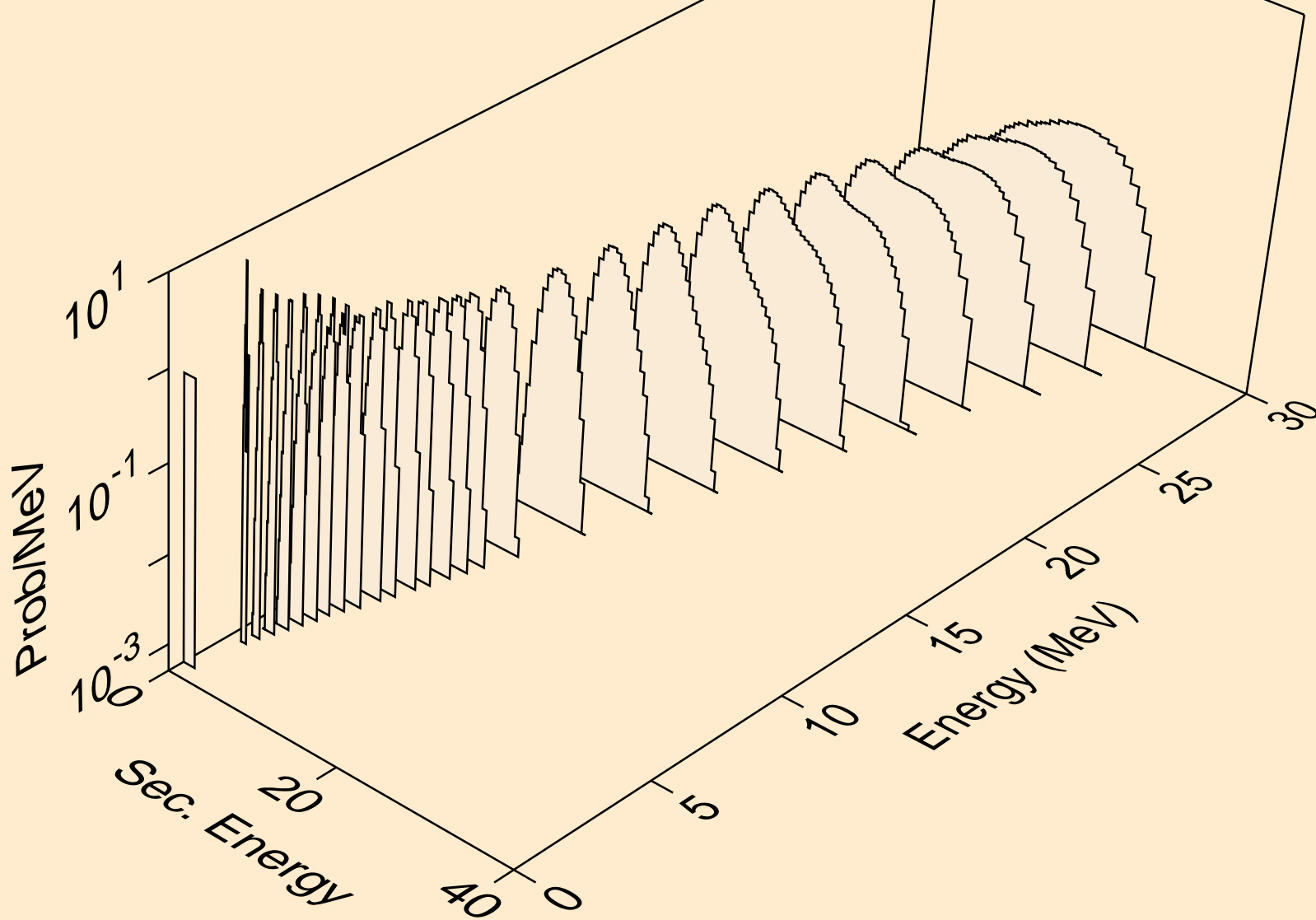

FR206M NEUTRON ACER TENDL-2019 LIBRARY; T=293.16K  
protons from (n,2np)

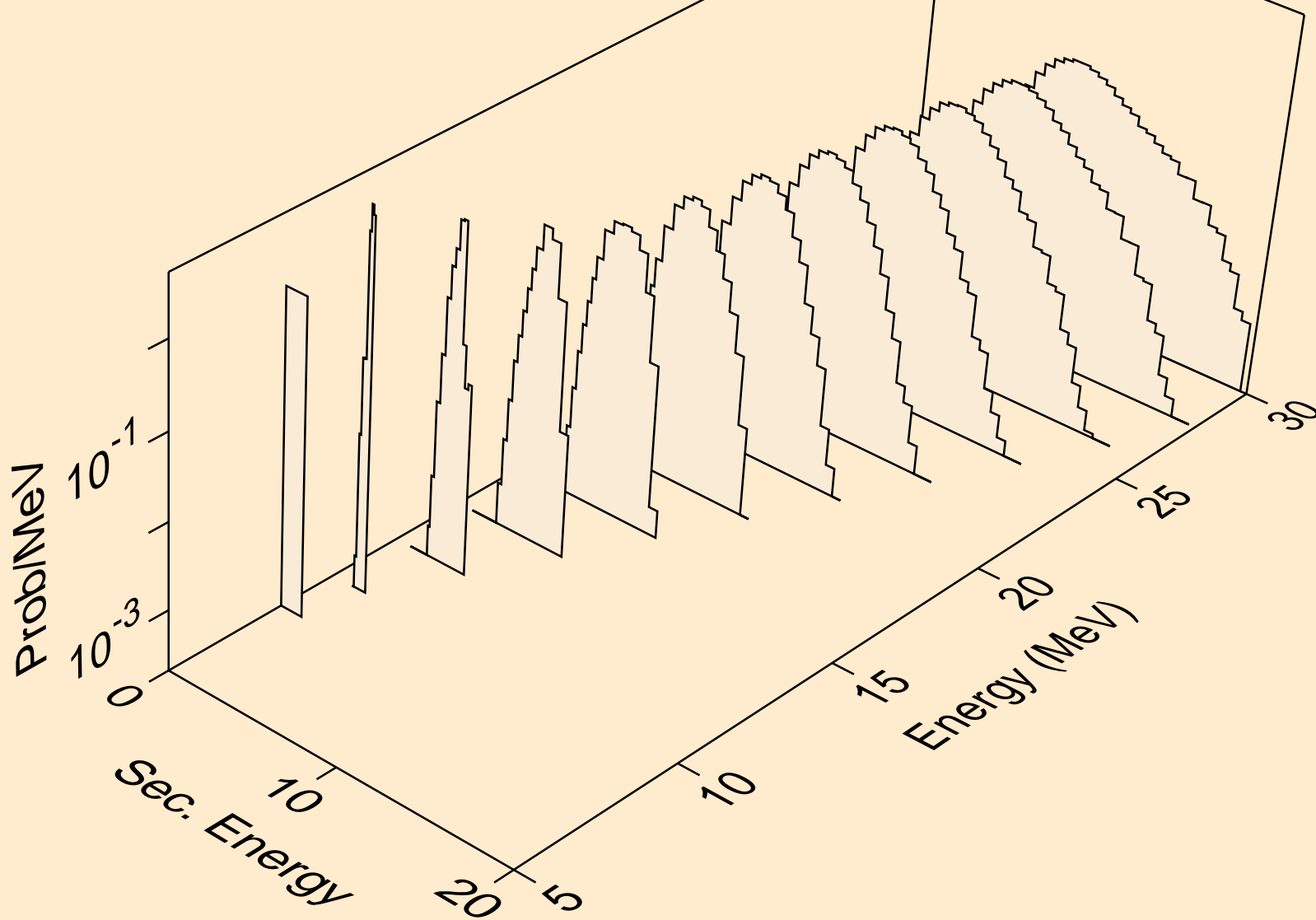



FR206M NEUTRON ACER TENDL-2019 LIBRARY; T=293.16K  
protons from (n,3np)

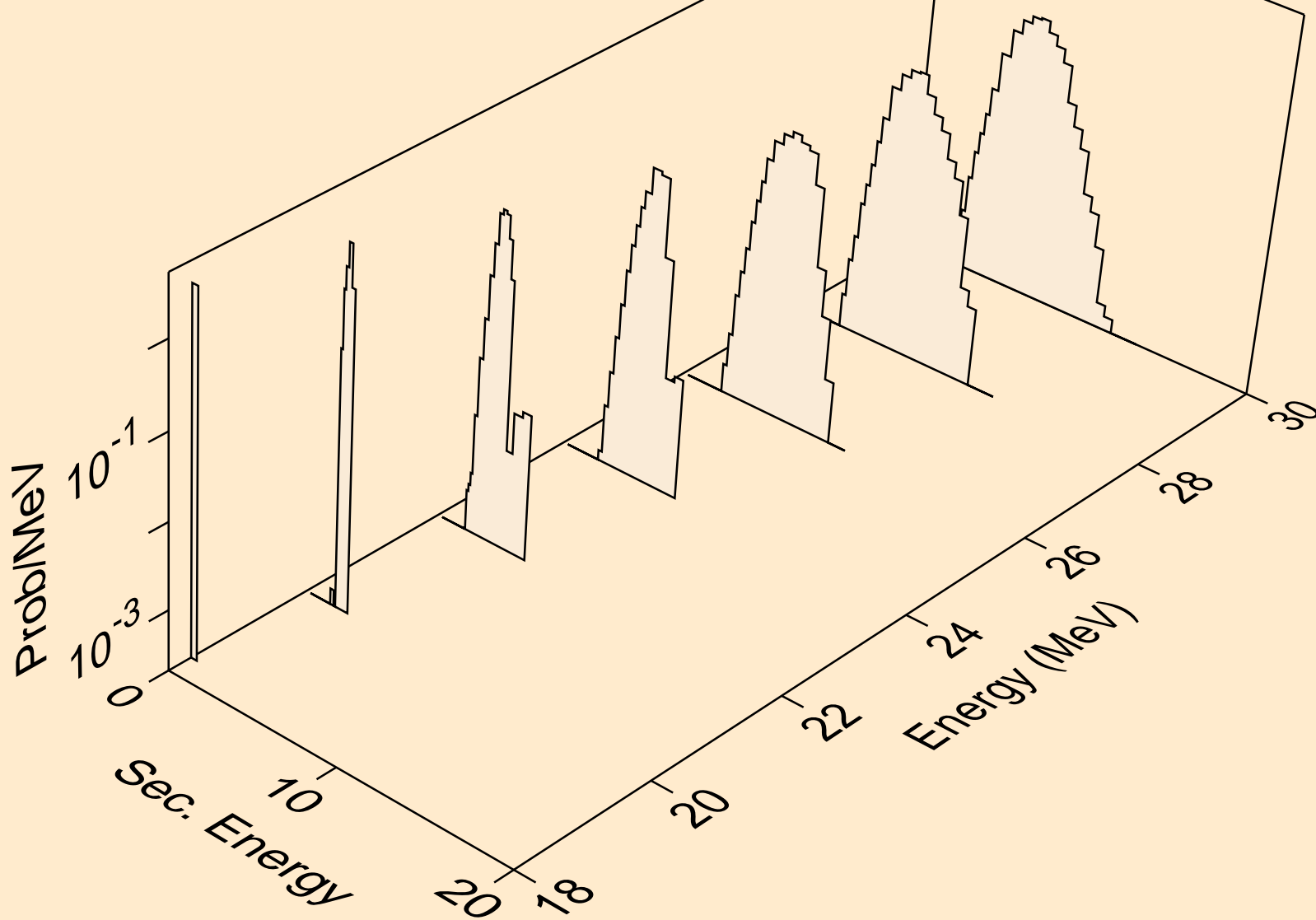

FR206M NEUTRON ACER TENDL-2019 LIBRARY; T=293.16K  
protons from (n,2np)

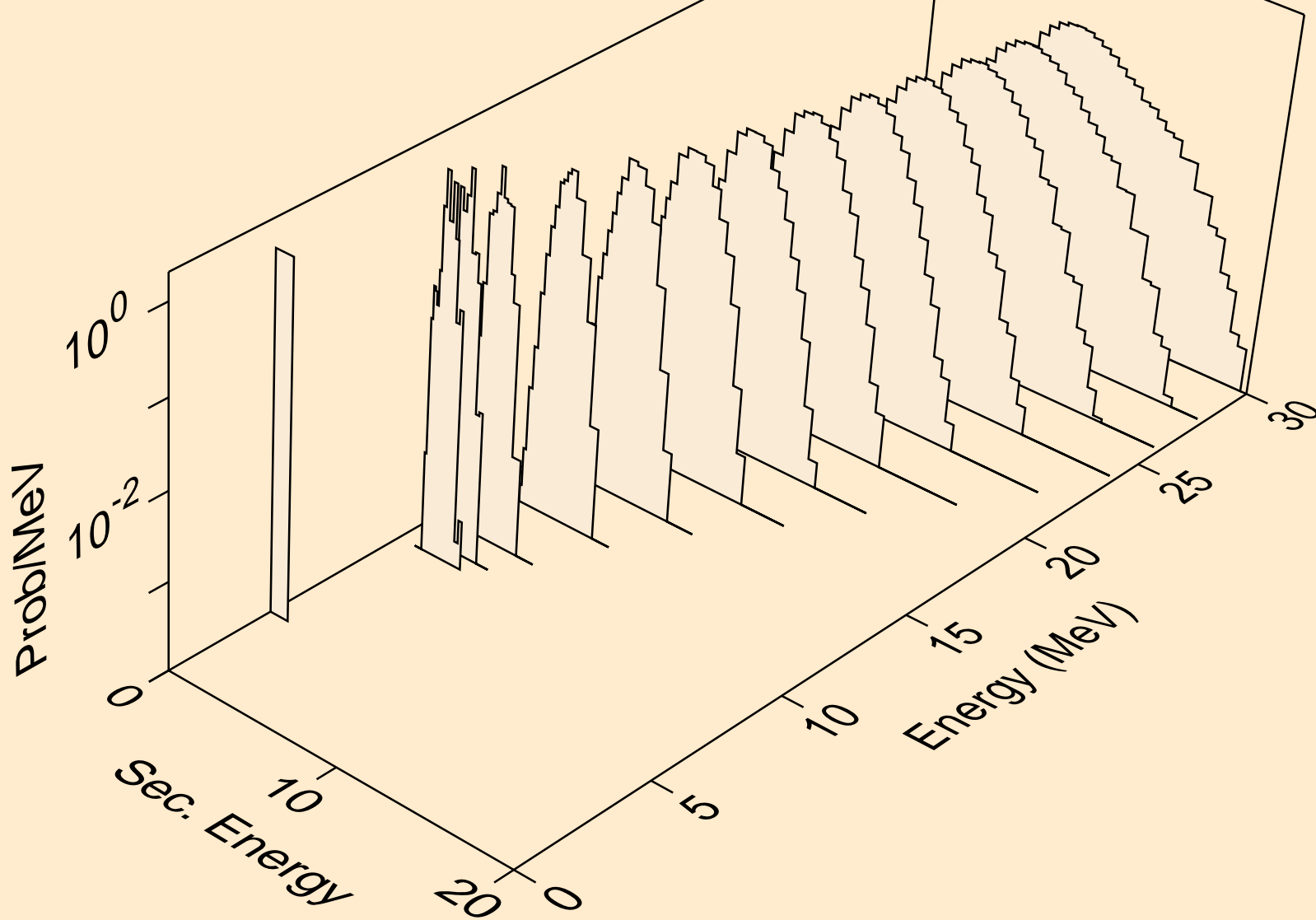

FR206M NEUTRON ACER TENDL-2019 LIBRARY; T=293.16K  
protons from (n,npa)

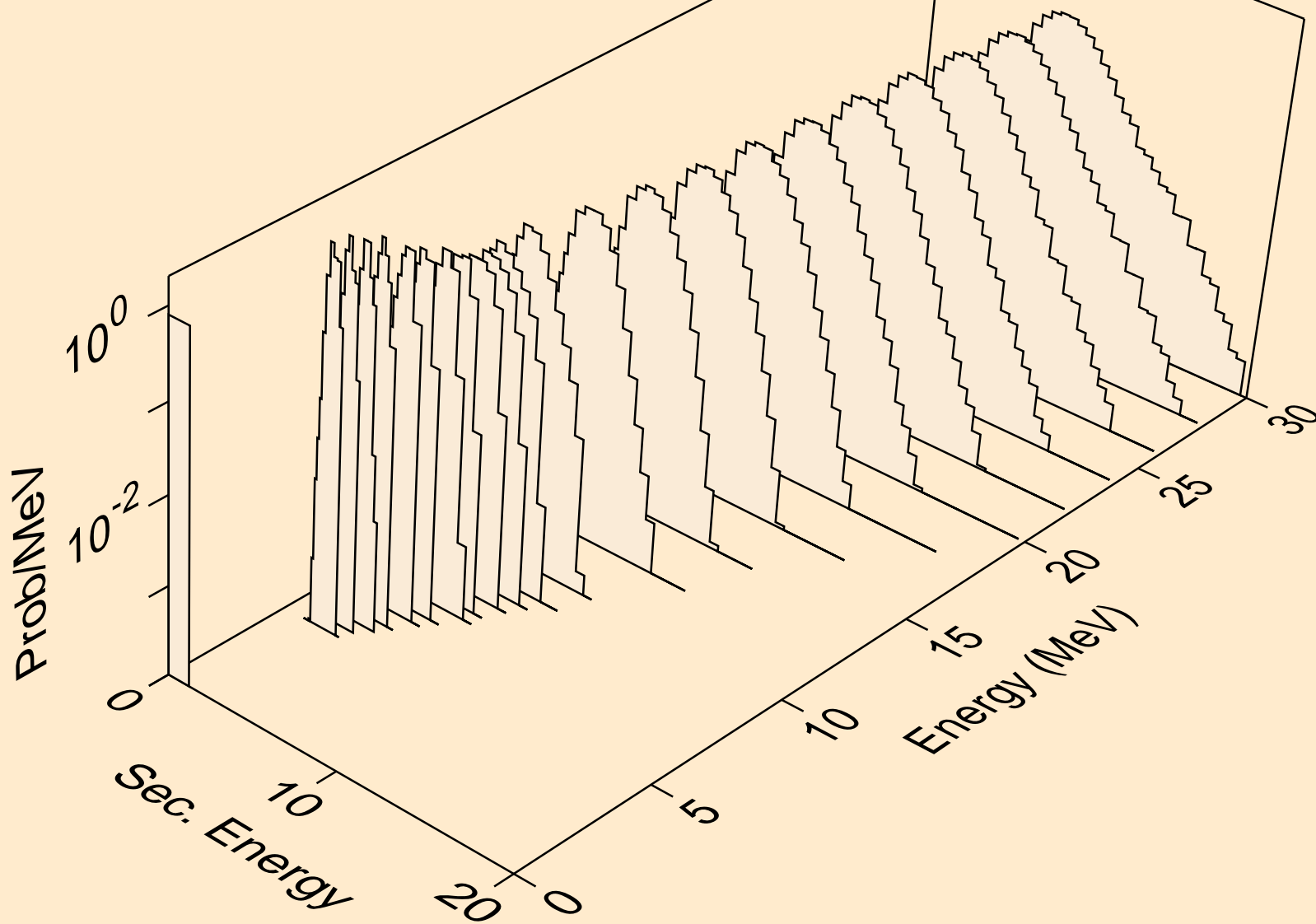

FR206M NEUTRON ACER TENDL-2019 LIBRARY; T=293.16K  
protons from (n,p)

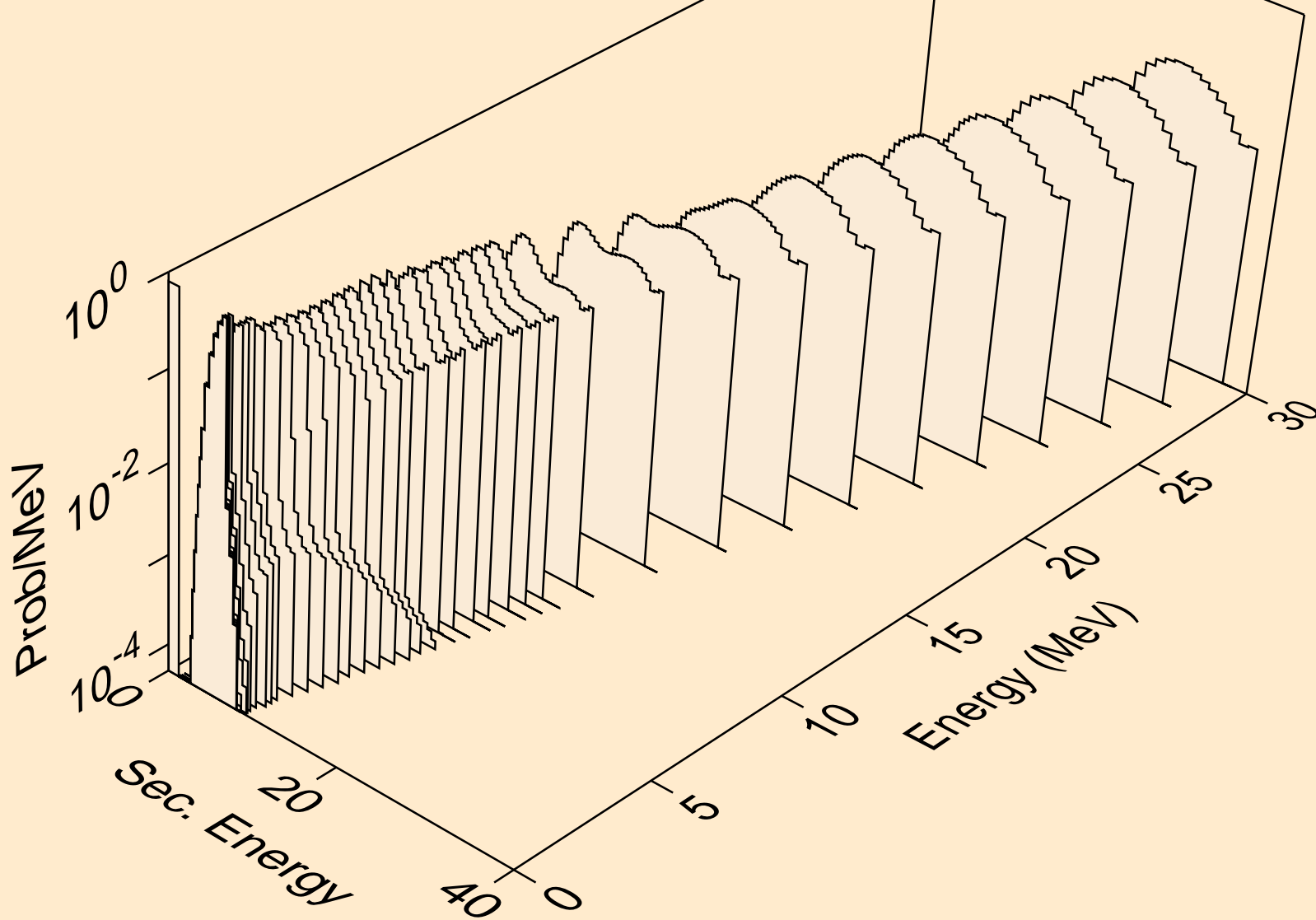

FR206M NEUTRON ACER TENDL-2019 LIBRARY; T=293.16K  
protons from (n,2p)

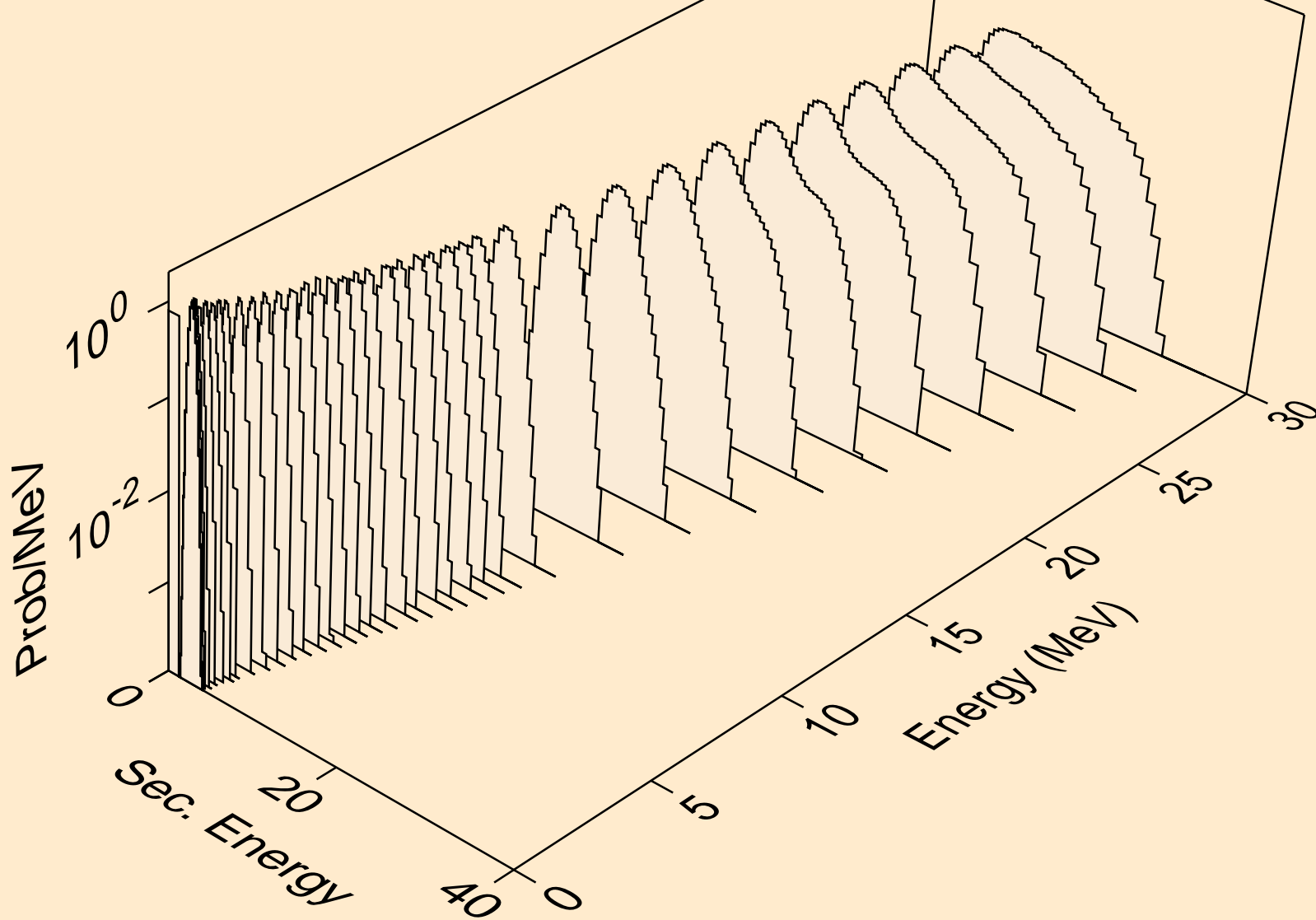

FR206M NEUTRON ACER TENDL-2019 LIBRARY; T=293.16K  
protons from (n,p)

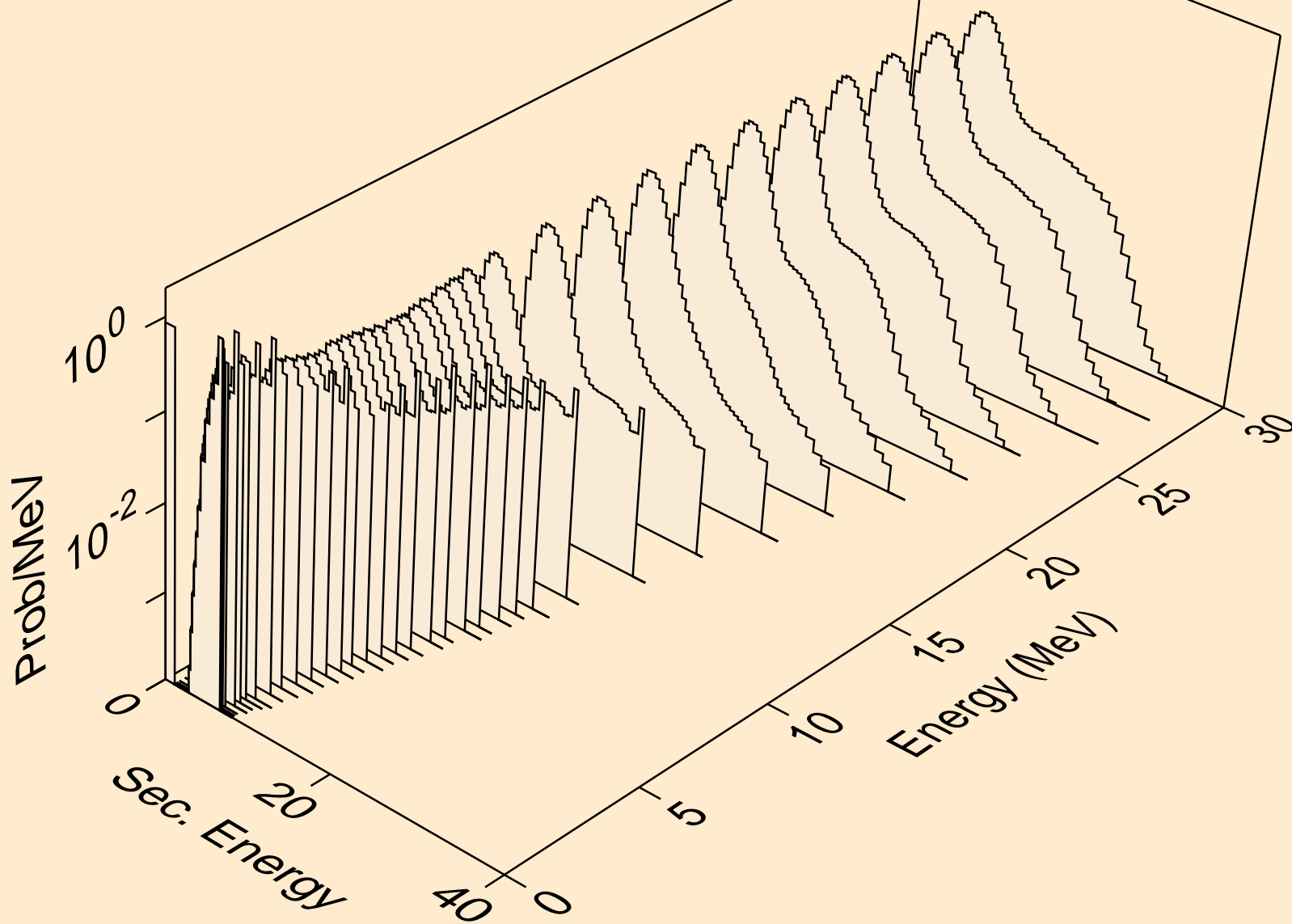

FR206M NEUTRON ACER TENDL-2019 LIBRARY; T=293.16K  
protons from (n,pd)

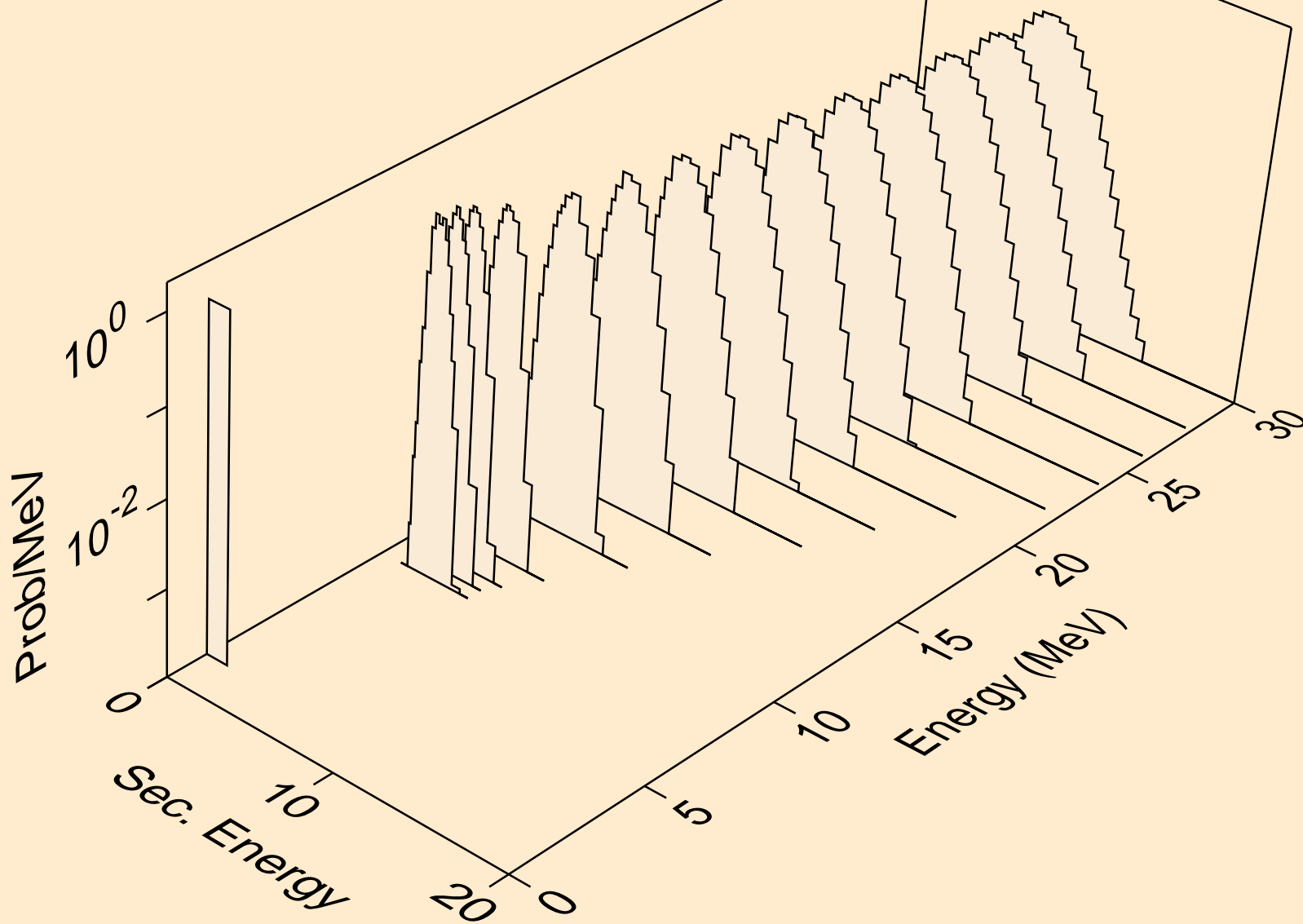

FR206M NEUTRON ACER TENDL-2019 LIBRARY; T=293.16K  
protons from (n,pt)

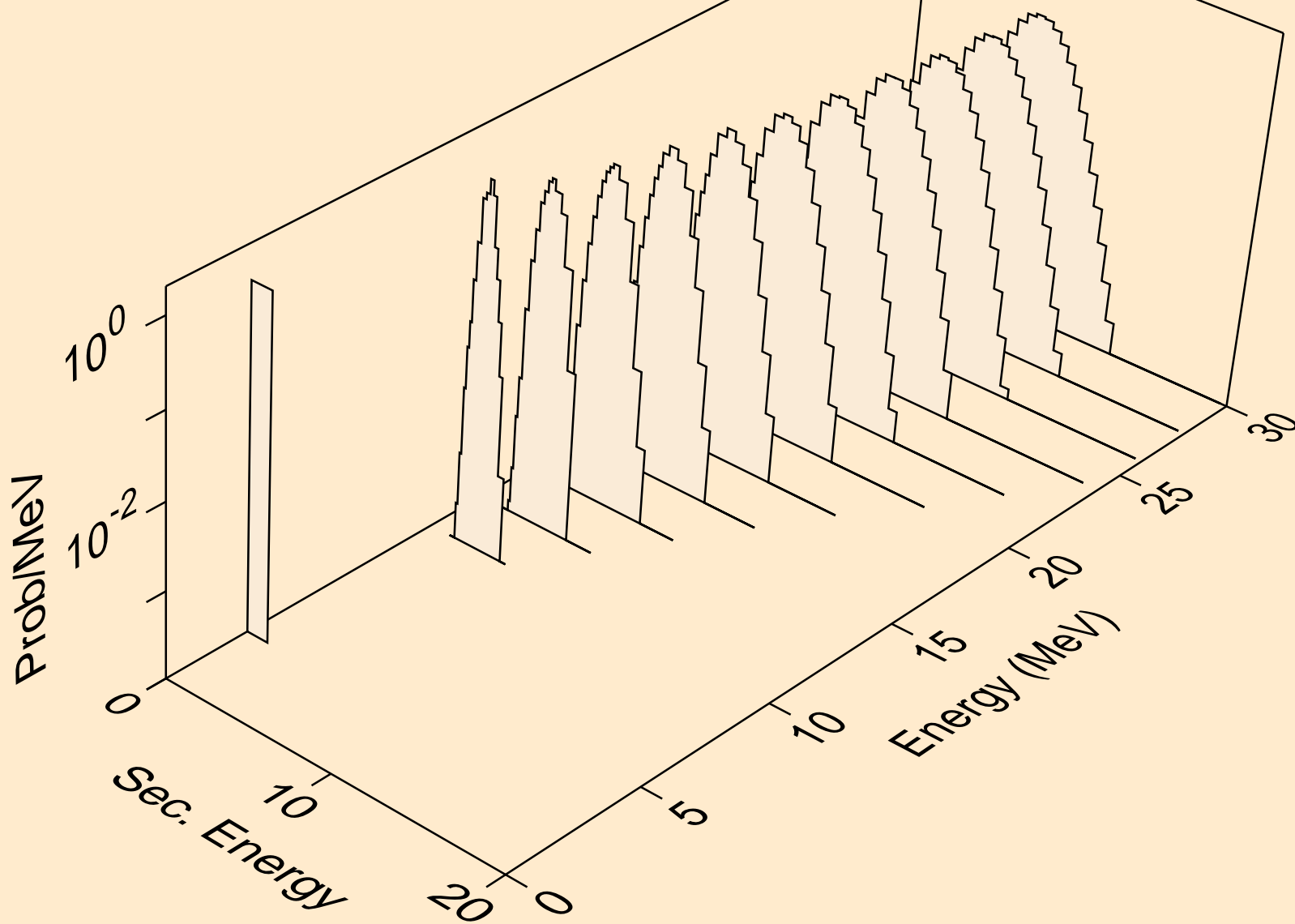



FR206M NEUTRON ACER TENDL-2019 LIBRARY; T=293.16K  
deuterons from (n,x)

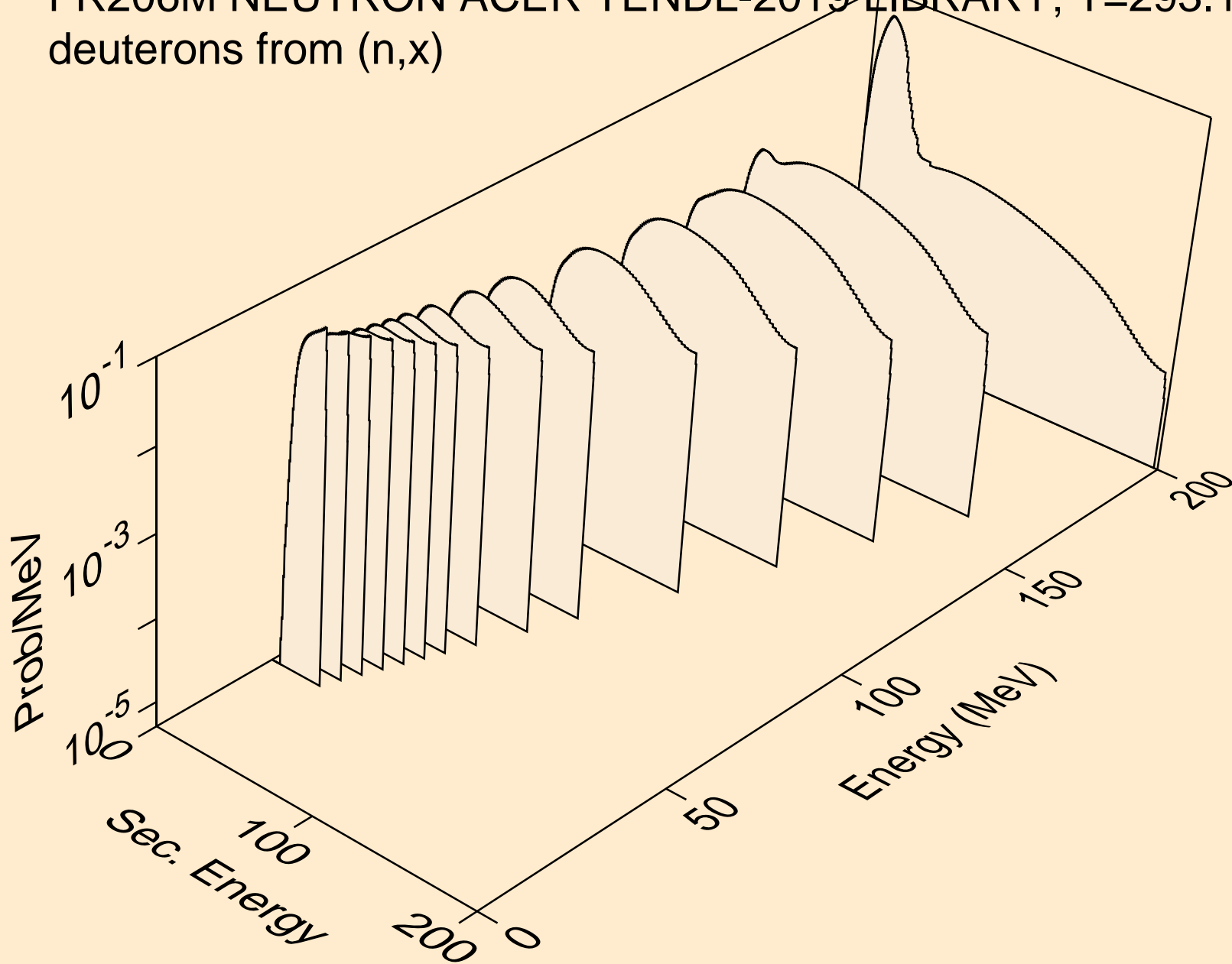

FR206M NEUTRON ACER TENDL-2019 LIBRARY; T=293.16K  
deuterons from (n,2nd)

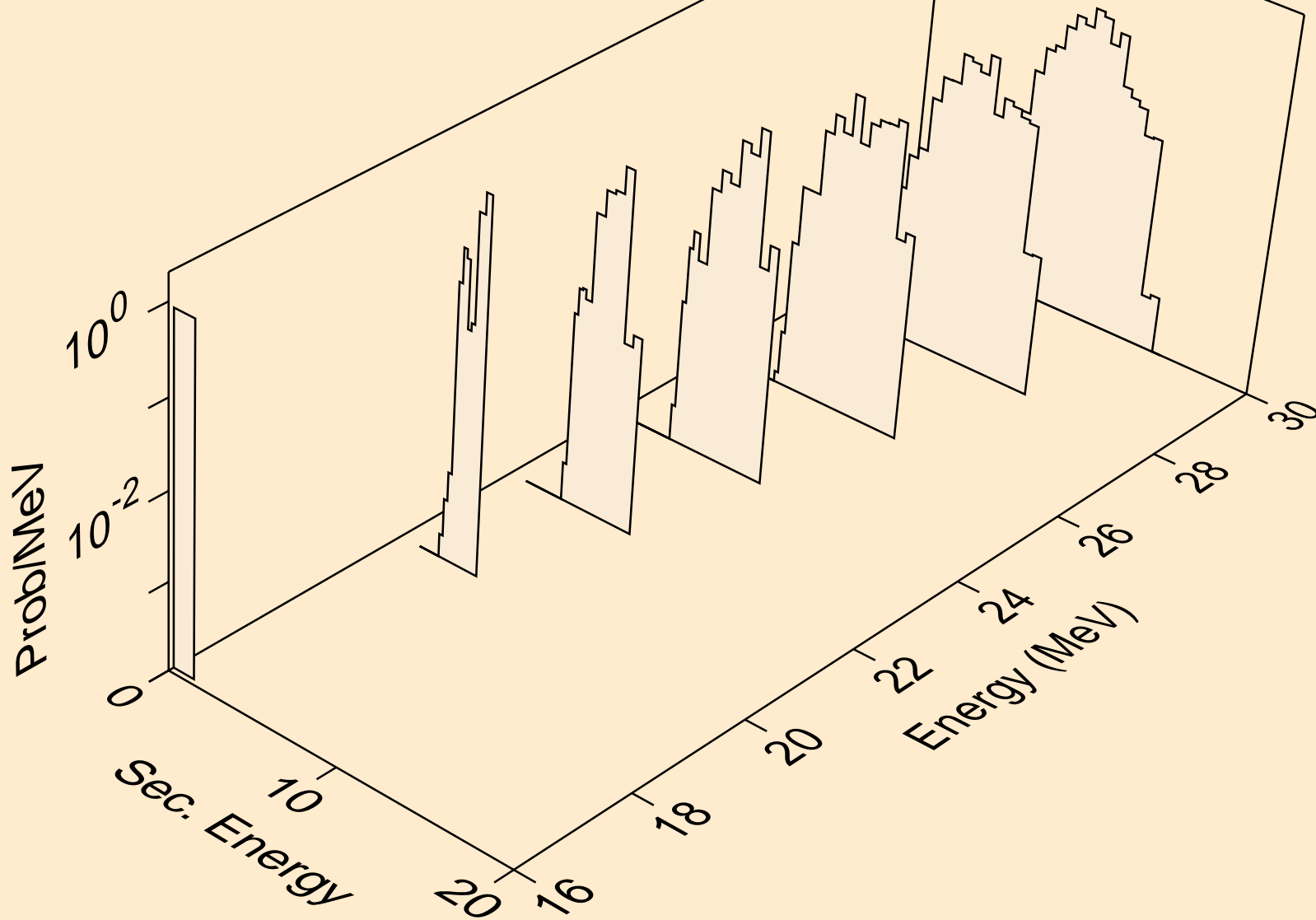

FR206M NEUTRON ACER TENDL-2019 LIBRARY; T=293.16K  
deuterons from (n,n\*)d

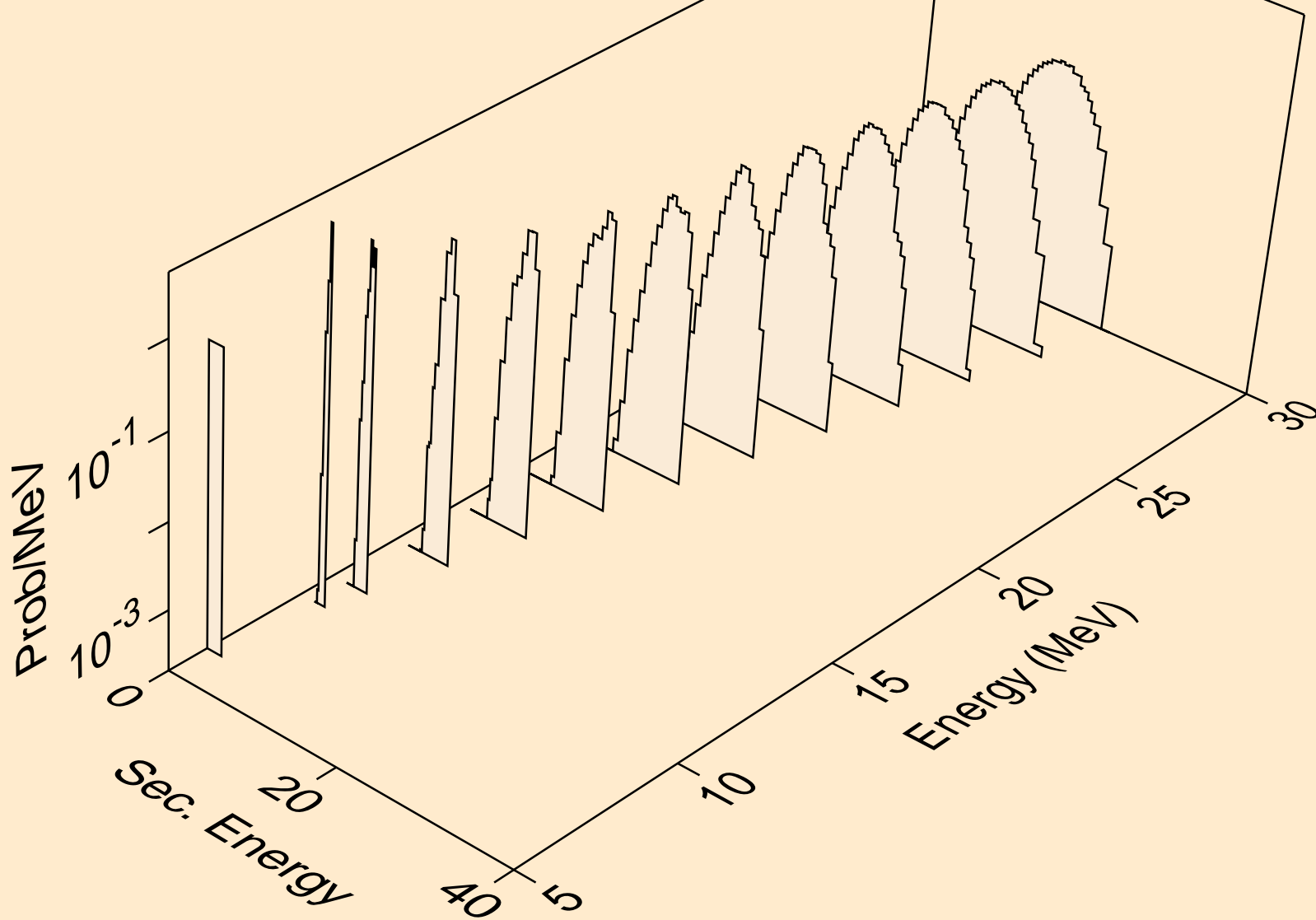

FR206M NEUTRON ACER TENDL-2019 LIBRARY; T=293.16K  
deuterons from (n,d)

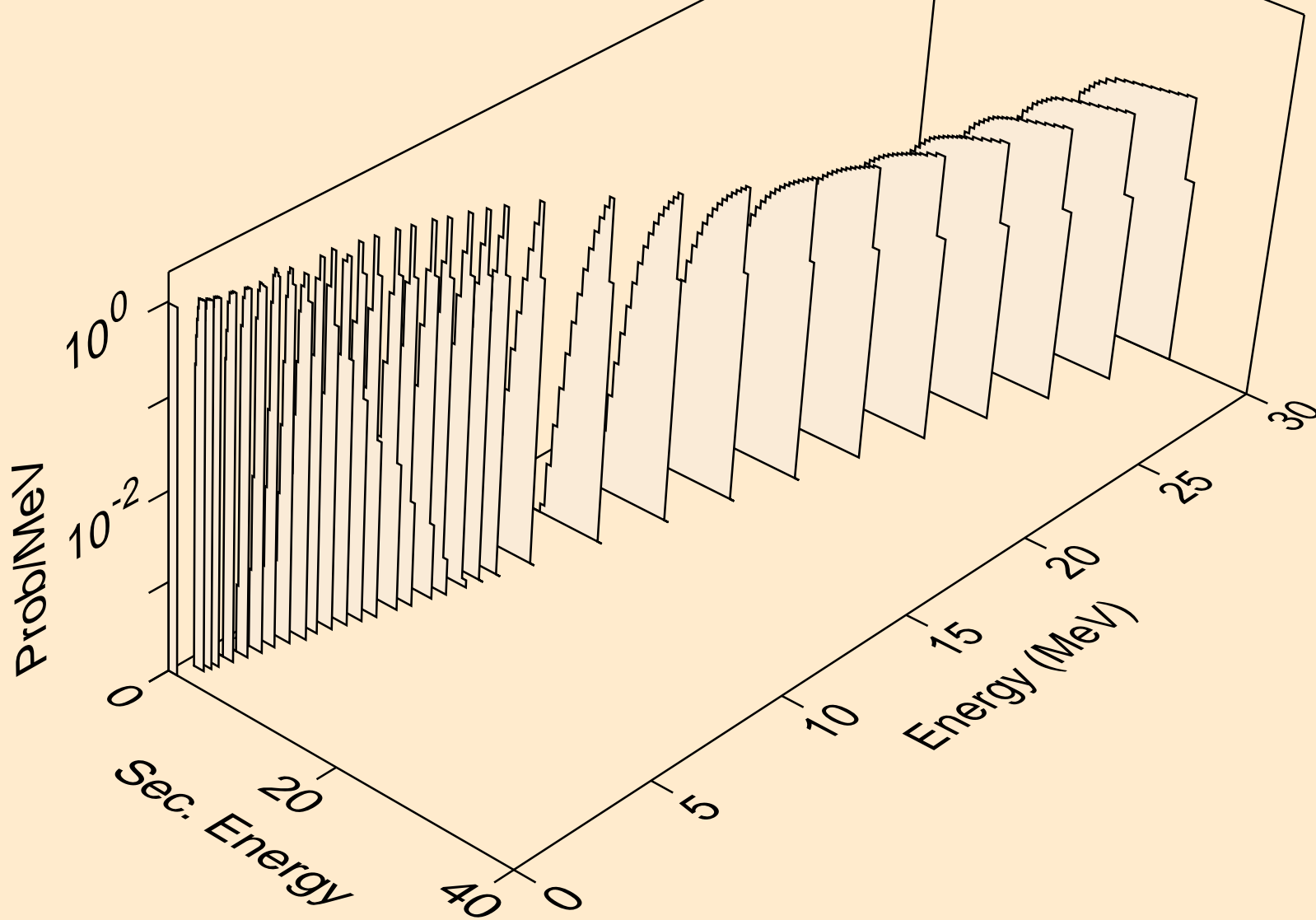

FR206M NEUTRON ACER TENDL-2019 LIBRARY; T=293.16K  
deuterons from (n,pd)

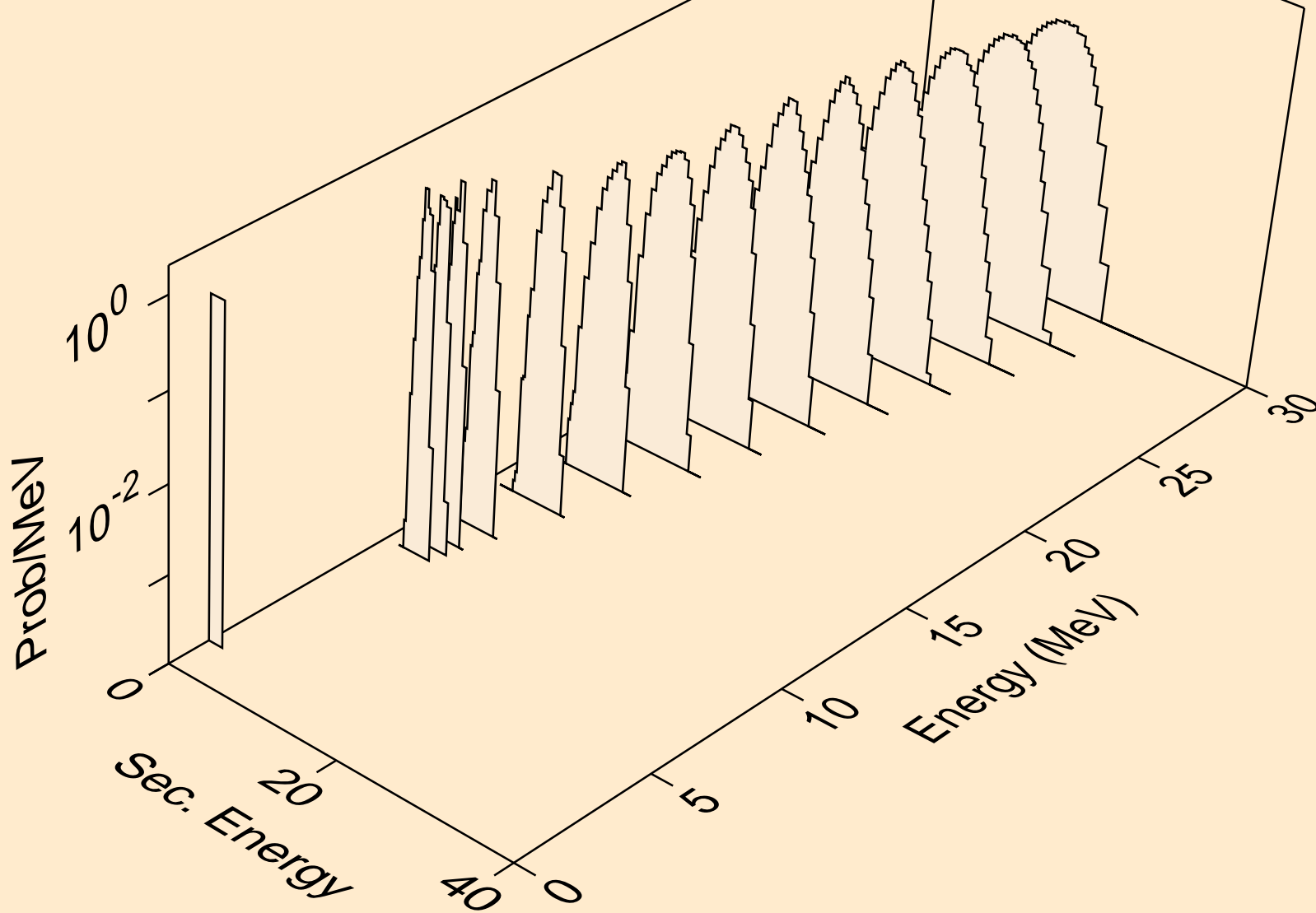

FR206M NEUTRON ACER TENDL-2019 LIBRARY; T=293.16K  
deuterons from (n,da)

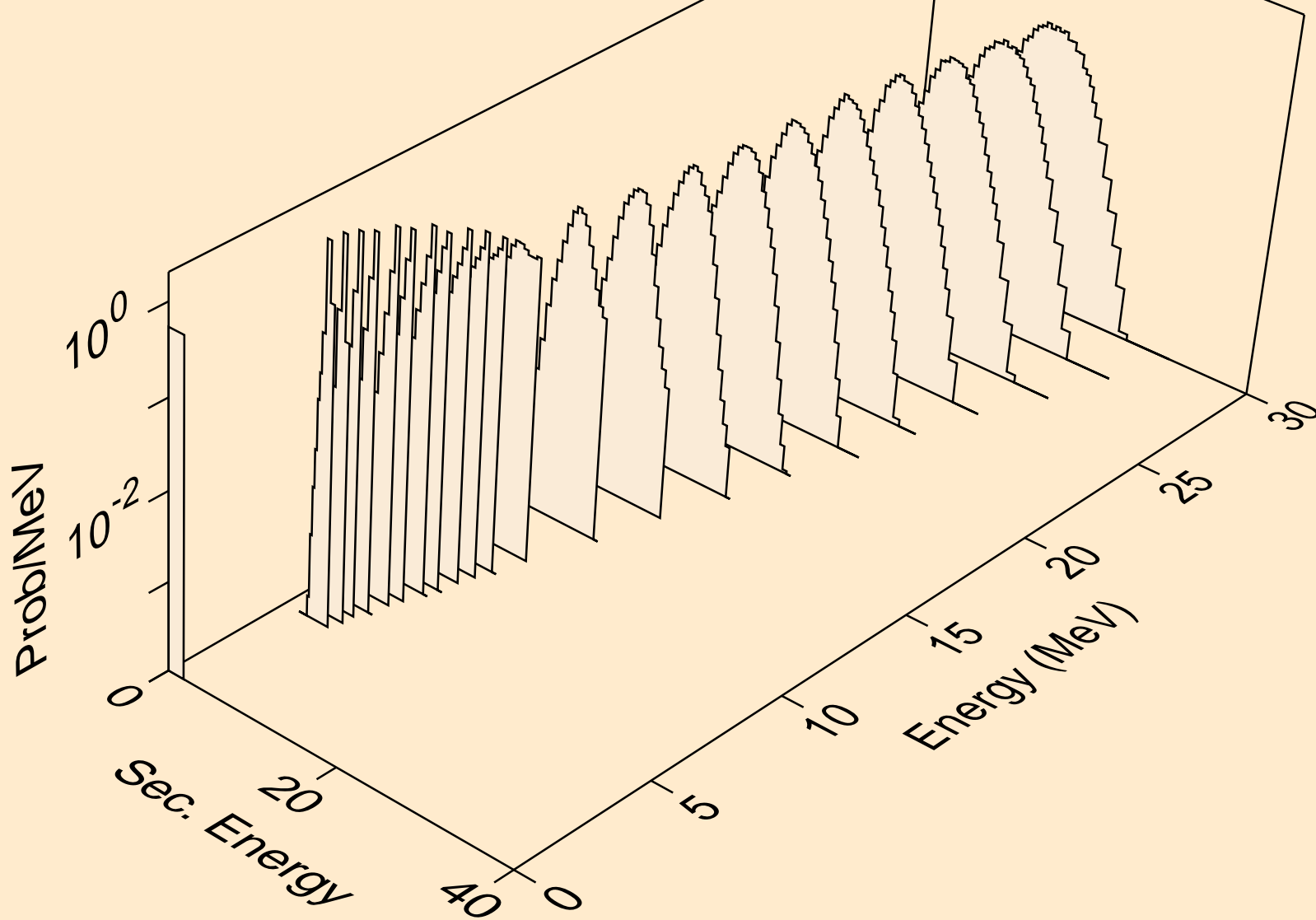

FR206M NEUTRON ACER TENDL-2019 LIBRARY; T=293.16K  
tritons from (n,x)

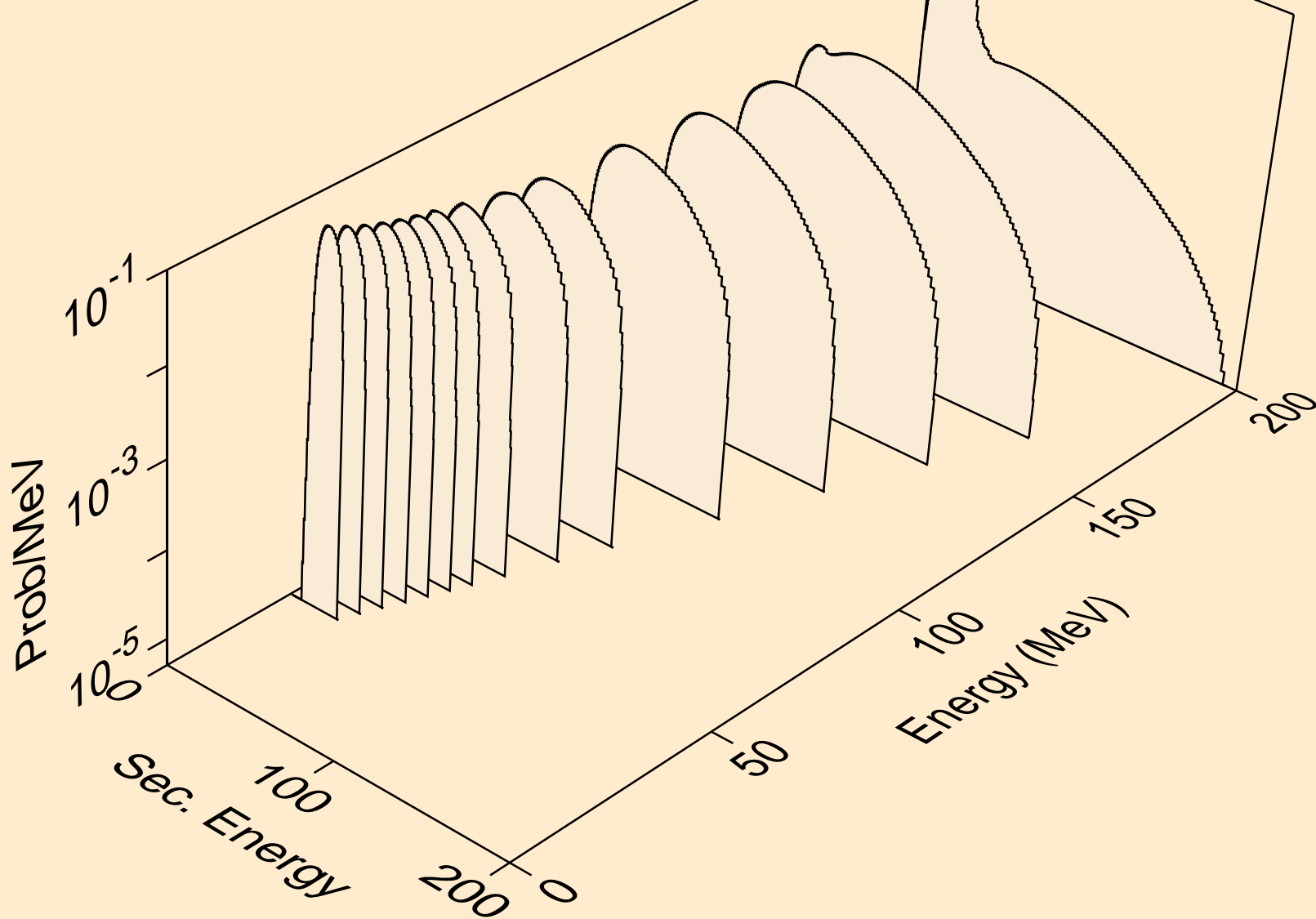

FR206M NEUTRON ACER TENDL-2019 LIBRARY; T=293.16K  
tritons from (n,n\*)t

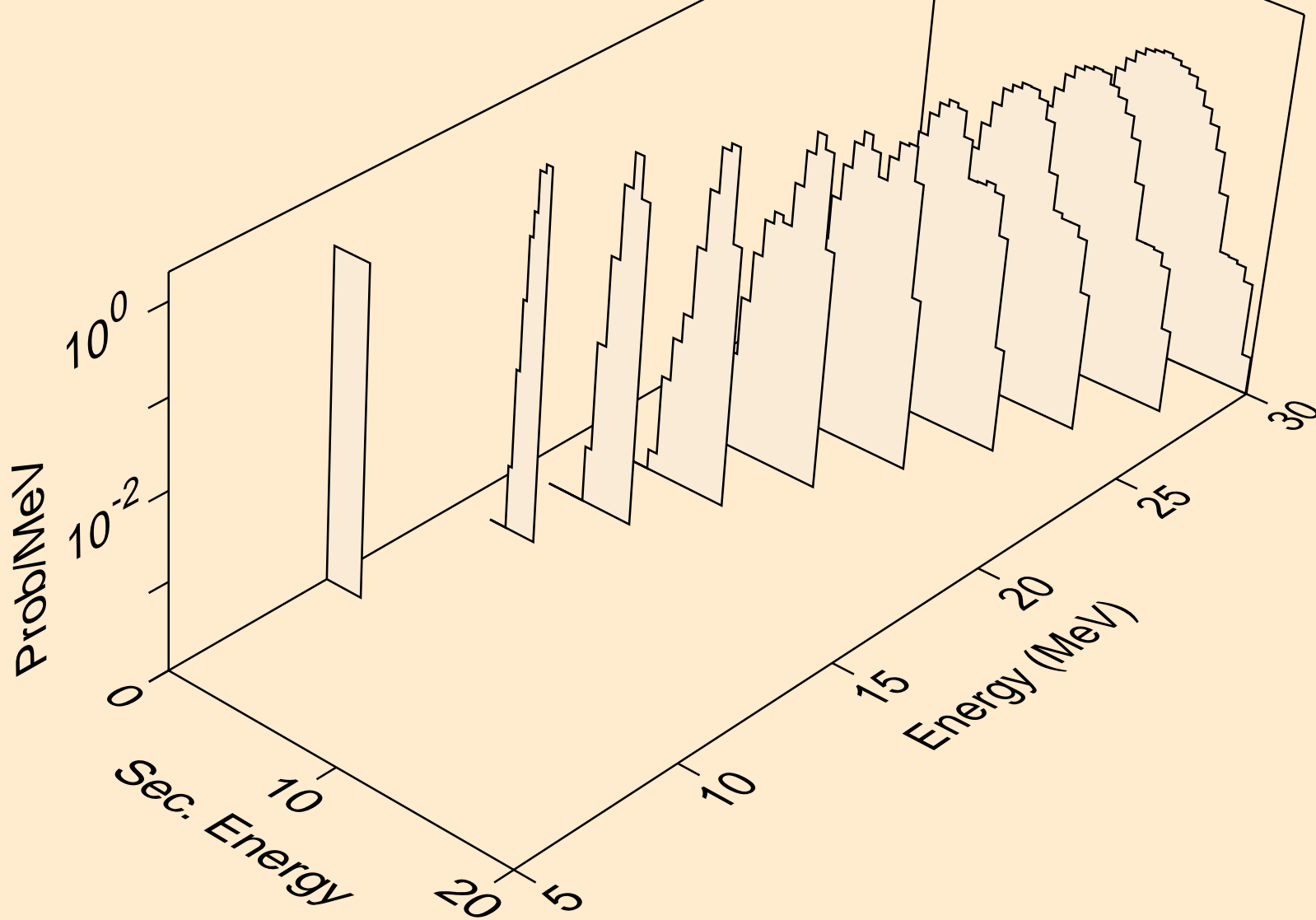



FR206M NEUTRON ACER TENDL-2019 LIBRARY; T=293.16K  
tritons from (n,t)

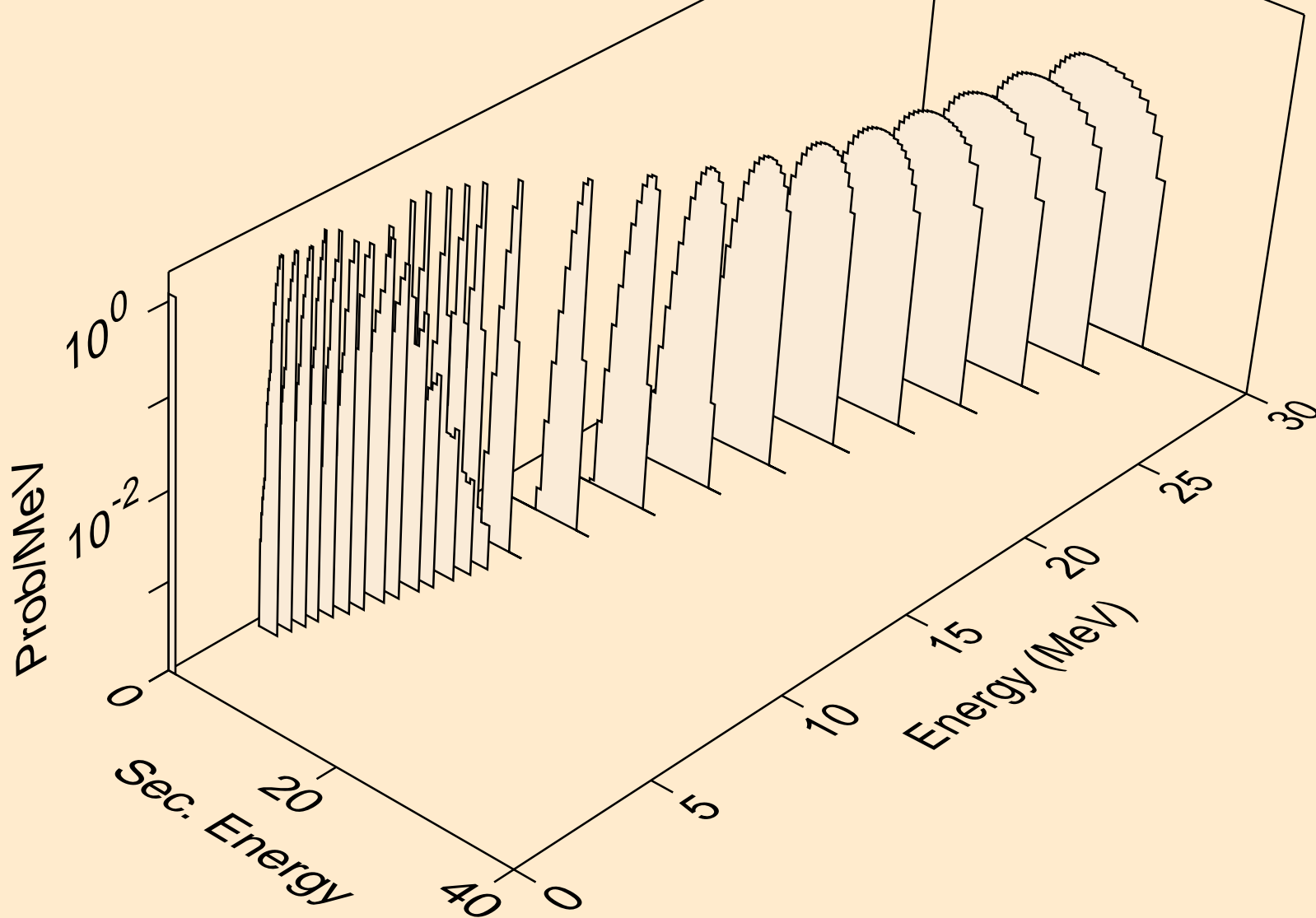

FR206M NEUTRON ACER TENDL-2019 LIBRARY; T=293.16K  
tritons from (n,pt)

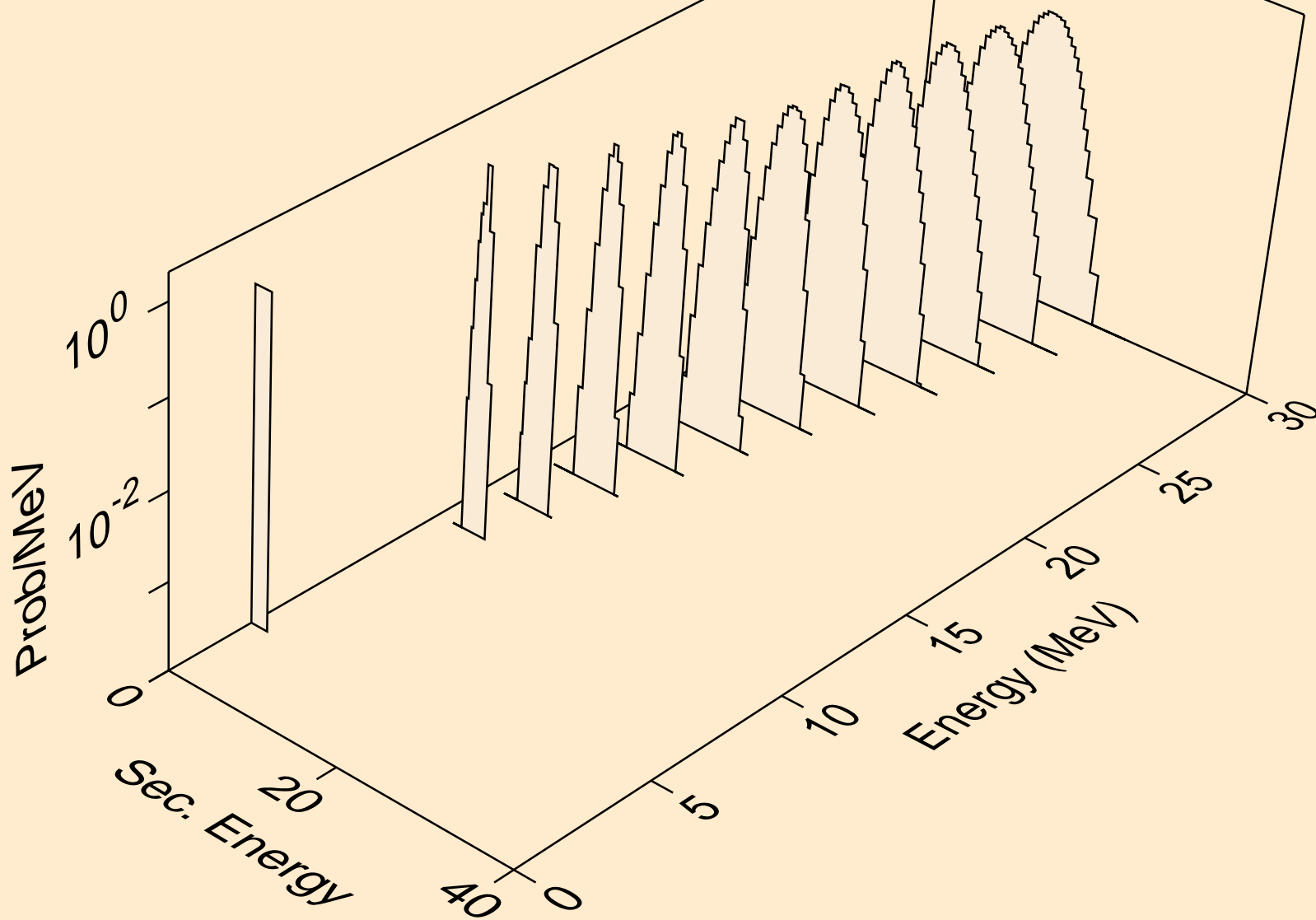

FR206M NEUTRON ACER TENDL-2019 LIBRARY; T=293.16K  
he3s from (n,x)

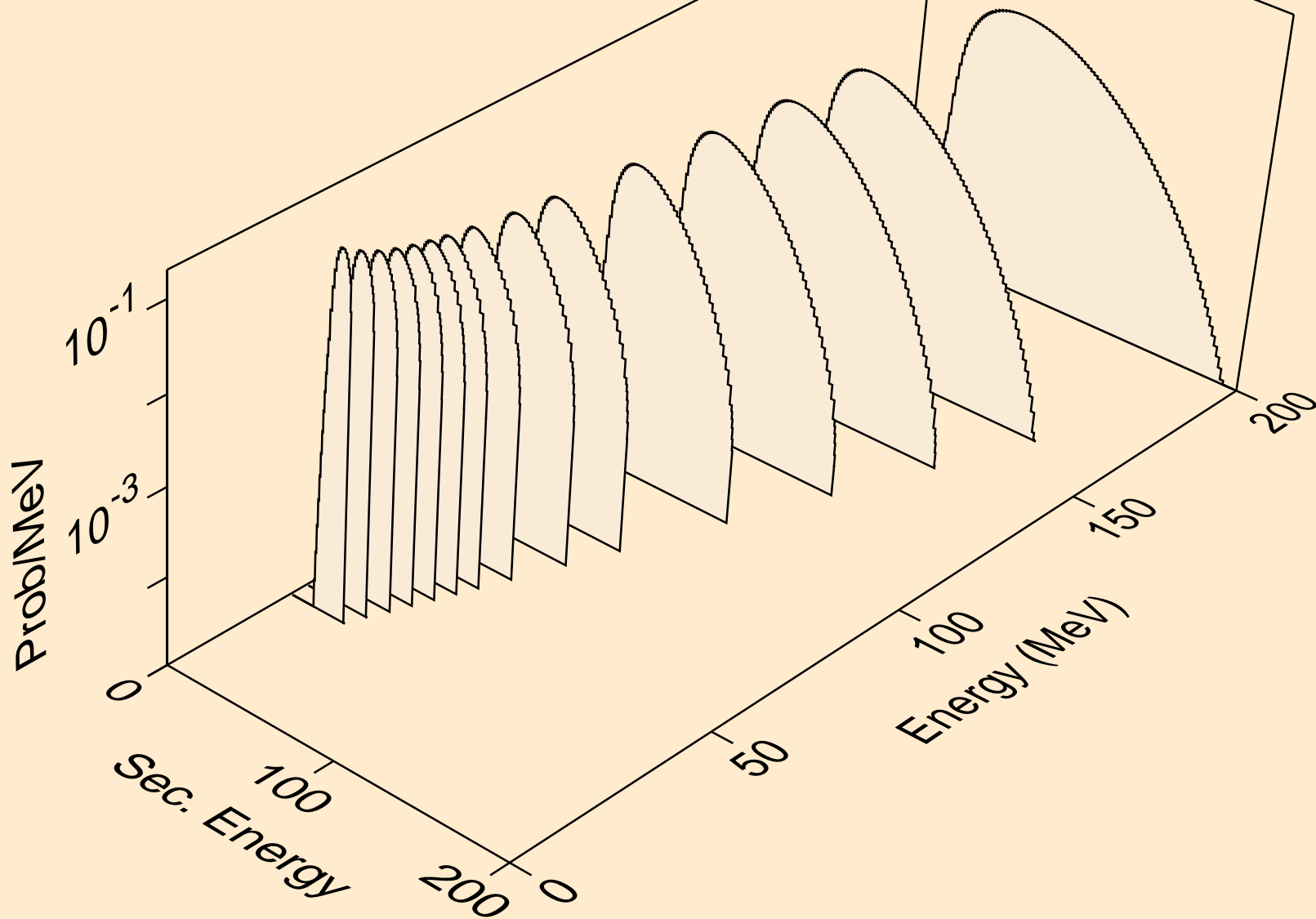

FR206M NEUTRON ACER TENDL-2019 LIBRARY; T=293.16K  
he3s from (n,n\*)he3

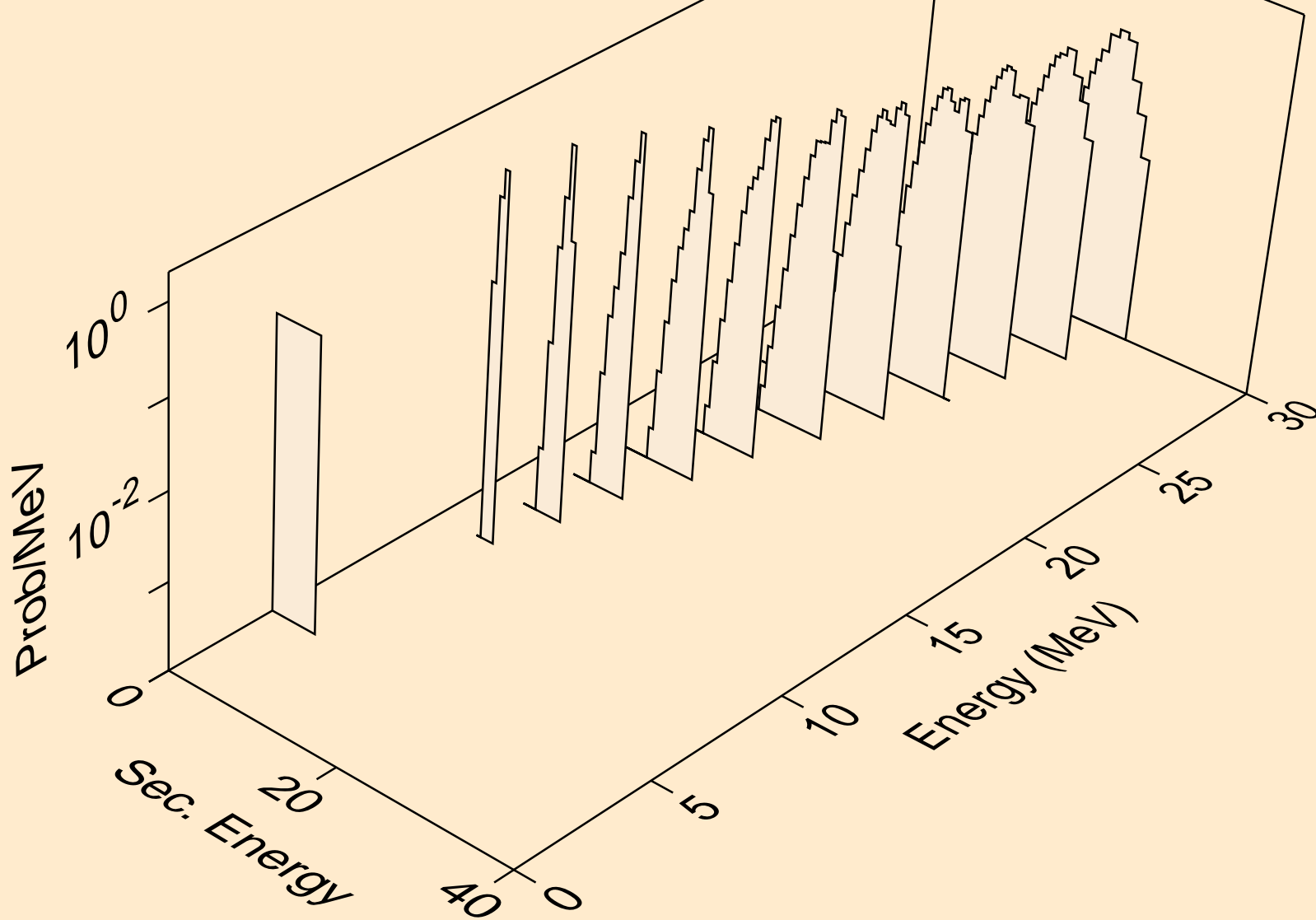

FR206M NEUTRON ACER TENDL-2019 LIBRARY; T=293.16K  
he3s from (n,he3)

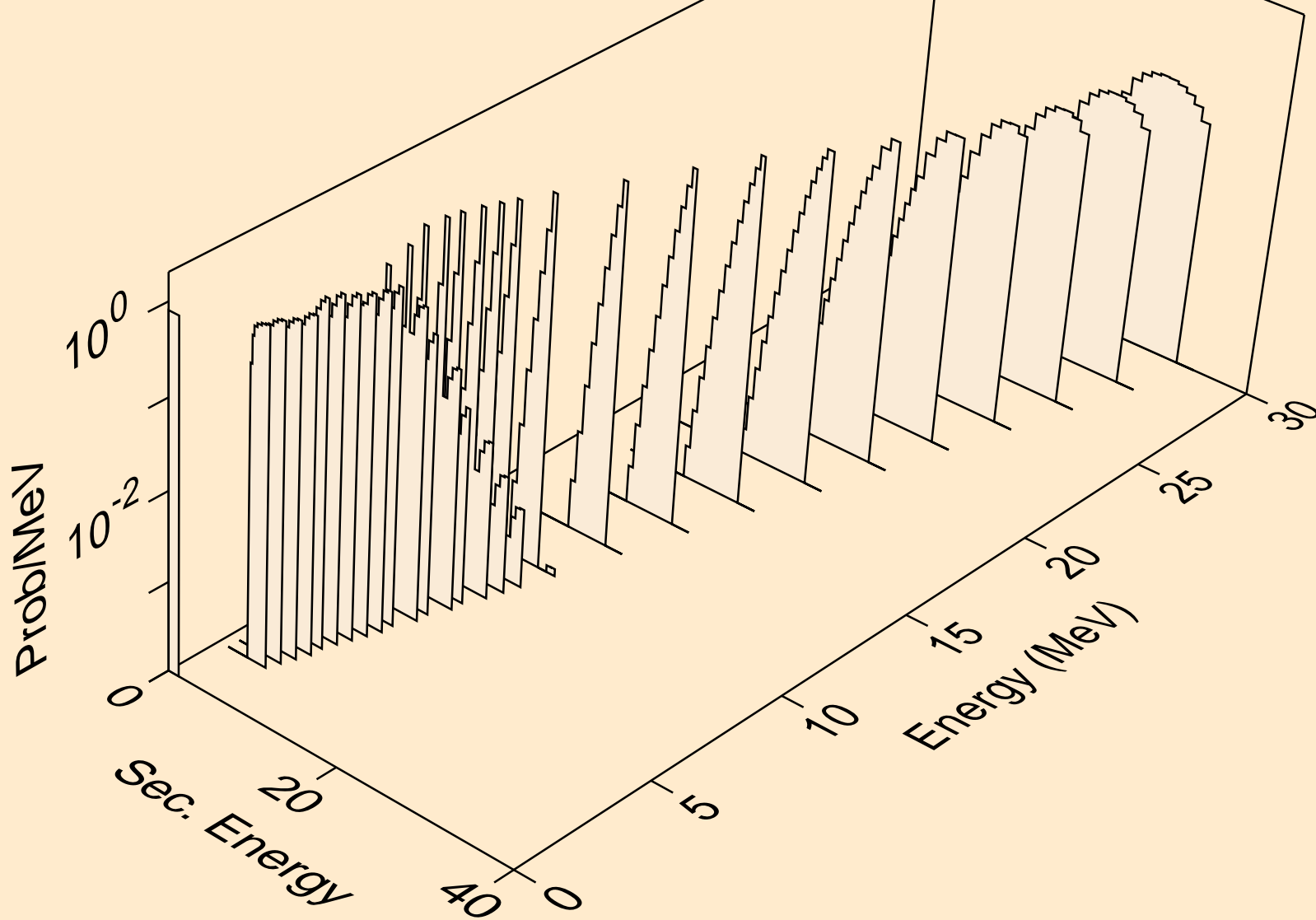

FR206M NEUTRON ACER TENDL-2019 LIBRARY; T=293.16K  
alphas from (n,x)

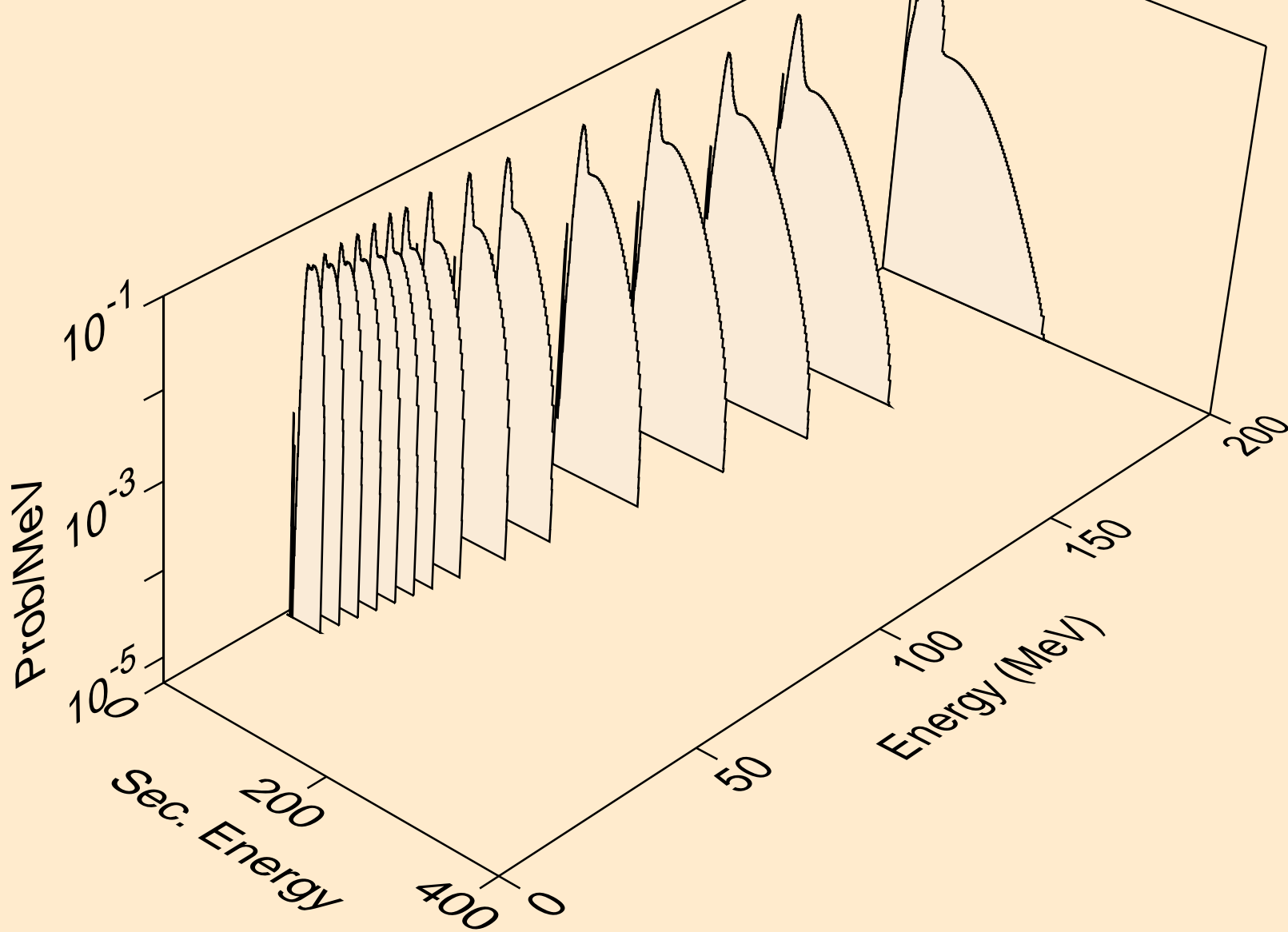

FR206M NEUTRON ACER TENDL-2019 LIBRARY; T=293.16K  
alphas from (n,n\*)a

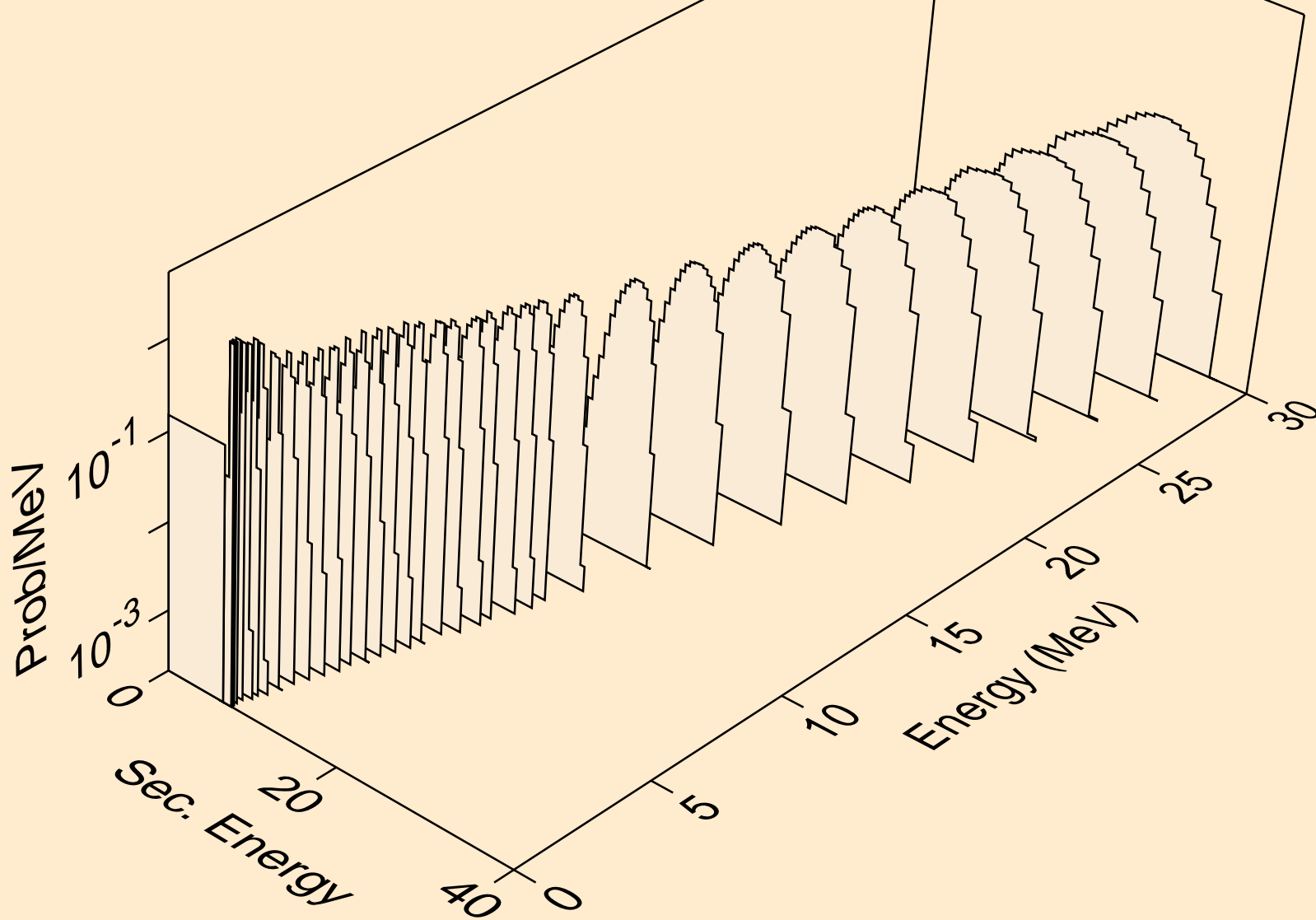

FR206M NEUTRON ACER TENDL-2019 LIBRARY; T=293.16K  
alphas from (n,2n)a

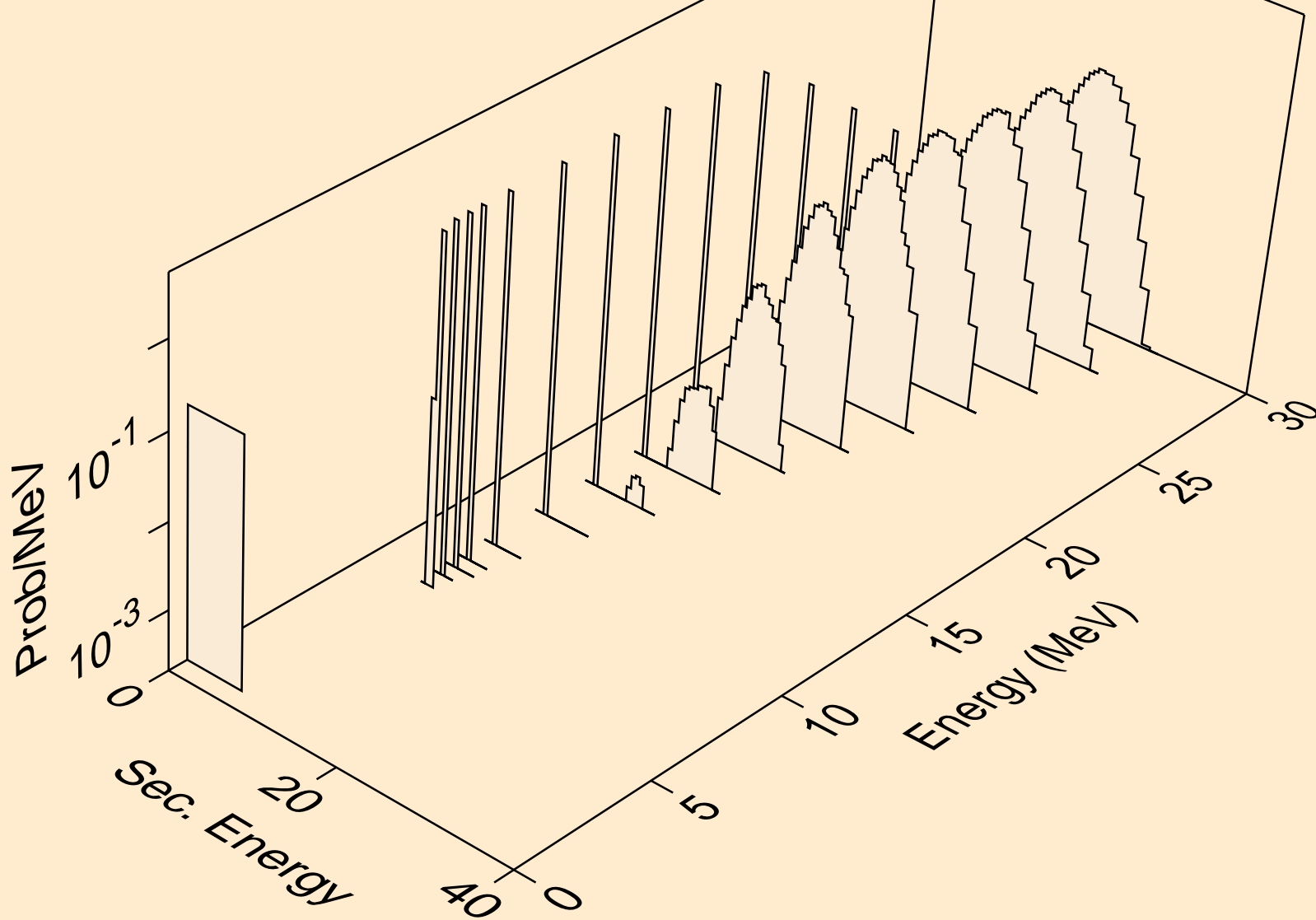



FR206M NEUTRON ACER TENDL-2019 LIBRARY; T=293.16K  
alphas from (n,3n)a

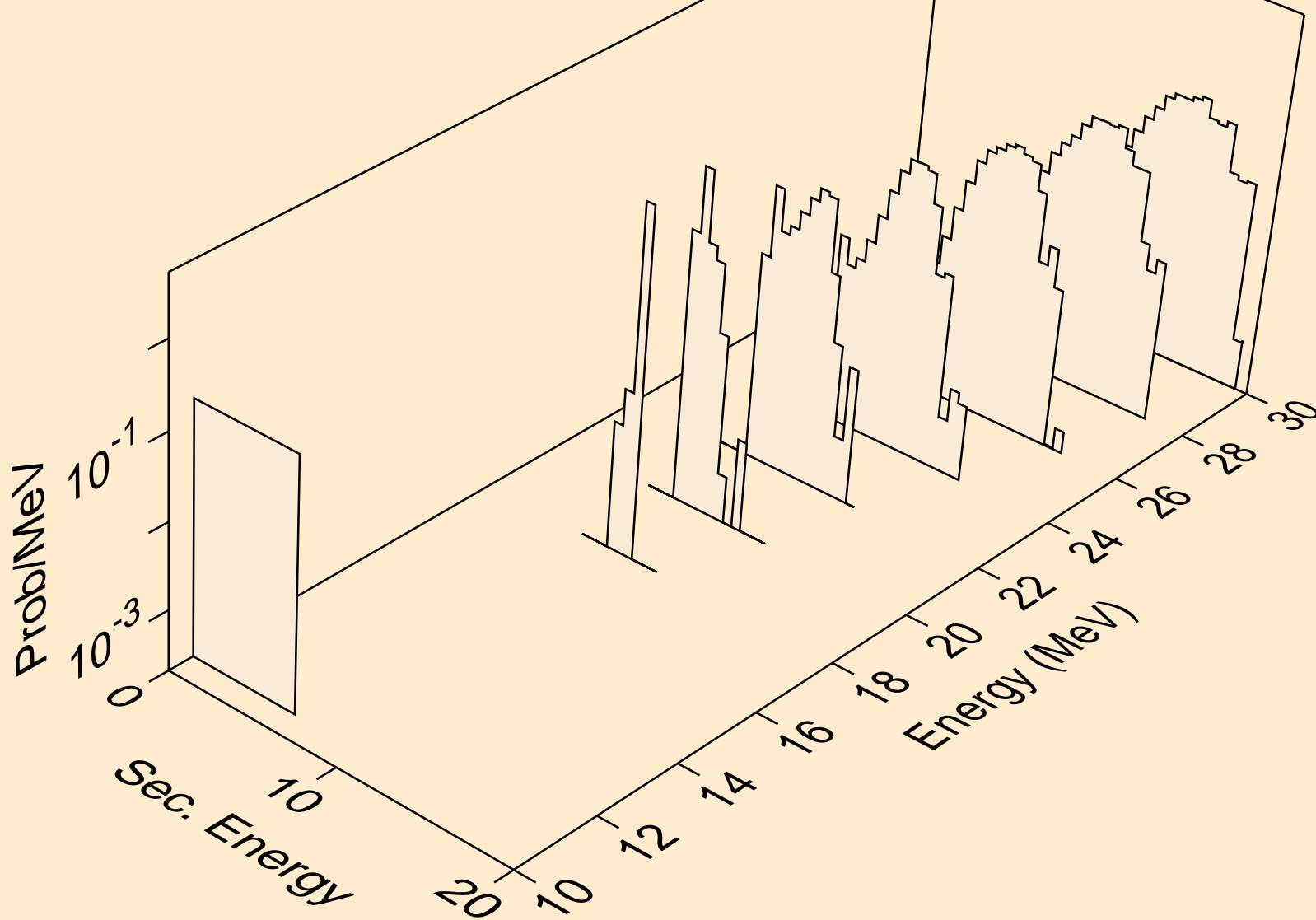

FR206M NEUTRON ACER TENDL-2019 LIBRARY; T=293.16K  
alphas from (n,n\*)2a

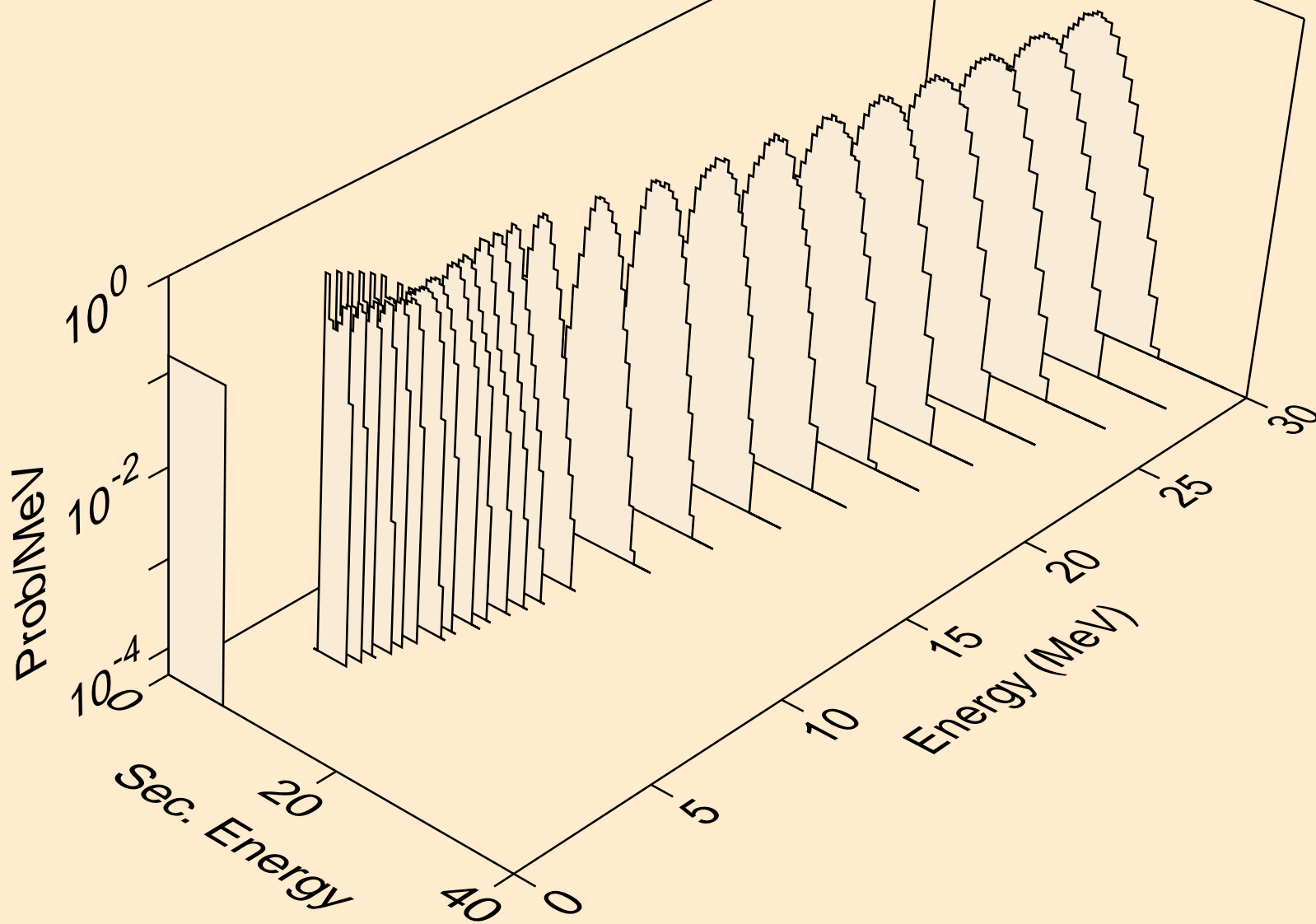

FR206M NEUTRON ACER TENDL-2019 LIBRARY; T=293.16K  
alphas from (n,2n)2a

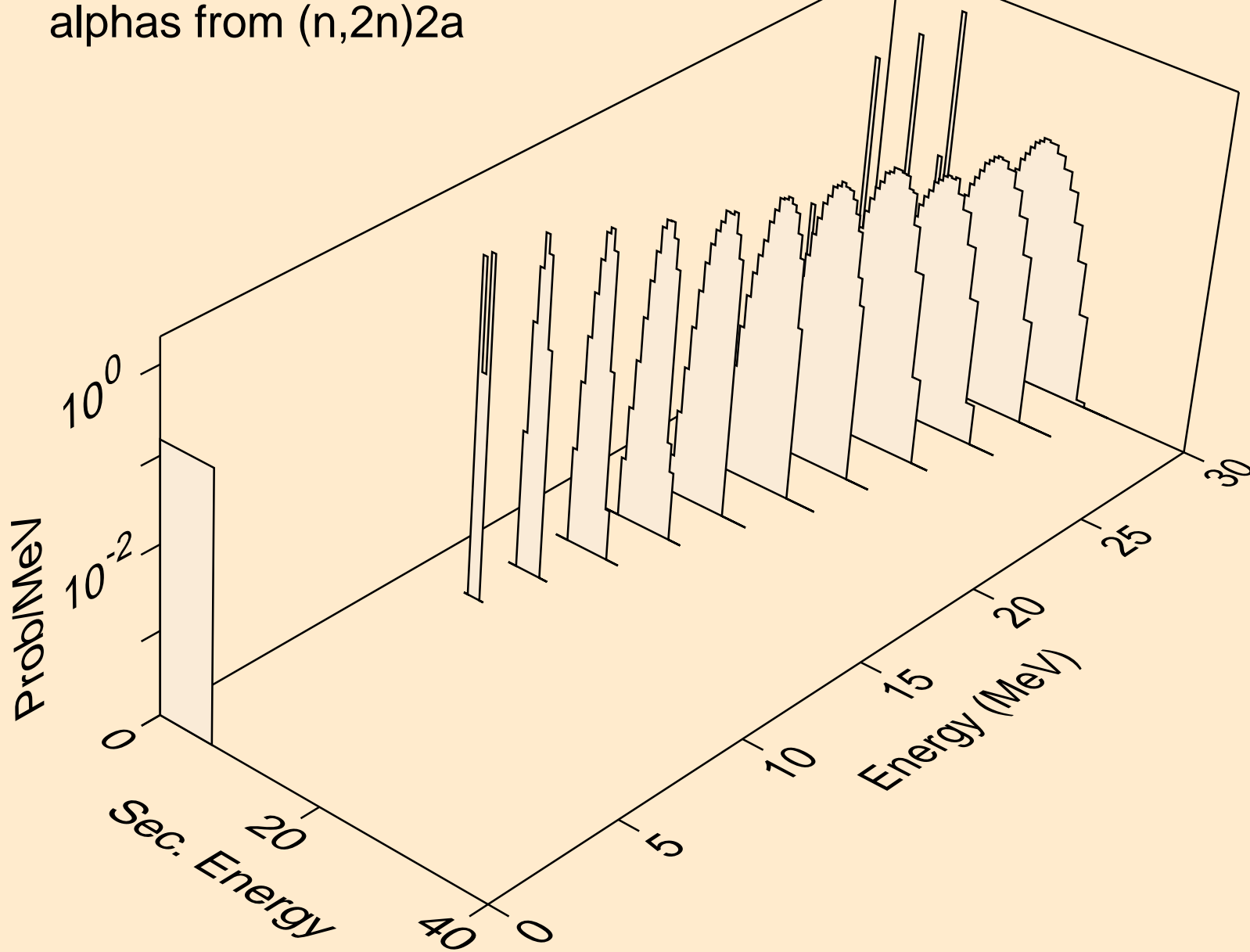

FR206M NEUTRON ACER TENDL-2019 LIBRARY; T=293.16K  
alphas from (n,npa)

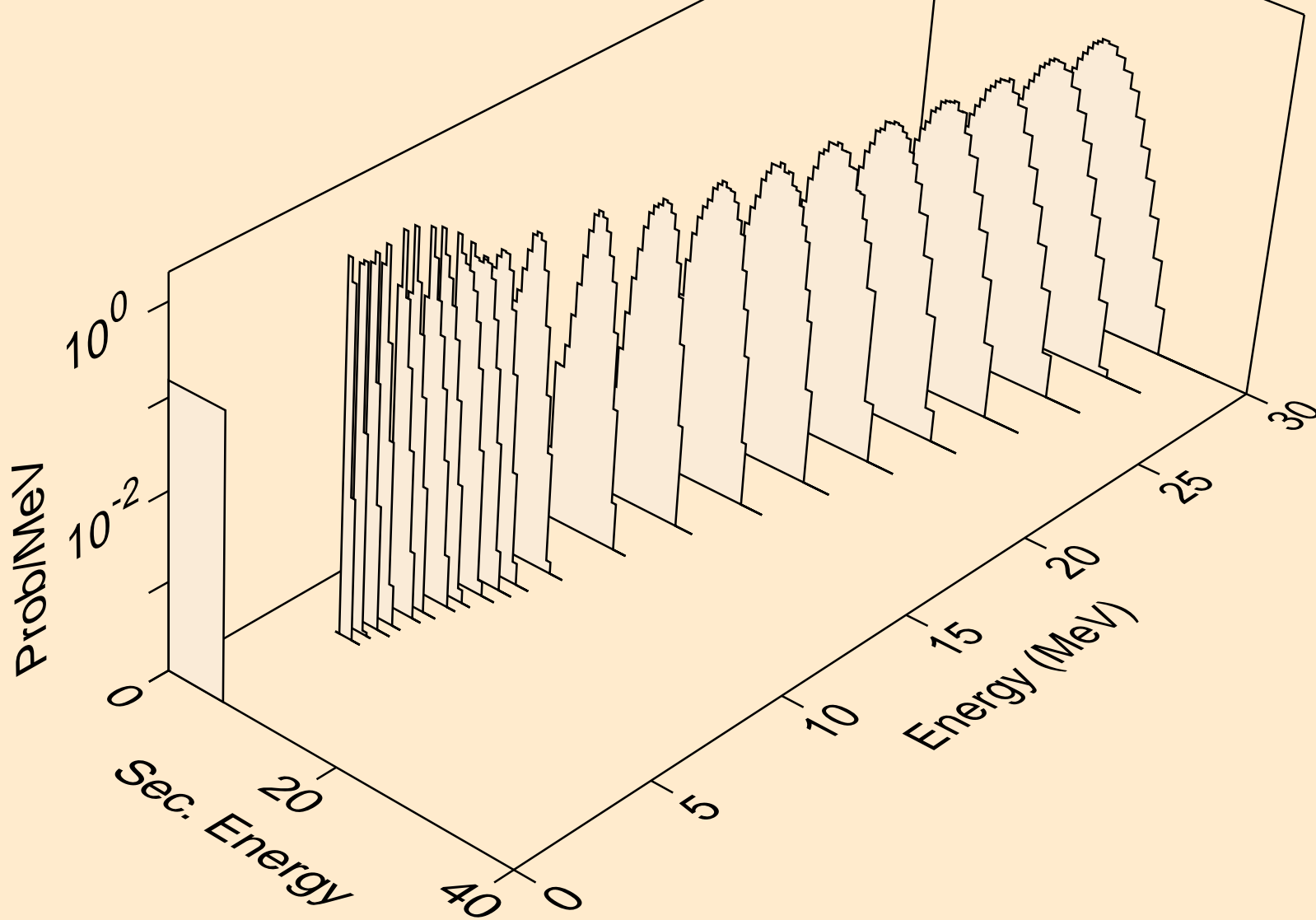

FR206M NEUTRON ACER TENDL-2019 LIBRARY; T=293.16K  
alphas from (n,a)

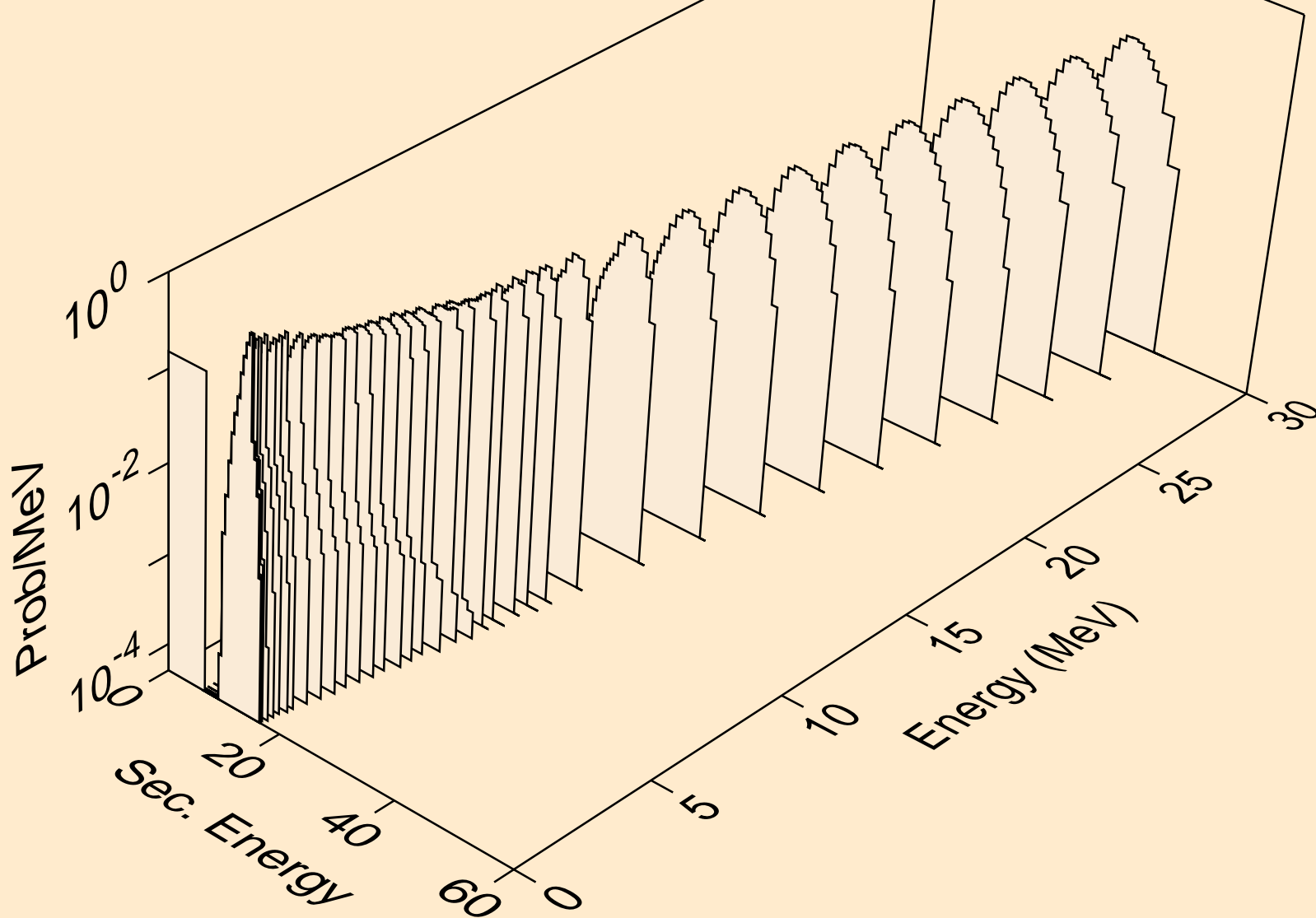

FR206M NEUTRON ACER TENDL-2019 LIBRARY; T=293.16K  
alphas from (n,2a)

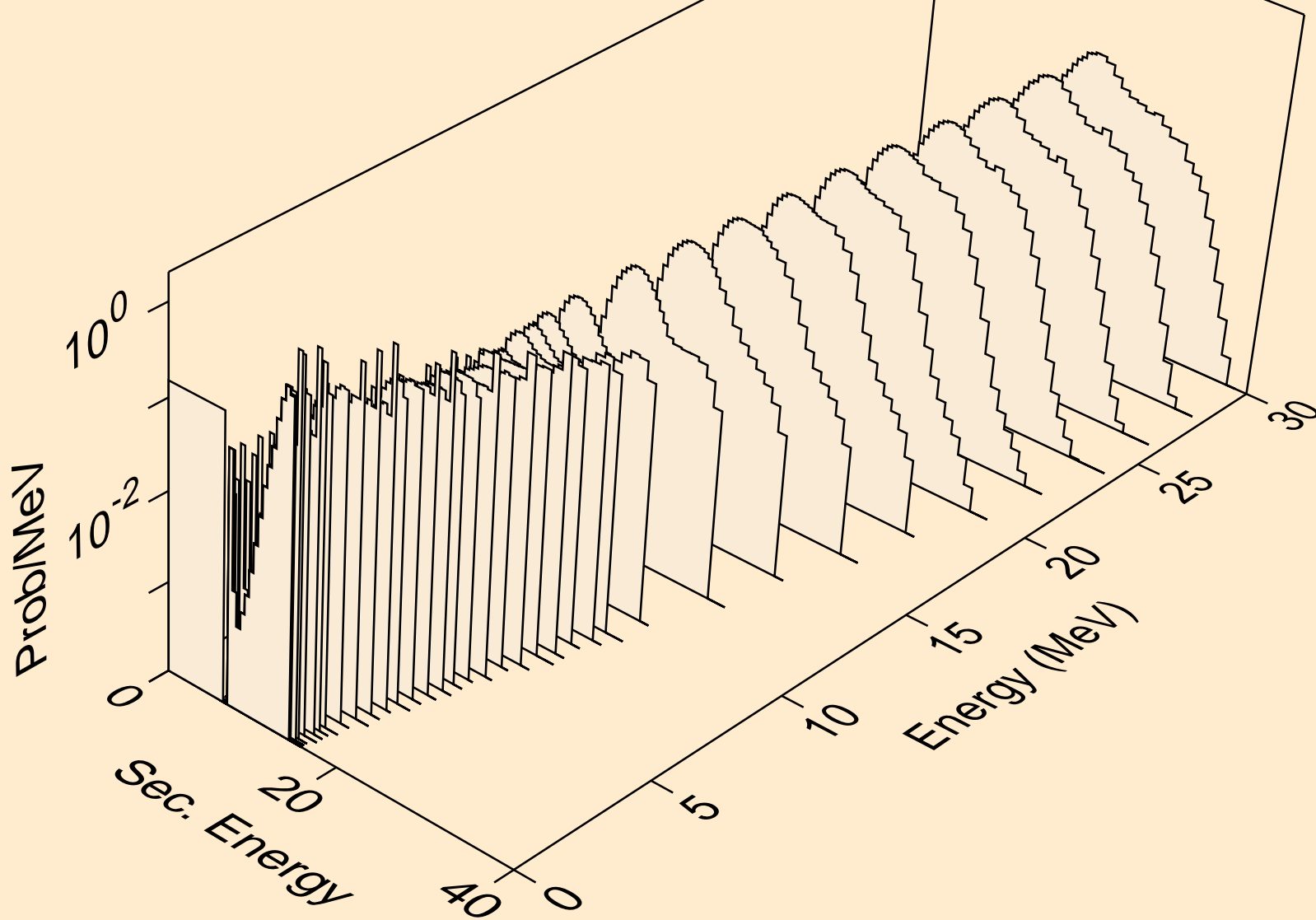

FR206M NEUTRON ACER TENDL-2019 LIBRARY; T=293.16K  
alphas from (n,pa)

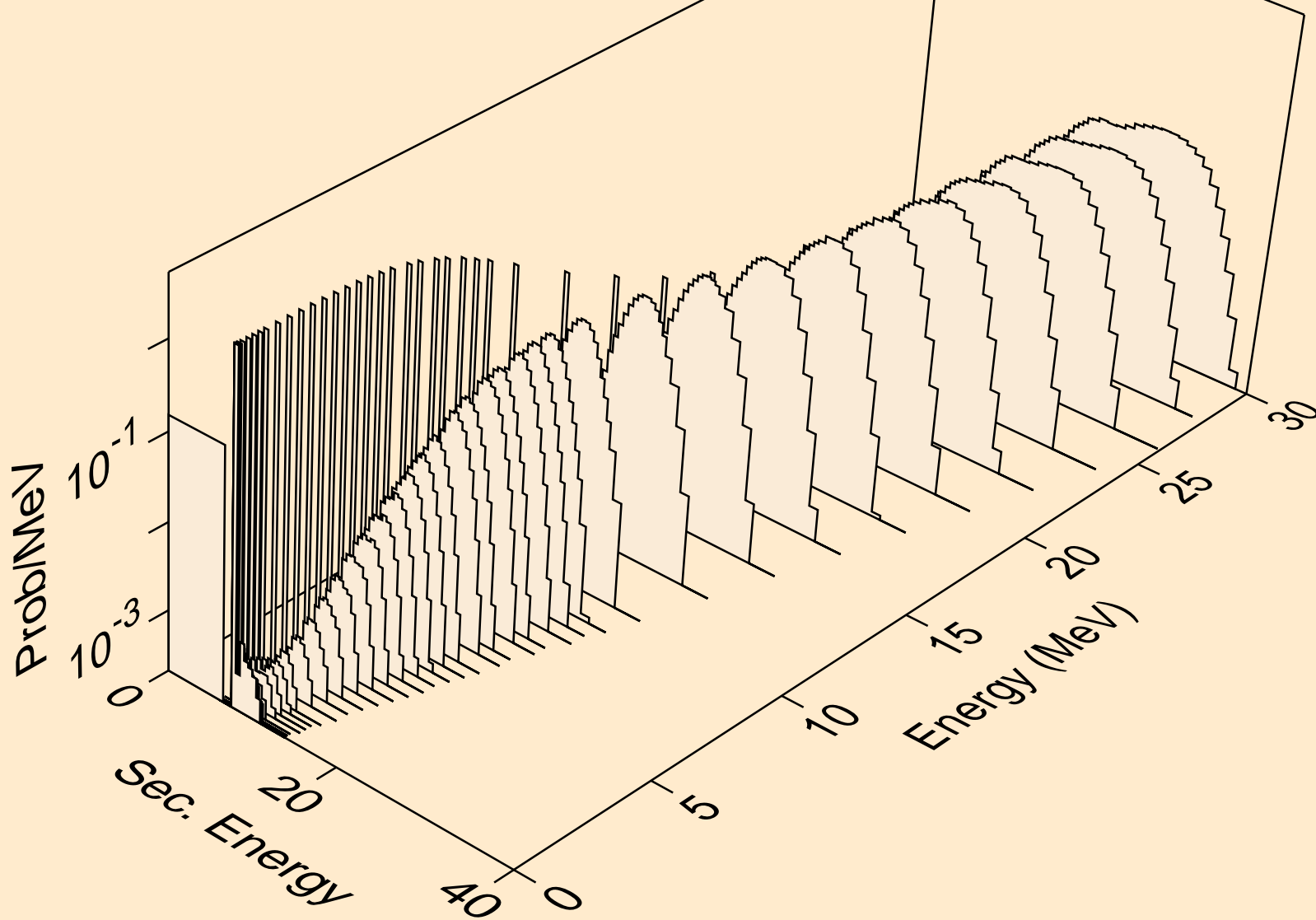

FR206M NEUTRON ACER TENDL-2019 LIBRARY; T=293.16K  
alphas from (n,da)

