

MT277 NEUTRON ACER TENDL-2019 LIBRARY; T=293.16K
Principal cross sections

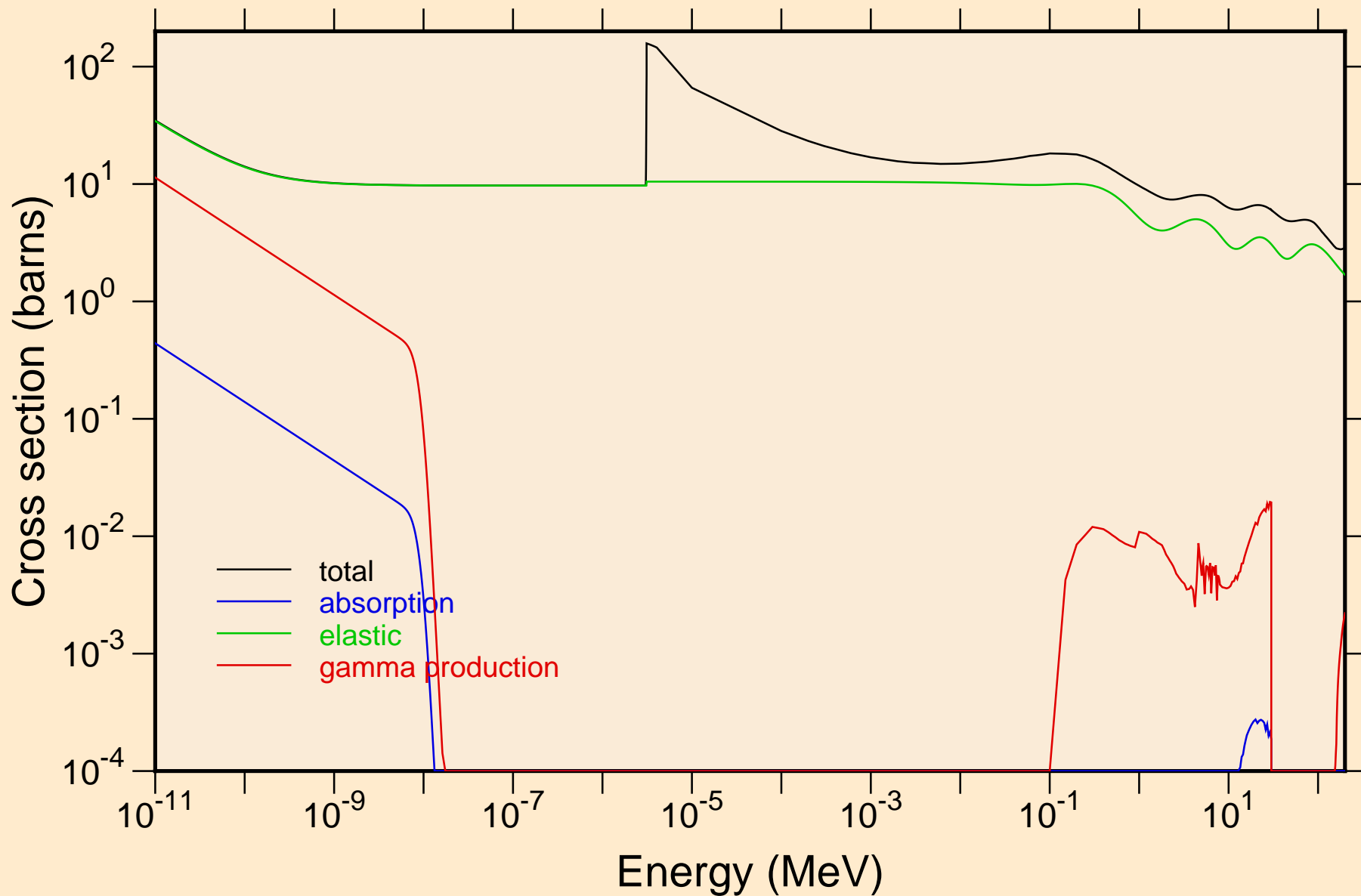

MT277 NEUTRON ACER TENDL-2019 LIBRARY; T=293.16K
Heating

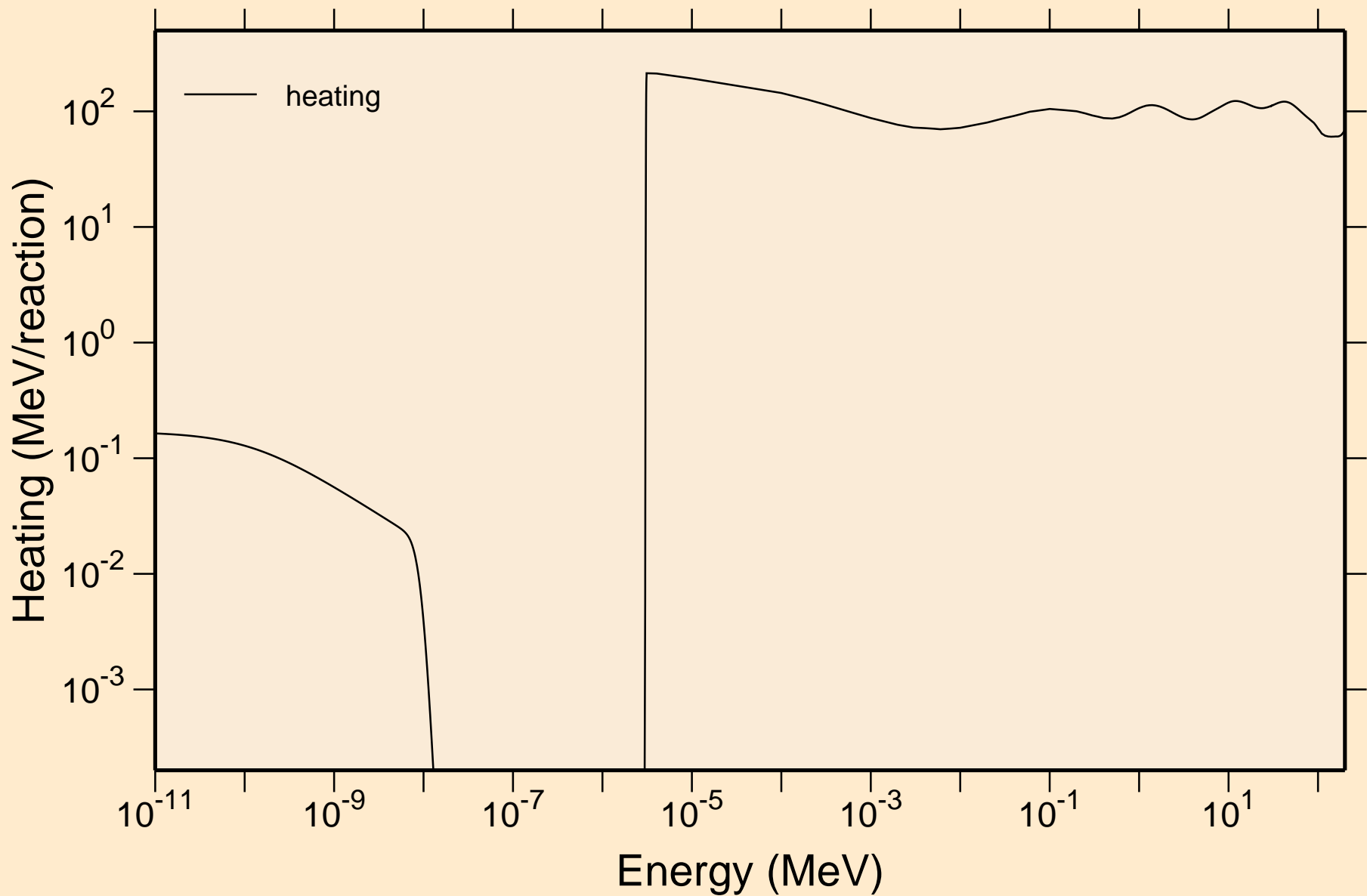

MT277 NEUTRON ACER TENDL-2019 LIBRARY; T=293.16K
Damage

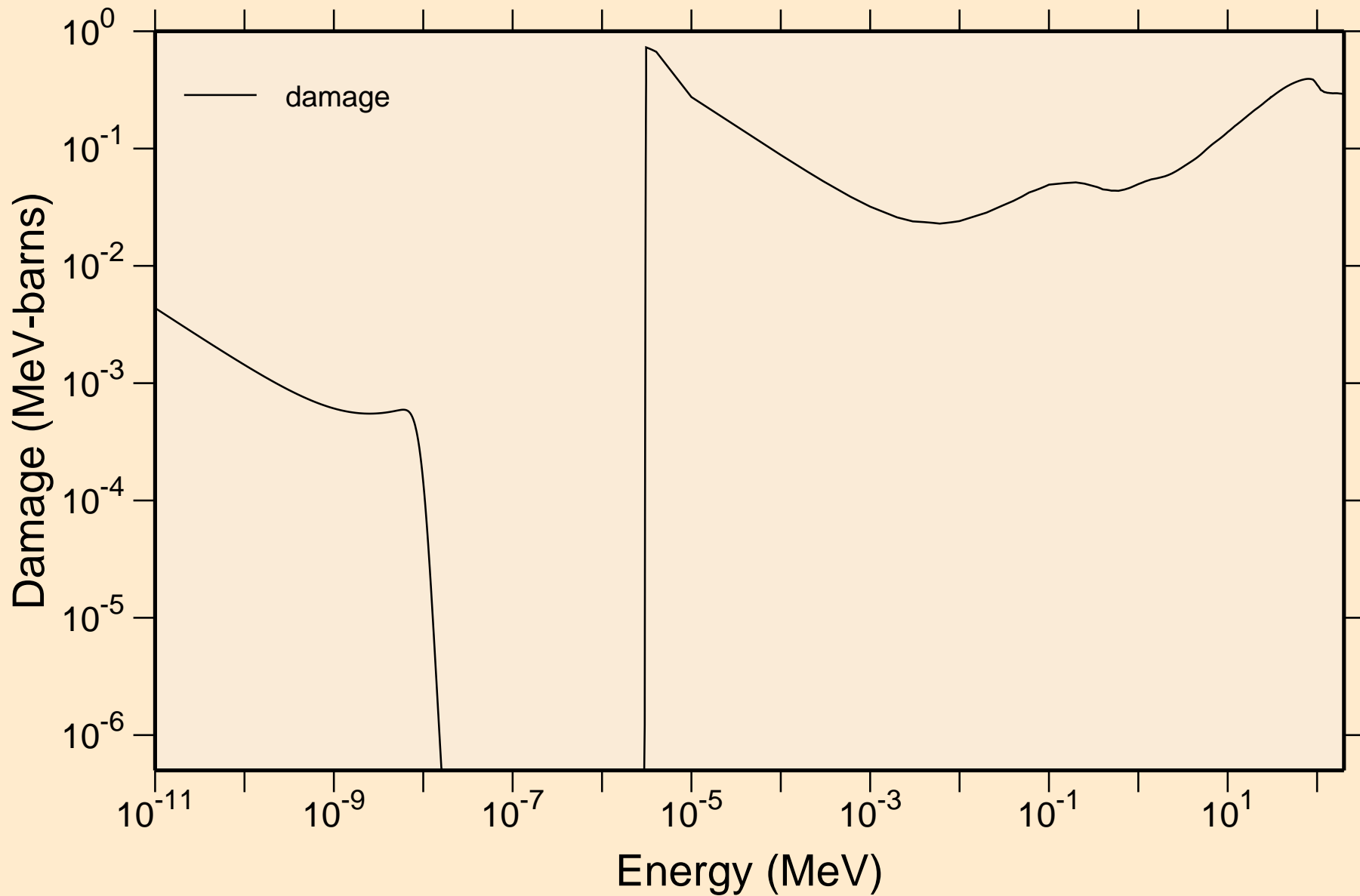

MT277 NEUTRON ACER TENDL-2019 LIBRARY; T=293.16K
Non-threshold reactions

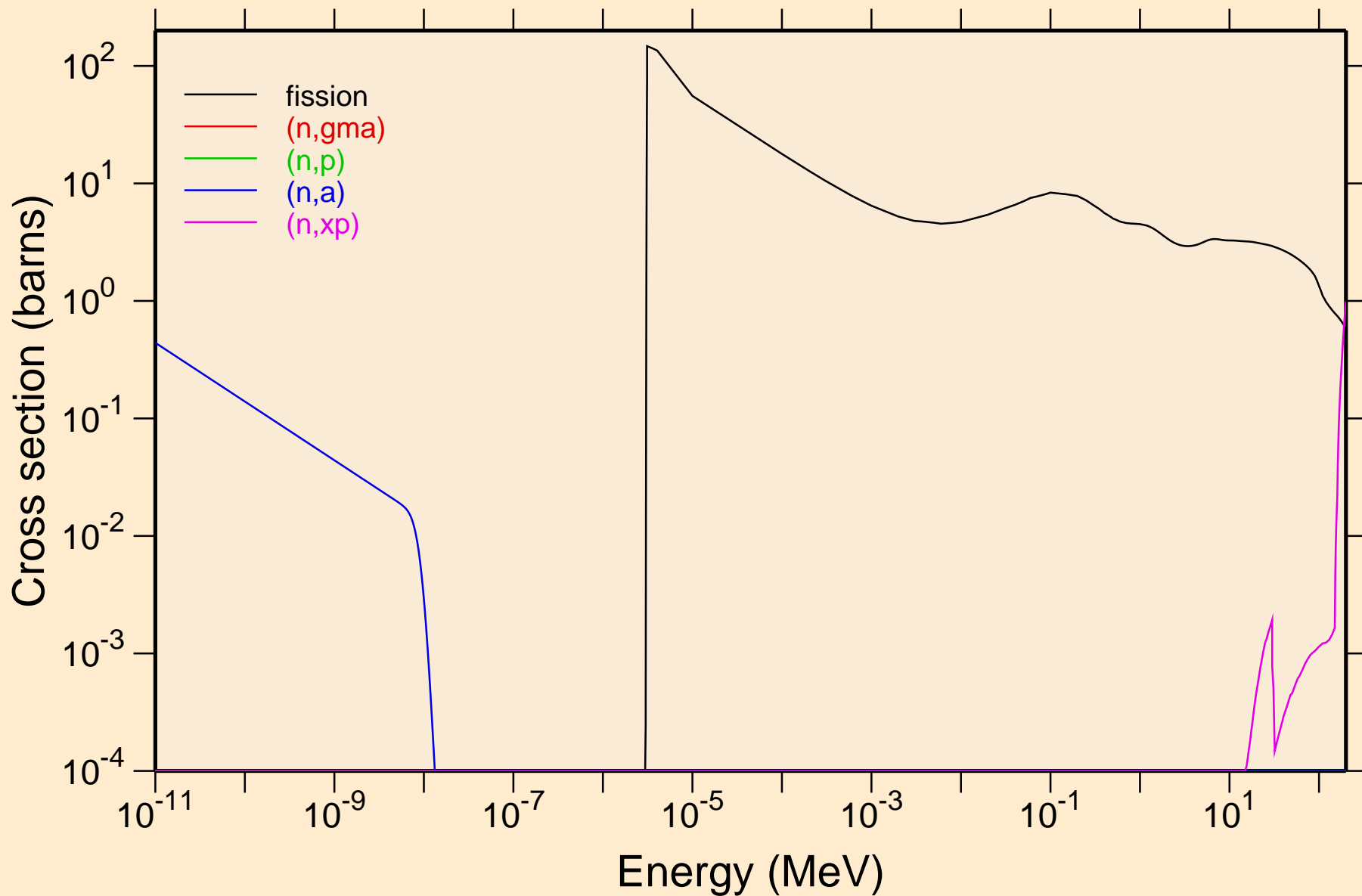

MT277 NEUTRON ACER TENDL-2019 LIBRARY; T=293.16K
Non-threshold reactions

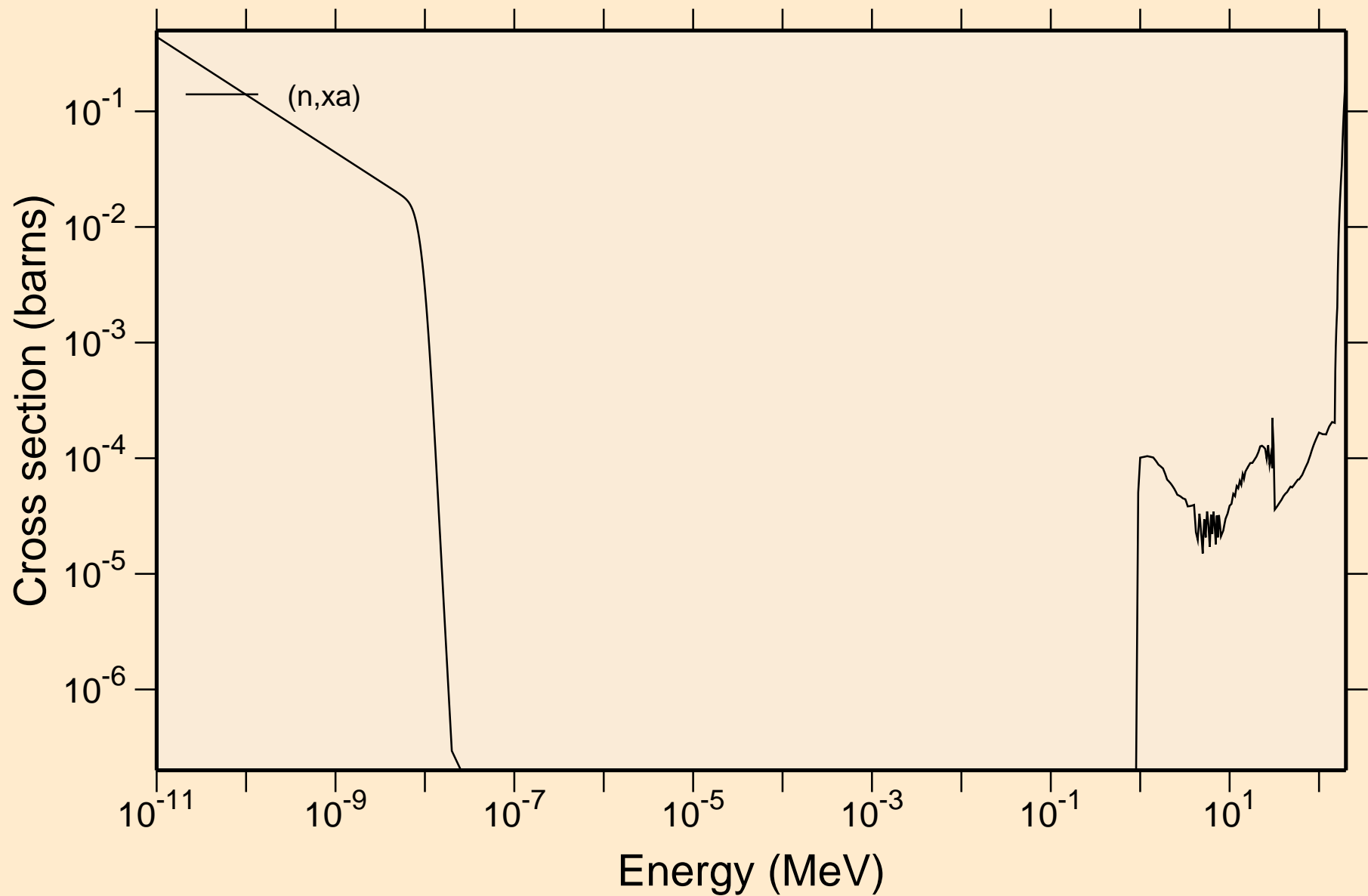

MT277 NEUTRON ACER TENDL-2019 LIBRARY; T=293.16K
Principal cross sections

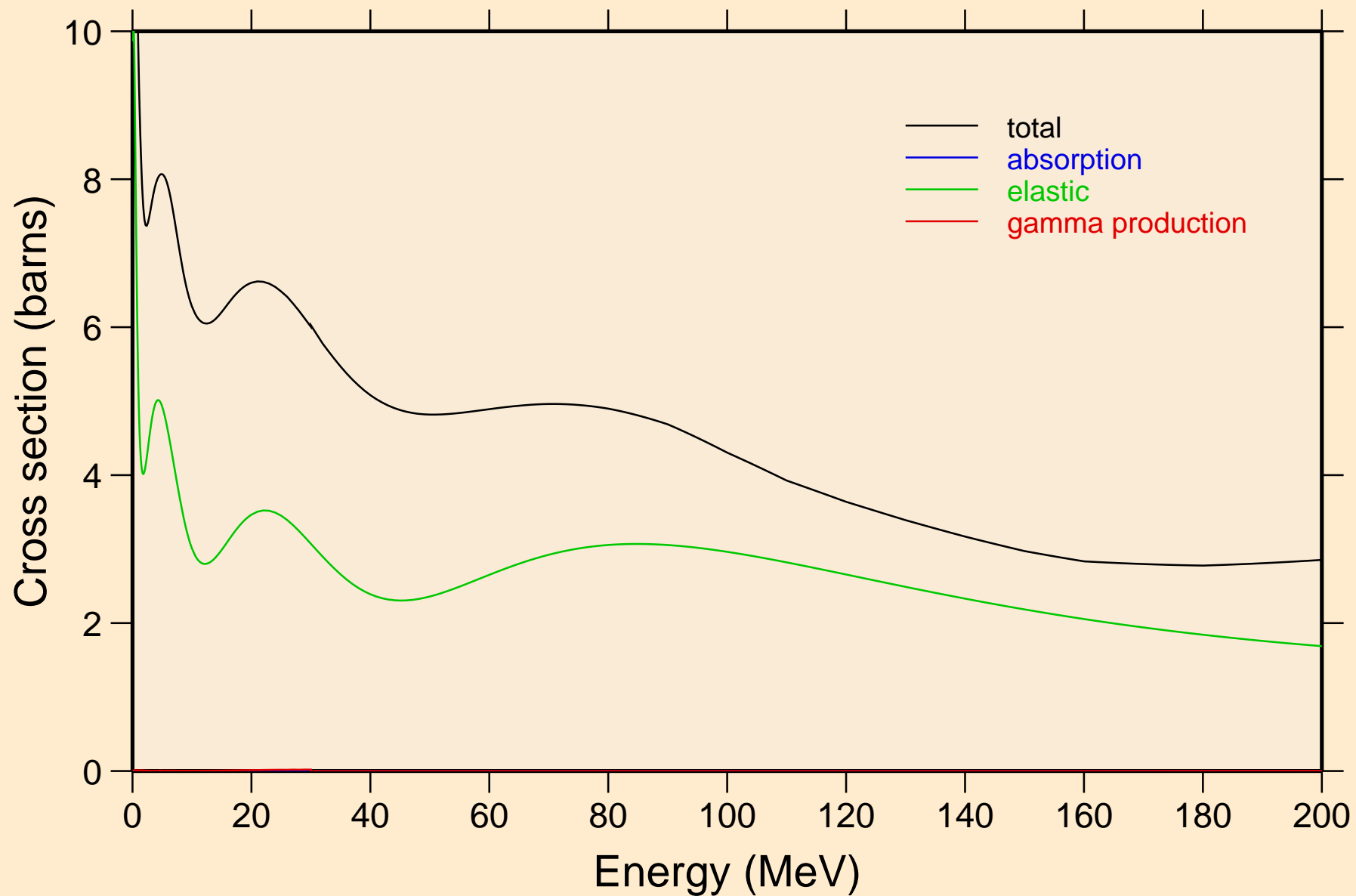

MT277 NEUTRON ACER TENDL-2019 LIBRARY; T=293.16K
Heating

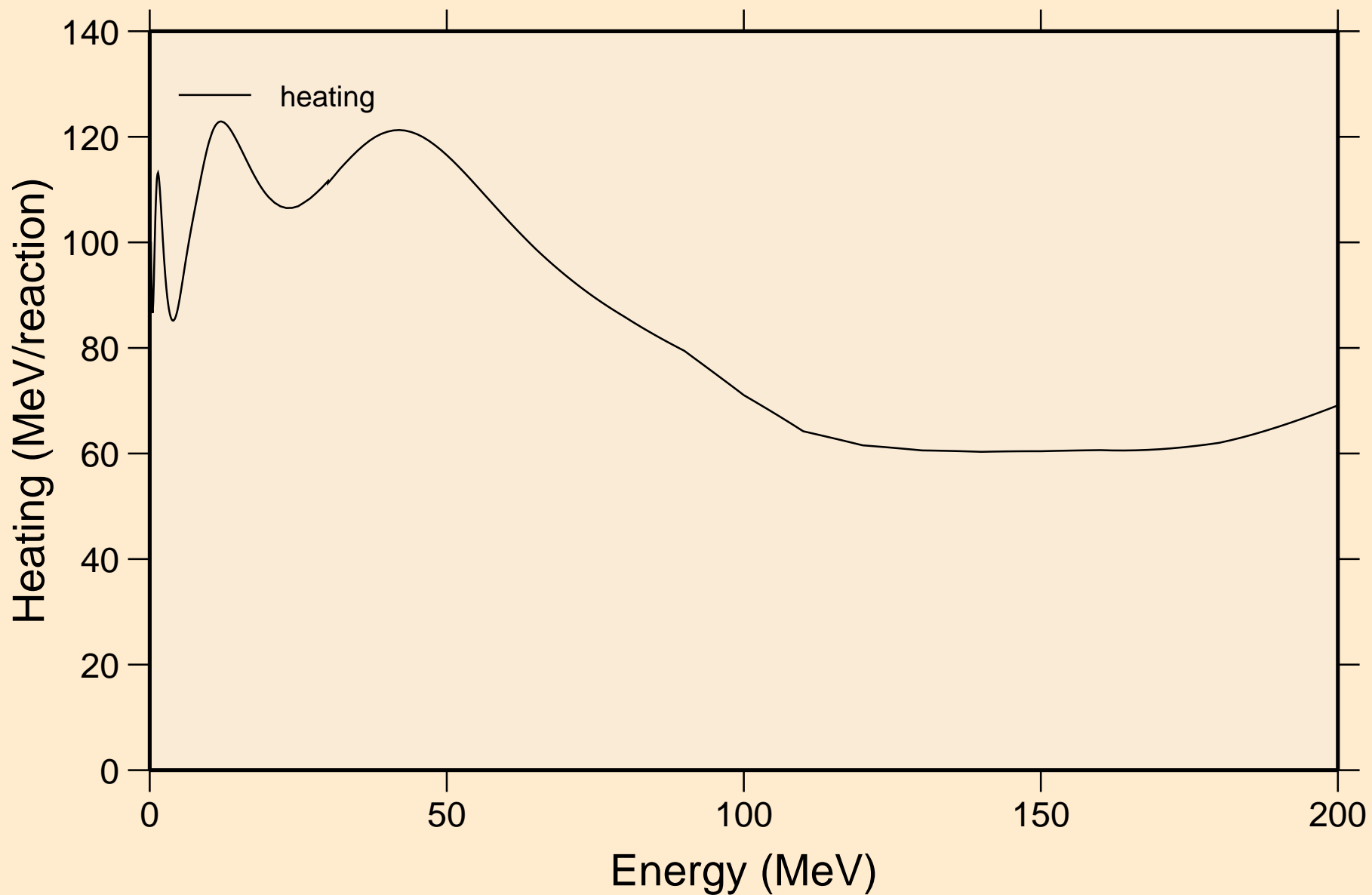

MT277 NEUTRON ACER TENDL-2019 LIBRARY; T=293.16K
Damage

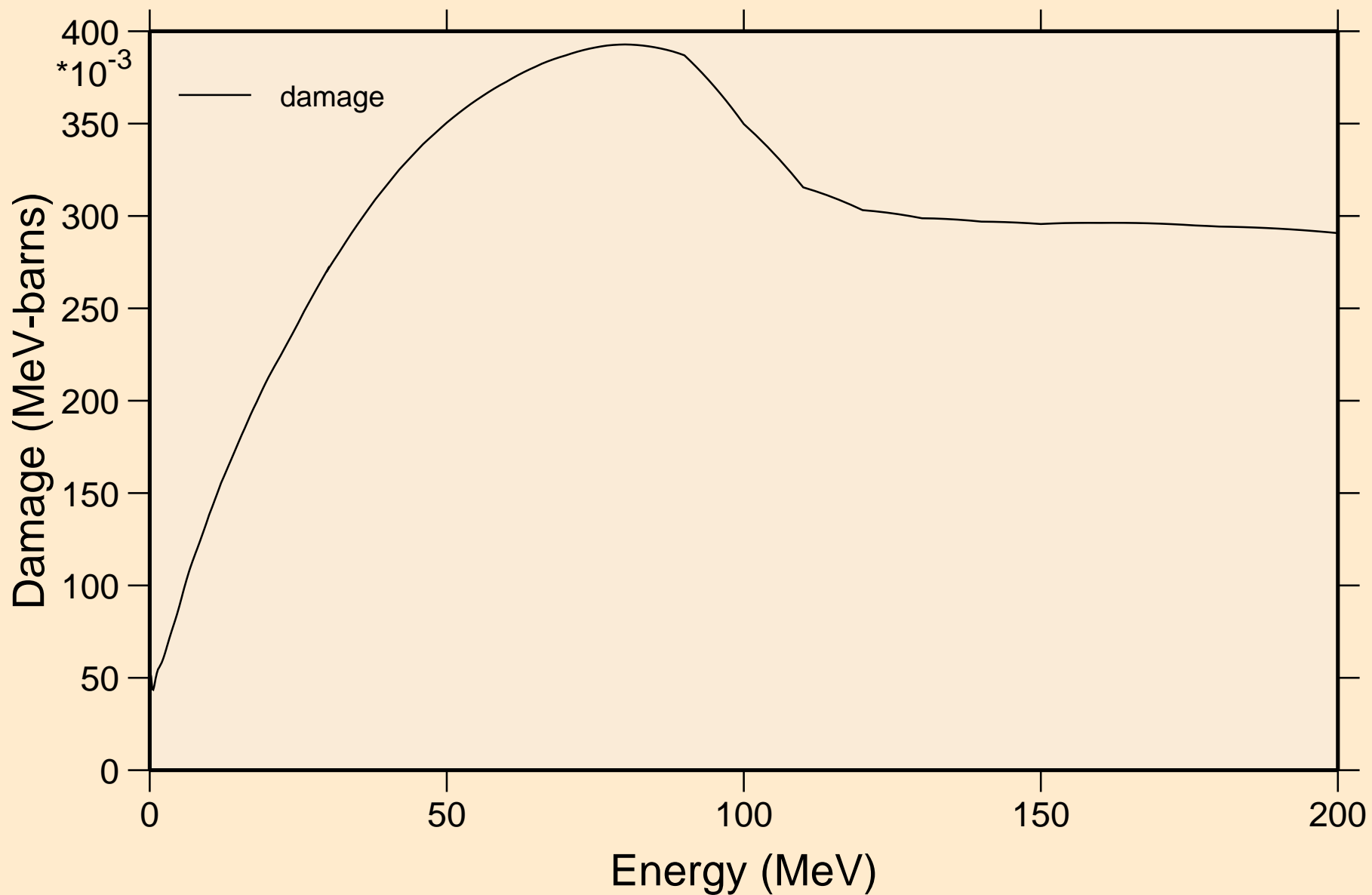

MT277 NEUTRON ACER TENDL-2019 LIBRARY; T=293.16K

Non-threshold reactions

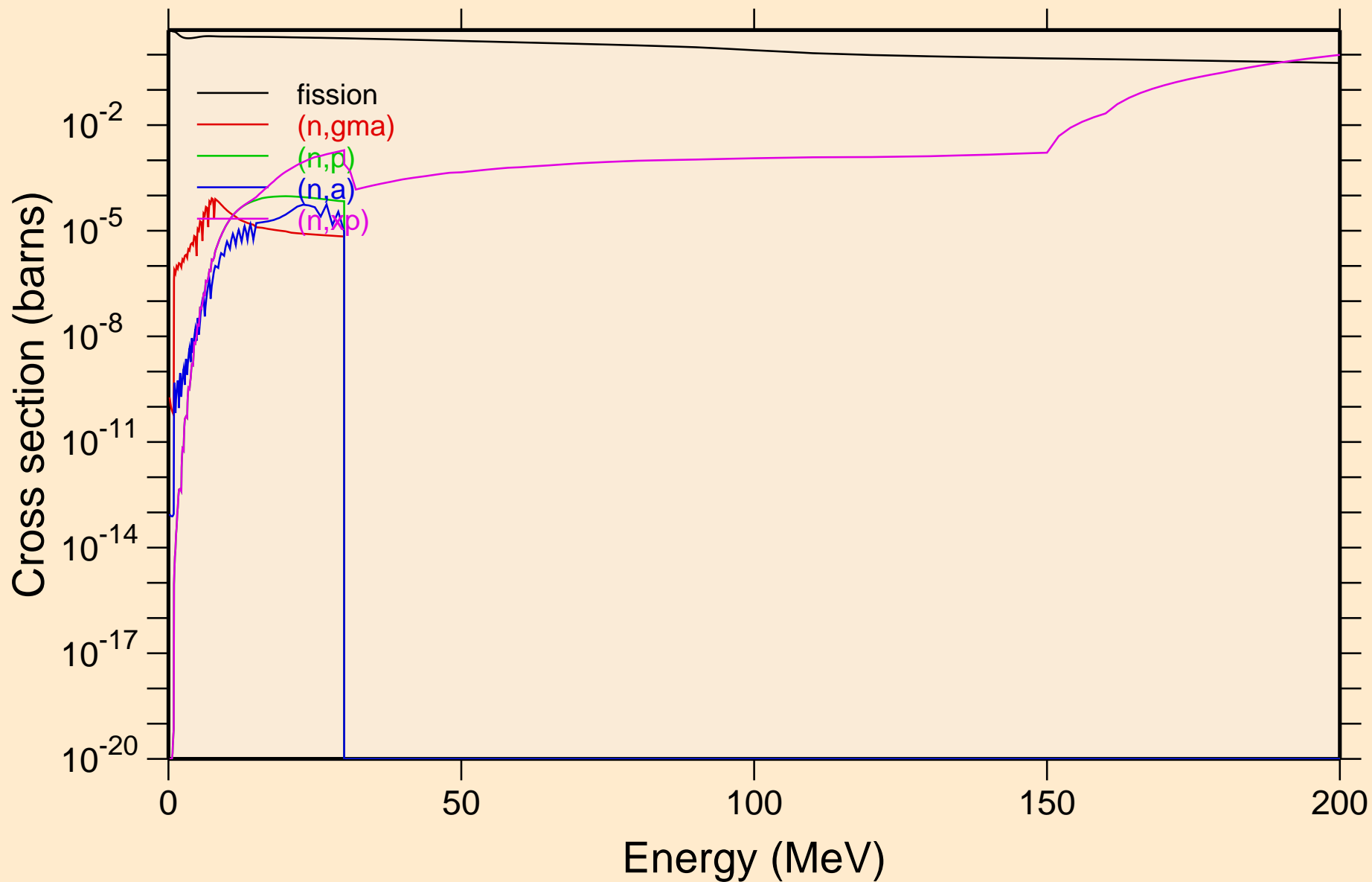

MT277 NEUTRON ACER TENDL-2019 LIBRARY; T=293.16K
Non-threshold reactions

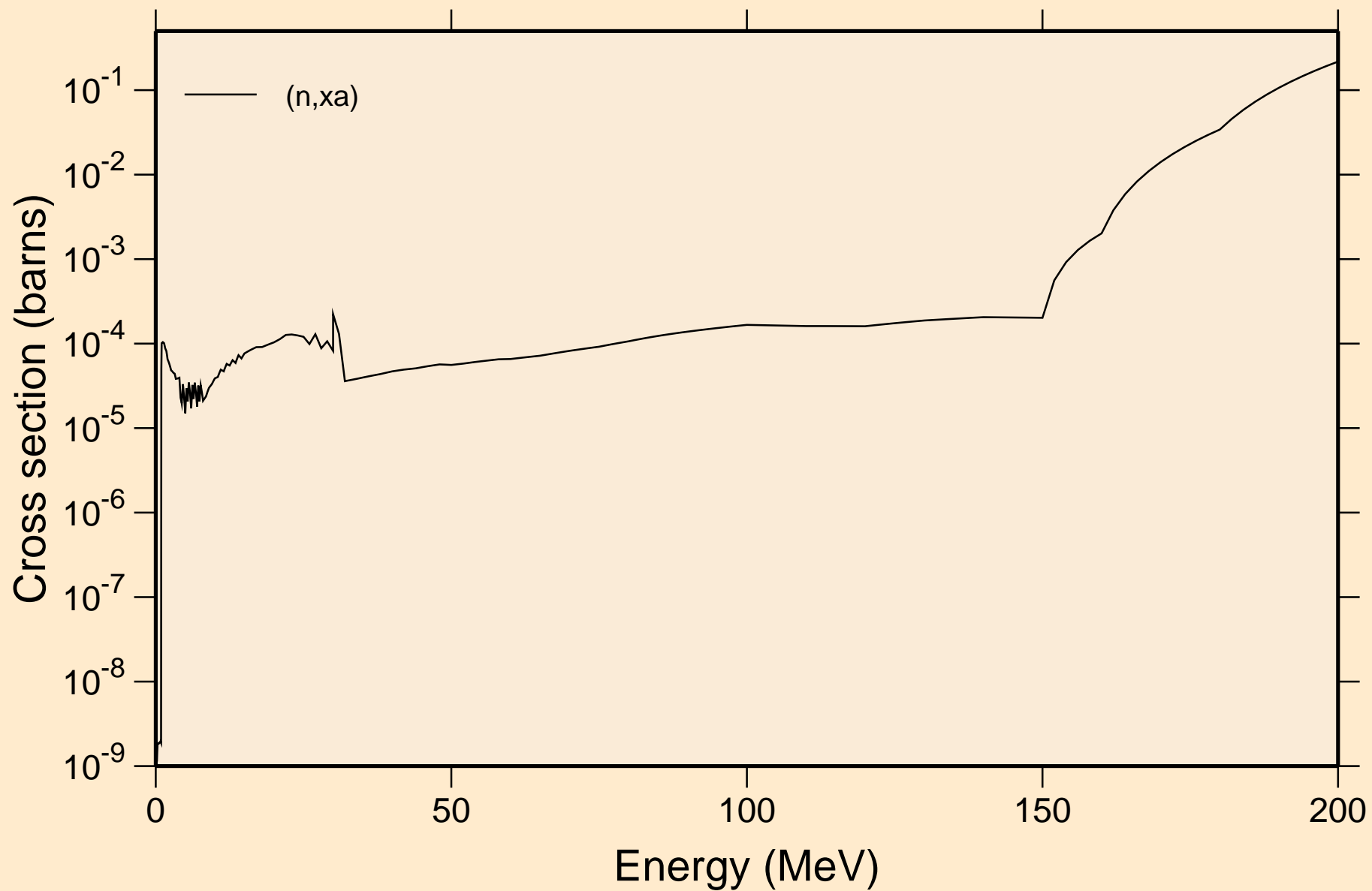

MT277 NEUTRON ACER TENDL-2019 LIBRARY; T=293.16K
Inelastic levels

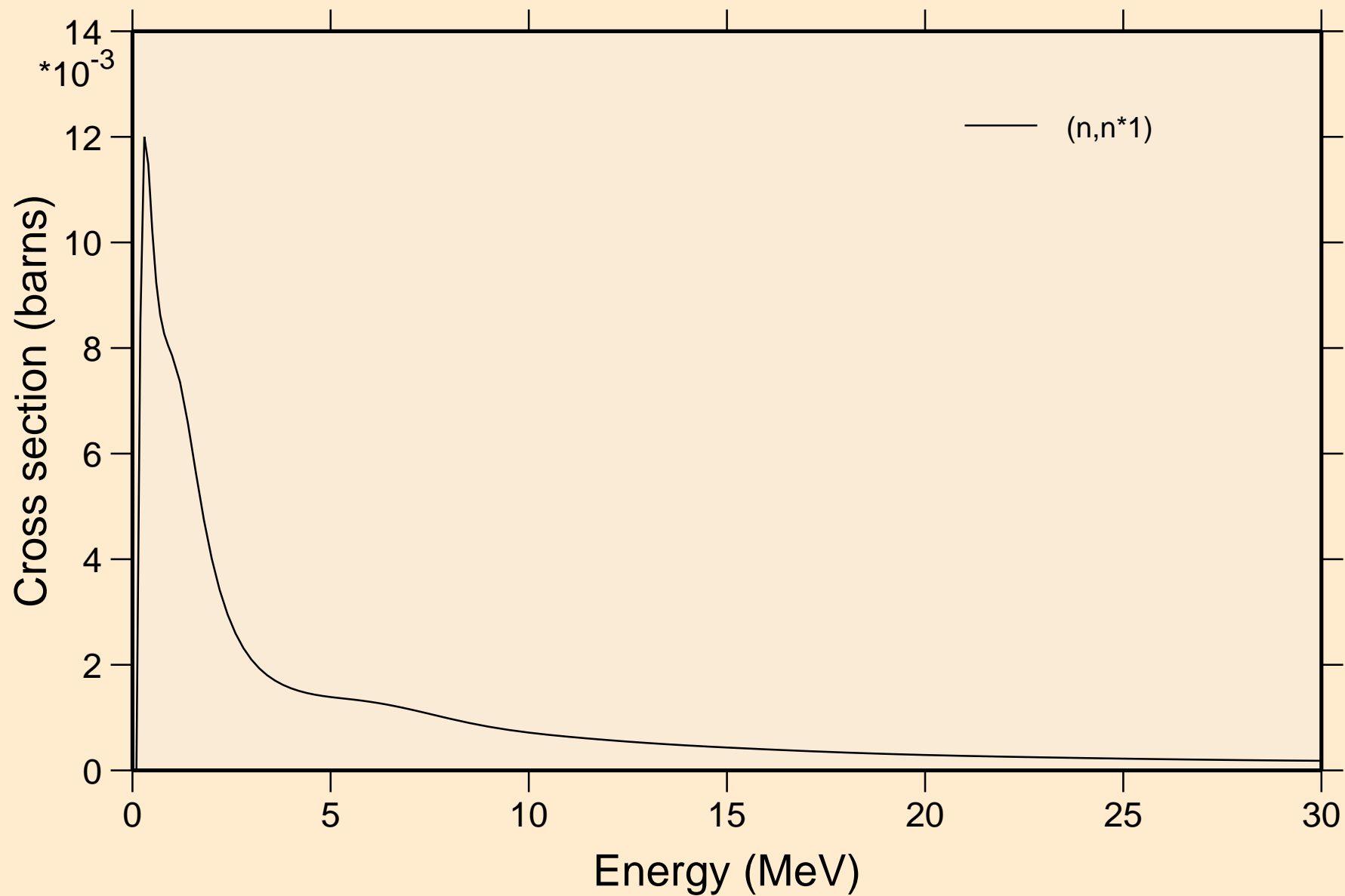

MT277 NEUTRON ACER TENDL-2019 LIBRARY; T=293.16K
Threshold reactions

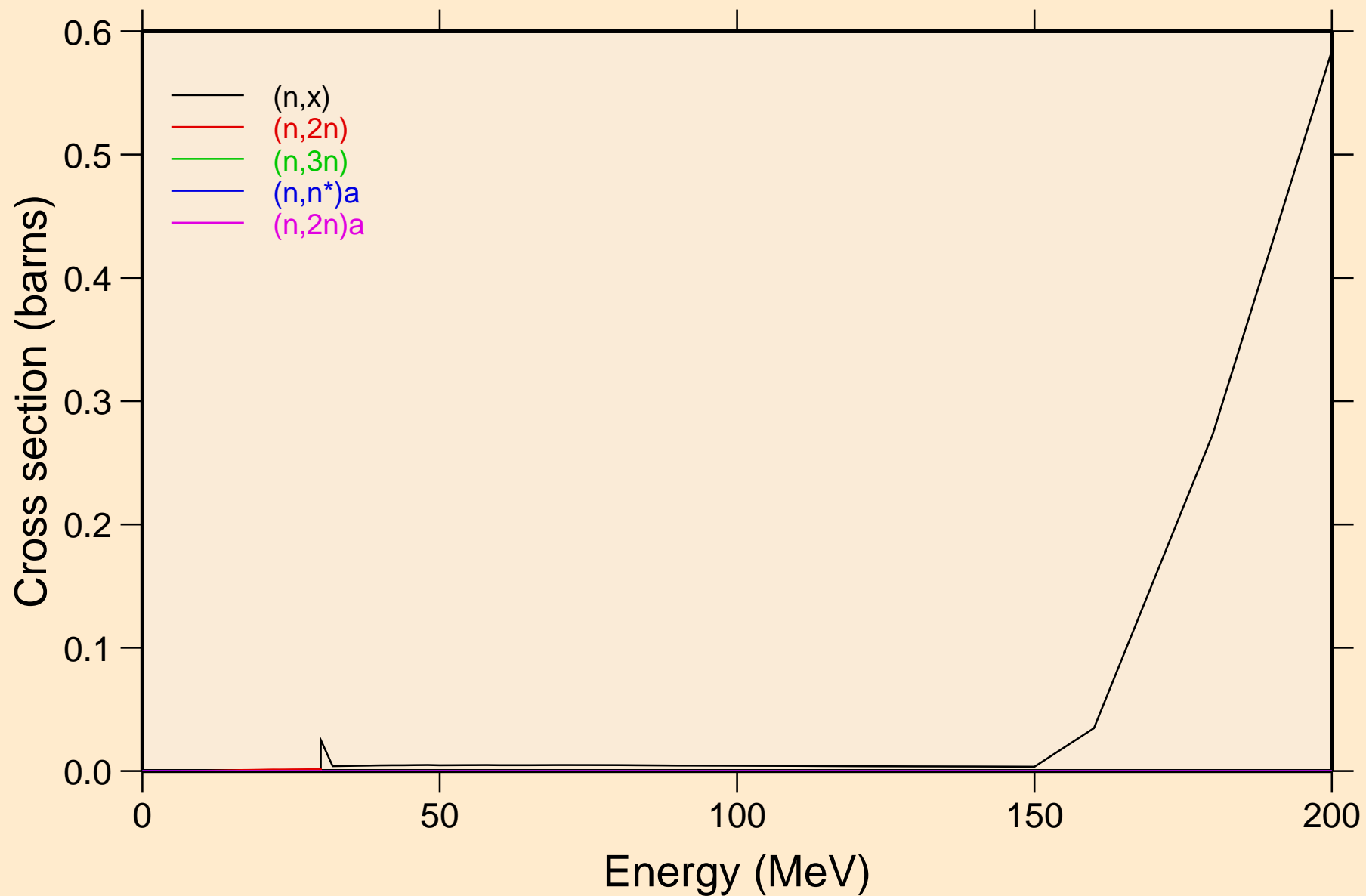

MT277 NEUTRON ACER TENDL-2019 LIBRARY; T=293.16K
Threshold reactions

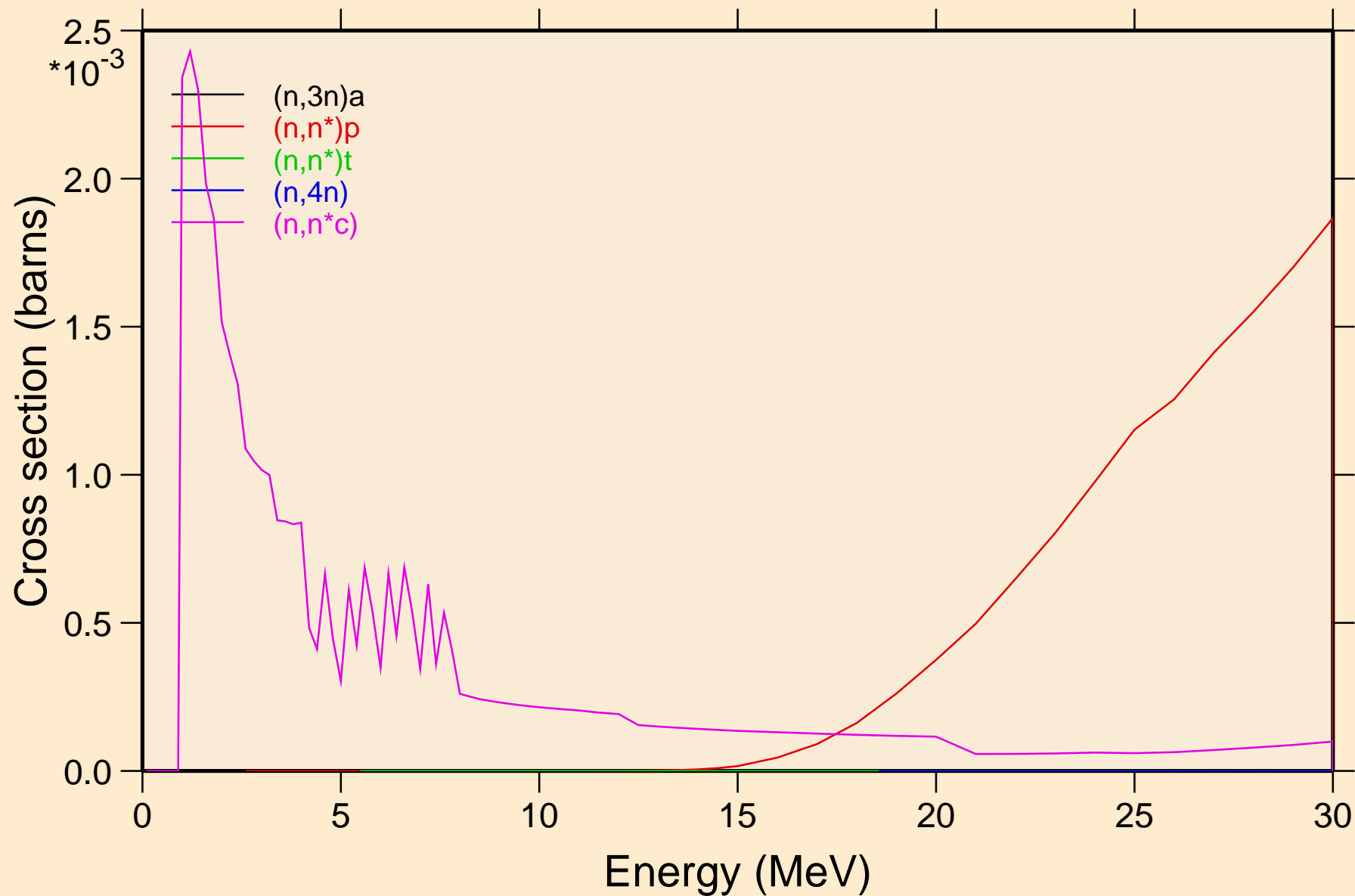

MT277 NEUTRON ACER TENDL-2019 LIBRARY; T=293.16K
Threshold reactions

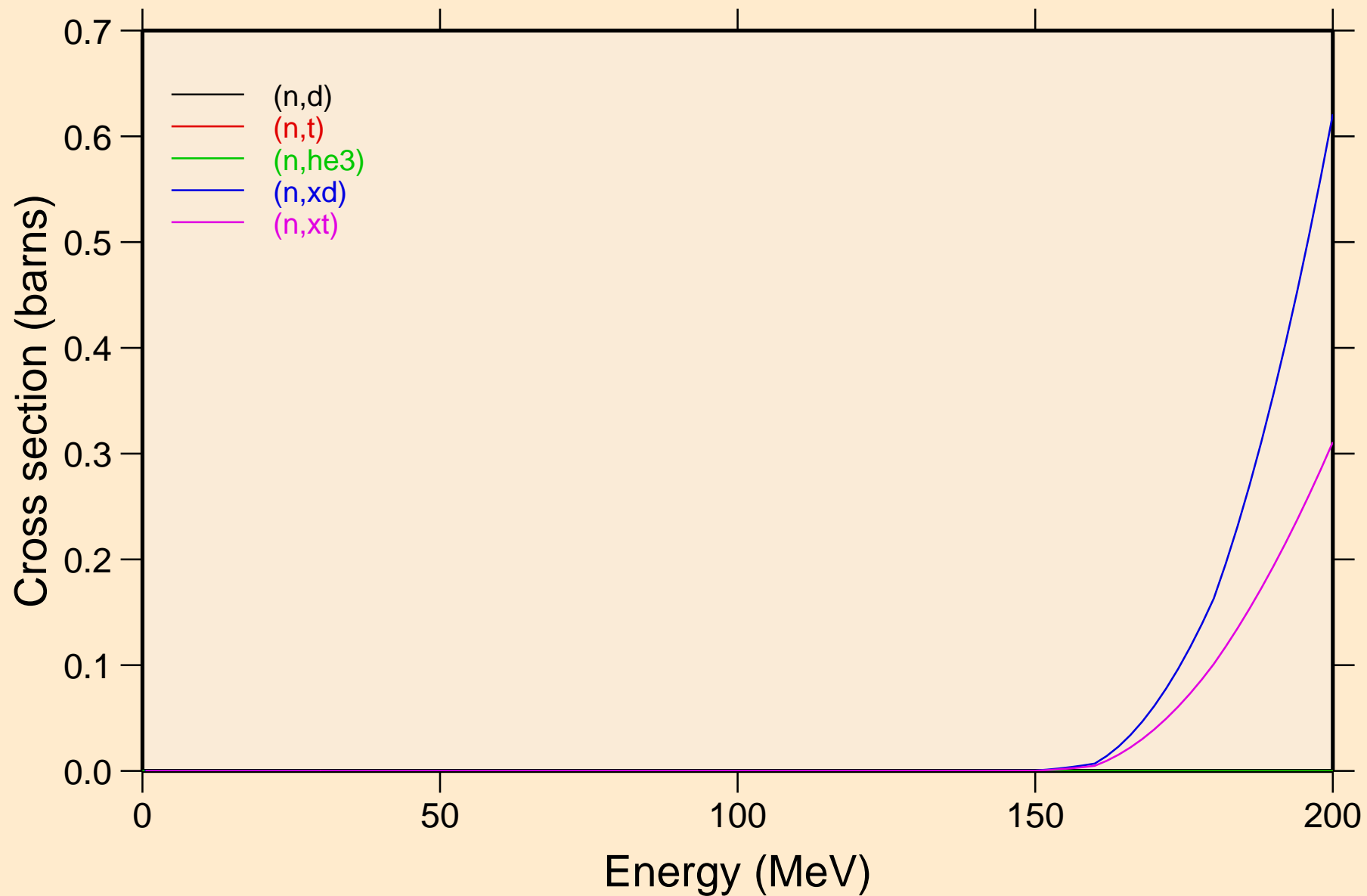

MT277 NEUTRON ACER TENDL-2019 LIBRARY; T=293.16K
Threshold reactions

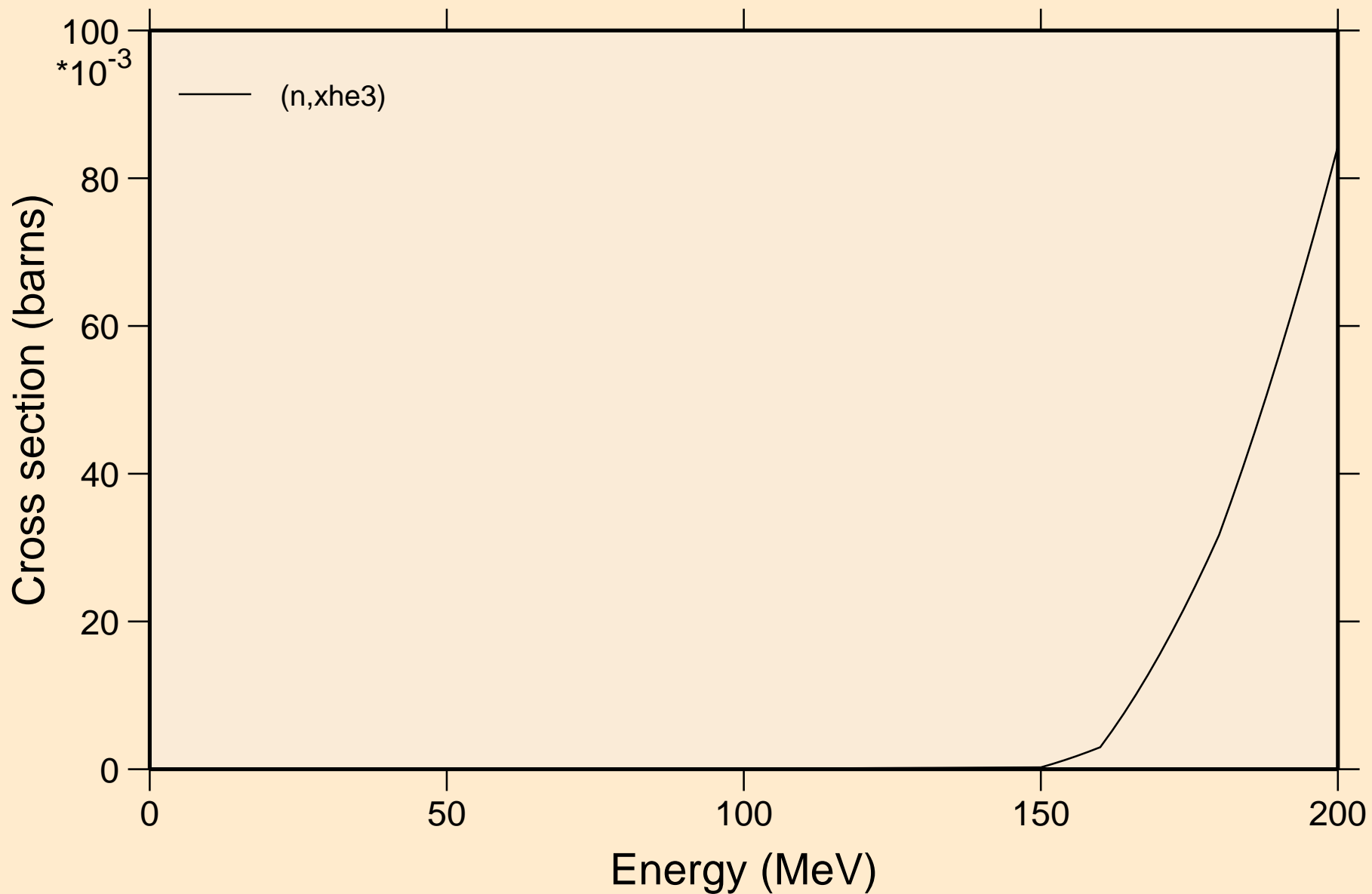

MT277 NEUTRON ACER TENDL-2019 LIBRARY; T=293.16K
angular distribution for elastic

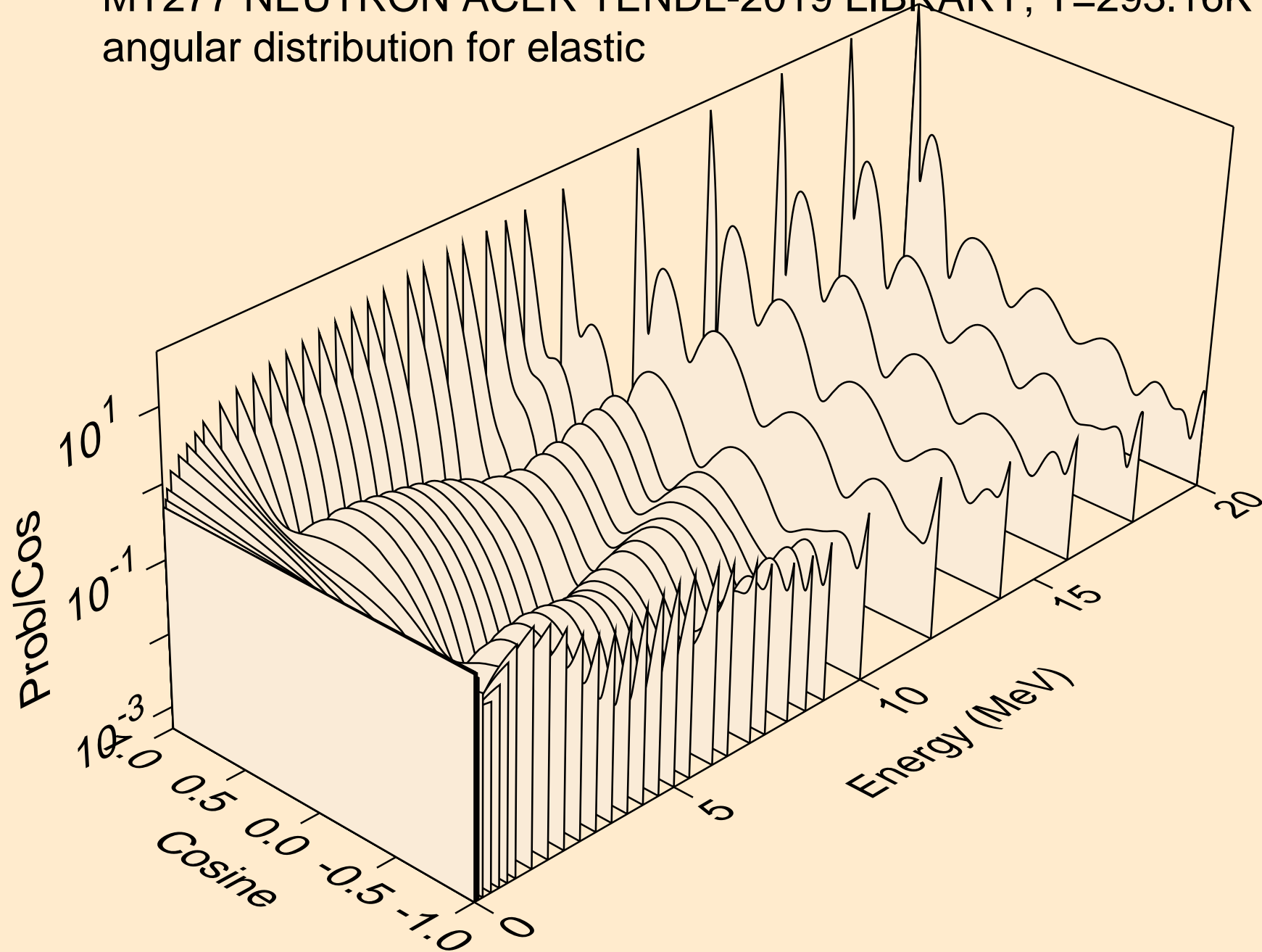

MT277 NEUTRON ACER TENDL-2019 LIBRARY; T=293.16K
angular distribution for elastic

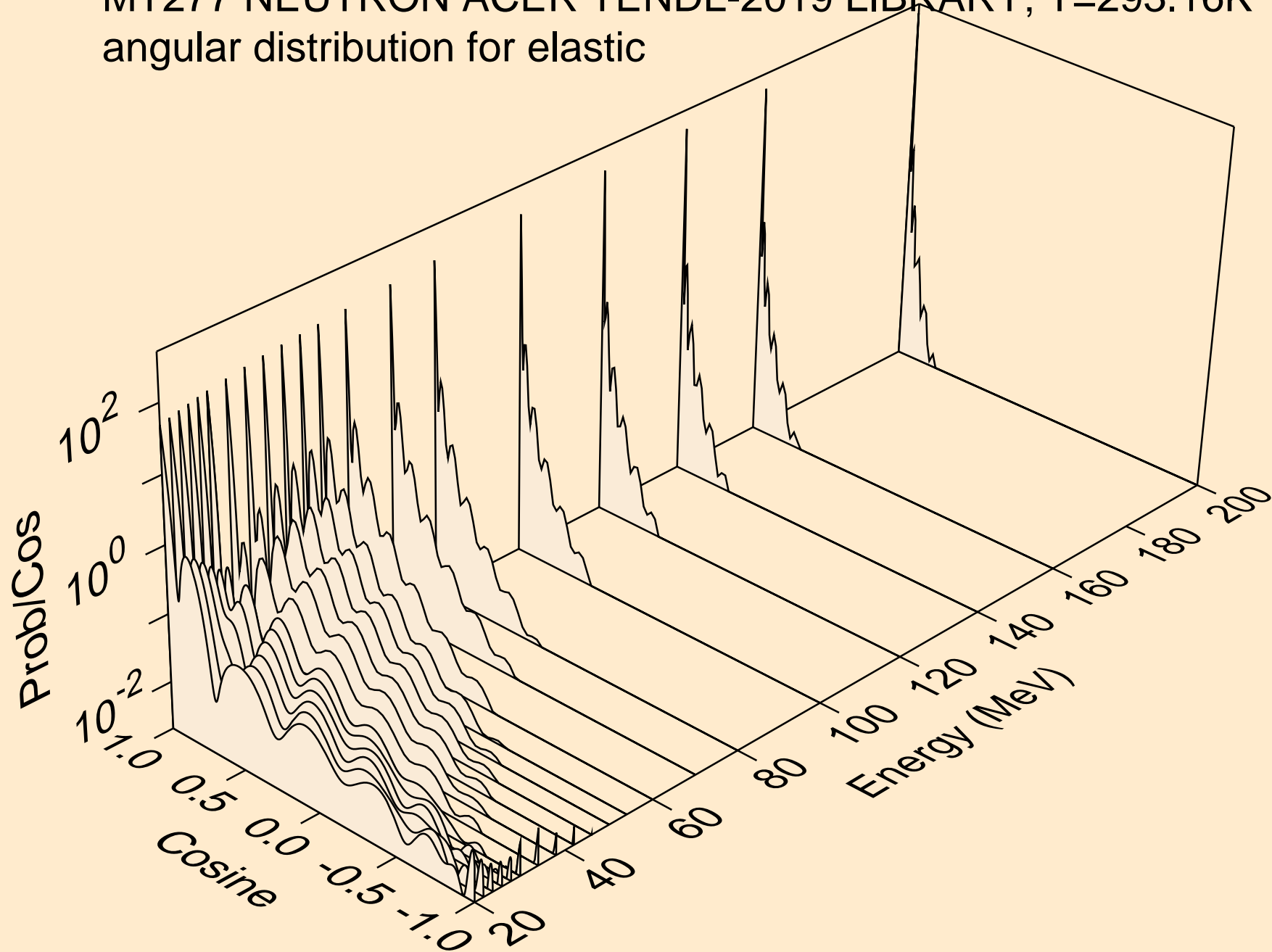

MT277 NEUTRON ACER TENDL-2019 LIBRARY; T=293.16K
angular distribution for (n,n*1)

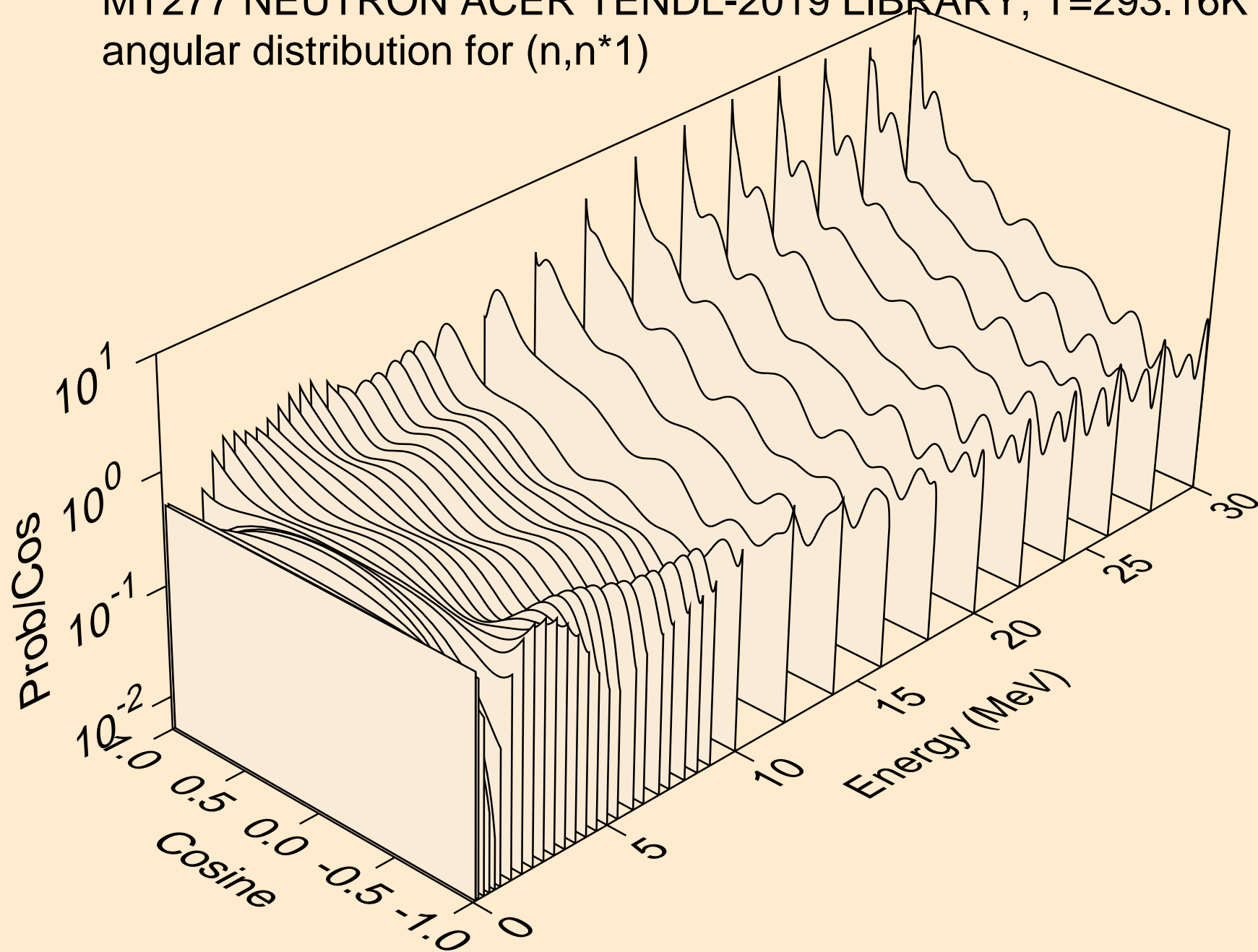

MT277 NEUTRON ACER TENDL-2019 LIBRARY; T=293.16K
Total fission nubar

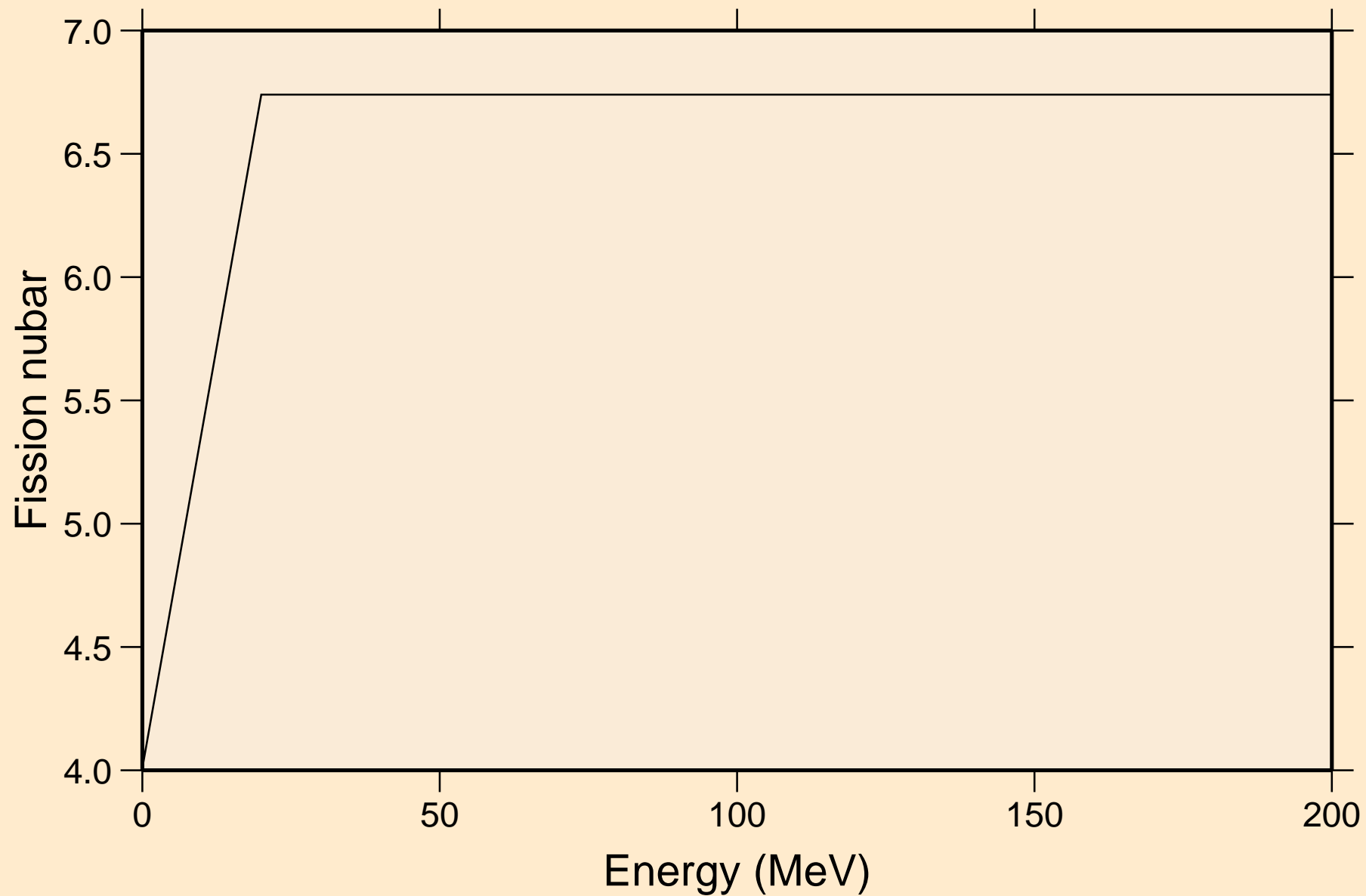

MT277 NEUTRON ACER TENDL-2019 LIBRARY; T=293.16K
Neutron emission for (n,x)

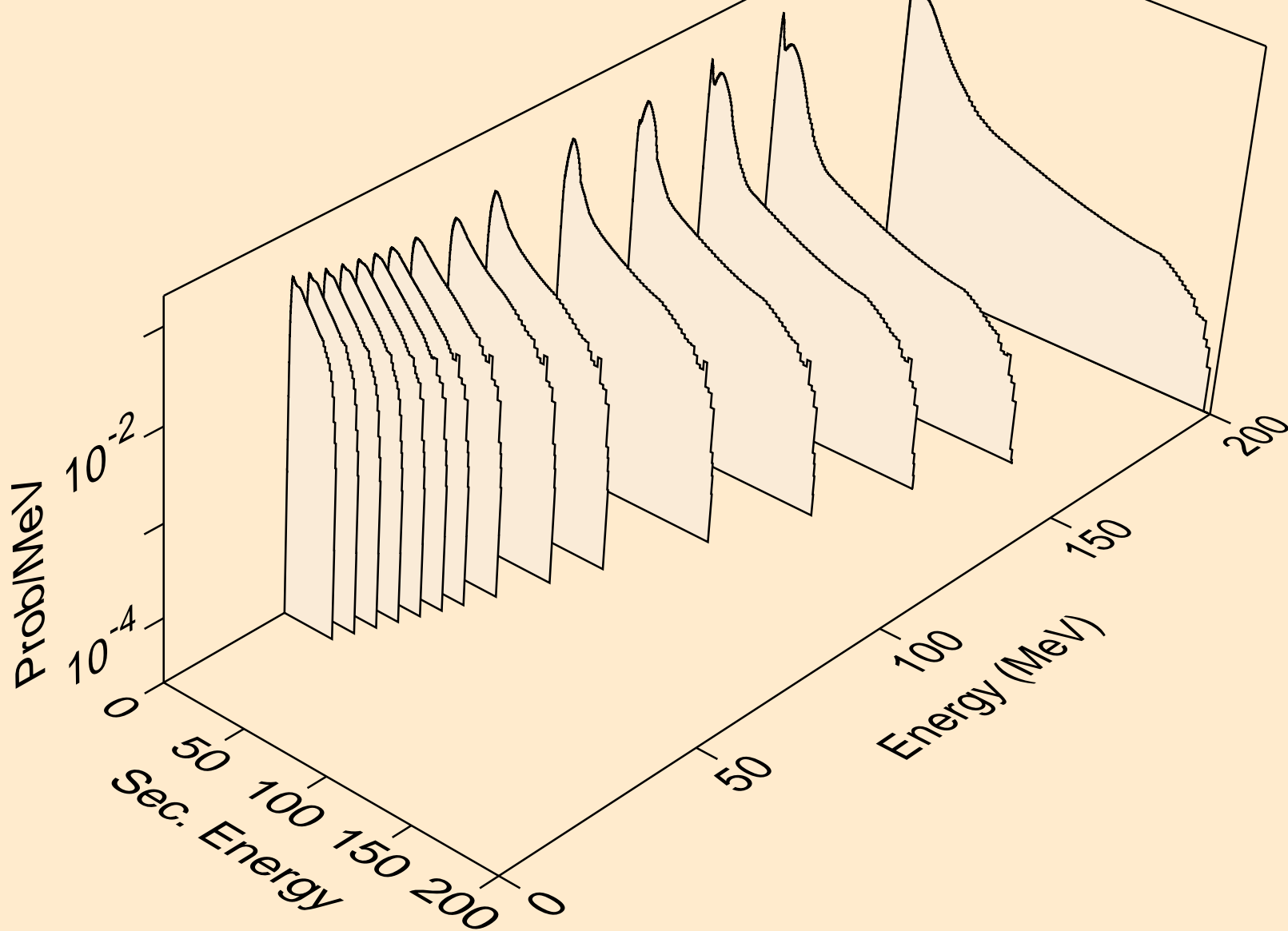

MT277 NEUTRON ACER TENDL-2019 LIBRARY; T=293.16K
Neutron emission for (n,2n)

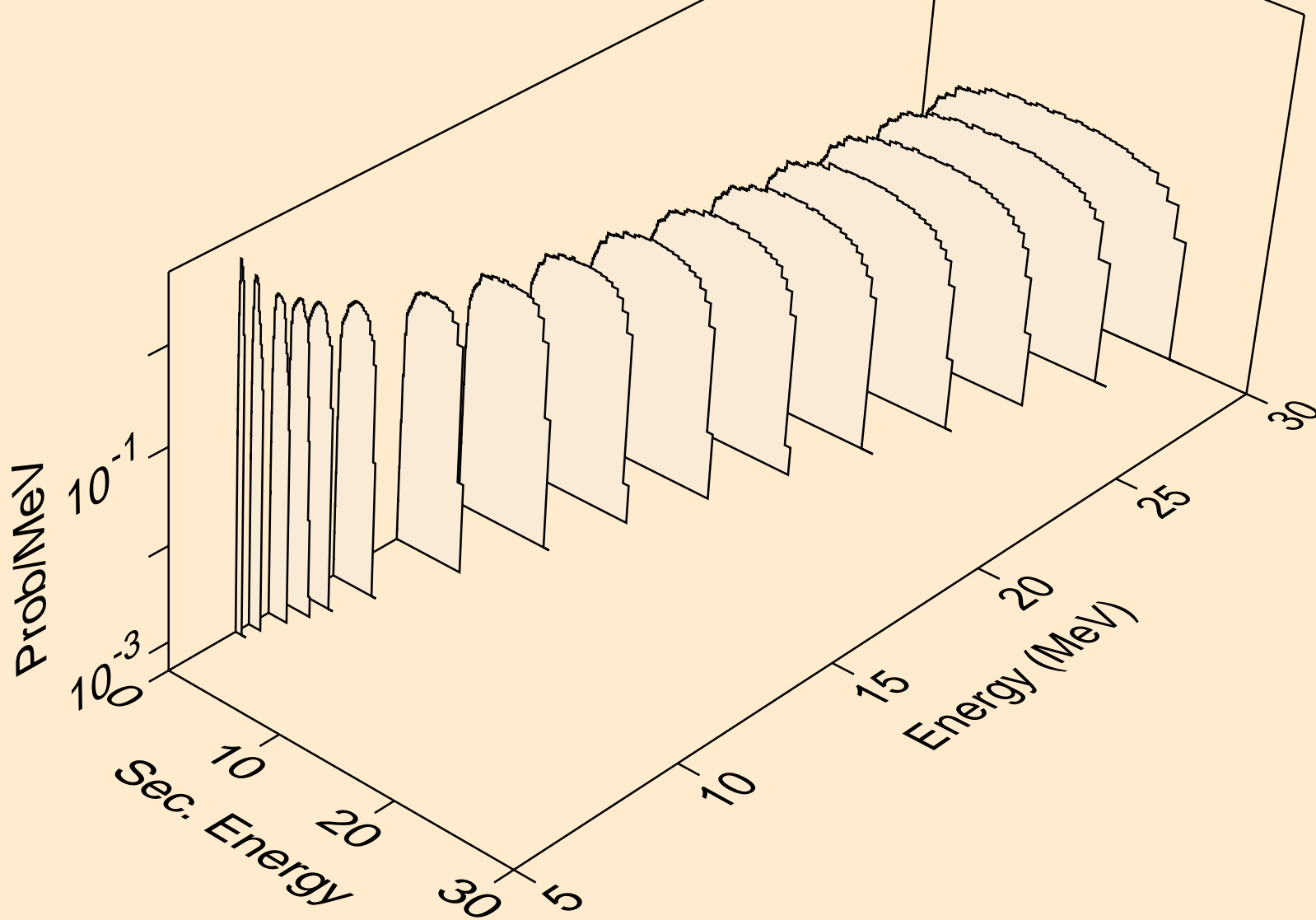

MT277 NEUTRON ACER TENDL-2019 LIBRARY; T=293.16K
Neutron emission for (n,3n)

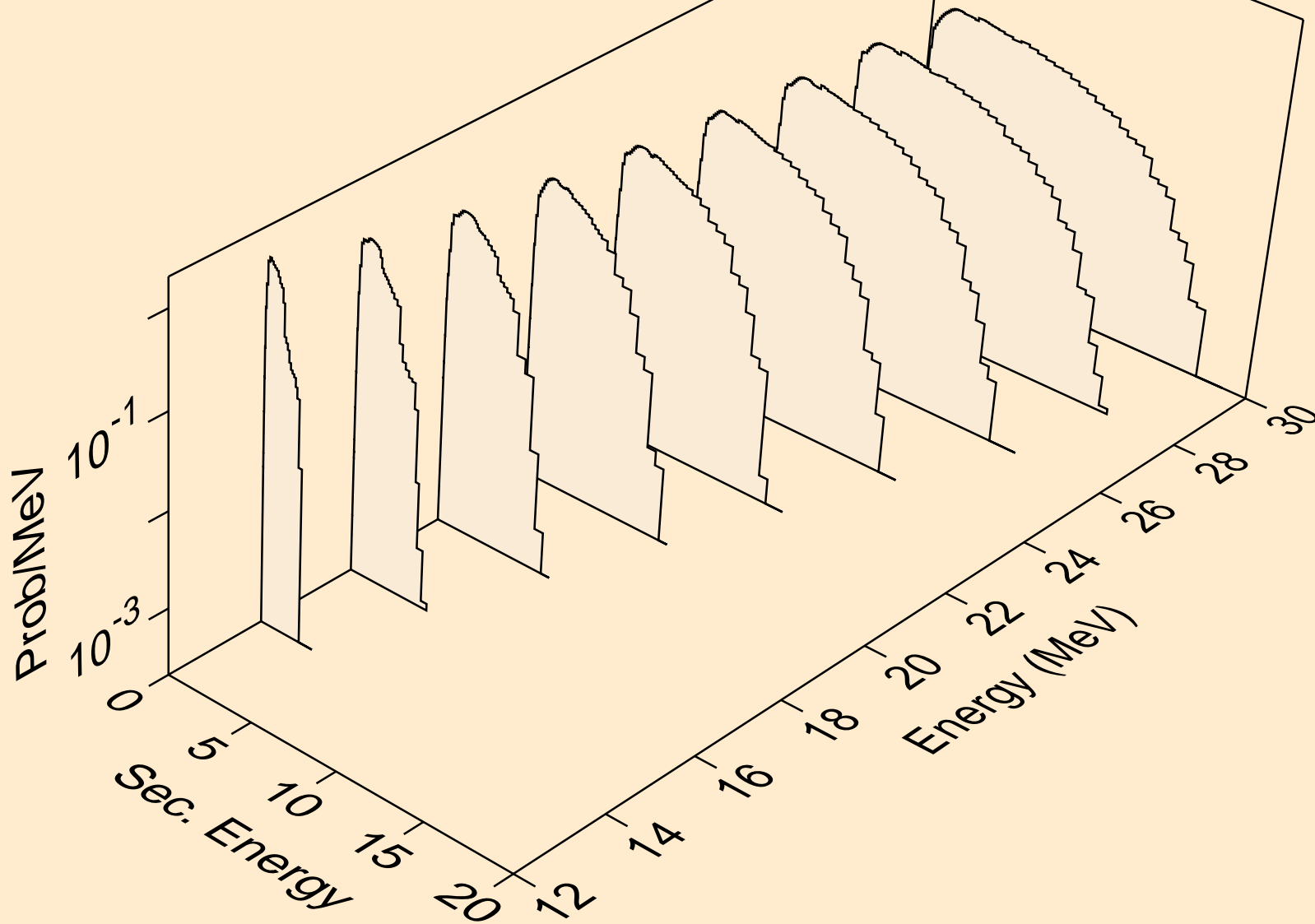

MT277 NEUTRON ACER TENDL-2019 LIBRARY; T=293.16K
Neutron emission for fission

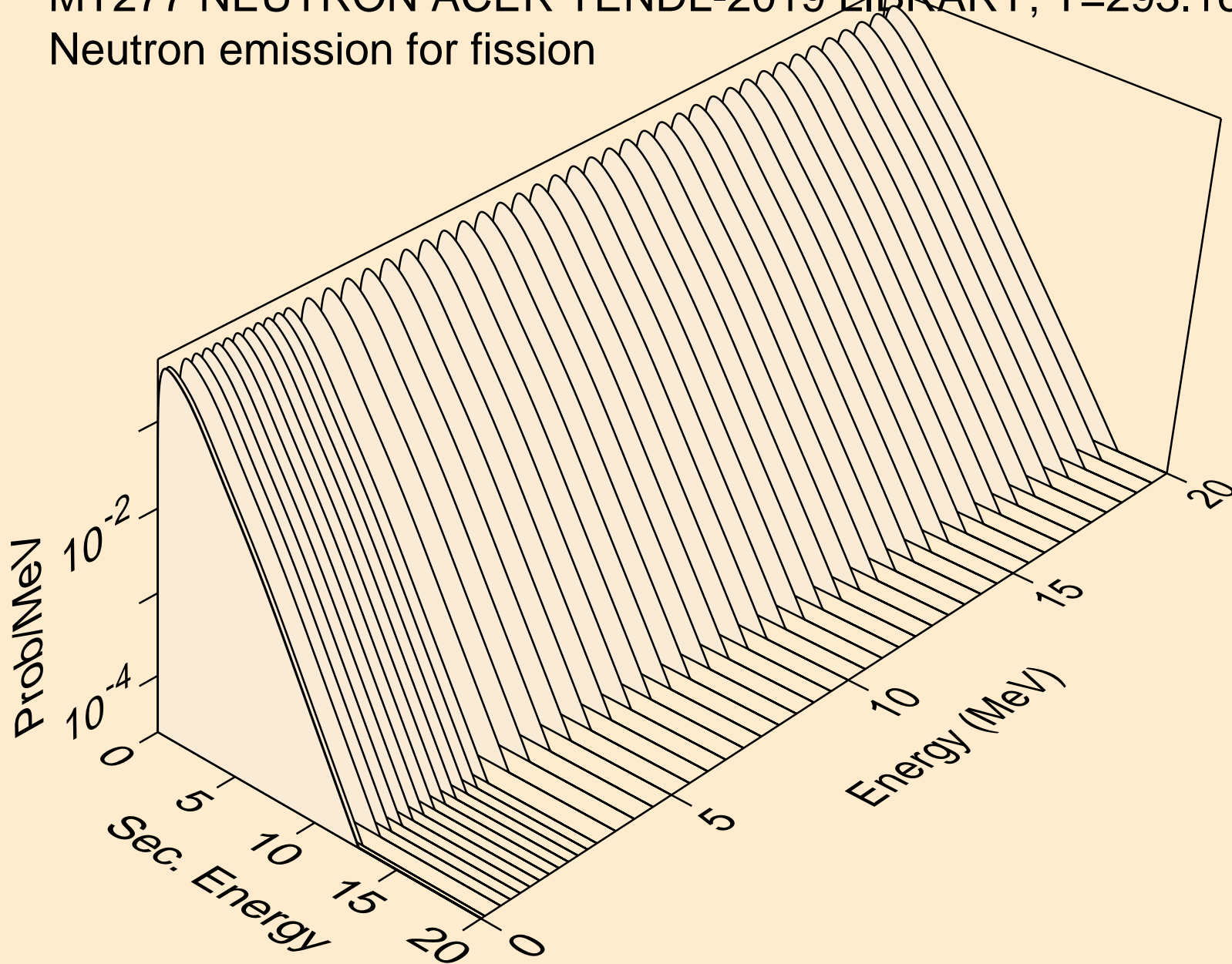

MT277 NEUTRON ACER TENDL-2019 LIBRARY; T=293.16K
Neutron emission for (n,n*)a

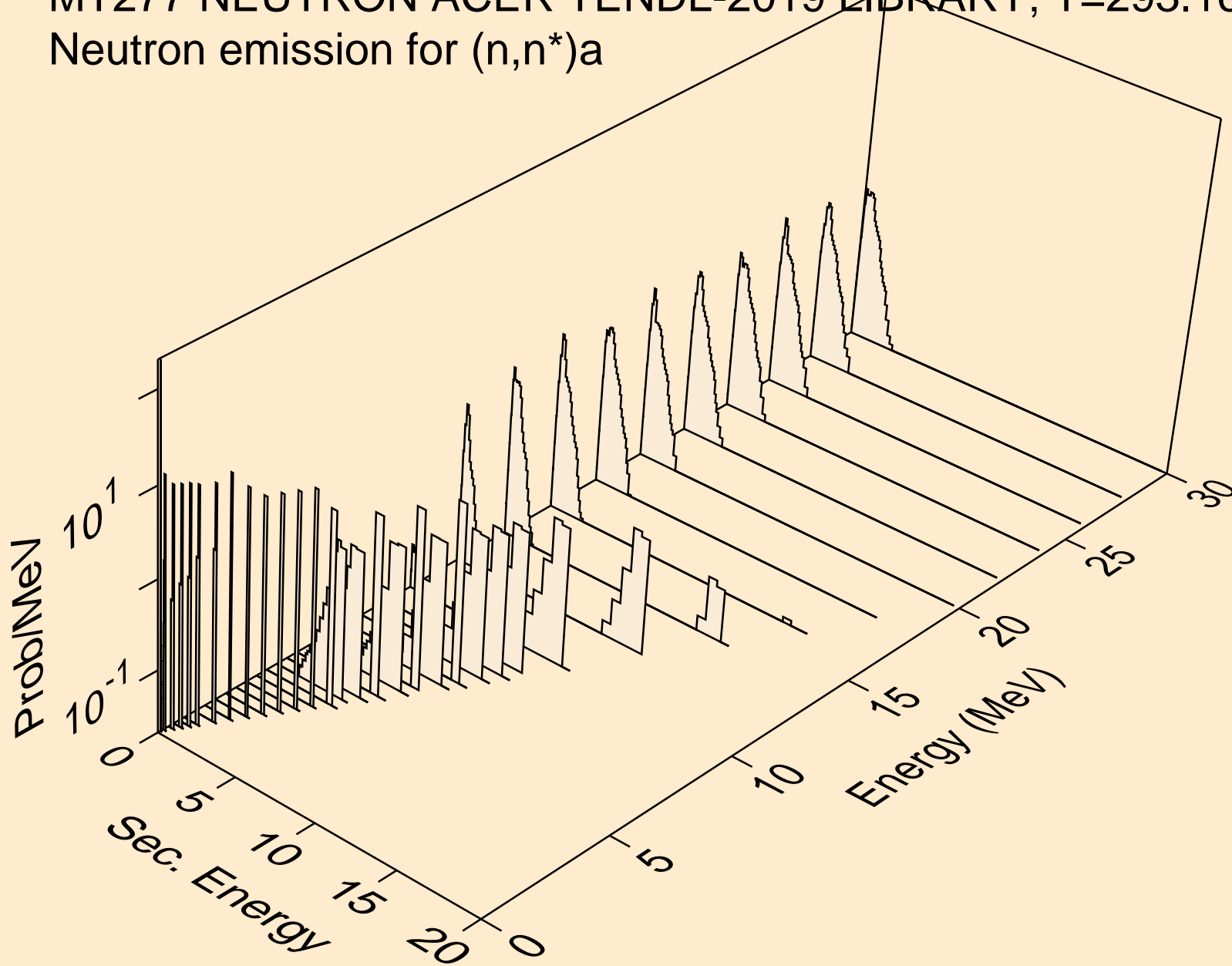

MT277 NEUTRON ACER TENDL-2019 LIBRARY; T=293.16K
Neutron emission for (n,2n)a

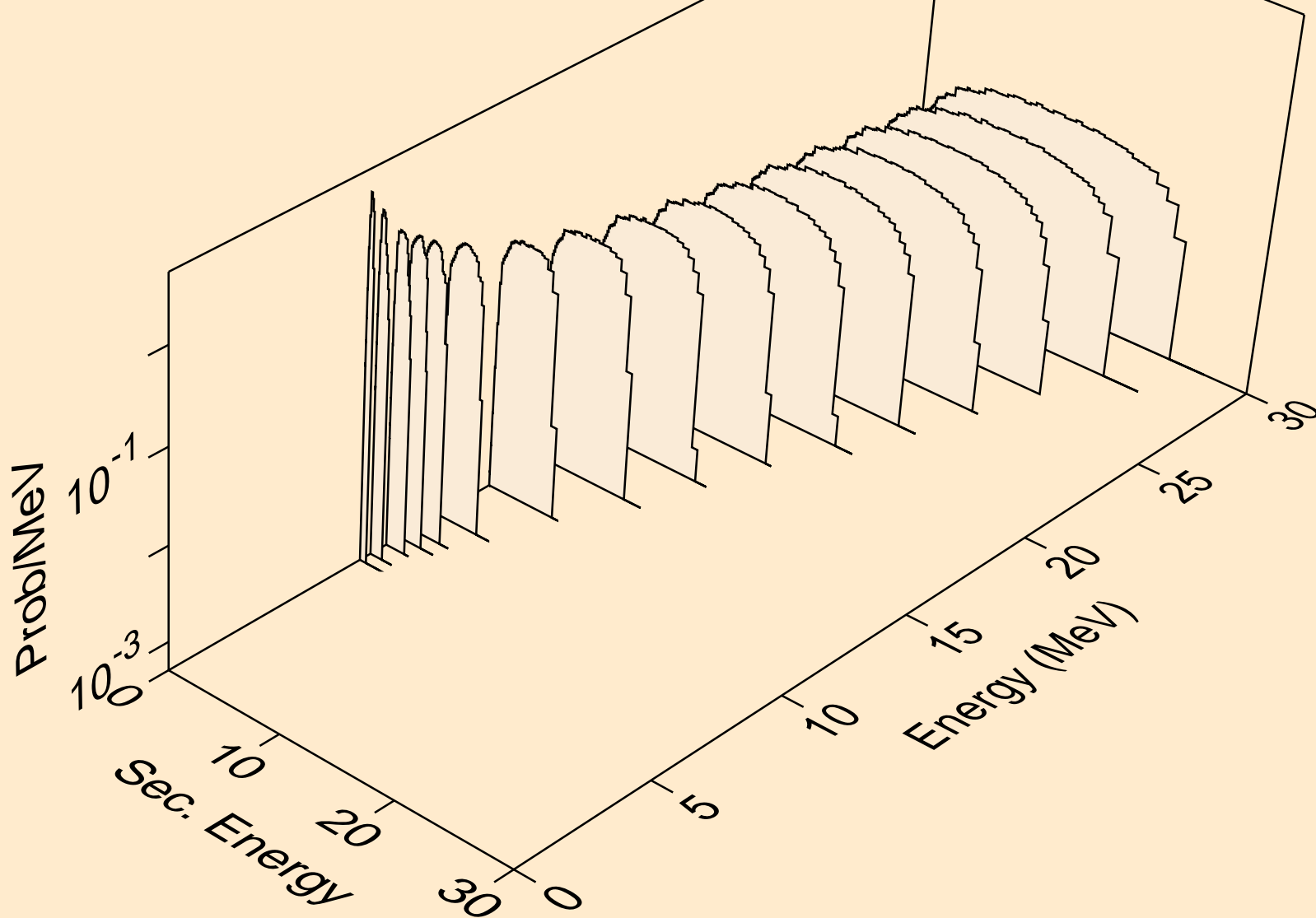

MT277 NEUTRON ACER TENDL-2019 LIBRARY; T=293.16K
Neutron emission for (n,3n)a

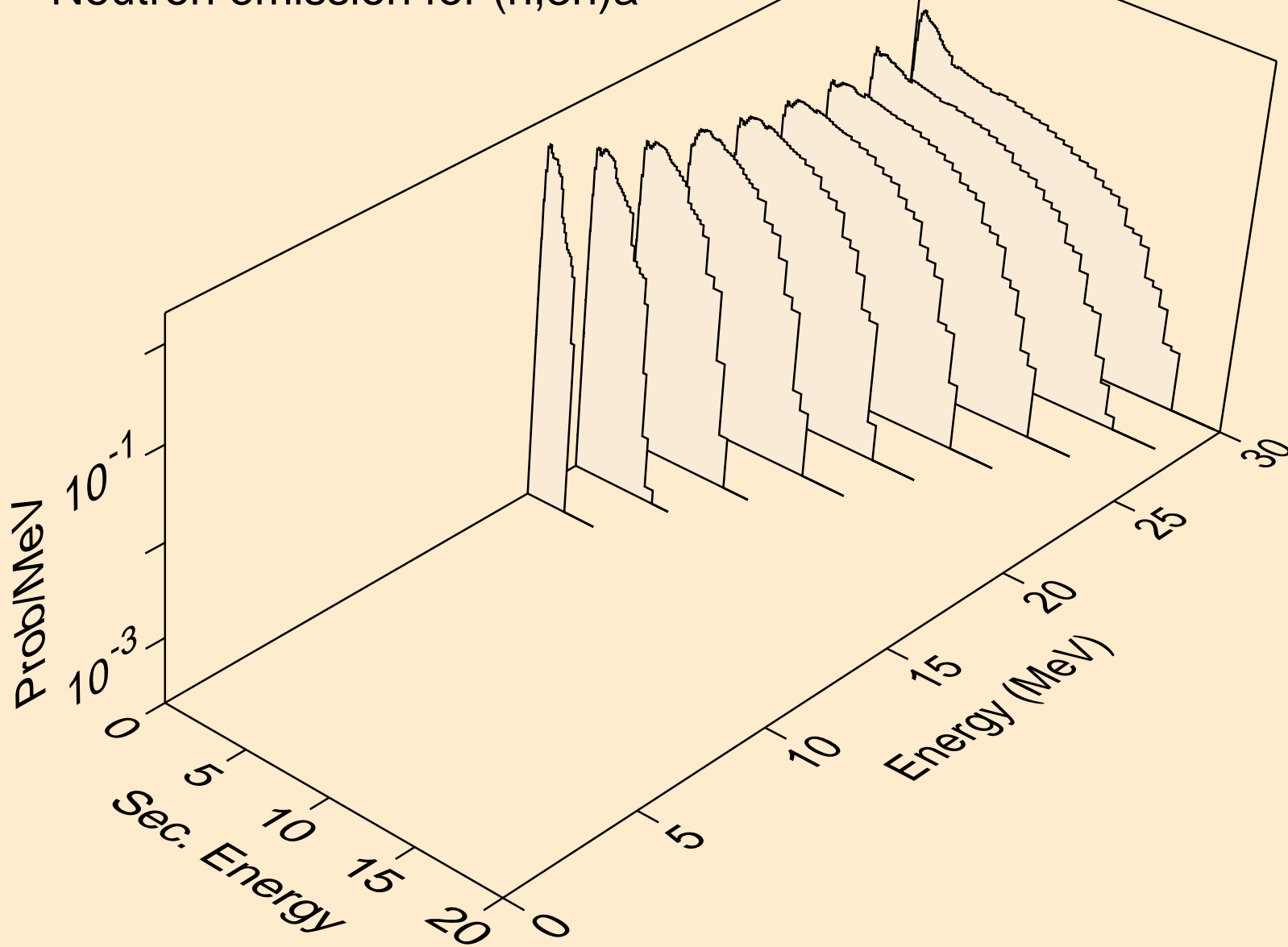

MT277 NEUTRON ACER TENDL-2019 LIBRARY; T=293.16K
Neutron emission for (n,n*)p

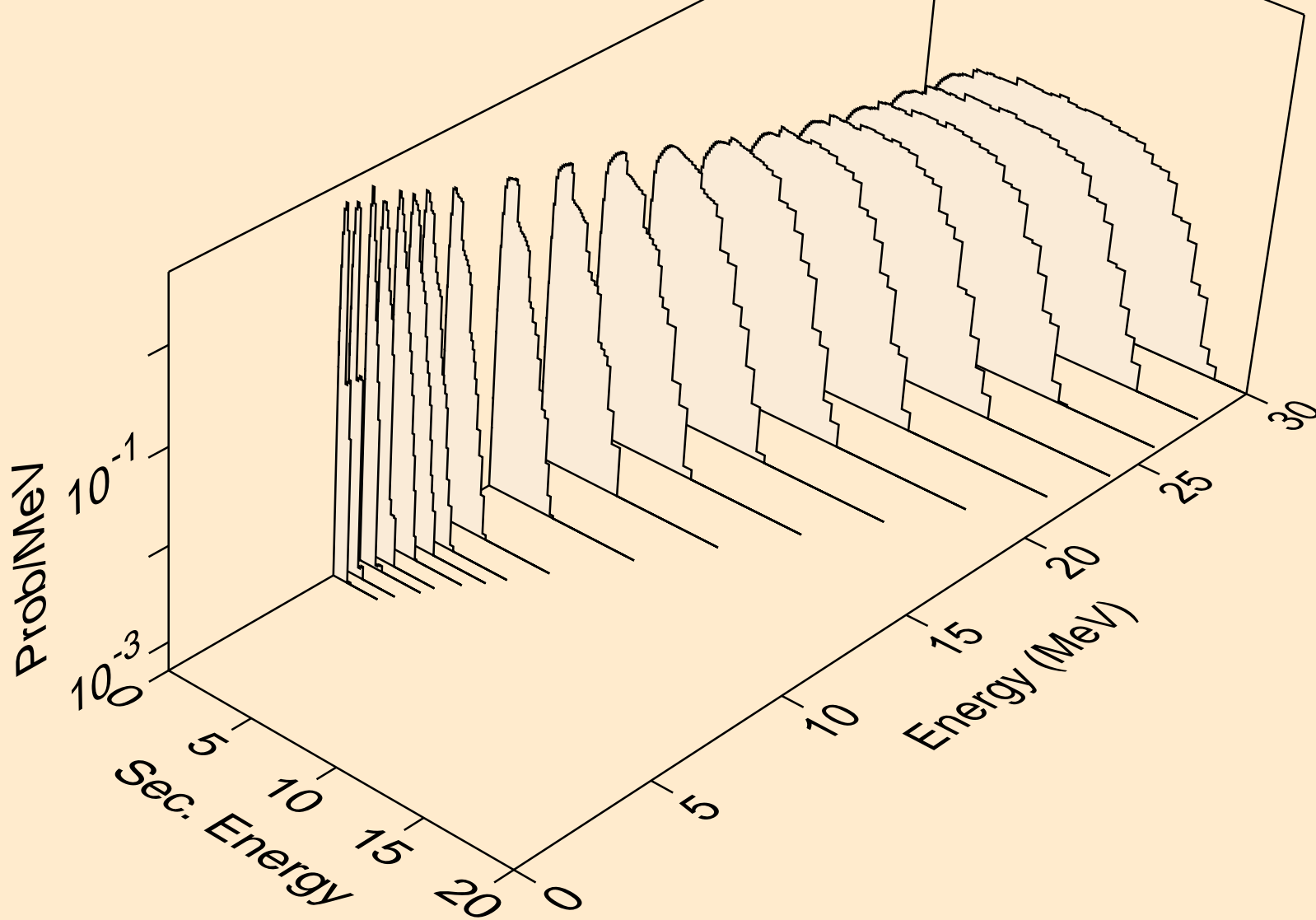

MT277 NEUTRON ACER TENDL-2019 LIBRARY; T=293.16K
Neutron emission for (n,n*)t

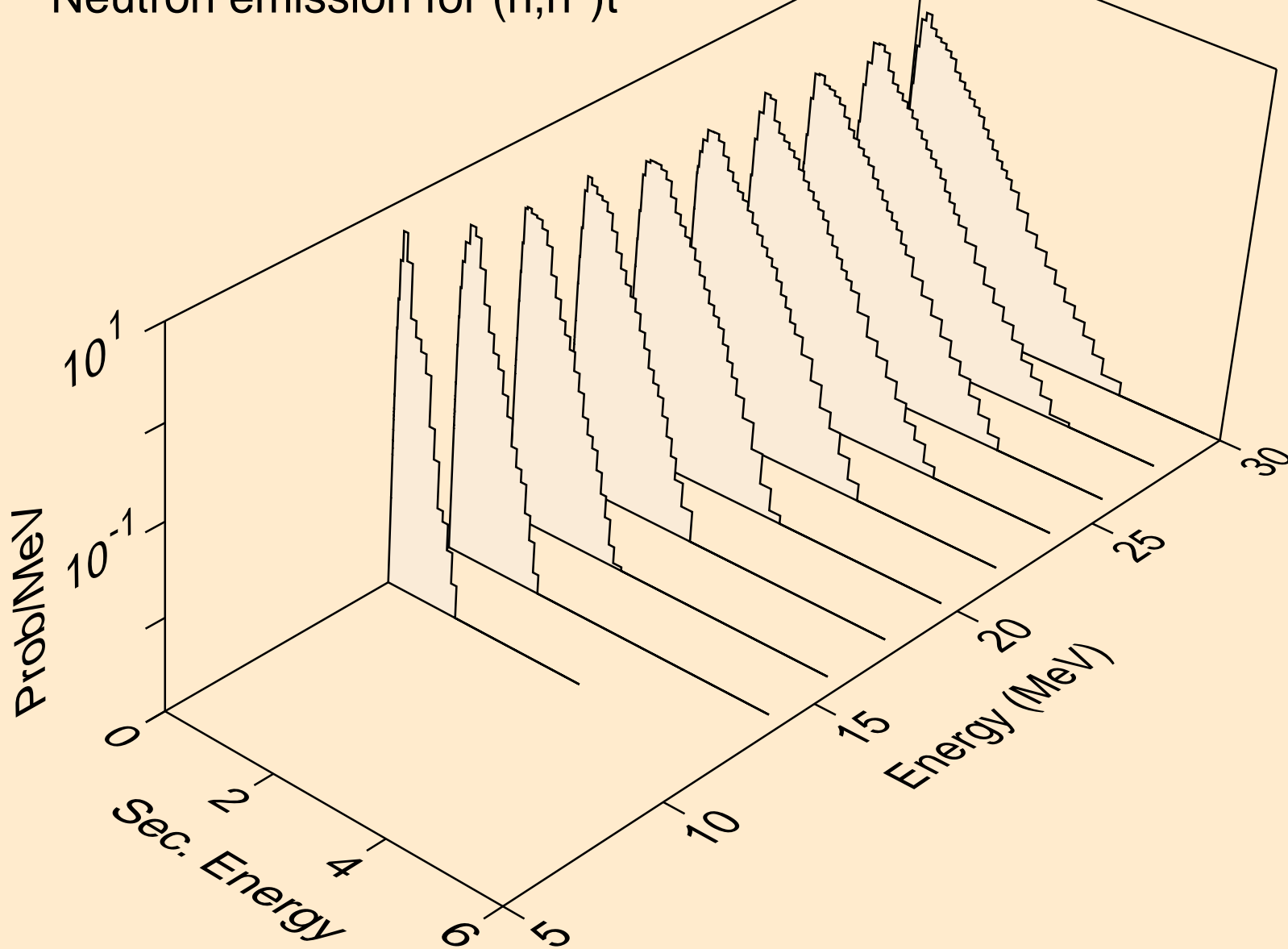

MT277 NEUTRON ACER TENDL-2019 LIBRARY; T=293.16K
Neutron emission for (n,4n)

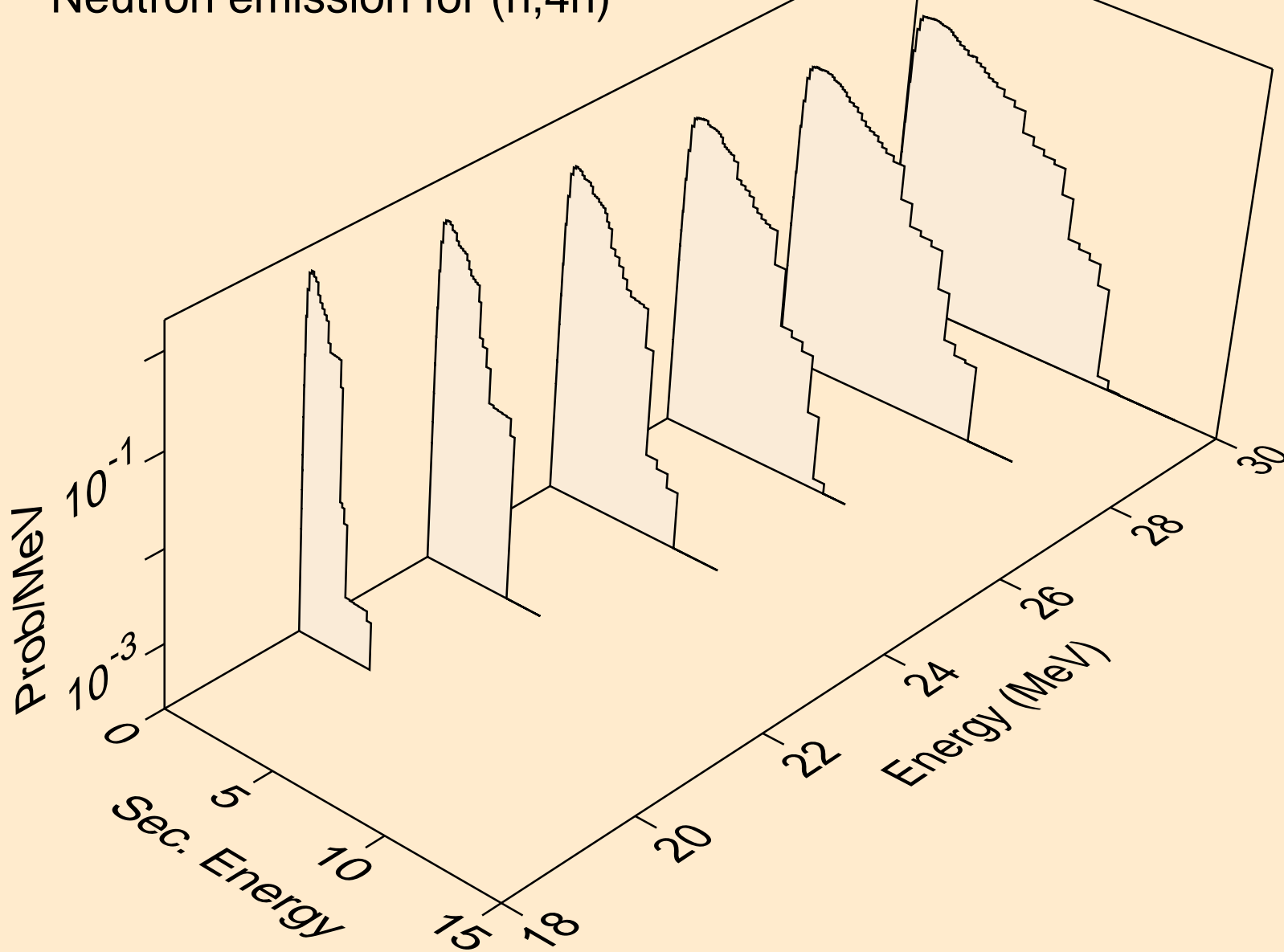

MT277 NEUTRON ACER TENDL-2019 LIBRARY; T=293.16K
Neutron emission for (n,n*c)

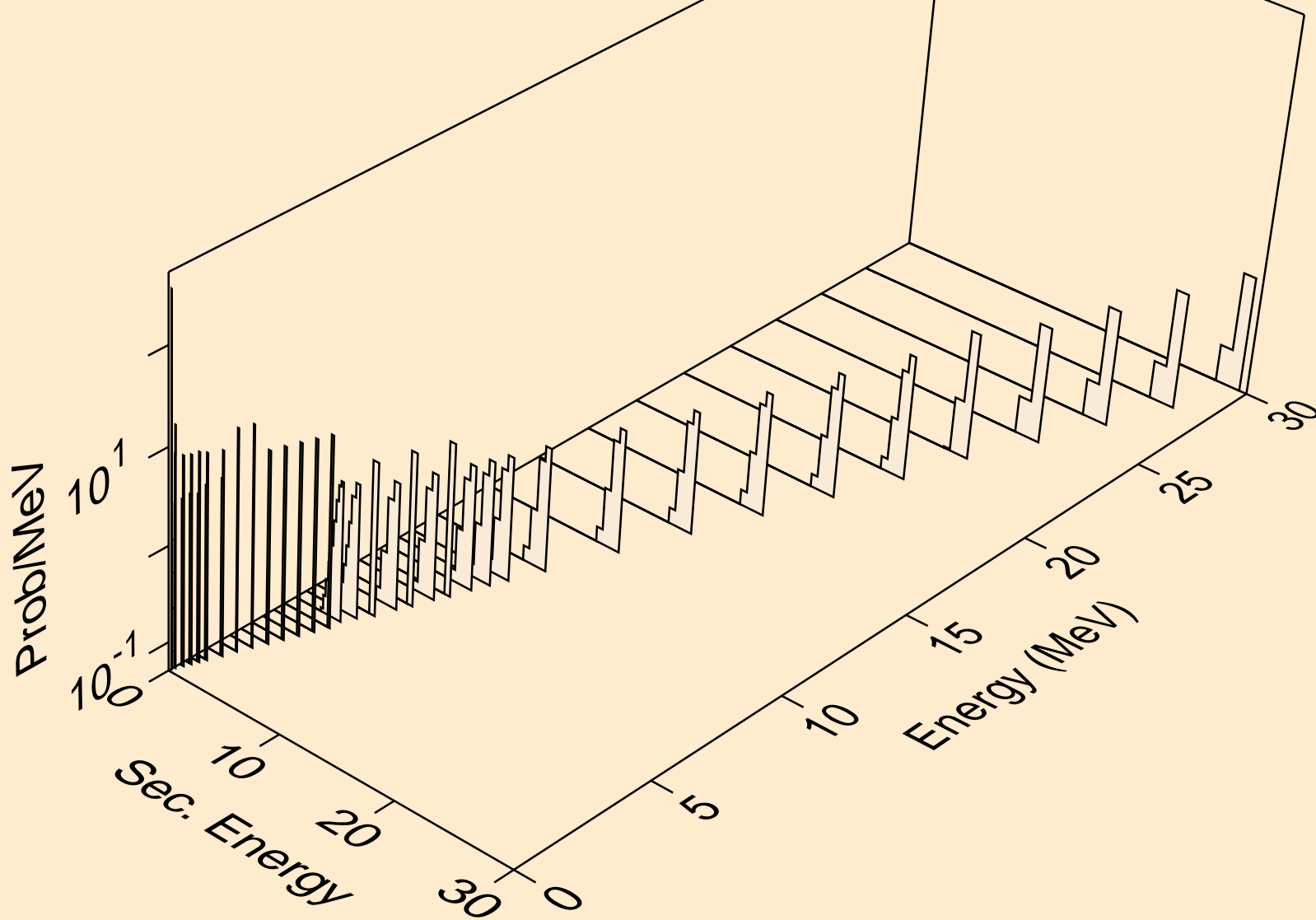

MT277 NEUTRON ACER TENDL-2019 LIBRARY; T=293.16K

Delayed nubar

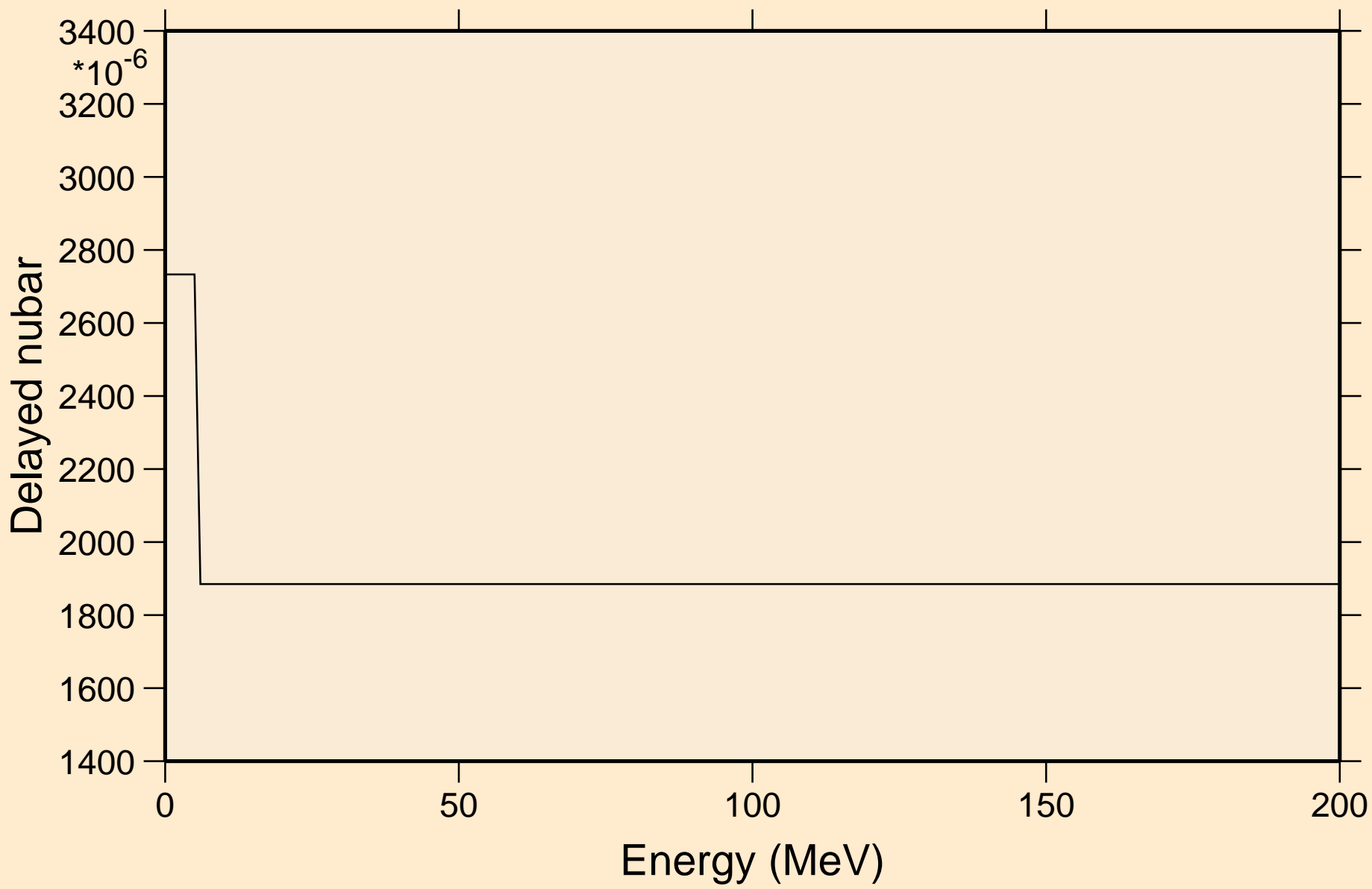

MT277 NEUTRON ACER TENDL-2019 LIBRARY; T=293.16K

Delayed neutron spectra

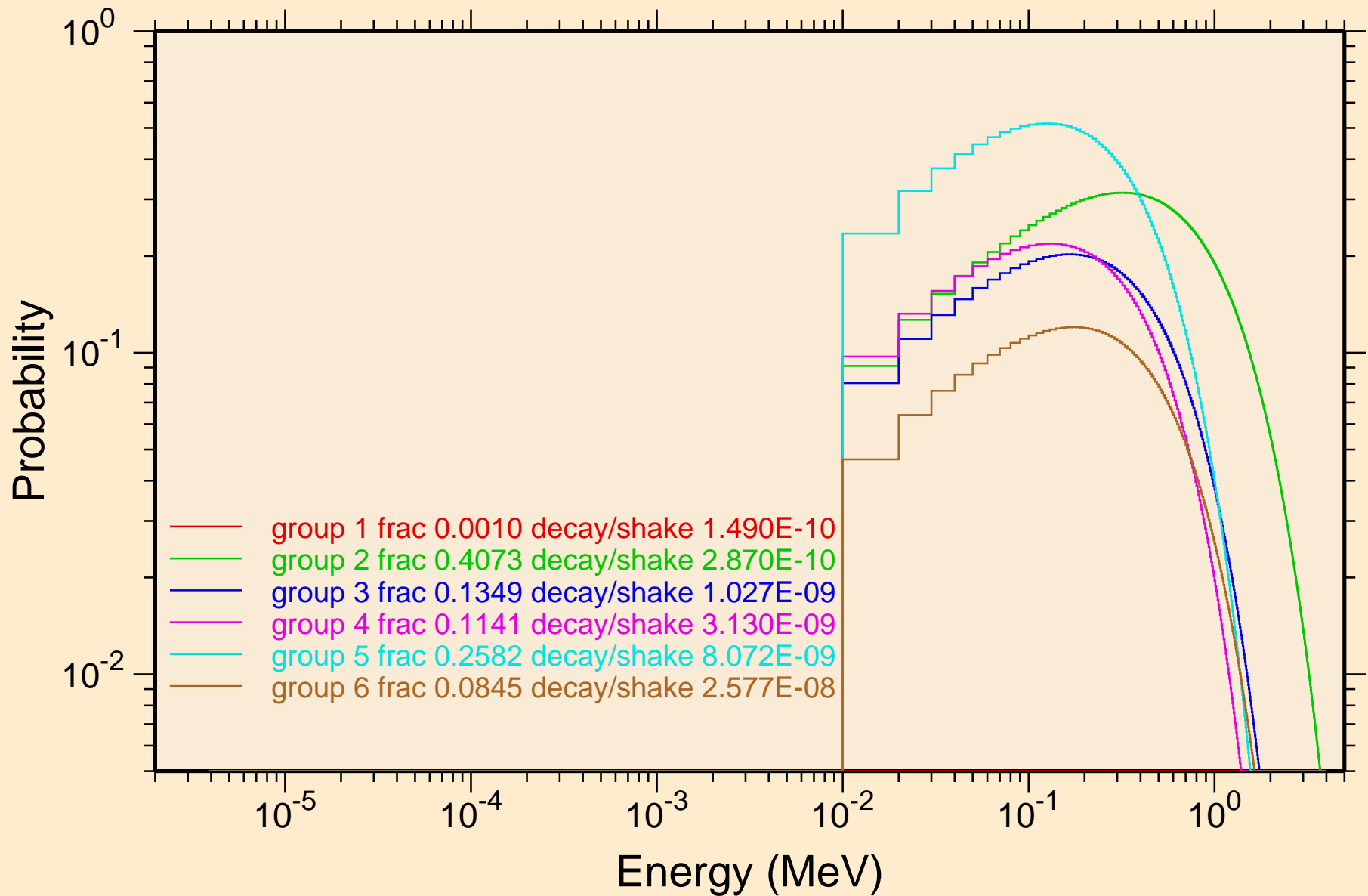

MT277 NEUTRON ACER TENDL-2019 LIBRARY; T=293.16K
Photon emission for (n,x)

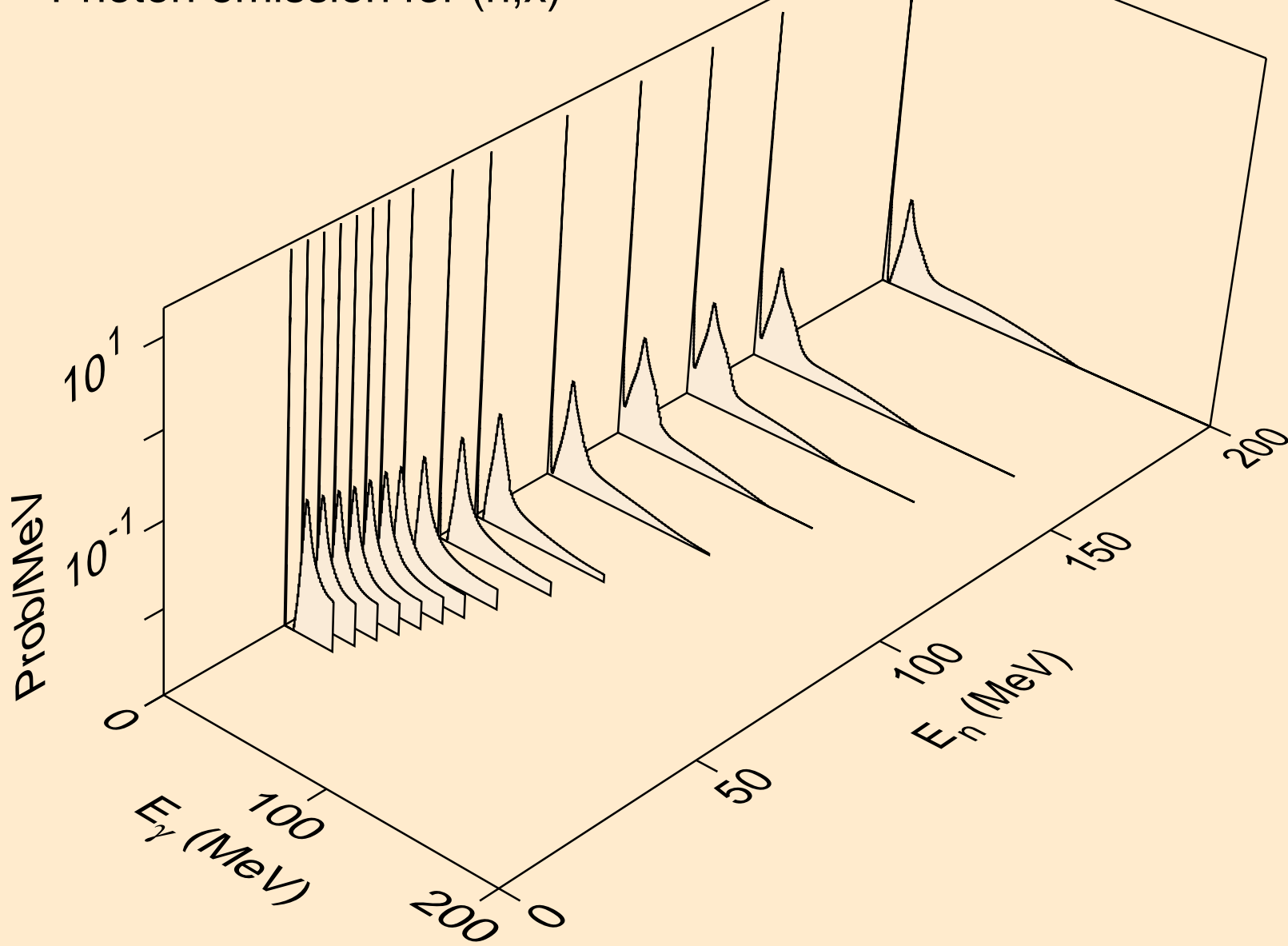

MT277 NEUTRON ACER TENDL-2019 LIBRARY; T=293.16K
Photon emission for (n,2n)

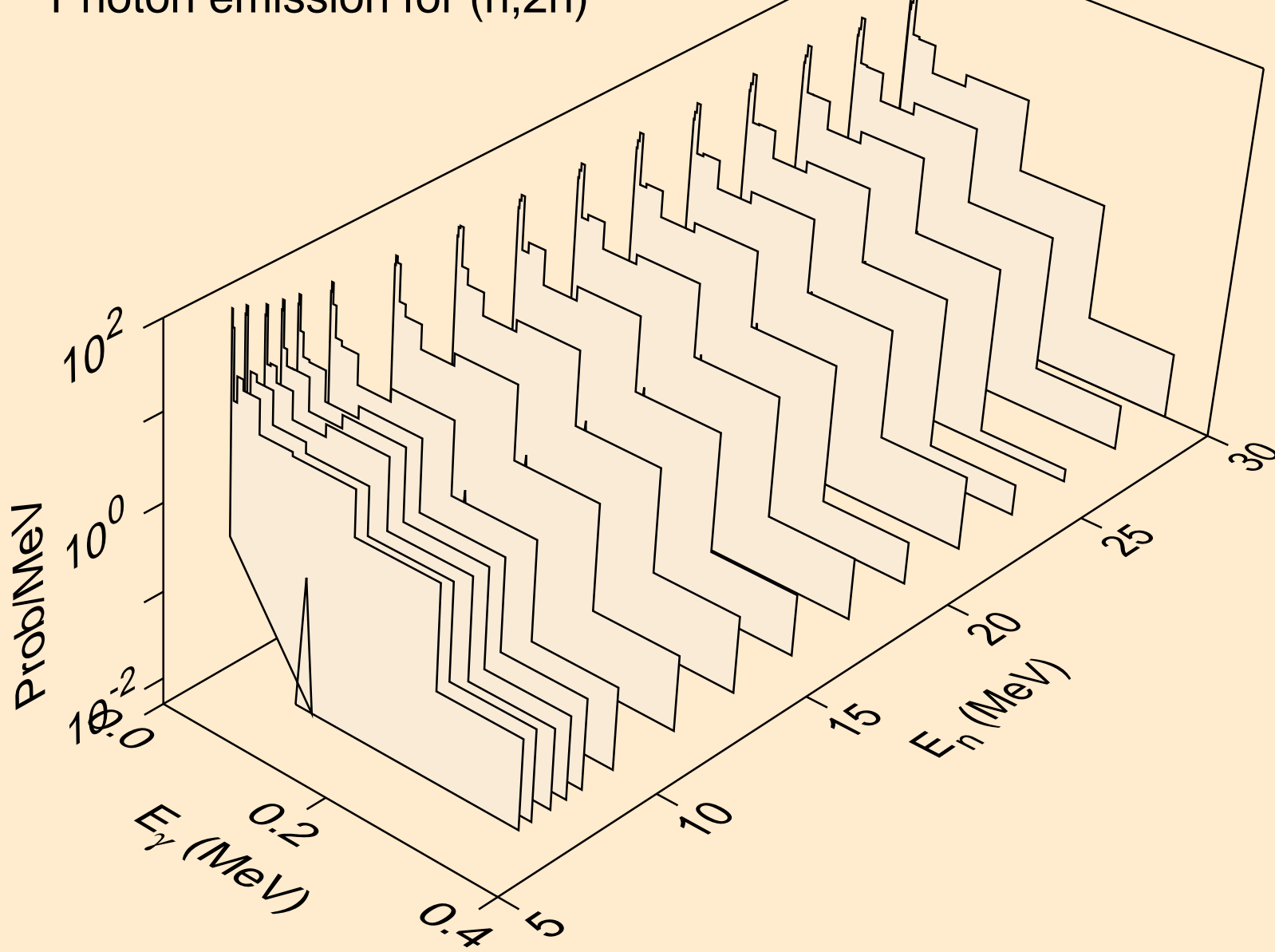

MT277 NEUTRON ACER TENDL-2019 LIBRARY; T=293.16K
Photon emission for (n,3n)

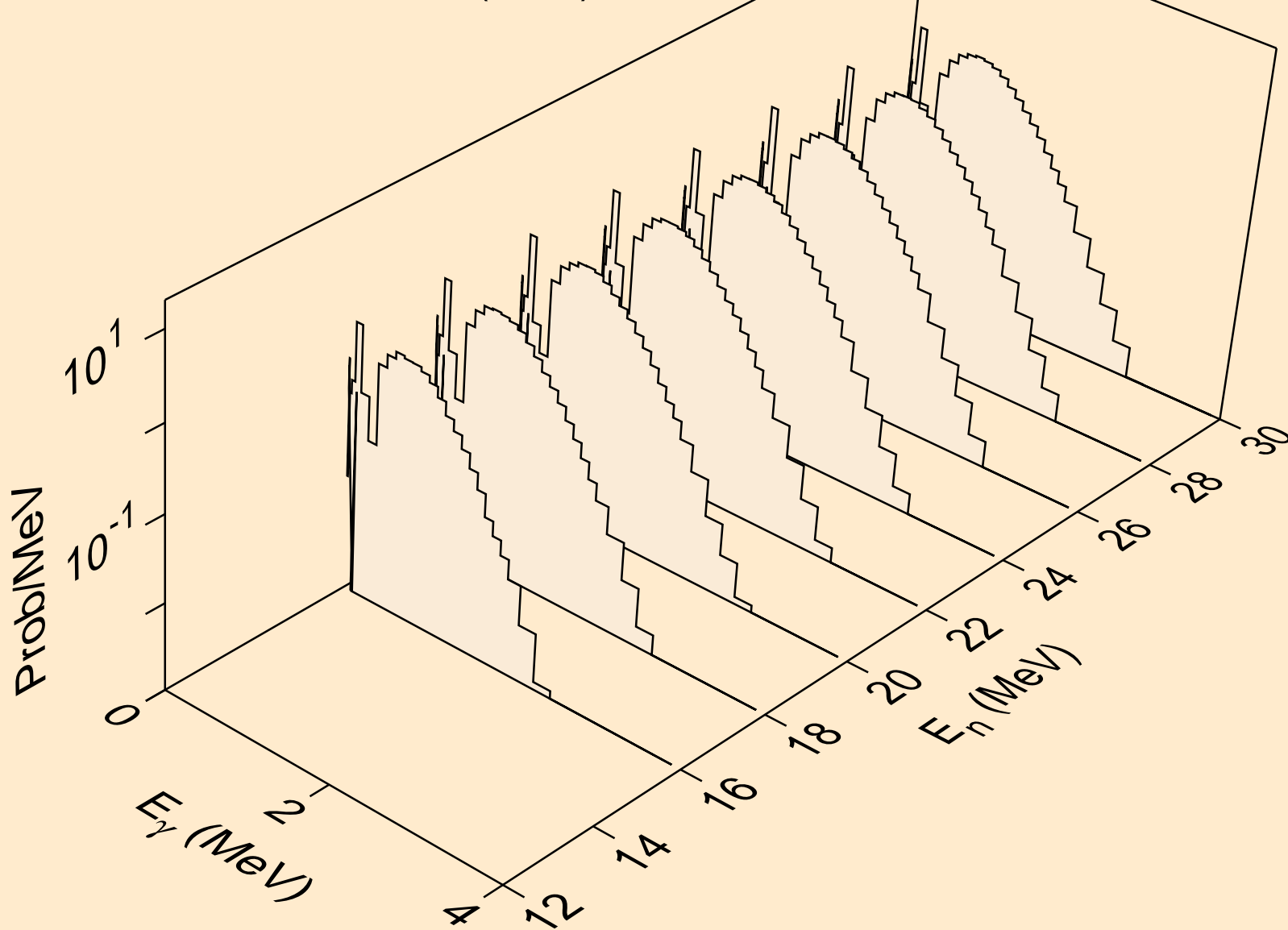

MT277 NEUTRON ACER TENDL-2019 LIBRARY; T=293.16K
Photon emission for (n,n*)a

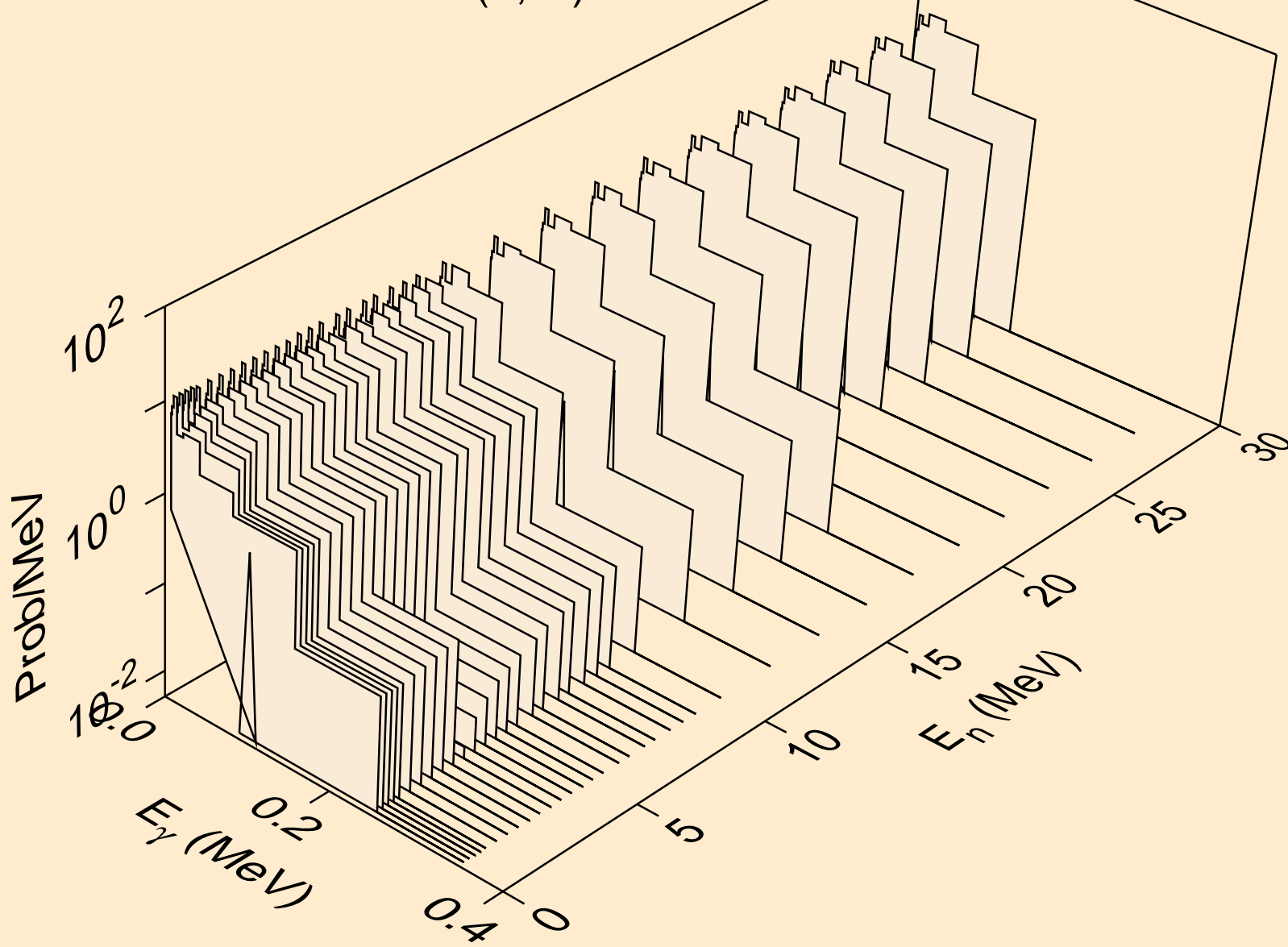

MT277 NEUTRON ACER TENDL-2019 LIBRARY; T=293.16K
Photon emission for (n,2n)a

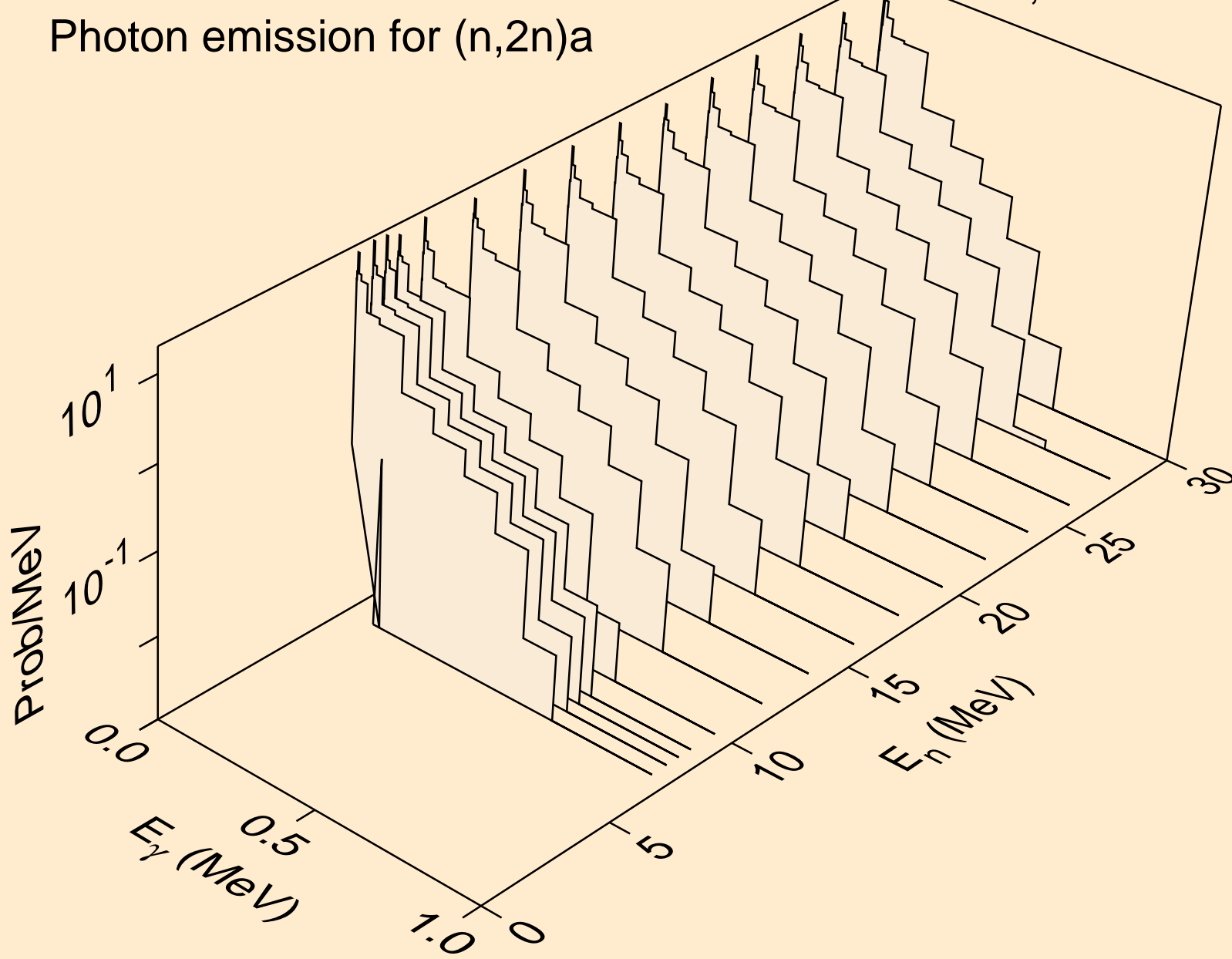

MT277 NEUTRON ACER TENDL-2019 LIBRARY; T=293.16K
Photon emission for (n,3n)a

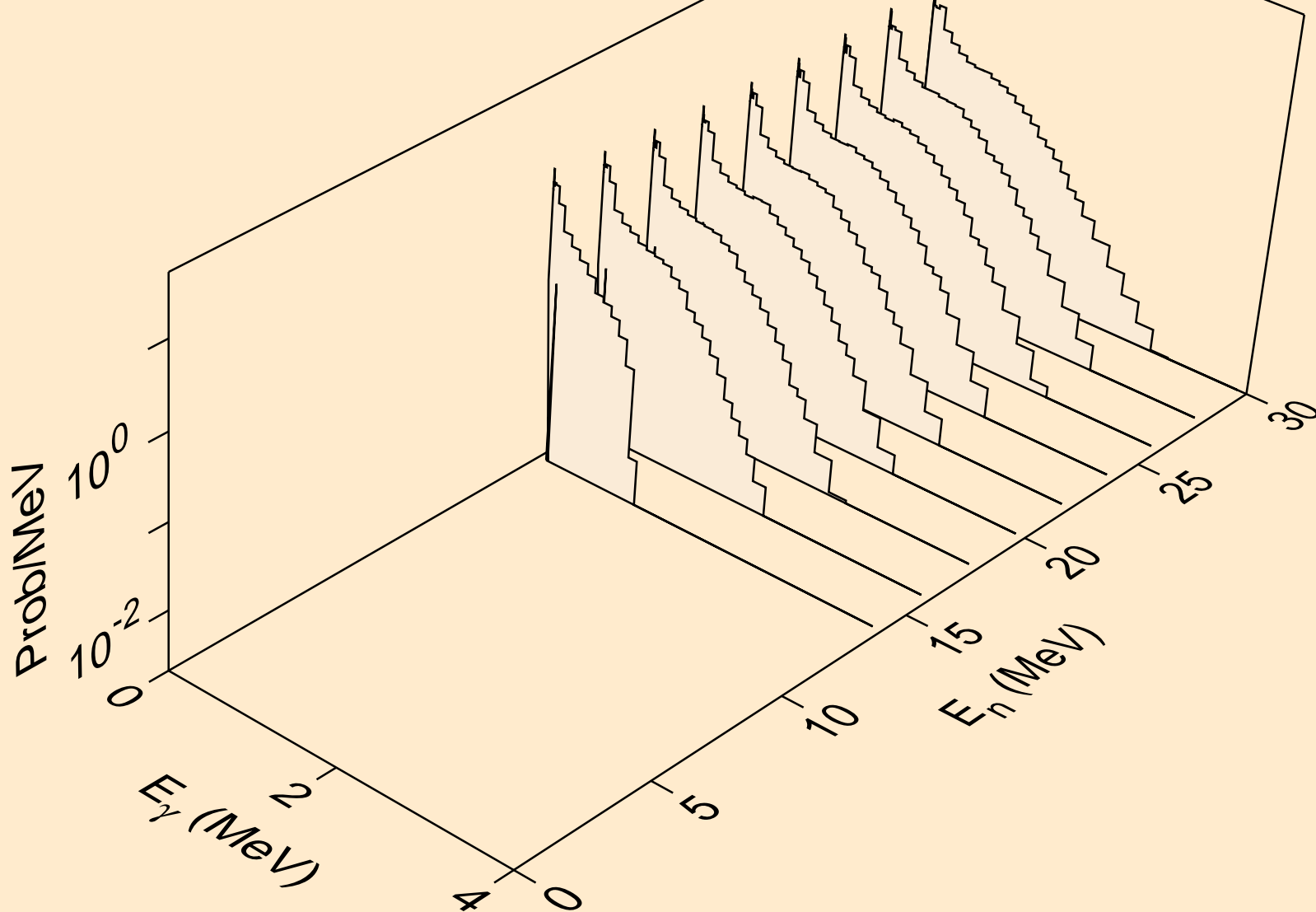

MT277 NEUTRON ACER TENDL-2019 LIBRARY; T=293.16K
Photon emission for (n,n*)p

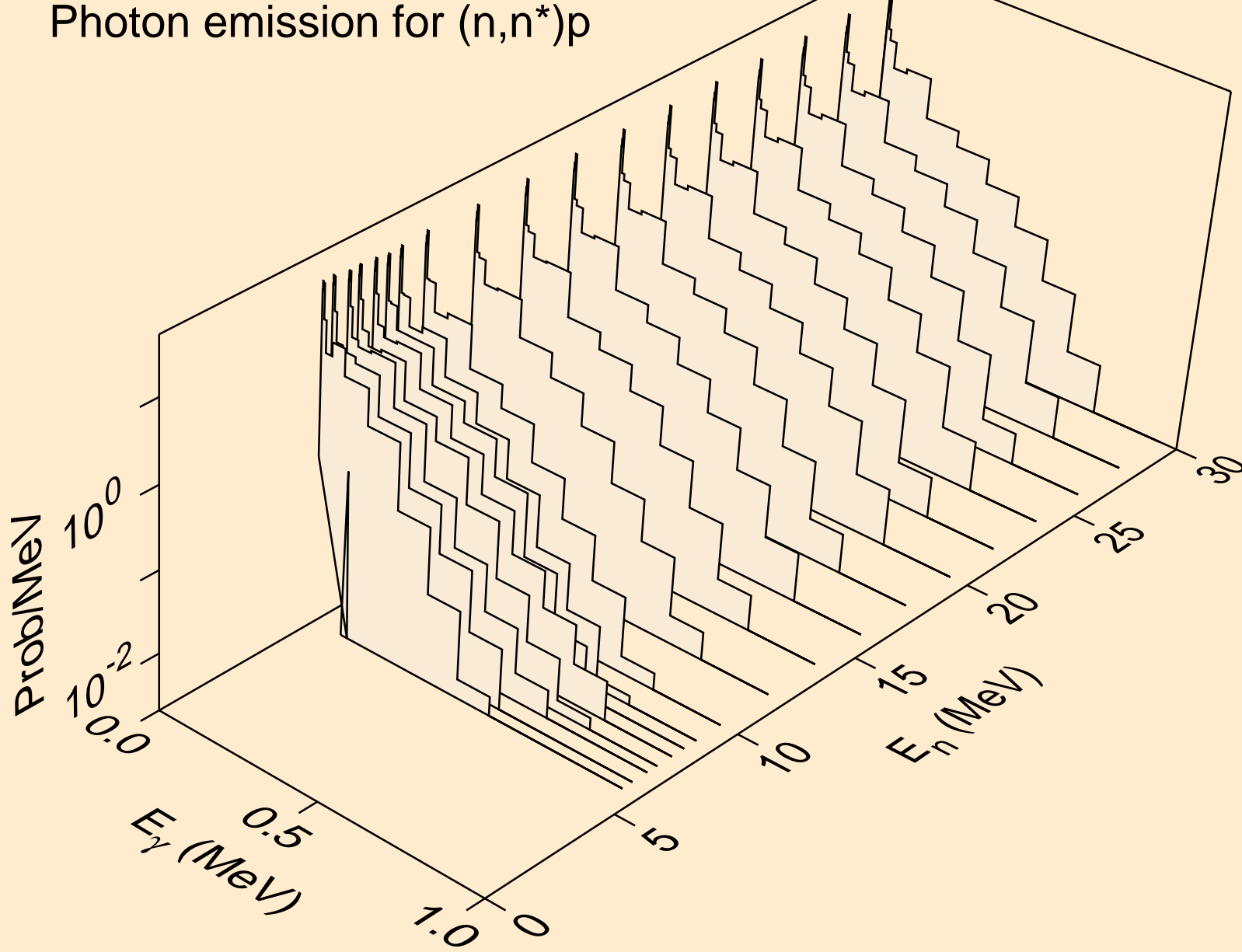

MT277 NEUTRON ACER TENDL-2019 LIBRARY; T=293.16K
Photon emission for (n,n*)t

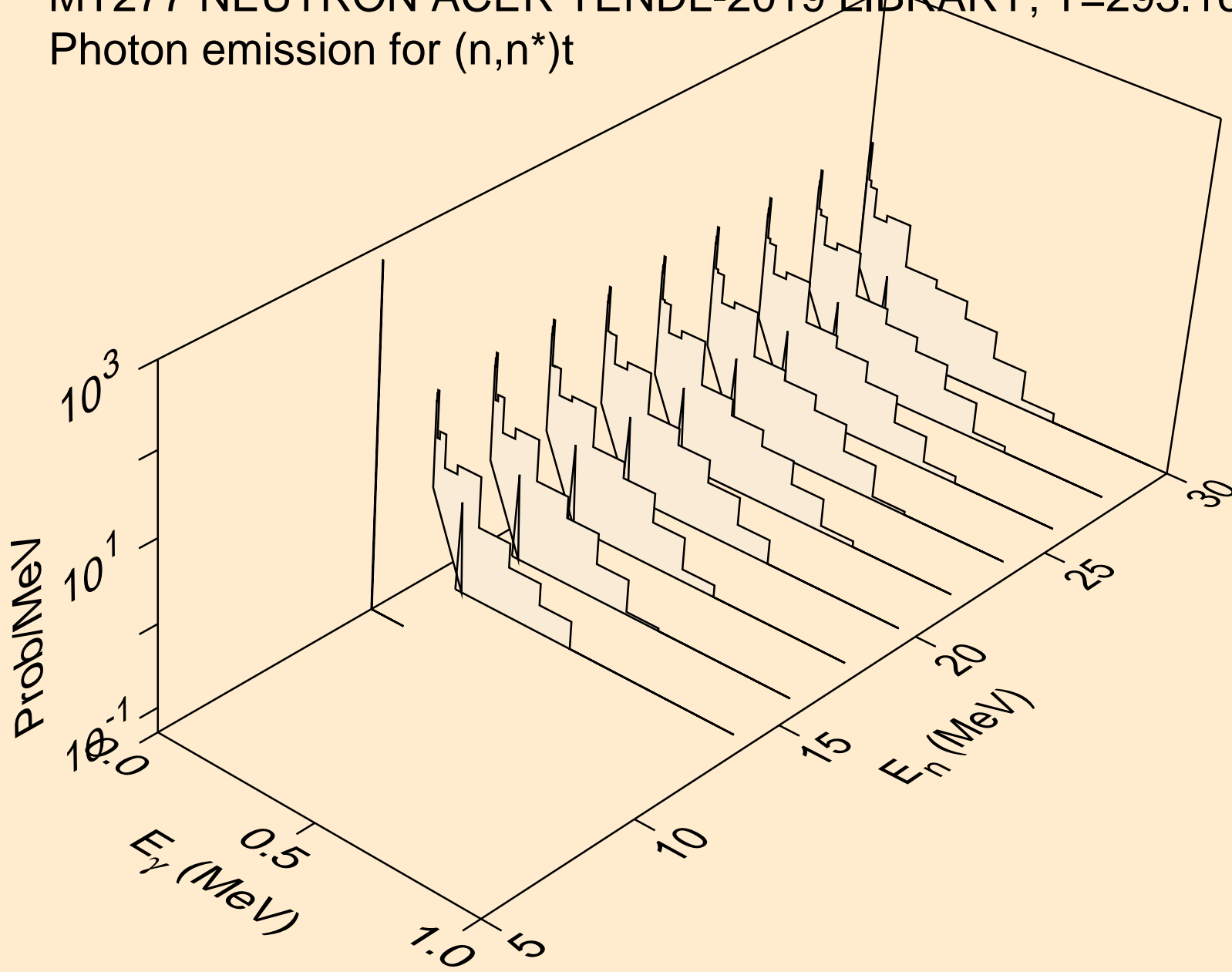

MT277 NEUTRON ACER TENDL-2019 LIBRARY; T=293.16K
Photon emission for (n,4n)

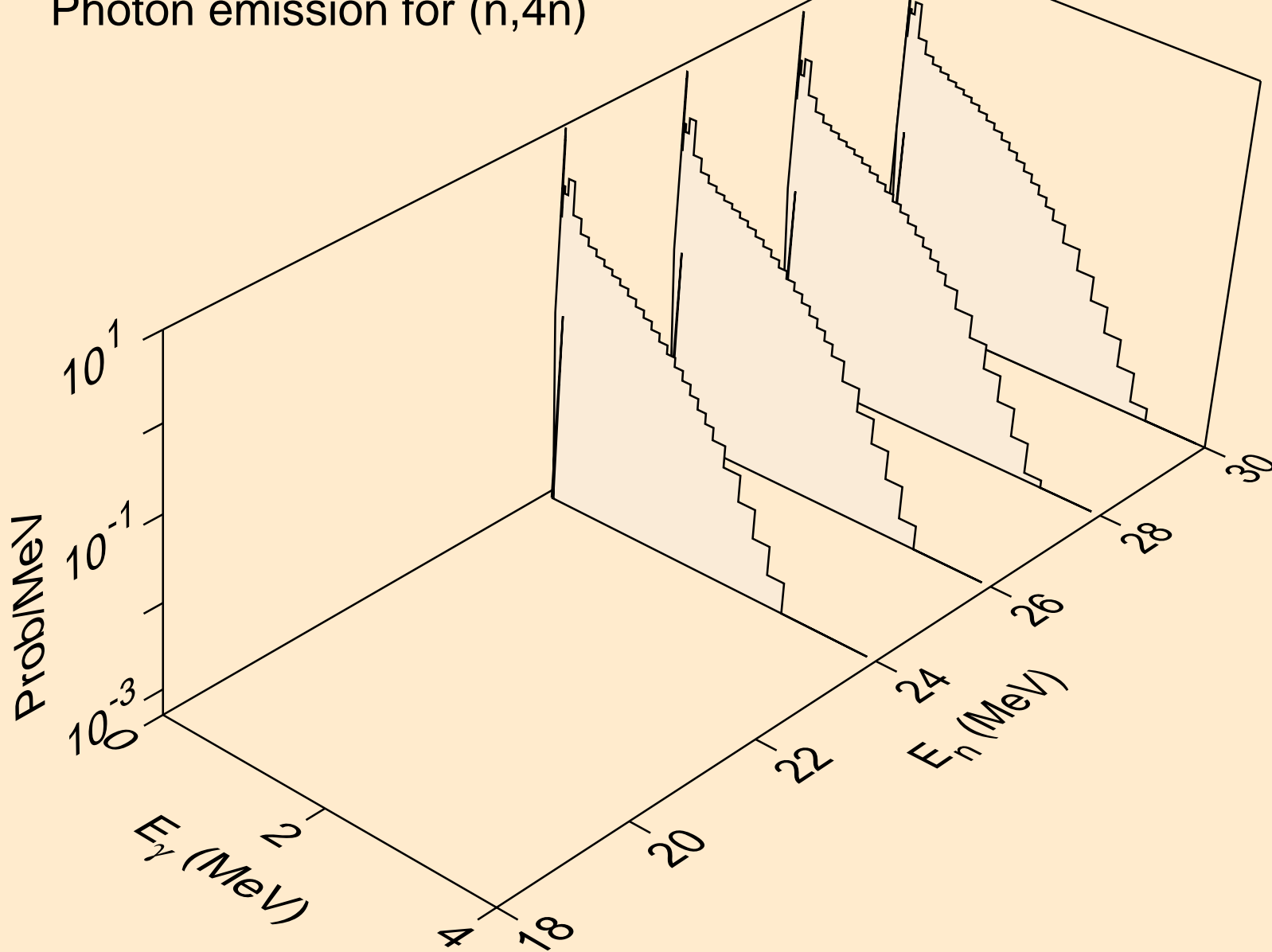

MT277 NEUTRON ACER TENDL-2019 LIBRARY; T=293.16K
Photon emission for (n,n*c)

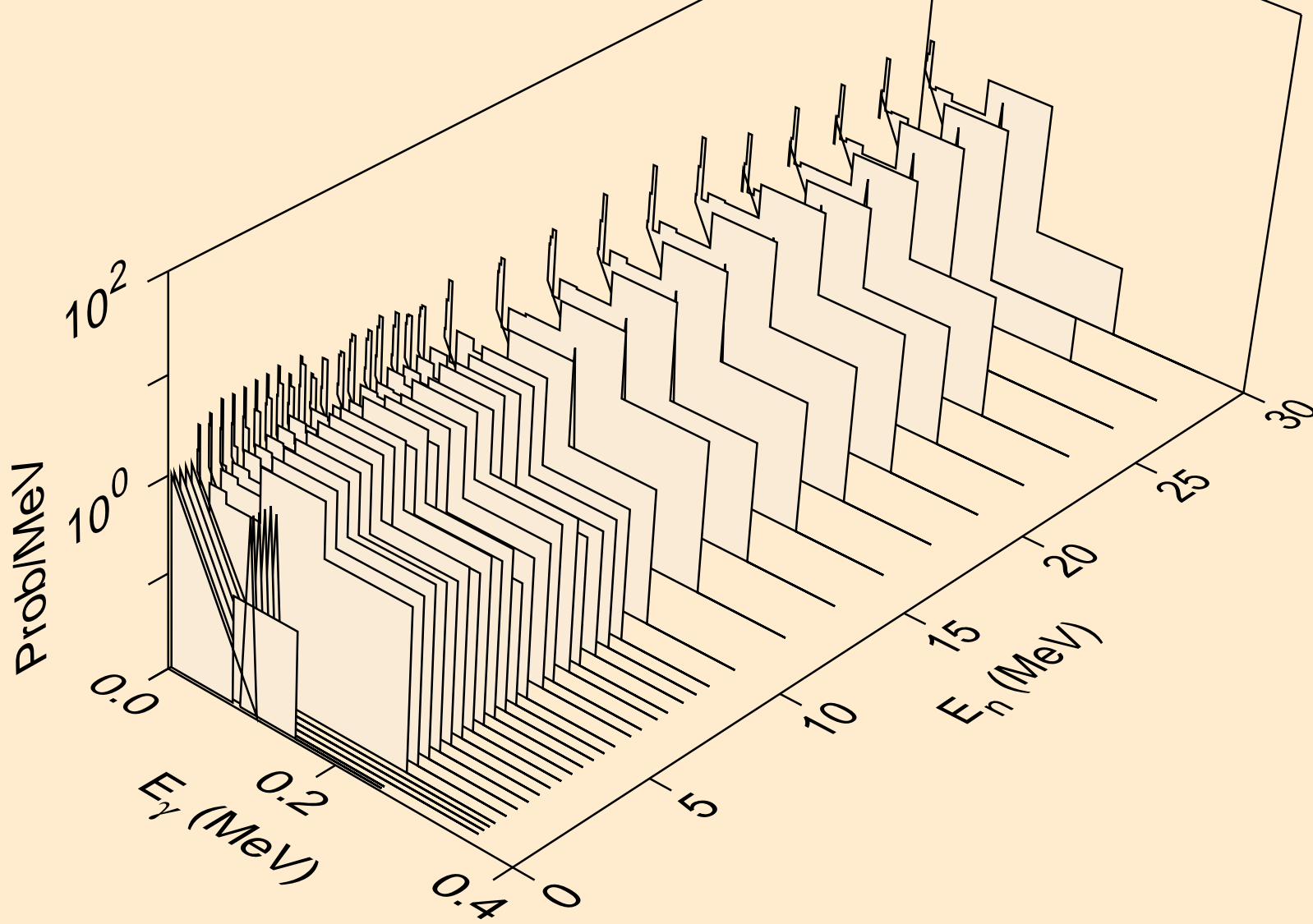

MT277 NEUTRON ACER TENDL-2019 LIBRARY; T=293.16K
Photon emission for (n,gma)

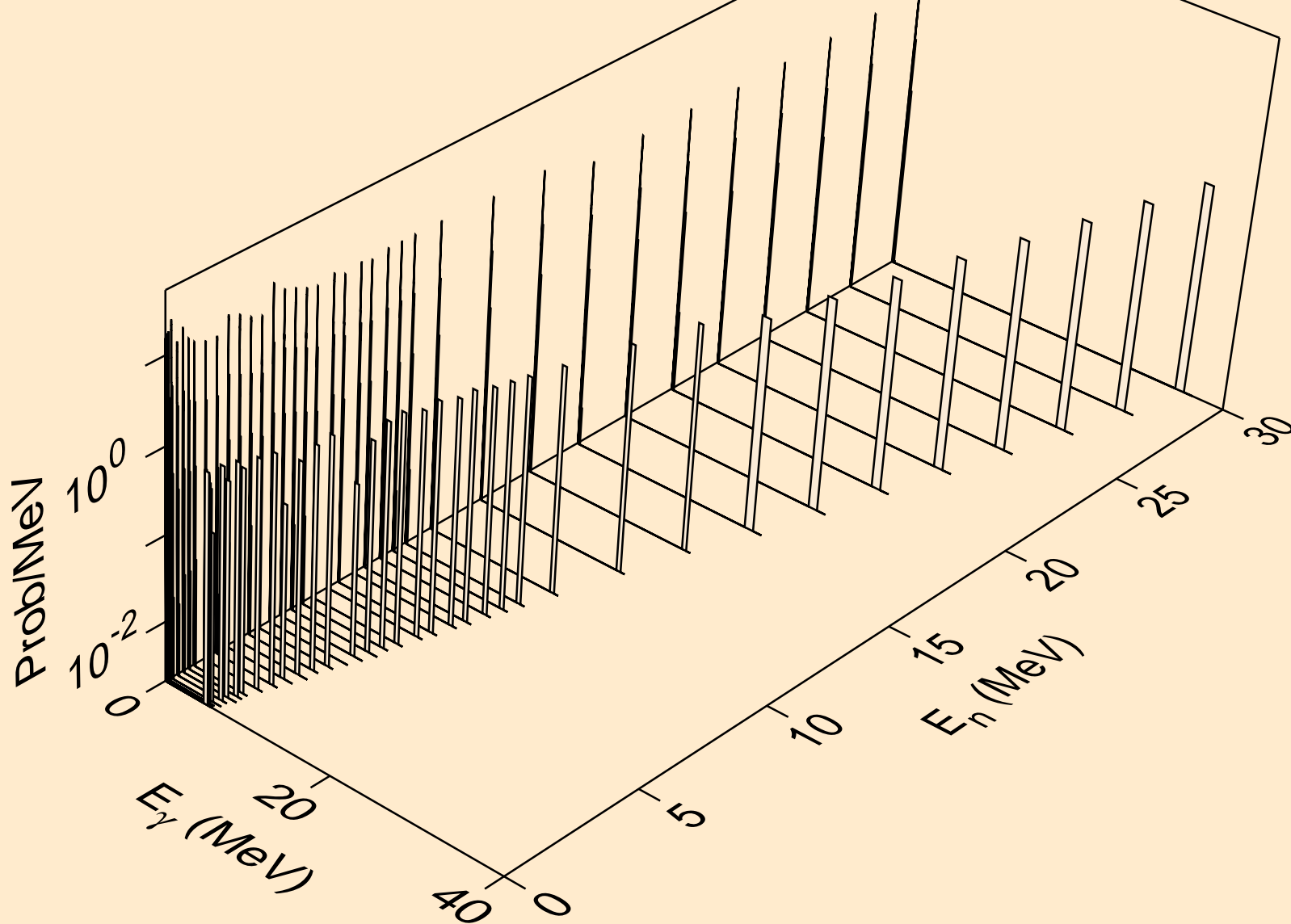

MT277 NEUTRON ACER TENDL-2019 LIBRARY; T=293.16K
Photon emission for (n,p)

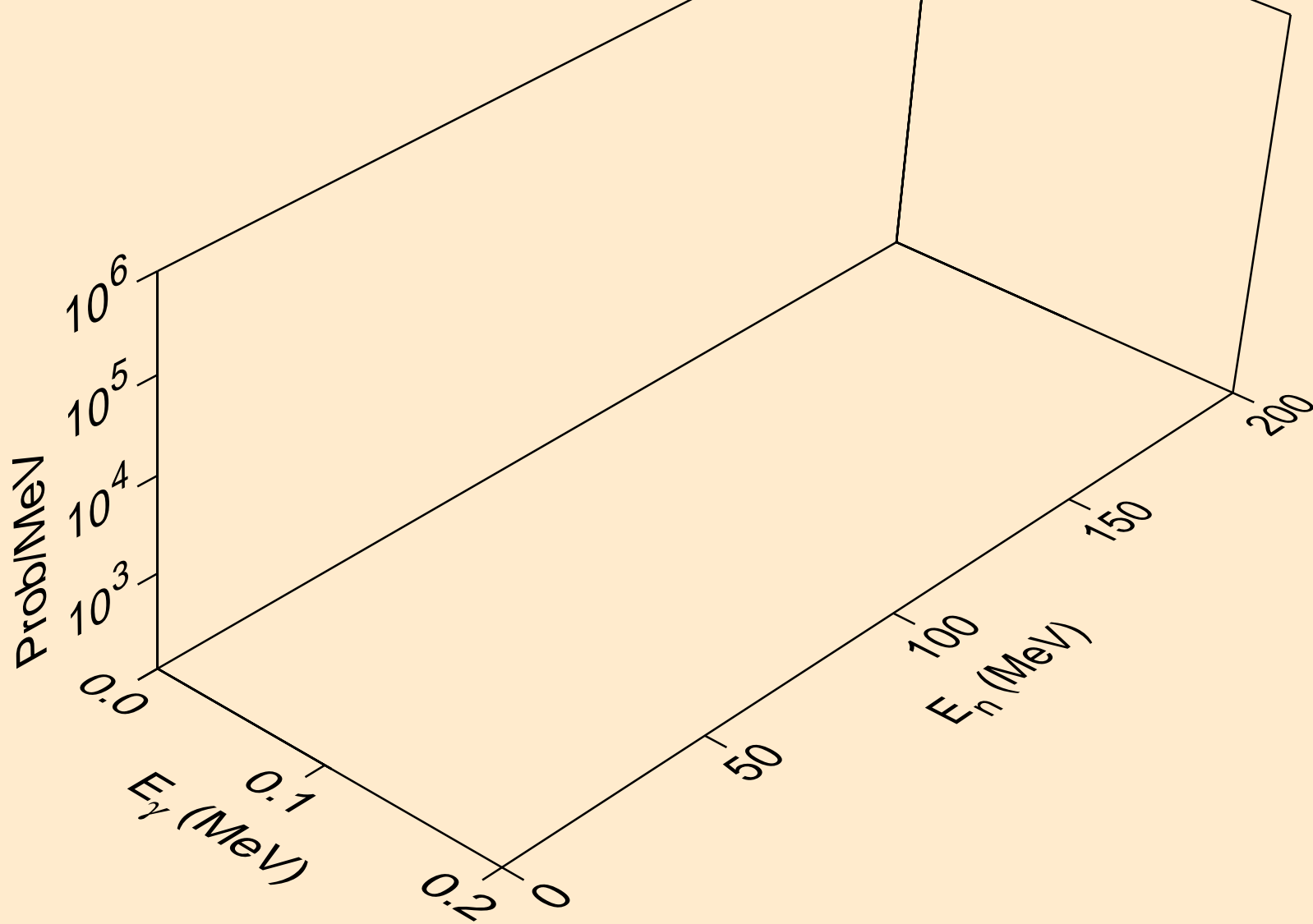

MT277 NEUTRON ACER TENDL-2019 LIBRARY; T=293.16K
Photon emission for (n,d)

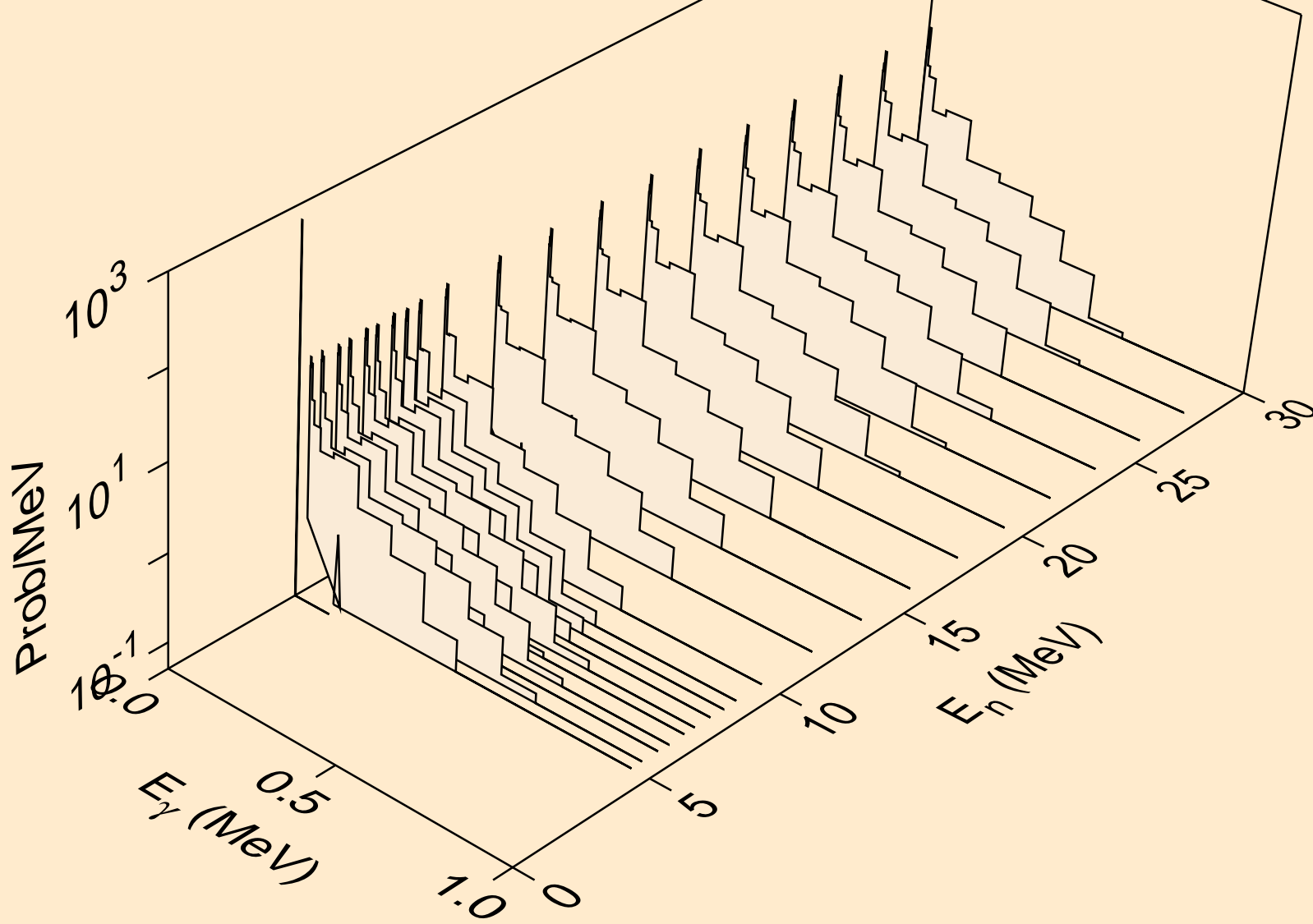

MT277 NEUTRON ACER TENDL-2019 LIBRARY; T=293.16K
Photon emission for (n,t)

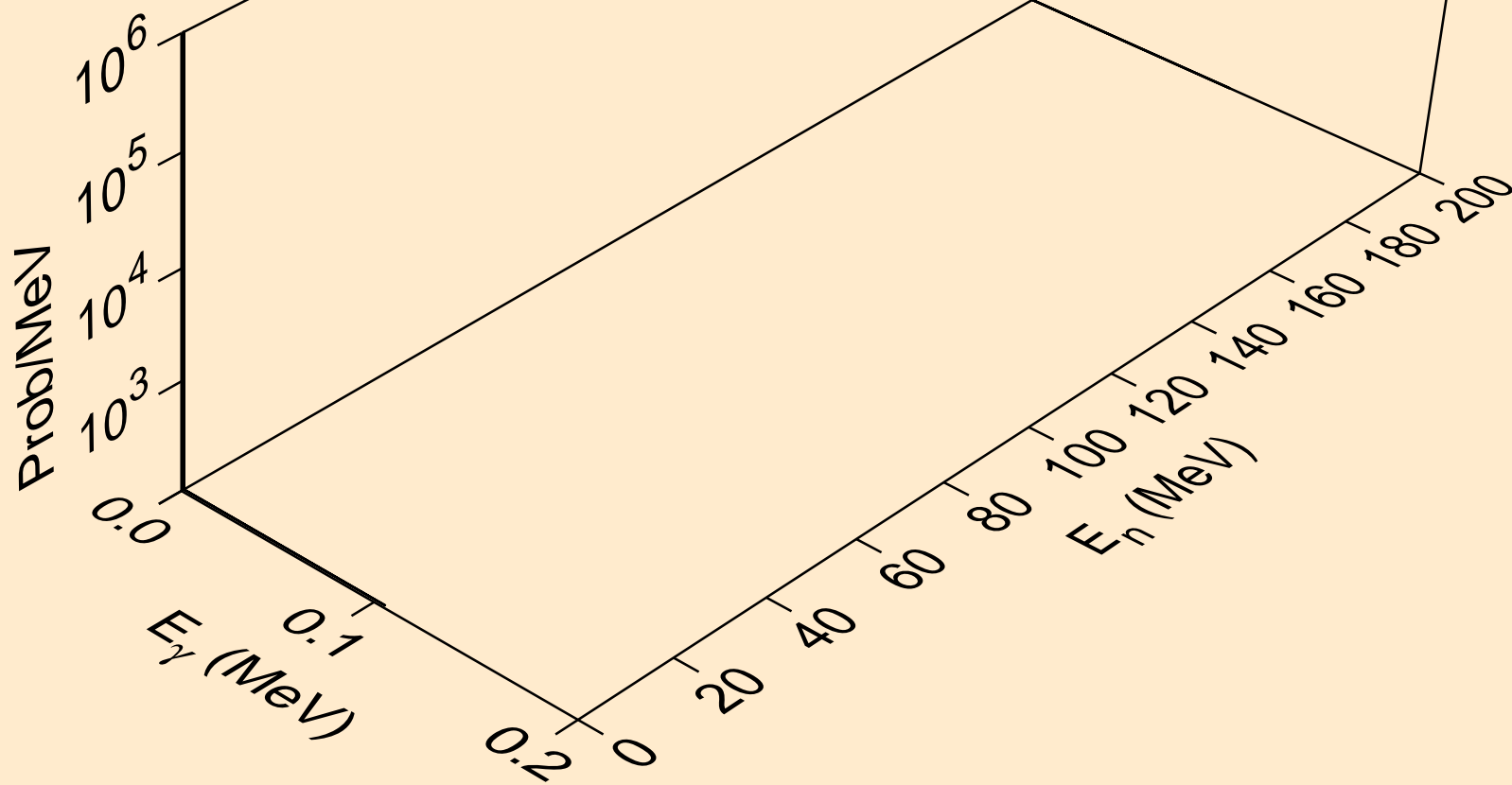

MT277 NEUTRON ACER TENDL-2019 LIBRARY; T=293.16K
Photon emission for (n,he3)

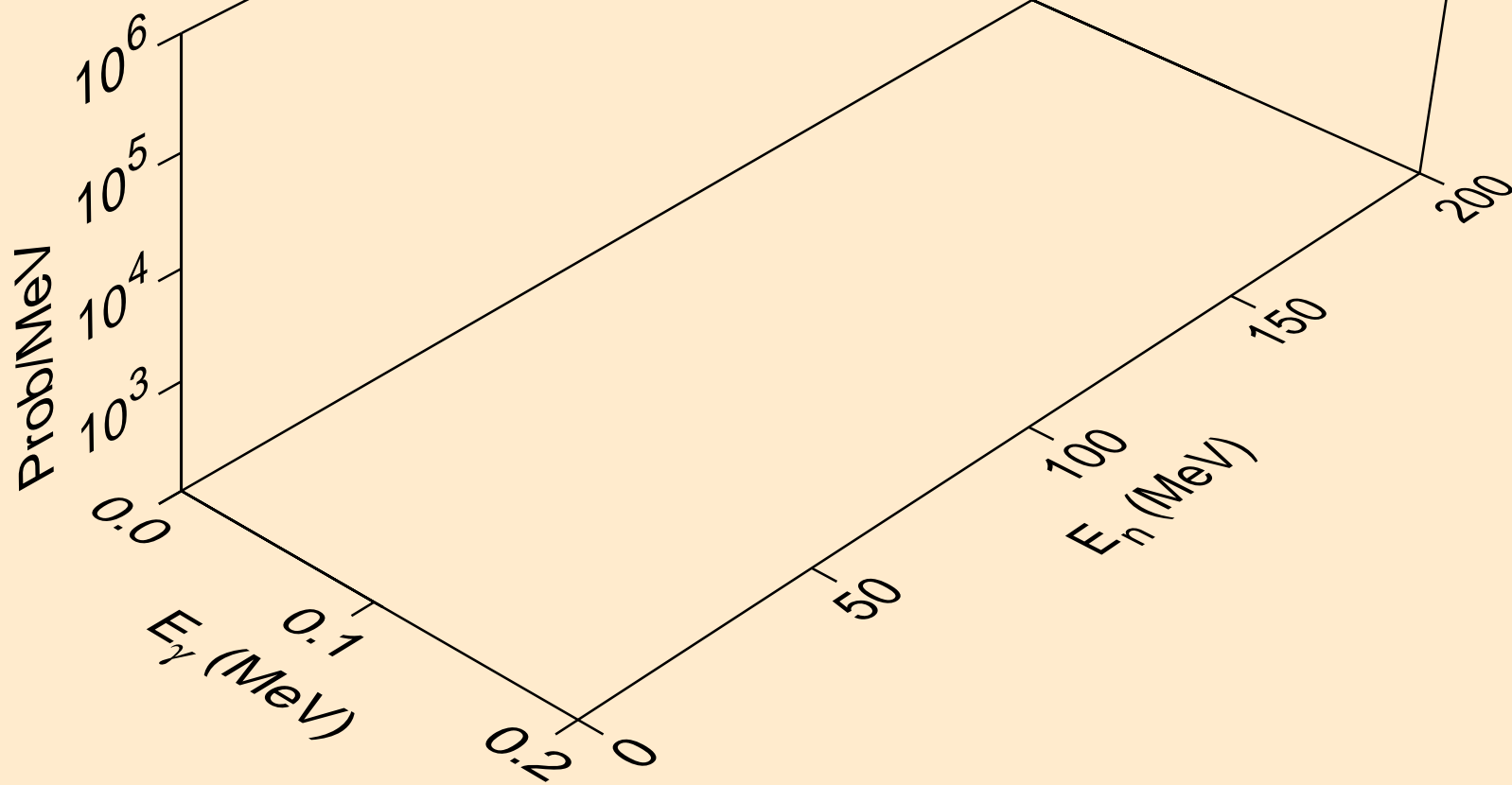

MT277 NEUTRON ACER TENDL-2019 LIBRARY; T=293.16K
Photon emission for (n,a)

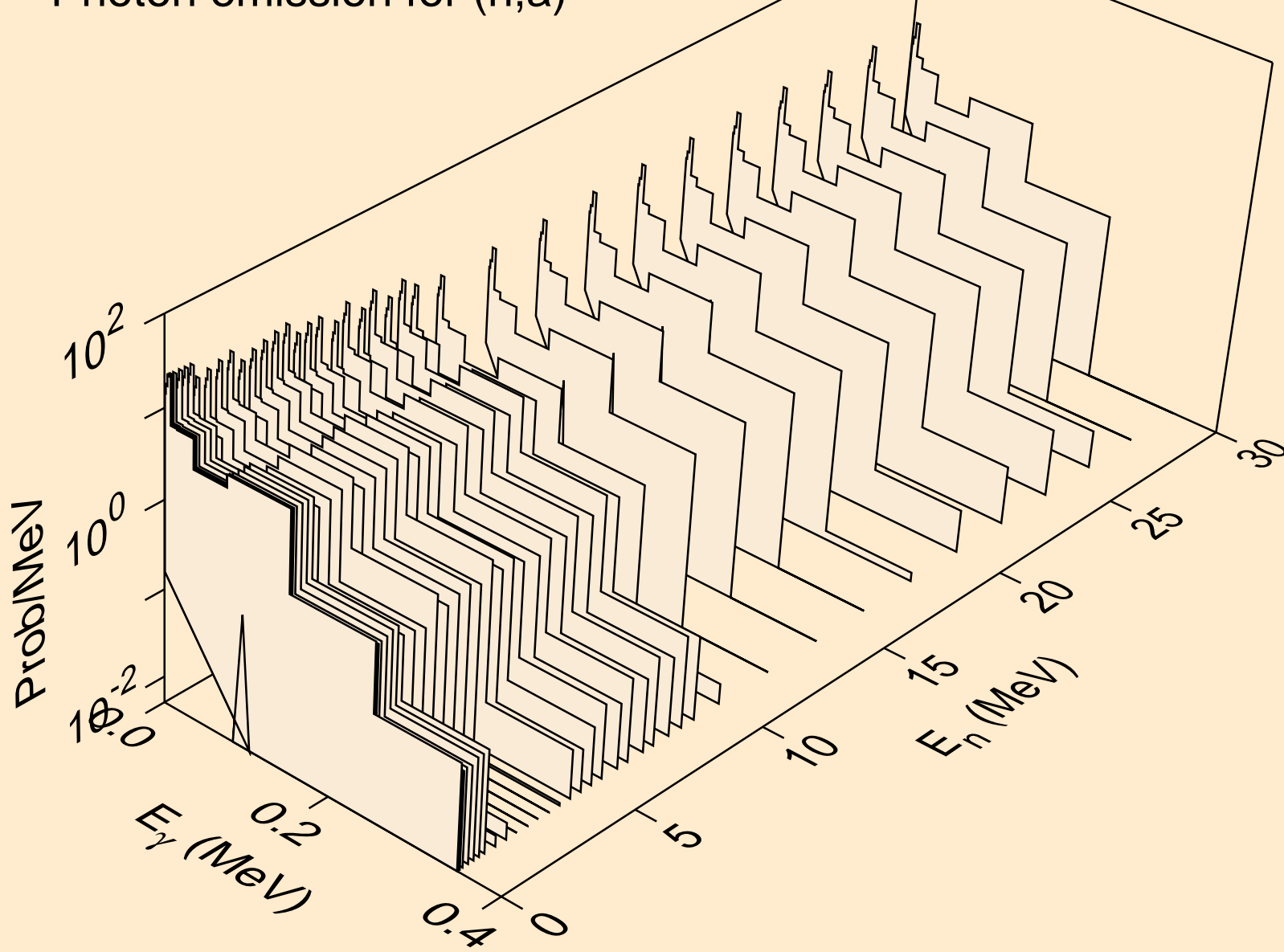

MT277 NEUTRON ACER TENDL-2019 LIBRARY; T=293.16K
thermal capture photon spectrum

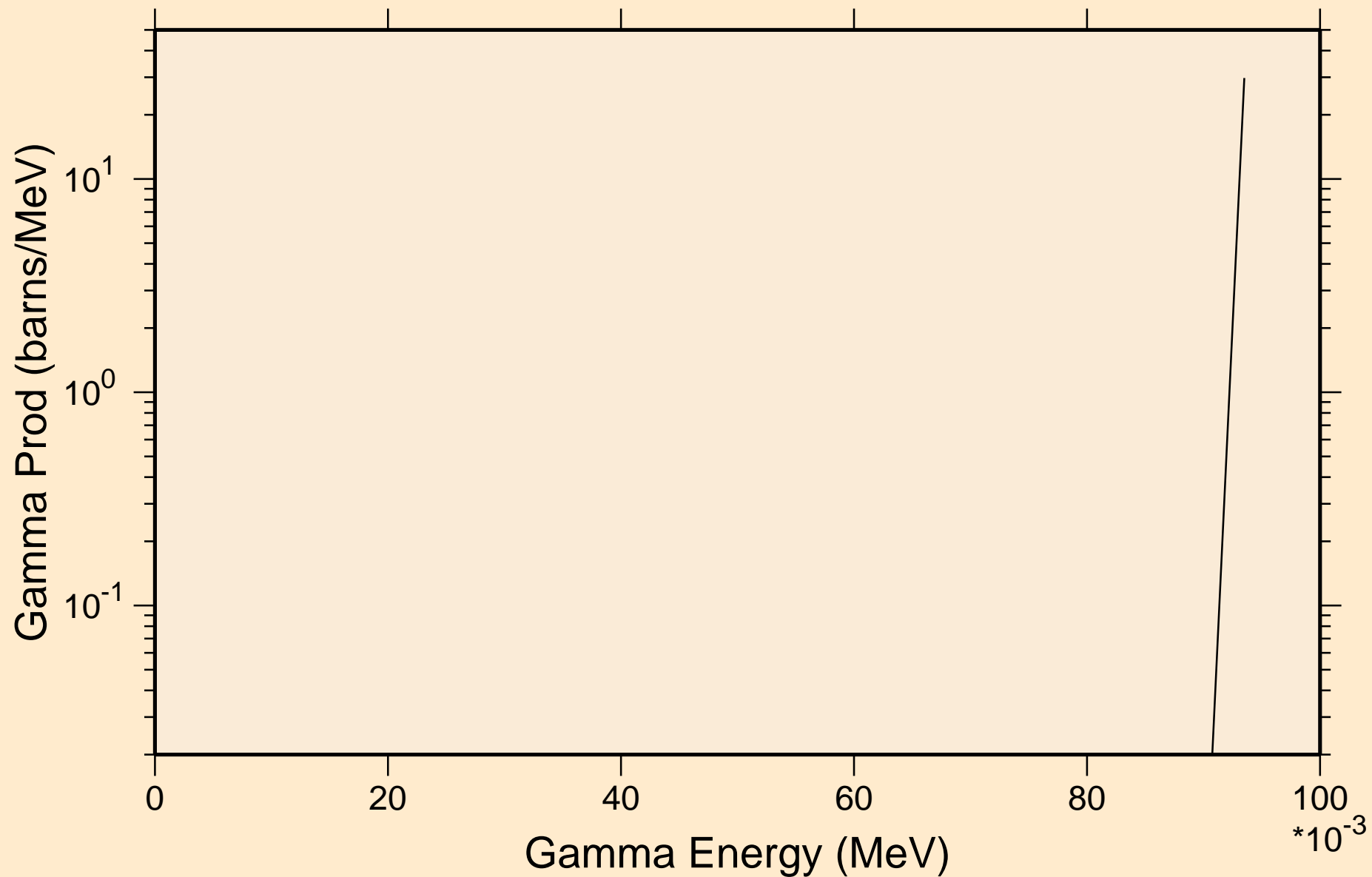

MT277 NEUTRON ACER TENDL-2019 LIBRARY; T=293.16K
14 MeV photon spectrum

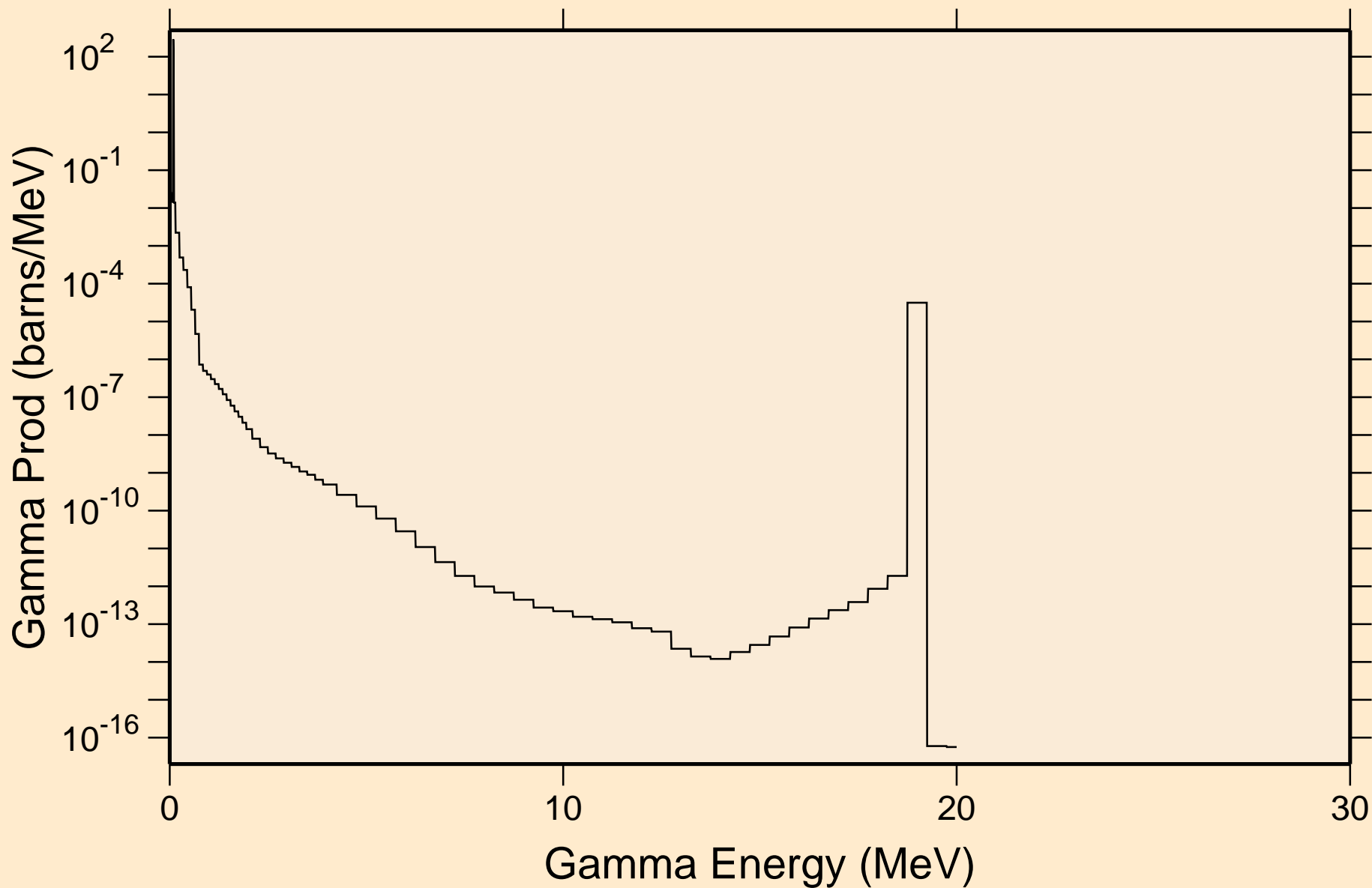

MT277 NEUTRON ACER TENDL-2019 LIBRARY; T=293.16K
Particle heating contributions

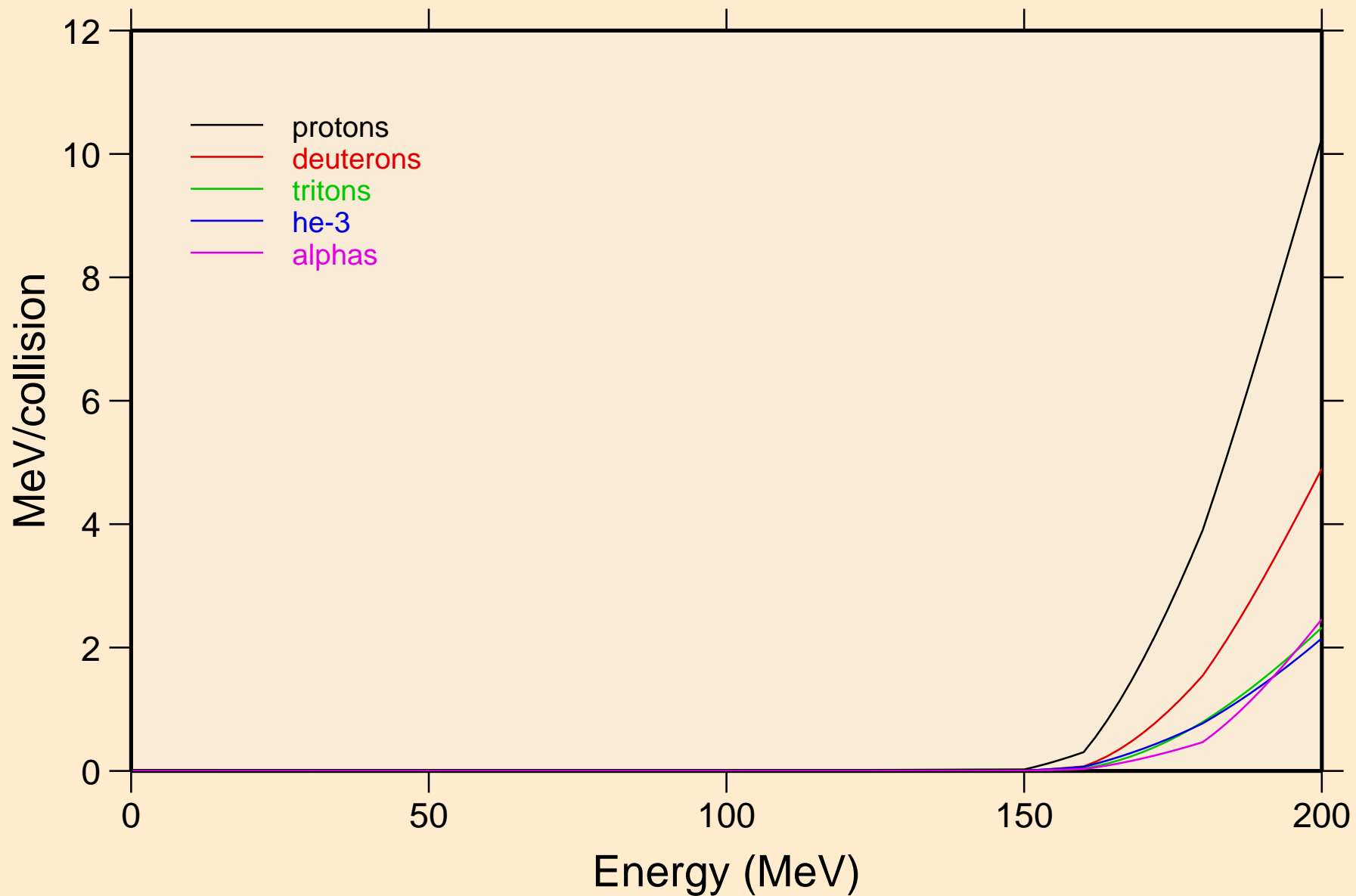

MT277 NEUTRON ACER TENDL-2019 LIBRARY; T=293.16K
Recoil Heating

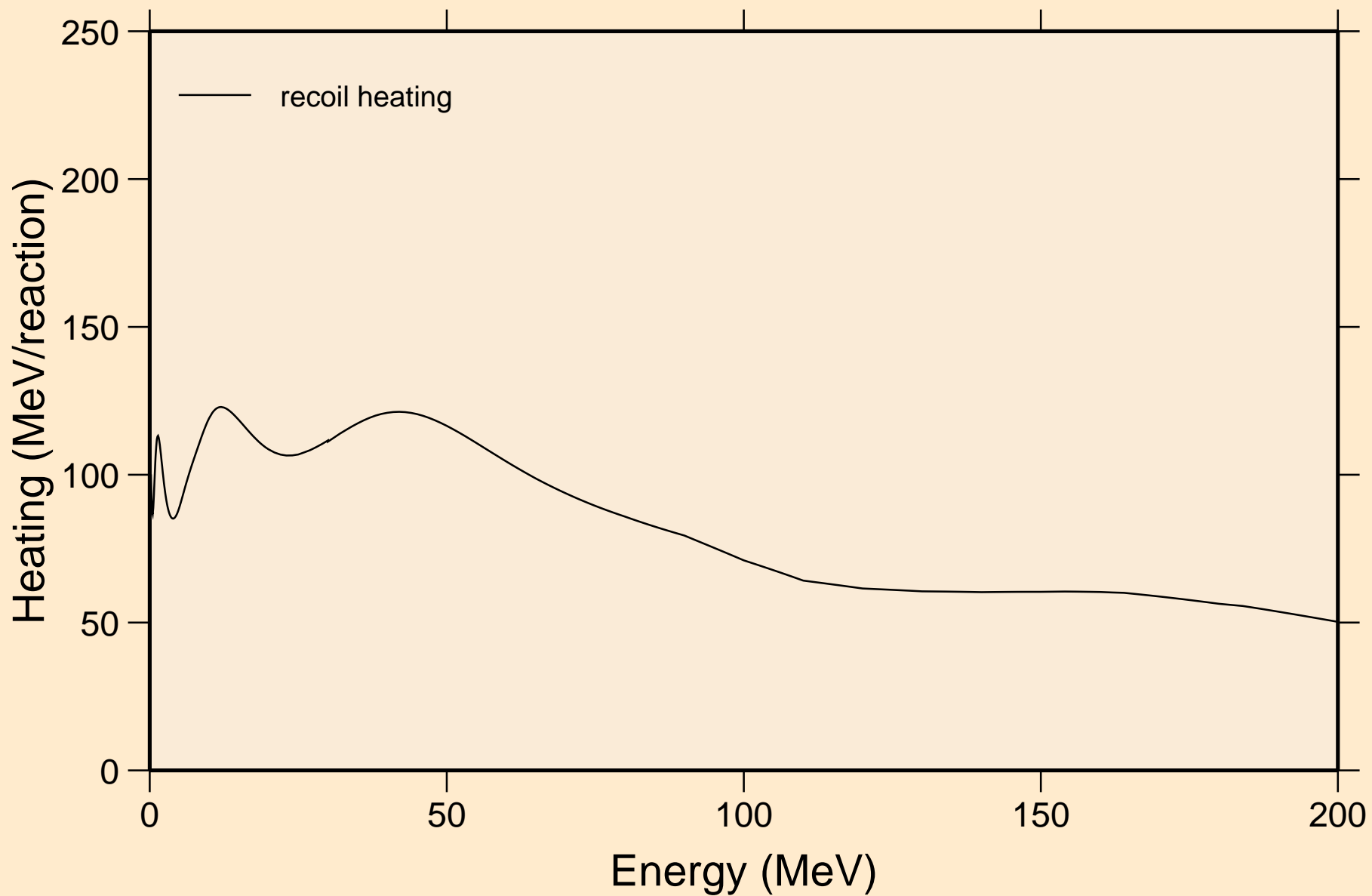

MT277 NEUTRON ACER TENDL-2019 LIBRARY; T=293.16K
Particle production cross sections

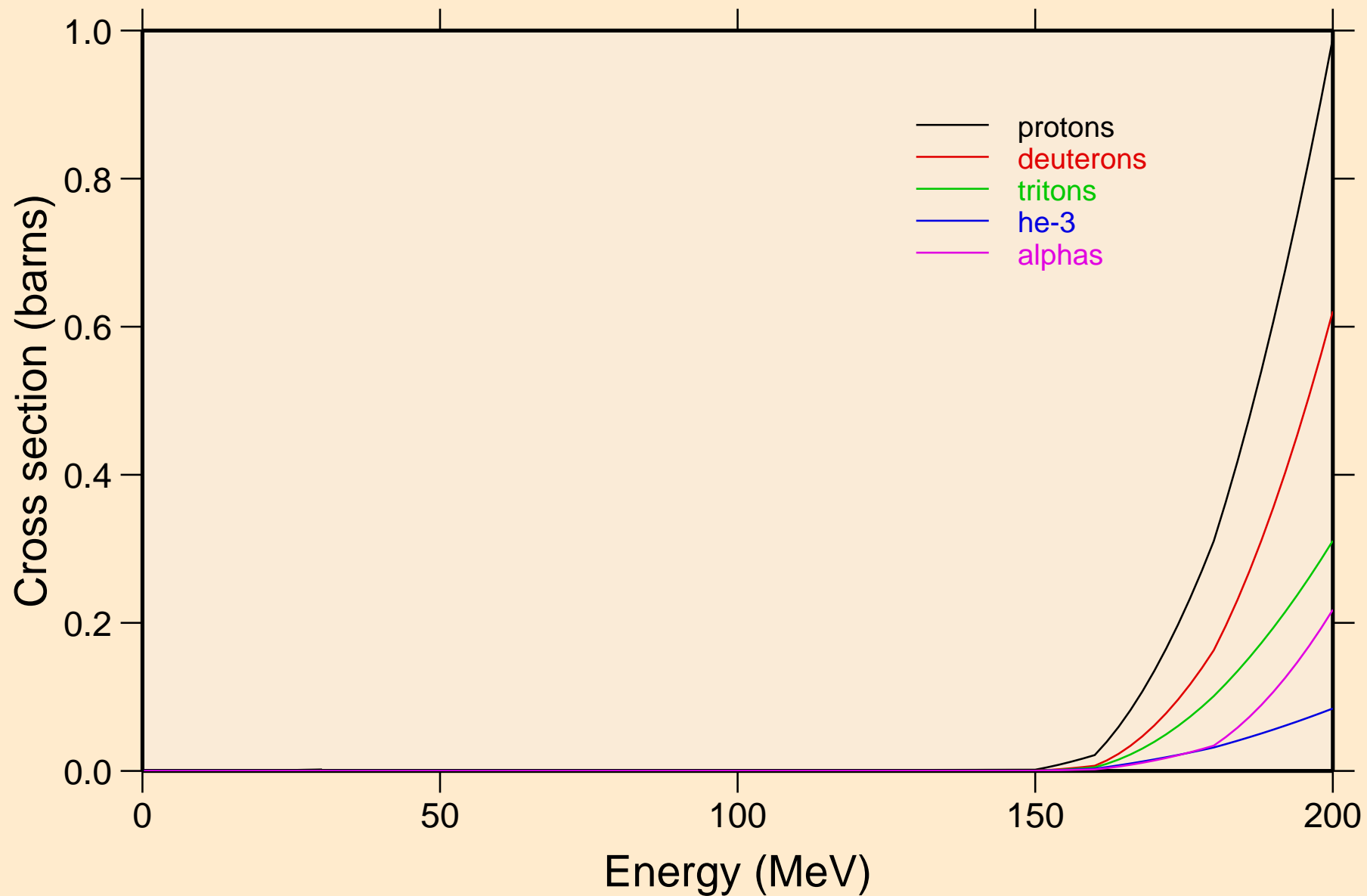

MT277 NEUTRON ACER TENDL-2019 LIBRARY; T=293.16K
protons from (n,x)

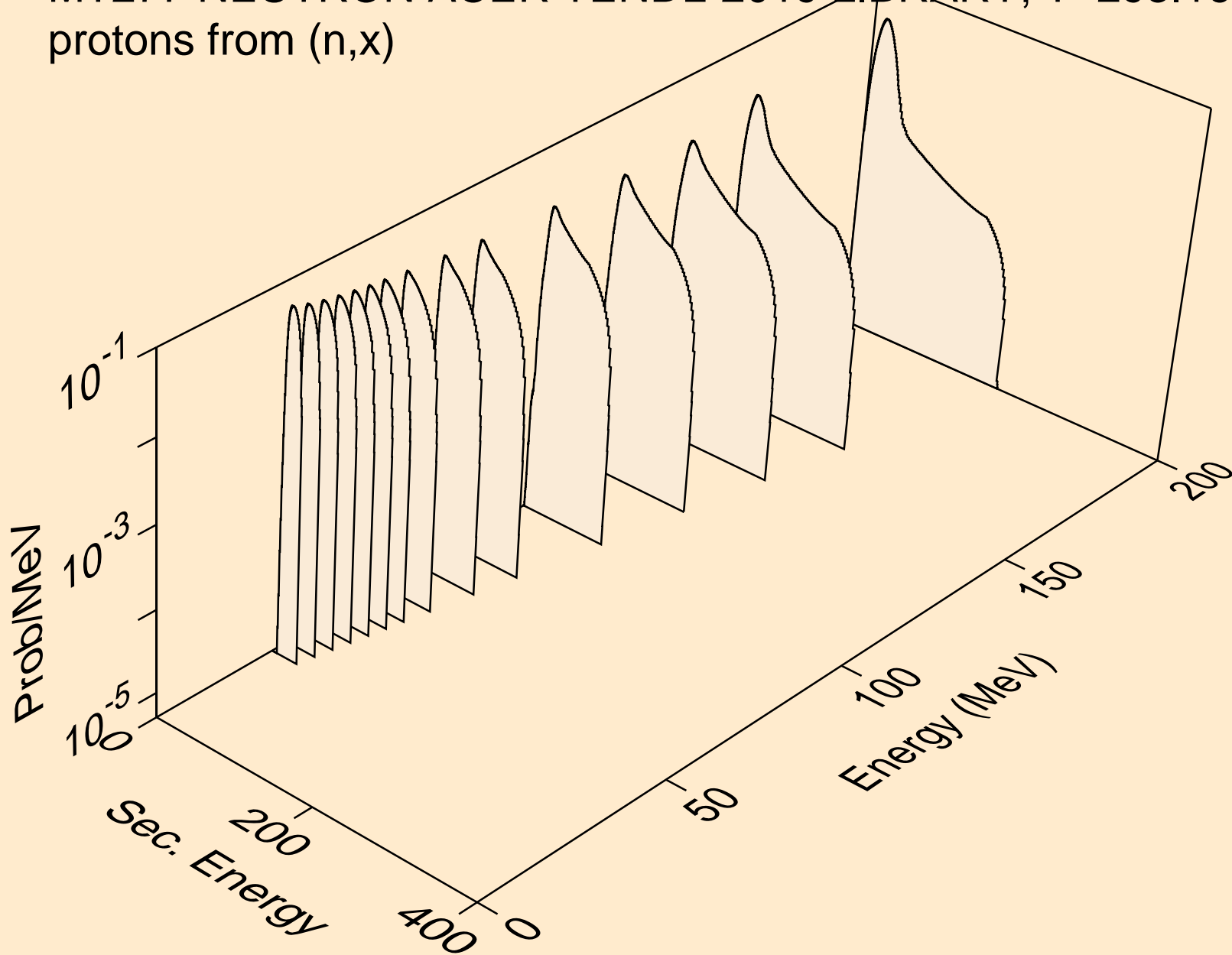

MT277 NEUTRON ACER TENDL-2019 LIBRARY; T=293.16K
protons from (n,n*)p

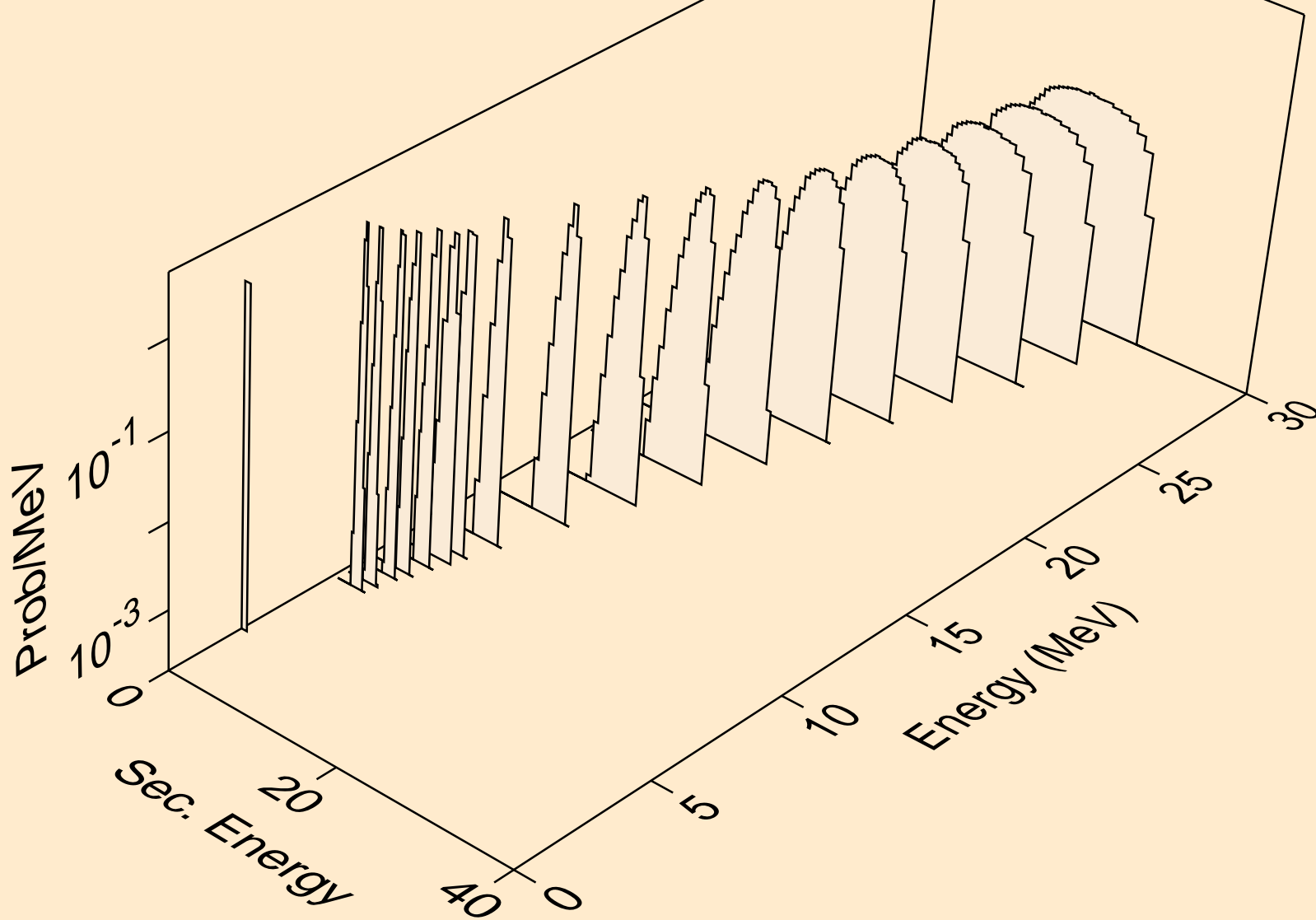

MT277 NEUTRON ACER TENDL-2019 LIBRARY; T=293.16K
protons from (n,p)

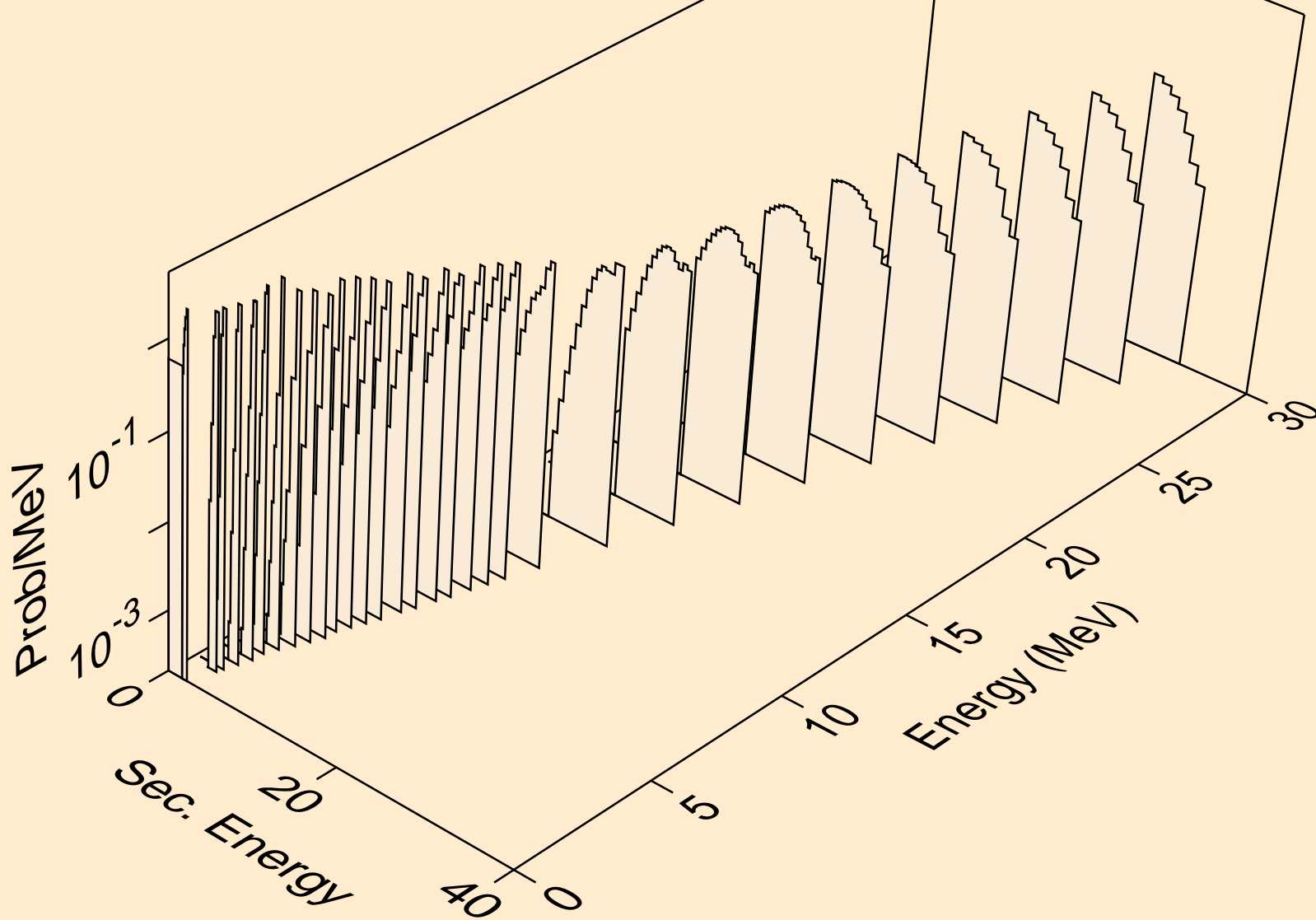

MT277 NEUTRON ACER TENDL-2019 LIBRARY; T=293.16K
deuterons from (n,x)

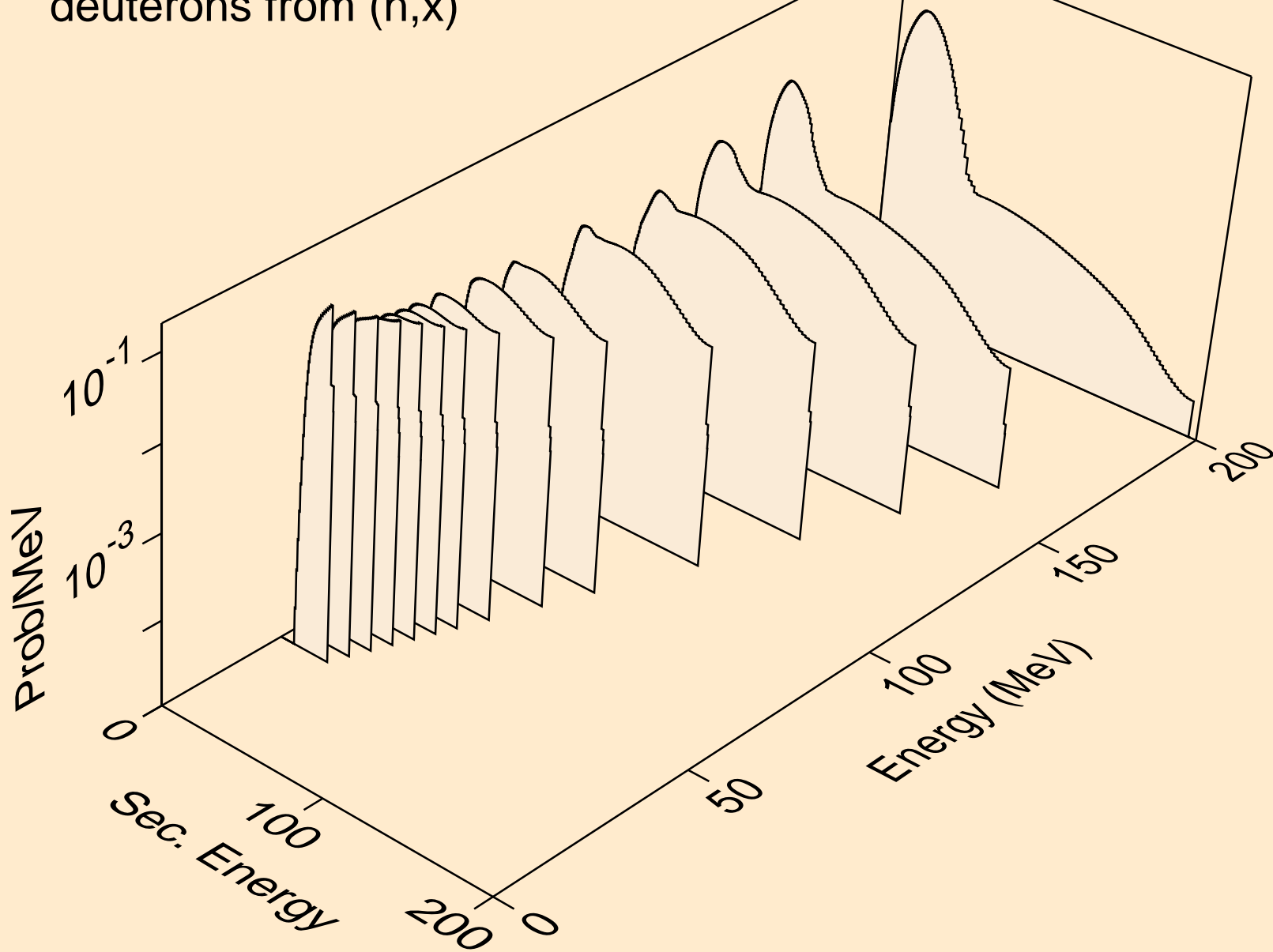

MT277 NEUTRON ACER TENDL-2019 LIBRARY; T=293.16K
deuterons from (n,d)

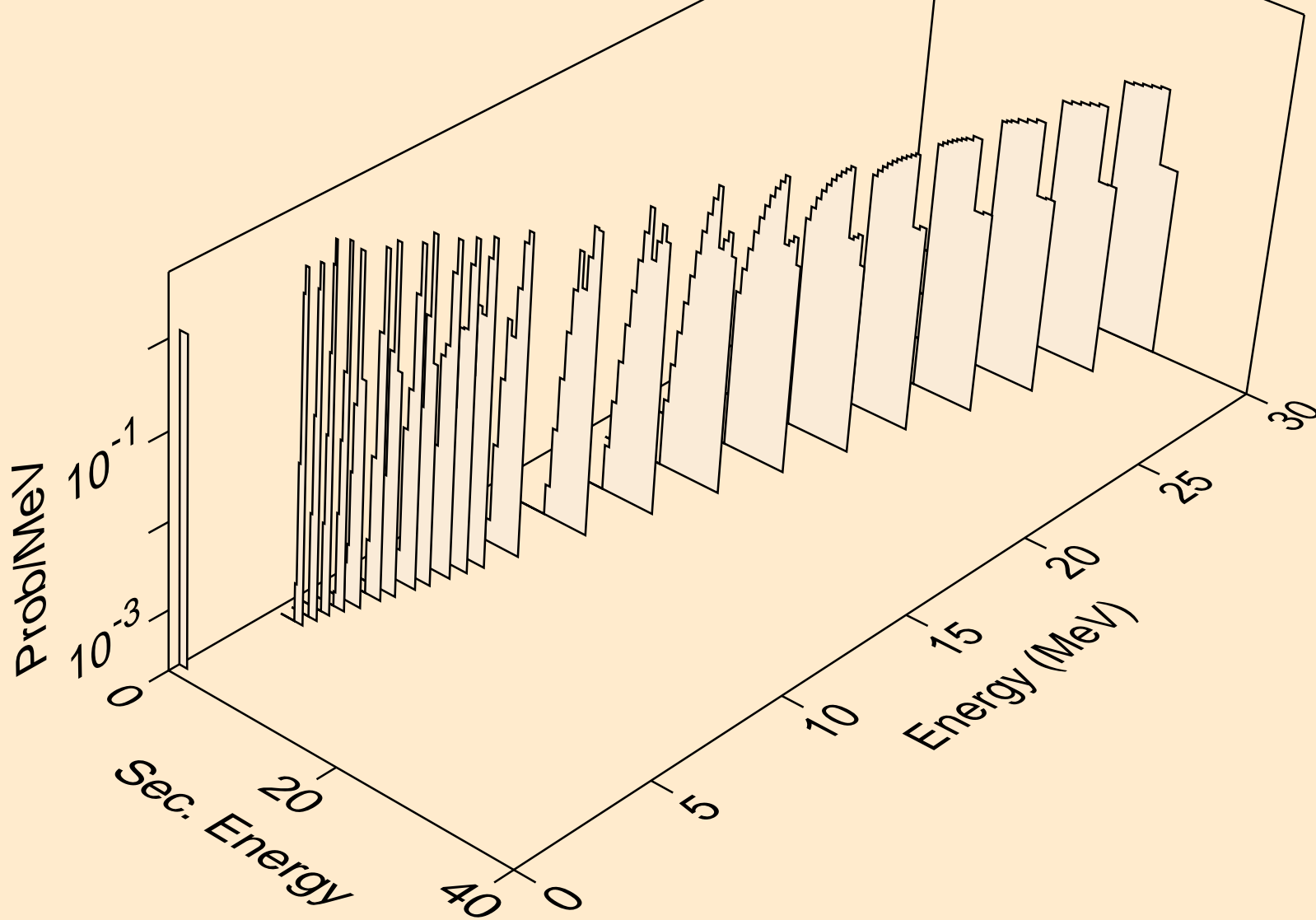

MT277 NEUTRON ACER TENDL-2019 LIBRARY; T=293.16K
tritons from (n,x)

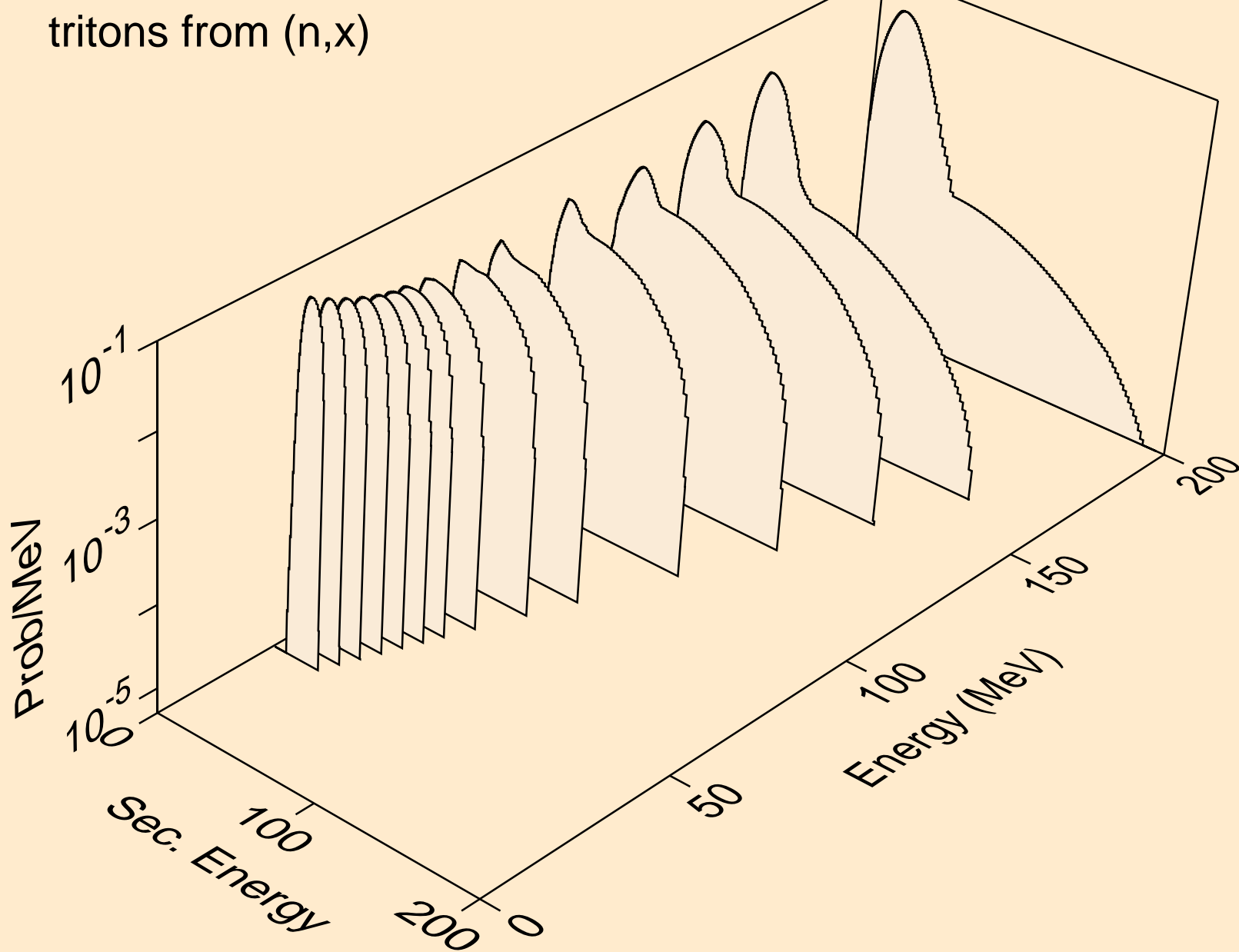

MT277 NEUTRON ACER TENDL-2019 LIBRARY; T=293.16K
tritons from (n,n*)t

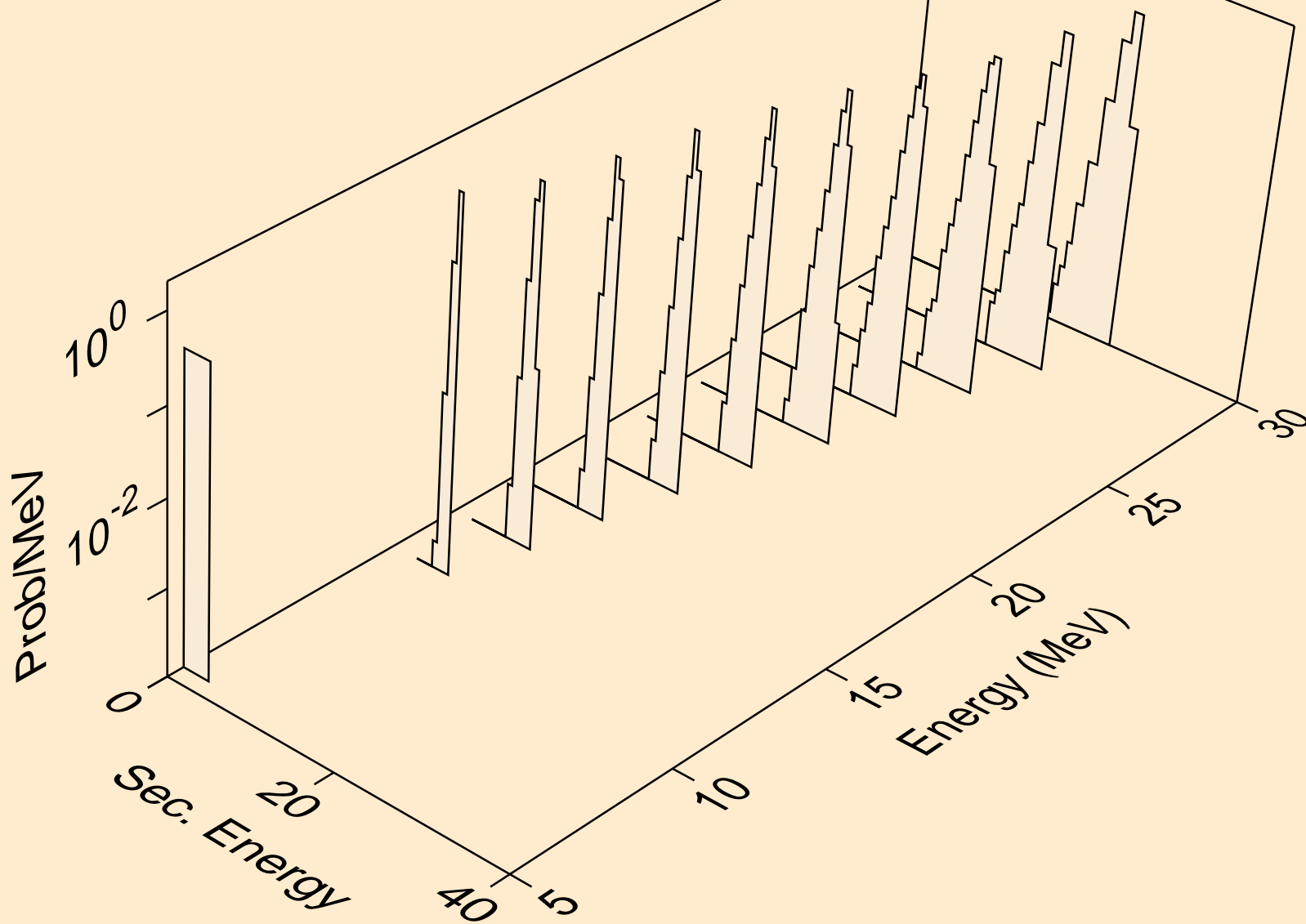

MT277 NEUTRON ACER TENDL-2019 LIBRARY; T=293.16K
tritons from (n,t)

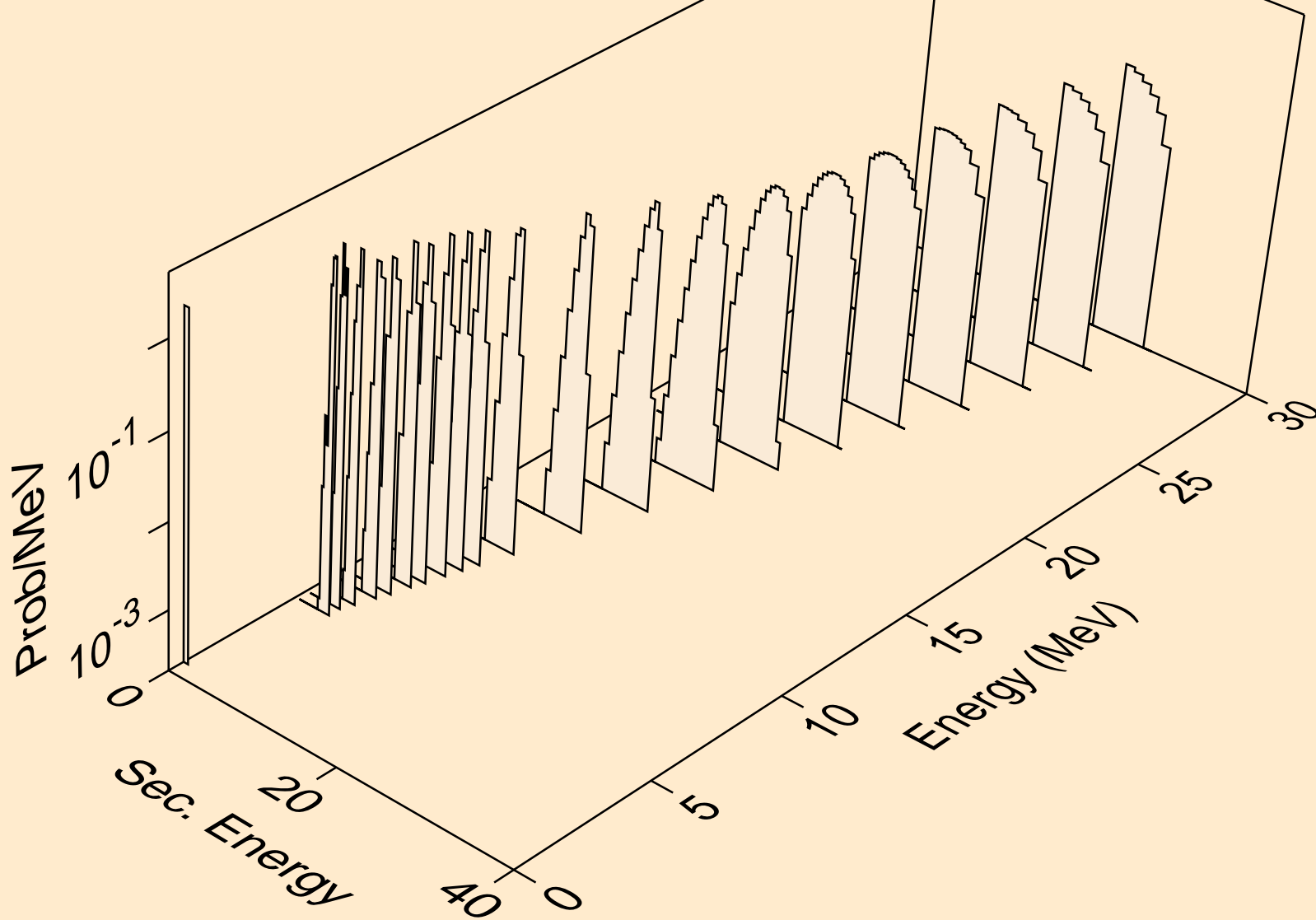

MT277 NEUTRON ACER TENDL-2019 LIBRARY; T=293.16K
he3s from (n,x)

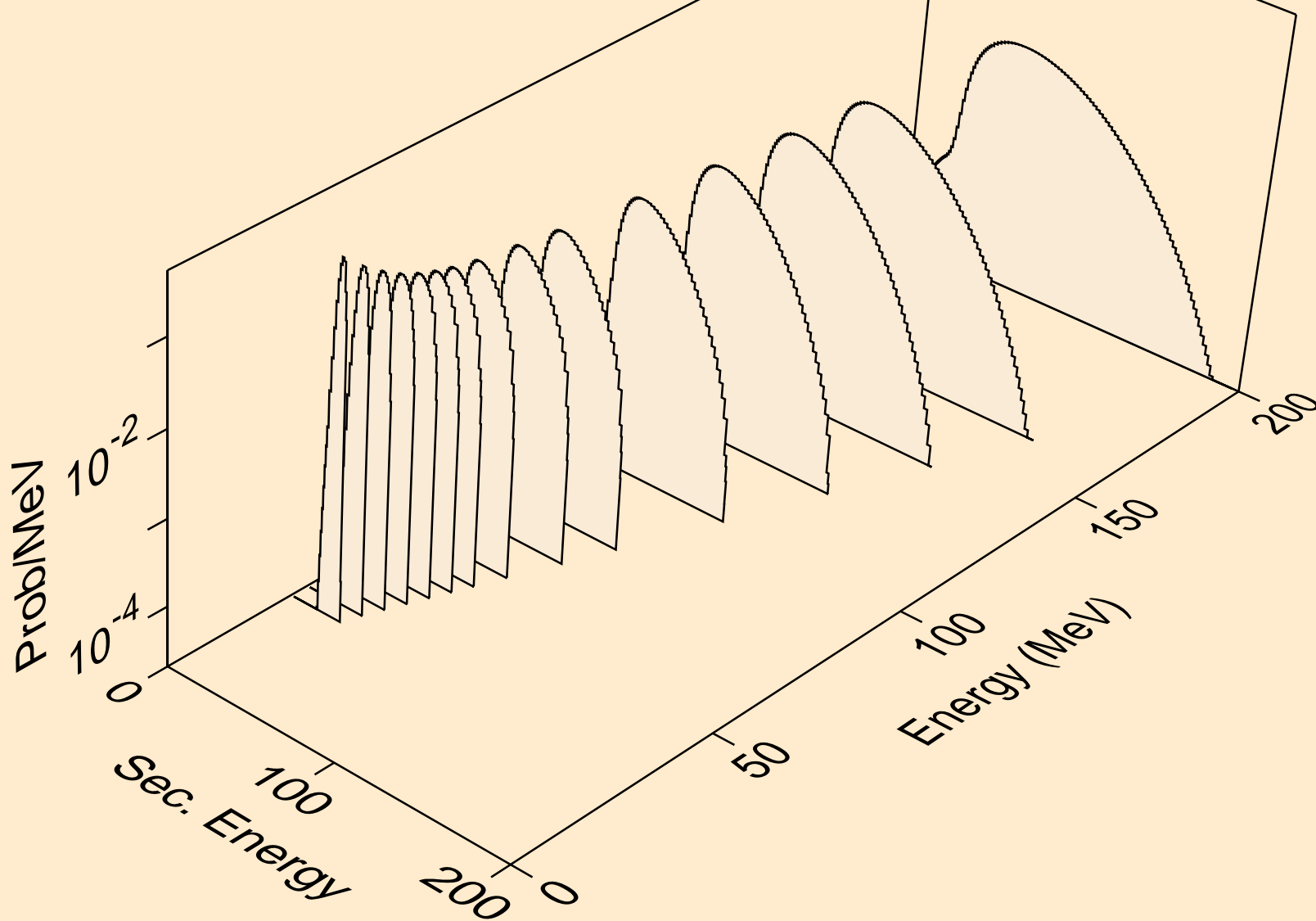

MT277 NEUTRON ACER TENDL-2019 LIBRARY; T=293.16K
he3s from (n,he3)

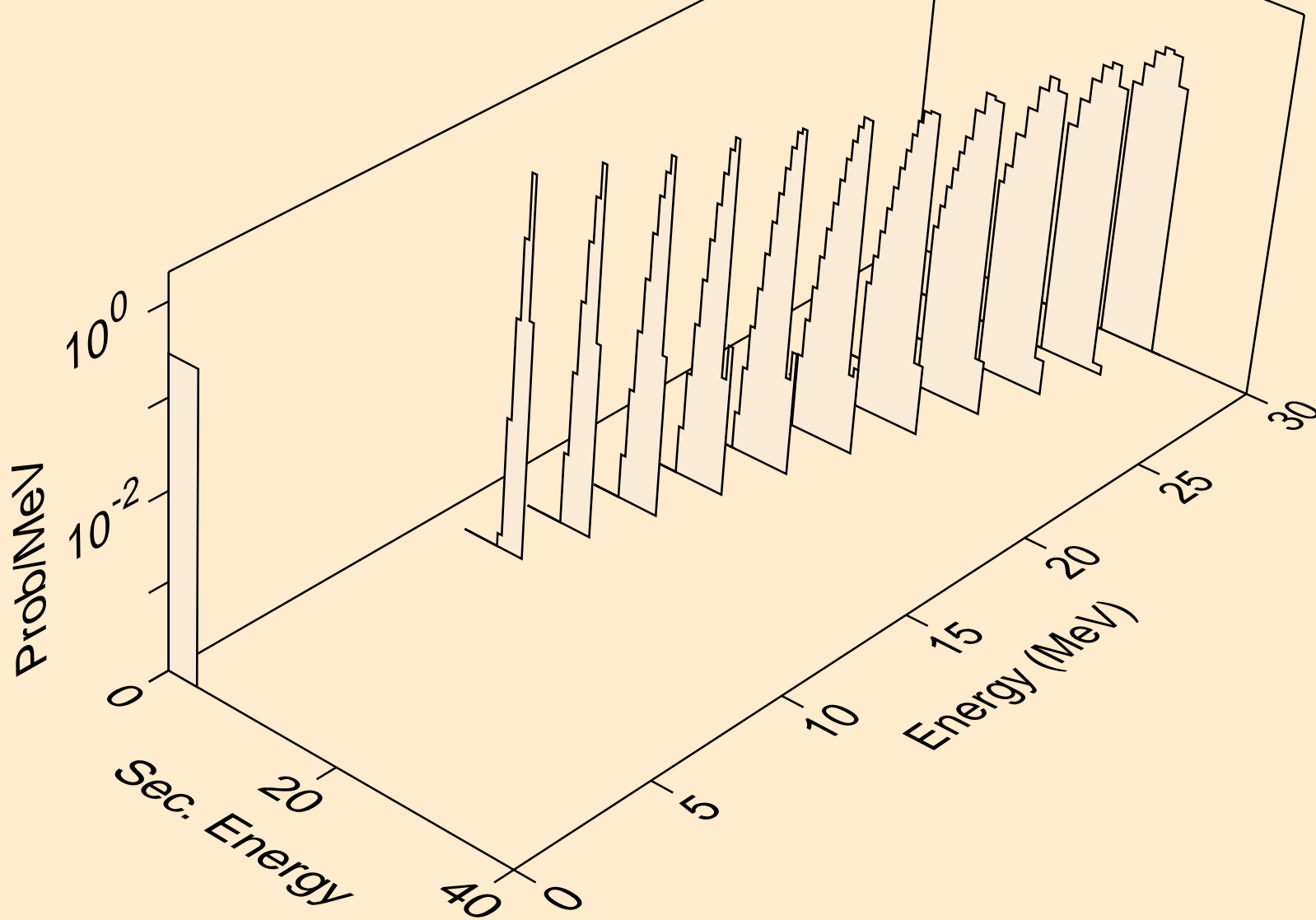

MT277 NEUTRON ACER TENDL-2019 LIBRARY; T=293.16K
alphas from (n,x)

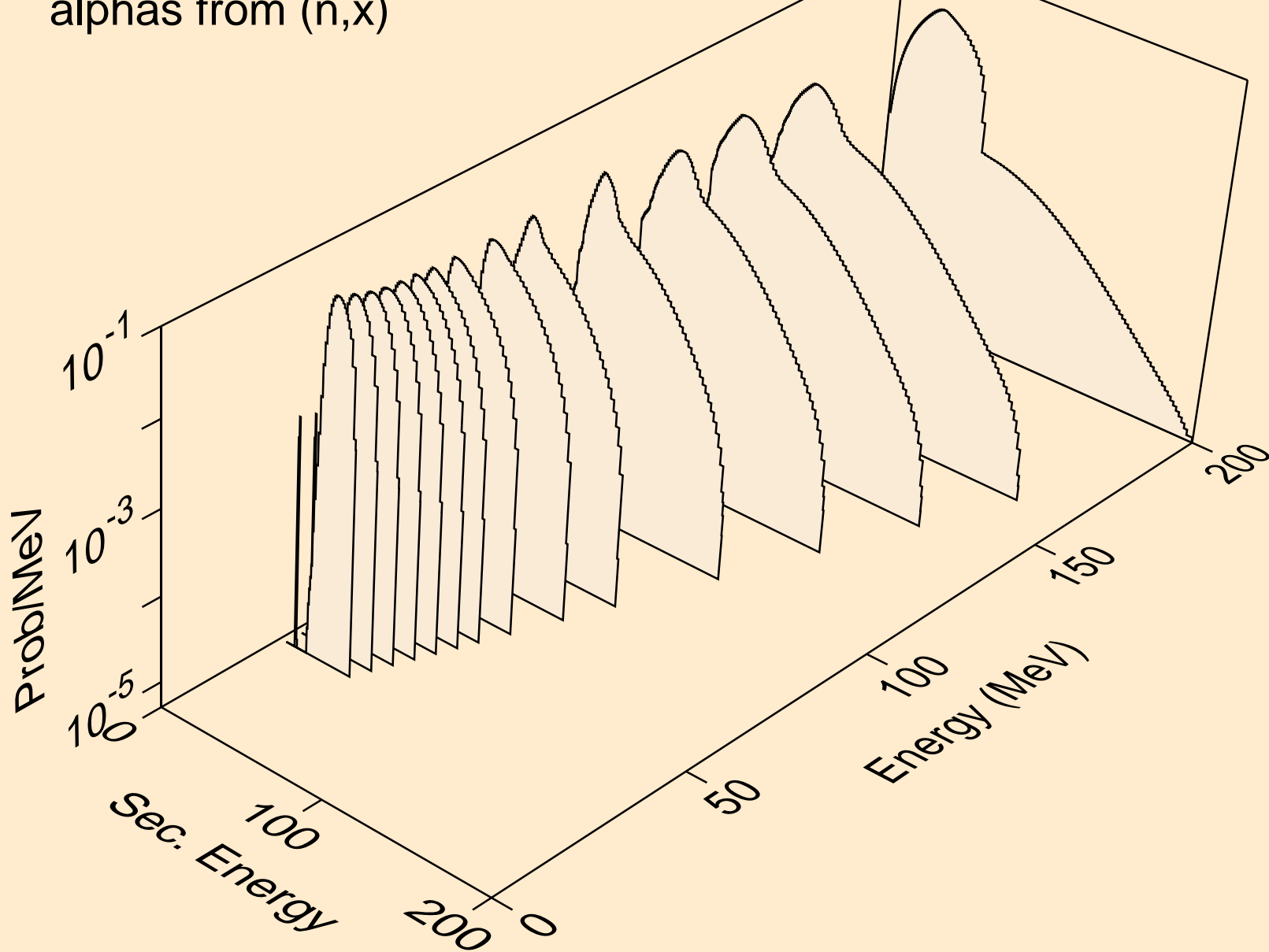

MT277 NEUTRON ACER TENDL-2019 LIBRARY; T=293.16K
alphas from (n,n*)a

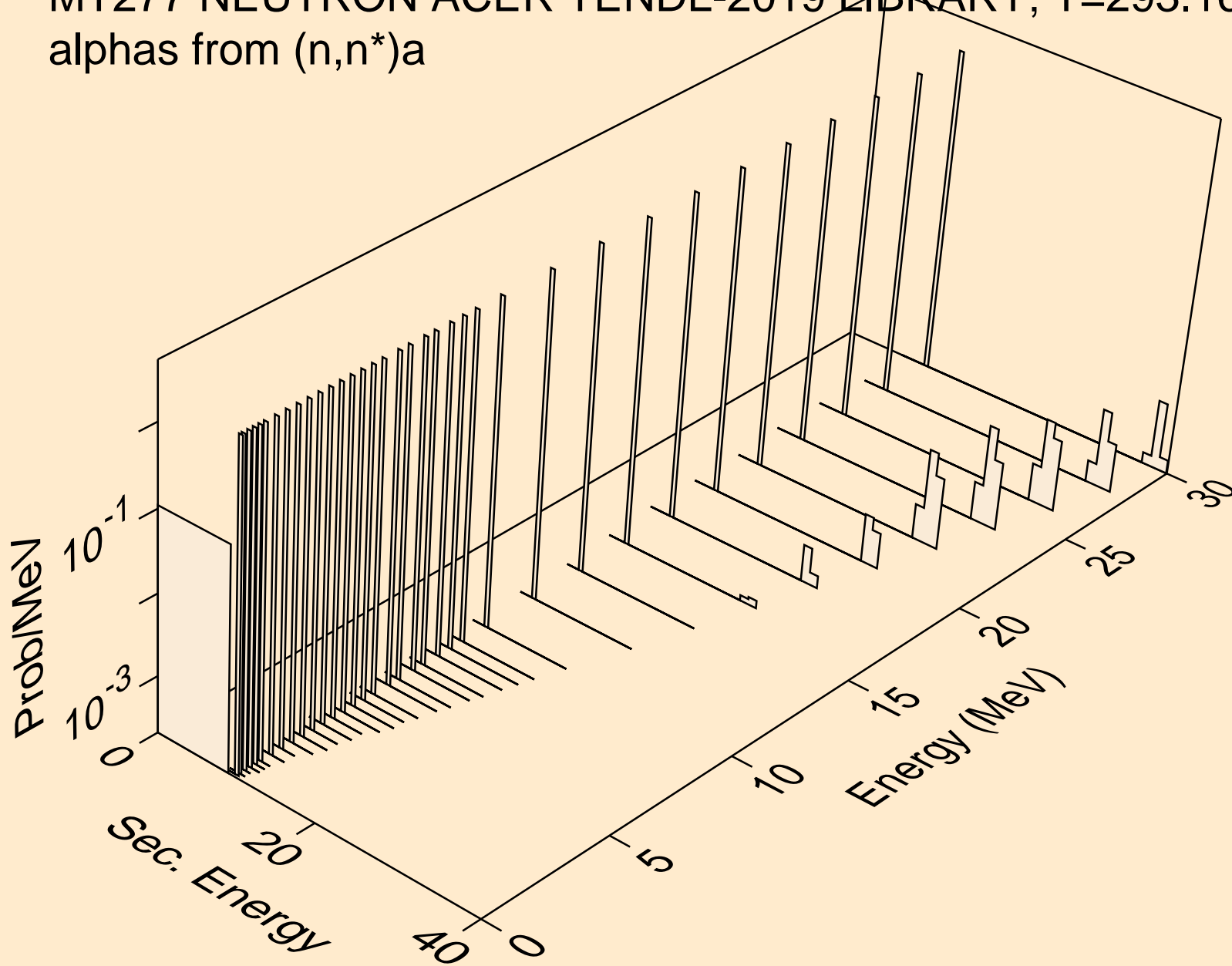

MT277 NEUTRON ACER TENDL-2019 LIBRARY; T=293.16K
alphas from (n,2n)a

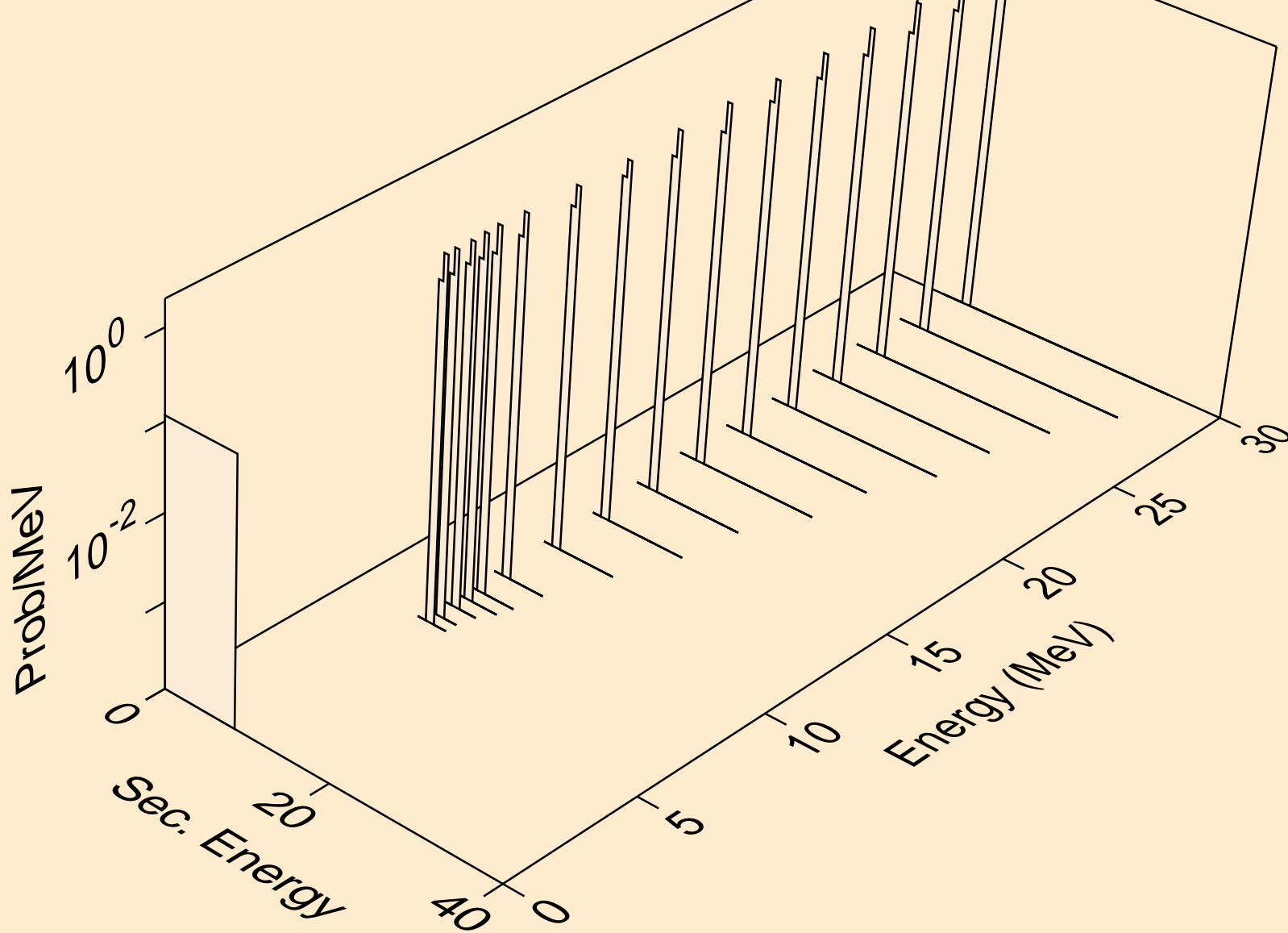

MT277 NEUTRON ACER TENDL-2019 LIBRARY; T=293.16K
alphas from (n,3n)a

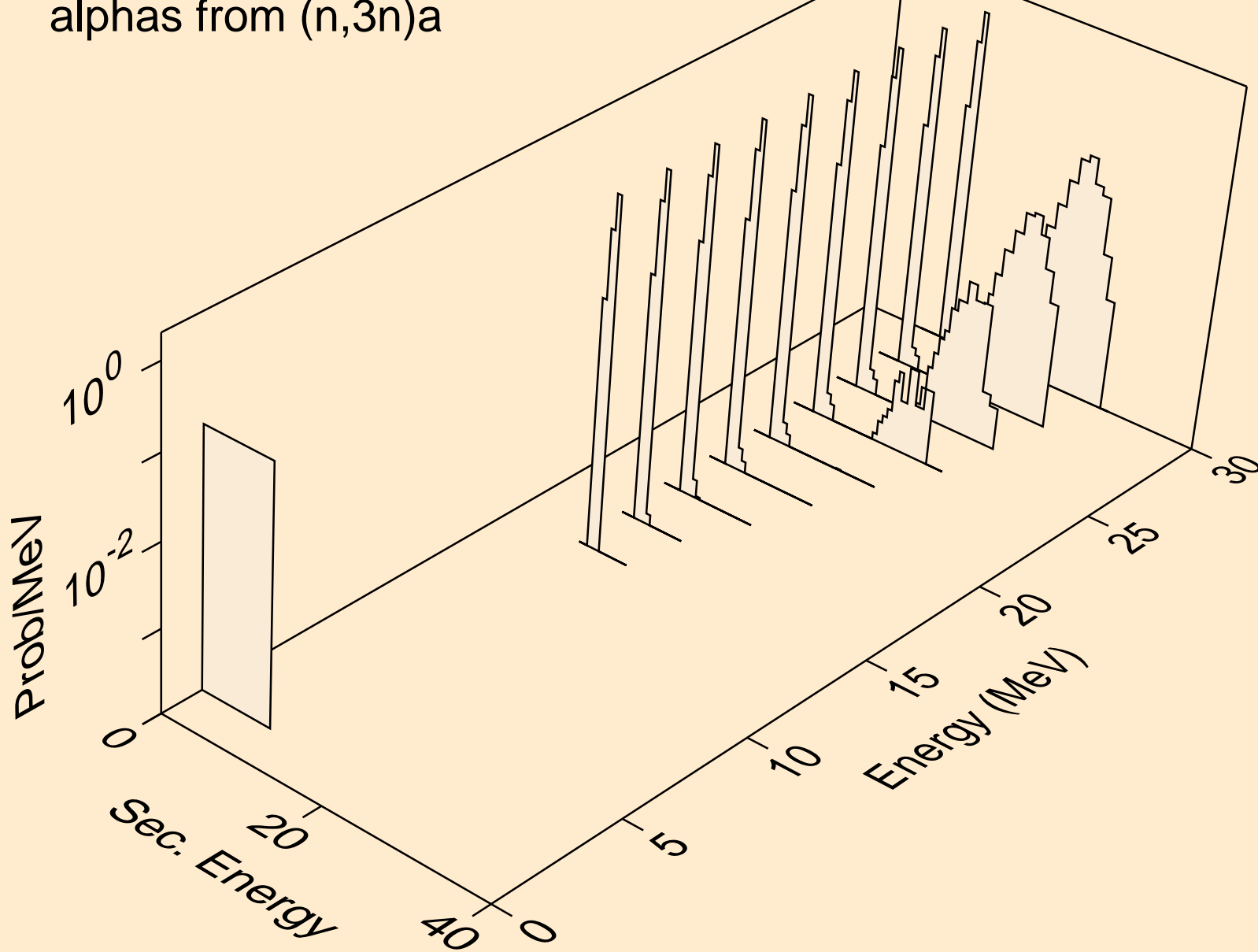

MT277 NEUTRON ACER TENDL-2019 LIBRARY; T=293.16K
alphas from (n,a)

