

U236 NEUTRON ACER TENDL-2019 LIBRARY; T=293.16K

Principal cross sections

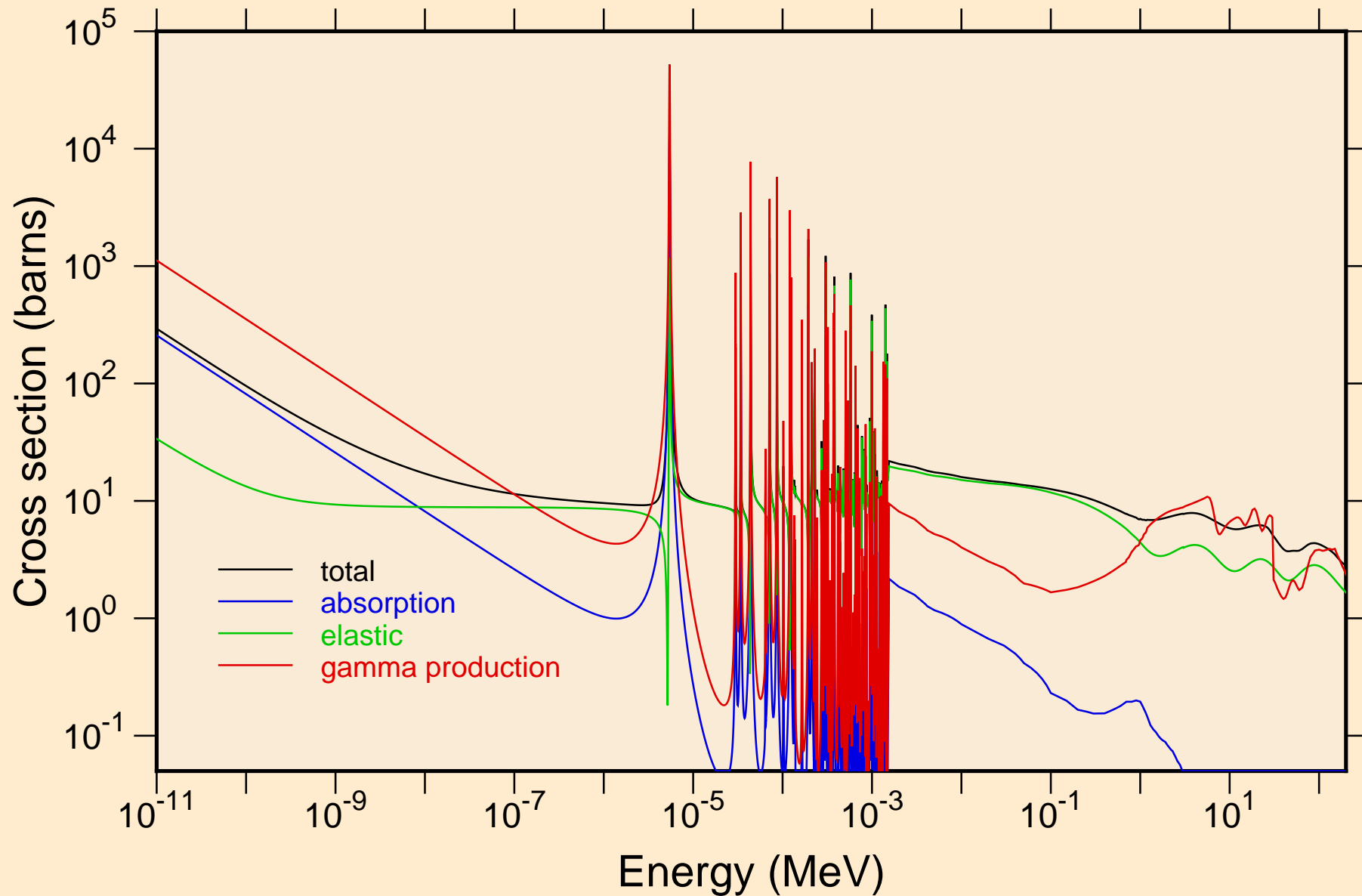

U236 NEUTRON ACER TENDL-2019 LIBRARY; T=293.16K
resonance total cross section

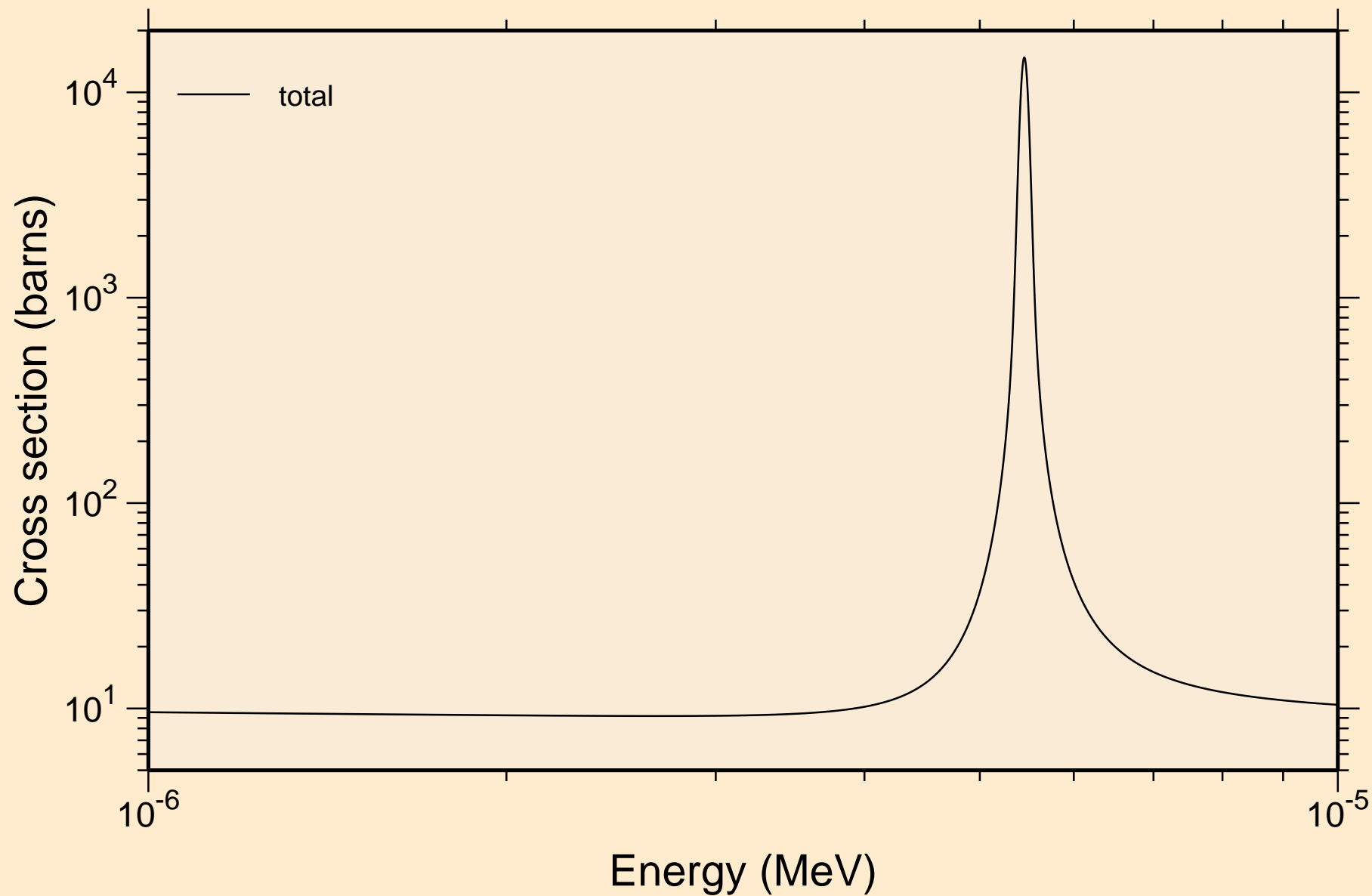

U236 NEUTRON ACER TENDL-2019 LIBRARY; T=293.16K
resonance total cross section

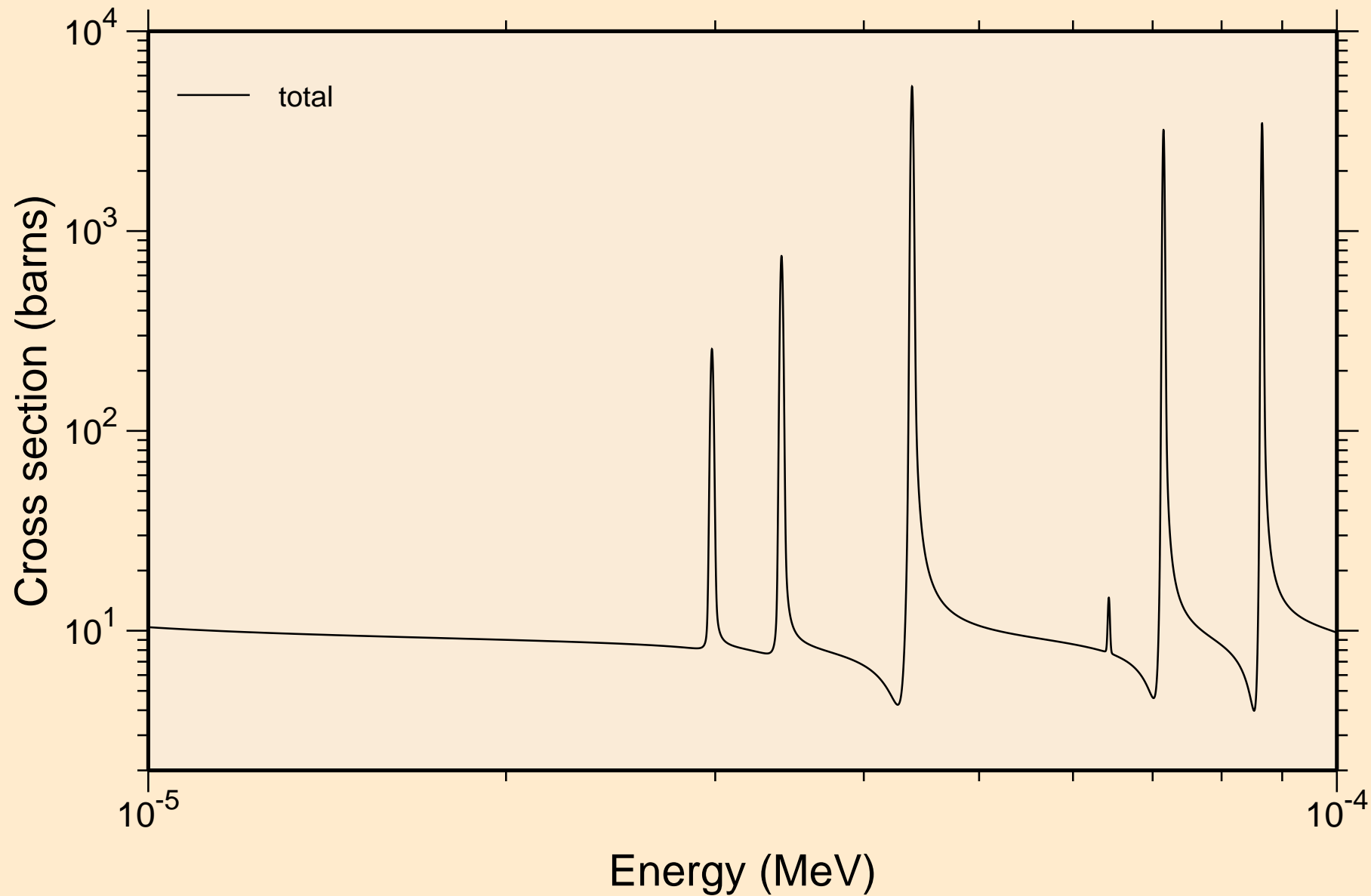

U236 NEUTRON ACER TENDL-2019 LIBRARY; T=293.16K
resonance total cross section

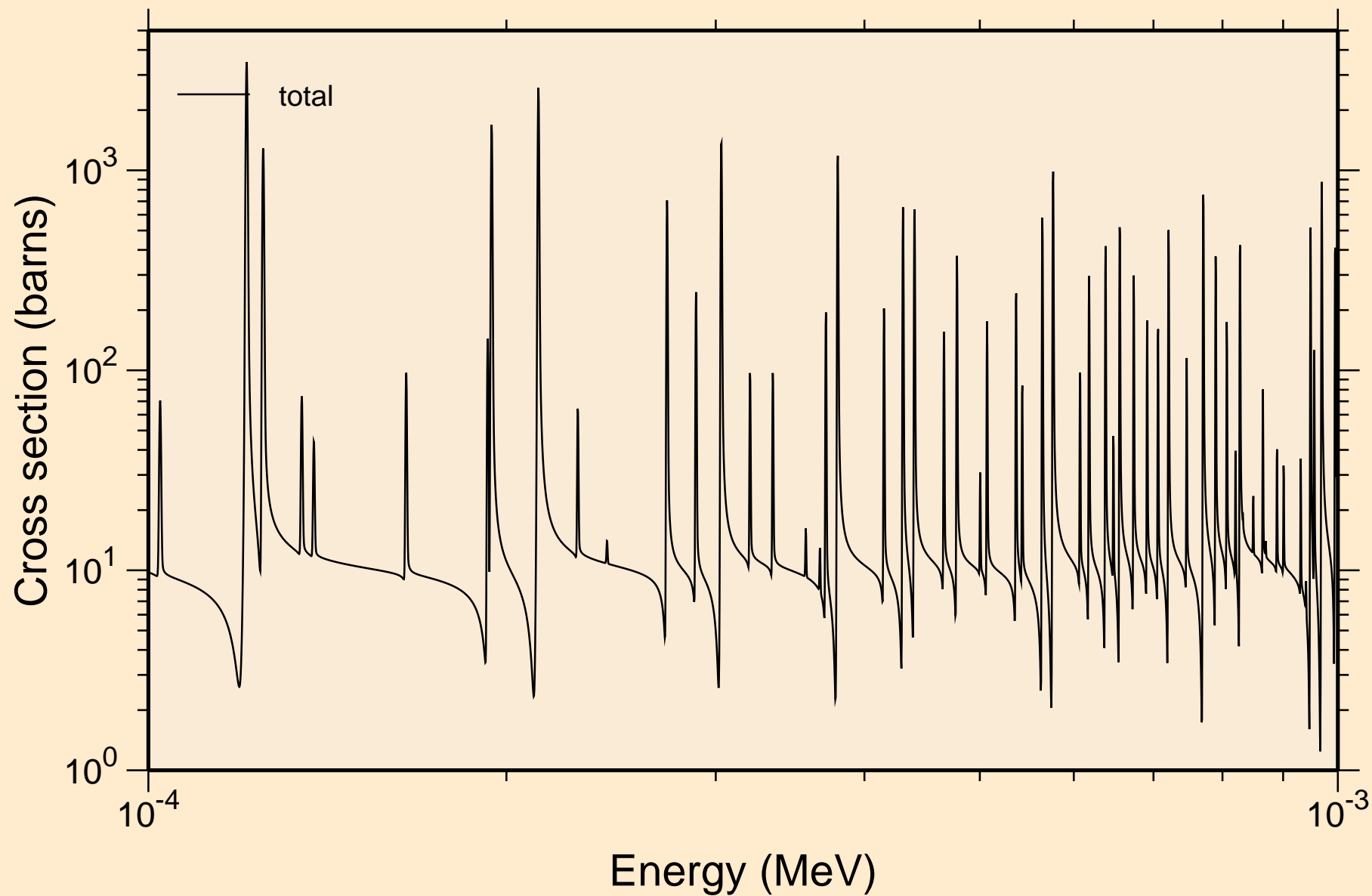

U236 NEUTRON ACER TENDL-2019 LIBRARY; T=293.16K
resonance total cross section

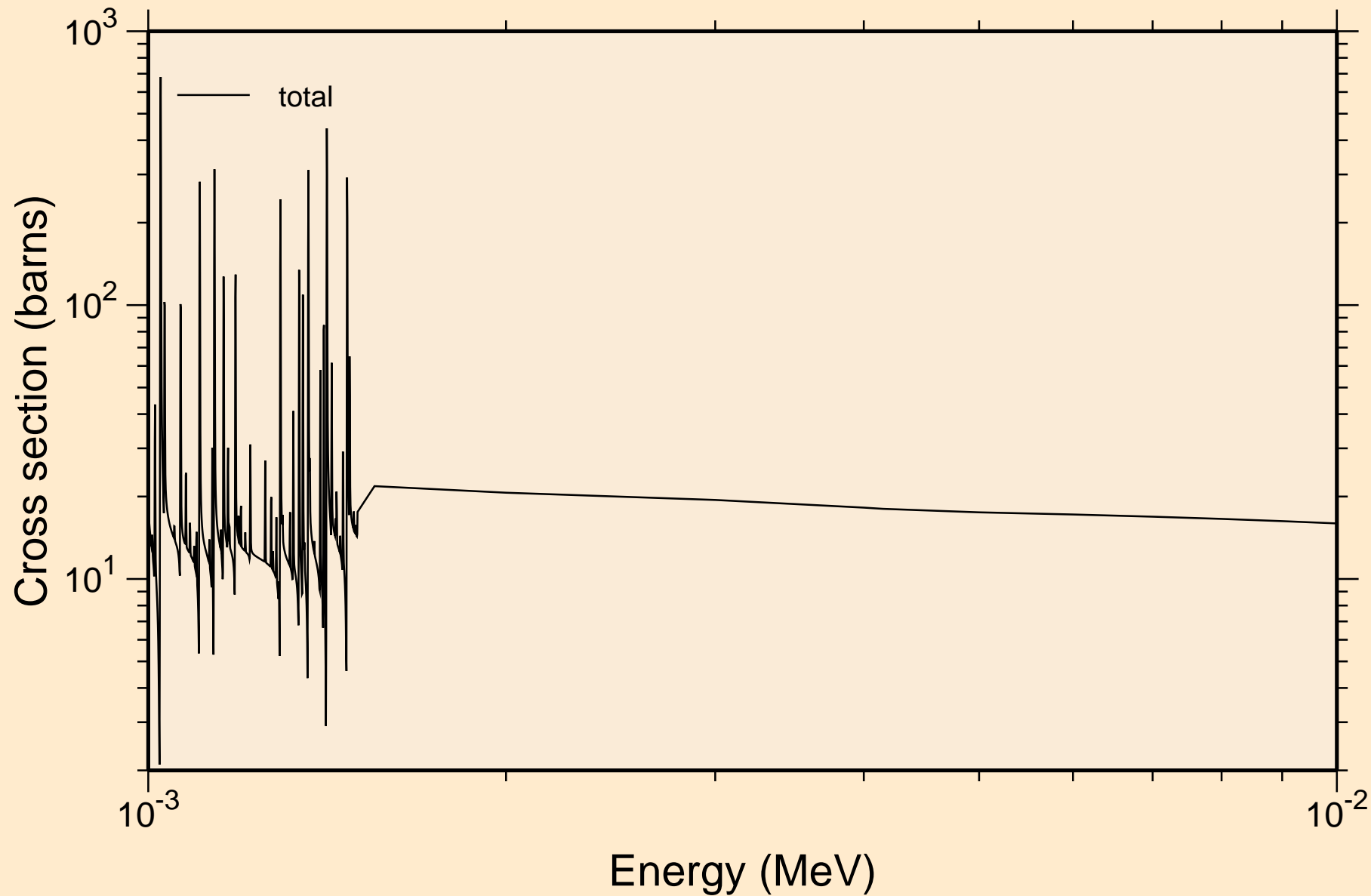

U236 NEUTRON ACER TENDL-2019 LIBRARY; T=293.16K
resonance total cross section

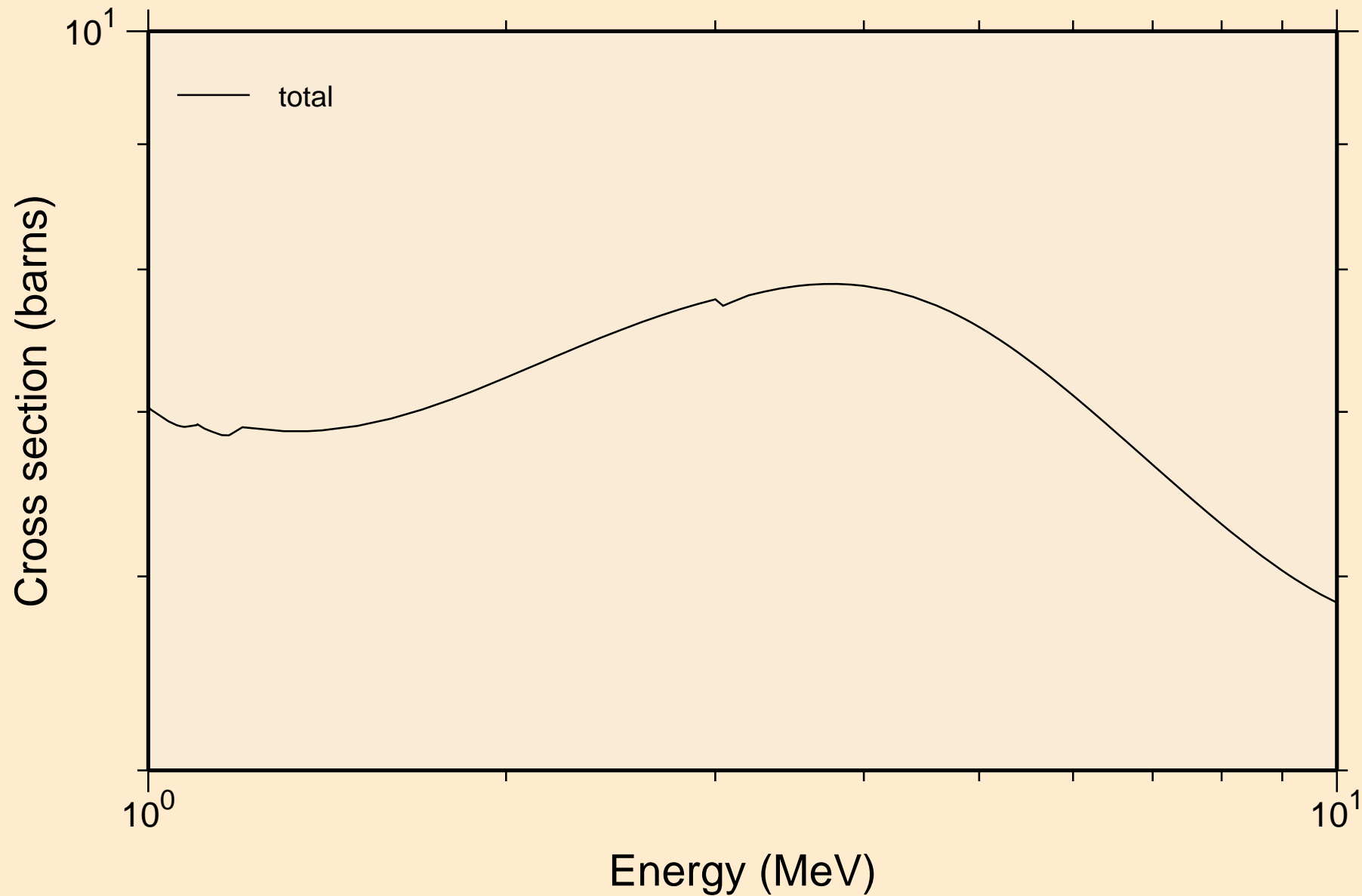

U236 NEUTRON ACER TENDL-2019 LIBRARY; T=293.16K
resonance absorption cross sections

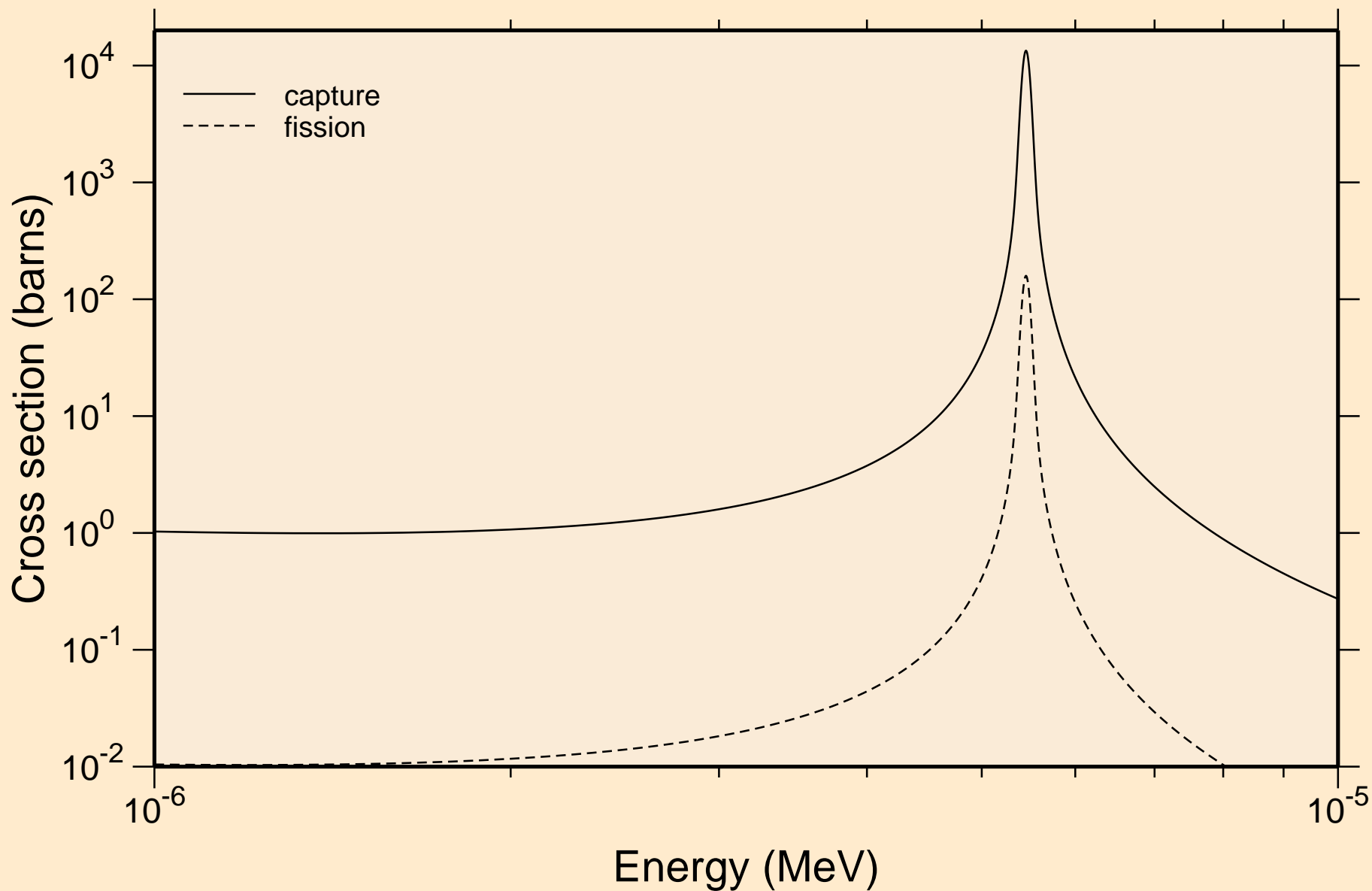

U236 NEUTRON ACER TENDL-2019 LIBRARY; T=293.16K
resonance absorption cross sections

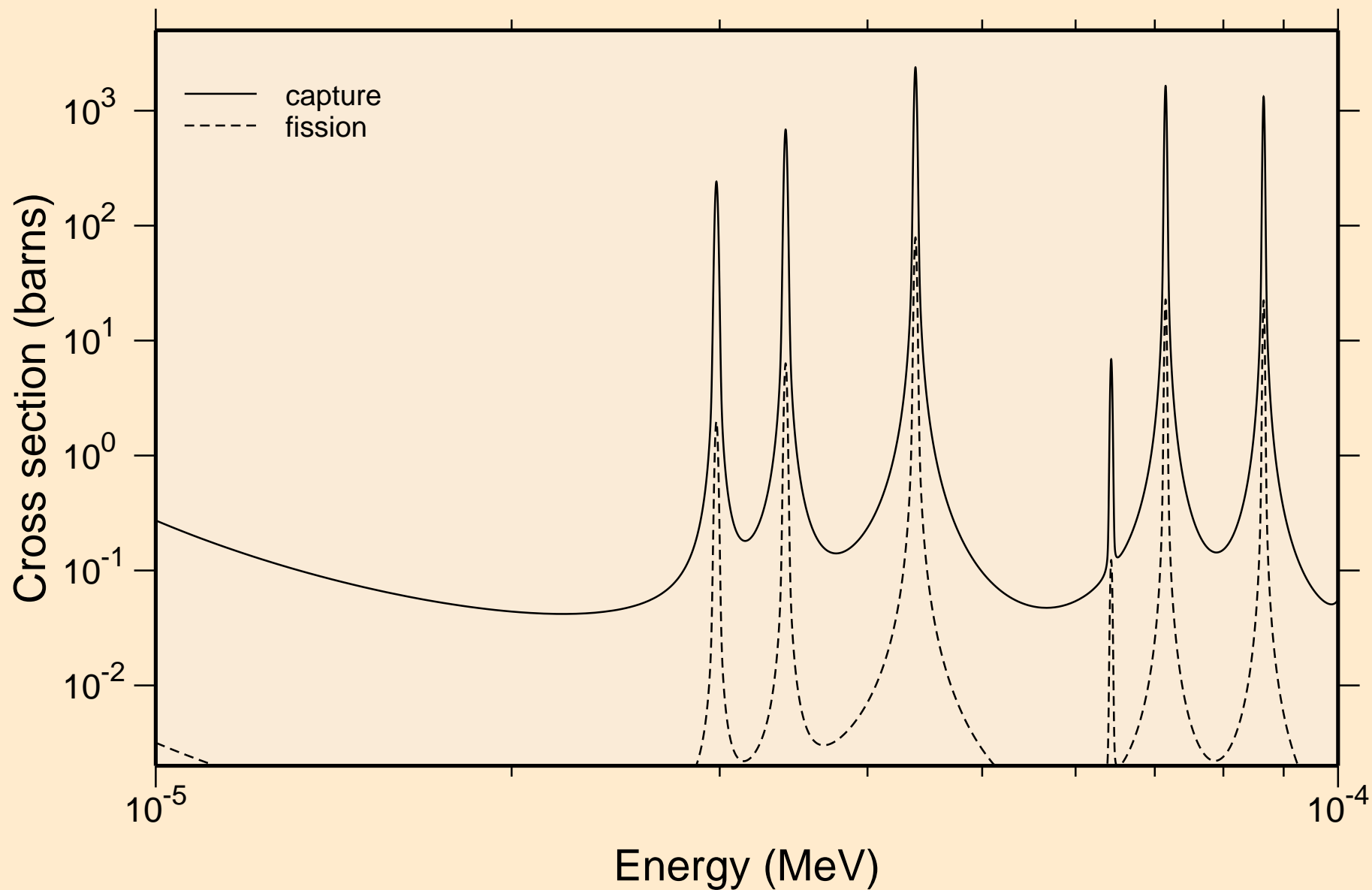

U236 NEUTRON ACER TENDL-2019 LIBRARY; T=293.16K
resonance absorption cross sections

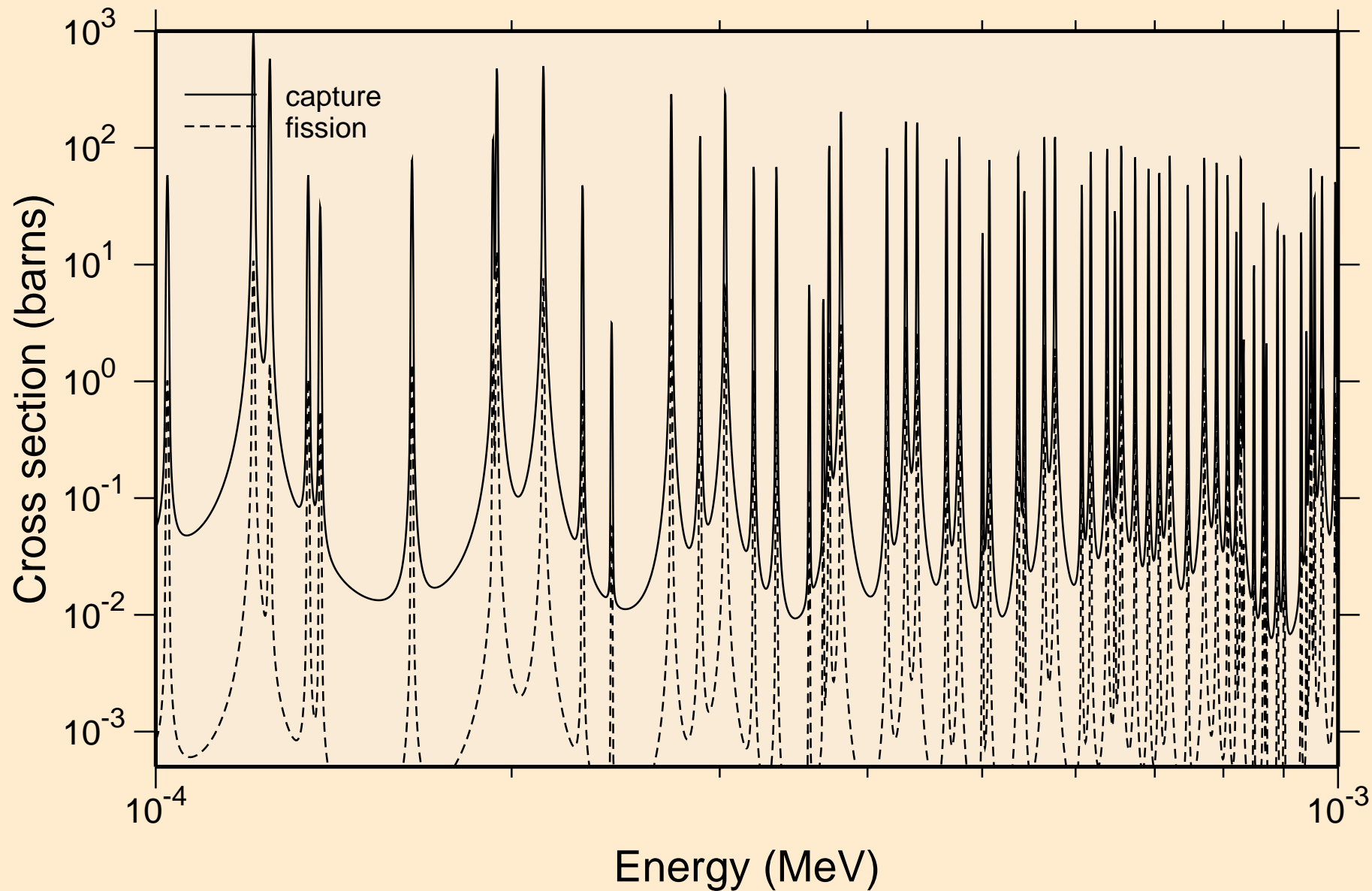

U236 NEUTRON ACER TENDL-2019 LIBRARY; T=293.16K
resonance absorption cross sections

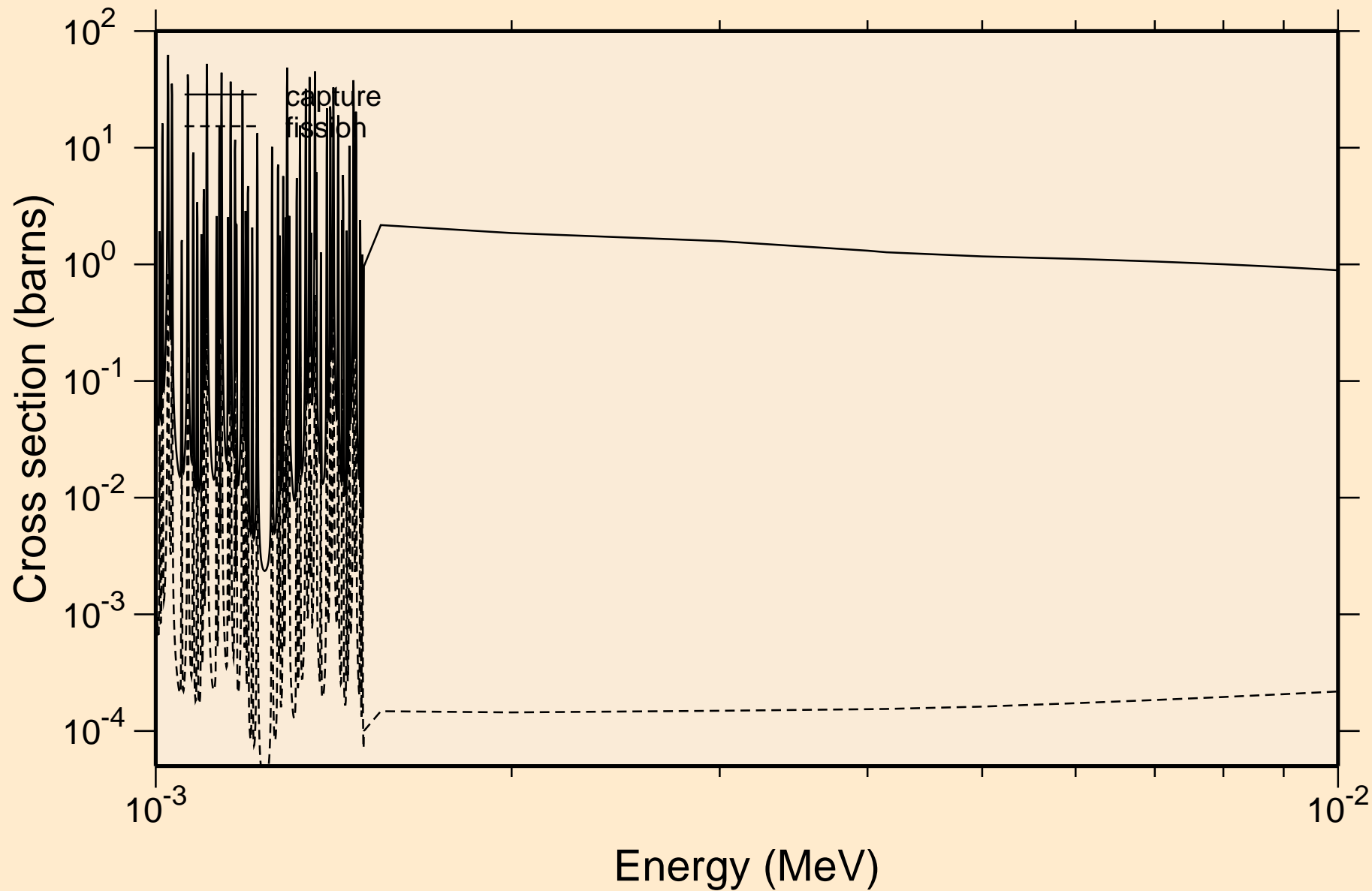

U236 NEUTRON ACER TENDL-2019 LIBRARY; T=293.16K
resonance absorption cross sections

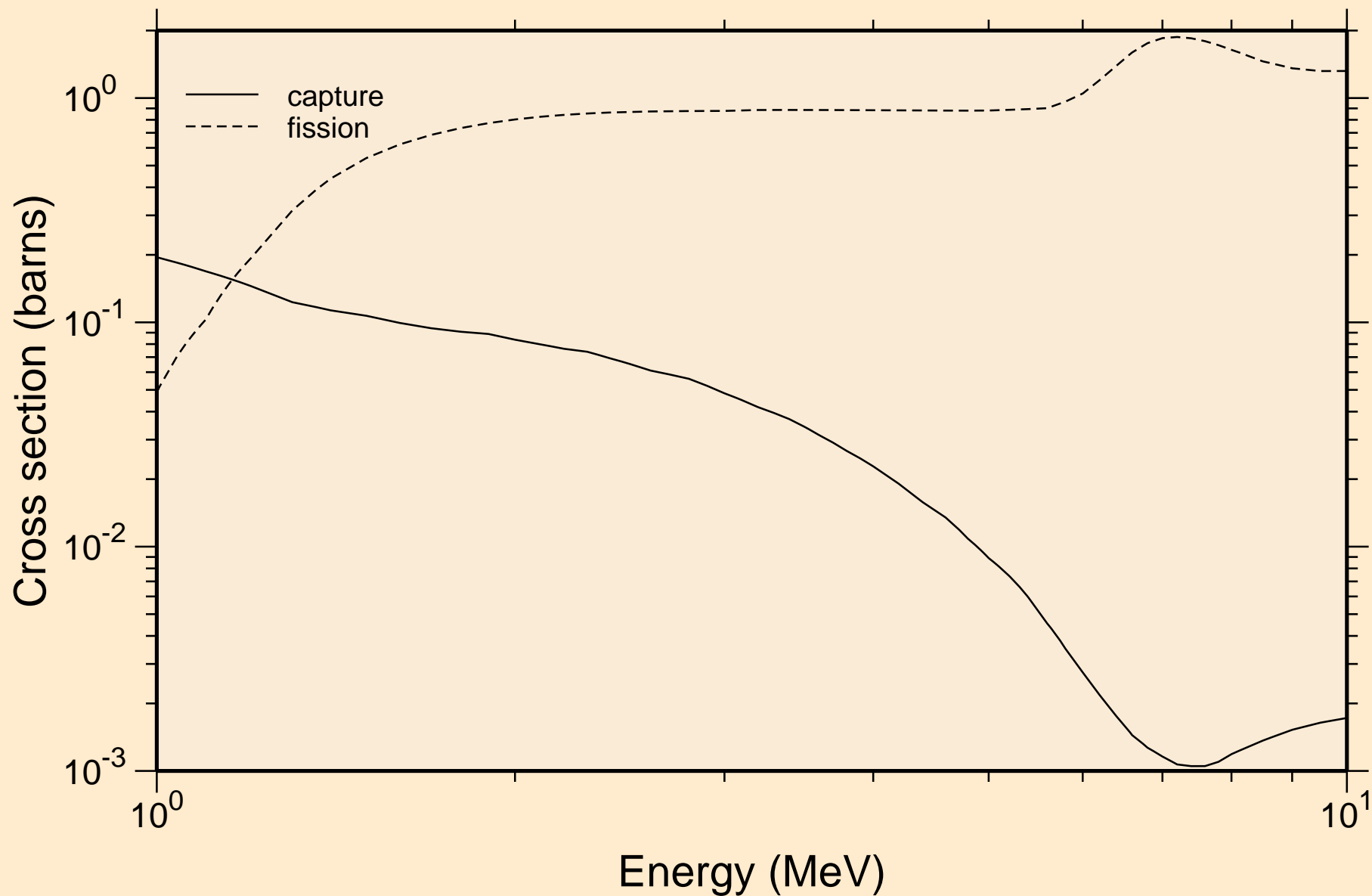

U236 NEUTRON ACER TENDL-2019 LIBRARY; T=293.16K
Heating

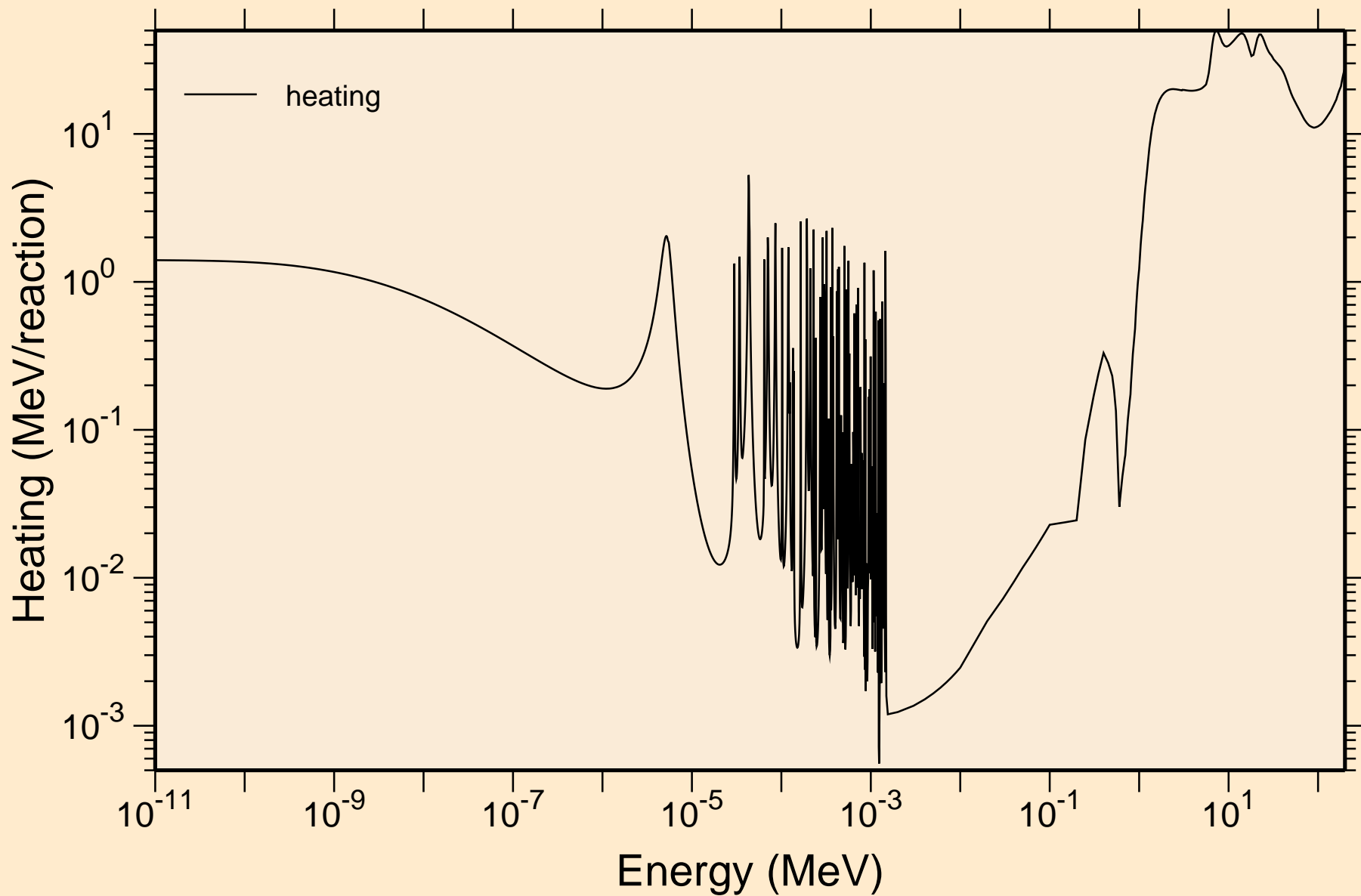

U236 NEUTRON ACER TENDL-2019 LIBRARY; T=293.16K
Damage

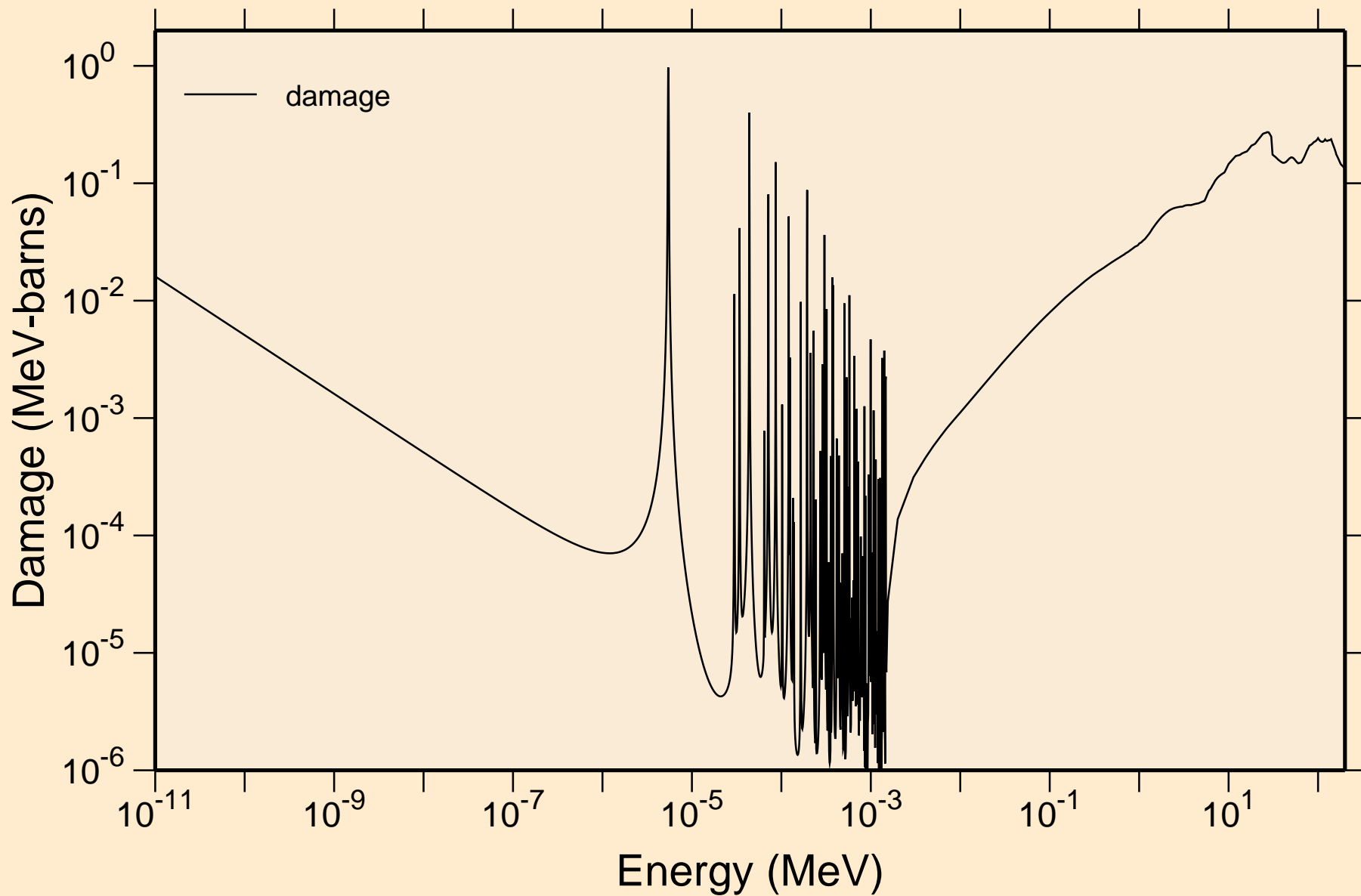

U236 NEUTRON ACER TENDL-2019 LIBRARY; T=293.16K
Non-threshold reactions

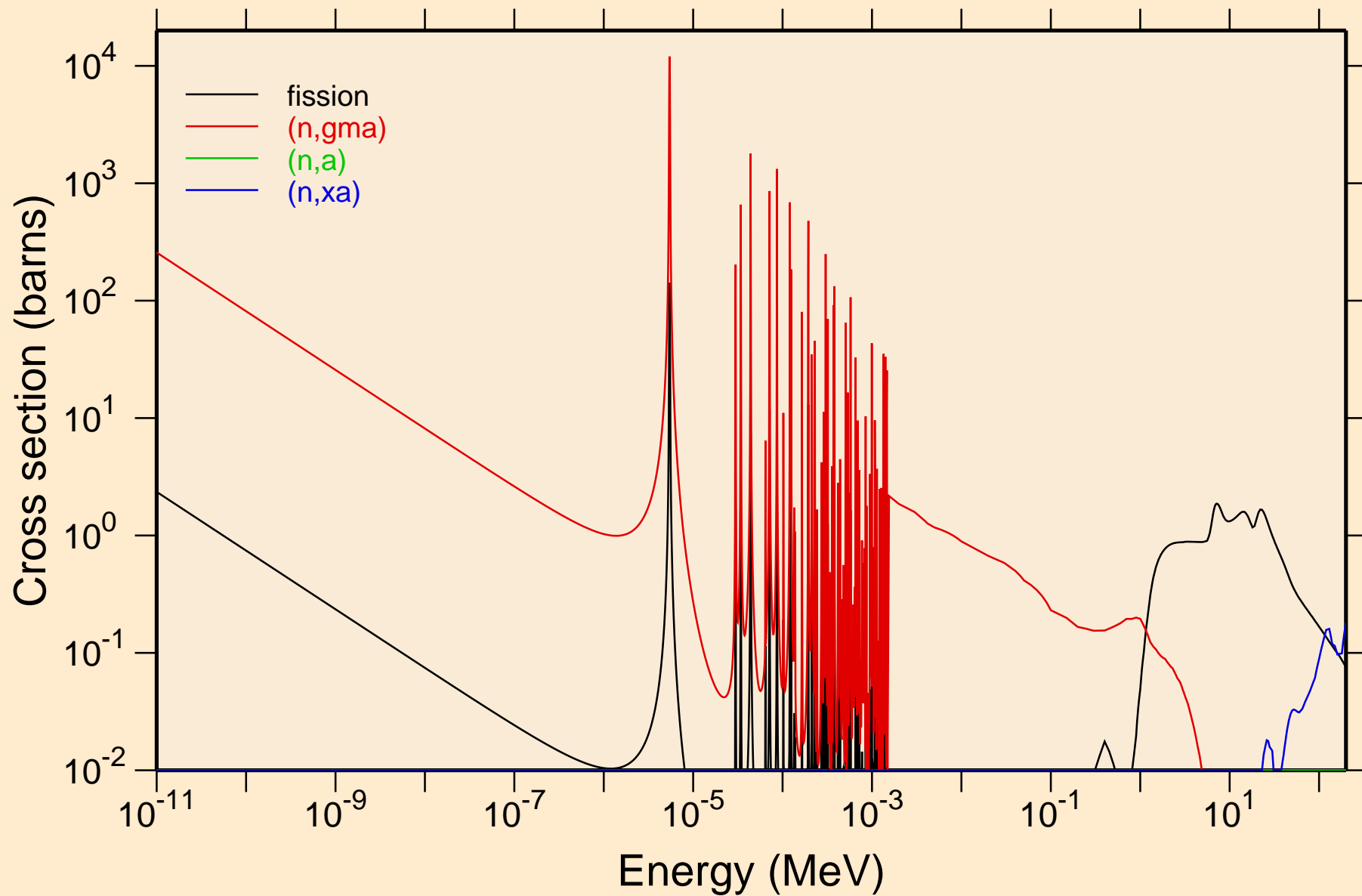

U236 NEUTRON ACER TENDL-2019 LIBRARY; T=293.16K
Principal cross sections

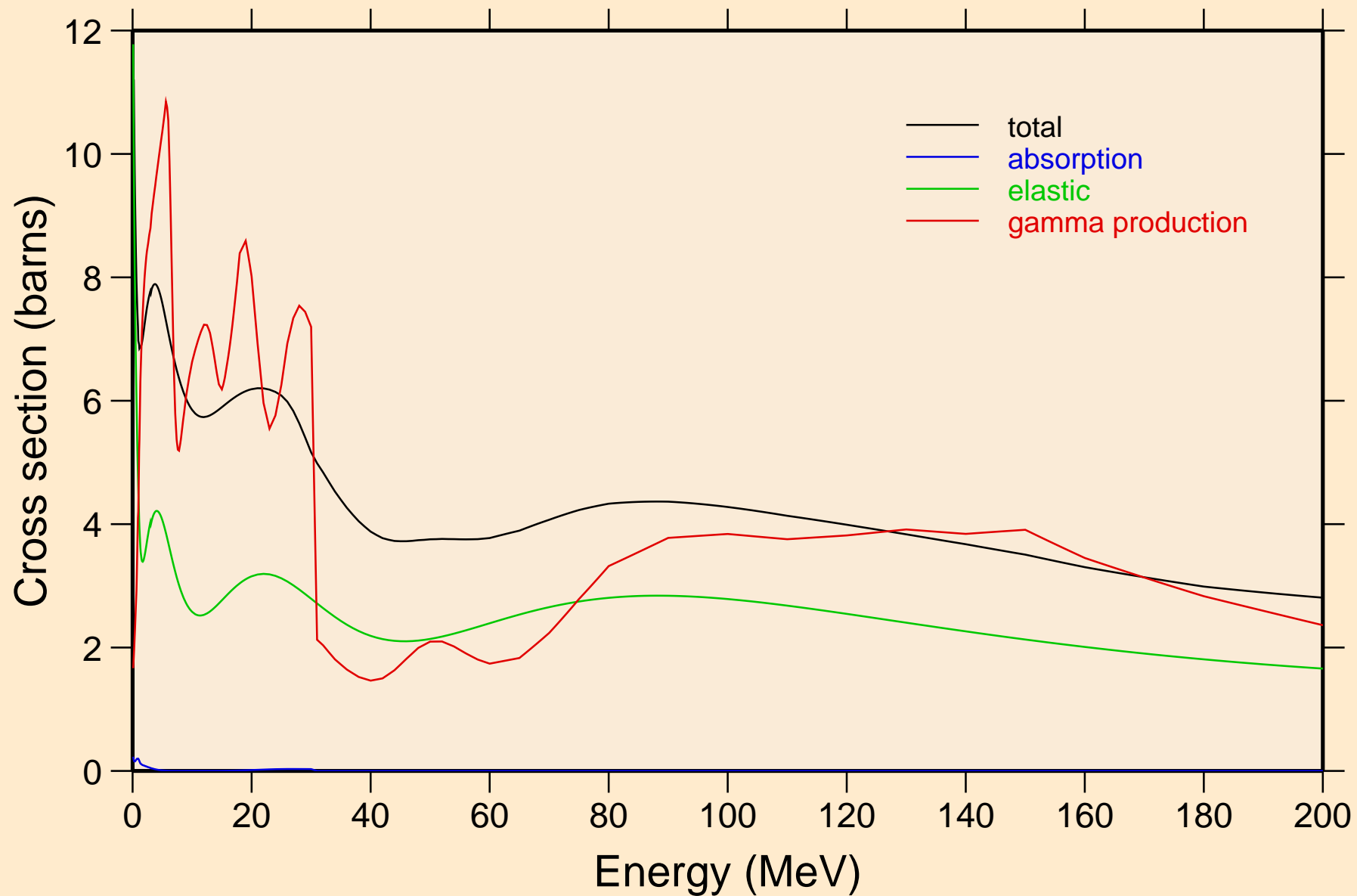

U236 NEUTRON ACER TENDL-2019 LIBRARY; T=293.16K
Heating

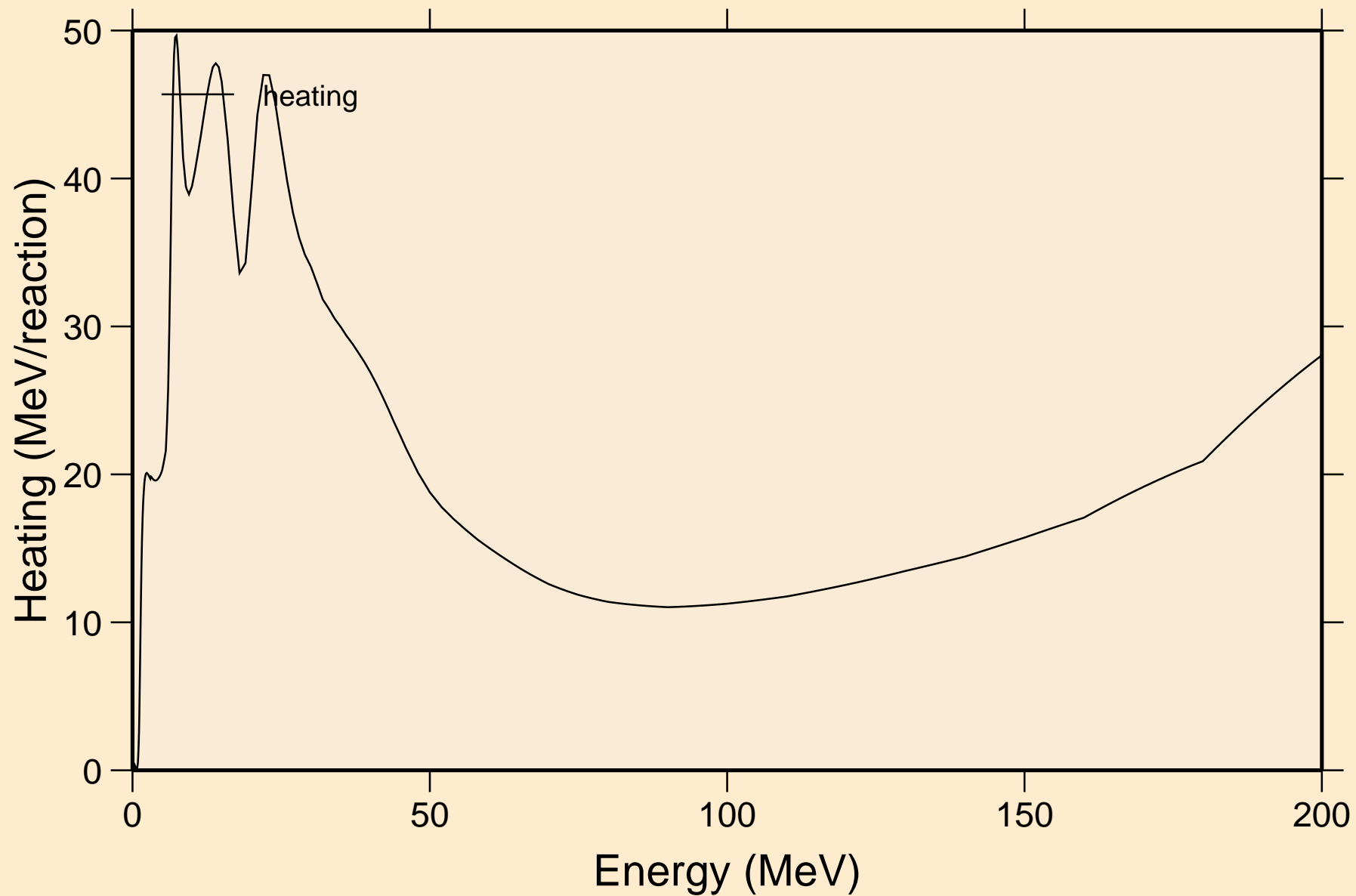

U236 NEUTRON ACER TENDL-2019 LIBRARY; T=293.16K
Damage

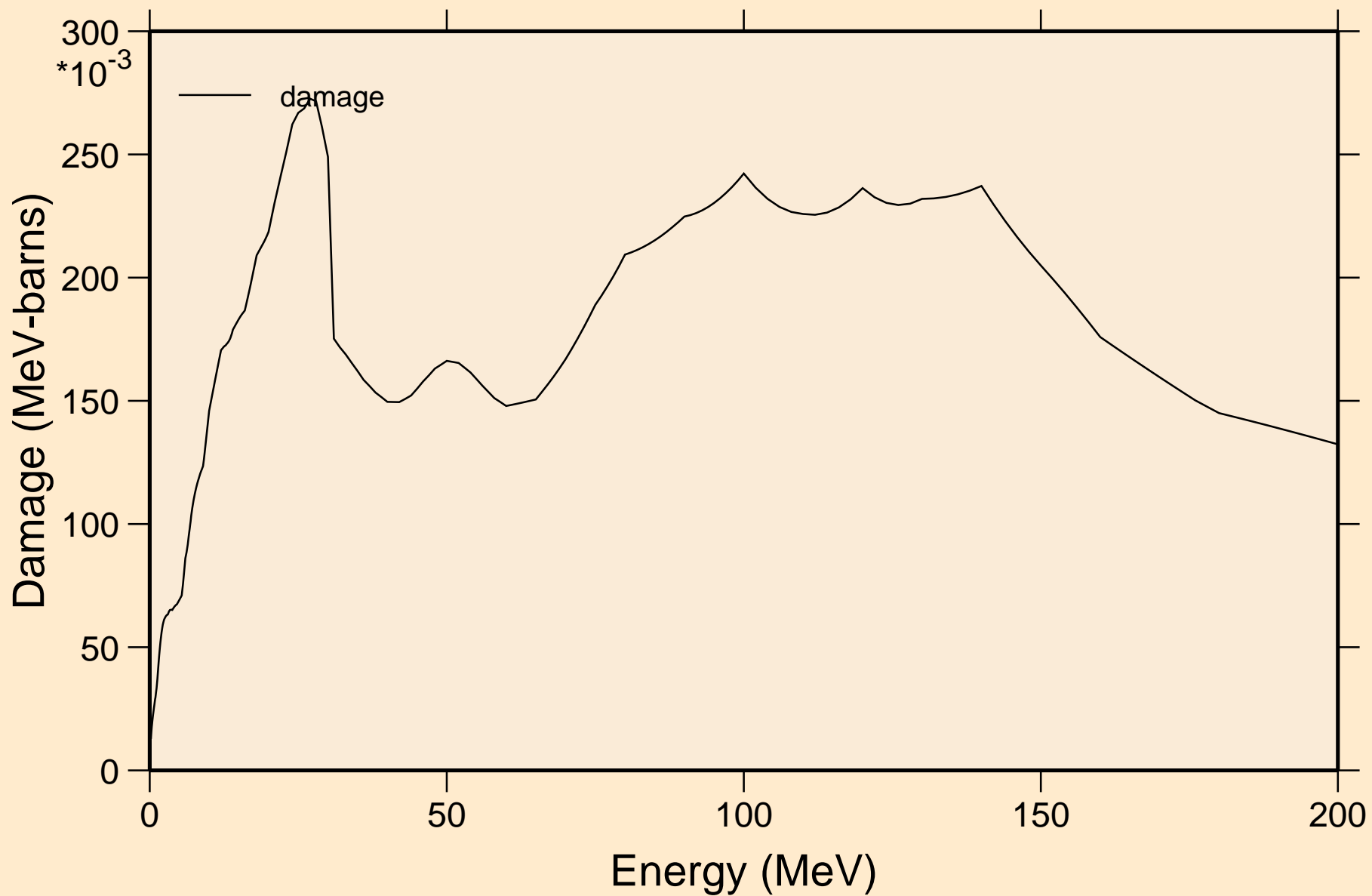

U236 NEUTRON ACER TENDL-2019 LIBRARY; T=293.16K
Non-threshold reactions

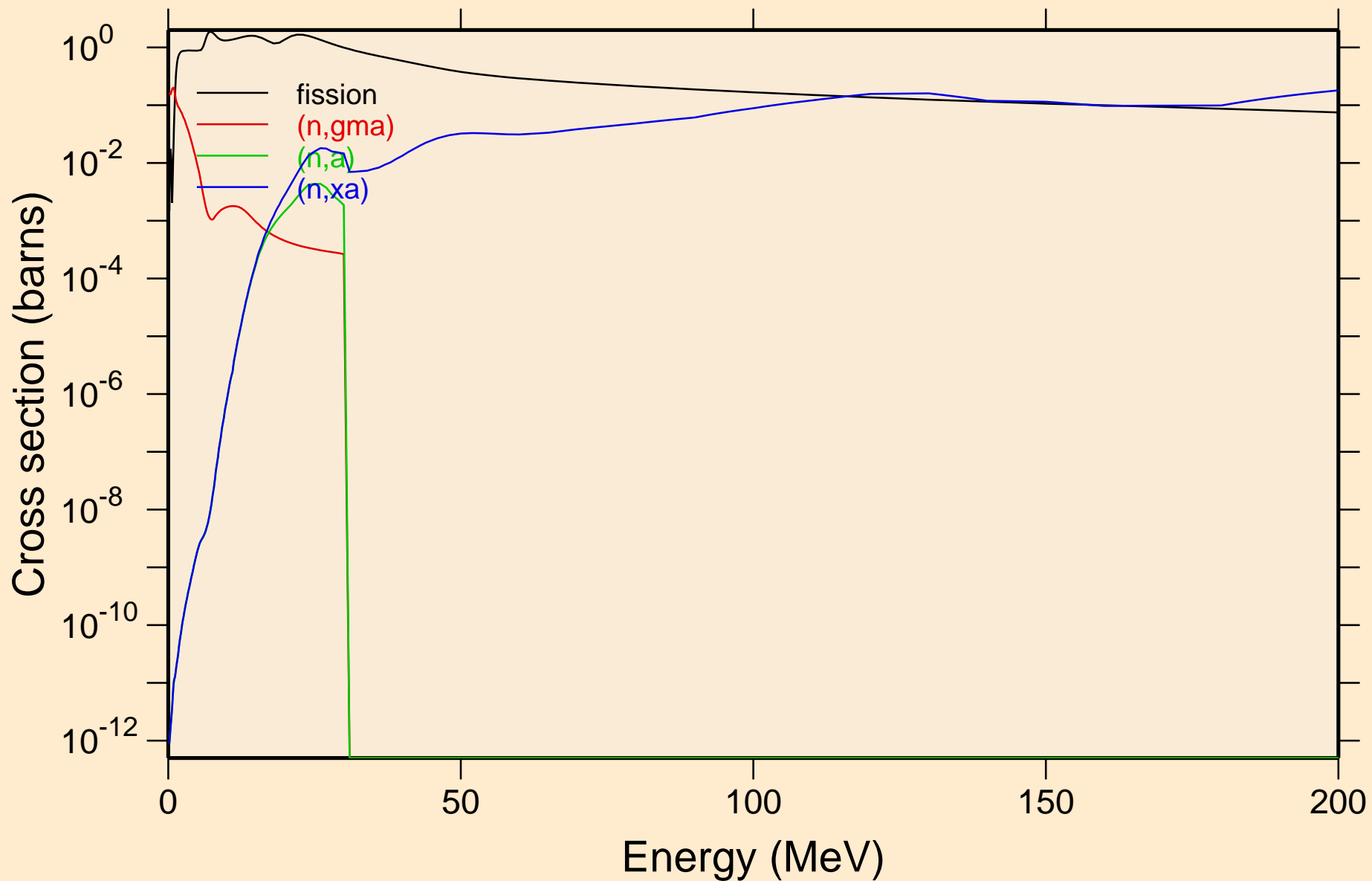

U236 NEUTRON ACER TENDL-2019 LIBRARY; T=293.16K
Inelastic levels

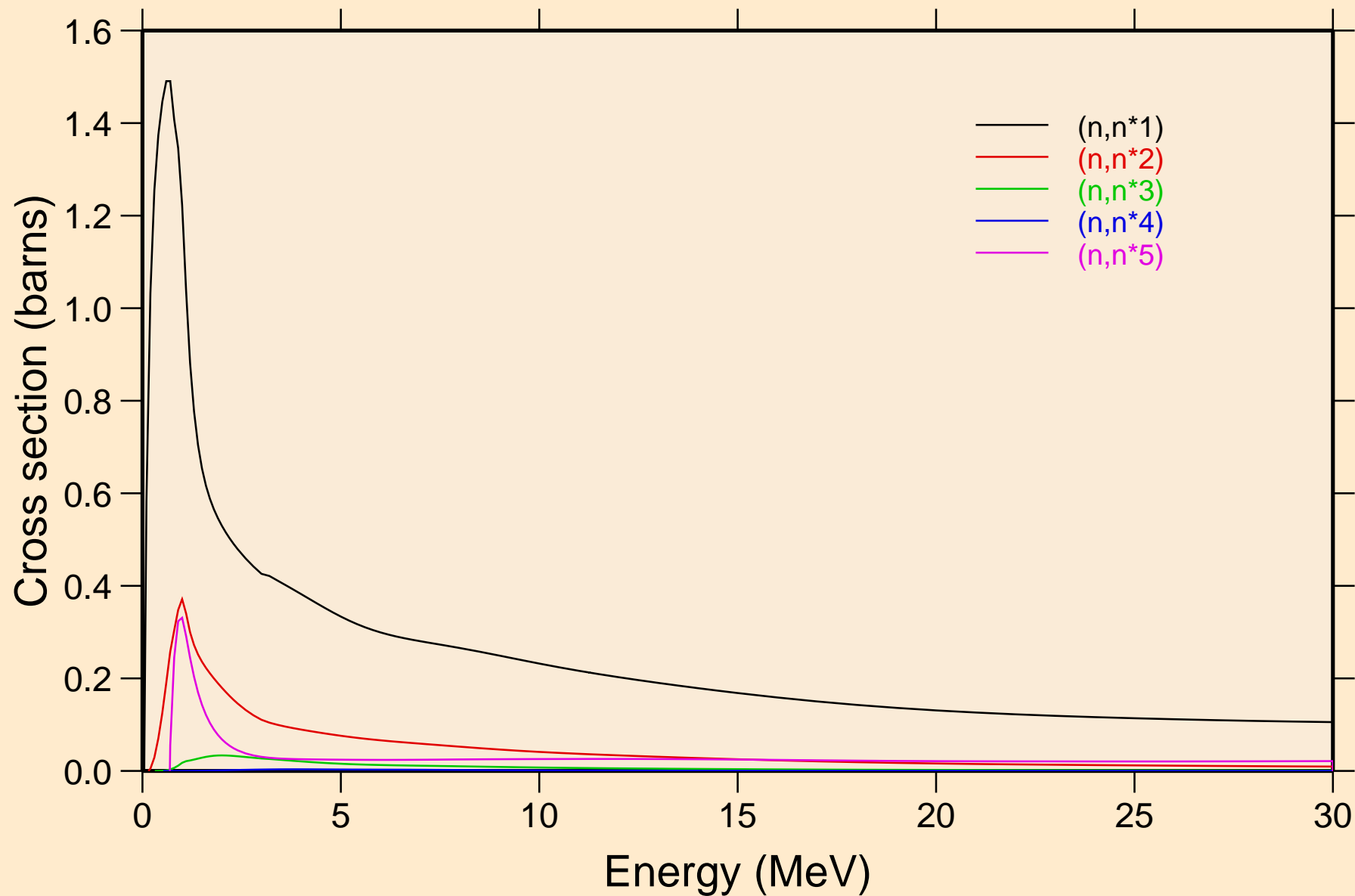

U236 NEUTRON ACER TENDL-2019 LIBRARY; T=293.16K
Inelastic levels

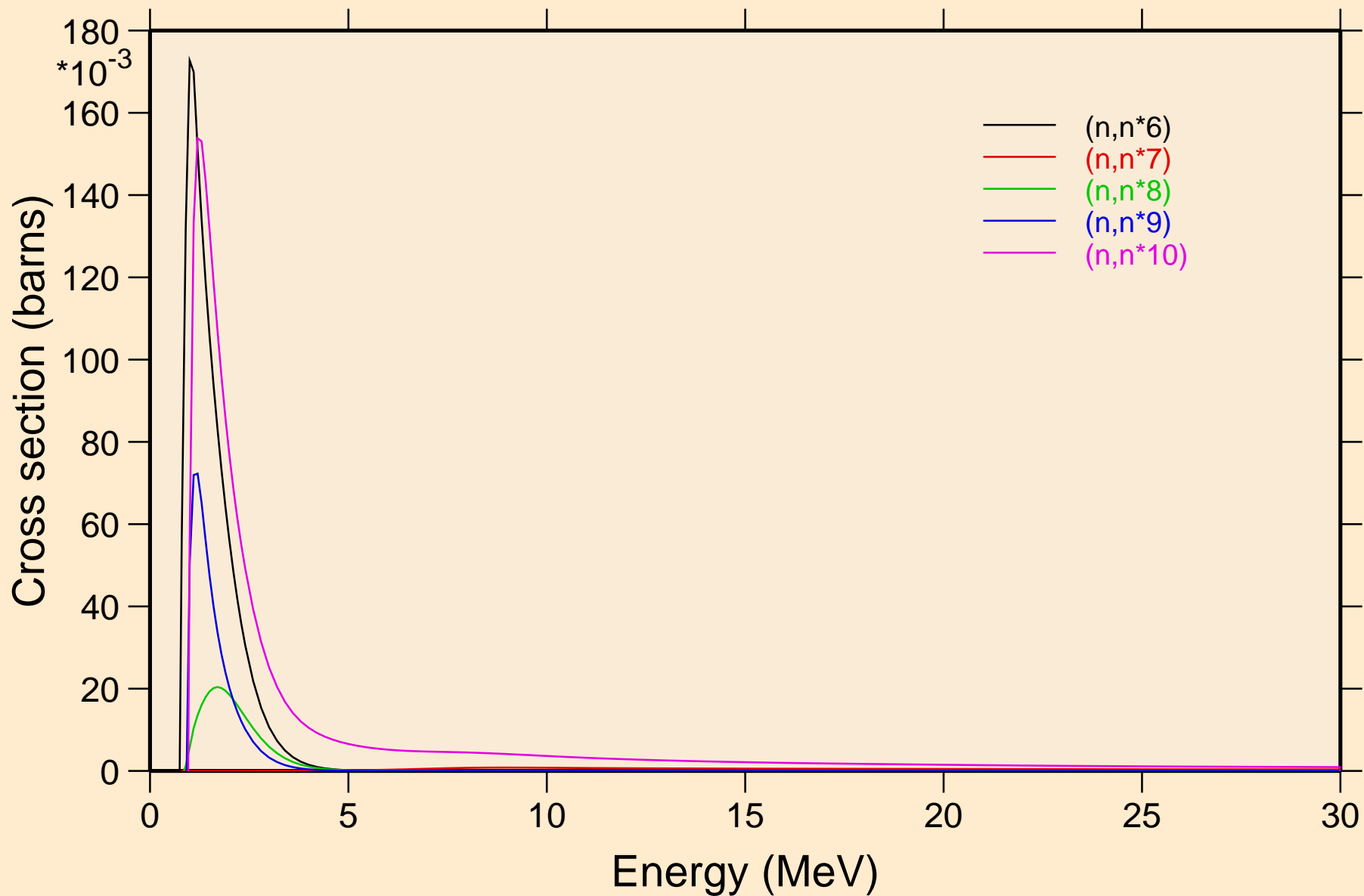

U236 NEUTRON ACER TENDL-2019 LIBRARY; T=293.16K
Inelastic levels

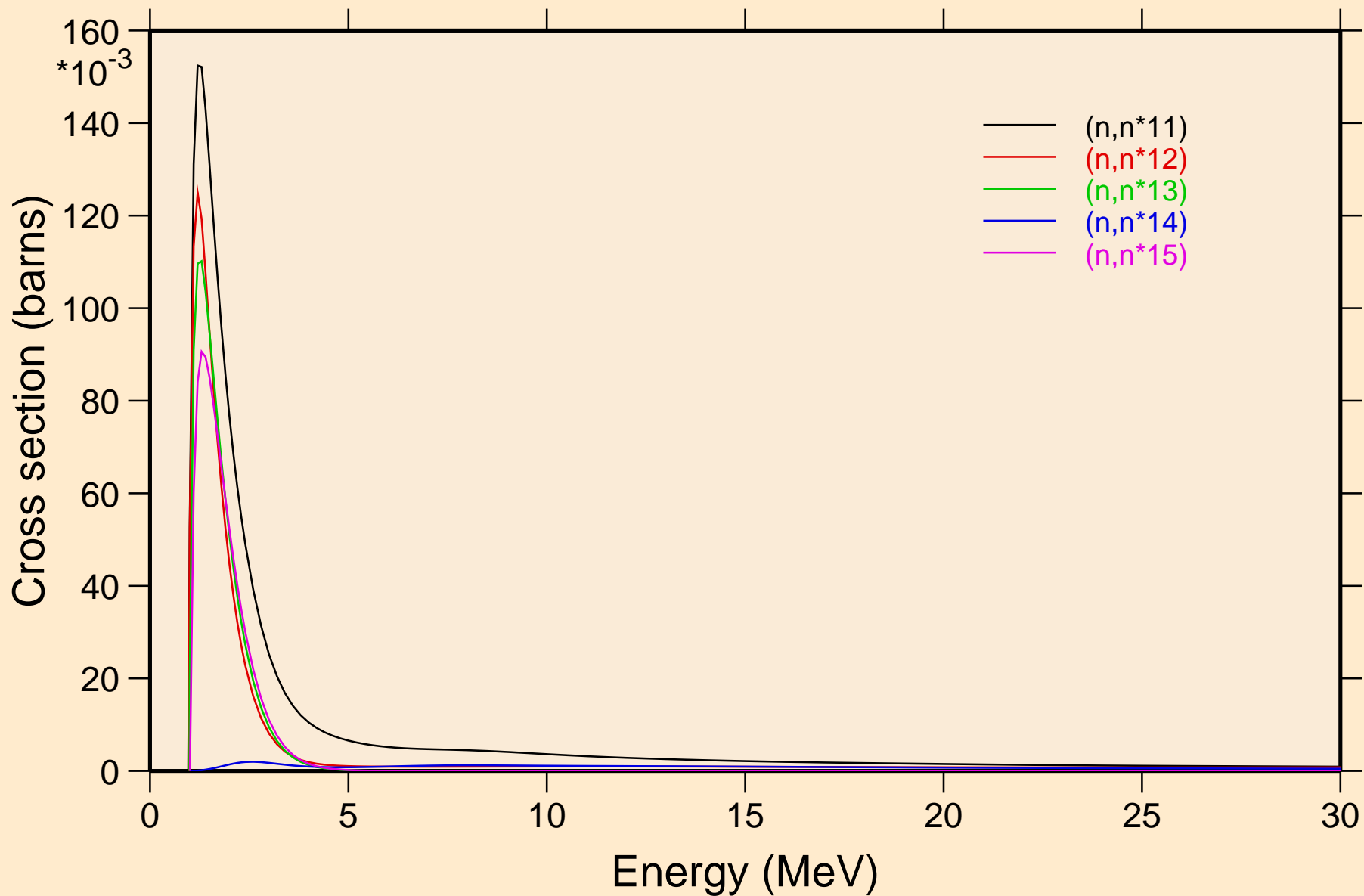

U236 NEUTRON ACER TENDL-2019 LIBRARY; T=293.16K

Inelastic levels

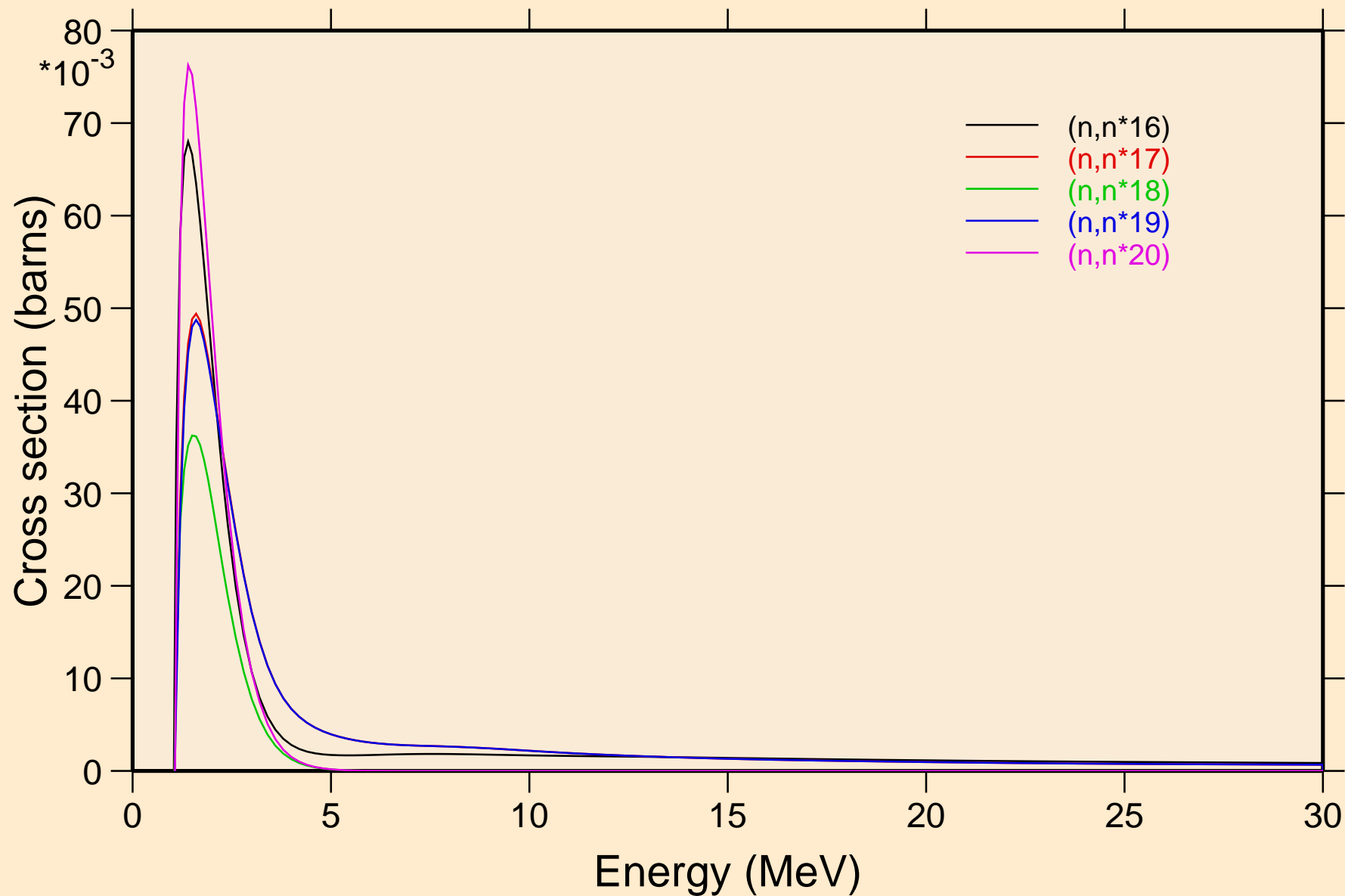

U236 NEUTRON ACER TENDL-2019 LIBRARY; T=293.16K
Inelastic levels

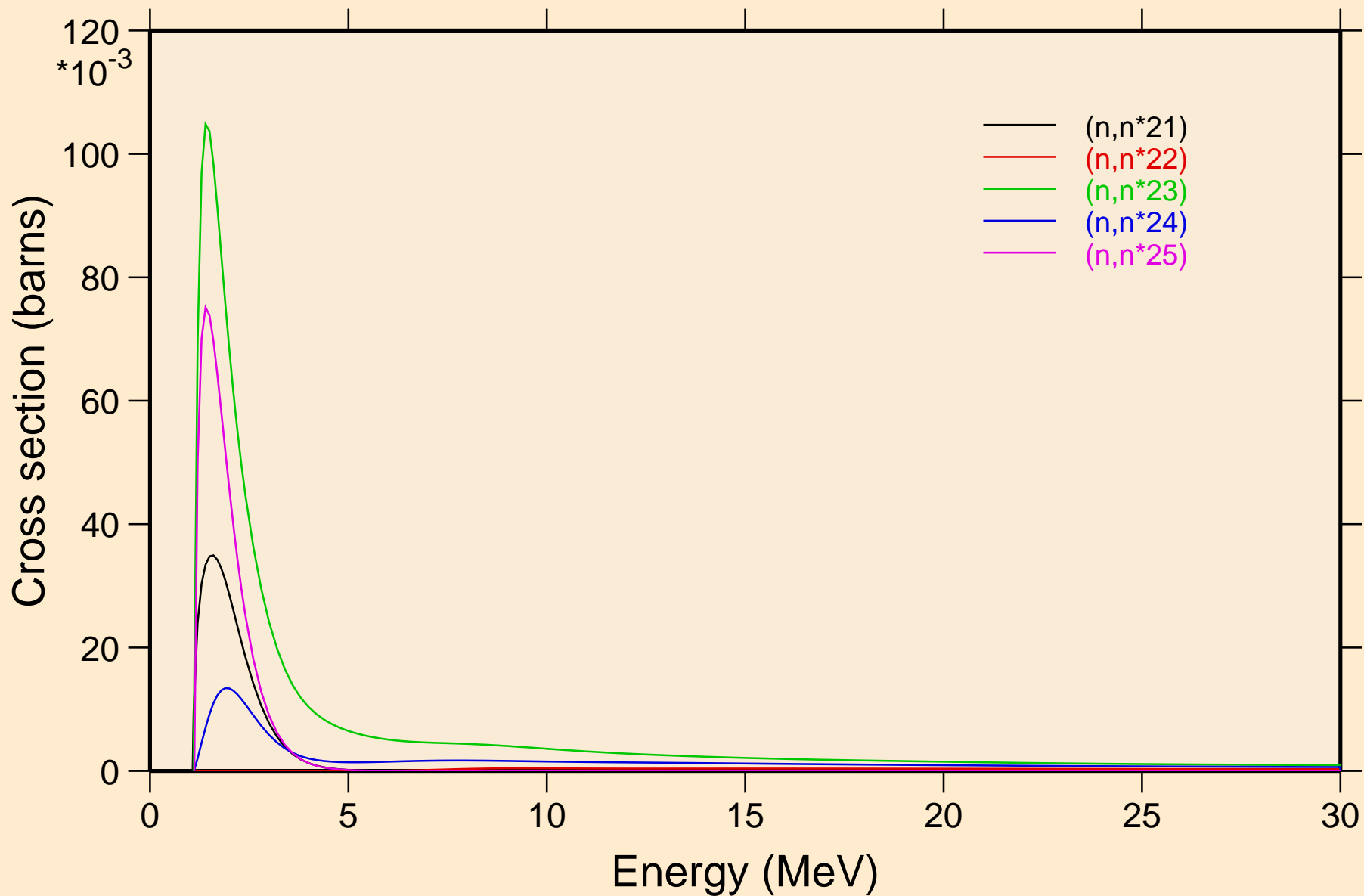

U236 NEUTRON ACER TENDL-2019 LIBRARY; T=293.16K
Inelastic levels

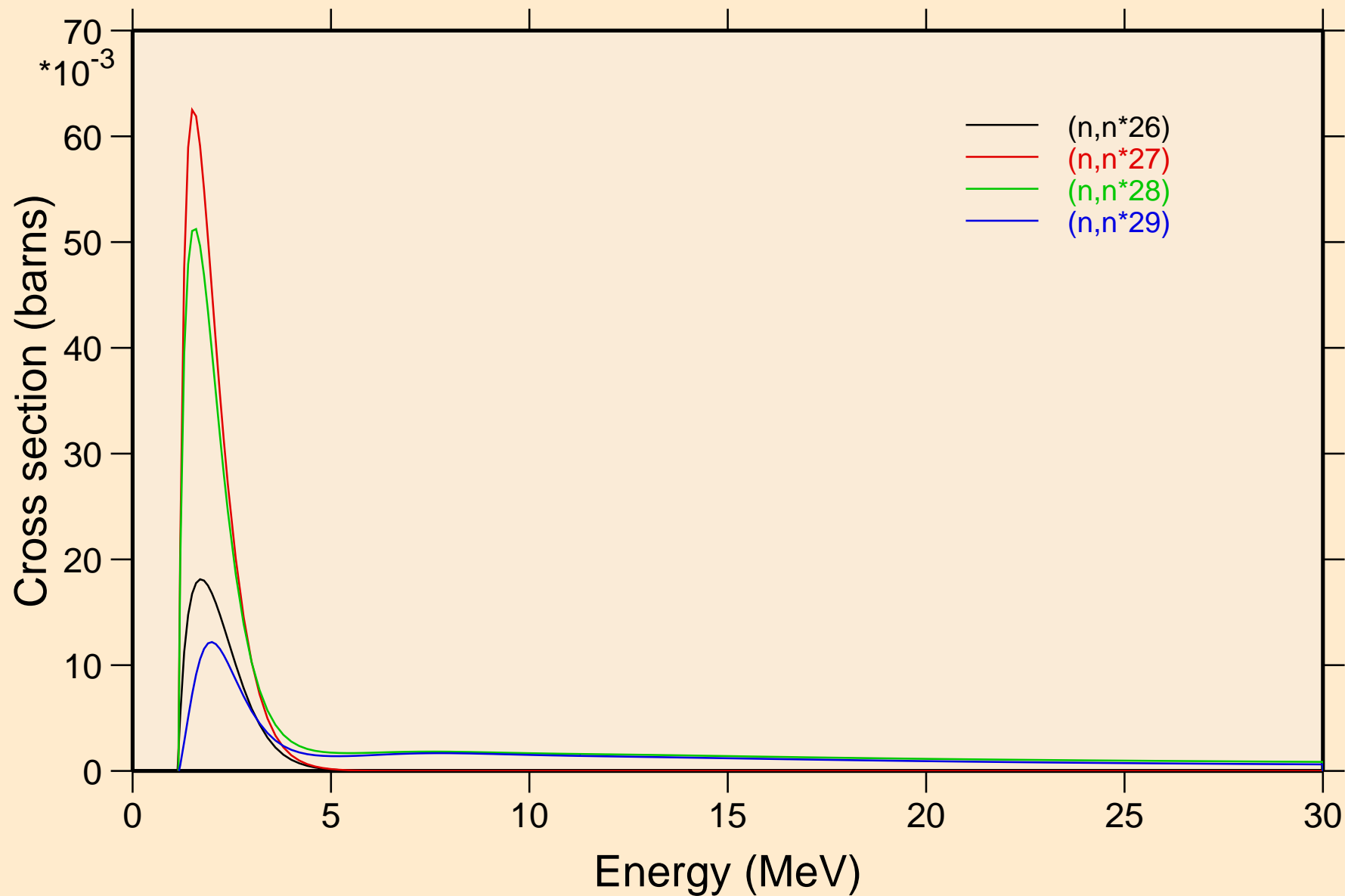

U236 NEUTRON ACER TENDL-2019 LIBRARY; T=293.16K

Threshold reactions

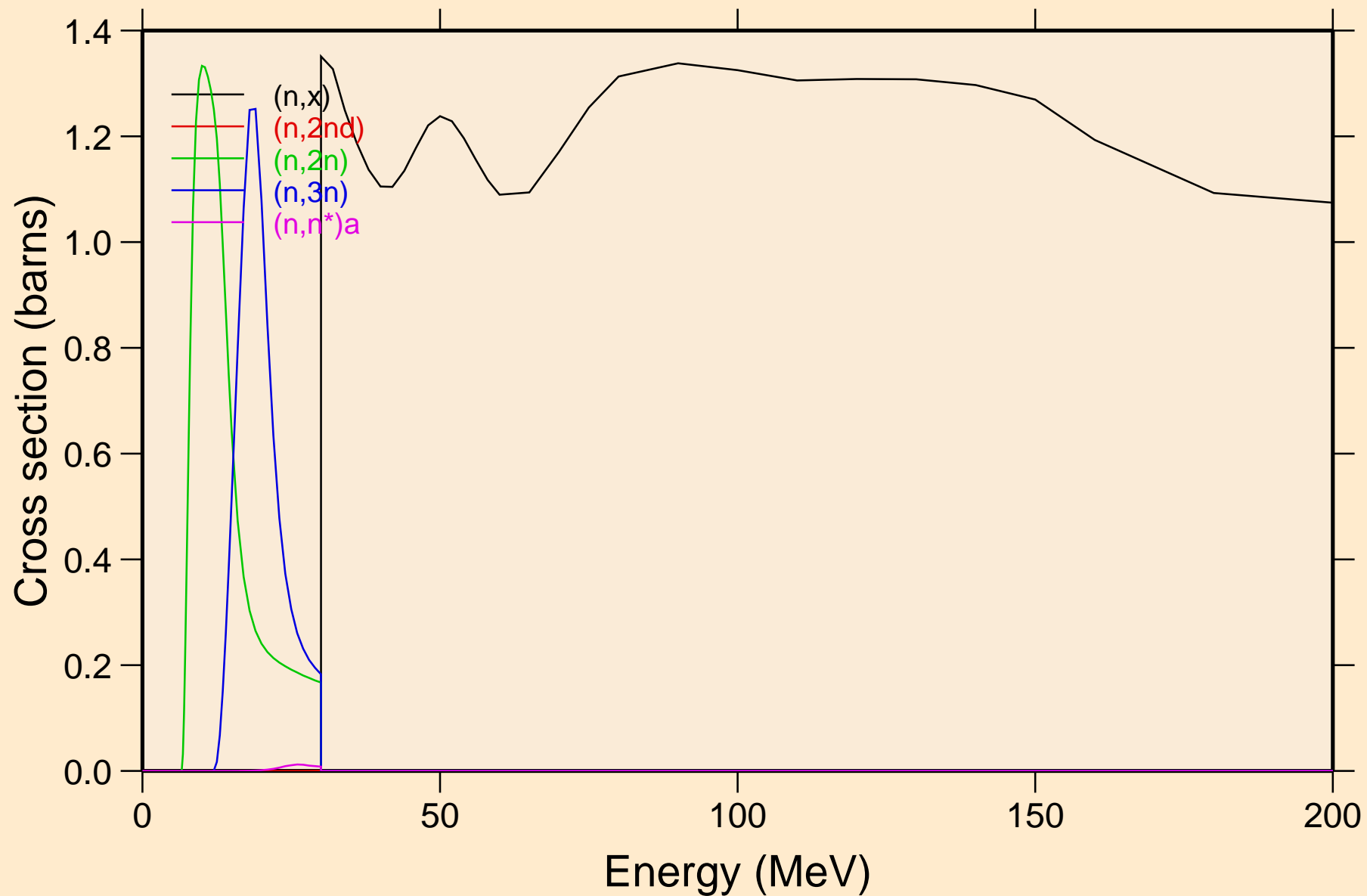

U236 NEUTRON ACER TENDL-2019 LIBRARY; T=293.16K
Threshold reactions

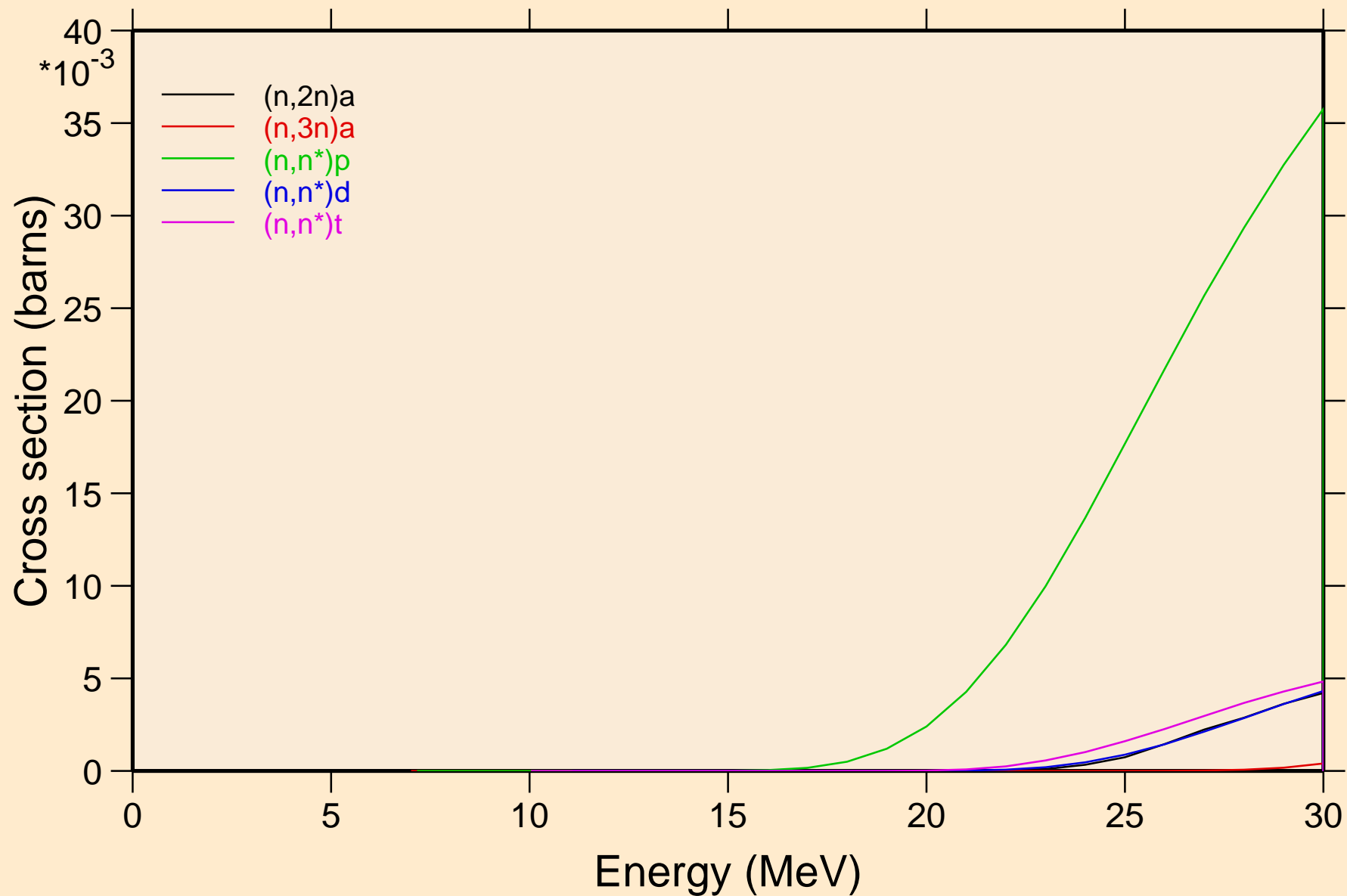

U236 NEUTRON ACER TENDL-2019 LIBRARY; T=293.16K
Threshold reactions

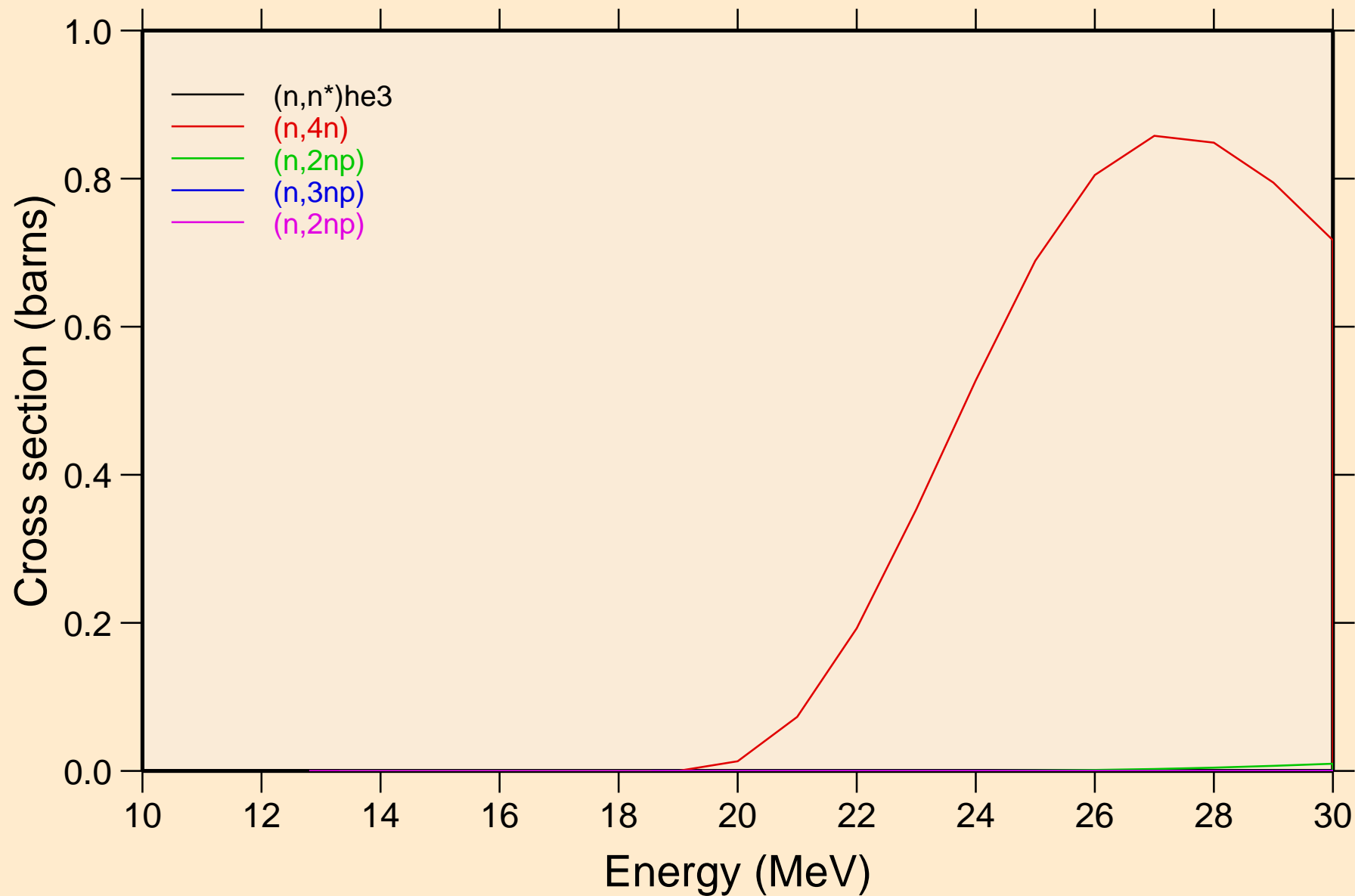

U236 NEUTRON ACER TENDL-2019 LIBRARY; T=293.16K
Threshold reactions

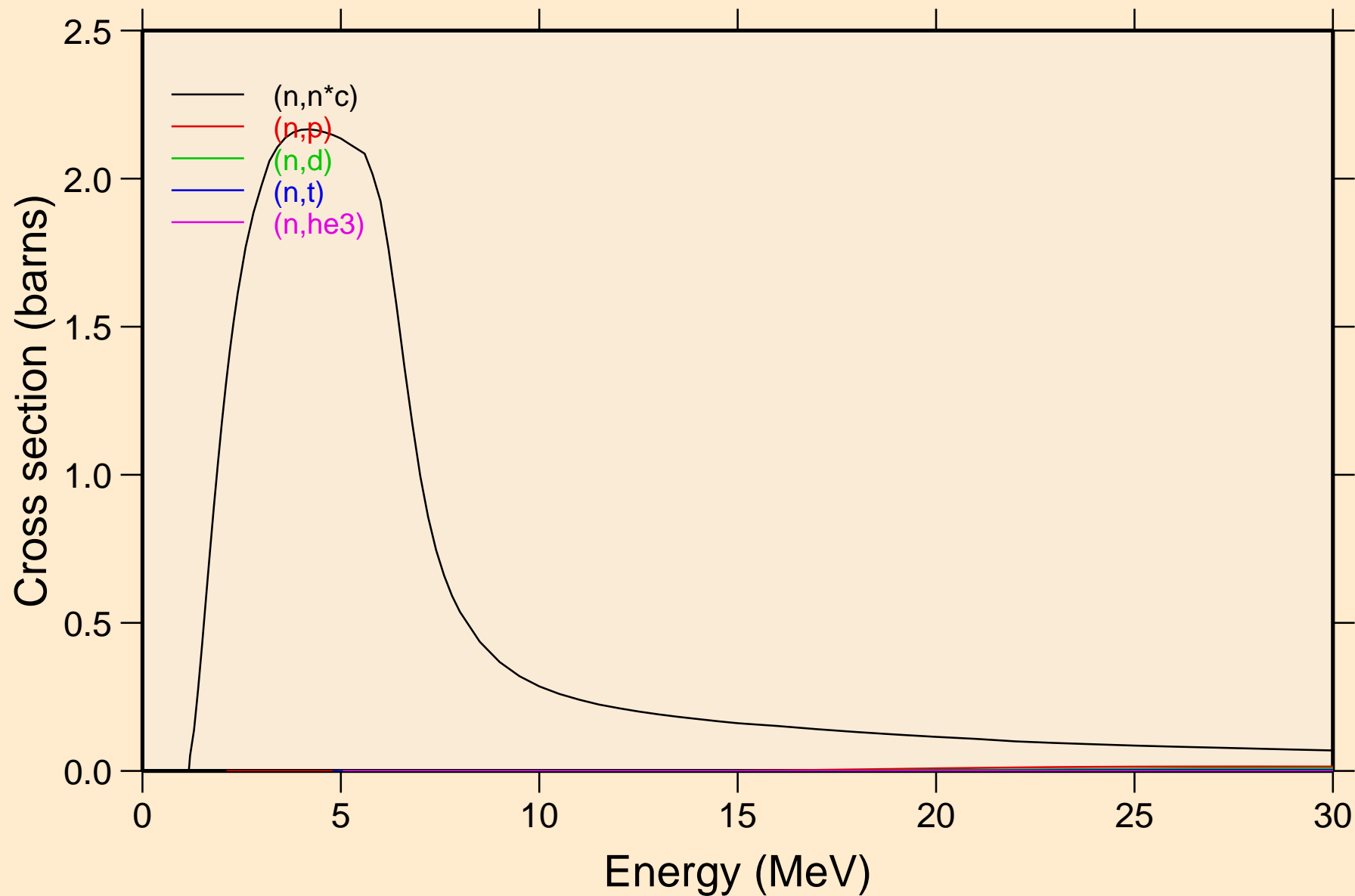

U236 NEUTRON ACER TENDL-2019 LIBRARY; T=293.16K
Threshold reactions

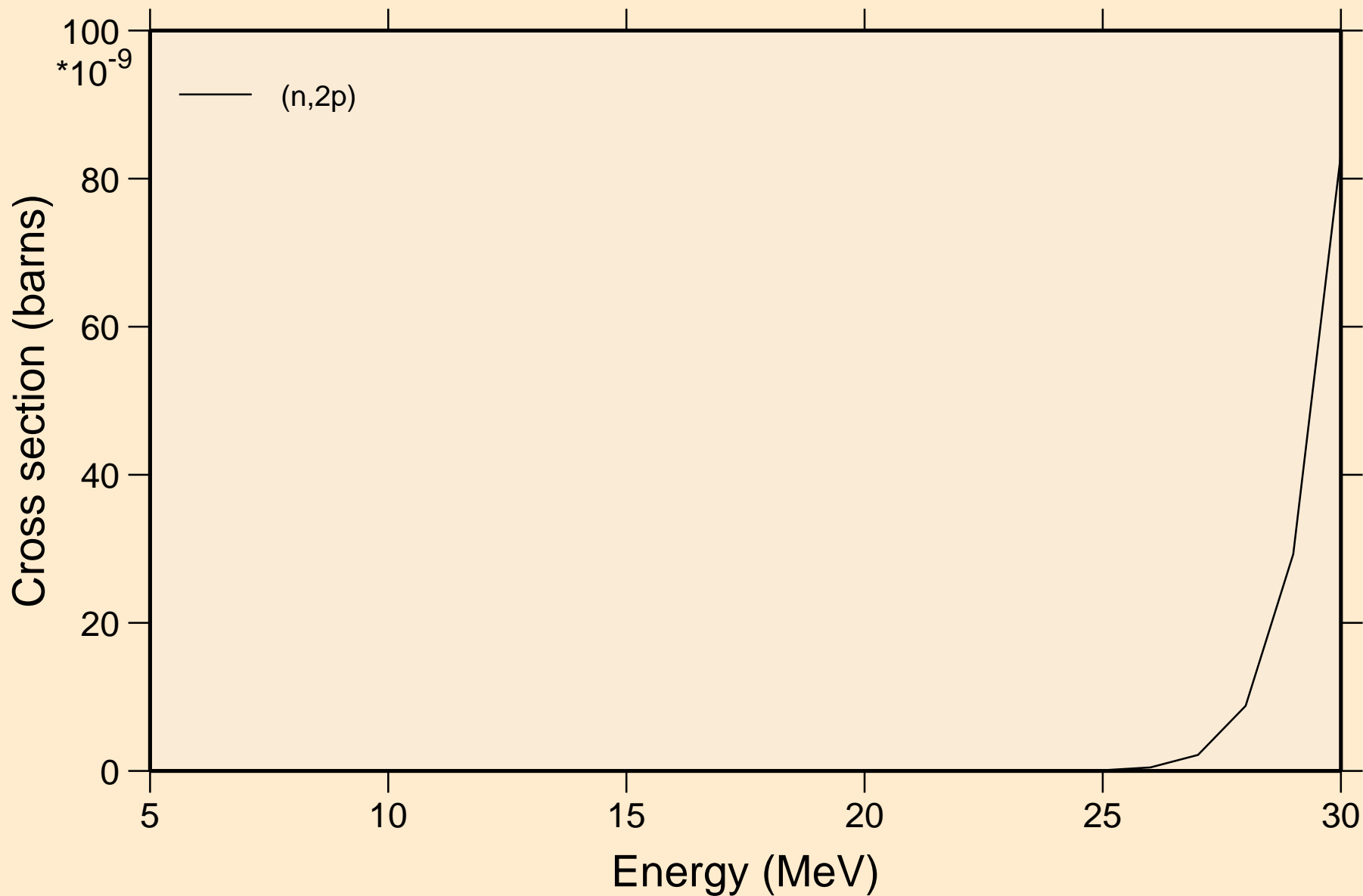

U236 NEUTRON ACER TENDL-2019 LIBRARY; T=293.16K
Threshold reactions

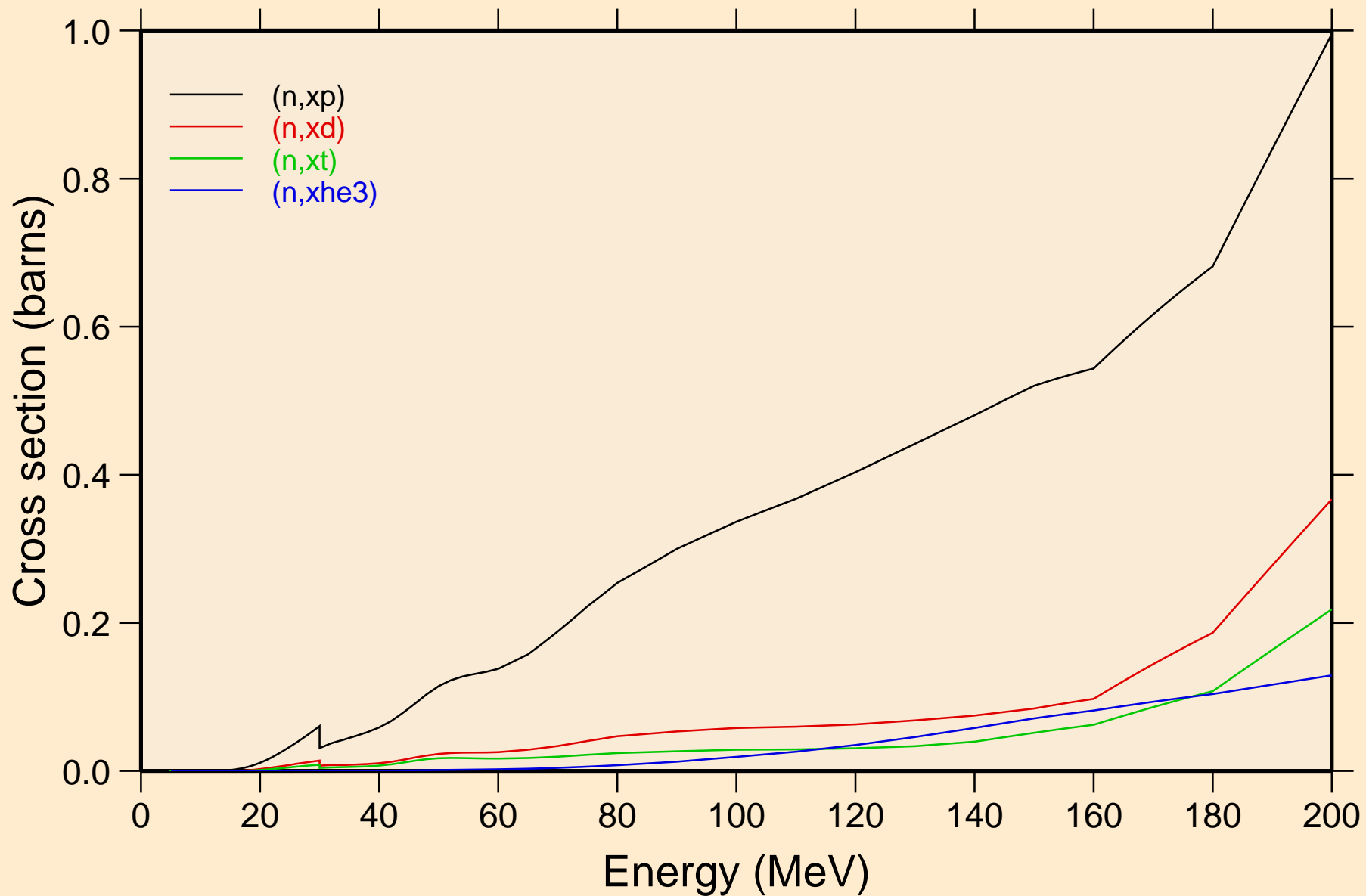

U236 NEUTRON ACER TENDL-2019 LIBRARY; T=293.16K
angular distribution for elastic

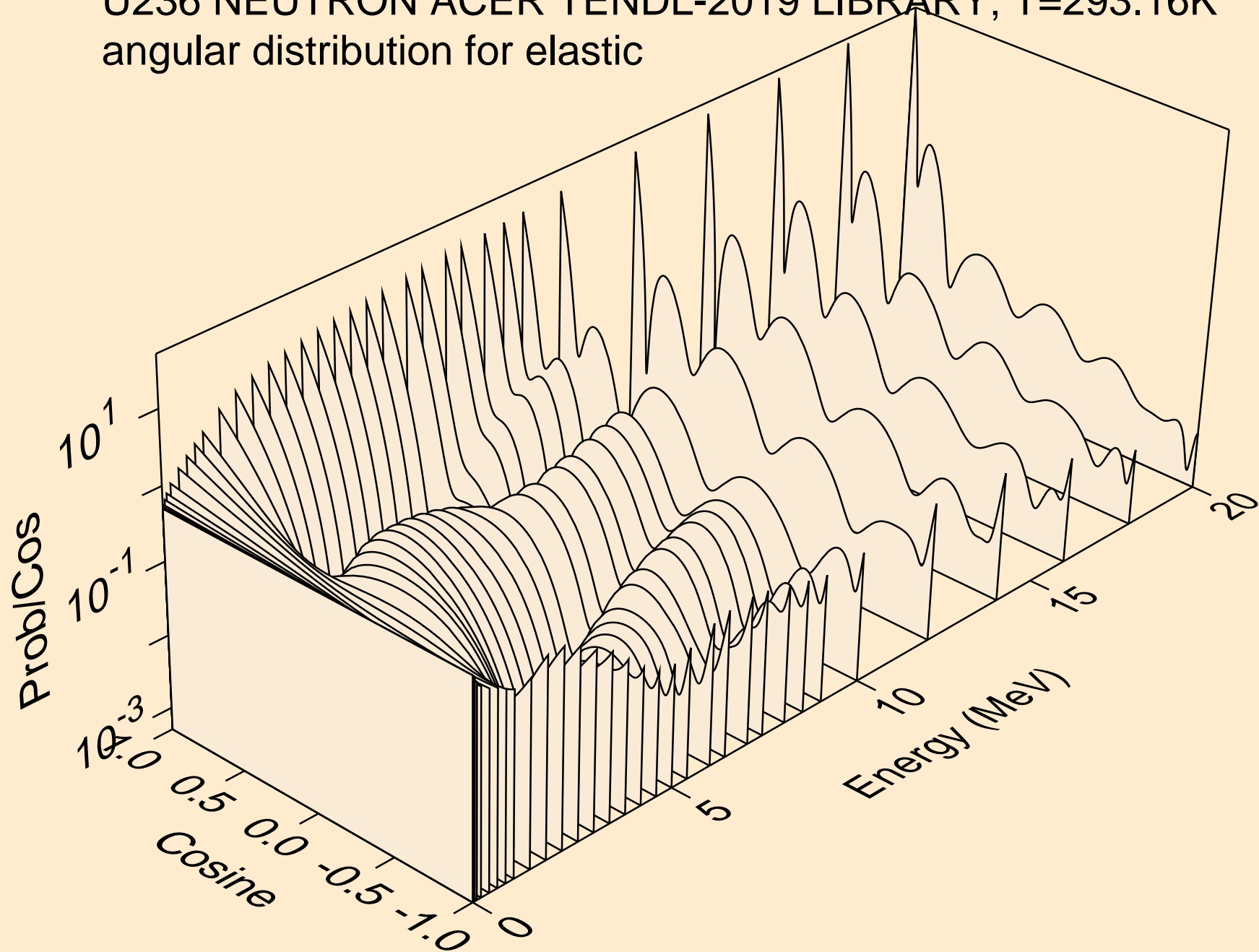

U236 NEUTRON ACER TENDL-2019 LIBRARY; T=293.16K
angular distribution for elastic

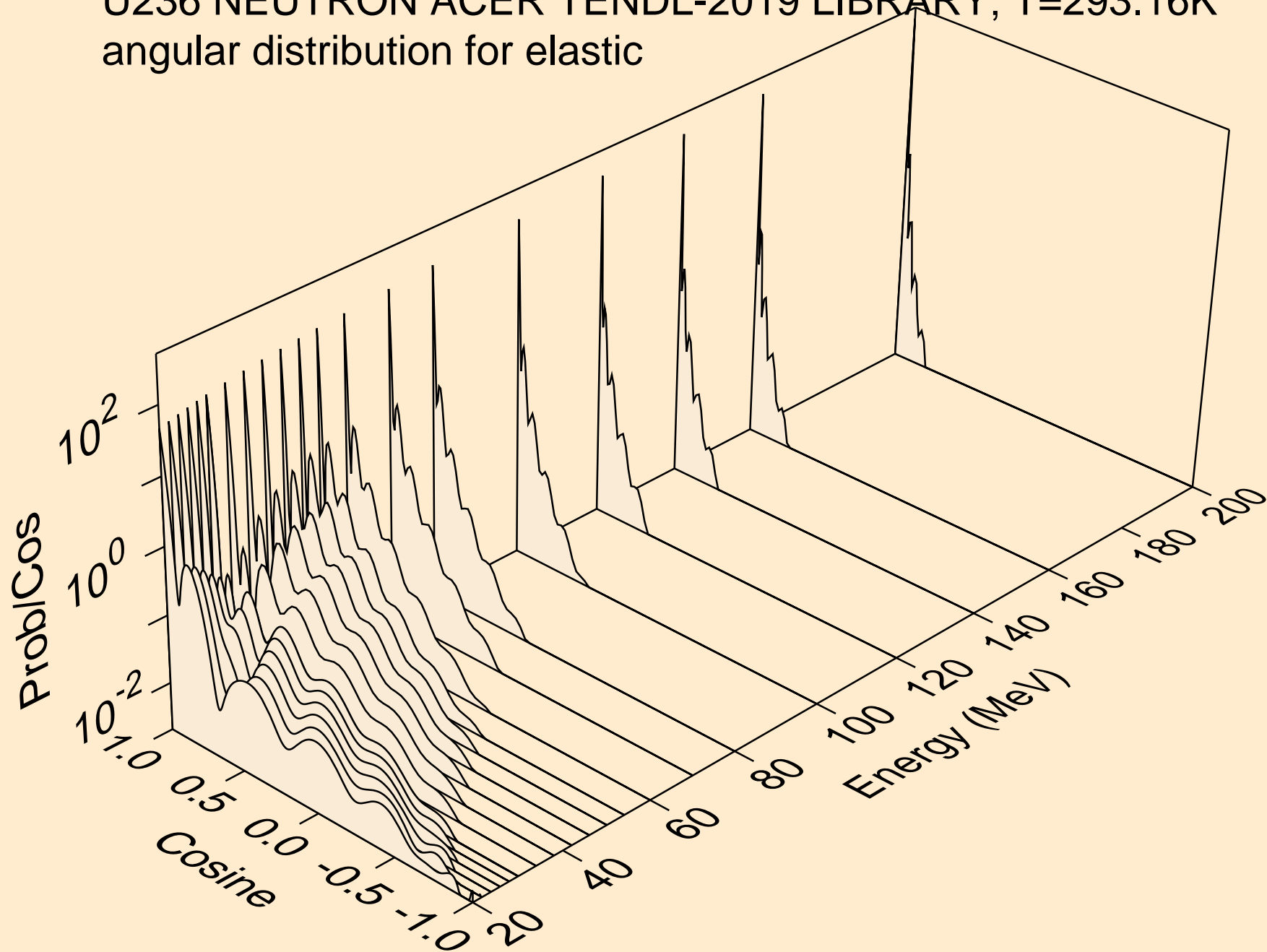

U236 NEUTRON ACER TENDL-2019 LIBRARY; T=293.16K
angular distribution for (n,n*1)

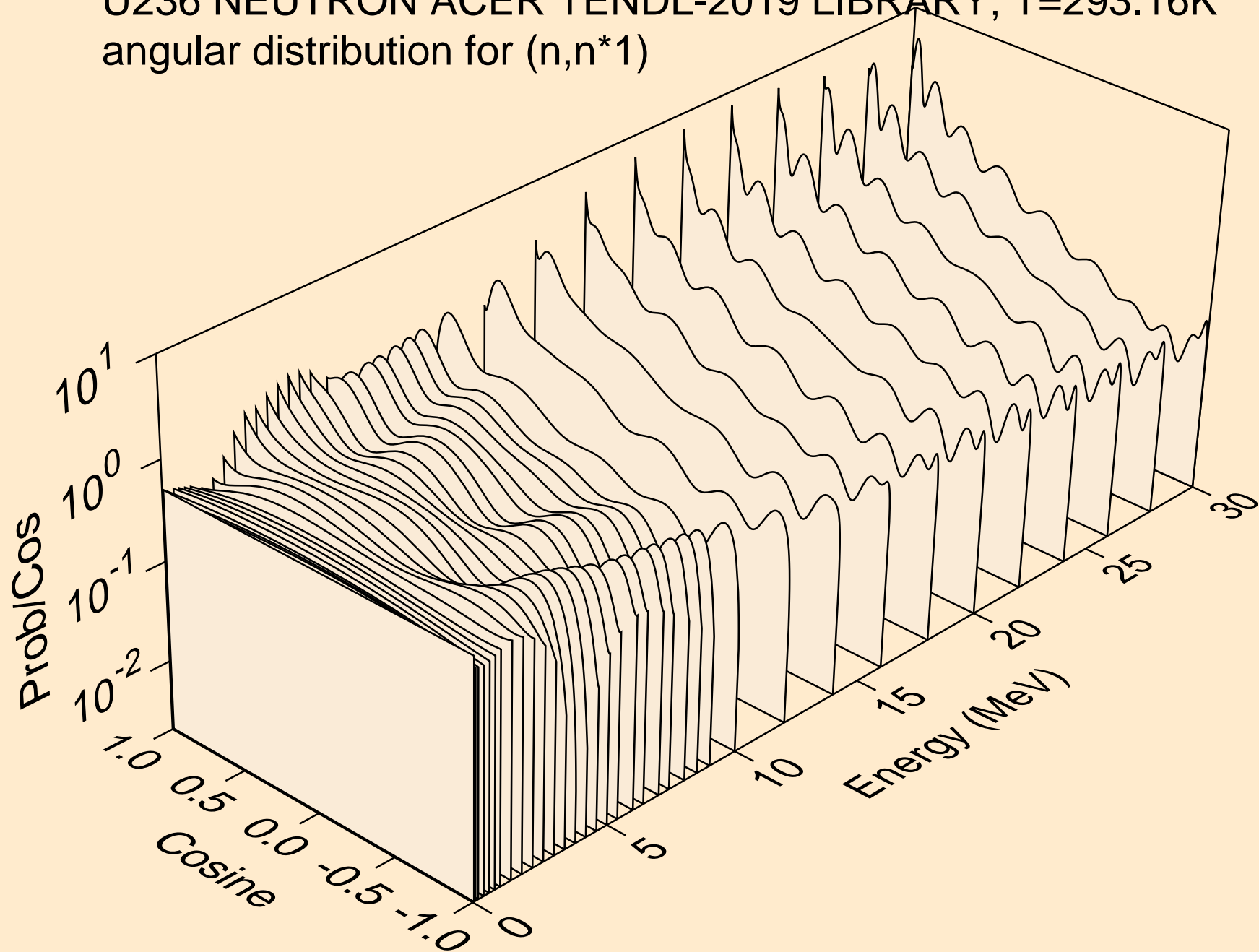

U236 NEUTRON ACER TENDL-2019 LIBRARY; T=293.16K
angular distribution for (n,n*2)

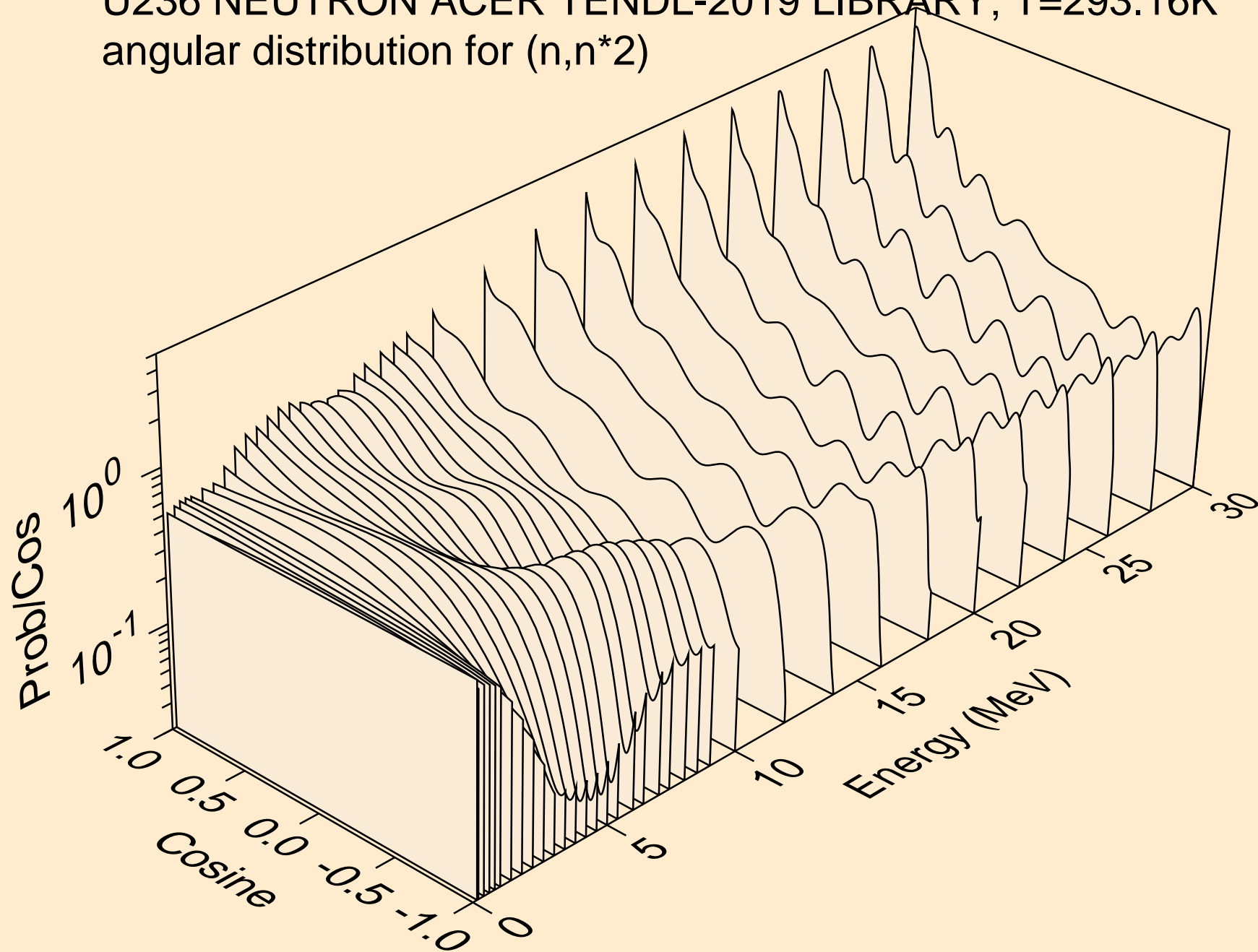

U236 NEUTRON ACER TENDL-2019 LIBRARY; T=293.16K
angular distribution for (n,n*3)

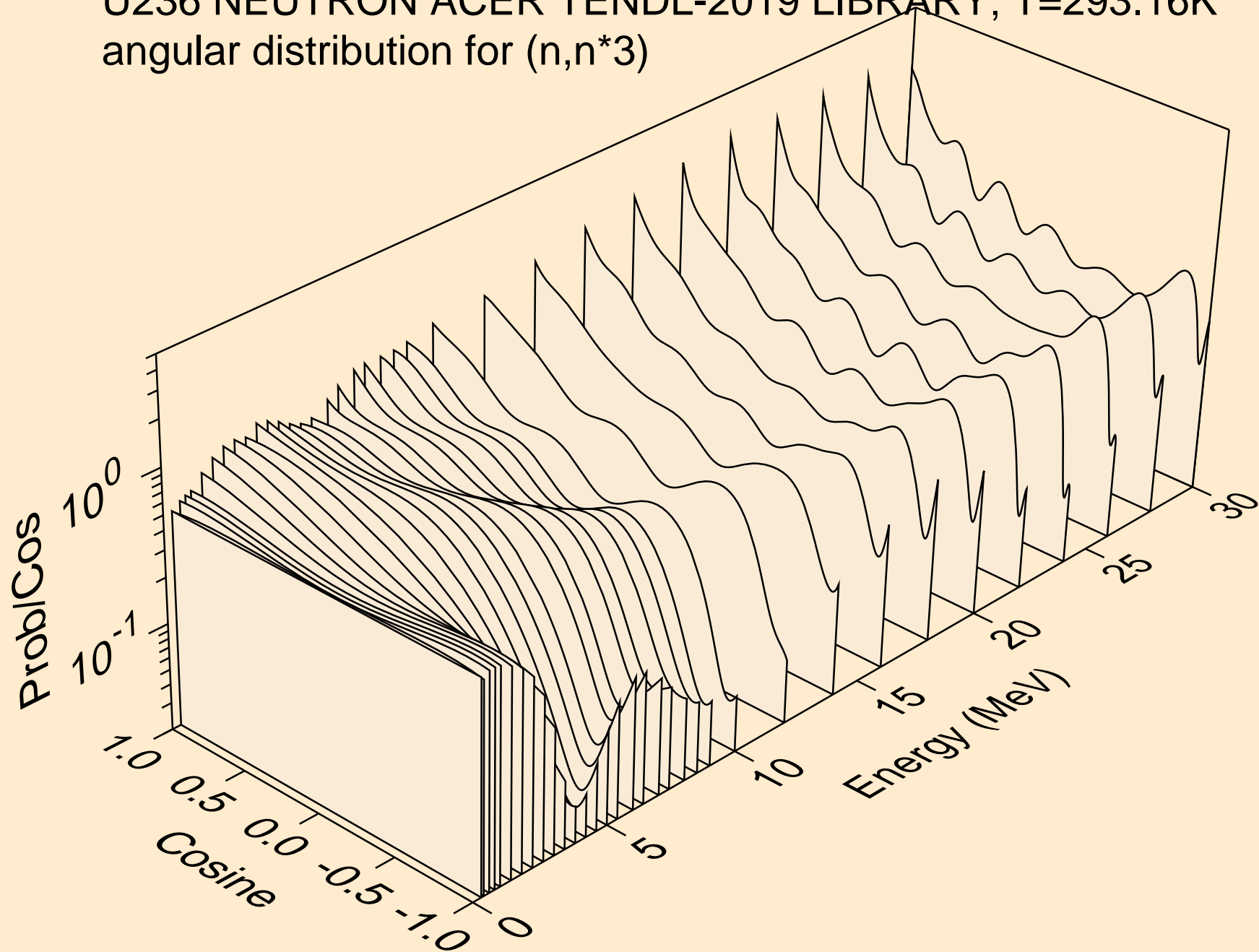

U236 NEUTRON ACER TENDL-2019 LIBRARY; T=293.16K
angular distribution for (n,n*4)

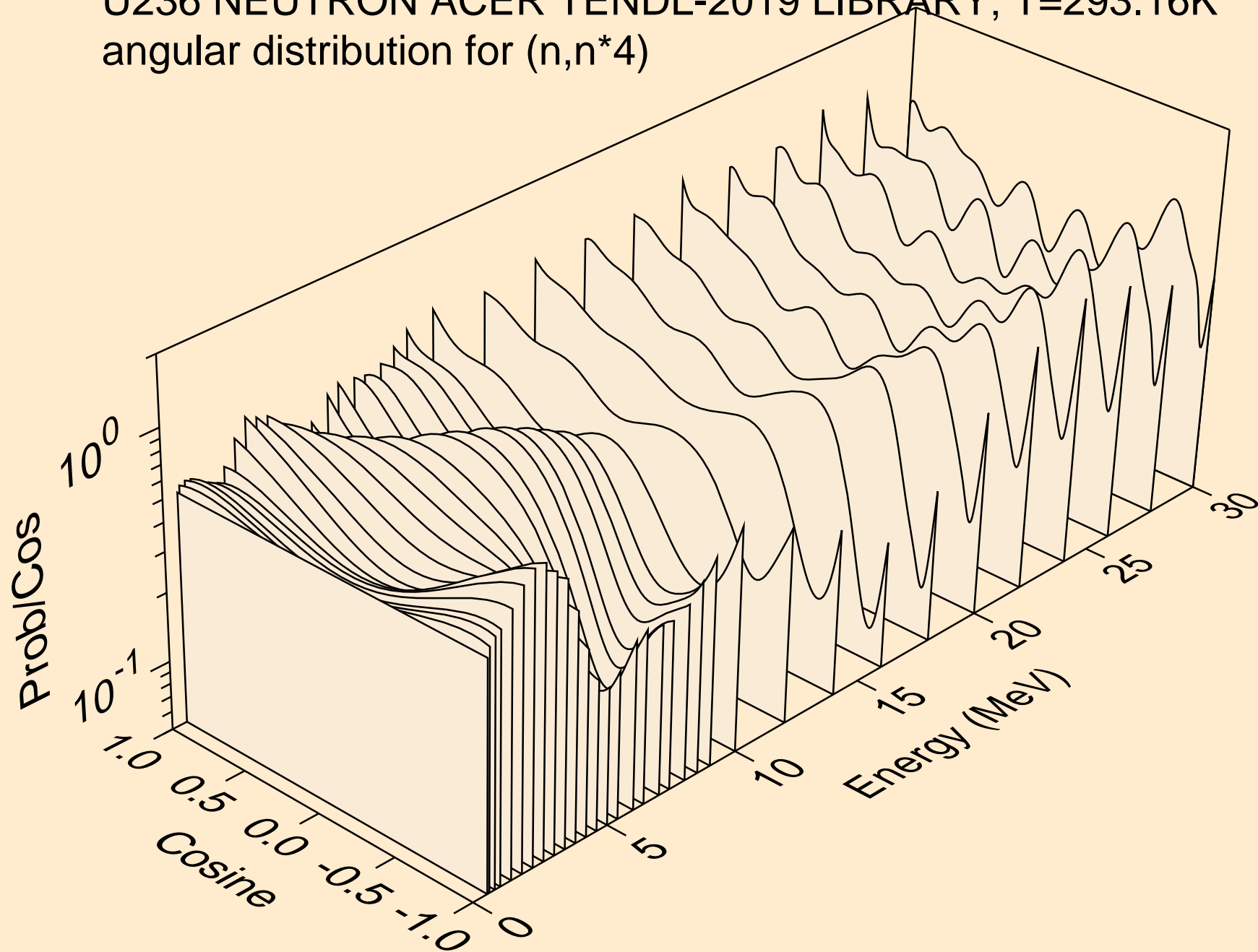

U236 NEUTRON ACER TENDL-2019 LIBRARY; T=293.16K
angular distribution for (n,n*5)

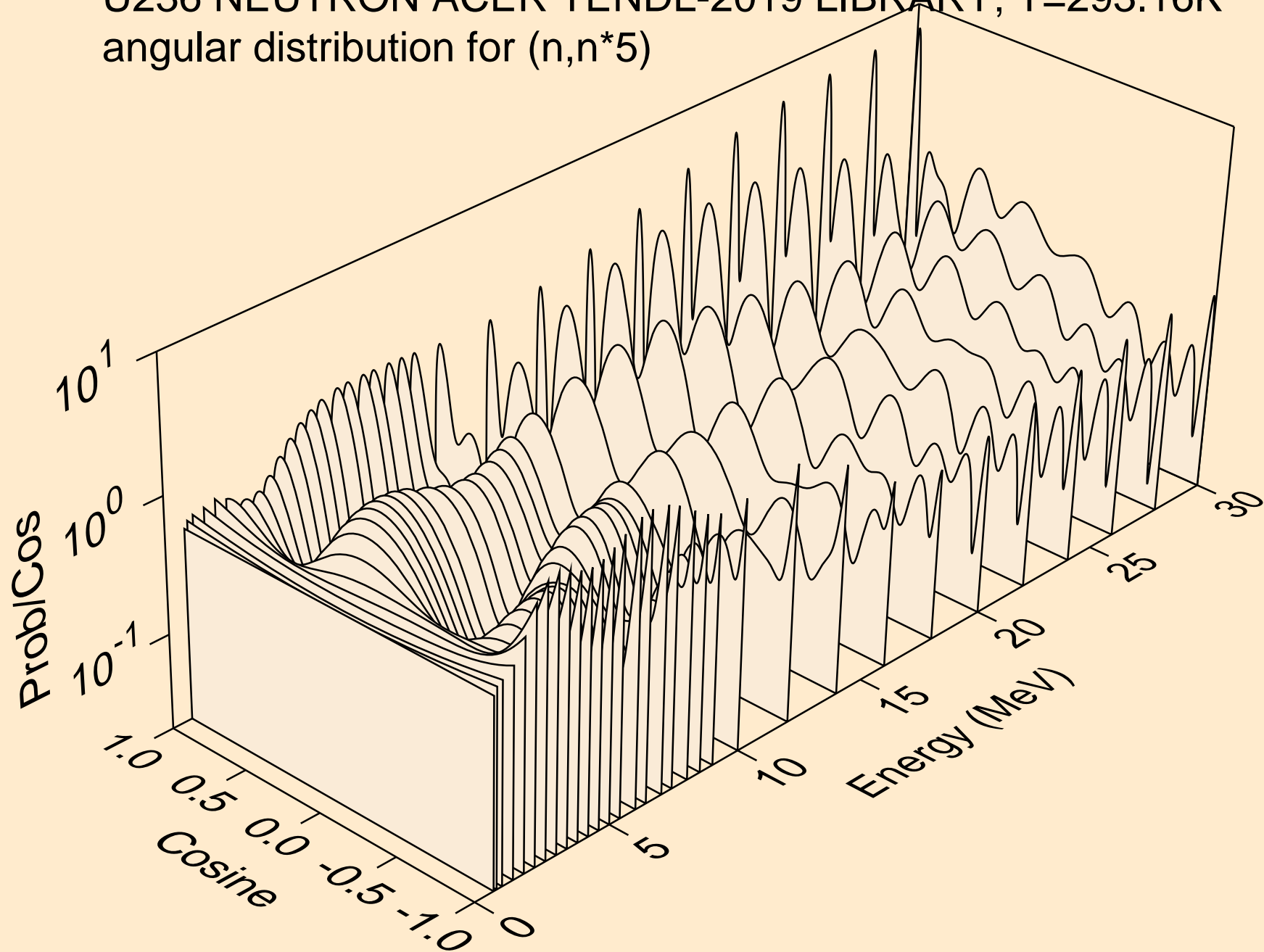

U236 NEUTRON ACER TENDL-2019 LIBRARY; T=293.16K
angular distribution for (n,n*6)

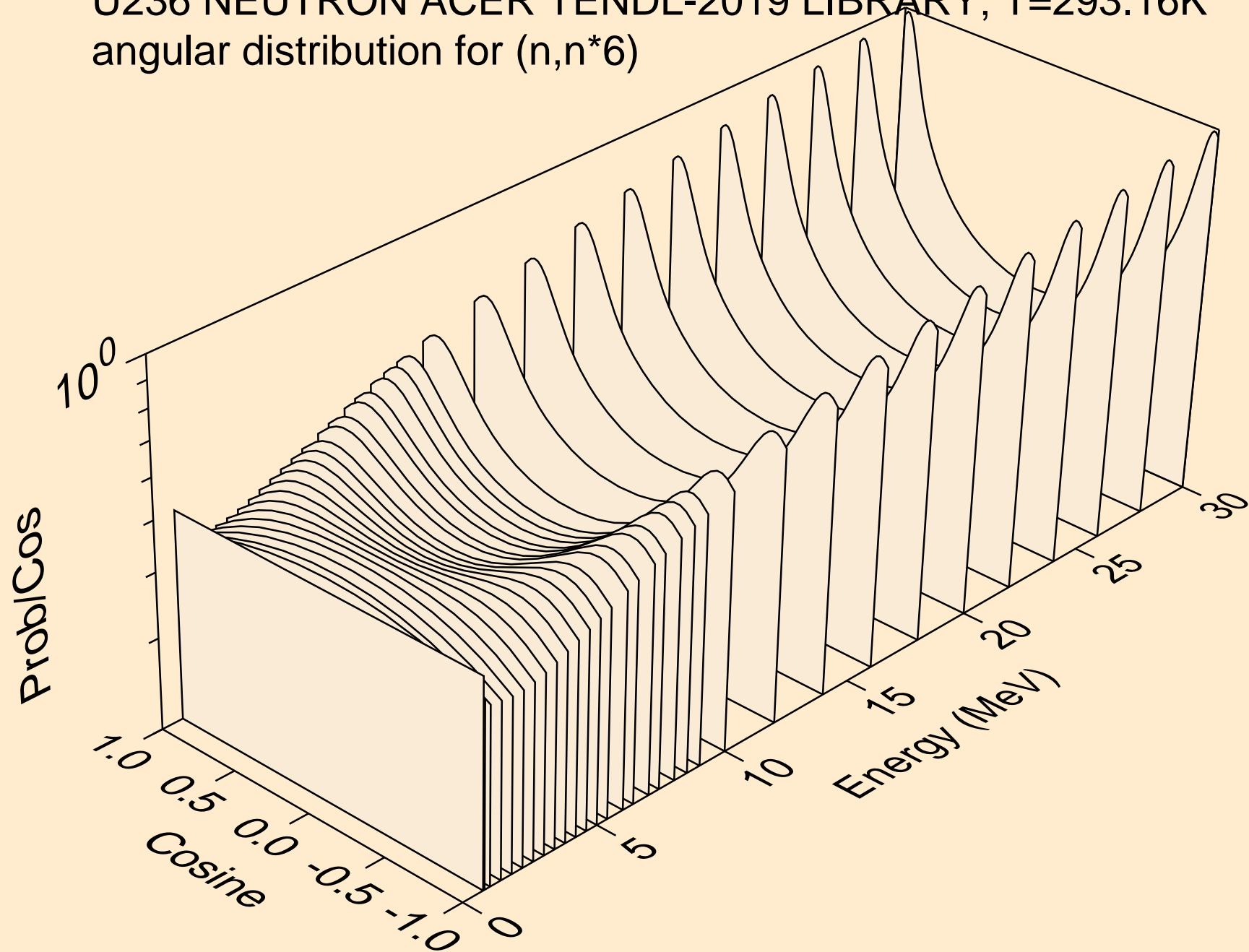

U236 NEUTRON ACER TENDL-2019 LIBRARY; T=293.16K
angular distribution for (n,n*7)

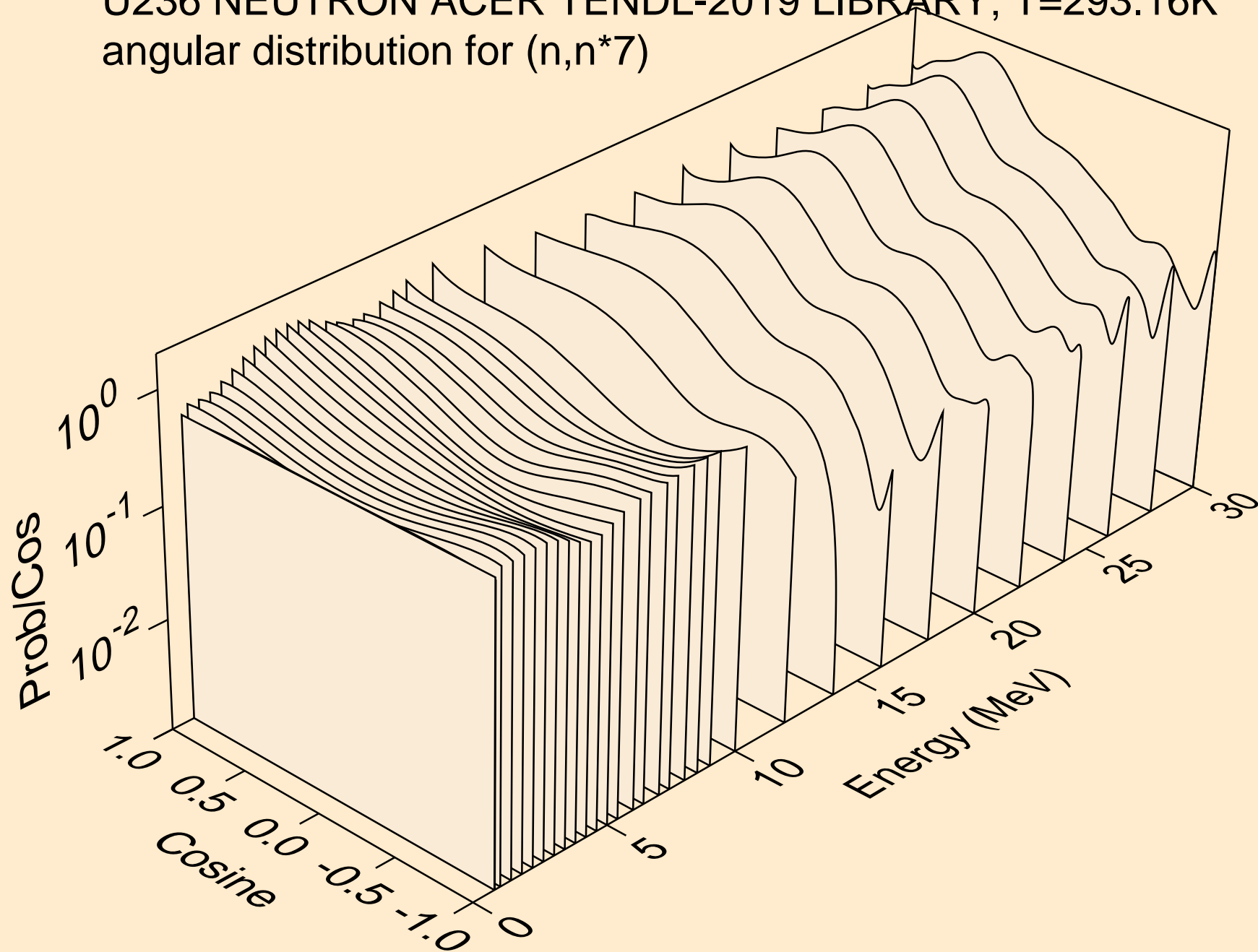

U236 NEUTRON ACER TENDL-2019 LIBRARY; T=293.16K
angular distribution for (n,n*8)

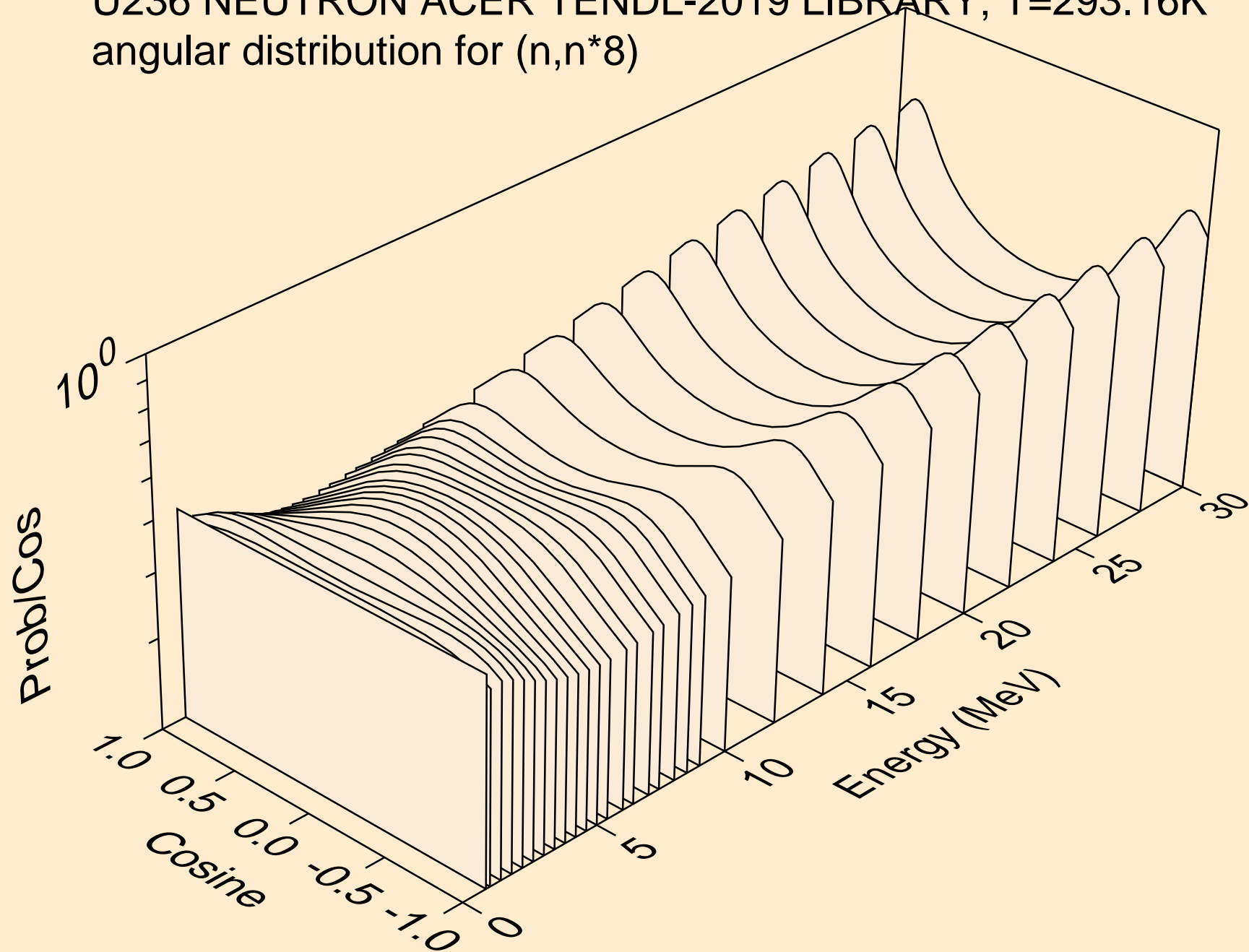

U236 NEUTRON ACER TENDL-2019 LIBRARY; T=293.16K
angular distribution for (n,n*9)

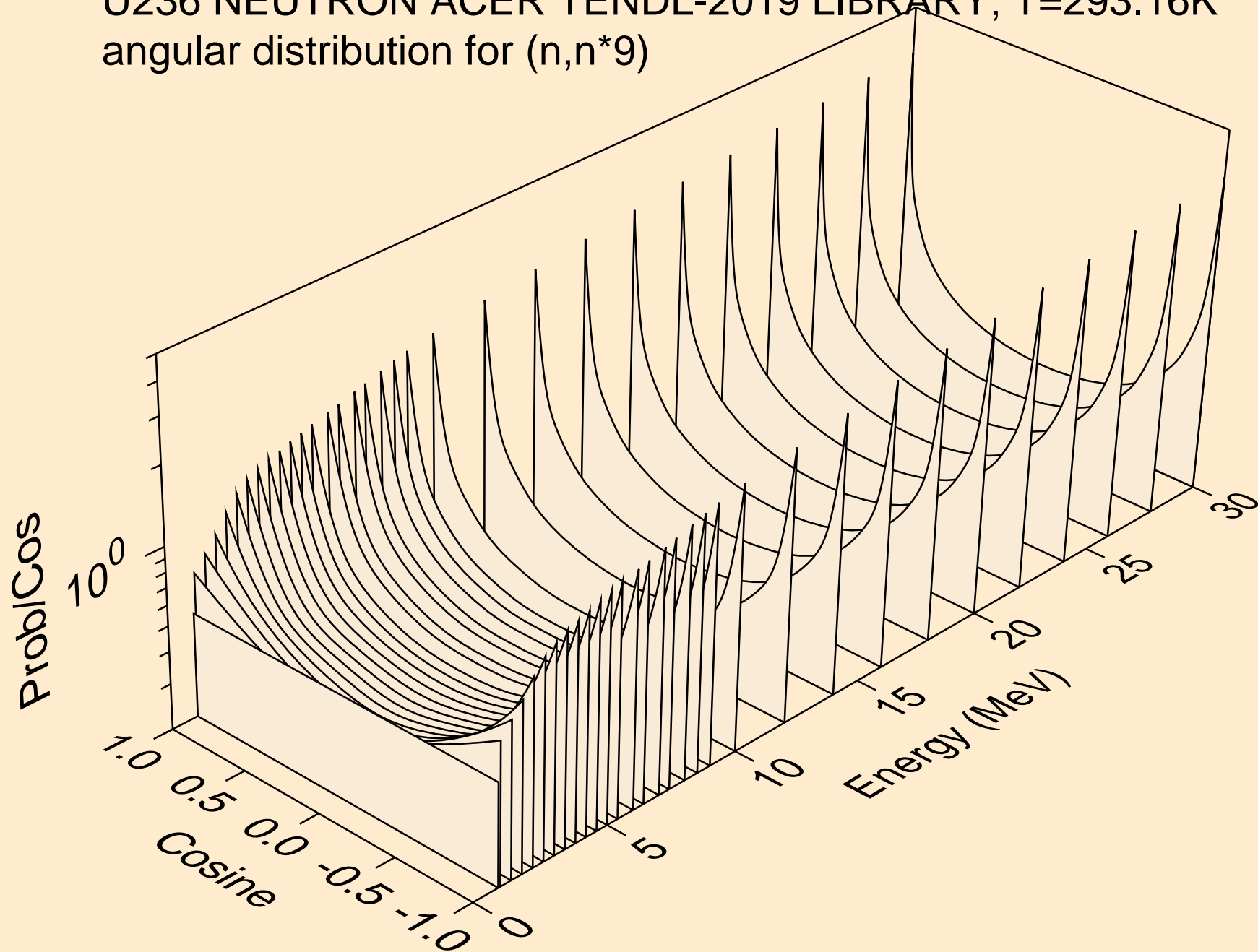

U236 NEUTRON ACER TENDL-2019 LIBRARY; T=293.16K
angular distribution for (n,n*10)

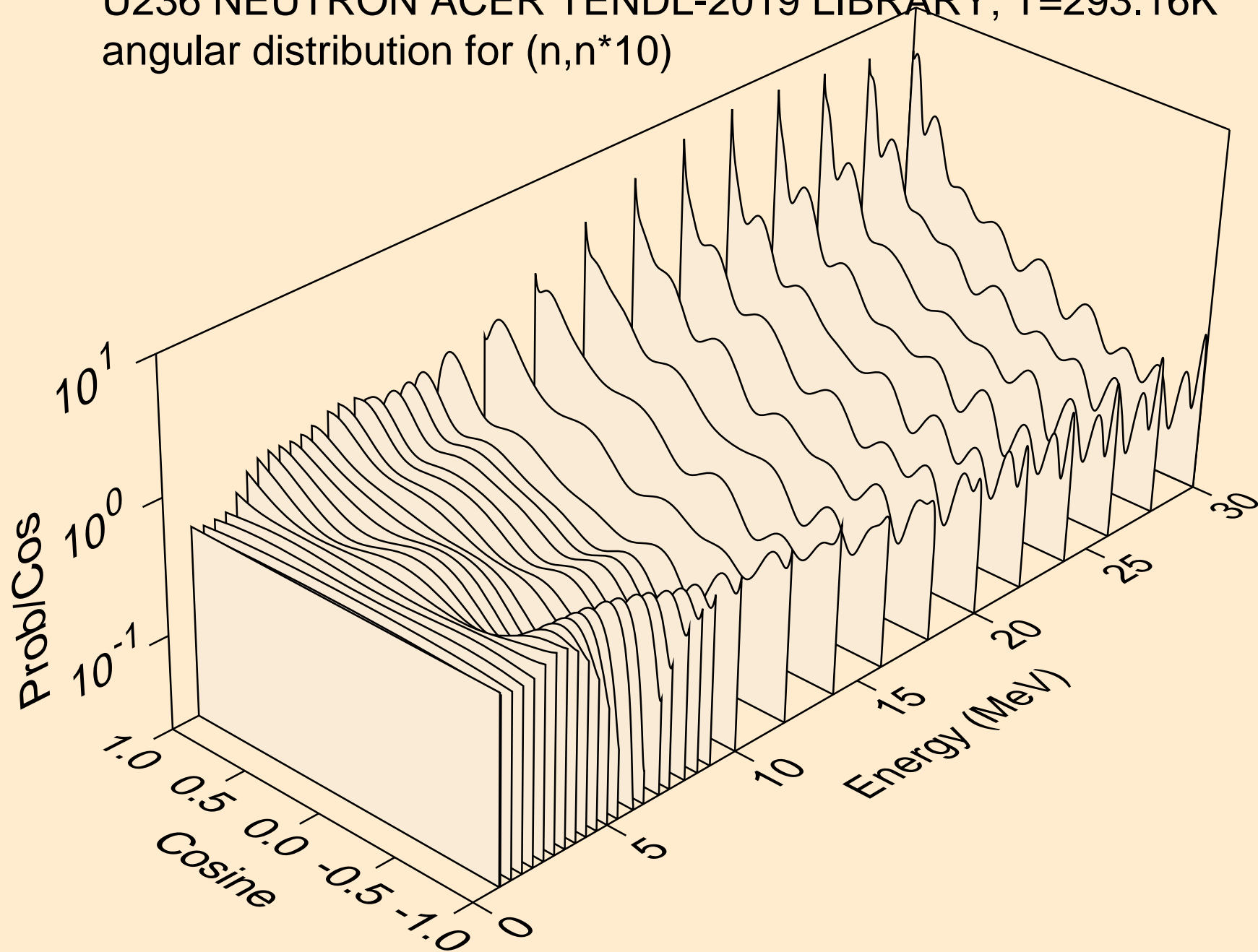

U236 NEUTRON ACER TENDL-2019 LIBRARY; T=293.16K
angular distribution for (n,n*11)

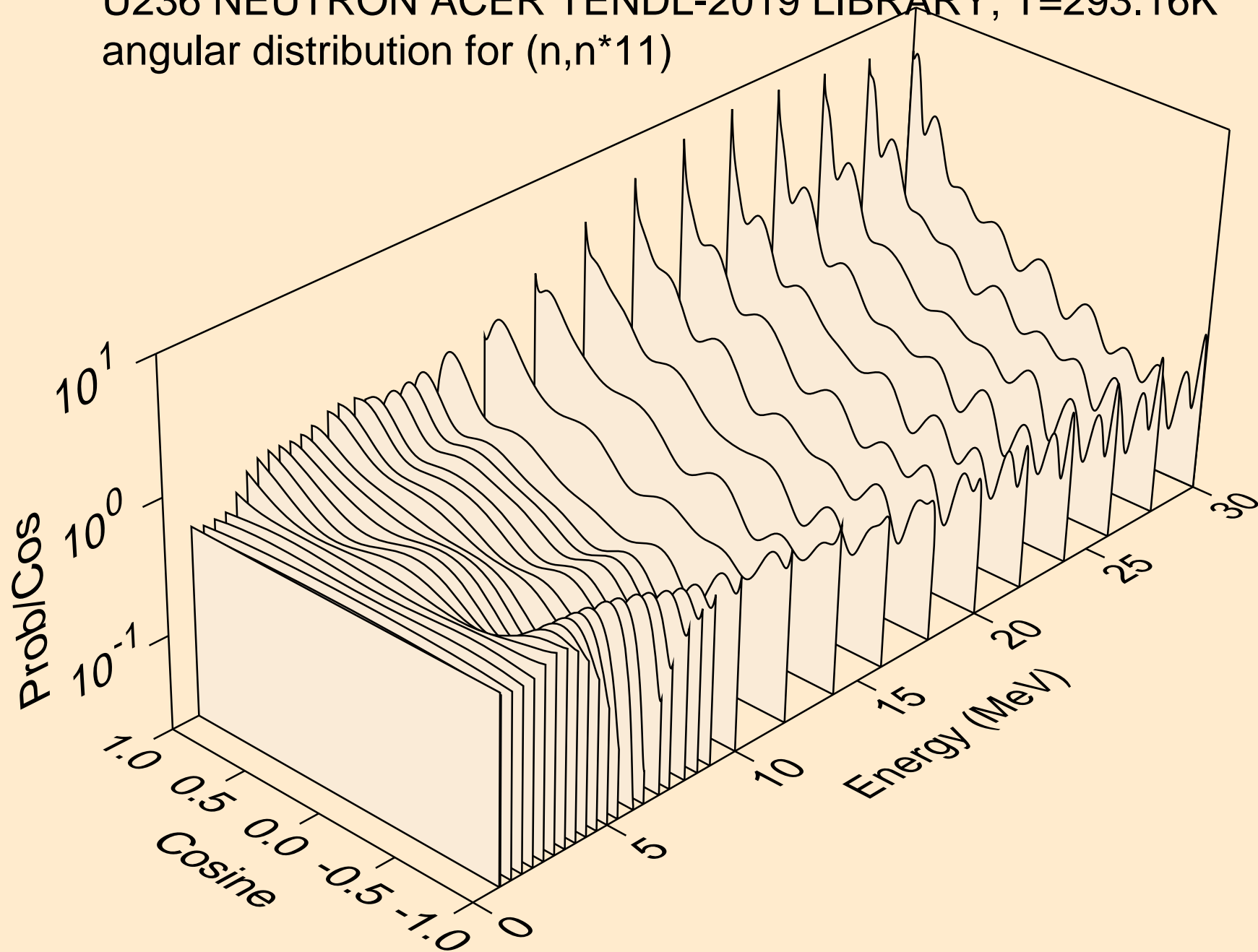

U236 NEUTRON ACER TENDL-2019 LIBRARY; T=293.16K
angular distribution for (n,n*12)

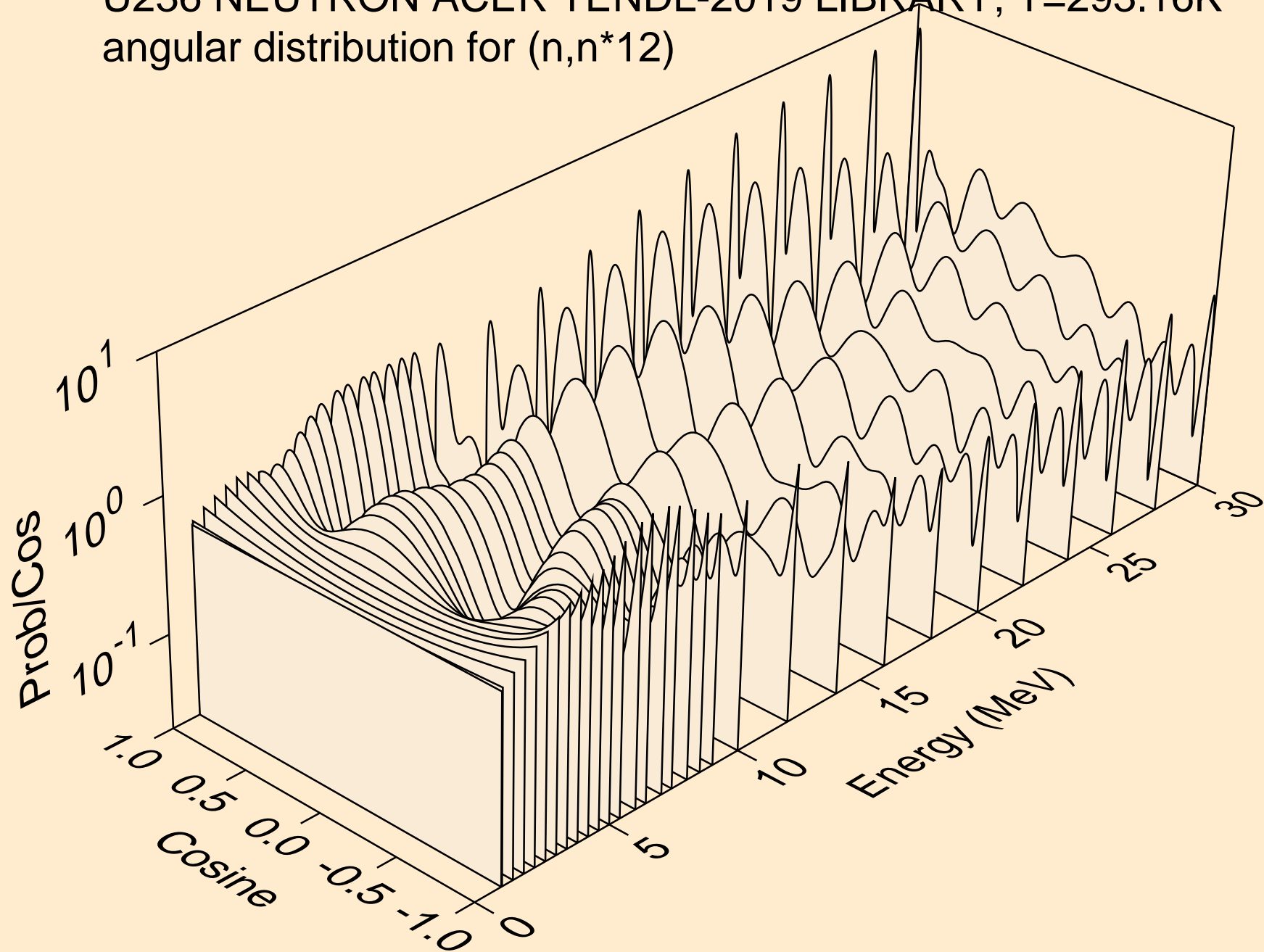

U236 NEUTRON ACER TENDL-2019 LIBRARY; T=293.16K
angular distribution for (n,n*13)

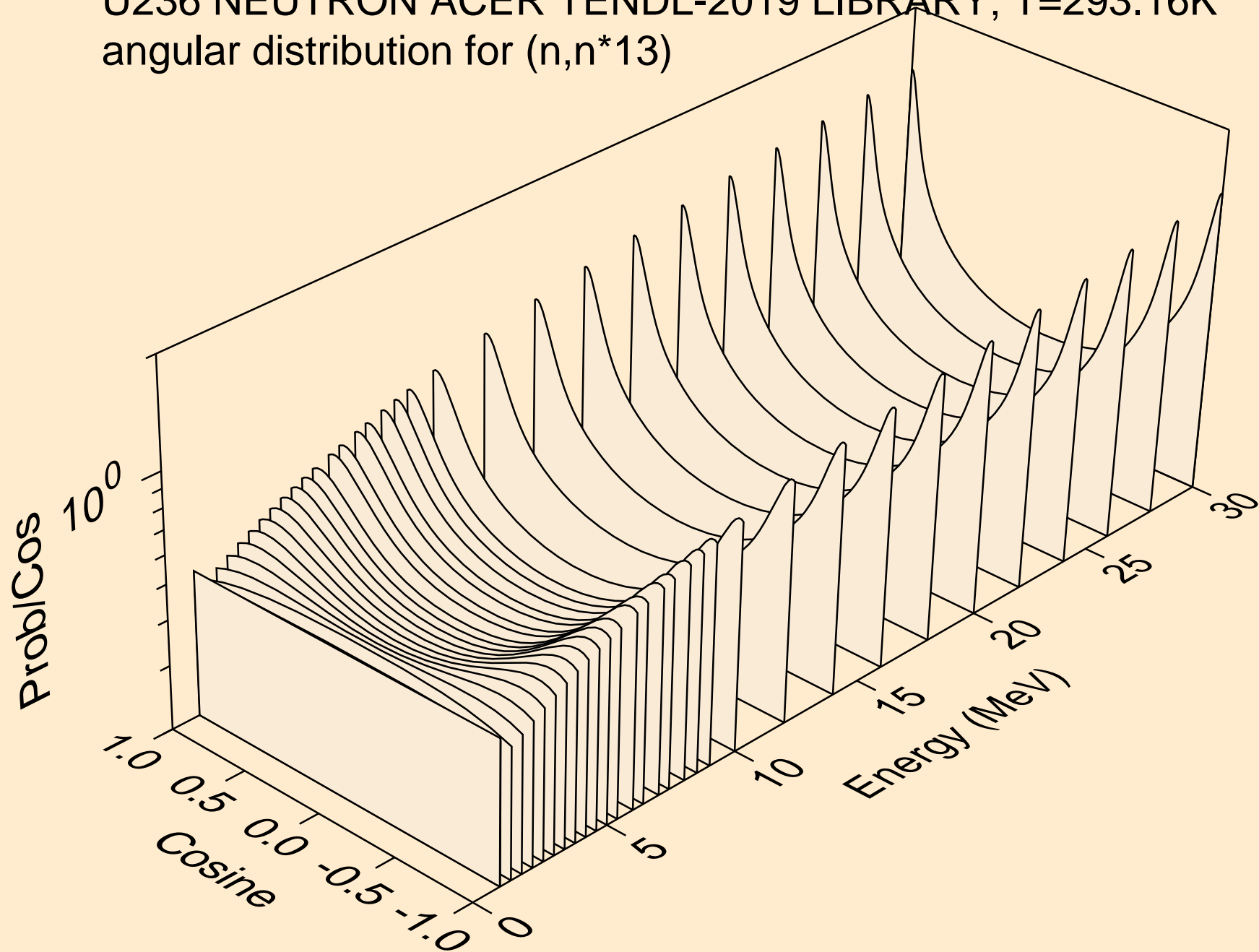

U236 NEUTRON ACER TENDL-2019 LIBRARY; T=293.16K
angular distribution for (n,n*14)

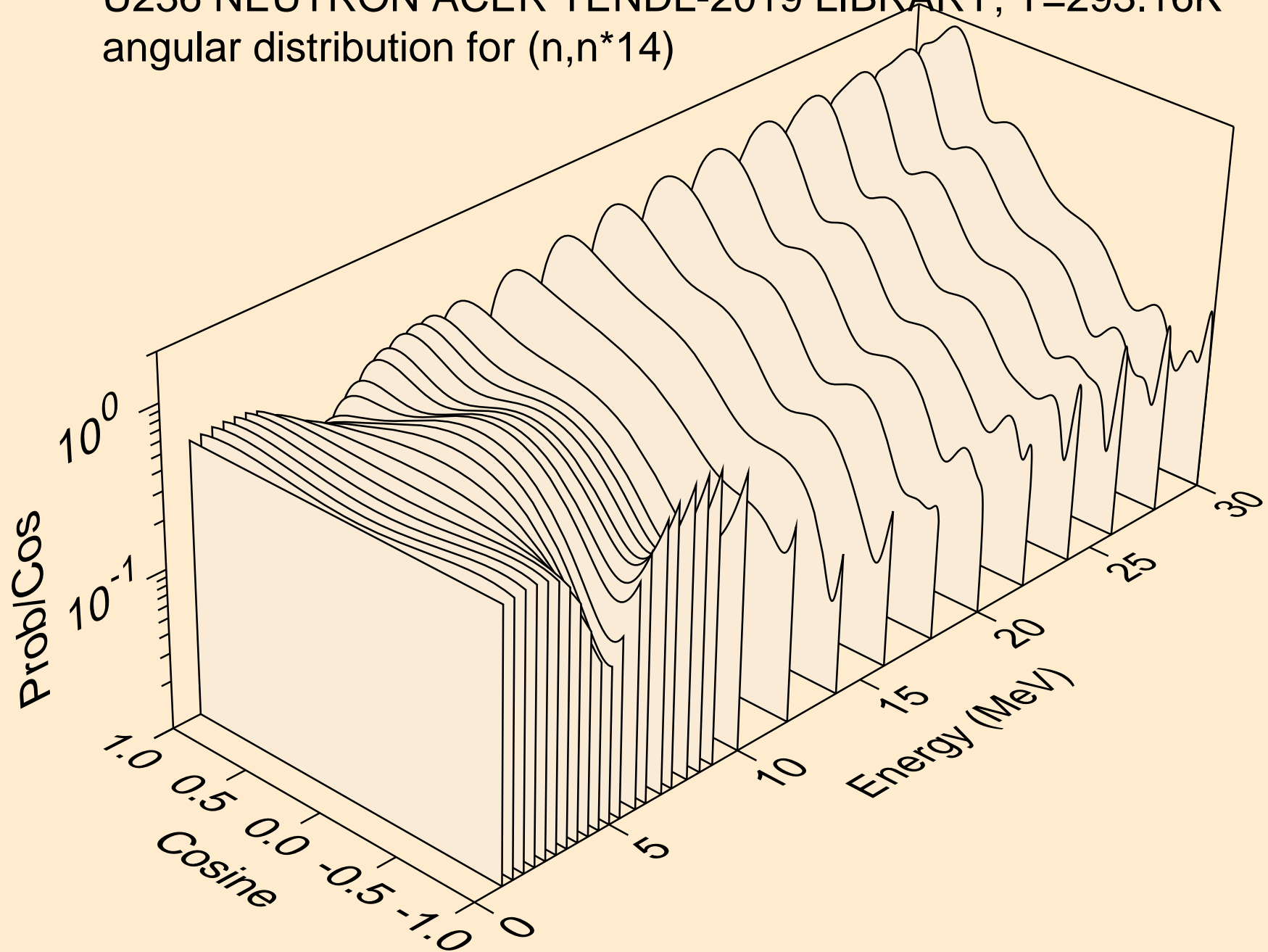

U236 NEUTRON ACER TENDL-2019 LIBRARY; T=293.16K
angular distribution for (n,n*15)

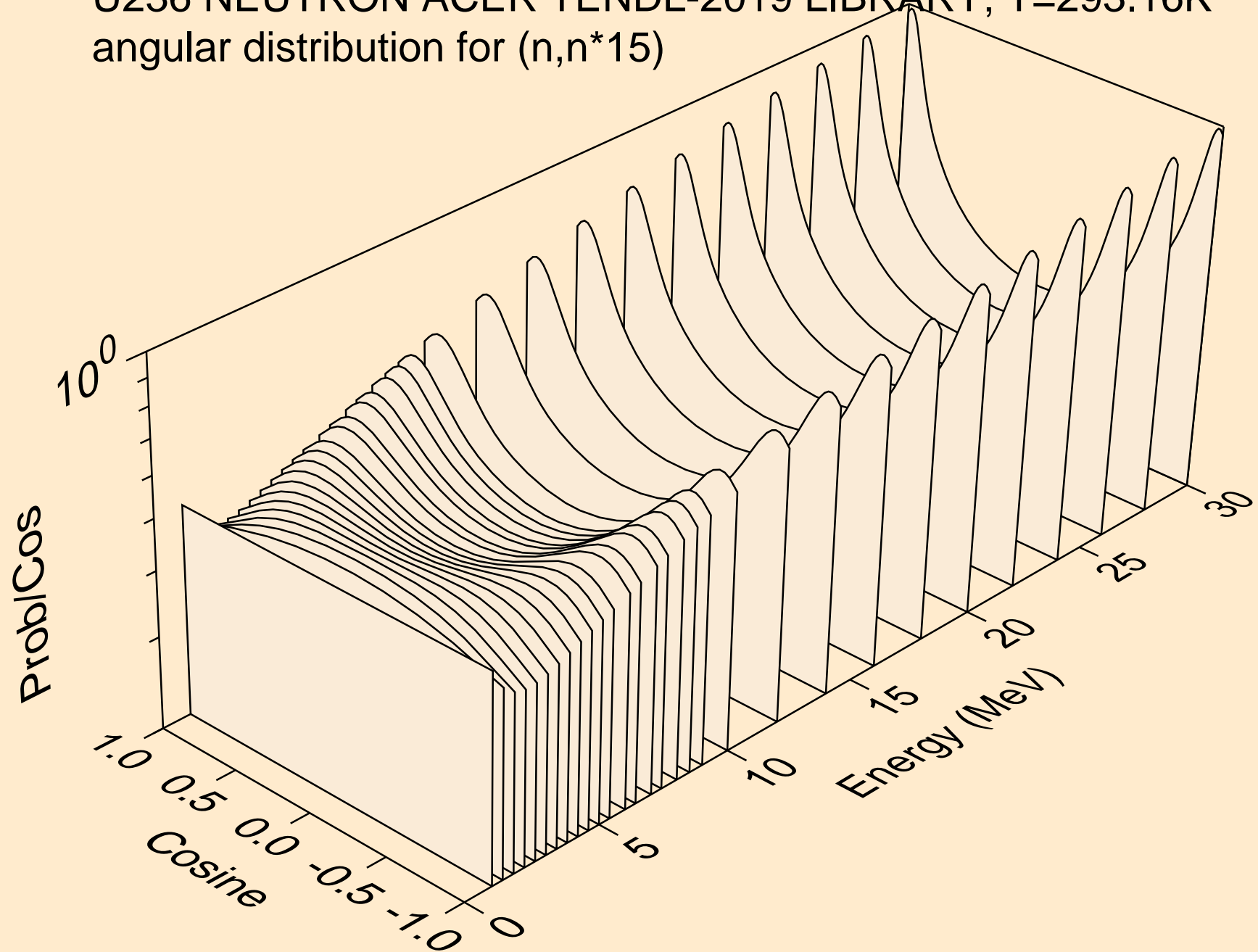

U236 NEUTRON ACER TENDL-2019 LIBRARY; T=293.16K
angular distribution for (n,n*16)

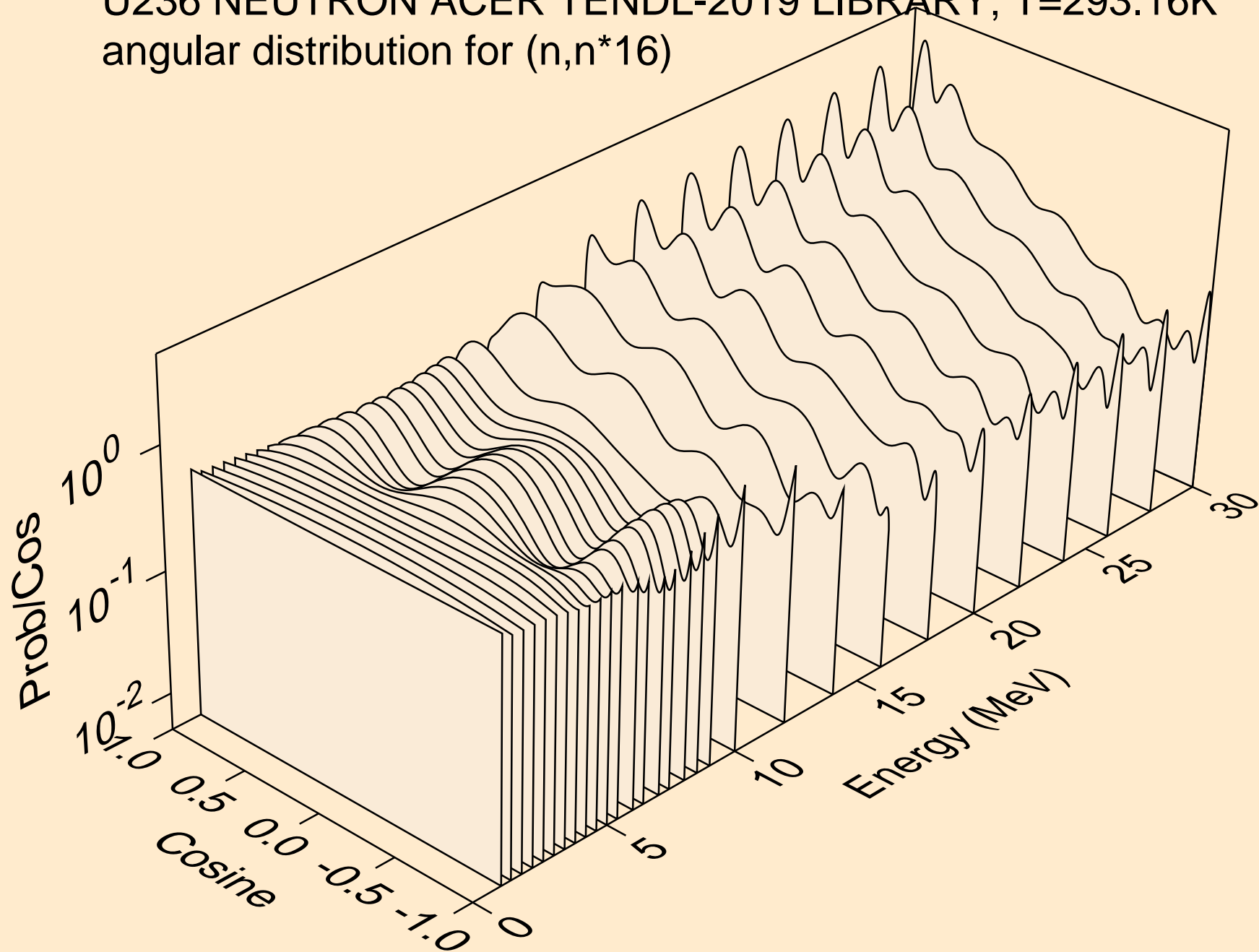

U236 NEUTRON ACER TENDL-2019 LIBRARY; T=293.16K
angular distribution for (n,n*17)

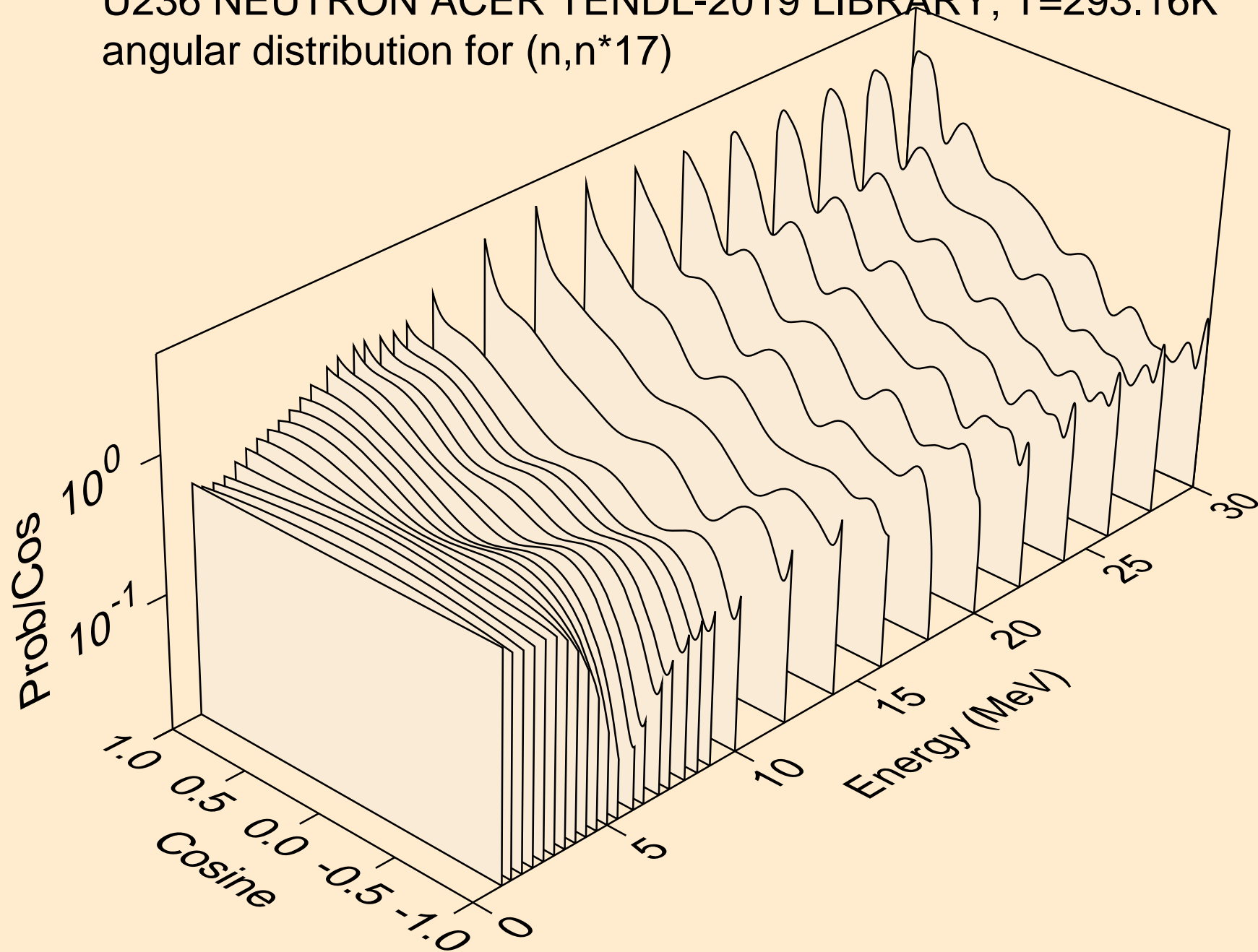

U236 NEUTRON ACER TENDL-2019 LIBRARY; T=293.16K
angular distribution for (n,n*18)

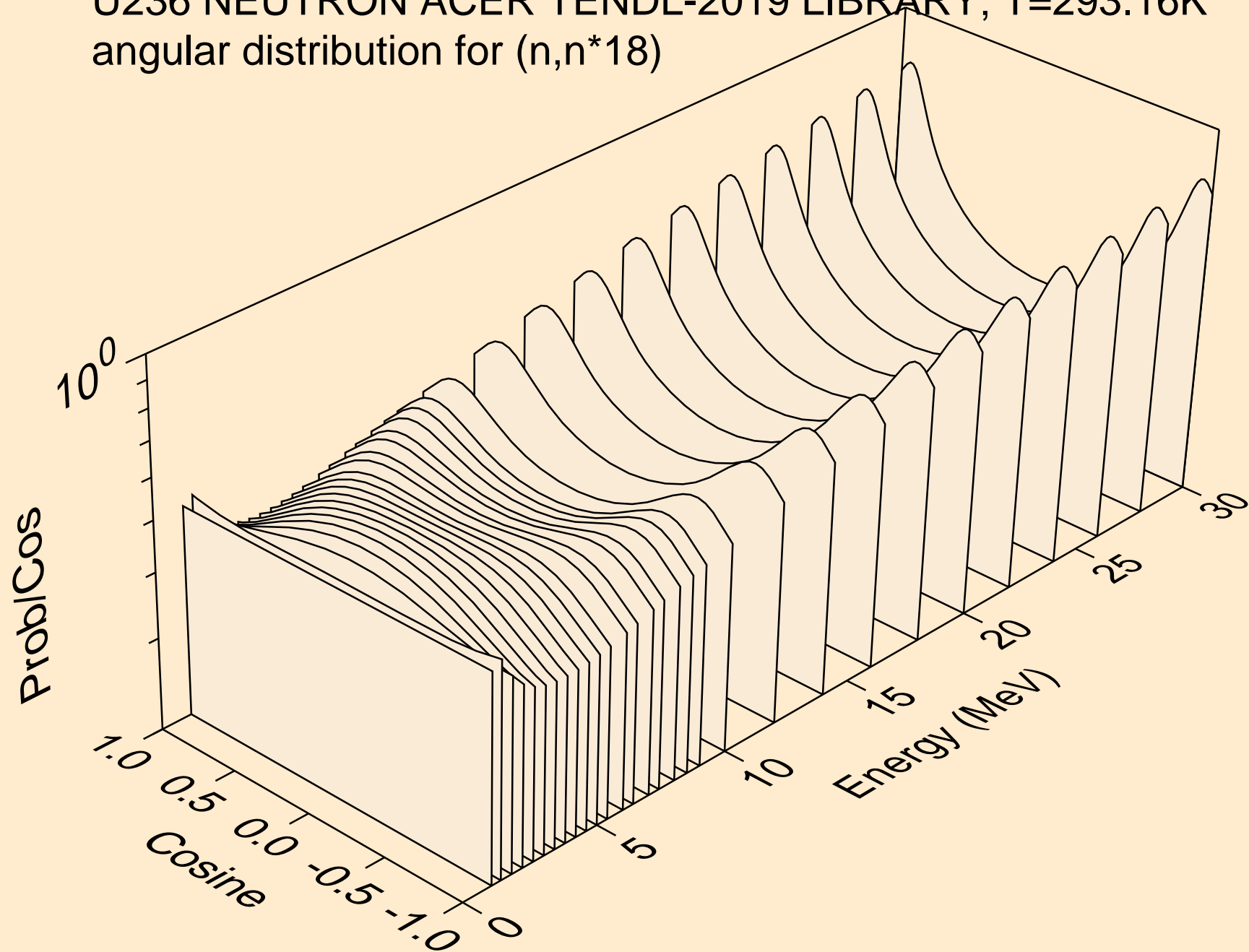

U236 NEUTRON ACER TENDL-2019 LIBRARY; T=293.16K
angular distribution for (n,n*19)

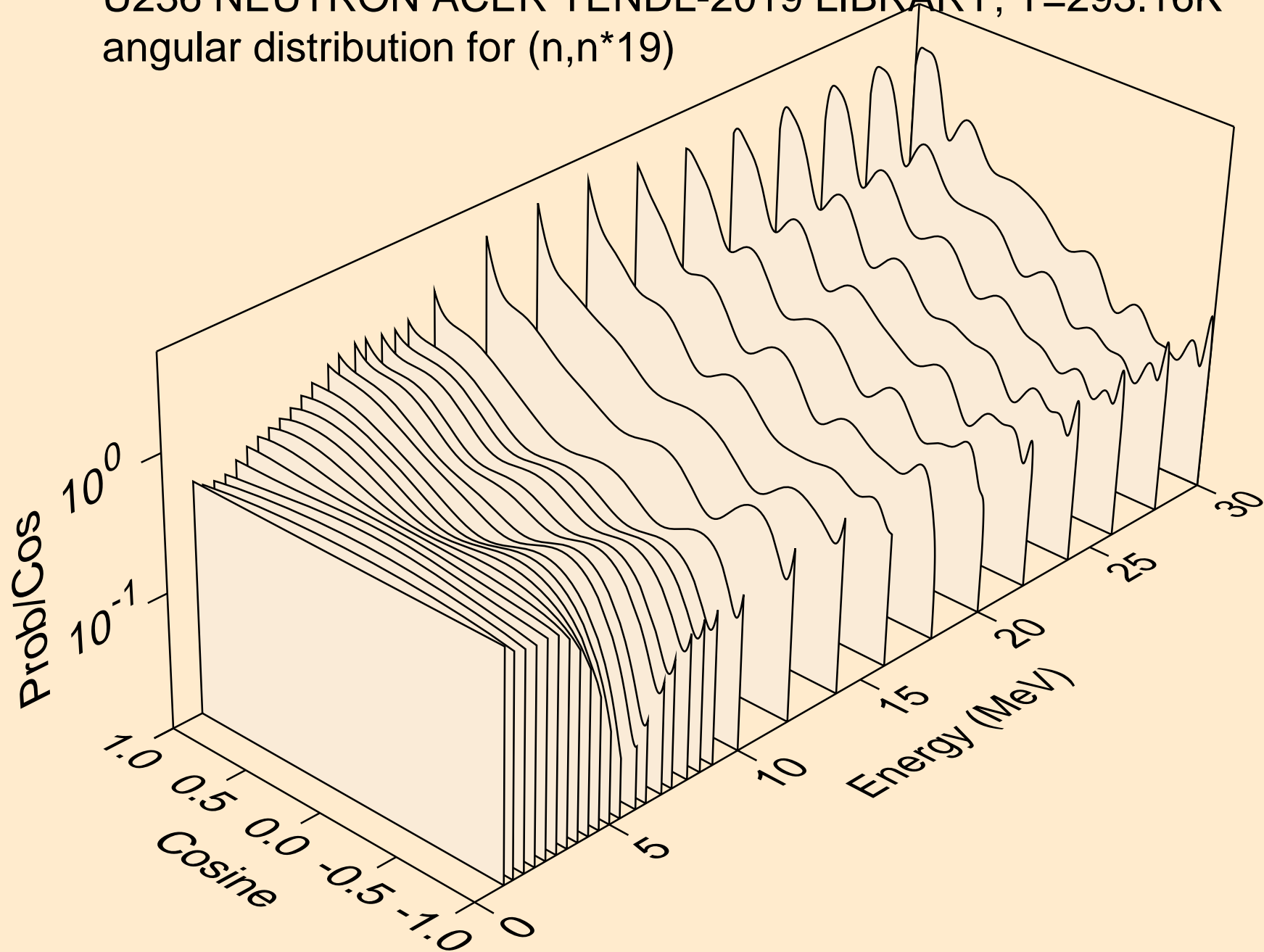

U236 NEUTRON ACER TENDL-2019 LIBRARY; T=293.16K
angular distribution for (n,n*20)

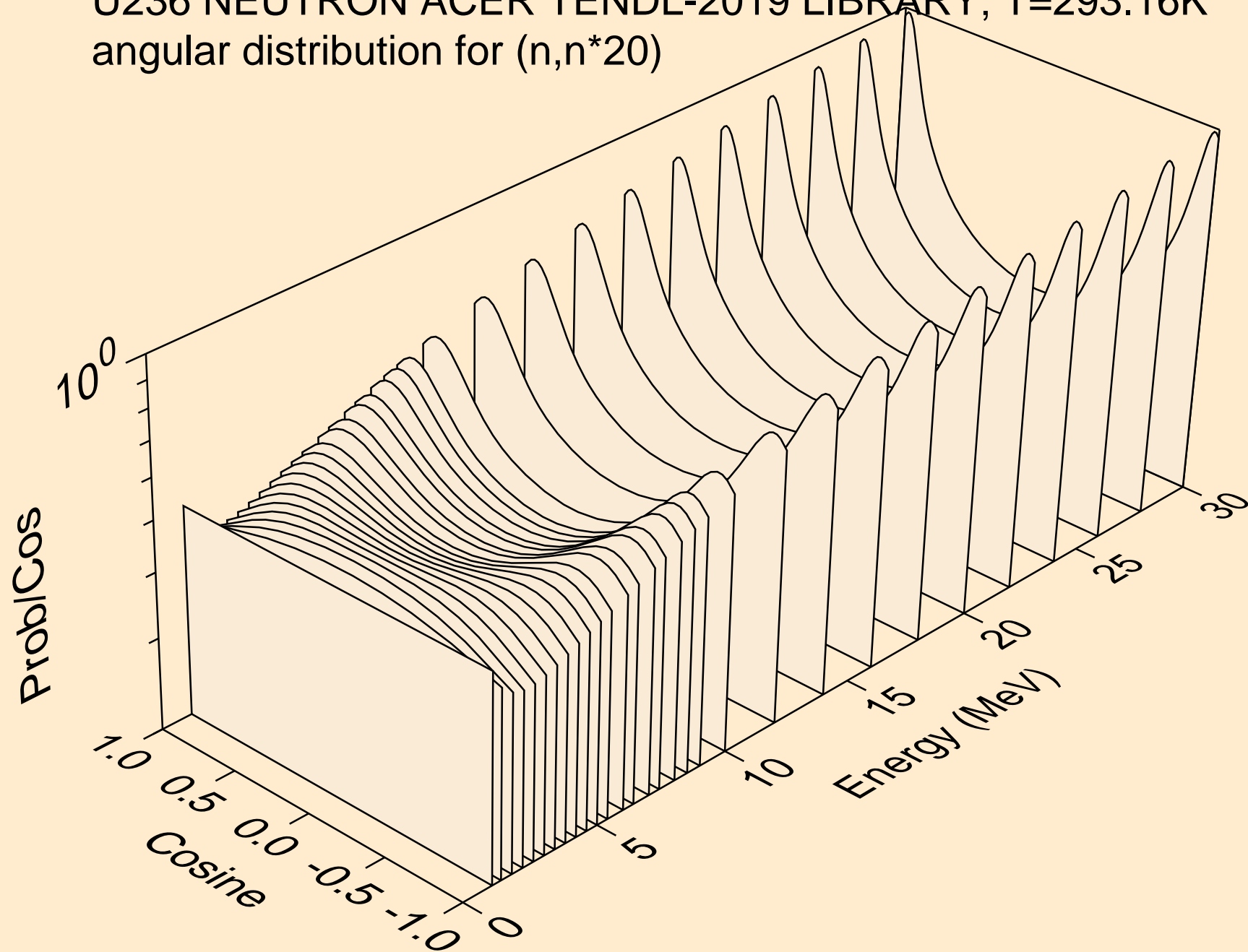

U236 NEUTRON ACER TENDL-2019 LIBRARY; T=293.16K
angular distribution for (n,n*21)

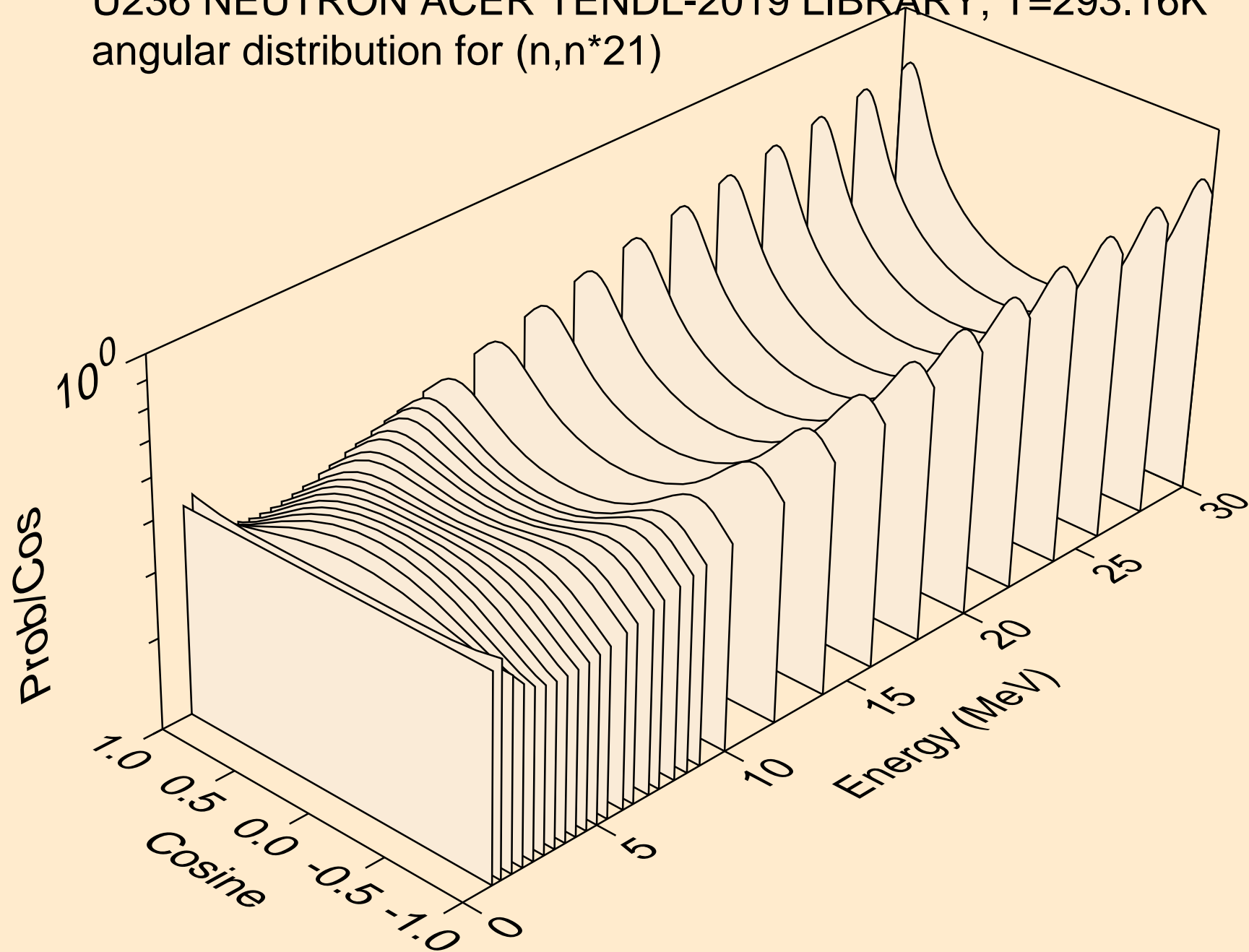

U236 NEUTRON ACER TENDL-2019 LIBRARY; T=293.16K
angular distribution for (n,n*22)

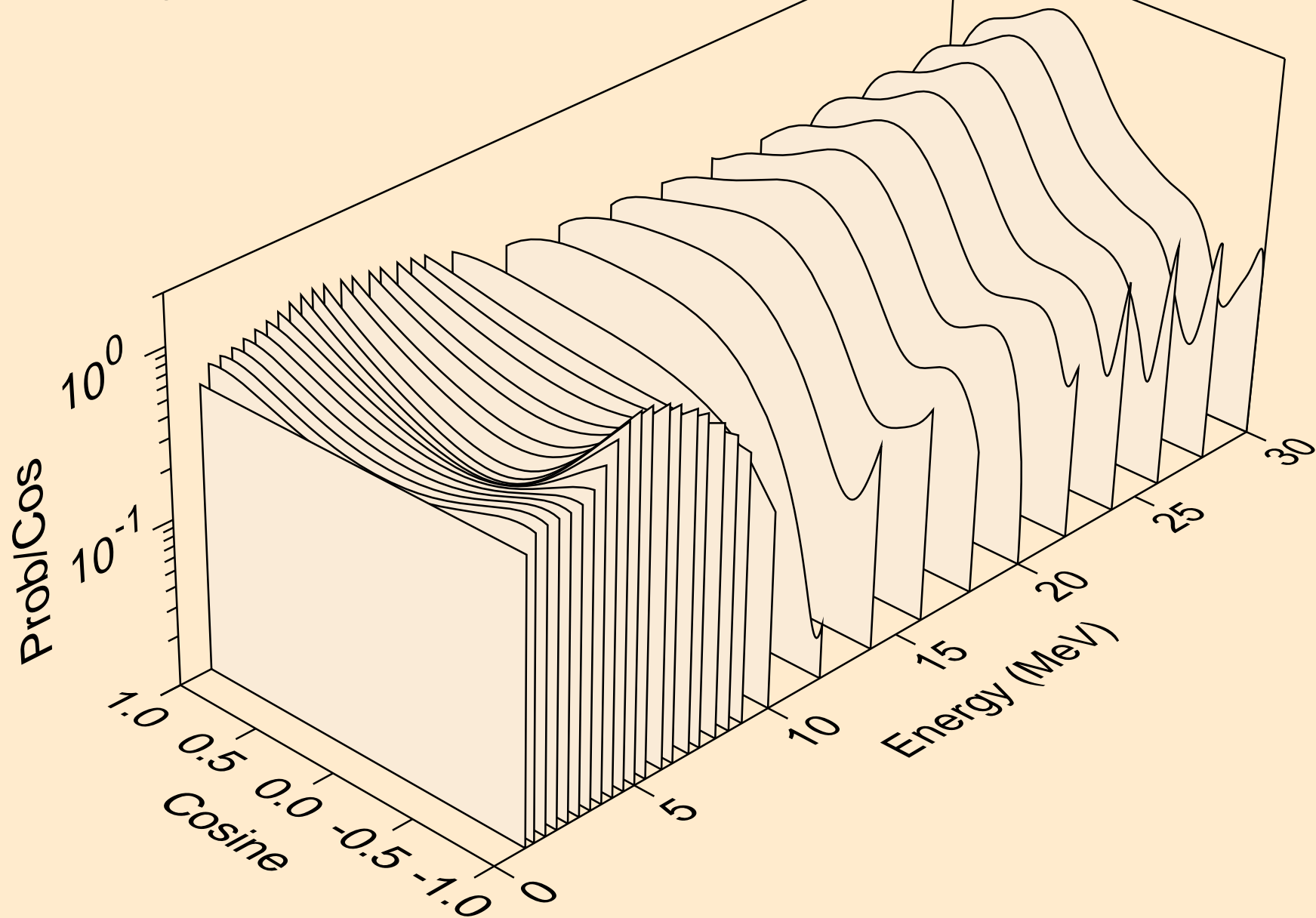

U236 NEUTRON ACER TENDL-2019 LIBRARY; T=293.16K
angular distribution for (n,n*23)

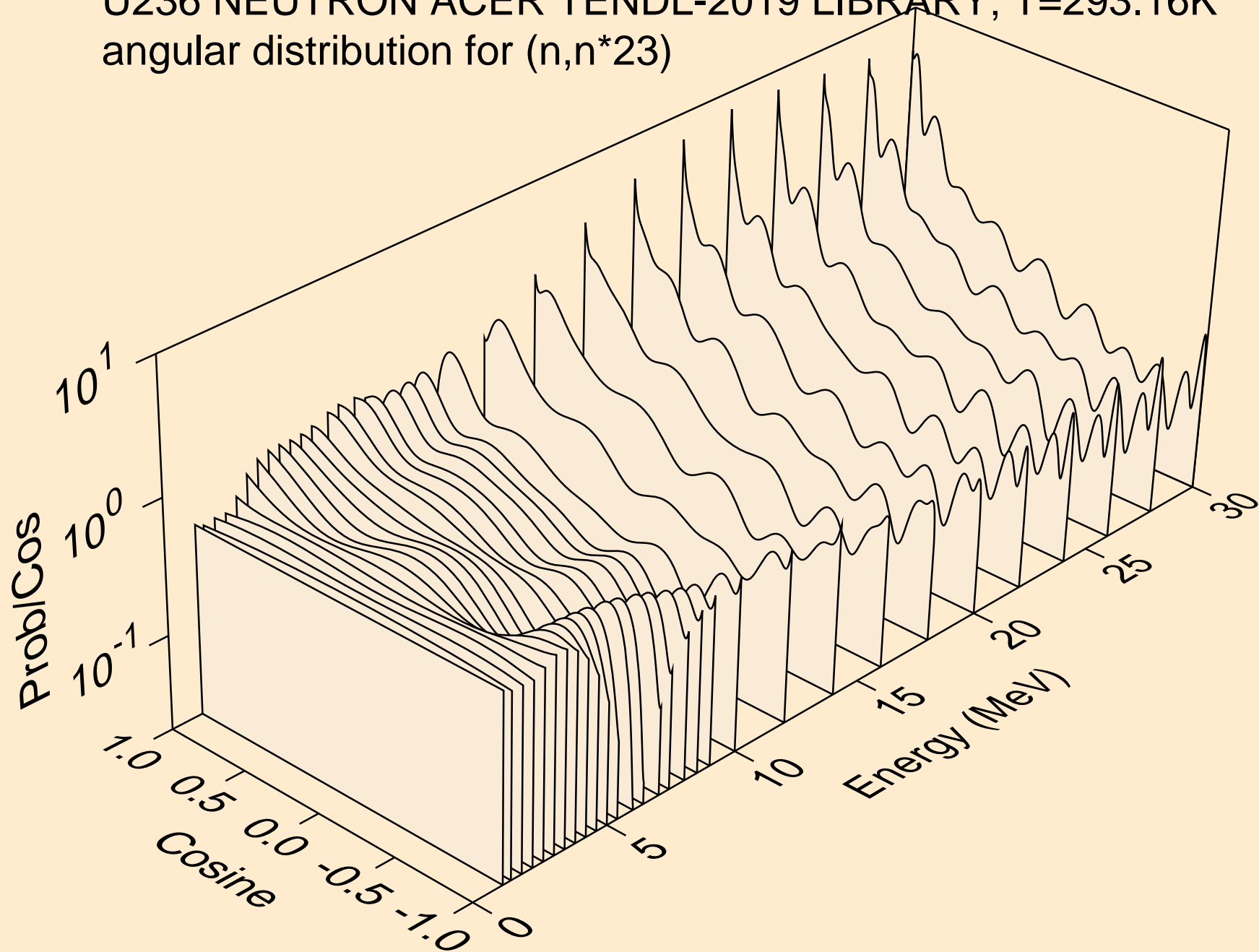

U236 NEUTRON ACER TENDL-2019 LIBRARY; T=293.16K
angular distribution for (n,n*24)

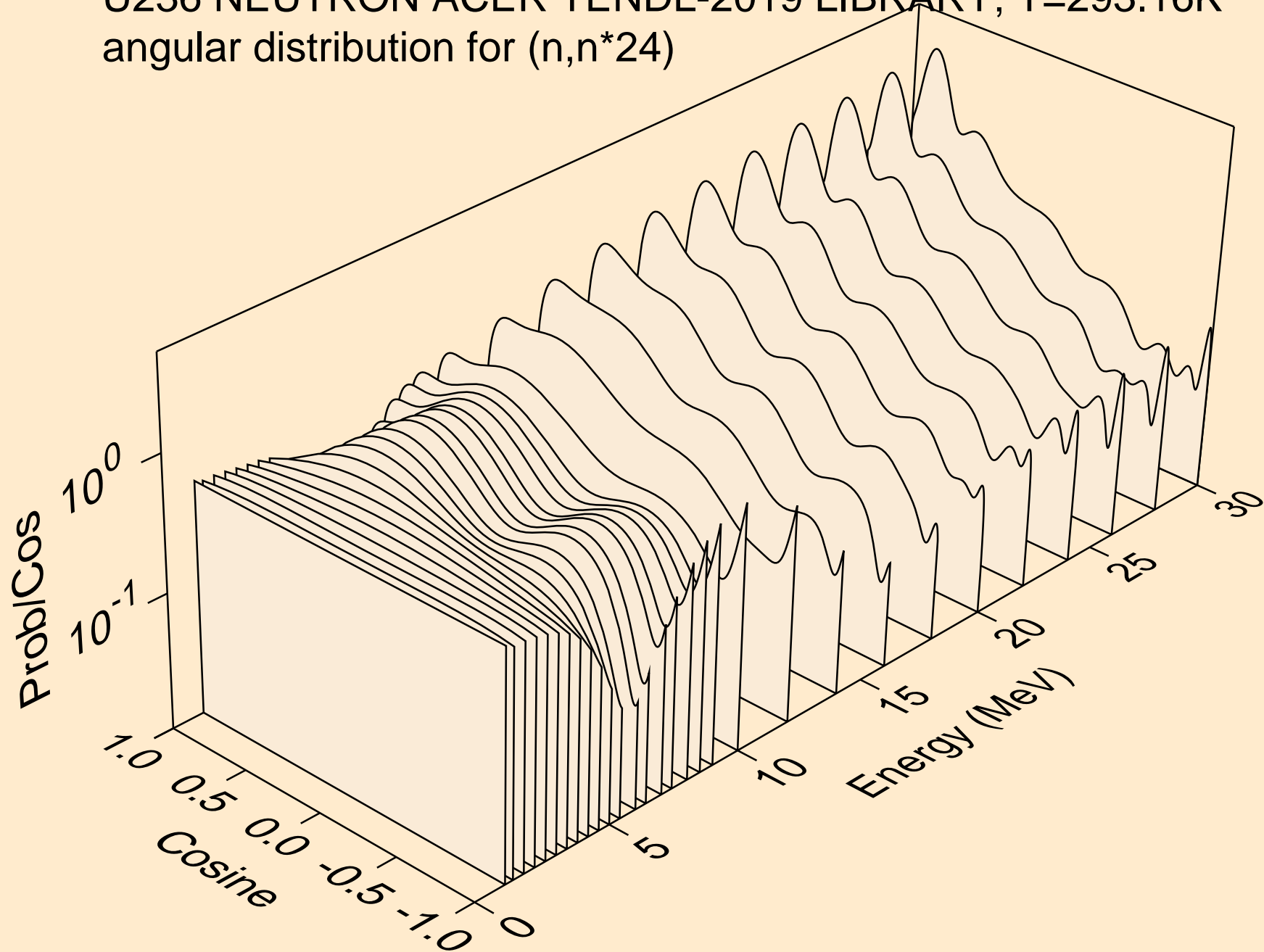

U236 NEUTRON ACER TENDL-2019 LIBRARY; T=293.16K
angular distribution for (n,n*25)

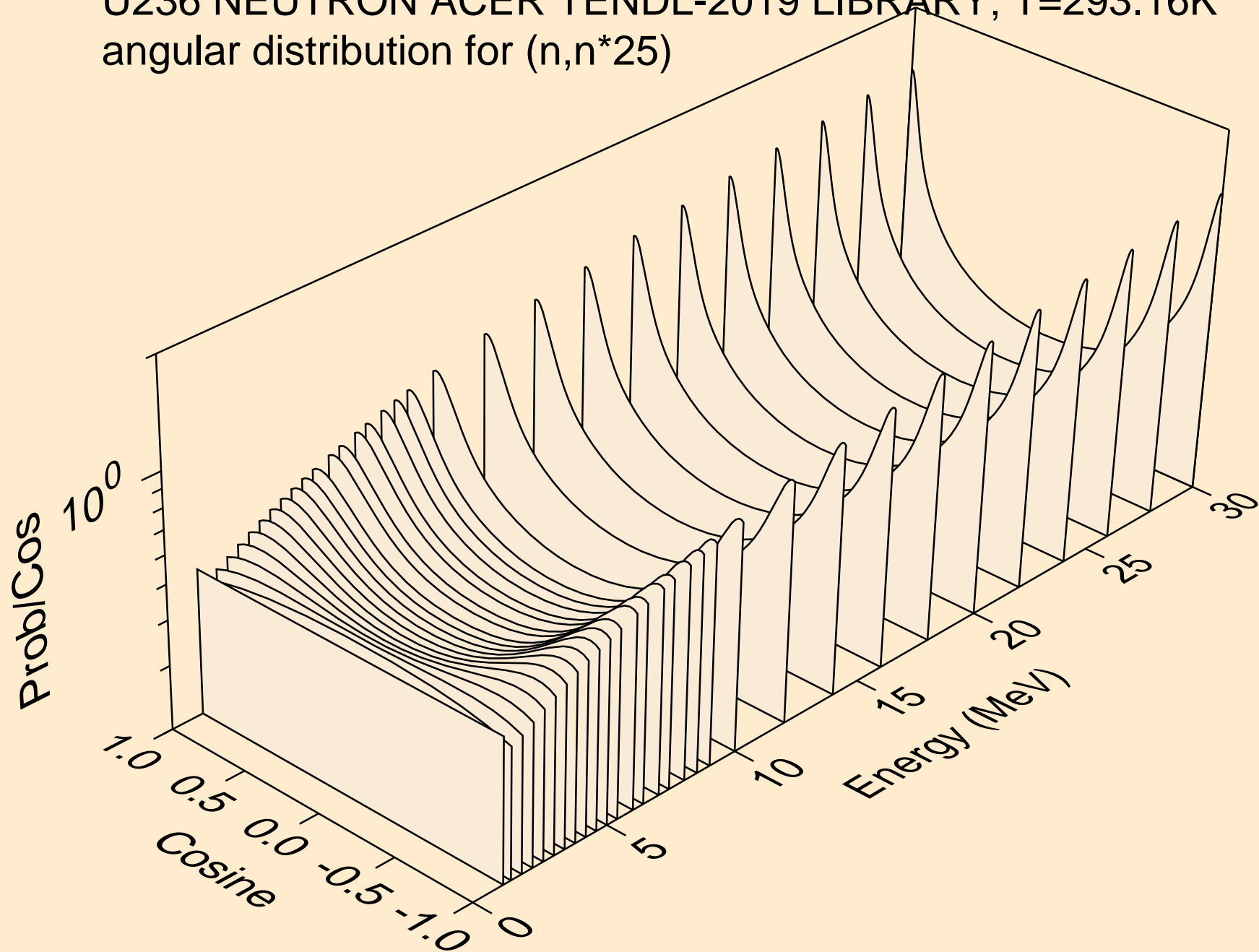

U236 NEUTRON ACER TENDL-2019 LIBRARY; T=293.16K
angular distribution for (n,n*26)

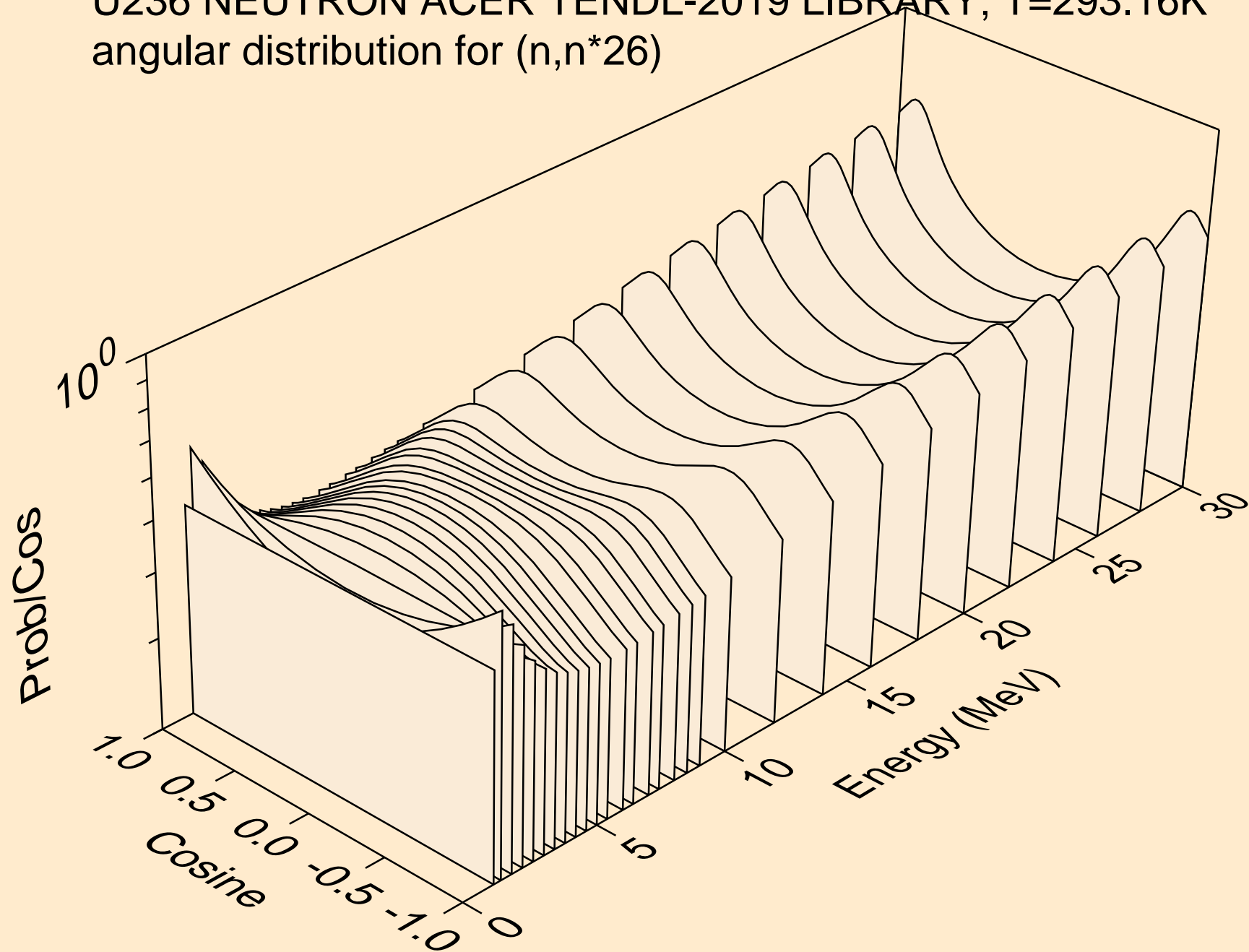

U236 NEUTRON ACER TENDL-2019 LIBRARY; T=293.16K
angular distribution for (n,n*27)

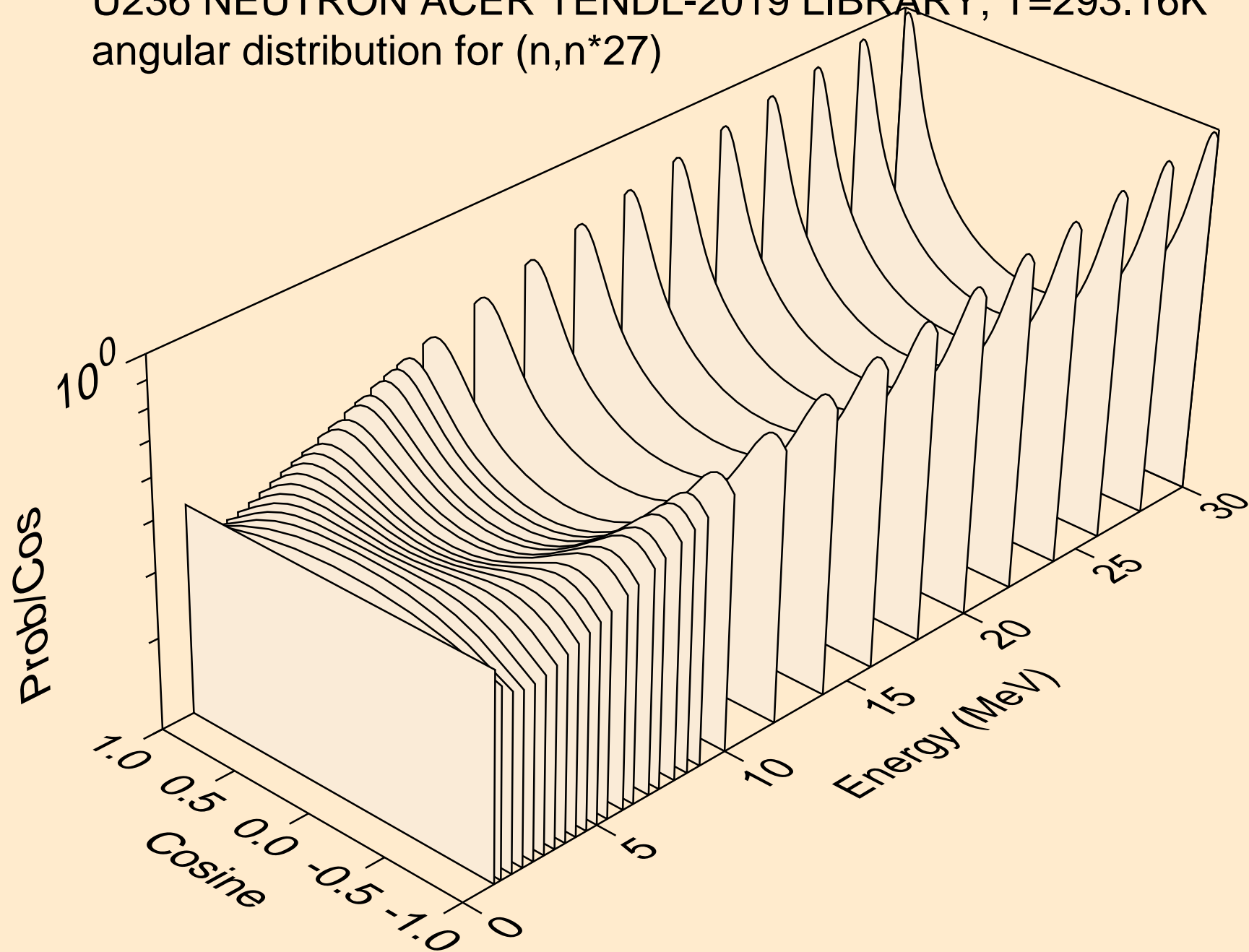

U236 NEUTRON ACER TENDL-2019 LIBRARY; T=293.16K
angular distribution for (n,n*28)

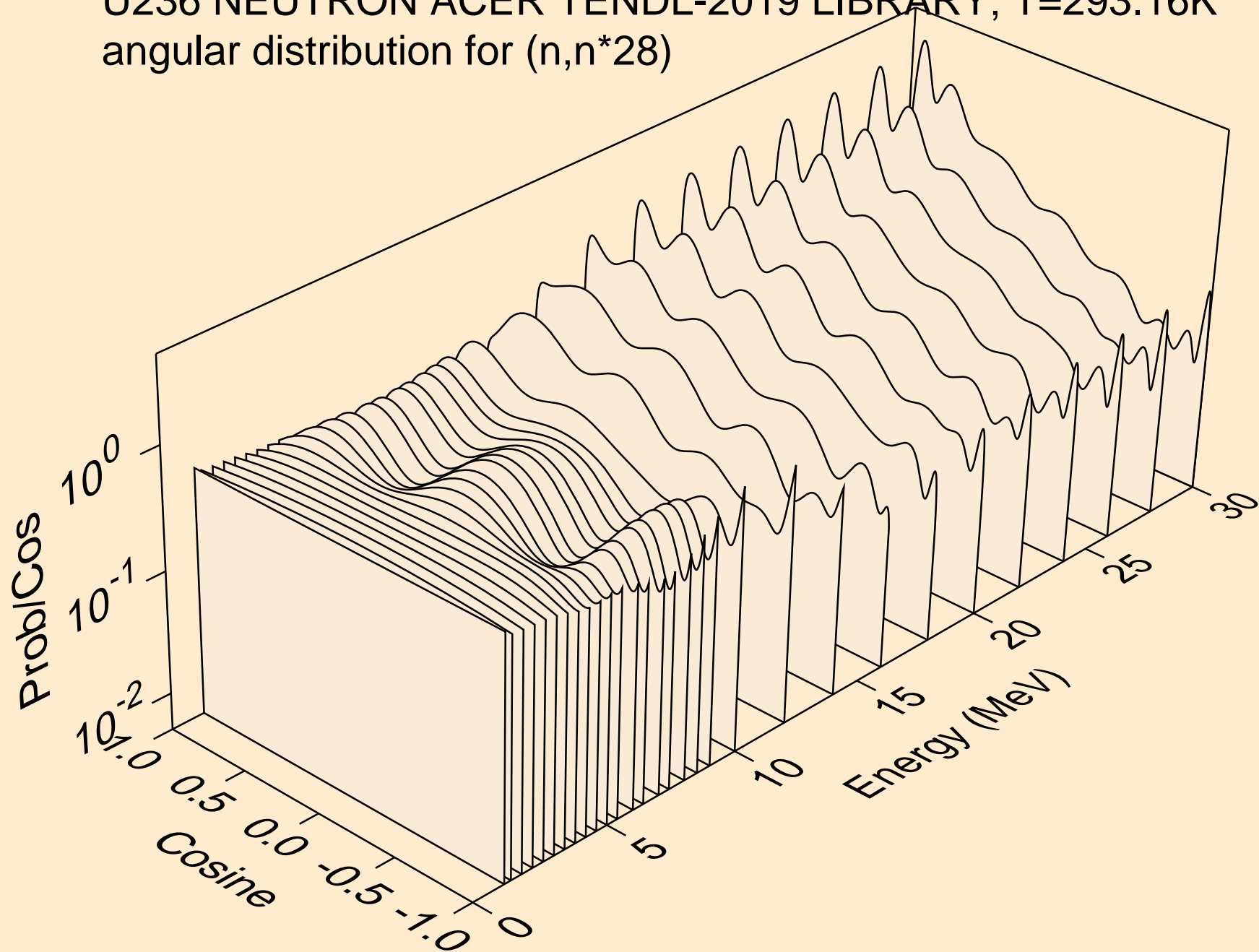

U236 NEUTRON ACER TENDL-2019 LIBRARY; T=293.16K
angular distribution for (n,n*29)

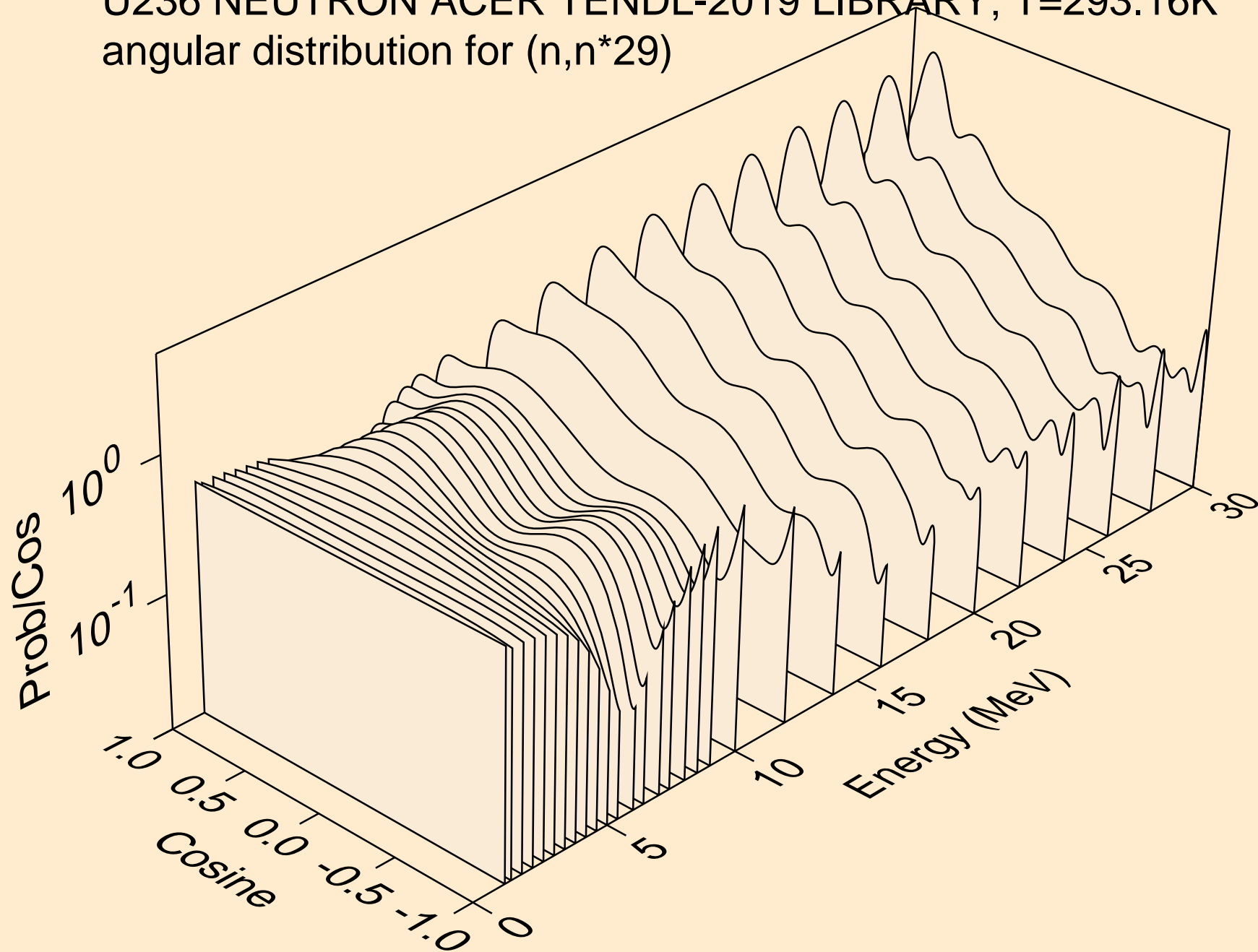

U236 NEUTRON ACER TENDL-2019 LIBRARY; T=293.16K
Total fission nubar

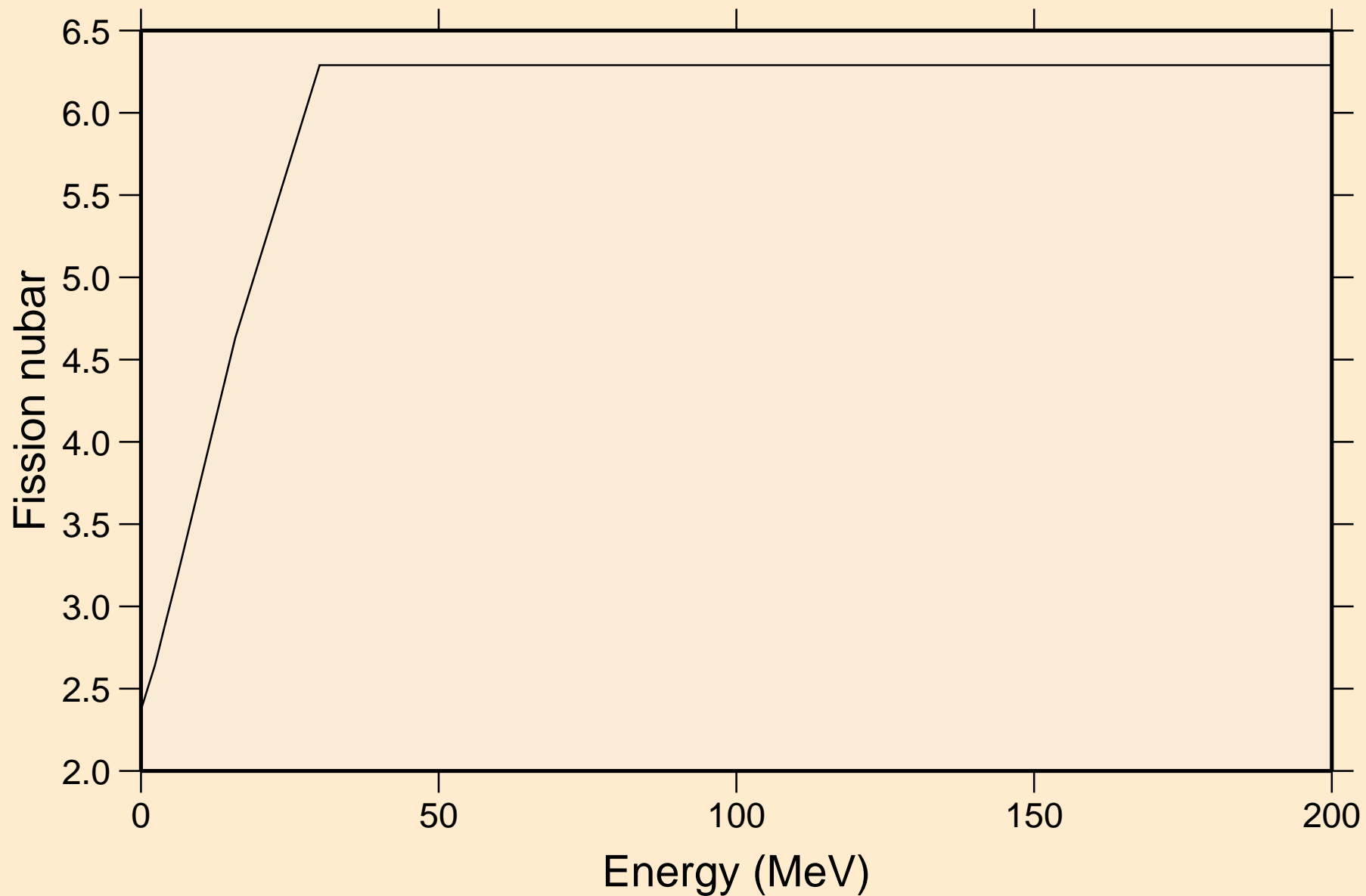

U236 NEUTRON ACER TENDL-2019 LIBRARY; T=293.16K
Neutron emission for (n,x)

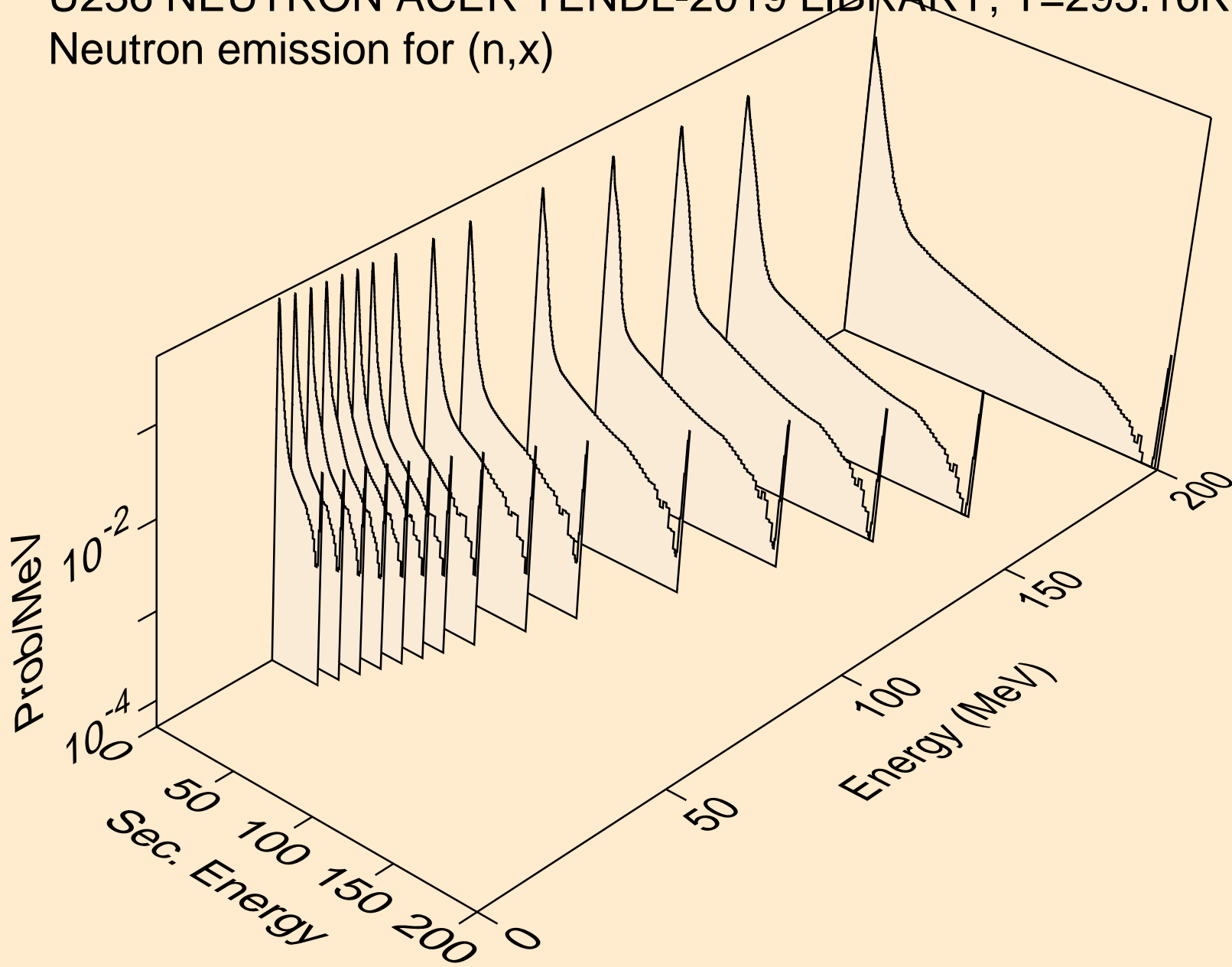

U236 NEUTRON ACER TENDL-2019 LIBRARY; T=293.16K
Neutron emission for (n,2nd)

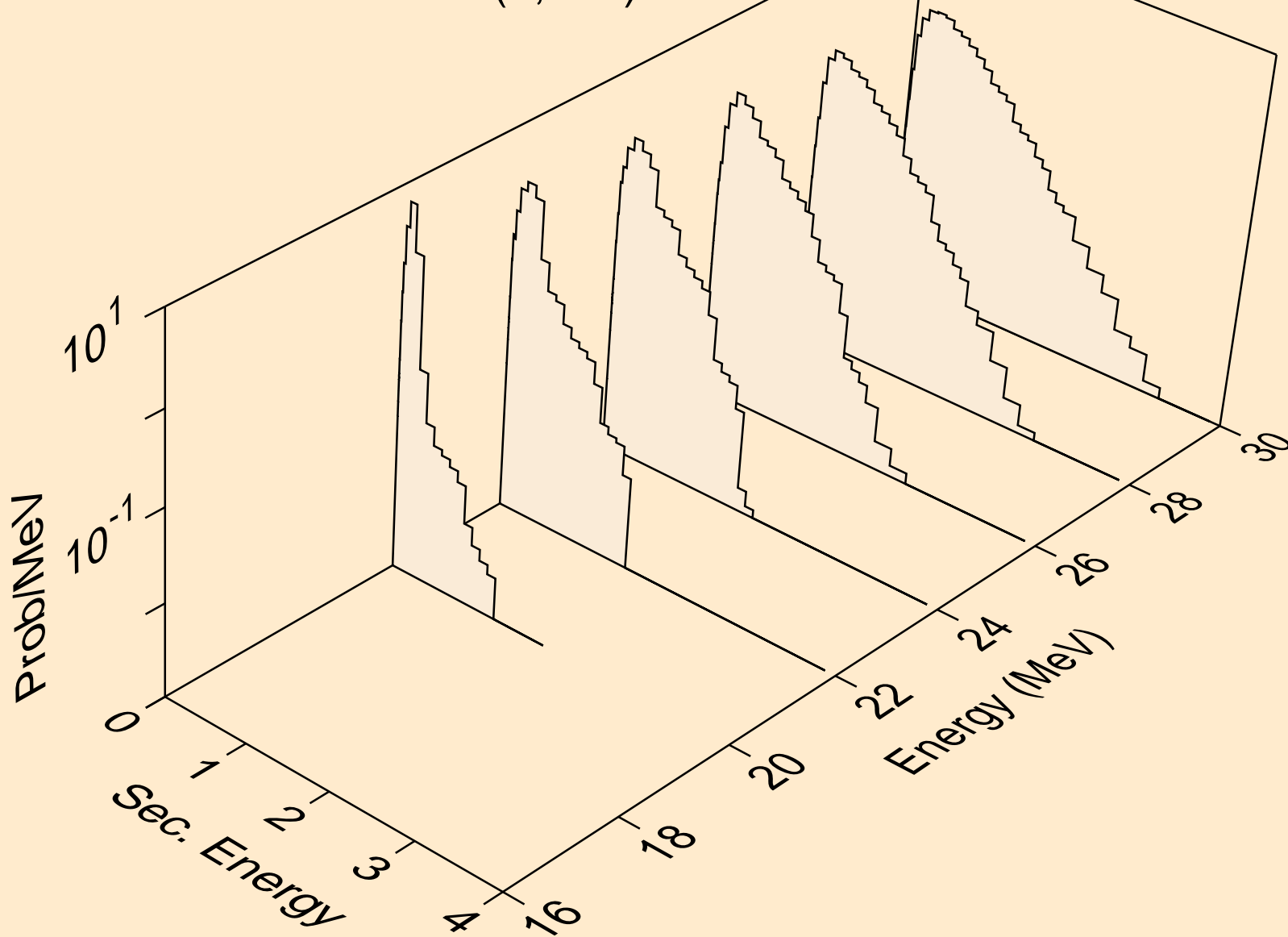

U236 NEUTRON ACER TENDL-2019 LIBRARY; T=293.16K
Neutron emission for (n,2n)

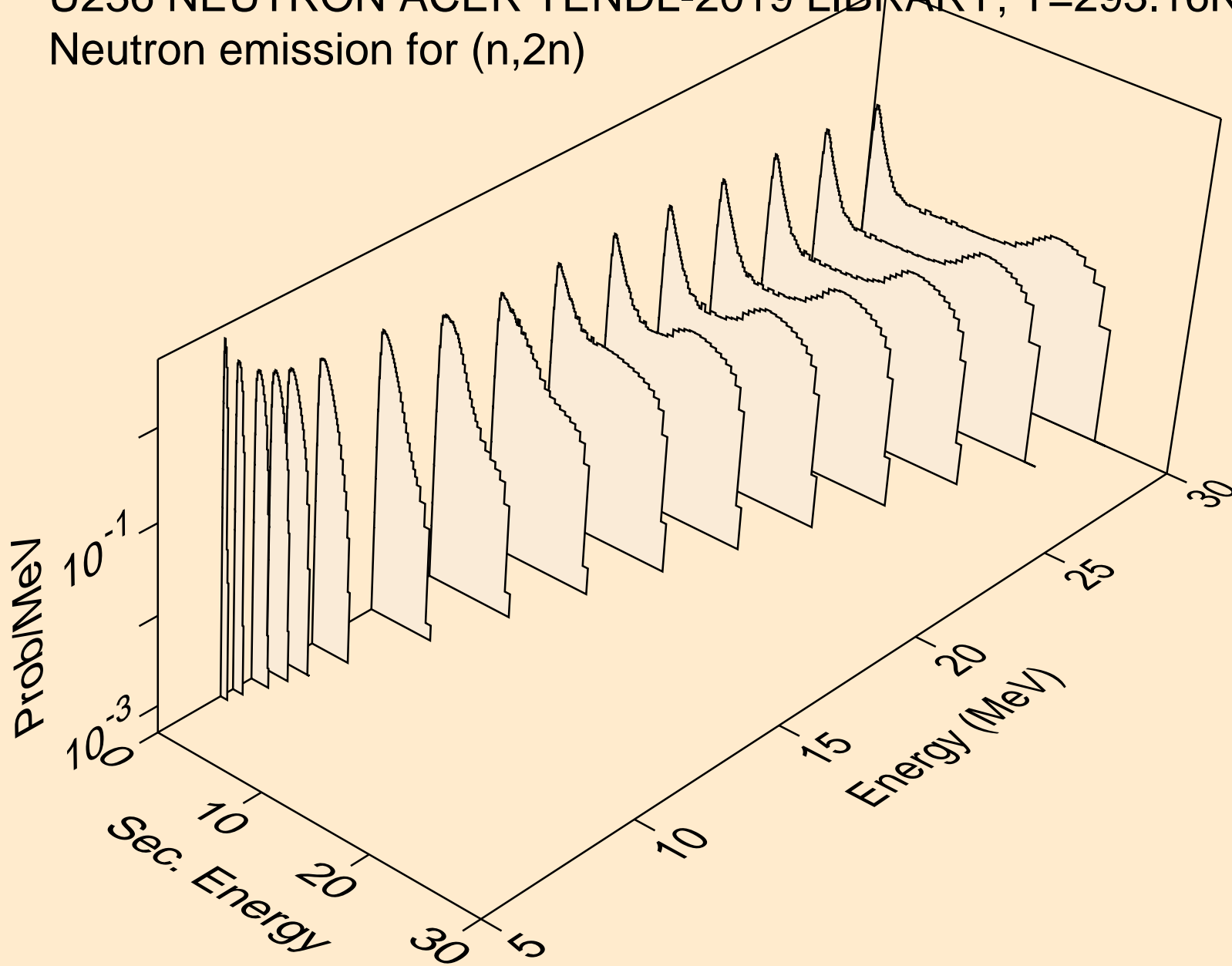

U236 NEUTRON ACER TENDL-2019 LIBRARY; T=293.16K
Neutron emission for (n,3n)

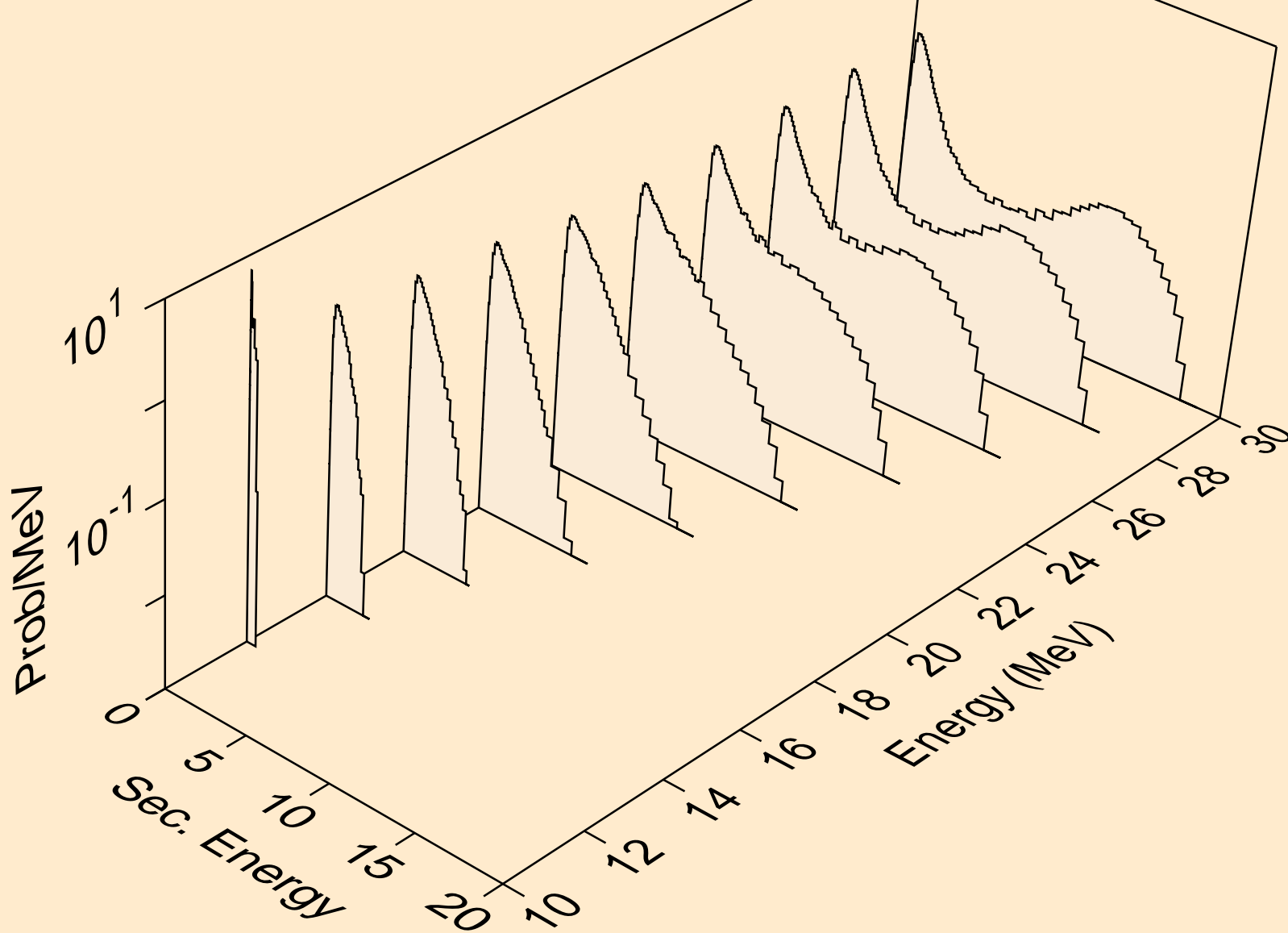

U236 NEUTRON ACER TENDL-2019 LIBRARY; T=293.16K
Neutron emission for fission

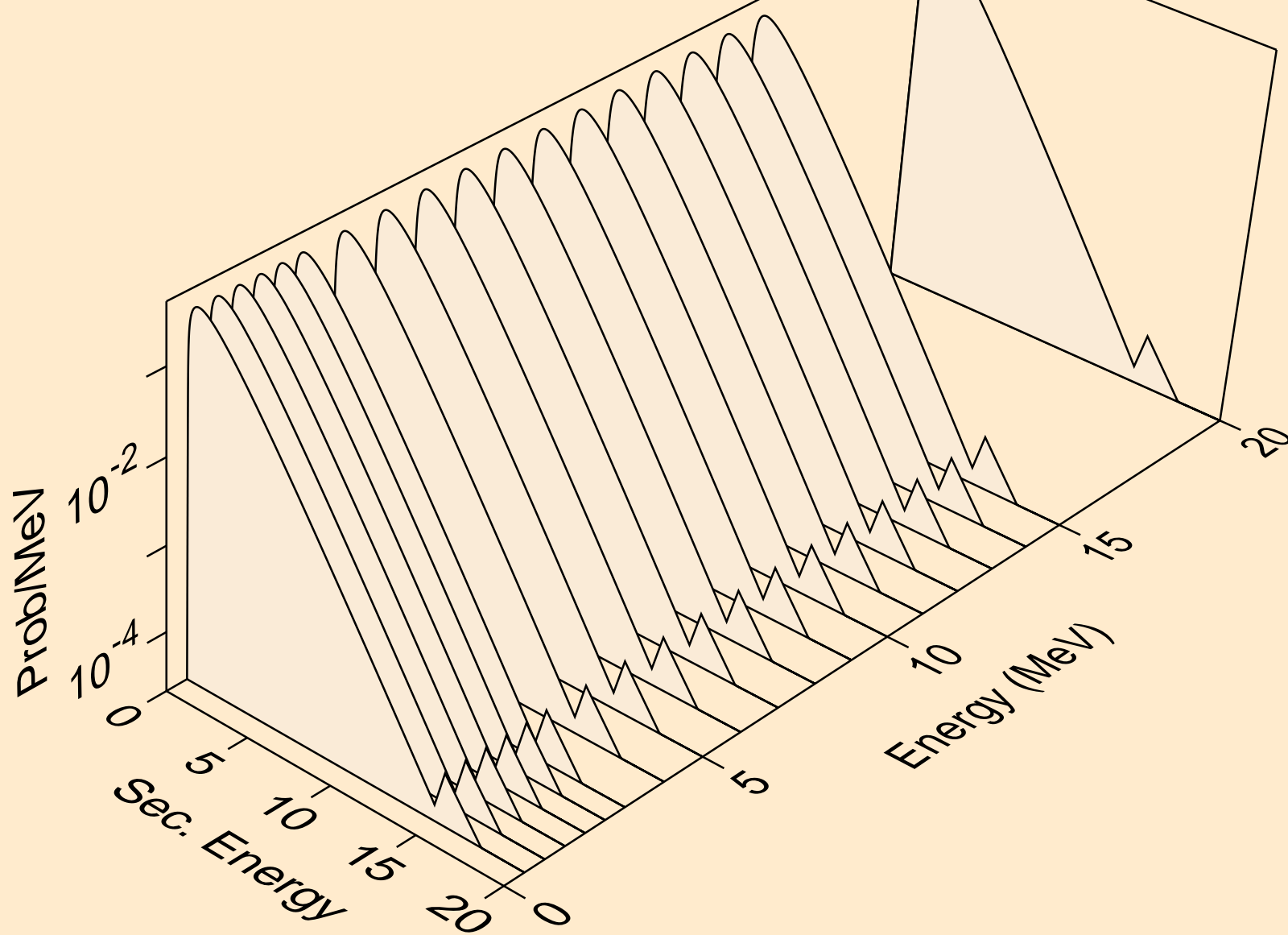

U236 NEUTRON ACER TENDL-2019 LIBRARY; T=293.16K
Neutron emission for (n,n*)a

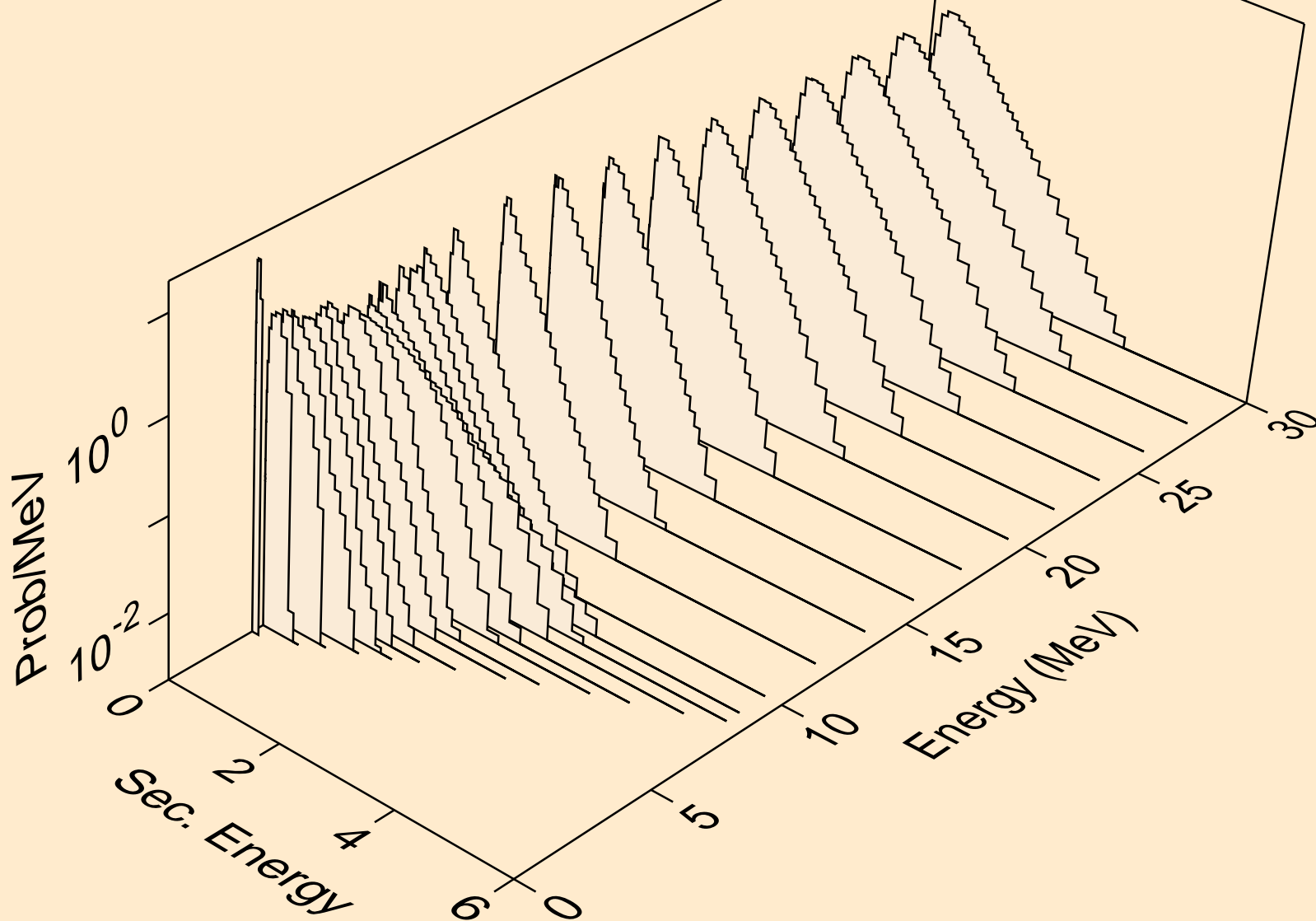

U236 NEUTRON ACER TENDL-2019 LIBRARY; T=293.16K
Neutron emission for (n,2n)a

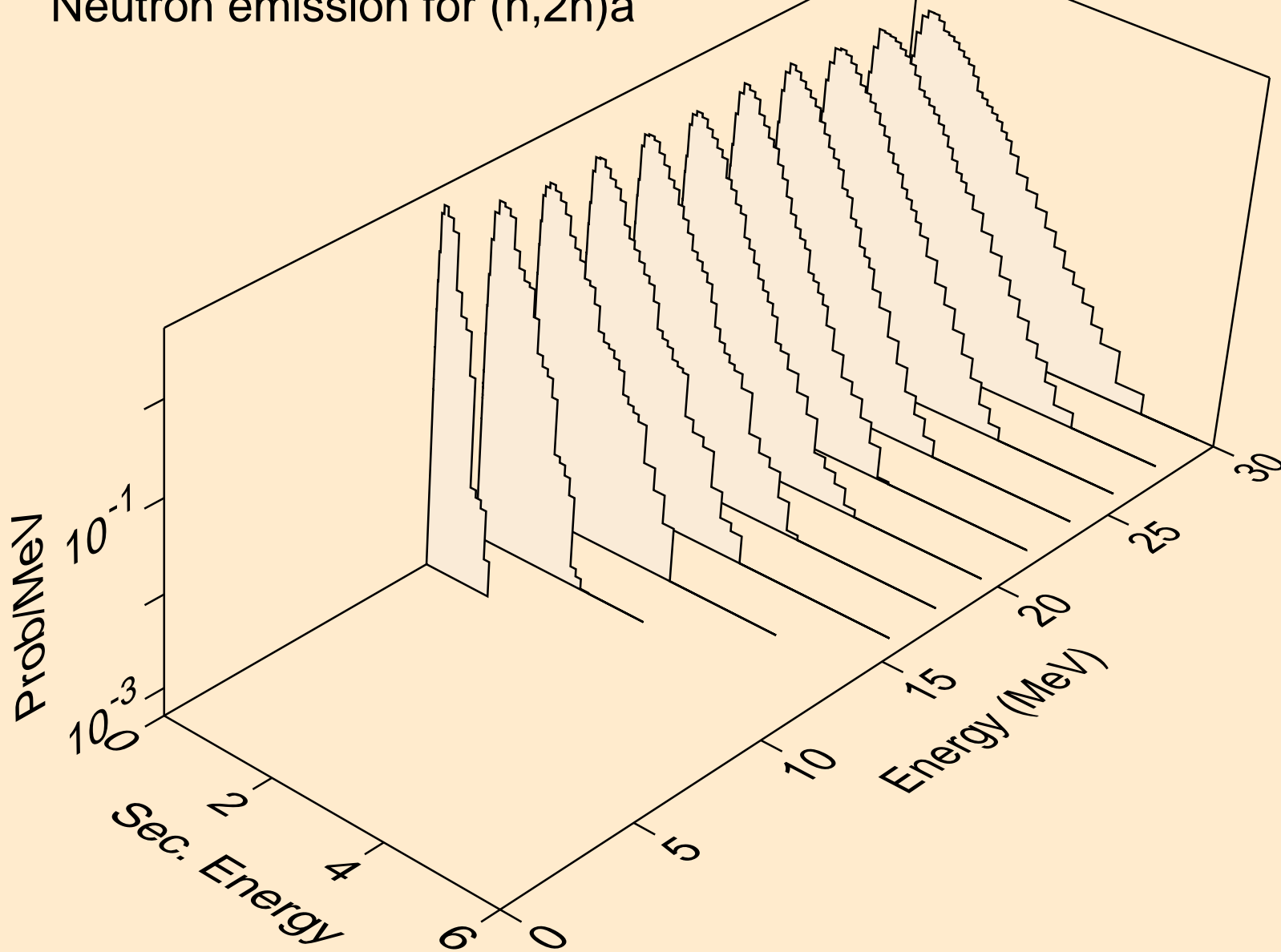

U236 NEUTRON ACER TENDL-2019 LIBRARY; T=293.16K
Neutron emission for (n,3n)a

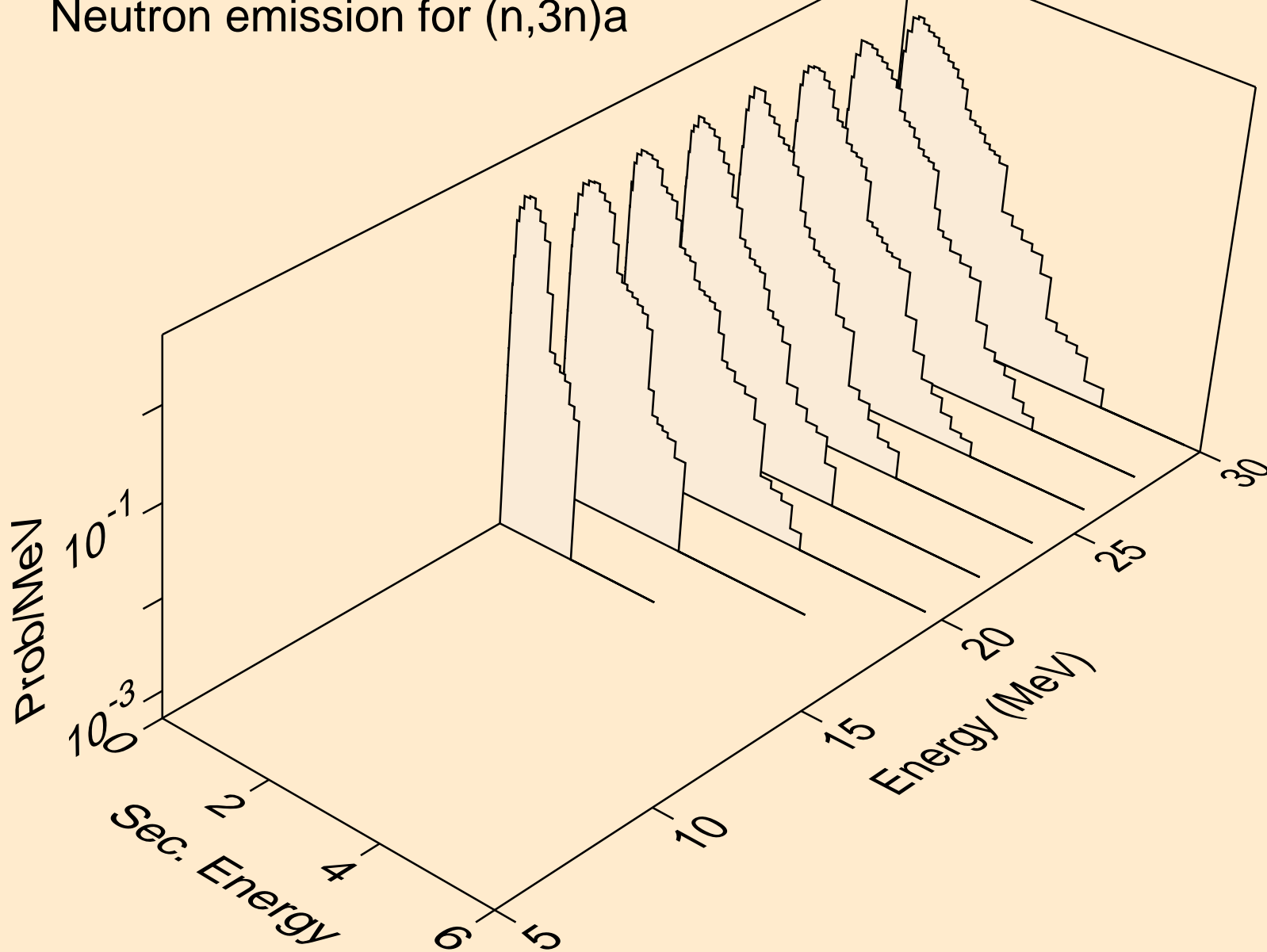

U236 NEUTRON ACER TENDL-2019 LIBRARY; T=293.16K
Neutron emission for (n,n*)p

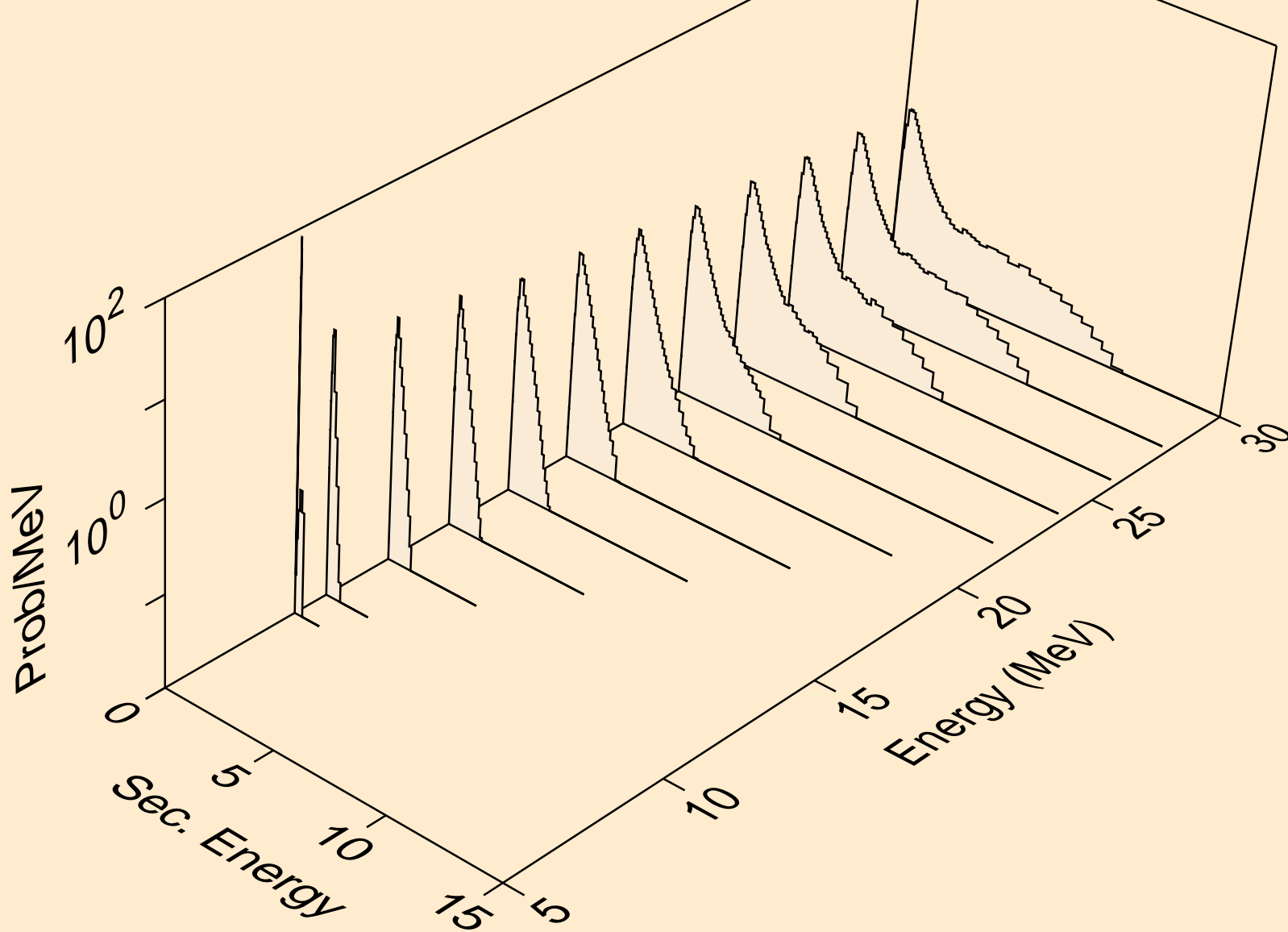

U236 NEUTRON ACER TENDL-2019 LIBRARY; T=293.16K
Neutron emission for (n,n*)d

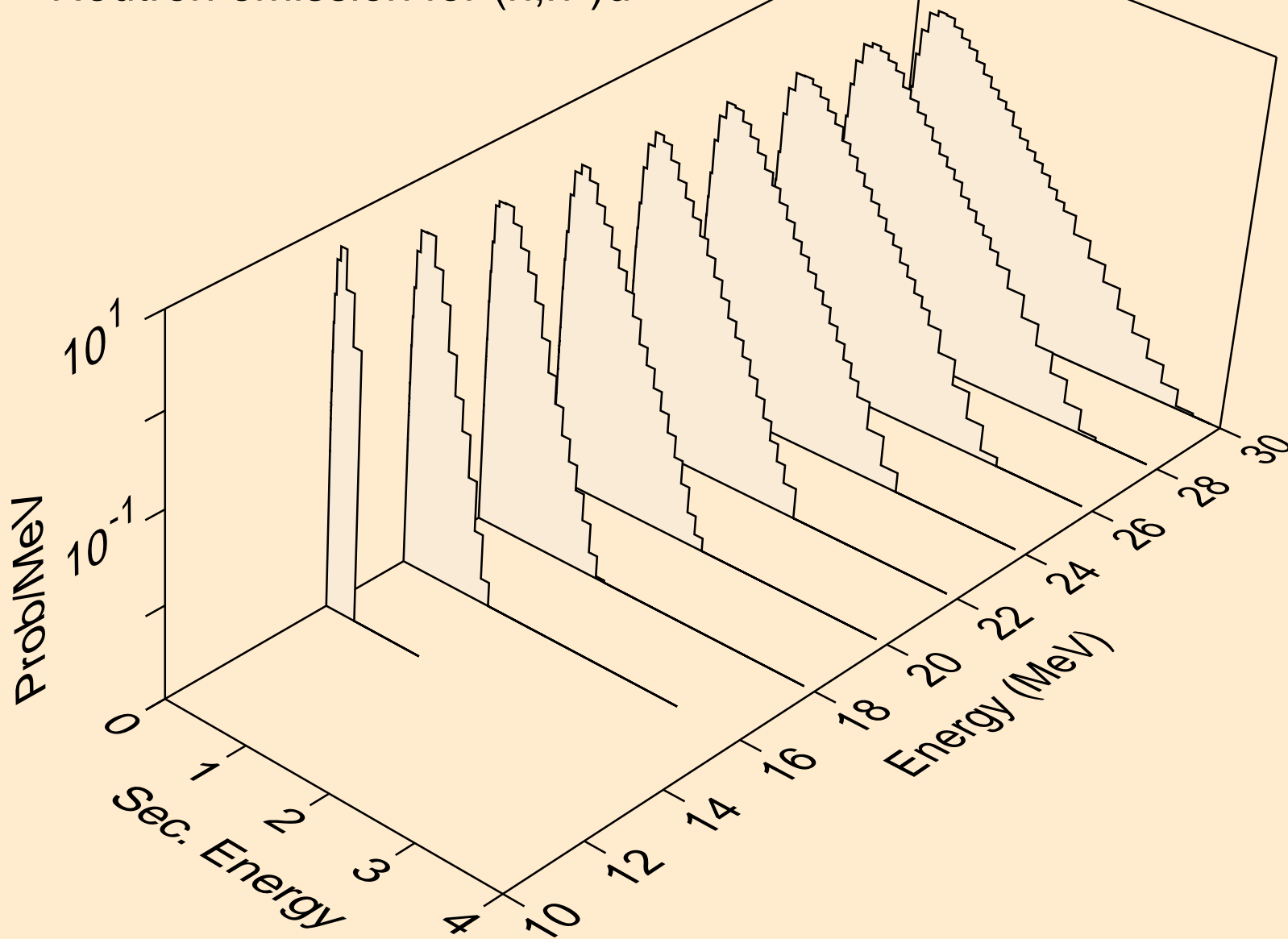

U236 NEUTRON ACER TENDL-2019 LIBRARY; T=293.16K
Neutron emission for (n,n*)t

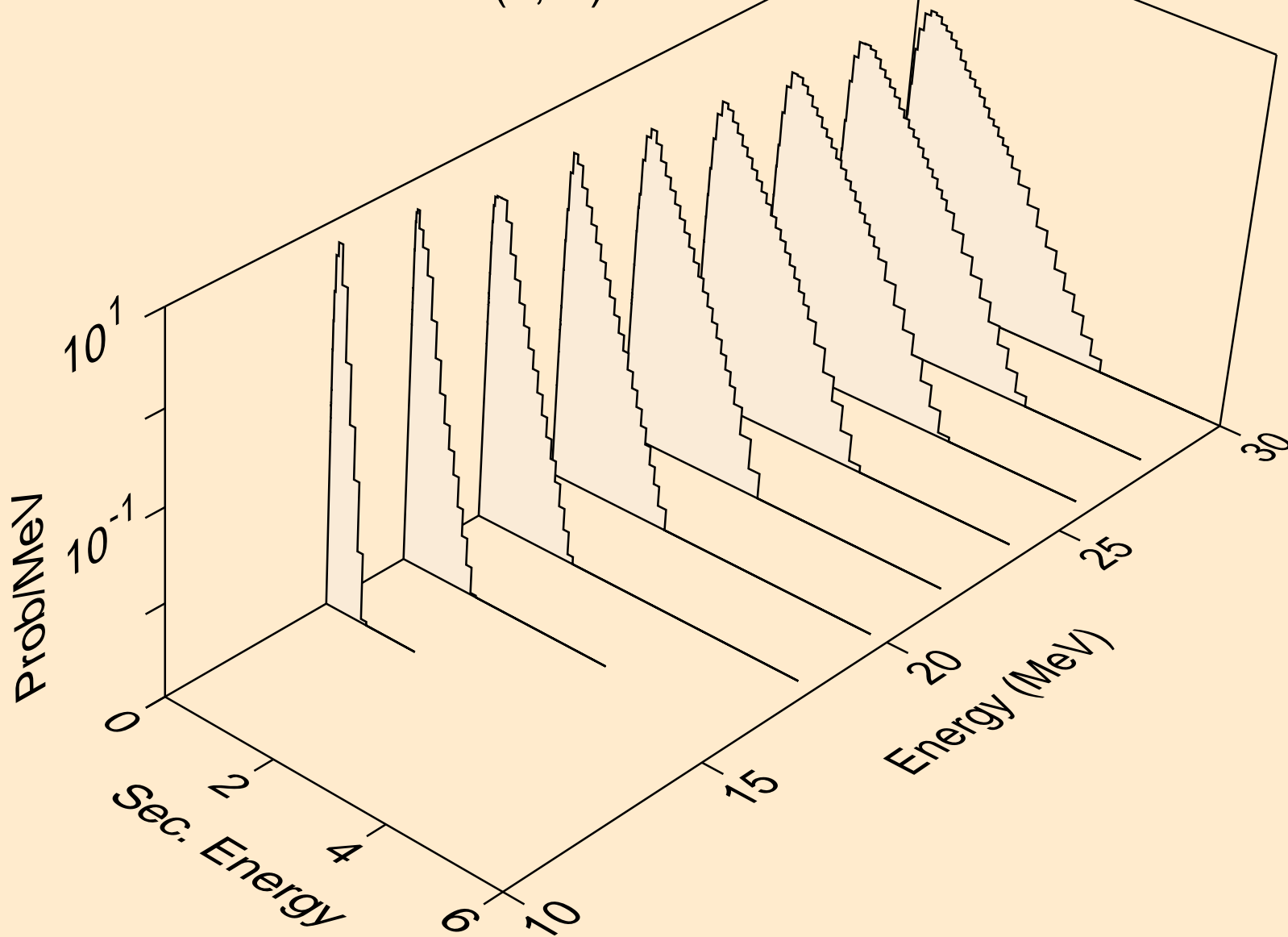

U236 NEUTRON ACER TENDL-2019 LIBRARY; T=293.16K
Neutron emission for (n,n*)he3

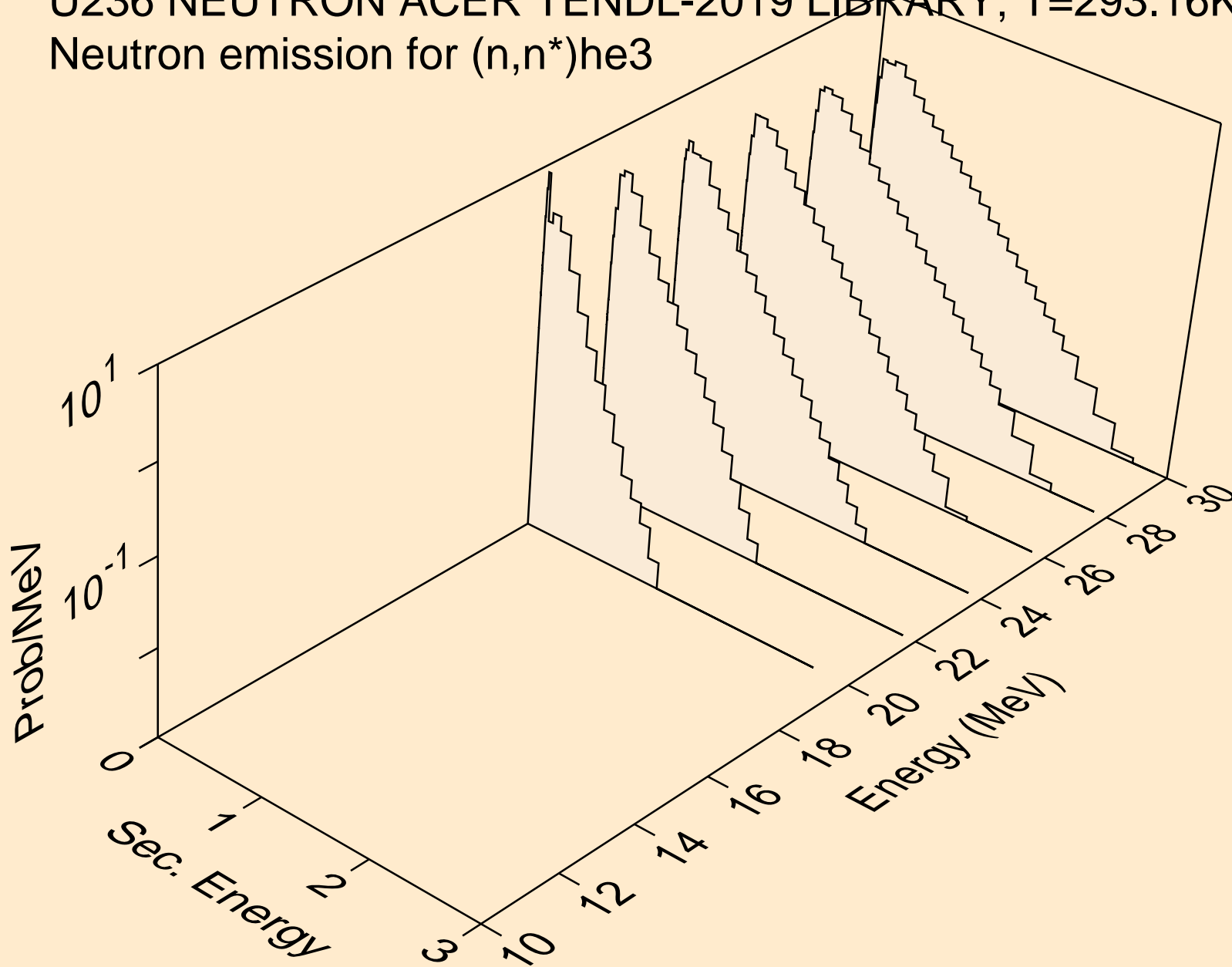

U236 NEUTRON ACER TENDL-2019 LIBRARY; T=293.16K
Neutron emission for (n,4n)

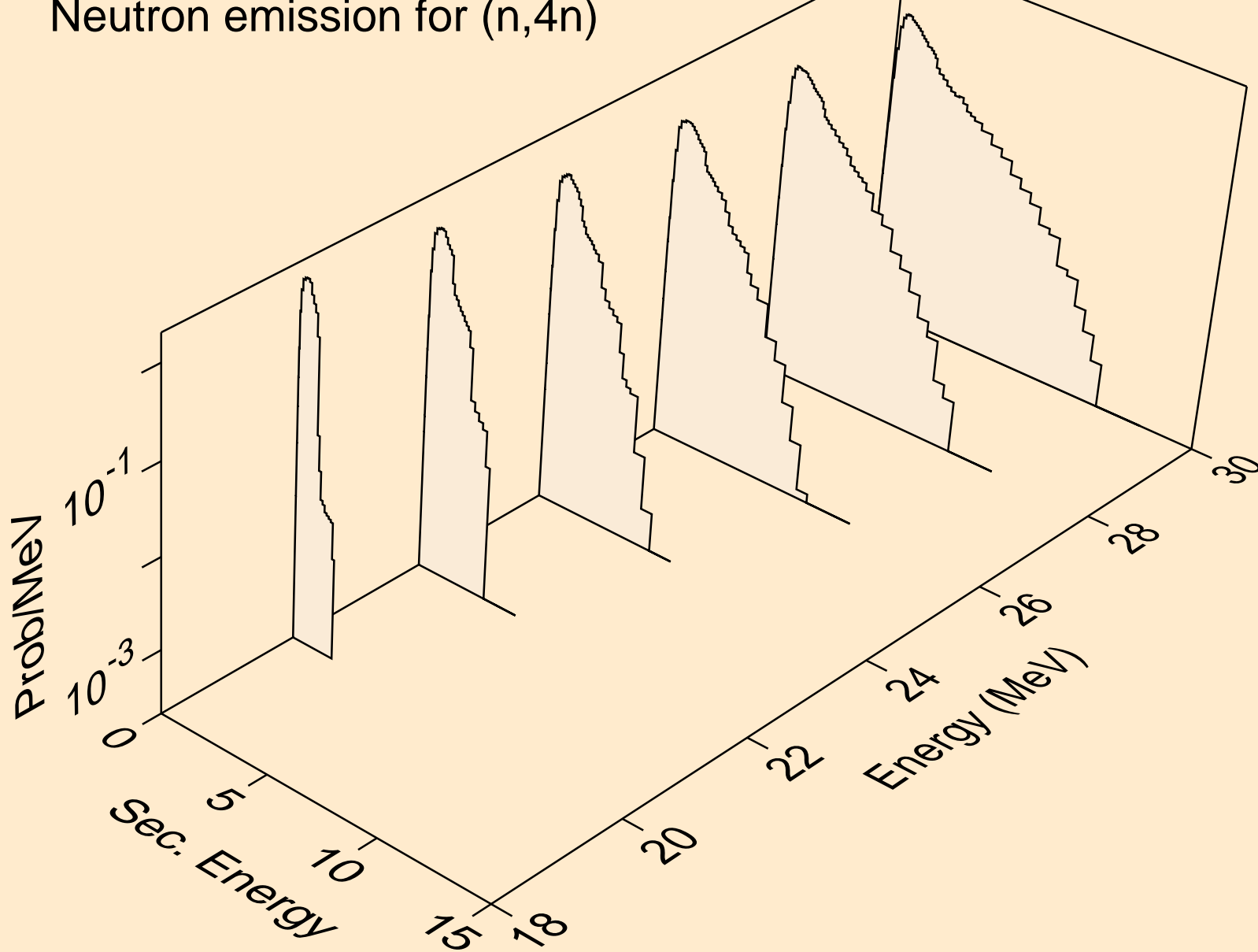

U236 NEUTRON ACER TENDL-2019 LIBRARY; T=293.16K
Neutron emission for (n,2np)

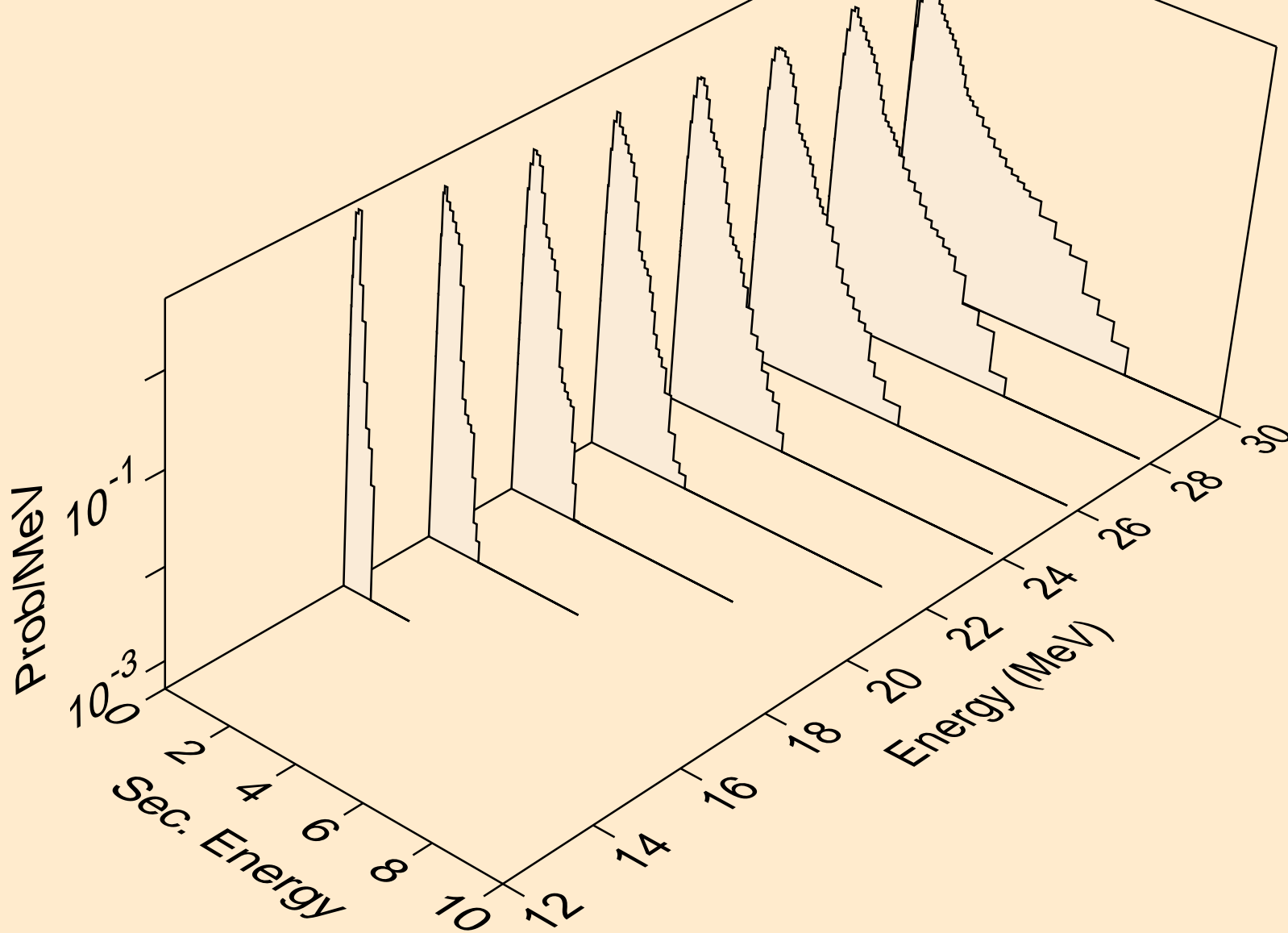

U236 NEUTRON ACER TENDL-2019 LIBRARY; T=293.16K
Neutron emission for (n,3np)

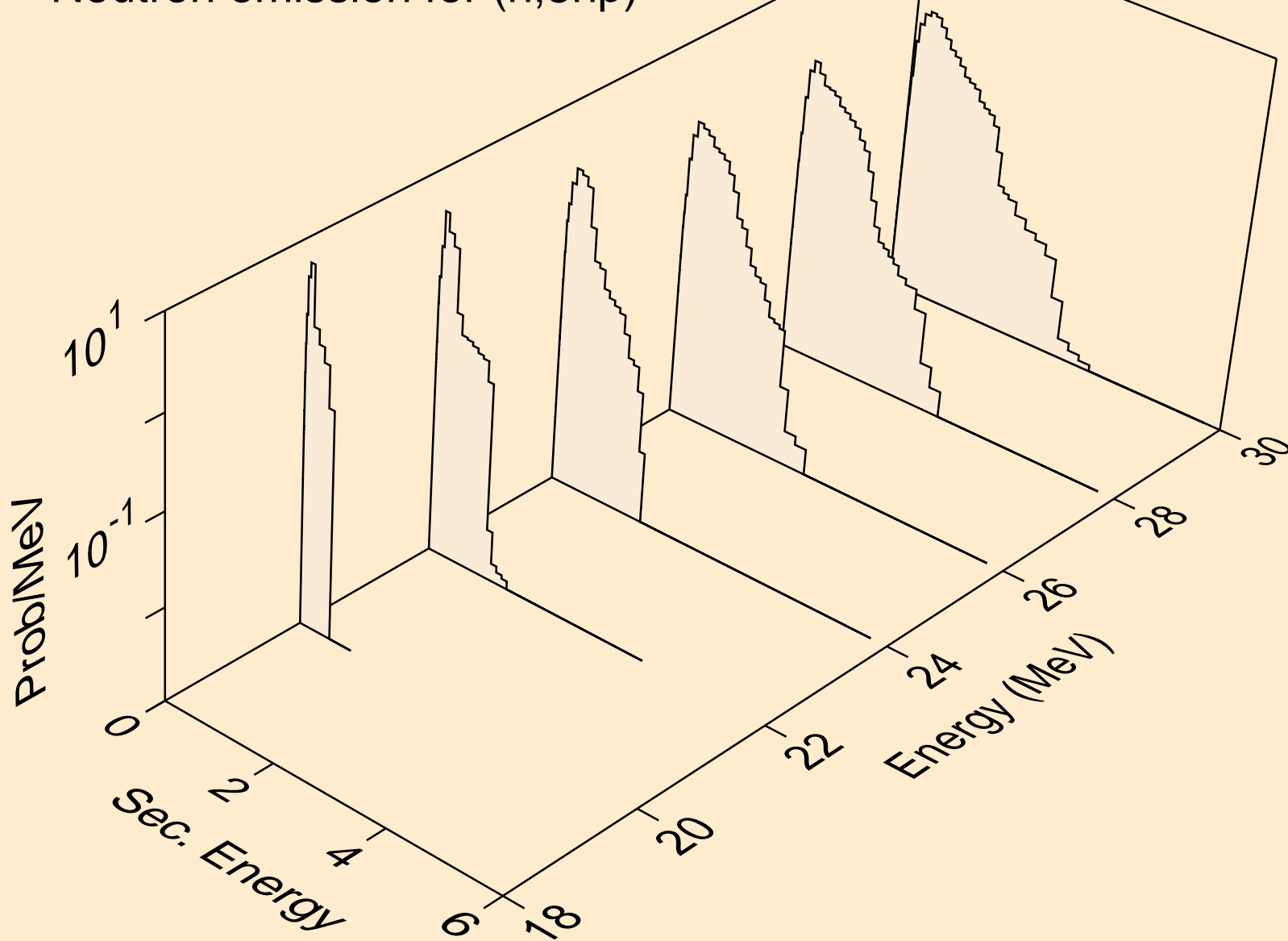

U236 NEUTRON ACER TENDL-2019 LIBRARY; T=293.16K
Neutron emission for (n,2np)

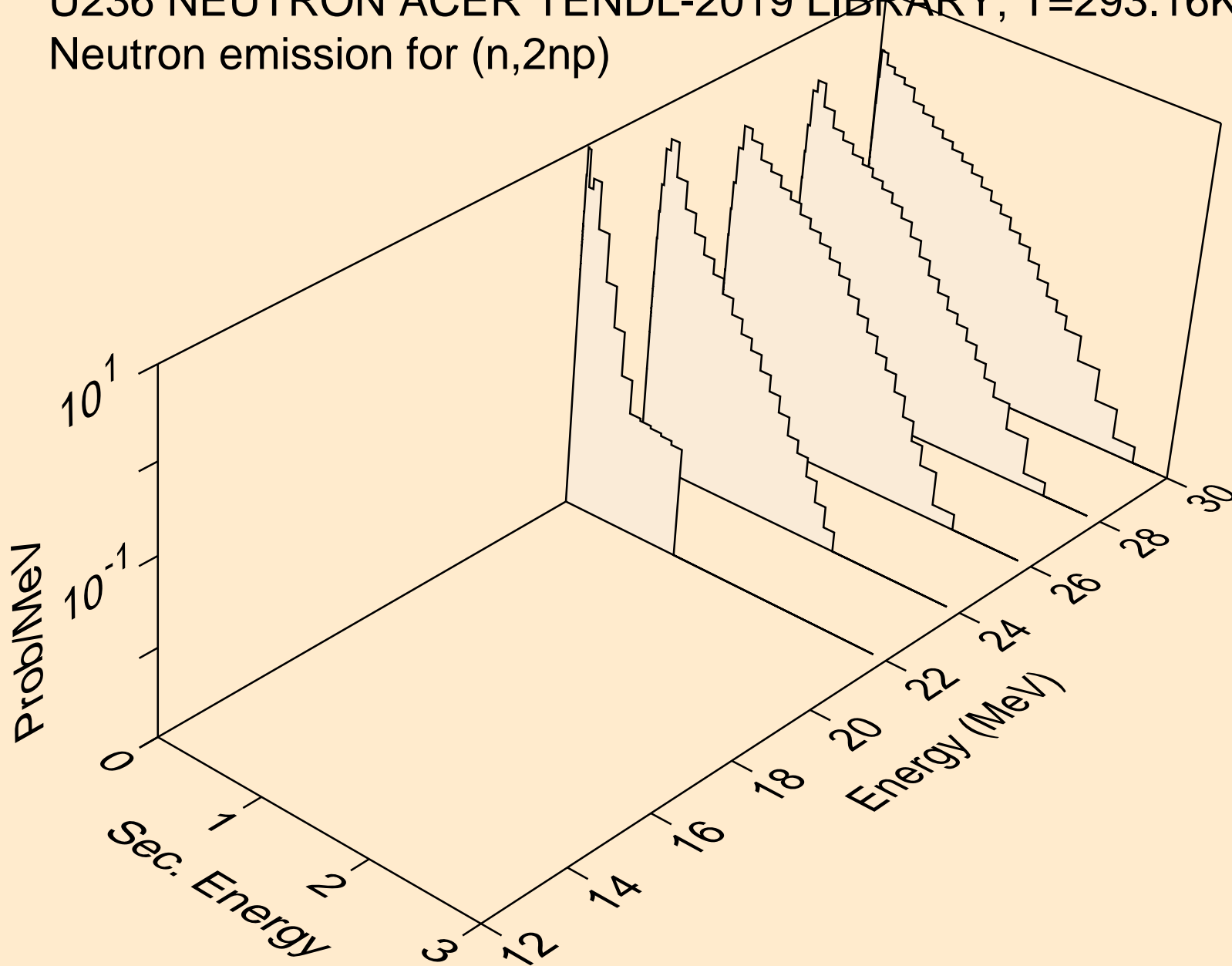

U236 NEUTRON ACER TENDL-2019 LIBRARY; T=293.16K
Neutron emission for (n,n*c)

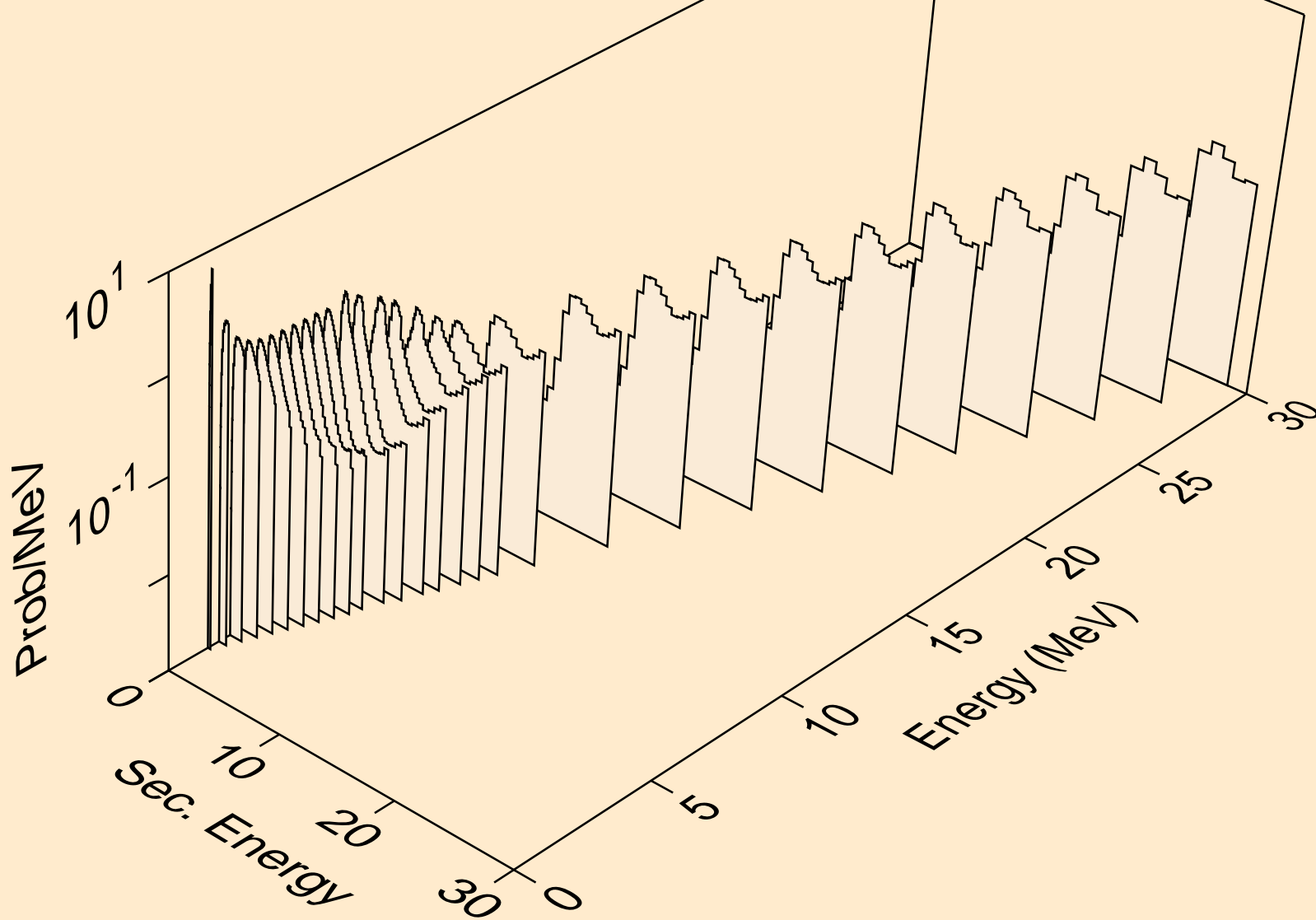

U236 NEUTRON ACER TENDL-2019 LIBRARY; T=293.16K

Delayed nubar

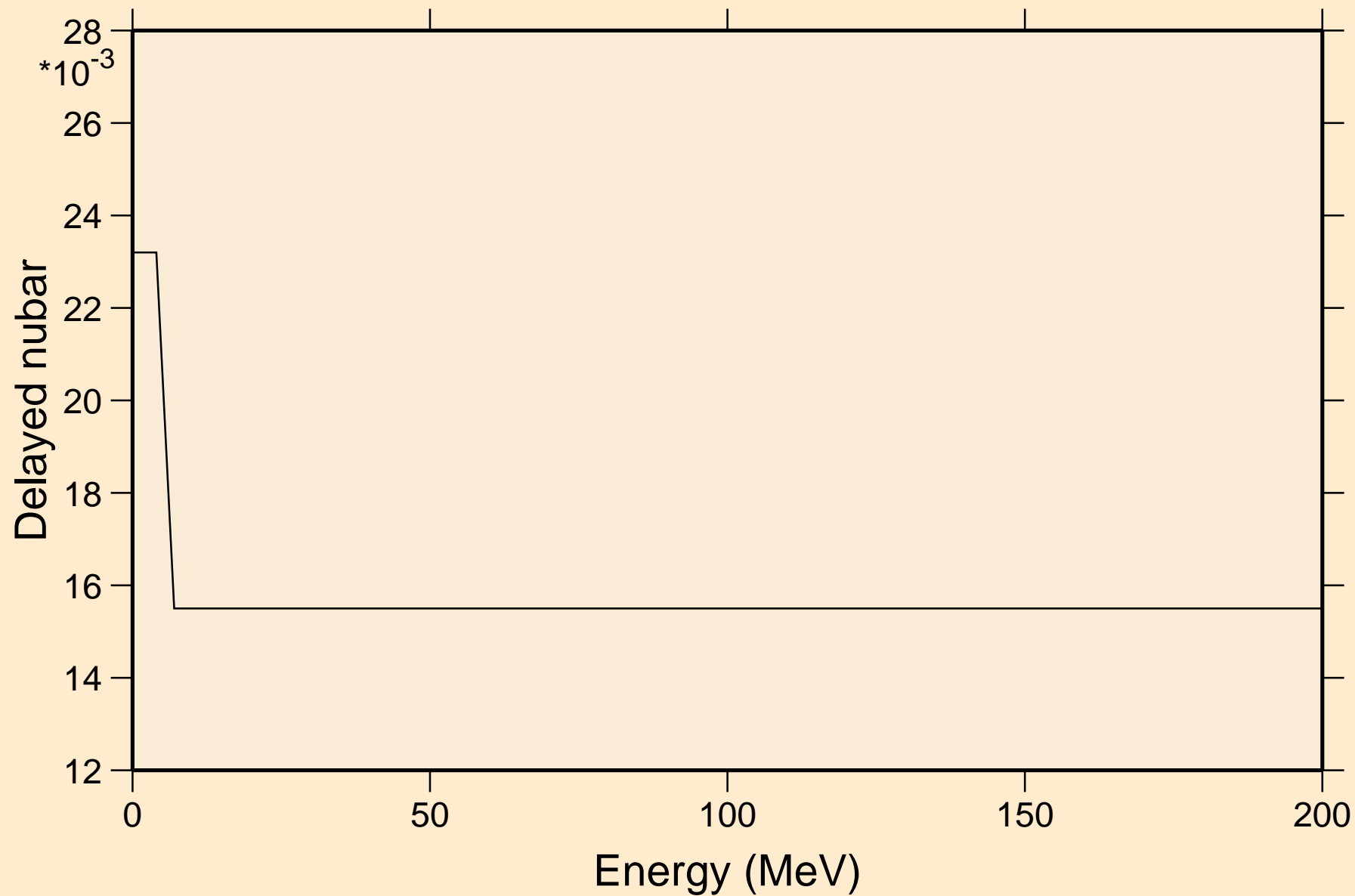

U236 NEUTRON ACER TENDL-2019 LIBRARY; T=293.16K

Delayed neutron spectra

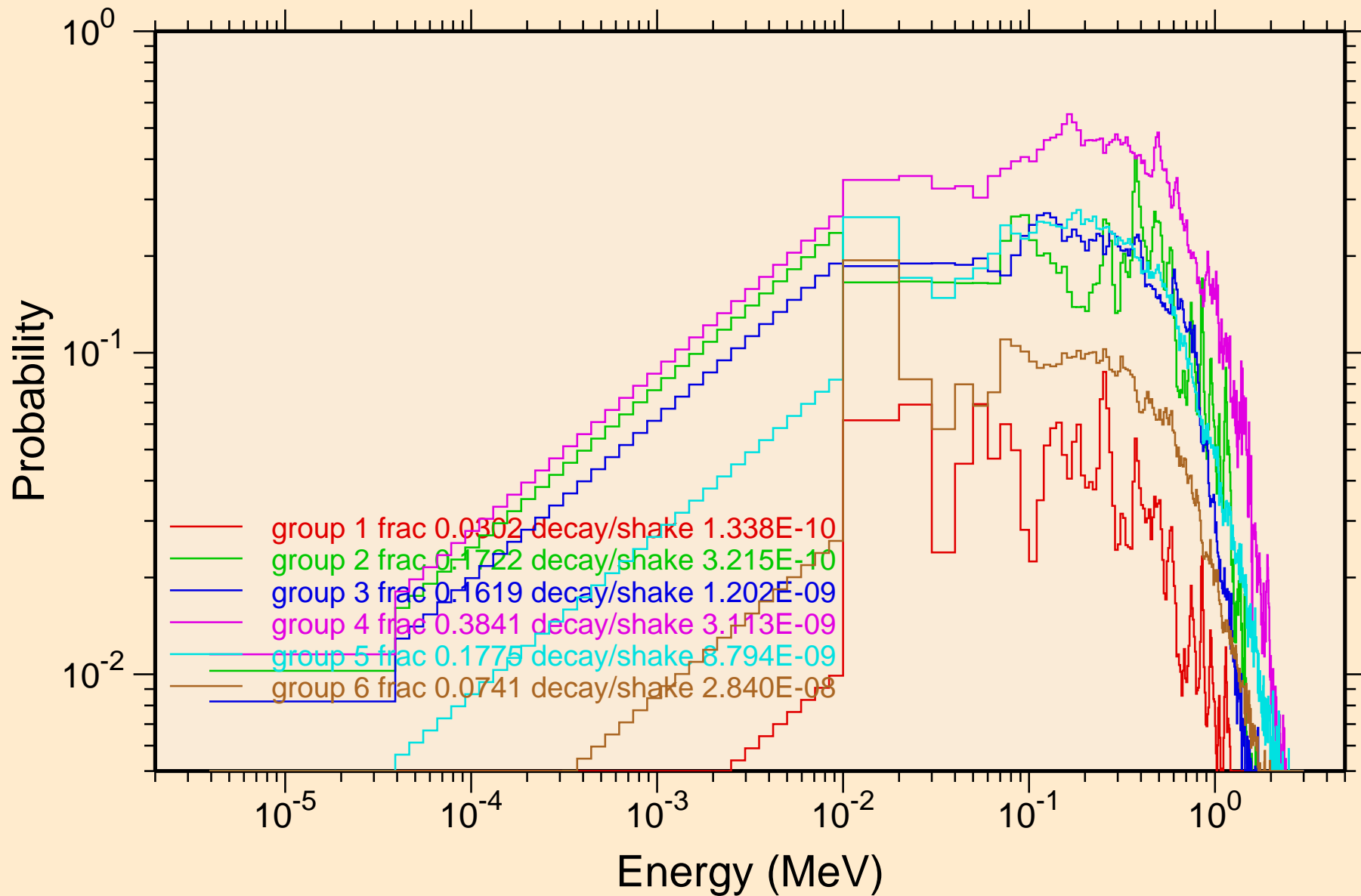

U236 NEUTRON ACER TENDL-2019 LIBRARY; T=293.16K
Photon emission for (n,x)

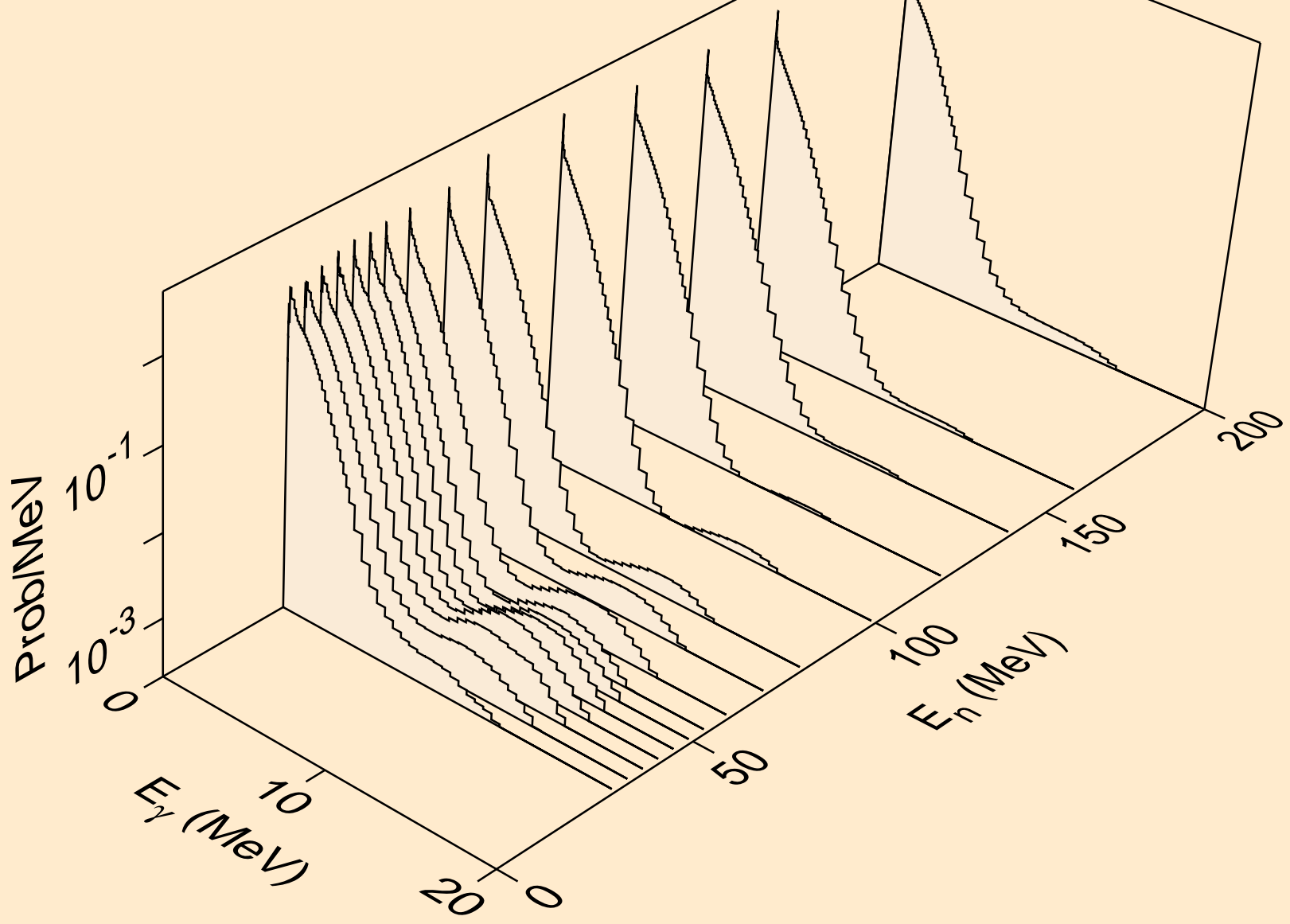

U236 NEUTRON ACER TENDL-2019 LIBRARY; T=293.16K
Photon emission for (n,2nd)

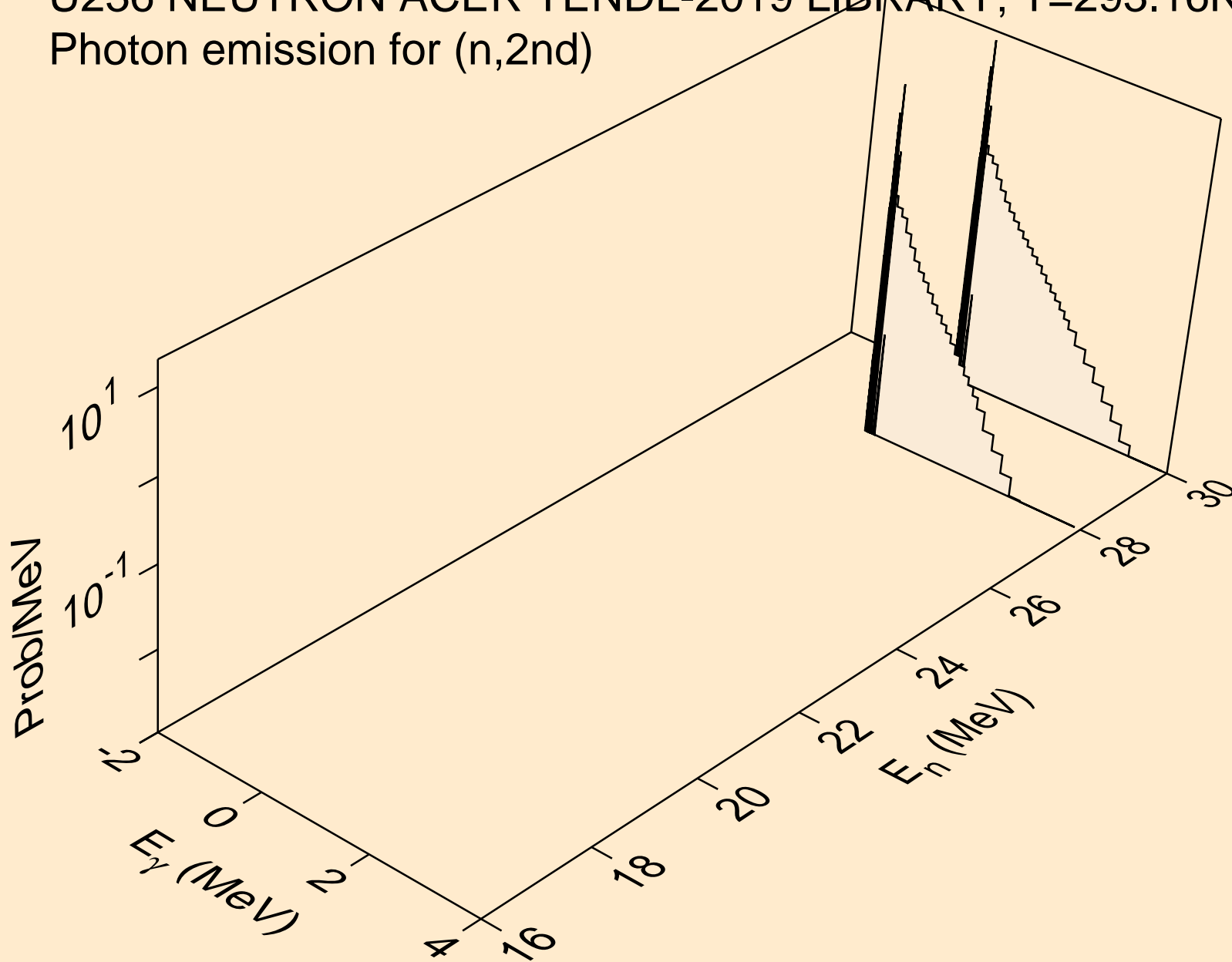

U236 NEUTRON ACER TENDL-2019 LIBRARY; T=293.16K
Photon emission for (n,2n)

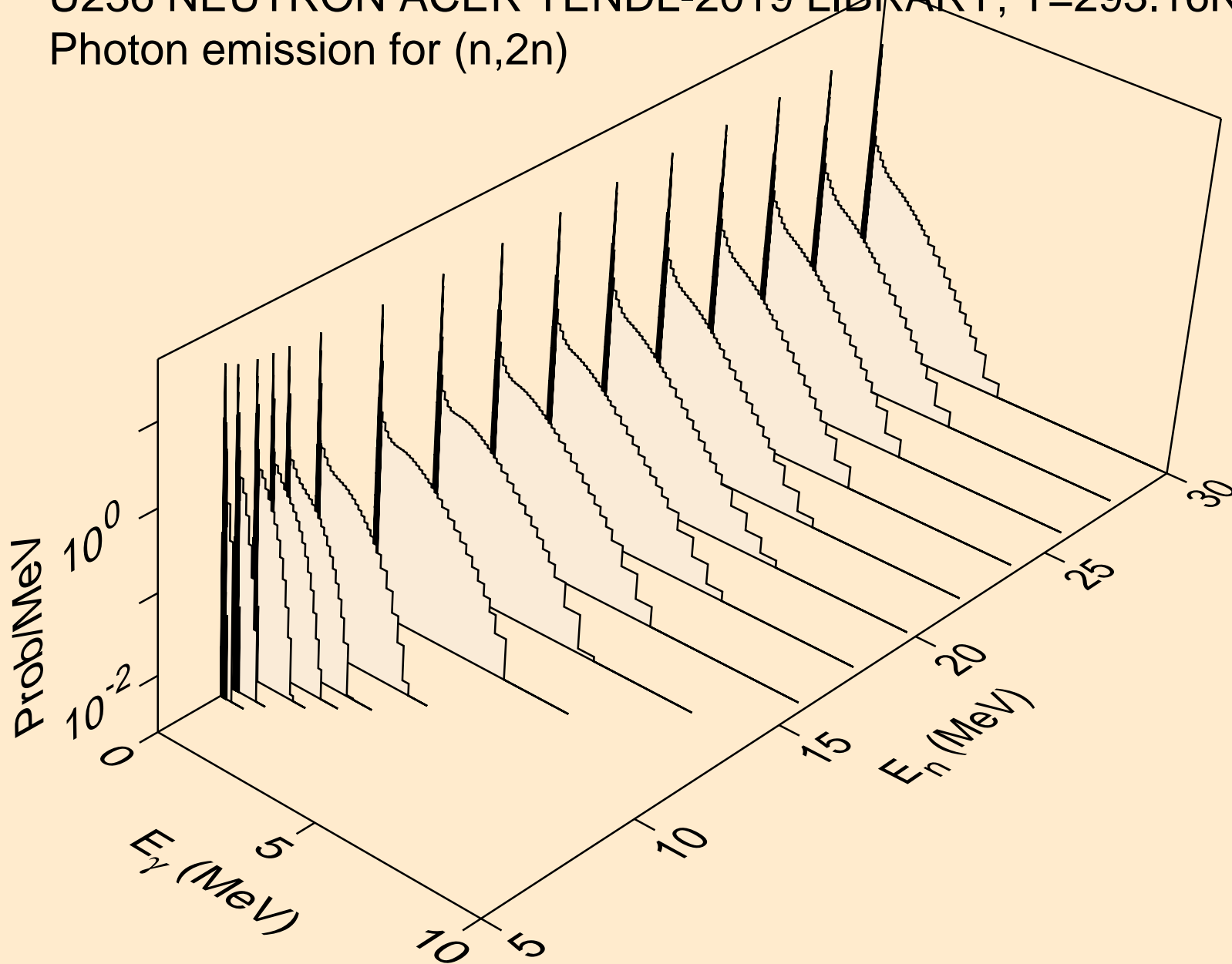

U236 NEUTRON ACER TENDL-2019 LIBRARY; T=293.16K
Photon emission for (n,3n)

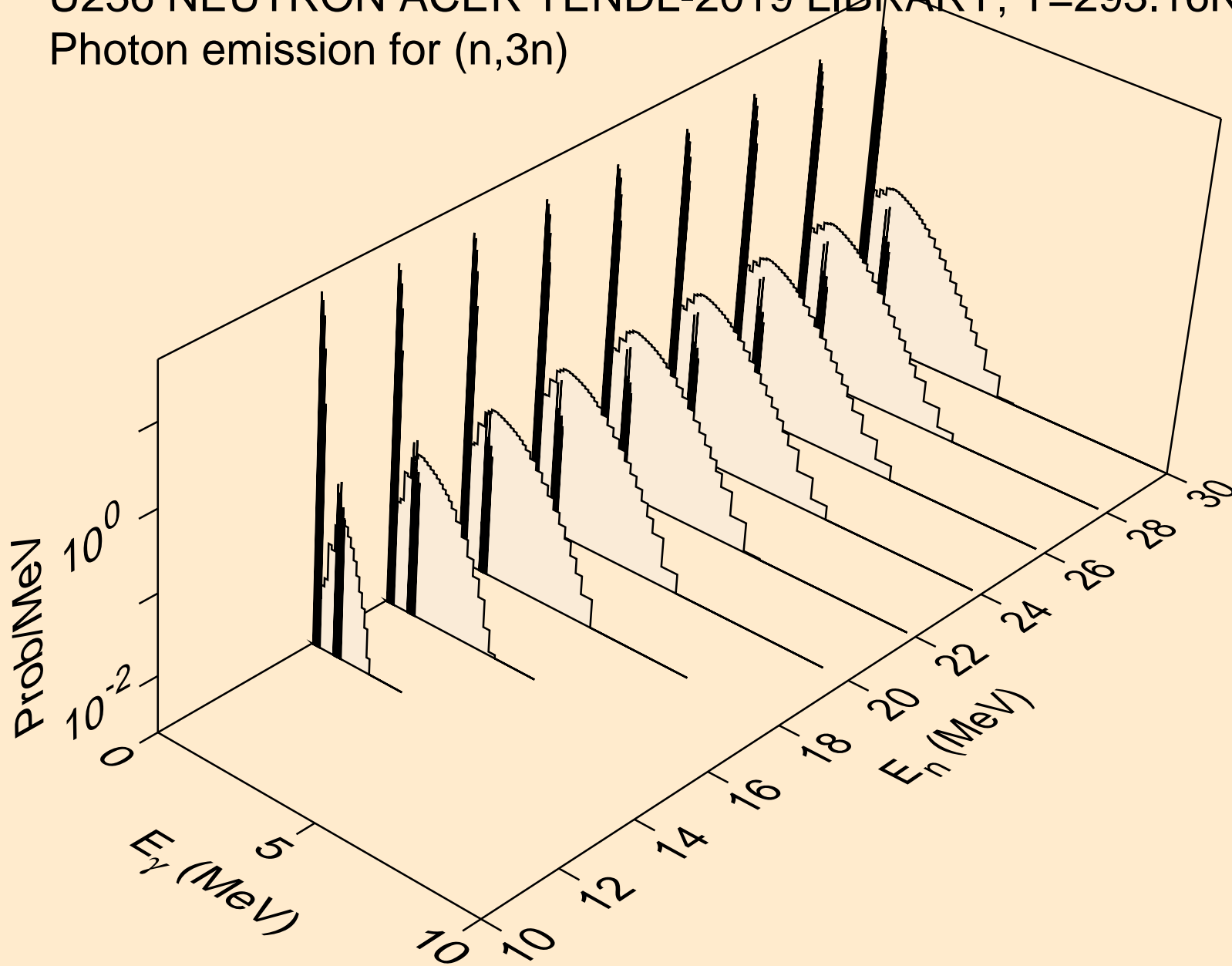

U236 NEUTRON ACER TENDL-2019 LIBRARY; T=293.16K
Photon emission for (n,n*)a

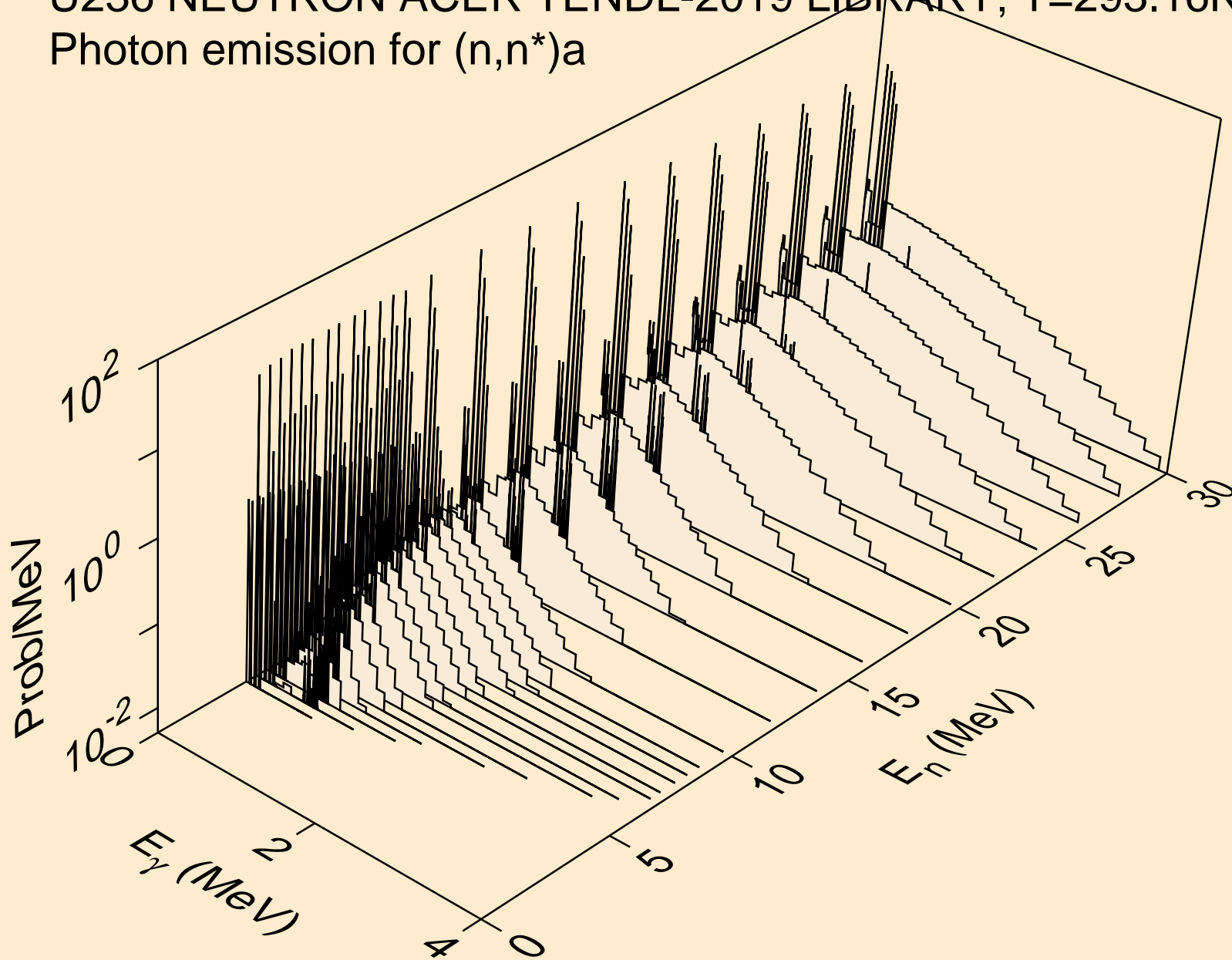

U236 NEUTRON ACER TENDL-2019 LIBRARY; T=293.16K
Photon emission for (n,2n) α

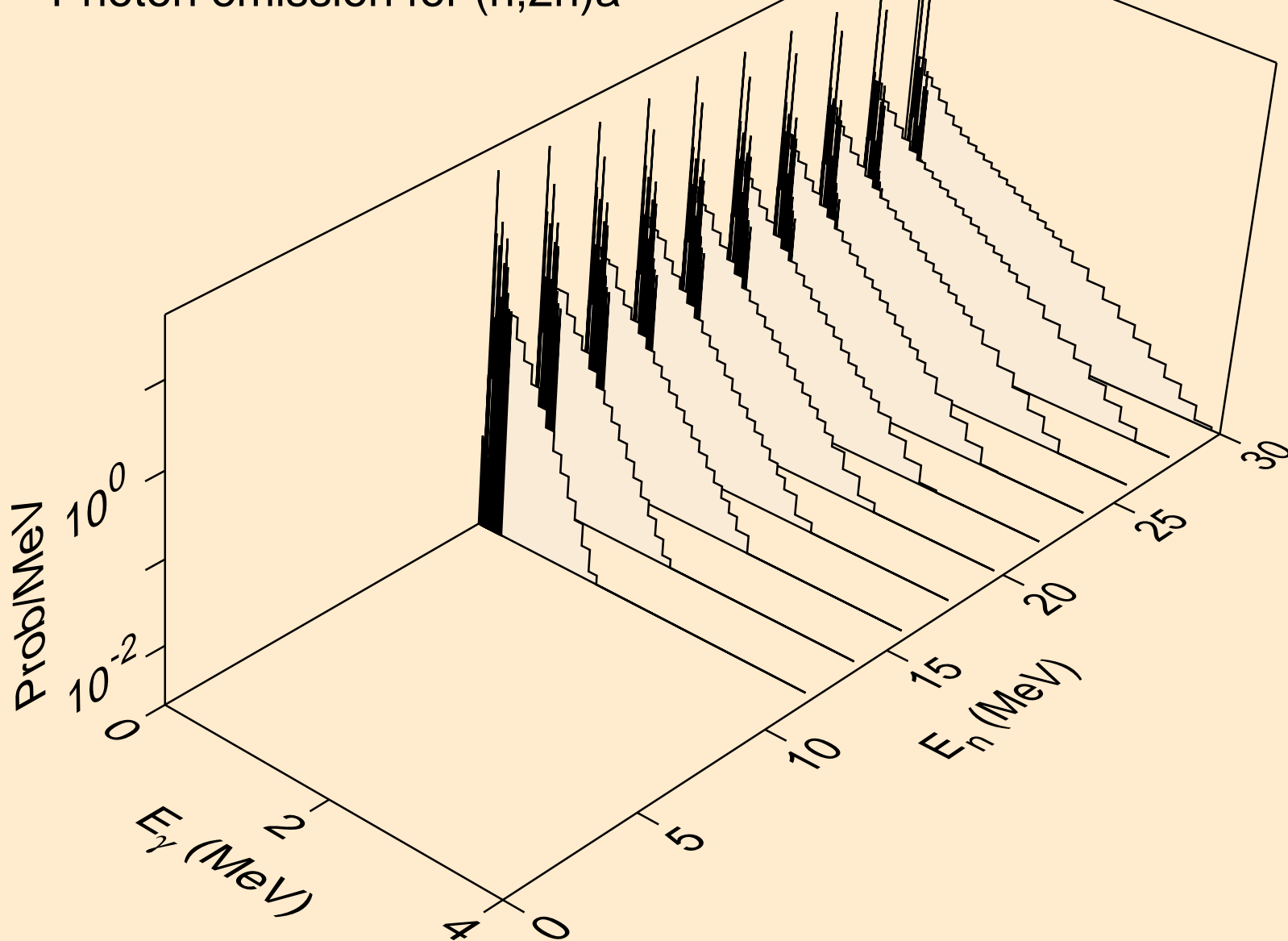

U236 NEUTRON ACER TENDL-2019 LIBRARY; T=293.16K
Photon emission for (n,3n)a

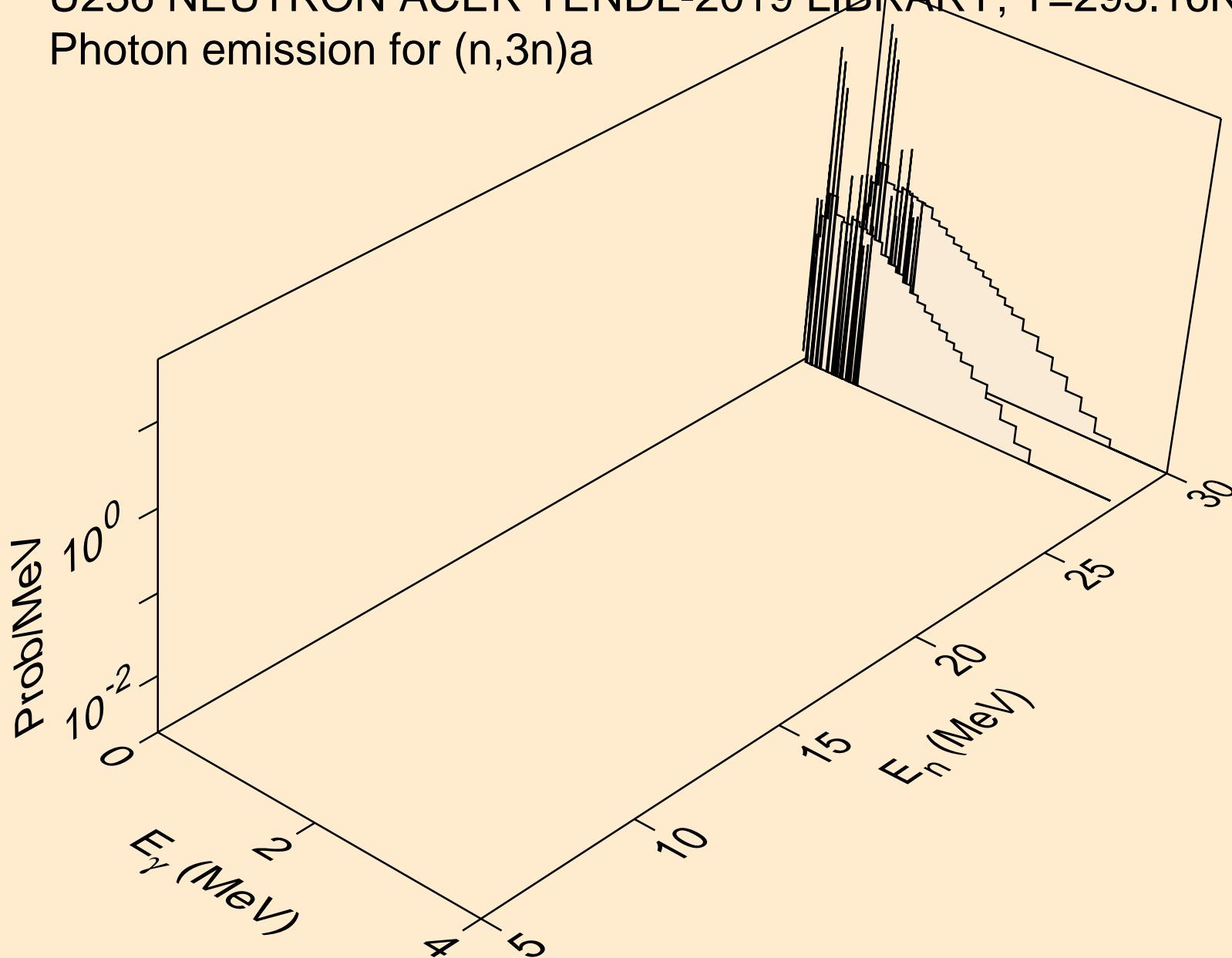

U236 NEUTRON ACER TENDL-2019 LIBRARY; T=293.16K
Photon emission for (n,n*)p

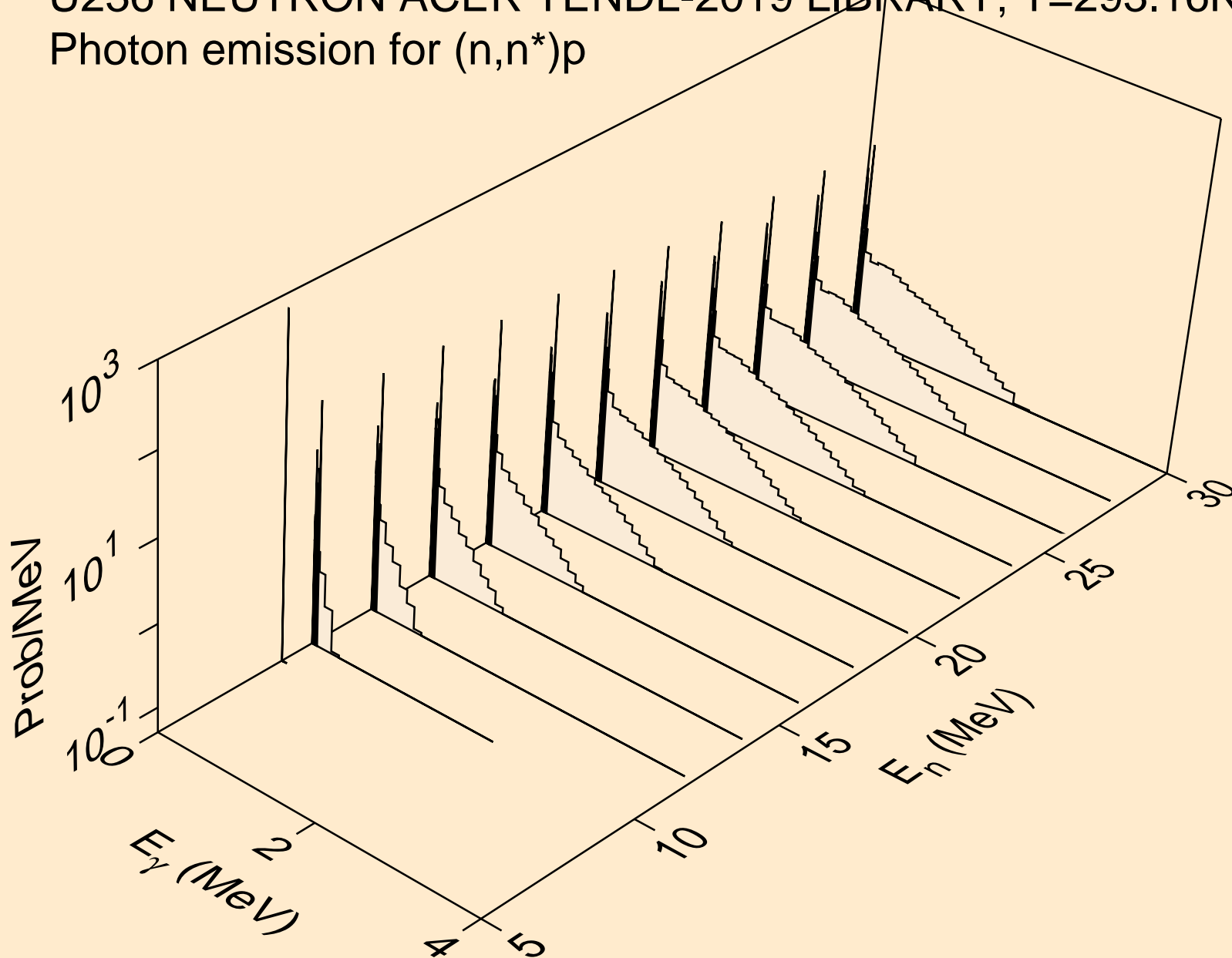

U236 NEUTRON ACER TENDL-2019 LIBRARY; T=293.16K
Photon emission for (n,n*)d

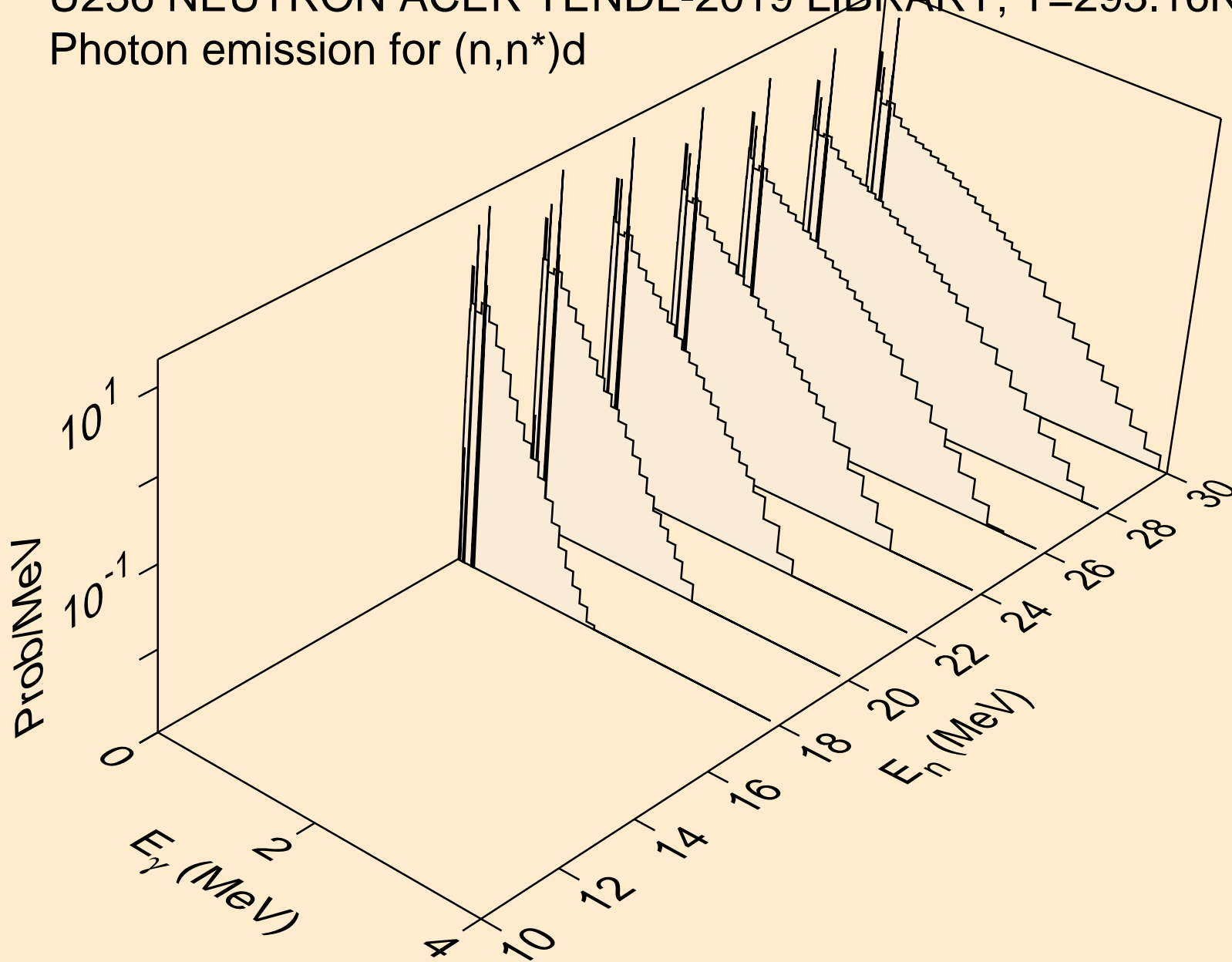

U236 NEUTRON ACER TENDL-2019 LIBRARY; T=293.16K
Photon emission for (n,n*)t

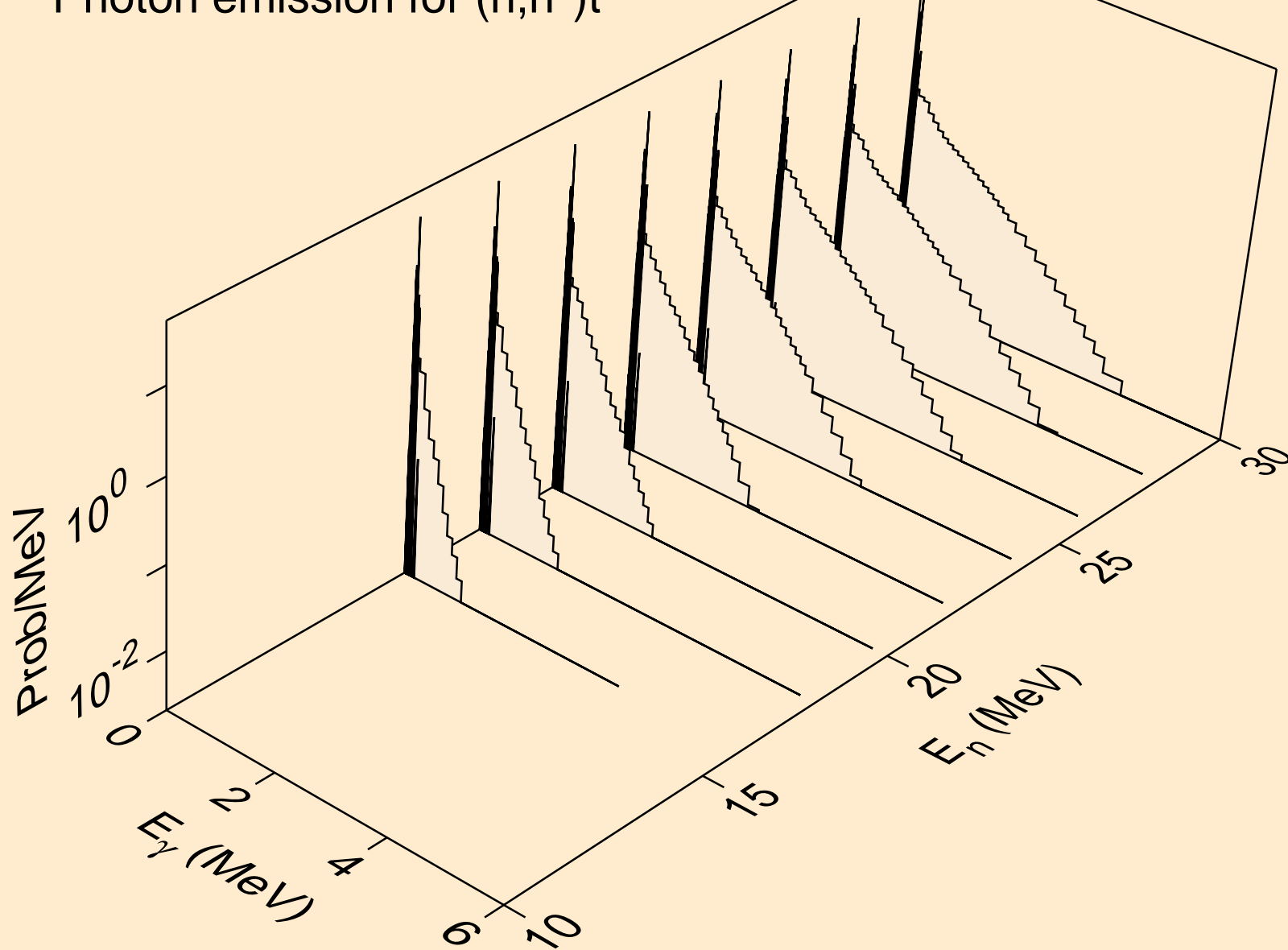

U236 NEUTRON ACER TENDL-2019 LIBRARY; T=293.16K
Photon emission for (n,n*)he3

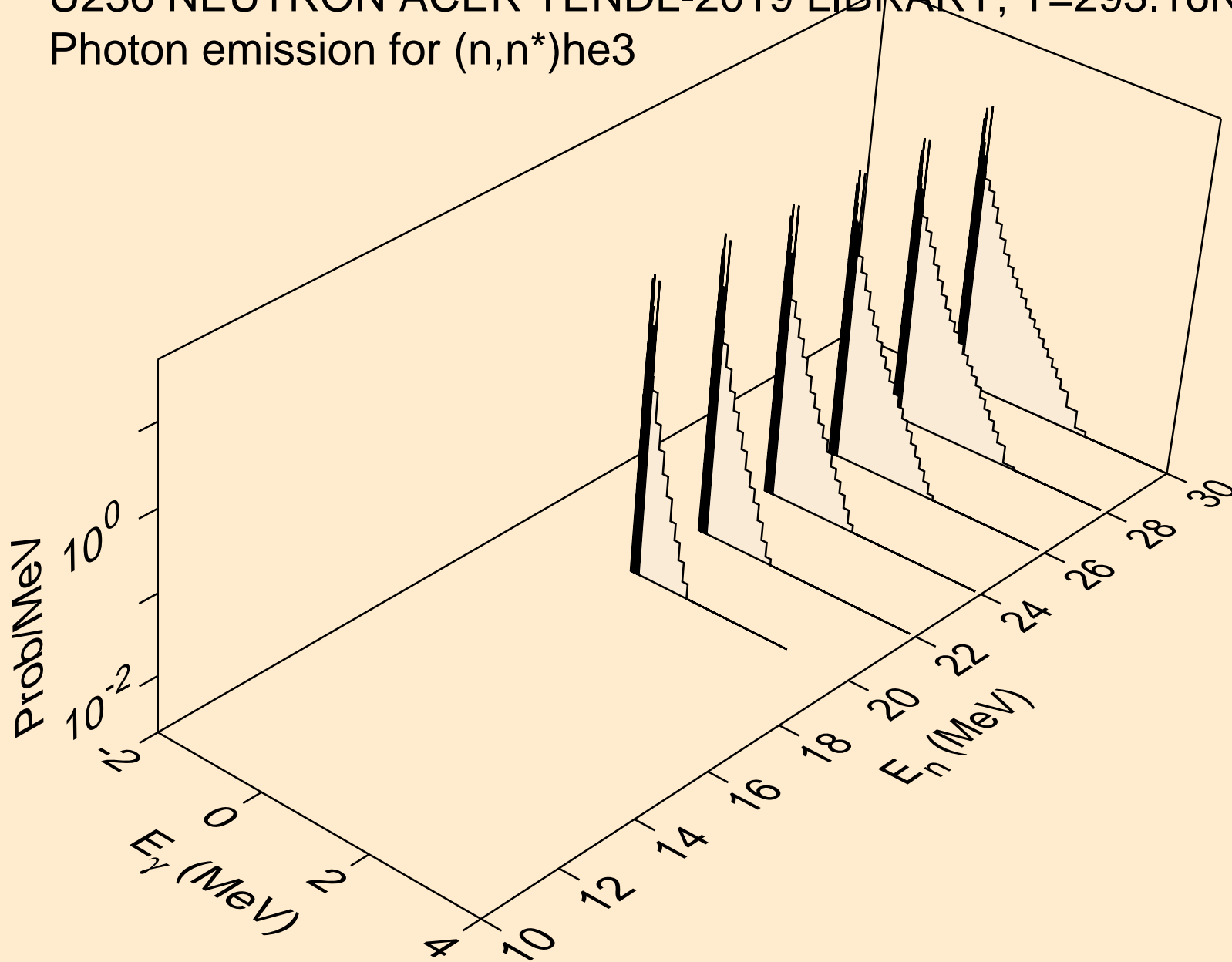

U236 NEUTRON ACER TENDL-2019 LIBRARY; T=293.16K
Photon emission for (n,4n)

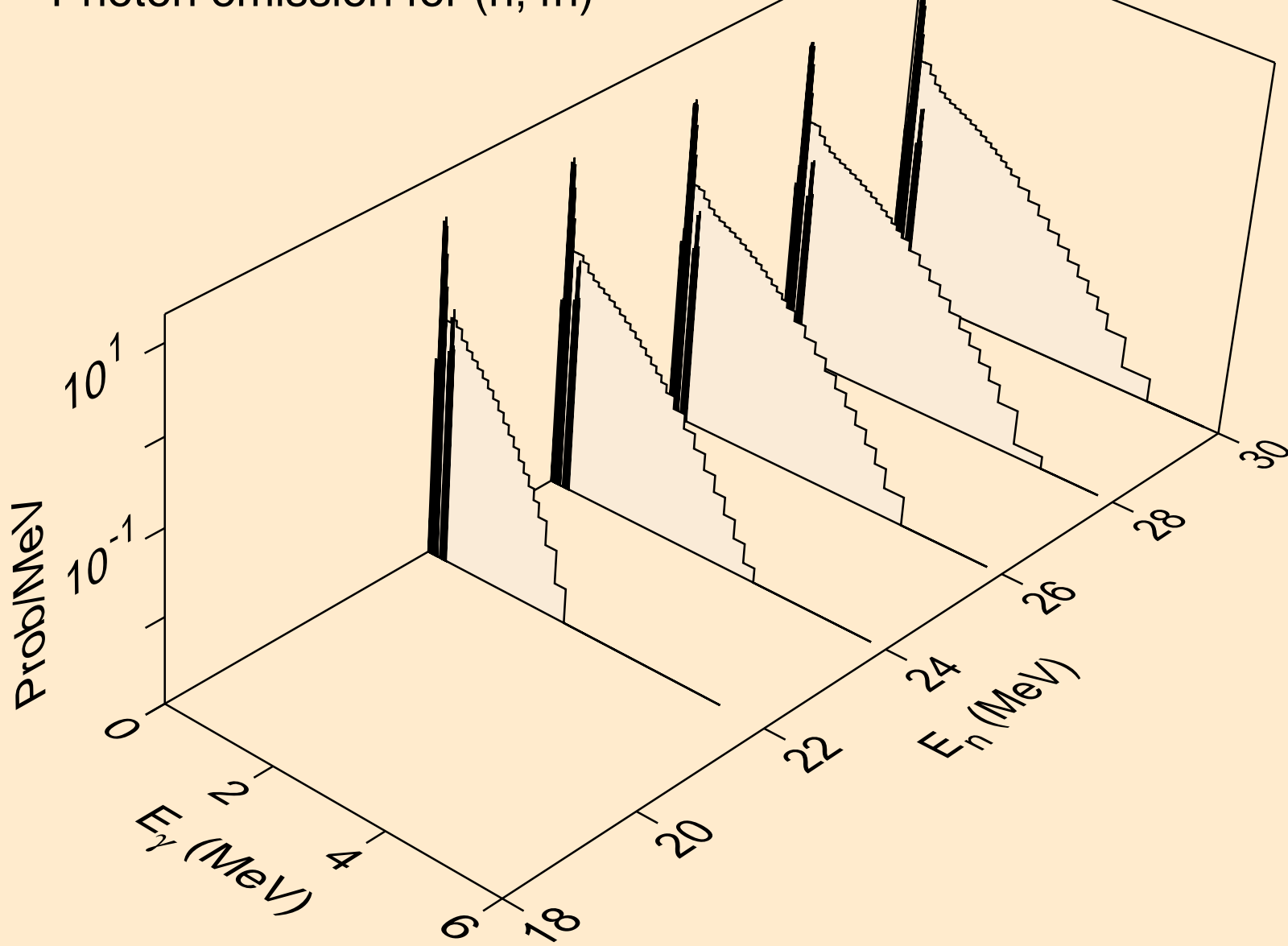

U236 NEUTRON ACER TENDL-2019 LIBRARY; T=293.16K
Photon emission for (n,2np)

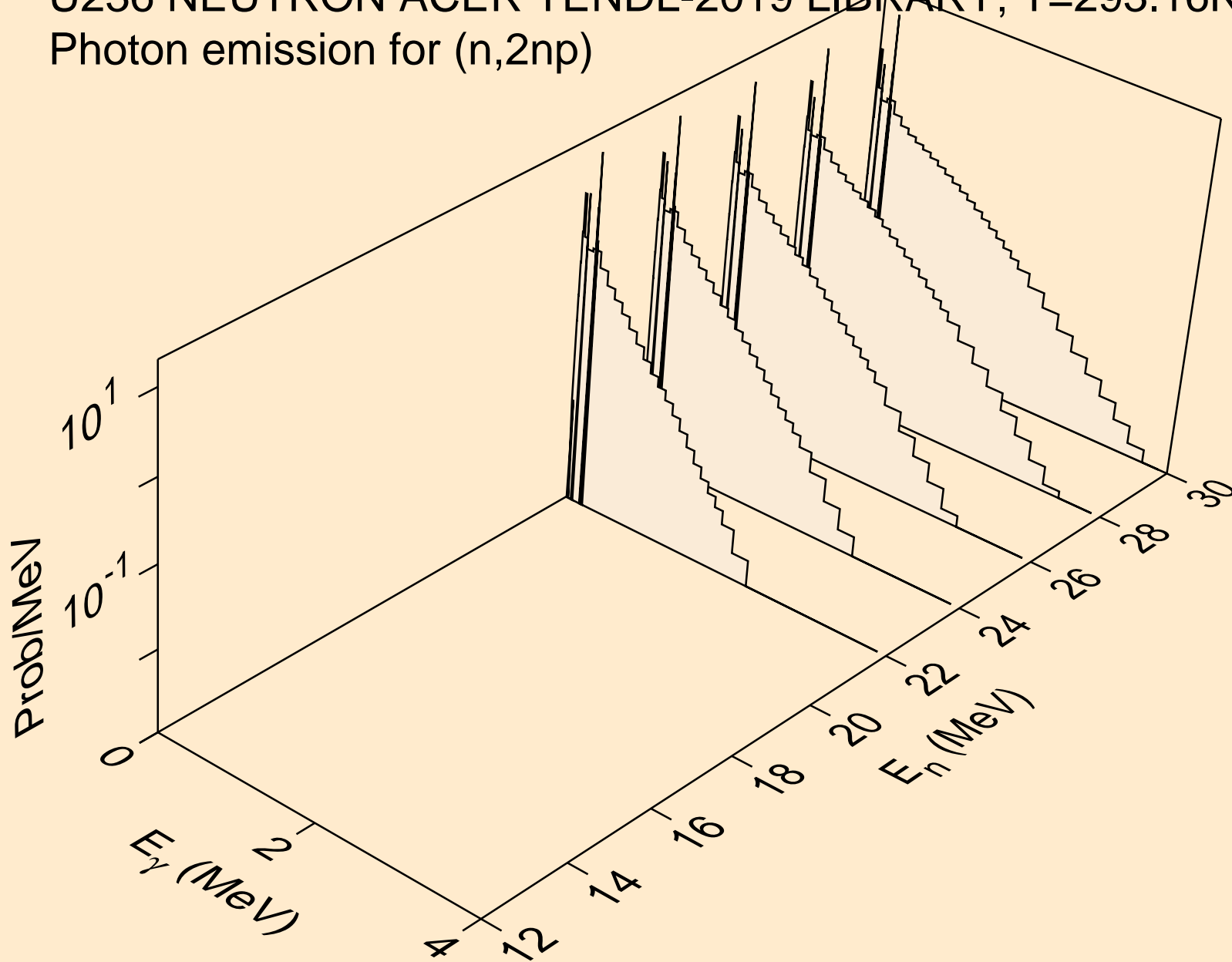

U236 NEUTRON ACER TENDL-2019 LIBRARY; T=293.16K
Photon emission for (n,3np)

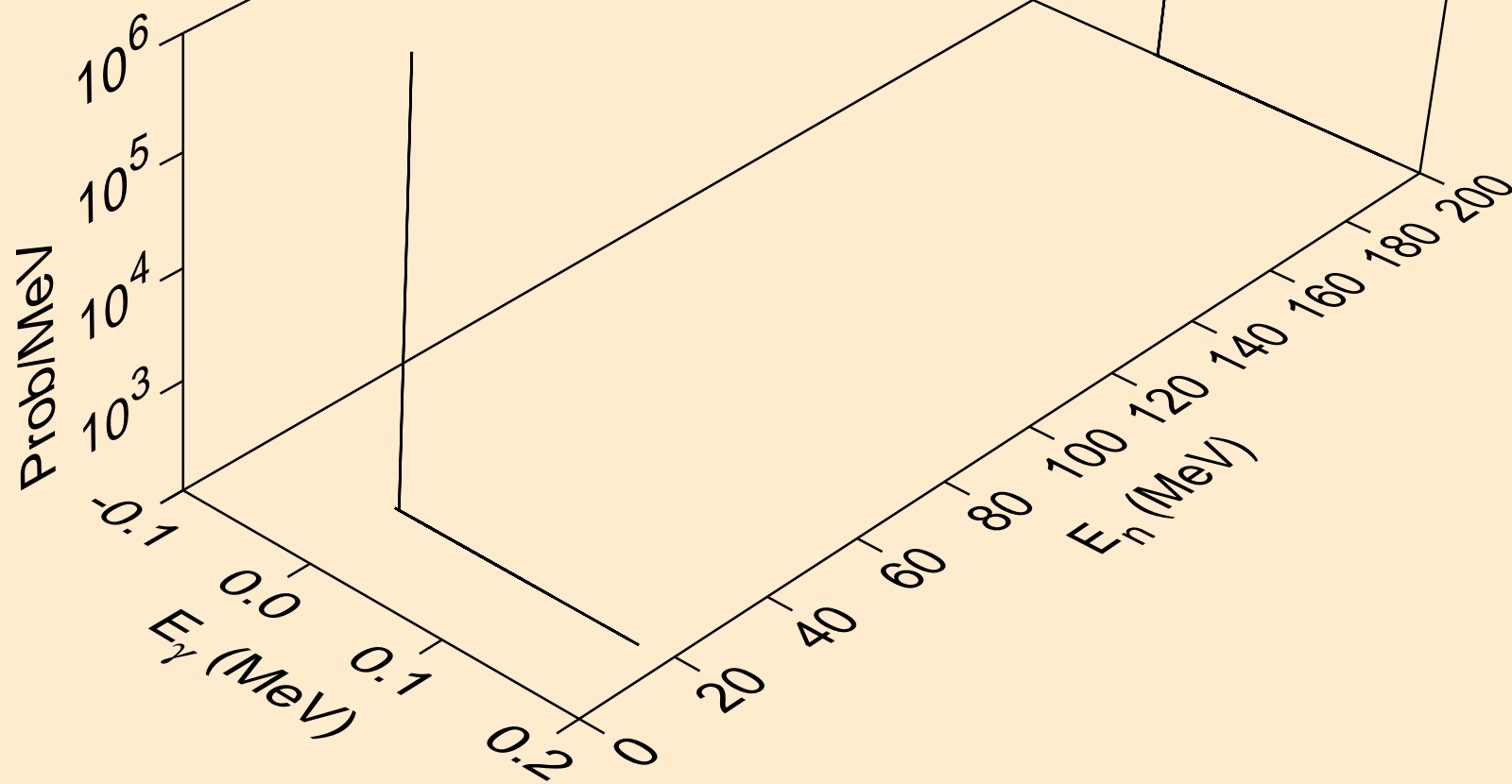

U236 NEUTRON ACER TENDL-2019 LIBRARY; T=293.16K
Photon emission for (n,2np)

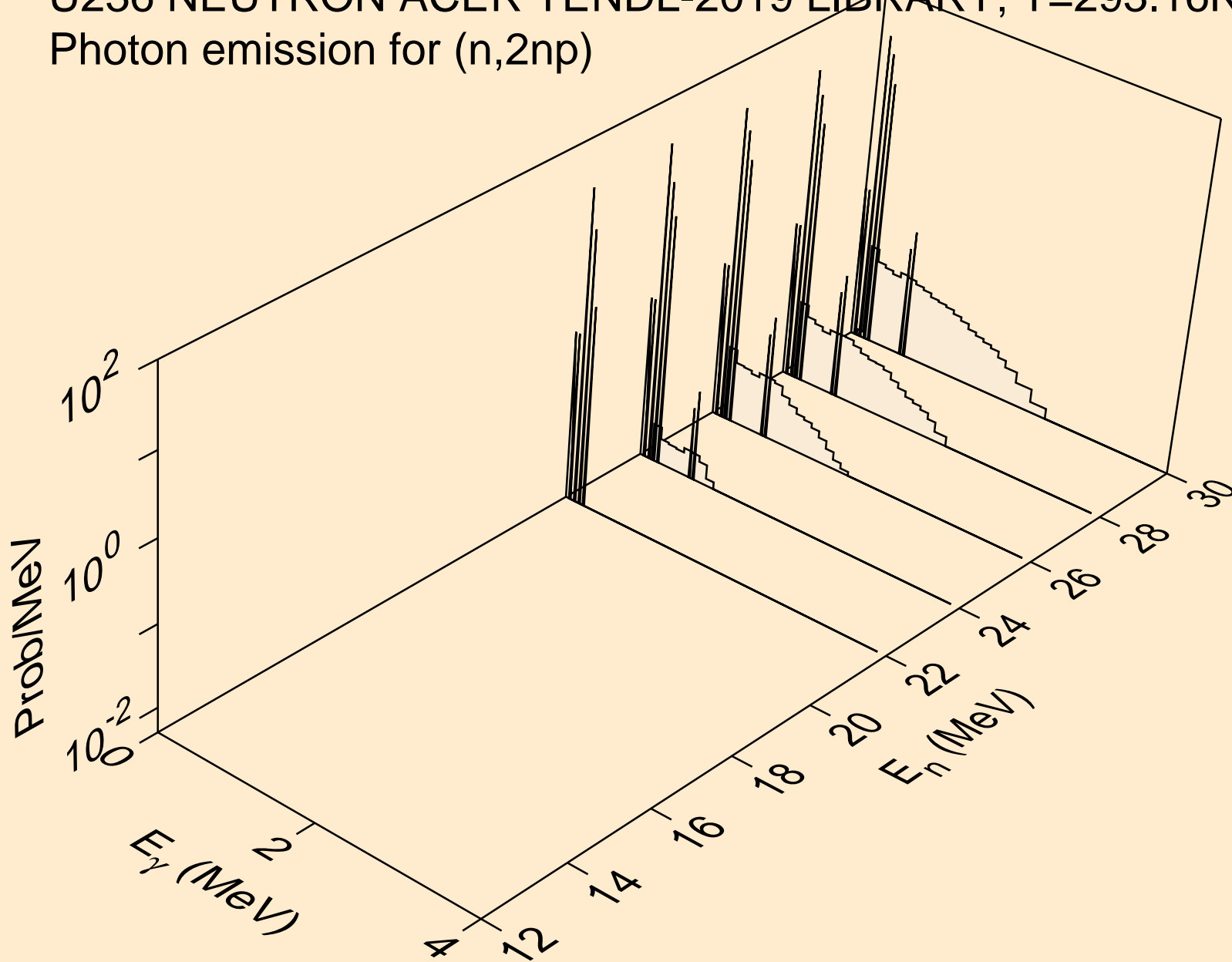

U236 NEUTRON ACER TENDL-2019 LIBRARY; T=293.16K
Photon emission for (n,n*c)

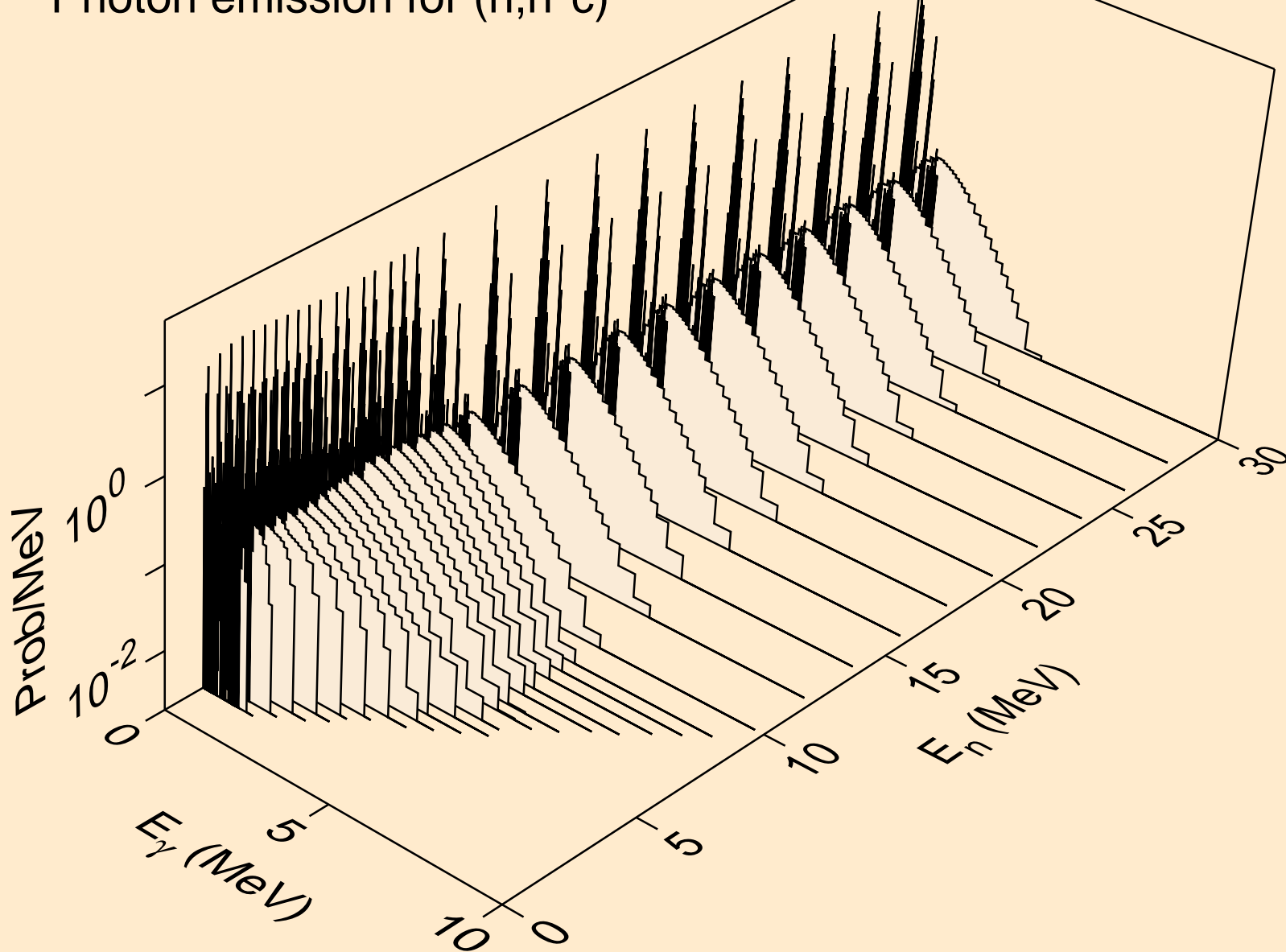

U236 NEUTRON ACER TENDL-2019 LIBRARY; T=293.16K
Photon emission for (n,gma)

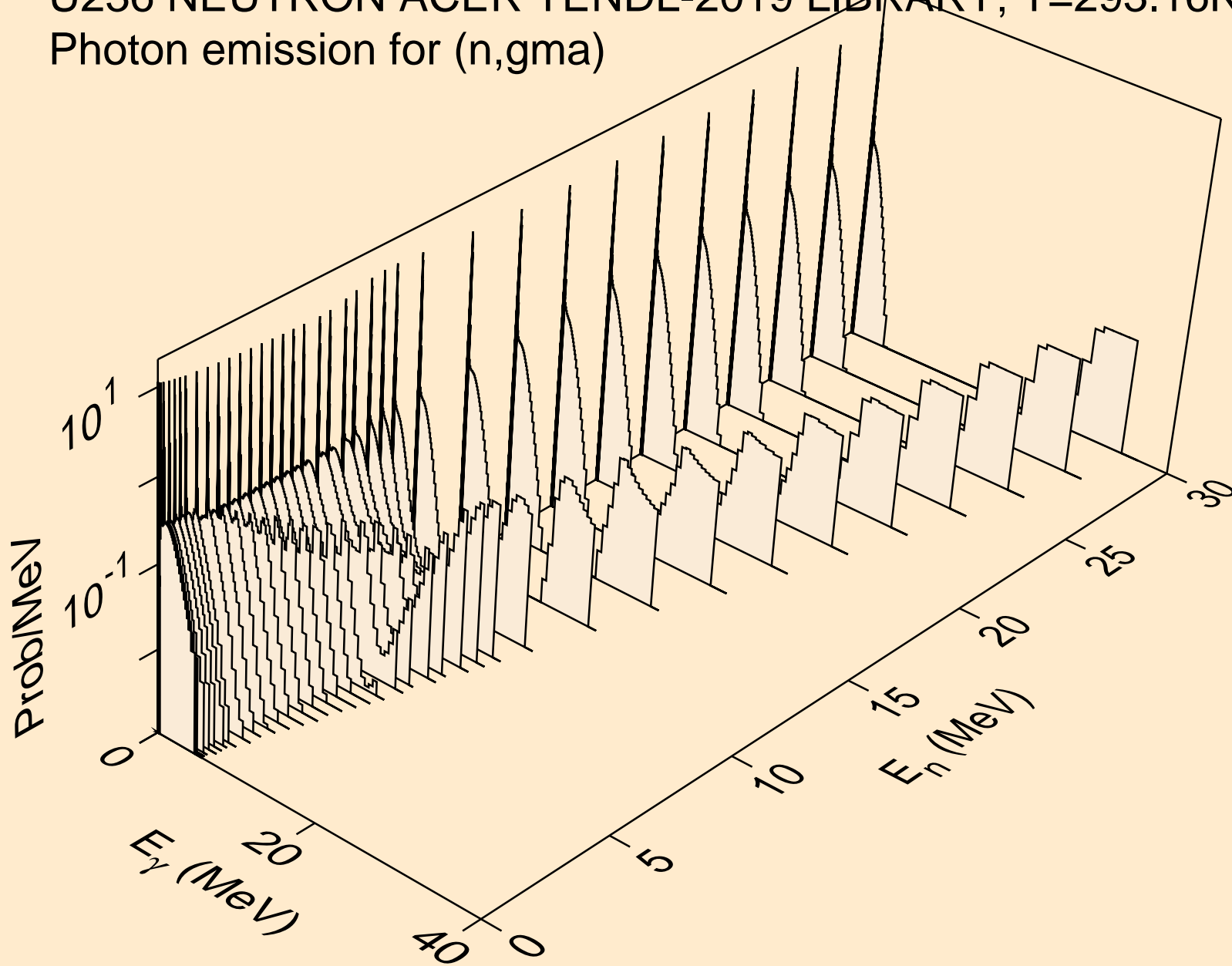

U236 NEUTRON ACER TENDL-2019 LIBRARY; T=293.16K
Photon emission for (n,p)

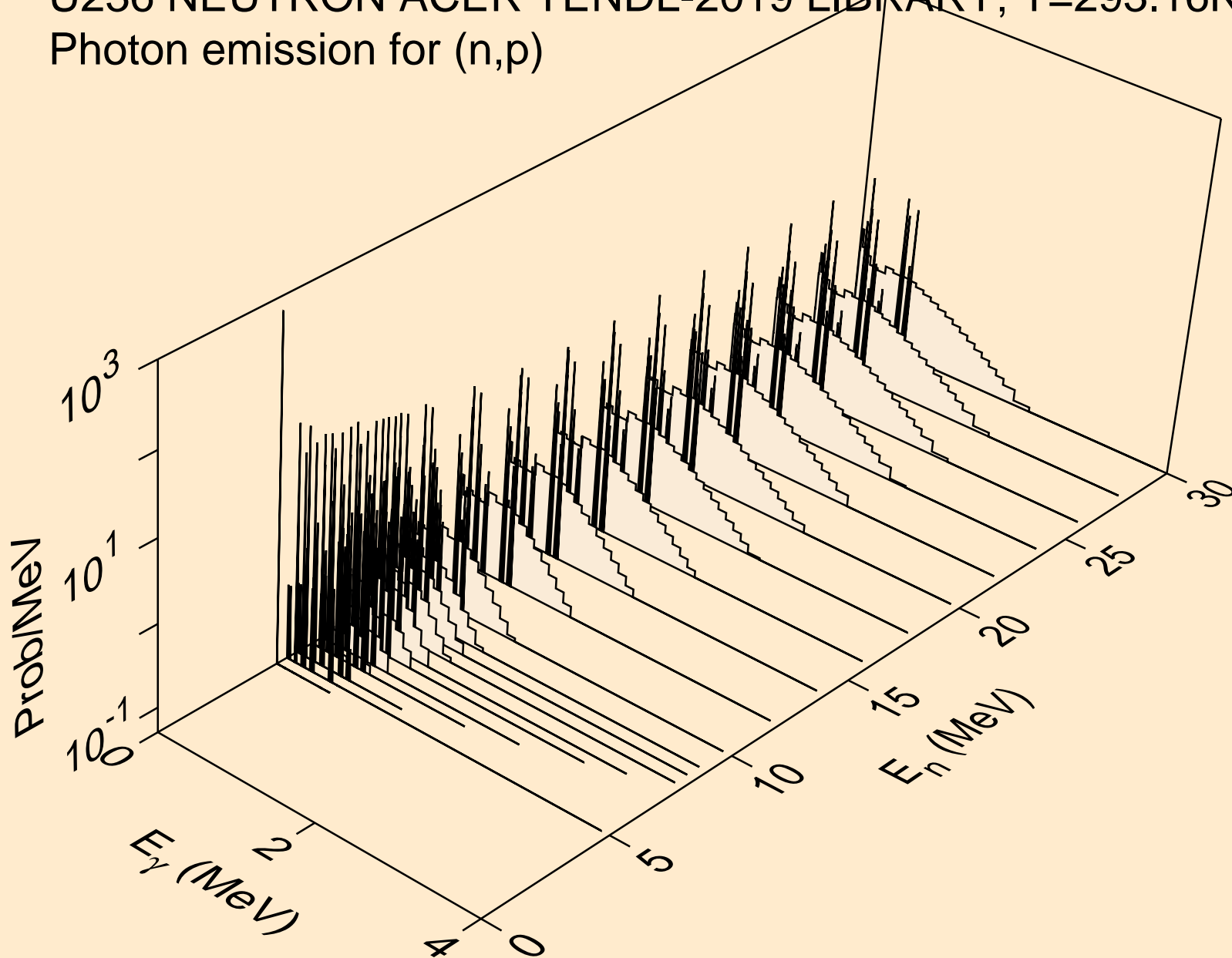

U236 NEUTRON ACER TENDL-2019 LIBRARY; T=293.16K
Photon emission for (n,d)

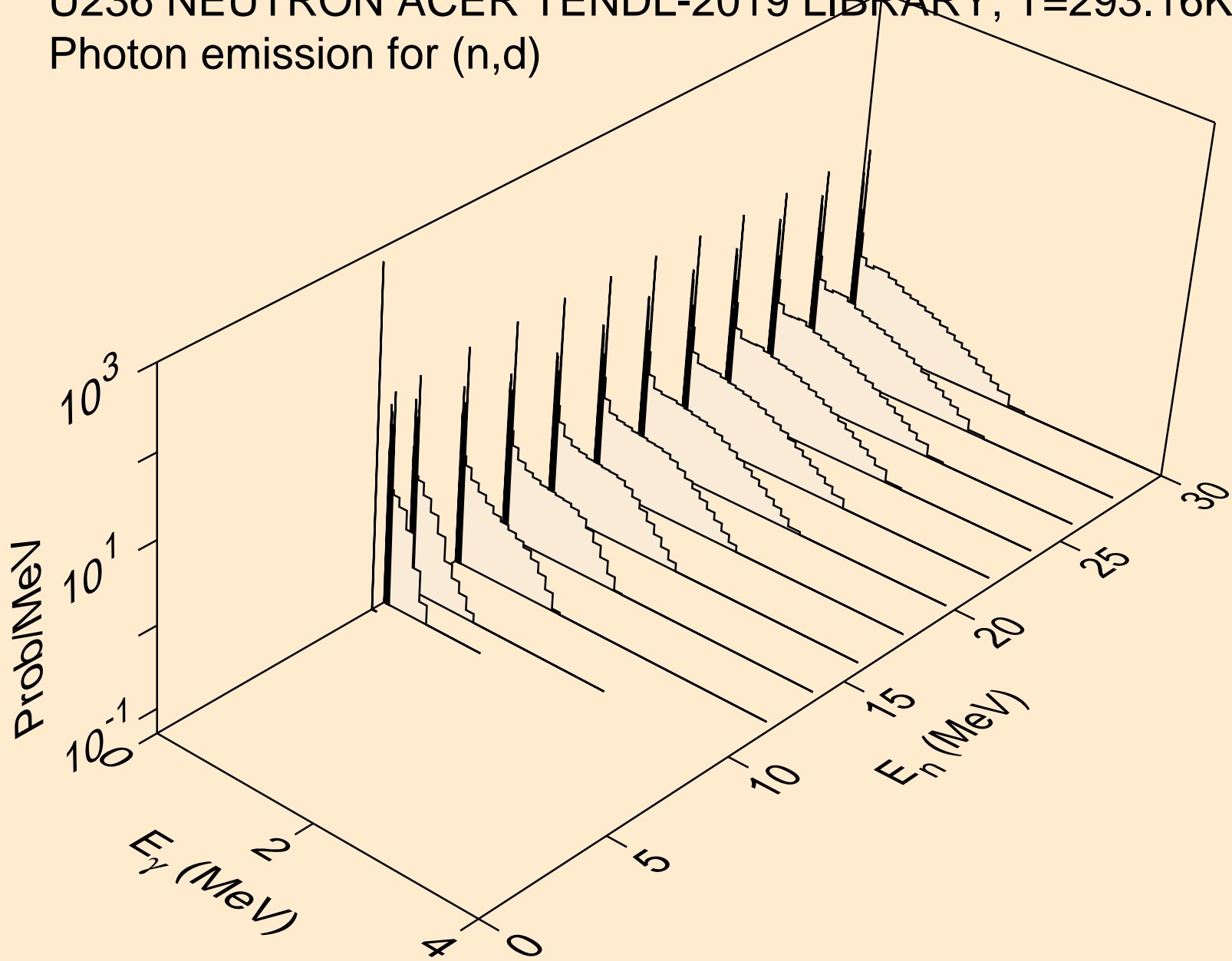

U236 NEUTRON ACER TENDL-2019 LIBRARY; T=293.16K
Photon emission for (n,t)

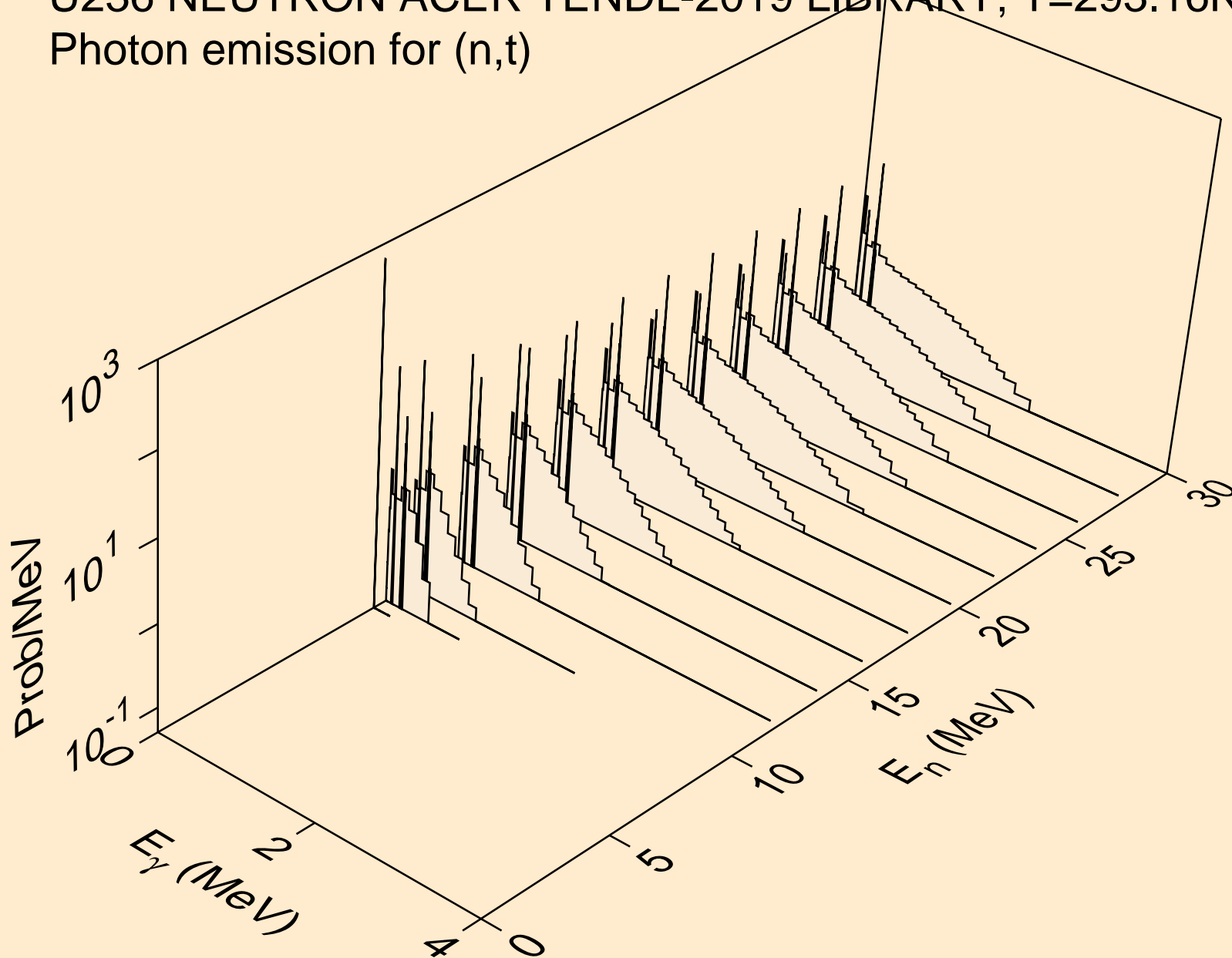

U236 NEUTRON ACER TENDL-2019 LIBRARY; T=293.16K
Photon emission for (n,he3)

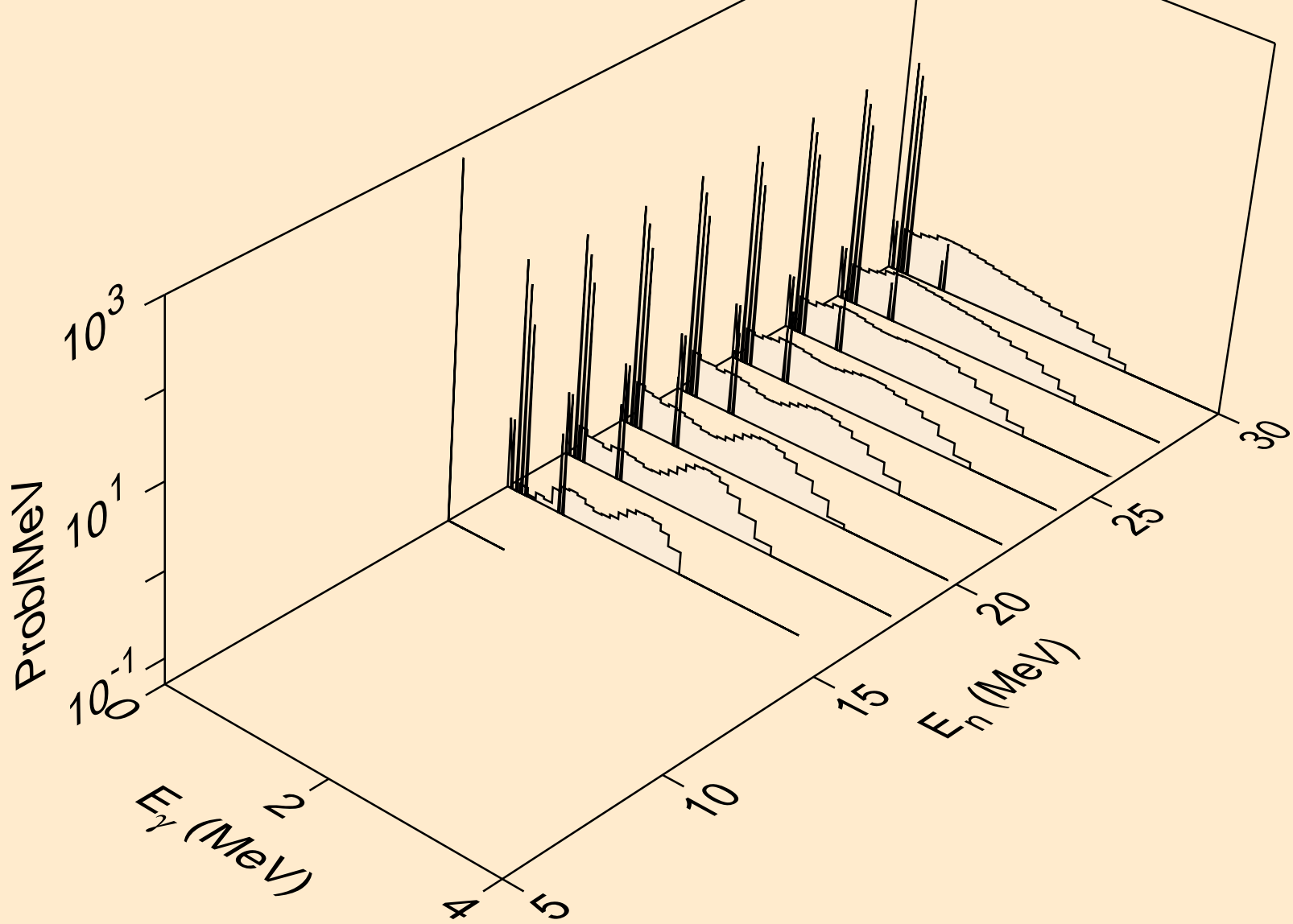

U236 NEUTRON ACER TENDL-2019 LIBRARY; T=293.16K
Photon emission for (n,a)

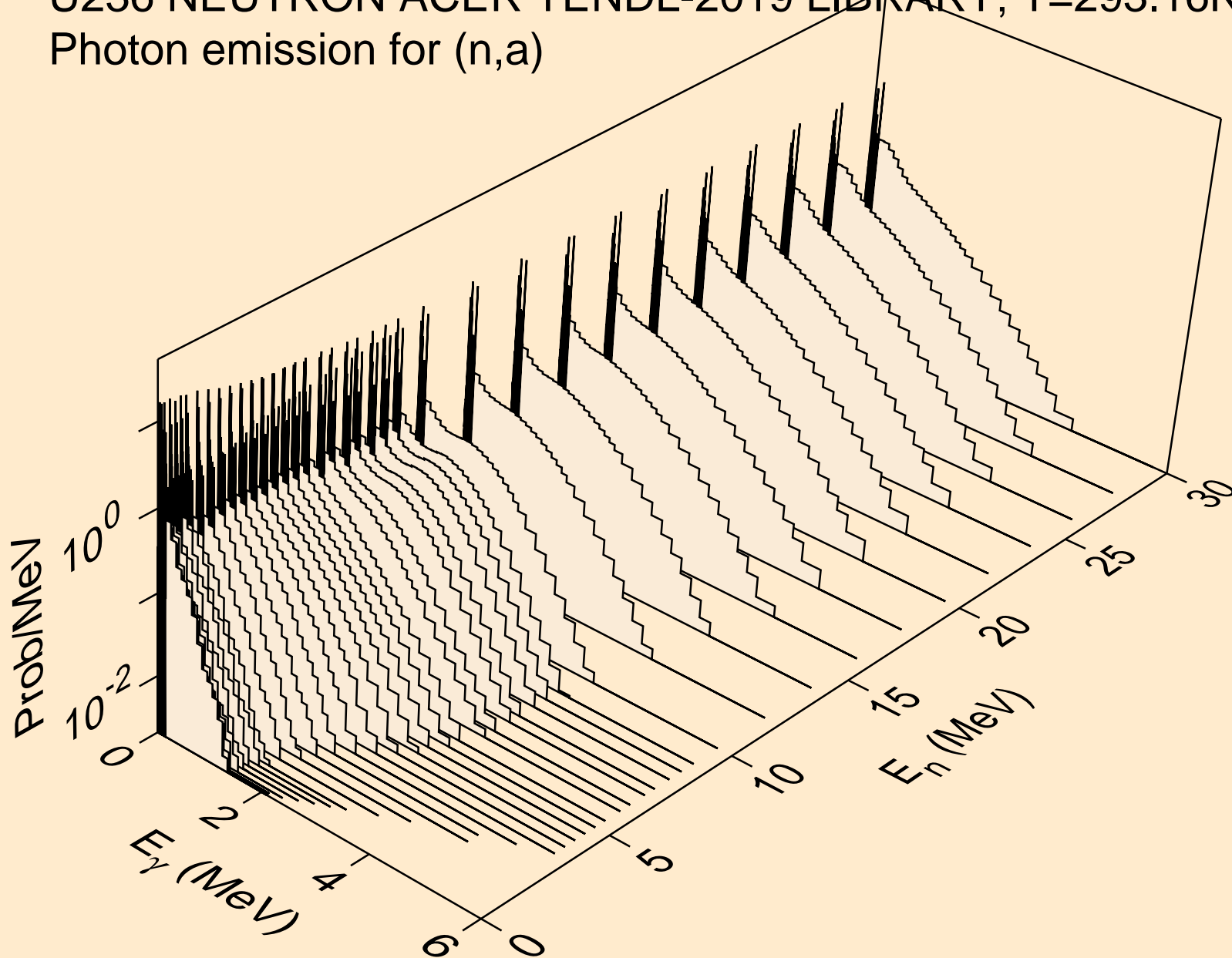

U236 NEUTRON ACER TENDL-2019 LIBRARY; T=293.16K
Photon emission for (n,2p)

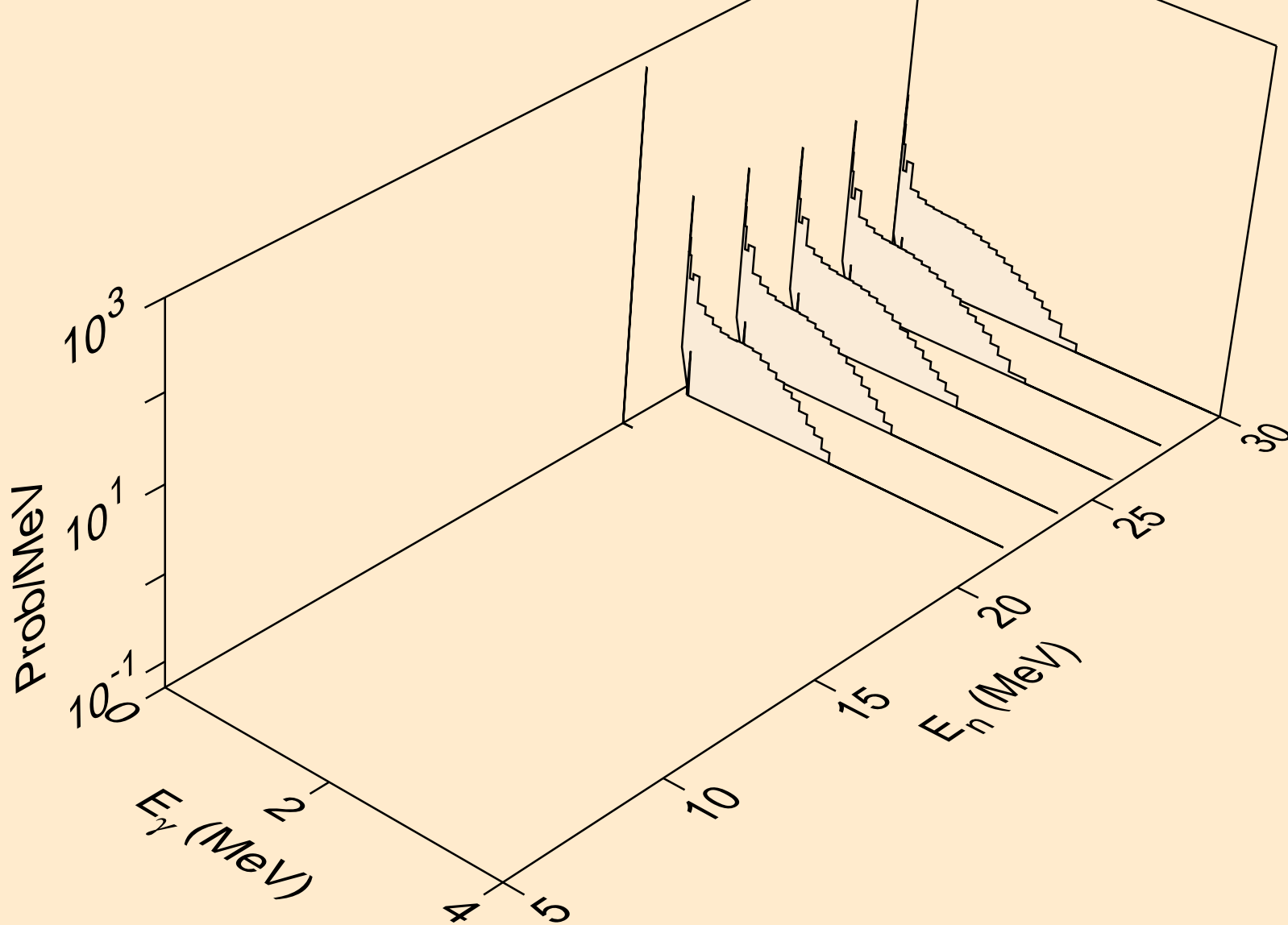

U236 NEUTRON ACER TENDL-2019 LIBRARY; T=293.16K
thermal capture photon spectrum

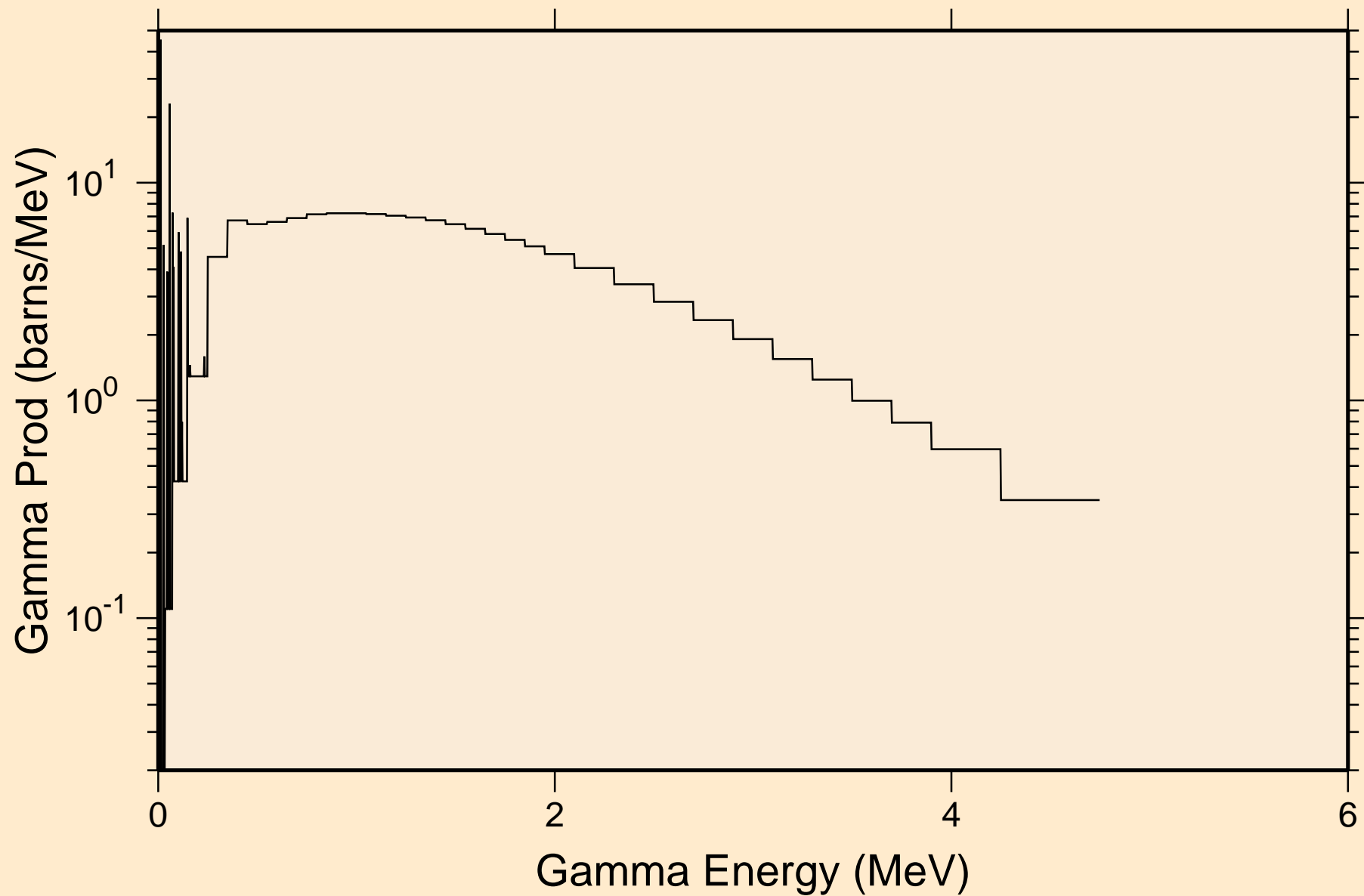

U236 NEUTRON ACER TENDL-2019 LIBRARY; T=293.16K
14 MeV photon spectrum

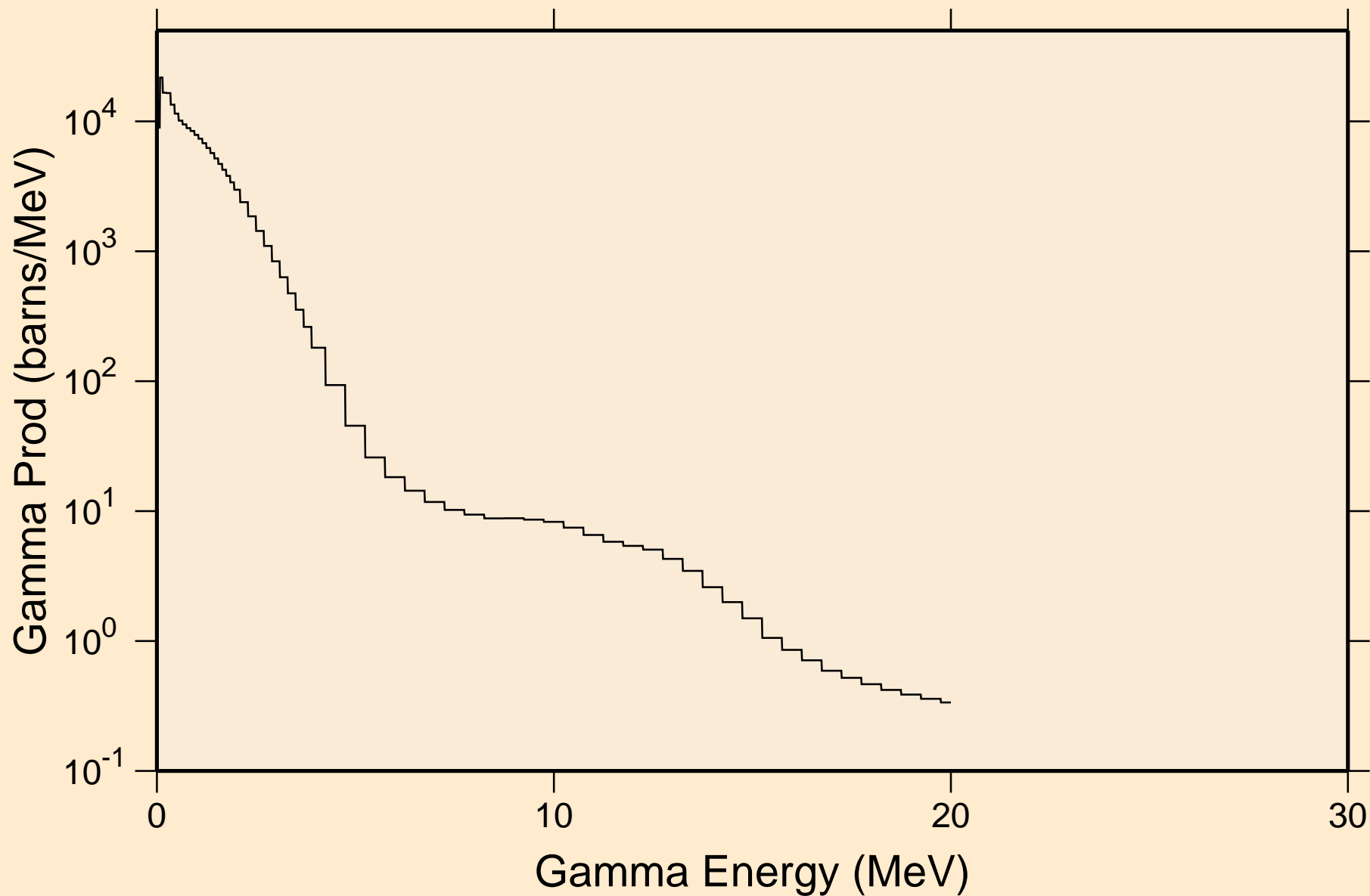

U236 NEUTRON ACER TENDL-2019 LIBRARY; T=293.16K

Particle heating contributions

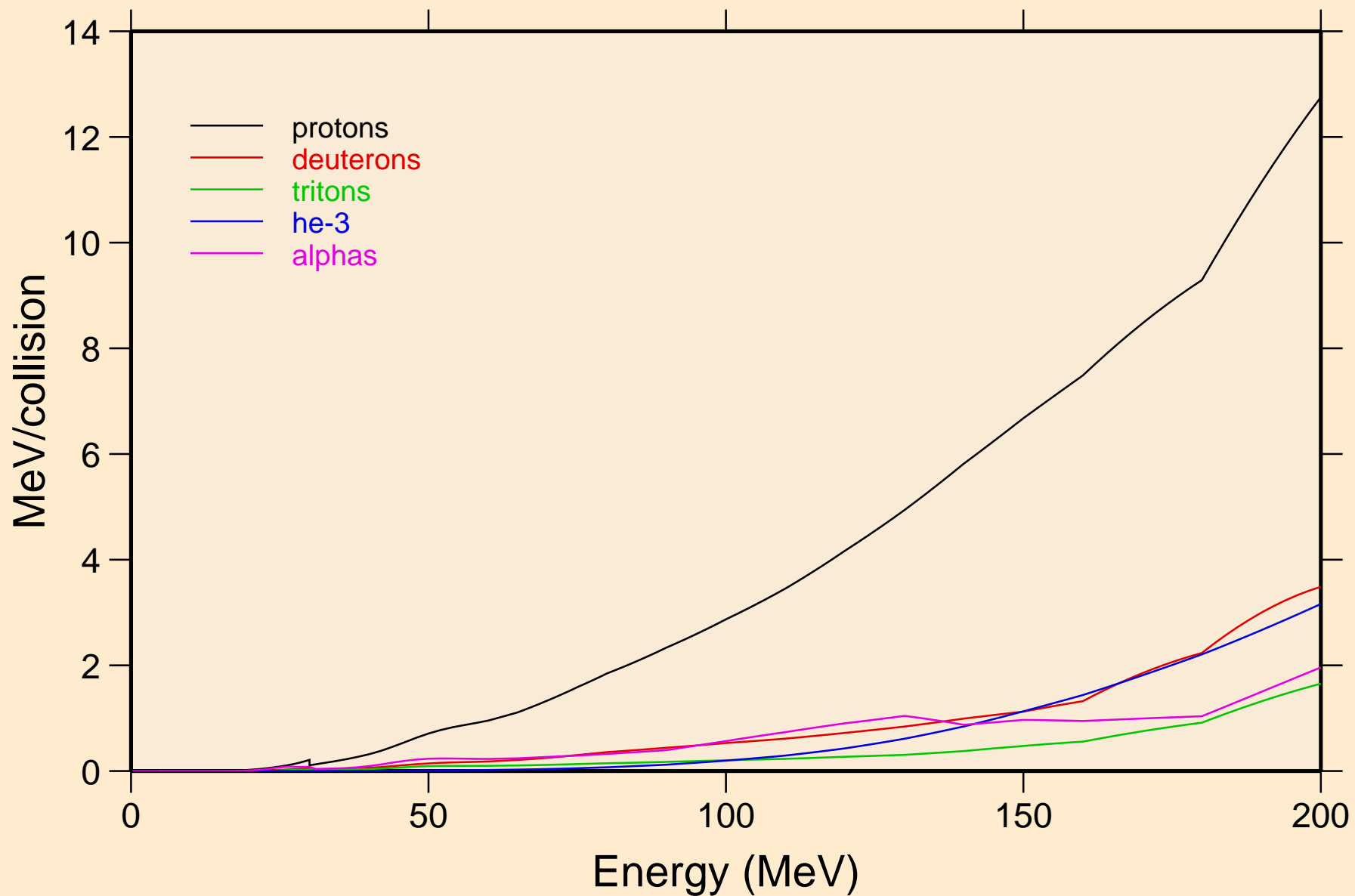

U236 NEUTRON ACER TENDL-2019 LIBRARY; T=293.16K
Recoil Heating

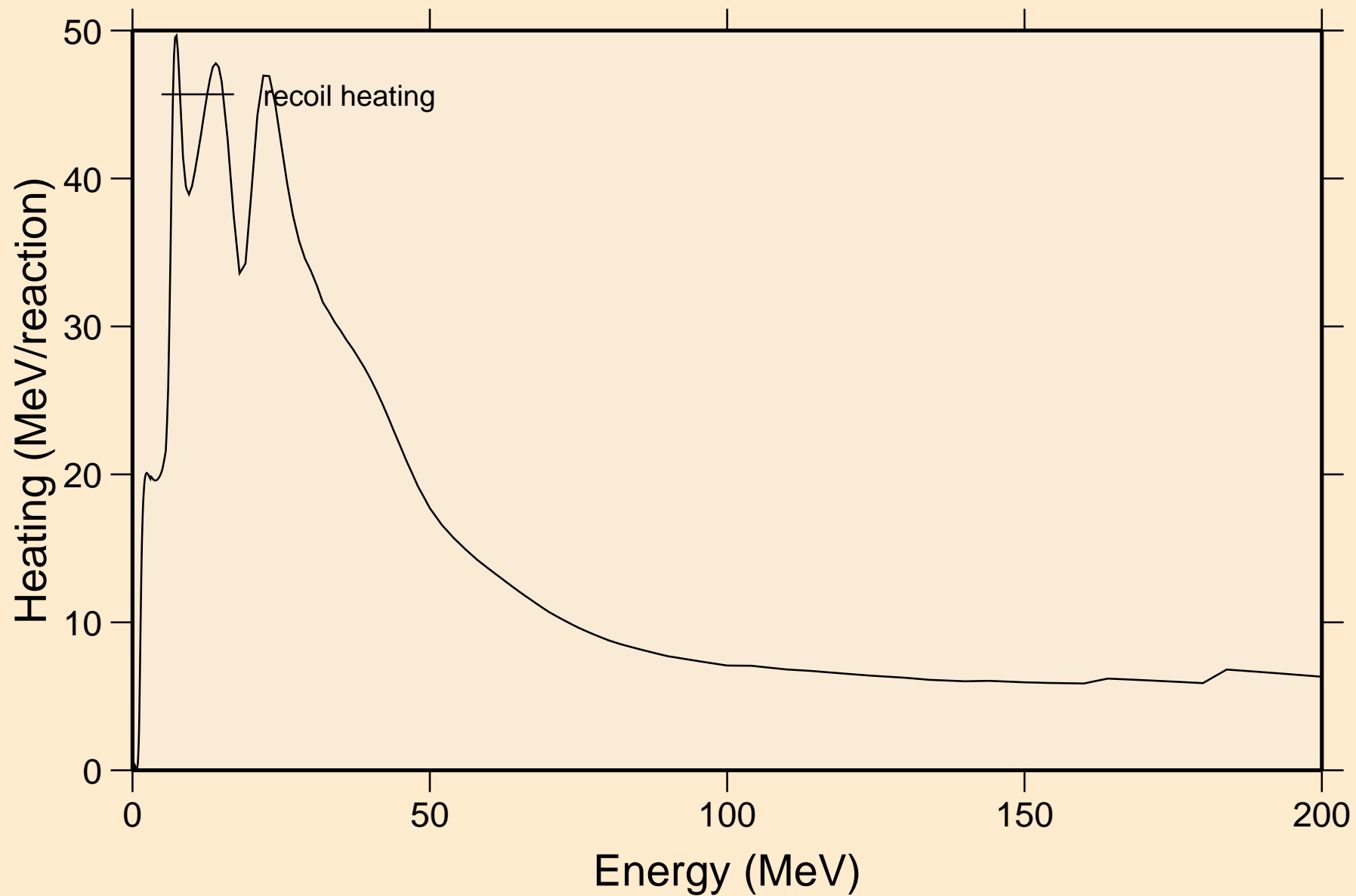

U236 NEUTRON ACER TENDL-2019 LIBRARY; T=293.16K

Particle production cross sections

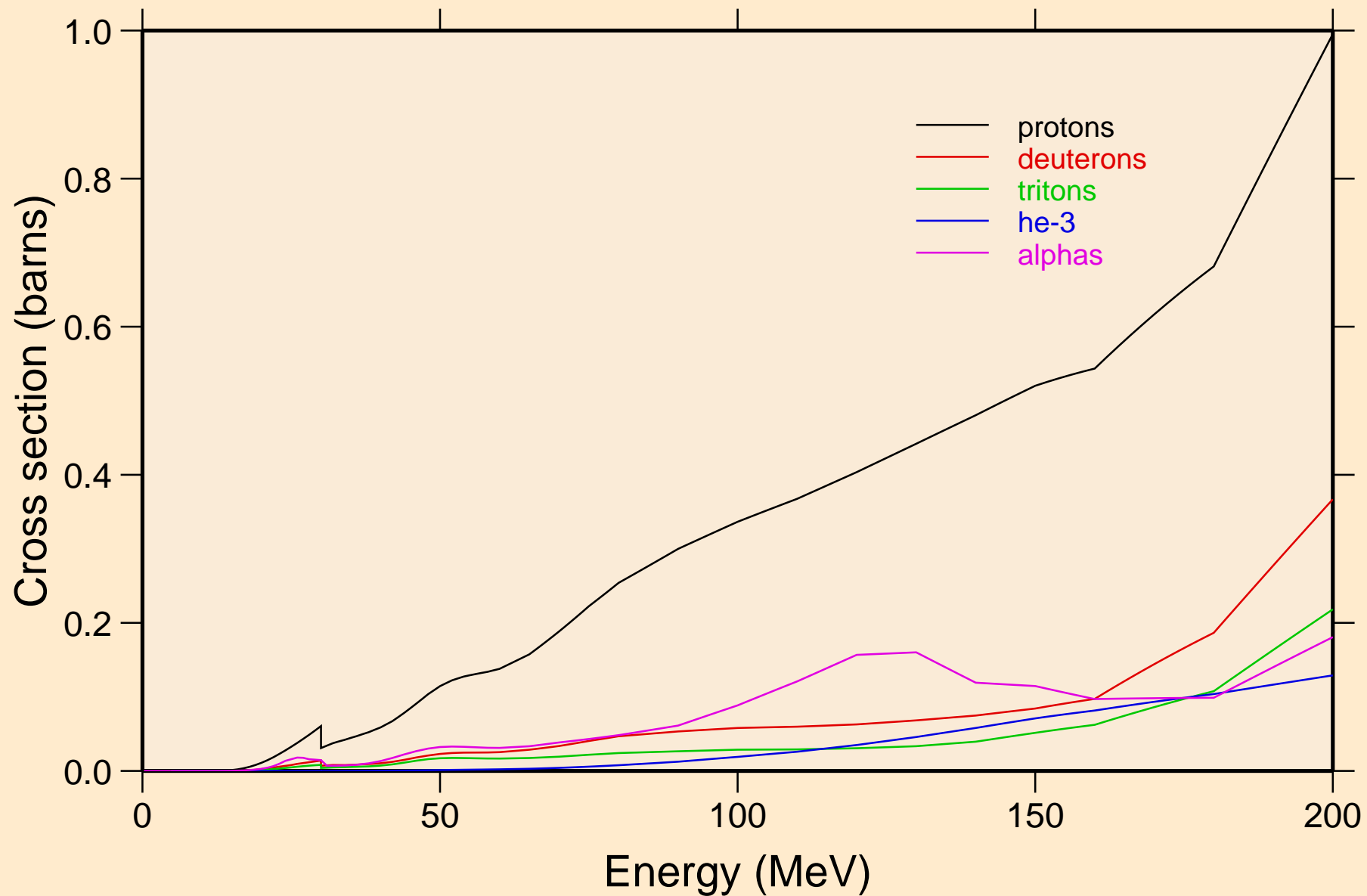

U236 NEUTRON ACER TENDL-2019 LIBRARY; T=293.16K
protons from (n,x)

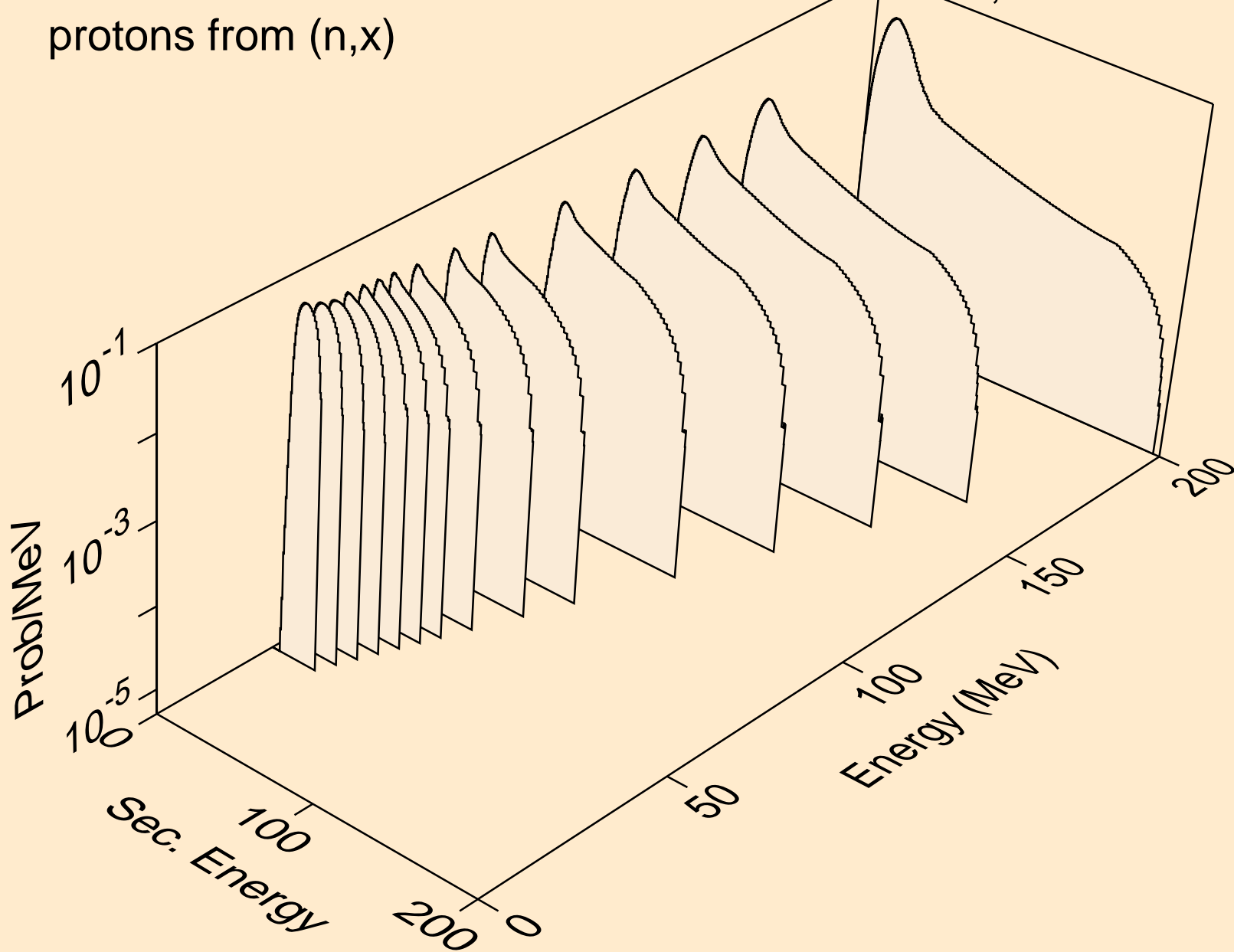

U236 NEUTRON ACER TENDL-2019 LIBRARY; T=293.16K
protons from (n,n*)p

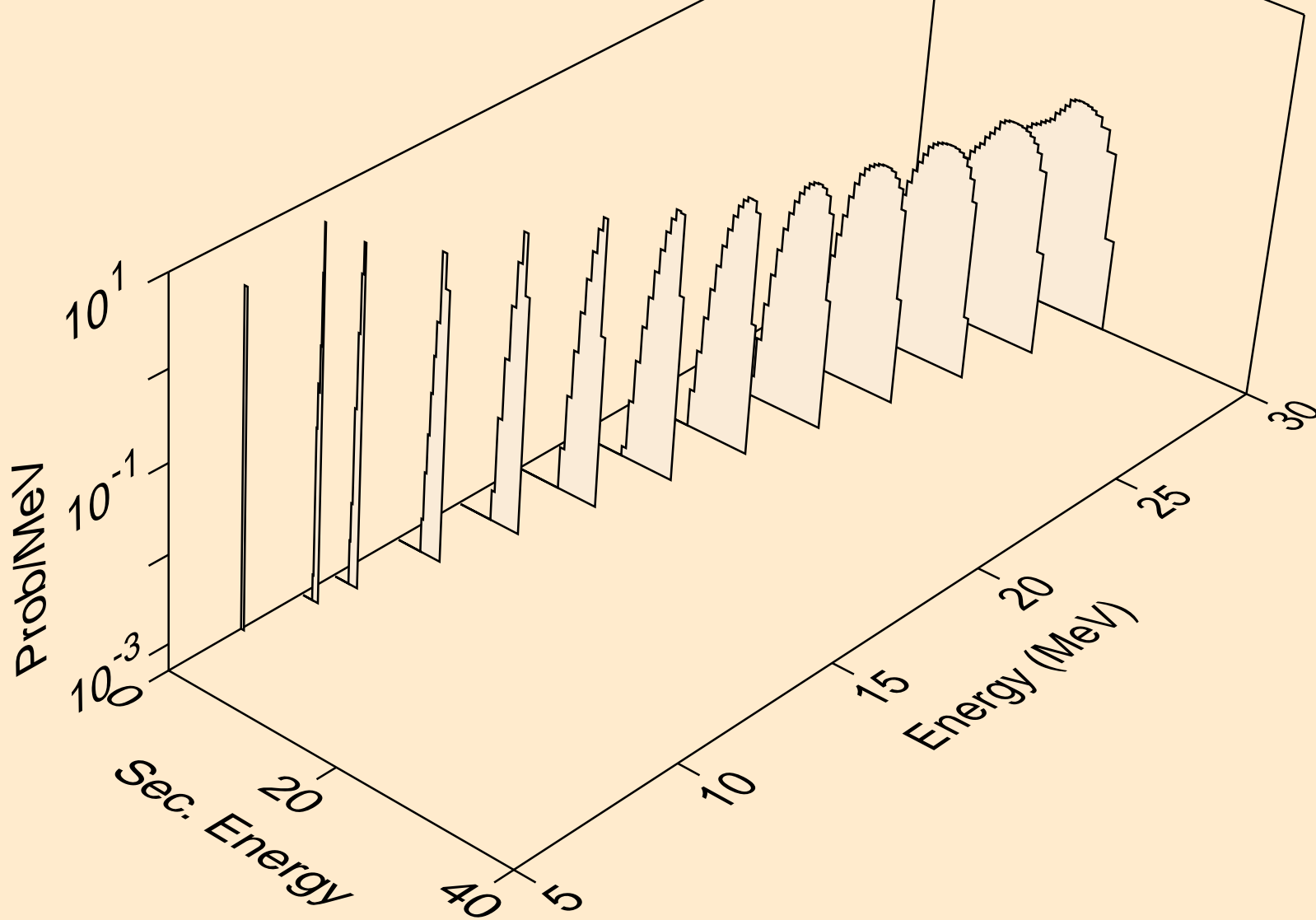

U236 NEUTRON ACER TENDL-2019 LIBRARY; T=293.16K
protons from (n,2np)

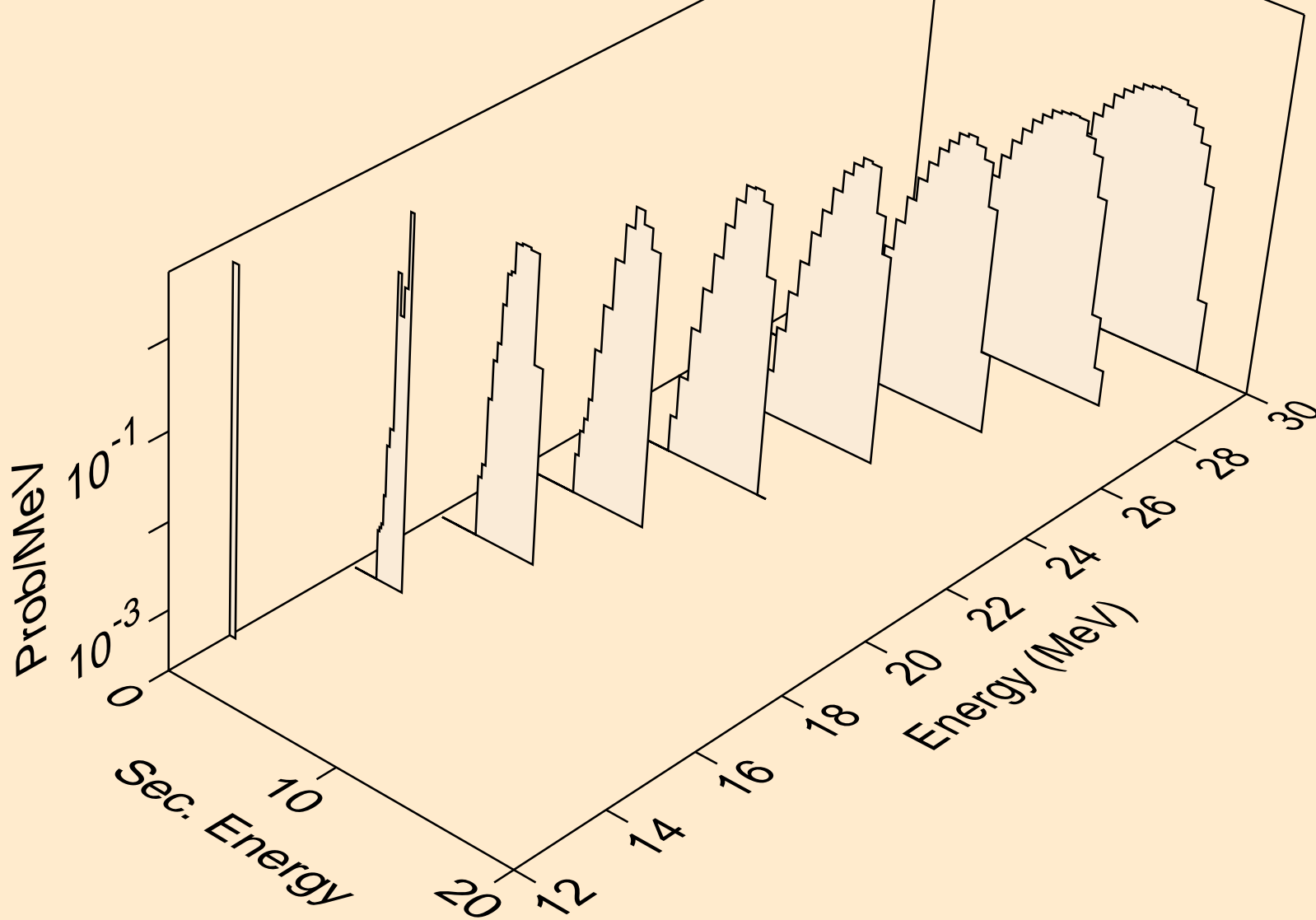

U236 NEUTRON ACER TENDL-2019 LIBRARY; T=293.16K
protons from (n,3np)

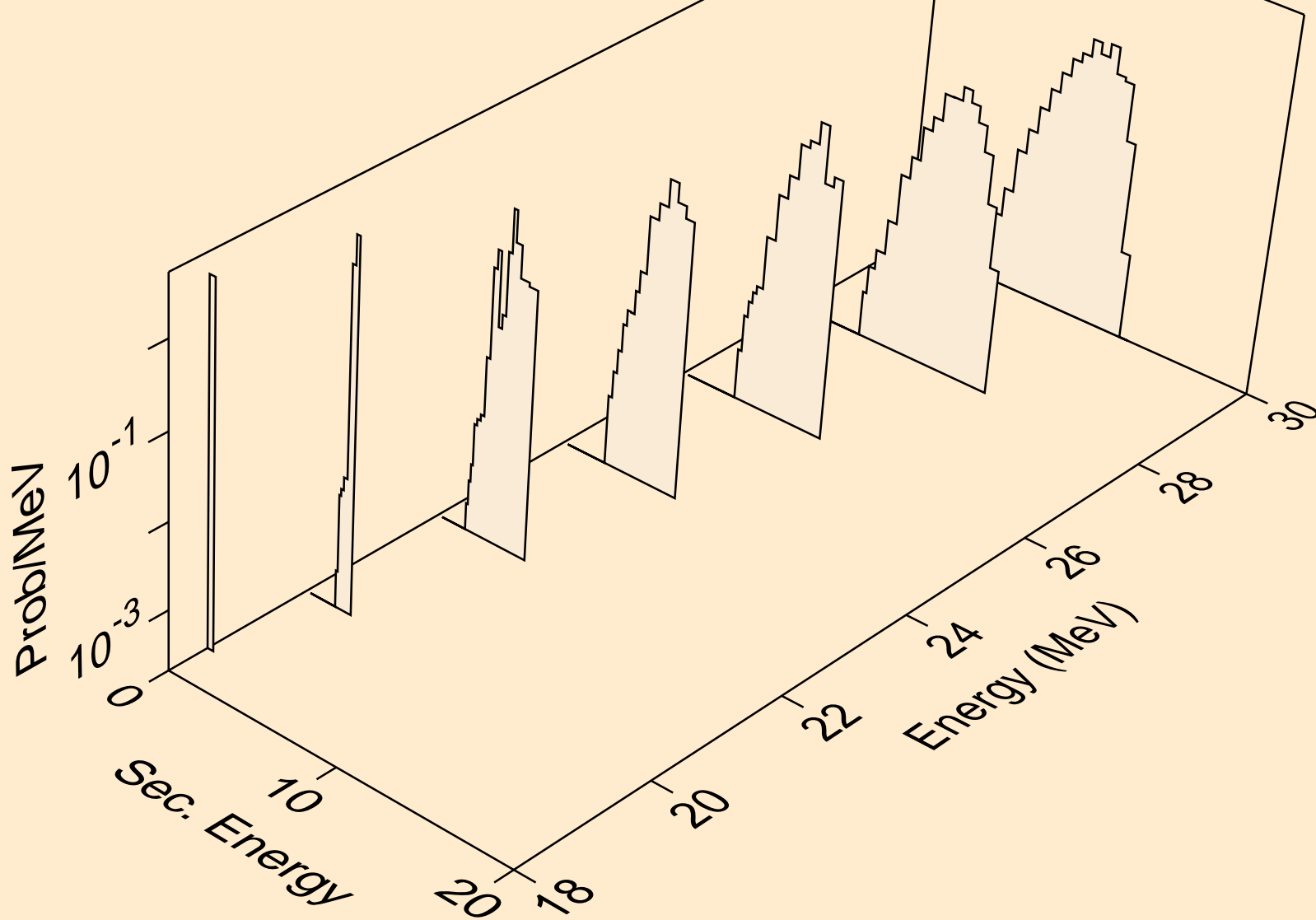

U236 NEUTRON ACER TENDL-2019 LIBRARY; T=293.16K
protons from (n,2np)

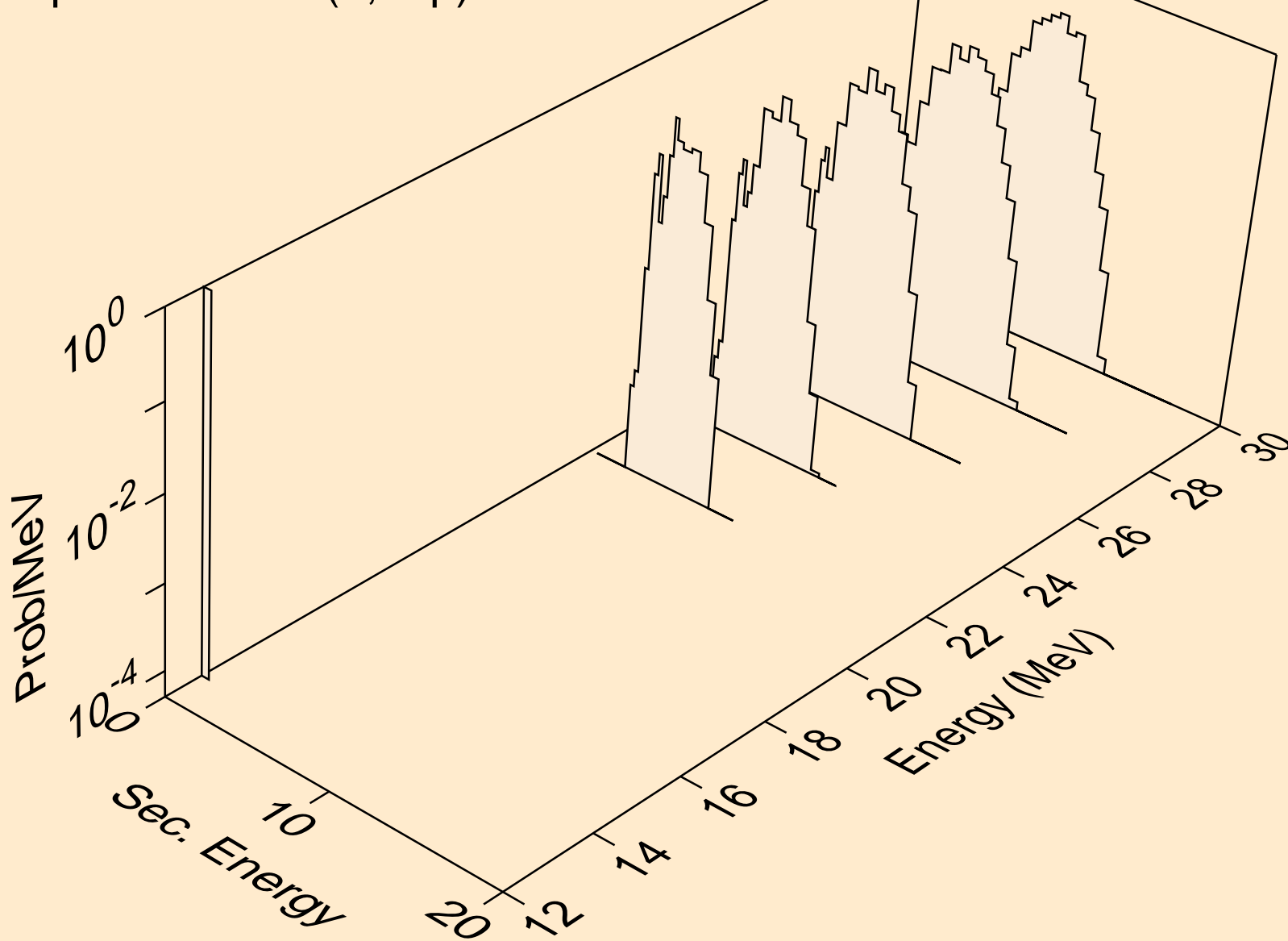

U236 NEUTRON ACER TENDL-2019 LIBRARY; T=293.16K
protons from (n,p)

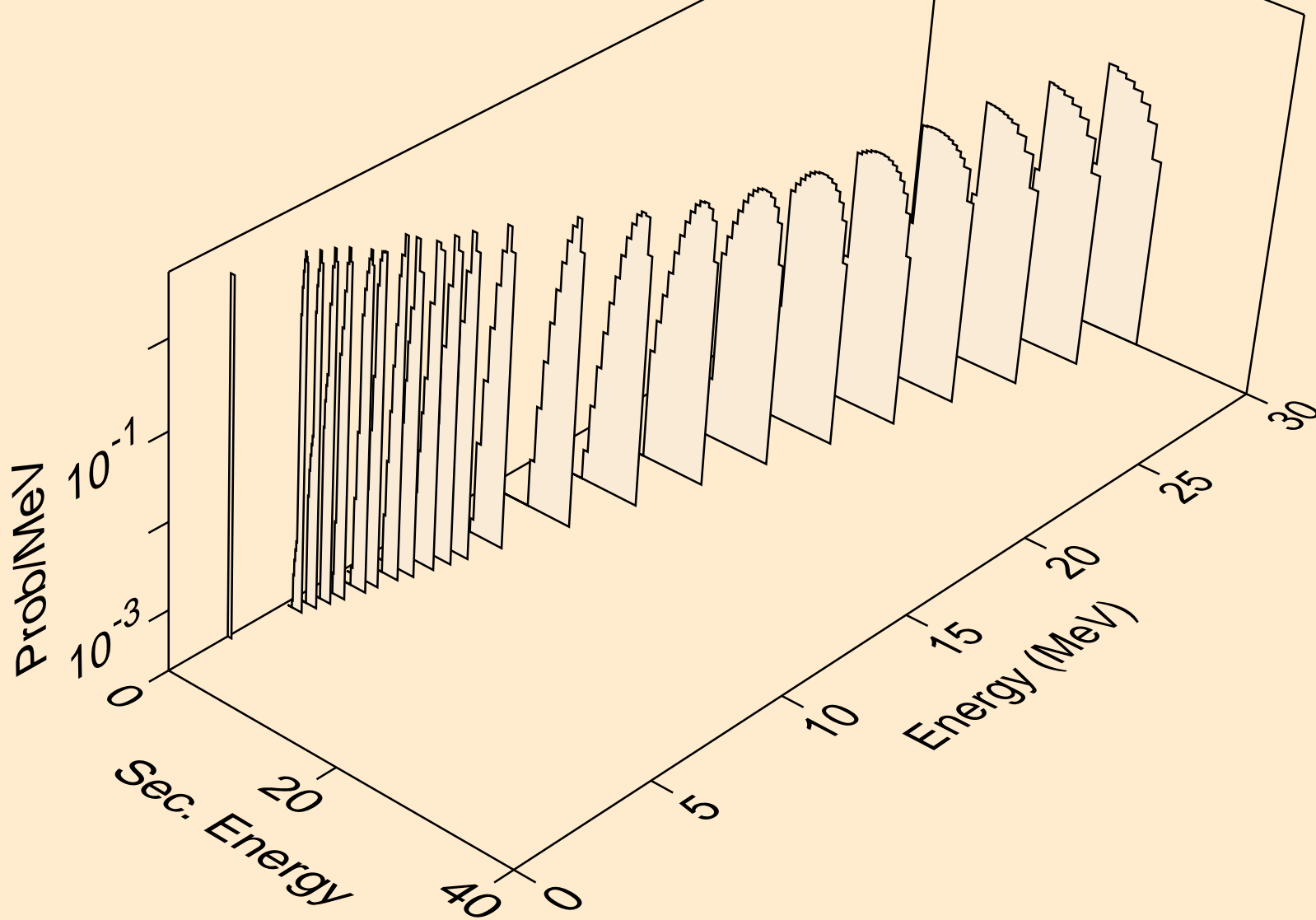

U236 NEUTRON ACER TENDL-2019 LIBRARY; T=293.16K
protons from (n,2p)

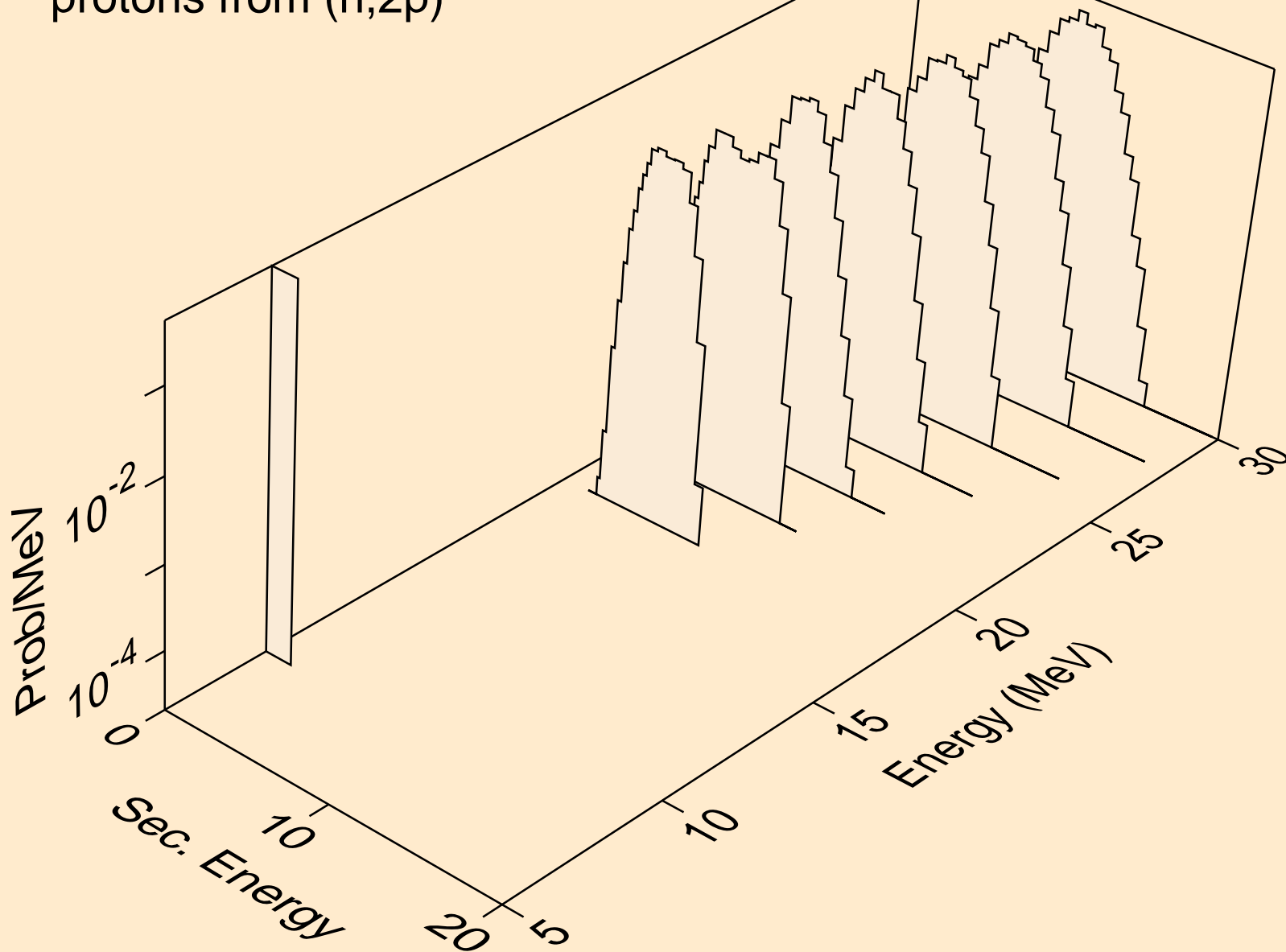

U236 NEUTRON ACER TENDL-2019 LIBRARY; T=293.16K
deuterons from (n,x)

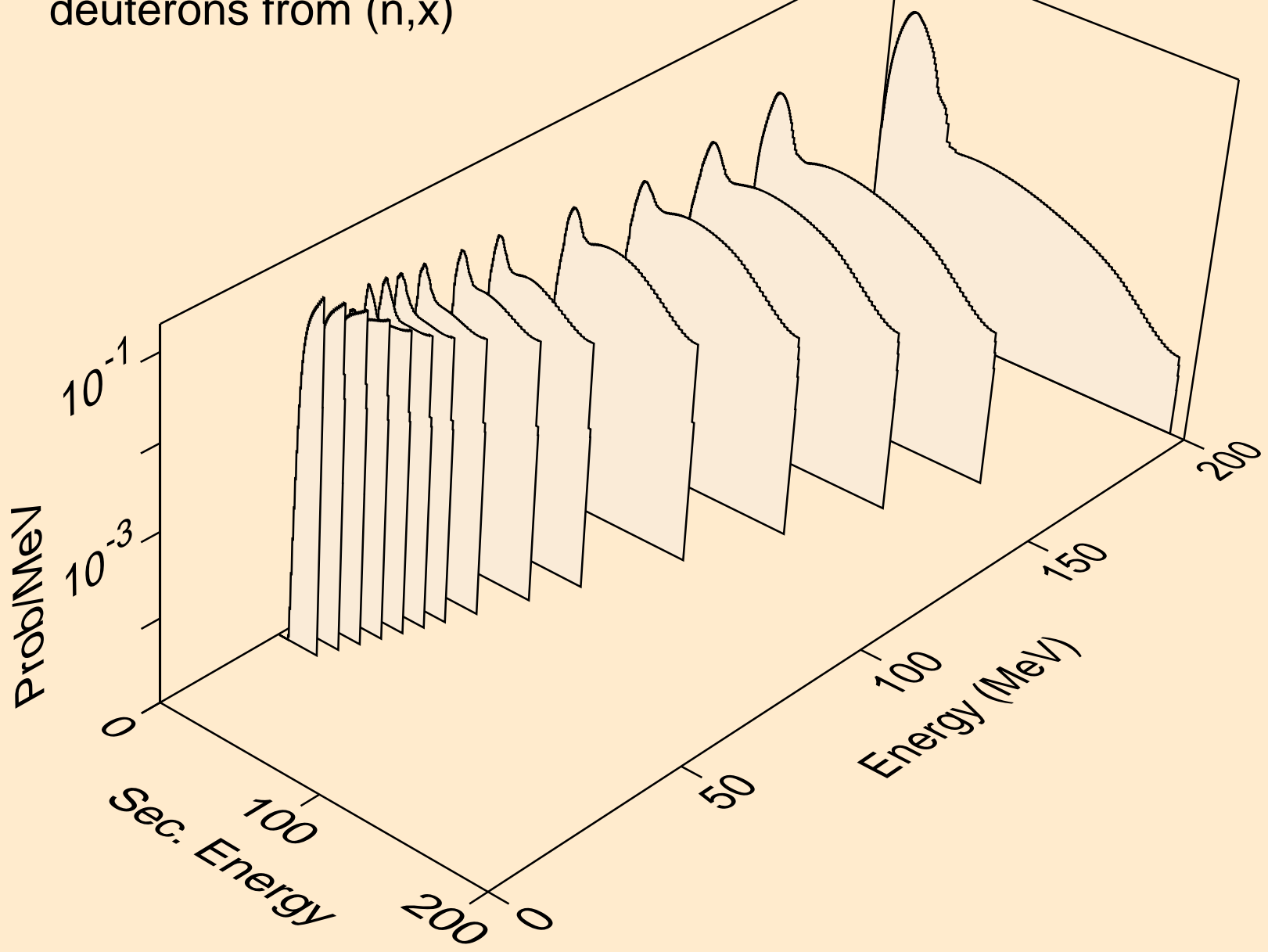

U236 NEUTRON ACER TENDL-2019 LIBRARY; T=293.16K
deuterons from (n,2nd)

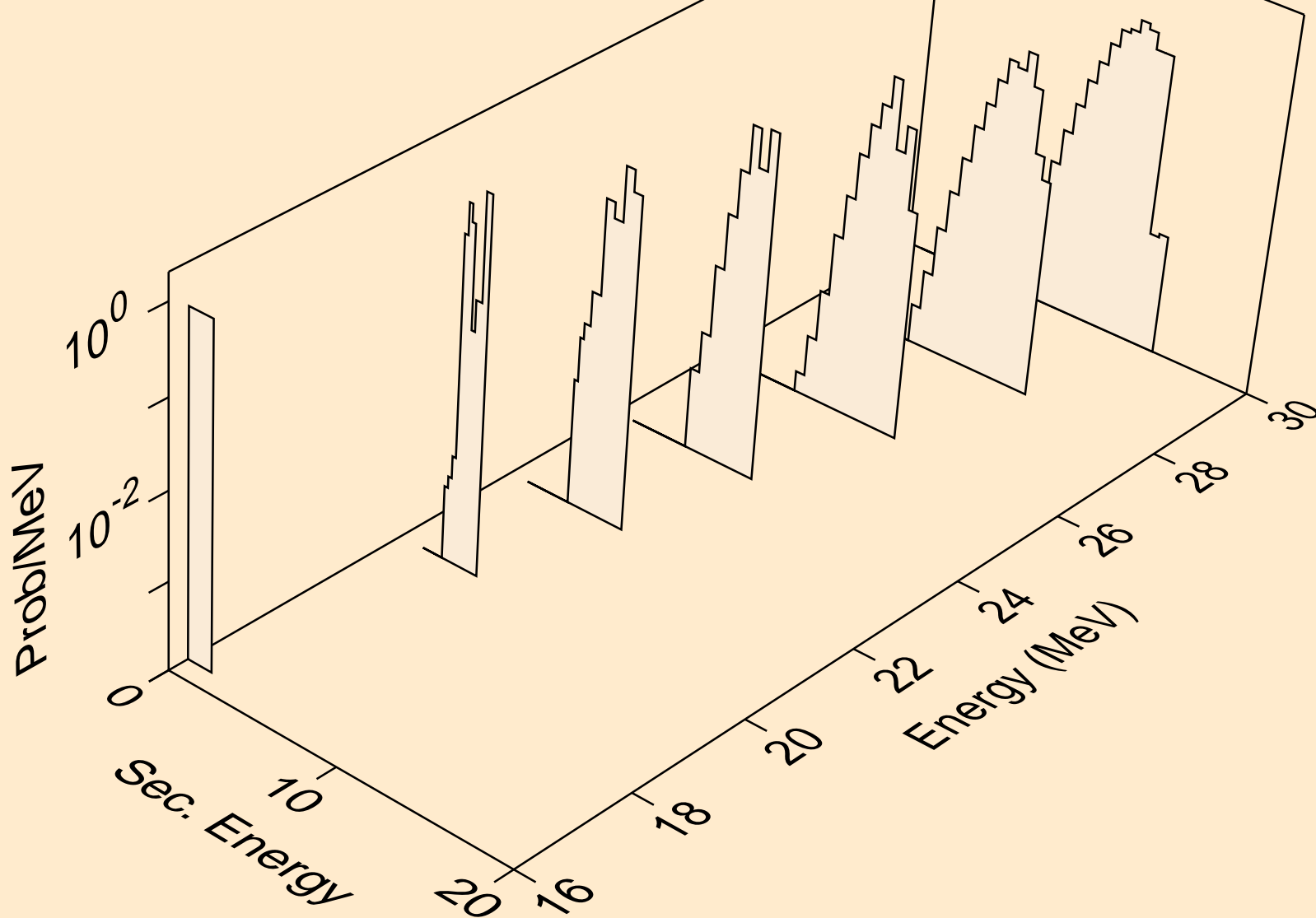

U236 NEUTRON ACER TENDL-2019 LIBRARY; T=293.16K
deuterons from (n,n*)d

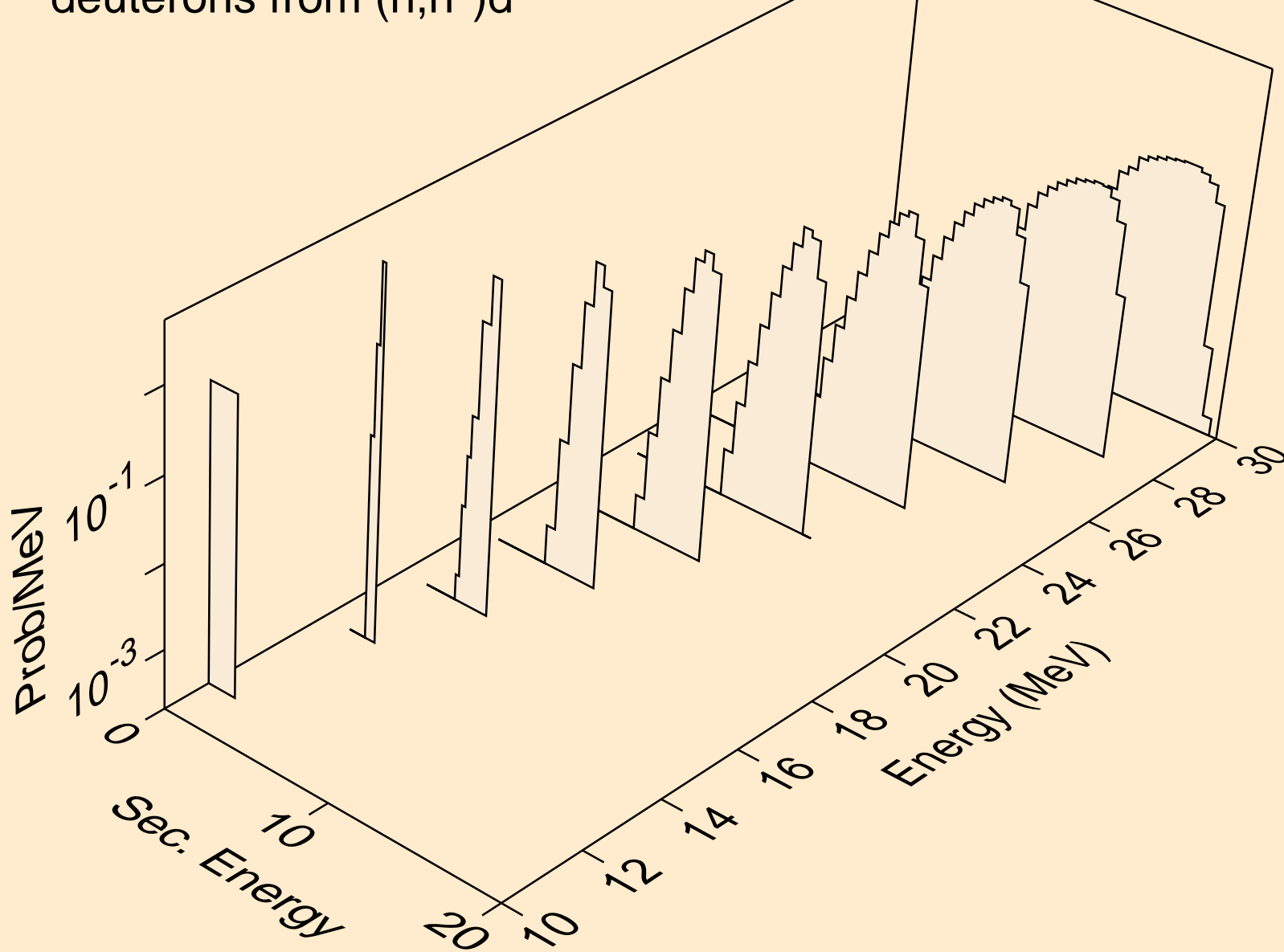

U236 NEUTRON ACER TENDL-2019 LIBRARY; T=293.16K
deuterons from (n,d)

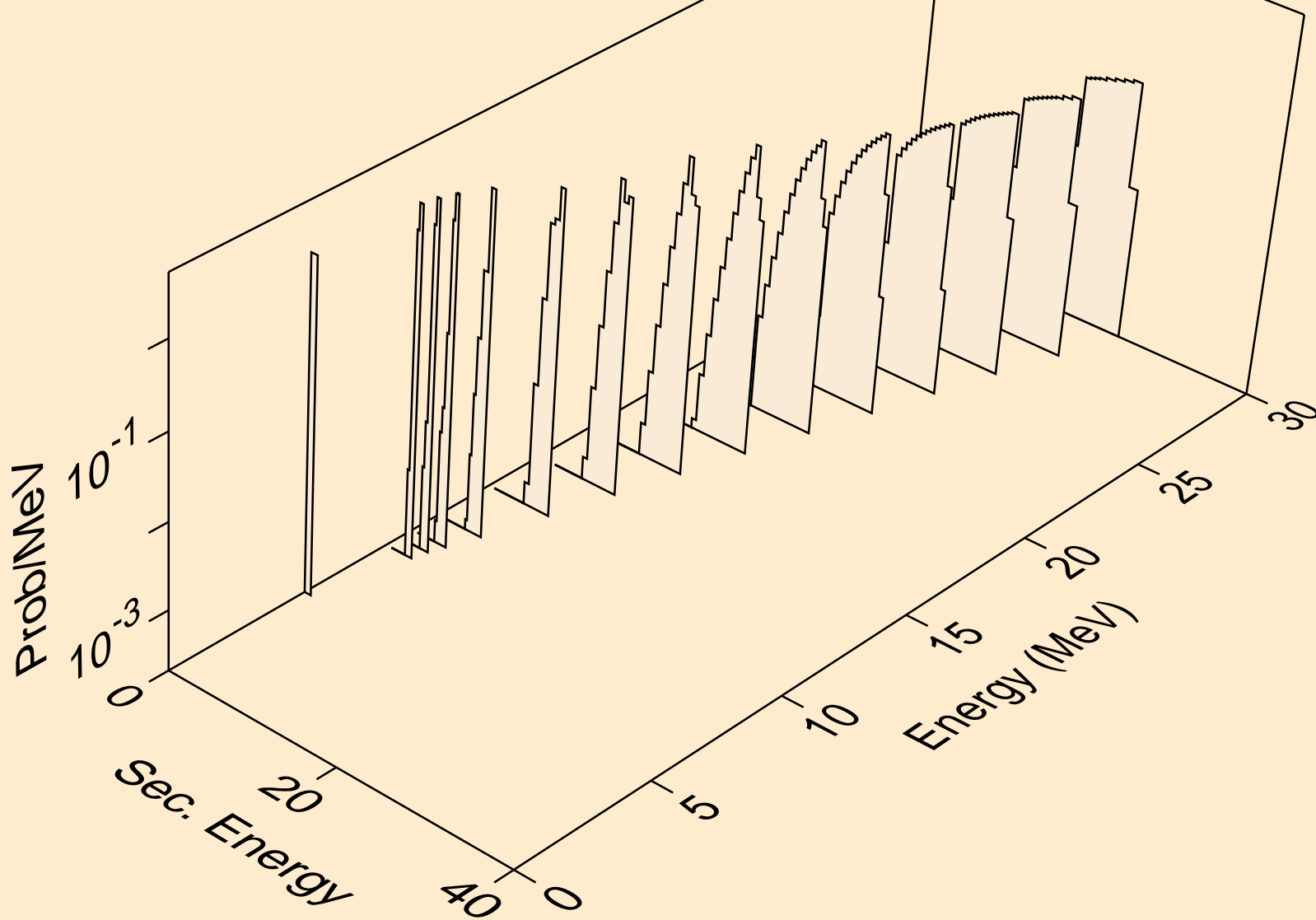

U236 NEUTRON ACER TENDL-2019 LIBRARY; T=293.16K
tritons from (n,x)

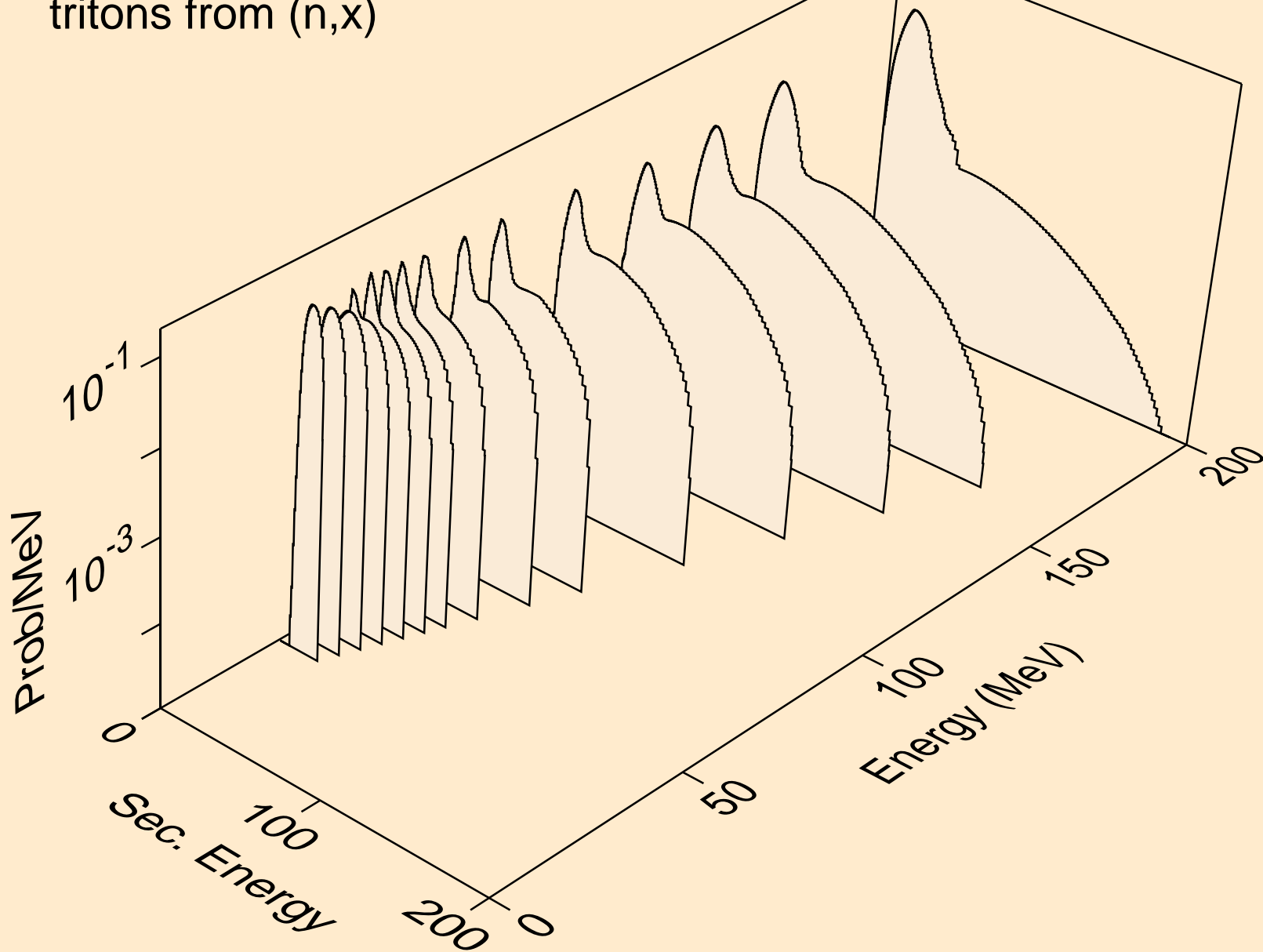

U236 NEUTRON ACER TENDL-2019 LIBRARY; T=293.16K
tritons from (n,n*)t

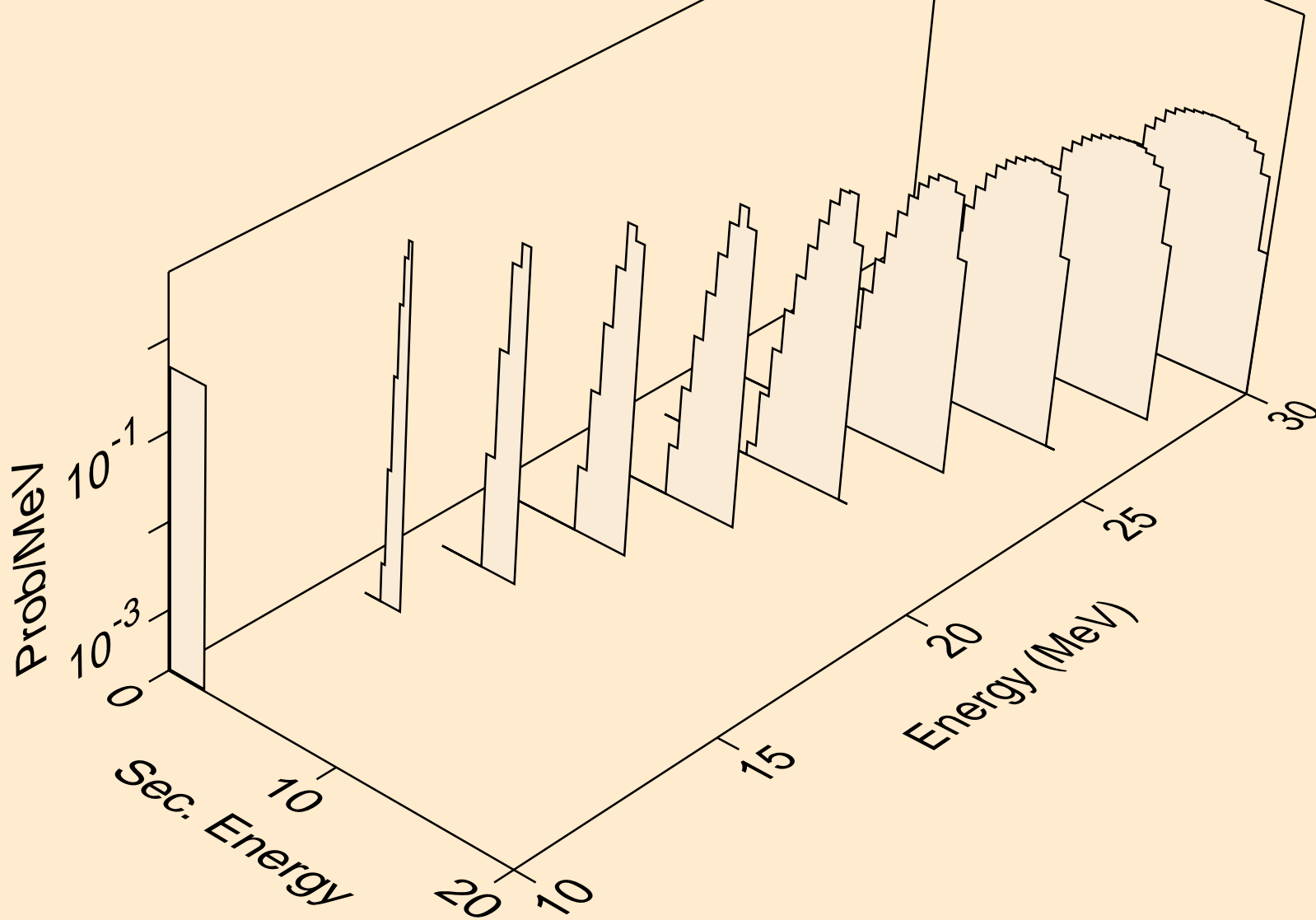

U236 NEUTRON ACER TENDL-2019 LIBRARY; T=293.16K
tritons from (n,t)

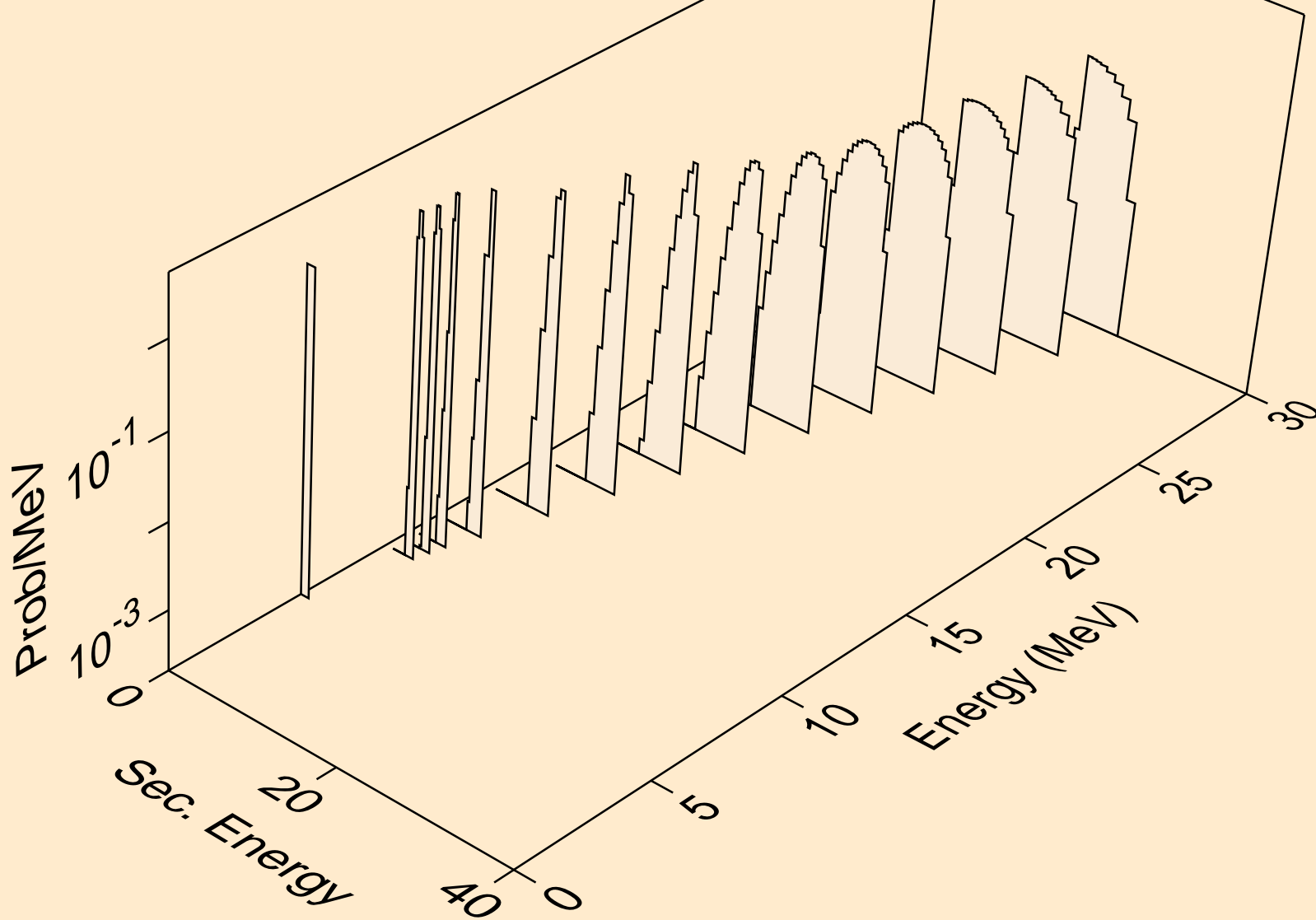

U236 NEUTRON ACER TENDL-2019 LIBRARY; T=293.16K
he3s from (n,x)

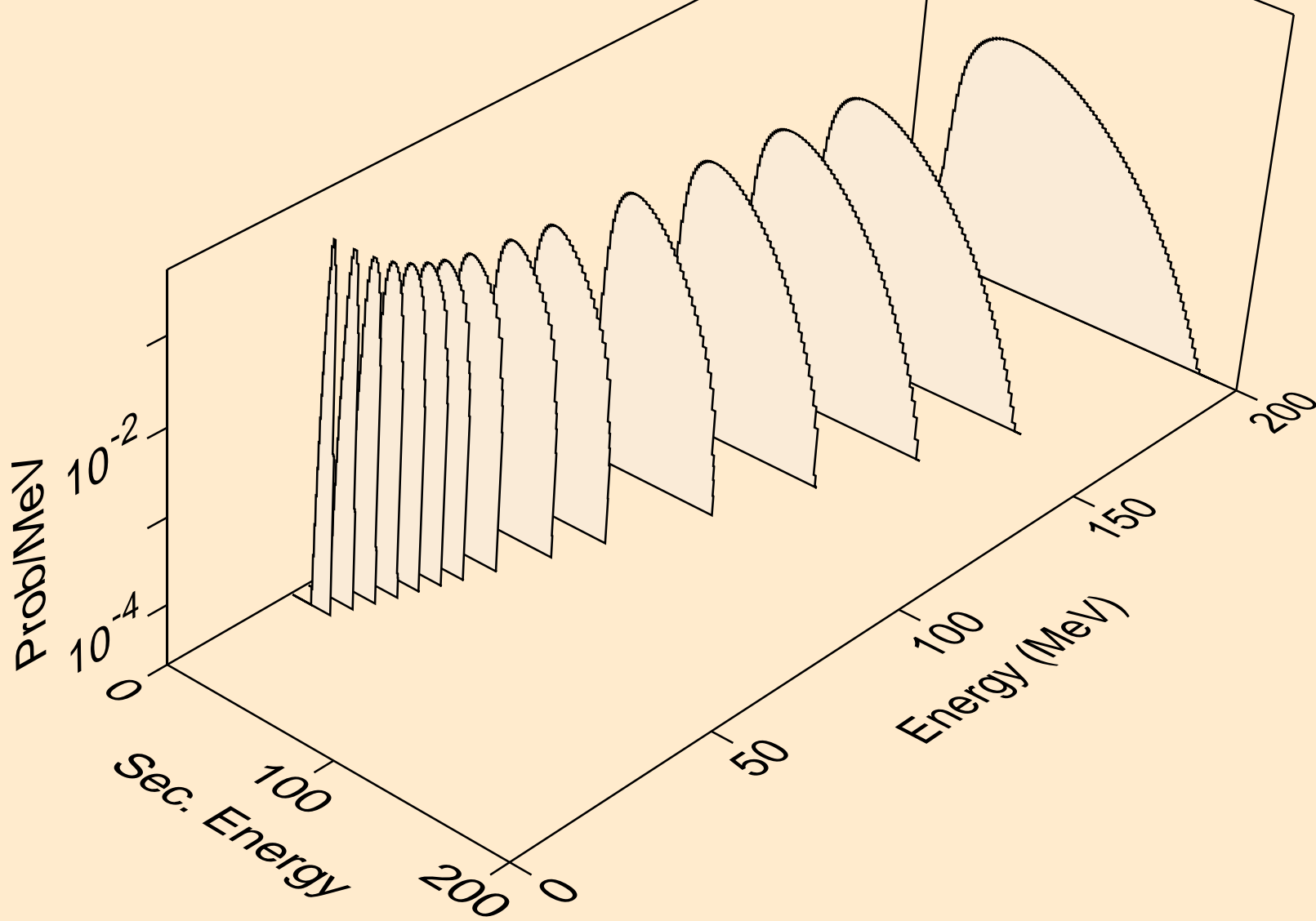

U236 NEUTRON ACER TENDL-2019 LIBRARY; T=293.16K
he3s from (n,n*)he3

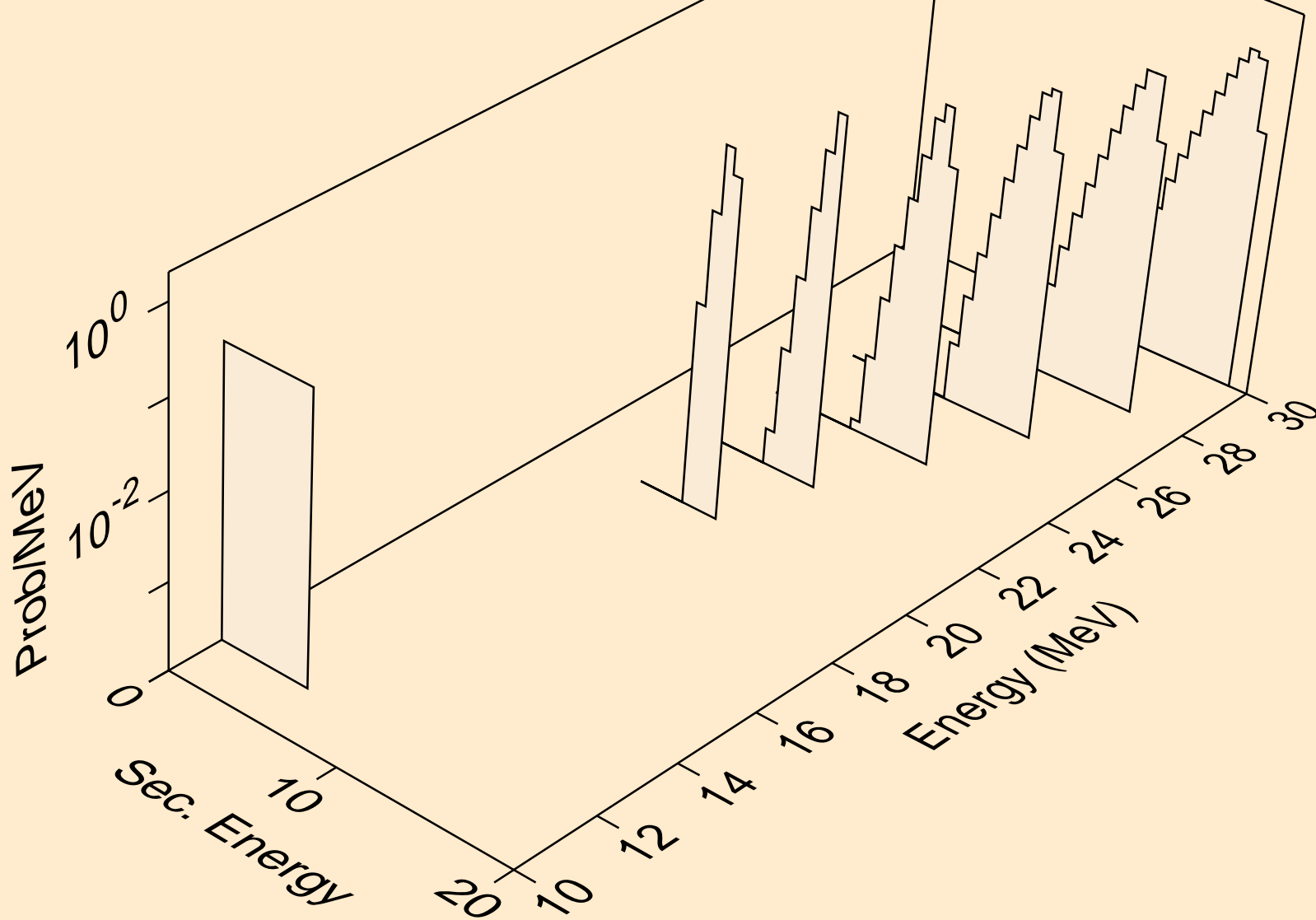

U236 NEUTRON ACER TENDL-2019 LIBRARY; T=293.16K
he3s from (n,he3)

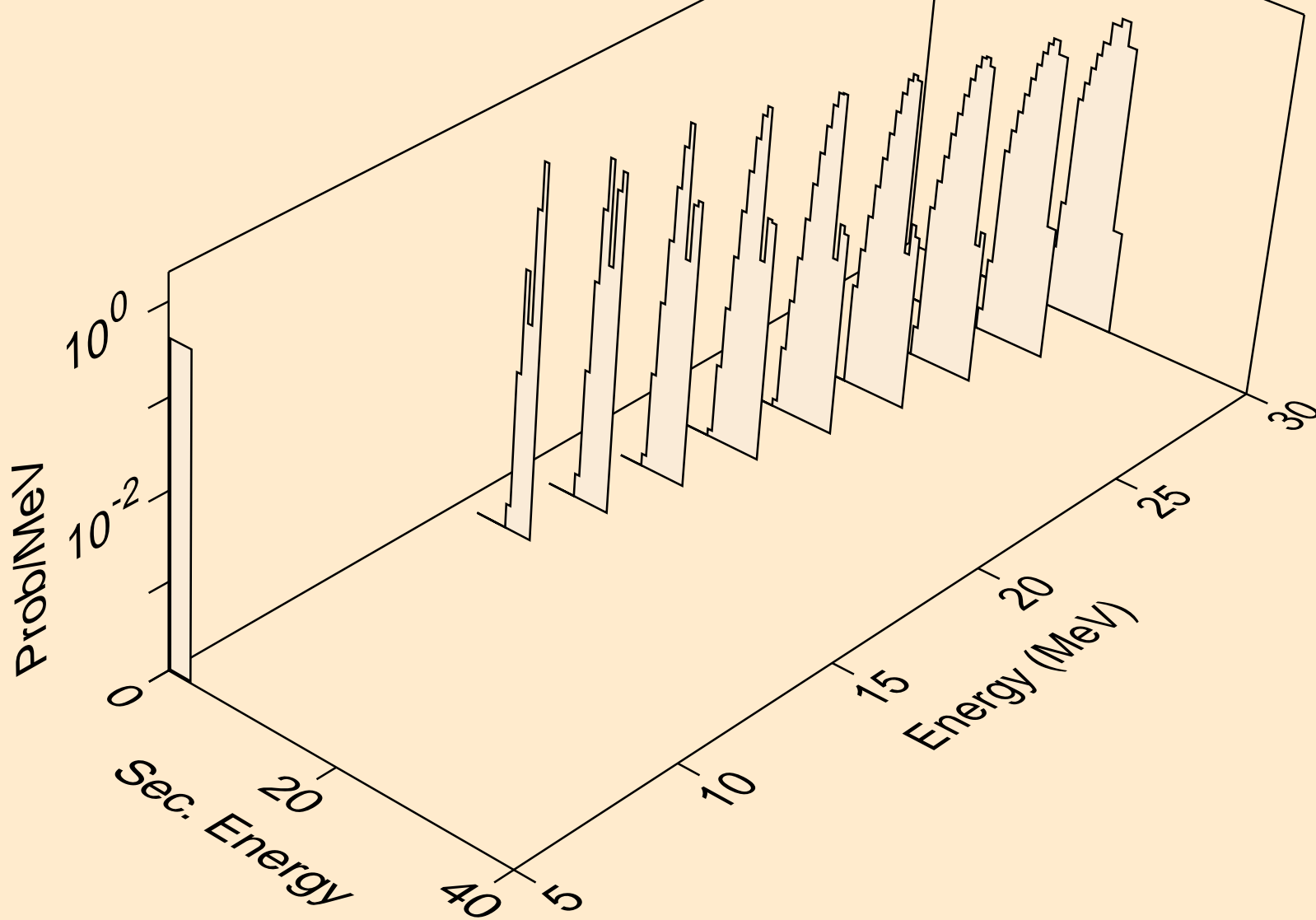

U236 NEUTRON ACER TENDL-2019 LIBRARY; T=293.16K
alphas from (n,x)

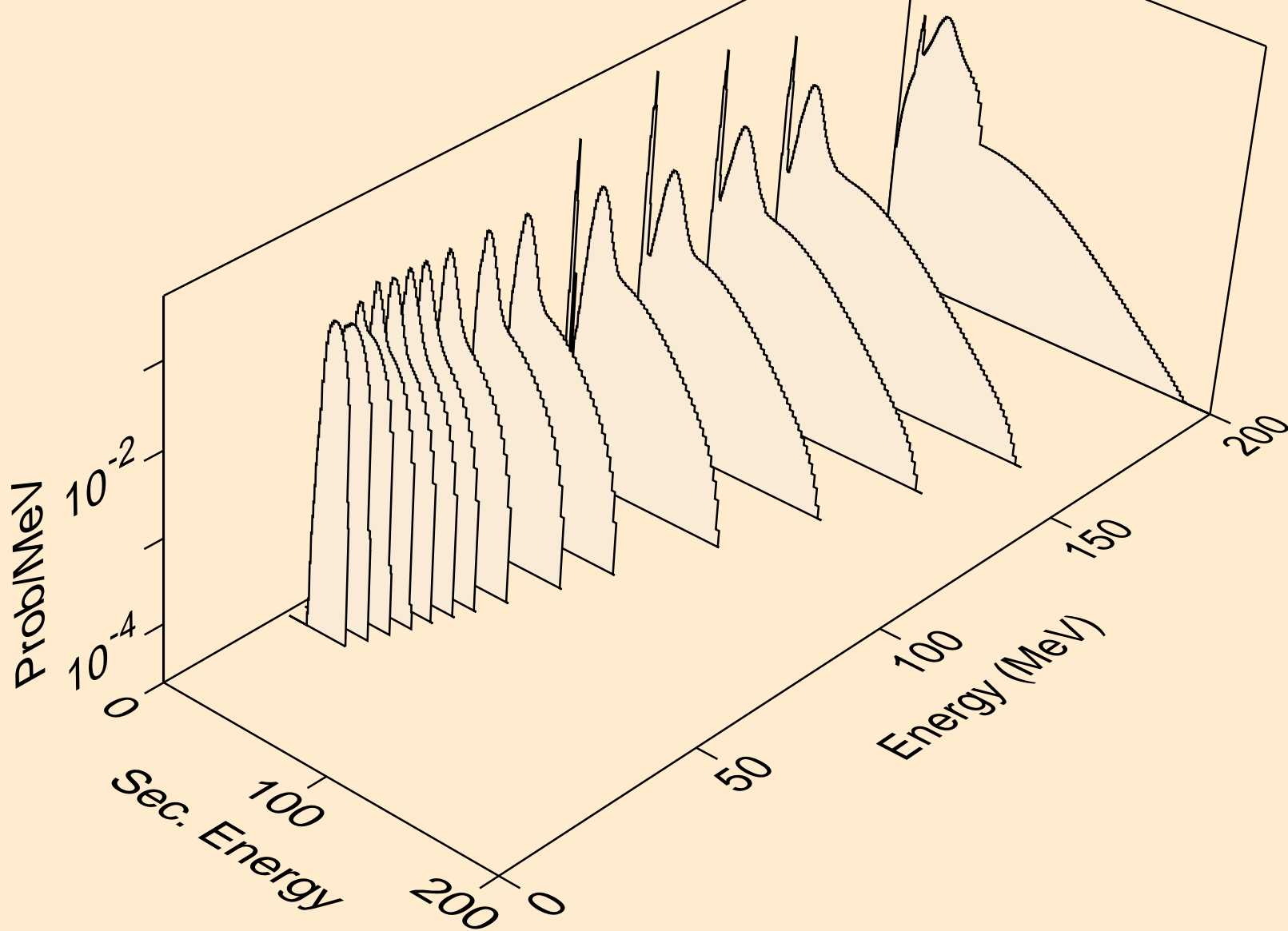

U236 NEUTRON ACER TENDL-2019 LIBRARY; T=293.16K
alphas from (n,n*)a

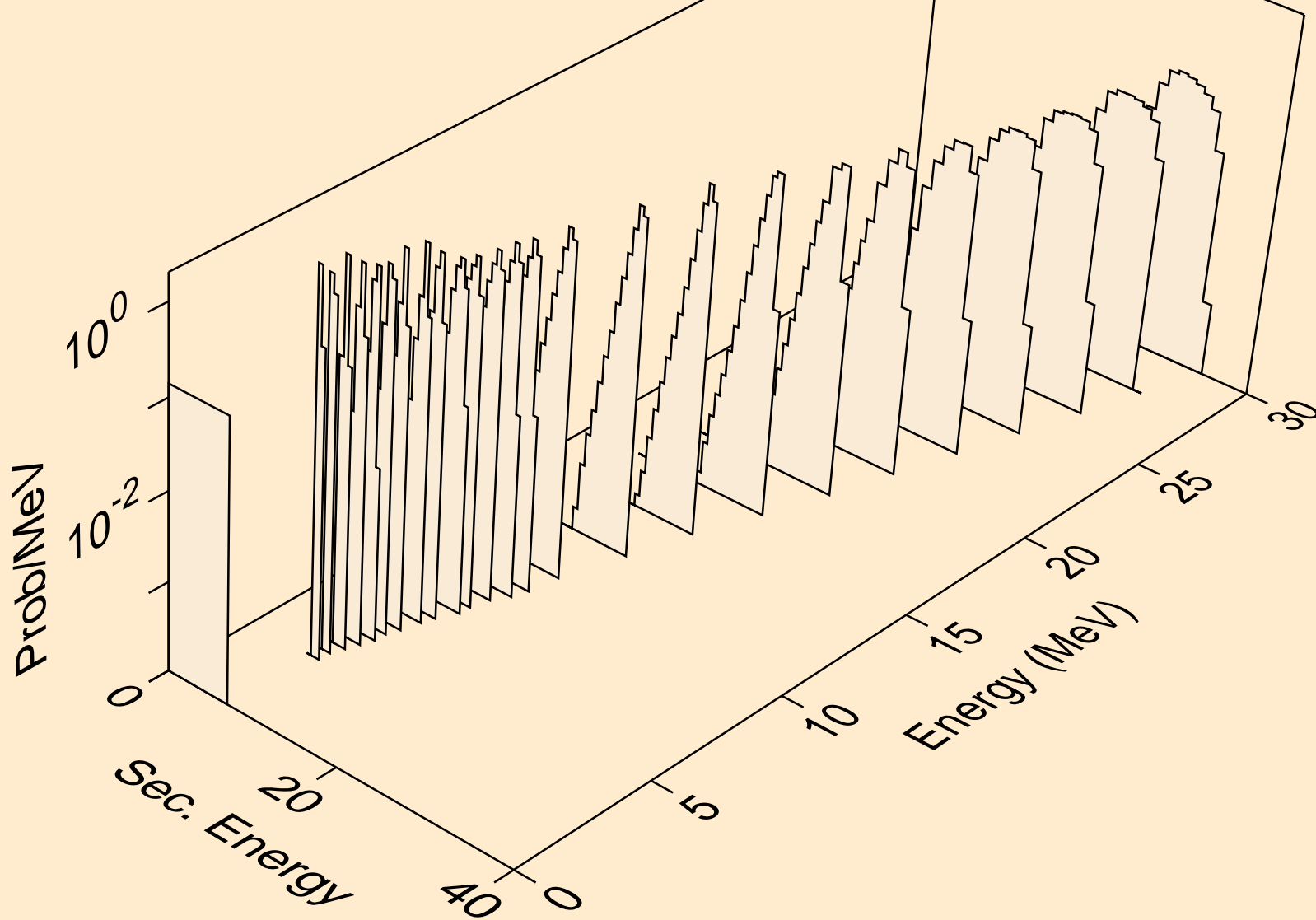

U236 NEUTRON ACER TENDL-2019 LIBRARY; T=293.16K
alphas from (n,2n)a

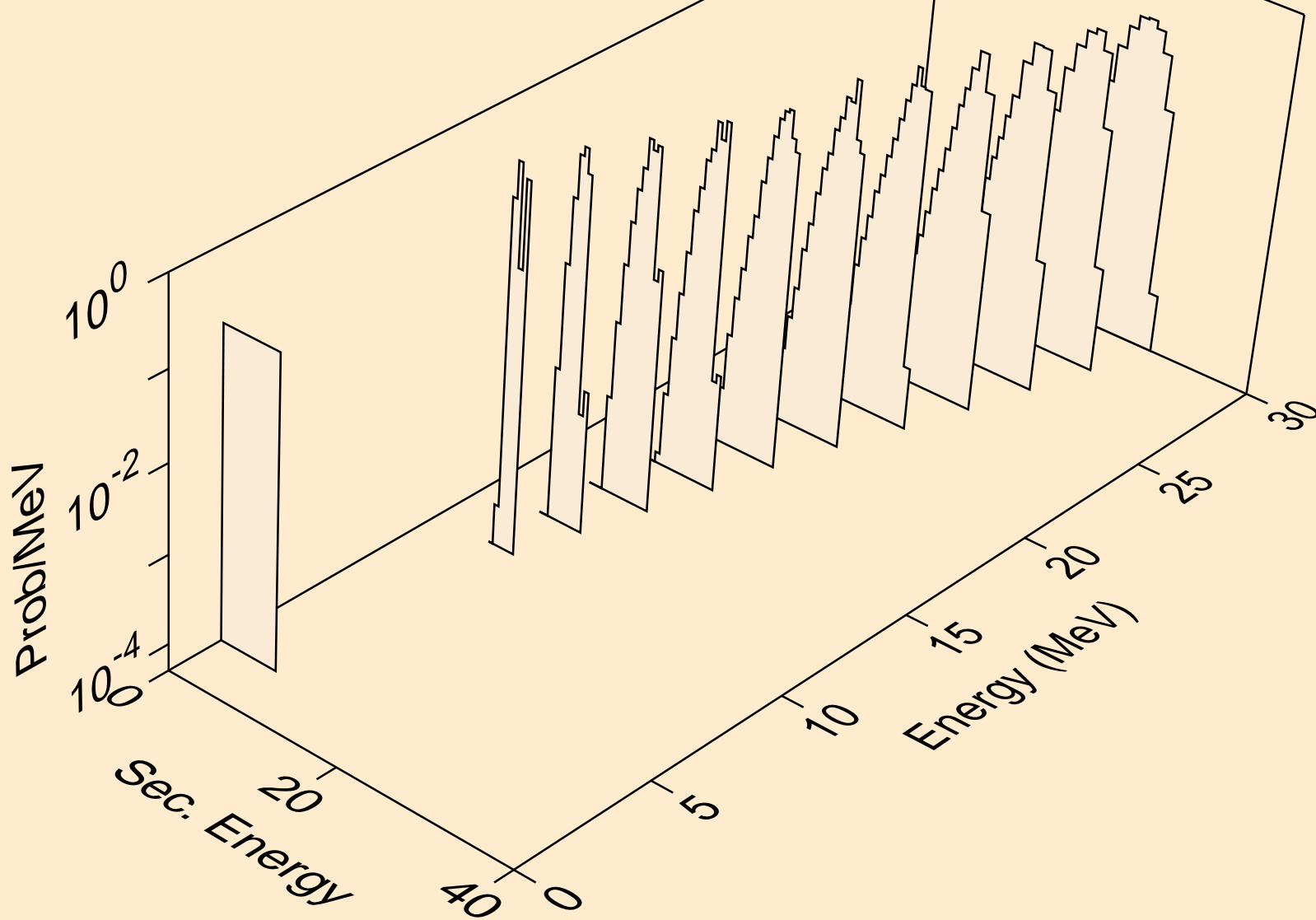

U236 NEUTRON ACER TENDL-2019 LIBRARY; T=293.16K
alphas from (n,3n)a

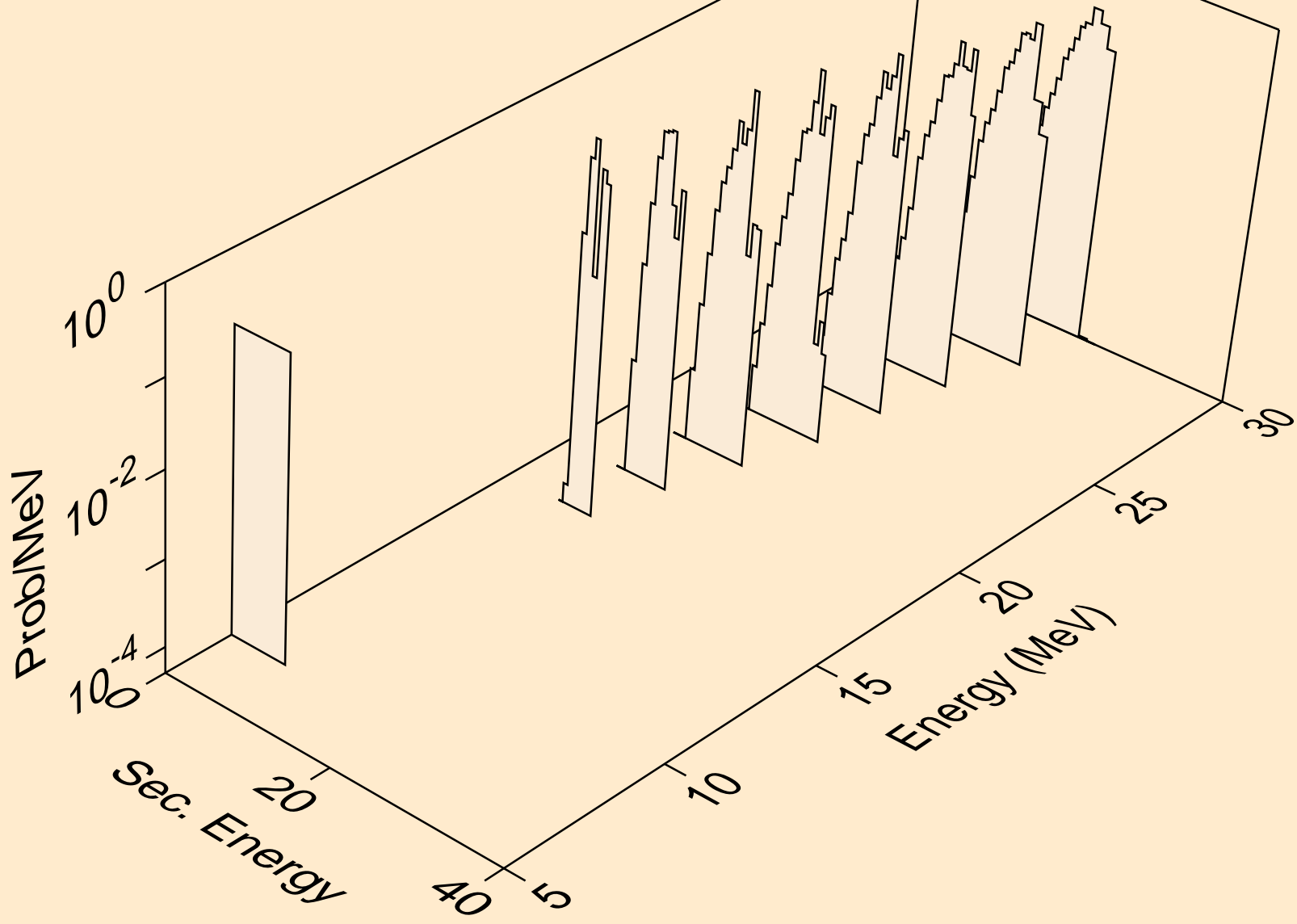

U236 NEUTRON ACER TENDL-2019 LIBRARY; T=293.16K
alphas from (n,a)

