

AR036 ALPHA ACER TENDL-2021 LIBRARY; T=0.K

Principal cross sections

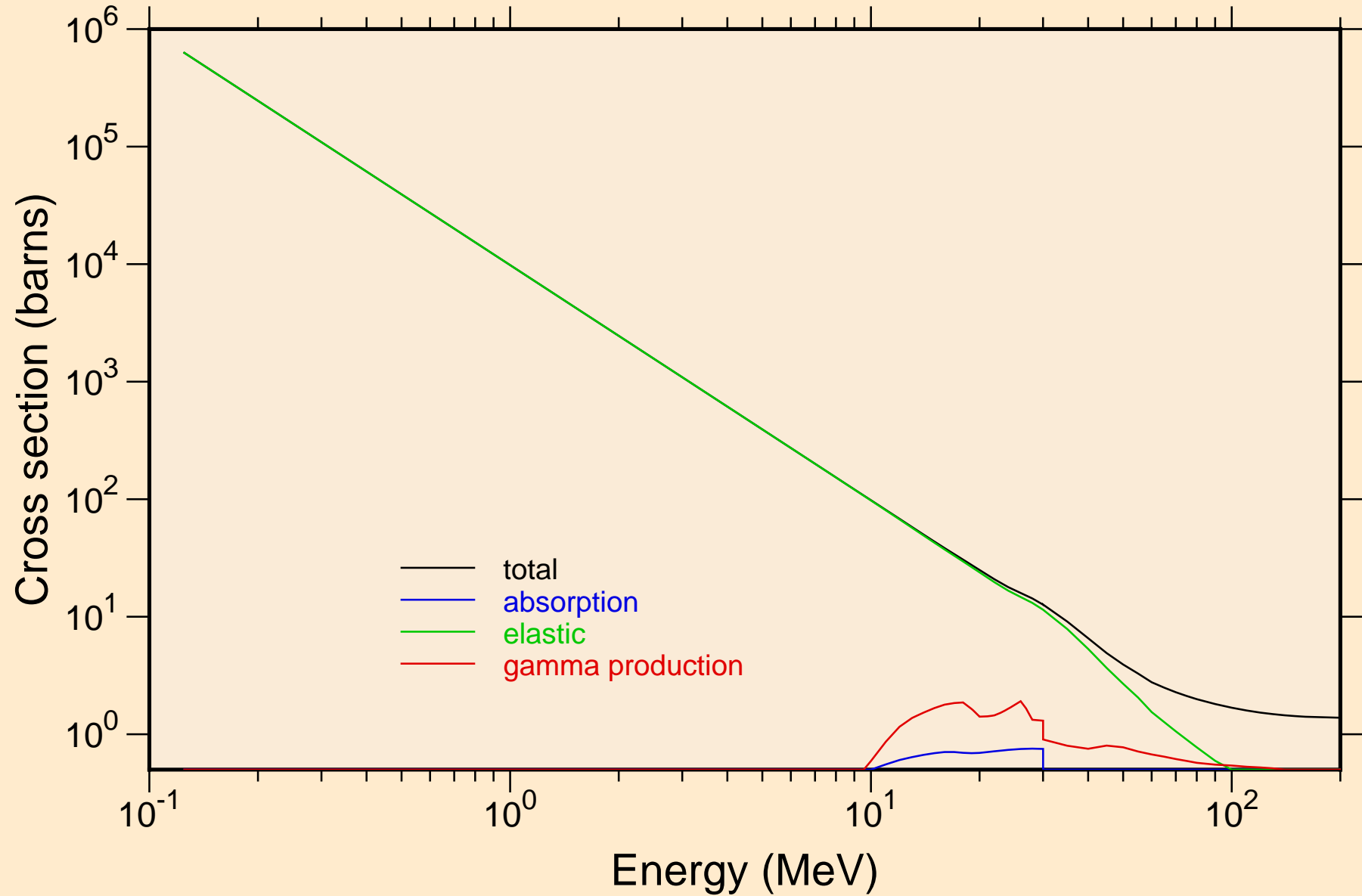

AR036 ALPHA ACER TENDL-2021 LIBRARY; T=0.K

Heating

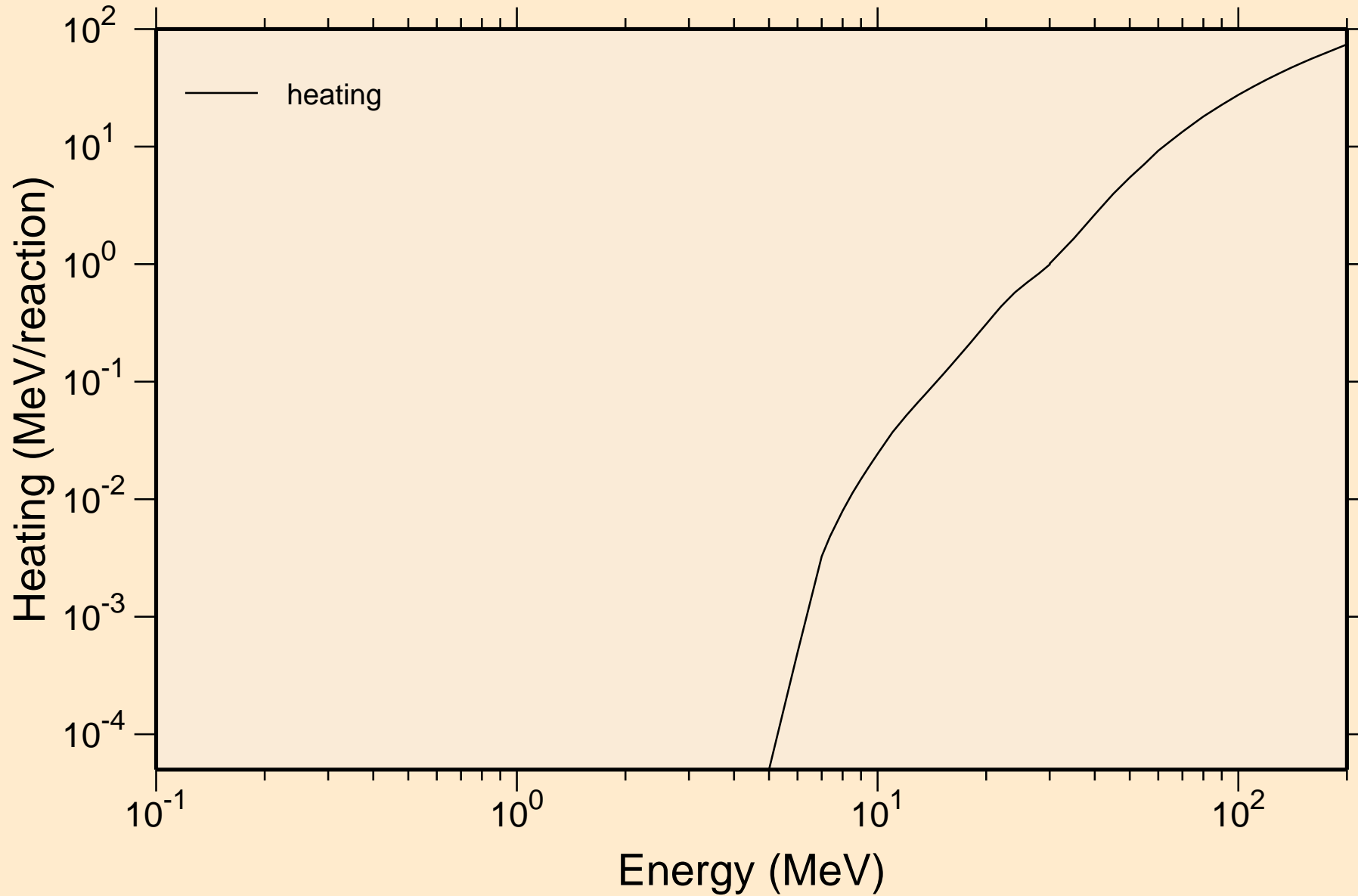

AR036 ALPHA ACER TENDL-2021 LIBRARY; T=0.K

Principal cross sections

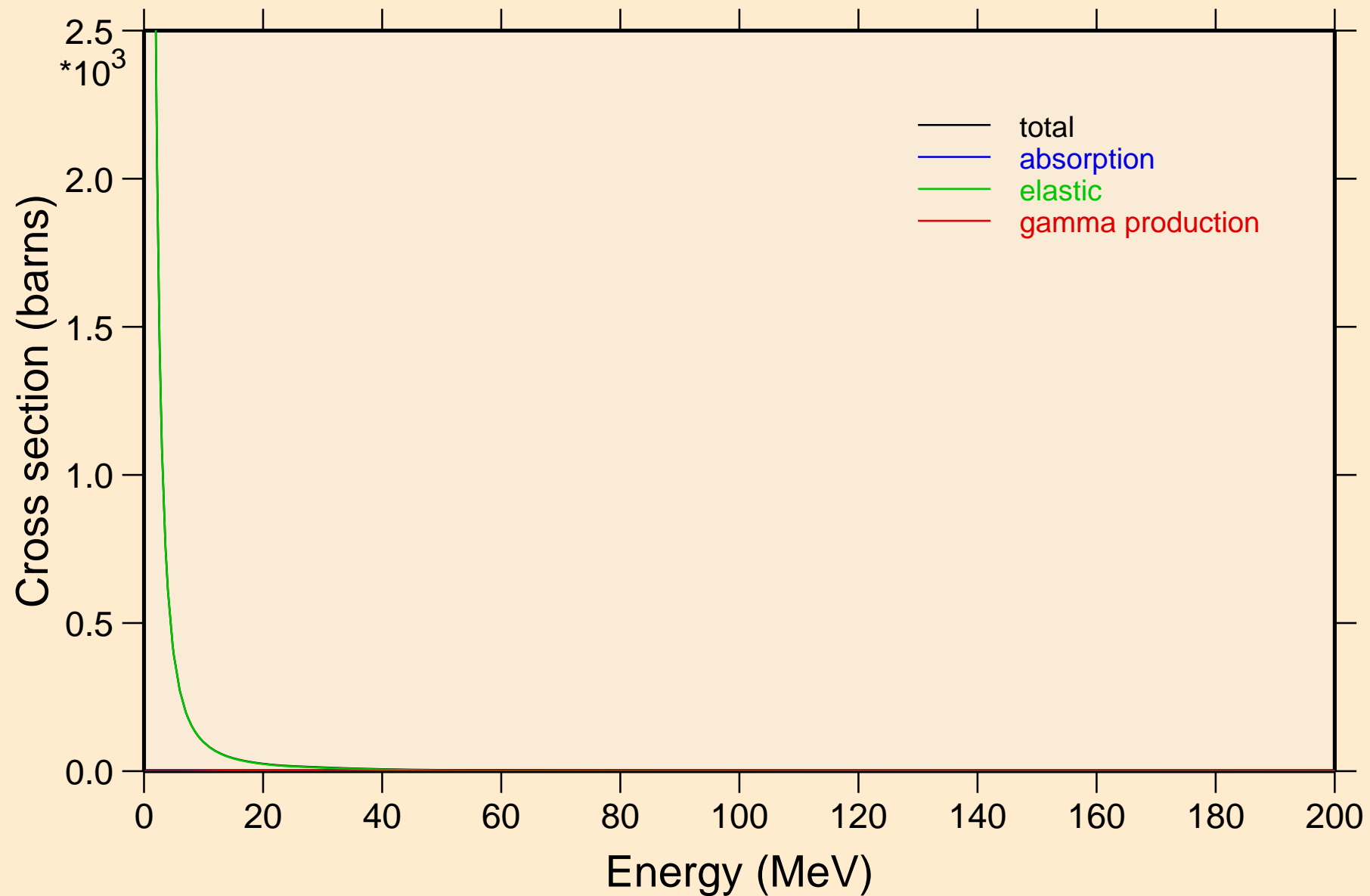

AR036 ALPHA ACER TENDL-2021 LIBRARY; T=0.K

Heating

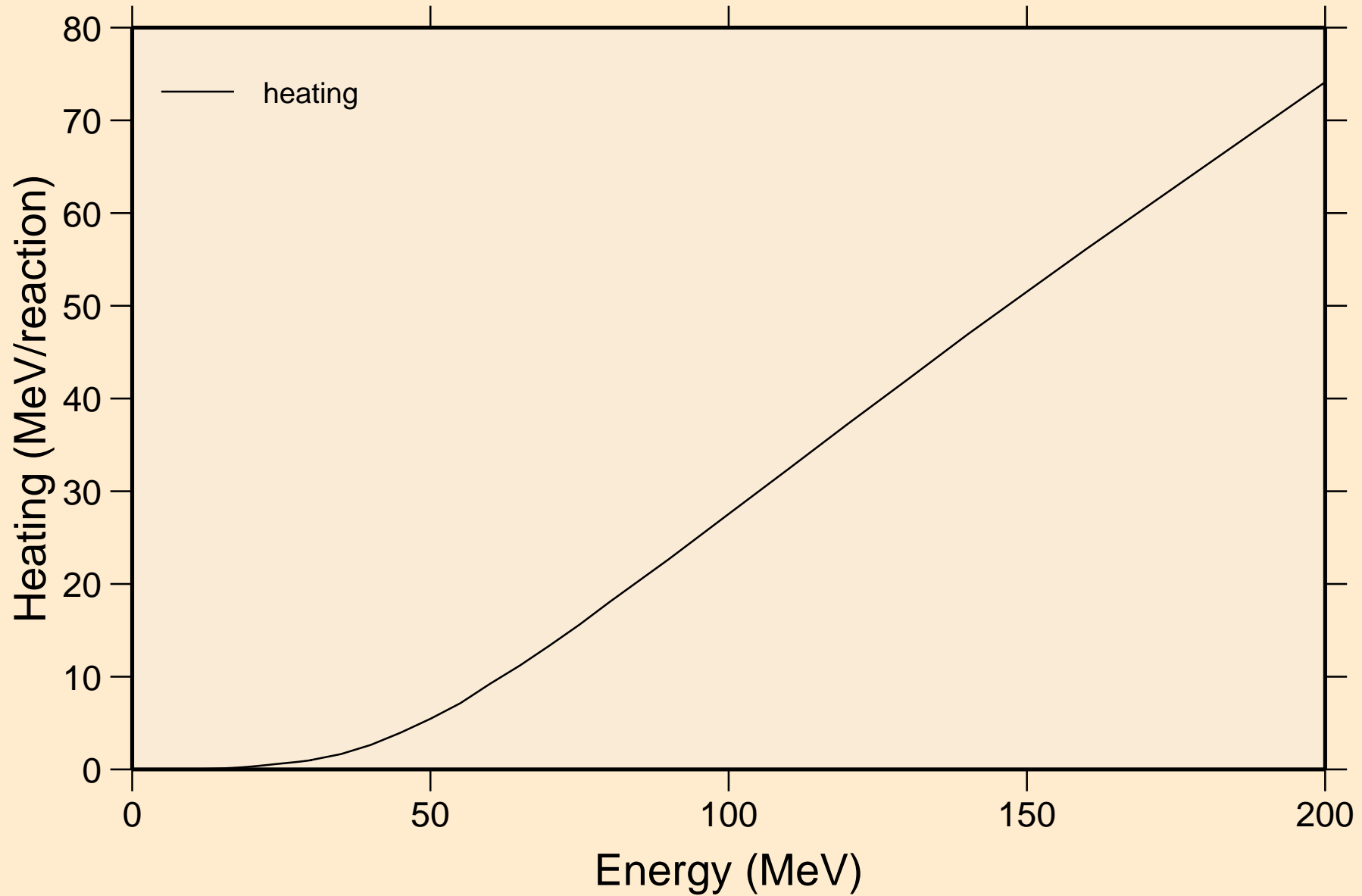

AR036 ALPHA ACER TENDL-2021 LIBRARY; T=0.K
Threshold reactions

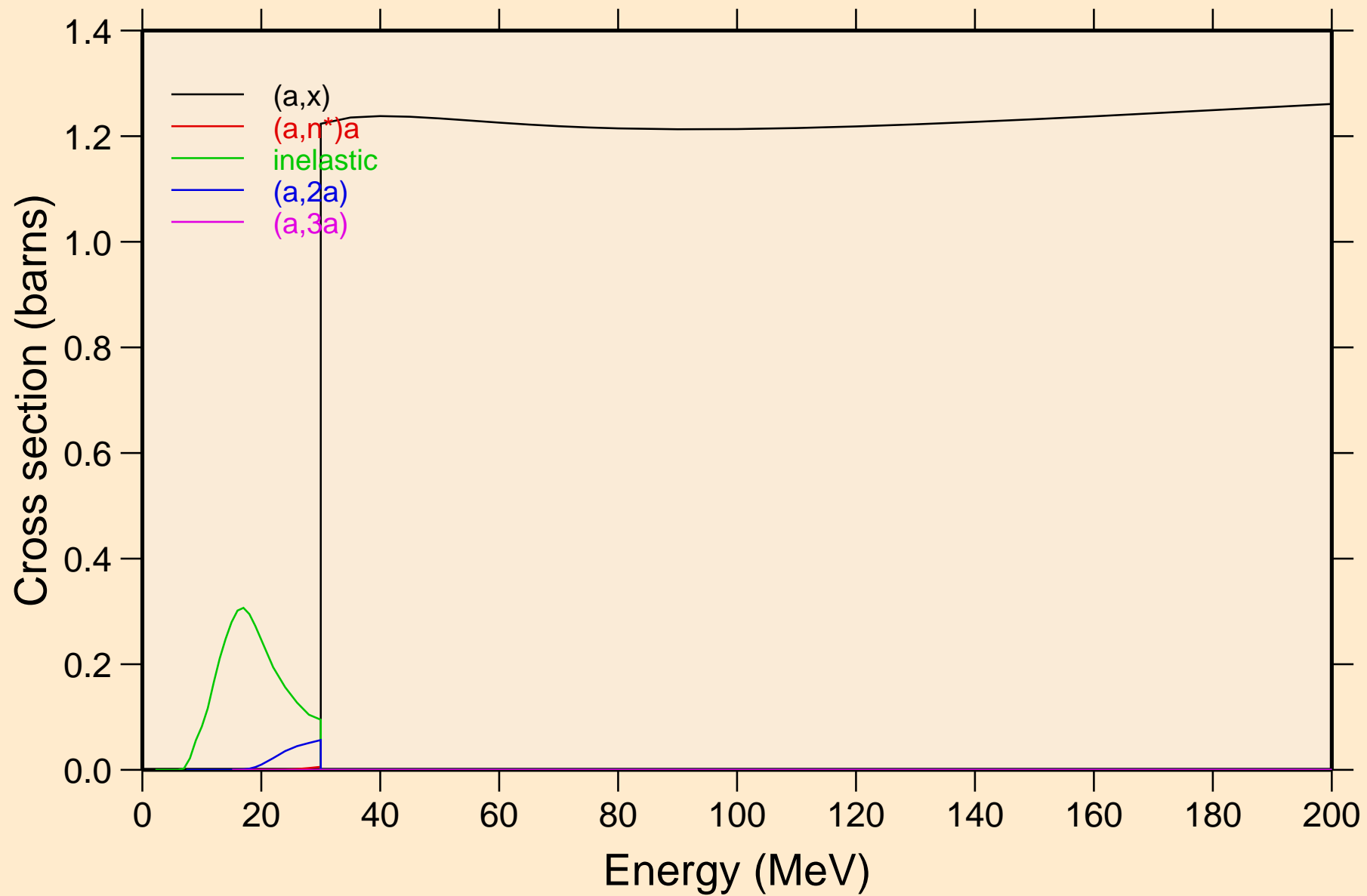

AR036 ALPHA ACER TENDL-2021 LIBRARY; T=0.K
Threshold reactions

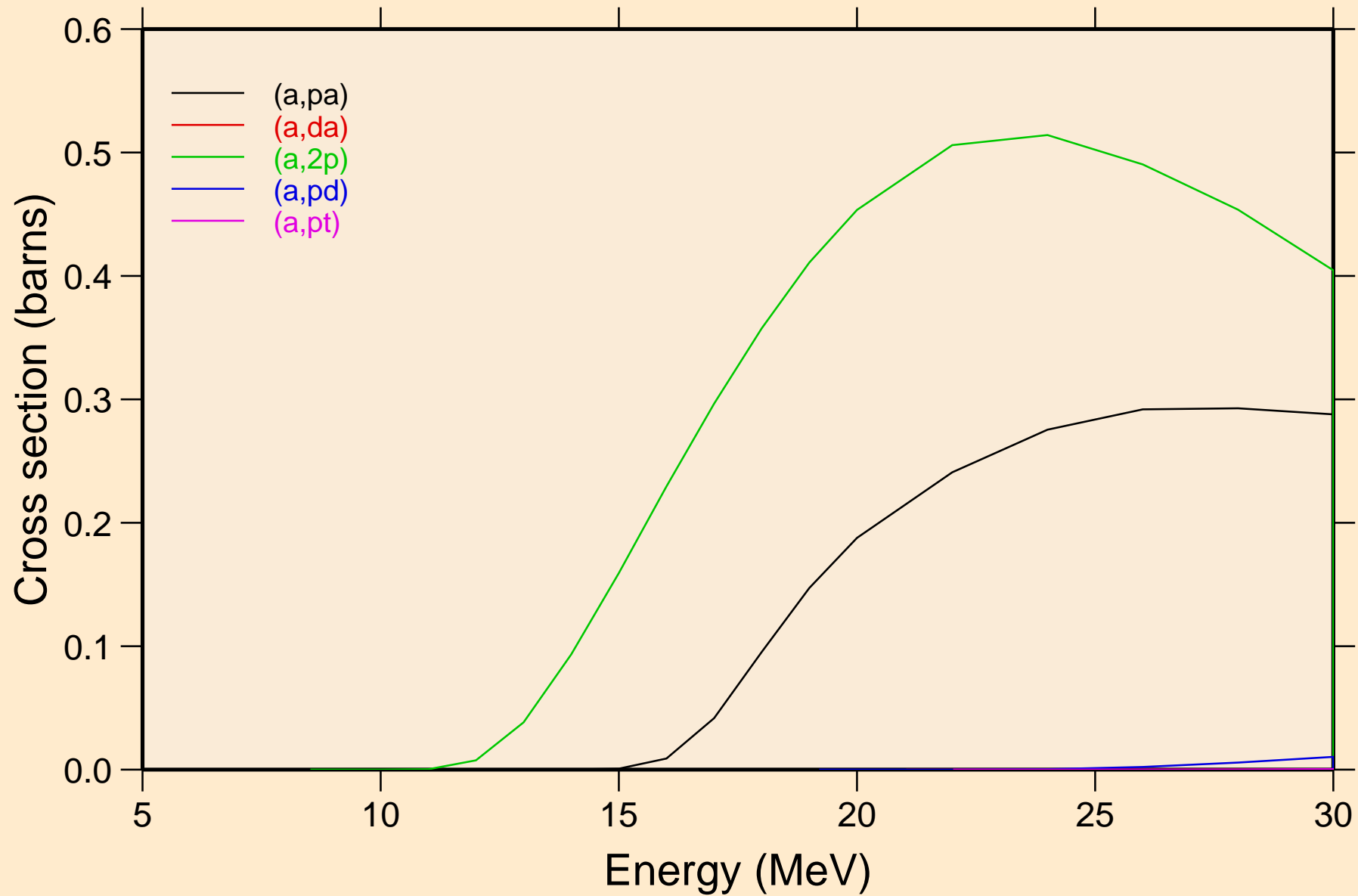

AR036 ALPHA ACER TENDL-2021 LIBRARY; T=0.K
Threshold reactions

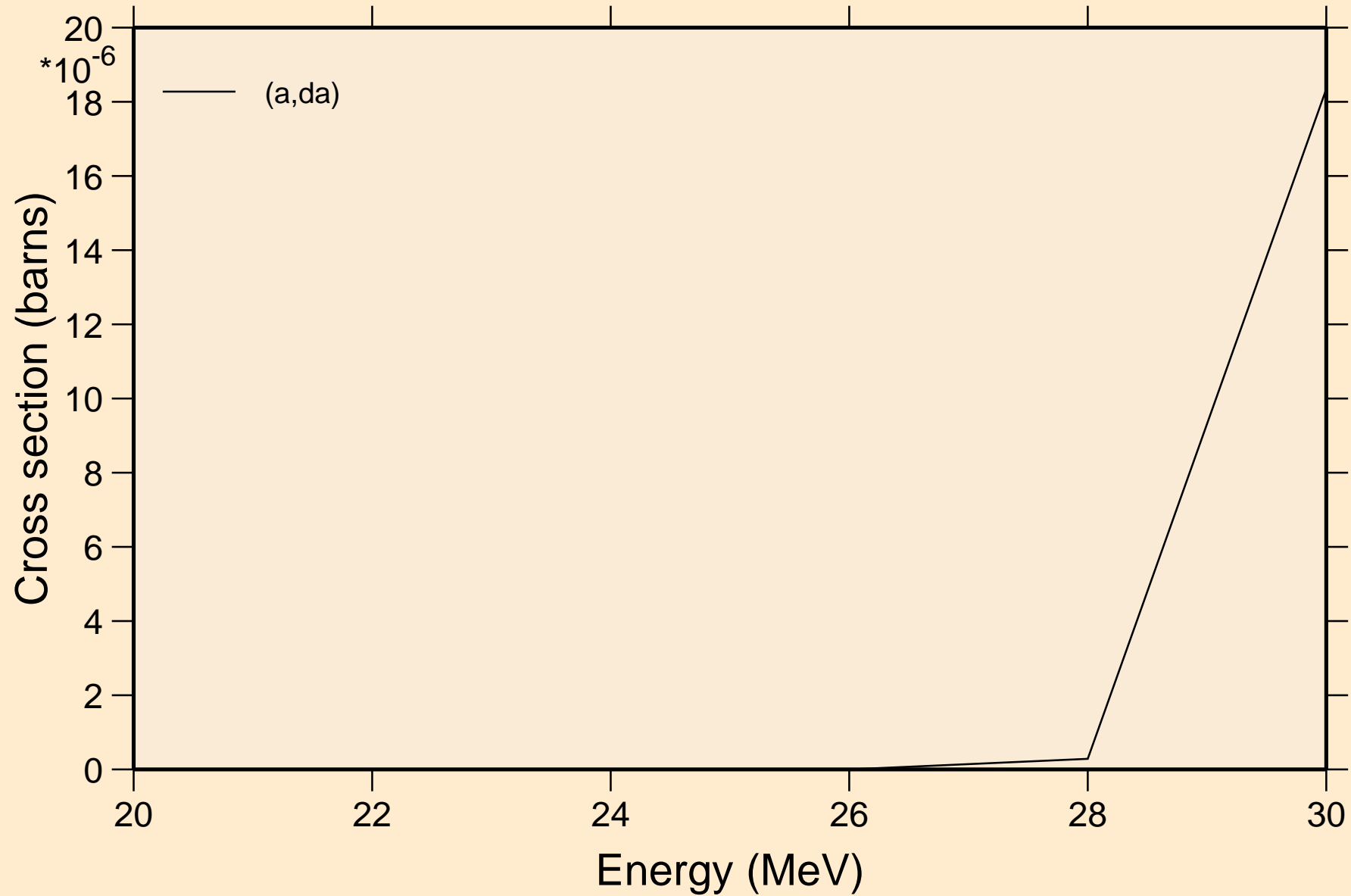

AR036 ALPHA ACER TENDL-2021 LIBRARY; T=0.K
angular distribution for elastic

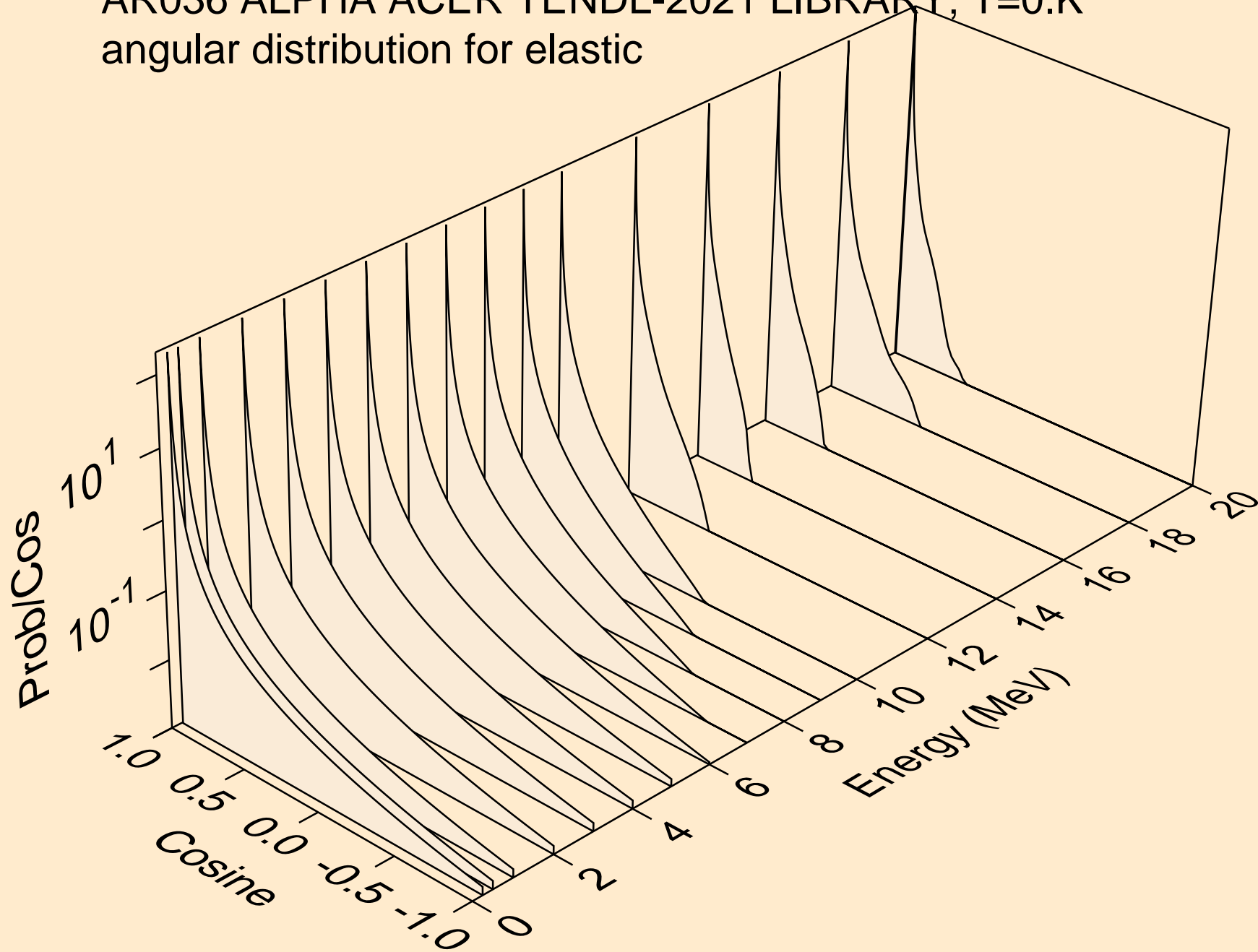

AR036 ALPHA ACER TENDL-2021 LIBRARY; T=0.K
angular distribution for elastic

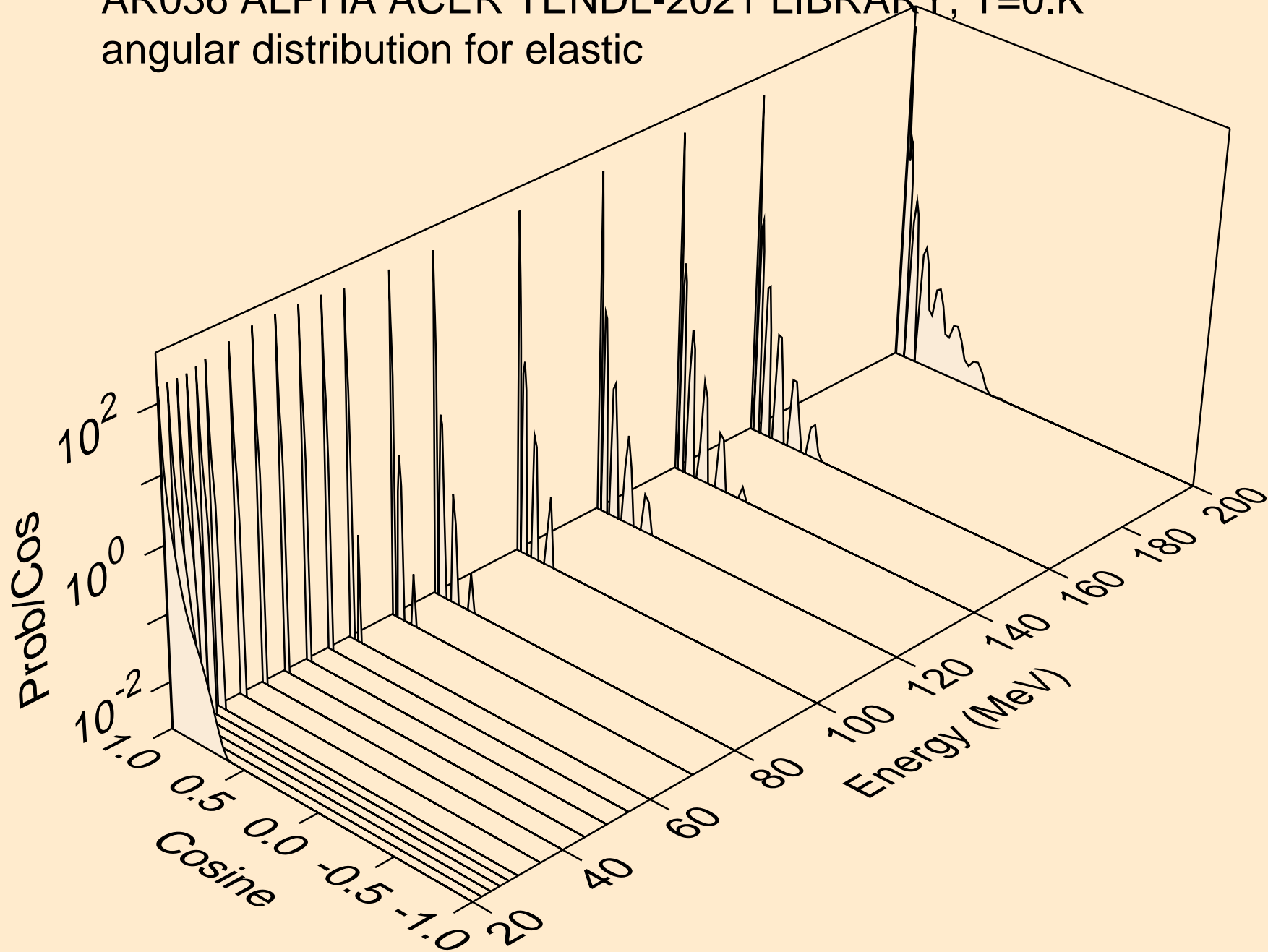

AR036 ALPHA ACER TENDL-2021 LIBRARY; T=0.K
Alpha emission for (a,x)

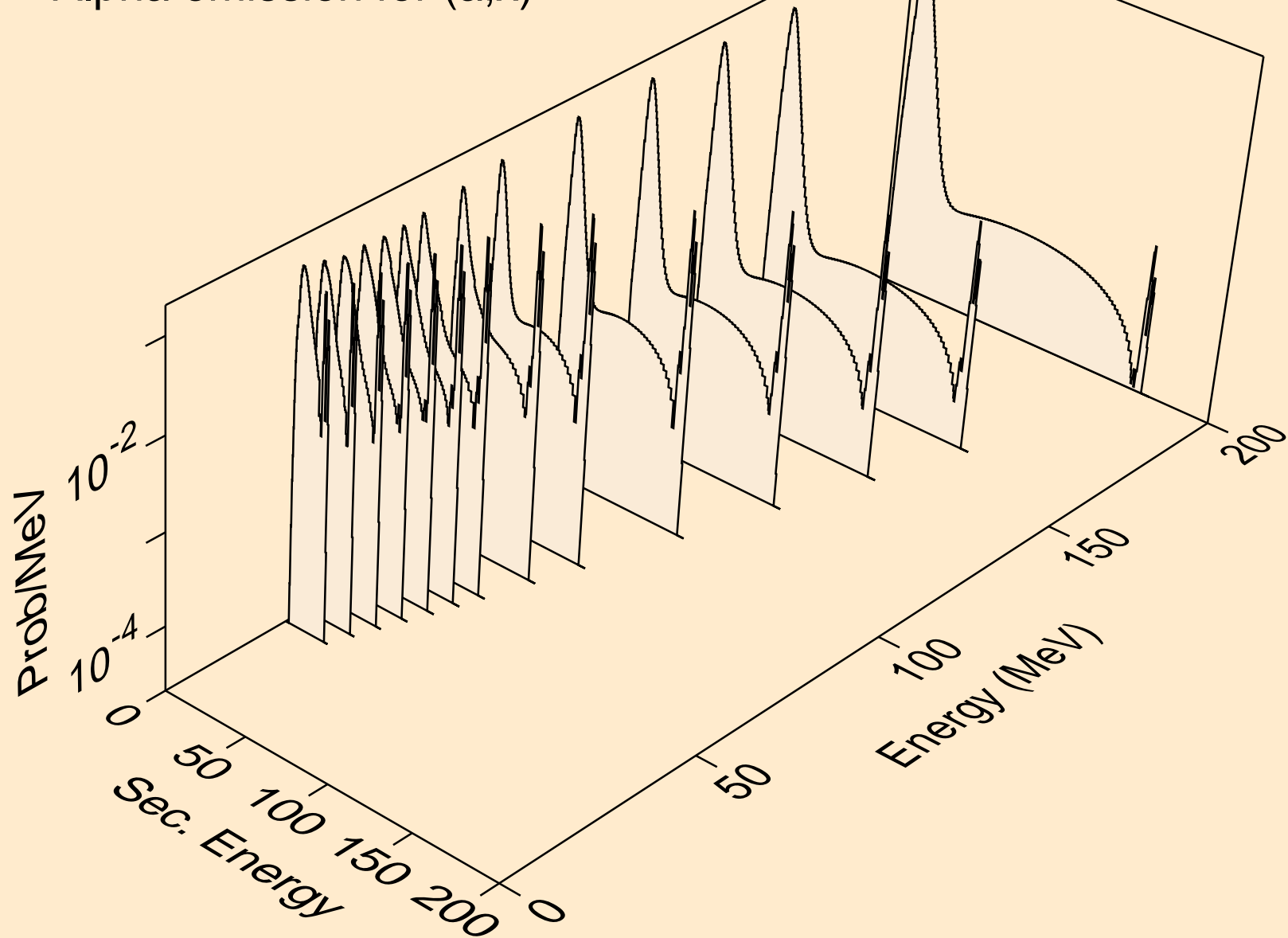

AR036 ALPHA ACER TENDL-2021 LIBRARY; T=0.K
Alpha emission for (a,n*)a

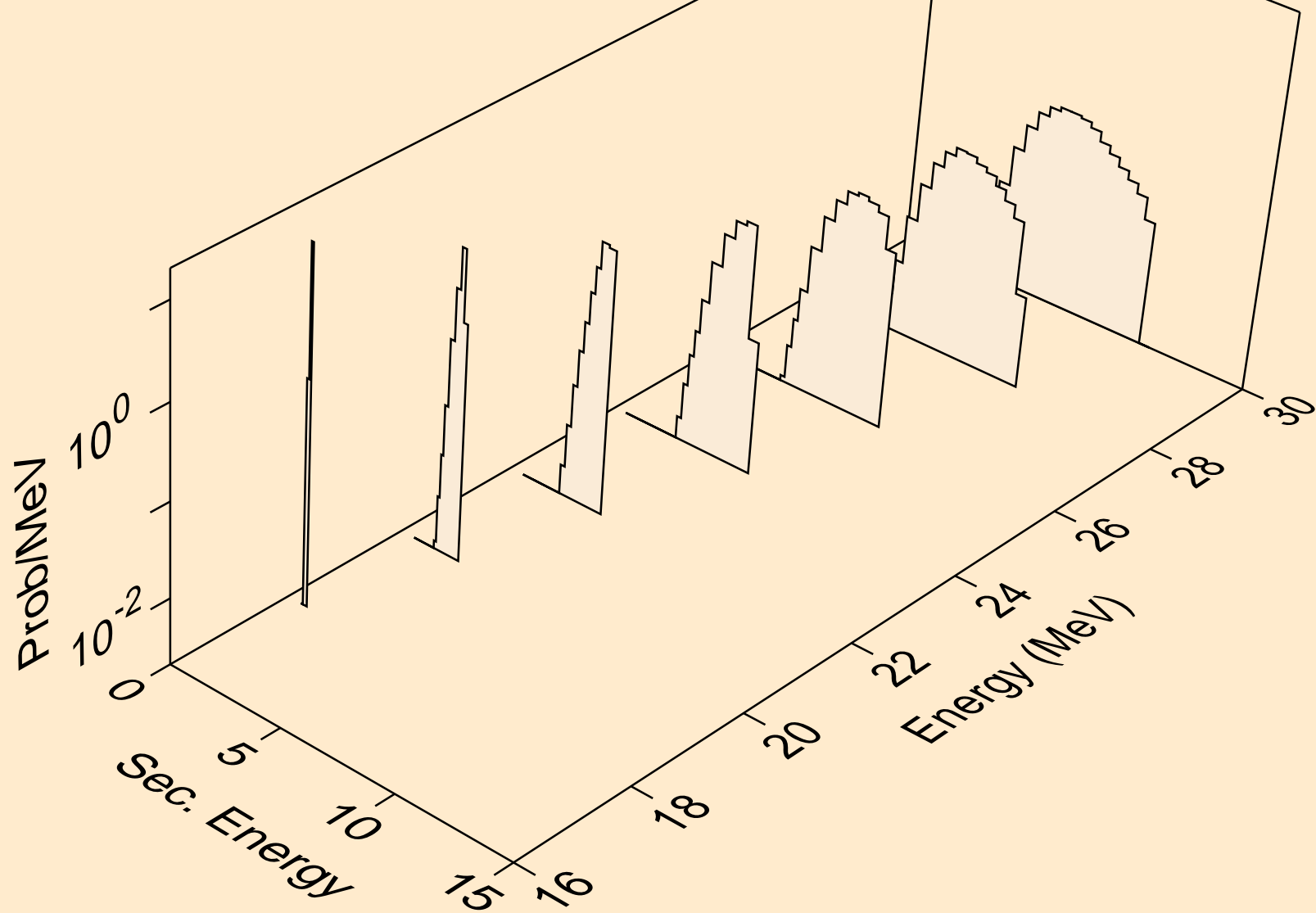

AR036 ALPHA ACER TENDL-2021 LIBRARY; T=0.K
Alpha emission for inelastic

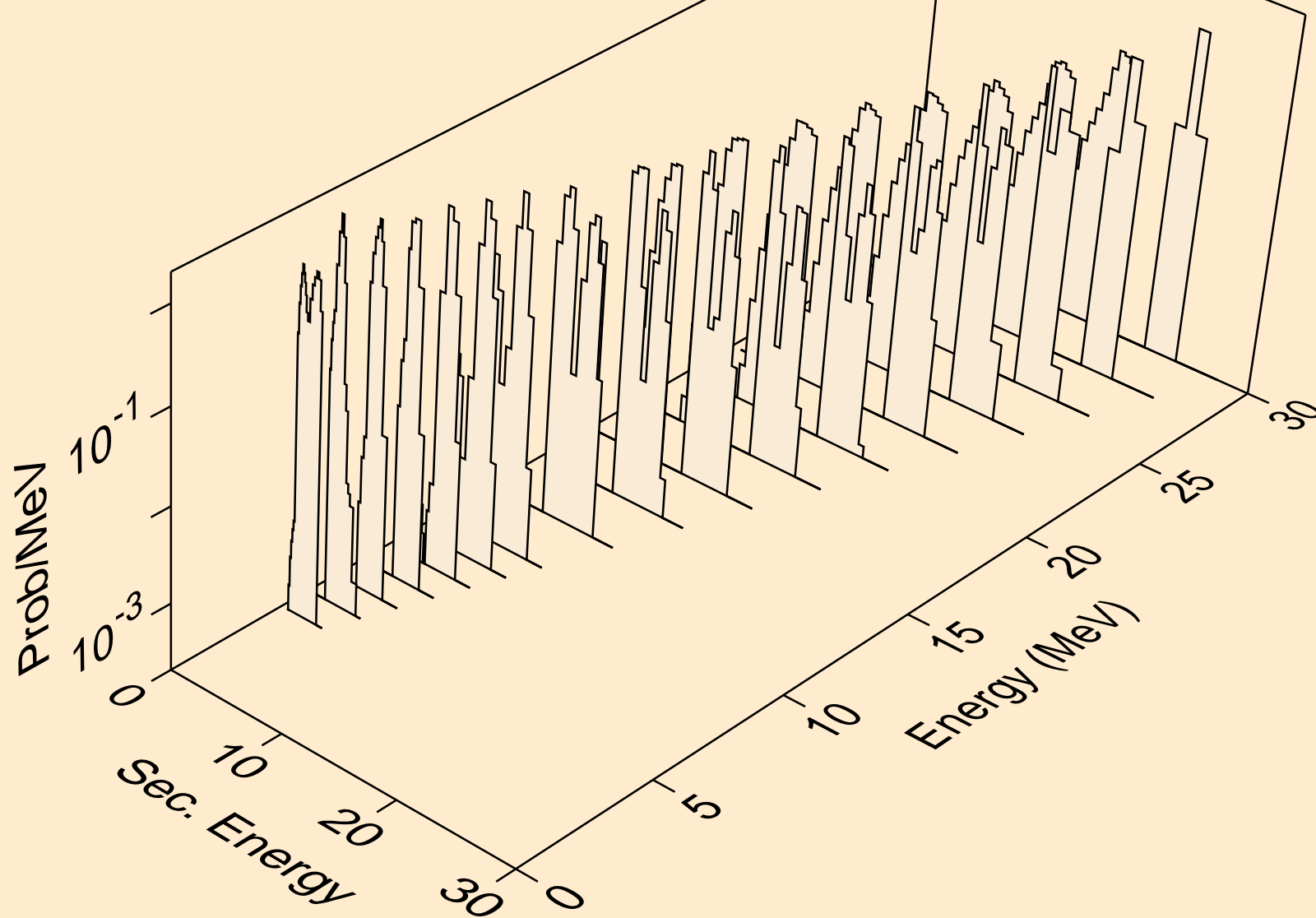

AR036 ALPHA ACER TENDL-2021 LIBRARY; T=0.K
Alpha emission for (a,2a)

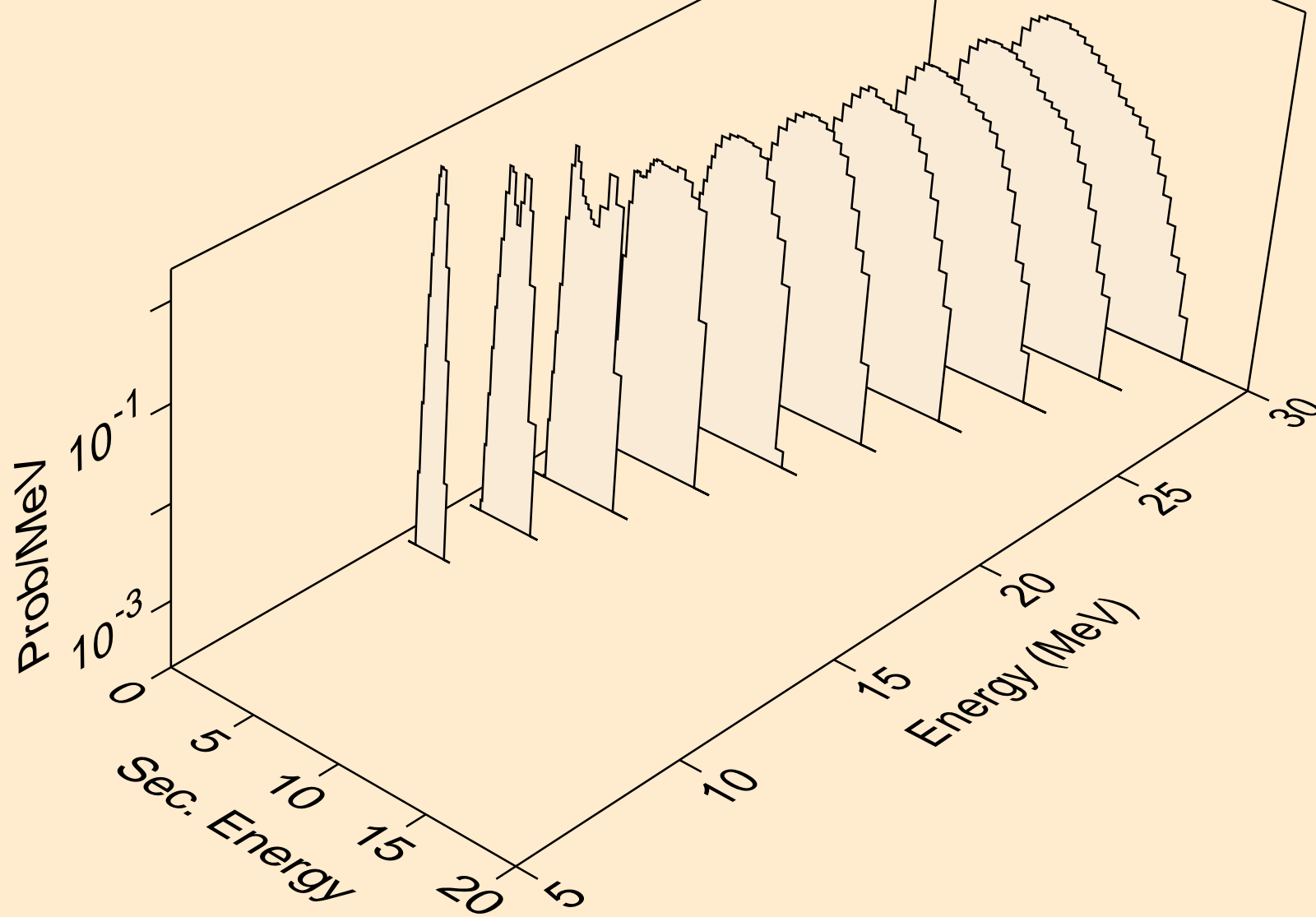

AR036 ALPHA ACER TENDL-2021 LIBRARY; T=0.K
Alpha emission for (a,3a)

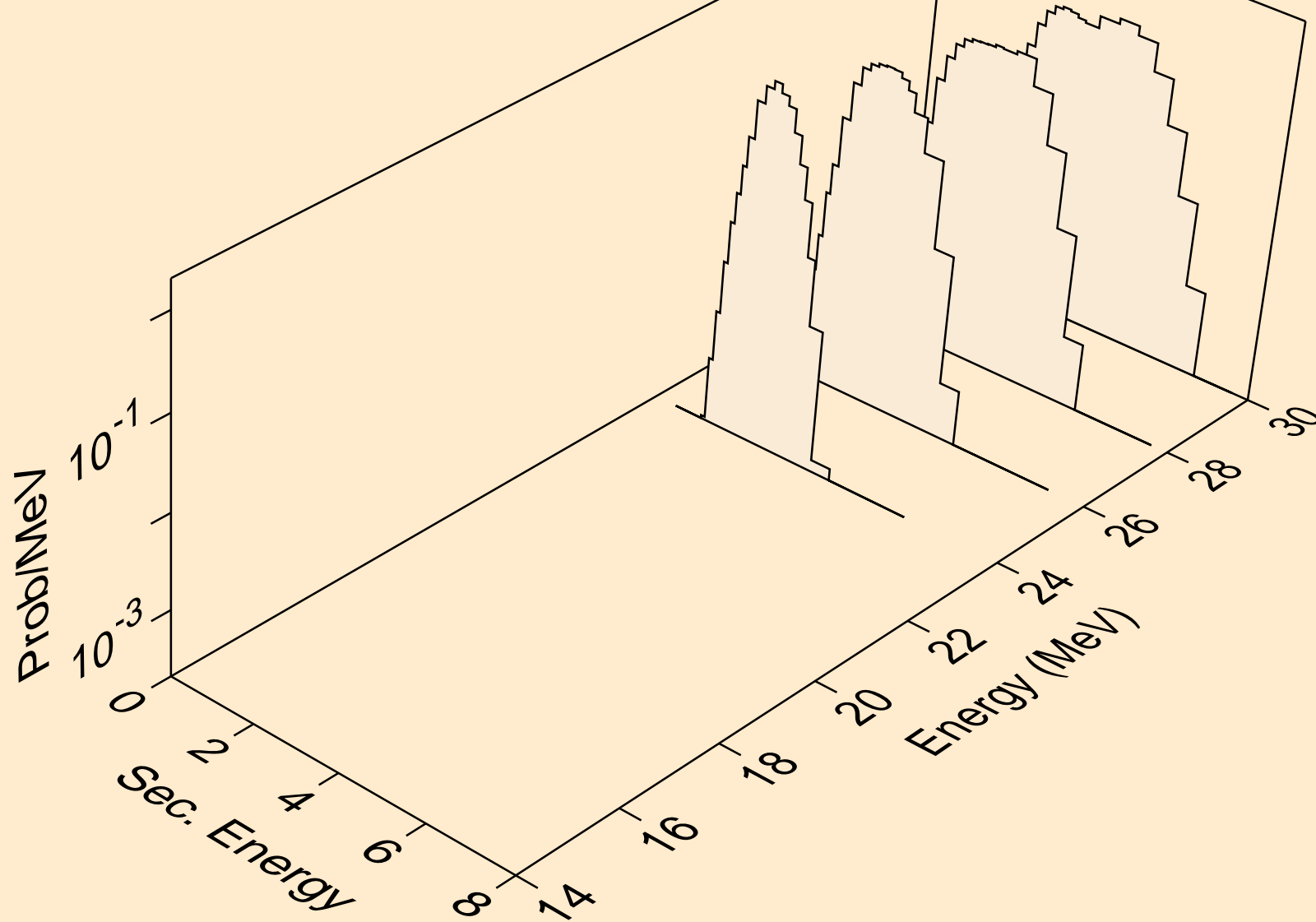

AR036 ALPHA ACER TENDL-2021 LIBRARY; T=0.K
Alpha emission for (a,pa)

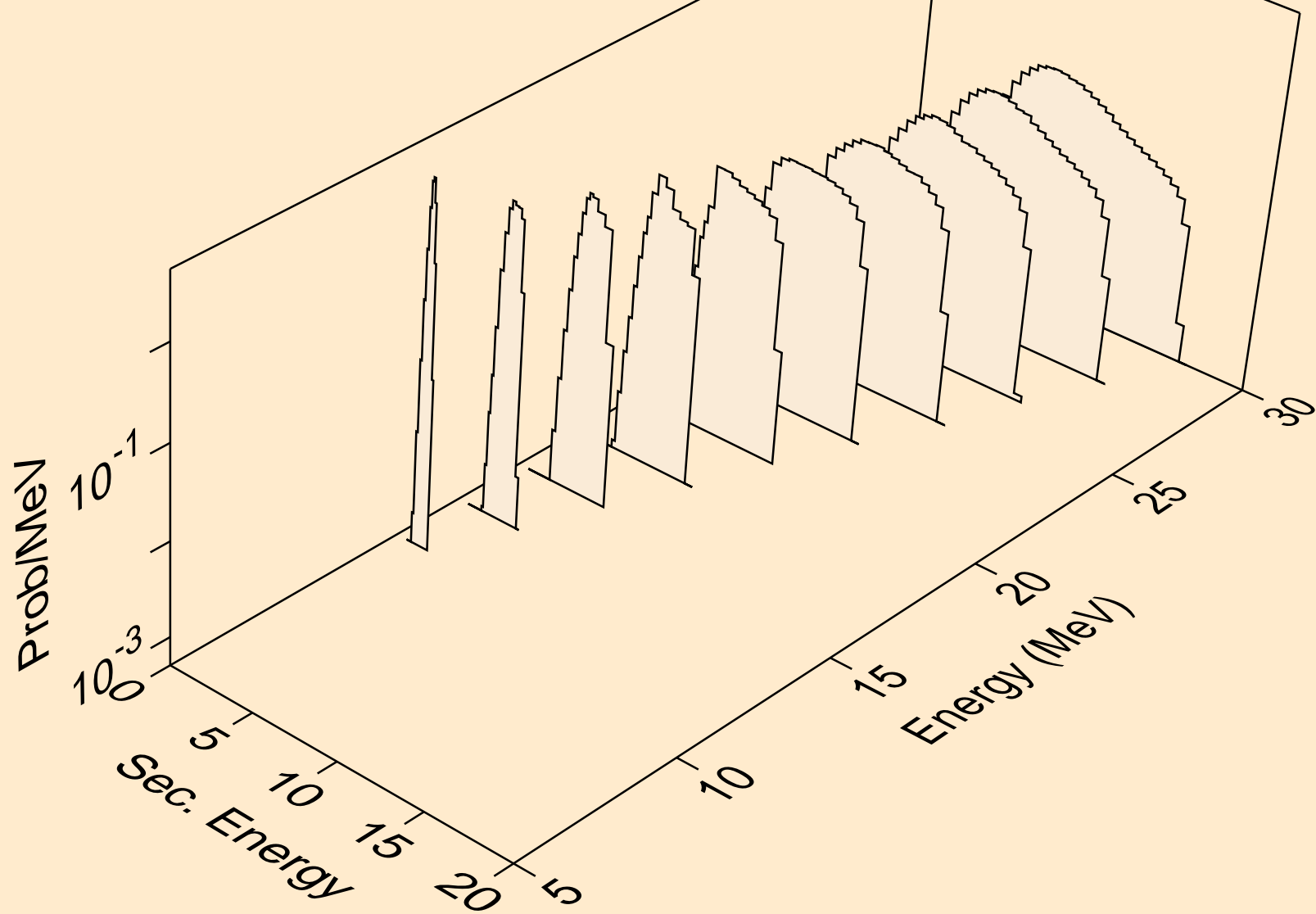

AR036 ALPHA ACER TENDL-2021 LIBRARY; T=0.K
Alpha emission for (a,da)

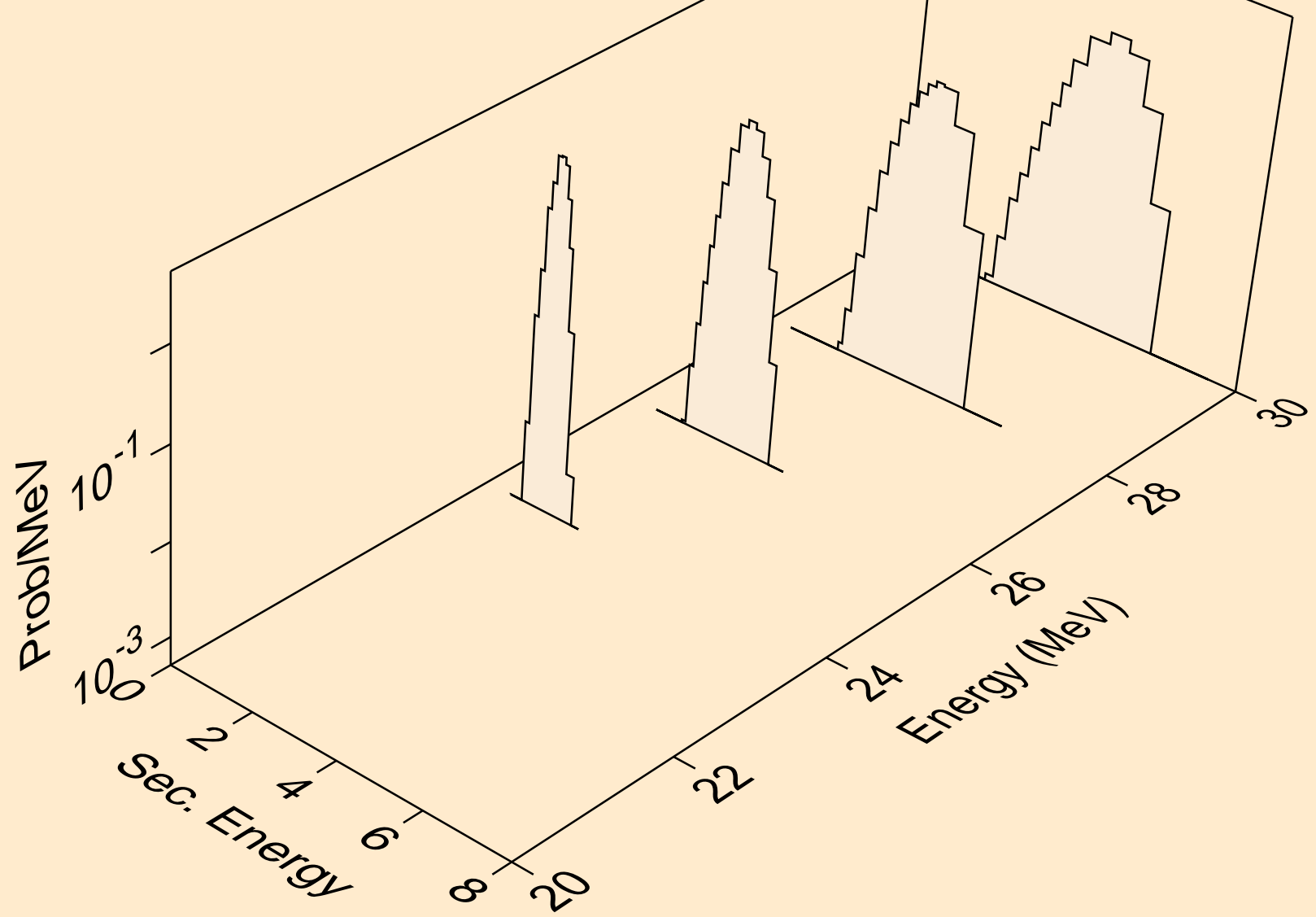

AR036 ALPHA ACER TENDL-2021 LIBRARY; T=0.K
Photon emission for (z,n)

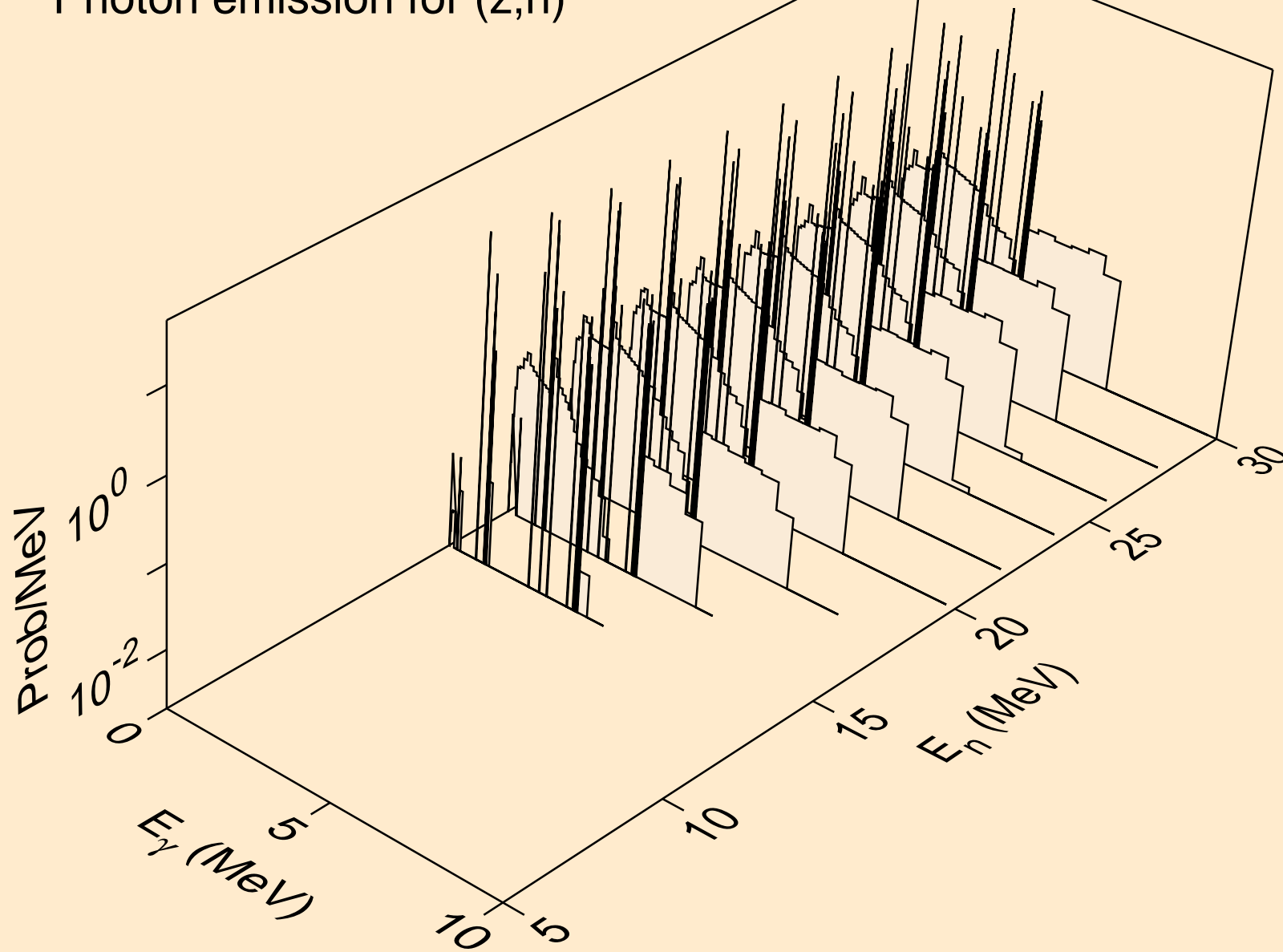

AR036 ALPHA ACER TENDL-2021 LIBRARY; T=0.K
Photon emission for (n,x)

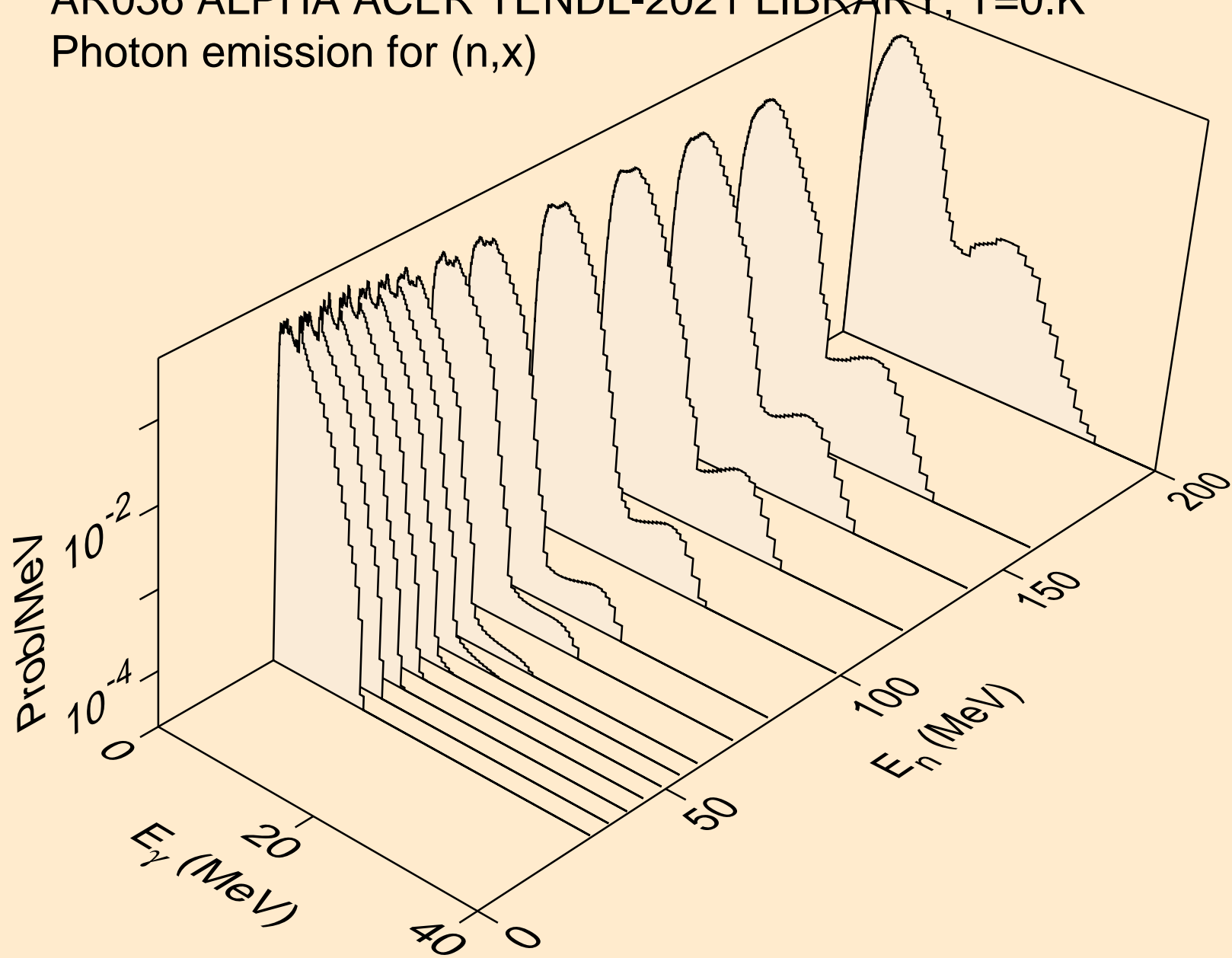

AR036 ALPHA ACER TENDL-2021 LIBRARY; T=0.K
Photon emission for (n,2n)

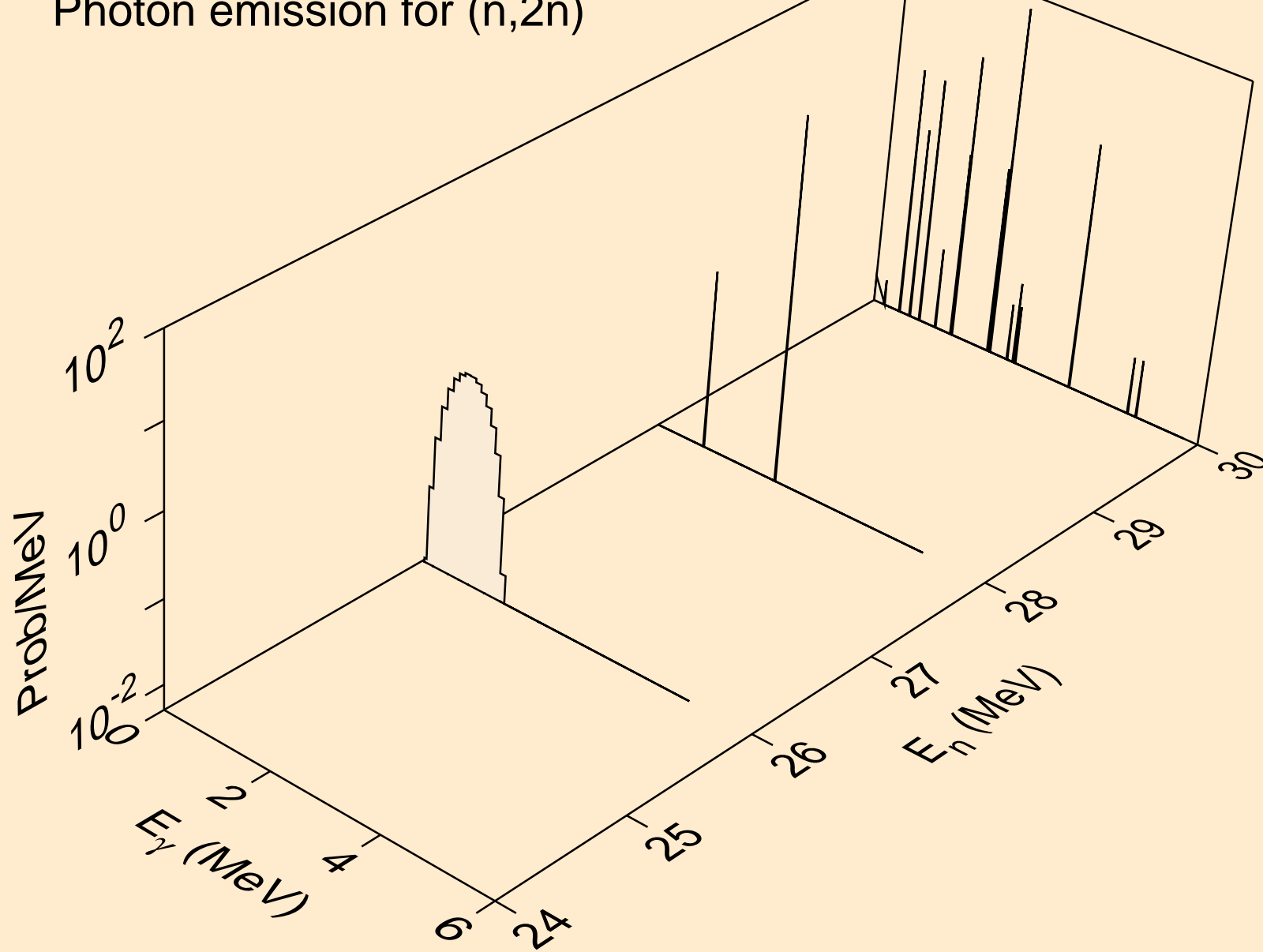

AR036 ALPHA ACER TENDL-2021 LIBRARY; T=0.K
Photon emission for (n,n*)a

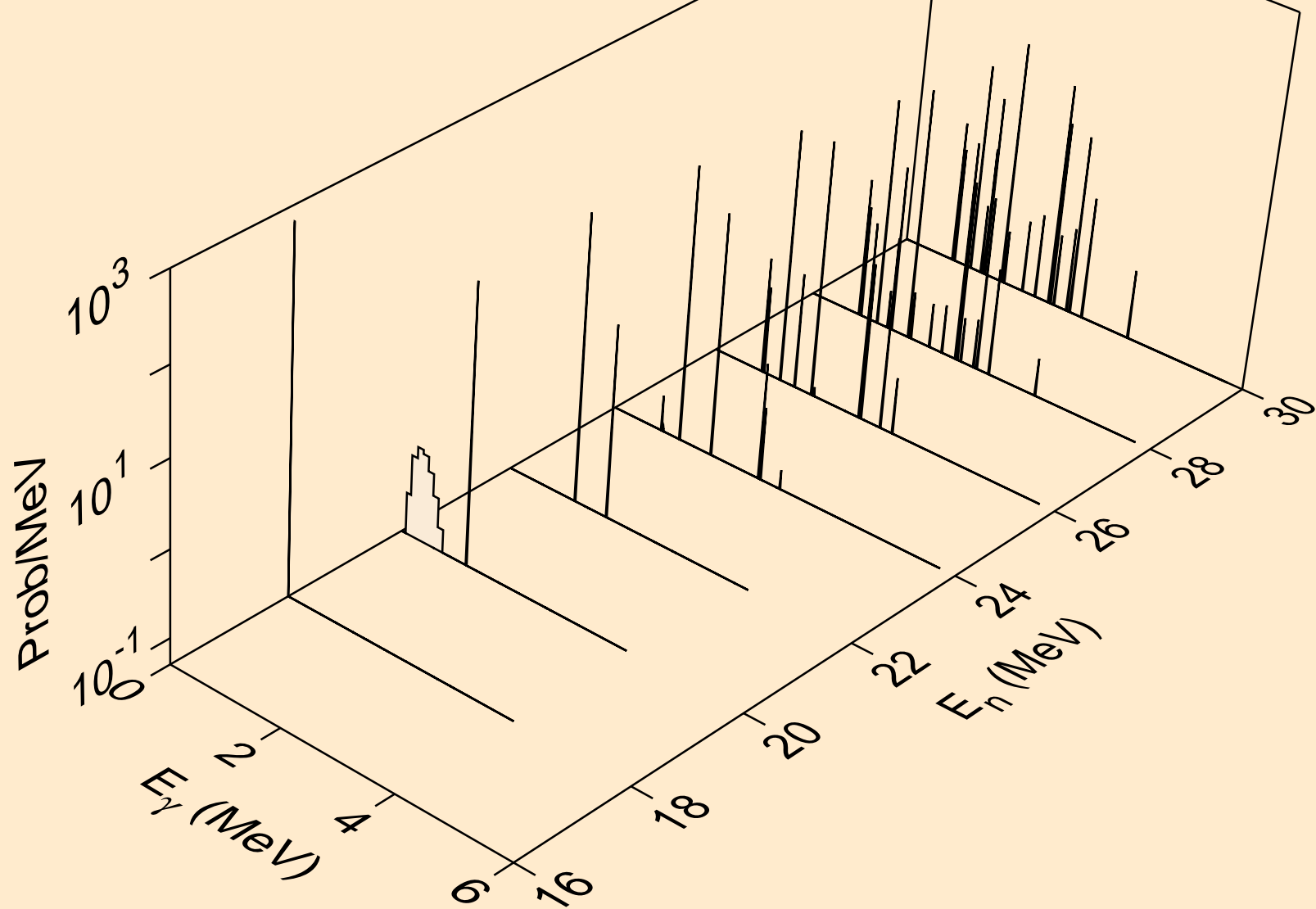

AR036 ALPHA ACER TENDL-2021 LIBRARY; T=0.K
Photon emission for (n,n*)p

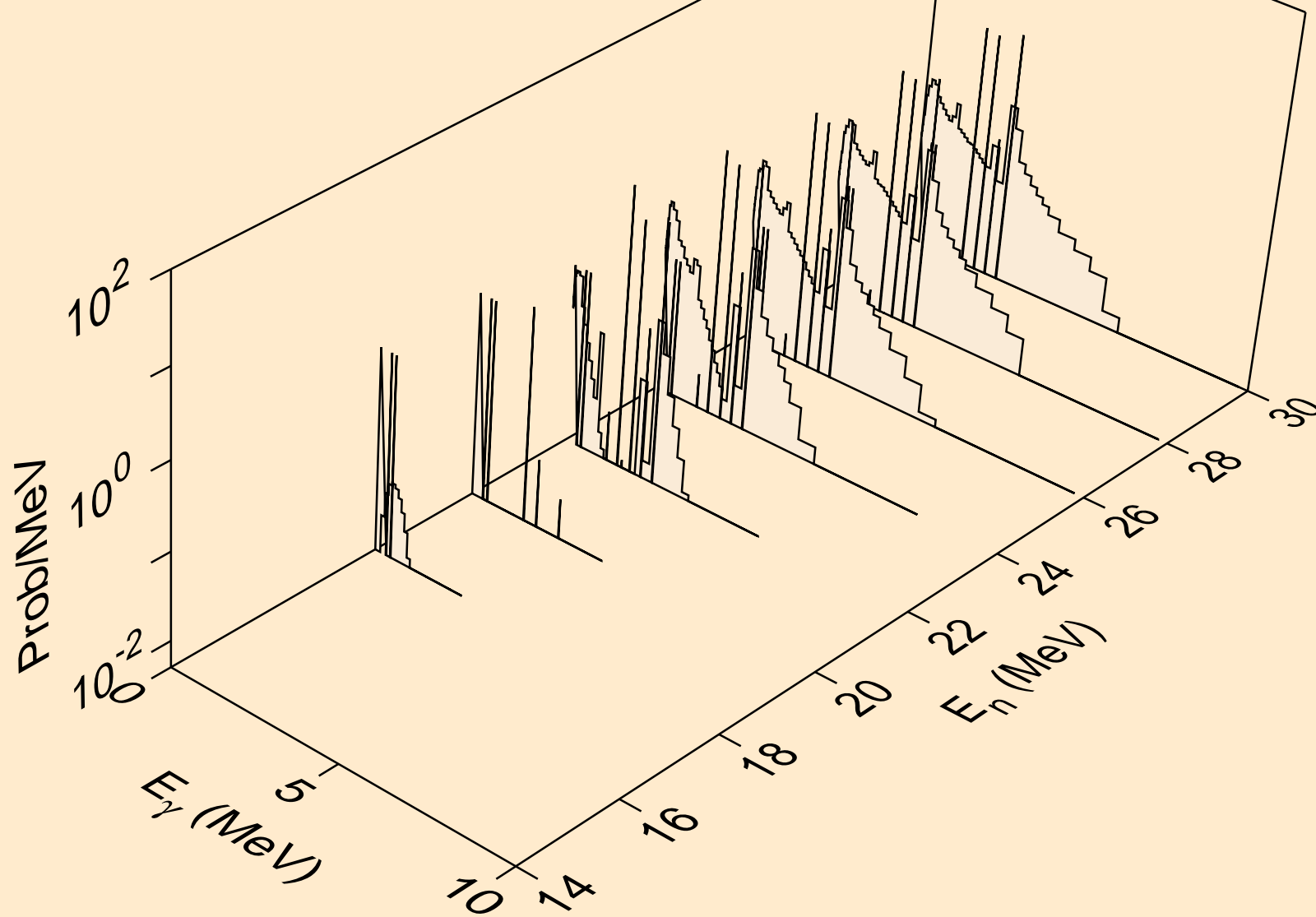

AR036 ALPHA ACER TENDL-2021 LIBRARY; T=0.K
Photon emission for (n,n*)d

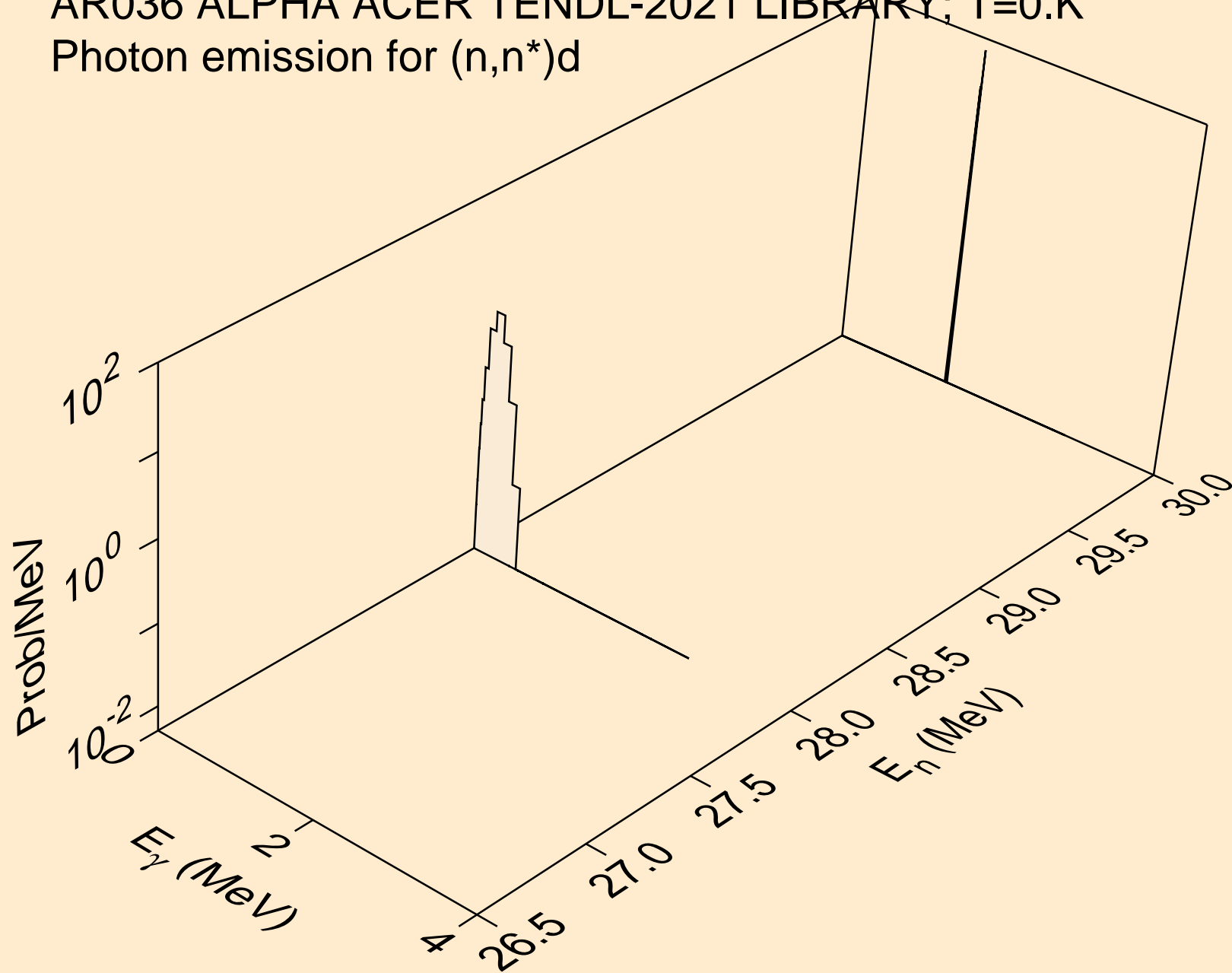

AR036 ALPHA ACER TENDL-2021 LIBRARY; T=0.K
Photon emission for (n,n*)he3

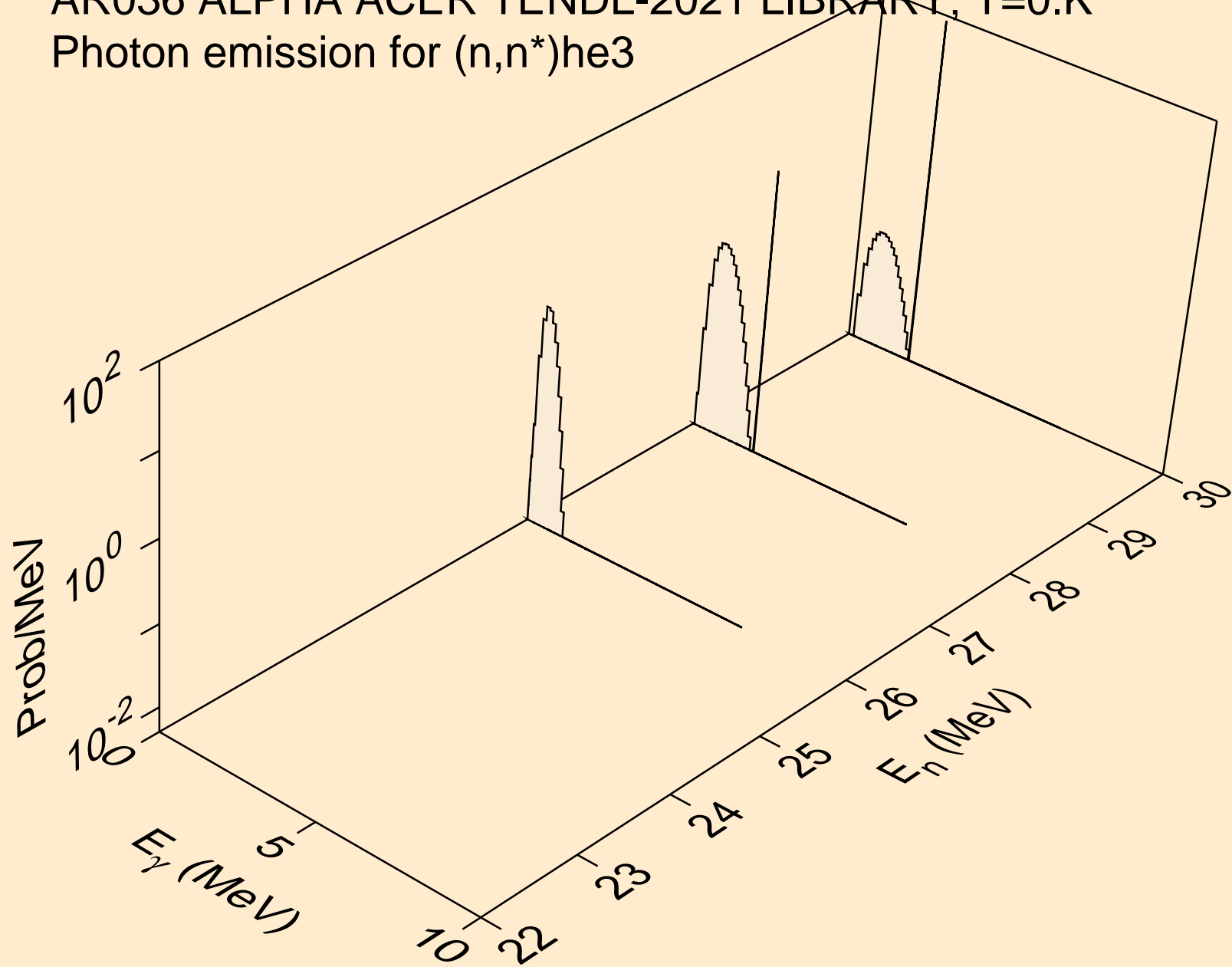

AR036 ALPHA ACER TENDL-2021 LIBRARY; T=0.K
Photon emission for (n,2np)

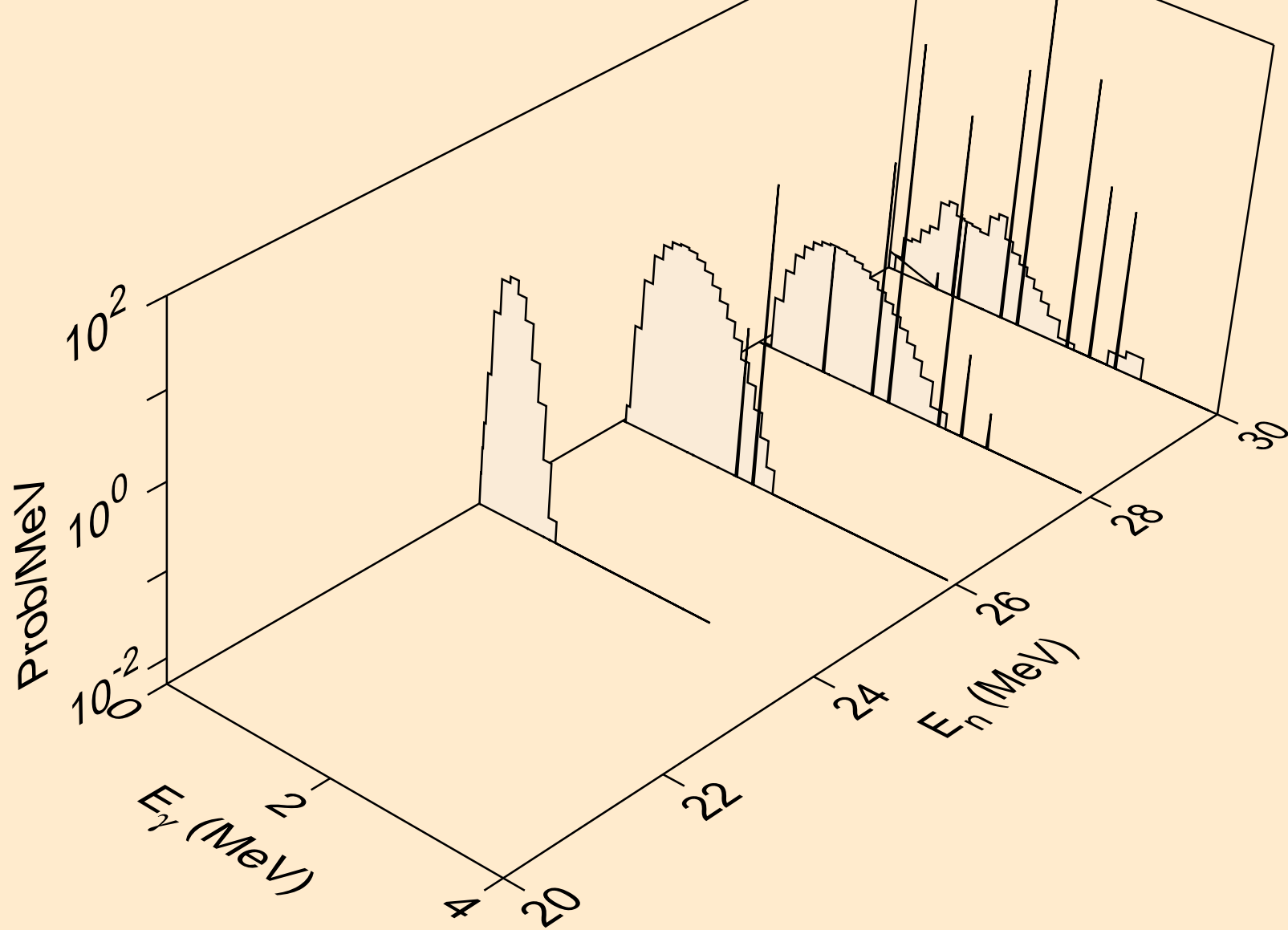

AR036 ALPHA ACER TENDL-2021 LIBRARY; T=0.K
Photon emission for (n,npa)

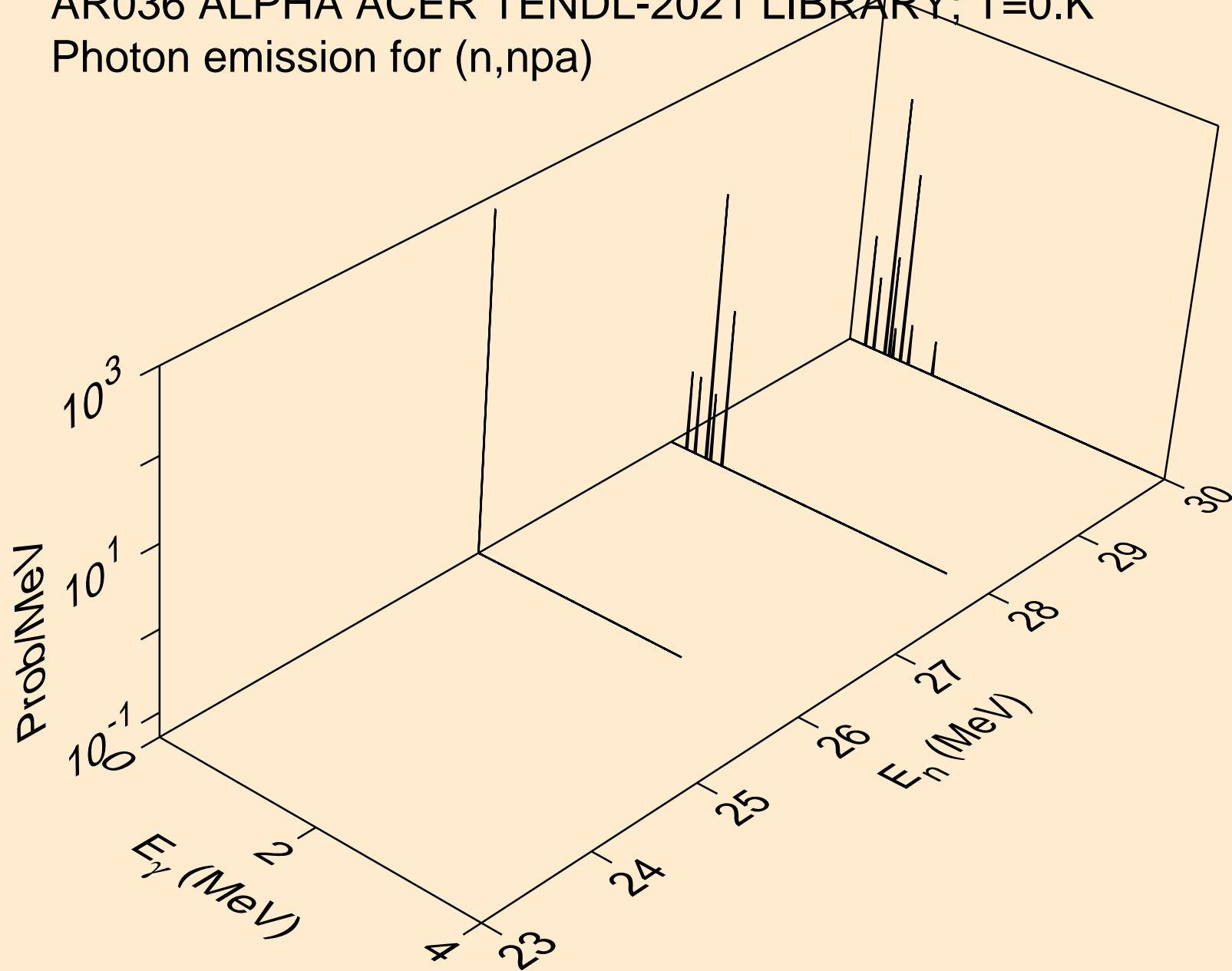

AR036 ALPHA ACER TENDL-2021 LIBRARY; T=0.K
Photon emission for (n,gma)

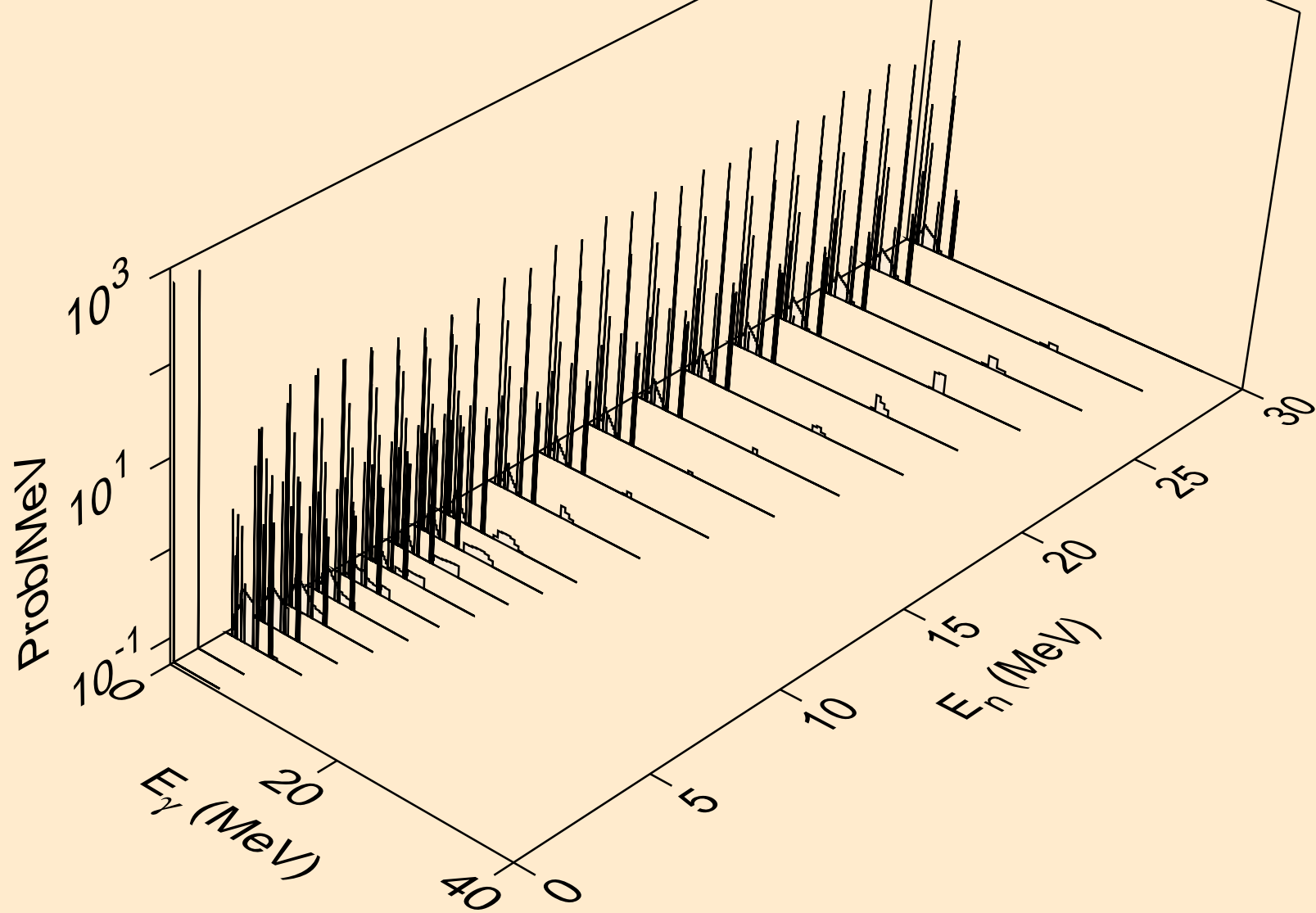

AR036 ALPHA ACER TENDL-2021 LIBRARY; T=0.K
Photon emission for (n,p)

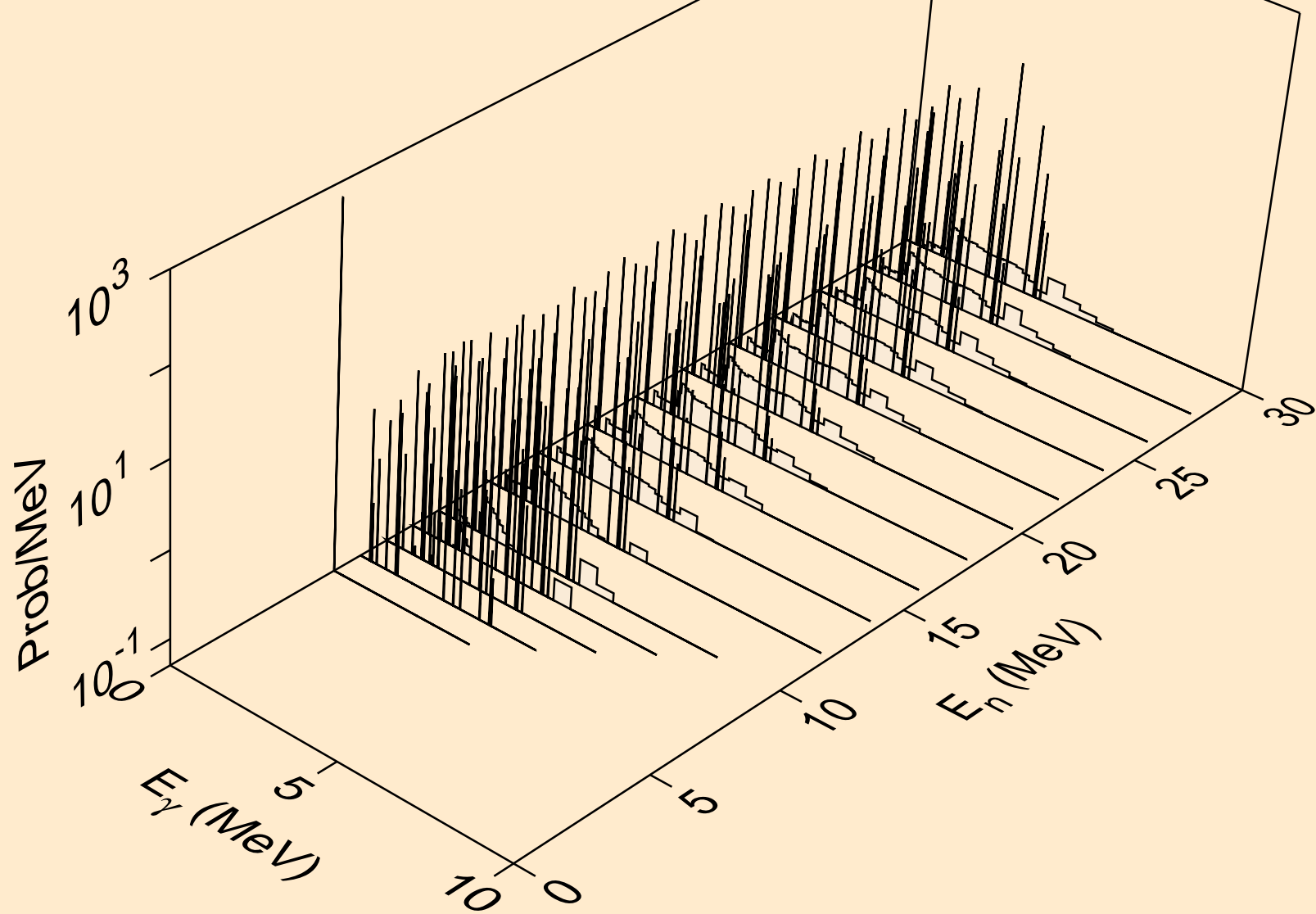

AR036 ALPHA ACER TENDL-2021 LIBRARY; T=0.K
Photon emission for (n,d)

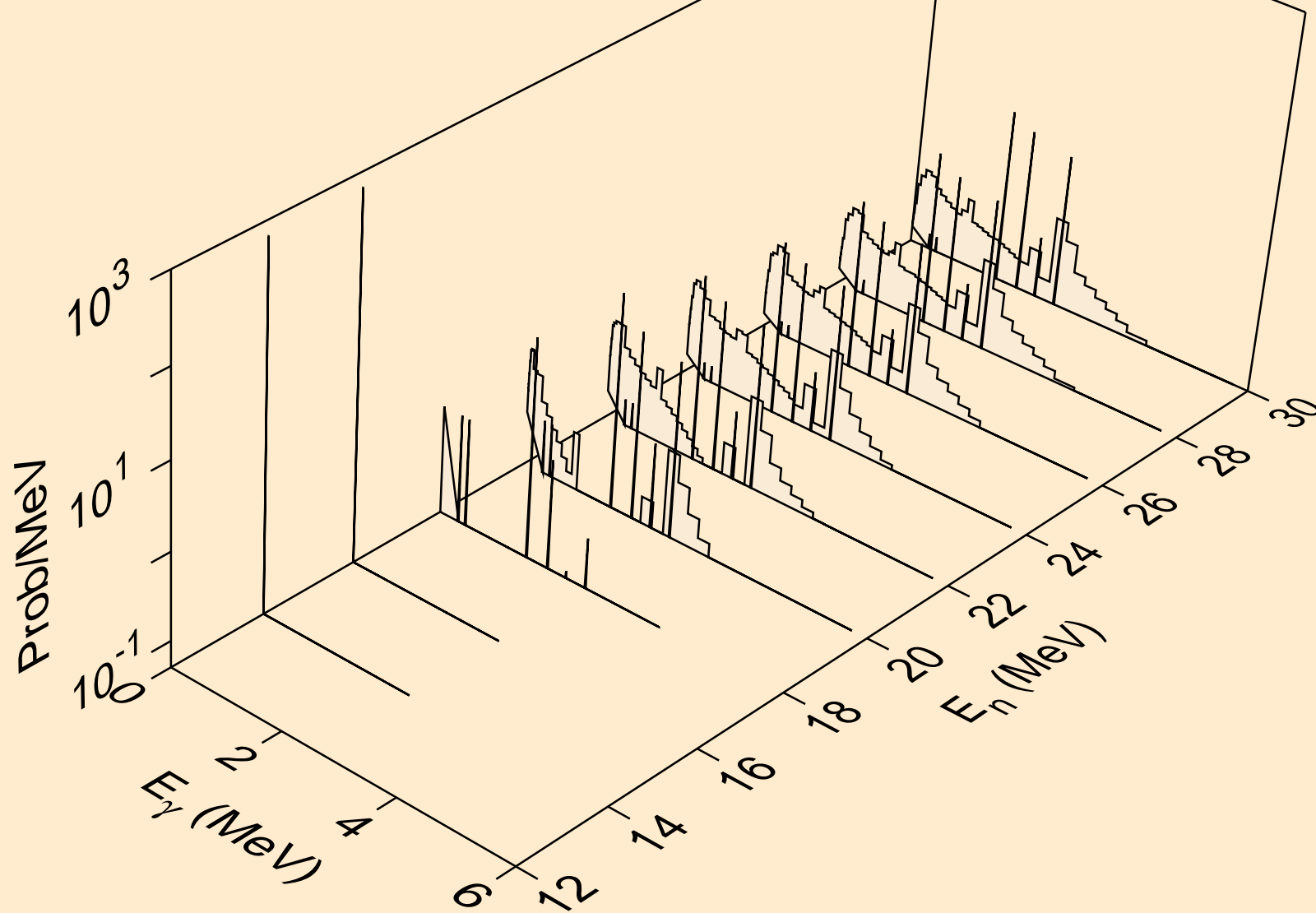

AR036 ALPHA ACER TENDL-2021 LIBRARY; T=0.K
Photon emission for (n,t)

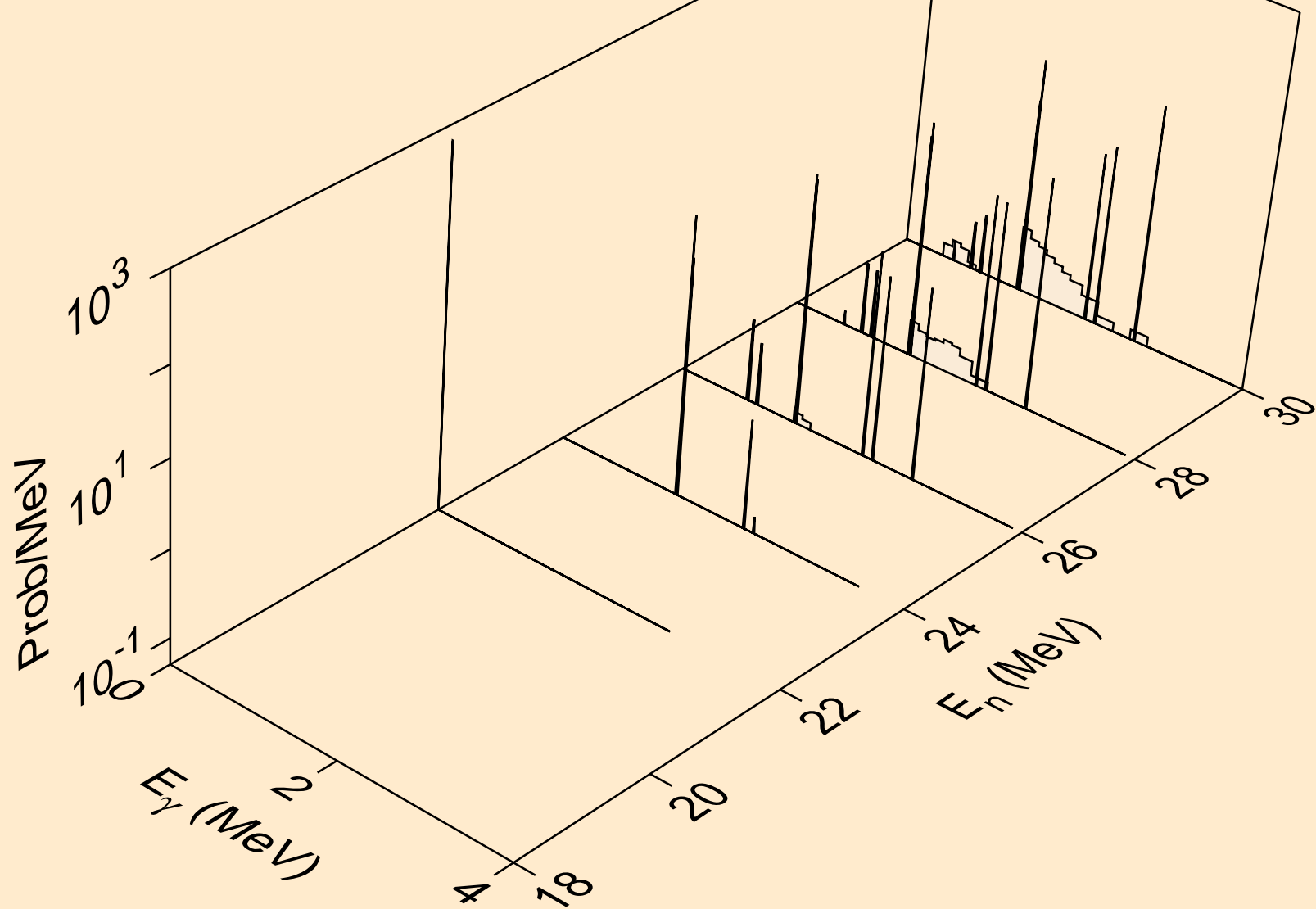

AR036 ALPHA ACER TENDL-2021 LIBRARY; T=0.K
Photon emission for (n,he3)

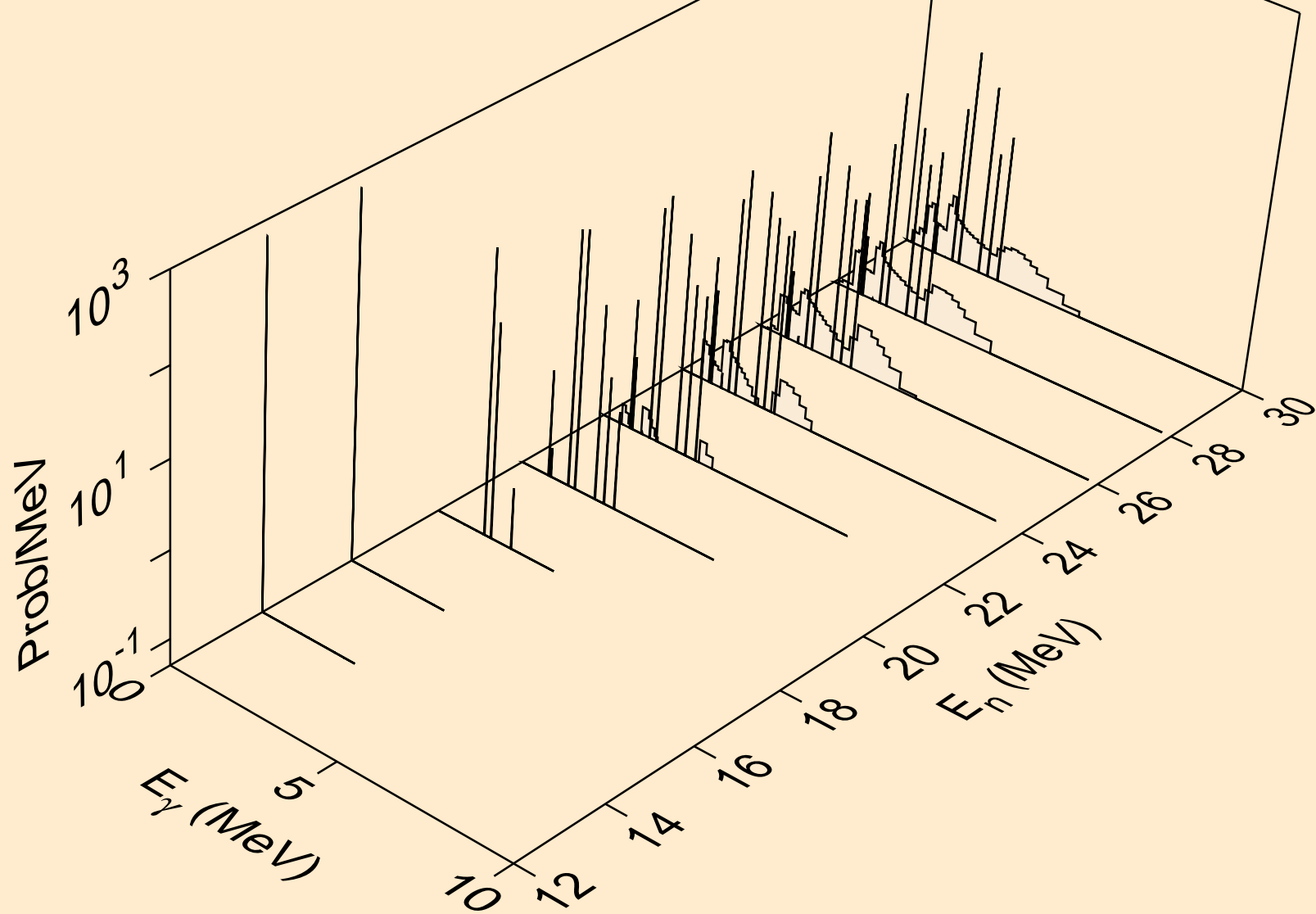

AR036 ALPHA ACER TENDL-2021 LIBRARY; T=0.K
Photon emission for inelastic

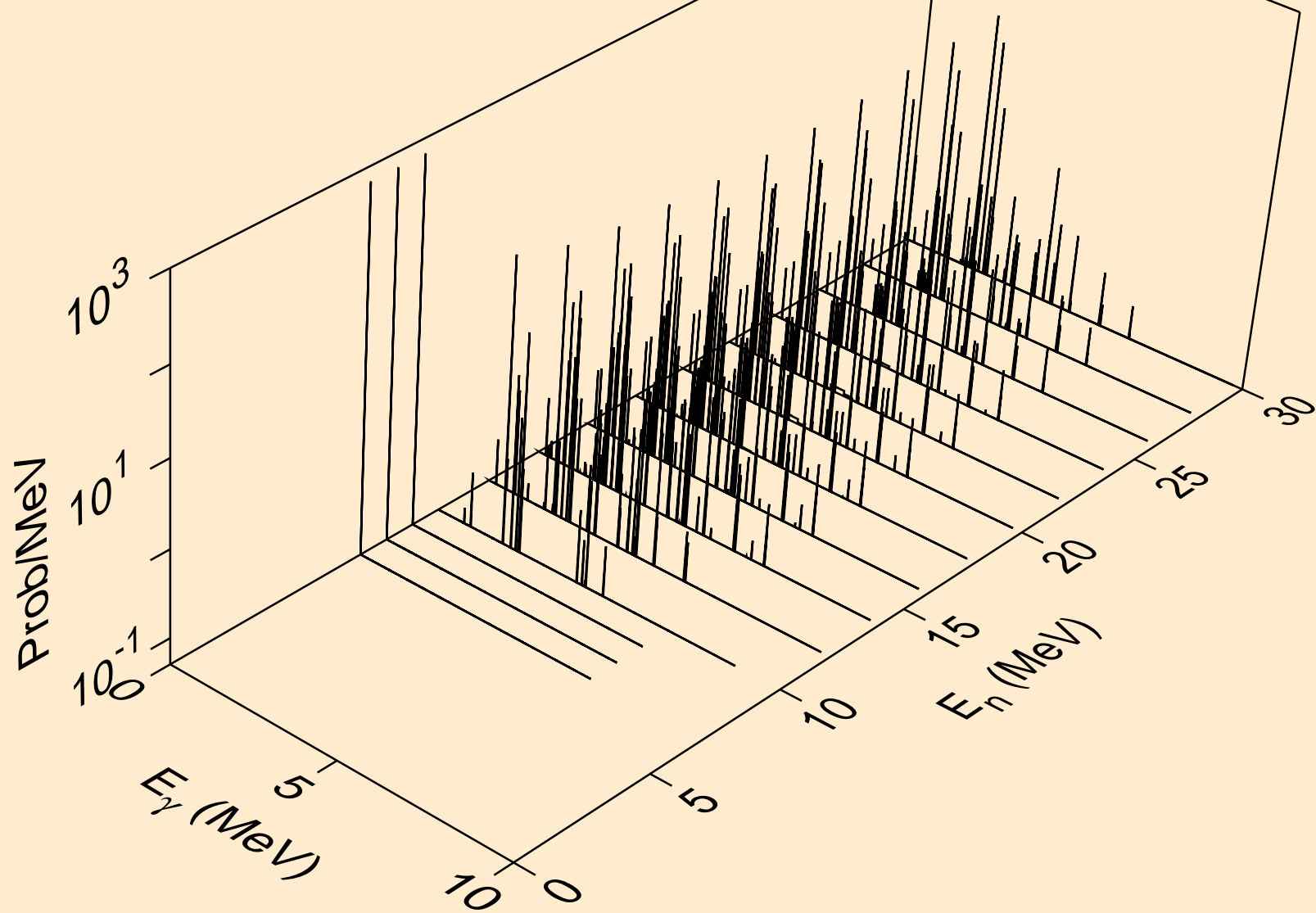

AR036 ALPHA ACER TENDL-2021 LIBRARY; T=0.K
Photon emission for (n,2a)

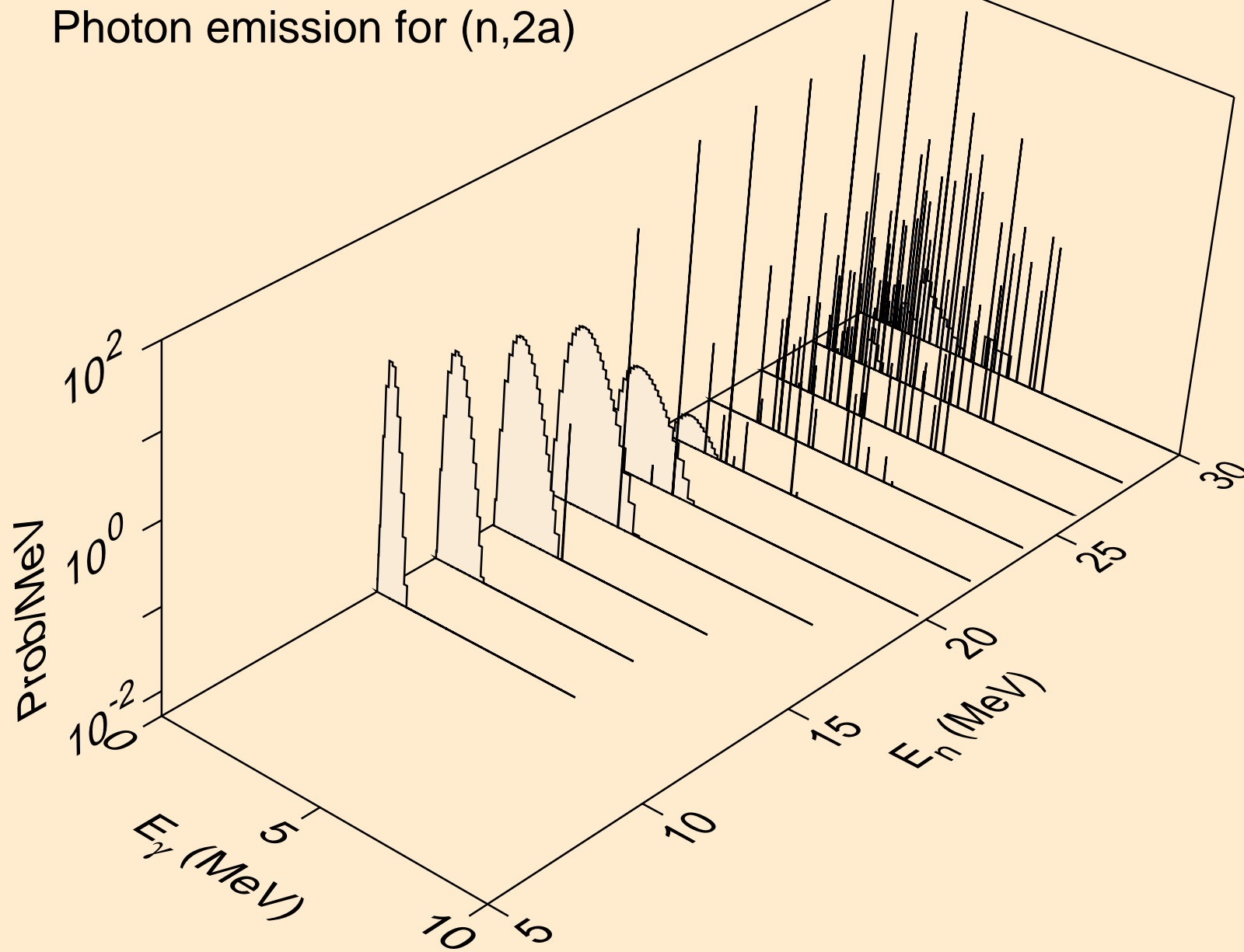

AR036 ALPHA ACER TENDL-2021 LIBRARY; T=0.K
Photon emission for (n,3a)

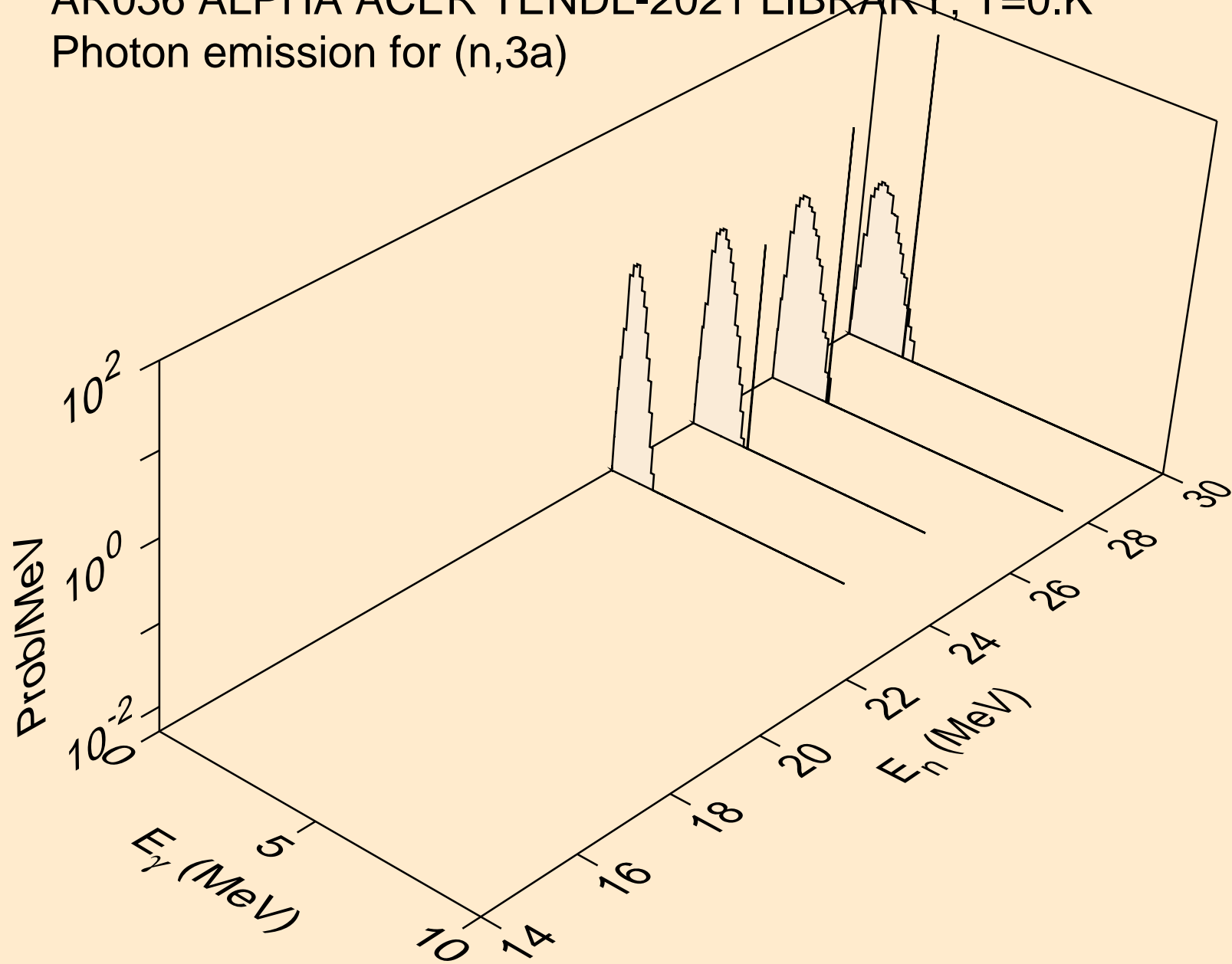

AR036 ALPHA ACER TENDL-2021 LIBRARY; T=0.K
Photon emission for (n,2p)

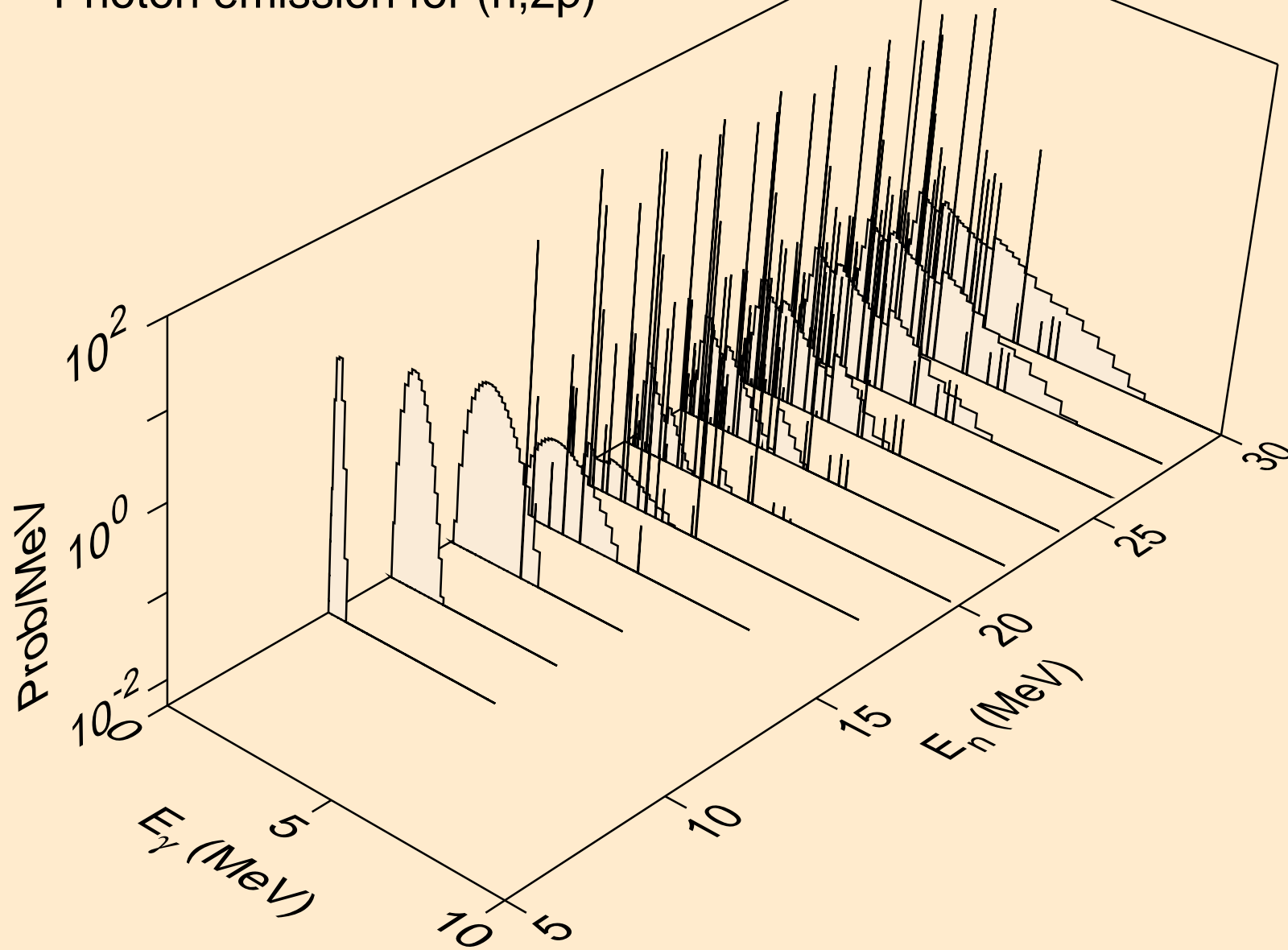

AR036 ALPHA ACER TENDL-2021 LIBRARY; T=0.K
Photon emission for (n,pa)

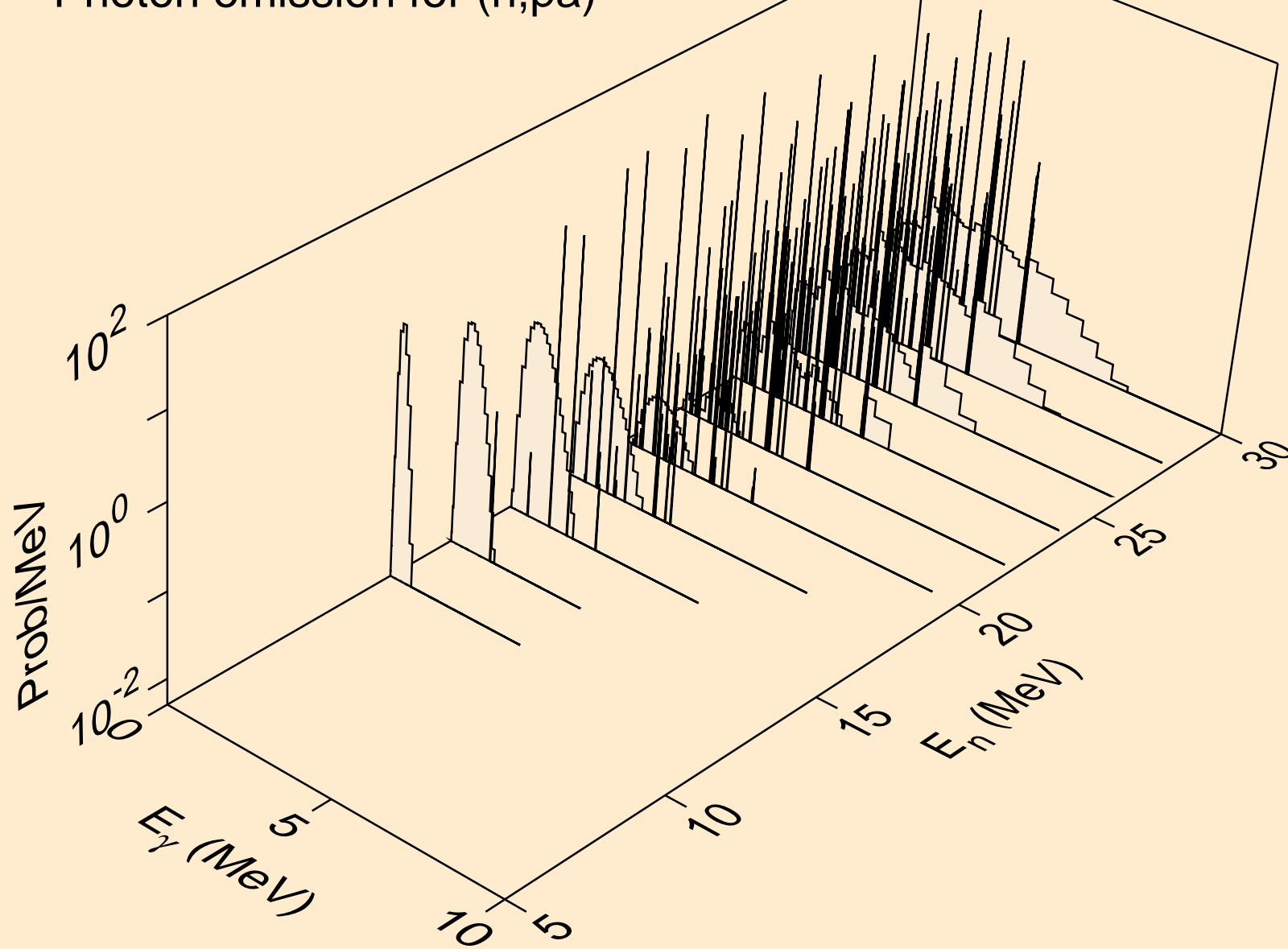

AR036 ALPHA ACER TENDL-2021 LIBRARY; T=0.K
Photon emission for (n,pd)

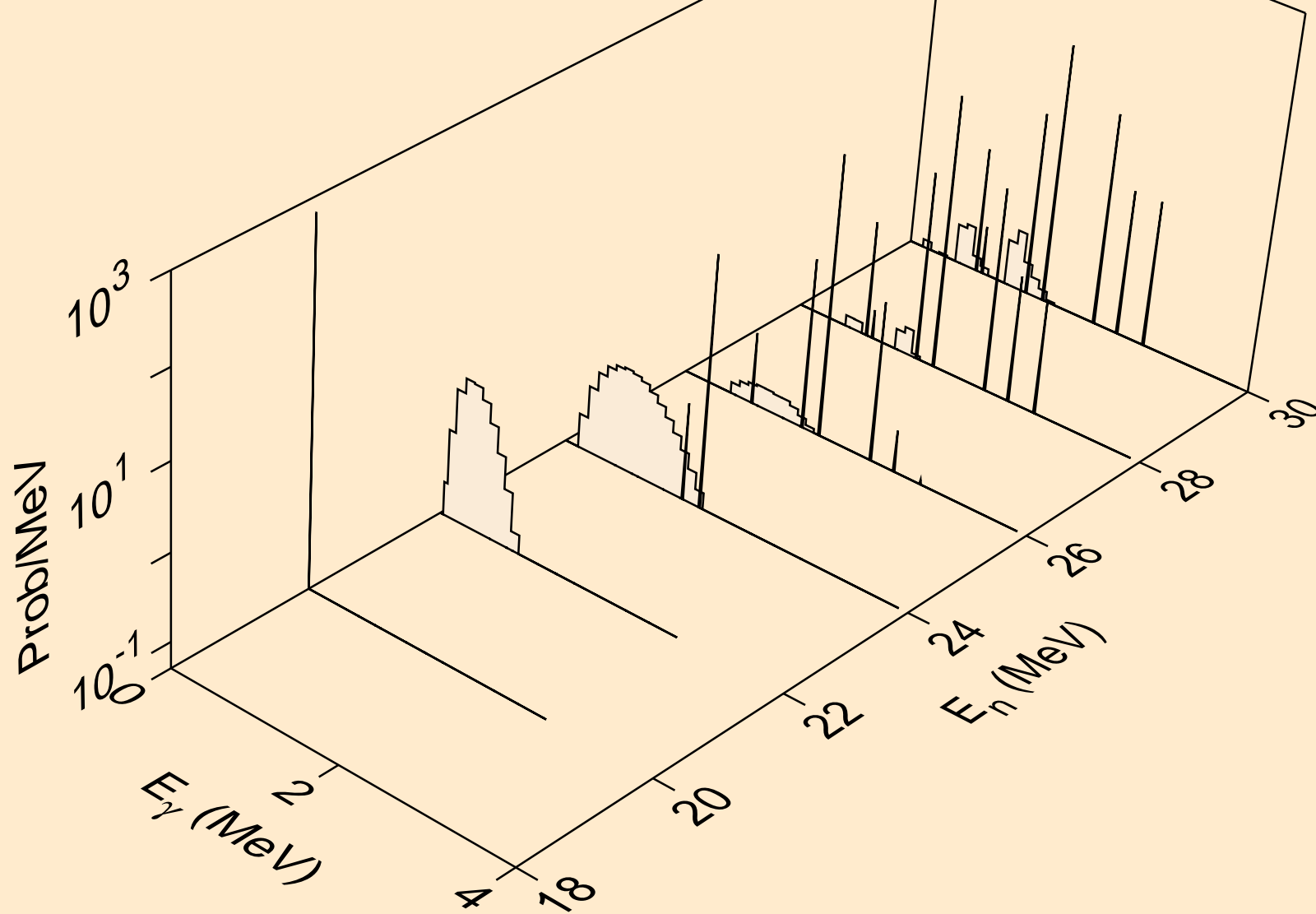

AR036 ALPHA ACER TENDL-2021 LIBRARY; T=0.K
Photon emission for (n,pt)

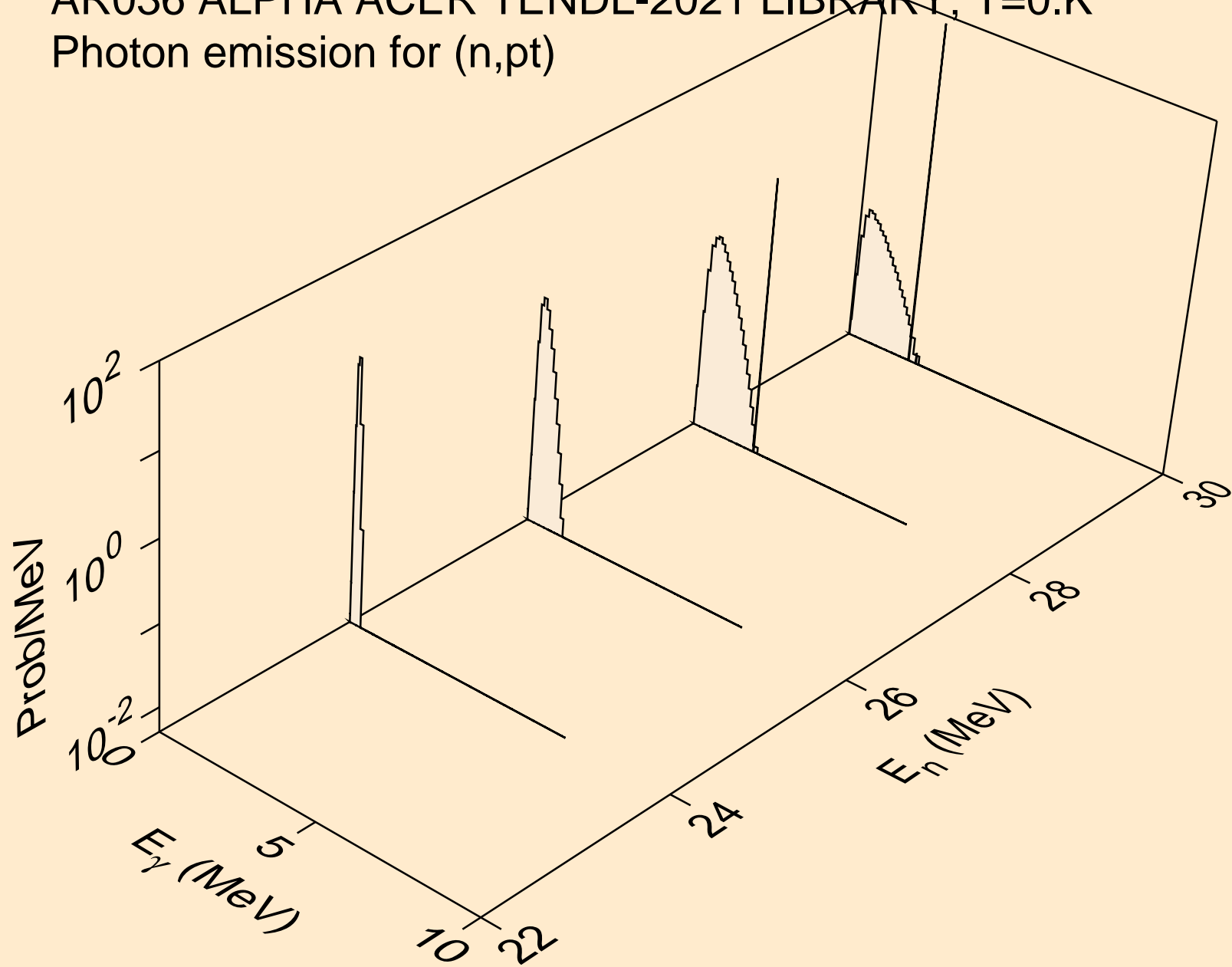

AR036 ALPHA ACER TENDL-2021 LIBRARY; T=0.K
Photon emission for (n,da)

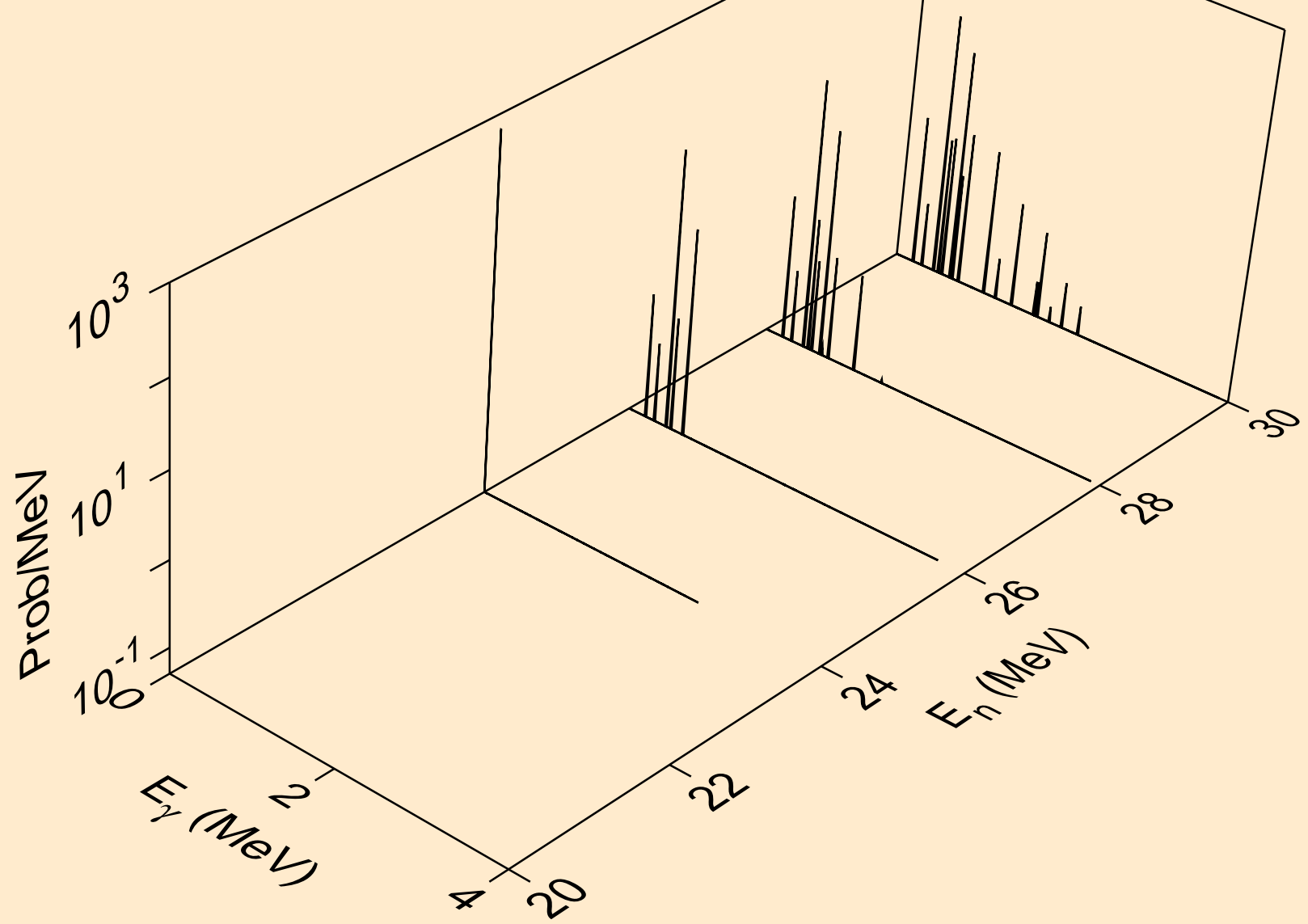

AR036 ALPHA ACER TENDL-2021 LIBRARY; T=0.K
Particle heating contributions

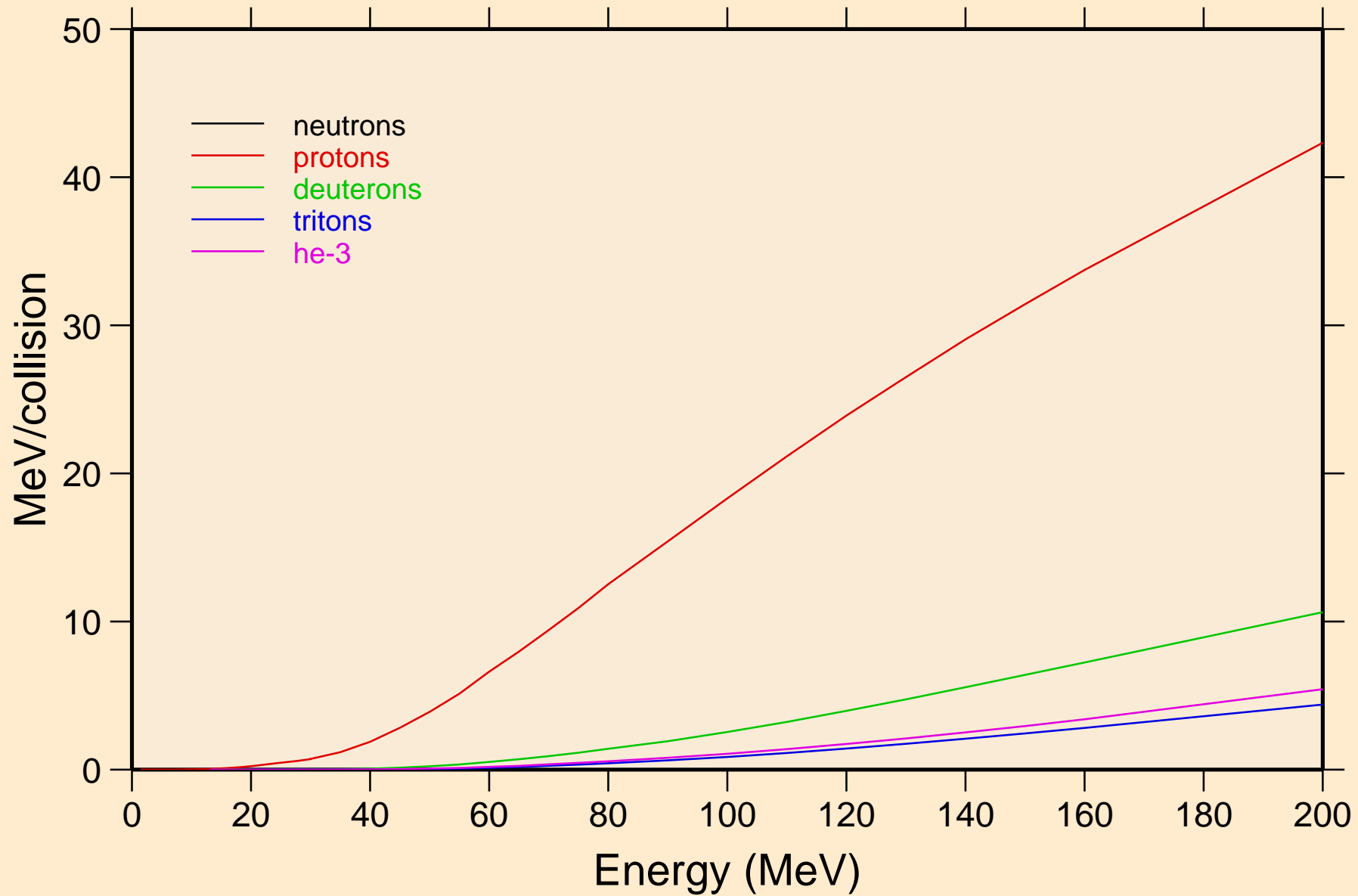

AR036 ALPHA ACER TENDL-2021 LIBRARY; T=0.K
Recoil Heating

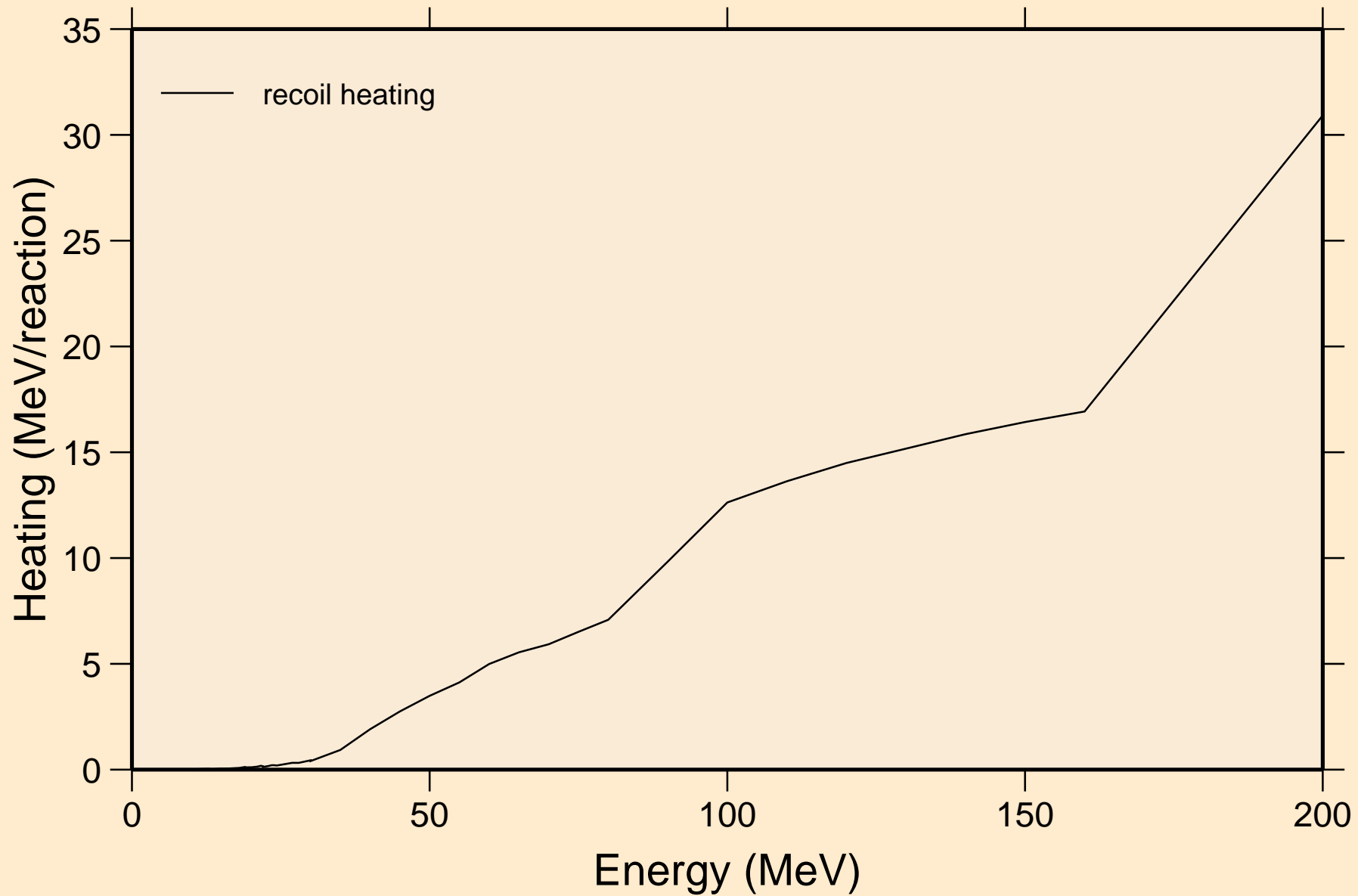

AR036 ALPHA ACER TENDL-2021 LIBRARY; T=0.K
Particle production cross sections

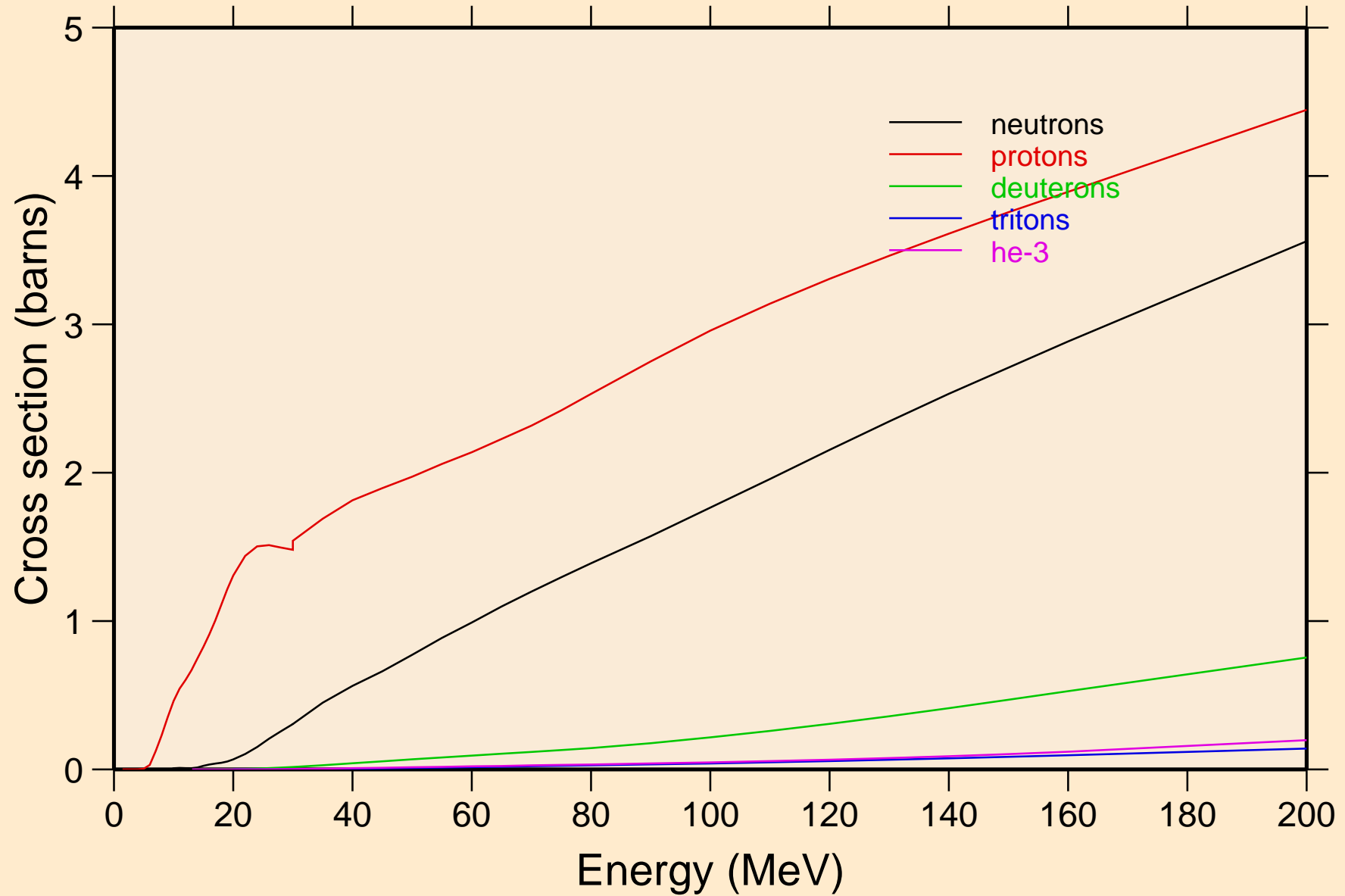

AR036 ALPHA ACER TENDL-2021 LIBRARY; T=0.K
neutrons from (a,n)

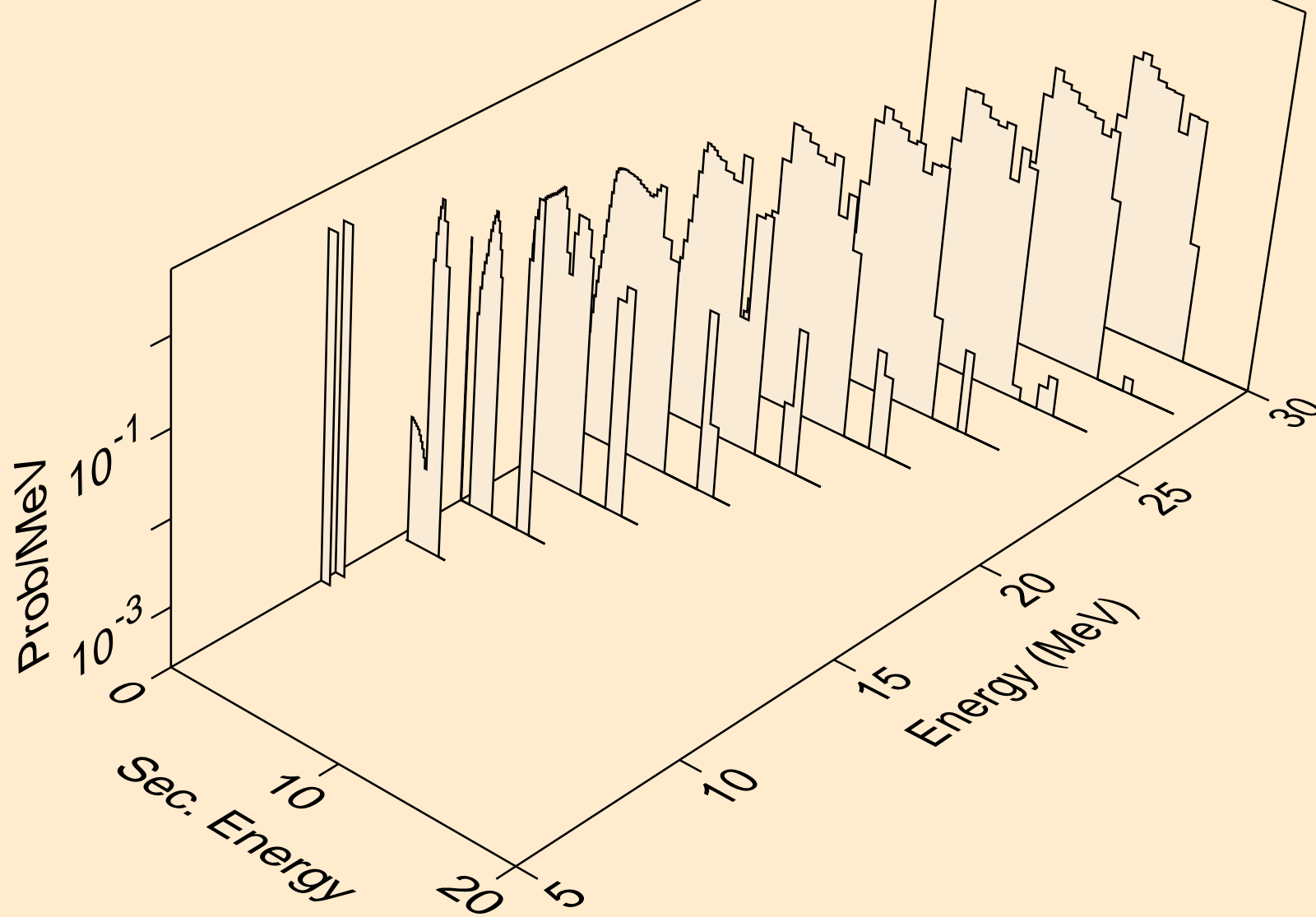

AR036 ALPHA ACER TENDL-2021 LIBRARY; T=0.K
neutrons from (a,x)

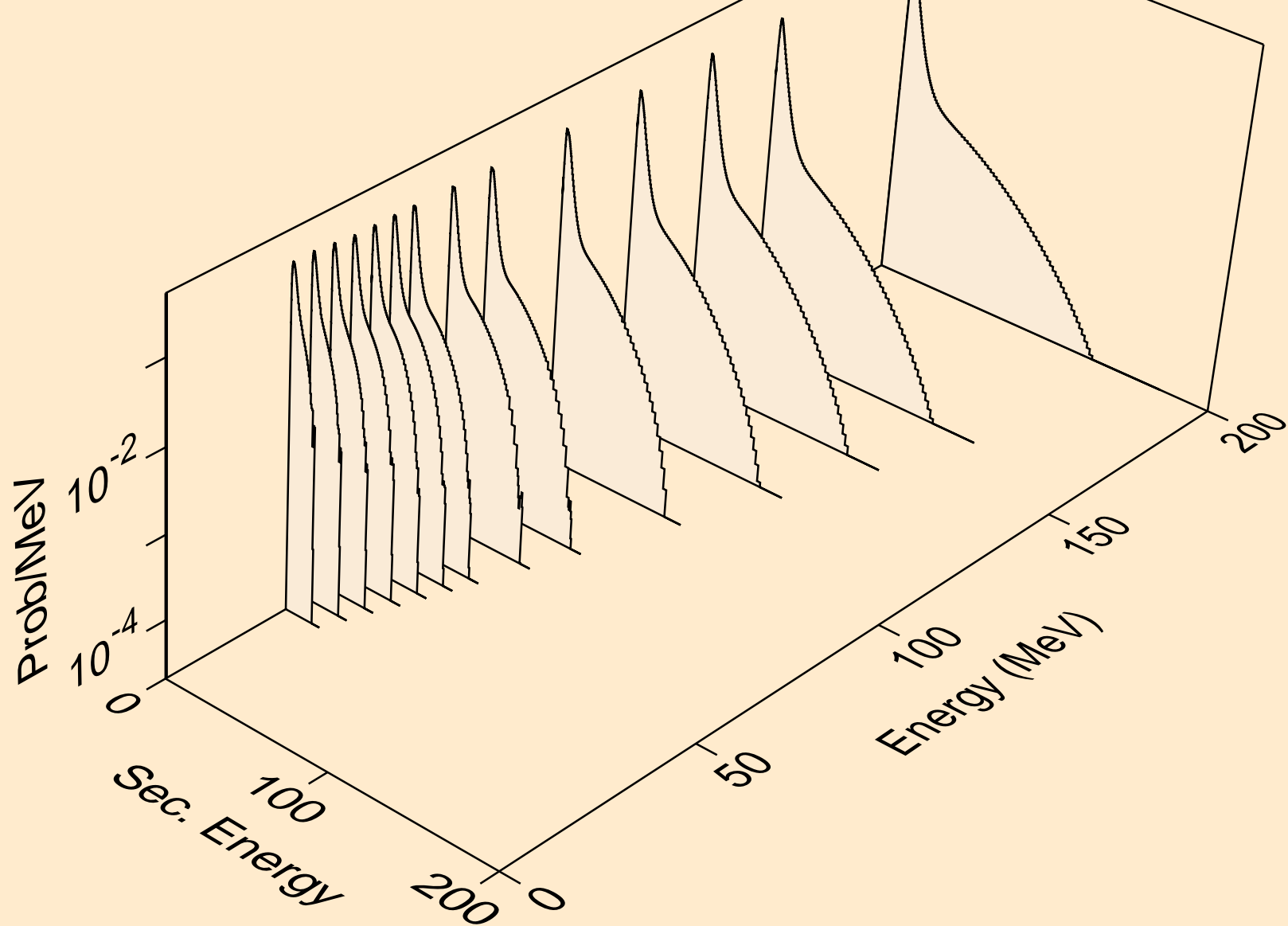

AR036 ALPHA ACER TENDL-2021 LIBRARY; T=0.K
neutrons from (a,2n)

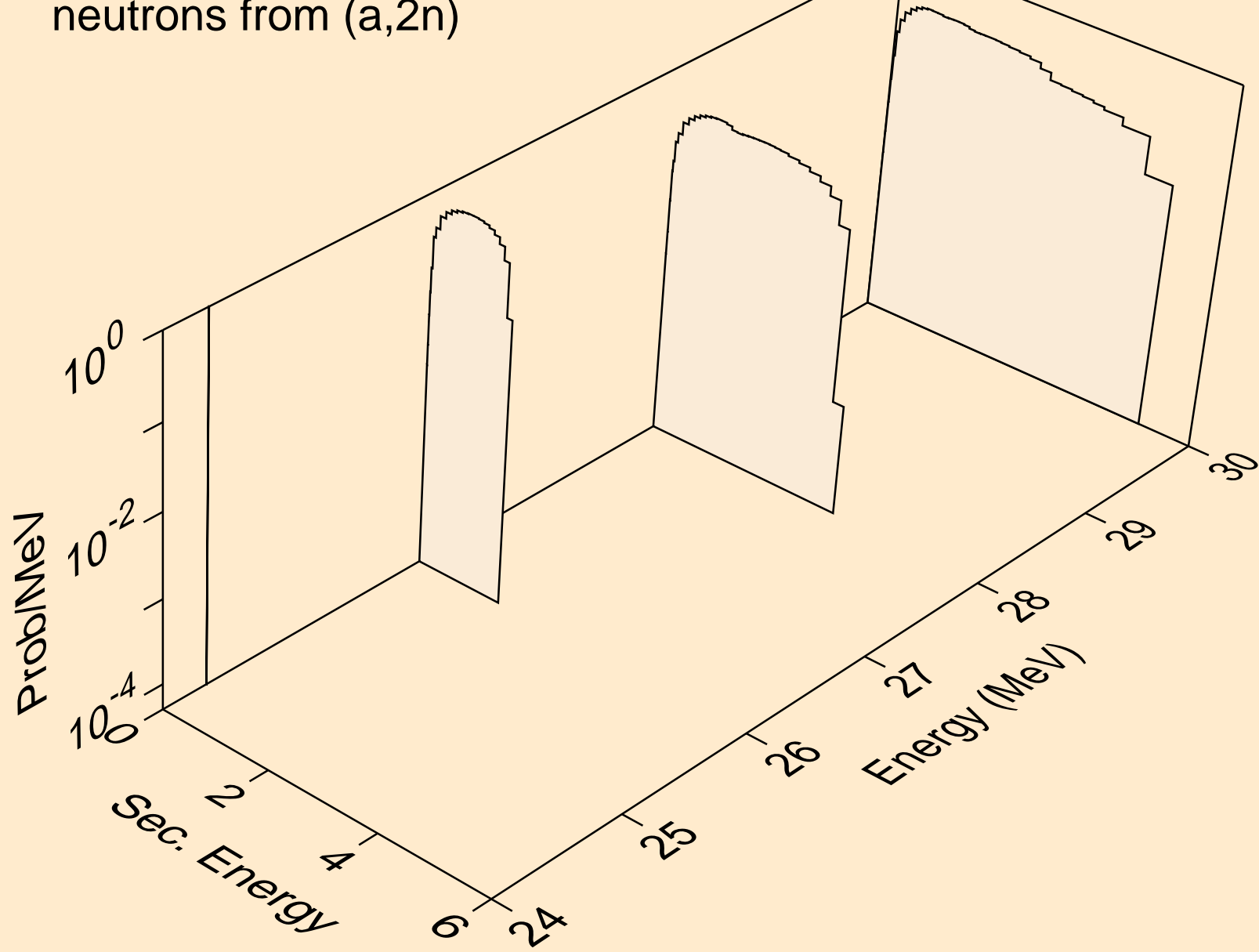

AR036 ALPHA ACER TENDL-2021 LIBRARY; T=0.K
neutrons from (a,n*)a

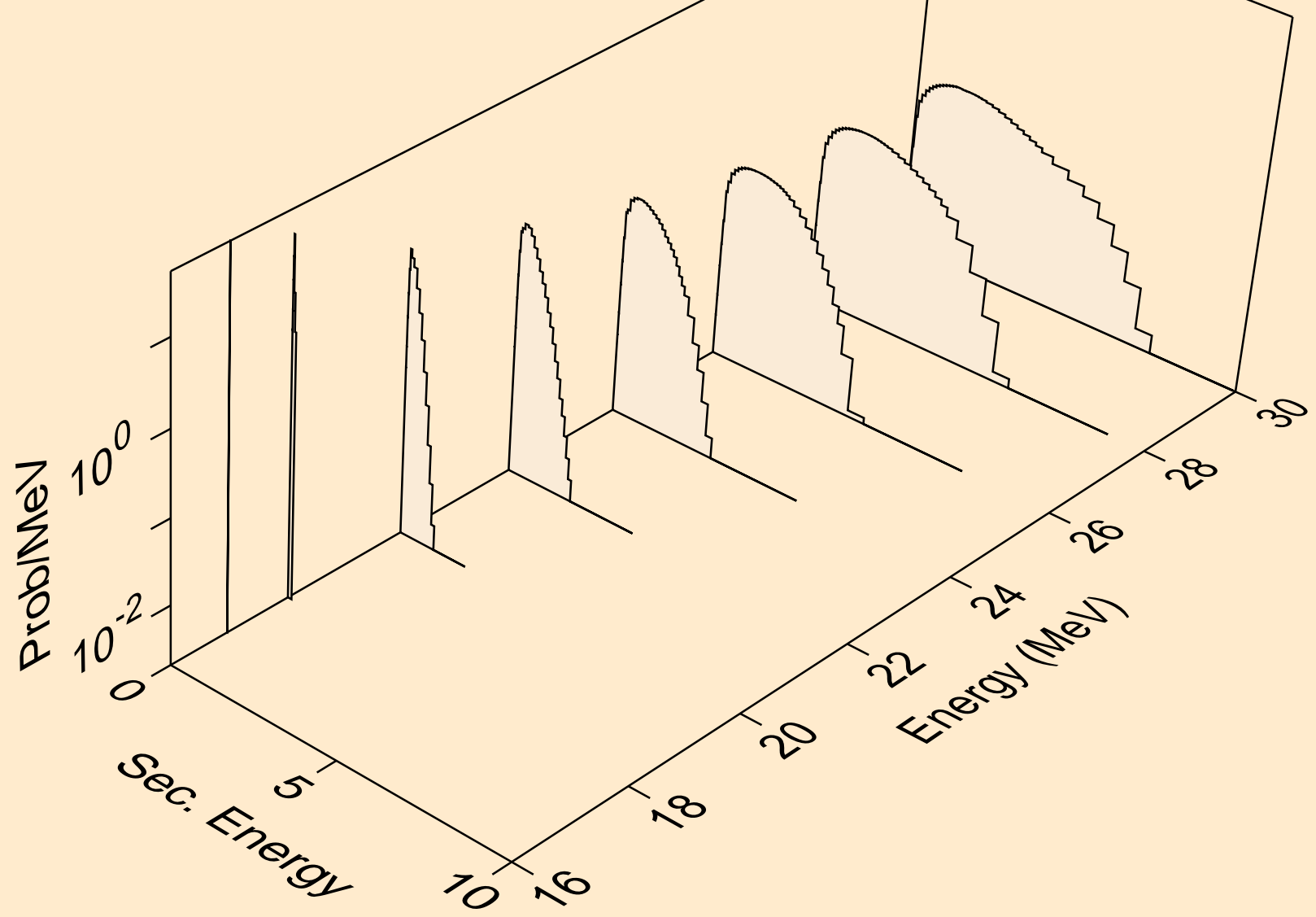

AR036 ALPHA ACER TENDL-2021 LIBRARY; T=0.K
neutrons from (a,n*)p

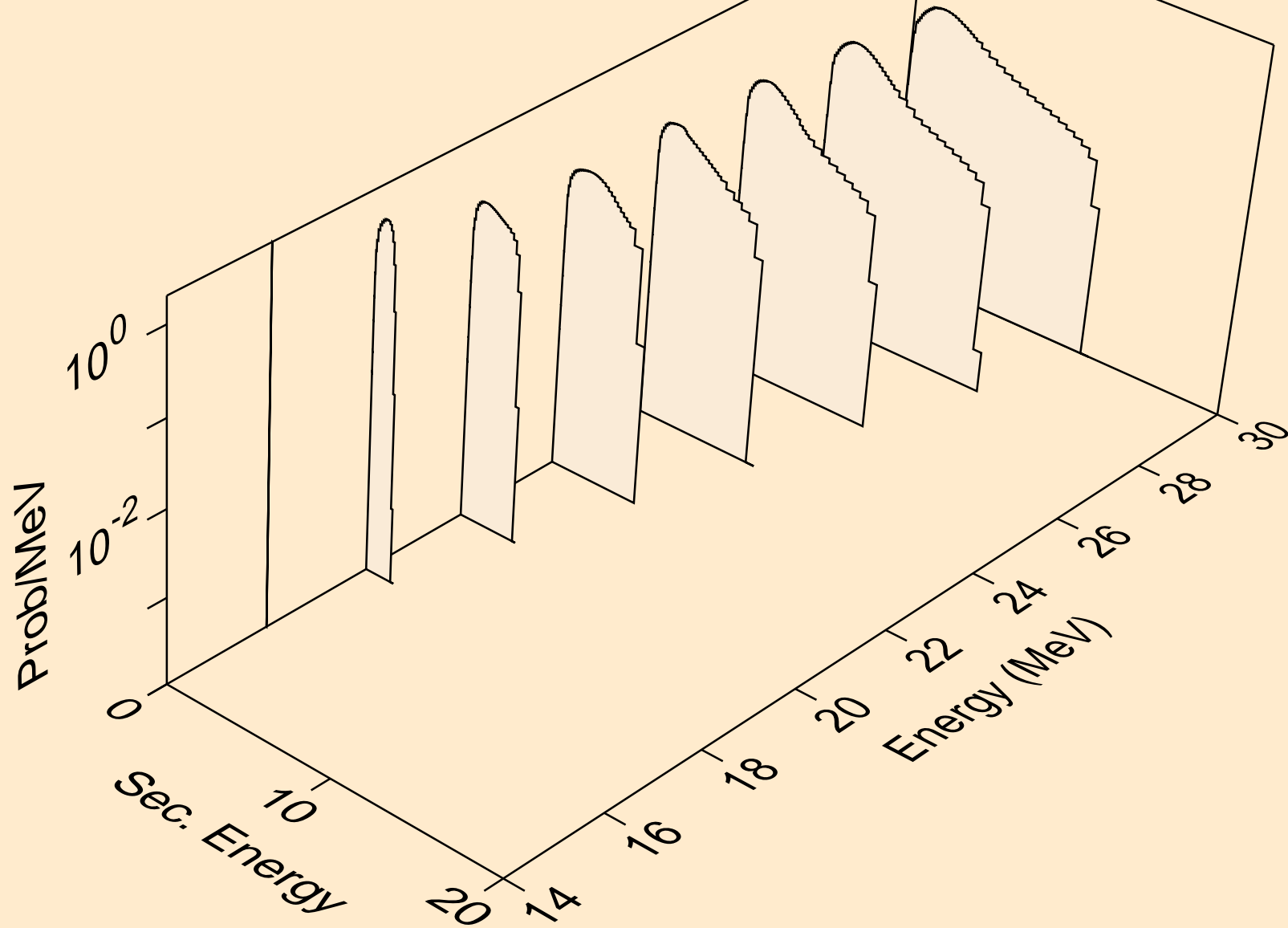

AR036 ALPHA ACER TENDL-2021 LIBRARY; T=0.K
neutrons from (a,n*)d

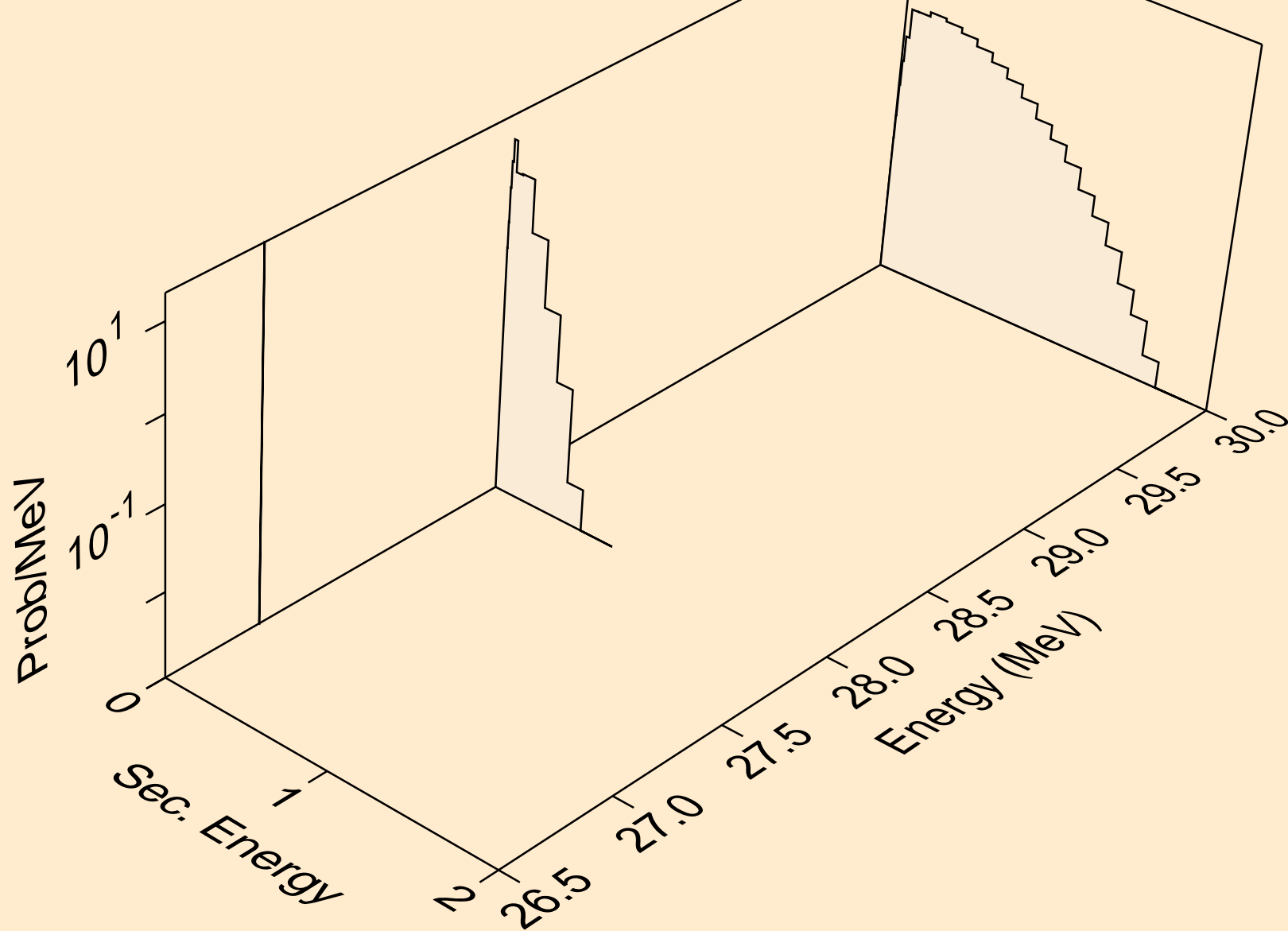

AR036 ALPHA ACER TENDL-2021 LIBRARY; T=0.K
neutrons from (a,n*)he3

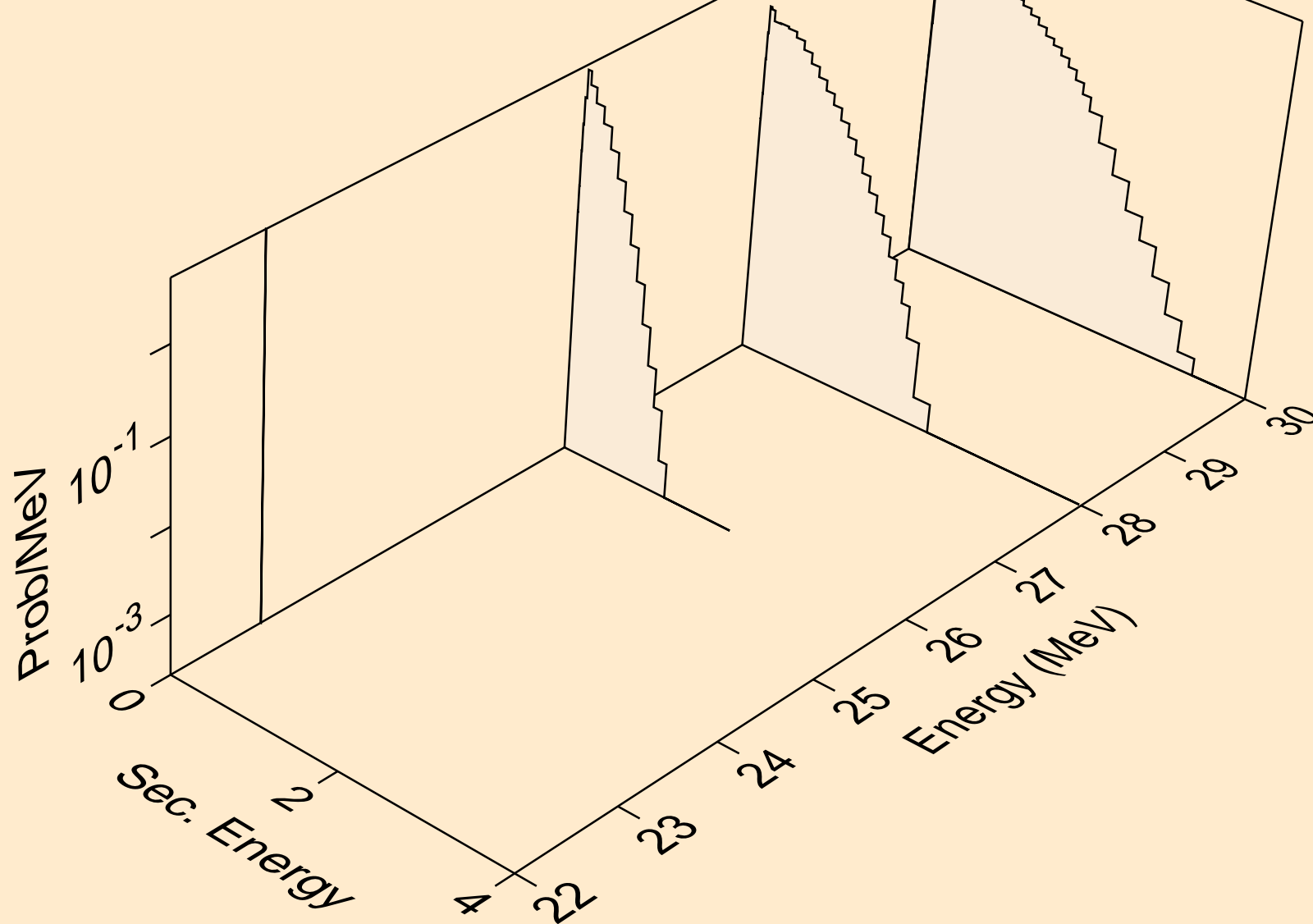

AR036 ALPHA ACER TENDL-2021 LIBRARY; T=0.K
neutrons from (a,2np)

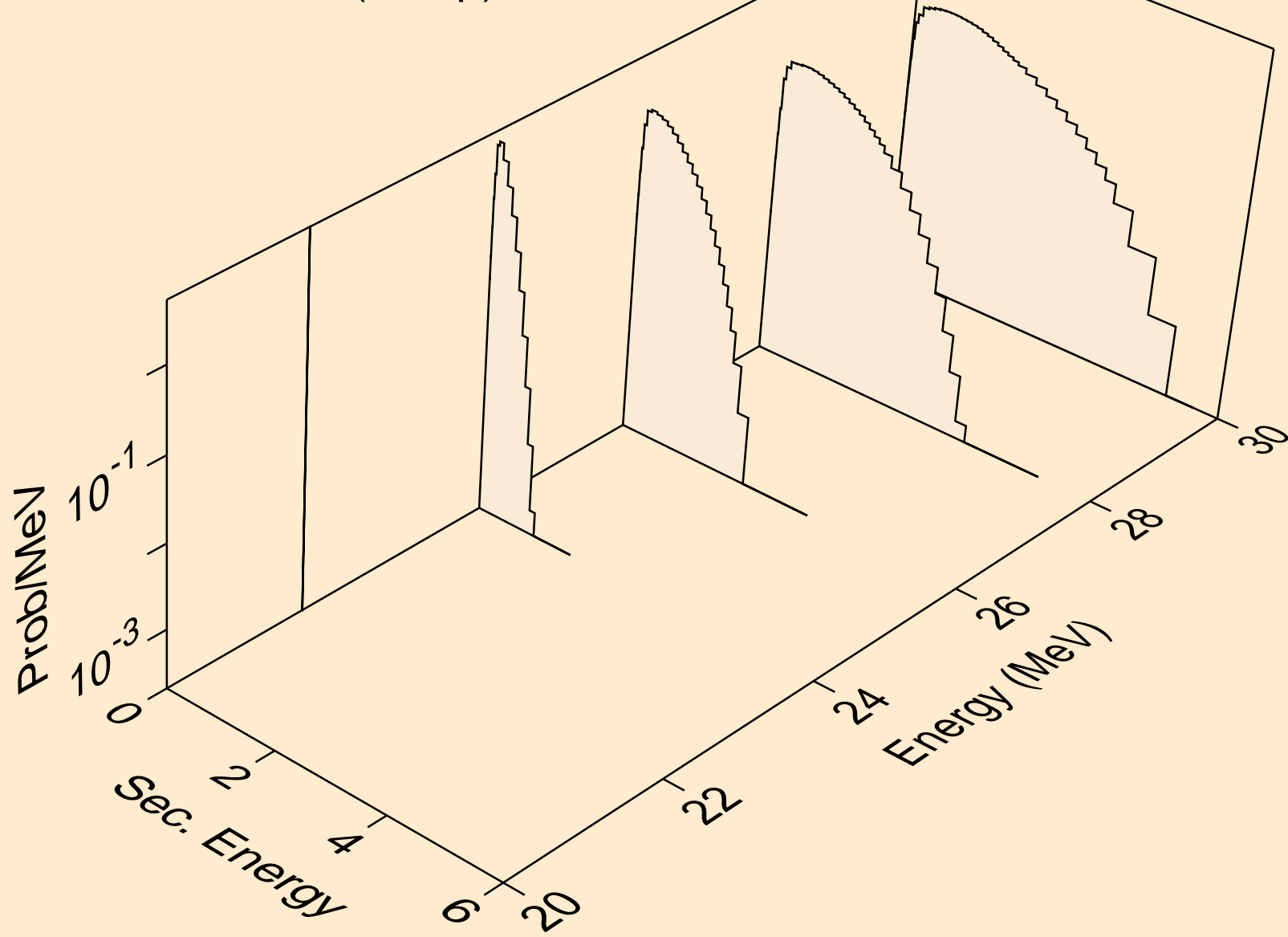

AR036 ALPHA ACER TENDL-2021 LIBRARY; T=0.K
neutrons from (a,npa)

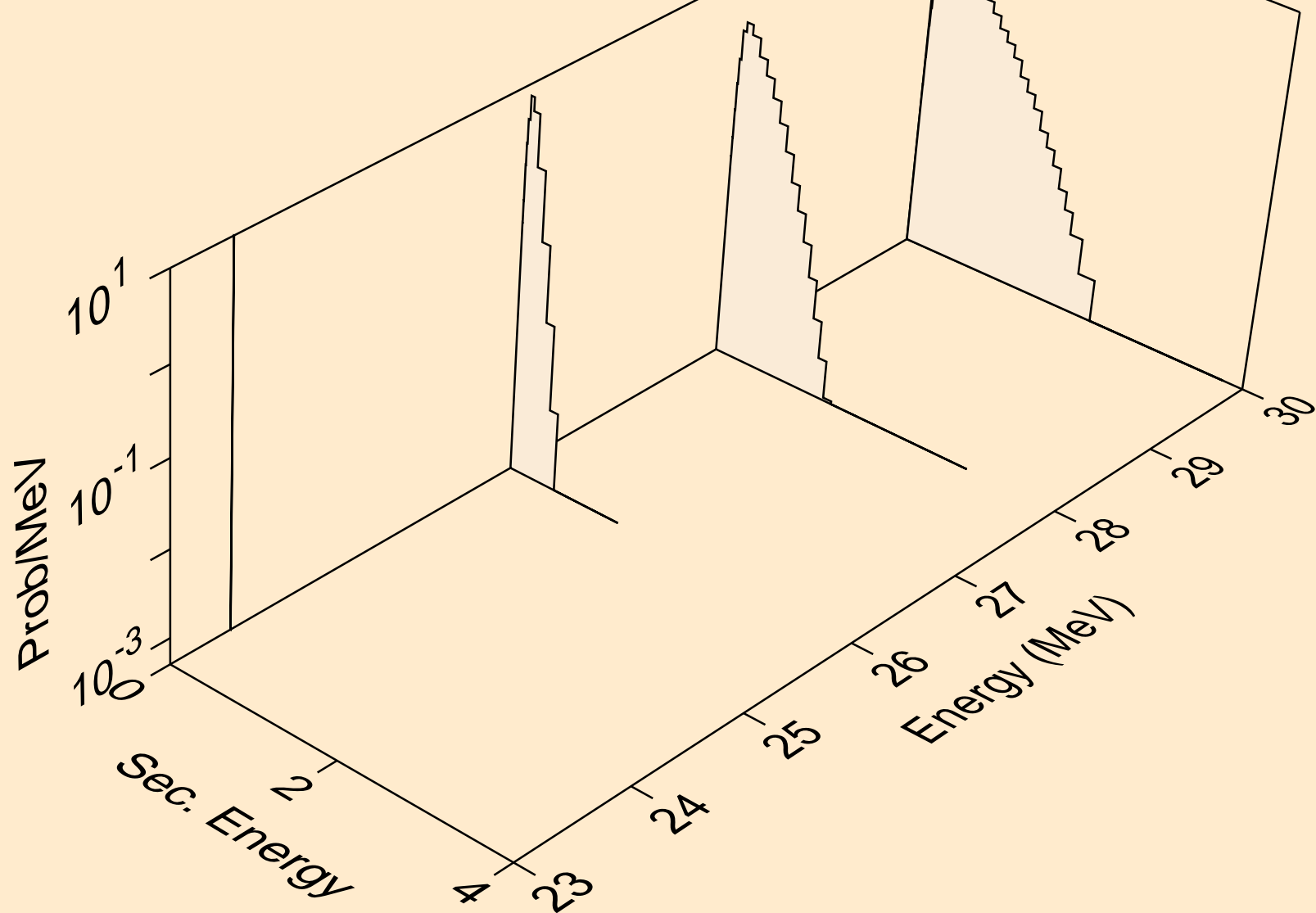

AR036 ALPHA ACER TENDL-2021 LIBRARY; T=0.K
protons from (a,x)

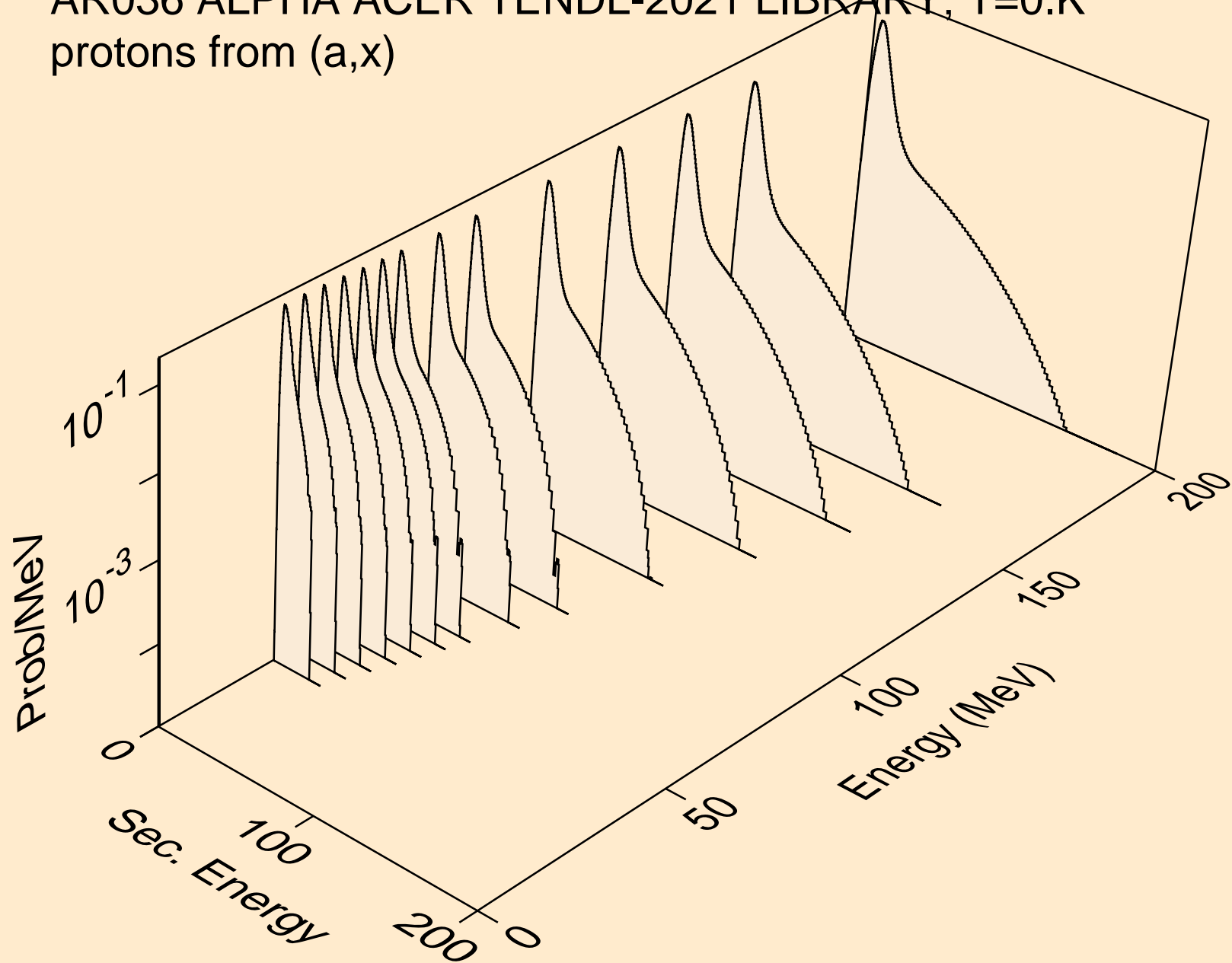

AR036 ALPHA ACER TENDL-2021 LIBRARY; T=0.K
protons from (a,n*)p

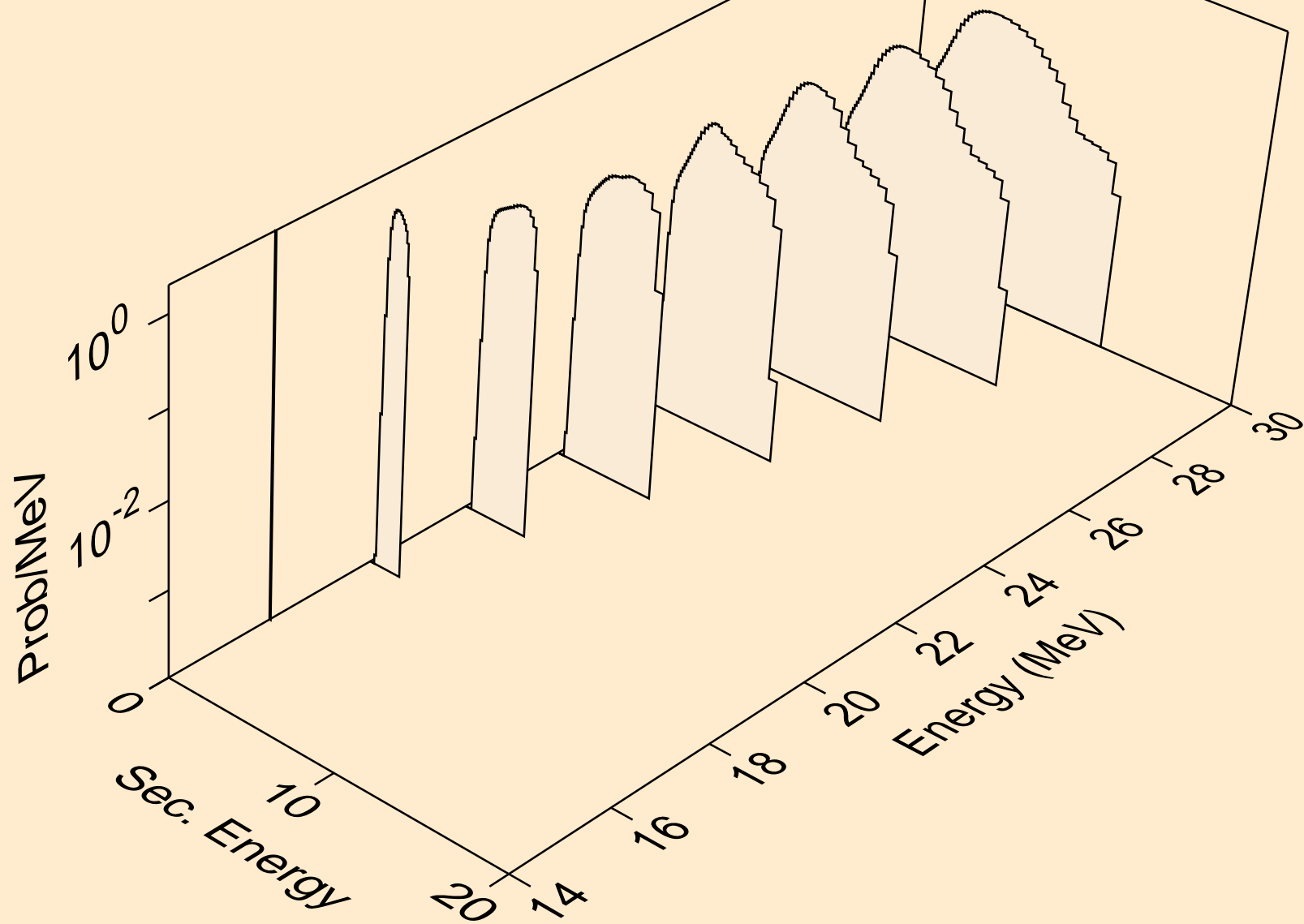

AR036 ALPHA ACER TENDL-2021 LIBRARY; T=0.K
protons from (a,2np)

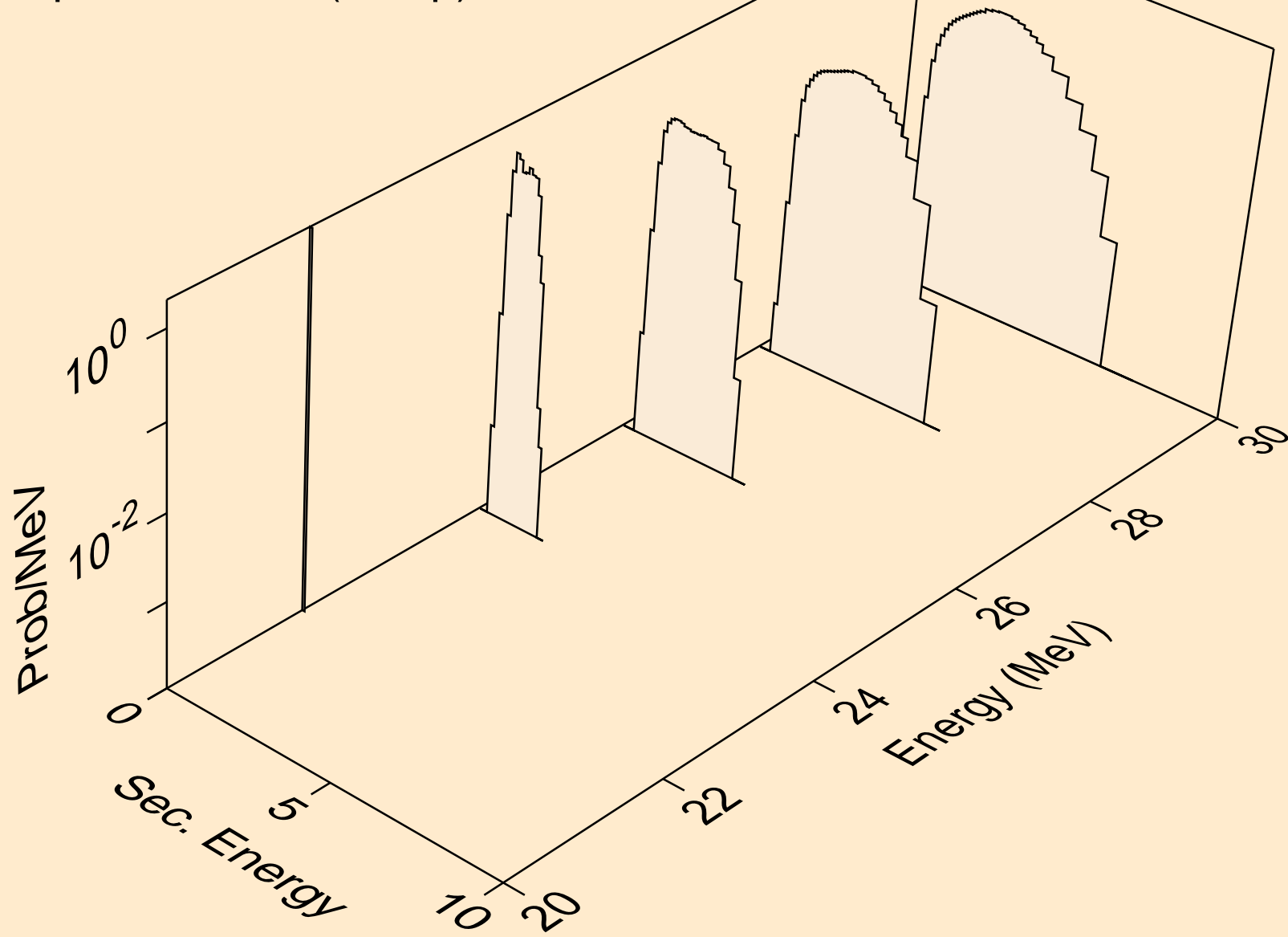

AR036 ALPHA ACER TENDL-2021 LIBRARY; T=0.K
protons from (a,npa)

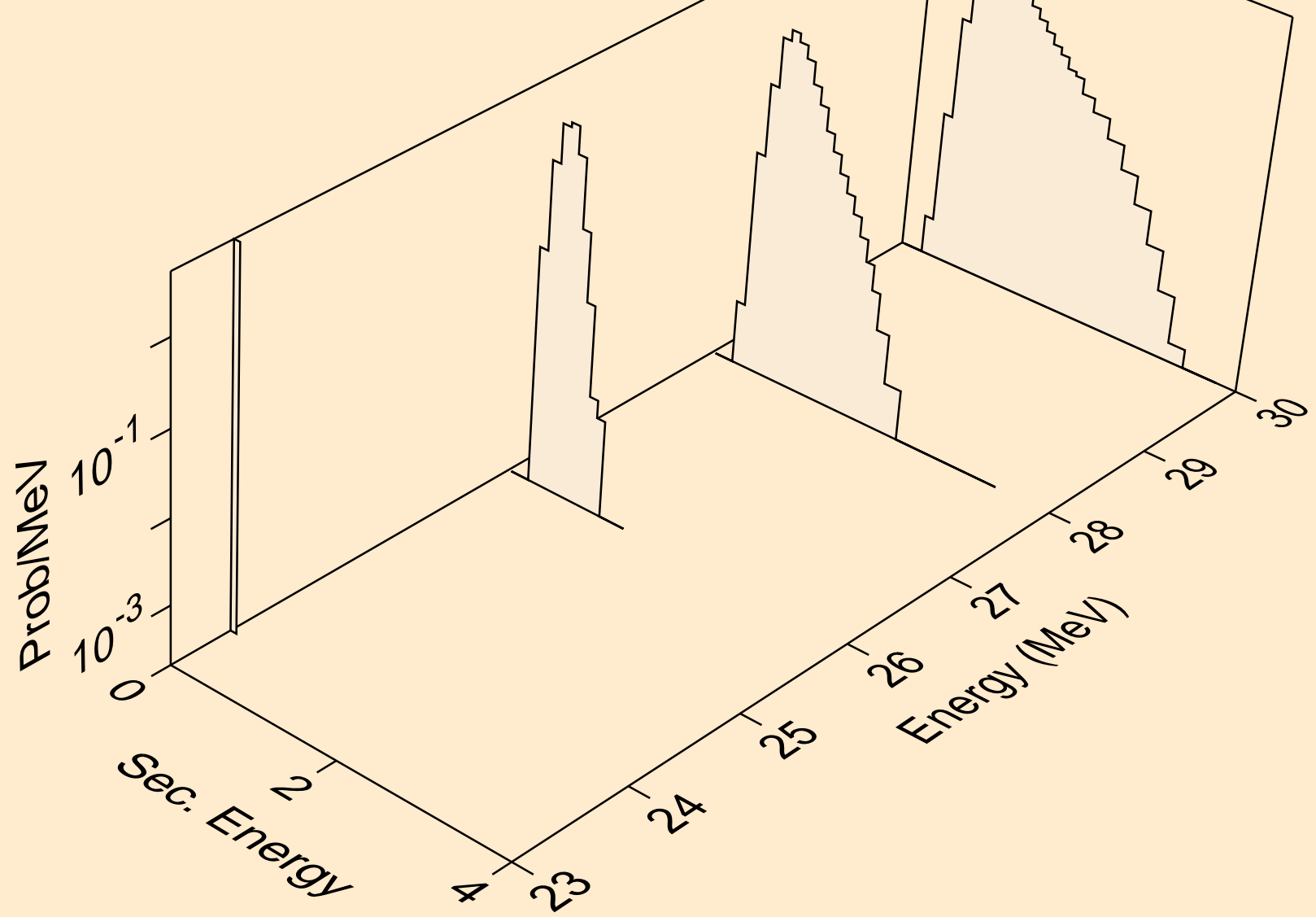

AR036 ALPHA ACER TENDL-2021 LIBRARY; T=0.K
protons from (a,p)

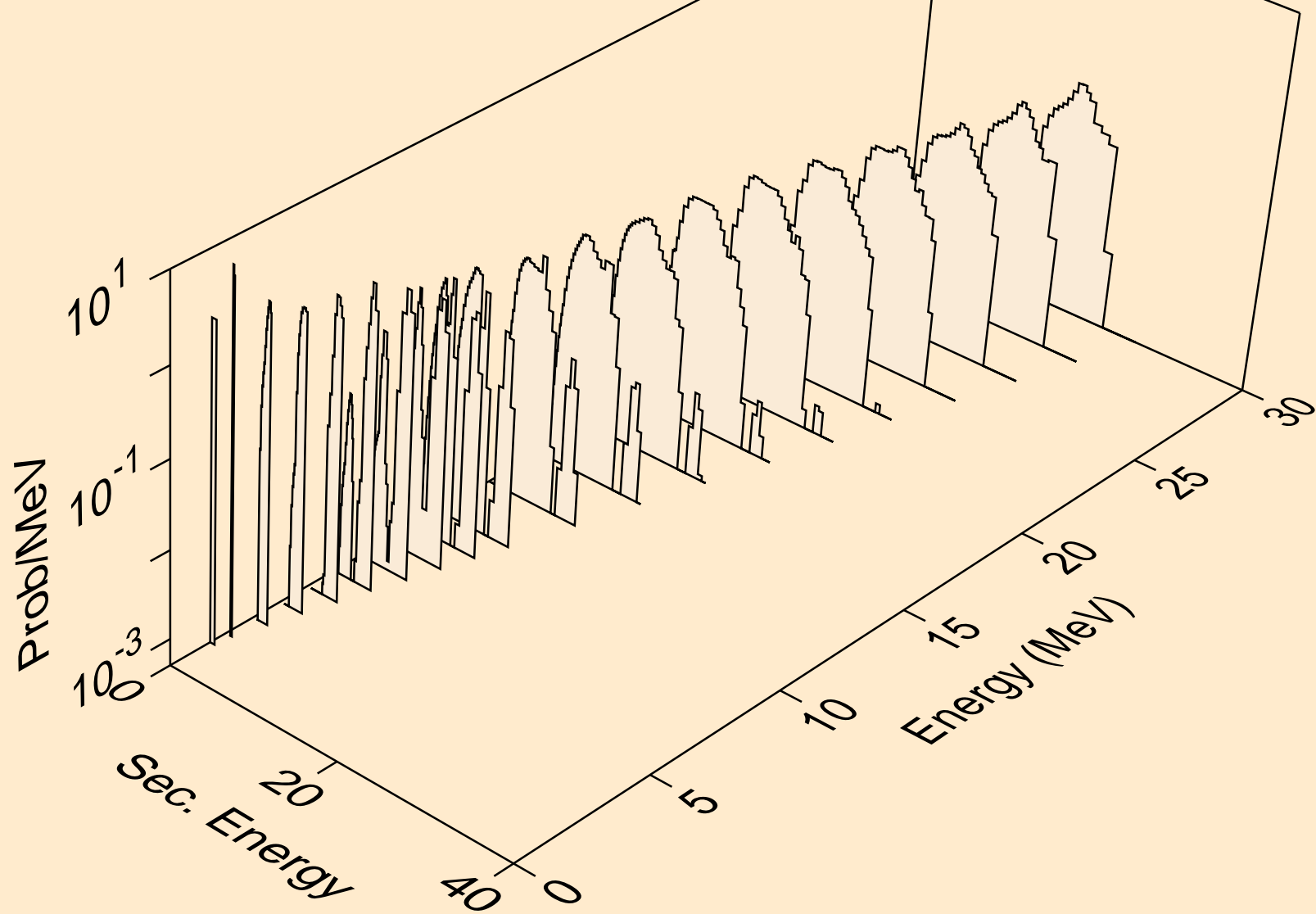

AR036 ALPHA ACER TENDL-2021 LIBRARY; T=0.K
protons from (a,2p)

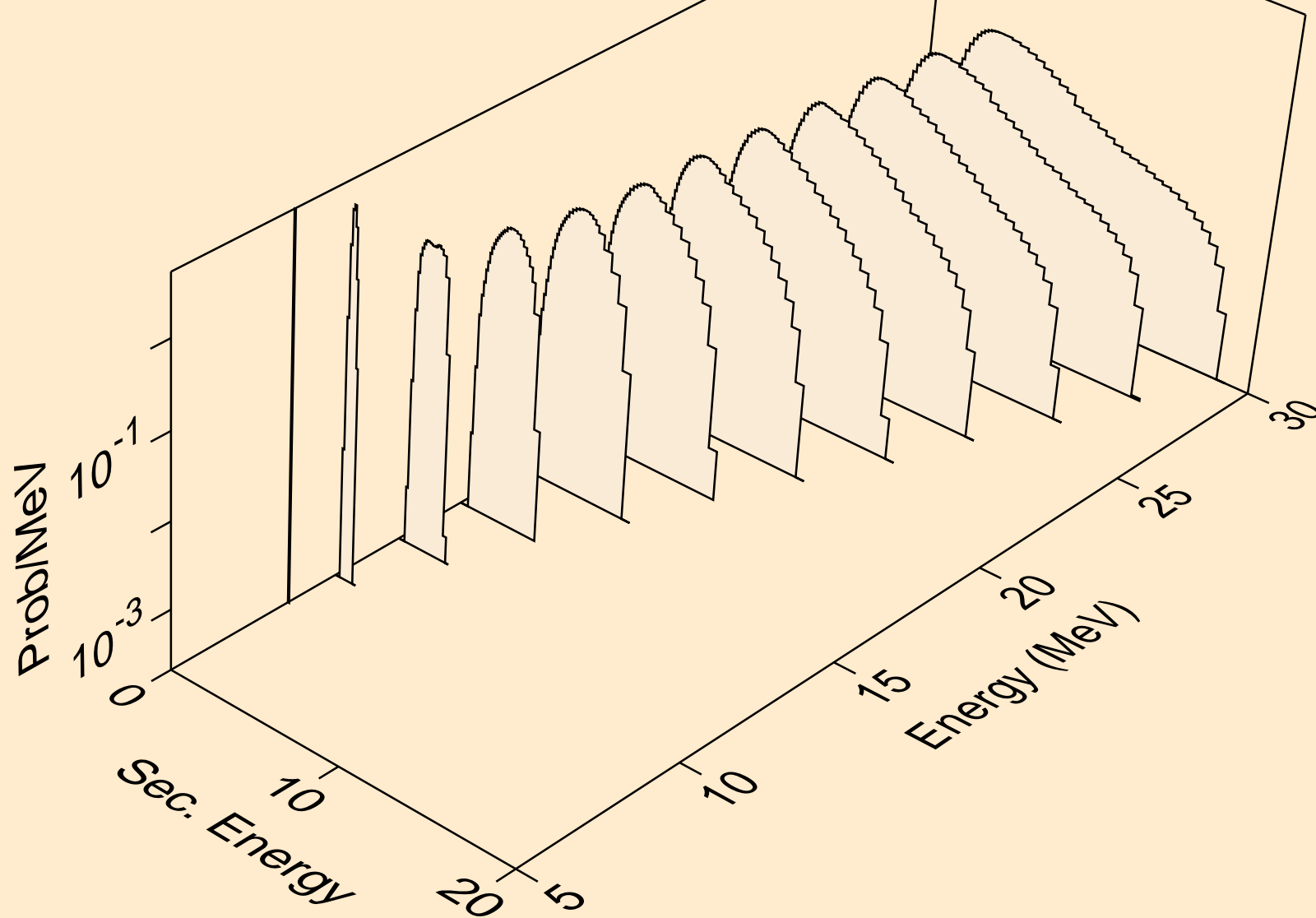

AR036 ALPHA ACER TENDL-2021 LIBRARY; T=0.K
protons from (a,pa)

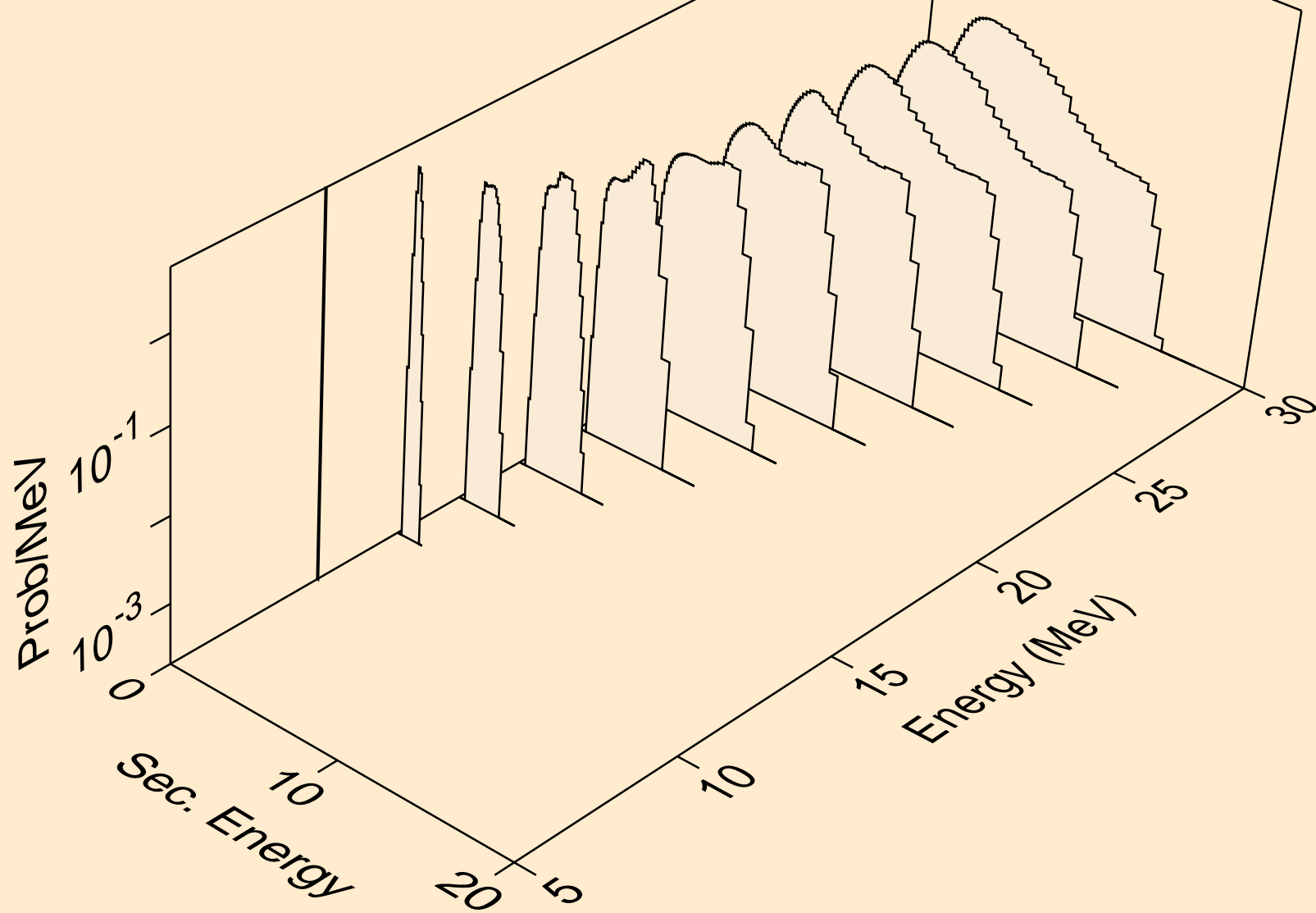

AR036 ALPHA ACER TENDL-2021 LIBRARY; T=0.K
protons from (a,pd)

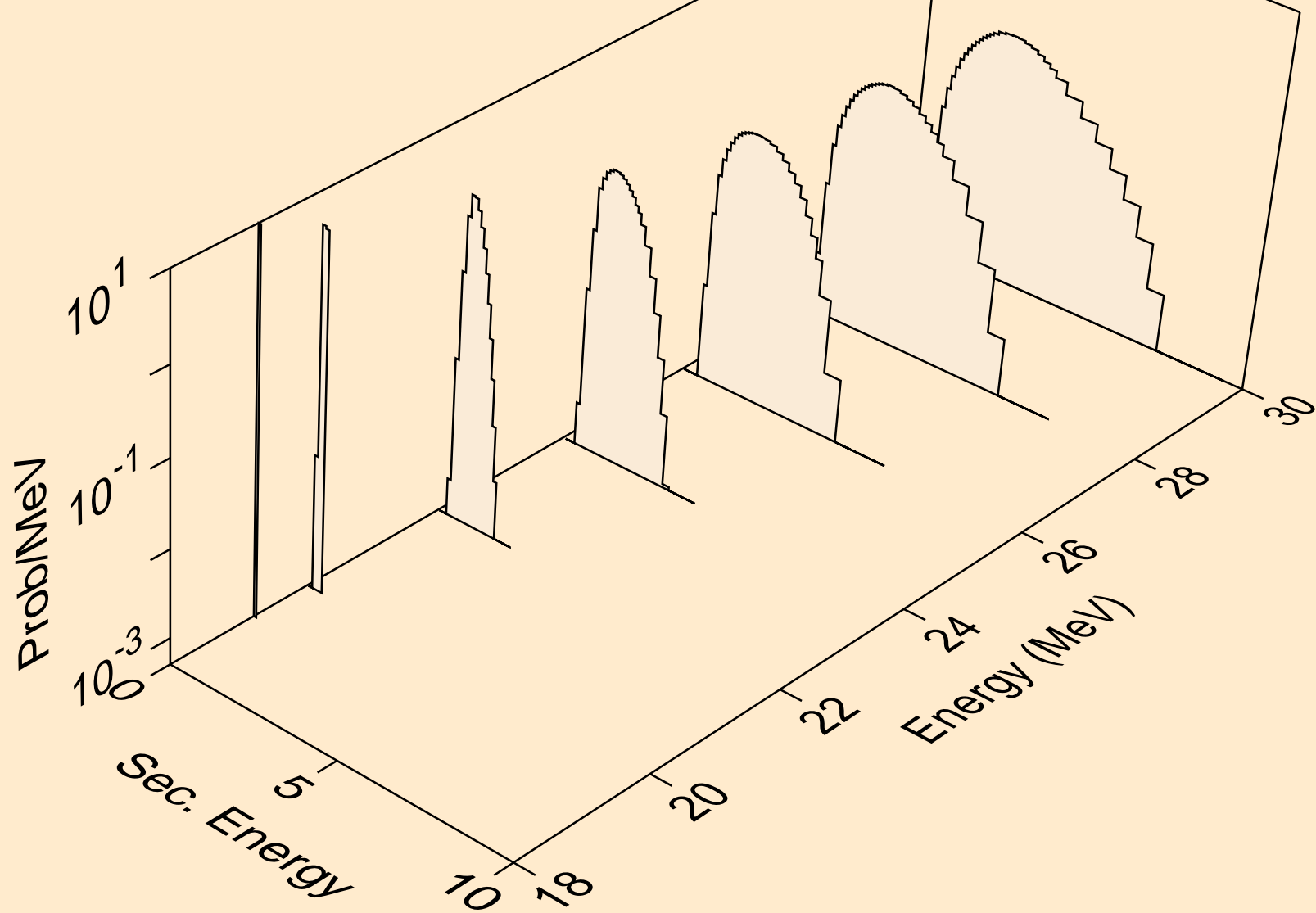

AR036 ALPHA ACER TENDL-2021 LIBRARY; T=0.K
protons from (a,pt)

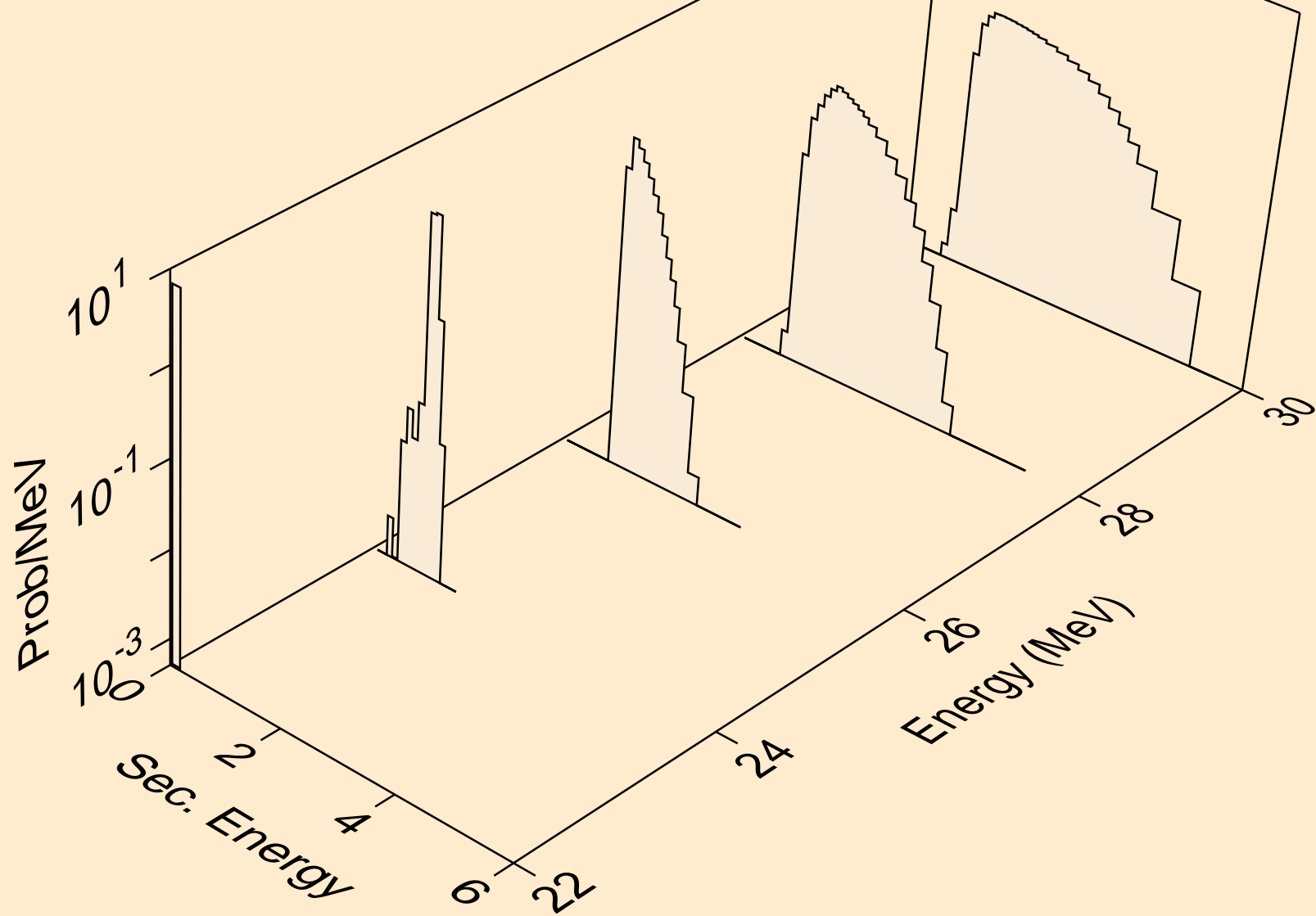

AR036 ALPHA ACER TENDL-2021 LIBRARY; T=0.K
deuterons from (a,x)

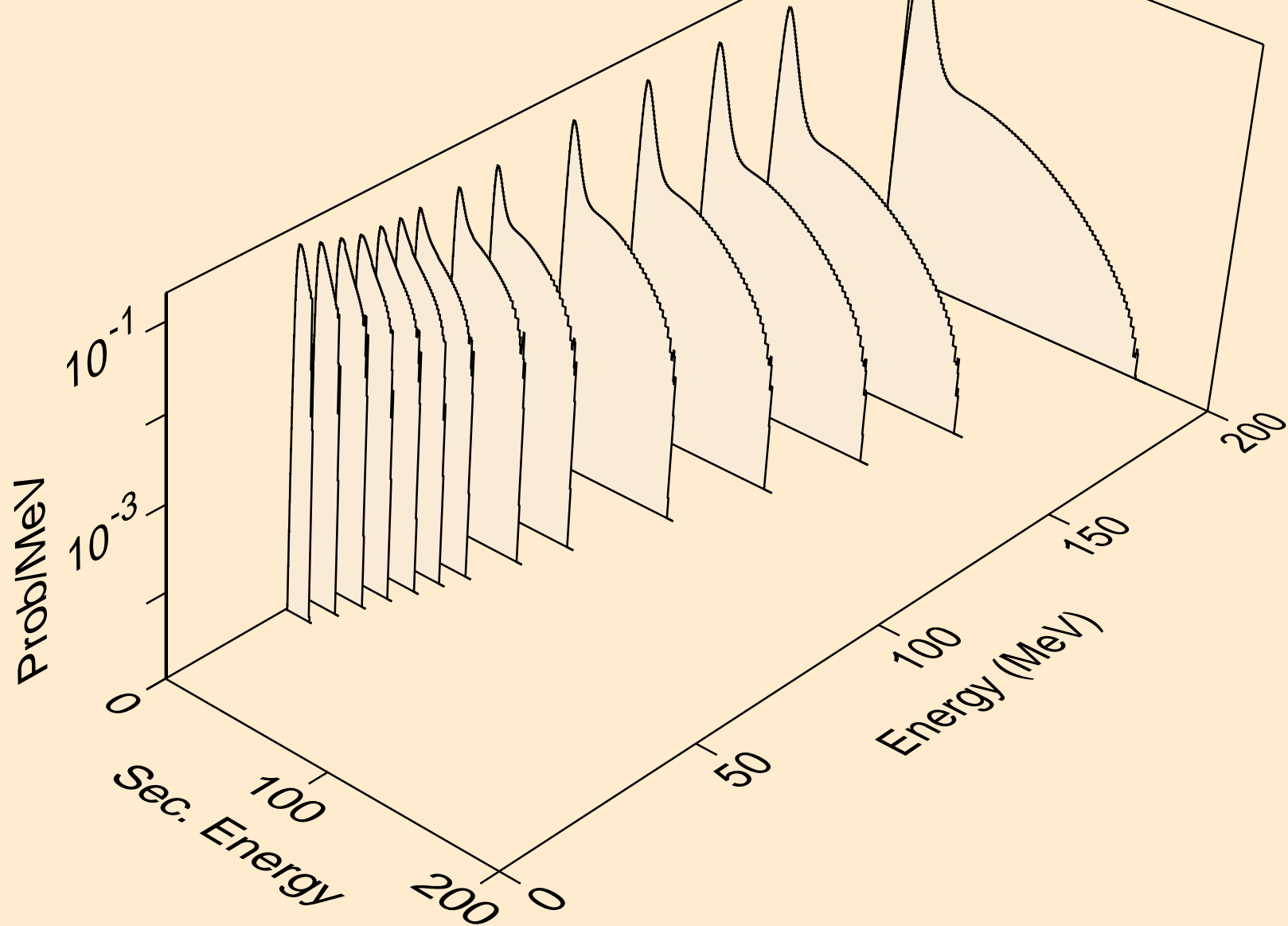

AR036 ALPHA ACER TENDL-2021 LIBRARY; T=0.K
deuterons from (a,n*)d

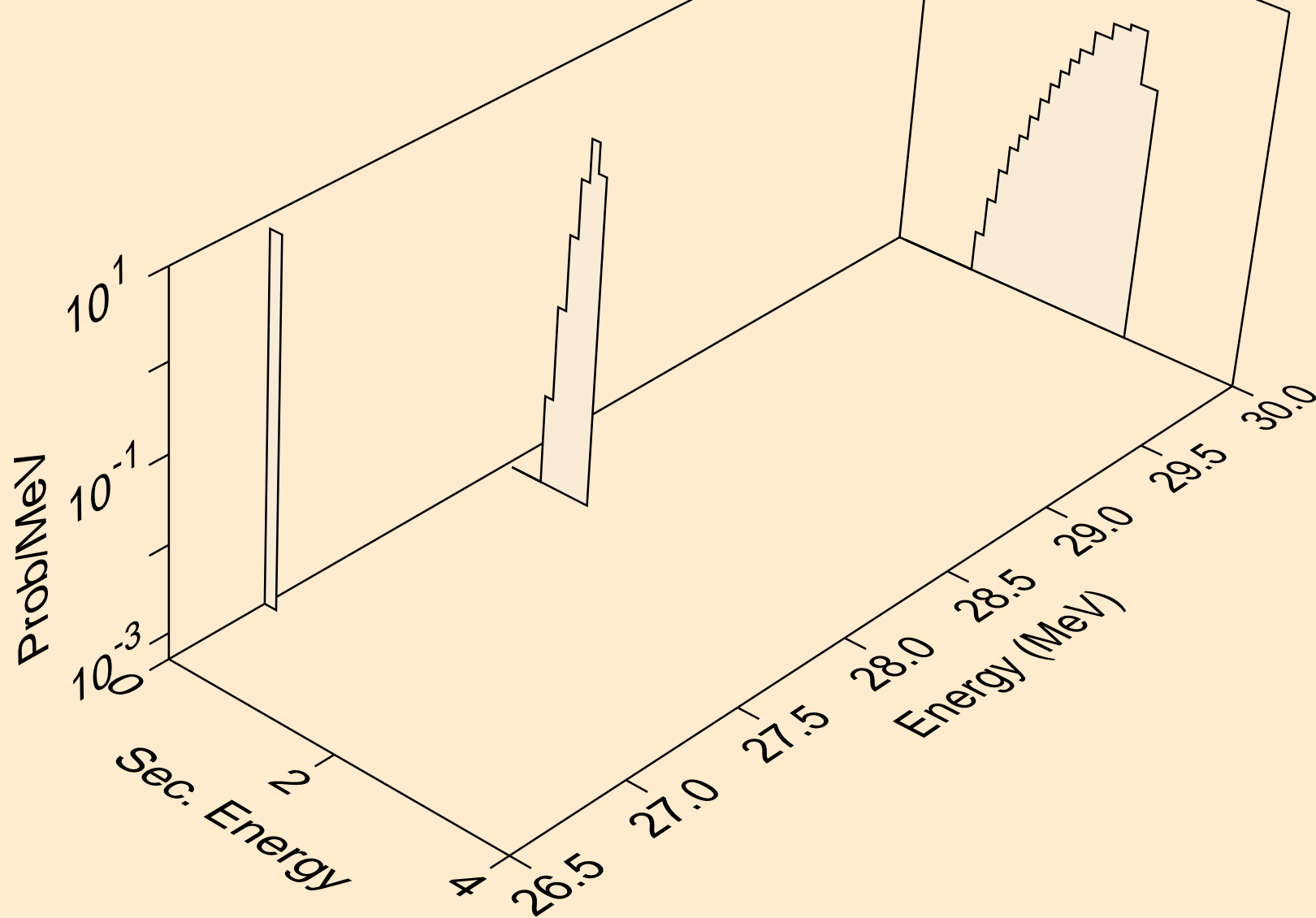

AR036 ALPHA ACER TENDL-2021 LIBRARY; T=0.K
deuterons from (a,d)

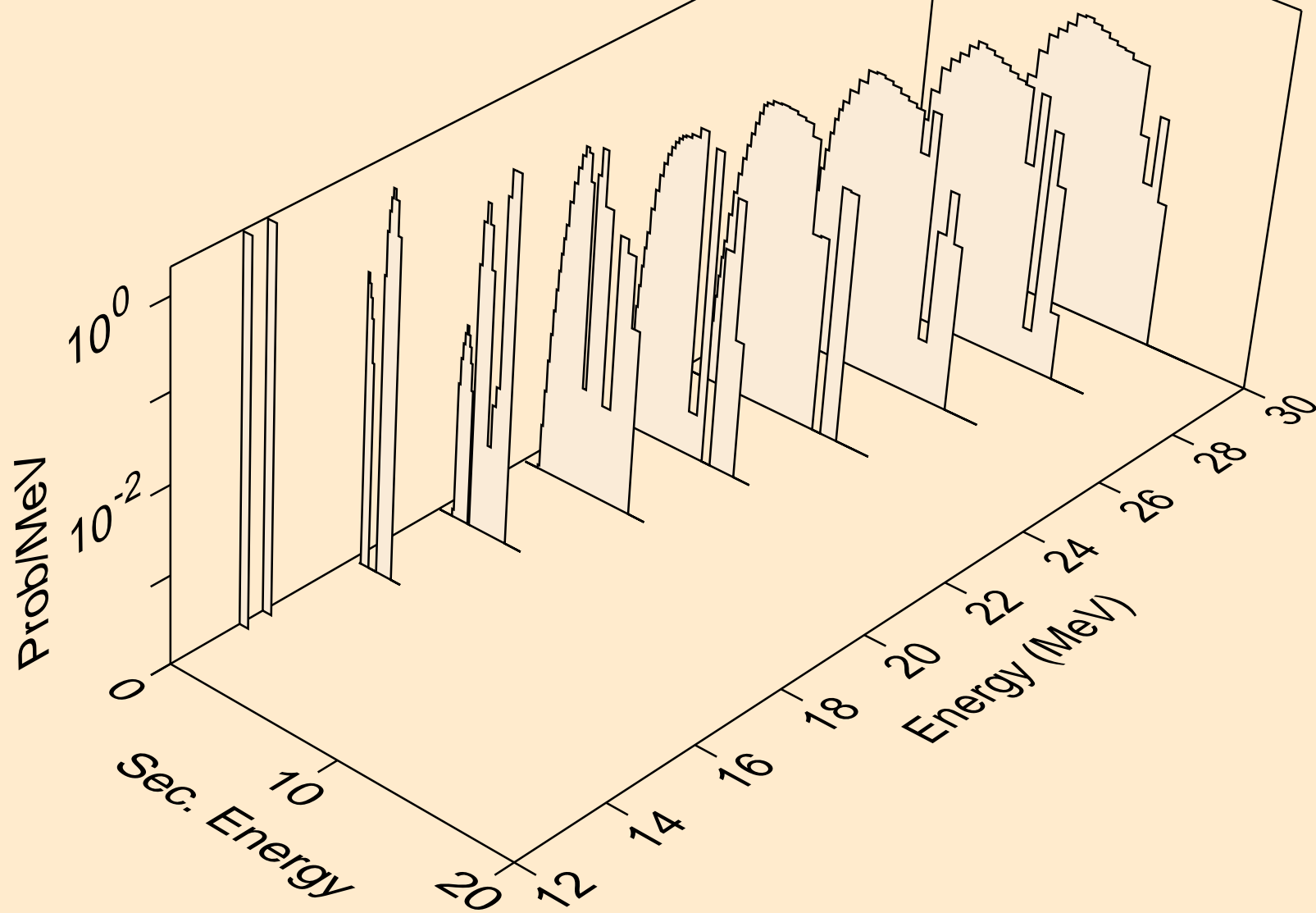

AR036 ALPHA ACER TENDL-2021 LIBRARY; T=0.K
deuterons from (a,pd)

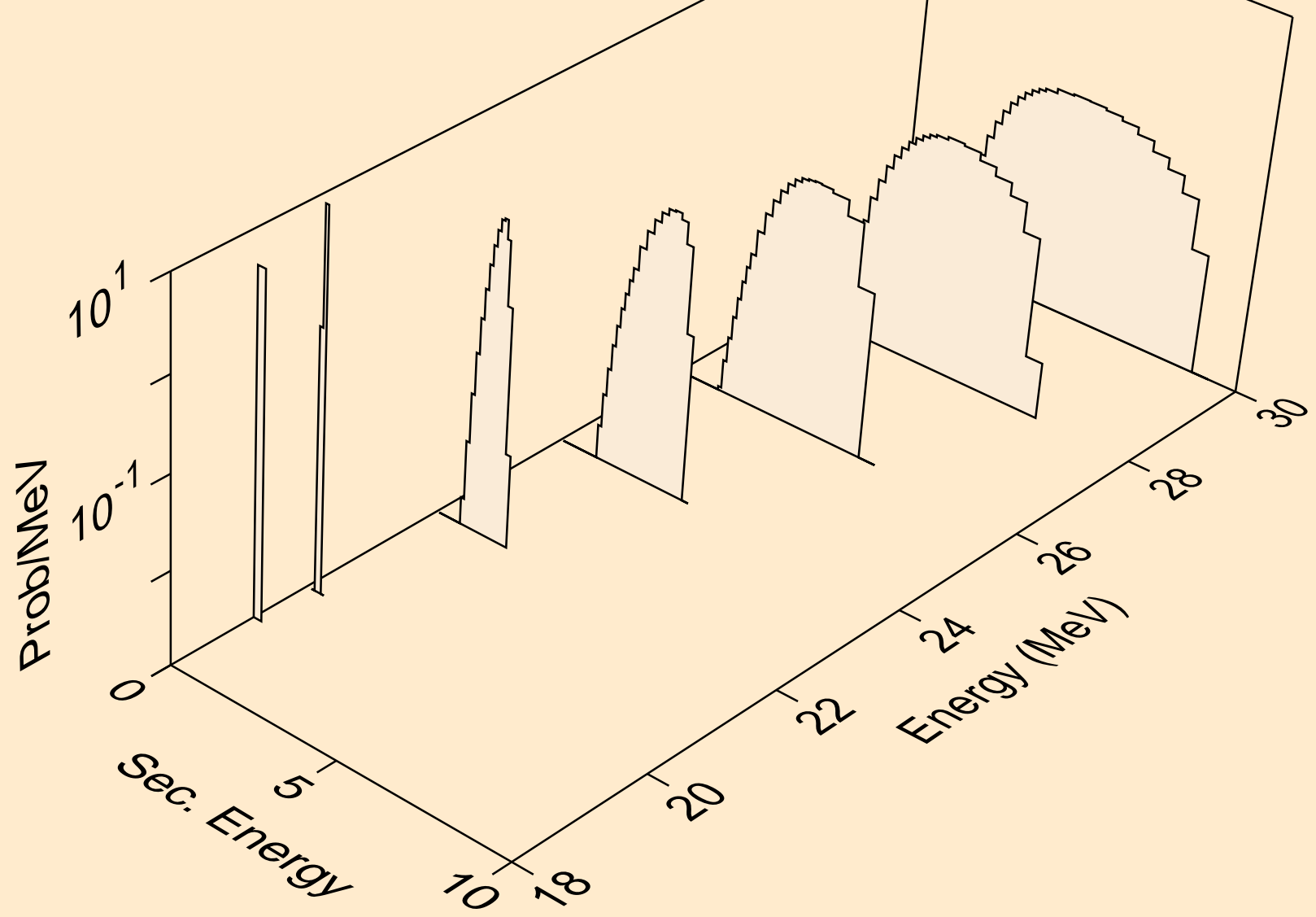

AR036 ALPHA ACER TENDL-2021 LIBRARY; T=0.K
deuterons from (a,da)

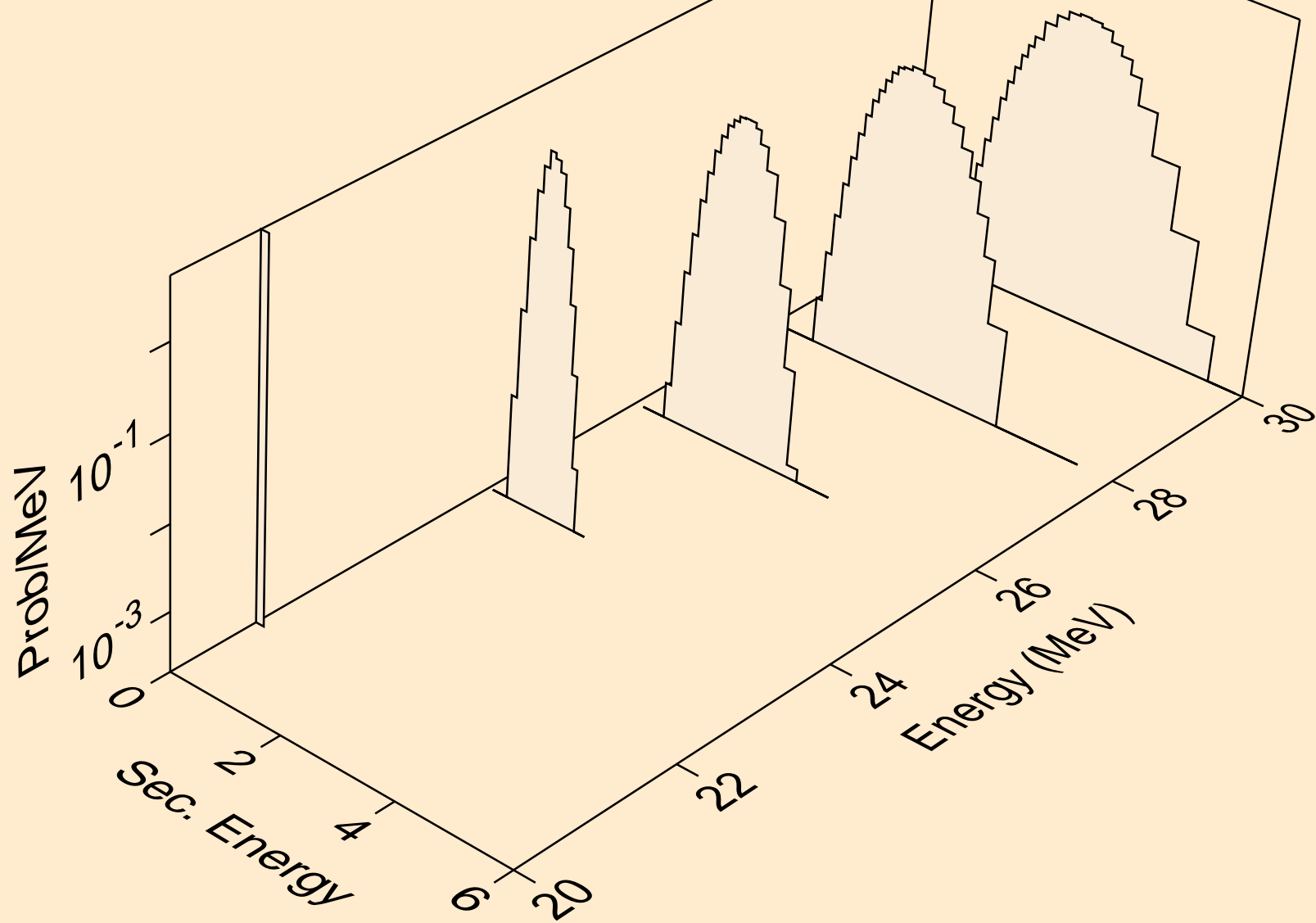

AR036 ALPHA ACER TENDL-2021 LIBRARY; T=0.K
tritons from (a,x)

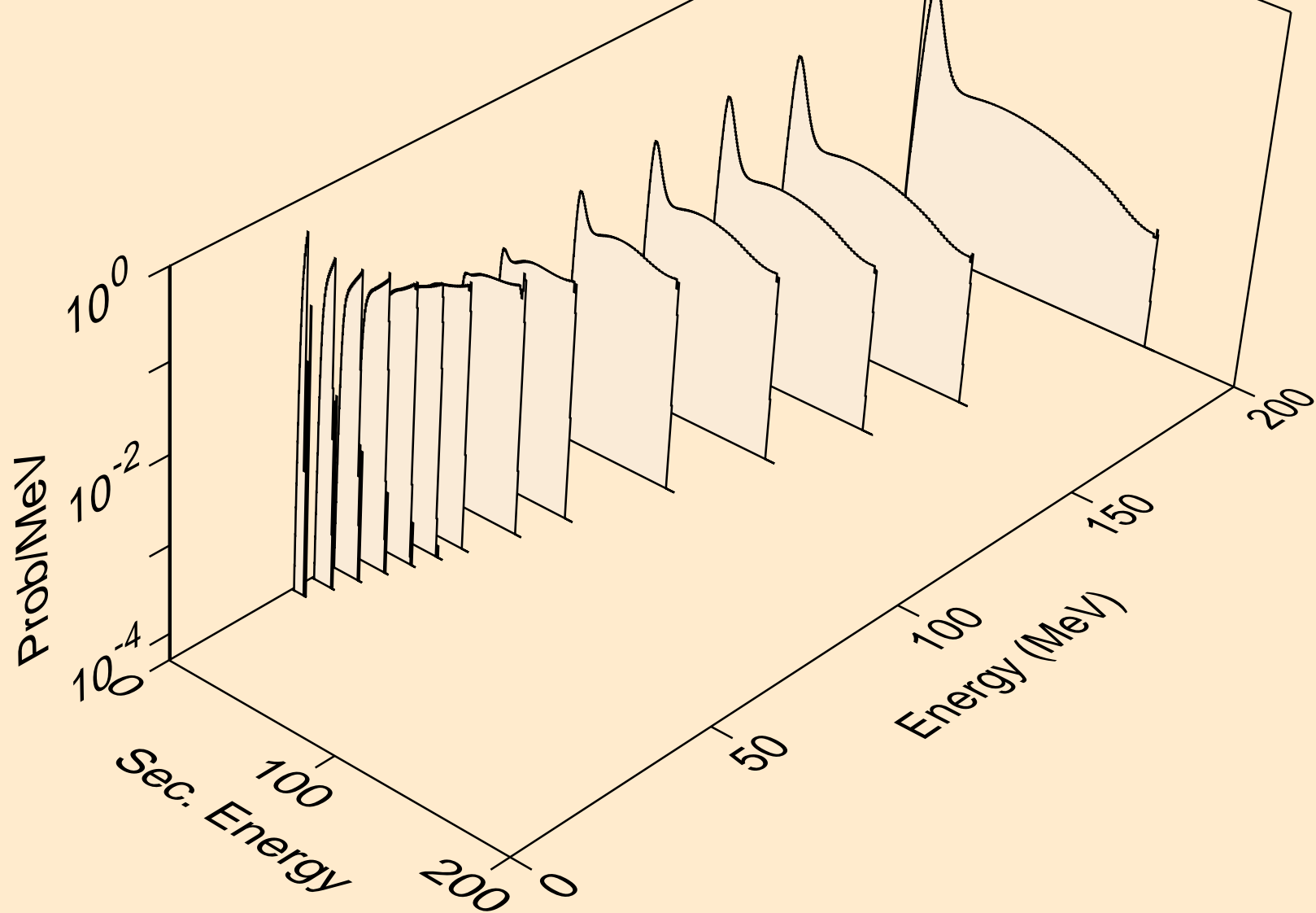

AR036 ALPHA ACER TENDL-2021 LIBRARY; T=0.K
tritons from (a,t)

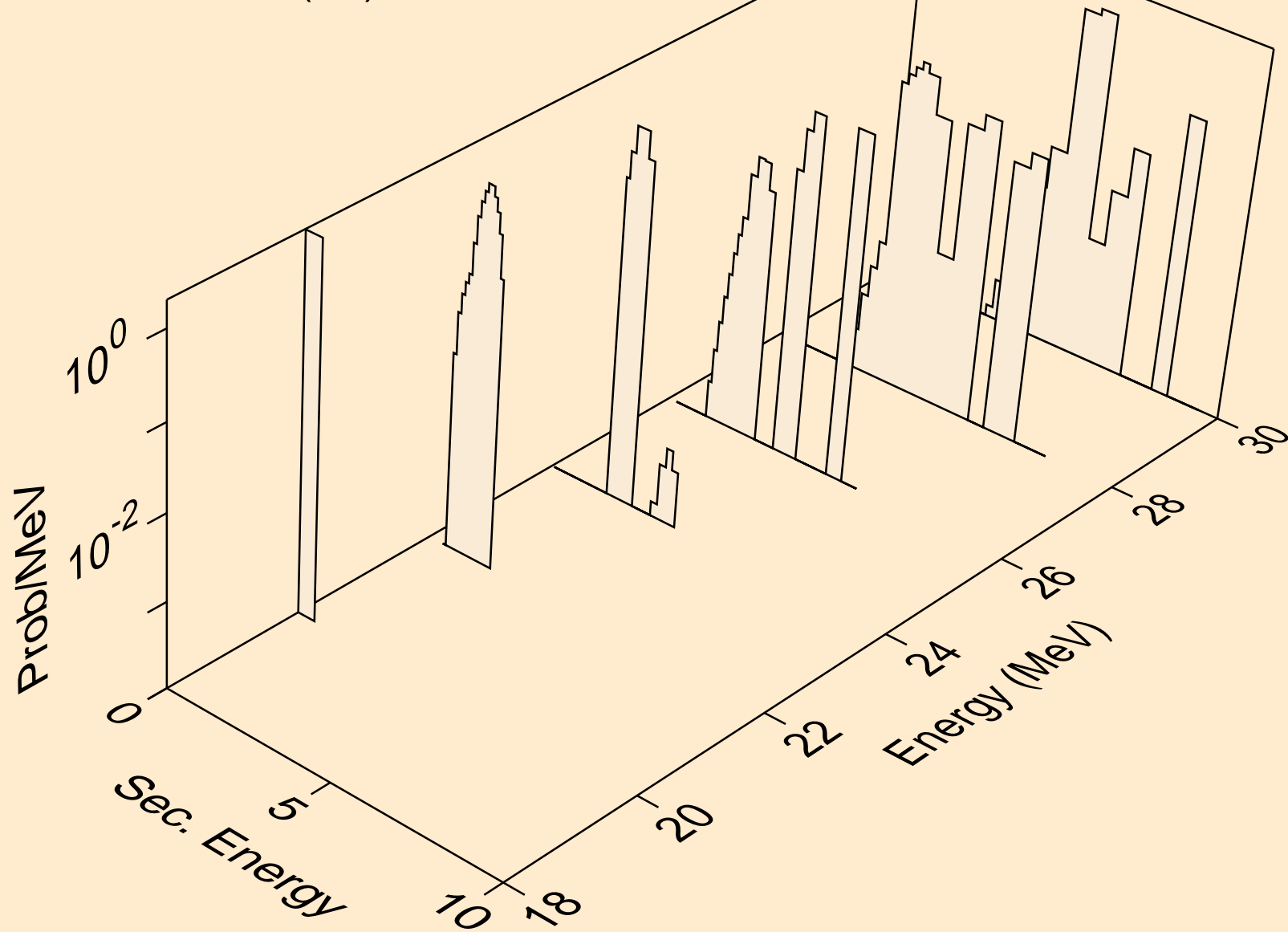

AR036 ALPHA ACER TENDL-2021 LIBRARY; T=0.K
tritons from (a,pt)

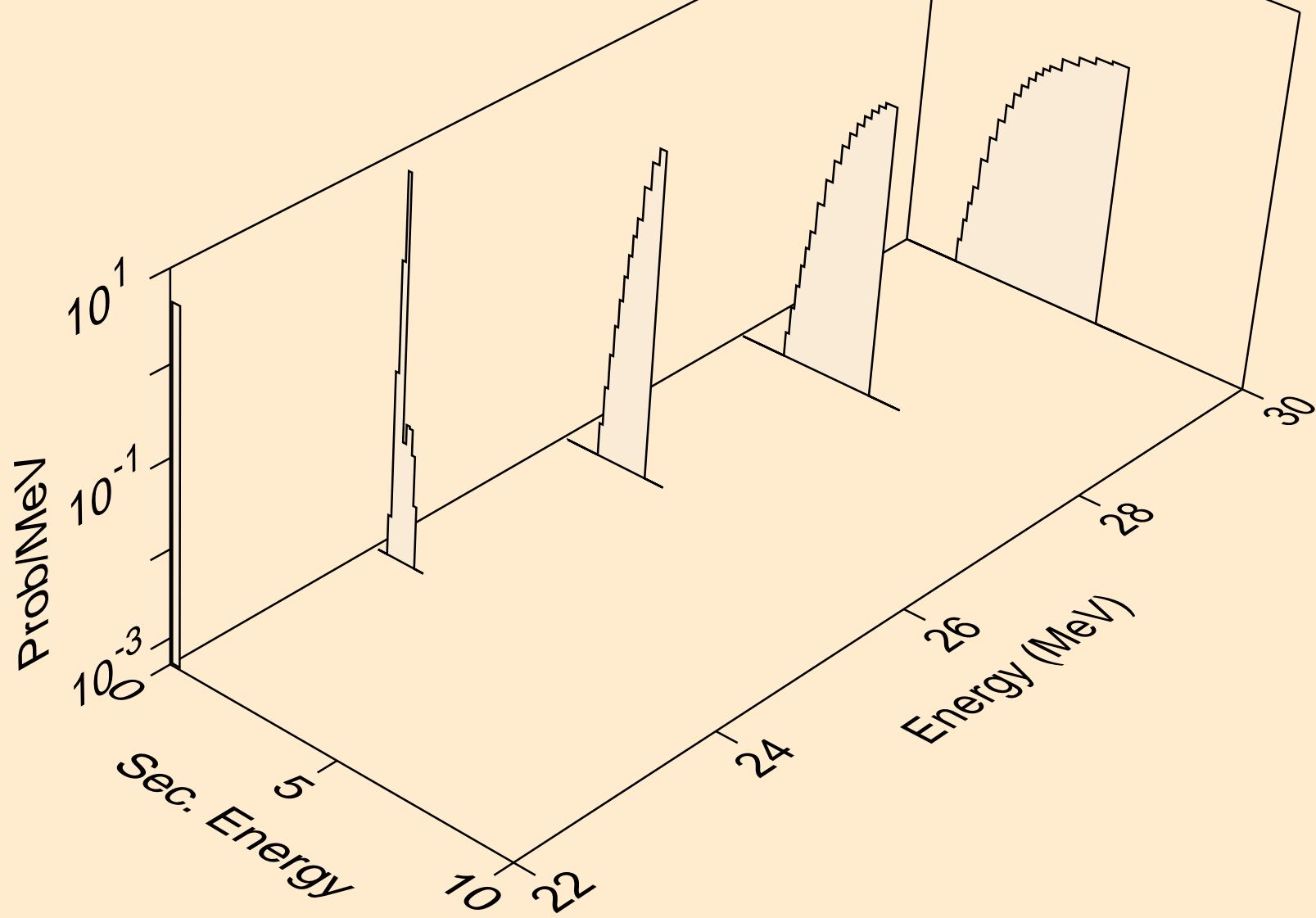

AR036 ALPHA ACER TENDL-2021 LIBRARY; T=0.K
he3s from (a,x)

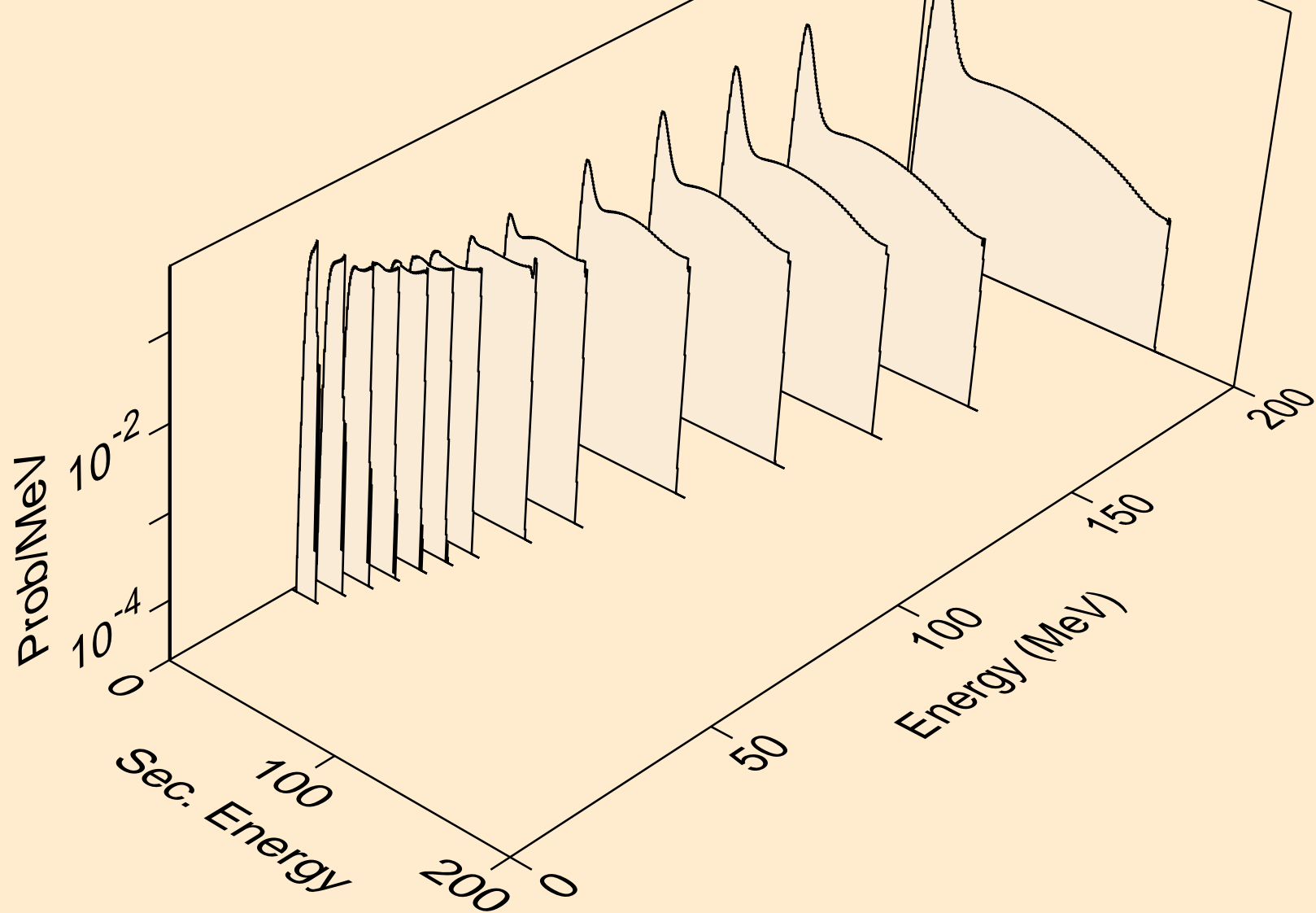

AR036 ALPHA ACER TENDL-2021 LIBRARY; T=0.K
he3s from (a,n*)he3

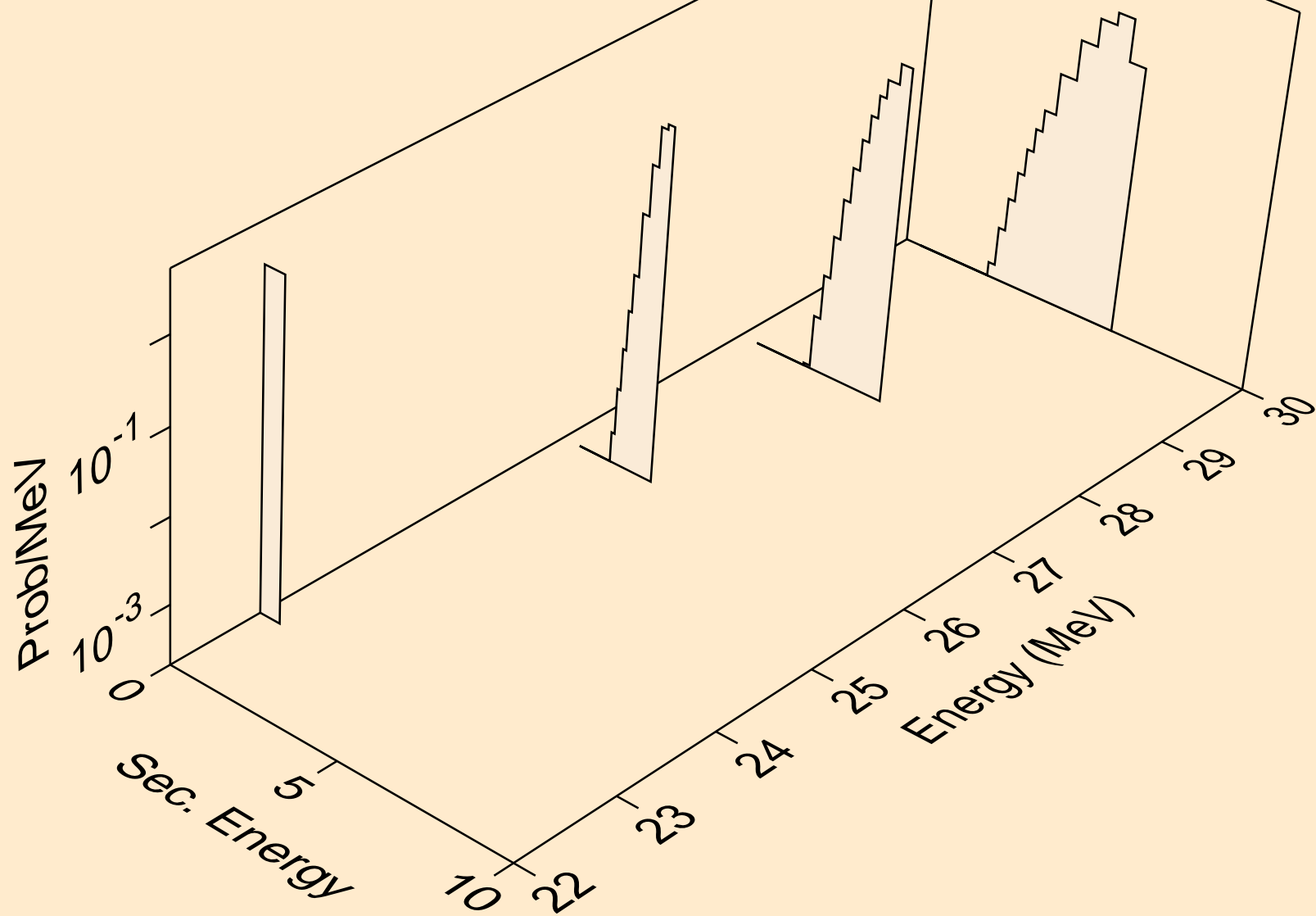

AR036 ALPHA ACER TENDL-2021 LIBRARY; T=0.K
he3s from (a,he3)

