

EU163 ALPHA ACER TENDL-2021 LIBRARY; T=0.K  
Principal cross sections

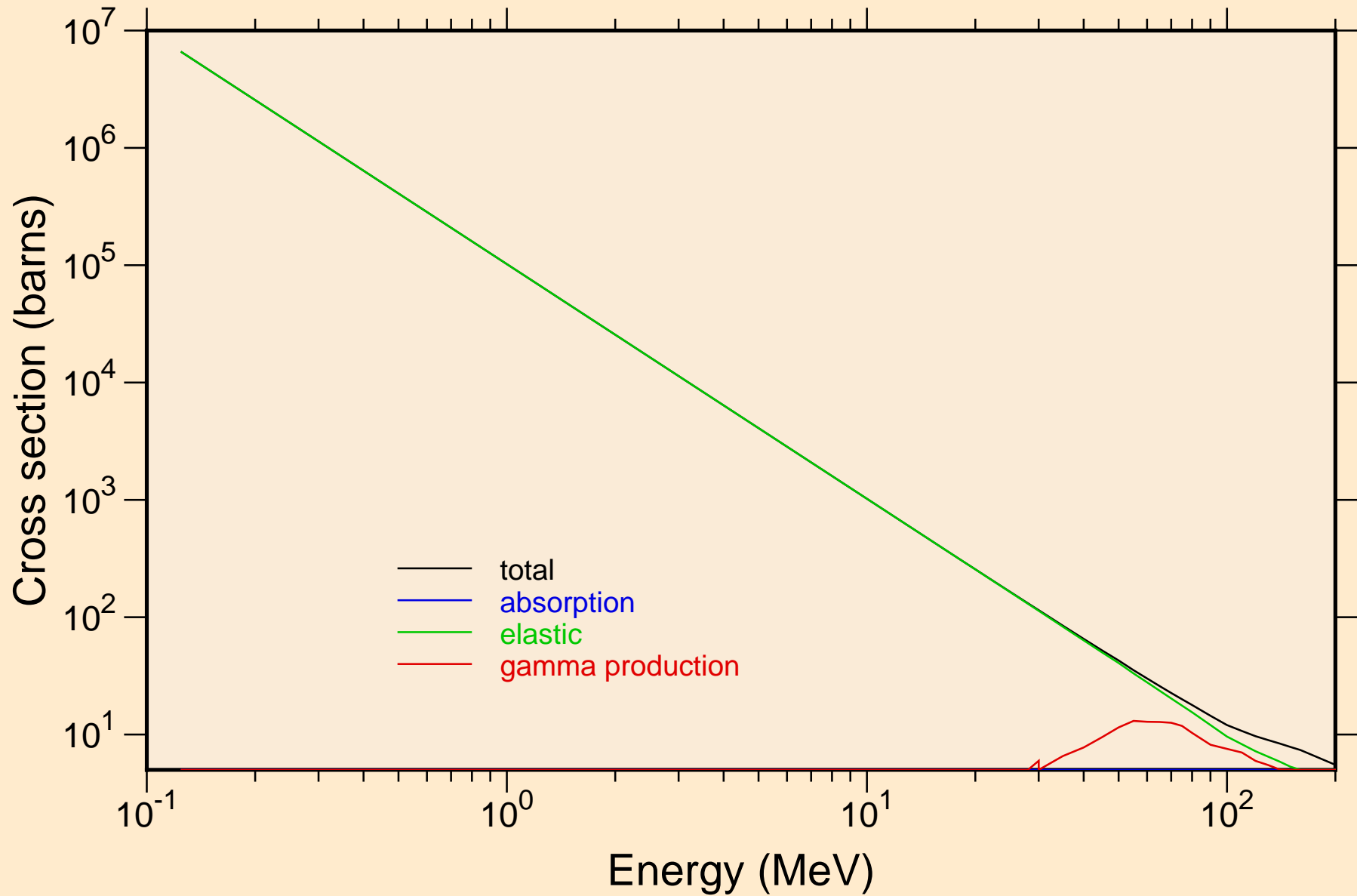

EU163 ALPHA ACER TENDL-2021 LIBRARY; T=0.K  
Heating

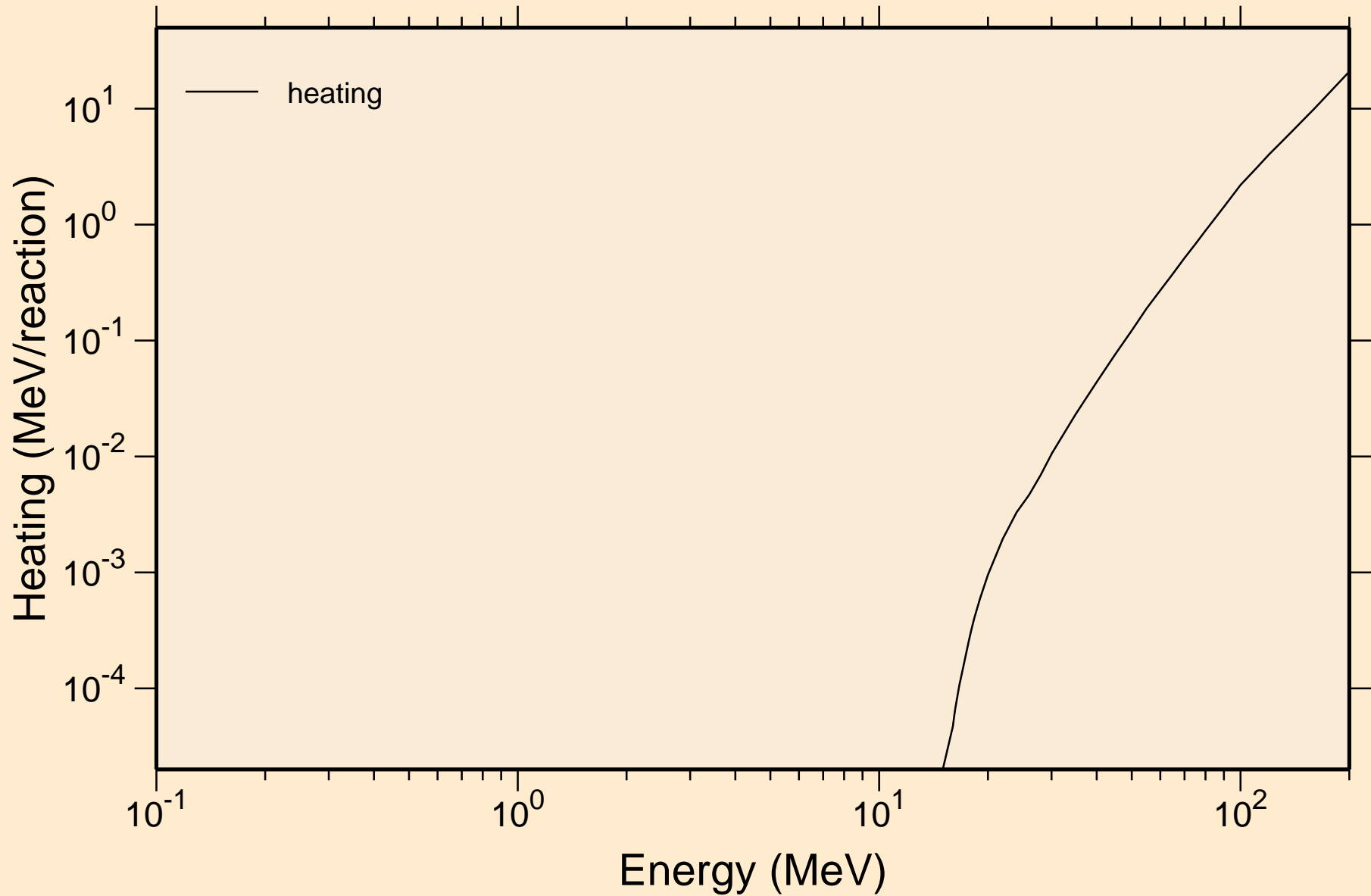

# EU163 ALPHA ACER TENDL-2021 LIBRARY; T=0.K

## Principal cross sections

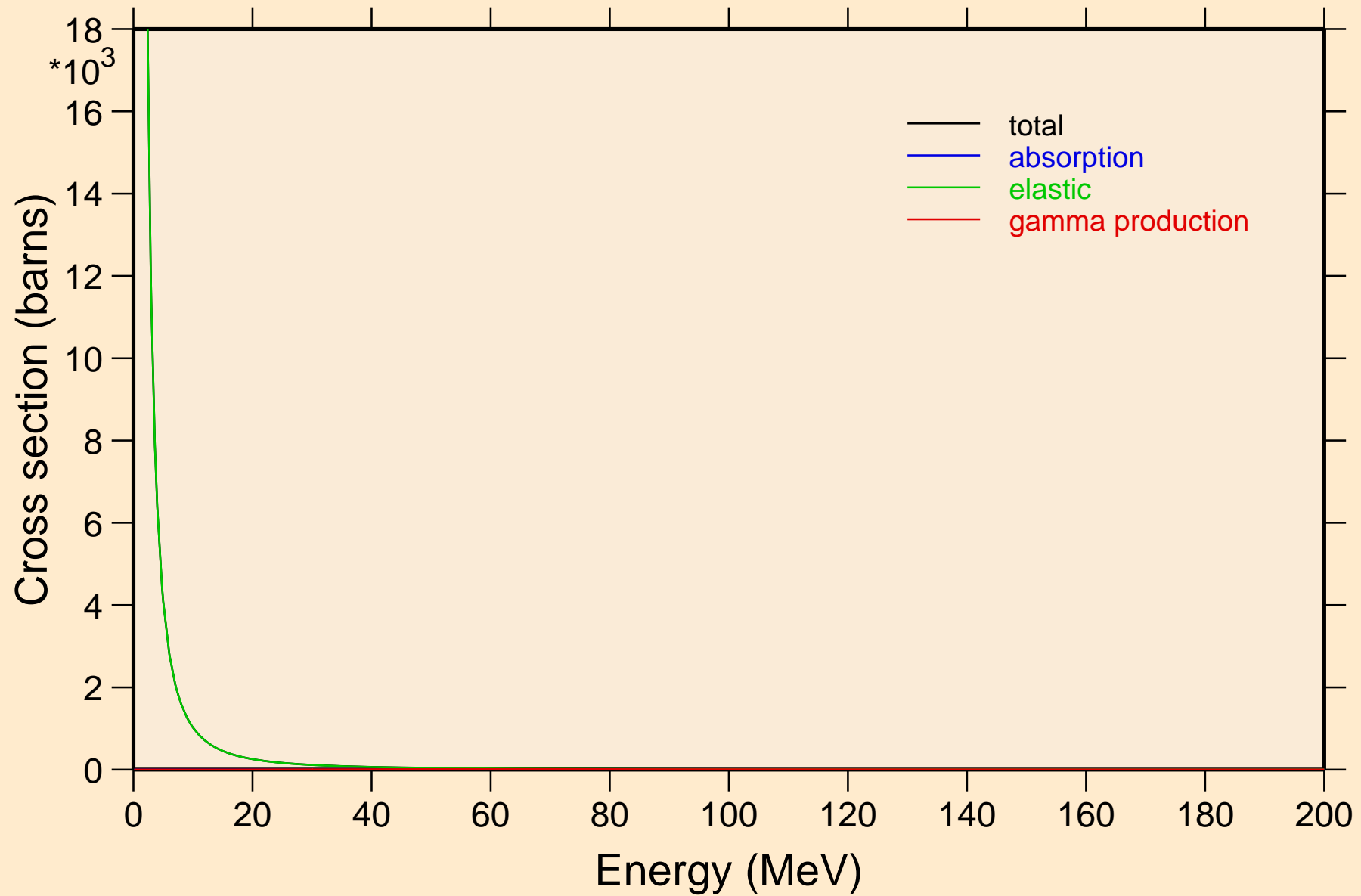

EU163 ALPHA ACER TENDL-2021 LIBRARY; T=0.K

Heating

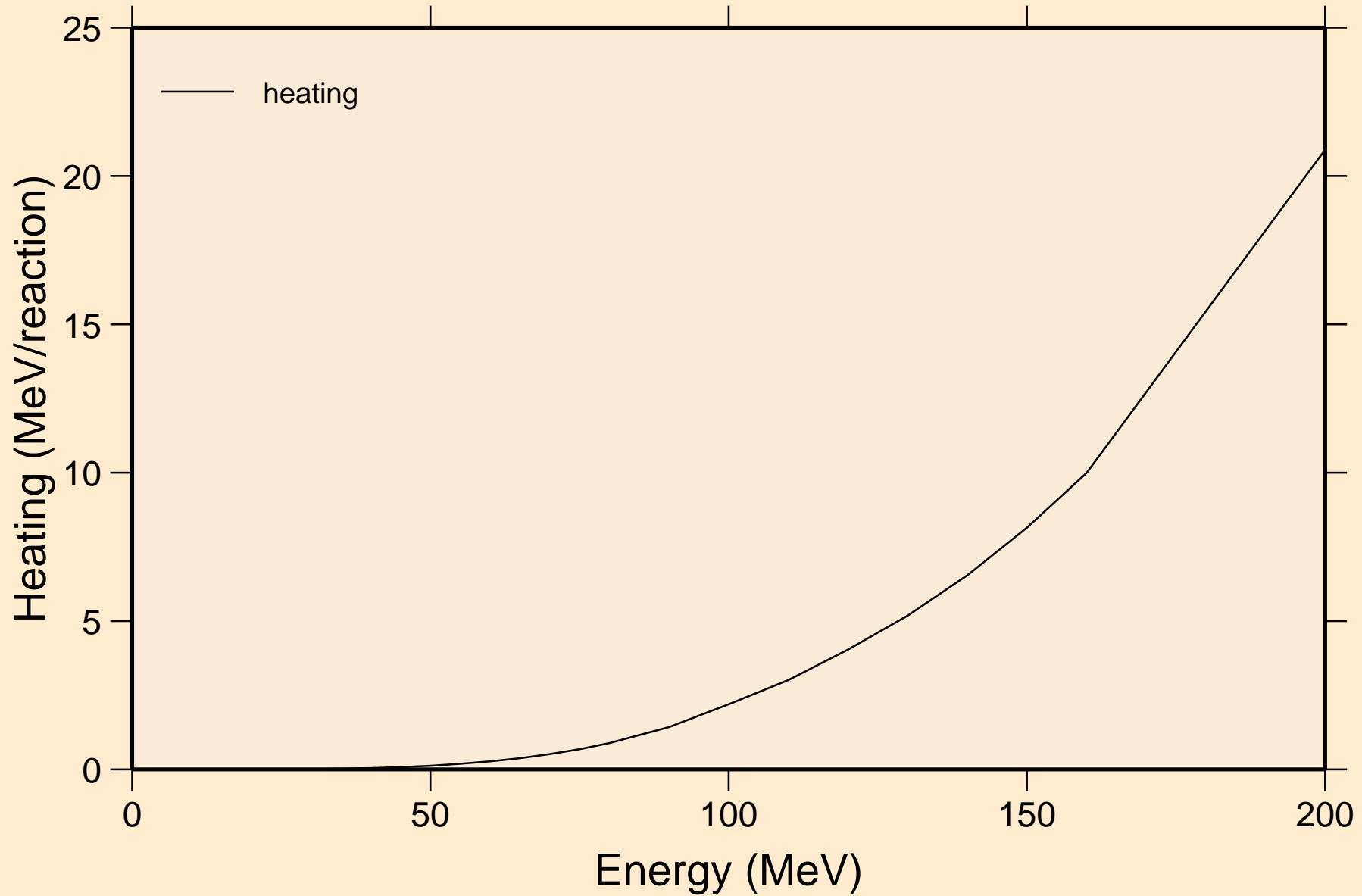

EU163 ALPHA ACER TENDL-2021 LIBRARY; T=0.K  
Threshold reactions

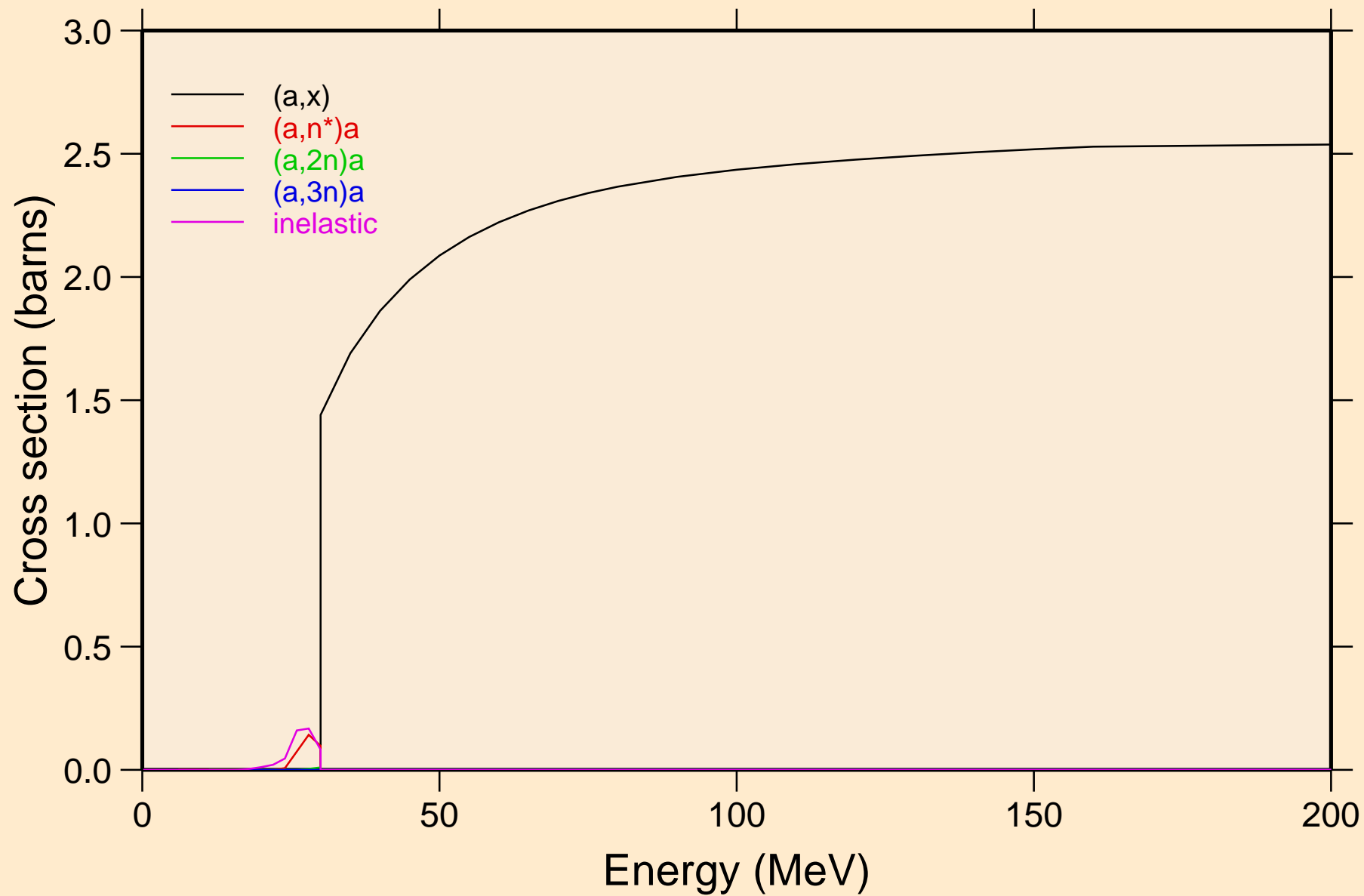

EU163 ALPHA ACER TENDL-2021 LIBRARY; T=0.K  
angular distribution for elastic

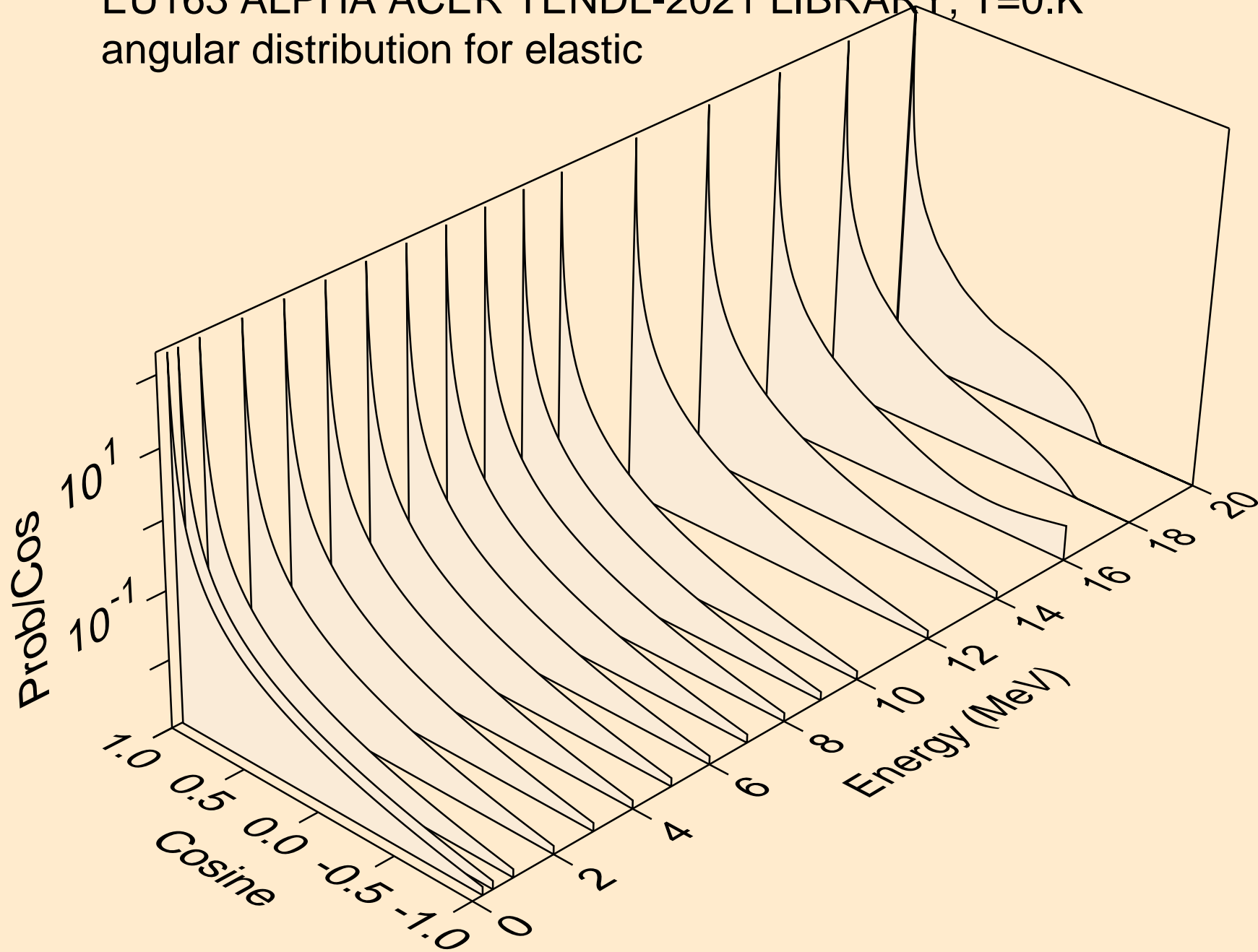

EU163 ALPHA ACER TENDL-2021 LIBRARY; T=0.K  
angular distribution for elastic

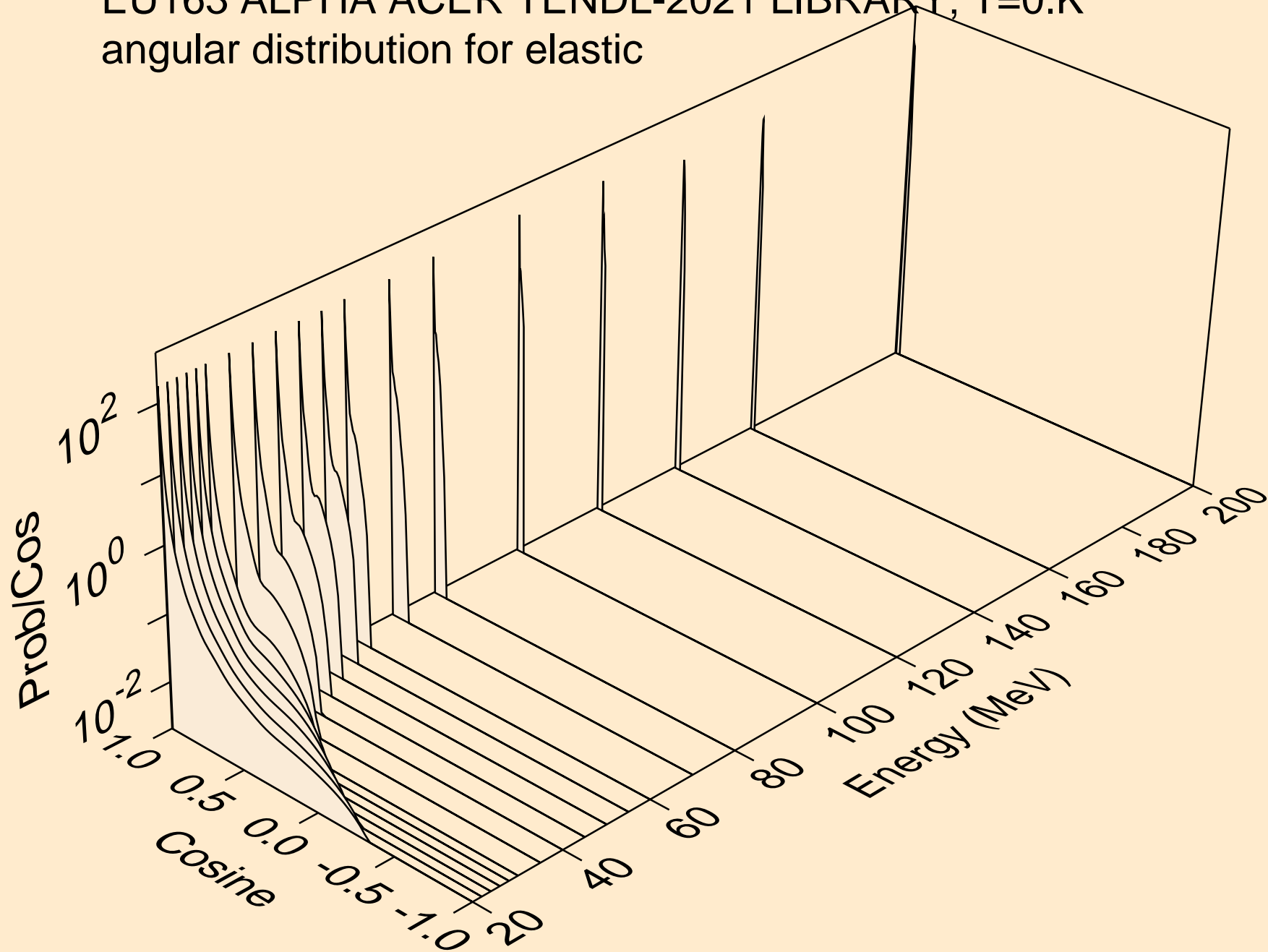

EU163 ALPHA ACER TENDL-2021 LIBRARY; T=0.K  
Alpha emission for (a,x)

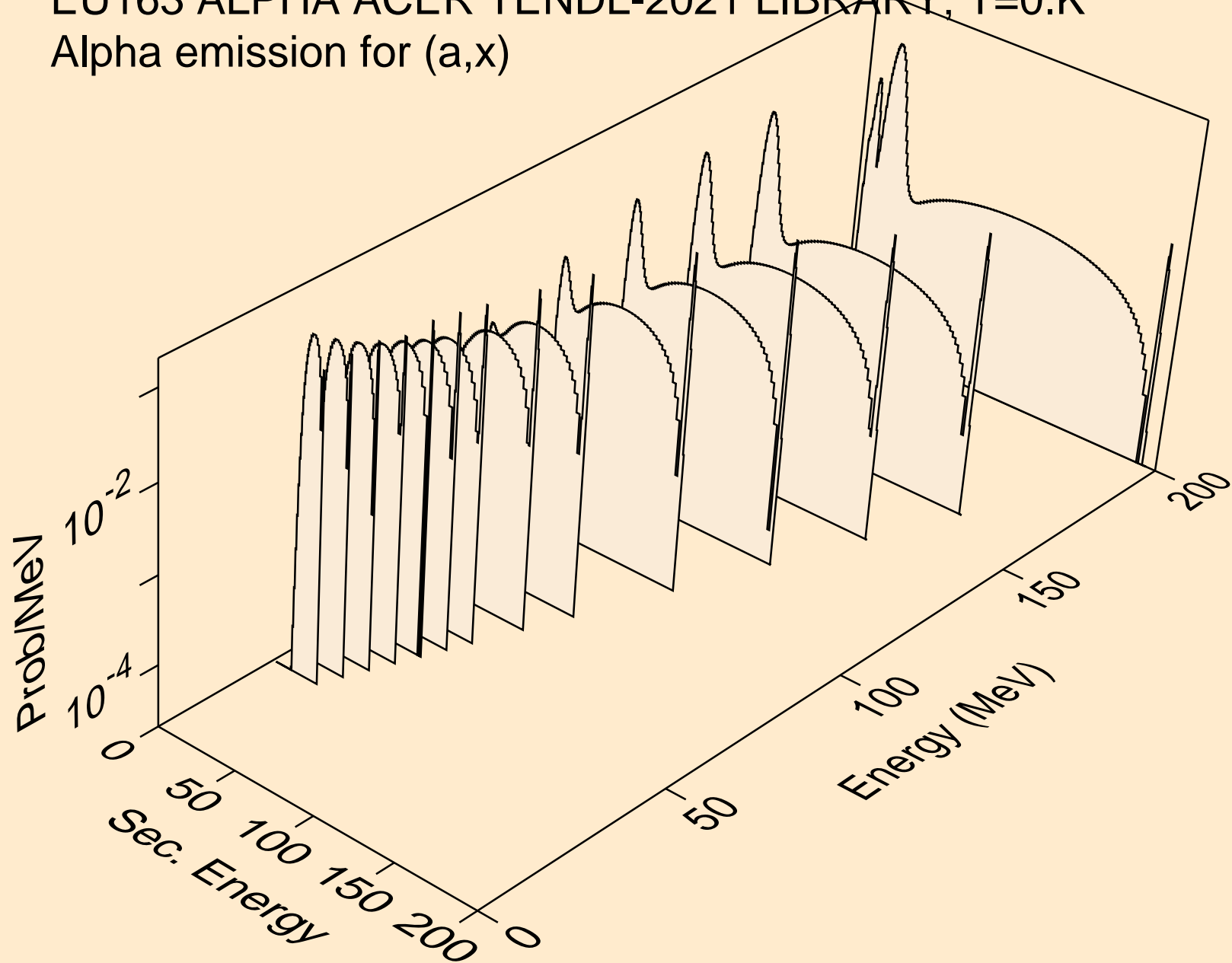



EU163 ALPHA ACER TENDL-2021 LIBRARY; T=0.K  
Alpha emission for (a,n\*)a

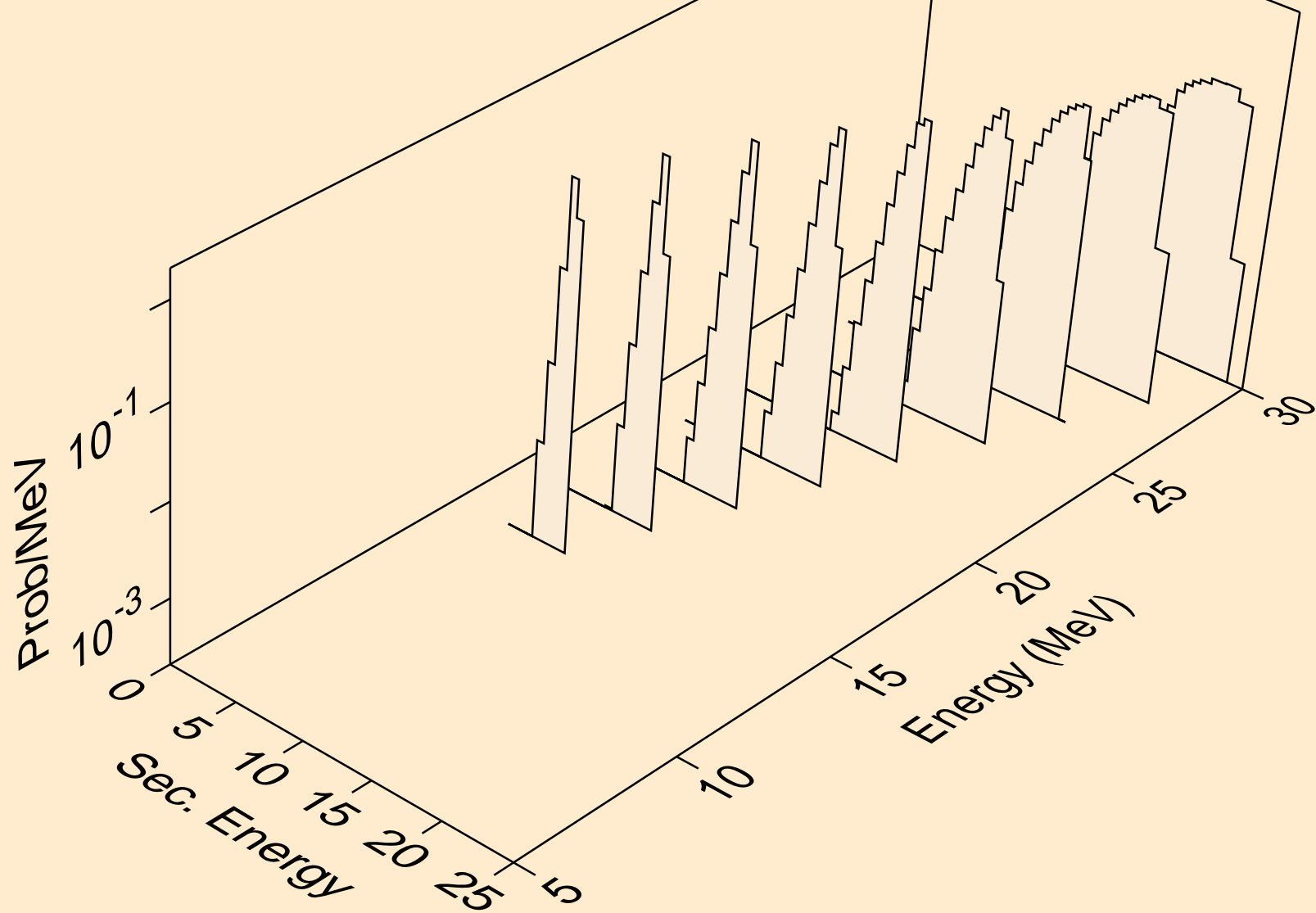

EU163 ALPHA ACER TENDL-2021 LIBRARY; T=0.K  
Alpha emission for (a,2n)a

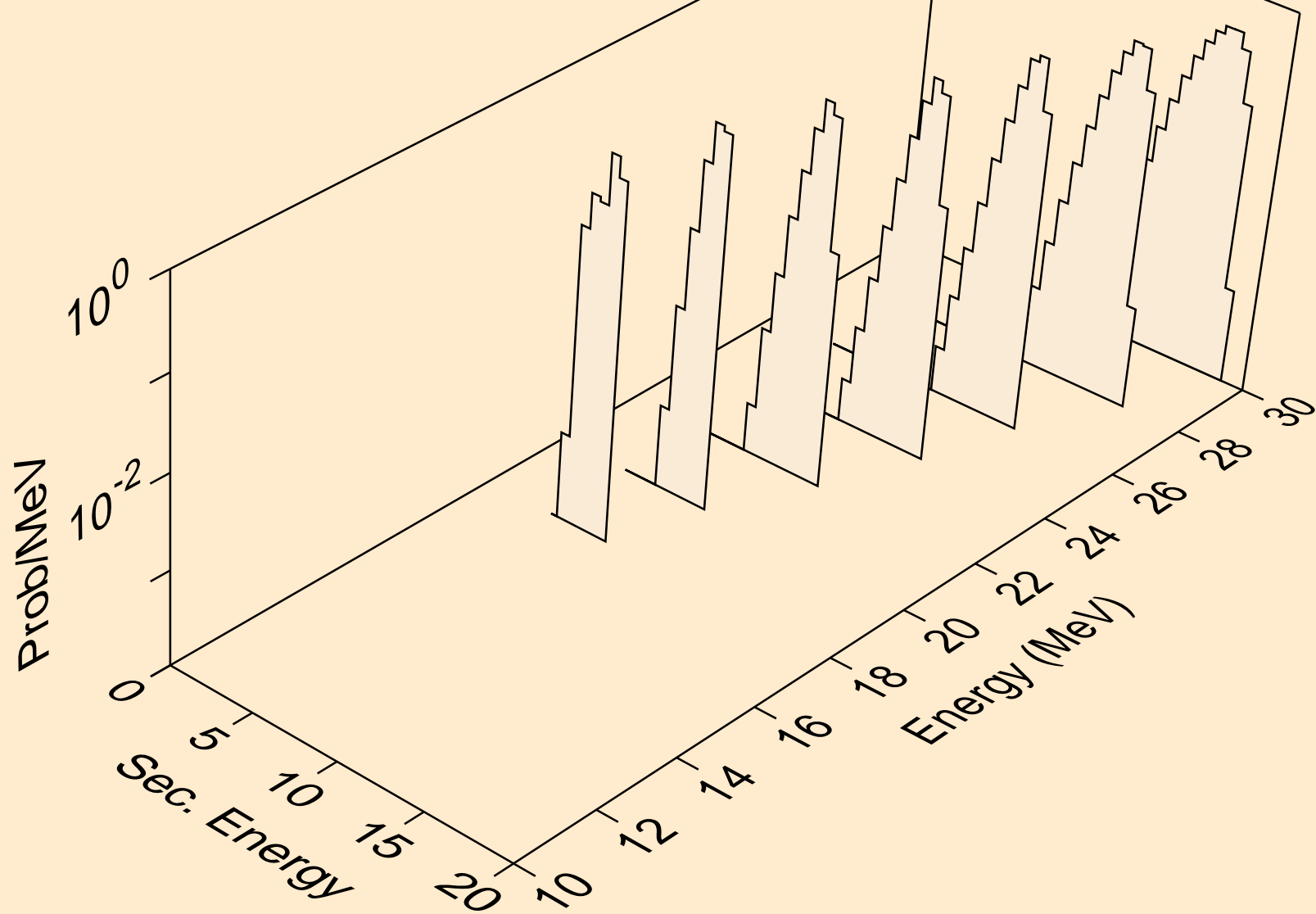

EU163 ALPHA ACER TENDL-2021 LIBRARY; T=0.K  
Alpha emission for (a,3n)a

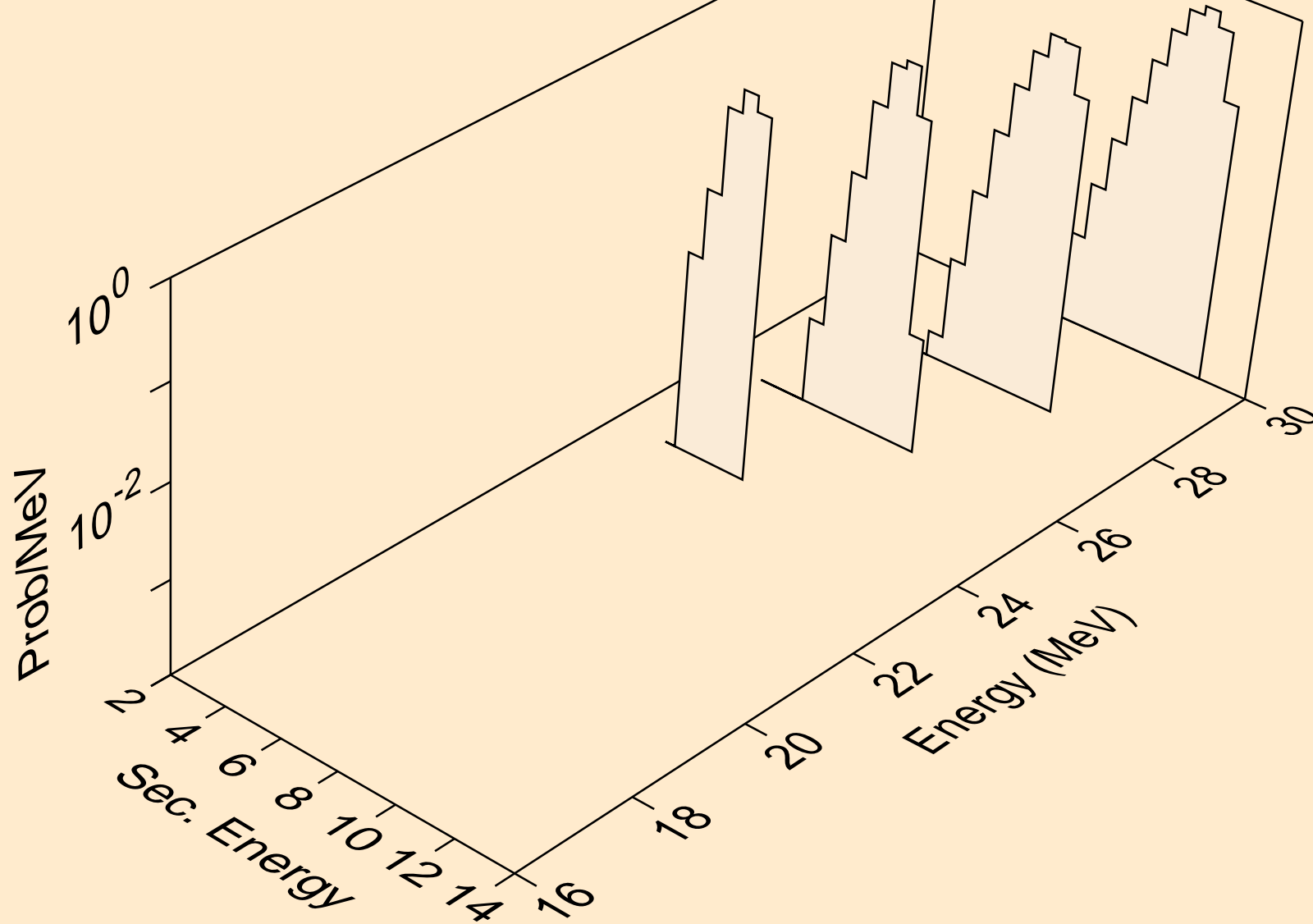

EU163 ALPHA ACER TENDL-2021 LIBRARY; T=0.K  
Alpha emission for inelastic

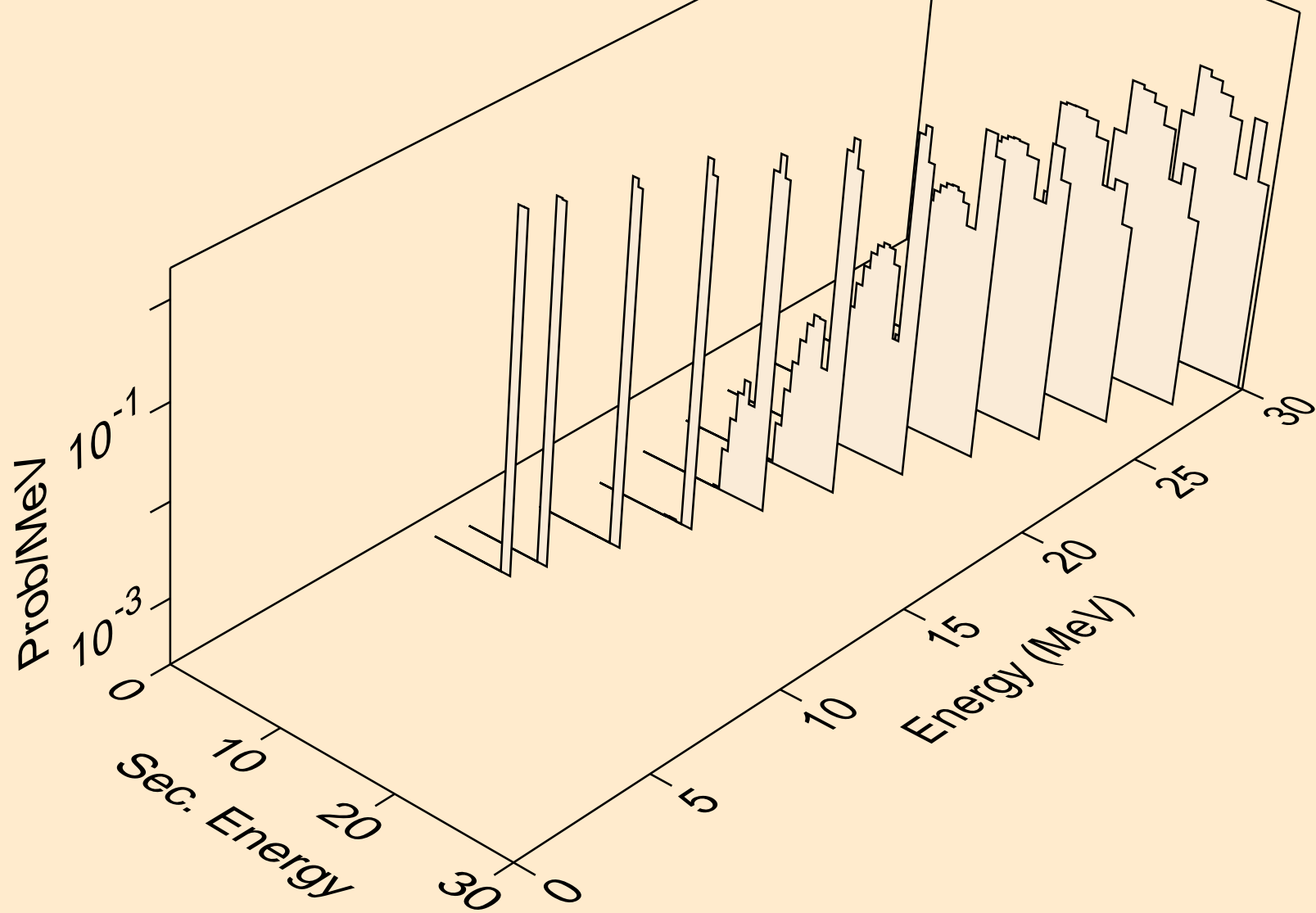

EU163 ALPHA ACER TENDL-2021 LIBRARY; T=0.K  
Photon emission for (z,n)

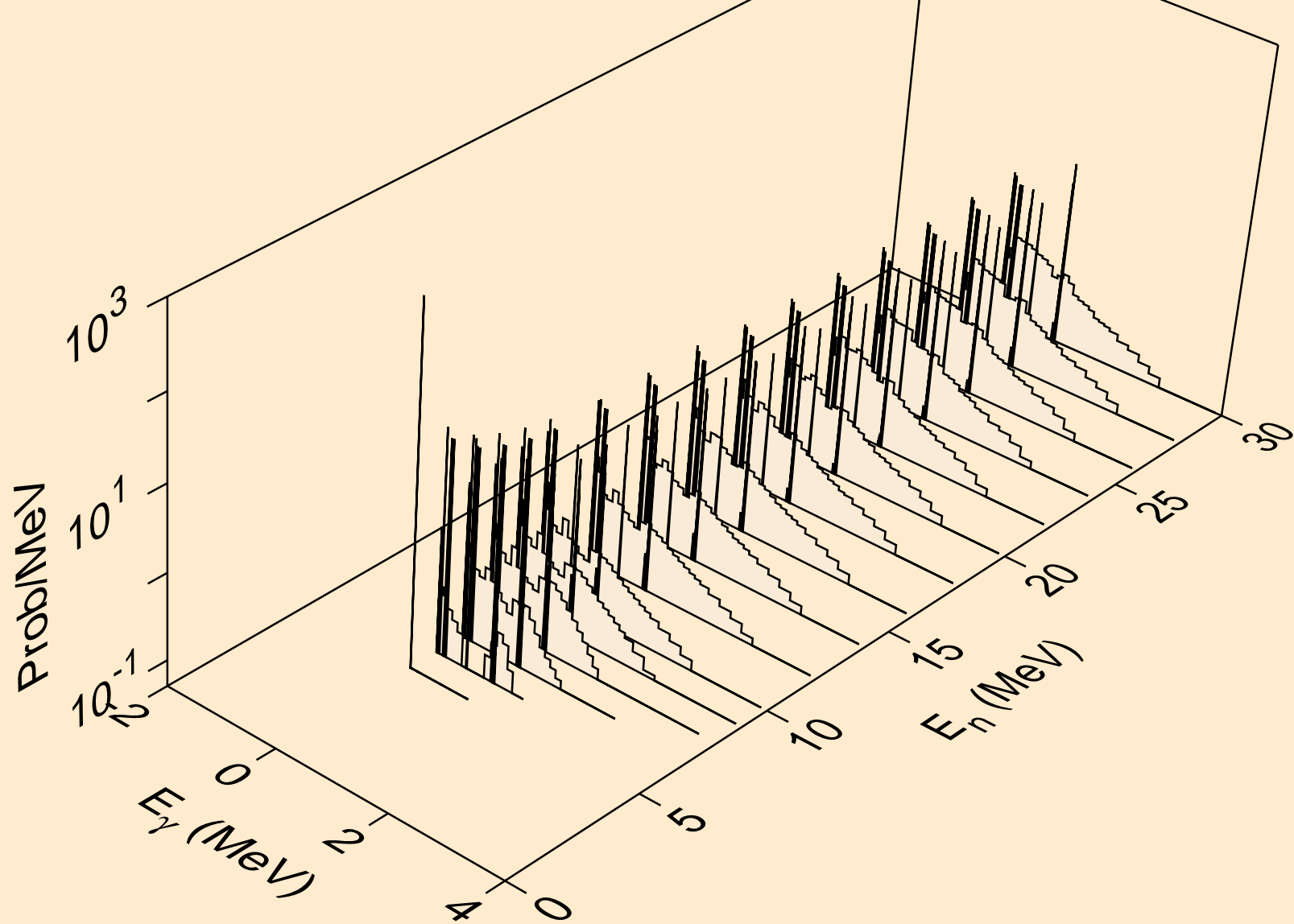

EU163 ALPHA ACER TENDL-2021 LIBRARY; T=0.K  
Photon emission for (n,x)

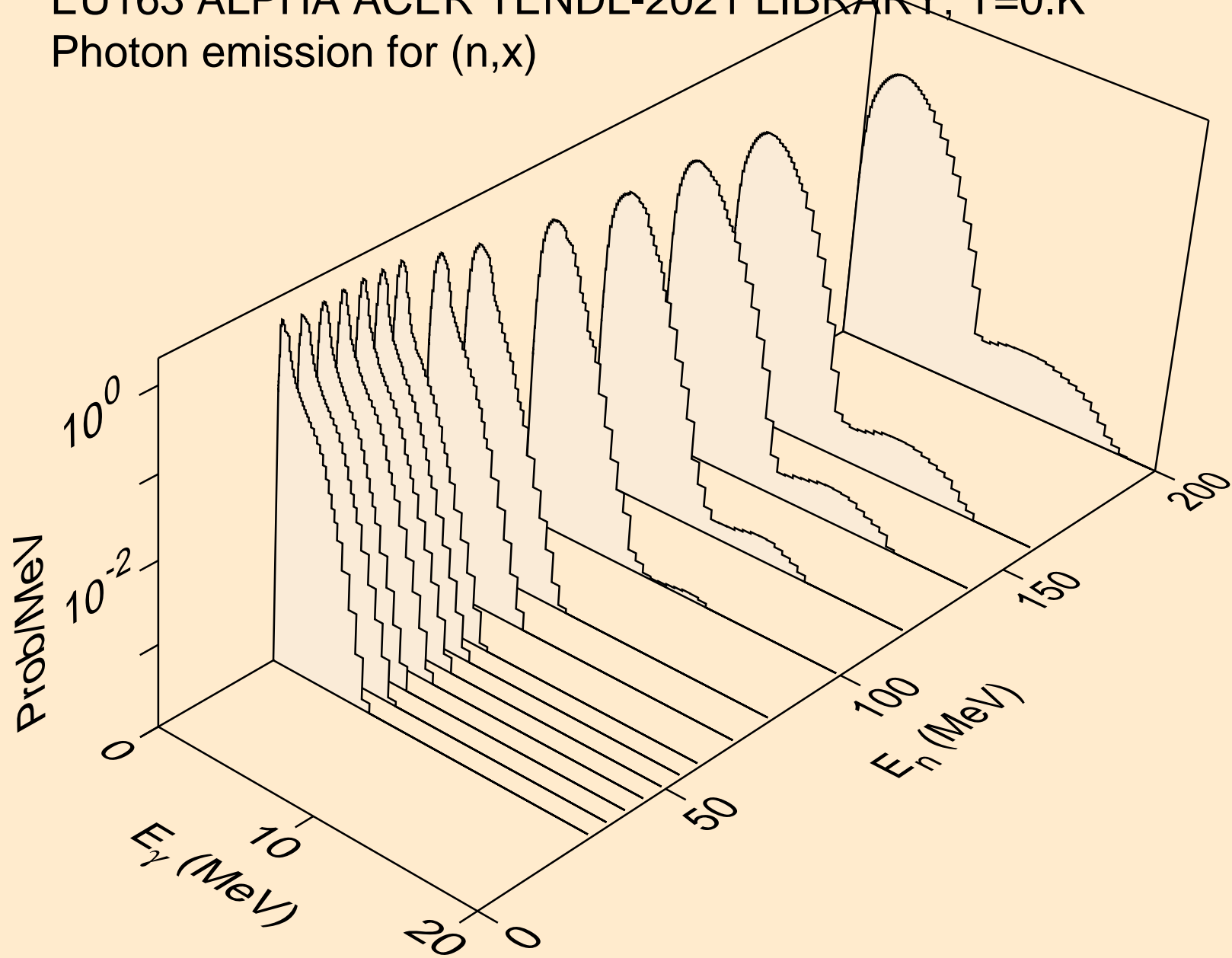

EU163 ALPHA ACER TENDL-2021 LIBRARY; T=0.K  
Photon emission for (n,2nd)

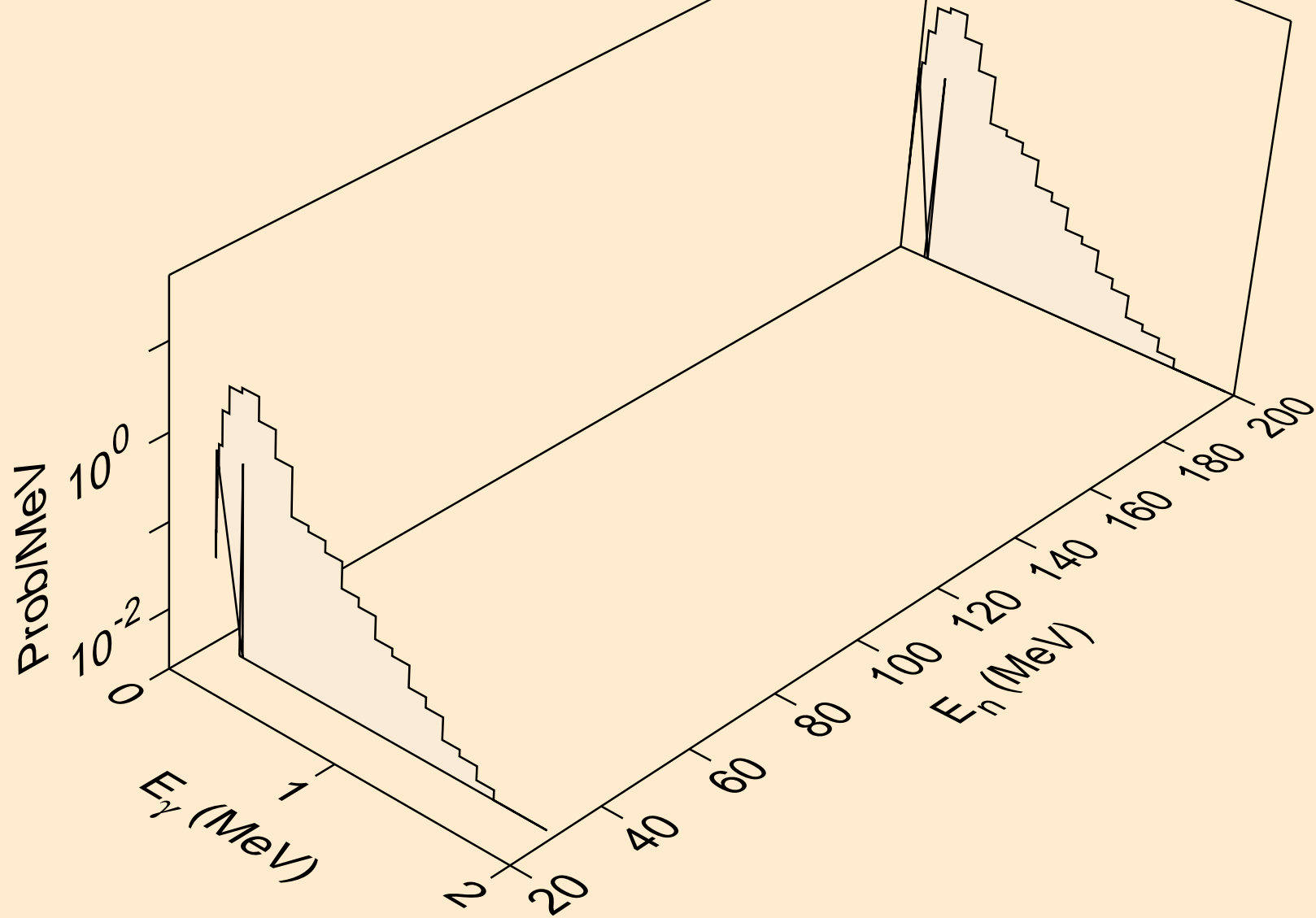

EU163 ALPHA ACER TENDL-2021 LIBRARY; T=0.K  
Photon emission for (n,2n)

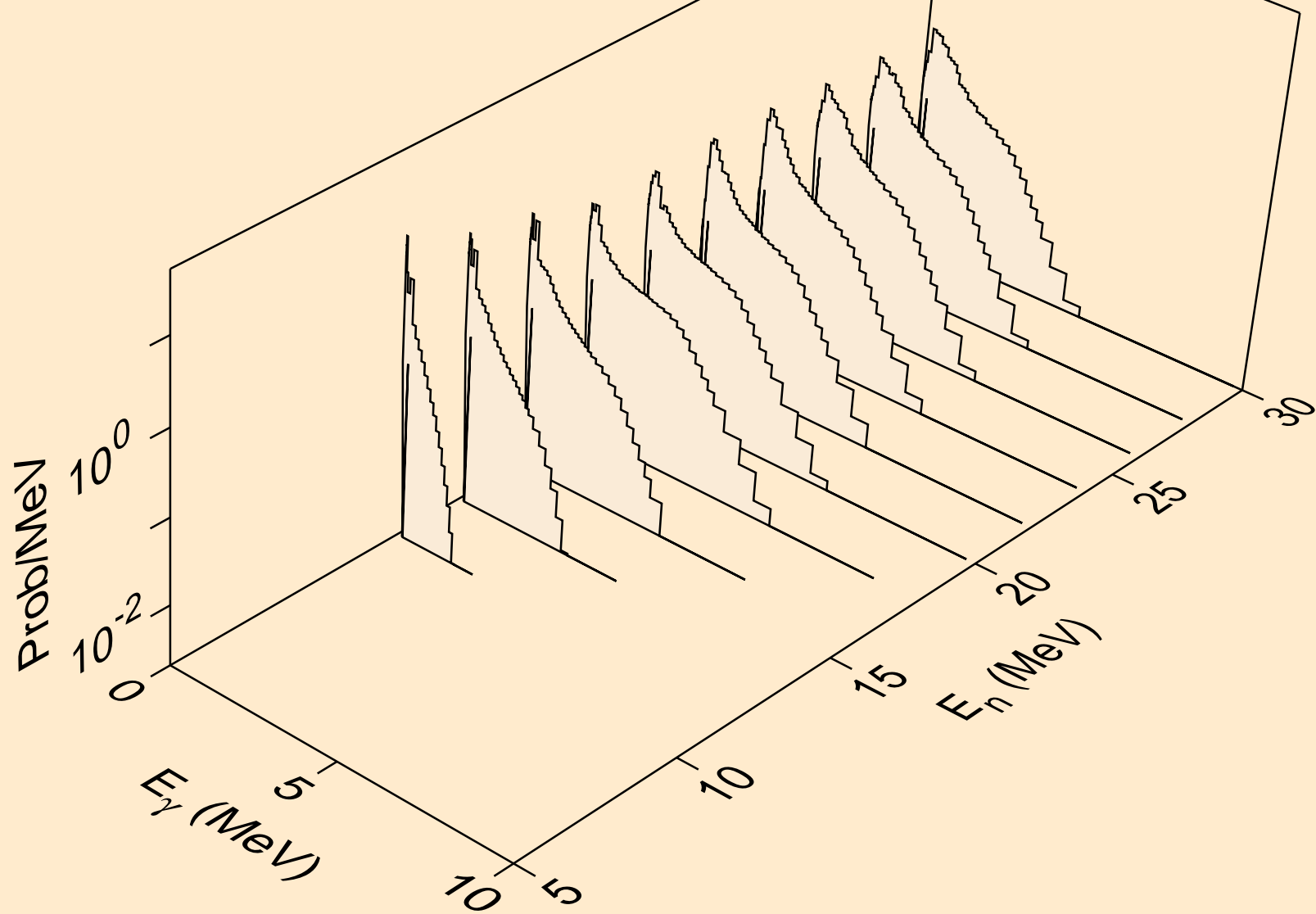



EU163 ALPHA ACER TENDL-2021 LIBRARY; T=0.K  
Photon emission for (n,3n)

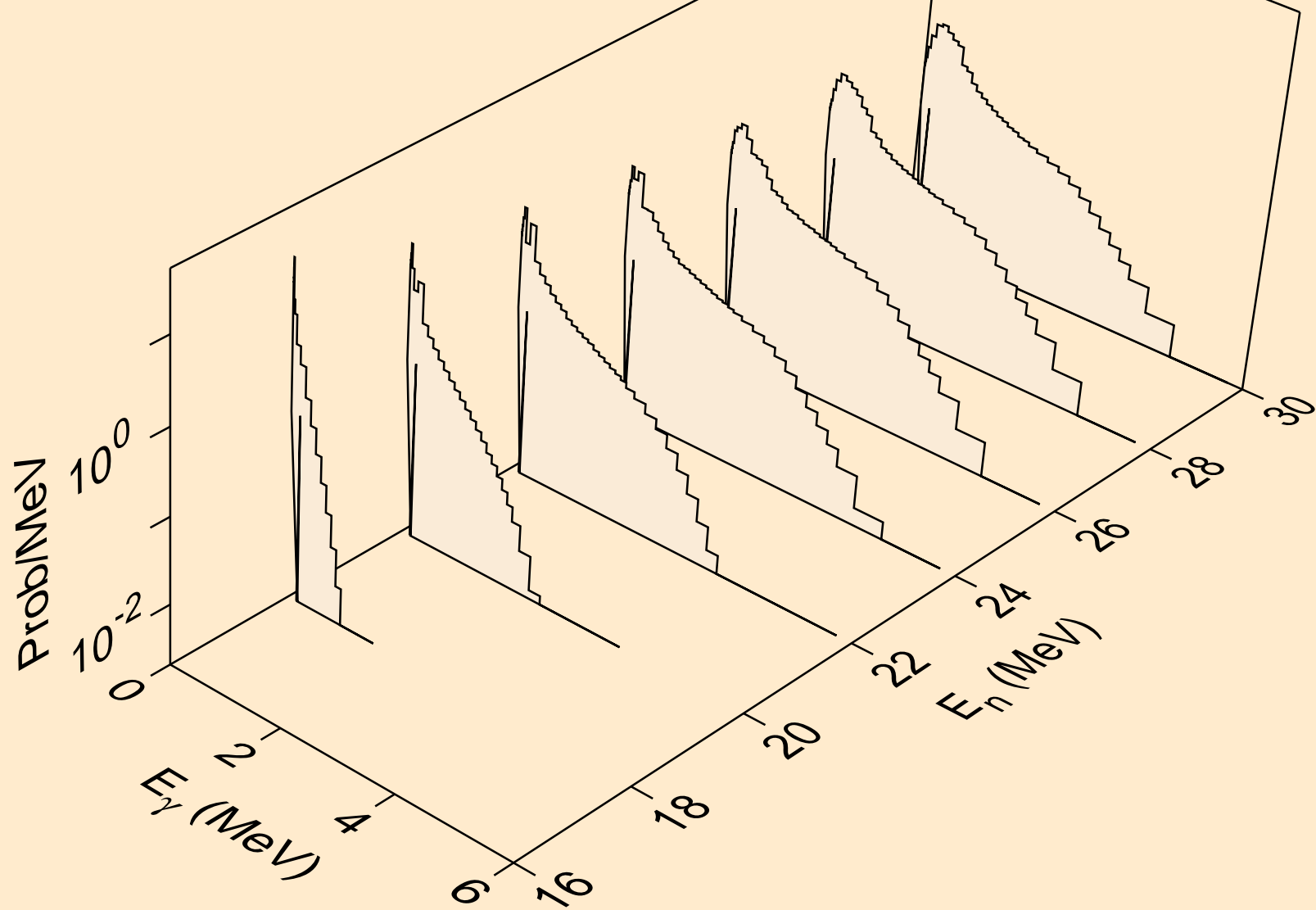

EU163 ALPHA ACER TENDL-2021 LIBRARY; T=0.K  
Photon emission for (n,n\*)a

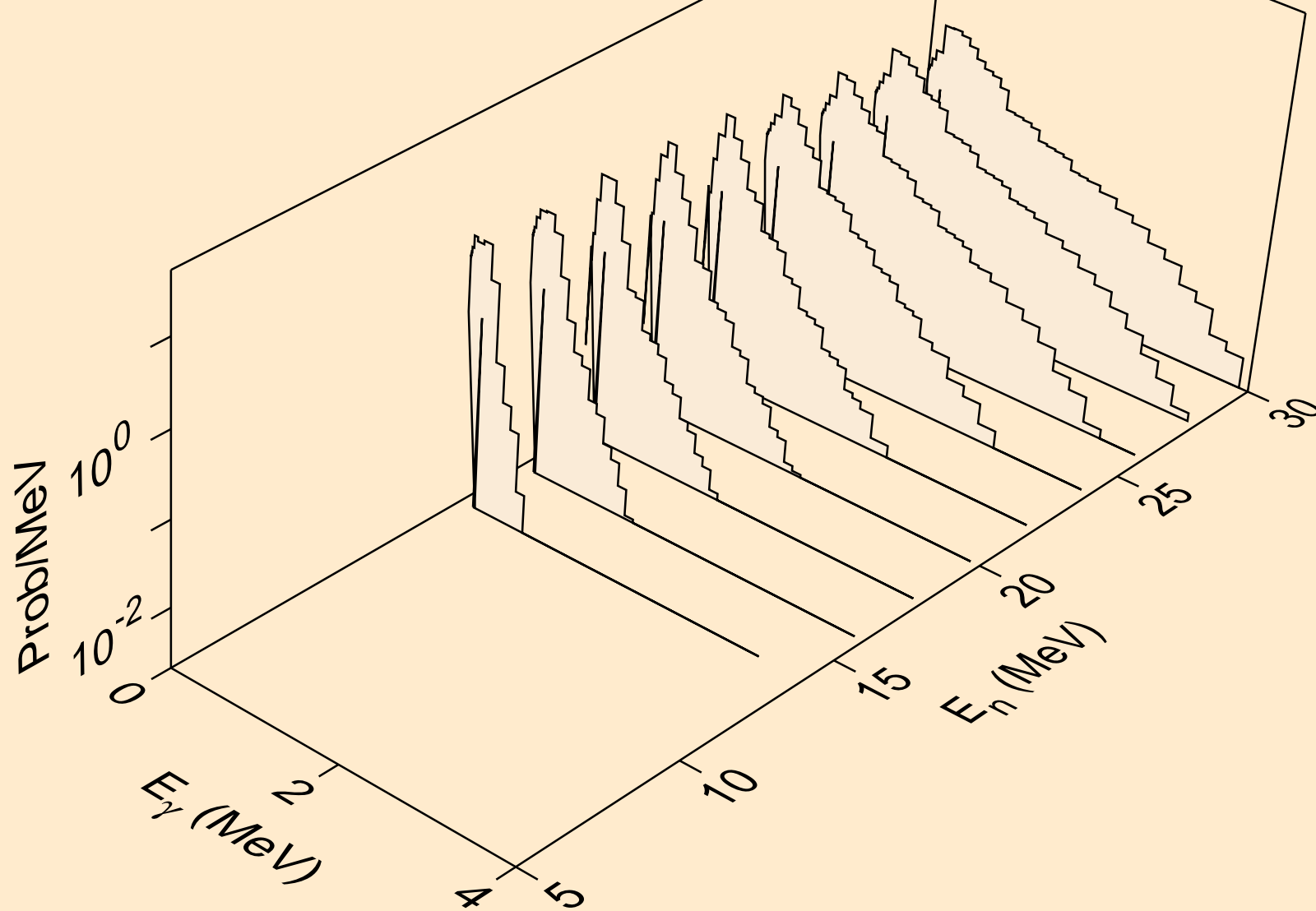

EU163 ALPHA ACER TENDL-2021 LIBRARY; T=0.K  
Photon emission for (n,2n)a

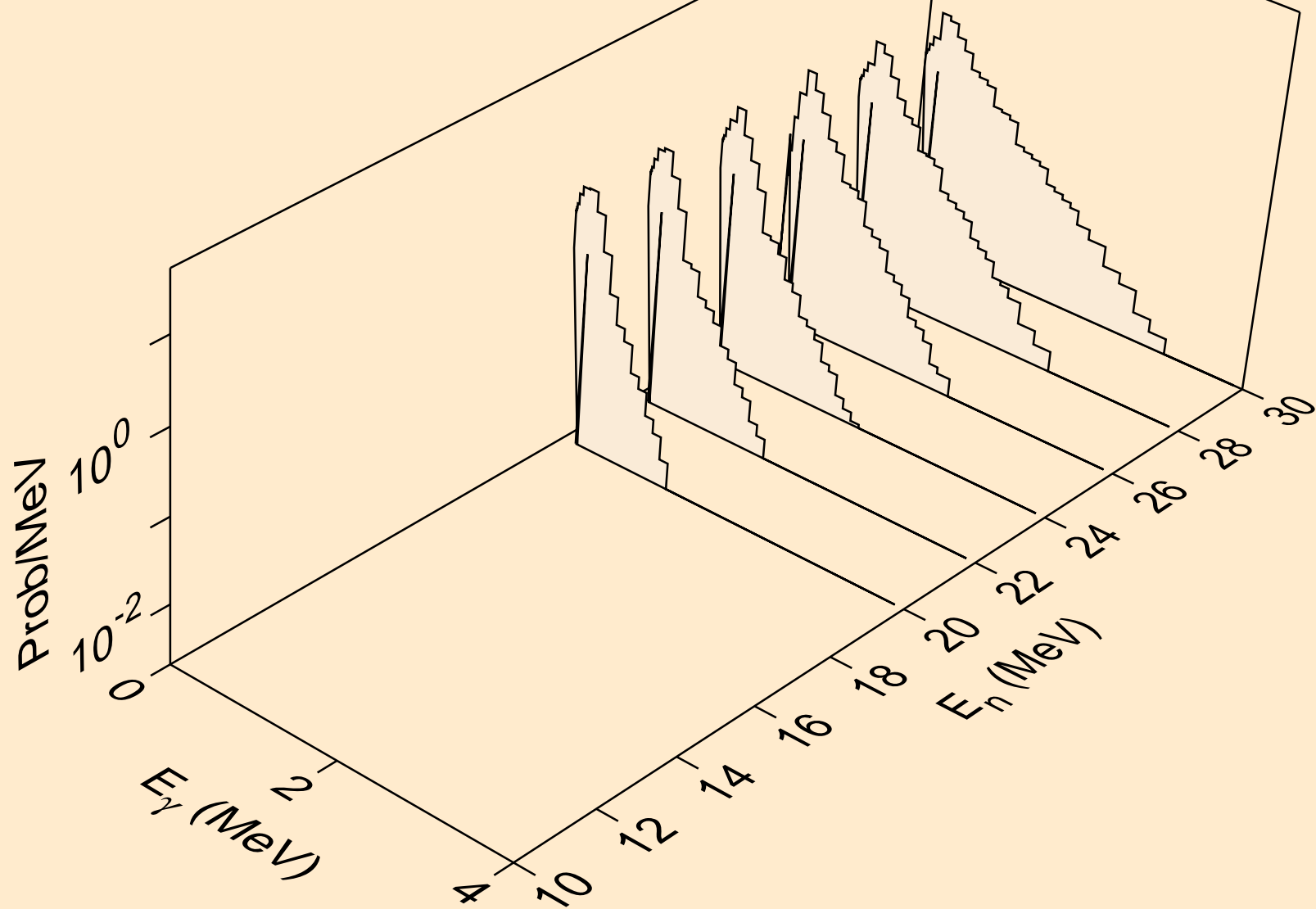

EU163 ALPHA ACER TENDL-2021 LIBRARY; T=0.K  
Photon emission for (n,3n)a

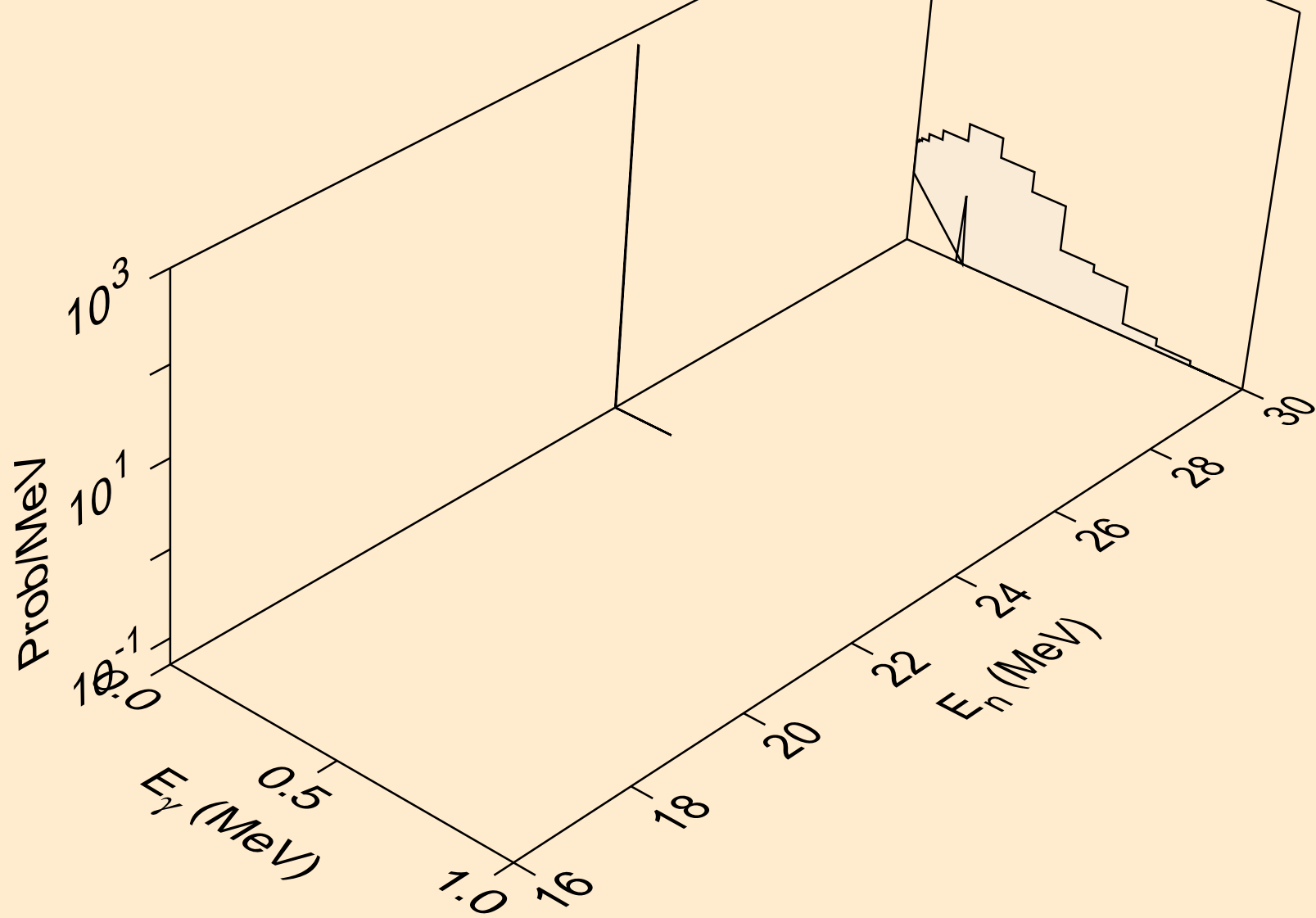

EU163 ALPHA ACER TENDL-2021 LIBRARY; T=0.K  
Photon emission for (n,n\*)p

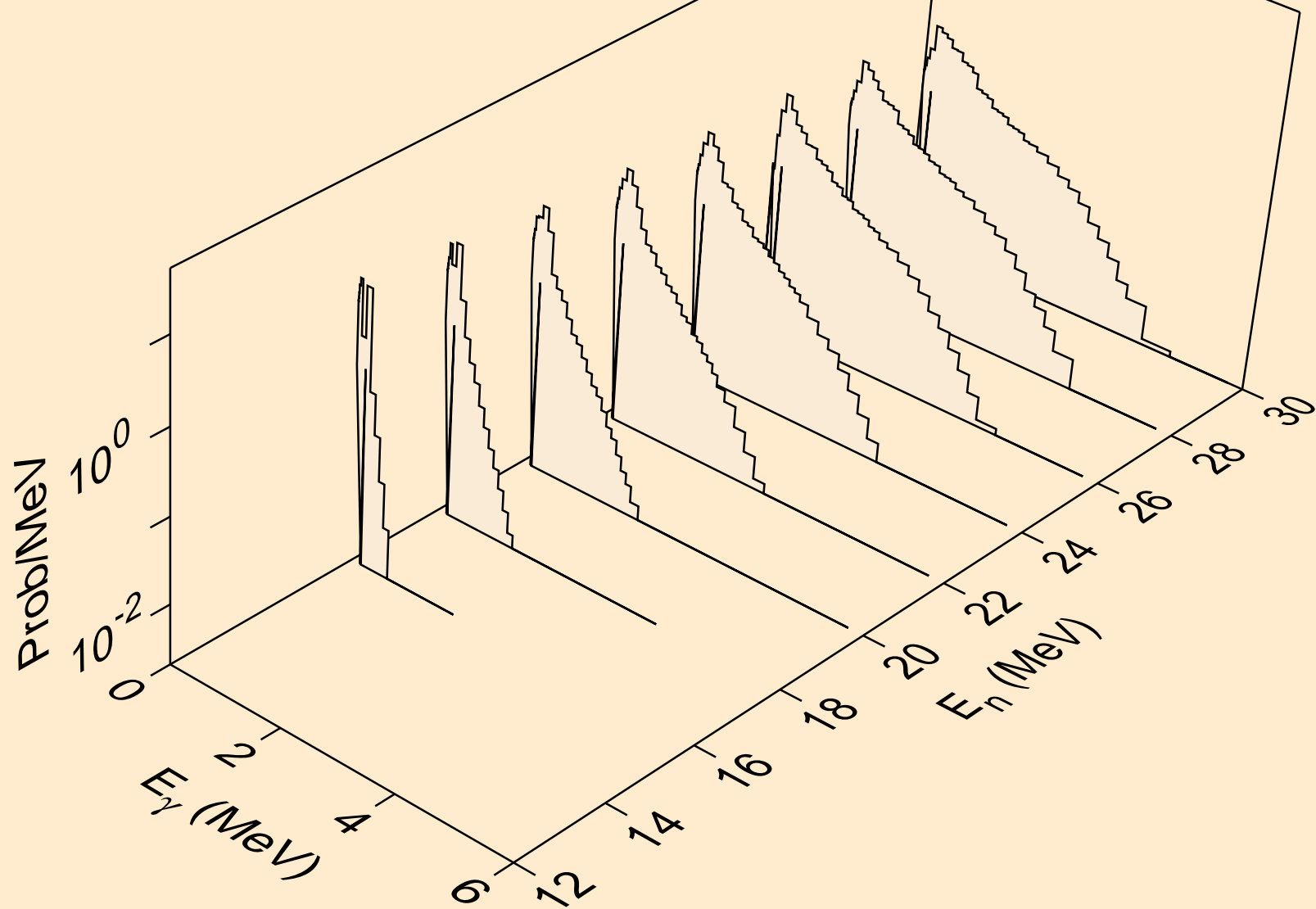

EU163 ALPHA ACER TENDL-2021 LIBRARY; T=0.K  
Photon emission for (n,n\*)d

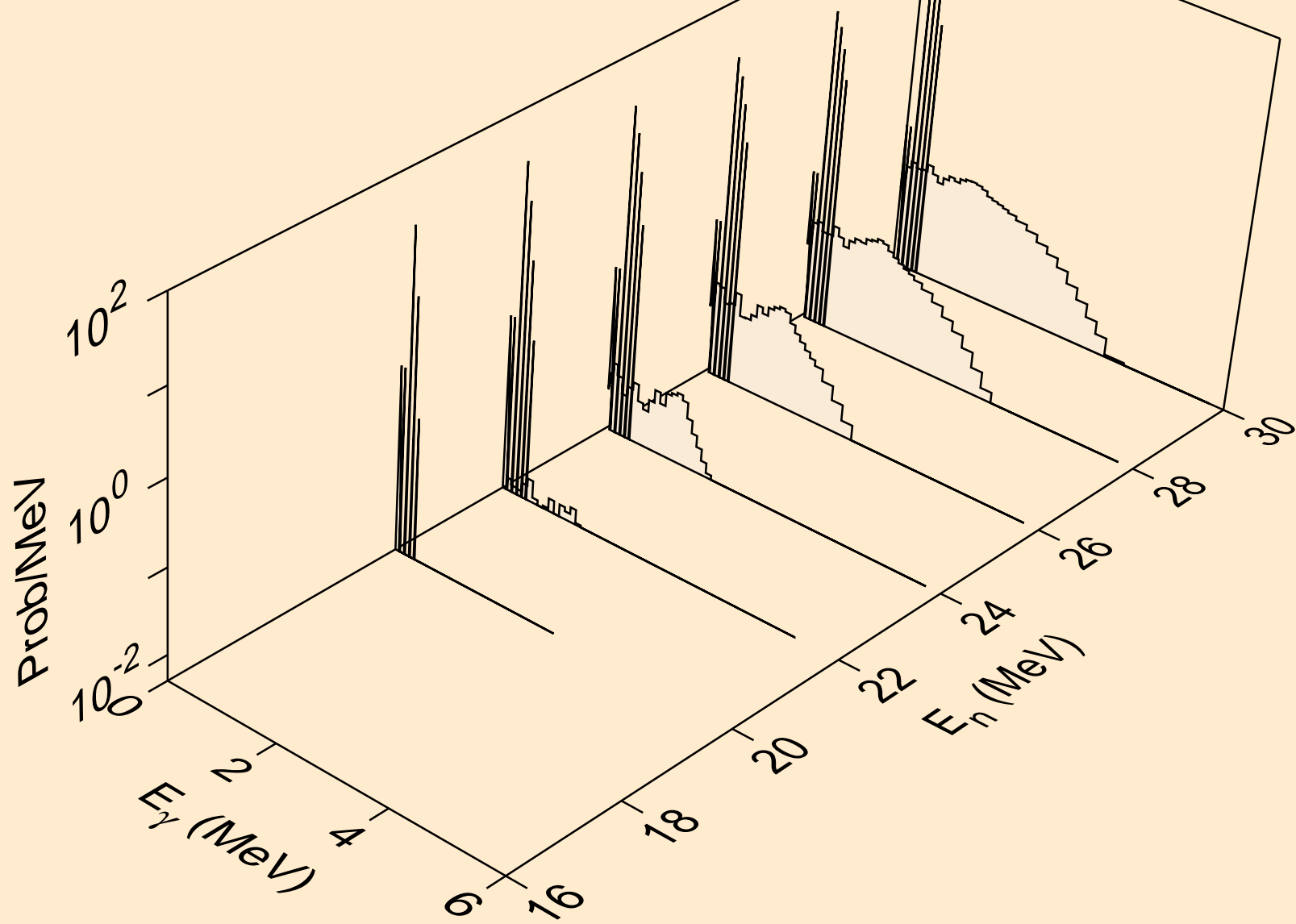

EU163 ALPHA ACER TENDL-2021 LIBRARY; T=0.K  
Photon emission for (n,n\*)t

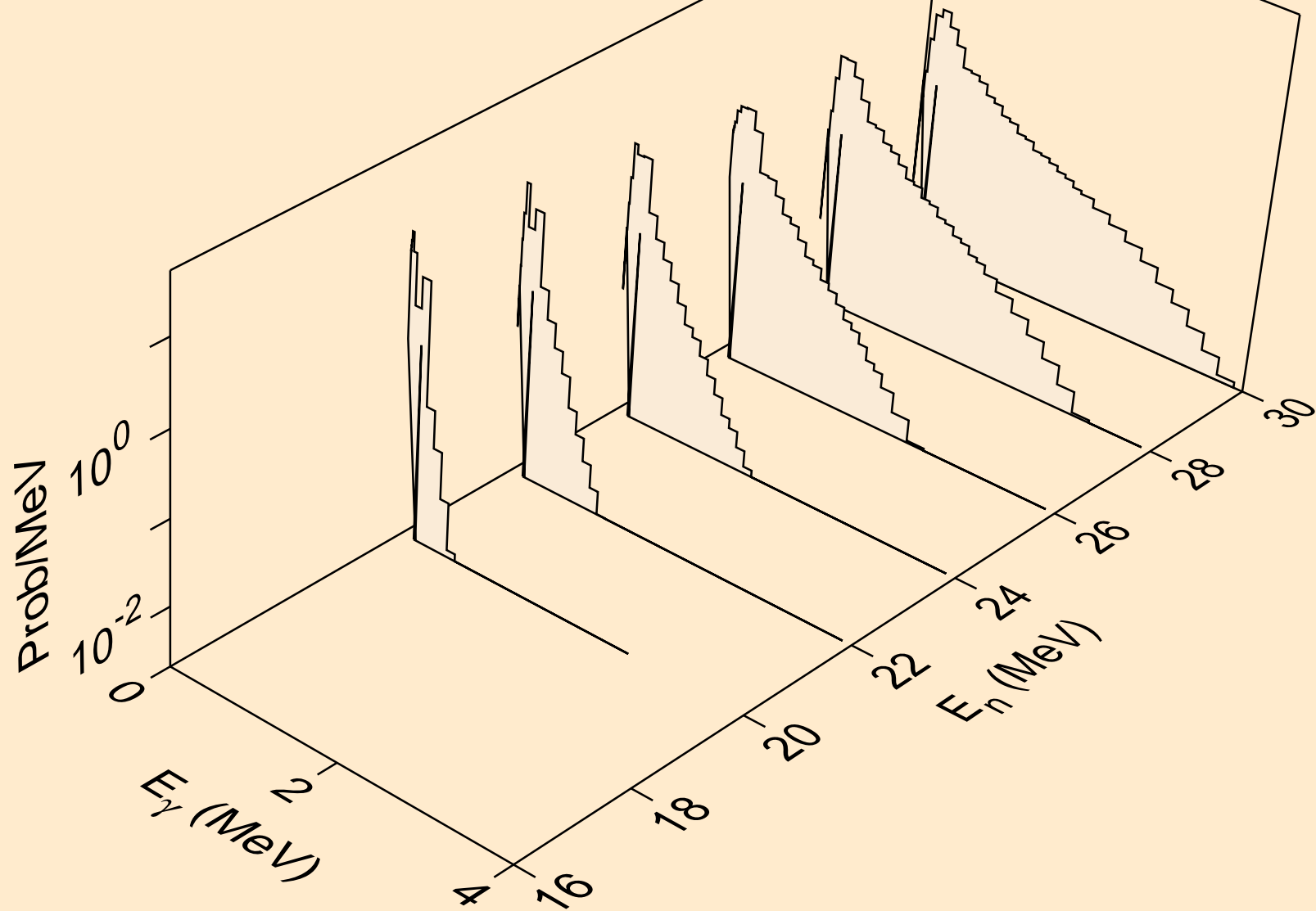

EU163 ALPHA ACER TENDL-2021 LIBRARY; T=0.K  
Photon emission for (n,4n)

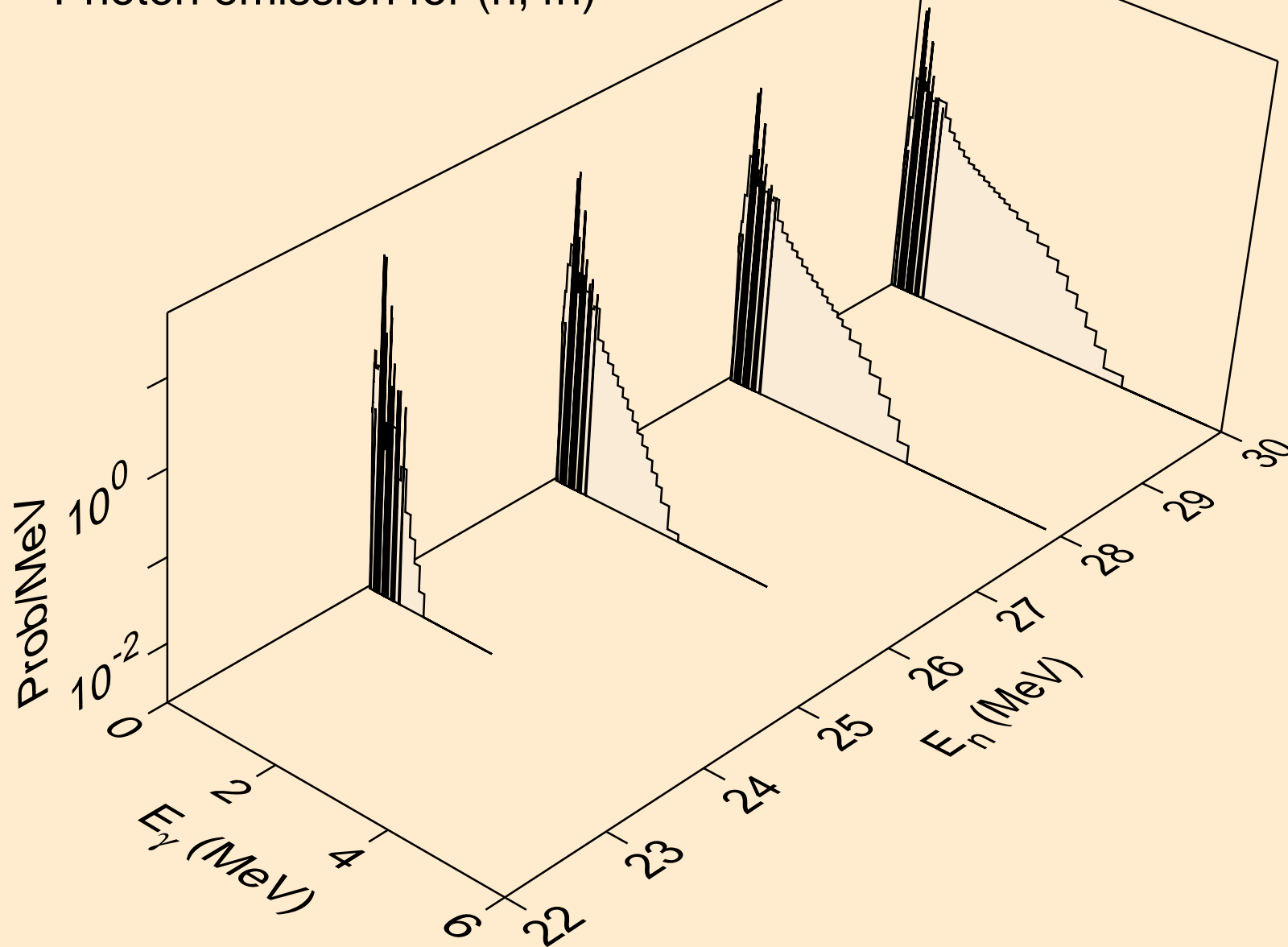



EU163 ALPHA ACER TENDL-2021 LIBRARY; T=0.K  
Photon emission for (n,2np)

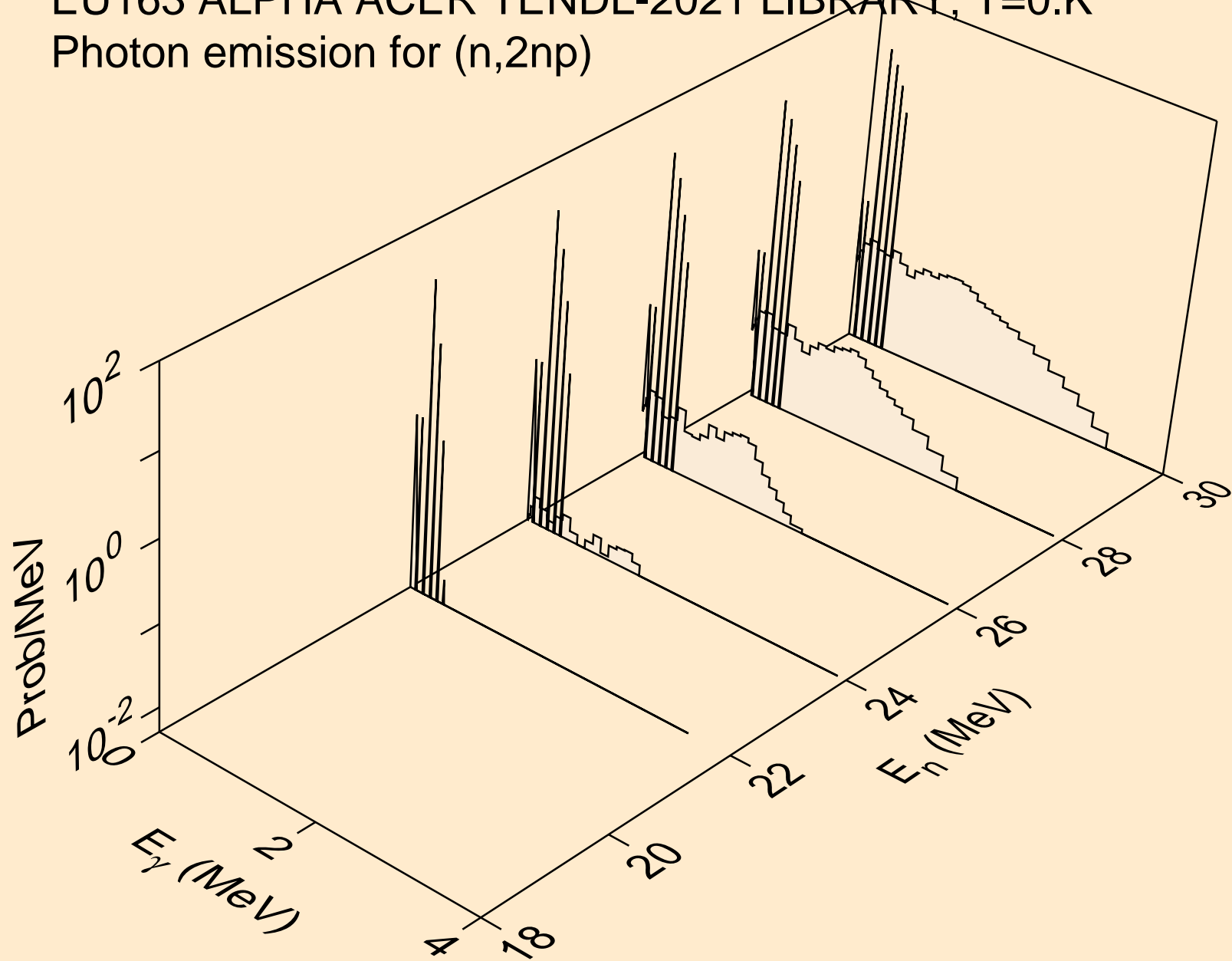

EU163 ALPHA ACER TENDL-2021 LIBRARY; T=0.K  
Photon emission for (n,3np)

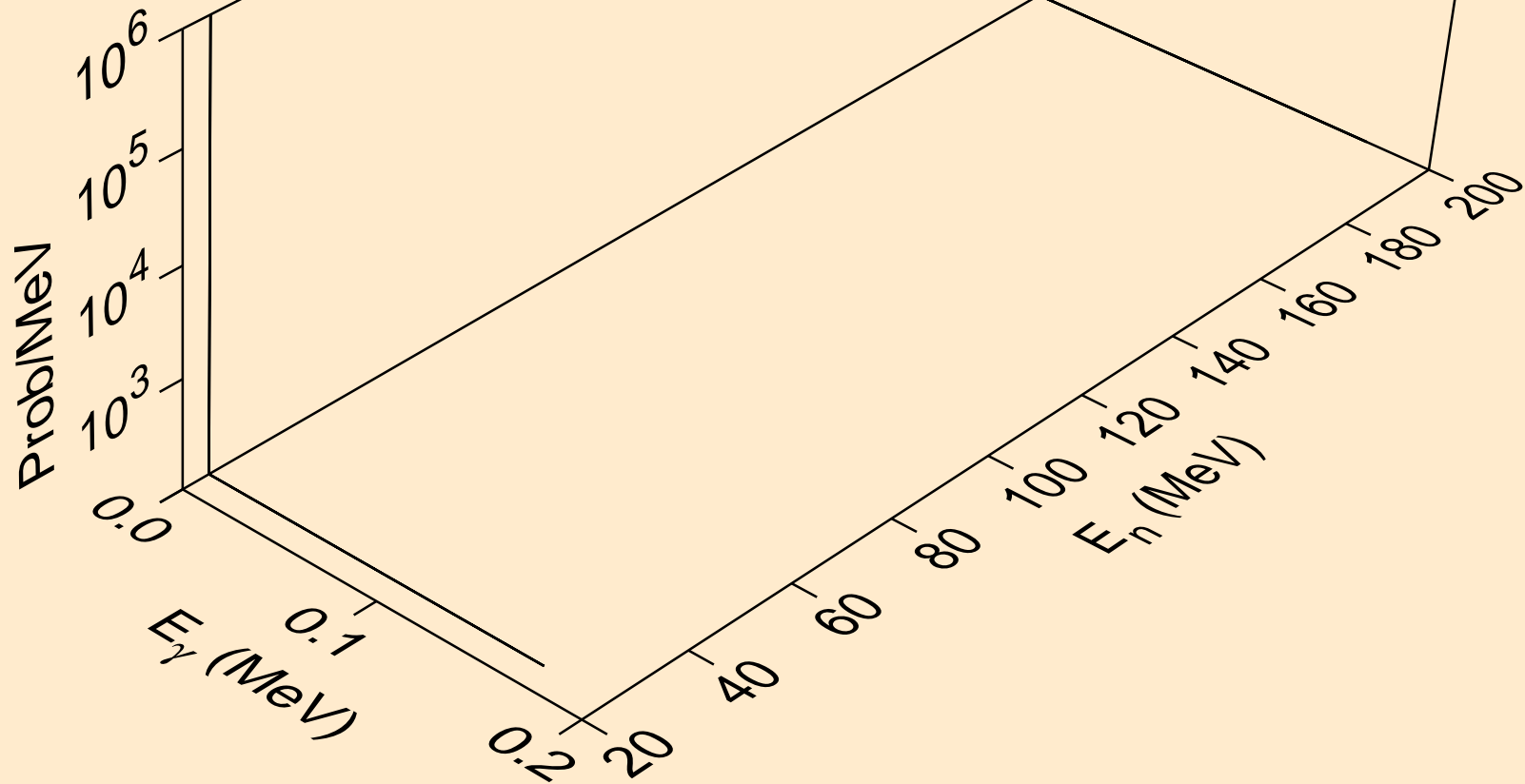

EU163 ALPHA ACER TENDL-2021 LIBRARY; T=0.K  
Photon emission for (n,gma)

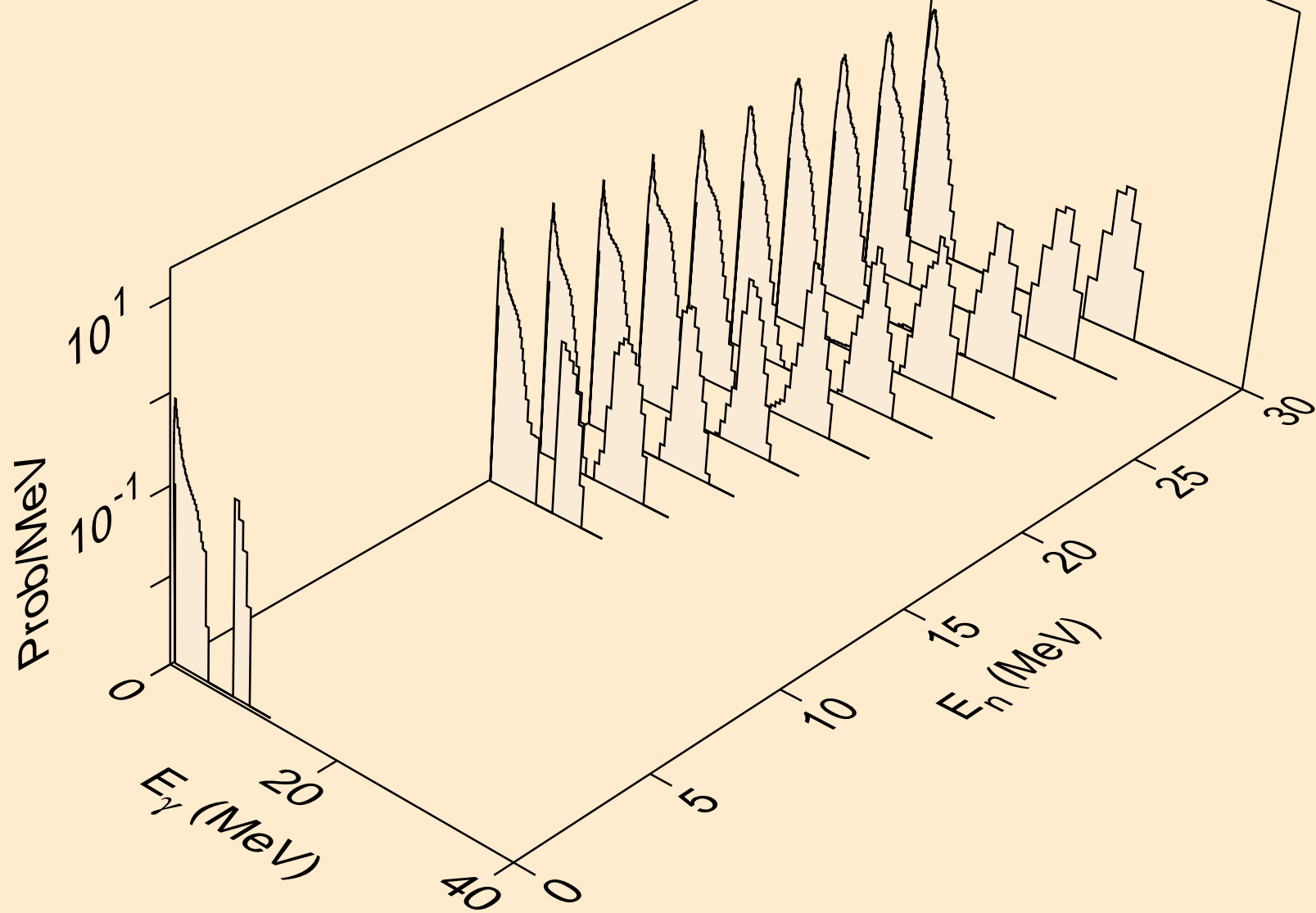

EU163 ALPHA ACER TENDL-2021 LIBRARY; T=0.K  
Photon emission for (n,p)

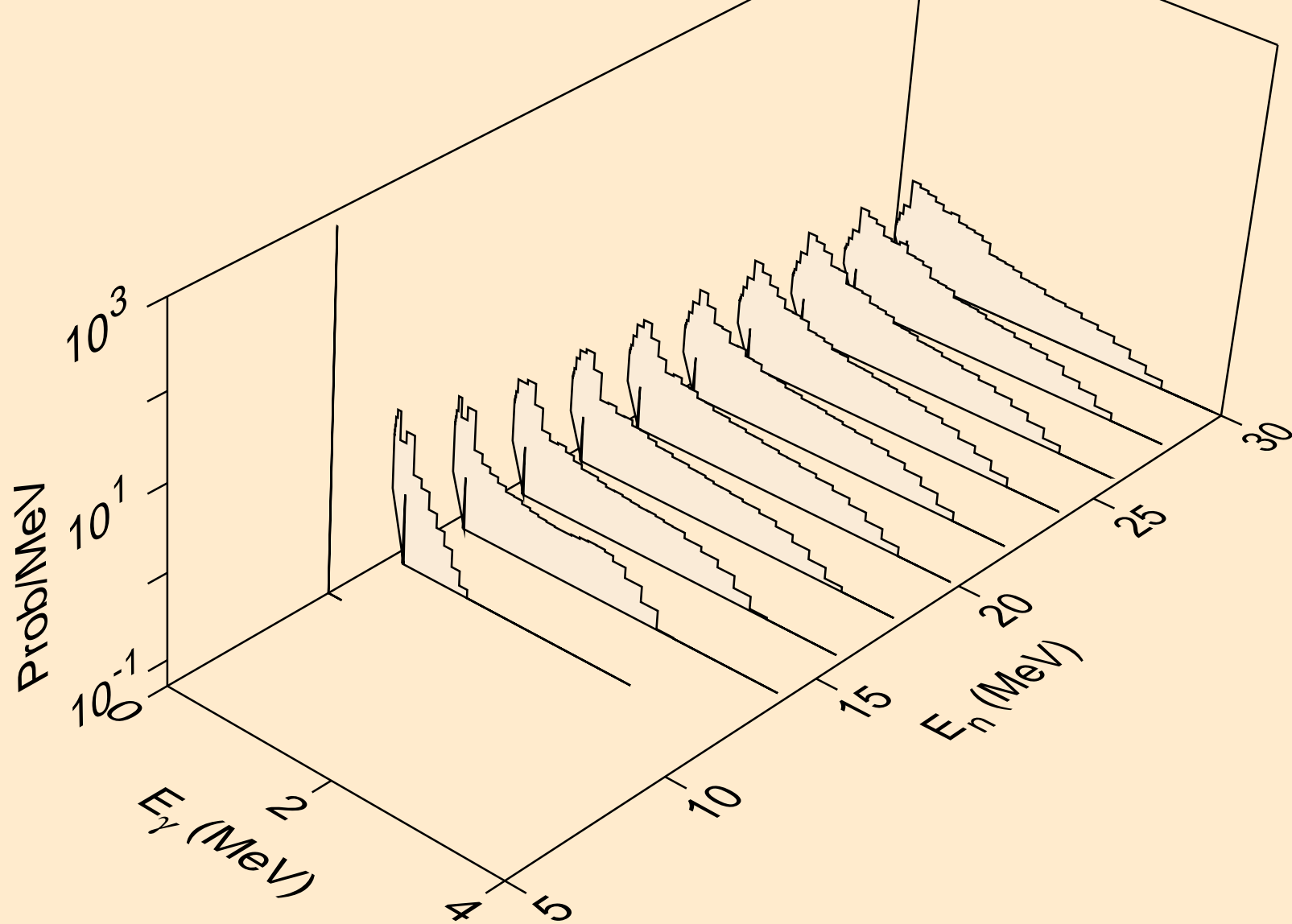

EU163 ALPHA ACER TENDL-2021 LIBRARY; T=0.K  
Photon emission for (n,d)

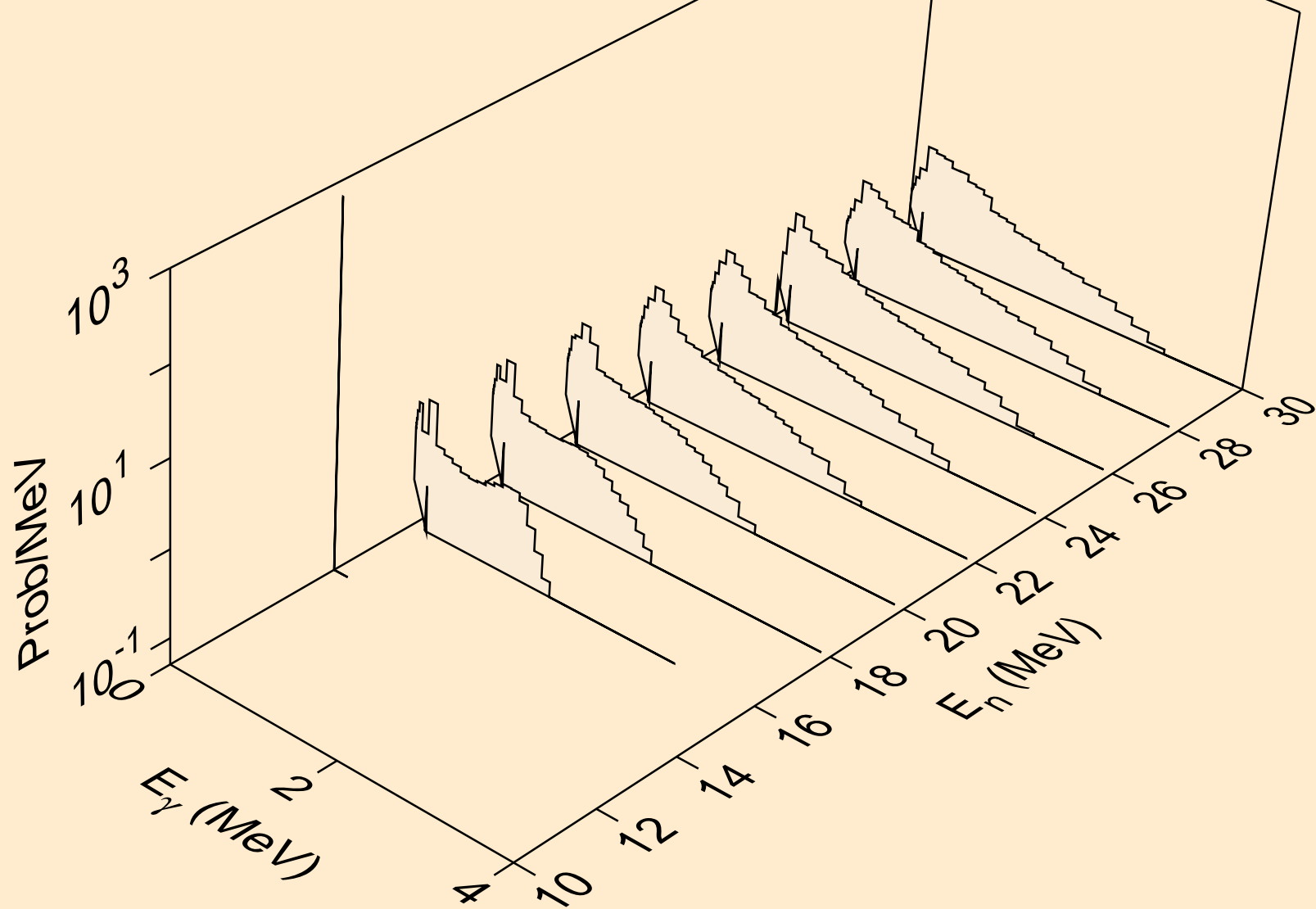

EU163 ALPHA ACER TENDL-2021 LIBRARY; T=0.K  
Photon emission for (n,t)

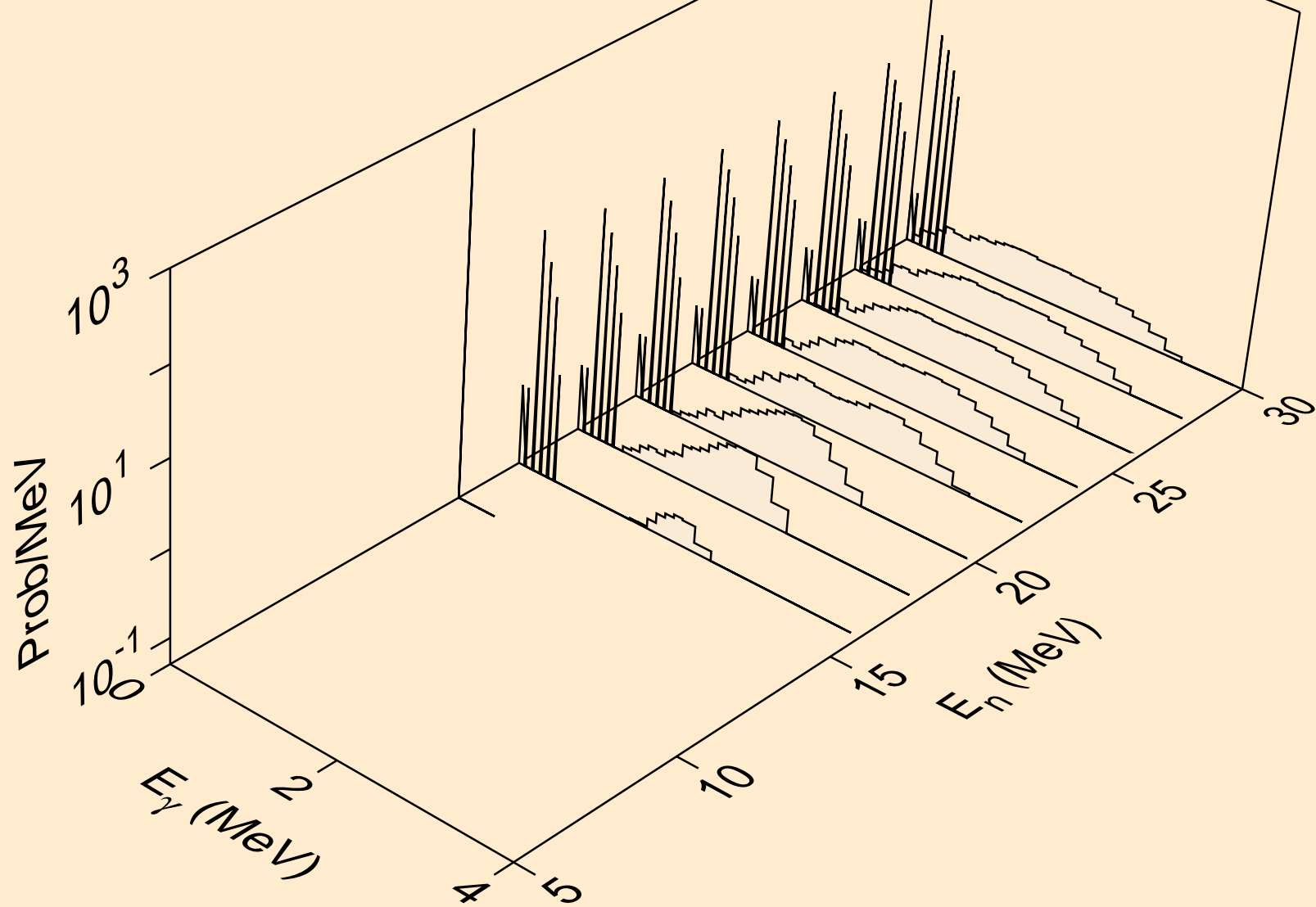

EU163 ALPHA ACER TENDL-2021 LIBRARY; T=0.K  
Photon emission for (n,he3)

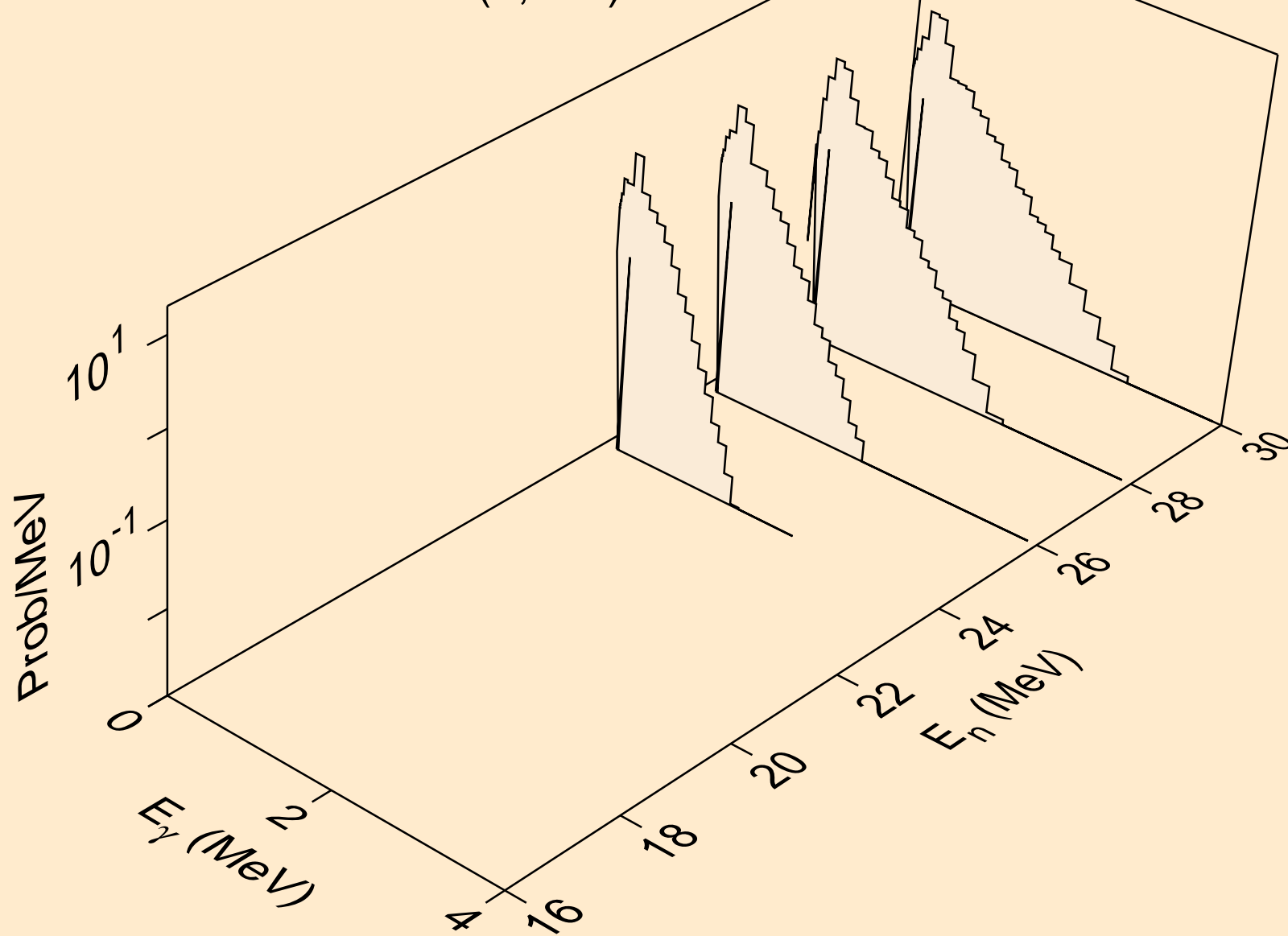

EU163 ALPHA ACER TENDL-2021 LIBRARY; T=0.K  
Photon emission for inelastic

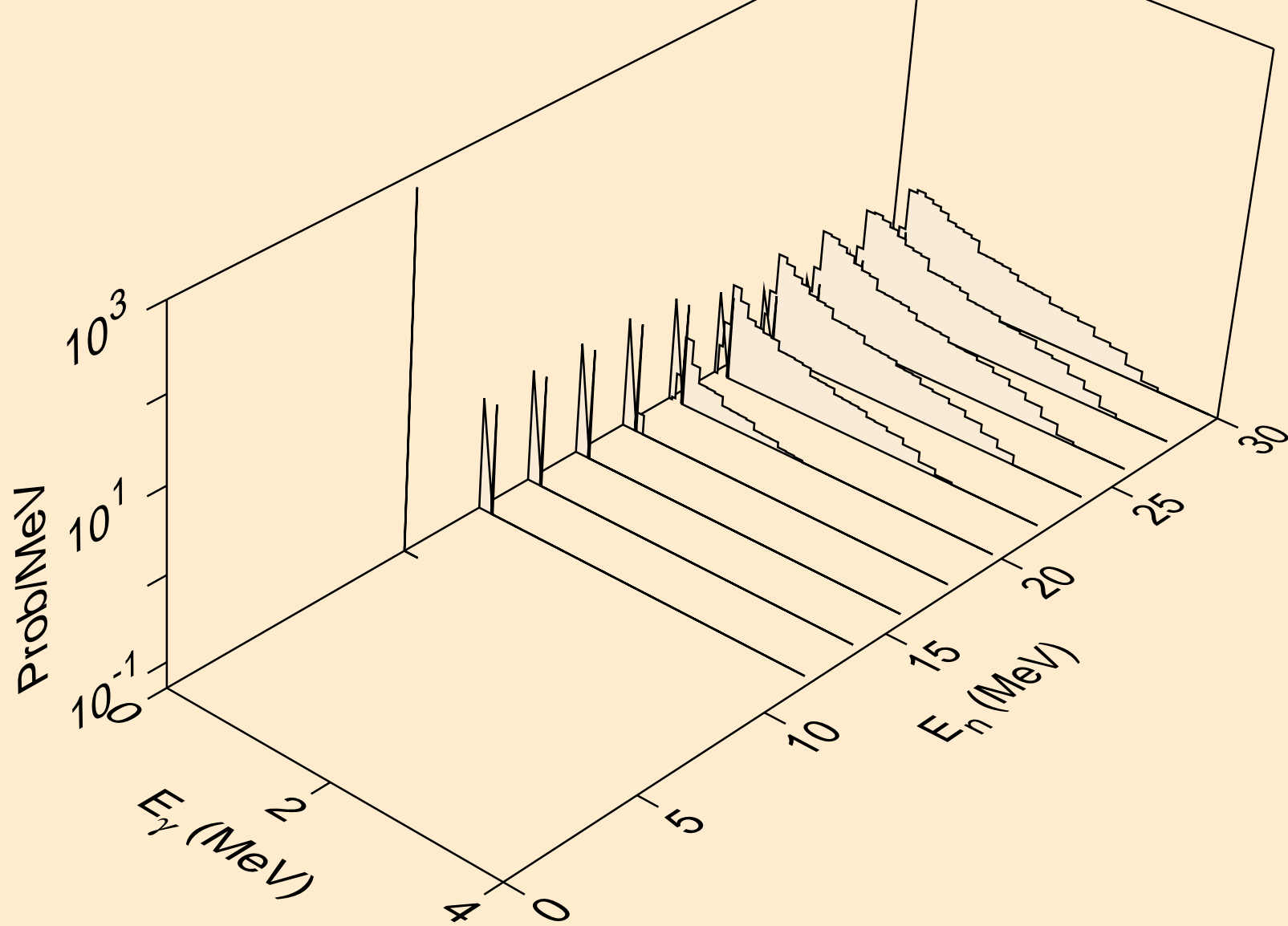



EU163 ALPHA ACER TENDL-2021 LIBRARY; T=0.K  
Particle heating contributions

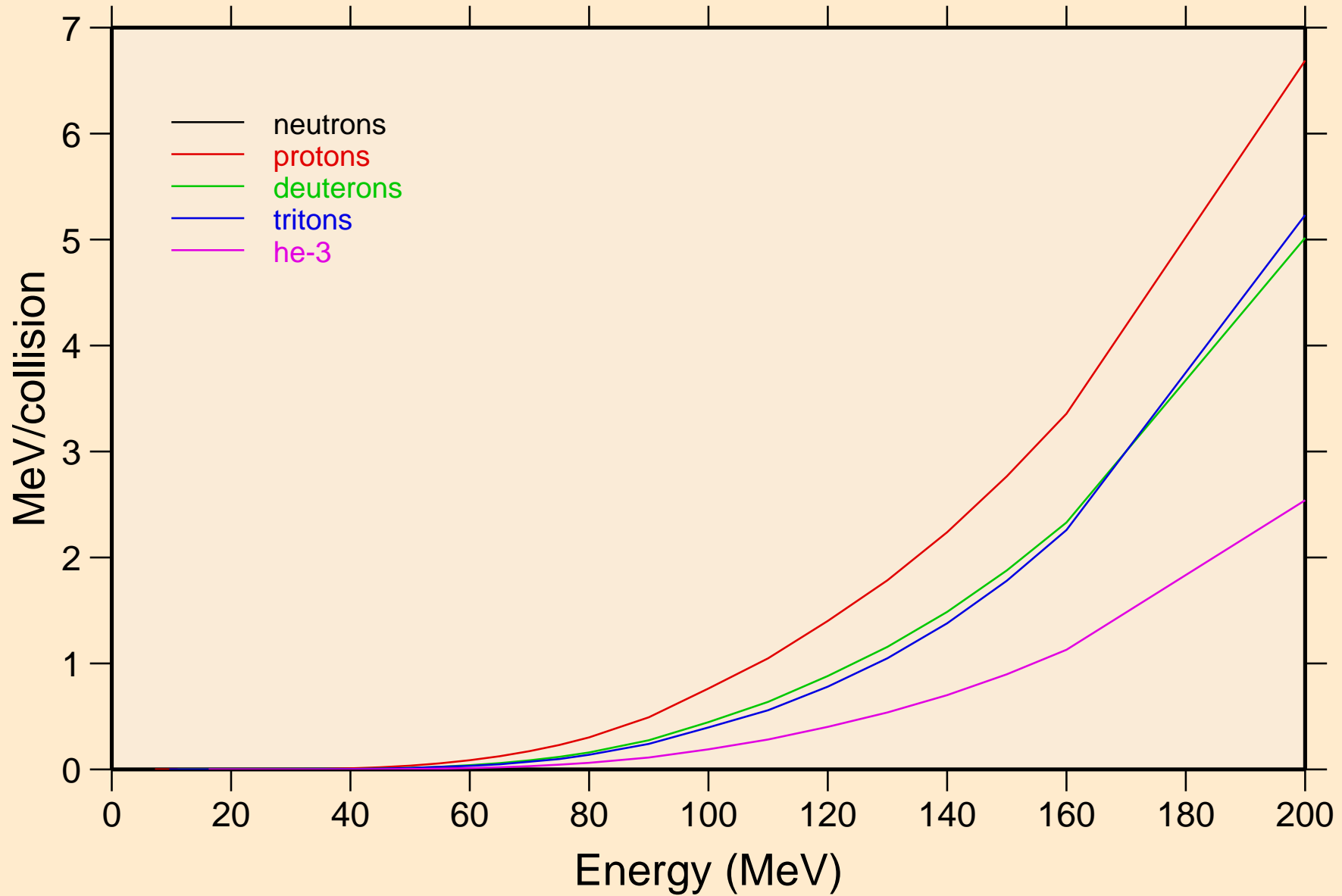

EU163 ALPHA ACER TENDL-2021 LIBRARY; T=0.K  
Recoil Heating

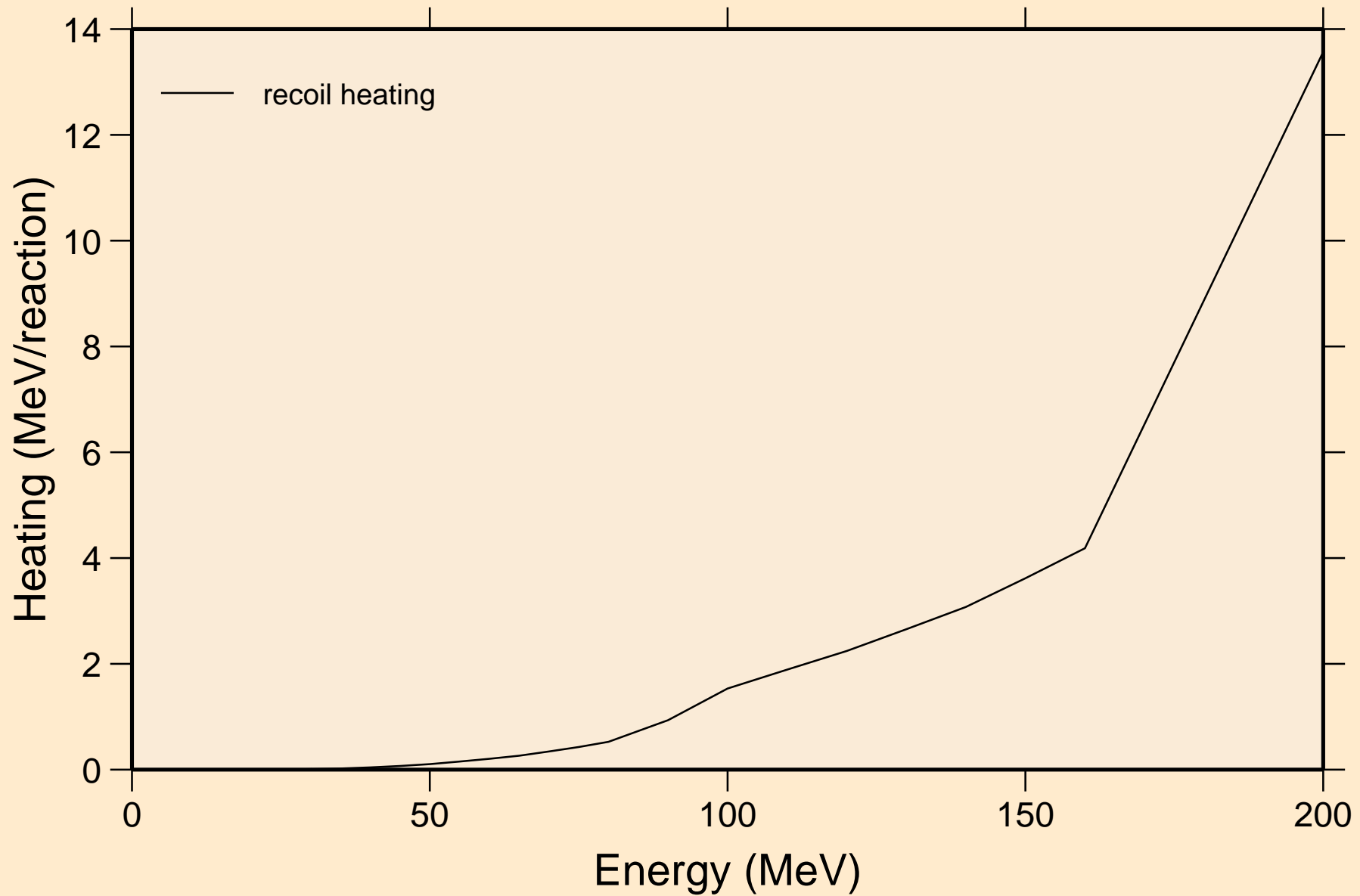

EU163 ALPHA ACER TENDL-2021 LIBRARY; T=0.K  
Particle production cross sections

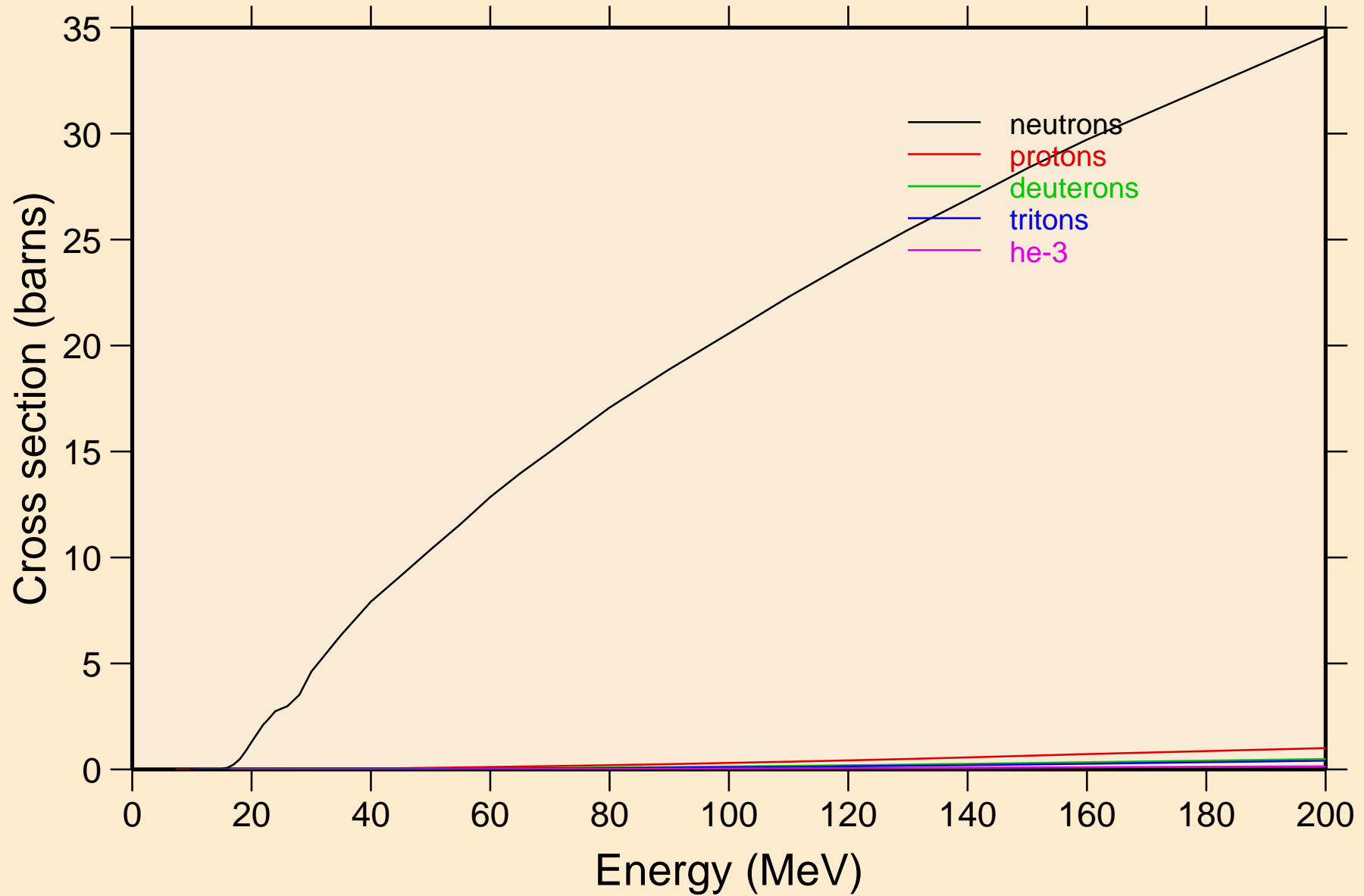

EU163 ALPHA ACER TENDL-2021 LIBRARY; T=0.K  
neutrons from (a,n)

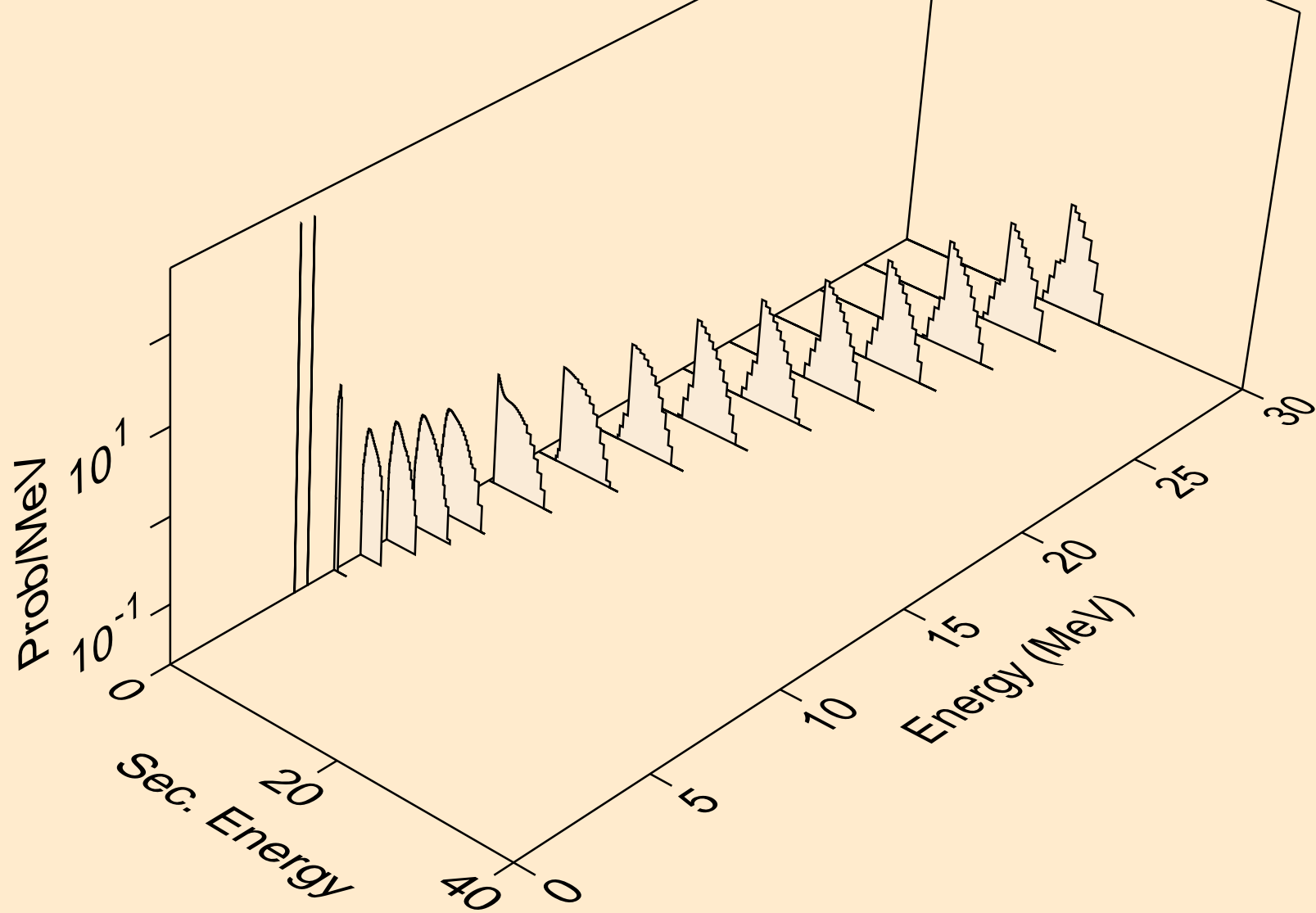

EU163 ALPHA ACER TENDL-2021 LIBRARY; T=0.K  
neutrons from (a,x)

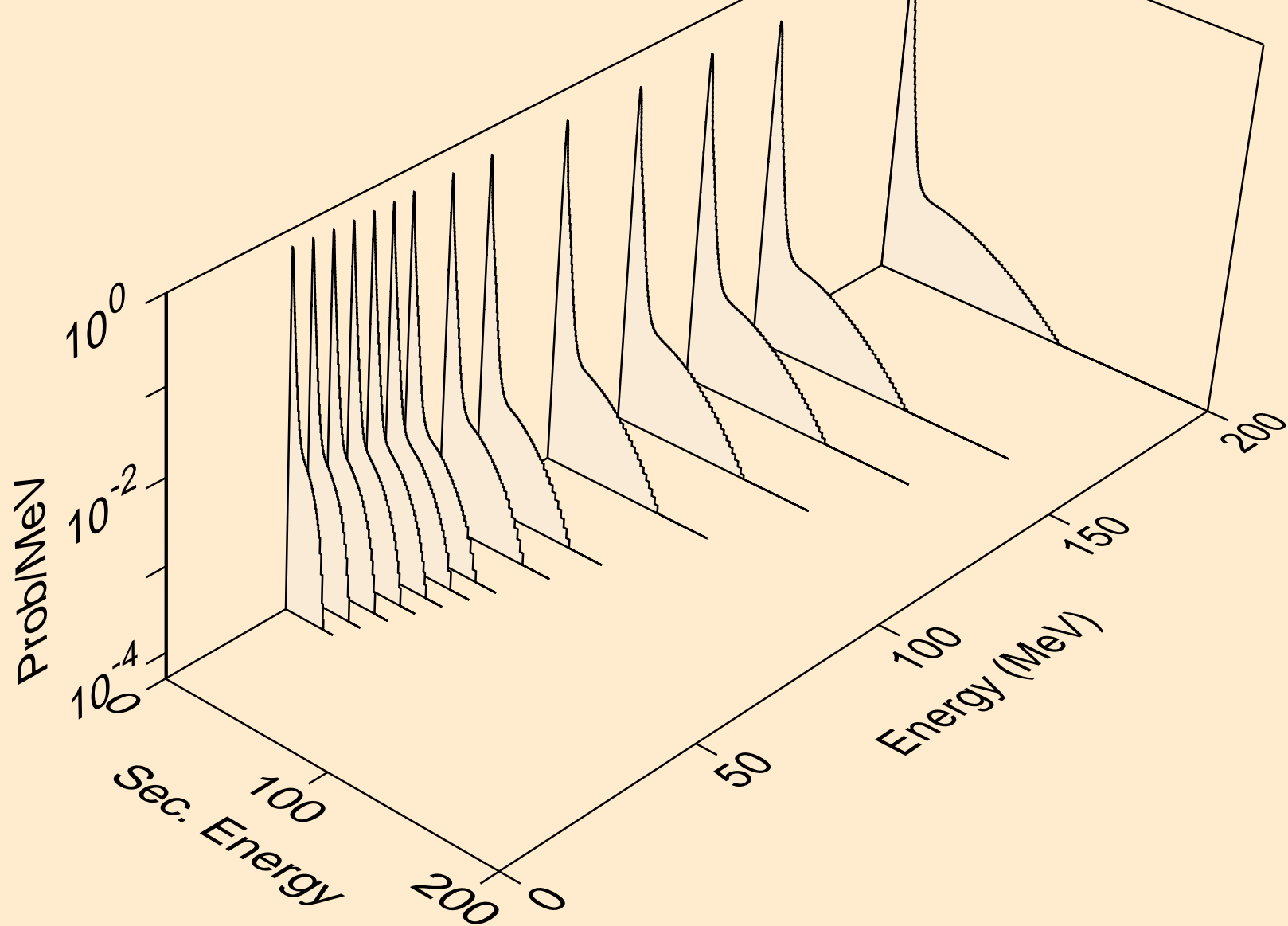

EU163 ALPHA ACER TENDL-2021 LIBRARY; T=0.K  
neutrons from (a,2nd)

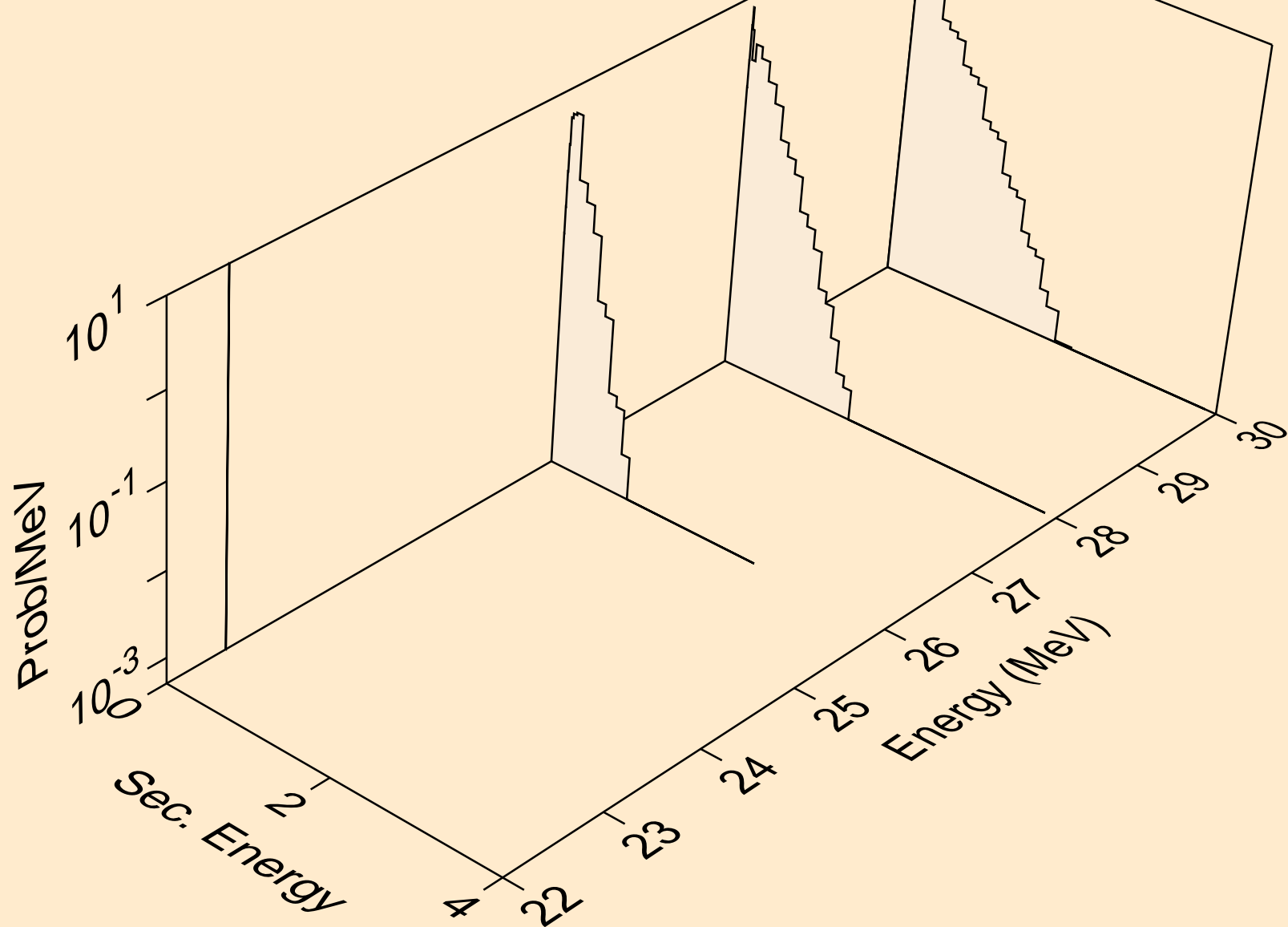

EU163 ALPHA ACER TENDL-2021 LIBRARY; T=0.K  
neutrons from (a,2n)

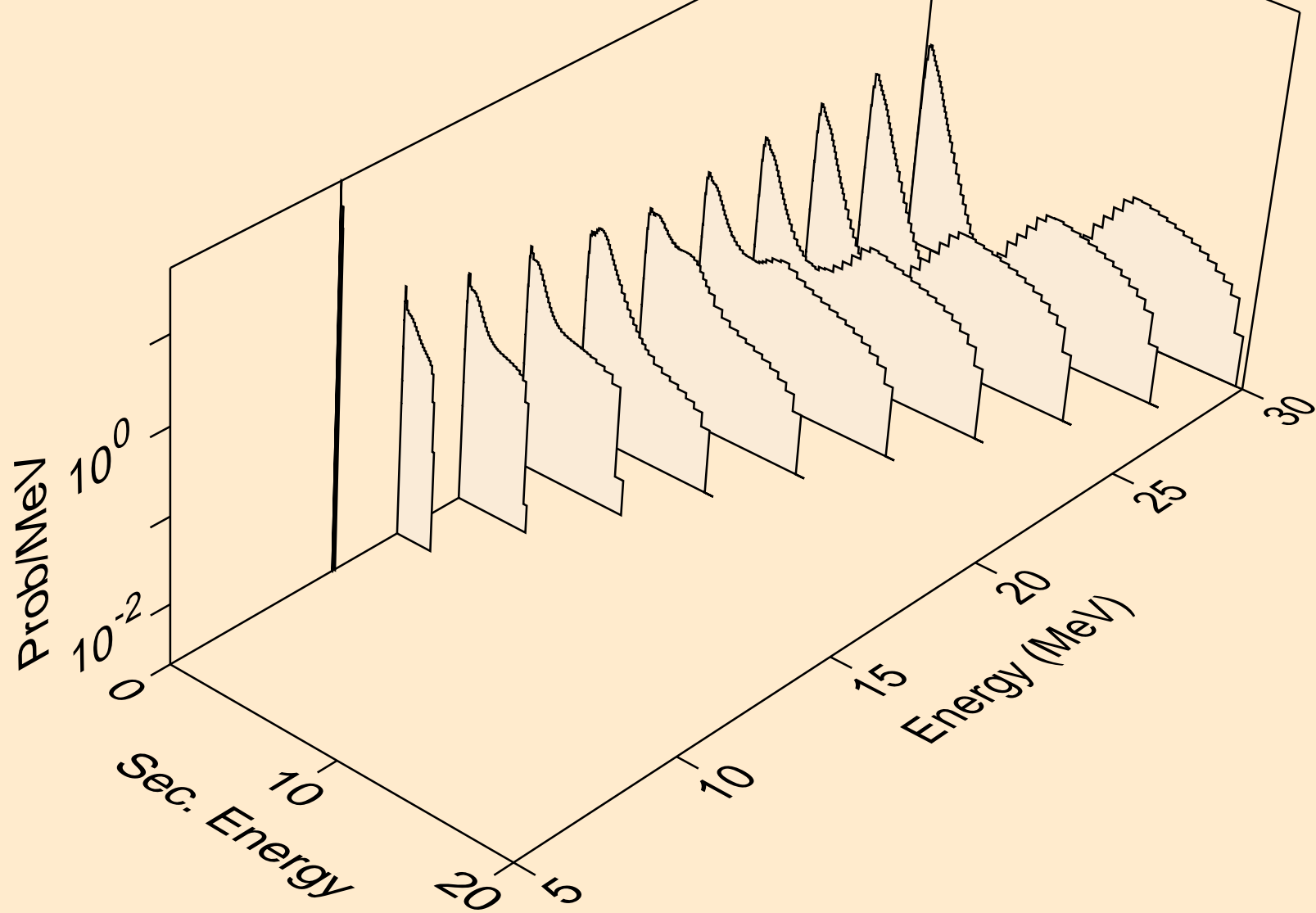

EU163 ALPHA ACER TENDL-2021 LIBRARY; T=0.K  
neutrons from (a,3n)

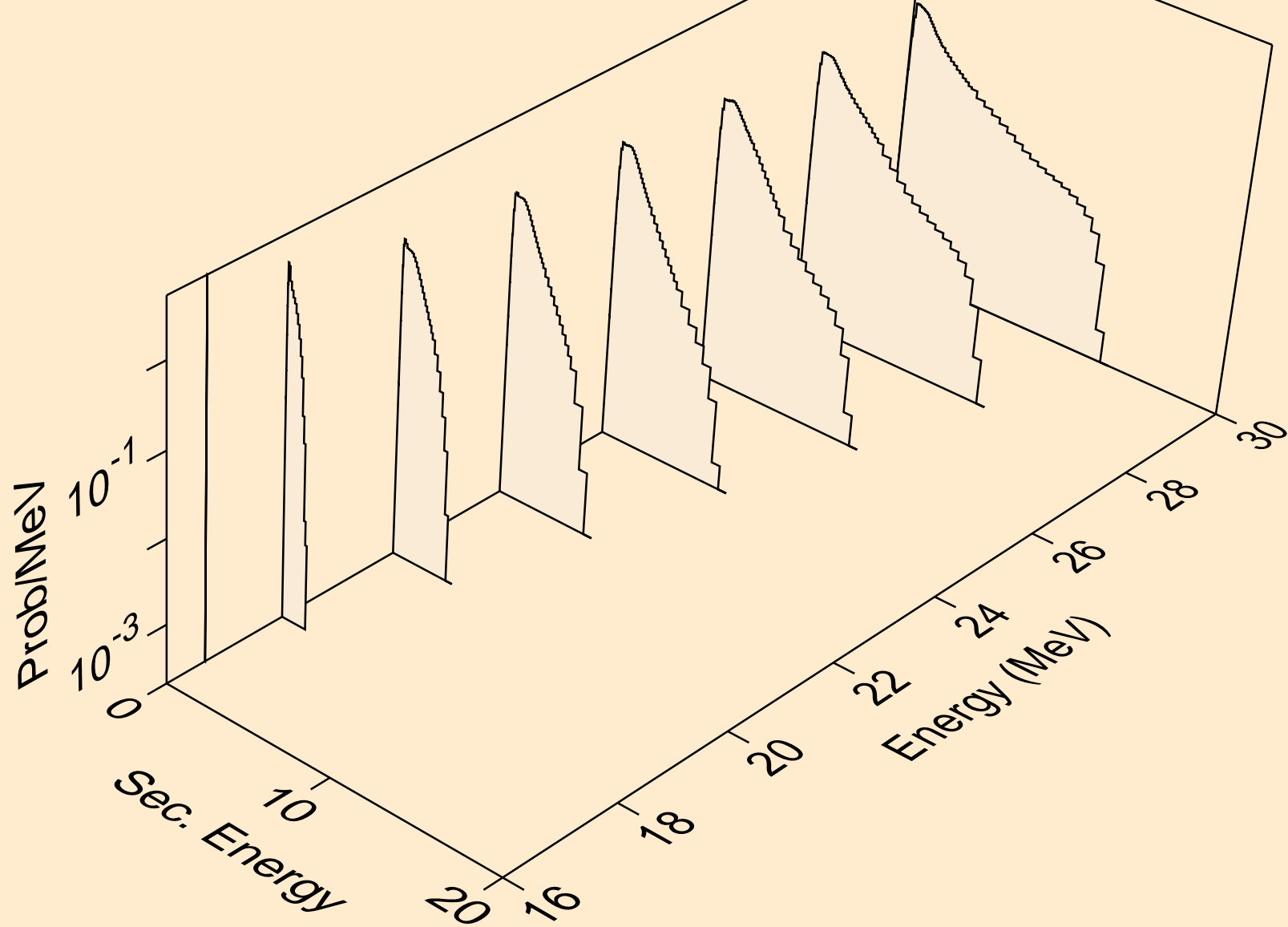



EU163 ALPHA ACER TENDL-2021 LIBRARY; T=0.K  
neutrons from (a,n\*)a

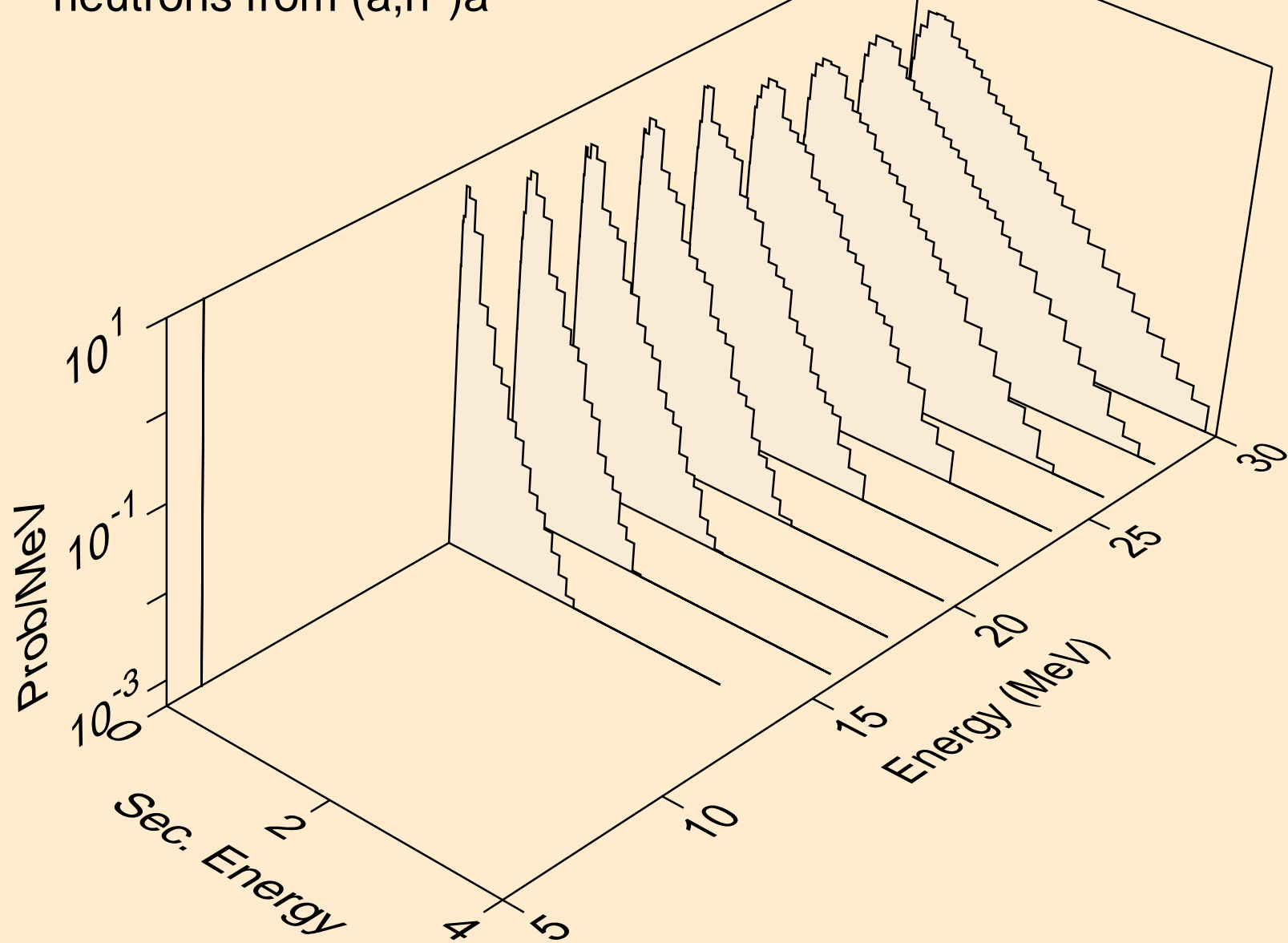

EU163 ALPHA ACER TENDL-2021 LIBRARY; T=0.K  
neutrons from (a,2n)a

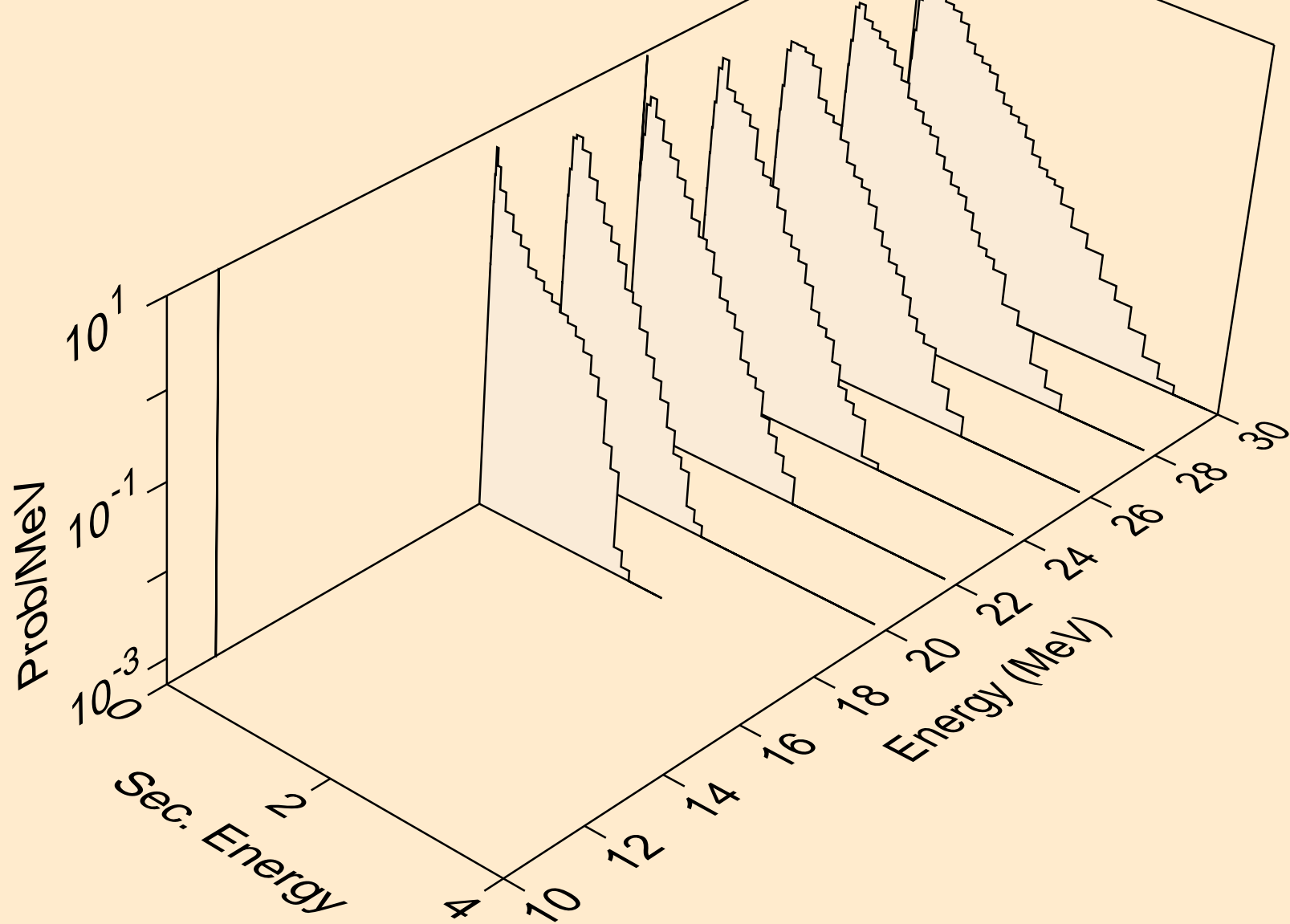

EU163 ALPHA ACER TENDL-2021 LIBRARY; T=0.K  
neutrons from (a,3n)a

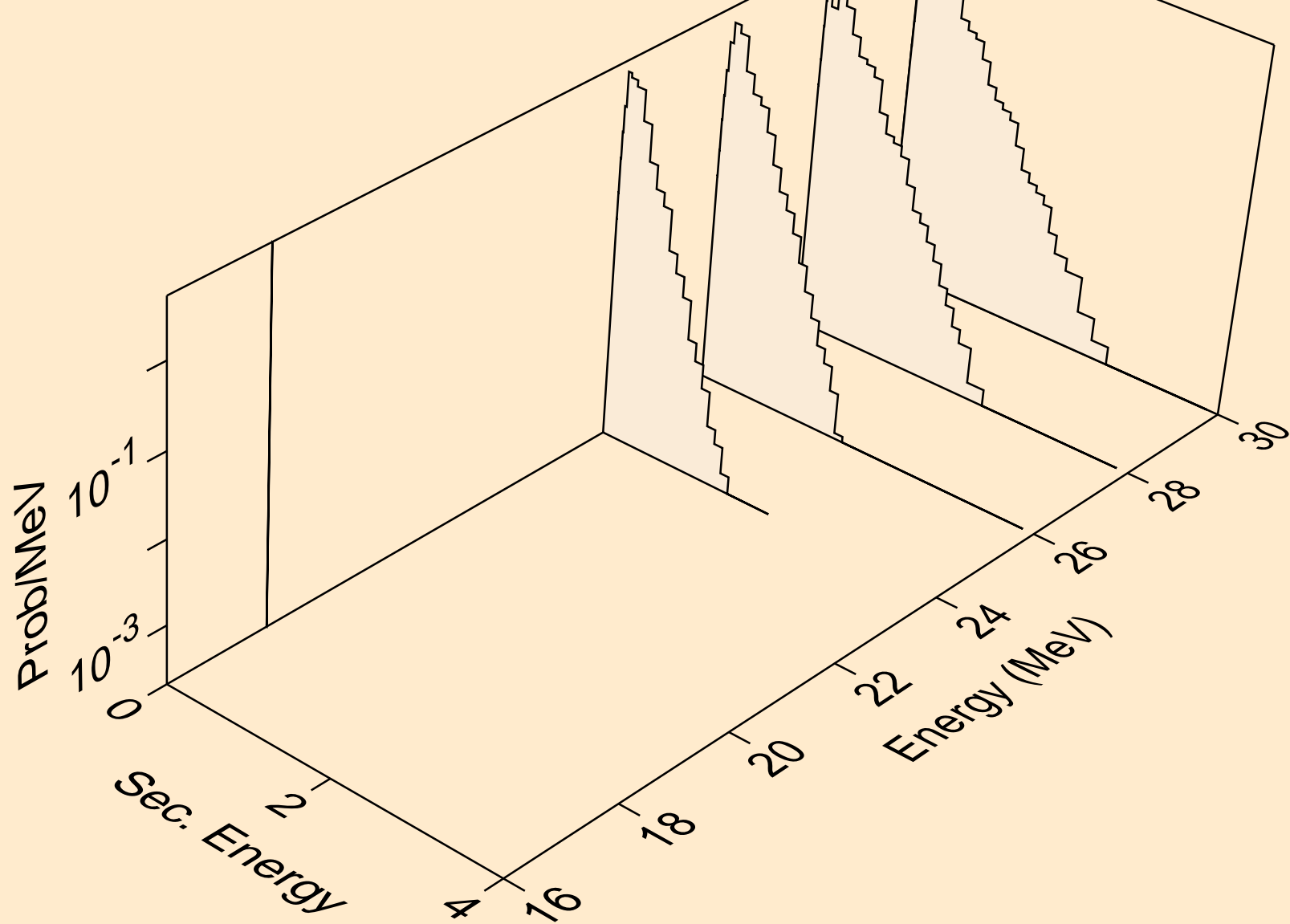

EU163 ALPHA ACER TENDL-2021 LIBRARY; T=0.K  
neutrons from (a,n\*)p

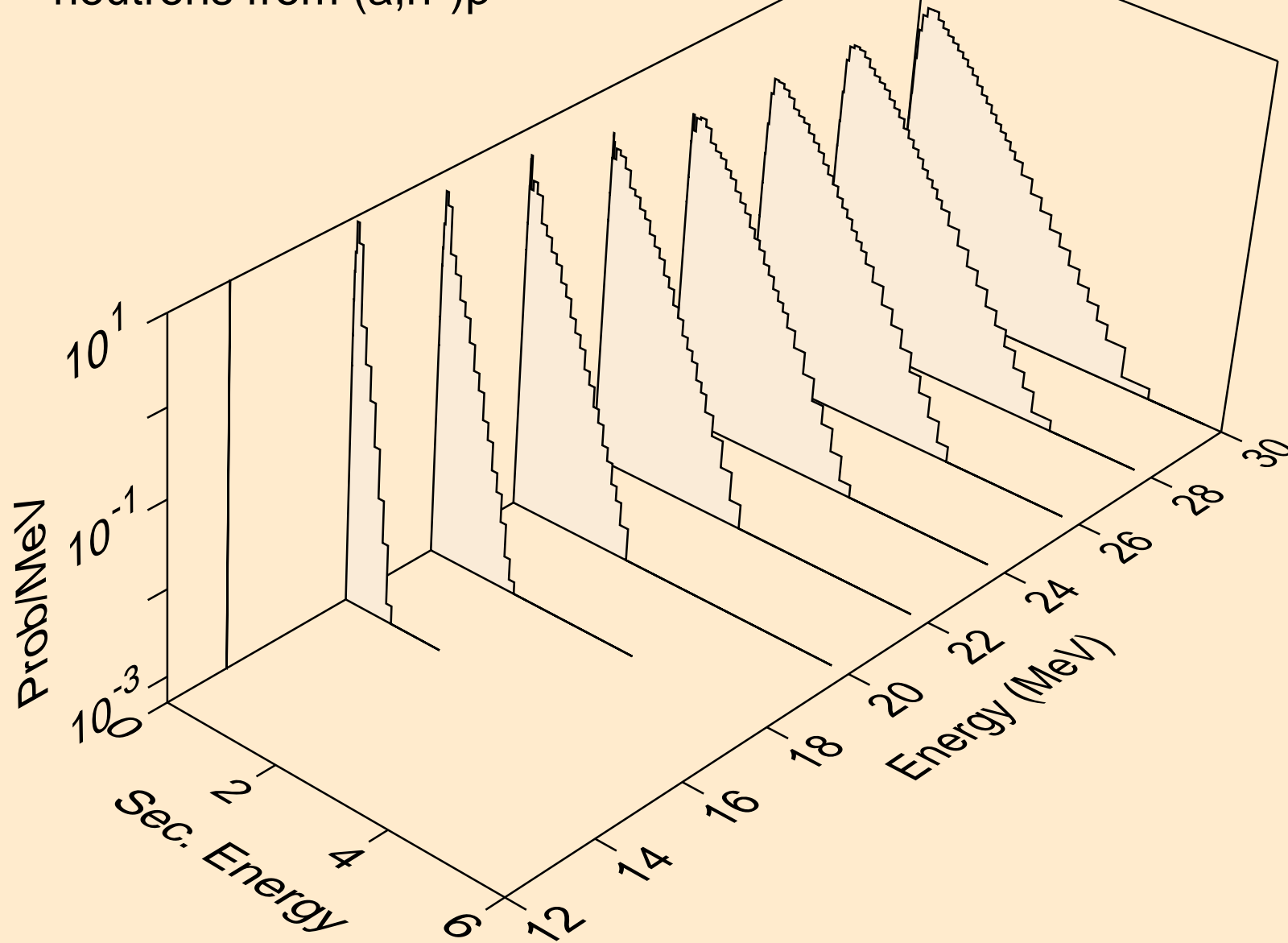

EU163 ALPHA ACER TENDL-2021 LIBRARY; T=0.K  
neutrons from (a,n\*)d

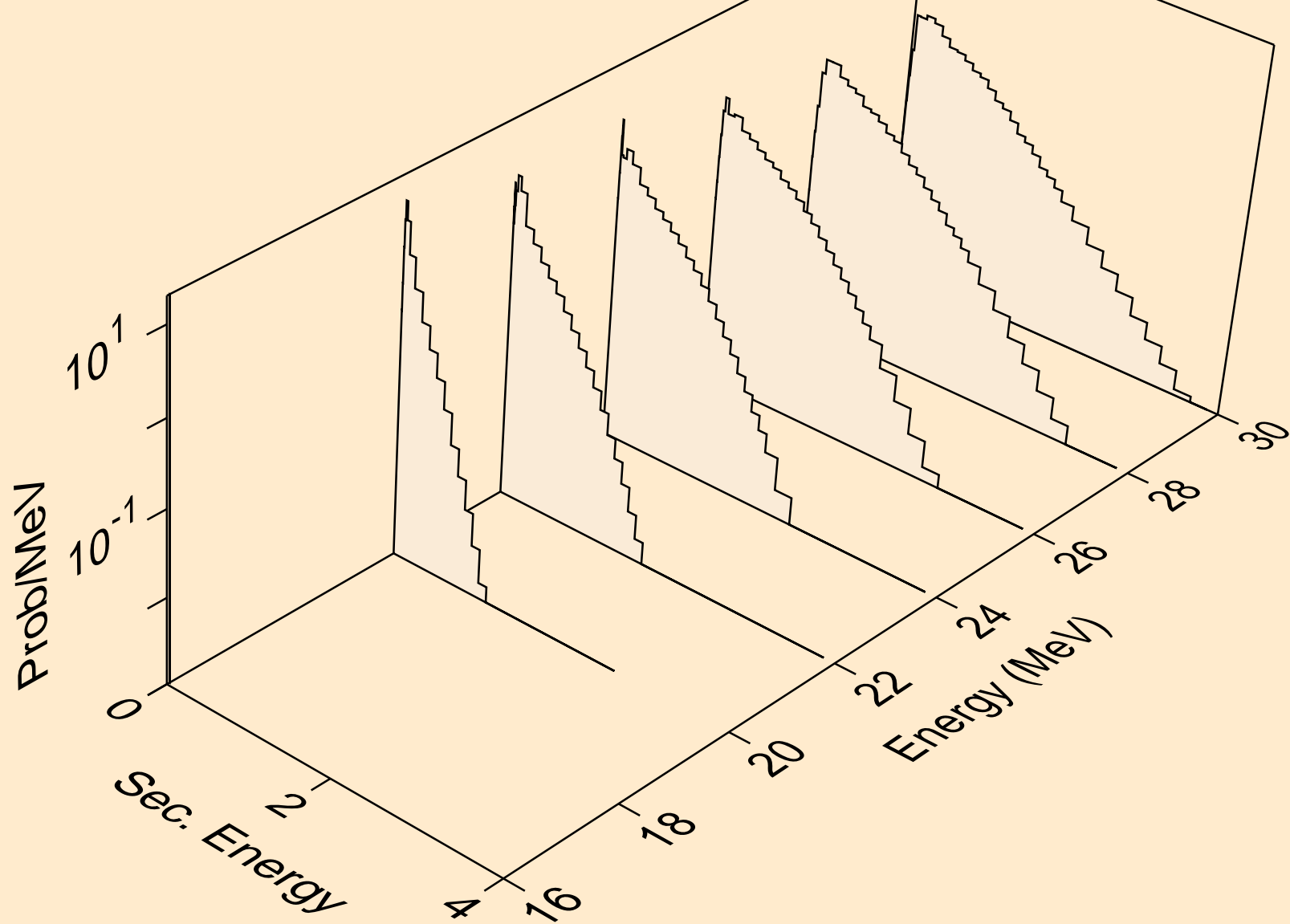

EU163 ALPHA ACER TENDL-2021 LIBRARY; T=0.K  
neutrons from (a,n\*)t

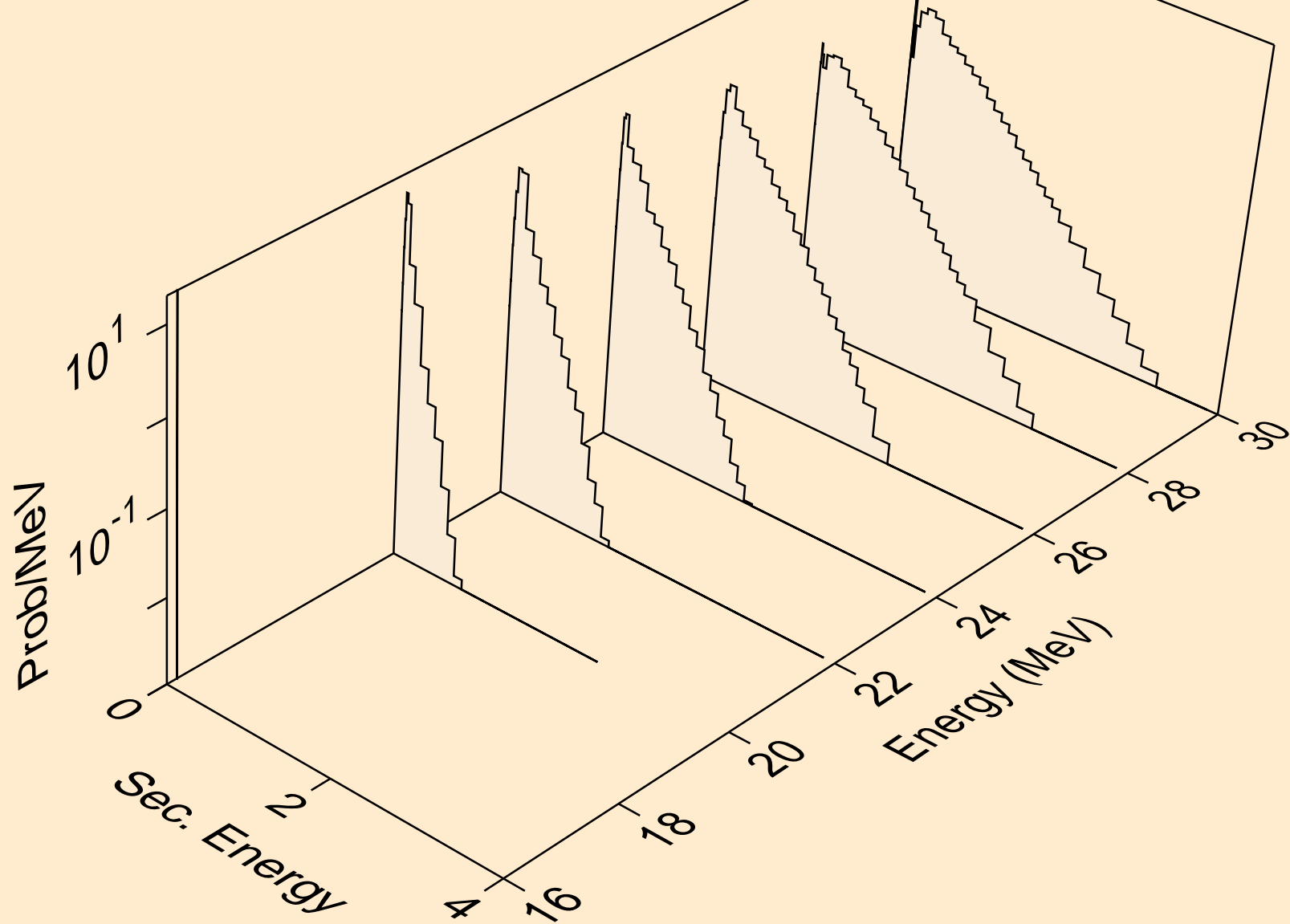

EU163 ALPHA ACER TENDL-2021 LIBRARY; T=0.K  
neutrons from (a,4n)

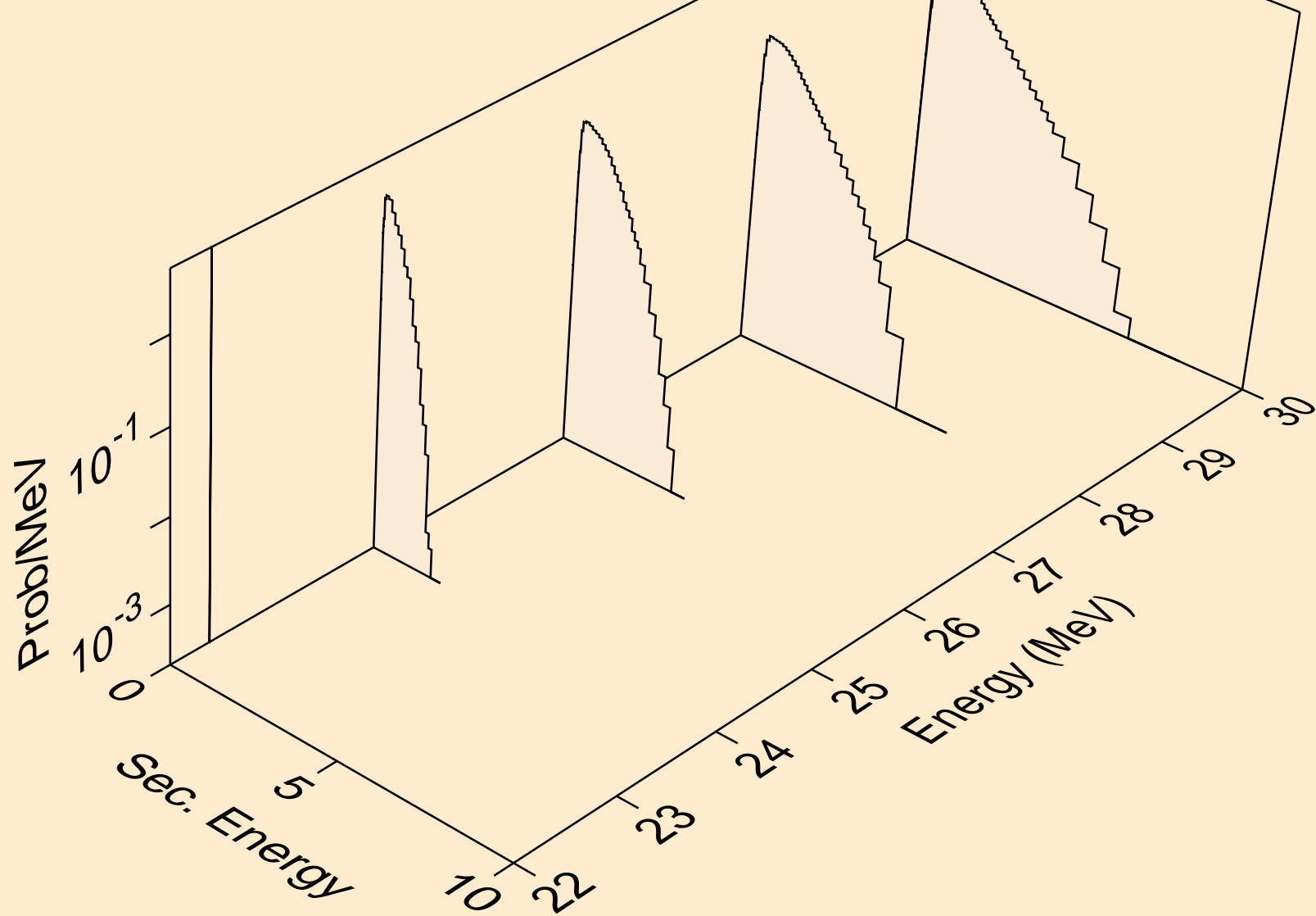

EU163 ALPHA ACER TENDL-2021 LIBRARY; T=0.K  
neutrons from (a,2np)

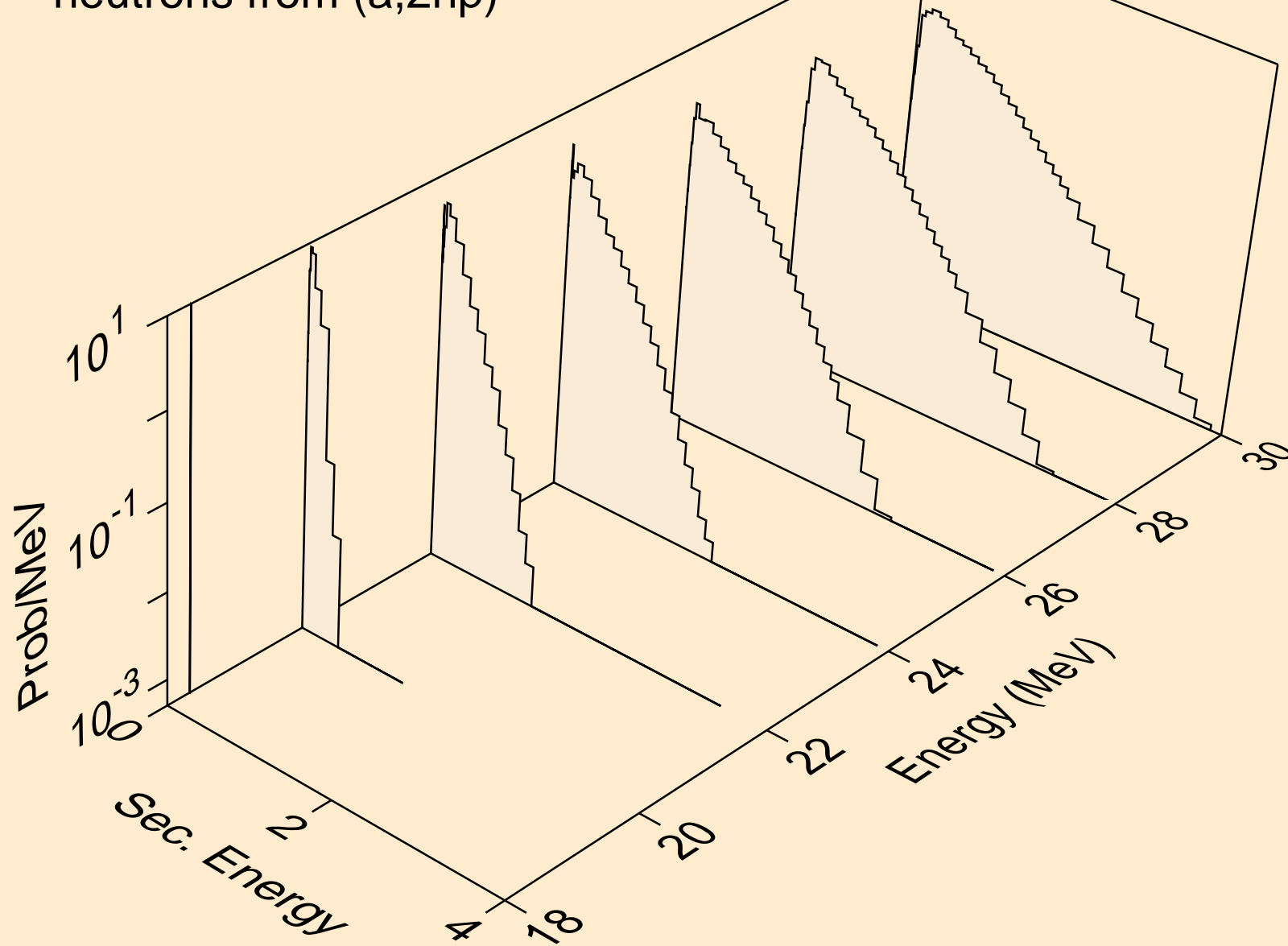



EU163 ALPHA ACER TENDL-2021 LIBRARY; T=0.K  
neutrons from (a,3np)

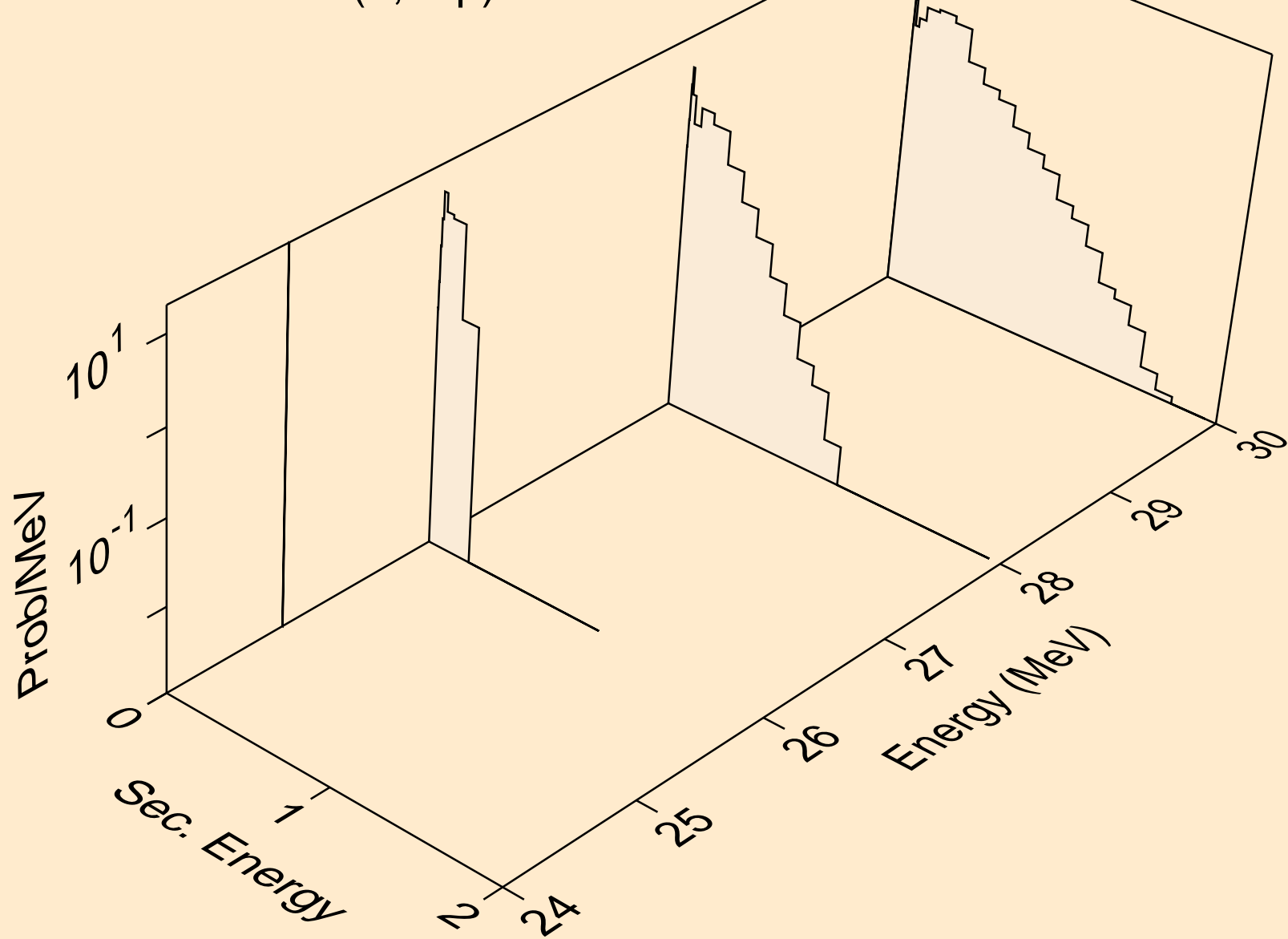

EU163 ALPHA ACER TENDL-2021 LIBRARY; T=0.K  
protons from (a,x)

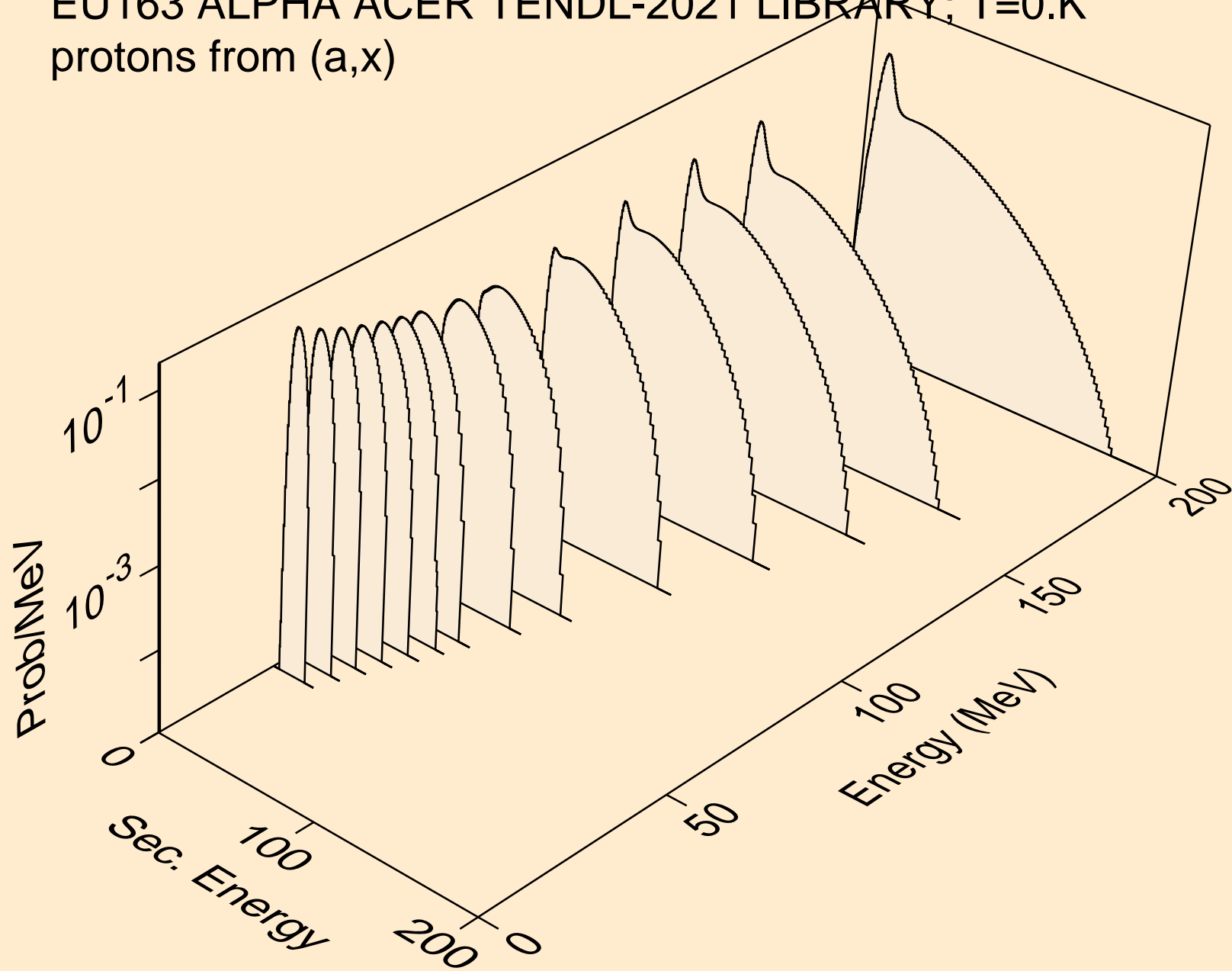

EU163 ALPHA ACER TENDL-2021 LIBRARY; T=0.K  
protons from (a,n\*)p

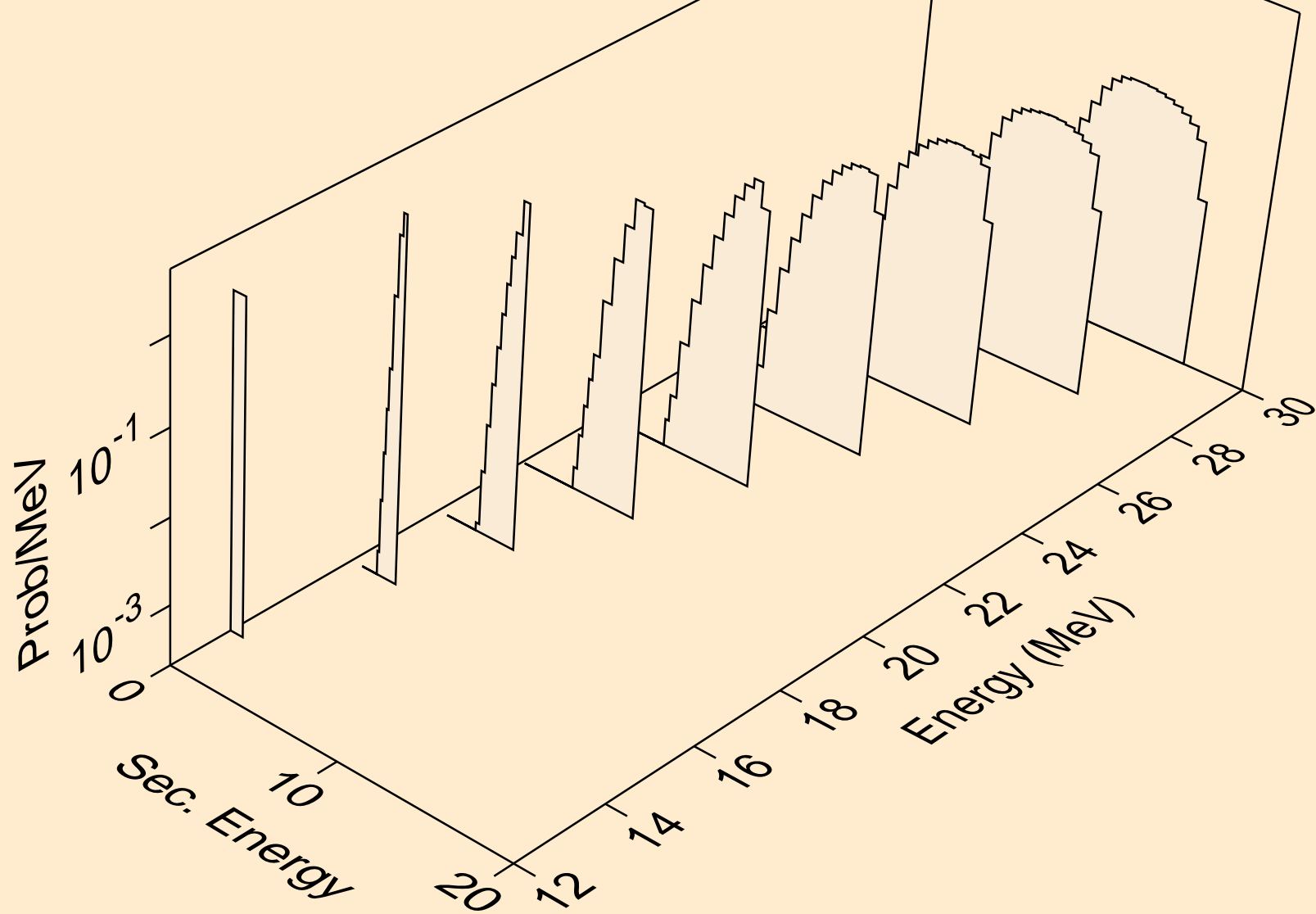

EU163 ALPHA ACER TENDL-2021 LIBRARY; T=0.K  
protons from (a,2np)

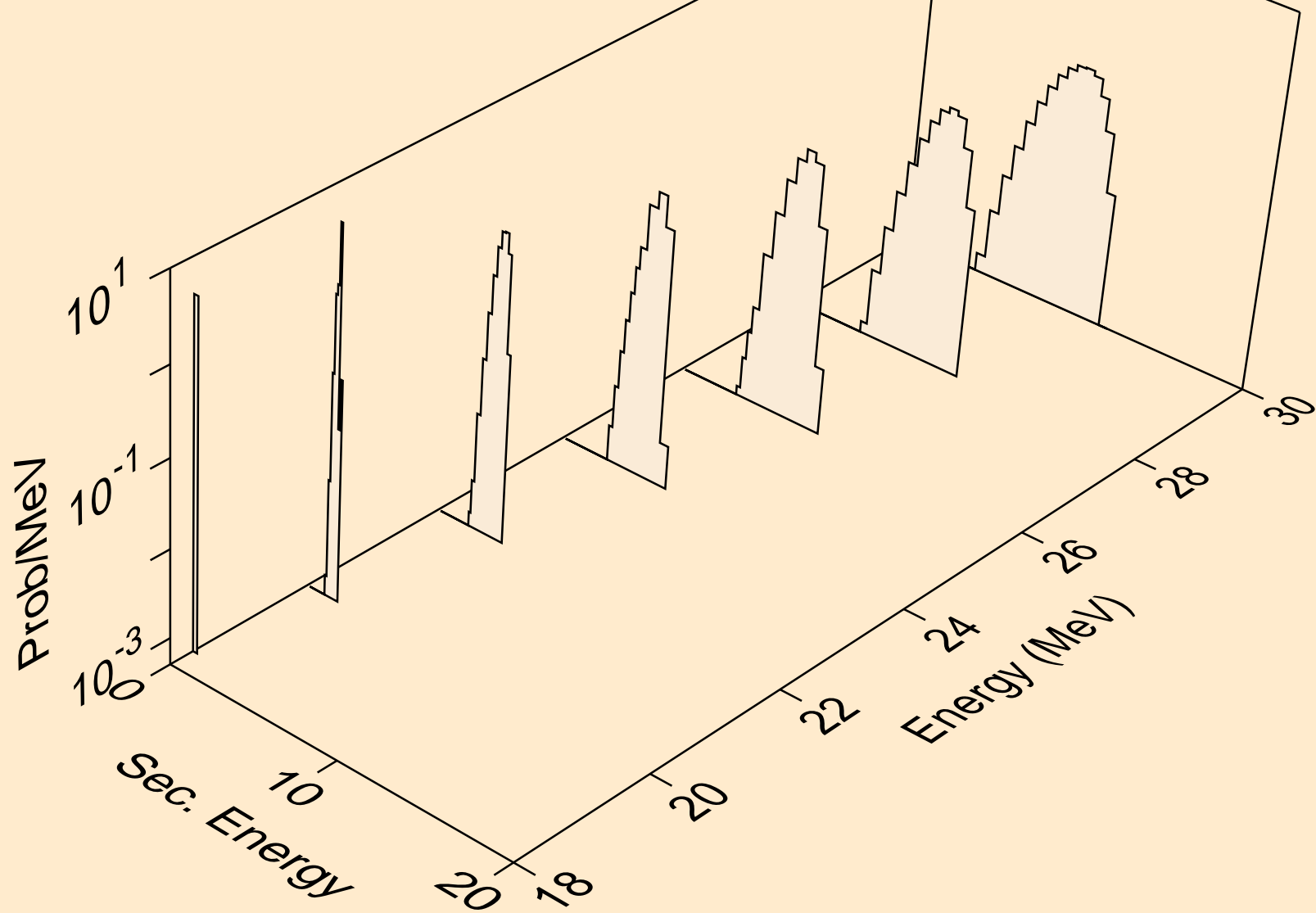

EU163 ALPHA ACER TENDL-2021 LIBRARY; T=0.K  
protons from (a,3np)

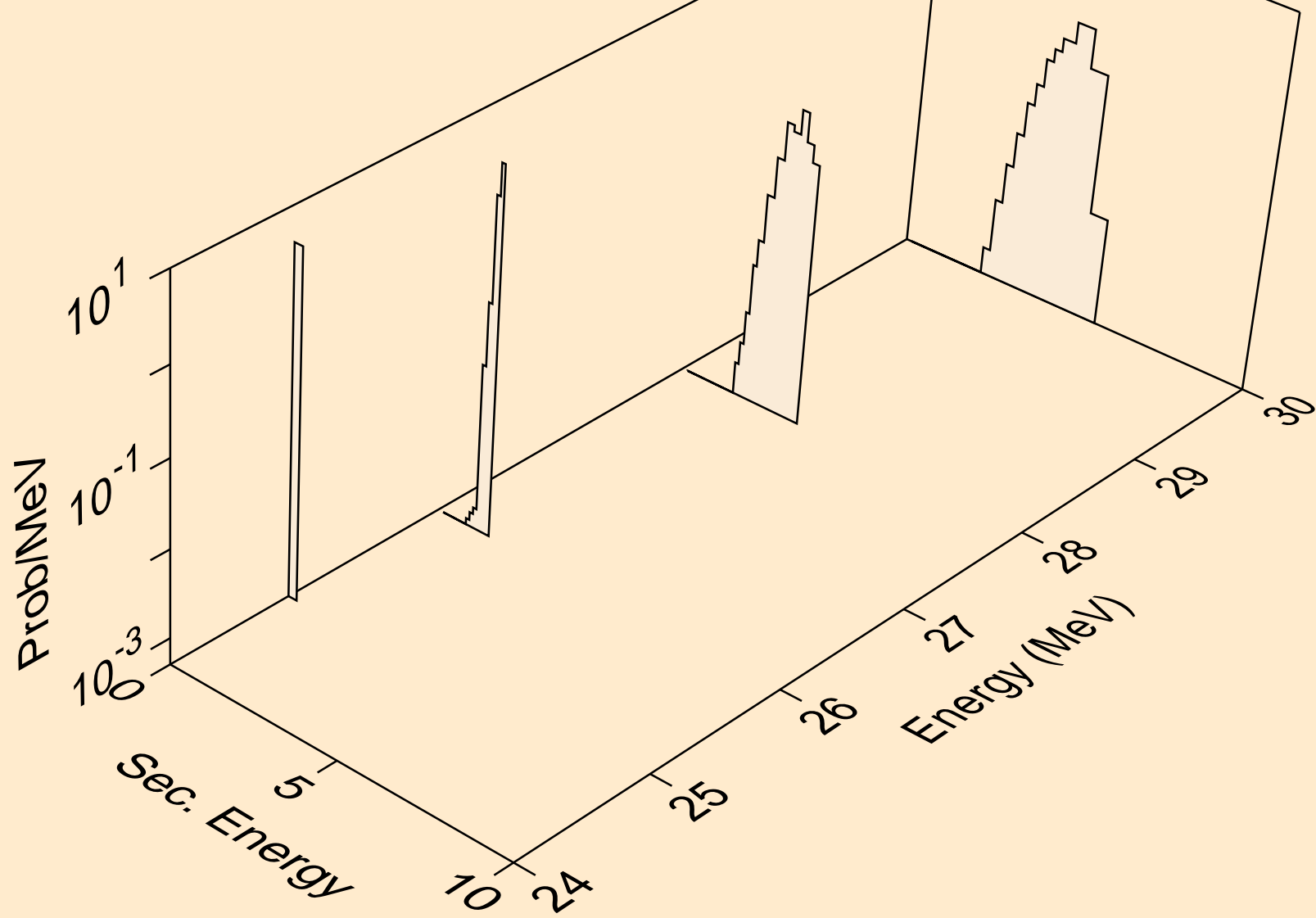

EU163 ALPHA ACER TENDL-2021 LIBRARY; T=0.K  
protons from (a,p)

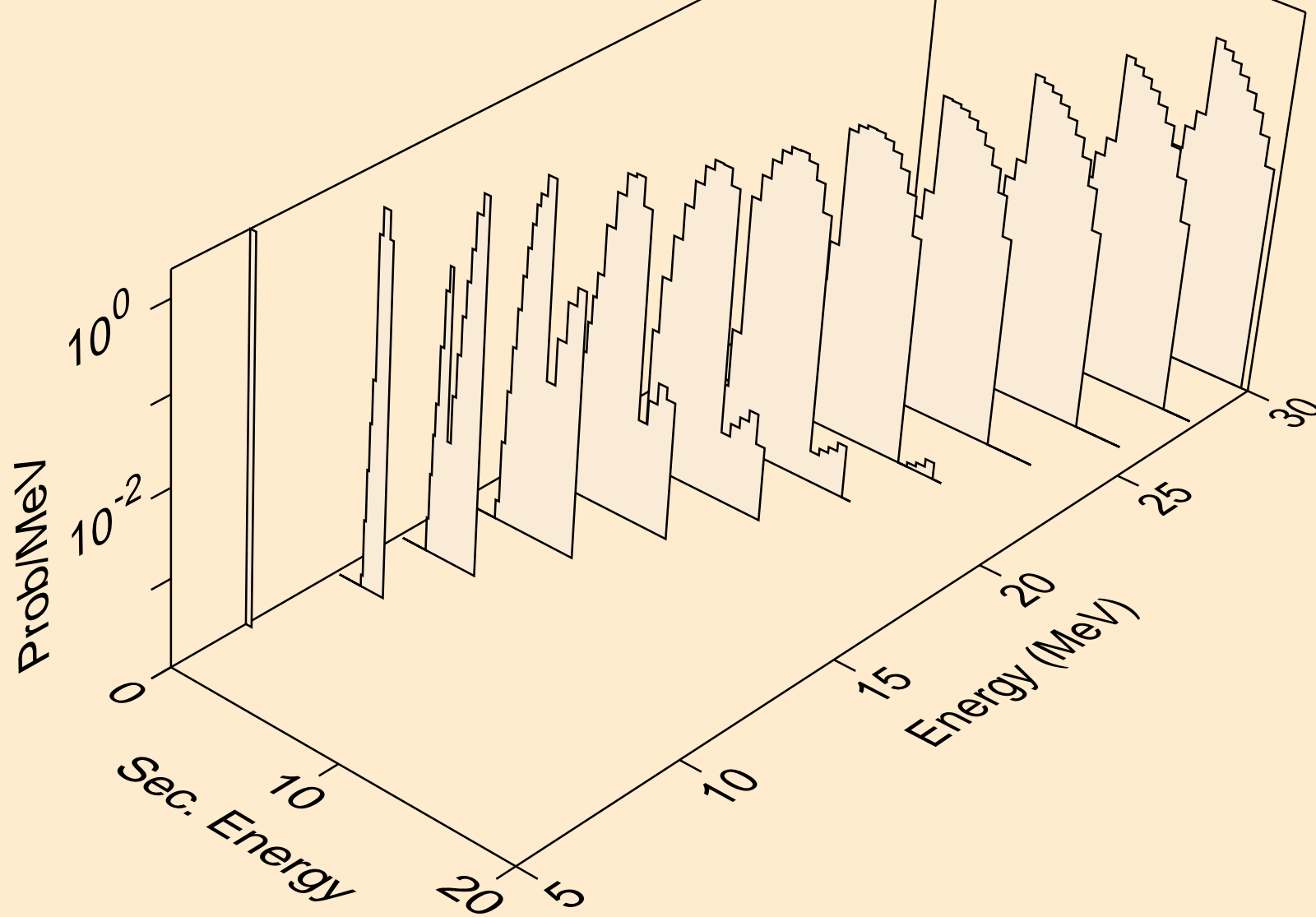

EU163 ALPHA ACER TENDL-2021 LIBRARY; T=0.K  
deuterons from (a,x)

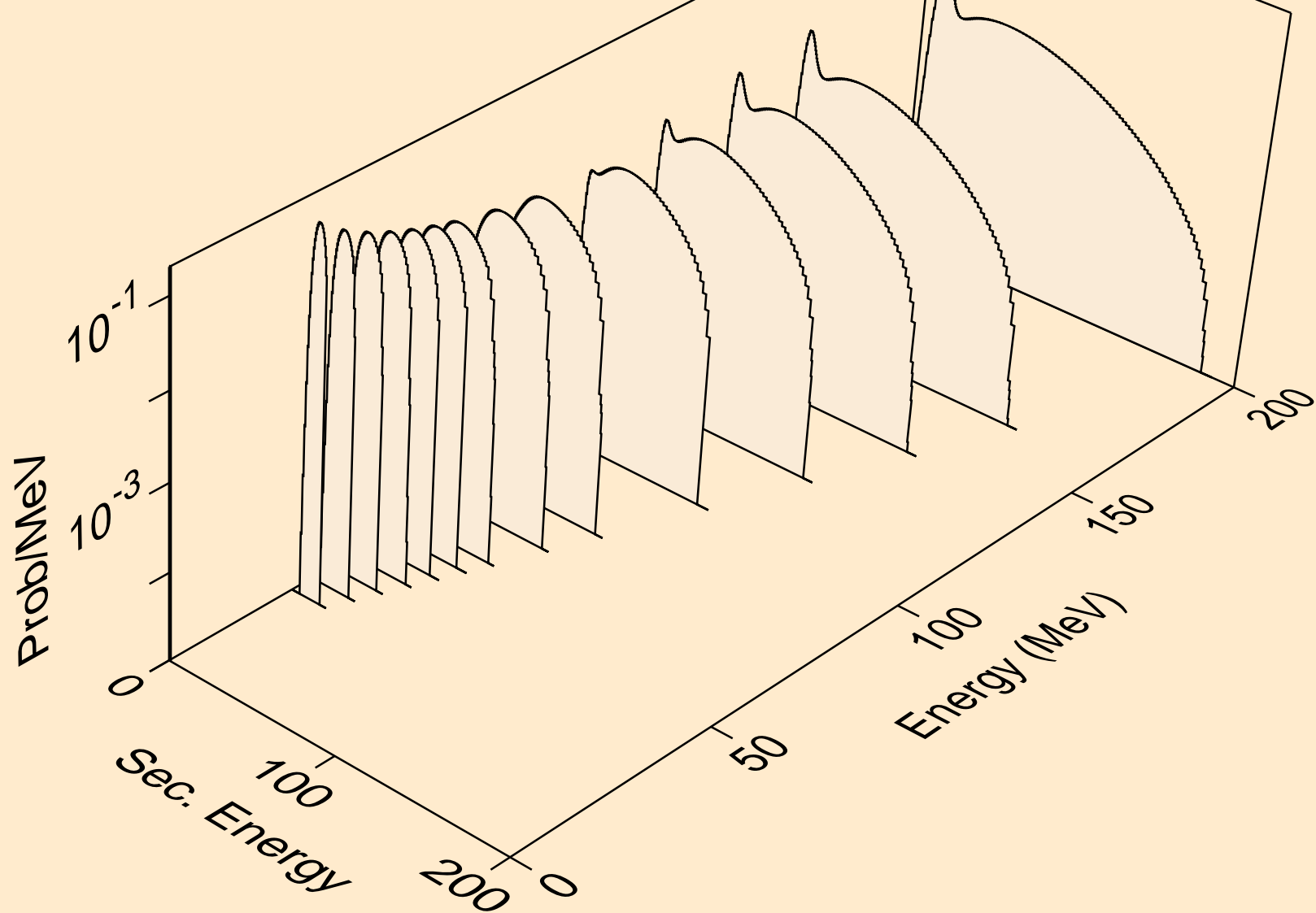

EU163 ALPHA ACER TENDL-2021 LIBRARY; T=0.K  
deuterons from (a,2nd)

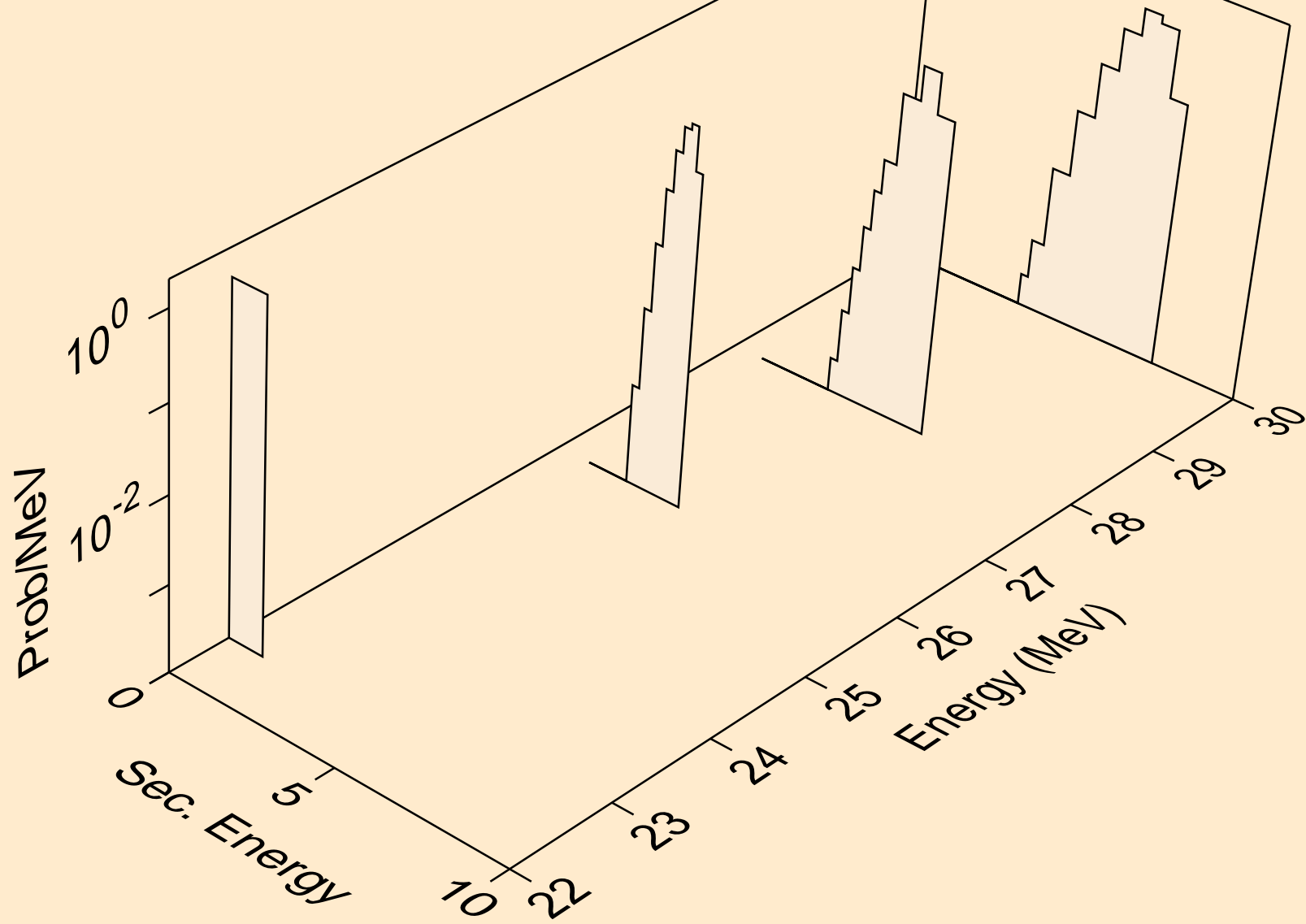



EU163 ALPHA ACER TENDL-2021 LIBRARY; T=0.K  
deuterons from (a,n\*)d

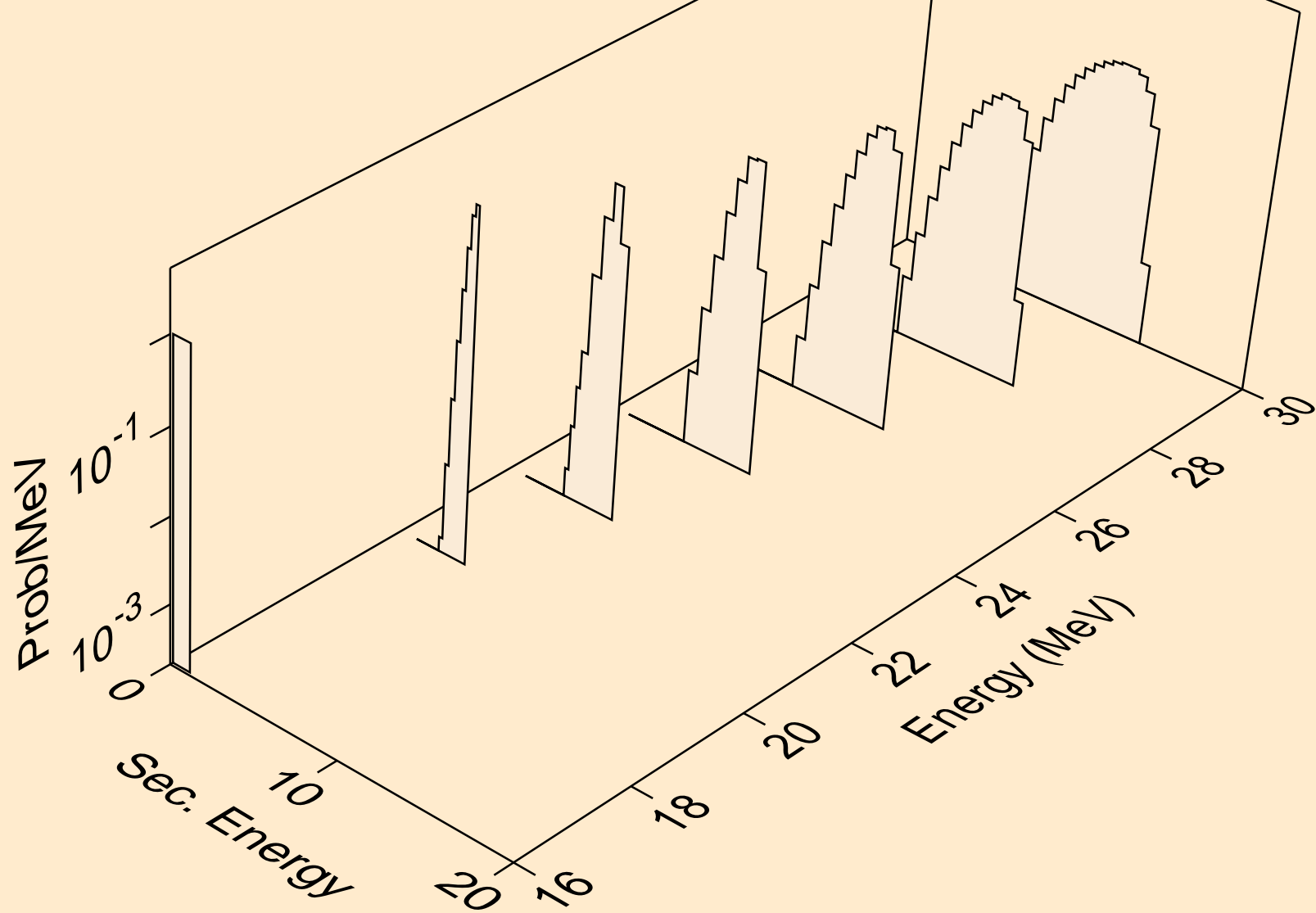

EU163 ALPHA ACER TENDL-2021 LIBRARY; T=0.K  
deuterons from (a,d)

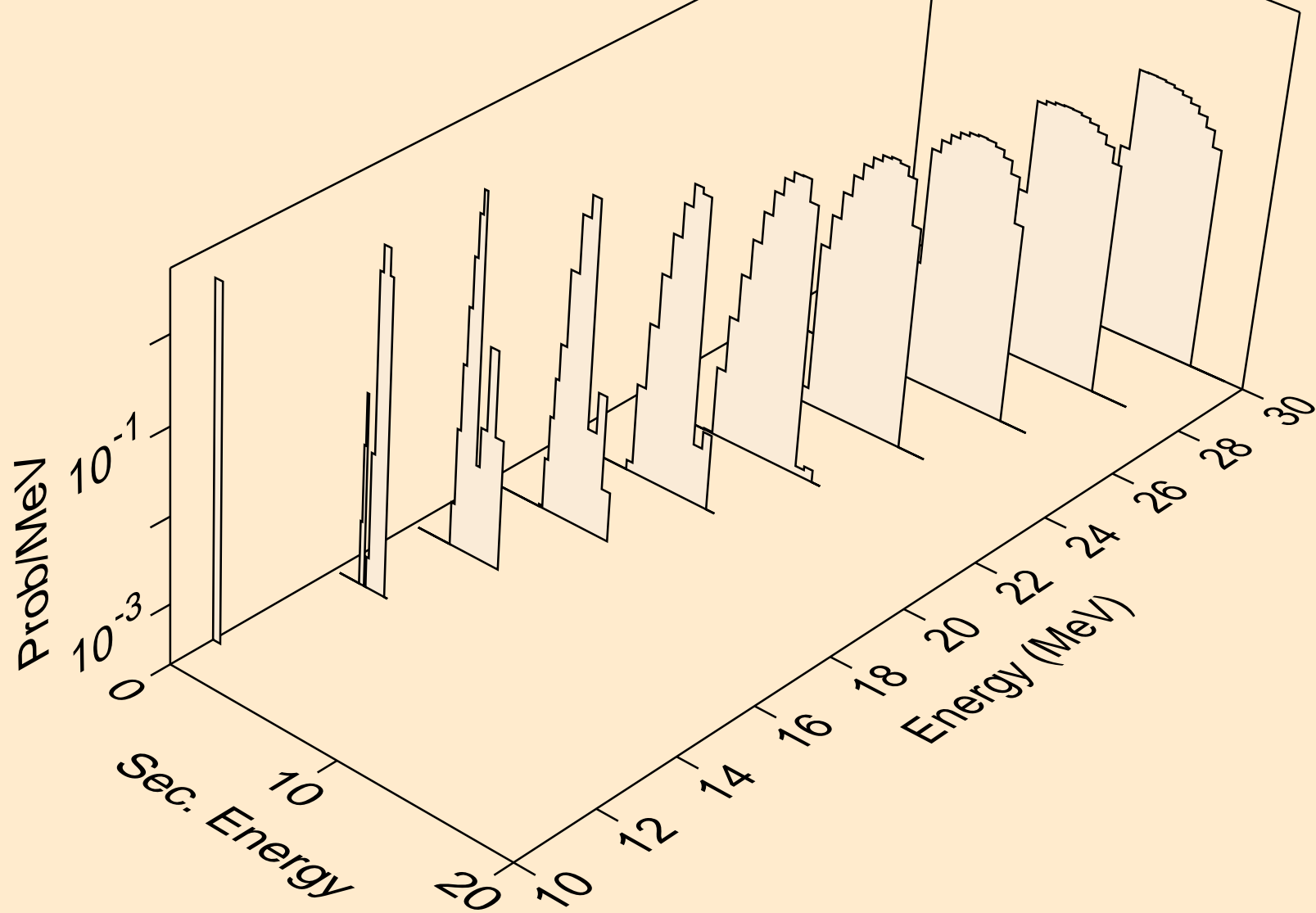

EU163 ALPHA ACER TENDL-2021 LIBRARY; T=0.K  
tritons from (a,x)

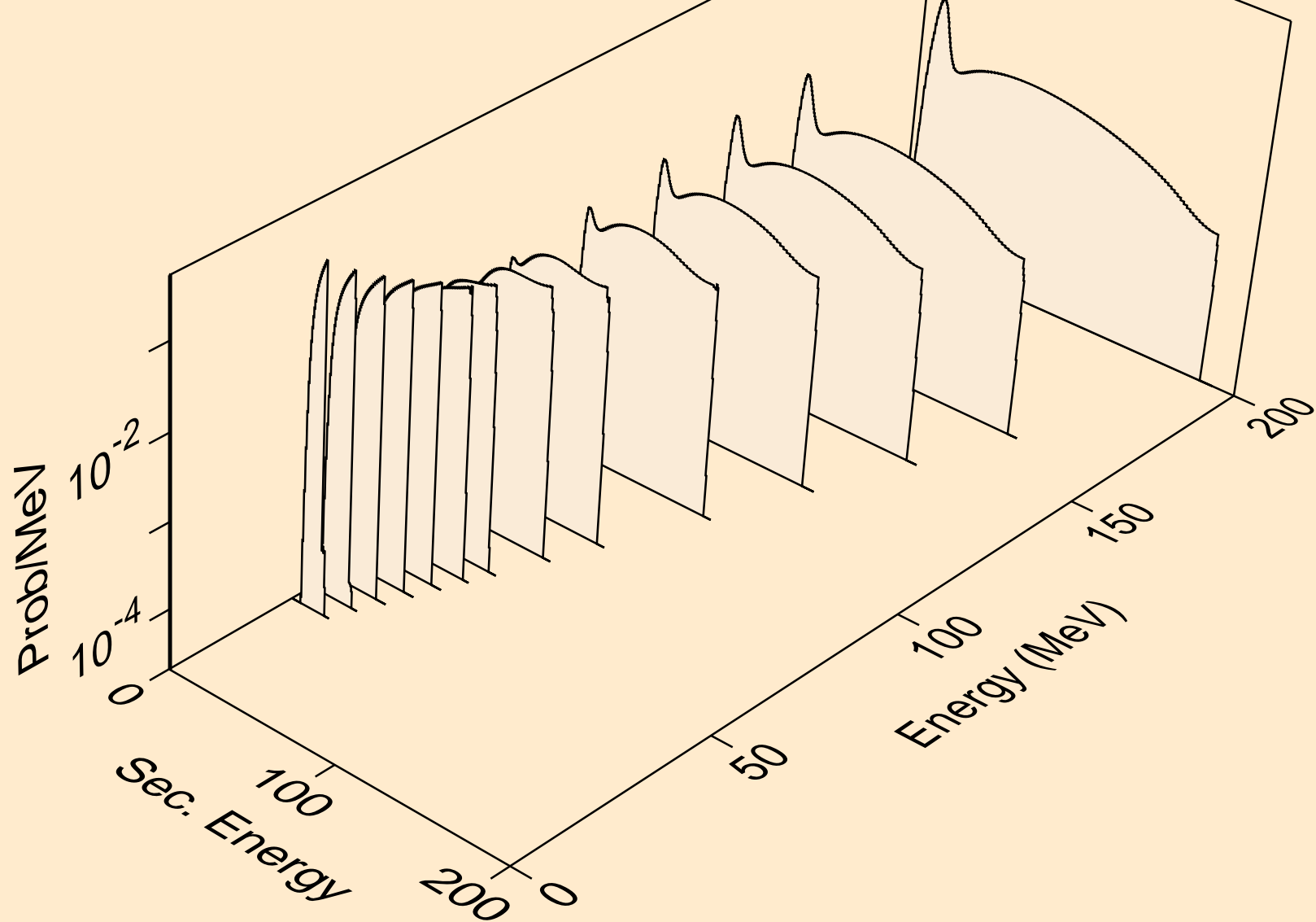

EU163 ALPHA ACER TENDL-2021 LIBRARY; T=0.K  
tritons from (a,n\*)t

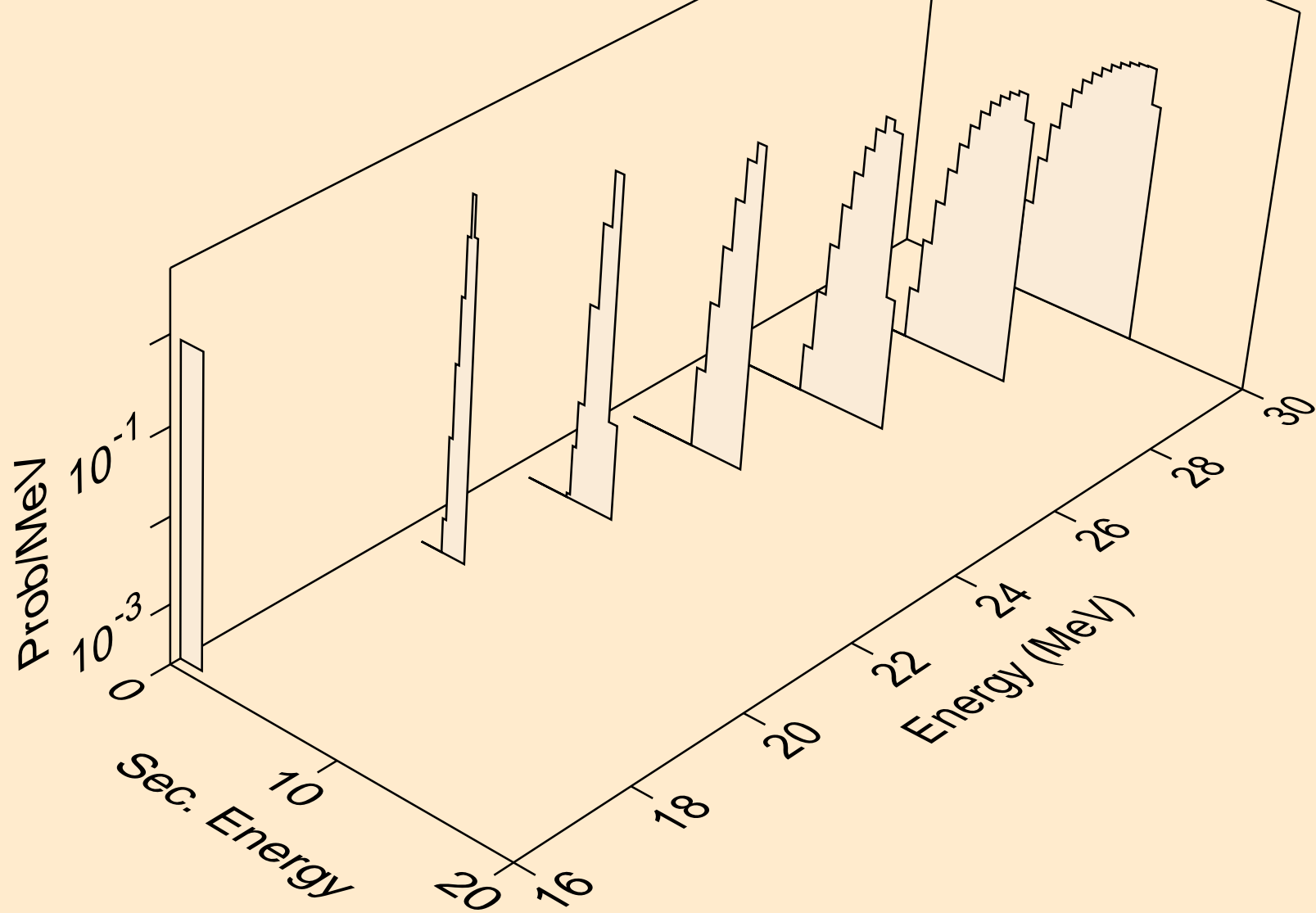

EU163 ALPHA ACER TENDL-2021 LIBRARY; T=0.K  
tritons from (a,t)

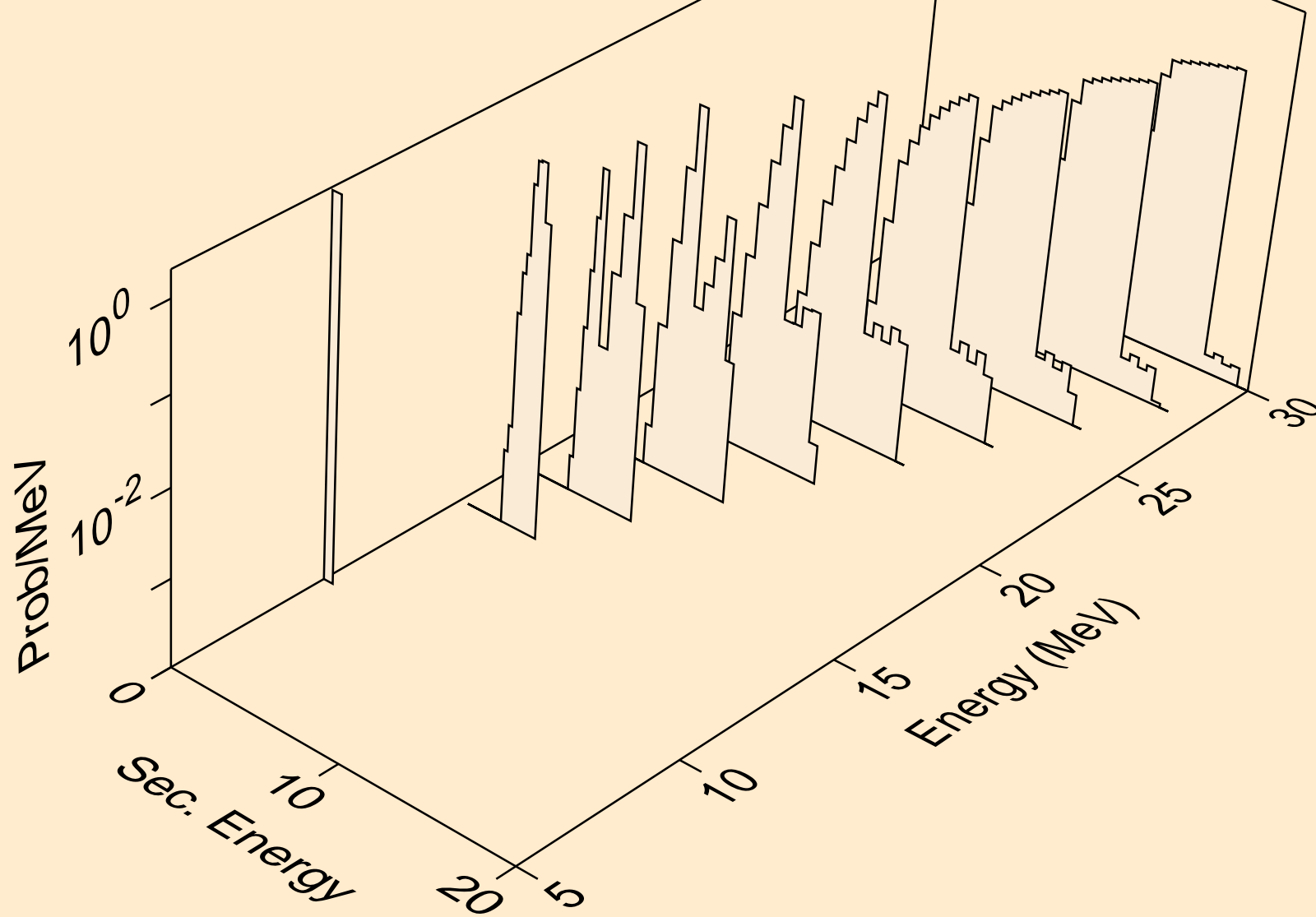

EU163 ALPHA ACER TENDL-2021 LIBRARY; T=0.K  
he3s from (a,x)

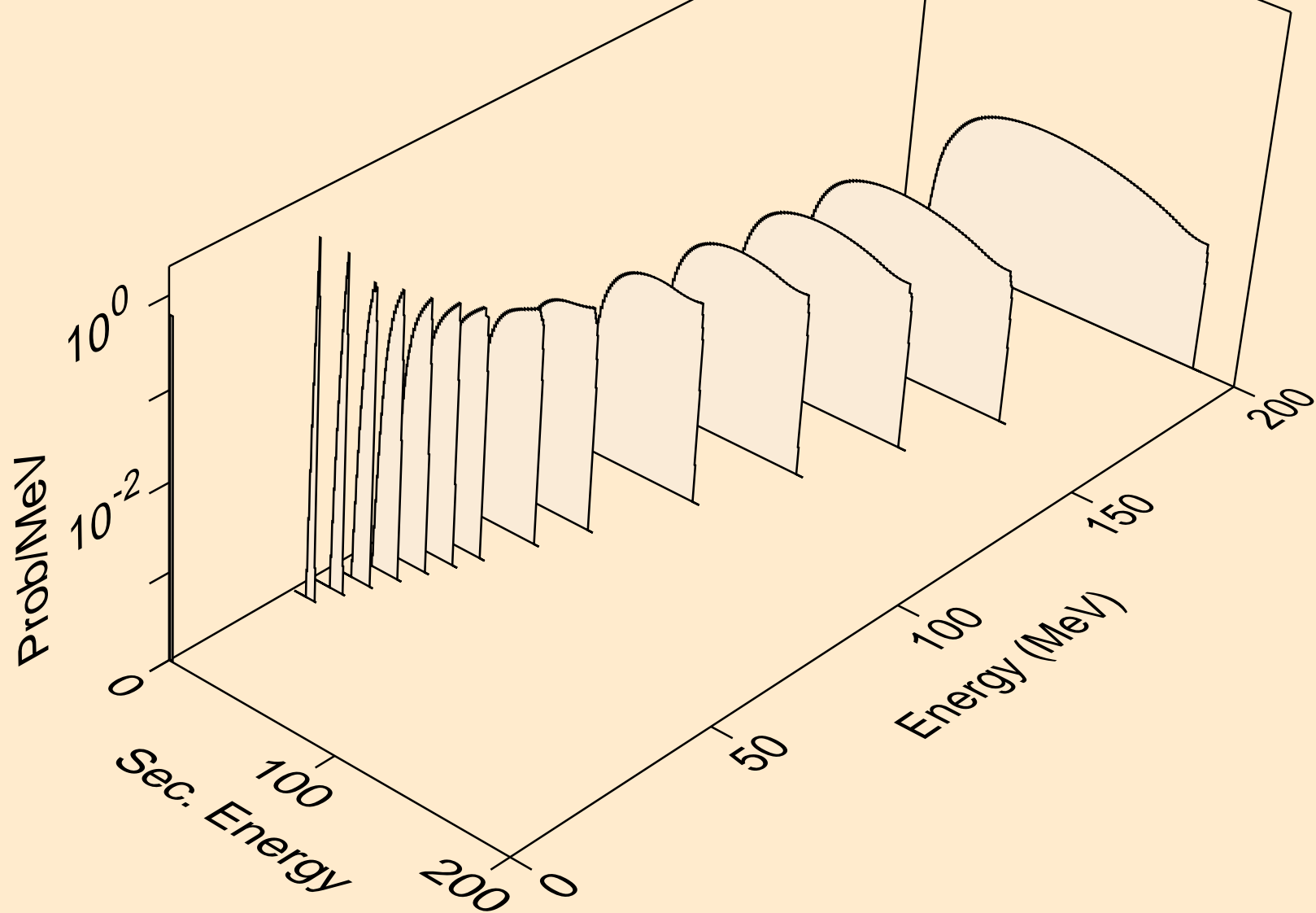

EU163 ALPHA ACER TENDL-2021 LIBRARY; T=0.K  
he3s from (a,he3)

