

IR203 ALPHA ACER TENDL-2021 LIBRARY; T=0.K  
Principal cross sections

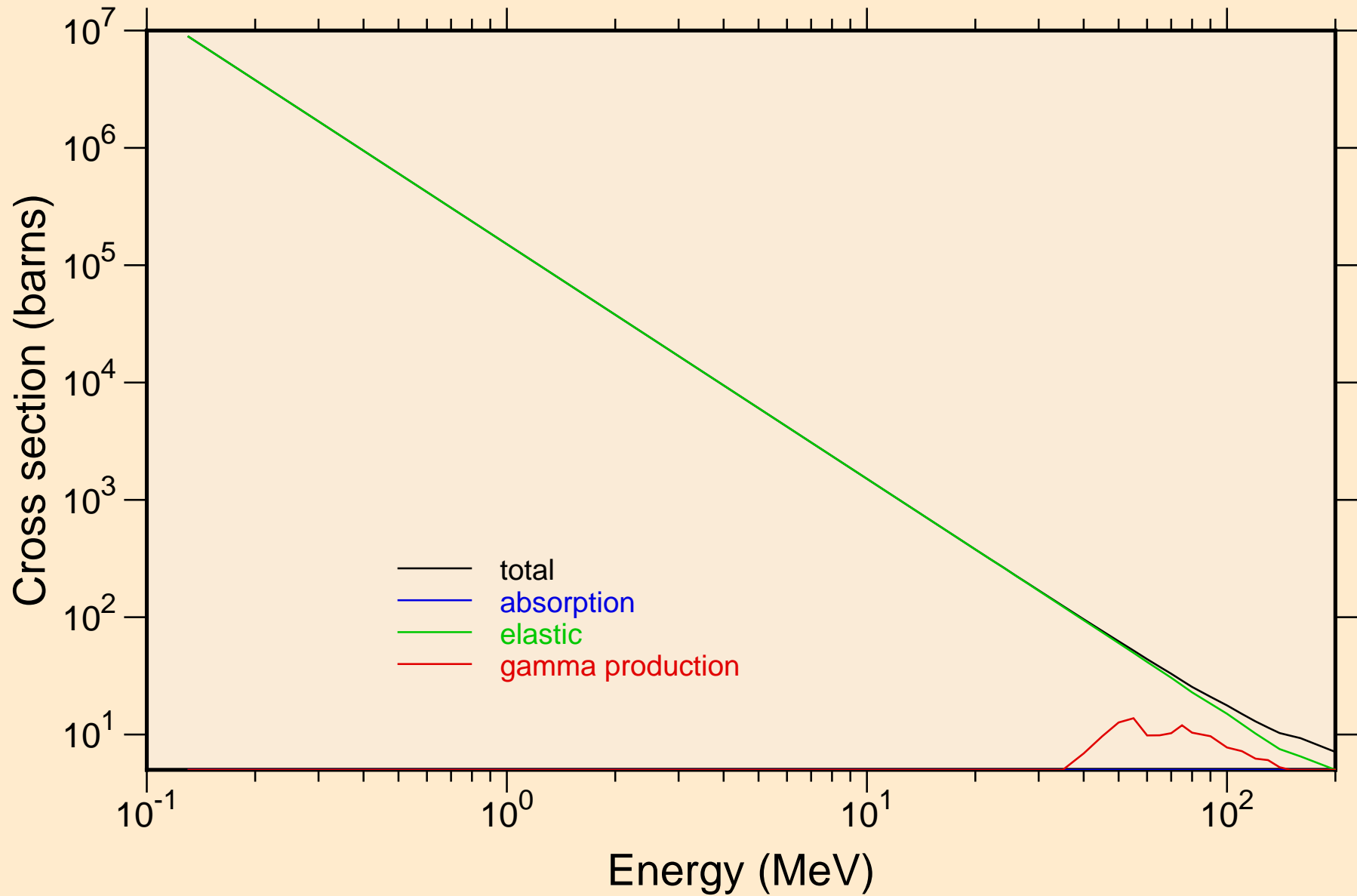

IR203 ALPHA ACER TENDL-2021 LIBRARY; T=0.K  
Heating

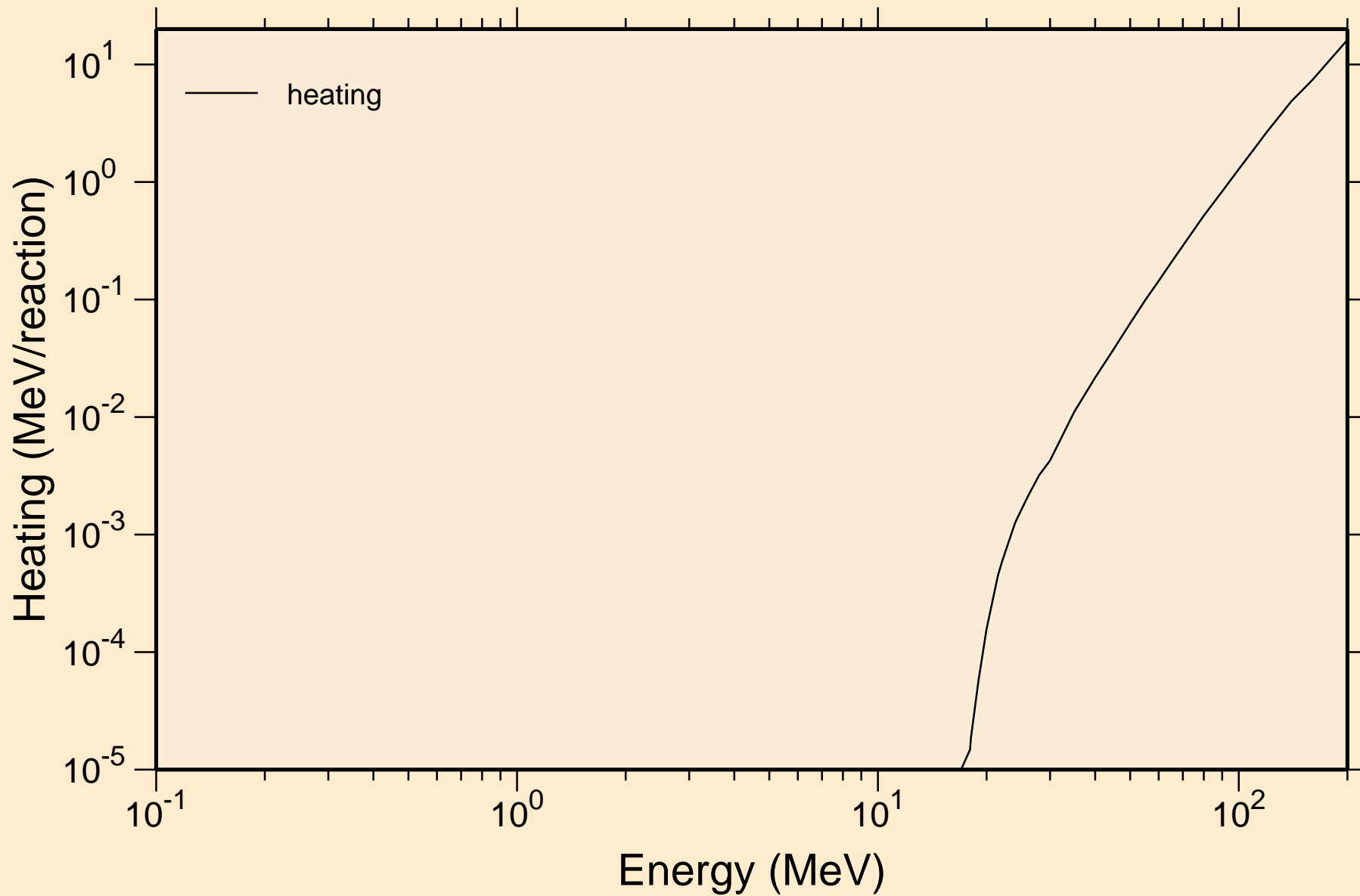

# IR203 ALPHA ACER TENDL-2021 LIBRARY; T=0.K

## Principal cross sections

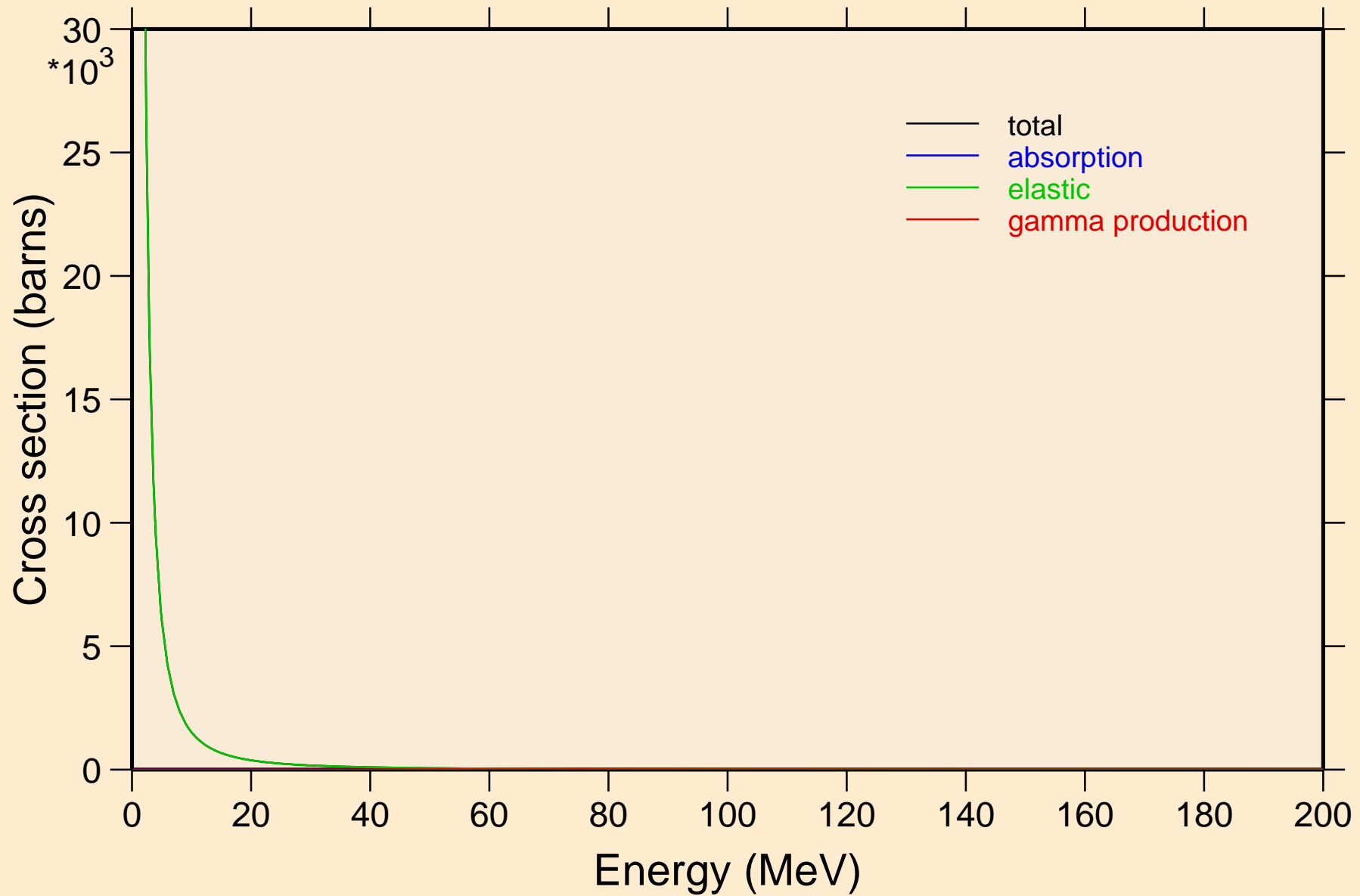

IR203 ALPHA ACER TENDL-2021 LIBRARY; T=0.K

Heating

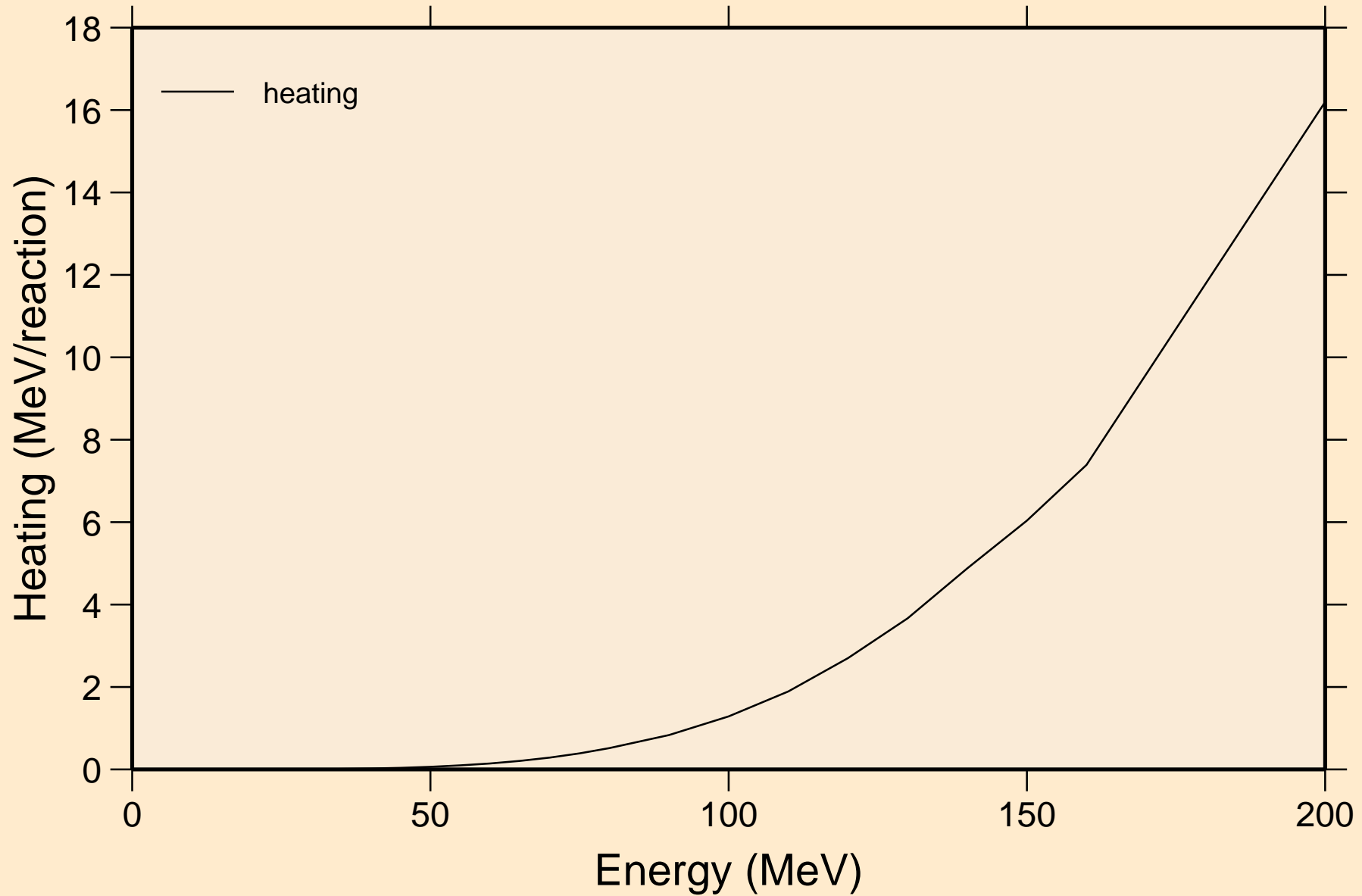

IR203 ALPHA ACER TENDL-2021 LIBRARY; T=0.K  
Threshold reactions

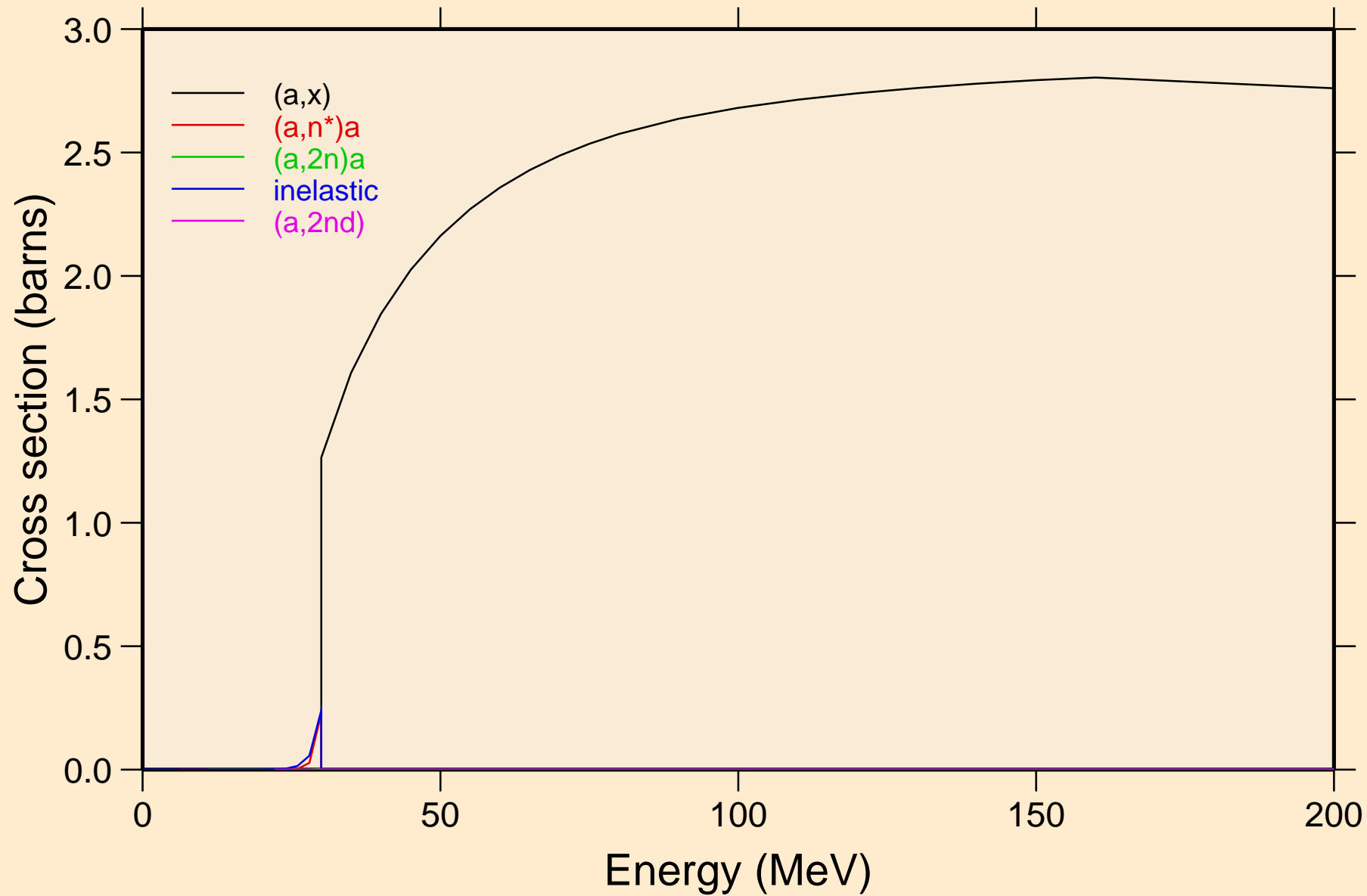

IR203 ALPHA ACER TENDL-2021 LIBRARY; T=0.K  
Threshold reactions

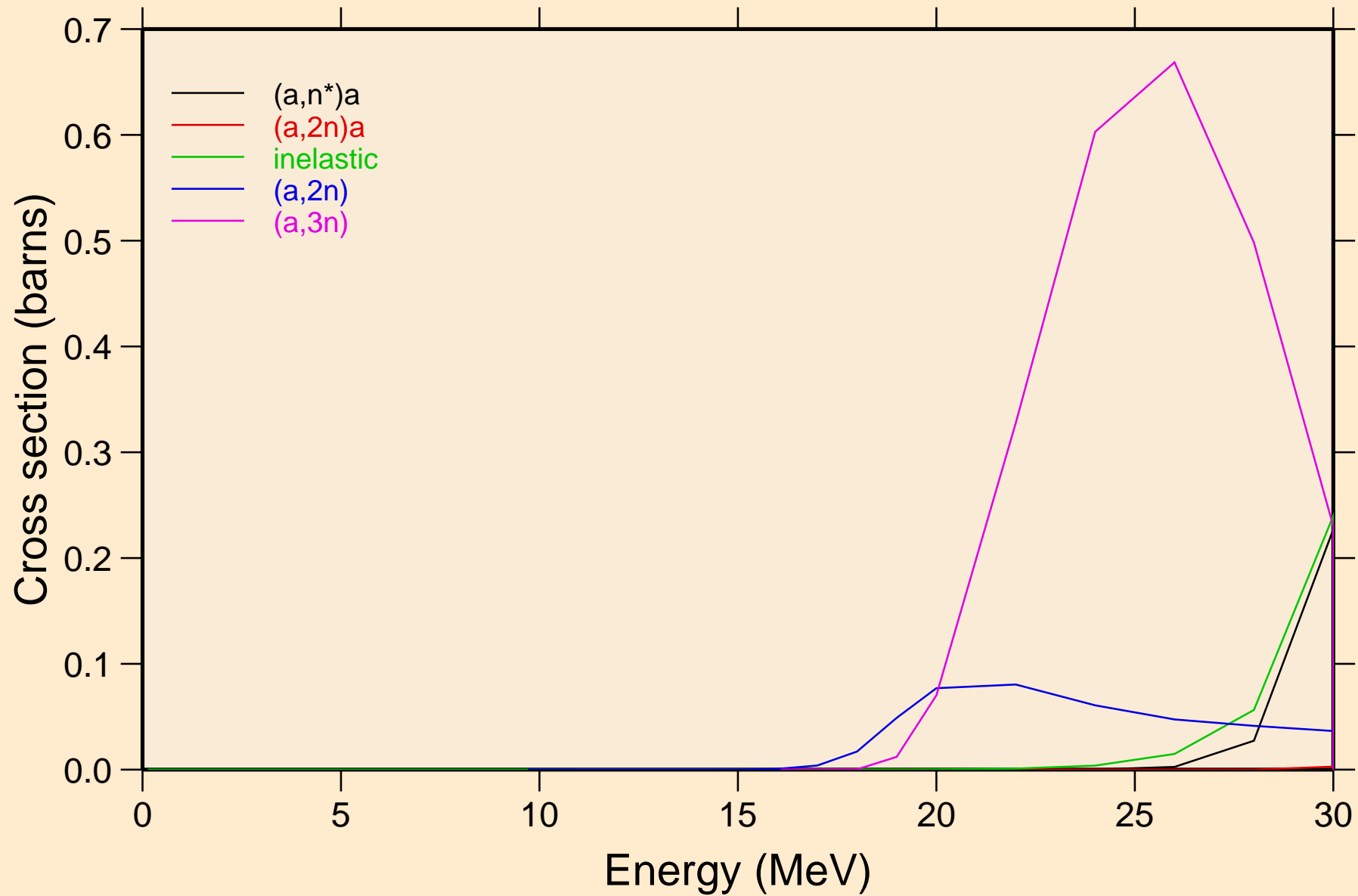

IR203 ALPHA ACER TENDL-2021 LIBRARY; T=0.K  
Threshold reactions

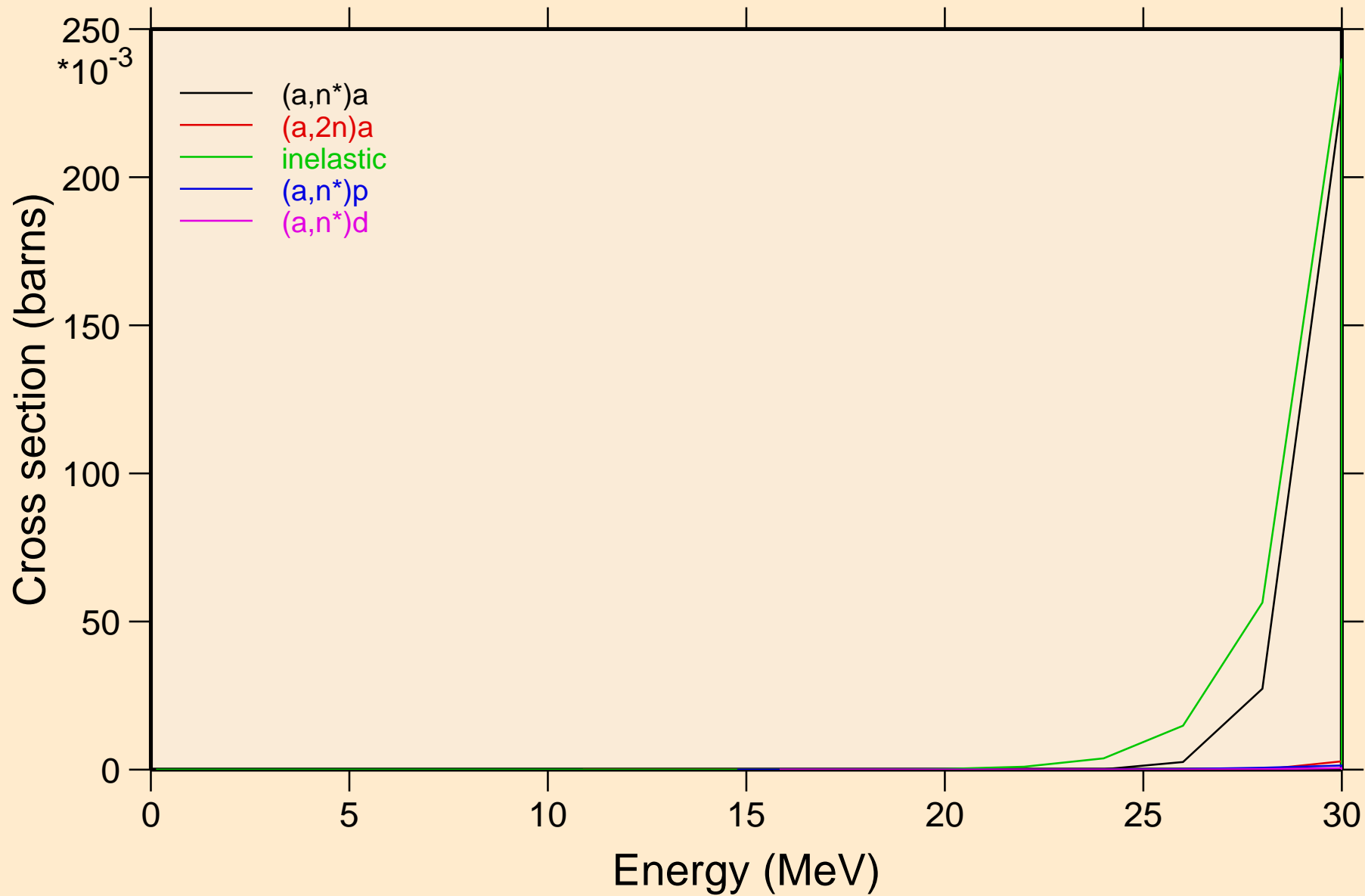

IR203 ALPHA ACER TENDL-2021 LIBRARY; T=0.K  
Threshold reactions

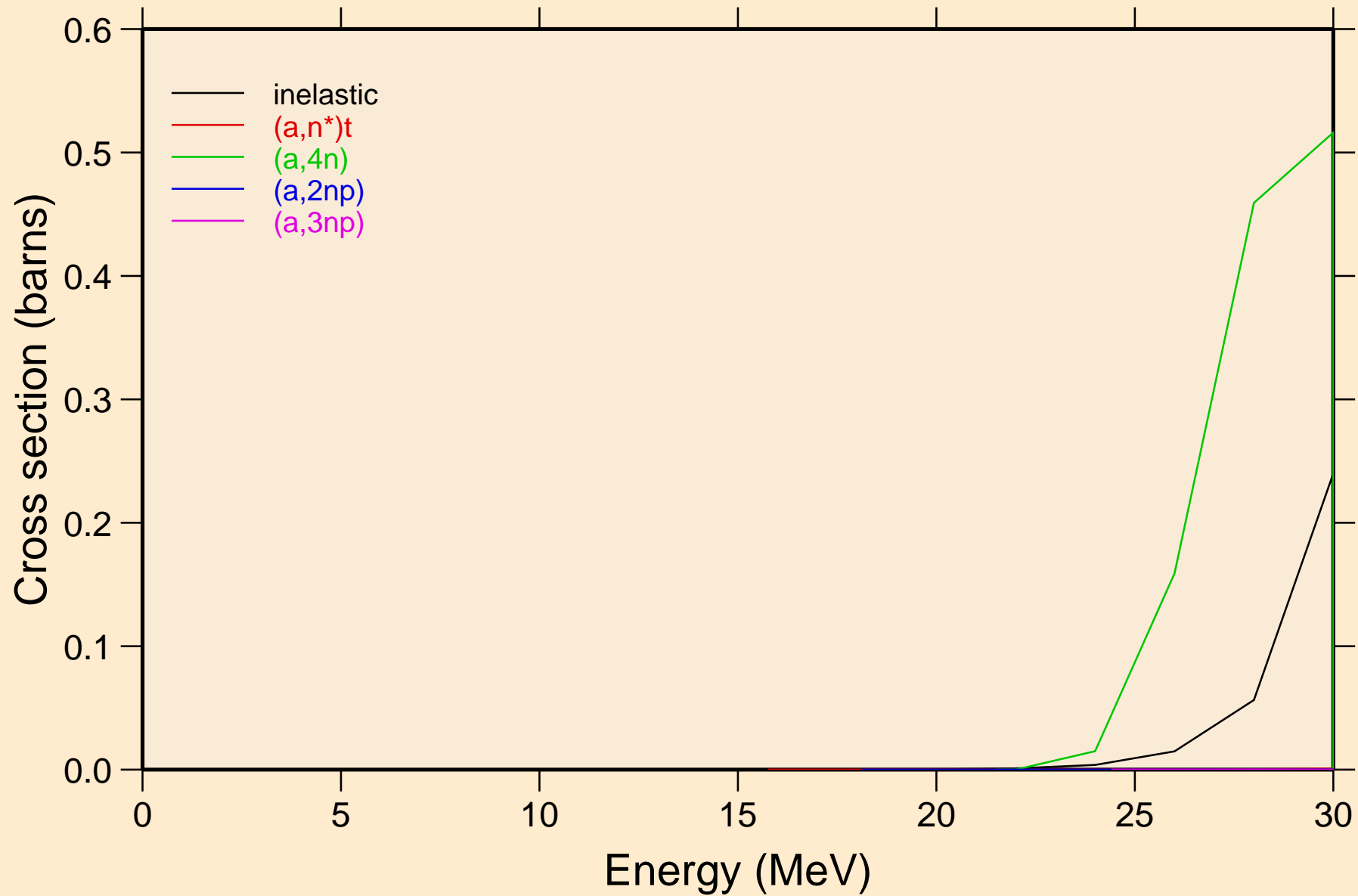



IR203 ALPHA ACER TENDL-2021 LIBRARY; T=0.K  
Threshold reactions

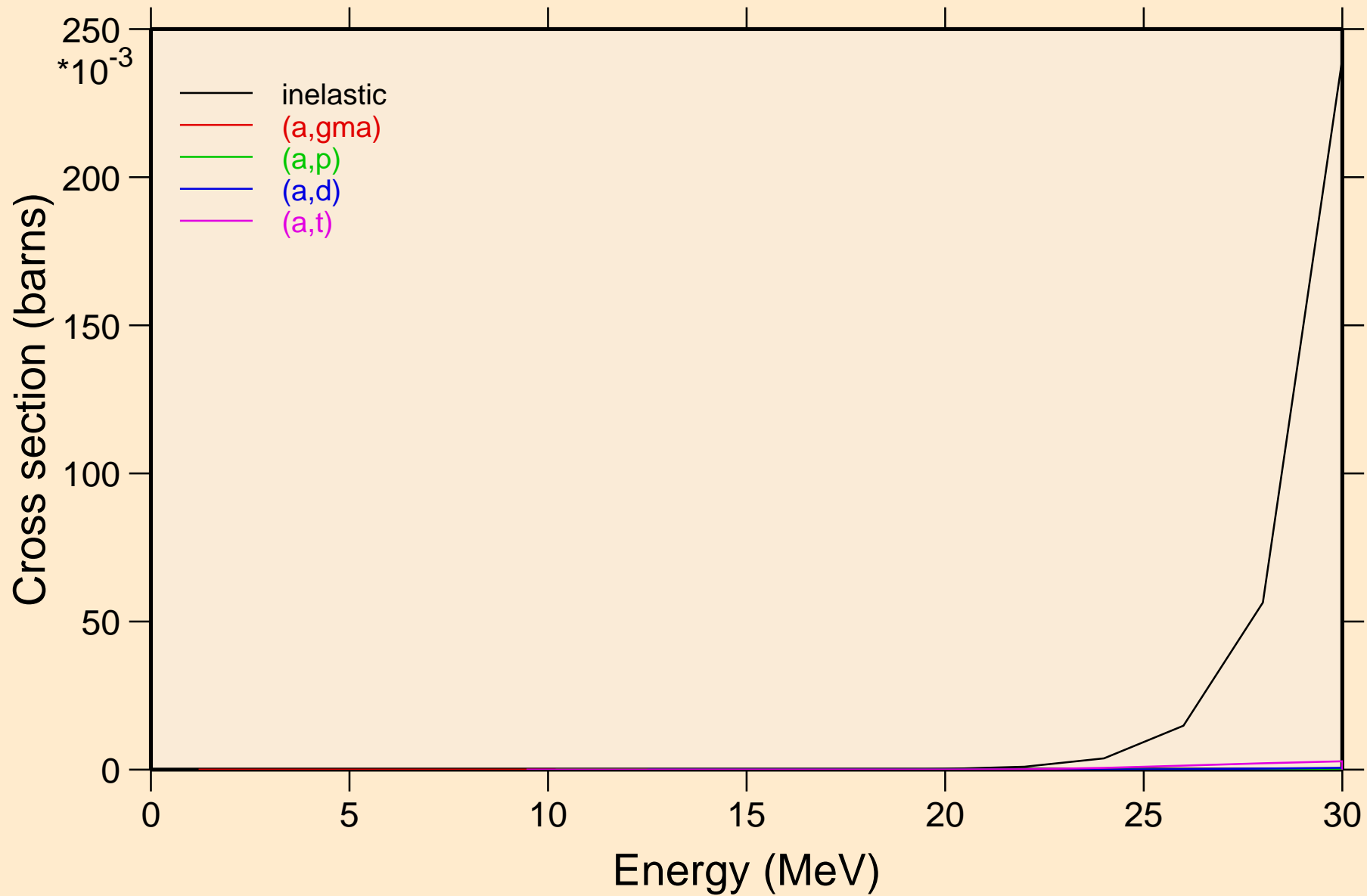

IR203 ALPHA ACER TENDL-2021 LIBRARY; T=0.K  
Threshold reactions

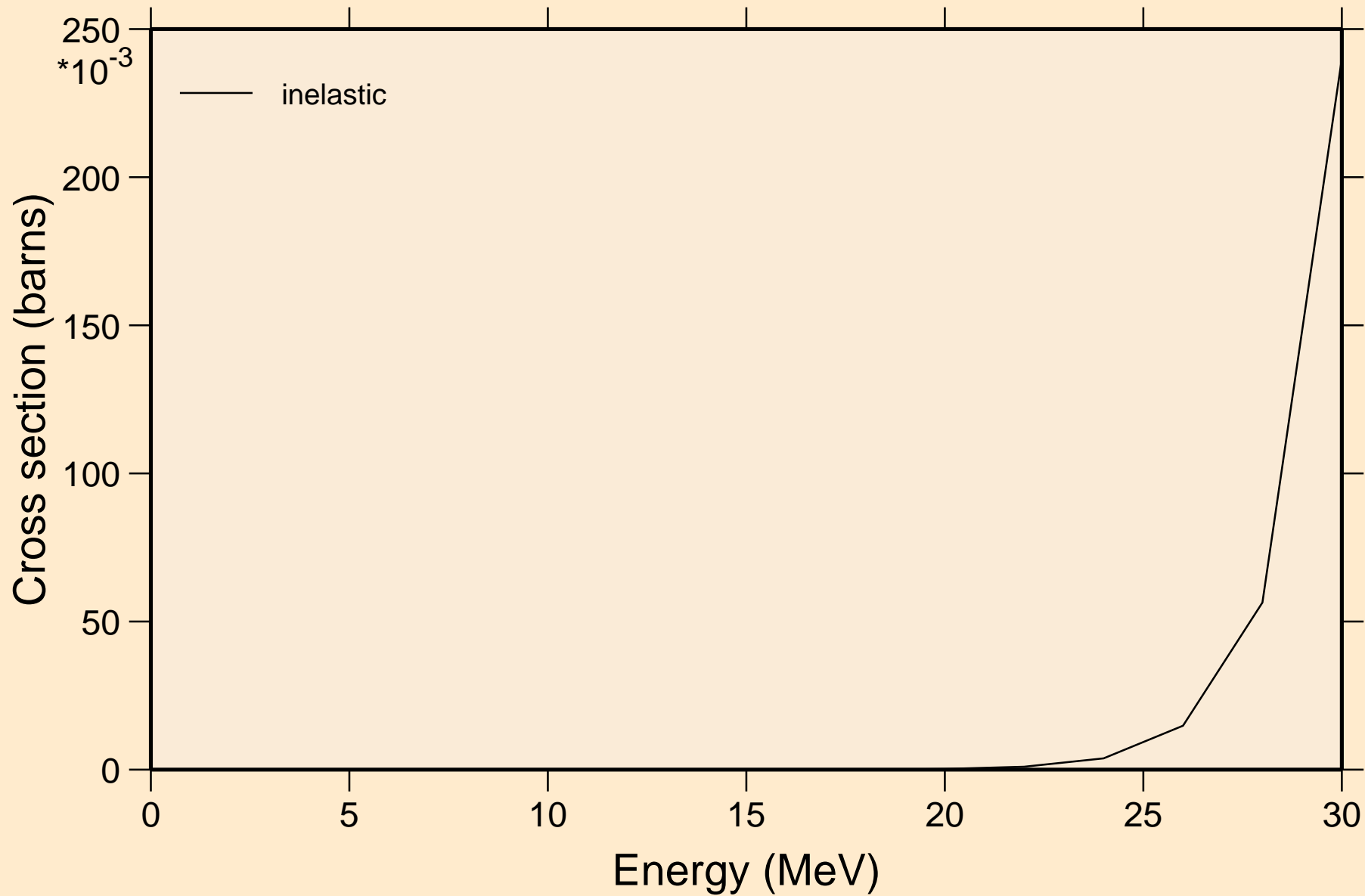

IR203 ALPHA ACER TENDL-2021 LIBRARY; T=0.K  
angular distribution for elastic

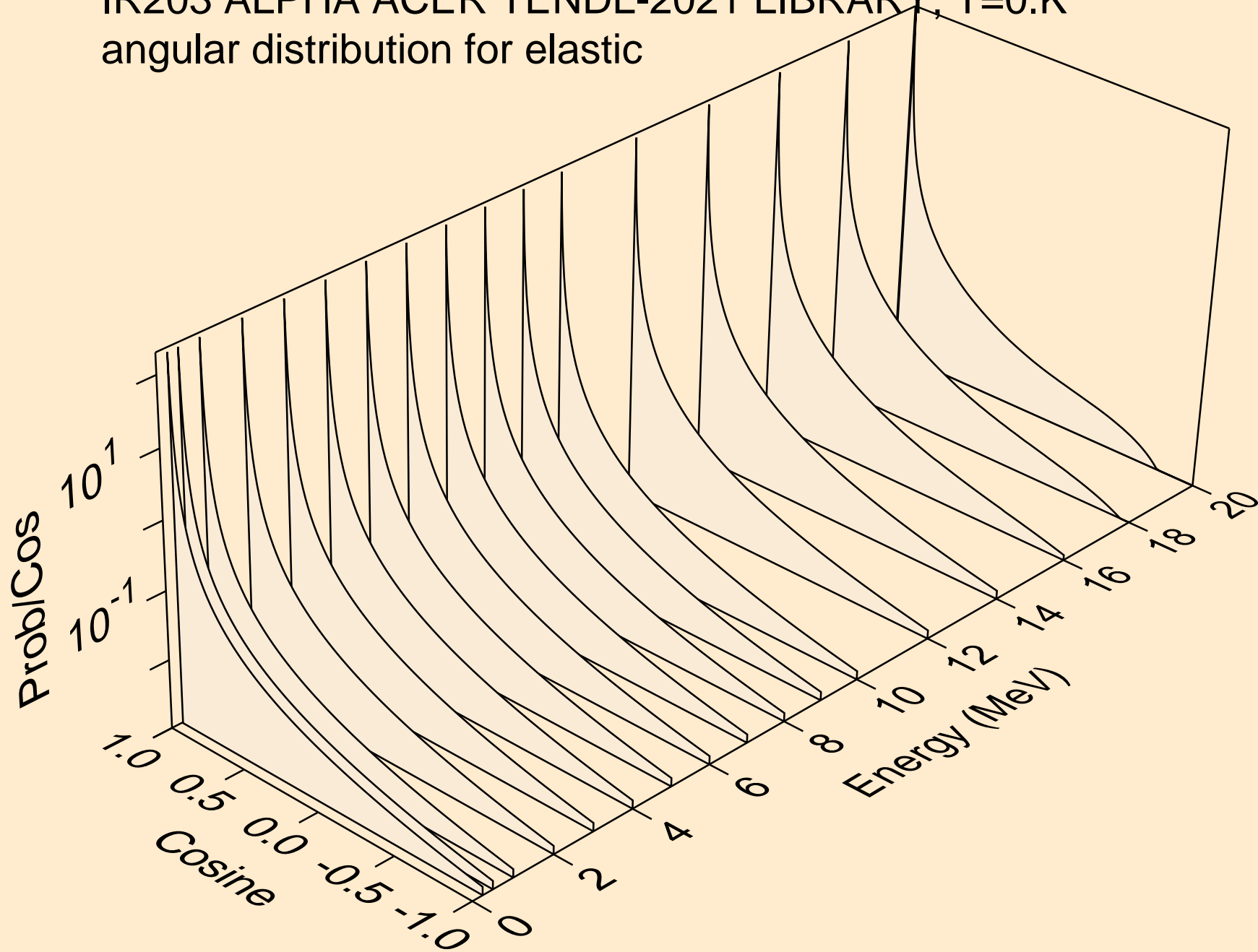

IR203 ALPHA ACER TENDL-2021 LIBRARY; T=0.K  
angular distribution for elastic

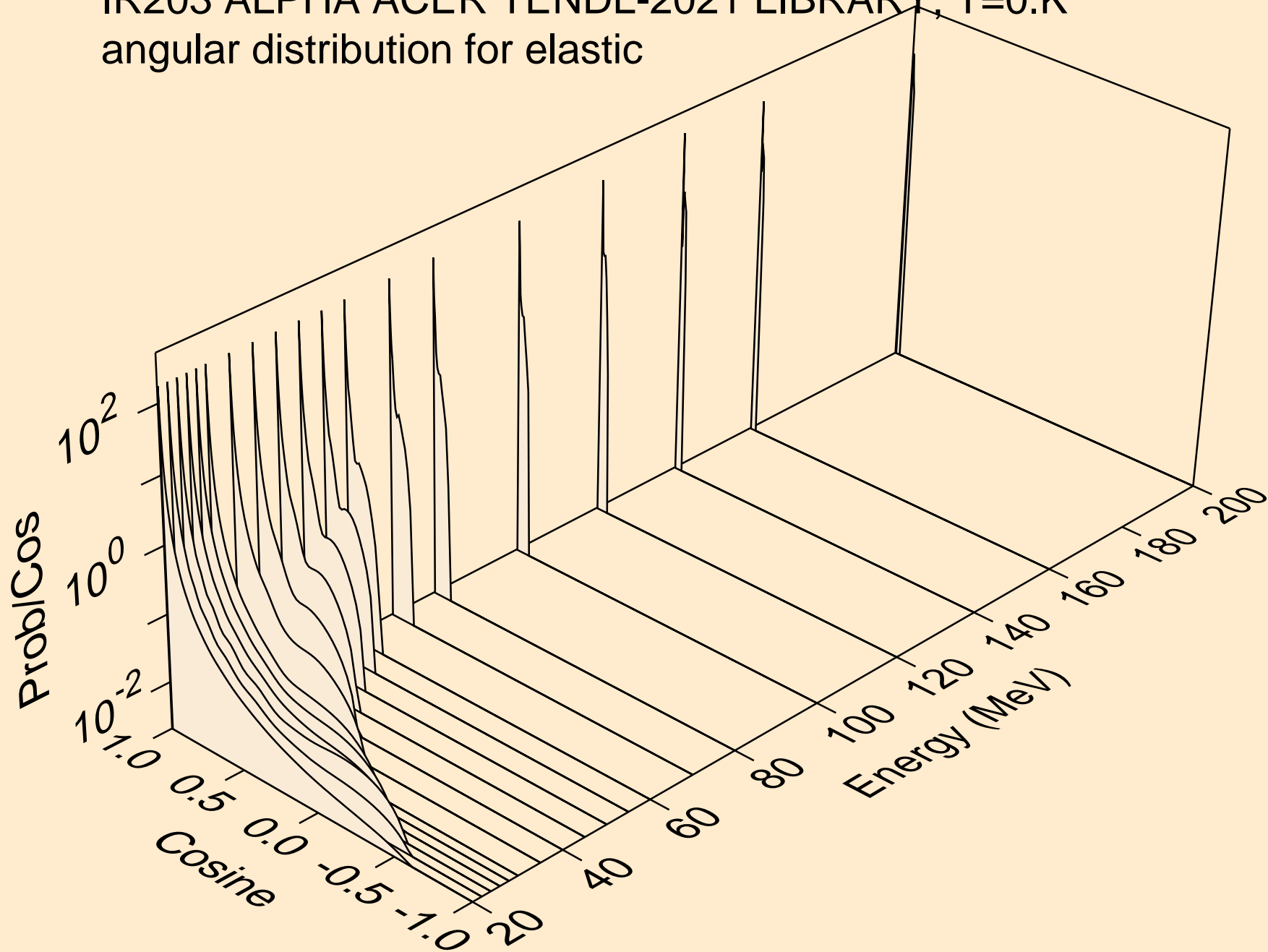

IR203 ALPHA ACER TENDL-2021 LIBRARY; T=0.K  
Alpha emission for (a,x)

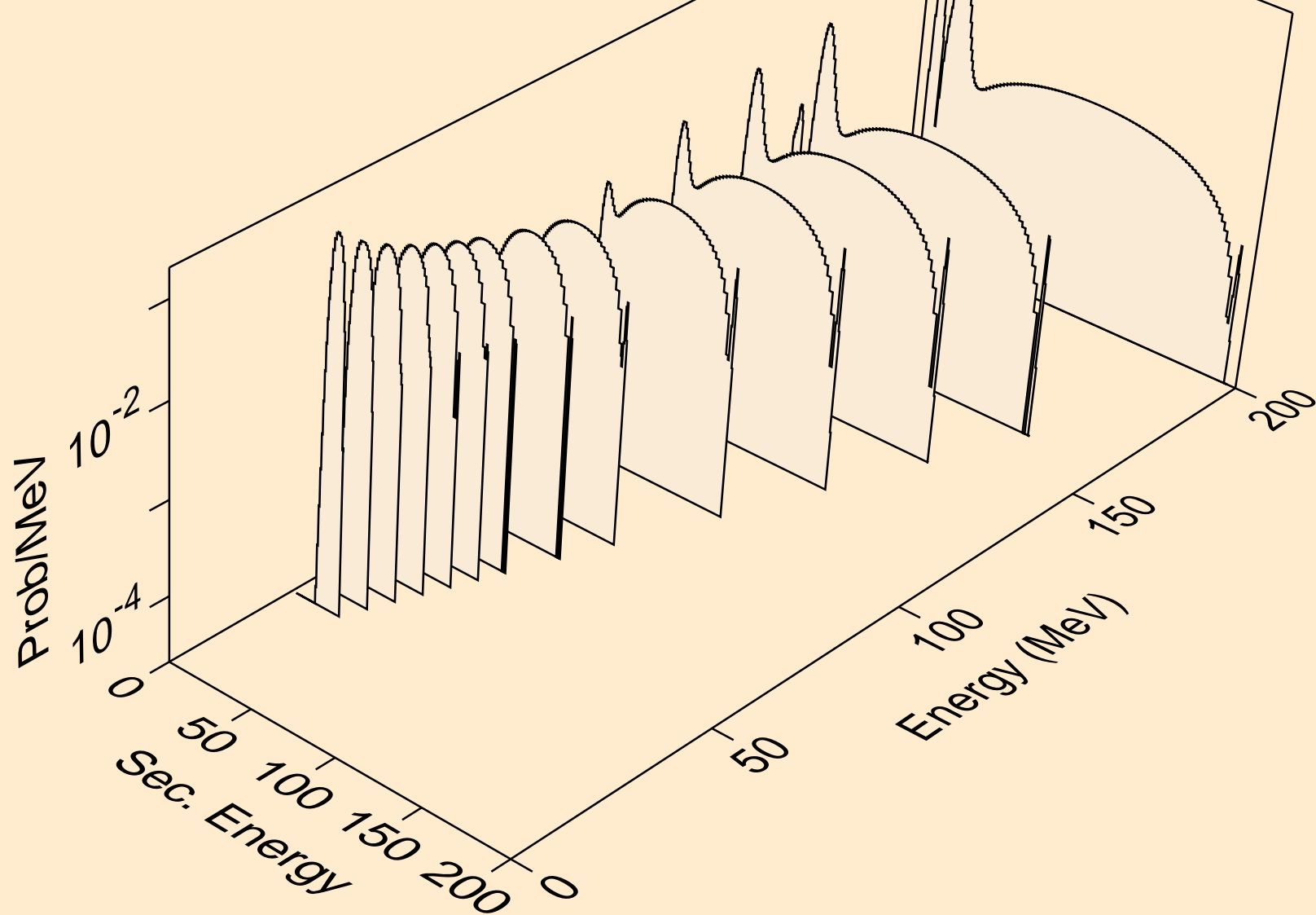

IR203 ALPHA ACER TENDL-2021 LIBRARY; T=0.K  
Alpha emission for (a,n\*)a

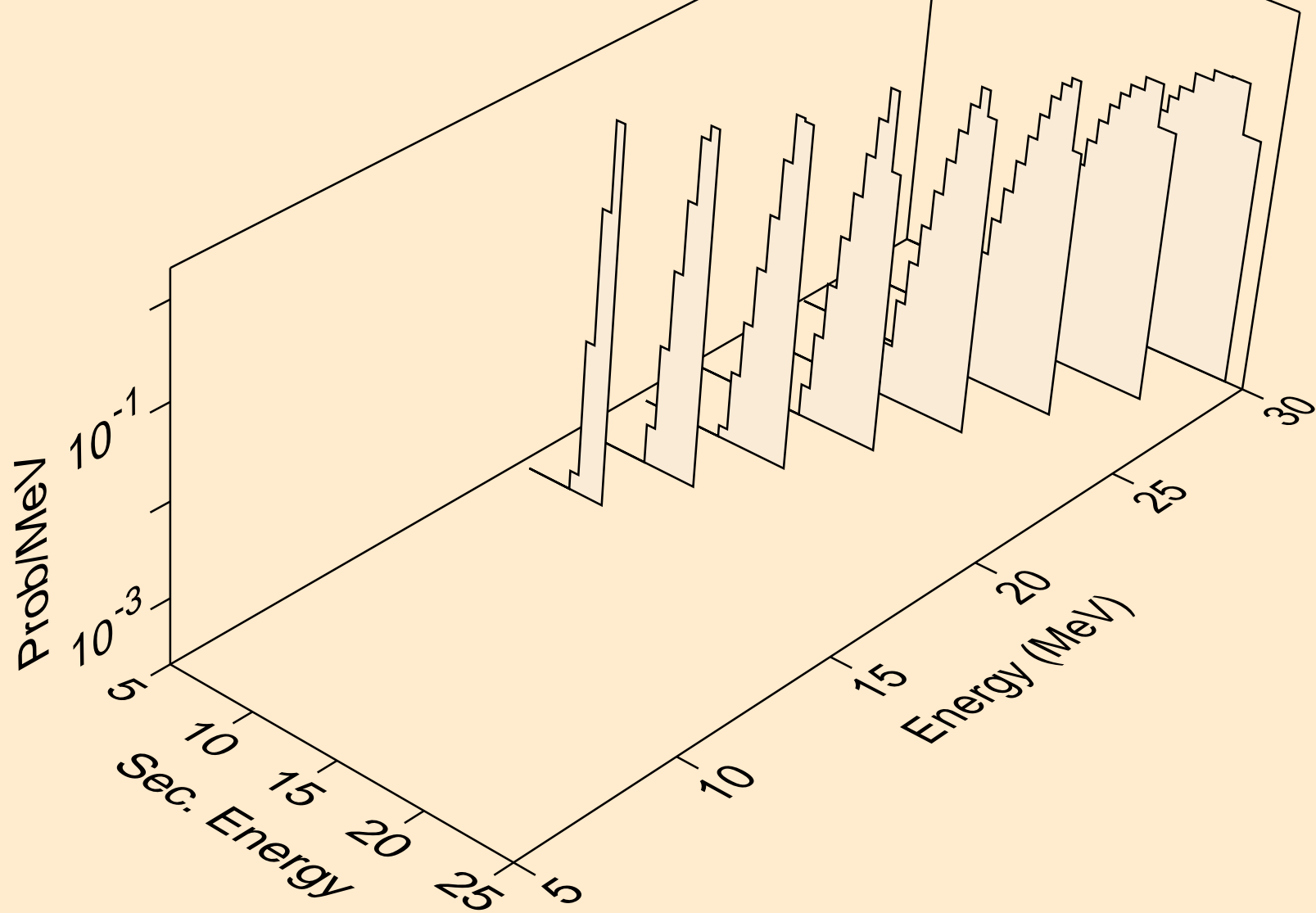

IR203 ALPHA ACER TENDL-2021 LIBRARY; T=0.K  
Alpha emission for (a,2n)a

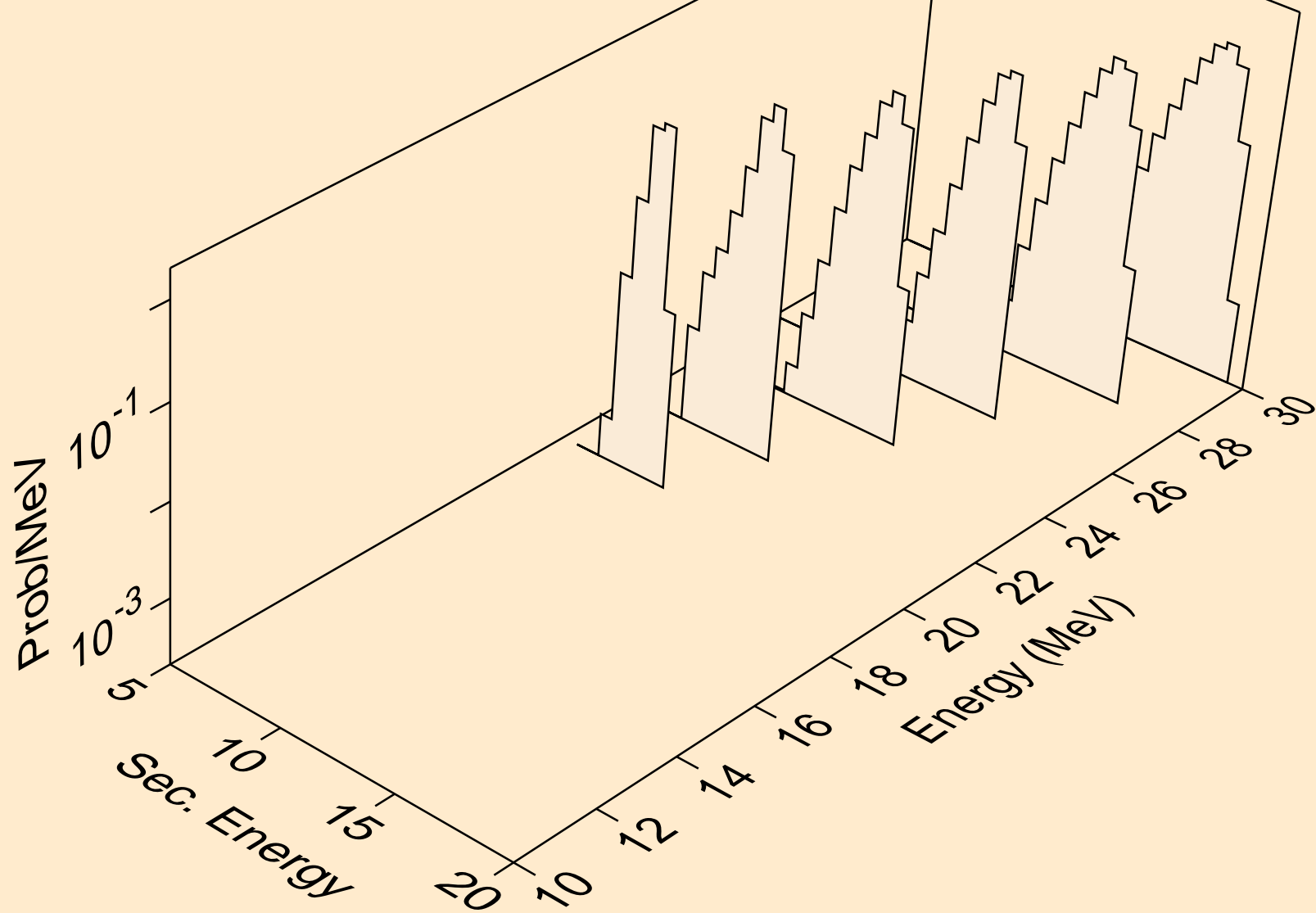

IR203 ALPHA ACER TENDL-2021 LIBRARY; T=0.K  
Alpha emission for inelastic

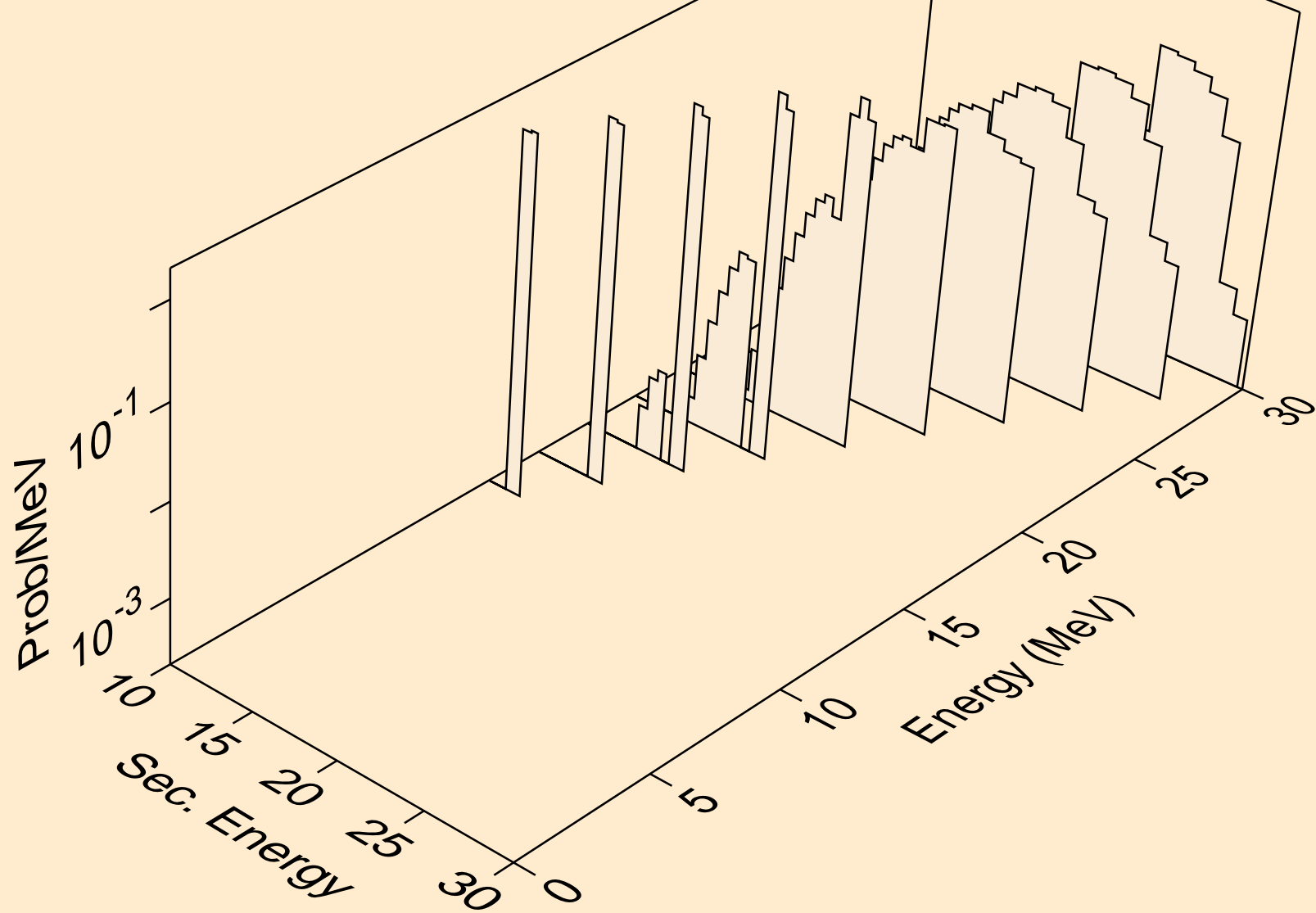



IR203 ALPHA ACER TENDL-2021 LIBRARY; T=0.K  
Photon emission for (z,n)

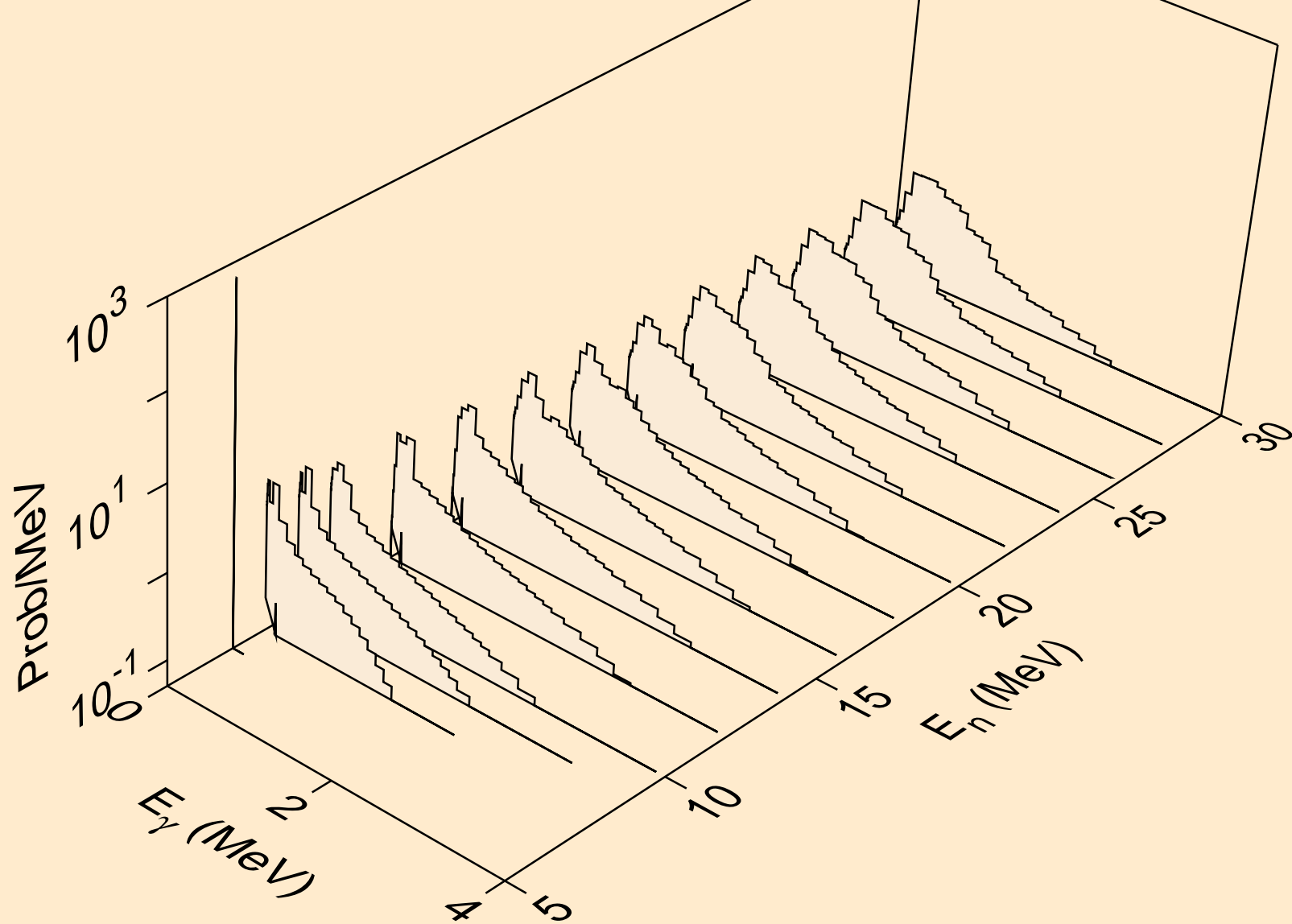

IR203 ALPHA ACER TENDL-2021 LIBRARY; T=0.K  
Photon emission for (n,x)

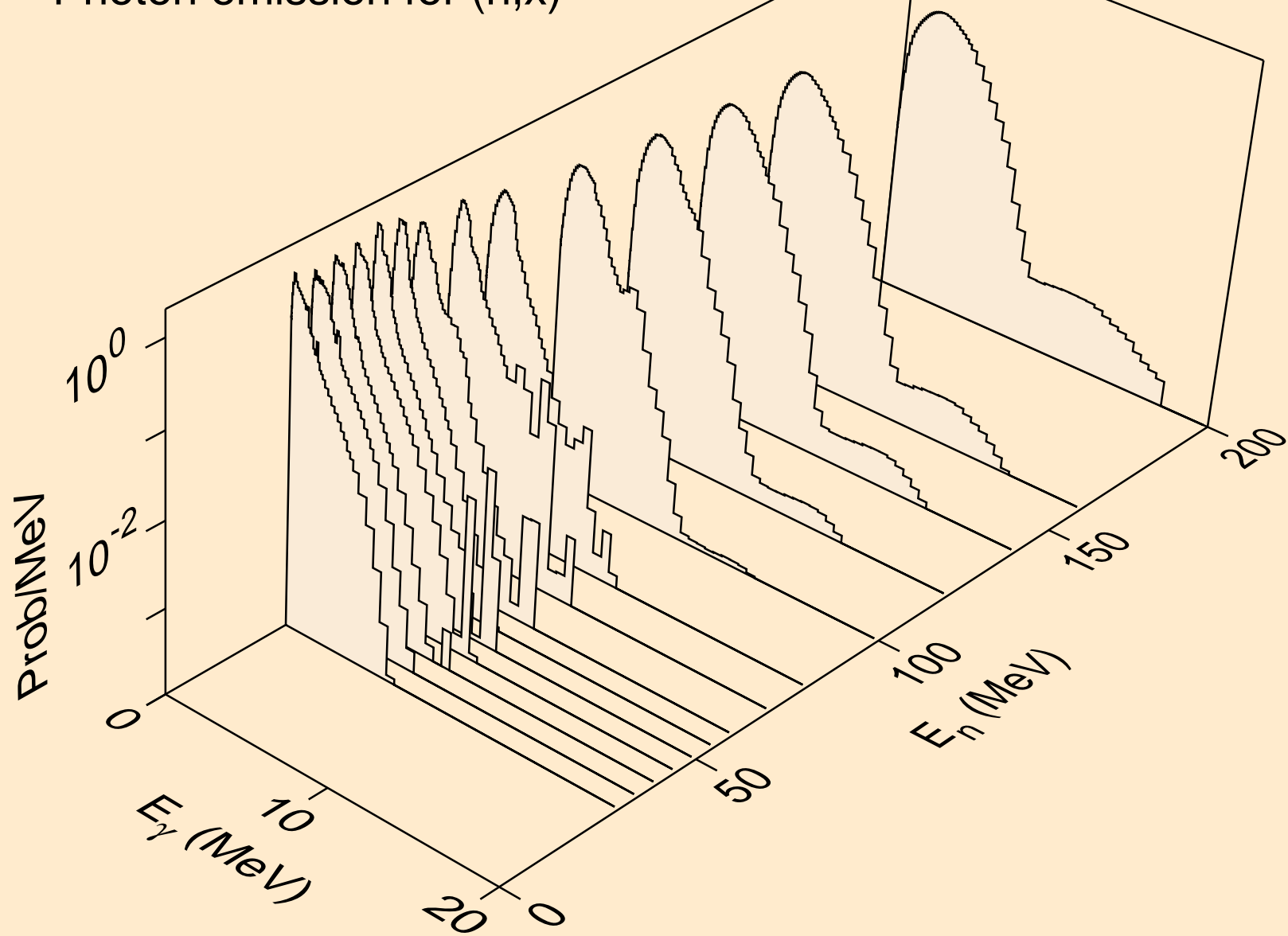

IR203 ALPHA ACER TENDL-2021 LIBRARY; T=0.K  
Photon emission for (n,2nd)

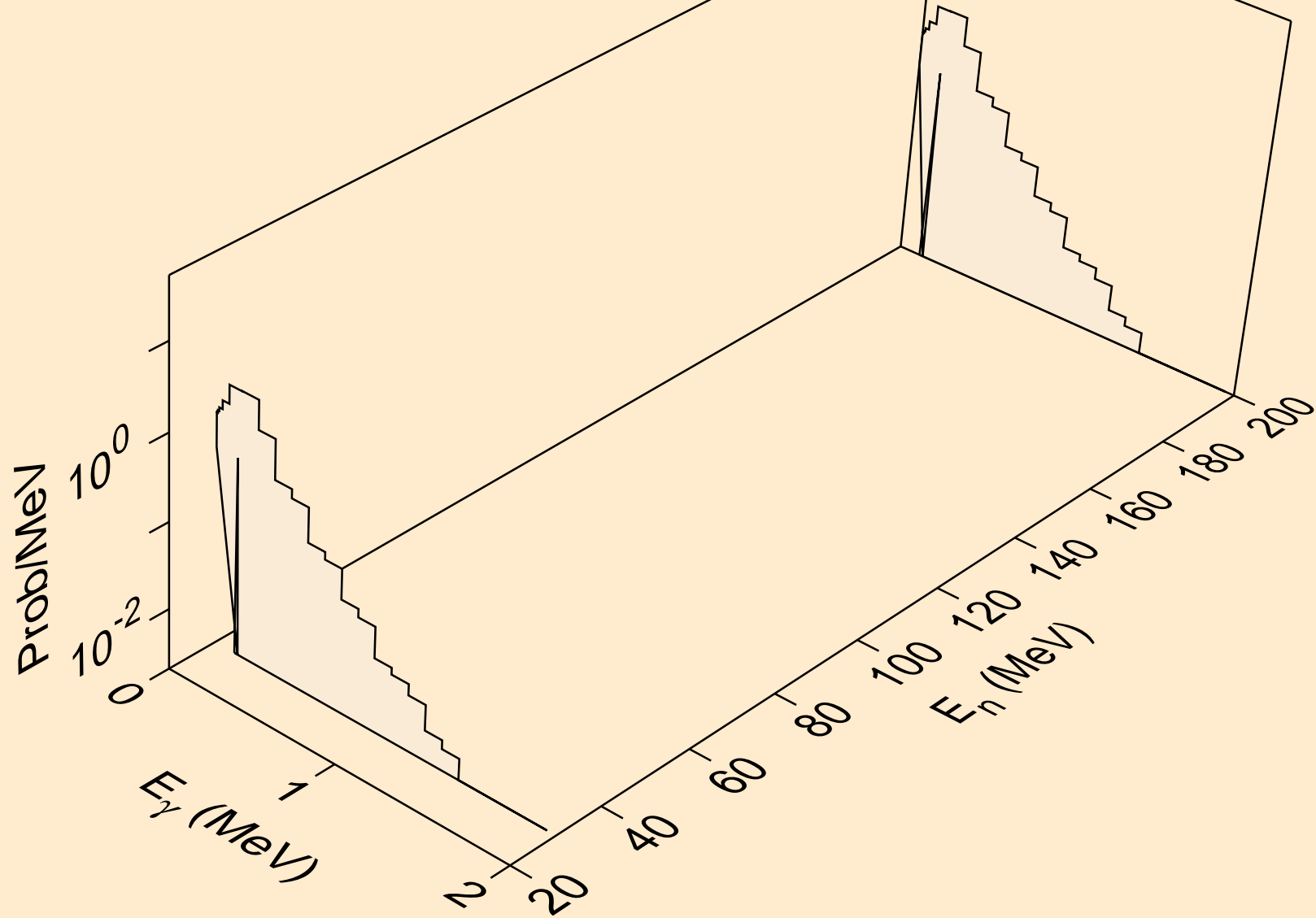

IR203 ALPHA ACER TENDL-2021 LIBRARY; T=0.K  
Photon emission for (n,2n)

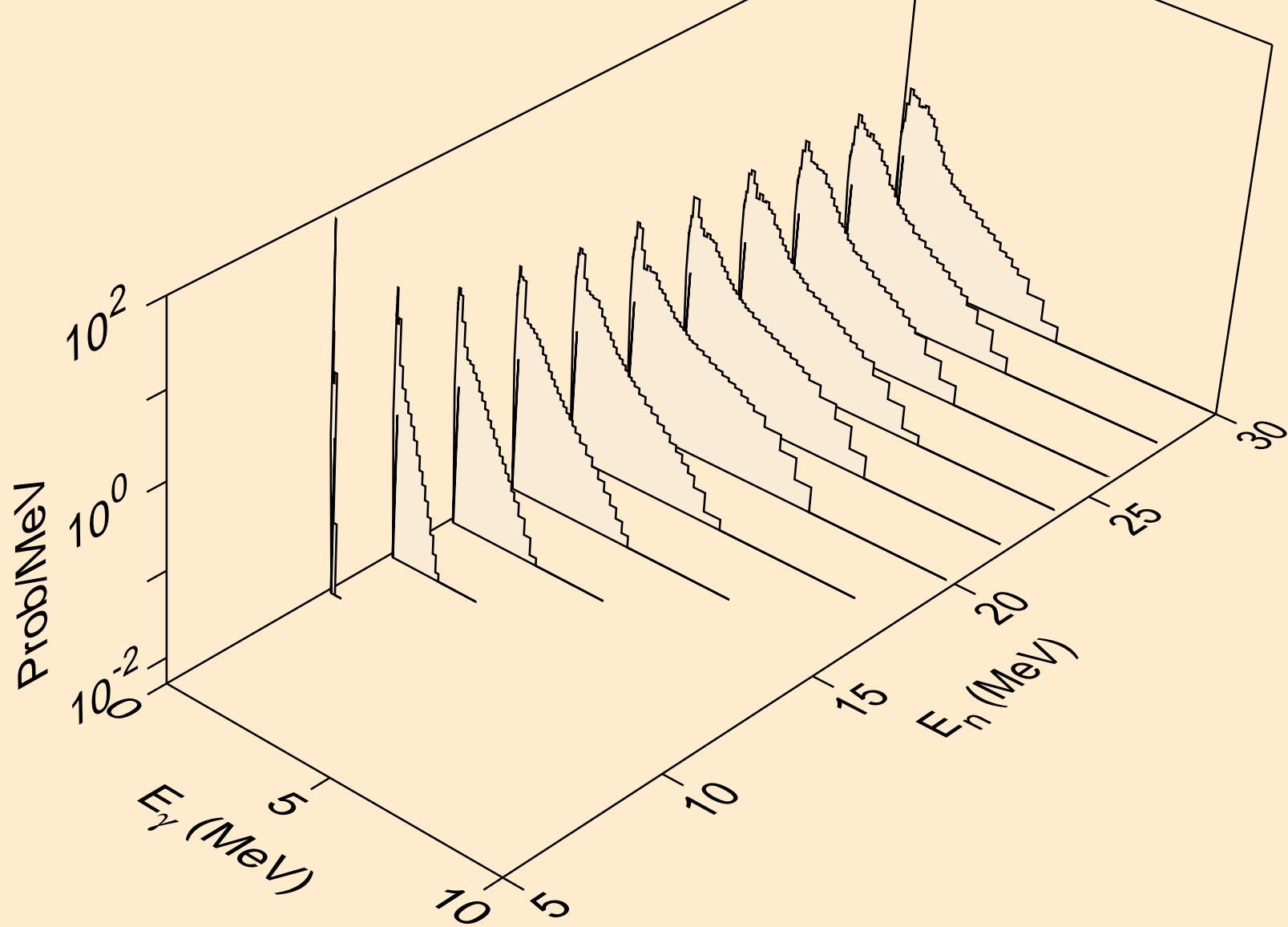

IR203 ALPHA ACER TENDL-2021 LIBRARY; T=0.K  
Photon emission for (n,3n)

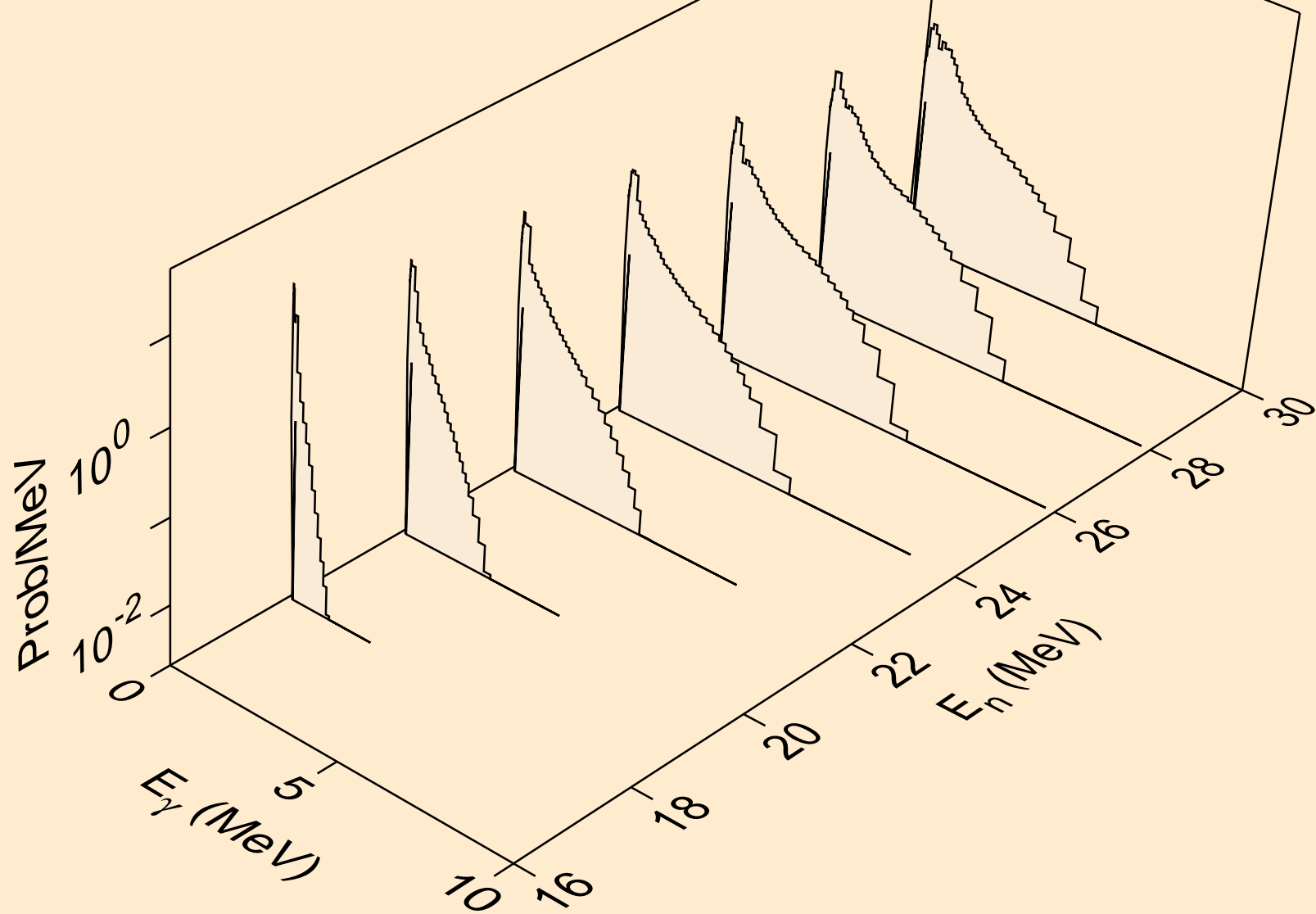

IR203 ALPHA ACER TENDL-2021 LIBRARY; T=0.K  
Photon emission for (n,n\*)a

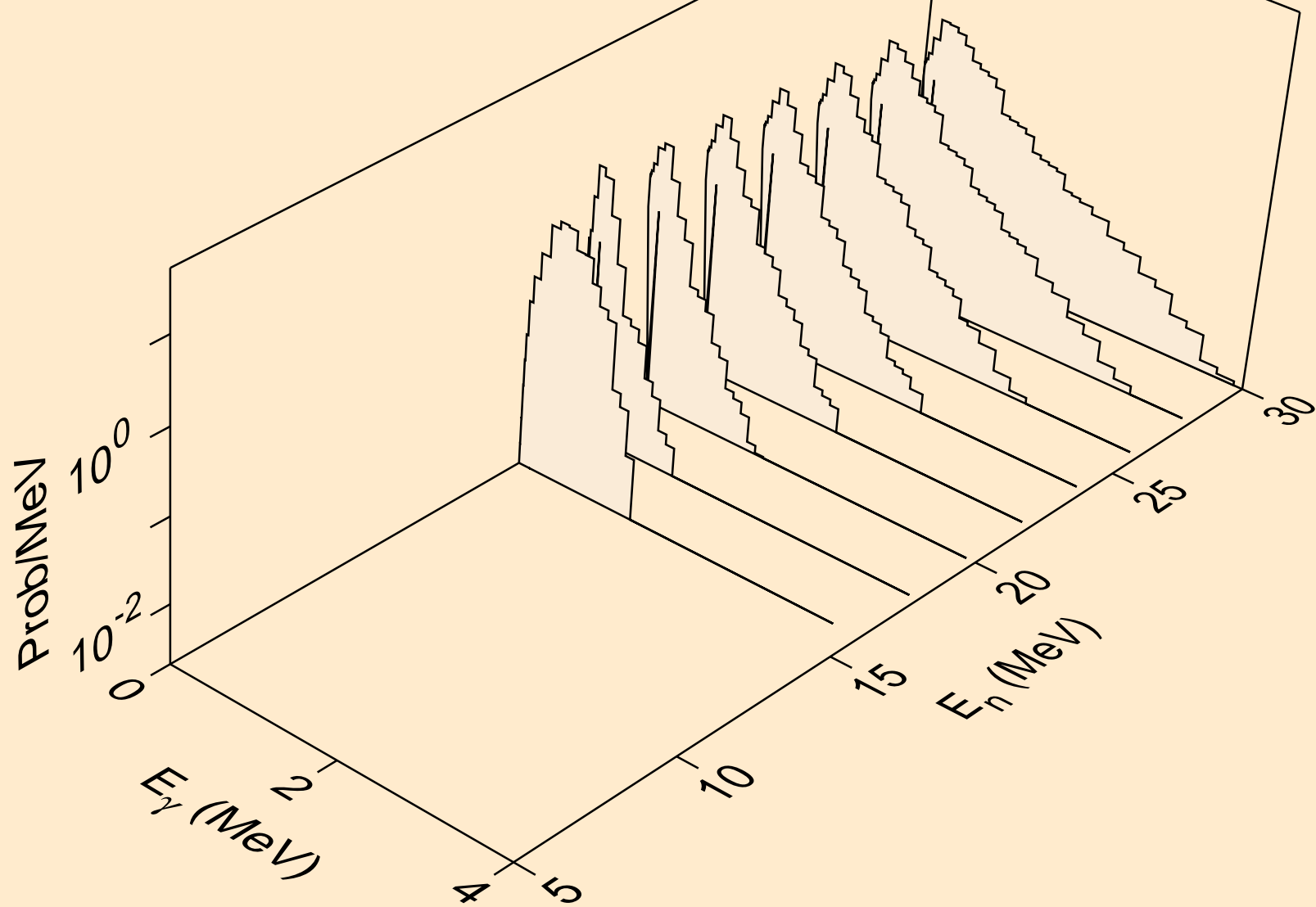

IR203 ALPHA ACER TENDL-2021 LIBRARY; T=0.K  
Photon emission for (n,2n)a

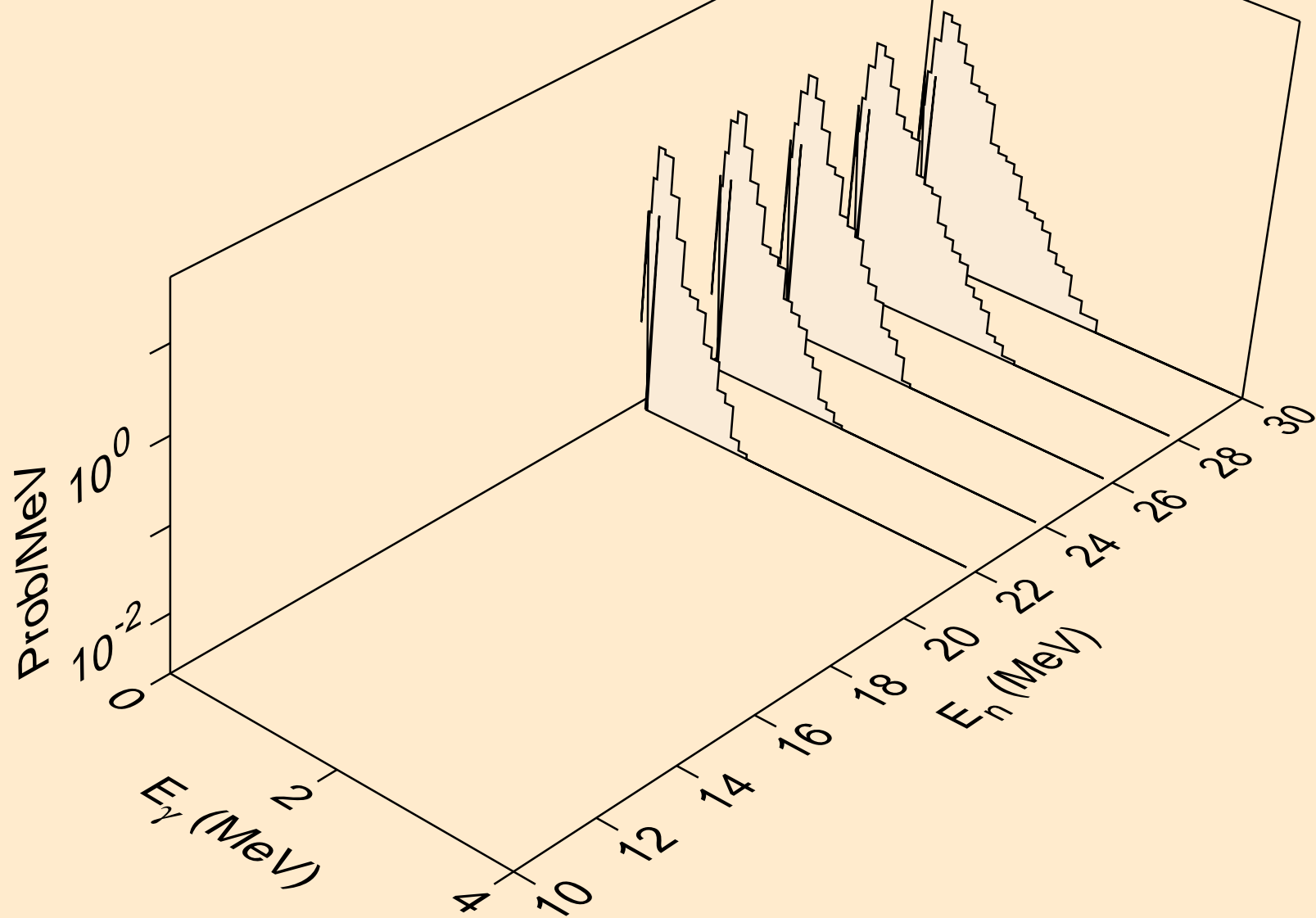

IR203 ALPHA ACER TENDL-2021 LIBRARY; T=0.K  
Photon emission for (n,n\*)p

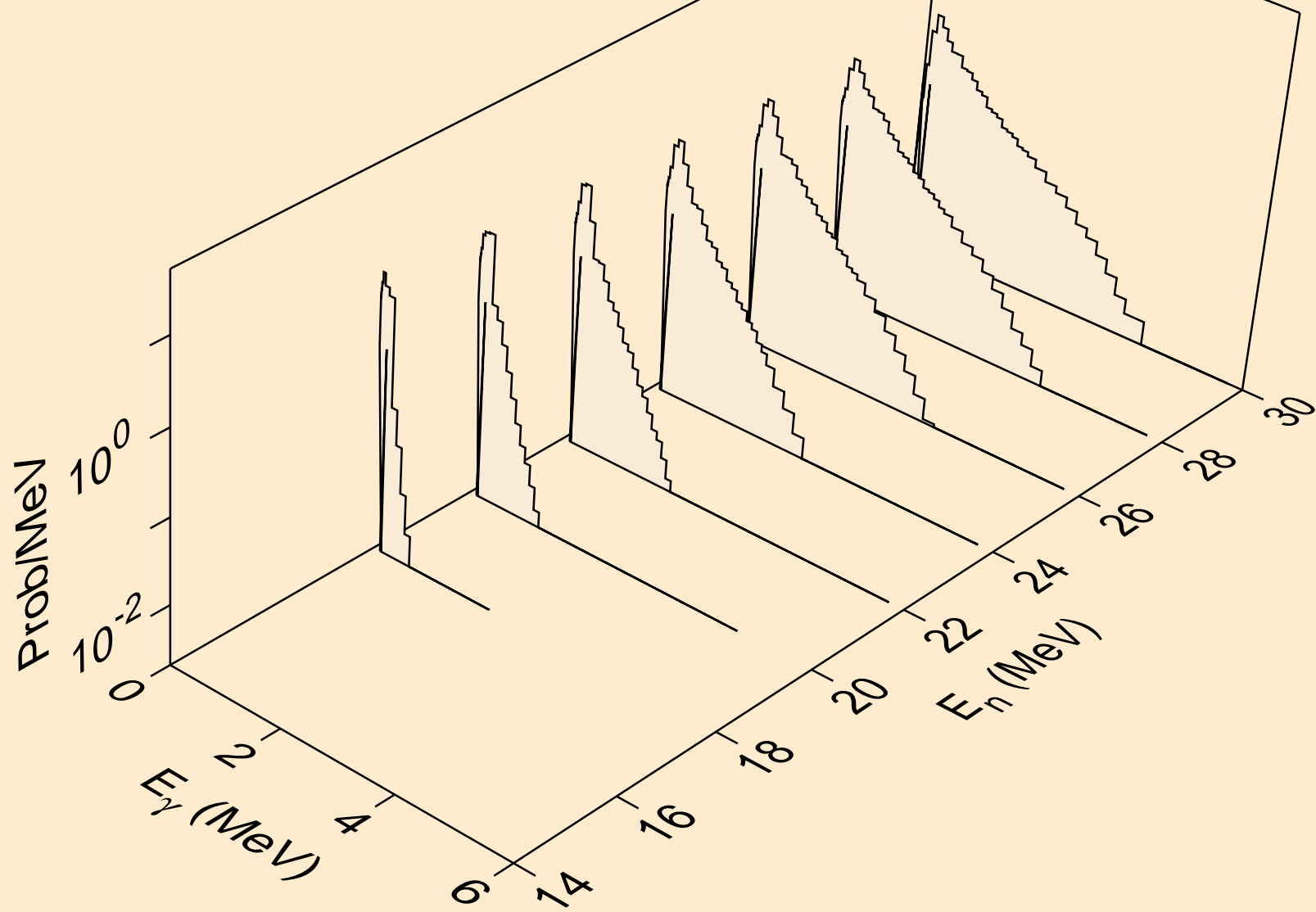



IR203 ALPHA ACER TENDL-2021 LIBRARY; T=0.K  
Photon emission for (n,n\*)d

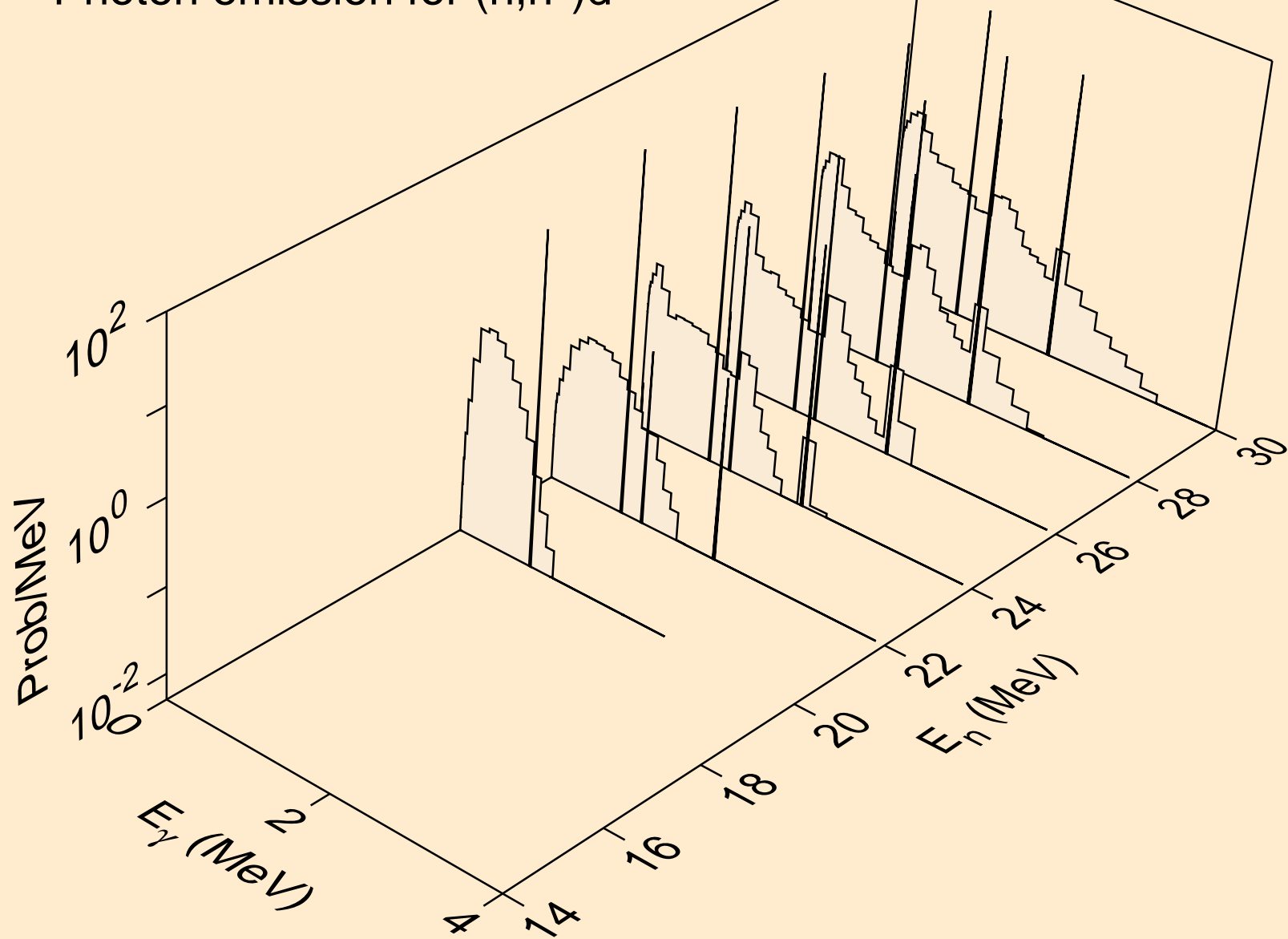

IR203 ALPHA ACER TENDL-2021 LIBRARY; T=0.K  
Photon emission for (n,n\*)t

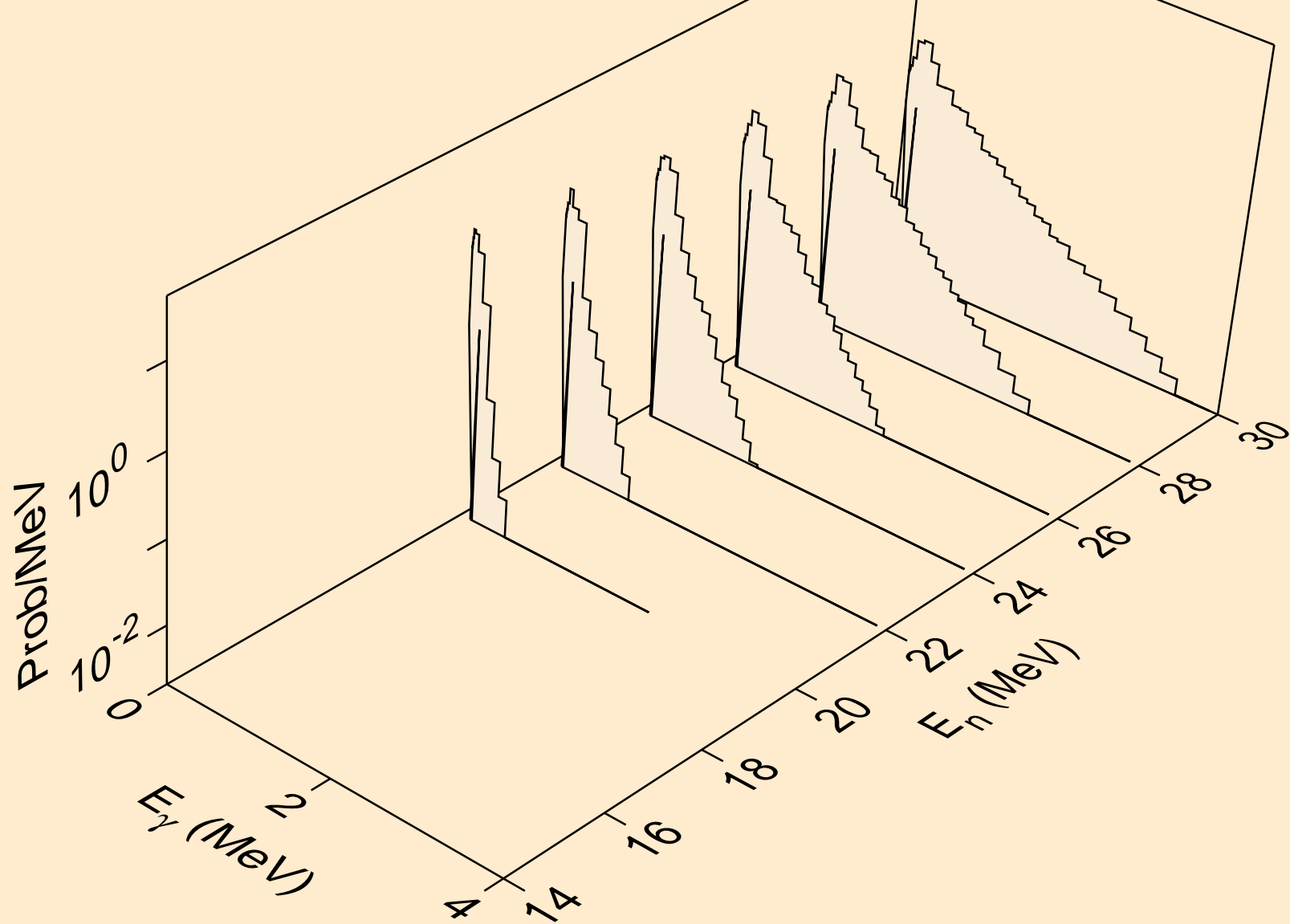

IR203 ALPHA ACER TENDL-2021 LIBRARY; T=0.K  
Photon emission for (n,4n)

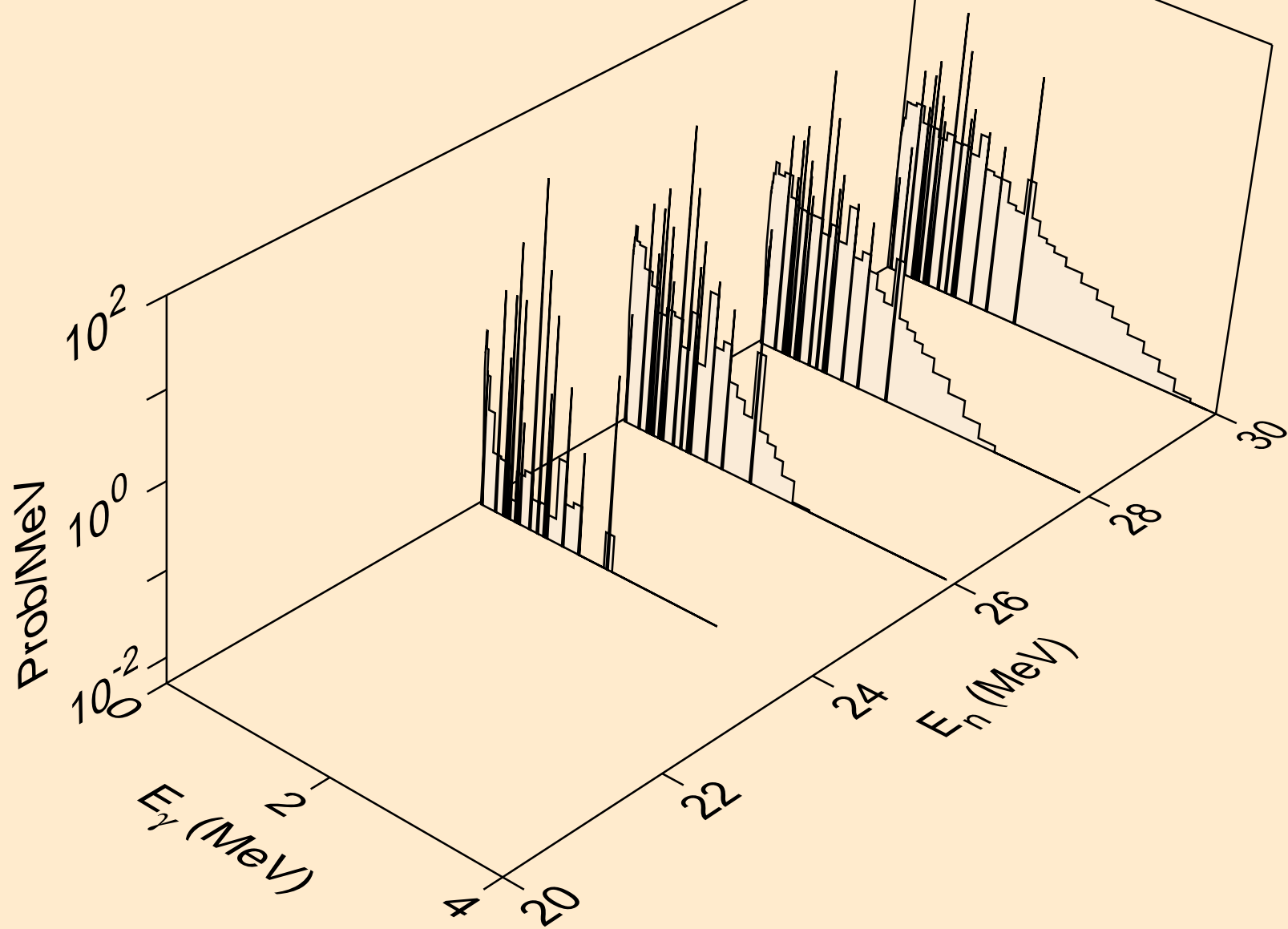

IR203 ALPHA ACER TENDL-2021 LIBRARY; T=0.K  
Photon emission for (n,2np)

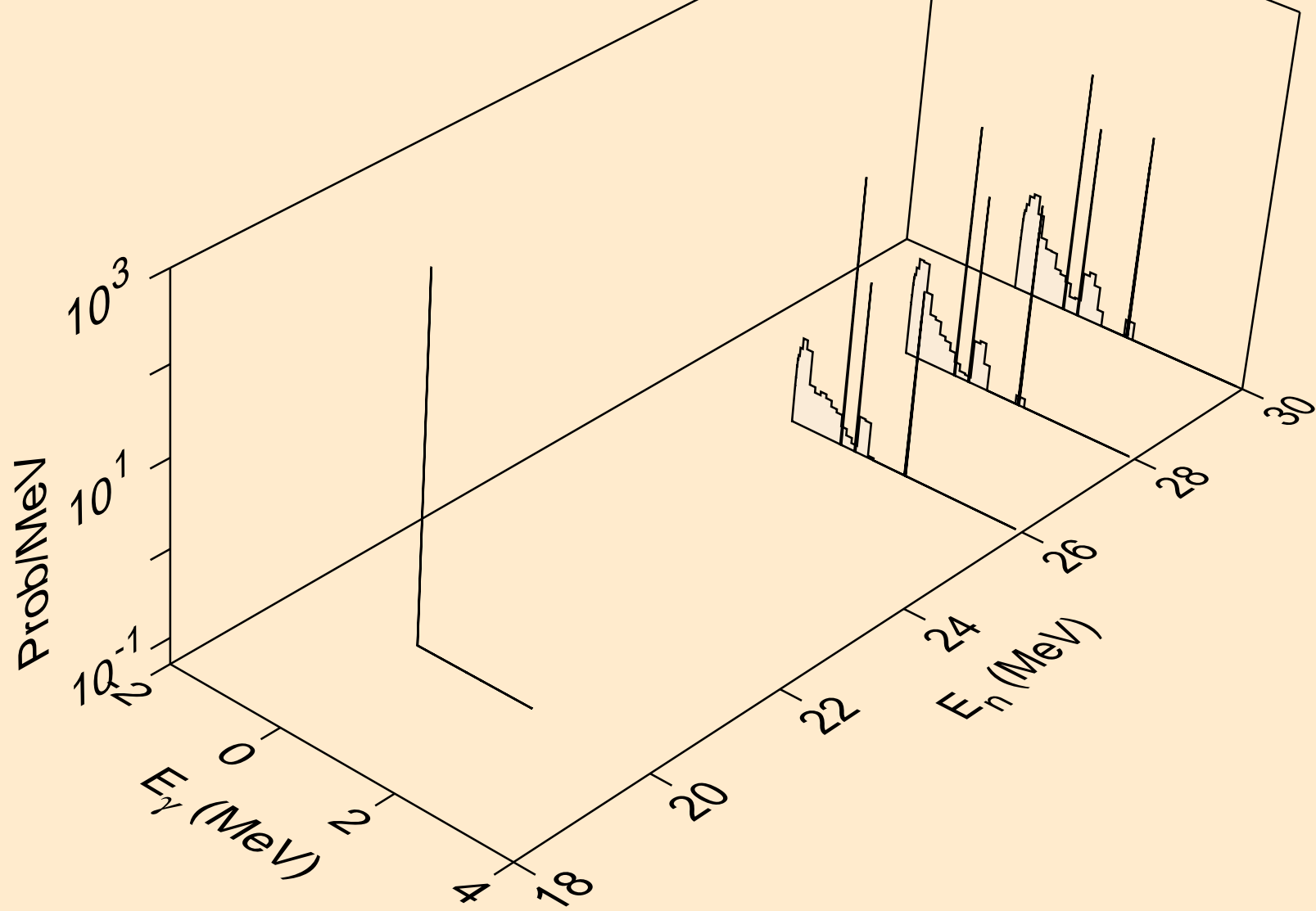

IR203 ALPHA ACER TENDL-2021 LIBRARY; T=0.K  
Photon emission for (n,3np)

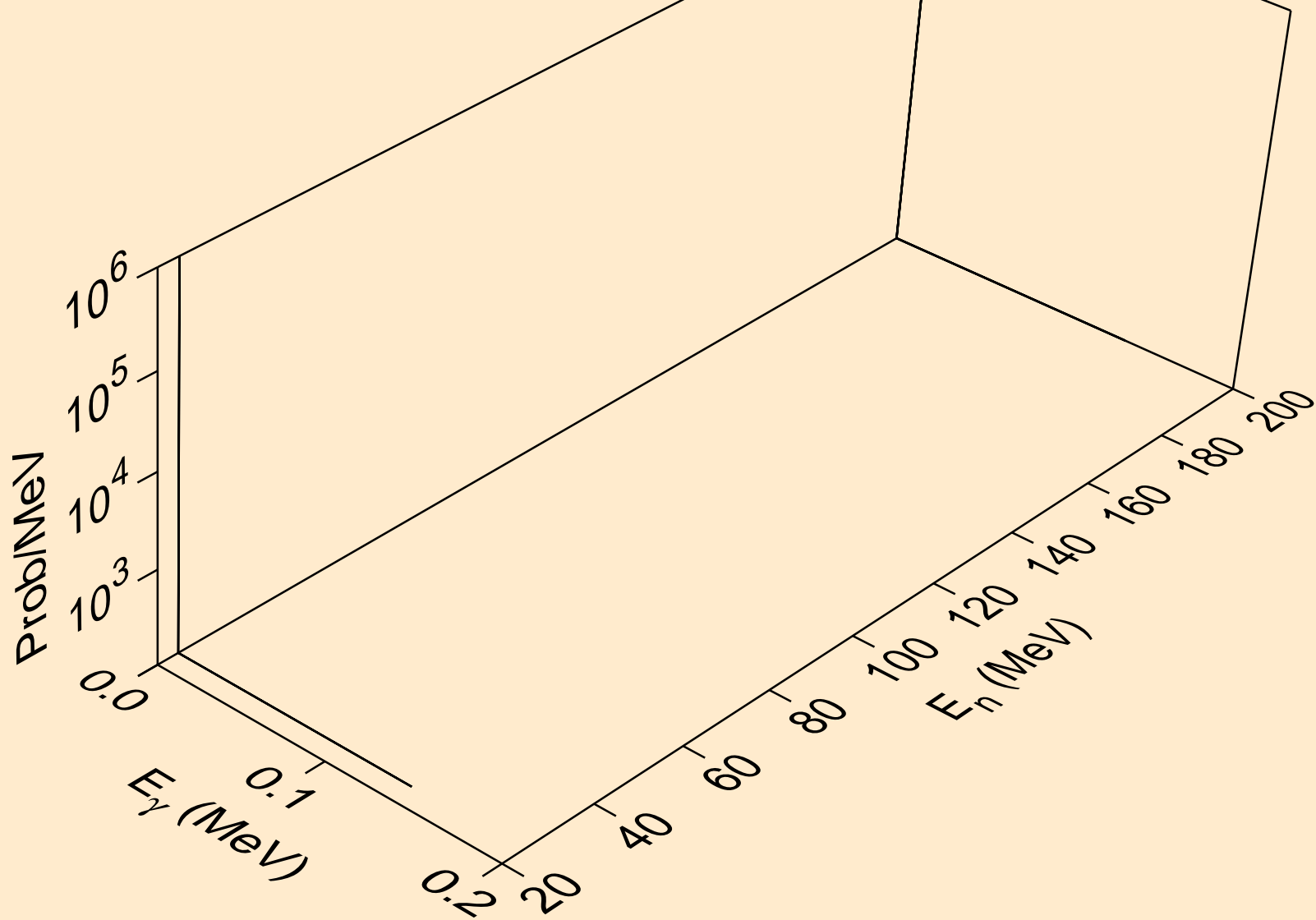

IR203 ALPHA ACER TENDL-2021 LIBRARY; T=0.K  
Photon emission for (n,gma)

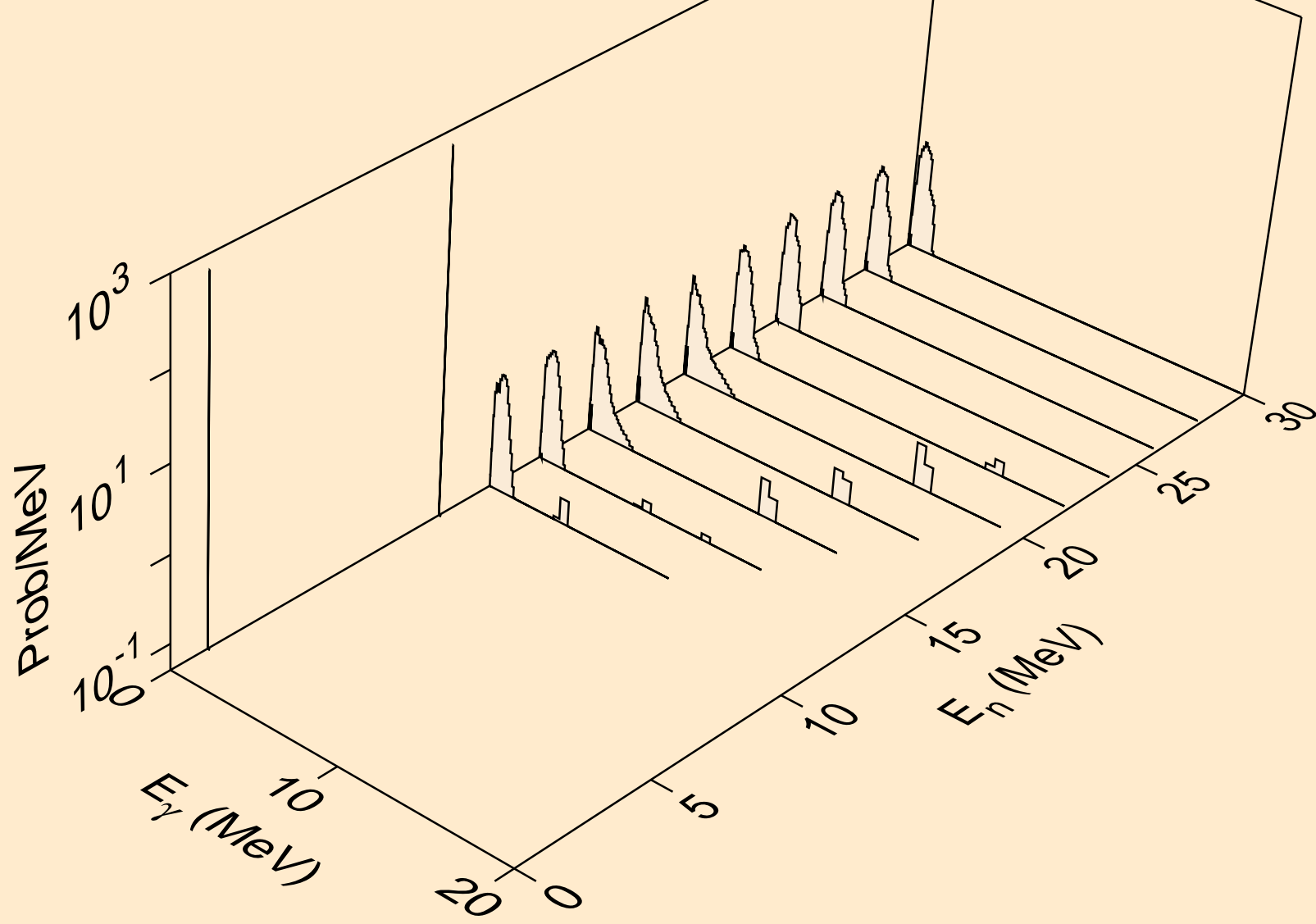

IR203 ALPHA ACER TENDL-2021 LIBRARY; T=0.K  
Photon emission for (n,p)

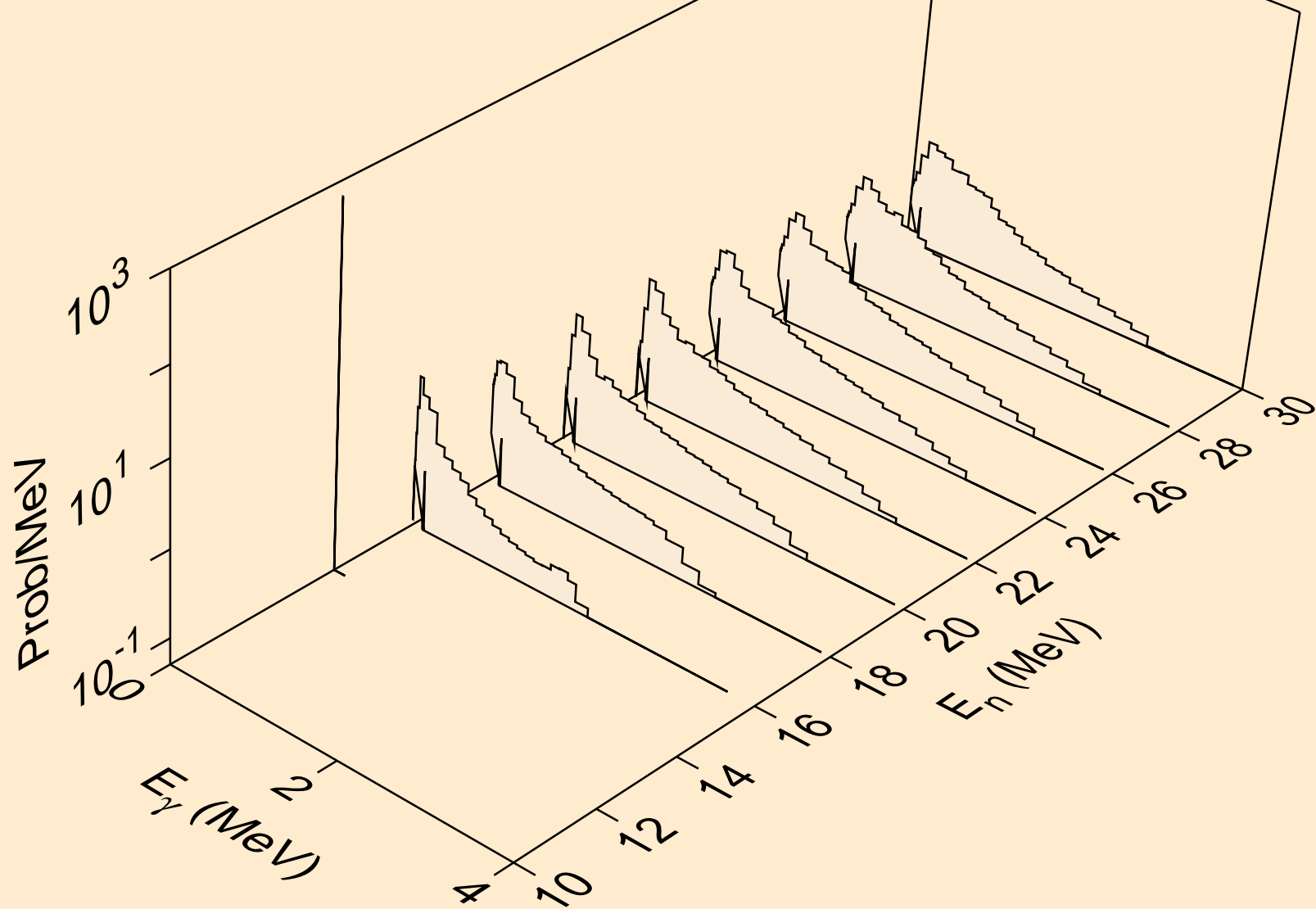

IR203 ALPHA ACER TENDL-2021 LIBRARY; T=0.K  
Photon emission for (n,d)

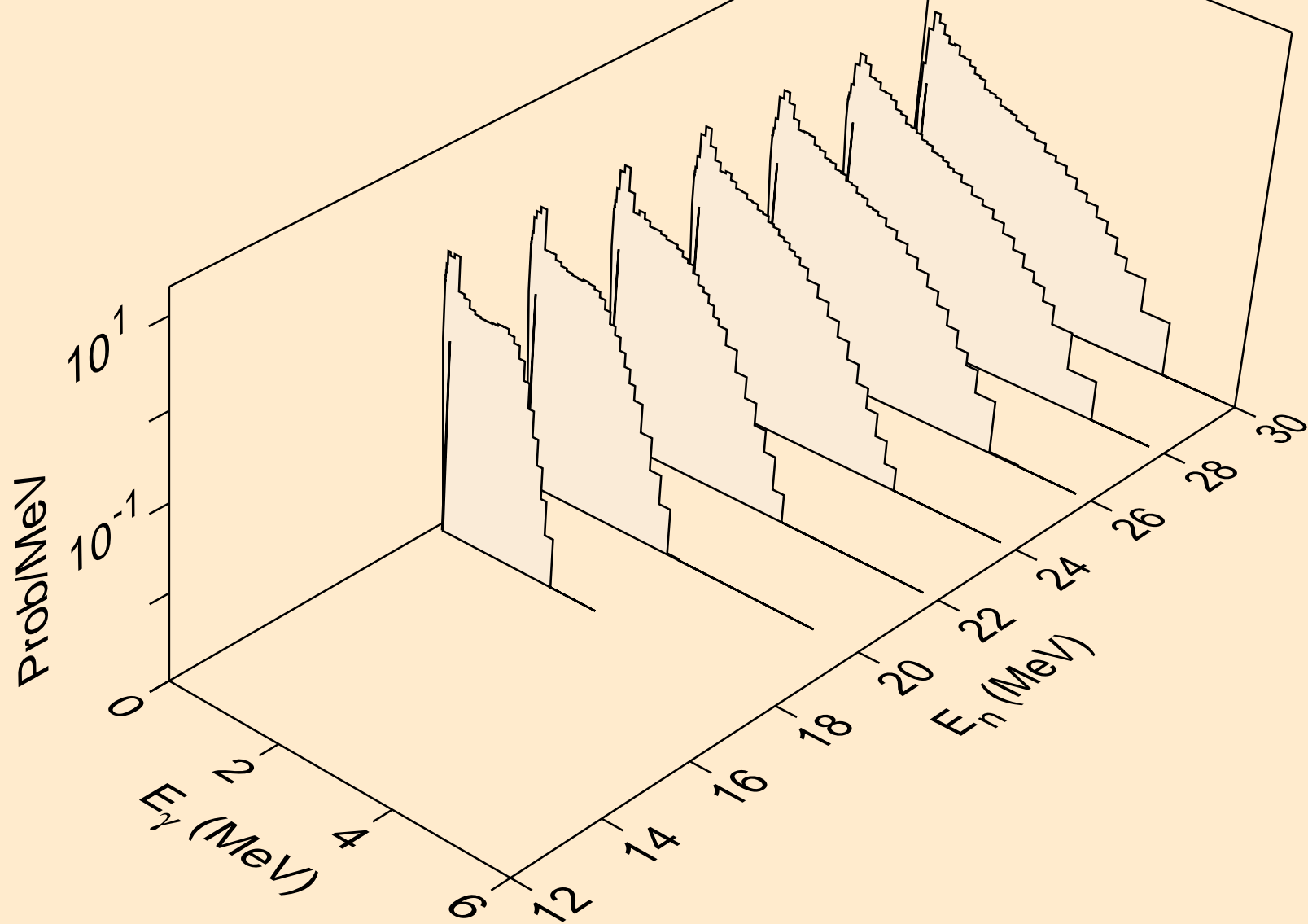



IR203 ALPHA ACER TENDL-2021 LIBRARY; T=0.K  
Photon emission for (n,t)

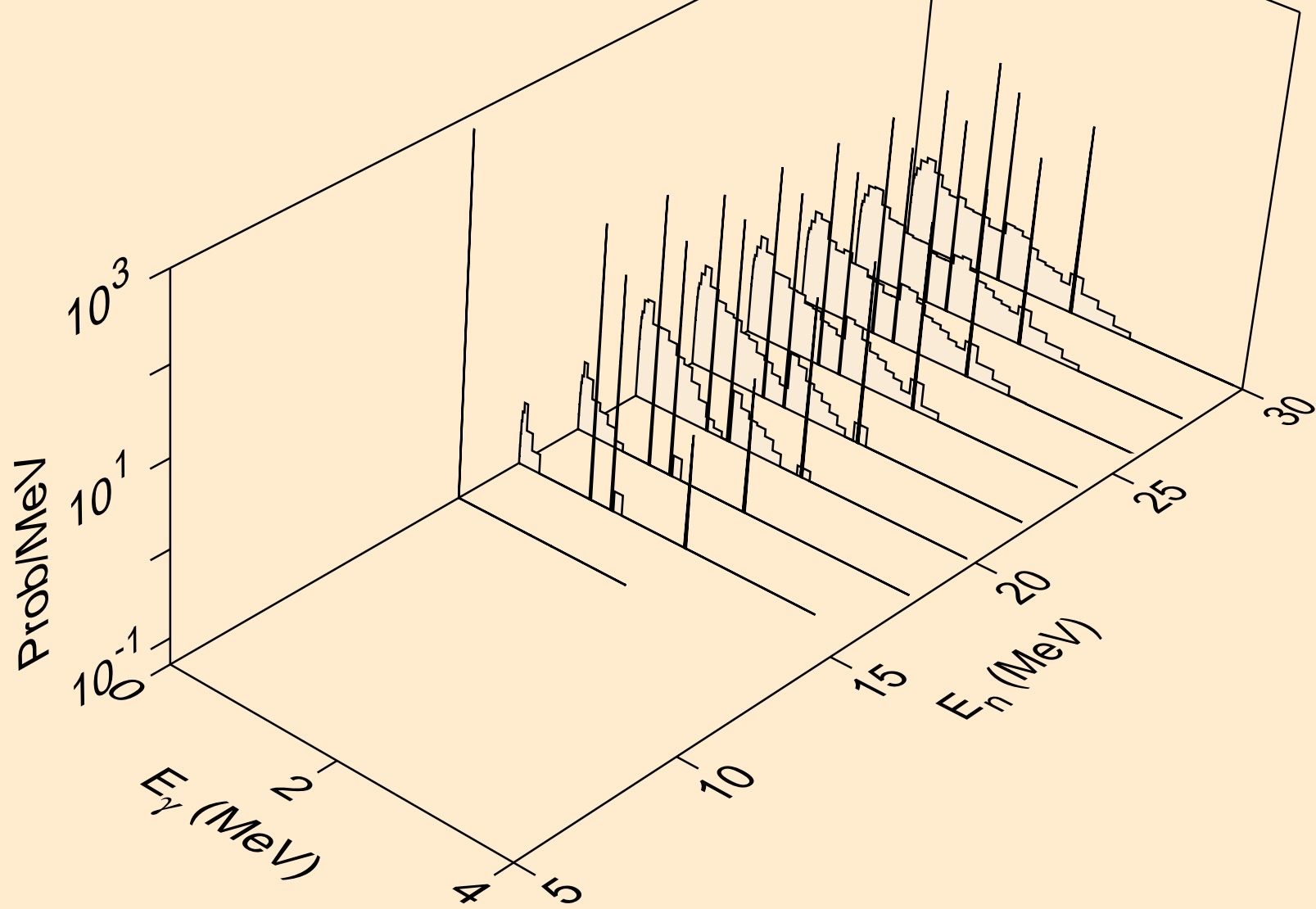

IR203 ALPHA ACER TENDL-2021 LIBRARY; T=0.K  
Photon emission for inelastic

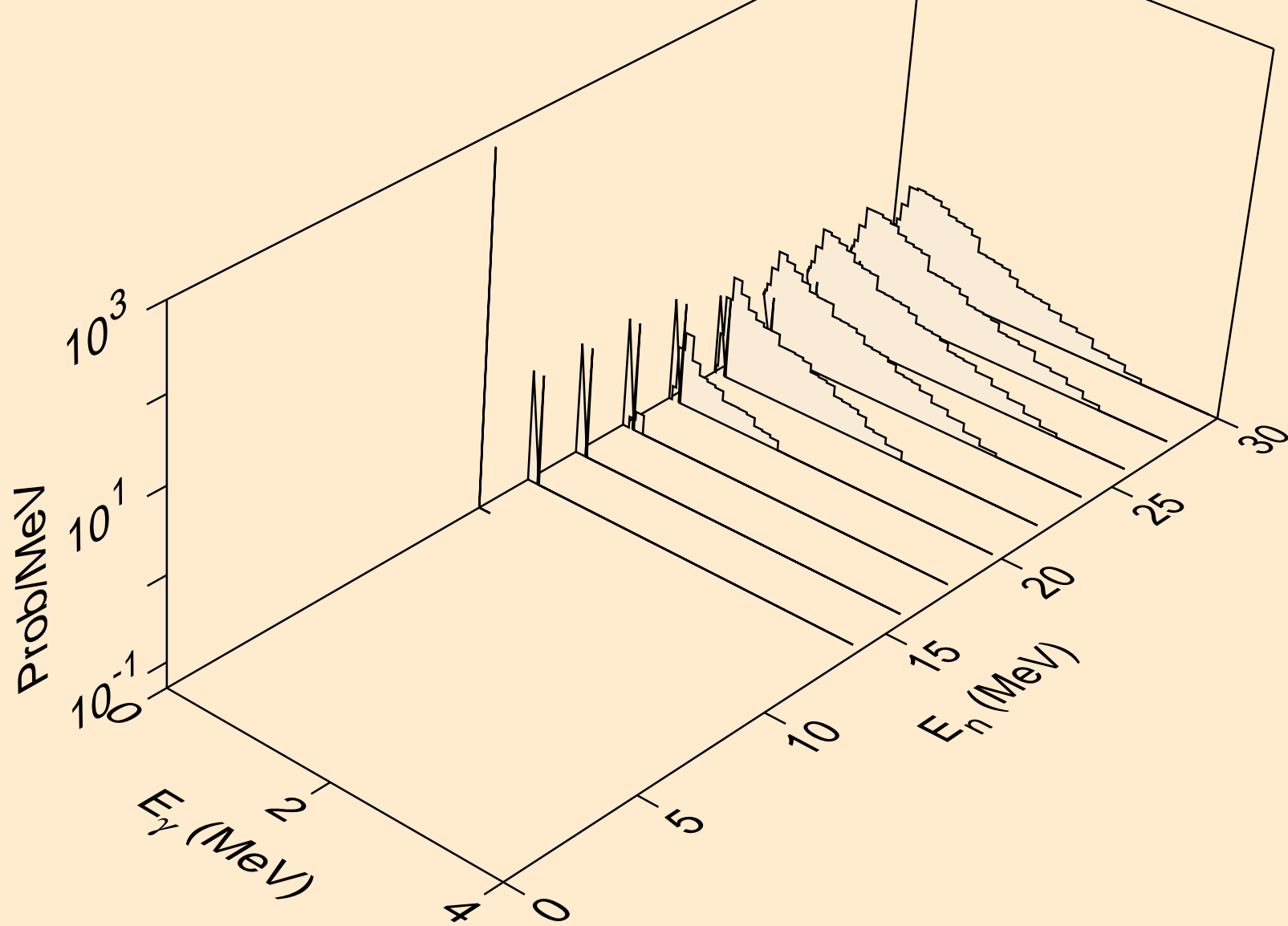

IR203 ALPHA ACER TENDL-2021 LIBRARY; T=0.K  
Particle heating contributions

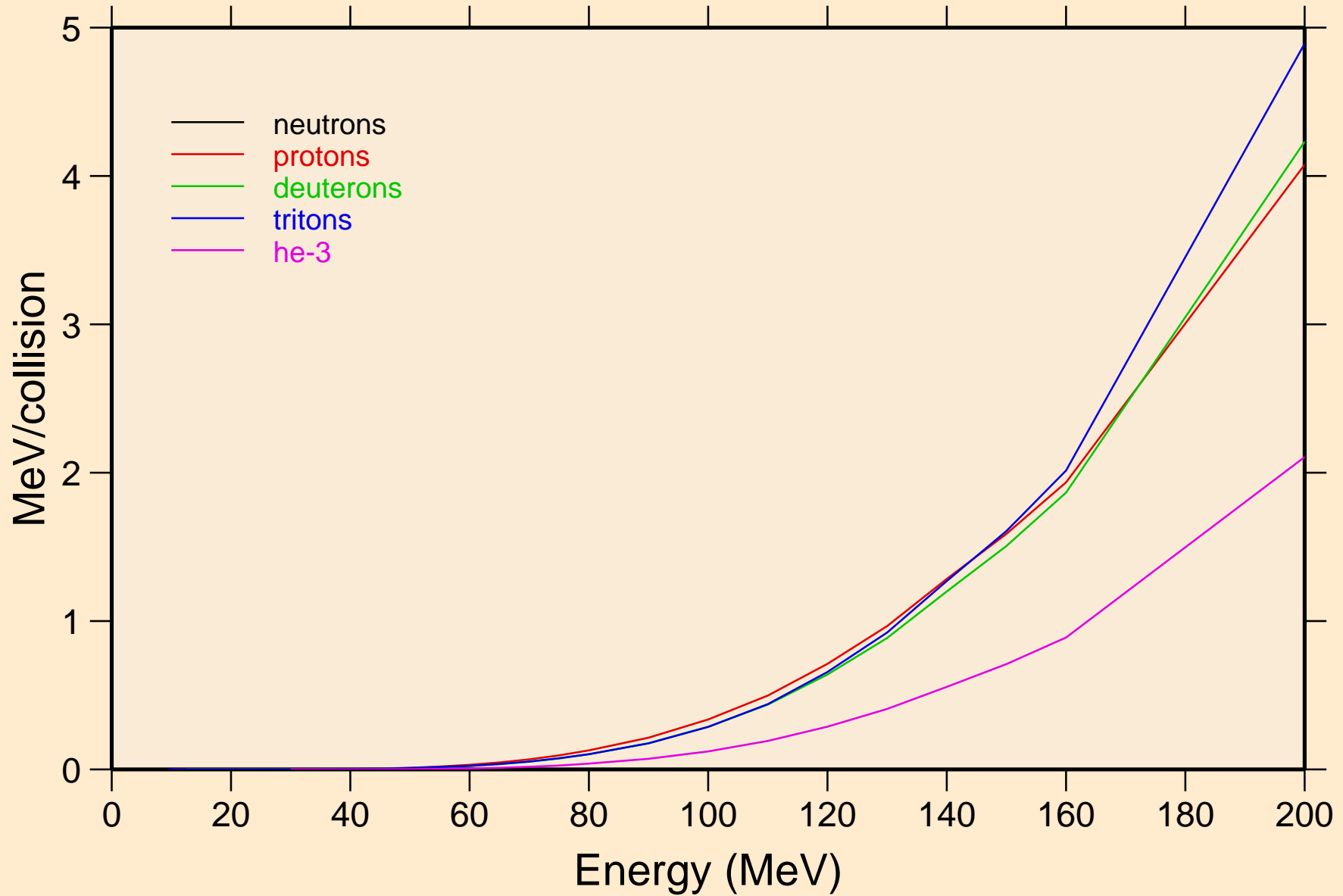

IR203 ALPHA ACER TENDL-2021 LIBRARY; T=0.K  
Recoil Heating

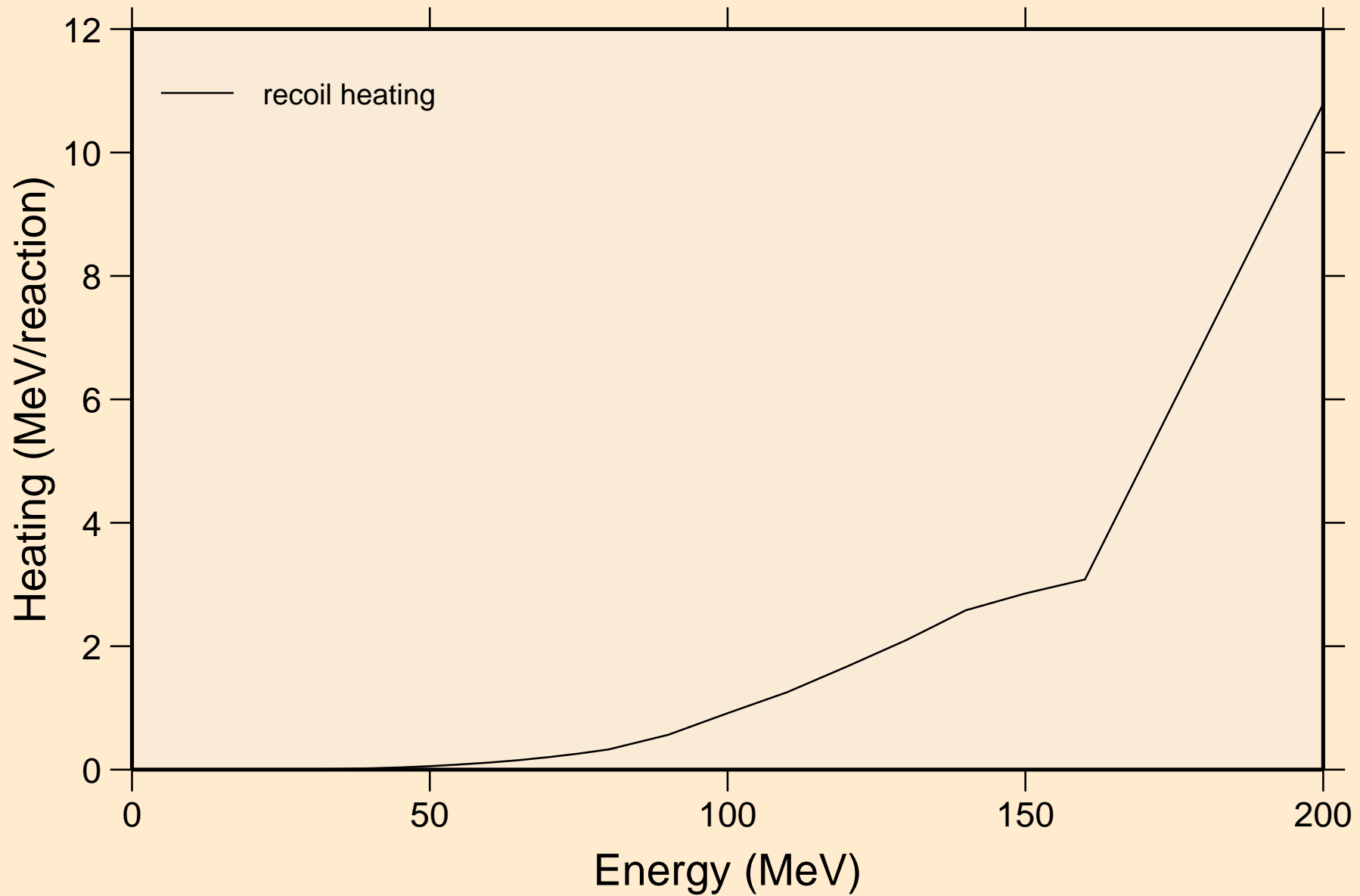

IR203 ALPHA ACER TENDL-2021 LIBRARY; T=0.K  
Particle production cross sections

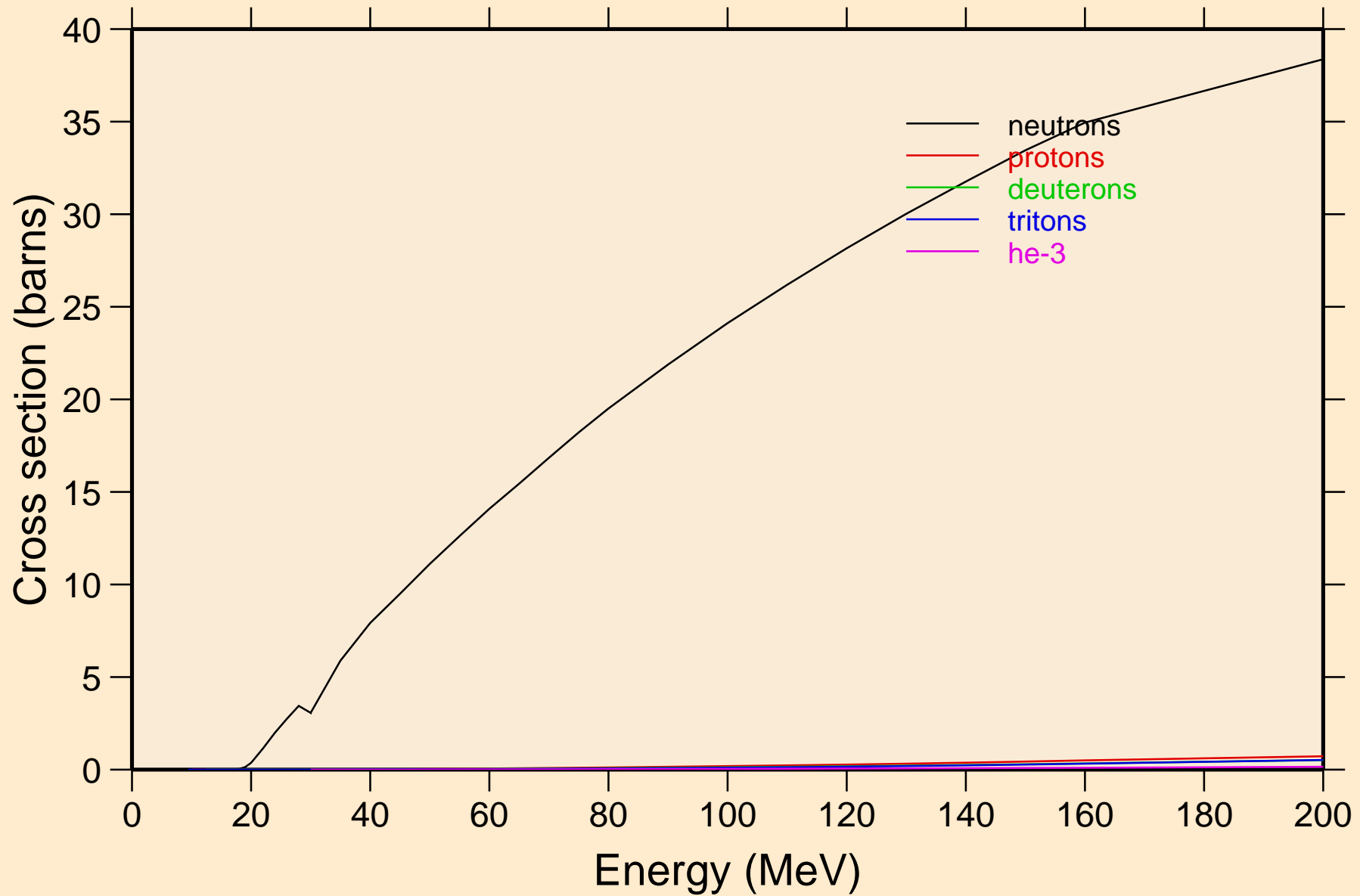

IR203 ALPHA ACER TENDL-2021 LIBRARY; T=0.K  
neutrons from (a,n)

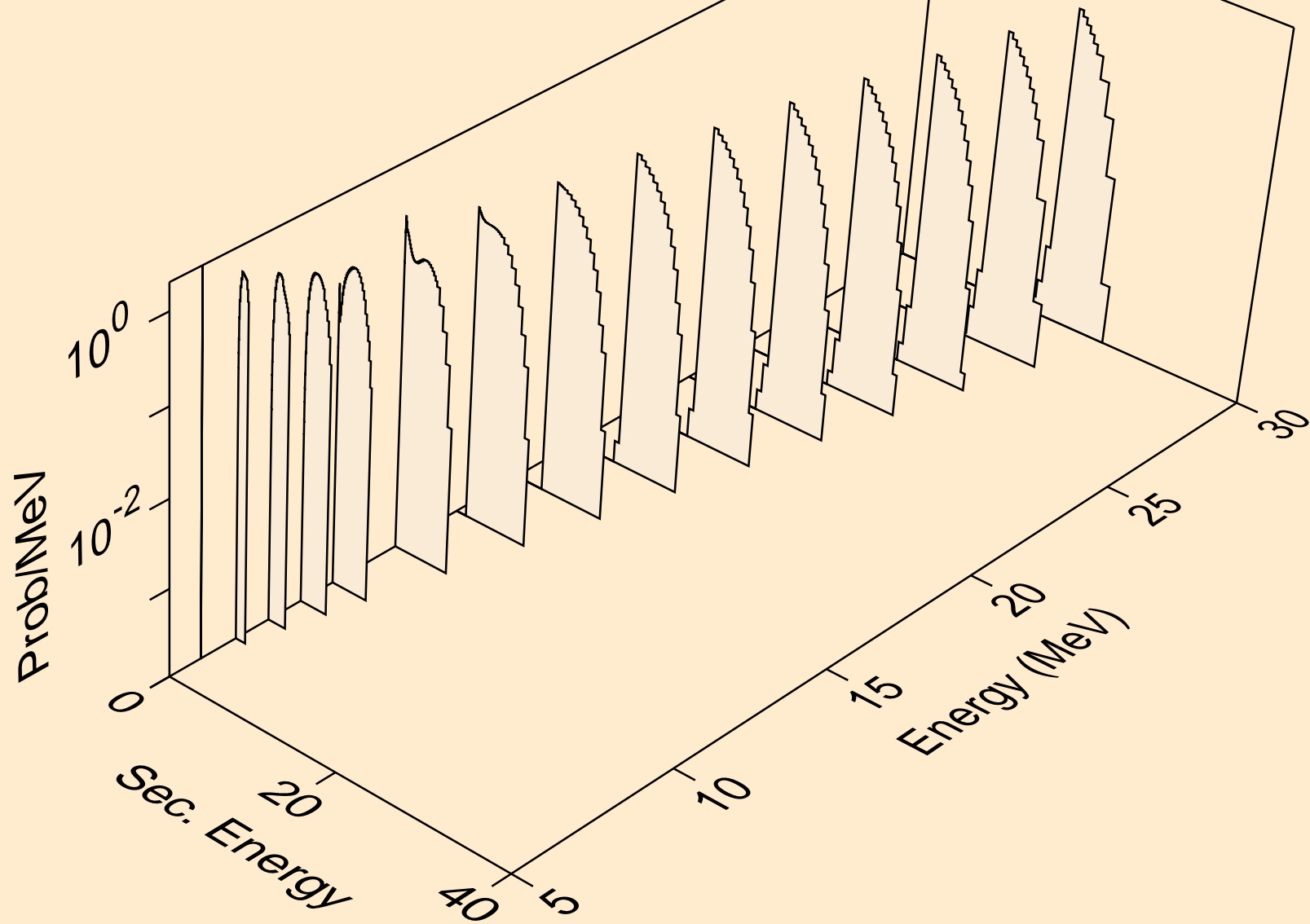

IR203 ALPHA ACER TENDL-2021 LIBRARY; T=0.K  
neutrons from (a,x)

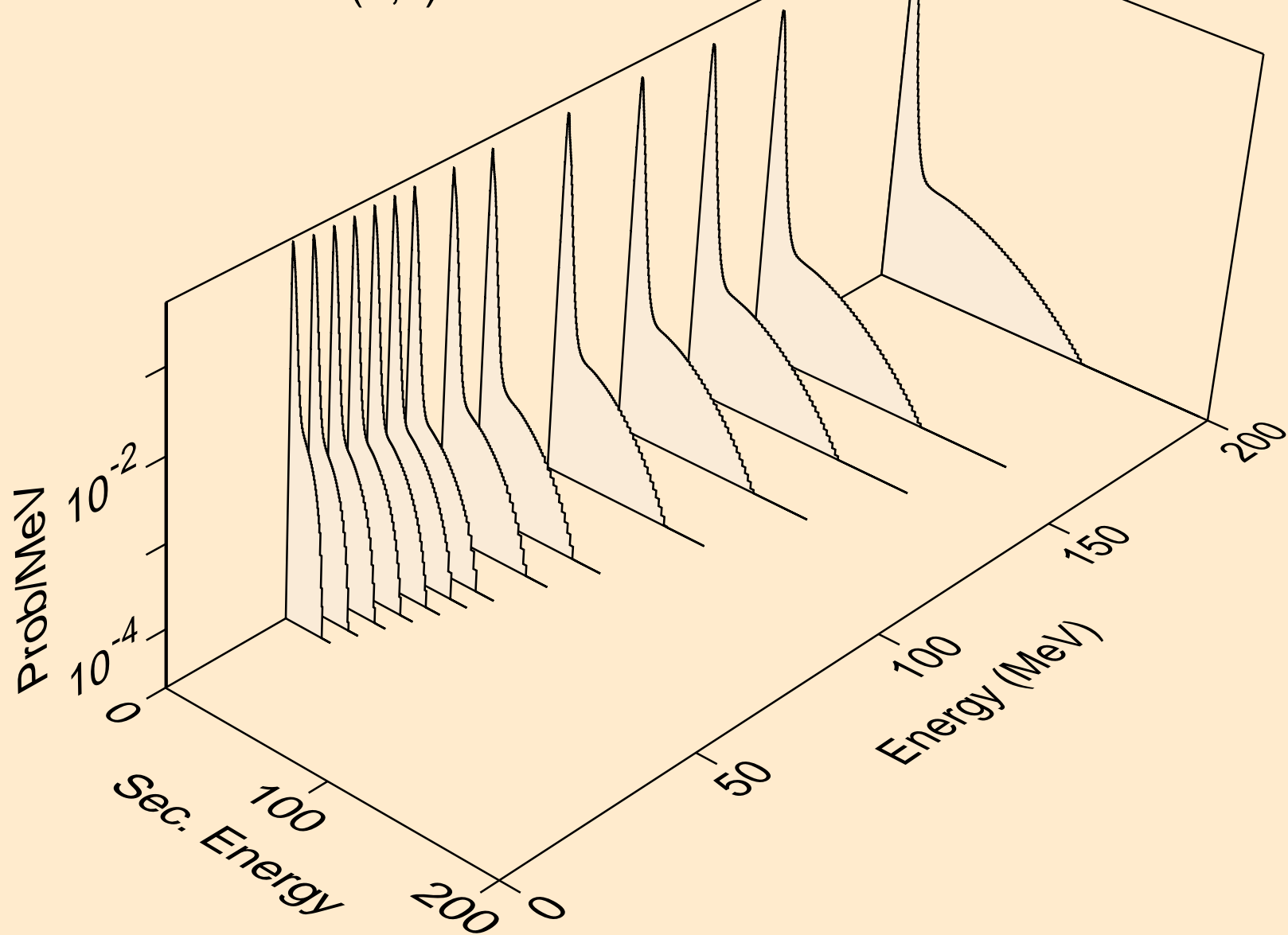

IR203 ALPHA ACER TENDL-2021 LIBRARY; T=0.K  
neutrons from (a,2nd)

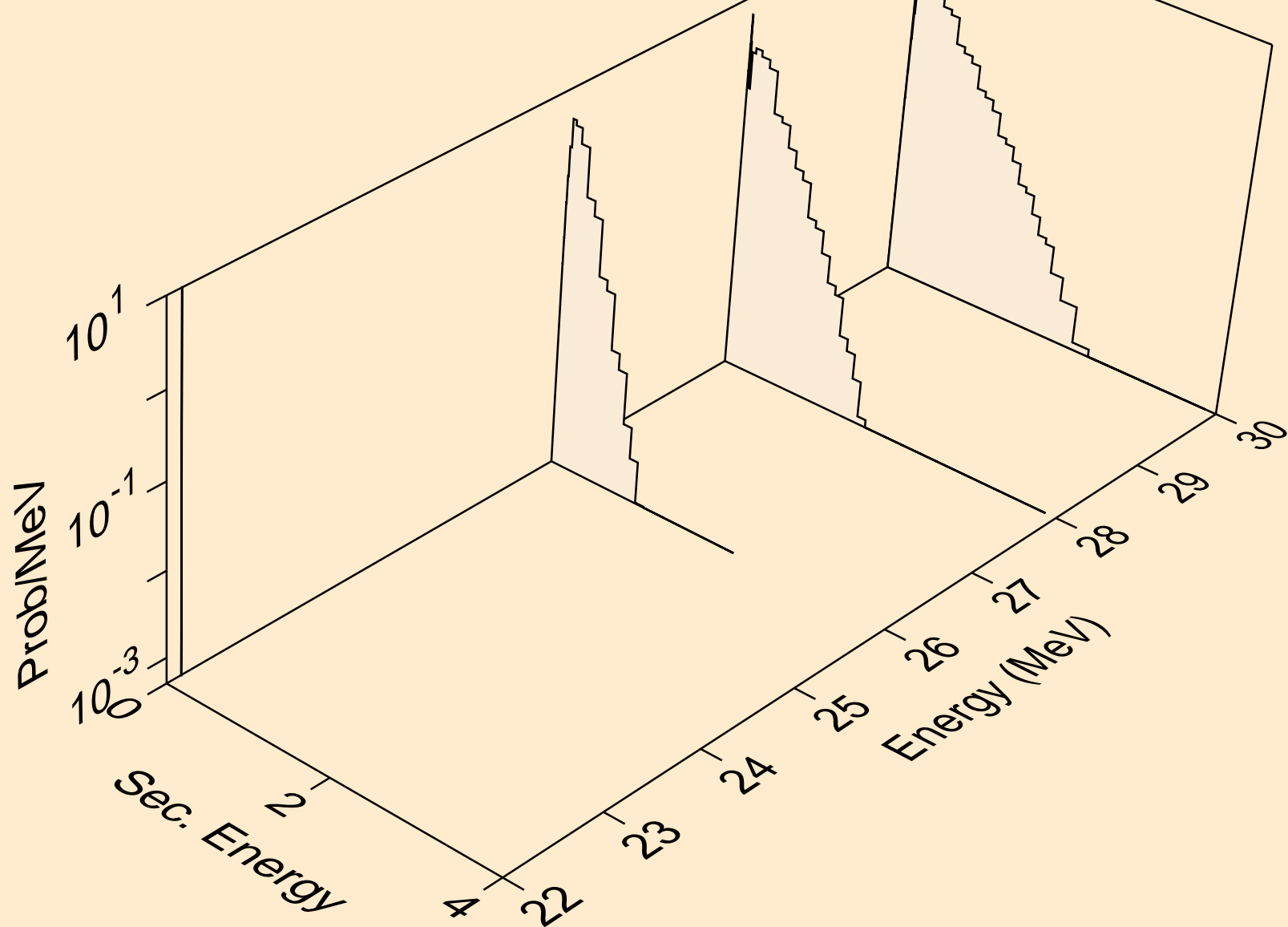



IR203 ALPHA ACER TENDL-2021 LIBRARY; T=0.K  
neutrons from (a,2n)

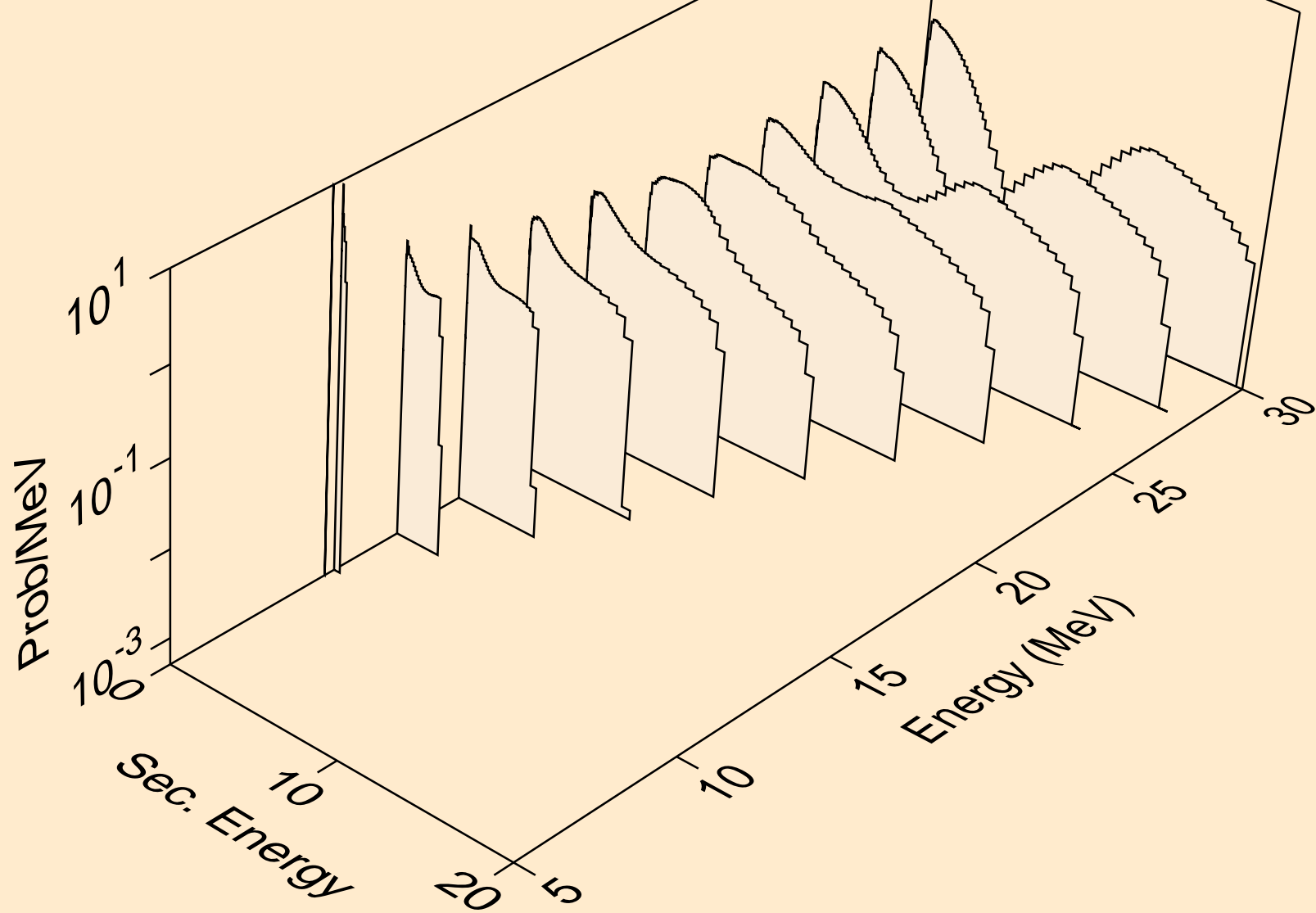

IR203 ALPHA ACER TENDL-2021 LIBRARY; T=0.K  
neutrons from (a,3n)

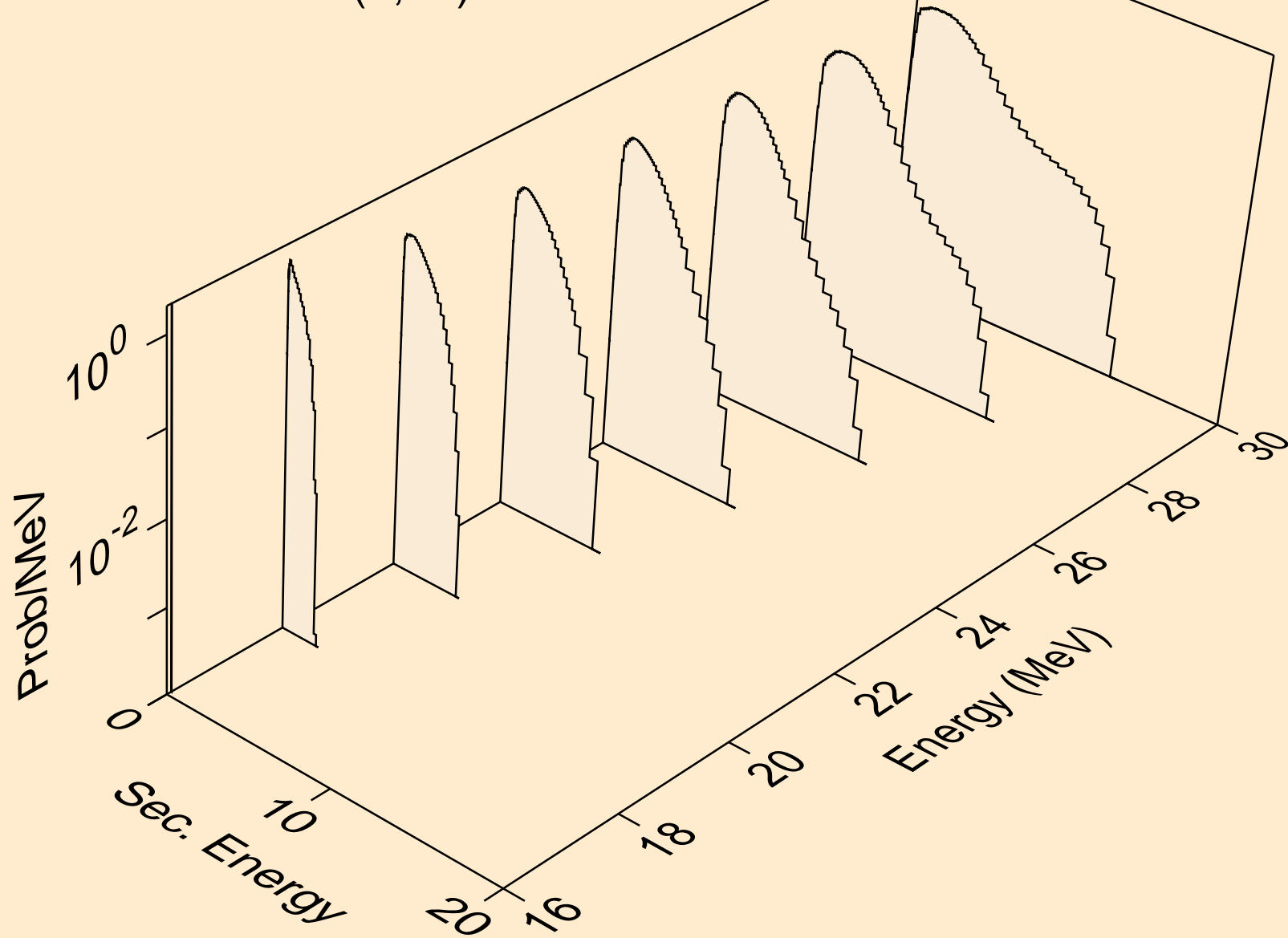

IR203 ALPHA ACER TENDL-2021 LIBRARY; T=0.K  
neutrons from (a,n\*)a

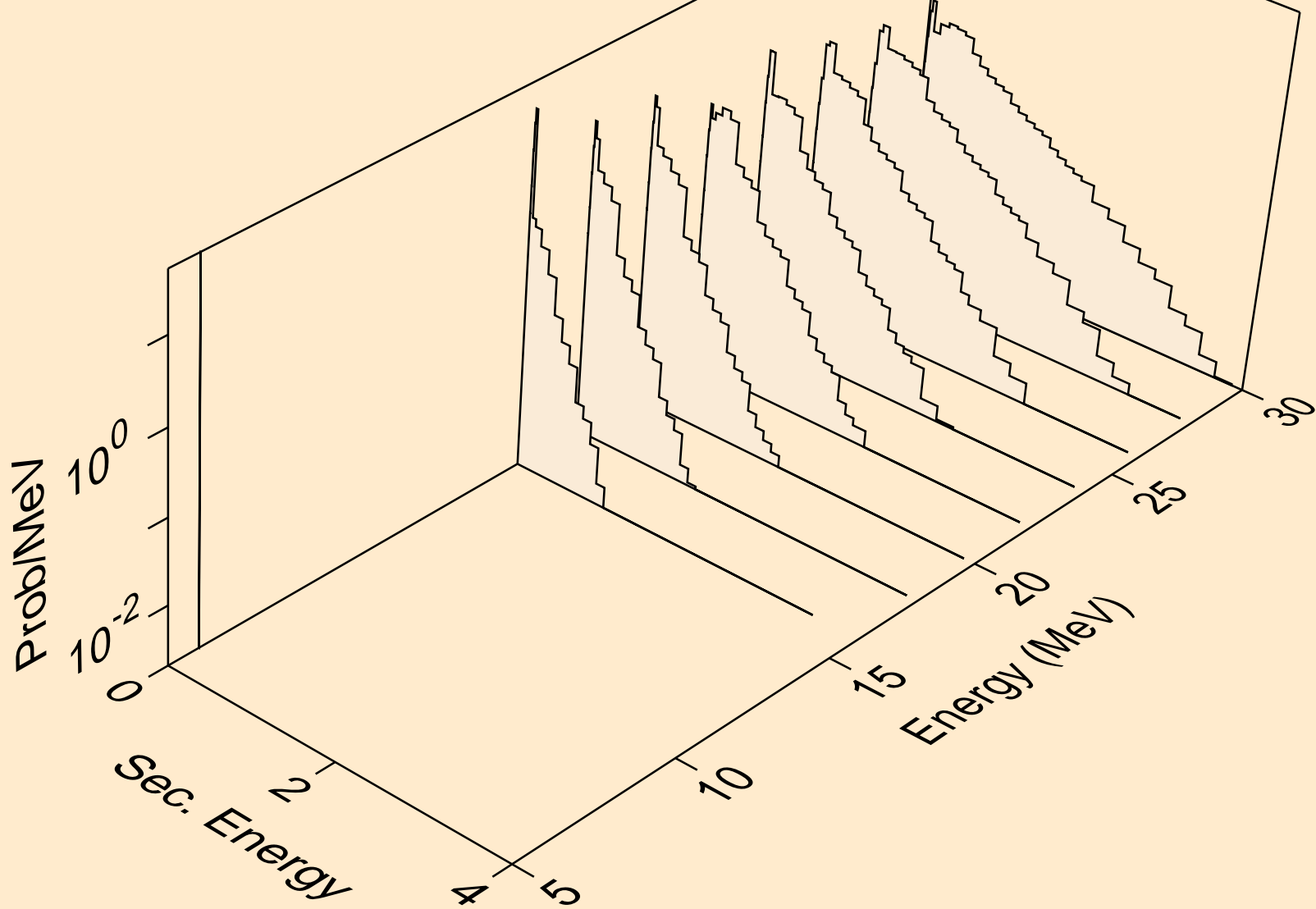

IR203 ALPHA ACER TENDL-2021 LIBRARY; T=0.K  
neutrons from (a,2n)a

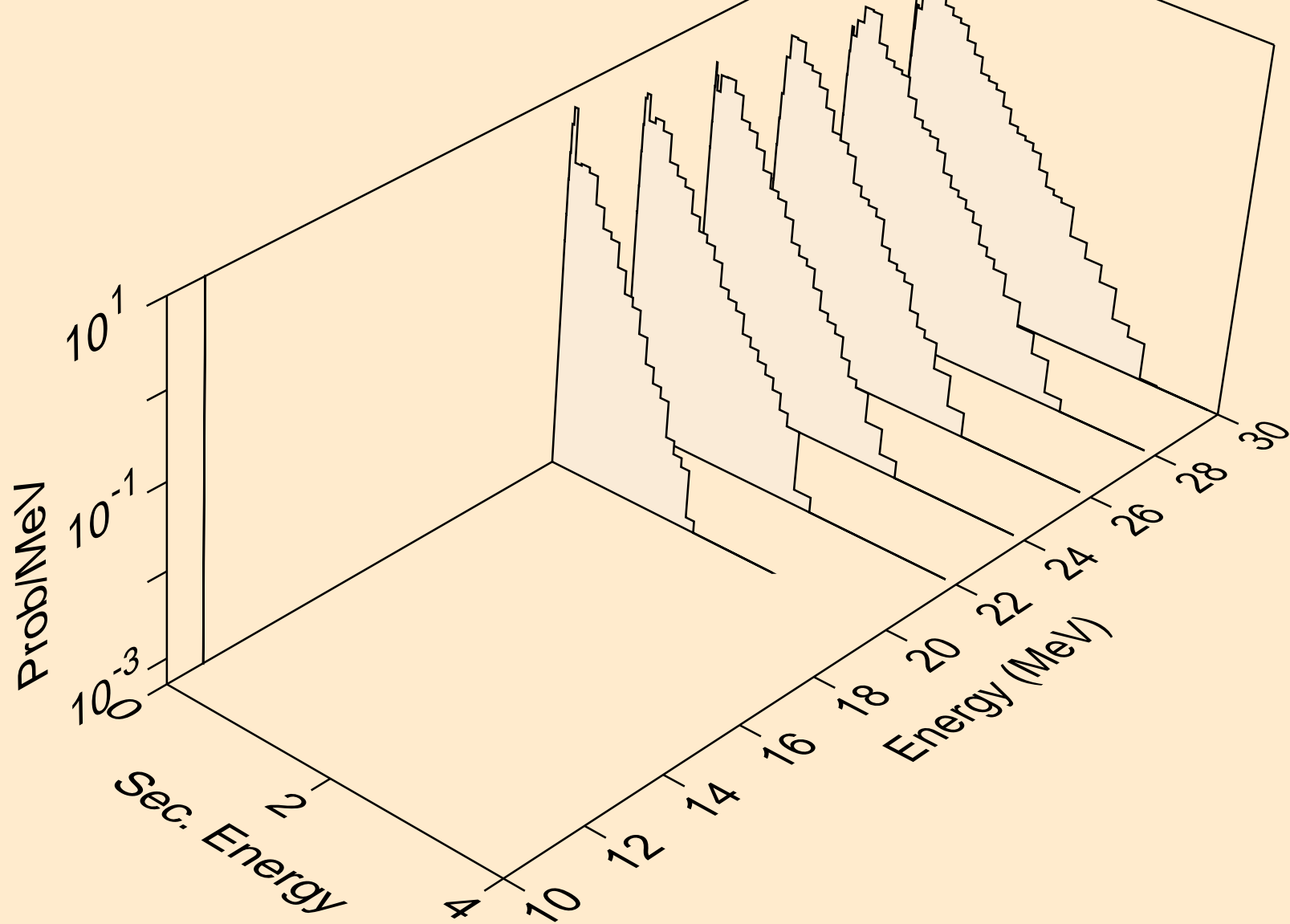

IR203 ALPHA ACER TENDL-2021 LIBRARY; T=0.K  
neutrons from (a,n\*)p

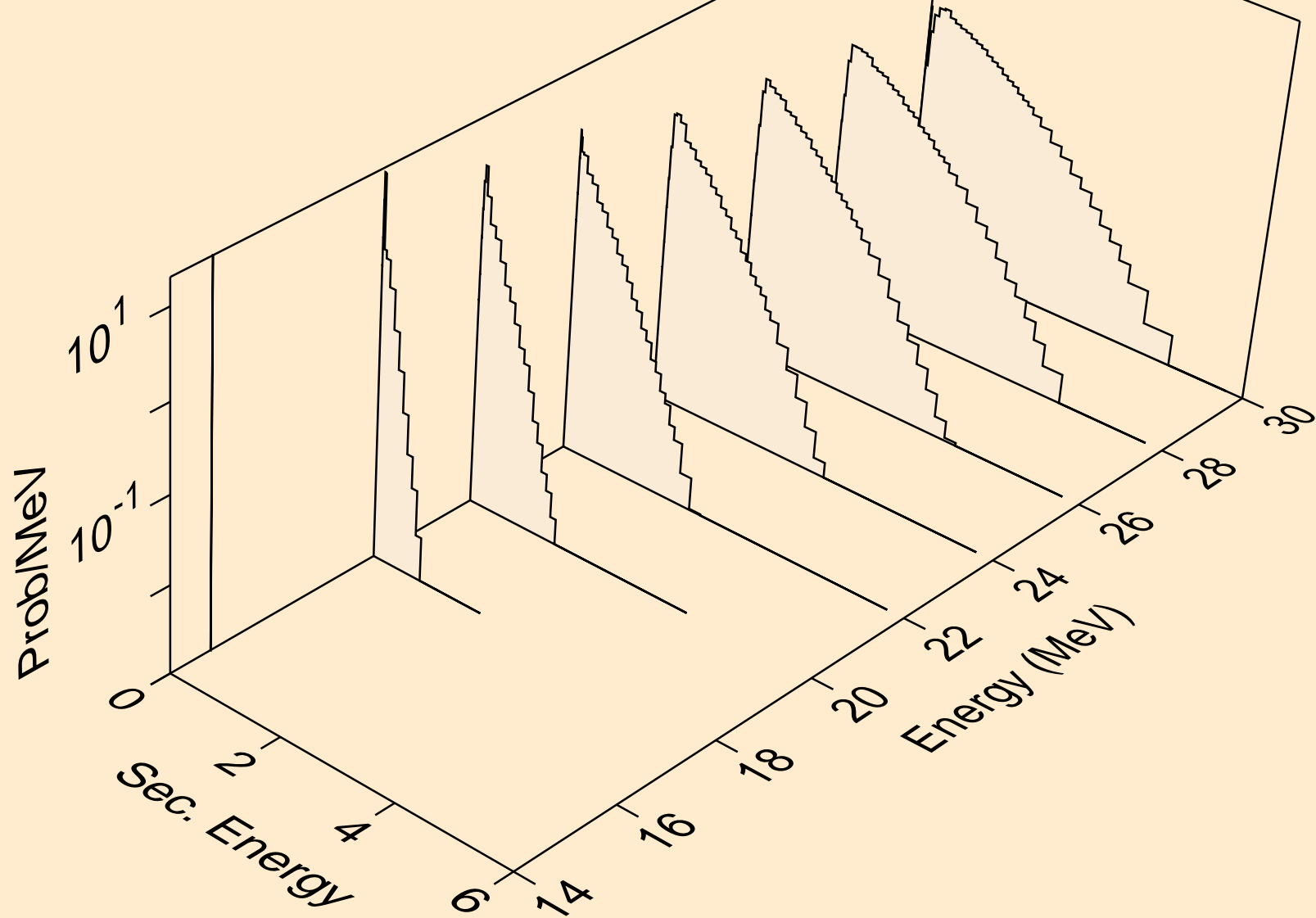

IR203 ALPHA ACER TENDL-2021 LIBRARY; T=0.K  
neutrons from (a,n\*)d

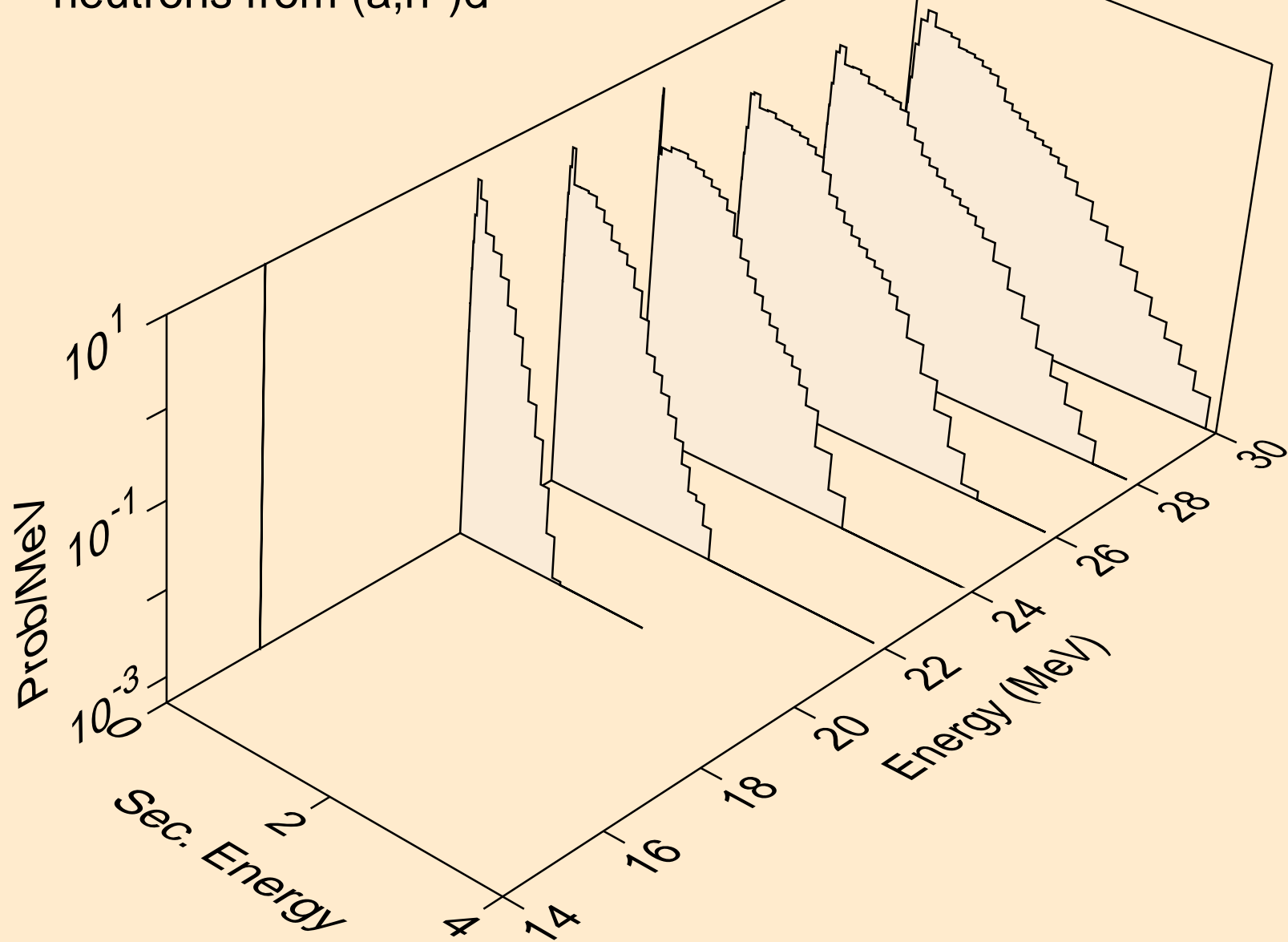

IR203 ALPHA ACER TENDL-2021 LIBRARY; T=0.K  
neutrons from (a,n\*)t

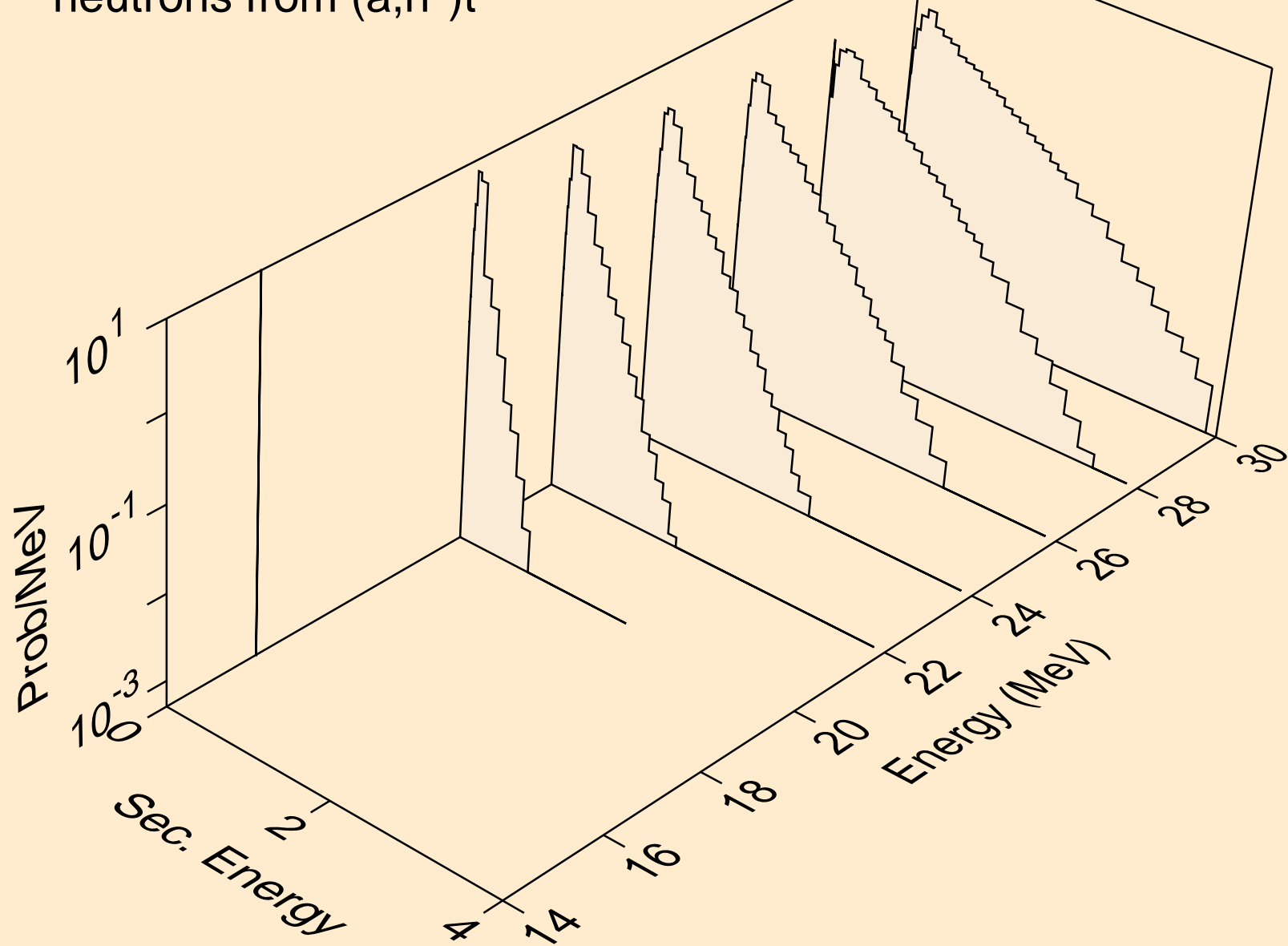

IR203 ALPHA ACER TENDL-2021 LIBRARY; T=0.K  
neutrons from (a,4n)

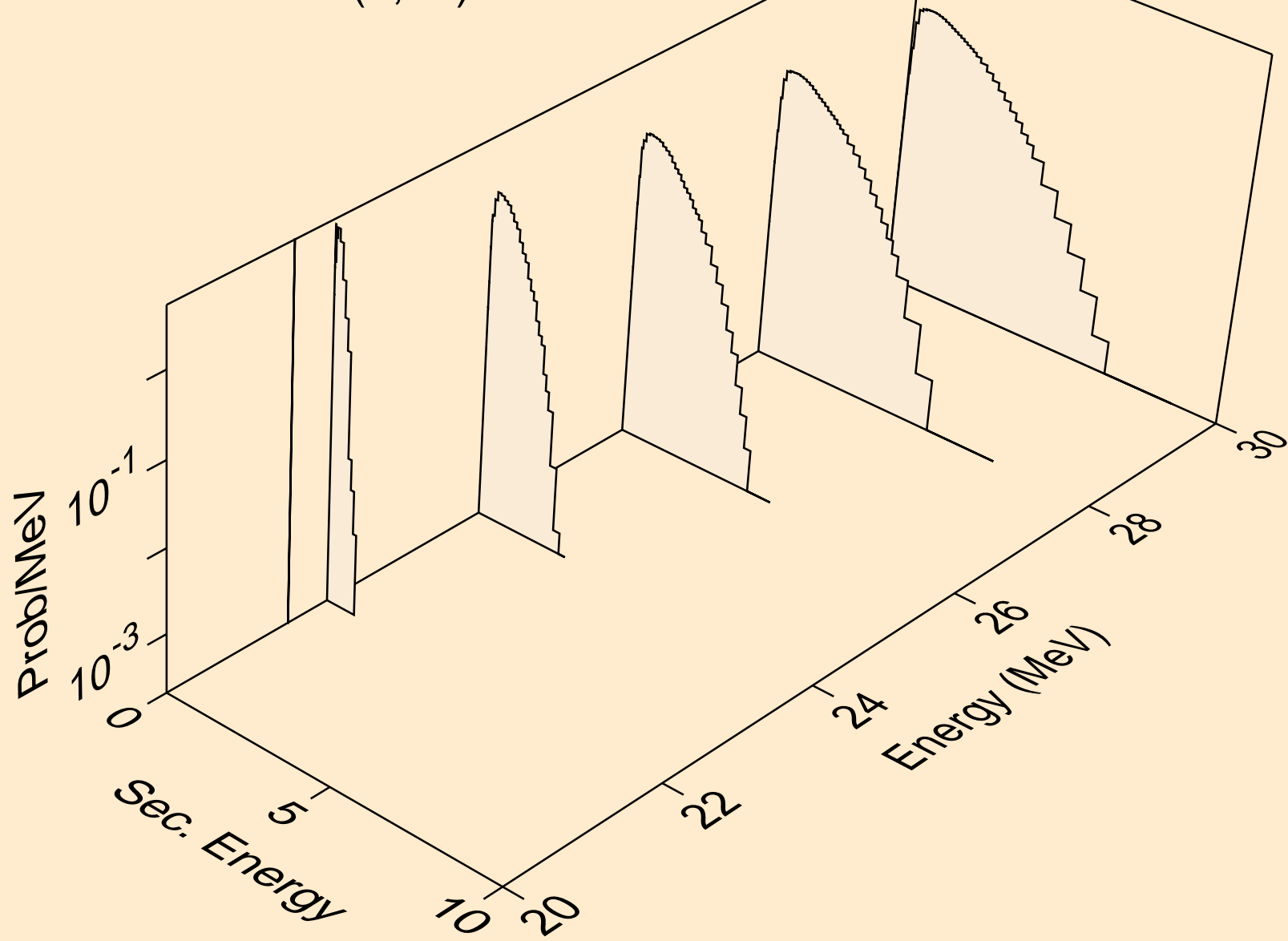



IR203 ALPHA ACER TENDL-2021 LIBRARY; T=0.K  
neutrons from (a,2np)

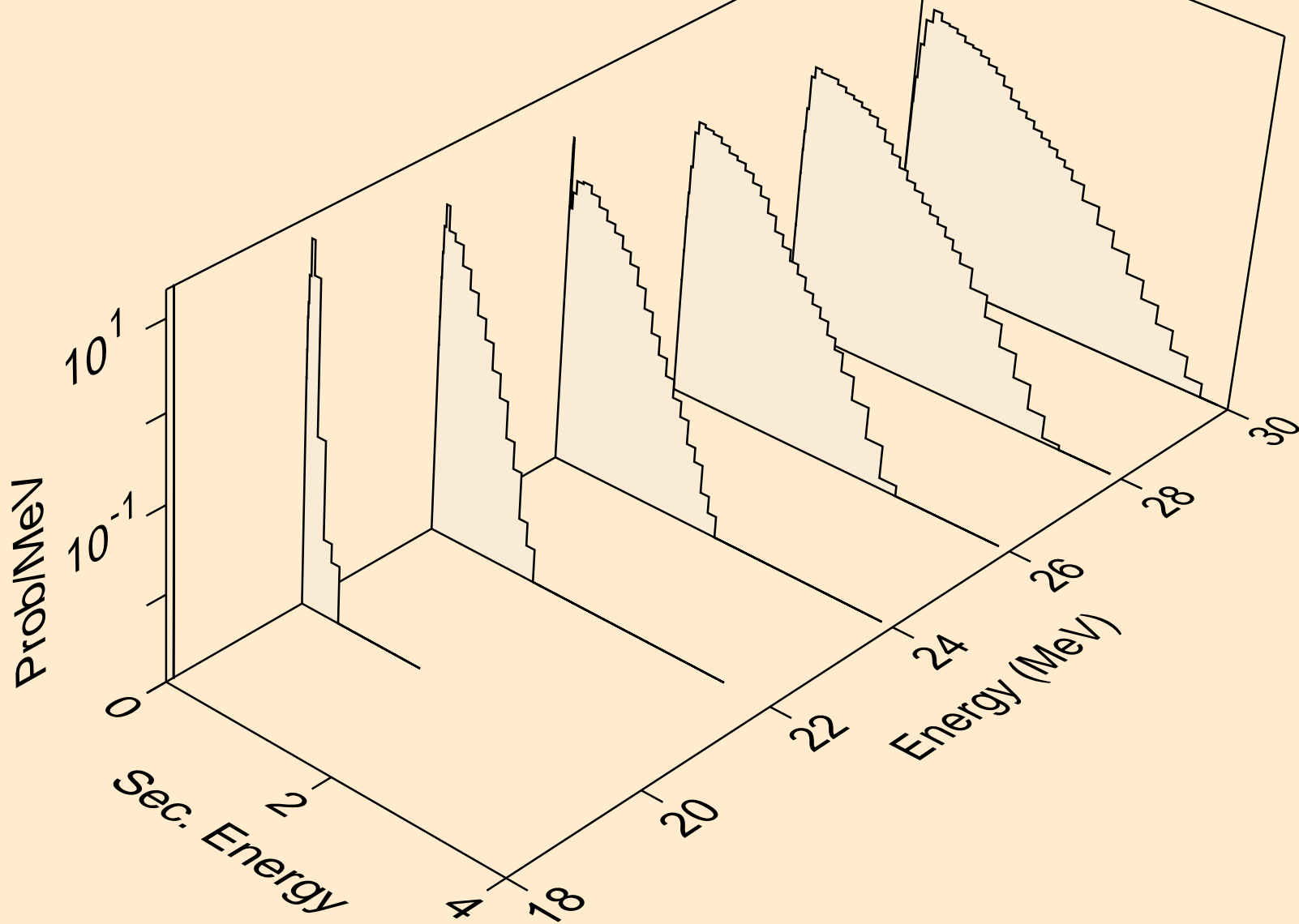

IR203 ALPHA ACER TENDL-2021 LIBRARY; T=0.K  
neutrons from (a,3np)

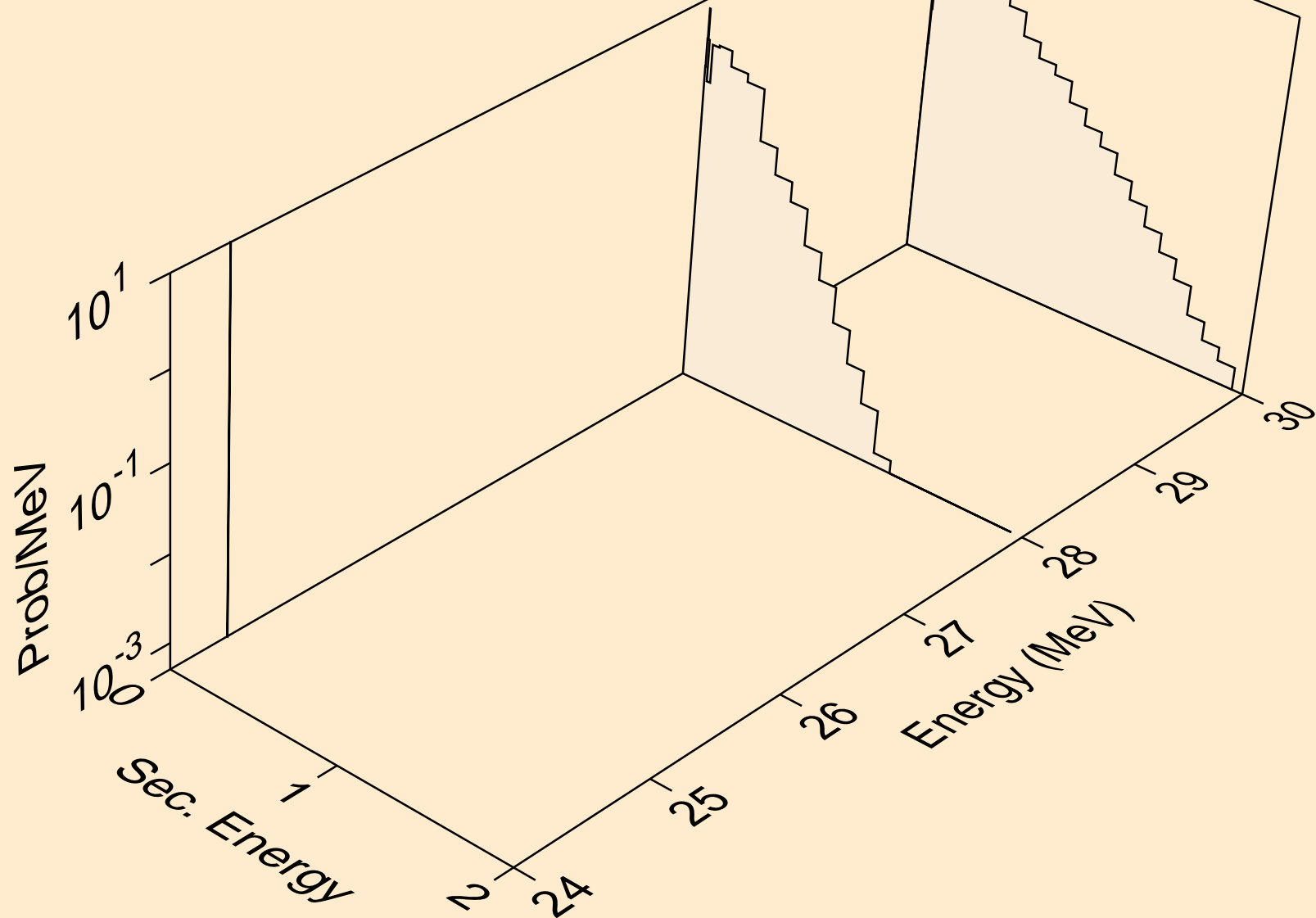

IR203 ALPHA ACER TENDL-2021 LIBRARY; T=0.K  
protons from (a,x)

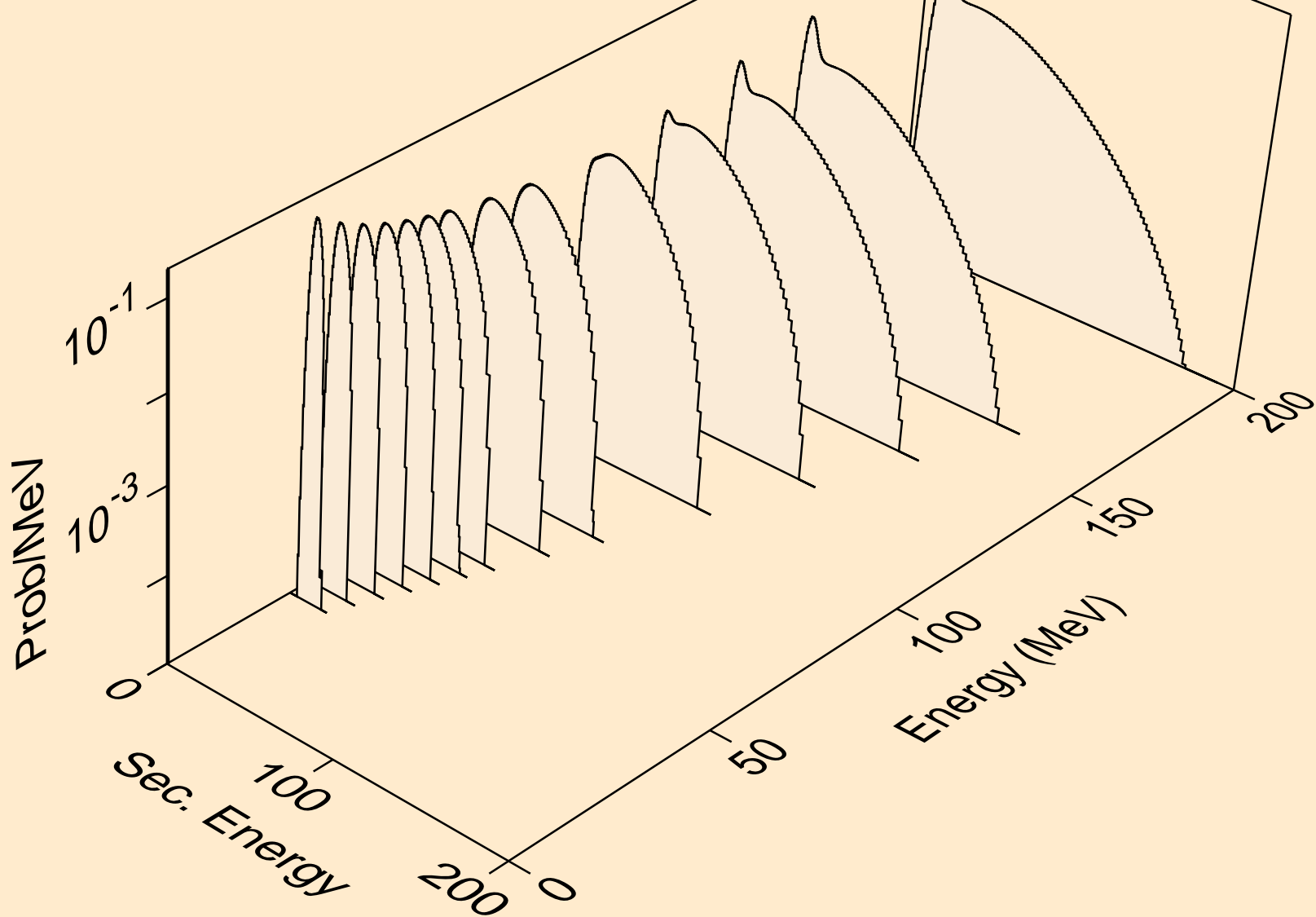

IR203 ALPHA ACER TENDL-2021 LIBRARY; T=0.K  
protons from (a,n\*)p

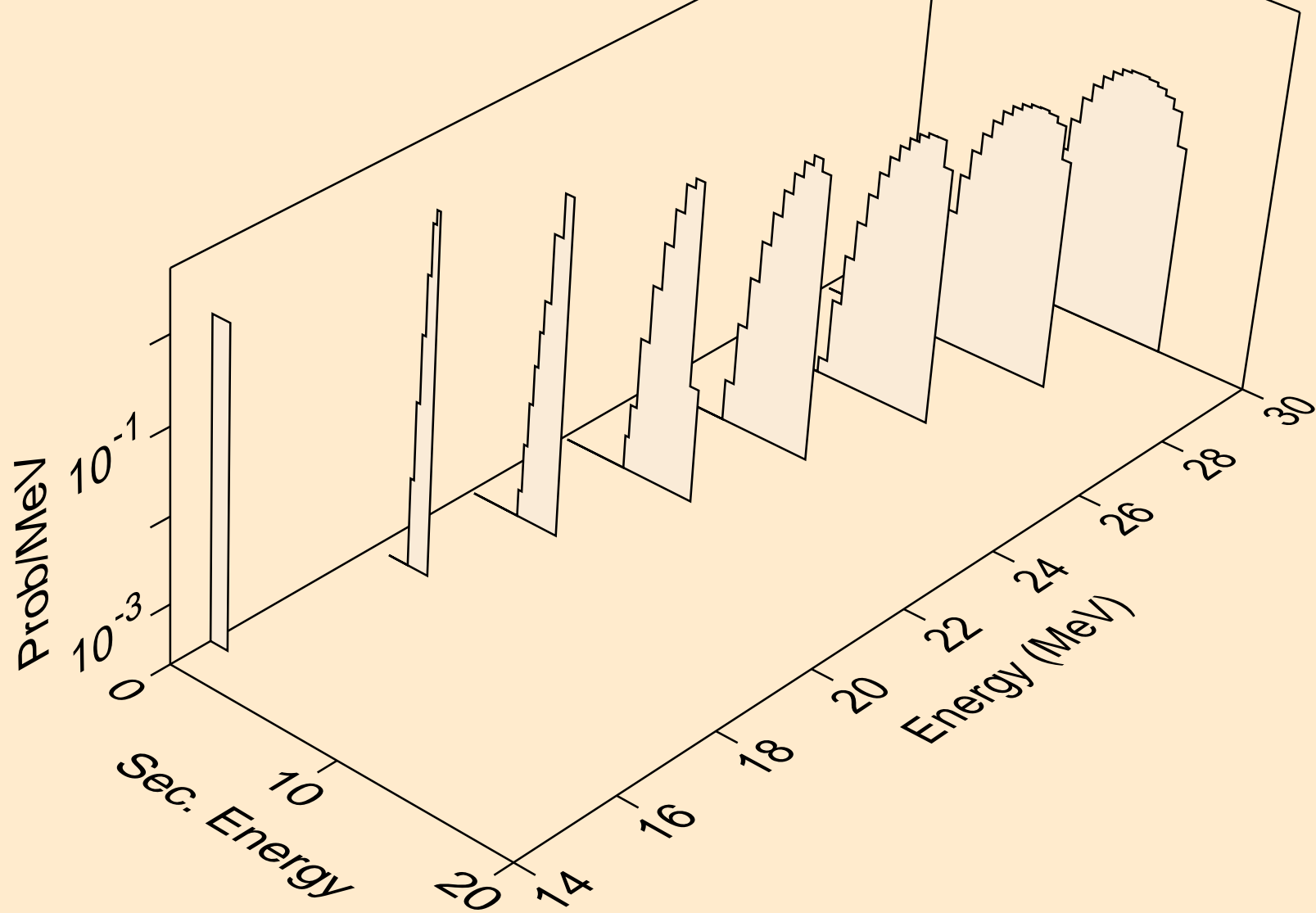

IR203 ALPHA ACER TENDL-2021 LIBRARY; T=0.K  
protons from (a,2np)

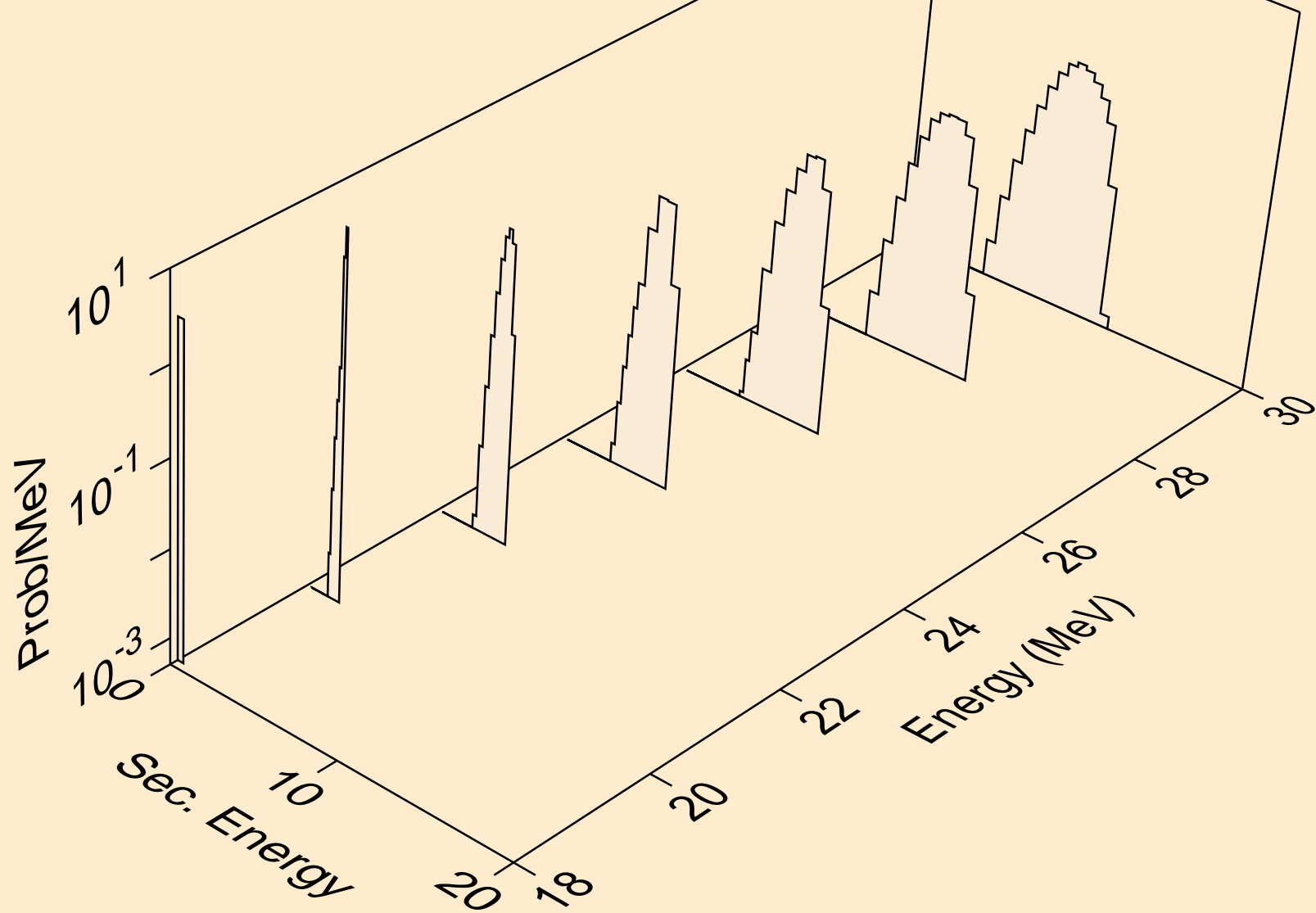

IR203 ALPHA ACER TENDL-2021 LIBRARY; T=0.K  
protons from (a,3np)

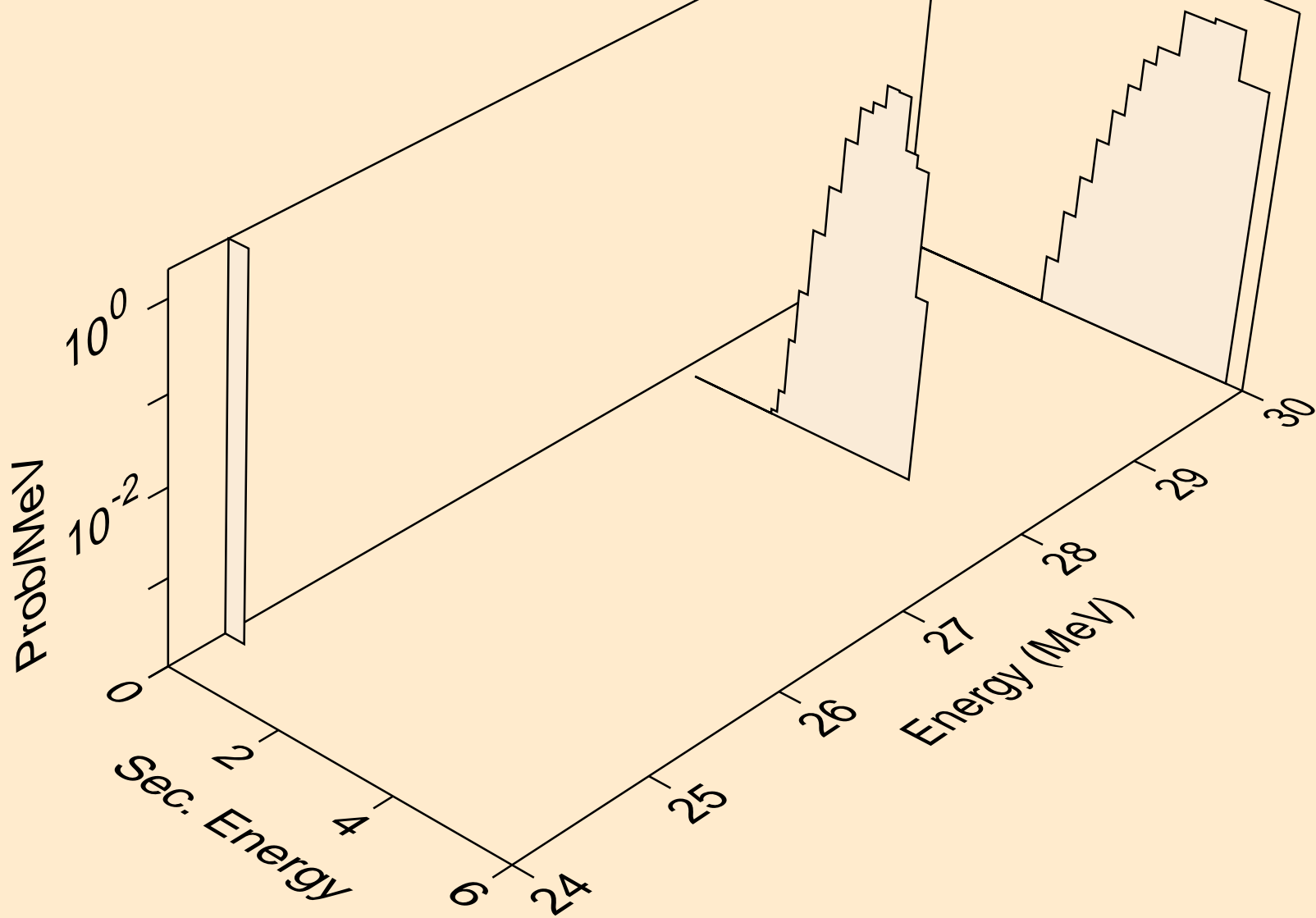

IR203 ALPHA ACER TENDL-2021 LIBRARY; T=0.K  
protons from (a,p)

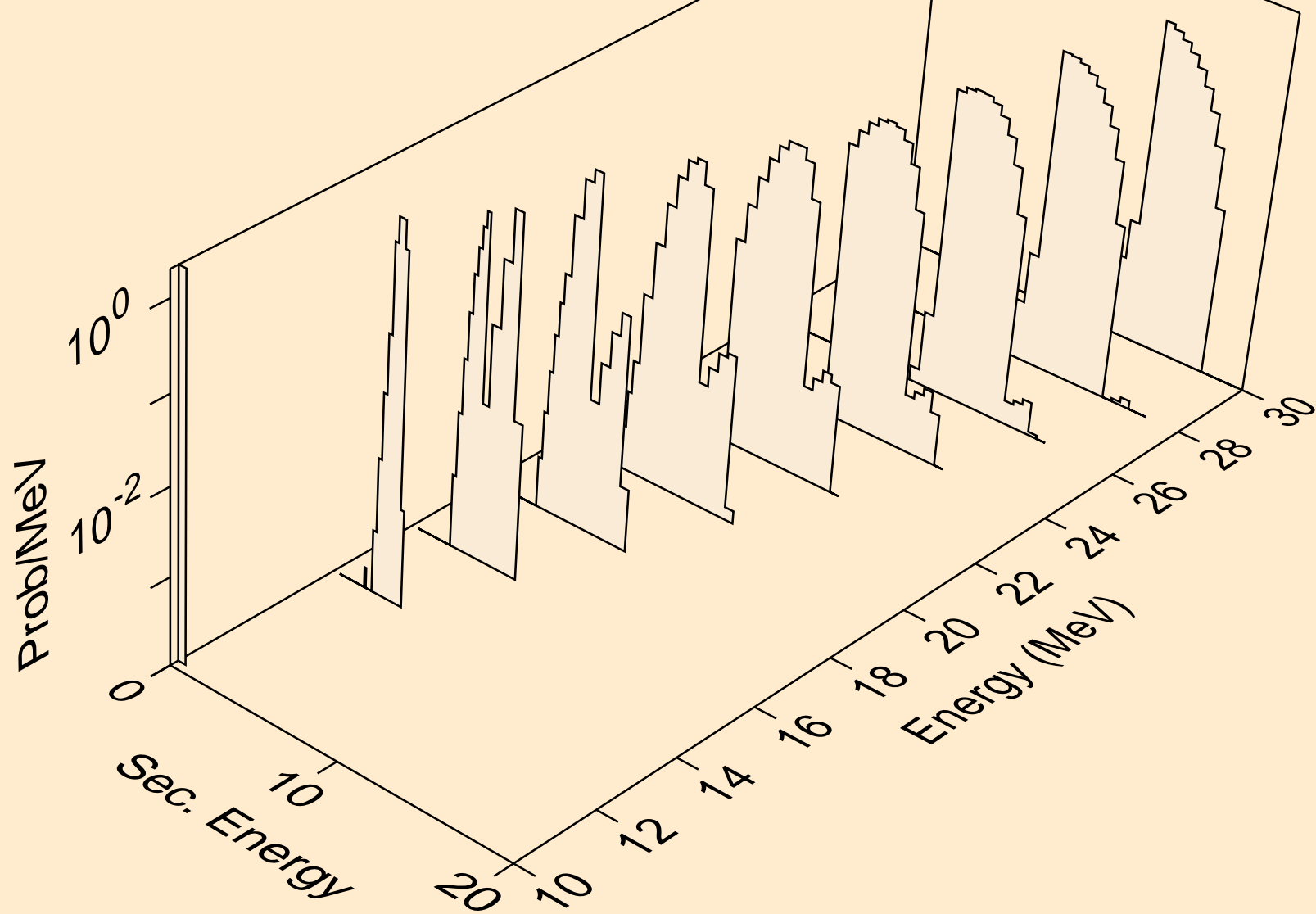

IR203 ALPHA ACER TENDL-2021 LIBRARY; T=0.K  
deuterons from (a,x)

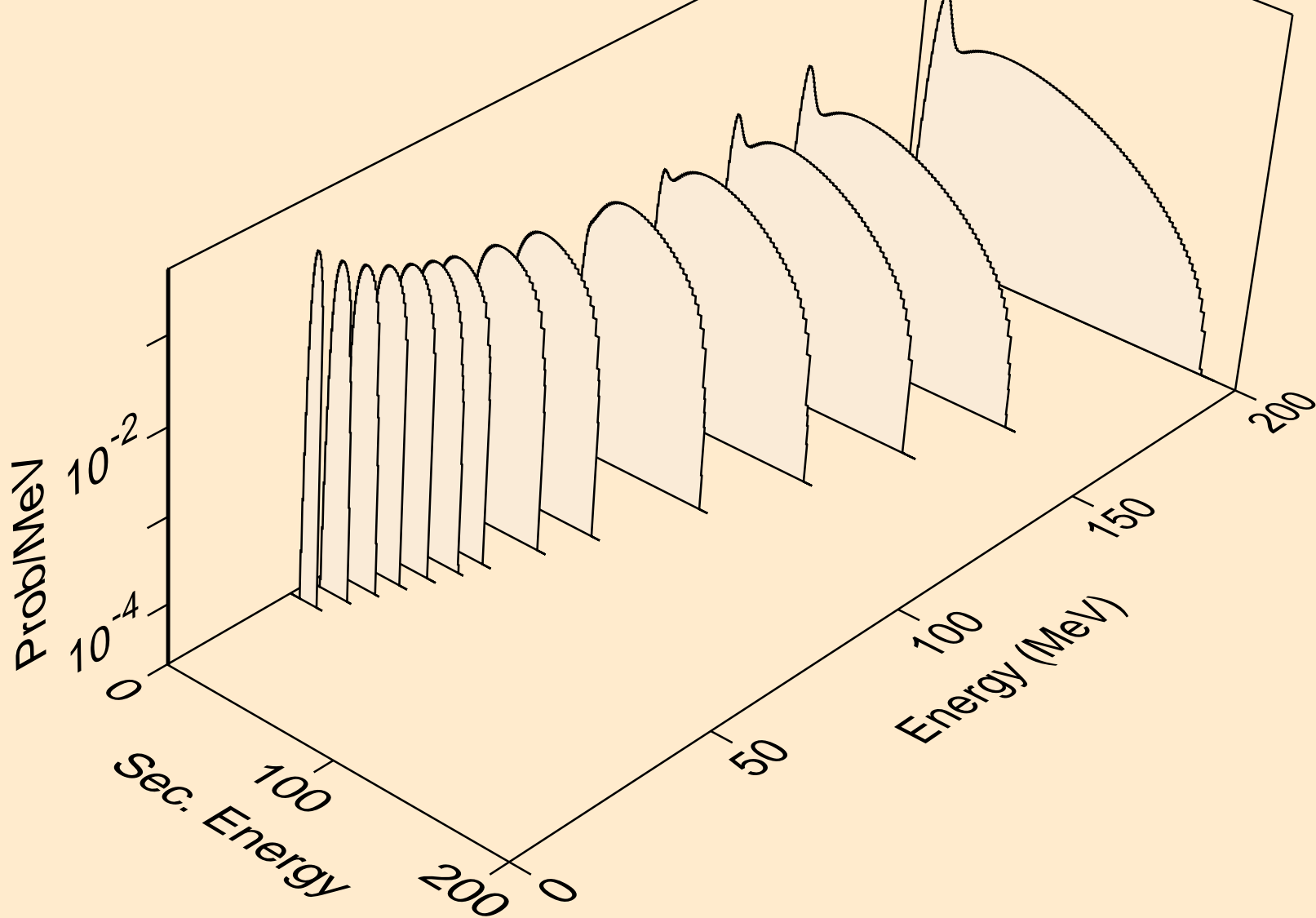



IR203 ALPHA ACER TENDL-2021 LIBRARY; T=0.K  
deuterons from (a,2nd)

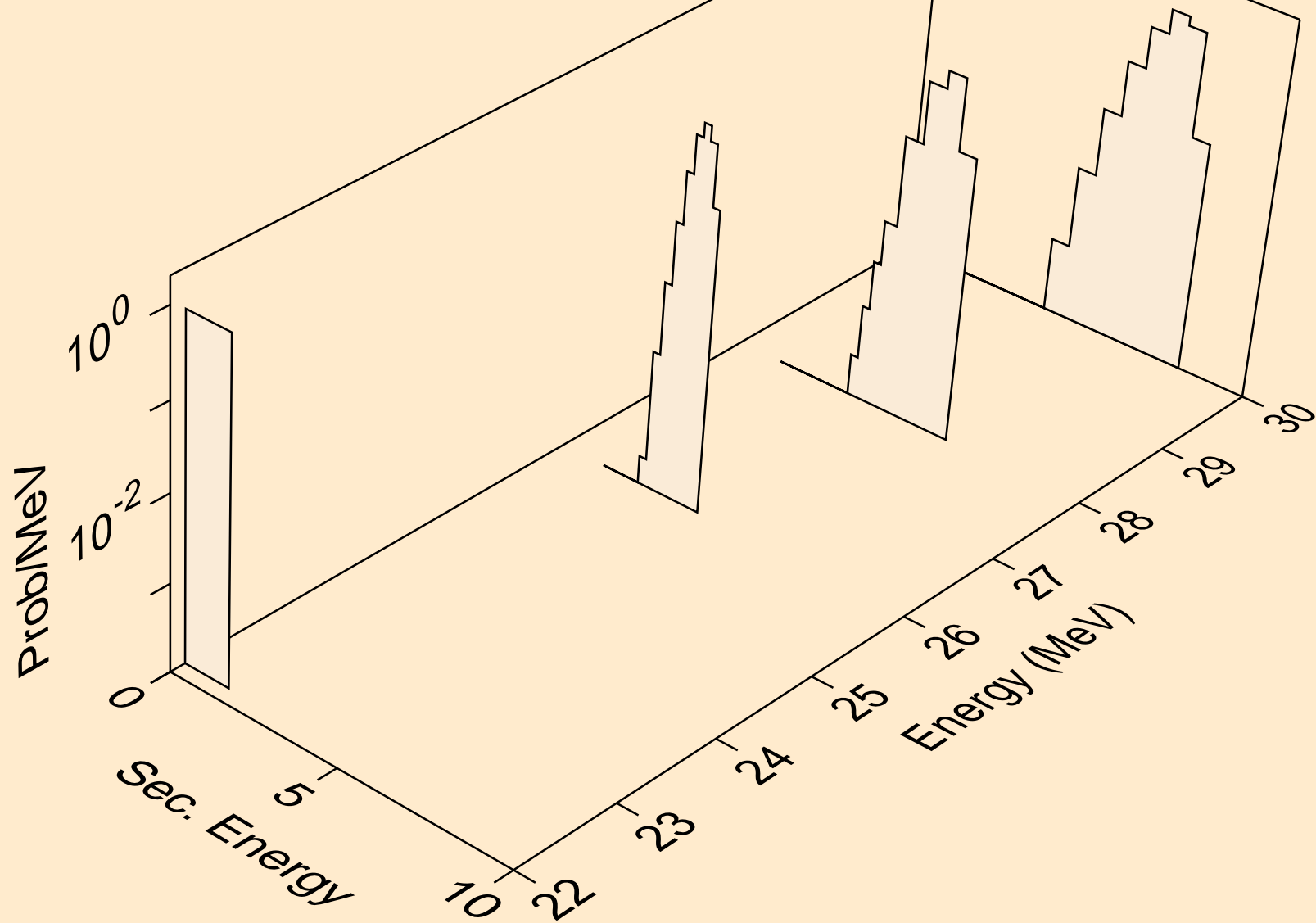

IR203 ALPHA ACER TENDL-2021 LIBRARY; T=0.K  
deuterons from (a,n\*)d

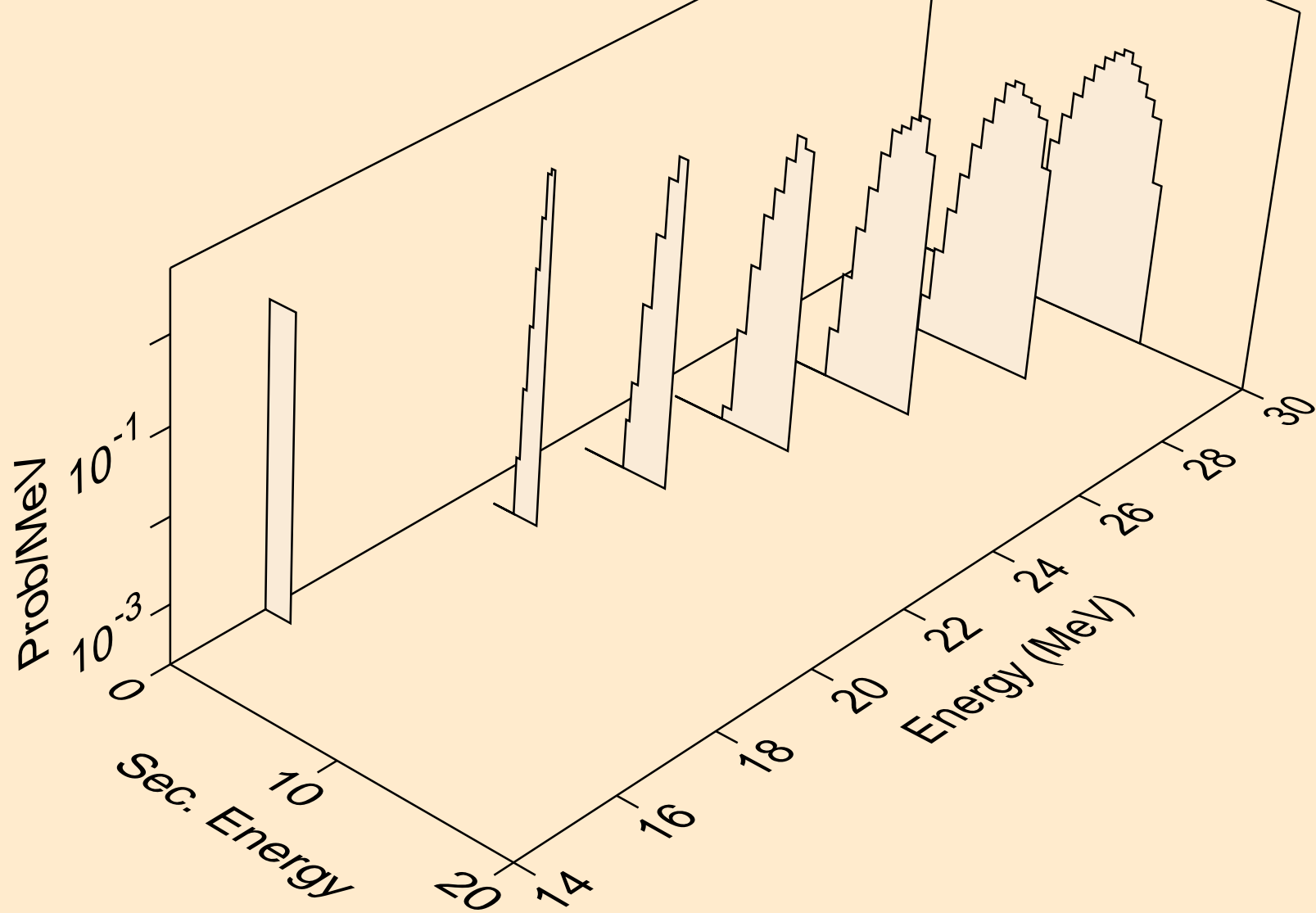

IR203 ALPHA ACER TENDL-2021 LIBRARY; T=0.K  
deuterons from (a,d)

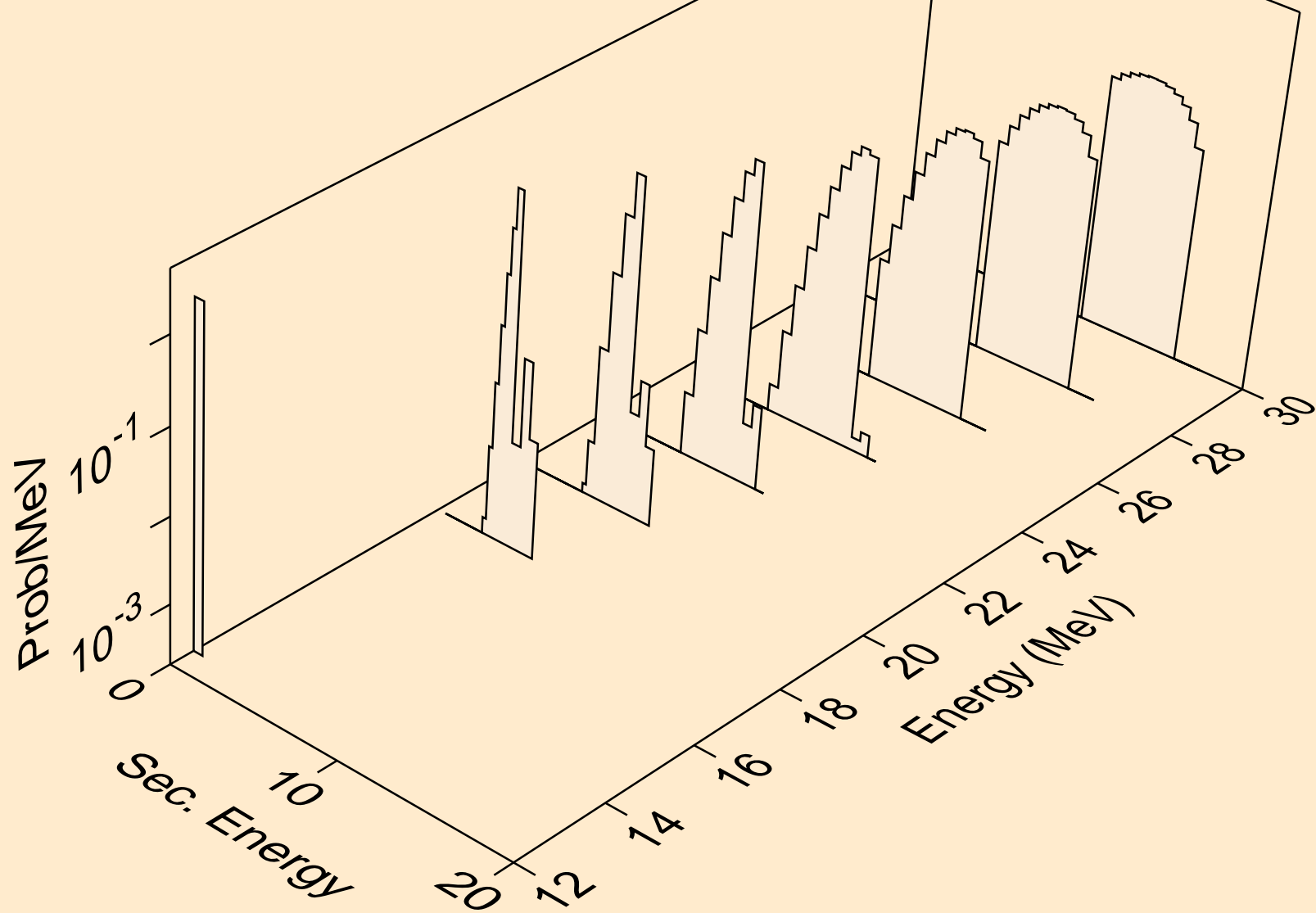

IR203 ALPHA ACER TENDL-2021 LIBRARY; T=0.K  
tritons from (a,x)

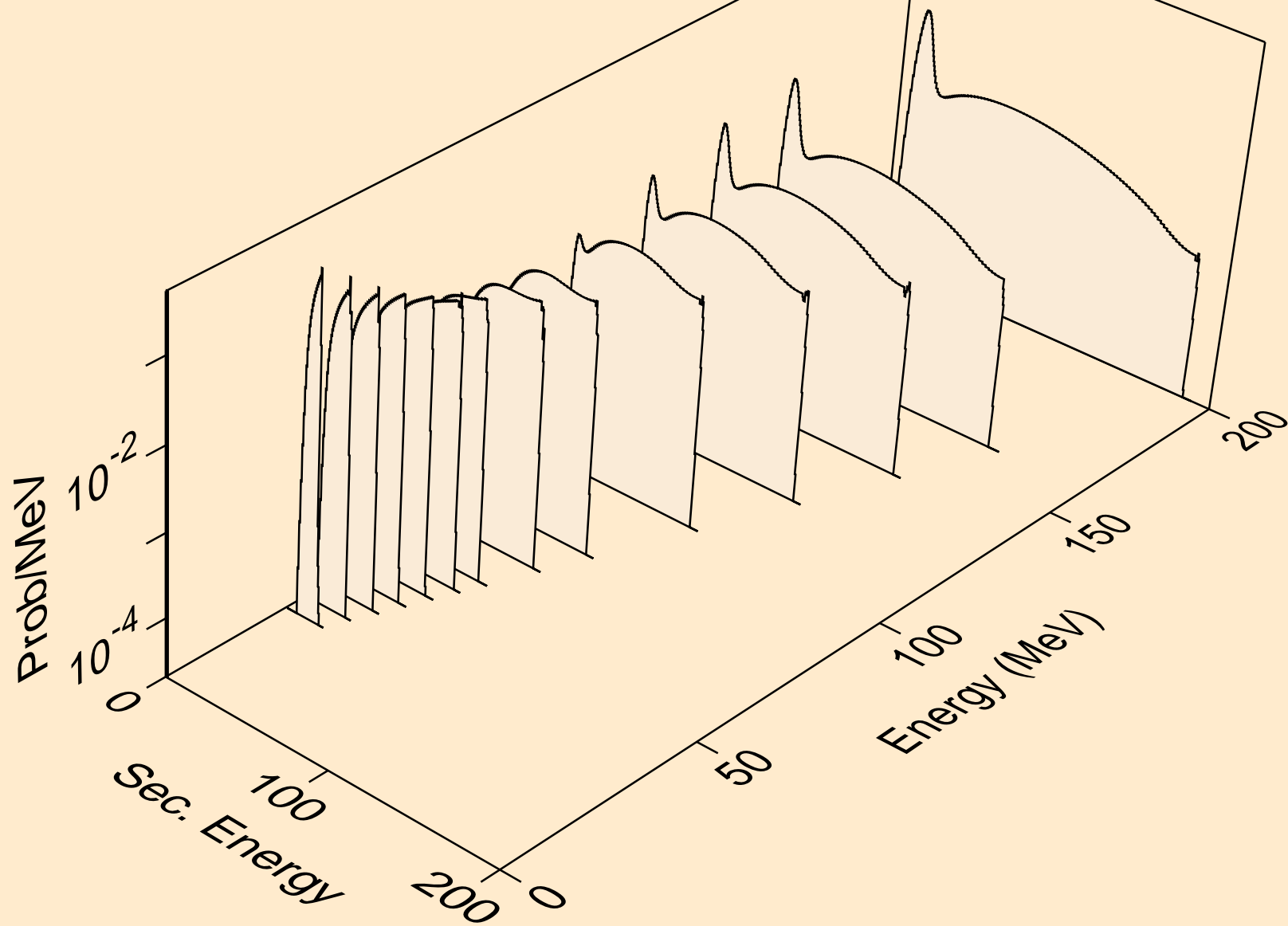

IR203 ALPHA ACER TENDL-2021 LIBRARY; T=0.K  
tritons from (a,n\*)t

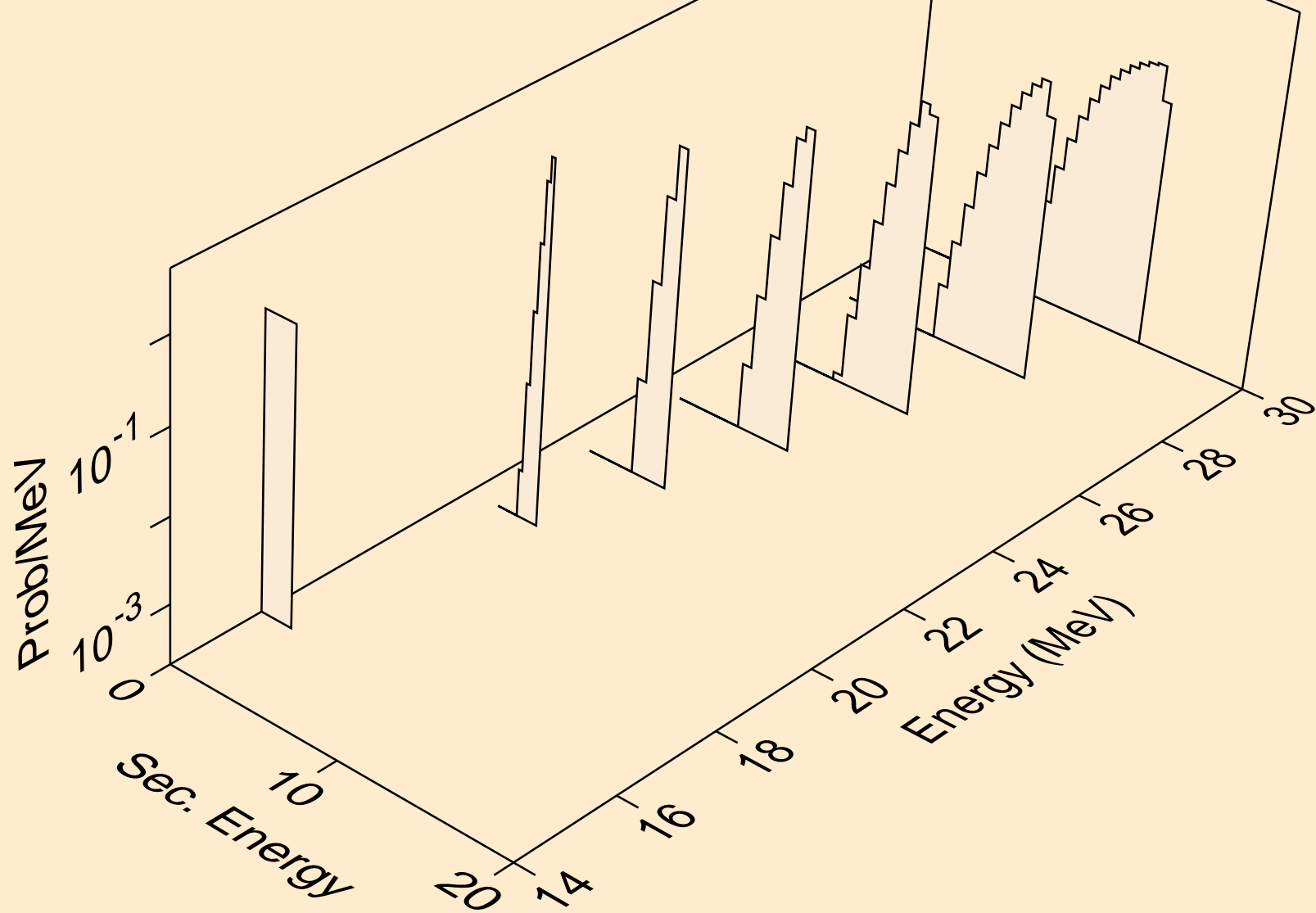

IR203 ALPHA ACER TENDL-2021 LIBRARY; T=0.K  
tritons from (a,t)

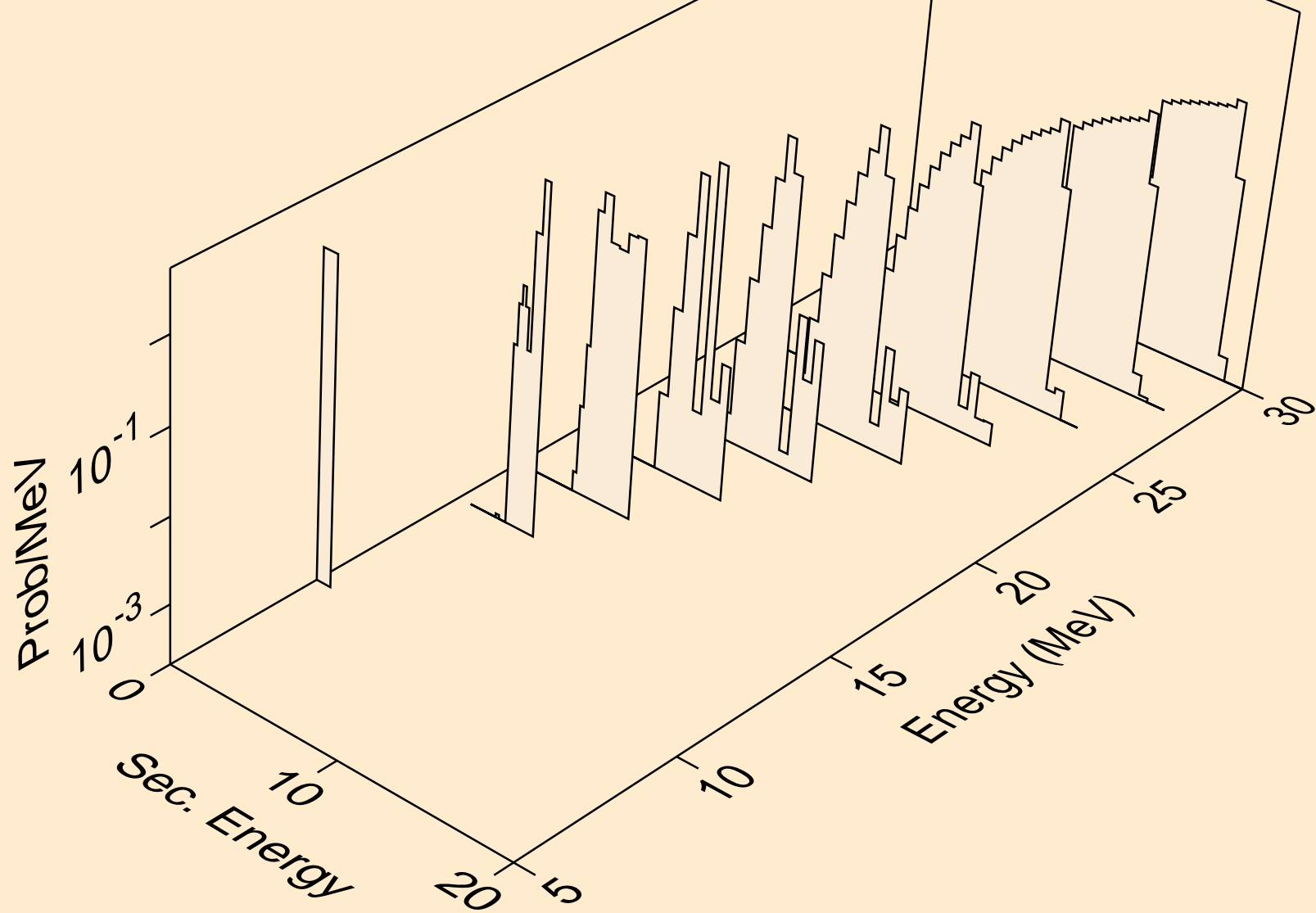

IR203 ALPHA ACER TENDL-2021 LIBRARY; T=0.K  
he3s from (a,x)

