

OS198 ALPHA ACER TENDL-2021 LIBRARY; T=0.K
Principal cross sections

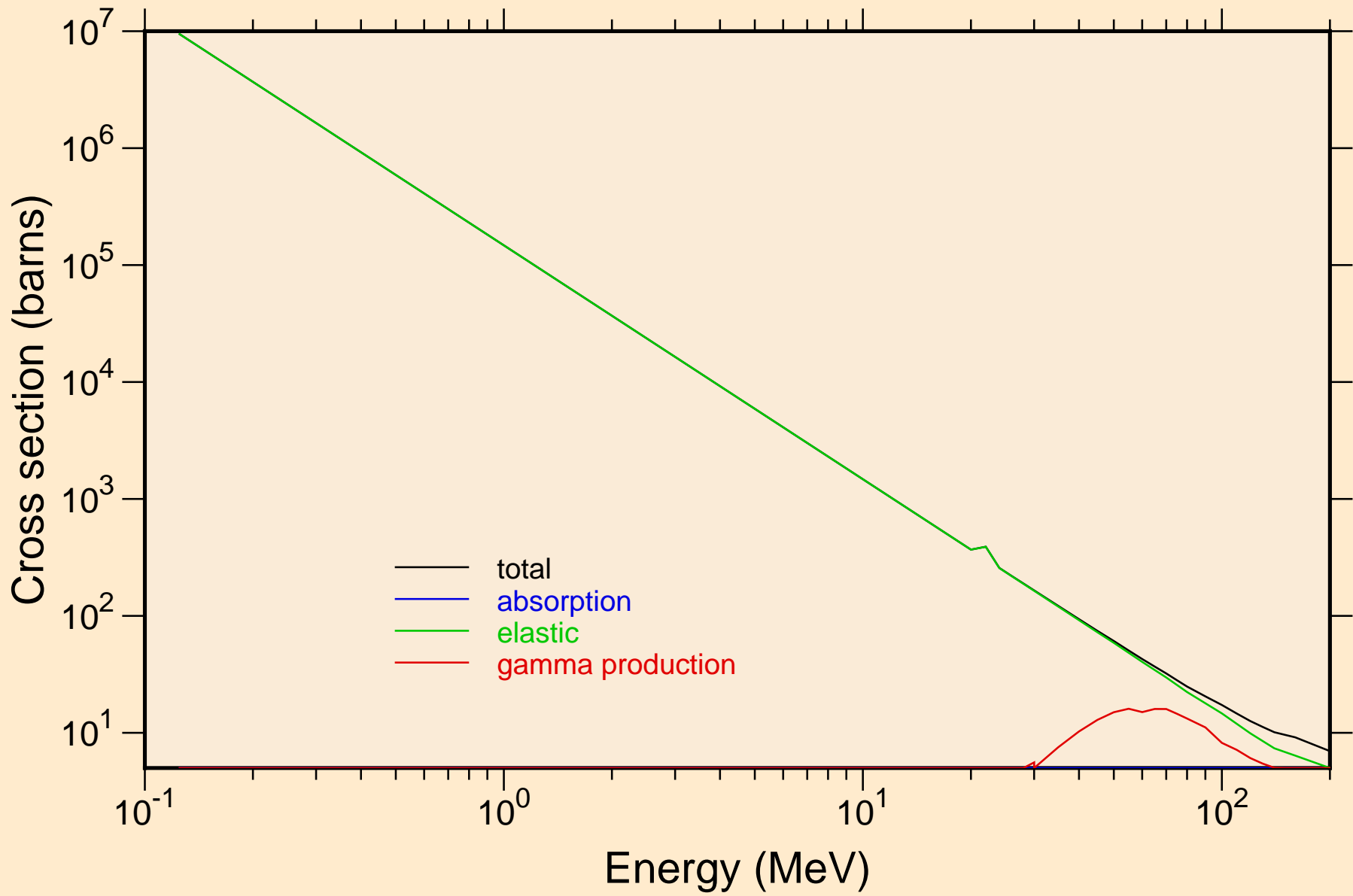

OS198 ALPHA ACER TENDL-2021 LIBRARY; T=0.K
Heating

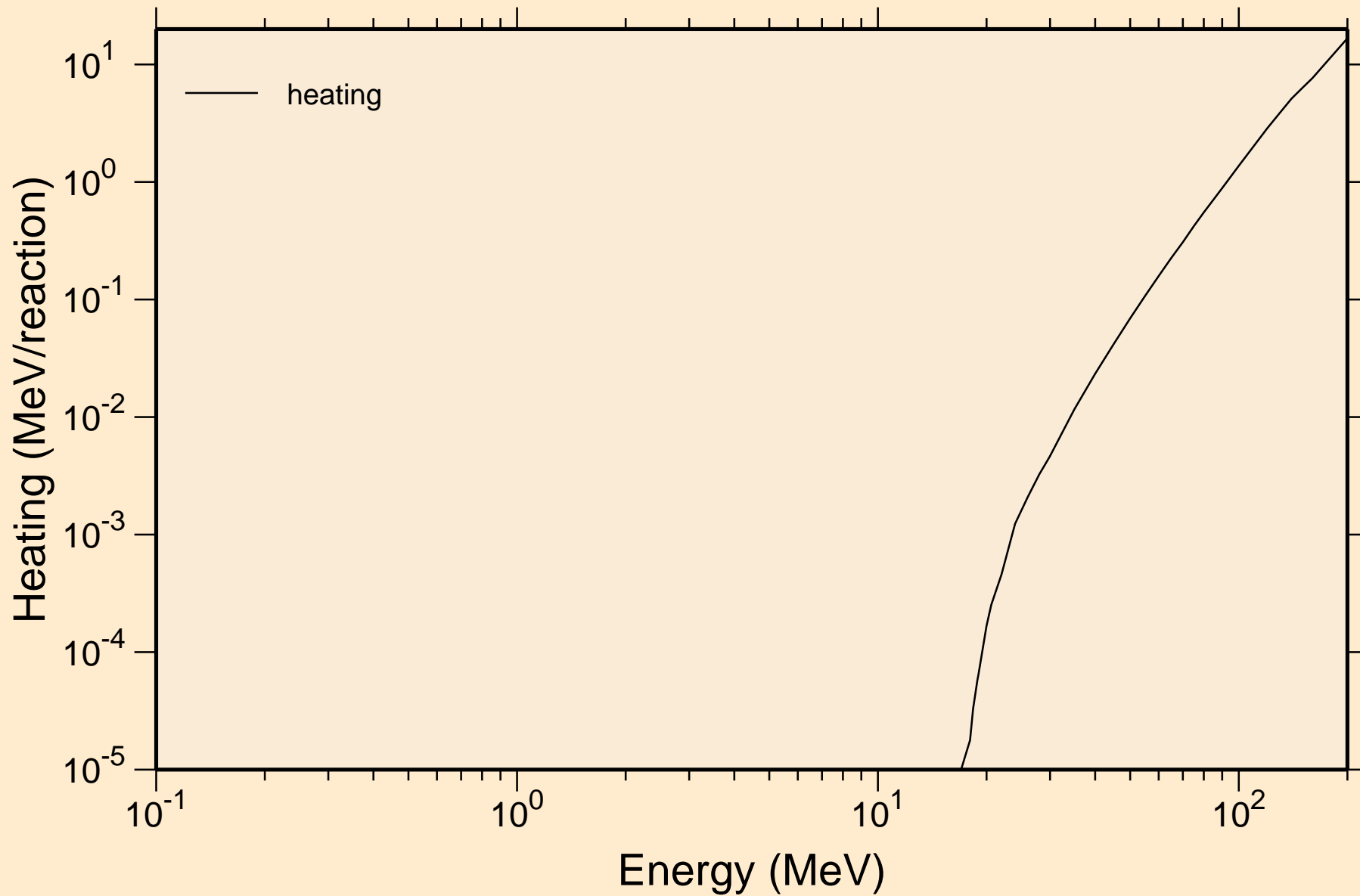

OS198 ALPHA ACER TENDL-2021 LIBRARY; T=0.K

Principal cross sections

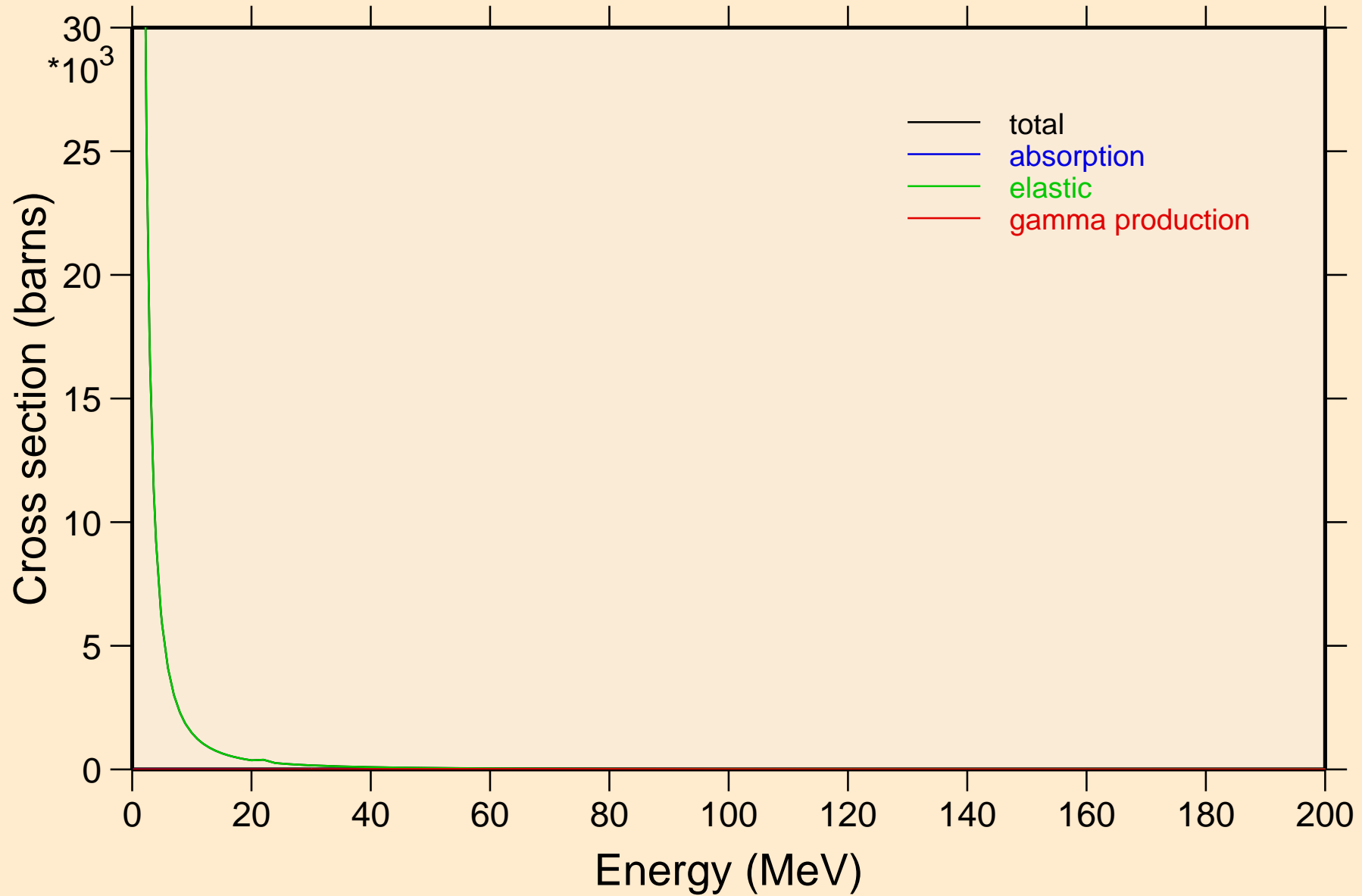

OS198 ALPHA ACER TENDL-2021 LIBRARY; T=0.K

Heating

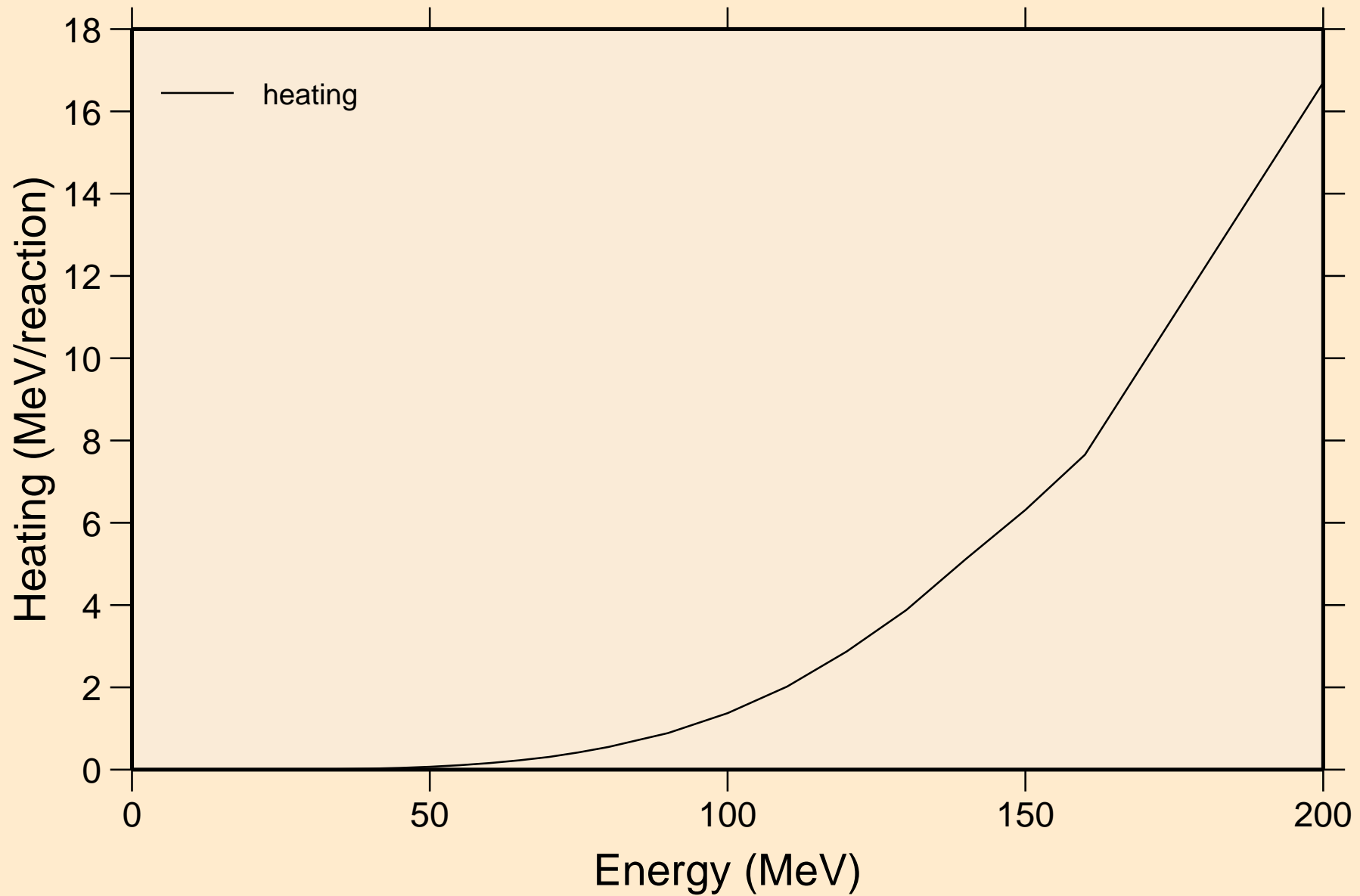

OS198 ALPHA ACER TENDL-2021 LIBRARY; T=0.K
Threshold reactions

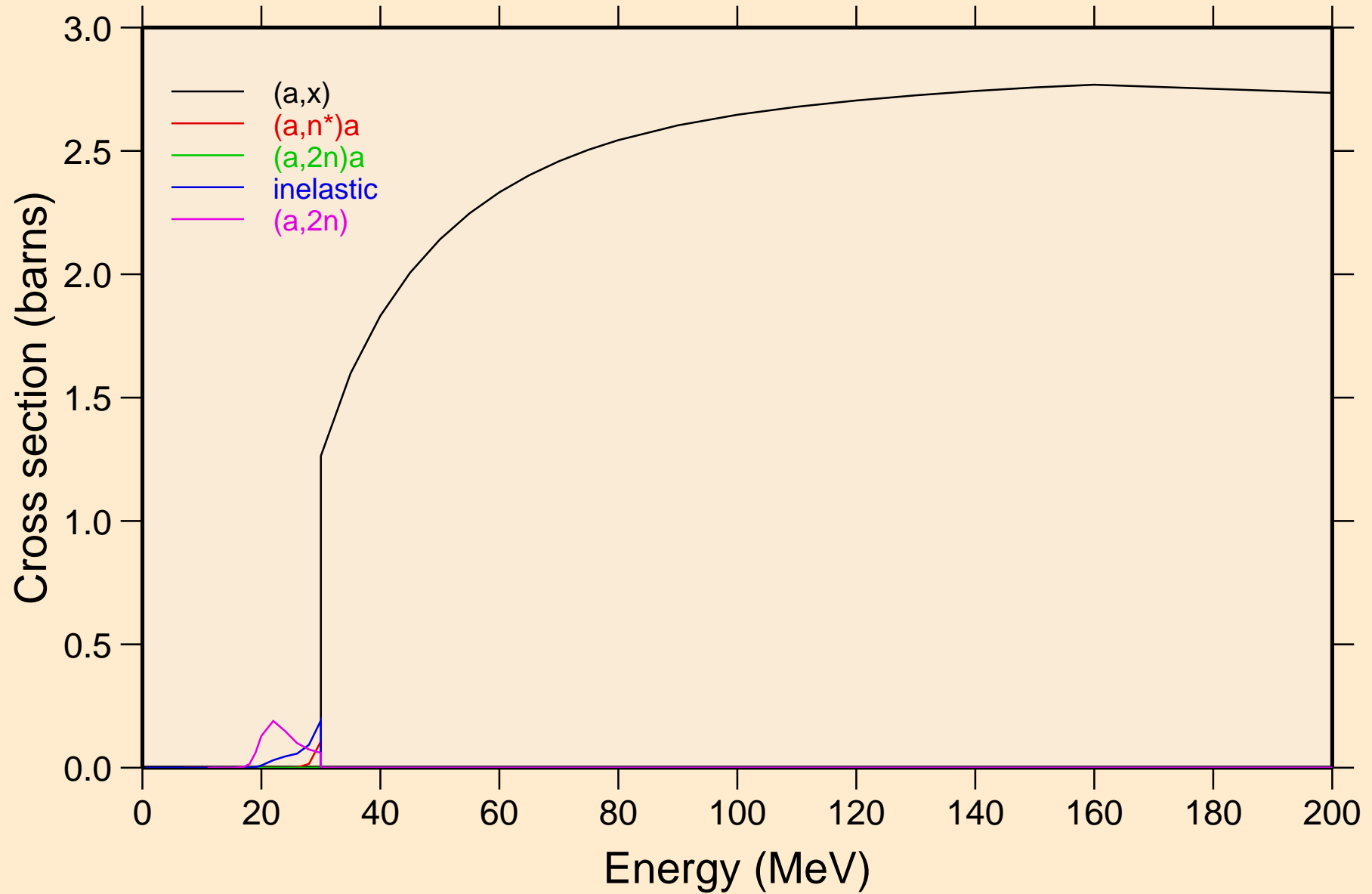

OS198 ALPHA ACER TENDL-2021 LIBRARY; T=0.K
Threshold reactions

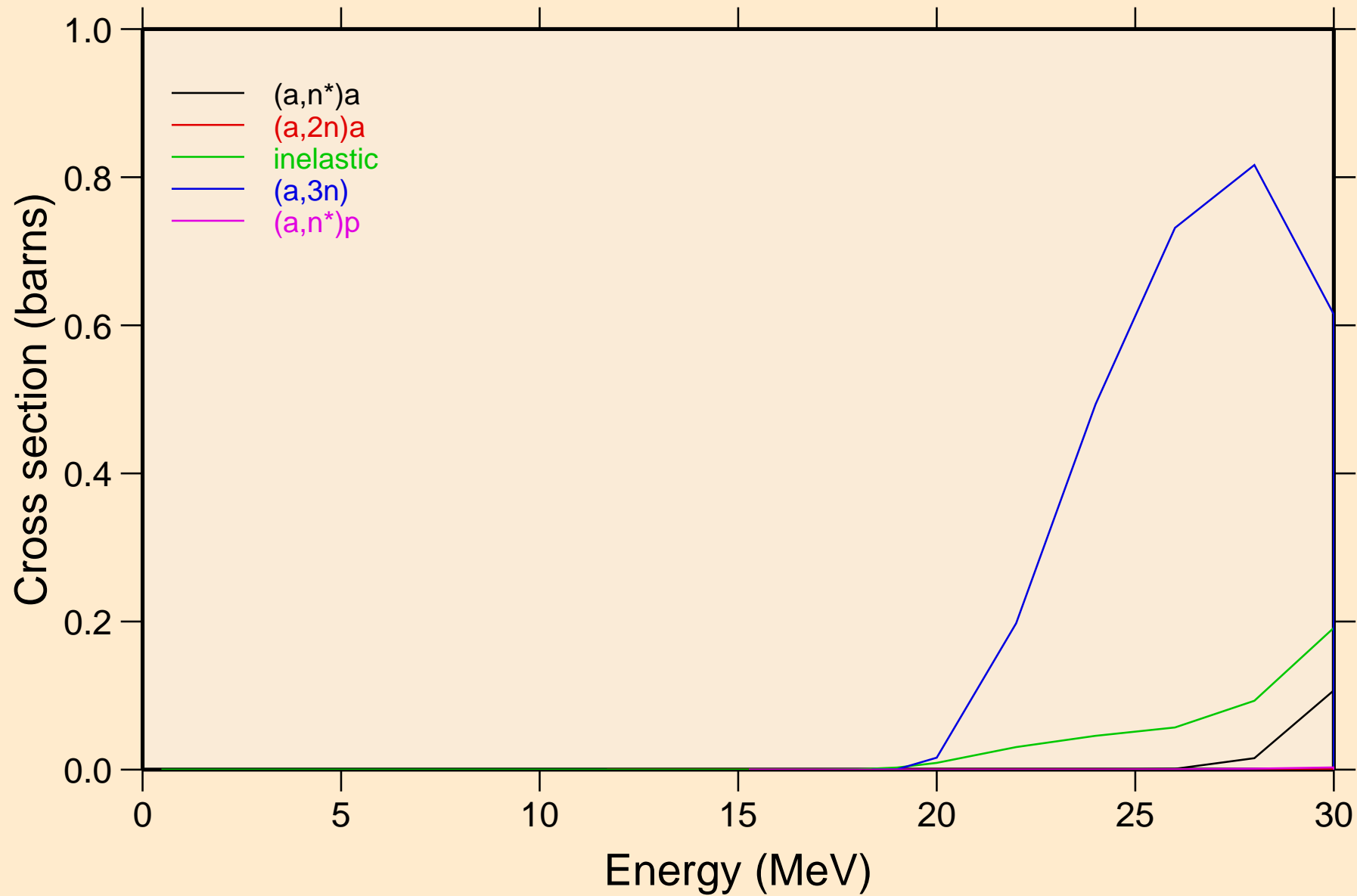

OS198 ALPHA ACER TENDL-2021 LIBRARY; T=0.K
Threshold reactions

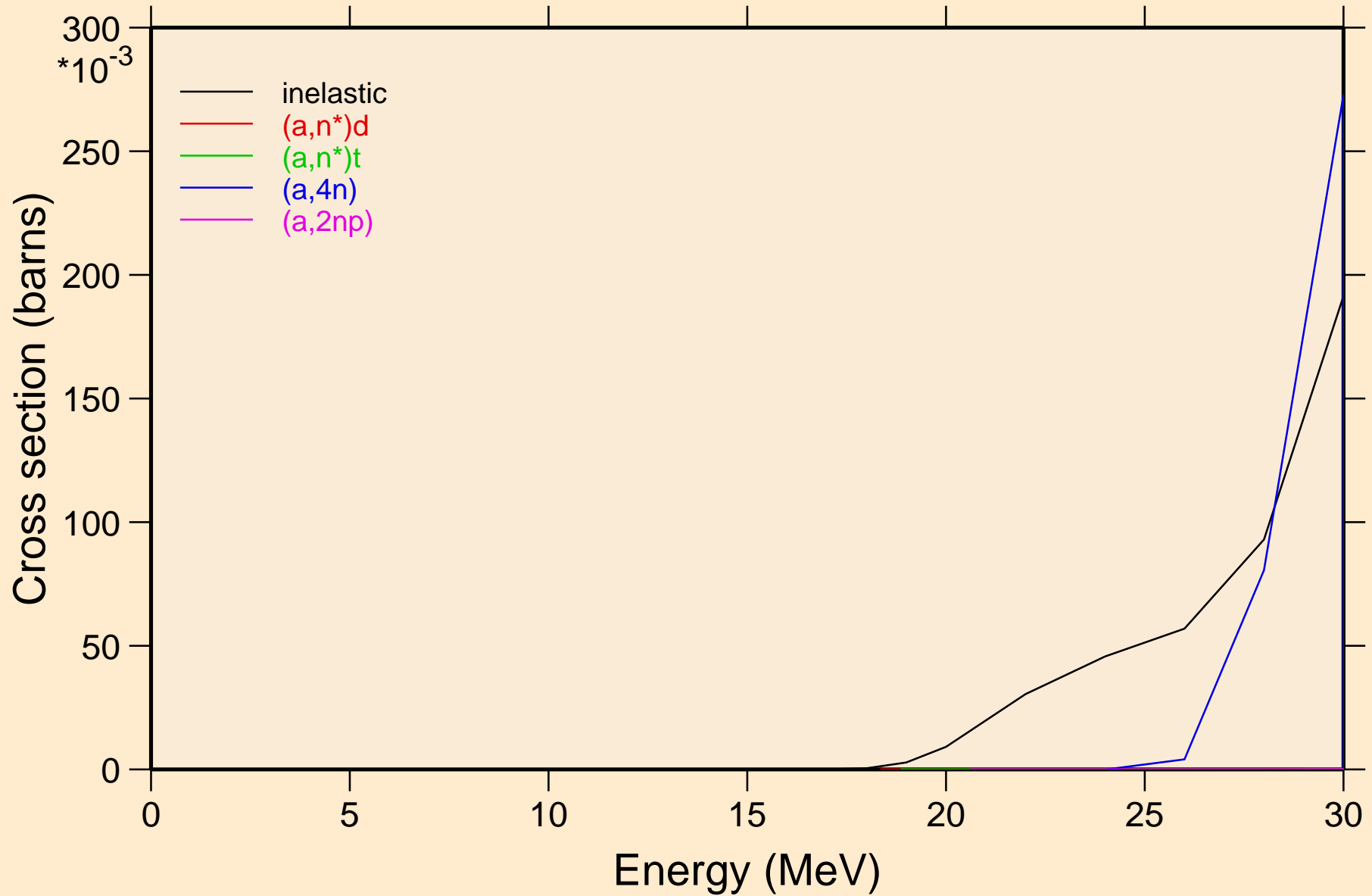

OS198 ALPHA ACER TENDL-2021 LIBRARY; T=0.K
Threshold reactions

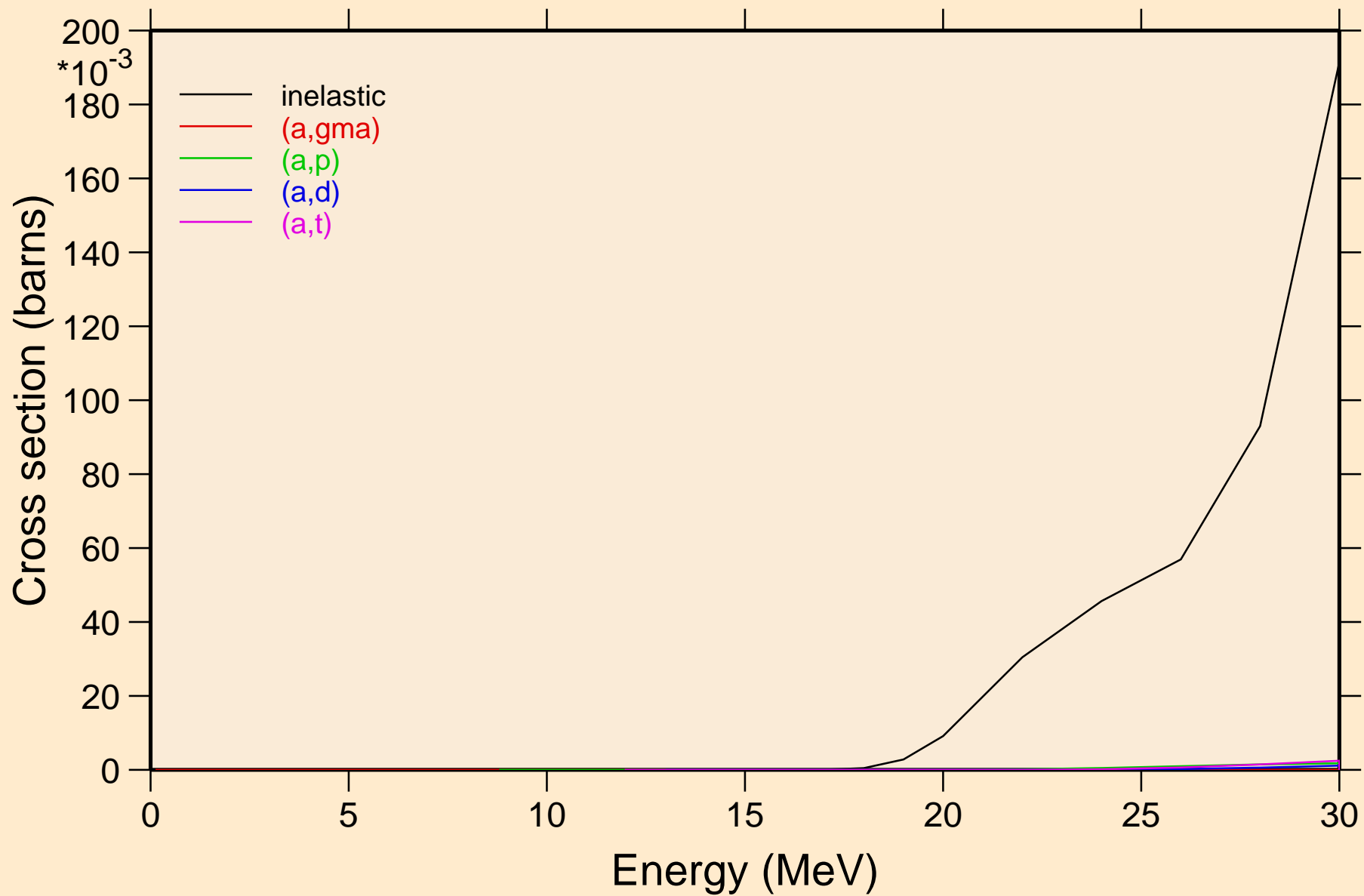

OS198 ALPHA ACER TENDL-2021 LIBRARY; T=0.K
Threshold reactions

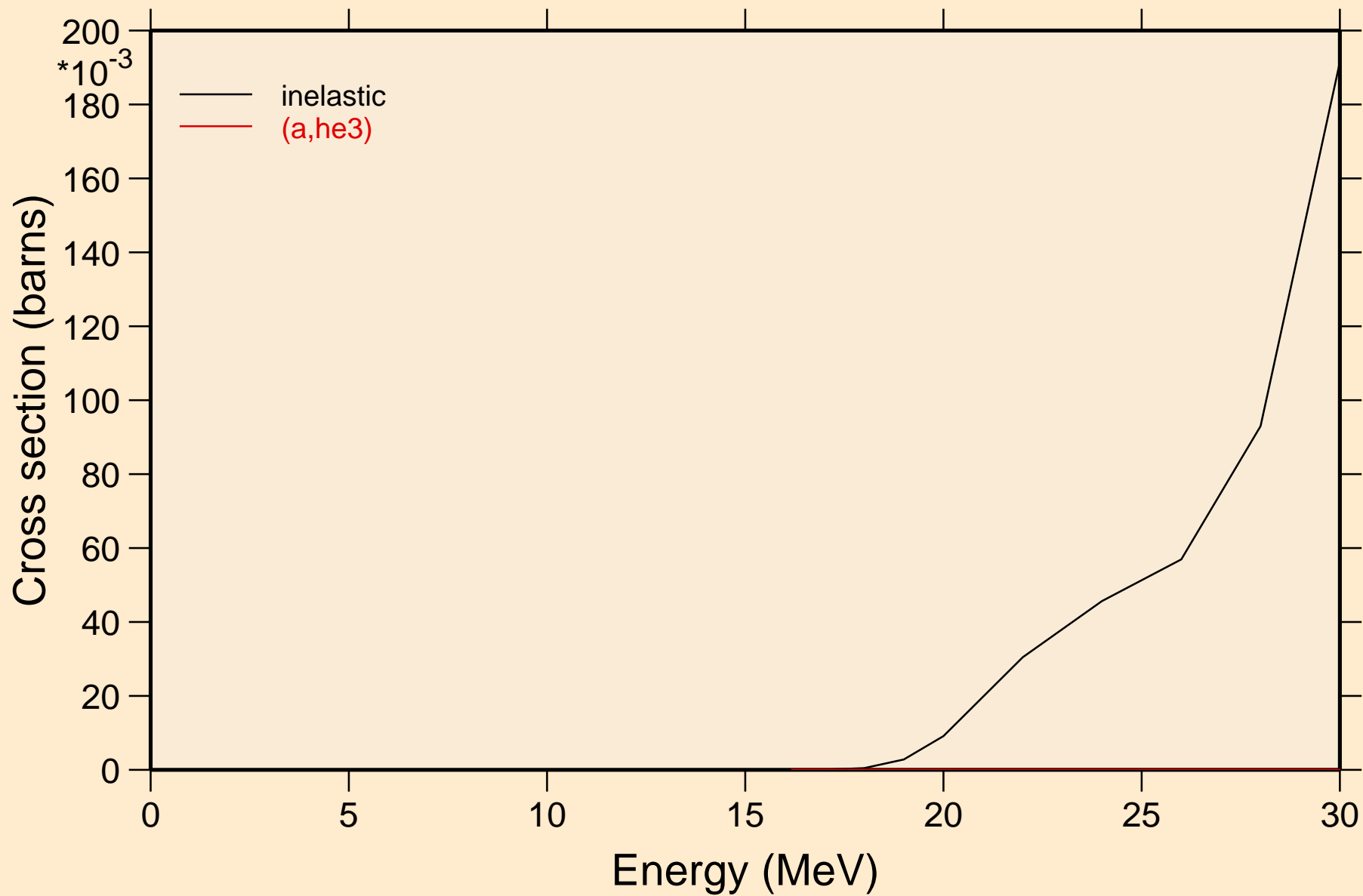

OS198 ALPHA ACER TENDL-2021 LIBRARY; T=0.K
Threshold reactions

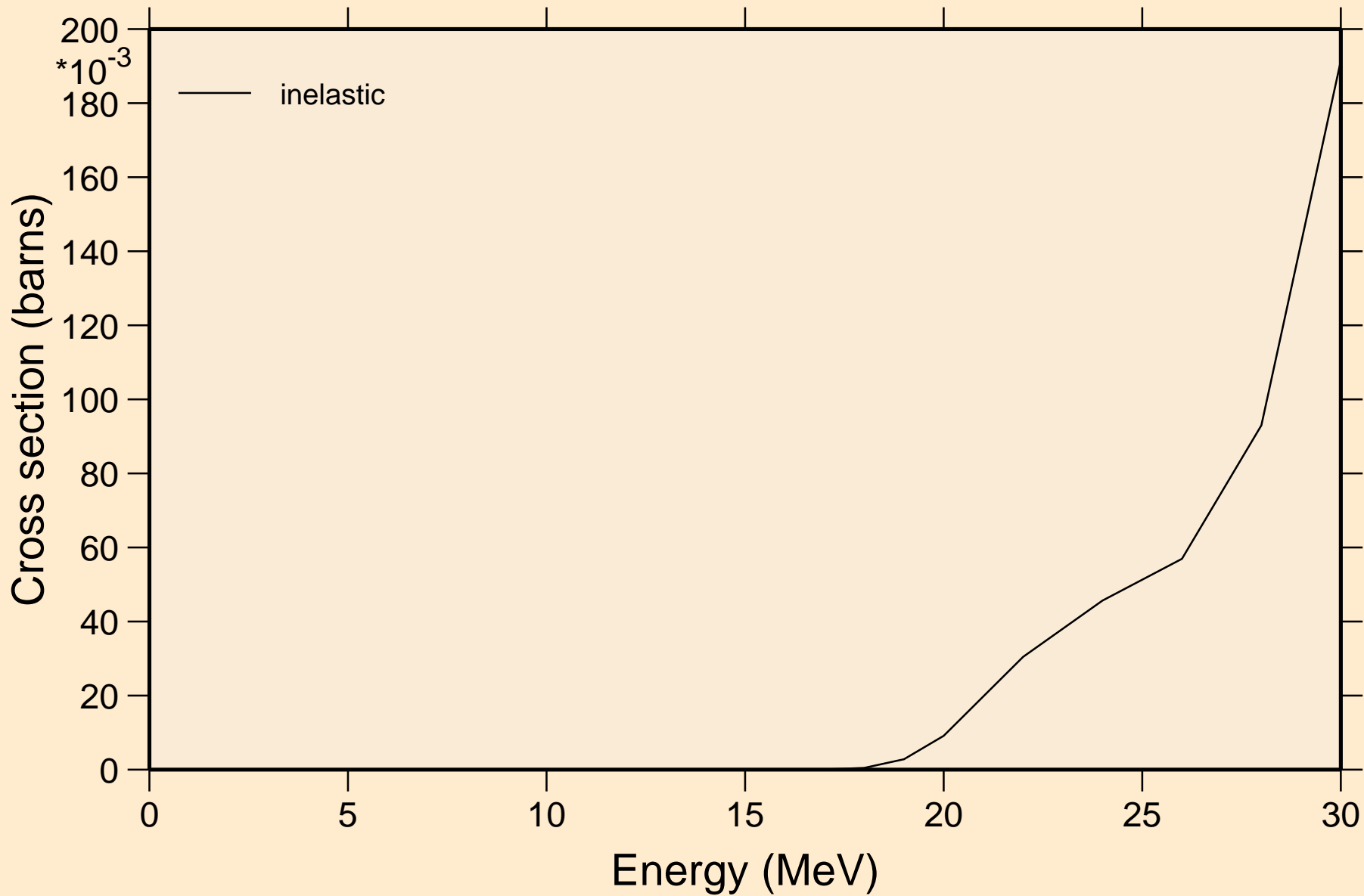

OS198 ALPHA ACER TENDL-2021 LIBRARY; T=0.K
angular distribution for elastic

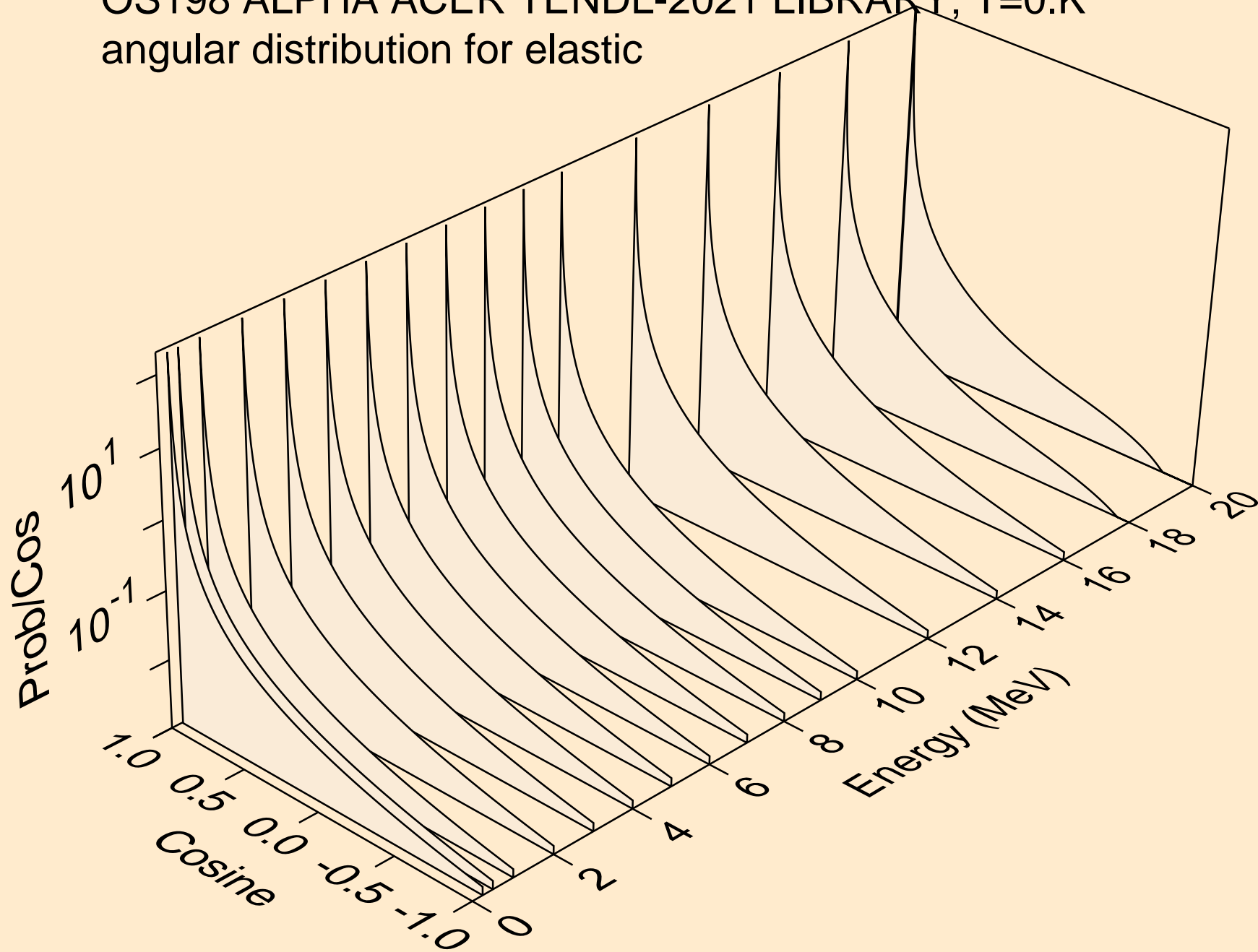

OS198 ALPHA ACER TENDL-2021 LIBRARY; T=0.K
angular distribution for elastic

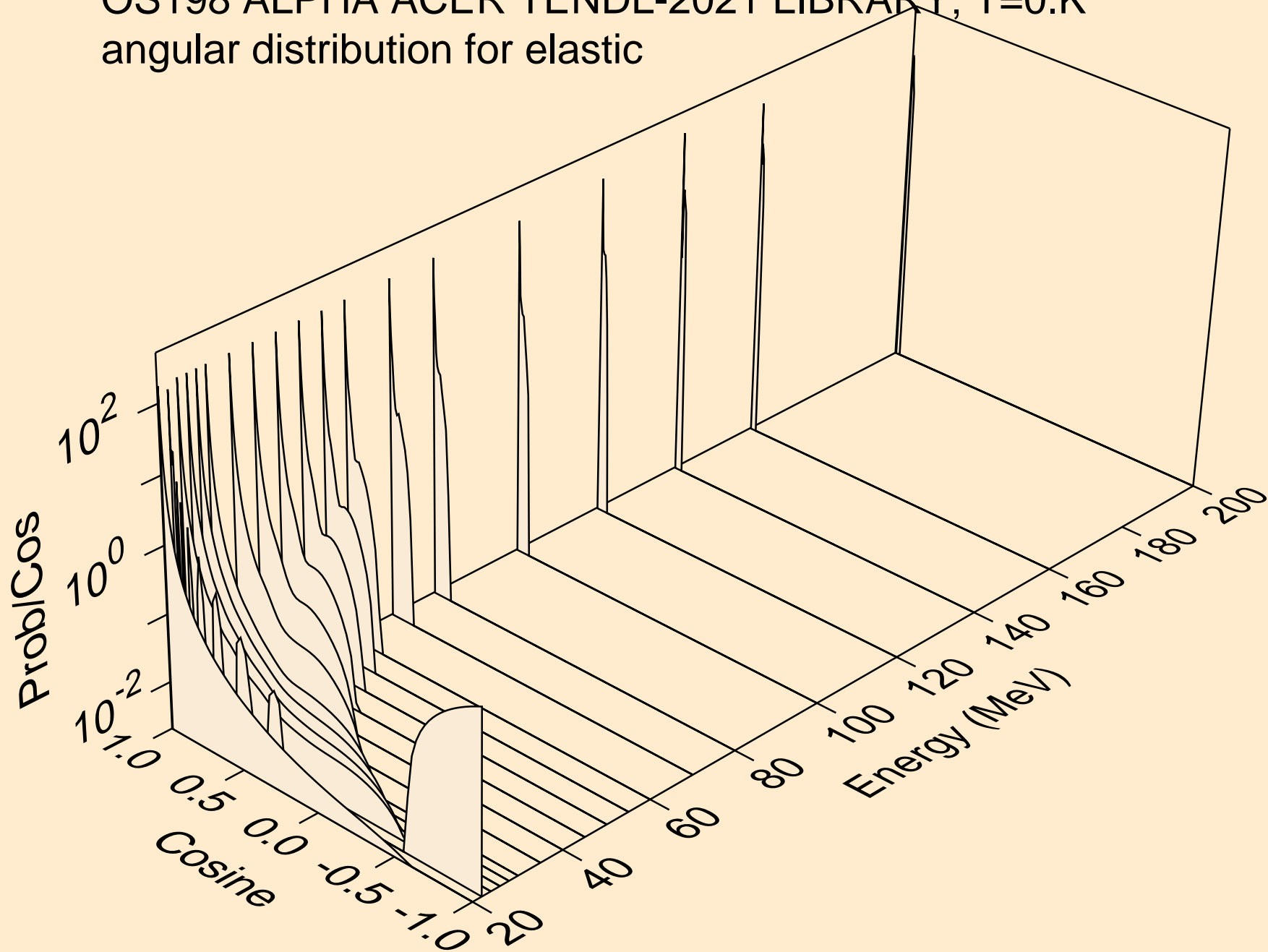

OS198 ALPHA ACER TENDL-2021 LIBRARY; T=0.K
Alpha emission for (a,x)

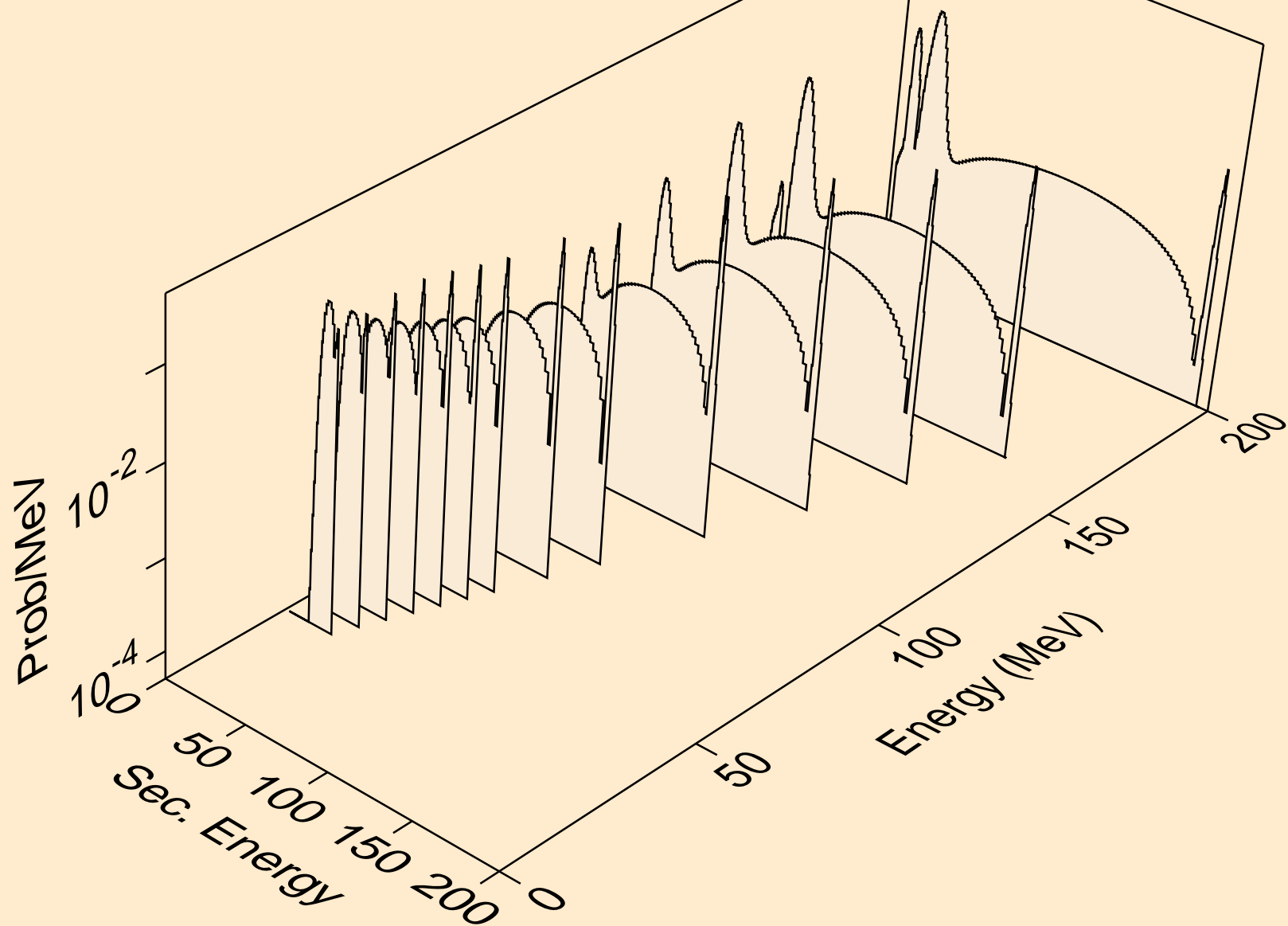

OS198 ALPHA ACER TENDL-2021 LIBRARY; T=0.K
Alpha emission for (a,n*)a

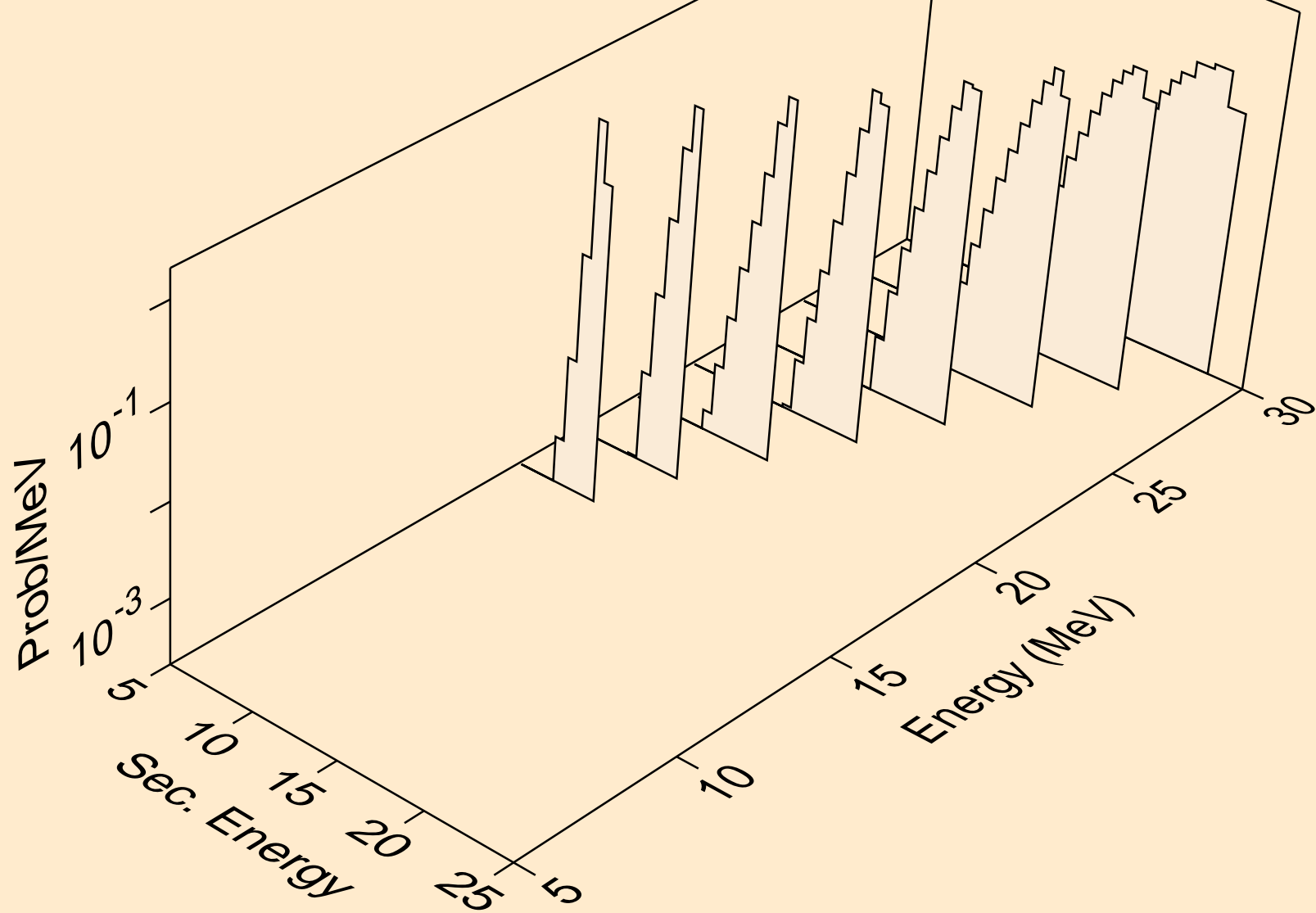

OS198 ALPHA ACER TENDL-2021 LIBRARY; T=0.K
Alpha emission for (a,2n)a

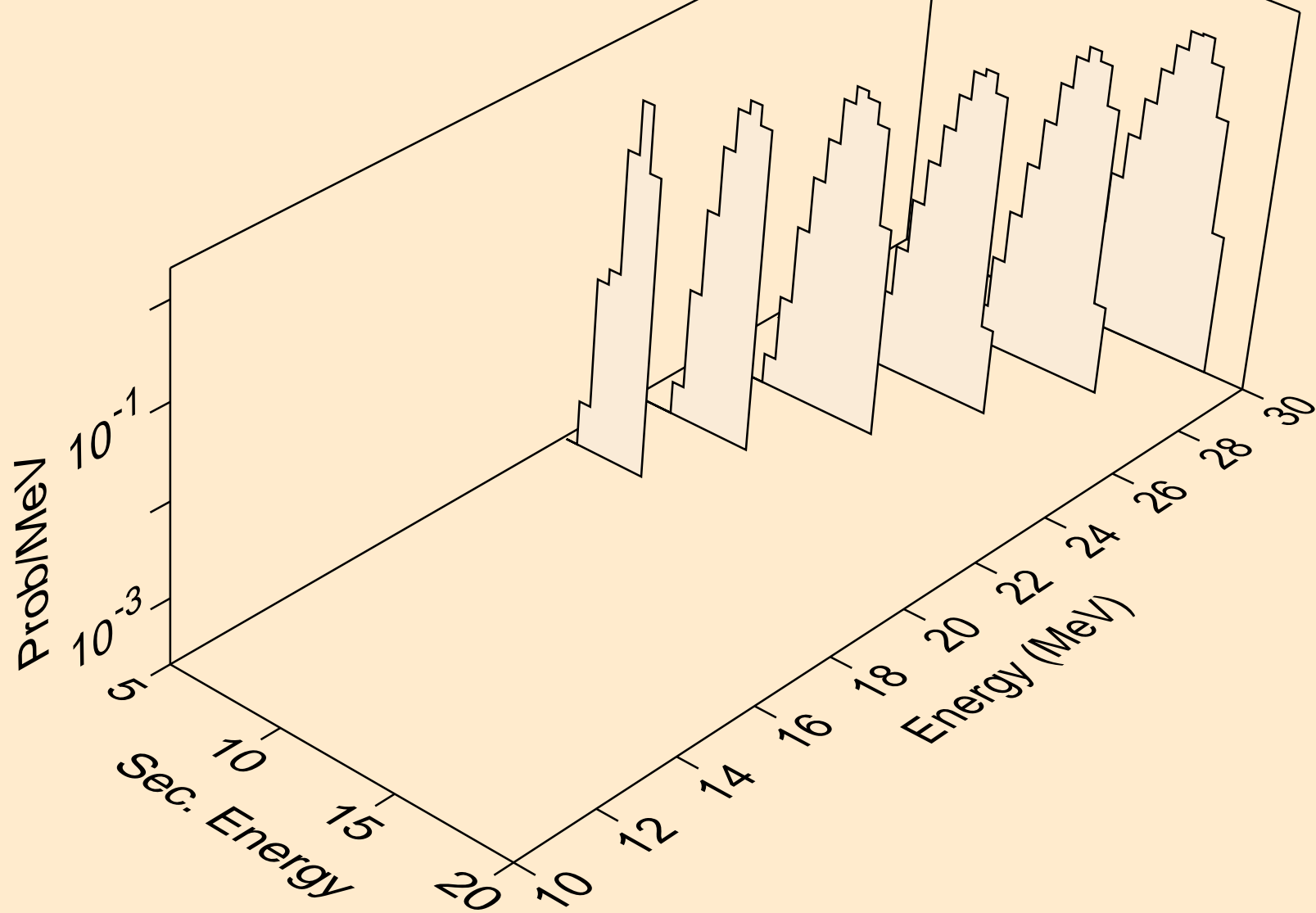

OS198 ALPHA ACER TENDL-2021 LIBRARY; T=0.K
Alpha emission for inelastic

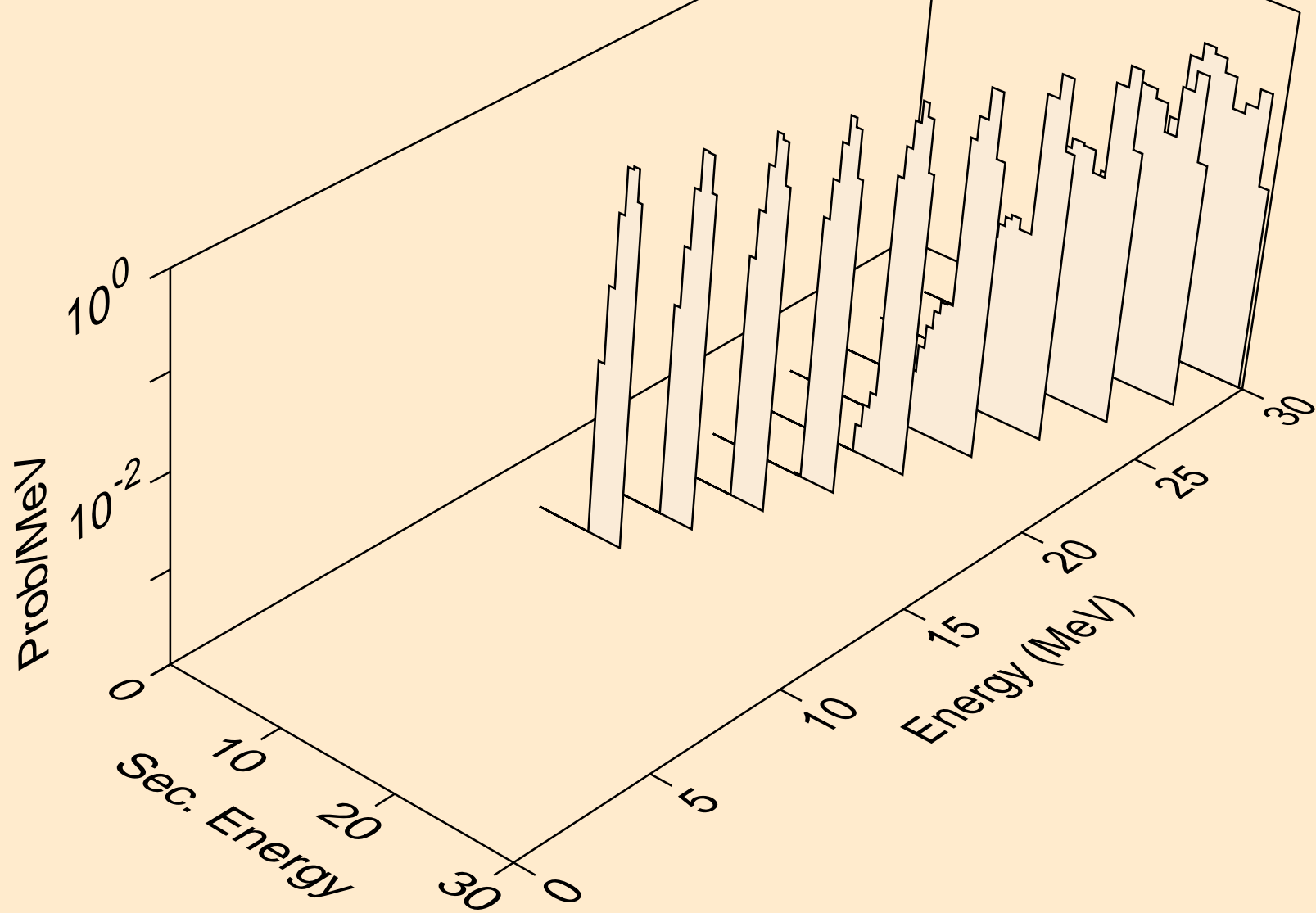

OS198 ALPHA ACER TENDL-2021 LIBRARY; T=0.K
Photon emission for (z,n)

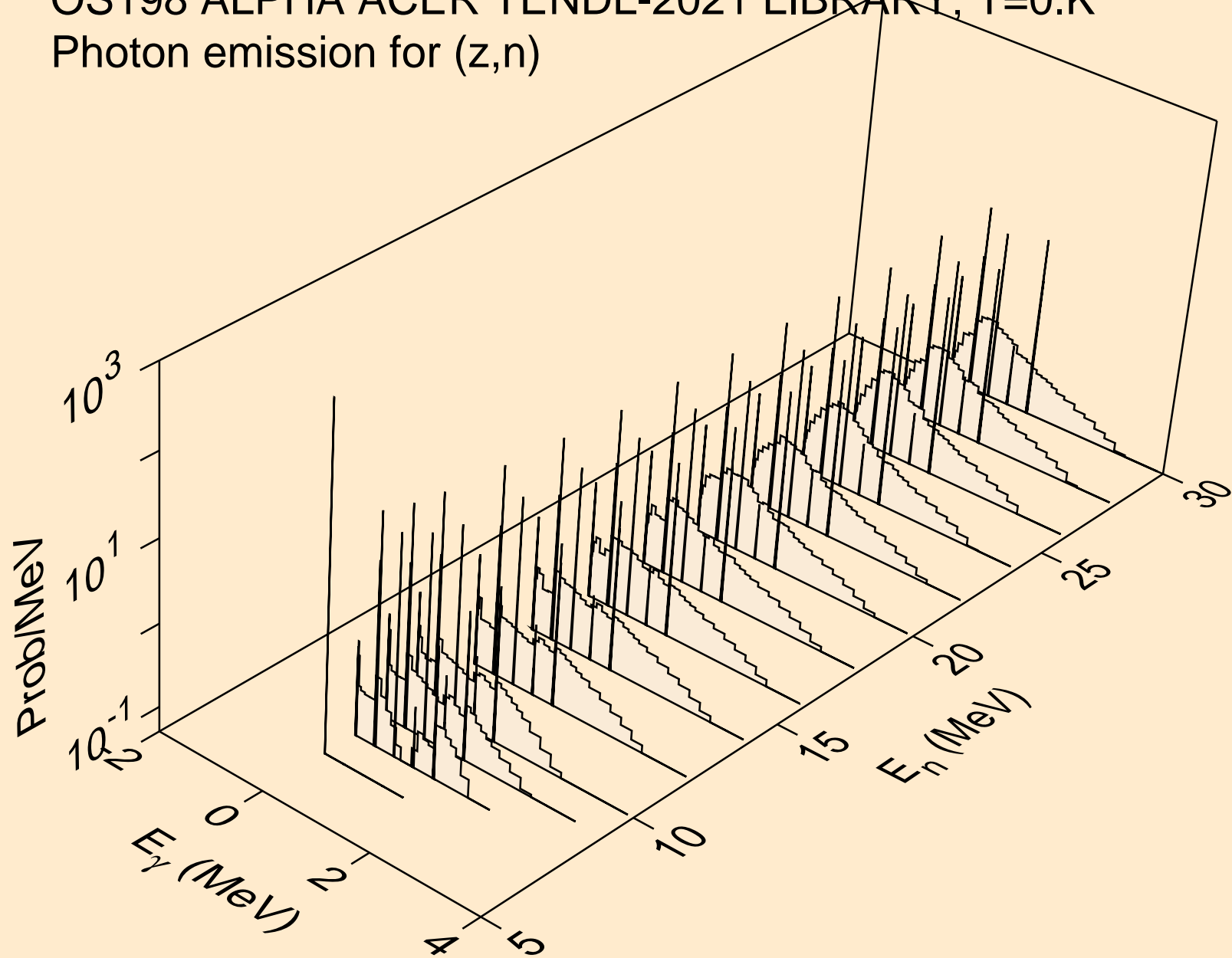

OS198 ALPHA ACER TENDL-2021 LIBRARY; T=0.K
Photon emission for (n,x)

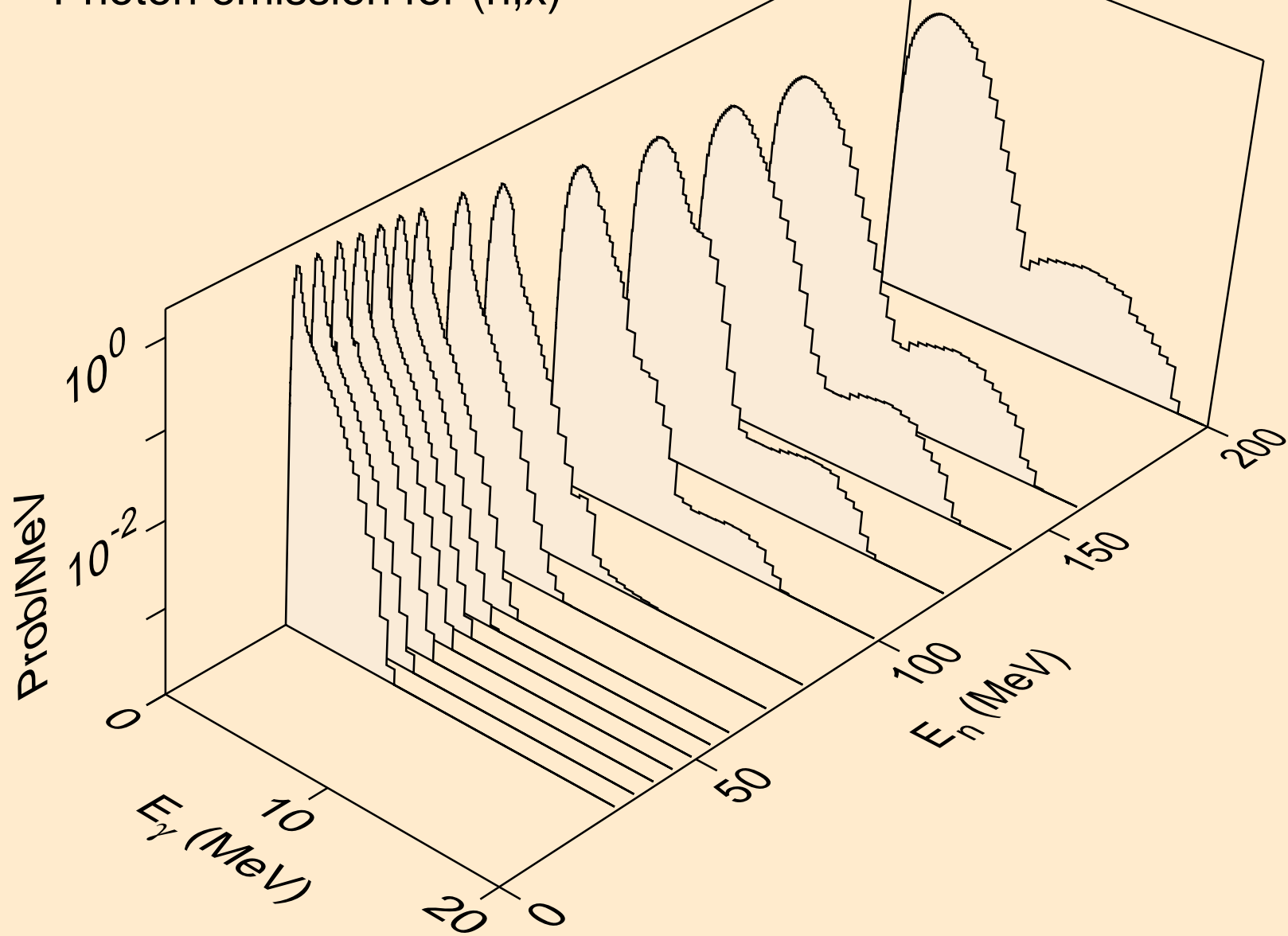

OS198 ALPHA ACER TENDL-2021 LIBRARY; T=0.K
Photon emission for (n,2n)

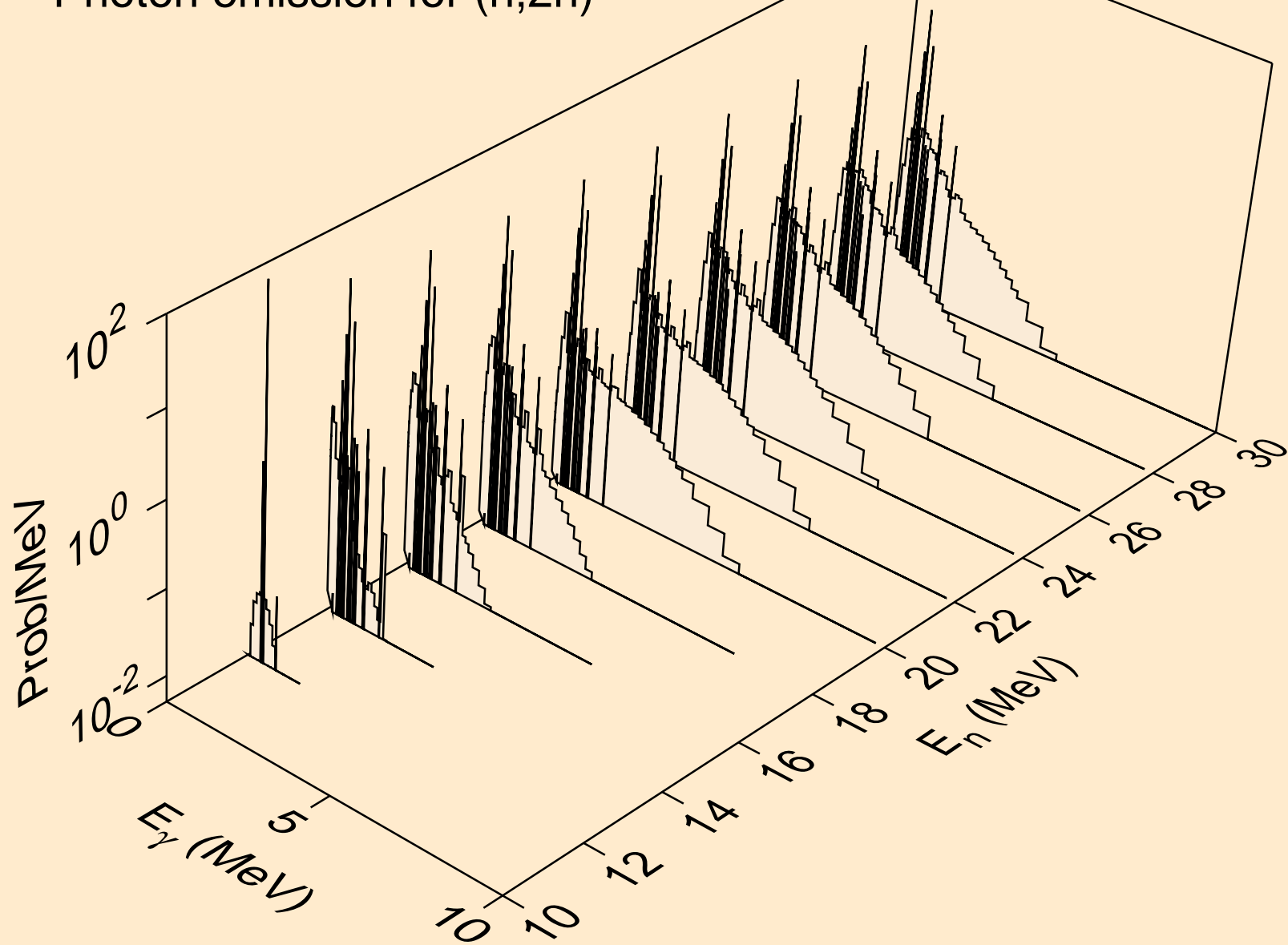

OS198 ALPHA ACER TENDL-2021 LIBRARY; T=0.K
Photon emission for (n,3n)

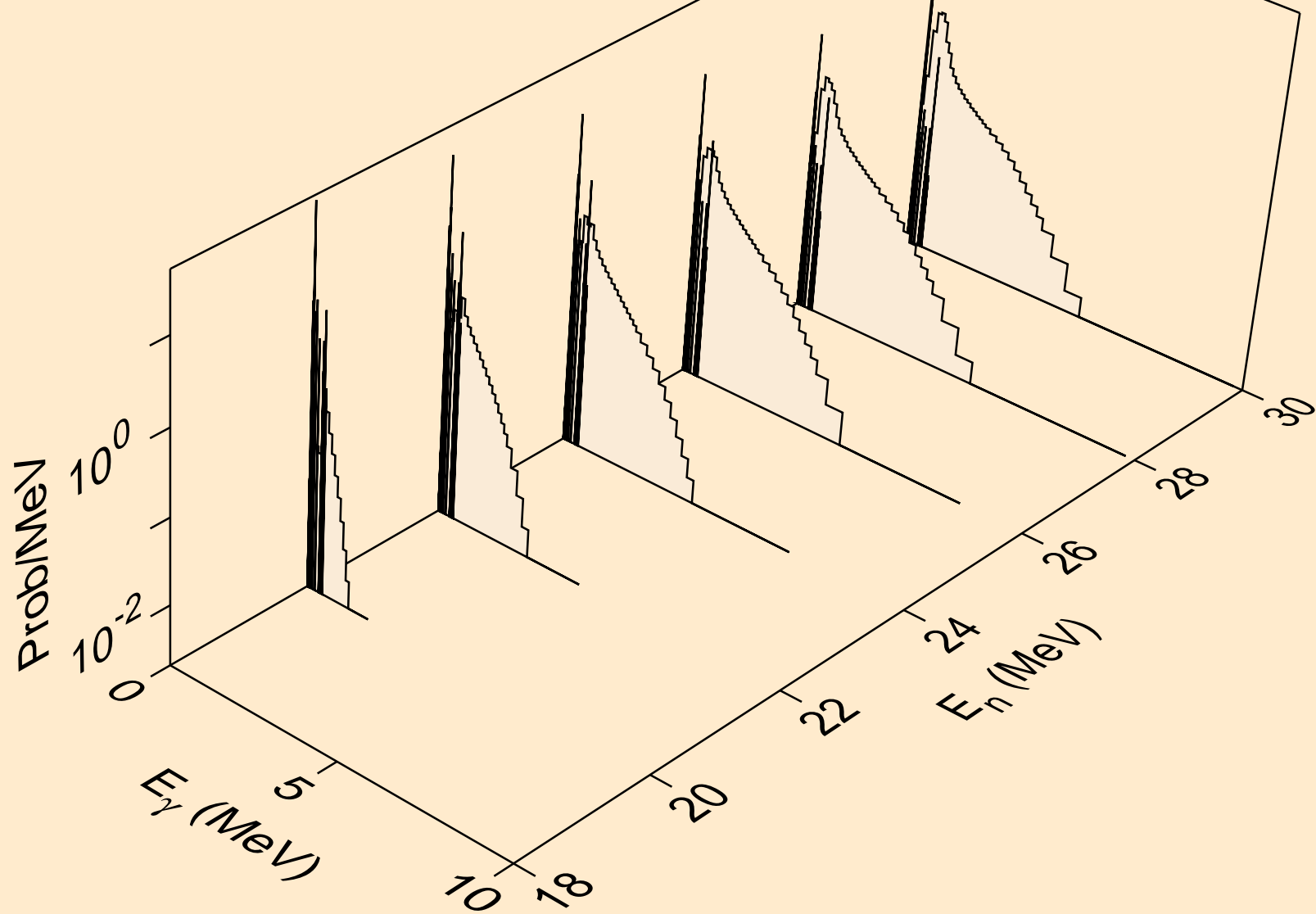

OS198 ALPHA ACER TENDL-2021 LIBRARY; T=0.K
Photon emission for (n,n*)a

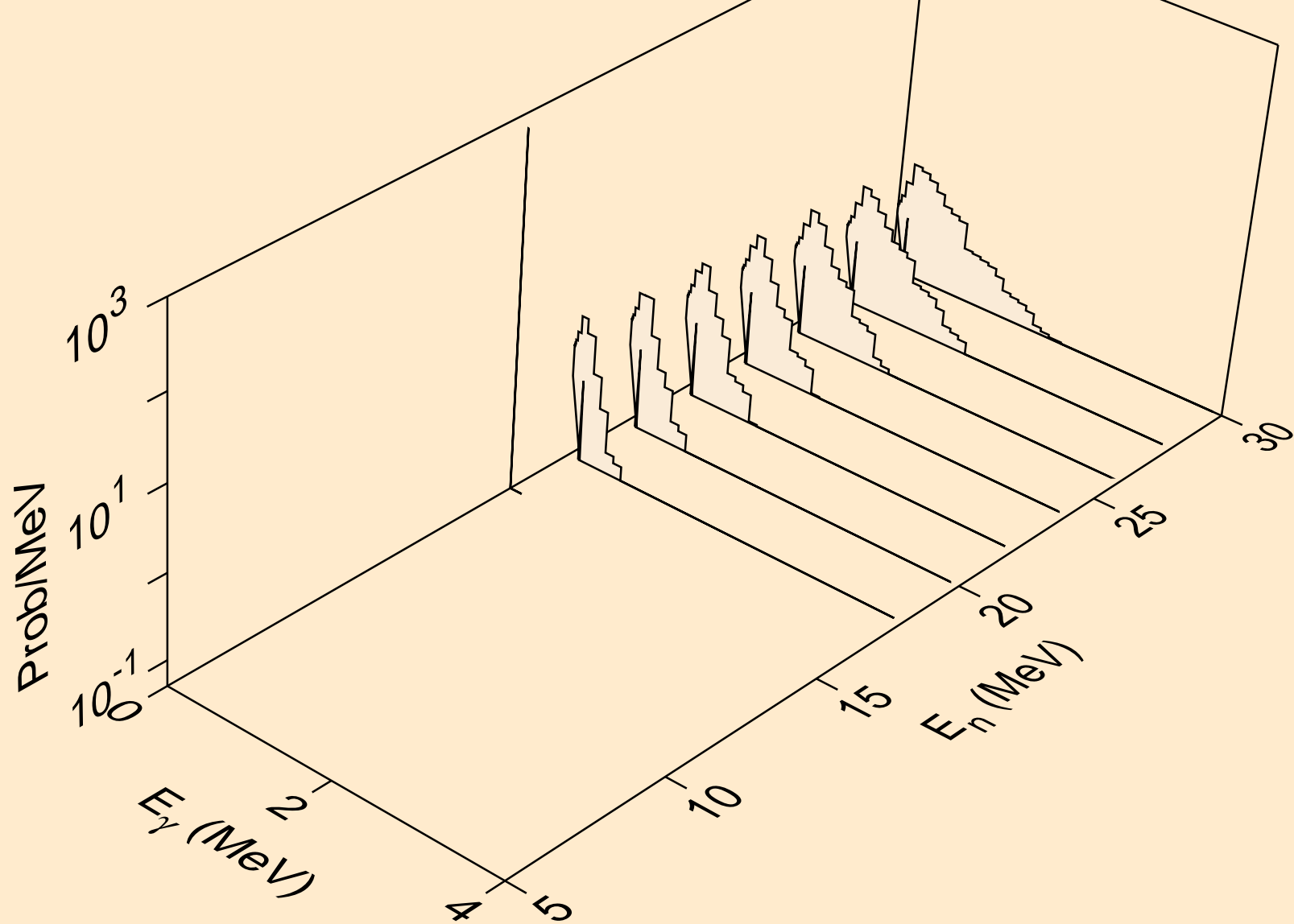

OS198 ALPHA ACER TENDL-2021 LIBRARY; T=0.K
Photon emission for (n,2n)a

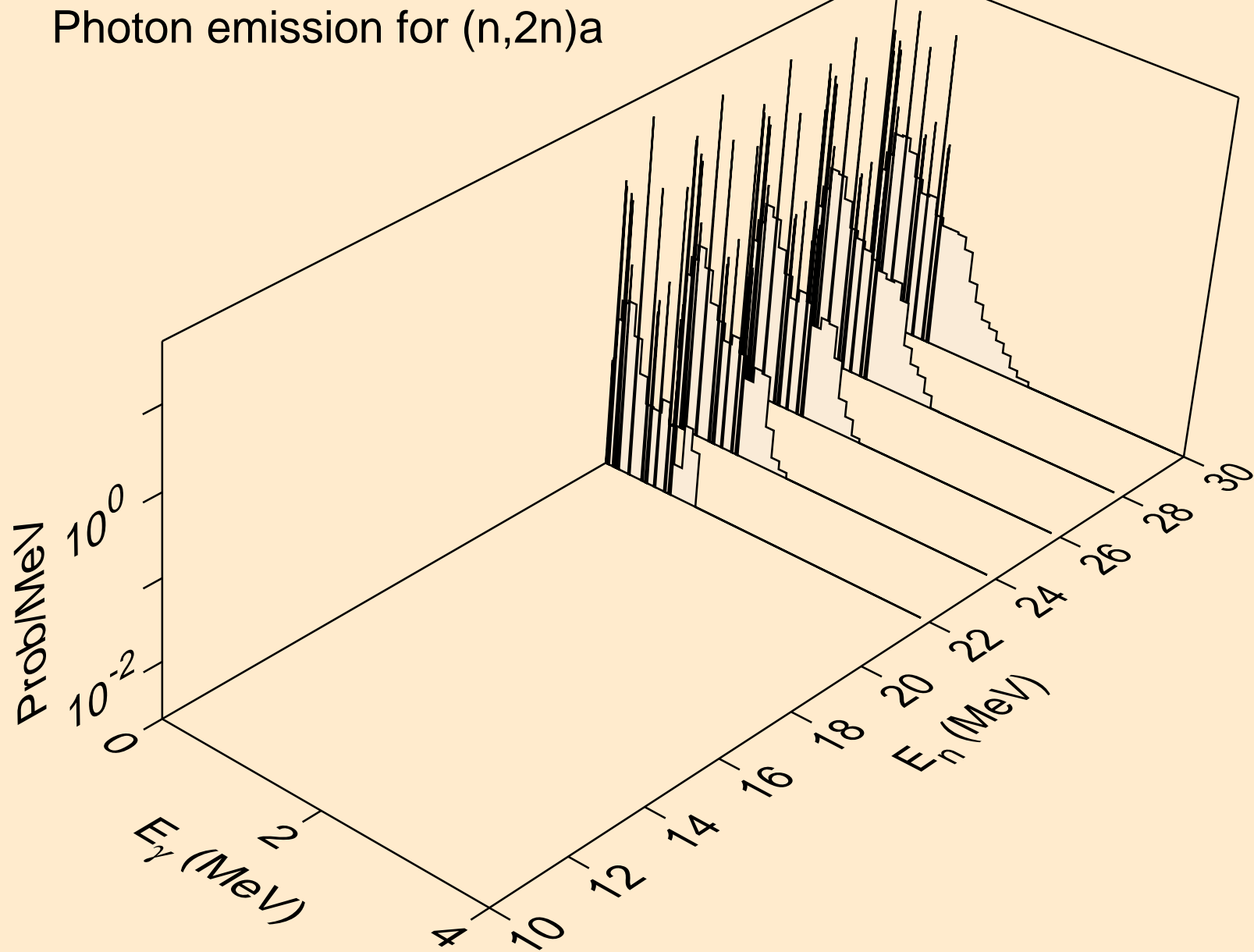

OS198 ALPHA ACER TENDL-2021 LIBRARY; T=0.K
Photon emission for (n,n*)p

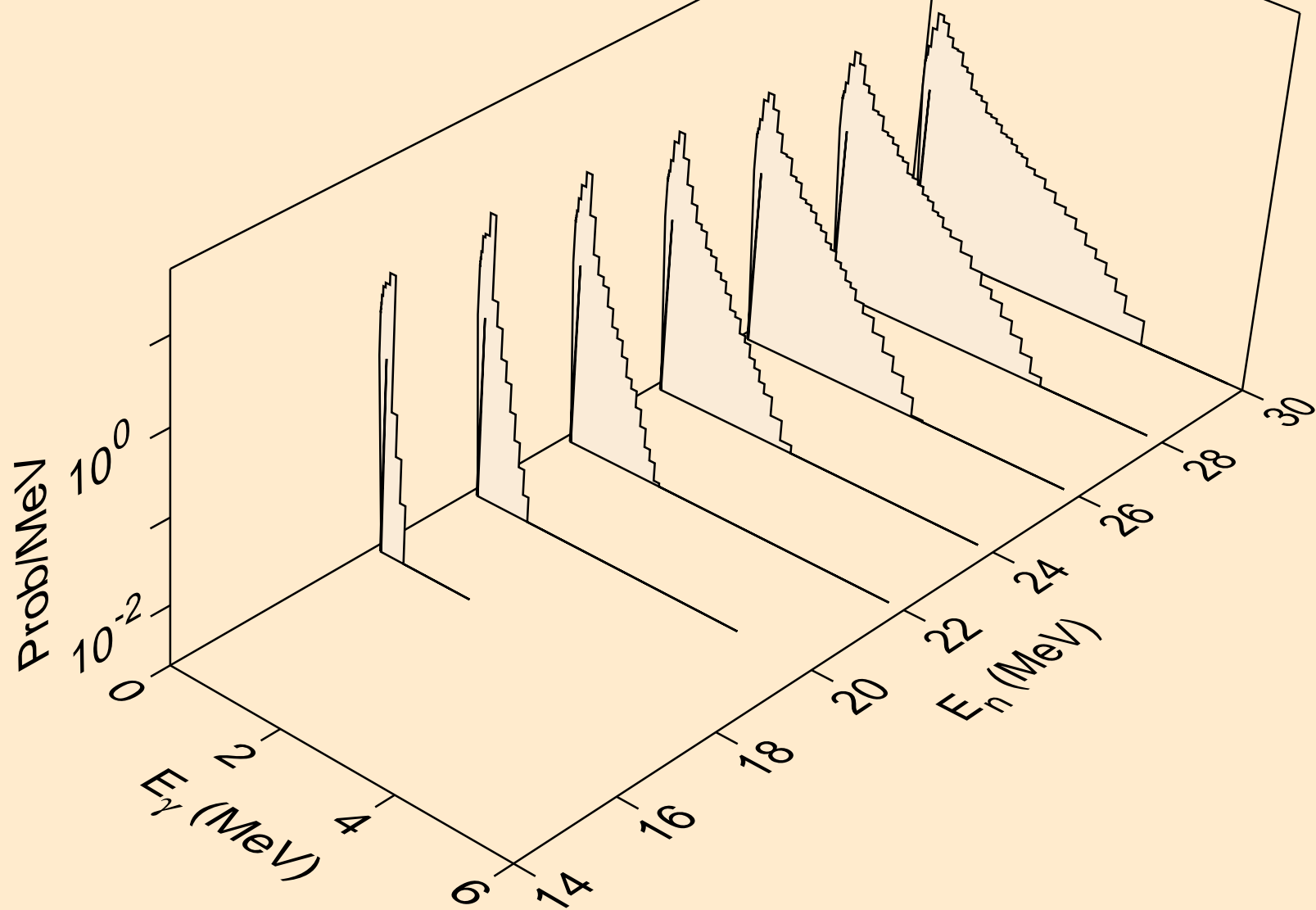

OS198 ALPHA ACER TENDL-2021 LIBRARY; T=0.K
Photon emission for (n,n*)d

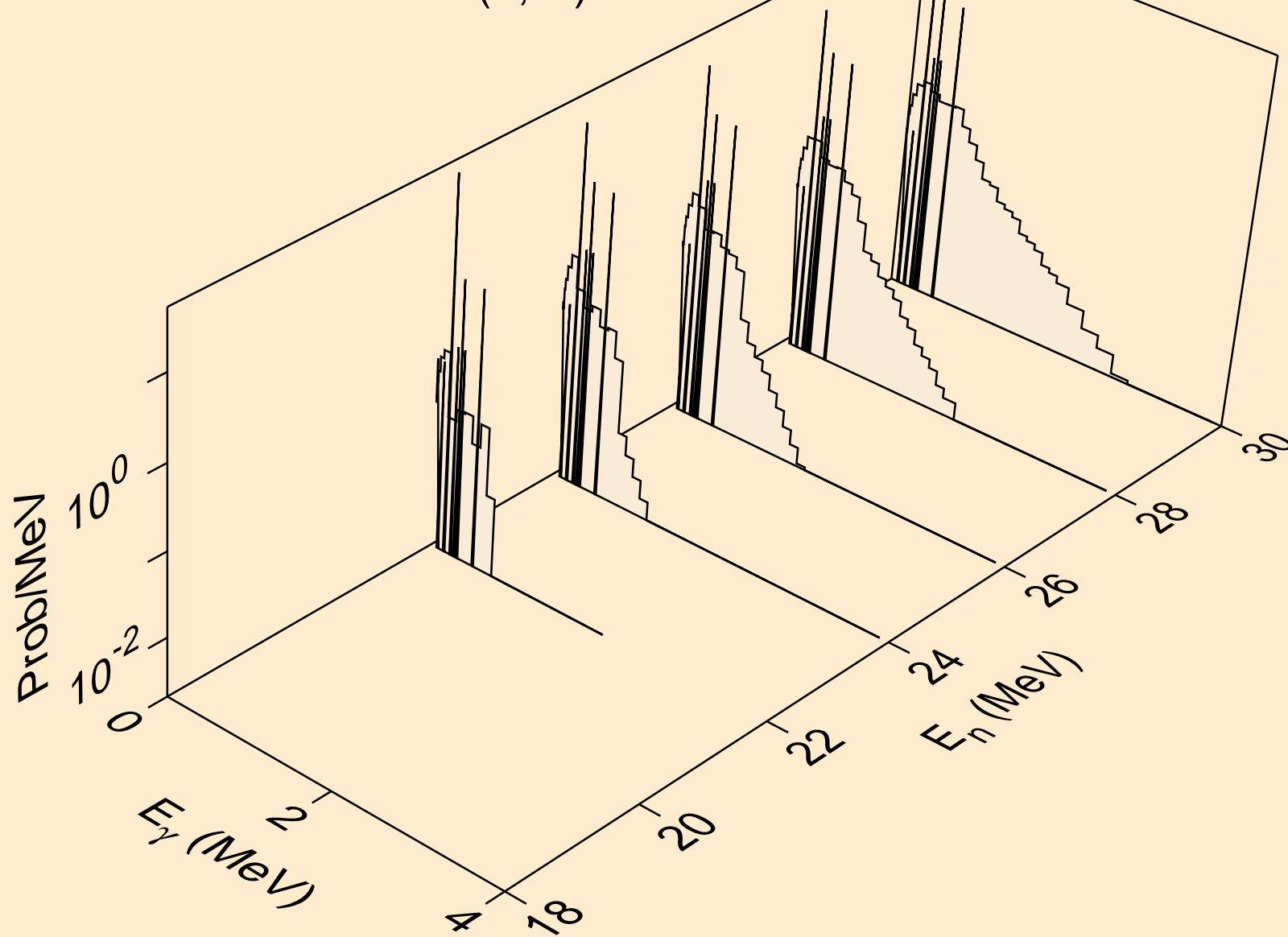

OS198 ALPHA ACER TENDL-2021 LIBRARY; T=0.K
Photon emission for (n,n*)t

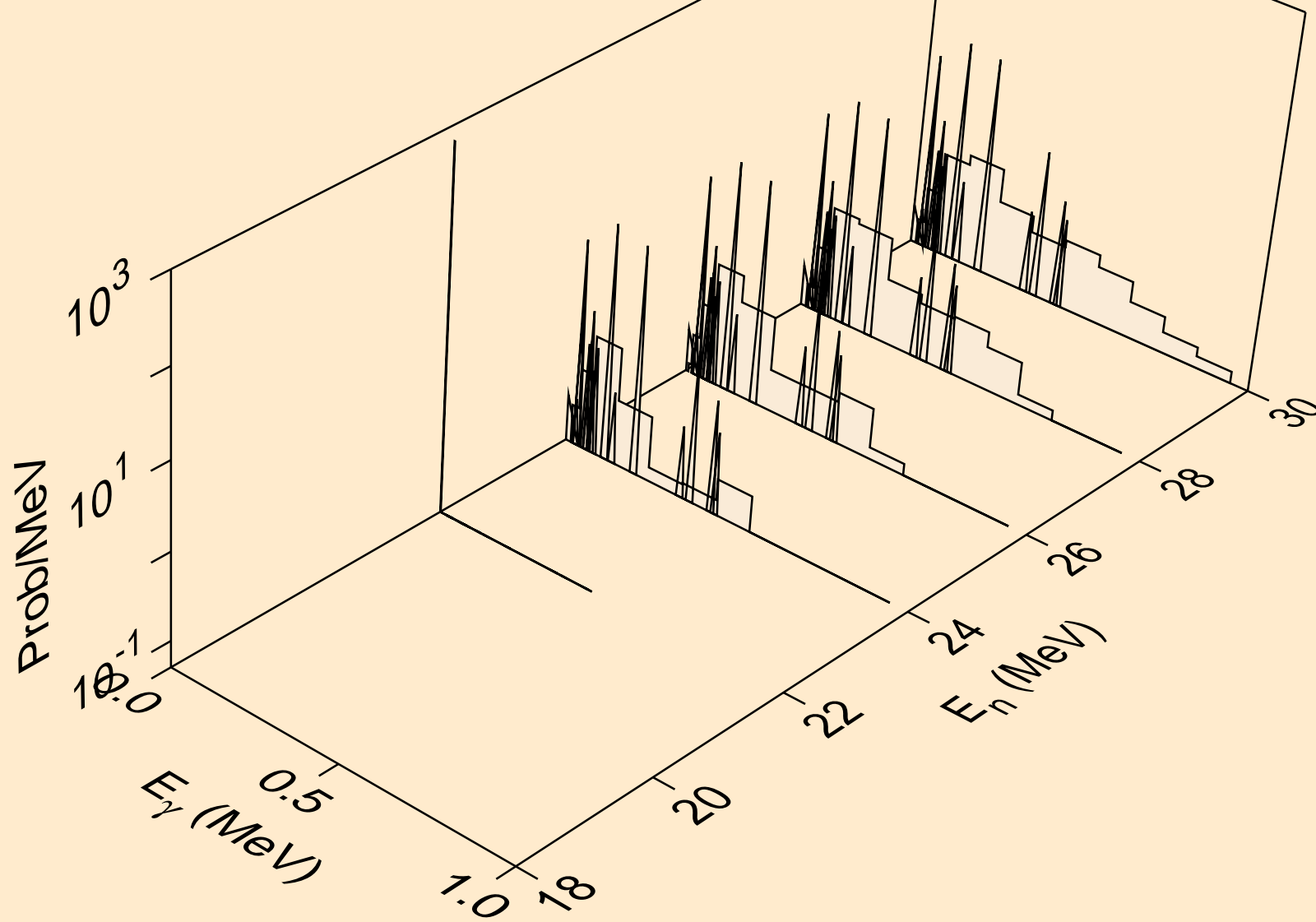

OS198 ALPHA ACER TENDL-2021 LIBRARY; T=0.K
Photon emission for (n,4n)

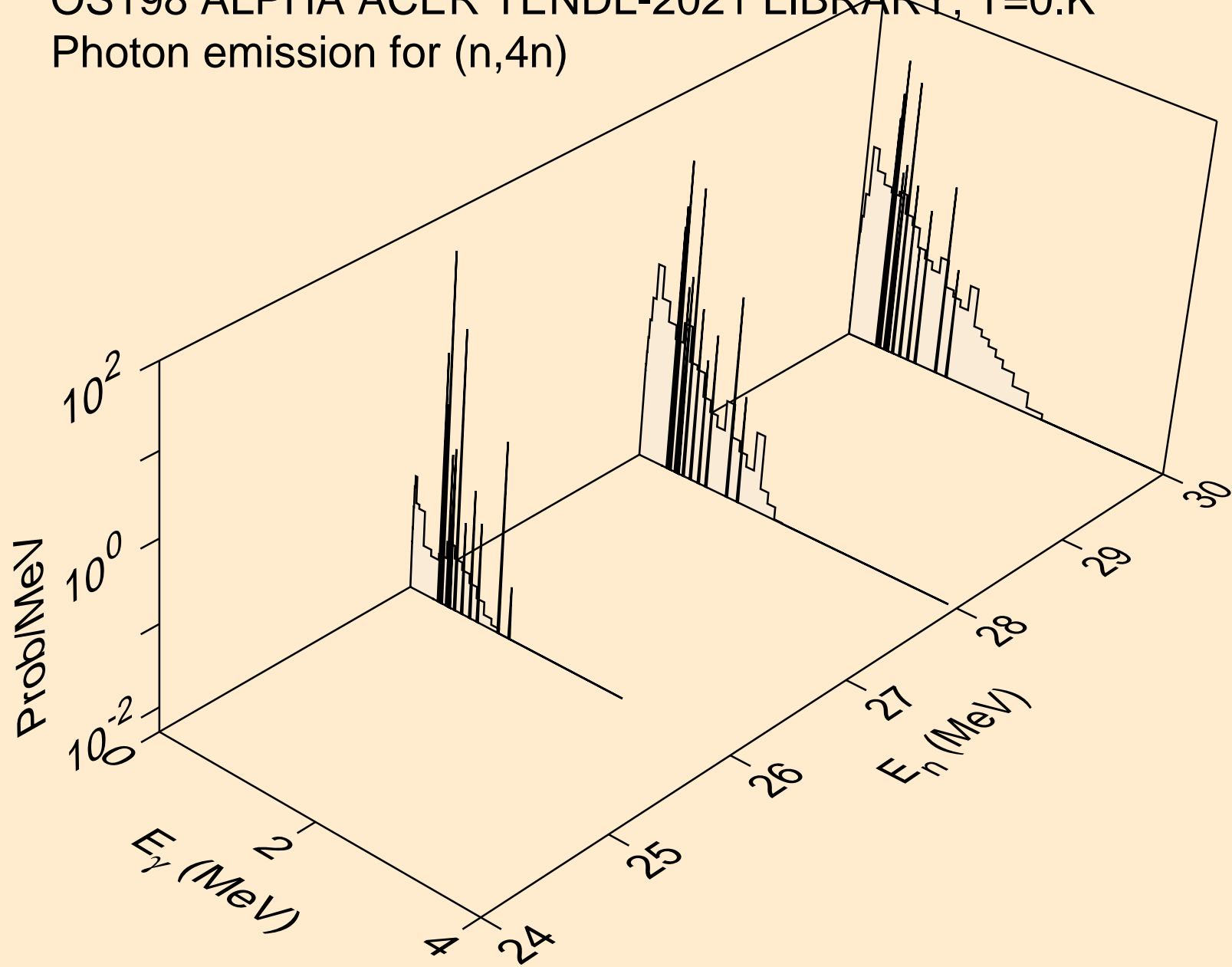

OS198 ALPHA ACER TENDL-2021 LIBRARY; T=0.K
Photon emission for (n,2np)

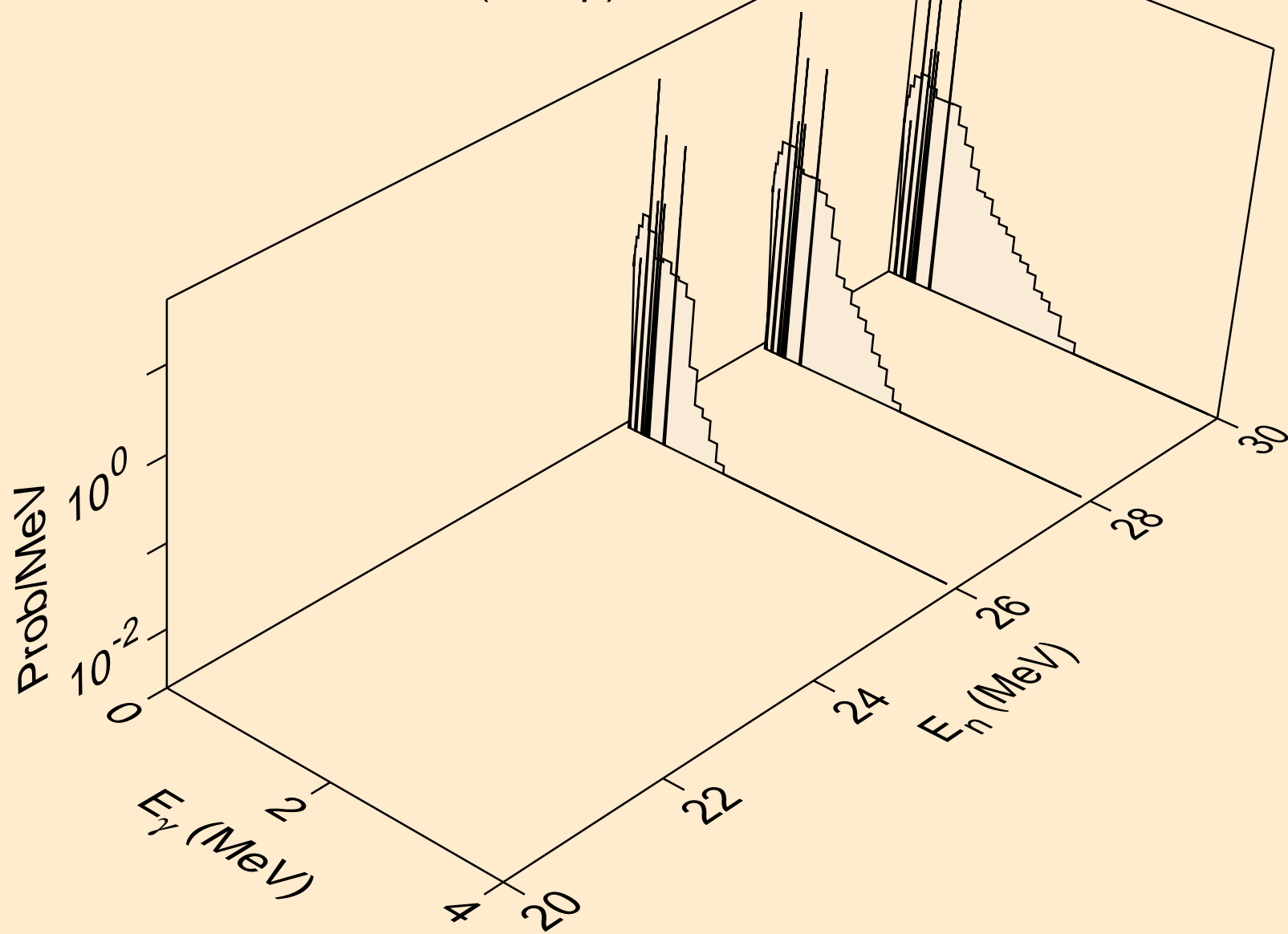

OS198 ALPHA ACER TENDL-2021 LIBRARY; T=0.K
Photon emission for (n,gma)

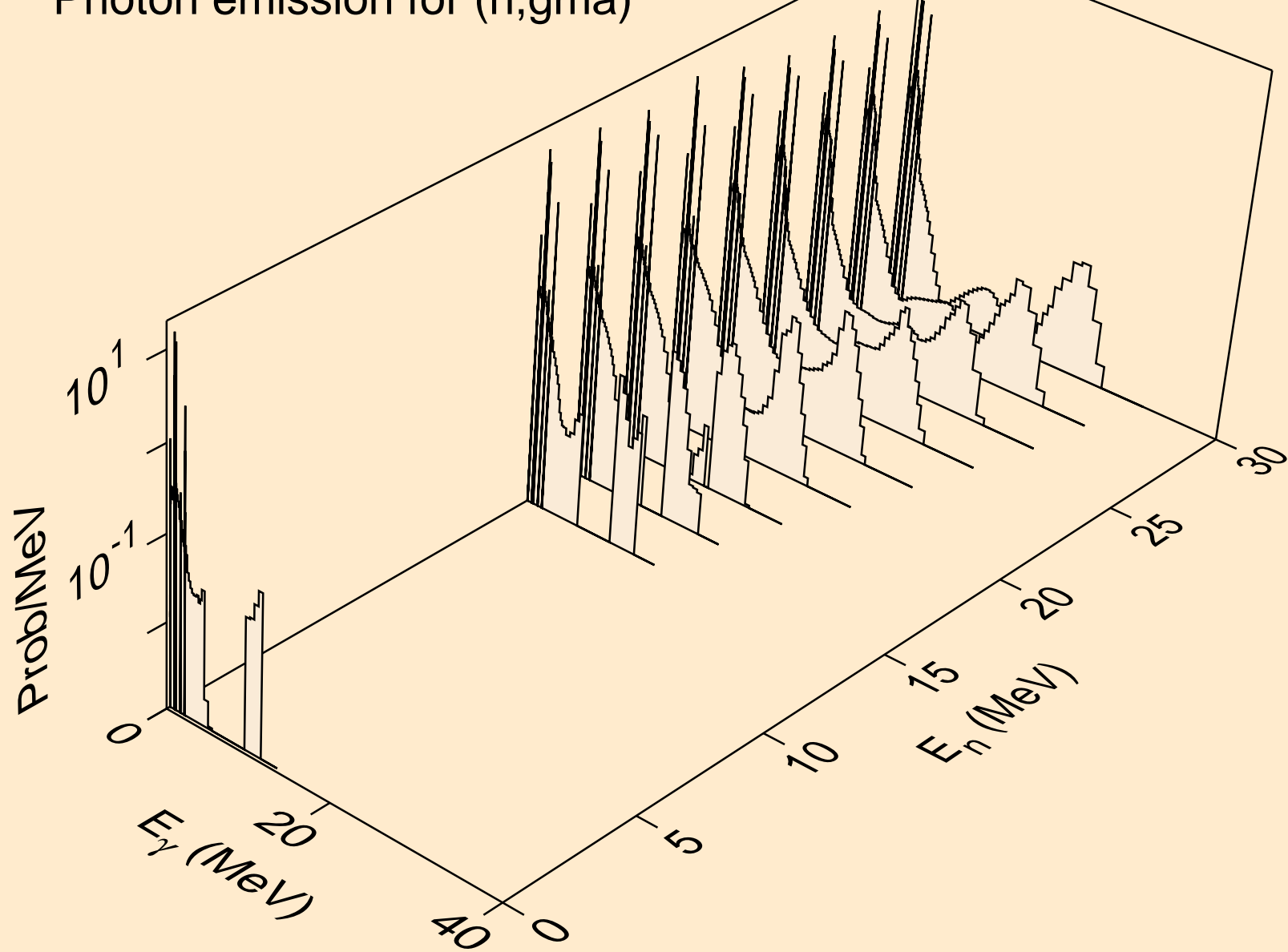

OS198 ALPHA ACER TENDL-2021 LIBRARY; T=0.K
Photon emission for (n,p)

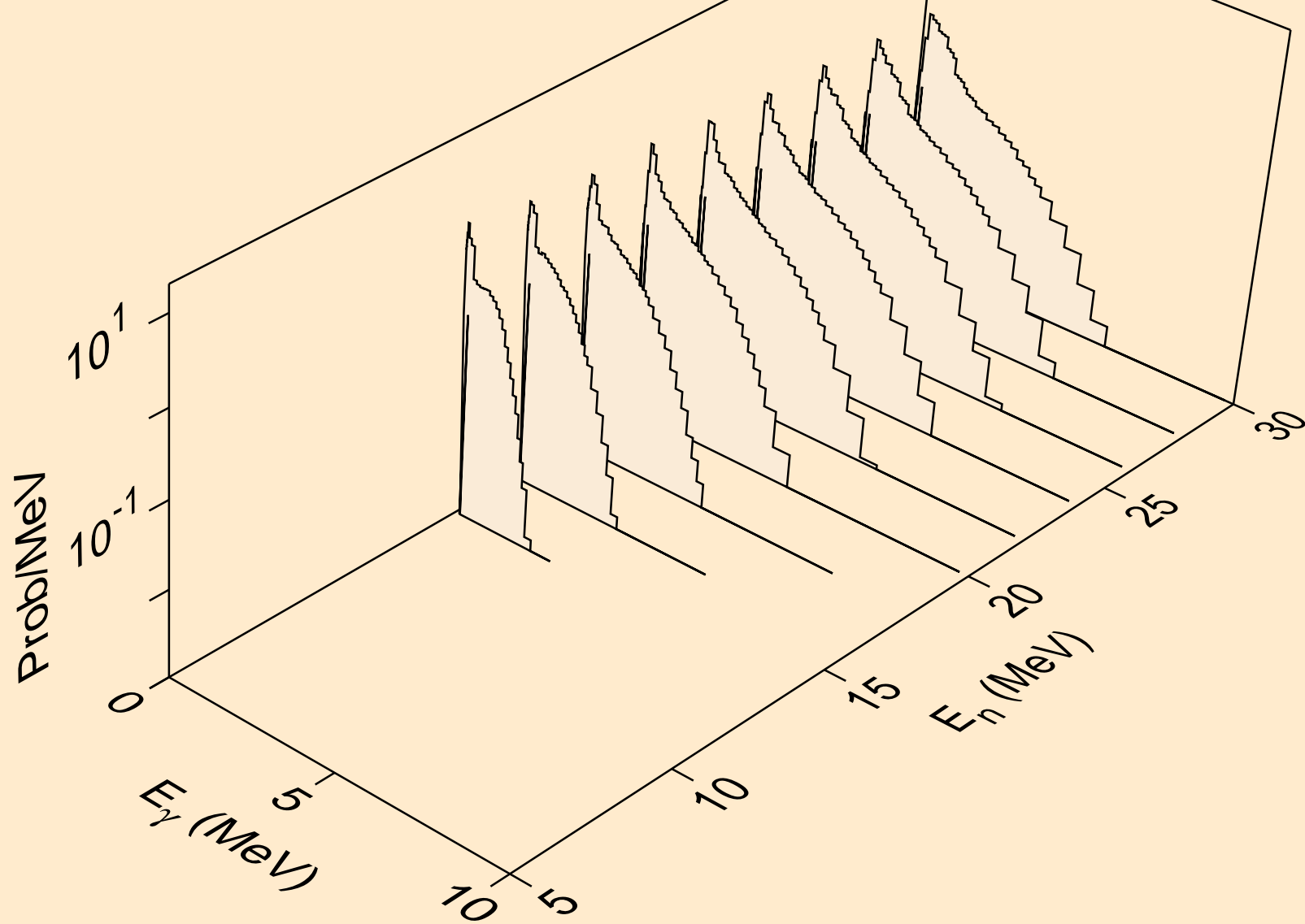

OS198 ALPHA ACER TENDL-2021 LIBRARY; T=0.K
Photon emission for (n,d)

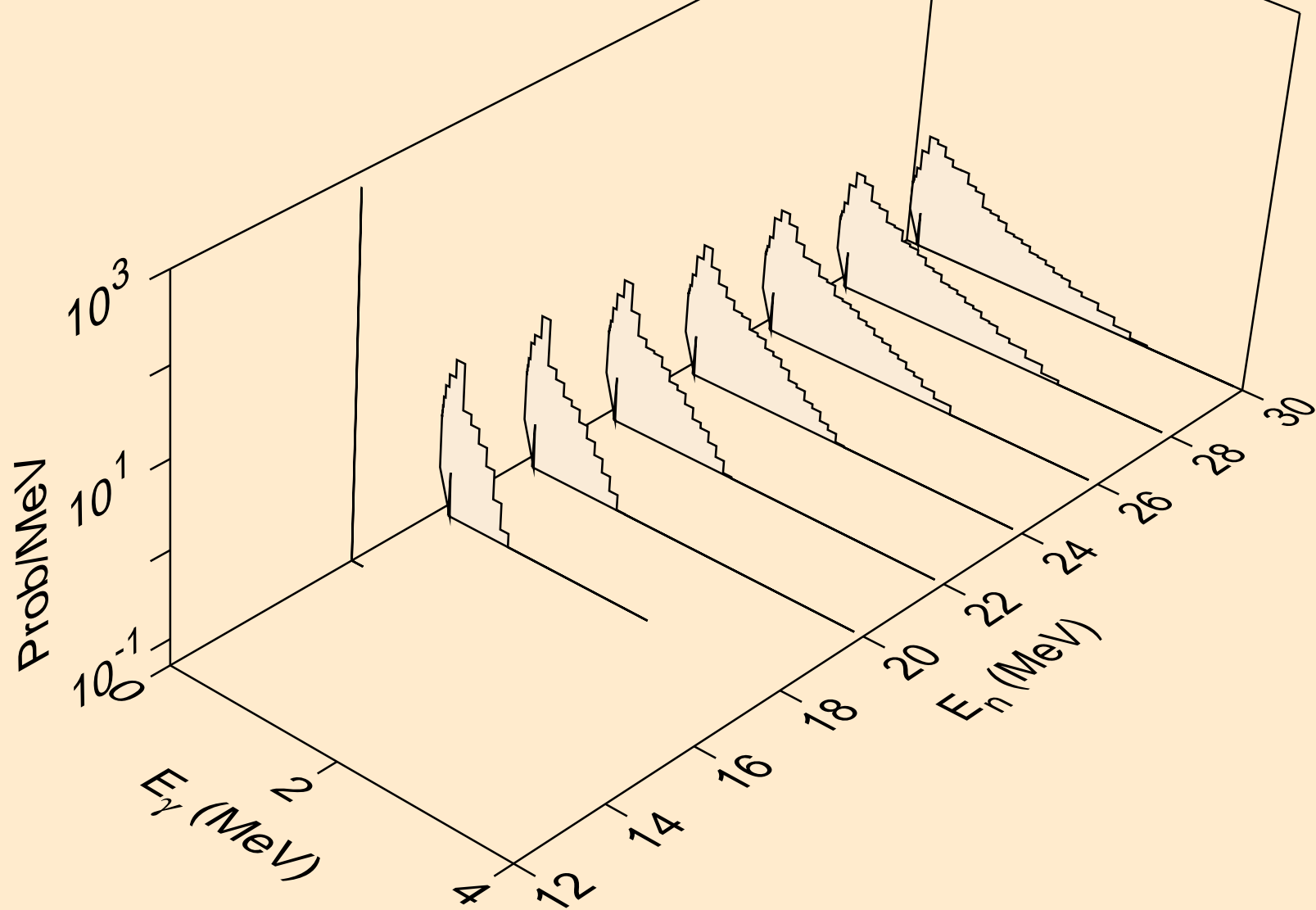

OS198 ALPHA ACER TENDL-2021 LIBRARY; T=0.K
Photon emission for (n,t)

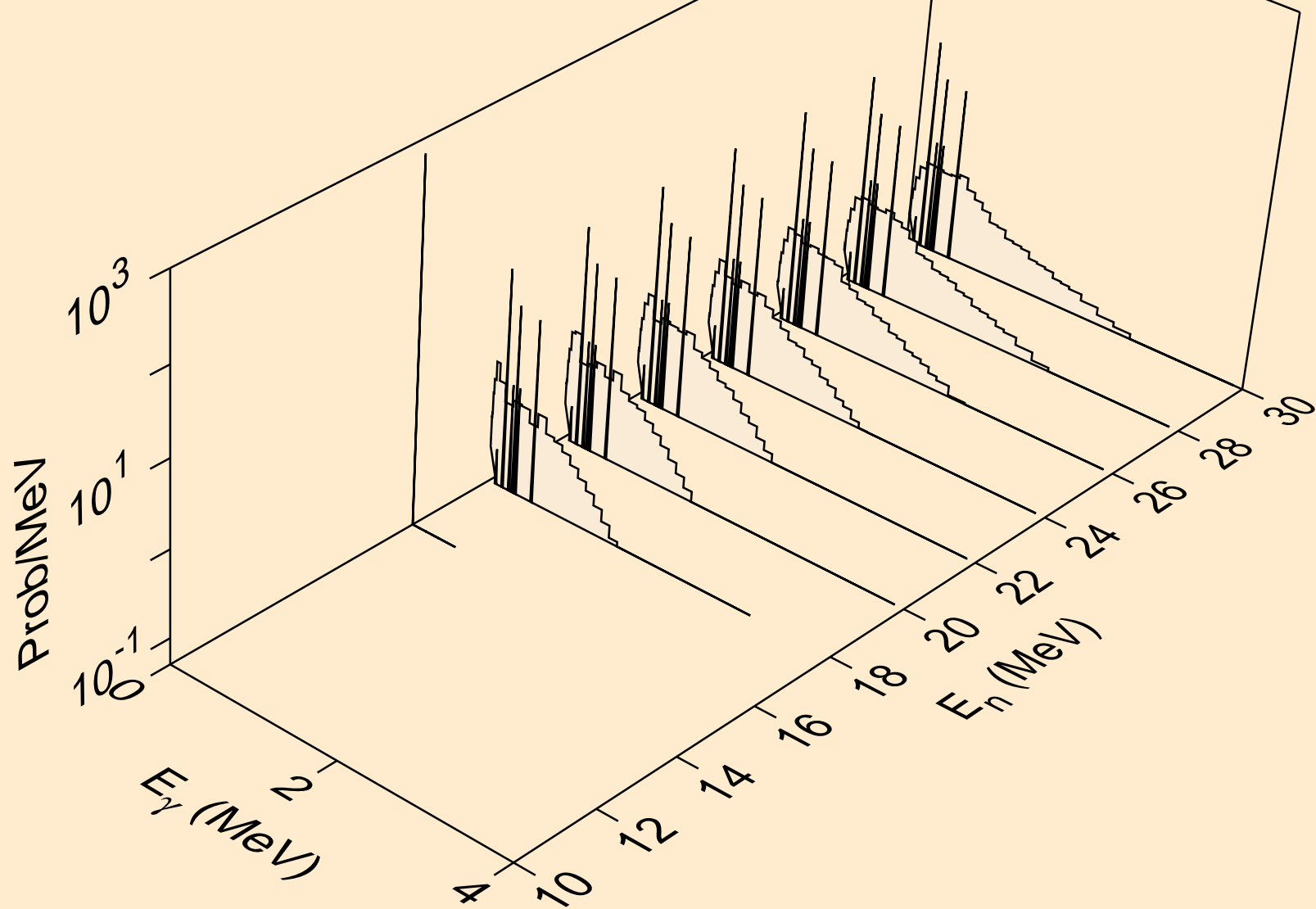

OS198 ALPHA ACER TENDL-2021 LIBRARY; T=0.K
Photon emission for (n,he3)

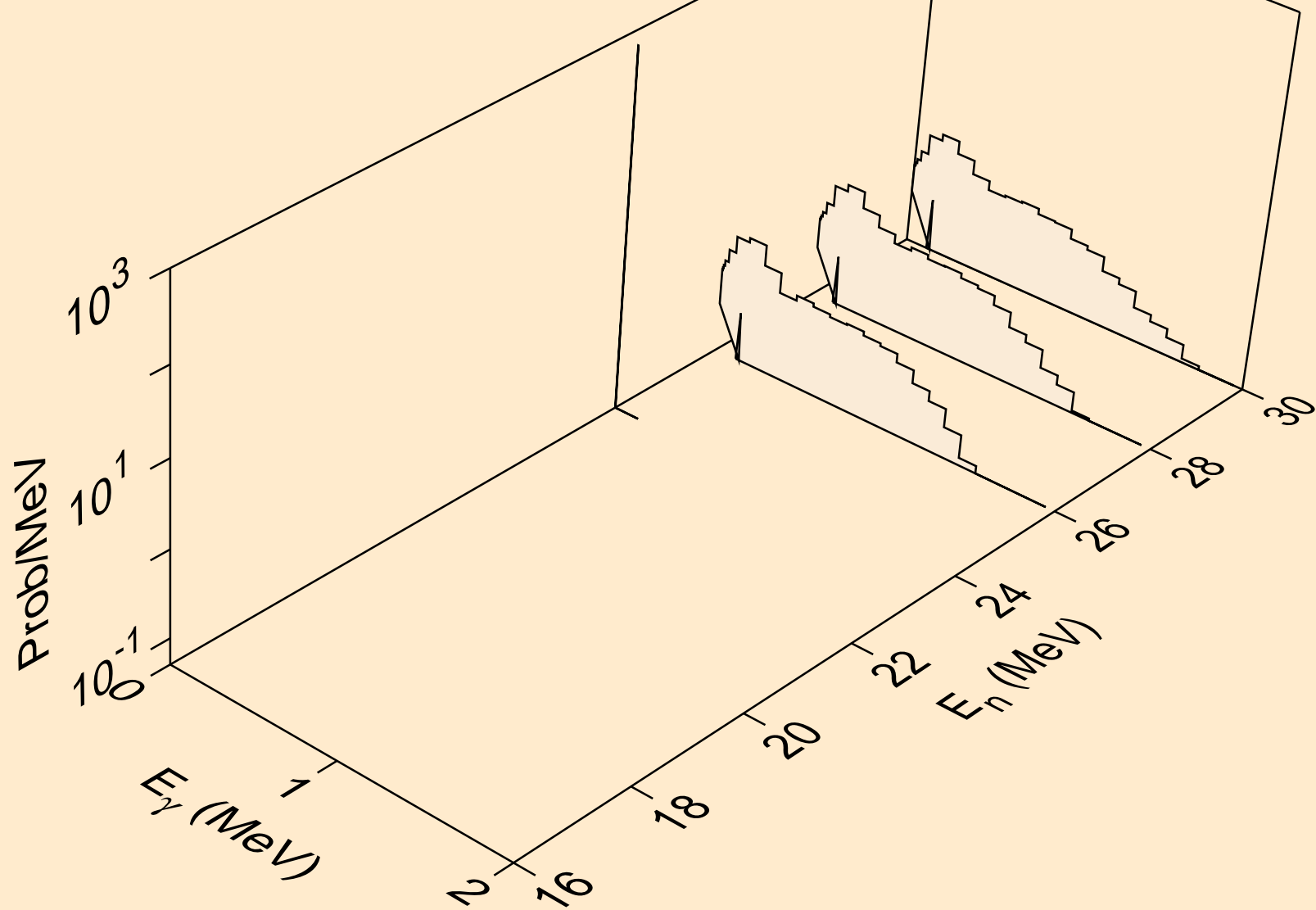

OS198 ALPHA ACER TENDL-2021 LIBRARY; T=0.K
Photon emission for inelastic

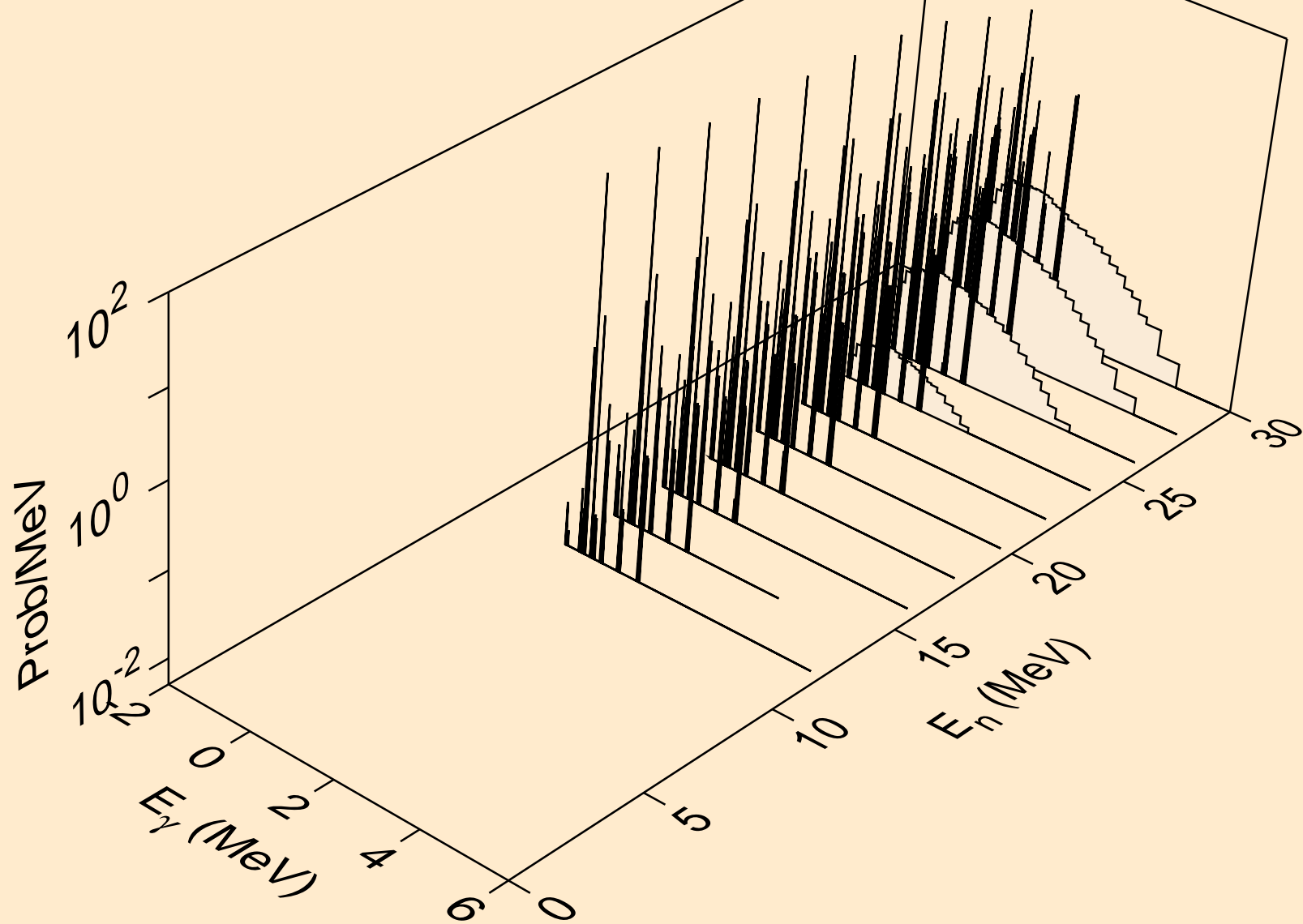

OS198 ALPHA ACER TENDL-2021 LIBRARY; T=0.K
Particle heating contributions

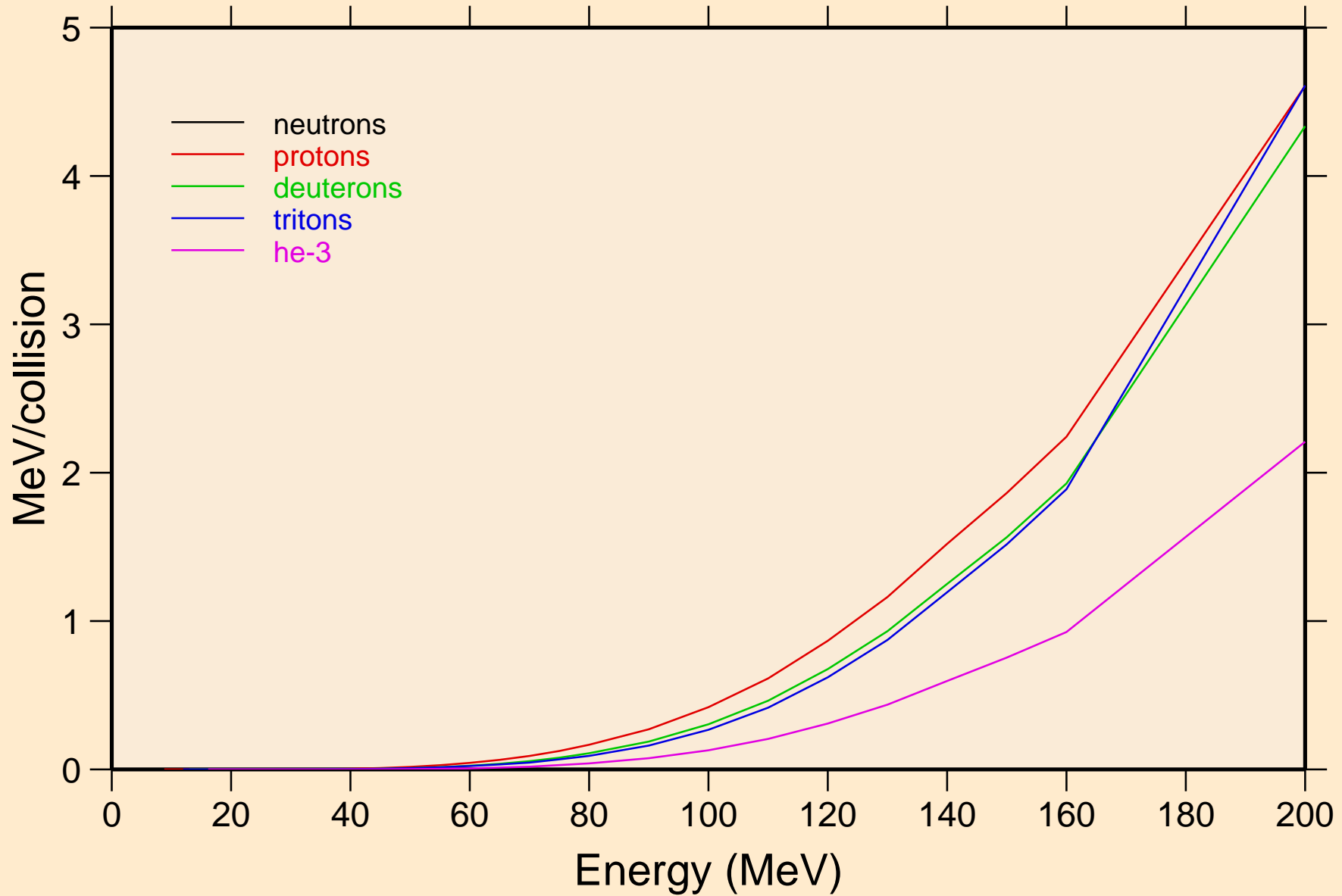

OS198 ALPHA ACER TENDL-2021 LIBRARY; T=0.K
Recoil Heating

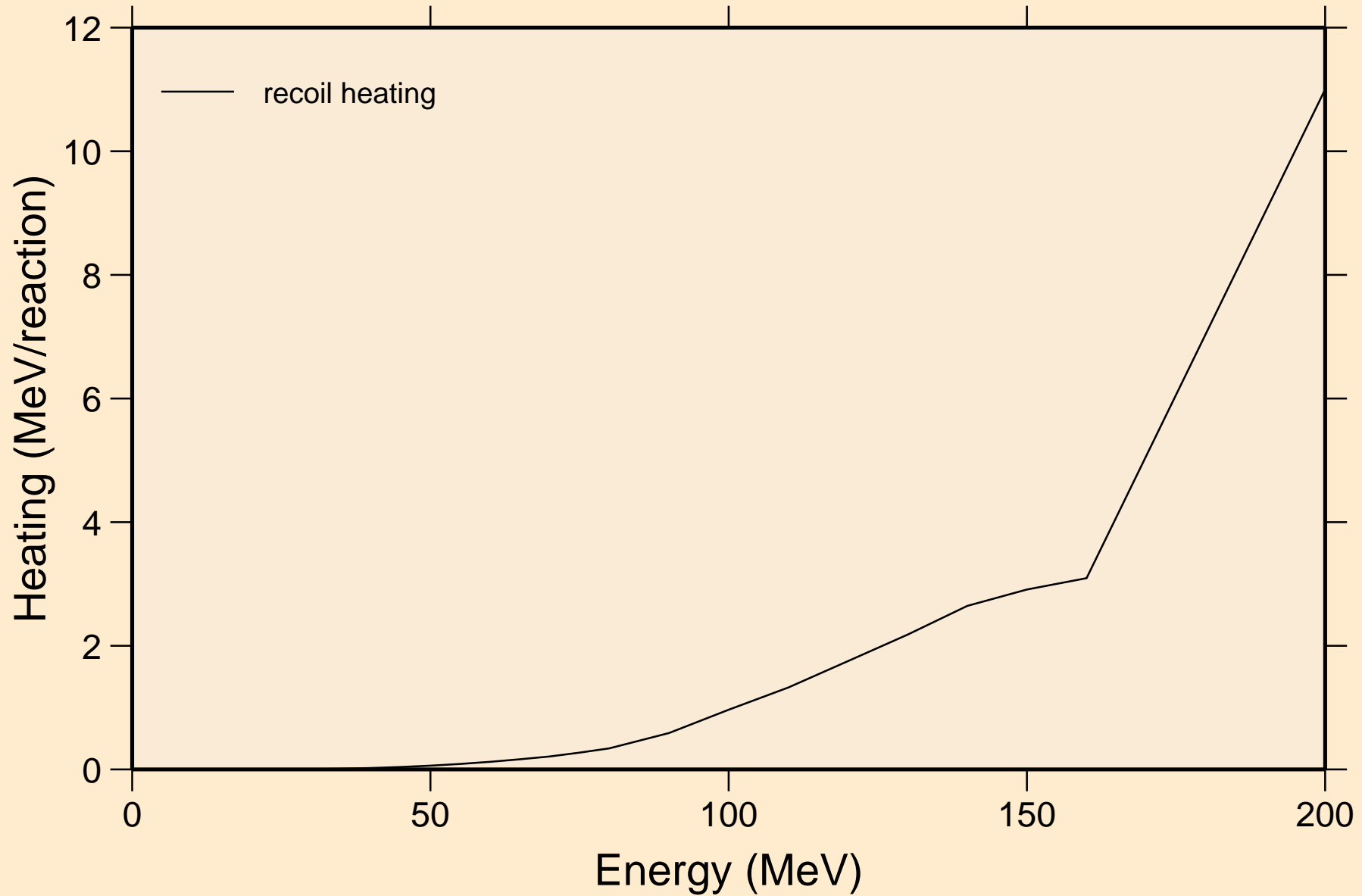

OS198 ALPHA ACER TENDL-2021 LIBRARY; T=0.K
Particle production cross sections

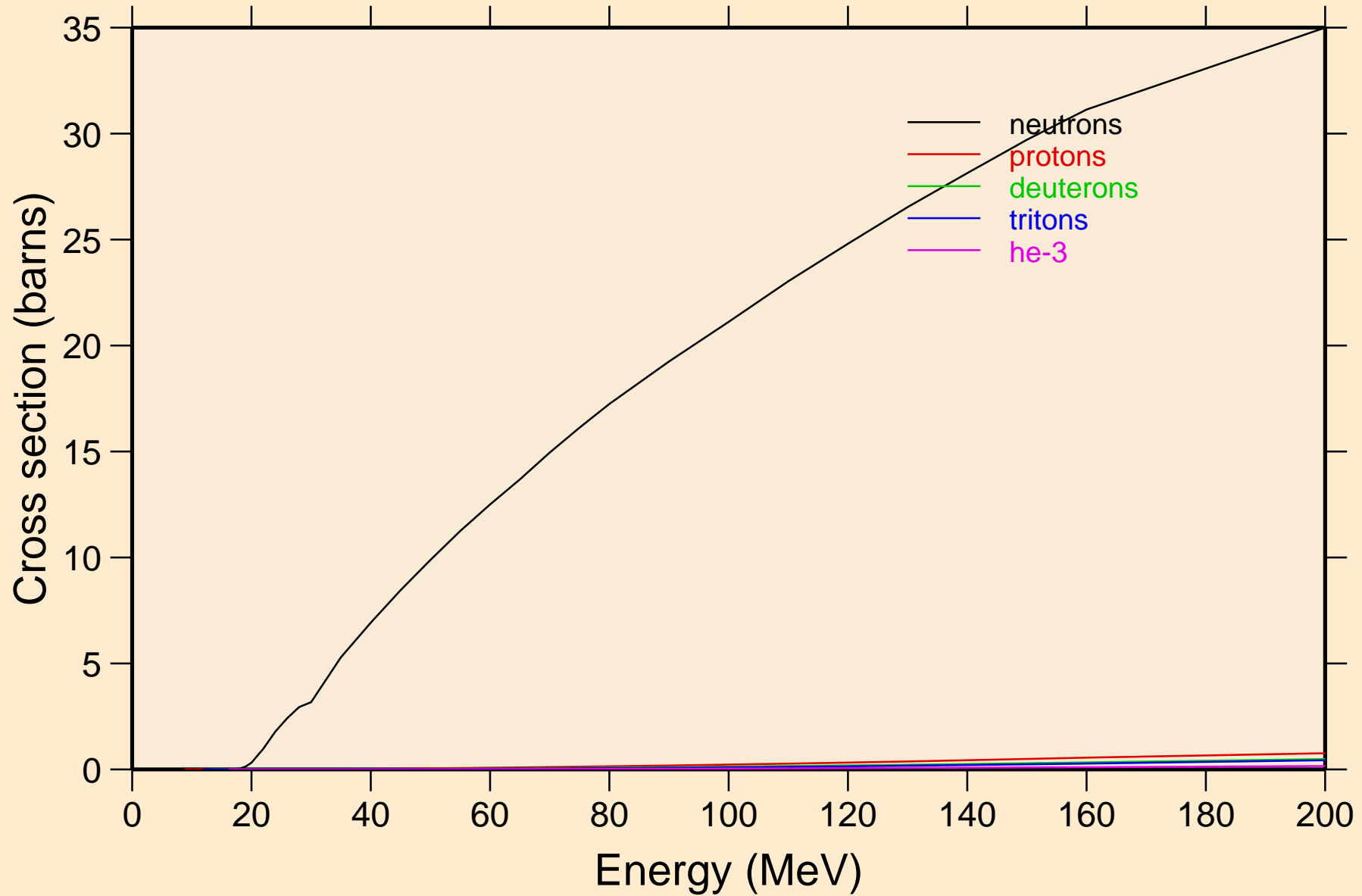

OS198 ALPHA ACER TENDL-2021 LIBRARY; T=0.K
neutrons from (a,n)

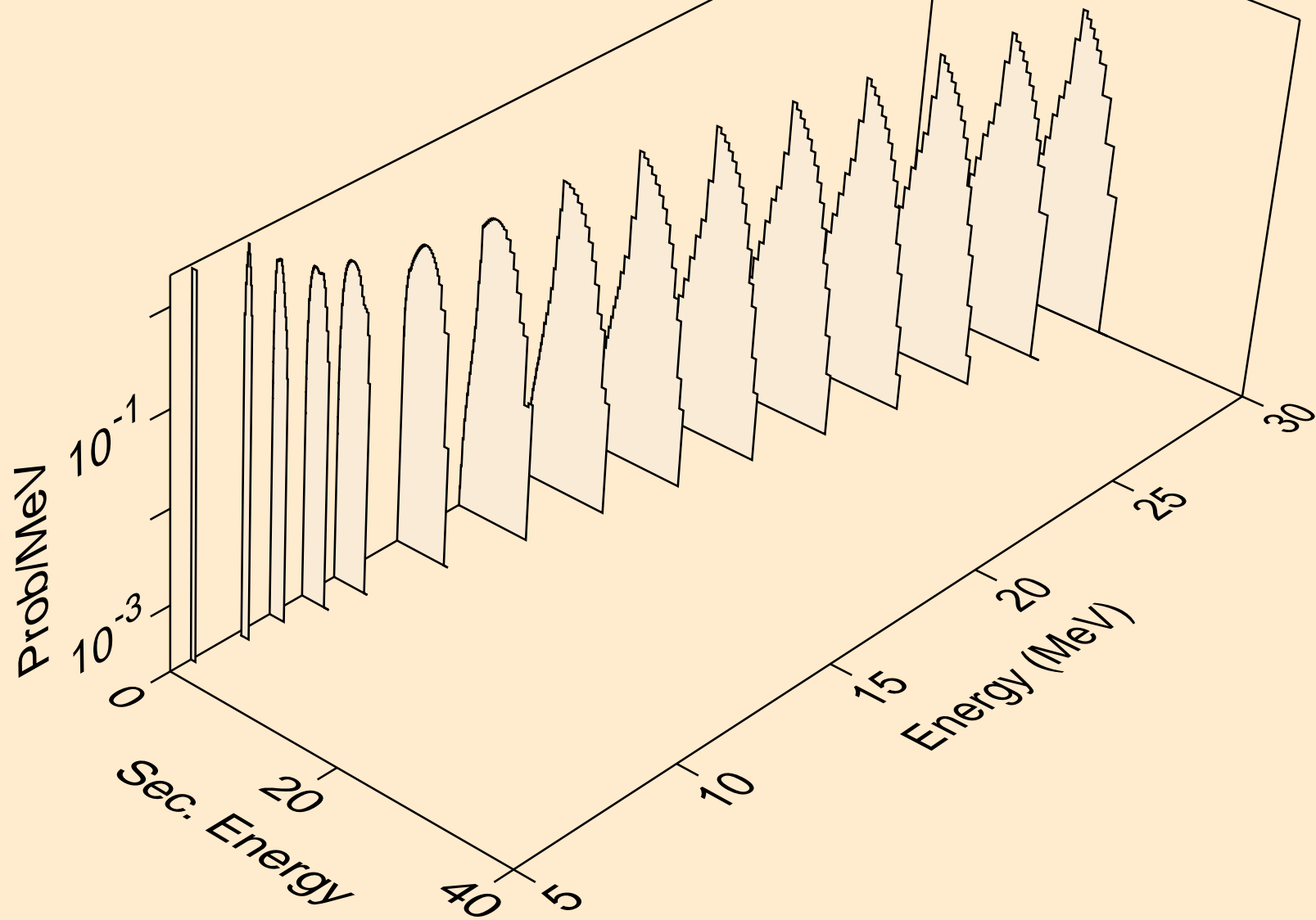

OS198 ALPHA ACER TENDL-2021 LIBRARY; T=0.K
neutrons from (a,x)

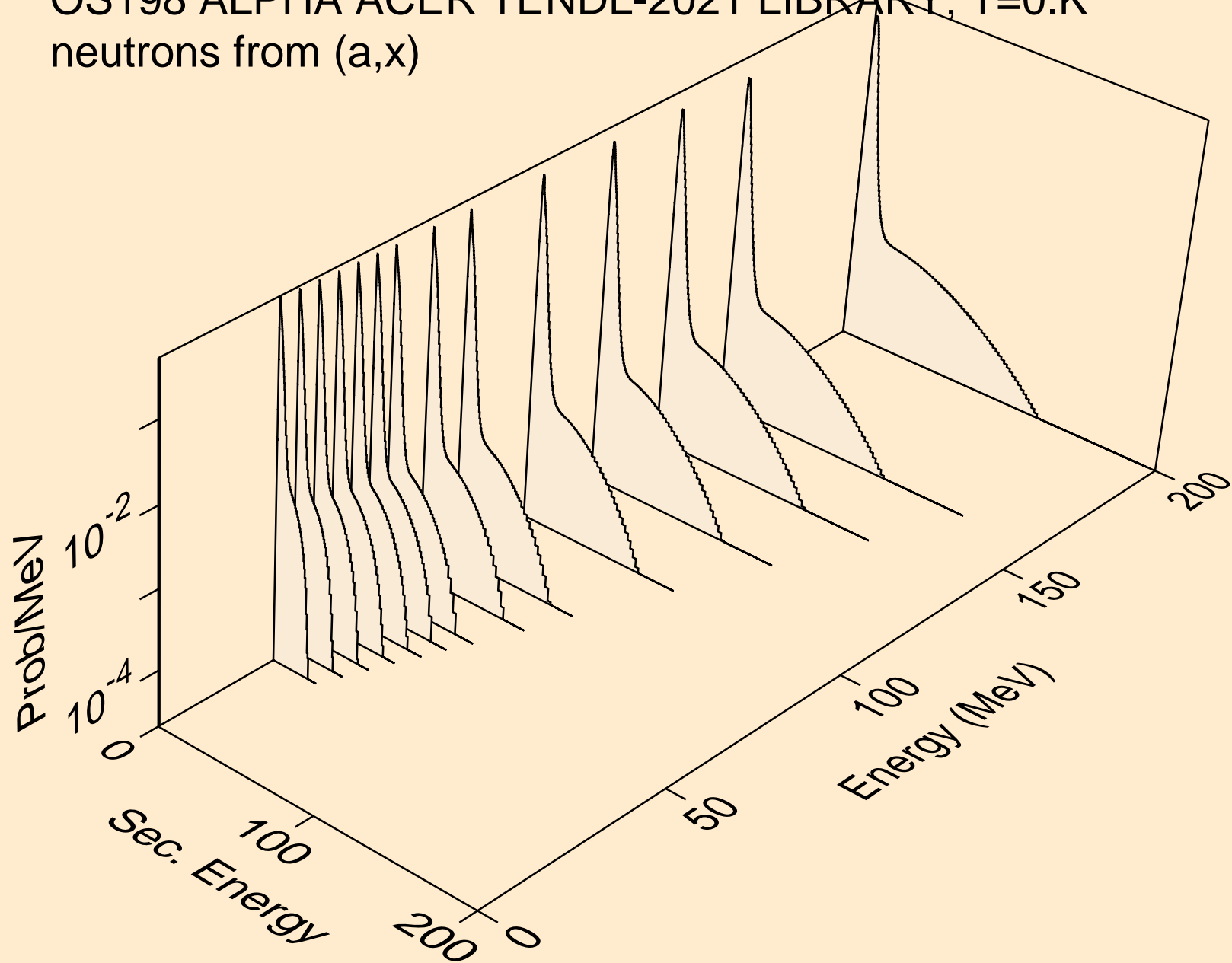

OS198 ALPHA ACER TENDL-2021 LIBRARY; T=0.K
neutrons from (a,2n)

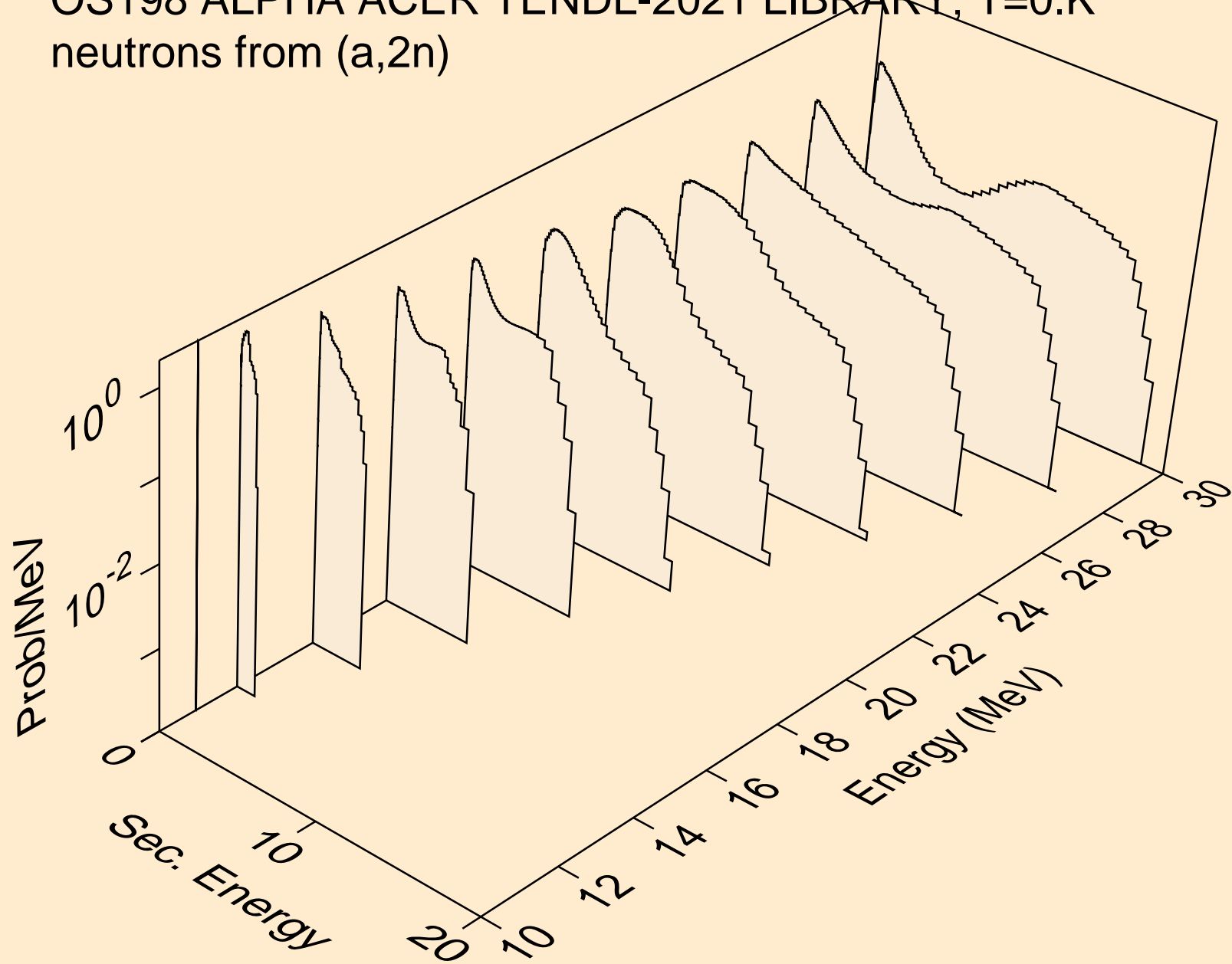

OS198 ALPHA ACER TENDL-2021 LIBRARY; T=0.K
neutrons from (a,3n)

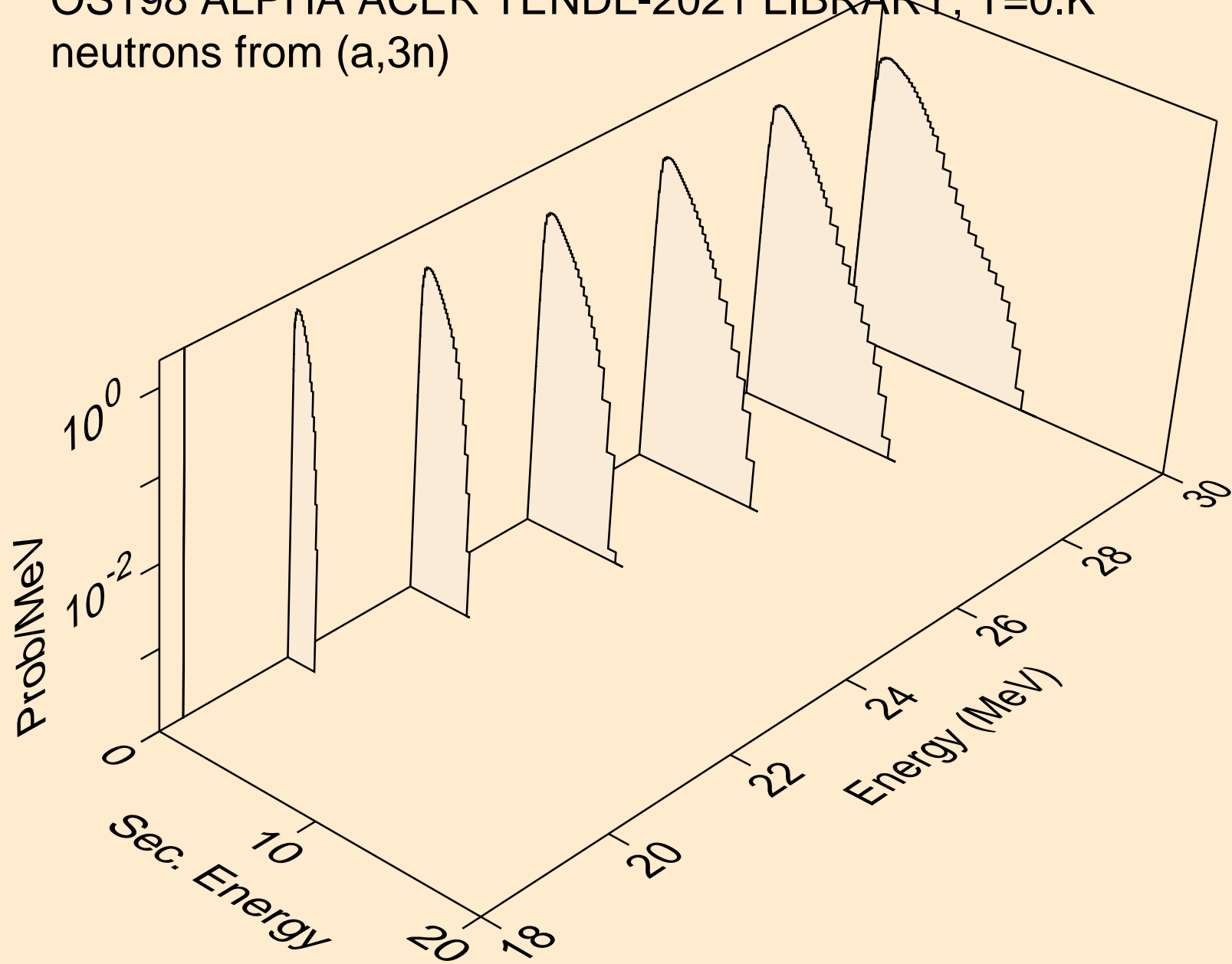

OS198 ALPHA ACER TENDL-2021 LIBRARY; T=0.K
neutrons from (a,n*)a

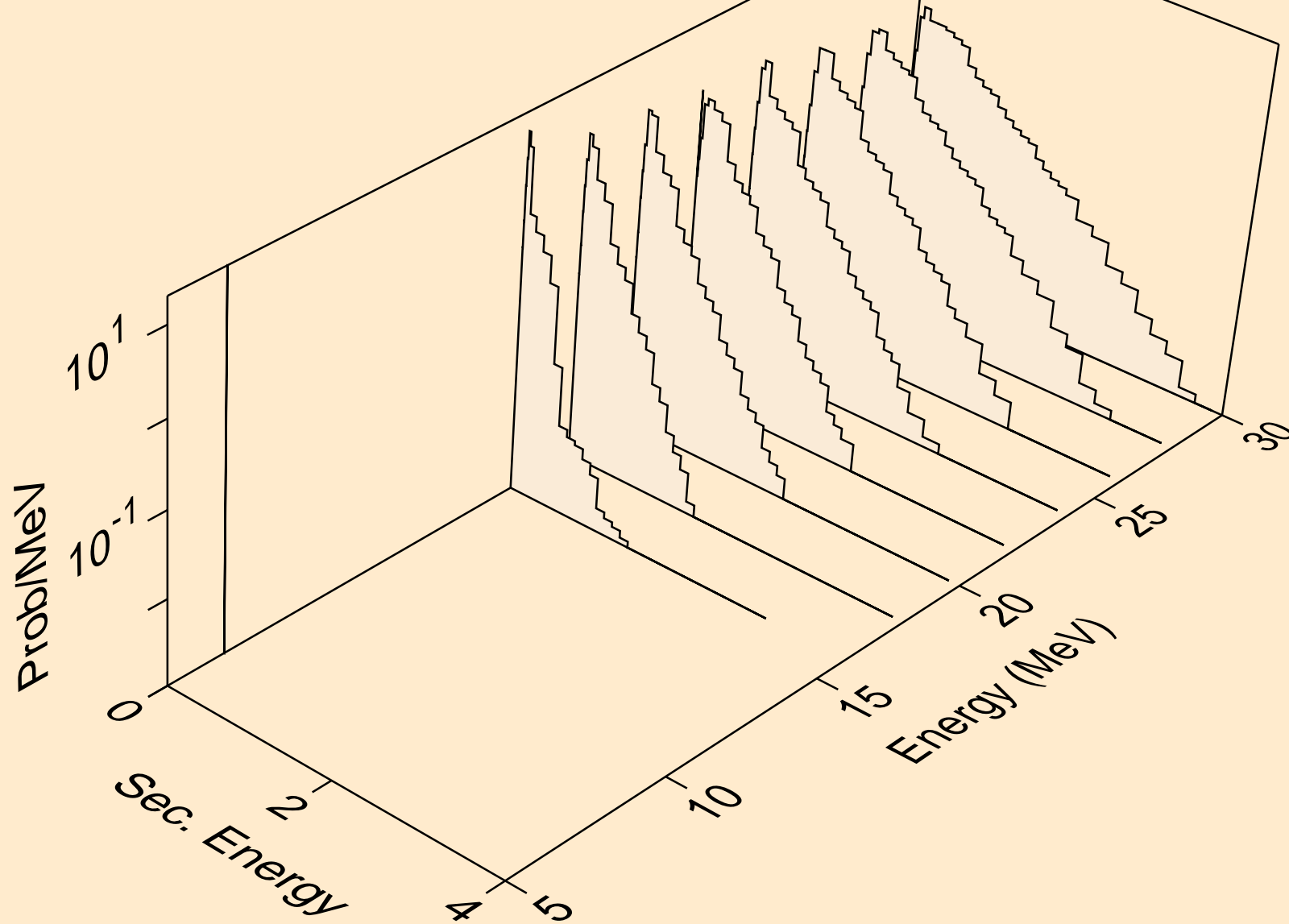

OS198 ALPHA ACER TENDL-2021 LIBRARY; T=0.K
neutrons from (a,2n)a

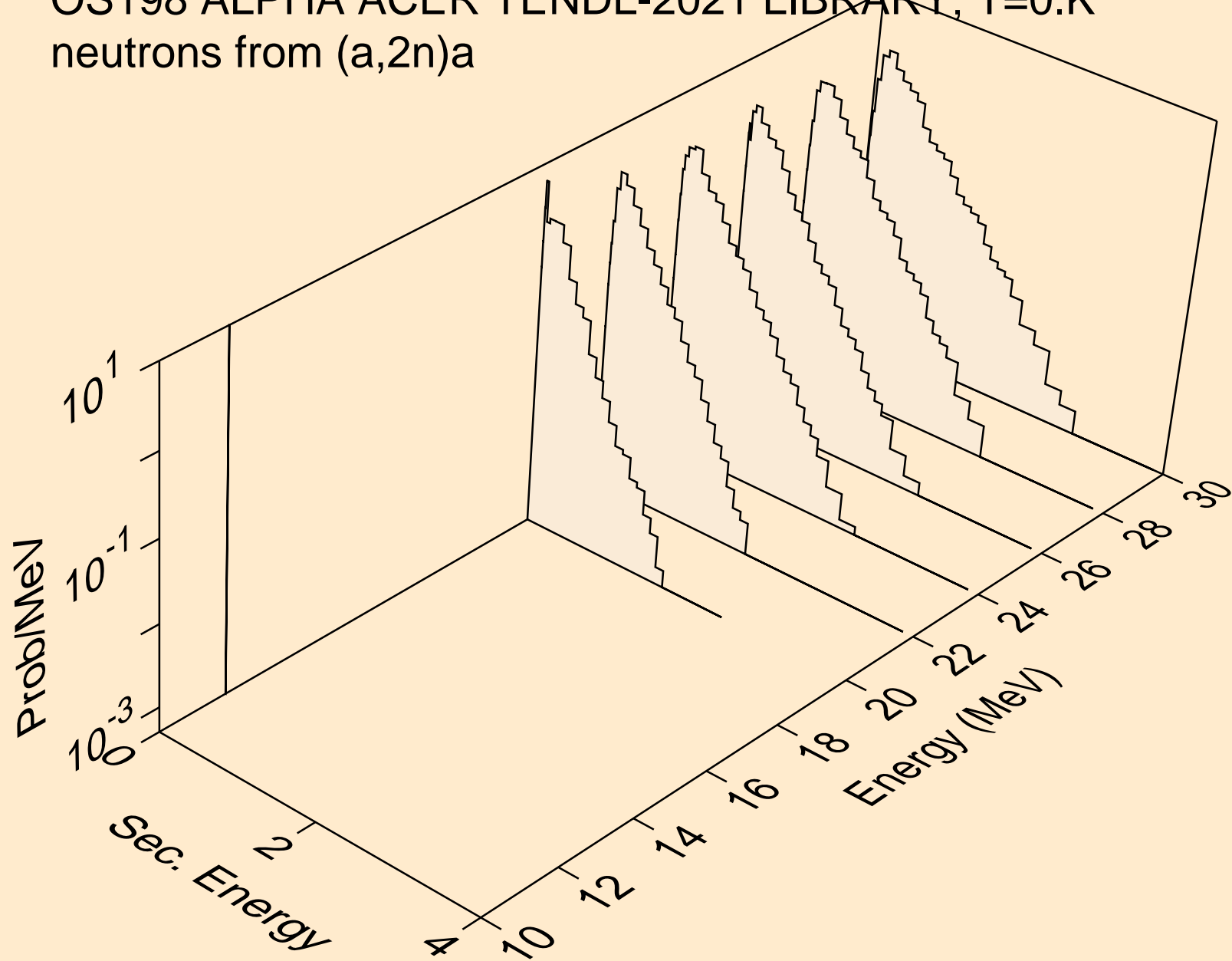

OS198 ALPHA ACER TENDL-2021 LIBRARY; T=0.K
neutrons from (a,n*)p

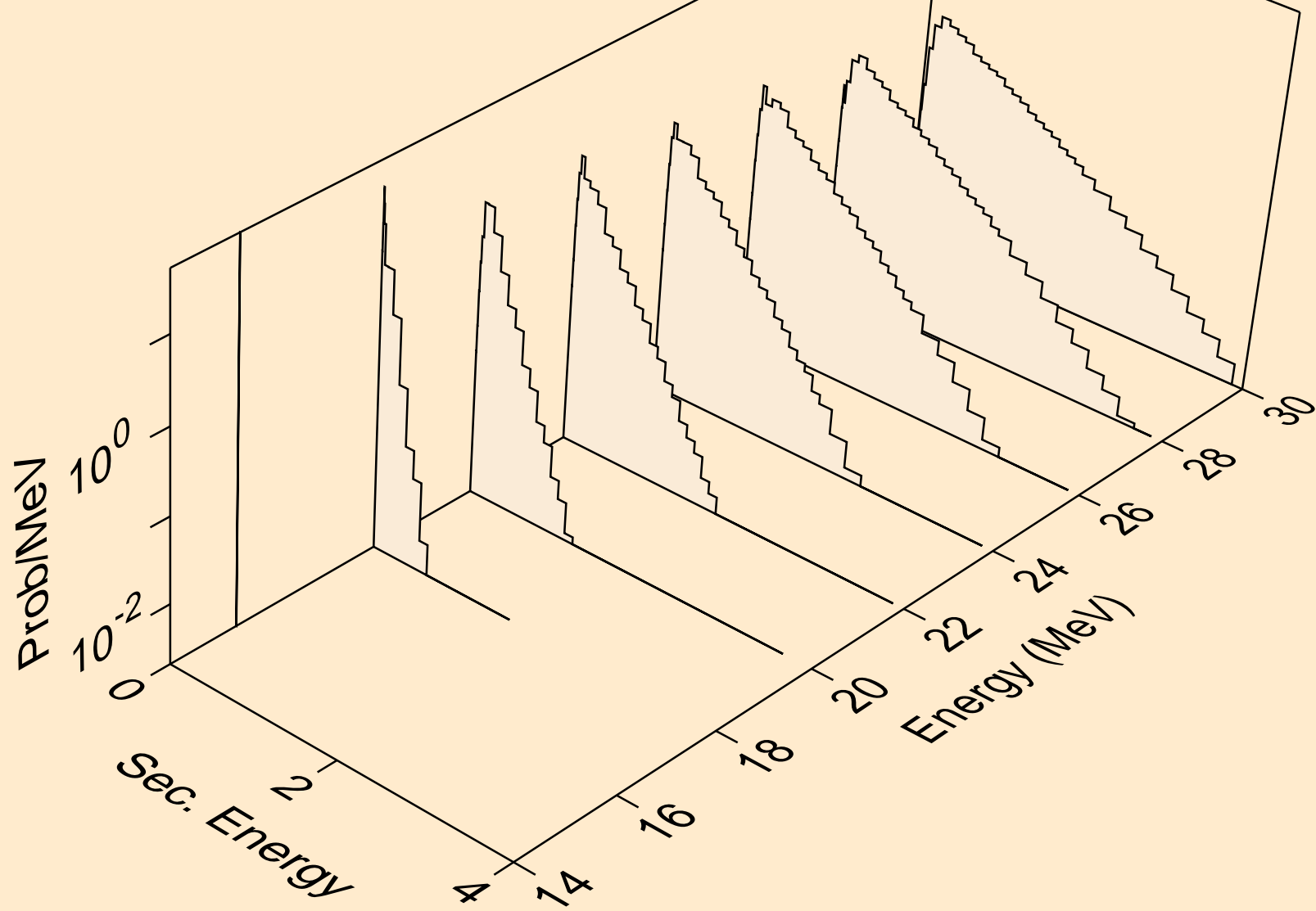

OS198 ALPHA ACER TENDL-2021 LIBRARY; T=0.K
neutrons from (a,n*)d

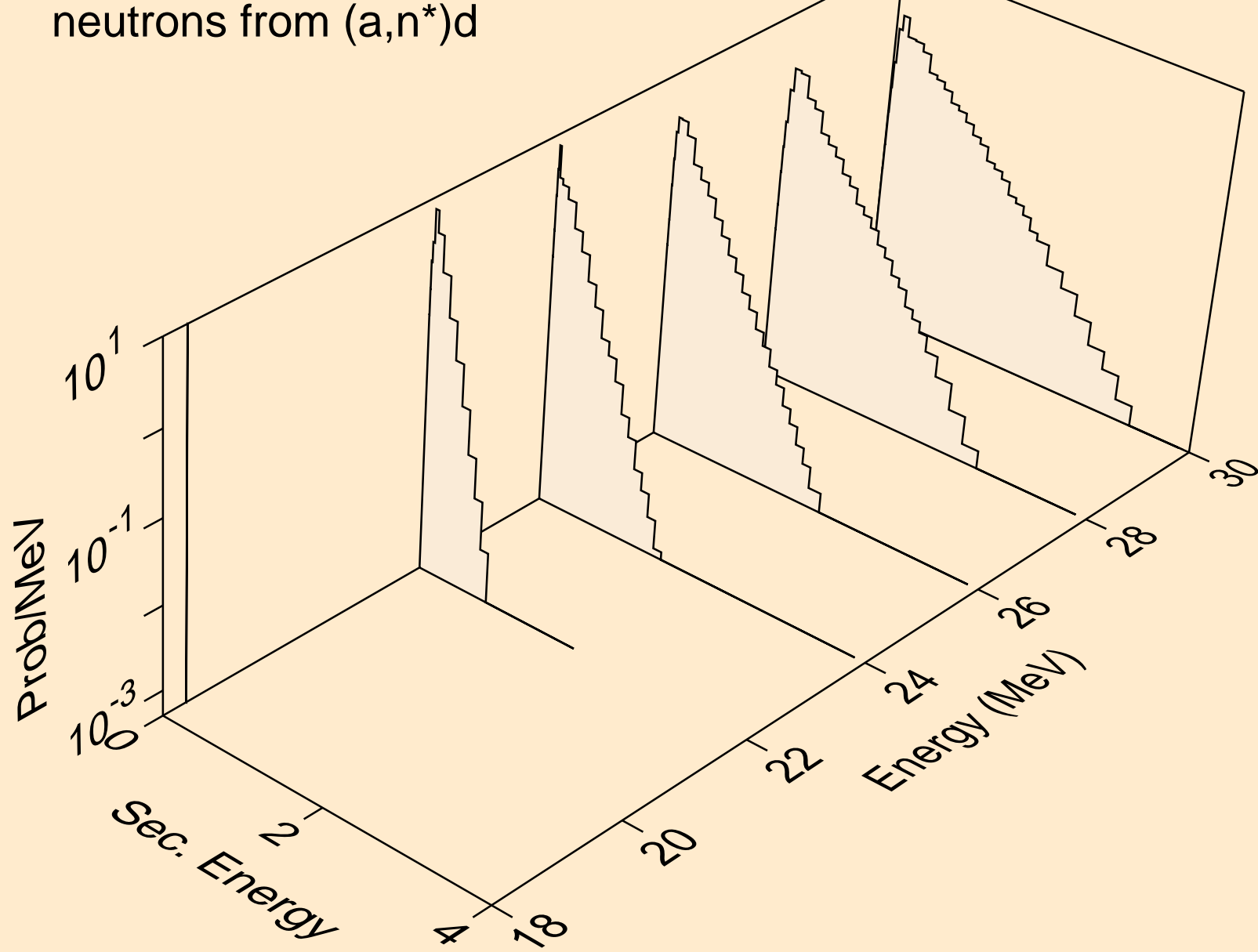

OS198 ALPHA ACER TENDL-2021 LIBRARY; T=0.K
neutrons from (a,n*)t

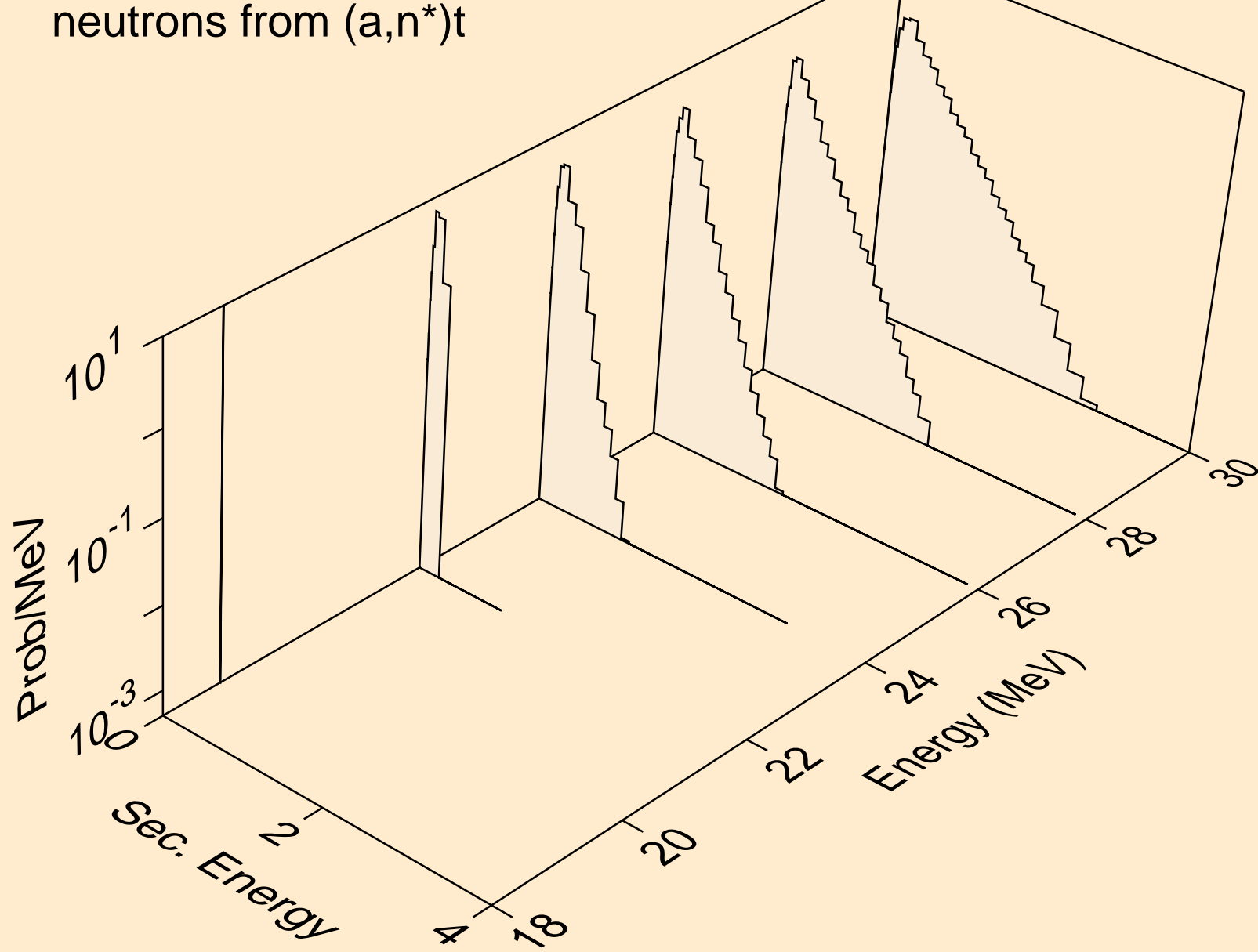

OS198 ALPHA ACER TENDL-2021 LIBRARY; T=0.K
neutrons from (a,4n)

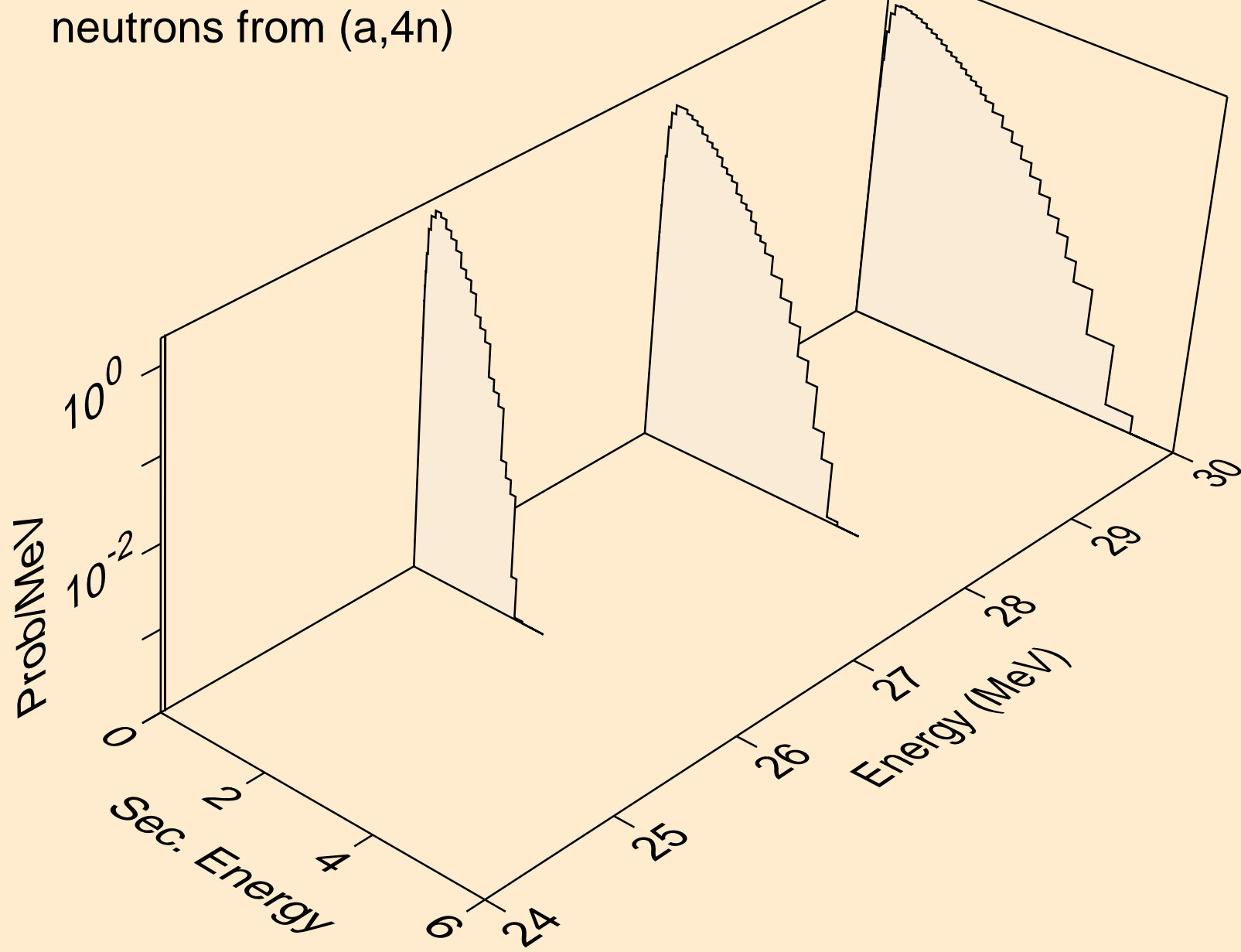

OS198 ALPHA ACER TENDL-2021 LIBRARY; T=0.K
neutrons from (a,2np)

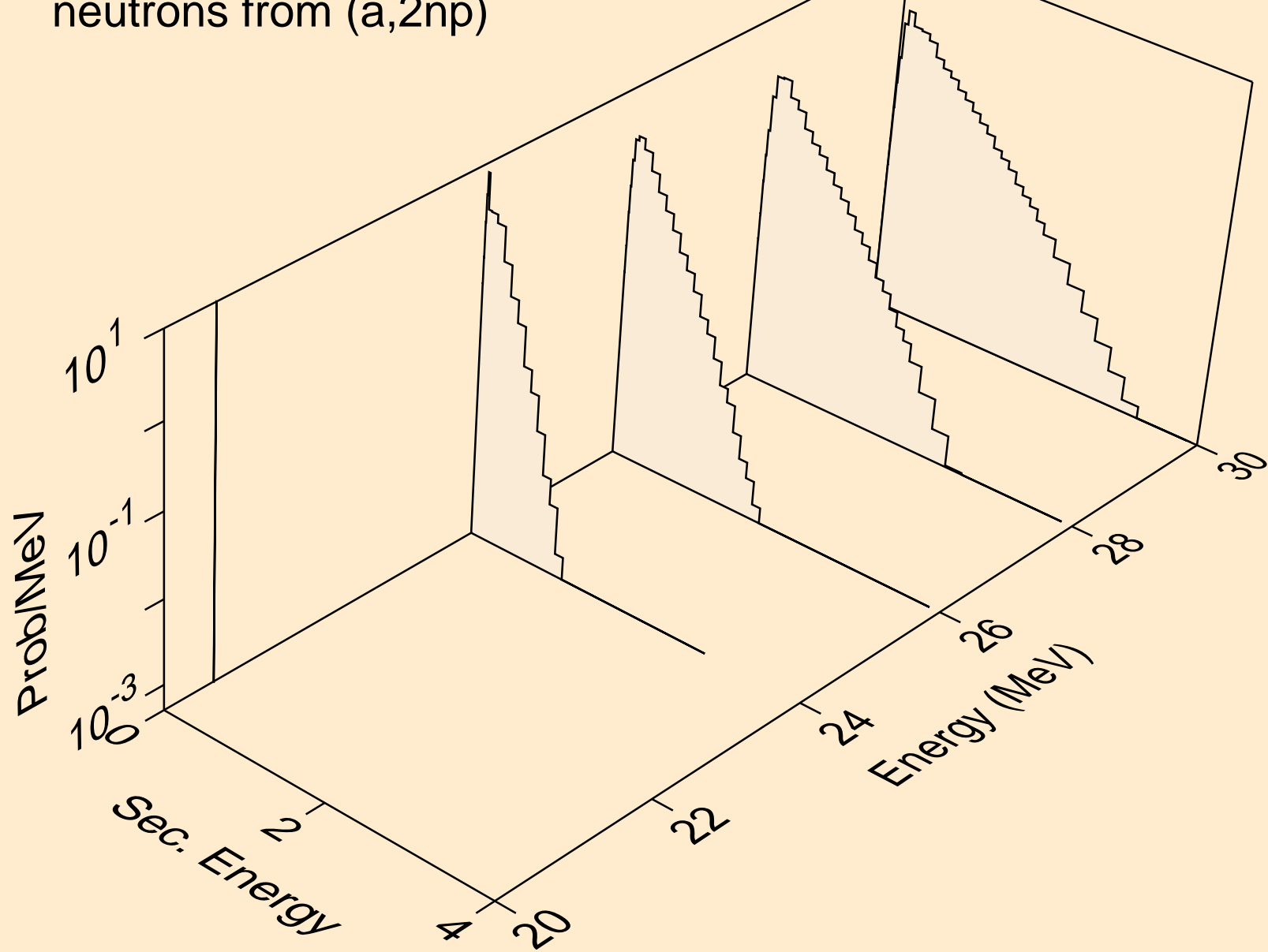

OS198 ALPHA ACER TENDL-2021 LIBRARY; T=0.K
protons from (a,x)

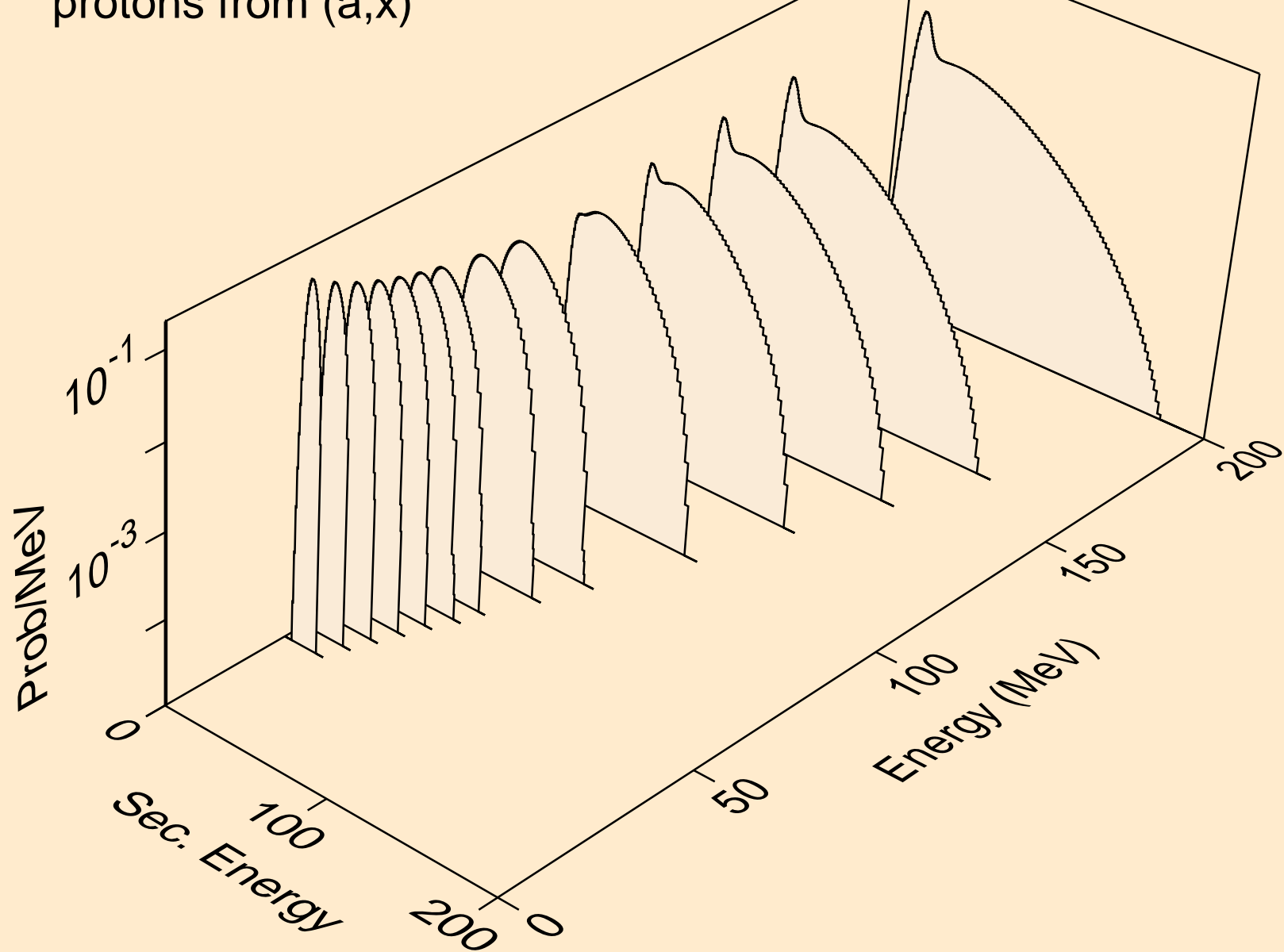

OS198 ALPHA ACER TENDL-2021 LIBRARY; T=0.K
protons from (a,n*)p

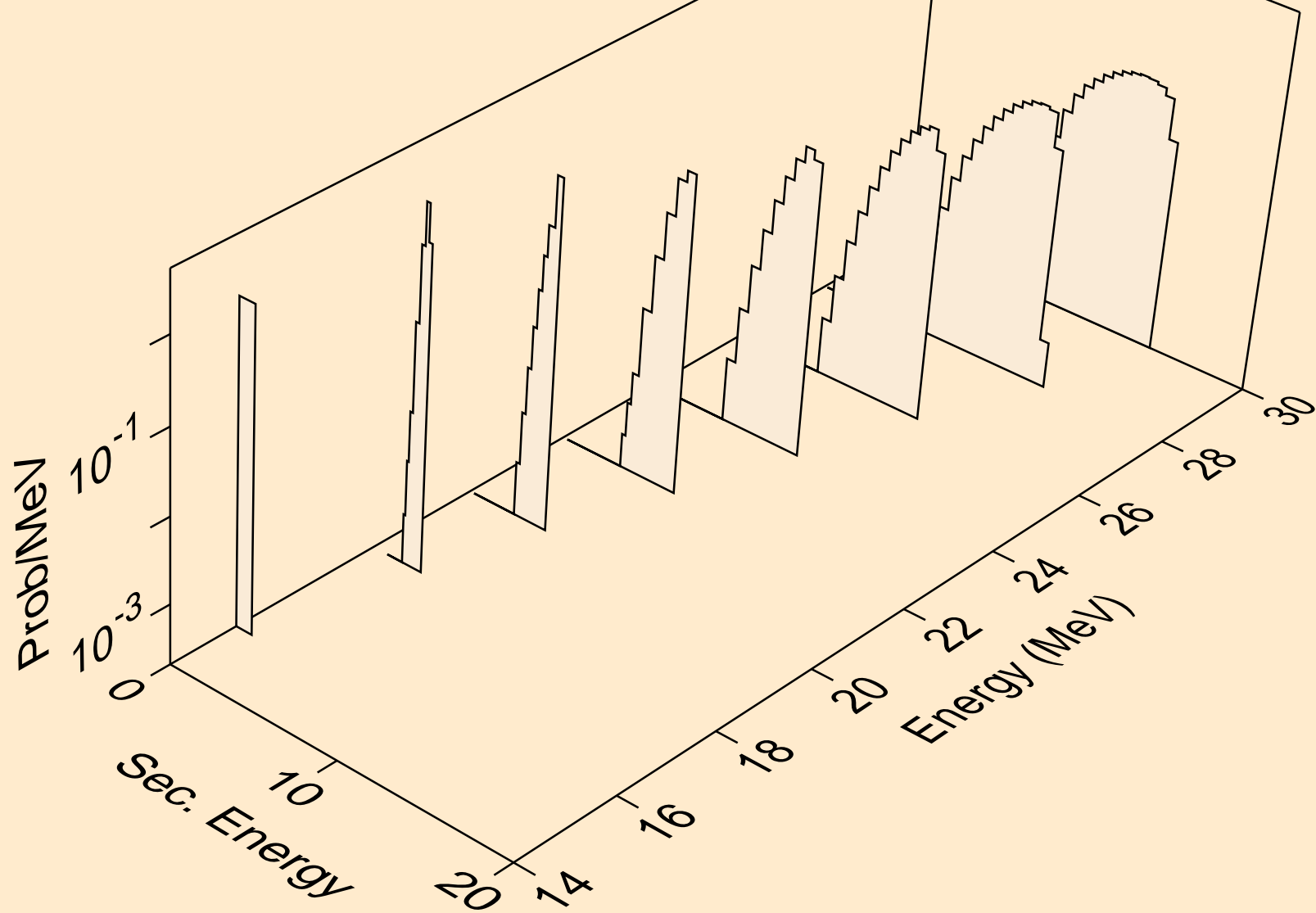

OS198 ALPHA ACER TENDL-2021 LIBRARY; T=0.K
protons from (a,2np)

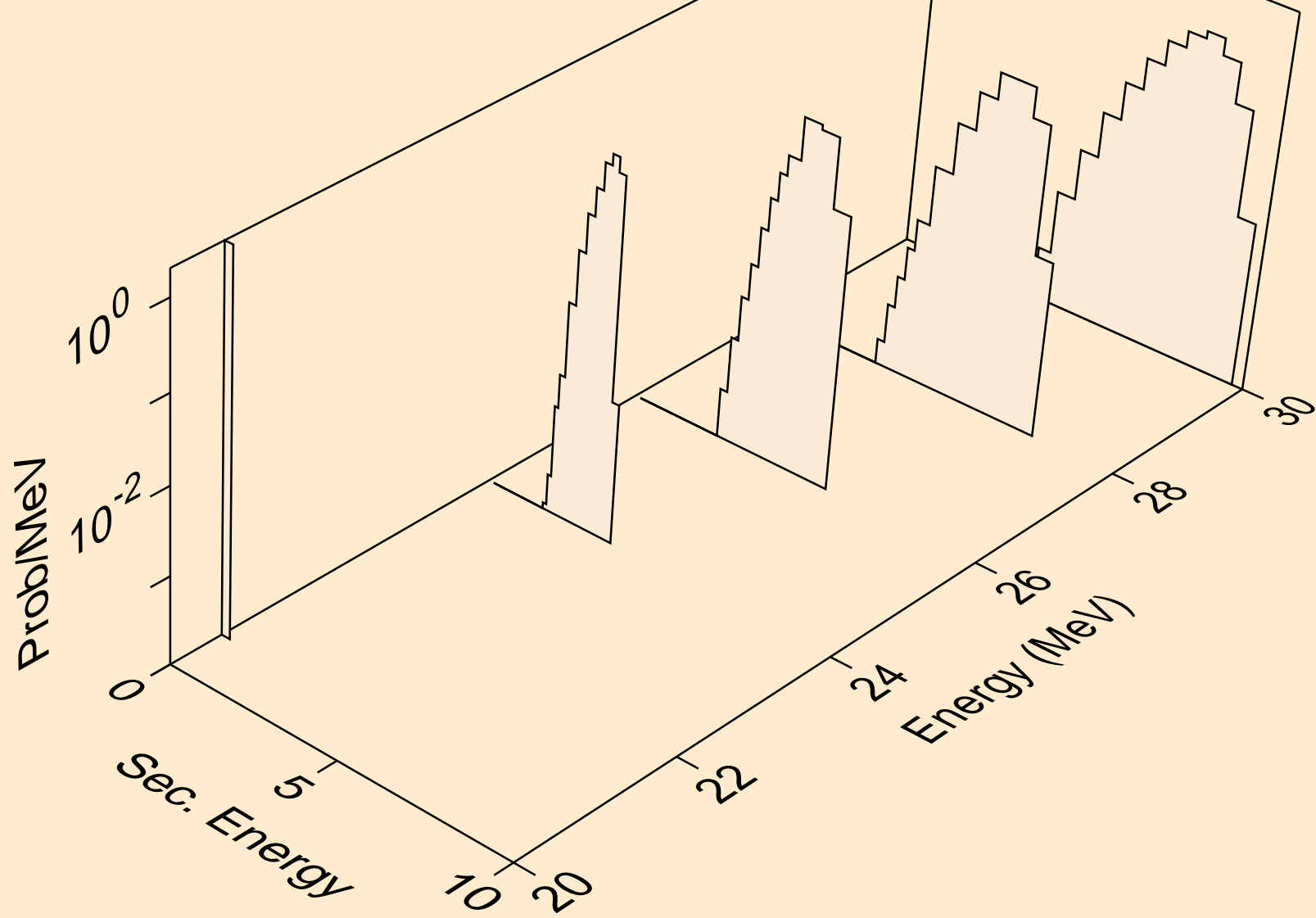

OS198 ALPHA ACER TENDL-2021 LIBRARY; T=0.K
protons from (a,p)

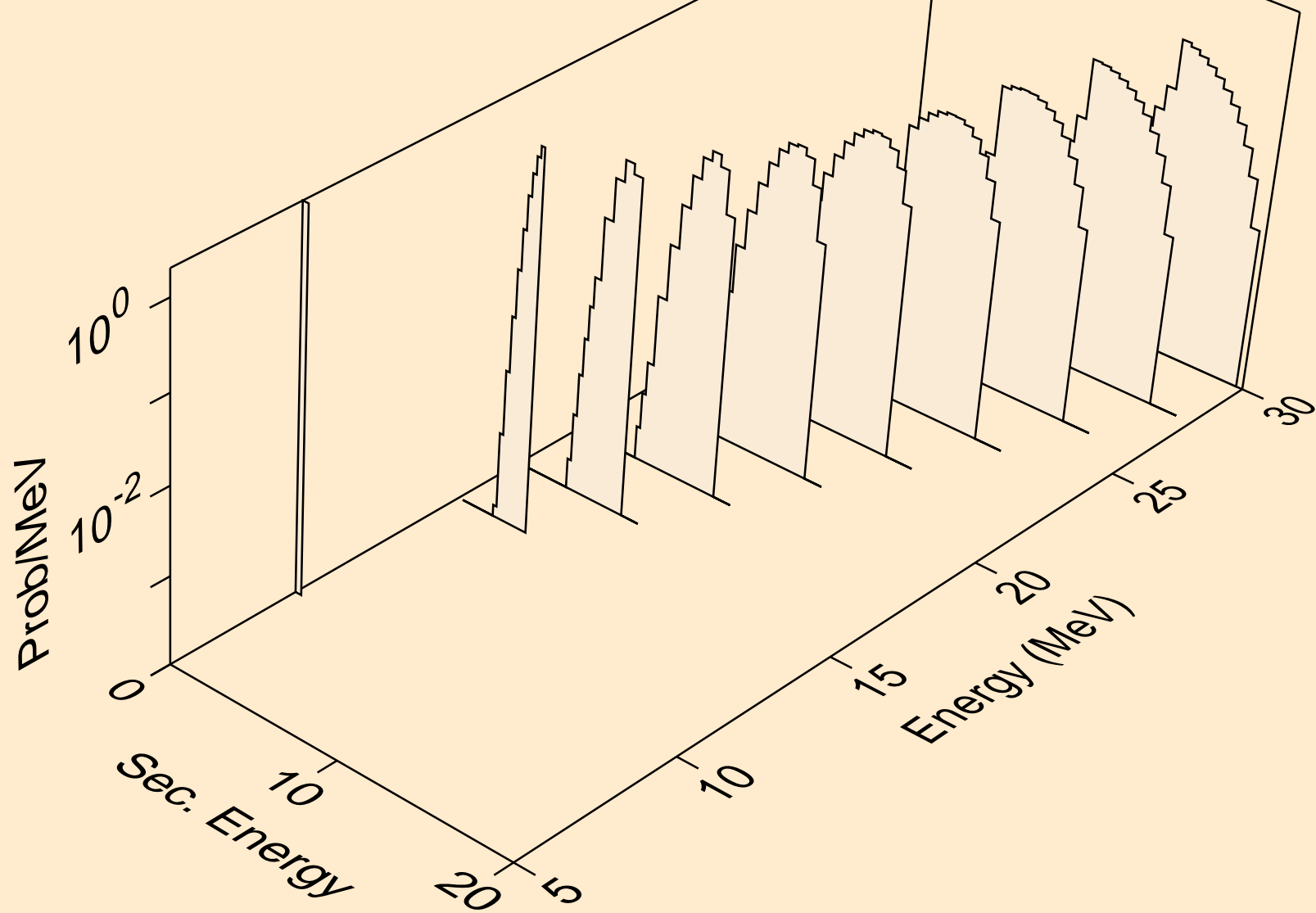

OS198 ALPHA ACER TENDL-2021 LIBRARY; T=0.K
deuterons from (a,x)

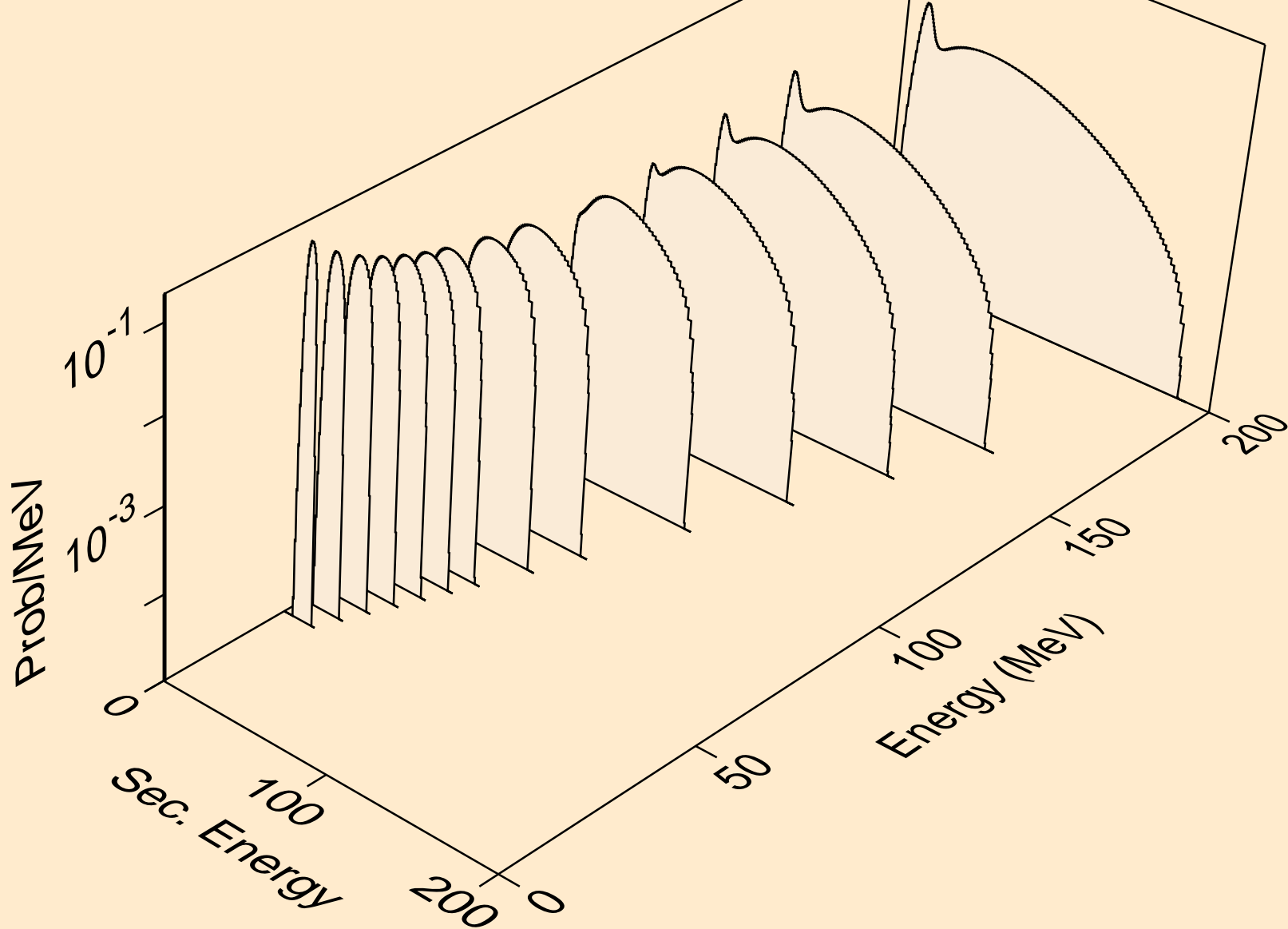

OS198 ALPHA ACER TENDL-2021 LIBRARY; T=0.K
deuterons from (a,n*)d

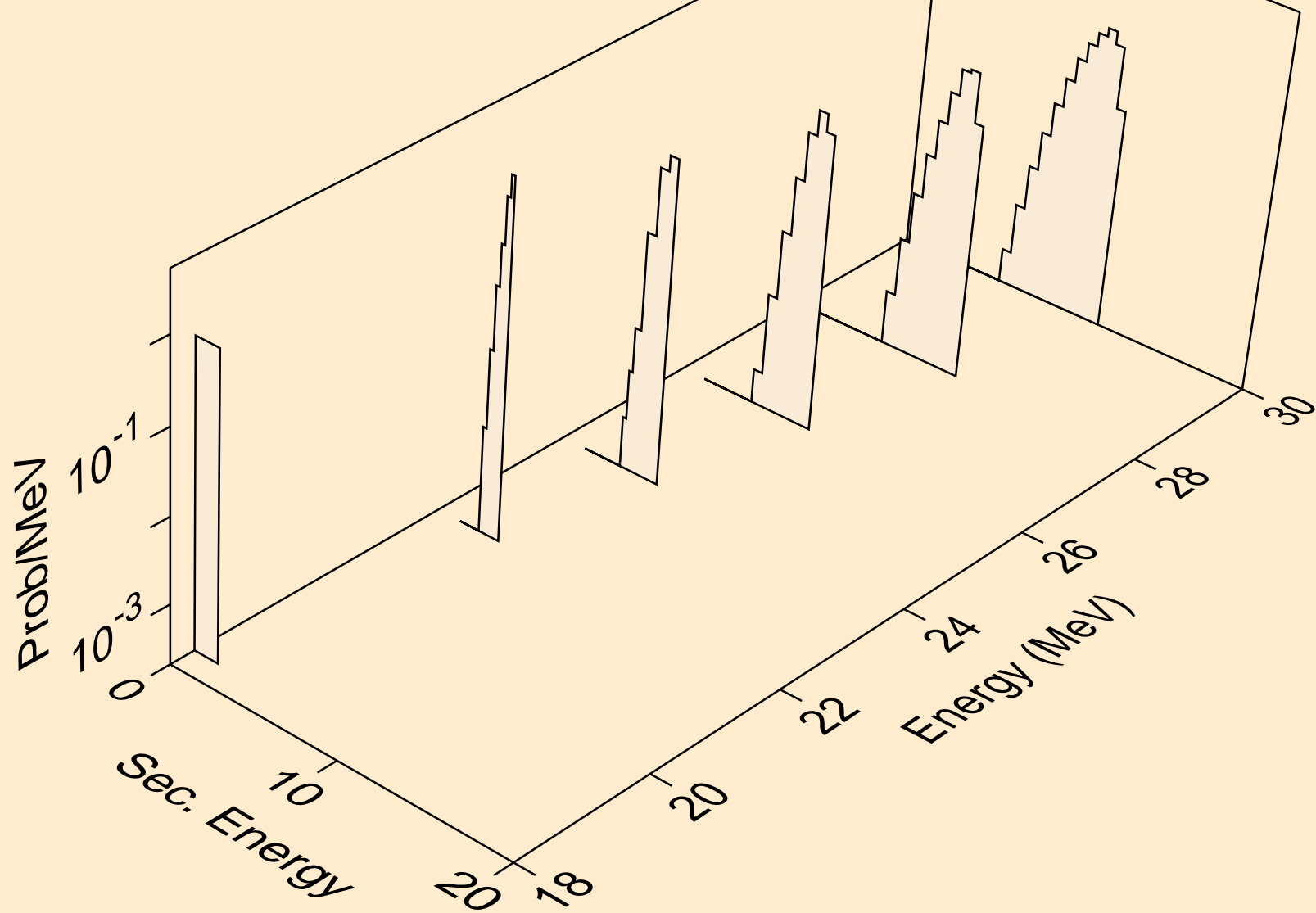

OS198 ALPHA ACER TENDL-2021 LIBRARY; T=0.K
deuterons from (a,d)

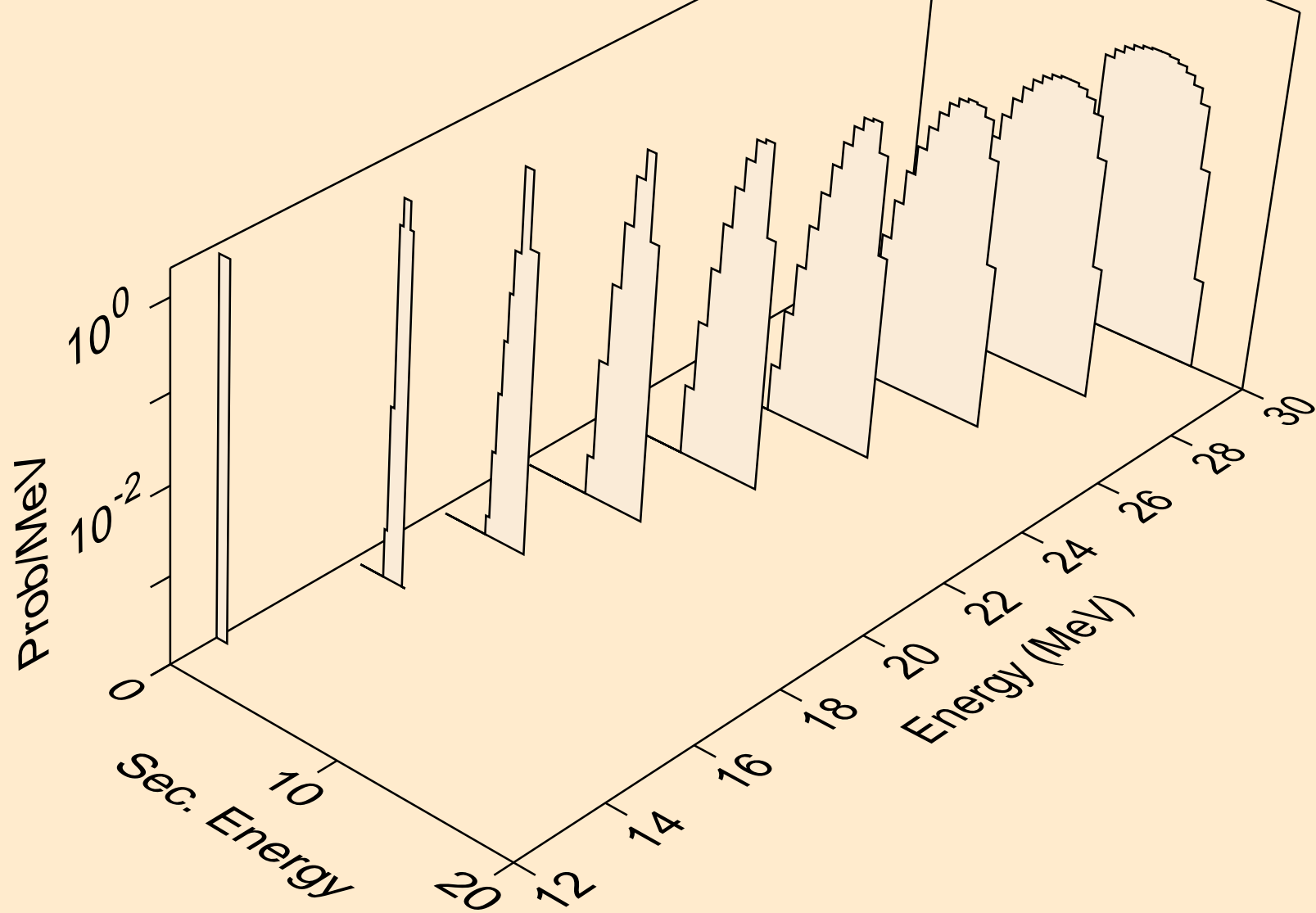

OS198 ALPHA ACER TENDL-2021 LIBRARY; T=0.K
tritons from (a,x)

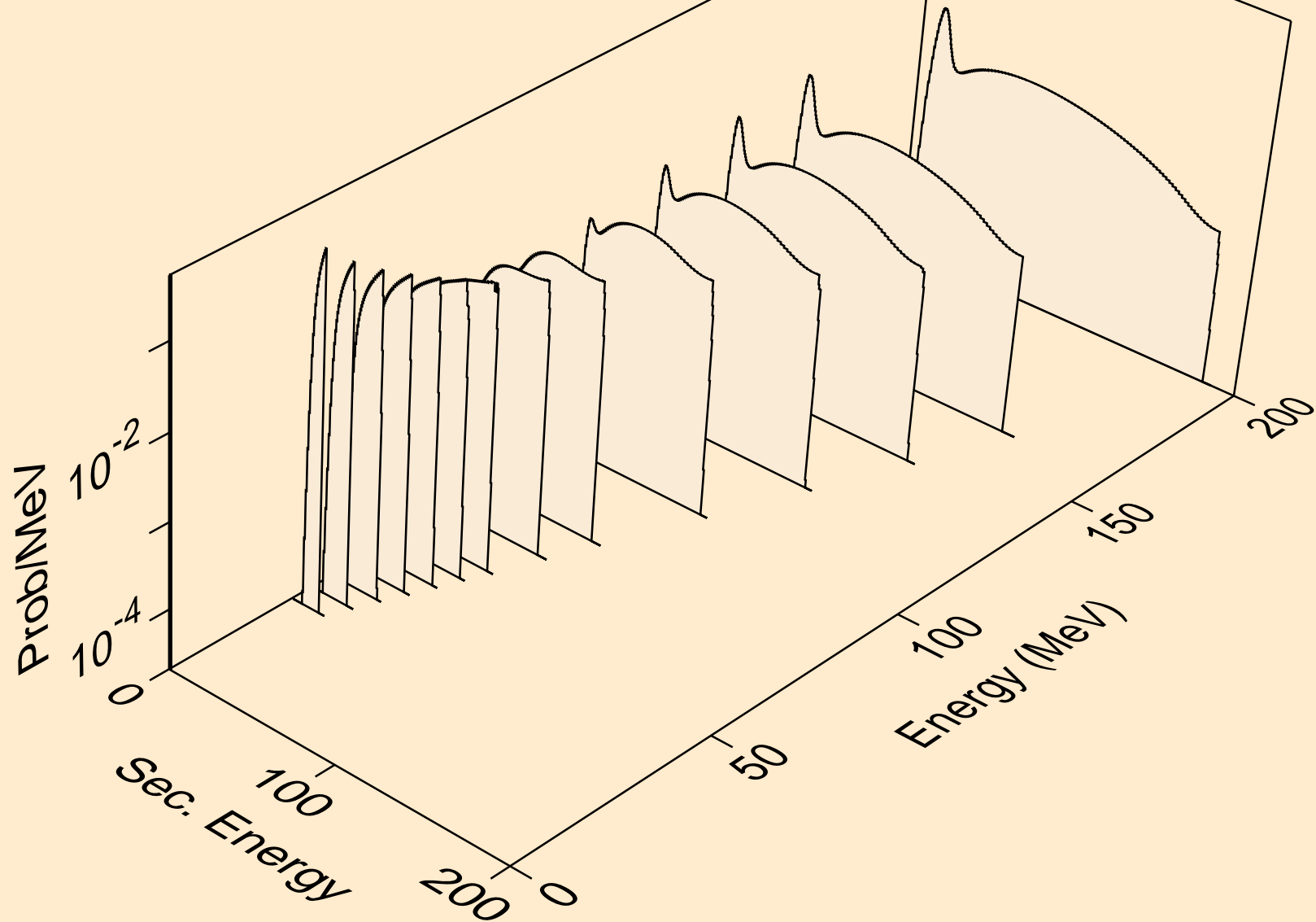

OS198 ALPHA ACER TENDL-2021 LIBRARY; T=0.K
tritons from (a,n*)t

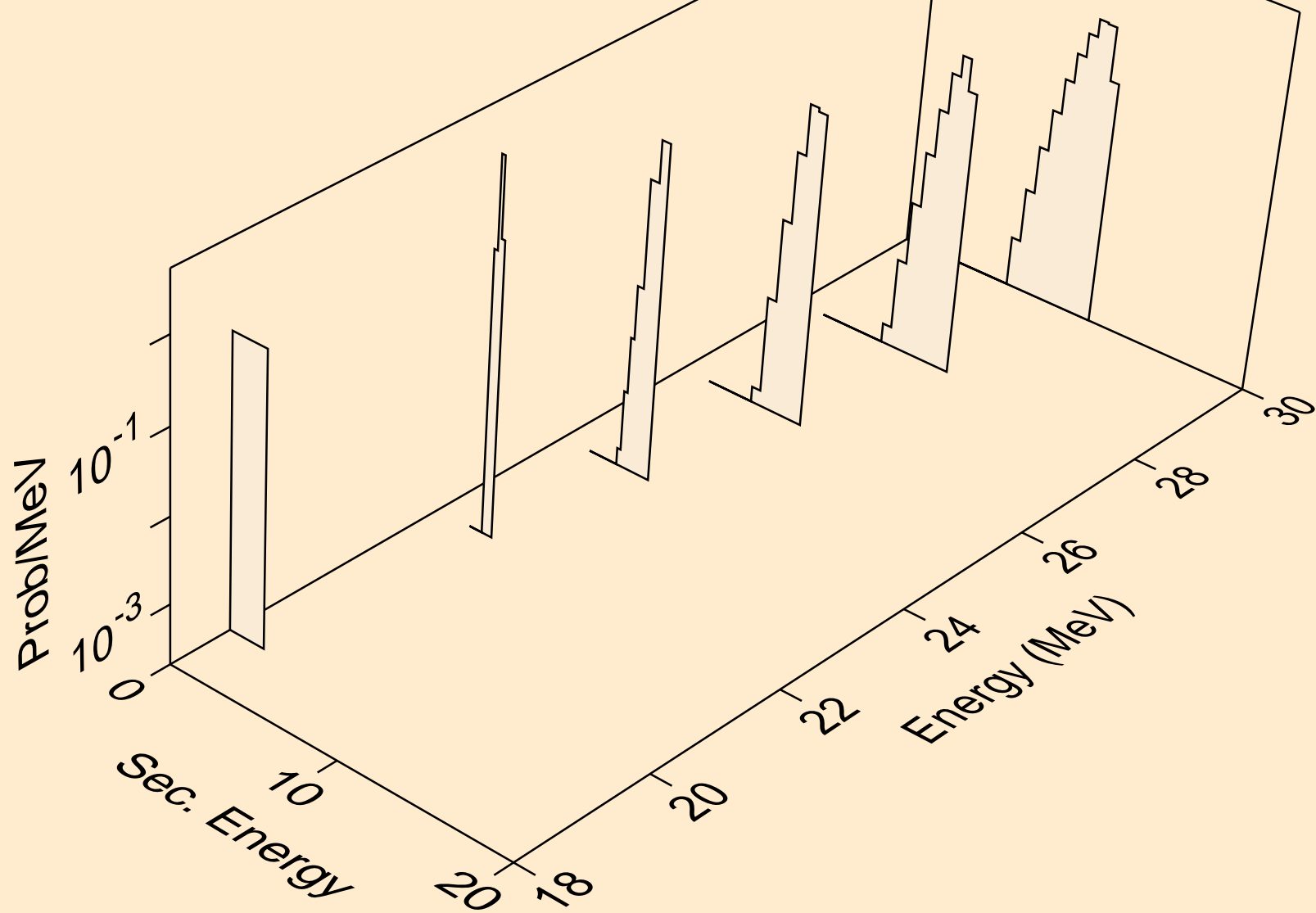

OS198 ALPHA ACER TENDL-2021 LIBRARY; T=0.K
tritons from (a,t)

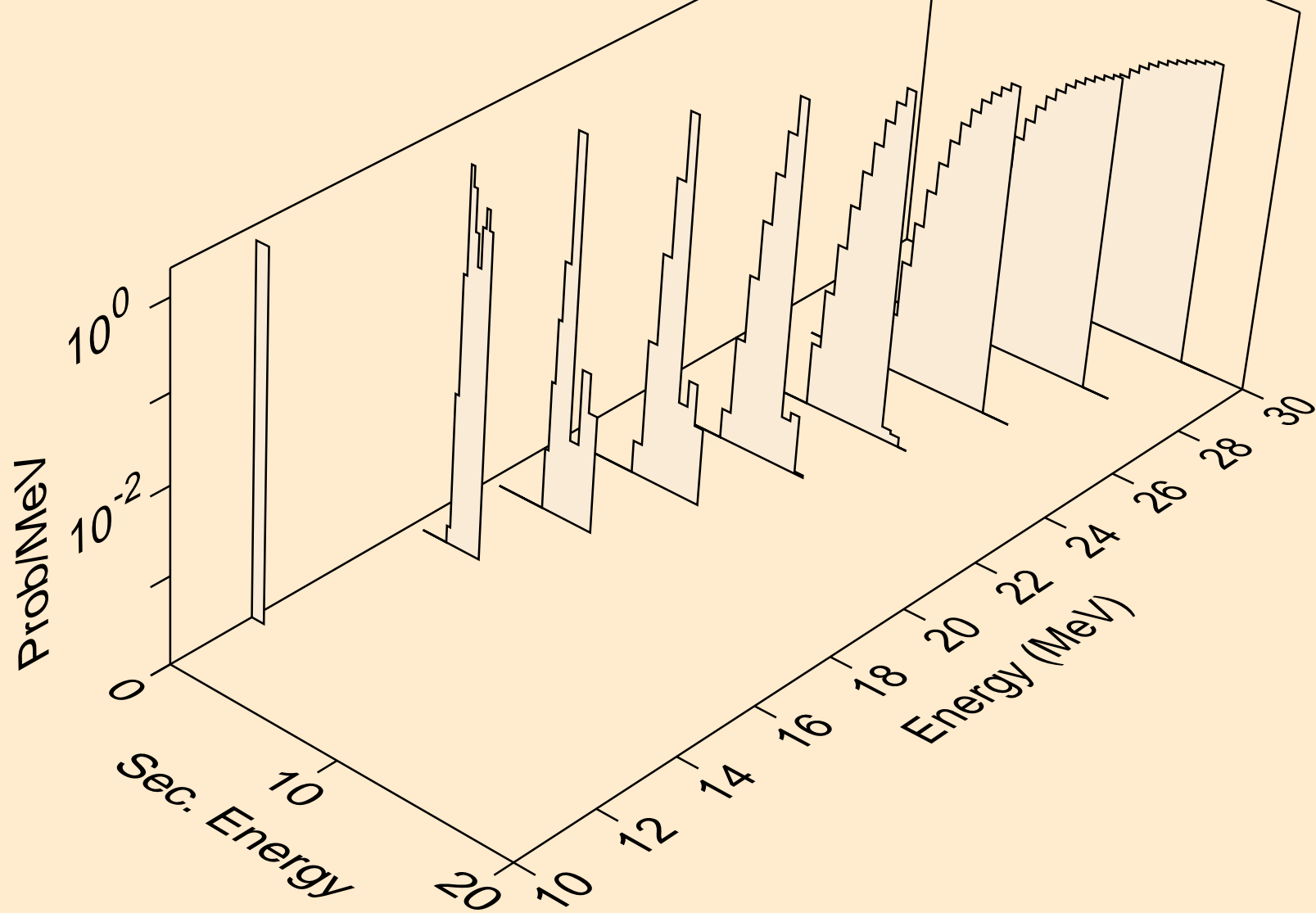

OS198 ALPHA ACER TENDL-2021 LIBRARY; T=0.K
he3s from (a,x)

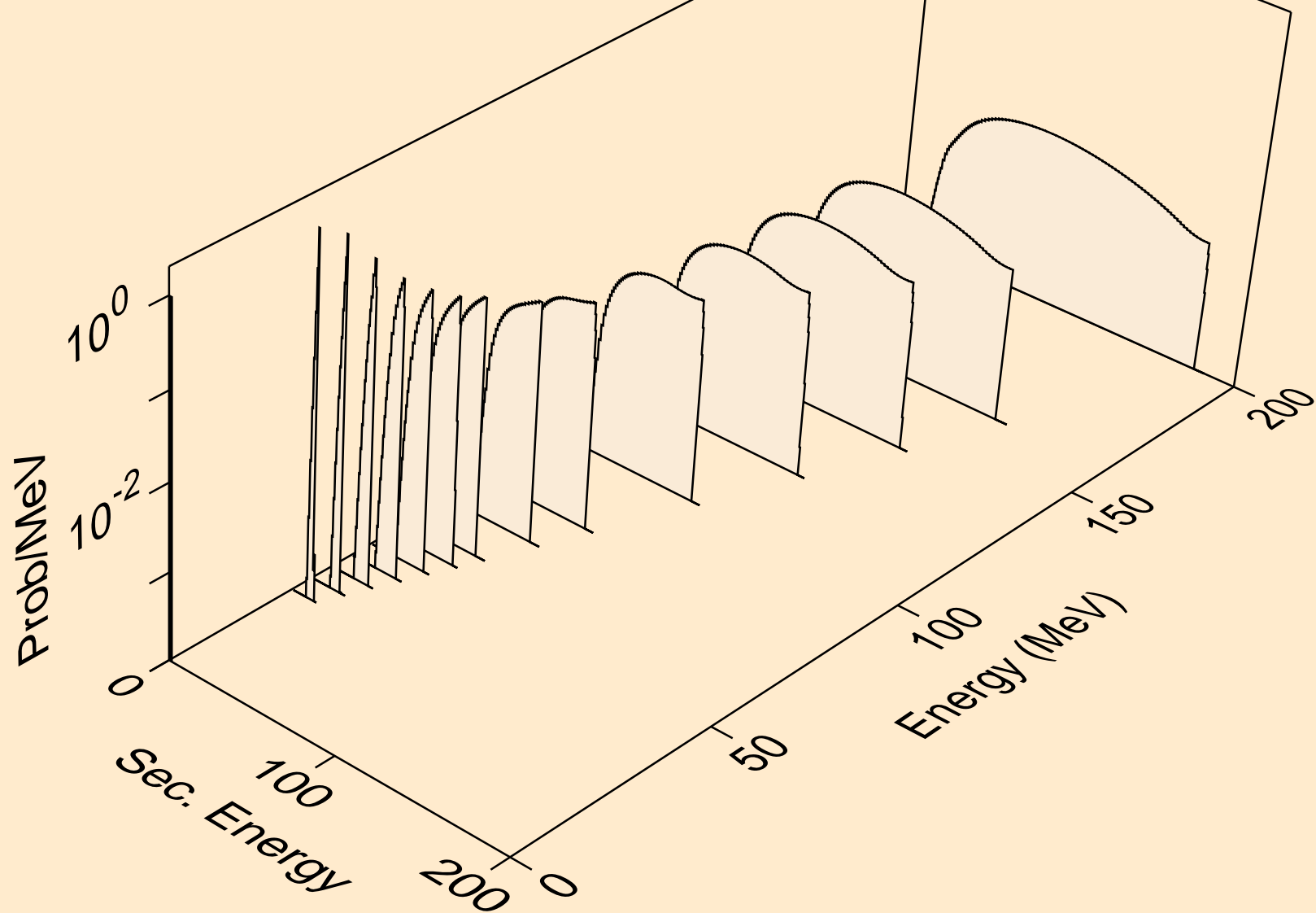

OS198 ALPHA ACER TENDL-2021 LIBRARY; T=0.K
he3s from (a,he3)

