

PA233 ALPHA ACER TENDL-2021 LIBRARY; T=0.K
Principal cross sections

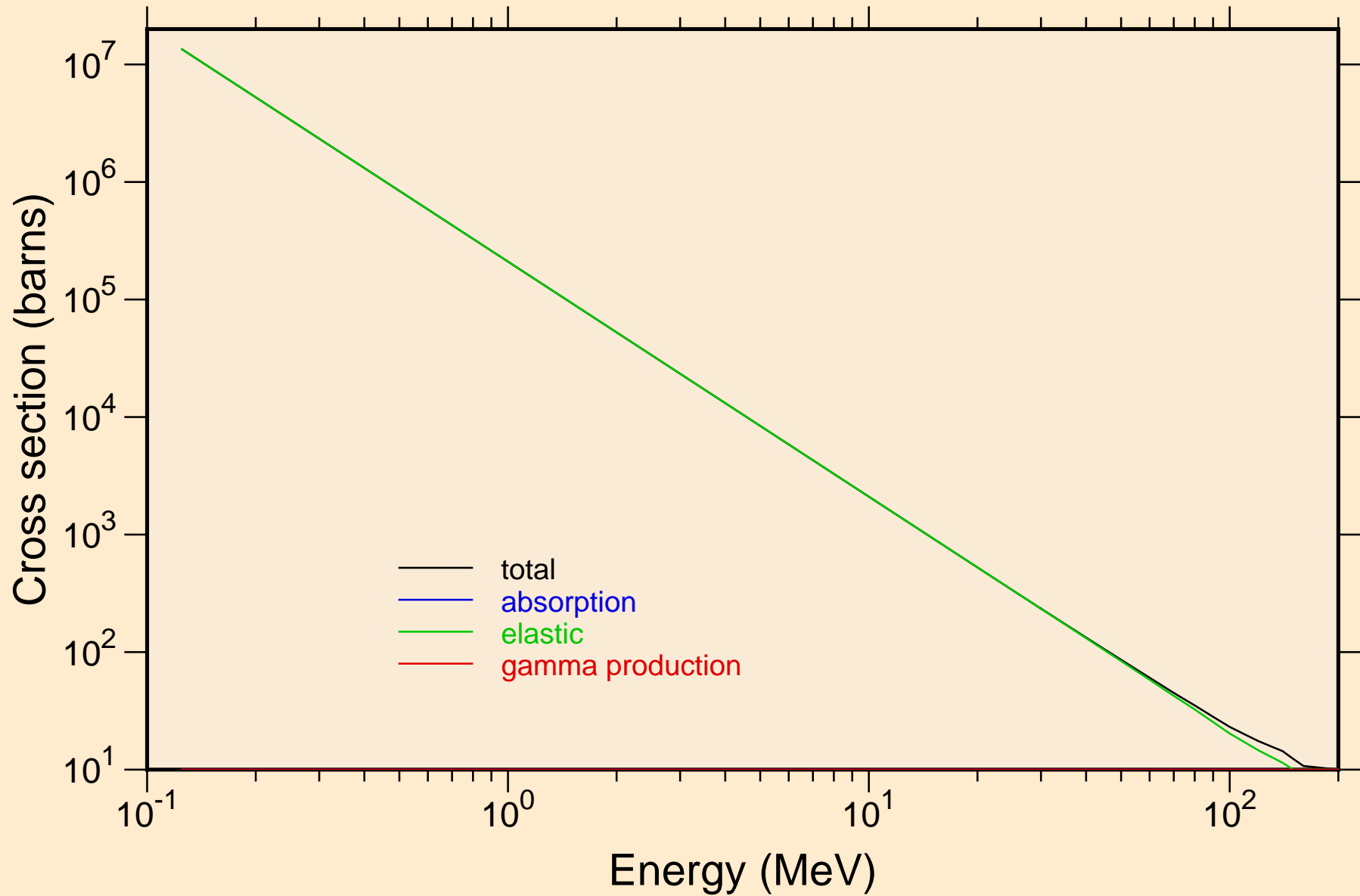

PA233 ALPHA ACER TENDL-2021 LIBRARY; T=0.K
Heating

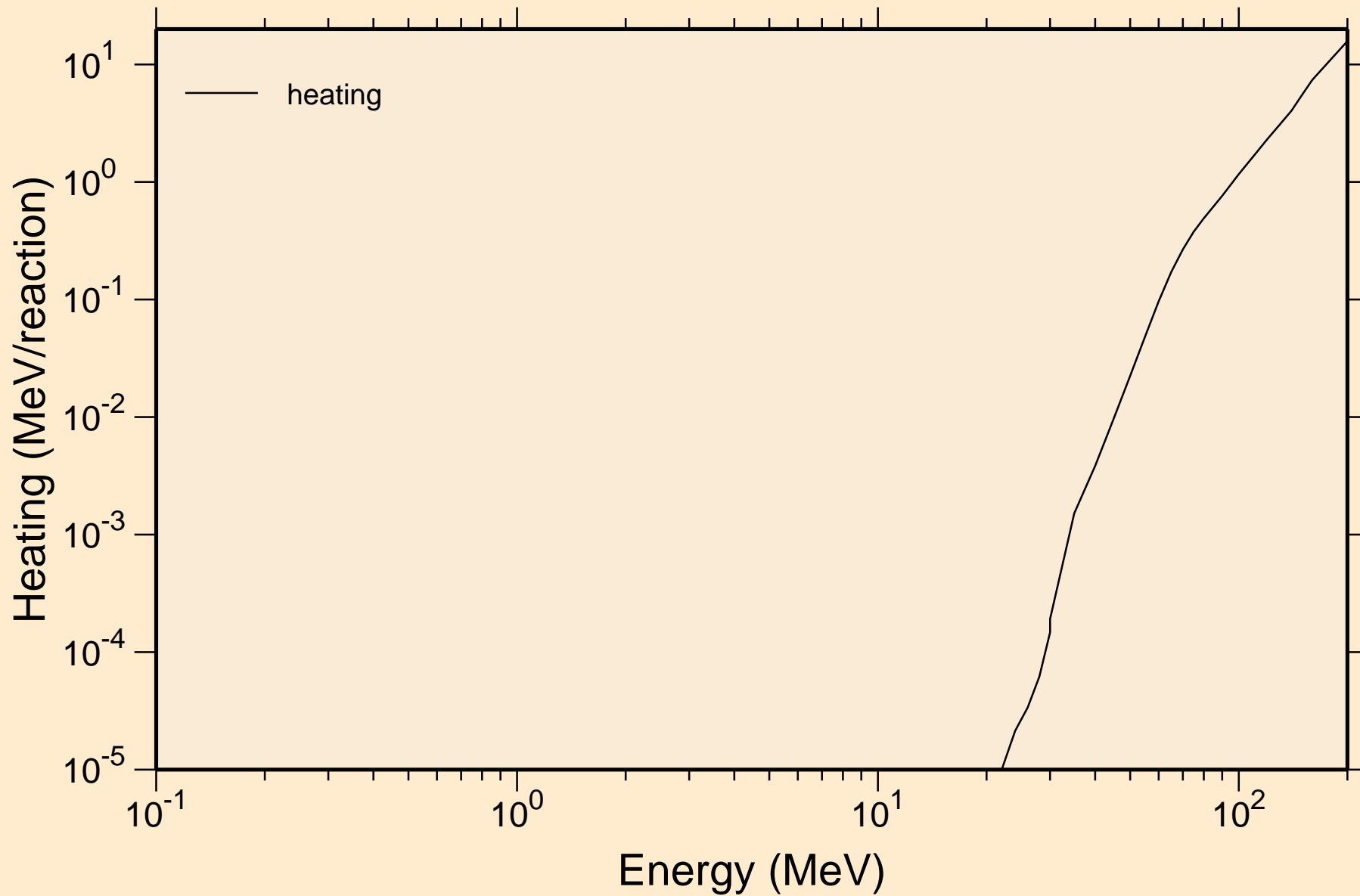

PA233 ALPHA ACER TENDL-2021 LIBRARY; T=0.K

Principal cross sections

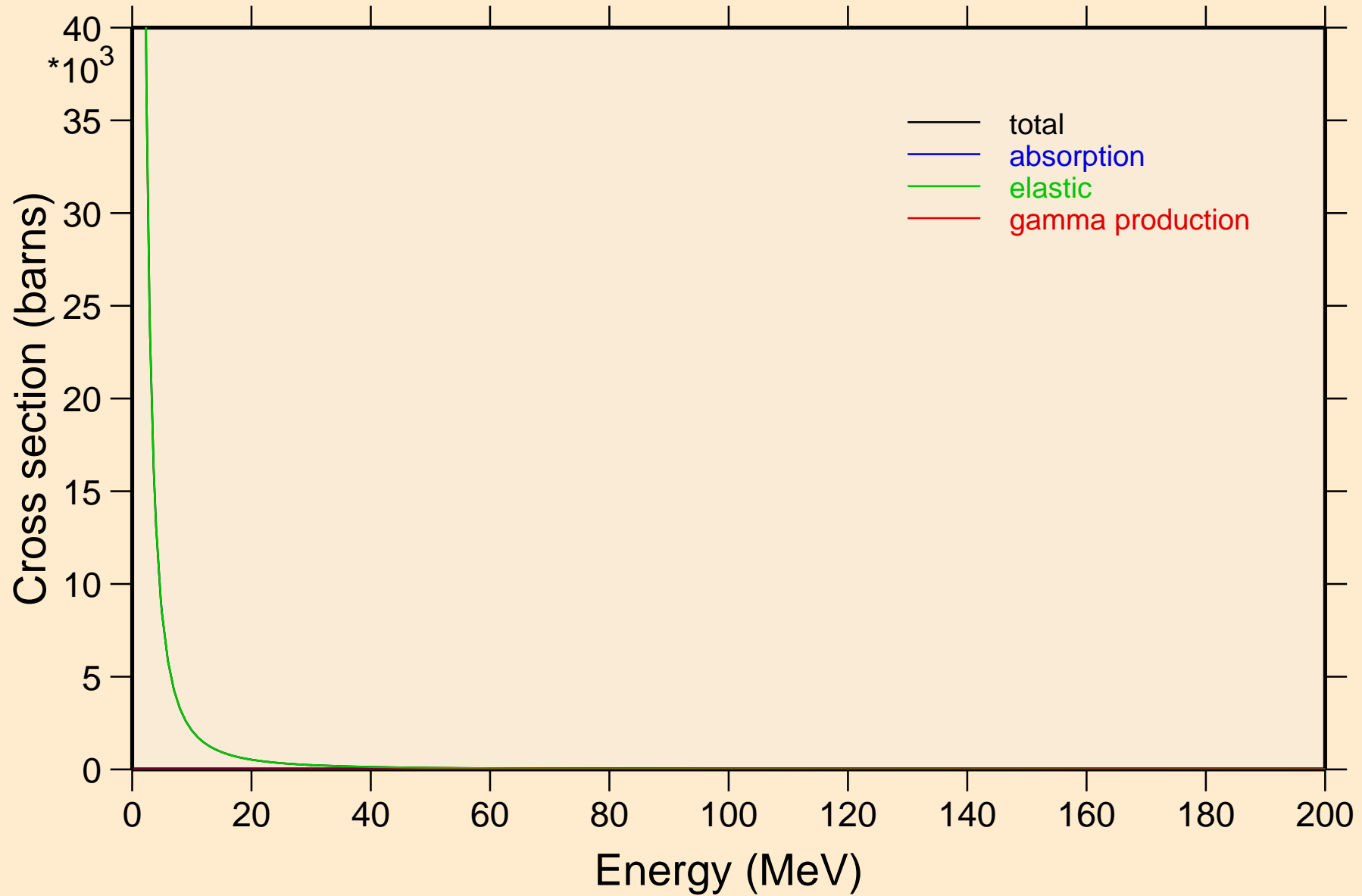

PA233 ALPHA ACER TENDL-2021 LIBRARY; T=0.K

Heating

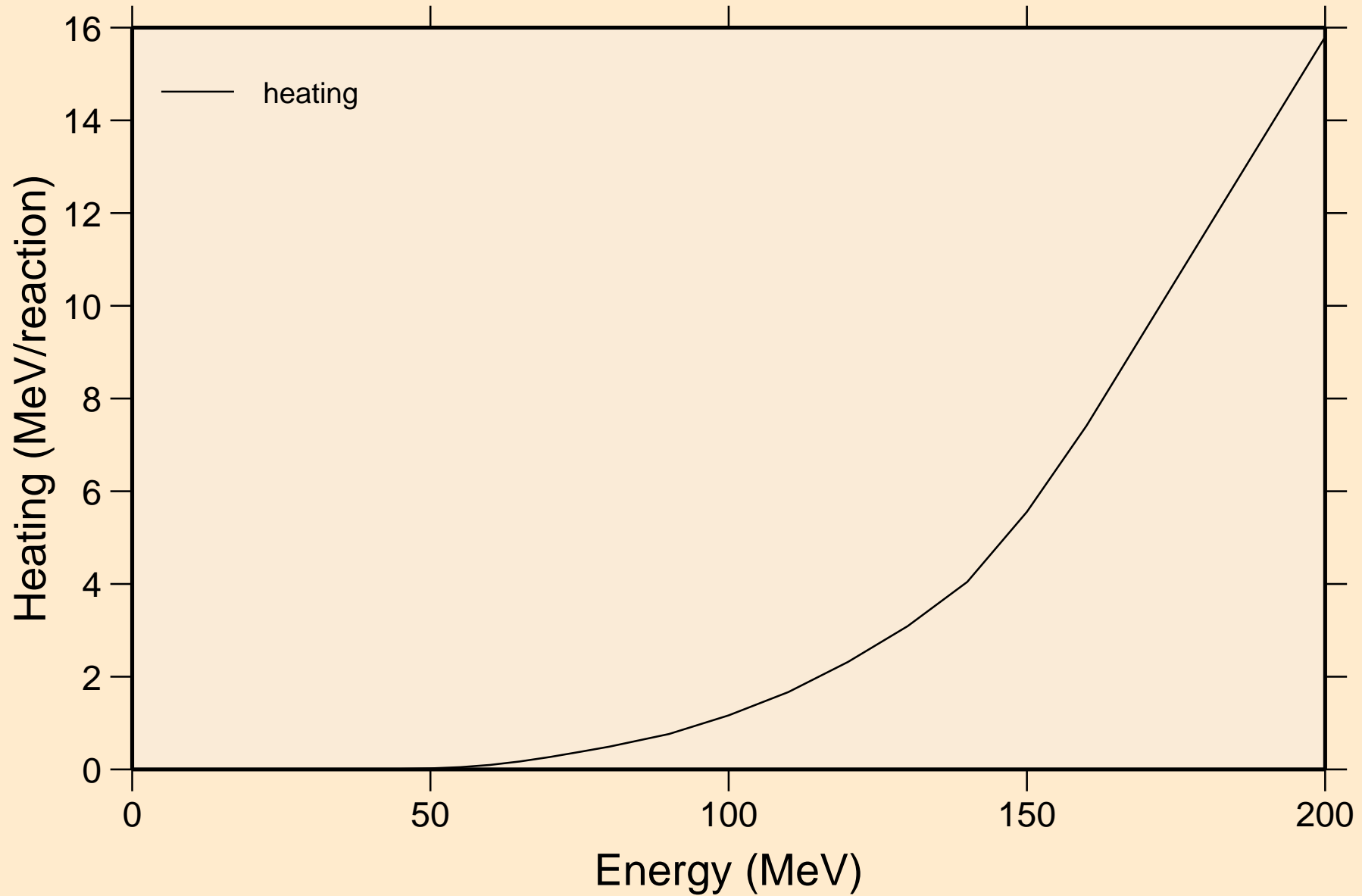

PA233 ALPHA ACER TENDL-2021 LIBRARY; T=0.K
Threshold reactions

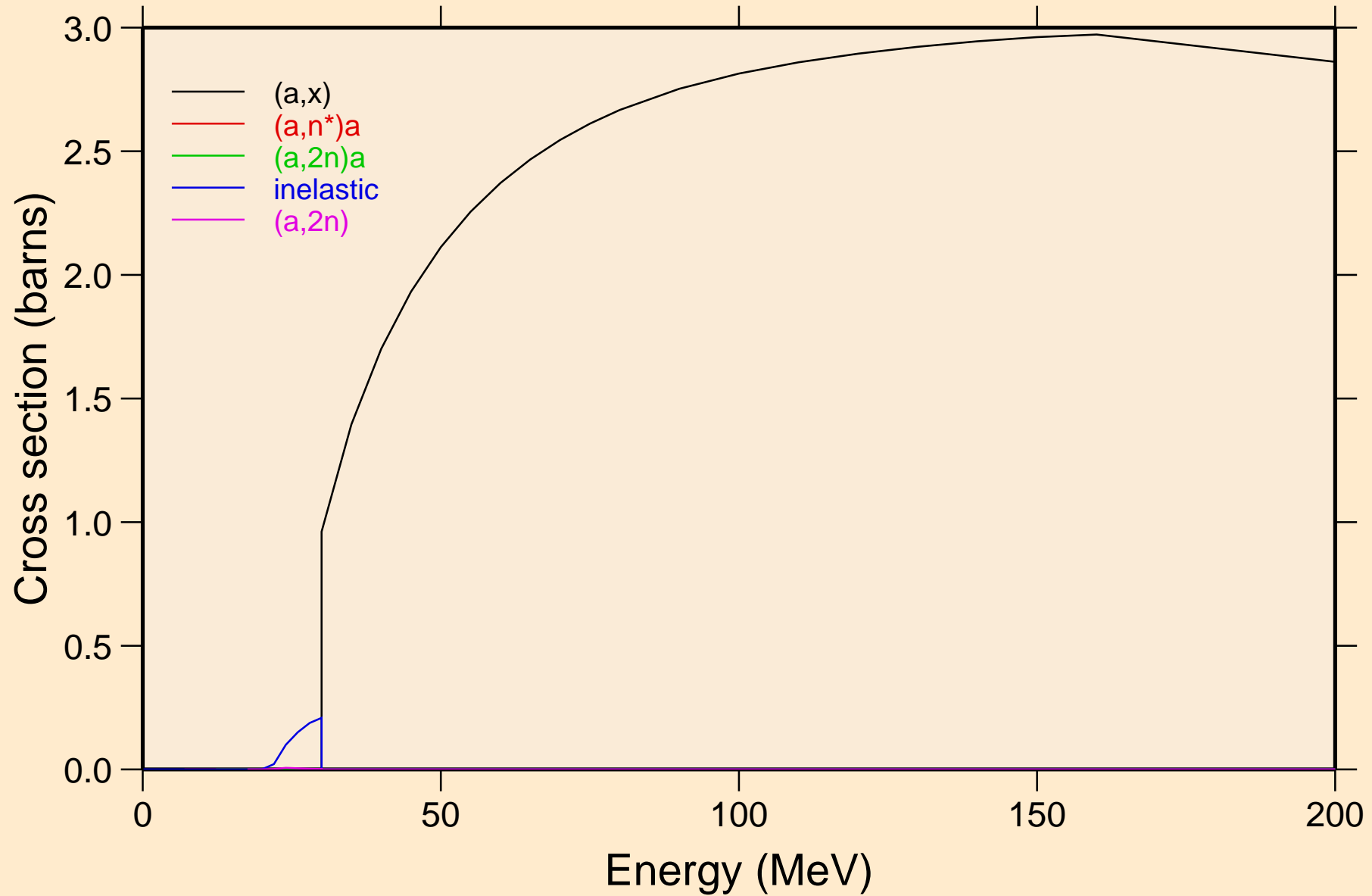

PA233 ALPHA ACER TENDL-2021 LIBRARY; T=0.K
Threshold reactions

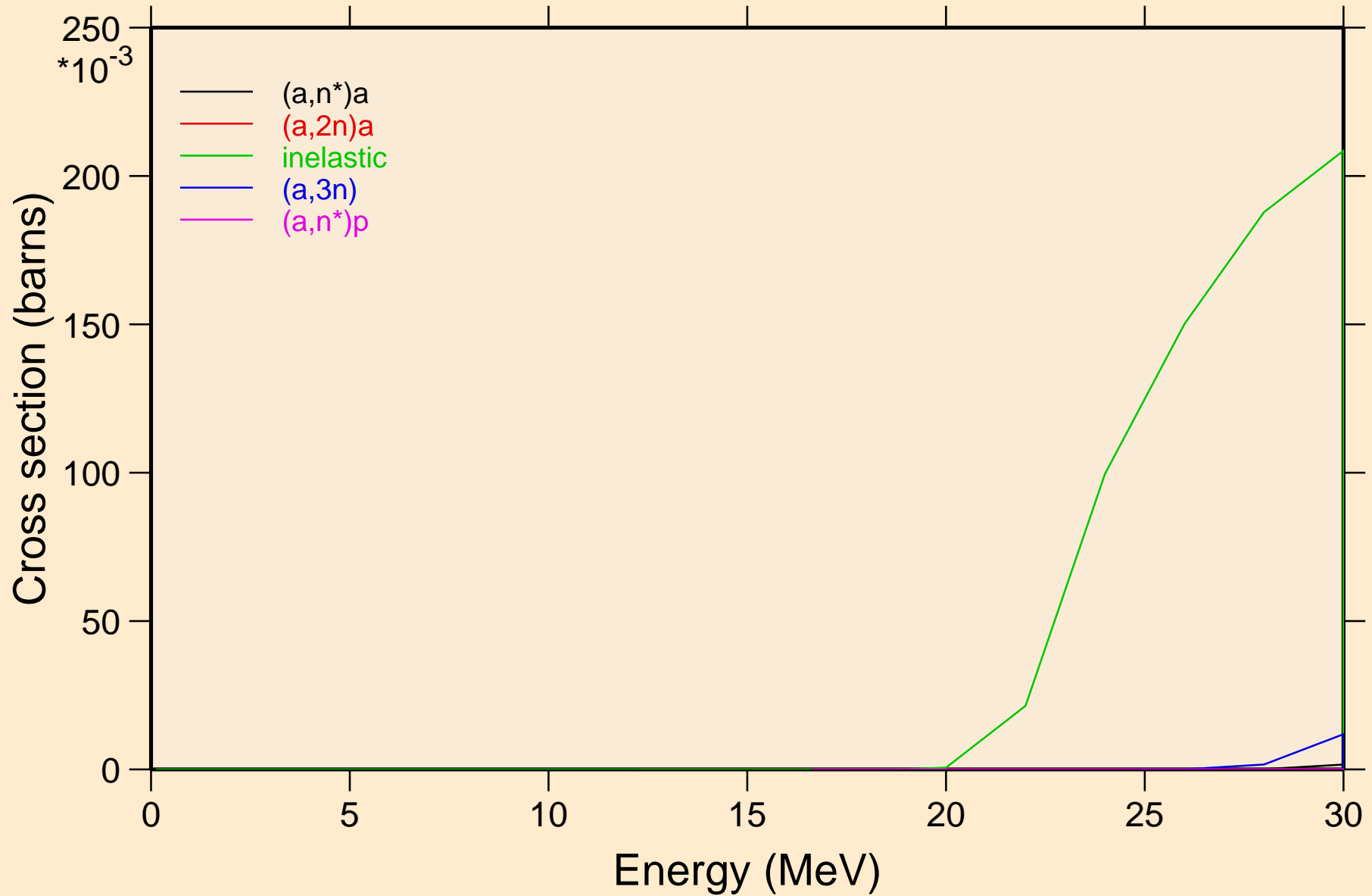

PA233 ALPHA ACER TENDL-2021 LIBRARY; T=0.K
Threshold reactions

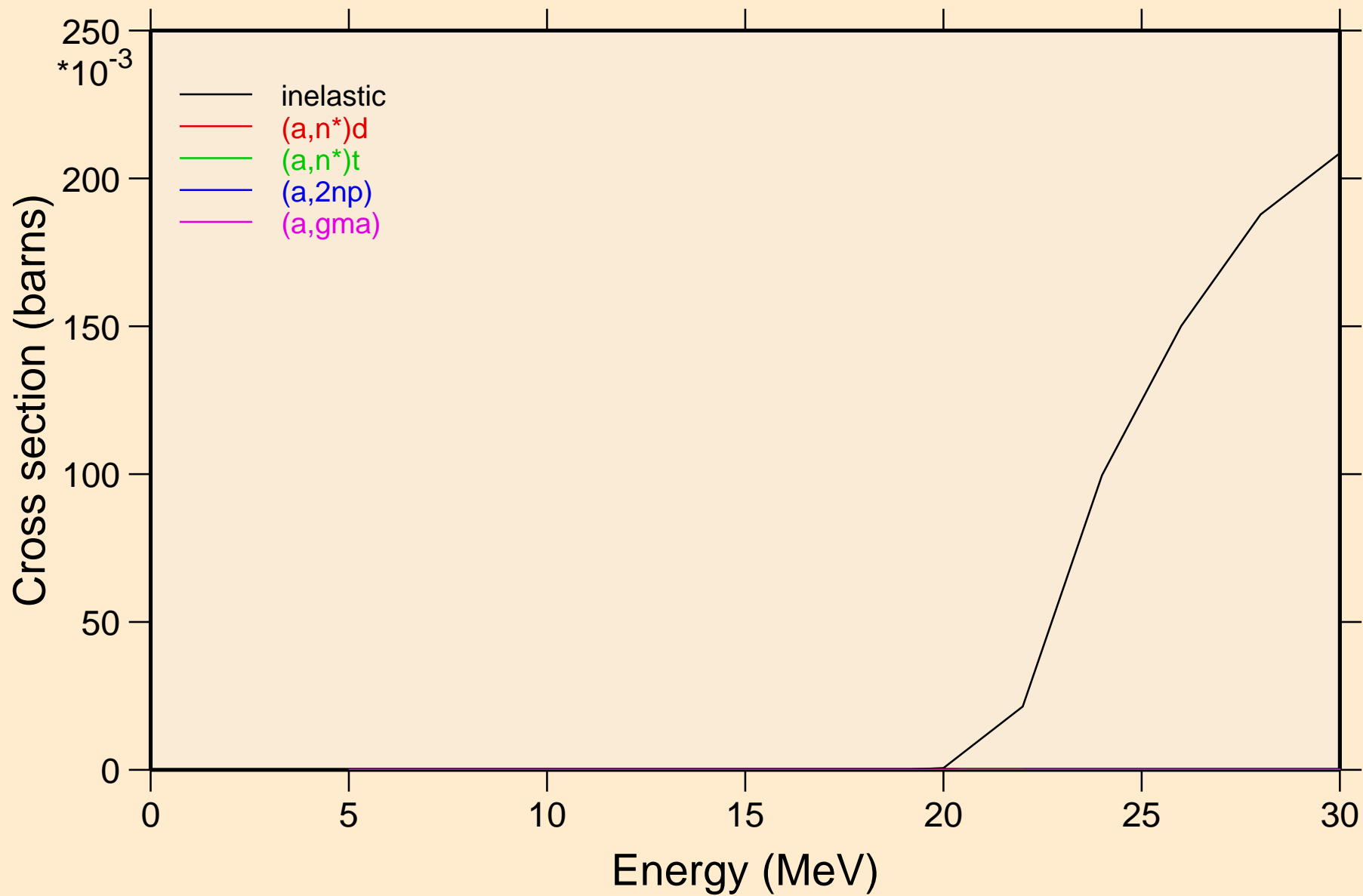

PA233 ALPHA ACER TENDL-2021 LIBRARY; T=0.K
Threshold reactions

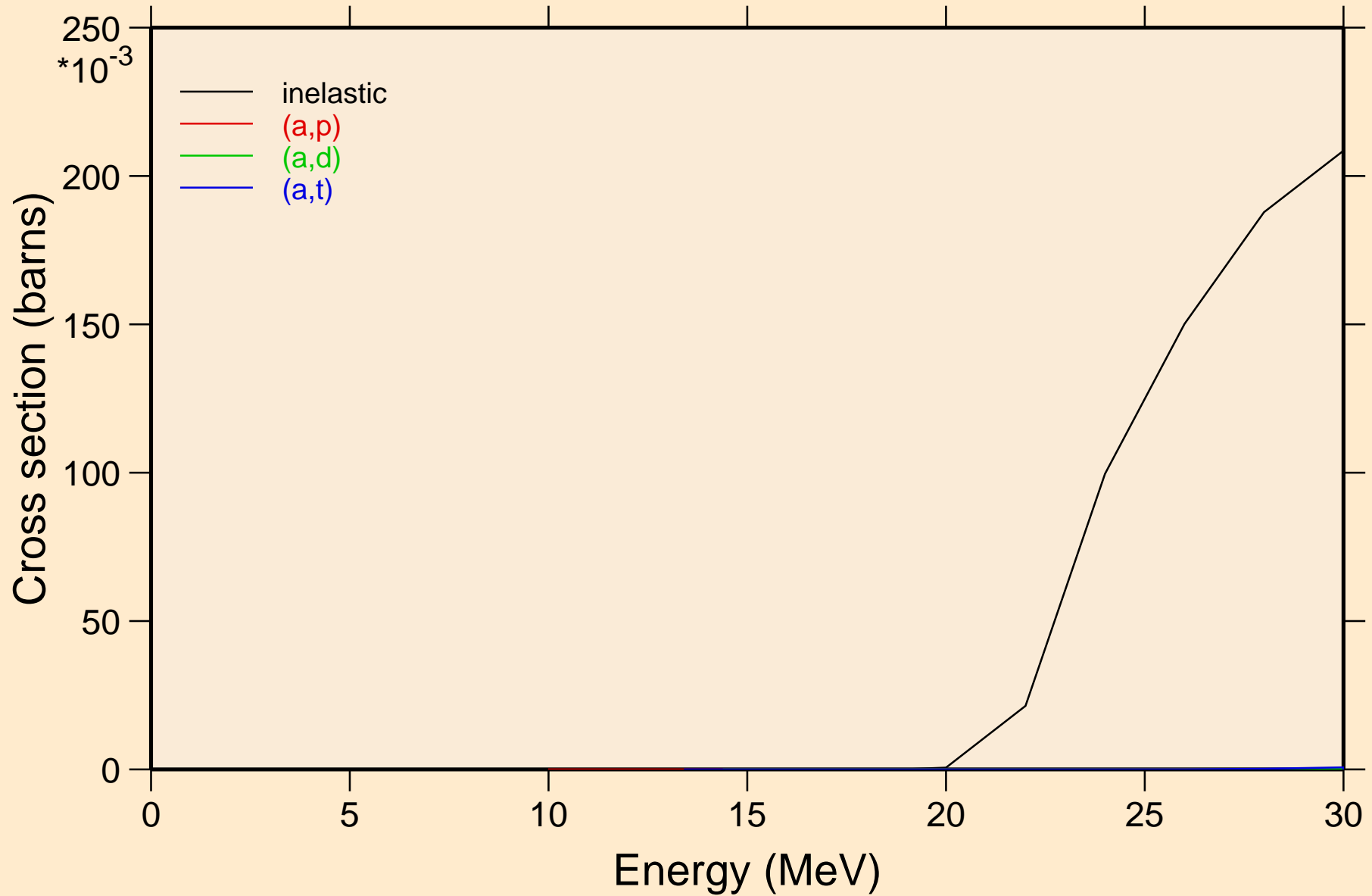

PA233 ALPHA ACER TENDL-2021 LIBRARY; T=0.K
Threshold reactions

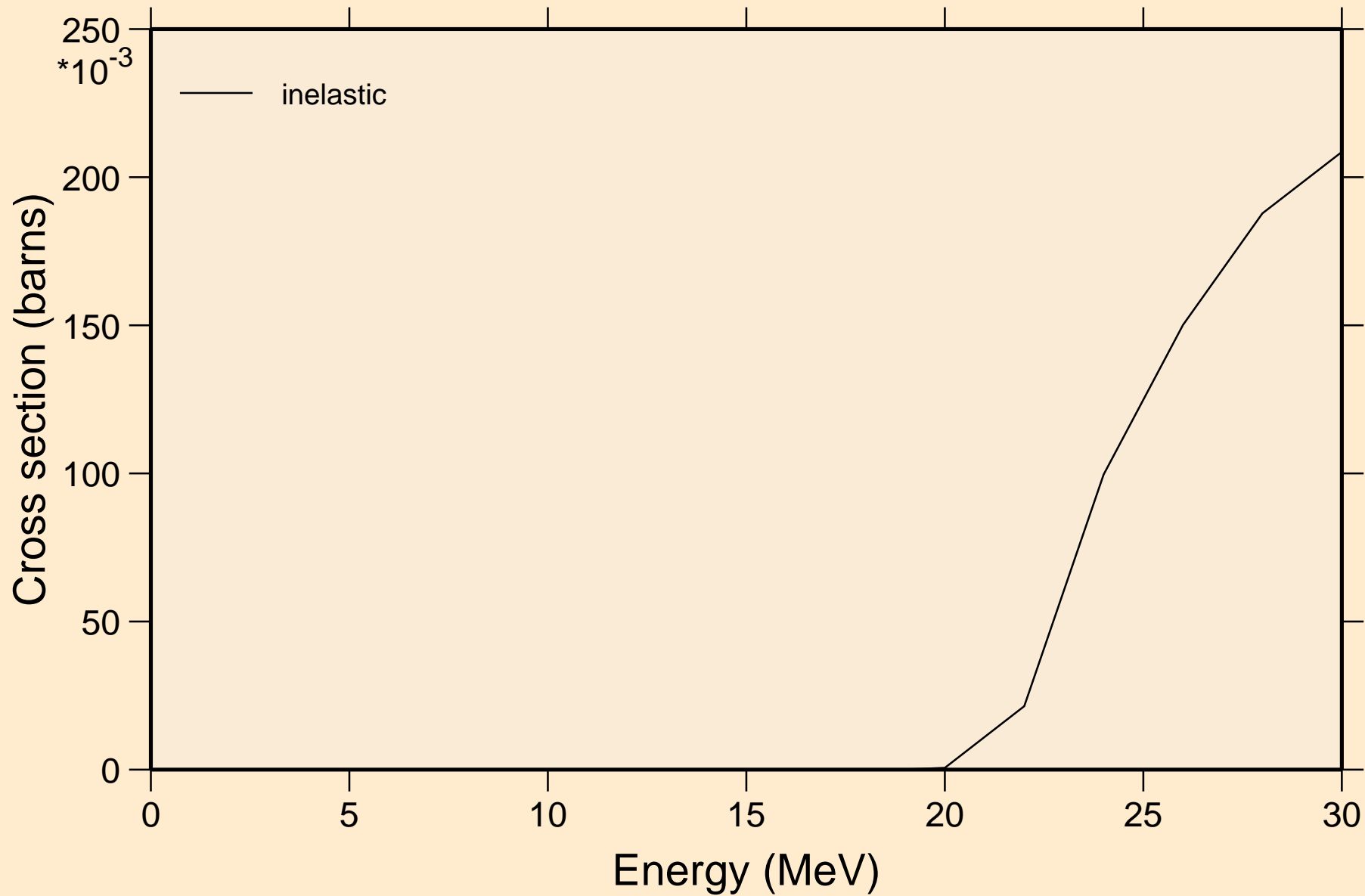

PA233 ALPHA ACER TENDL-2021 LIBRARY; T=0.K
angular distribution for elastic

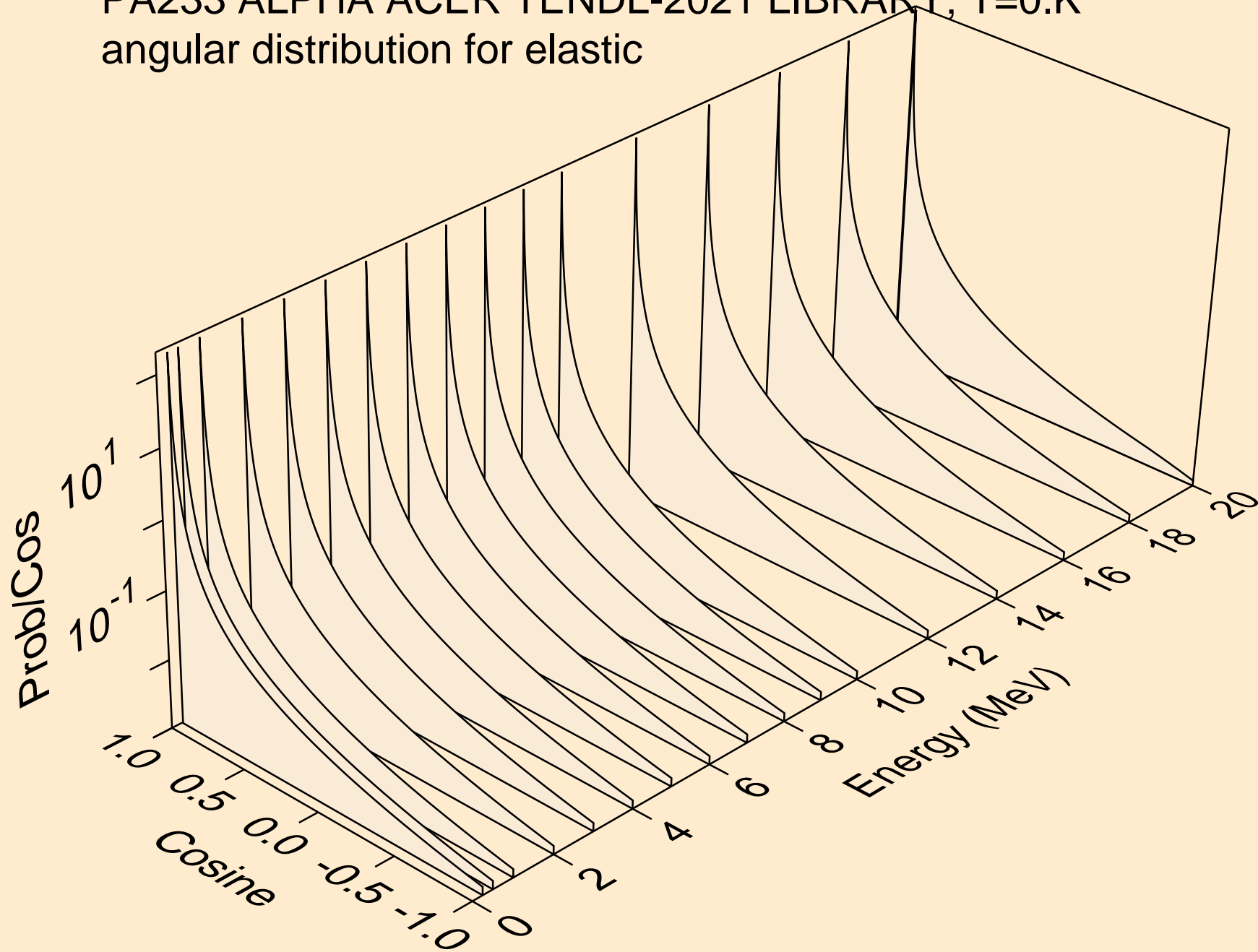

PA233 ALPHA ACER TENDL-2021 LIBRARY; T=0.K
angular distribution for elastic

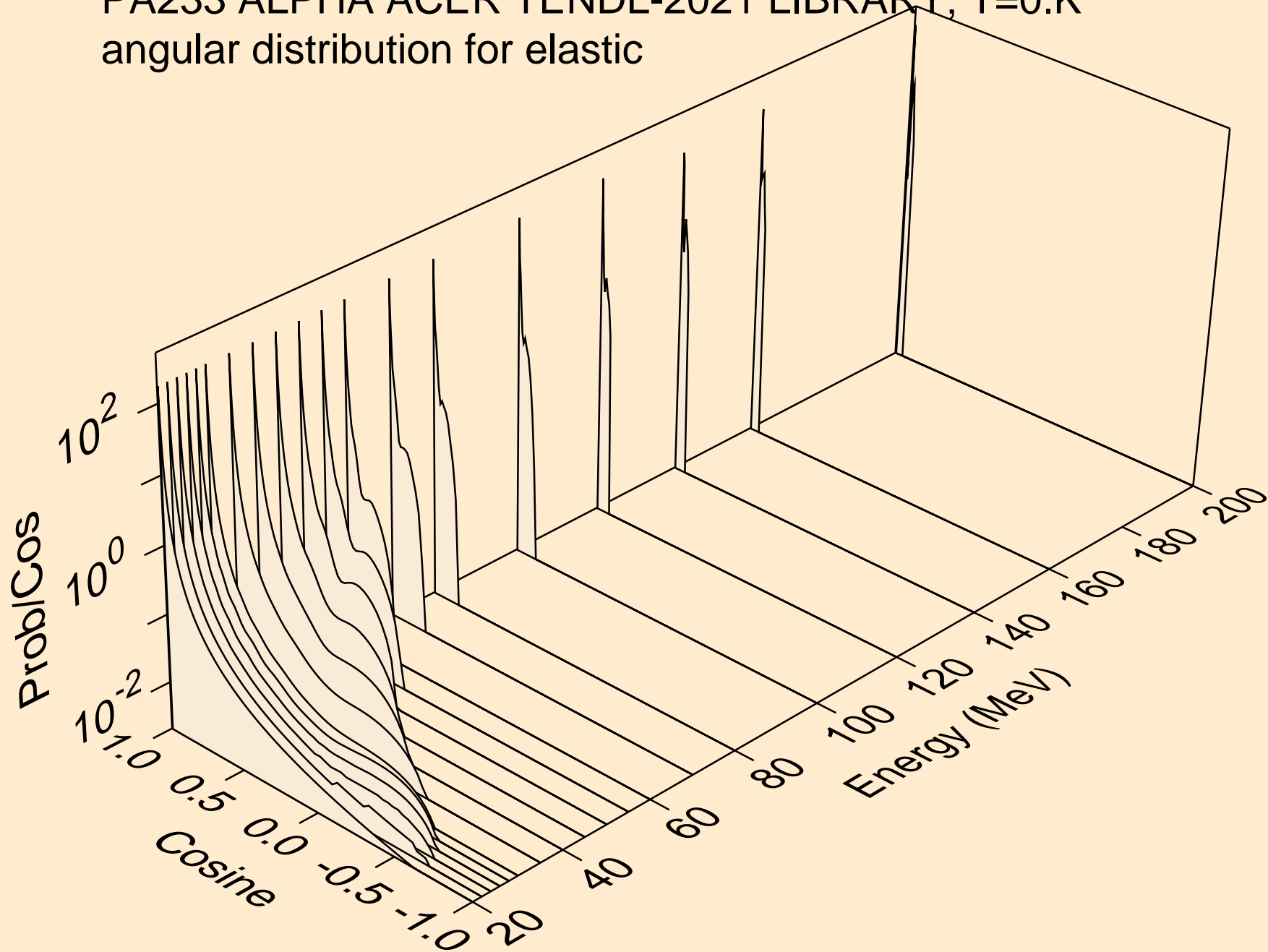

PA233 ALPHA ACER TENDL-2021 LIBRARY; T=0.K
Alpha emission for (a,x)

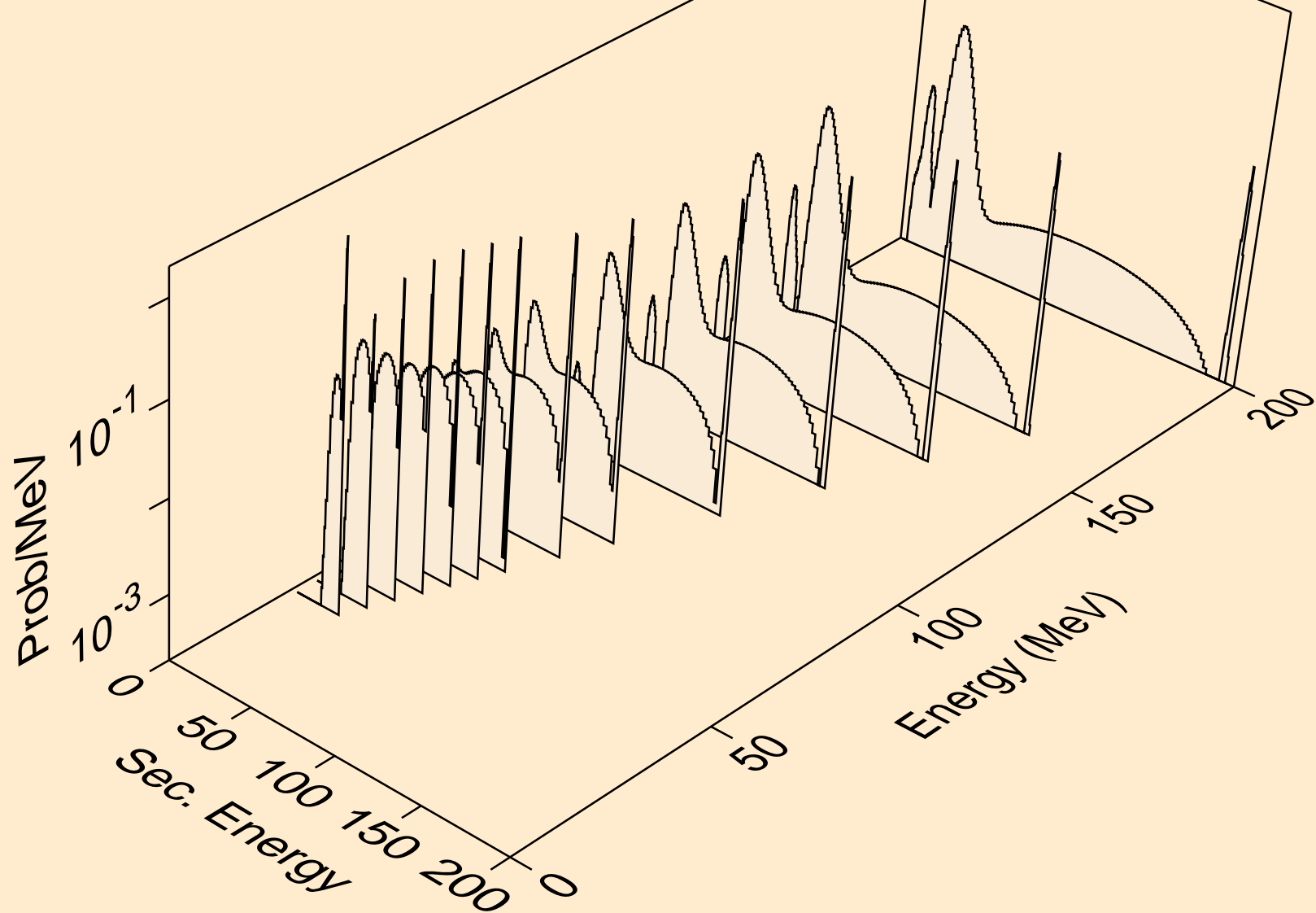

PA233 ALPHA ACER TENDL-2021 LIBRARY; T=0.K
Alpha emission for (a,n*)a

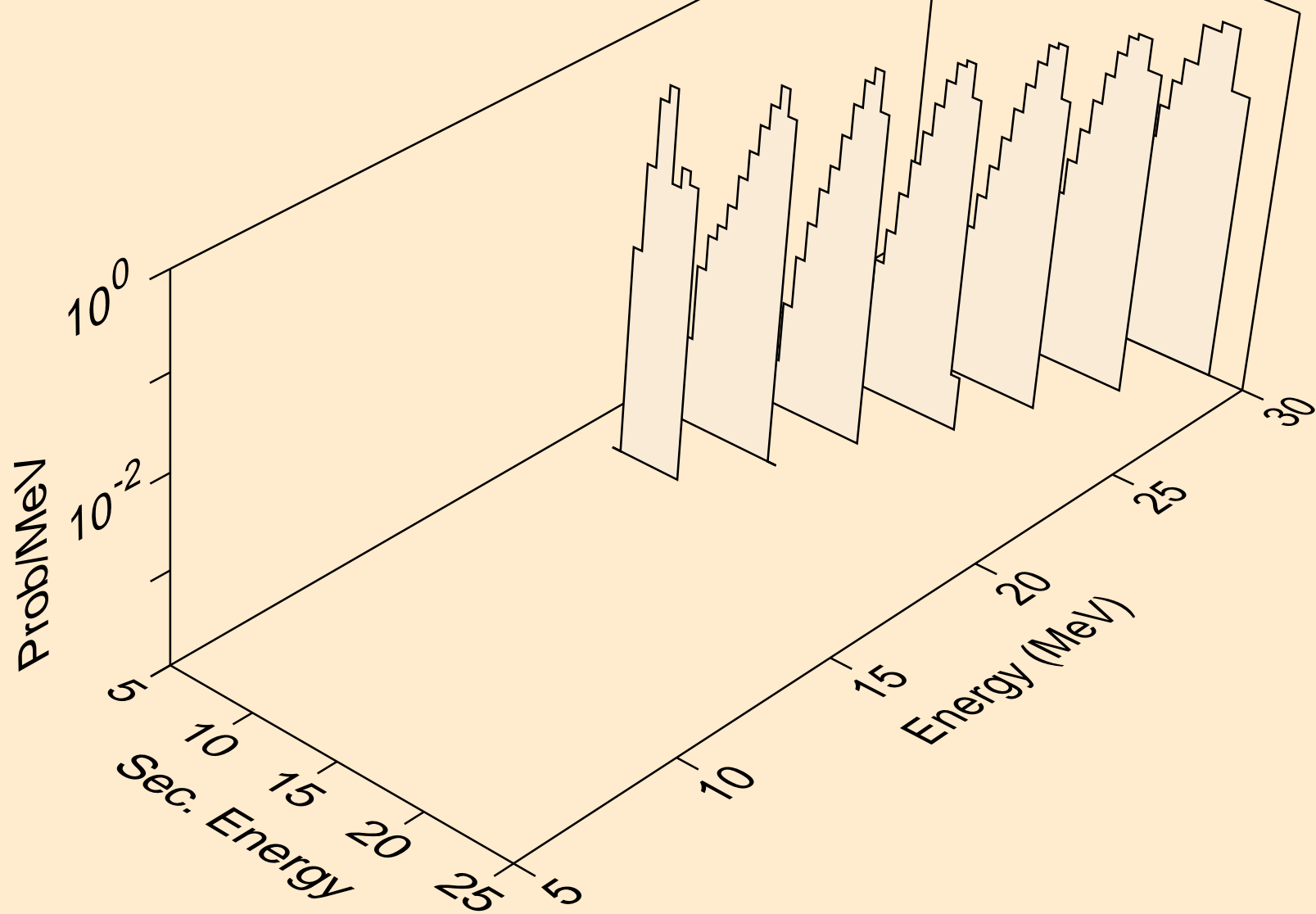

PA233 ALPHA ACER TENDL-2021 LIBRARY; T=0.K
Alpha emission for (a,2n)a

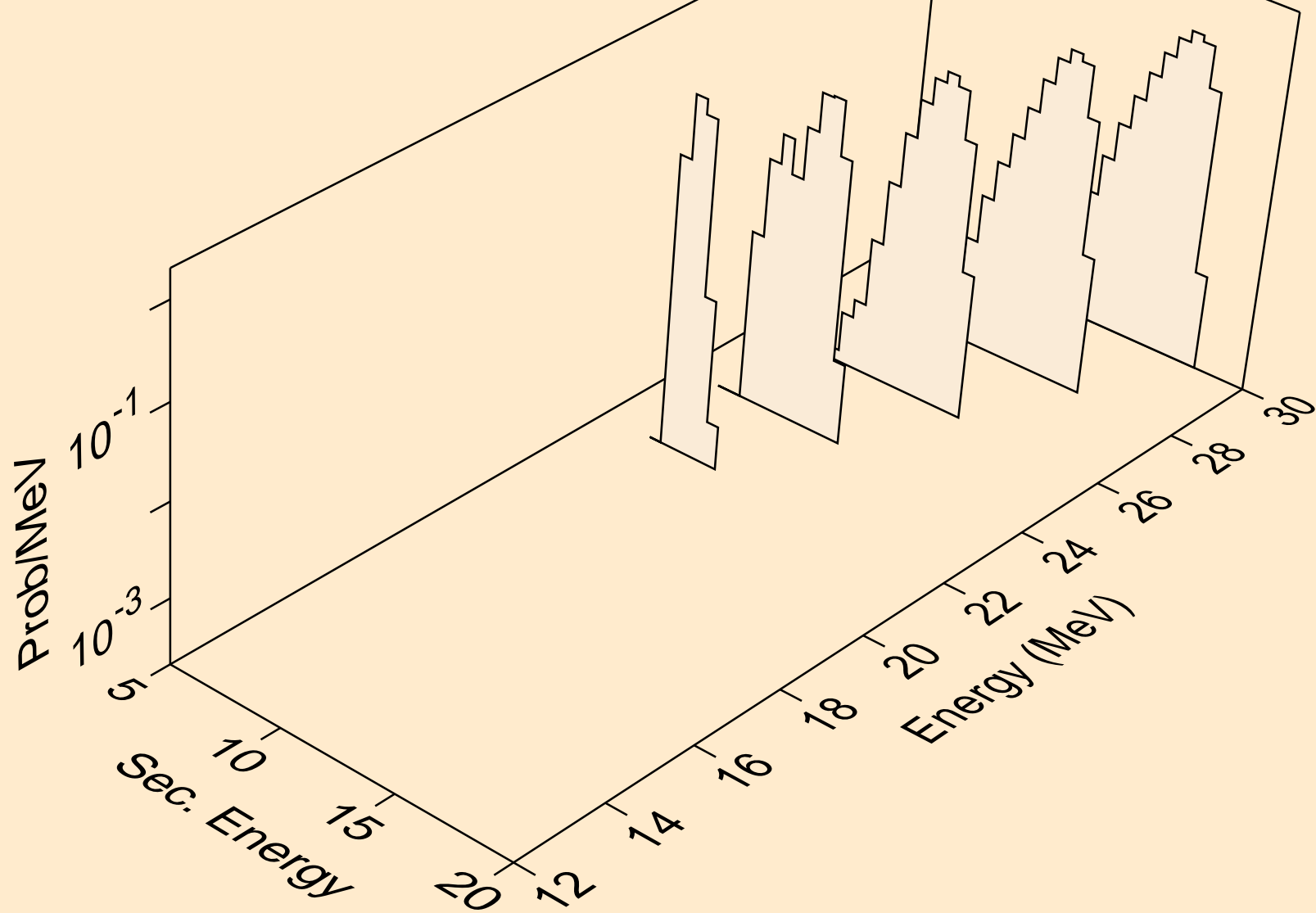

PA233 ALPHA ACER TENDL-2021 LIBRARY; T=0.K
Alpha emission for inelastic

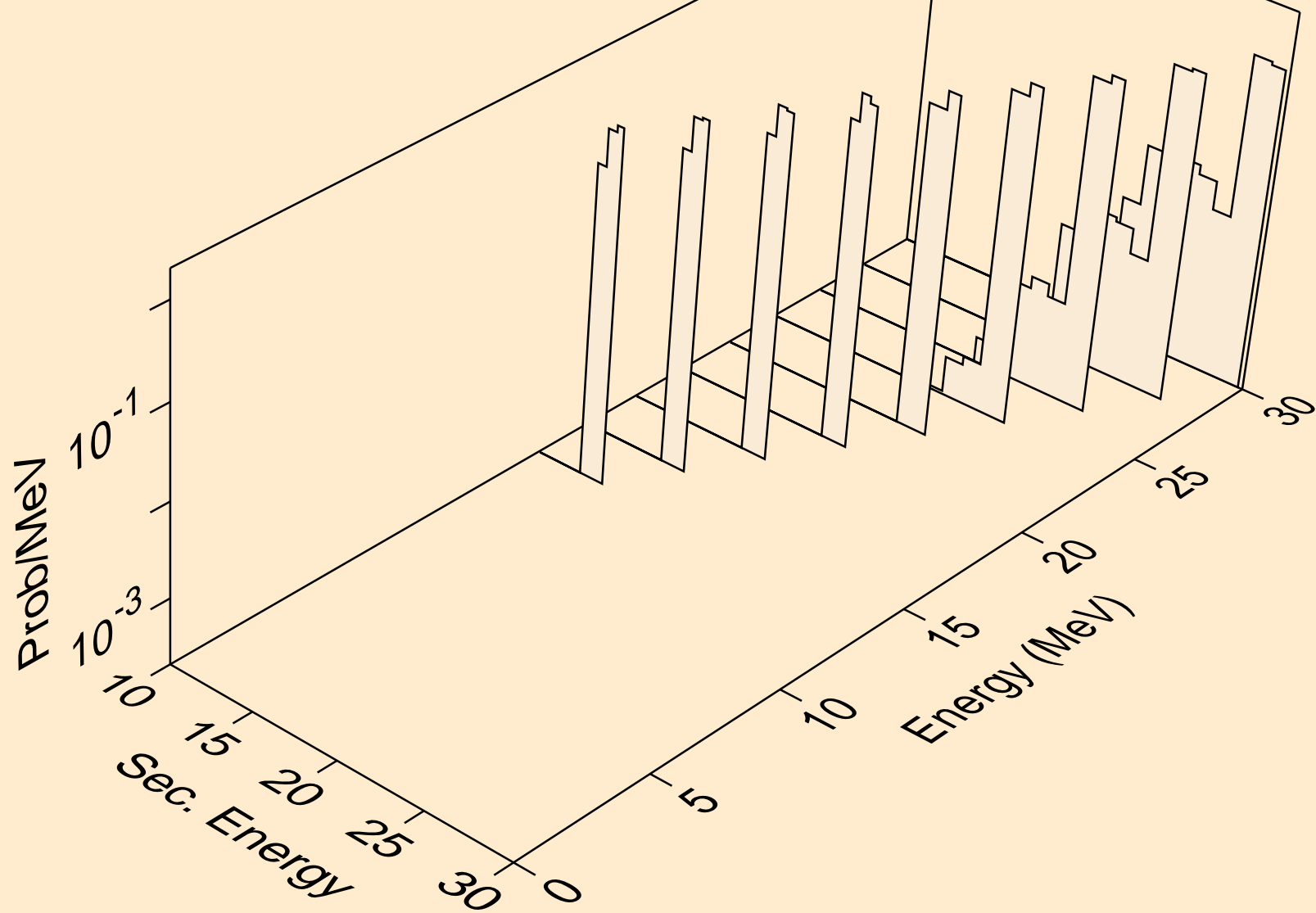

PA233 ALPHA ACER TENDL-2021 LIBRARY; T=0.K
Photon emission for (z,n)

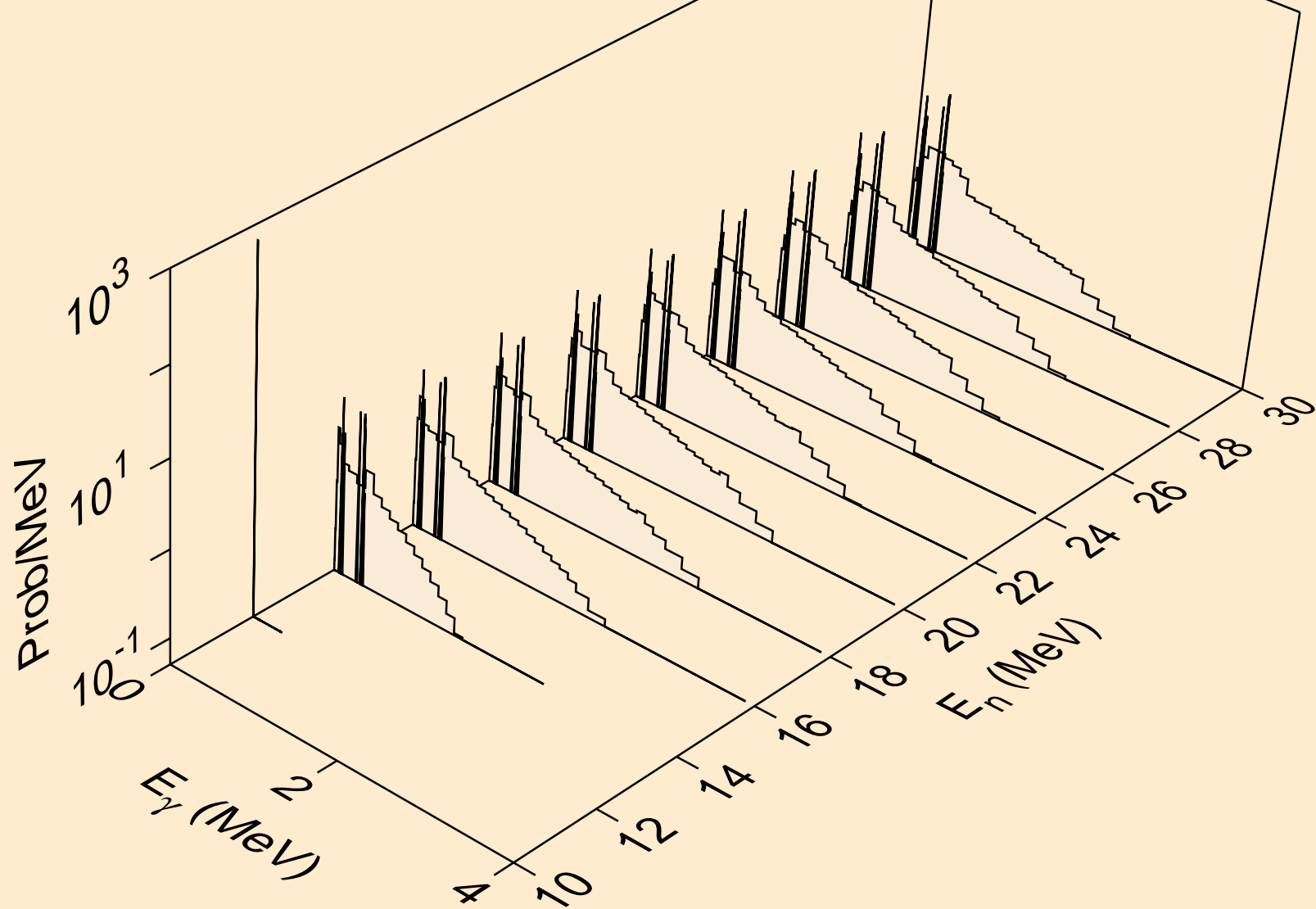

PA233 ALPHA ACER TENDL-2021 LIBRARY; T=0.K
Photon emission for (n,x)

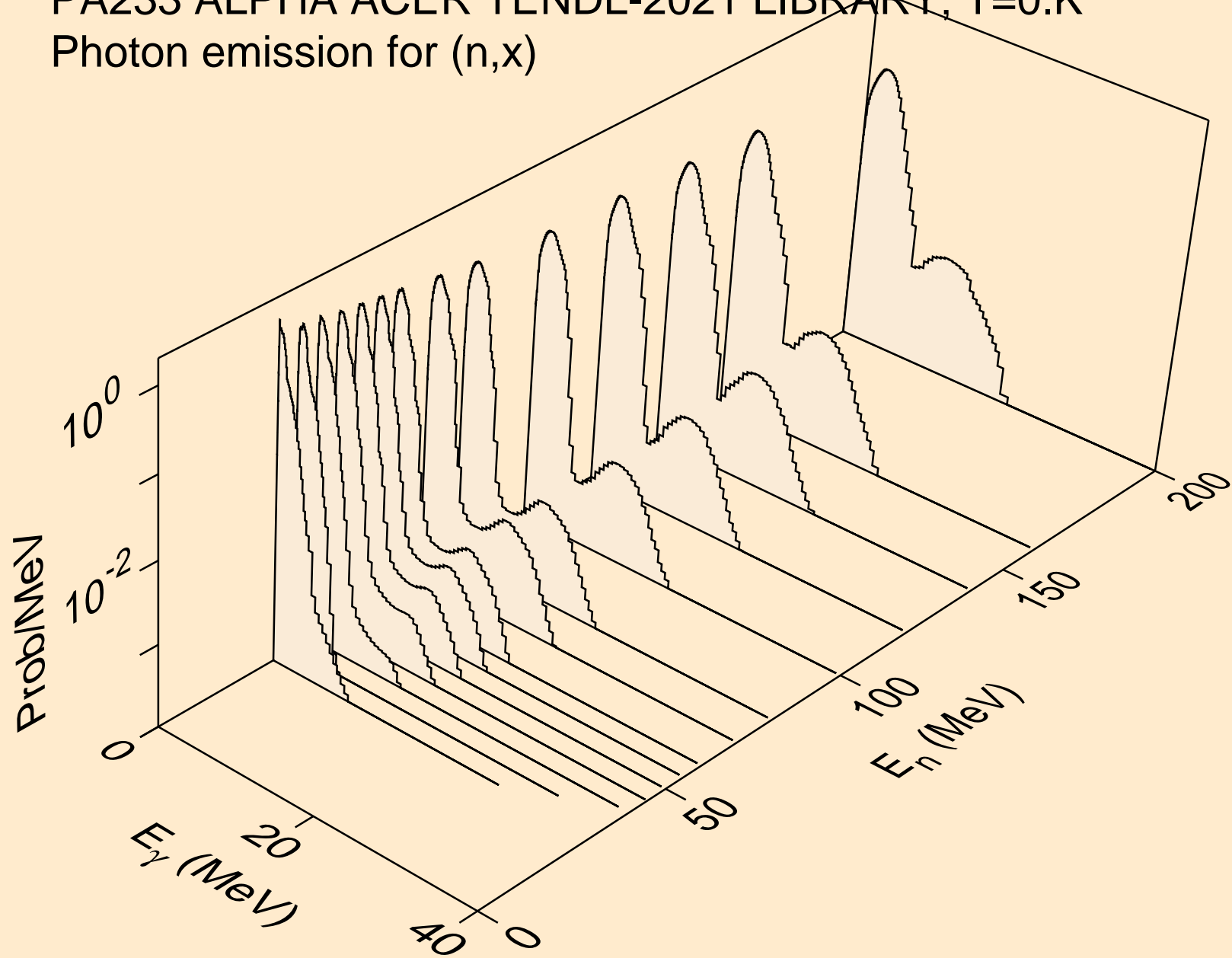

PA233 ALPHA ACER TENDL-2021 LIBRARY; T=0.K
Photon emission for (n,2n)

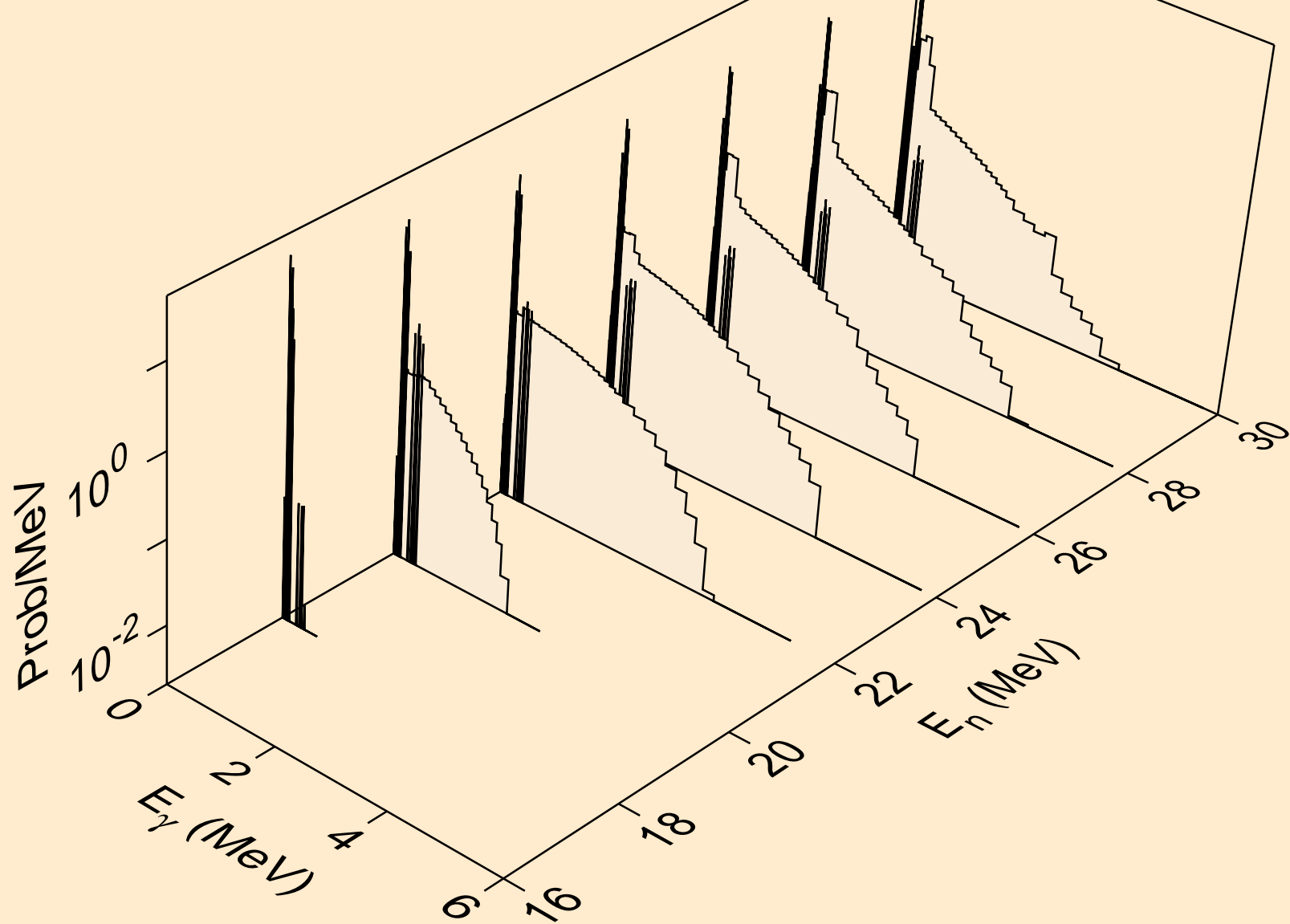

PA233 ALPHA ACER TENDL-2021 LIBRARY; T=0.K
Photon emission for (n,3n)

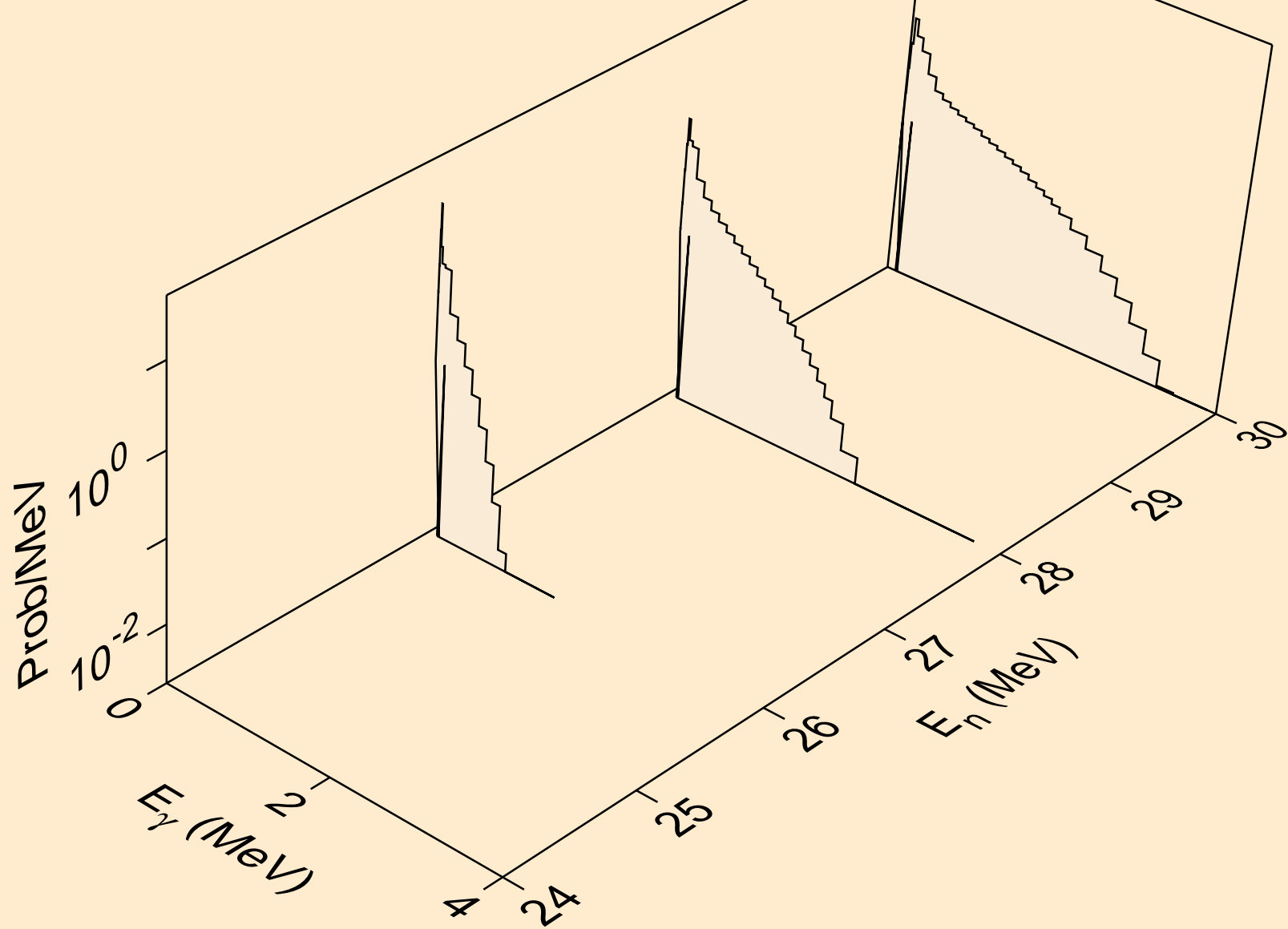

PA233 ALPHA ACER TENDL-2021 LIBRARY; T=0.K
Photon emission for (n,n*)a

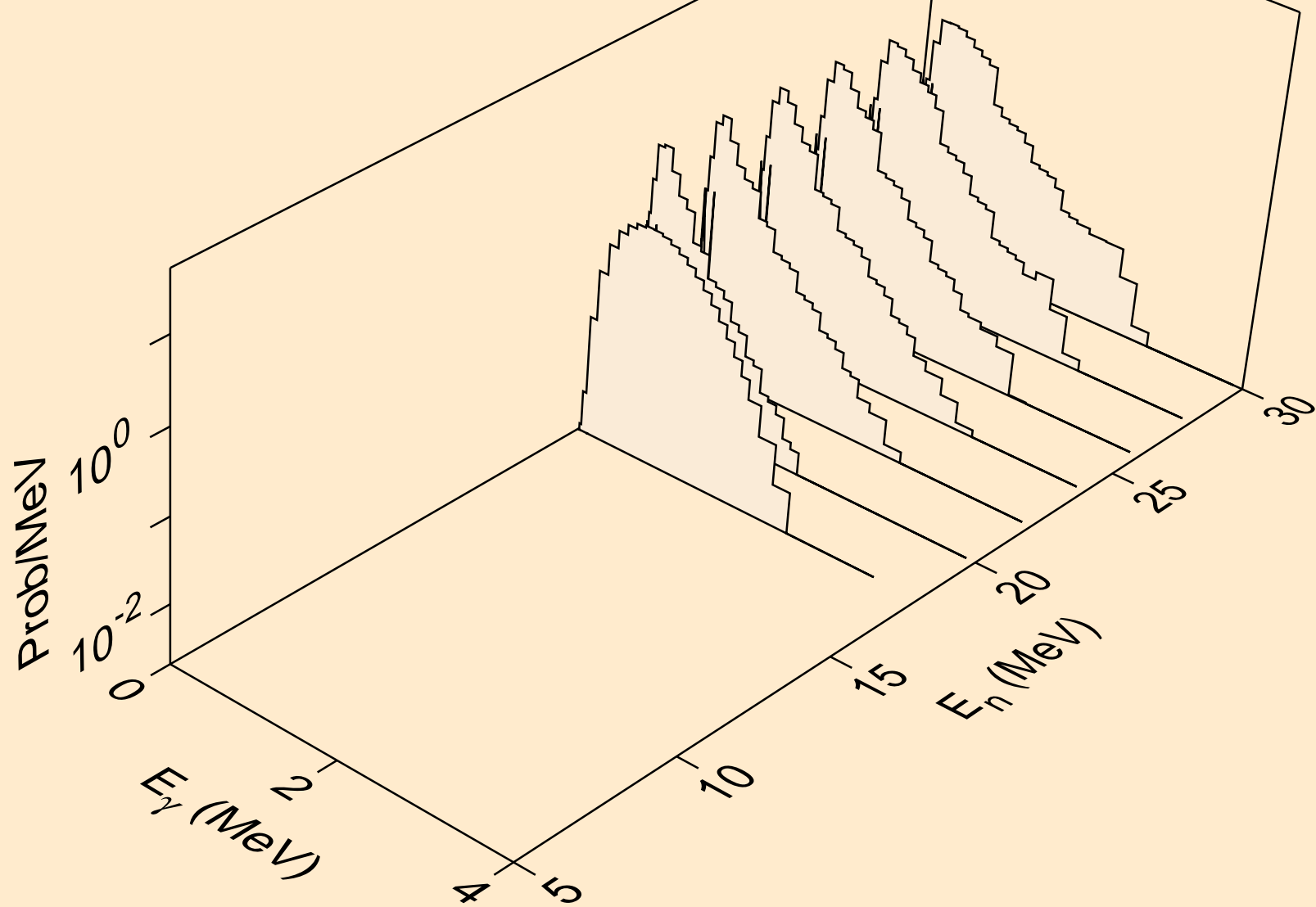

PA233 ALPHA ACER TENDL-2021 LIBRARY; T=0.K
Photon emission for (n,2n)a

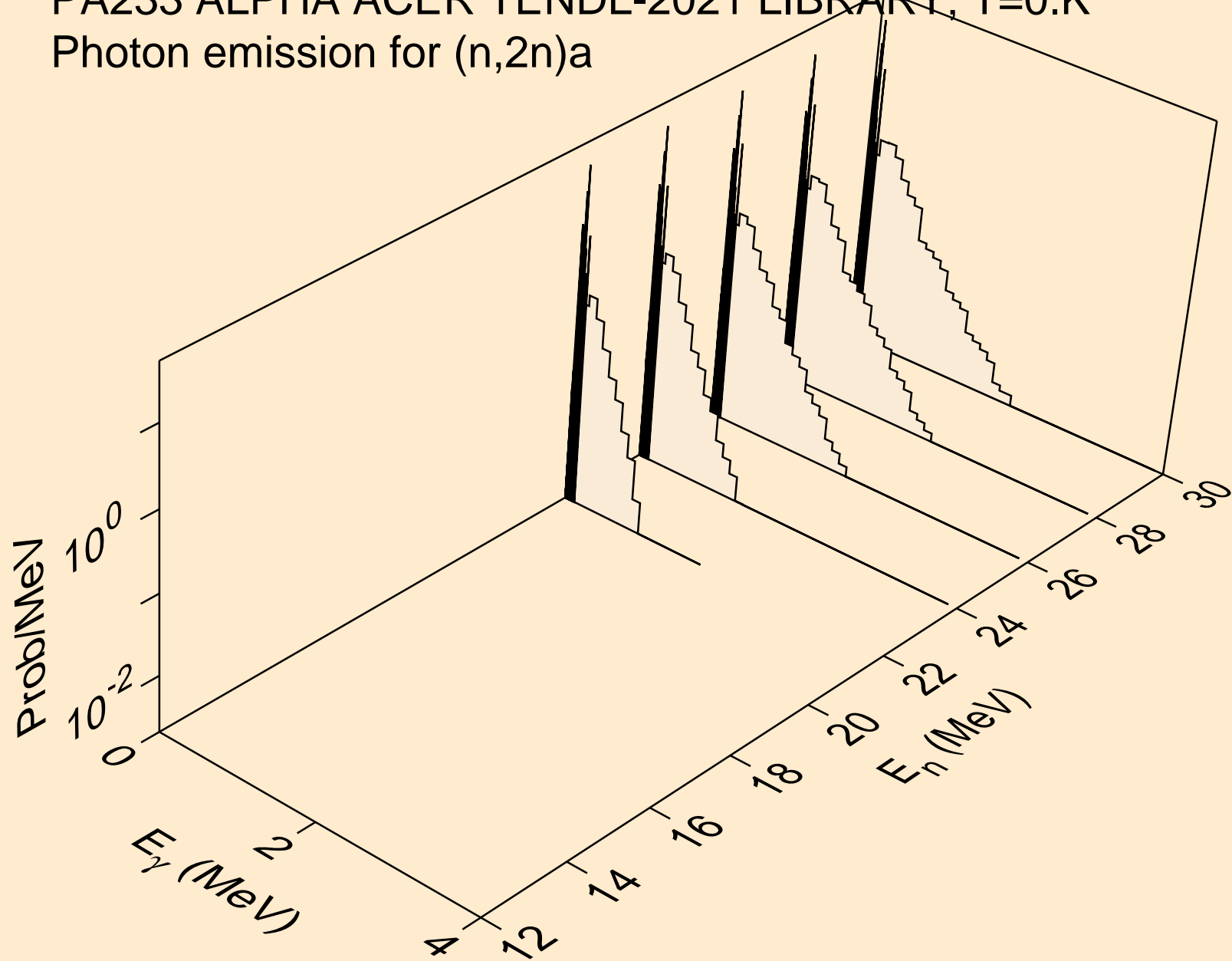

PA233 ALPHA ACER TENDL-2021 LIBRARY; T=0.K
Photon emission for (n,n*)p

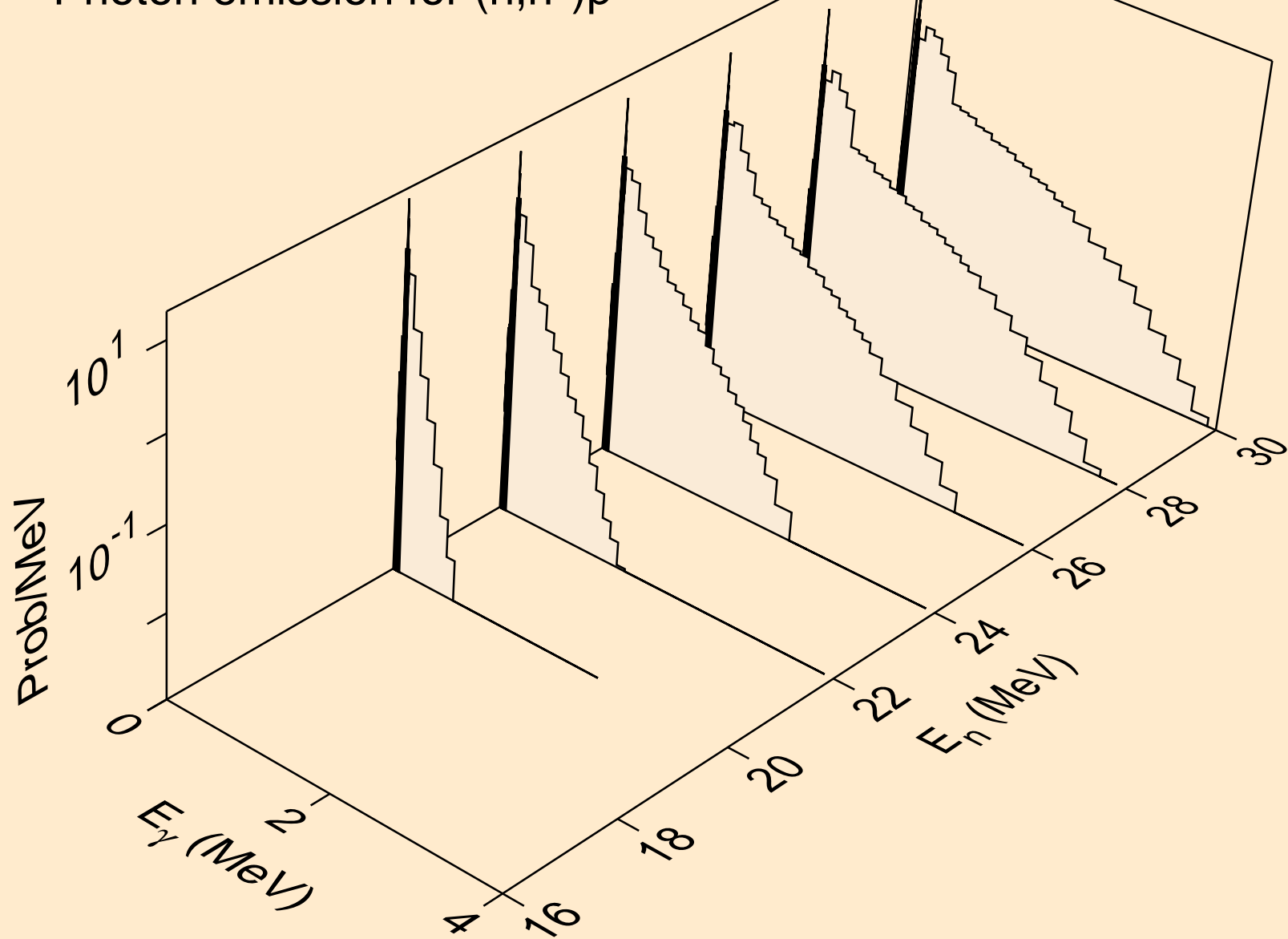

PA233 ALPHA ACER TENDL-2021 LIBRARY; T=0.K
Photon emission for (n,n*)d

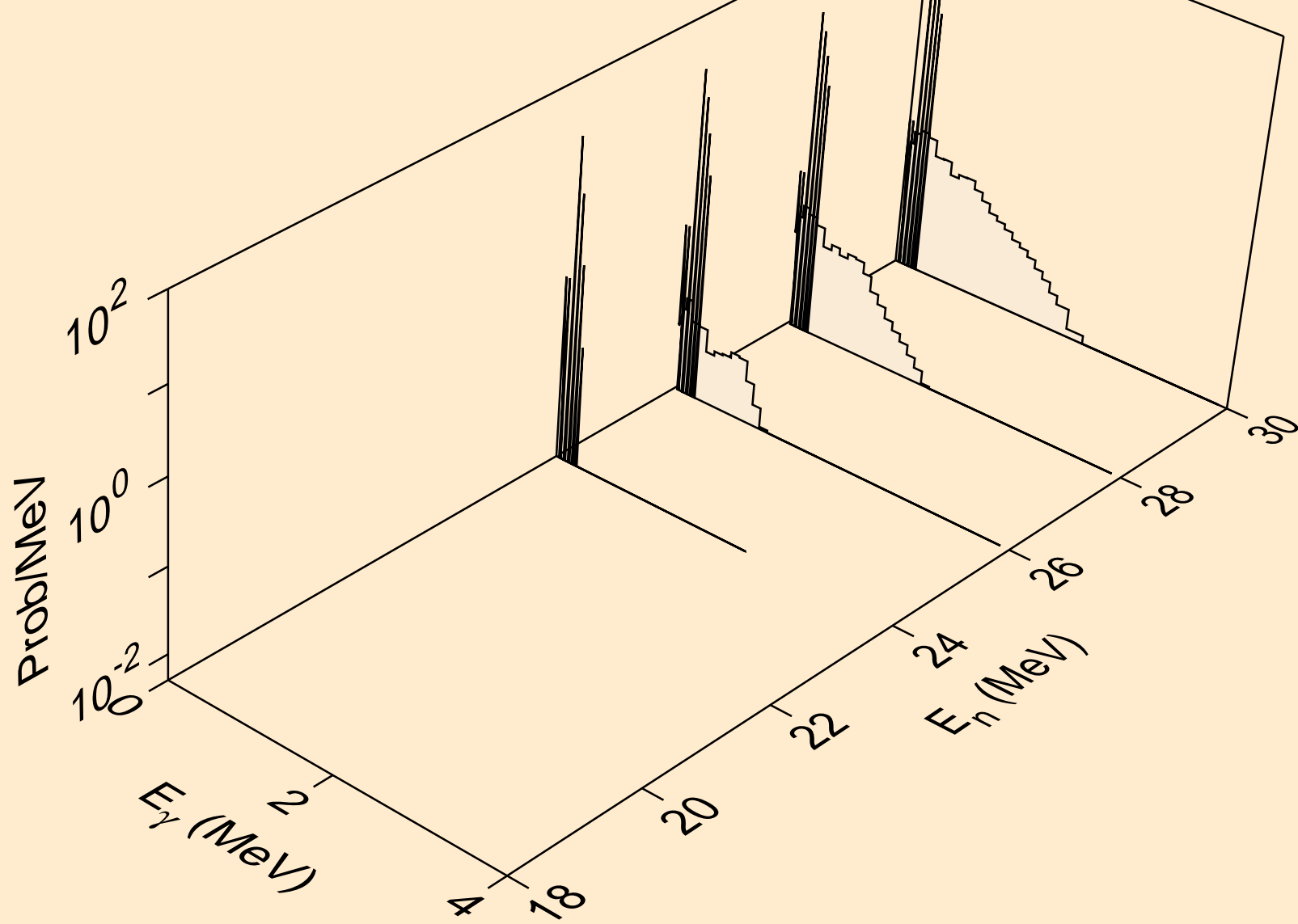

PA233 ALPHA ACER TENDL-2021 LIBRARY; T=0.K
Photon emission for (n,n*)t

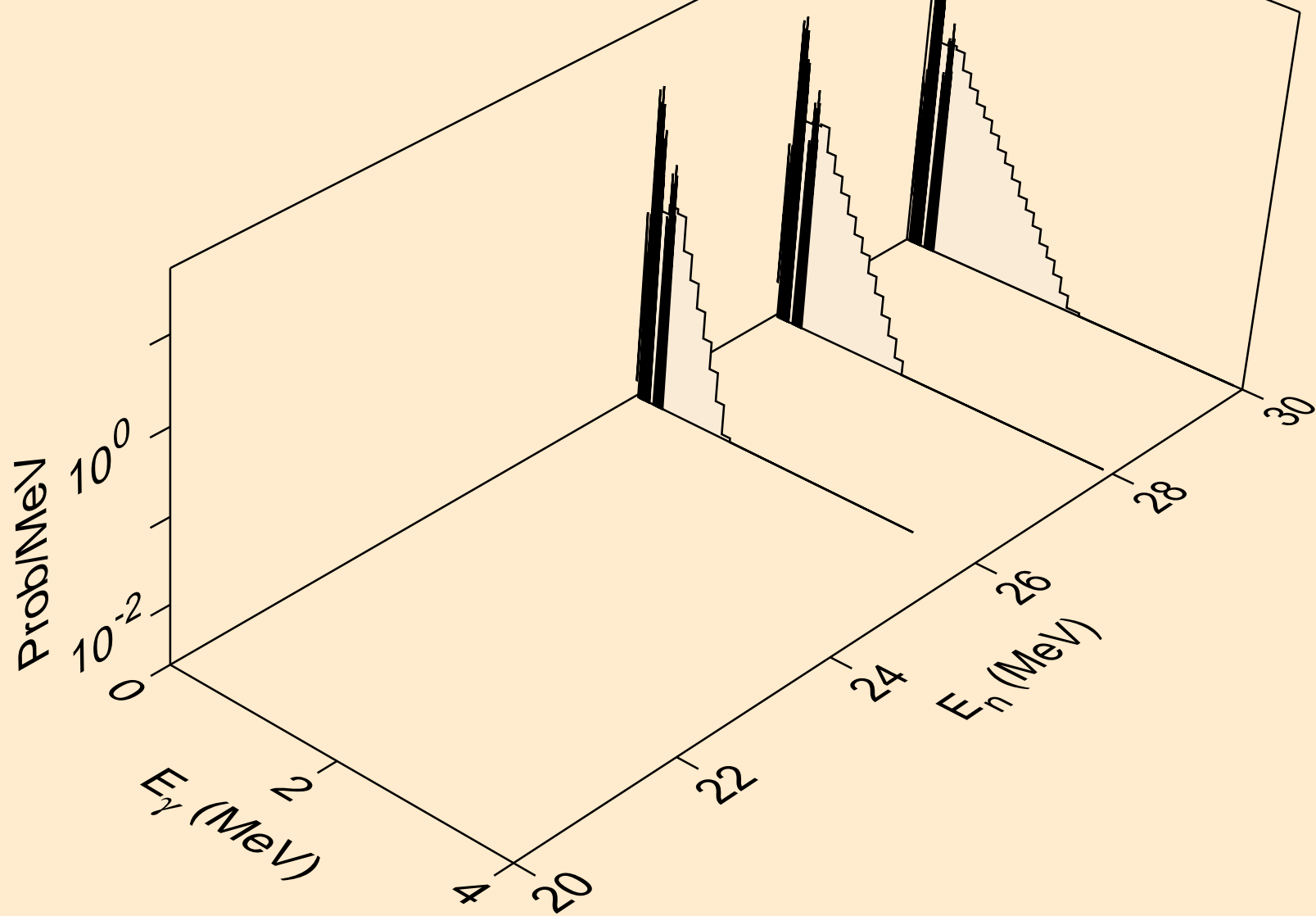

PA233 ALPHA ACER TENDL-2021 LIBRARY; T=0.K
Photon emission for (n,2np)

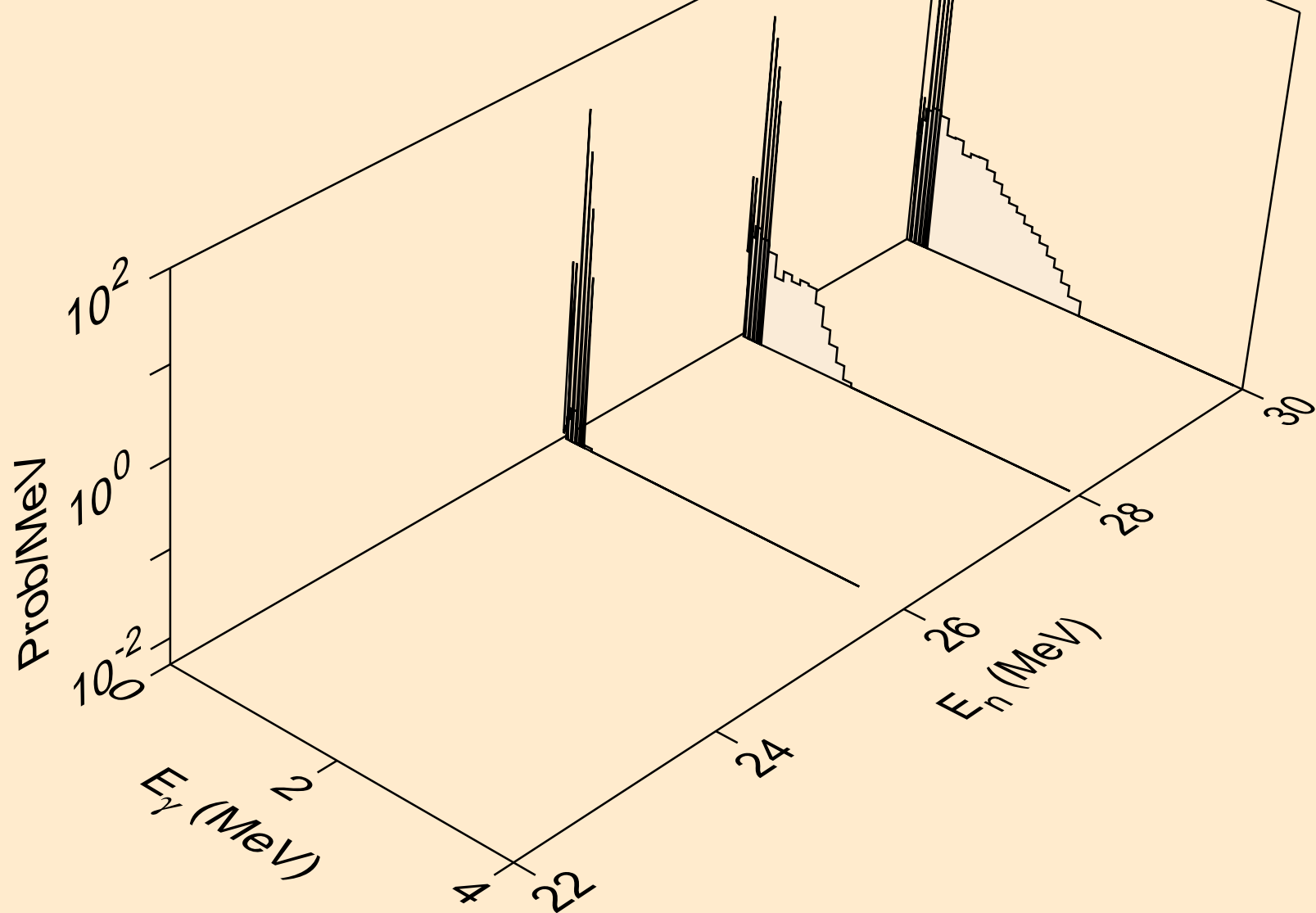

PA233 ALPHA ACER TENDL-2021 LIBRARY; T=0.K
Photon emission for (n,gma)

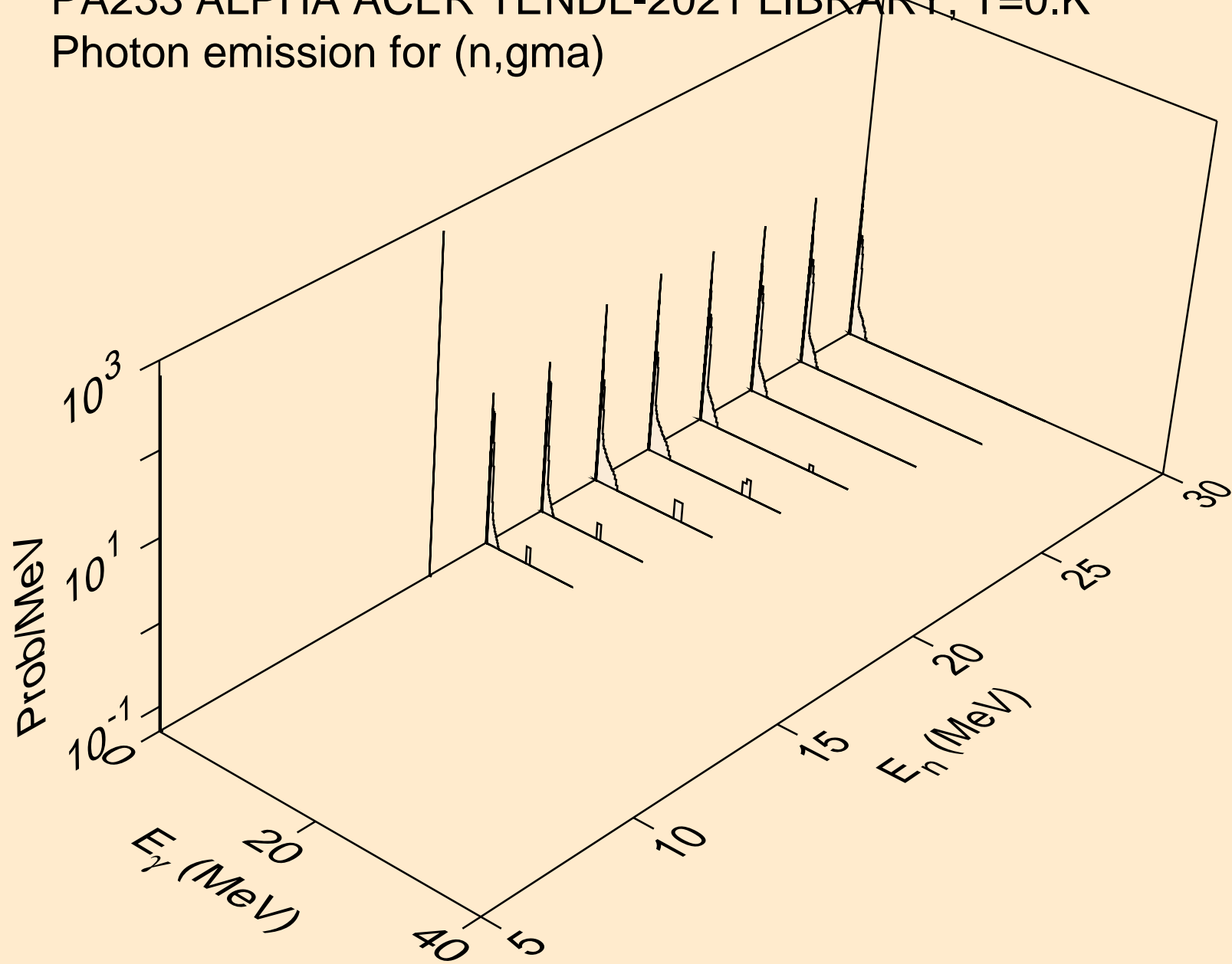

PA233 ALPHA ACER TENDL-2021 LIBRARY; T=0.K
Photon emission for (n,p)

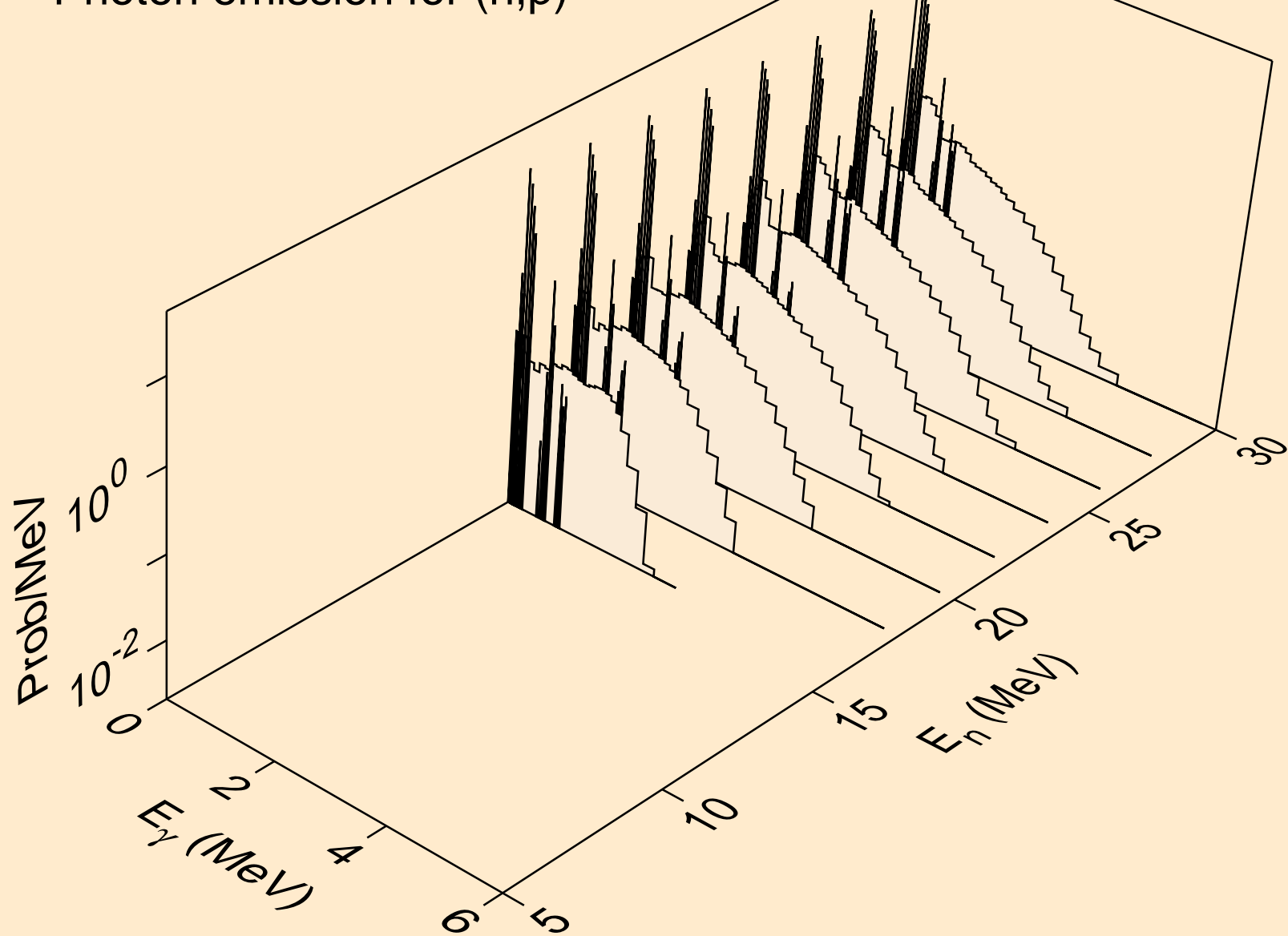

PA233 ALPHA ACER TENDL-2021 LIBRARY; T=0.K
Photon emission for (n,d)

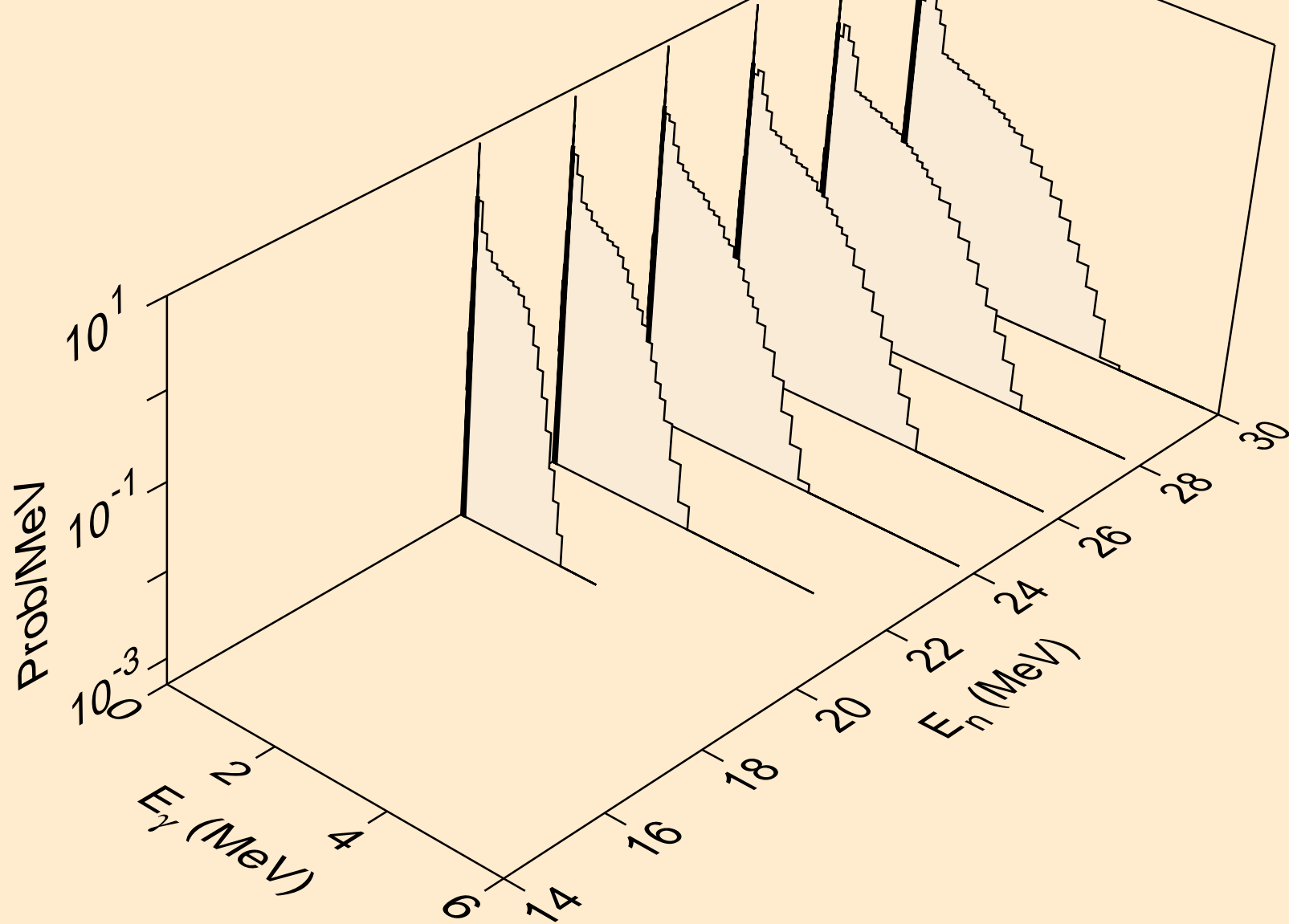

PA233 ALPHA ACER TENDL-2021 LIBRARY; T=0.K
Photon emission for (n,t)

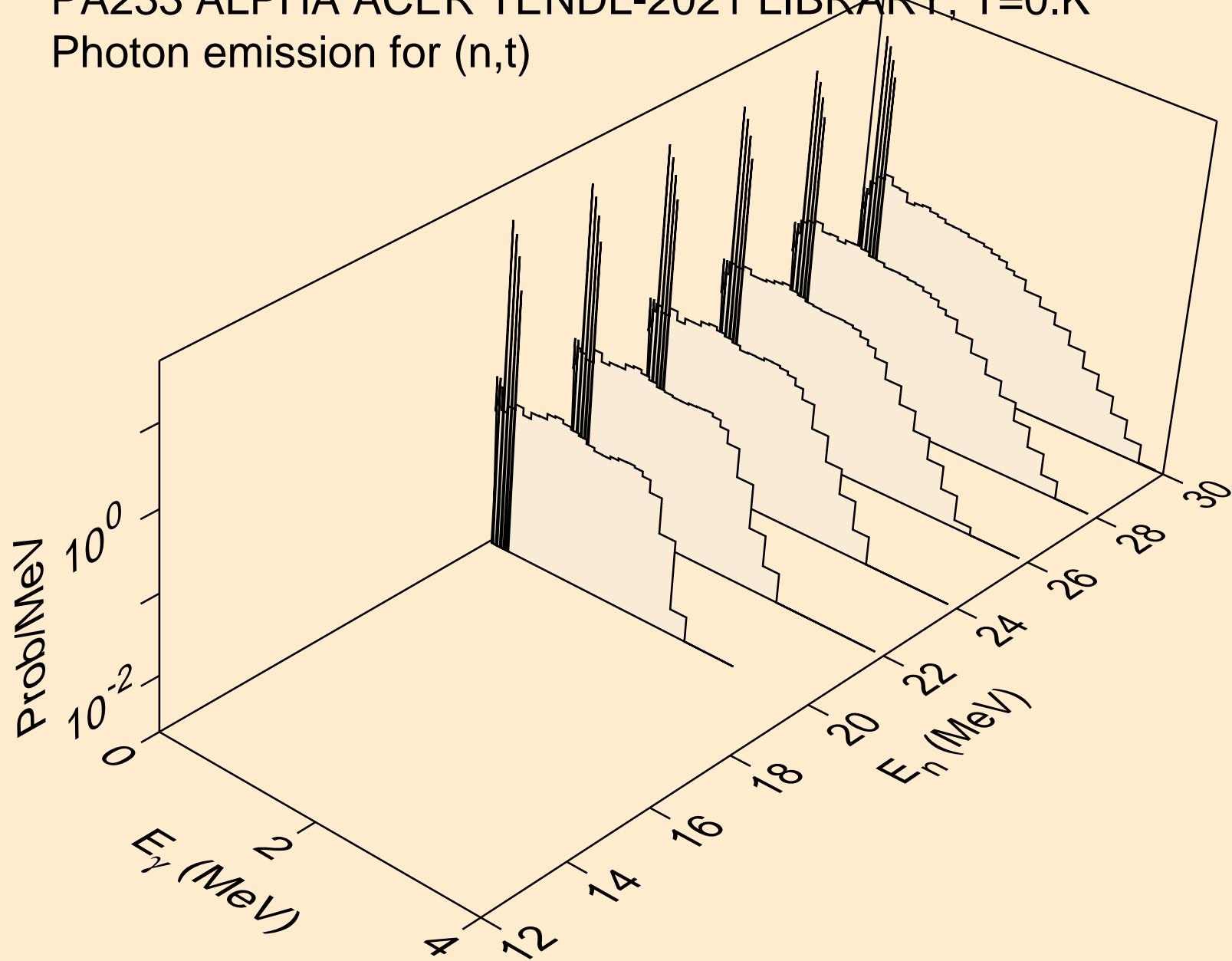

PA233 ALPHA ACER TENDL-2021 LIBRARY; T=0.K
Photon emission for inelastic

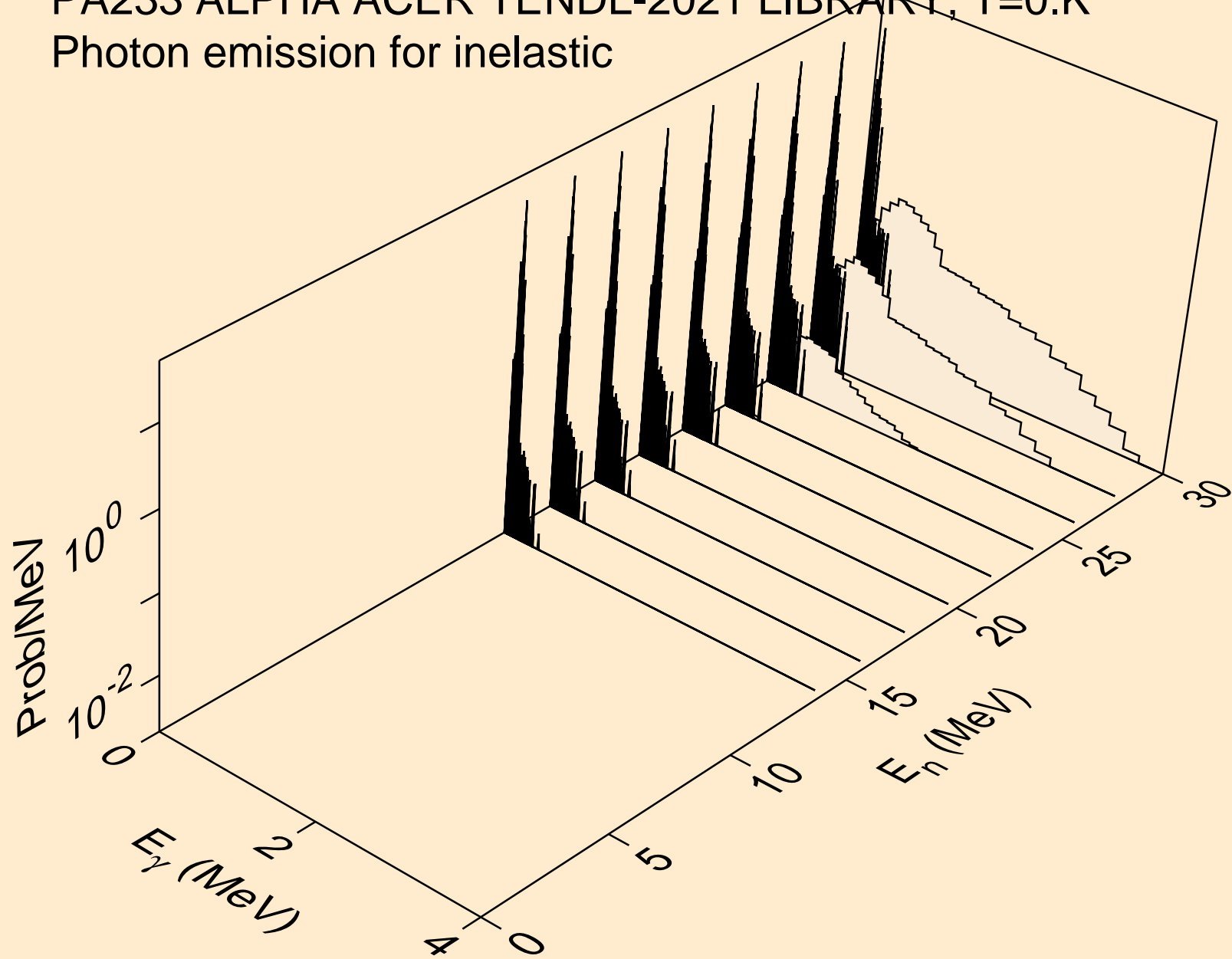

PA233 ALPHA ACER TENDL-2021 LIBRARY; T=0.K
Particle heating contributions

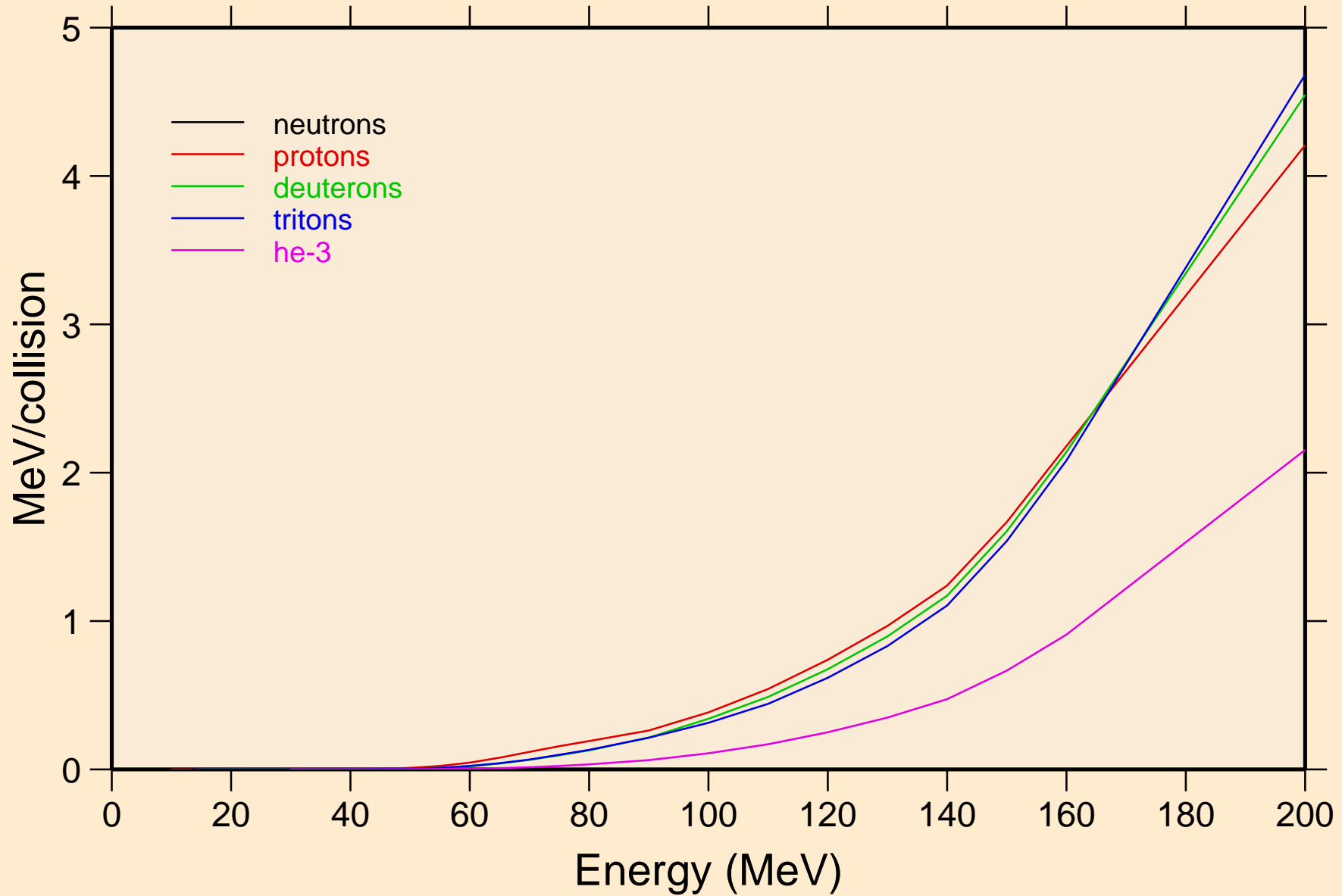

PA233 ALPHA ACER TENDL-2021 LIBRARY; T=0.K
Recoil Heating

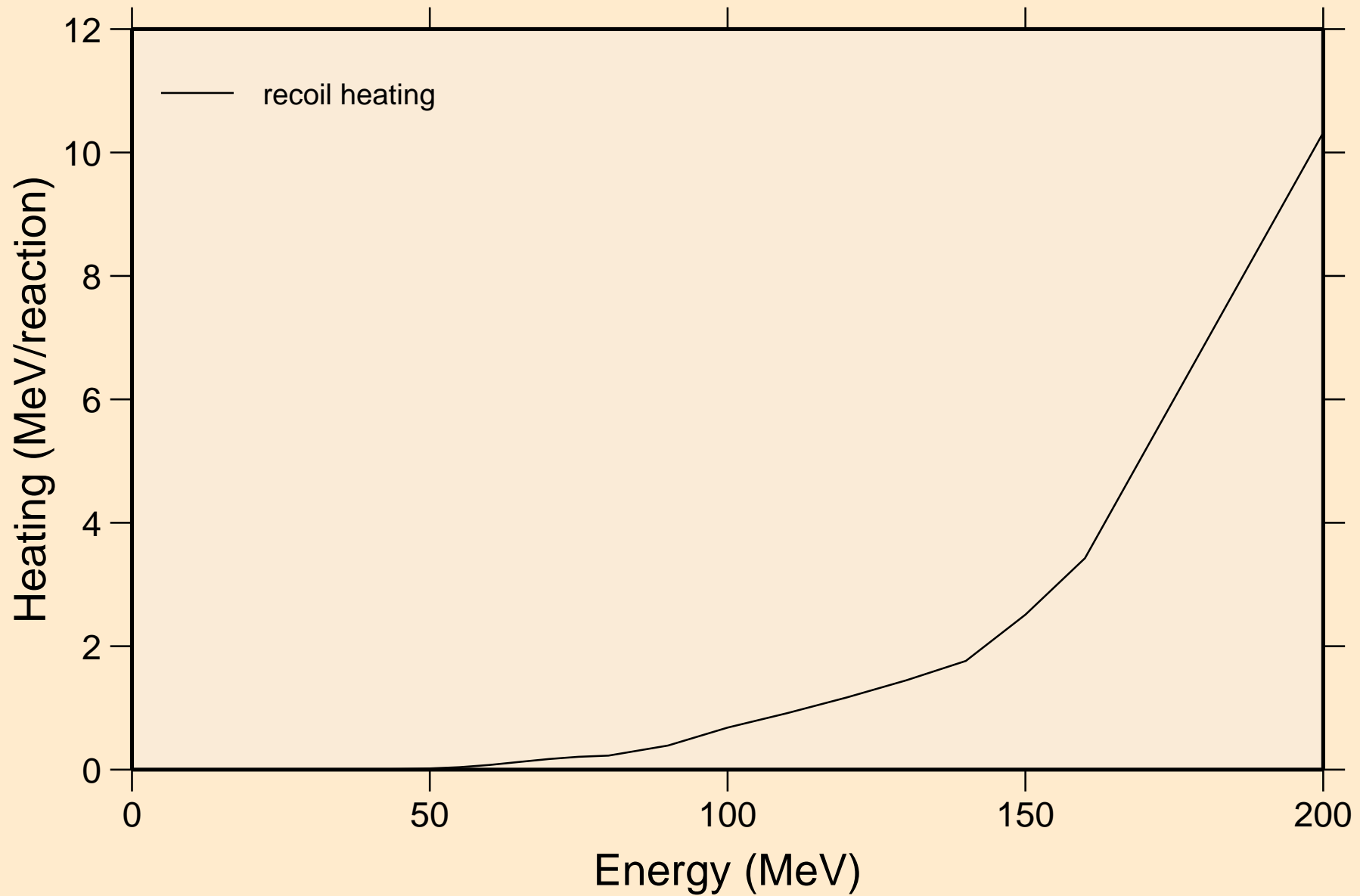

PA233 ALPHA ACER TENDL-2021 LIBRARY; T=0.K
Particle production cross sections

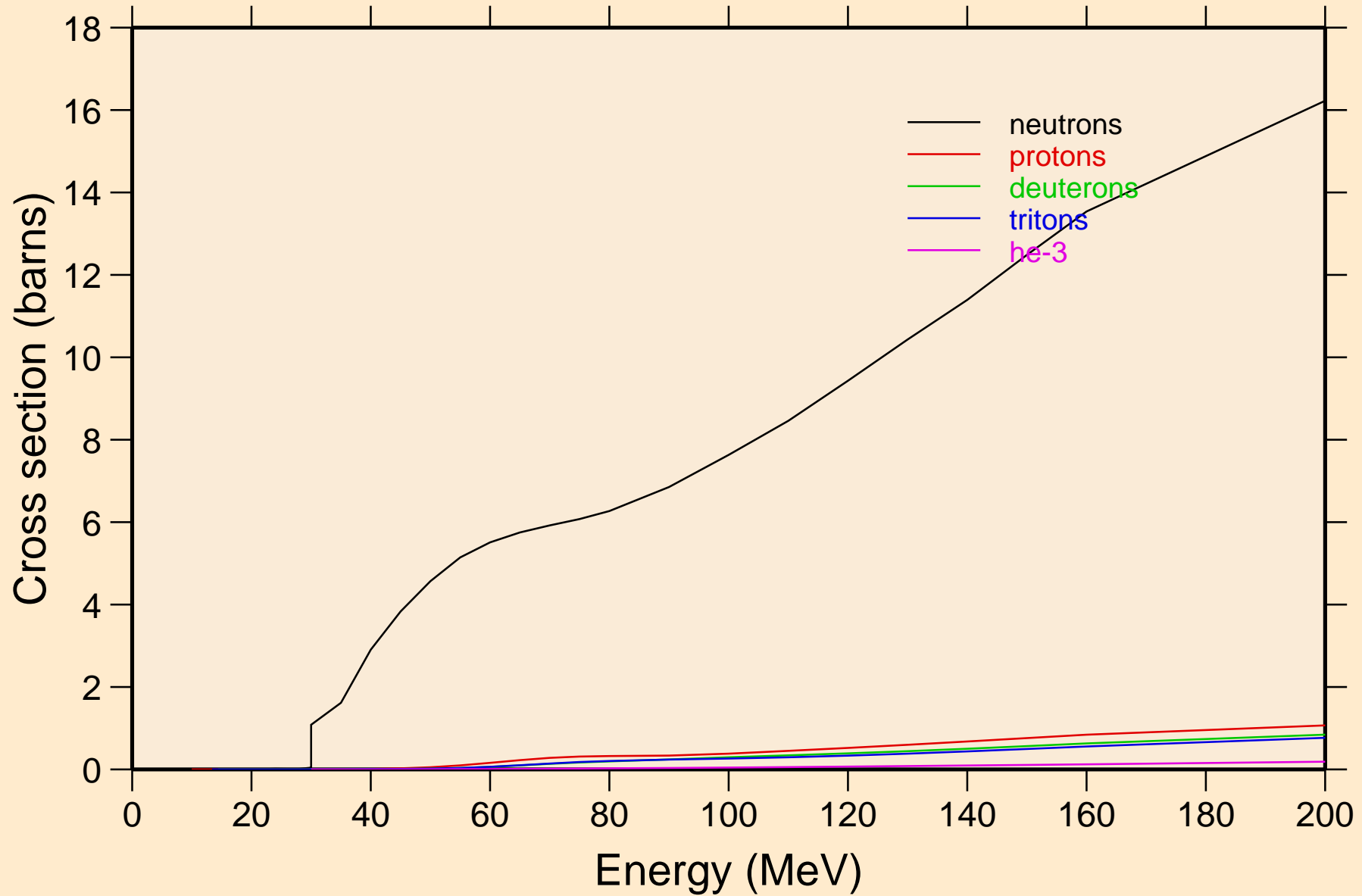

PA233 ALPHA ACER TENDL-2021 LIBRARY; T=0.K
neutrons from (a,n)

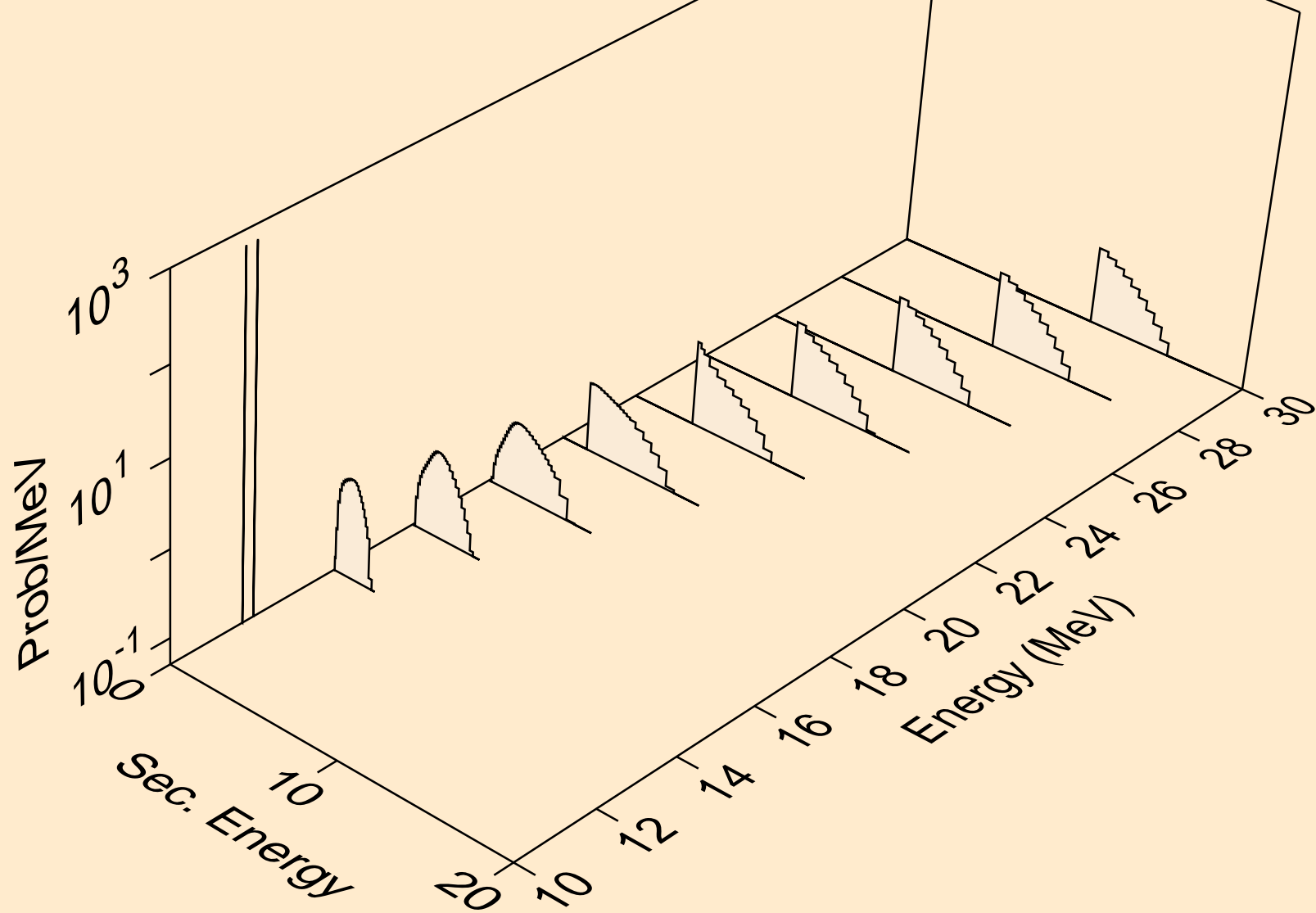

PA233 ALPHA ACER TENDL-2021 LIBRARY; T=0.K
neutrons from (a,x)

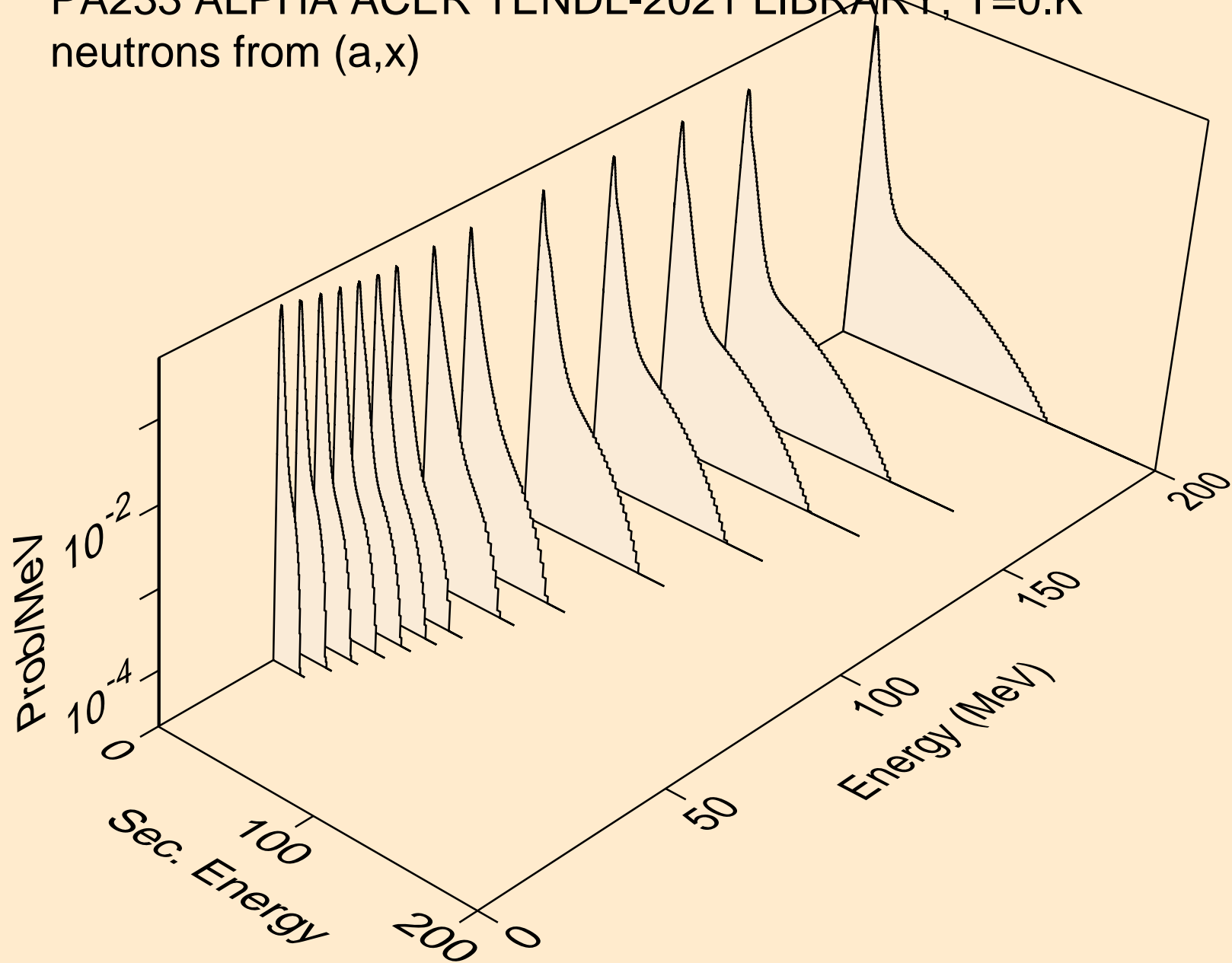

PA233 ALPHA ACER TENDL-2021 LIBRARY; T=0.K
neutrons from (a,2n)

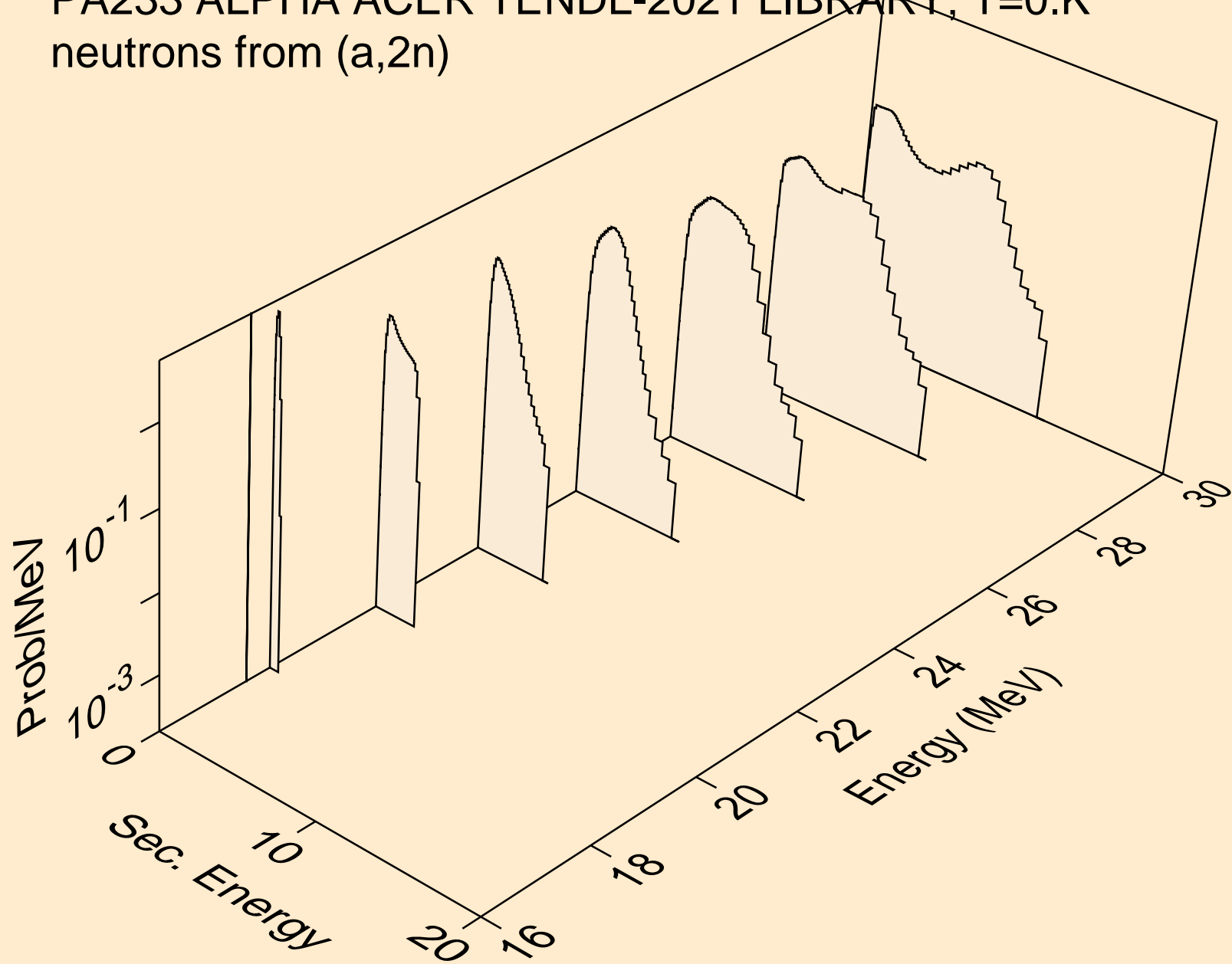

PA233 ALPHA ACER TENDL-2021 LIBRARY; T=0.K
neutrons from (a,3n)

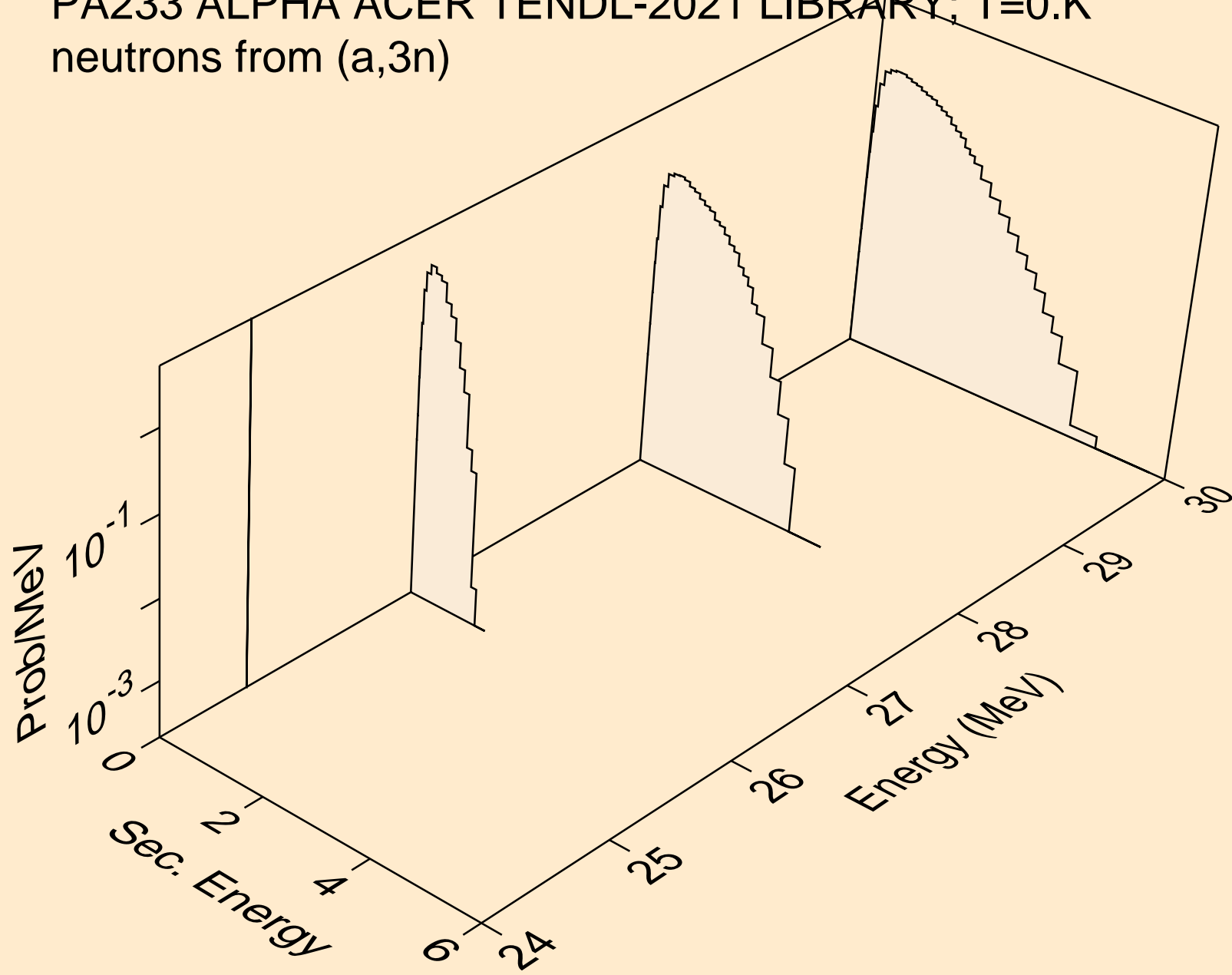

PA233 ALPHA ACER TENDL-2021 LIBRARY; T=0.K
neutrons from (a,n*)a

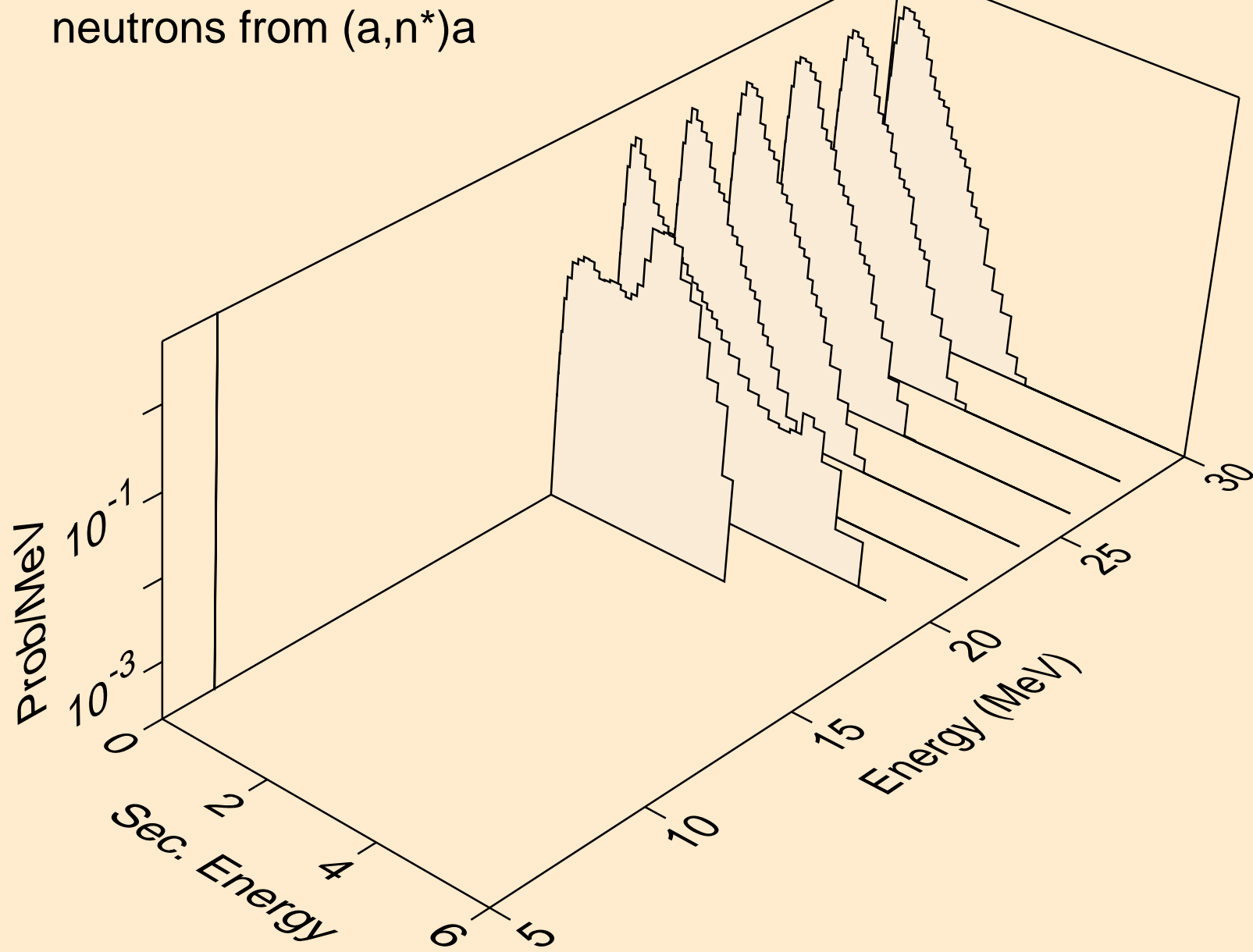

PA233 ALPHA ACER TENDL-2021 LIBRARY; T=0.K
neutrons from (a,2n)a

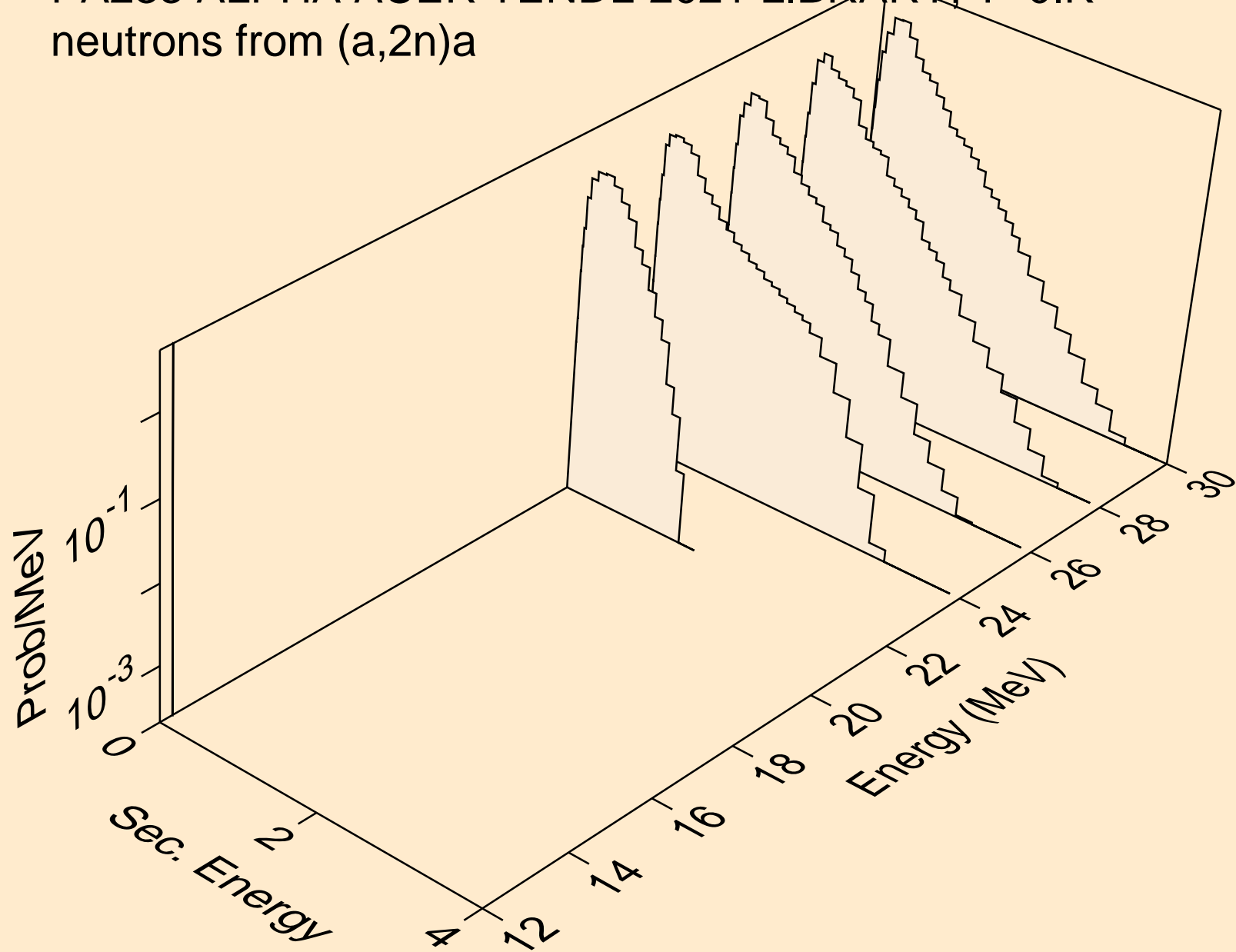

PA233 ALPHA ACER TENDL-2021 LIBRARY; T=0.K
neutrons from (a,n*)p

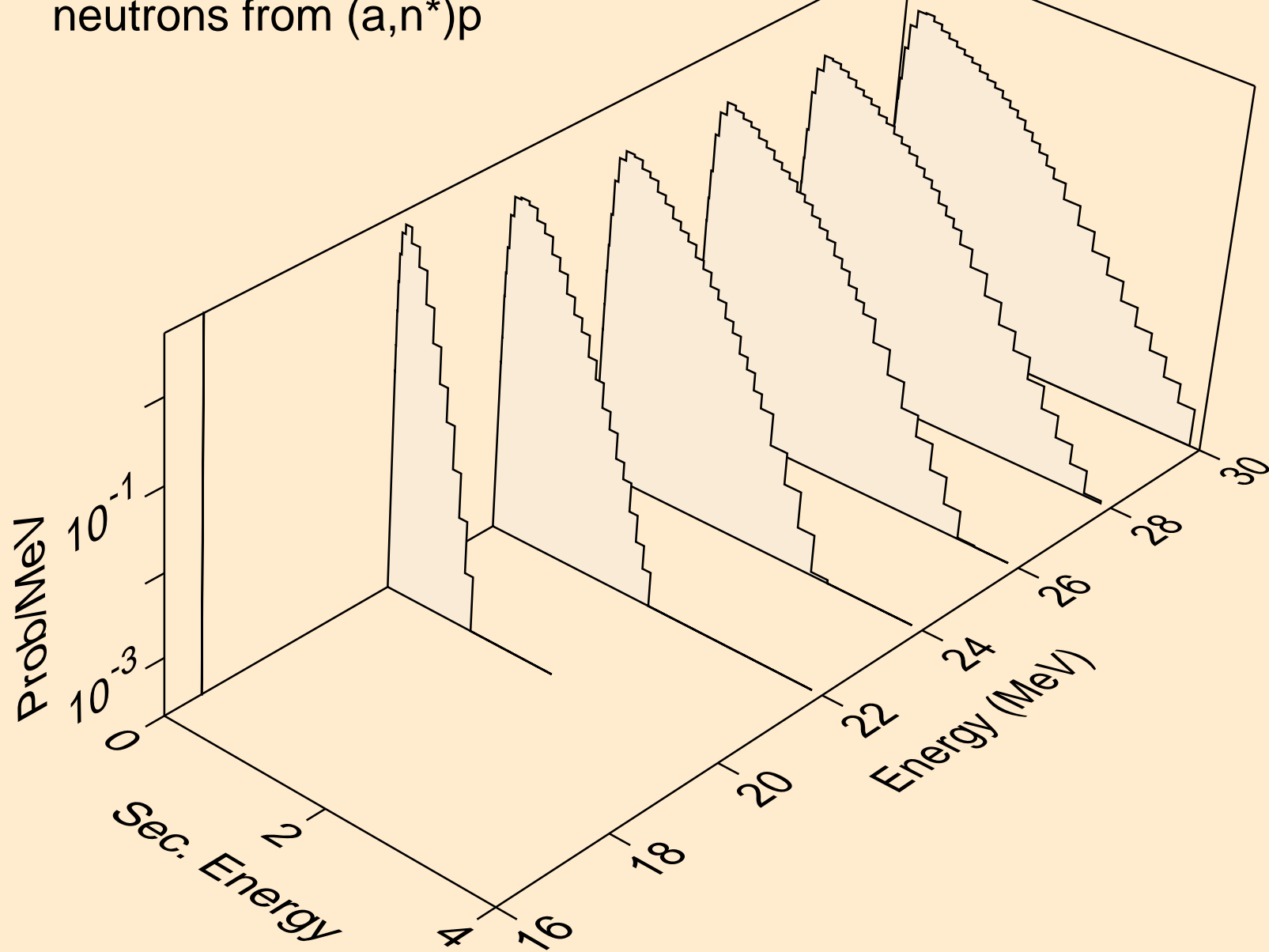

PA233 ALPHA ACER TENDL-2021 LIBRARY; T=0.K
neutrons from (a,n*)d

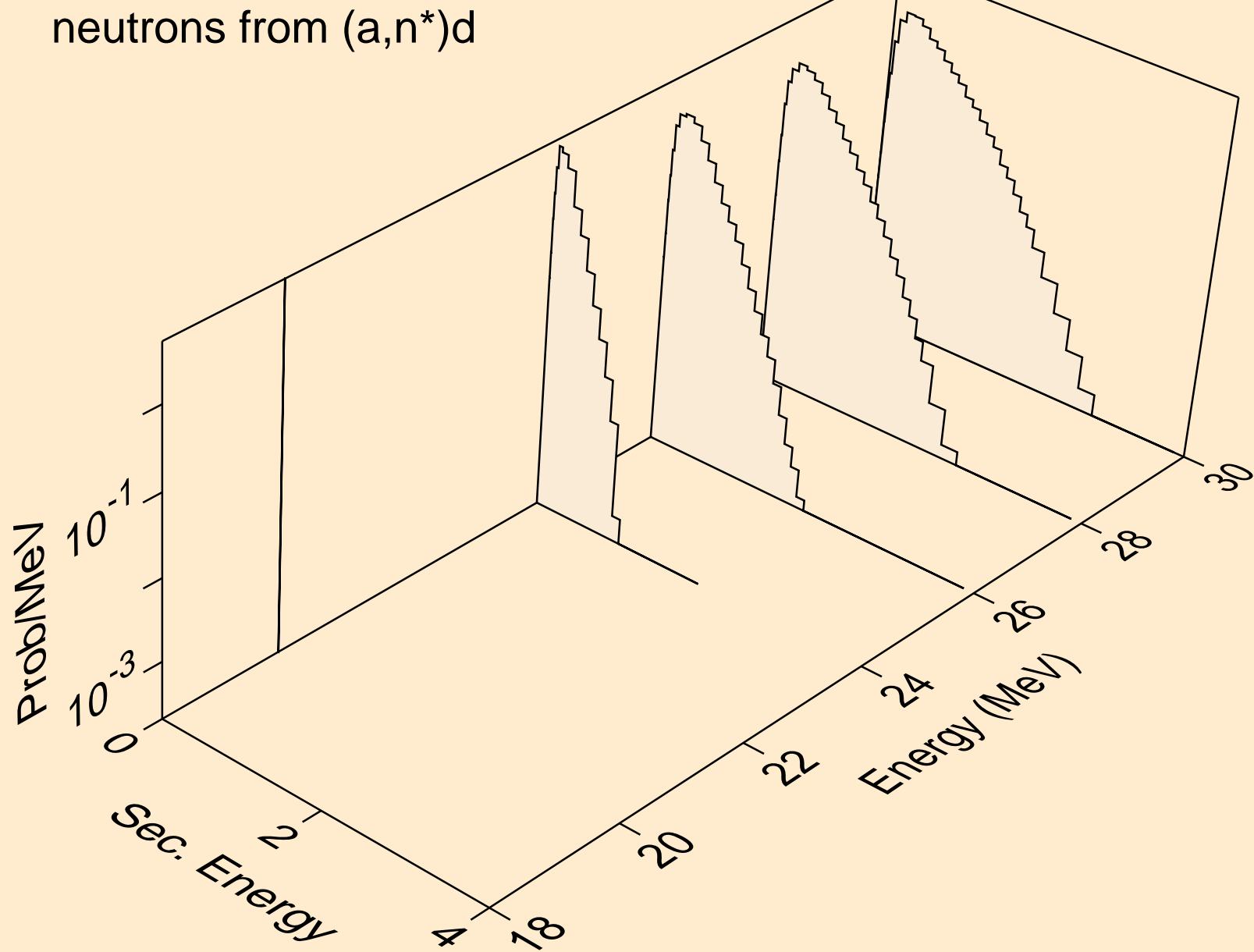

PA233 ALPHA ACER TENDL-2021 LIBRARY; T=0.K
neutrons from (a,n*)t

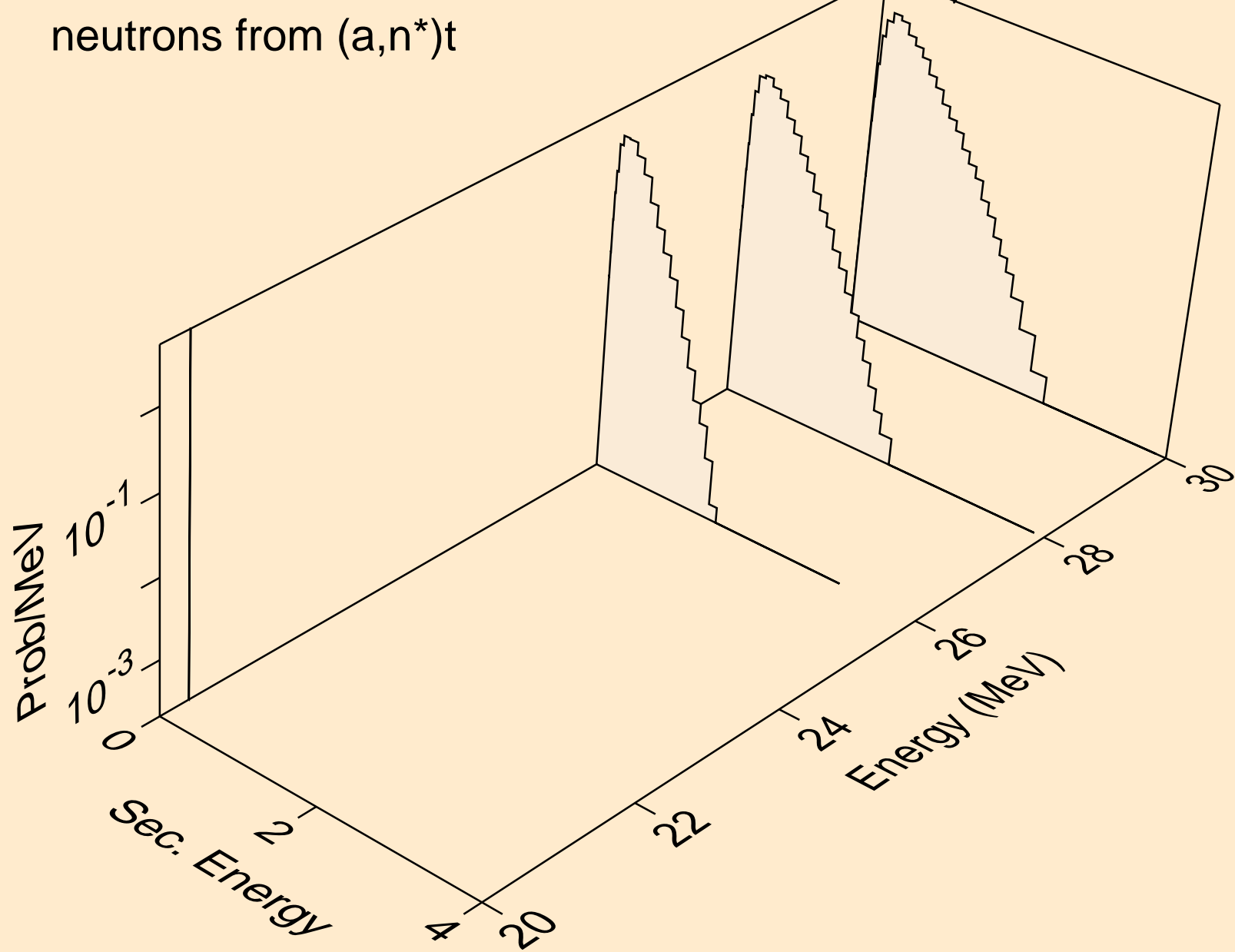

PA233 ALPHA ACER TENDL-2021 LIBRARY; T=0.K
neutrons from (a,2np)

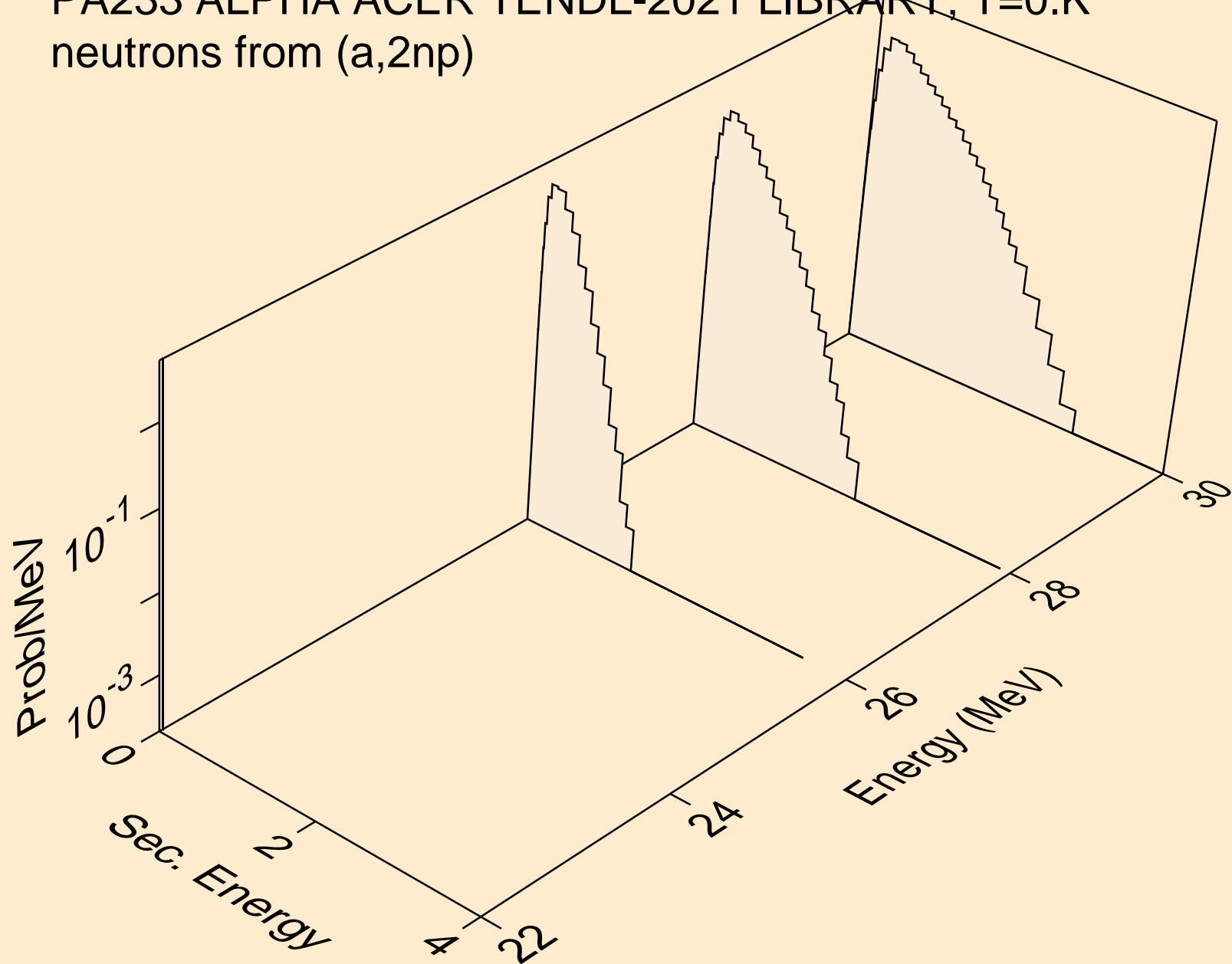

PA233 ALPHA ACER TENDL-2021 LIBRARY; T=0.K
protons from (a,x)

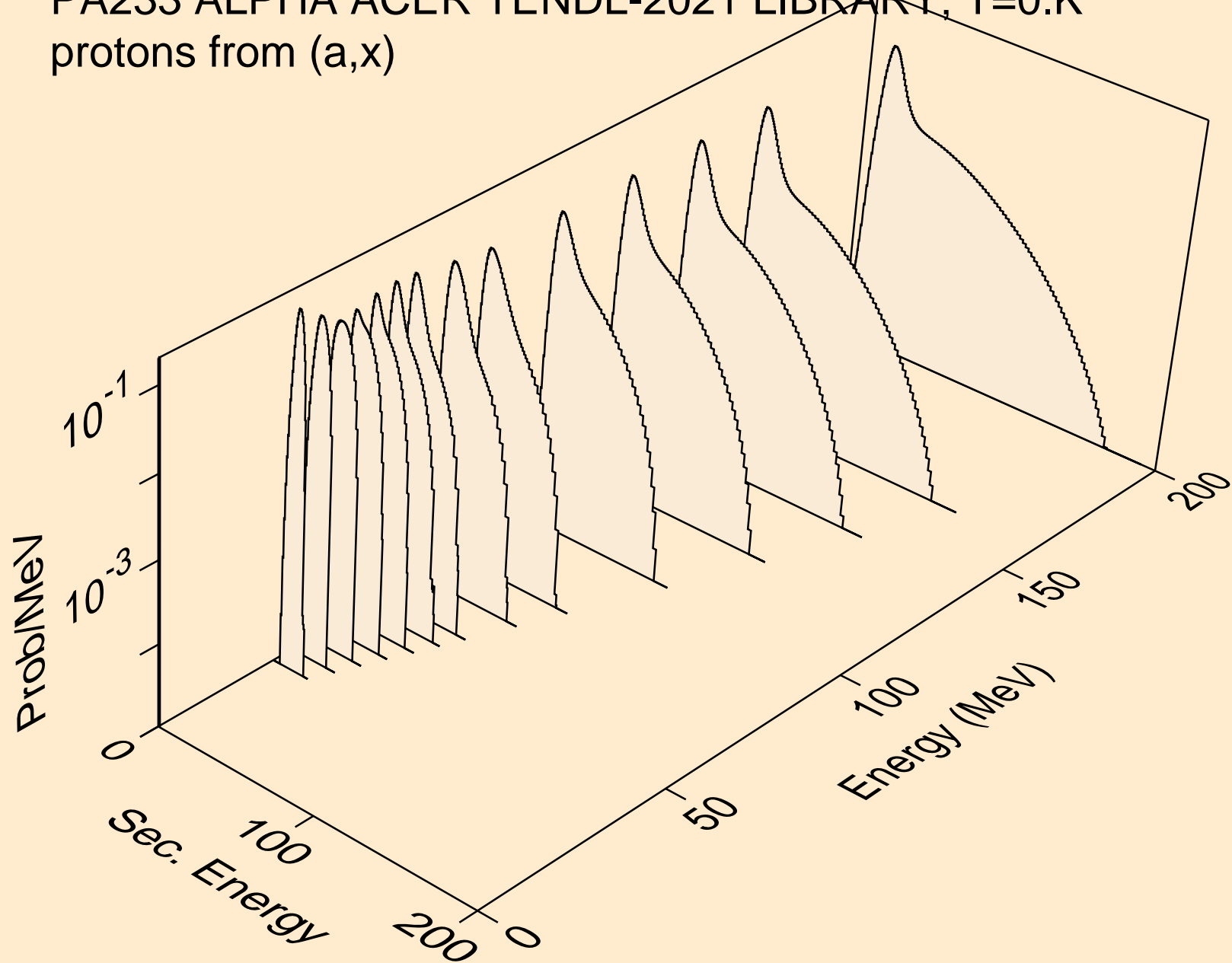

PA233 ALPHA ACER TENDL-2021 LIBRARY; T=0.K
protons from (a,n*)p

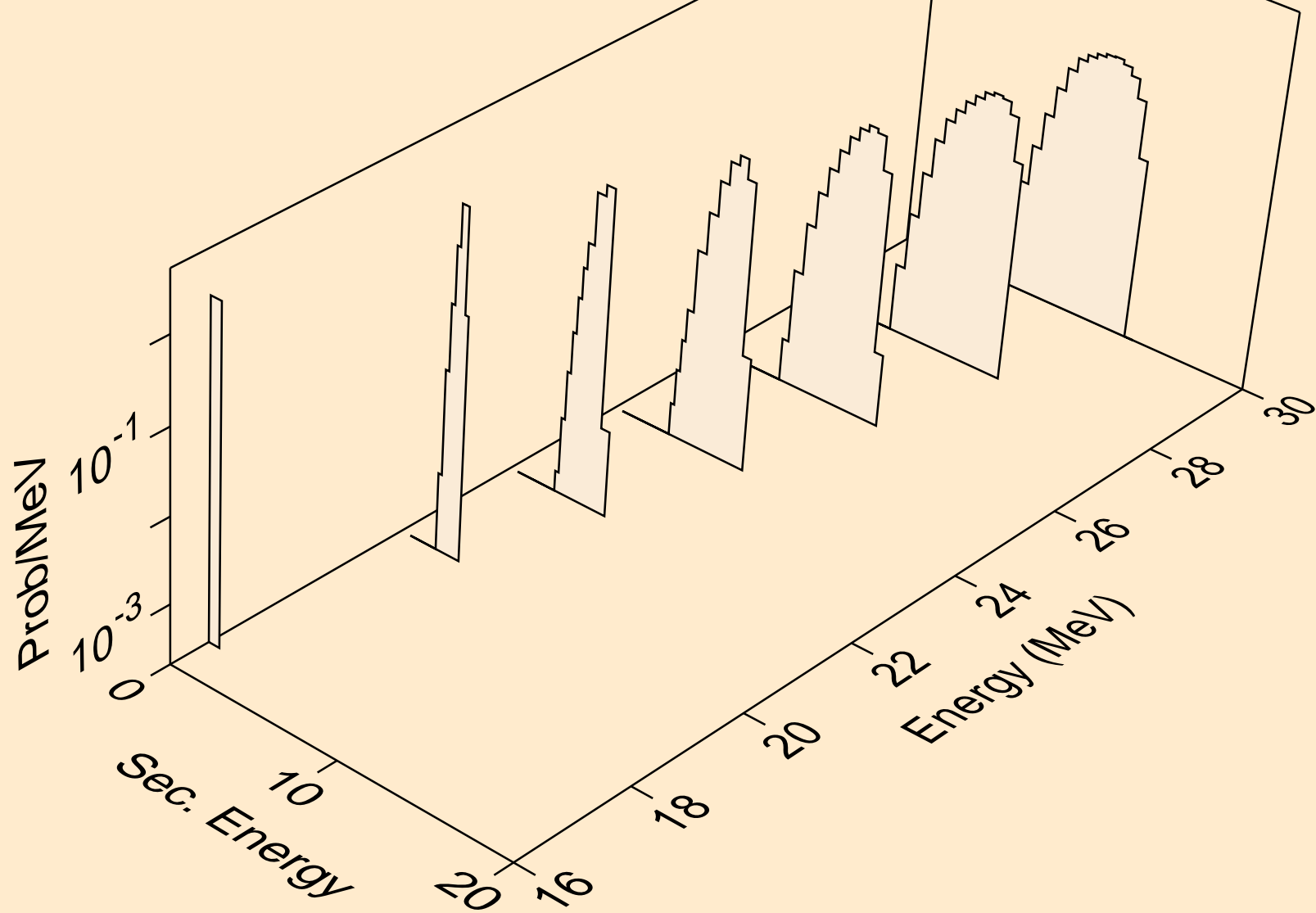

PA233 ALPHA ACER TENDL-2021 LIBRARY; T=0.K
protons from (a,2np)

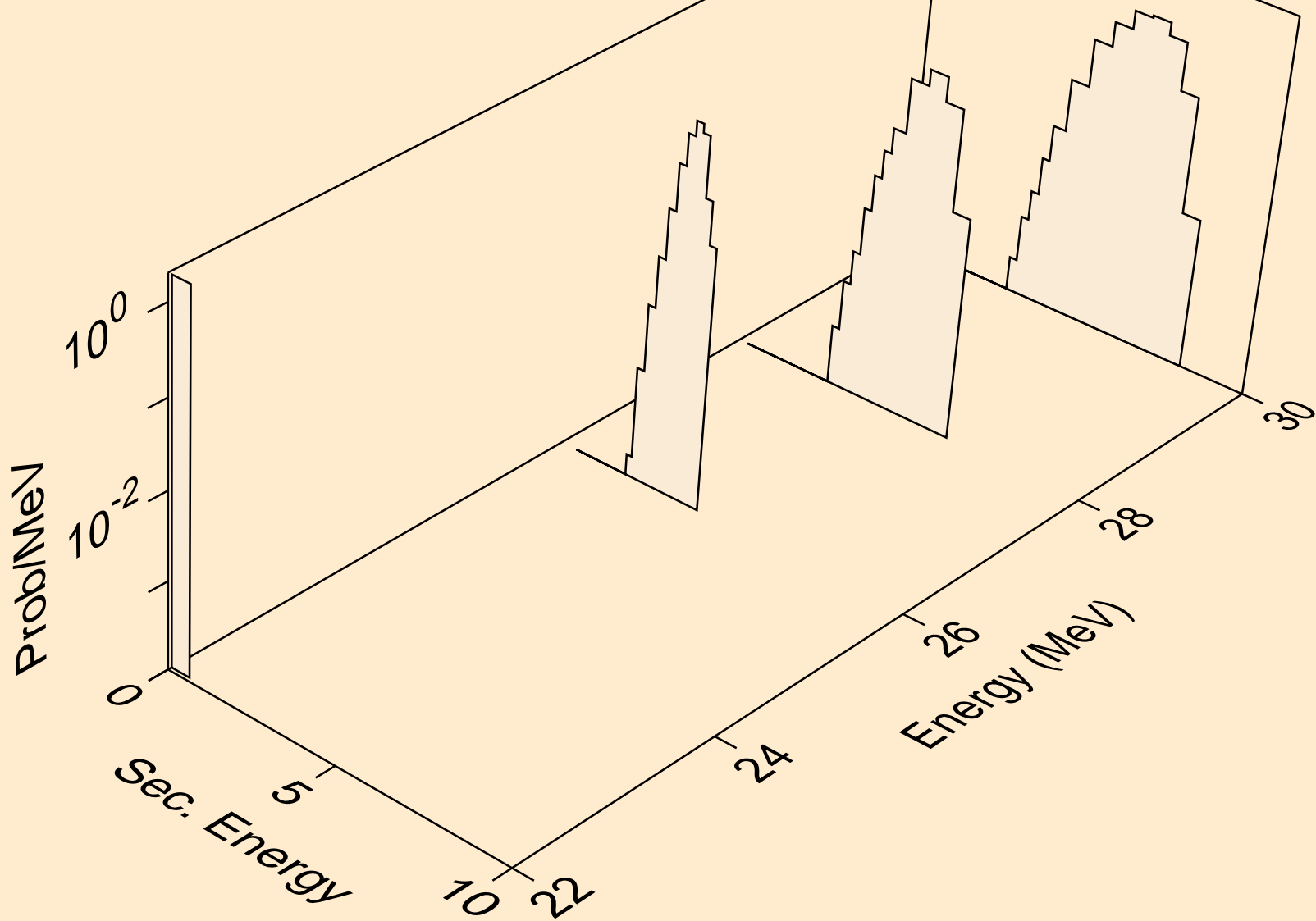

PA233 ALPHA ACER TENDL-2021 LIBRARY; T=0.K
protons from (a,p)

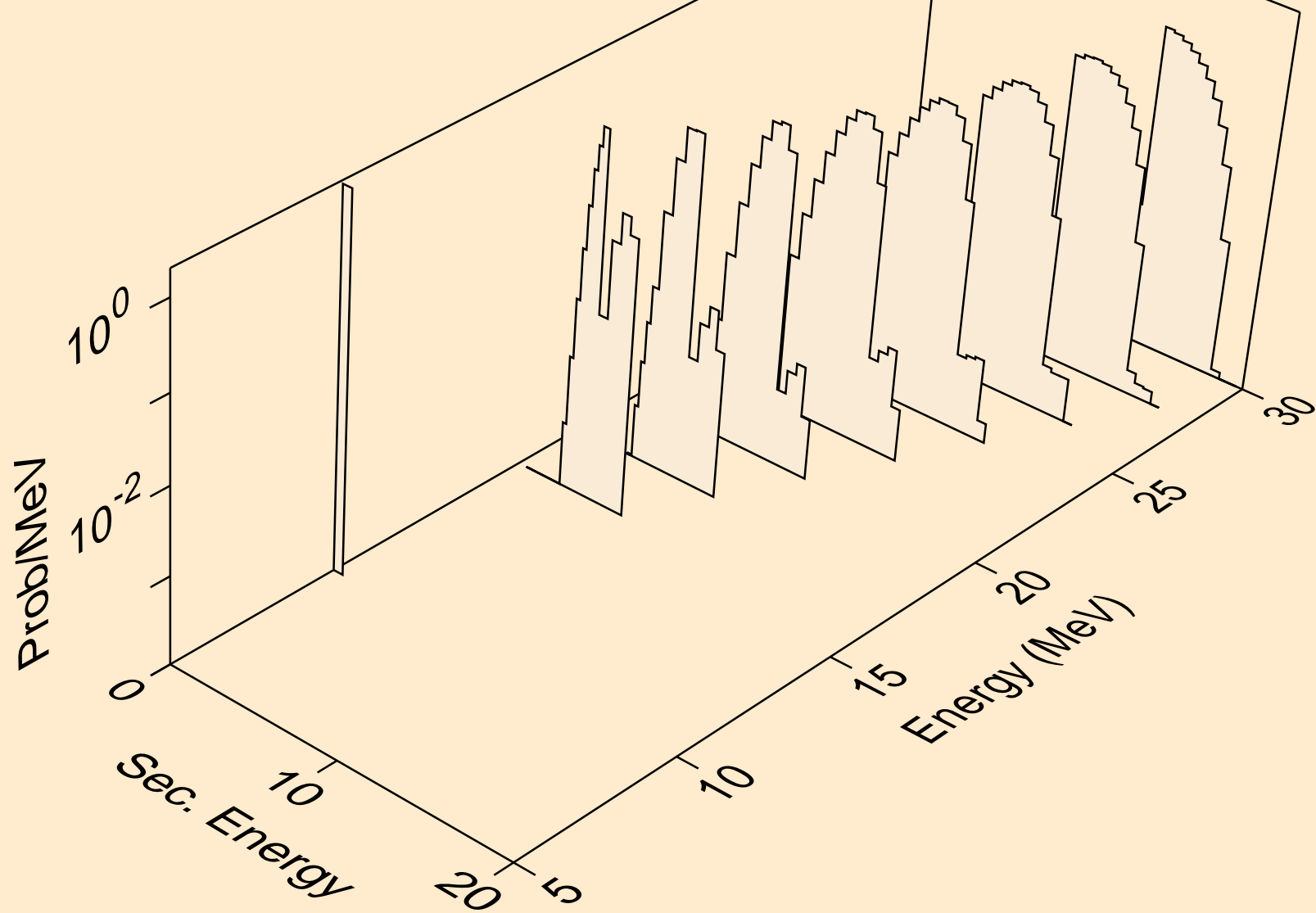

PA233 ALPHA ACER TENDL-2021 LIBRARY; T=0.K
deuterons from (a,x)

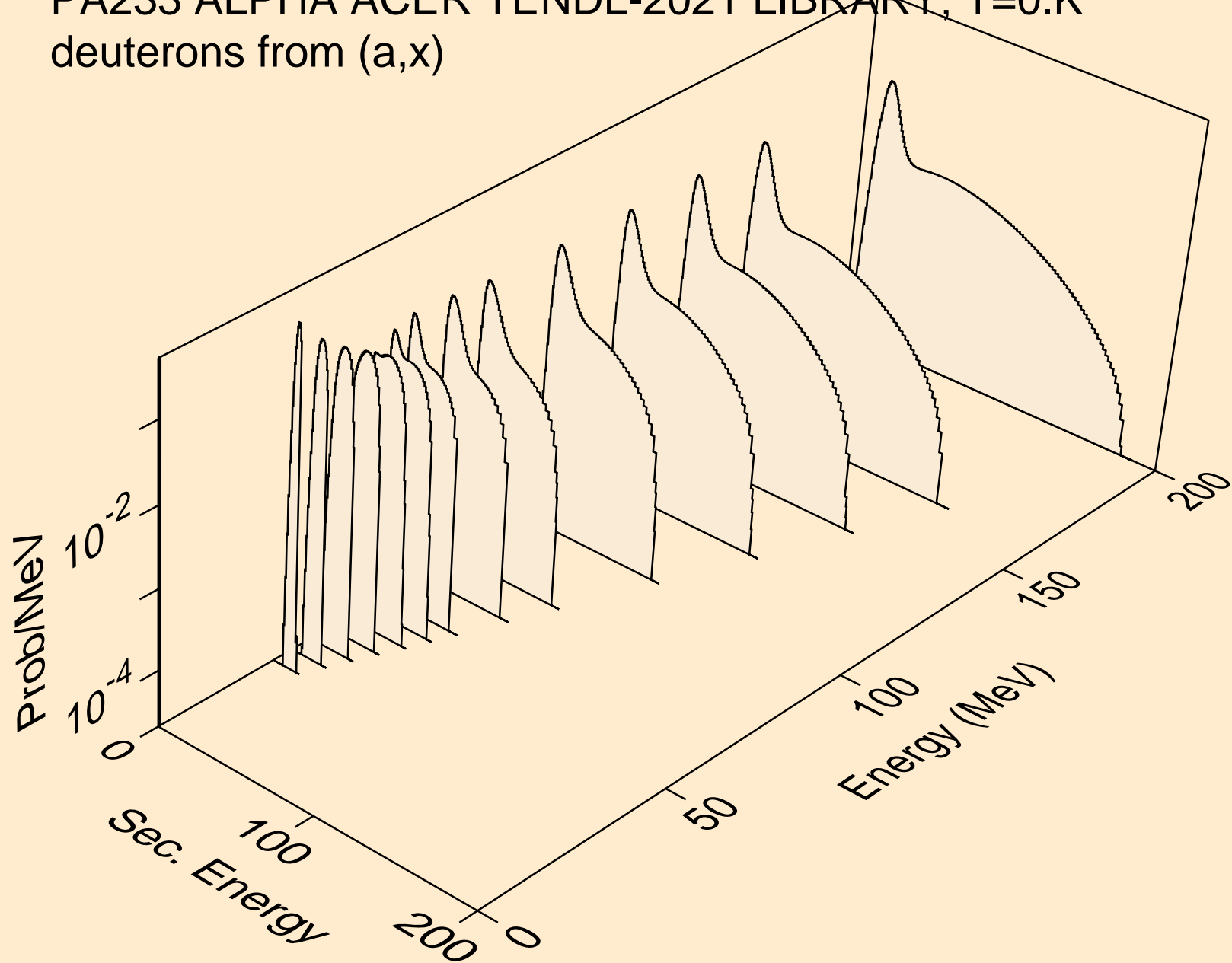

PA233 ALPHA ACER TENDL-2021 LIBRARY; T=0.K
deuterons from (a,n*)d

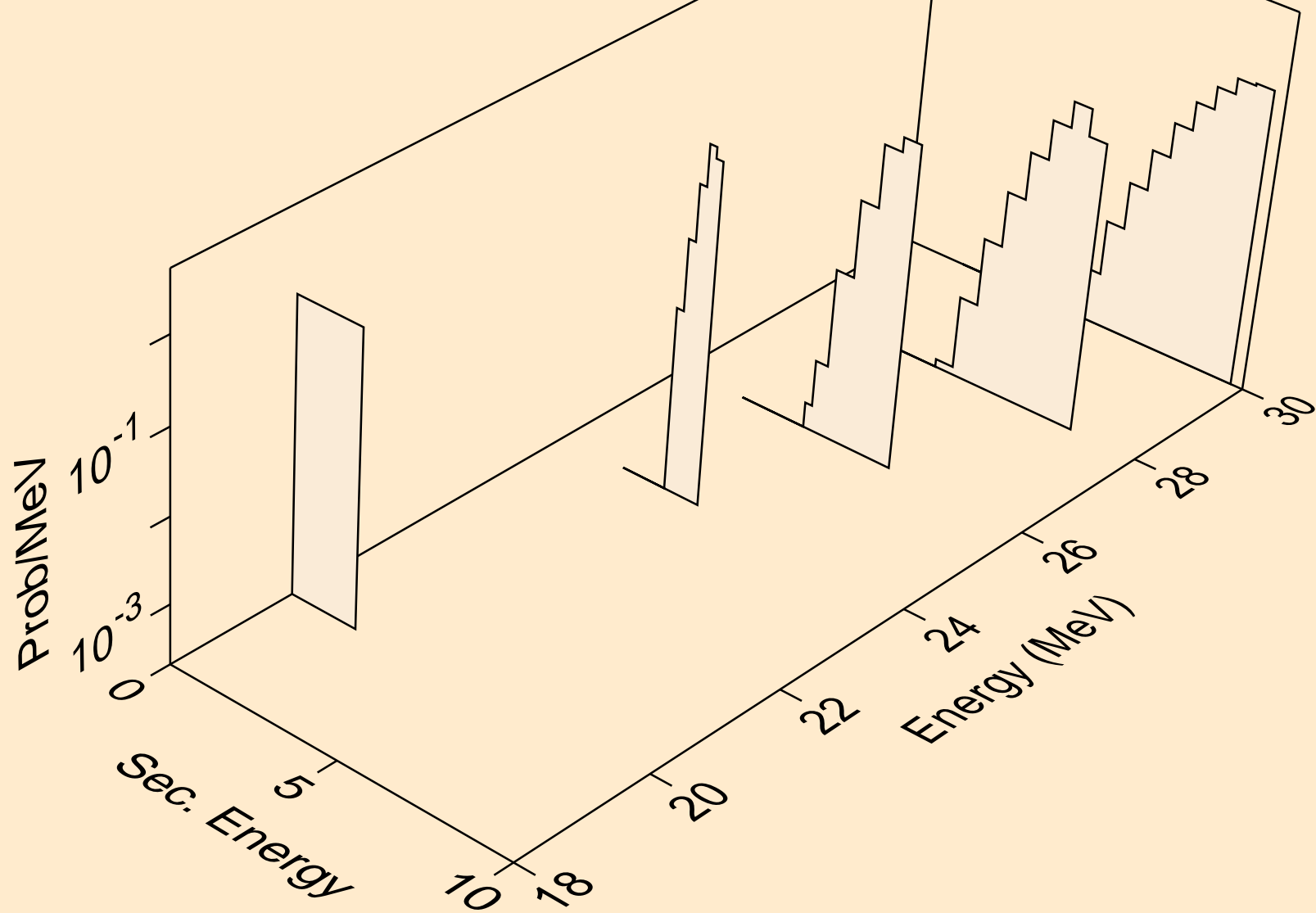

PA233 ALPHA ACER TENDL-2021 LIBRARY; T=0.K
deuterons from (a,d)

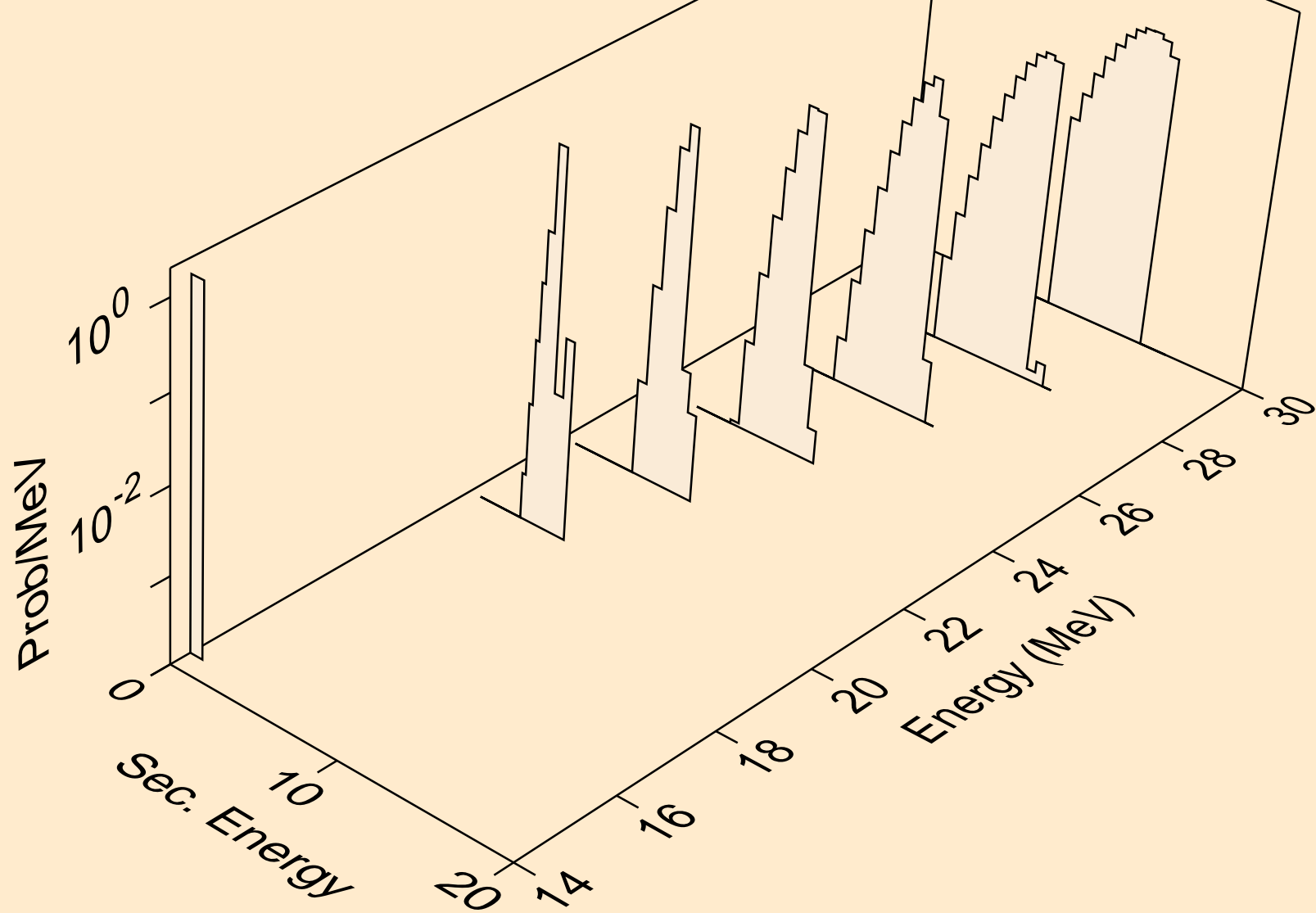

PA233 ALPHA ACER TENDL-2021 LIBRARY; T=0.K
tritons from (a,x)

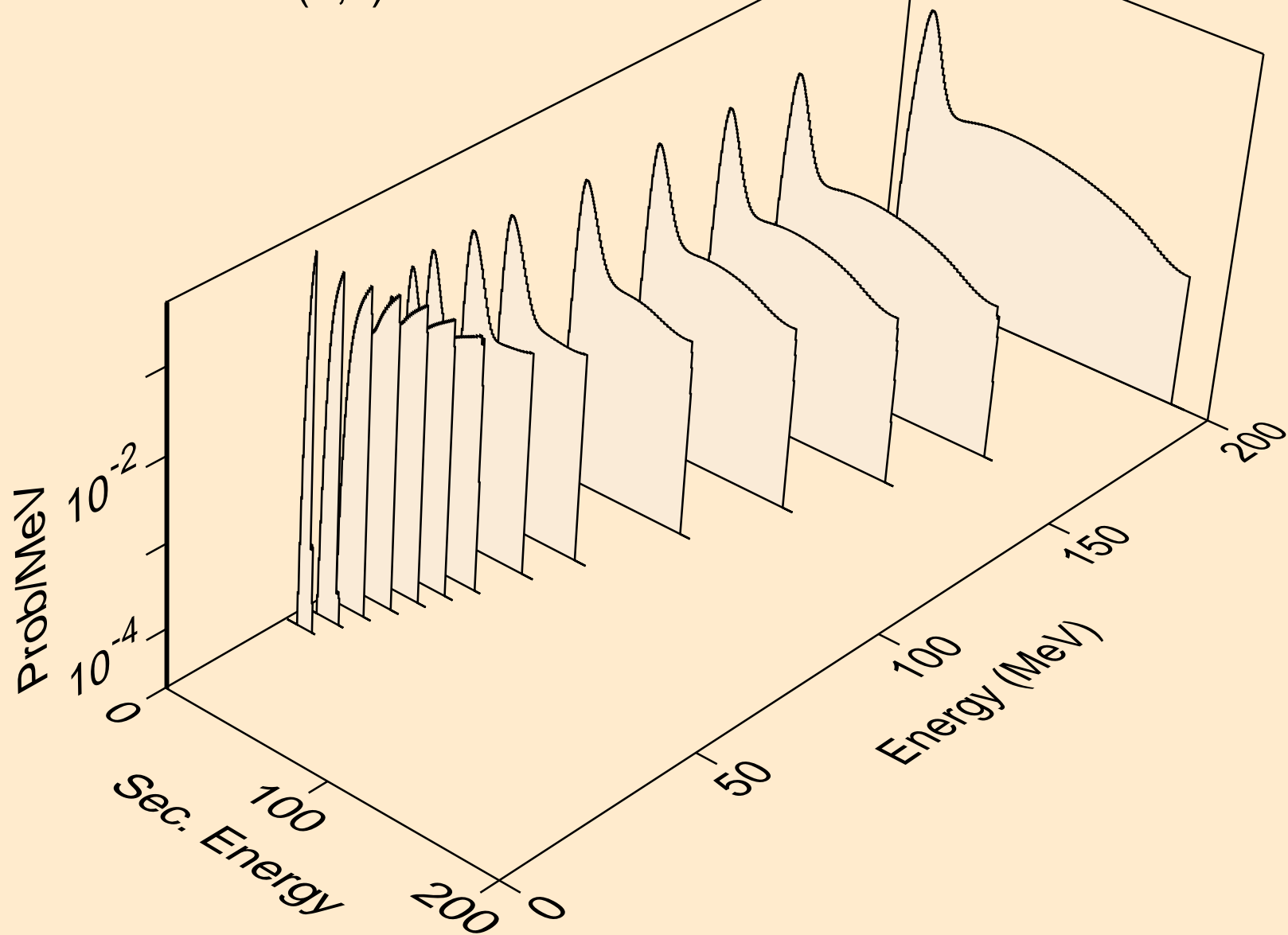

PA233 ALPHA ACER TENDL-2021 LIBRARY; T=0.K
tritons from (a,n*)t

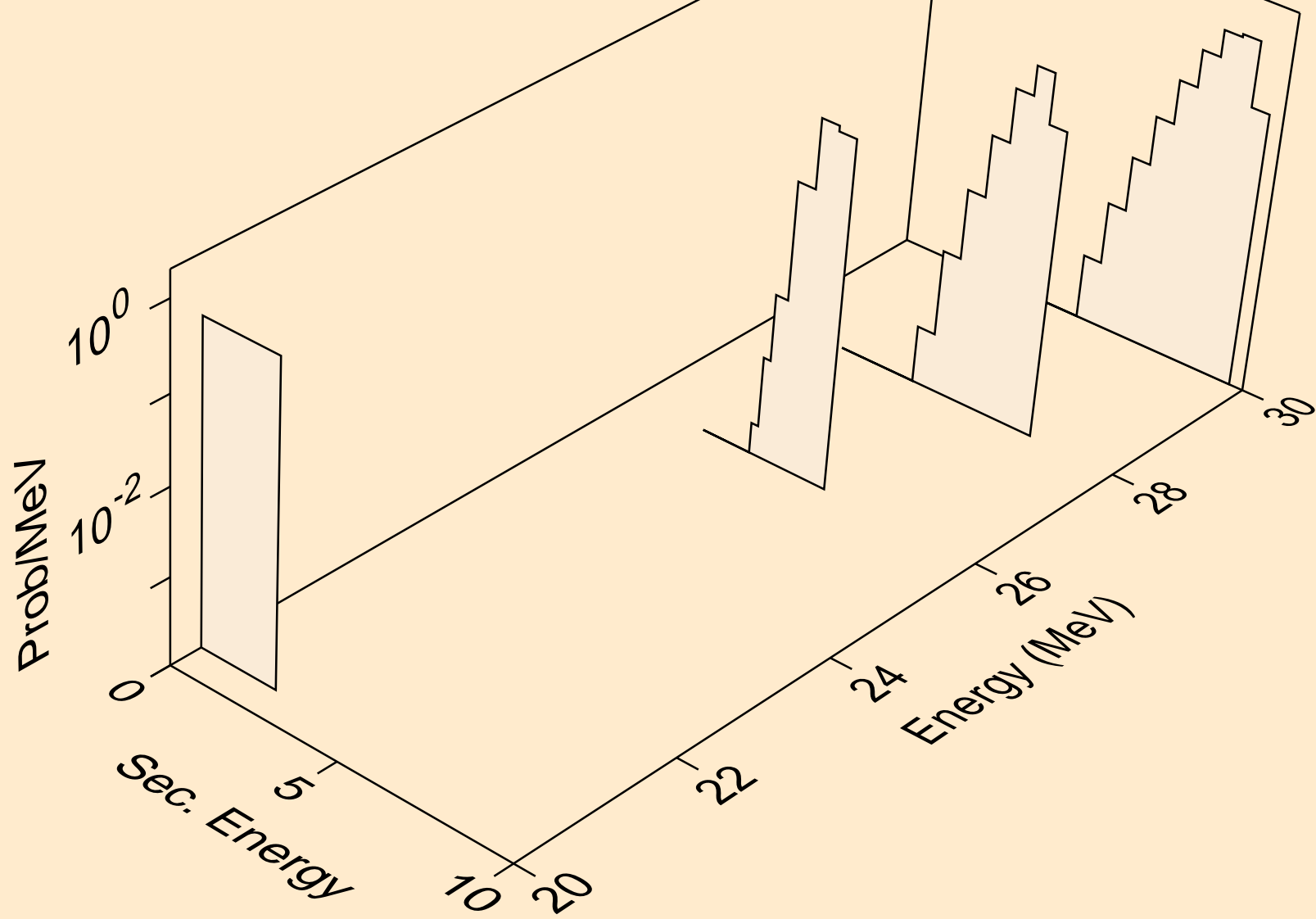

PA233 ALPHA ACER TENDL-2021 LIBRARY; T=0.K
tritons from (a,t)

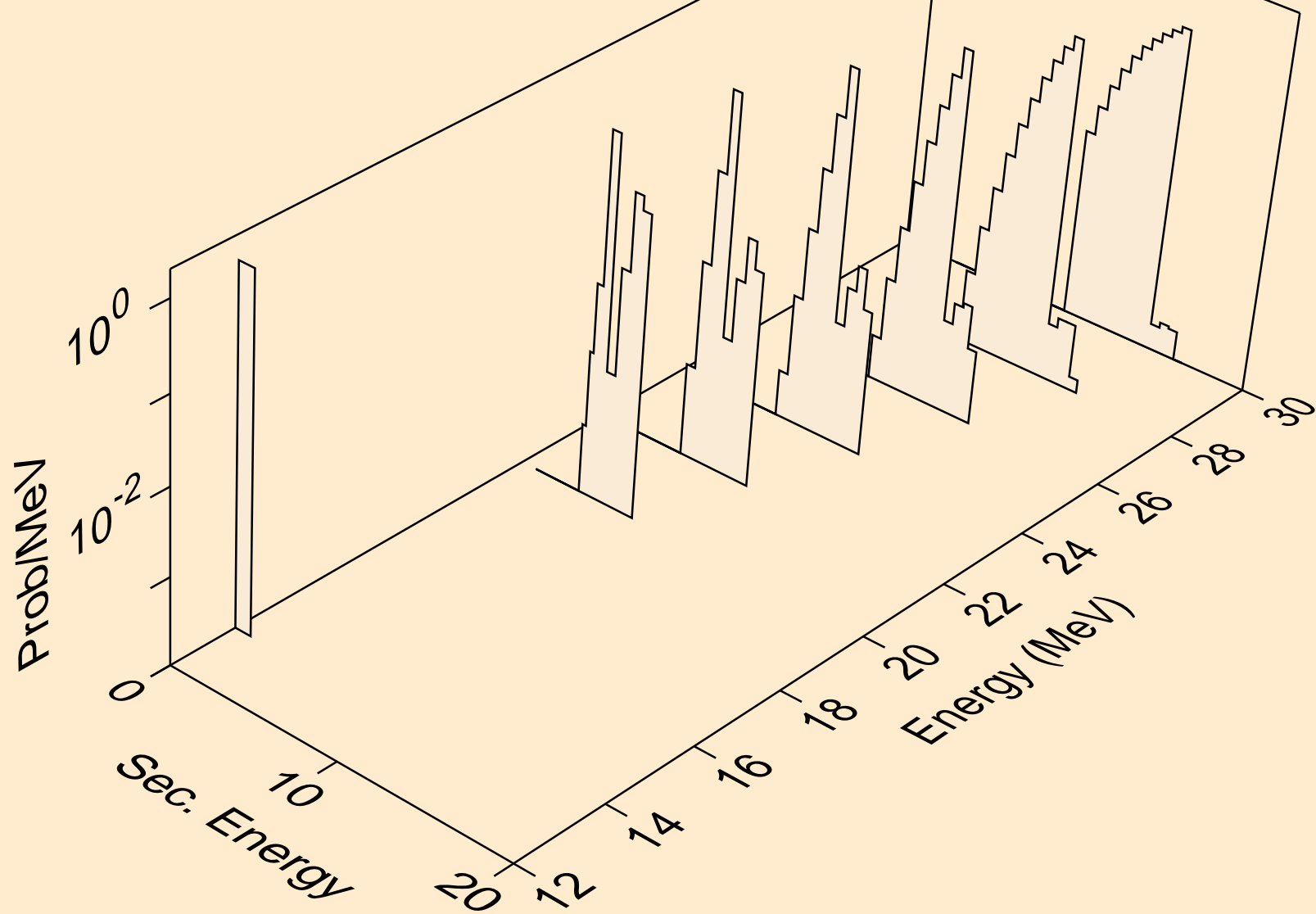

PA233 ALPHA ACER TENDL-2021 LIBRARY; T=0.K
he3s from (a,x)

