

RE193 ALPHA ACER TENDL-2021 LIBRARY; T=0.K

Principal cross sections

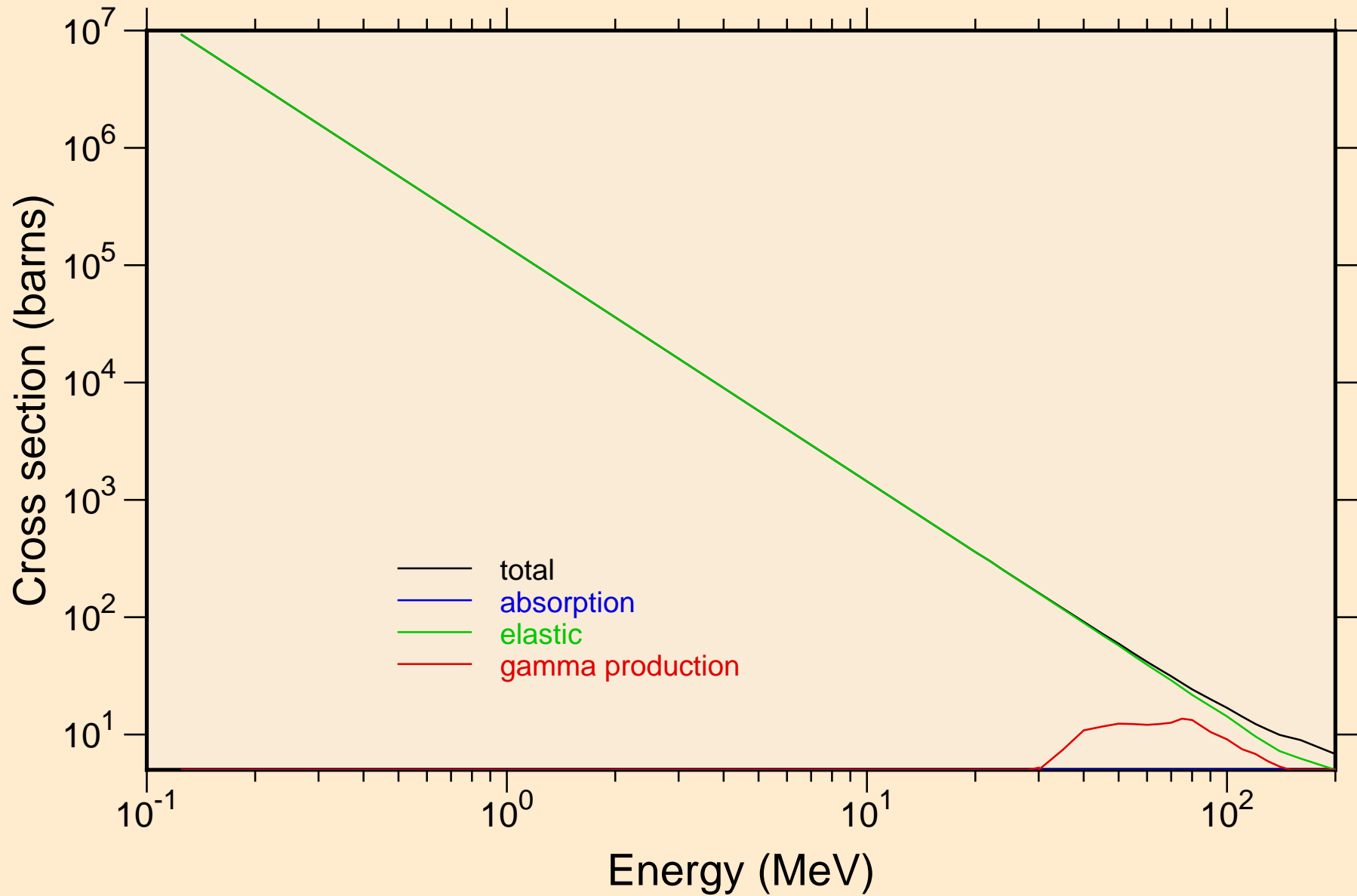

RE193 ALPHA ACER TENDL-2021 LIBRARY; T=0.K
Heating

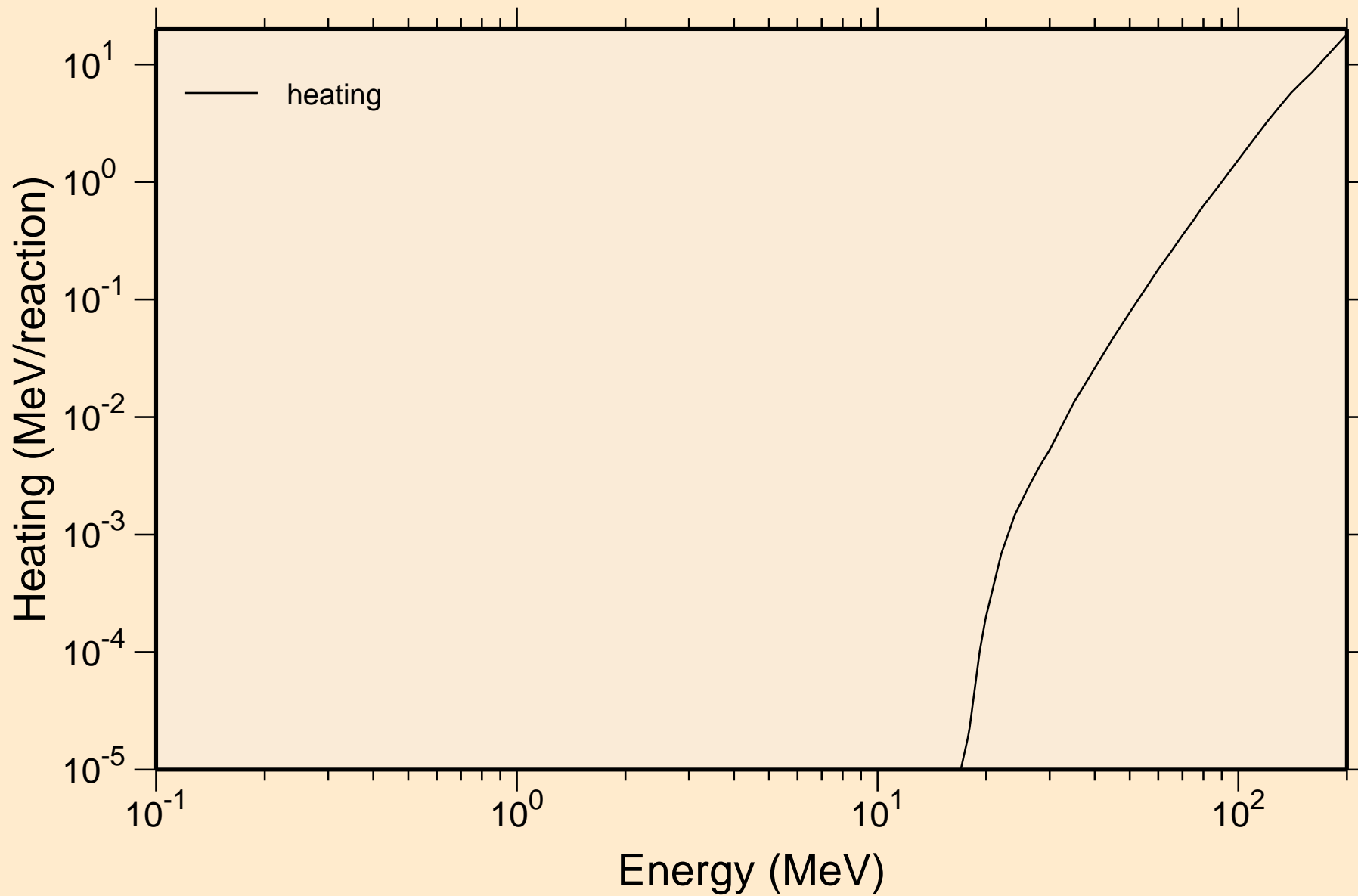

RE193 ALPHA ACER TENDL-2021 LIBRARY; T=0.K

Principal cross sections

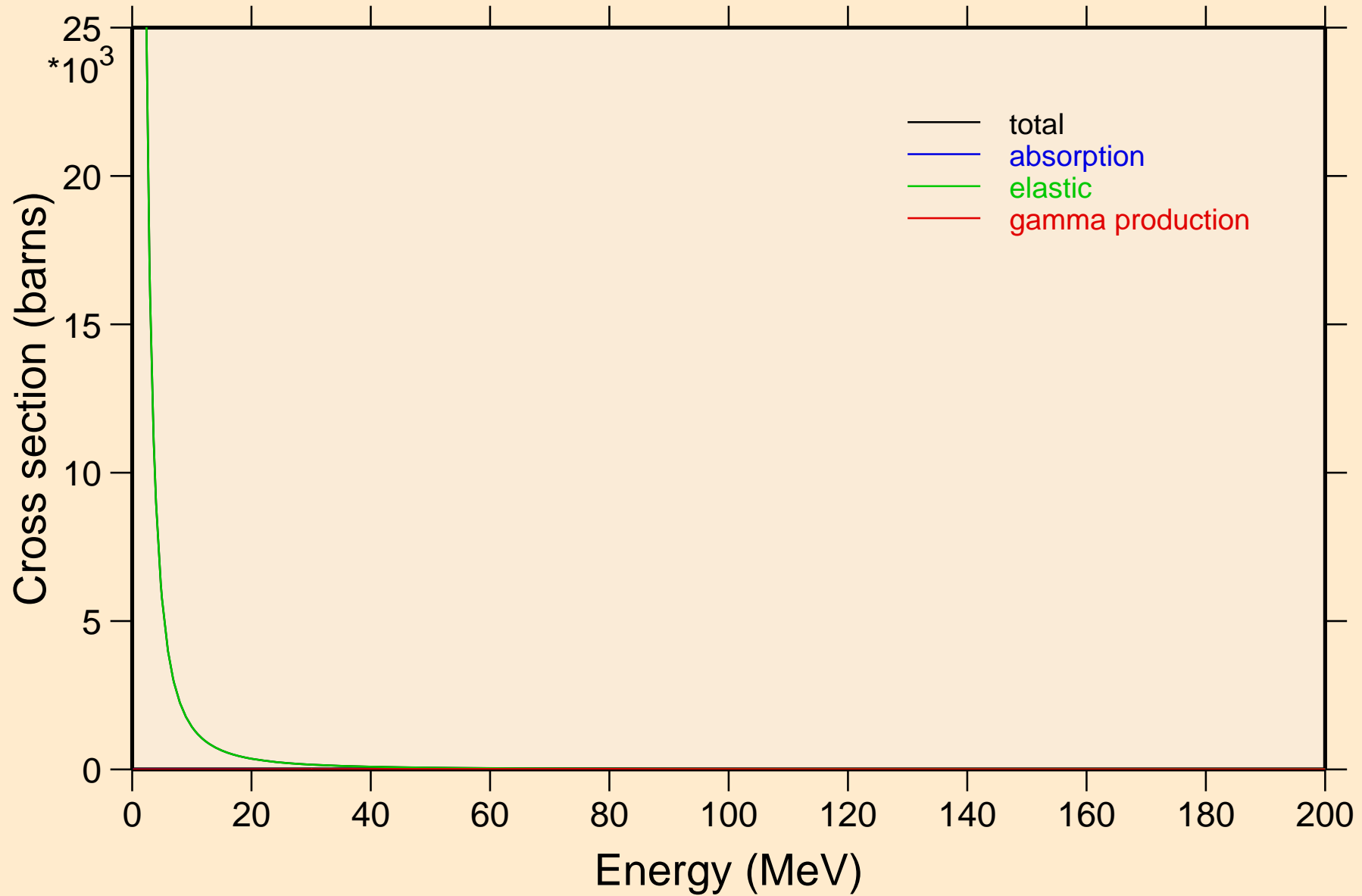

RE193 ALPHA ACER TENDL-2021 LIBRARY; T=0.K

Heating

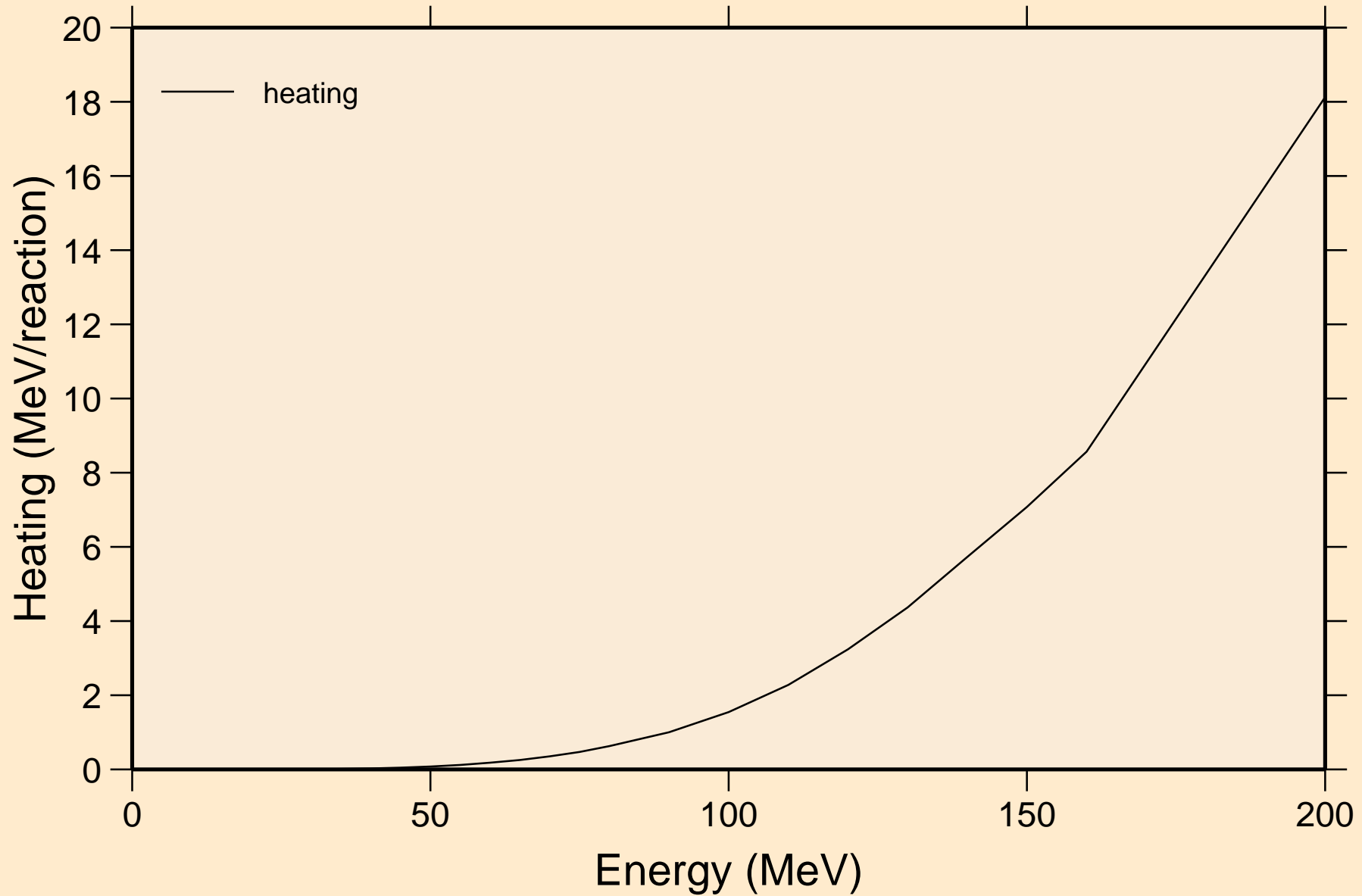

RE193 ALPHA ACER TENDL-2021 LIBRARY; T=0.K
Threshold reactions

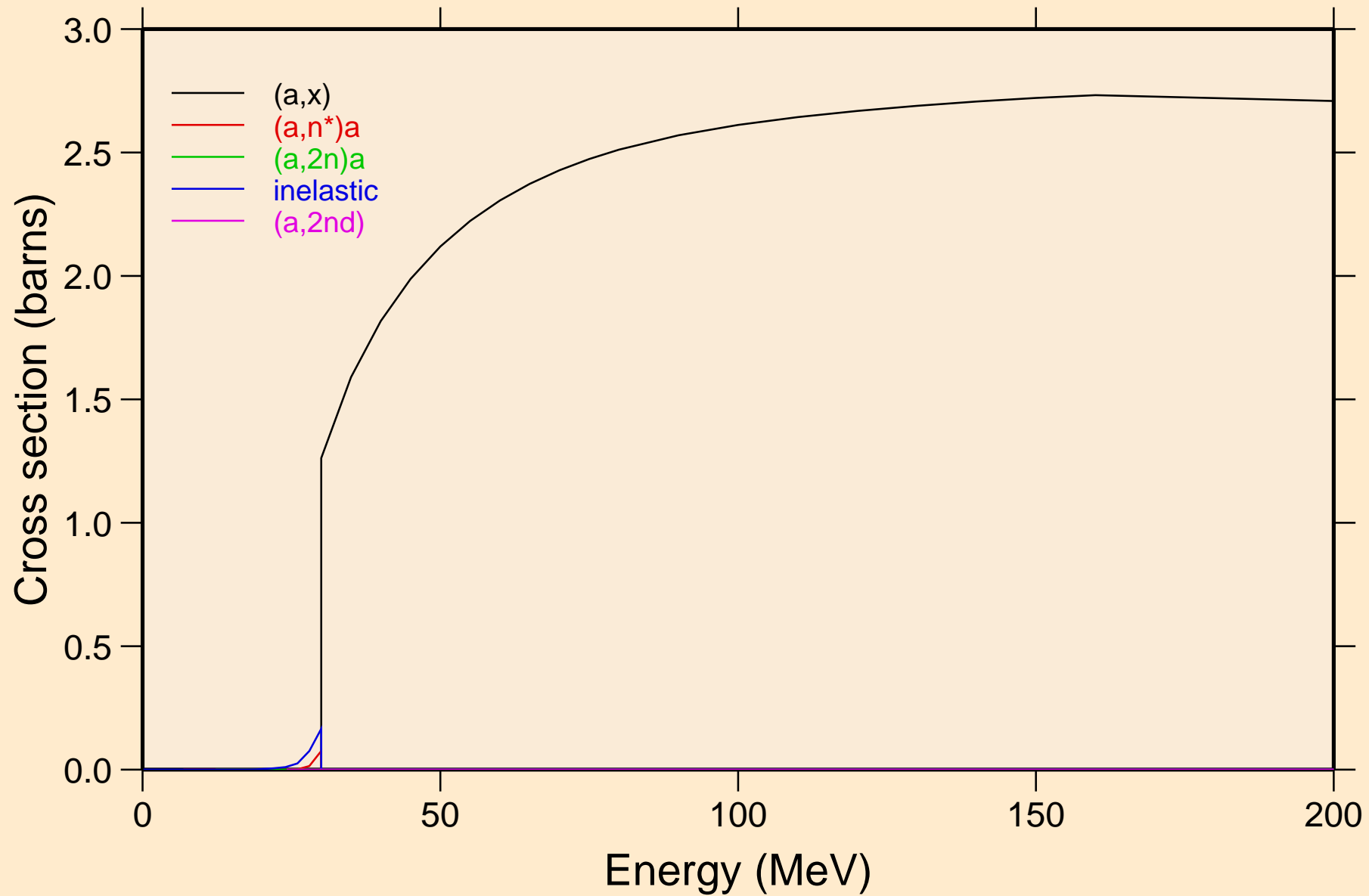

RE193 ALPHA ACER TENDL-2021 LIBRARY; T=0.K
Threshold reactions

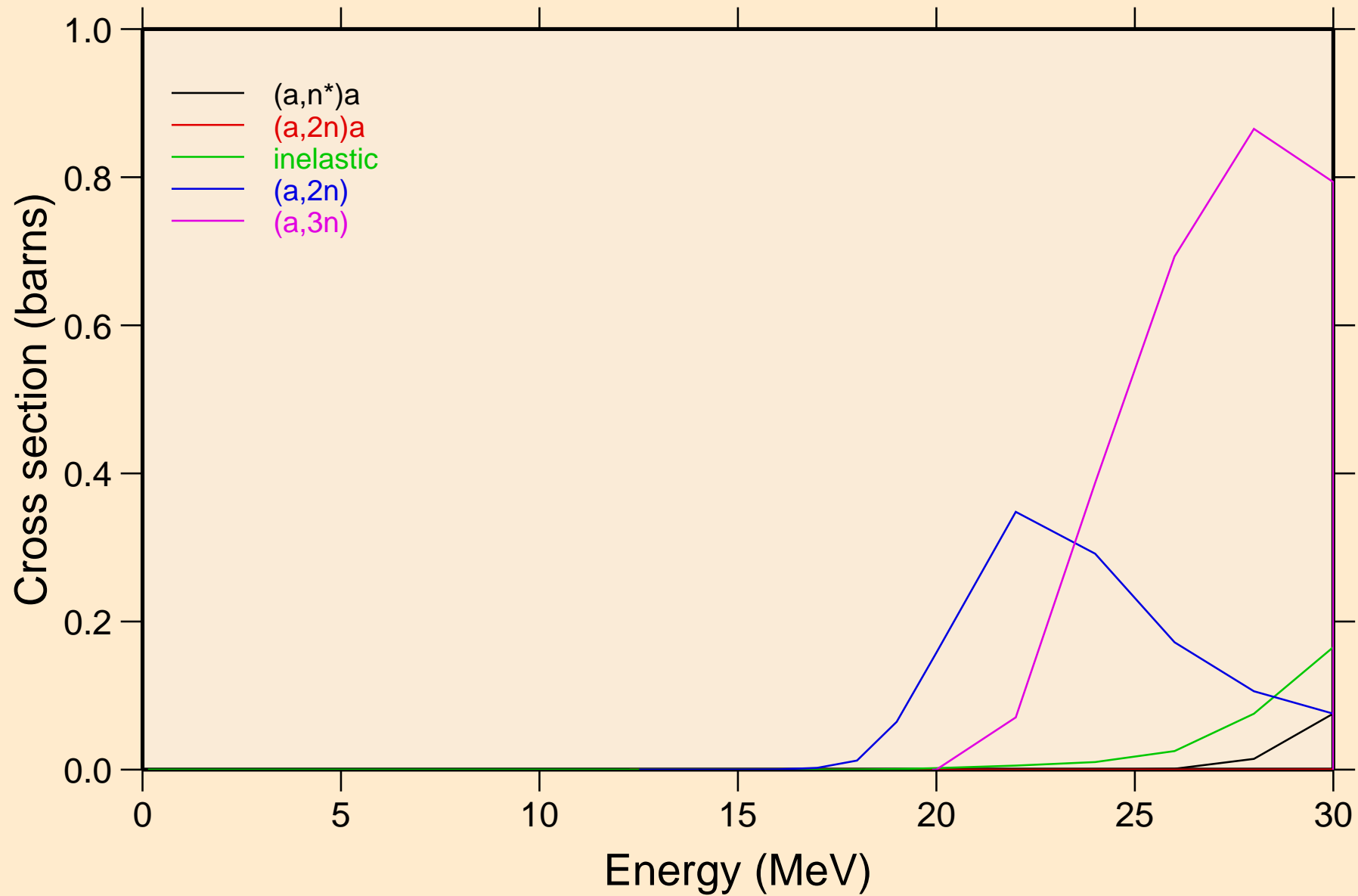

RE193 ALPHA ACER TENDL-2021 LIBRARY; T=0.K
Threshold reactions

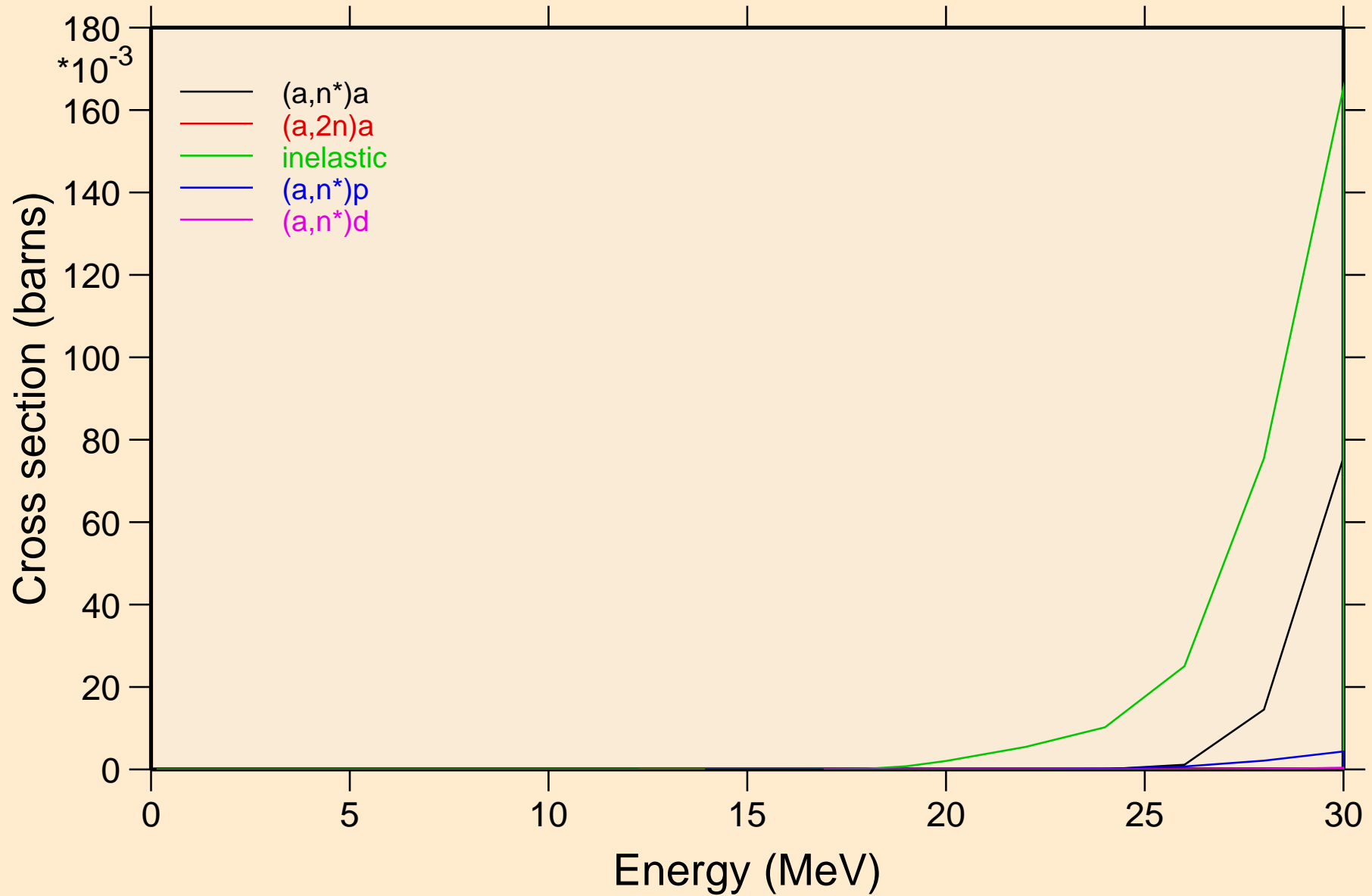

RE193 ALPHA ACER TENDL-2021 LIBRARY; T=0.K
Threshold reactions

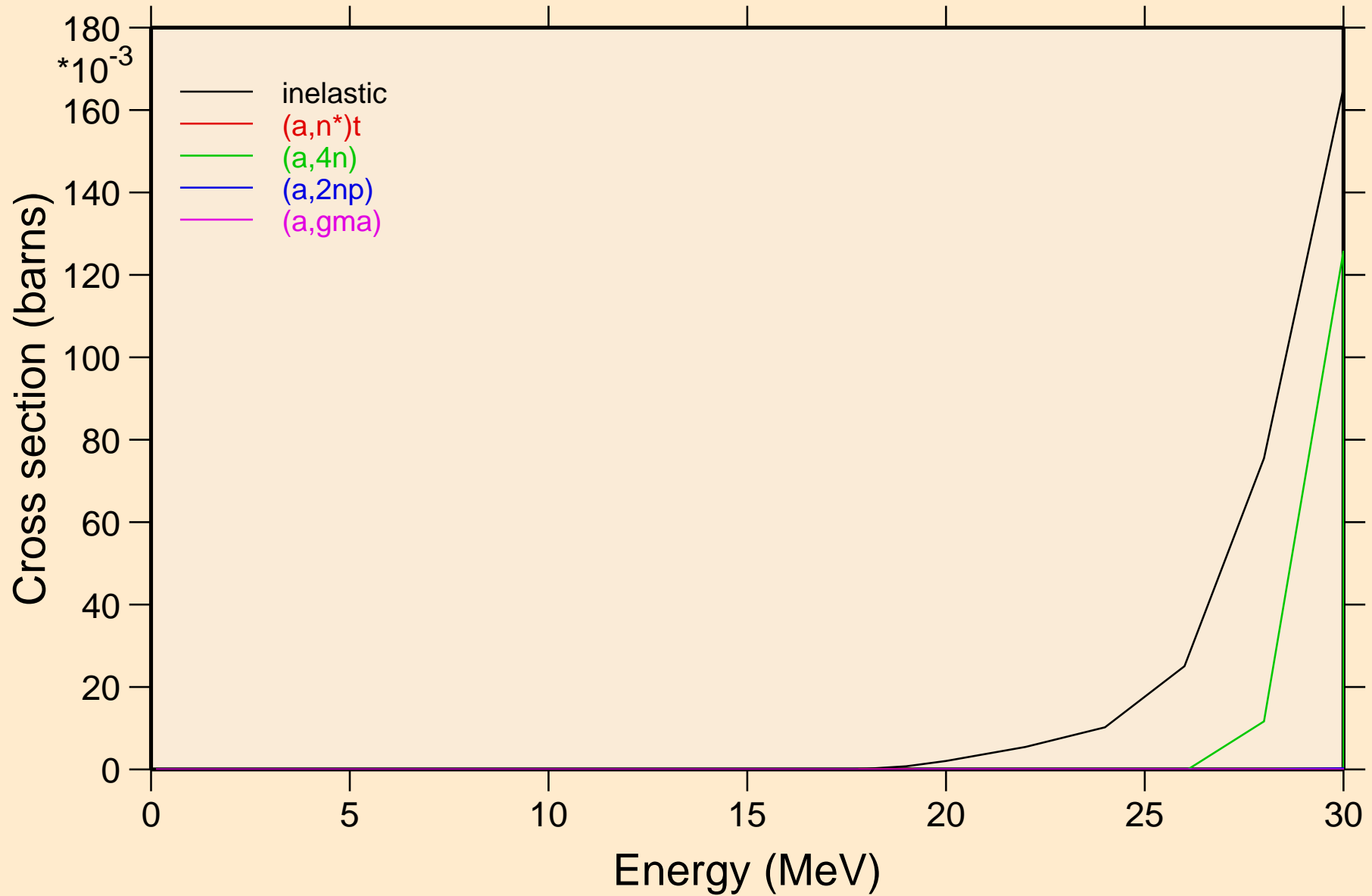

RE193 ALPHA ACER TENDL-2021 LIBRARY; T=0.K
Threshold reactions

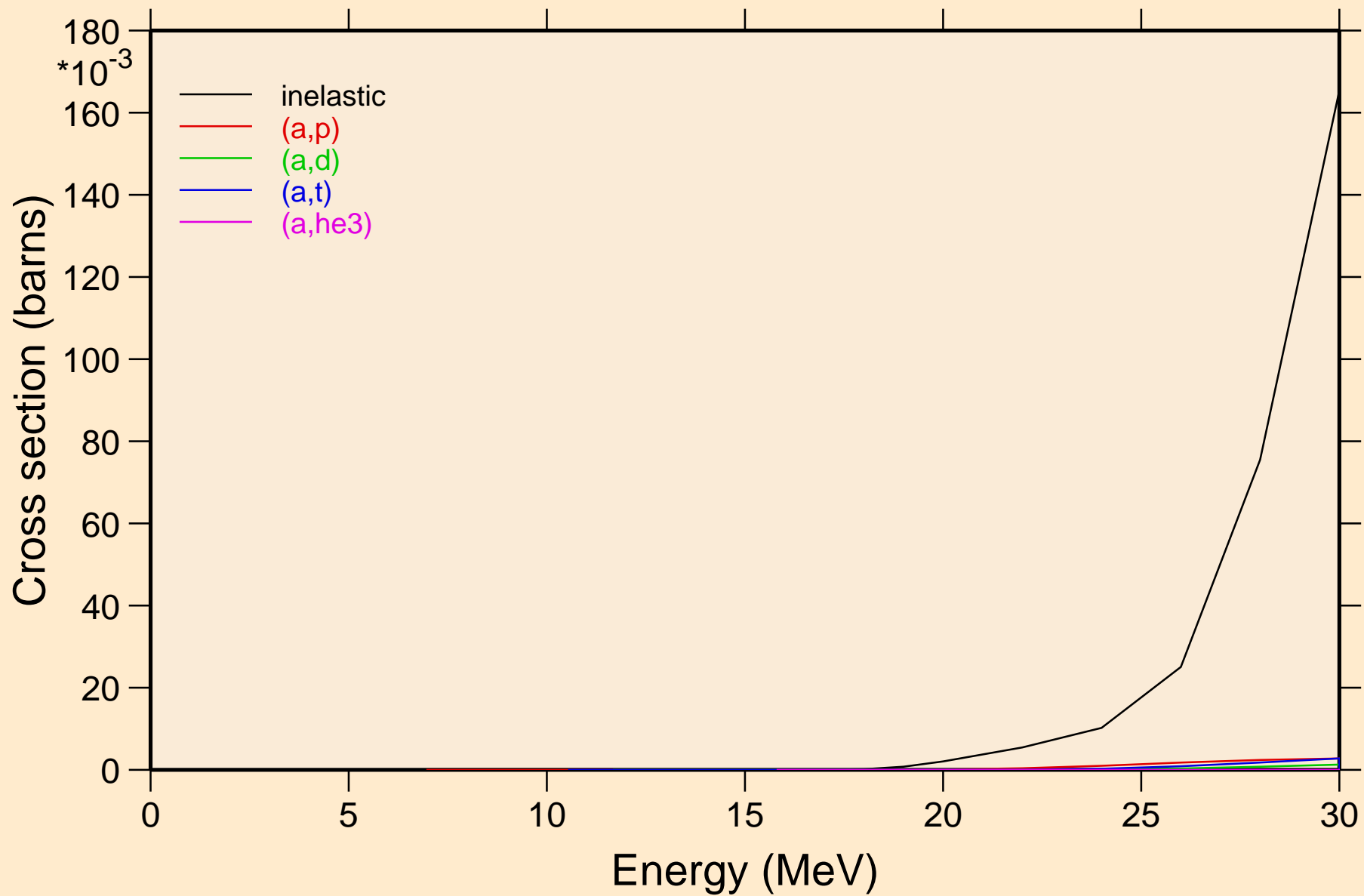

RE193 ALPHA ACER TENDL-2021 LIBRARY; T=0.K
Threshold reactions

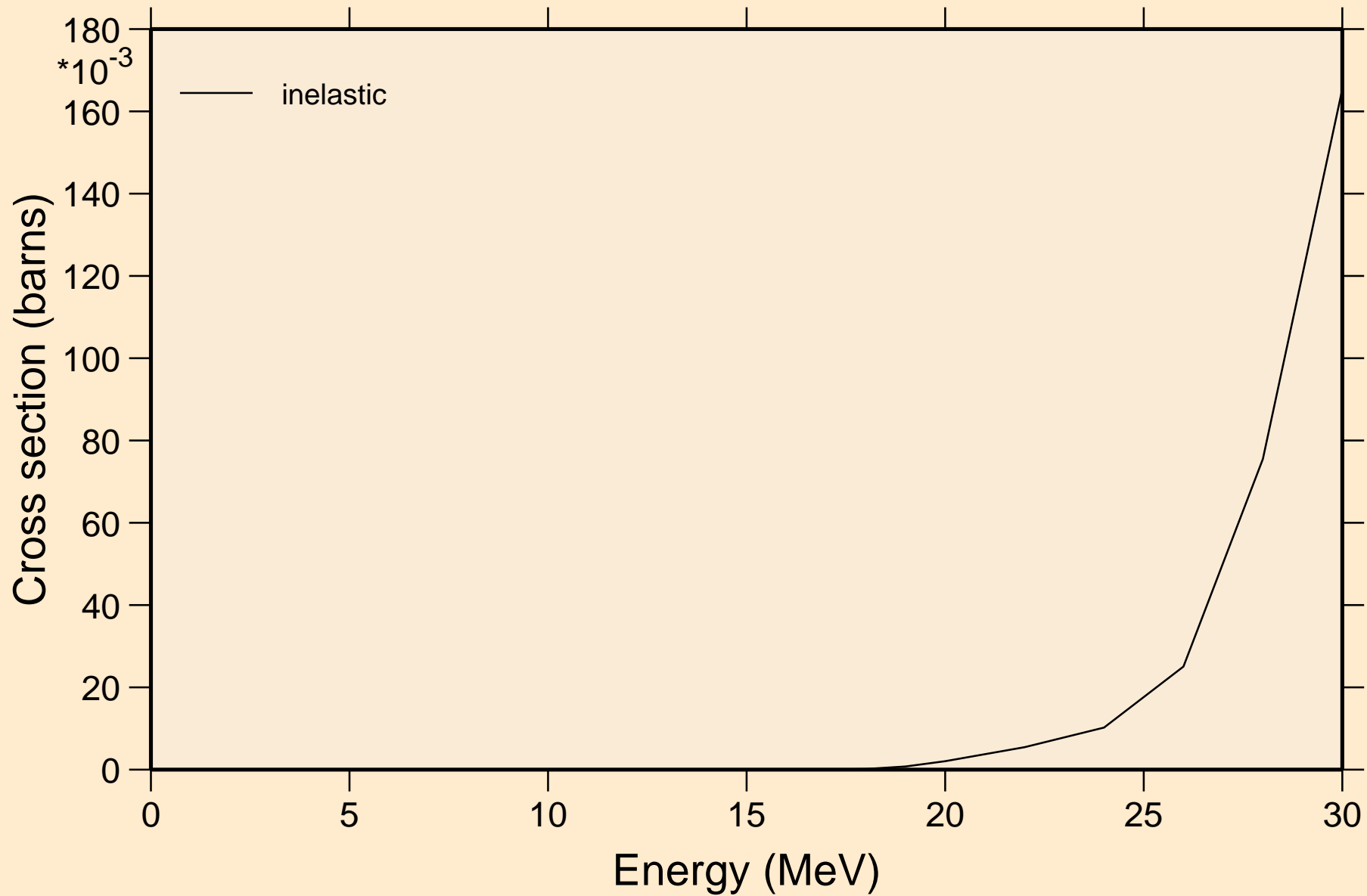

RE193 ALPHA ACER TENDL-2021 LIBRARY; T=0.K
angular distribution for elastic

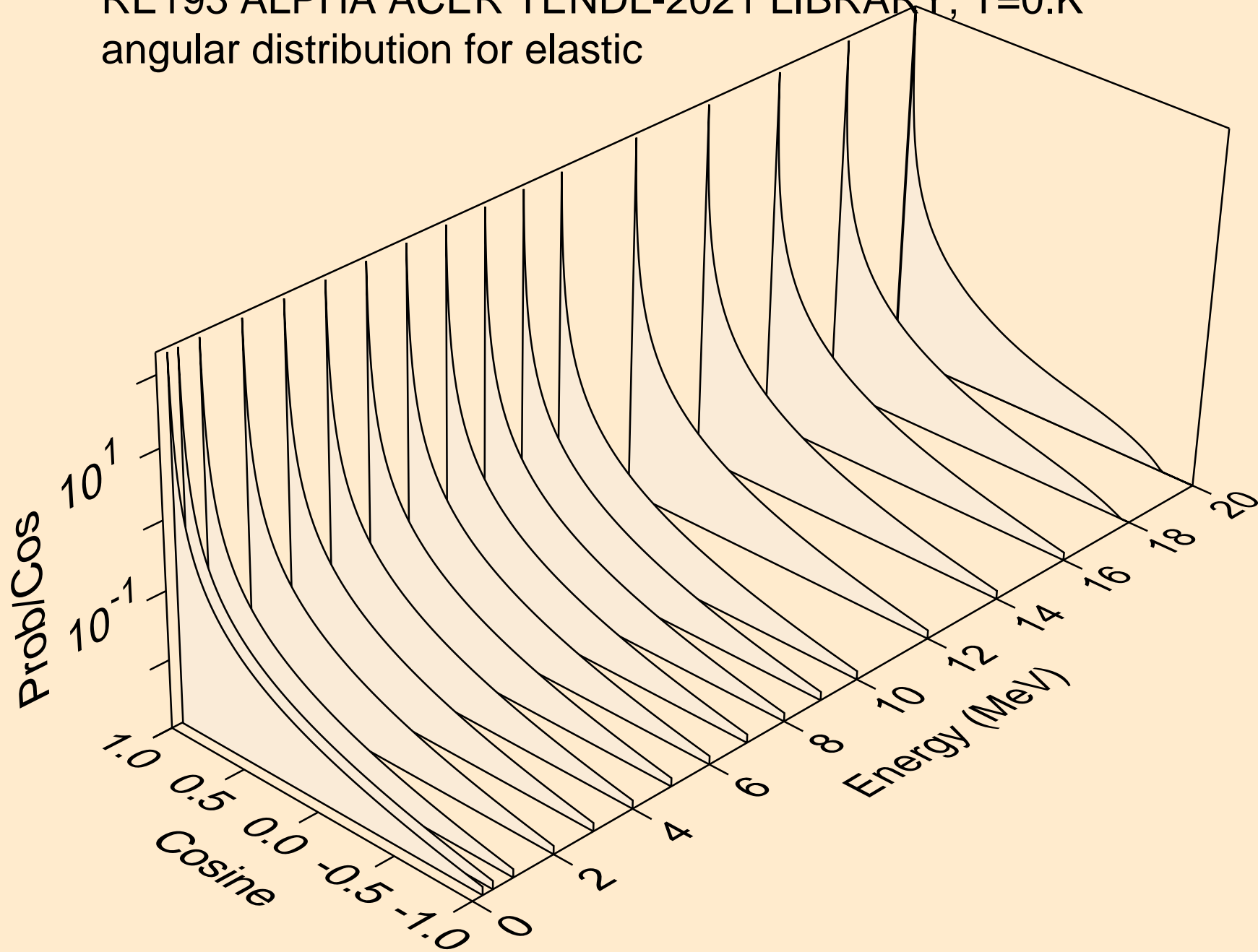

RE193 ALPHA ACER TENDL-2021 LIBRARY; T=0.K
angular distribution for elastic

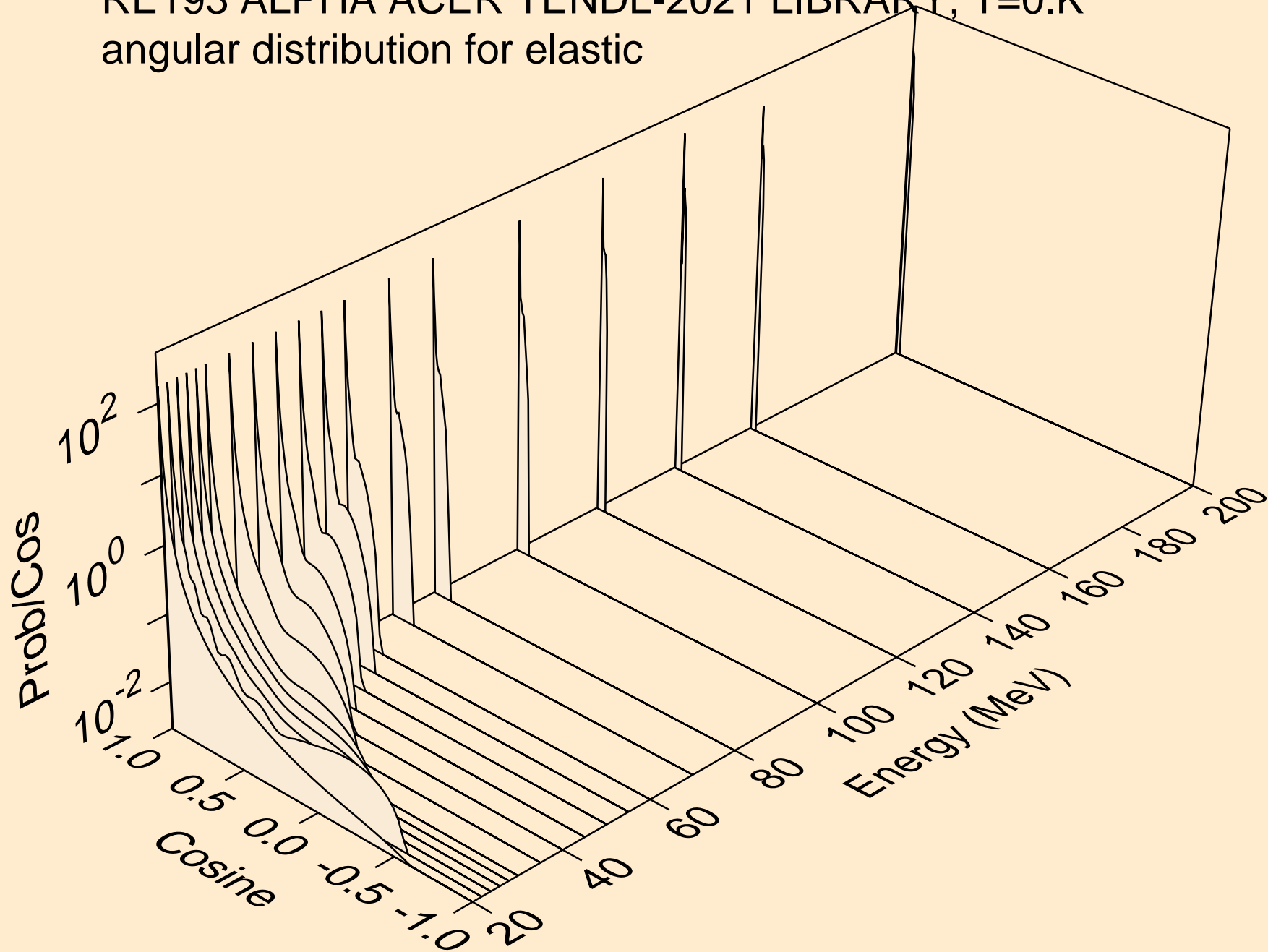

RE193 ALPHA ACER TENDL-2021 LIBRARY; T=0.K
Alpha emission for (a,x)

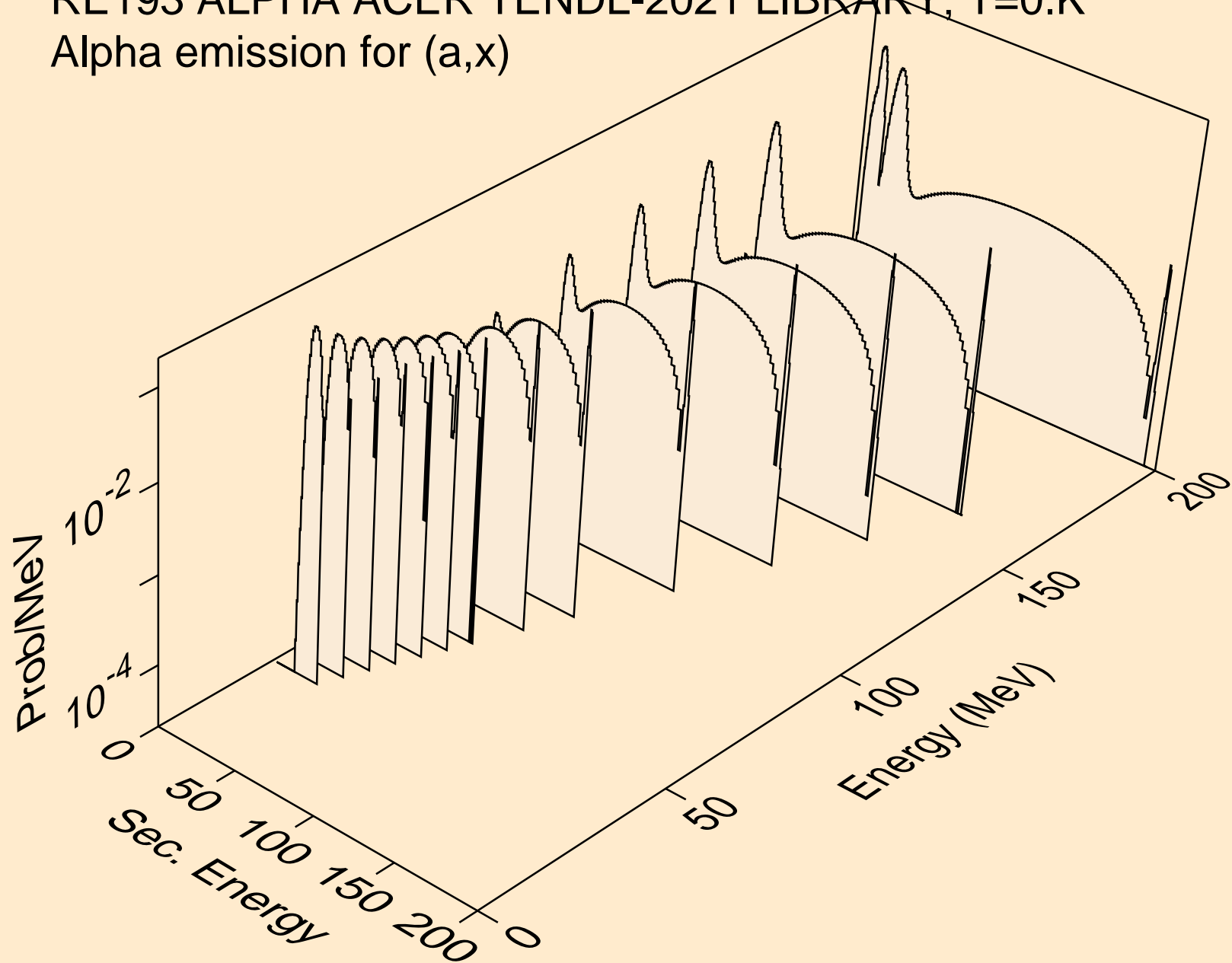

RE193 ALPHA ACER TENDL-2021 LIBRARY; T=0.K
Alpha emission for (a,n*)a

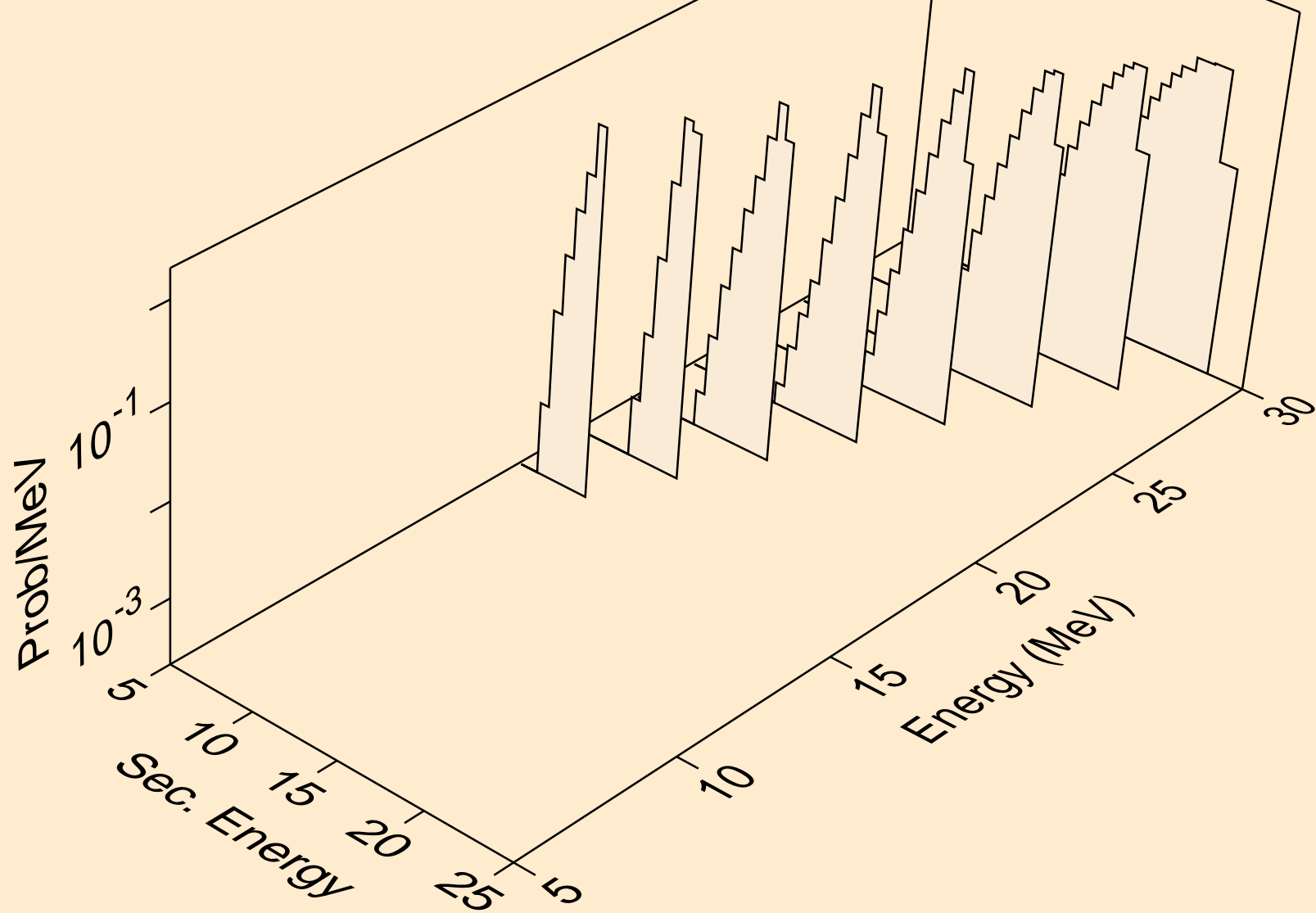

RE193 ALPHA ACER TENDL-2021 LIBRARY; T=0.K
Alpha emission for (a,2n)a

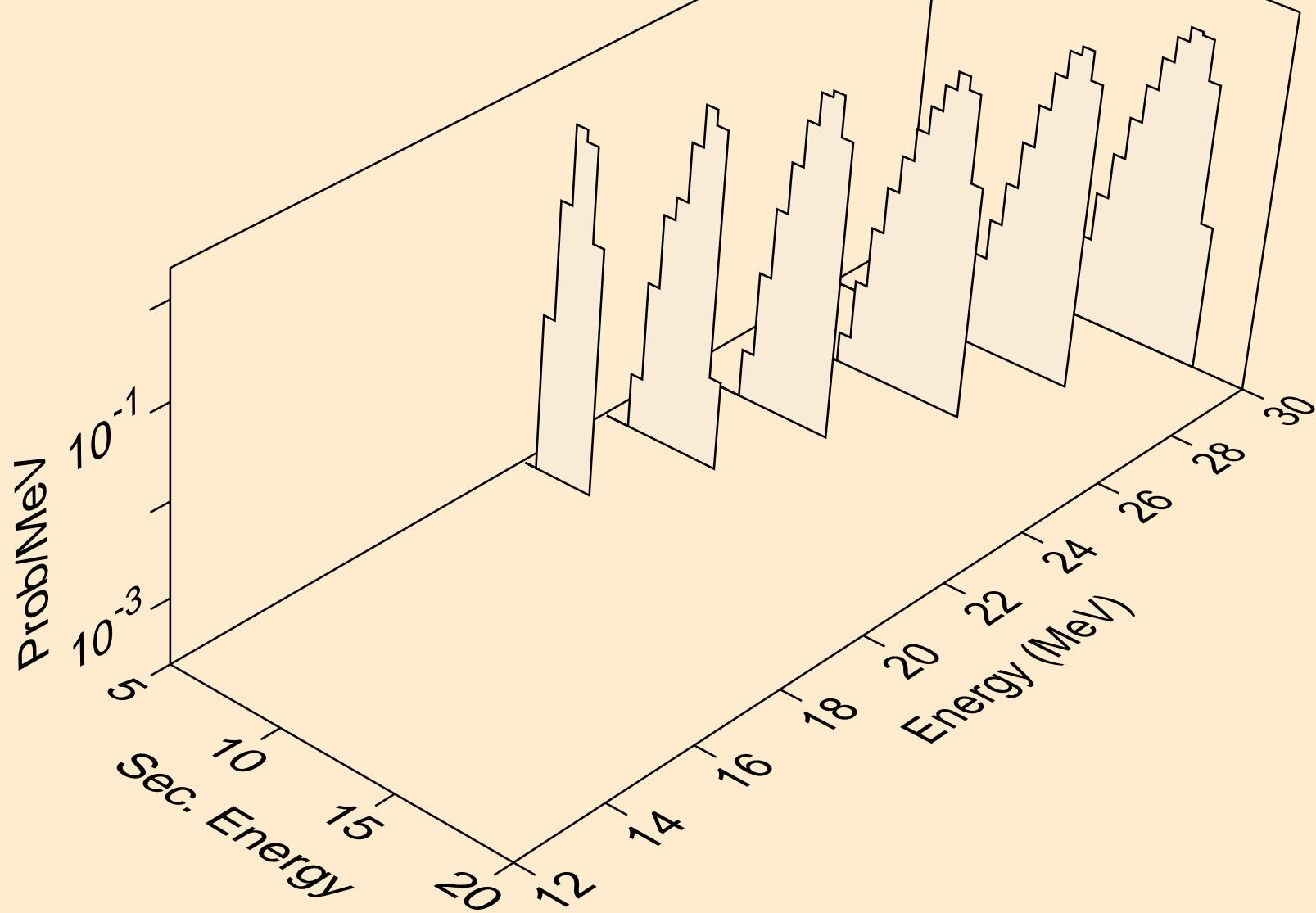

RE193 ALPHA ACER TENDL-2021 LIBRARY; T=0.K
Alpha emission for inelastic

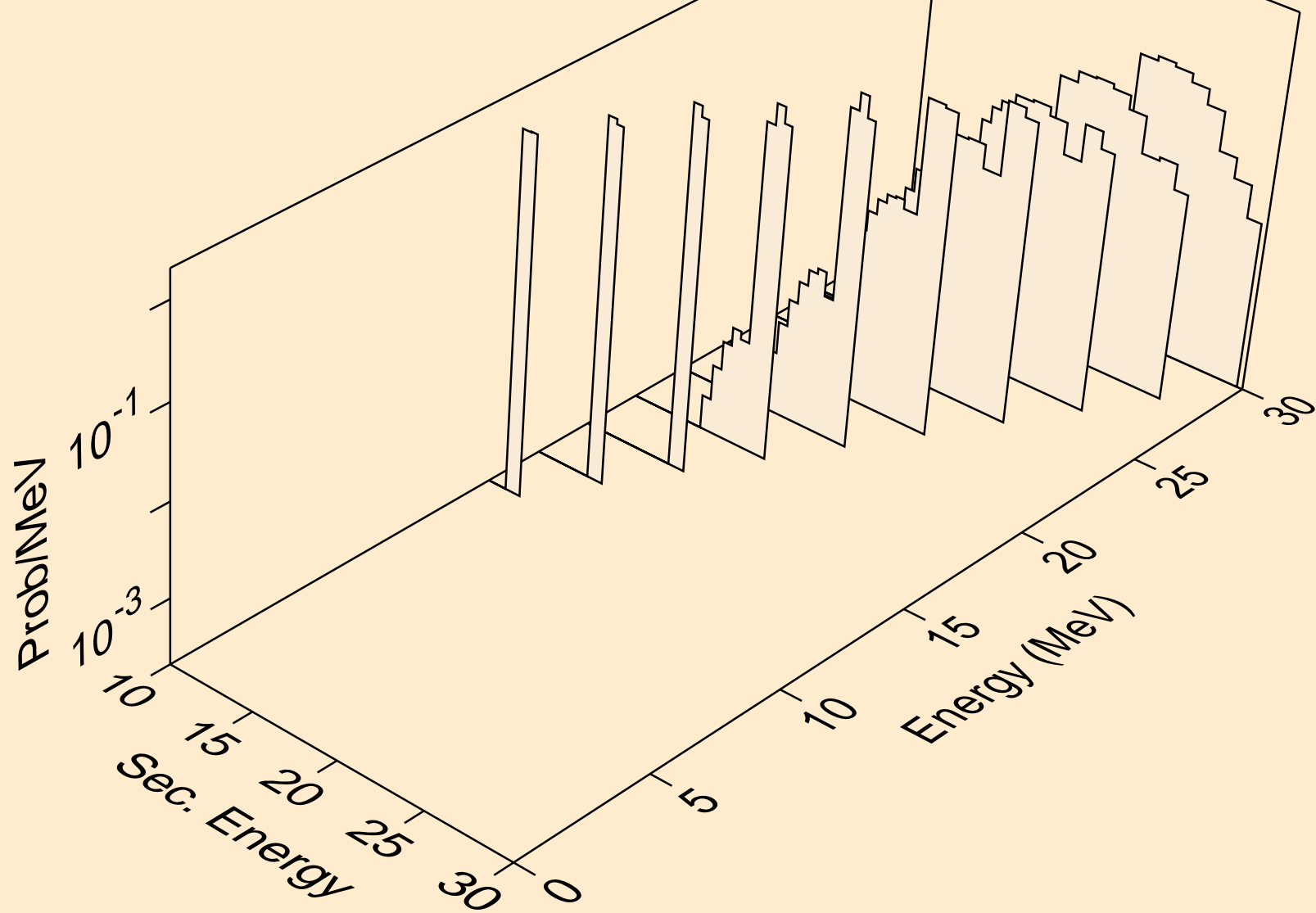

RE193 ALPHA ACER TENDL-2021 LIBRARY; T=0.K
Photon emission for (z,n)

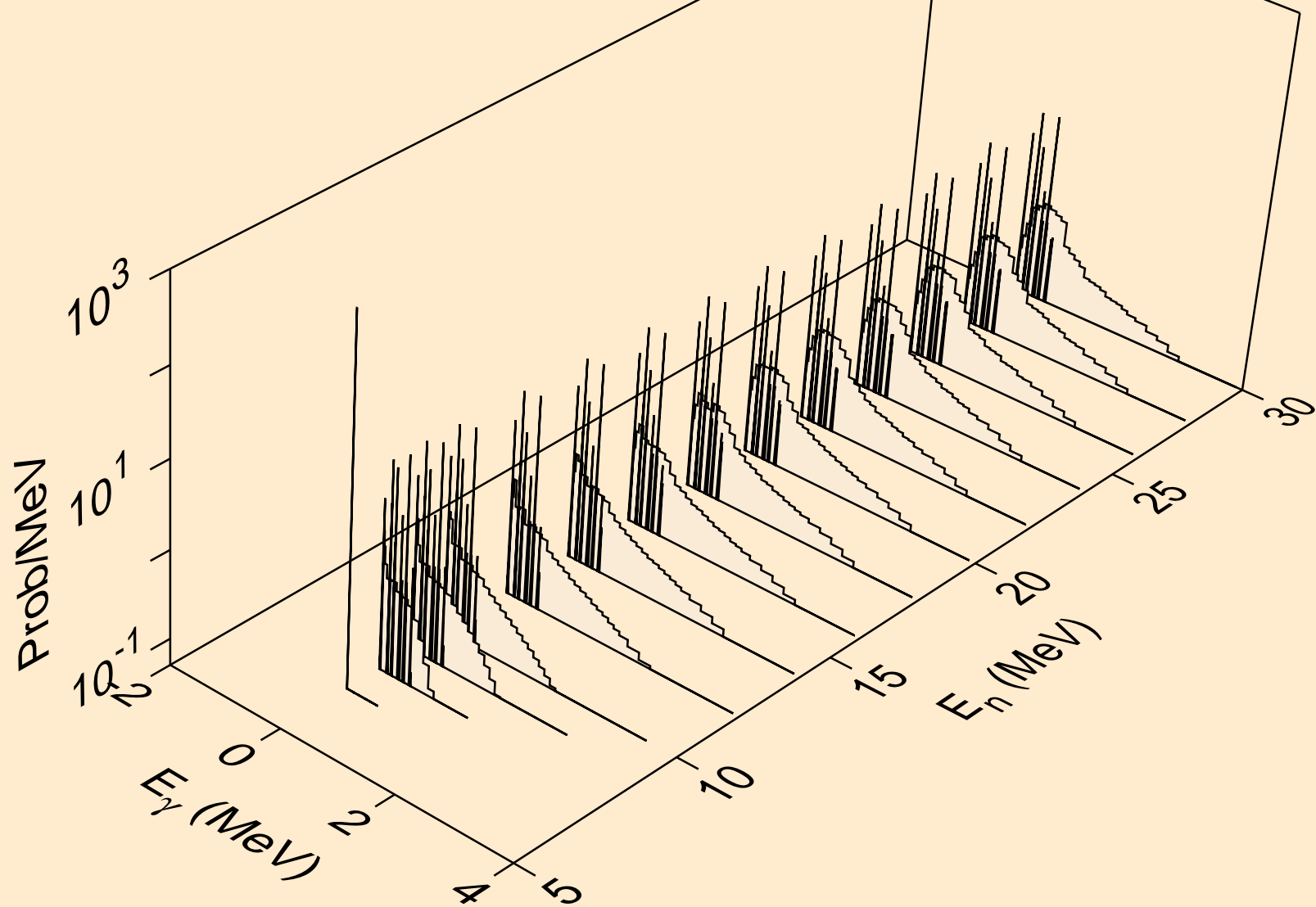

RE193 ALPHA ACER TENDL-2021 LIBRARY; T=0.K
Photon emission for (n,x)

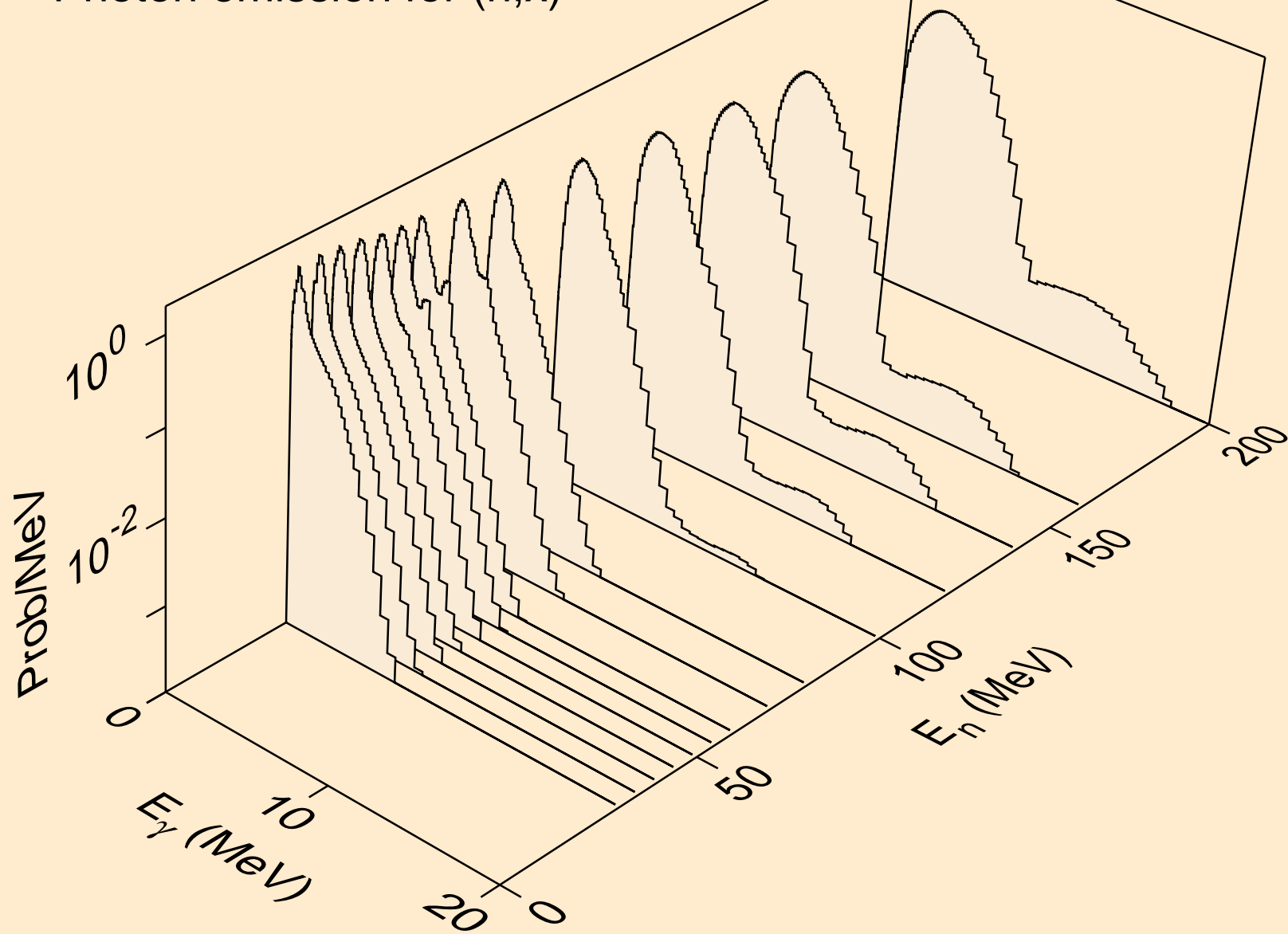

RE193 ALPHA ACER TENDL-2021 LIBRARY; T=0.K
Photon emission for (n,2nd)

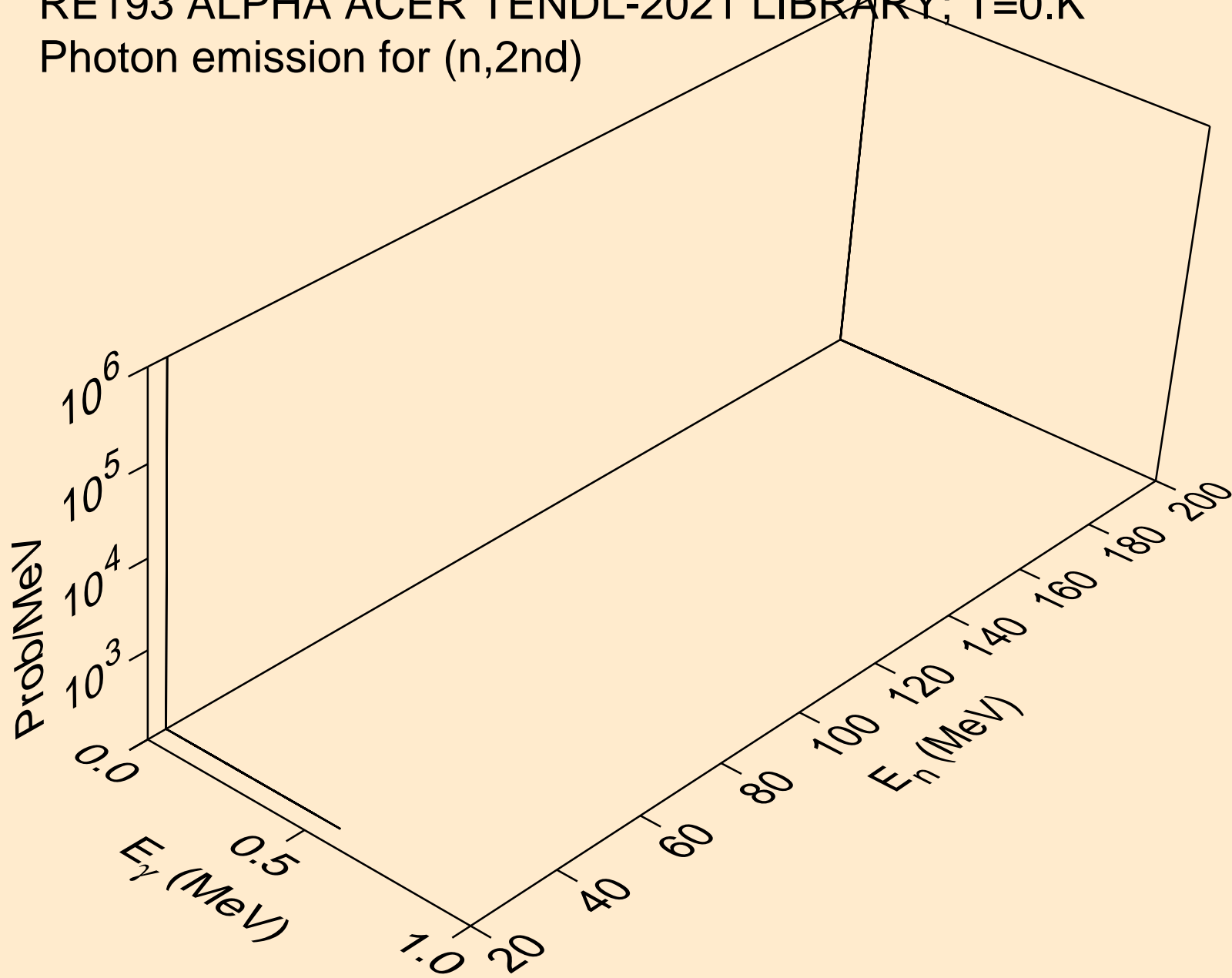

RE193 ALPHA ACER TENDL-2021 LIBRARY; T=0.K
Photon emission for (n,2n)

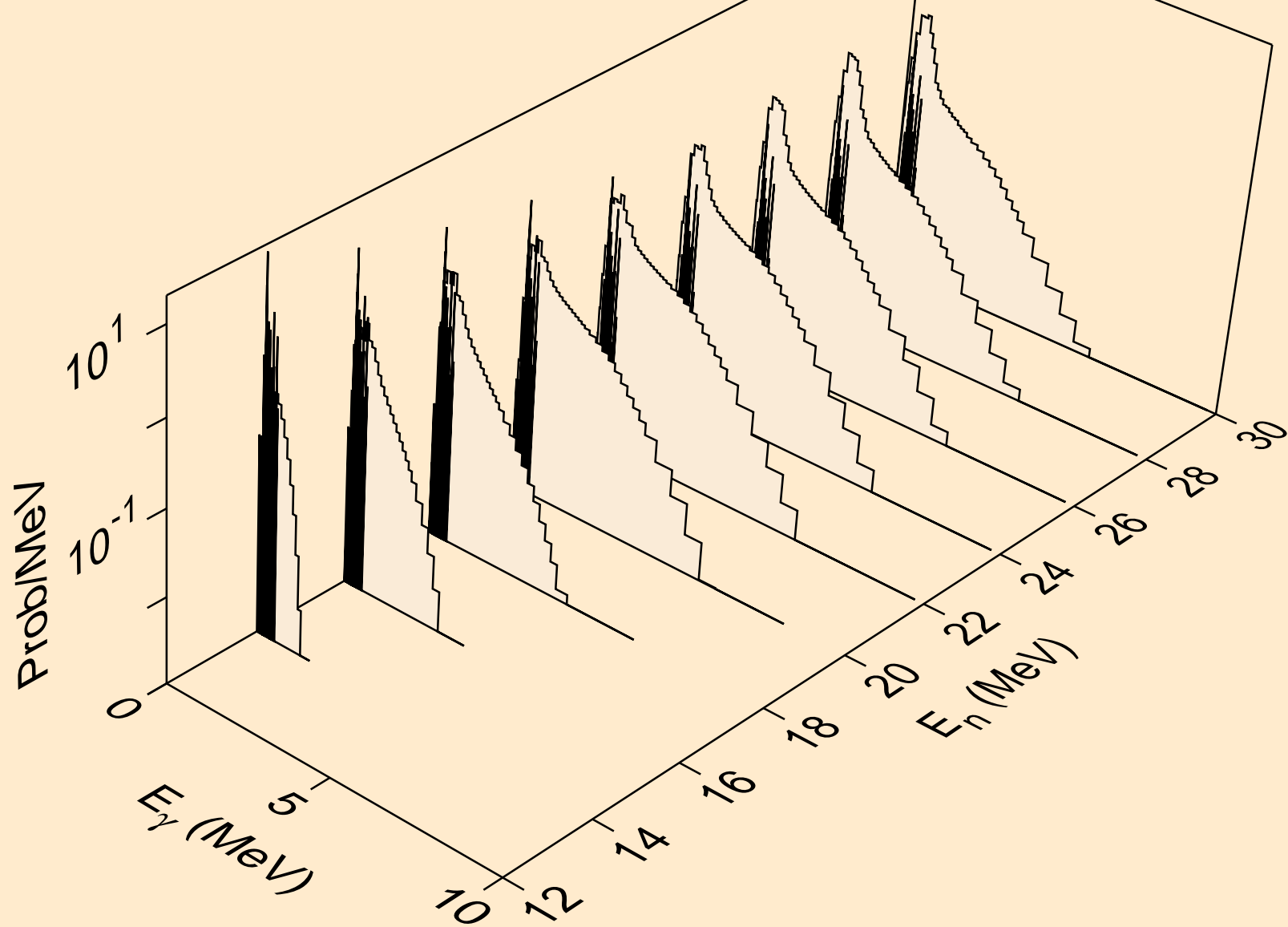

RE193 ALPHA ACER TENDL-2021 LIBRARY; T=0.K
Photon emission for (n,3n)

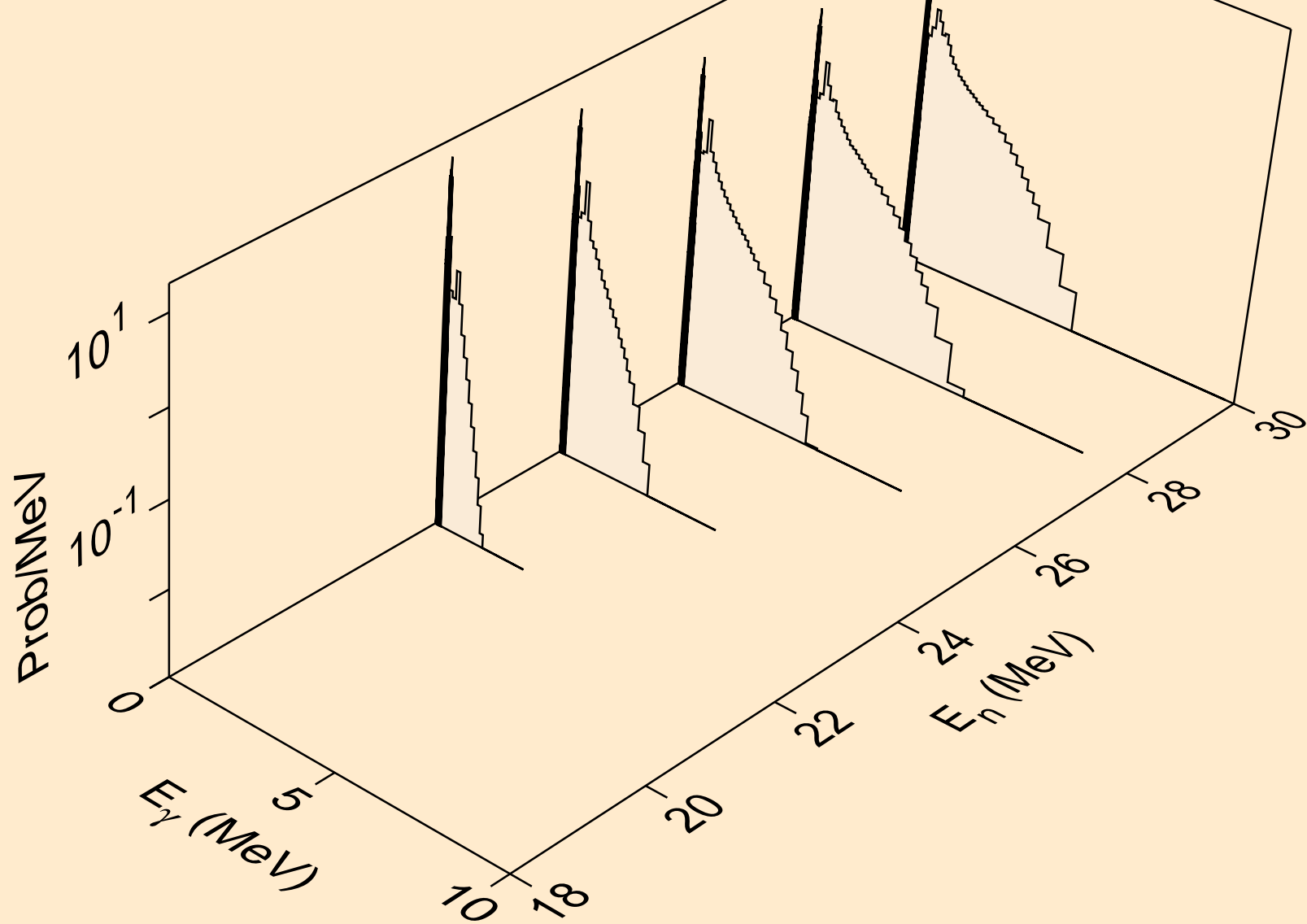

RE193 ALPHA ACER TENDL-2021 LIBRARY; T=0.K
Photon emission for (n,n*)a

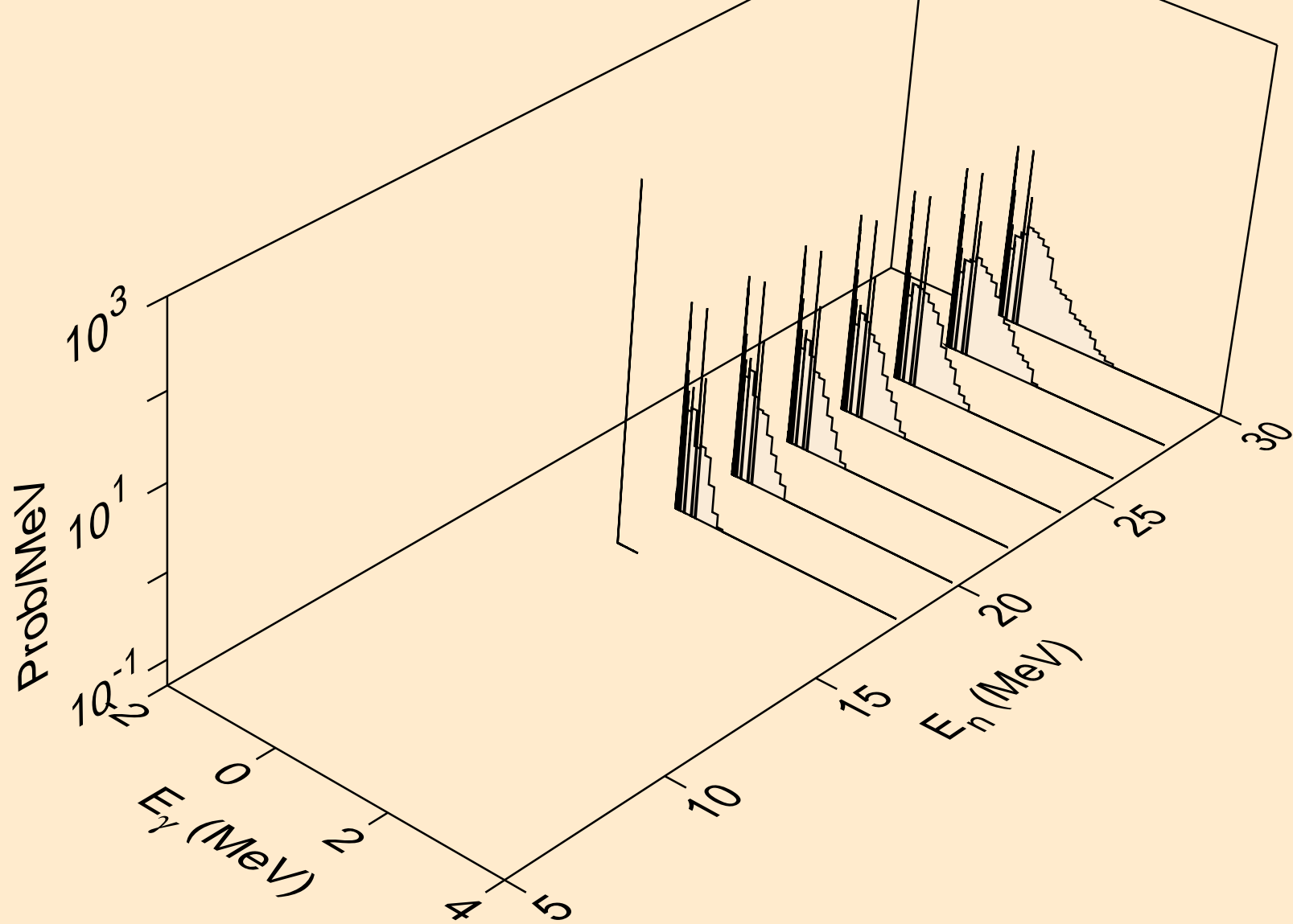

RE193 ALPHA ACER TENDL-2021 LIBRARY; T=0.K
Photon emission for (n,2n)a

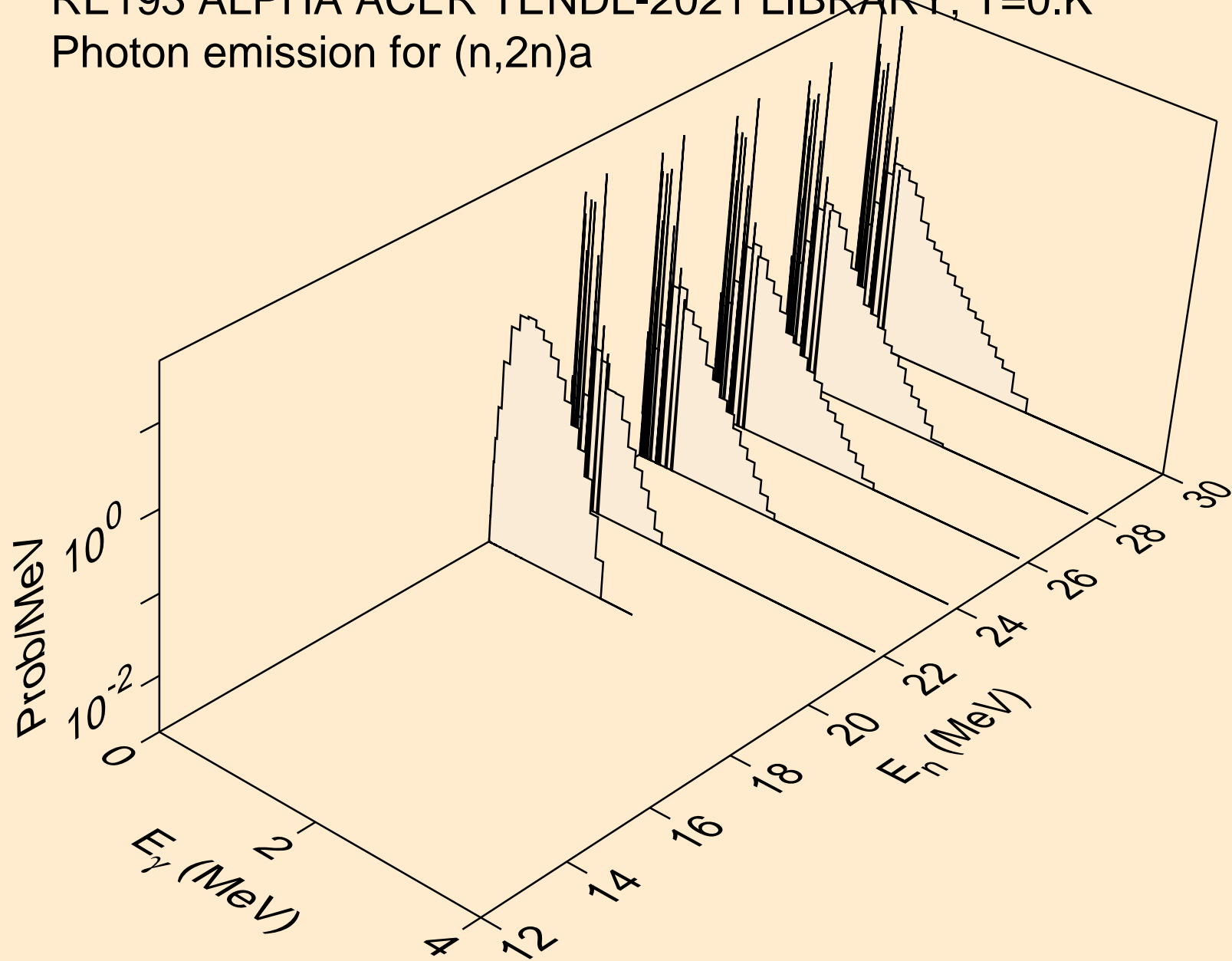

RE193 ALPHA ACER TENDL-2021 LIBRARY; T=0.K
Photon emission for (n,n*)p

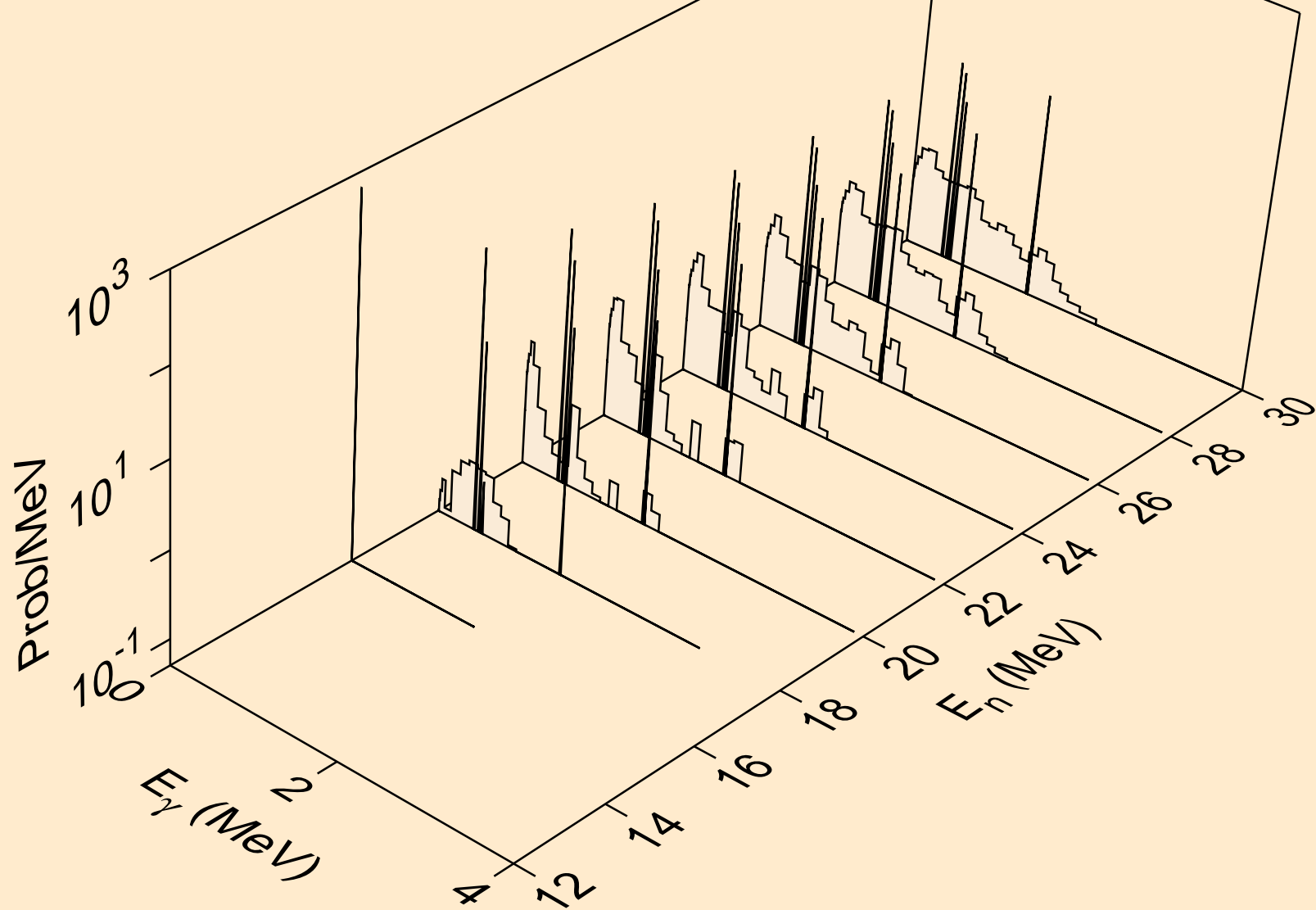

RE193 ALPHA ACER TENDL-2021 LIBRARY; T=0.K
Photon emission for (n,n*)d

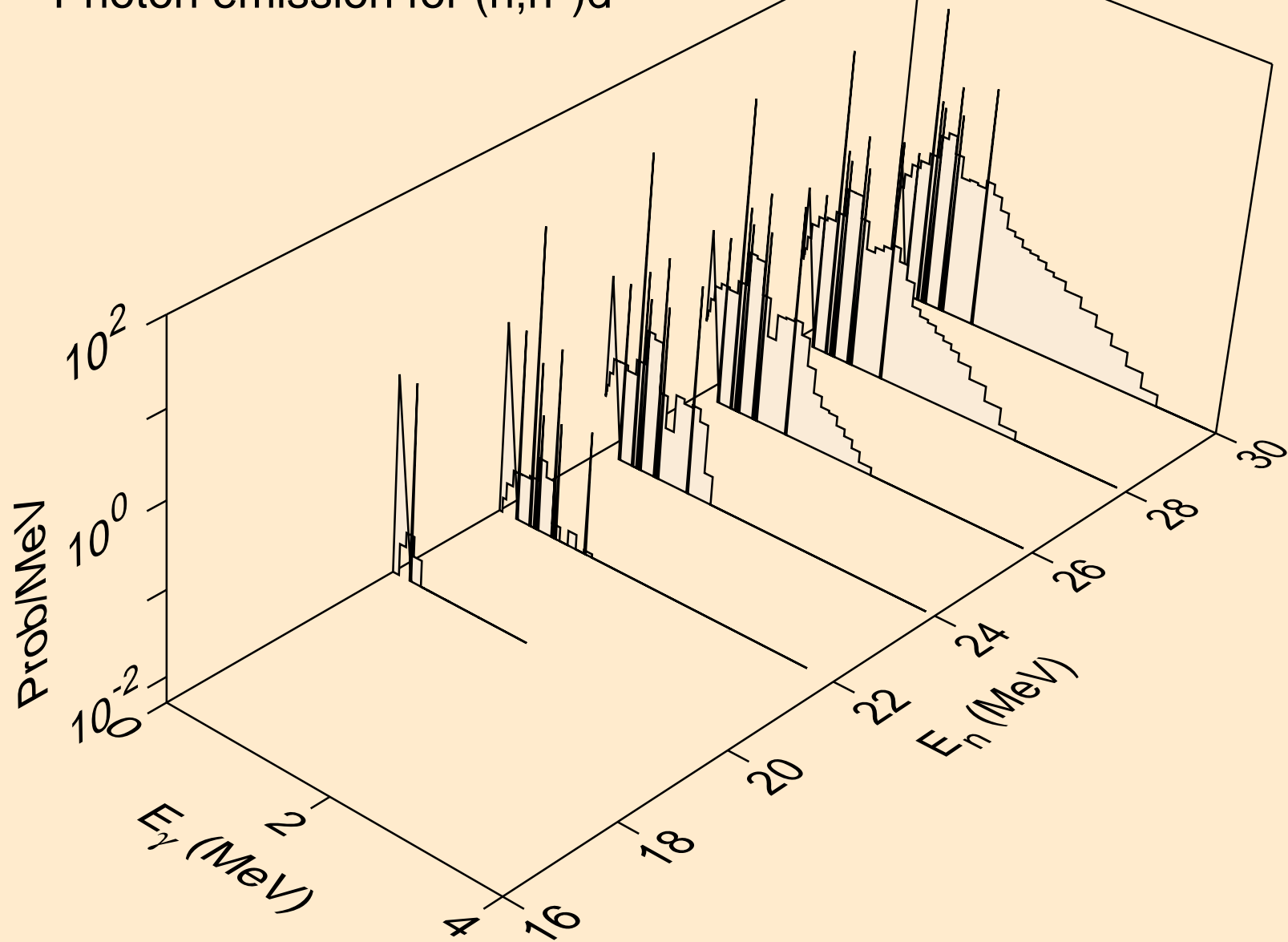

RE193 ALPHA ACER TENDL-2021 LIBRARY; T=0.K
Photon emission for (n,n*)t

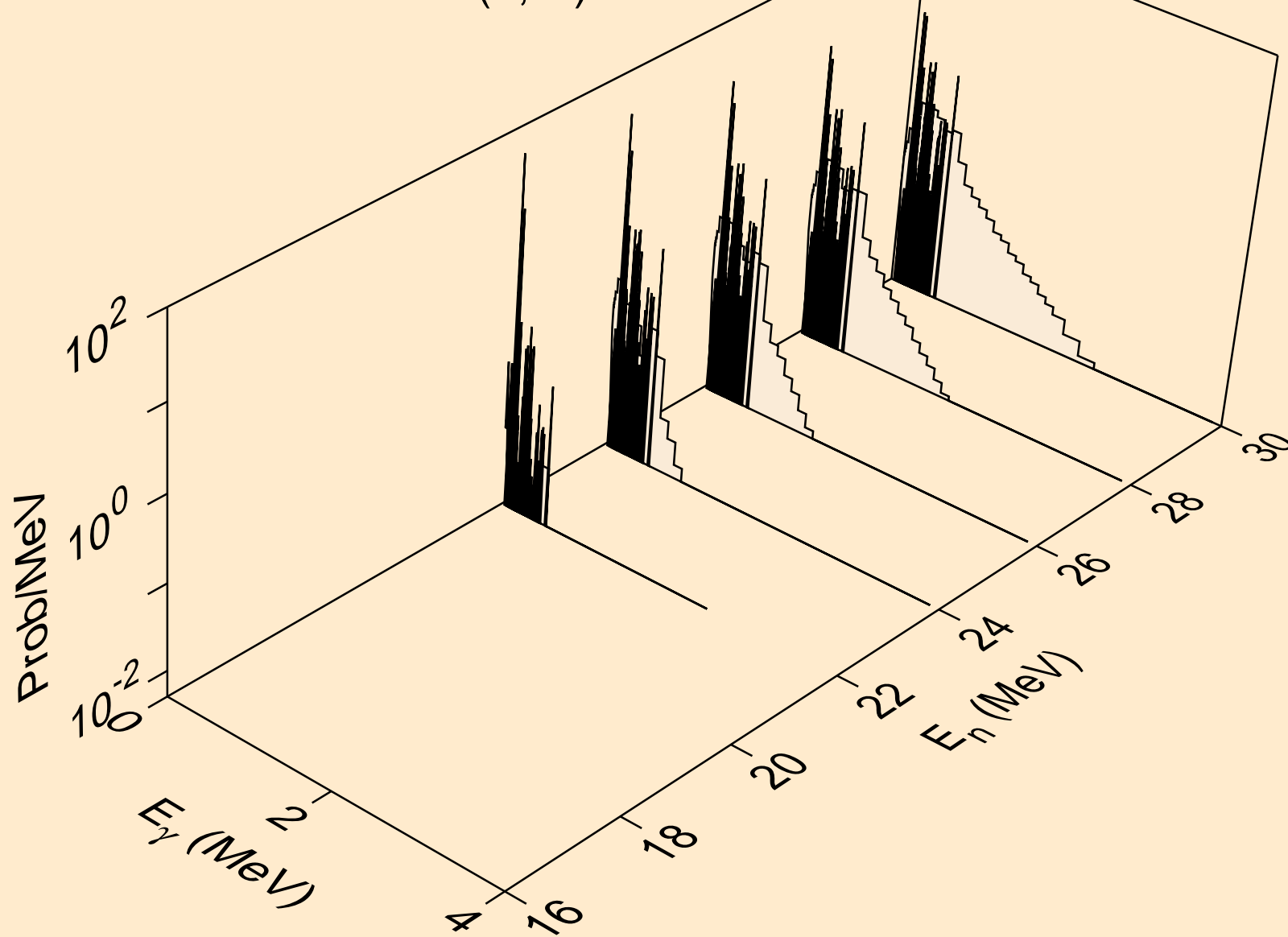

RE193 ALPHA ACER TENDL-2021 LIBRARY; T=0.K
Photon emission for (n,4n)

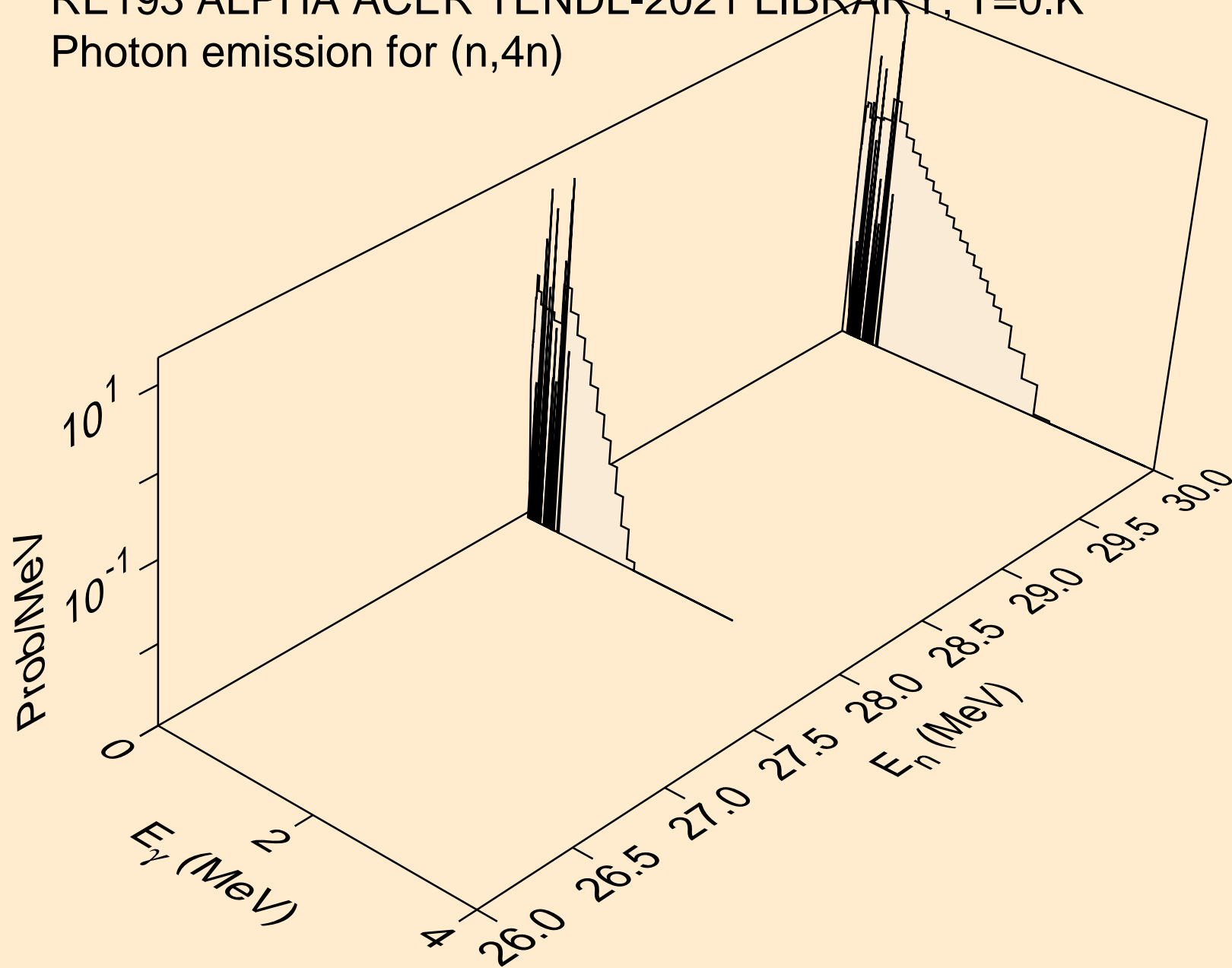

RE193 ALPHA ACER TENDL-2021 LIBRARY; T=0.K
Photon emission for (n,2np)

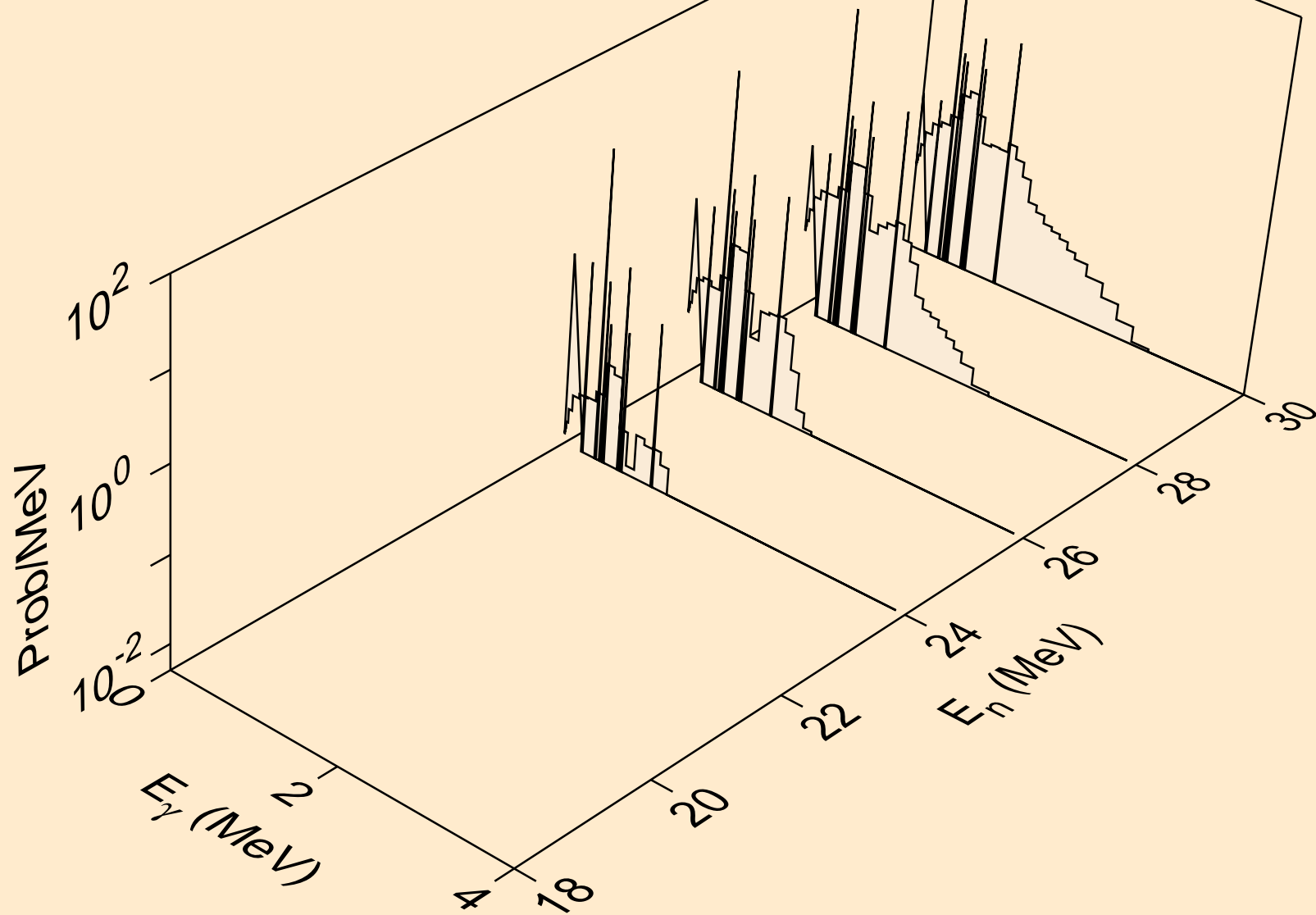

RE193 ALPHA ACER TENDL-2021 LIBRARY; T=0.K
Photon emission for (n,gma)

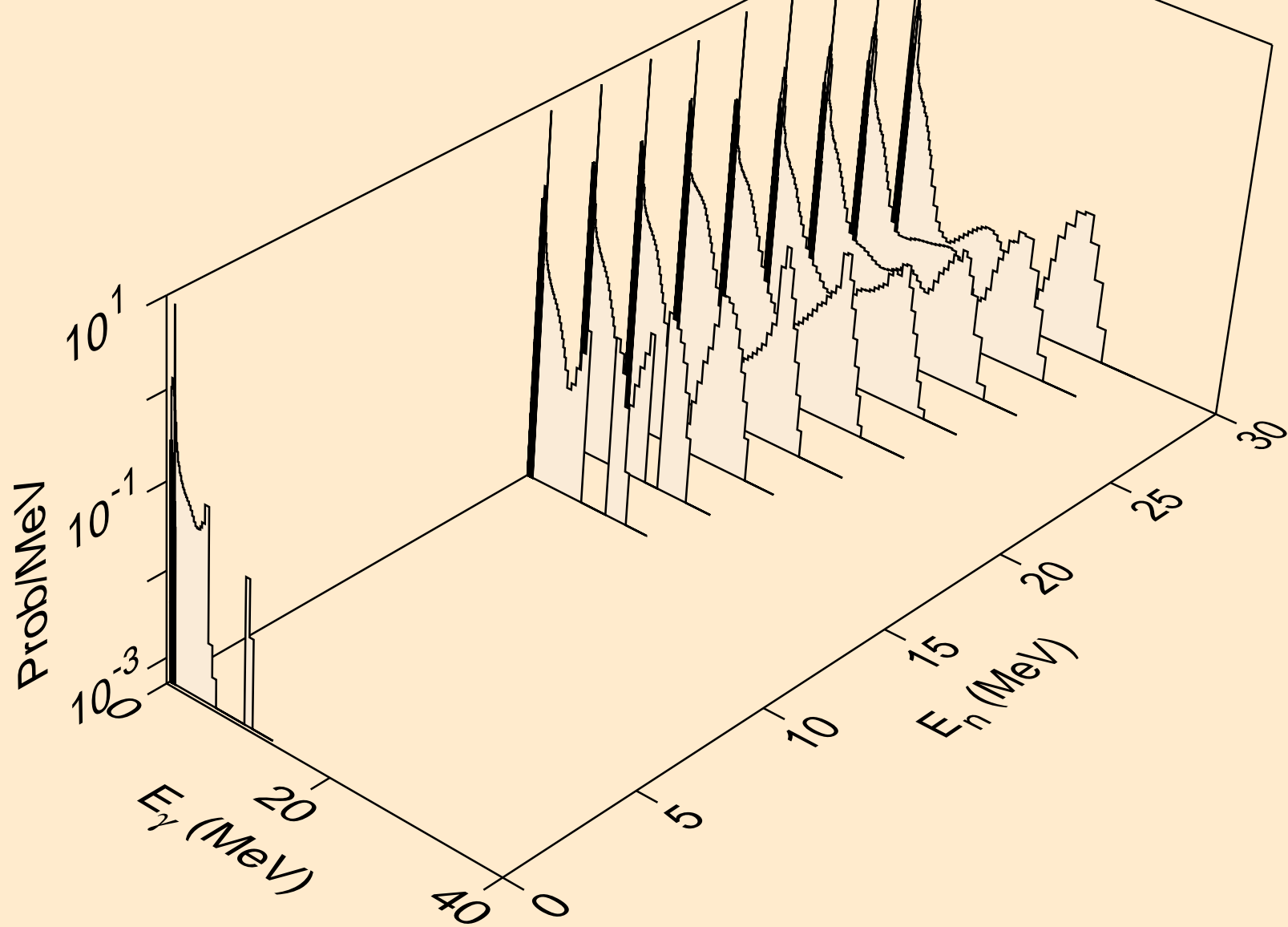

RE193 ALPHA ACER TENDL-2021 LIBRARY; T=0.K
Photon emission for (n,p)

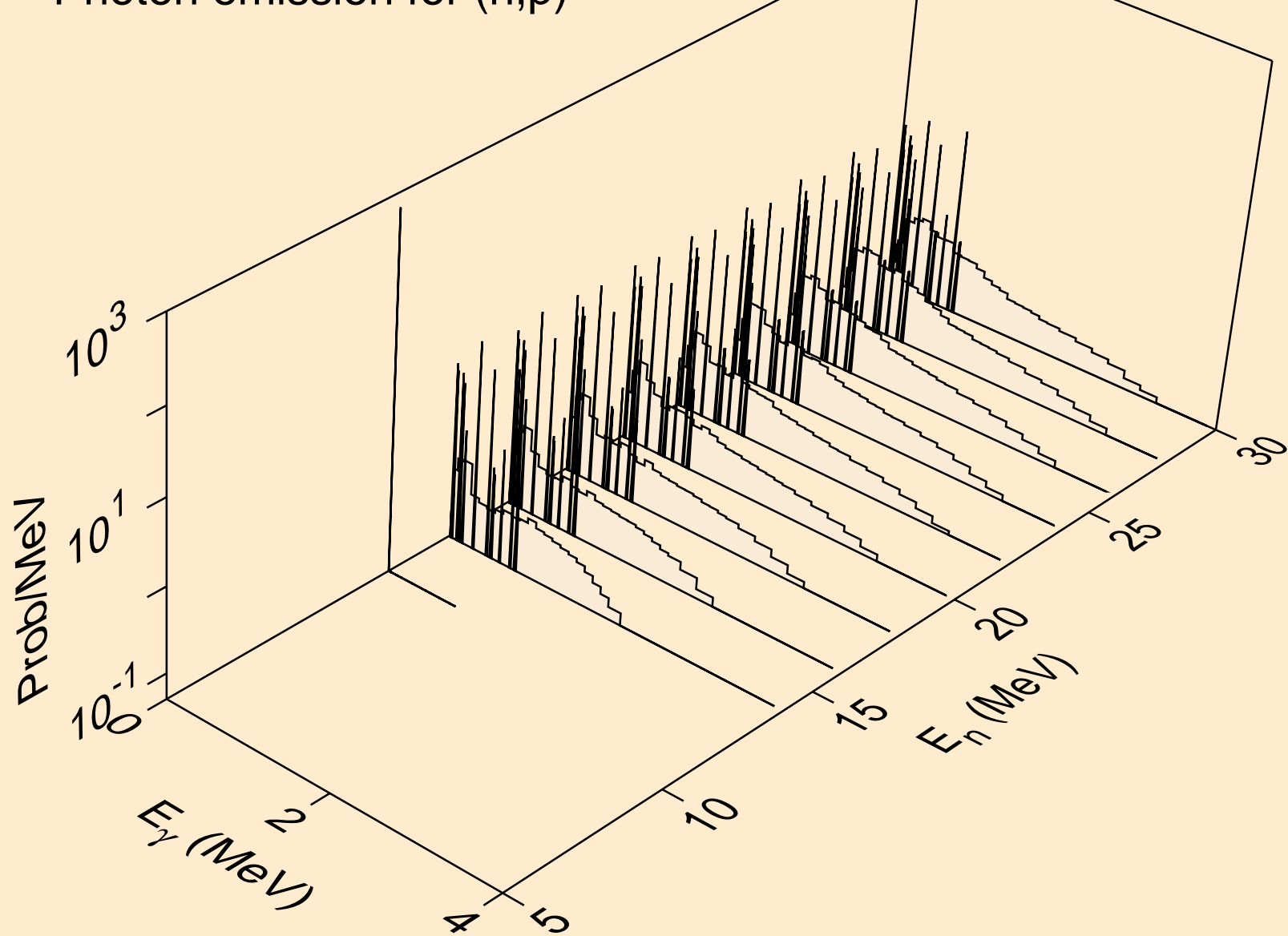

RE193 ALPHA ACER TENDL-2021 LIBRARY; T=0.K
Photon emission for (n,d)

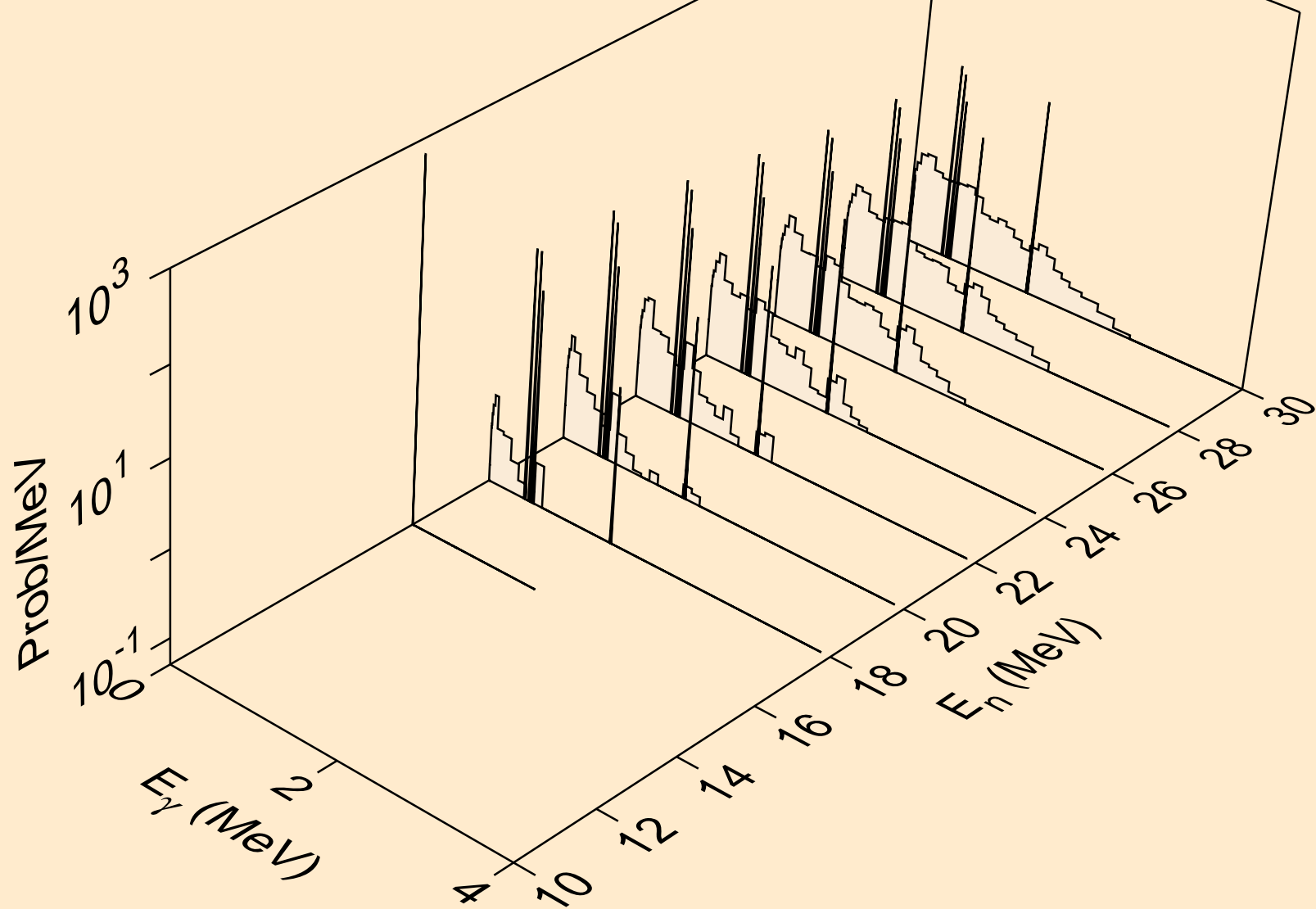

RE193 ALPHA ACER TENDL-2021 LIBRARY; T=0.K
Photon emission for (n,t)

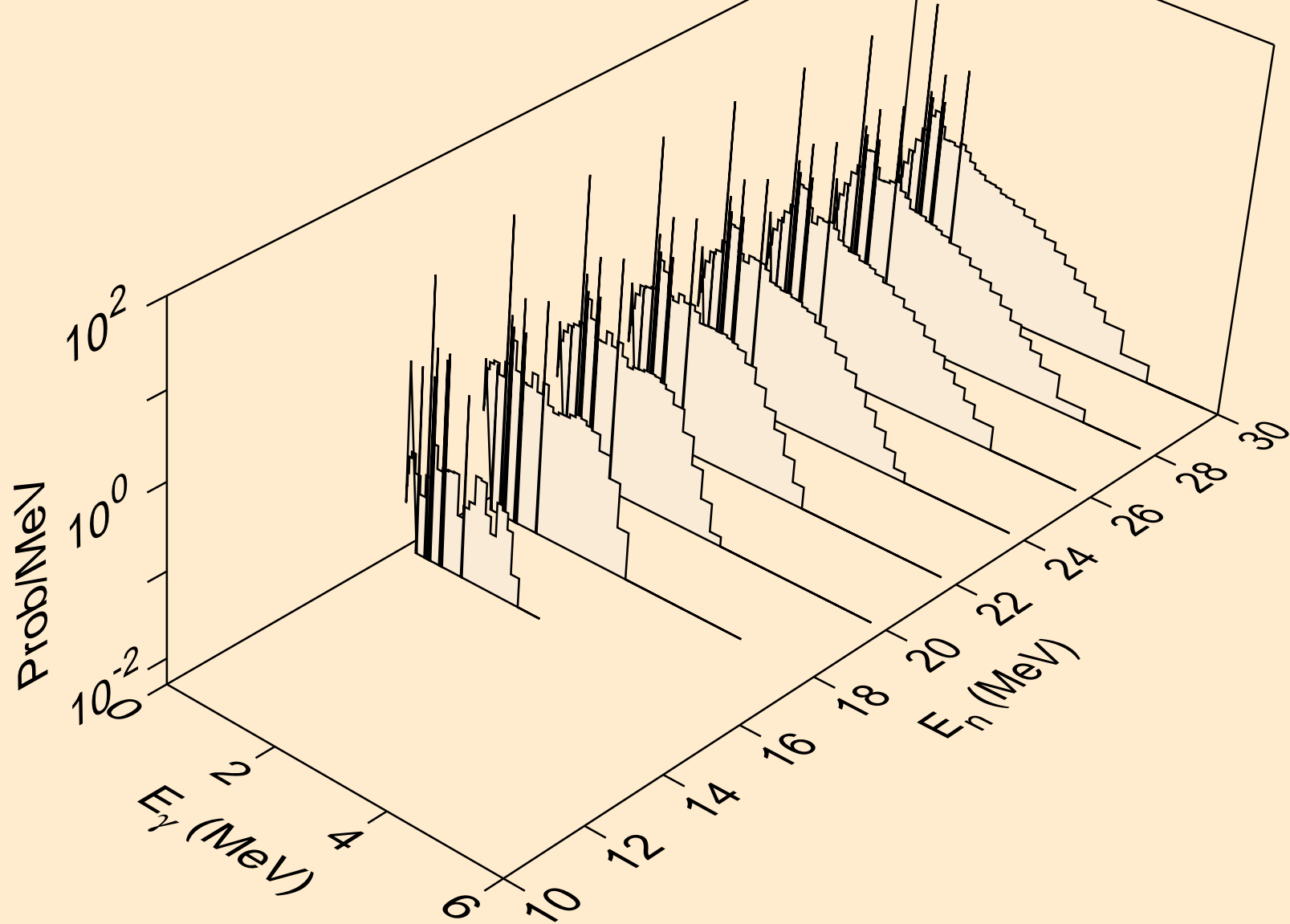

RE193 ALPHA ACER TENDL-2021 LIBRARY; T=0.K
Photon emission for (n,he3)

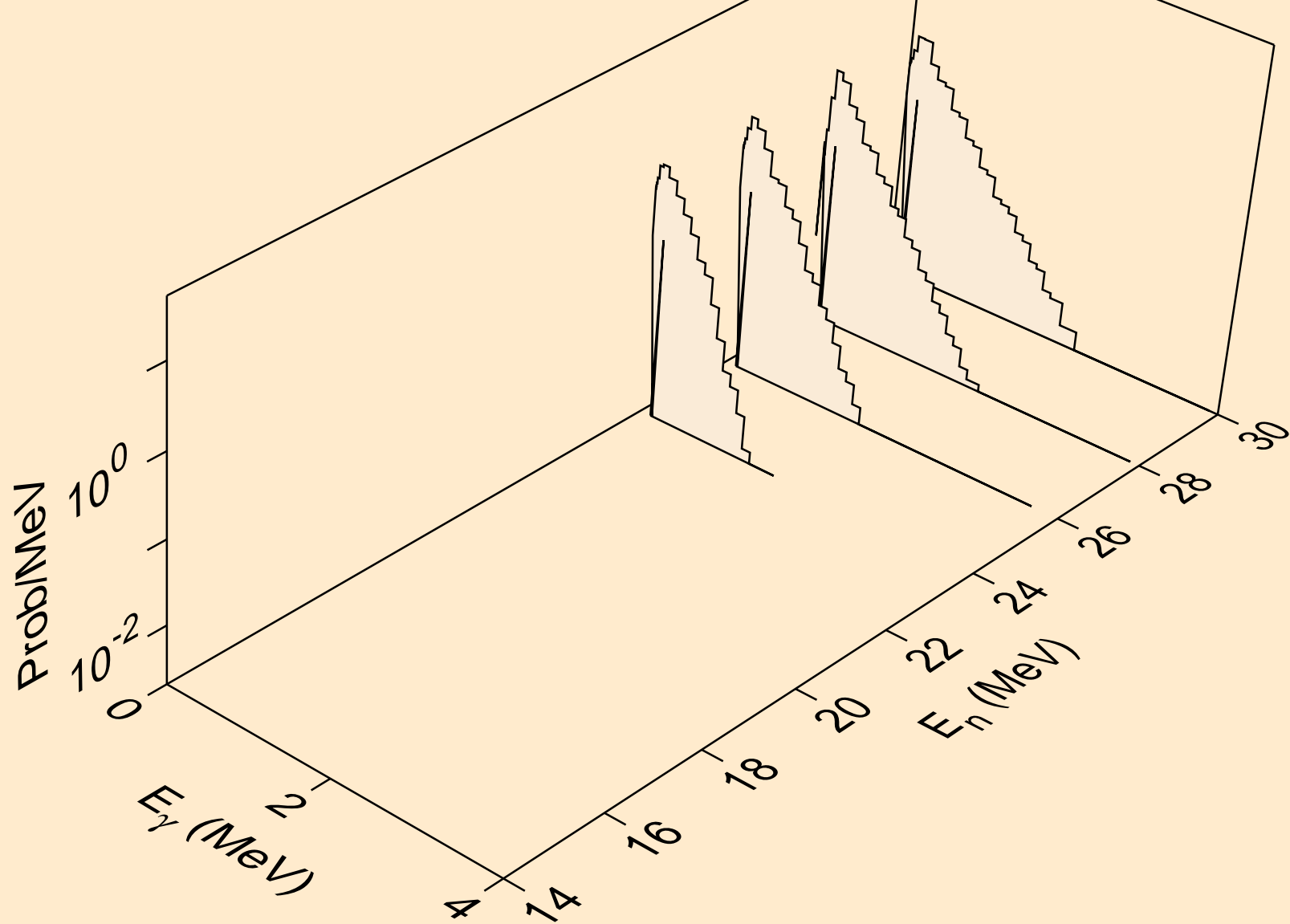

RE193 ALPHA ACER TENDL-2021 LIBRARY; T=0.K
Photon emission for inelastic

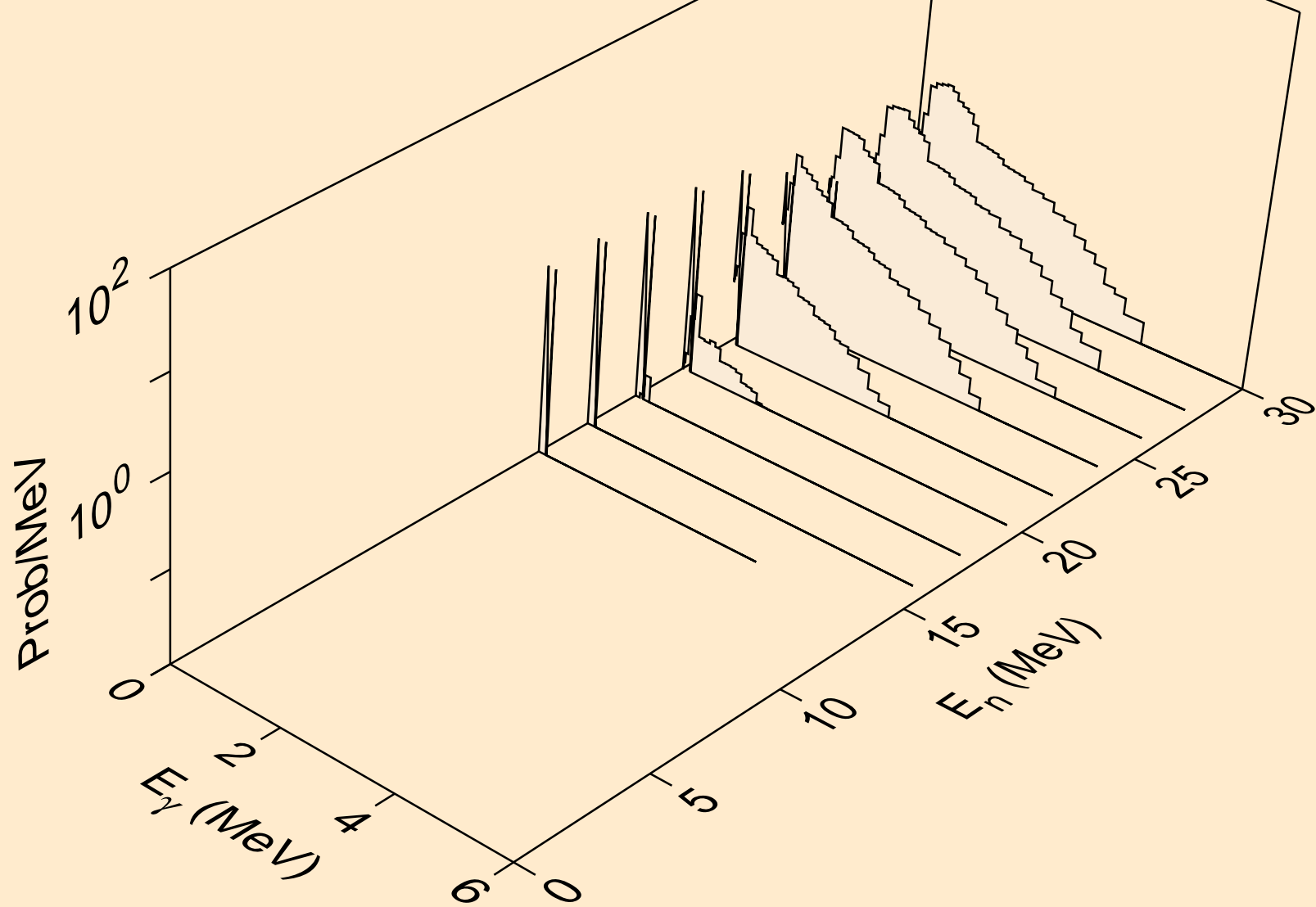

RE193 ALPHA ACER TENDL-2021 LIBRARY; T=0.K
Particle heating contributions

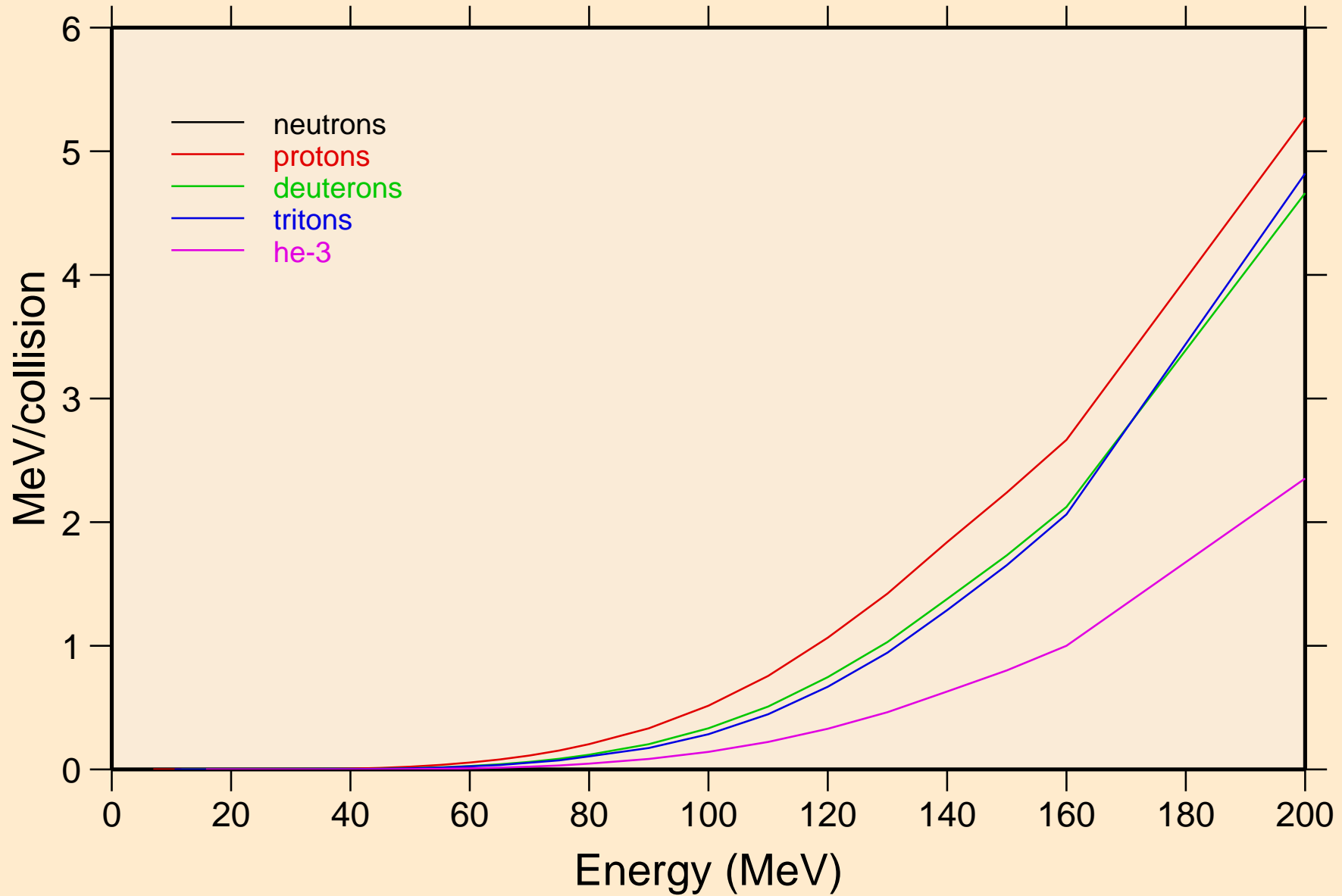

RE193 ALPHA ACER TENDL-2021 LIBRARY; T=0.K
Recoil Heating

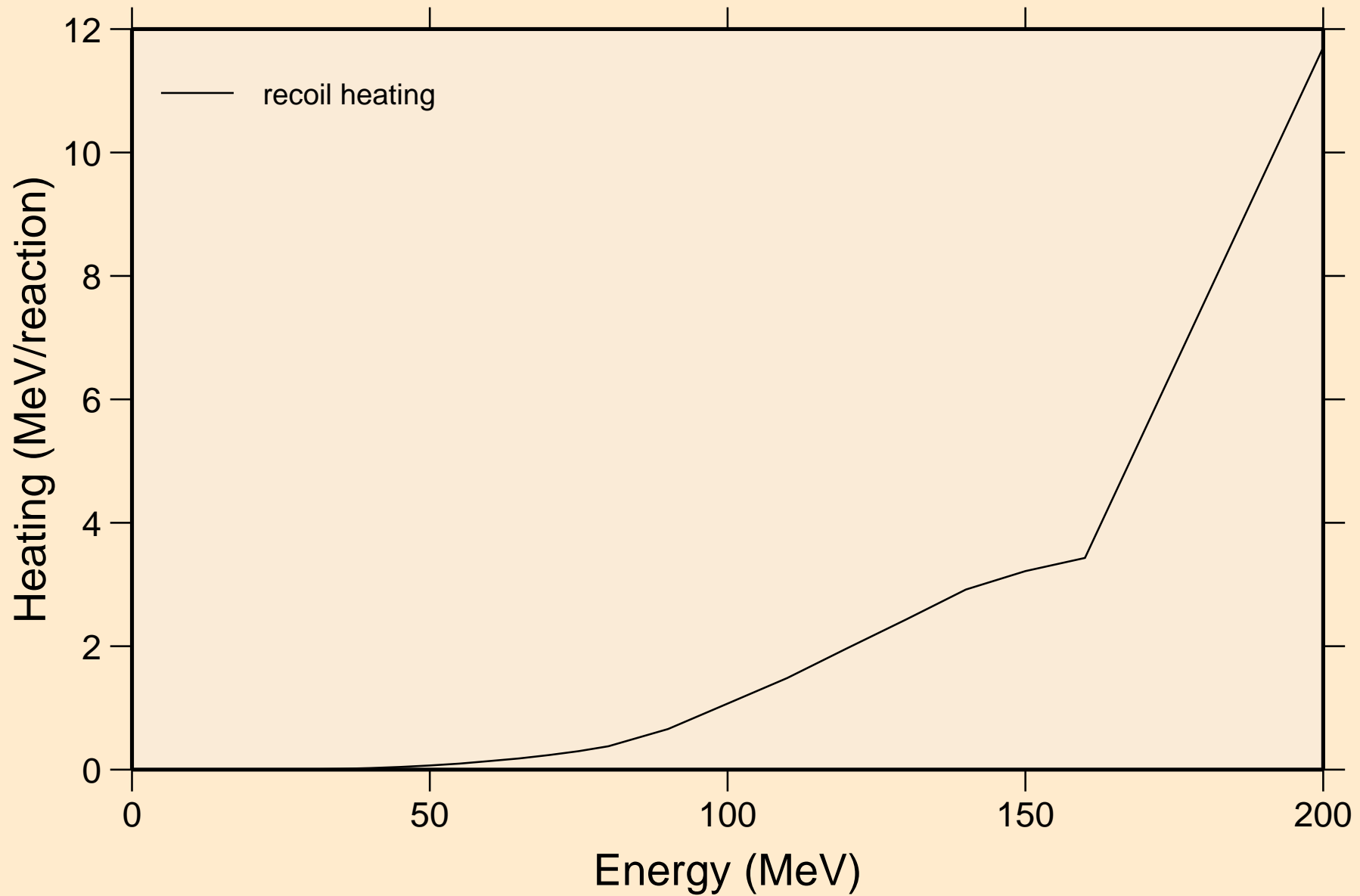

RE193 ALPHA ACER TENDL-2021 LIBRARY; T=0.K

Particle production cross sections

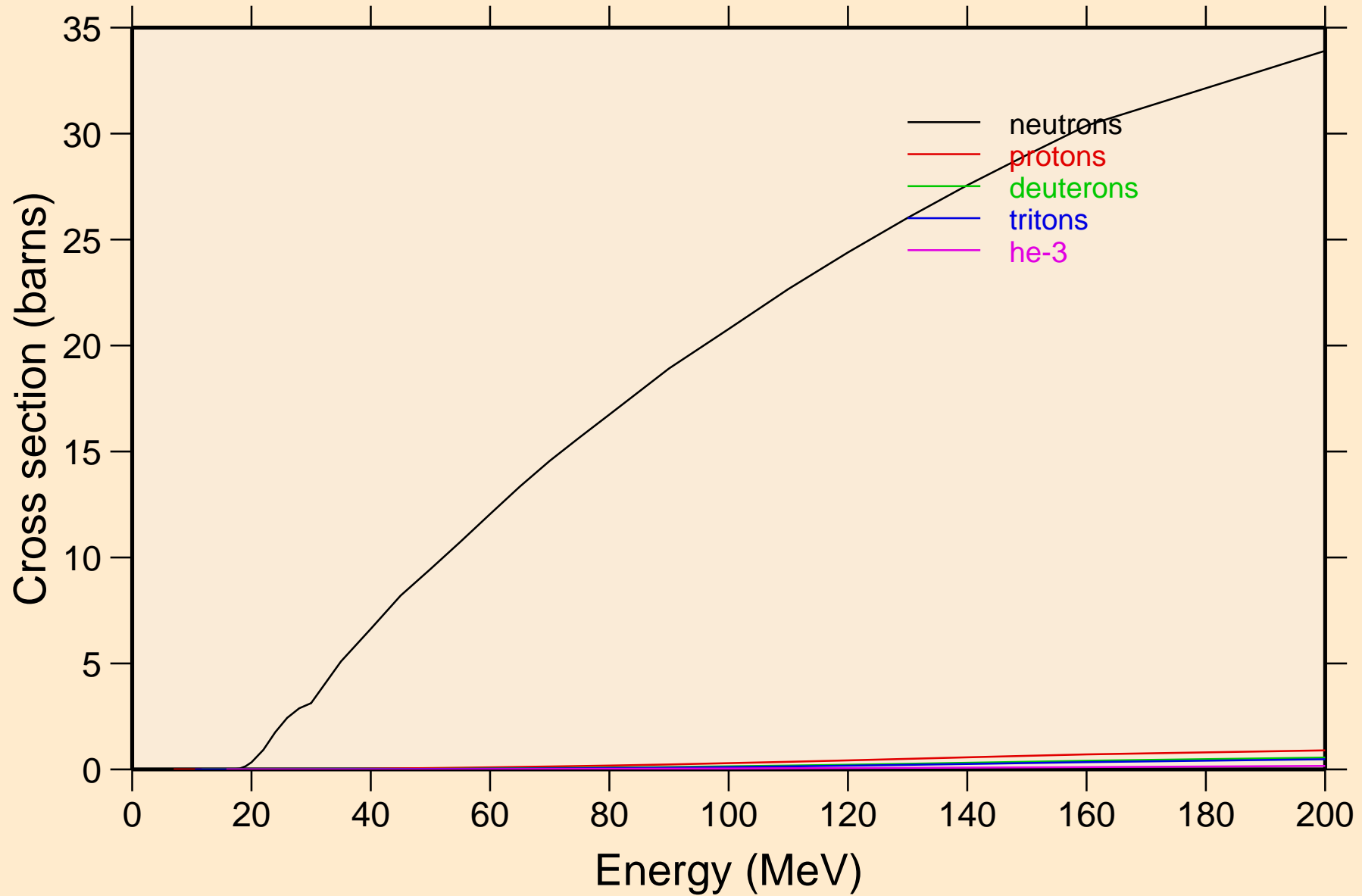

RE193 ALPHA ACER TENDL-2021 LIBRARY; T=0.K
neutrons from (a,n)

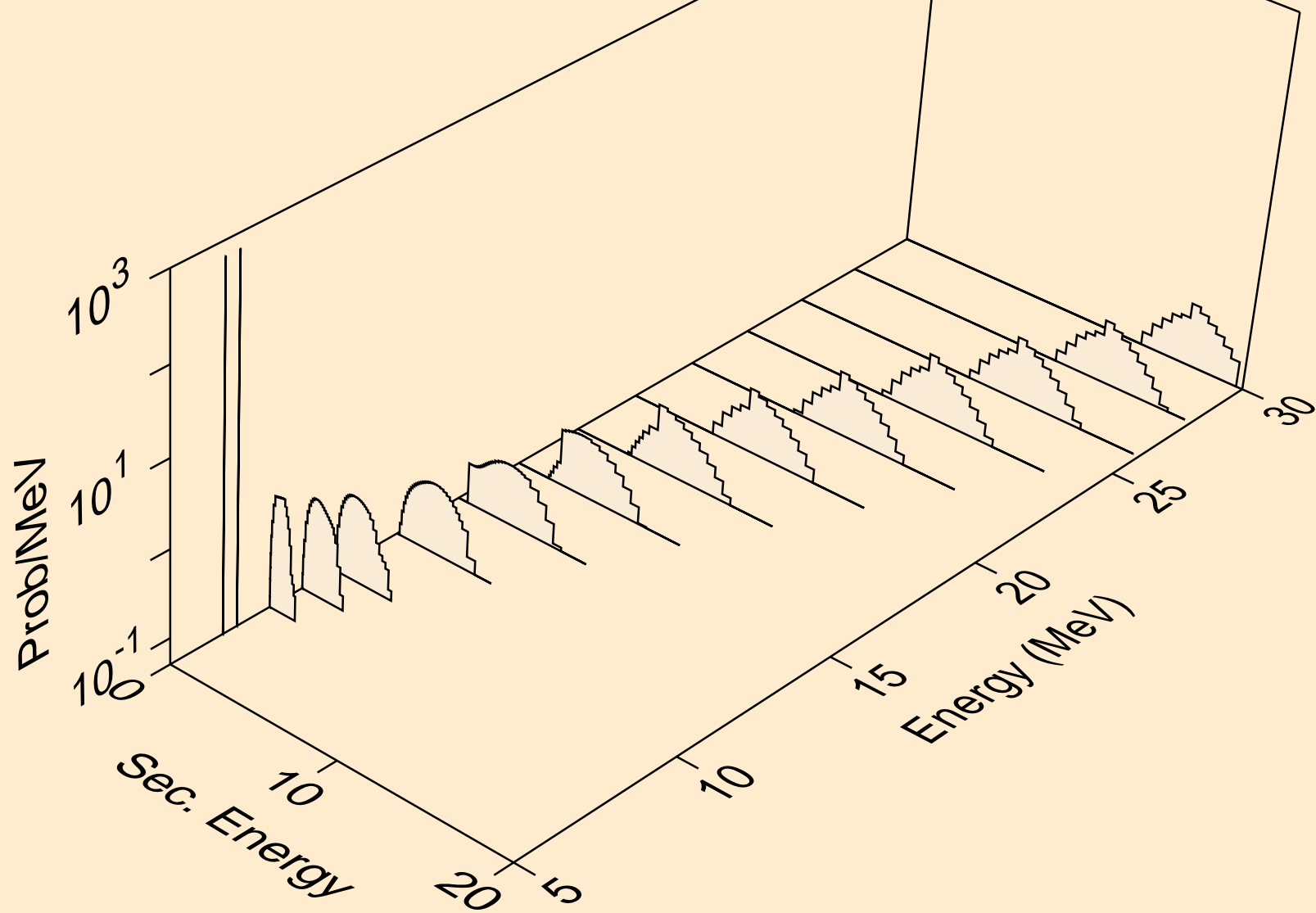

RE193 ALPHA ACER TENDL-2021 LIBRARY; T=0.K
neutrons from (a,x)

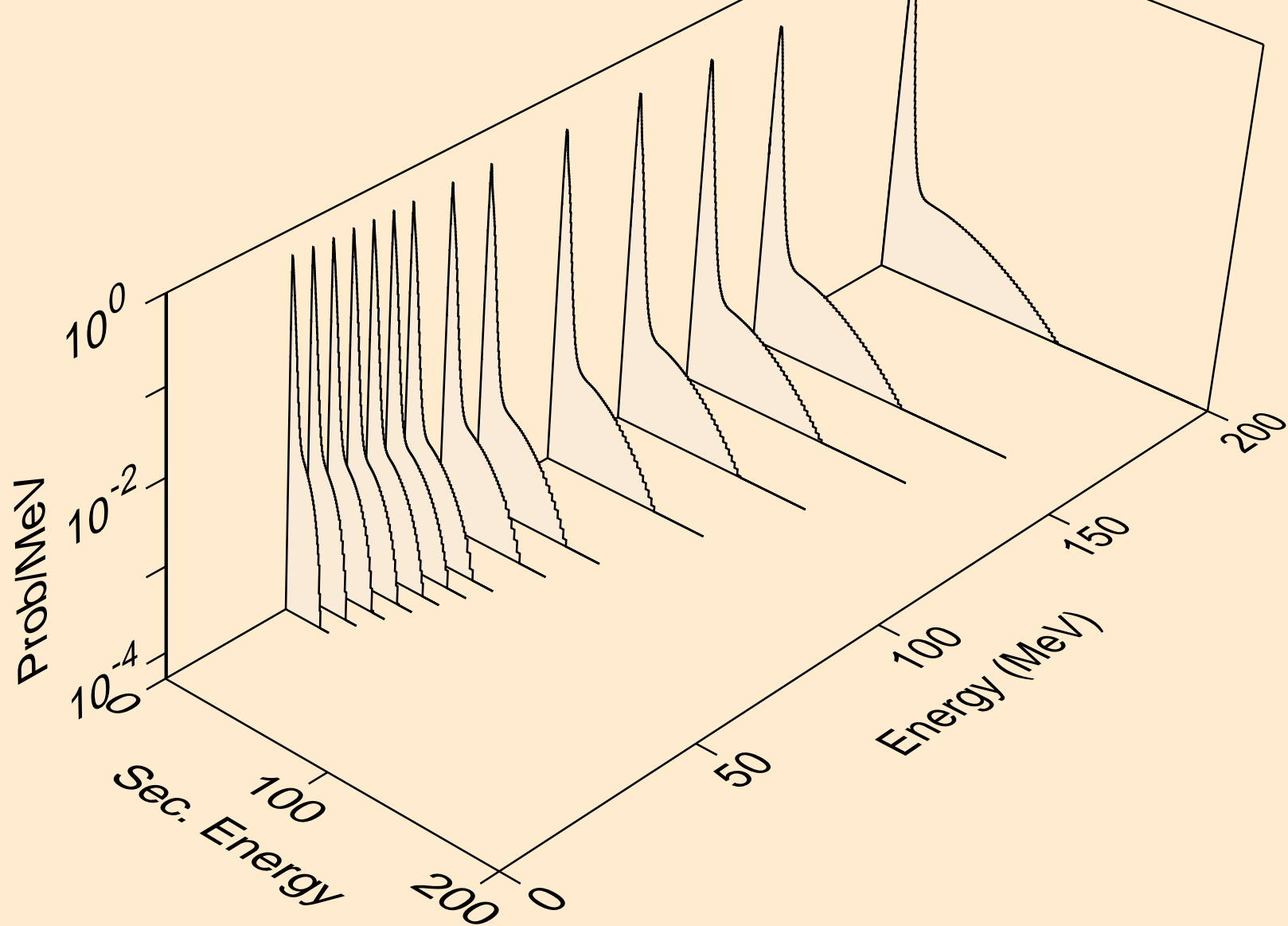

RE193 ALPHA ACER TENDL-2021 LIBRARY; T=0.K
neutrons from (a,2nd)

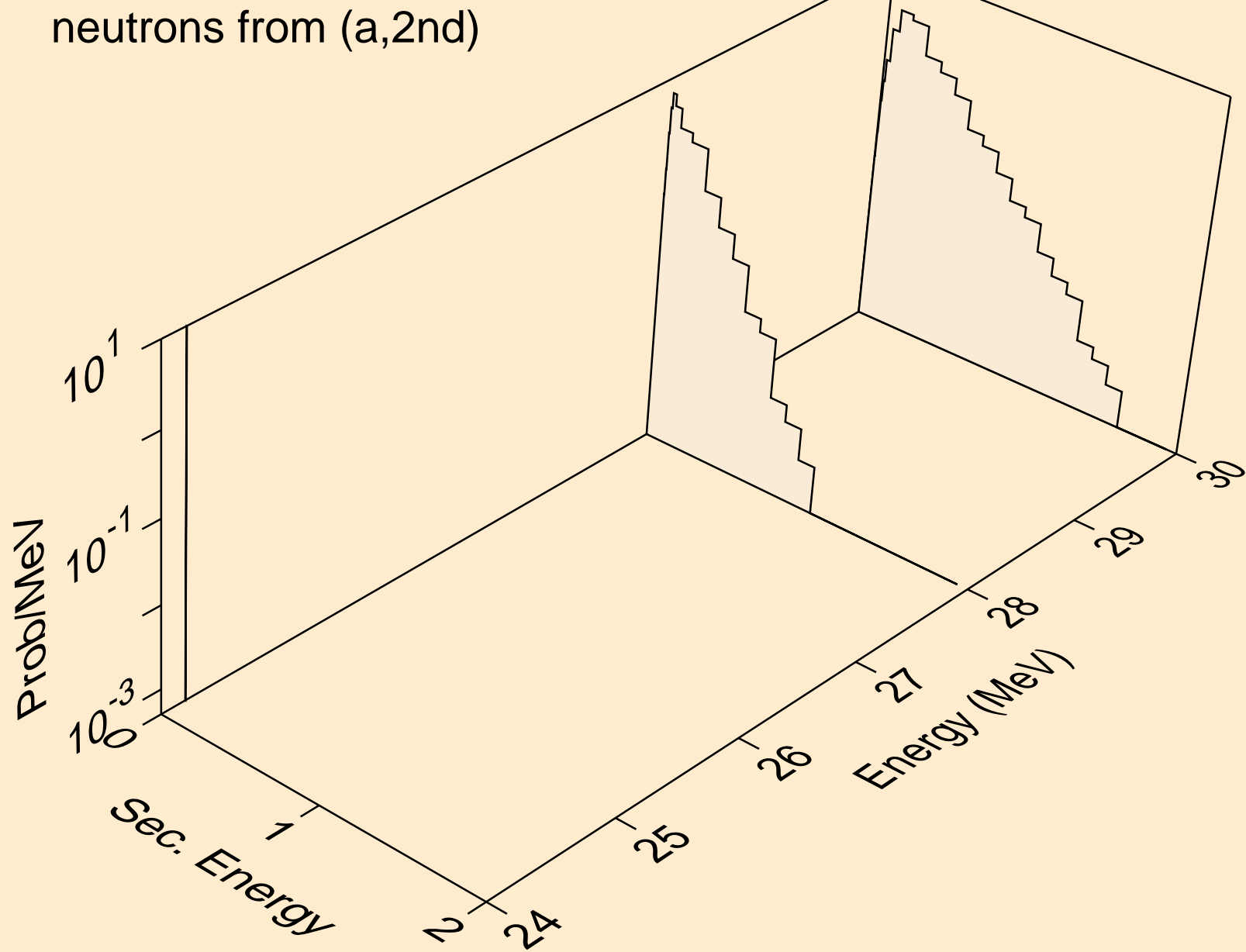

RE193 ALPHA ACER TENDL-2021 LIBRARY; T=0.K
neutrons from (a,2n)

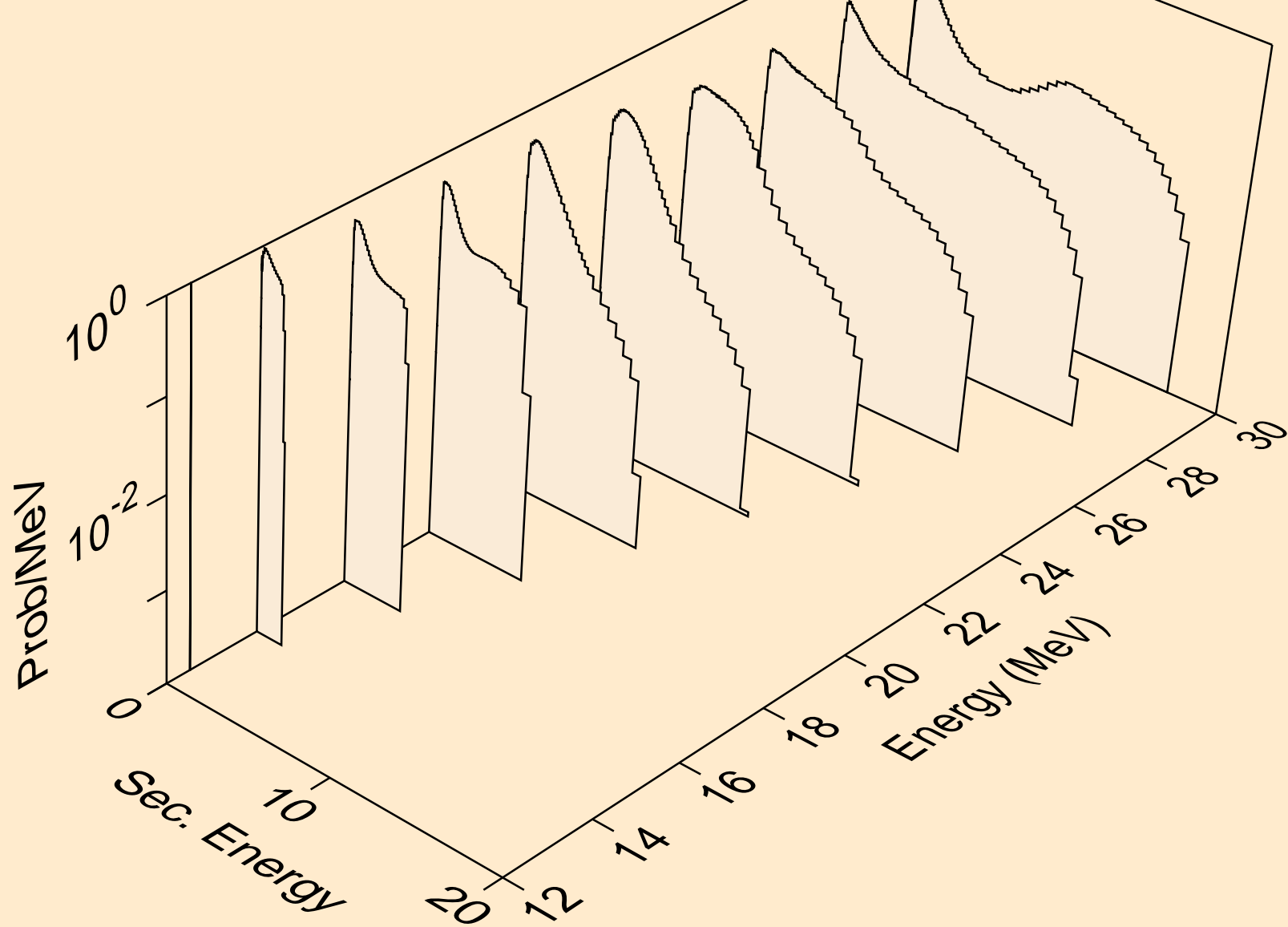

RE193 ALPHA ACER TENDL-2021 LIBRARY; T=0.K
neutrons from (a,3n)

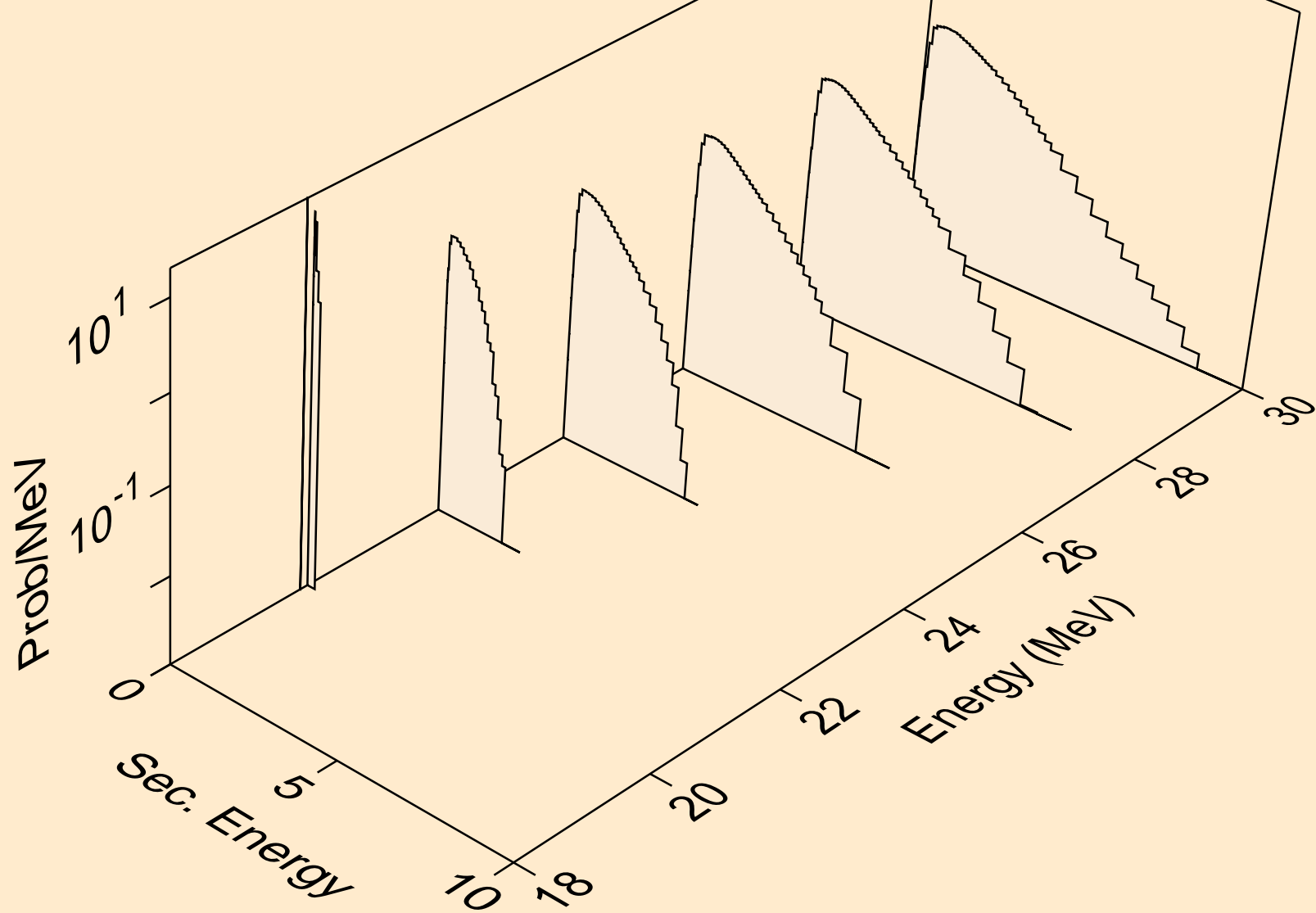

RE193 ALPHA ACER TENDL-2021 LIBRARY; T=0.K
neutrons from (a,n*)a

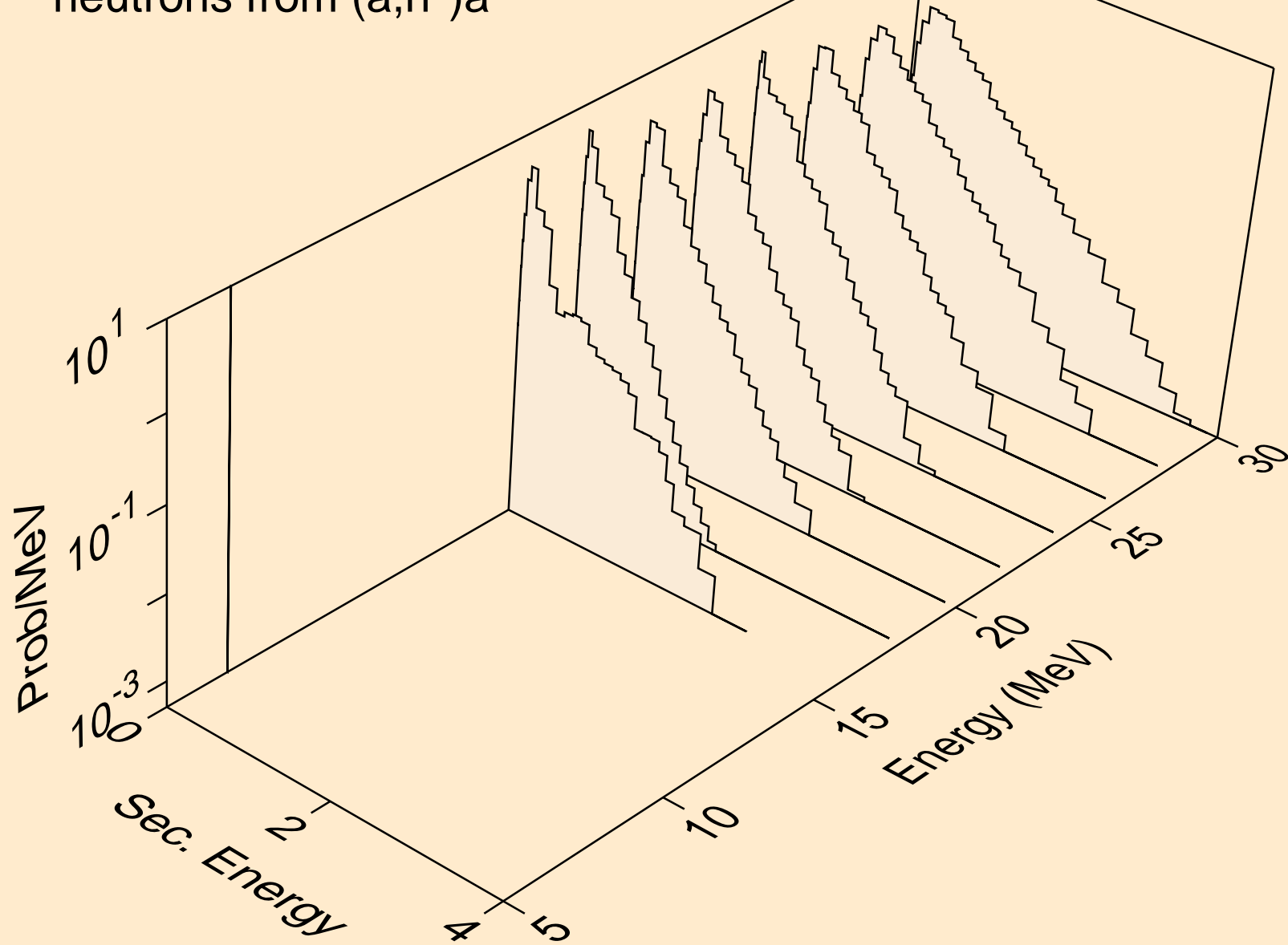

RE193 ALPHA ACER TENDL-2021 LIBRARY; T=0.K
neutrons from (a,2n)a

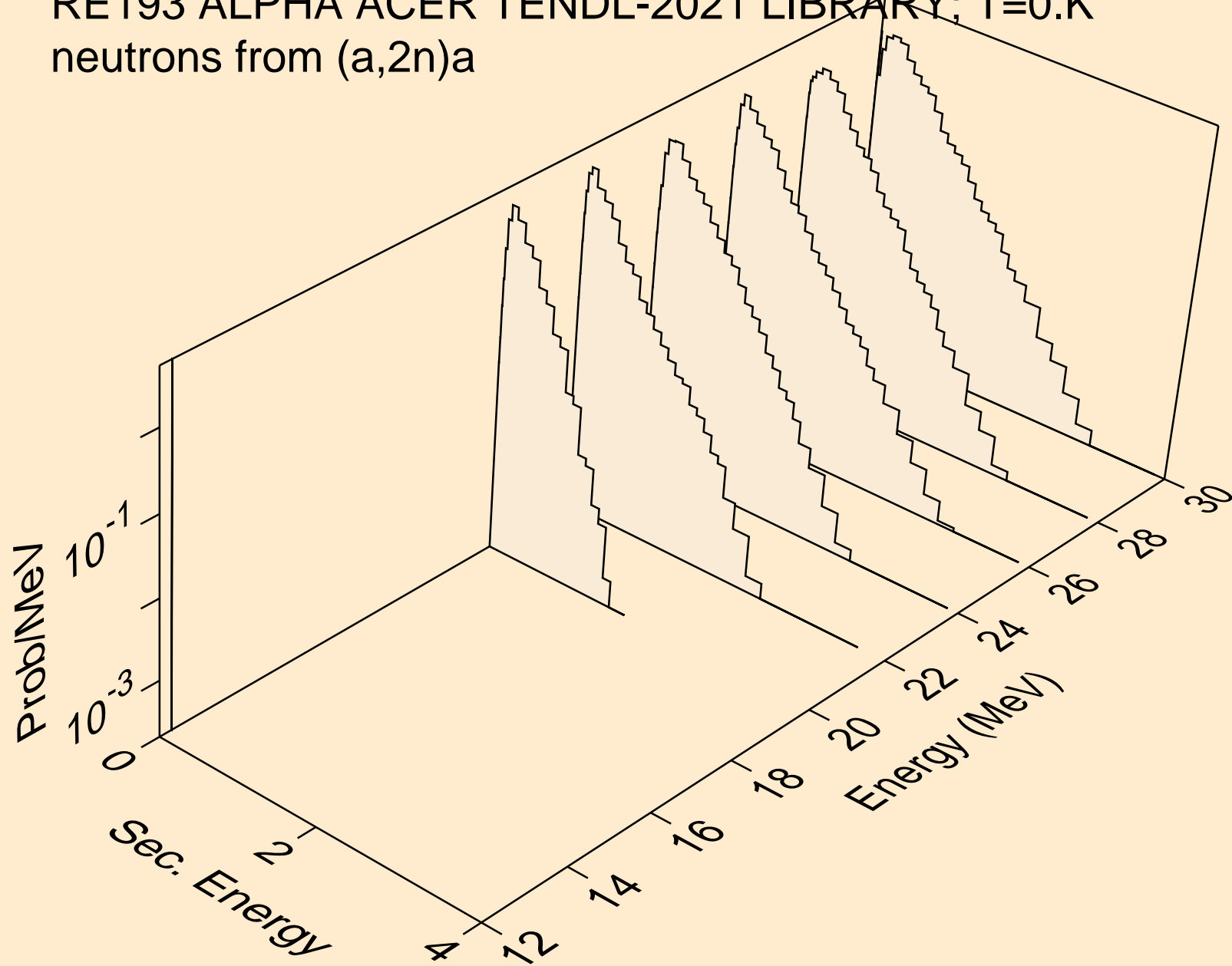

RE193 ALPHA ACER TENDL-2021 LIBRARY; T=0.K
neutrons from (a,n*)p

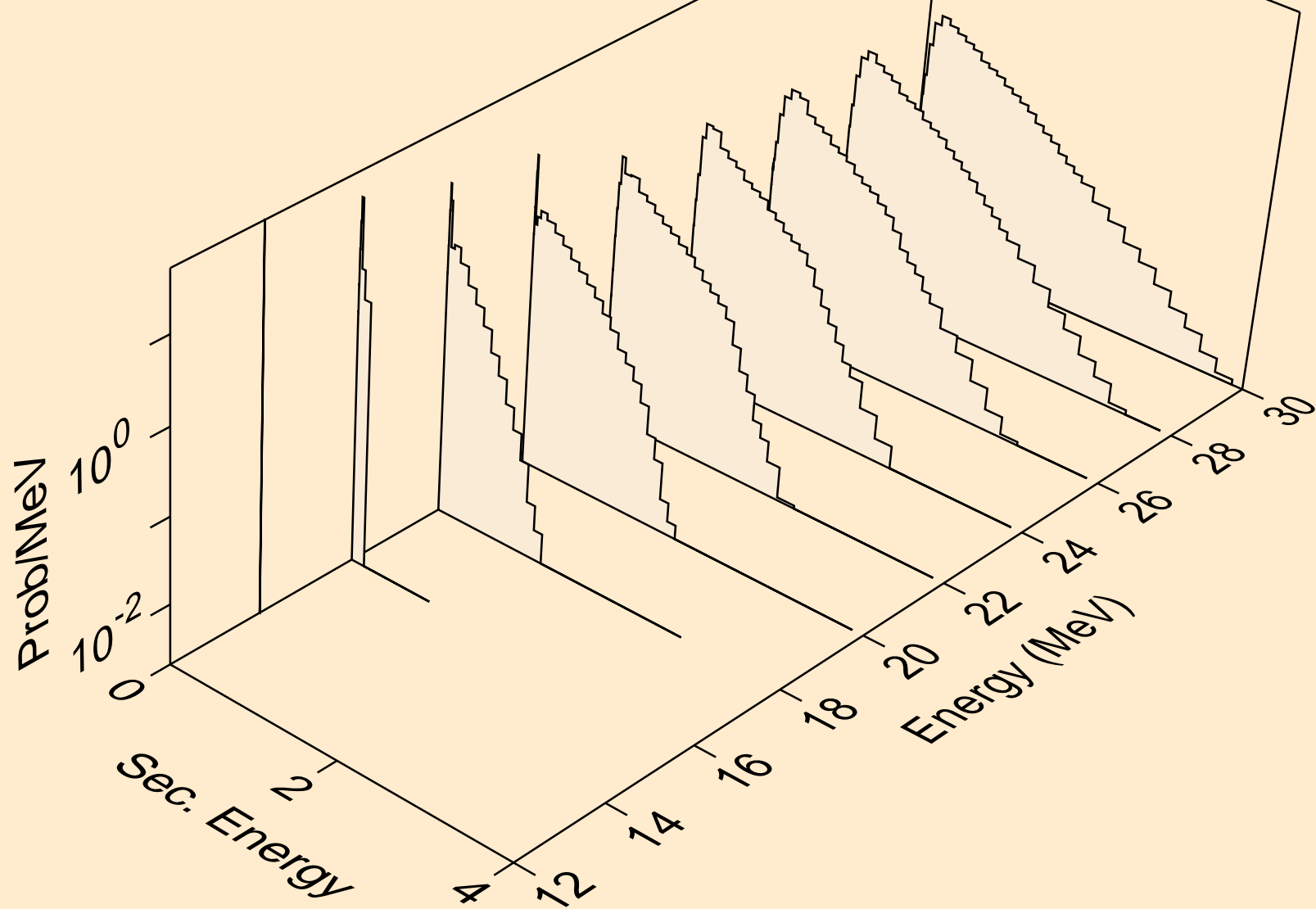

RE193 ALPHA ACER TENDL-2021 LIBRARY; T=0.K
neutrons from (a,n*)d

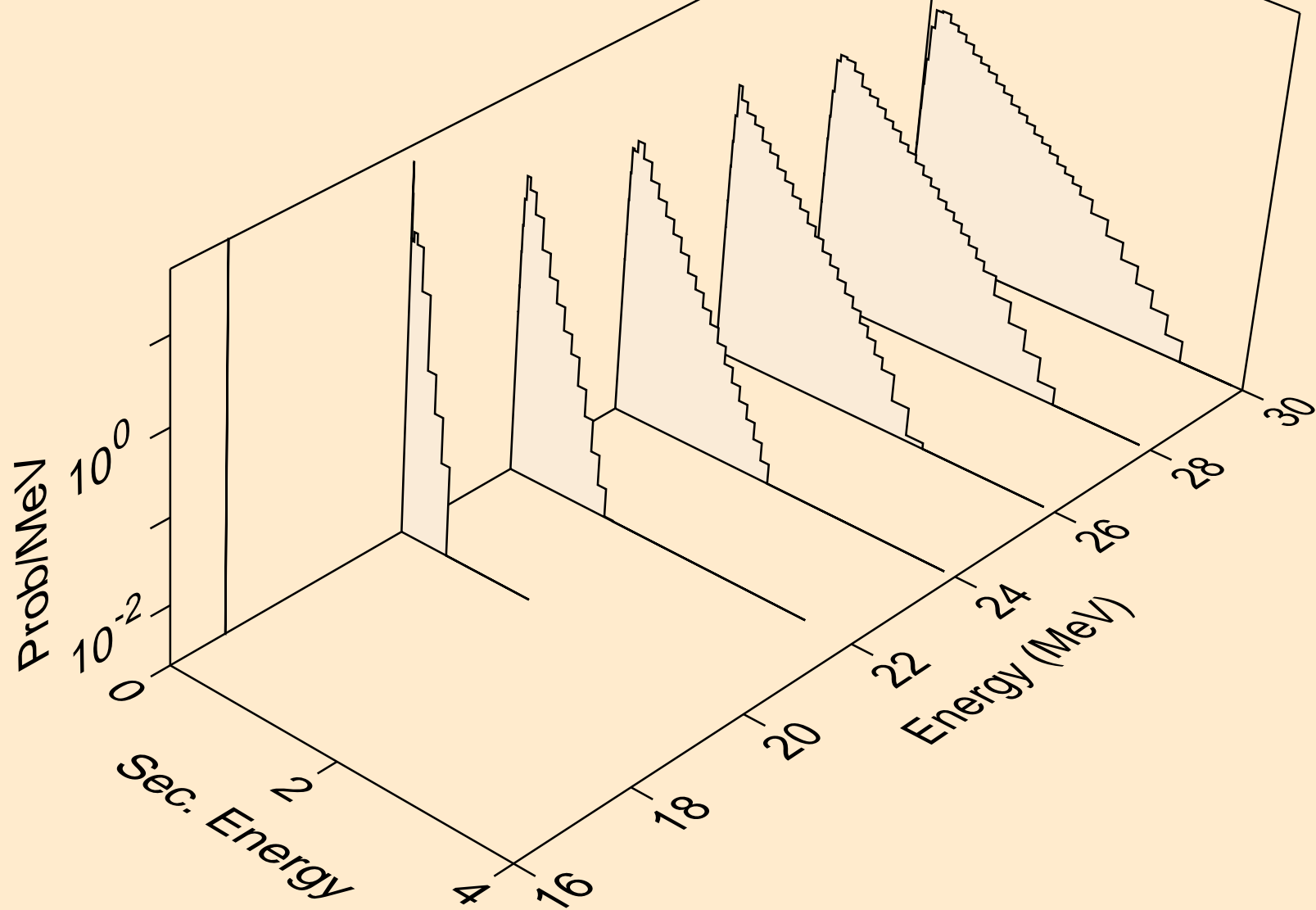

RE193 ALPHA ACER TENDL-2021 LIBRARY; T=0.K
neutrons from (a,n*)t

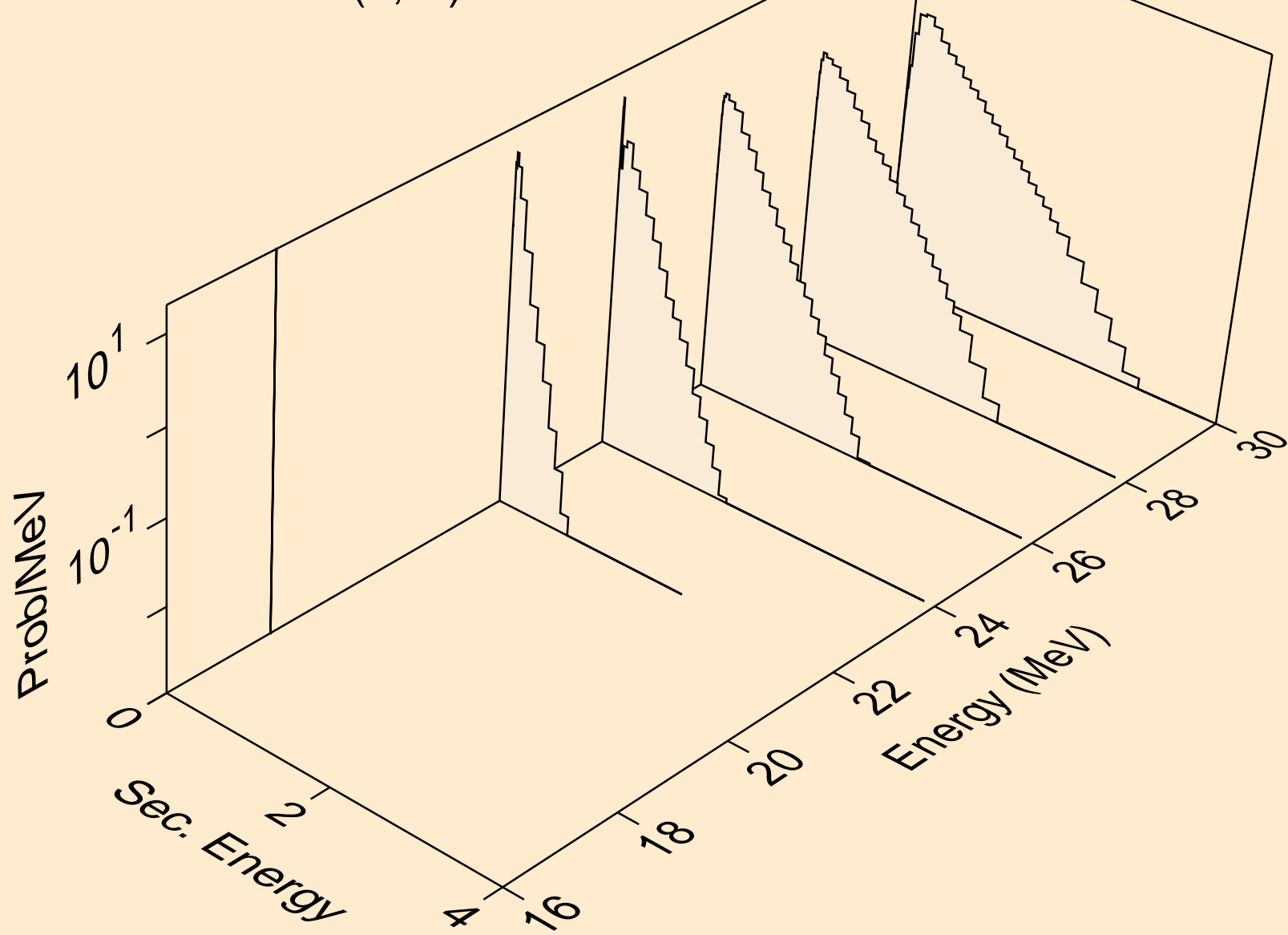

RE193 ALPHA ACER TENDL-2021 LIBRARY; T=0.K
neutrons from (a,4n)

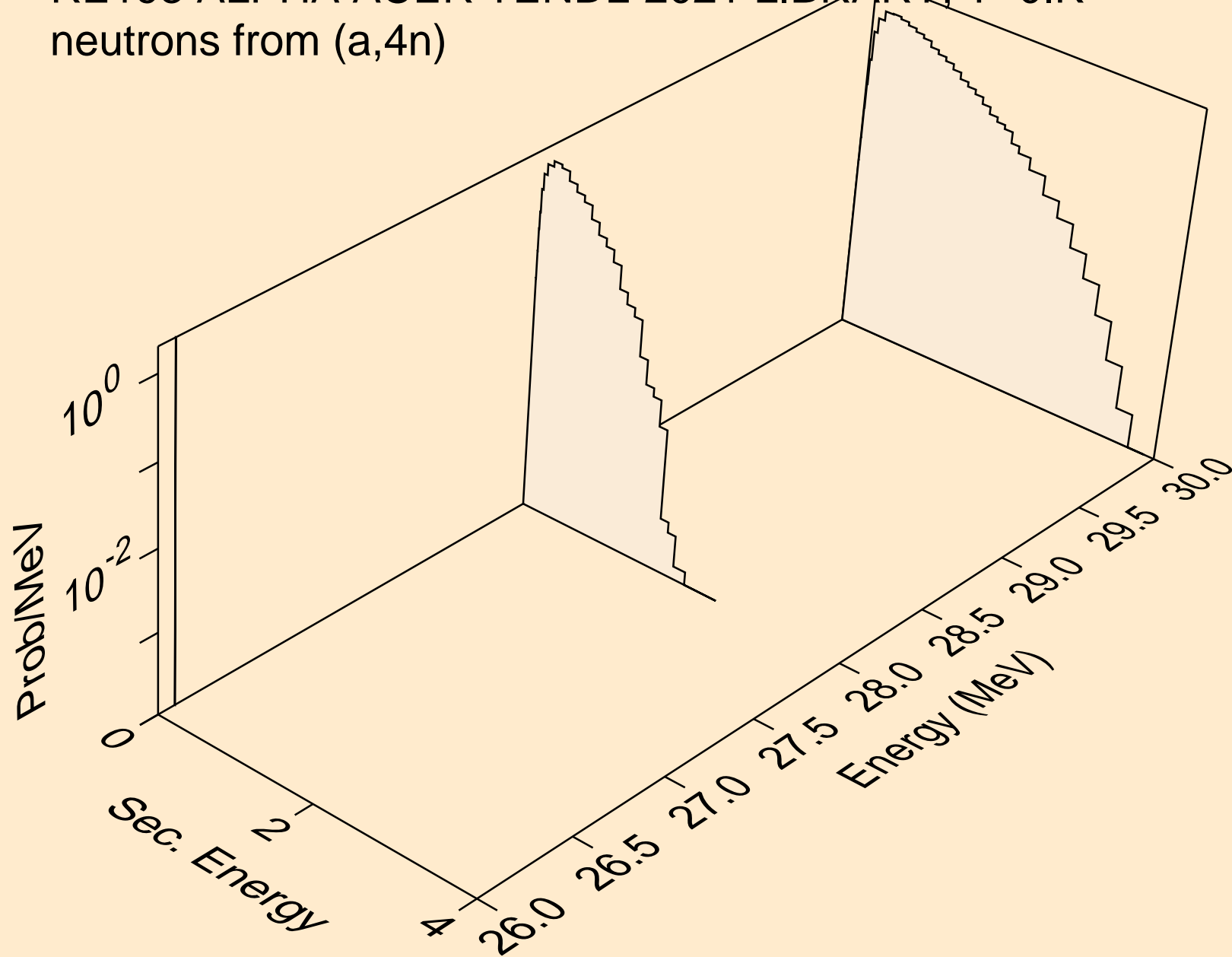

RE193 ALPHA ACER TENDL-2021 LIBRARY; T=0.K
neutrons from (a,2np)

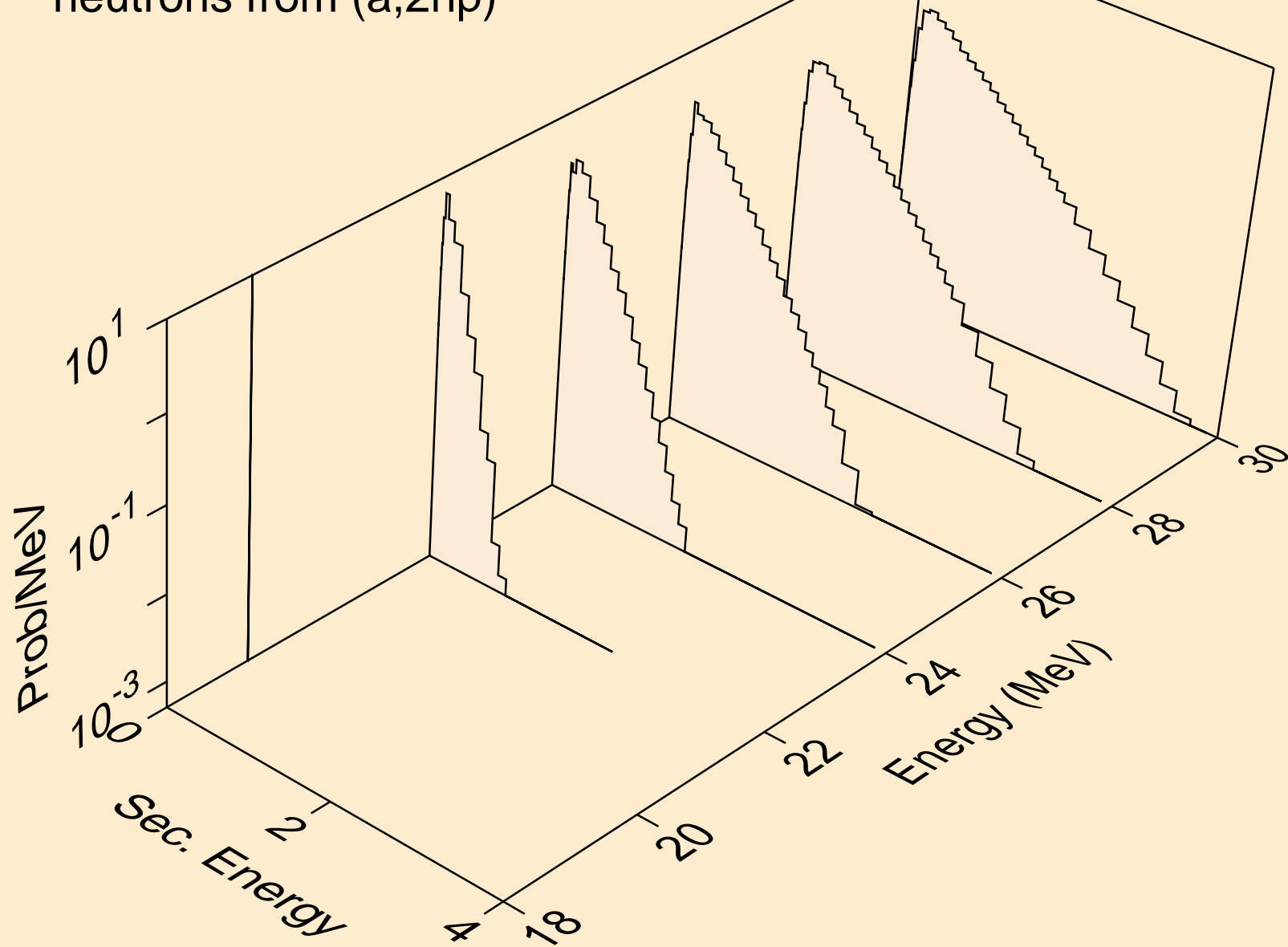

RE193 ALPHA ACER TENDL-2021 LIBRARY; T=0.K
protons from (a,x)

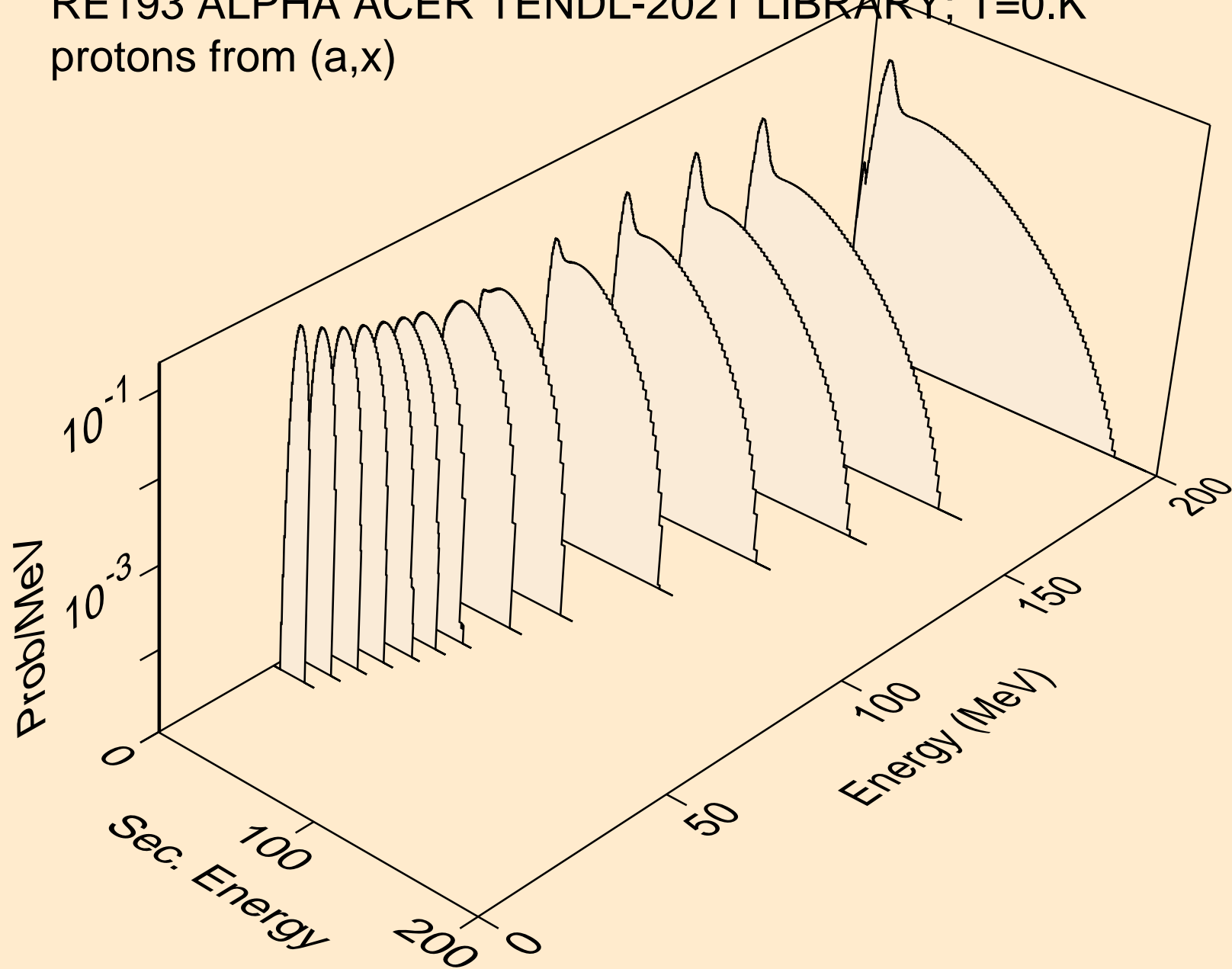

RE193 ALPHA ACER TENDL-2021 LIBRARY; T=0.K
protons from (a,n*)p

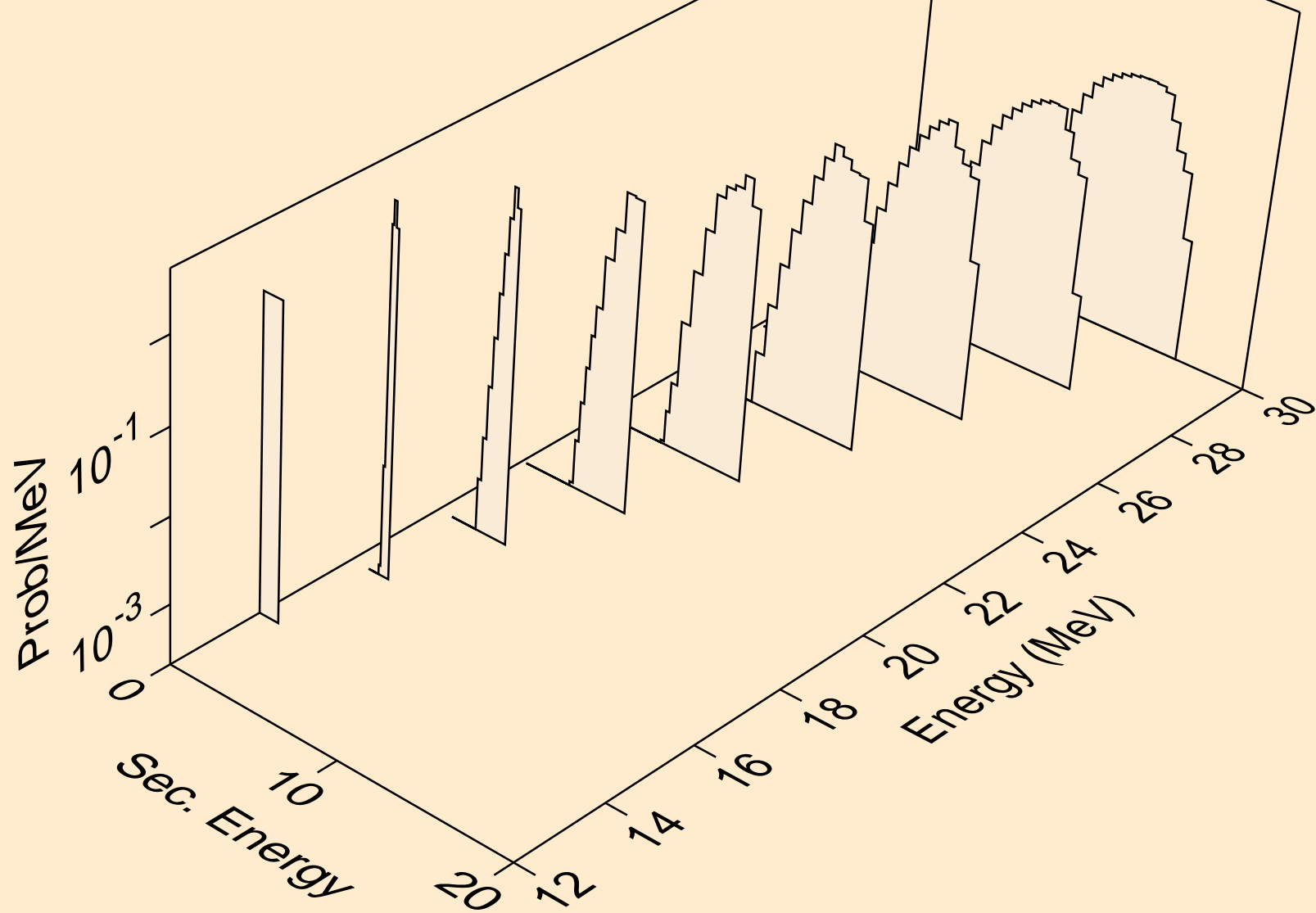

RE193 ALPHA ACER TENDL-2021 LIBRARY; T=0.K
protons from (a,2np)

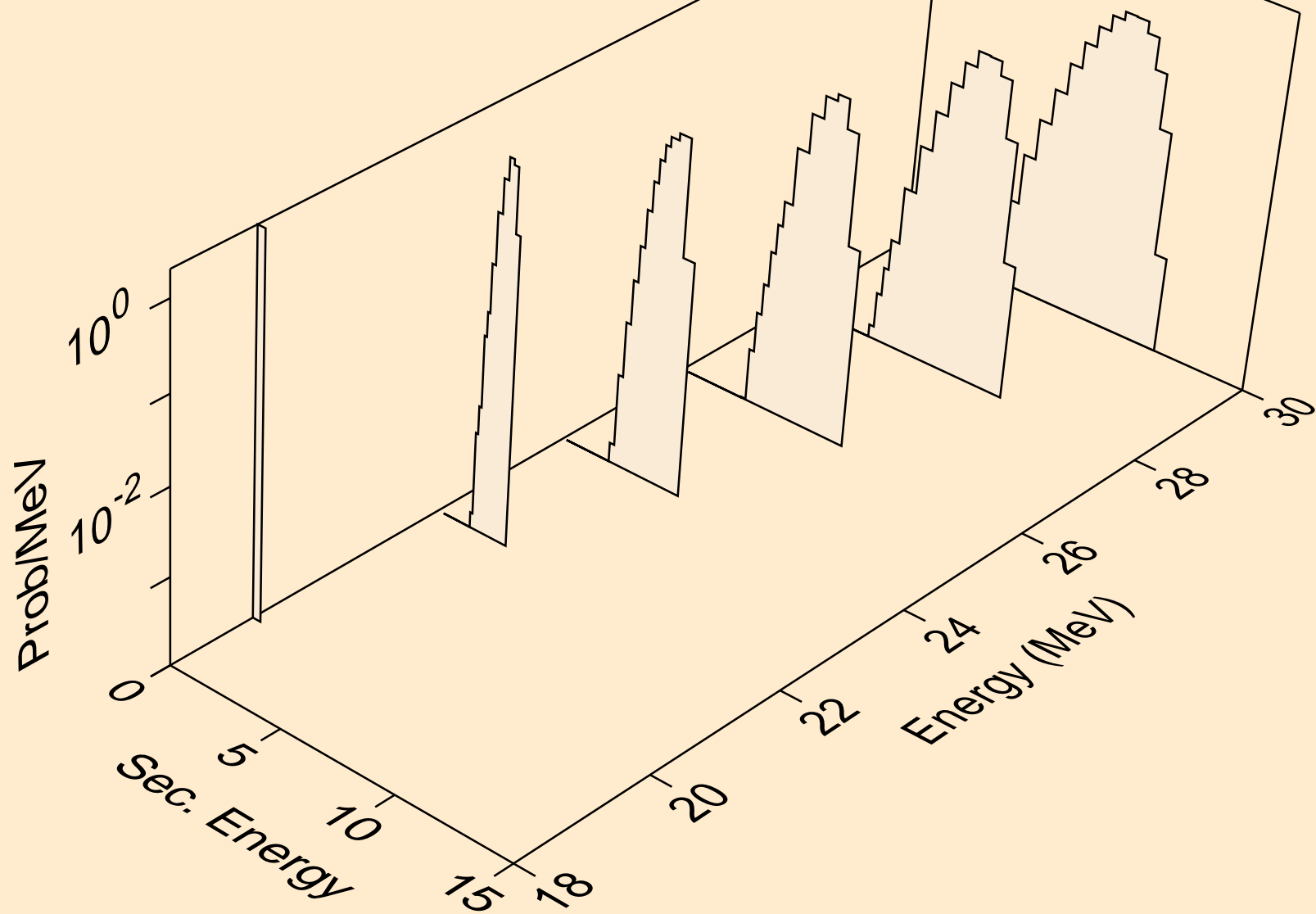

RE193 ALPHA ACER TENDL-2021 LIBRARY; T=0.K
protons from (a,p)

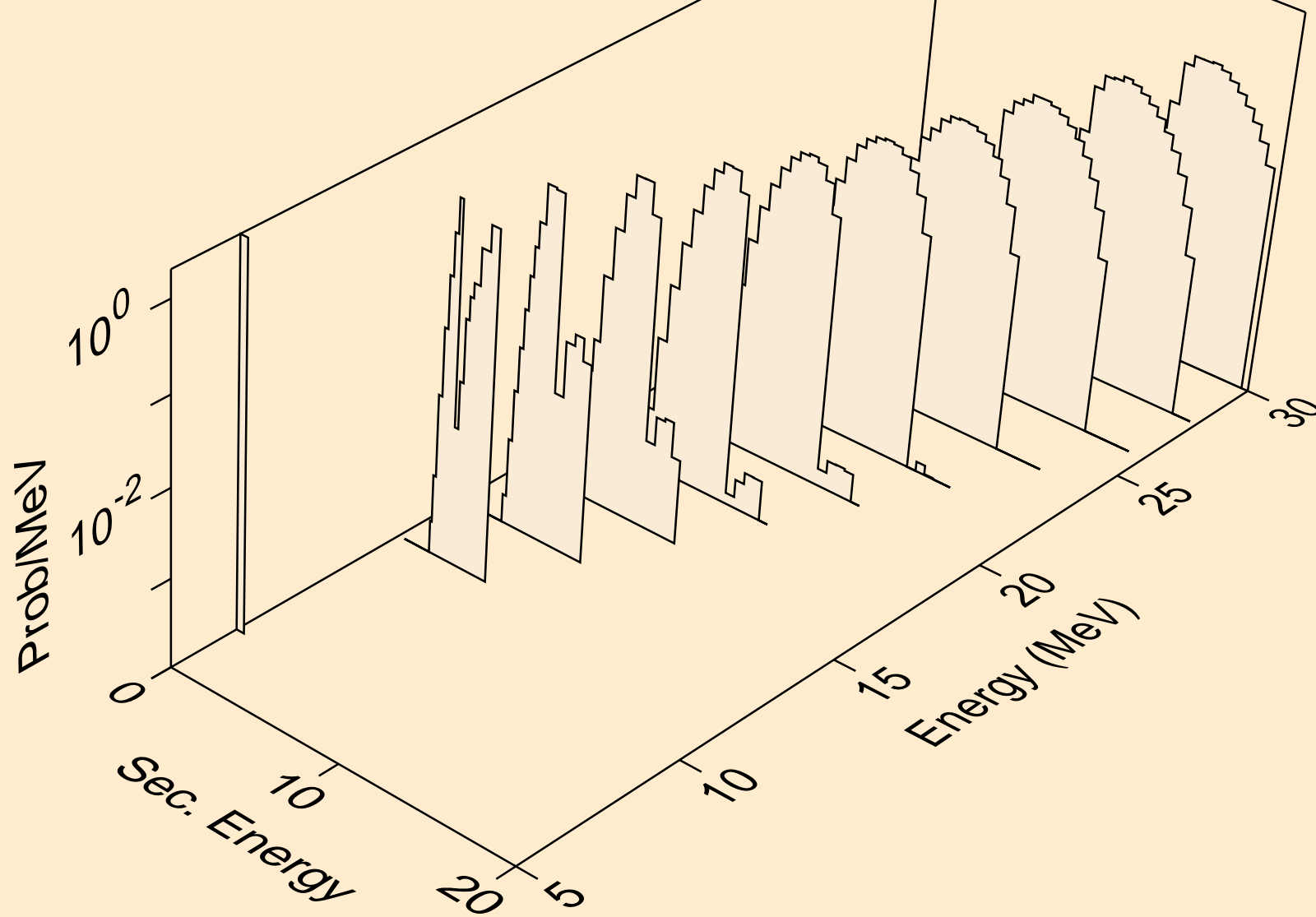

RE193 ALPHA ACER TENDL-2021 LIBRARY; T=0.K
deuterons from (a,x)

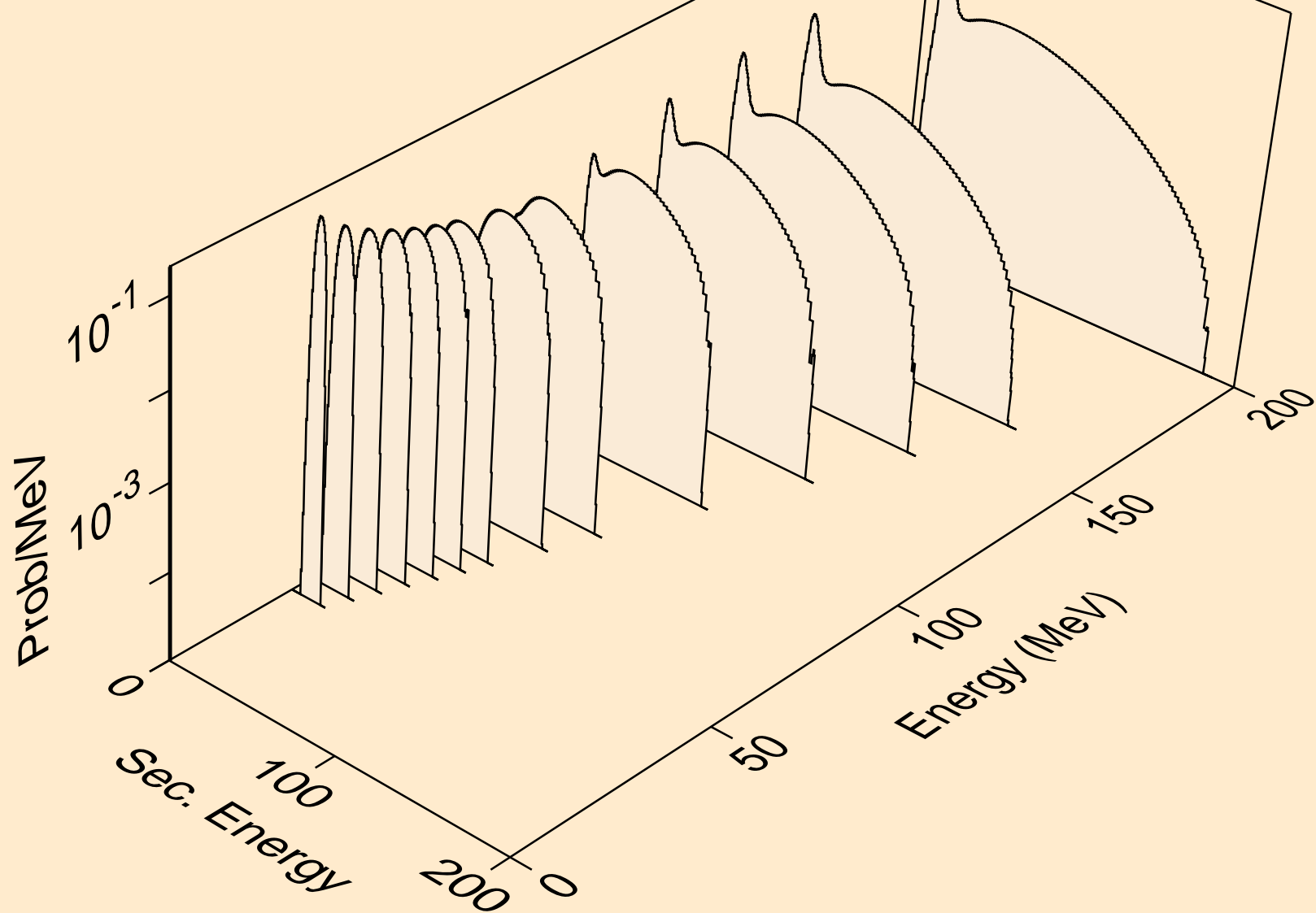

RE193 ALPHA ACER TENDL-2021 LIBRARY; T=0.K
deuterons from (a,2nd)

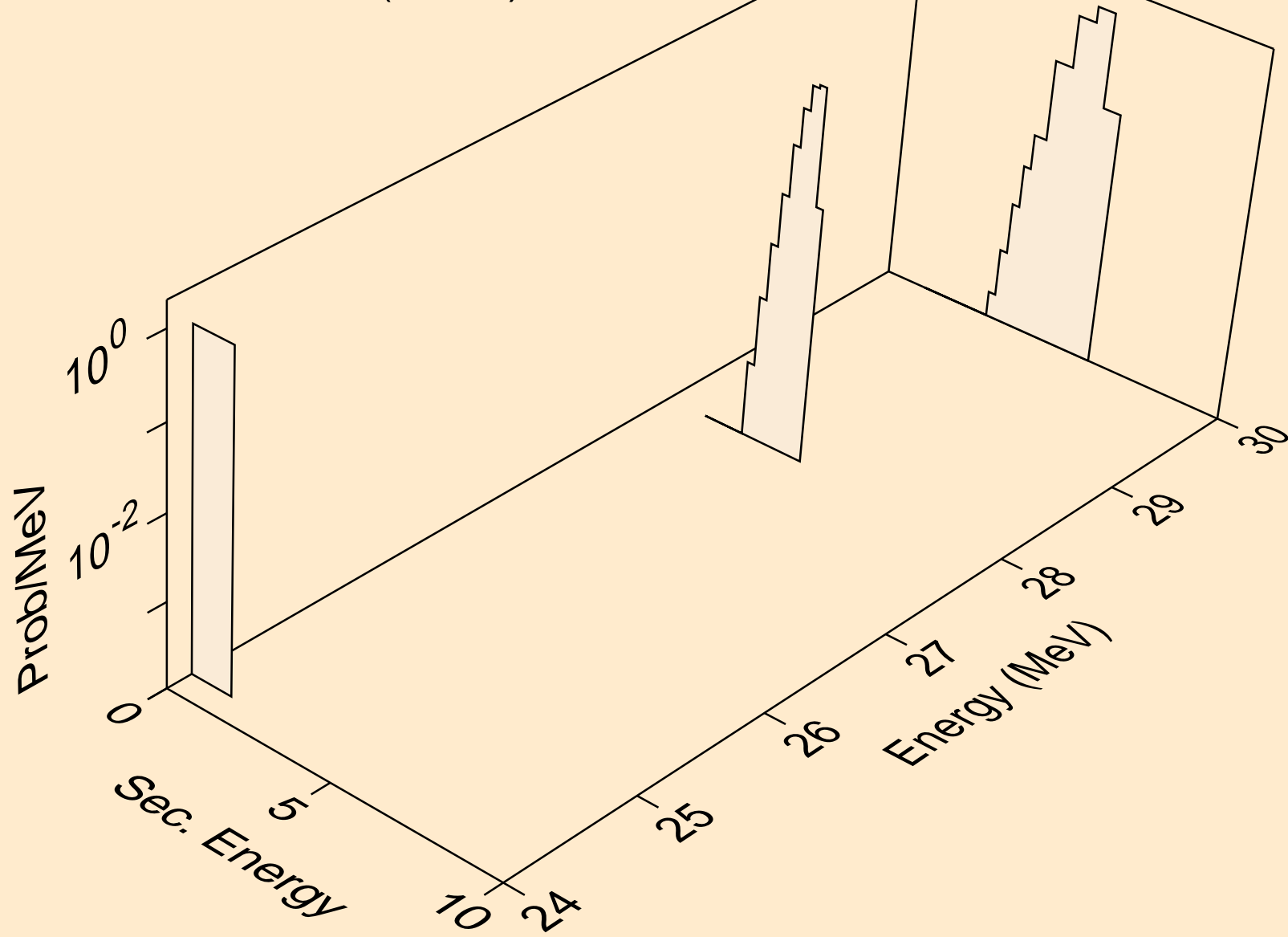

RE193 ALPHA ACER TENDL-2021 LIBRARY; T=0.K
deuterons from (a,n*)d

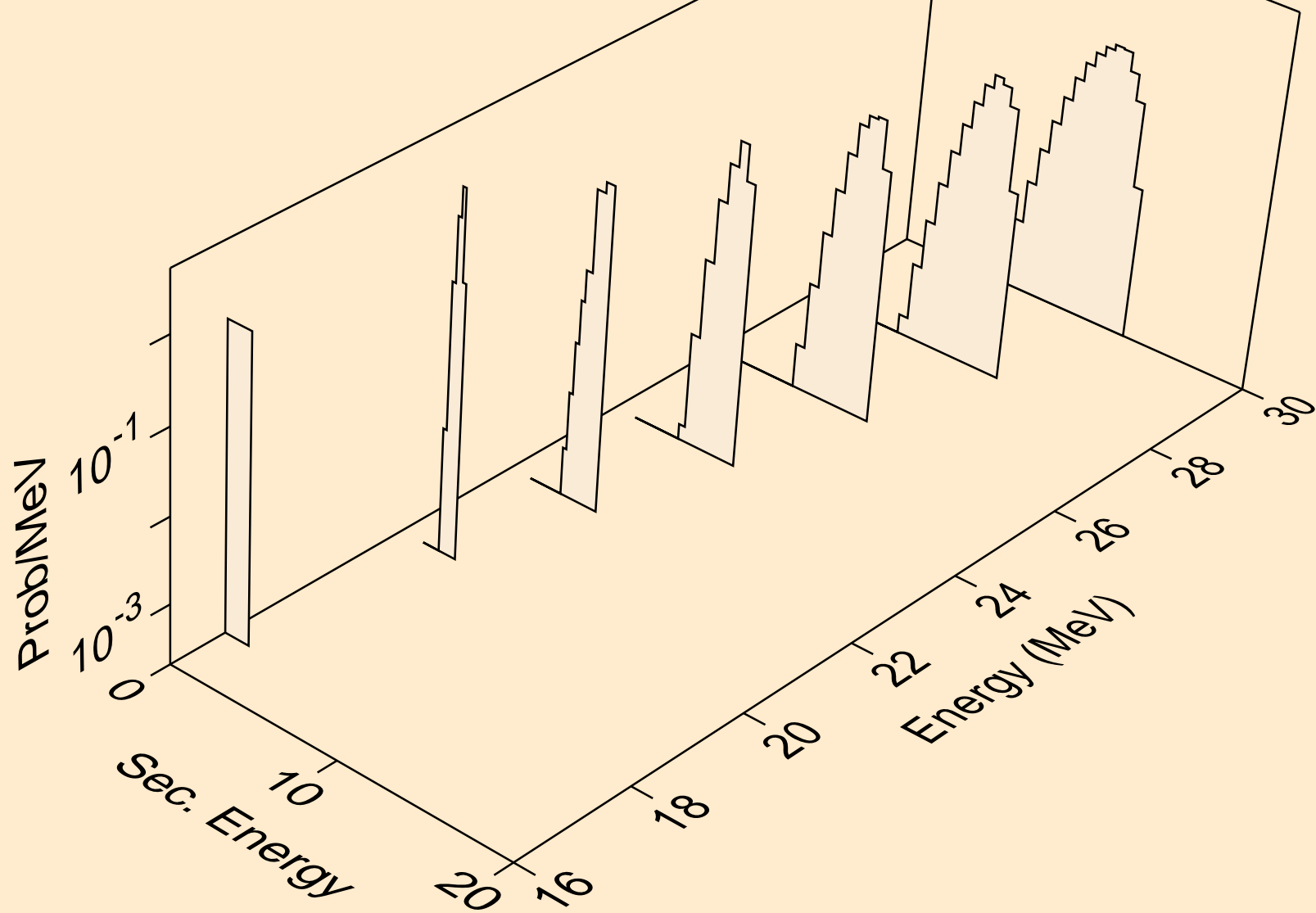

RE193 ALPHA ACER TENDL-2021 LIBRARY; T=0.K
deuterons from (a,d)

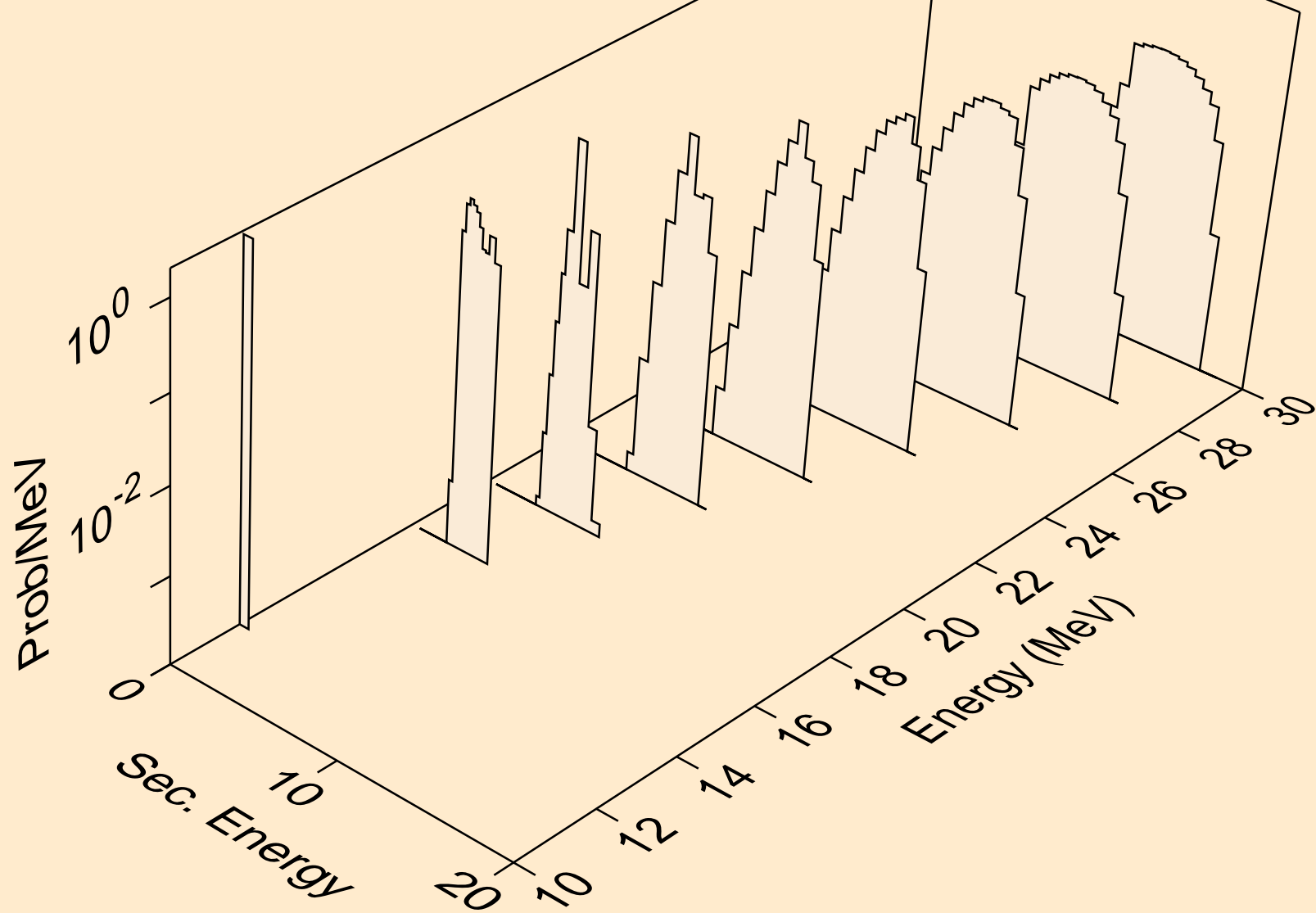

RE193 ALPHA ACER TENDL-2021 LIBRARY; T=0.K
tritons from (a,x)

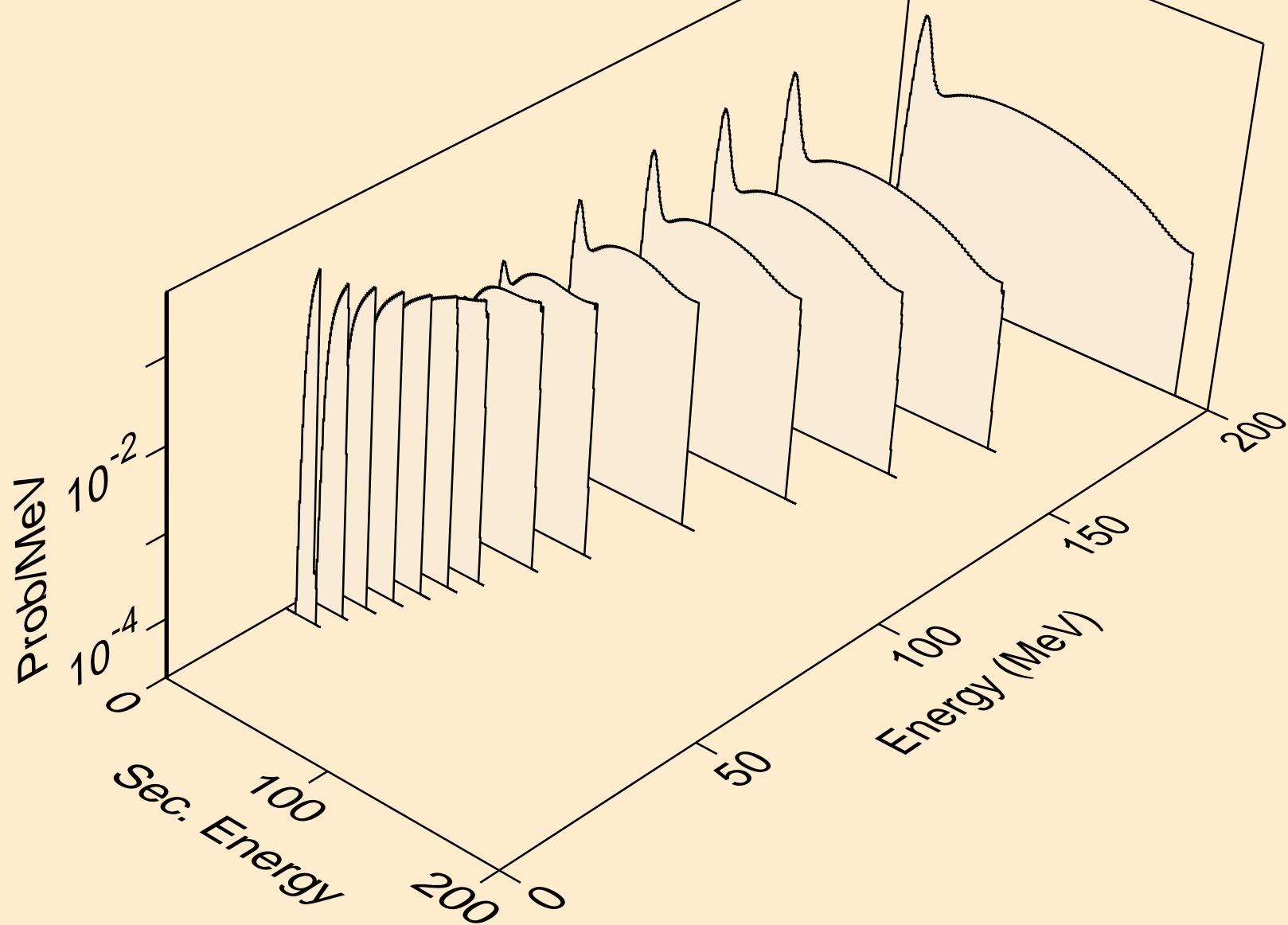

RE193 ALPHA ACER TENDL-2021 LIBRARY; T=0.K
tritons from (a,n*)t

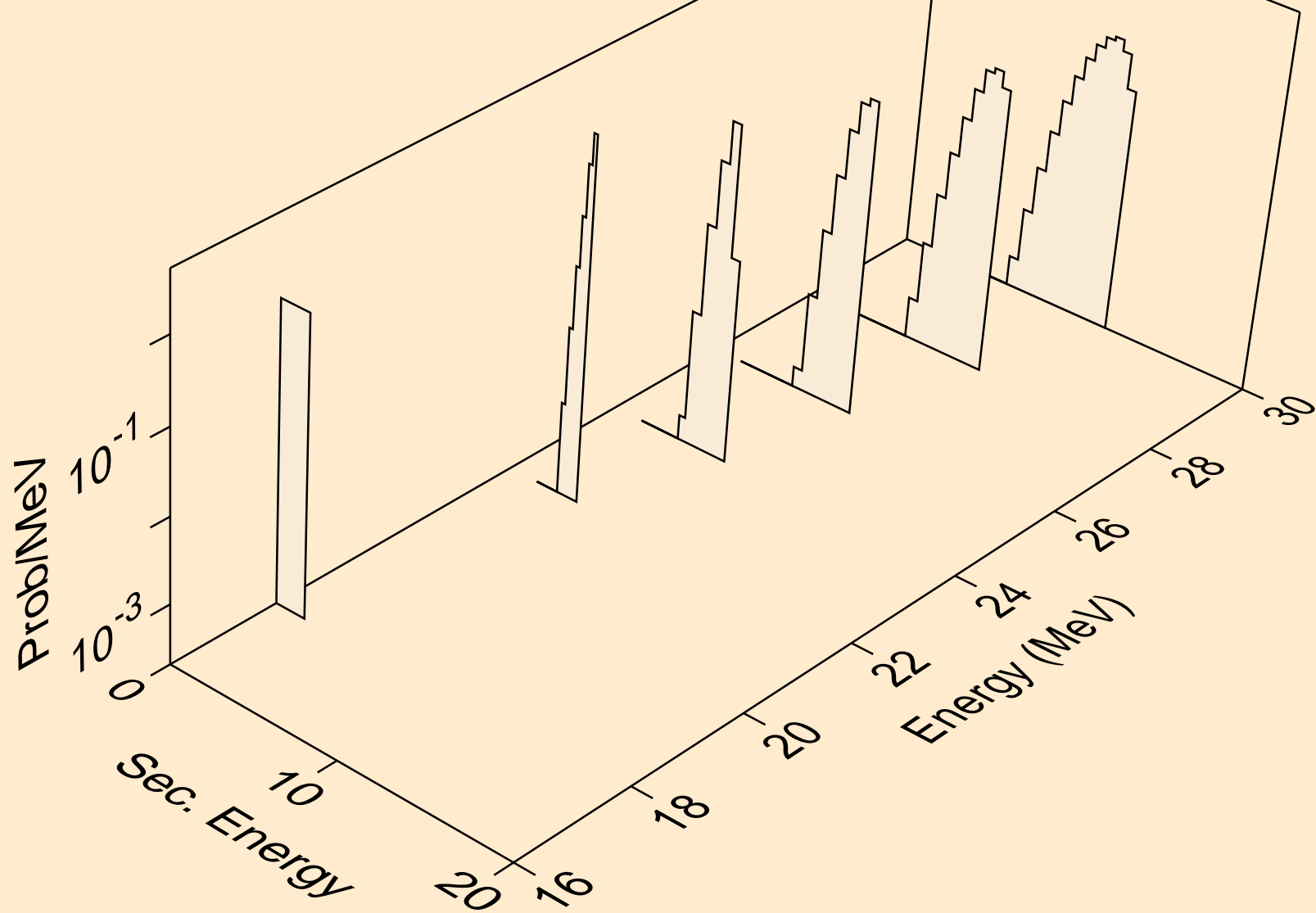

RE193 ALPHA ACER TENDL-2021 LIBRARY; T=0.K
tritons from (a,t)

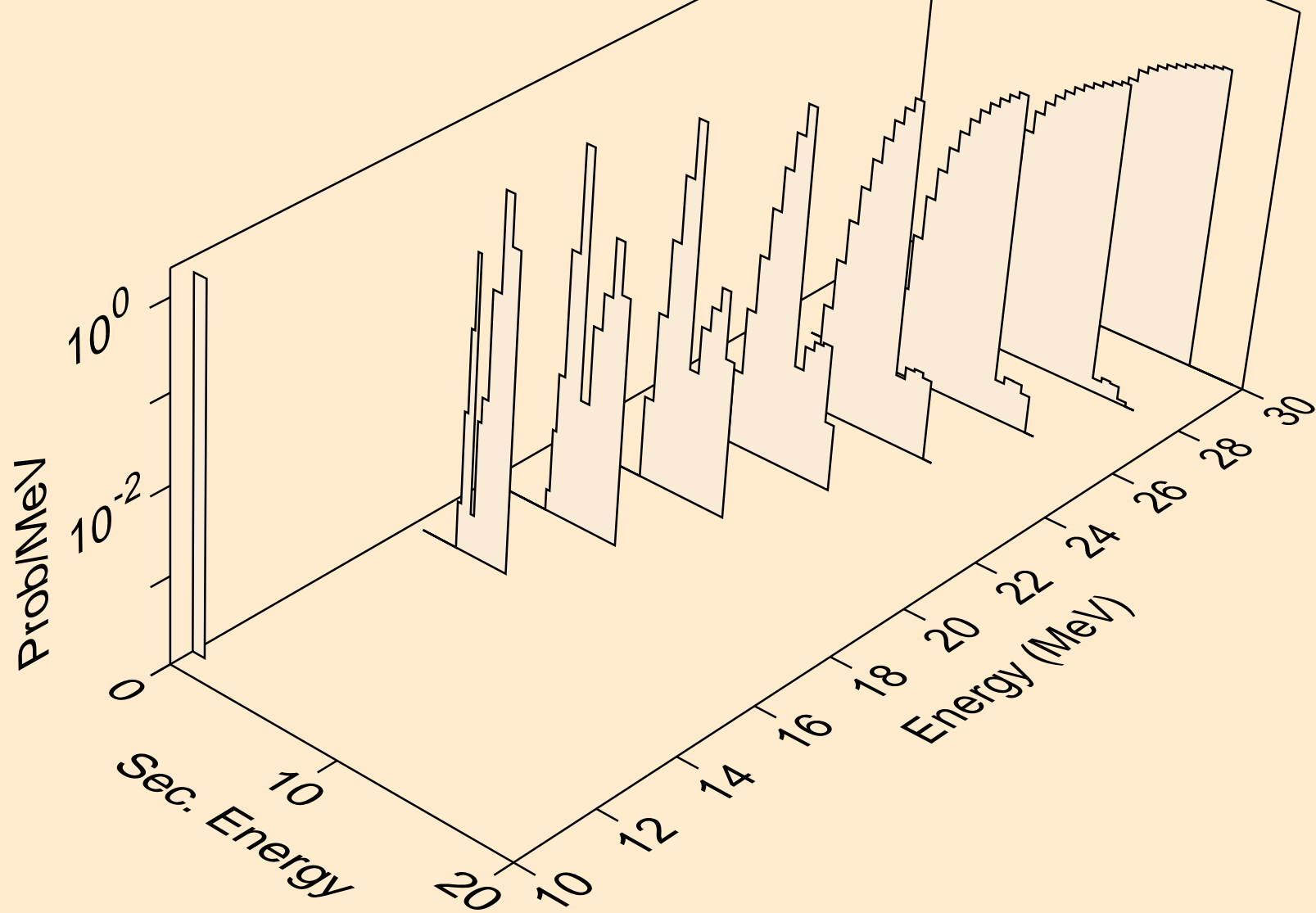

RE193 ALPHA ACER TENDL-2021 LIBRARY; T=0.K
he3s from (a,x)

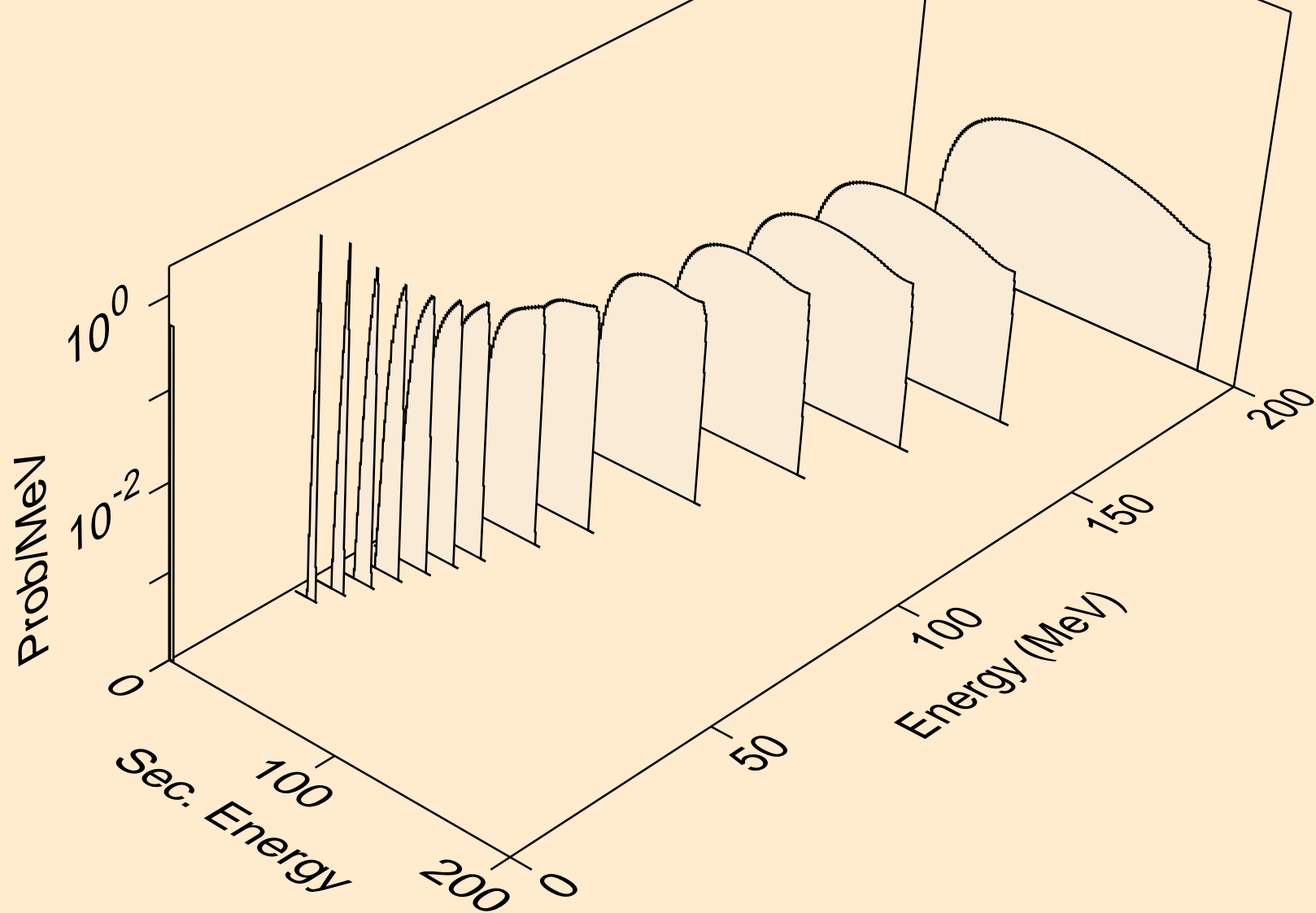

RE193 ALPHA ACER TENDL-2021 LIBRARY; T=0.K
he3s from (a,he3)

