

DS281 DEUTERON ACER TENDL-2021 LIBRARY; T=0.K
Principal cross sections

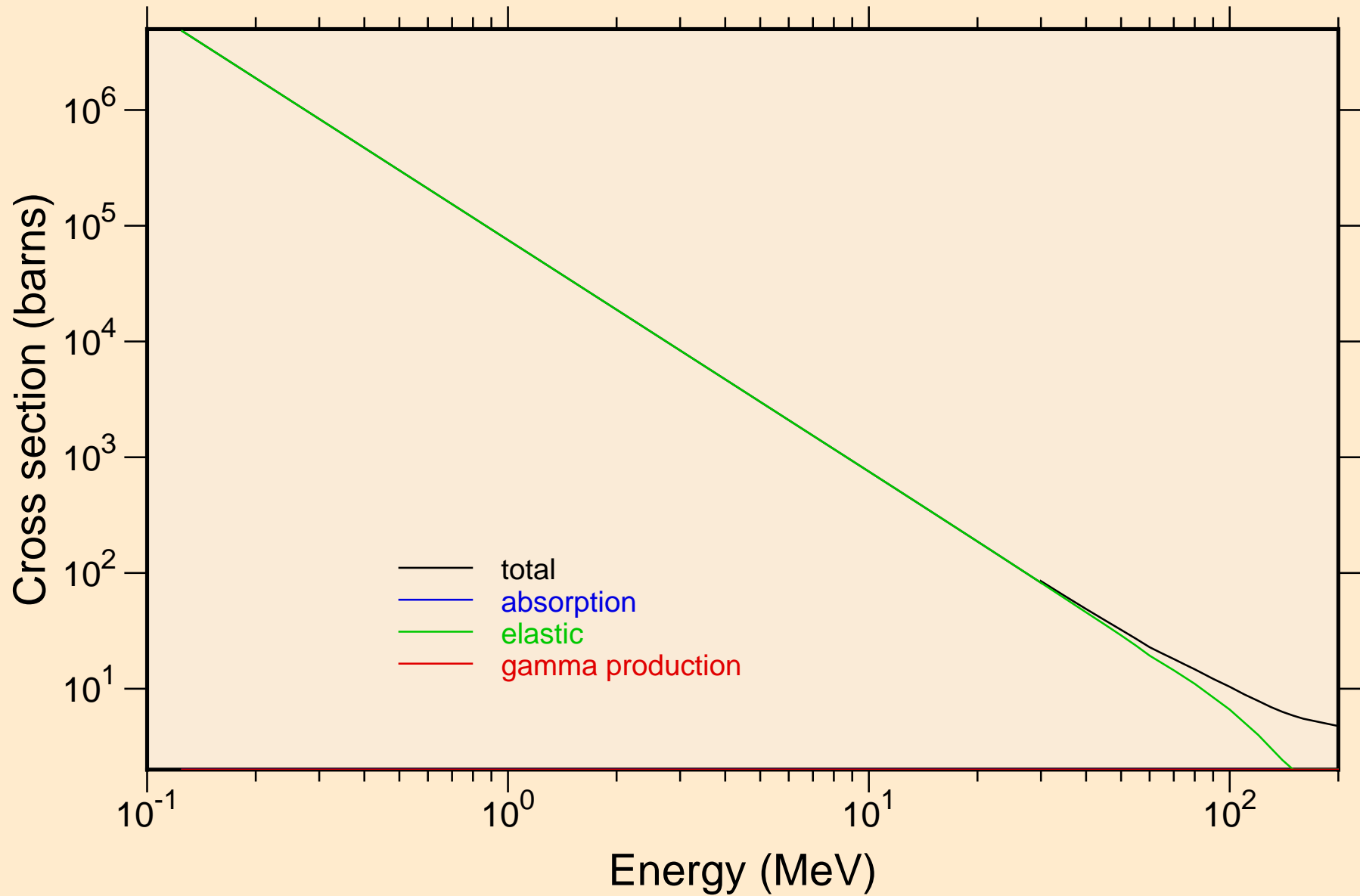

DS281 DEUTERON ACER TENDL-2021 LIBRARY; T=0.K
Heating

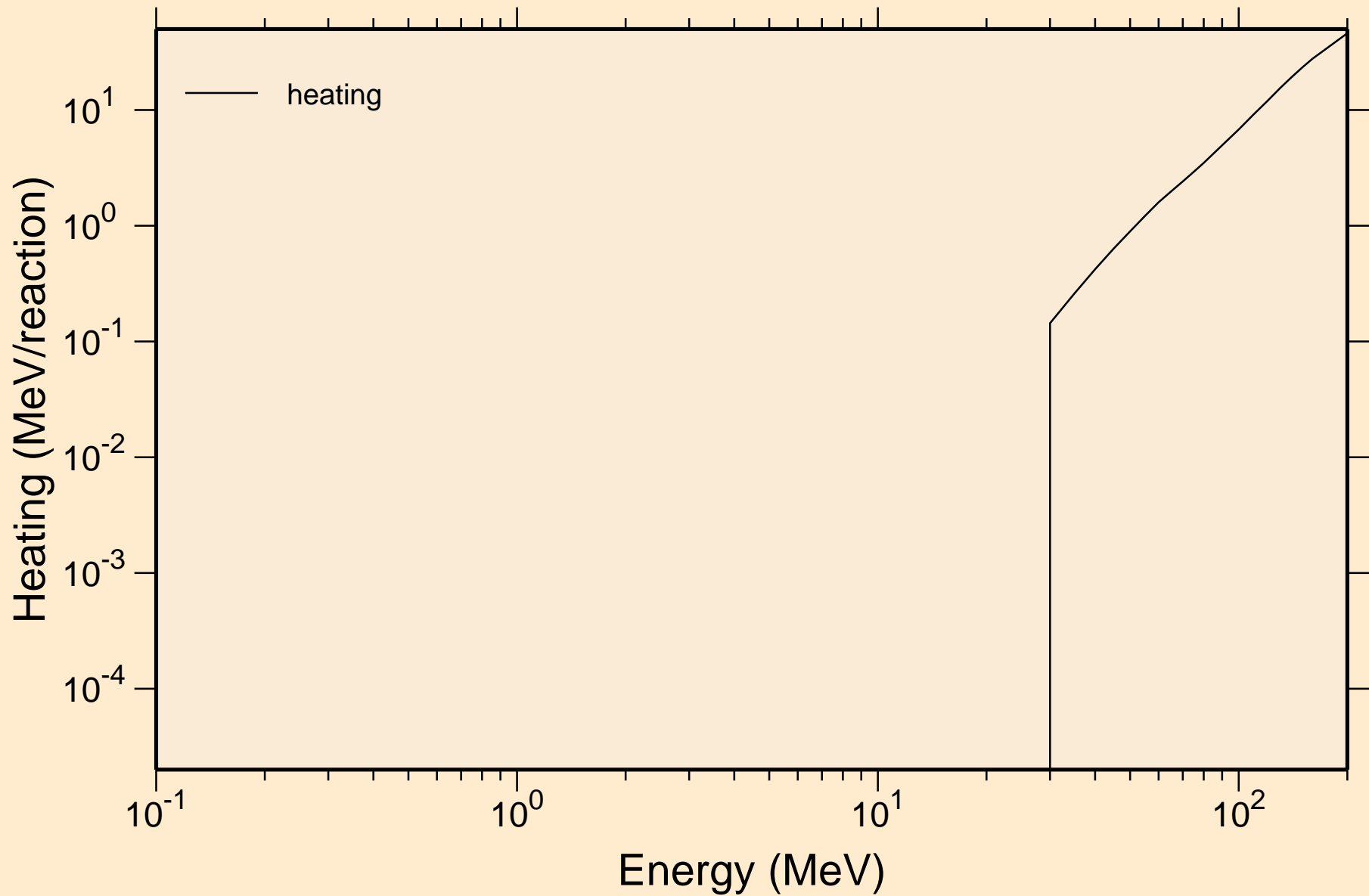

DS281 DEUTERON ACER TENDL-2021 LIBRARY; T=0.K
Principal cross sections

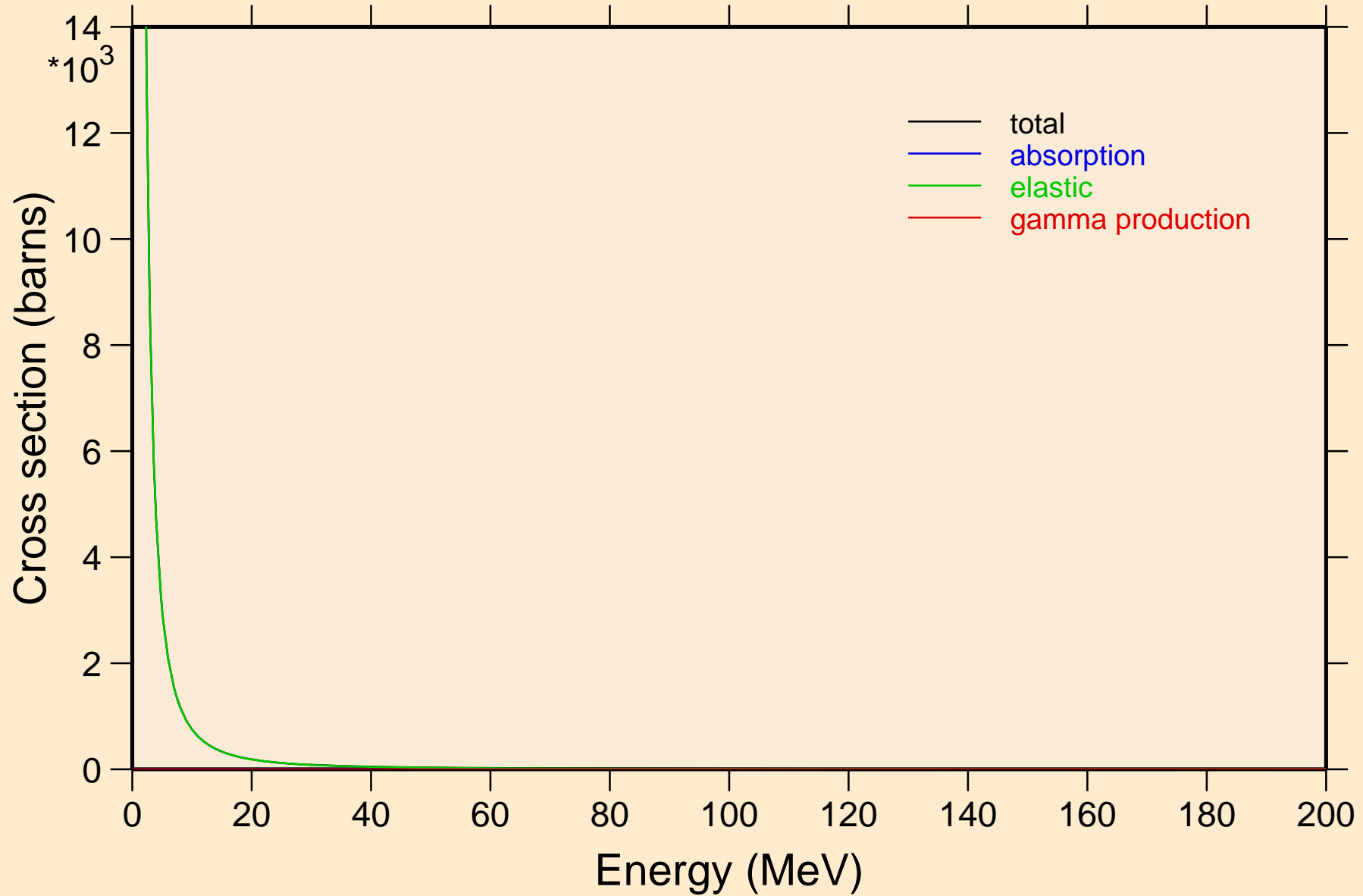

DS281 DEUTERON ACER TENDL-2021 LIBRARY; T=0.K

Heating

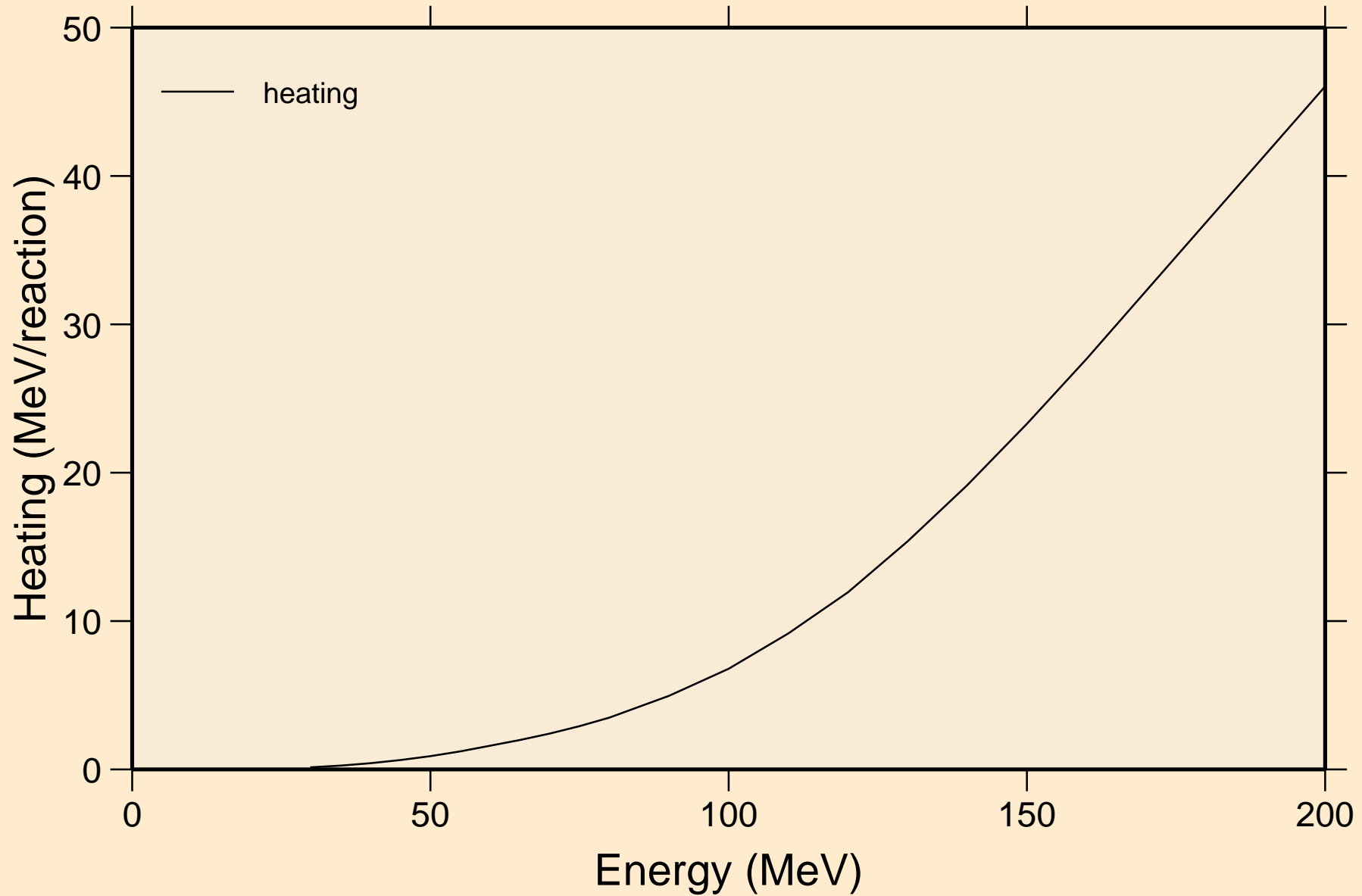

DS281 DEUTERON ACER TENDL-2021 LIBRARY; T=0.K
Threshold reactions

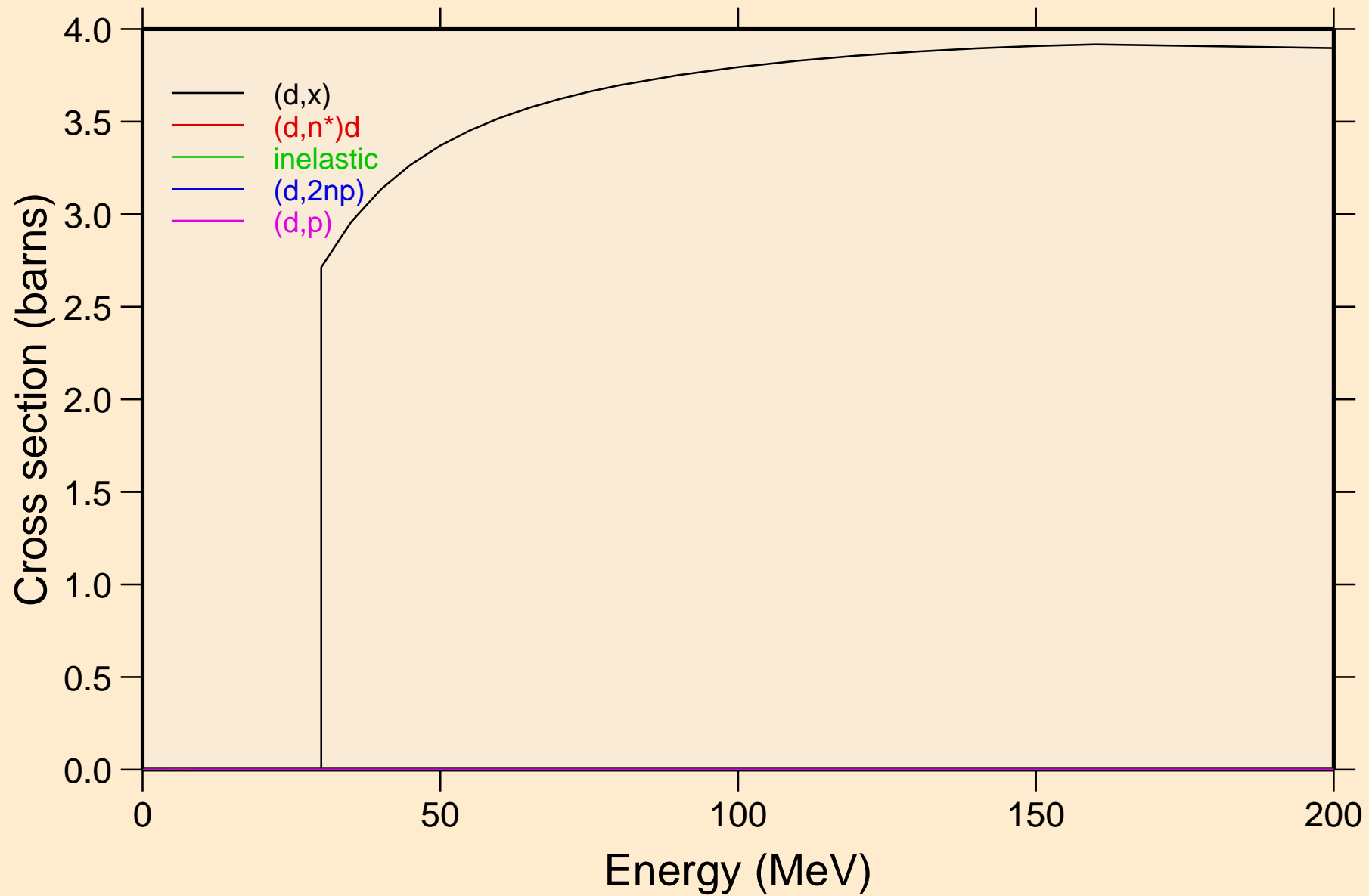

DS281 DEUTERON ACER TENDL-2021 LIBRARY; T=0.K
Threshold reactions

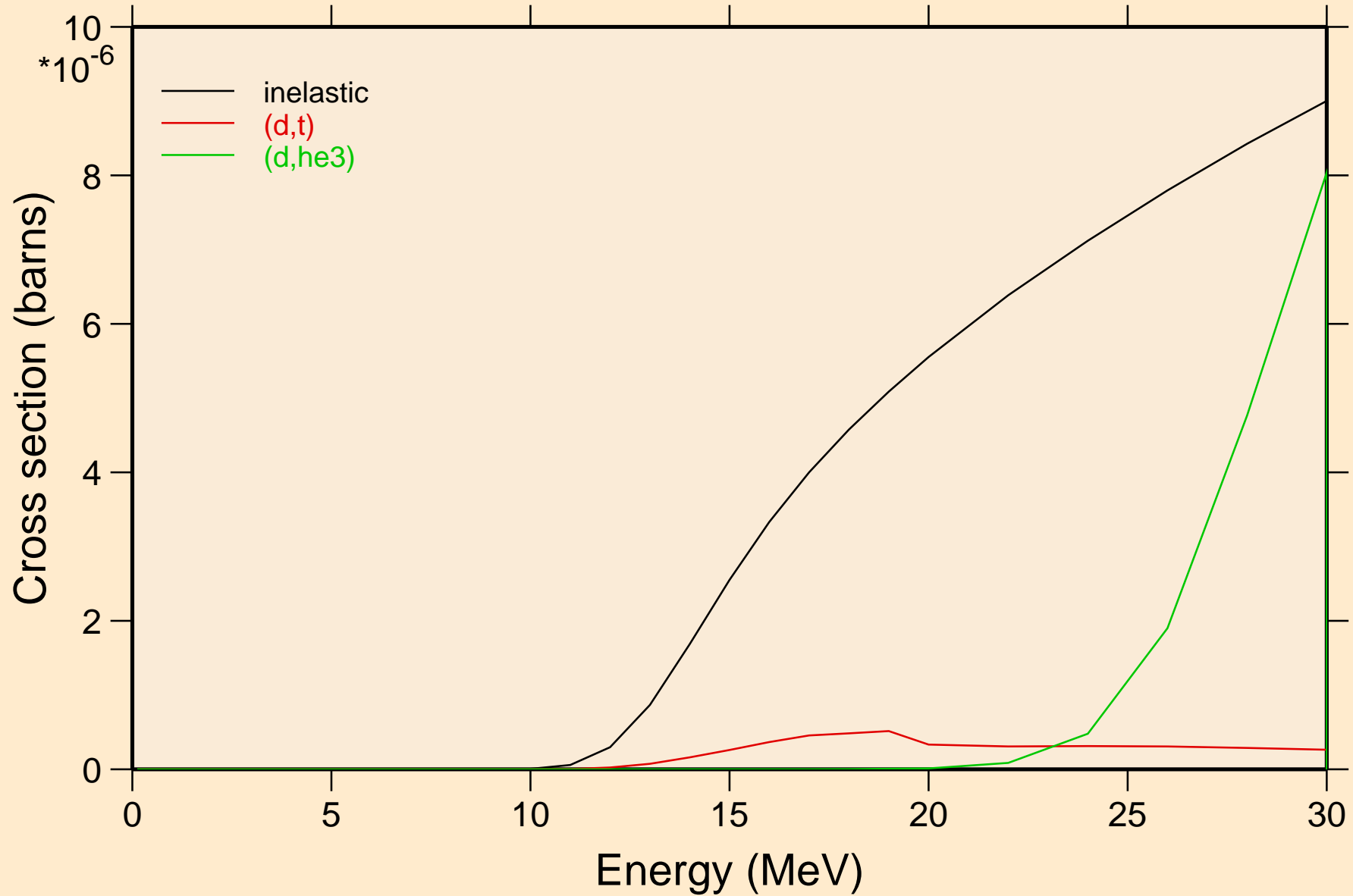

DS281 DEUTERON ACER TENDL-2021 LIBRARY; T=0.K
angular distribution for elastic

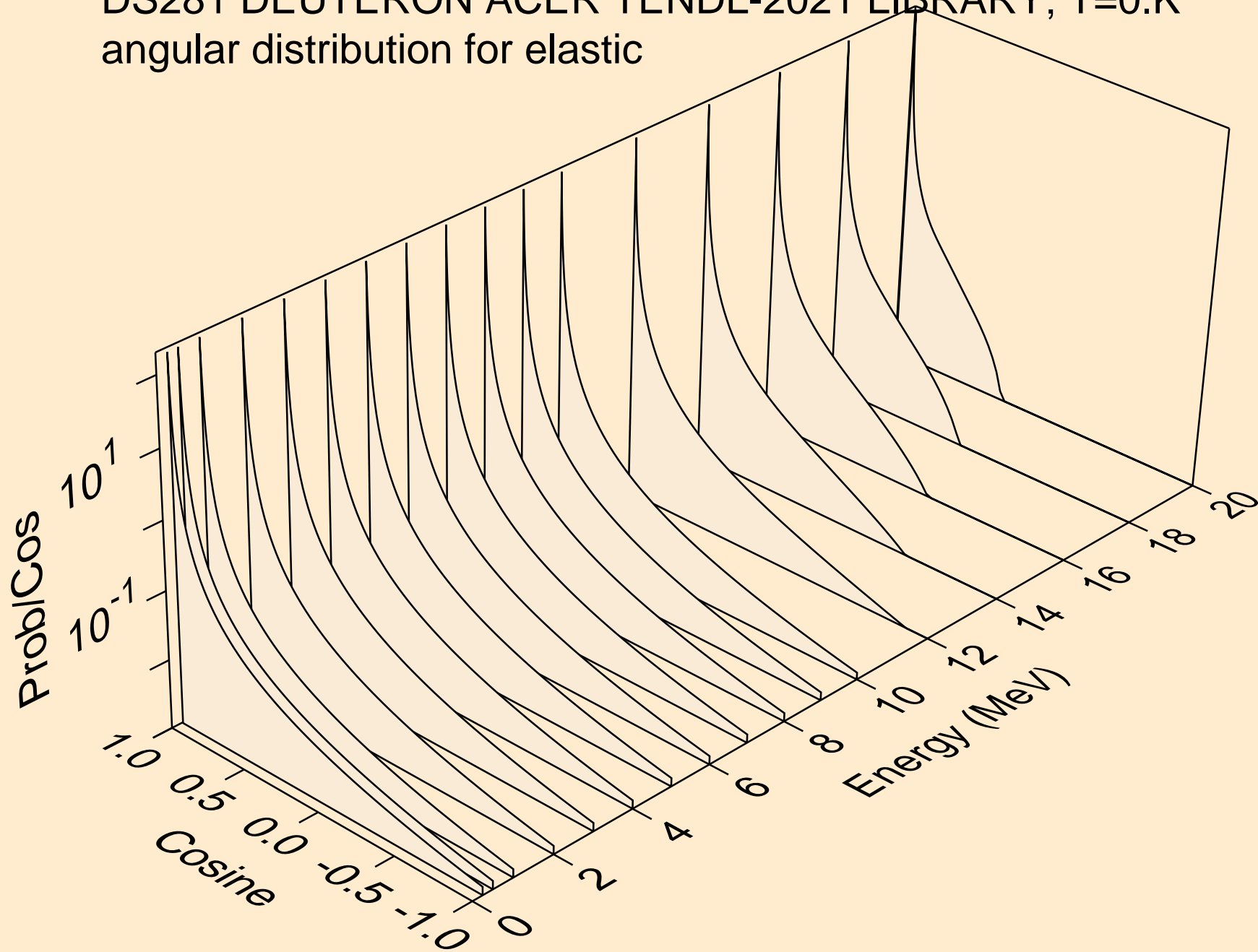

DS281 DEUTERON ACER TENDL-2021 LIBRARY; T=0.K
angular distribution for elastic

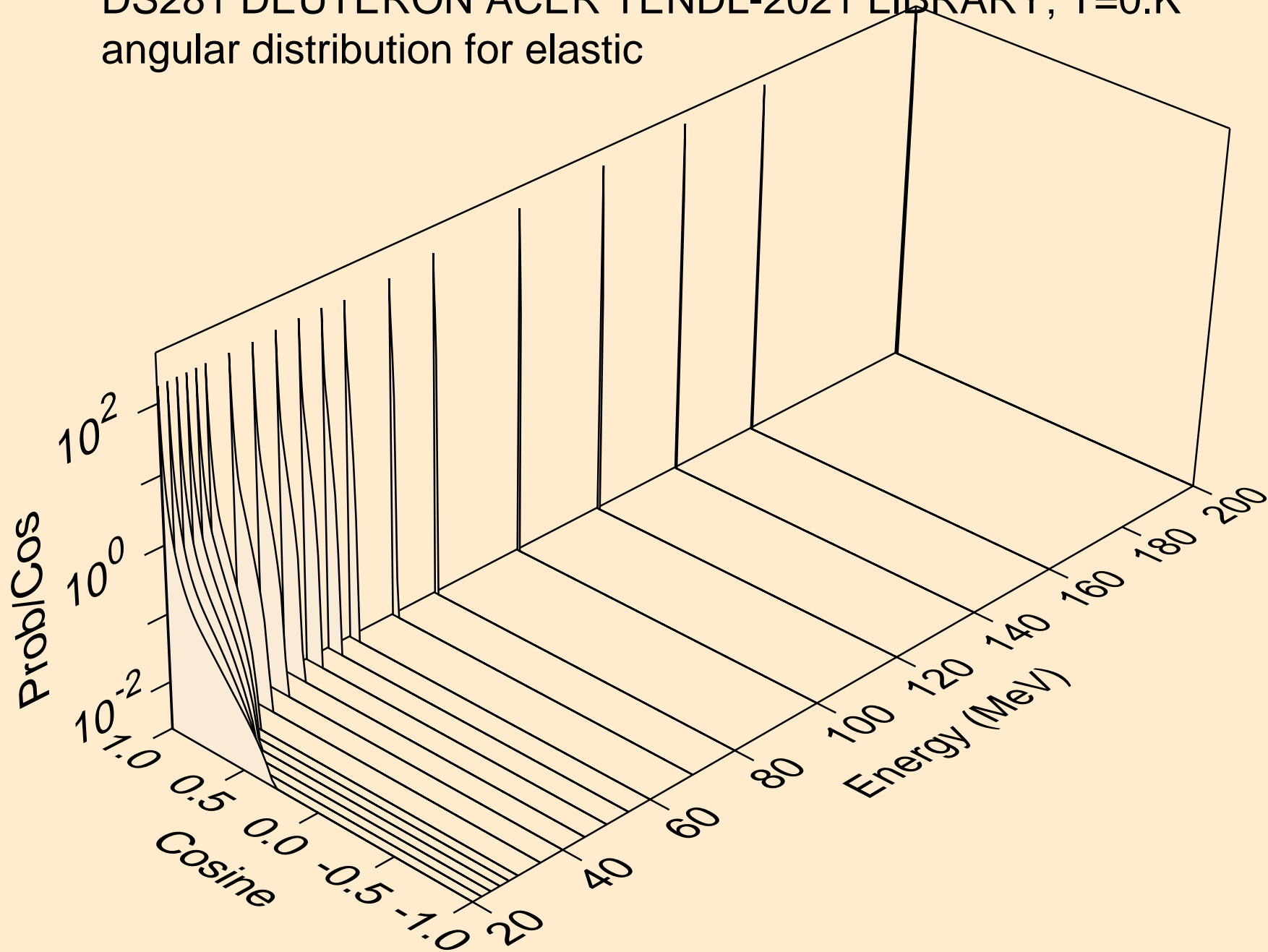

DS281 DEUTERON ACER TENDL-2021 LIBRARY; T=0.K
Deuteron emission for (d,x)

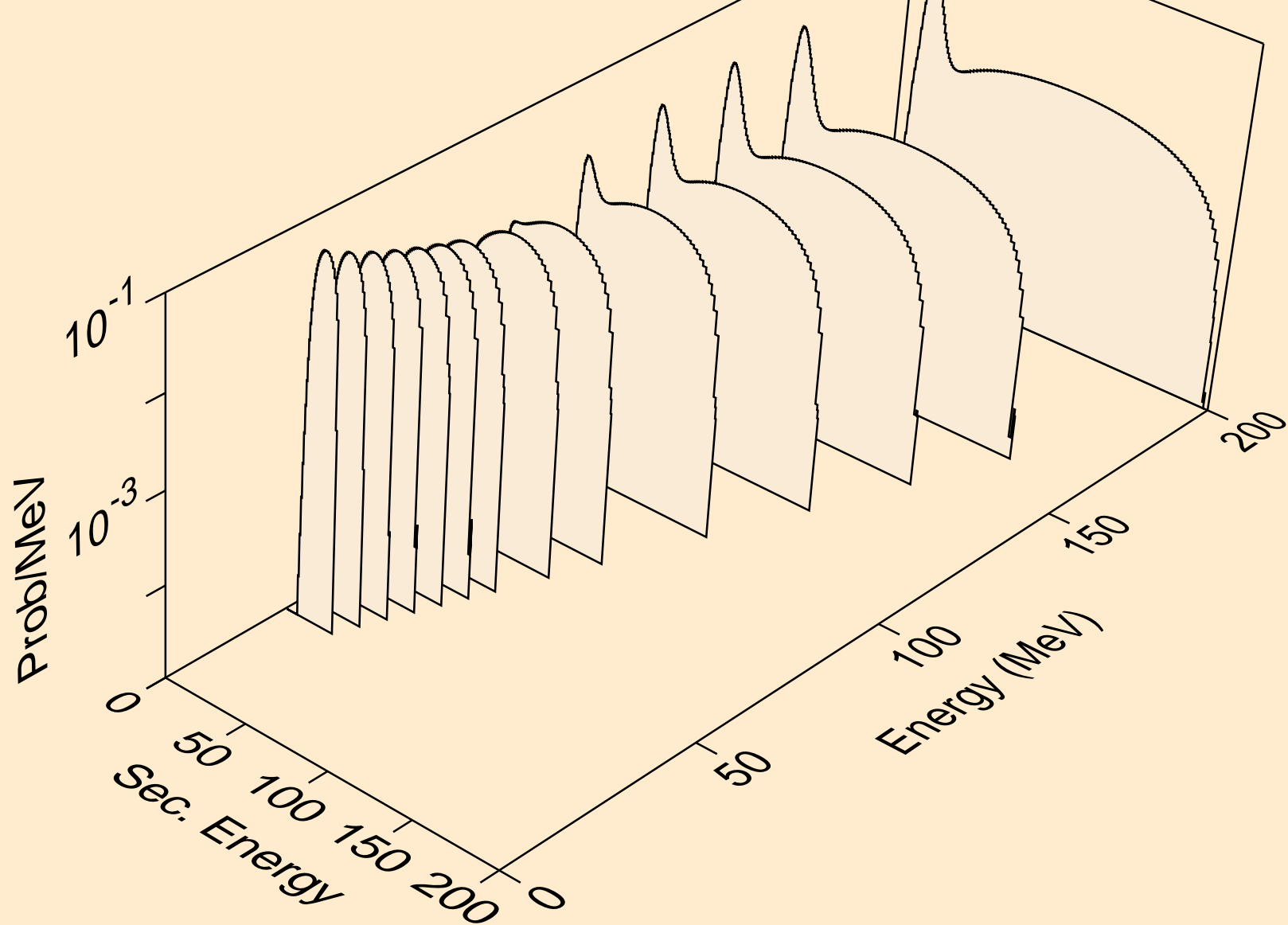

DS281 DEUTERON ACER TENDL-2021 LIBRARY; T=0.K
Deuteron emission for (d,n*)d

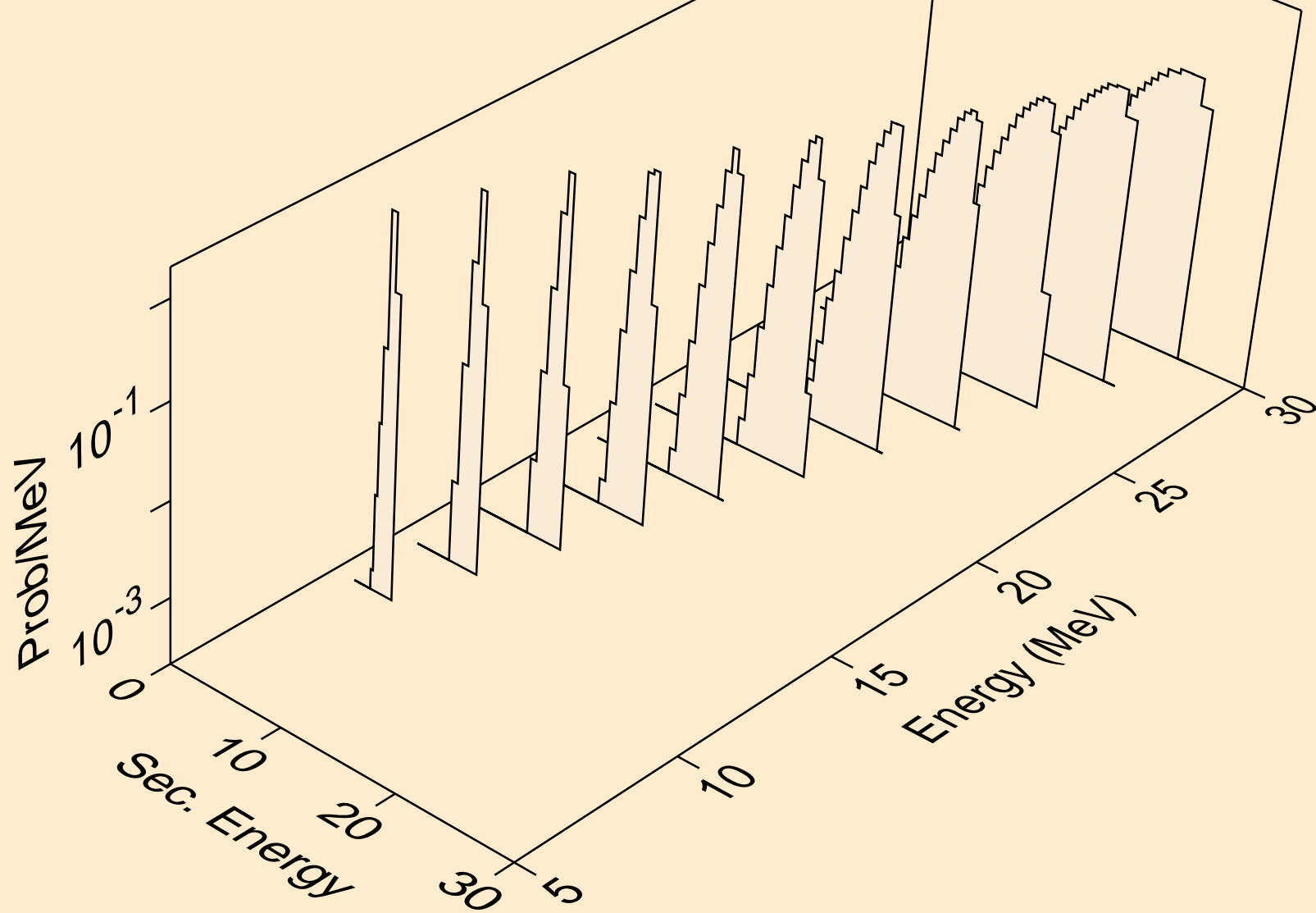

DS281 DEUTERON ACER TENDL-2021 LIBRARY; T=0.K
Deuteron emission for inelastic

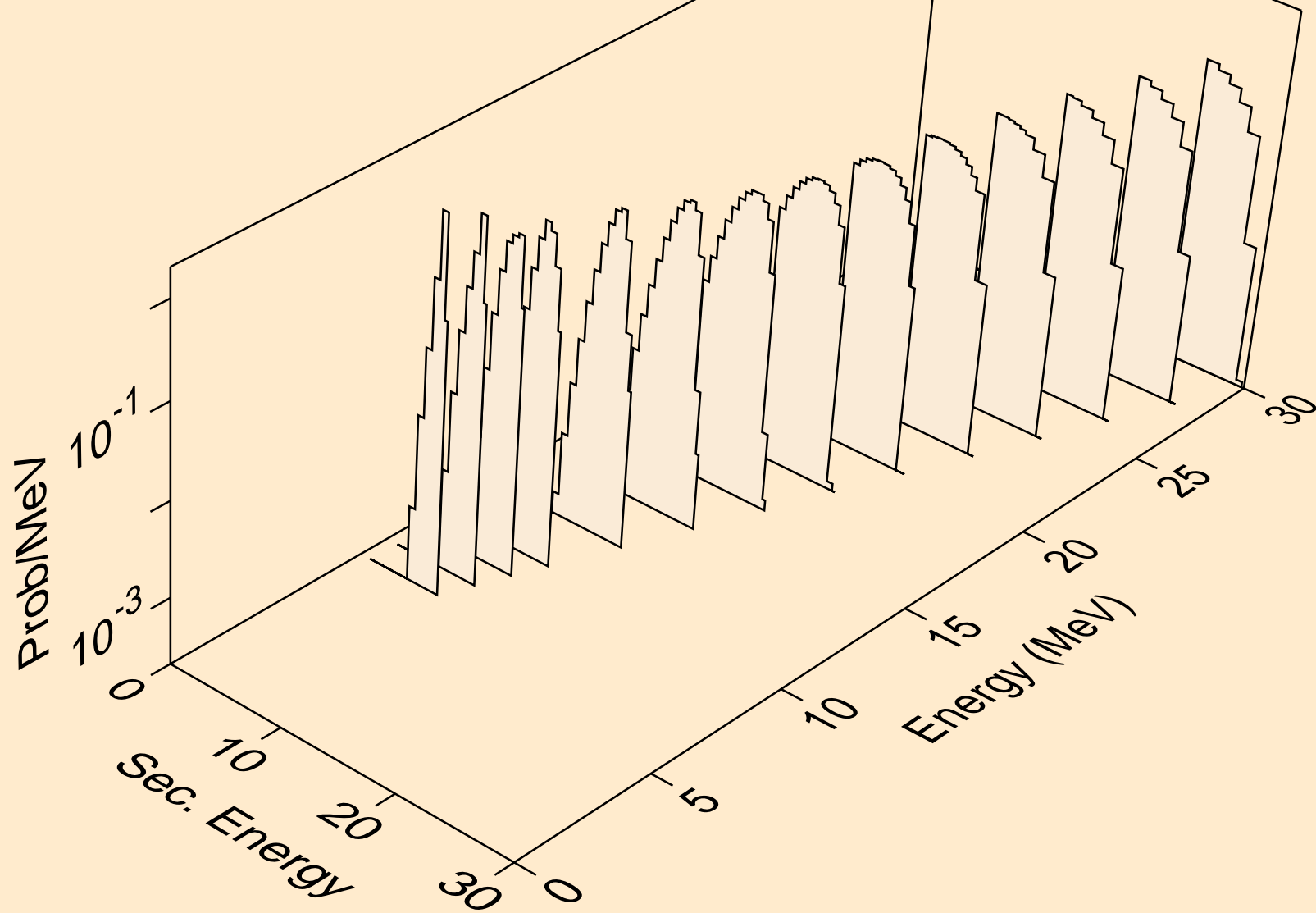

DS281 DEUTERON ACER TENDL-2021 LIBRARY; T=0.K
Photon emission for (z,n)

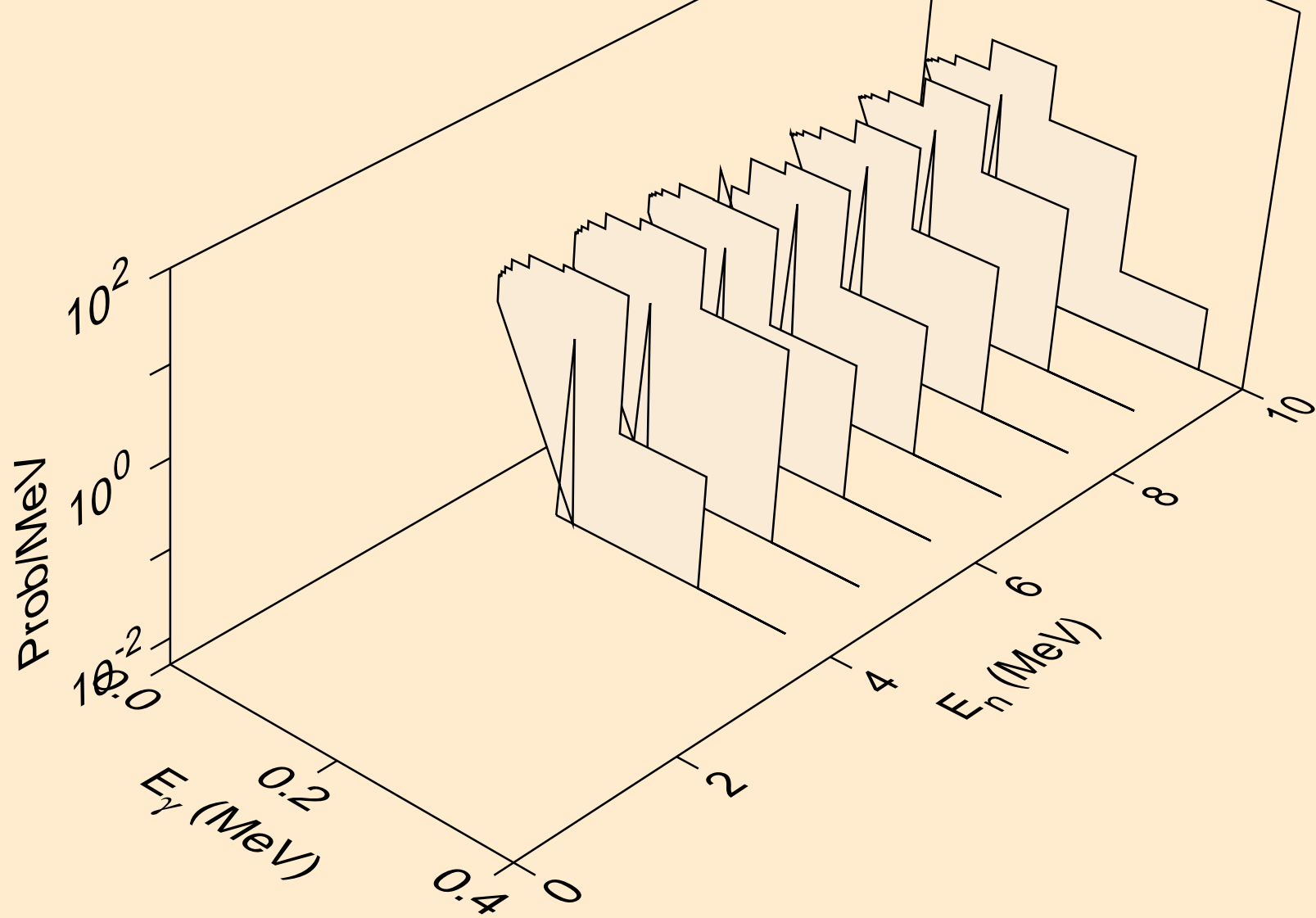

DS281 DEUTERON ACER TENDL-2021 LIBRARY; T=0.K
Photon emission for (n,x)

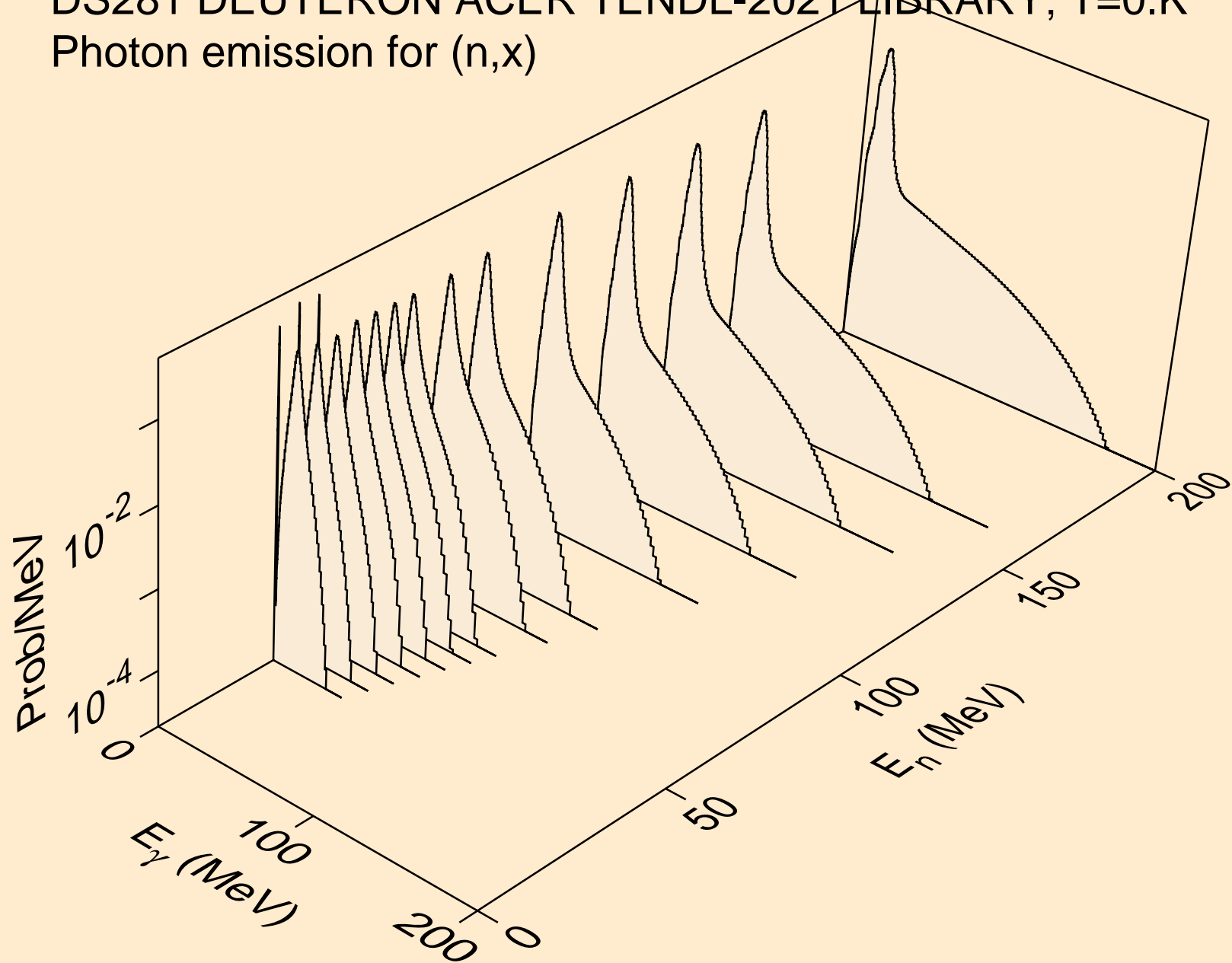

DS281 DEUTERON ACER TENDL-2021 LIBRARY; T=0.K
Photon emission for (n,n*)d

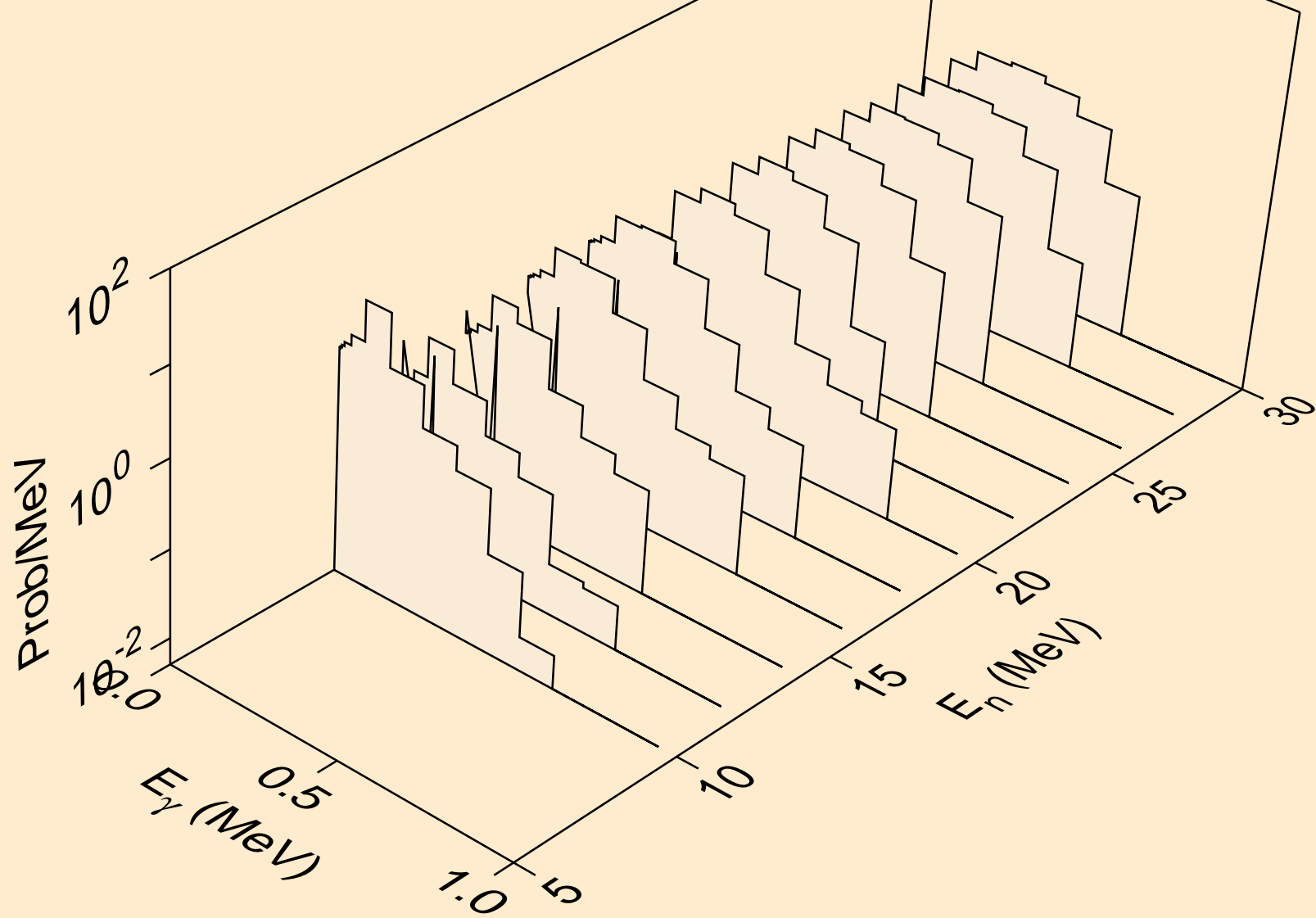

DS281 DEUTERON ACER TENDL-2021 LIBRARY; T=0.K
Photon emission for (n,2np)

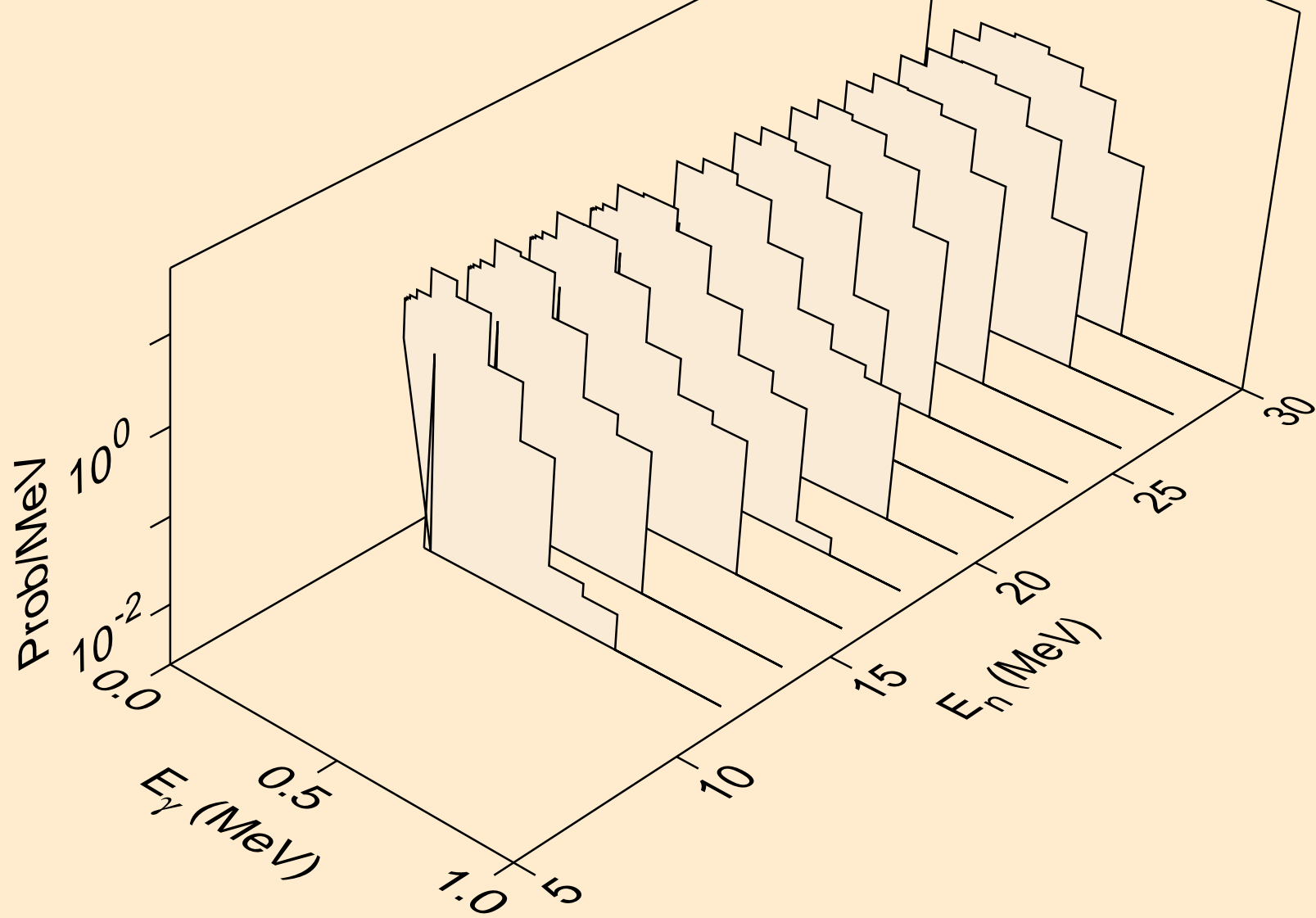

DS281 DEUTERON ACER TENDL-2021 LIBRARY; T=0.K
Photon emission for (n,p)

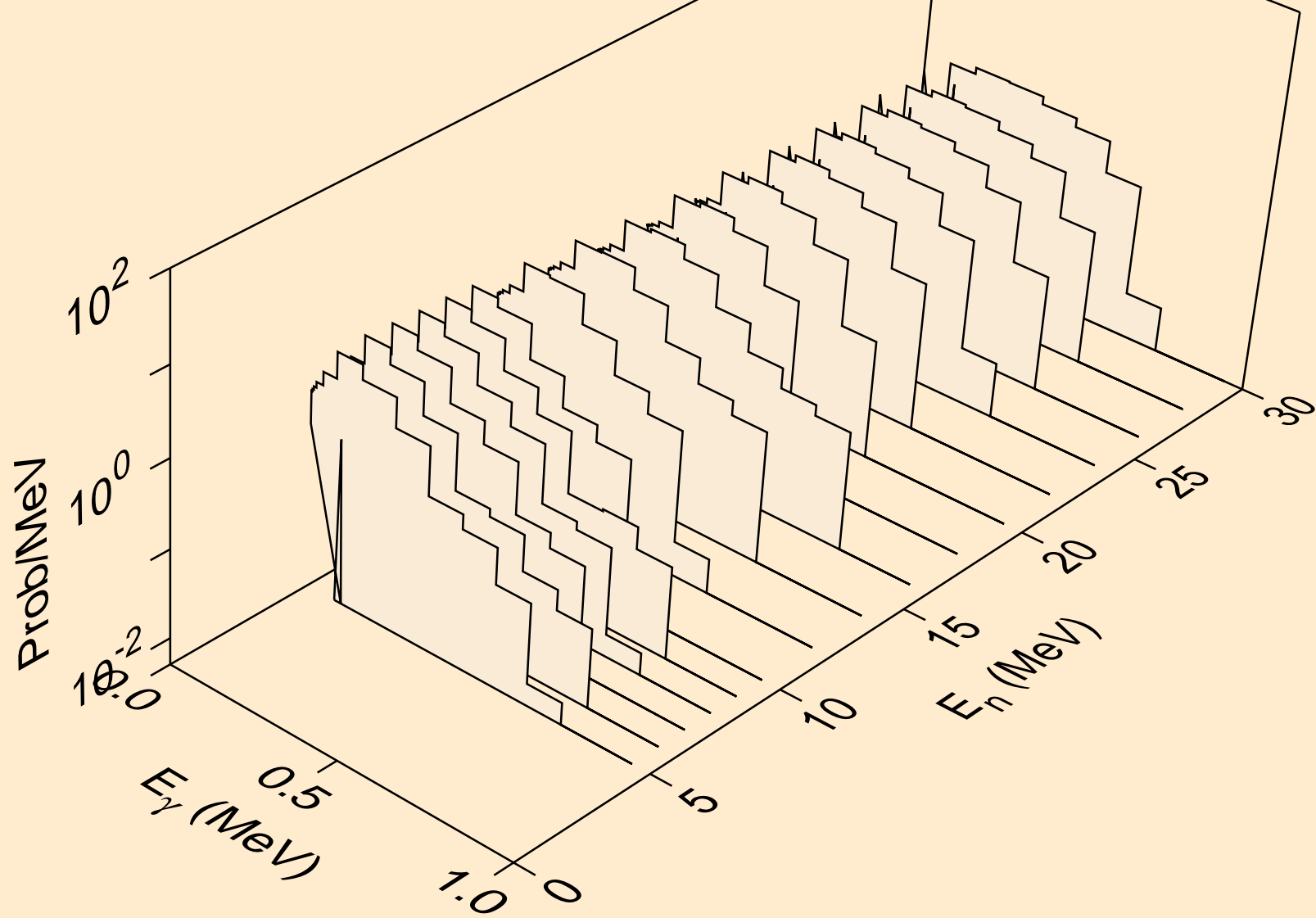

DS281 DEUTERON ACER TENDL-2021 LIBRARY; T=0.K
Photon emission for inelastic

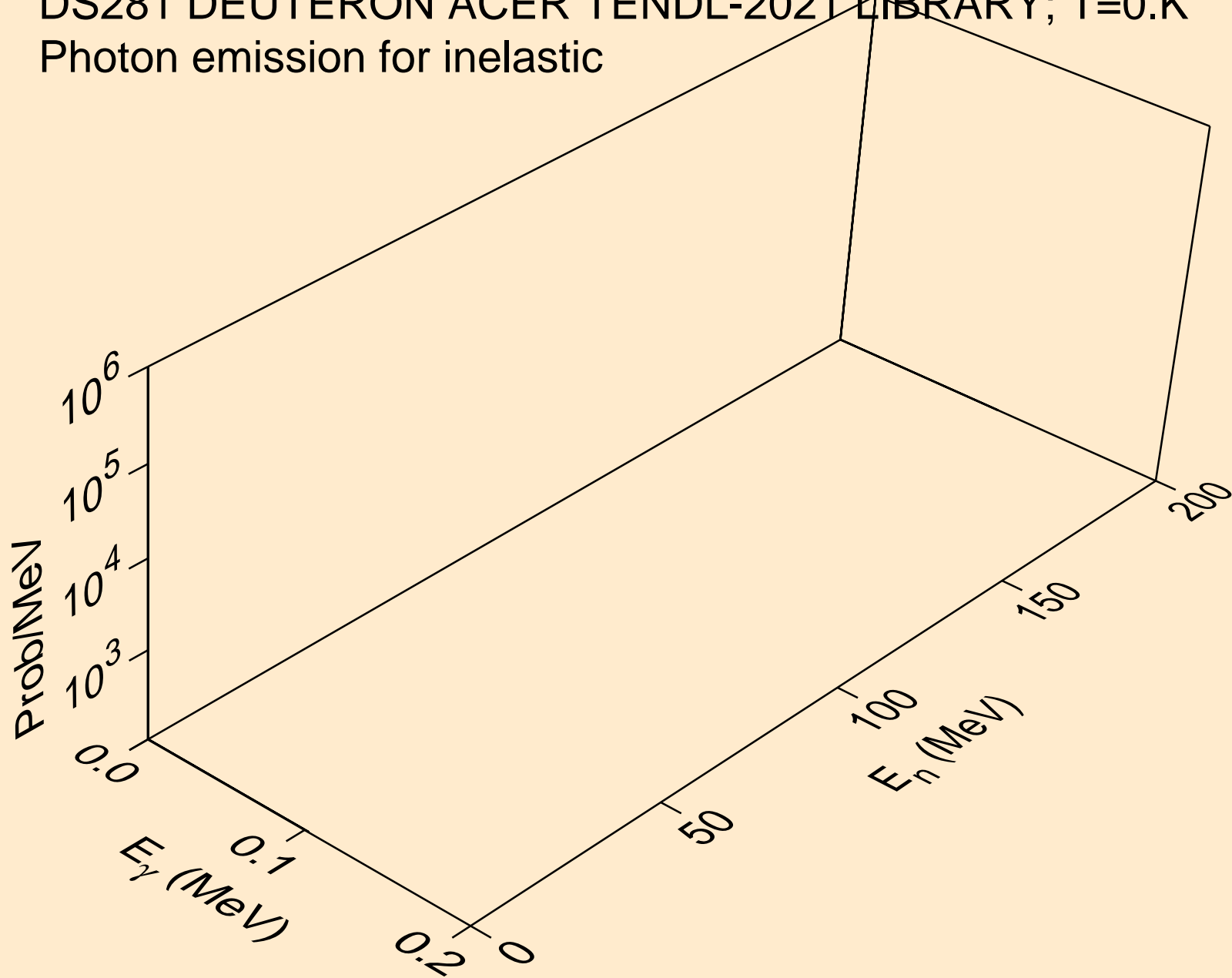

DS281 DEUTERON ACER TENDL-2021 LIBRARY; T=0.K
Photon emission for (n,t)

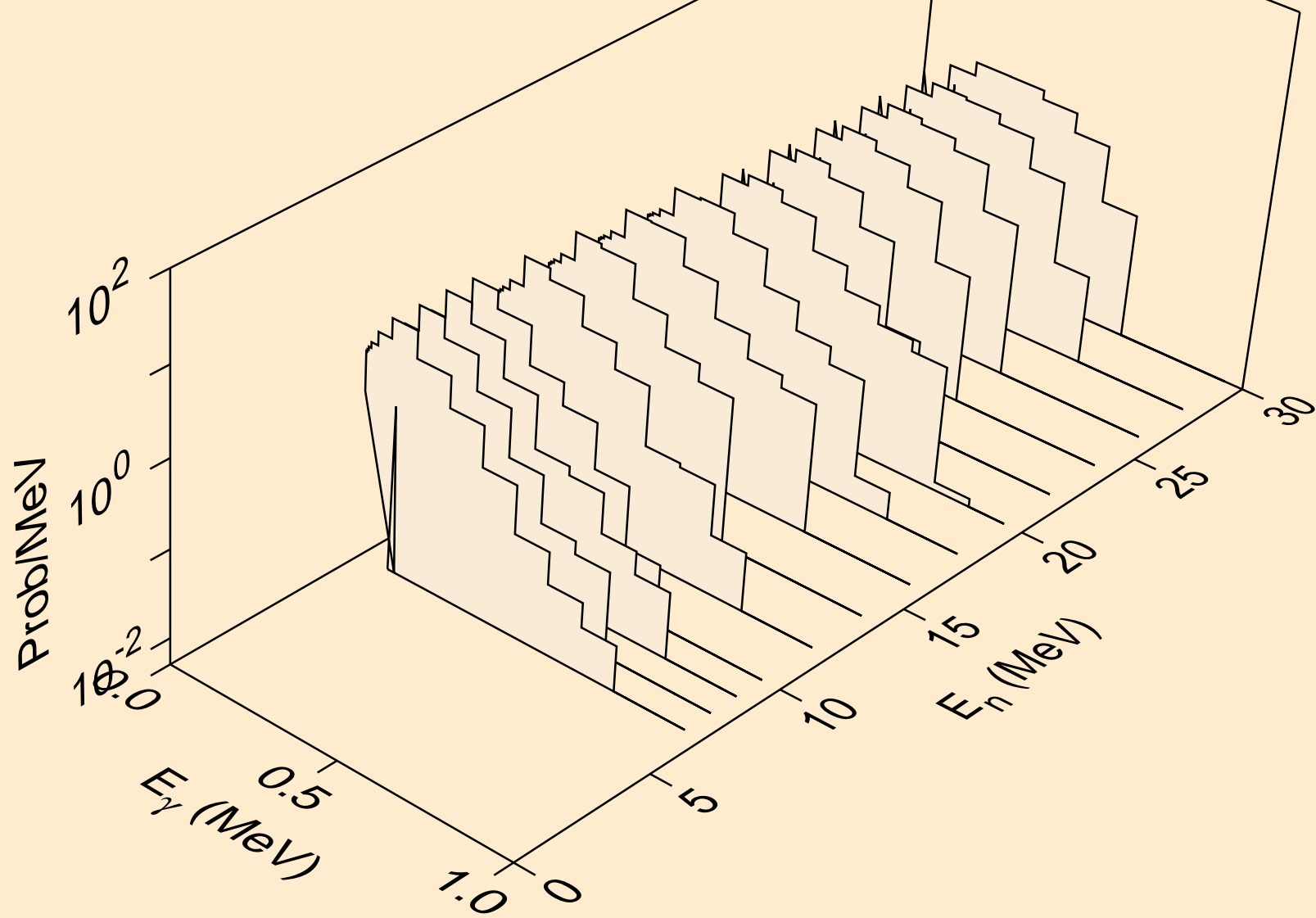

DS281 DEUTERON ACER TENDL-2021 LIBRARY; T=0.K
Photon emission for (n,he3)

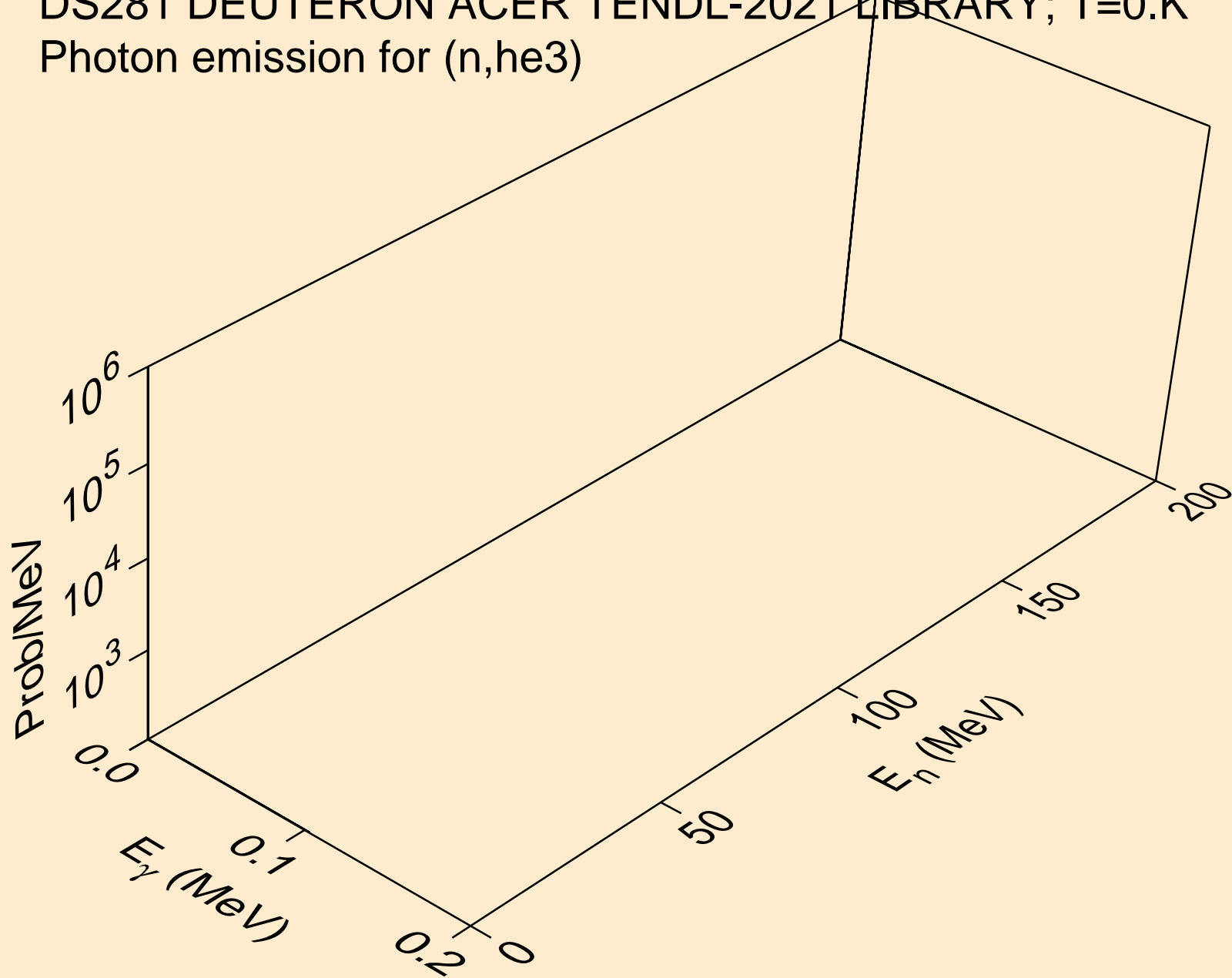

DS281 DEUTERON ACER TENDL-2021 LIBRARY; T=0.K
Particle heating contributions

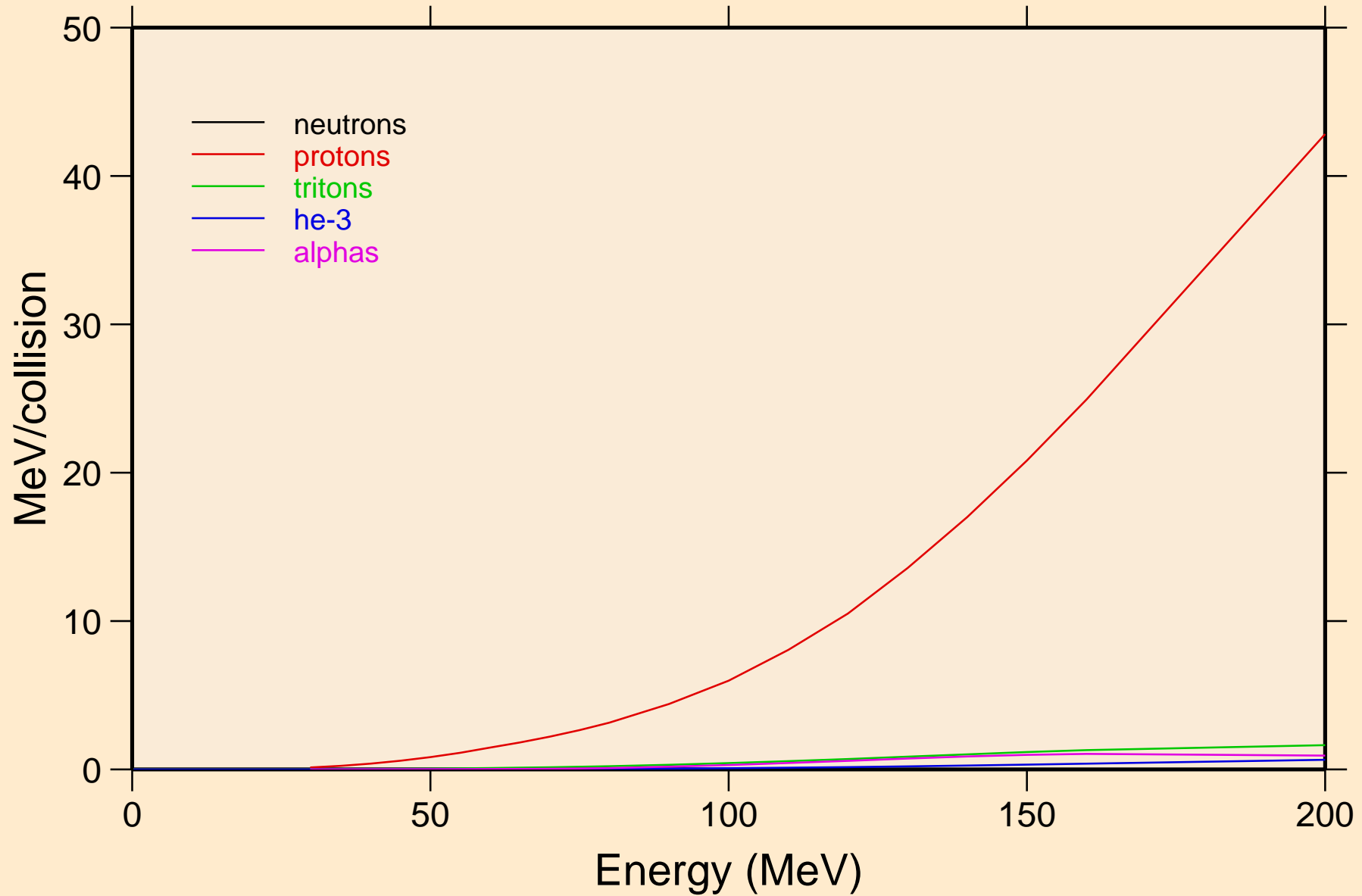

DS281 DEUTERON ACER TENDL-2021 LIBRARY; T=0.K
Recoil Heating

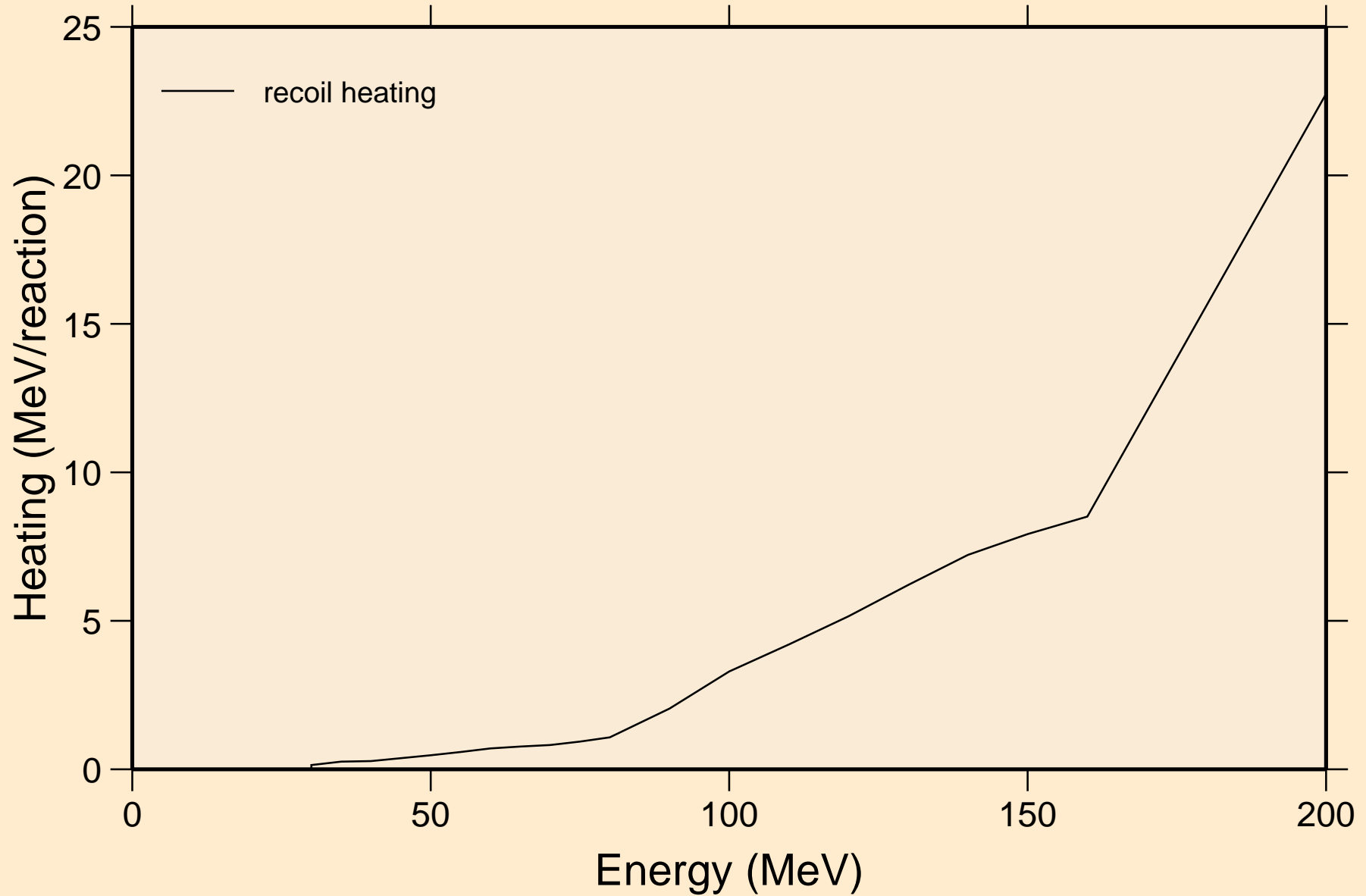

DS281 DEUTERON ACER TENDL-2021 LIBRARY; T=0.K
Particle production cross sections

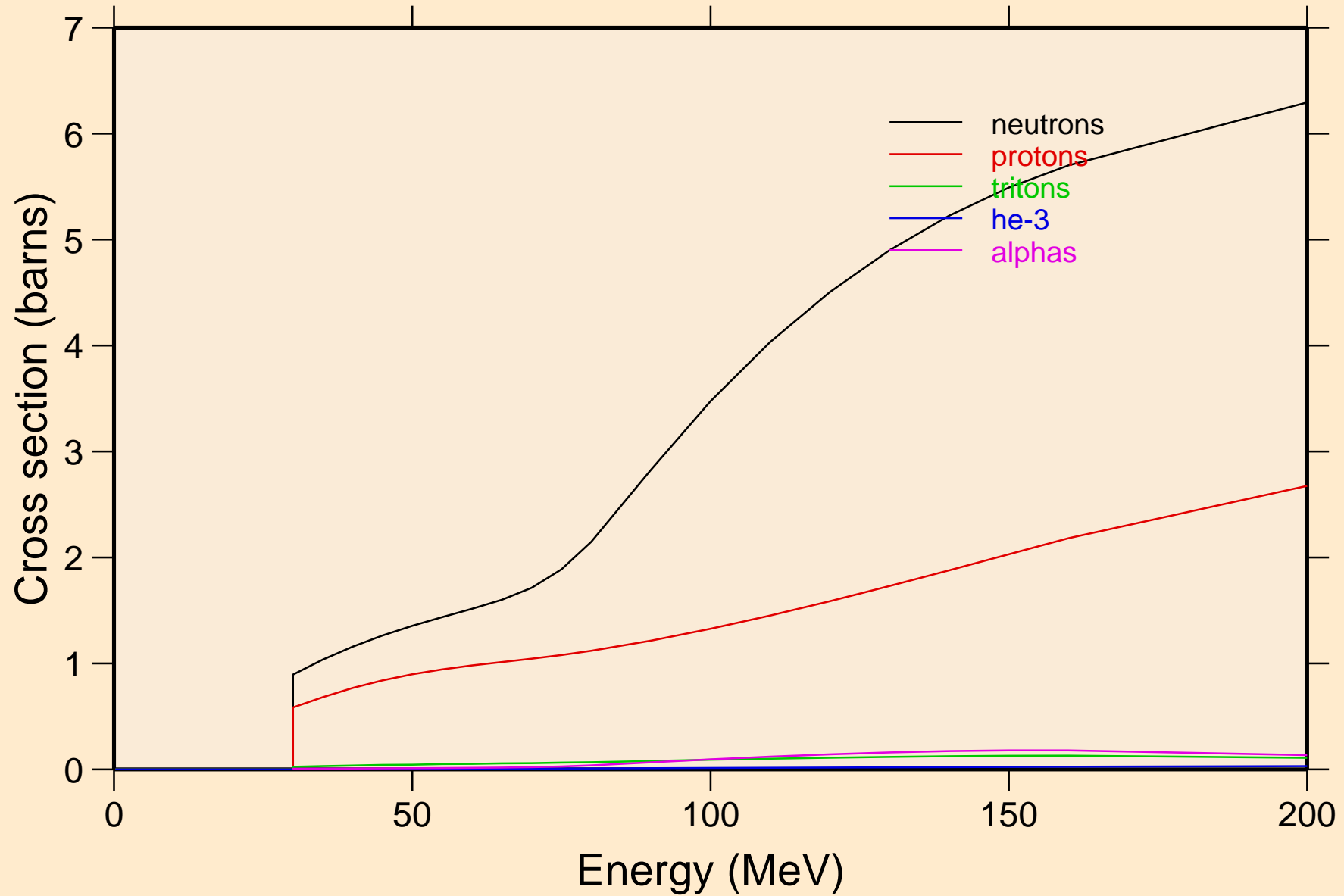

DS281 DEUTERON ACER TENDL-2021 LIBRARY; T=0.K
neutrons from (d,n)

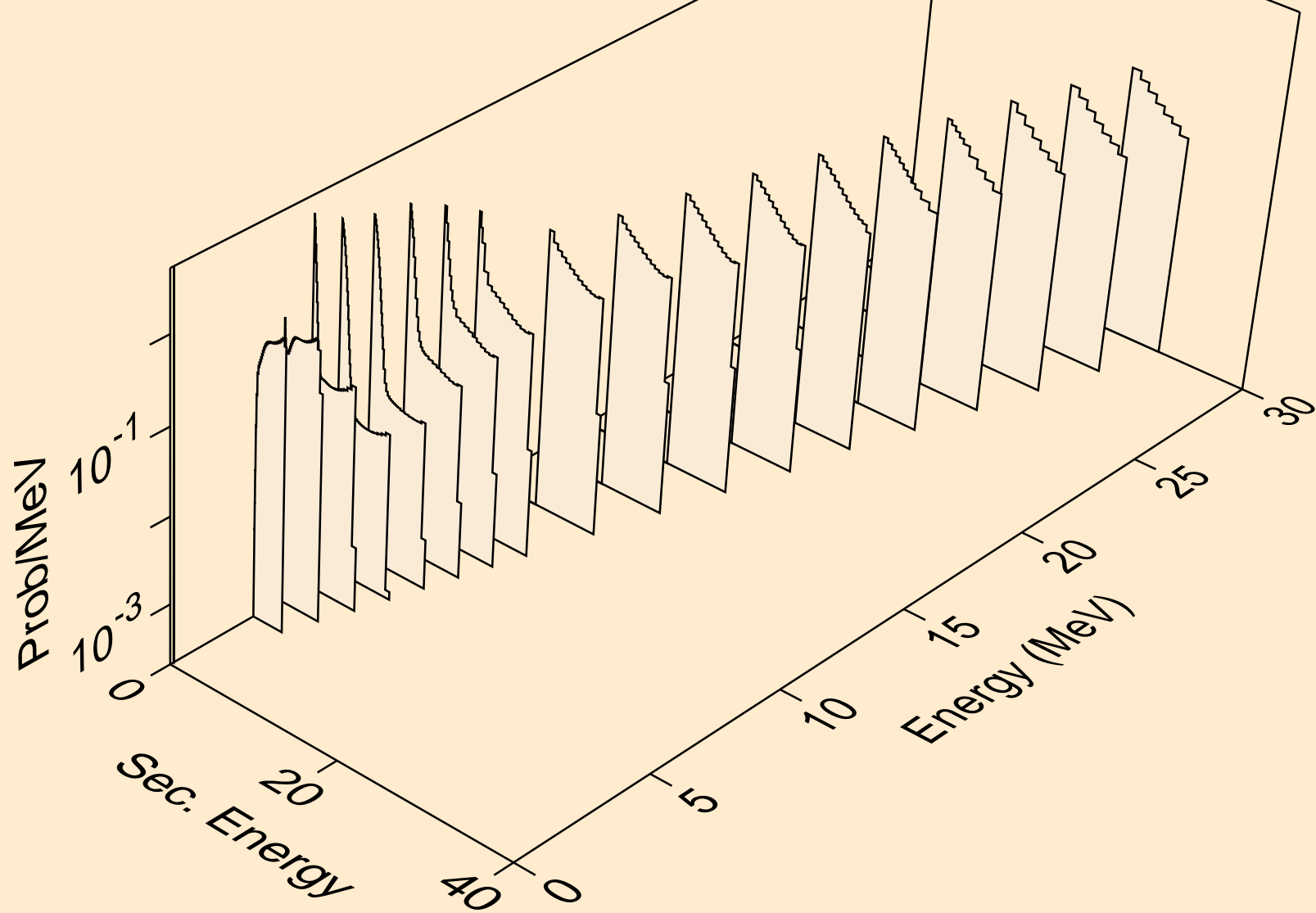

DS281 DEUTERON ACER TENDL-2021 LIBRARY; T=0.K
neutrons from (d,x)

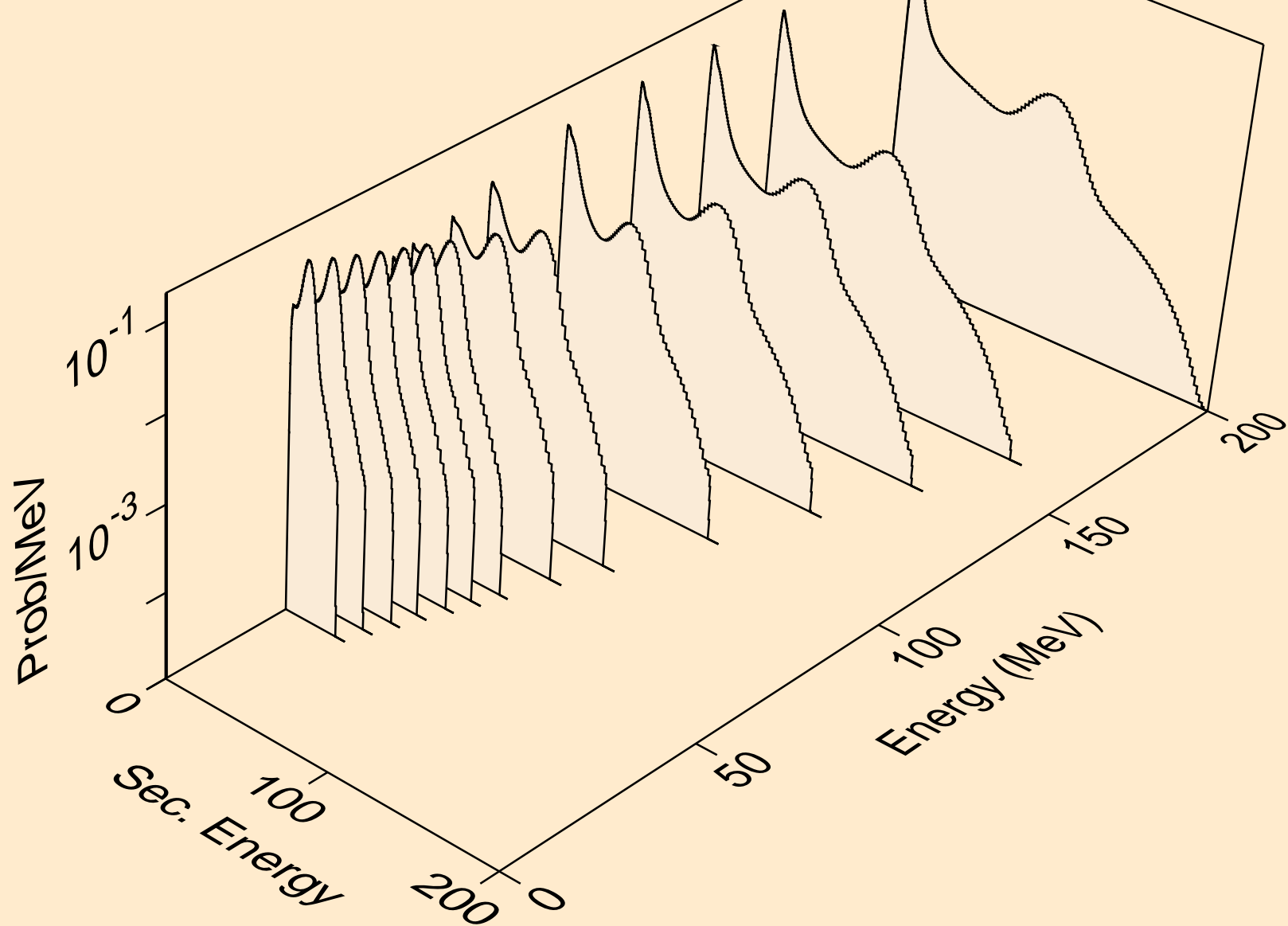

DS281 DEUTERON ACER TENDL-2021 LIBRARY; T=0.K
neutrons from (d,n*)d

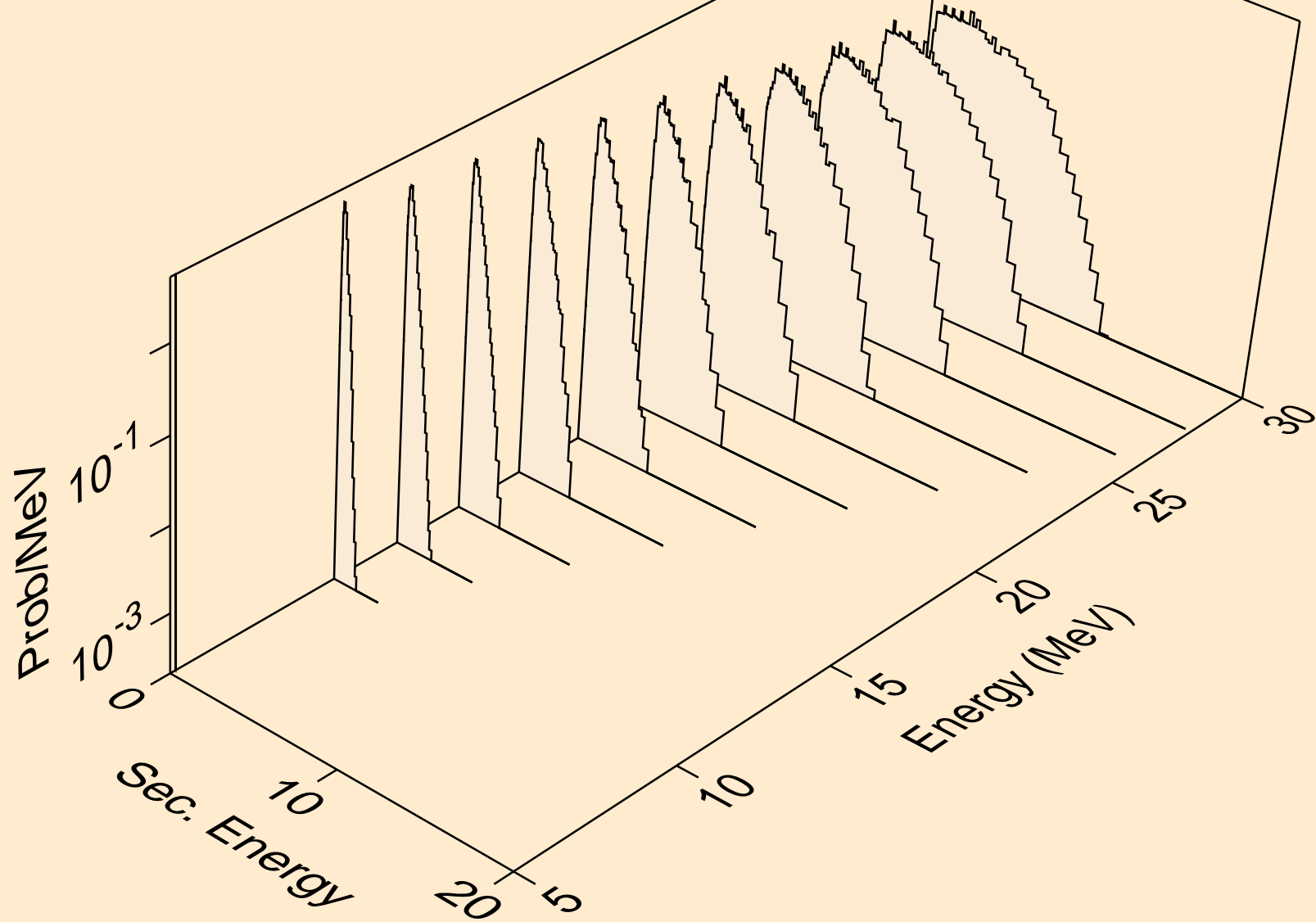

DS281 DEUTERON ACER TENDL-2021 LIBRARY; T=0.K
neutrons from (d,2np)

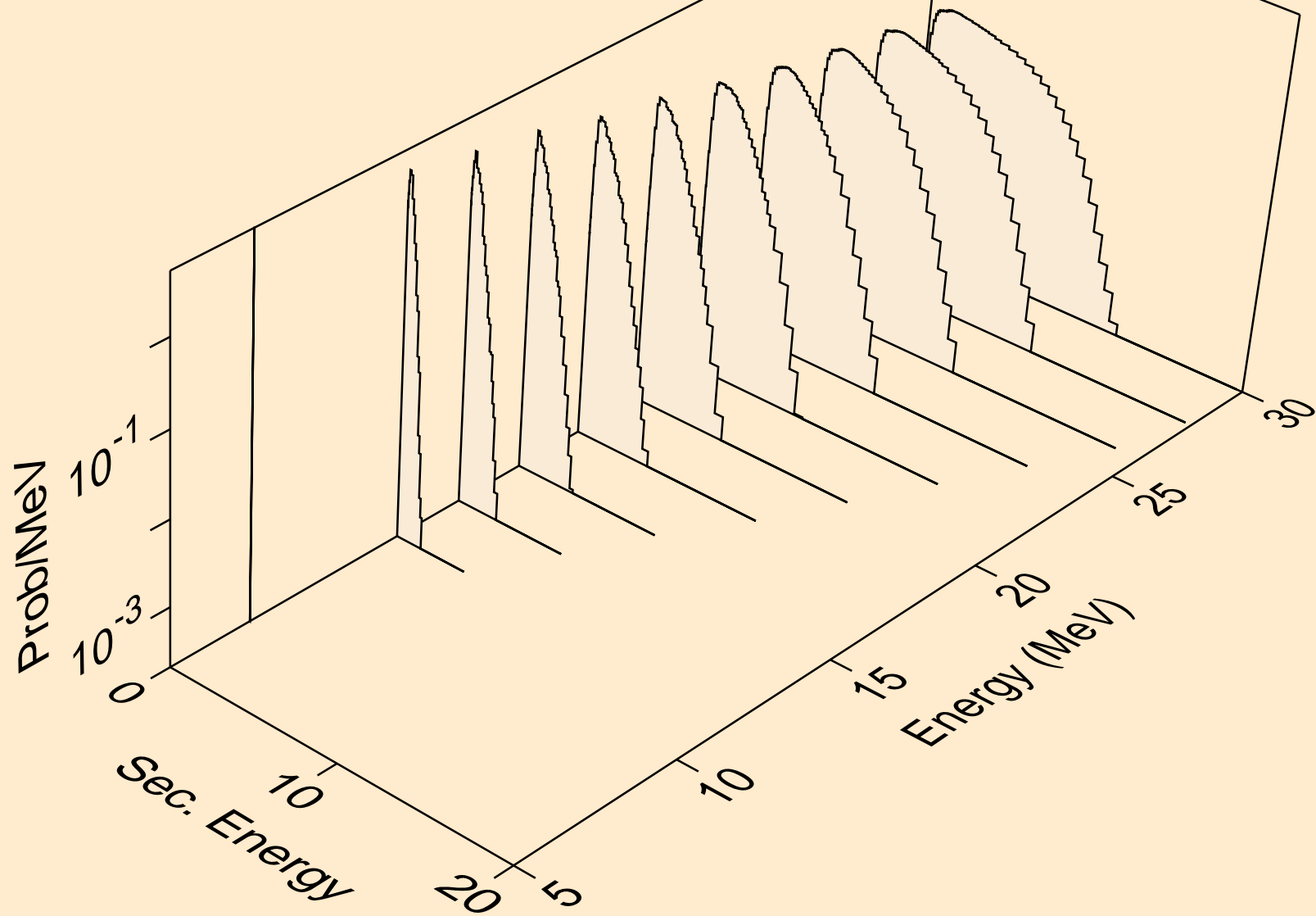

DS281 DEUTERON ACER TENDL-2021 LIBRARY; T=0.K
protons from (d,x)

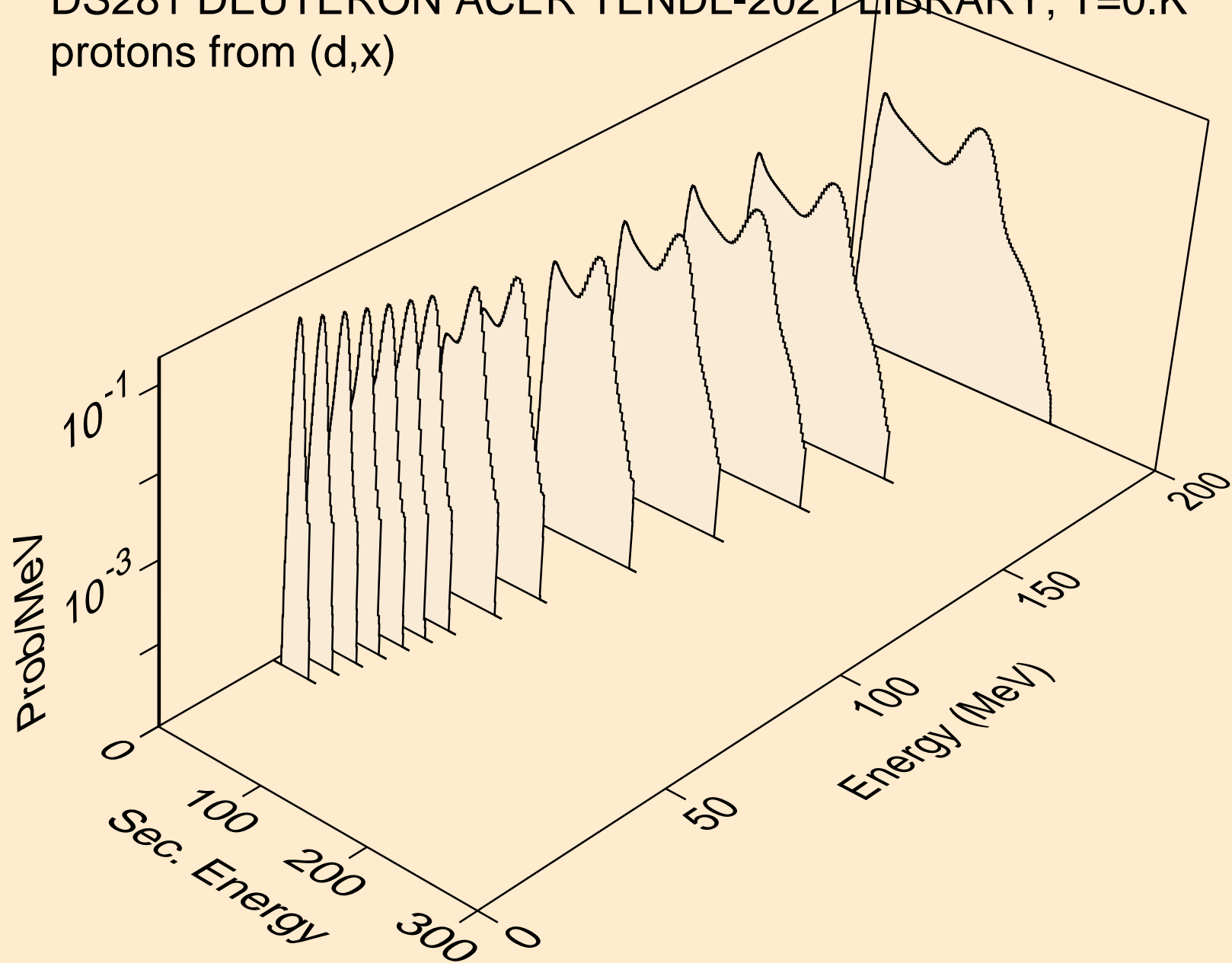

DS281 DEUTERON ACER TENDL-2021 LIBRARY; T=0.K
protons from (d,2np)

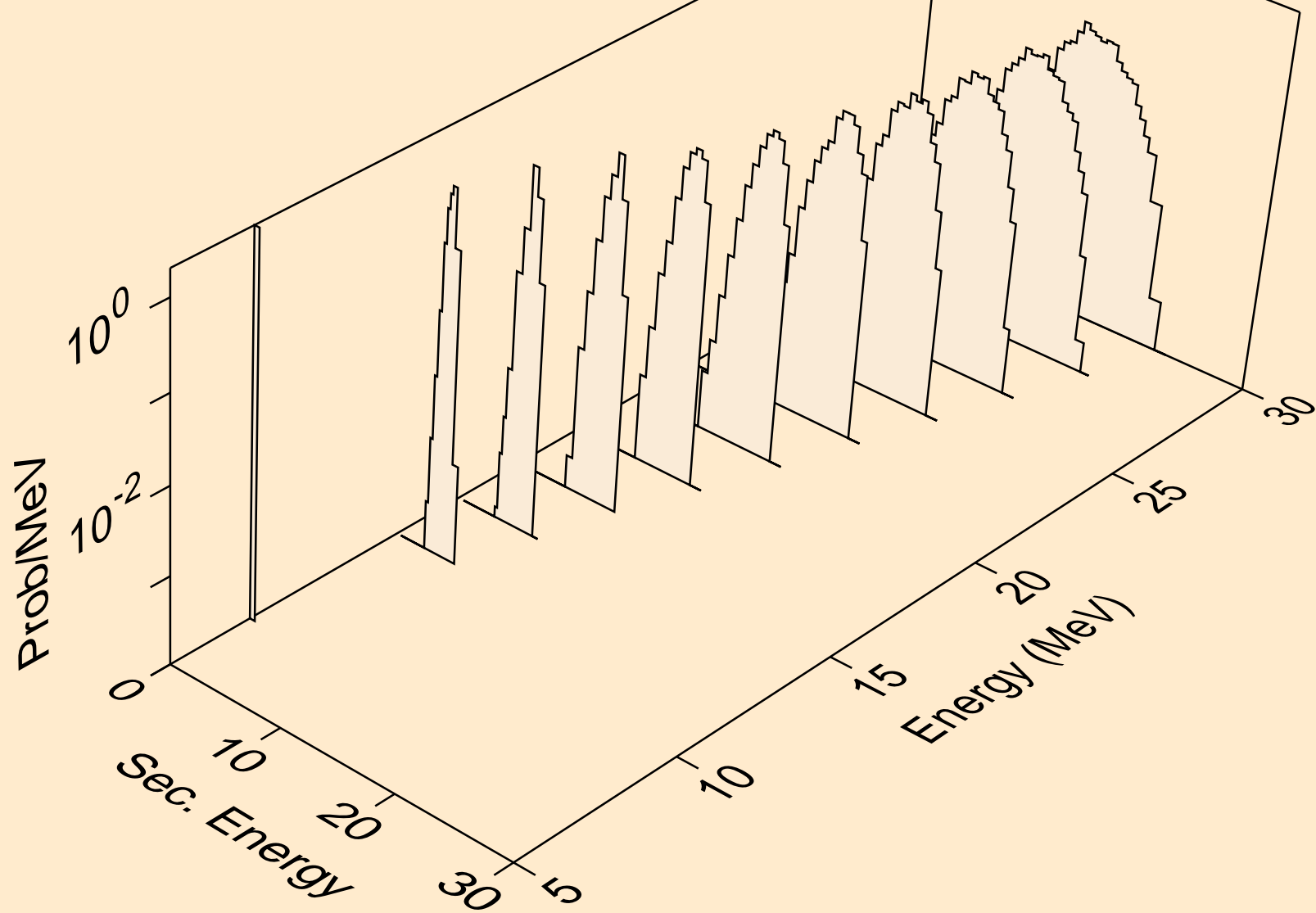

DS281 DEUTERON ACER TENDL-2021 LIBRARY; T=0.K
protons from (d,p)

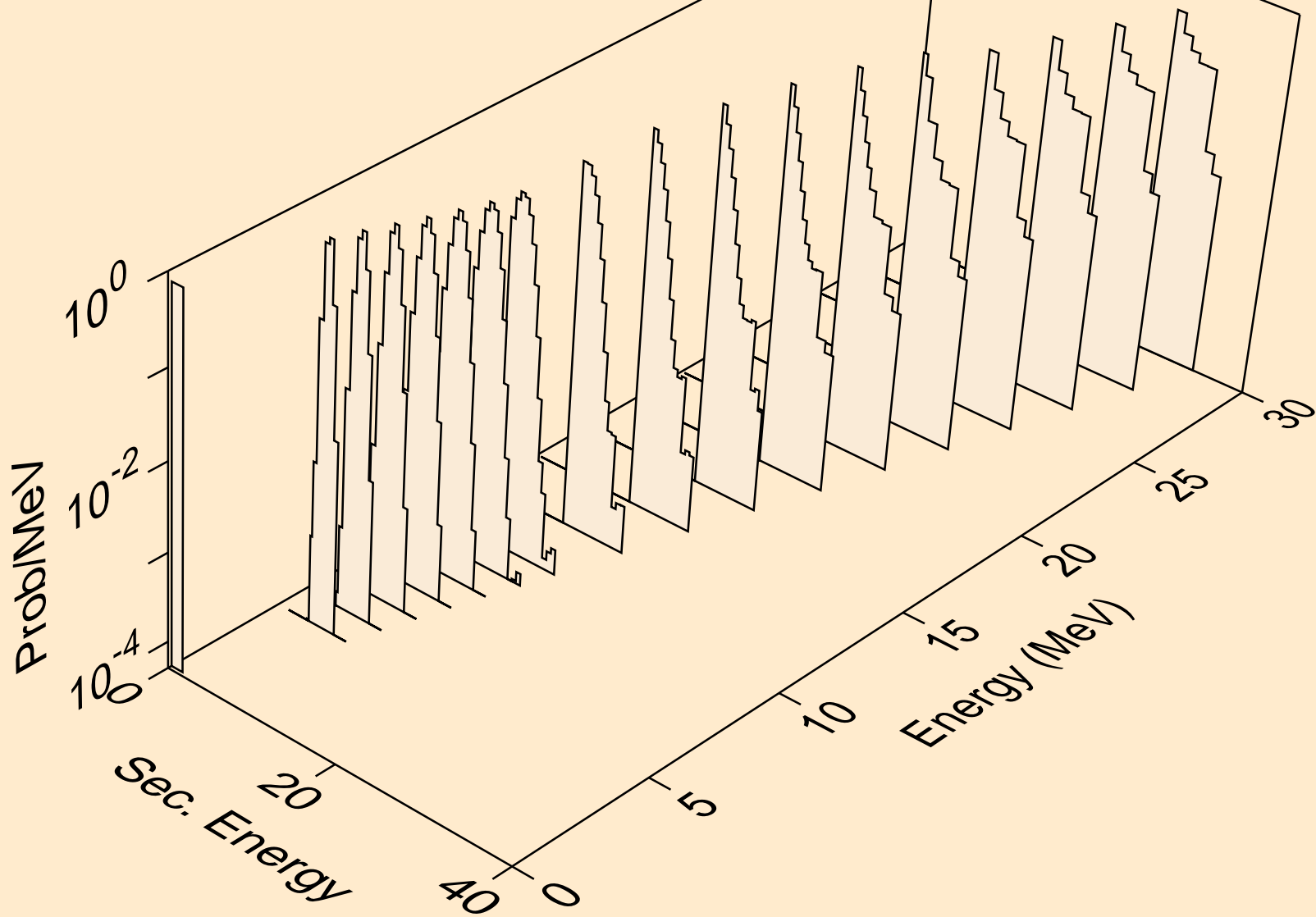

DS281 DEUTERON ACER TENDL-2021 LIBRARY; T=0.K
tritons from (d,x)

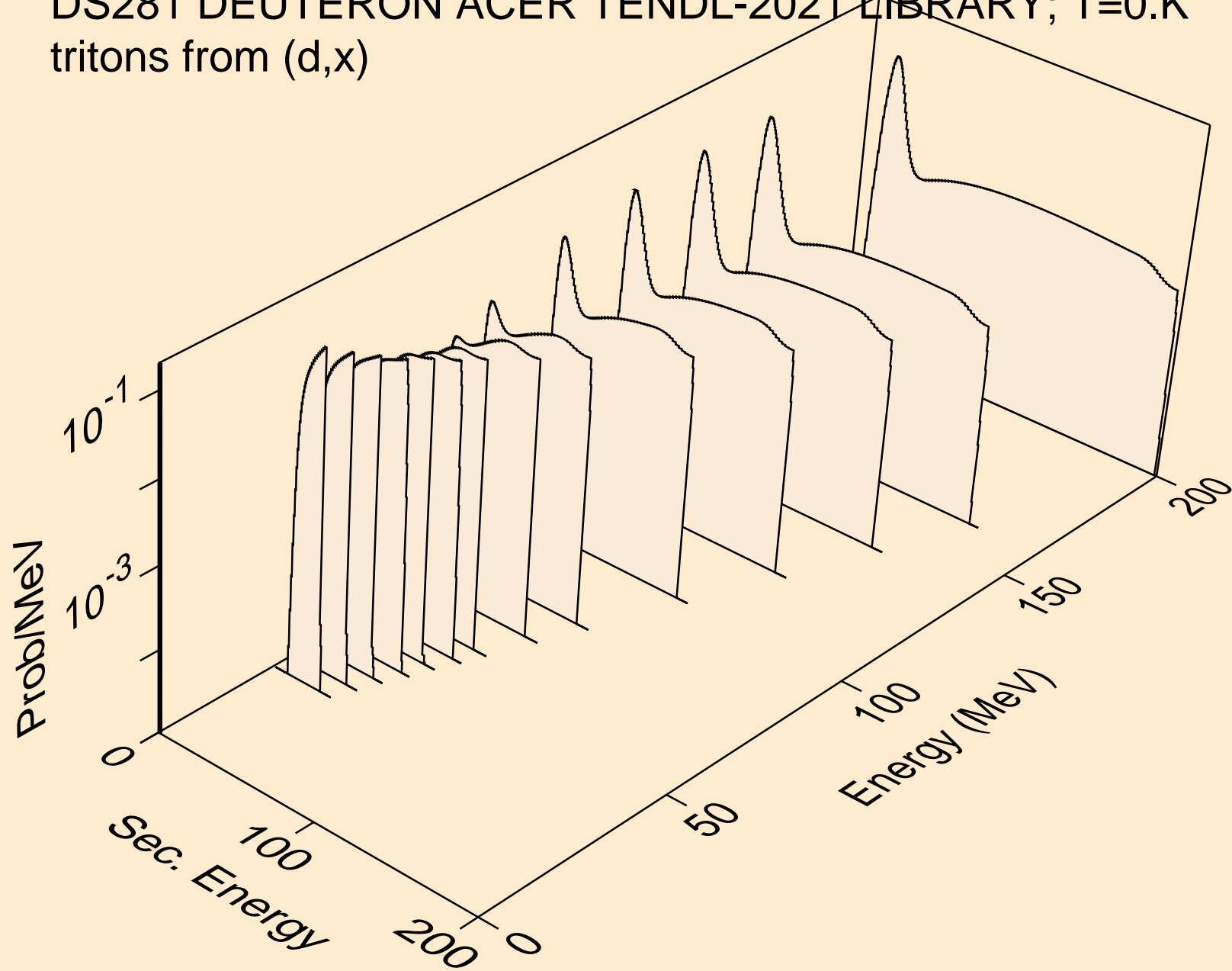

DS281 DEUTERON ACER TENDL-2021 LIBRARY; T=0.K
tritons from (d,t)

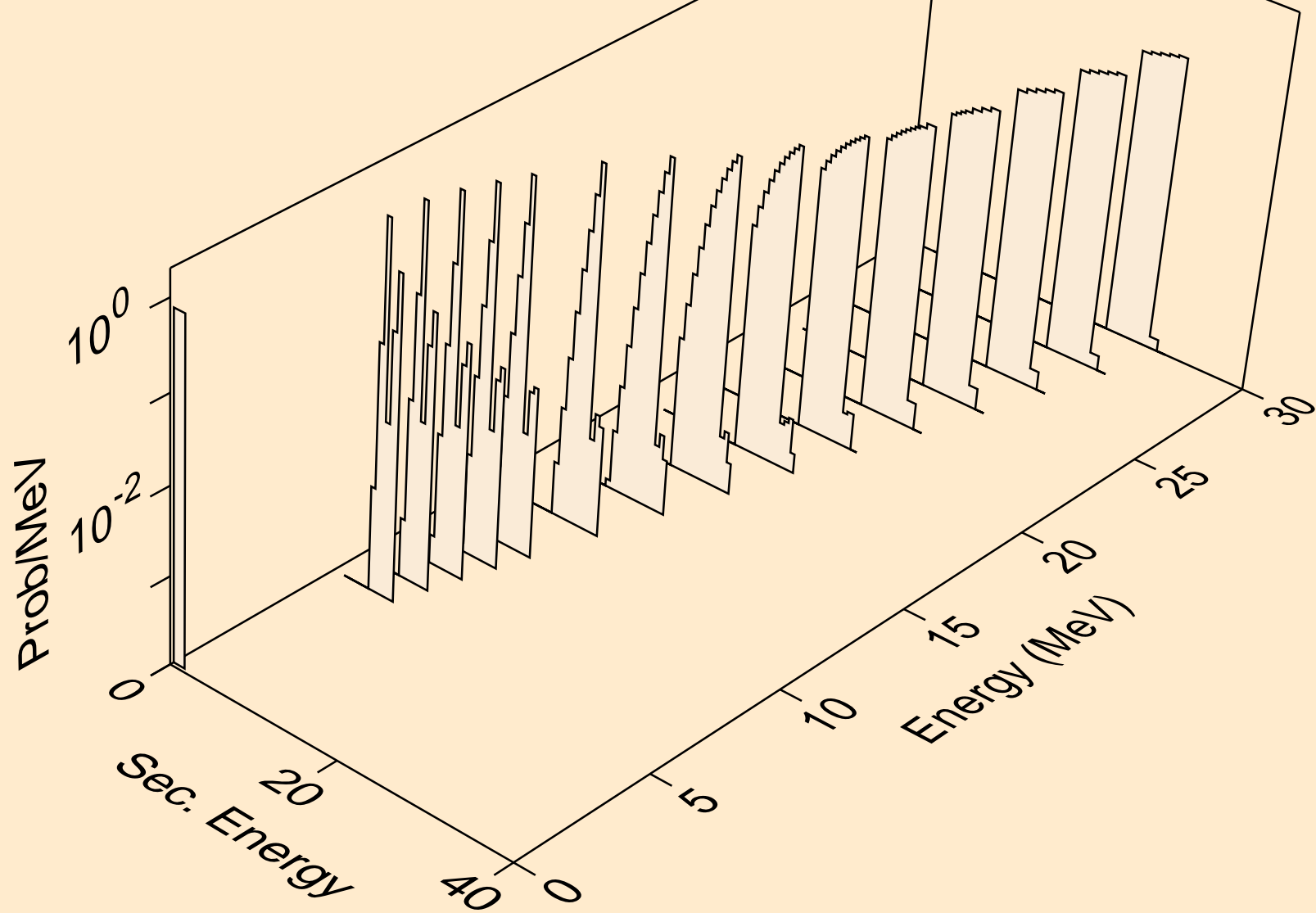

DS281 DEUTERON ACER TENDL-2021 LIBRARY; T=0.K
he3s from (d,x)

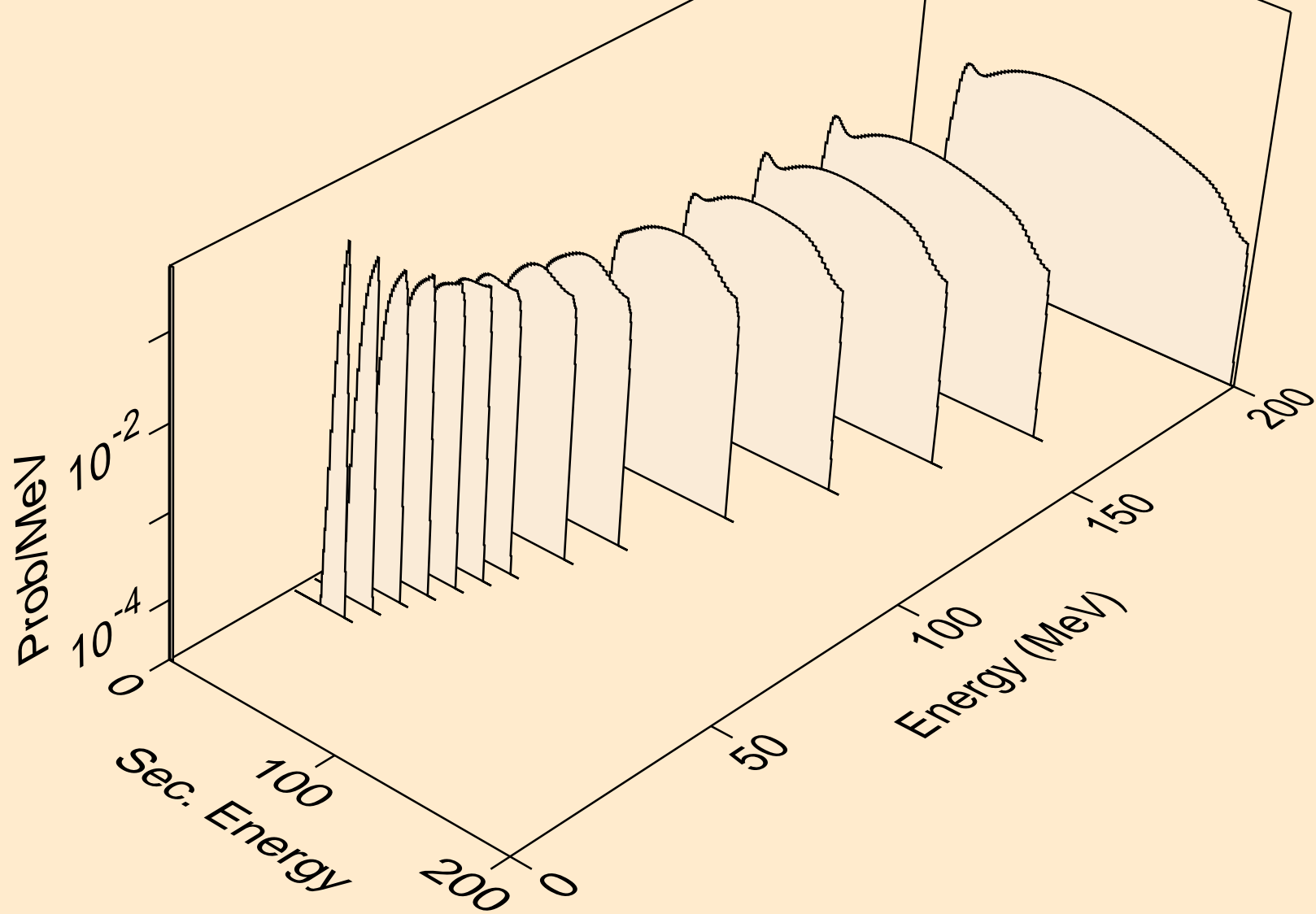

DS281 DEUTERON ACER TENDL-2021 LIBRARY; T=0.K
he3s from (d,he3)

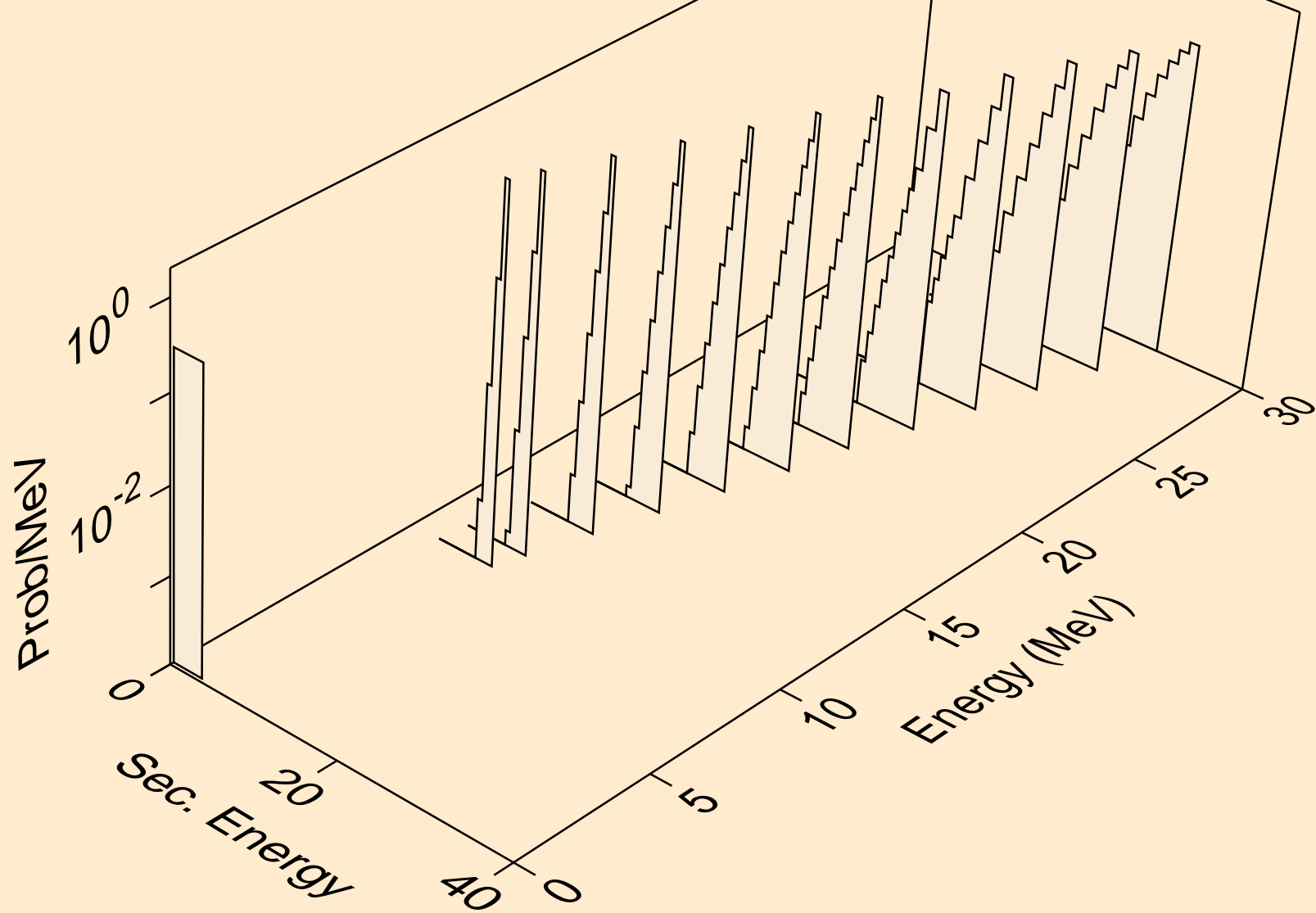

DS281 DEUTERON ACER TENDL-2021 LIBRARY; T=0.K
alphas from (d,x)

