

IN098M DEUTERON ACER TENDL-2021 LIBRARY; T=0.K
Principal cross sections

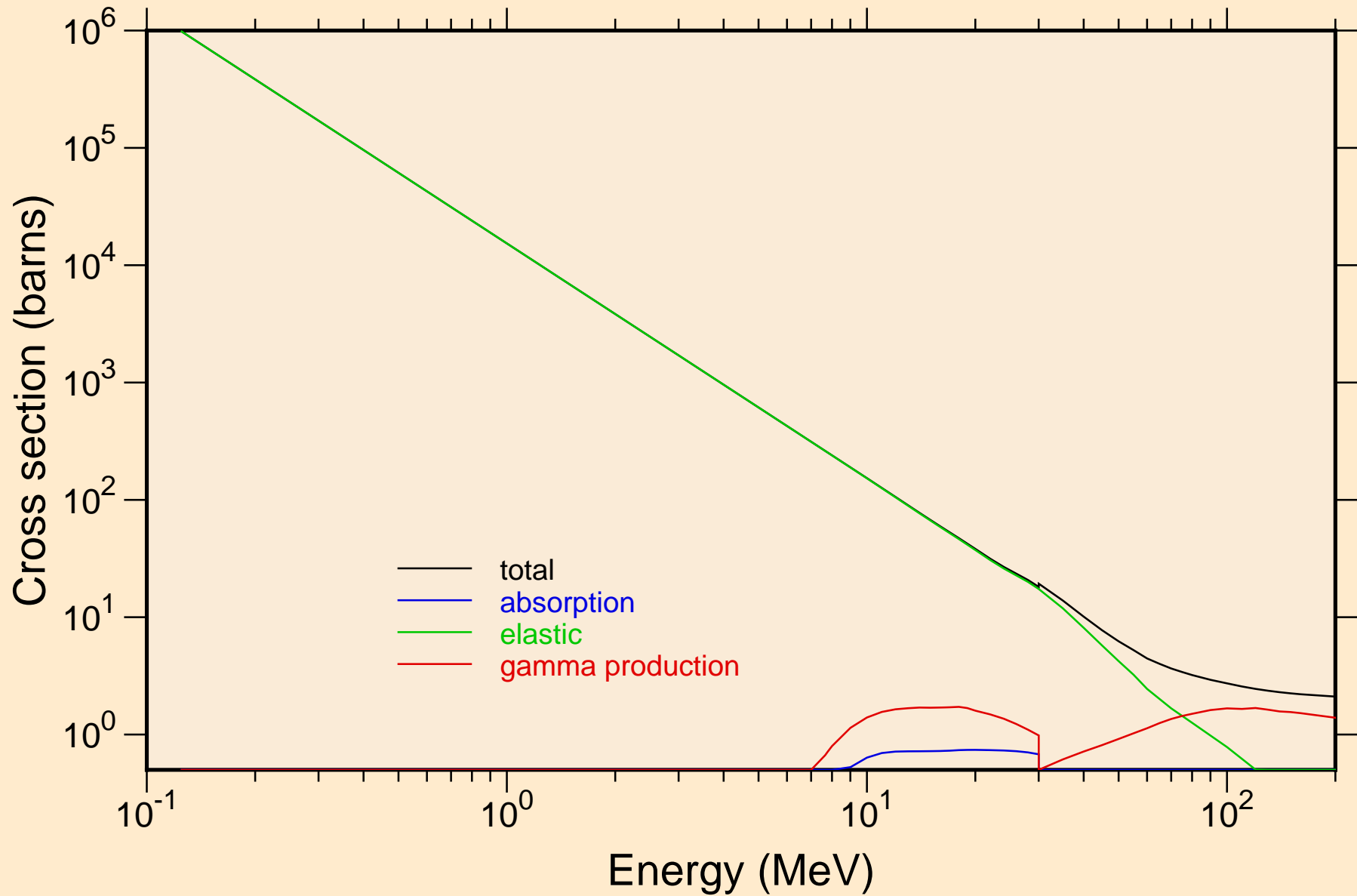

IN098M DEUTERON ACER TENDL-2021 LIBRARY; T=0.K
Heating

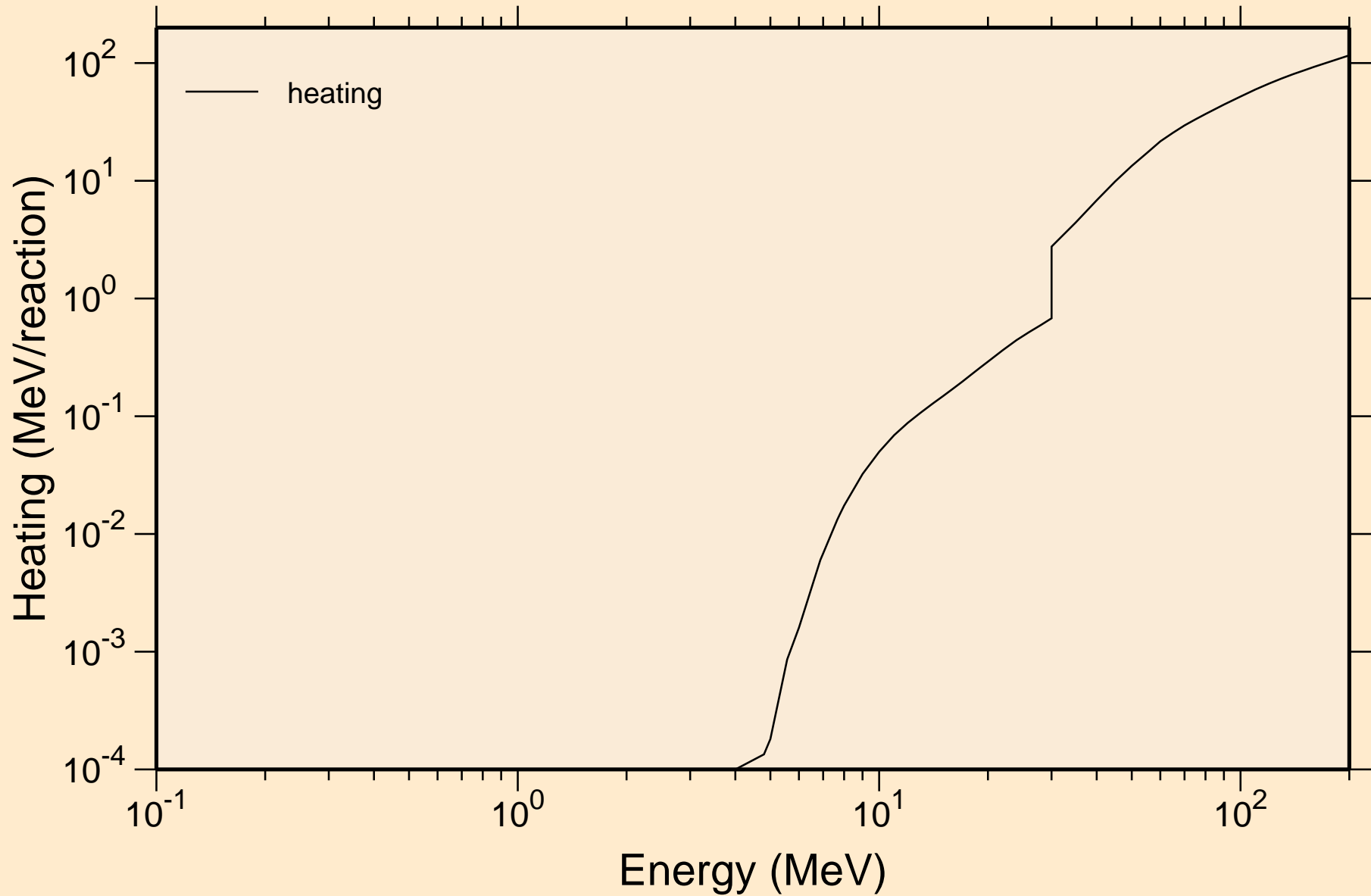

IN098M DEUTERON ACER TENDL-2021 LIBRARY; T=0.K
Principal cross sections

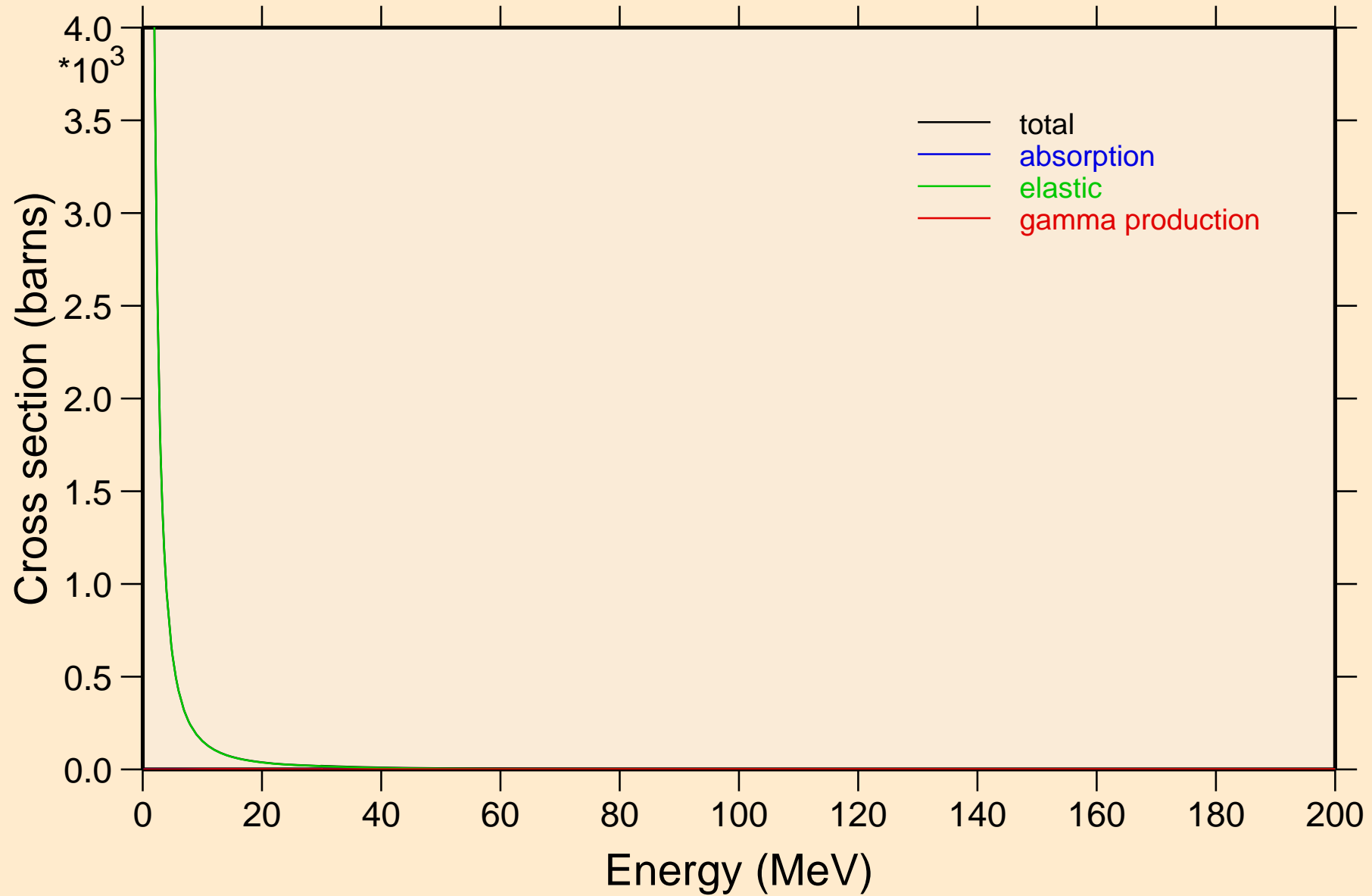

IN098M DEUTERON ACER TENDL-2021 LIBRARY; T=0.K
Heating

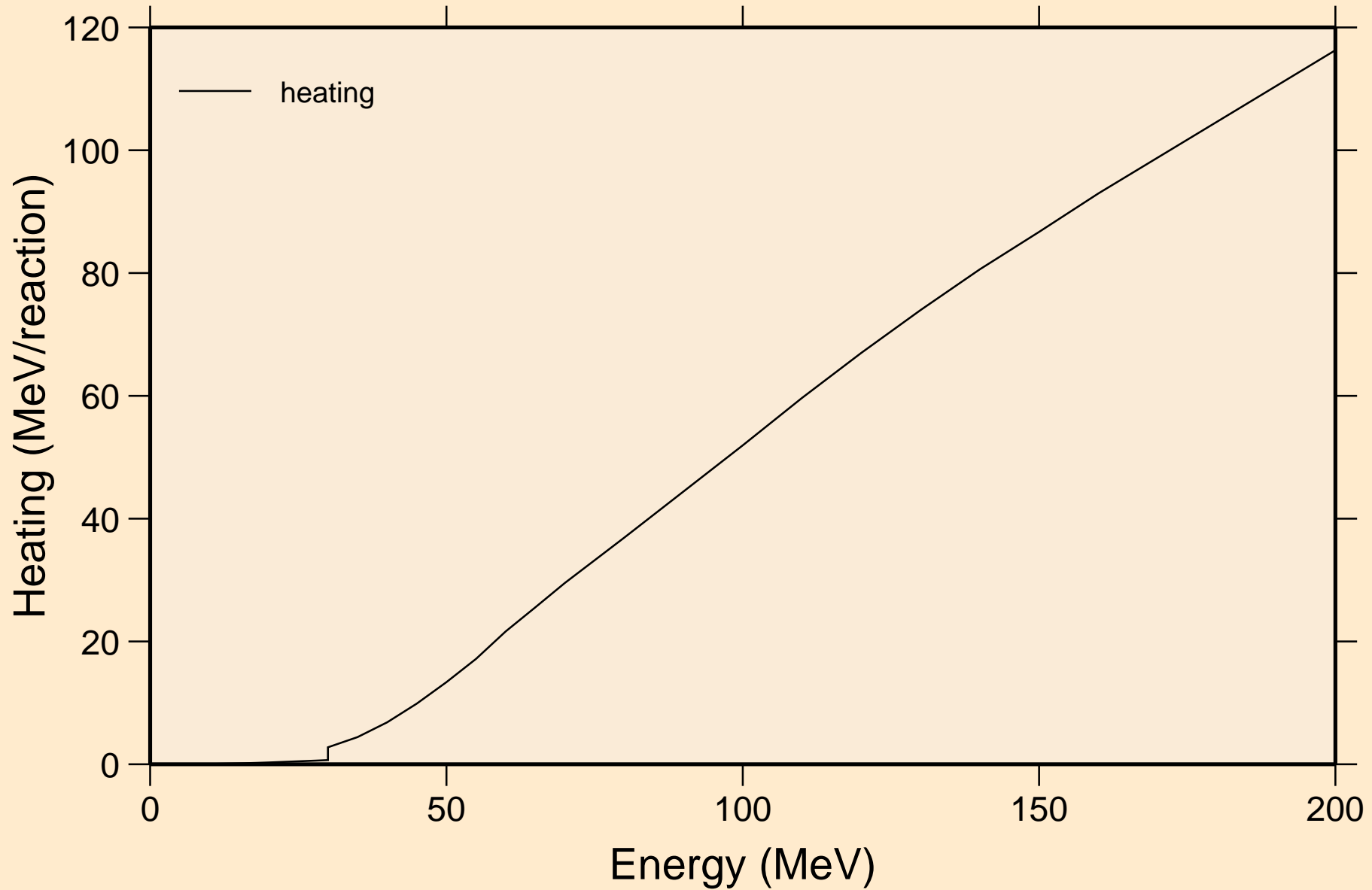

IN098M DEUTERON ACER TENDL-2021 LIBRARY; T=0.K
Threshold reactions

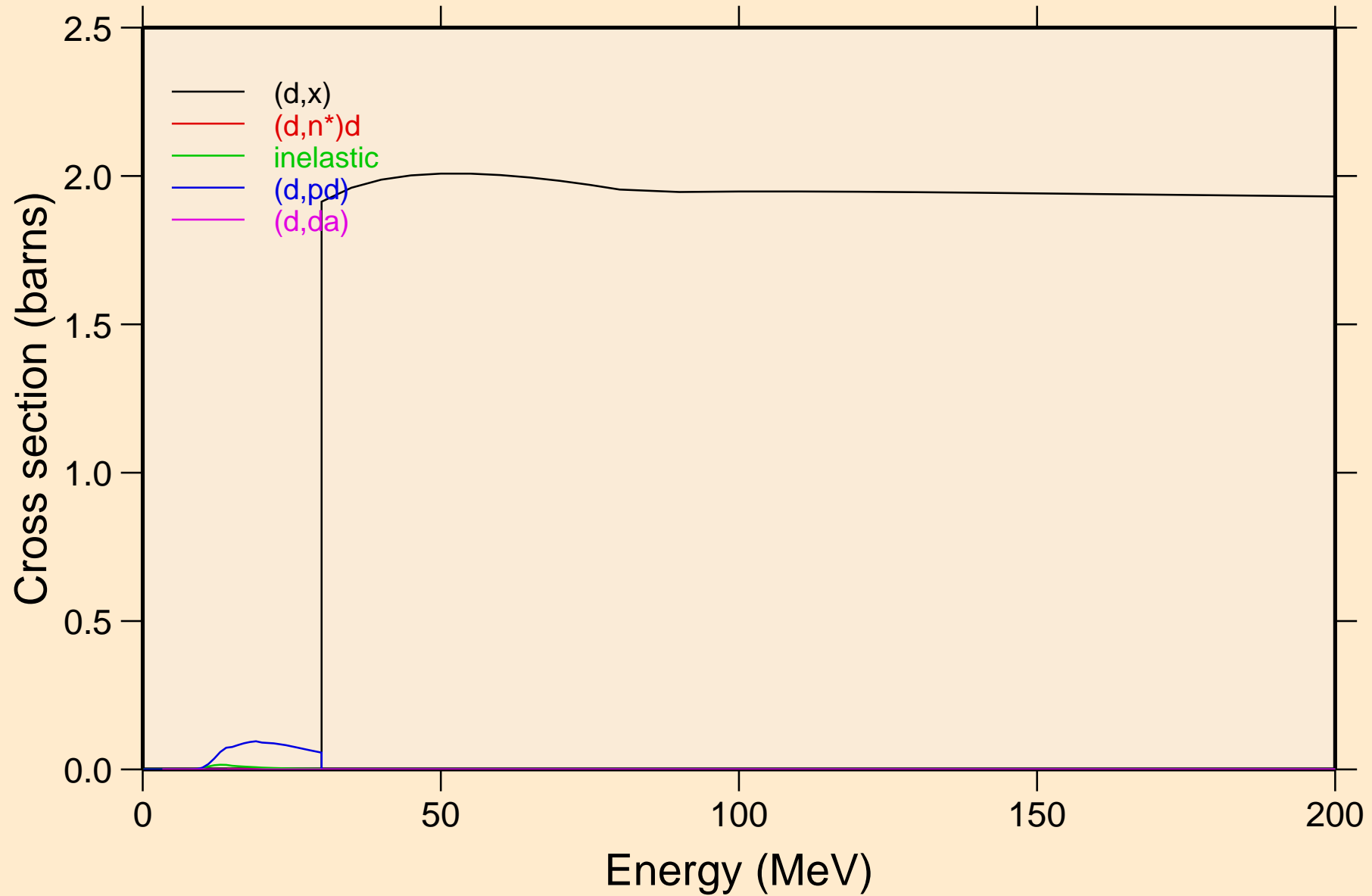

IN098M DEUTERON ACER TENDL-2021 LIBRARY; T=0.K
angular distribution for elastic

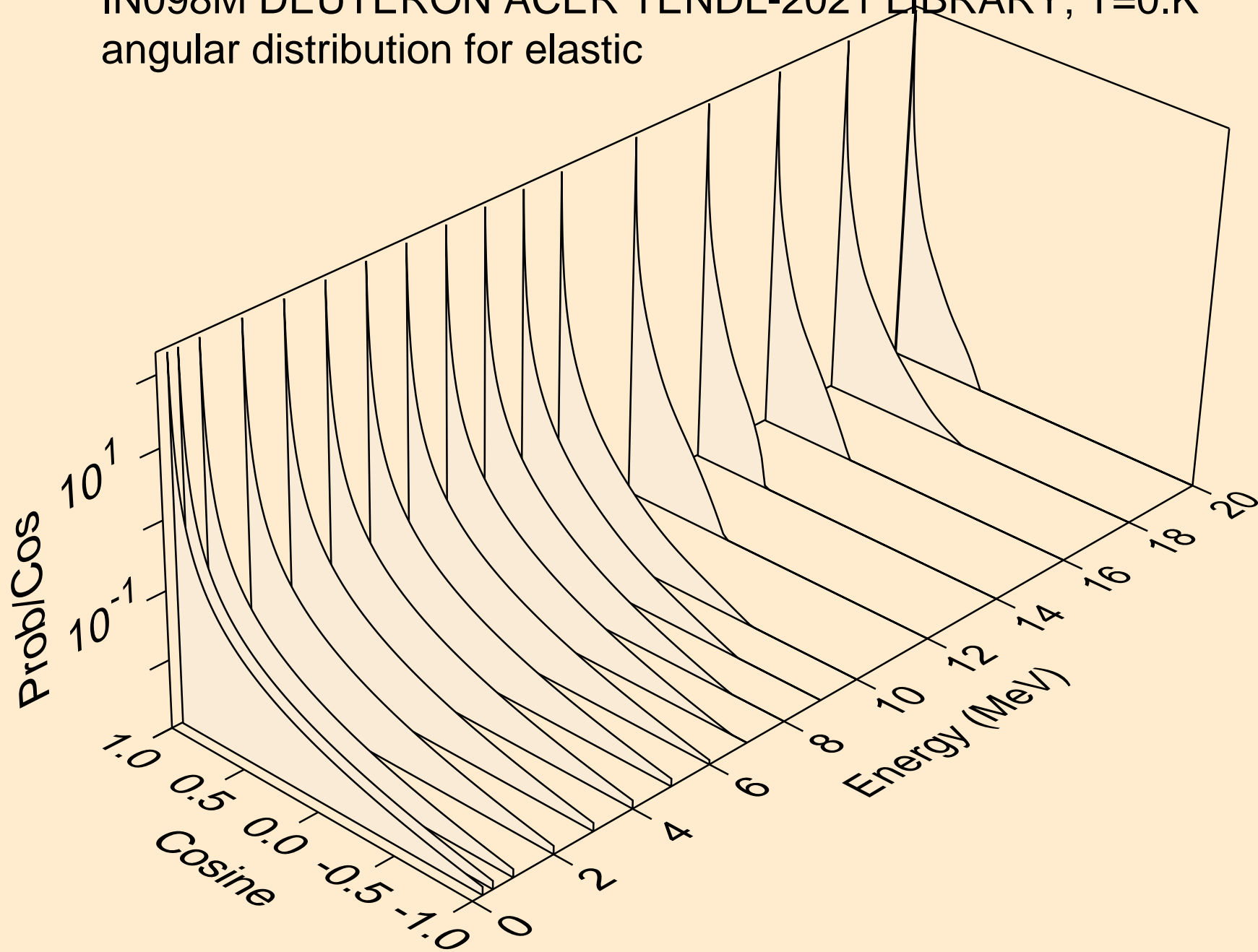

IN098M DEUTERON ACER TENDL-2021 LIBRARY; T=0.K
angular distribution for elastic

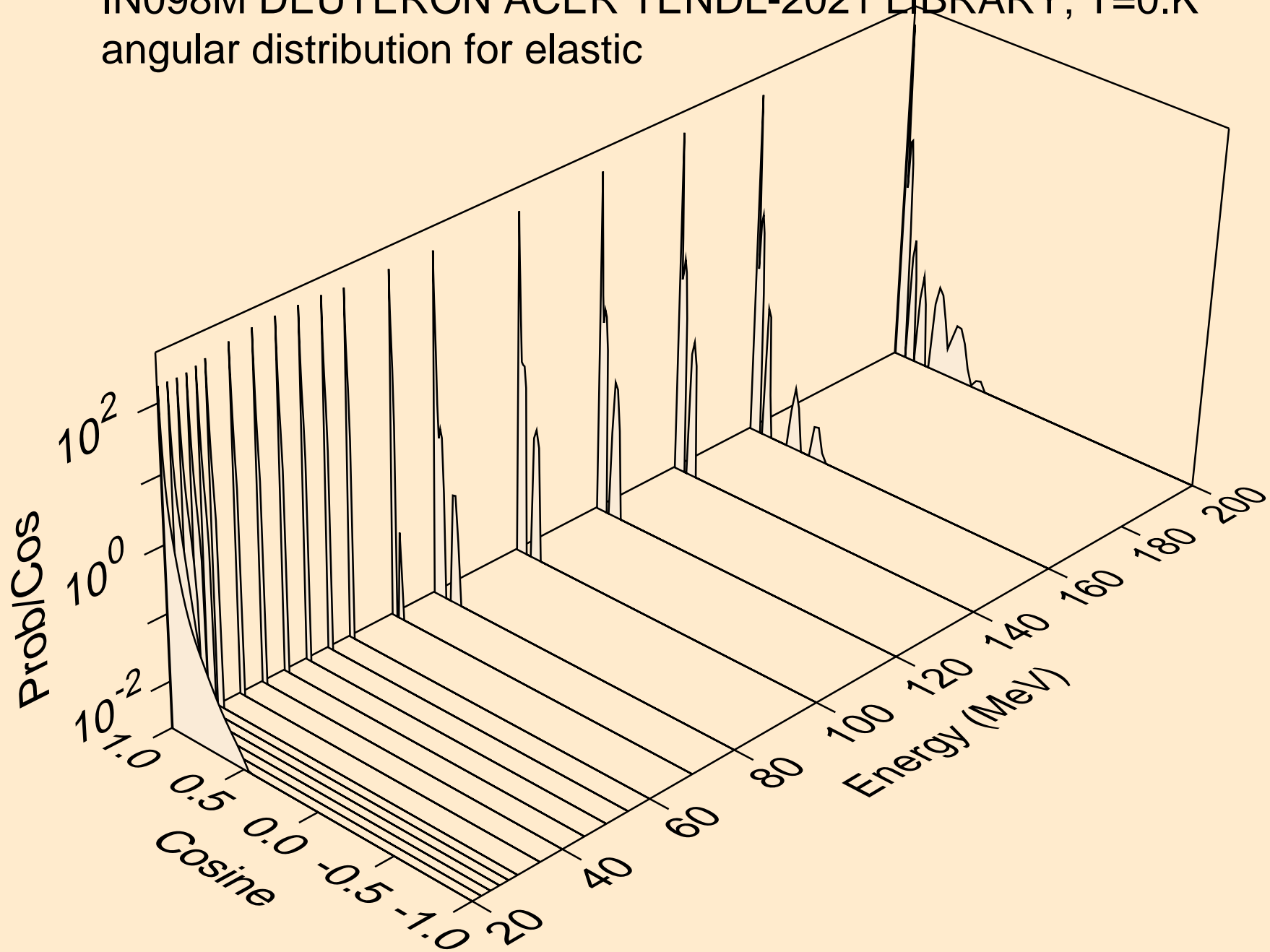

IN098M DEUTERON ACER TENDL-2021 LIBRARY; T=0.K
Deuteron emission for (d,x)

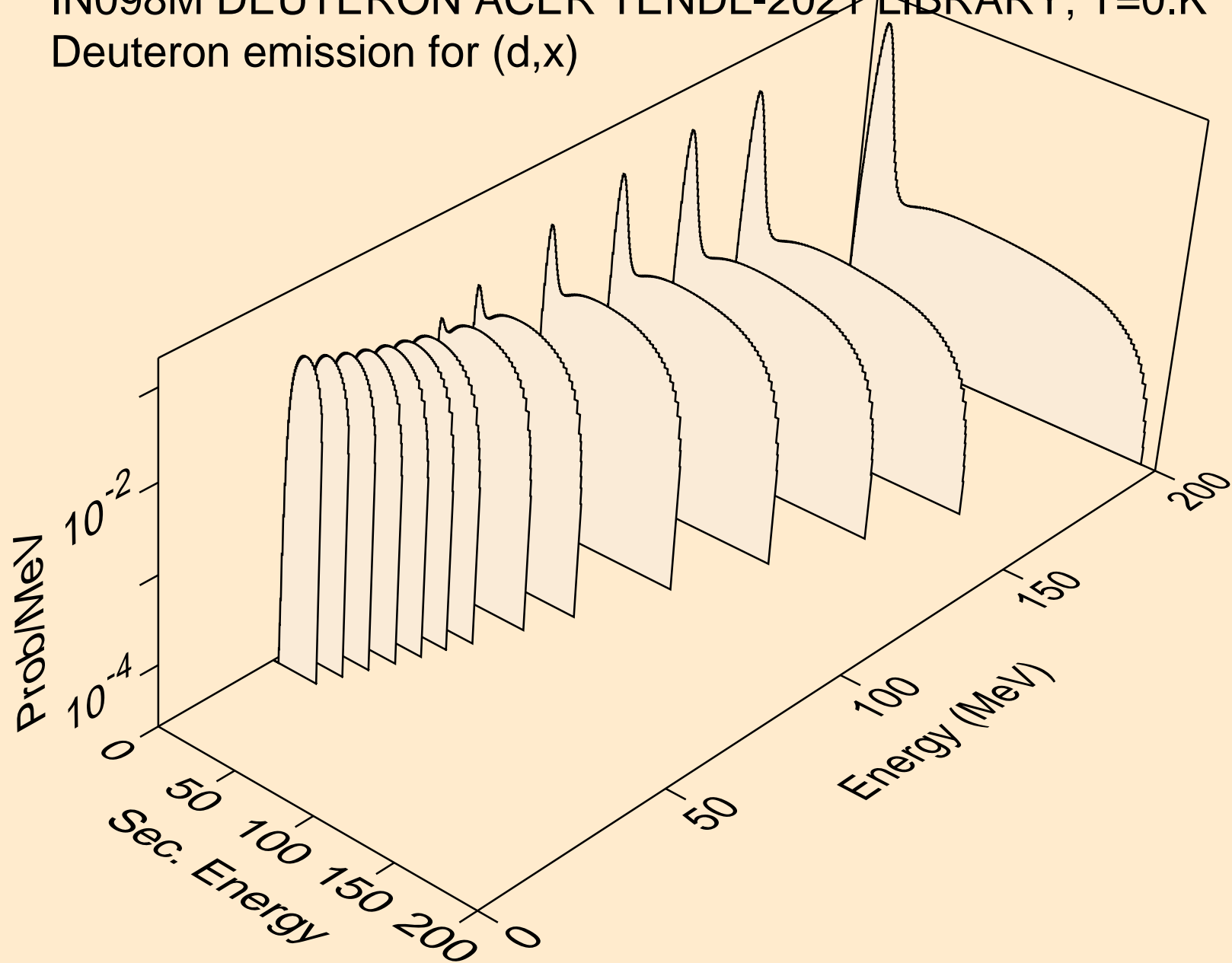

IN098M DEUTERON ACER TENDL-2021 LIBRARY; T=0.K
Deuteron emission for (d,n*)d

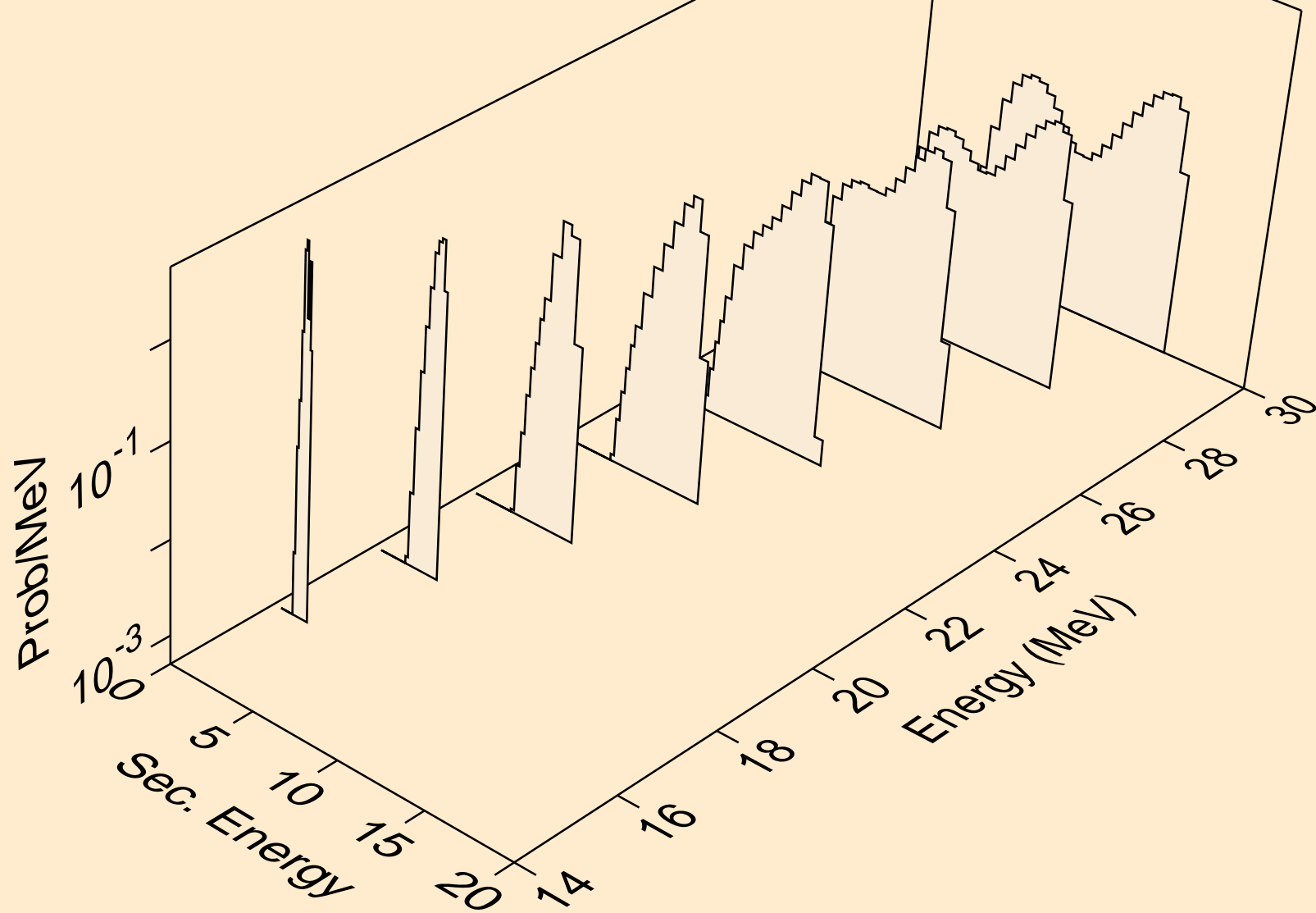

IN098M DEUTERON ACER TENDL-2021 LIBRARY; T=0.K
Deuteron emission for inelastic

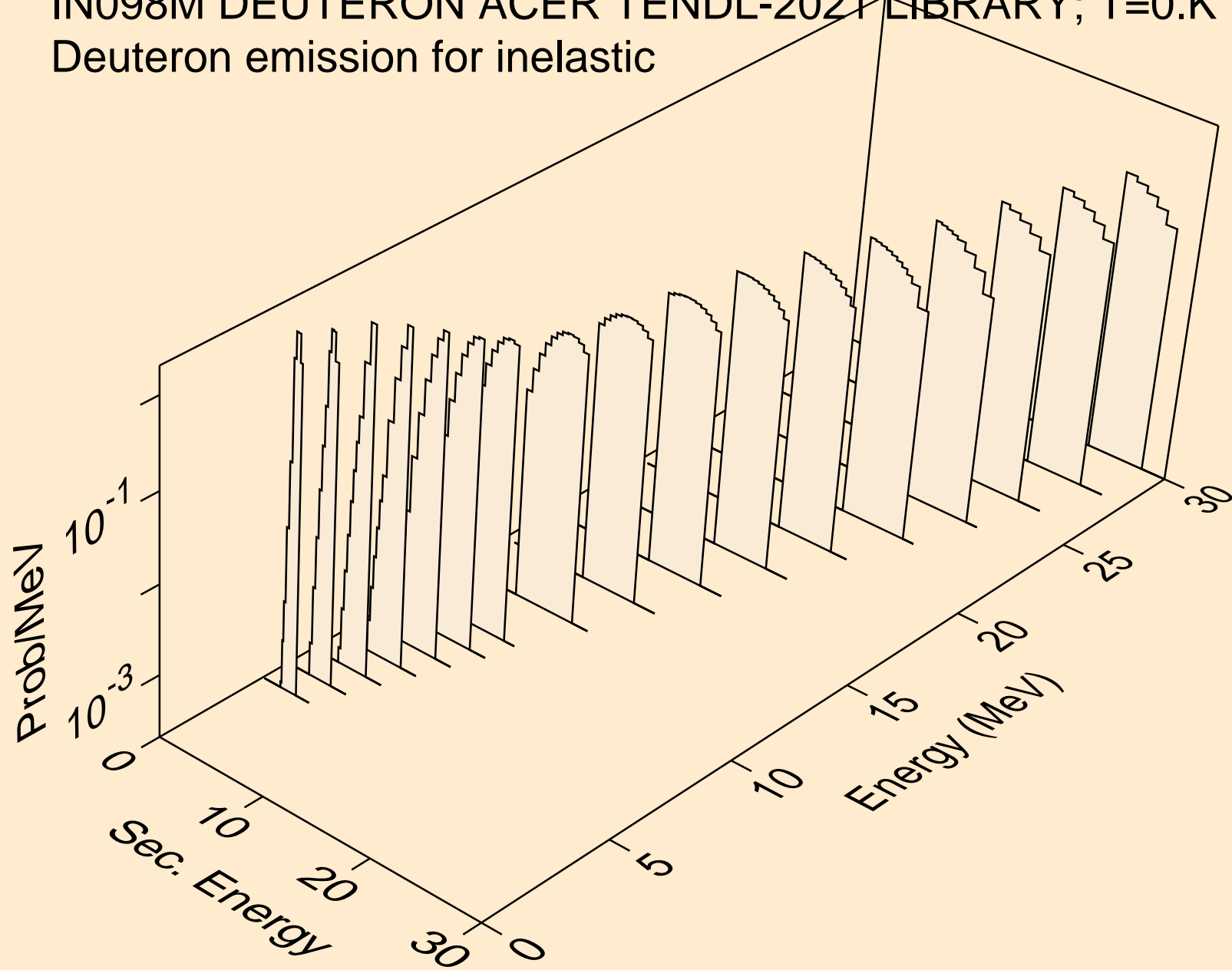

IN098M DEUTERON ACER TENDL-2021 LIBRARY; T=0.K
Deuteron emission for (d,pd)

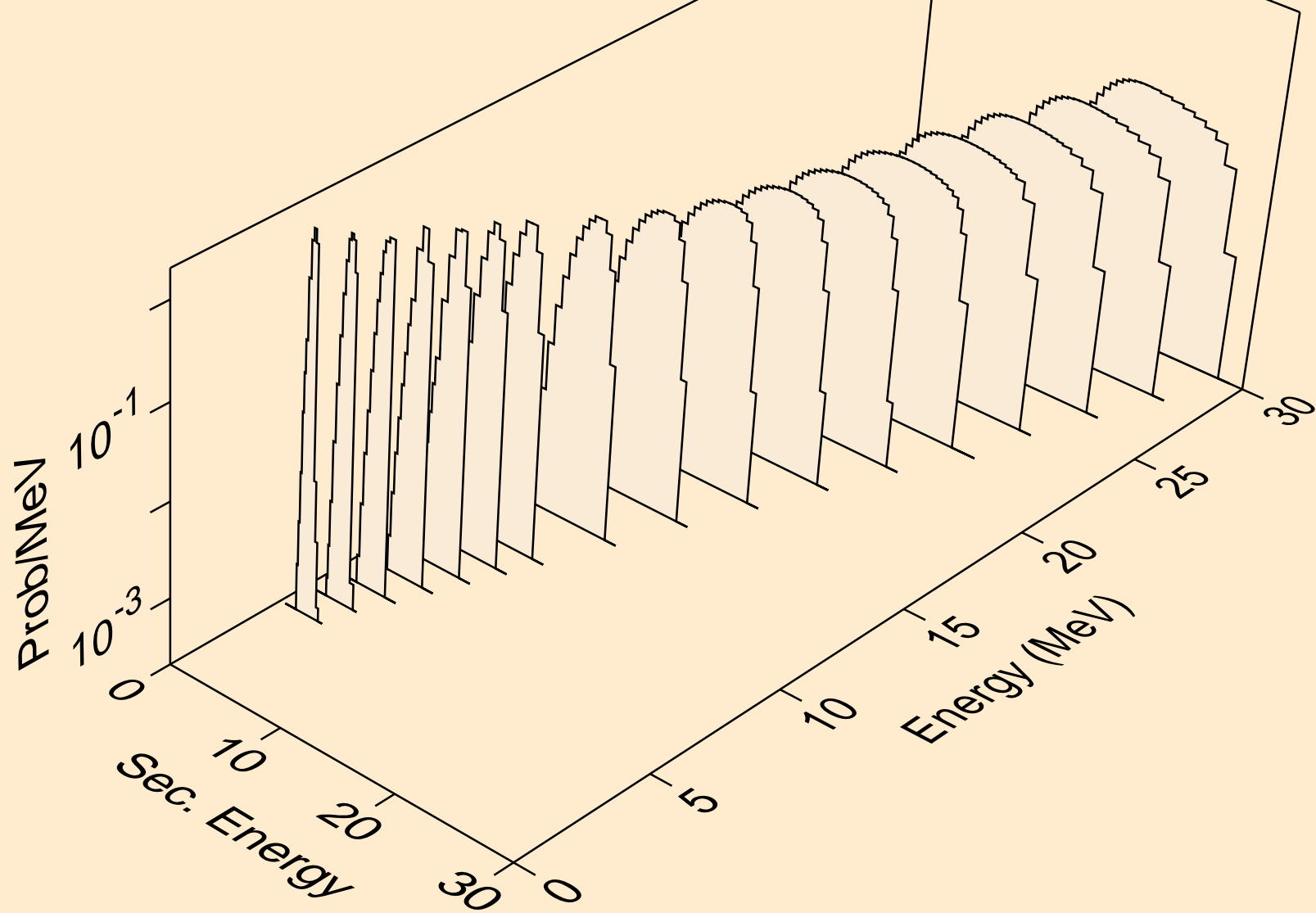

IN098M DEUTERON ACER TENDL-2021 LIBRARY; T=0.K
Deuteron emission for (d,da)

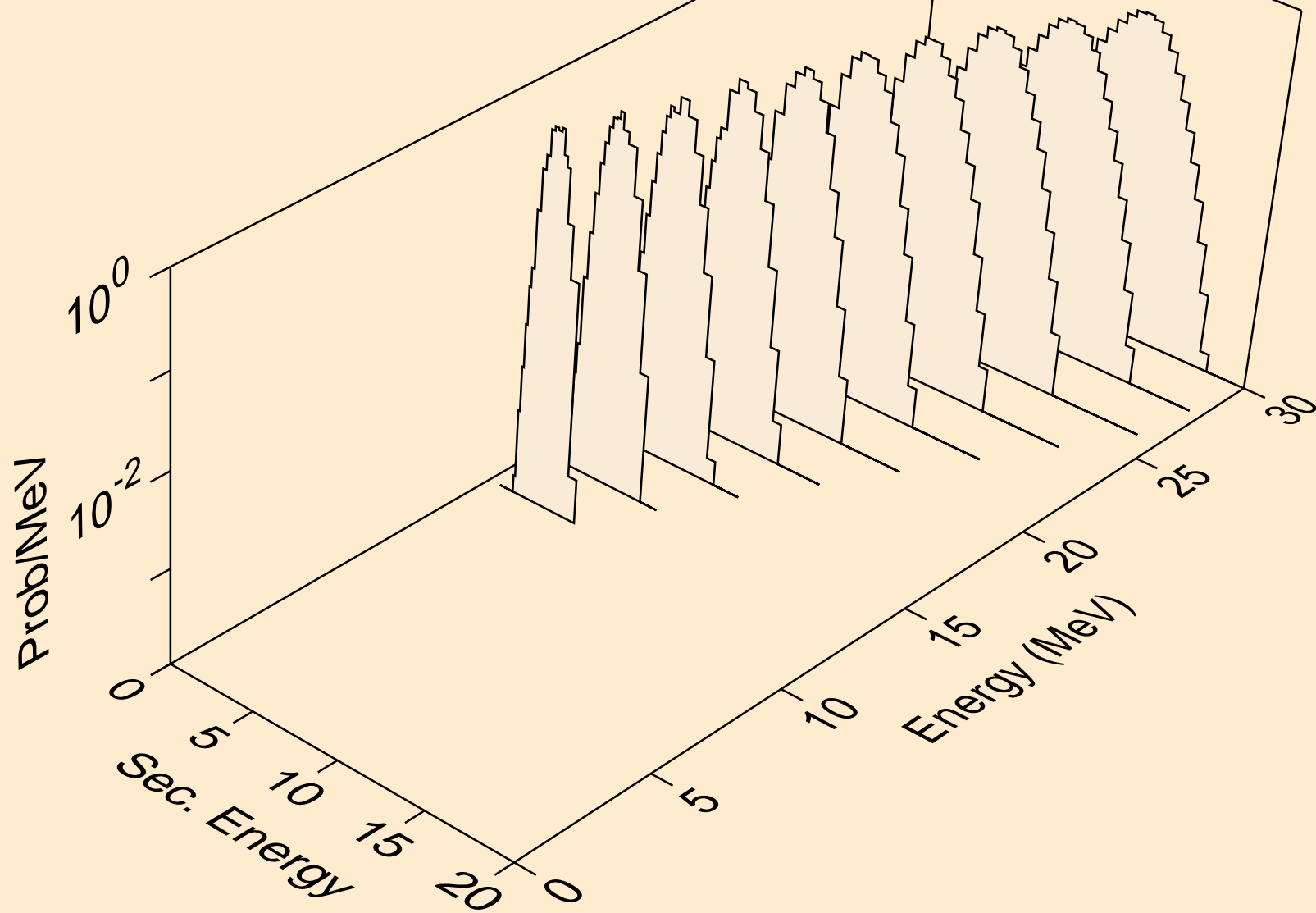

IN098M DEUTERON ACER TENDL-2021 LIBRARY; T=0.K
Photon emission for (z,n)

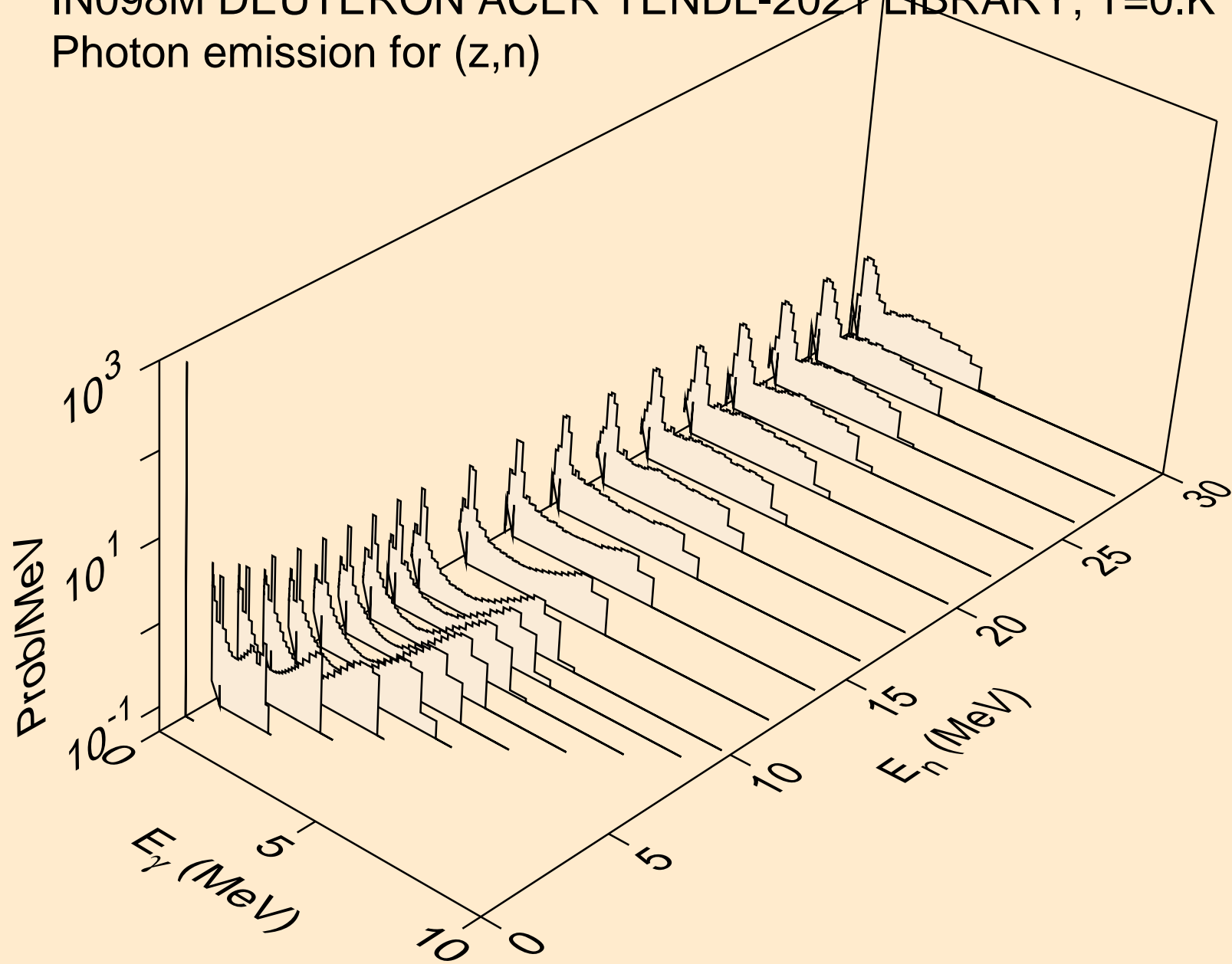

IN098M DEUTERON ACER TENDL-2021 LIBRARY; T=0.K
Photon emission for (n,x)

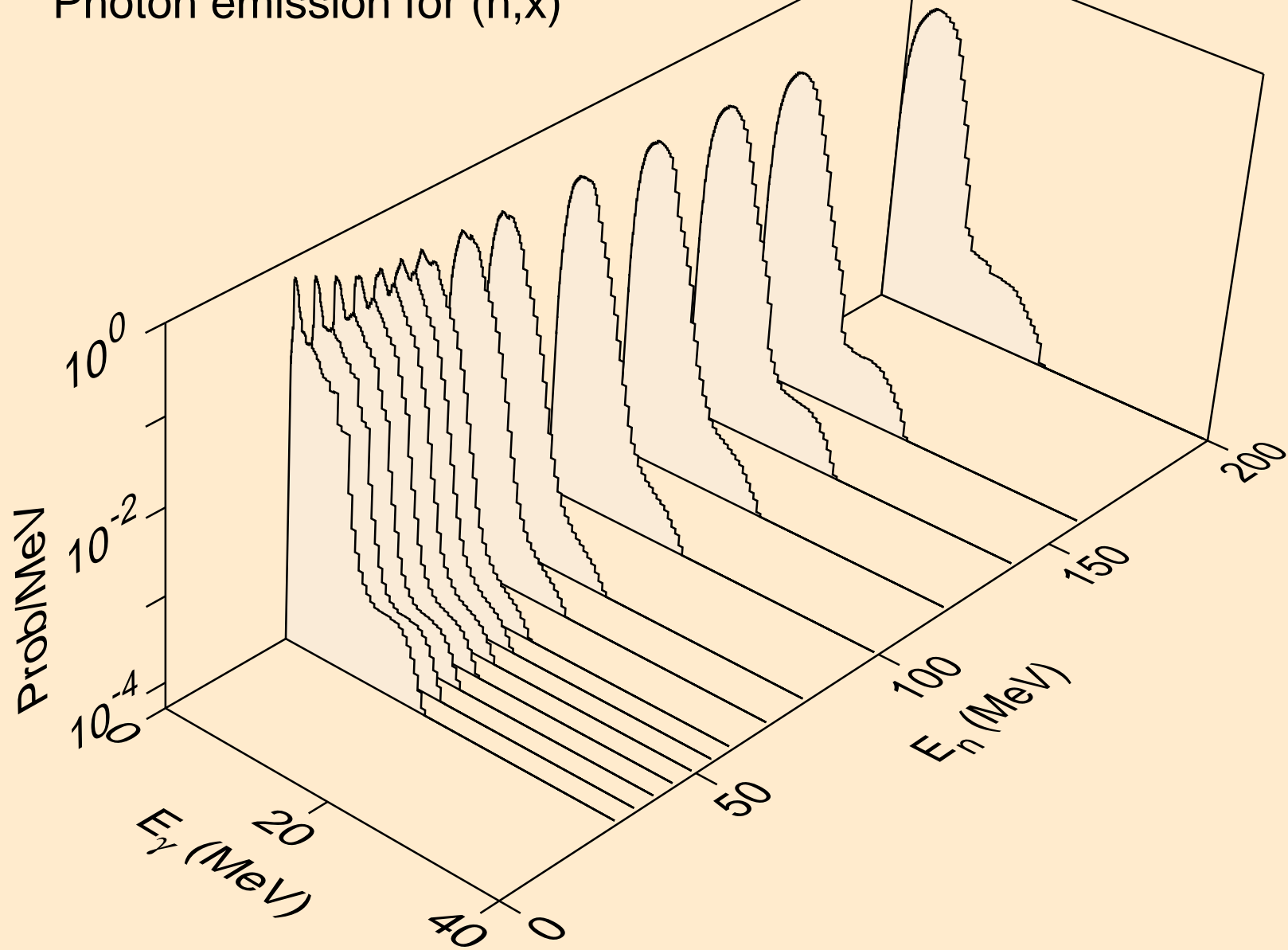

IN098M DEUTERON ACER TENDL-2021 LIBRARY; T=0.K
Photon emission for (n,2n)

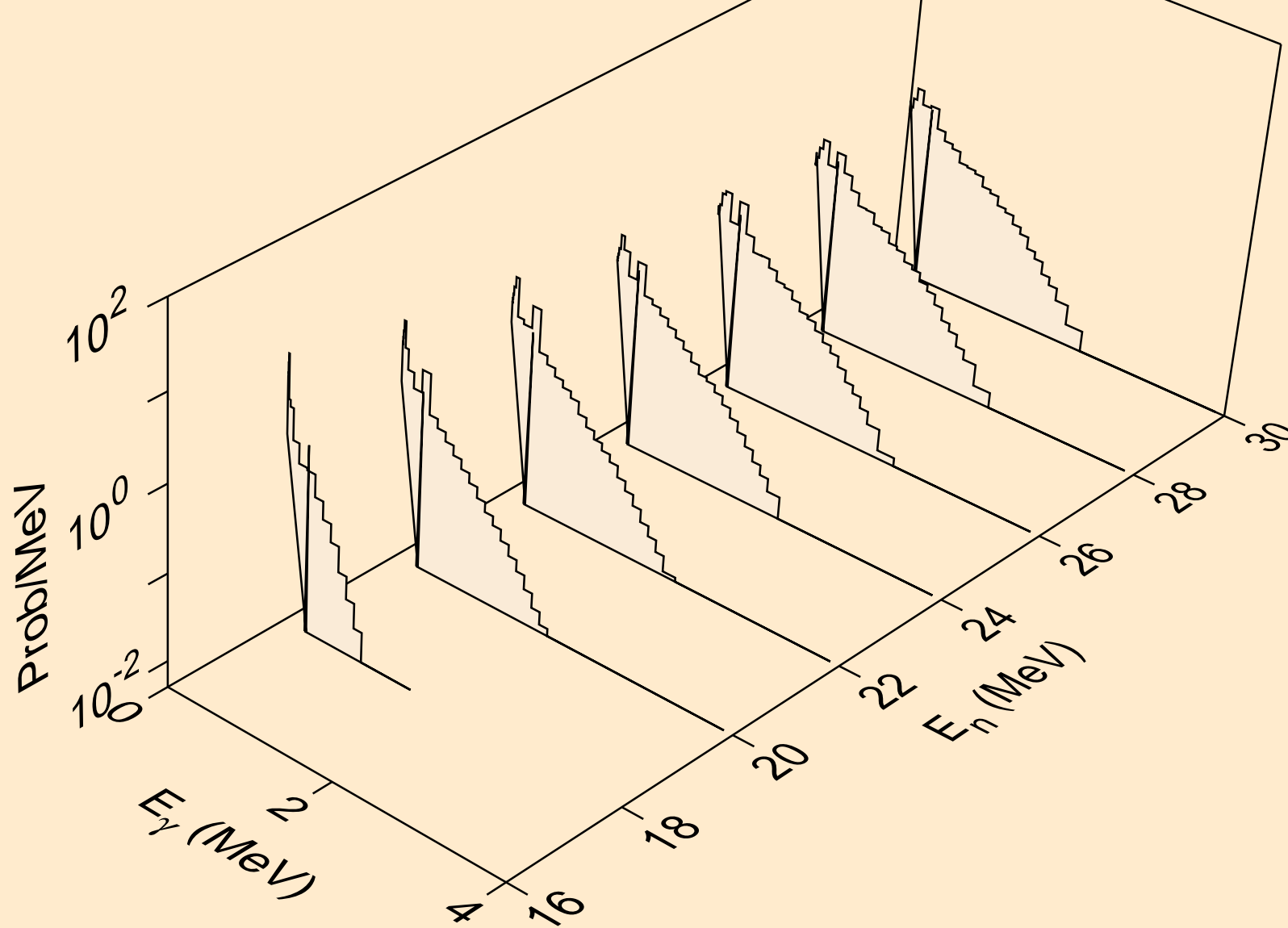

IN098M DEUTERON ACER TENDL-2021 LIBRARY; T=0.K
Photon emission for (n,n*)a

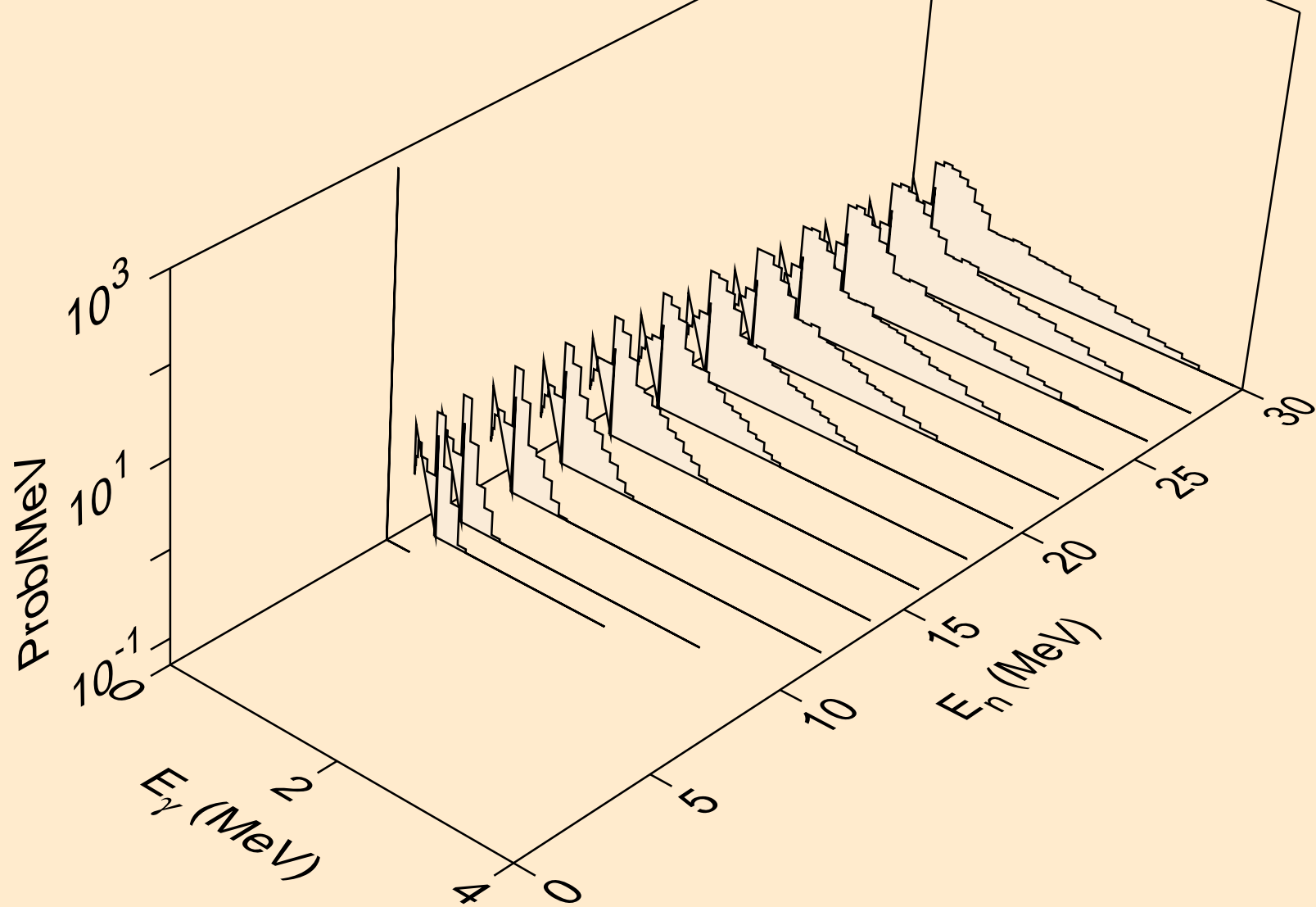

IN098M DEUTERON ACER TENDL-2021 LIBRARY; T=0.K
Photon emission for (n,n*)p

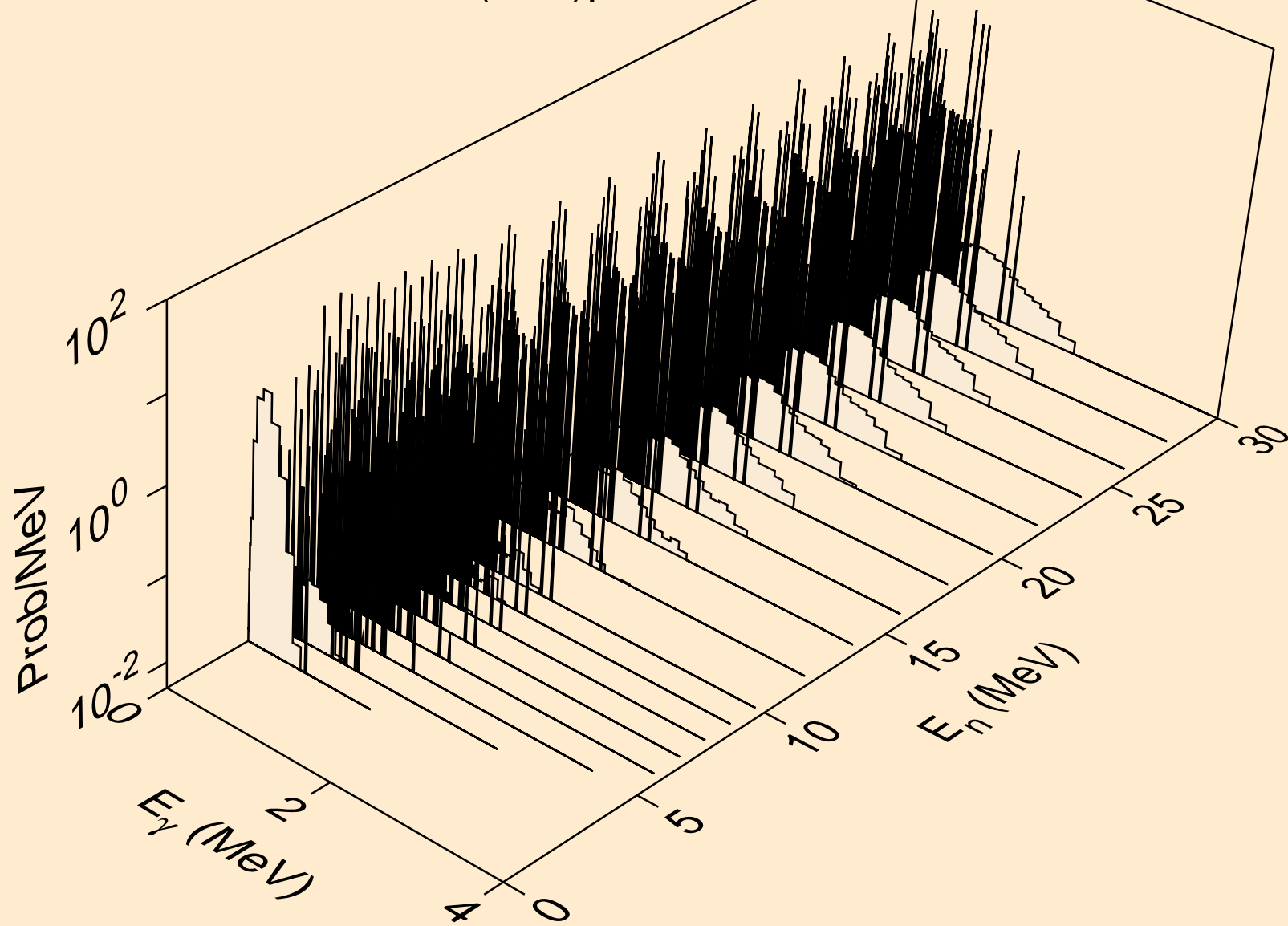

IN098M DEUTERON ACER TENDL-2021 LIBRARY; T=0.K
Photon emission for (n,n*)2a

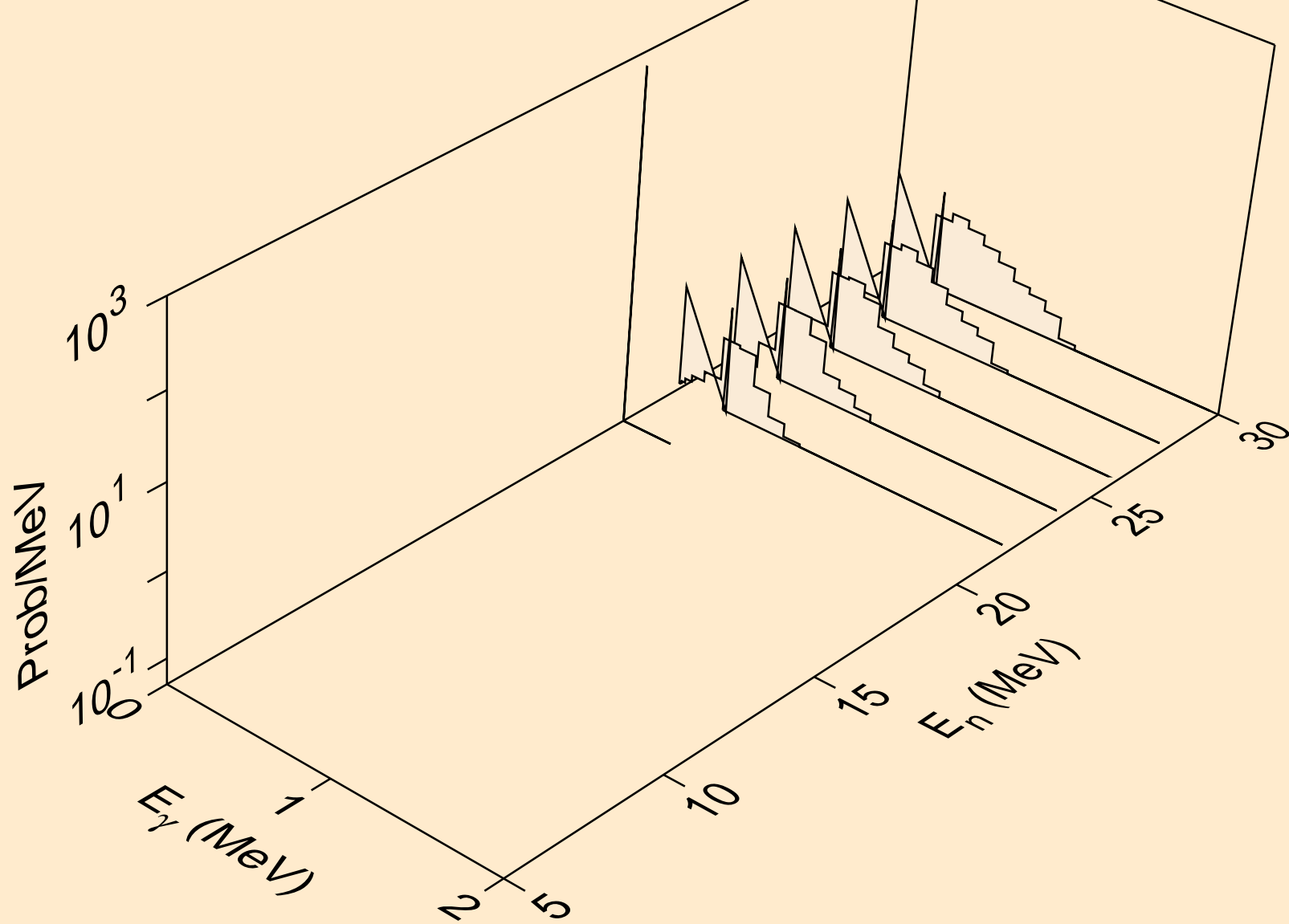

IN098M DEUTERON ACER TENDL-2021 LIBRARY; T=0.K
Photon emission for (n,n*)d

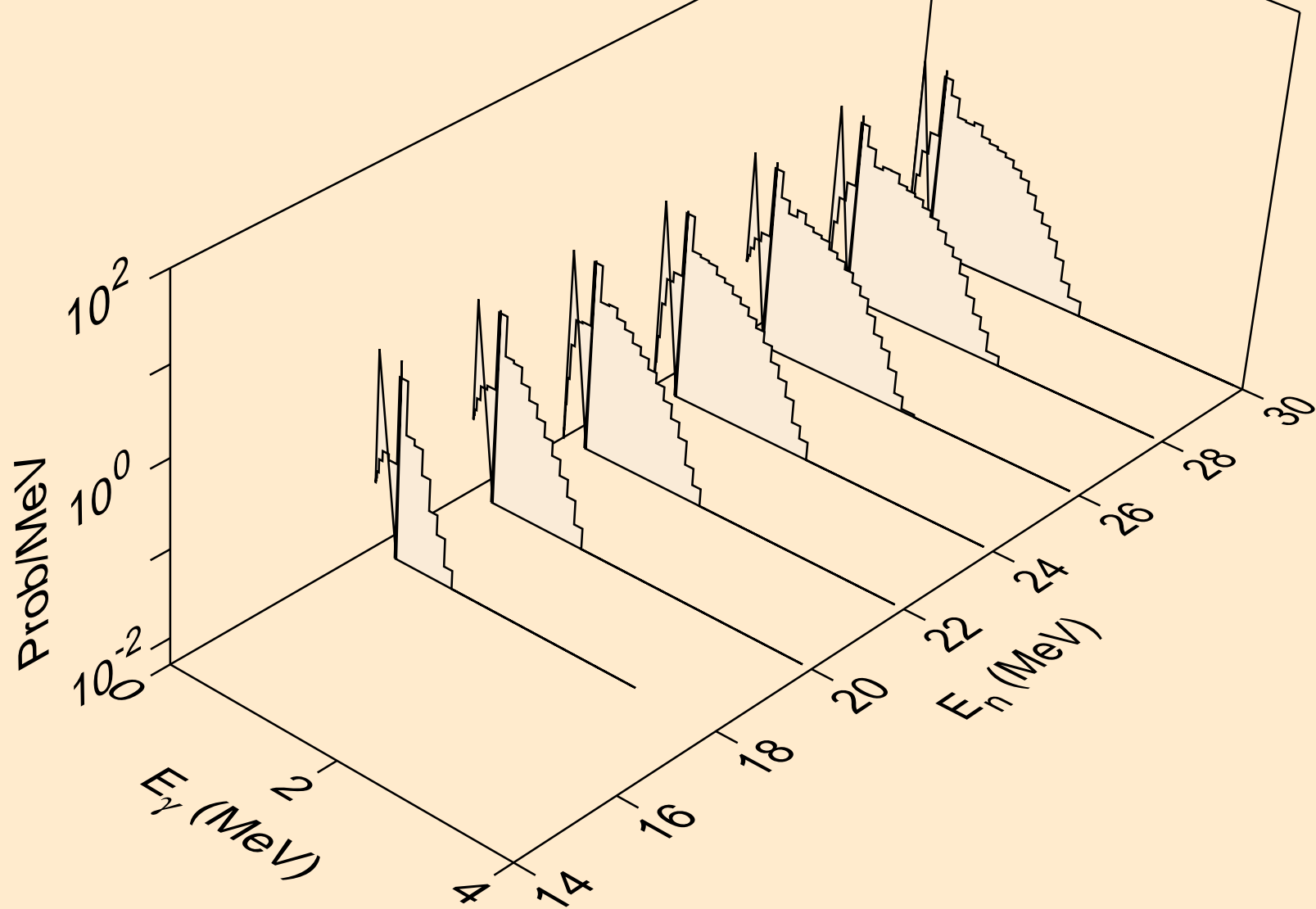

IN098M DEUTERON ACER TENDL-2021 LIBRARY; T=0.K
Photon emission for (n,n*)he3

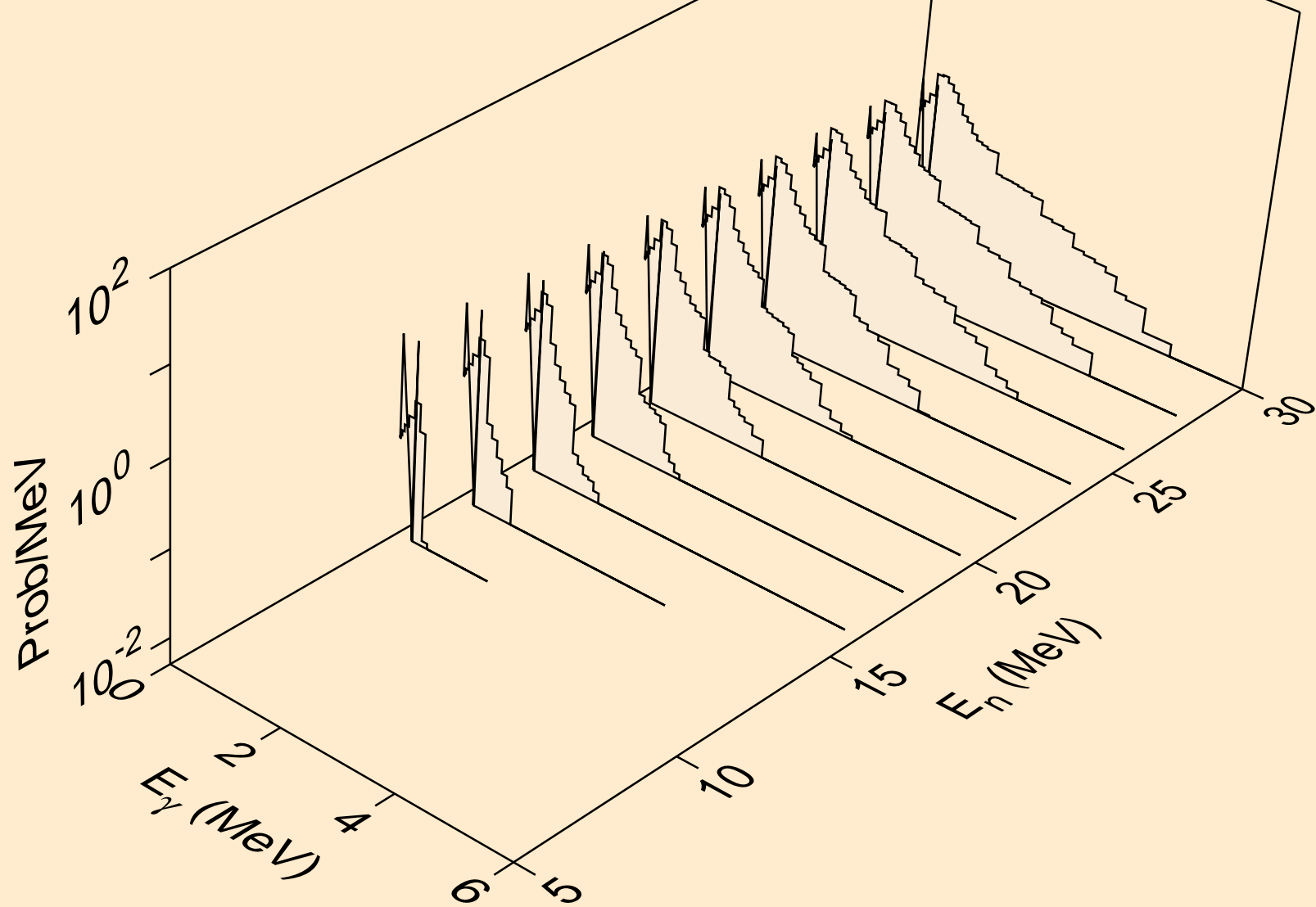

IN098M DEUTERON ACER TENDL-2021 LIBRARY; T=0.K
Photon emission for (n,2np)

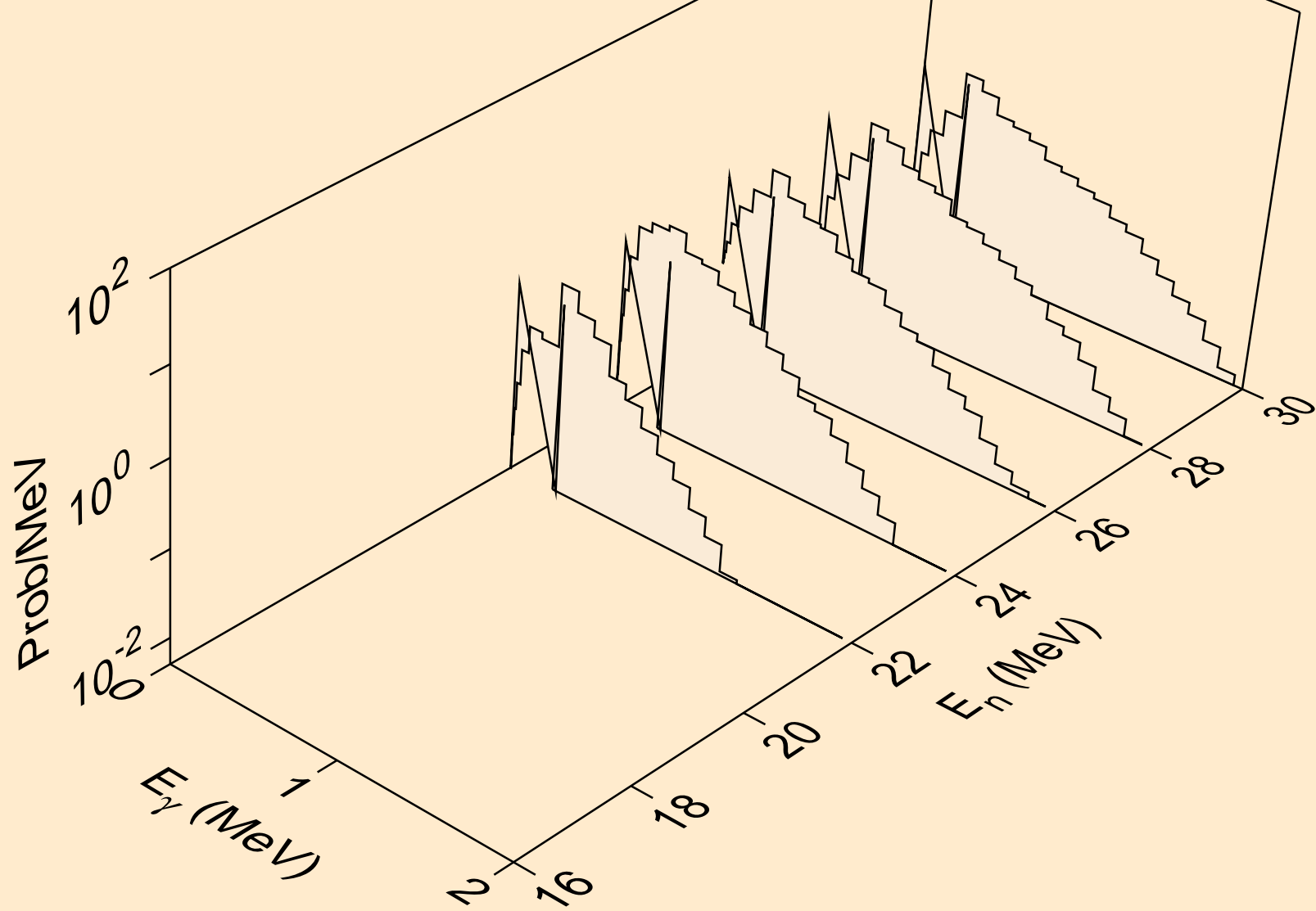

IN098M DEUTERON ACER TENDL-2021 LIBRARY; T=0.K
Photon emission for (n,2np)

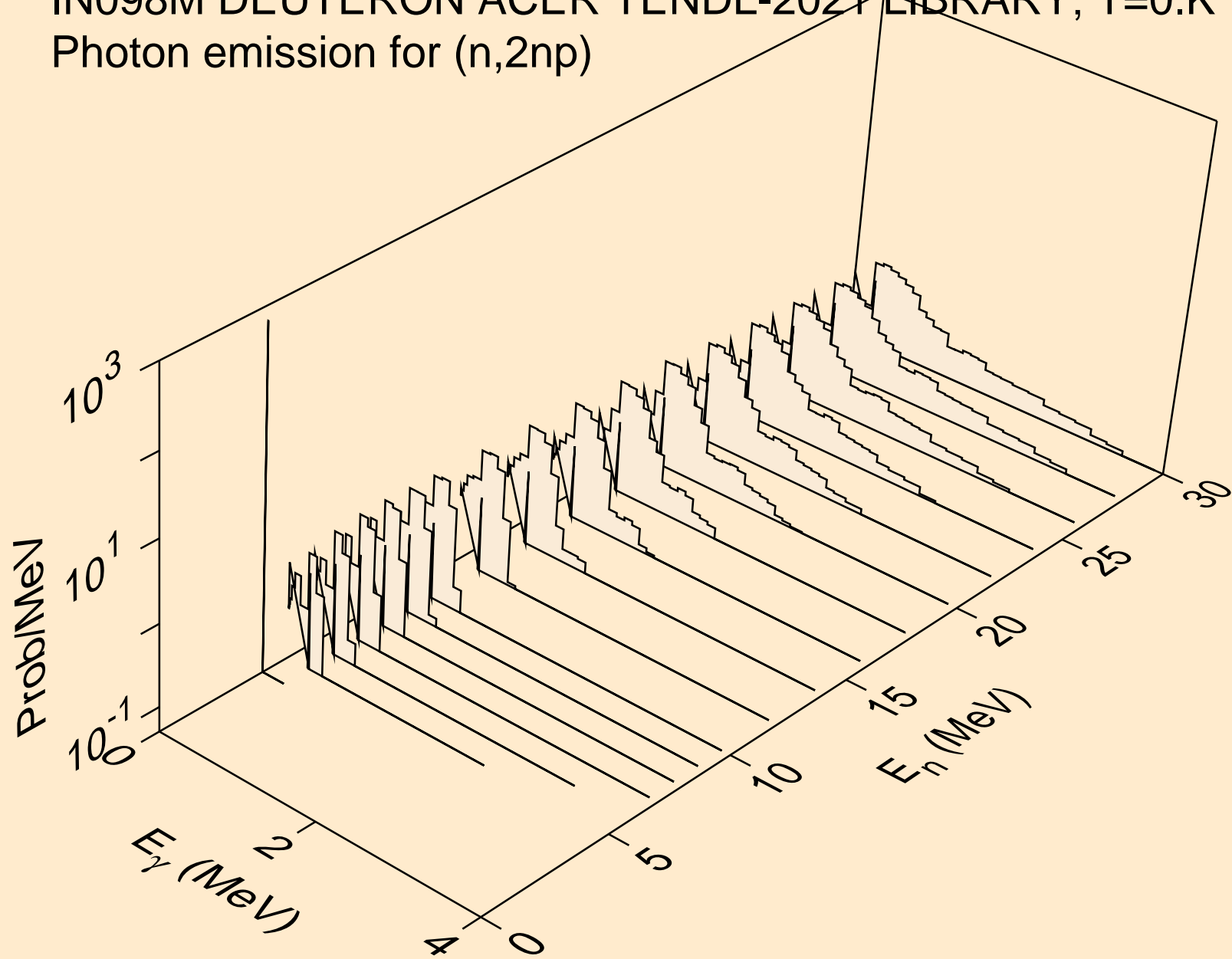

IN098M DEUTERON ACER TENDL-2021 LIBRARY; T=0.K
Photon emission for (n,npa)

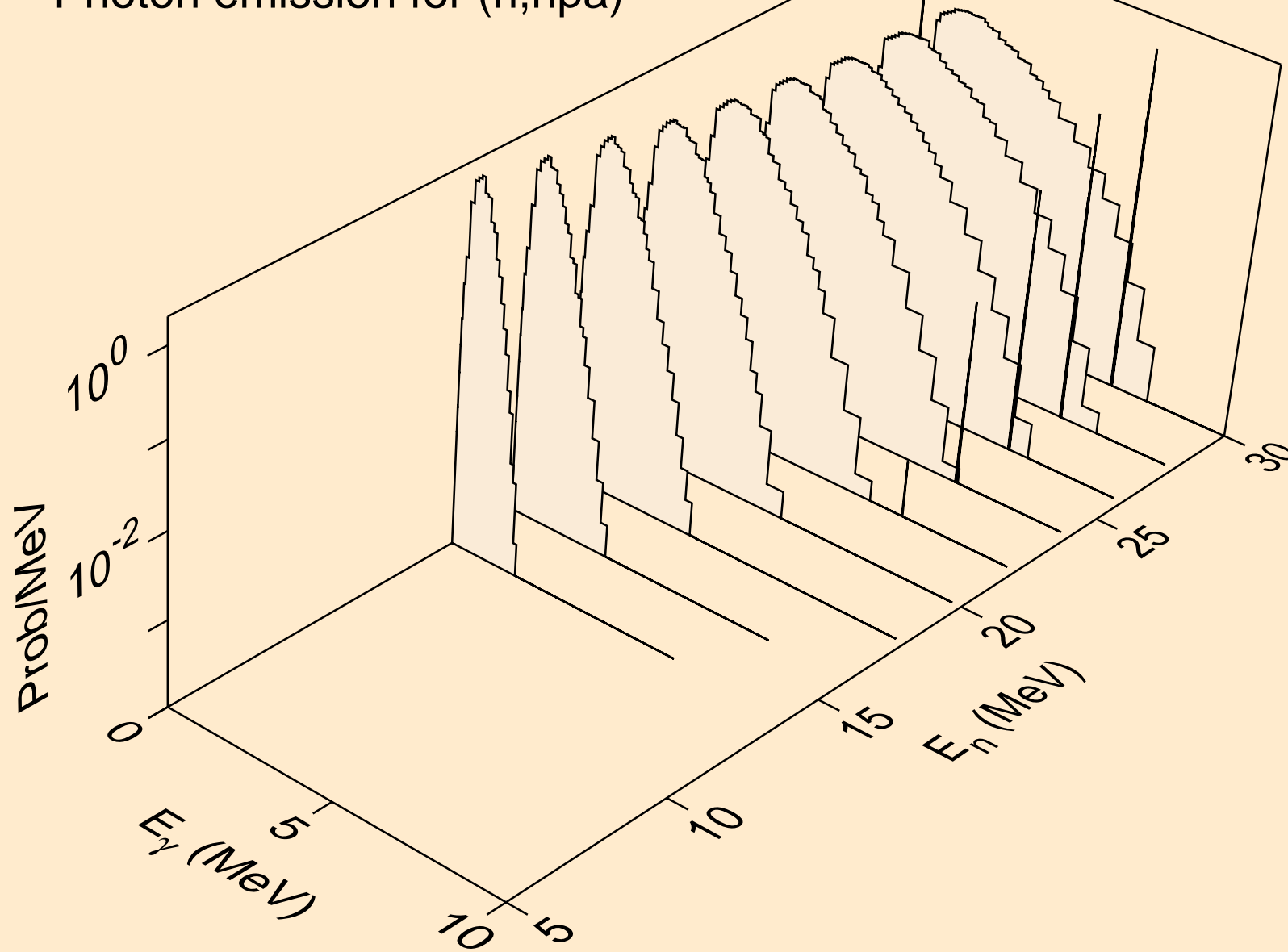

IN098M DEUTERON ACER TENDL-2021 LIBRARY; T=0.K
Photon emission for (n,gma)

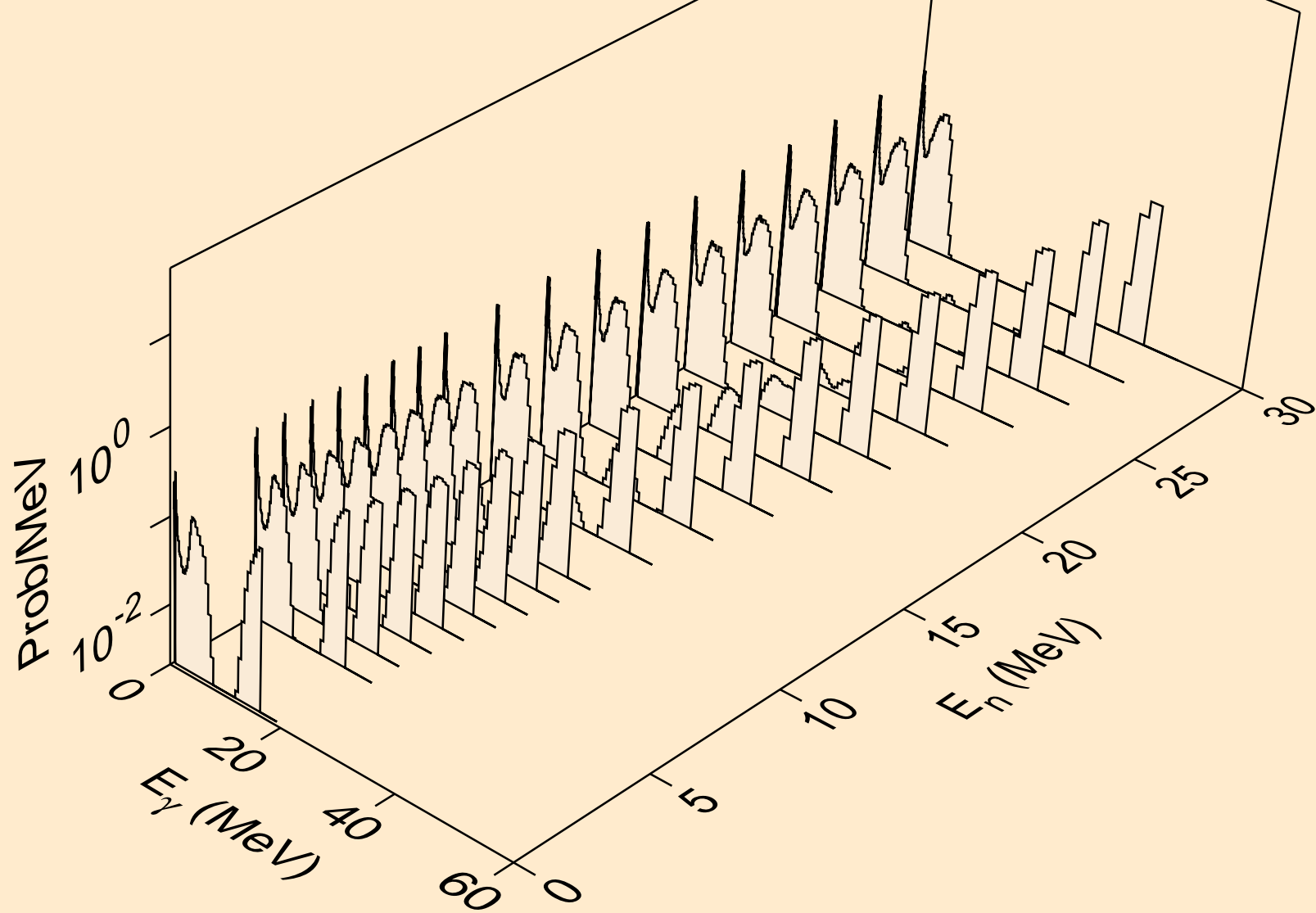

IN098M DEUTERON ACER TENDL-2021 LIBRARY; T=0.K
Photon emission for (n,p)

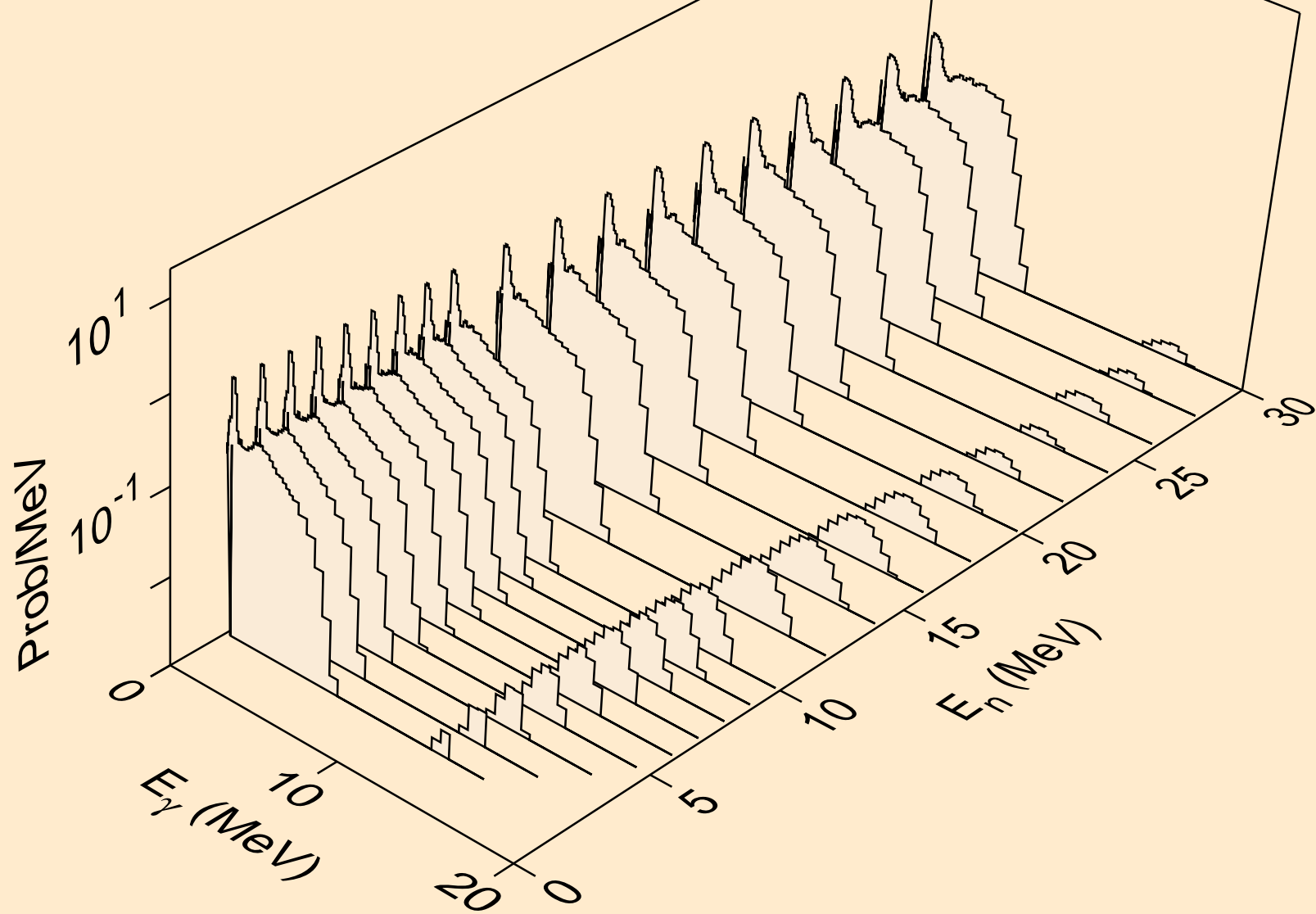

IN098M DEUTERON ACER TENDL-2021 LIBRARY; T=0.K
Photon emission for inelastic

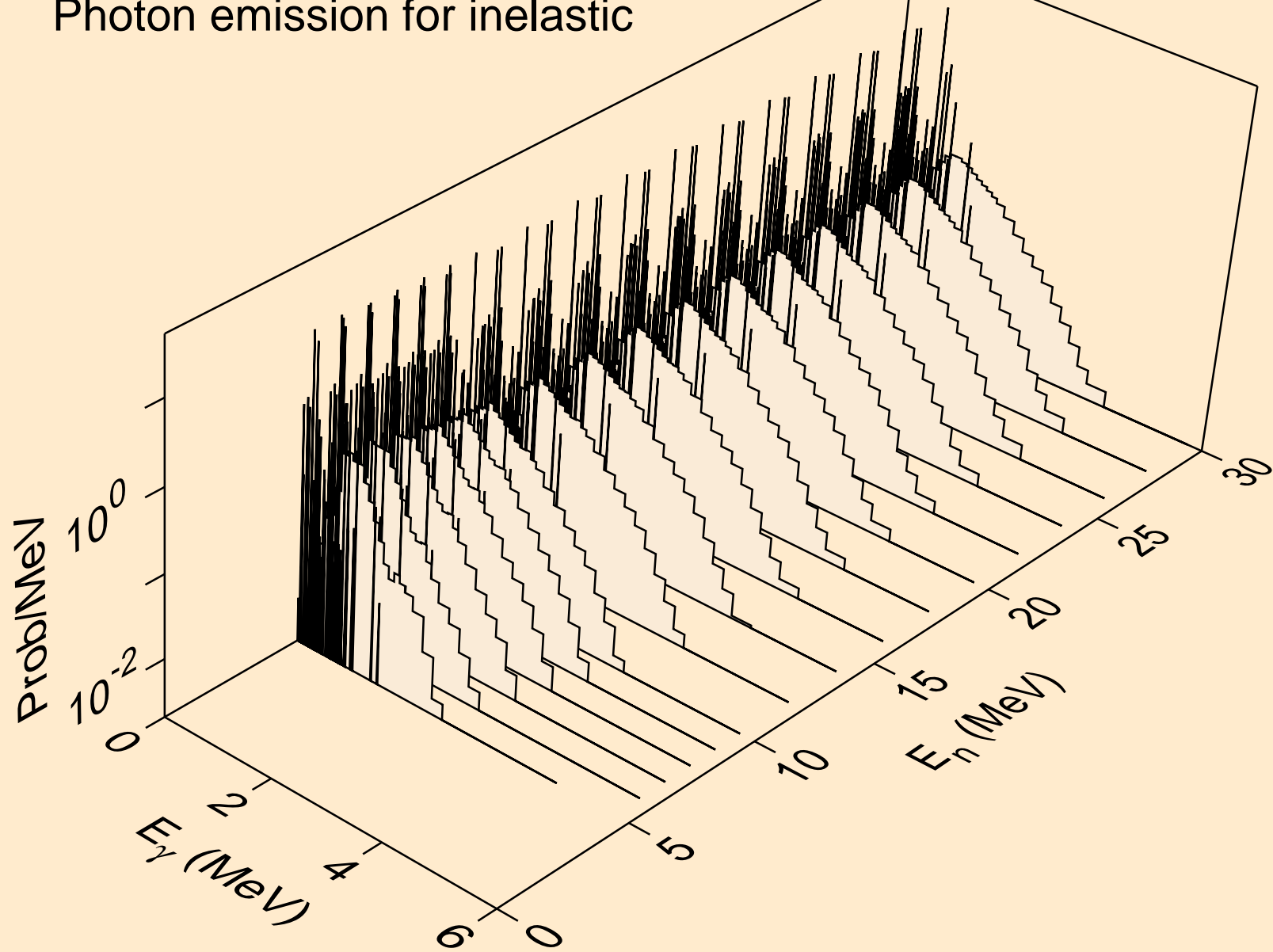

IN098M DEUTERON ACER TENDL-2021 LIBRARY; T=0.K
Photon emission for (n,t)

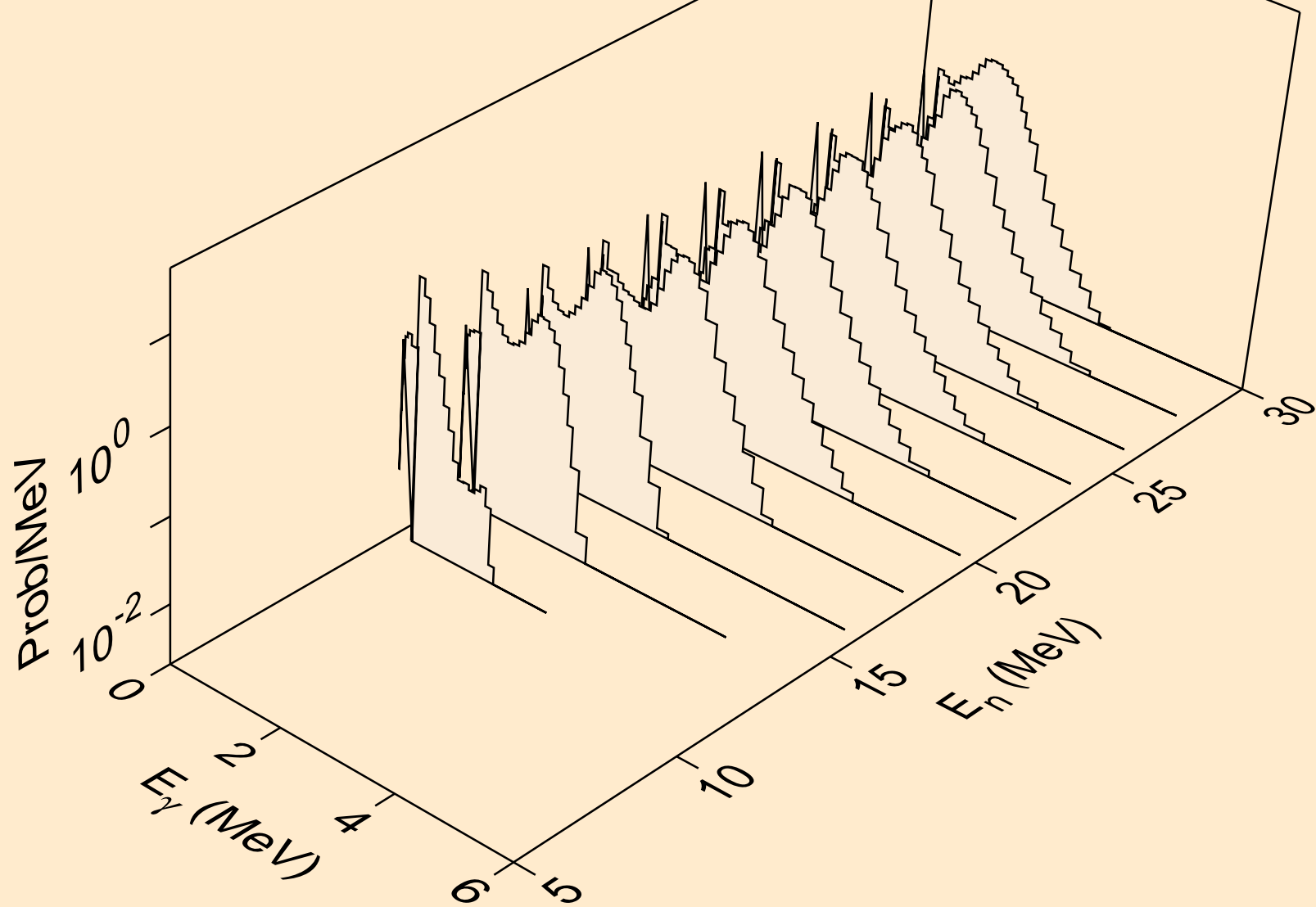

IN098M DEUTERON ACER TENDL-2021 LIBRARY; T=0.K
Photon emission for (n,he3)

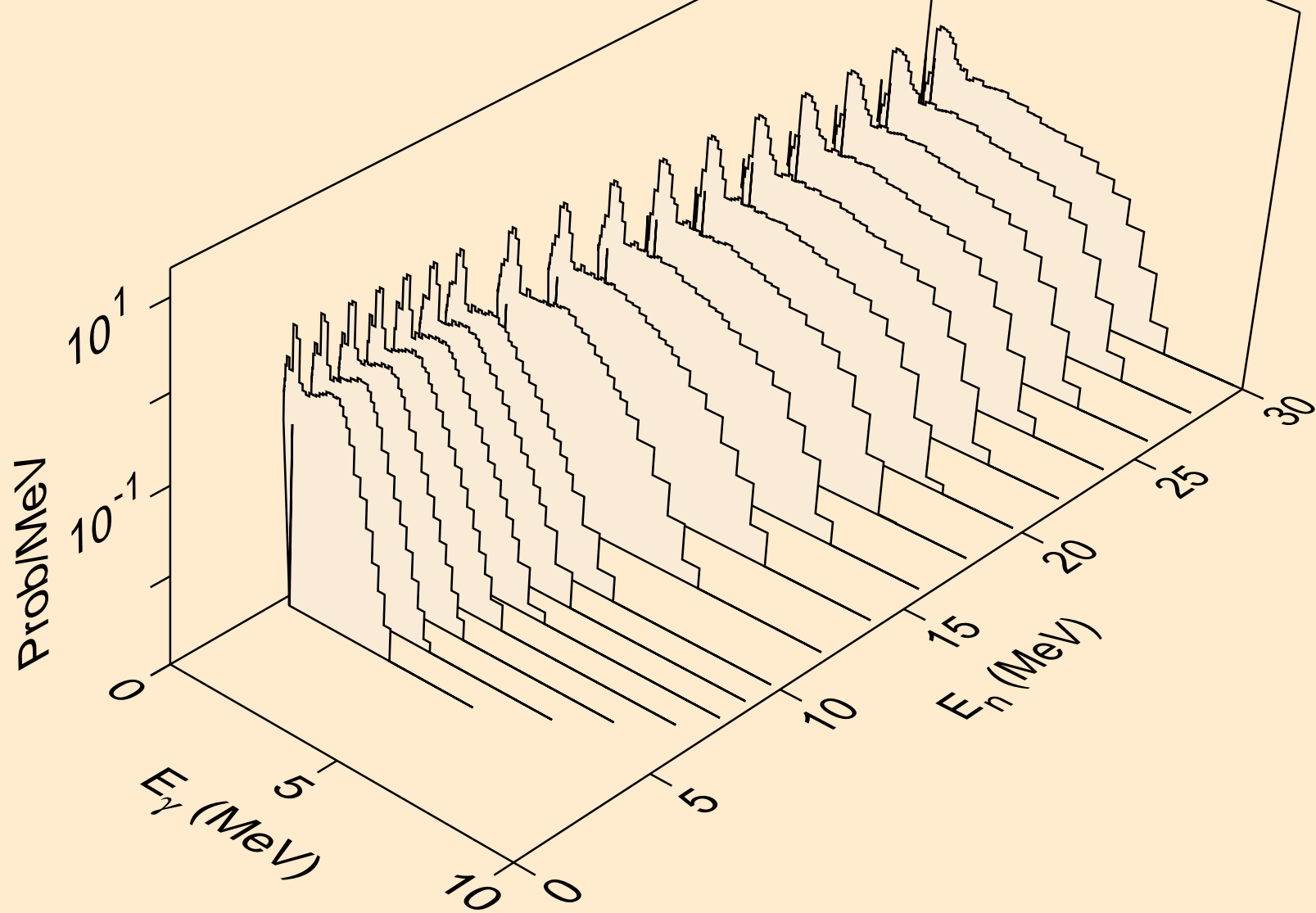

IN098M DEUTERON ACER TENDL-2021 LIBRARY; T=0.K
Photon emission for (n,a)

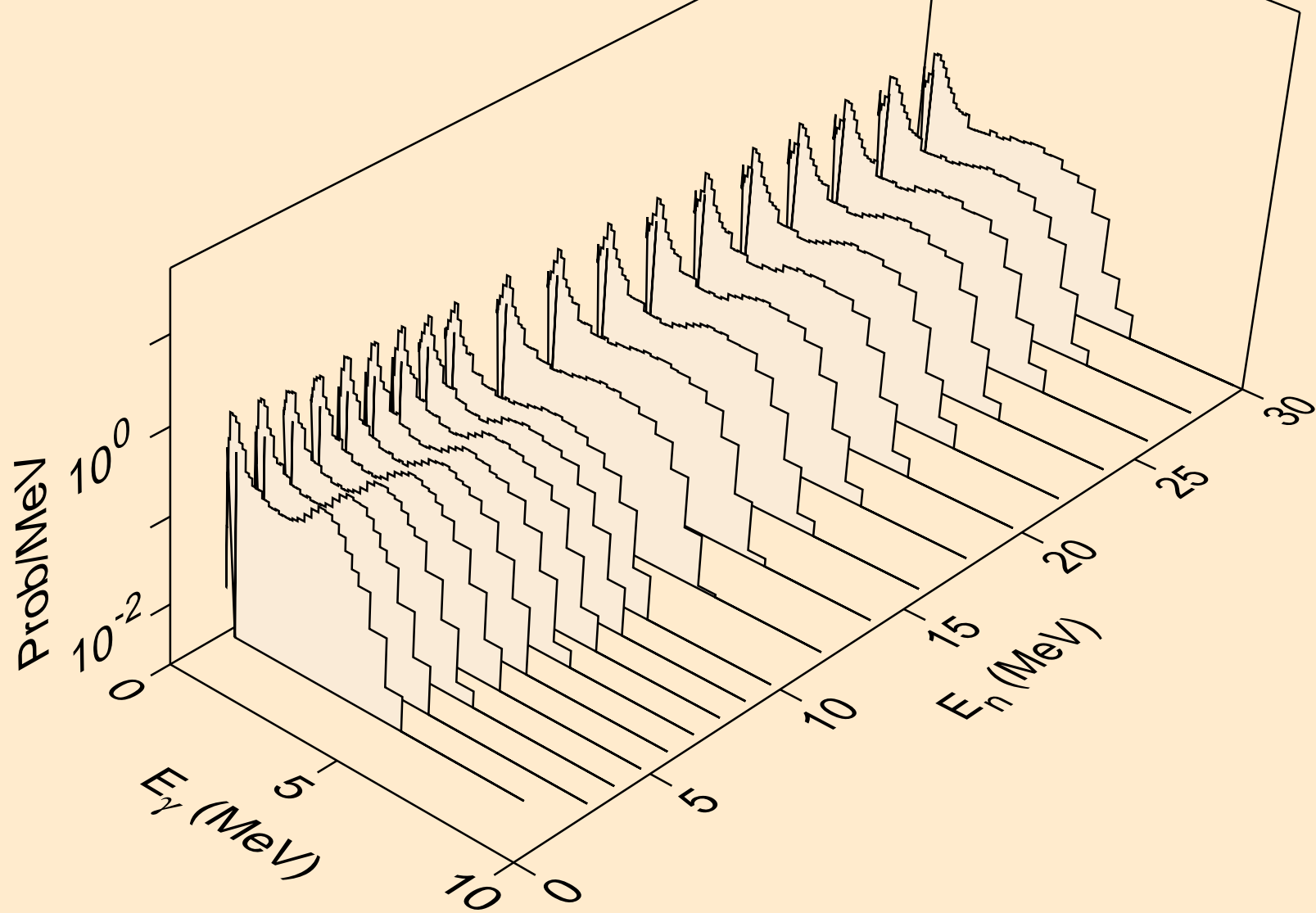

IN098M DEUTERON ACER TENDL-2021 LIBRARY; T=0.K
Photon emission for (n,2a)

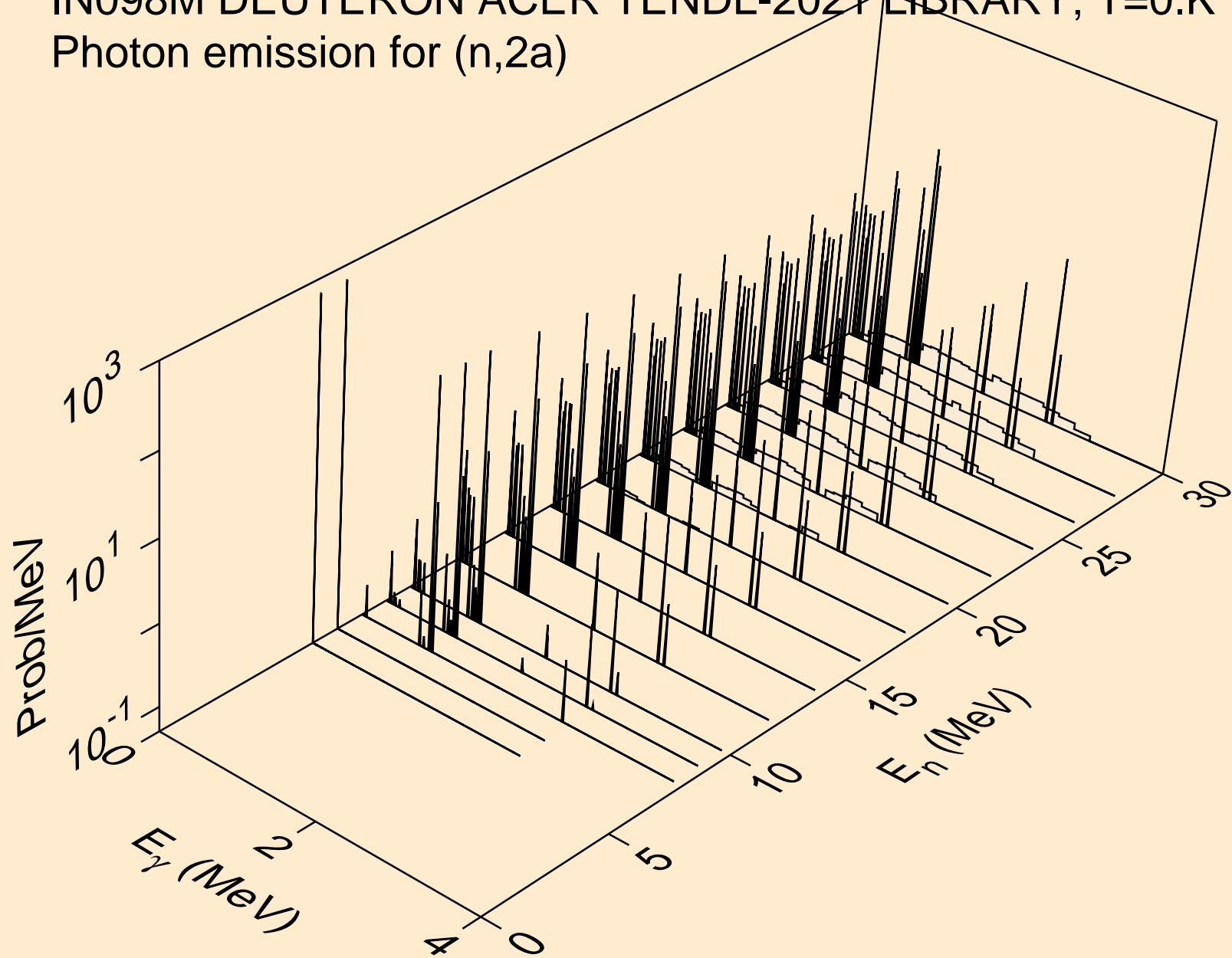

IN098M DEUTERON ACER TENDL-2021 LIBRARY; T=0.K
Photon emission for (n,2p)

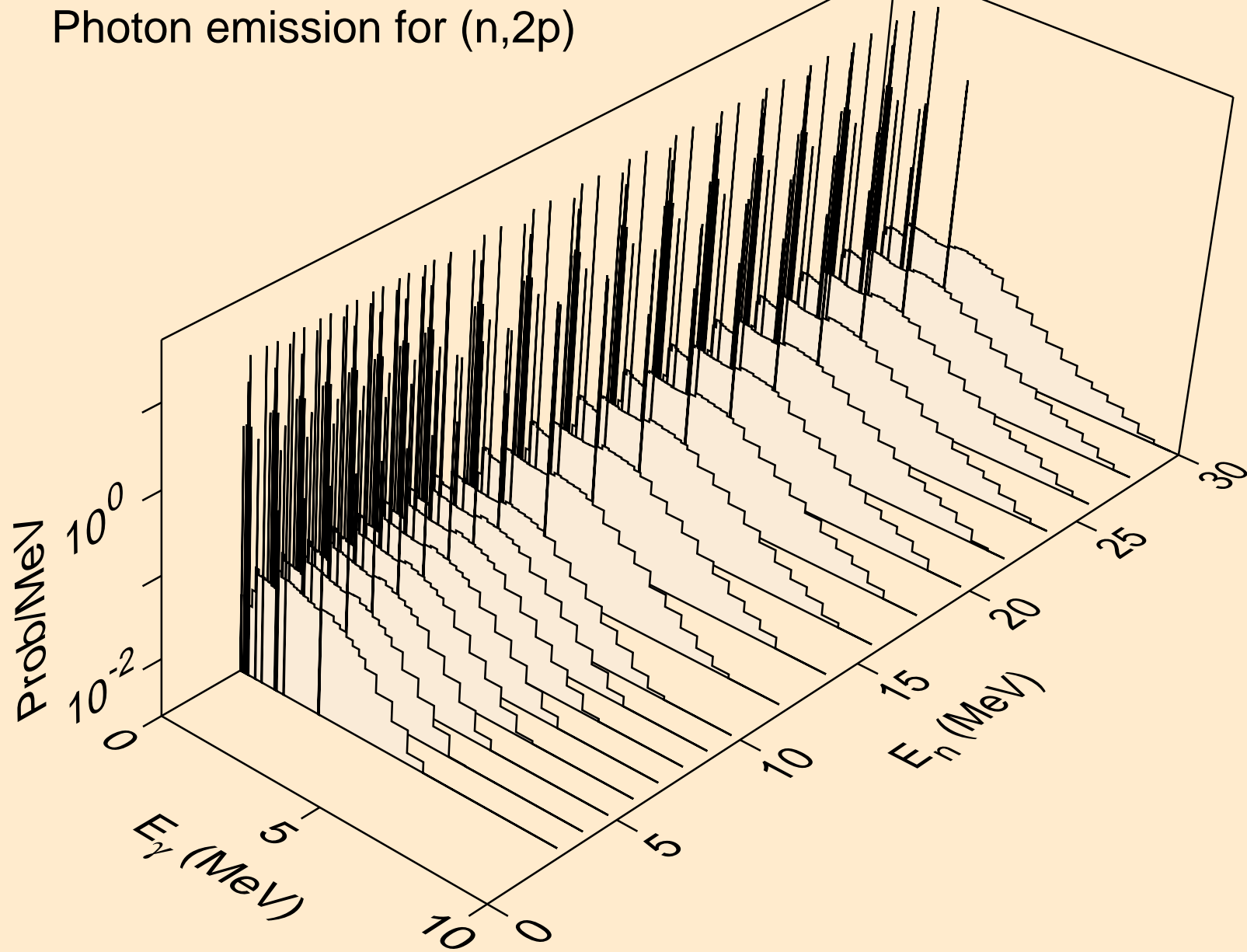

IN098M DEUTERON ACER TENDL-2021 LIBRARY; T=0.K
Photon emission for (n,p)

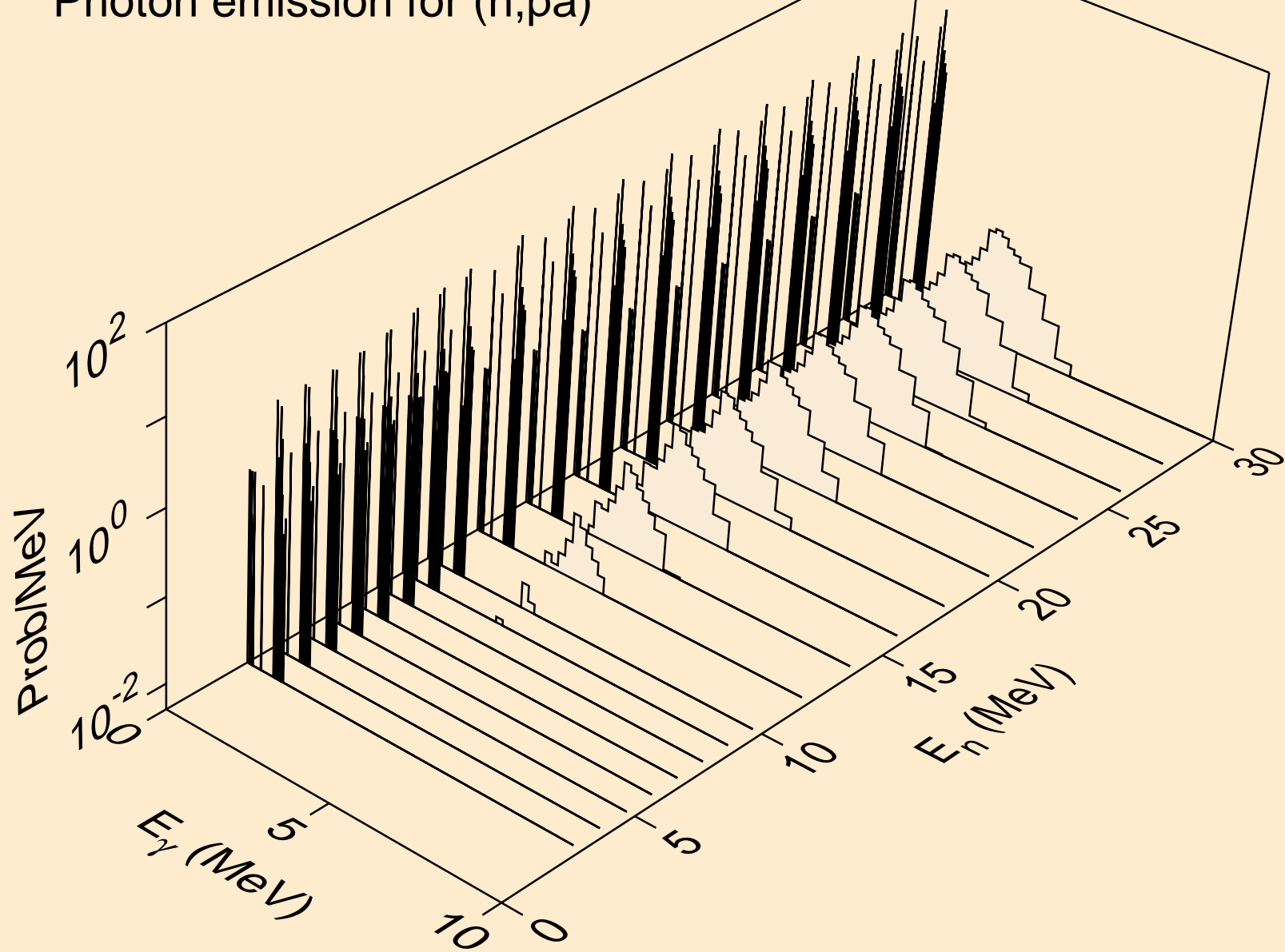

IN098M DEUTERON ACER TENDL-2021 LIBRARY; T=0.K
Photon emission for (n,pd)

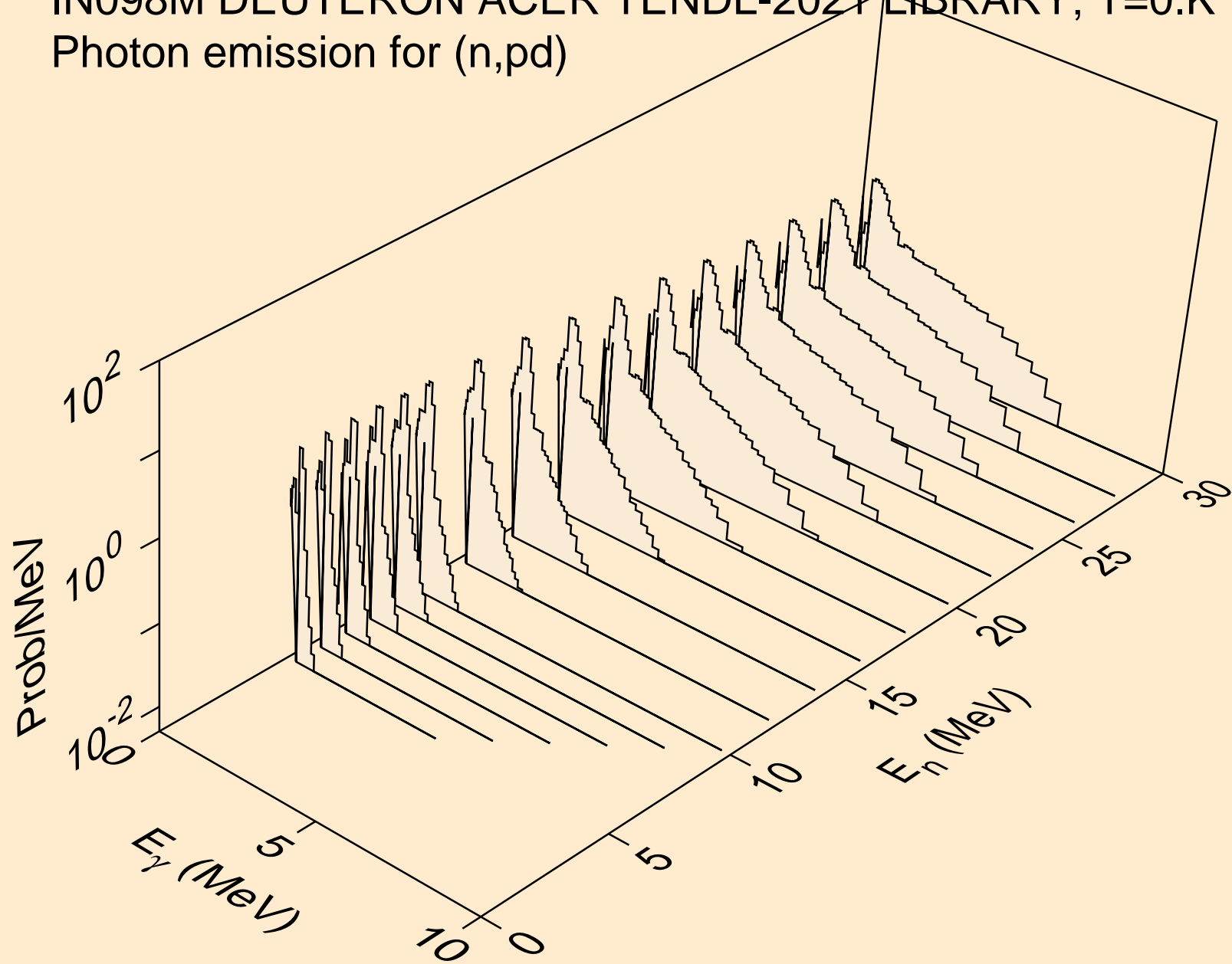

IN098M DEUTERON ACER TENDL-2021 LIBRARY; T=0.K
Photon emission for (n,pt)

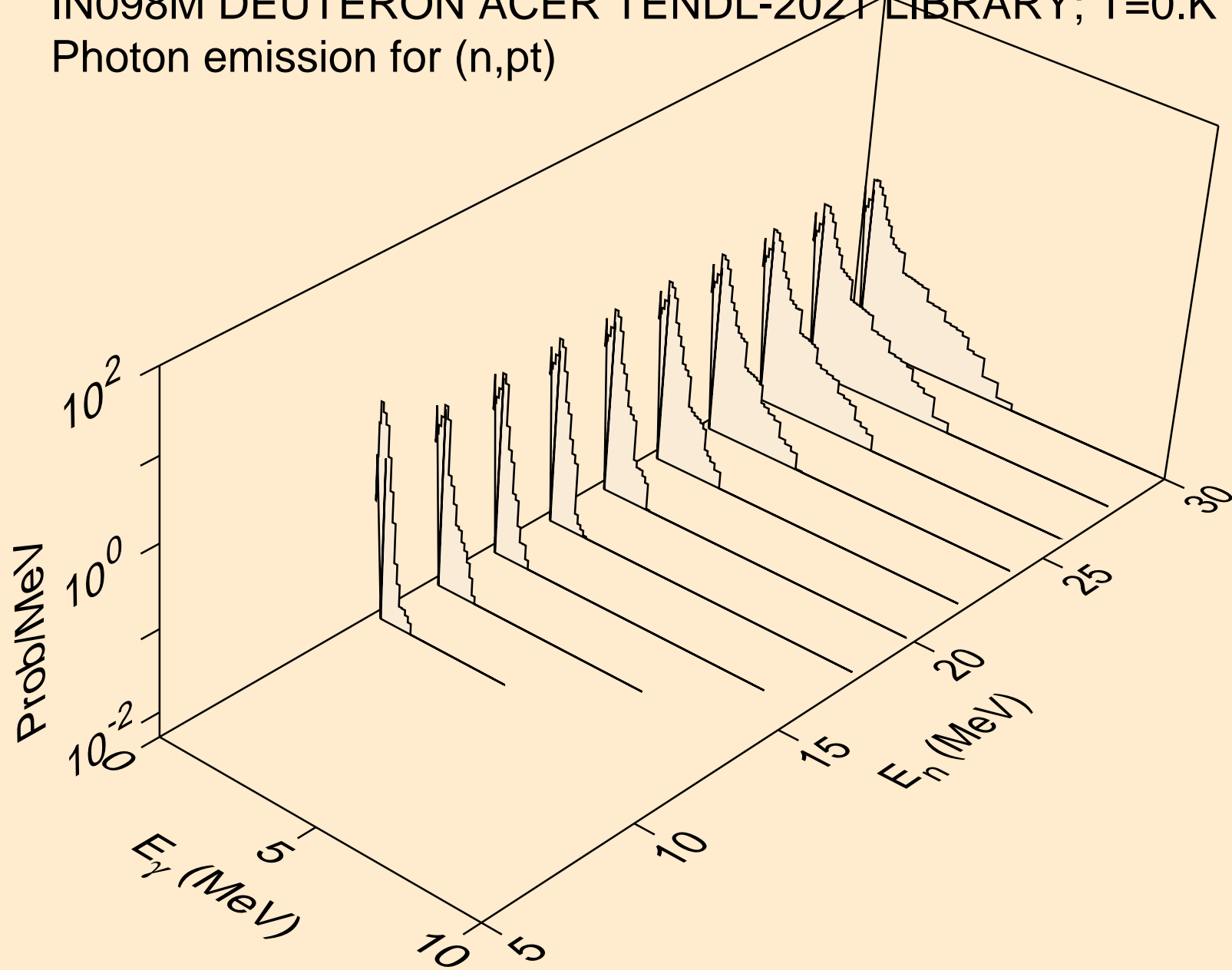

IN098M DEUTERON ACER TENDL-2021 LIBRARY; T=0.K
Photon emission for (n,da)

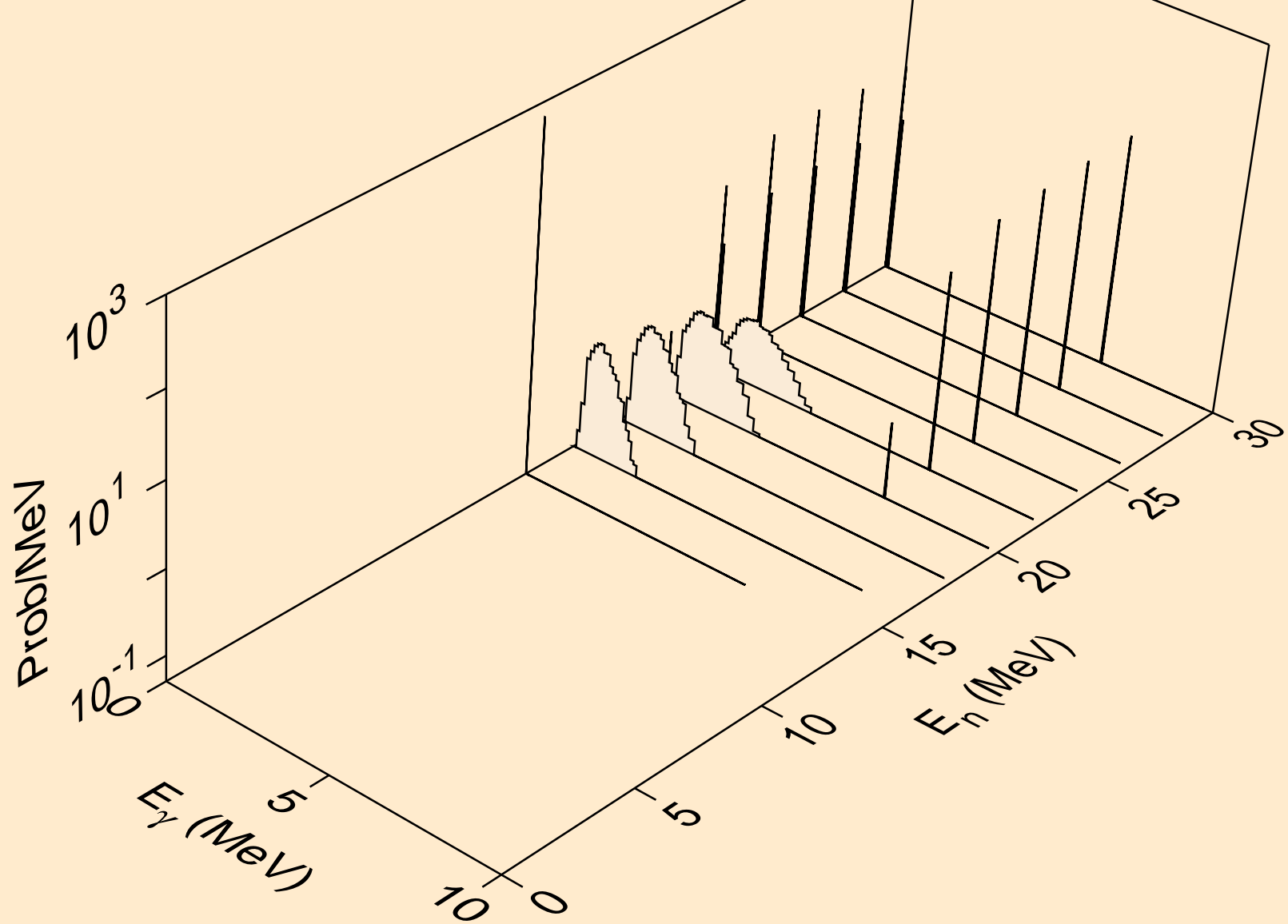

IN098M DEUTERON ACER TENDL-2021 LIBRARY; T=0.K

Particle heating contributions

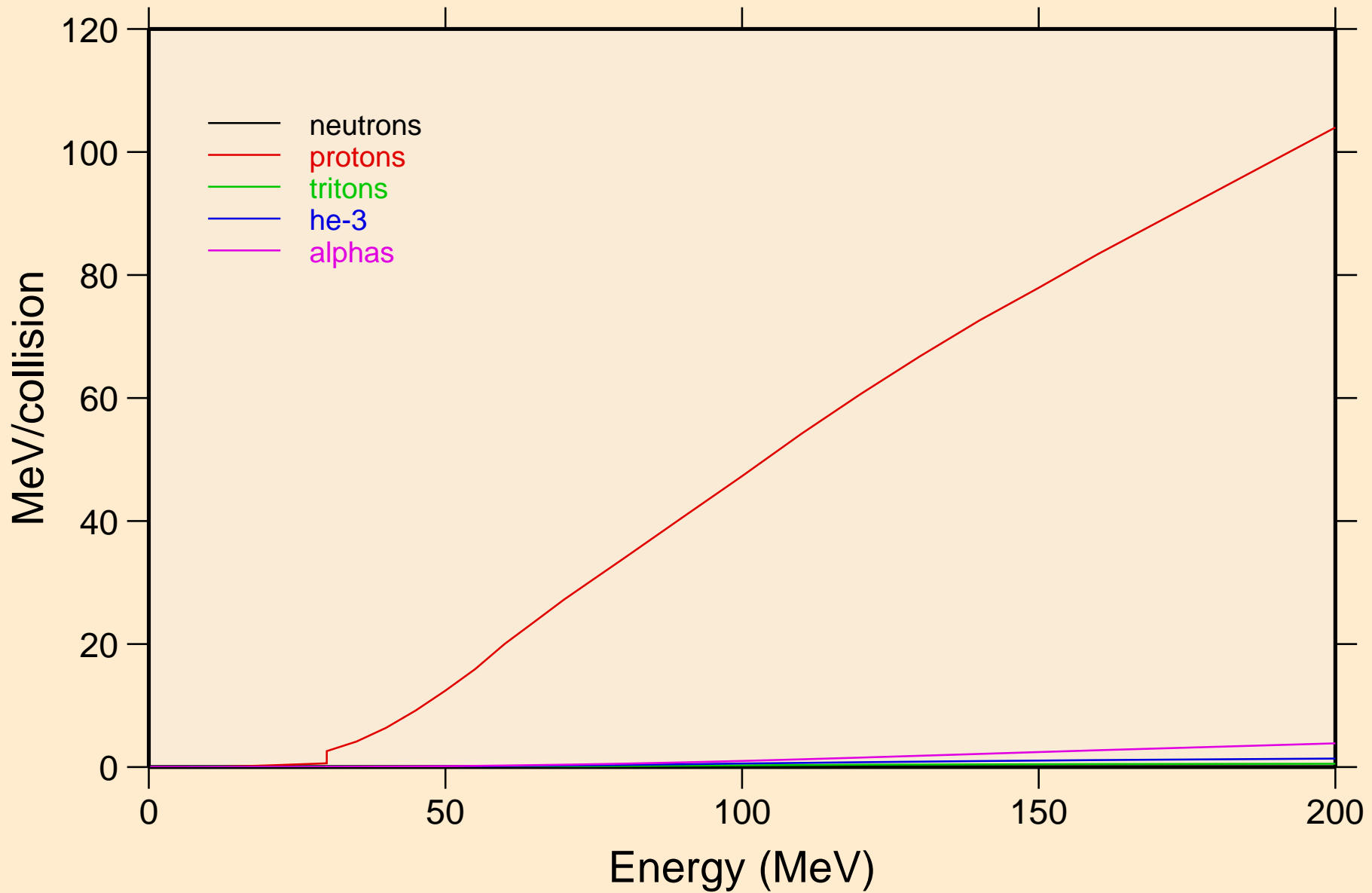

IN098M DEUTERON ACER TENDL-2021 LIBRARY; T=0.K
Recoil Heating

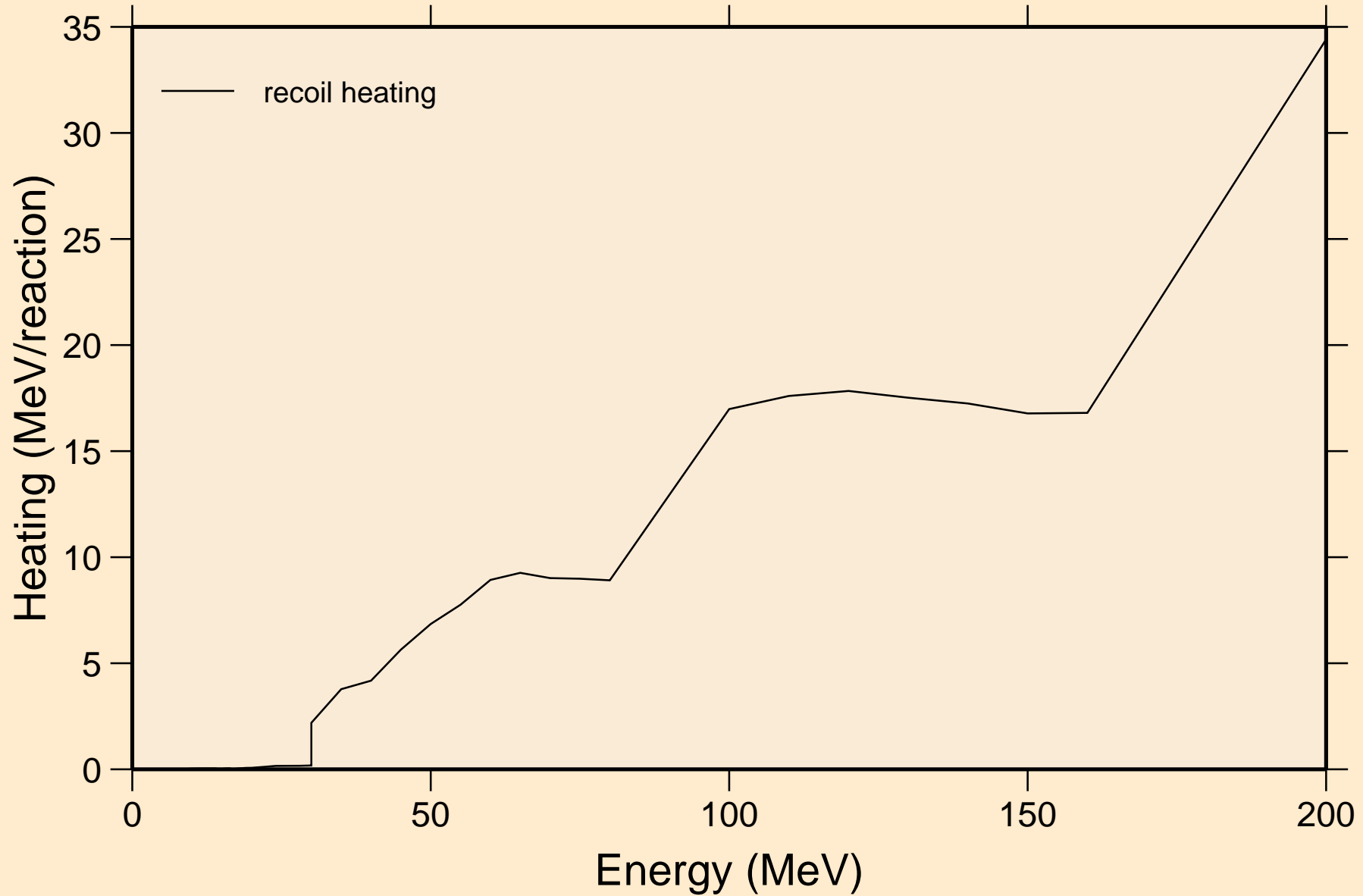

IN098M DEUTERON ACER TENDL-2021 LIBRARY; T=0.K
Particle production cross sections

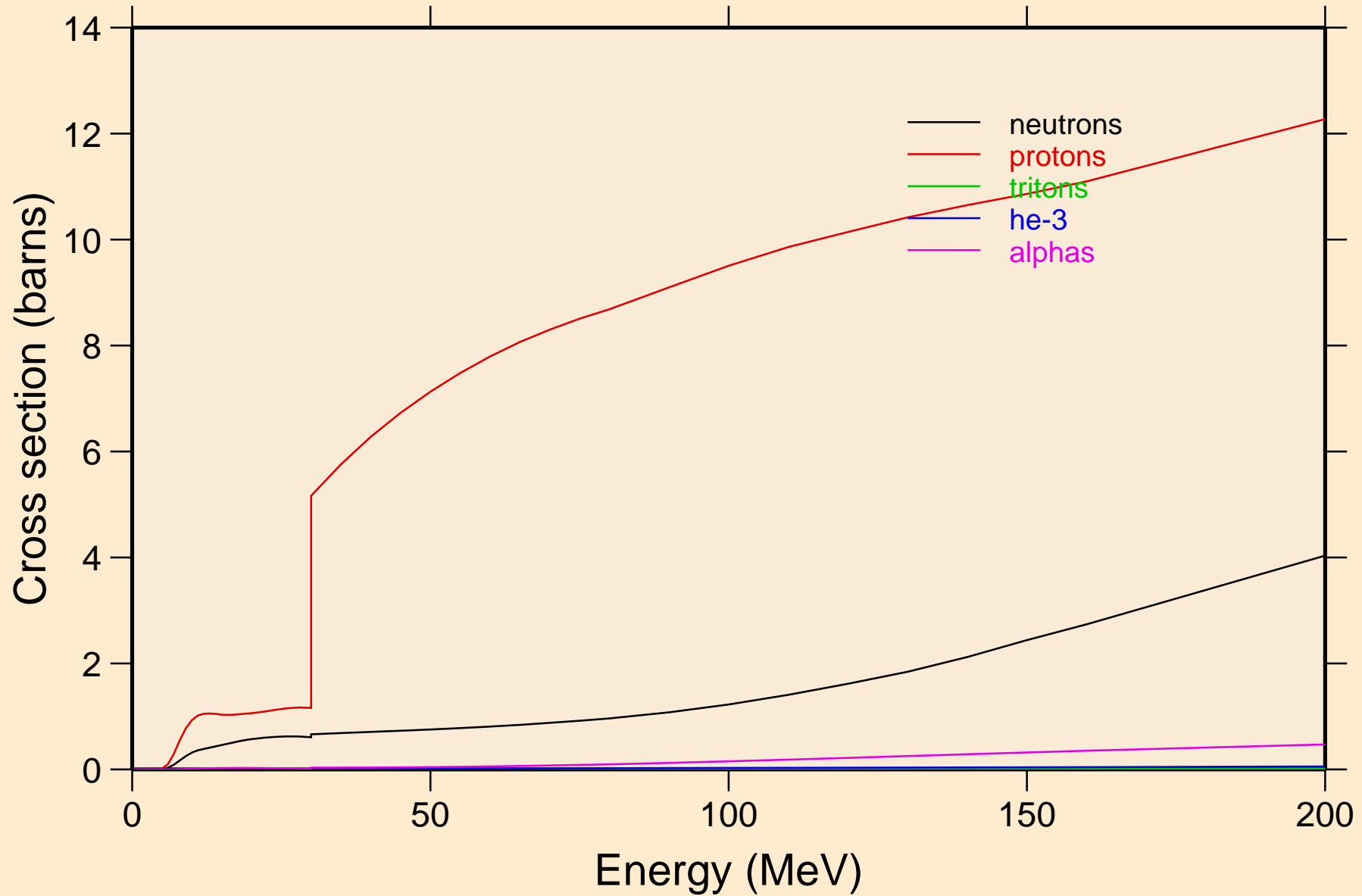

IN098M DEUTERON ACER TENDL-2021 LIBRARY; T=0.K
neutrons from (d,n)

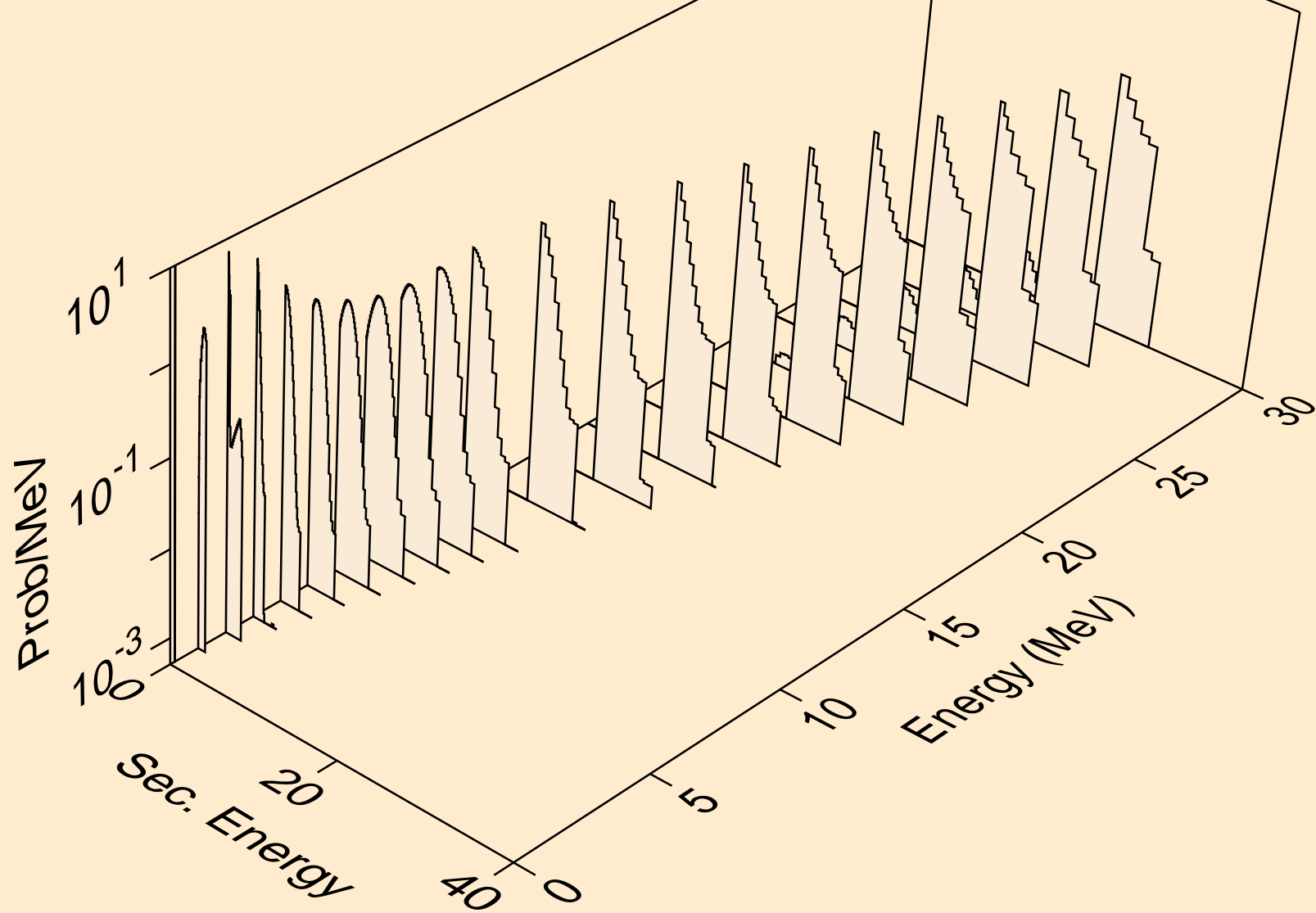

IN098M DEUTERON ACER TENDL-2021 LIBRARY; T=0.K
neutrons from (d,x)

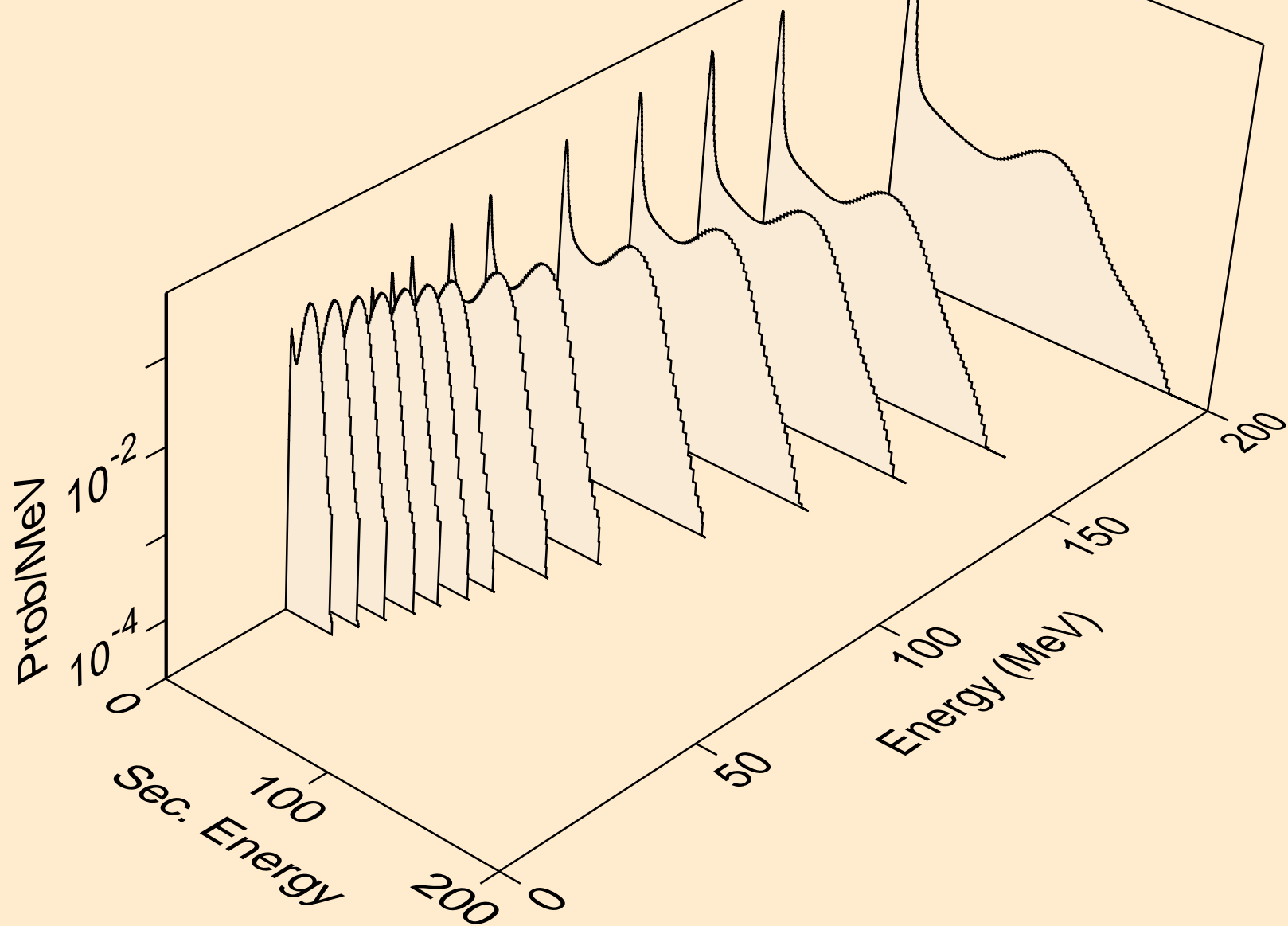

IN098M DEUTERON ACER TENDL-2021 LIBRARY; T=0.K
neutrons from (d,2n)

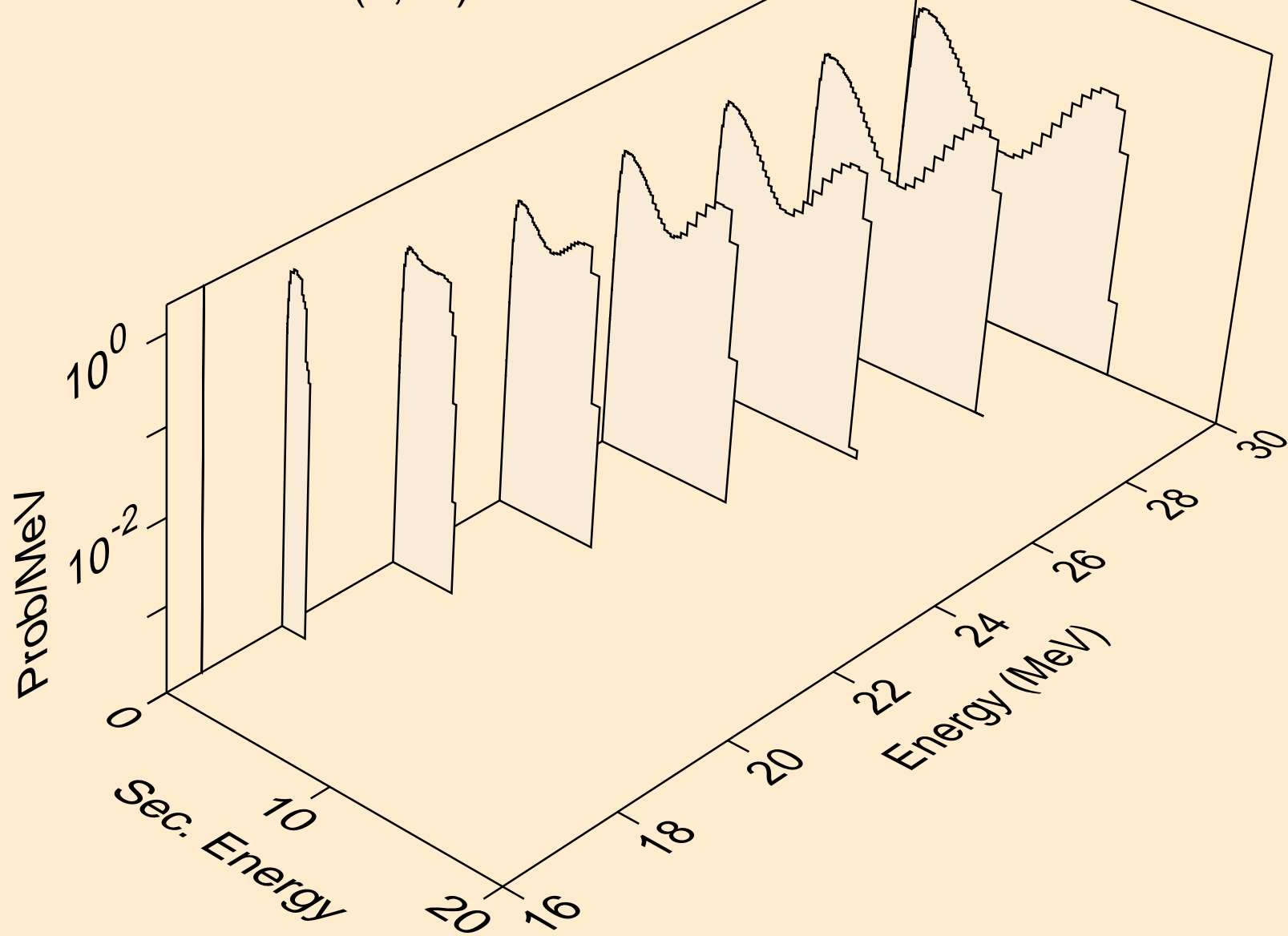

IN098M DEUTERON ACER TENDL-2021 LIBRARY; T=0.K
neutrons from (d,n*)a

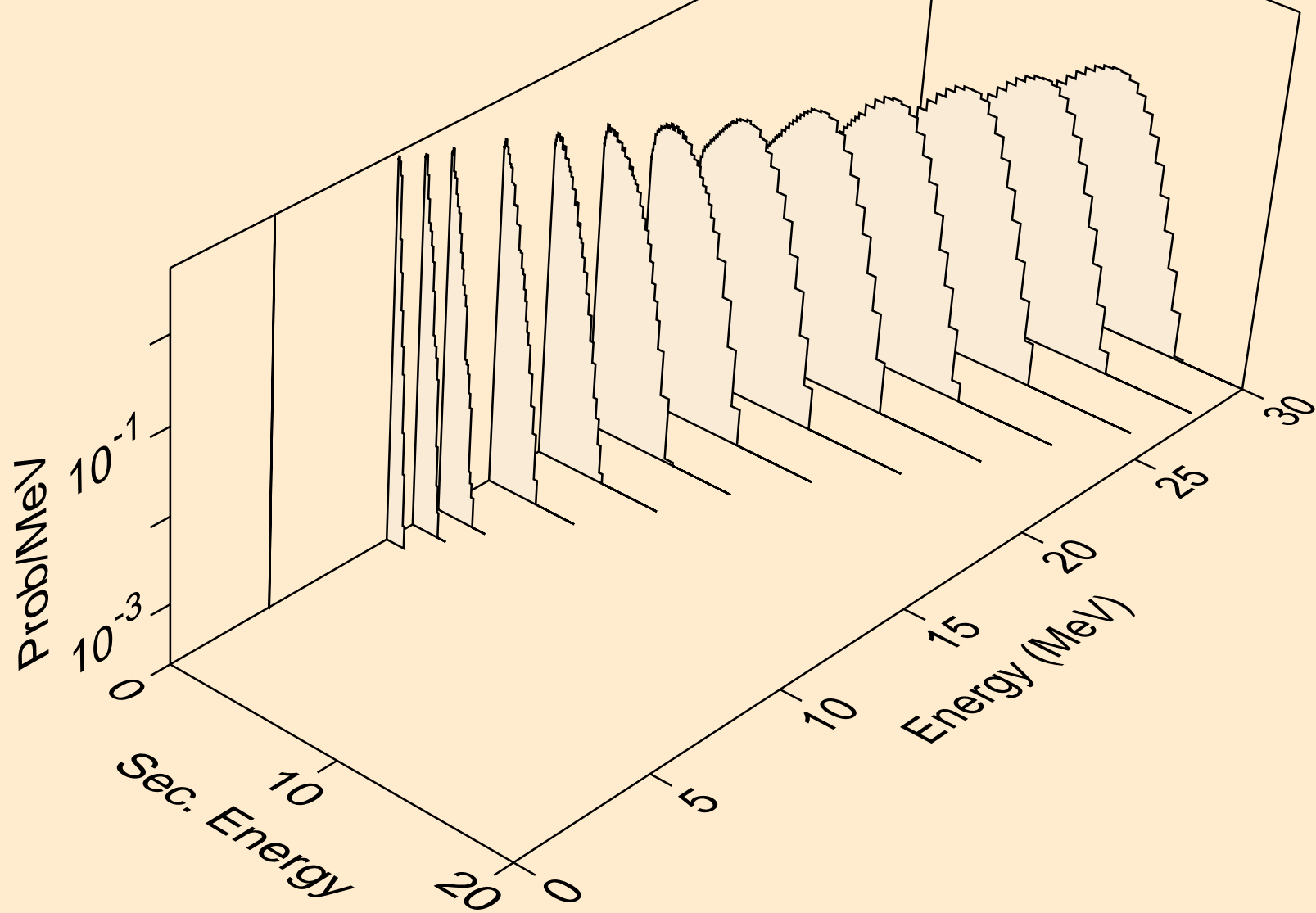

IN098M DEUTERON ACER TENDL-2021 LIBRARY; T=0.K
neutrons from (d,n*)p

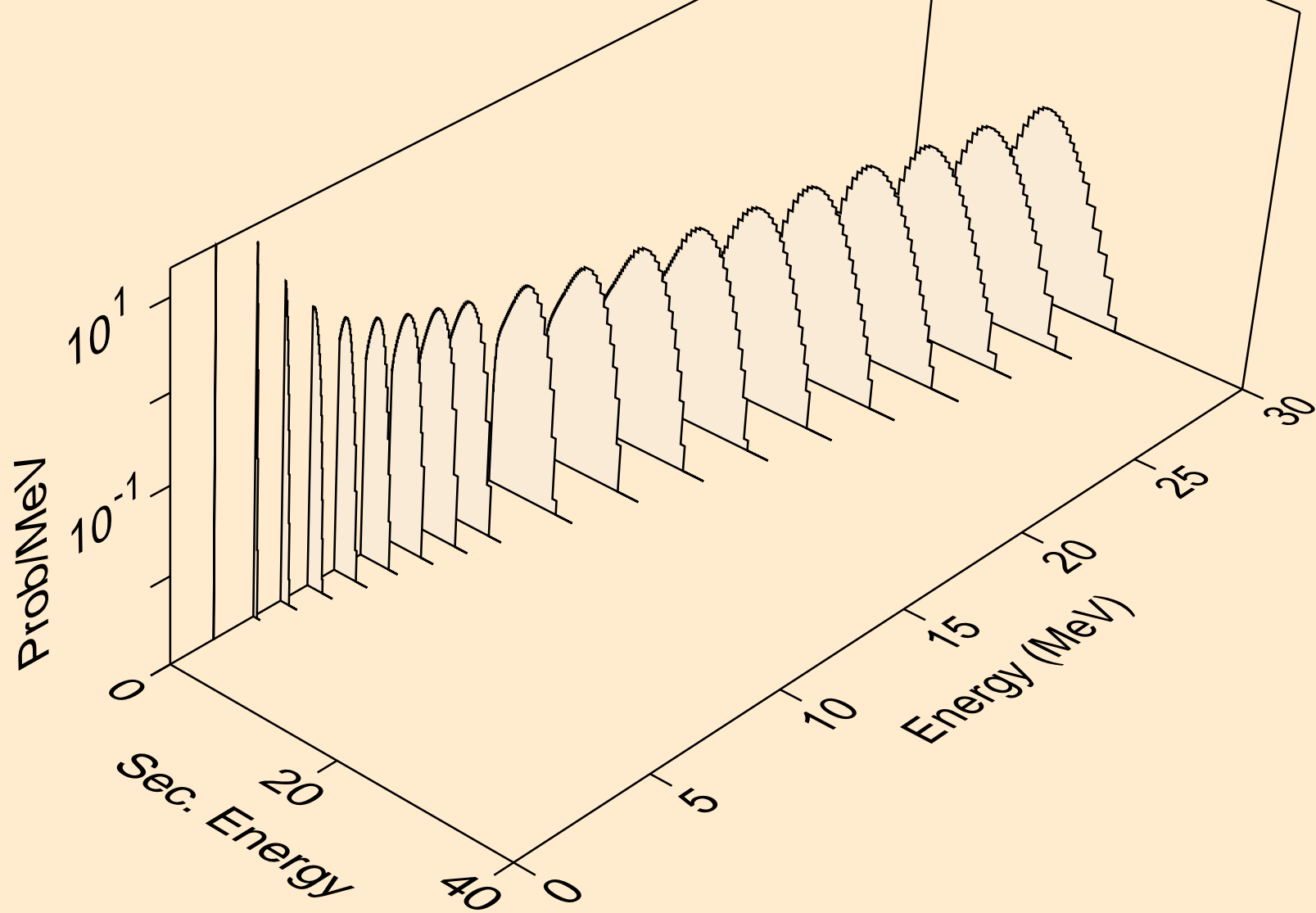

IN098M DEUTERON ACER TENDL-2021 LIBRARY; T=0.K
neutrons from (d,n*)2a

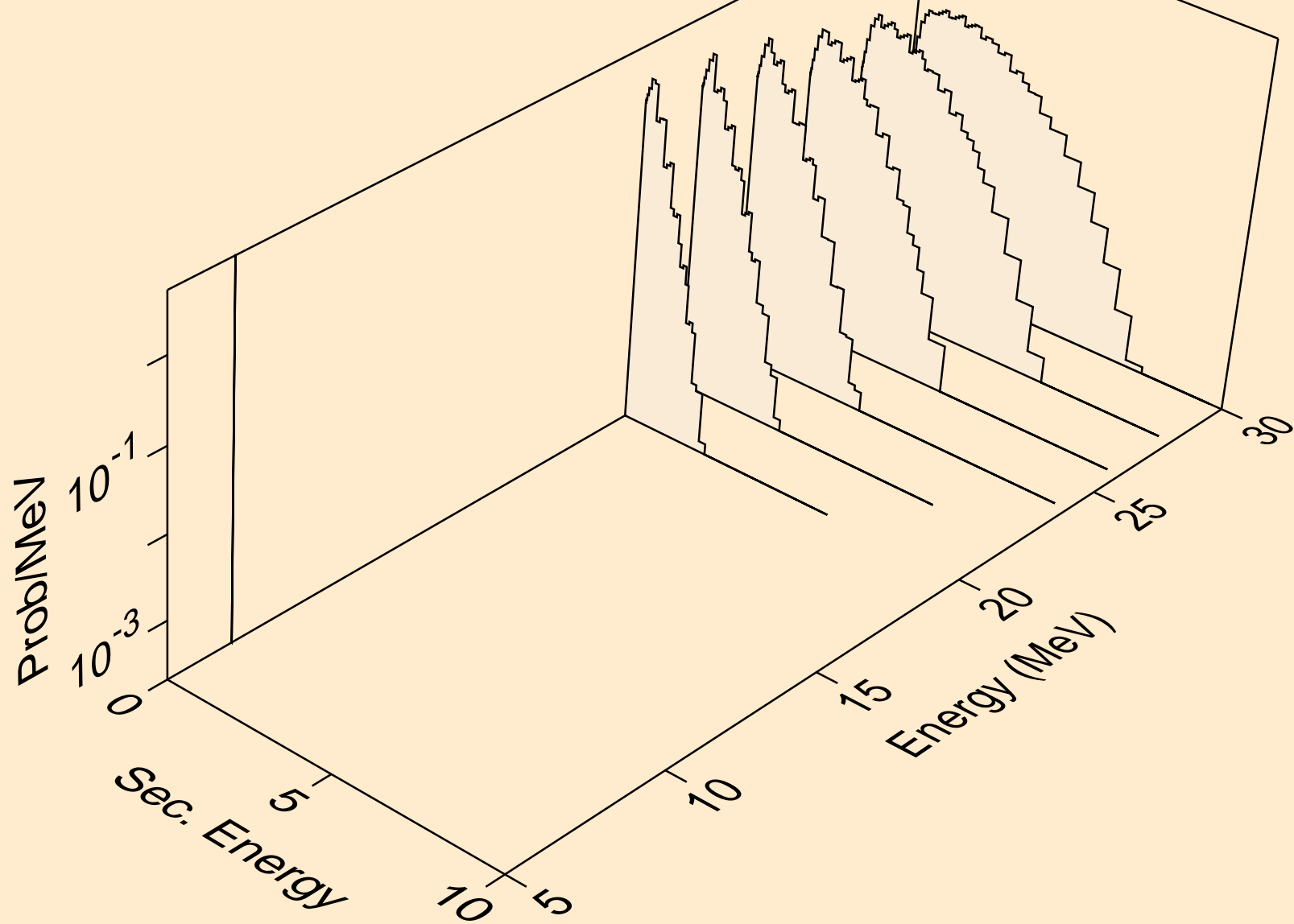

IN098M DEUTERON ACER TENDL-2021 LIBRARY; T=0.K
neutrons from (d,n*)d

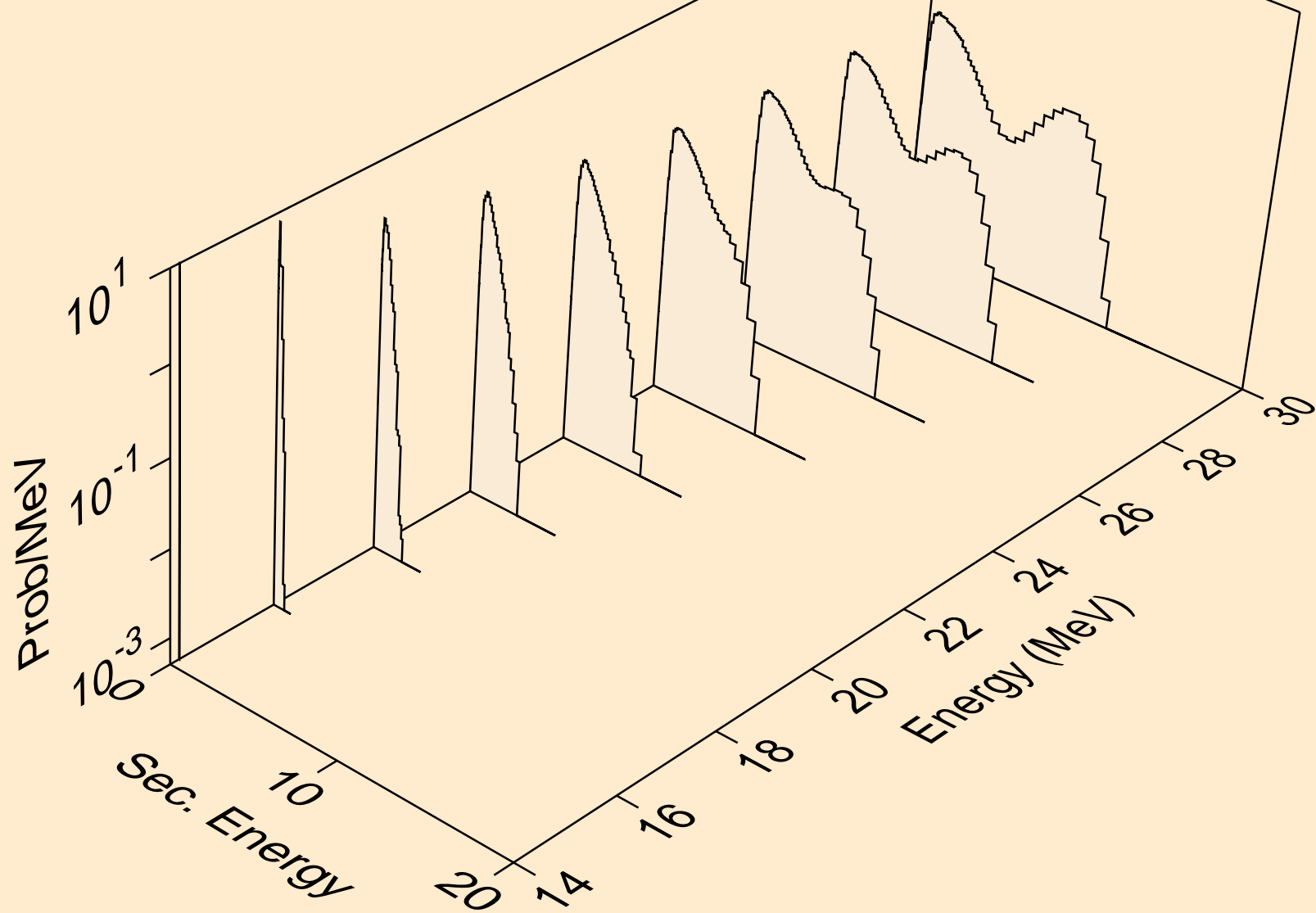

IN098M DEUTERON ACER TENDL-2021 LIBRARY; T=0.K
neutrons from (d,n*)he3

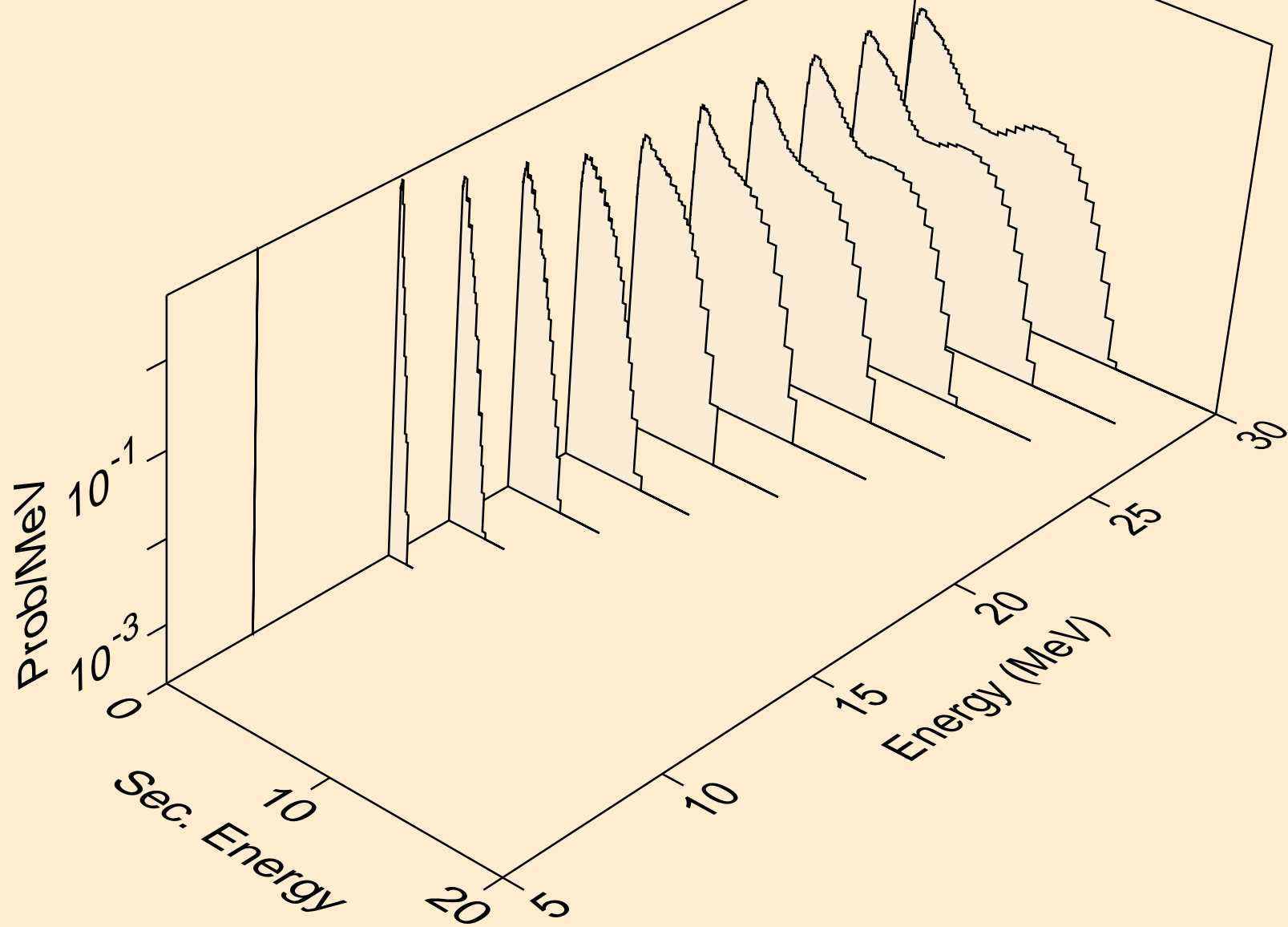

IN098M DEUTERON ACER TENDL-2021 LIBRARY; T=0.K
neutrons from (d,2np)

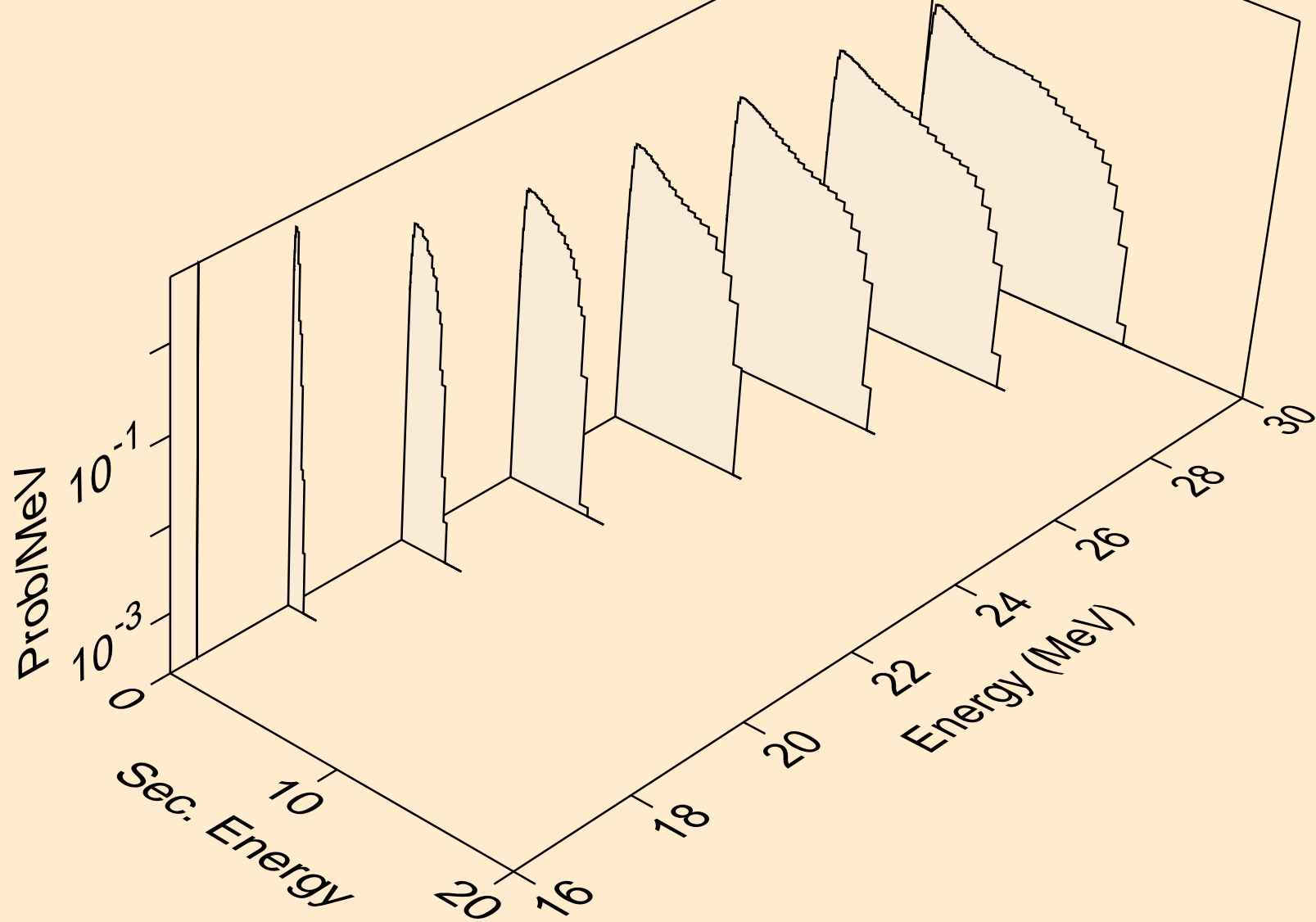

IN098M DEUTERON ACER TENDL-2021 LIBRARY; T=0.K
neutrons from (d,2np)

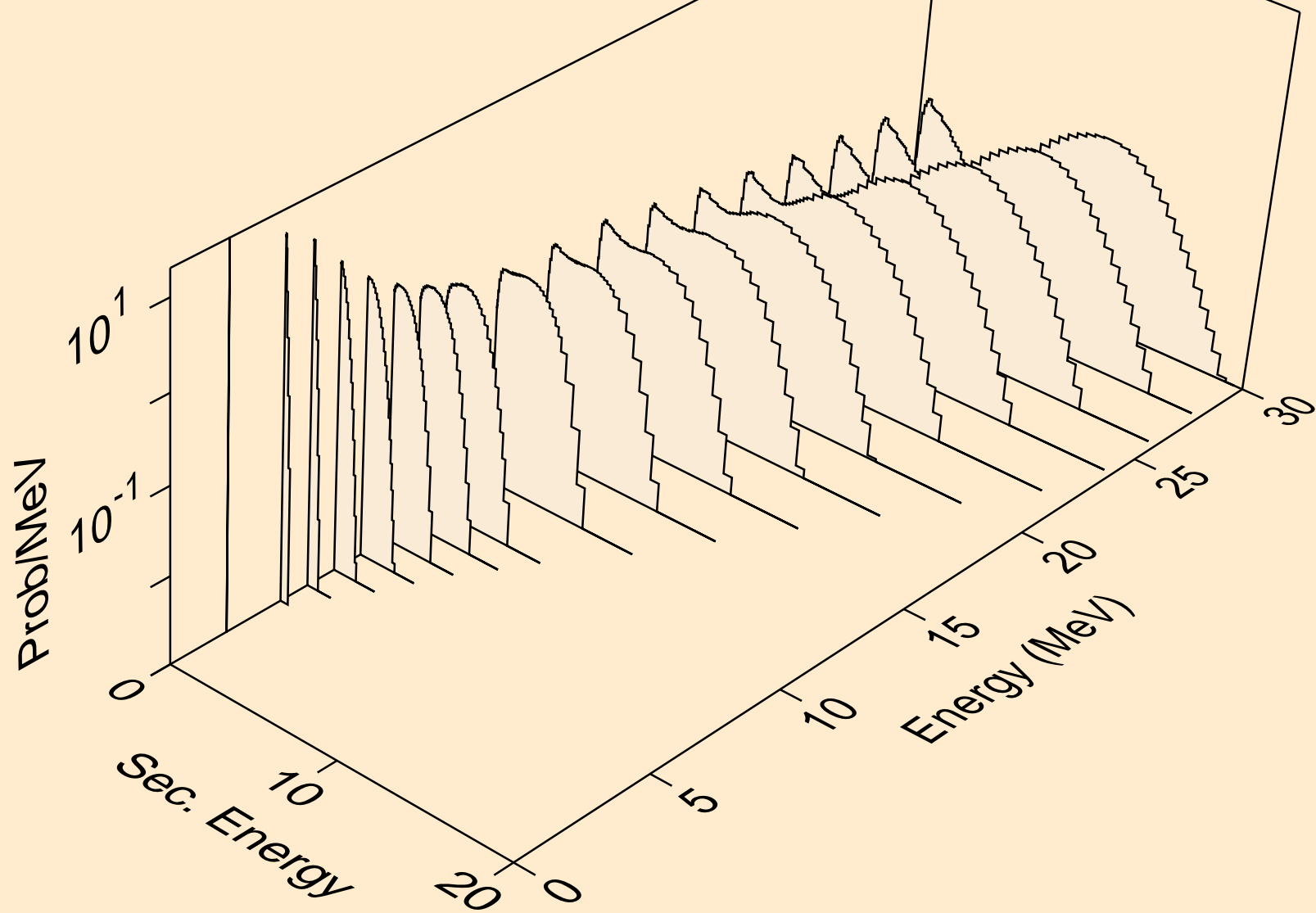

IN098M DEUTERON ACER TENDL-2021 LIBRARY; T=0.K
neutrons from (d,npa)

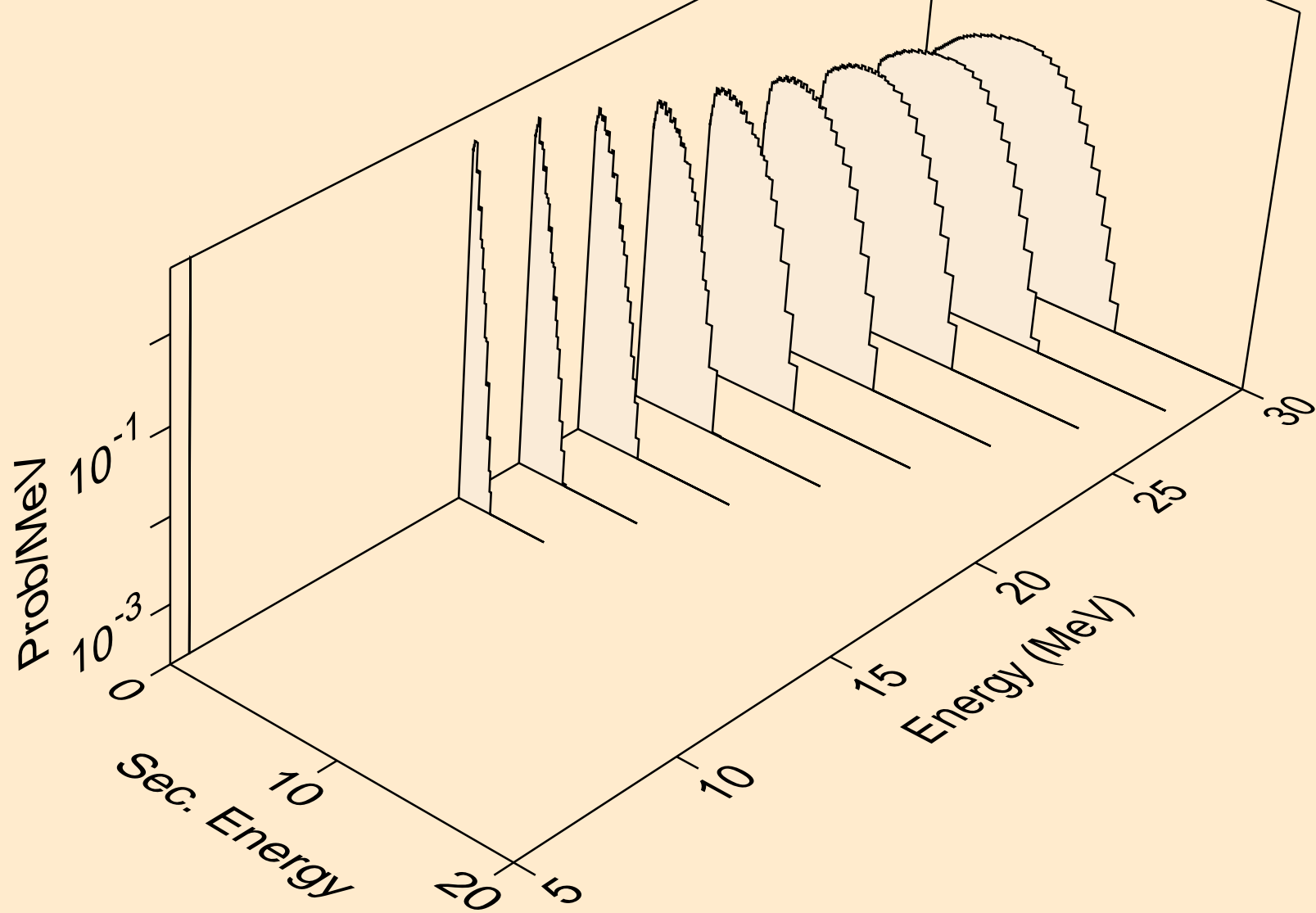

IN098M DEUTERON ACER TENDL-2021 LIBRARY; T=0.K
protons from (d,x)

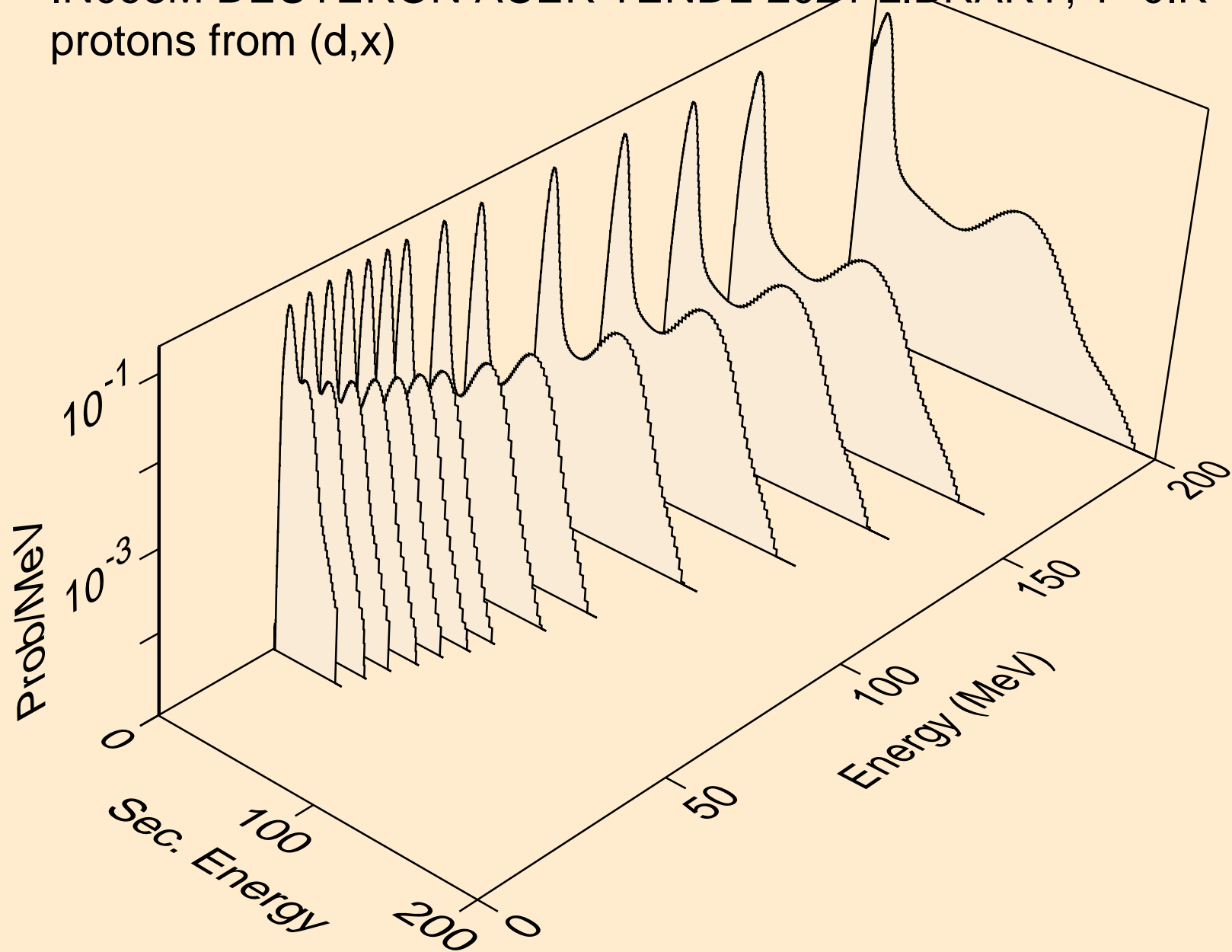

IN098M DEUTERON ACER TENDL-2021 LIBRARY; T=0.K
protons from (d,n*)p

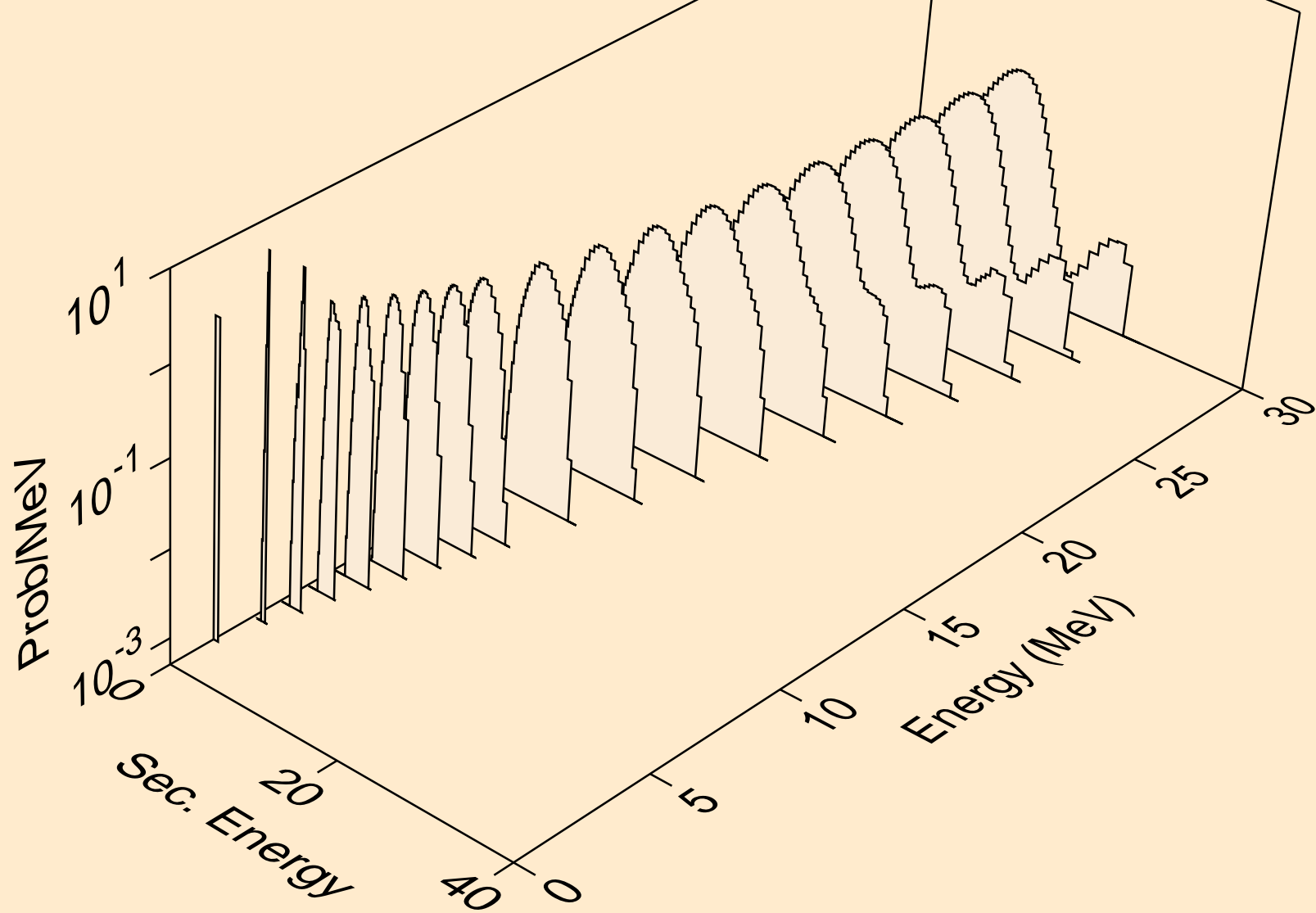

IN098M DEUTERON ACER TENDL-2021 LIBRARY; T=0.K
protons from (d,2np)

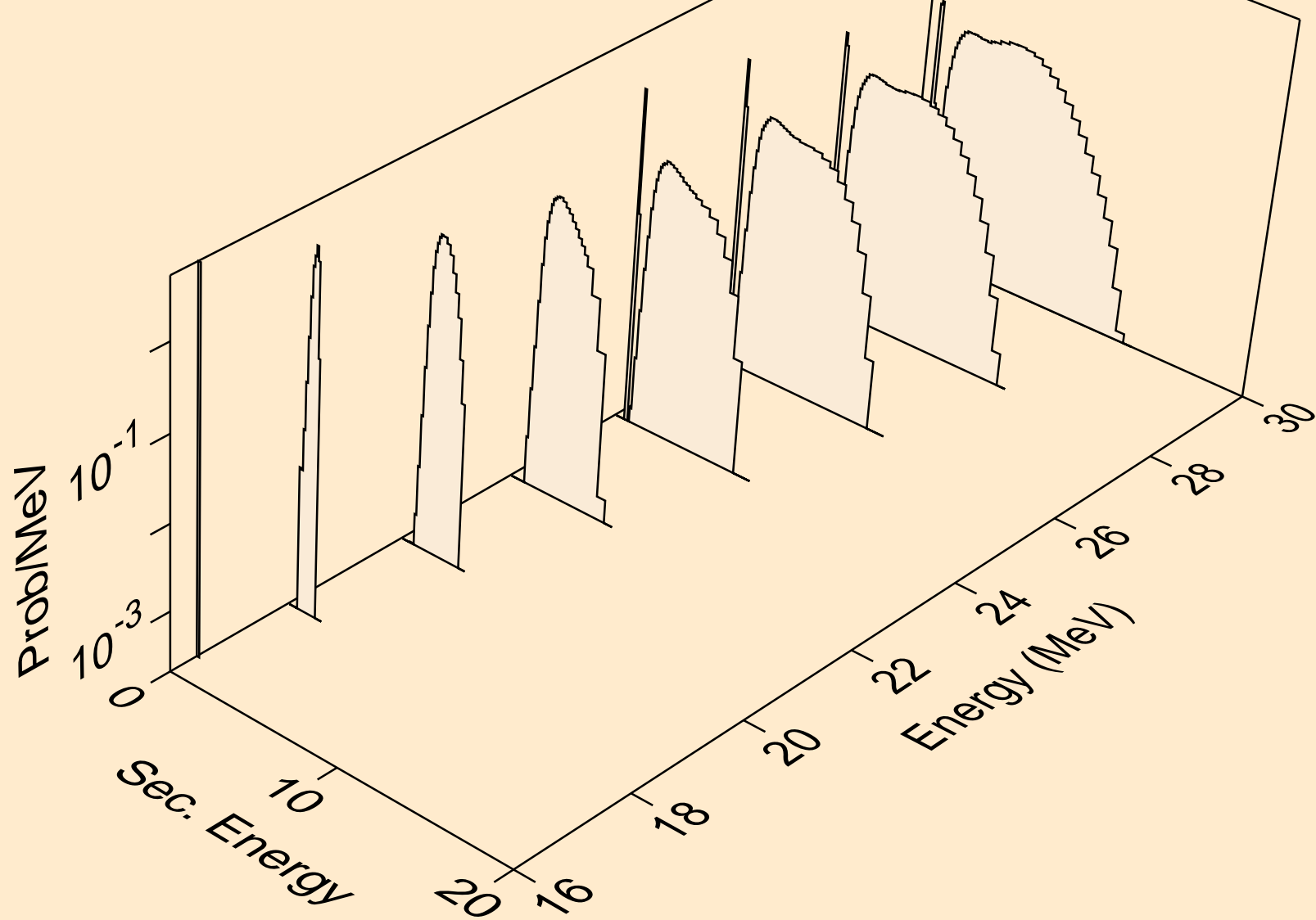

IN098M DEUTERON ACER TENDL-2021 LIBRARY; T=0.K
protons from (d,2np)

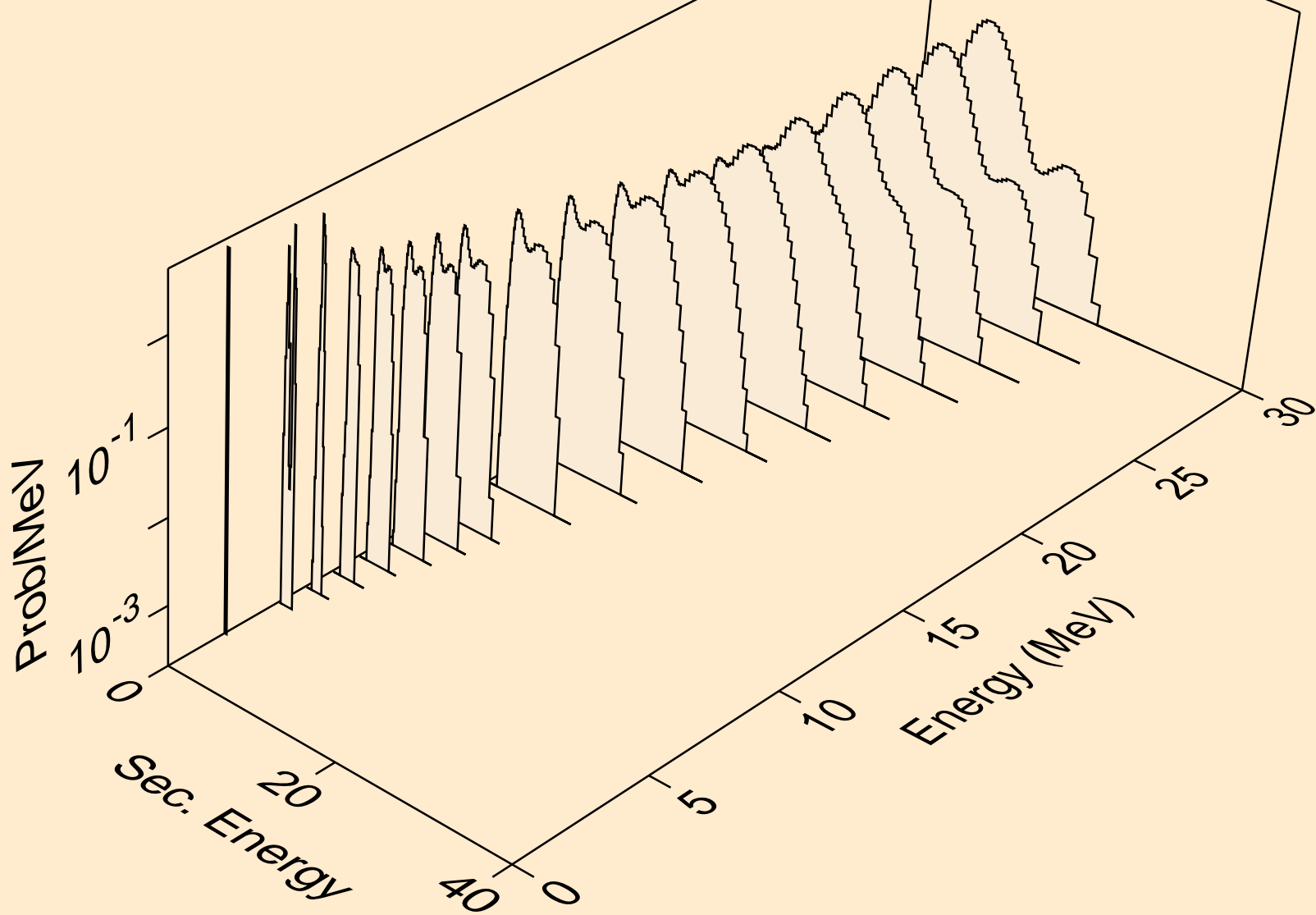

IN098M DEUTERON ACER TENDL-2021 LIBRARY; T=0.K
protons from (d,npa)

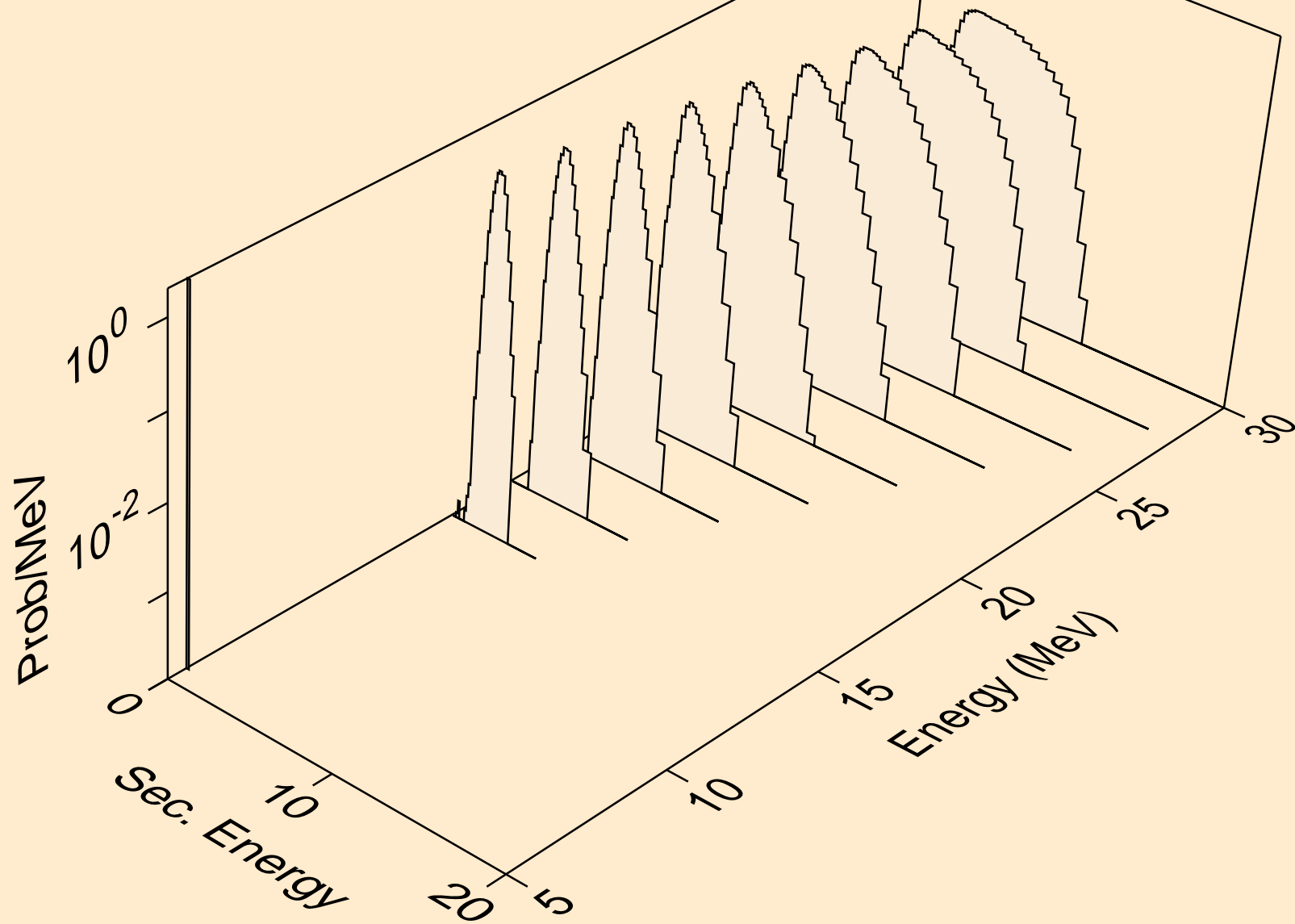

IN098M DEUTERON ACER TENDL-2021 LIBRARY; T=0.K
protons from (d,p)

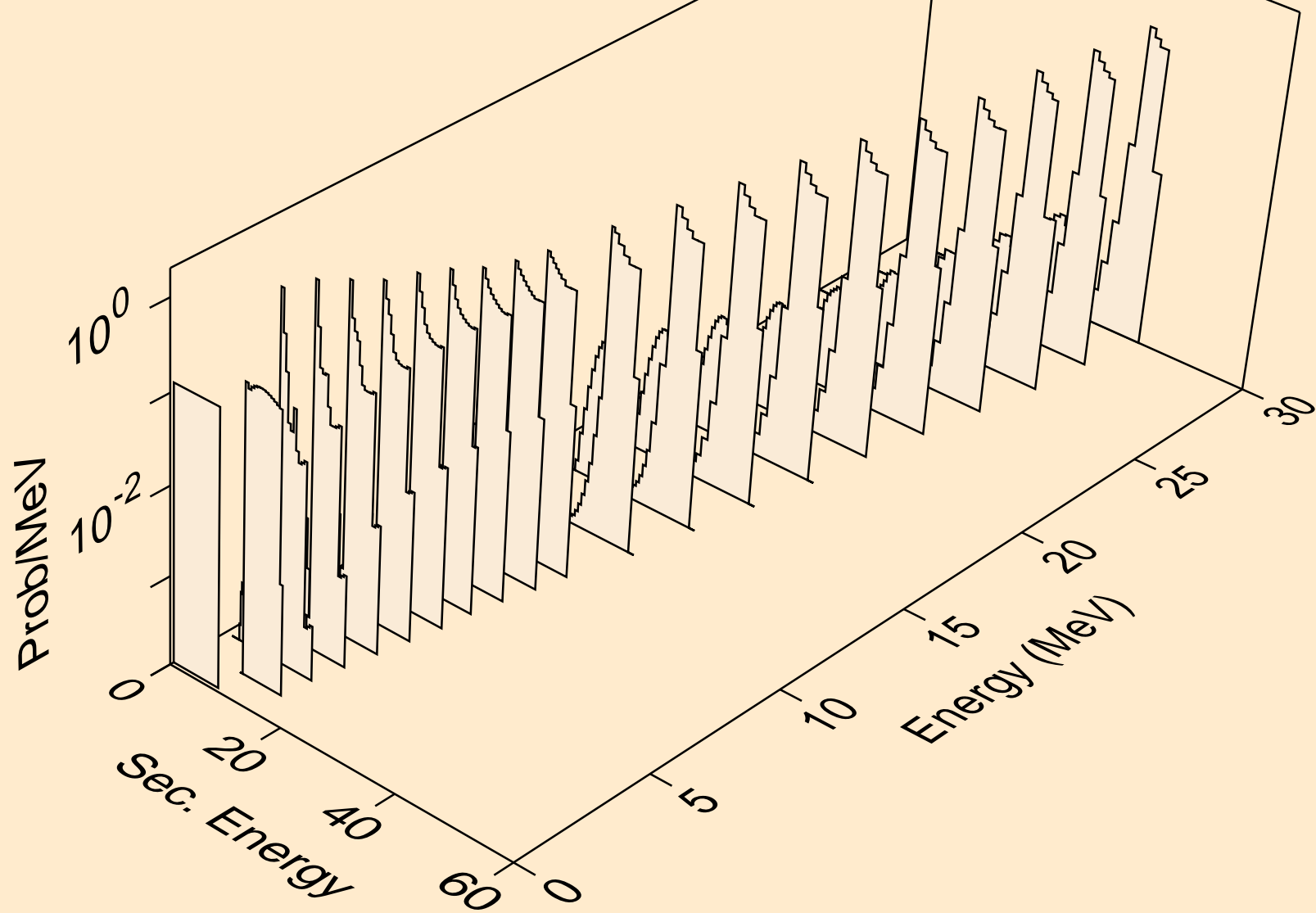

IN098M DEUTERON ACER TENDL-2021 LIBRARY; T=0.K
protons from (d,2p)

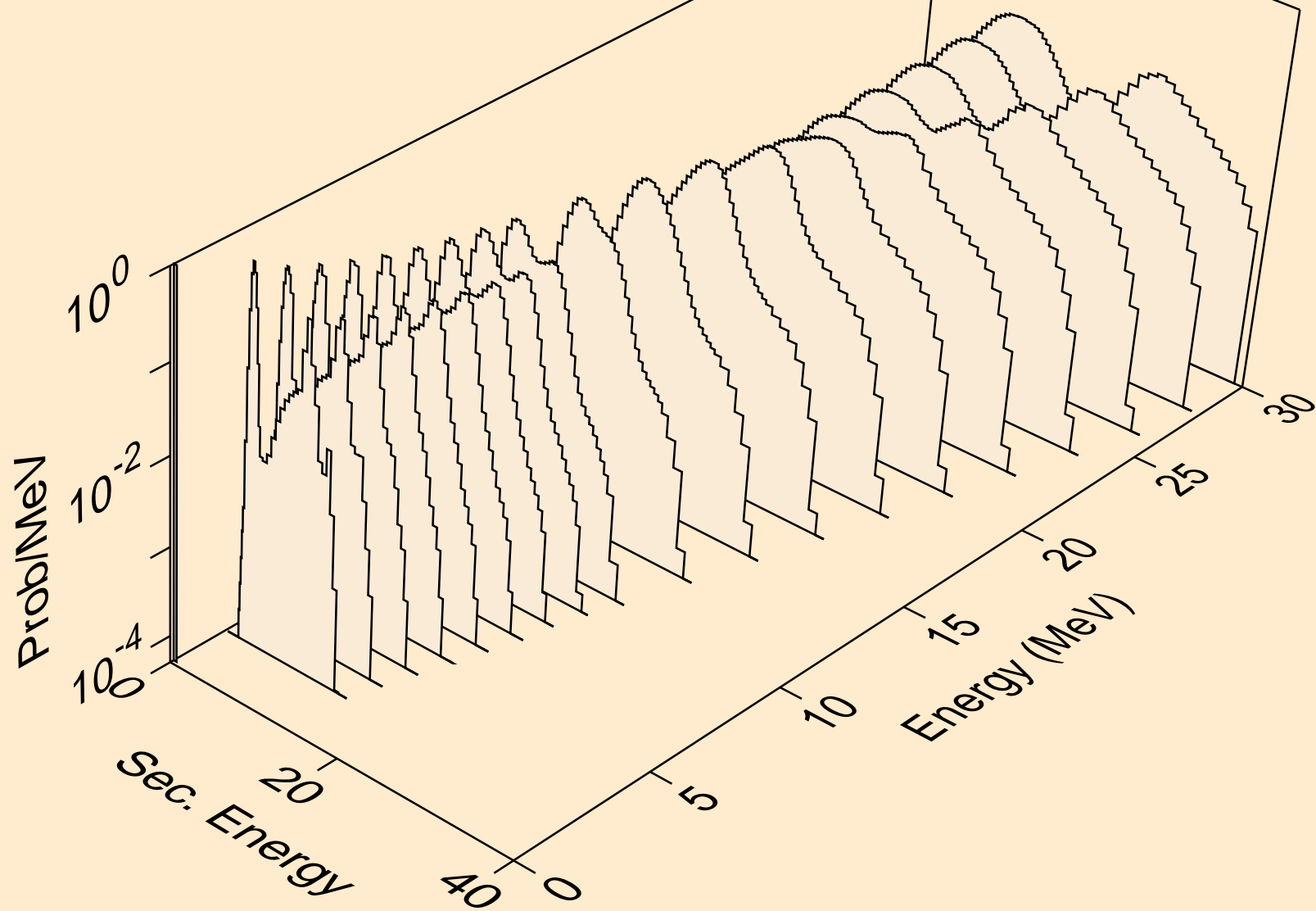

IN098M DEUTERON ACER TENDL-2021 LIBRARY; T=0.K
protons from (d,pa)

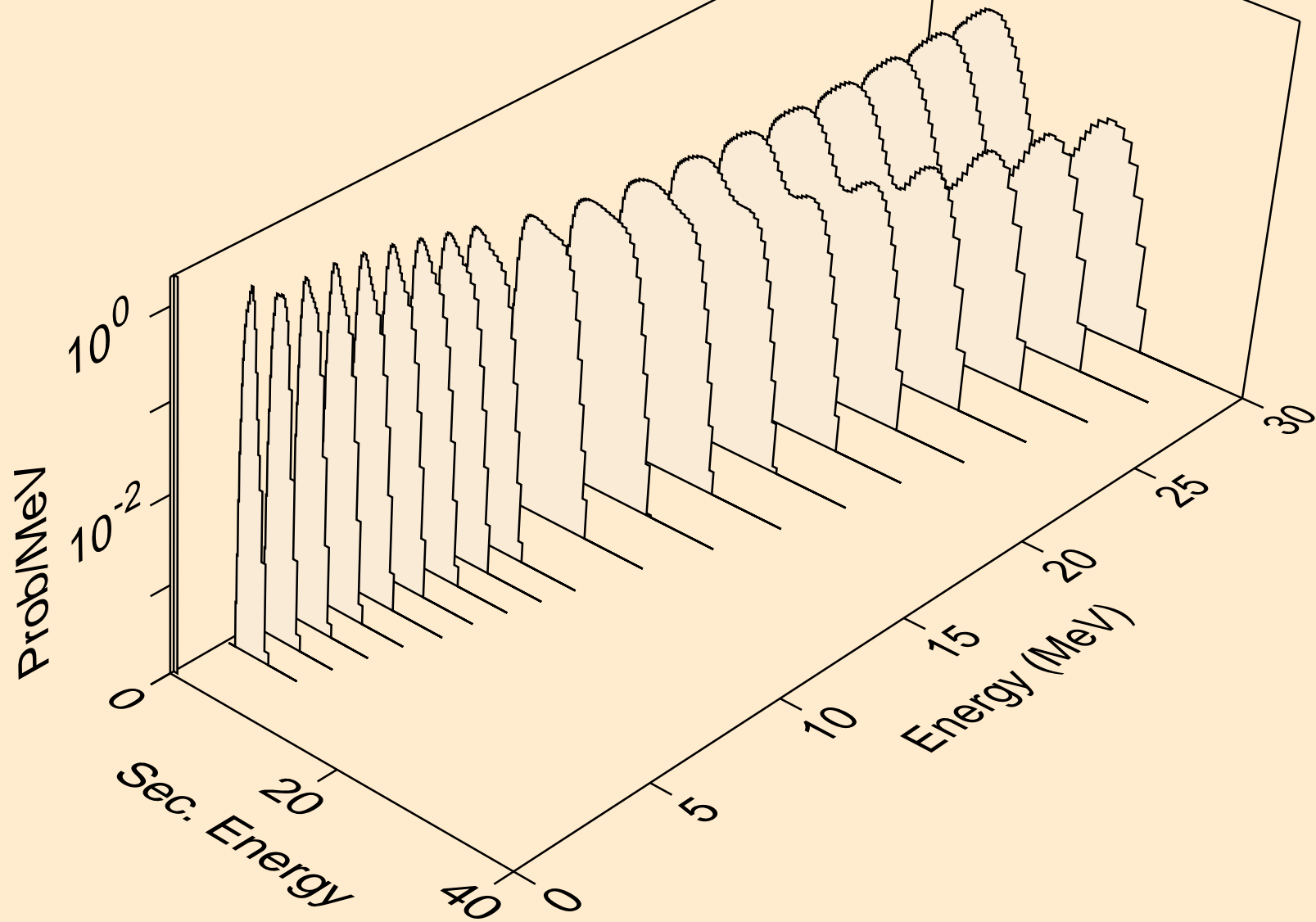

IN098M DEUTERON ACER TENDL-2021 LIBRARY; T=0.K
protons from (d,pd)

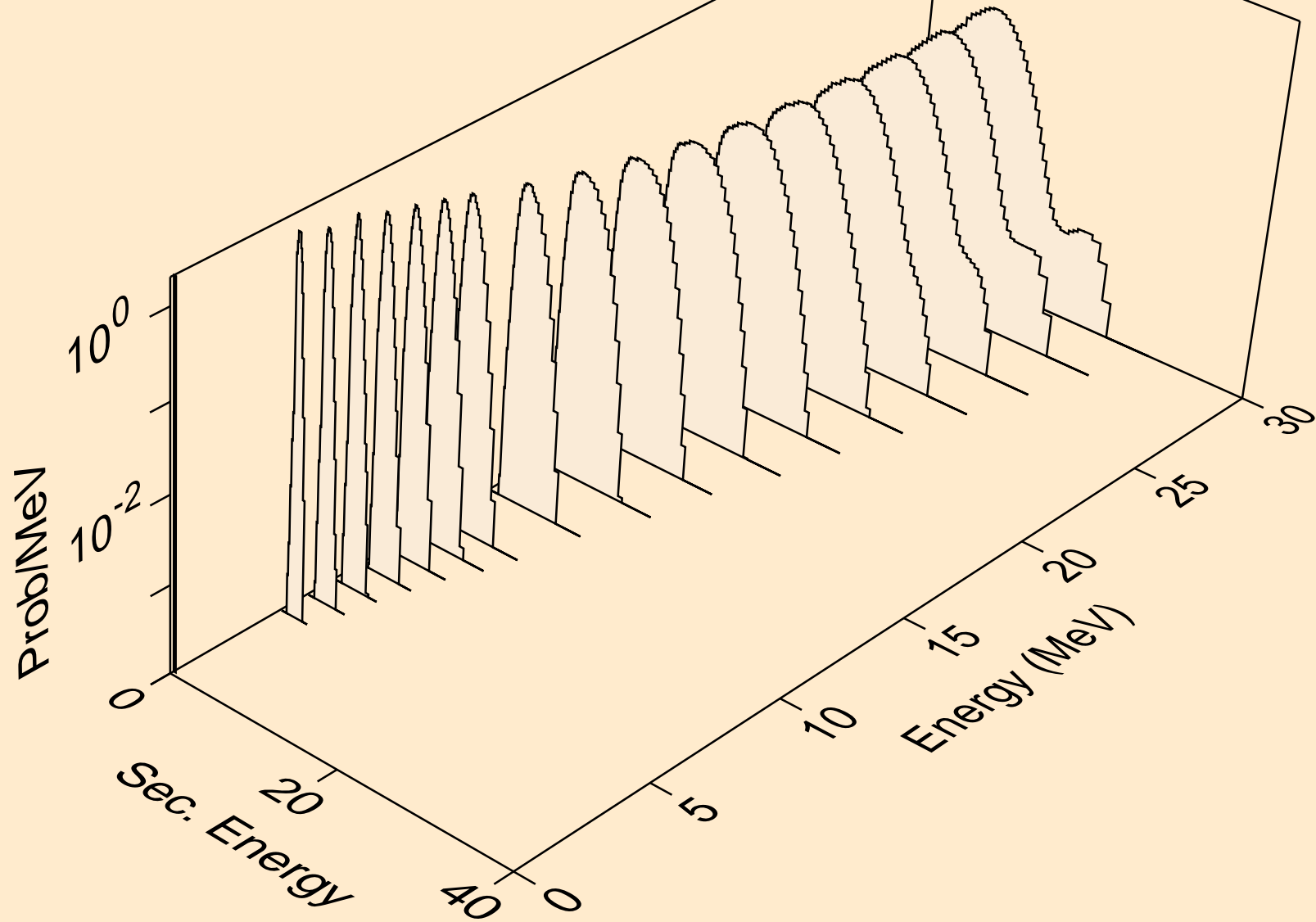

IN098M DEUTERON ACER TENDL-2021 LIBRARY; T=0.K
protons from (d,pt)

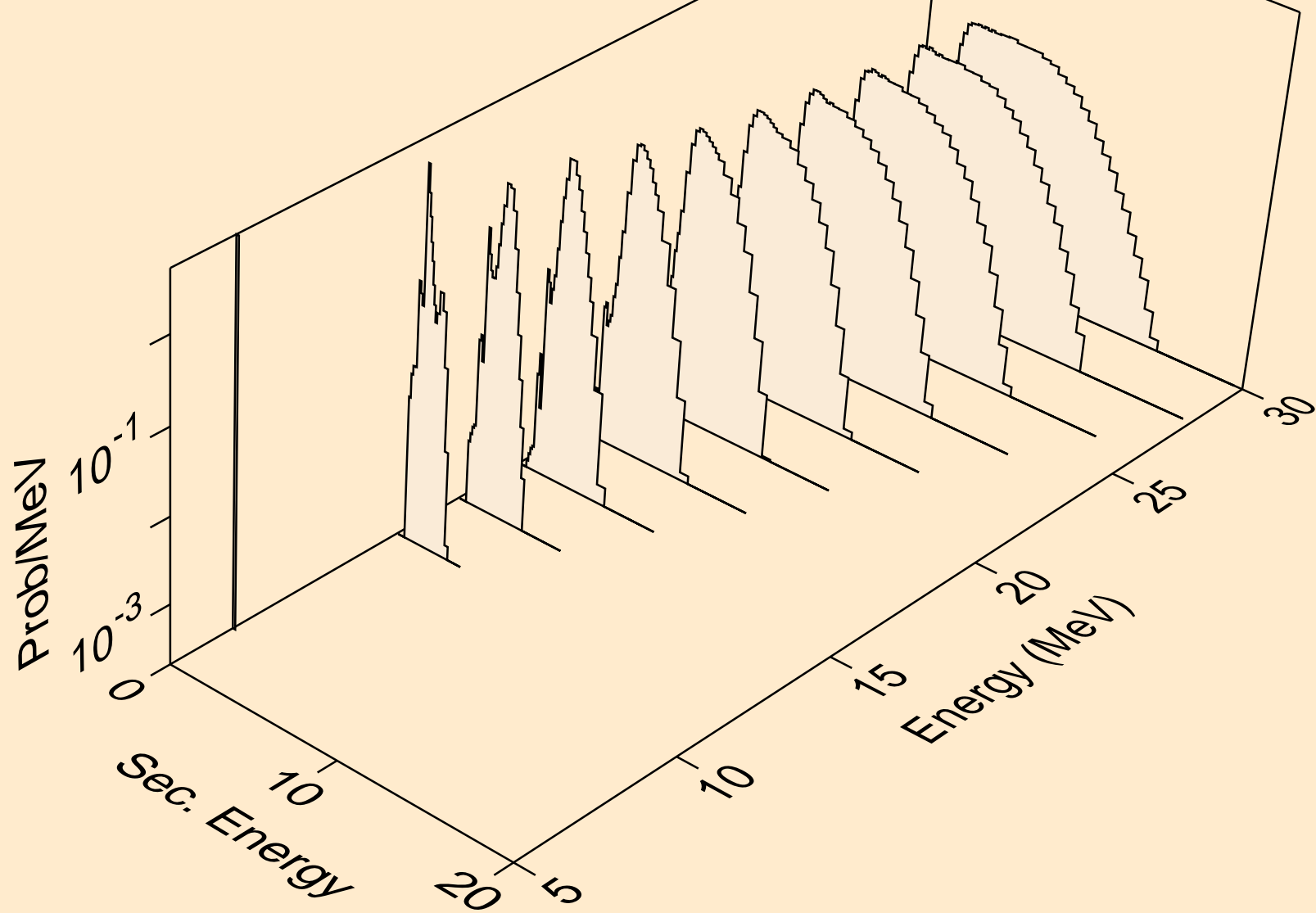

IN098M DEUTERON ACER TENDL-2021 LIBRARY; T=0.K
tritons from (d,x)

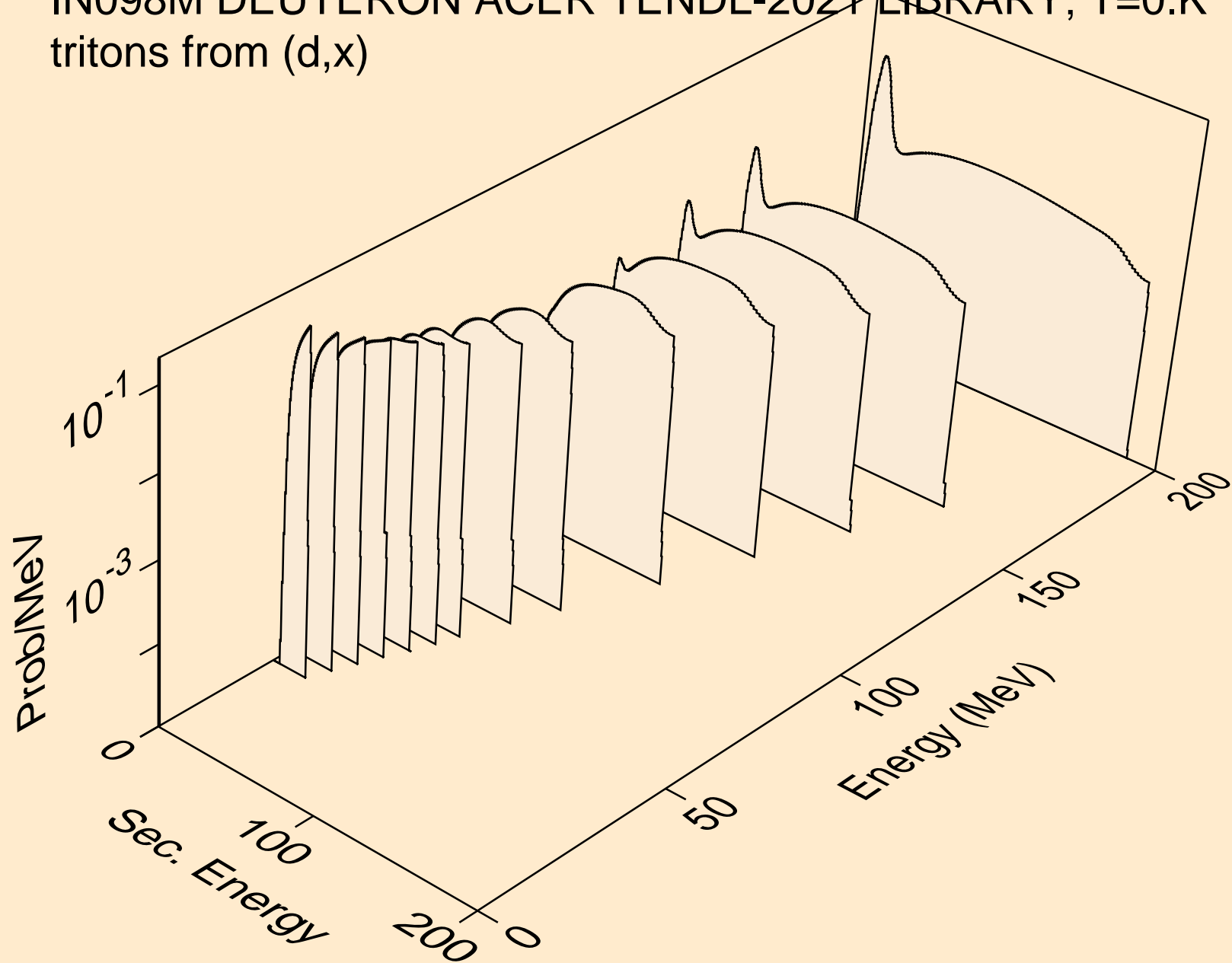

IN098M DEUTERON ACER TENDL-2021 LIBRARY; T=0.K
tritons from (d,t)

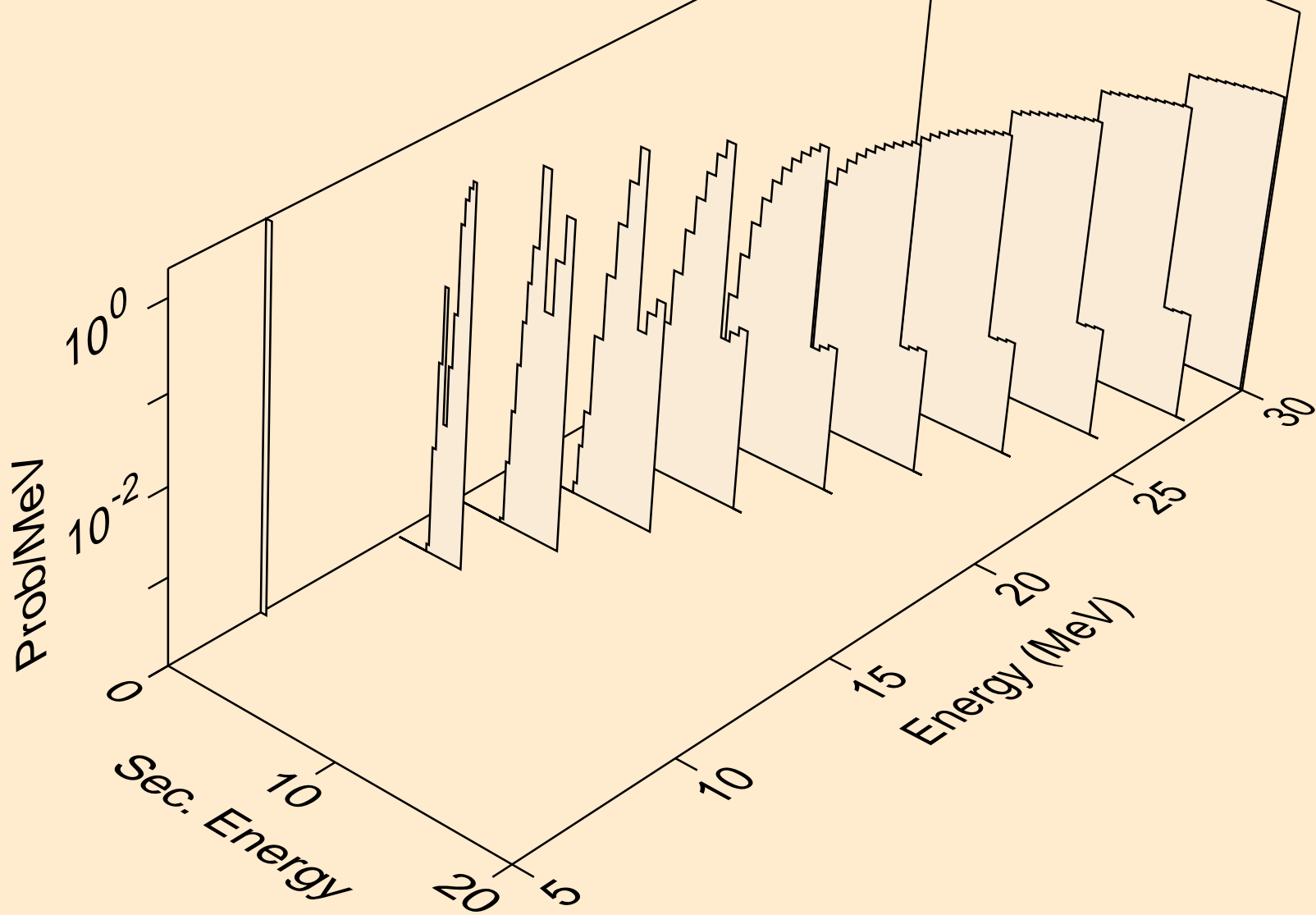

IN098M DEUTERON ACER TENDL-2021 LIBRARY; T=0.K
tritons from (d,pt)

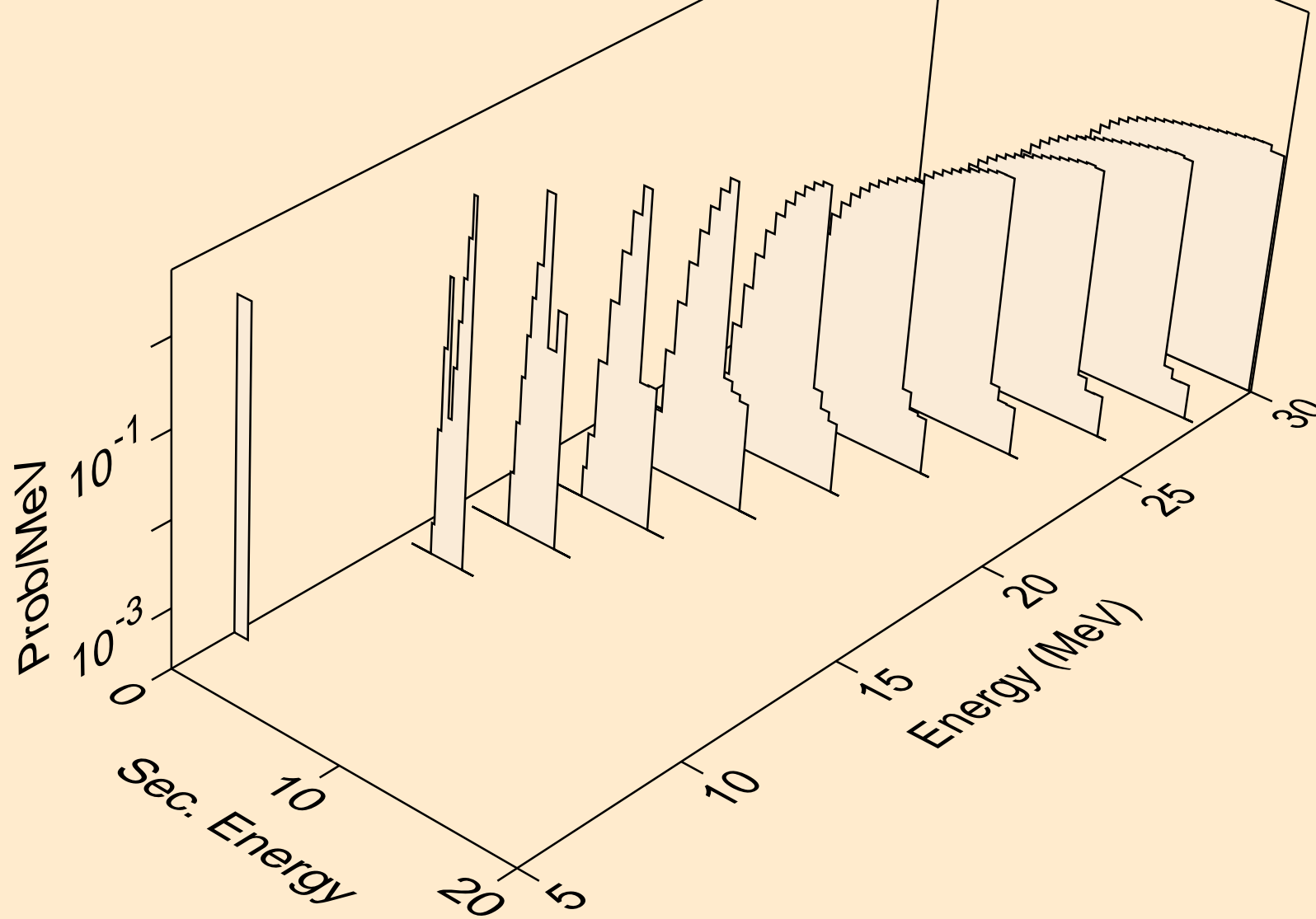

IN098M DEUTERON ACER TENDL-2021 LIBRARY; T=0.K
he3s from (d,x)

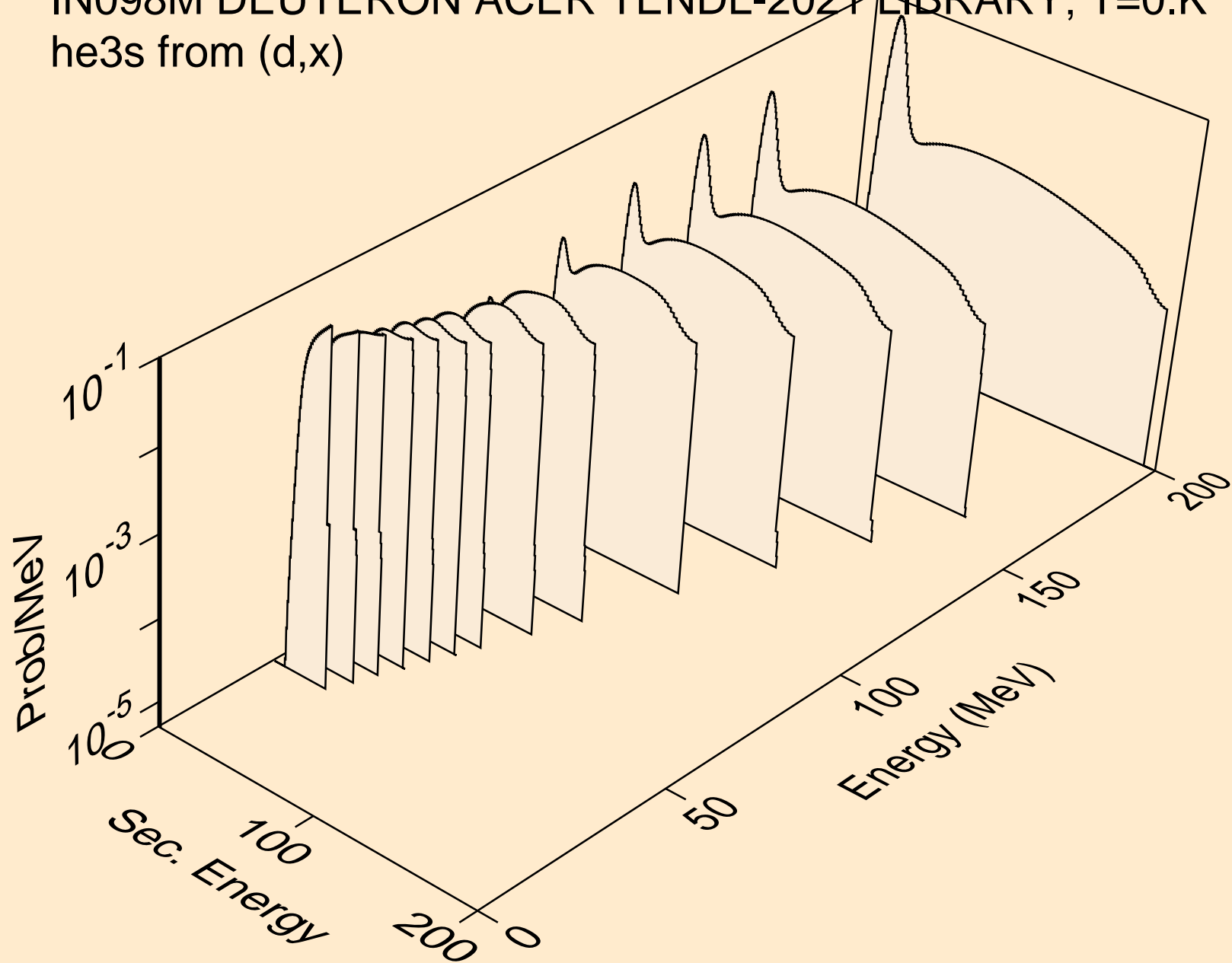

IN098M DEUTERON ACER TENDL-2021 LIBRARY; T=0.K
he3s from (d,n*)he3

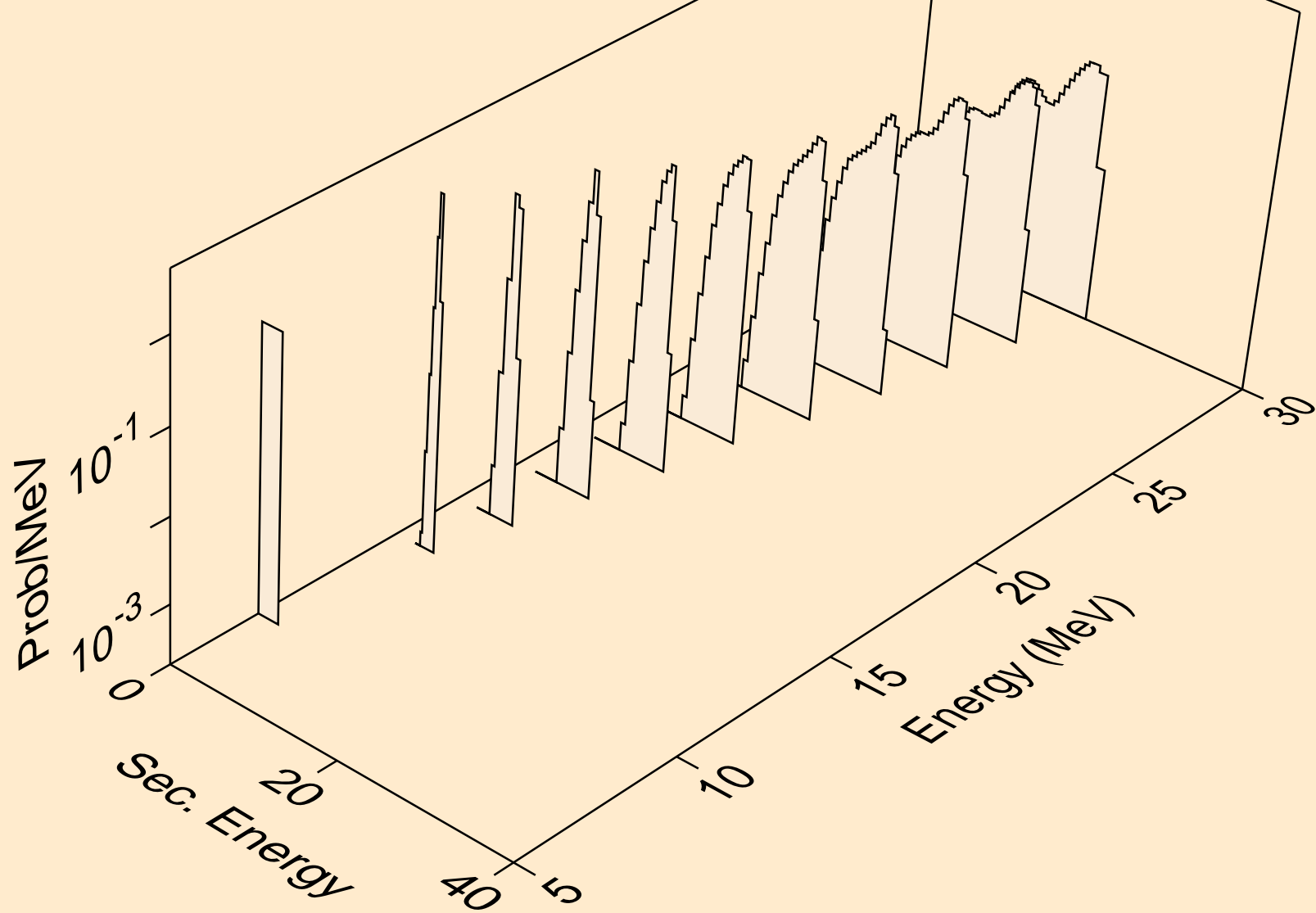

IN098M DEUTERON ACER TENDL-2021 LIBRARY; T=0.K
he3s from (d,he3)

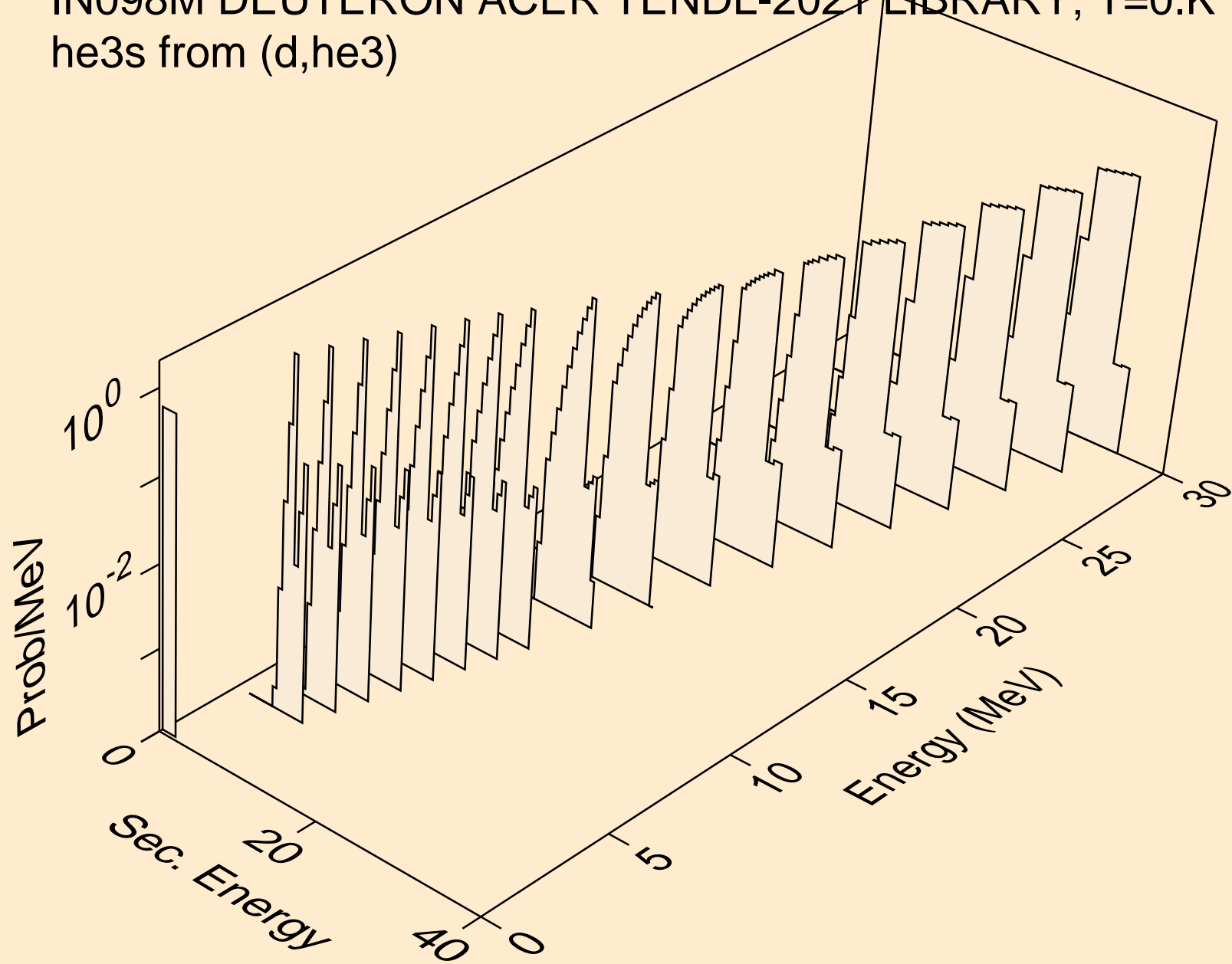

IN098M DEUTERON ACER TENDL-2021 LIBRARY; T=0.K
alphas from (d,x)

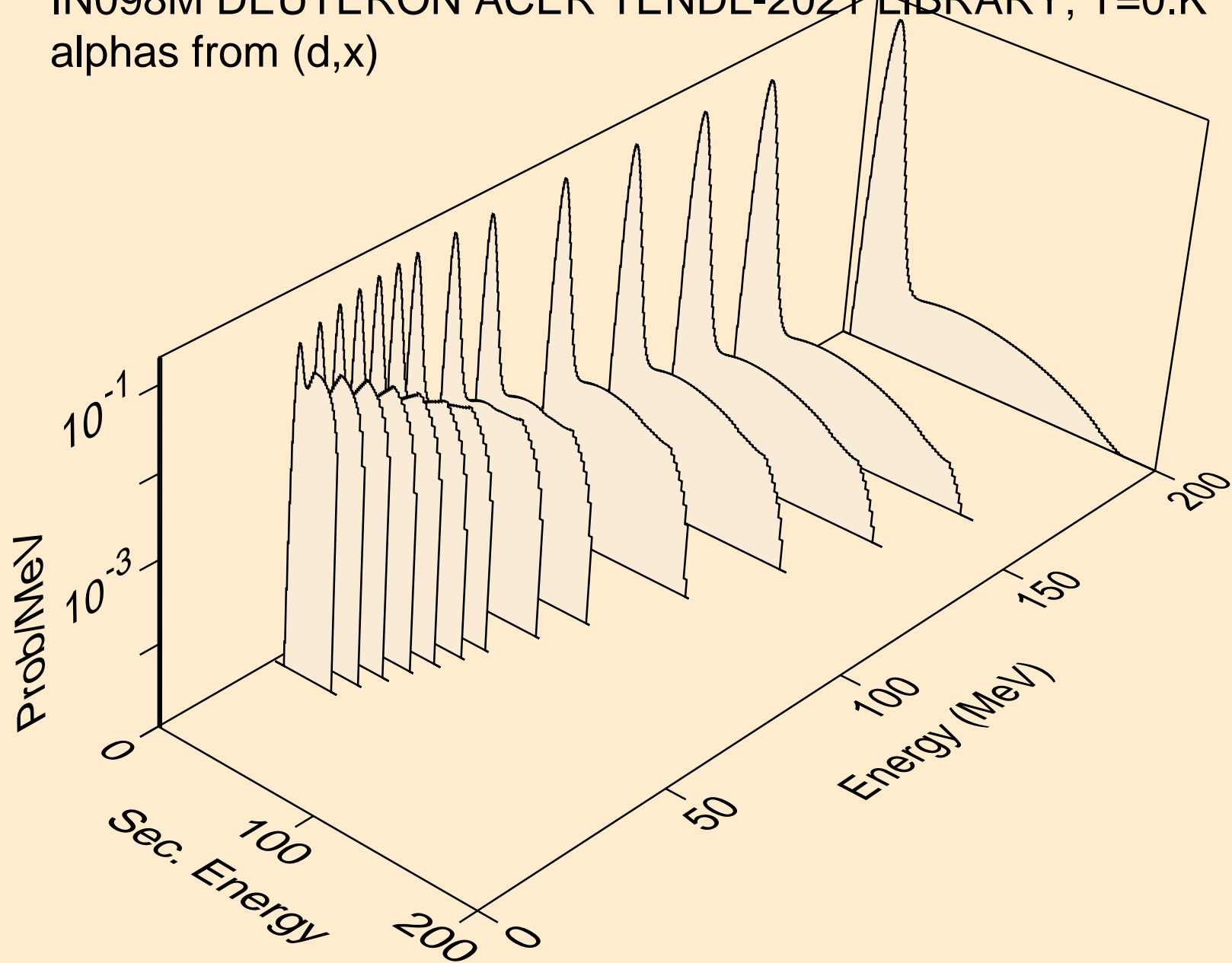

IN098M DEUTERON ACER TENDL-2021 LIBRARY; T=0.K
alphas from (d,n*)a

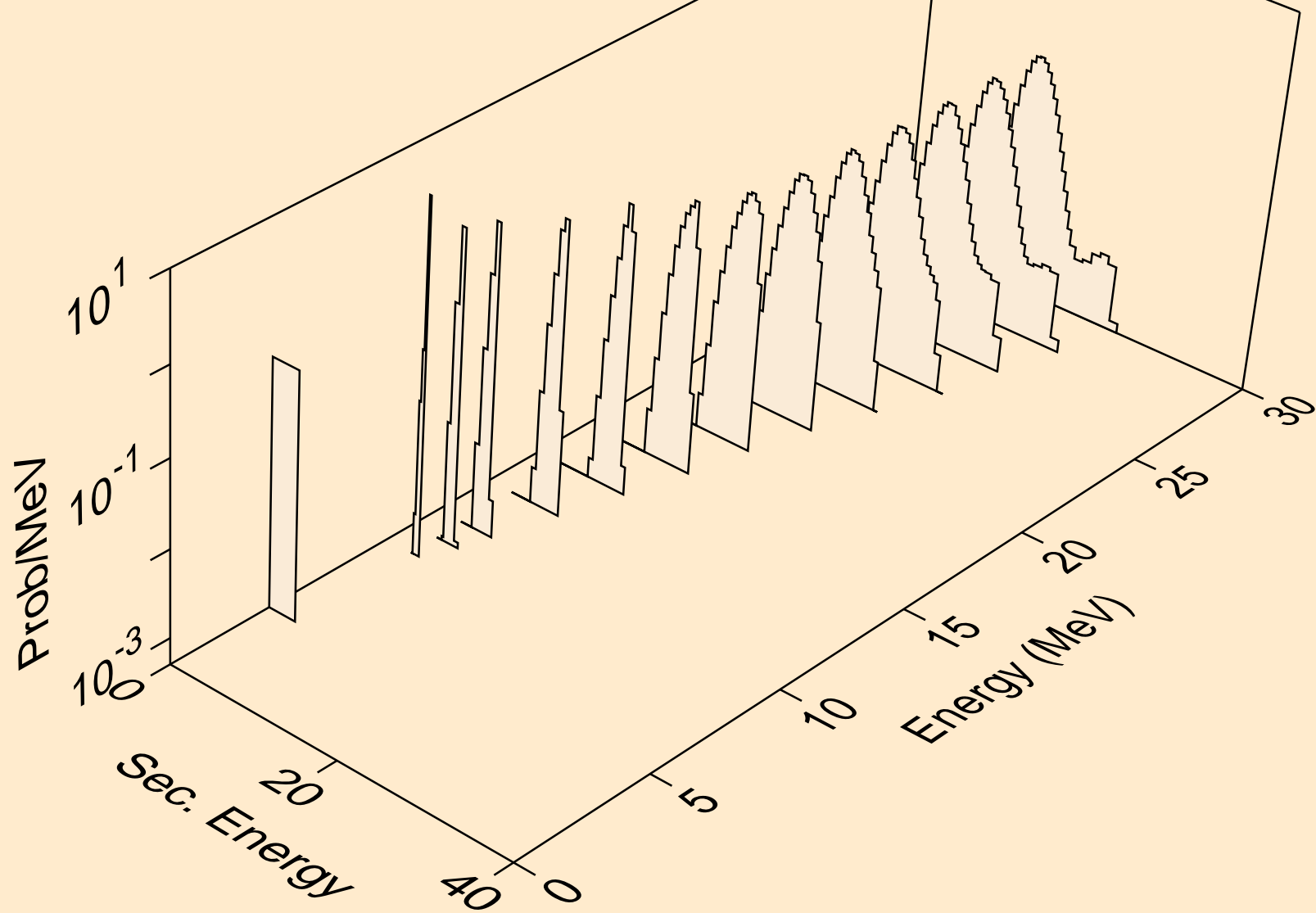

IN098M DEUTERON ACER TENDL-2021 LIBRARY; T=0.K
alphas from (d,n*)2a

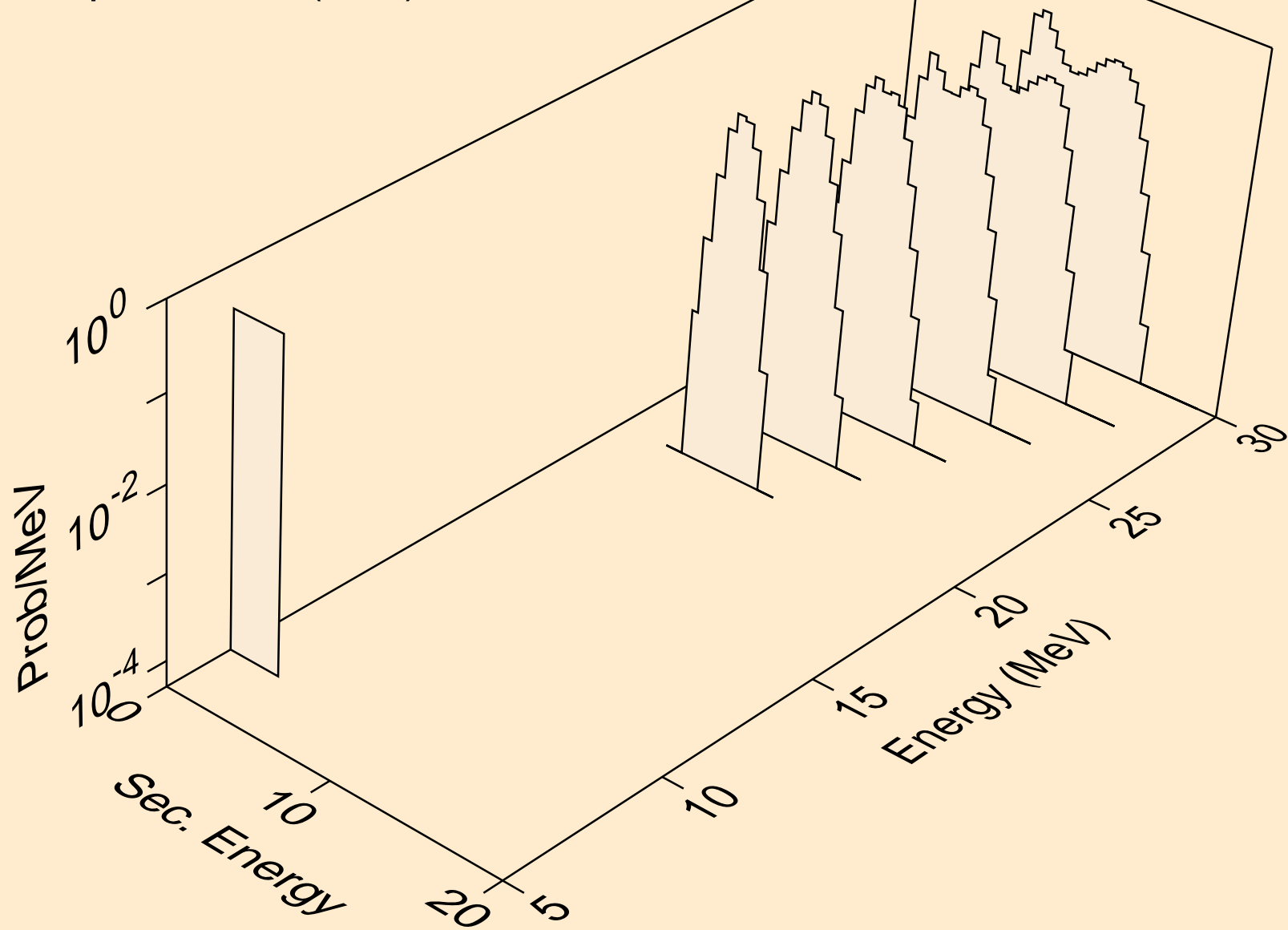

IN098M DEUTERON ACER TENDL-2021 LIBRARY; T=0.K
alphas from (d,npa)

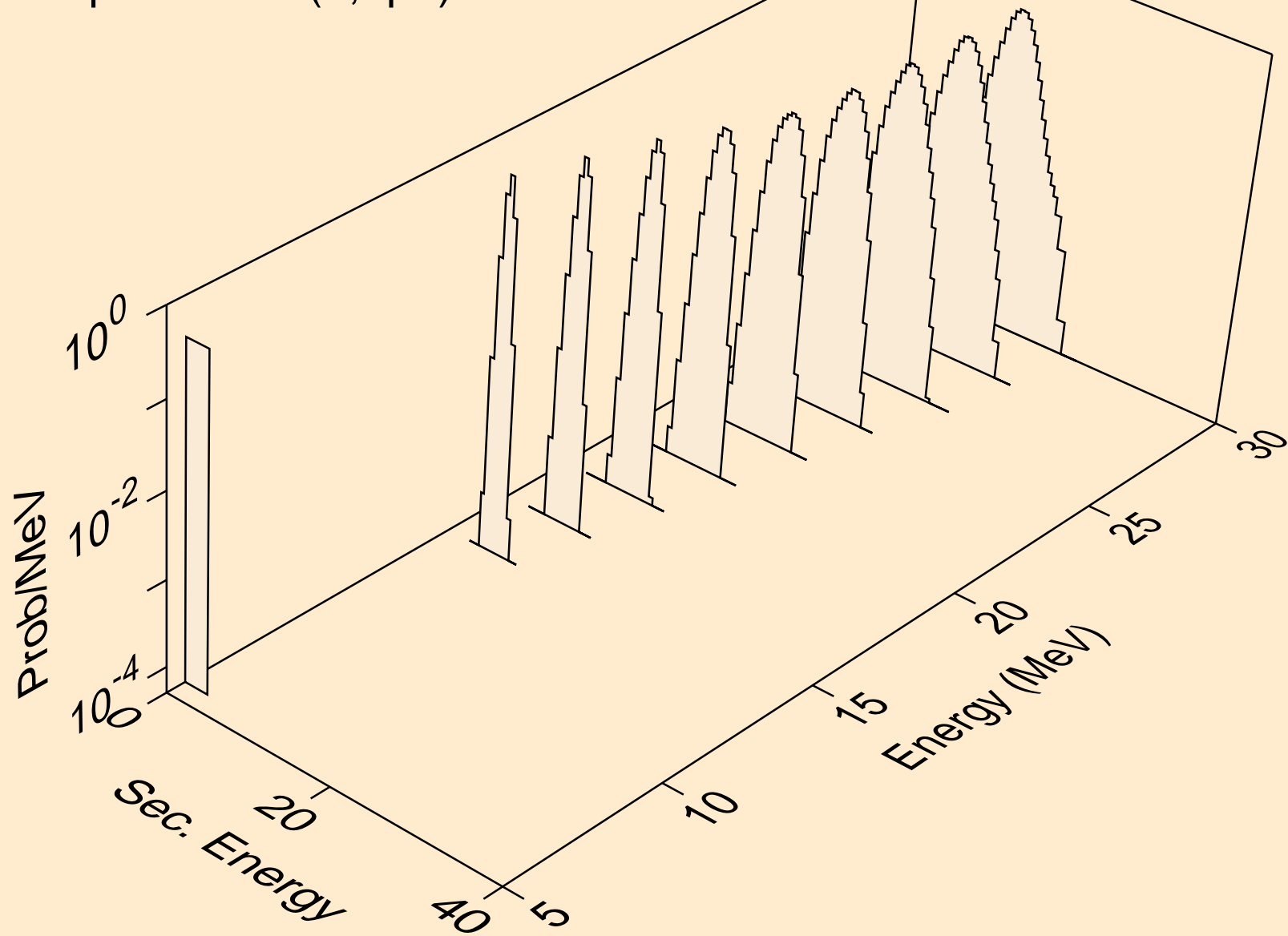

IN098M DEUTERON ACER TENDL-2021 LIBRARY; T=0.K
alphas from (d,a)

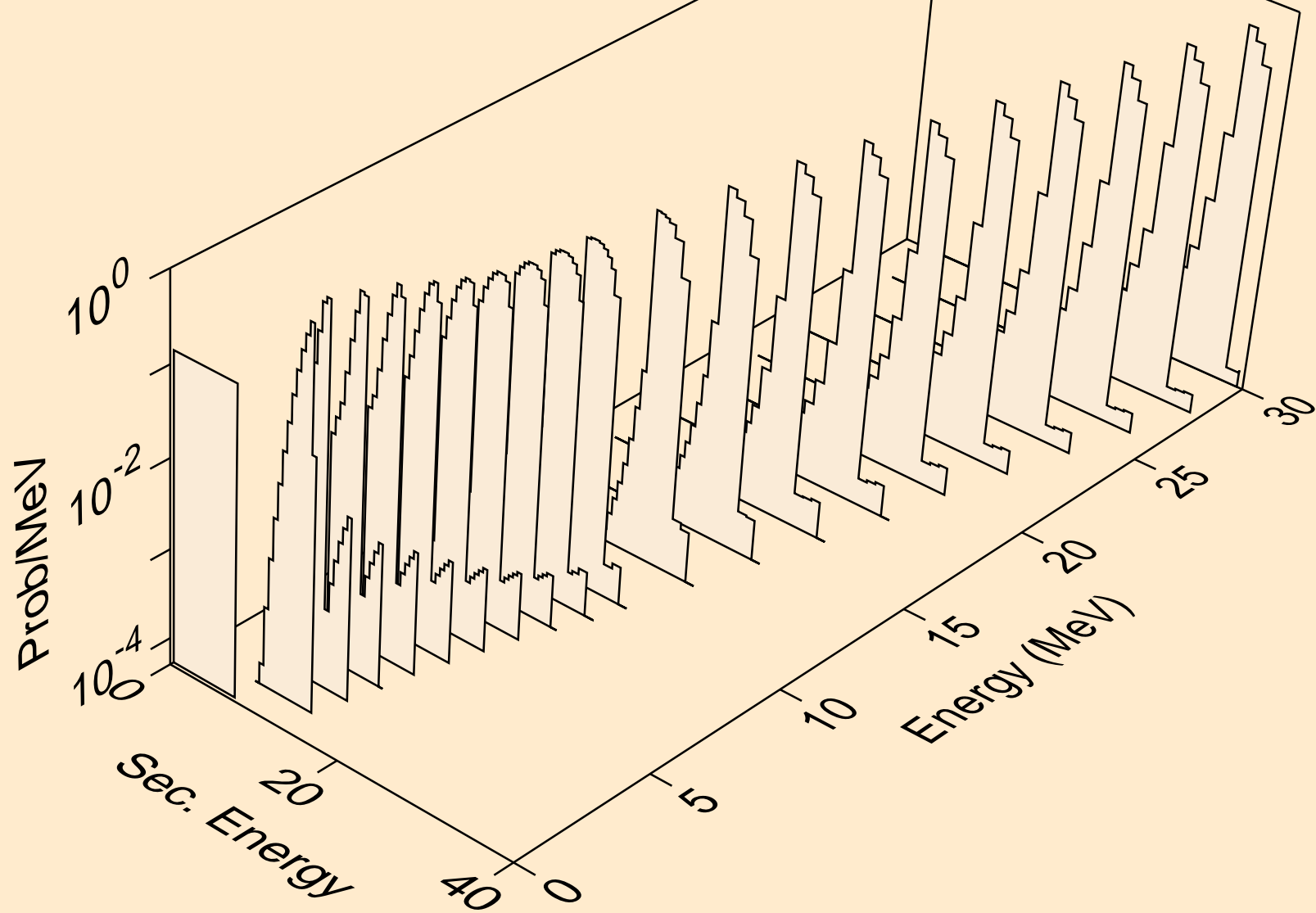

IN098M DEUTERON ACER TENDL-2021 LIBRARY; T=0.K
alphas from (d,2a)

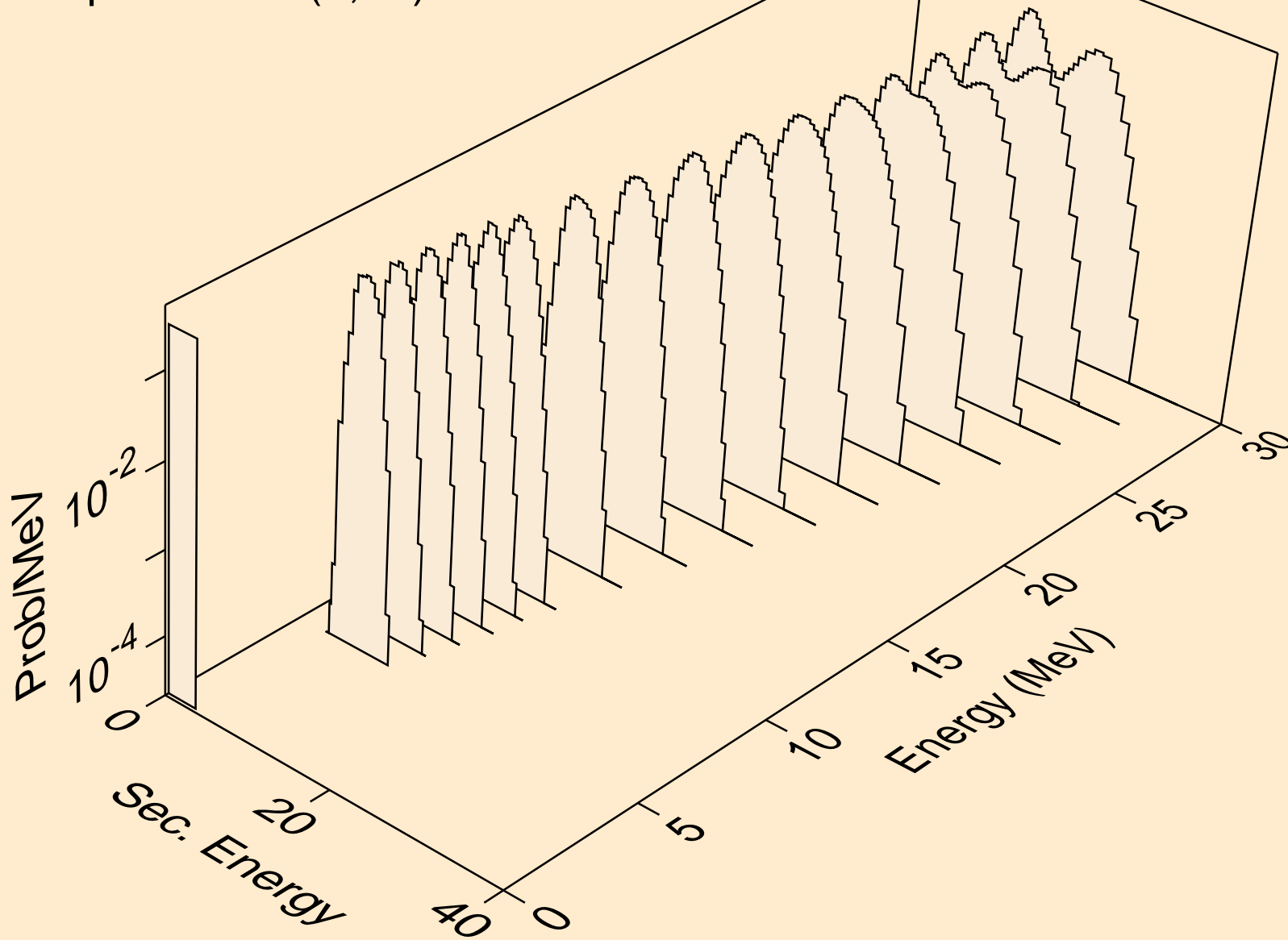

IN098M DEUTERON ACER TENDL-2021 LIBRARY; T=0.K
alphas from (d,pa)

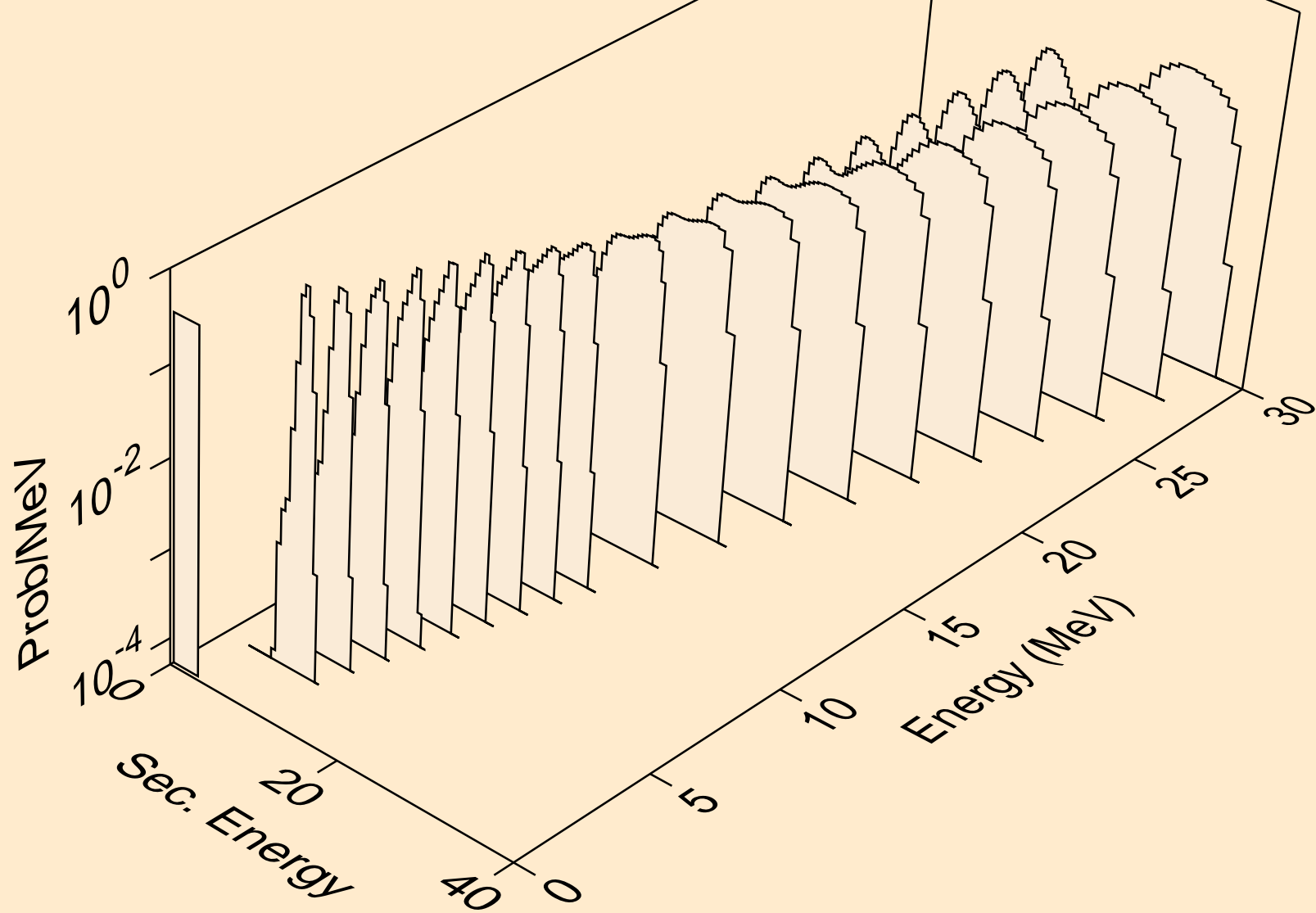

IN098M DEUTERON ACER TENDL-2021 LIBRARY; T=0.K
alphas from (d,da)

