

PO223 DEUTERON ACER TENDL-2021 LIBRARY; T=0.K  
Principal cross sections

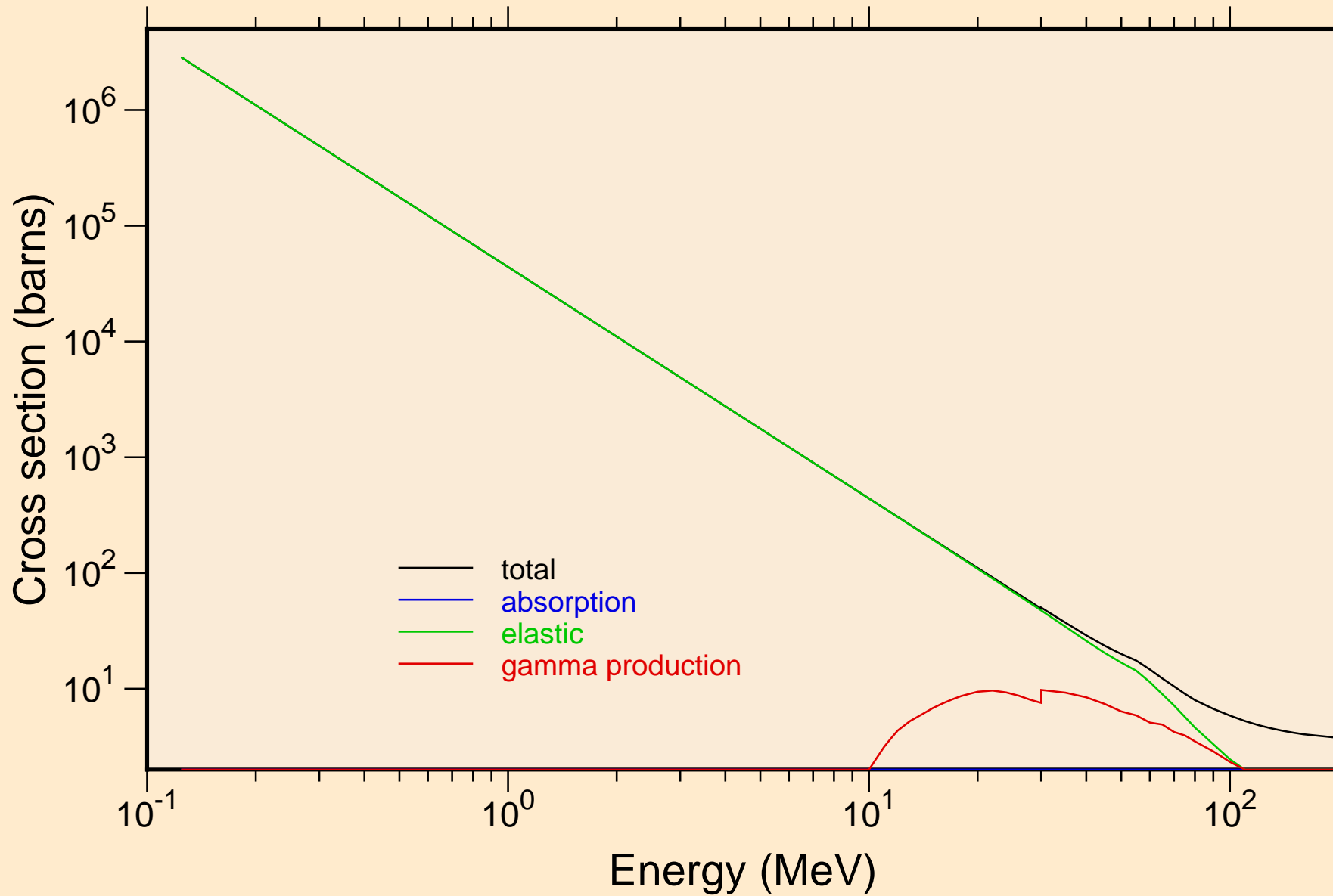

PO223 DEUTERON ACER TENDL-2021 LIBRARY; T=0.K  
Heating

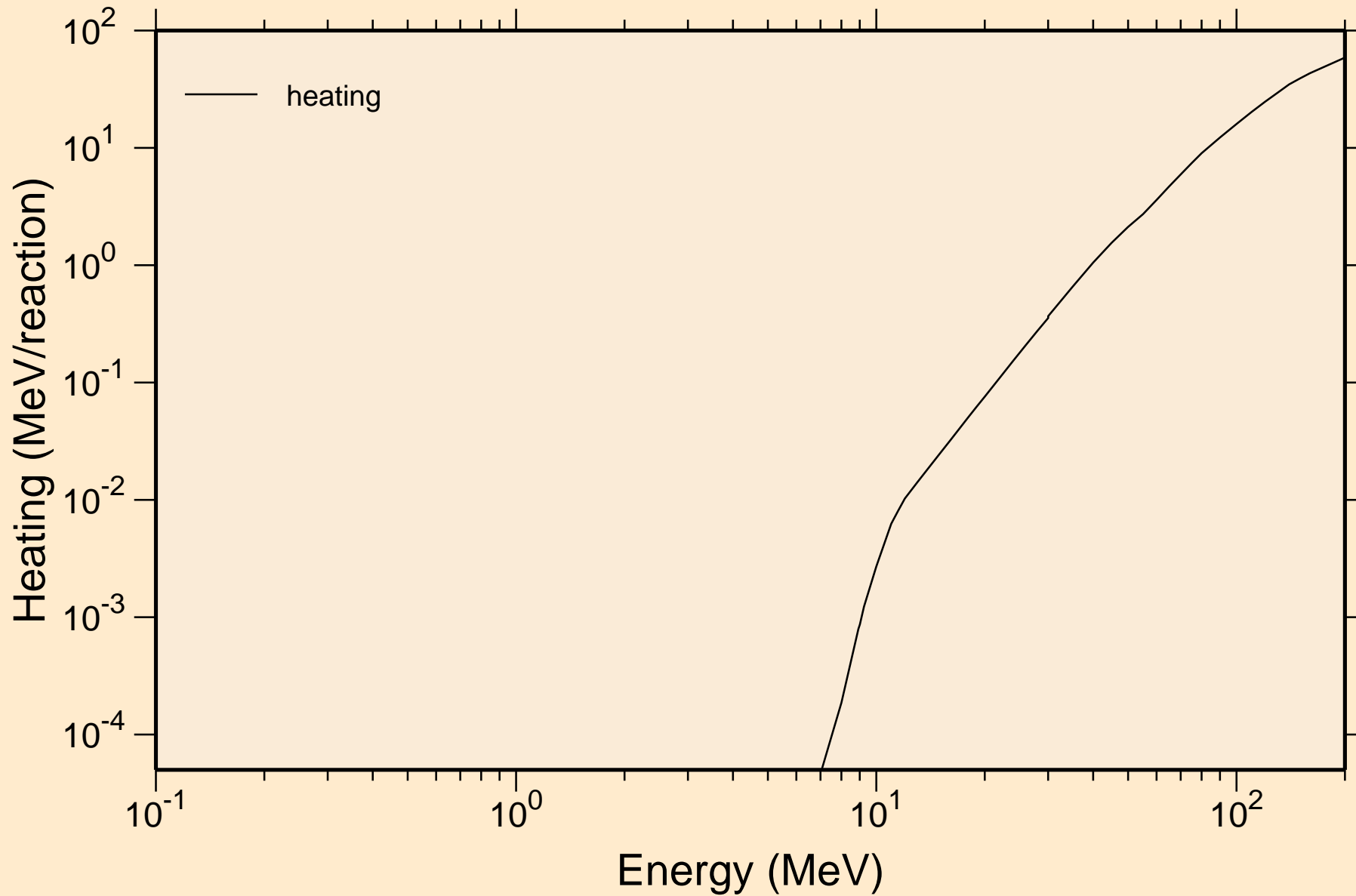

PO223 DEUTERON ACER TENDL-2021 LIBRARY; T=0.K  
Principal cross sections

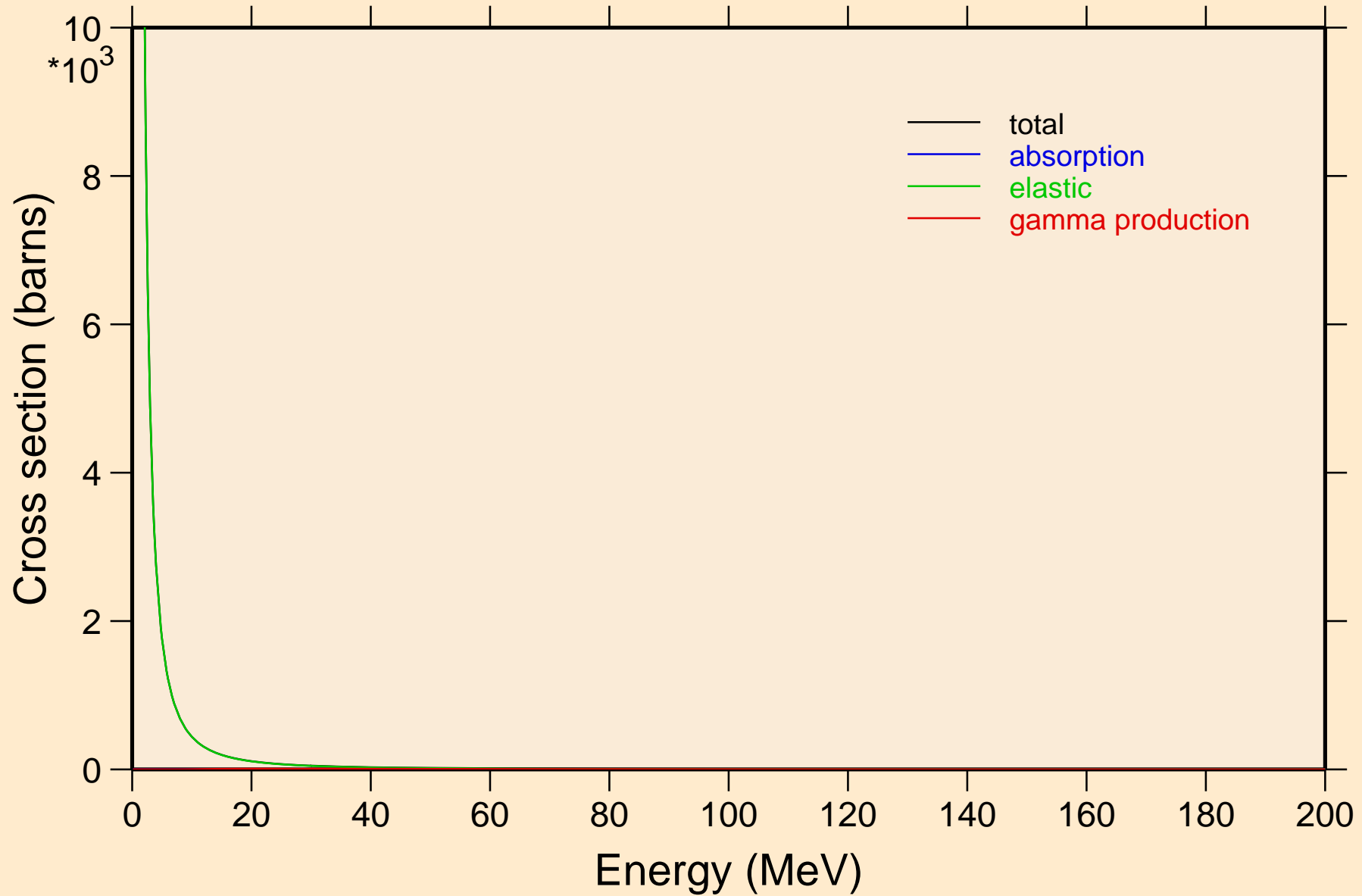

PO223 DEUTERON ACER TENDL-2021 LIBRARY; T=0.K

Heating

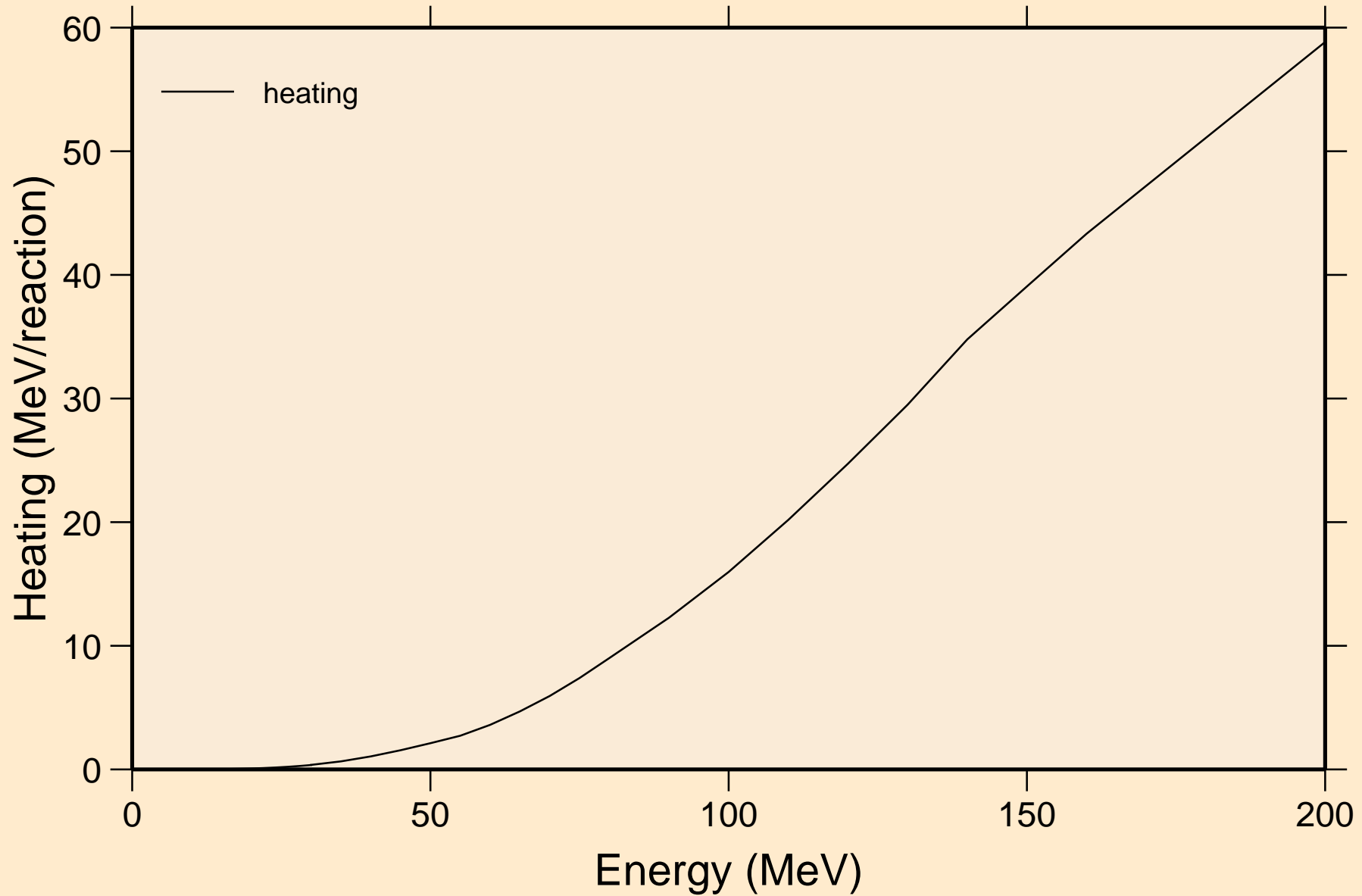

PO223 DEUTERON ACER TENDL-2021 LIBRARY; T=0.K  
Threshold reactions

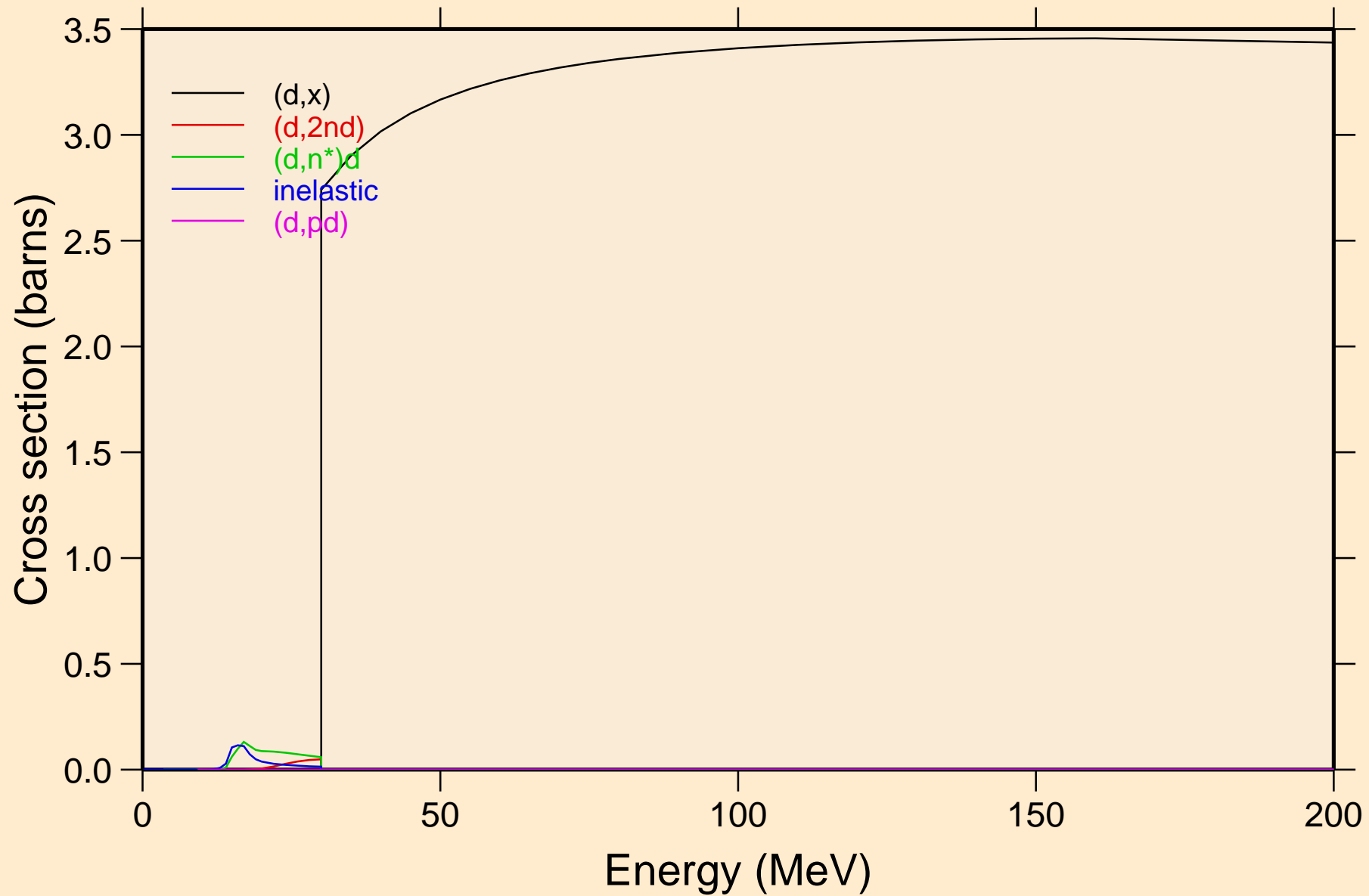

PO223 DEUTERON ACER TENDL-2021 LIBRARY; T=0.K  
angular distribution for elastic

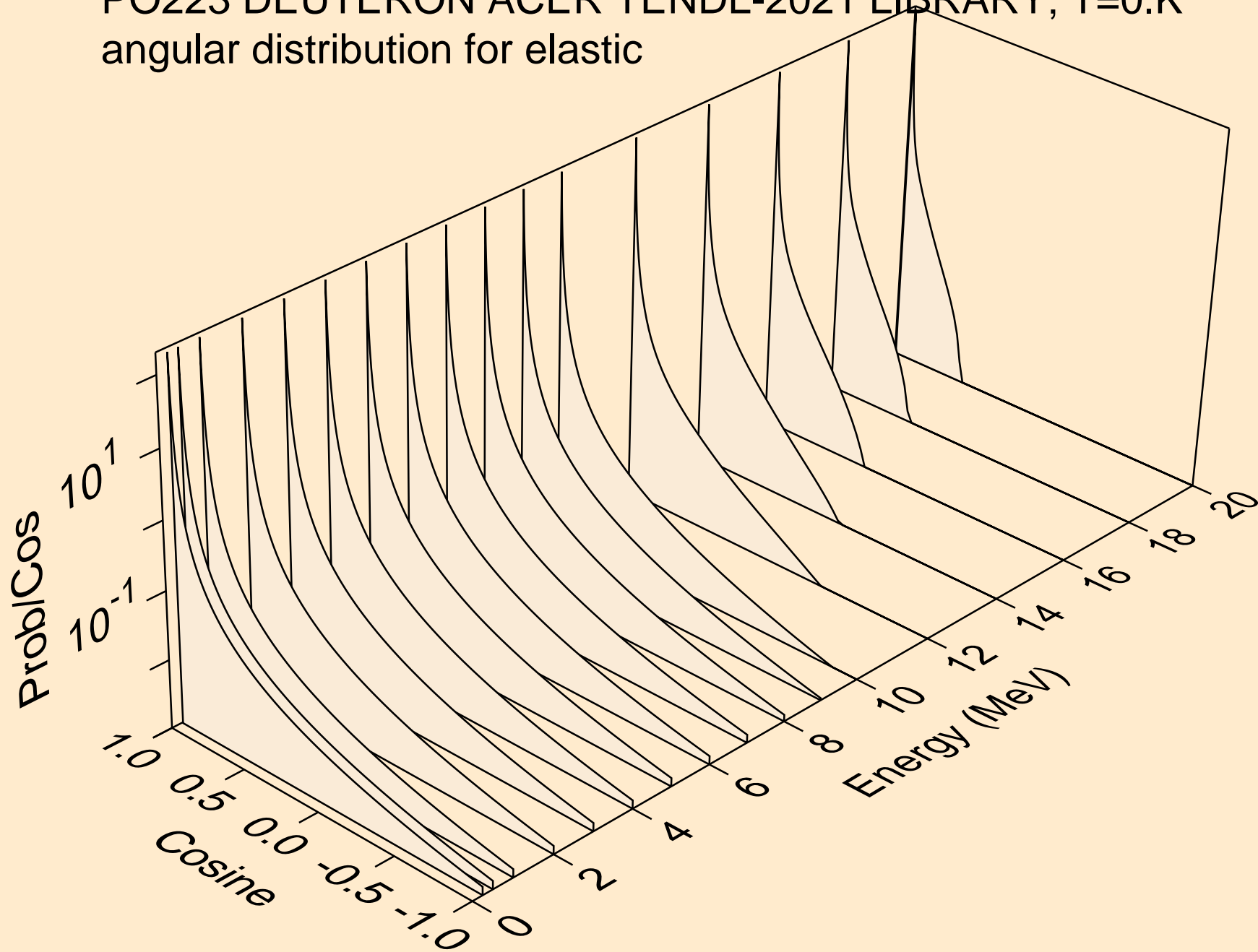

PO223 DEUTERON ACER TENDL-2021 LIBRARY; T=0.K  
angular distribution for elastic

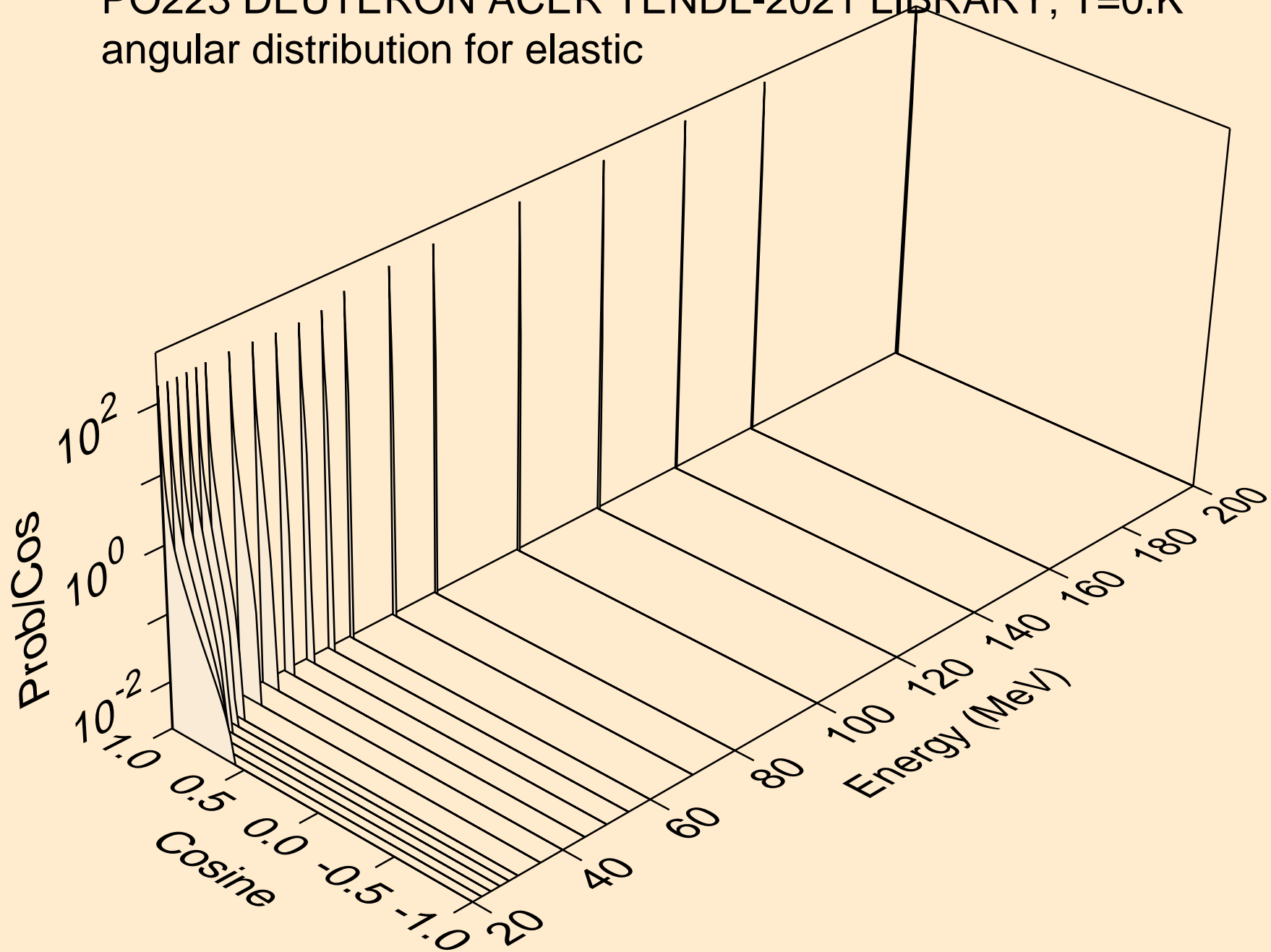

PO223 DEUTERON ACER TENDL-2021 LIBRARY; T=0.K  
Deuteron emission for (d,x)

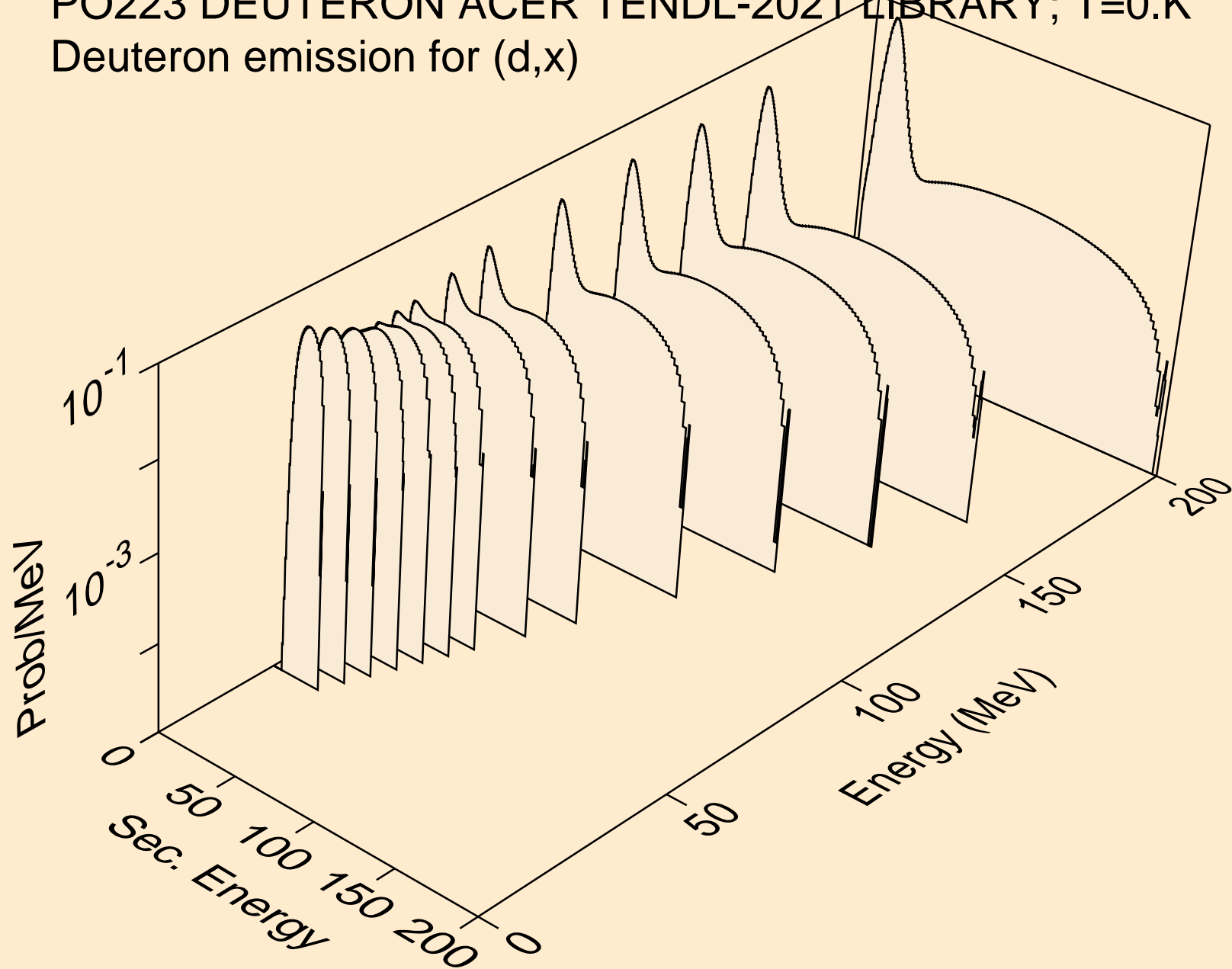



PO223 DEUTERON ACER TENDL-2021 LIBRARY; T=0.K  
Deuteron emission for (d,2nd)

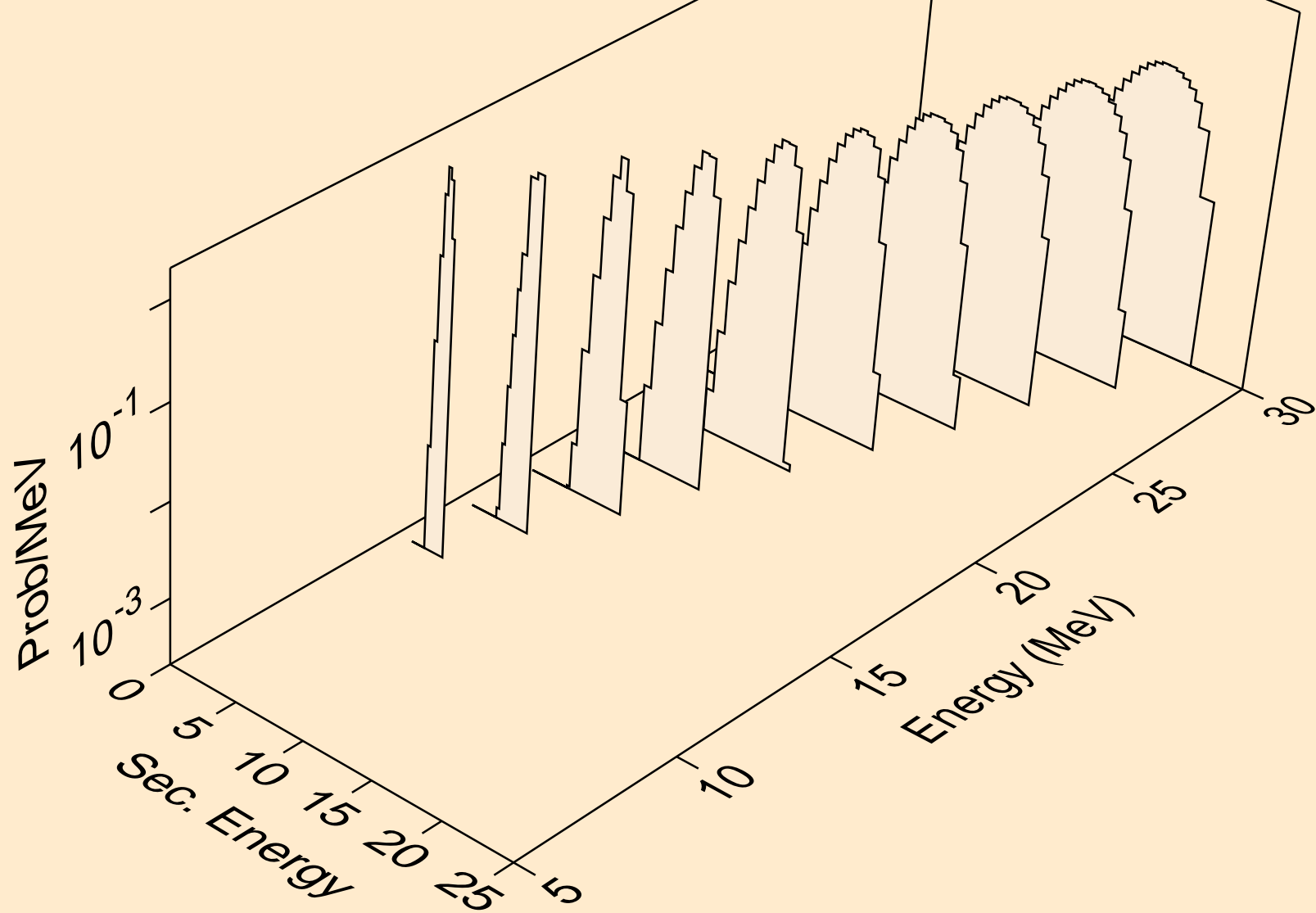

PO223 DEUTERON ACER TENDL-2021 LIBRARY; T=0.K  
Deuteron emission for (d,n\*)d

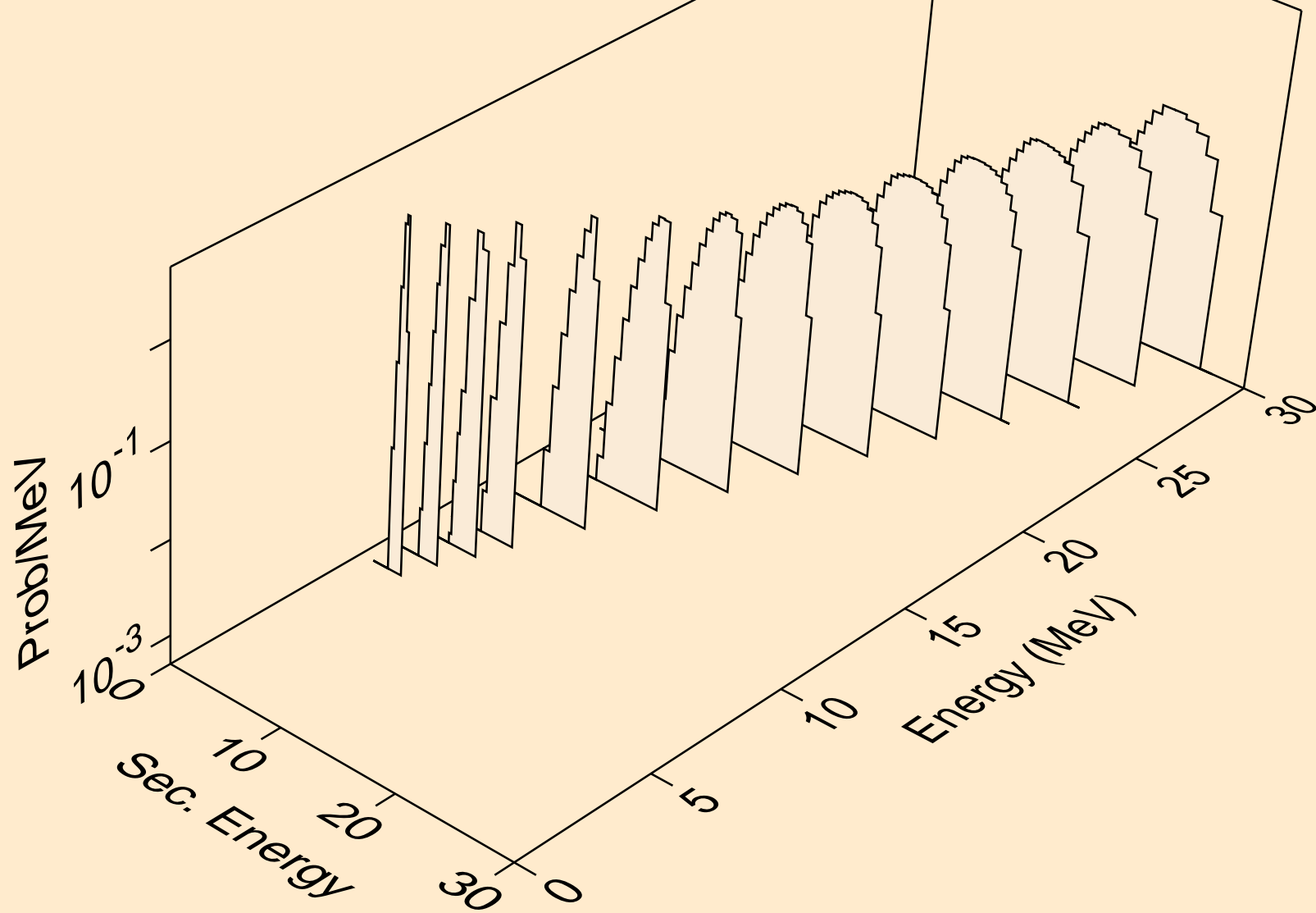

PO223 DEUTERON ACER TENDL-2021 LIBRARY; T=0.K  
Deuteron emission for inelastic

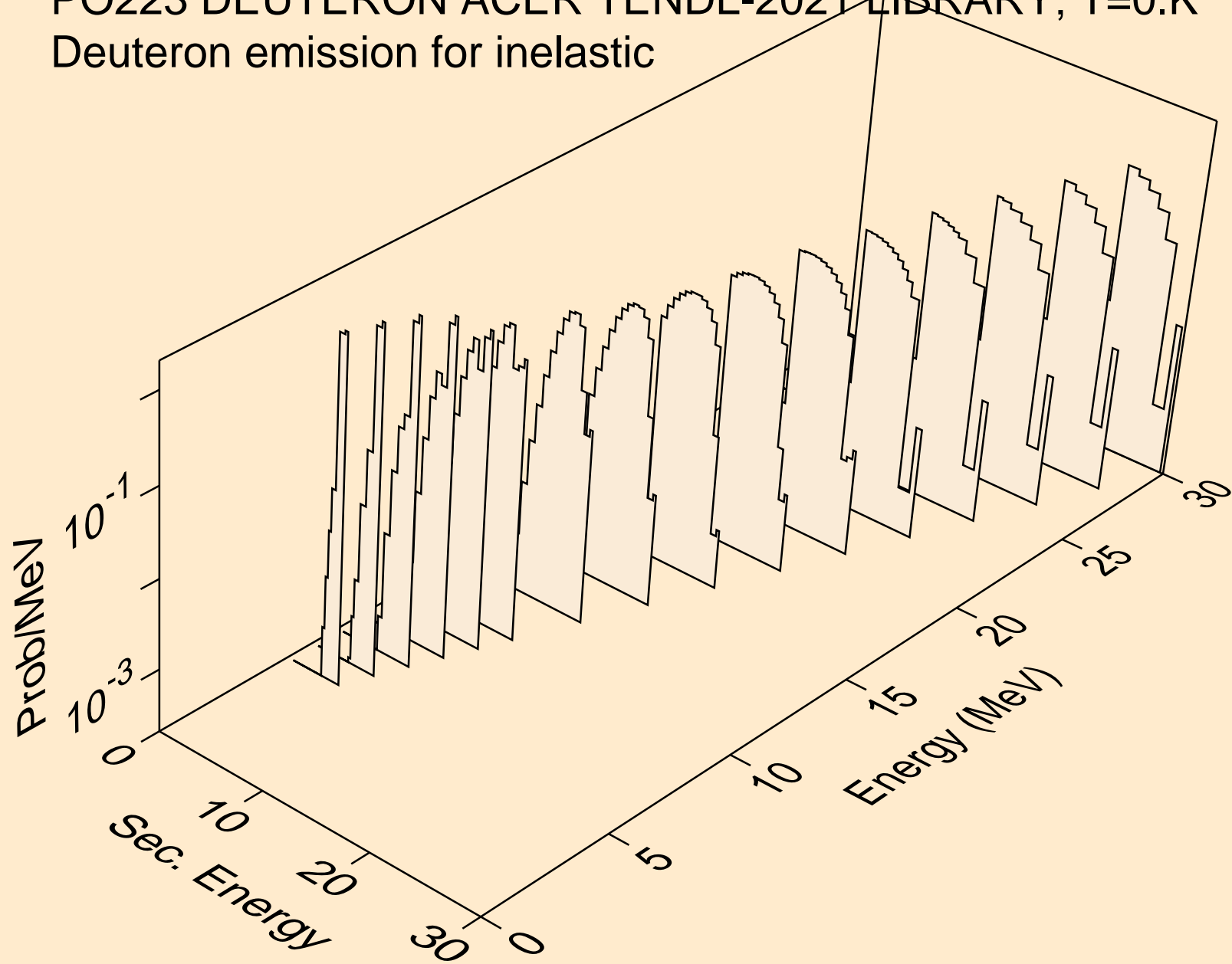

PO223 DEUTERON ACER TENDL-2021 LIBRARY; T=0.K  
Deuteron emission for (d,pd)

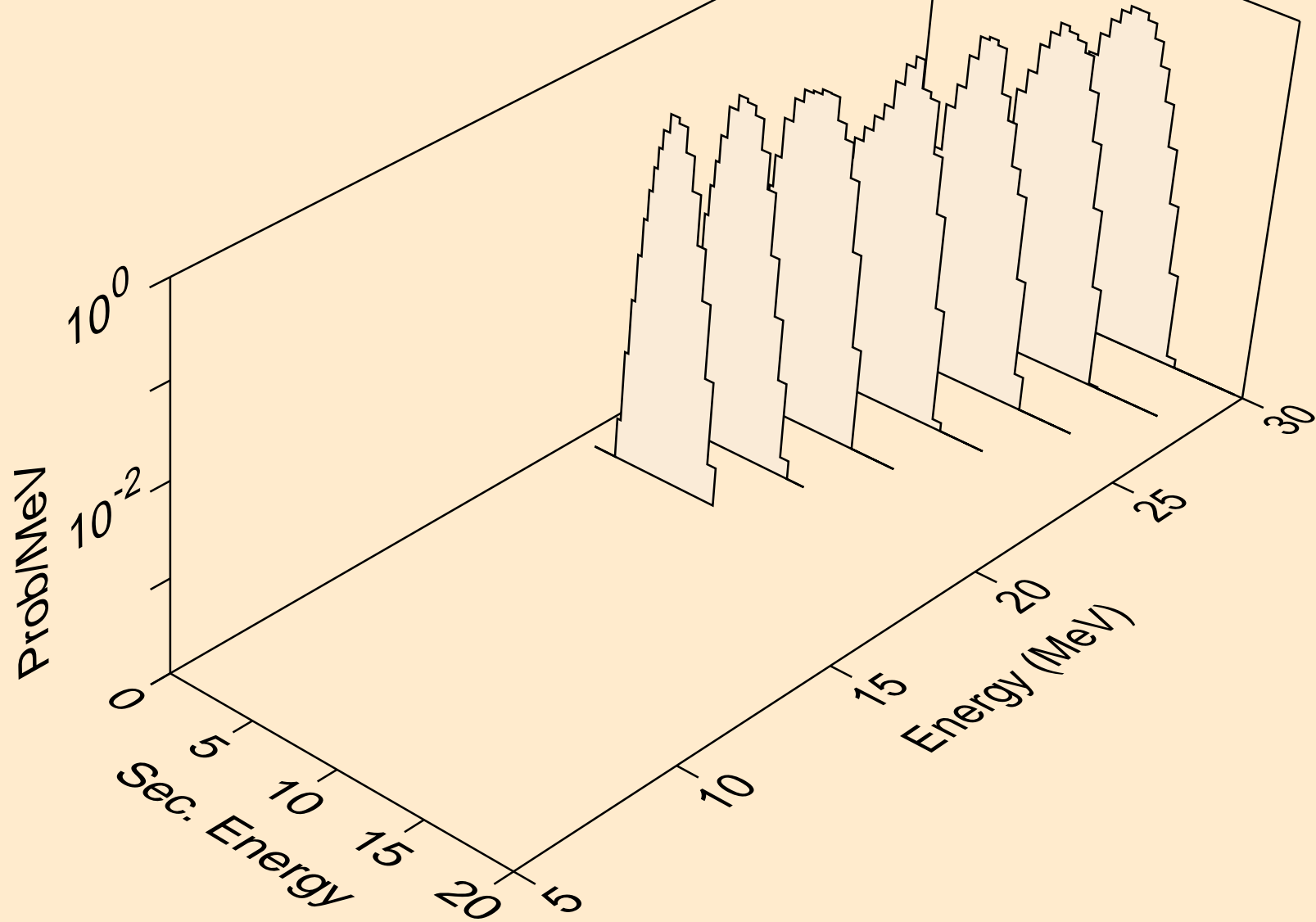

PO223 DEUTERON ACER TENDL-2021 LIBRARY; T=0.K  
Photon emission for (z,n)

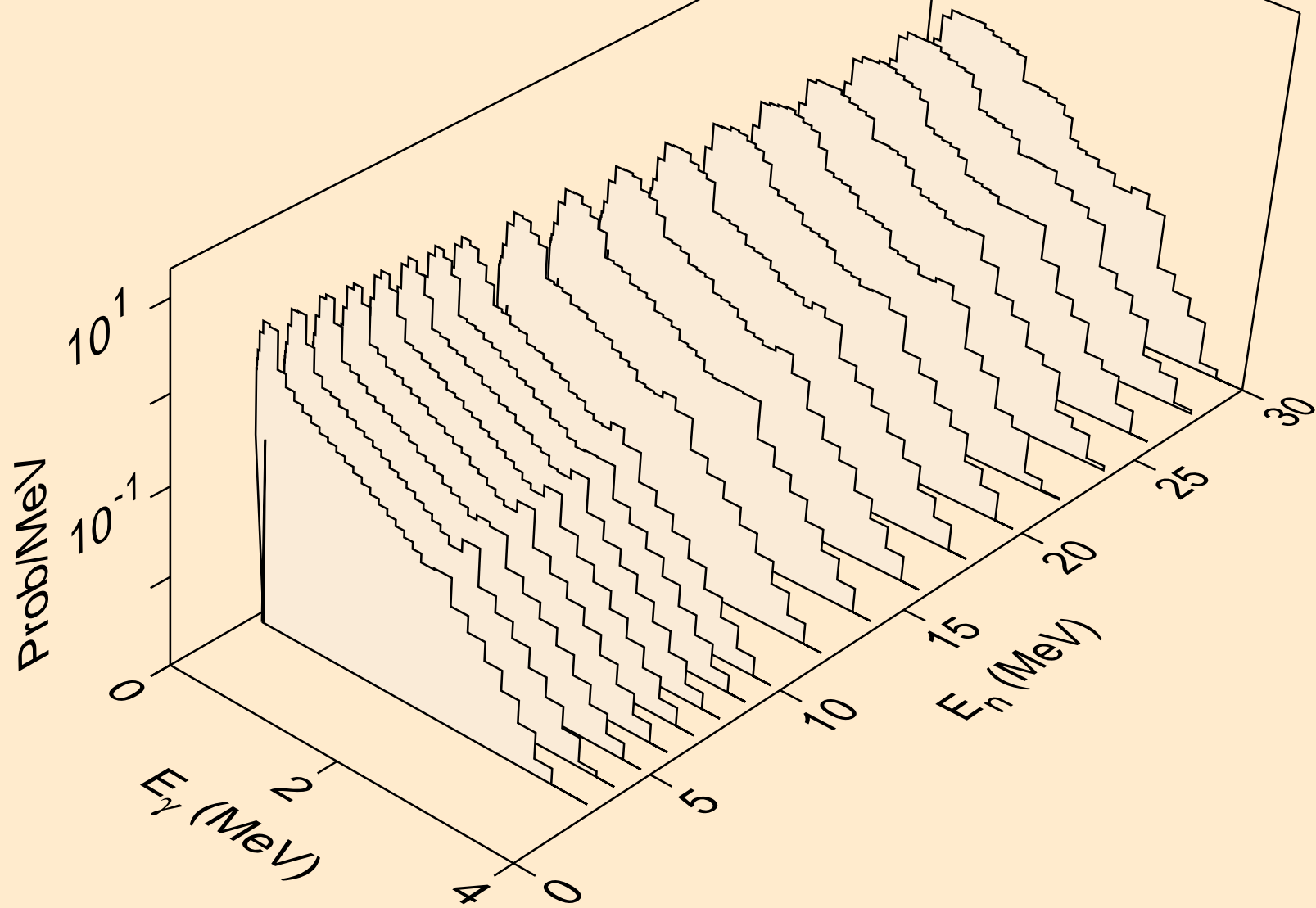

PO223 DEUTERON ACER TENDL-2021 LIBRARY; T=0.K  
Photon emission for (n,x)

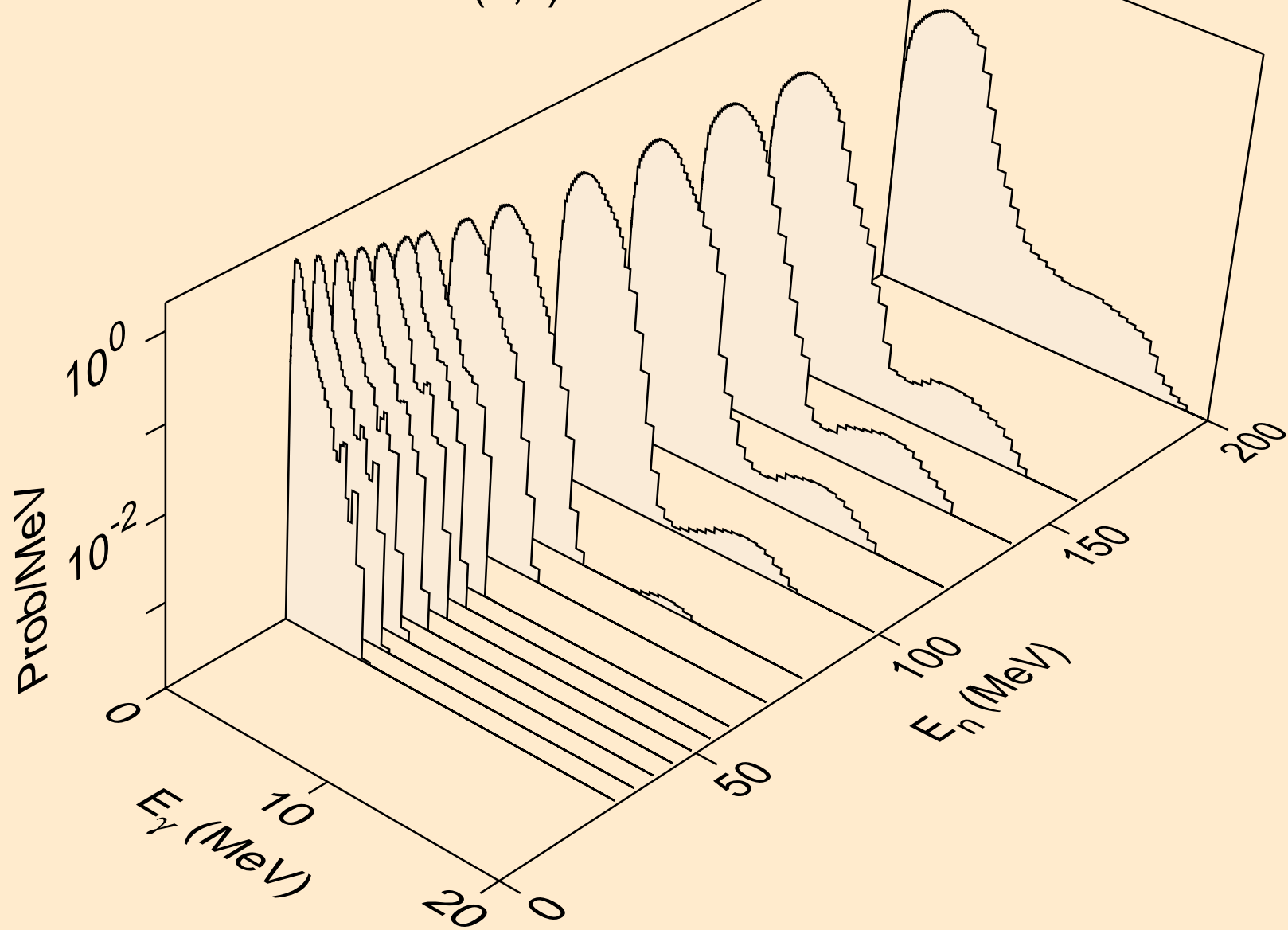

PO223 DEUTERON ACER TENDL-2021 LIBRARY; T=0.K  
Photon emission for (n,2nd)

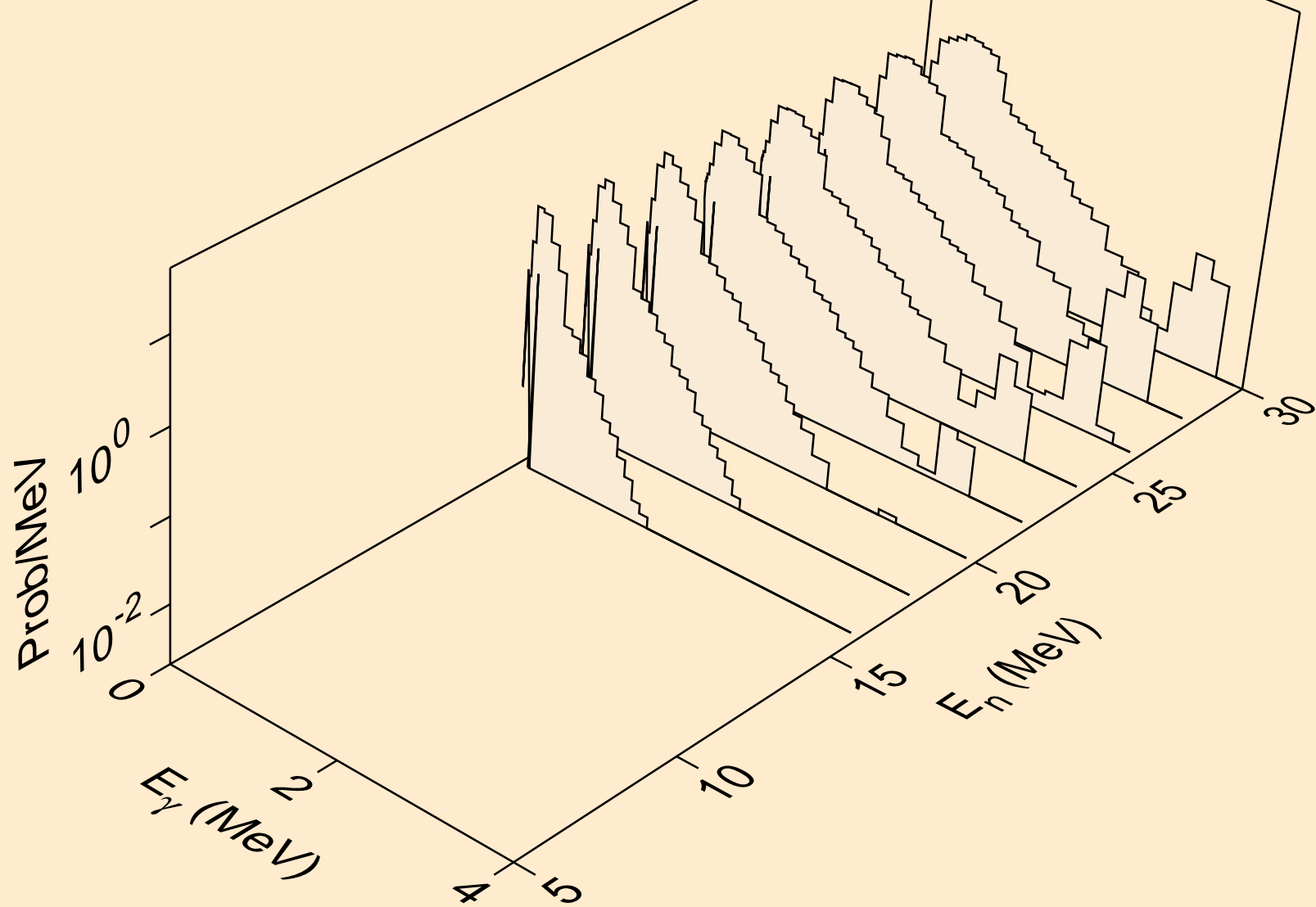

PO223 DEUTERON ACER TENDL-2021 LIBRARY; T=0.K  
Photon emission for (n,2n)

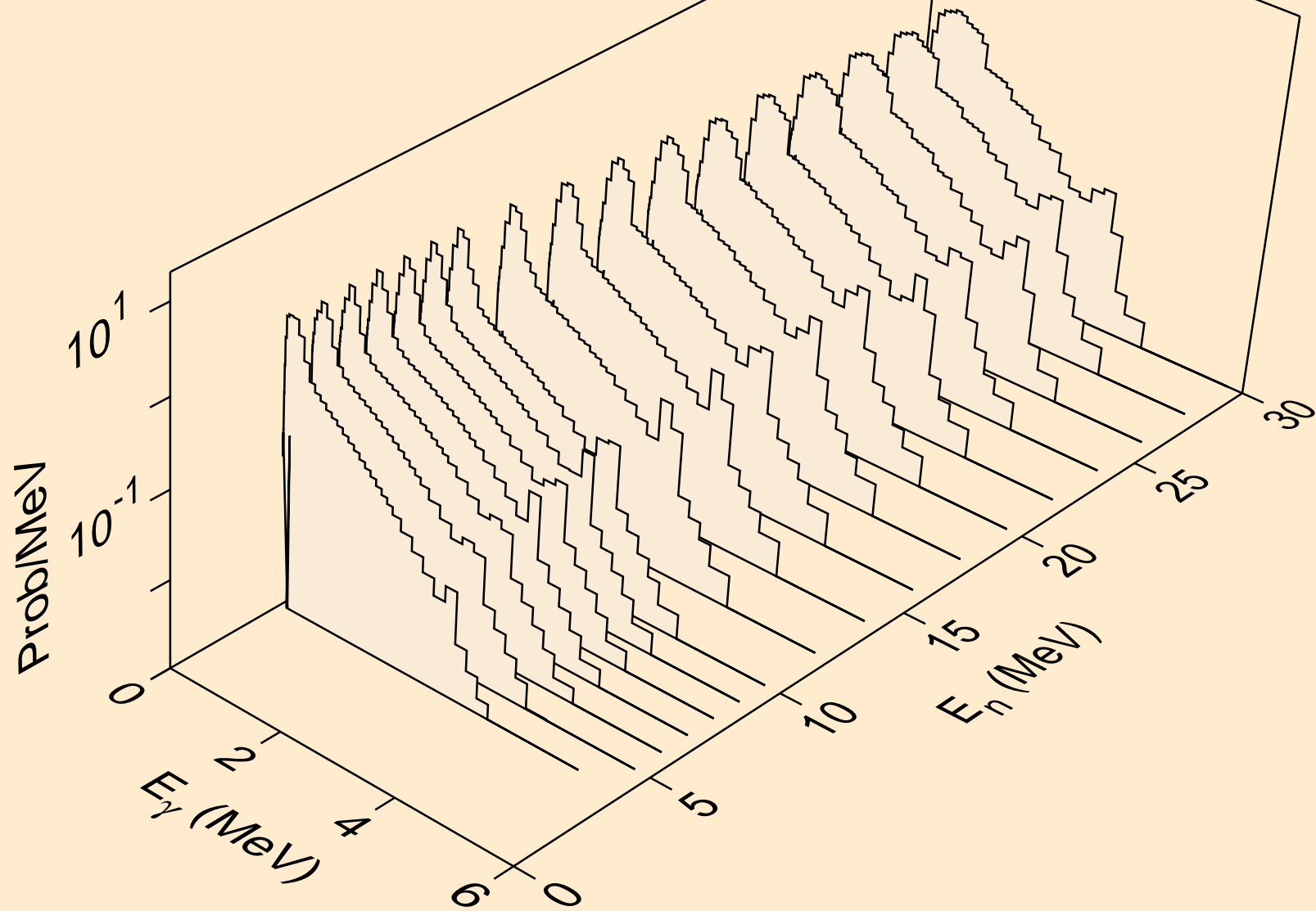



PO223 DEUTERON ACER TENDL-2021 LIBRARY; T=0.K  
Photon emission for (n,3n)

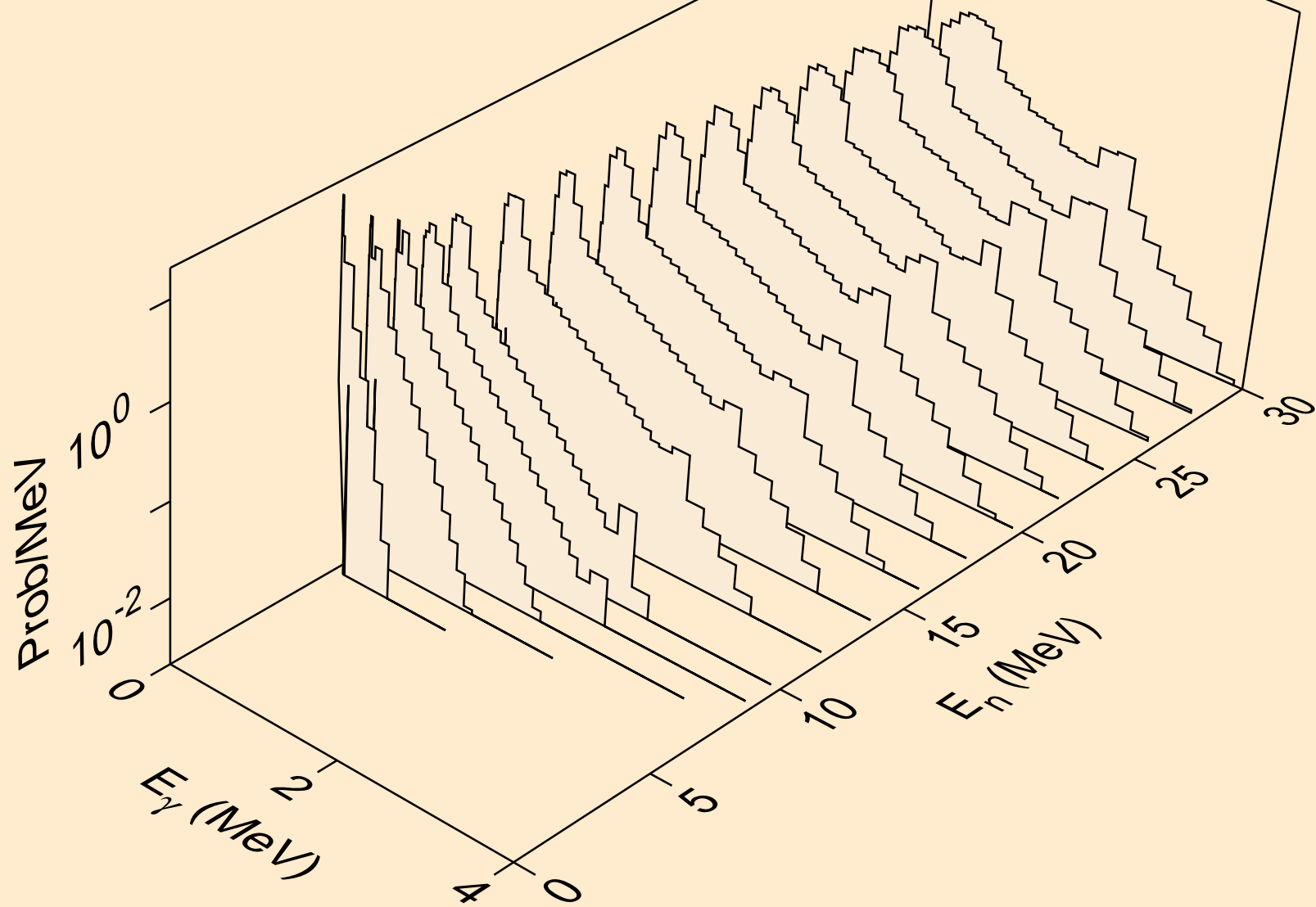

PO223 DEUTERON ACER TENDL-2021 LIBRARY; T=0.K  
Photon emission for (n,n\*)a

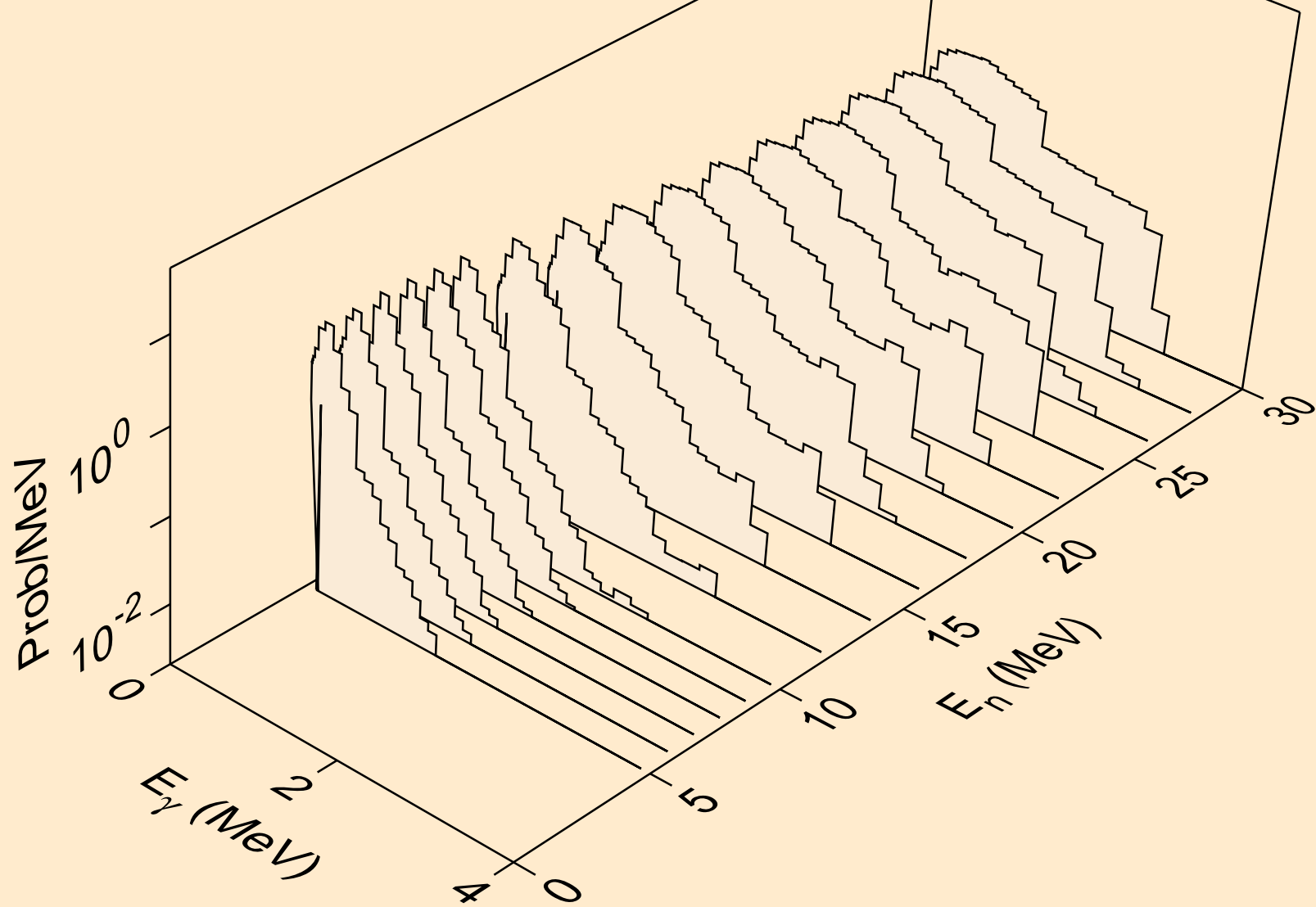

PO223 DEUTERON ACER TENDL-2021 LIBRARY; T=0.K  
Photon emission for (n,2n)a

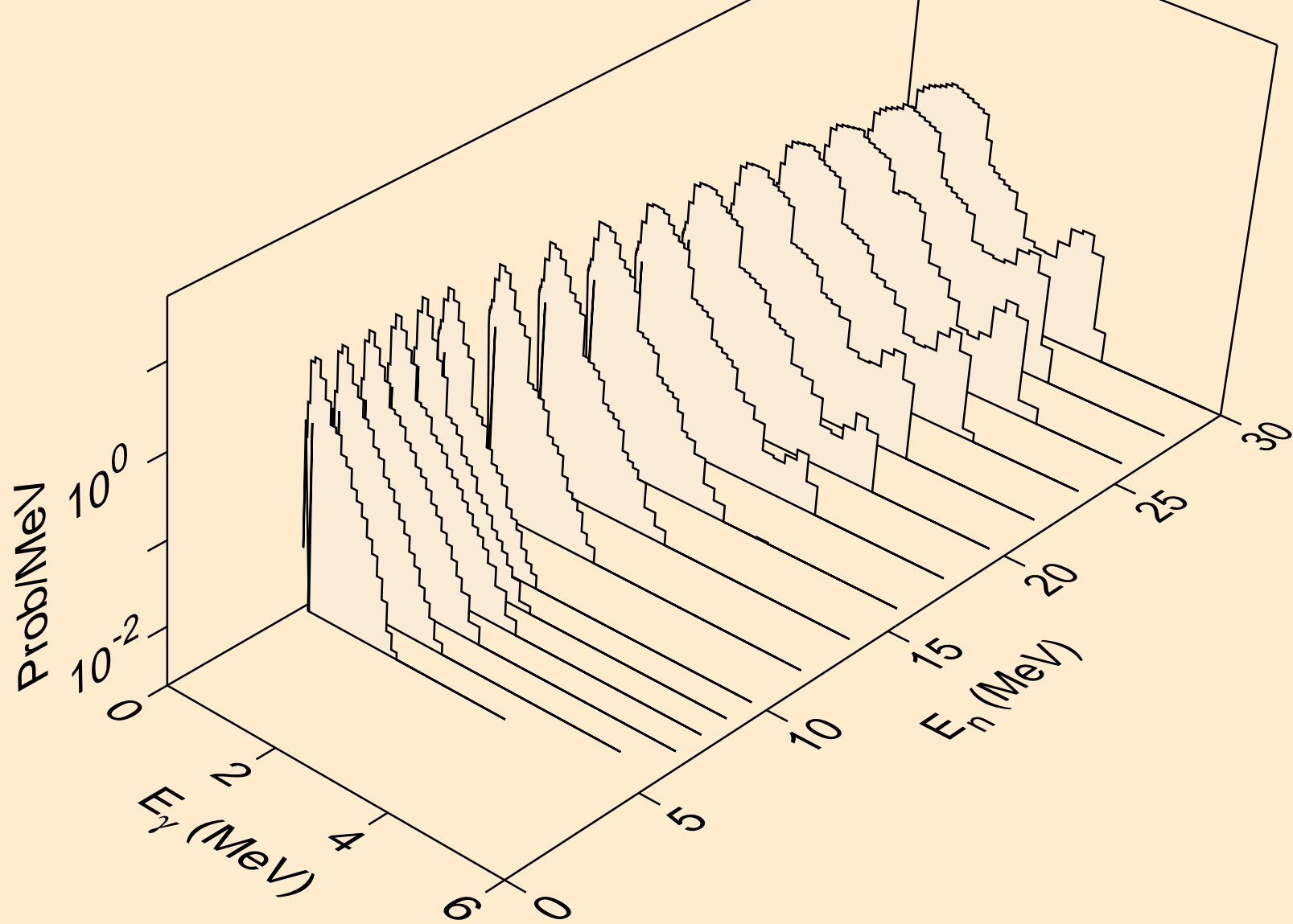

PO223 DEUTERON ACER TENDL-2021 LIBRARY; T=0.K  
Photon emission for (n,3n)a

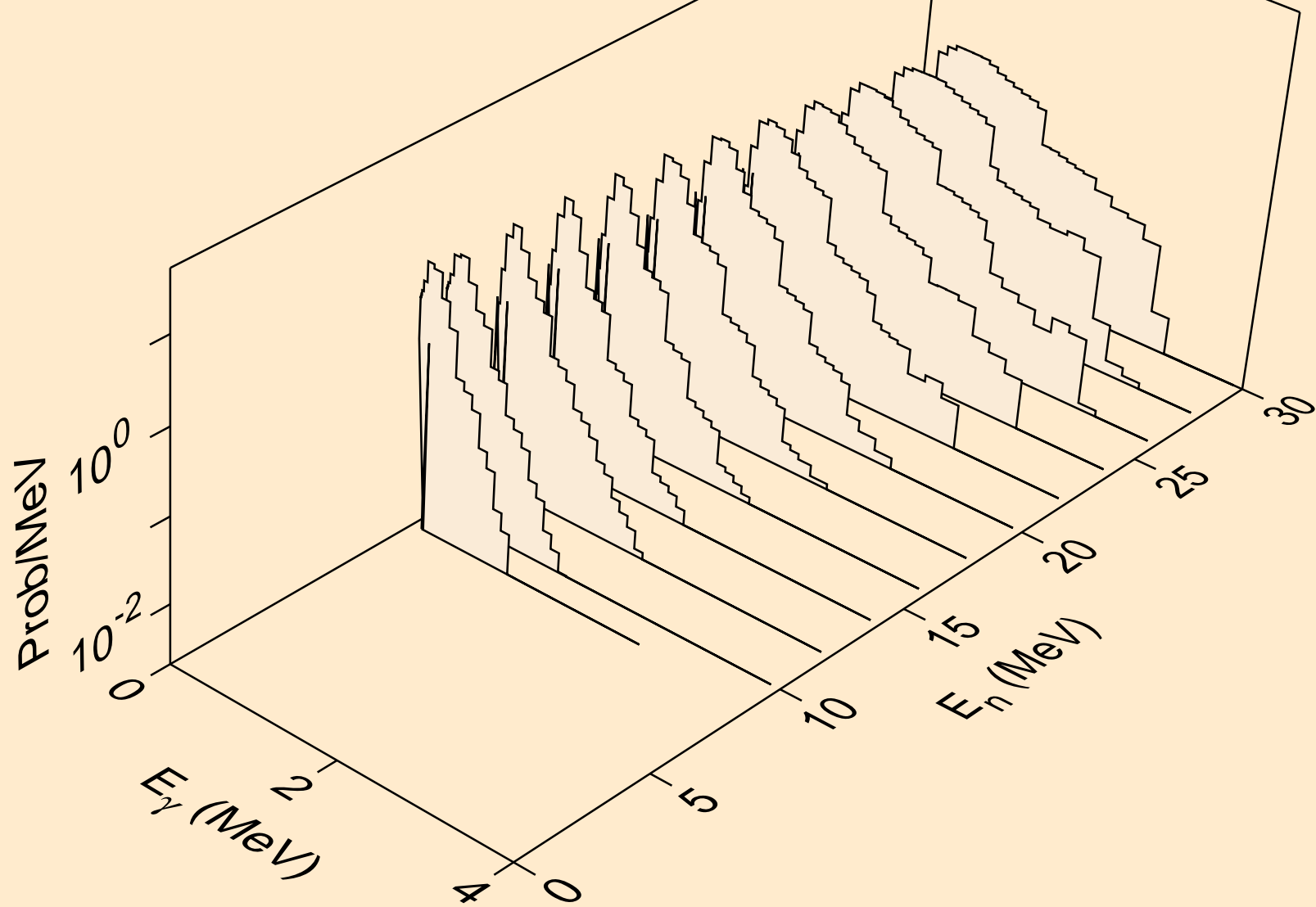

PO223 DEUTERON ACER TENDL-2021 LIBRARY; T=0.K  
Photon emission for (n,n\*)p

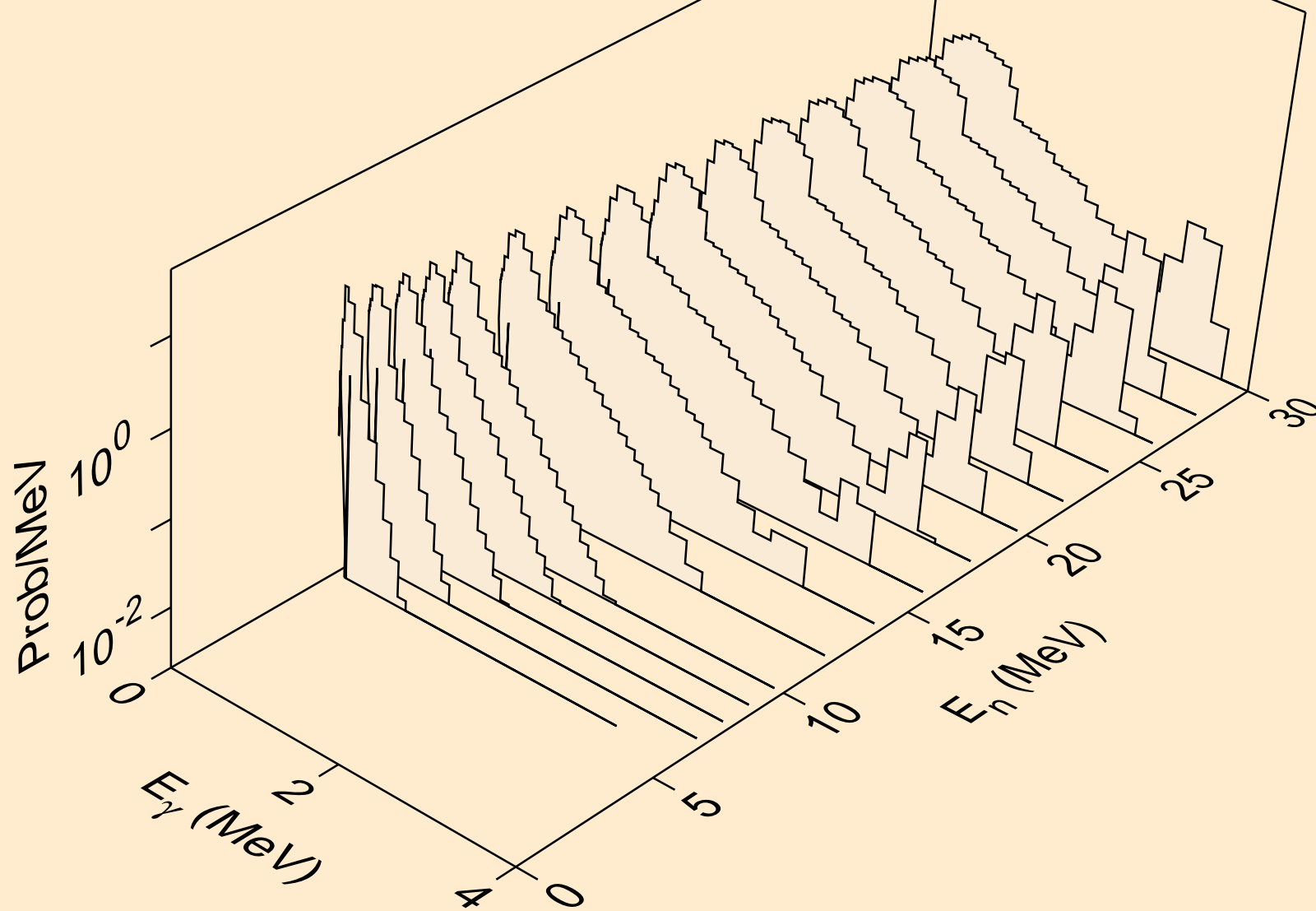

PO223 DEUTERON ACER TENDL-2021 LIBRARY; T=0.K  
Photon emission for (n,2n)2a

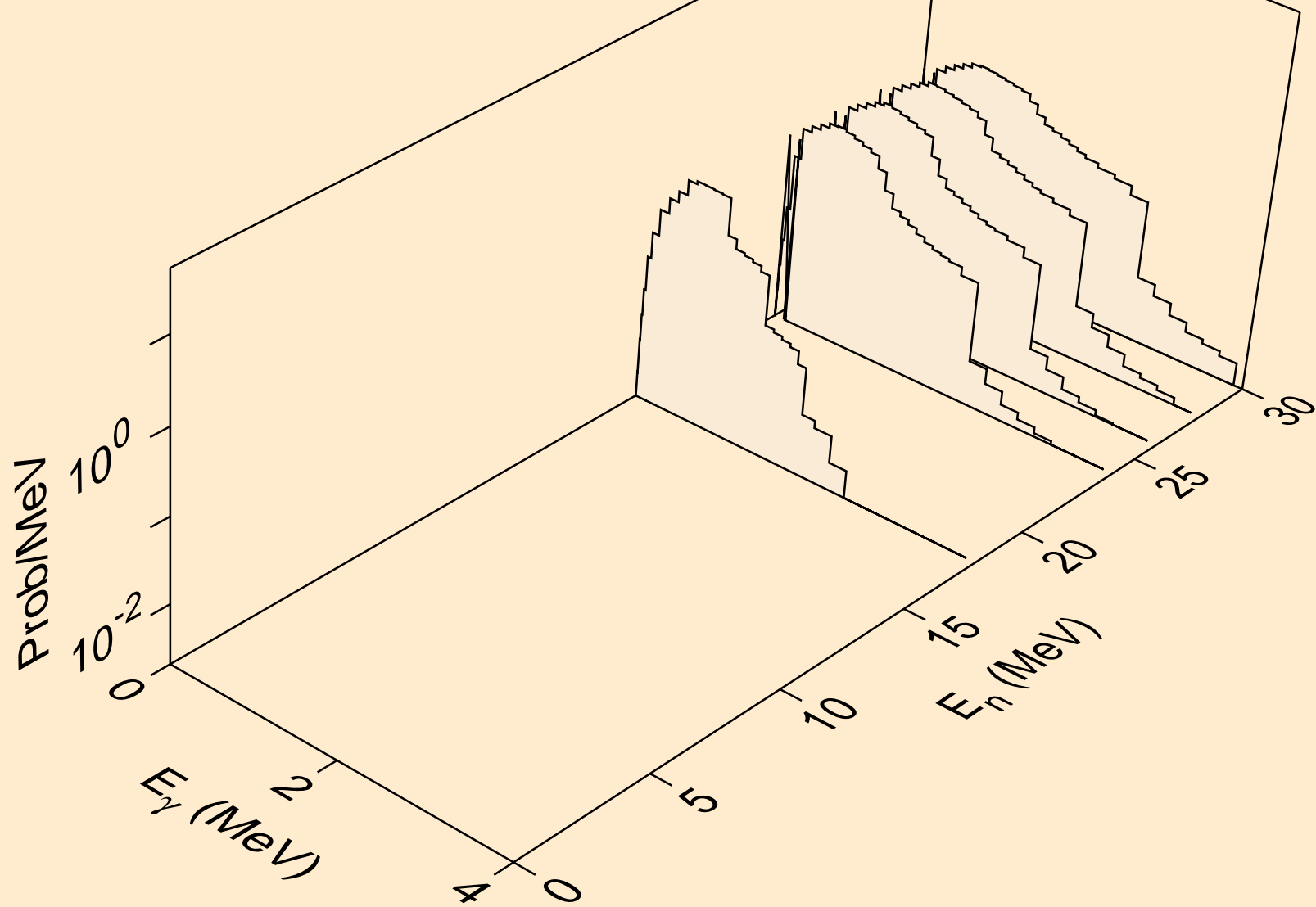

PO223 DEUTERON ACER TENDL-2021 LIBRARY; T=0.K  
Photon emission for (n,n\*)d

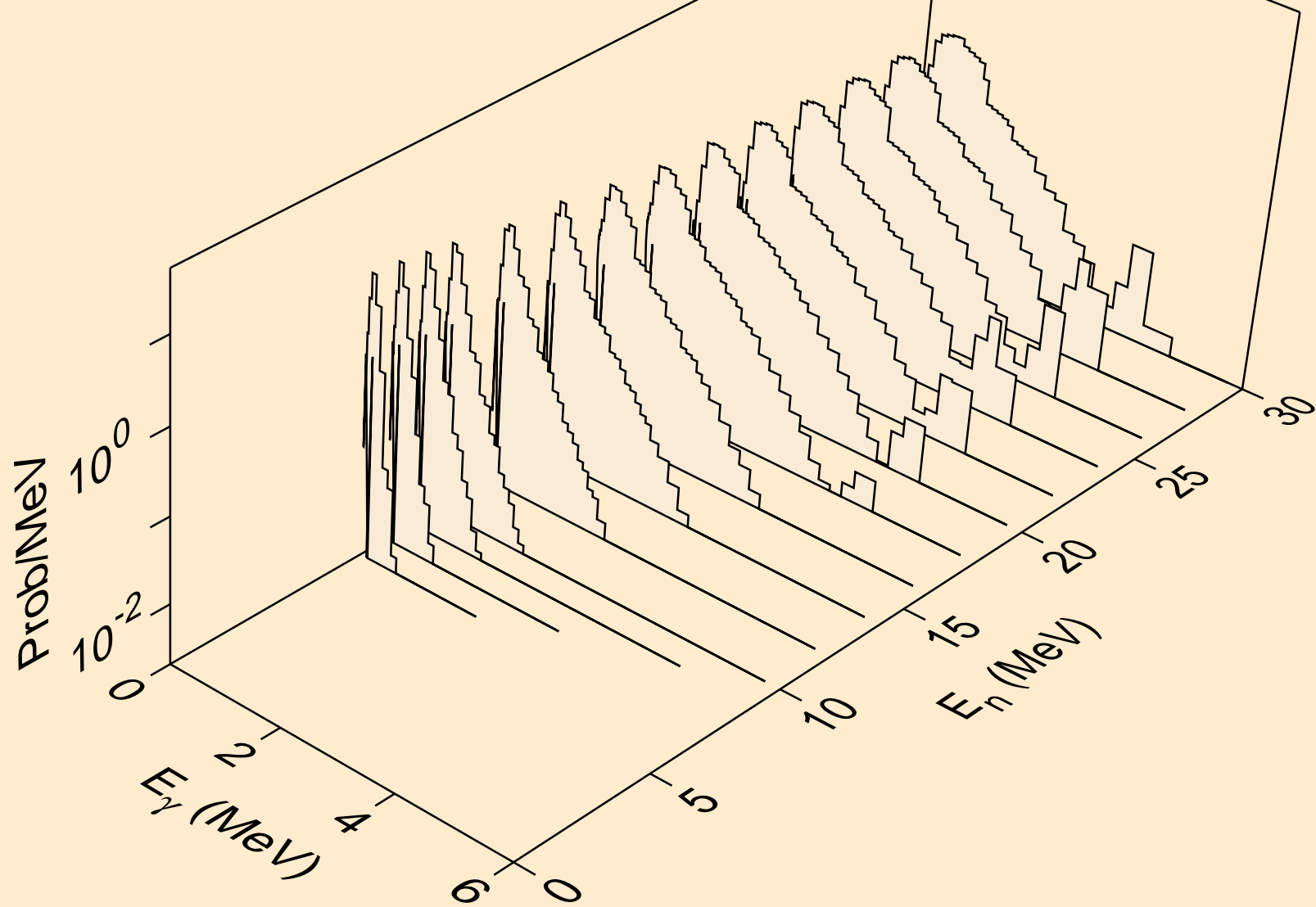

PO223 DEUTERON ACER TENDL-2021 LIBRARY; T=0.K  
Photon emission for (n,n\*)t

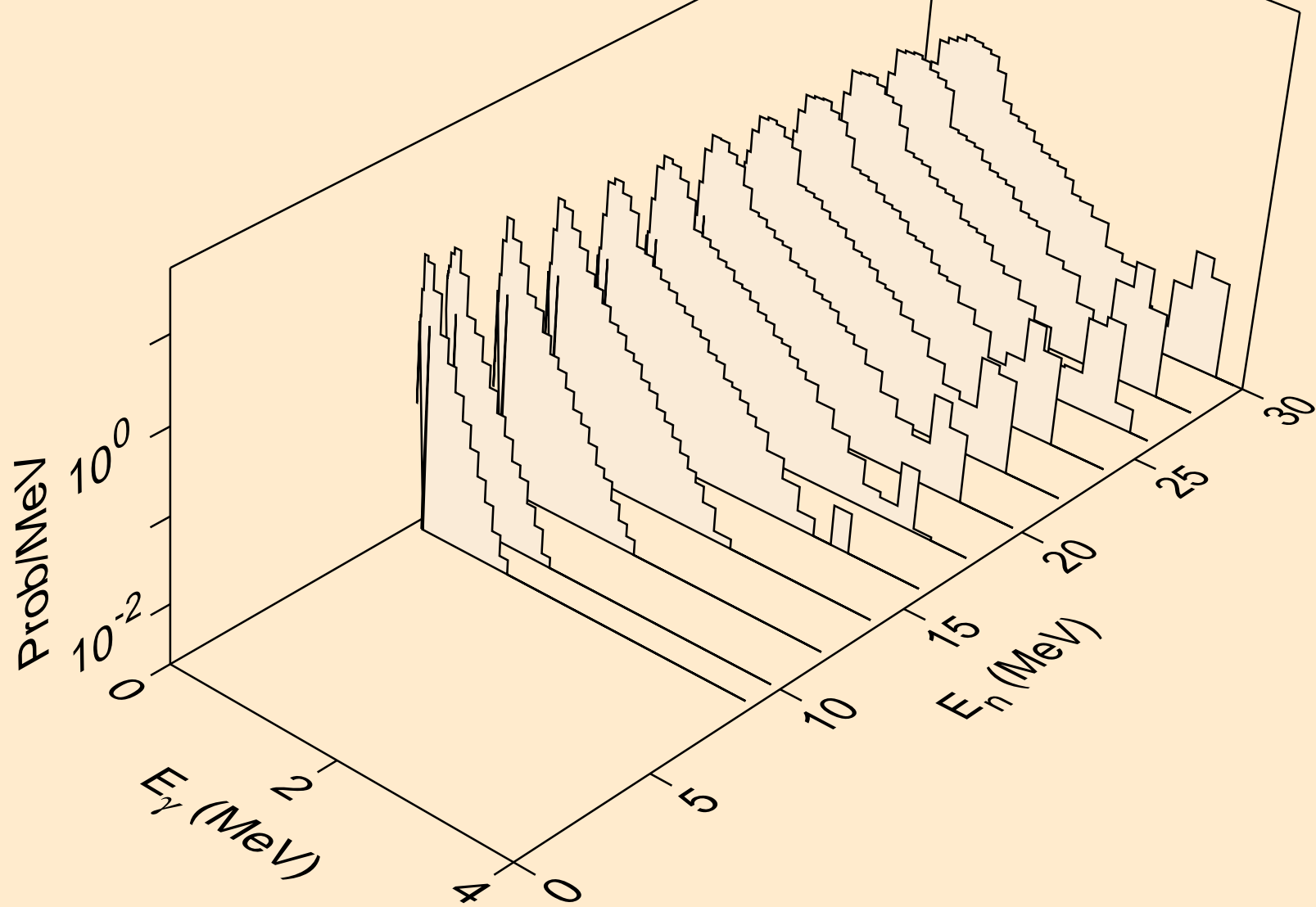



PO223 DEUTERON ACER TENDL-2021 LIBRARY; T=0.K  
Photon emission for (n,n\*)he3

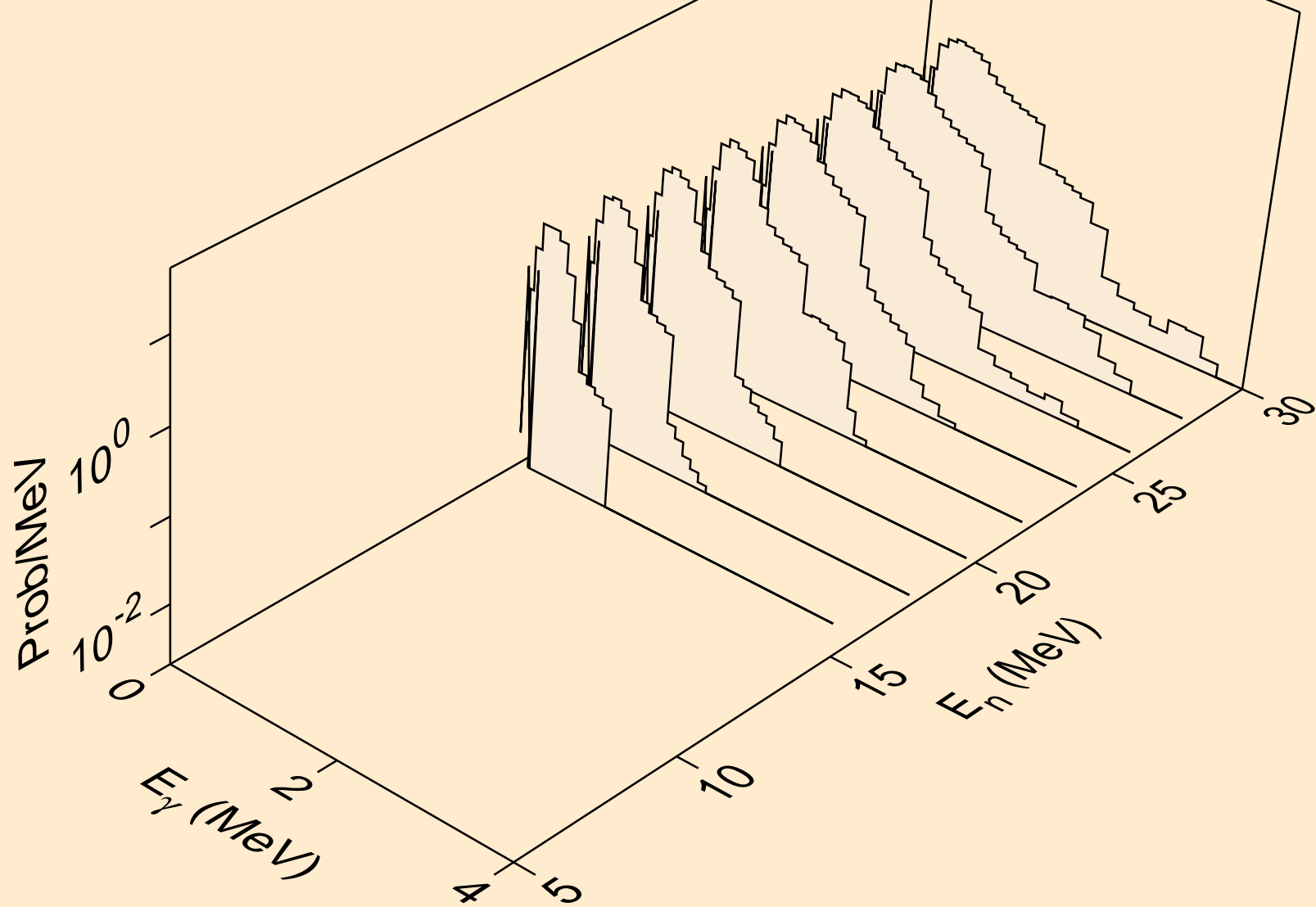

PO223 DEUTERON ACER TENDL-2021 LIBRARY; T=0.K  
Photon emission for (n,4n)

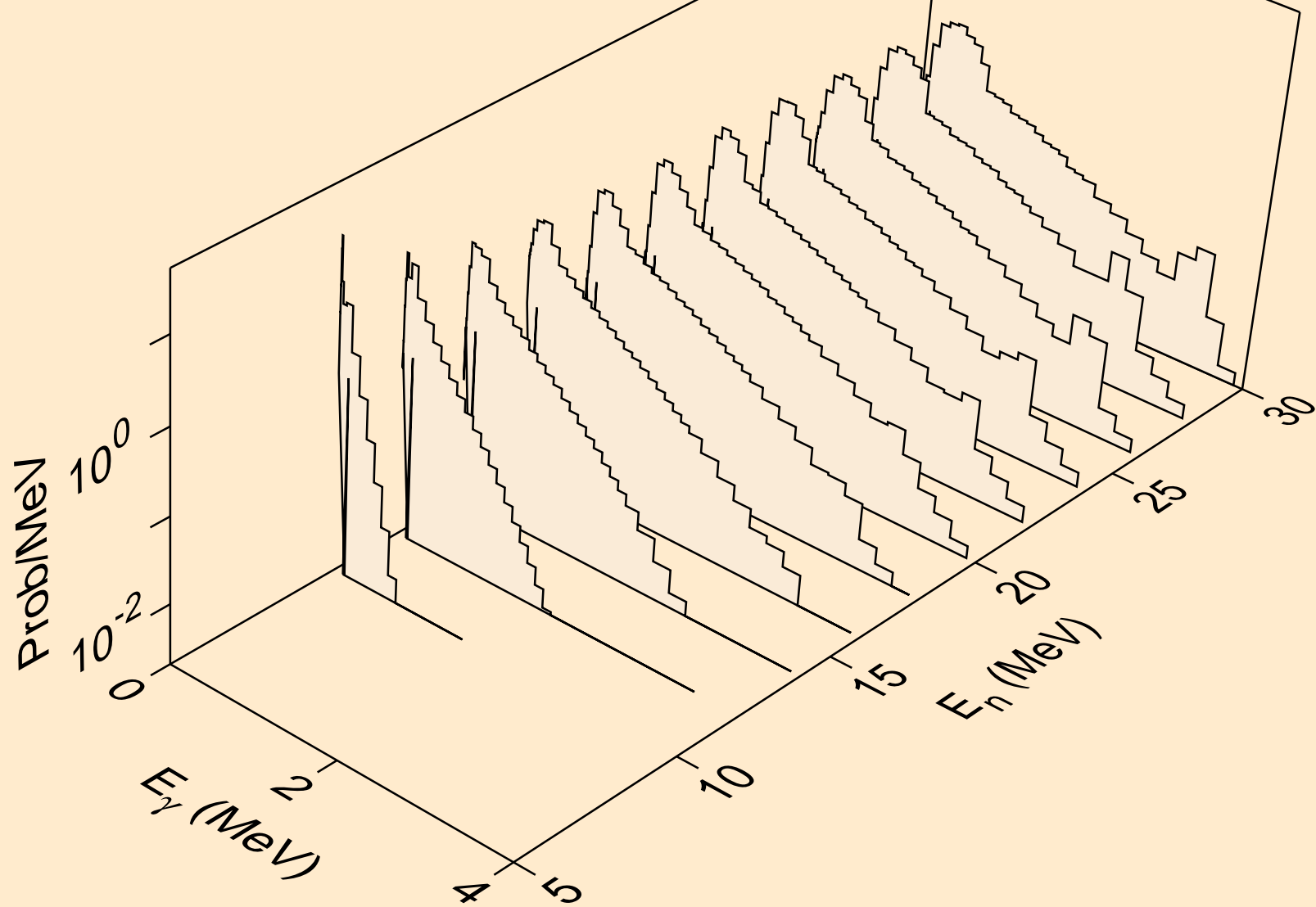

PO223 DEUTERON ACER TENDL-2021 LIBRARY; T=0.K  
Photon emission for (n,2np)

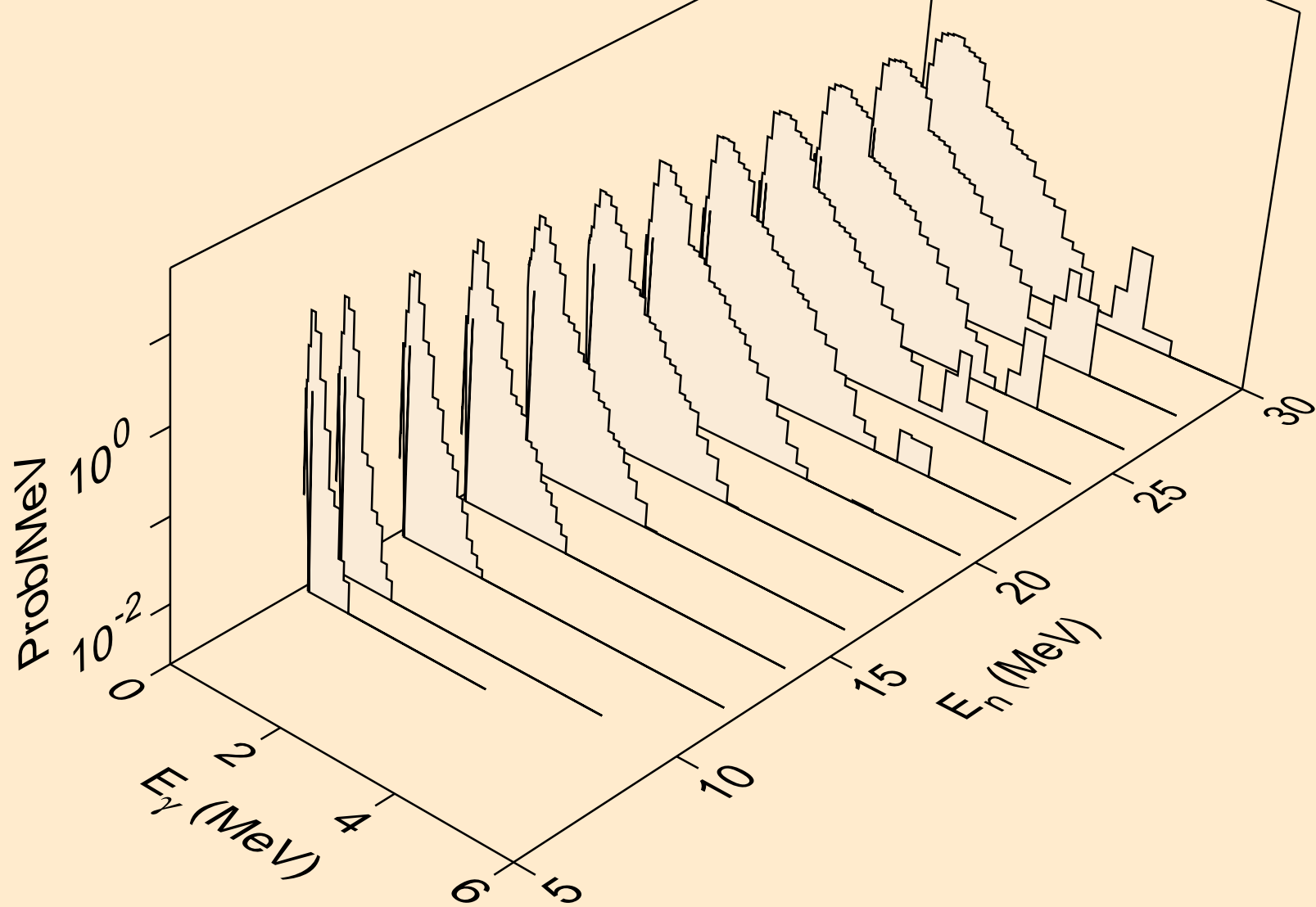

PO223 DEUTERON ACER TENDL-2021 LIBRARY; T=0.K  
Photon emission for (n,3np)

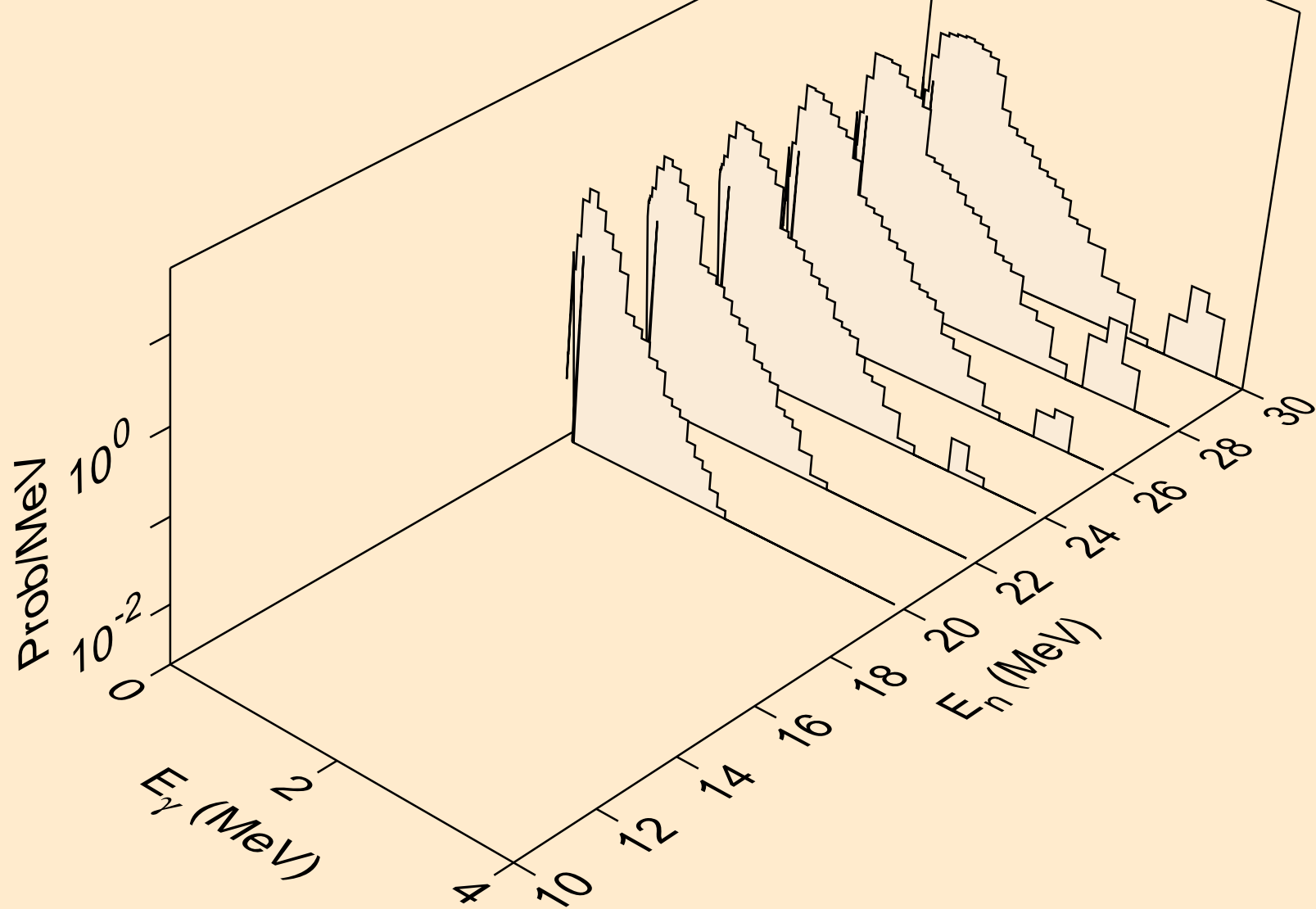

PO223 DEUTERON ACER TENDL-2021 LIBRARY; T=0.K  
Photon emission for (n,2np)

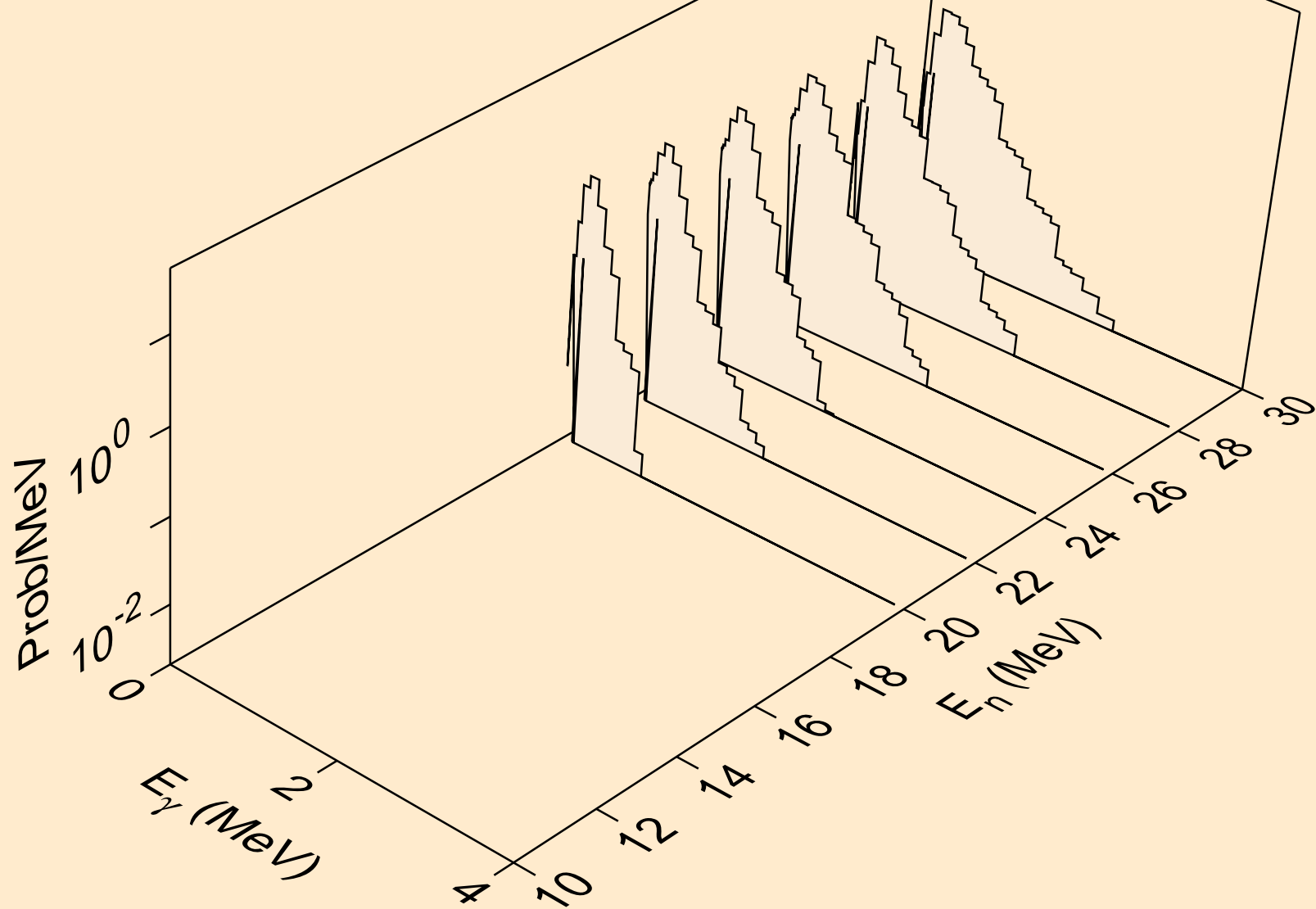

PO223 DEUTERON ACER TENDL-2021 LIBRARY; T=0.K  
Photon emission for (n,npa)

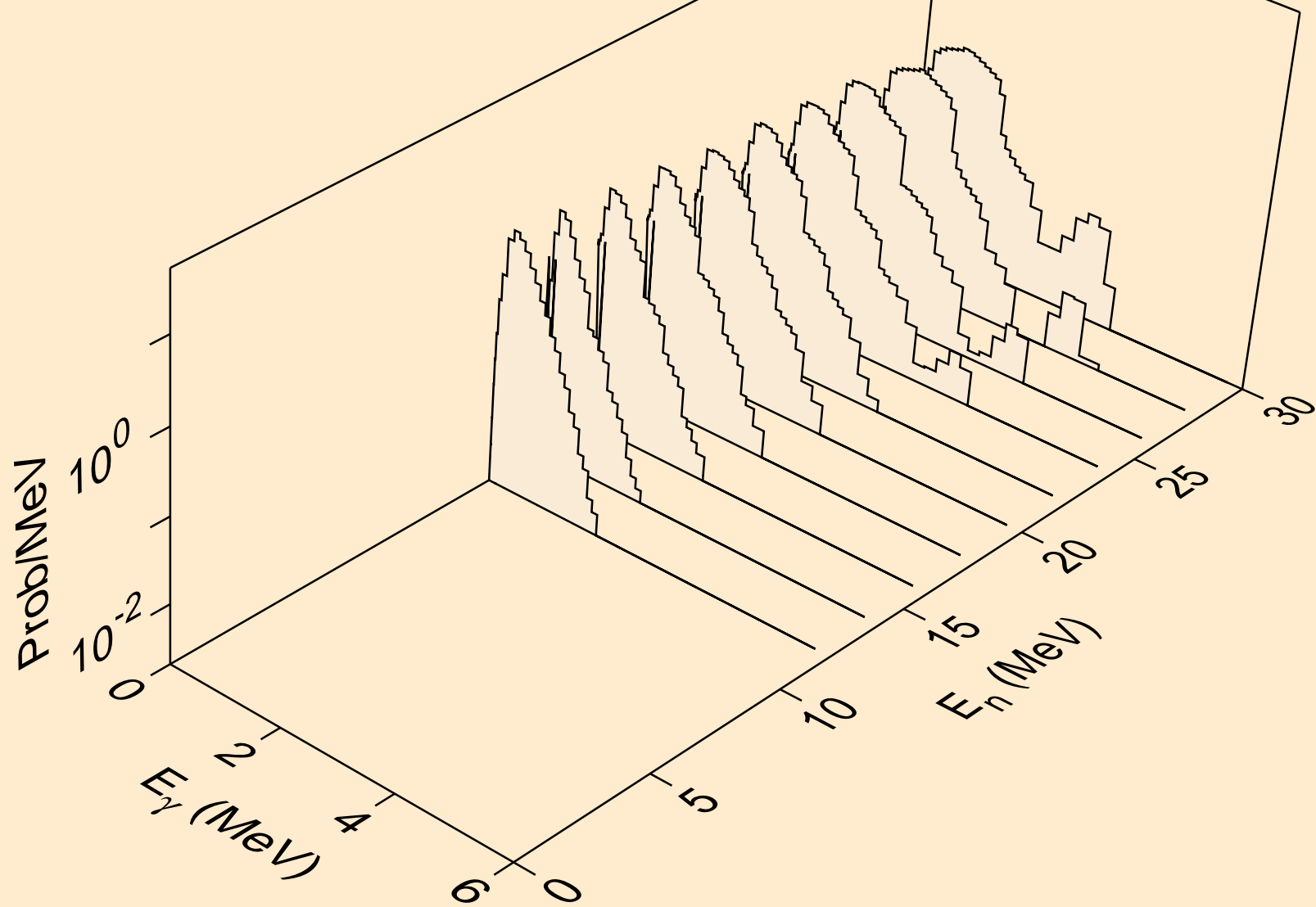

PO223 DEUTERON ACER TENDL-2021 LIBRARY; T=0.K  
Photon emission for (n,gma)

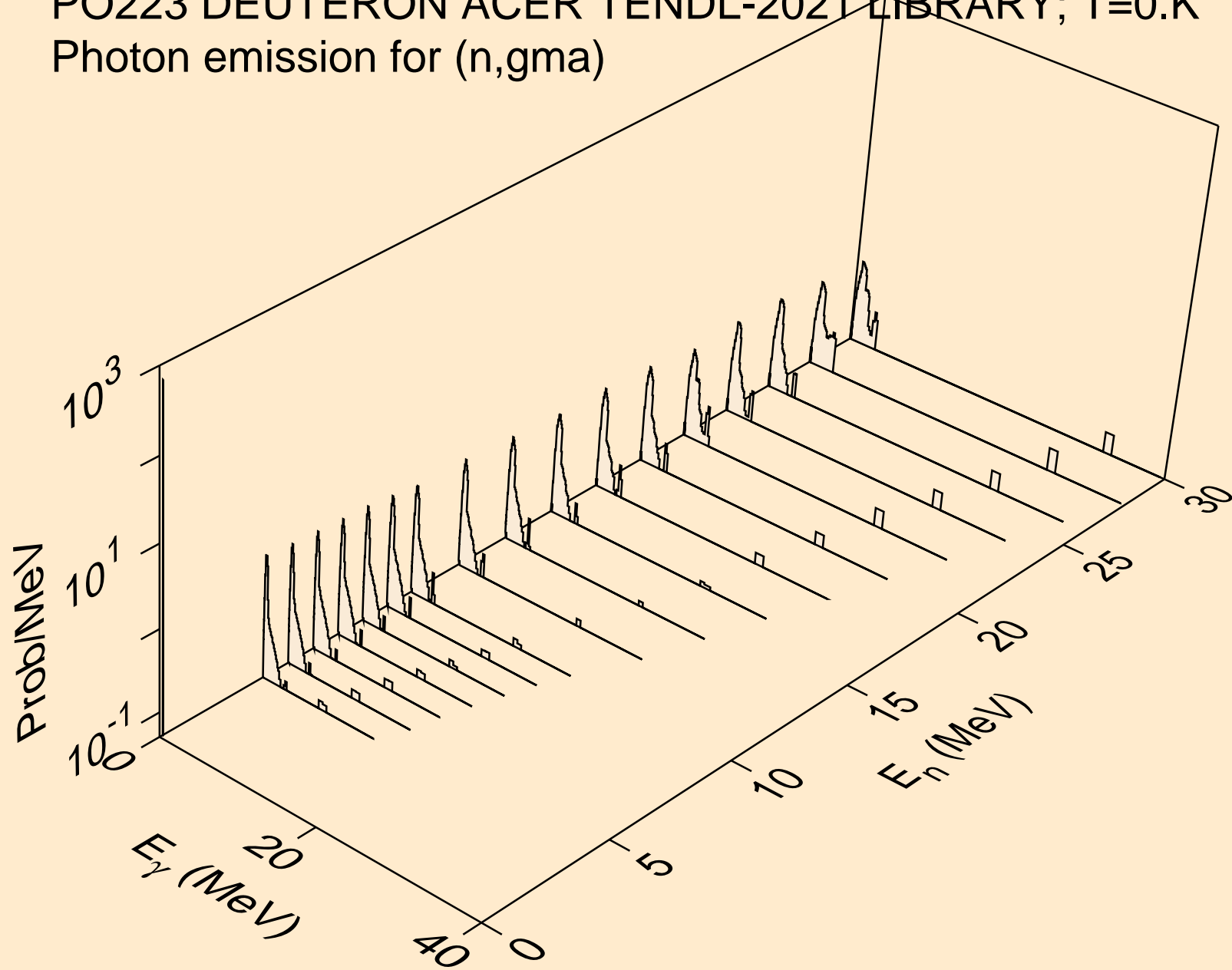

PO223 DEUTERON ACER TENDL-2021 LIBRARY; T=0.K  
Photon emission for (n,p)

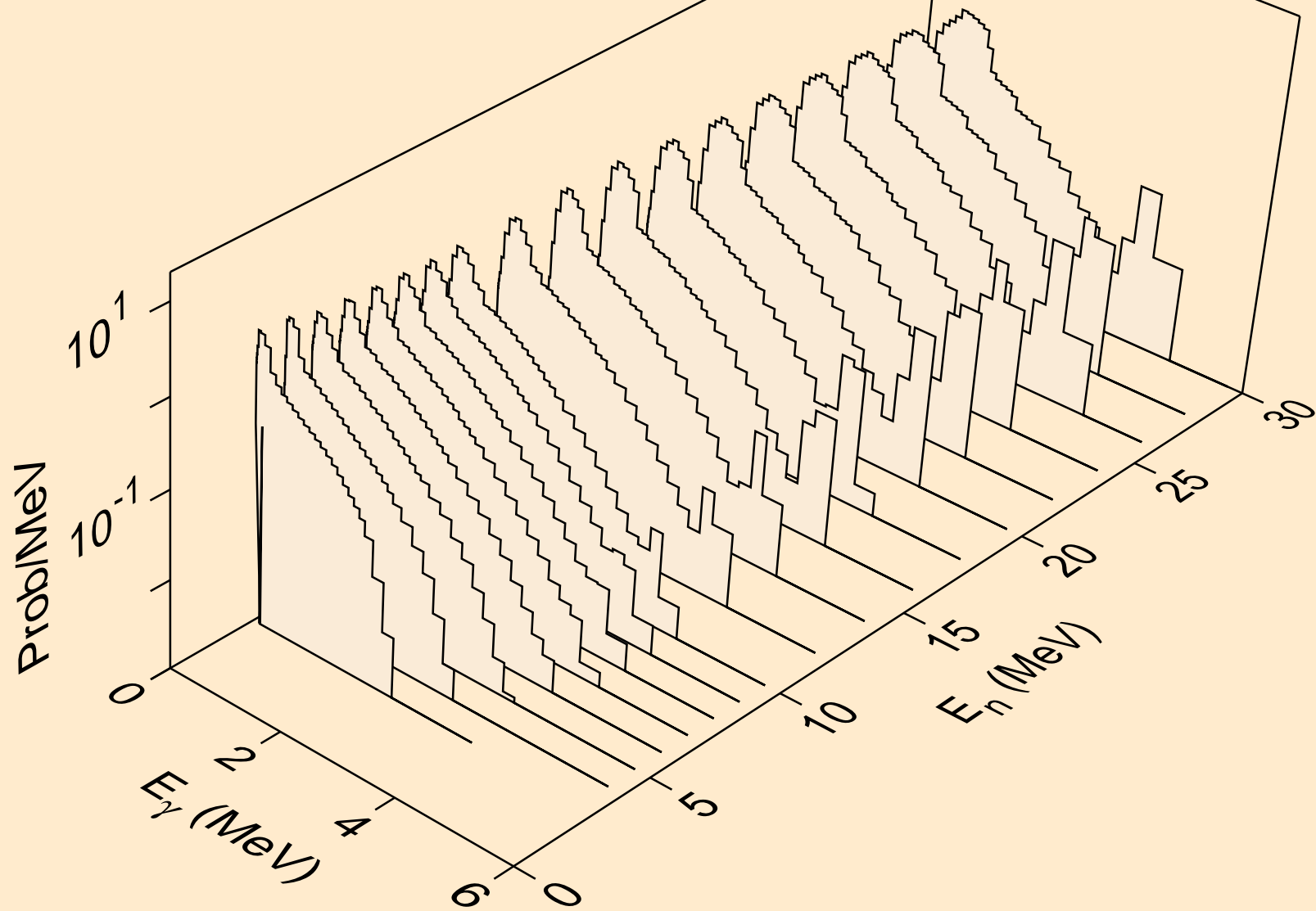



PO223 DEUTERON ACER TENDL-2021 LIBRARY; T=0.K  
Photon emission for inelastic

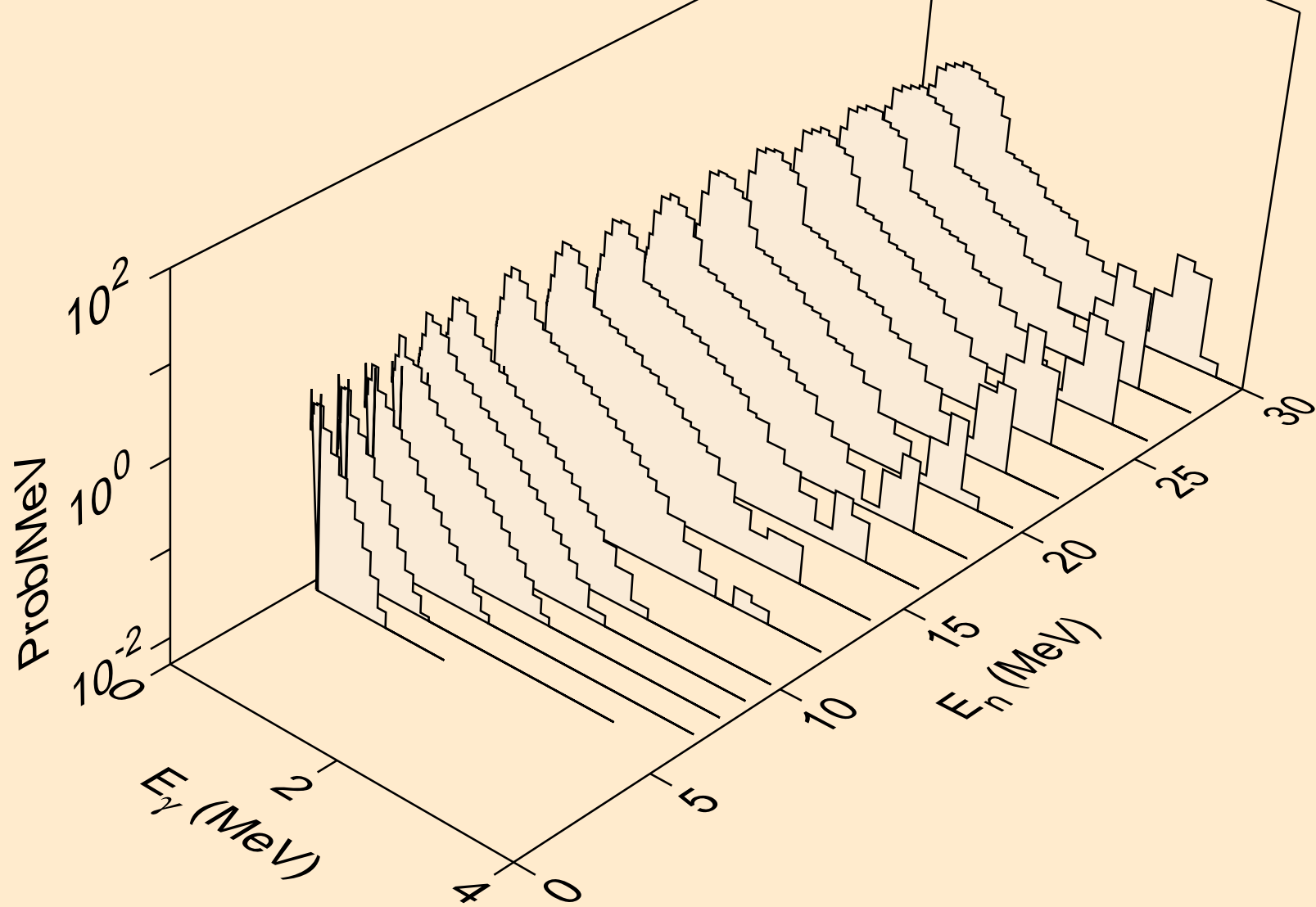

PO223 DEUTERON ACER TENDL-2021 LIBRARY; T=0.K  
Photon emission for (n,t)

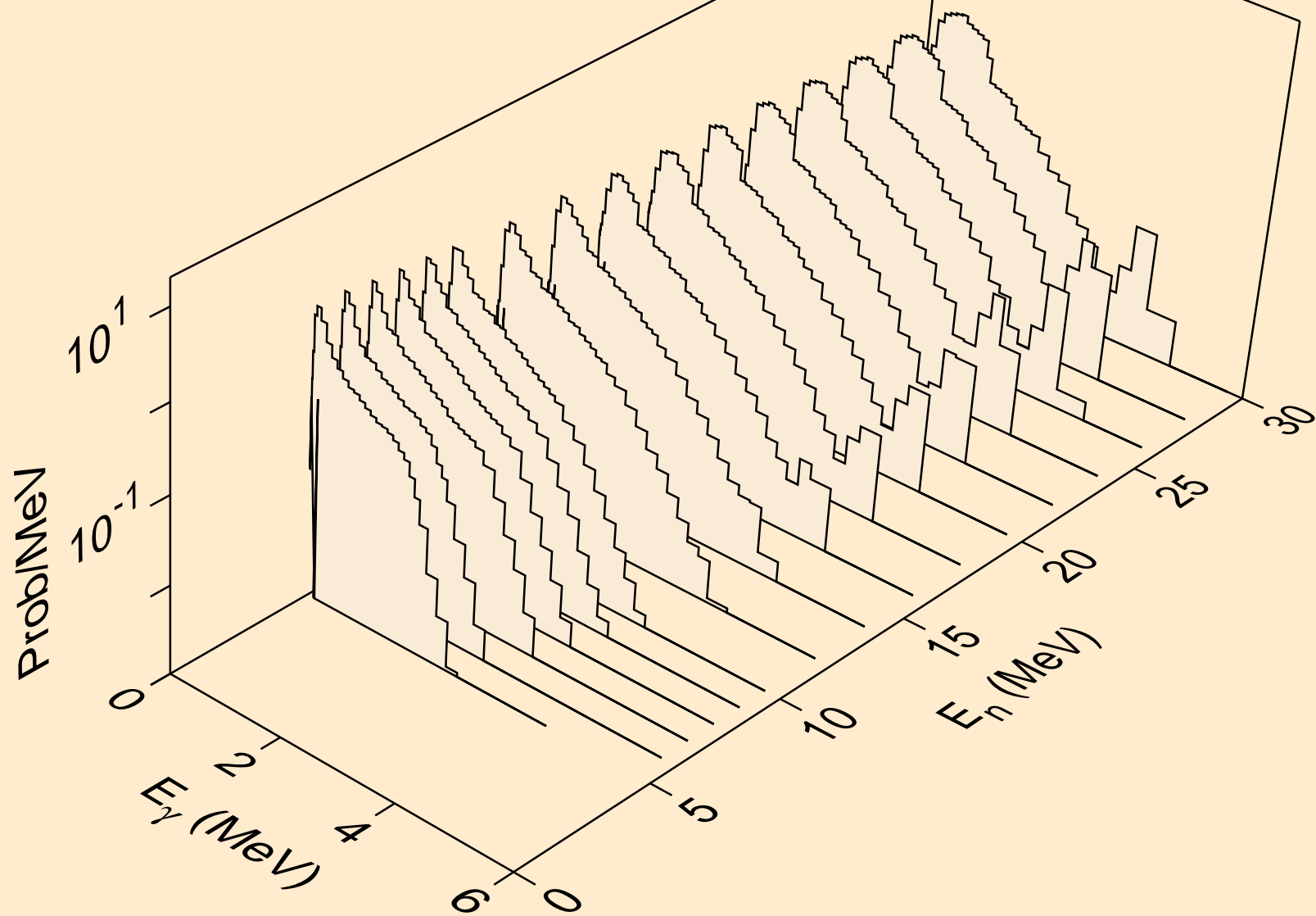

PO223 DEUTERON ACER TENDL-2021 LIBRARY; T=0.K  
Photon emission for (n,he3)

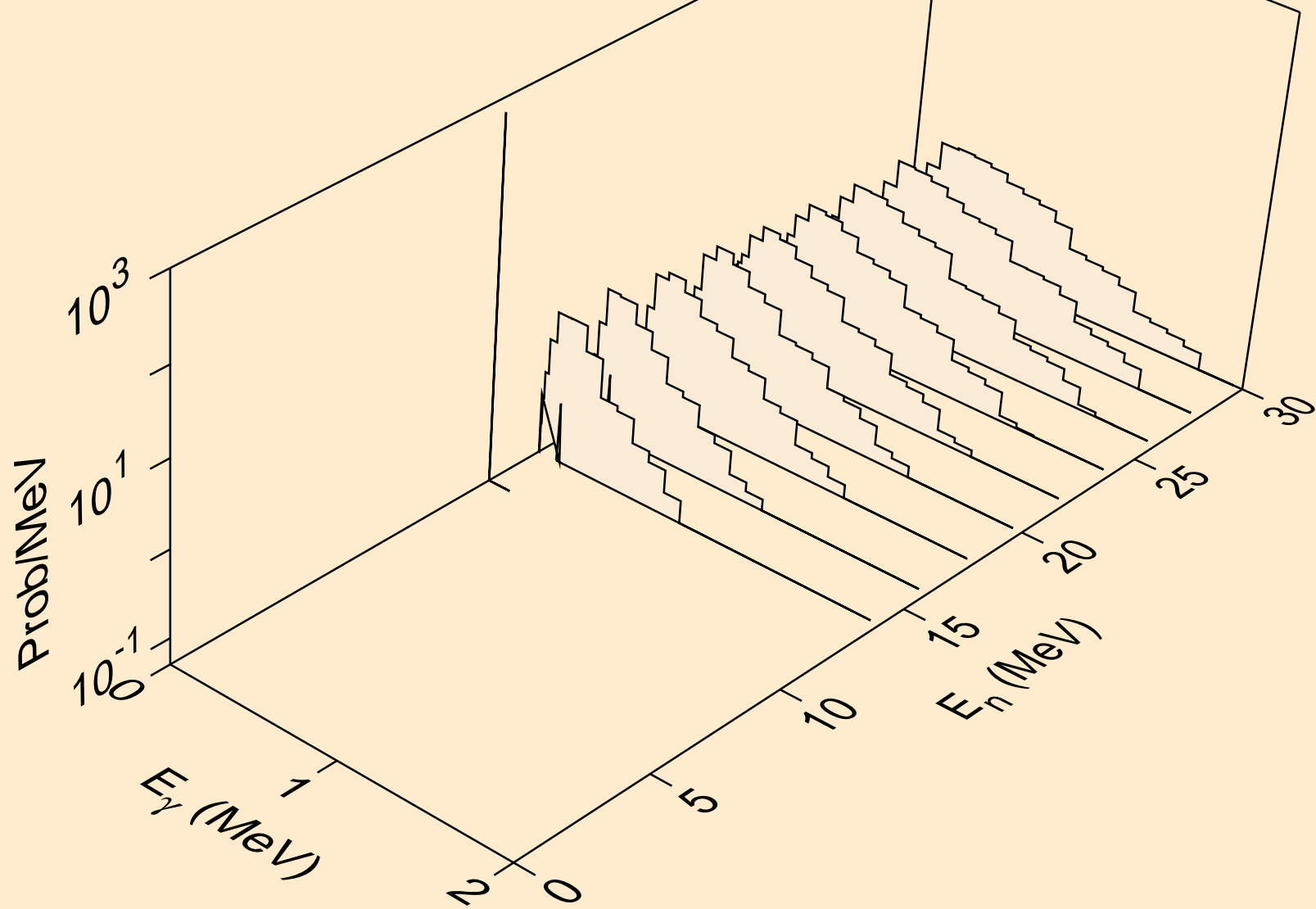

PO223 DEUTERON ACER TENDL-2021 LIBRARY; T=0.K  
Photon emission for (n,a)

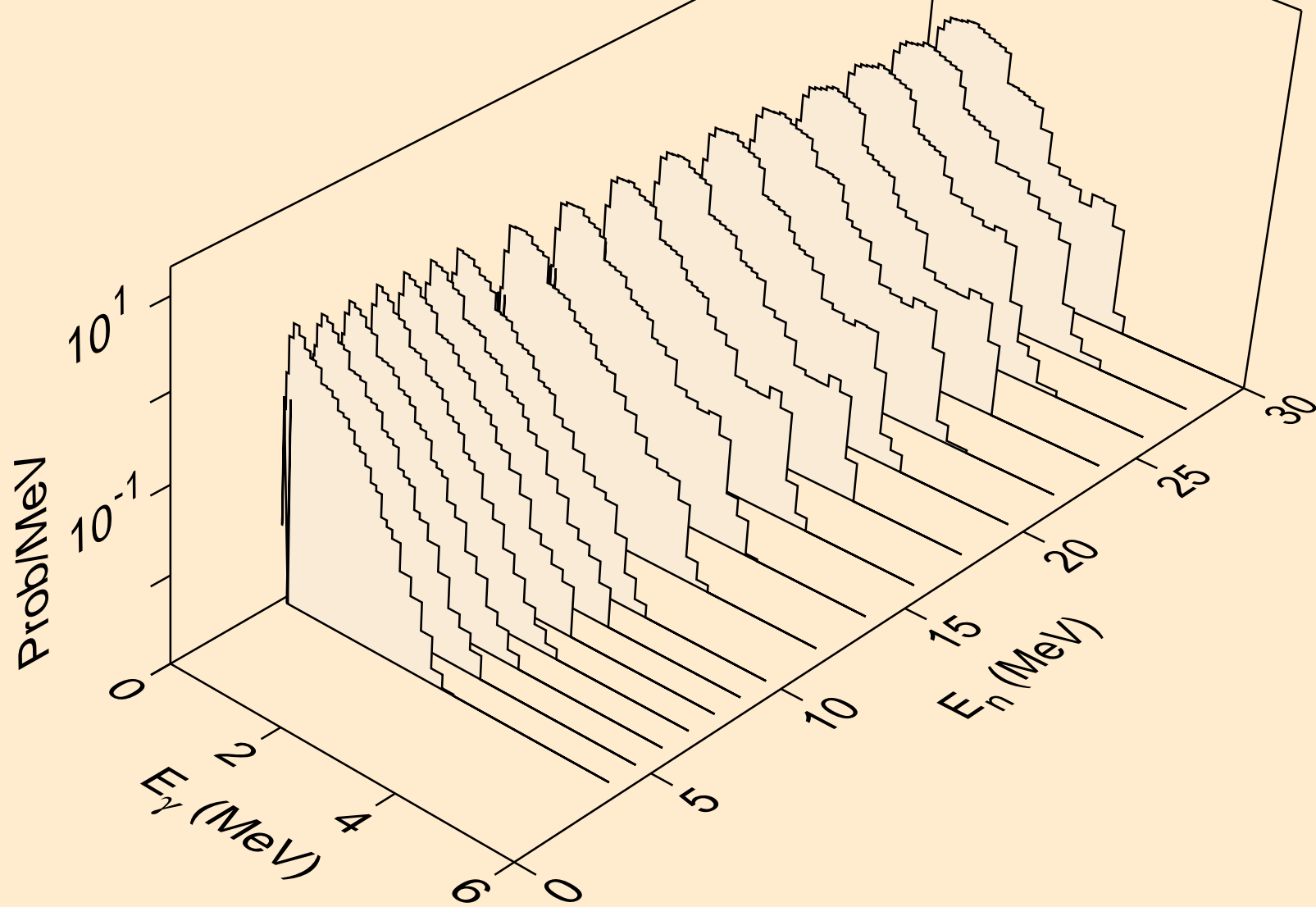

PO223 DEUTERON ACER TENDL-2021 LIBRARY; T=0.K  
Photon emission for (n,2p)

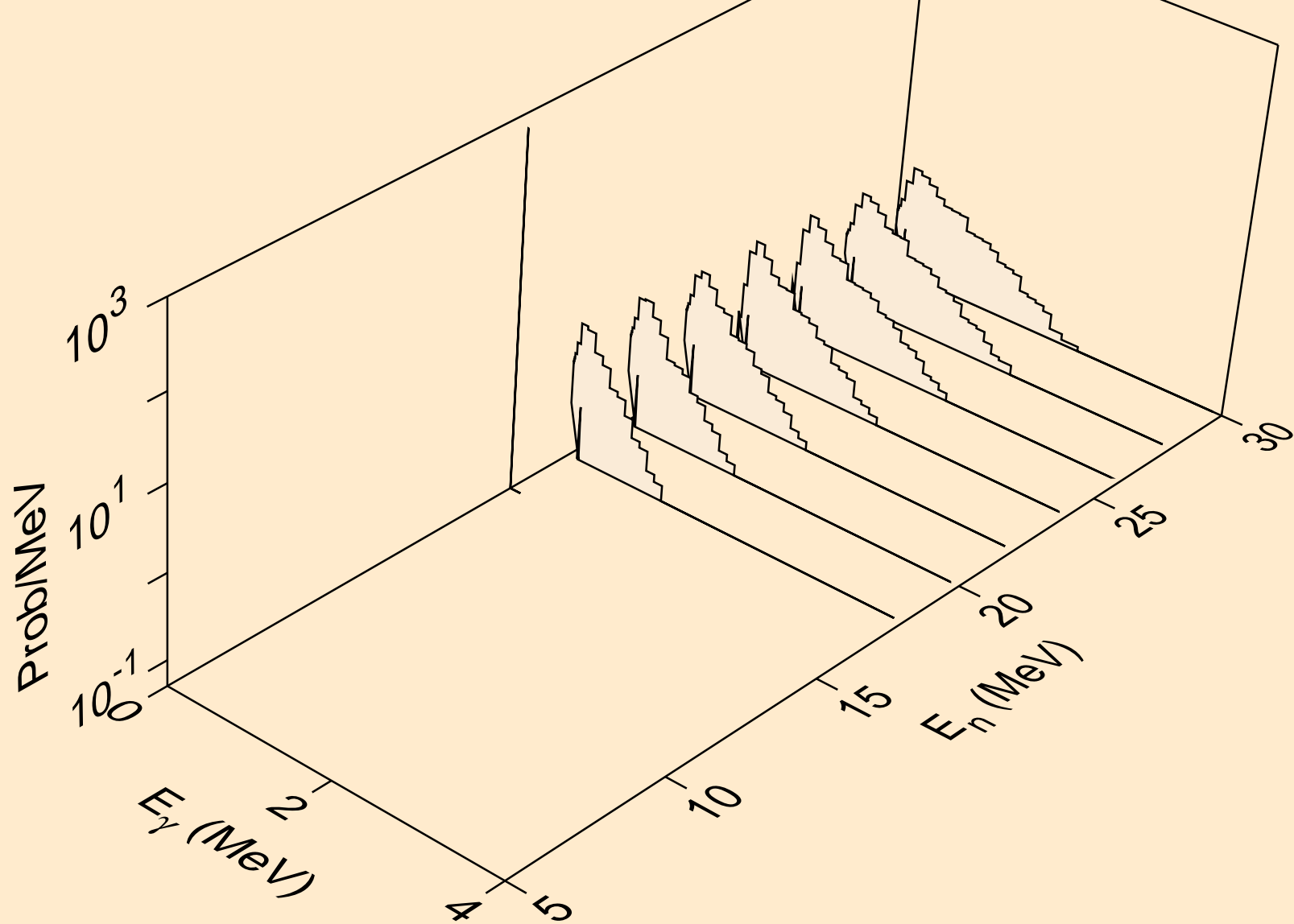

PO223 DEUTERON ACER TENDL-2021 LIBRARY; T=0.K  
Photon emission for (n,pd)

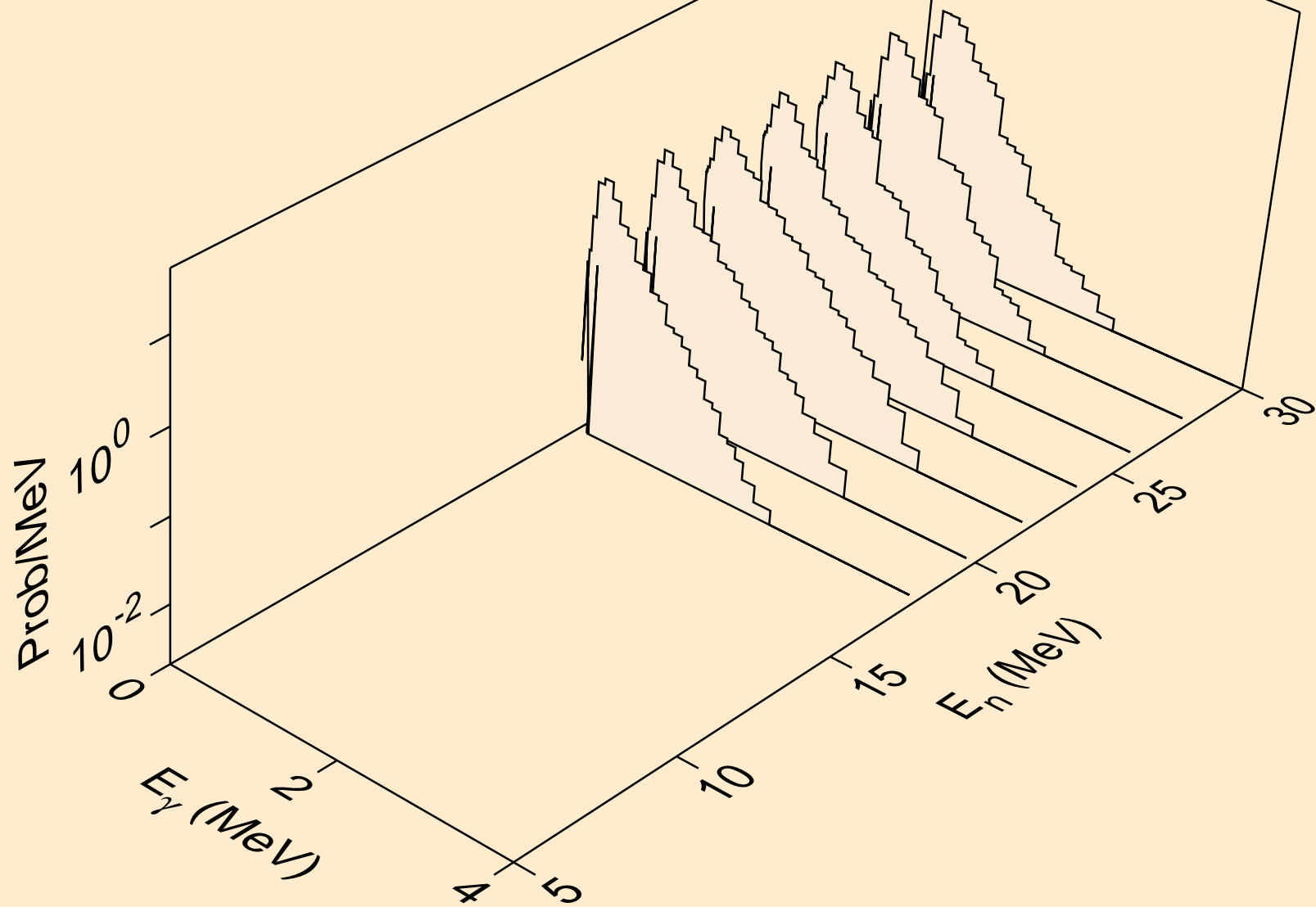

PO223 DEUTERON ACER TENDL-2021 LIBRARY; T=0.K  
Particle heating contributions

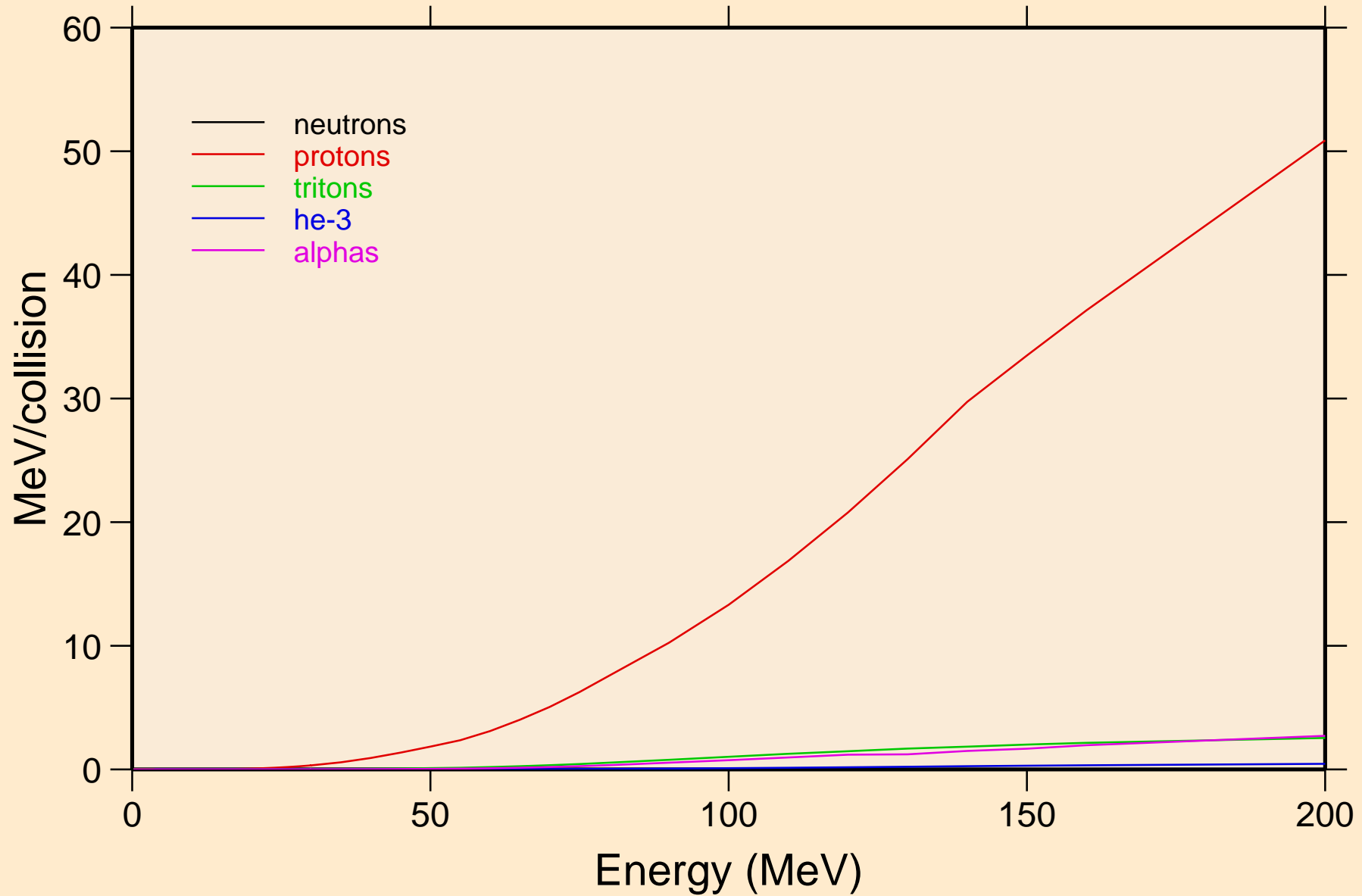

PO223 DEUTERON ACER TENDL-2021 LIBRARY; T=0.K  
Recoil Heating

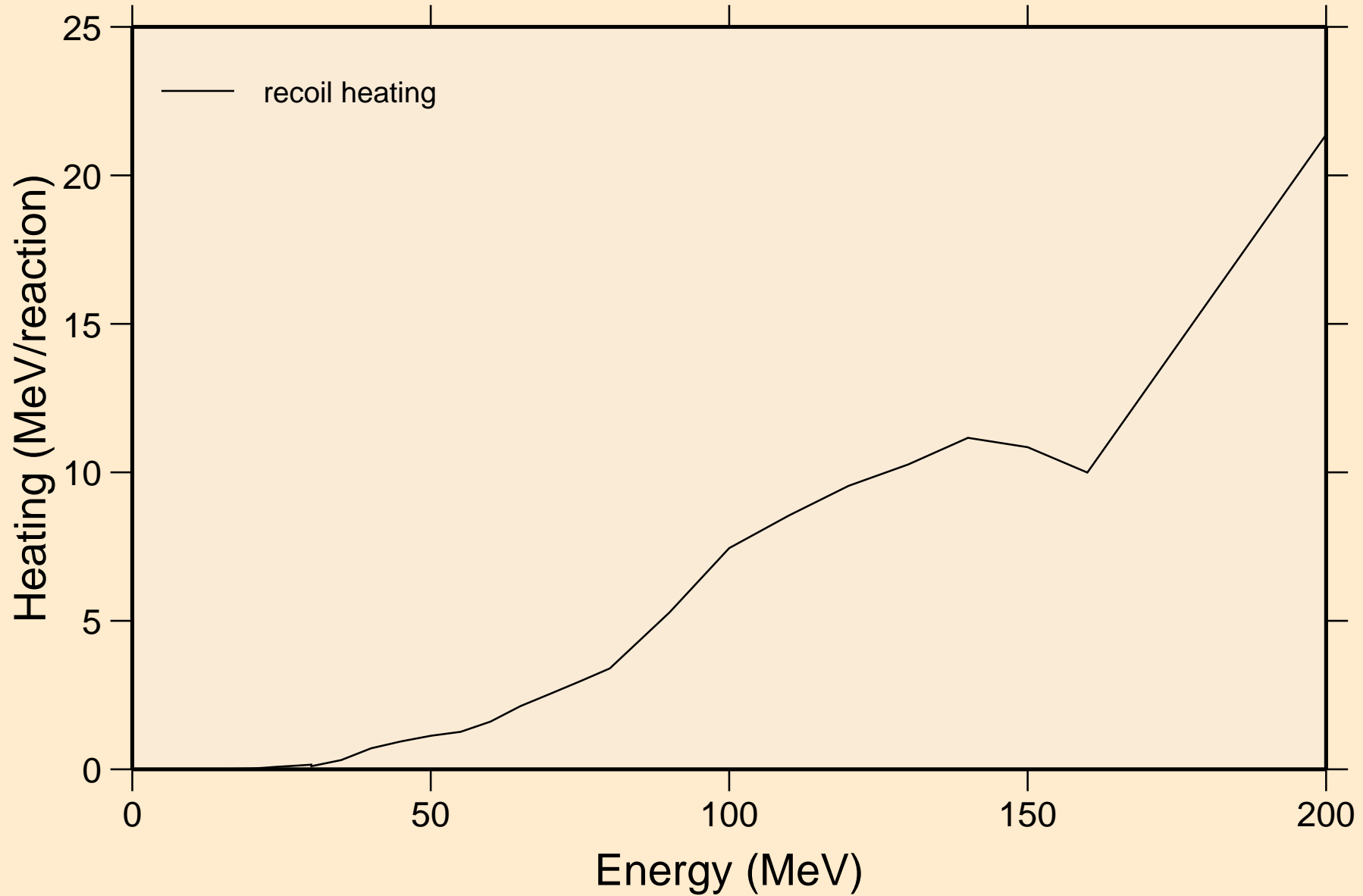



PO223 DEUTERON ACER TENDL-2021 LIBRARY; T=0.K  
Particle production cross sections

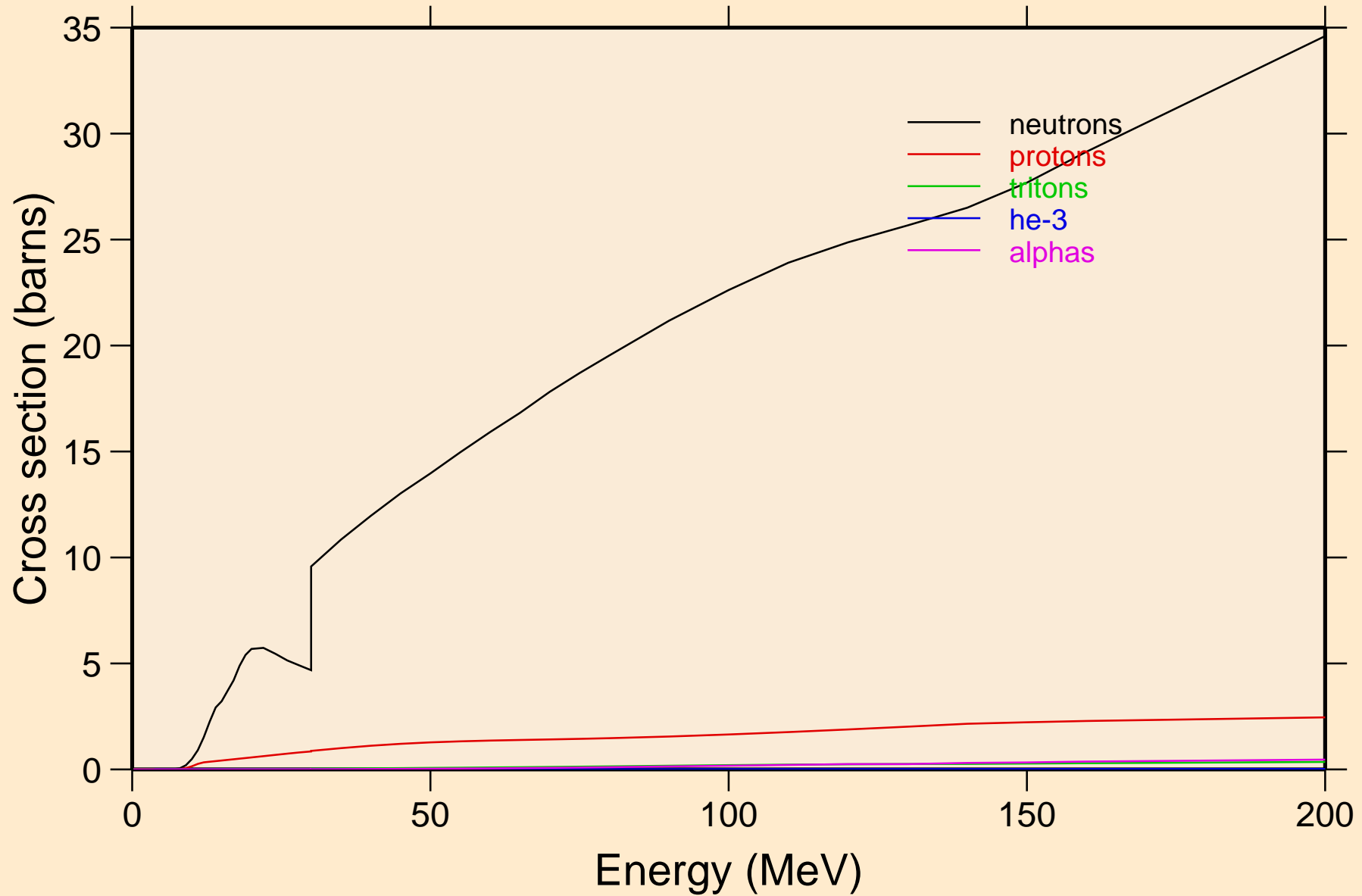

PO223 DEUTERON ACER TENDL-2021 LIBRARY; T=0.K  
neutrons from (d,n)

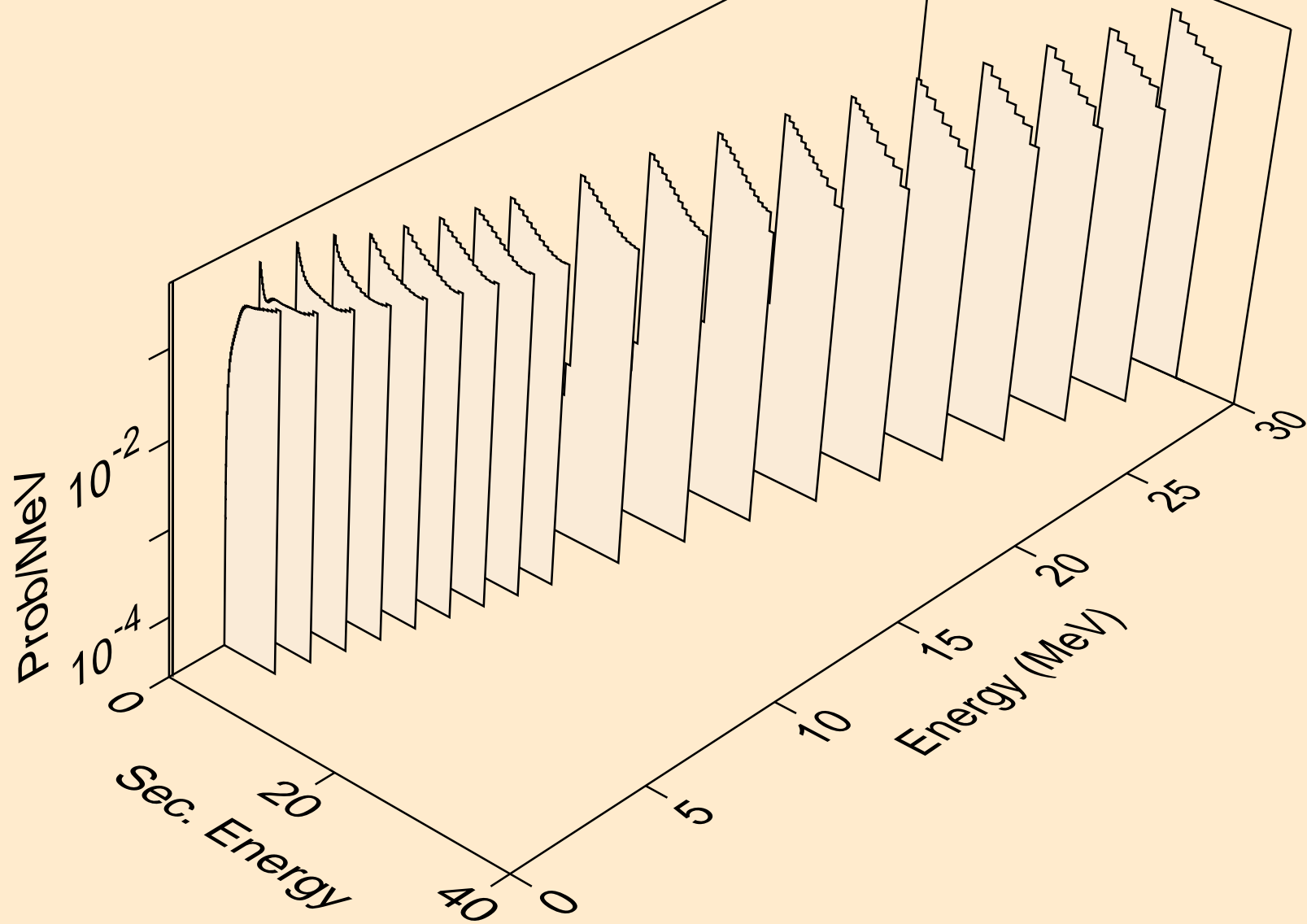

PO223 DEUTERON ACER TENDL-2021 LIBRARY; T=0.K  
neutrons from (d,x)

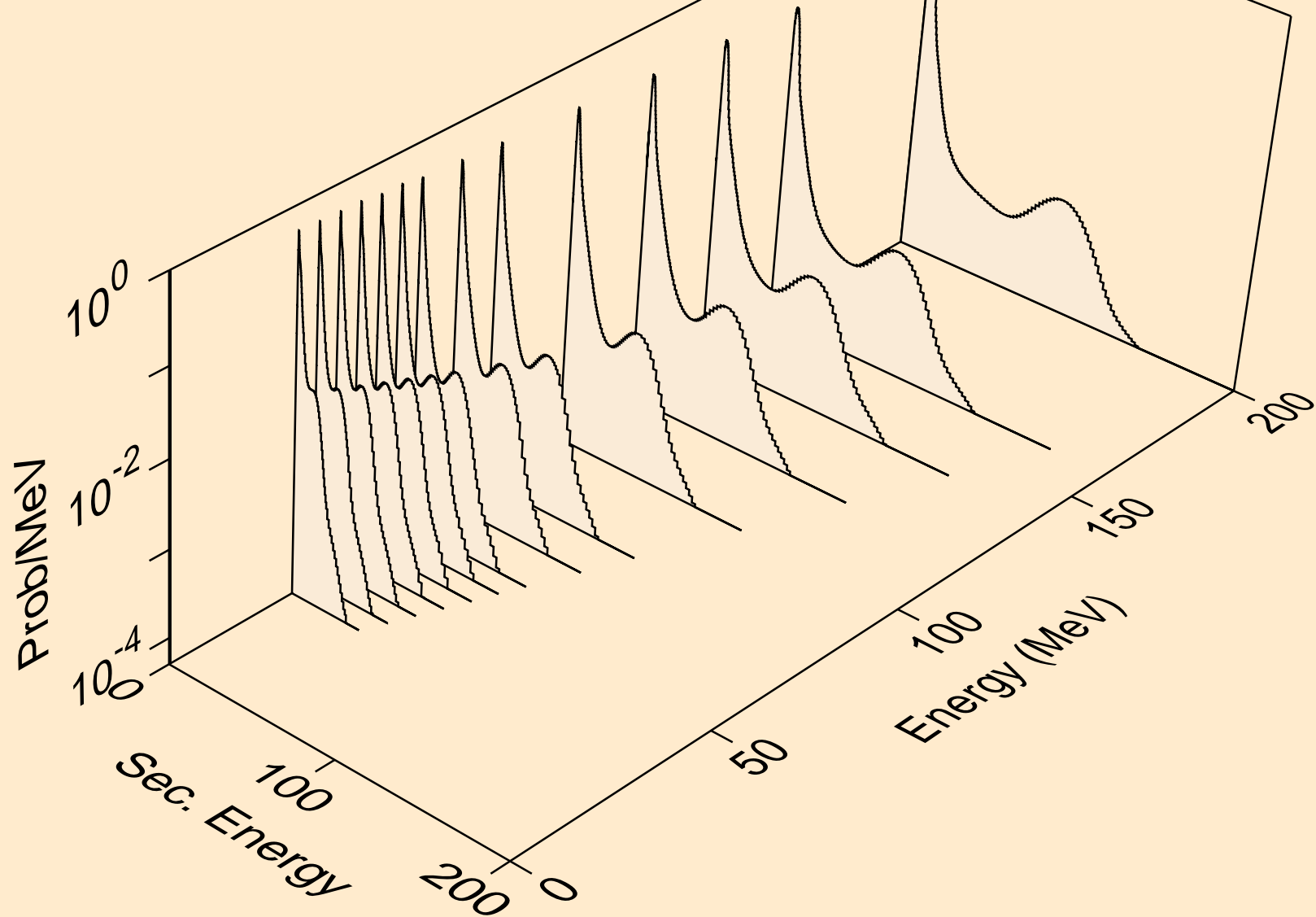

PO223 DEUTERON ACER TENDL-2021 LIBRARY; T=0.K  
neutrons from (d,2nd)

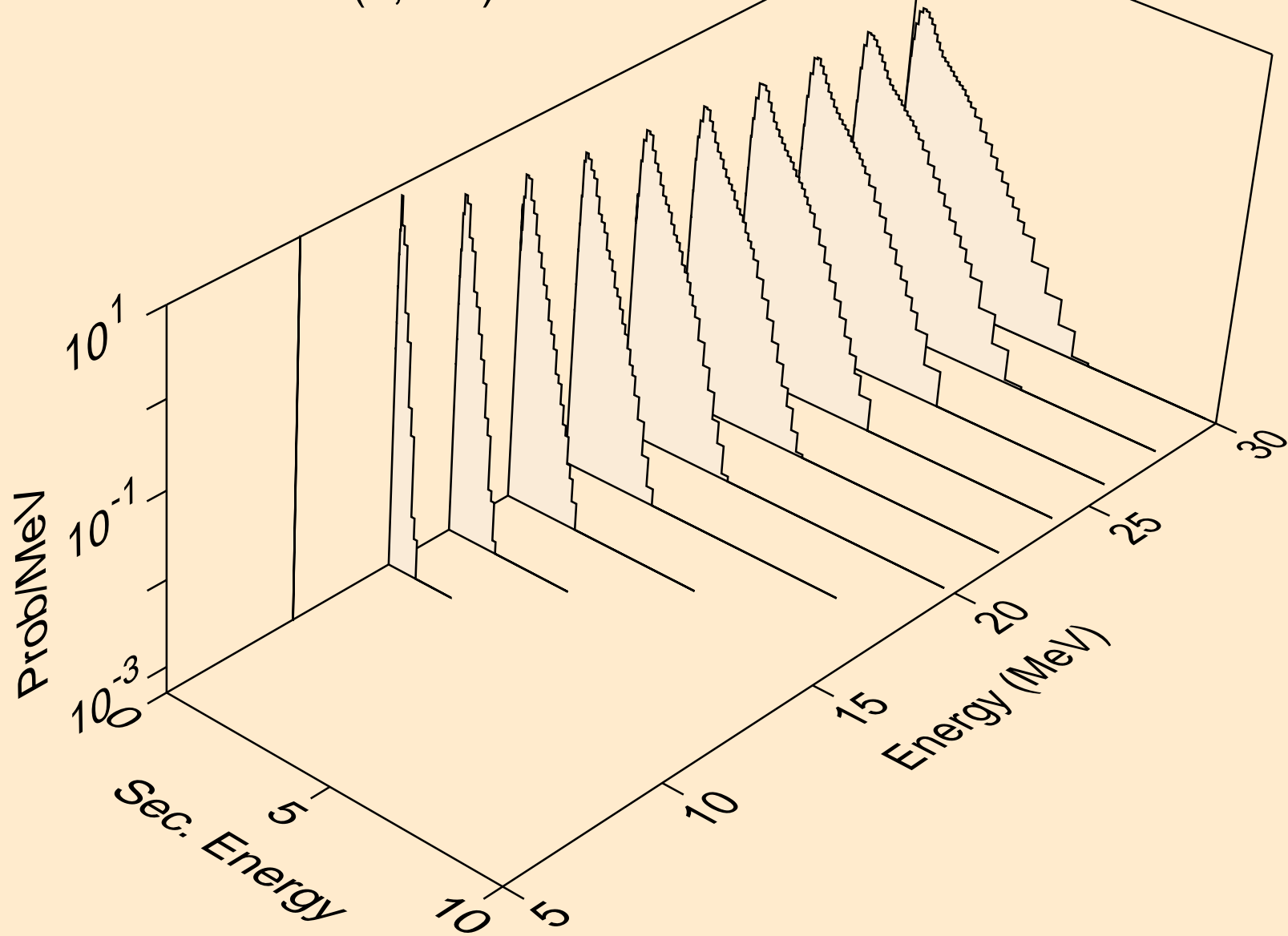

PO223 DEUTERON ACER TENDL-2021 LIBRARY; T=0.K  
neutrons from (d,2n)

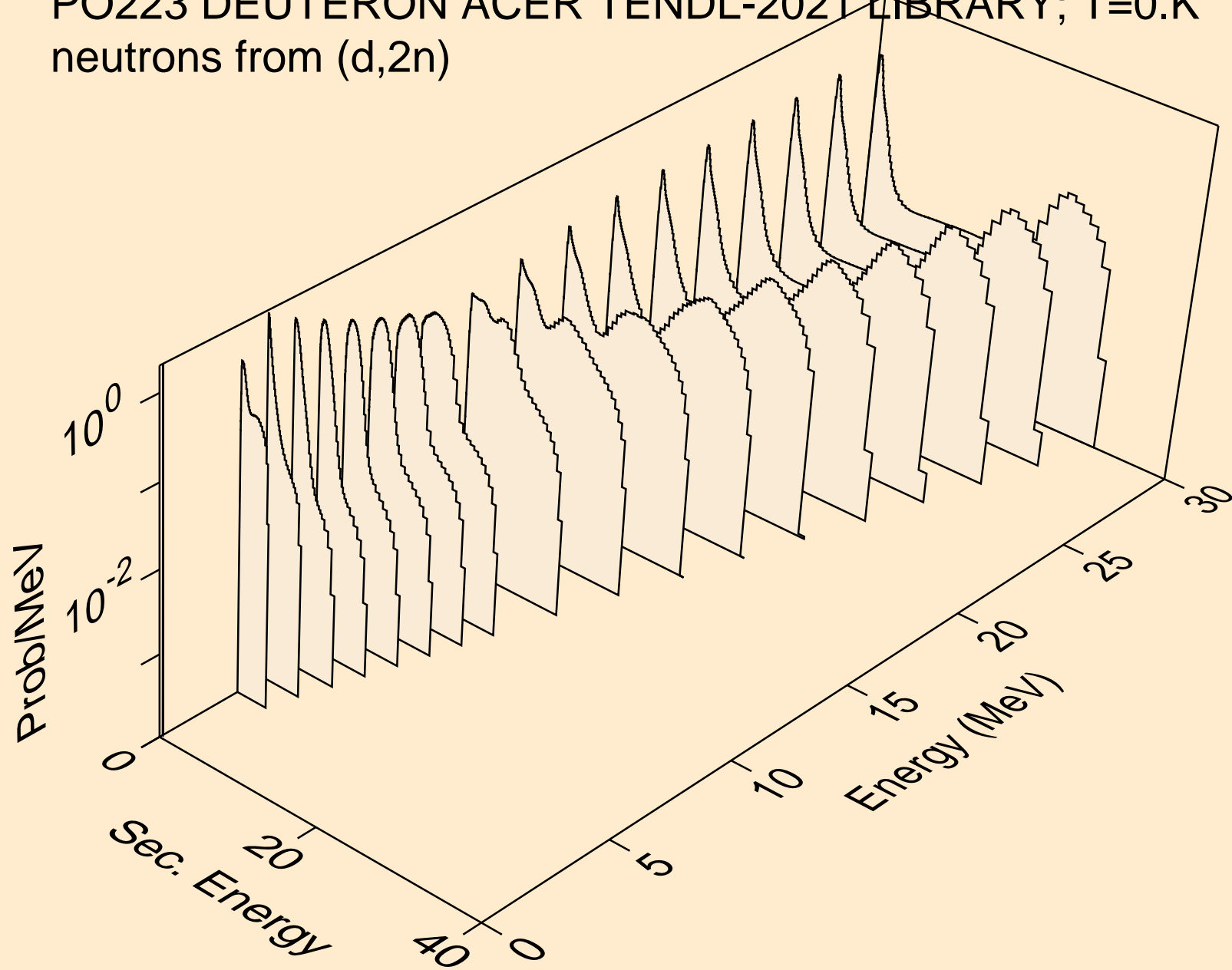

PO223 DEUTERON ACER TENDL-2021 LIBRARY; T=0.K  
neutrons from (d,3n)

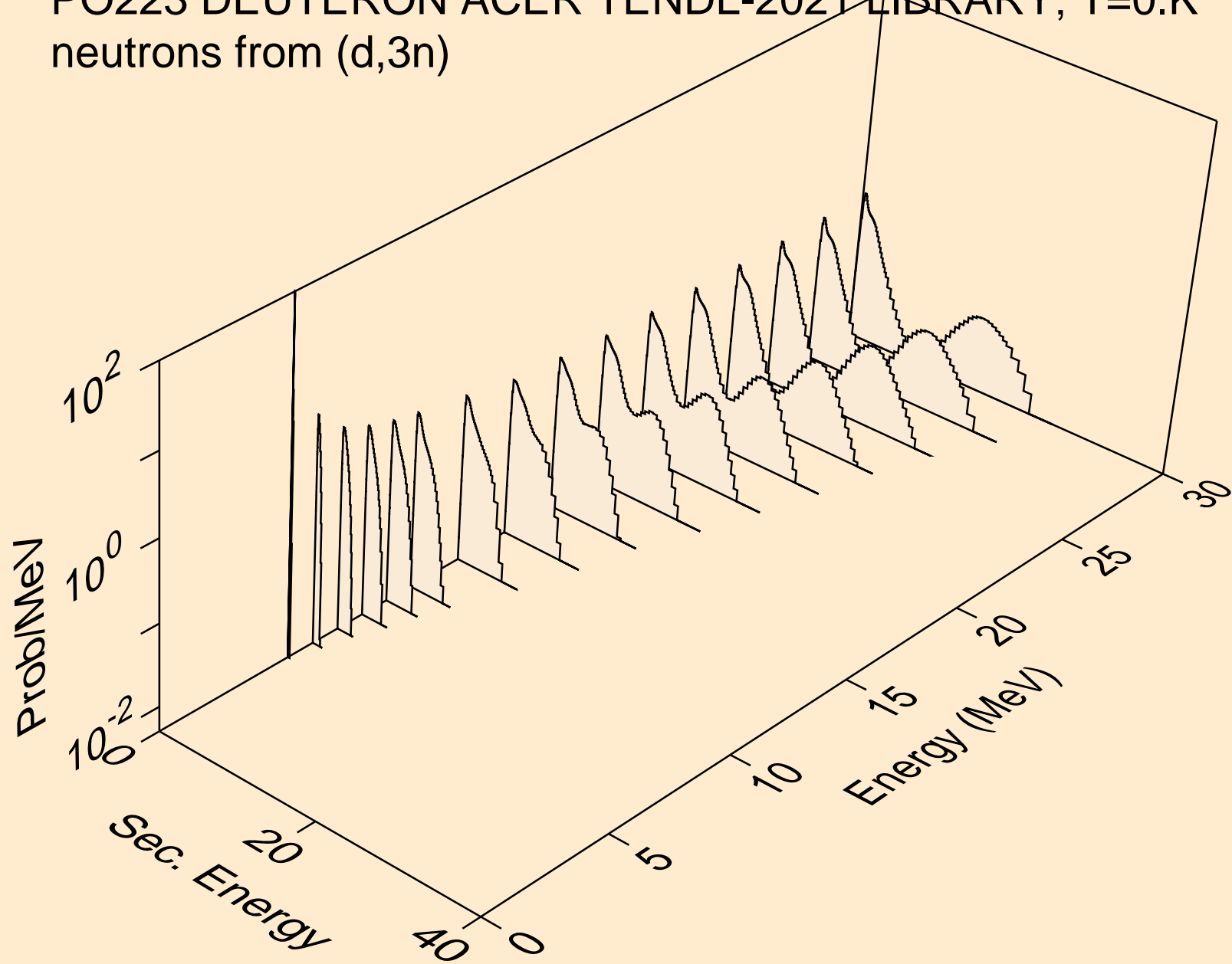

PO223 DEUTERON ACER TENDL-2021 LIBRARY; T=0.K  
neutrons from (d,n\*)a

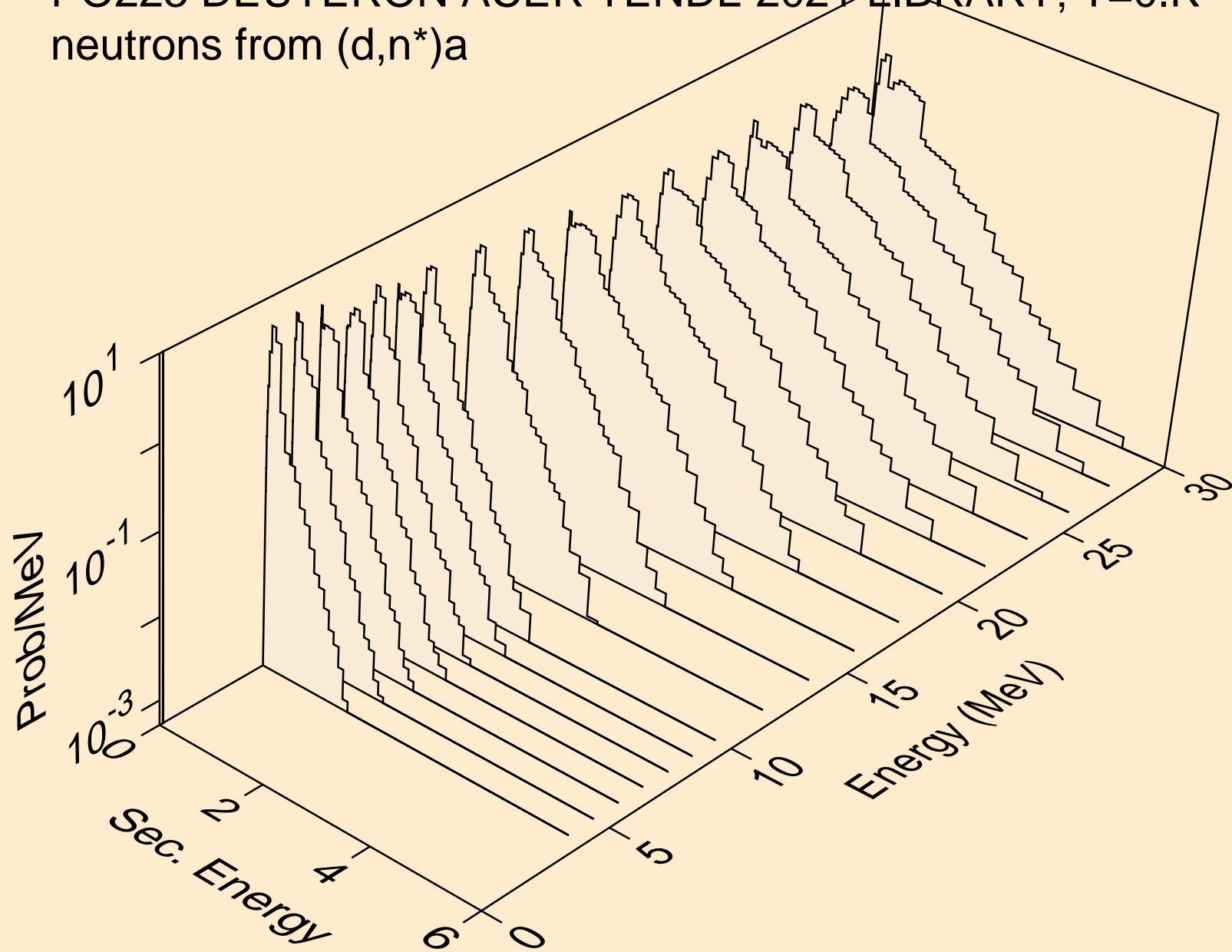

PO223 DEUTERON ACER TENDL-2021 LIBRARY; T=0.K  
neutrons from (d,2n)a

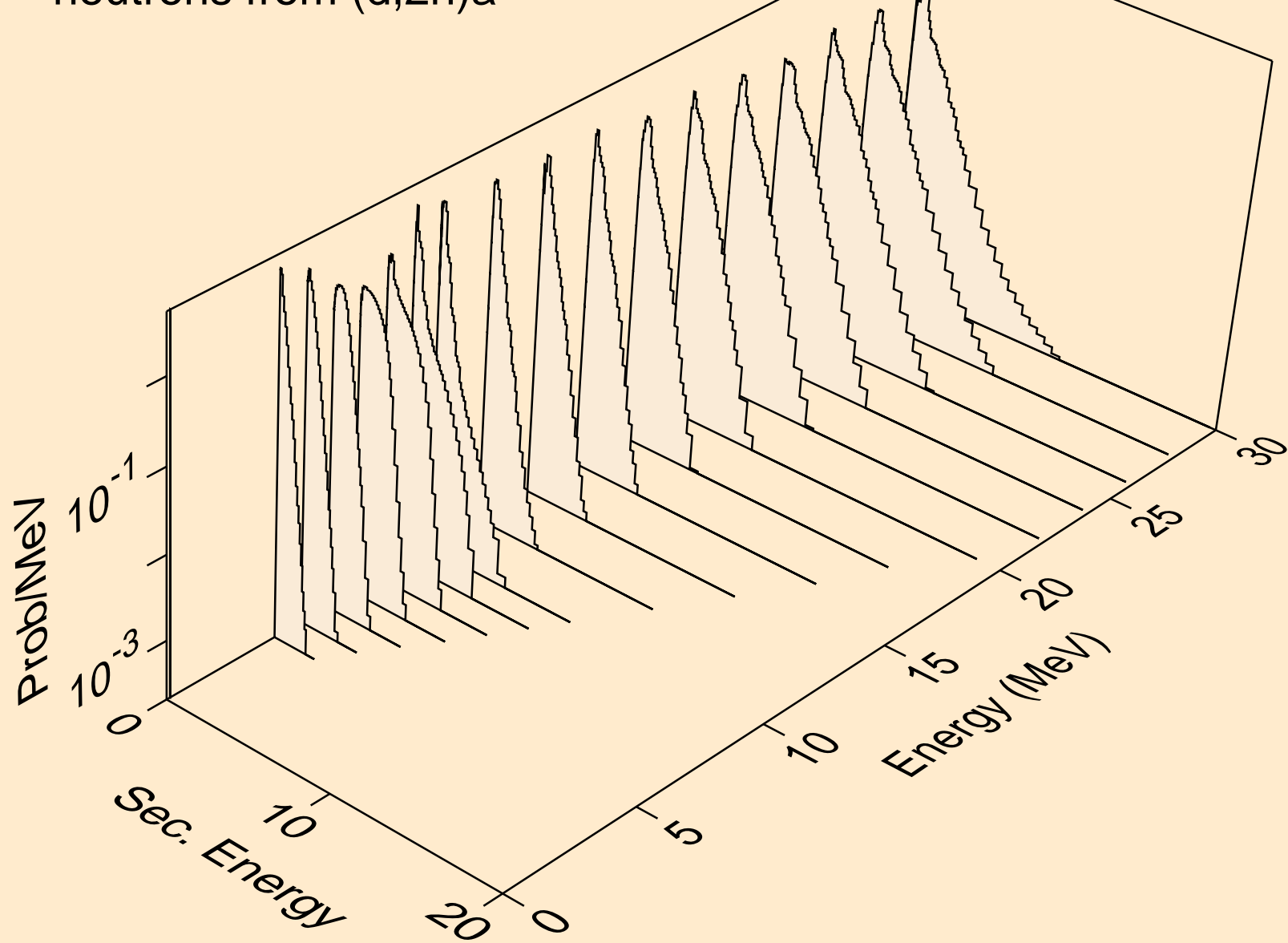



PO223 DEUTERON ACER TENDL-2021 LIBRARY; T=0.K  
neutrons from (d,3n)a

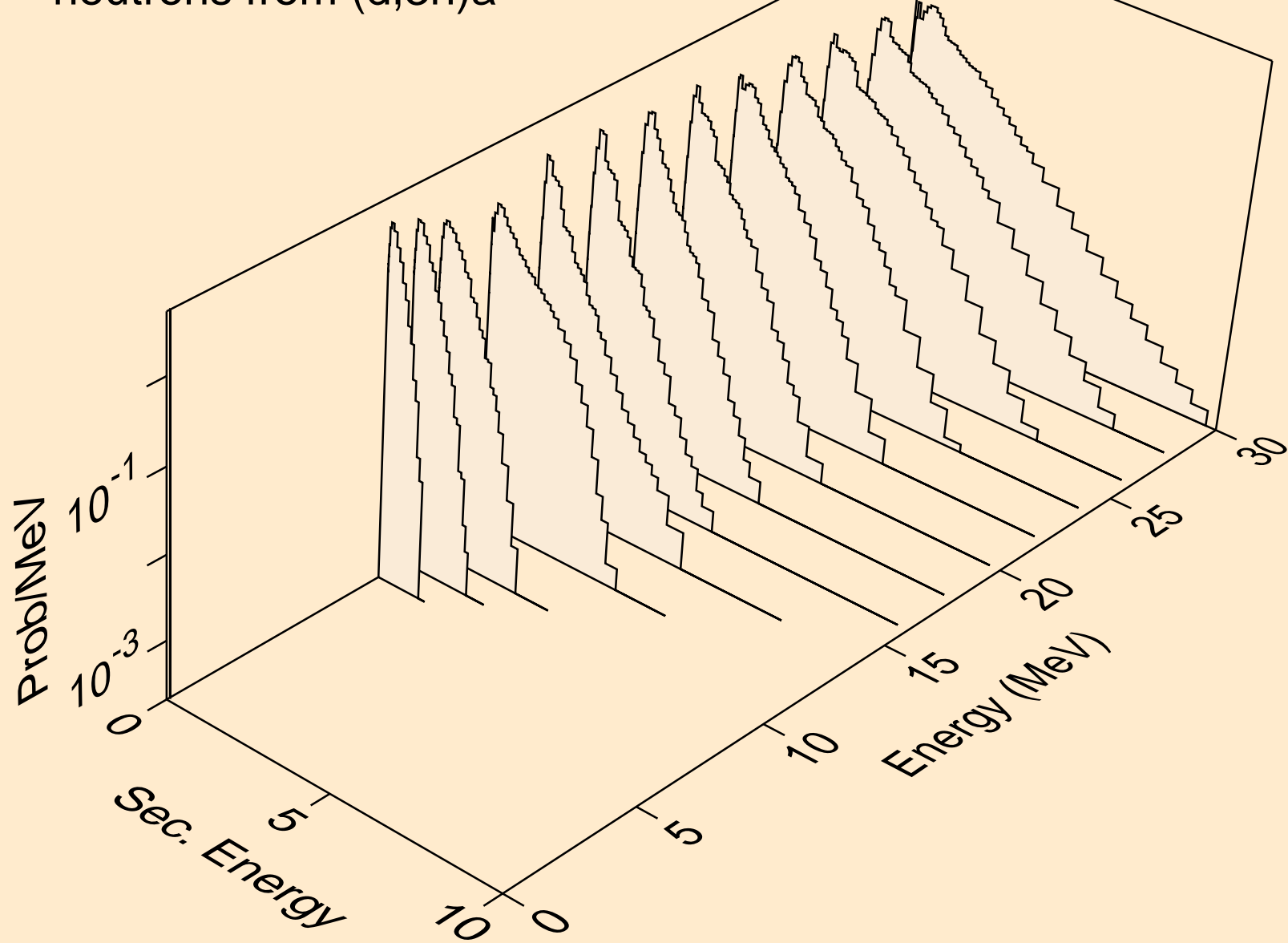

PO223 DEUTERON ACER TENDL-2021 LIBRARY; T=0.K  
neutrons from (d,n\*)p

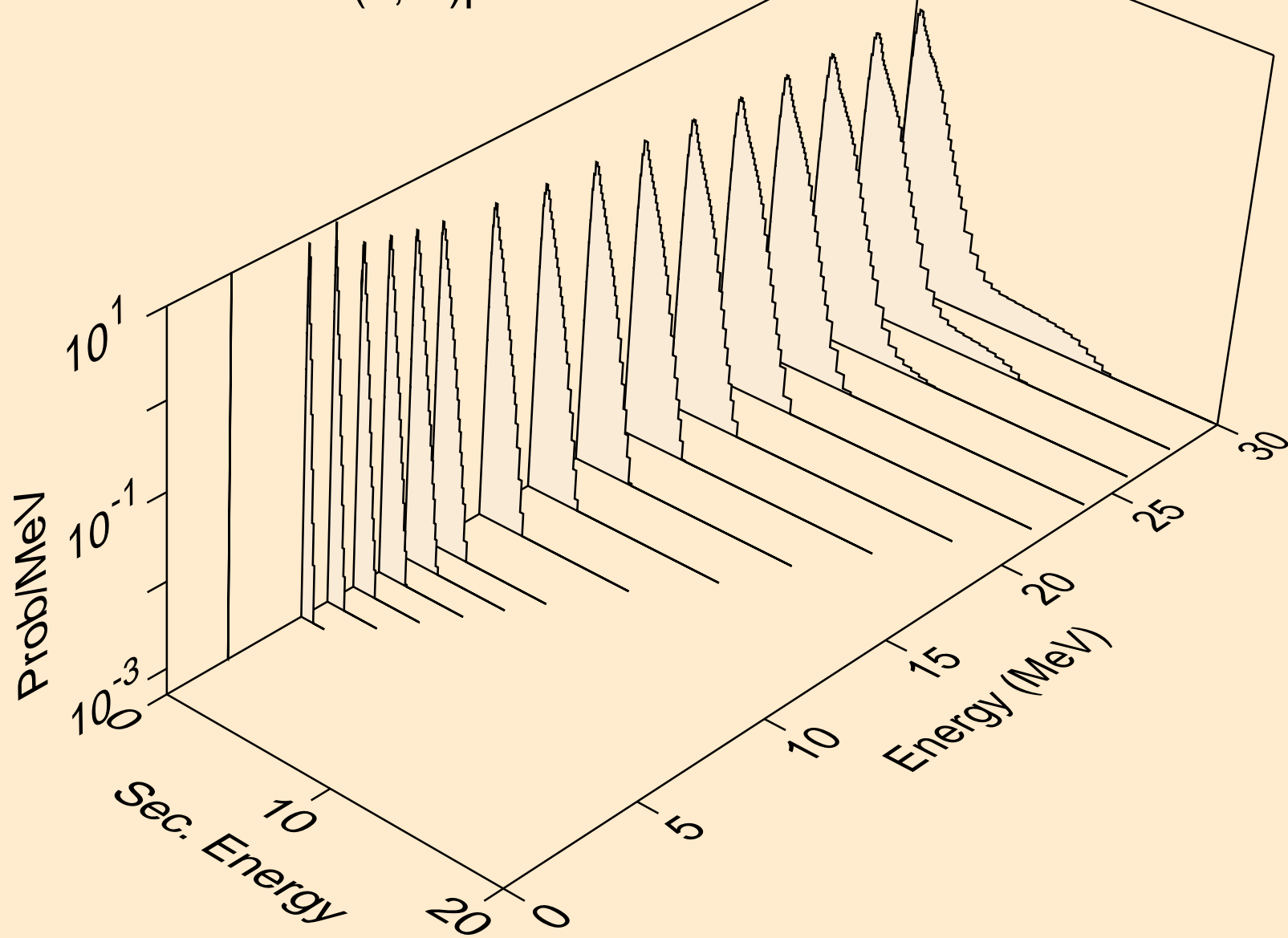

PO223 DEUTERON ACER TENDL-2021 LIBRARY; T=0.K  
neutrons from (d,2n)2a

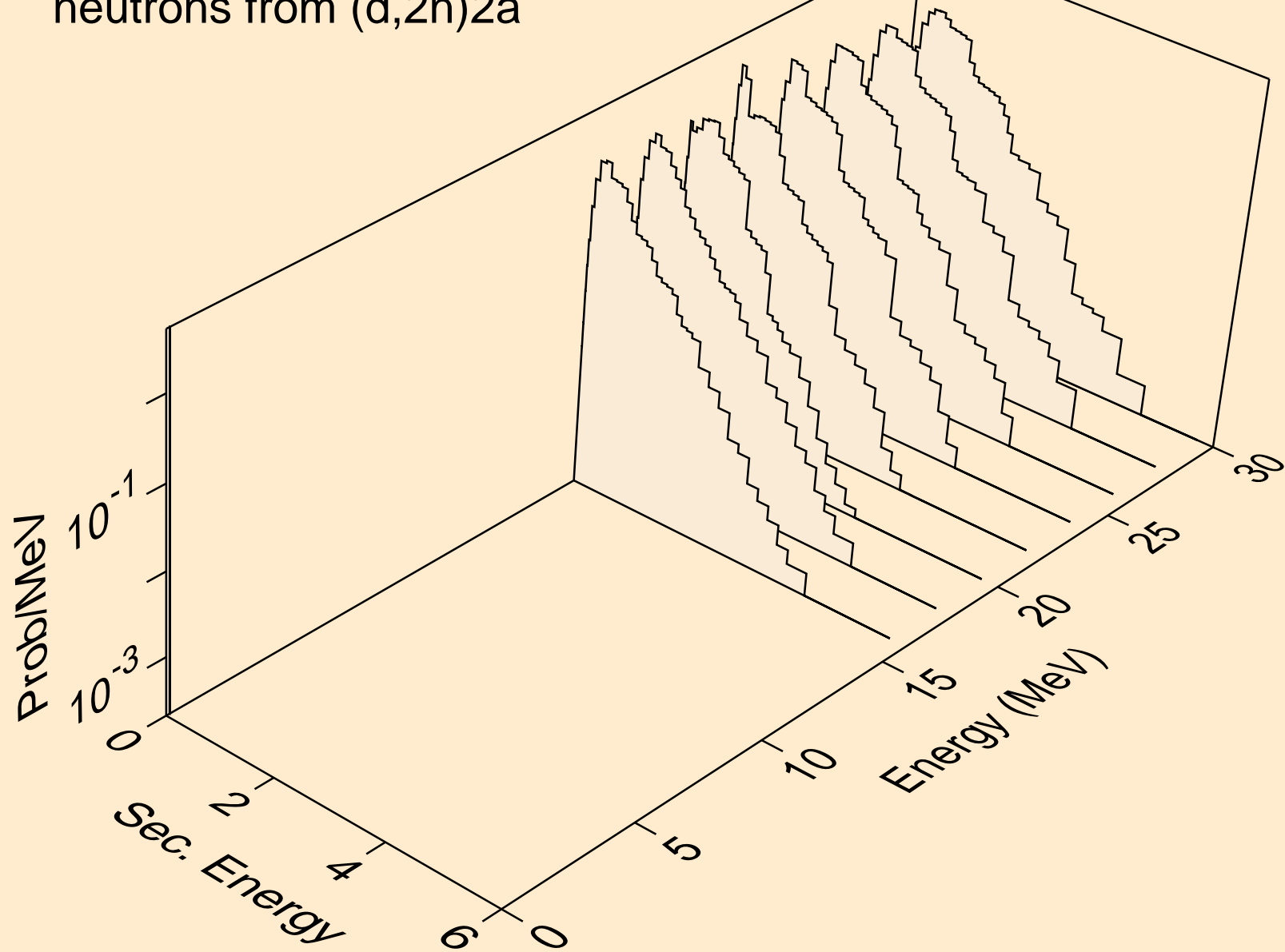

PO223 DEUTERON ACER TENDL-2021 LIBRARY; T=0.K  
neutrons from (d,n\*)d

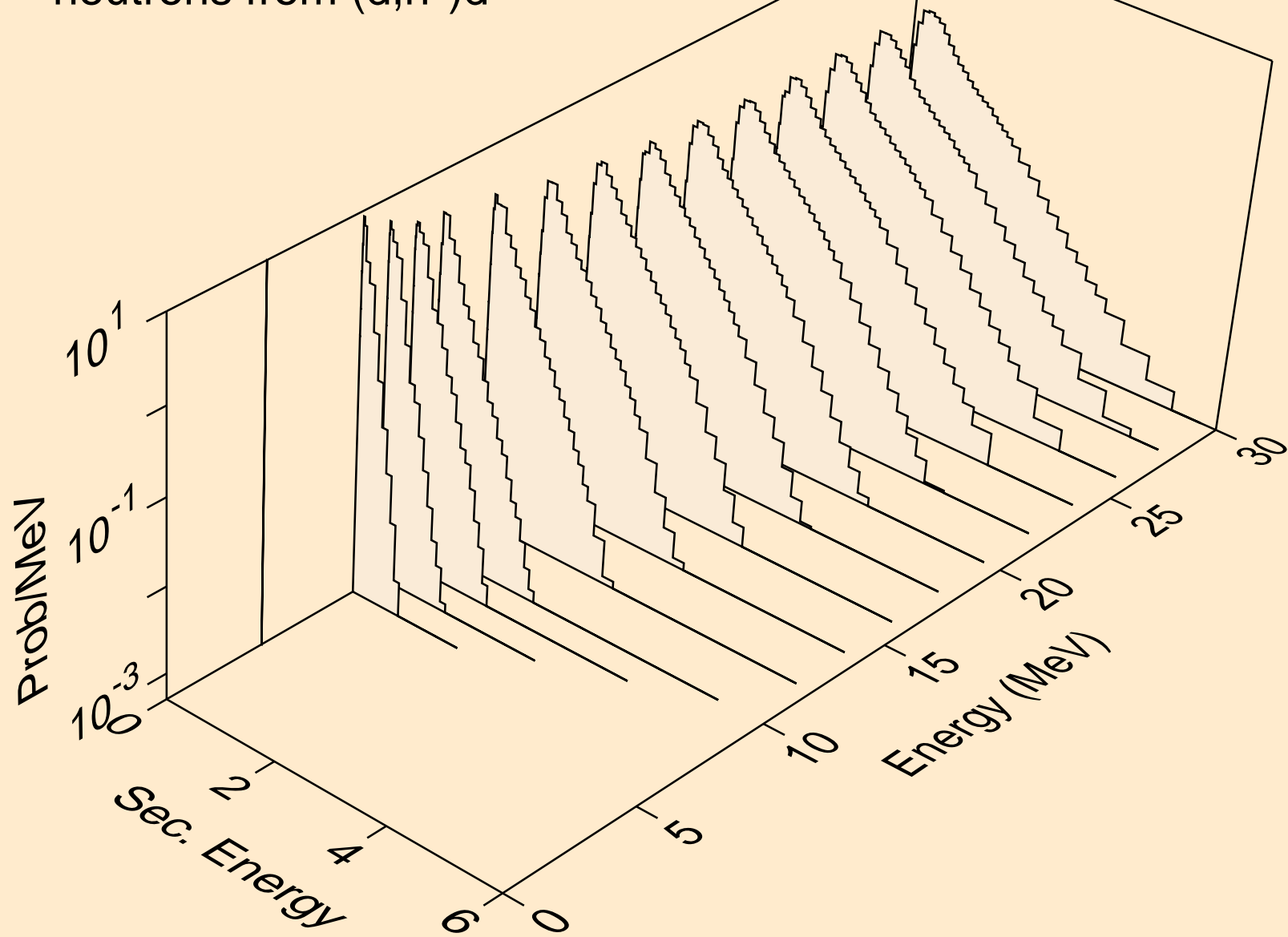

PO223 DEUTERON ACER TENDL-2021 LIBRARY; T=0.K  
neutrons from (d,n\*)t

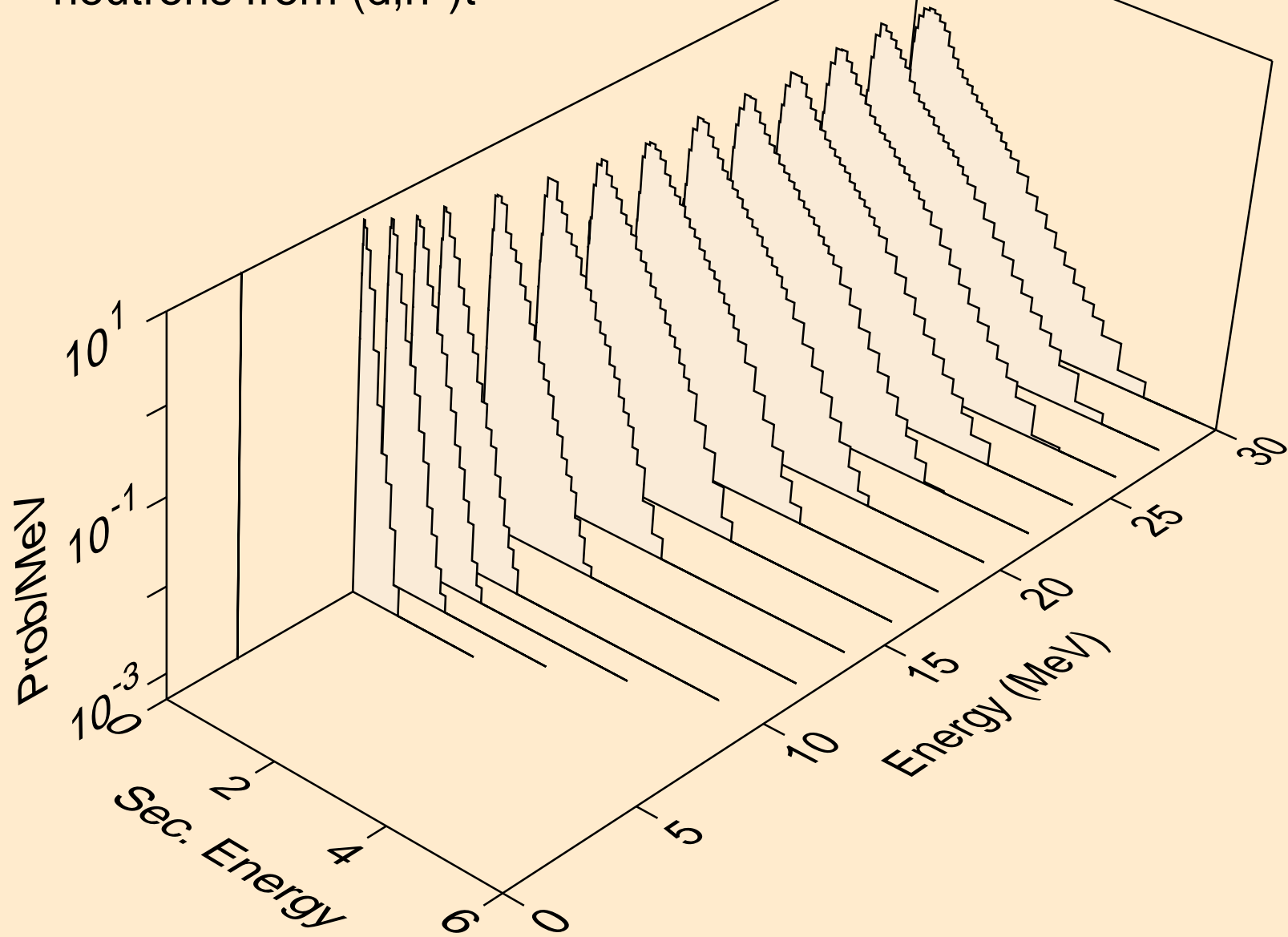

PO223 DEUTERON ACER TENDL-2021 LIBRARY; T=0.K  
neutrons from (d,n\*)he3

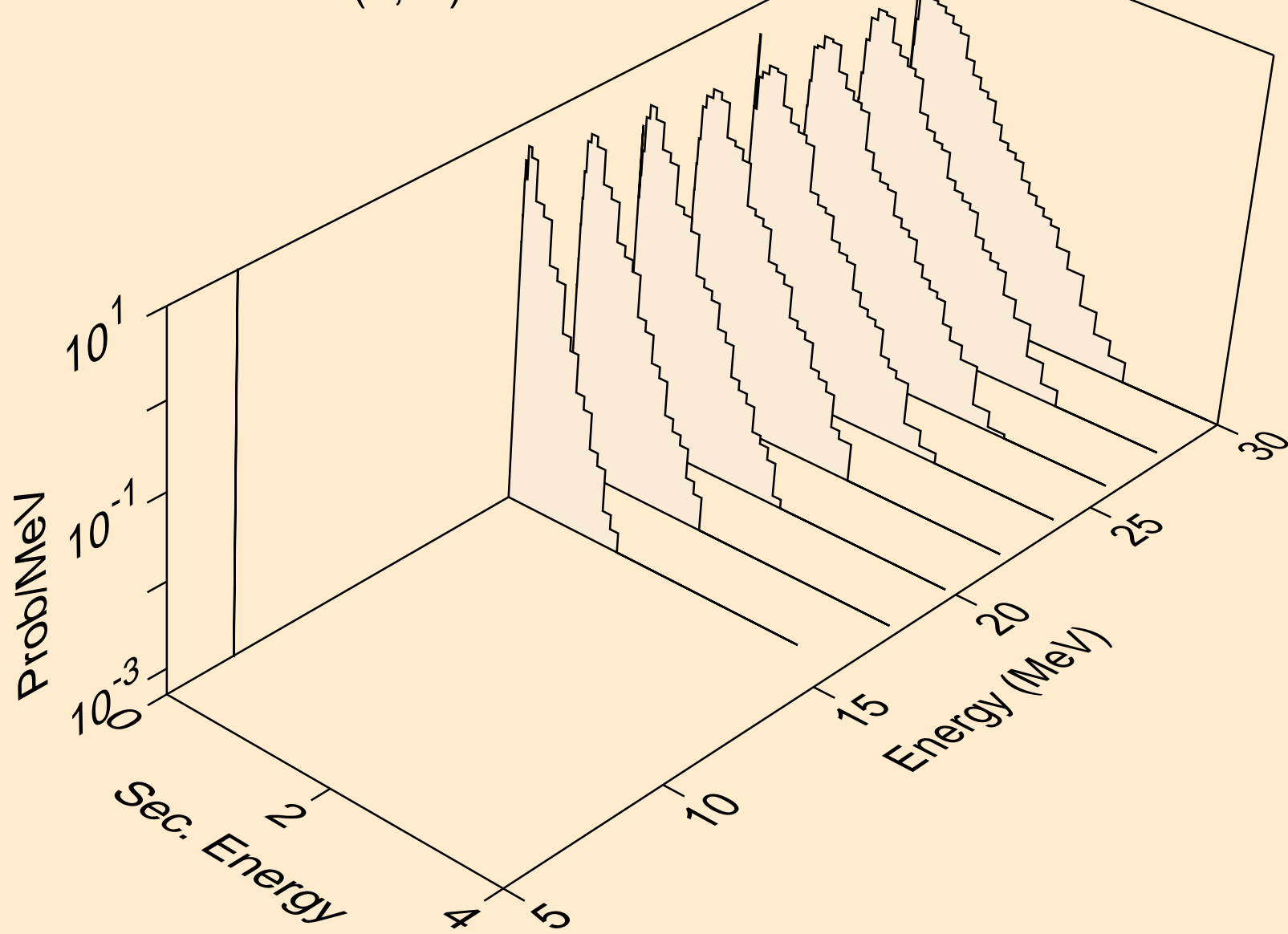

PO223 DEUTERON ACER TENDL-2021 LIBRARY; T=0.K  
neutrons from (d,4n)

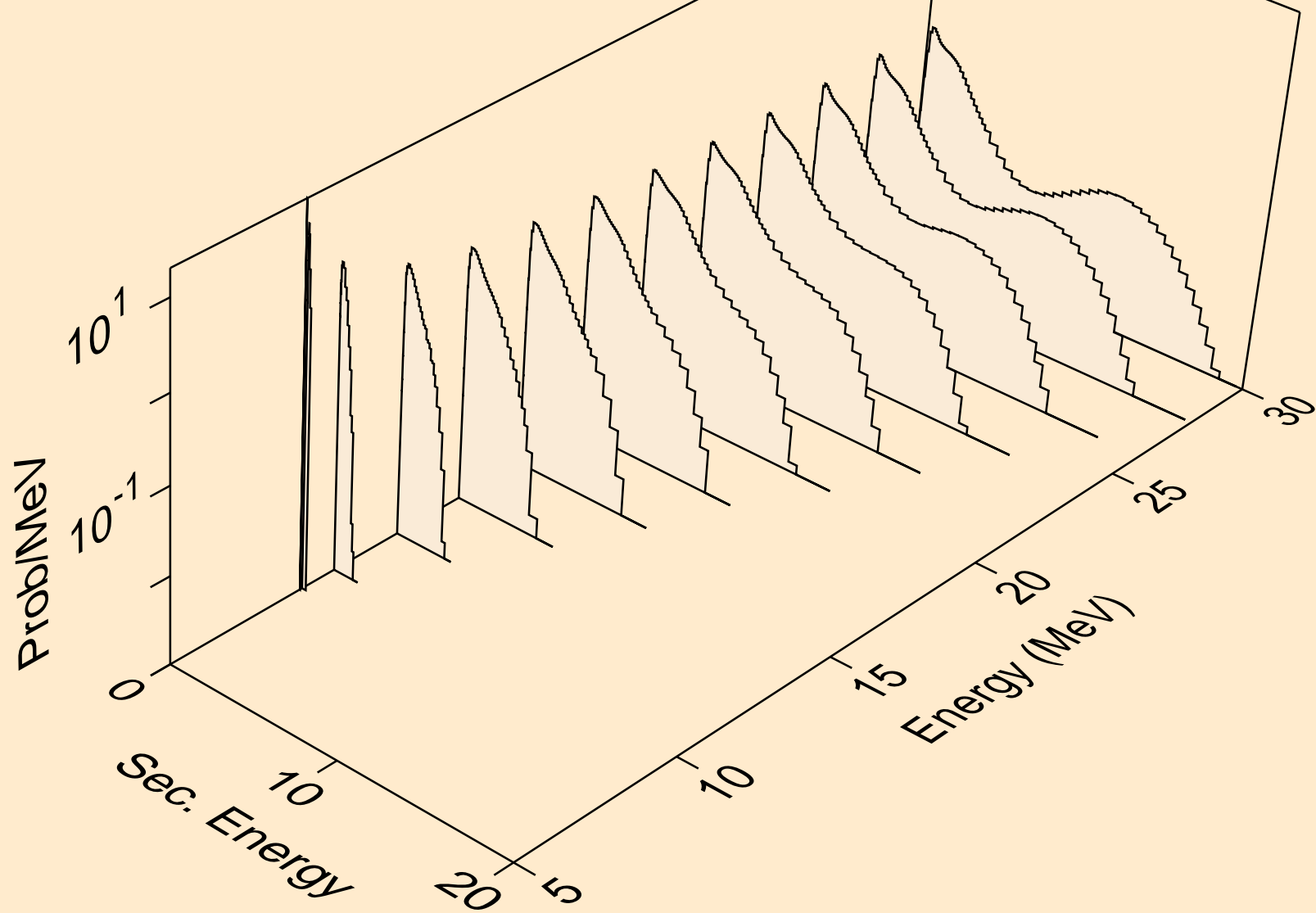

PO223 DEUTERON ACER TENDL-2021 LIBRARY; T=0.K  
neutrons from (d,2np)

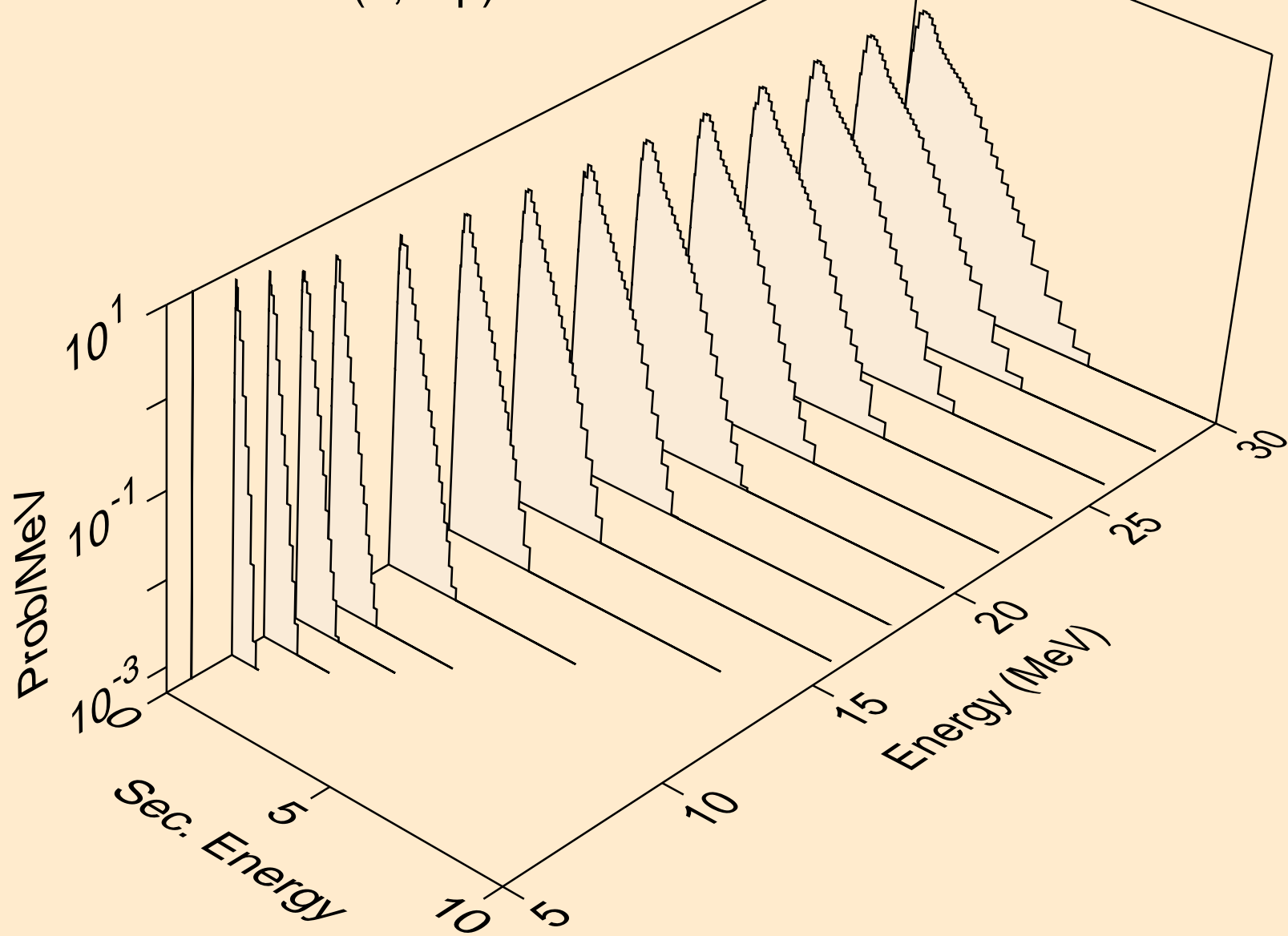



PO223 DEUTERON ACER TENDL-2021 LIBRARY; T=0.K  
neutrons from (d,3np)

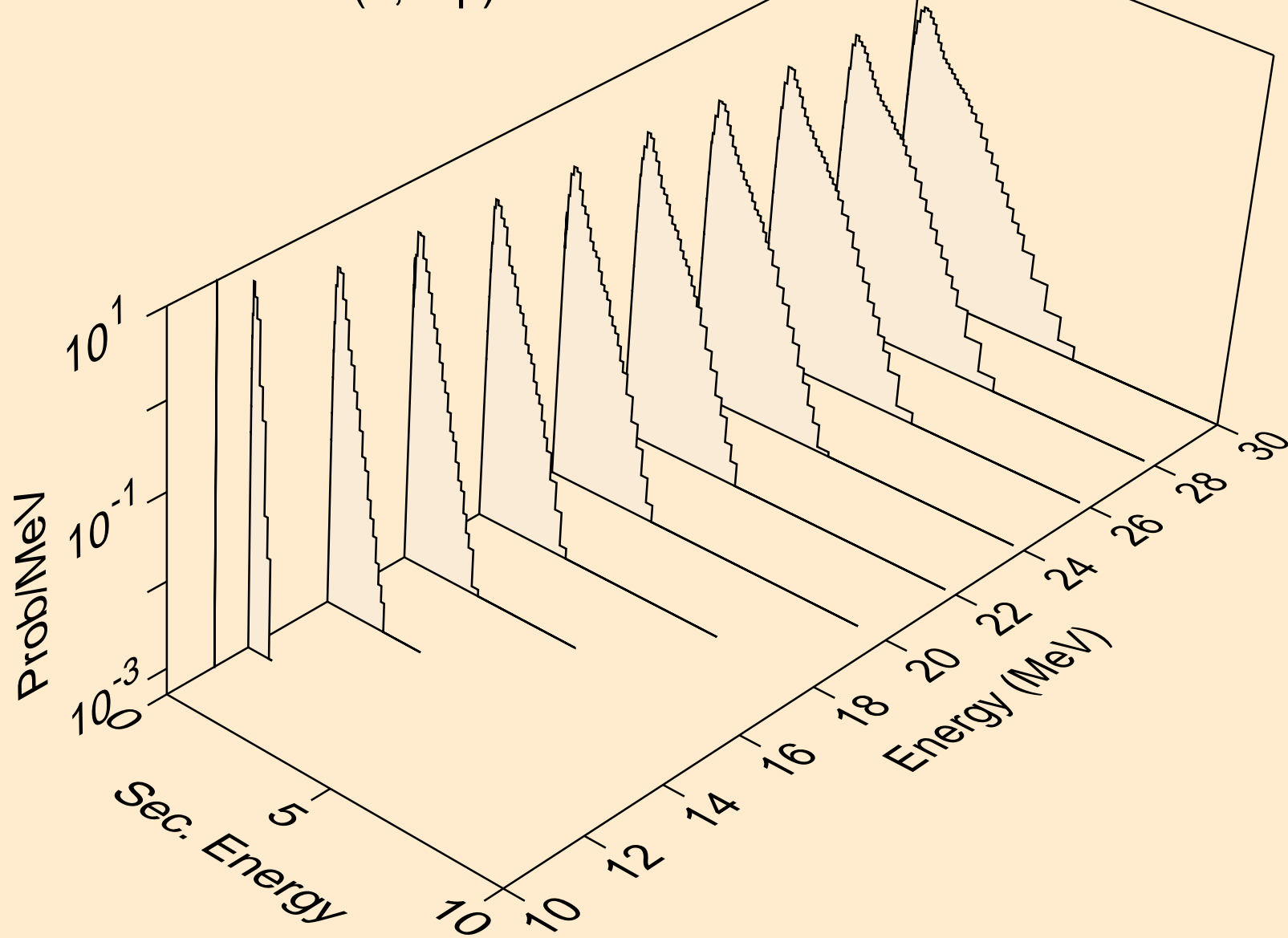

PO223 DEUTERON ACER TENDL-2021 LIBRARY; T=0.K  
neutrons from (d,2np)

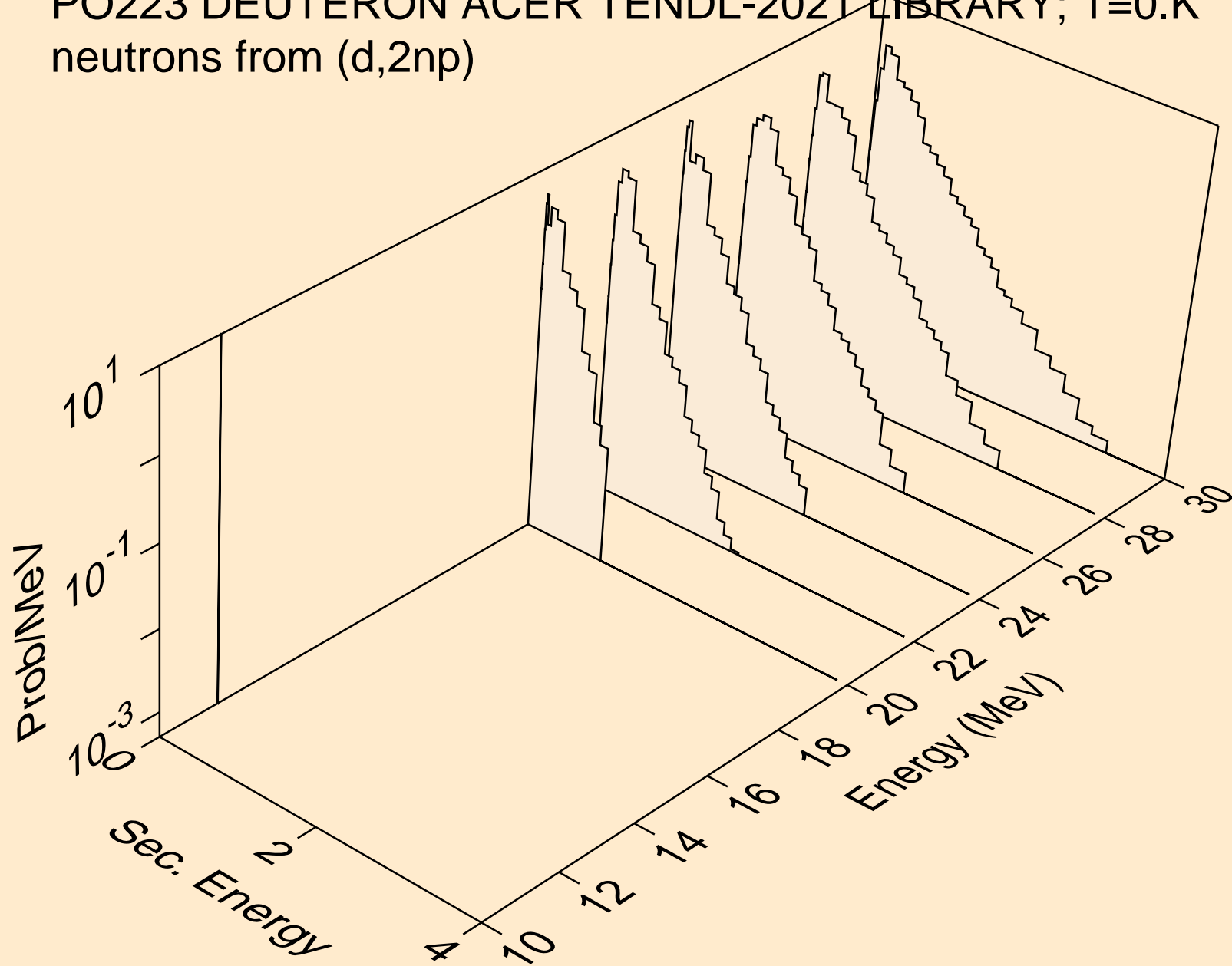

PO223 DEUTERON ACER TENDL-2021 LIBRARY; T=0.K  
neutrons from (d,npa)

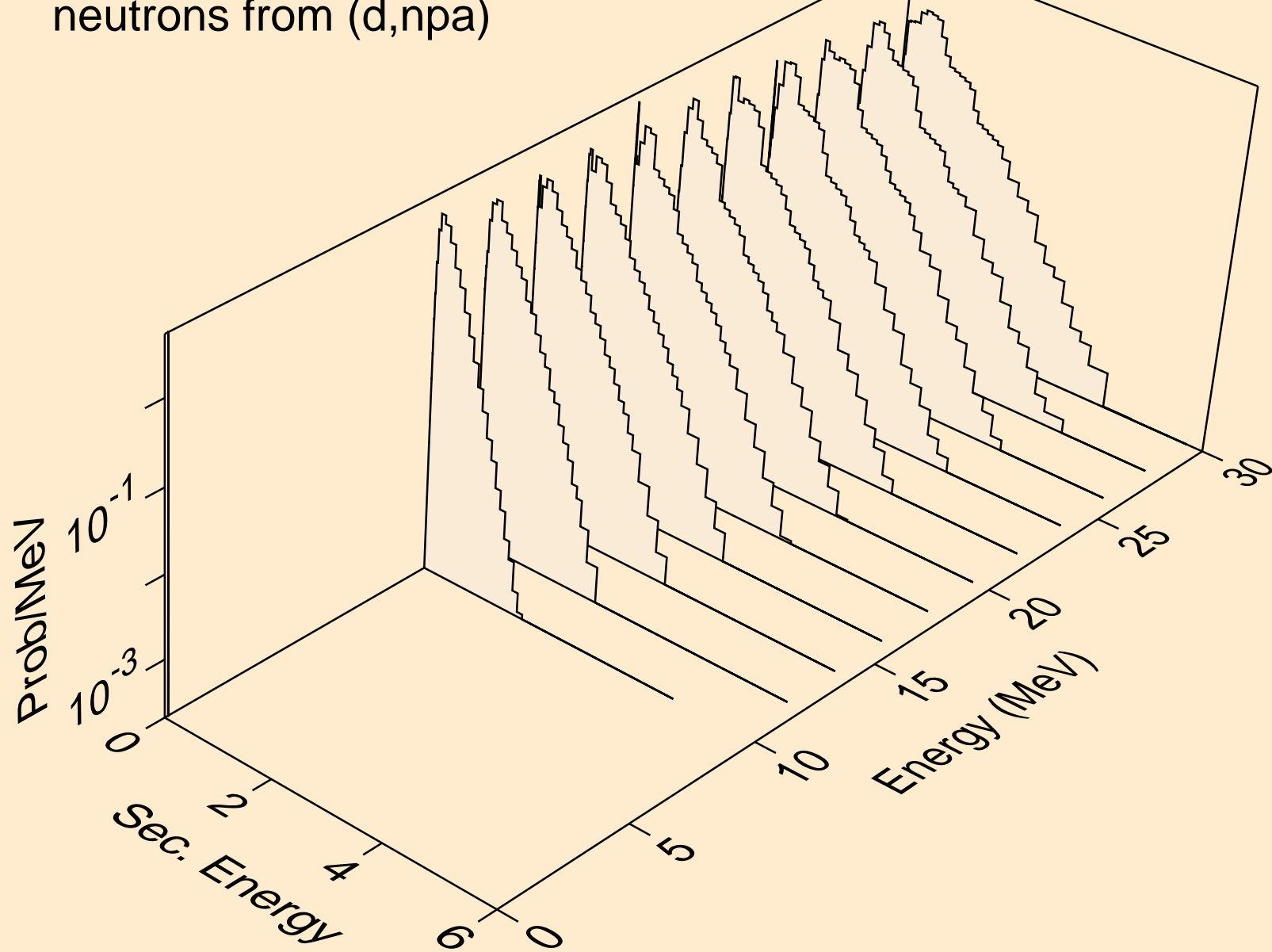

PO223 DEUTERON ACER TENDL-2021 LIBRARY; T=0.K  
protons from (d,x)

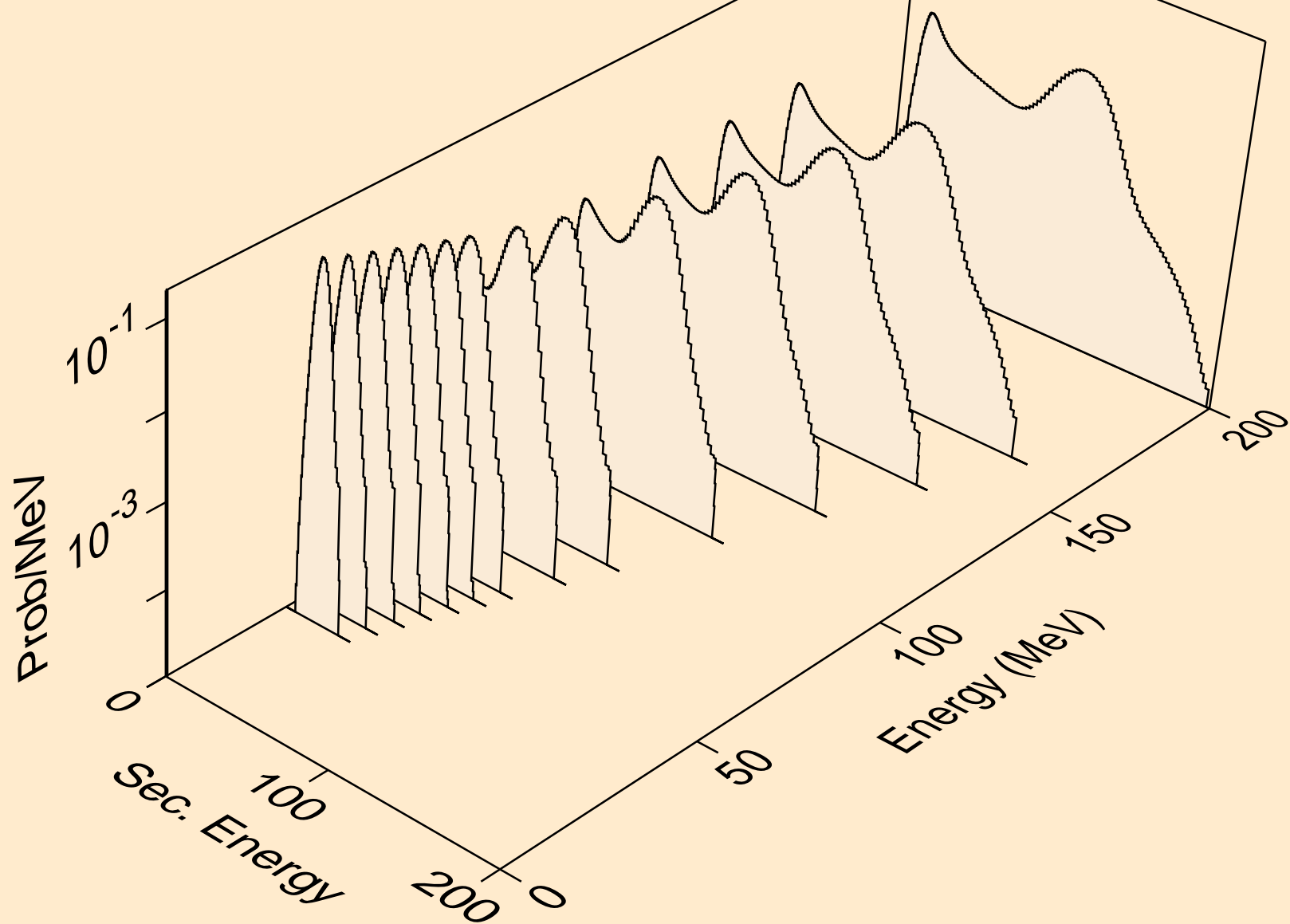

PO223 DEUTERON ACER TENDL-2021 LIBRARY; T=0.K  
protons from (d,n\*)p

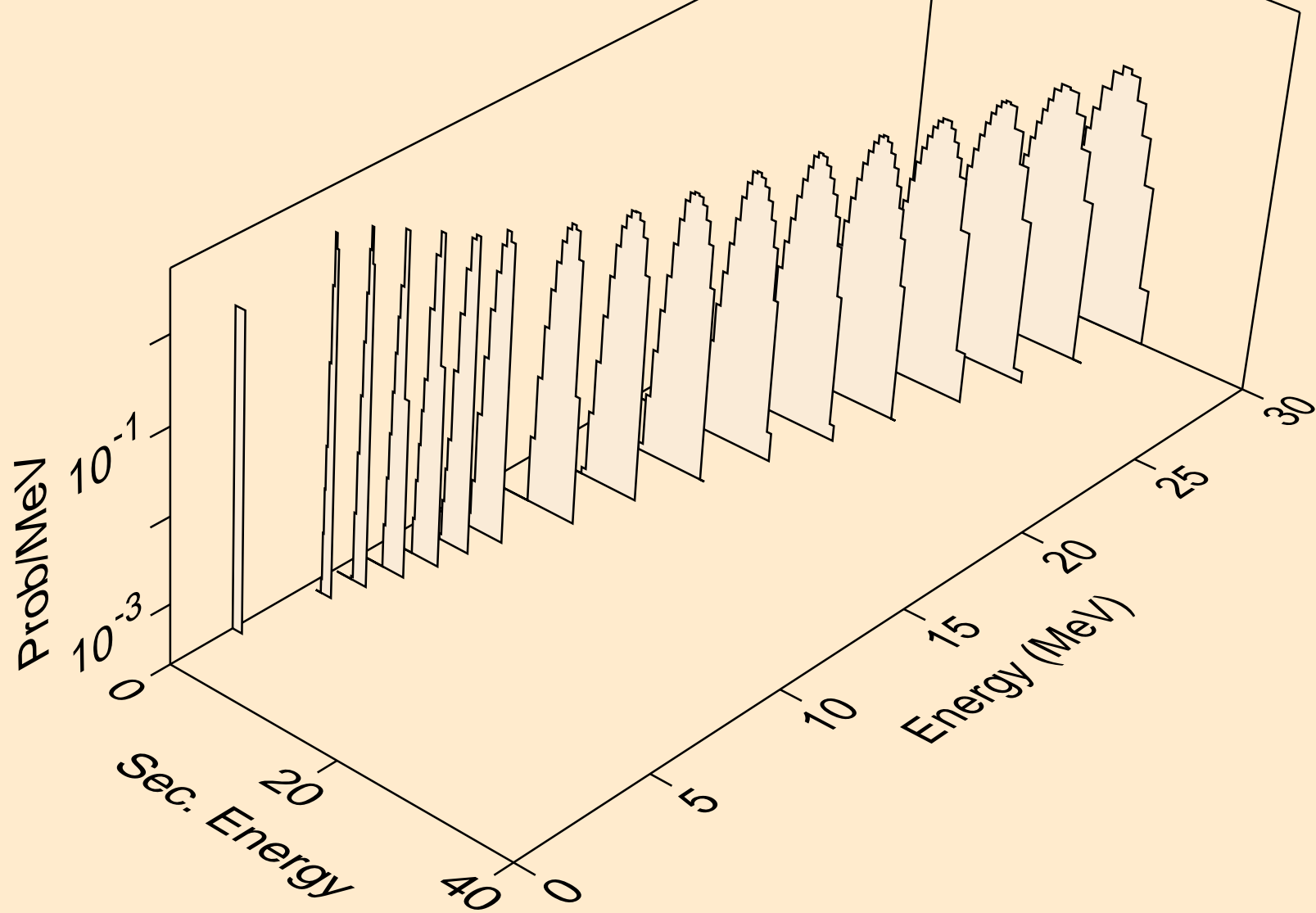

PO223 DEUTERON ACER TENDL-2021 LIBRARY; T=0.K  
protons from (d,2np)

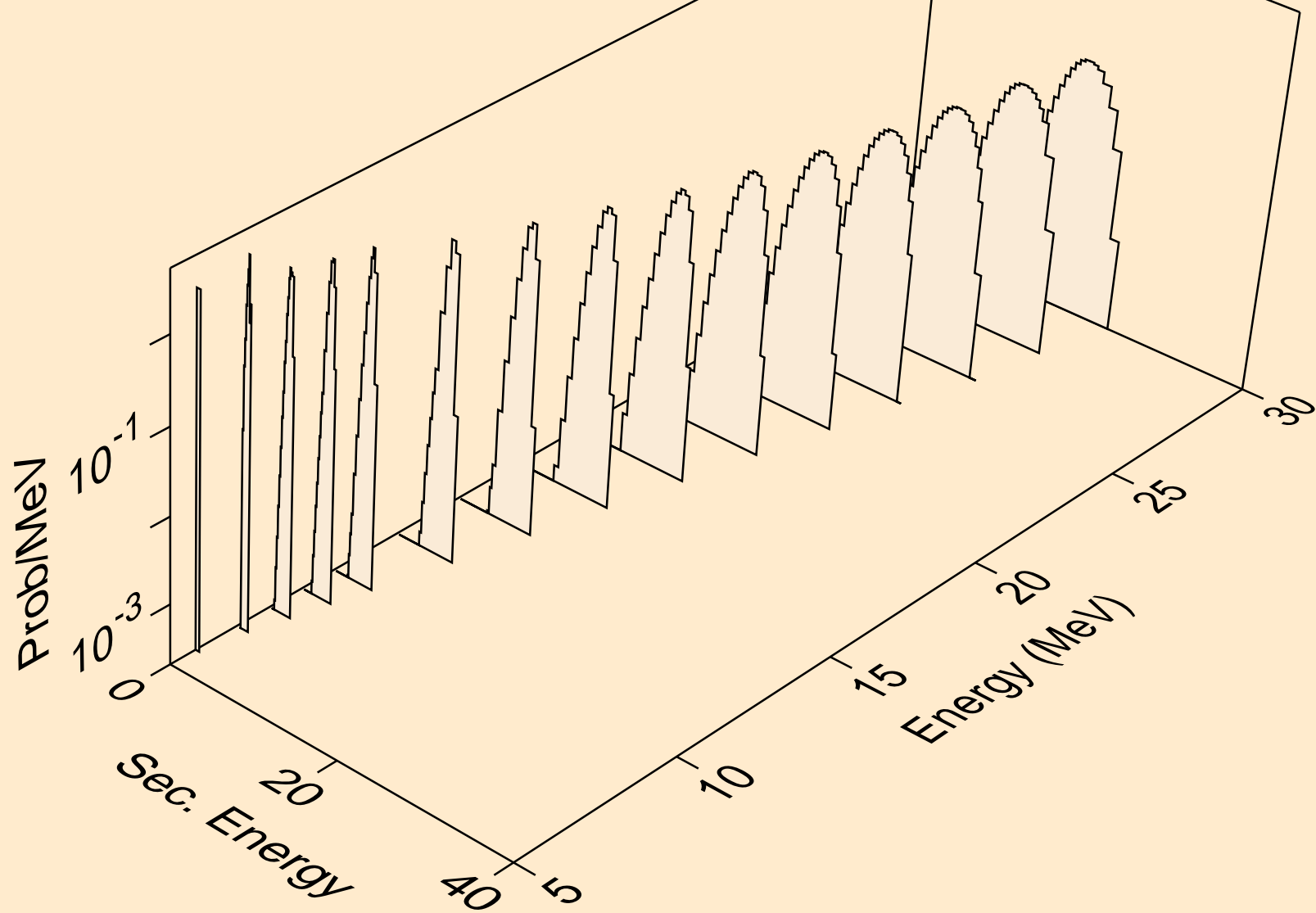

PO223 DEUTERON ACER TENDL-2021 LIBRARY; T=0.K  
protons from (d,3np)

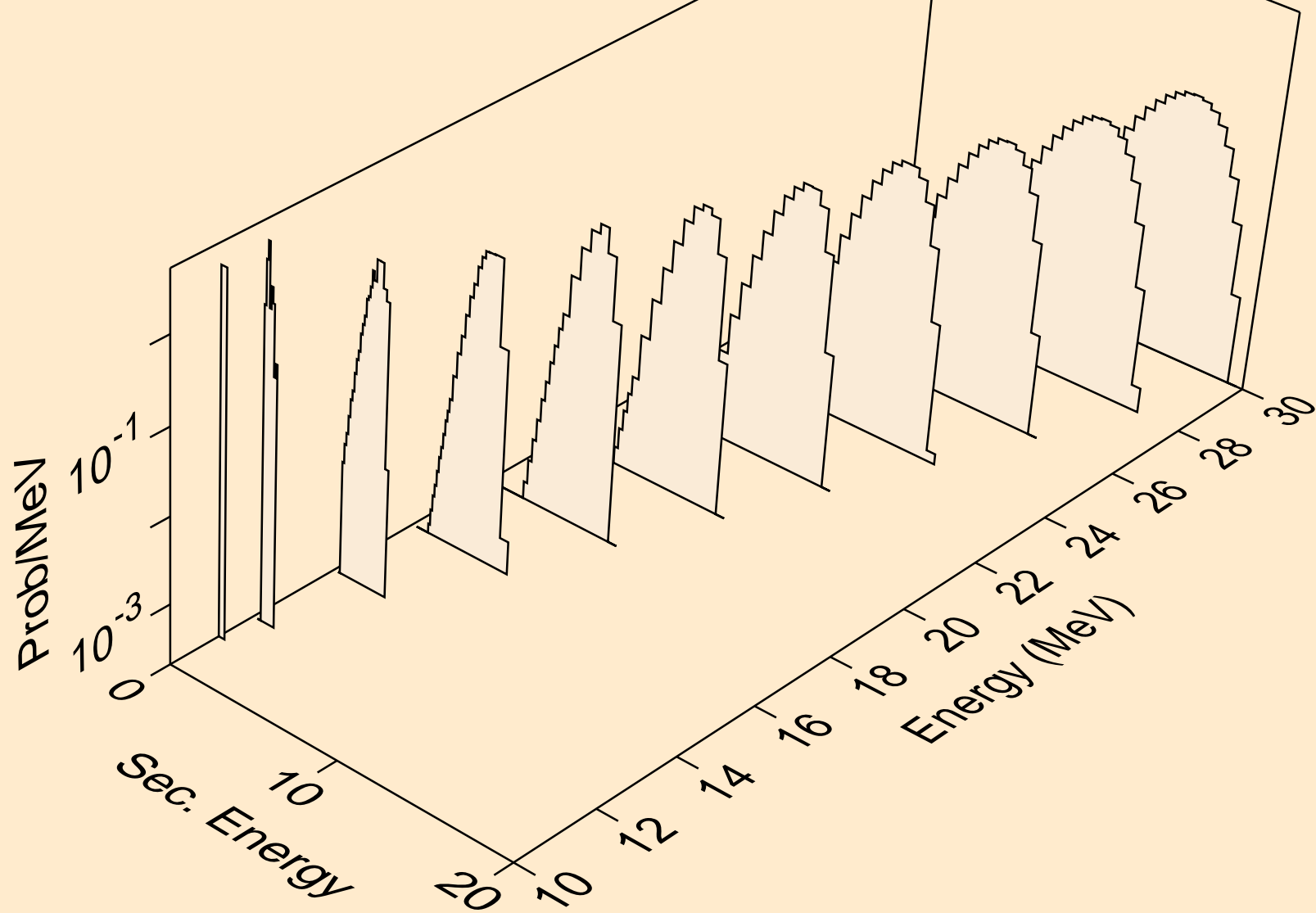

PO223 DEUTERON ACER TENDL-2021 LIBRARY; T=0.K  
protons from (d,2np)

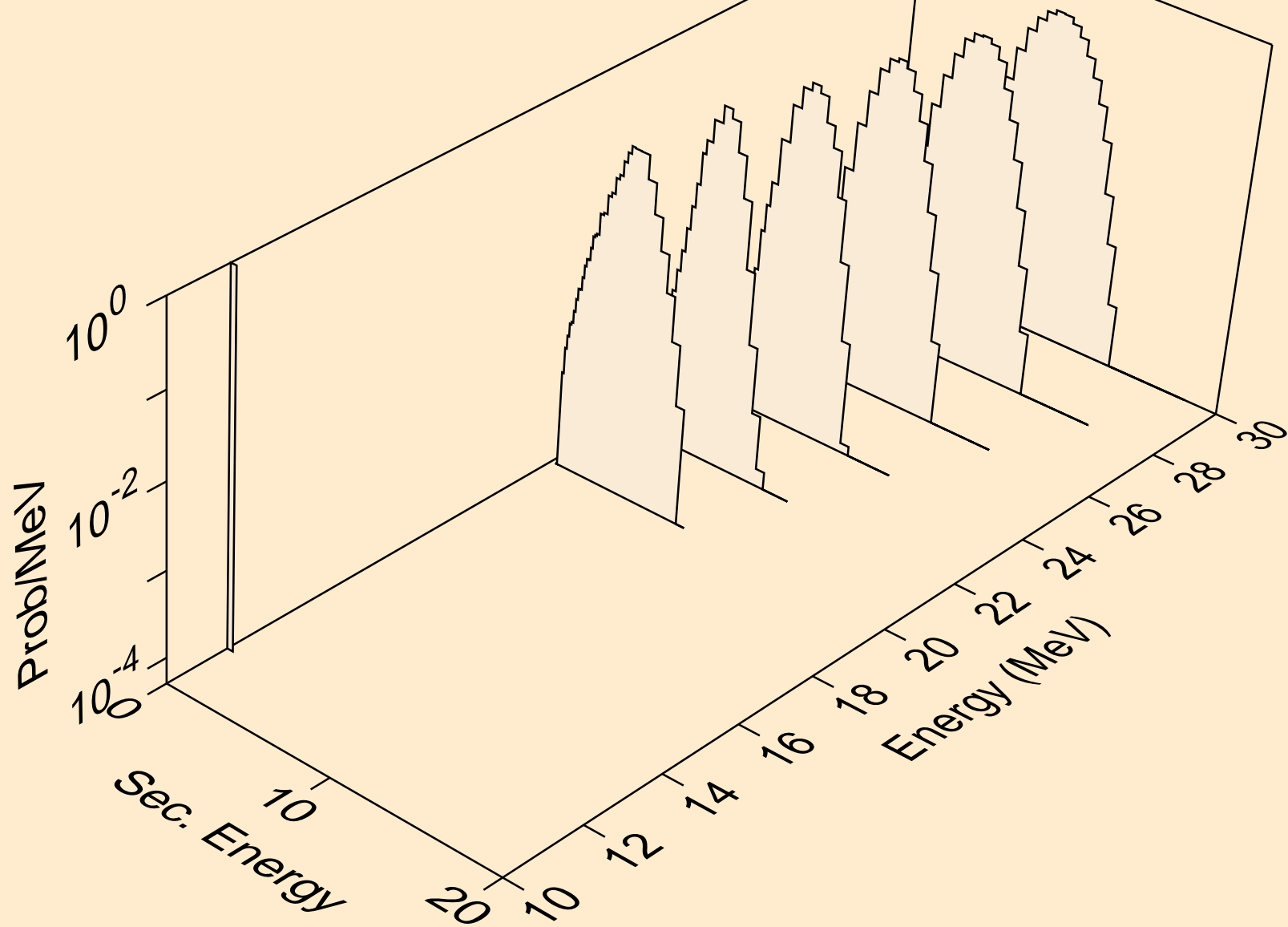



PO223 DEUTERON ACER TENDL-2021 LIBRARY; T=0.K  
protons from (d,npa)

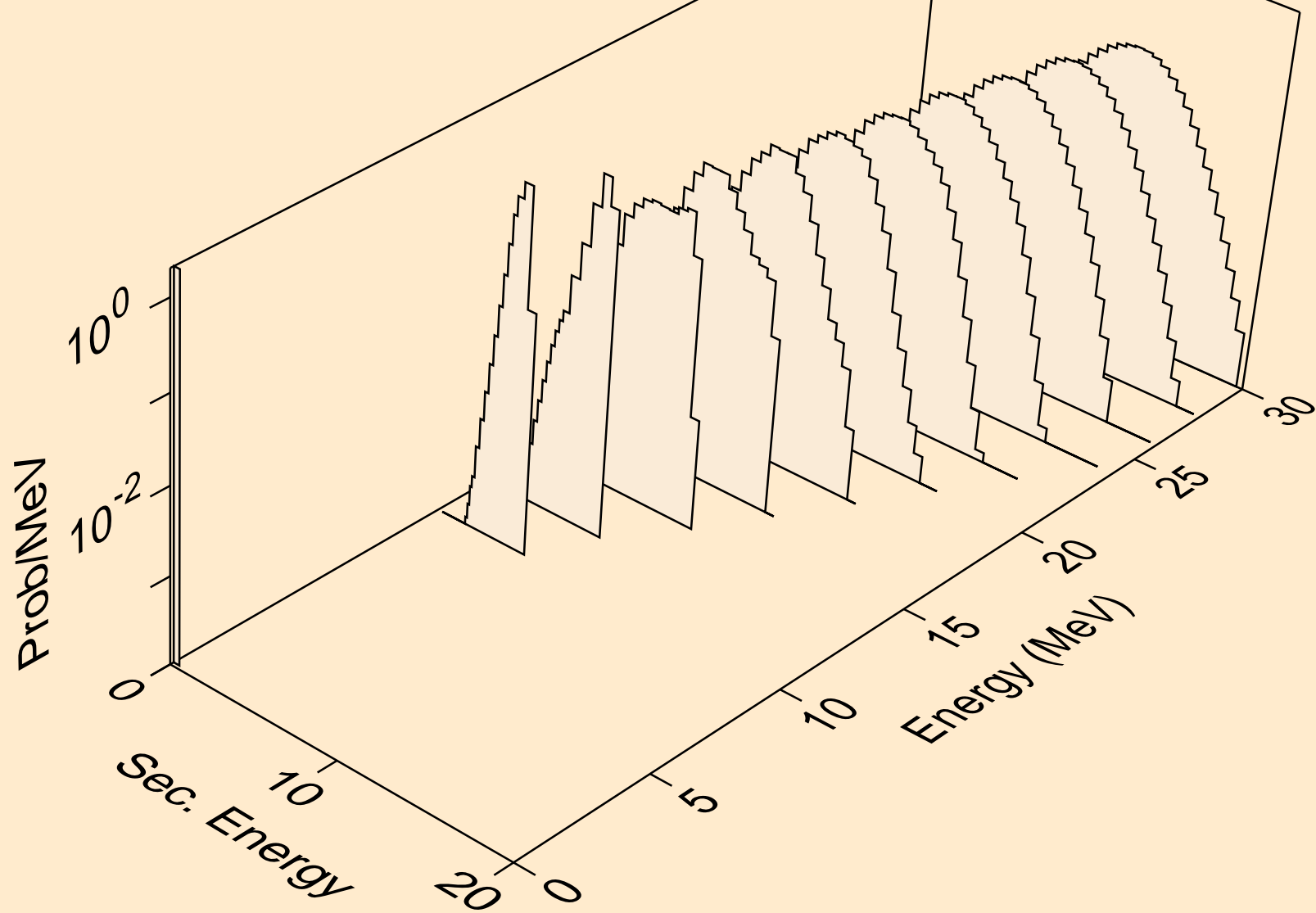

PO223 DEUTERON ACER TENDL-2021 LIBRARY; T=0.K  
protons from (d,p)

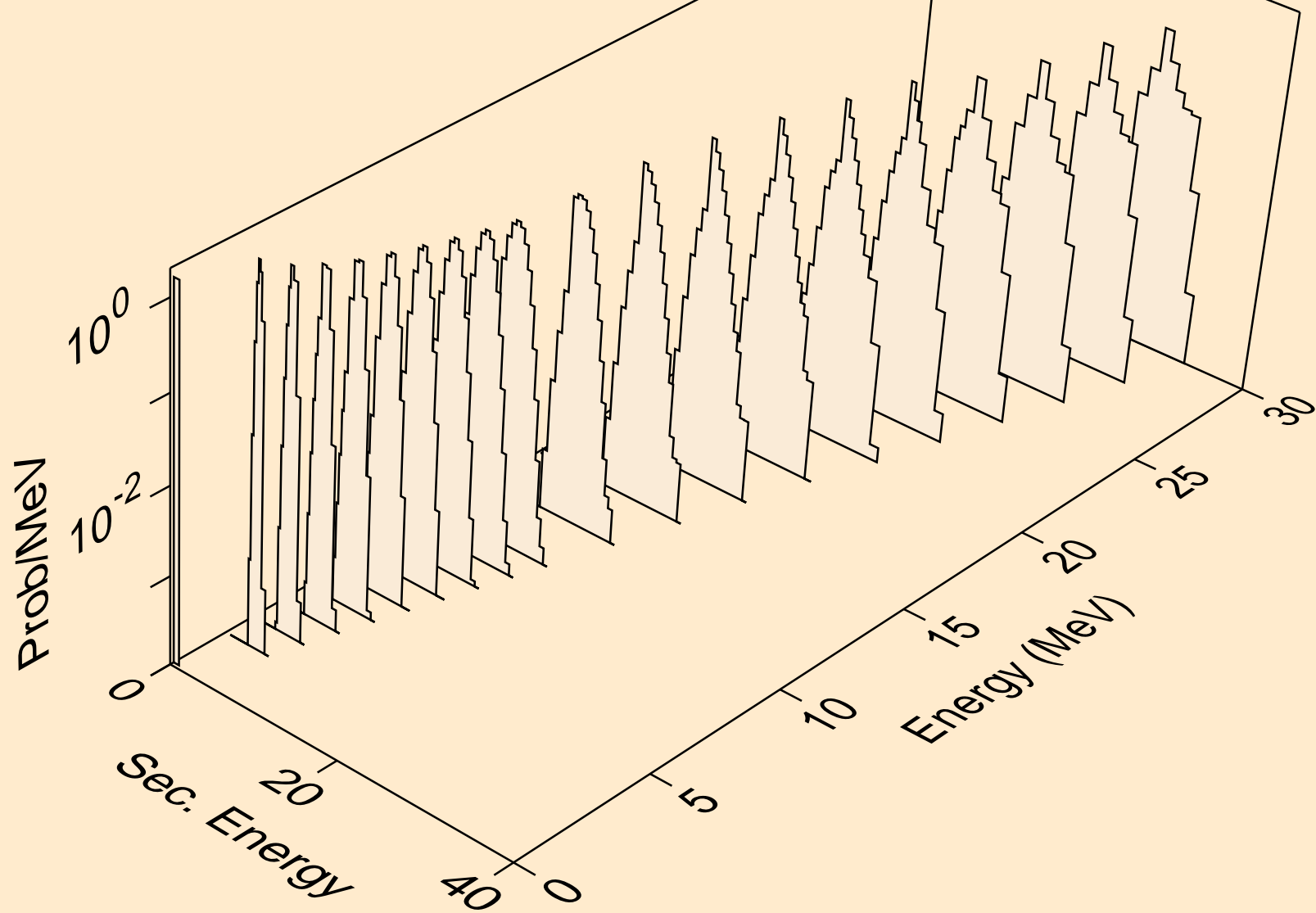

PO223 DEUTERON ACER TENDL-2021 LIBRARY; T=0.K  
protons from (d,2p)

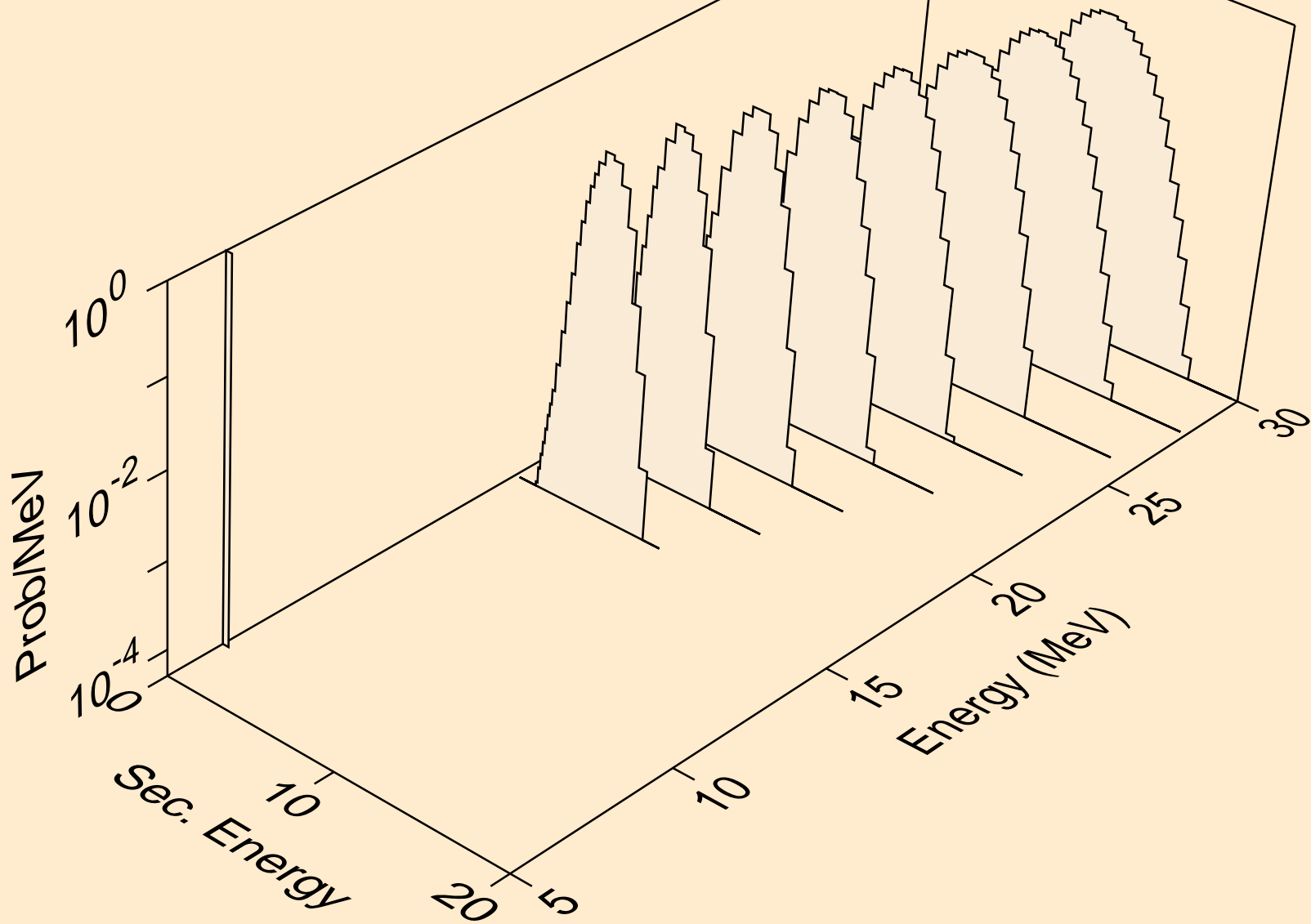

PO223 DEUTERON ACER TENDL-2021 LIBRARY; T=0.K  
protons from (d,pd)

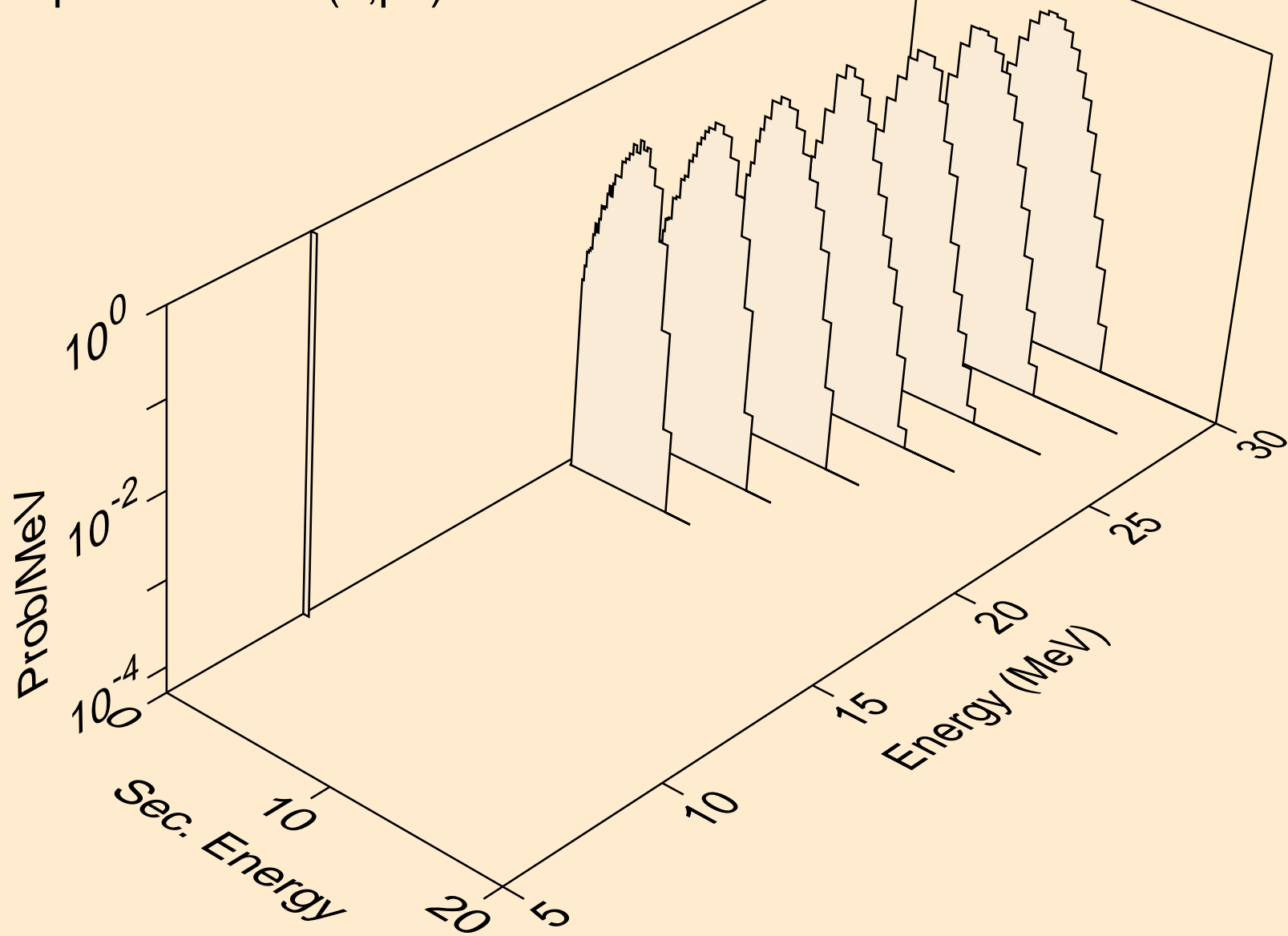

PO223 DEUTERON ACER TENDL-2021 LIBRARY; T=0.K  
tritons from (d,x)

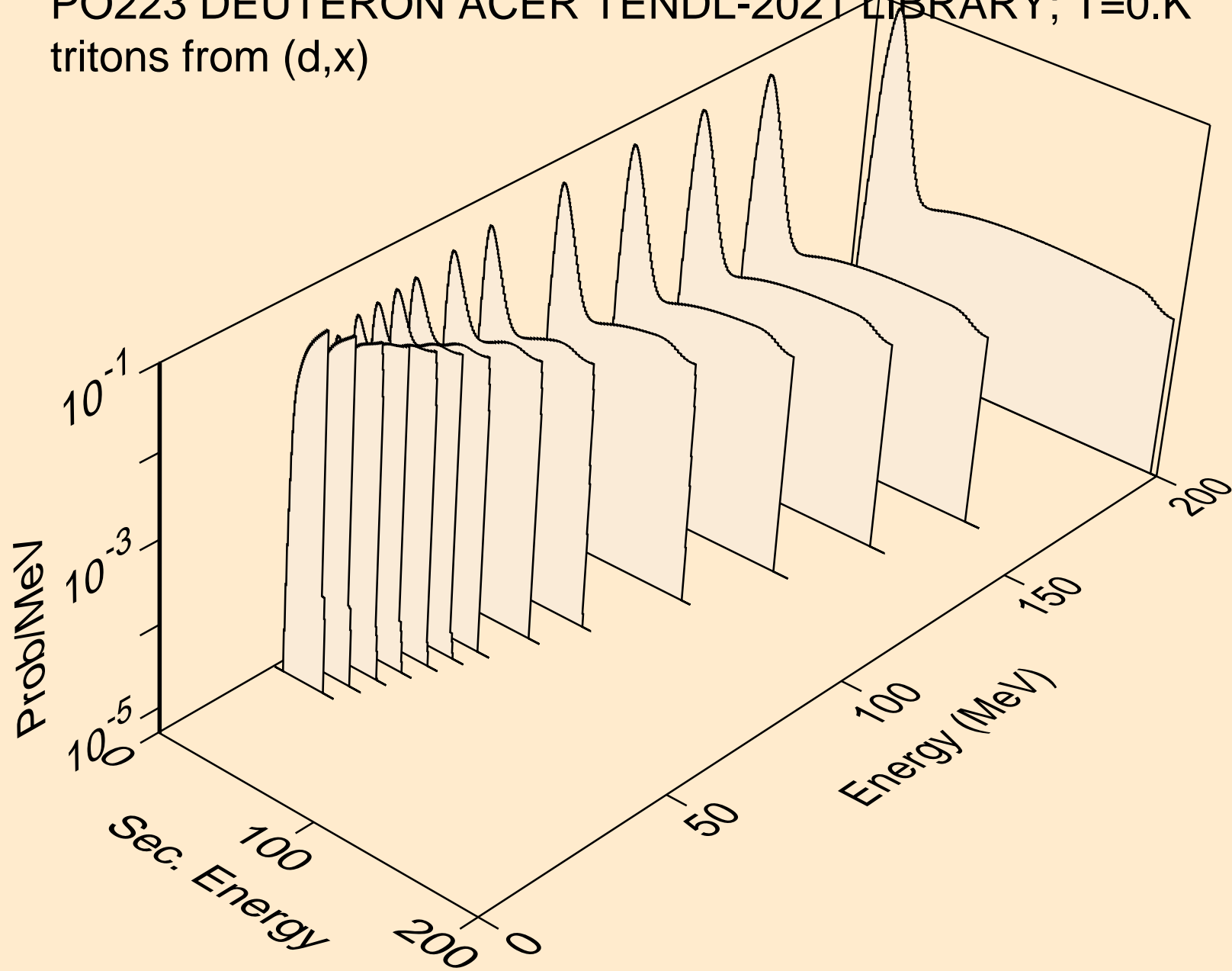

PO223 DEUTERON ACER TENDL-2021 LIBRARY; T=0.K  
tritons from (d,n\*)t

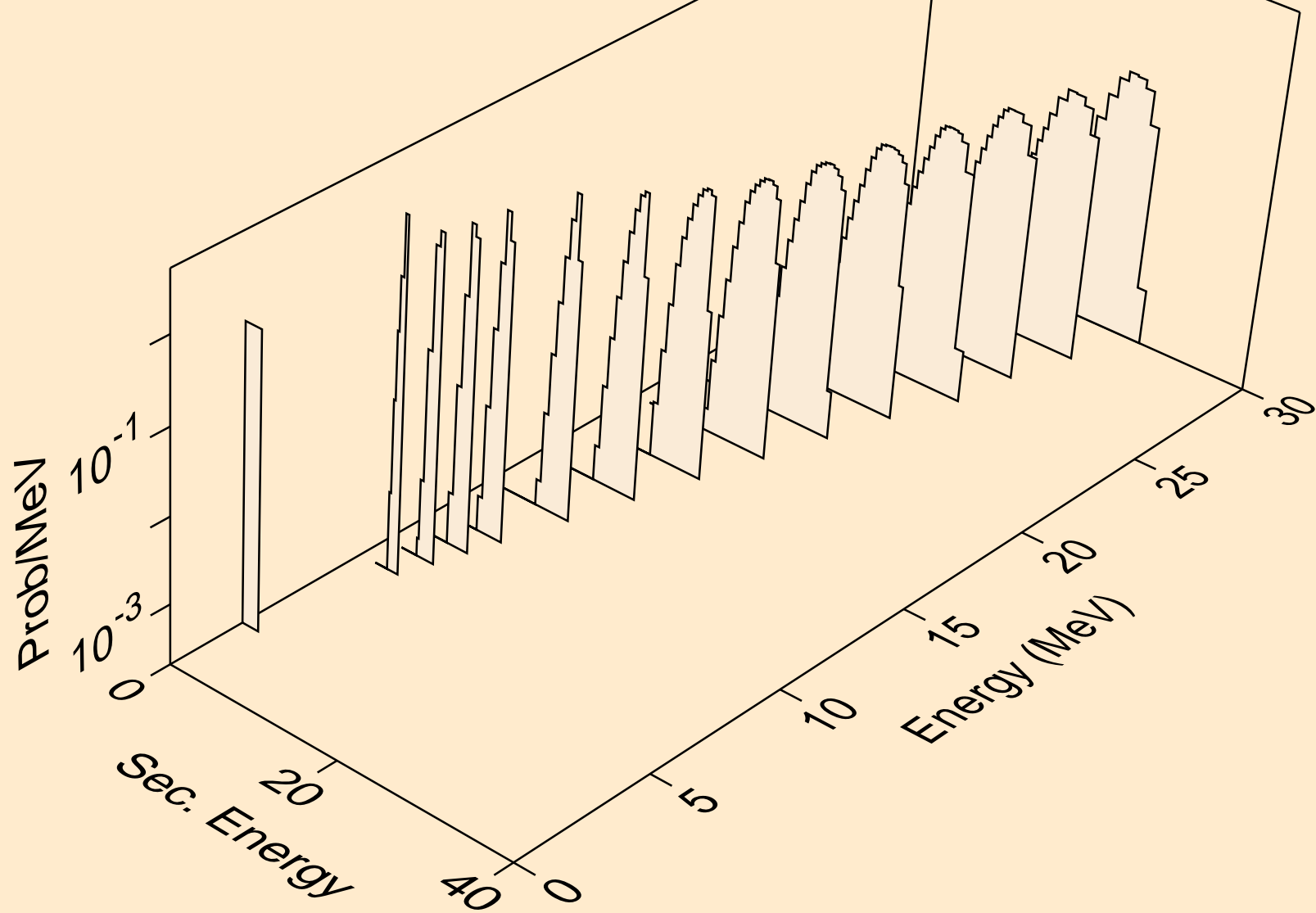

PO223 DEUTERON ACER TENDL-2021 LIBRARY; T=0.K  
tritons from (d,t)

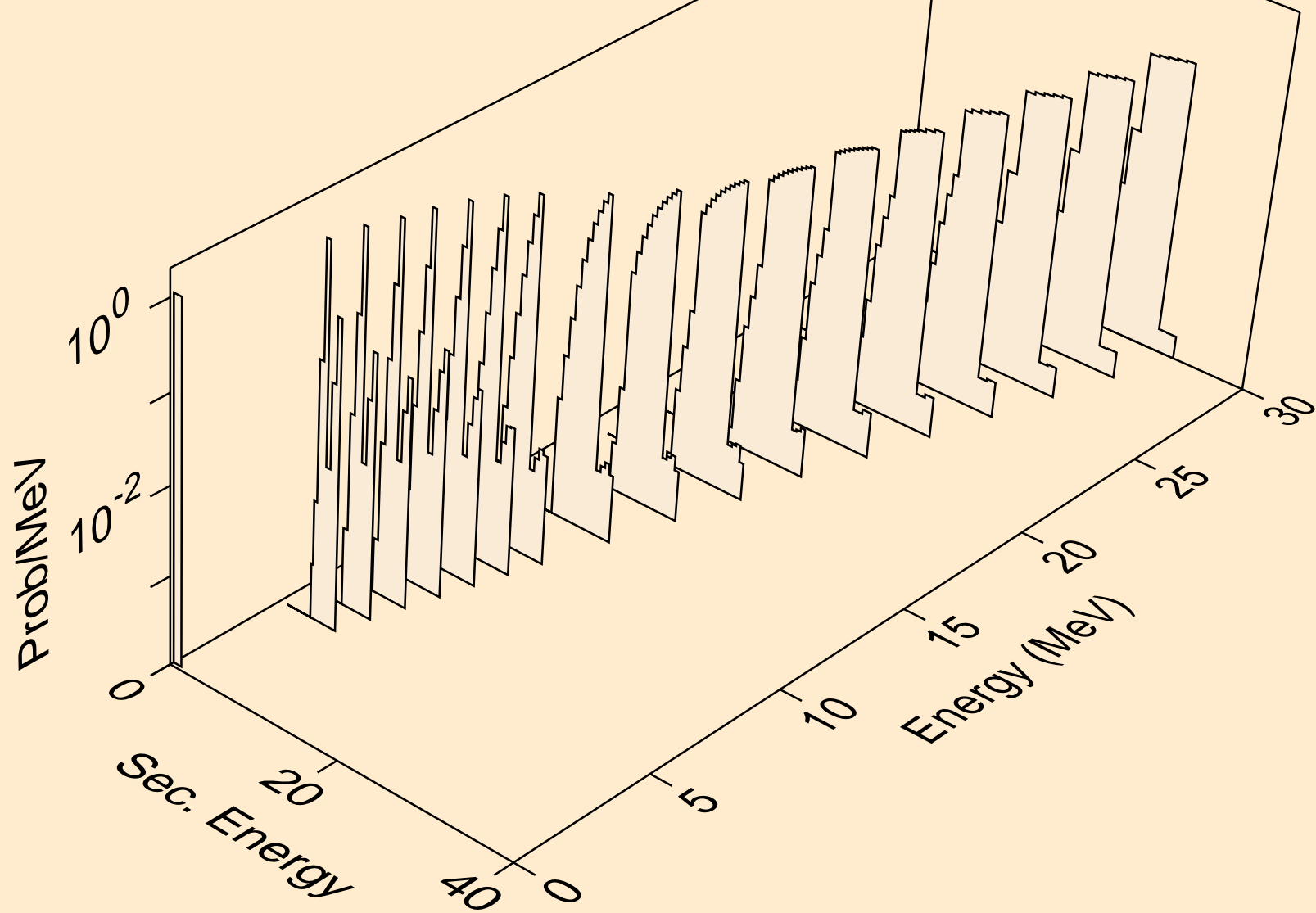

PO223 DEUTERON ACER TENDL-2021 LIBRARY; T=0.K  
he3s from (d,x)

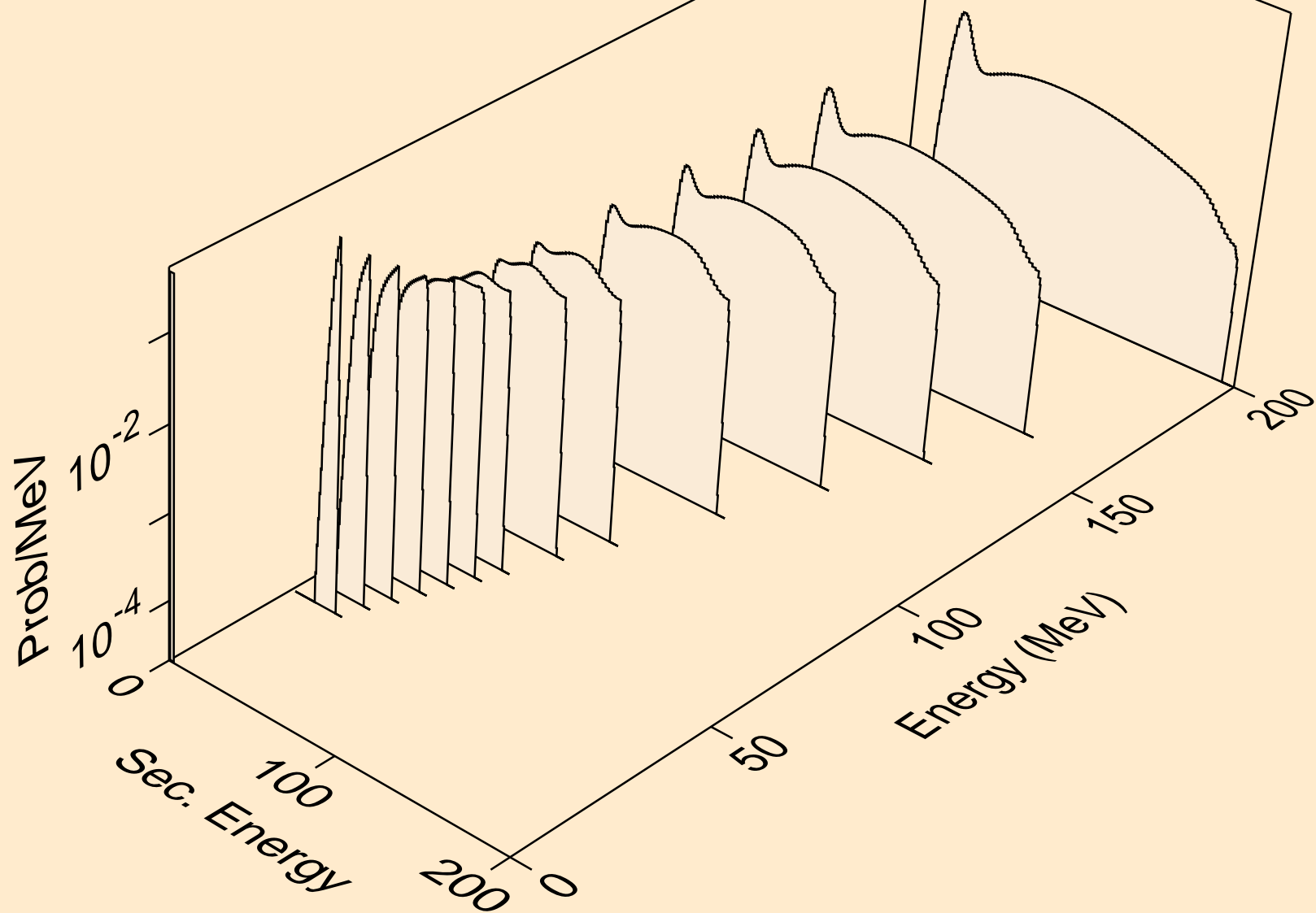



PO223 DEUTERON ACER TENDL-2021 LIBRARY; T=0.K  
he3s from (d,n\*)he3

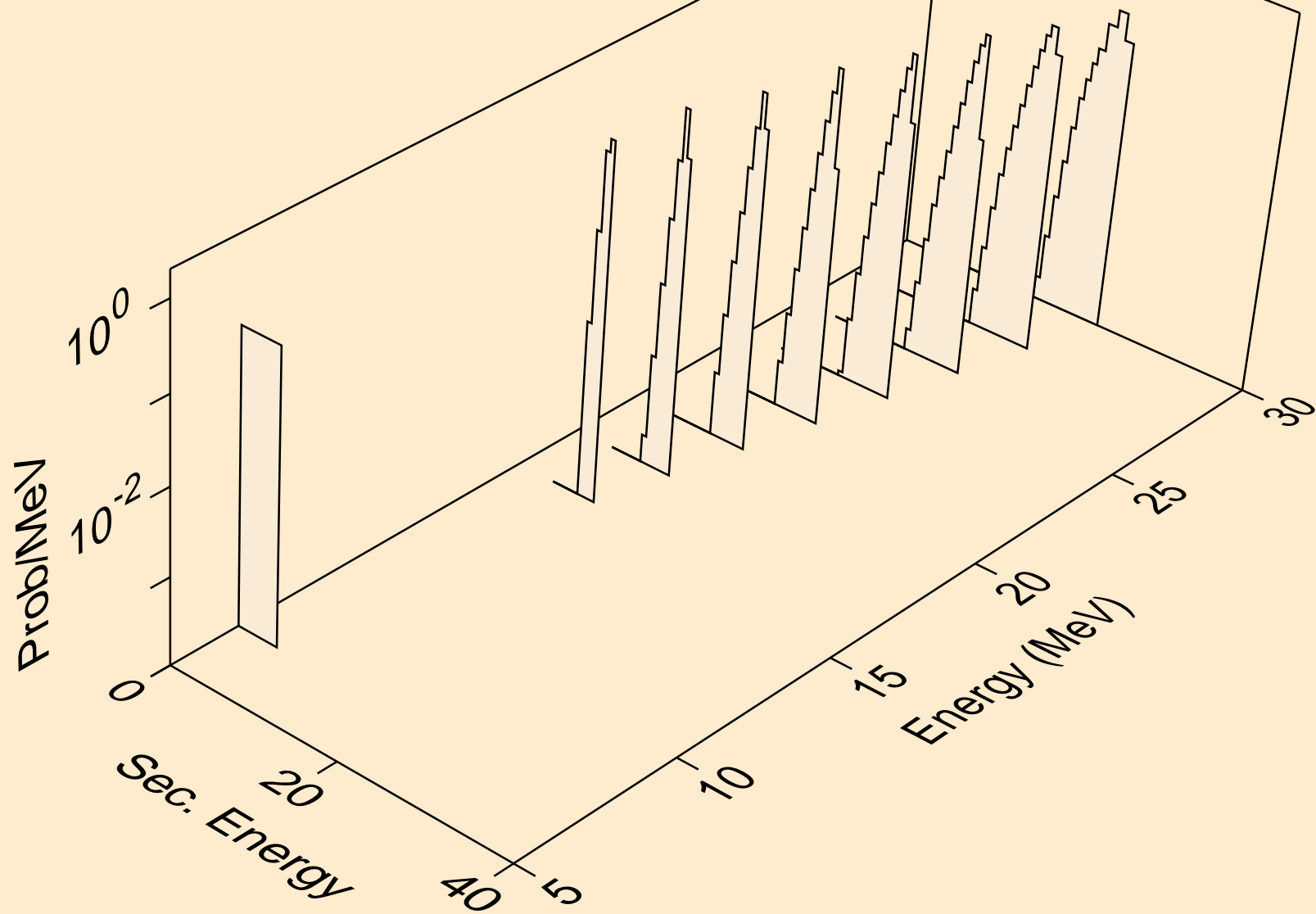

PO223 DEUTERON ACER TENDL-2021 LIBRARY; T=0.K  
he3s from (d,he3)

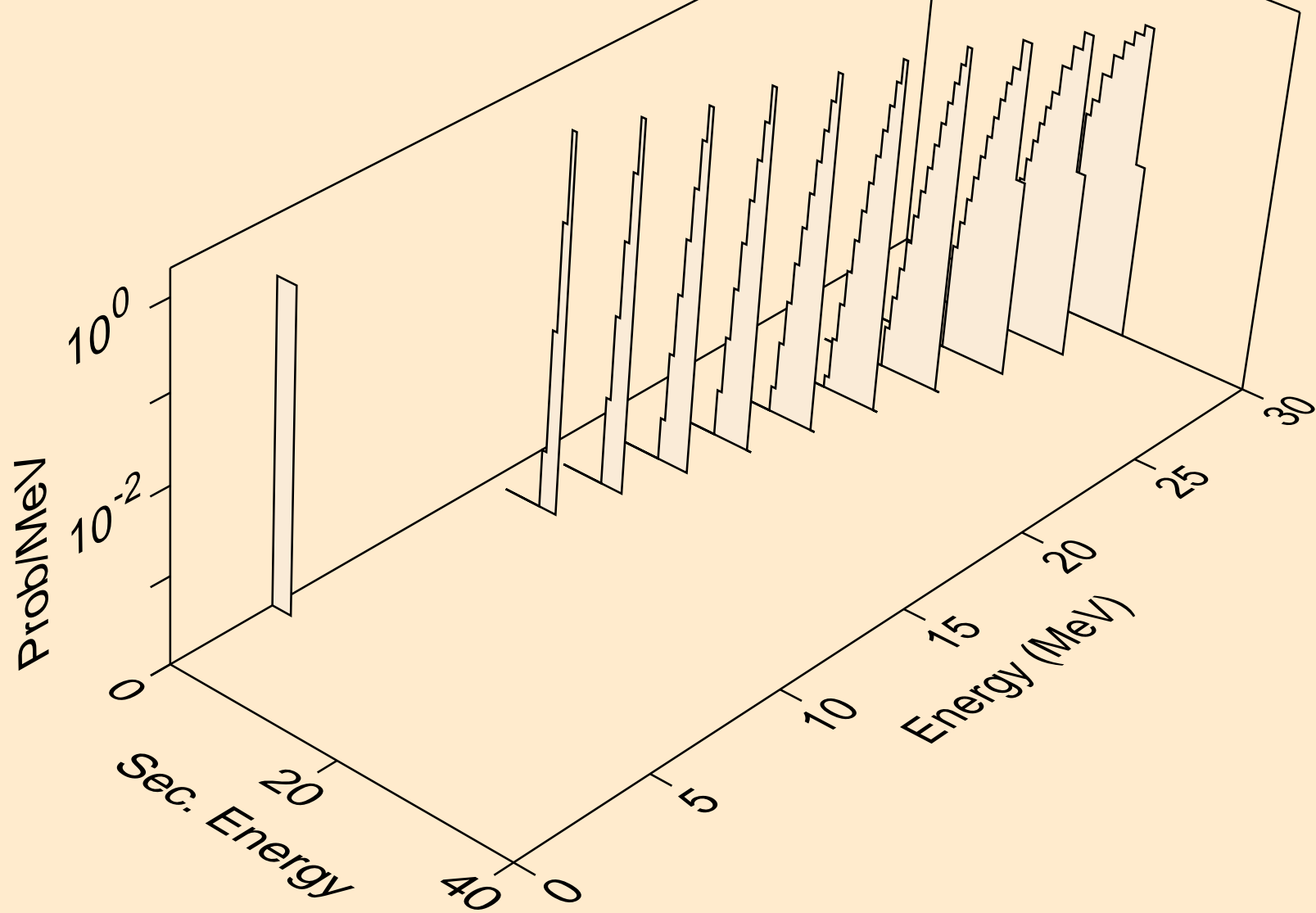

PO223 DEUTERON ACER TENDL-2021 LIBRARY; T=0.K  
alphas from (d,x)

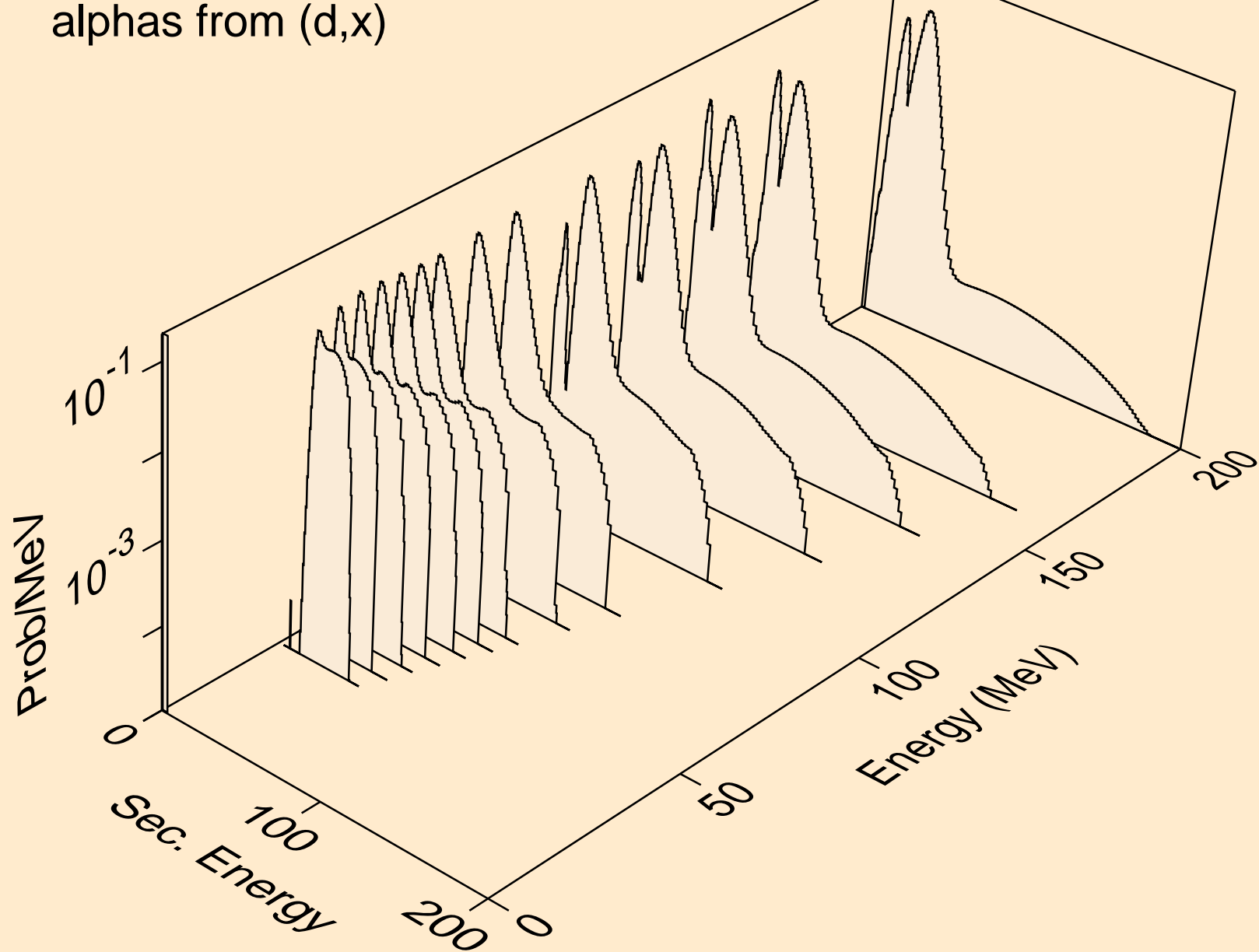

PO223 DEUTERON ACER TENDL-2021 LIBRARY; T=0.K  
alphas from (d,n\*)a

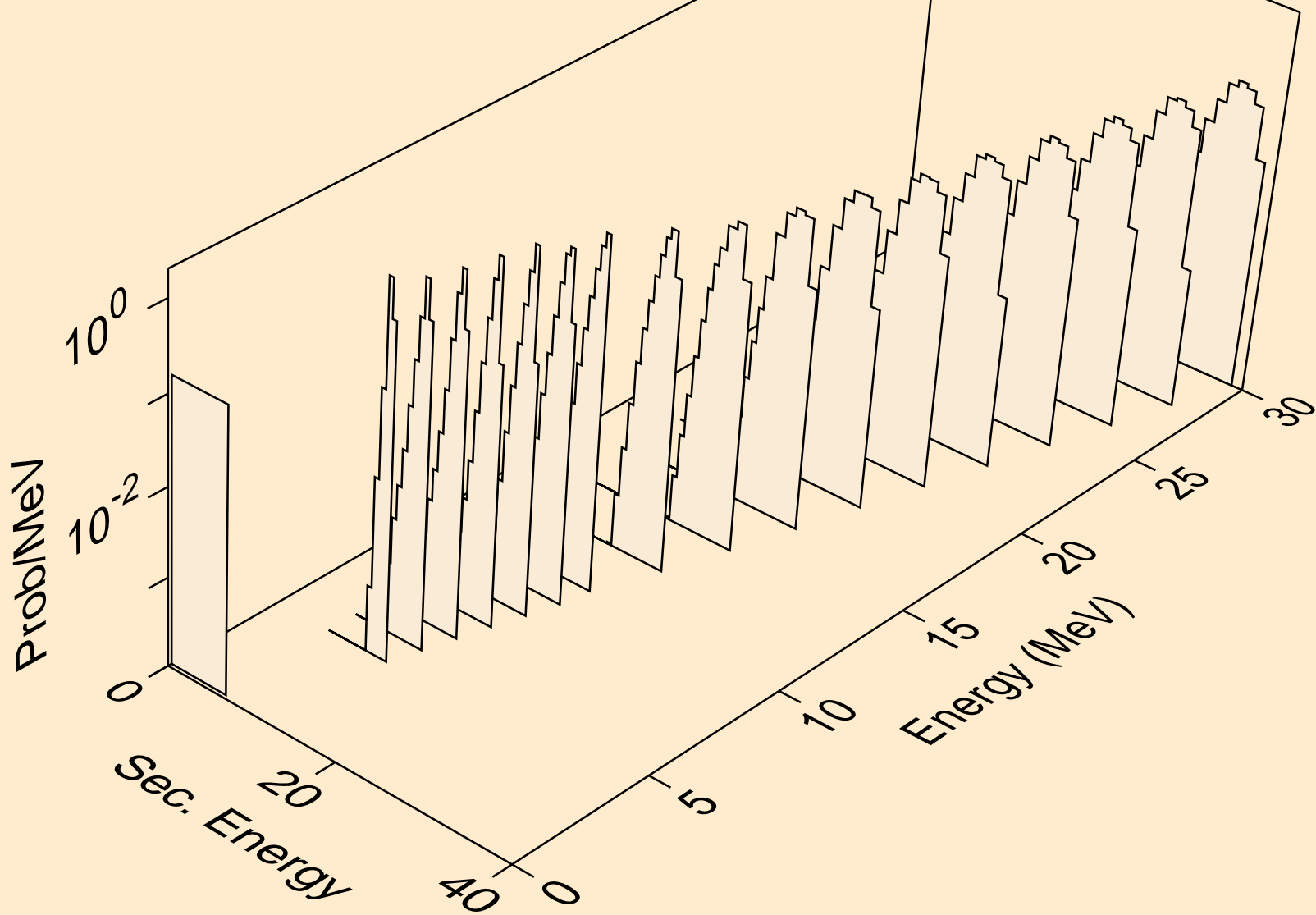

PO223 DEUTERON ACER TENDL-2021 LIBRARY; T=0.K  
alphas from (d,2n)a

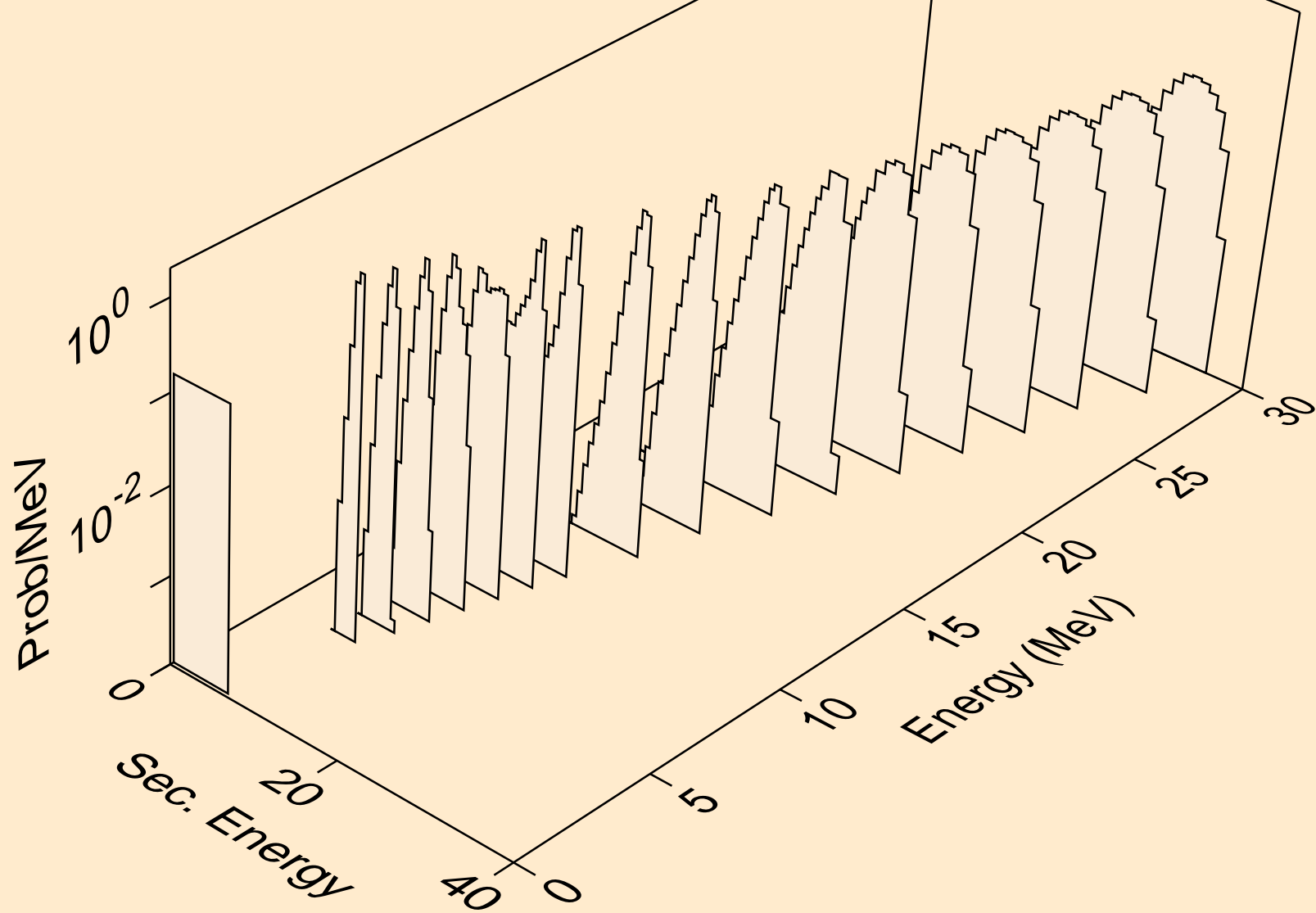

PO223 DEUTERON ACER TENDL-2021 LIBRARY; T=0.K  
alphas from (d,3n)a

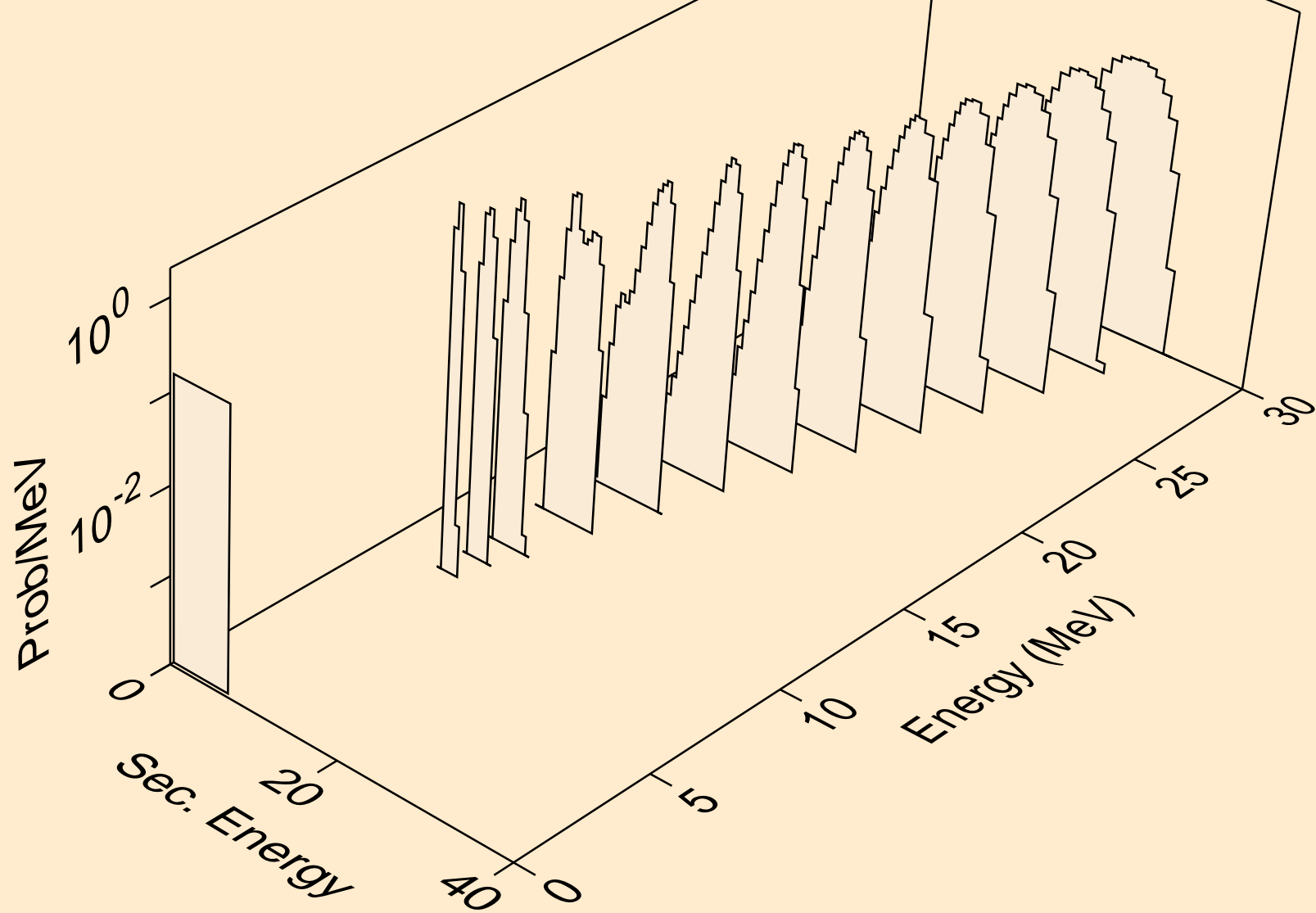

PO223 DEUTERON ACER TENDL-2021 LIBRARY; T=0.K  
alphas from (d,2n)2a

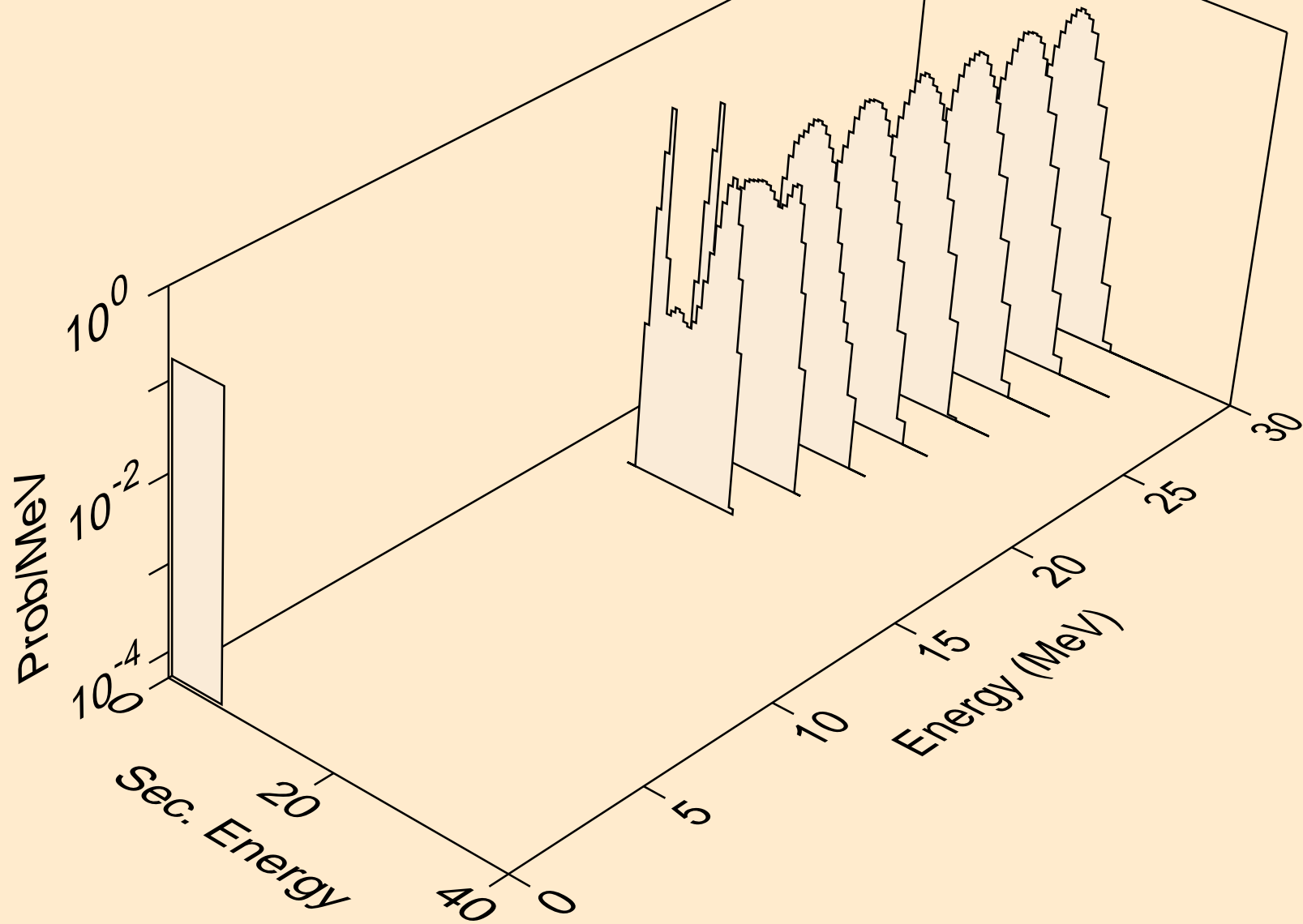

PO223 DEUTERON ACER TENDL-2021 LIBRARY; T=0.K  
alphas from (d,npa)

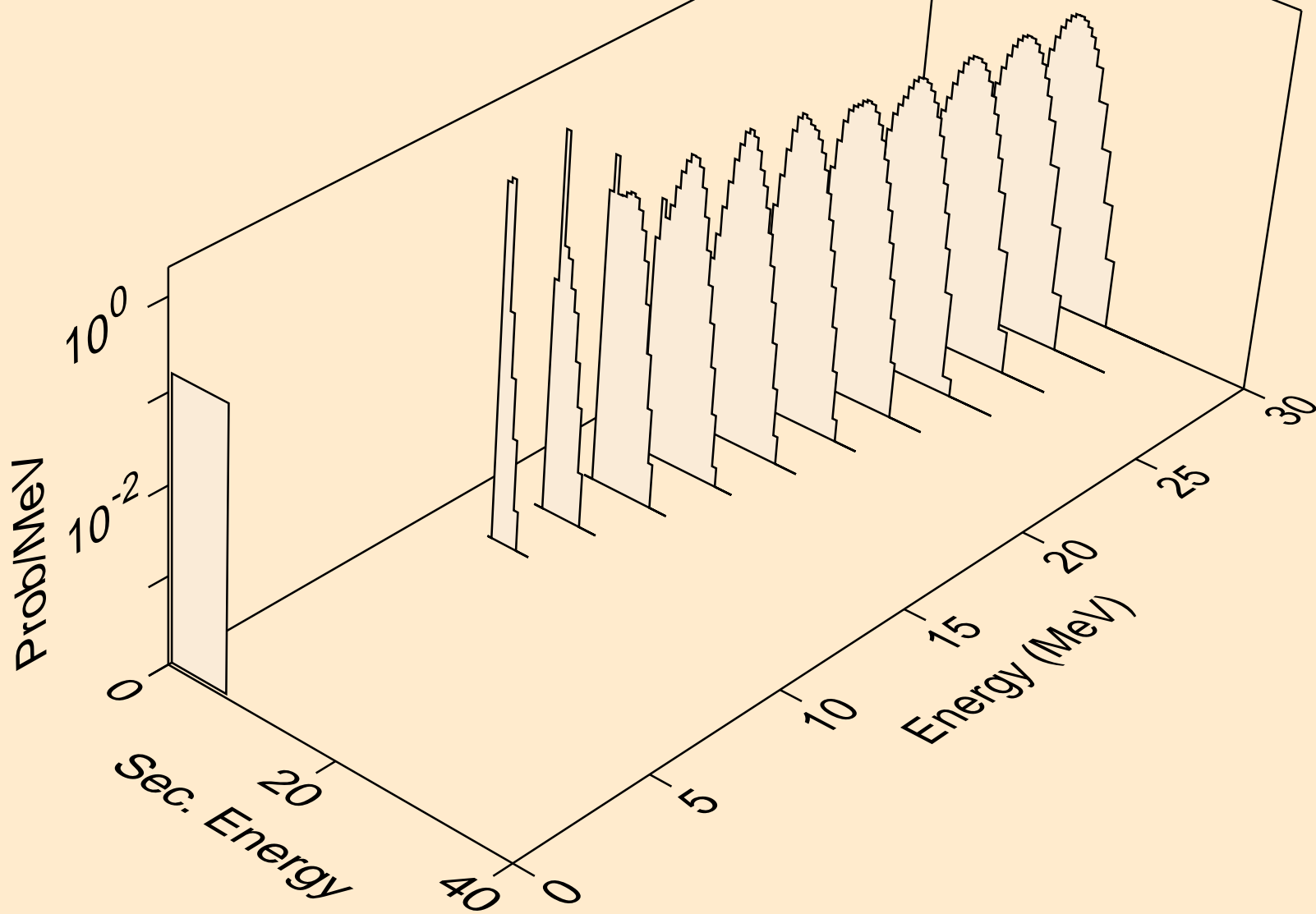



PO223 DEUTERON ACER TENDL-2021 LIBRARY; T=0.K  
alphas from (d,a)

