

# CL043 HELION ACER TENDL-2021 LIBRARY; T=0.K

## Principal cross sections

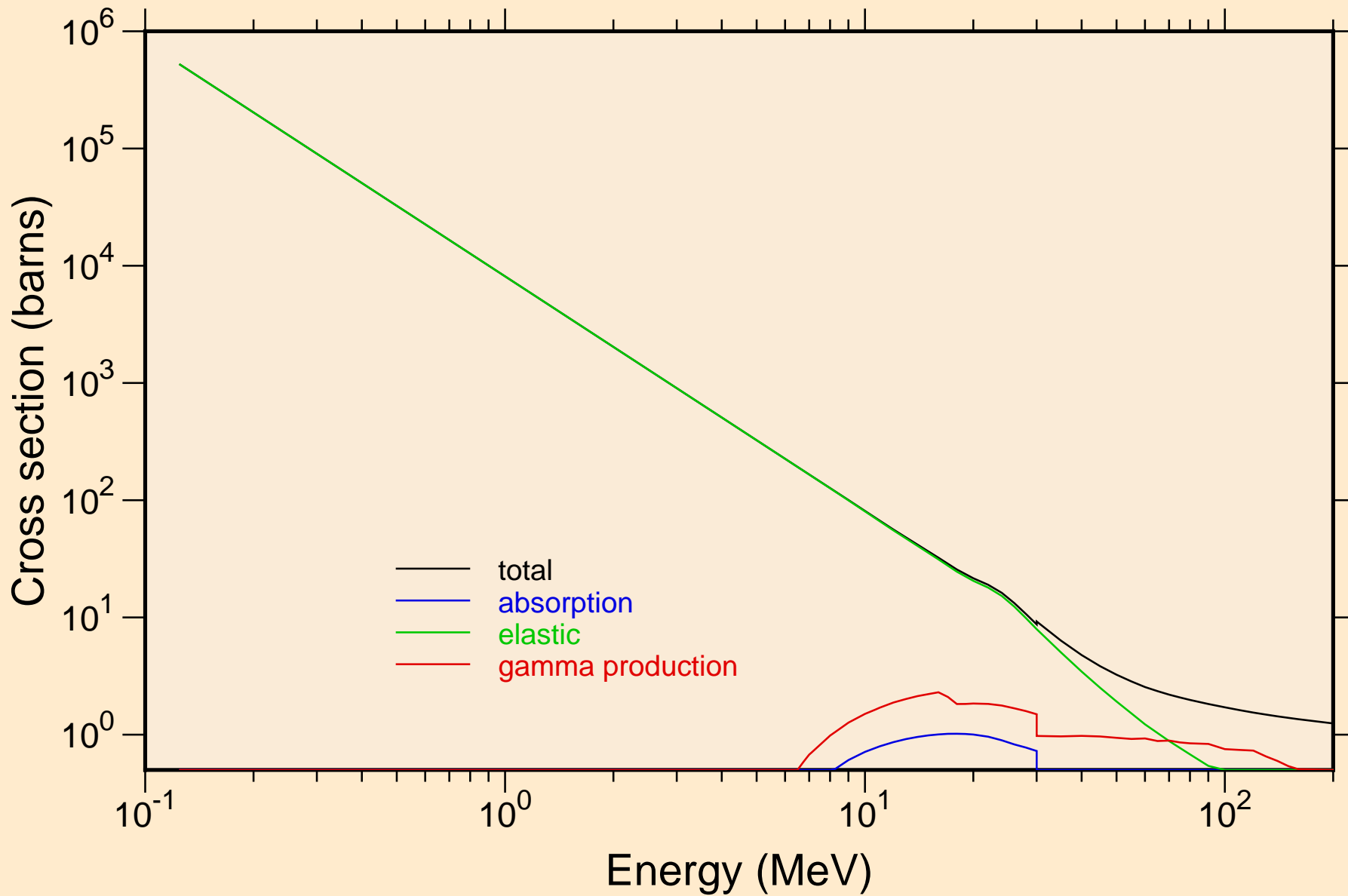

CL043 HELION ACER TENDL-2021 LIBRARY; T=0.K

Heating

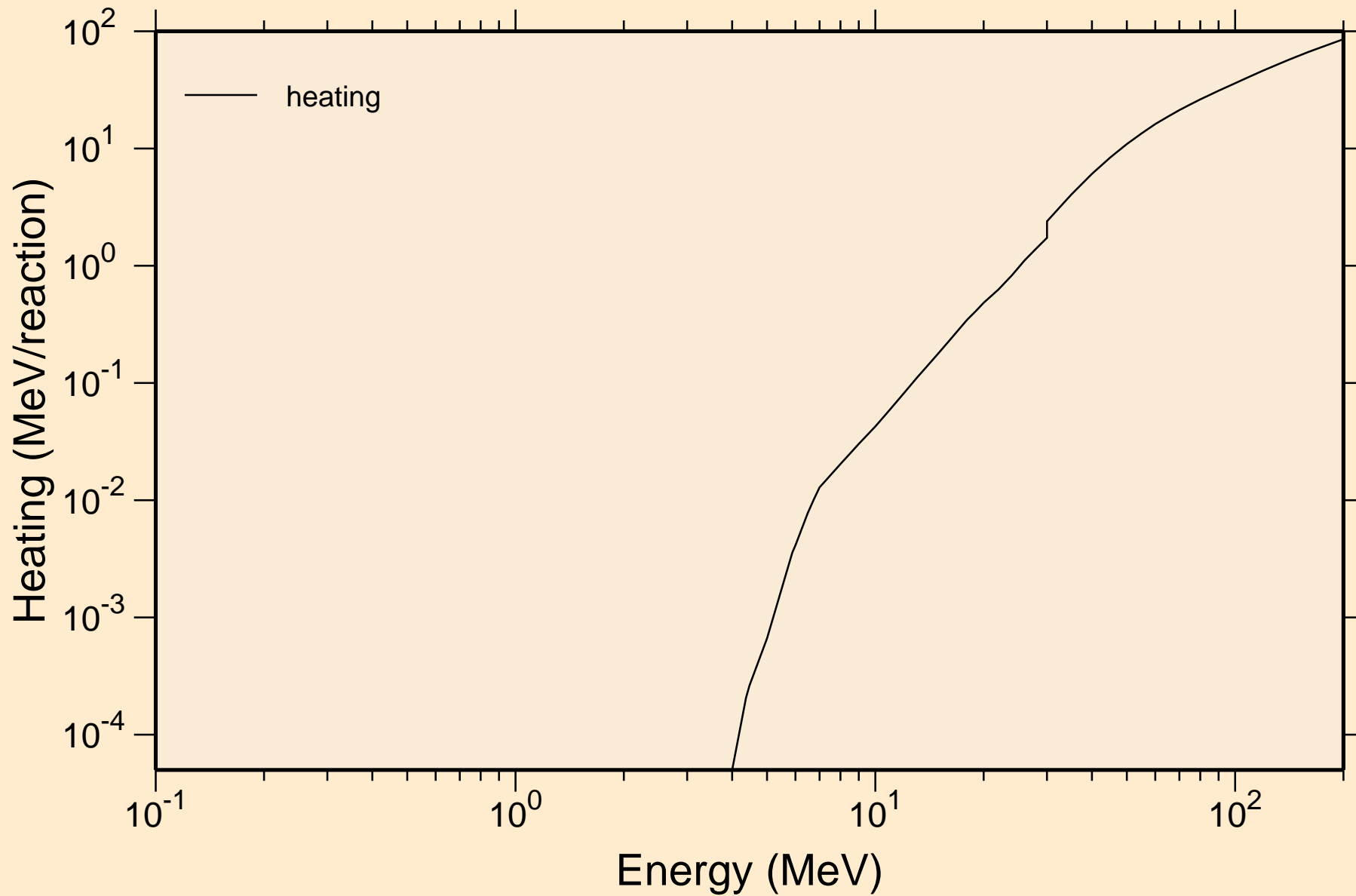

# CL043 HELION ACER TENDL-2021 LIBRARY; T=0.K

## Principal cross sections

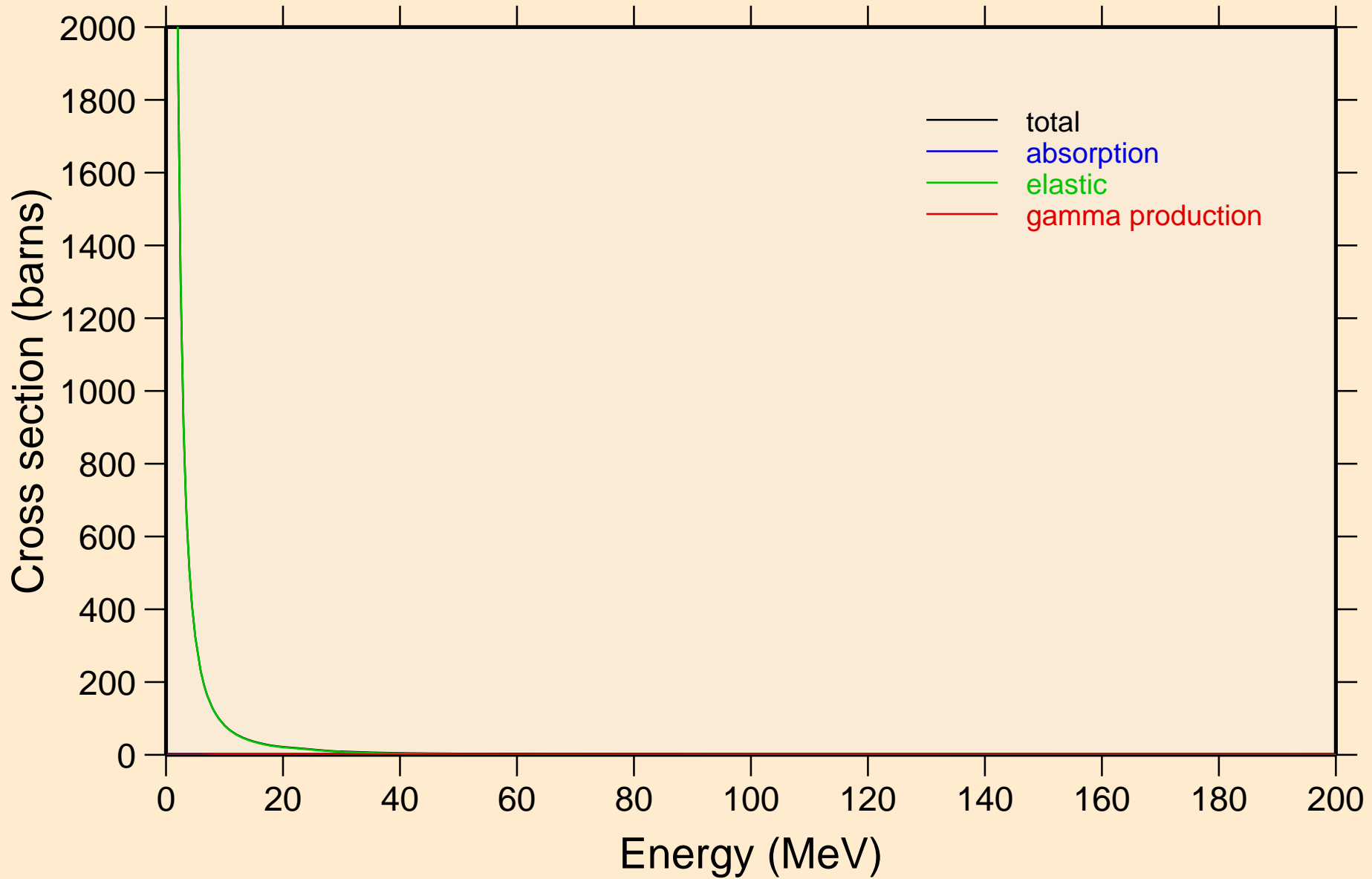

CL043 HELION ACER TENDL-2021 LIBRARY; T=0.K

Heating

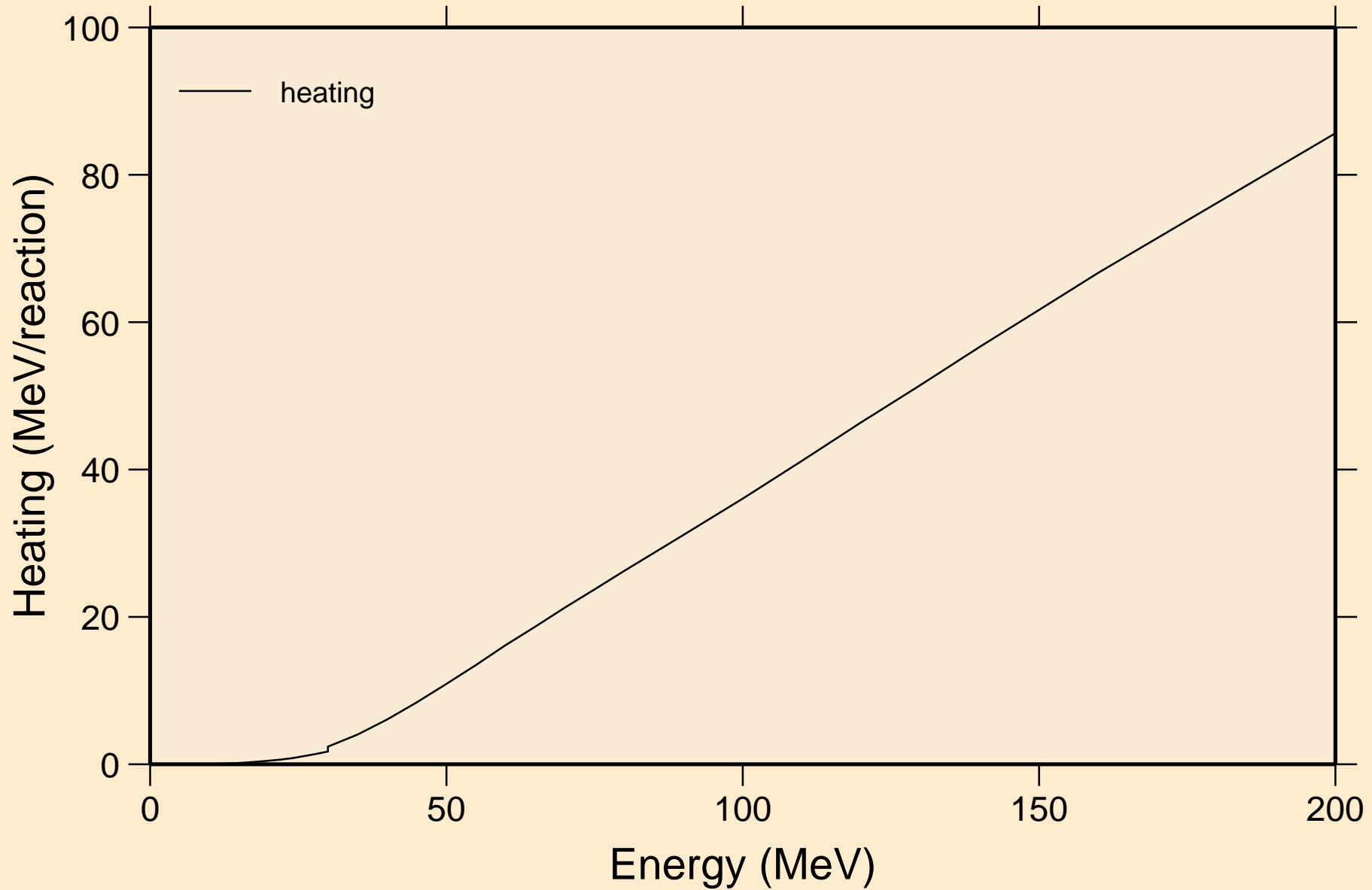

CL043 HELION ACER TENDL-2021 LIBRARY; T=0.K  
Threshold reactions

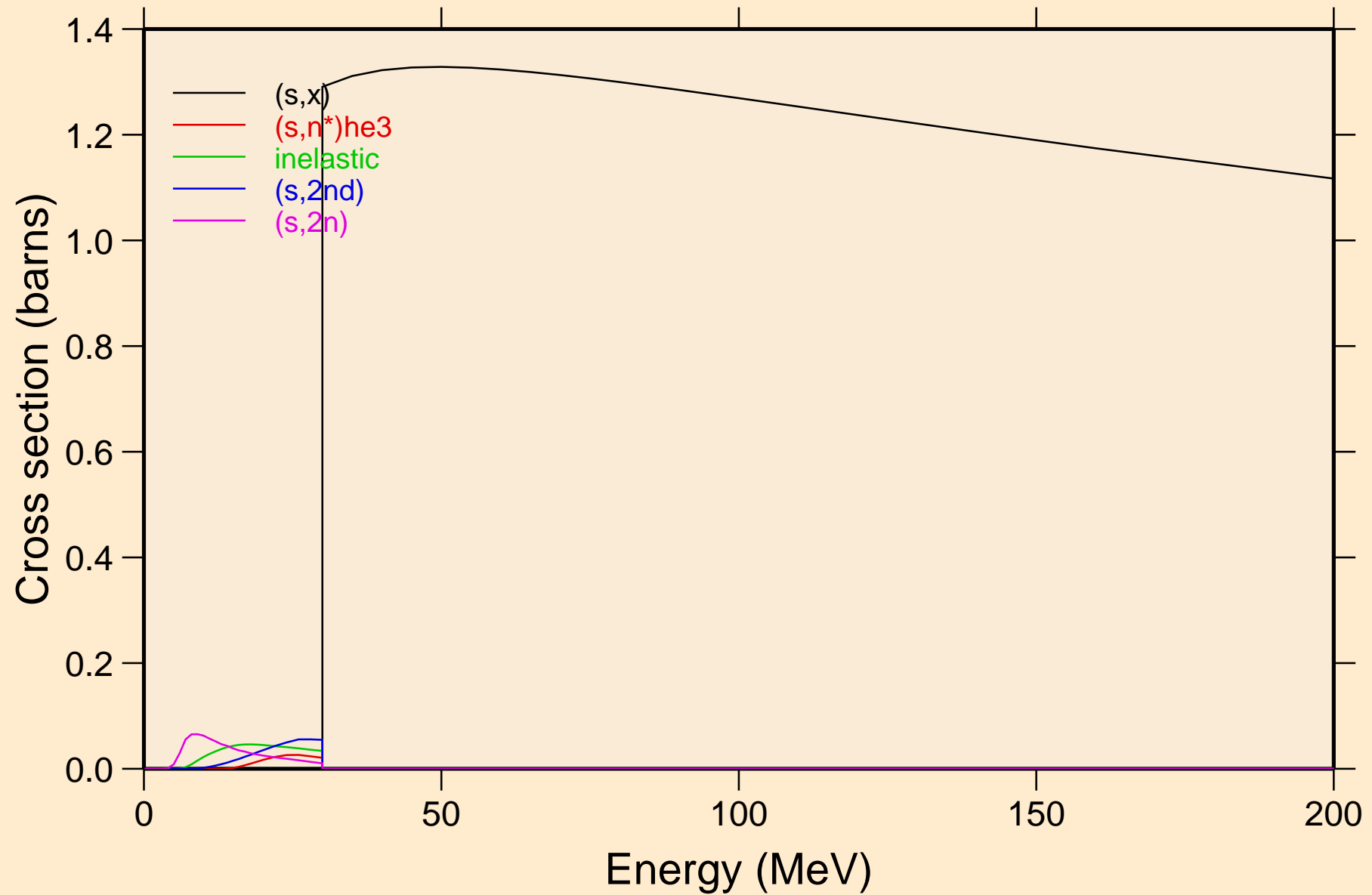

CL043 HELION ACER TENDL-2021 LIBRARY; T=0.K  
Threshold reactions

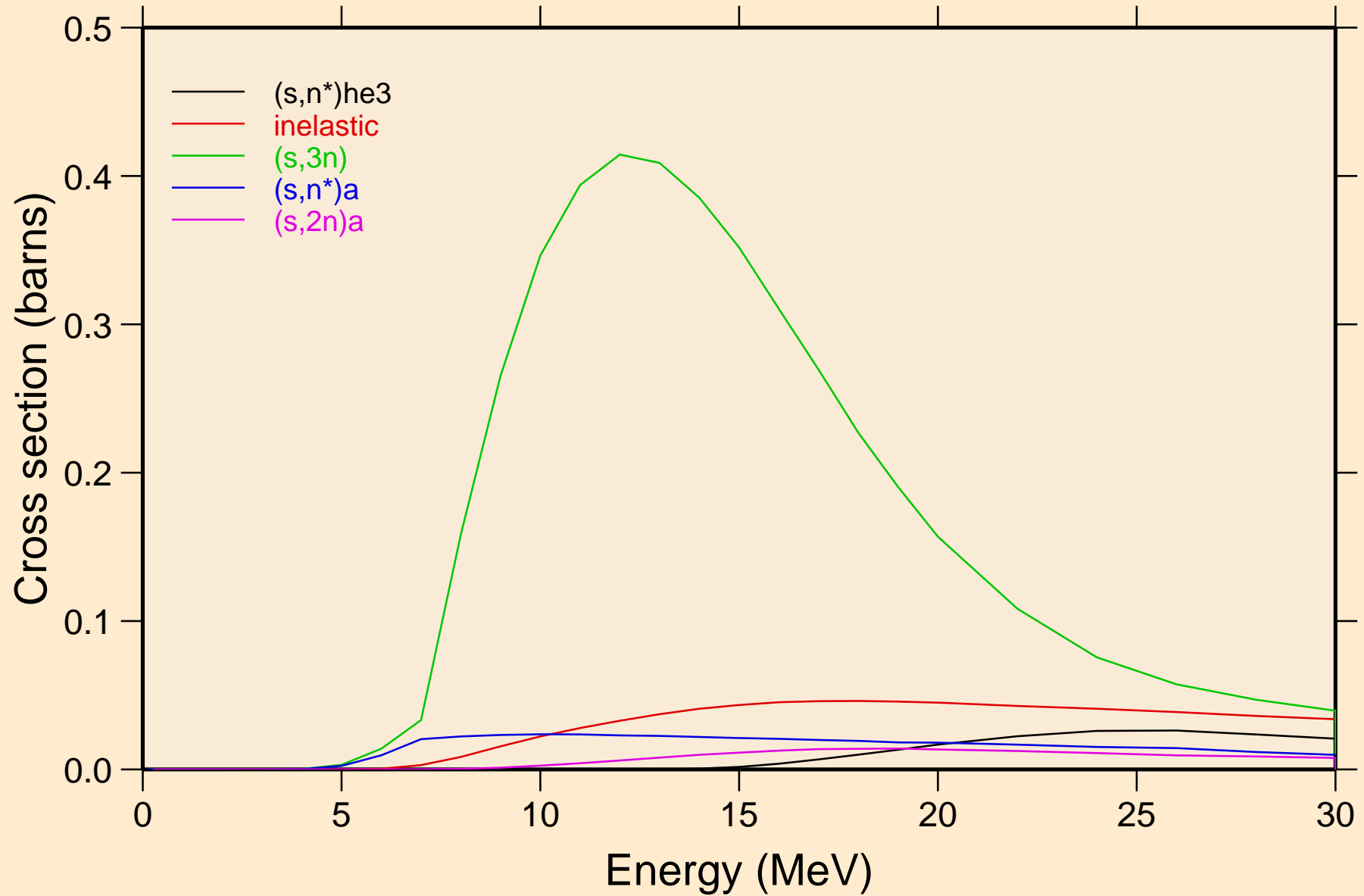

CL043 HELION ACER TENDL-2021 LIBRARY; T=0.K  
Threshold reactions

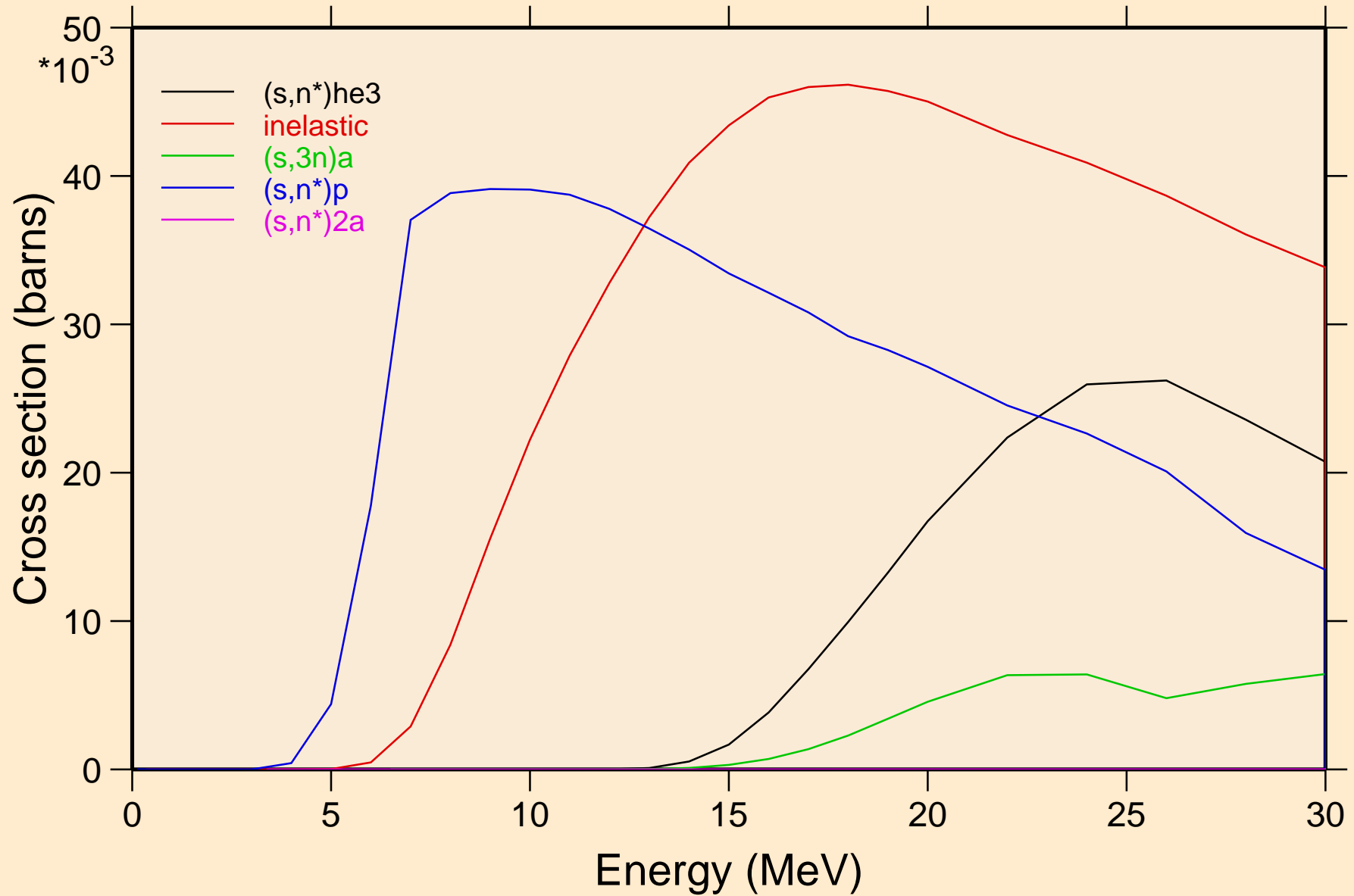

CL043 HELION ACER TENDL-2021 LIBRARY; T=0.K  
Threshold reactions

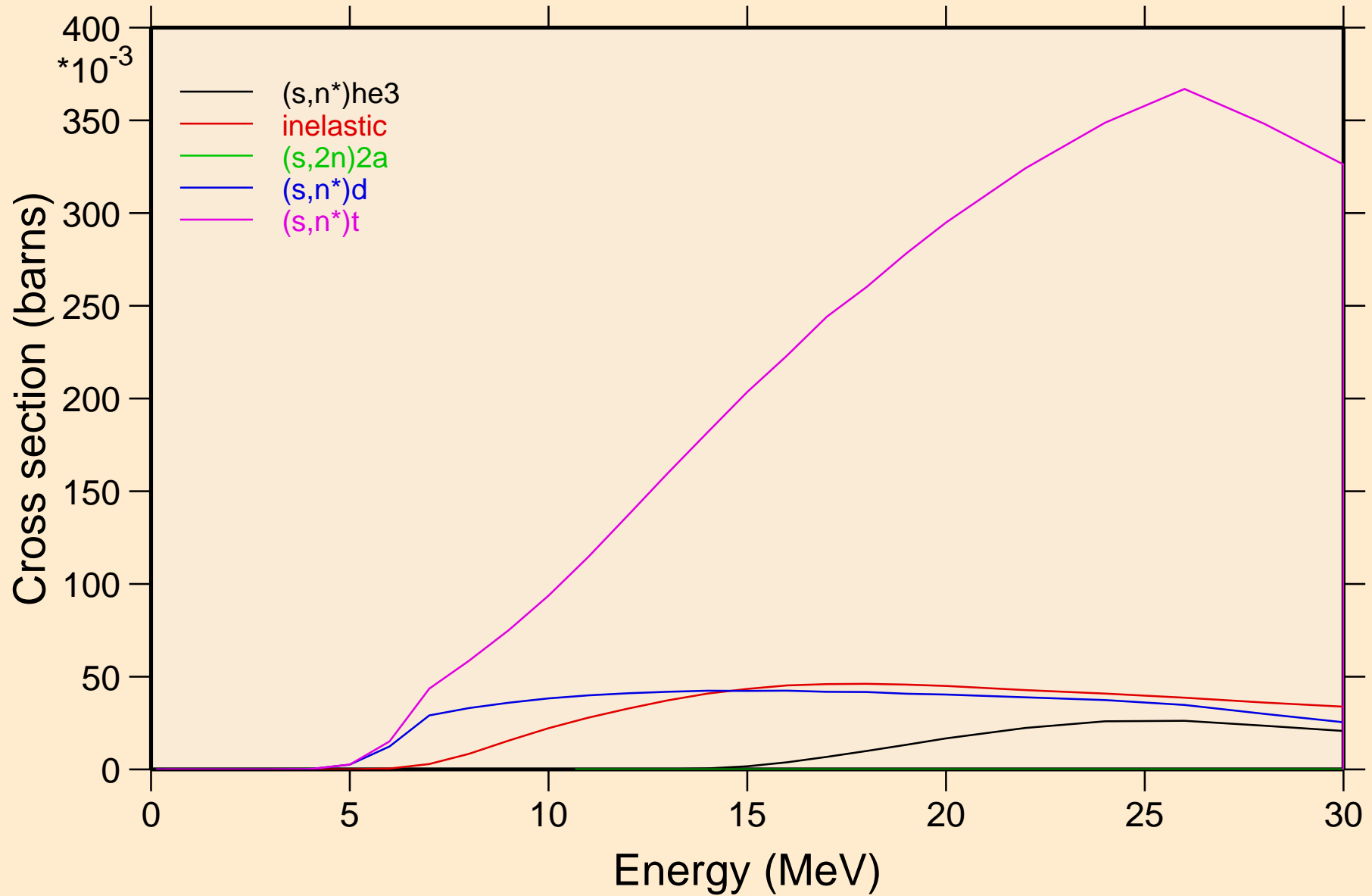



# CL043 HELION ACER TENDL-2021 LIBRARY; T=0.K

## Threshold reactions

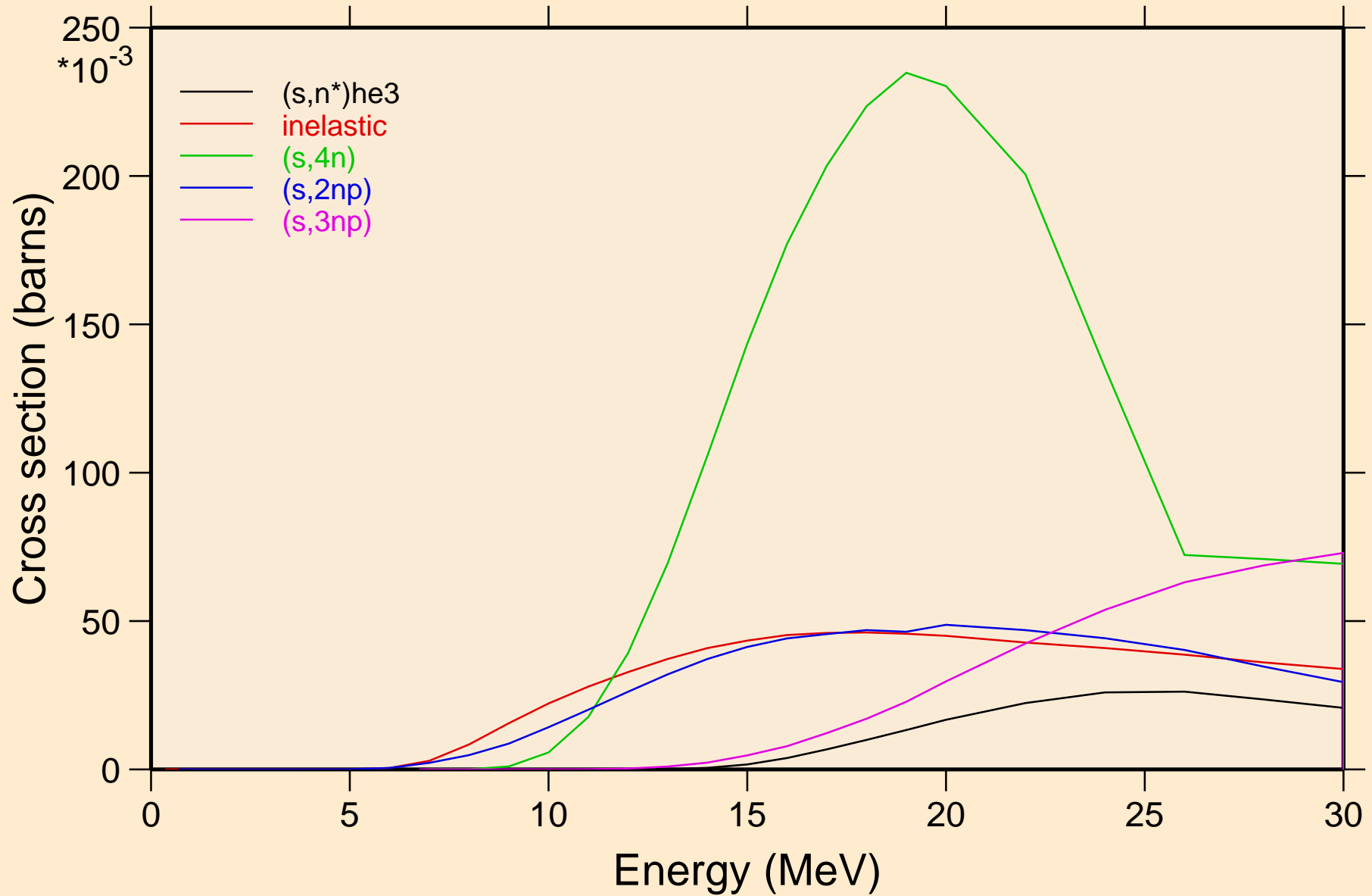

CL043 HELION ACER TENDL-2021 LIBRARY; T=0.K  
Threshold reactions

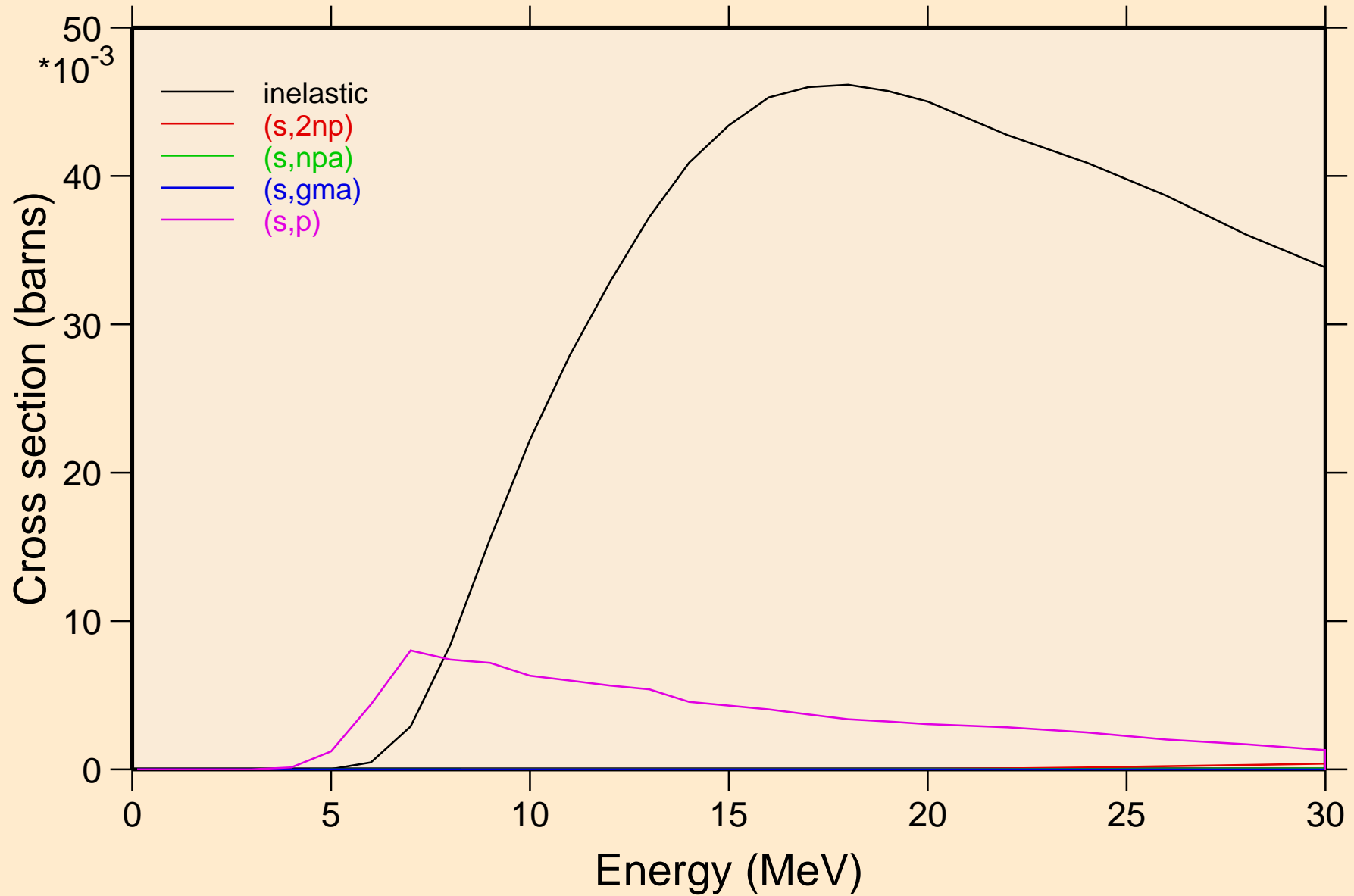

# CL043 HELION ACER TENDL-2021 LIBRARY; T=0.K

## Threshold reactions

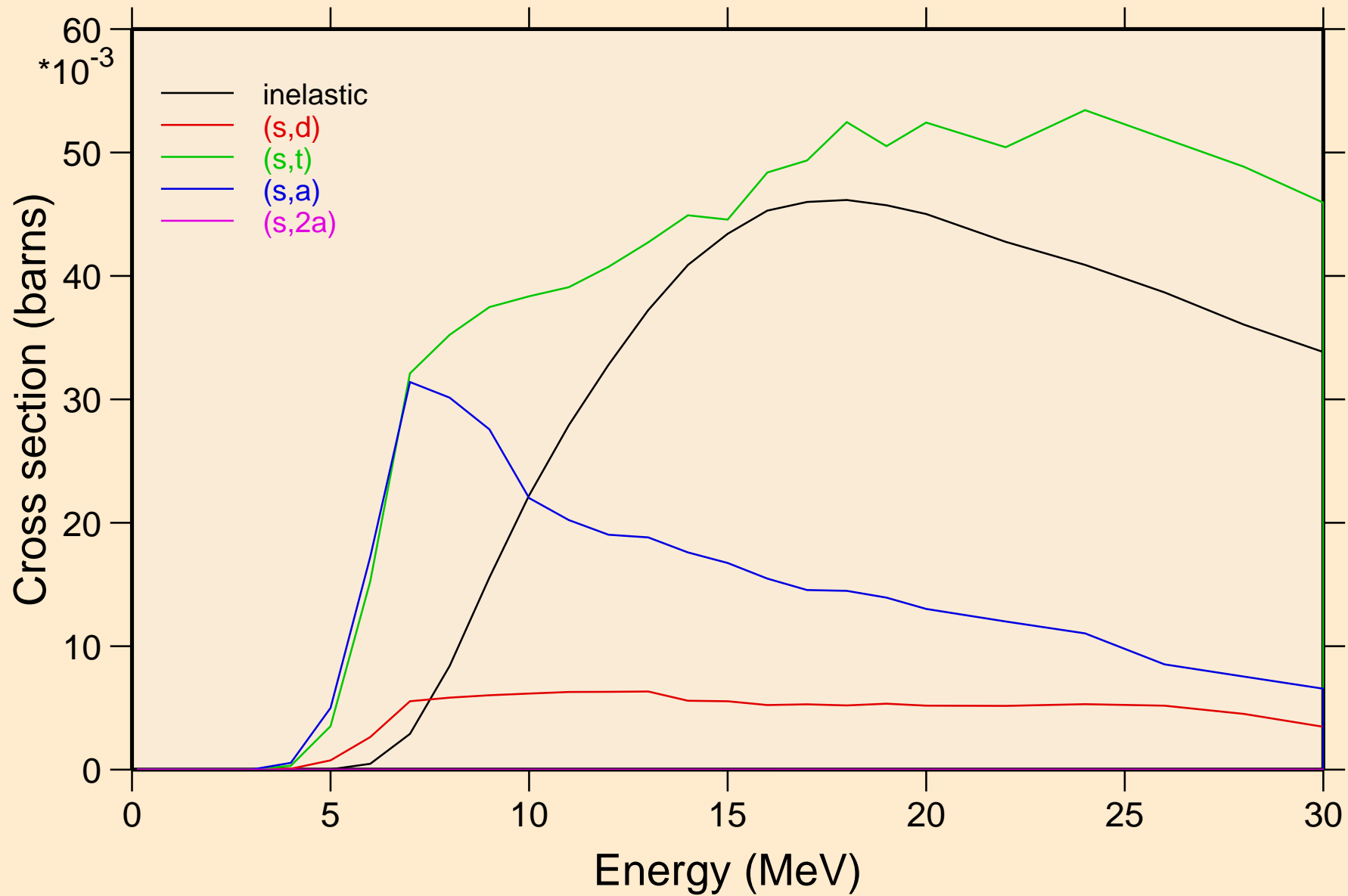

CL043 HELION ACER TENDL-2021 LIBRARY; T=0.K  
Threshold reactions

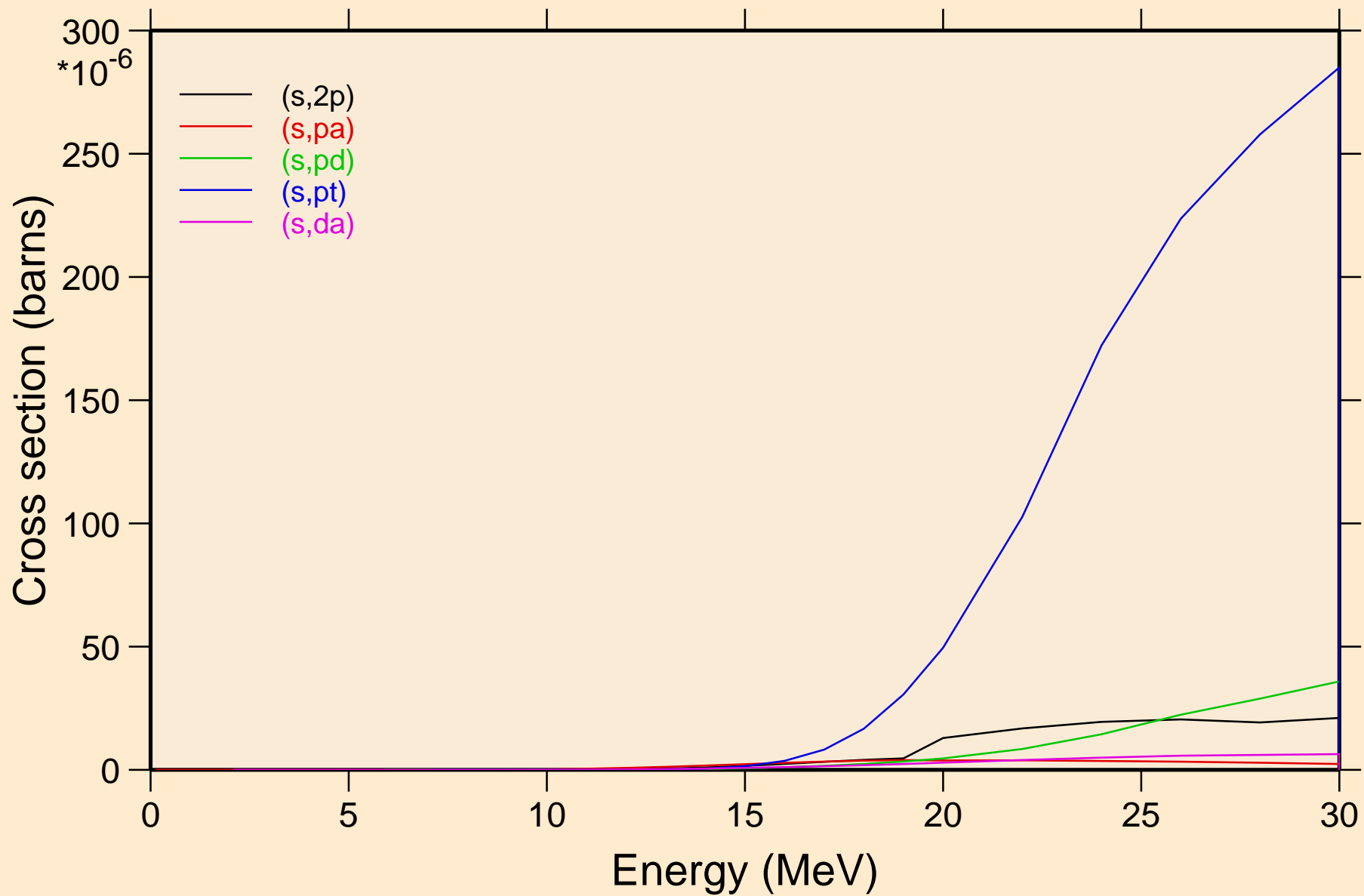

CL043 HELION ACER TENDL-2021 LIBRARY; T=0.K  
angular distribution for elastic

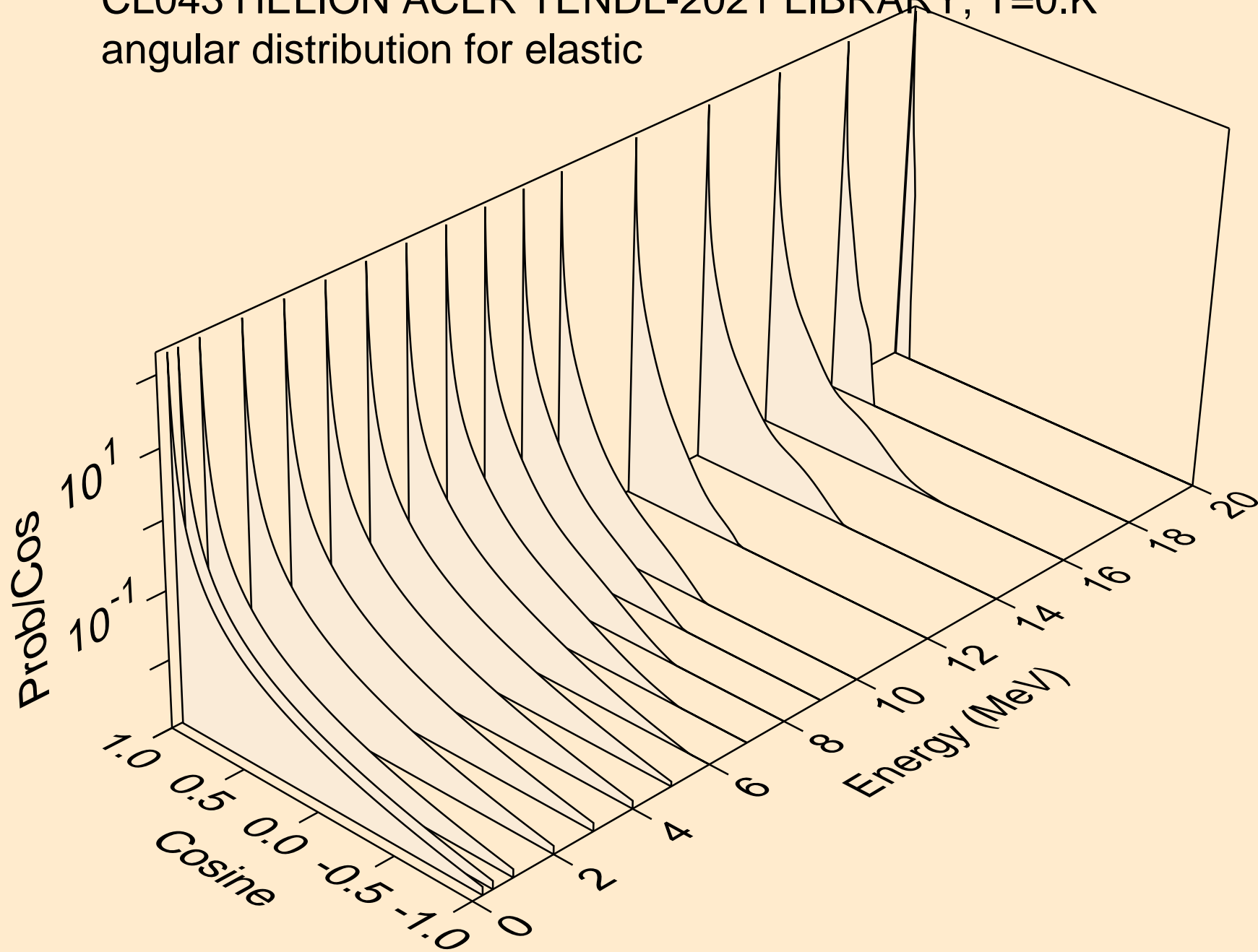

CL043 HELION ACER TENDL-2021 LIBRARY; T=0.K  
angular distribution for elastic

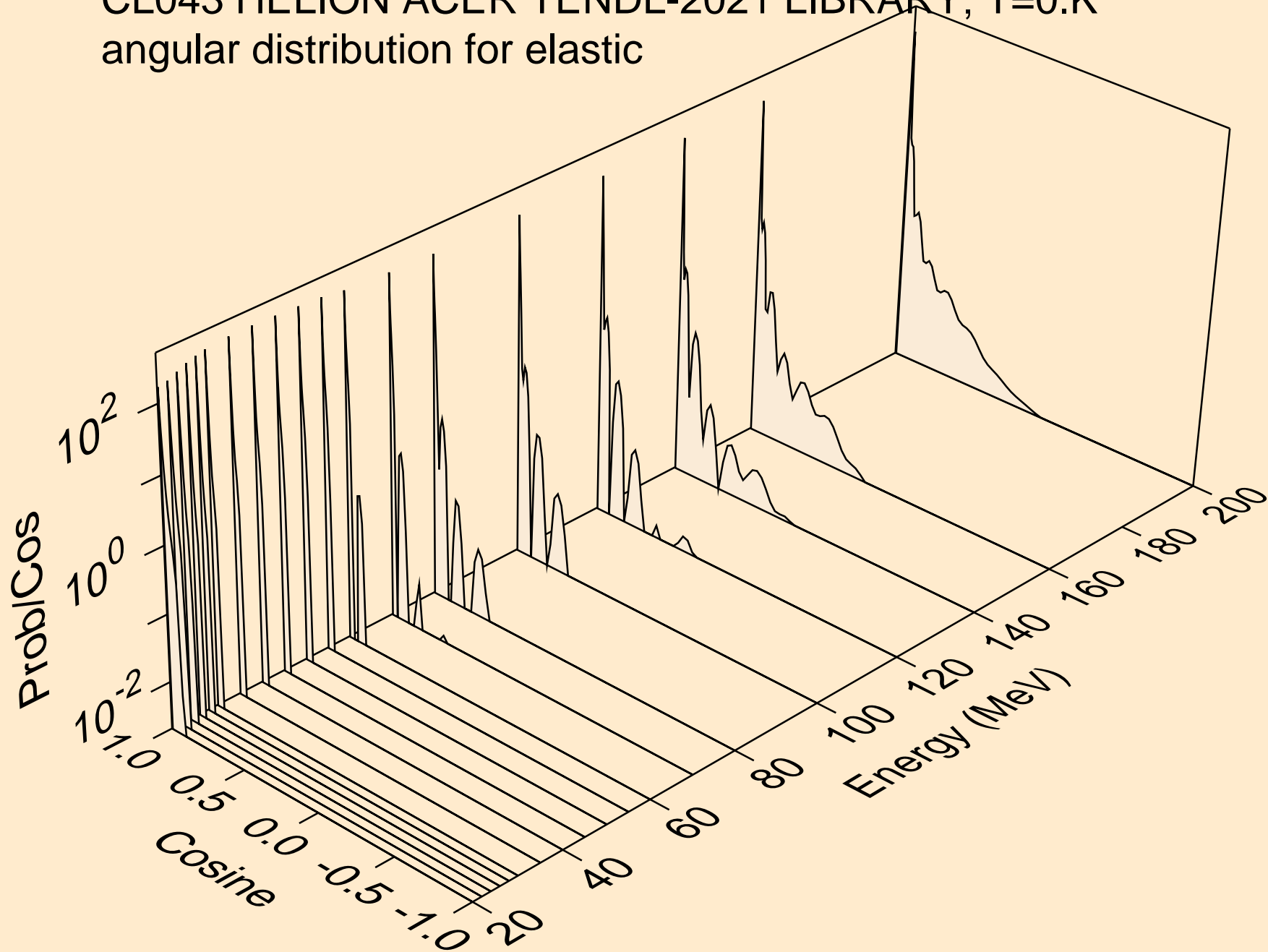

CL043 HELION ACER TENDL-2021 LIBRARY; T=0.K  
He-3 emission for (s,x)

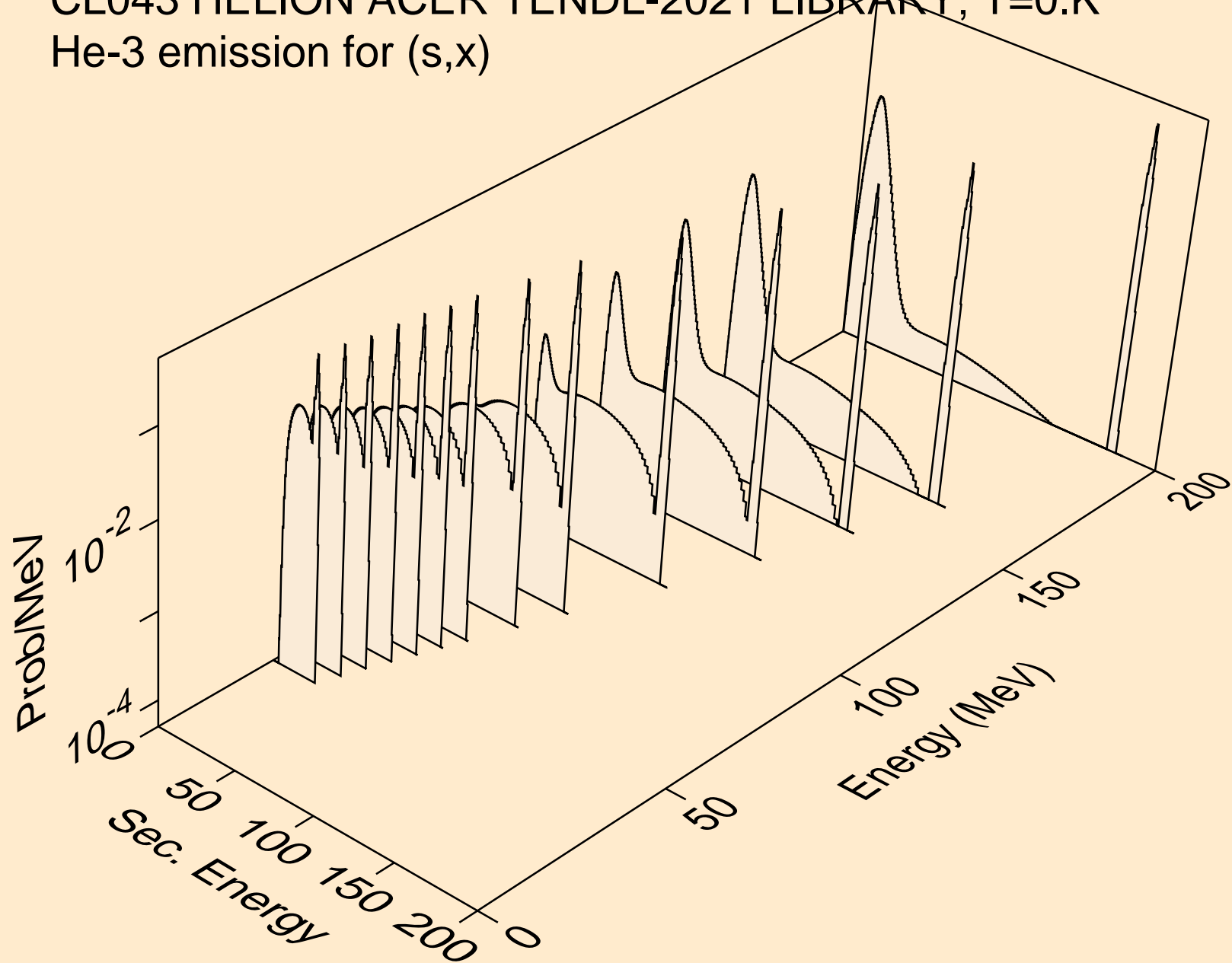

CL043 HELION ACER TENDL-2021 LIBRARY; T=0.K  
He-3 emission for (s,n\*)he3

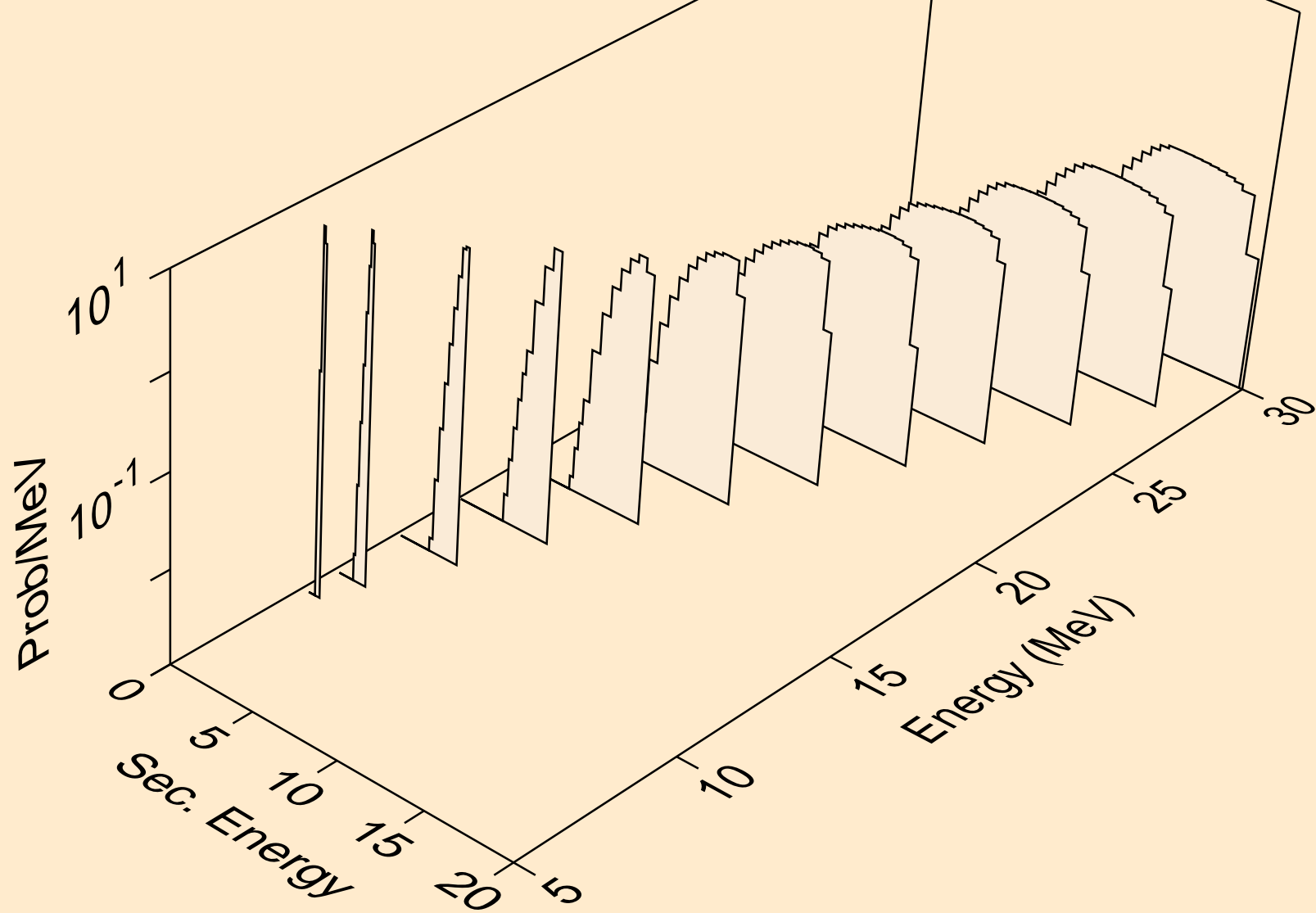



CL043 HELION ACER TENDL-2021 LIBRARY; T=0.K  
He-3 emission for inelastic

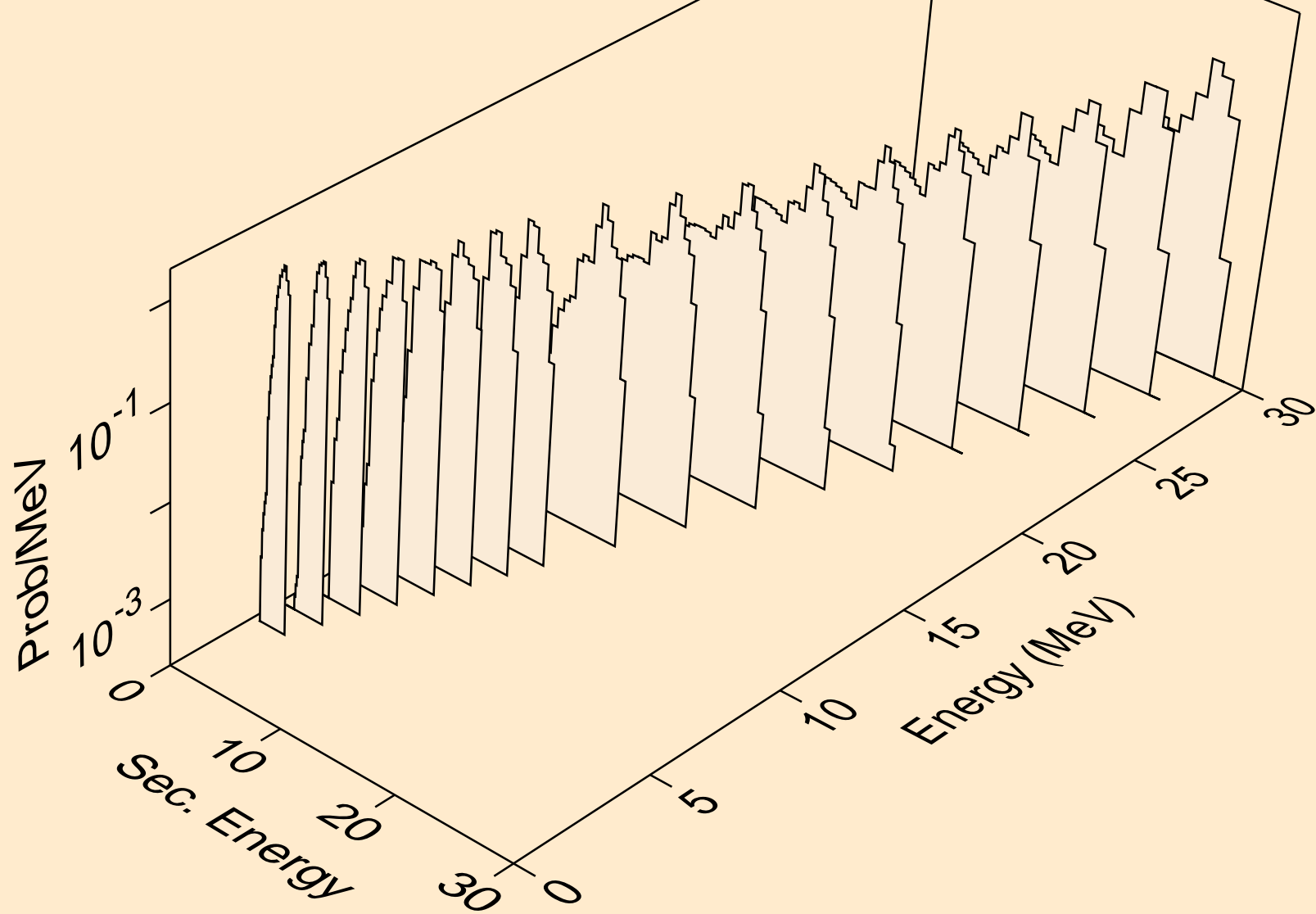

CL043 HELION ACER TENDL-2021 LIBRARY; T=0.K  
Photon emission for (z,n)

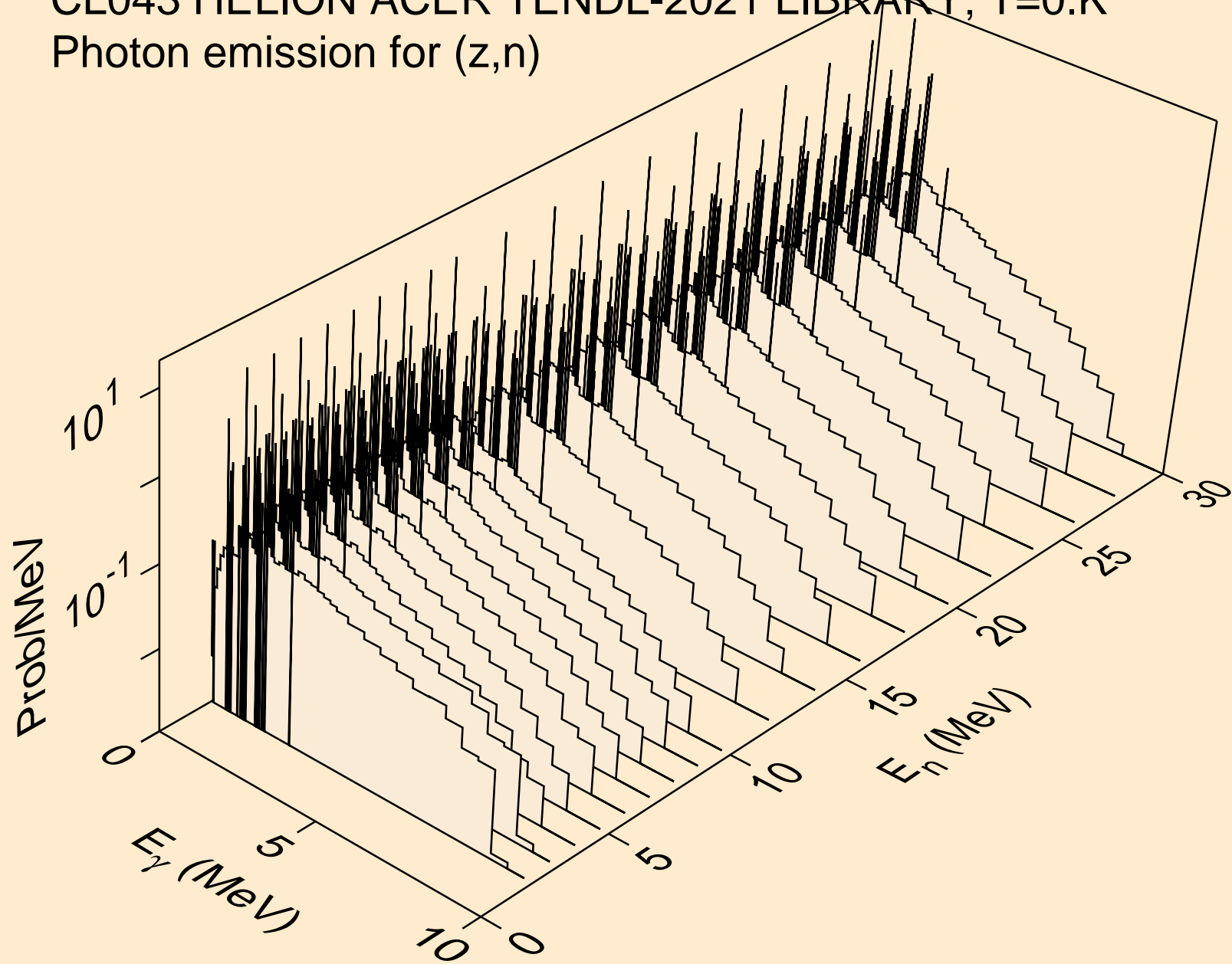

CL043 HELION ACER TENDL-2021 LIBRARY; T=0.K  
Photon emission for (n,x)

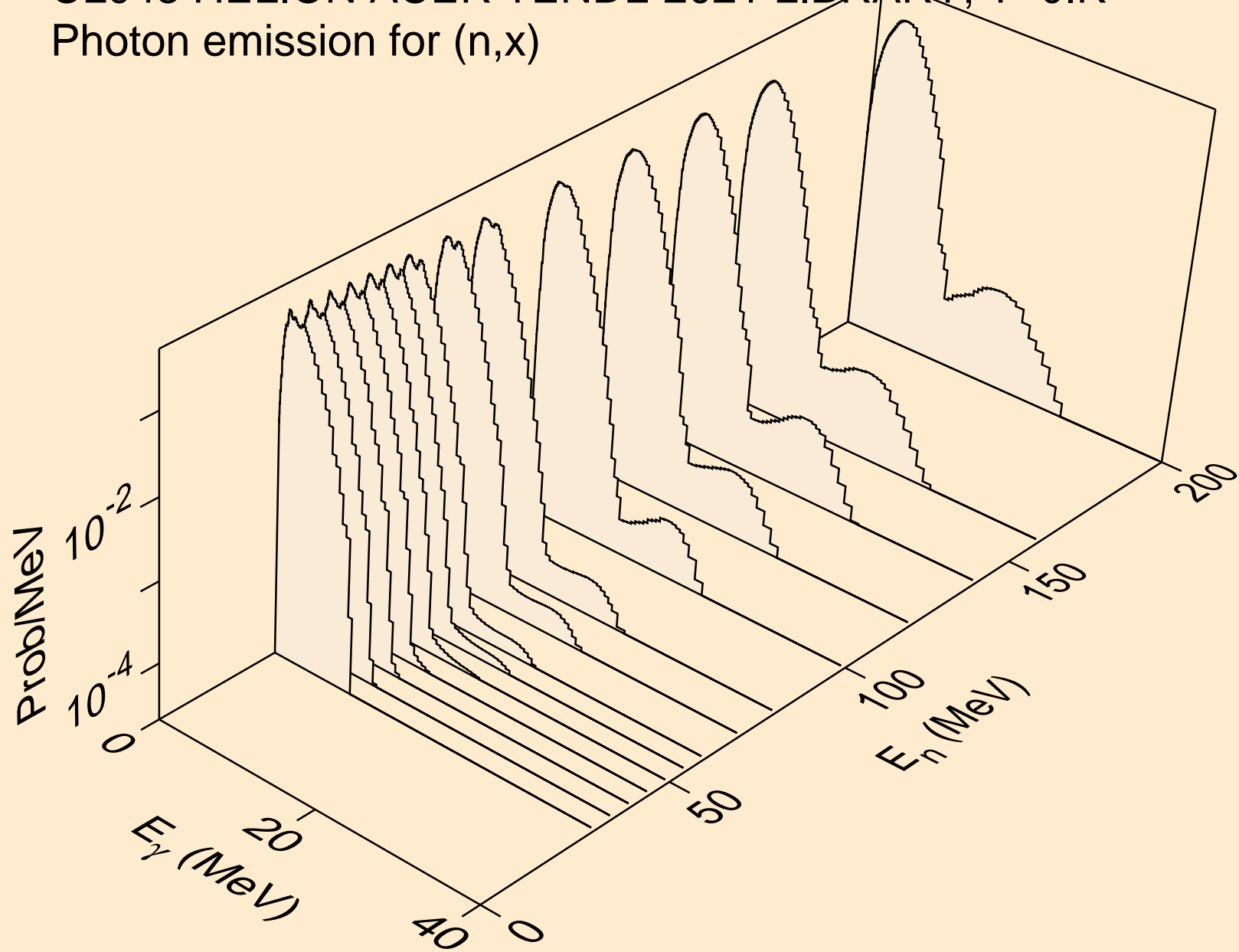

CL043 HELION ACER TENDL-2021 LIBRARY; T=0.K  
Photon emission for (n,2nd)

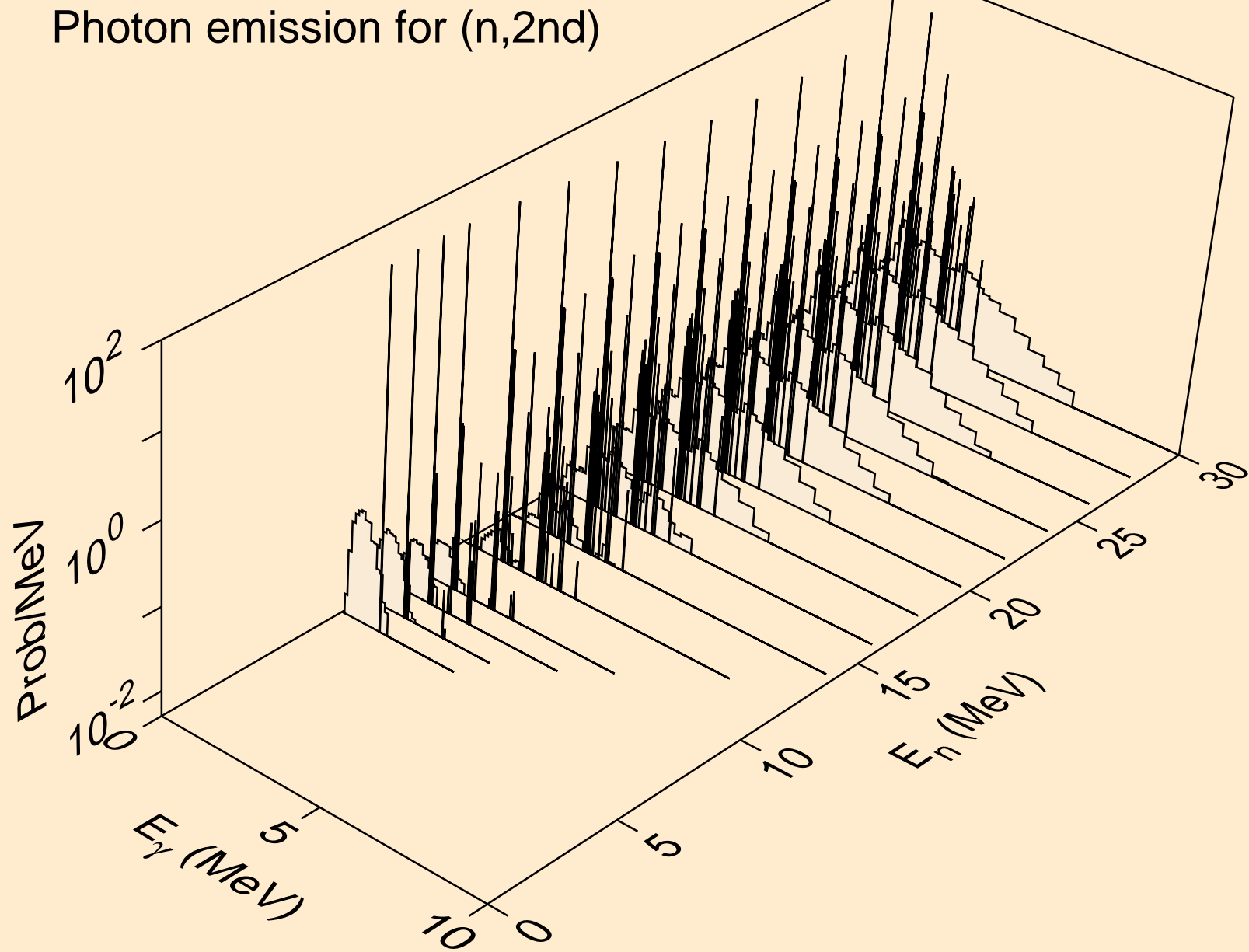

CL043 HELION ACER TENDL-2021 LIBRARY; T=0.K  
Photon emission for (n,2n)

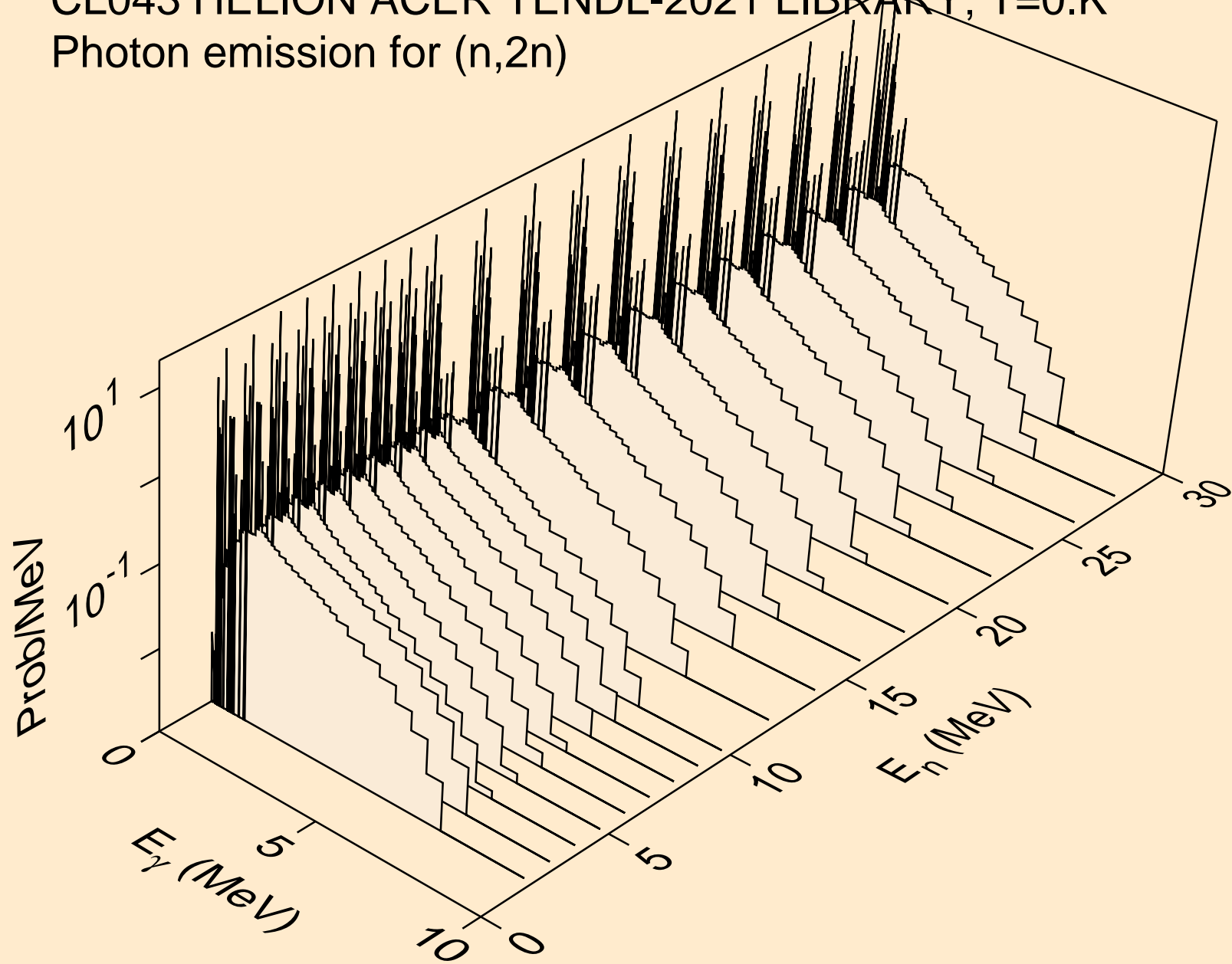

CL043 HELION ACER TENDL-2021 LIBRARY; T=0.K  
Photon emission for (n,3n)

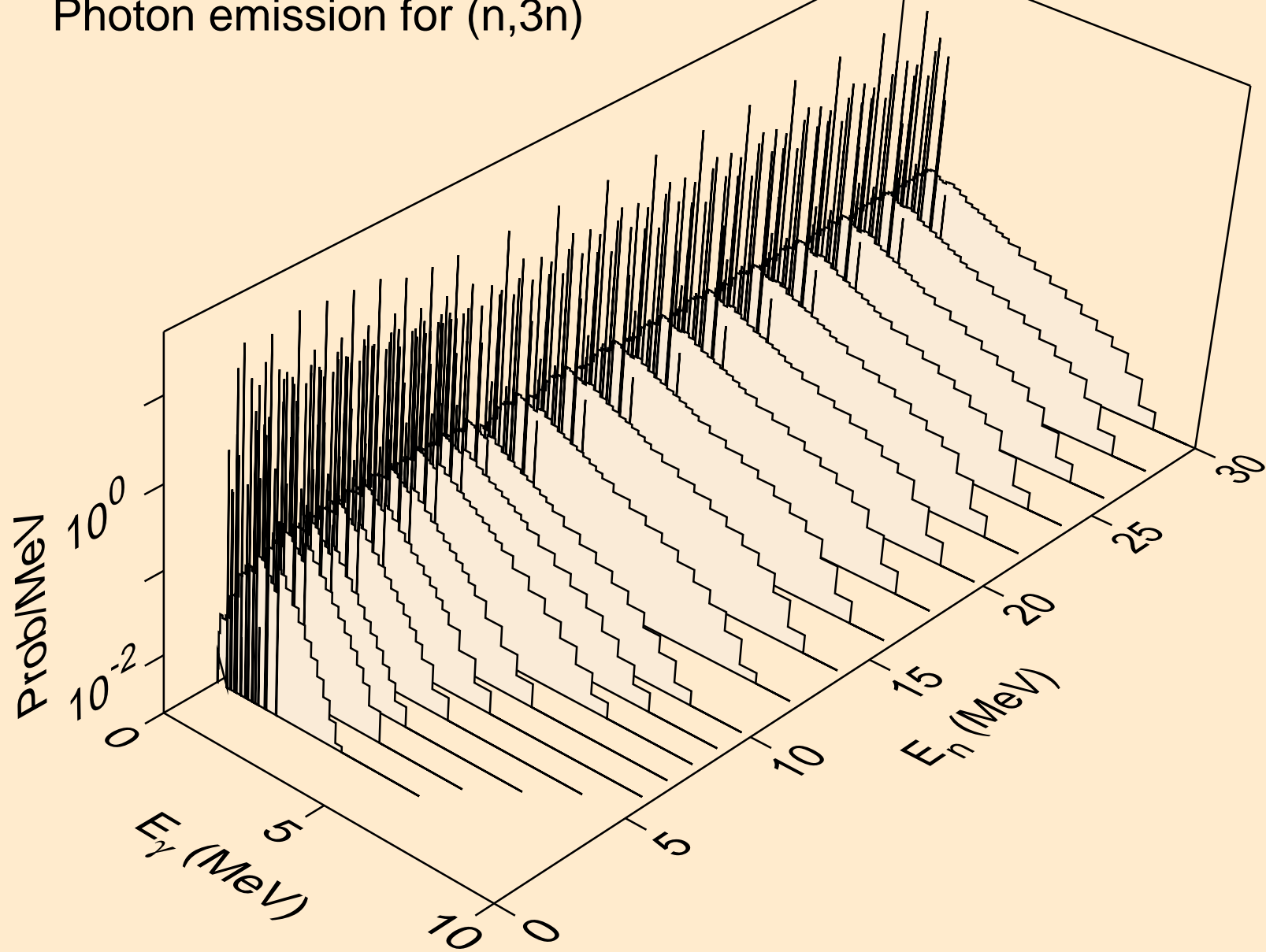

CL043 HELION ACER TENDL-2021 LIBRARY; T=0.K  
Photon emission for (n,n\*)a

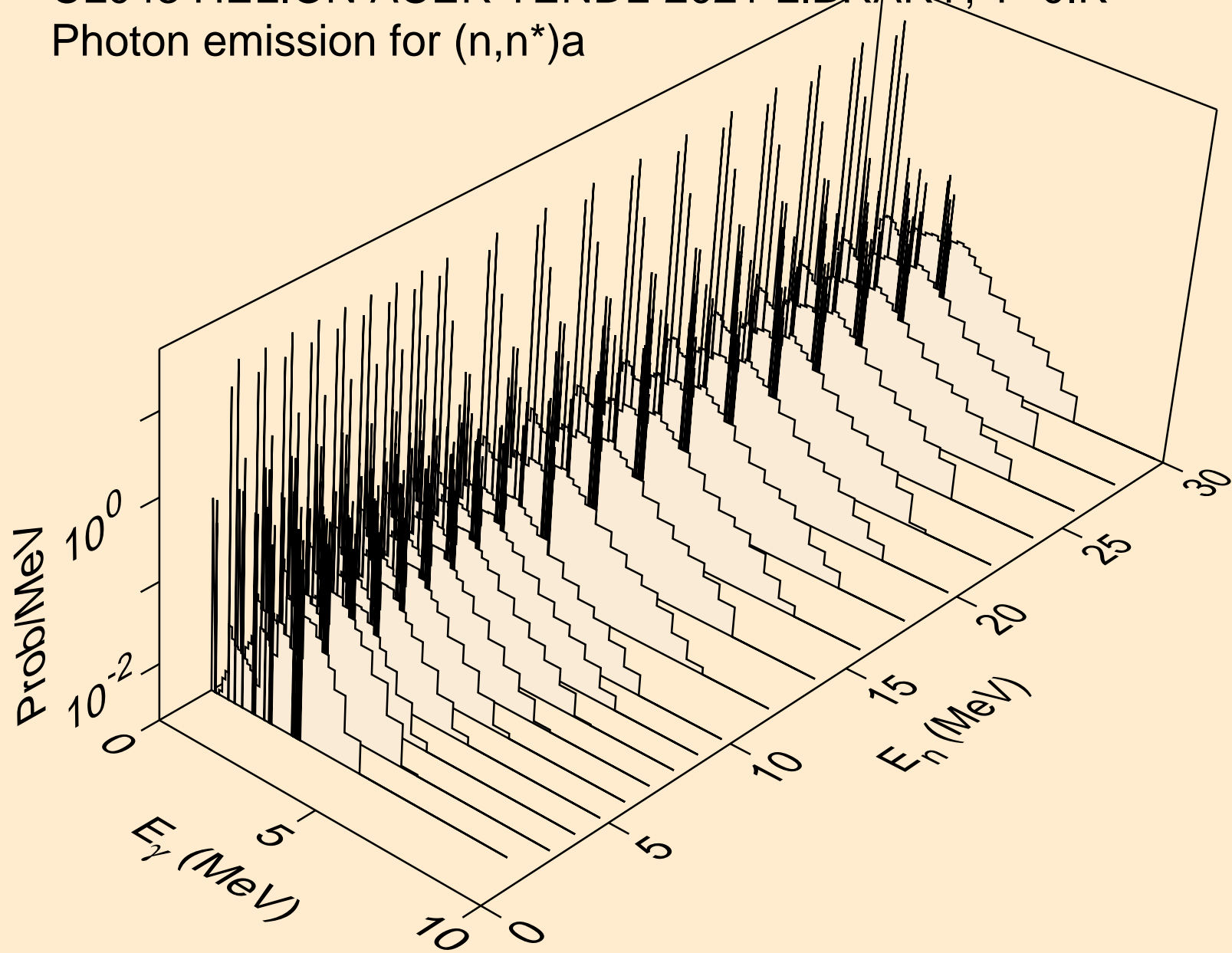

CL043 HELION ACER TENDL-2021 LIBRARY; T=0.K  
Photon emission for (n,2n)a

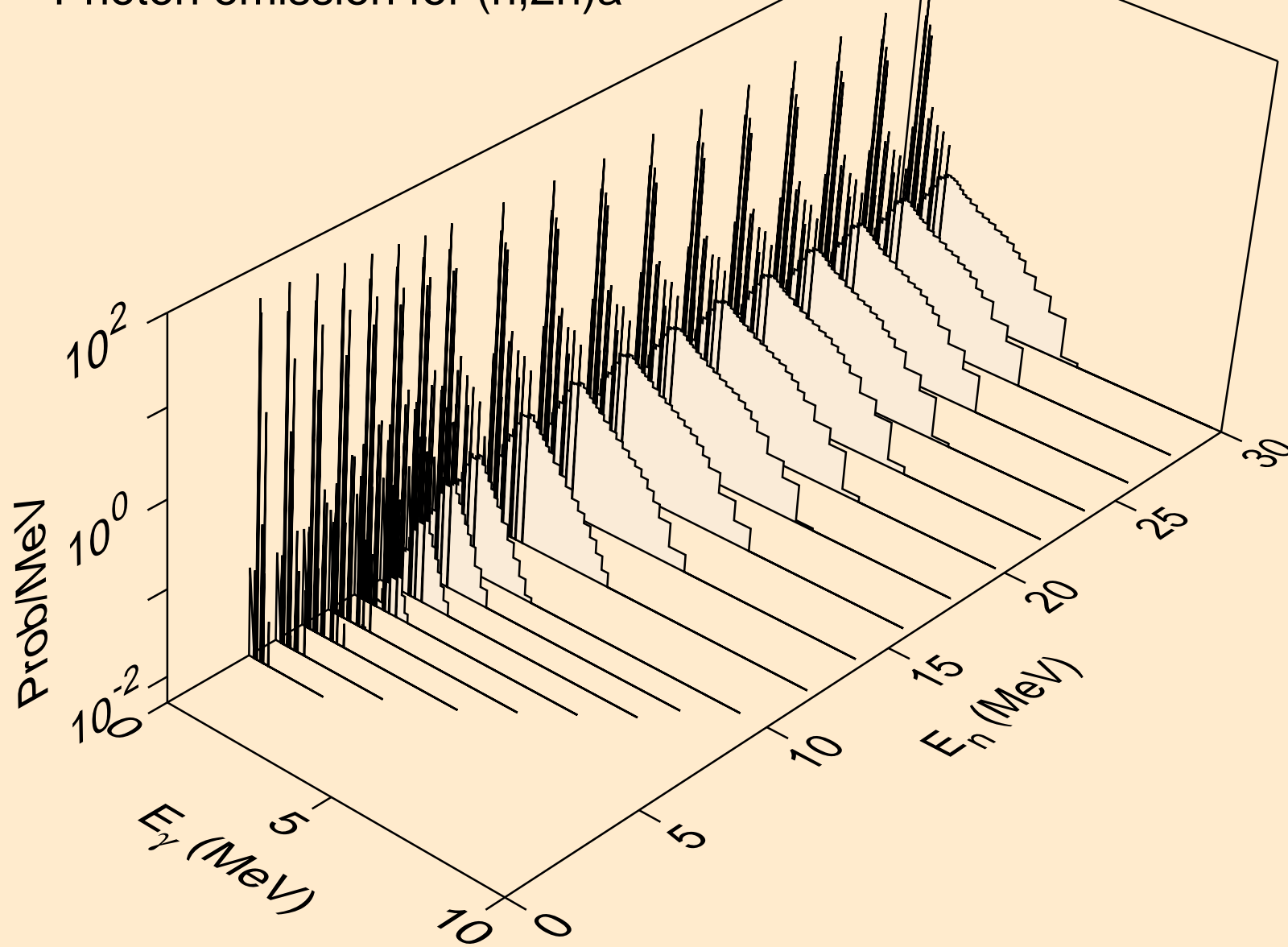



CL043 HELION ACER TENDL-2021 LIBRARY; T=0.K  
Photon emission for (n,3n)a

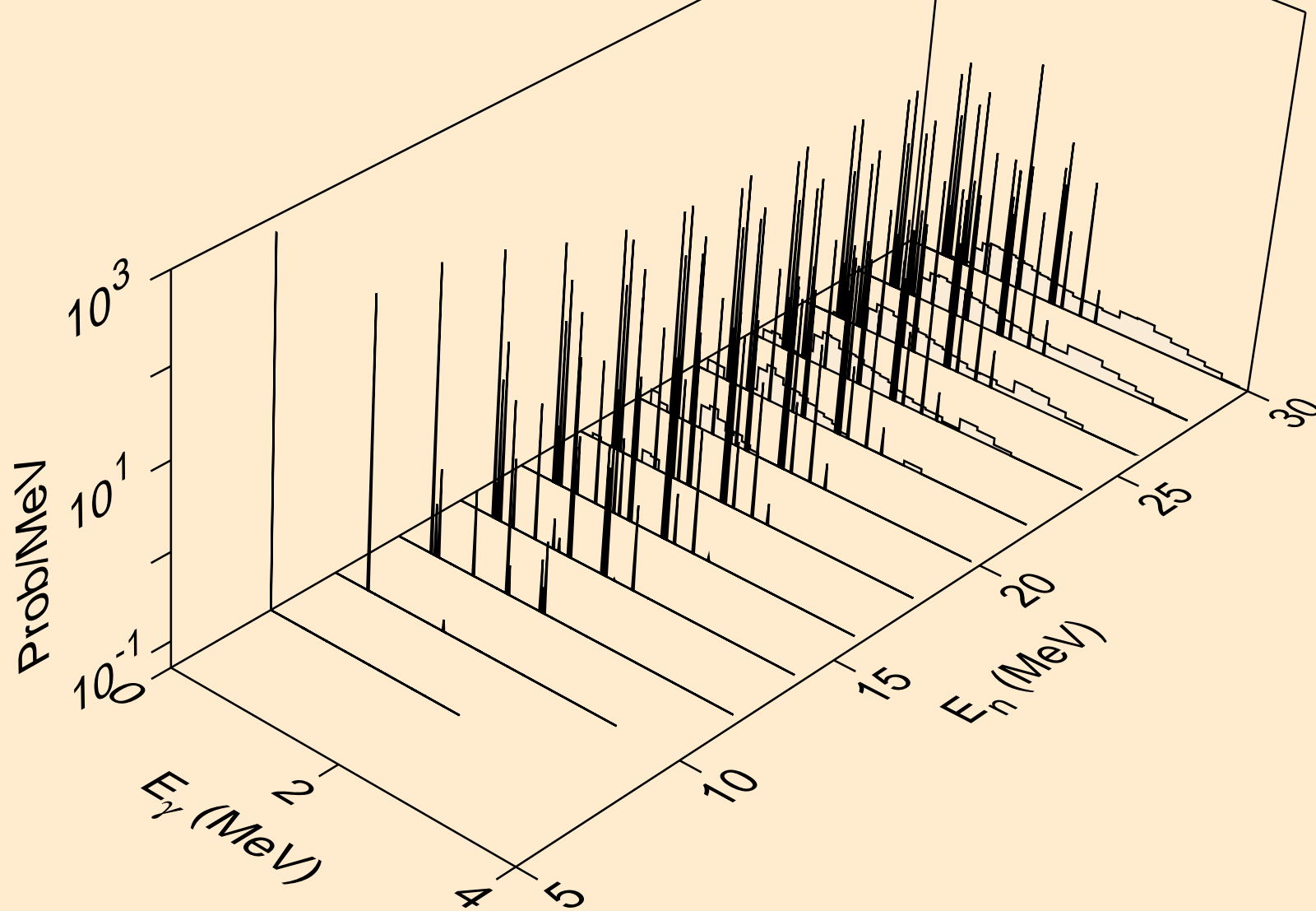

CL043 HELION ACER TENDL-2021 LIBRARY; T=0.K  
Photon emission for (n,n\*)p

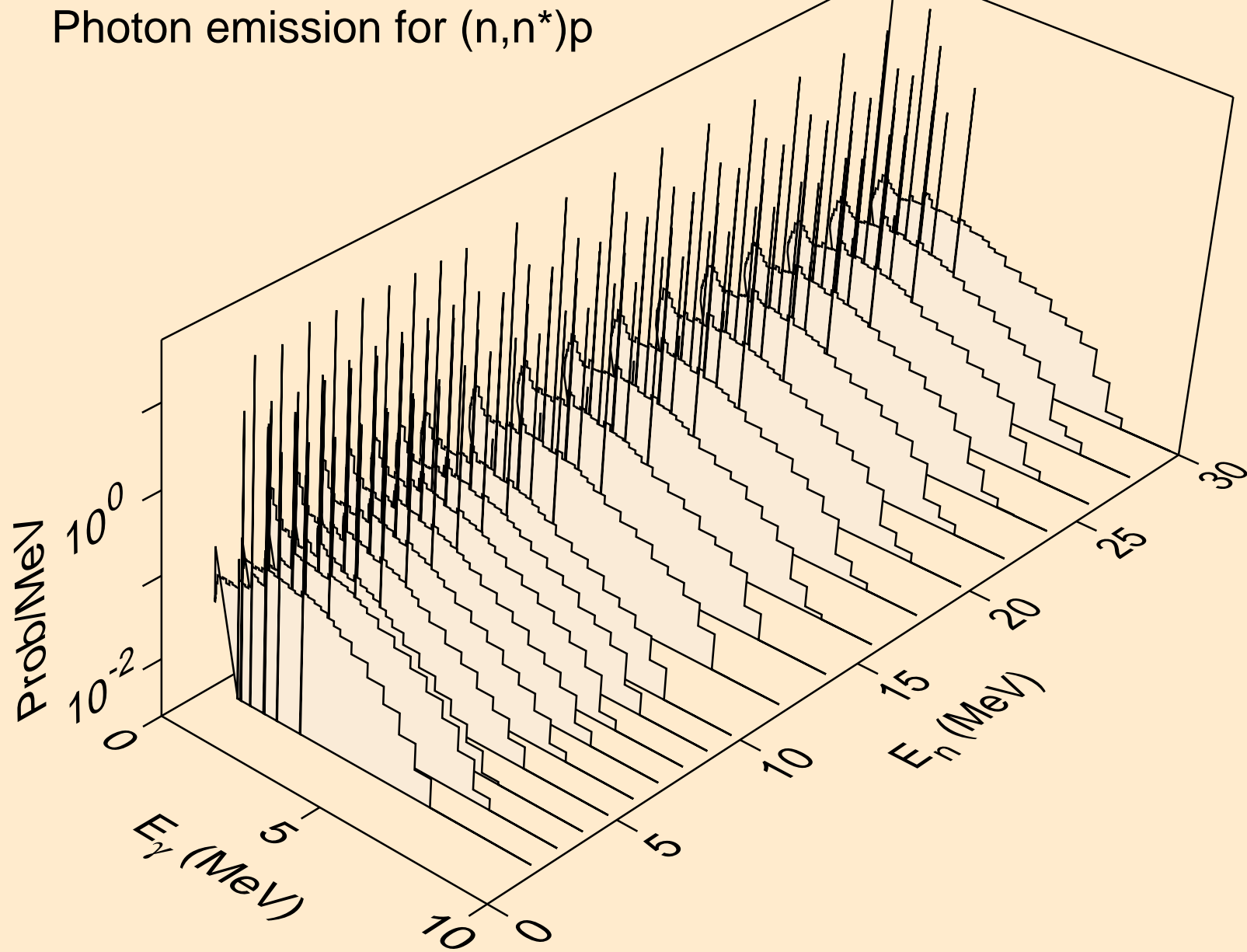

CL043 HELION ACER TENDL-2021 LIBRARY; T=0.K  
Photon emission for (n,n\*)2a

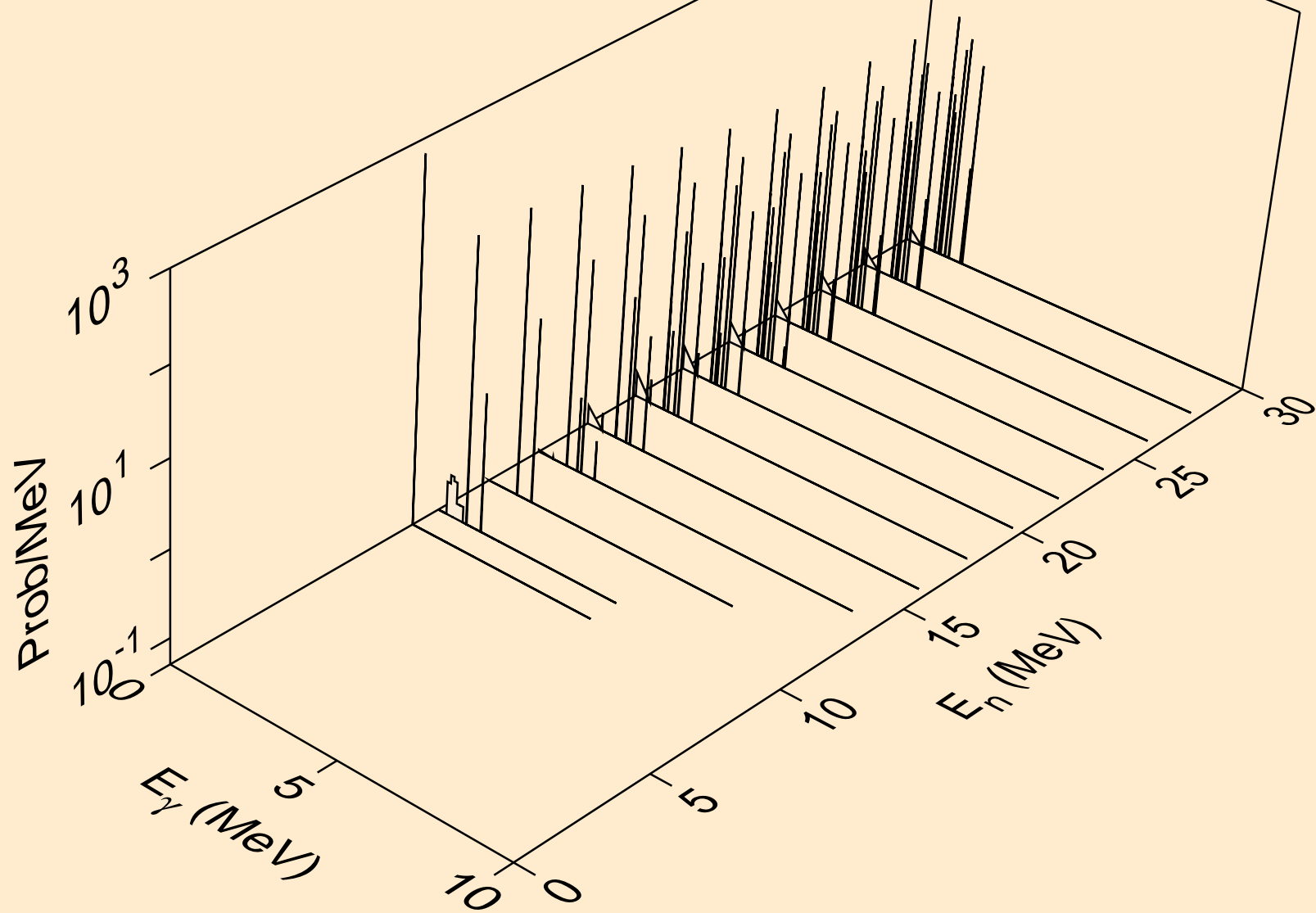

CL043 HELION ACER TENDL-2021 LIBRARY; T=0.K  
Photon emission for (n,2n)2a

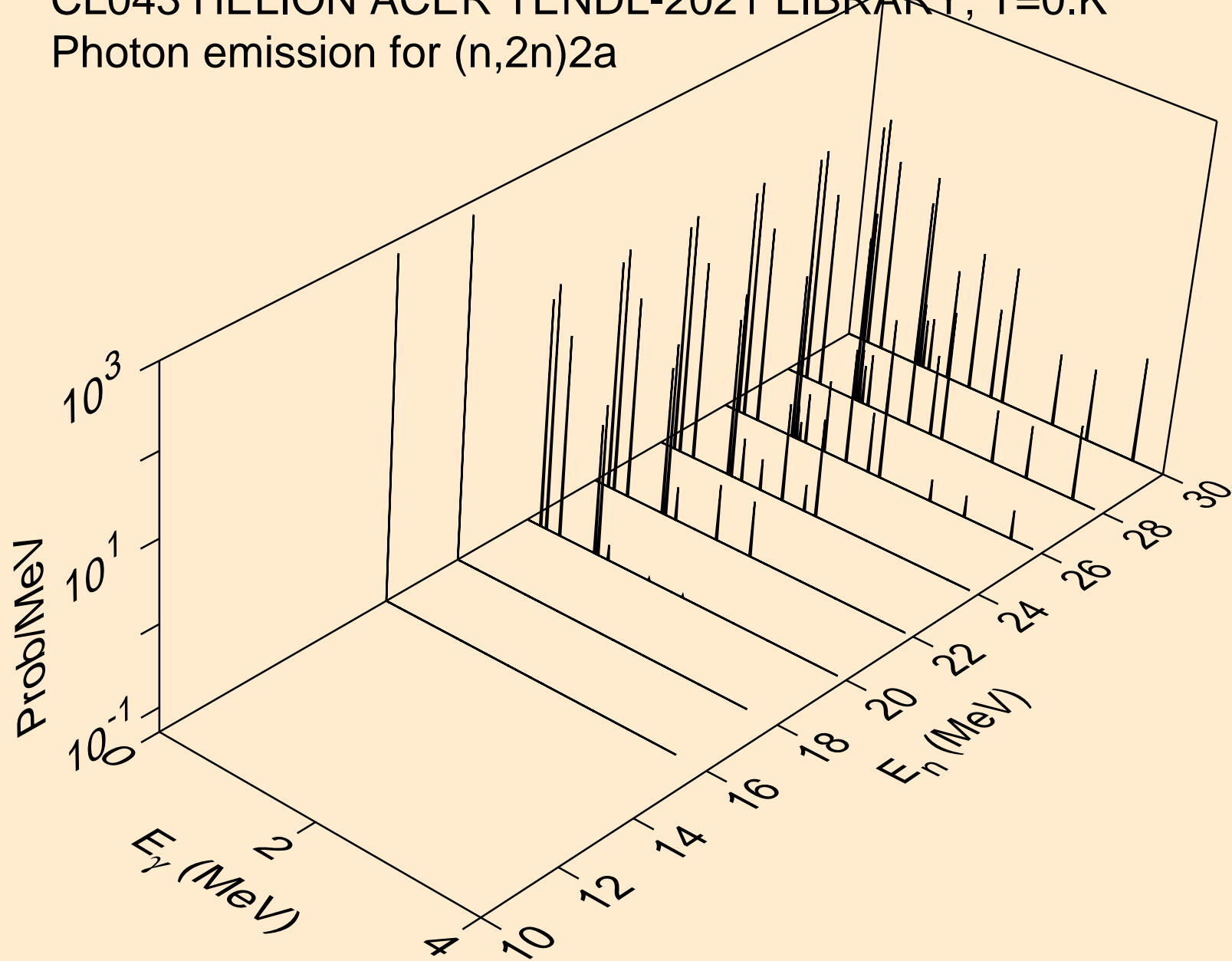

CL043 HELION ACER TENDL-2021 LIBRARY; T=0.K  
Photon emission for (n,n\*)d

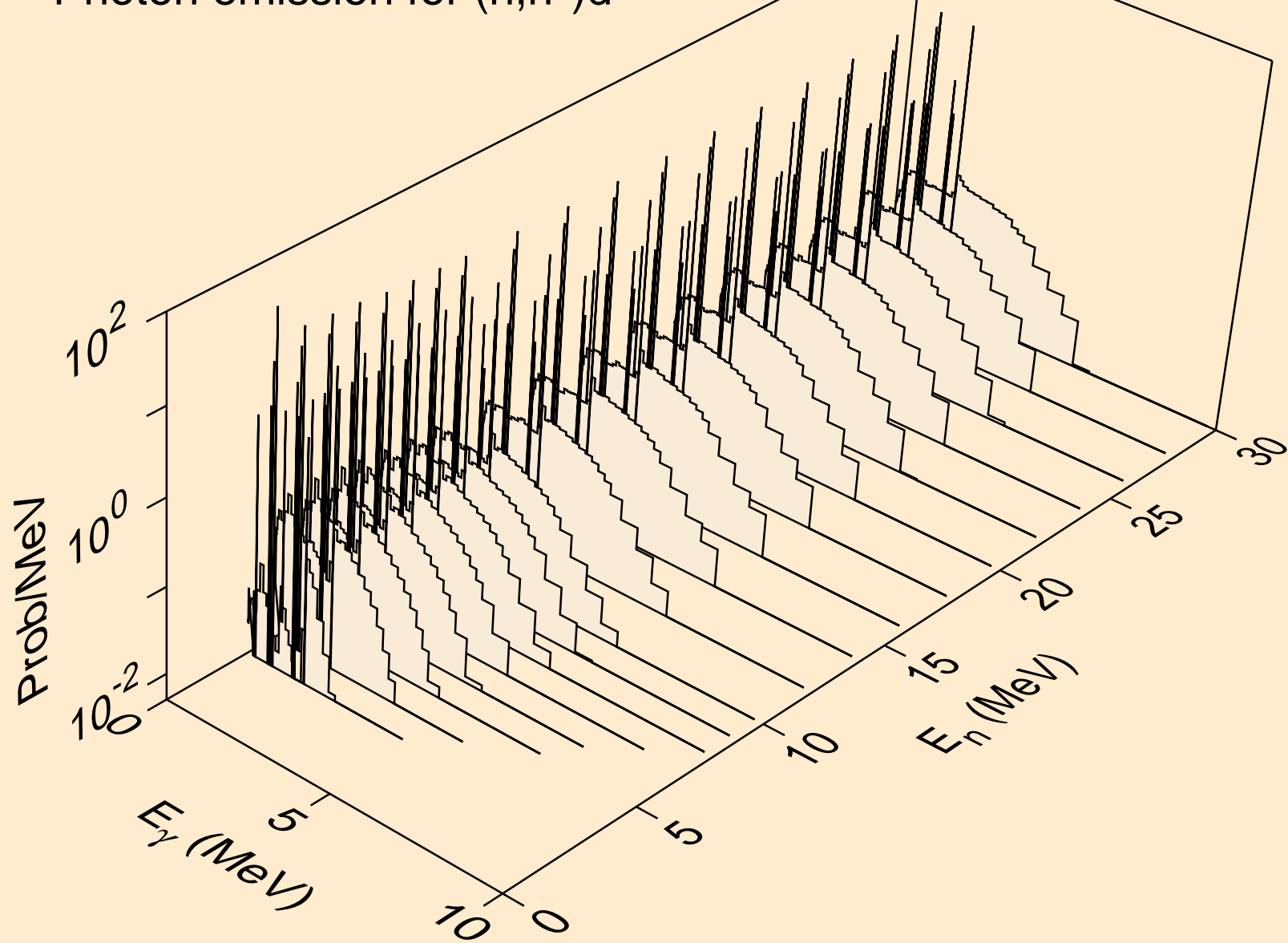

CL043 HELION ACER TENDL-2021 LIBRARY; T=0.K  
Photon emission for (n,n\*)t

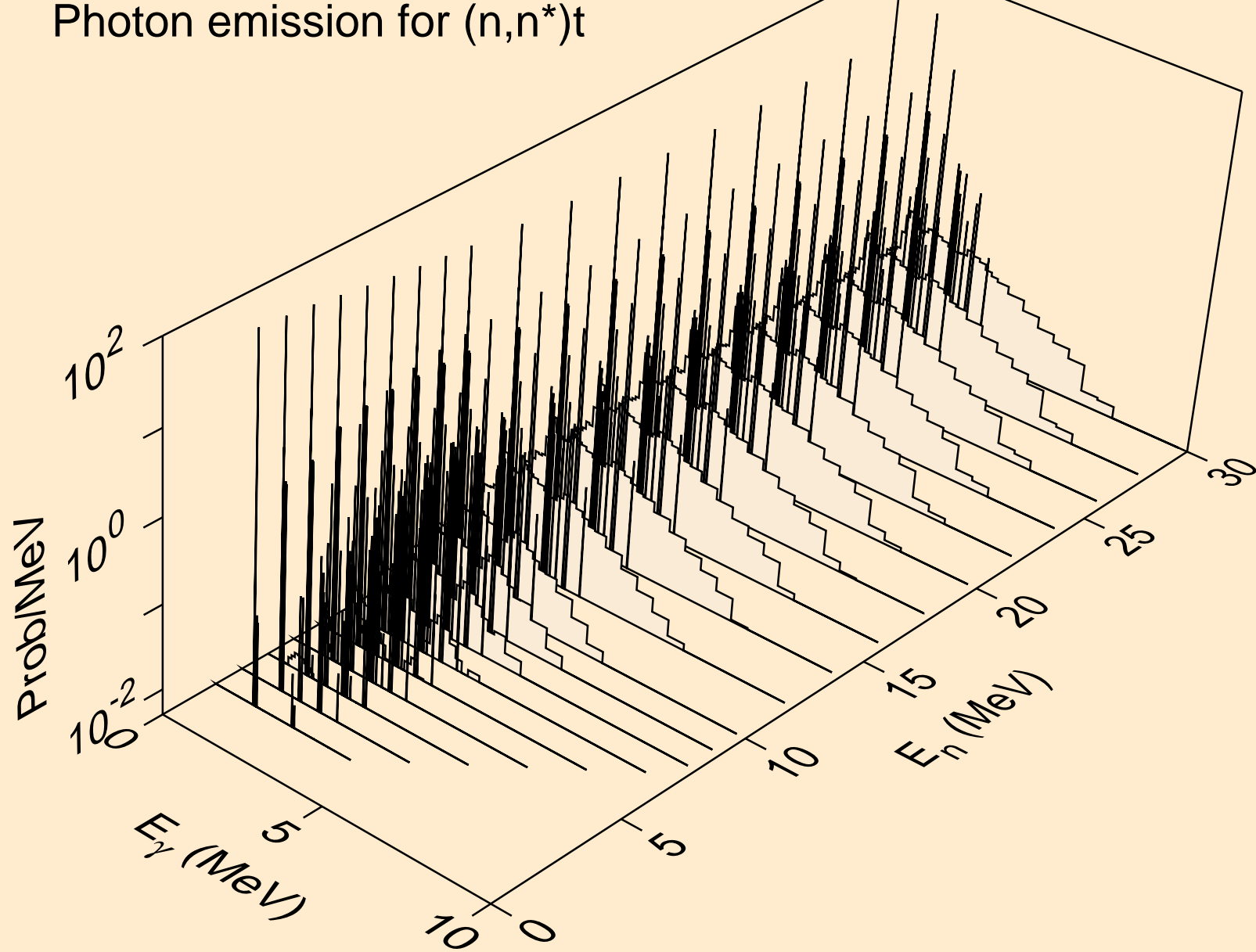

CL043 HELION ACER TENDL-2021 LIBRARY; T=0.K  
Photon emission for (n,n\*)he3

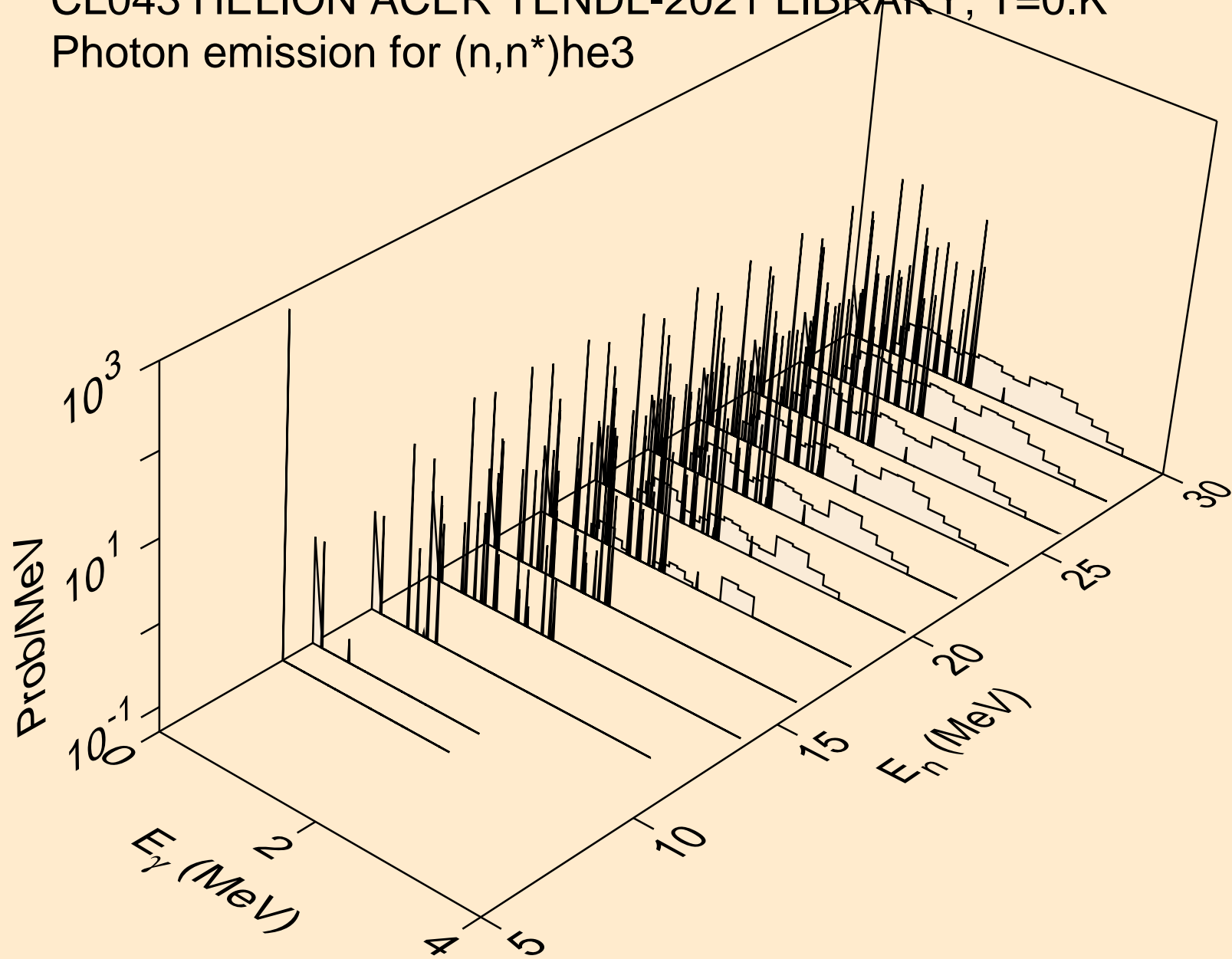

CL043 HELION ACER TENDL-2021 LIBRARY; T=0.K  
Photon emission for (n,4n)

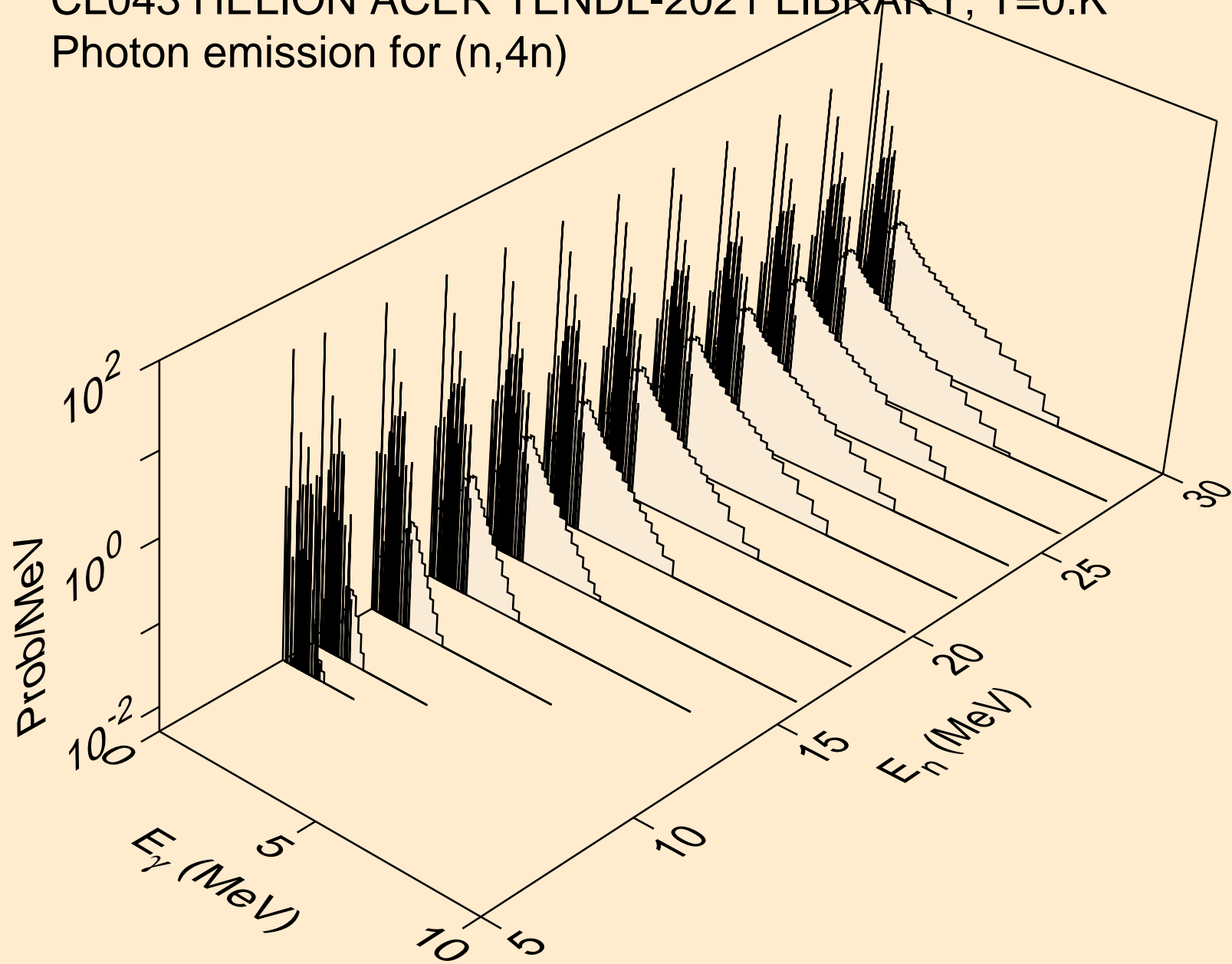



CL043 HELION ACER TENDL-2021 LIBRARY; T=0.K  
Photon emission for (n,2np)

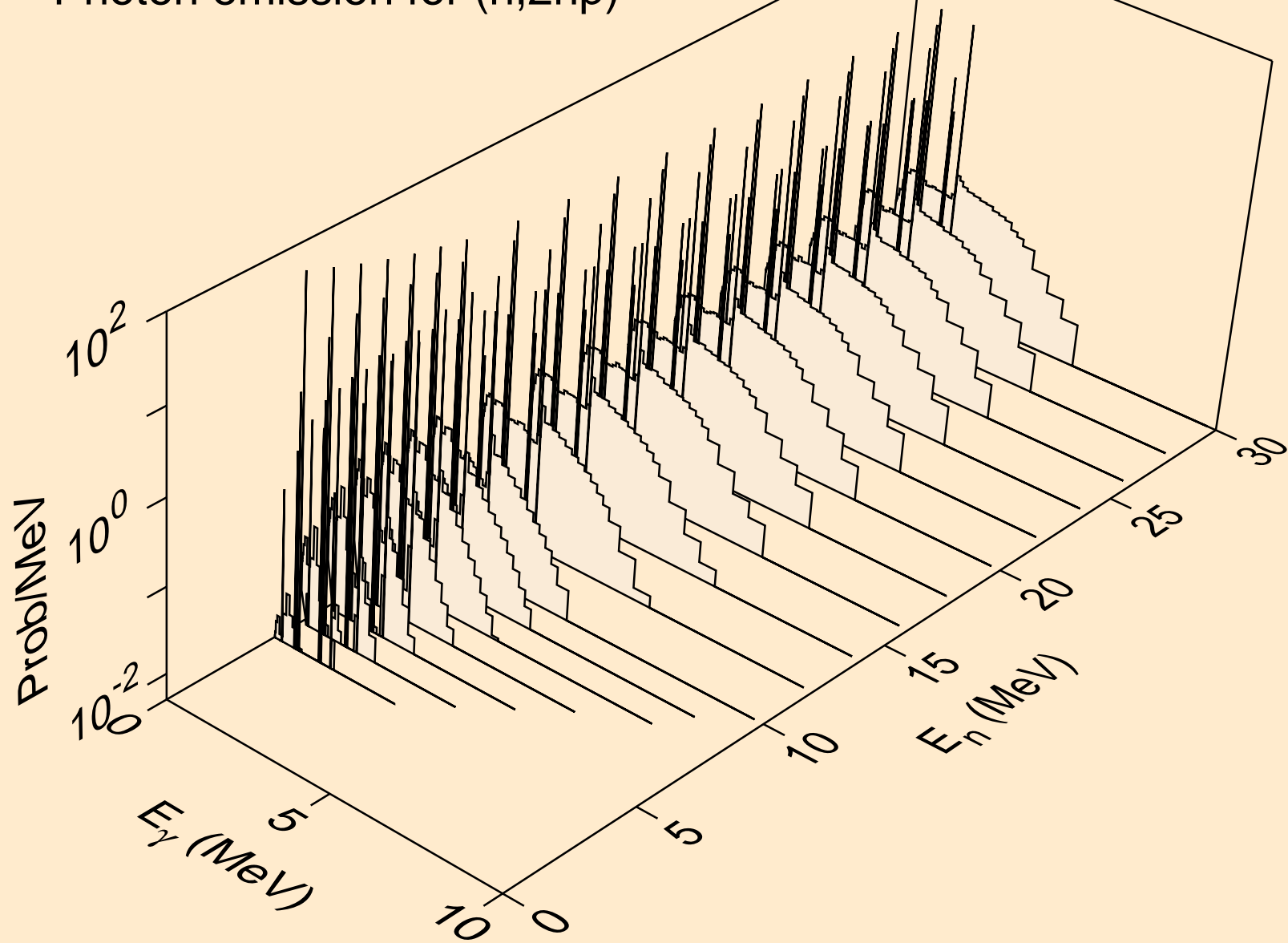

CL043 HELION ACER TENDL-2021 LIBRARY; T=0.K  
Photon emission for (n,3np)

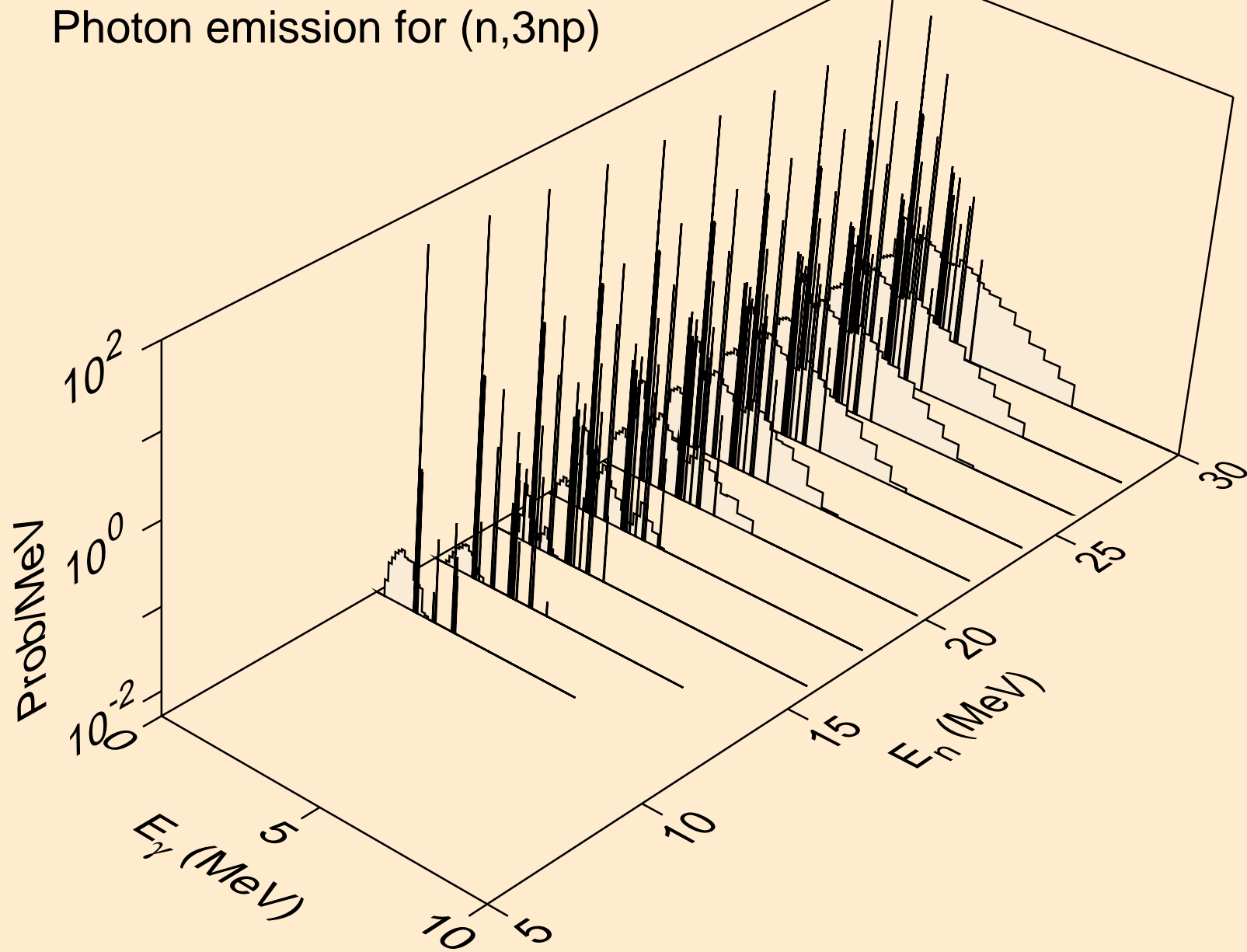

CL043 HELION ACER TENDL-2021 LIBRARY; T=0.K  
Photon emission for (n,2np)

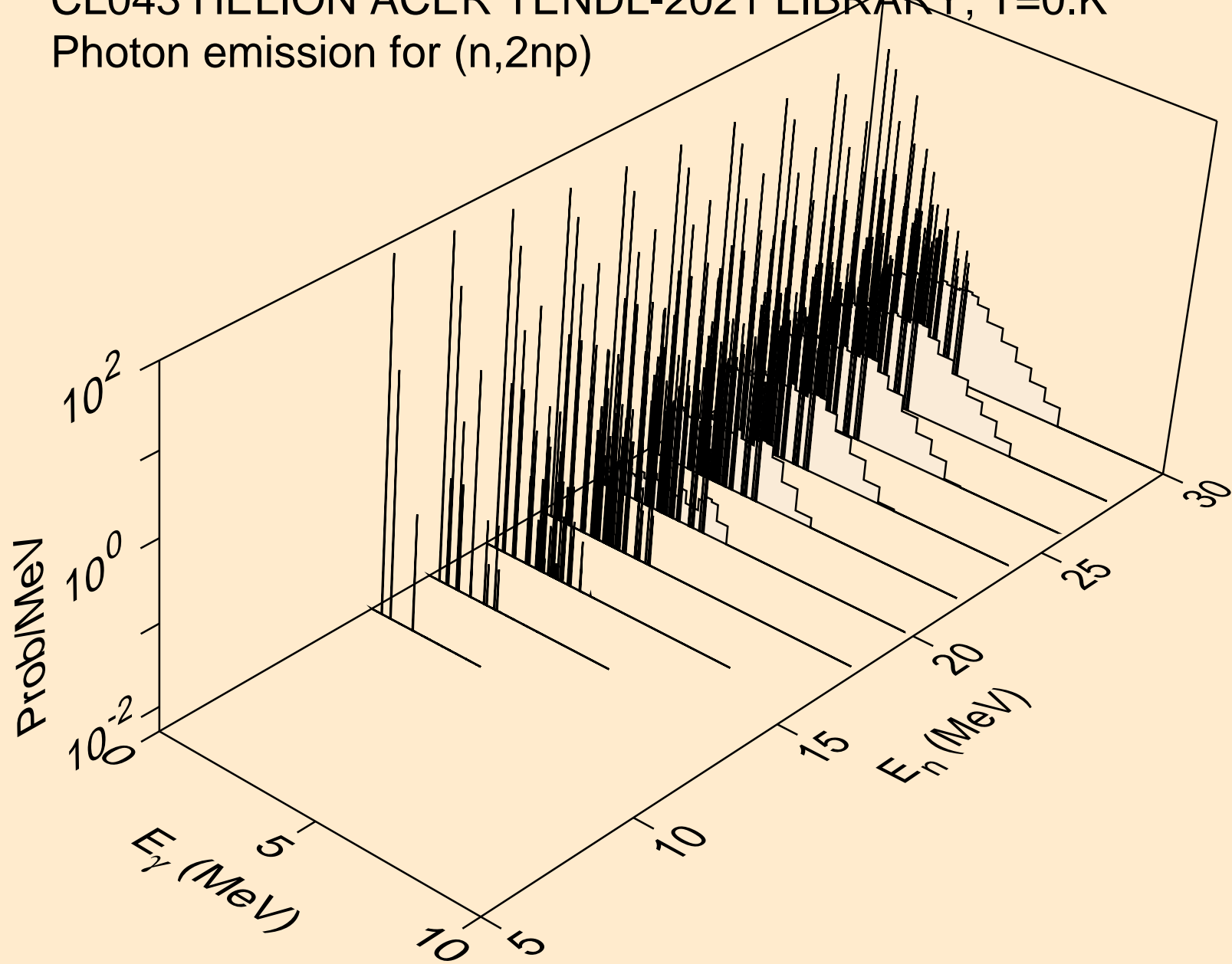

CL043 HELION ACER TENDL-2021 LIBRARY; T=0.K  
Photon emission for (n,npa)

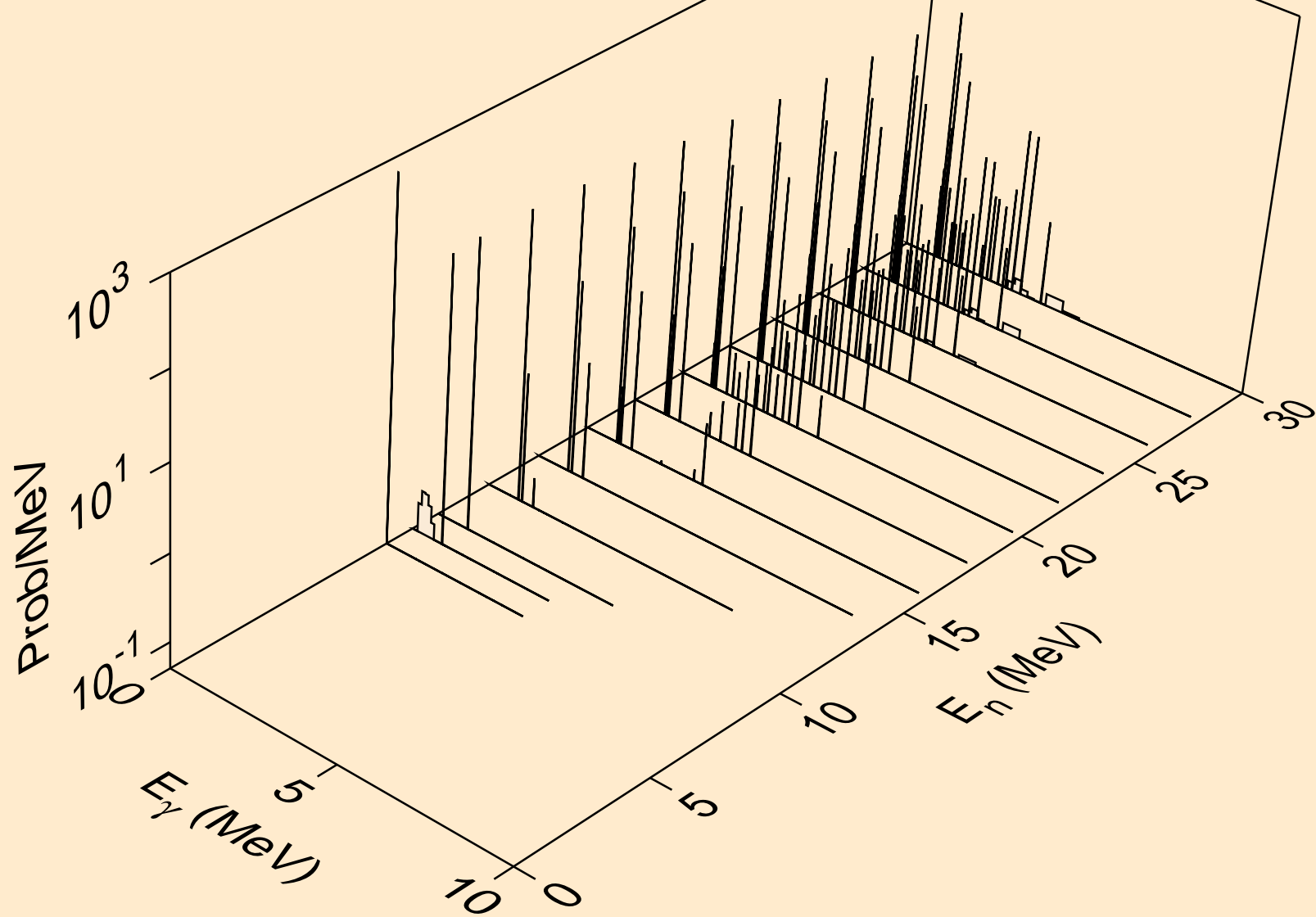

CL043 HELION ACER TENDL-2021 LIBRARY; T=0.K  
Photon emission for (n,gma)

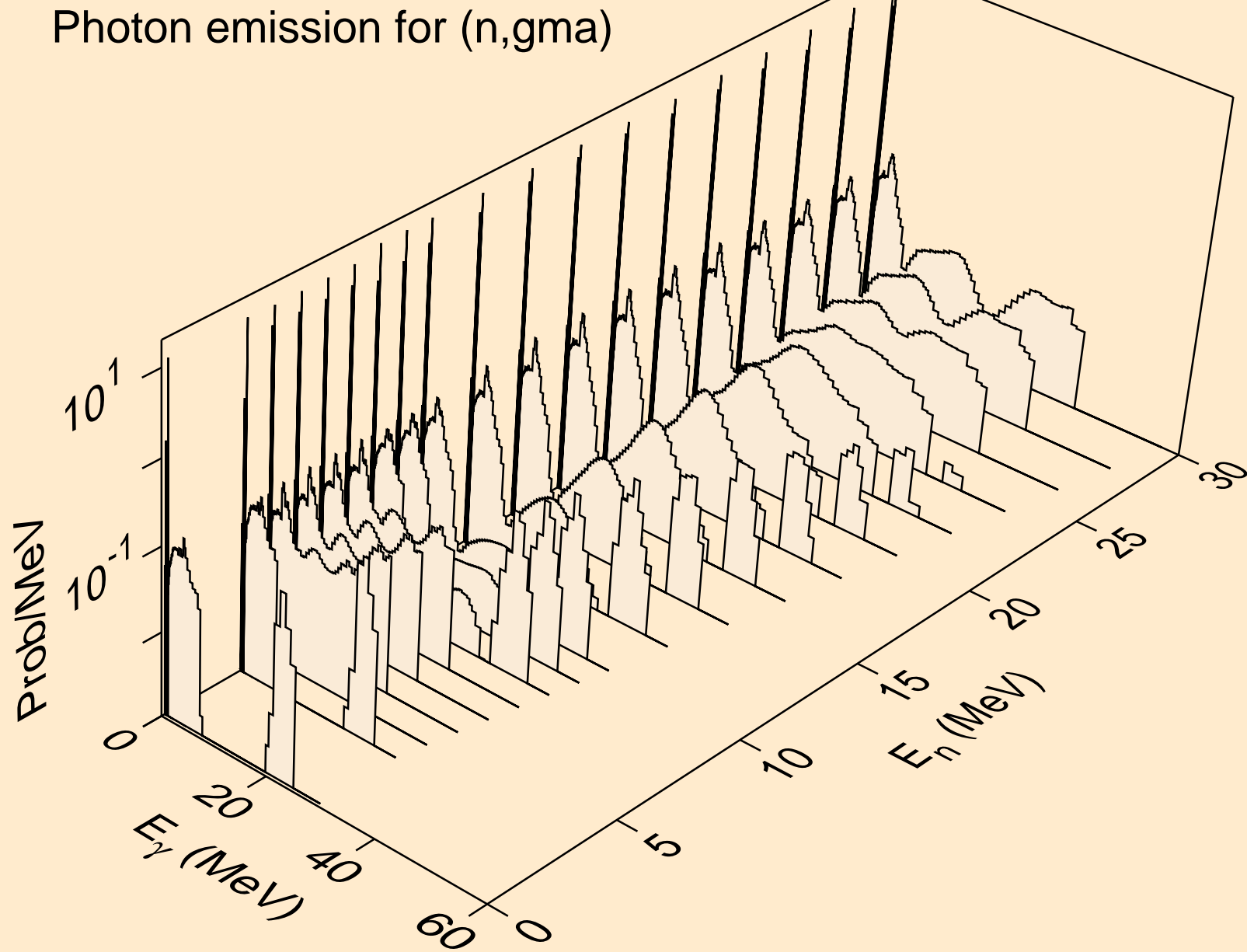

CL043 HELION ACER TENDL-2021 LIBRARY; T=0.K  
Photon emission for (n,p)

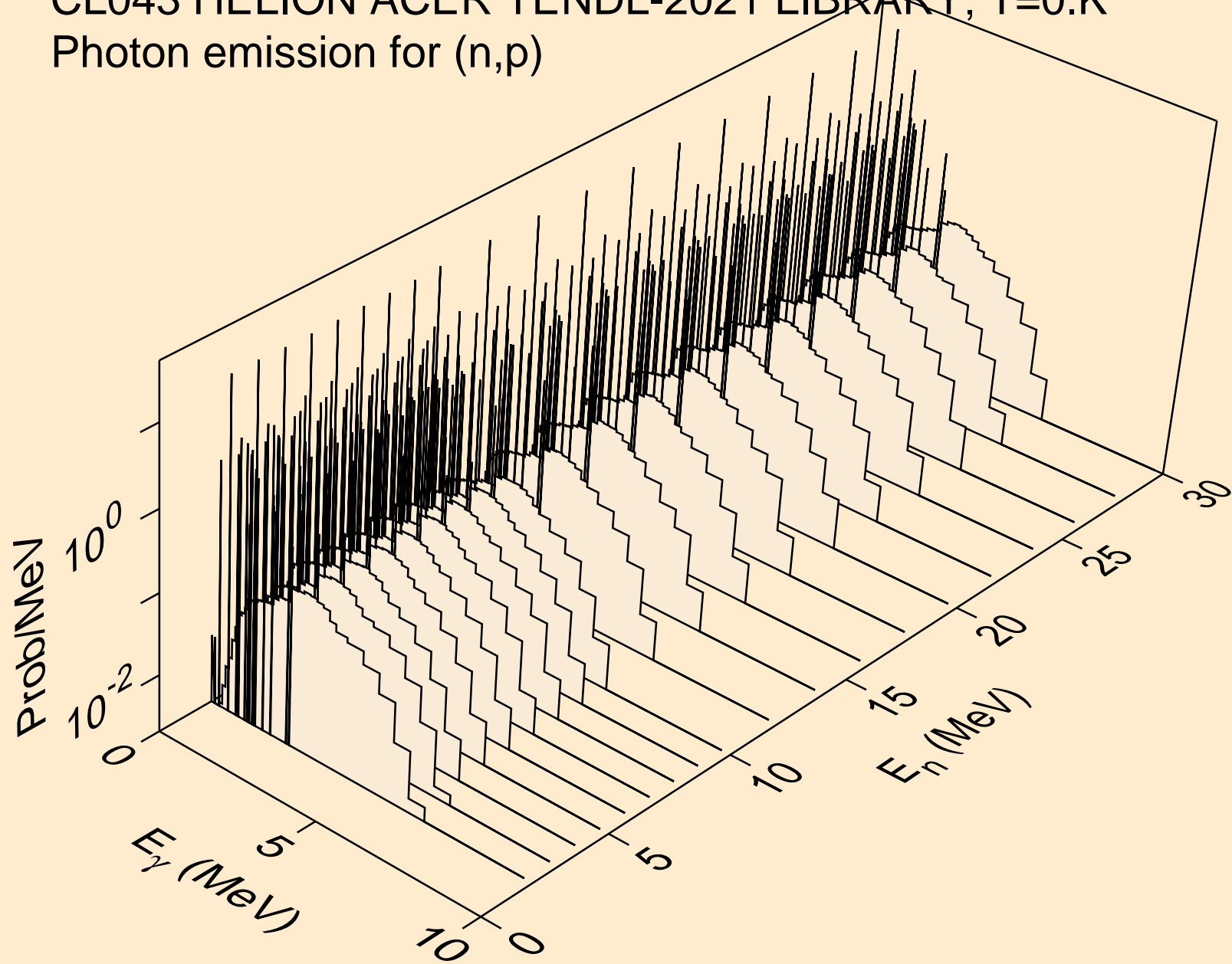

CL043 HELION ACER TENDL-2021 LIBRARY; T=0.K  
Photon emission for (n,d)

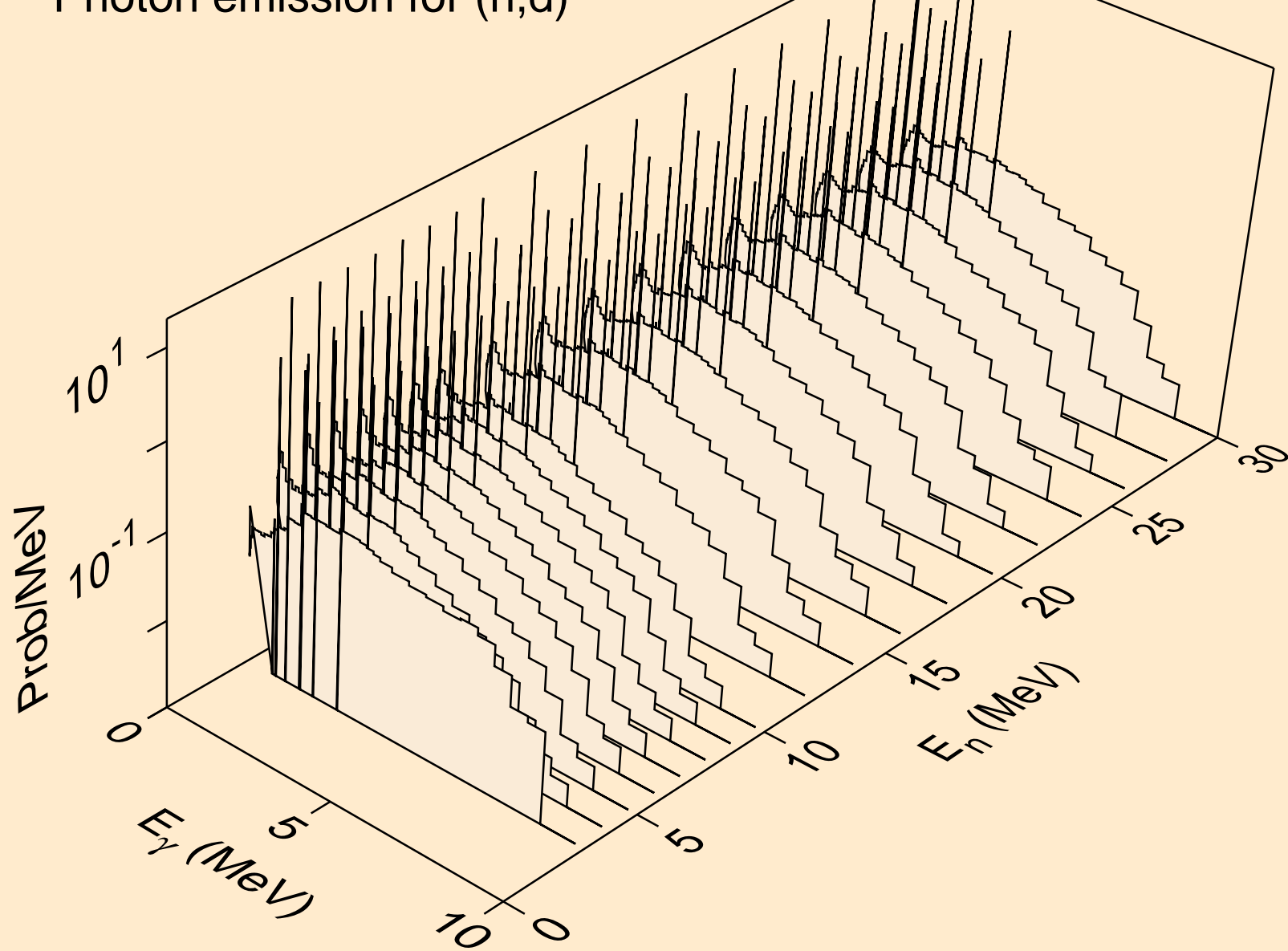

CL043 HELION ACER TENDL-2021 LIBRARY; T=0.K  
Photon emission for (n,t)

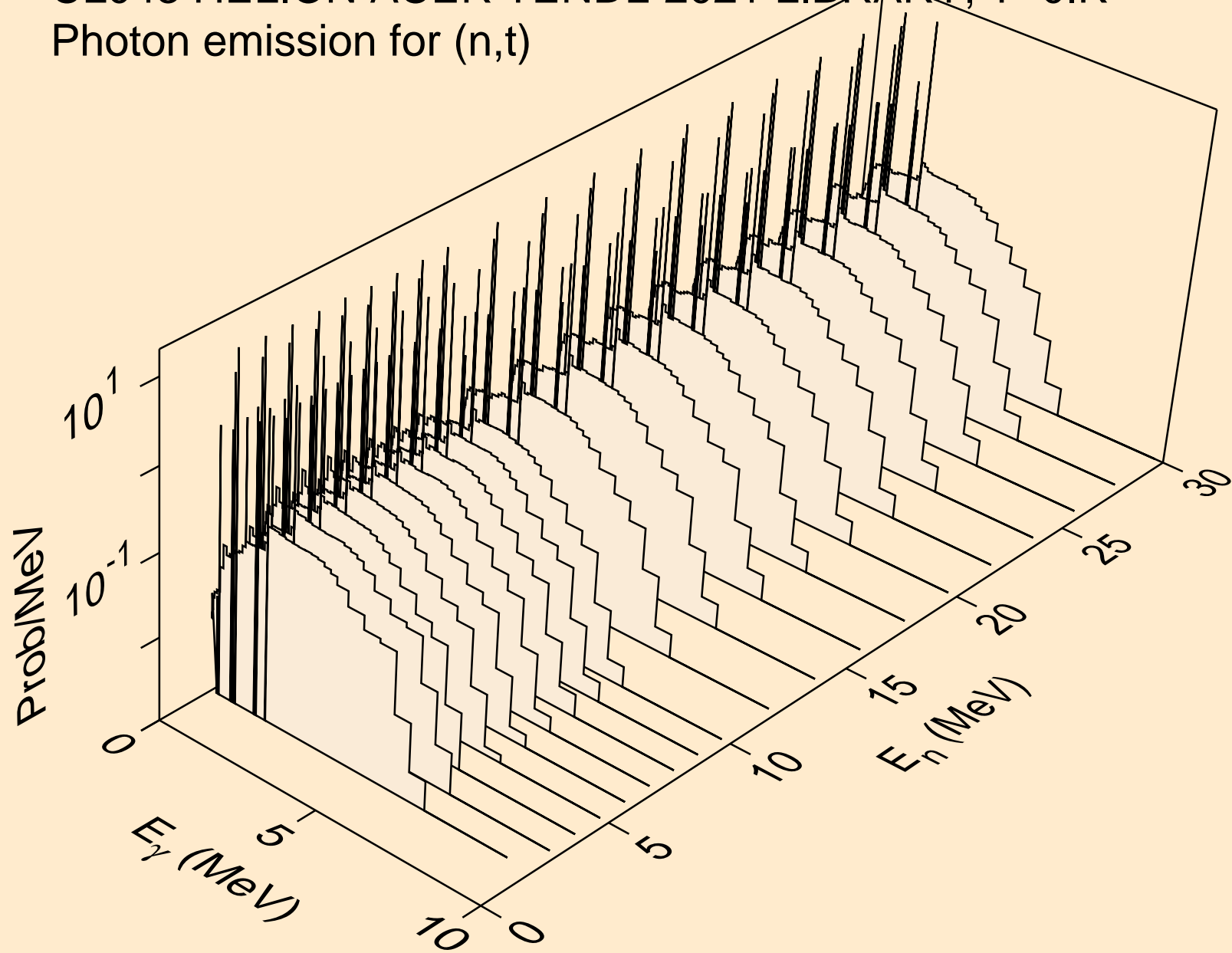



CL043 HELION ACER TENDL-2021 LIBRARY; T=0.K  
Photon emission for inelastic

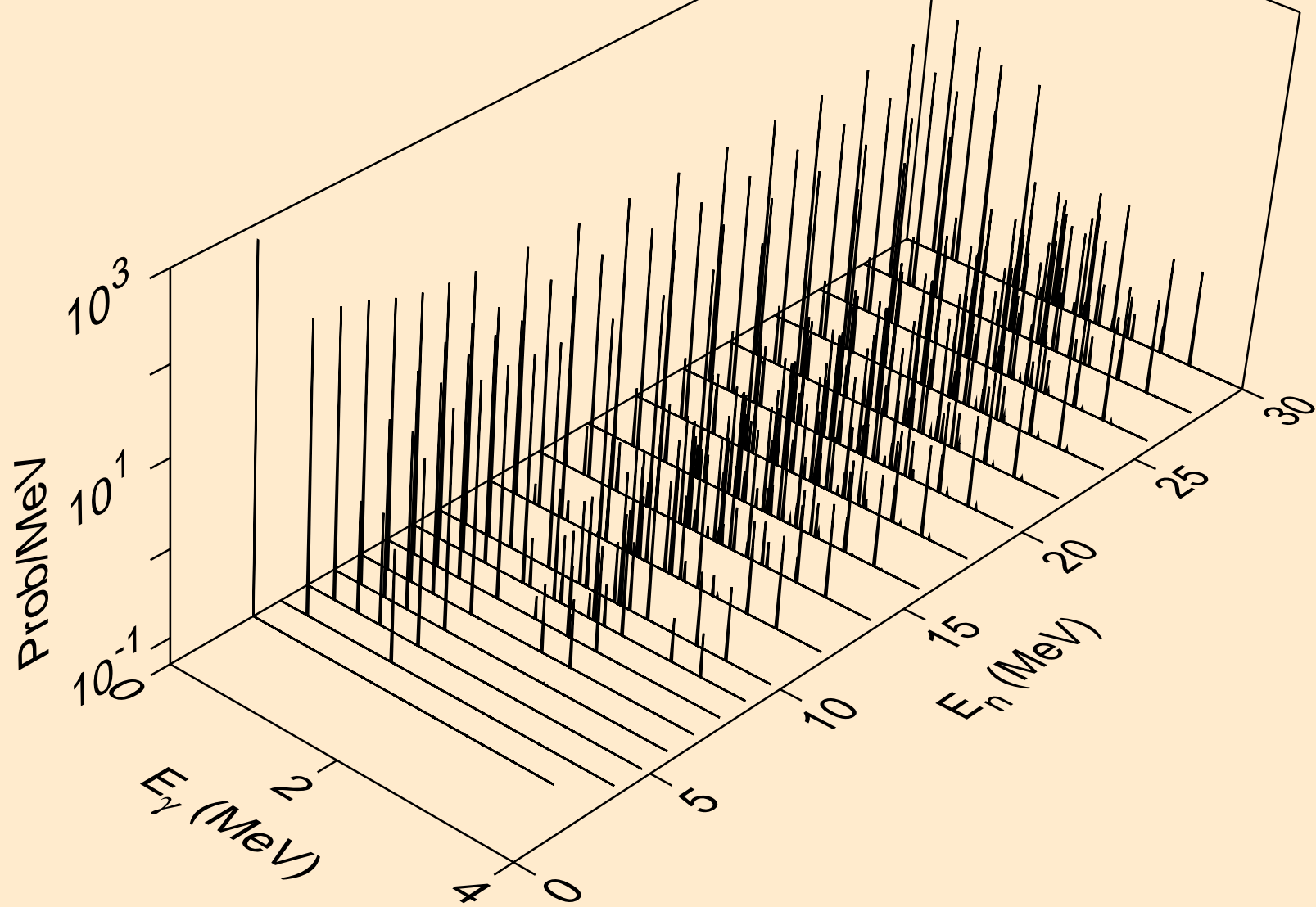

CL043 HELION ACER TENDL-2021 LIBRARY; T=0.K  
Photon emission for (n,a)

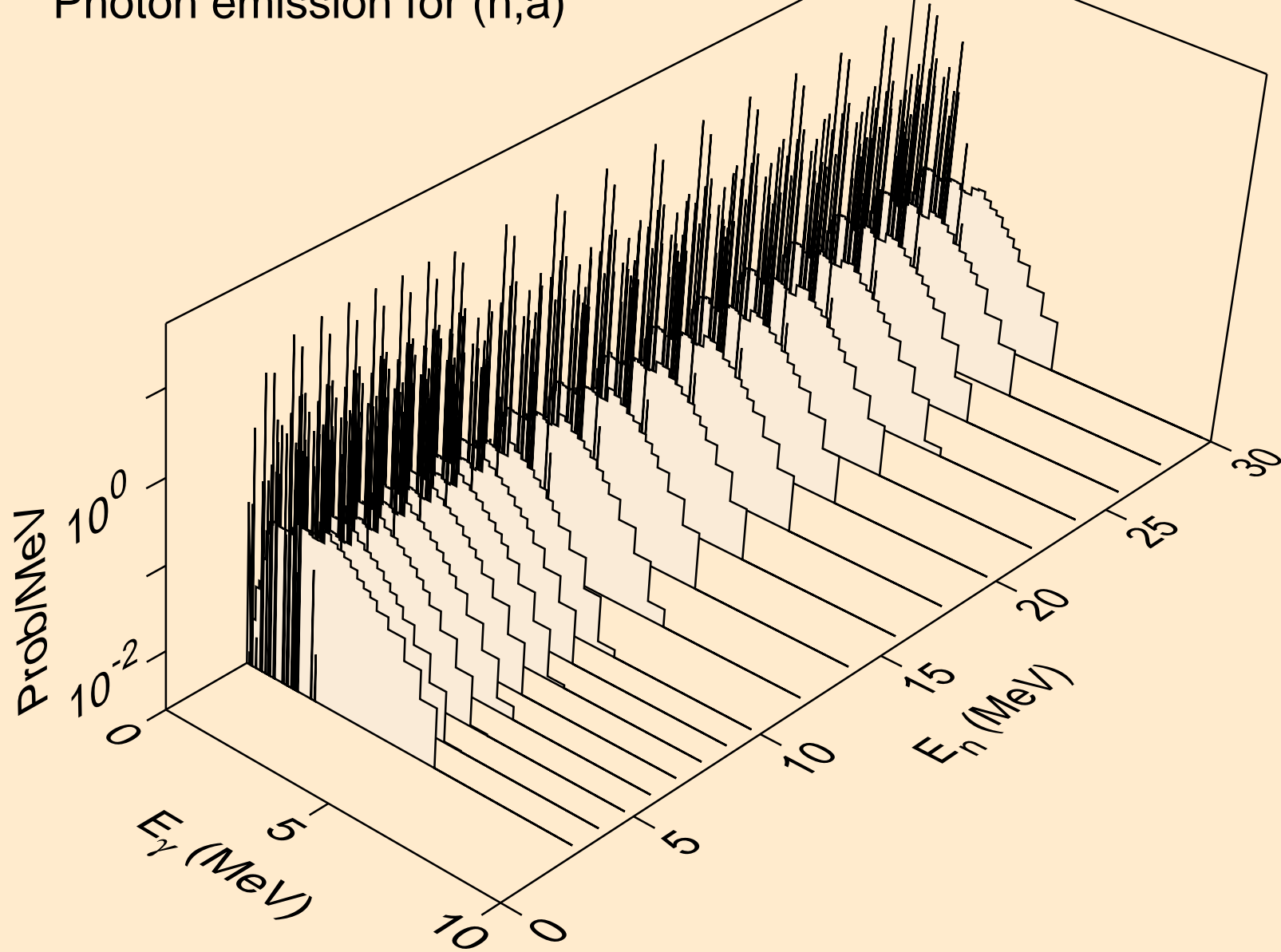

CL043 HELION ACER TENDL-2021 LIBRARY; T=0.K  
Photon emission for (n,2a)

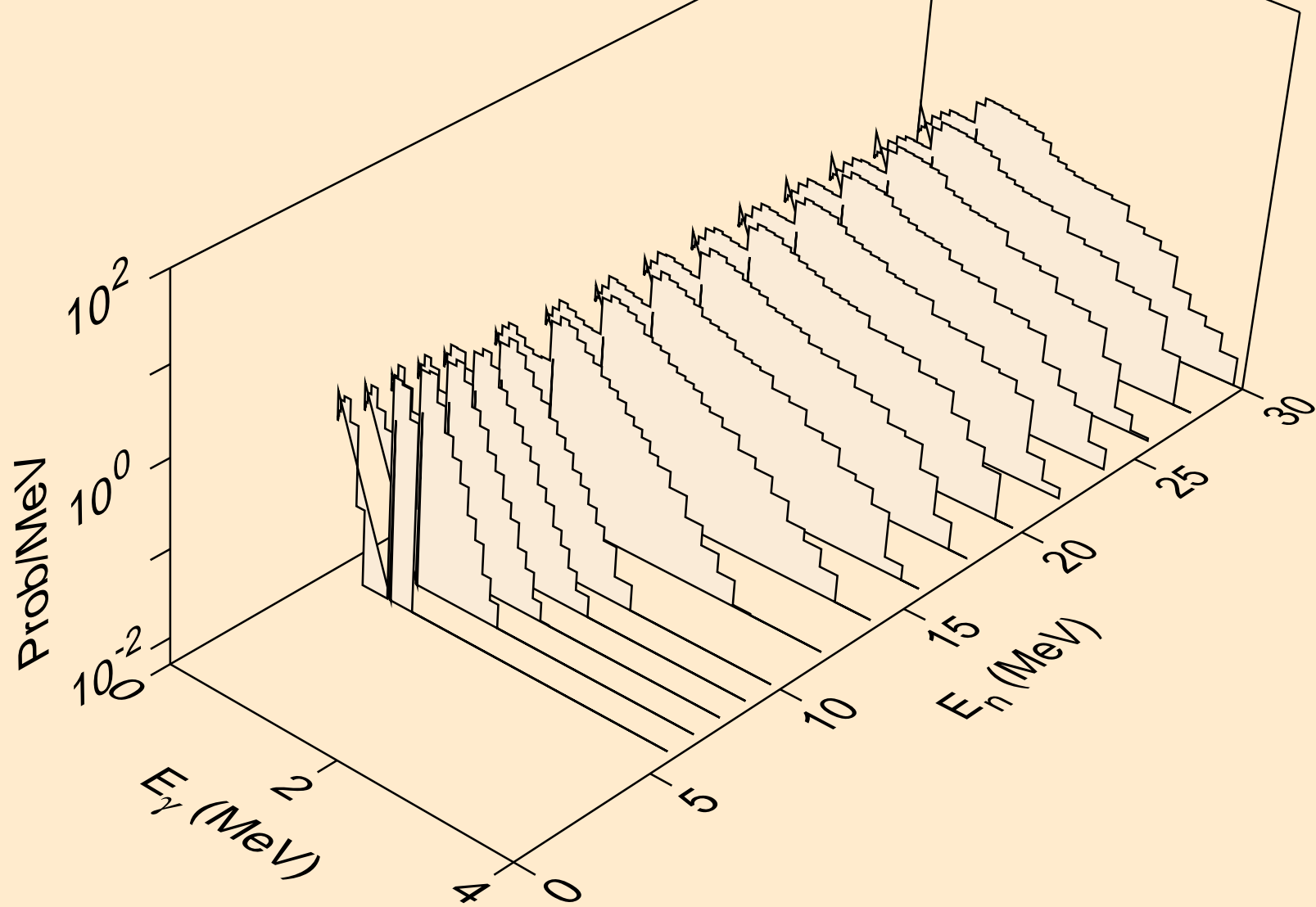

CL043 HELION ACER TENDL-2021 LIBRARY; T=0.K  
Photon emission for (n,2p)

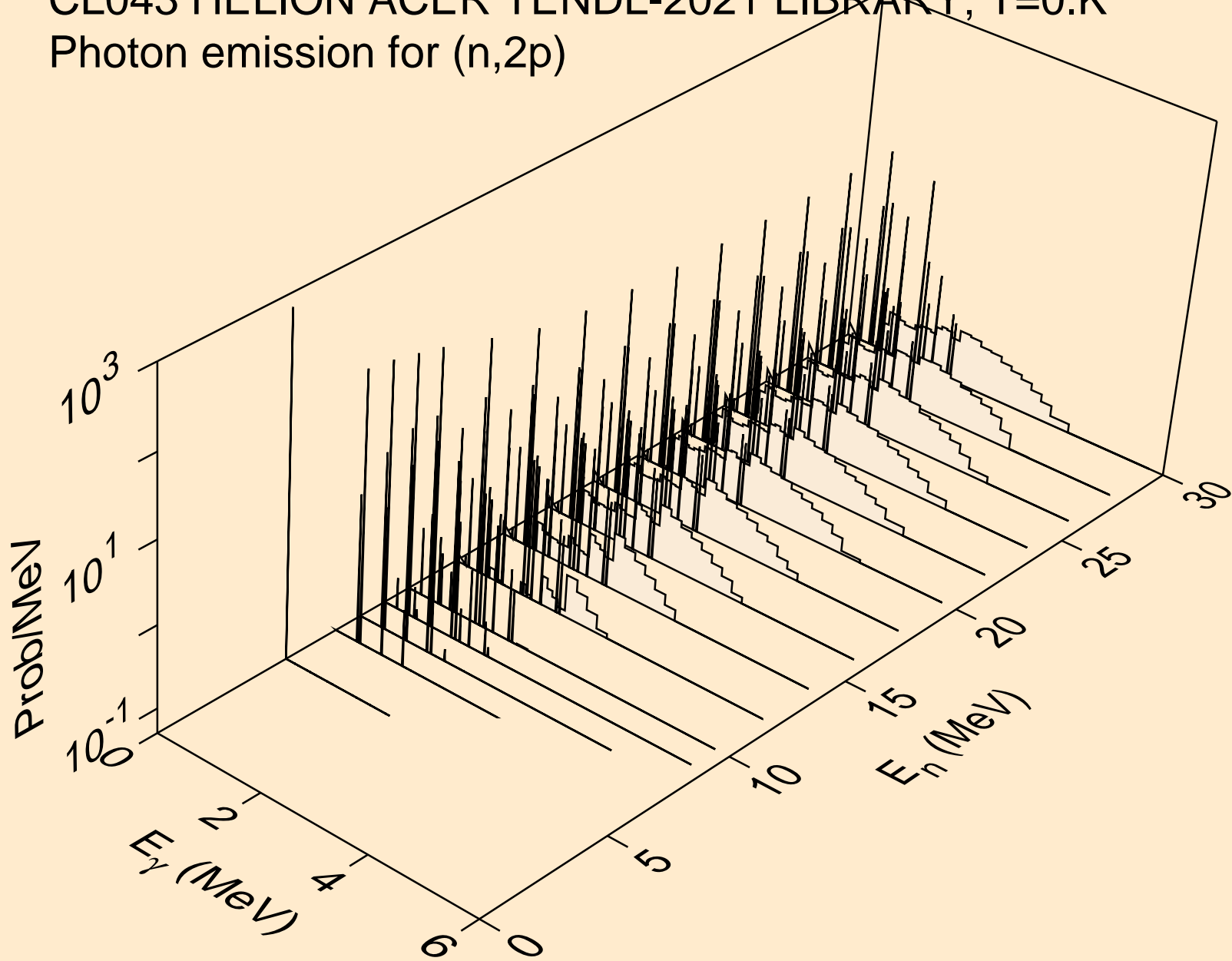

CL043 HELION ACER TENDL-2021 LIBRARY; T=0.K  
Photon emission for (n,pa)

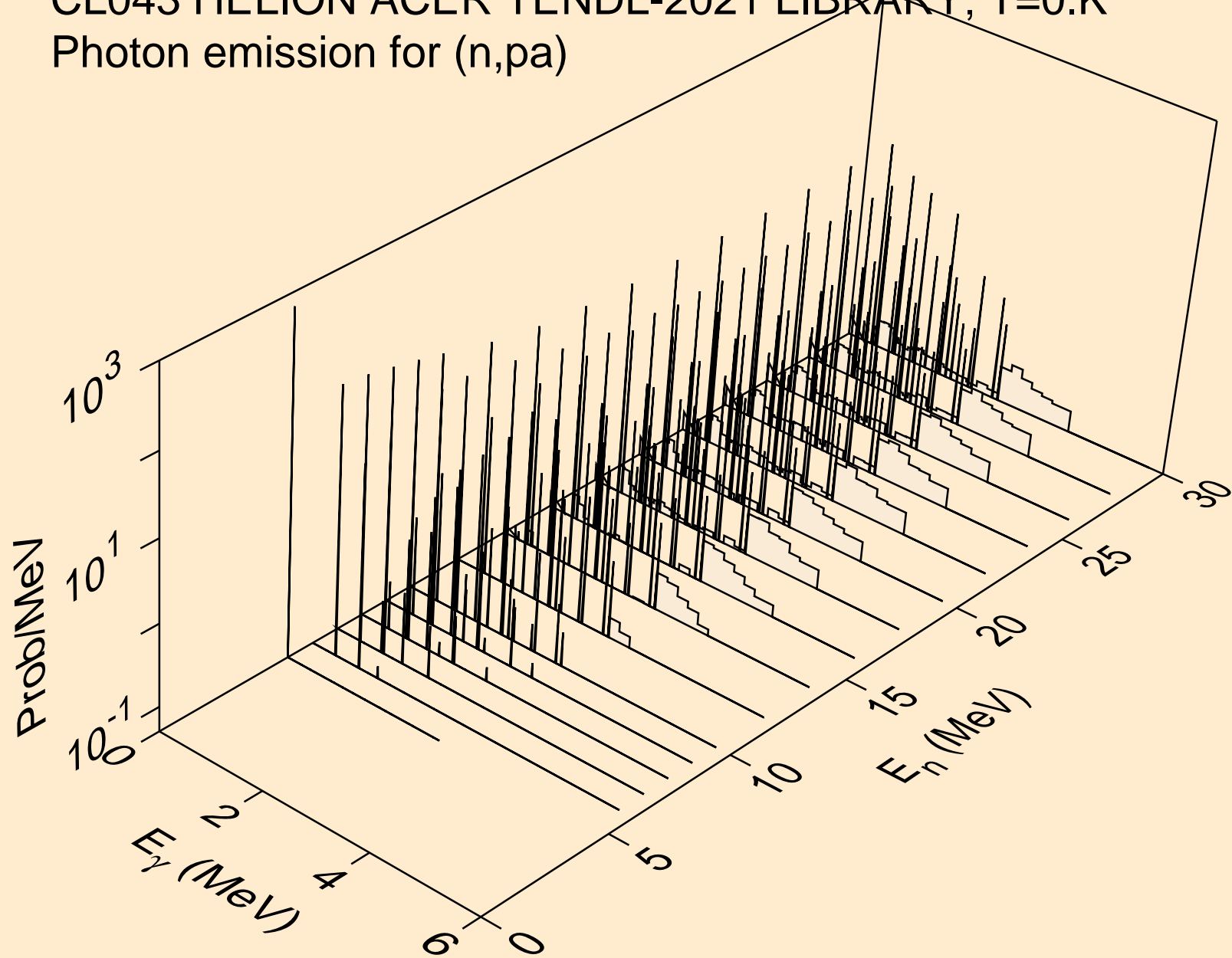

CL043 HELION ACER TENDL-2021 LIBRARY; T=0.K  
Photon emission for (n,pd)

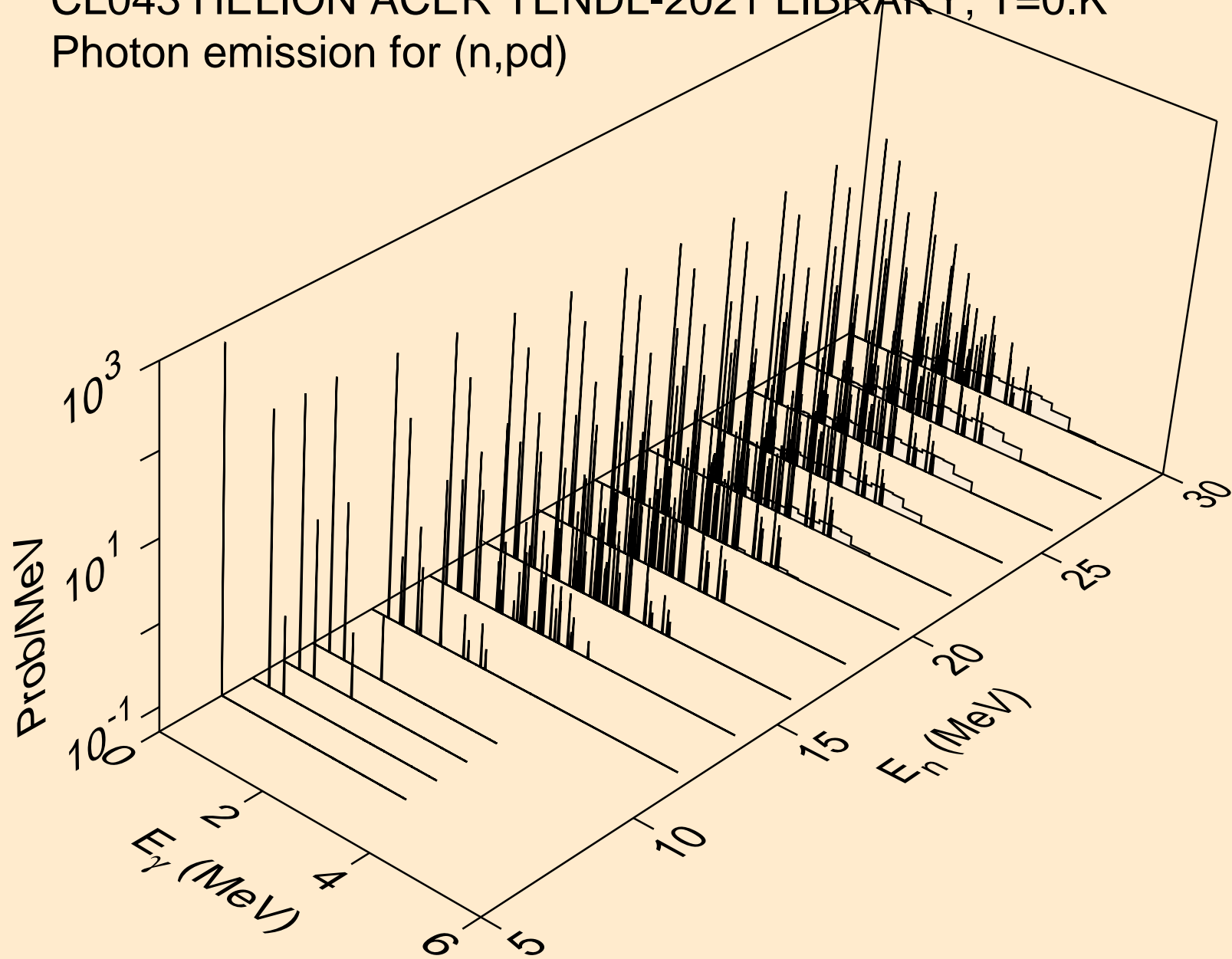

CL043 HELION ACER TENDL-2021 LIBRARY; T=0.K  
Photon emission for (n,pt)

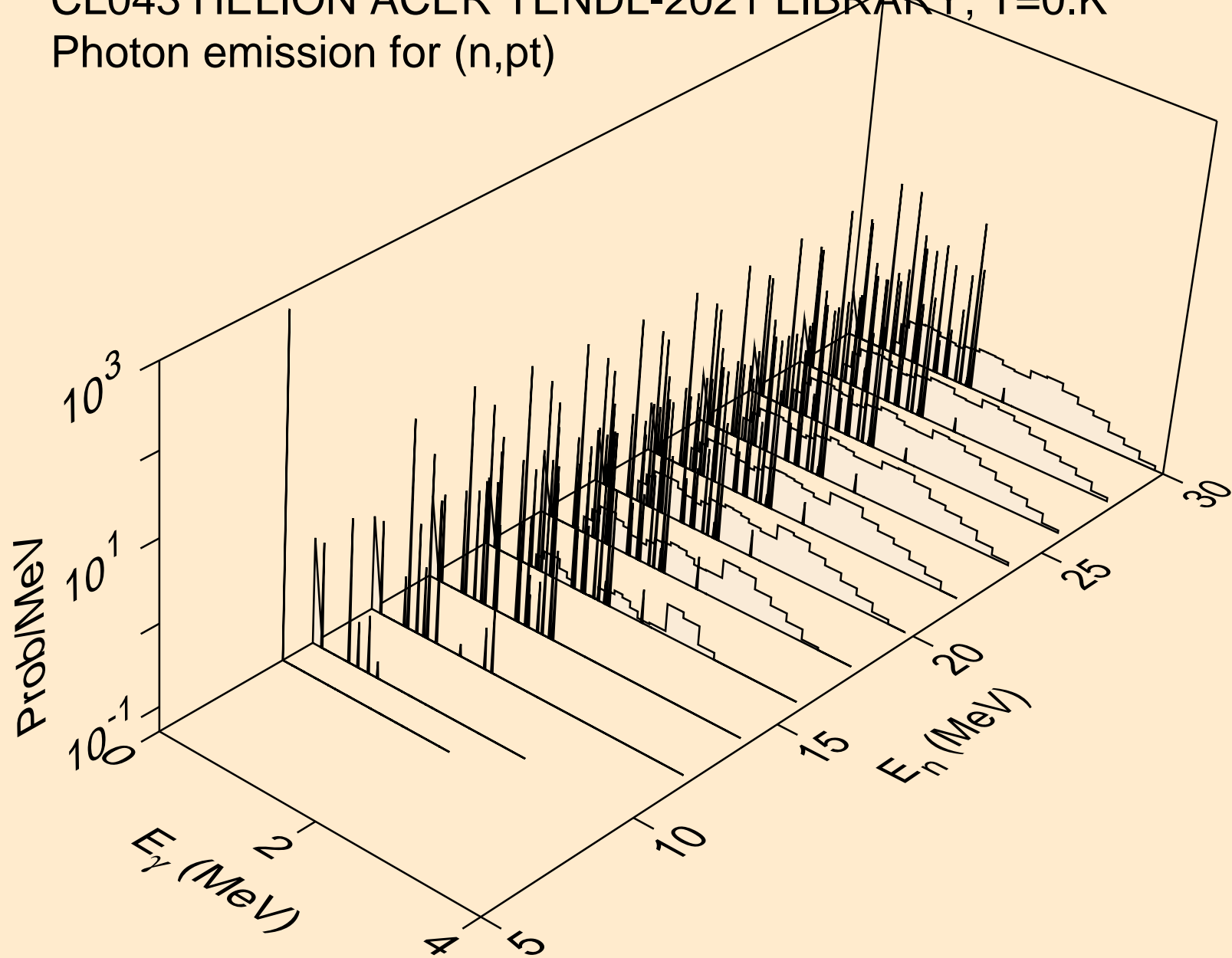

CL043 HELION ACER TENDL-2021 LIBRARY; T=0.K  
Photon emission for (n,da)

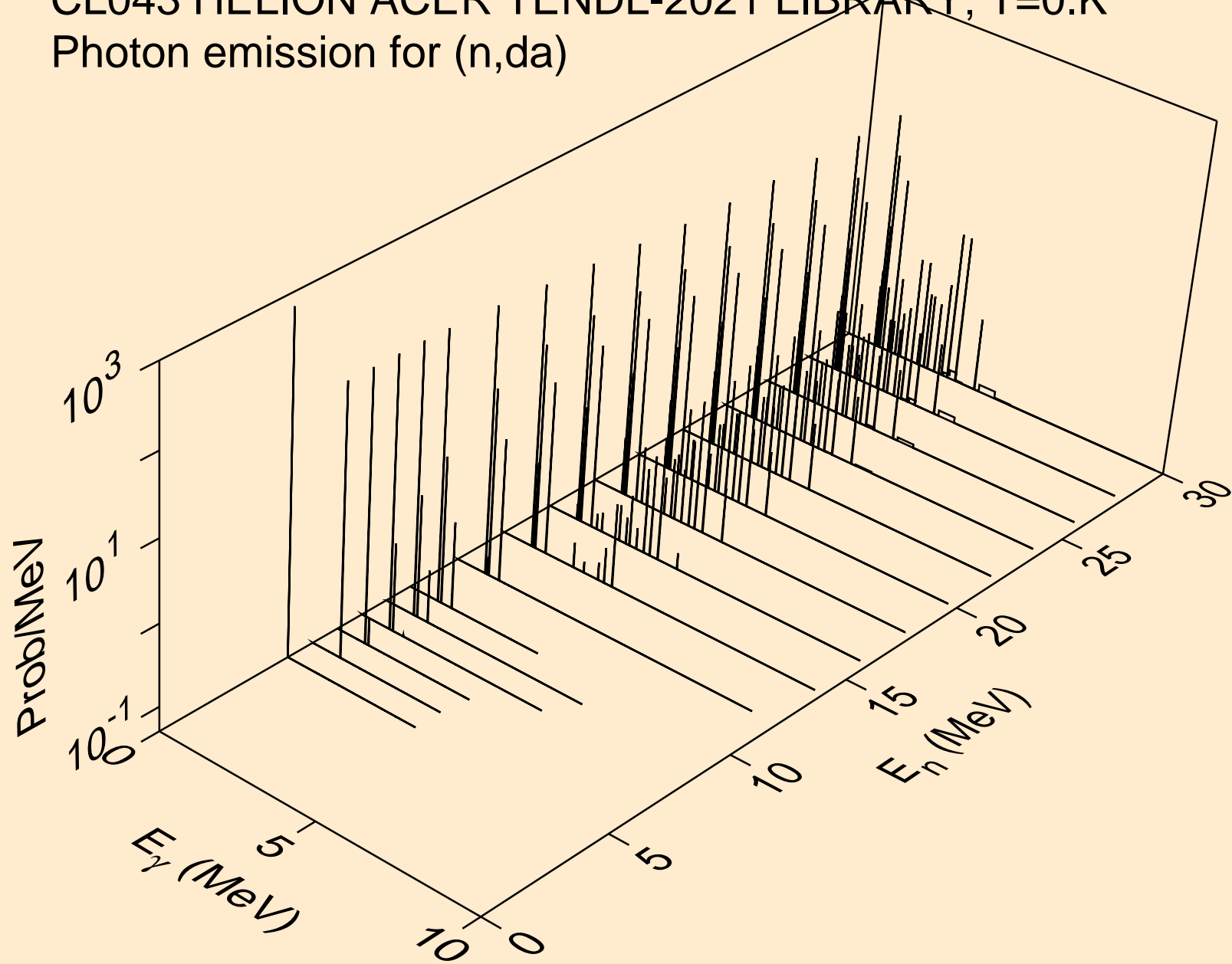



CL043 HELION ACER TENDL-2021 LIBRARY; T=0.K  
Particle heating contributions

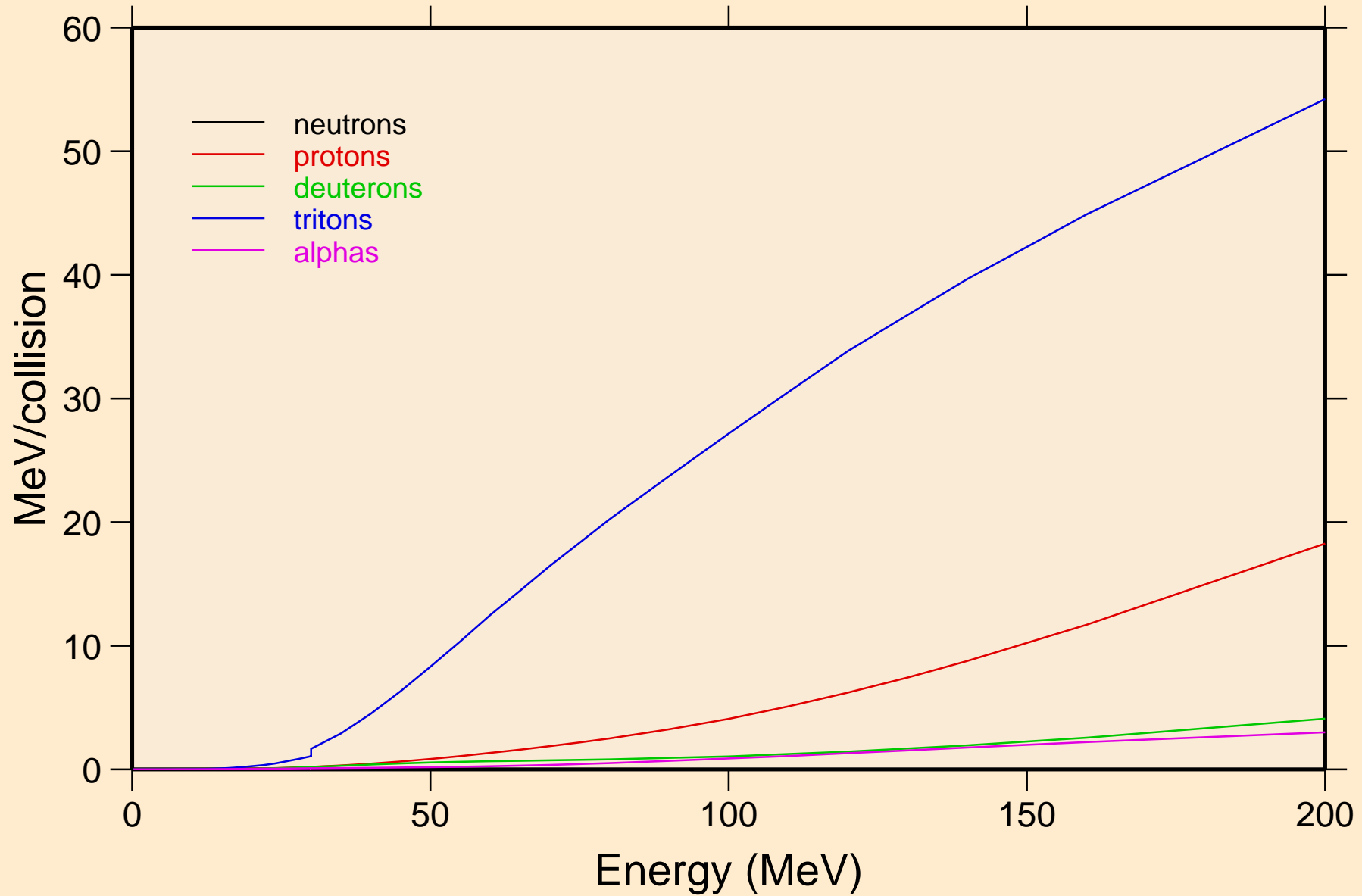

CL043 HELION ACER TENDL-2021 LIBRARY; T=0.K  
Recoil Heating

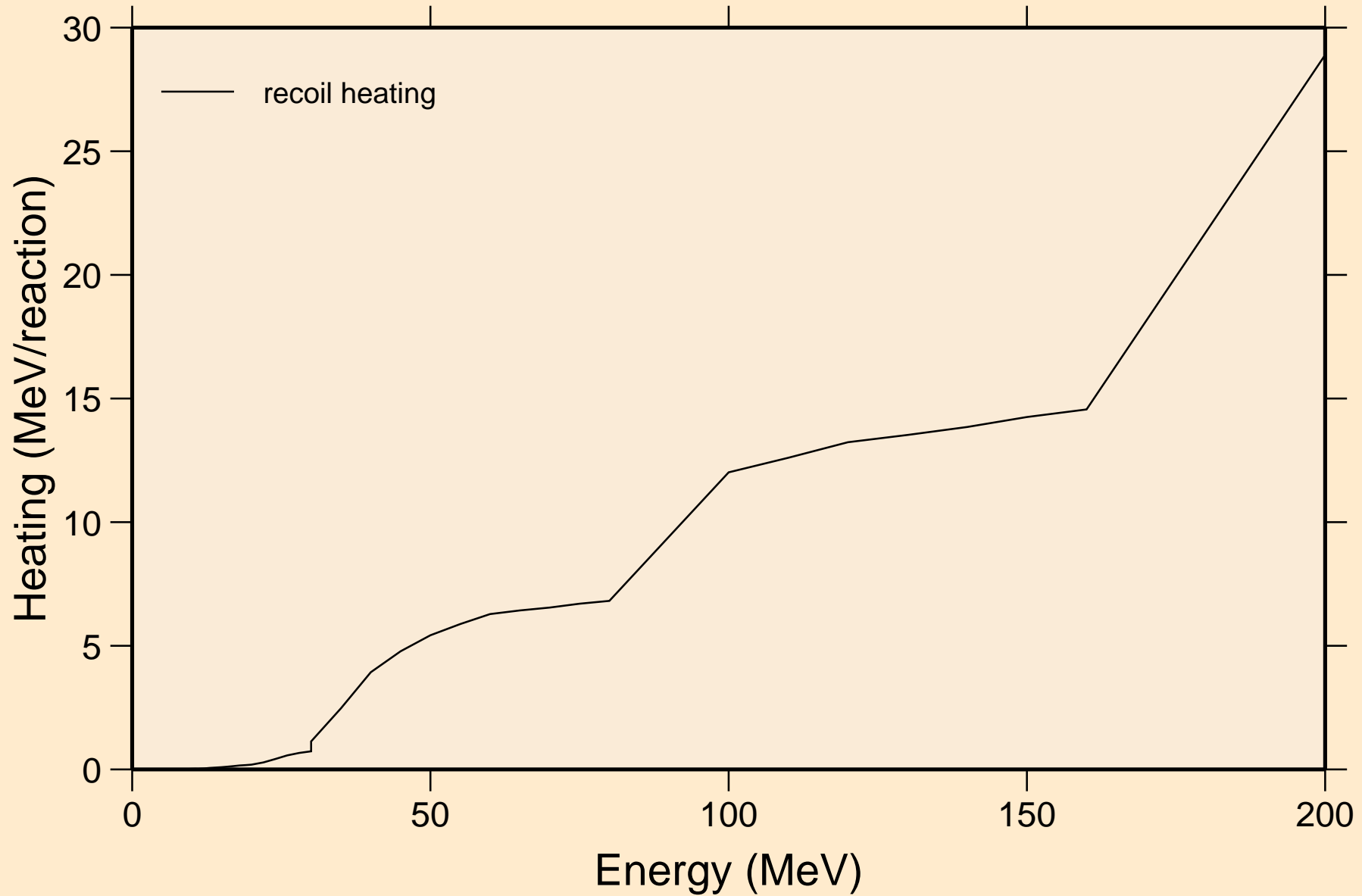

CL043 HELION ACER TENDL-2021 LIBRARY; T=0.K  
Particle production cross sections

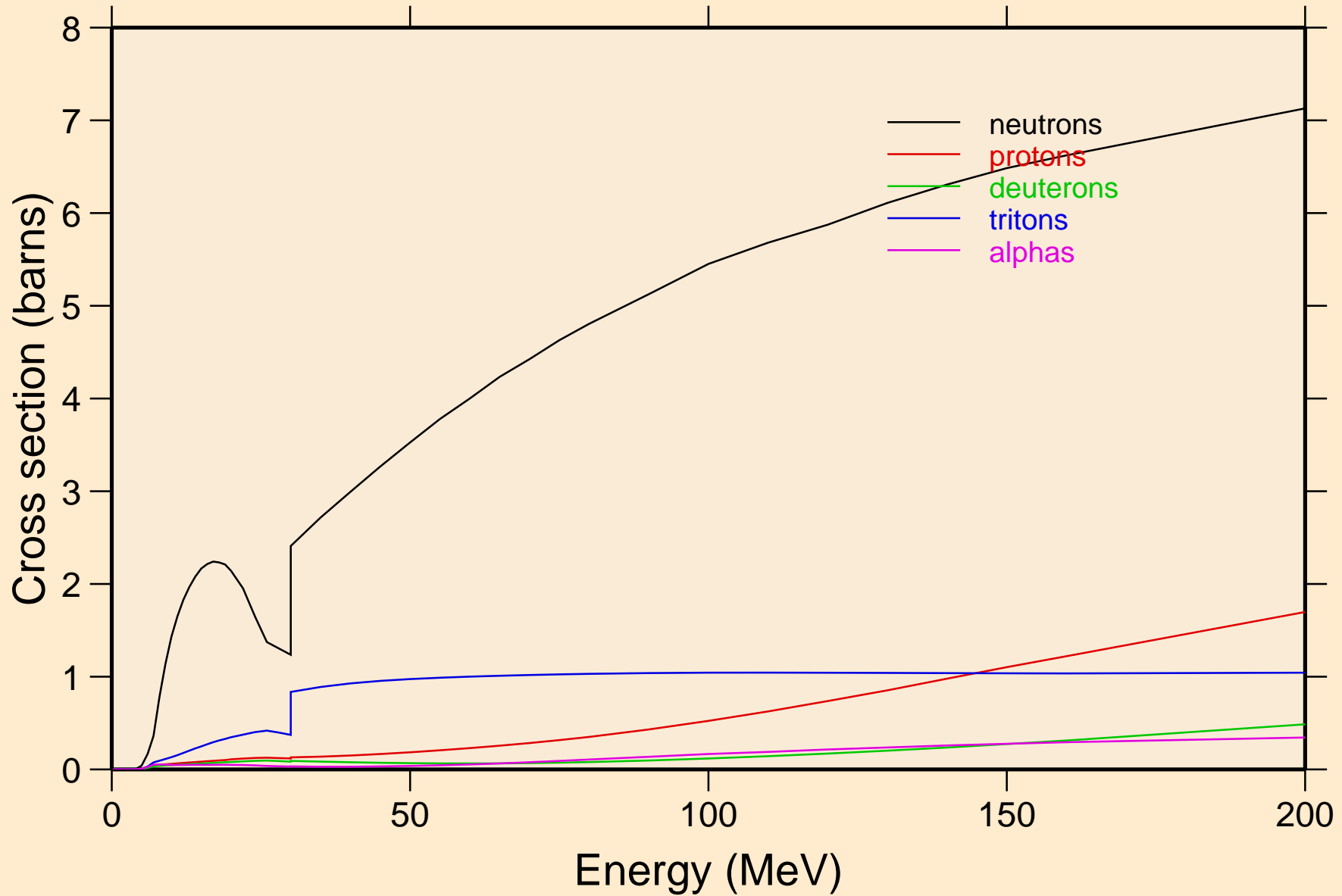

CL043 HELION ACER TENDL-2021 LIBRARY; T=0.K  
neutrons from (s,n)

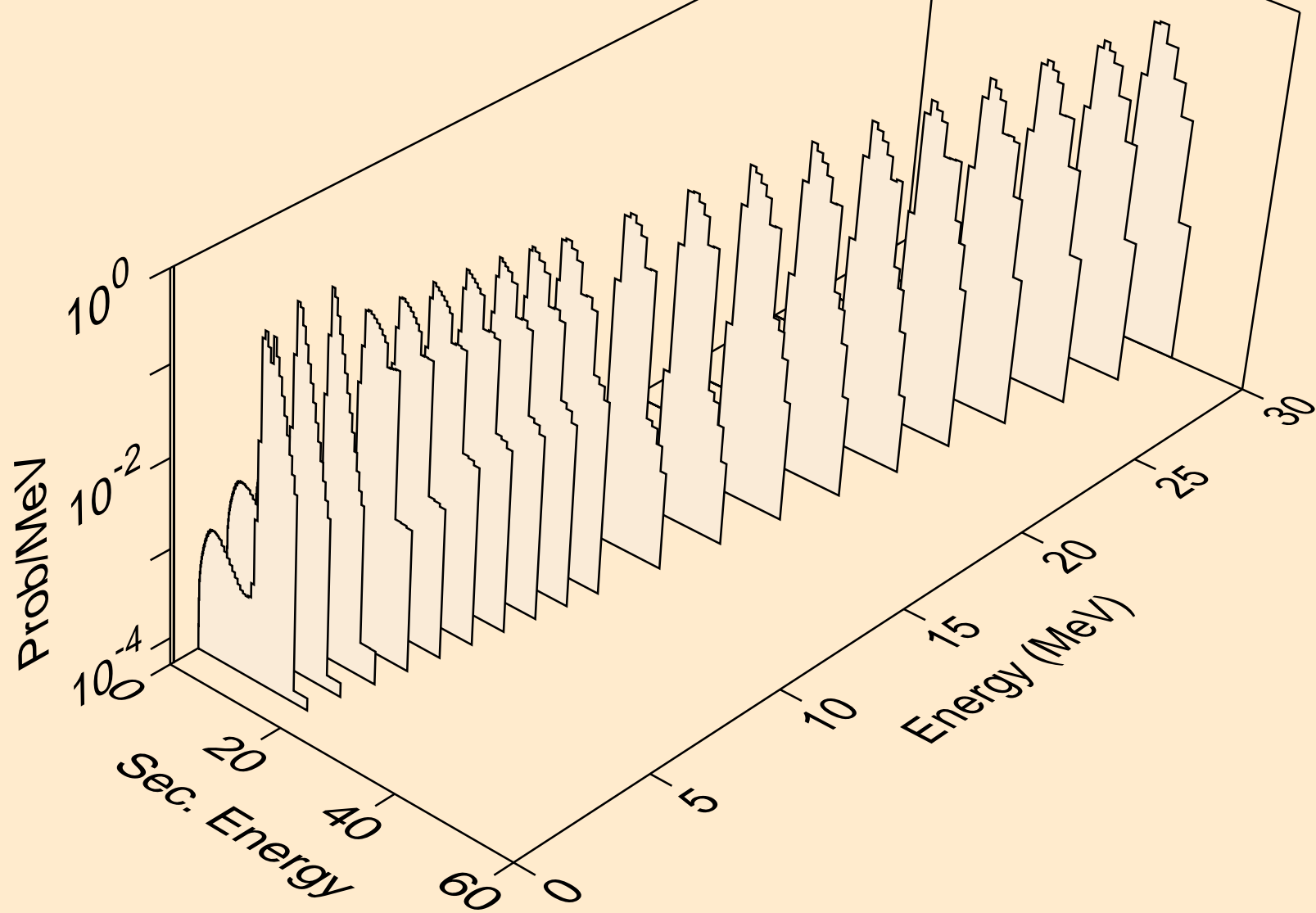

CL043 HELION ACER TENDL-2021 LIBRARY; T=0.K  
neutrons from (s,x)

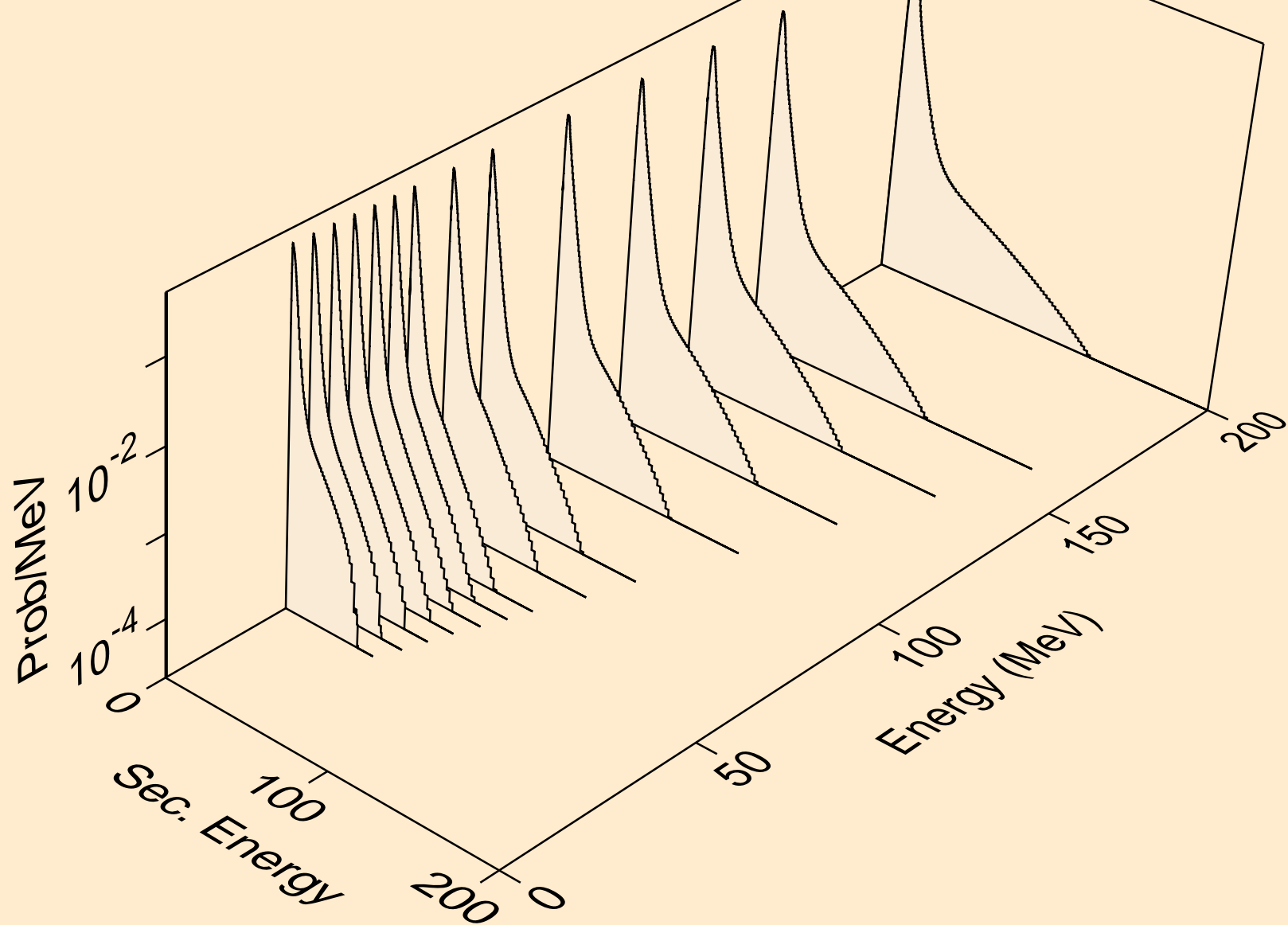

CL043 HELION ACER TENDL-2021 LIBRARY; T=0.K  
neutrons from (s,2nd)

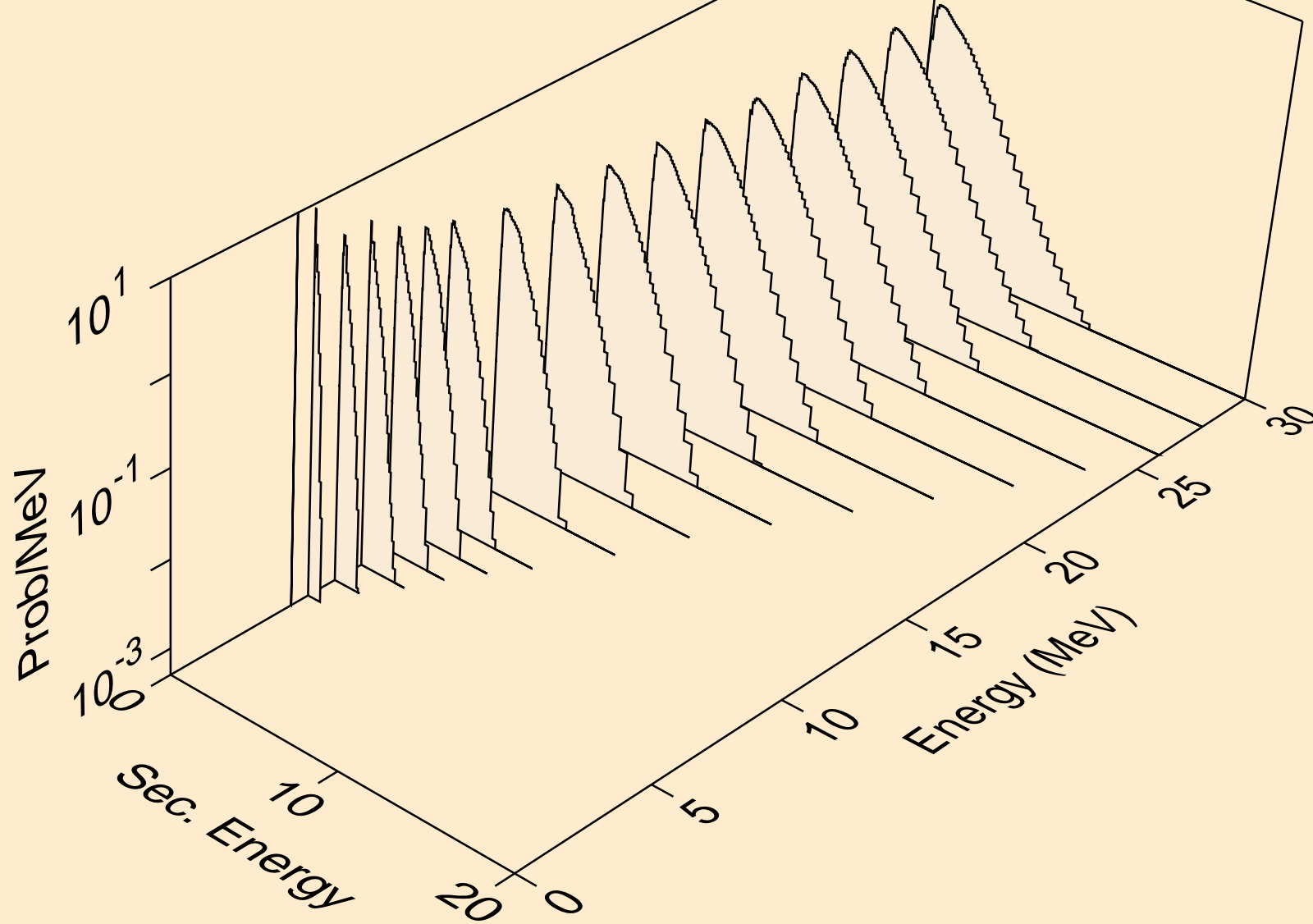

CL043 HELION ACER TENDL-2021 LIBRARY; T=0.K  
neutrons from (s,2n)

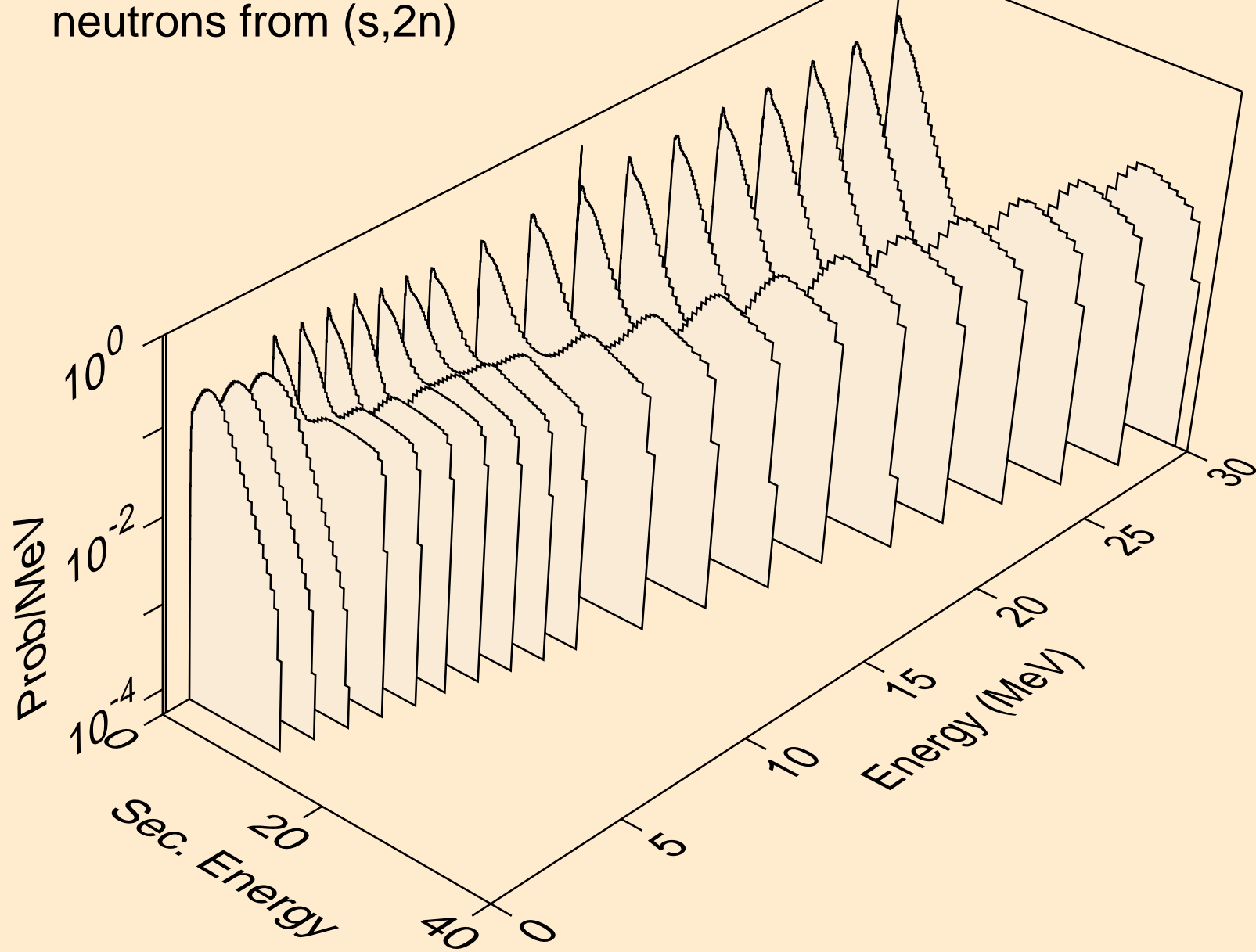

CL043 HELION ACER TENDL-2021 LIBRARY; T=0.K  
neutrons from (s,3n)

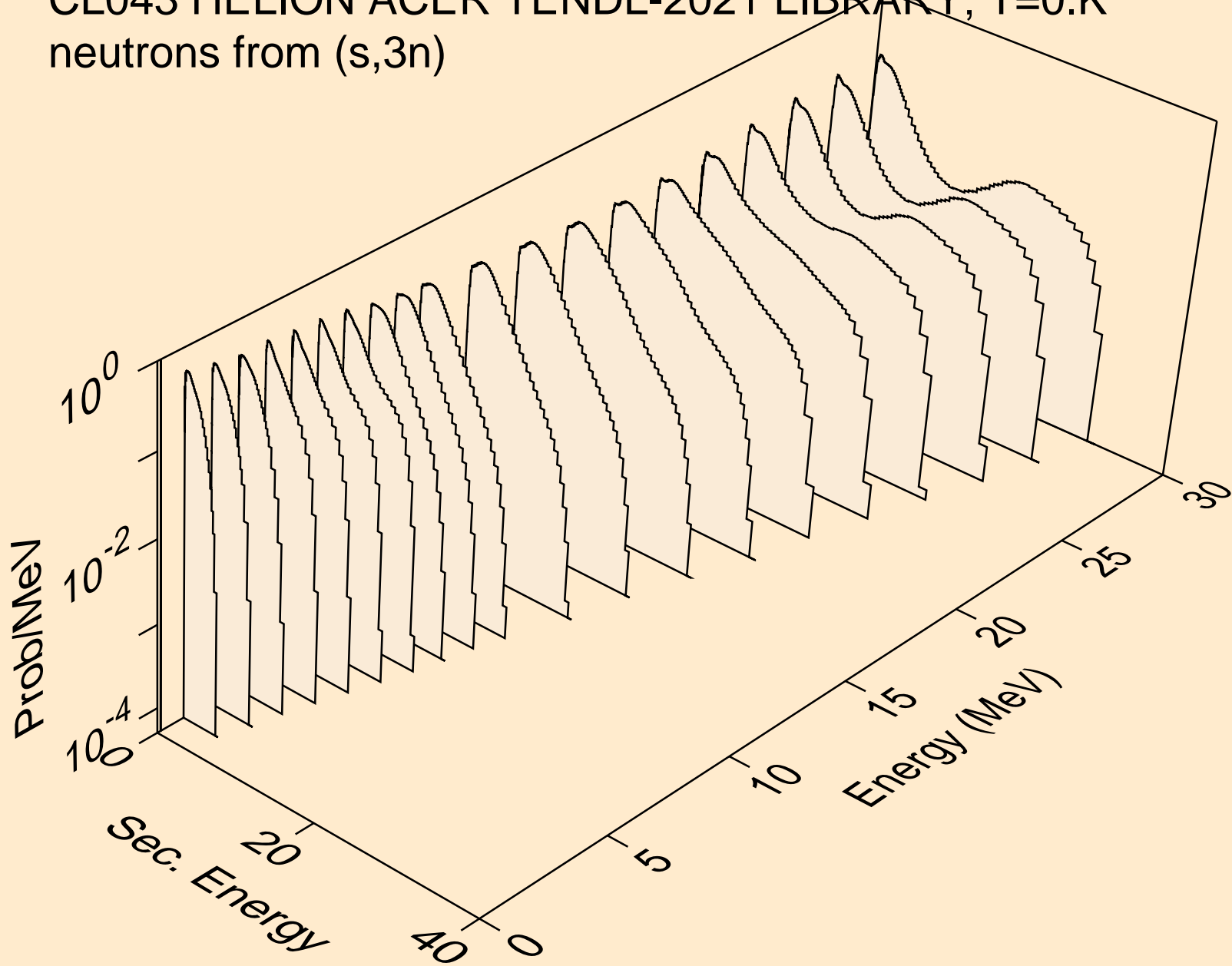



CL043 HELION ACER TENDL-2021 LIBRARY; T=0.K  
neutrons from (s,n\*)a

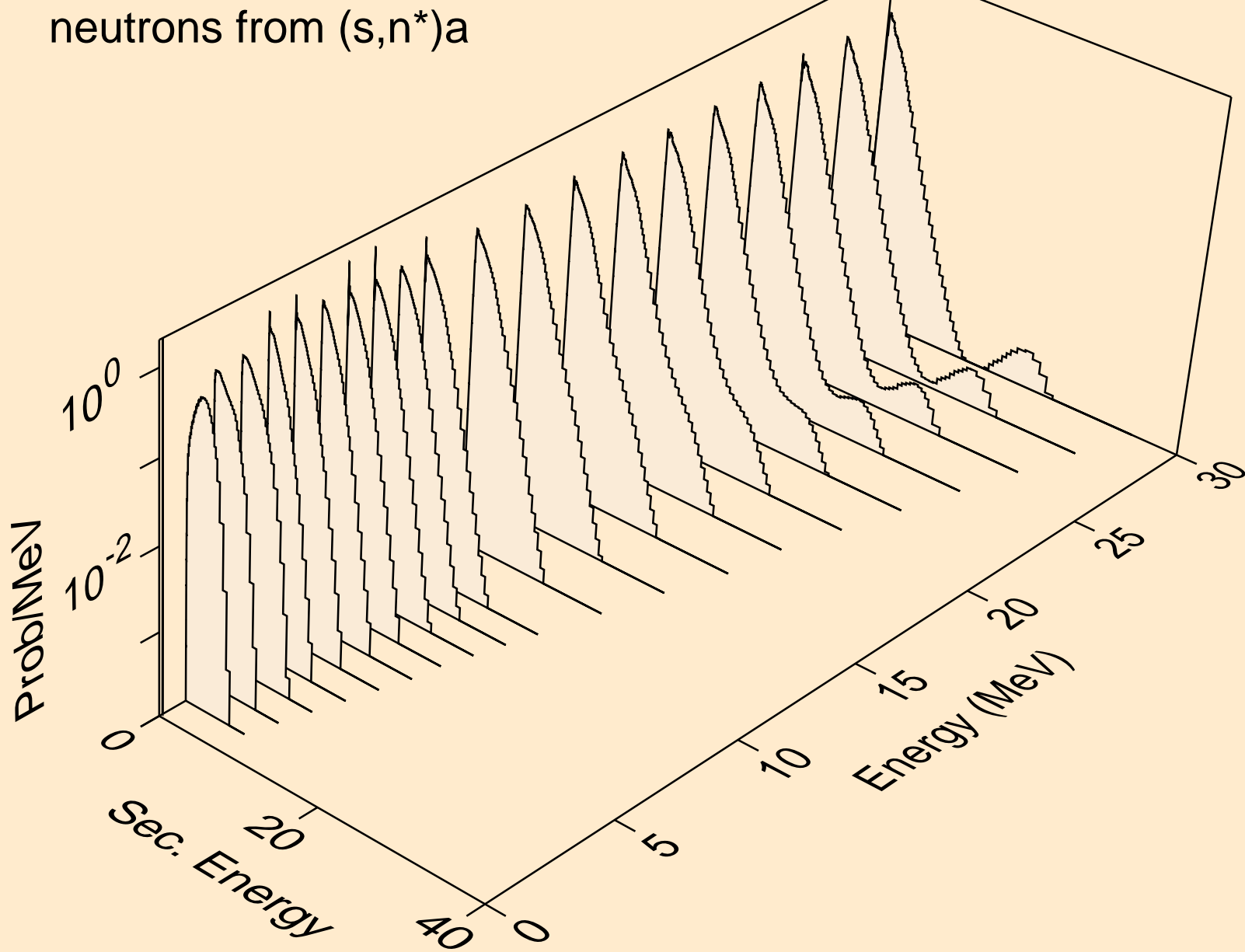

CL043 HELION ACER TENDL-2021 LIBRARY; T=0.K  
neutrons from (s,2n)a

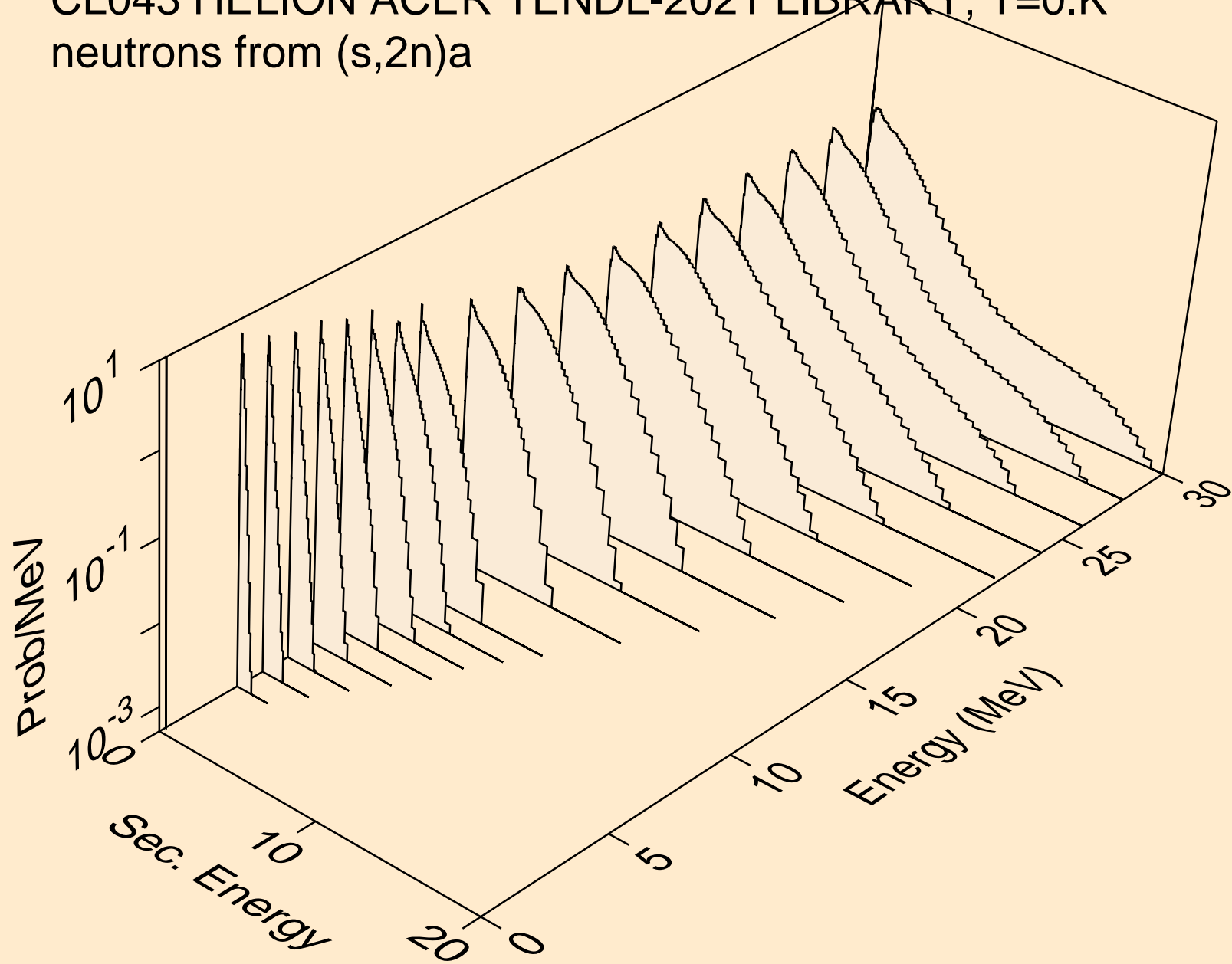

CL043 HELION ACER TENDL-2021 LIBRARY; T=0.K  
neutrons from (s,3n)a

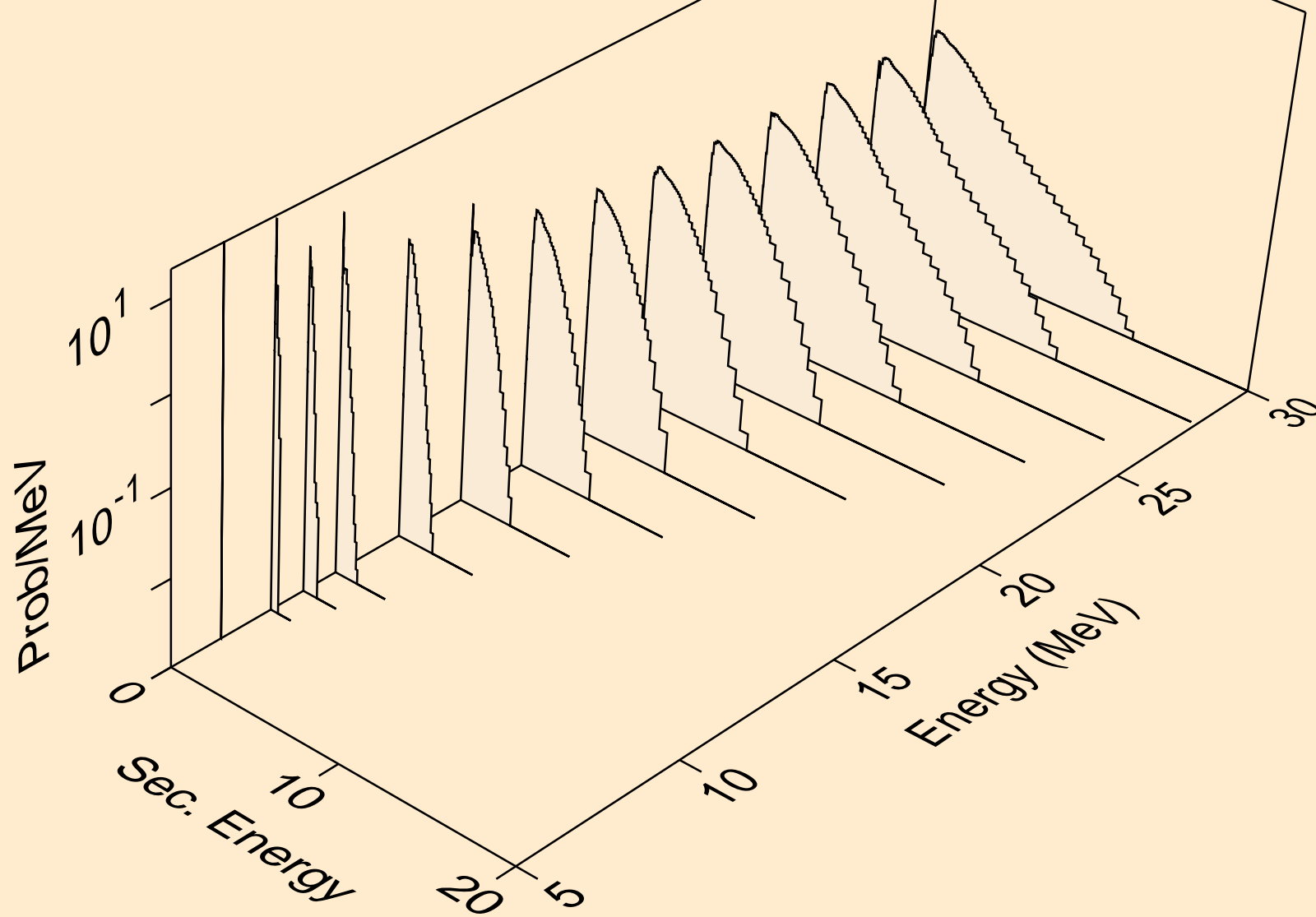

CL043 HELION ACER TENDL-2021 LIBRARY; T=0.K  
neutrons from (s,n\*)p

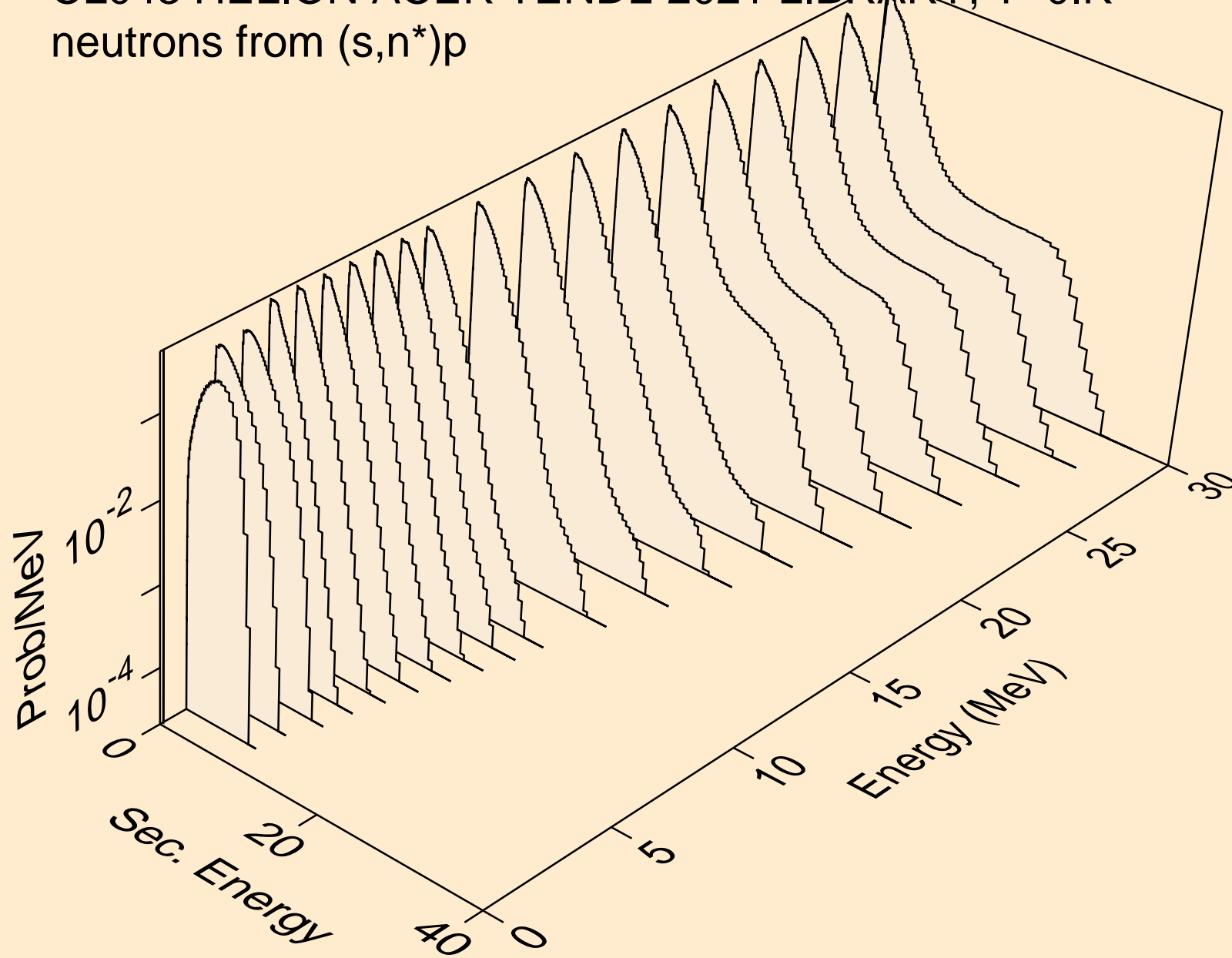

CL043 HELION ACER TENDL-2021 LIBRARY; T=0.K  
neutrons from (s,n\*)2a

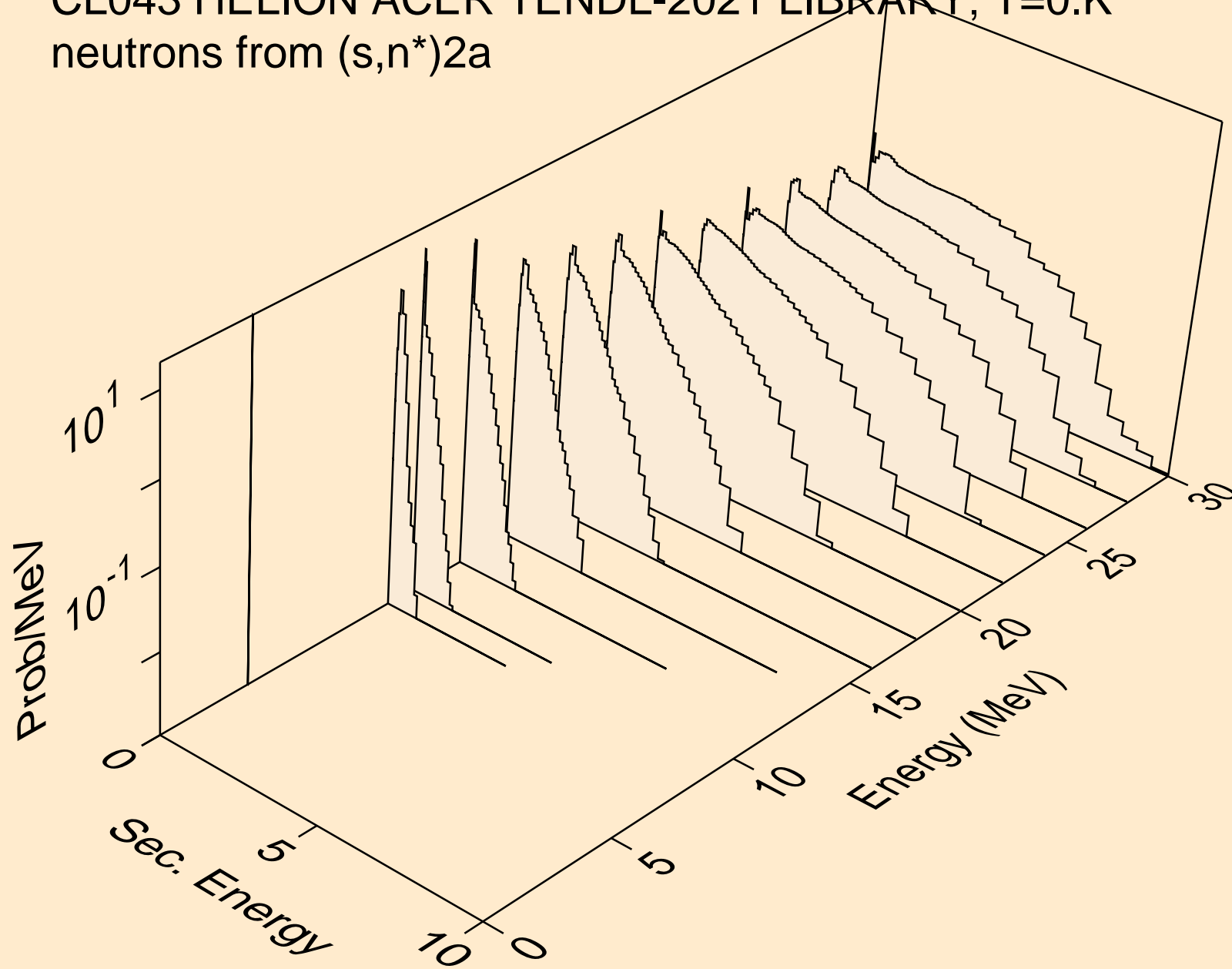

CL043 HELION ACER TENDL-2021 LIBRARY; T=0.K  
neutrons from (s,2n)2a

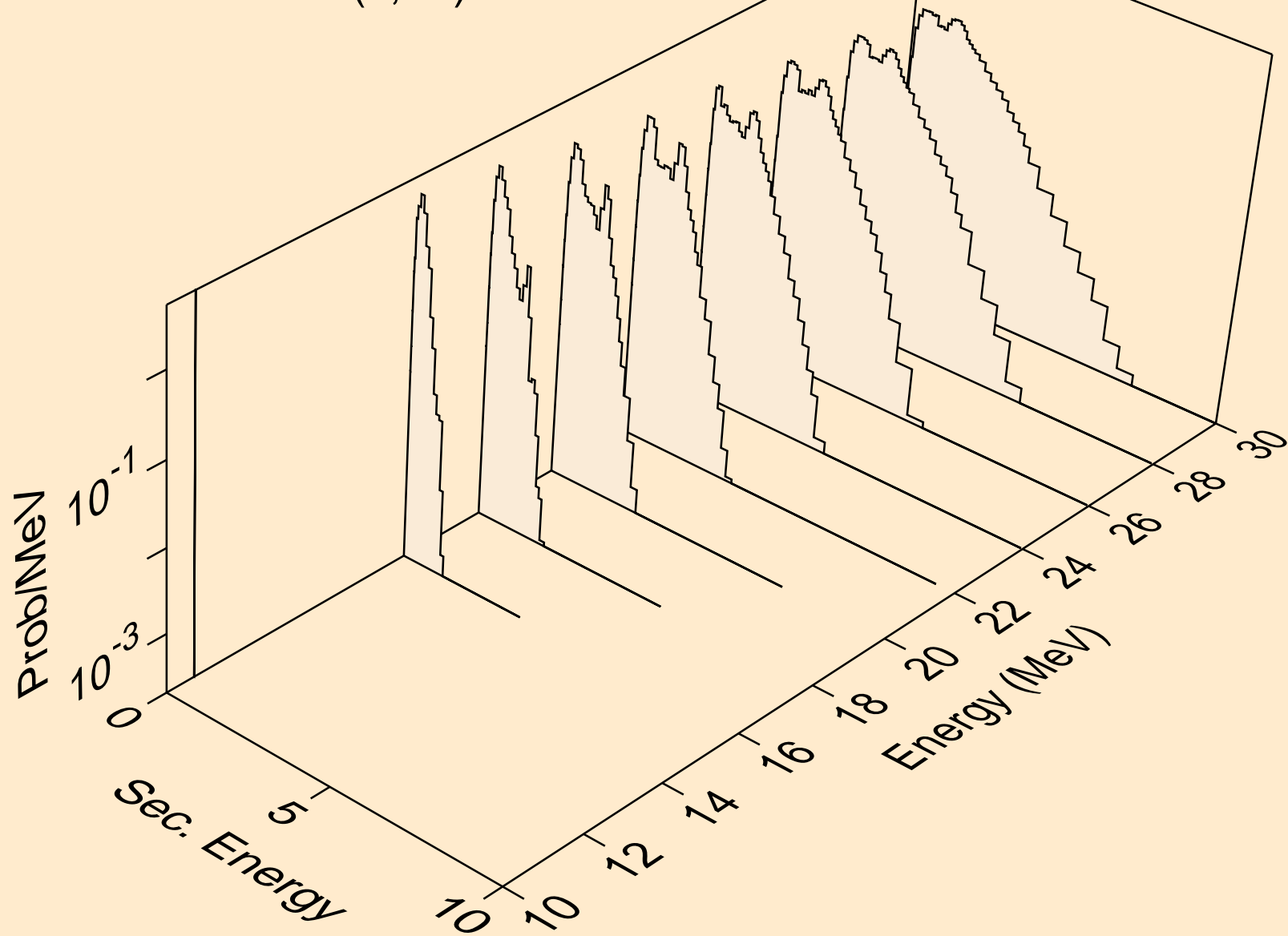

CL043 HELION ACER TENDL-2021 LIBRARY; T=0.K  
neutrons from (s,n\*)d

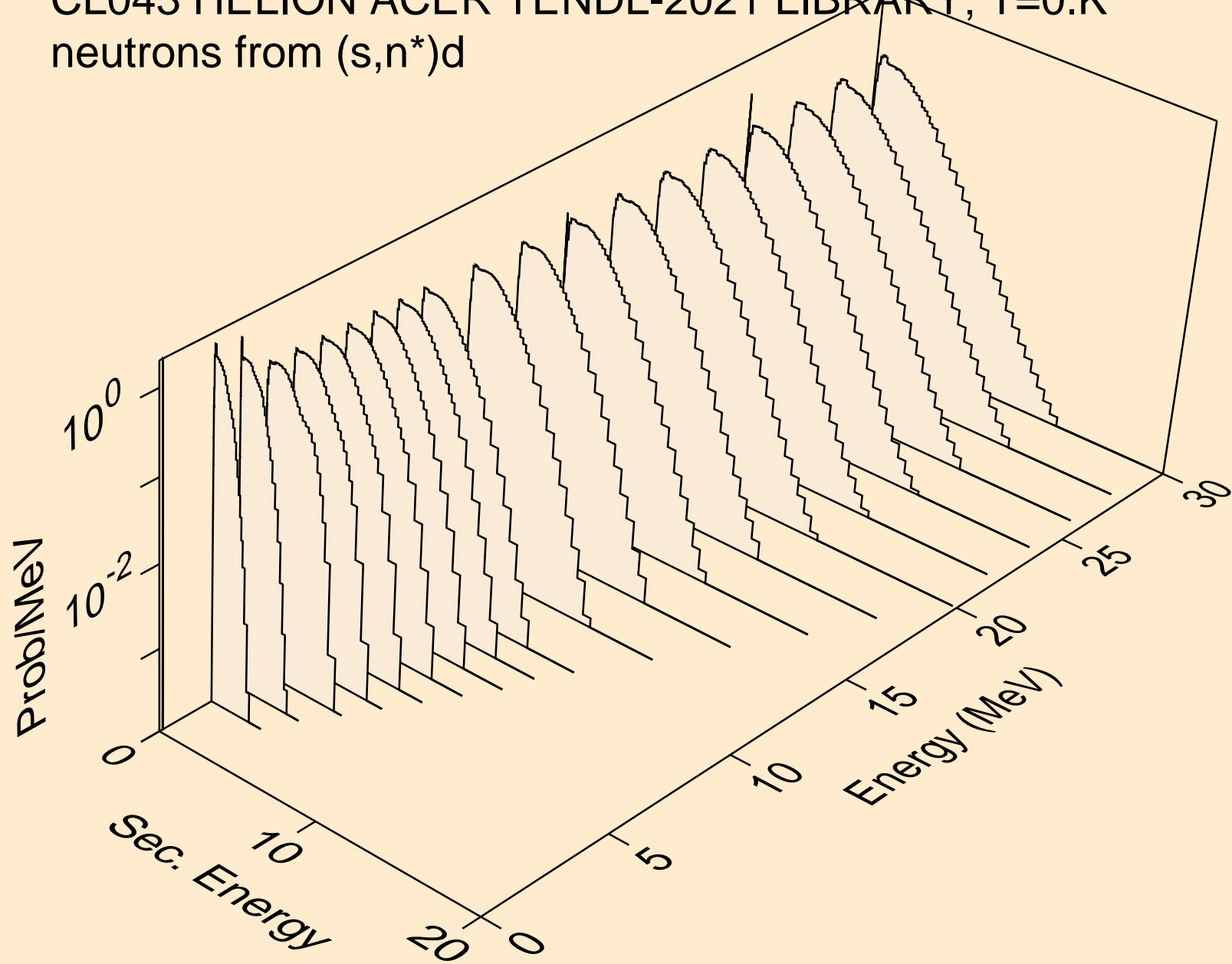

CL043 HELION ACER TENDL-2021 LIBRARY; T=0.K  
neutrons from (s,n\*)t

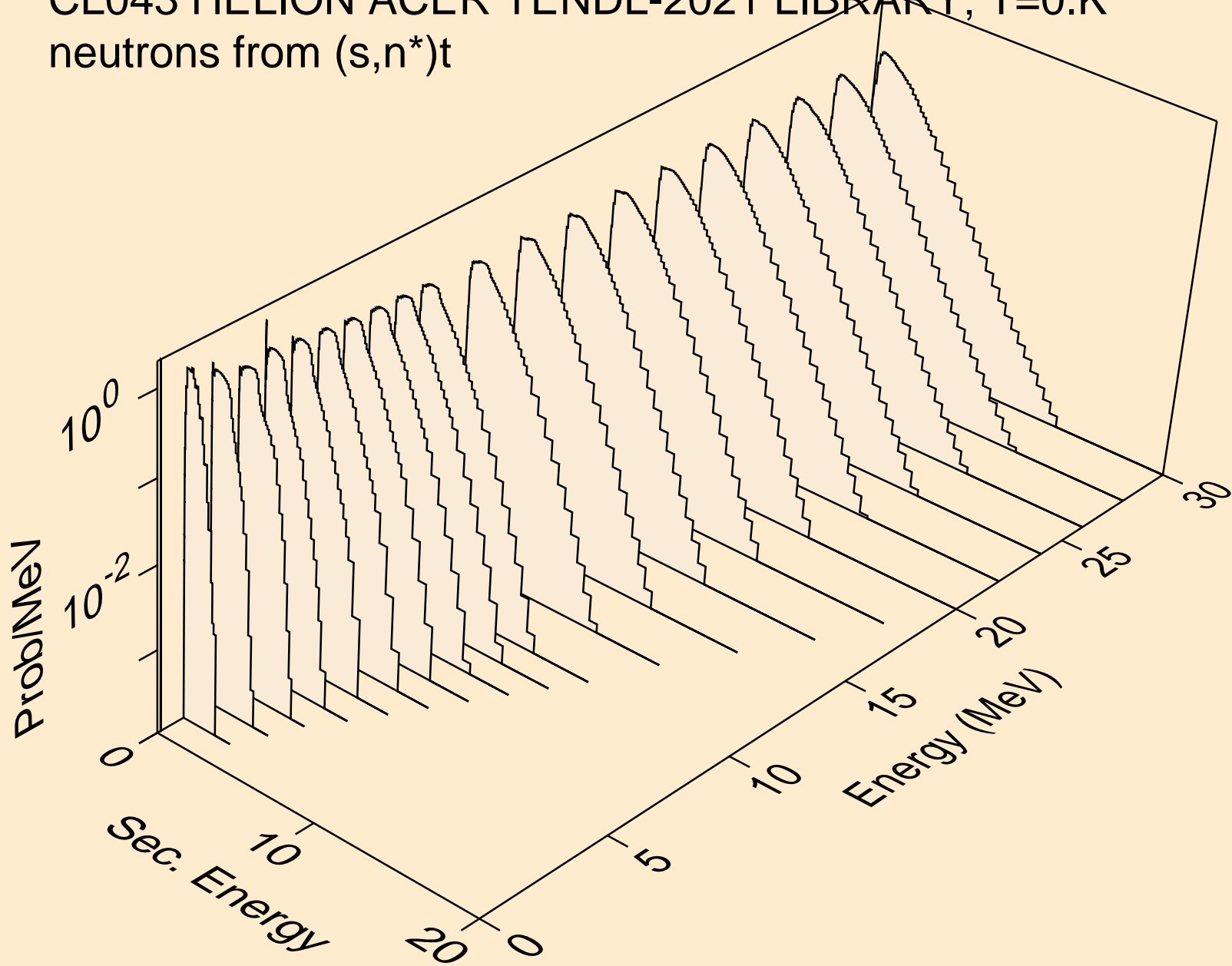



CL043 HELION ACER TENDL-2021 LIBRARY; T=0.K  
neutrons from (s,n\*)he3

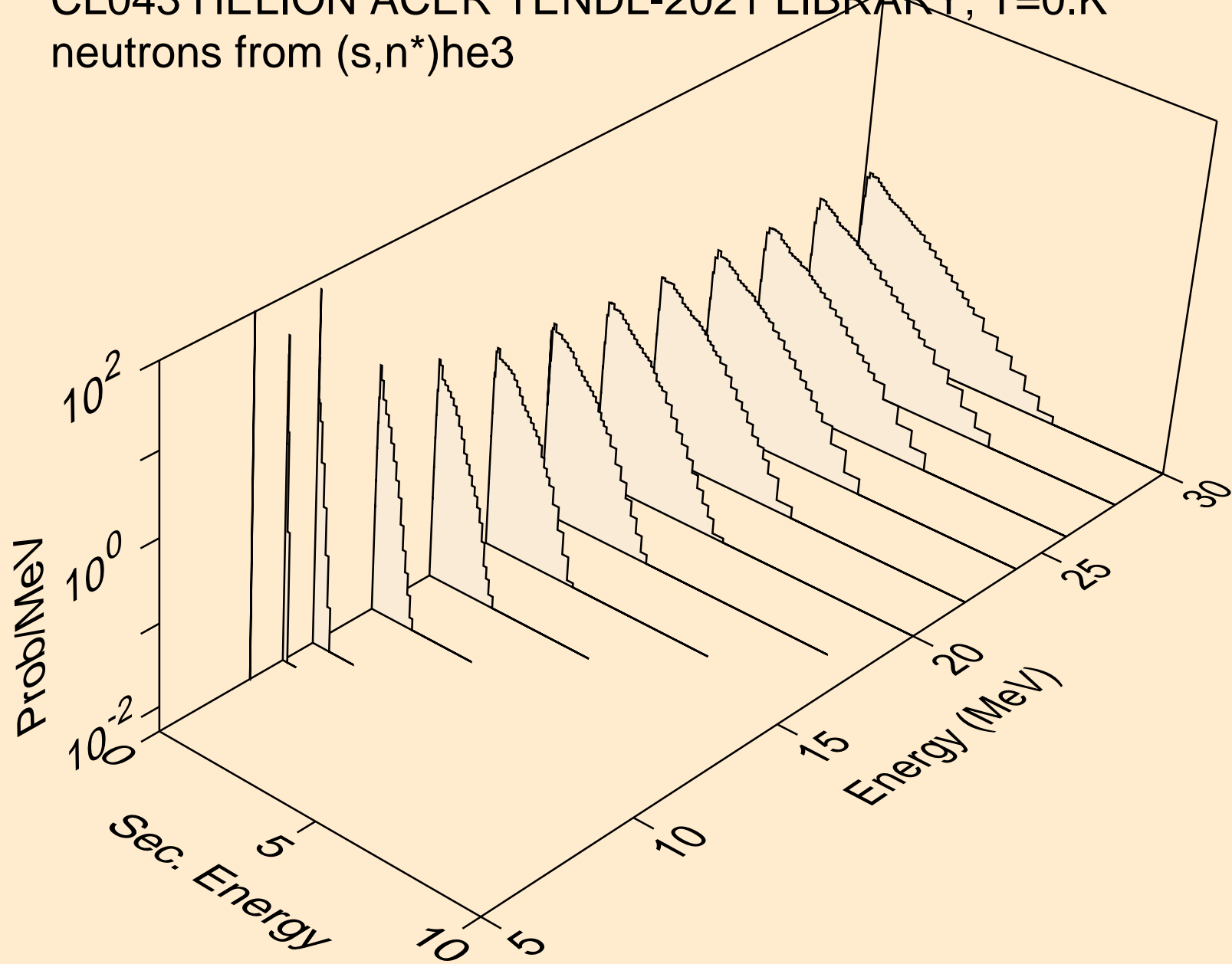

CL043 HELION ACER TENDL-2021 LIBRARY; T=0.K  
neutrons from (s,4n)

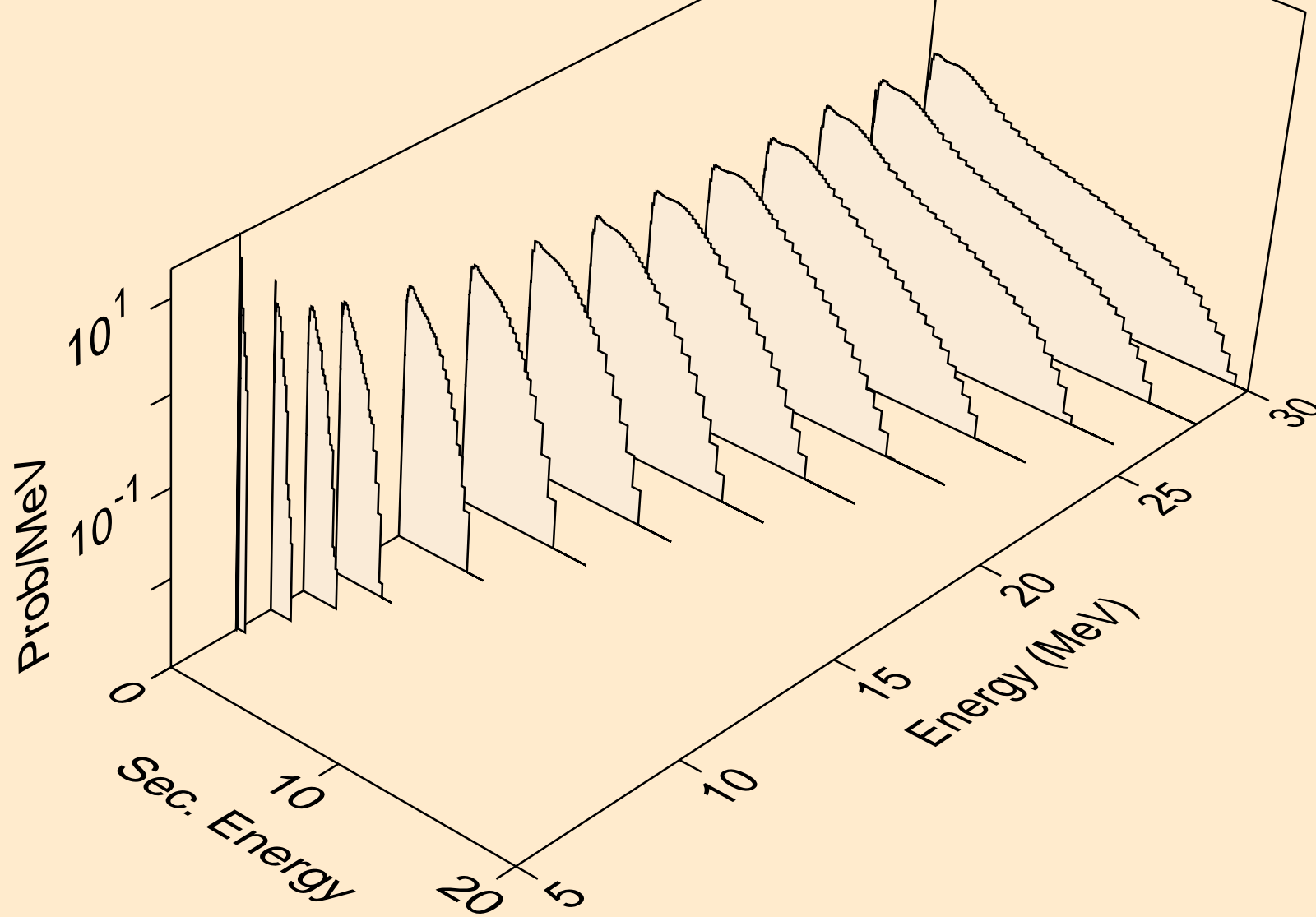

CL043 HELION ACER TENDL-2021 LIBRARY; T=0.K  
neutrons from (s,2np)

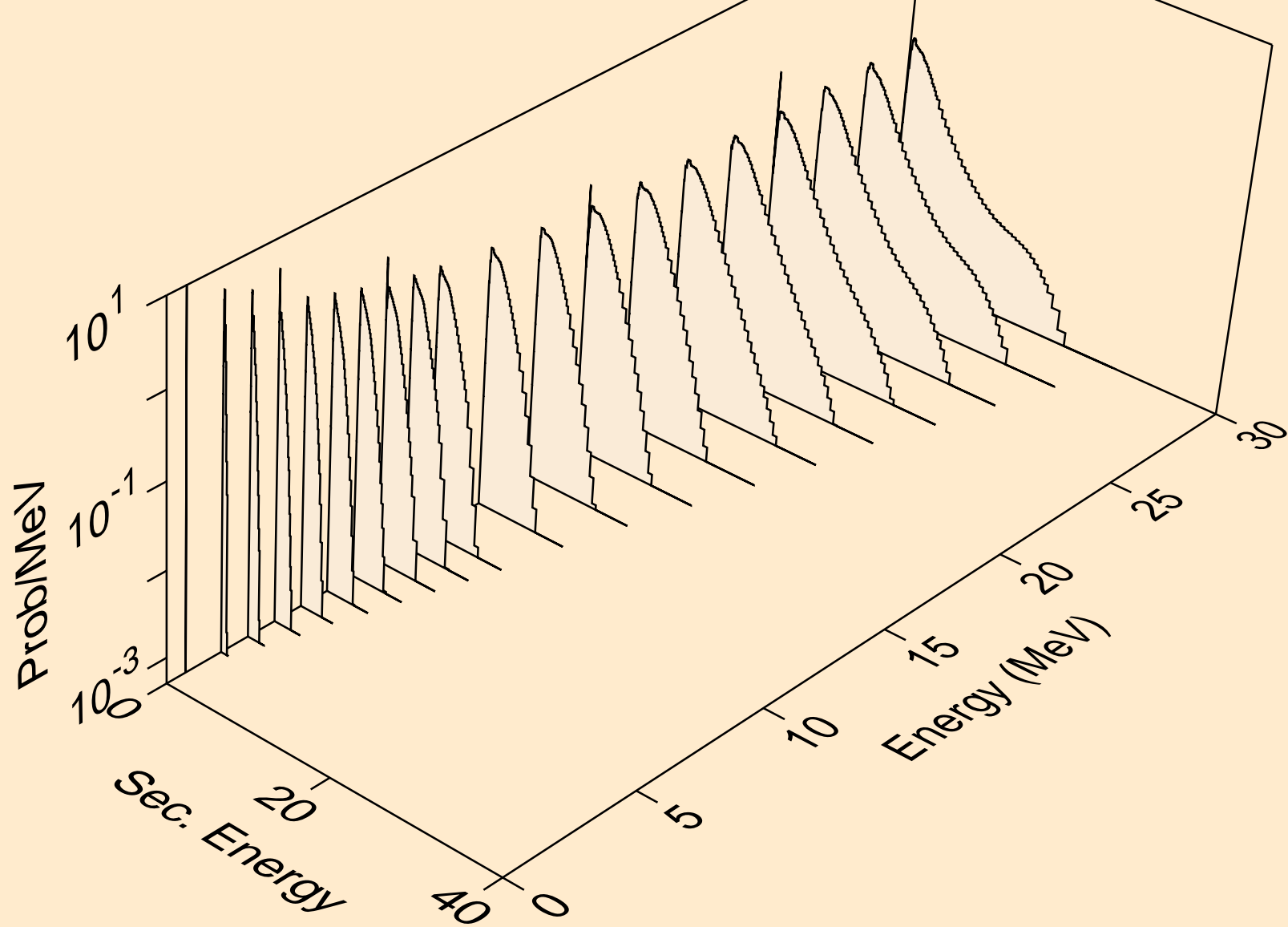

CL043 HELION ACER TENDL-2021 LIBRARY; T=0.K  
neutrons from (s,3np)

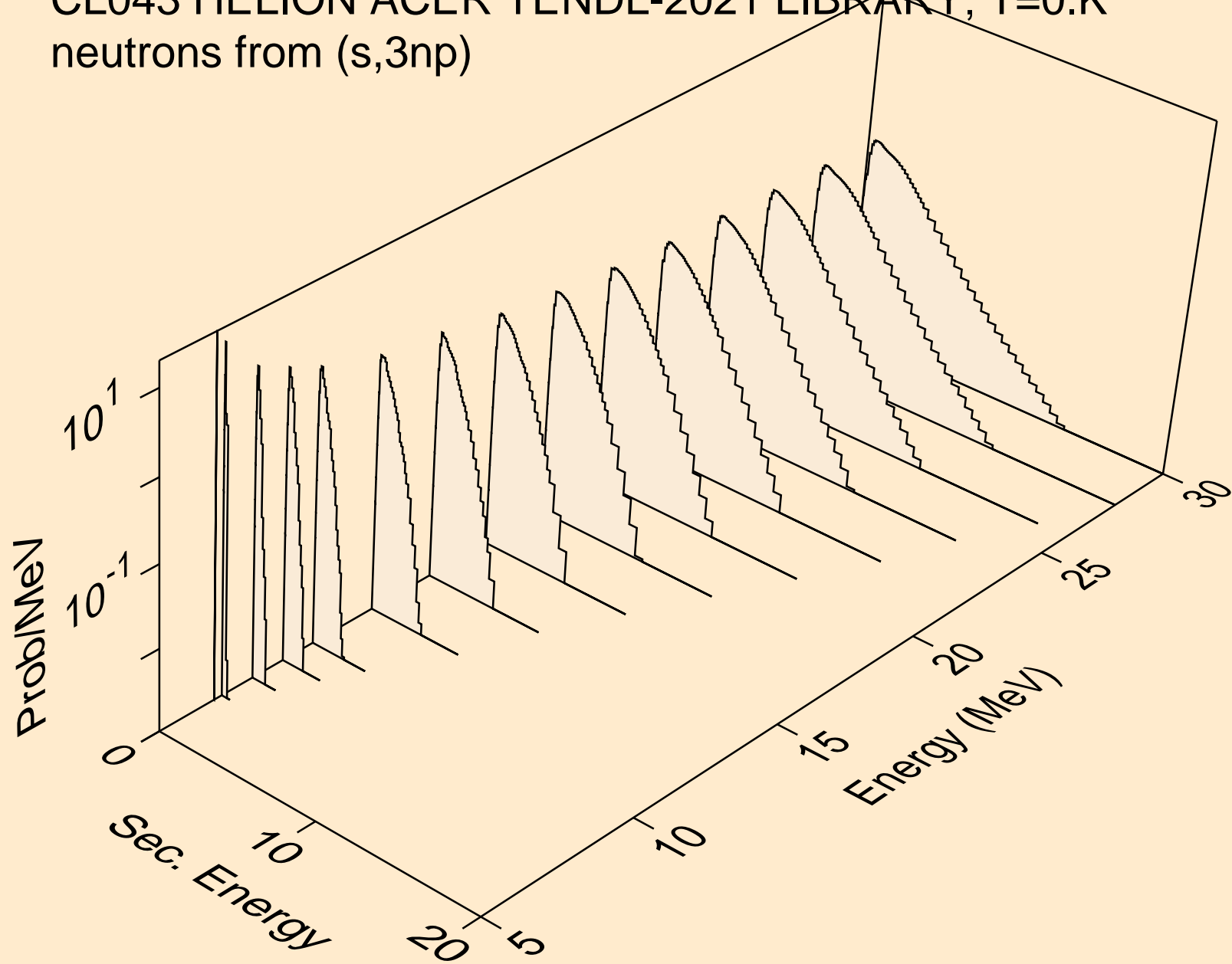

CL043 HELION ACER TENDL-2021 LIBRARY; T=0.K  
neutrons from (s,2np)

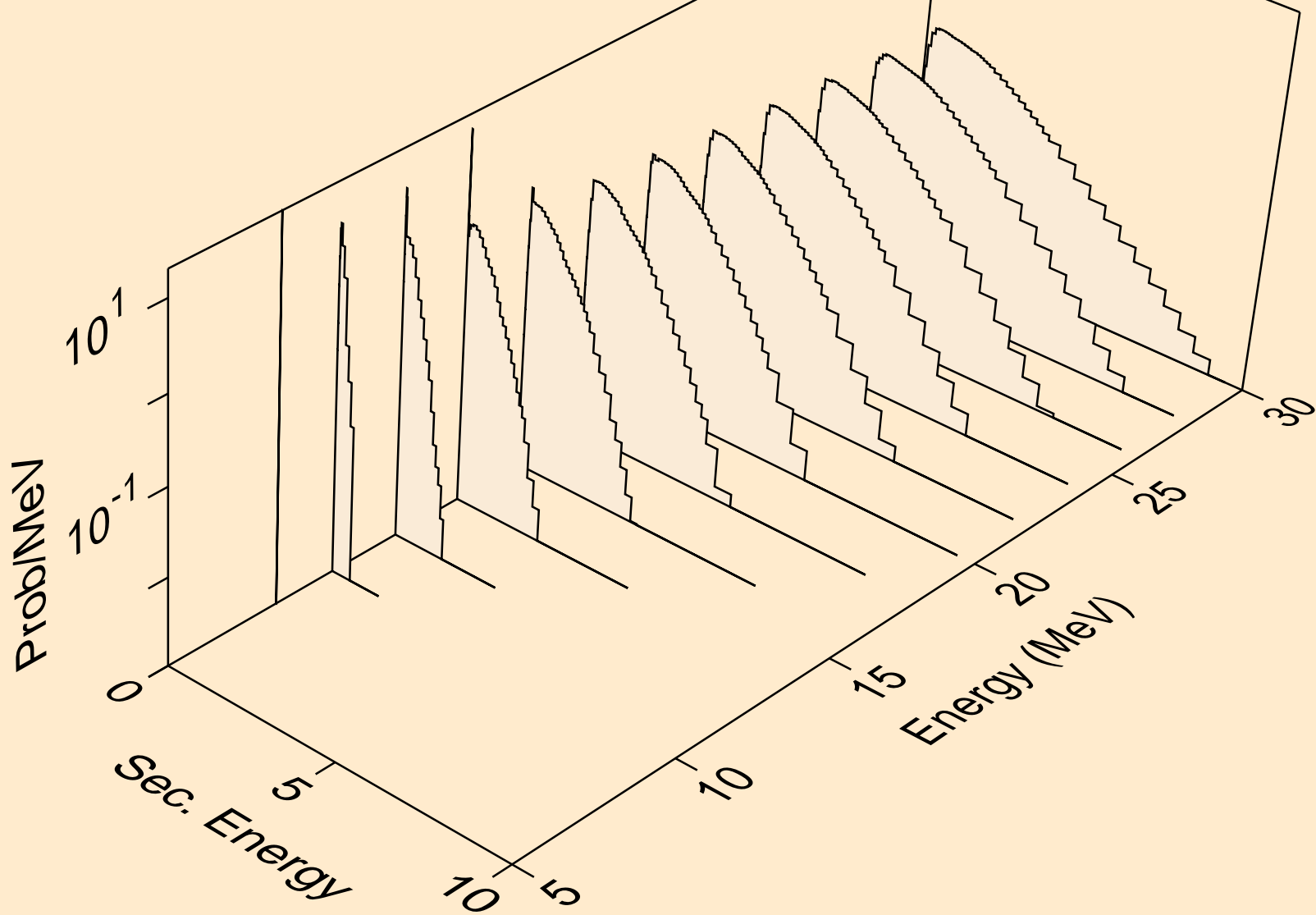

CL043 HELION ACER TENDL-2021 LIBRARY; T=0.K  
neutrons from (s,npa)

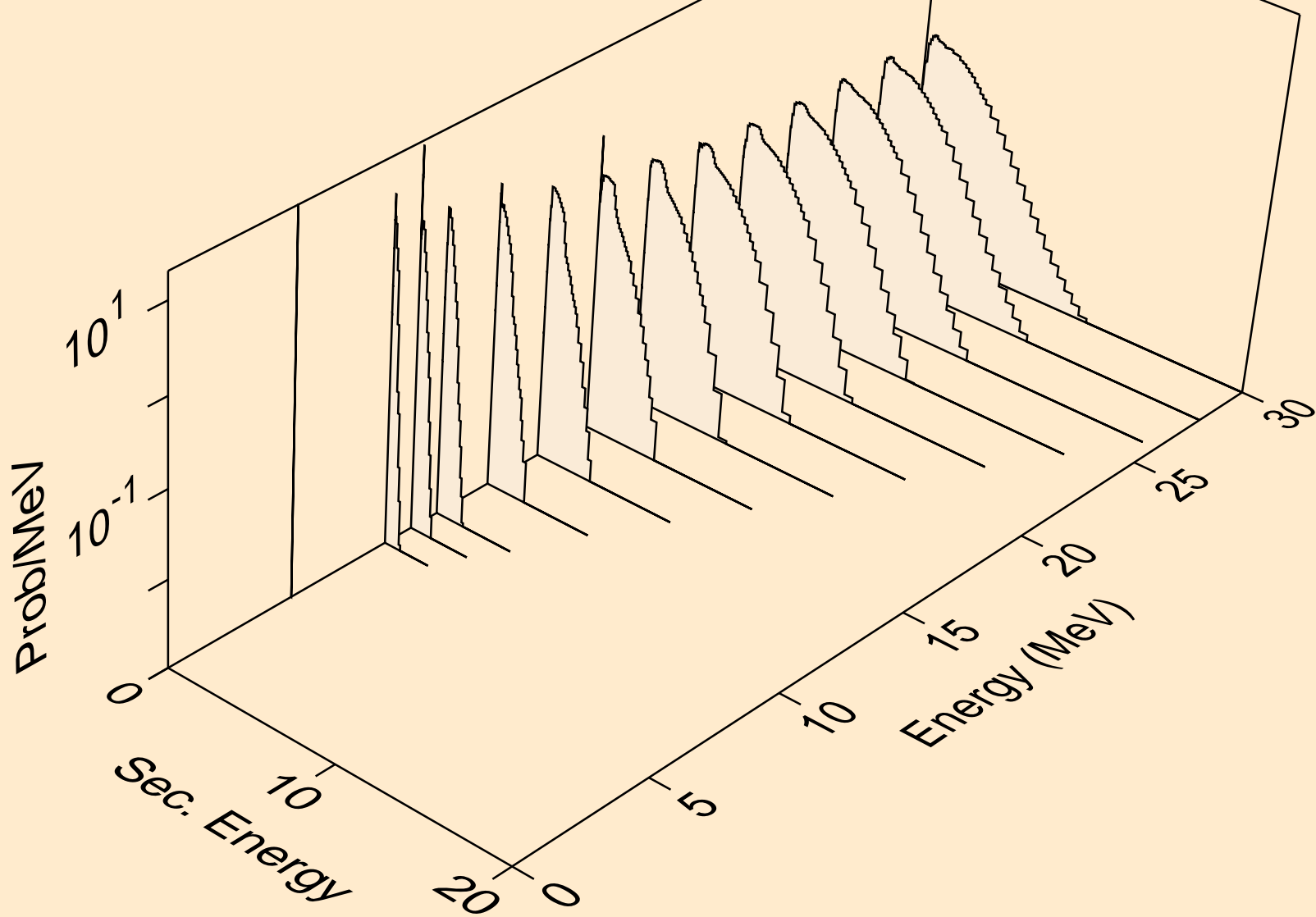

CL043 HELION ACER TENDL-2021 LIBRARY; T=0.K  
protons from (s,x)

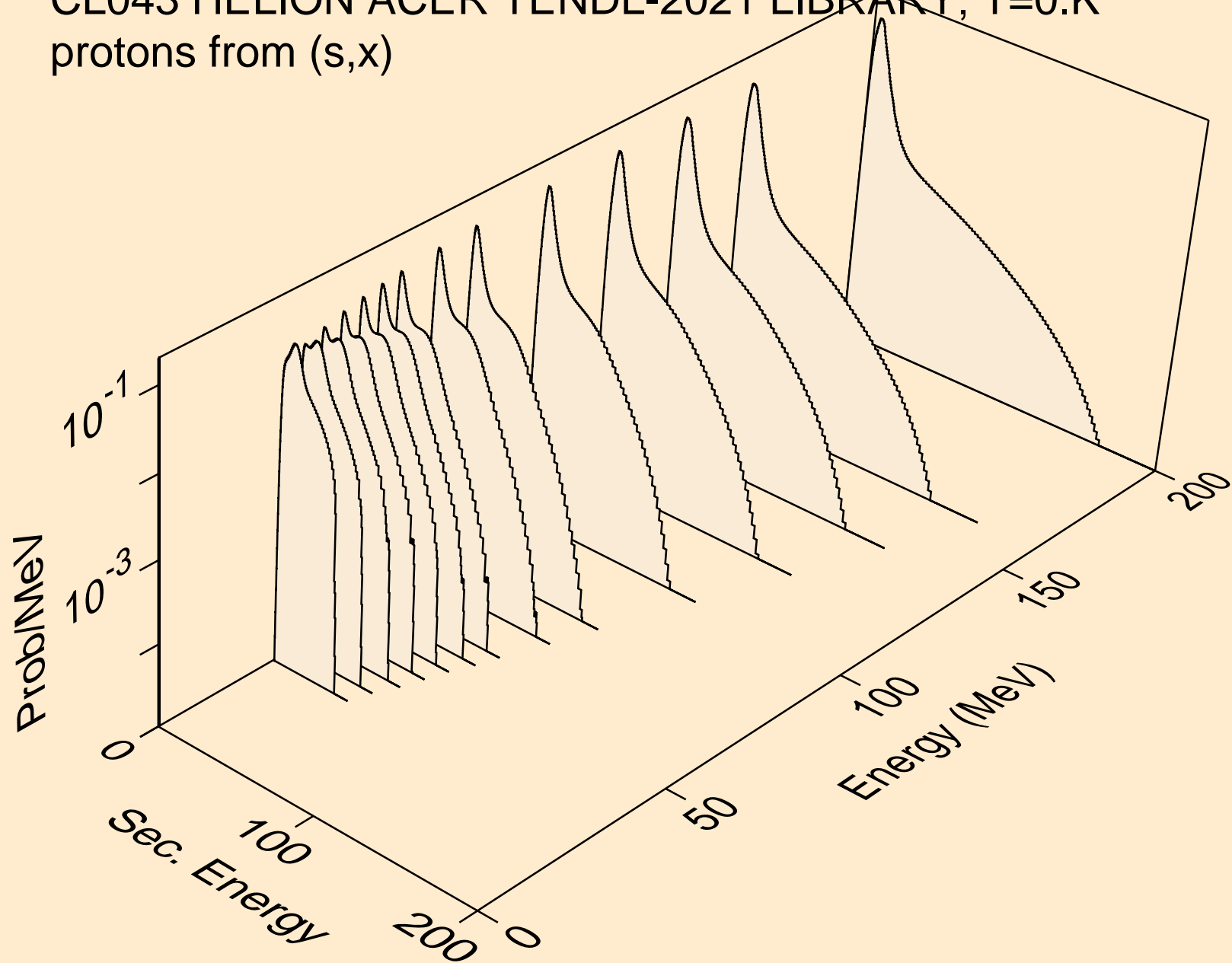

CL043 HELION ACER TENDL-2021 LIBRARY; T=0.K  
protons from (s,n\*)p

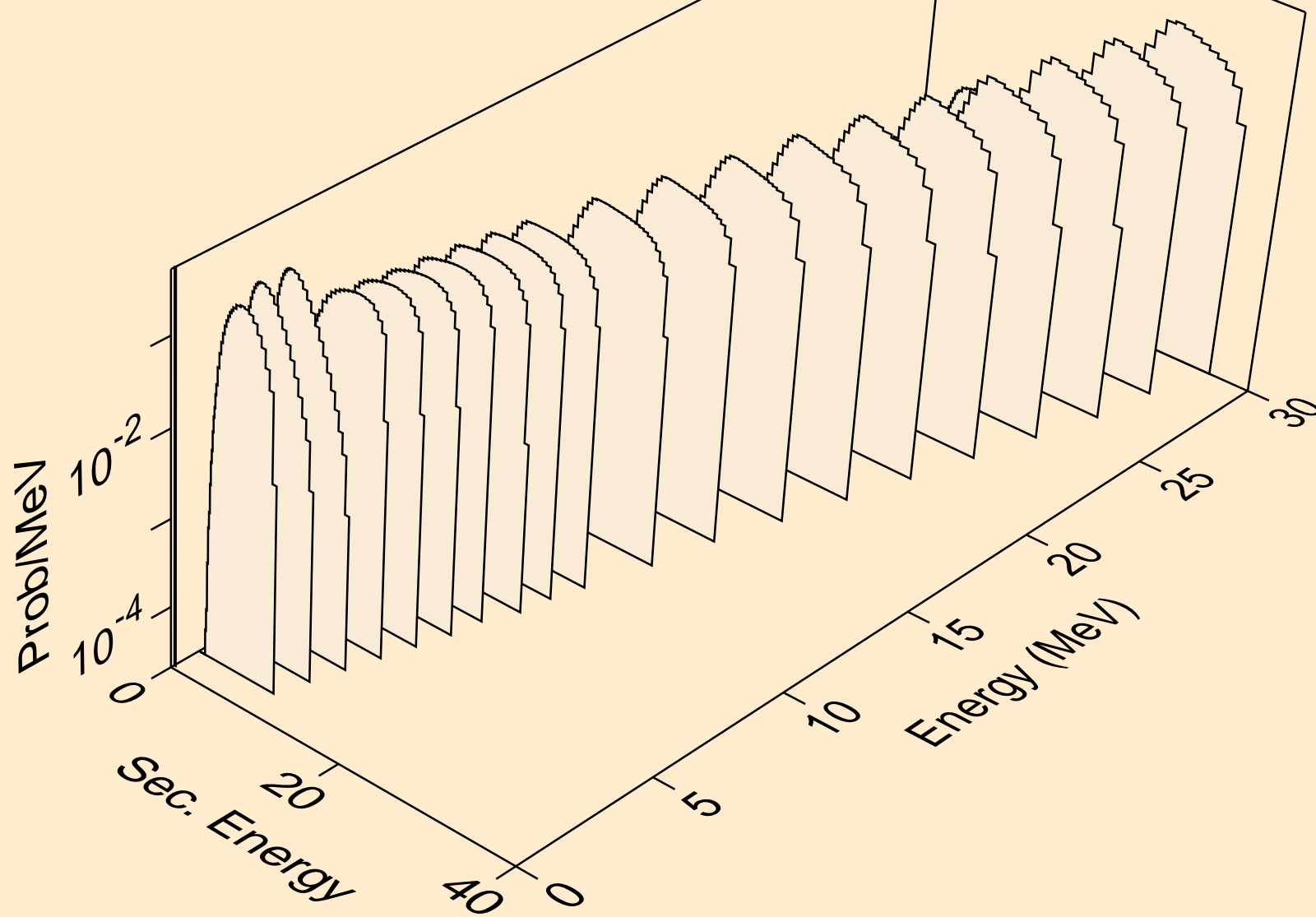



CL043 HELION ACER TENDL-2021 LIBRARY; T=0.K  
protons from (s,2np)

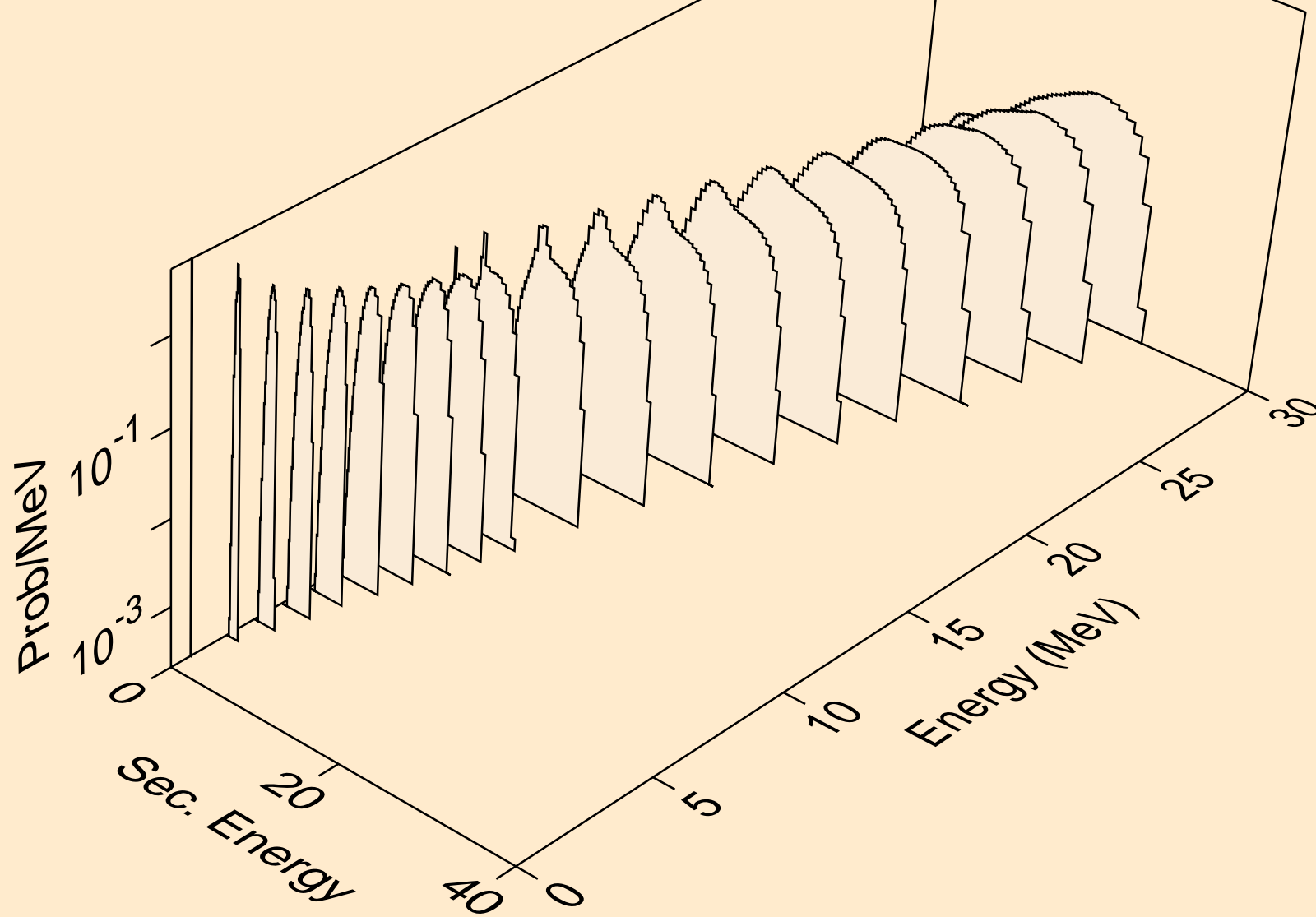

CL043 HELION ACER TENDL-2021 LIBRARY; T=0.K  
protons from (s,3np)

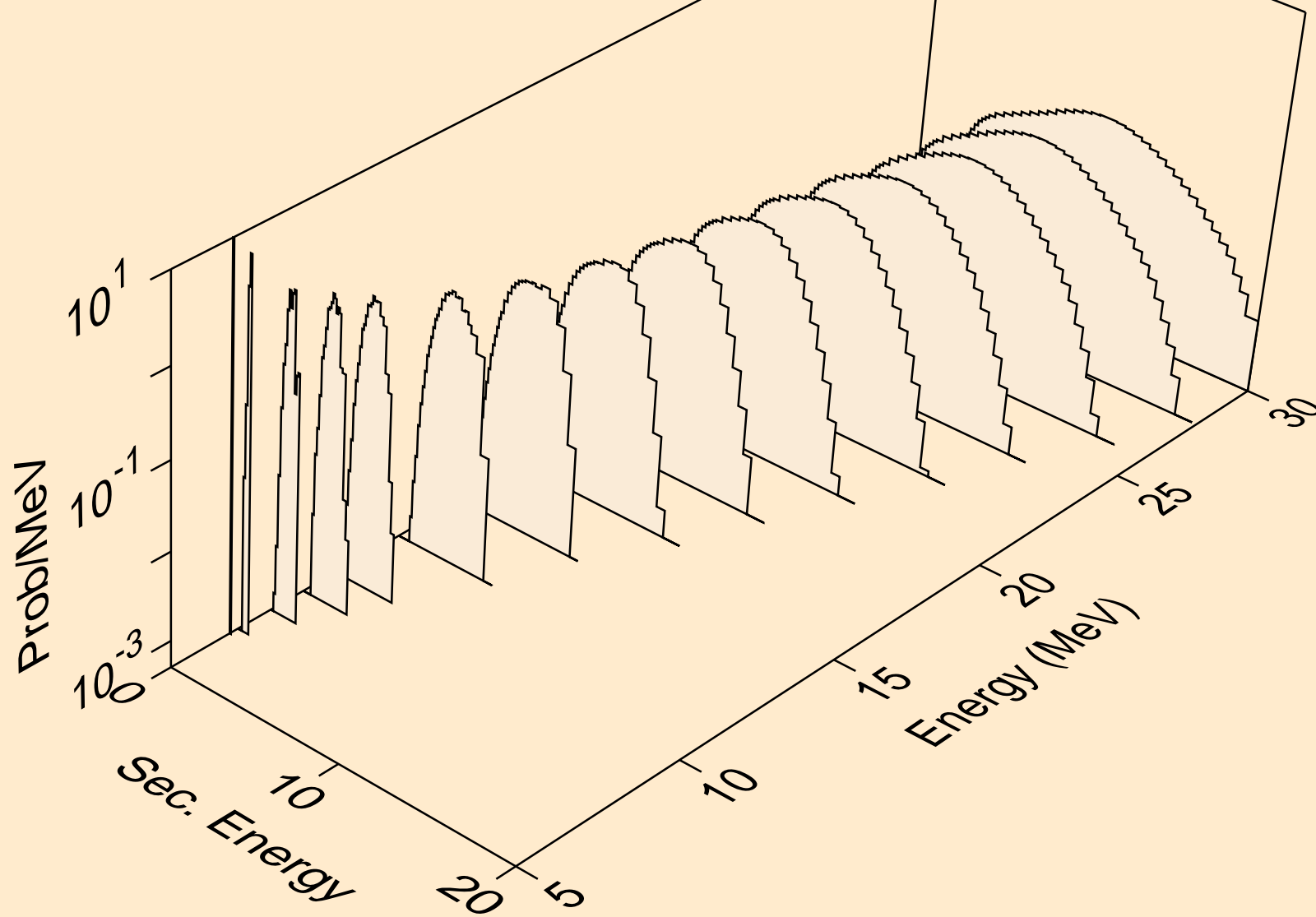

CL043 HELION ACER TENDL-2021 LIBRARY; T=0.K  
protons from (s,2np)

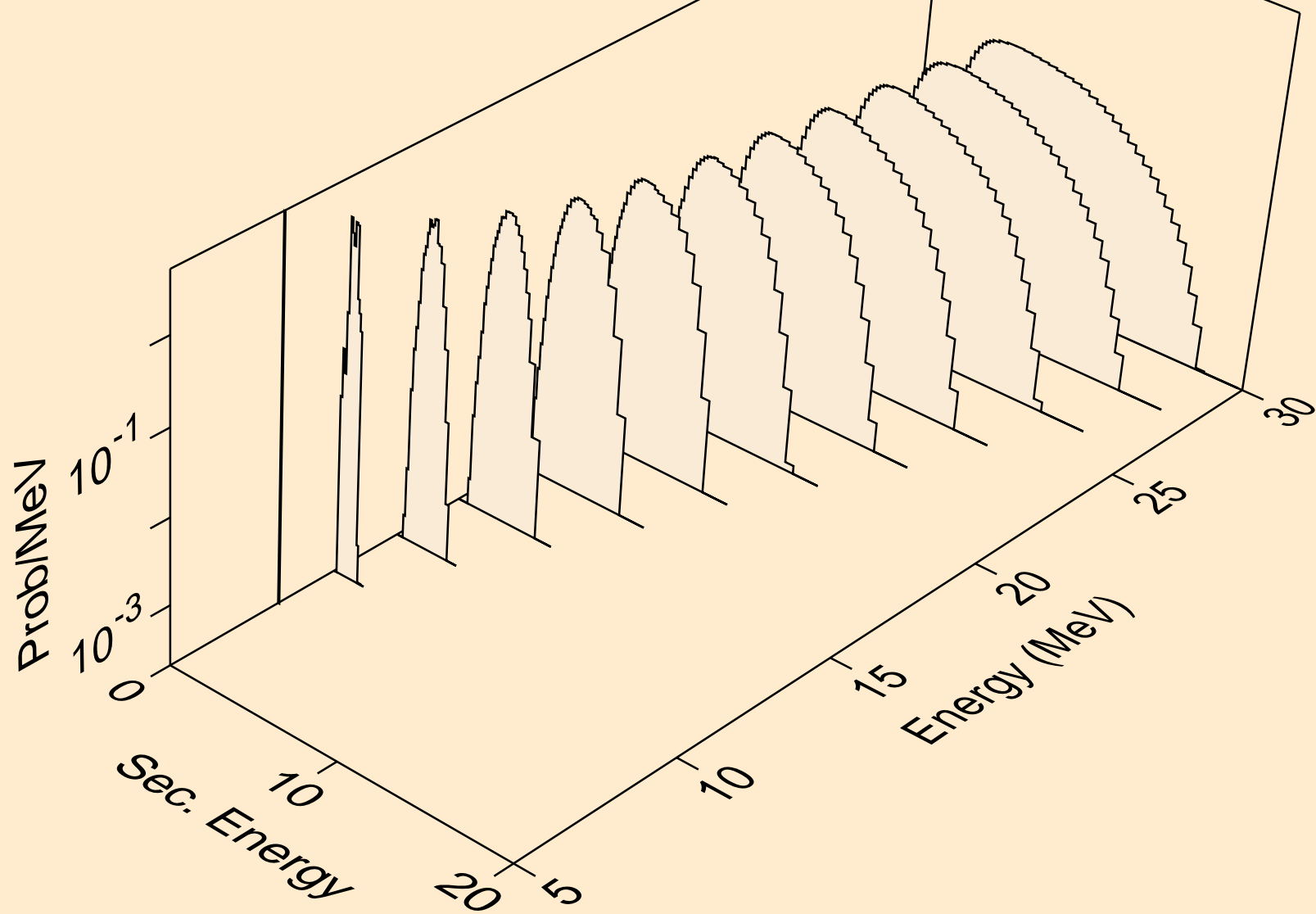

CL043 HELION ACER TENDL-2021 LIBRARY; T=0.K  
protons from (s,npa)

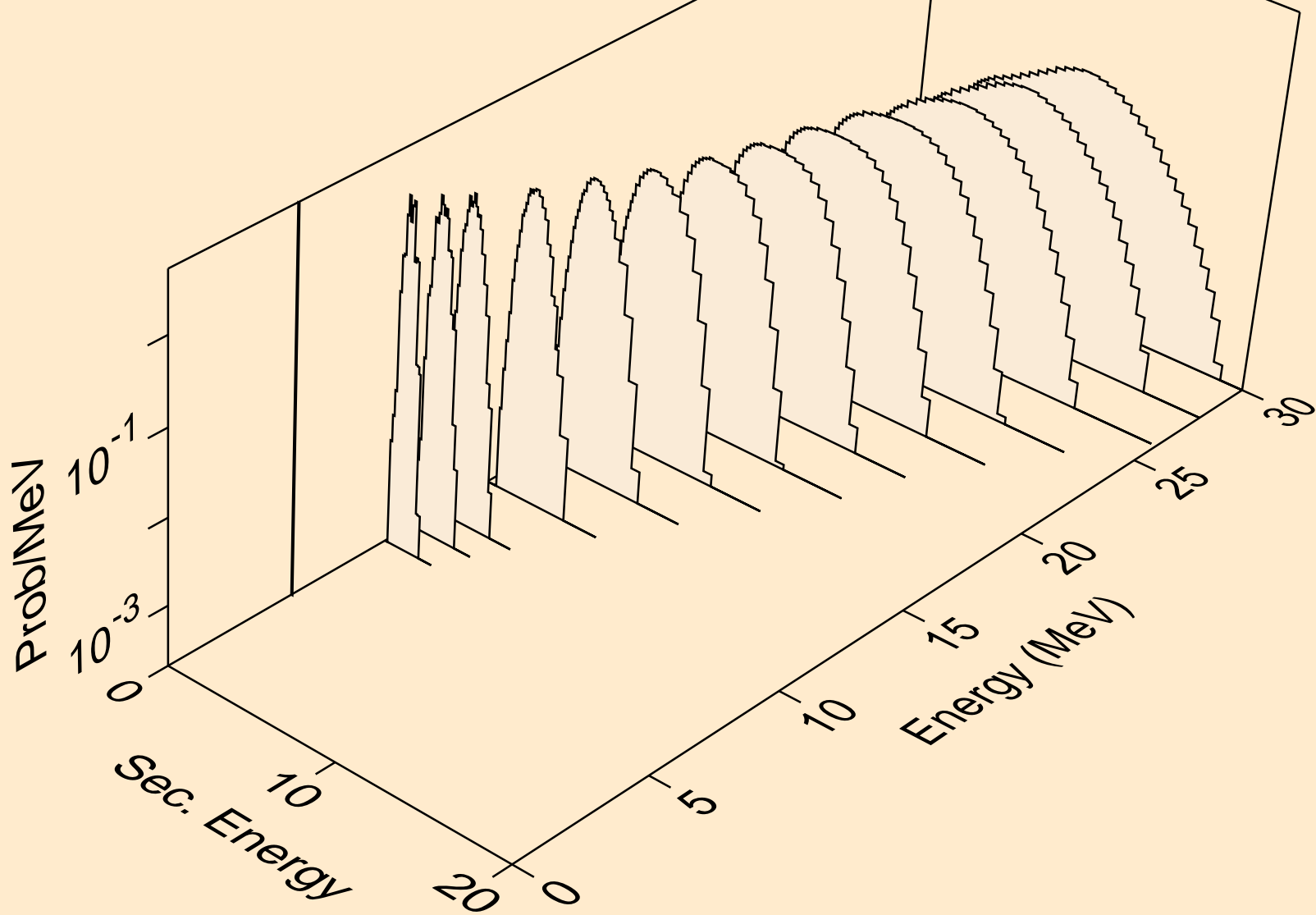

CL043 HELION ACER TENDL-2021 LIBRARY; T=0.K  
protons from (s,p)

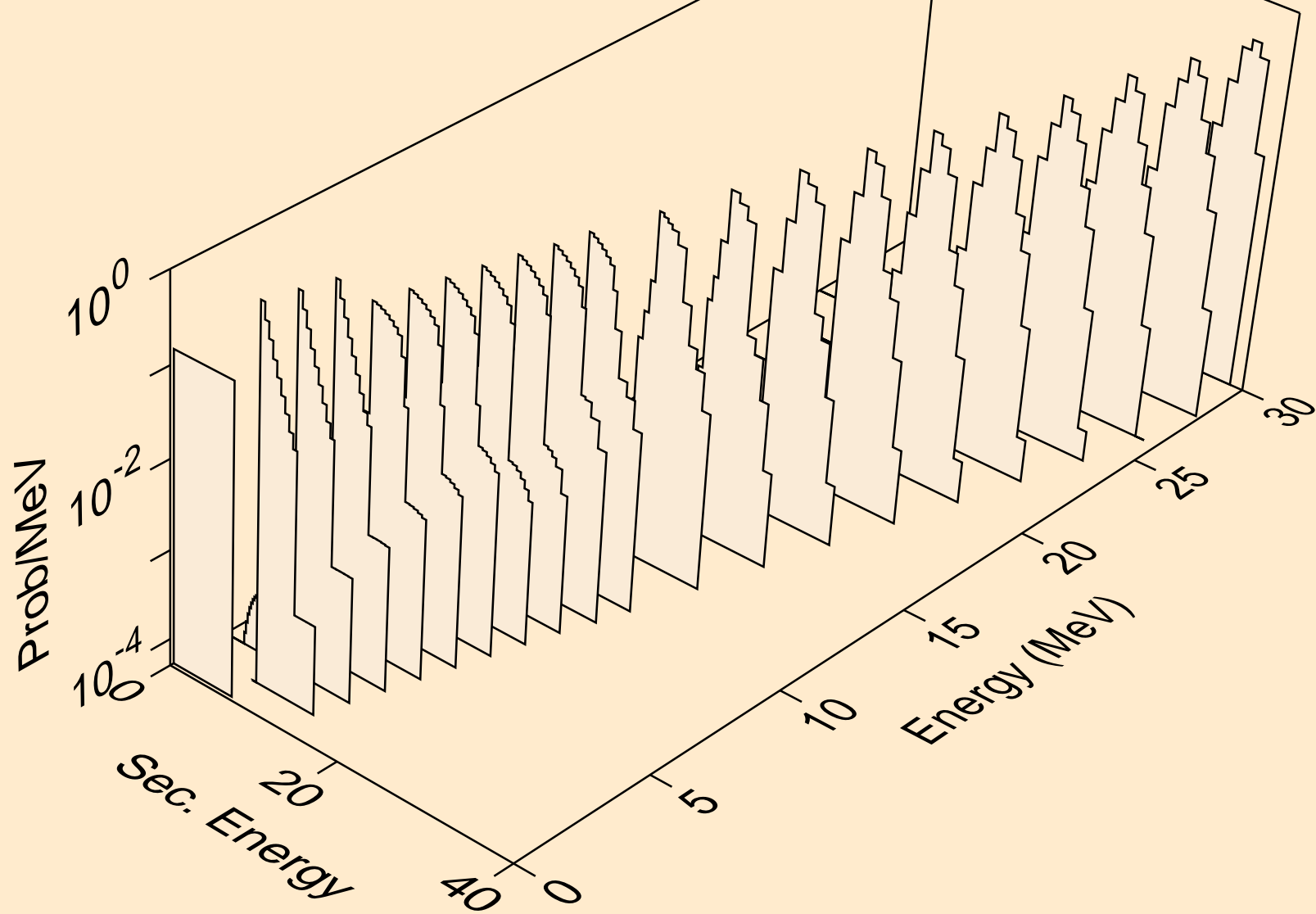

CL043 HELION ACER TENDL-2021 LIBRARY; T=0.K  
protons from (s,2p)

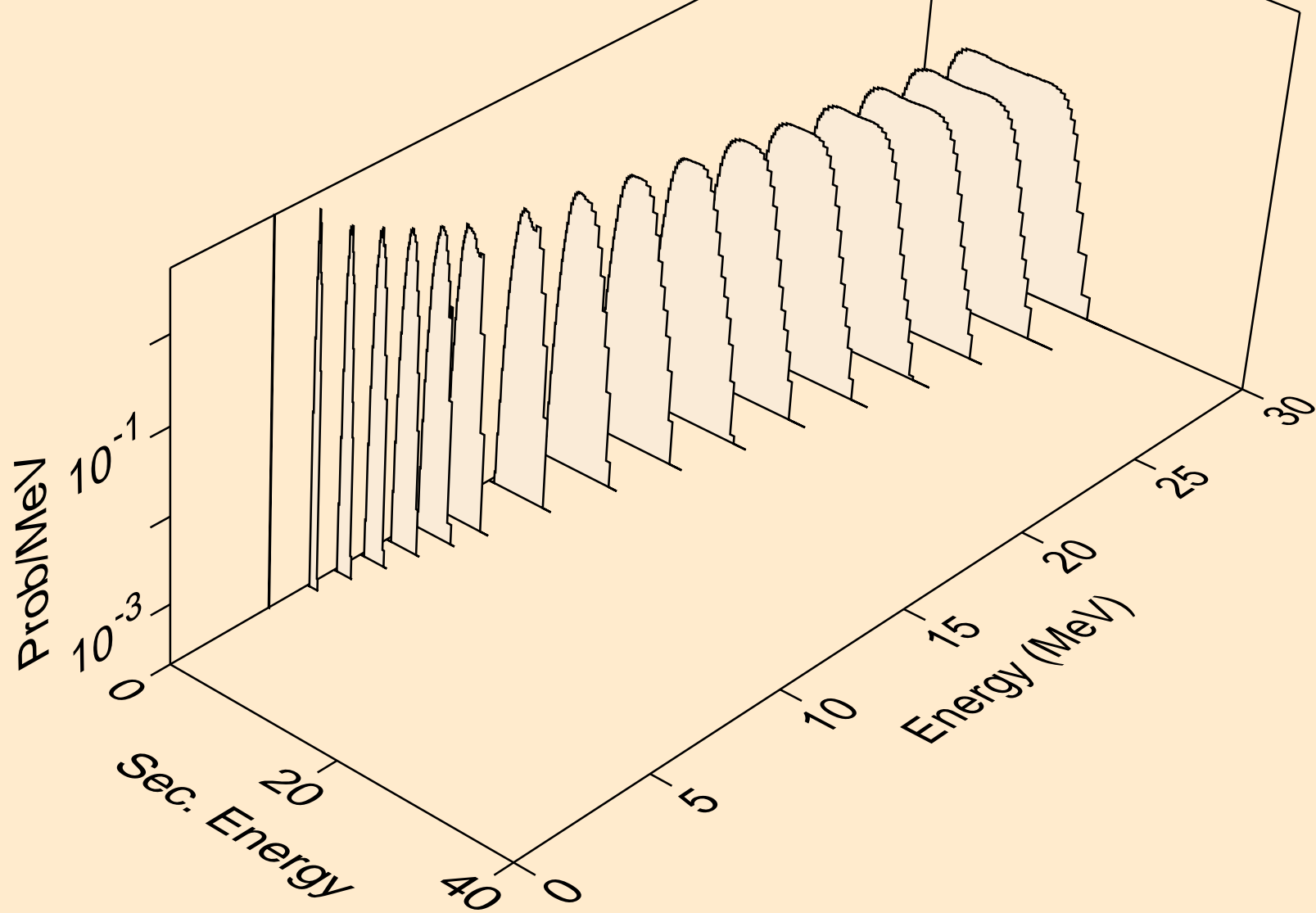

CL043 HELION ACER TENDL-2021 LIBRARY; T=0.K  
protons from (s,pa)

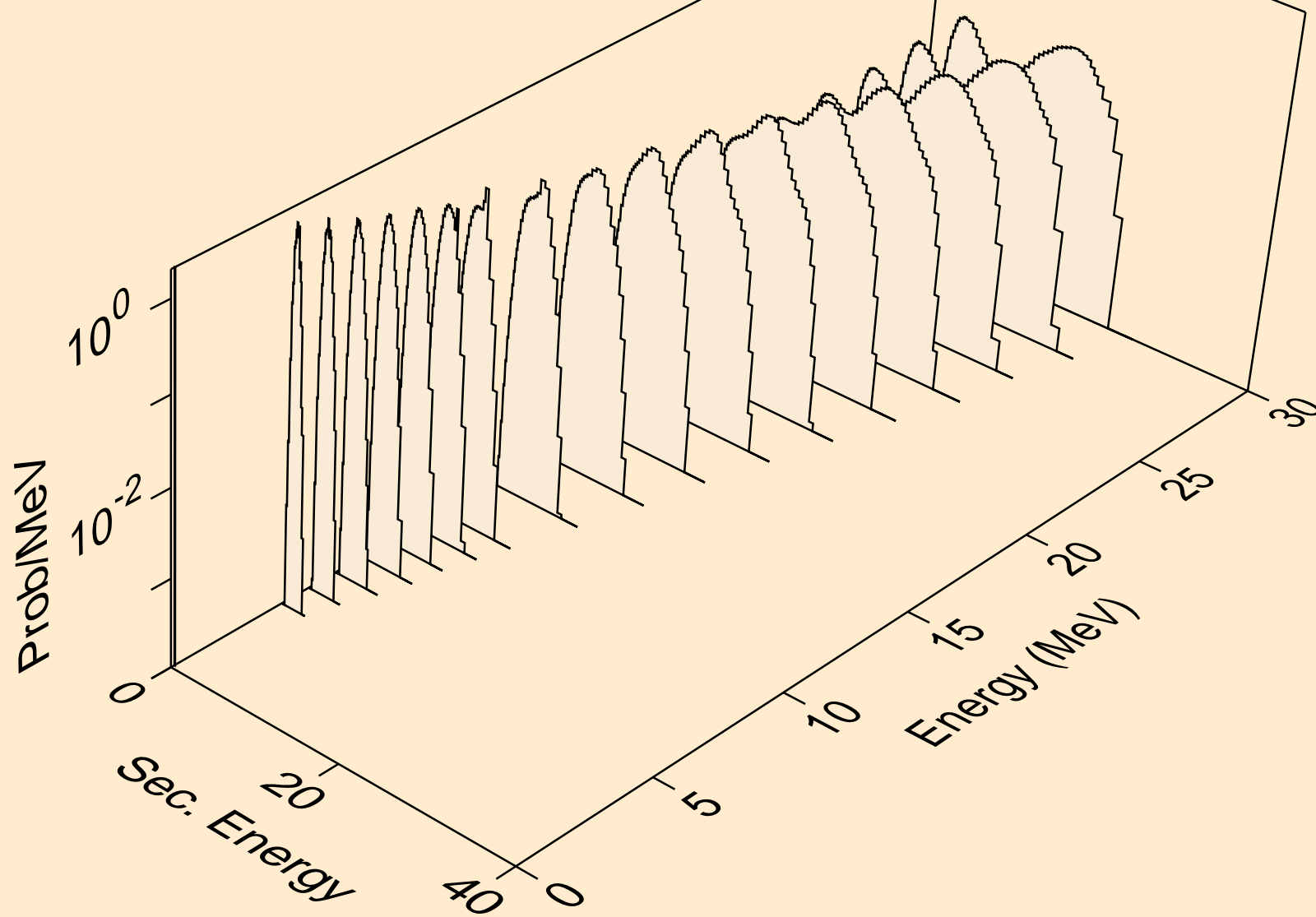

CL043 HELION ACER TENDL-2021 LIBRARY; T=0.K  
protons from (s,pd)

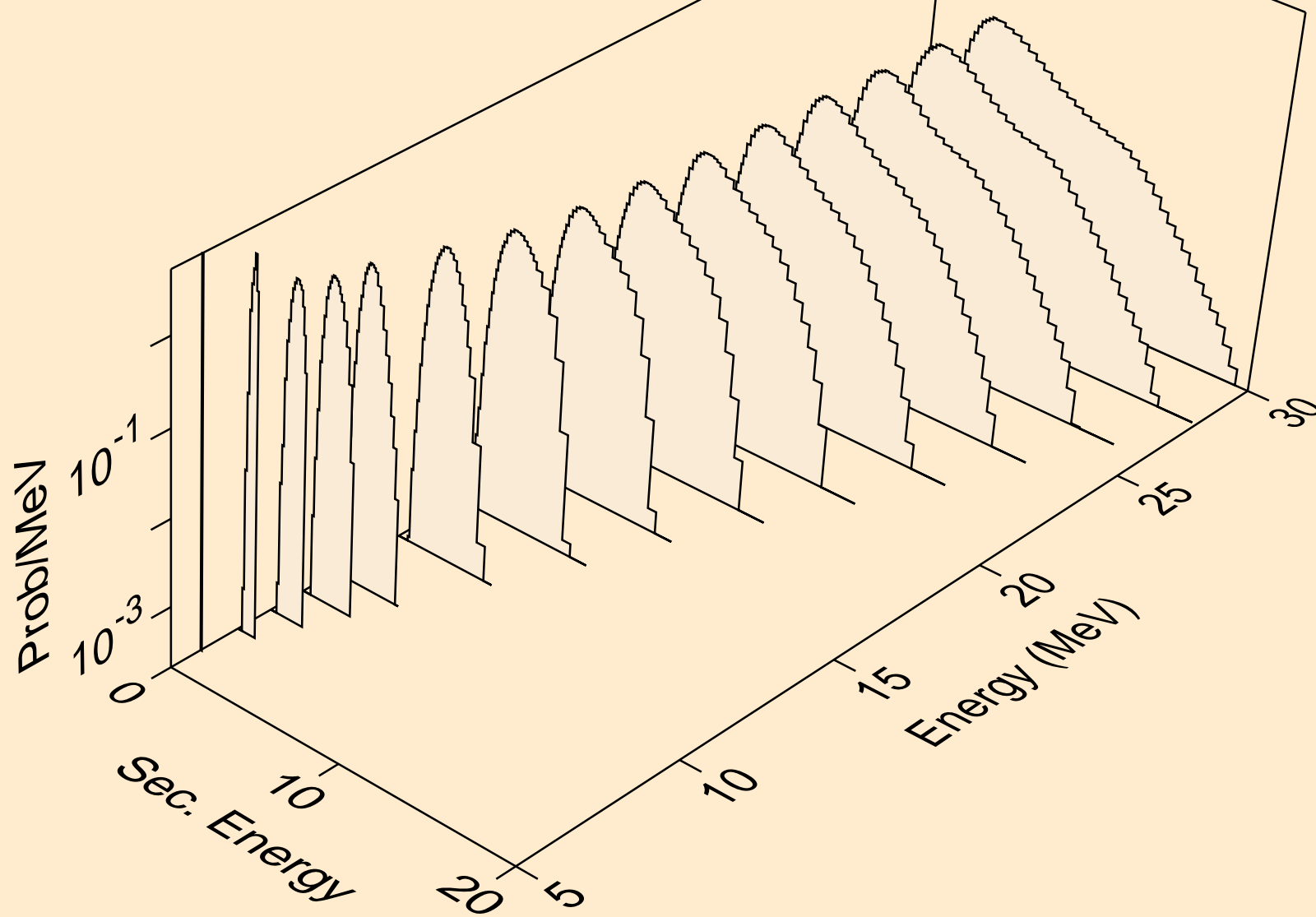



CL043 HELION ACER TENDL-2021 LIBRARY; T=0.K  
protons from (s,pt)

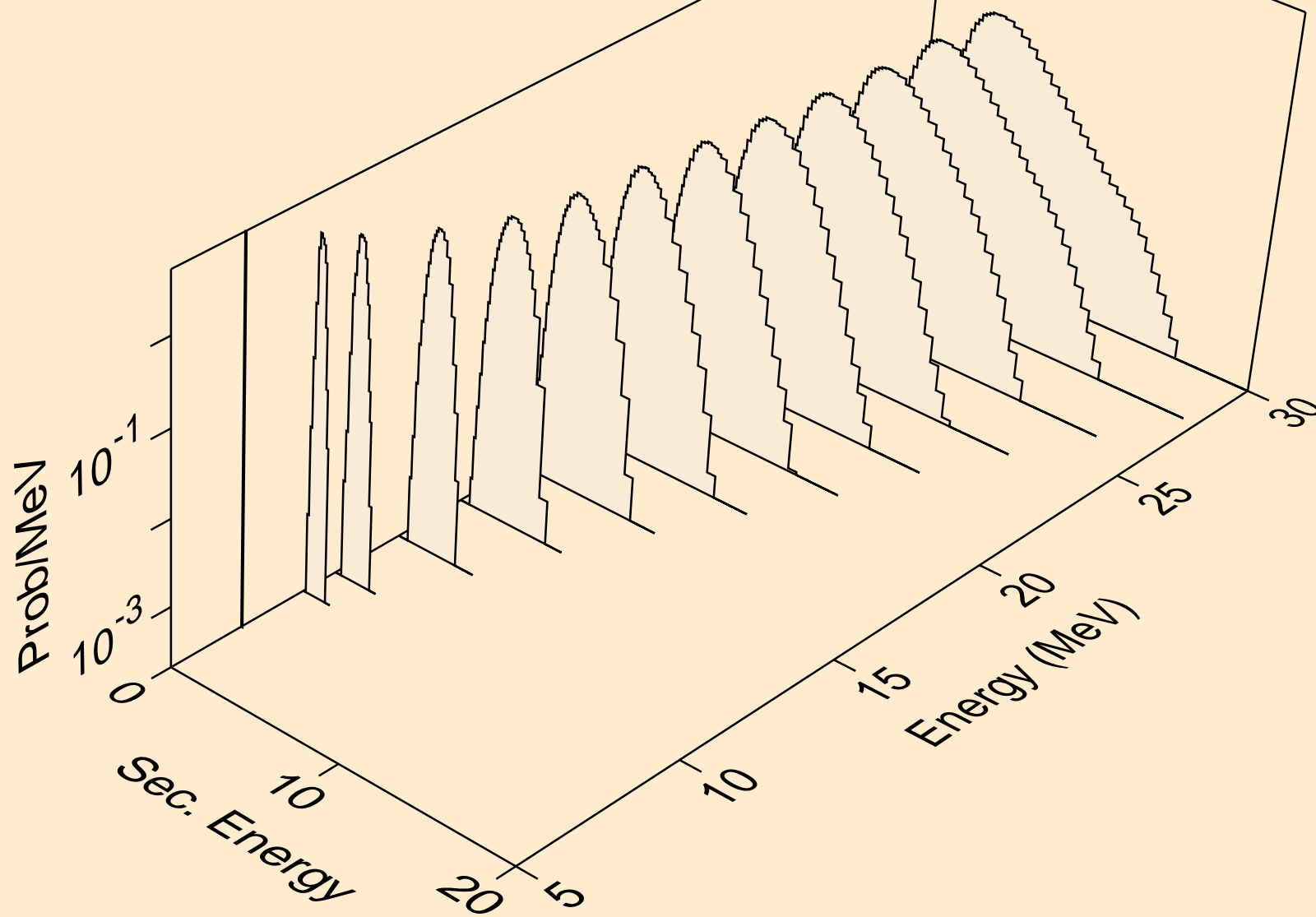

CL043 HELION ACER TENDL-2021 LIBRARY; T=0.K  
deuterons from (s,x)

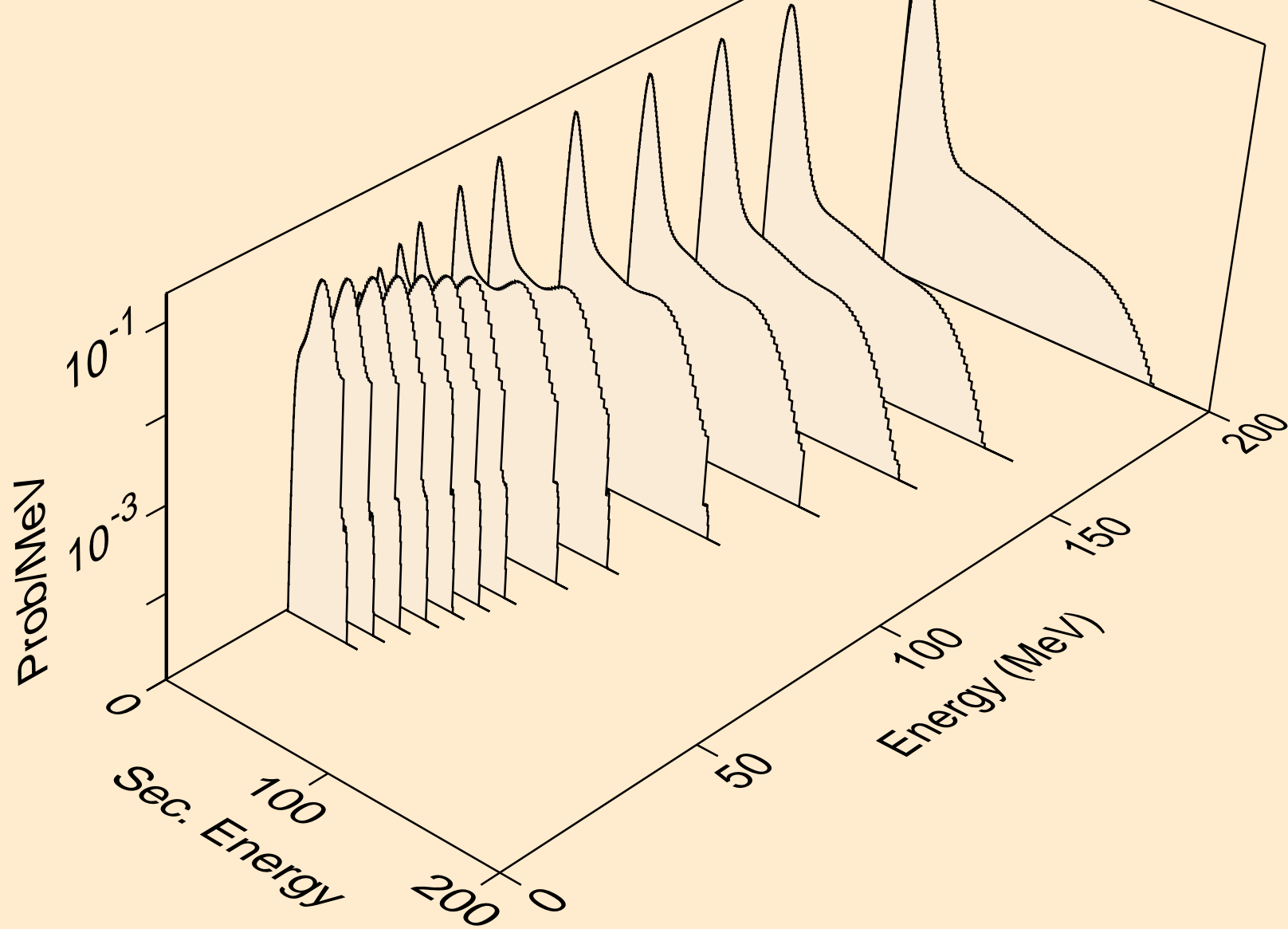

CL043 HELION ACER TENDL-2021 LIBRARY; T=0.K  
deuterons from (s,2nd)

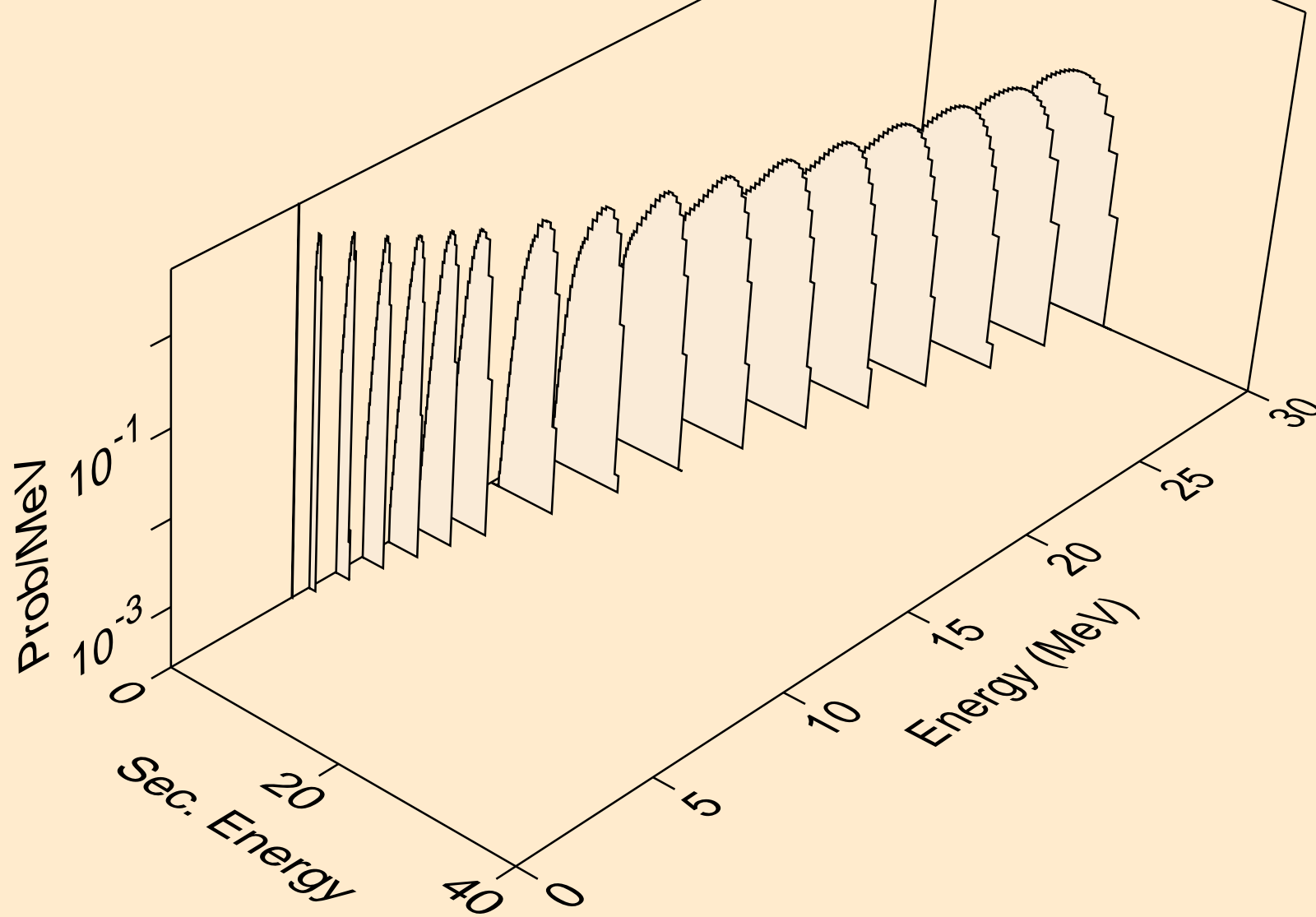

CL043 HELION ACER TENDL-2021 LIBRARY; T=0.K  
deuterons from (s,n\*)d

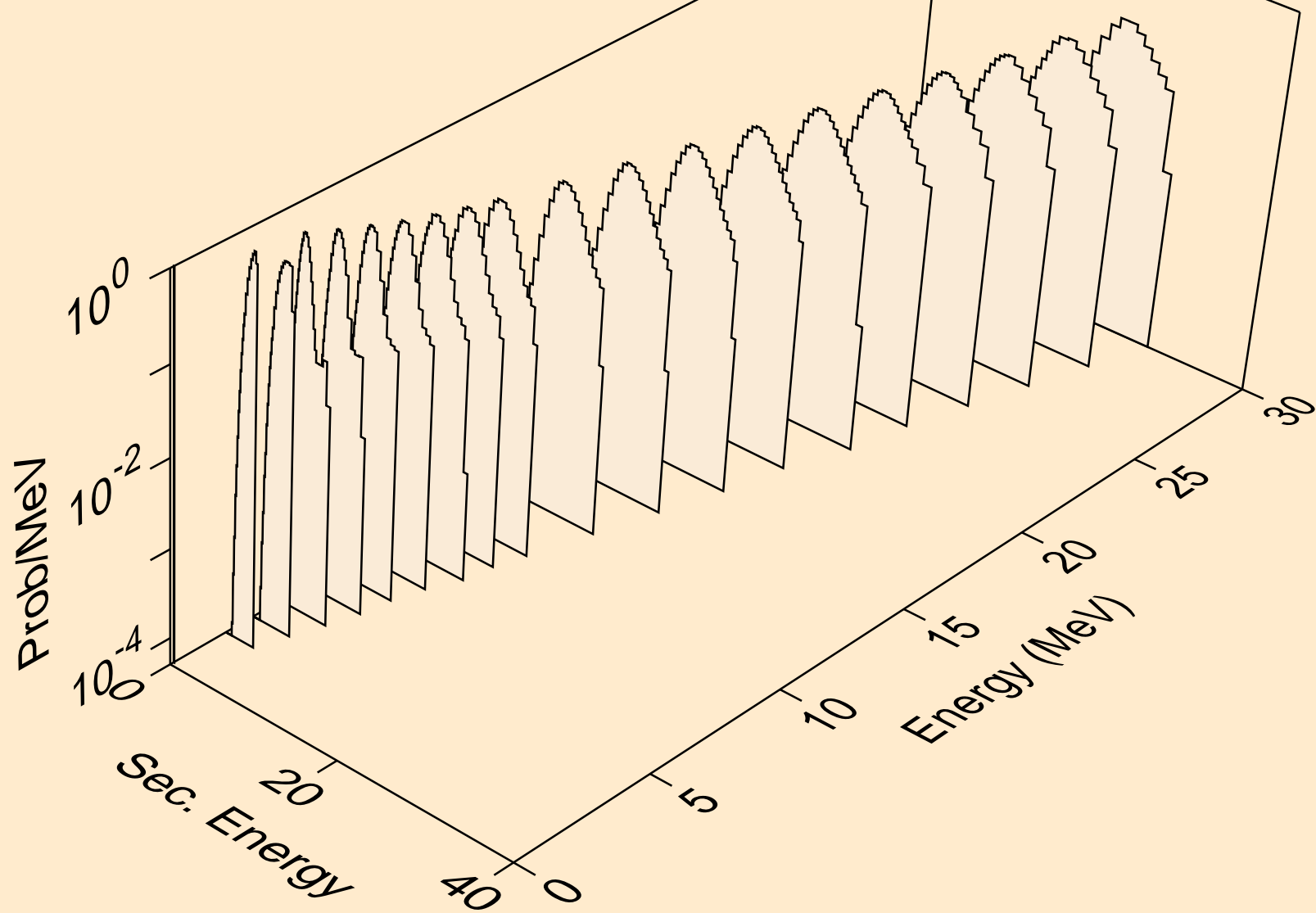

CL043 HELION ACER TENDL-2021 LIBRARY; T=0.K  
deuterons from (s,d)

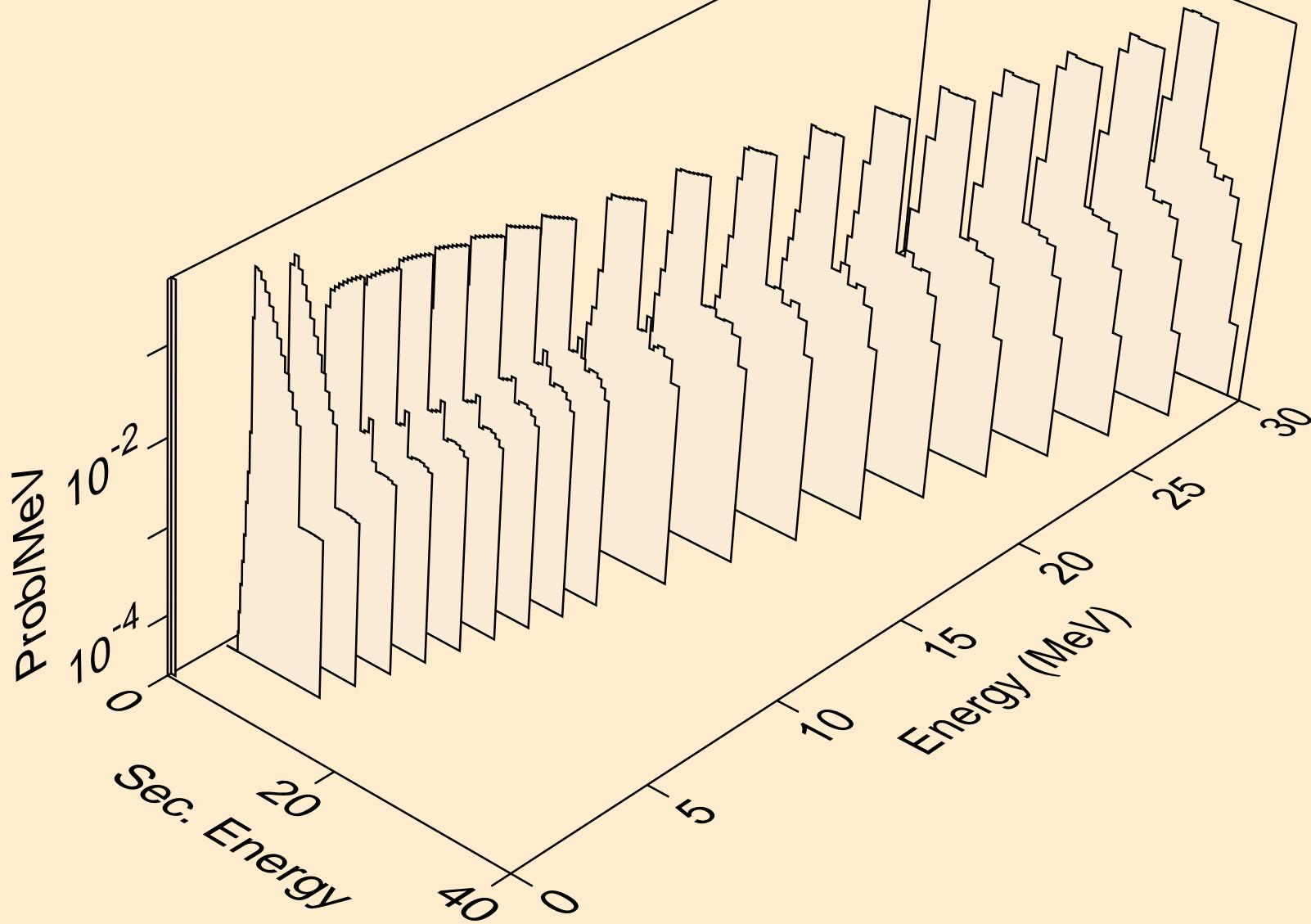

CL043 HELION ACER TENDL-2021 LIBRARY; T=0.K  
deuterons from (s,pd)

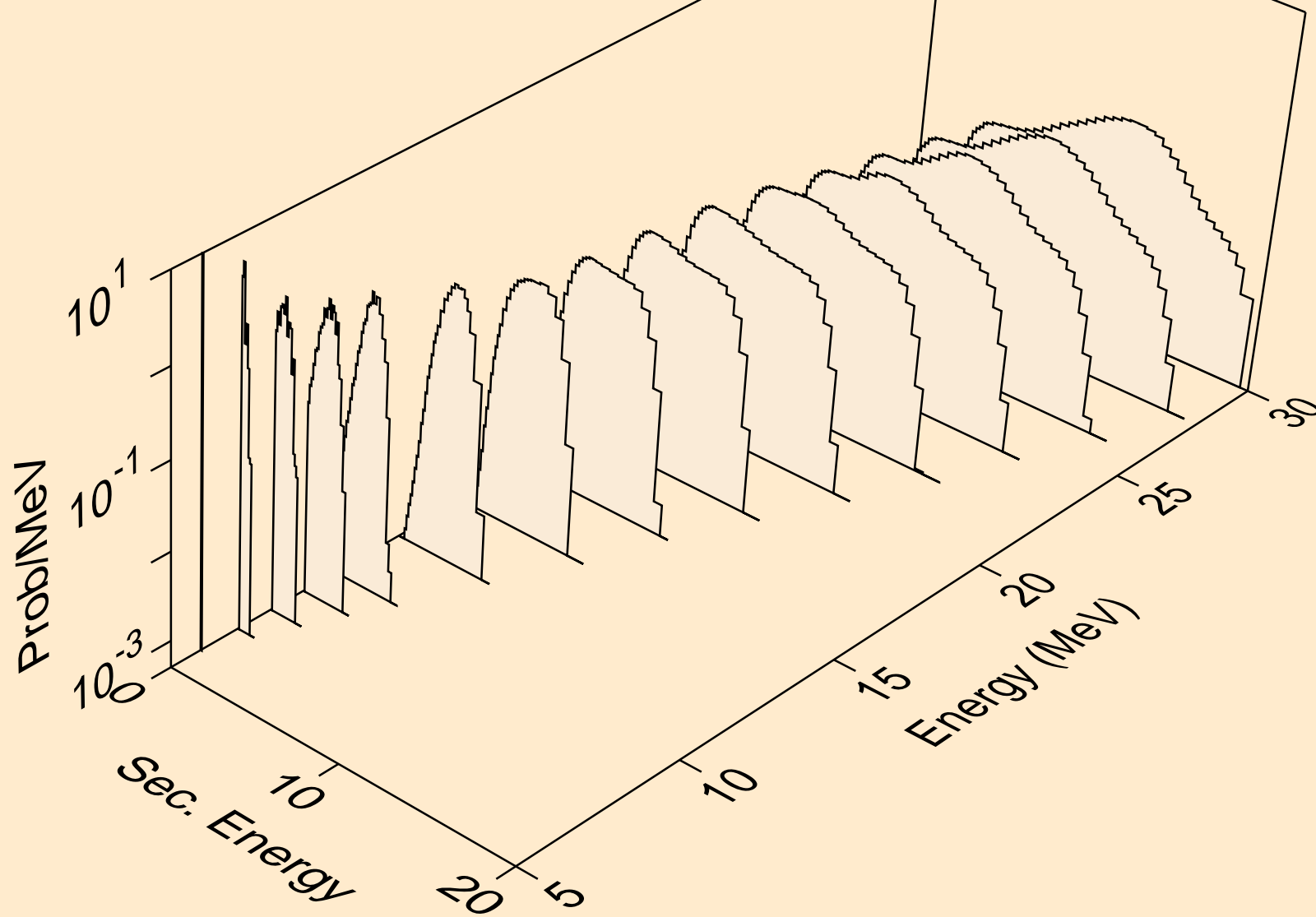

CL043 HELION ACER TENDL-2021 LIBRARY; T=0.K  
deuterons from (s,da)

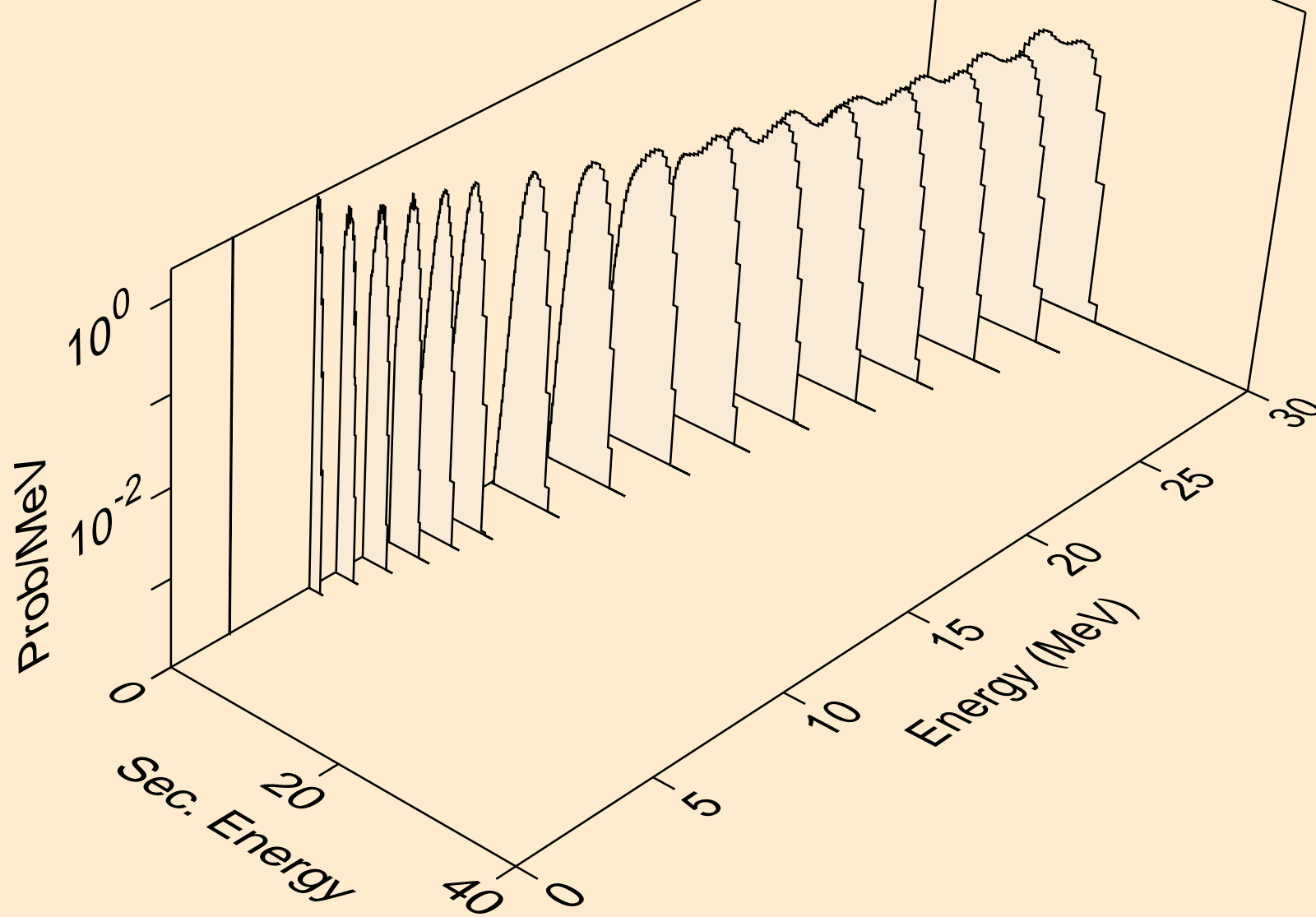

CL043 HELION ACER TENDL-2021 LIBRARY; T=0.K  
tritons from (s,x)

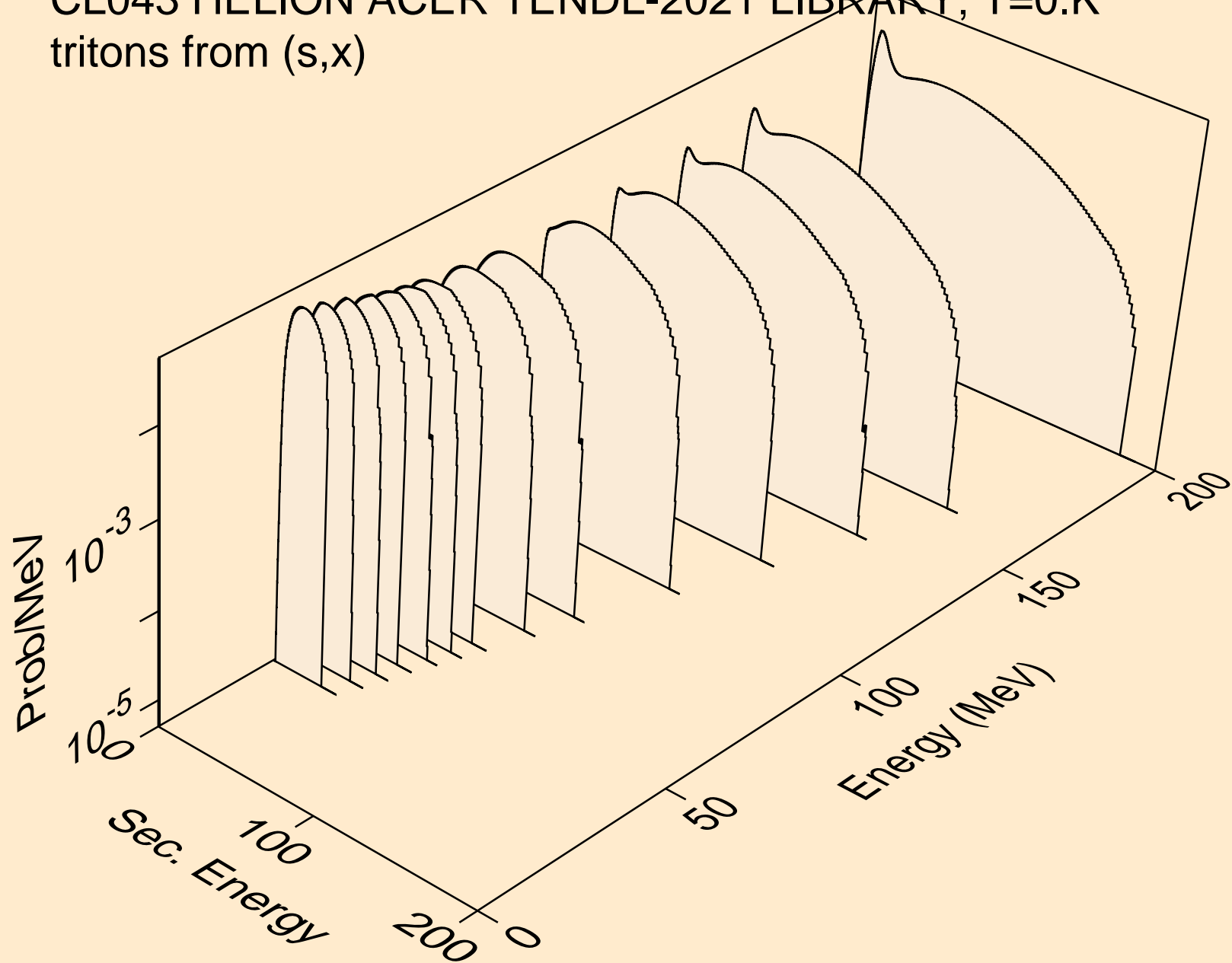



CL043 HELION ACER TENDL-2021 LIBRARY; T=0.K  
tritons from (s,n\*)t

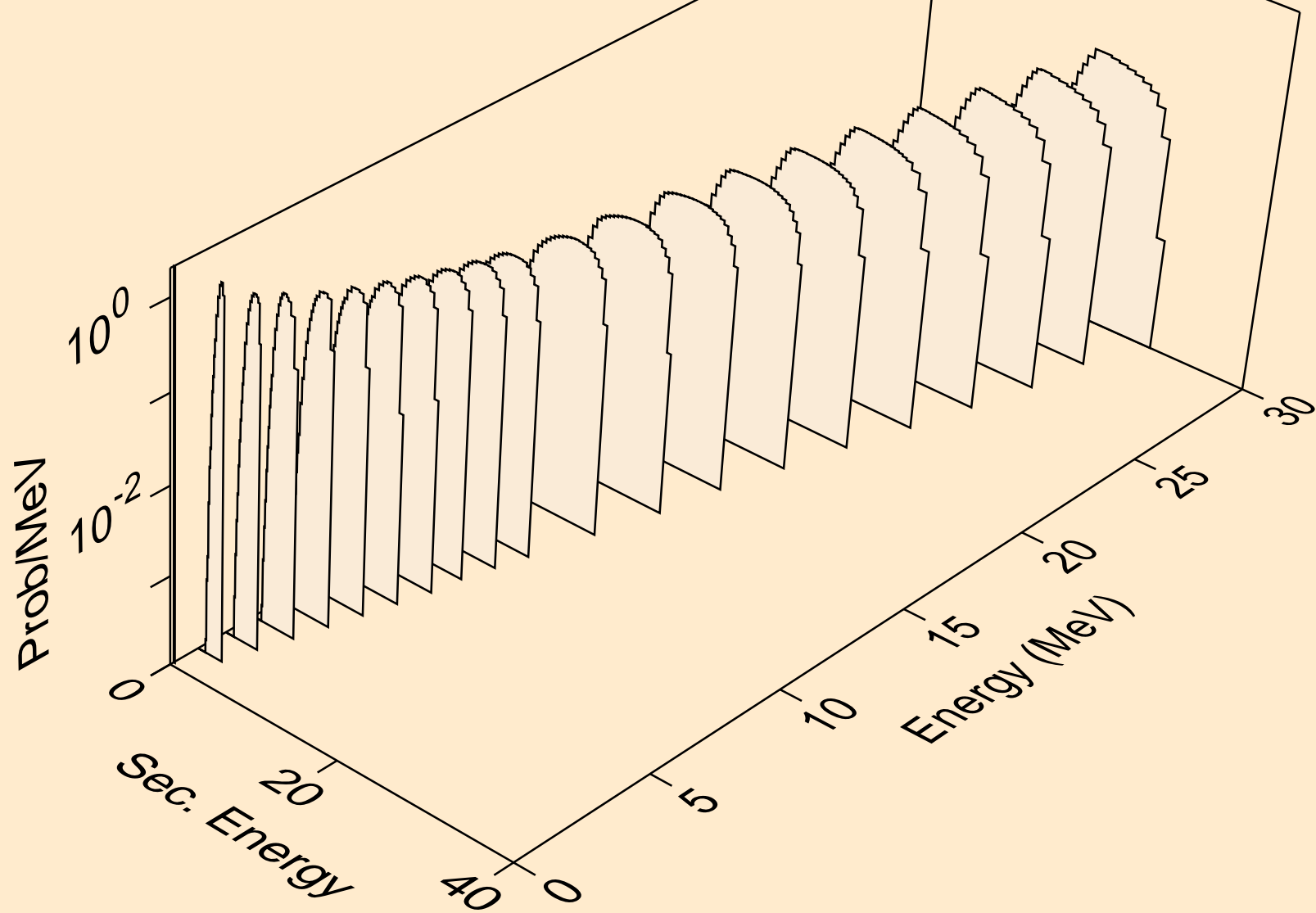

CL043 HELION ACER TENDL-2021 LIBRARY; T=0.K  
tritons from (s,t)

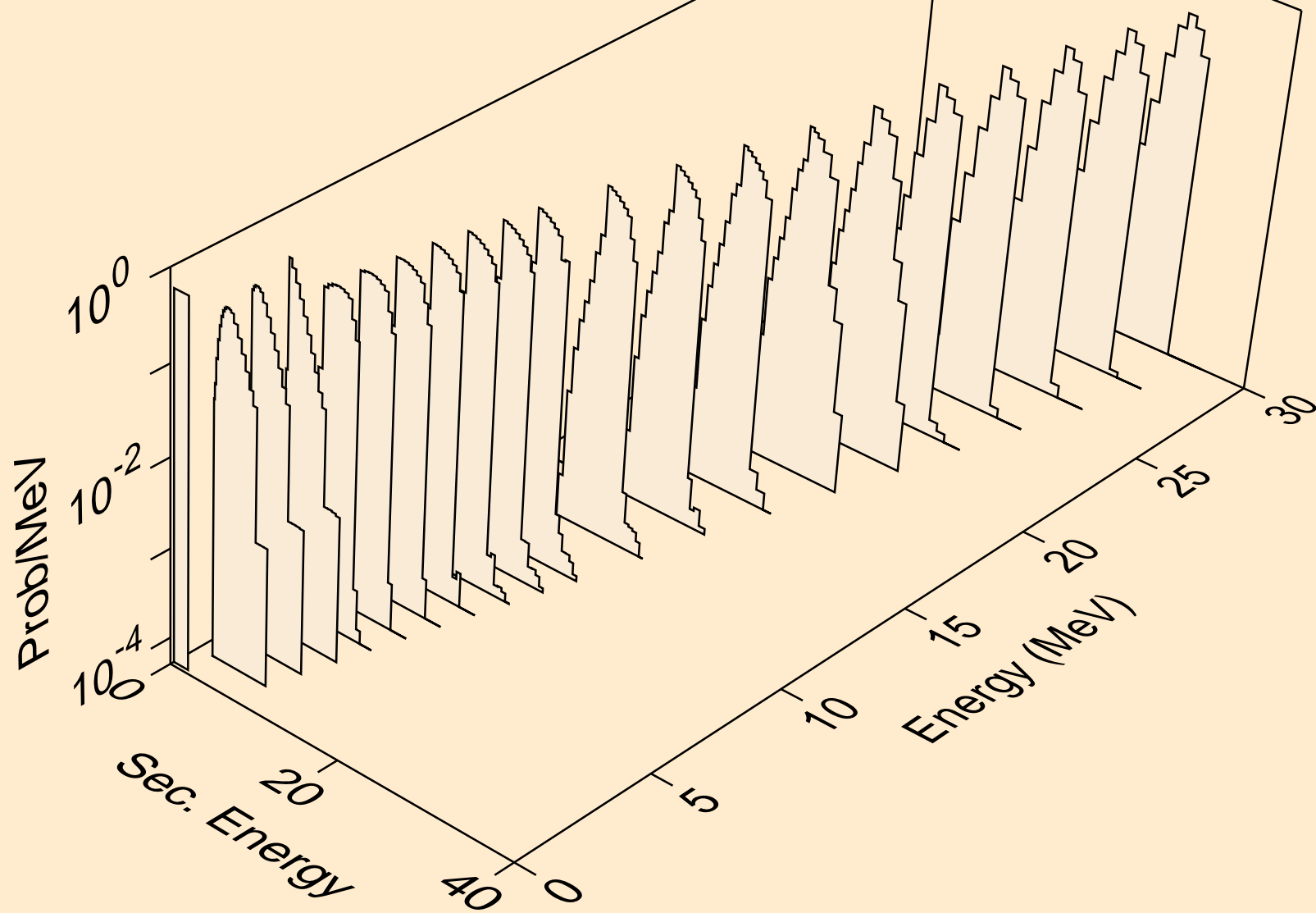

CL043 HELION ACER TENDL-2021 LIBRARY; T=0.K  
tritons from (s,pt)

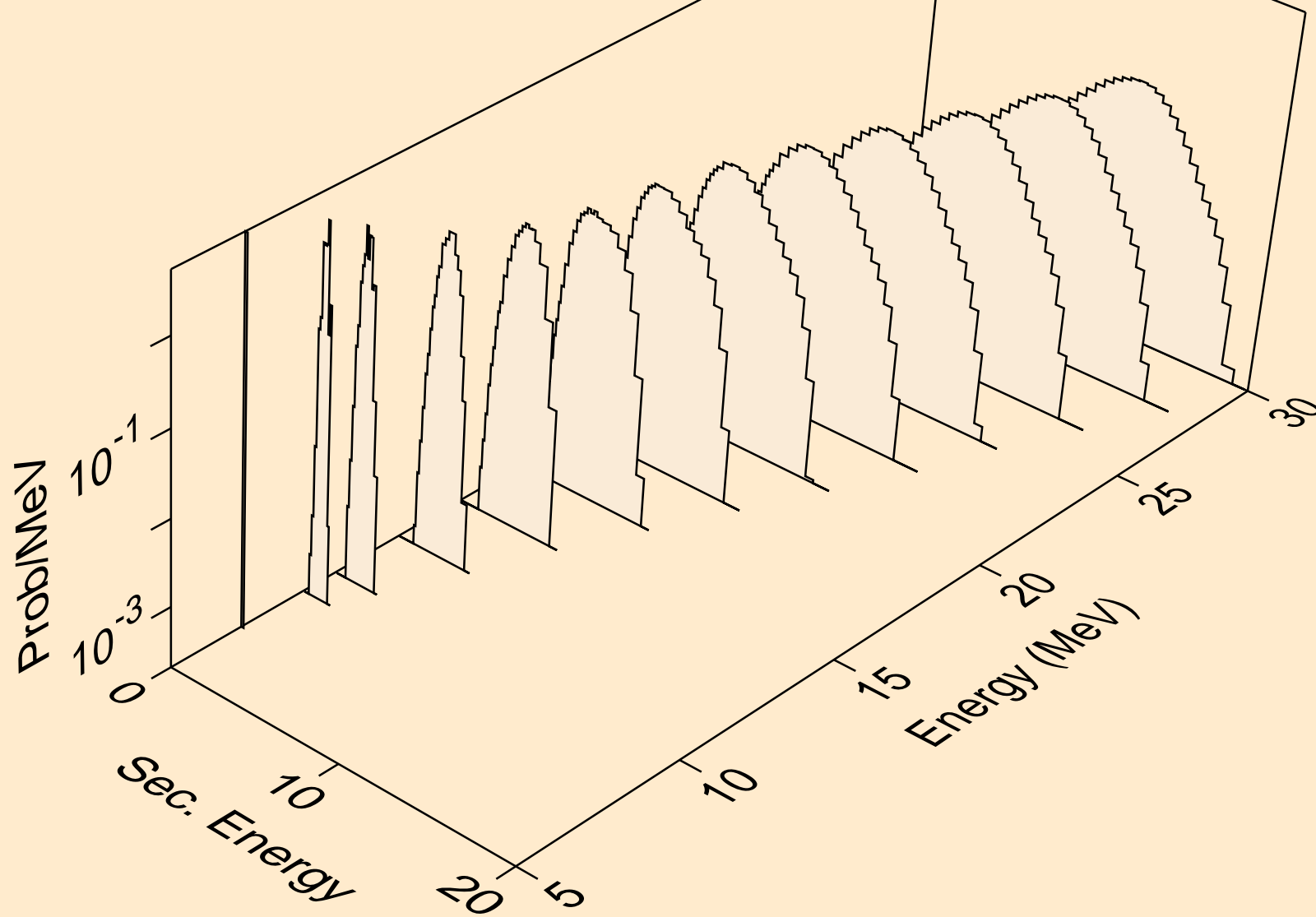

CL043 HELION ACER TENDL-2021 LIBRARY; T=0.K  
alphas from (s,x)

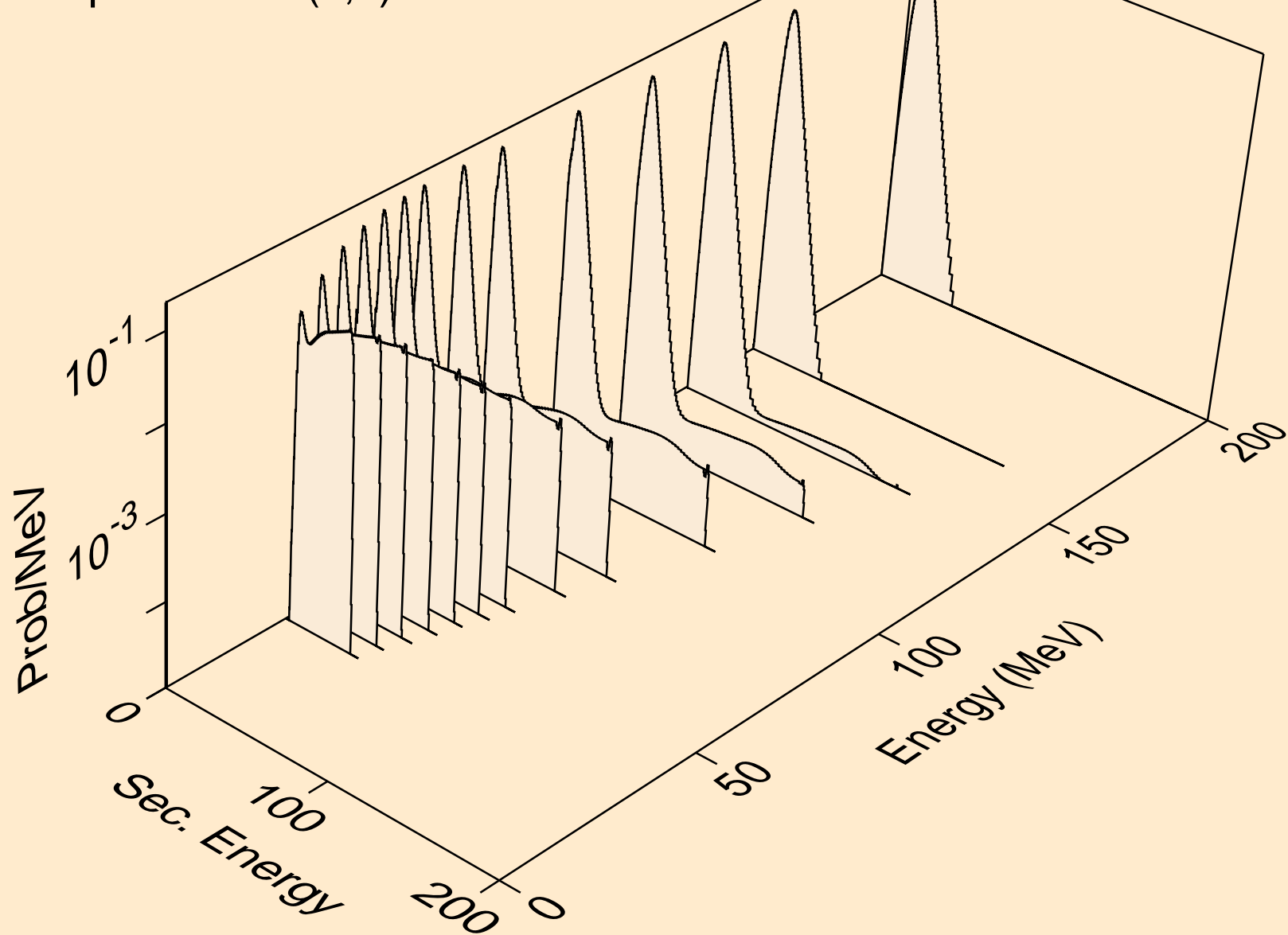

CL043 HELION ACER TENDL-2021 LIBRARY; T=0.K  
alphas from (s,n\*)a

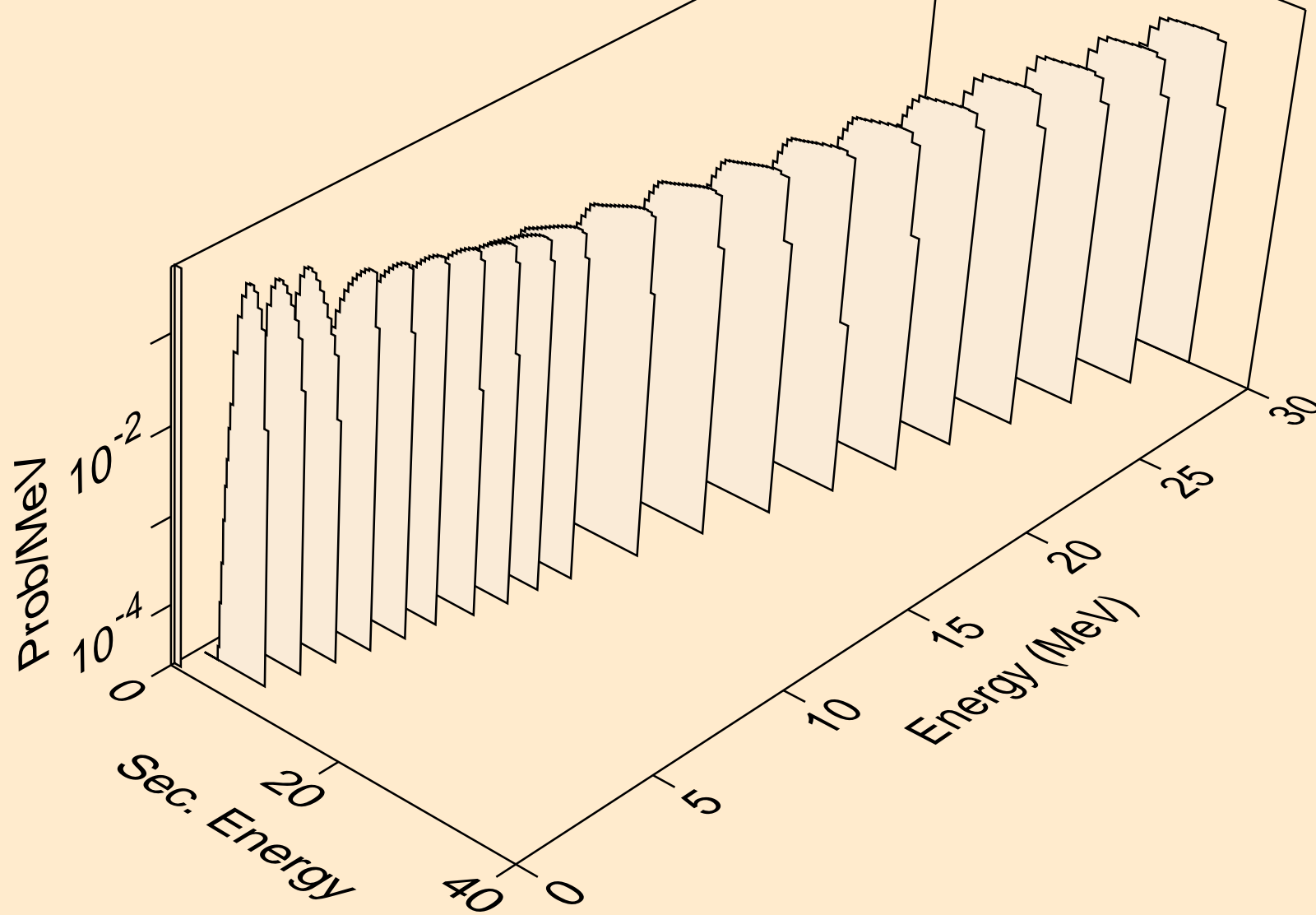

CL043 HELION ACER TENDL-2021 LIBRARY; T=0.K  
alphas from (s,2n)a

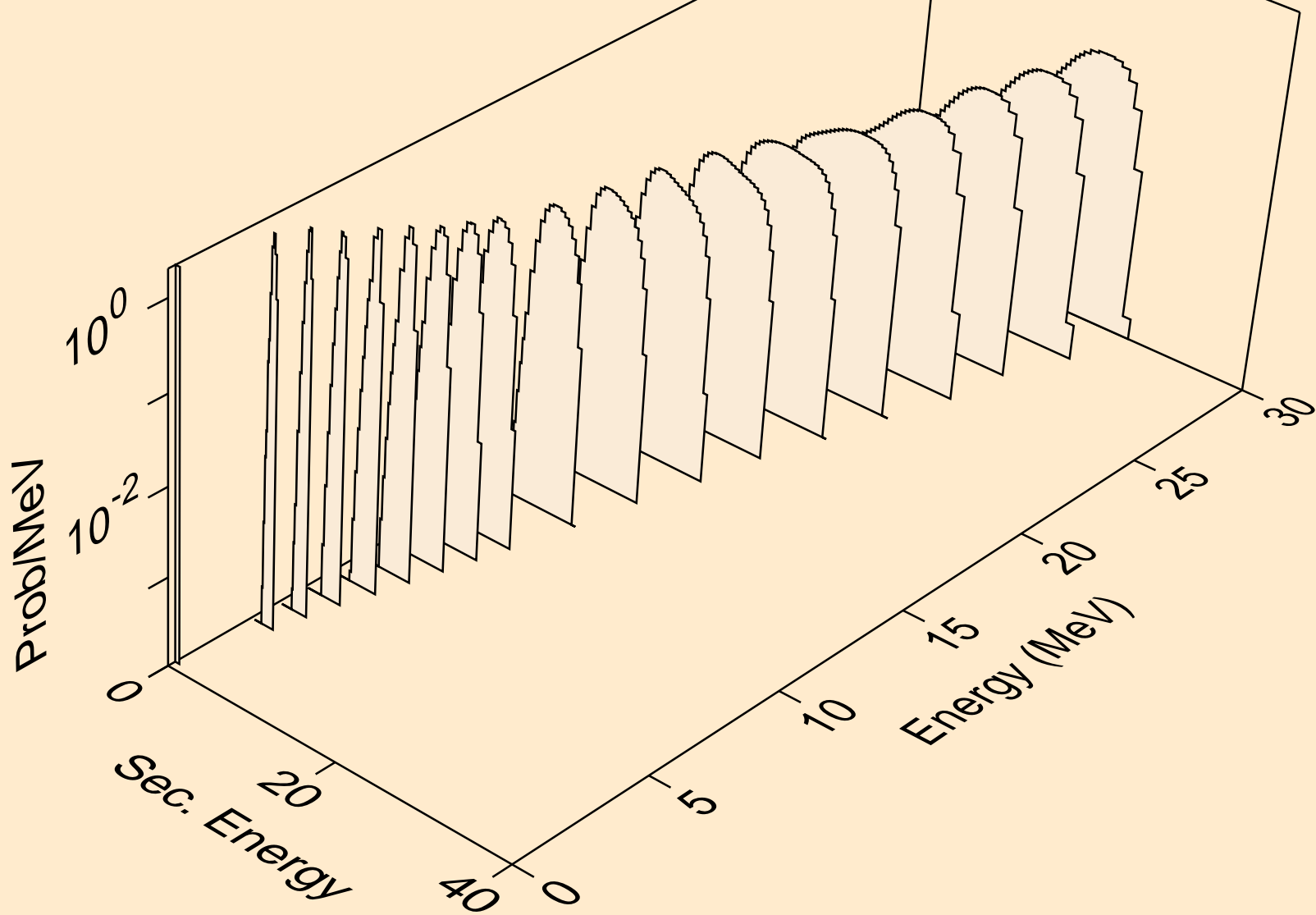

CL043 HELION ACER TENDL-2021 LIBRARY; T=0.K  
alphas from (s,3n)a

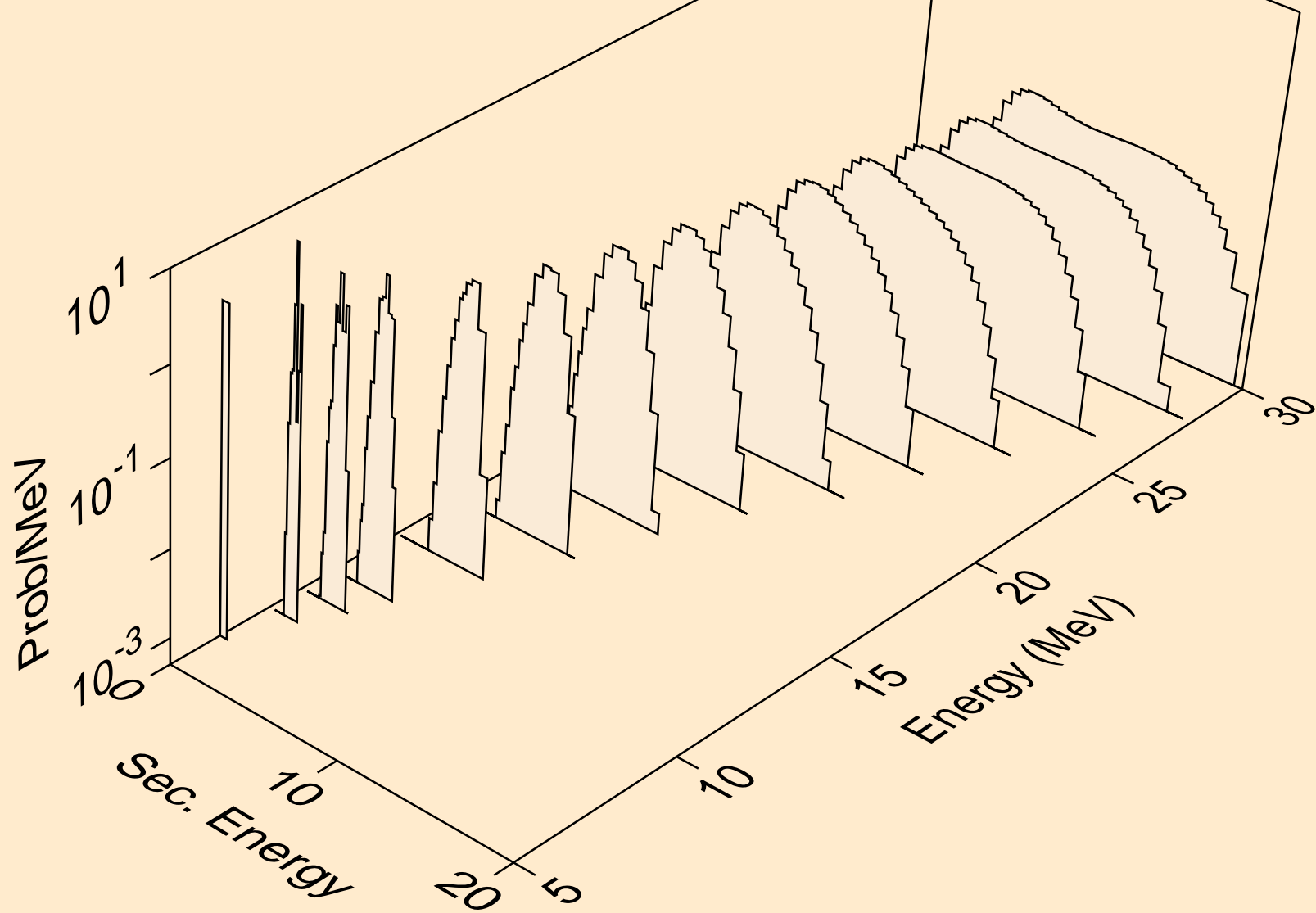

CL043 HELION ACER TENDL-2021 LIBRARY; T=0.K  
alphas from (s,n\*)2a

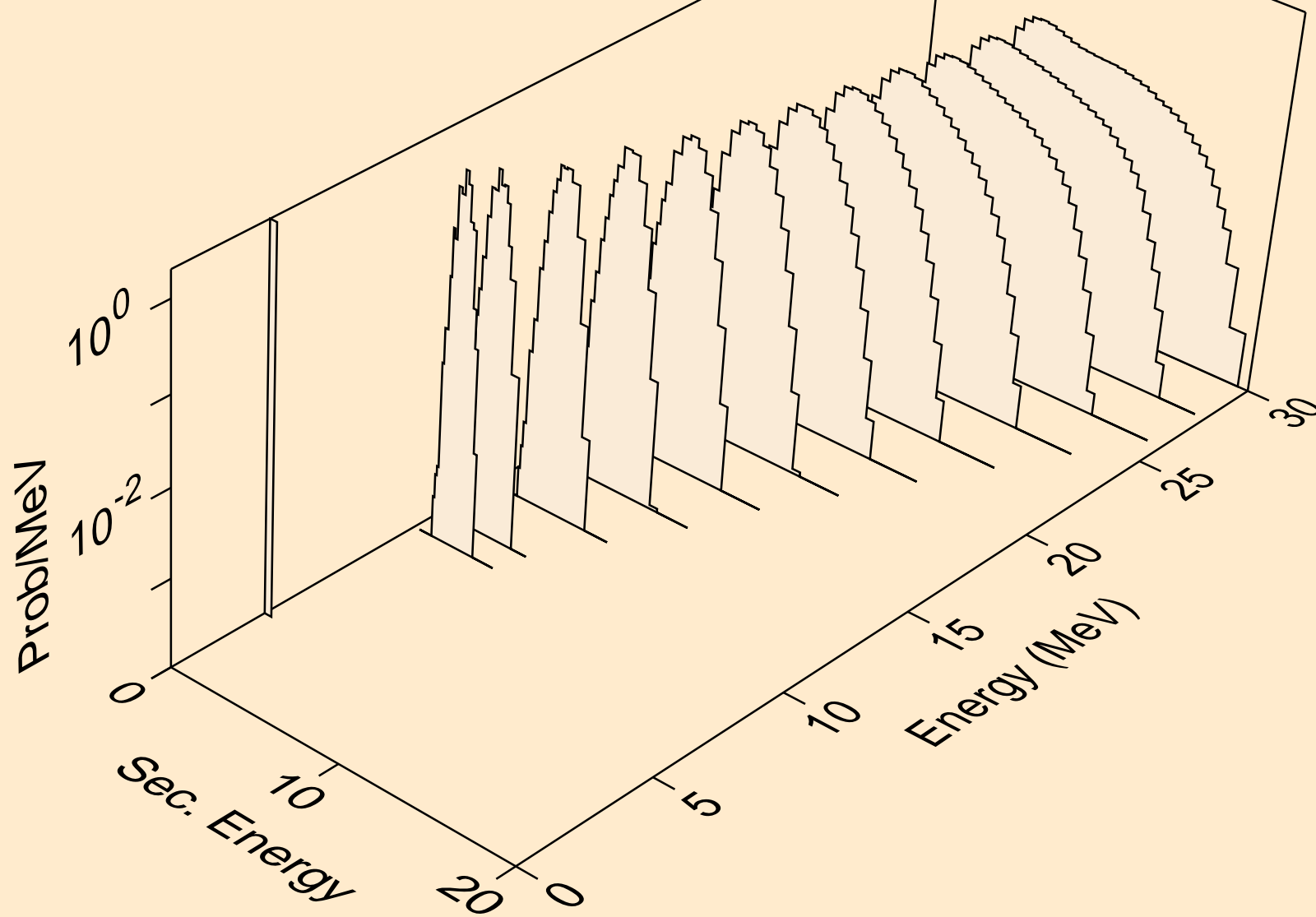



CL043 HELION ACER TENDL-2021 LIBRARY; T=0.K  
alphas from (s,2n)2a

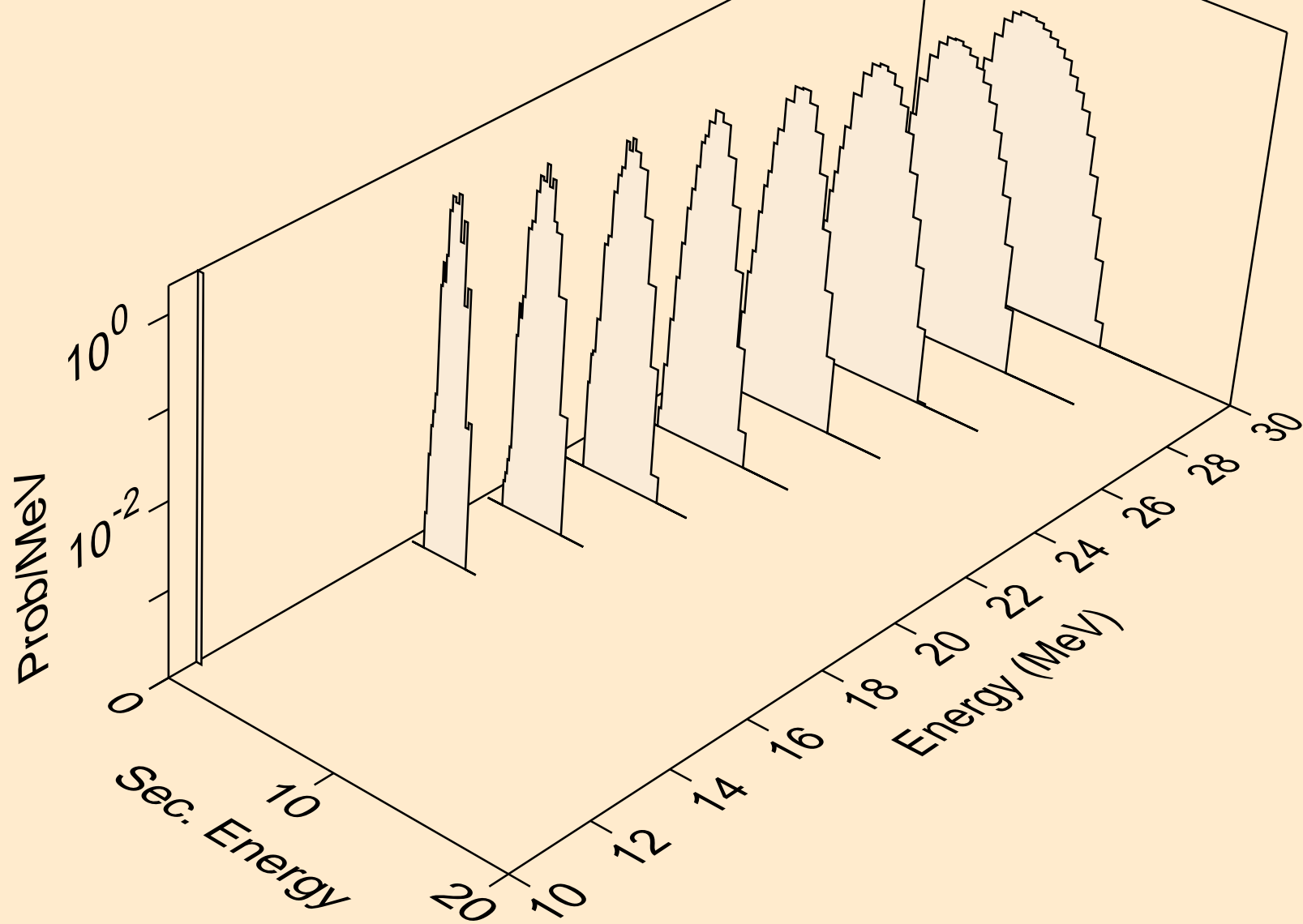

CL043 HELION ACER TENDL-2021 LIBRARY; T=0.K  
alphas from (s,npa)

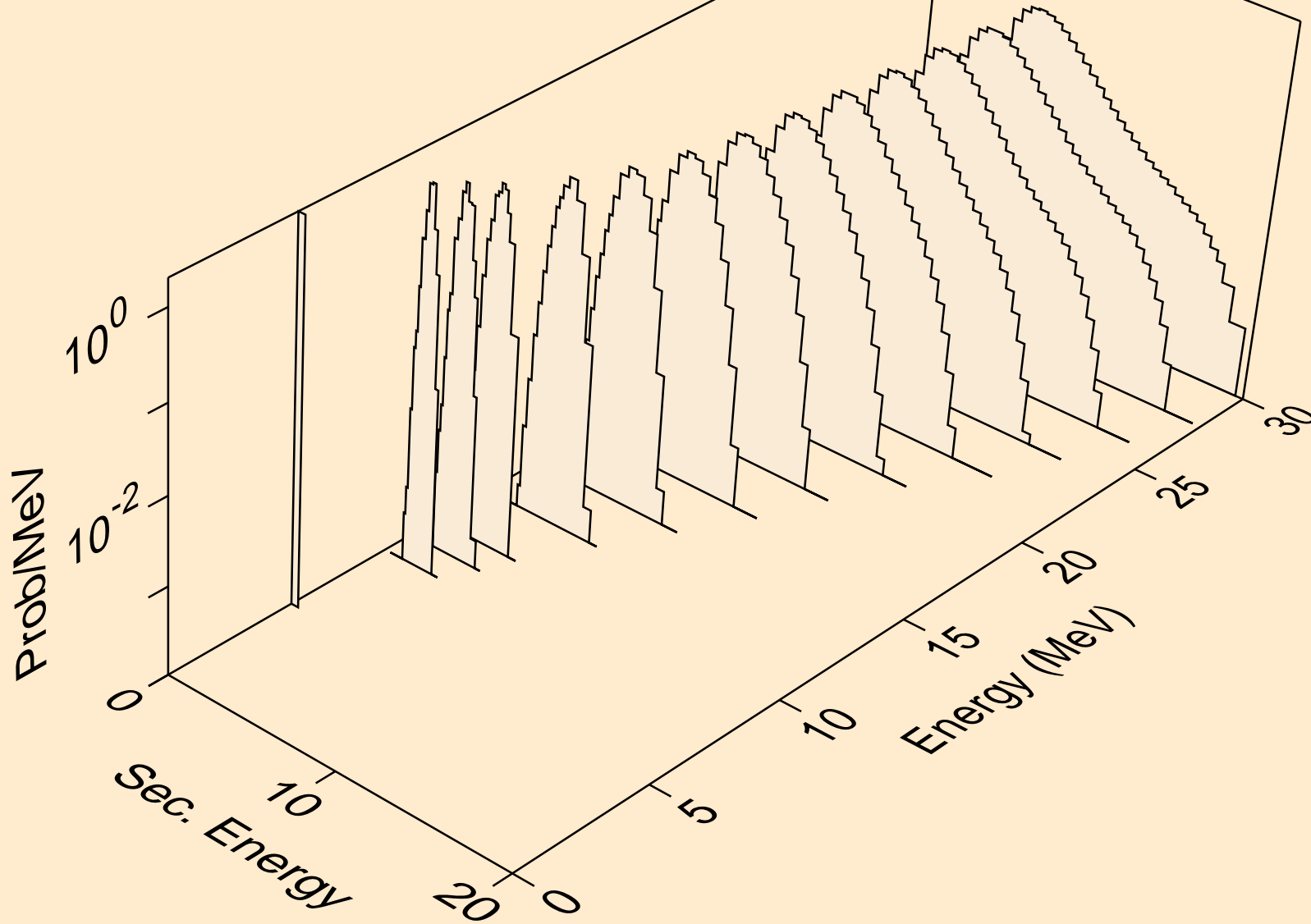

CL043 HELION ACER TENDL-2021 LIBRARY; T=0.K  
alphas from (s,a)

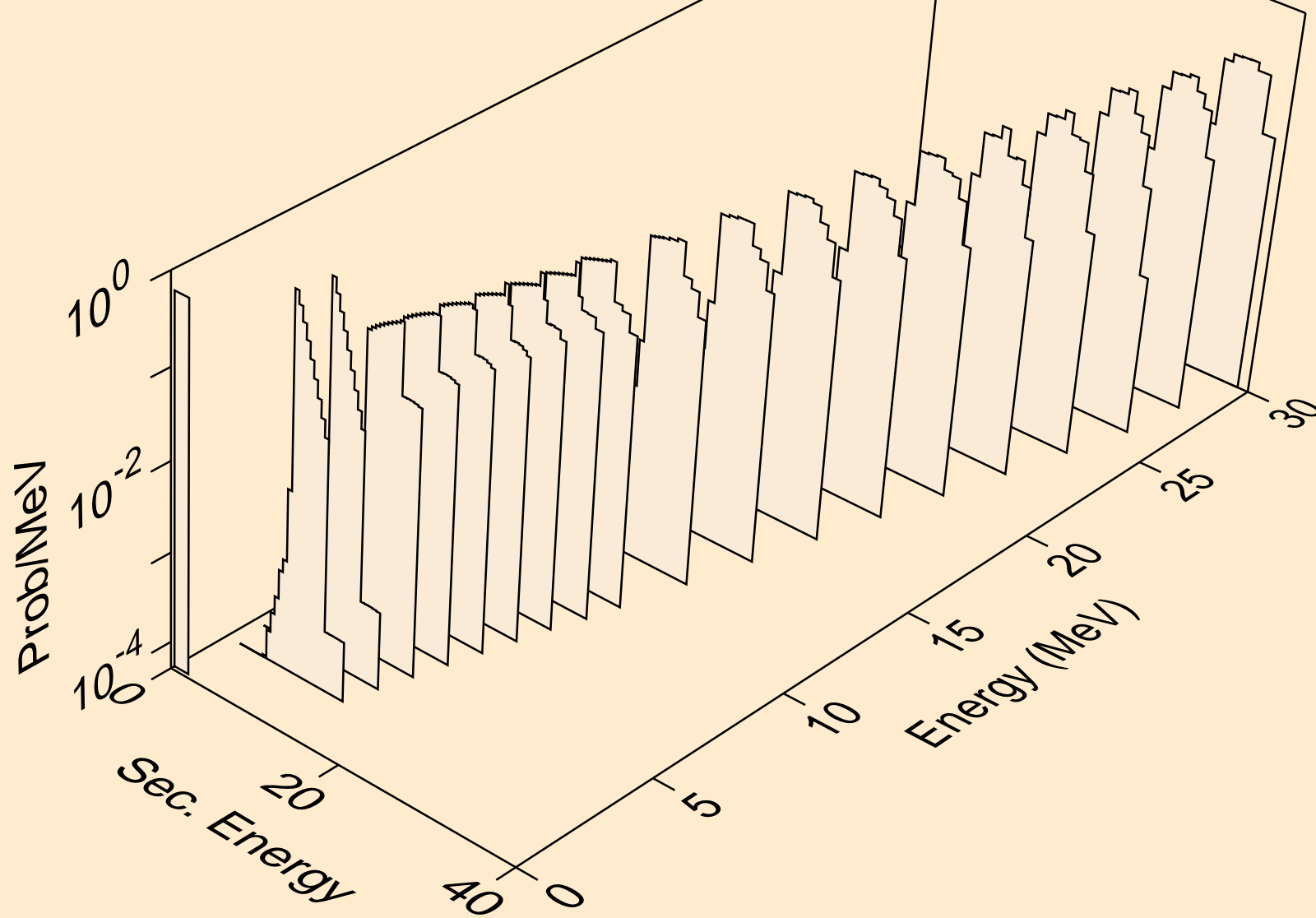

CL043 HELION ACER TENDL-2021 LIBRARY; T=0.K  
alphas from (s,2a)

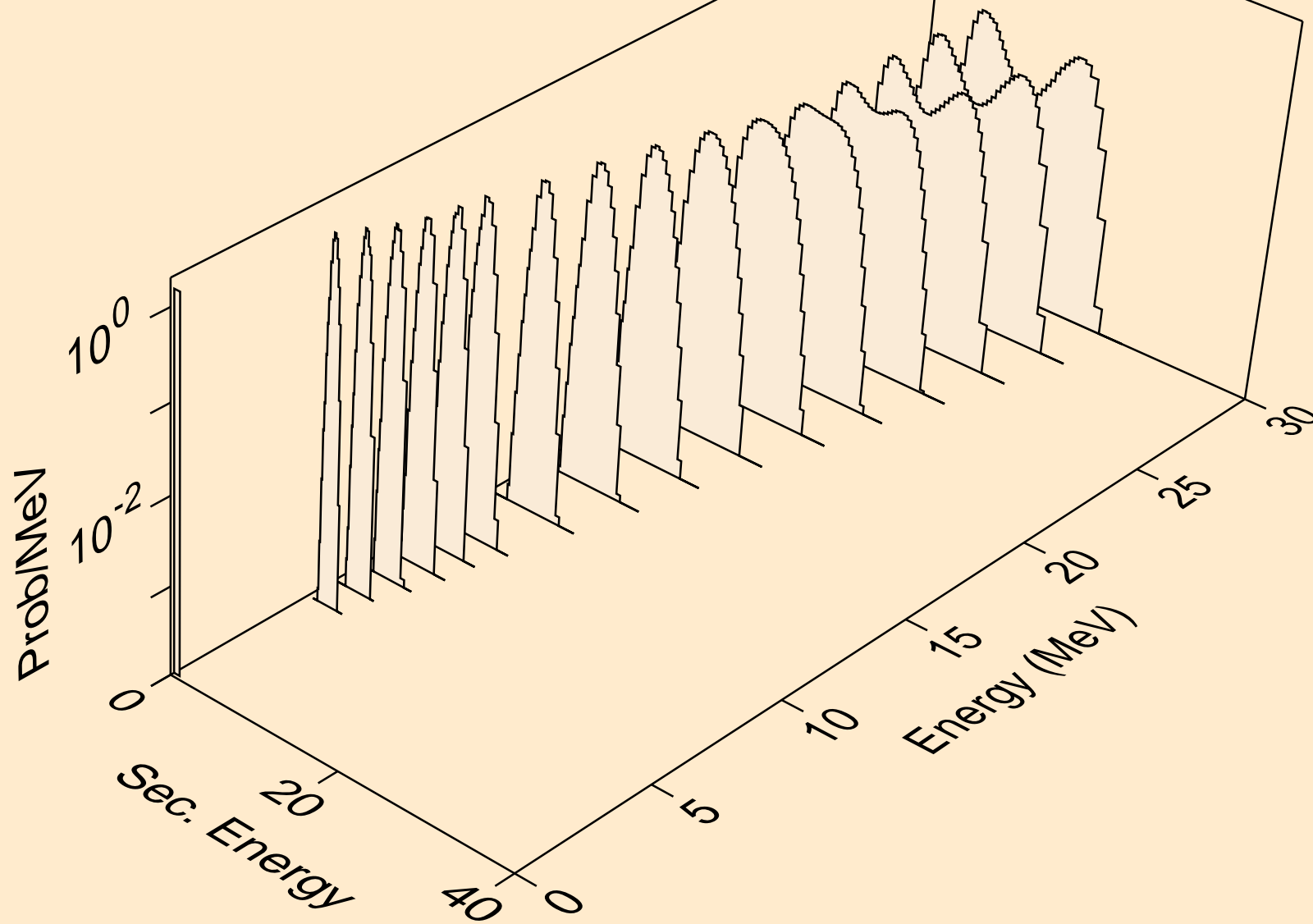

CL043 HELION ACER TENDL-2021 LIBRARY; T=0.K  
alphas from (s,pa)

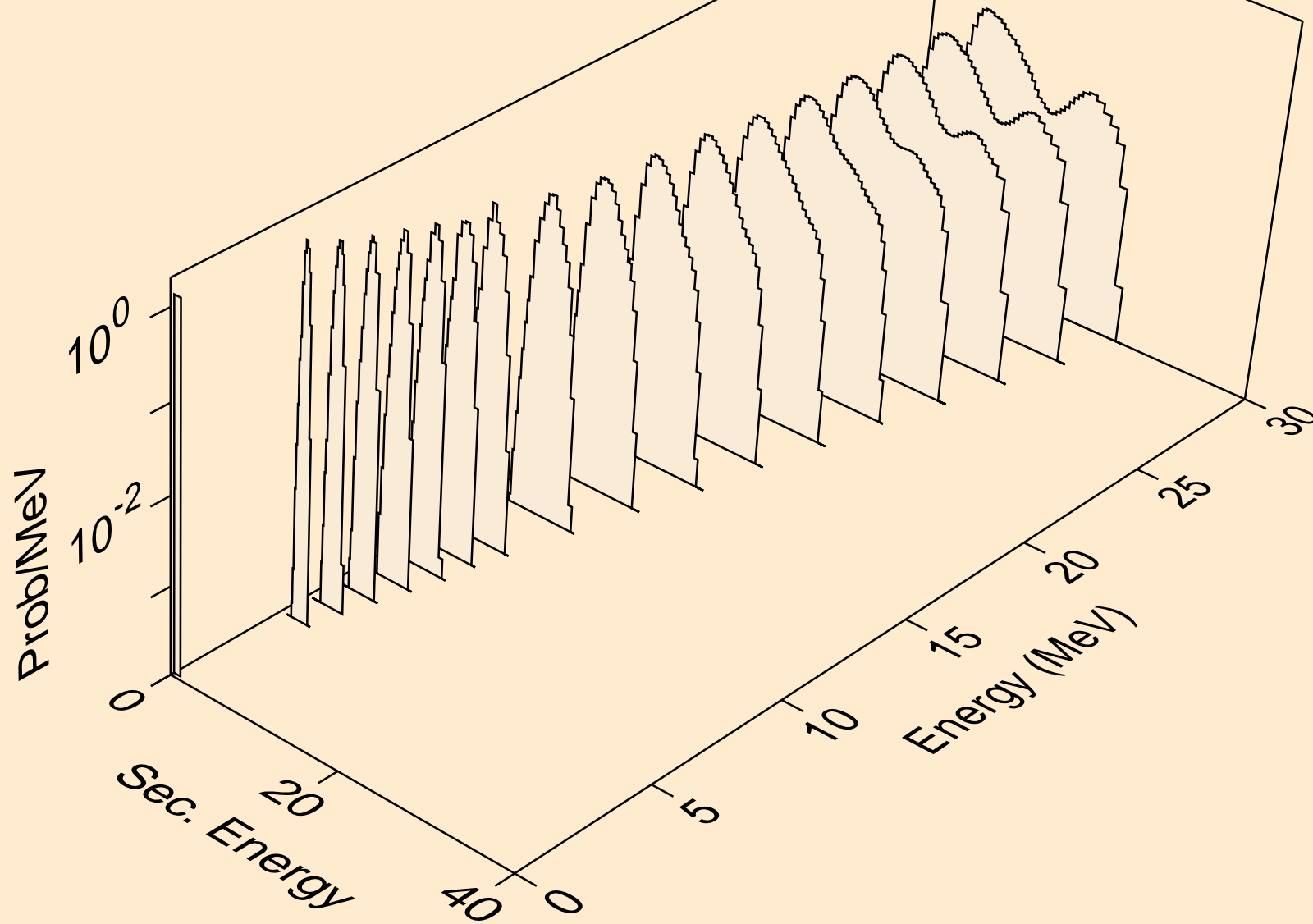

CL043 HELION ACER TENDL-2021 LIBRARY; T=0.K  
alphas from (s,da)

