

NO264 HELION ACER TENDL-2021 LIBRARY; T=0.K  
Principal cross sections

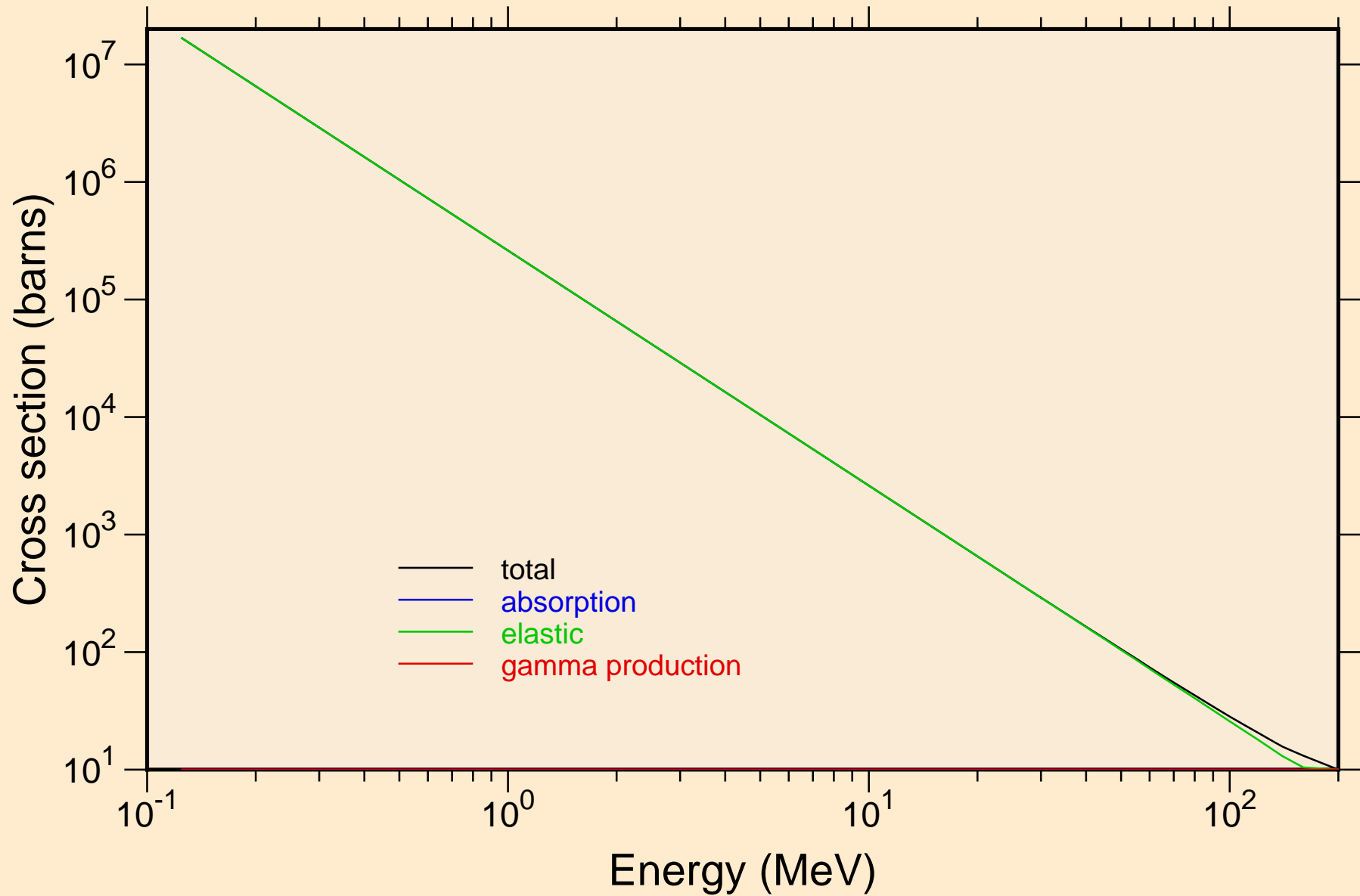

NO264 HELION ACER TENDL-2021 LIBRARY; T=0.K

Heating

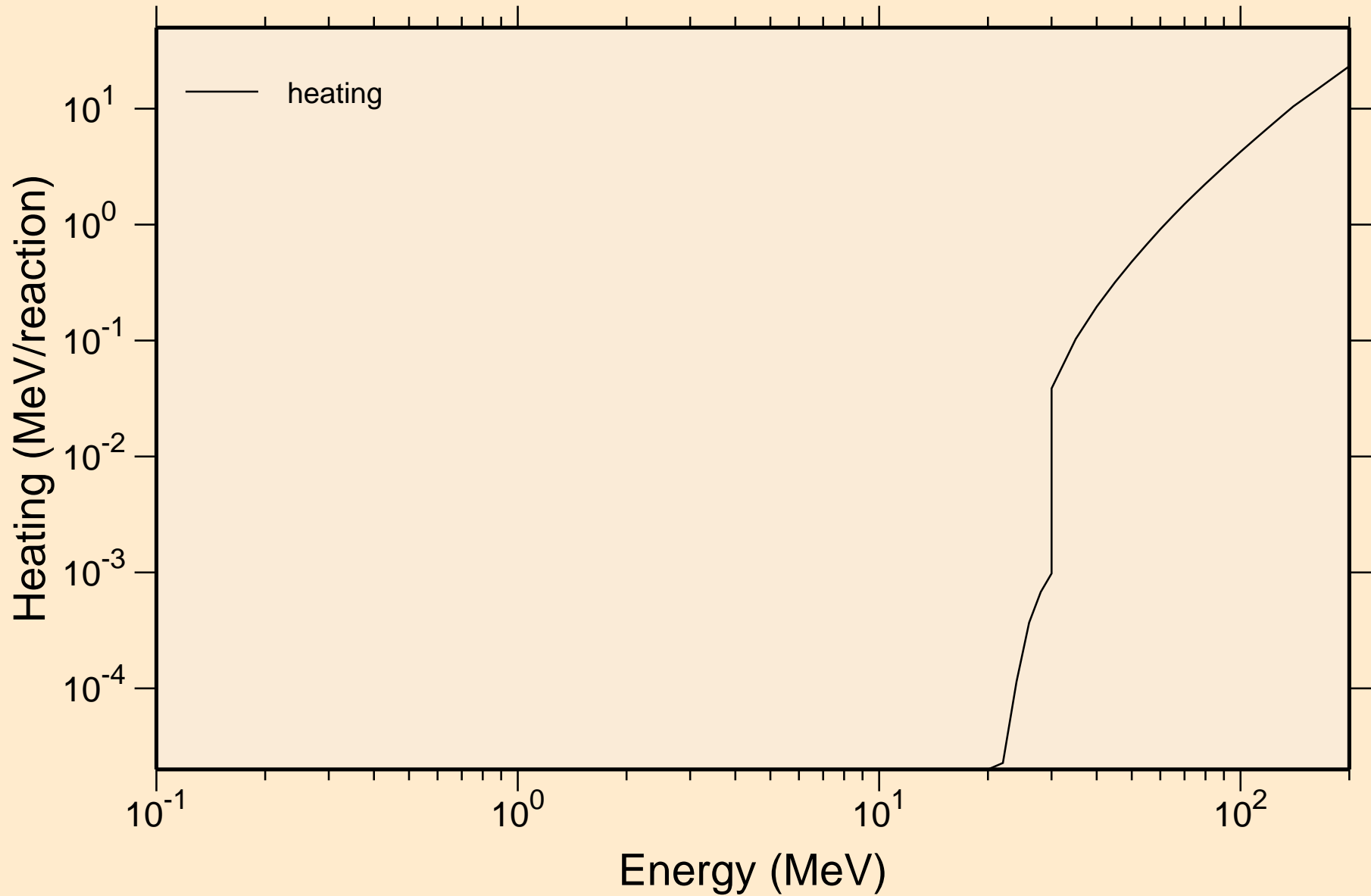

# NO264 HELION ACER TENDL-2021 LIBRARY; T=0.K

## Principal cross sections

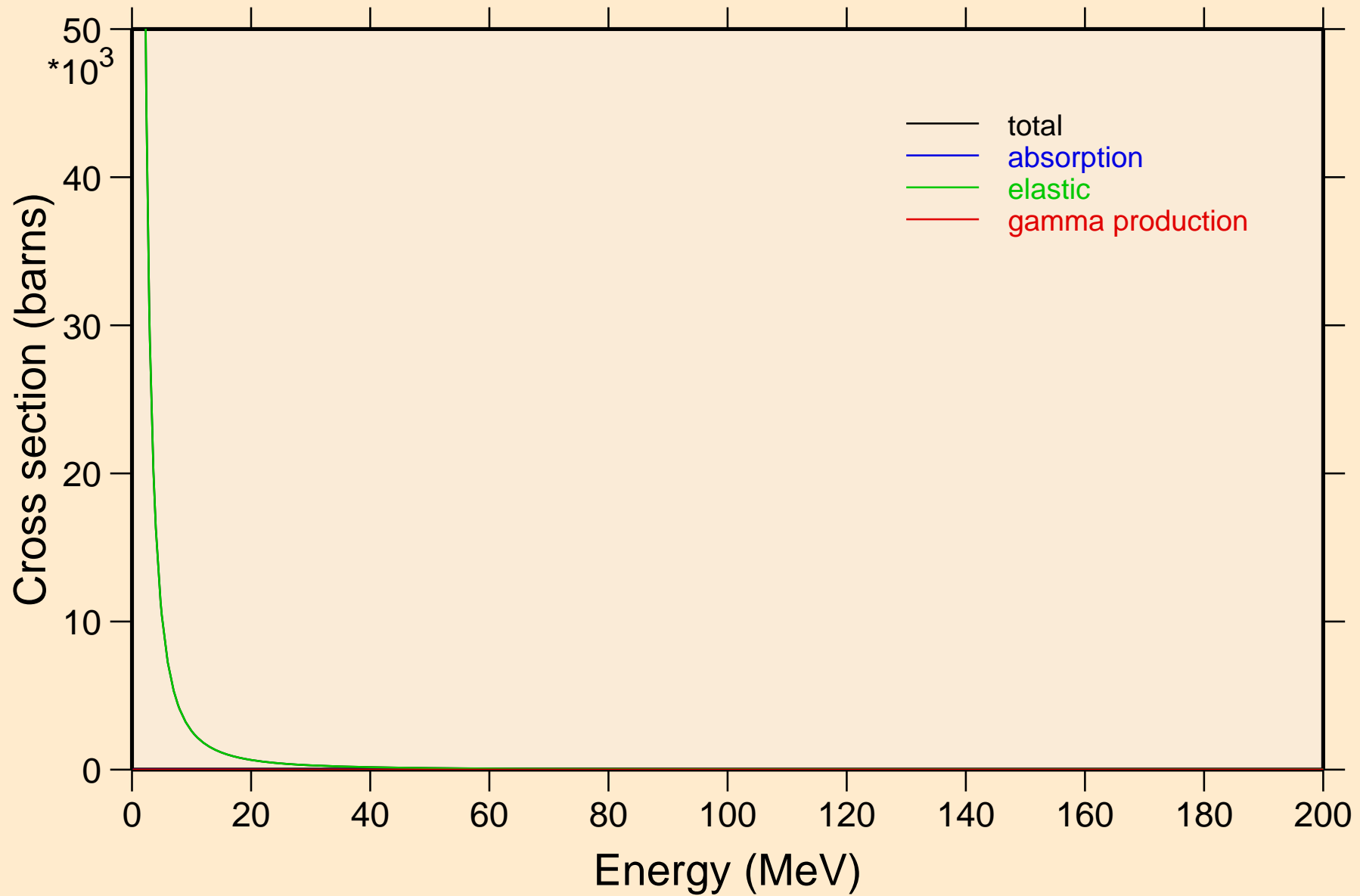

NO264 HELION ACER TENDL-2021 LIBRARY; T=0.K

Heating

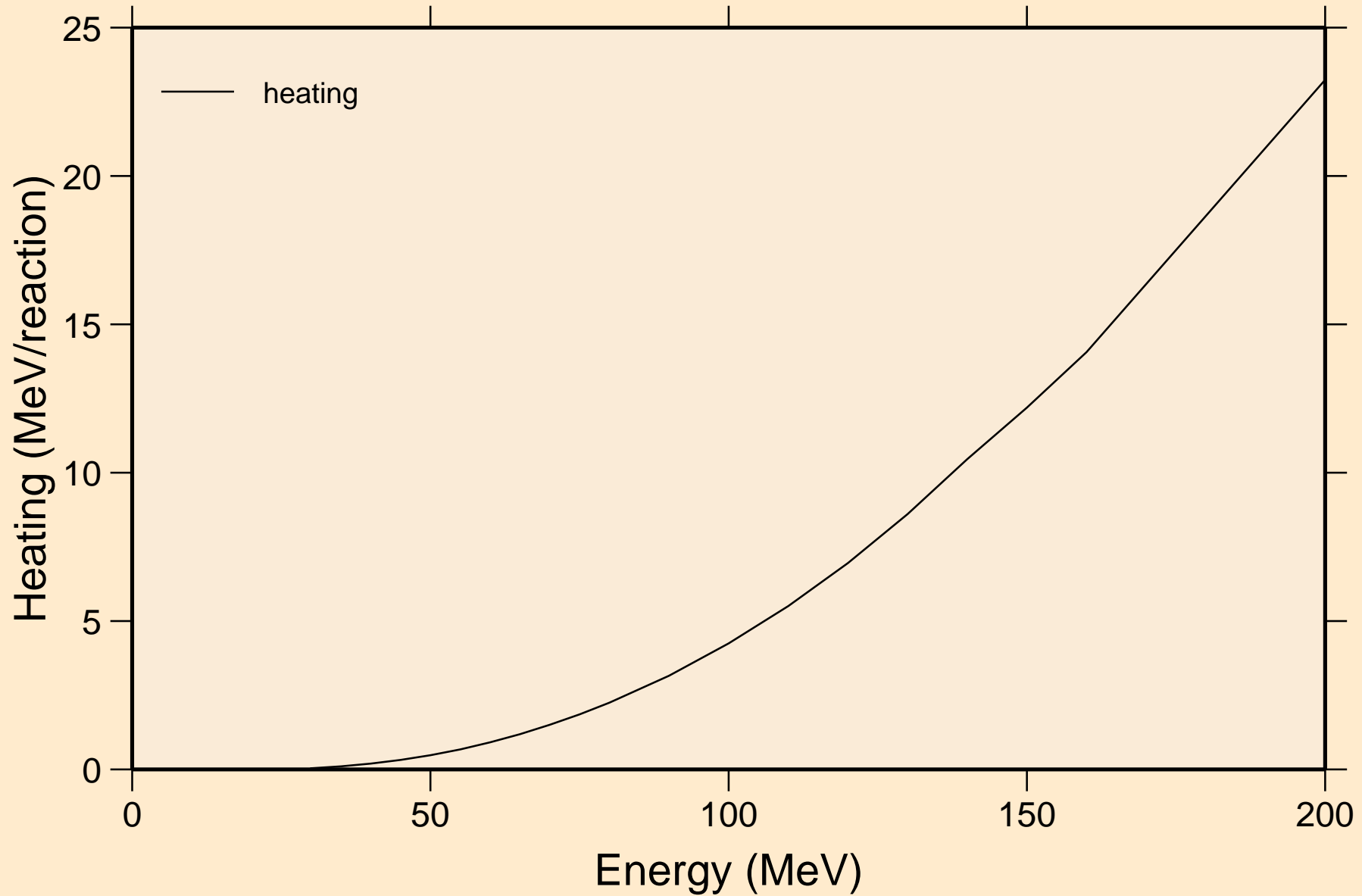

NO264 HELION ACER TENDL-2021 LIBRARY; T=0.K  
Threshold reactions

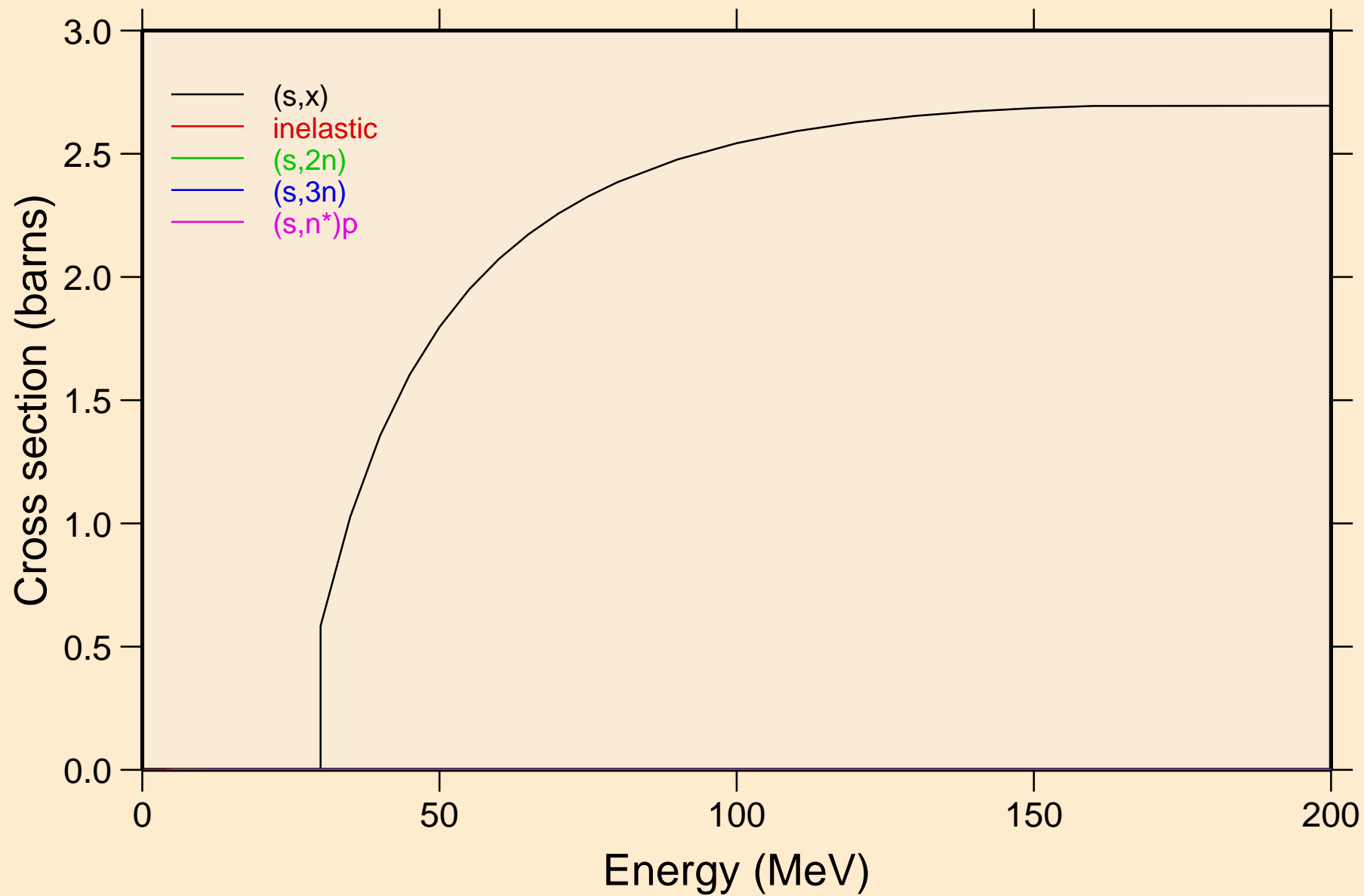

NO264 HELION ACER TENDL-2021 LIBRARY; T=0.K  
Threshold reactions

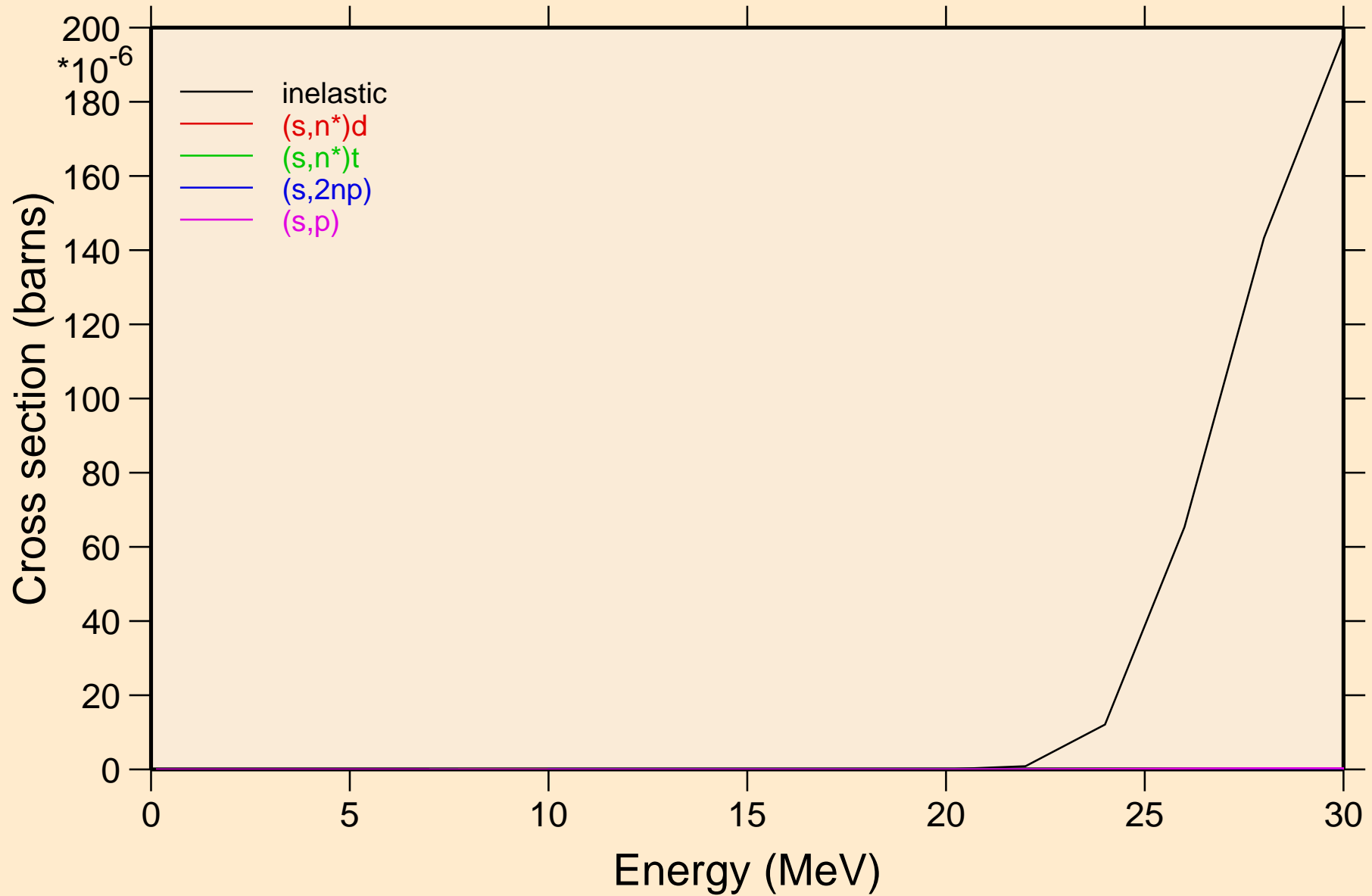

NO264 HELION ACER TENDL-2021 LIBRARY; T=0.K  
Threshold reactions

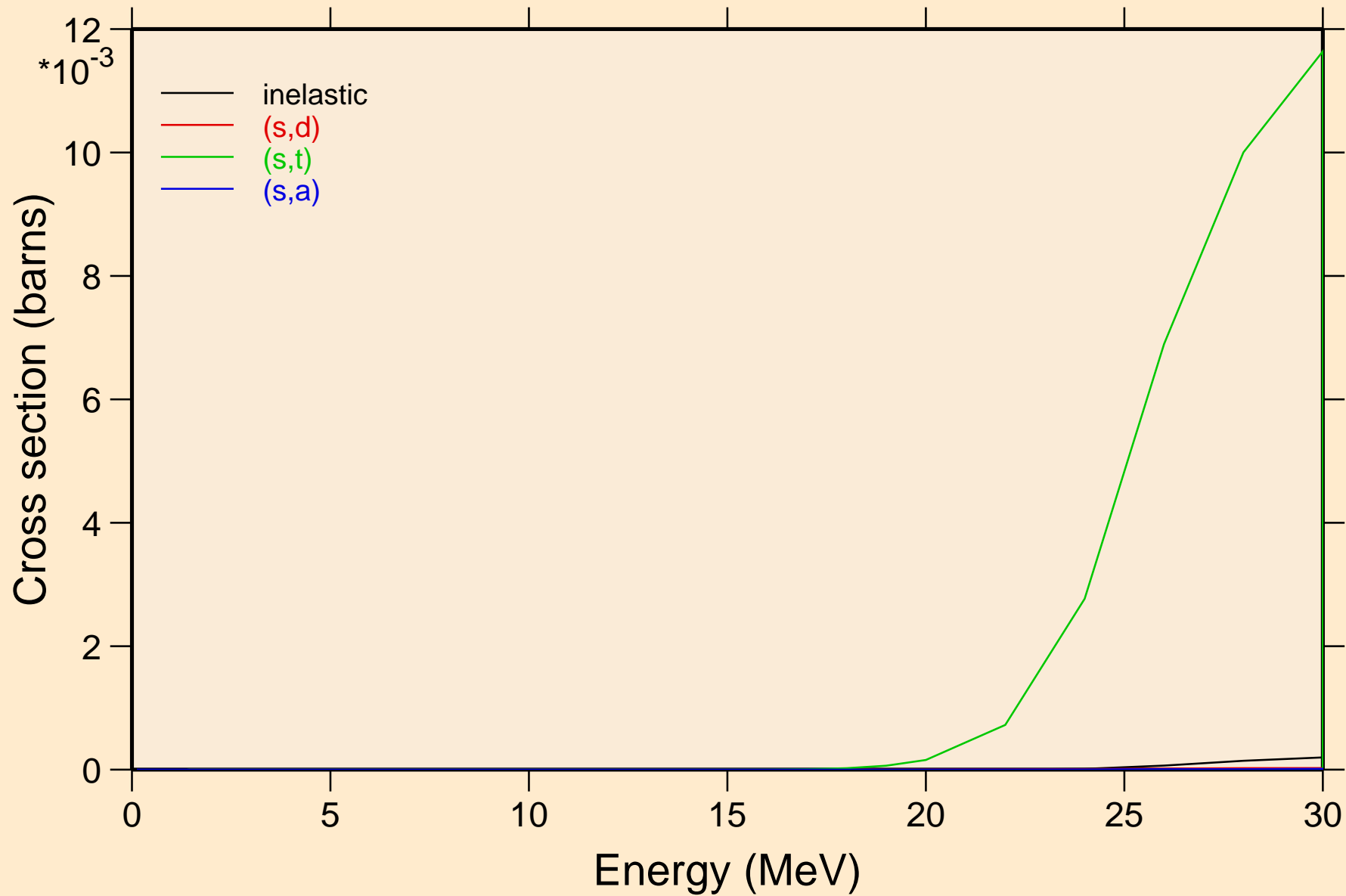

NO264 HELION ACER TENDL-2021 LIBRARY; T=0.K  
angular distribution for elastic

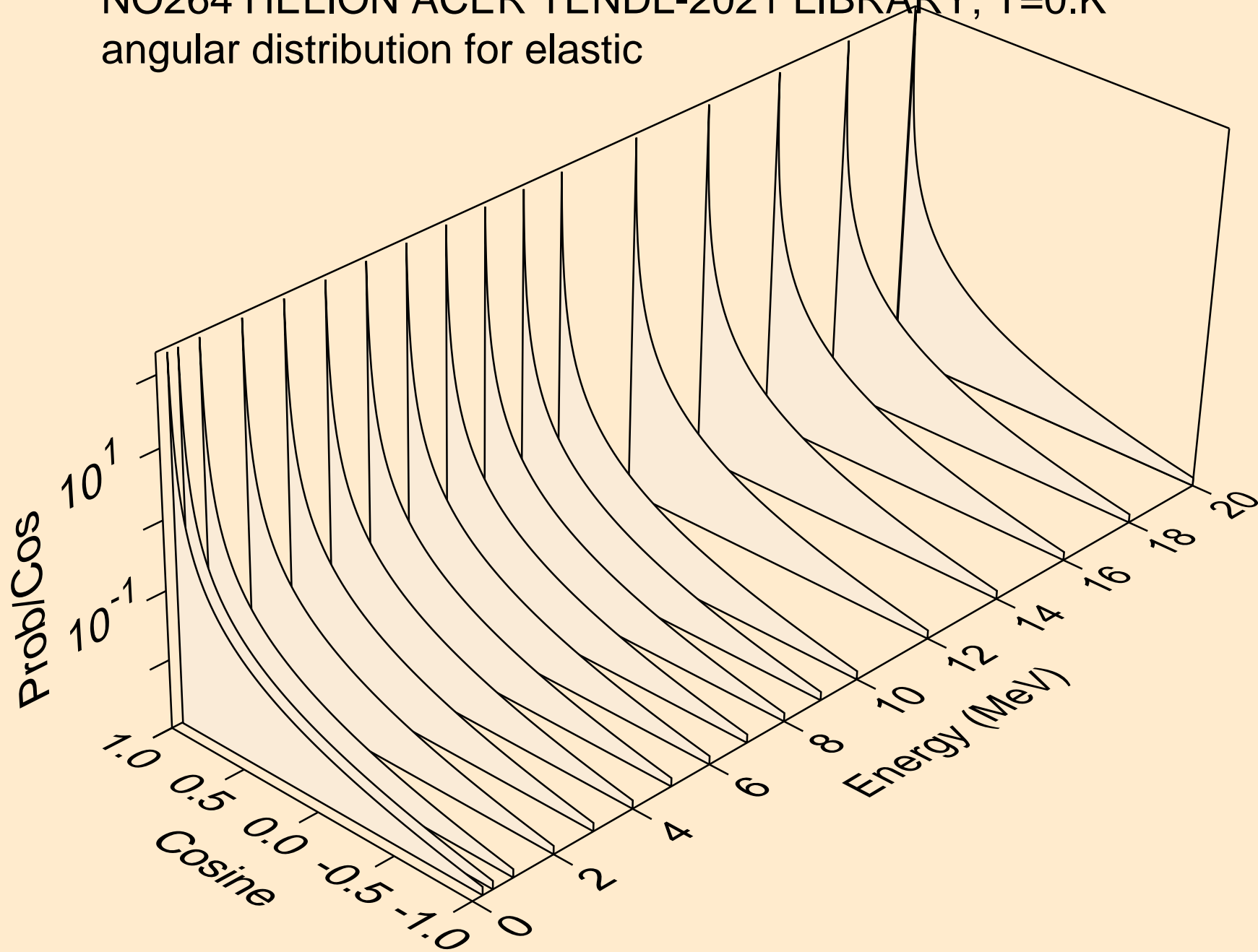



NO264 HELION ACER TENDL-2021 LIBRARY; T=0.K  
angular distribution for elastic

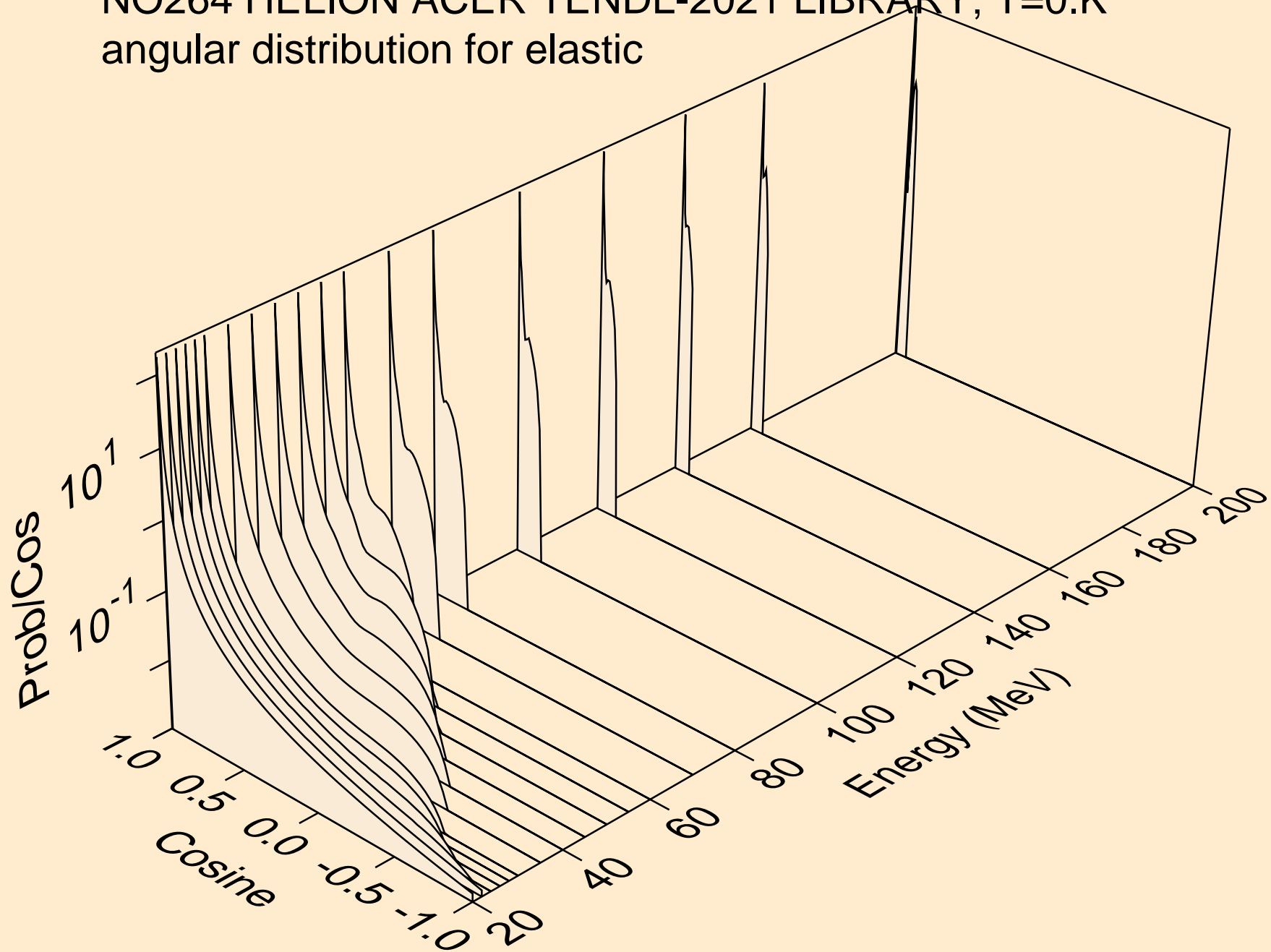

NO264 HELION ACER TENDL-2021 LIBRARY; T=0.K  
He-3 emission for (s,x)

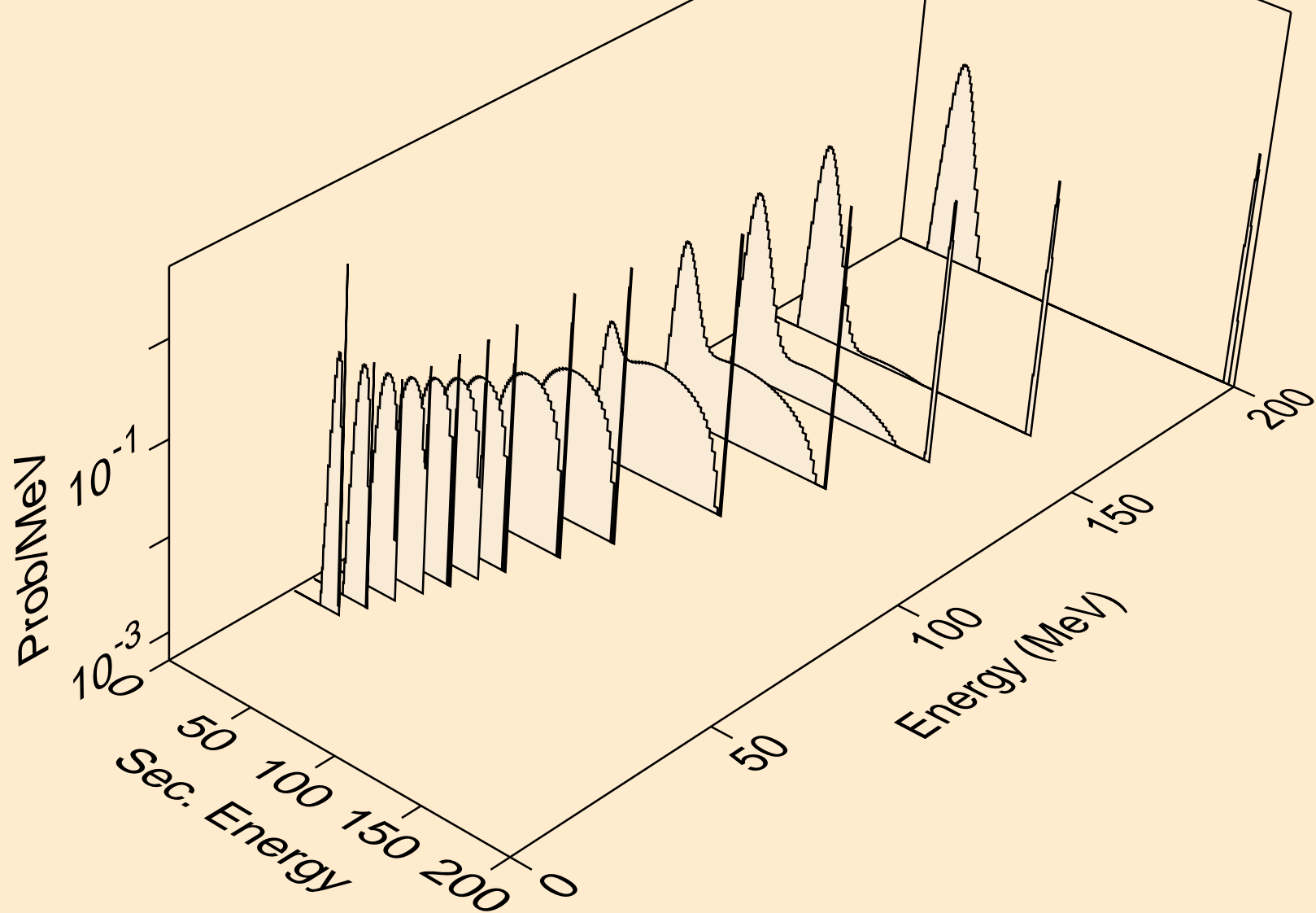

NO264 HELION ACER TENDL-2021 LIBRARY; T=0.K  
He-3 emission for inelastic

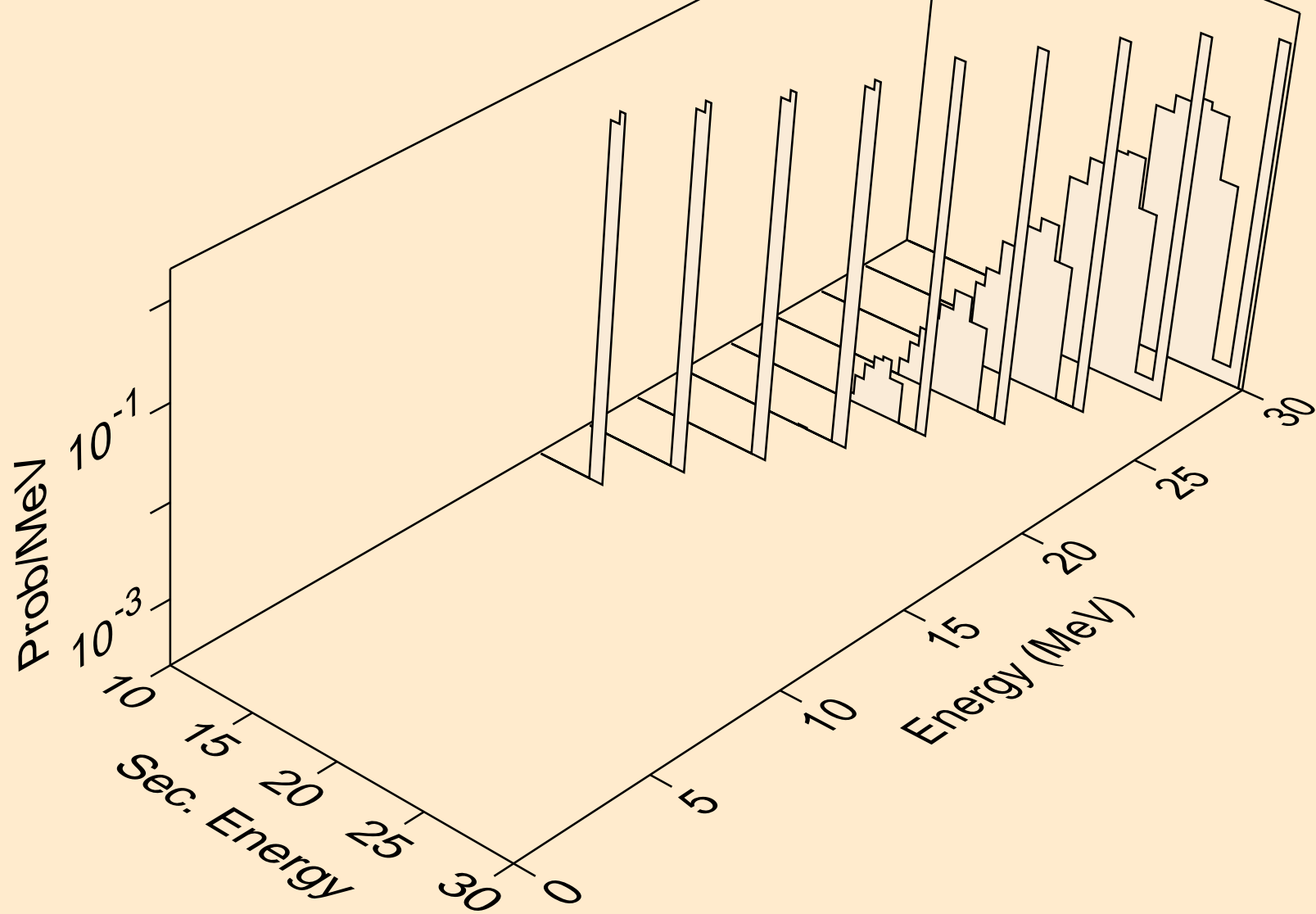

NO264 HELION ACER TENDL-2021 LIBRARY; T=0.K  
Photon emission for (z,n)

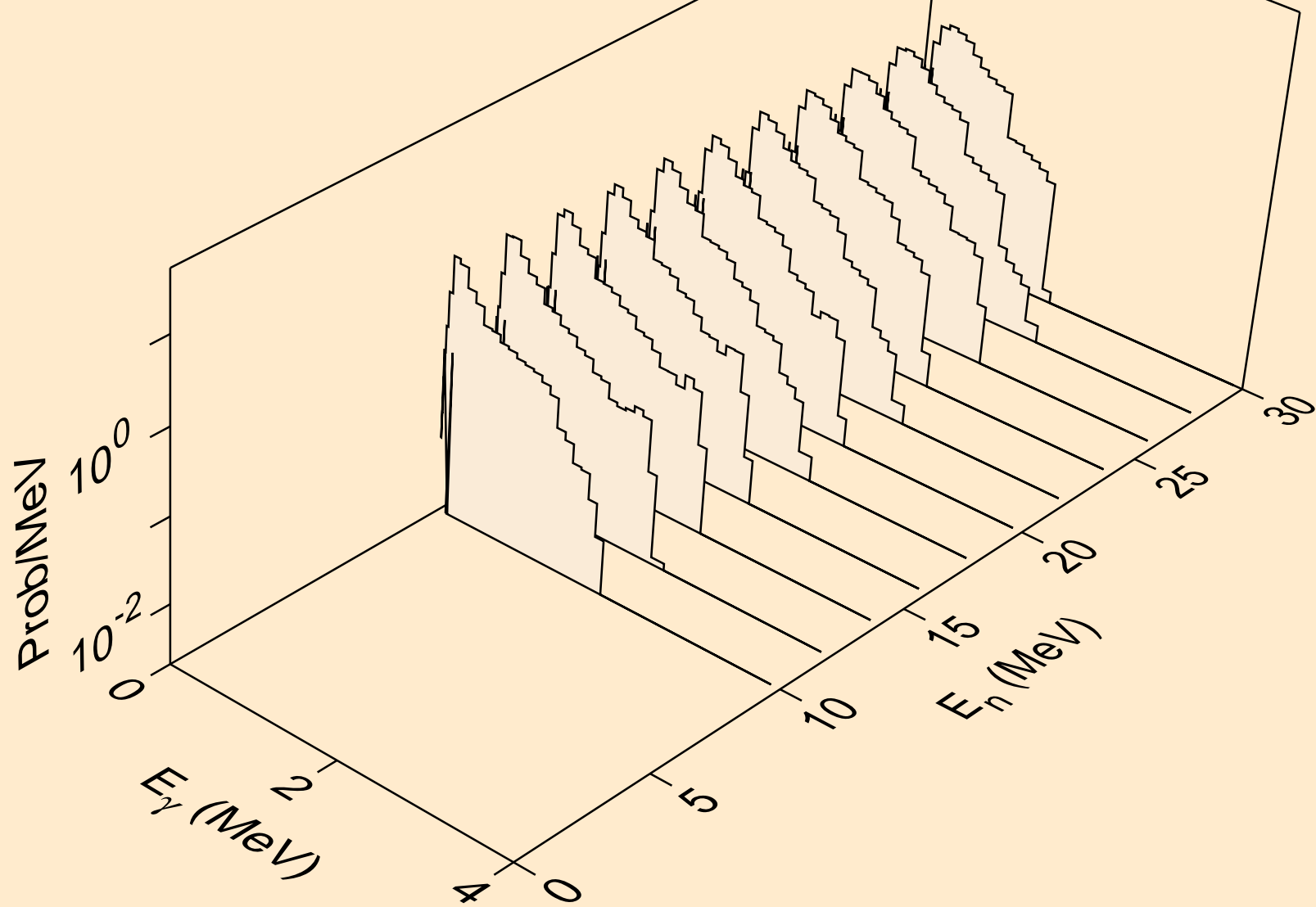

NO264 HELION ACER TENDL-2021 LIBRARY; T=0.K  
Photon emission for (n,x)

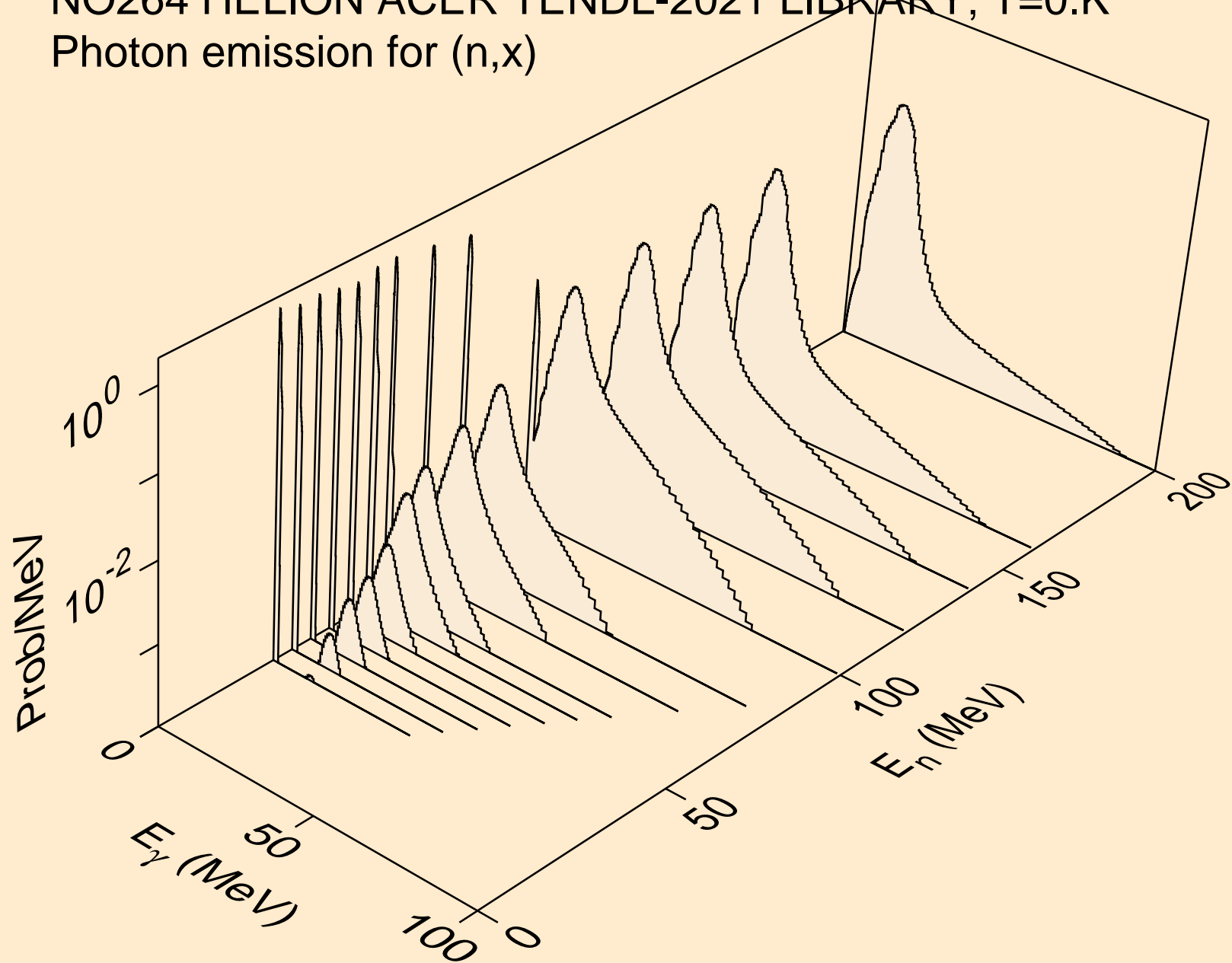

NO264 HELION ACER TENDL-2021 LIBRARY; T=0.K  
Photon emission for (n,2n)

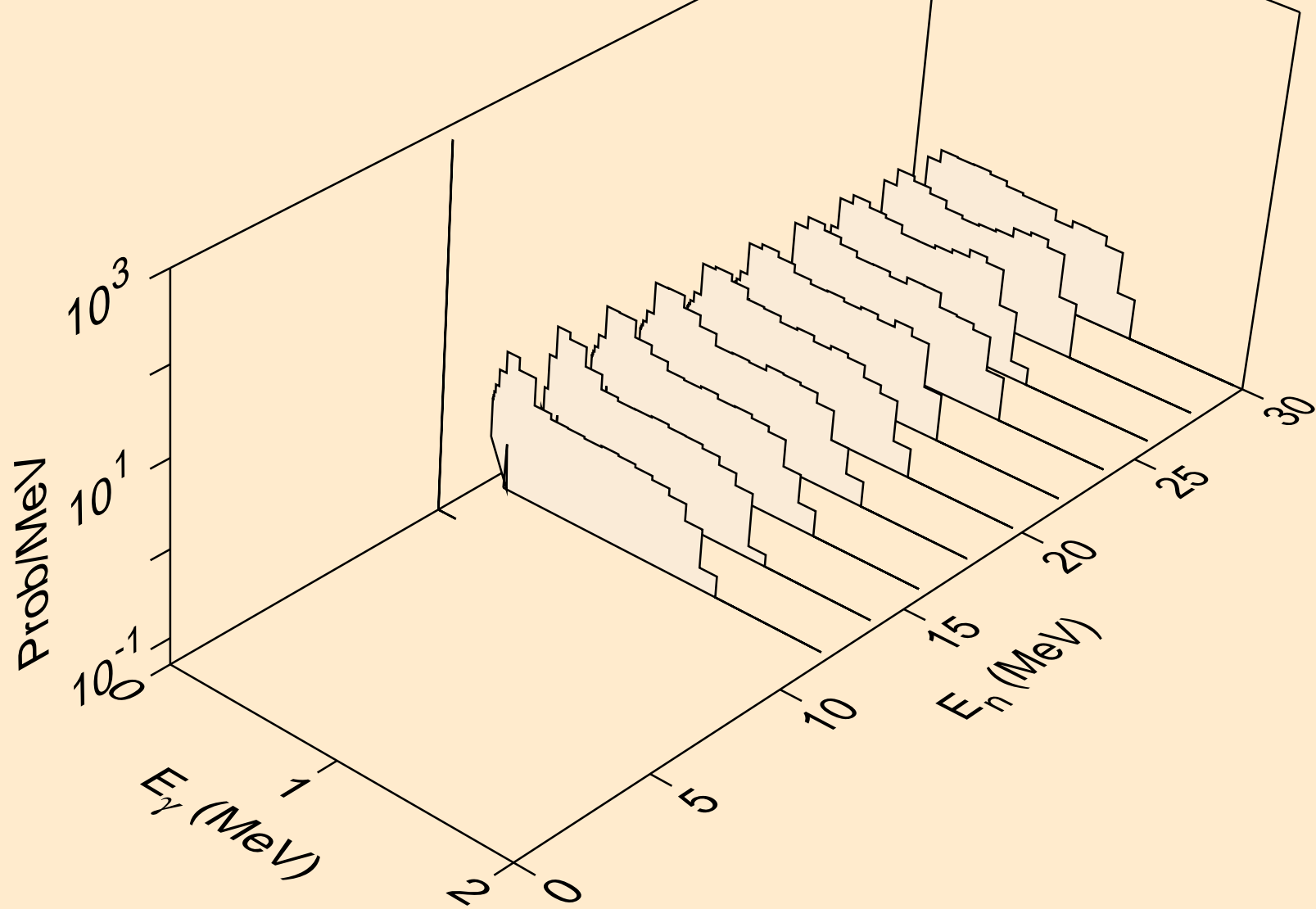

NO264 HELION ACER TENDL-2021 LIBRARY; T=0.K  
Photon emission for (n,3n)

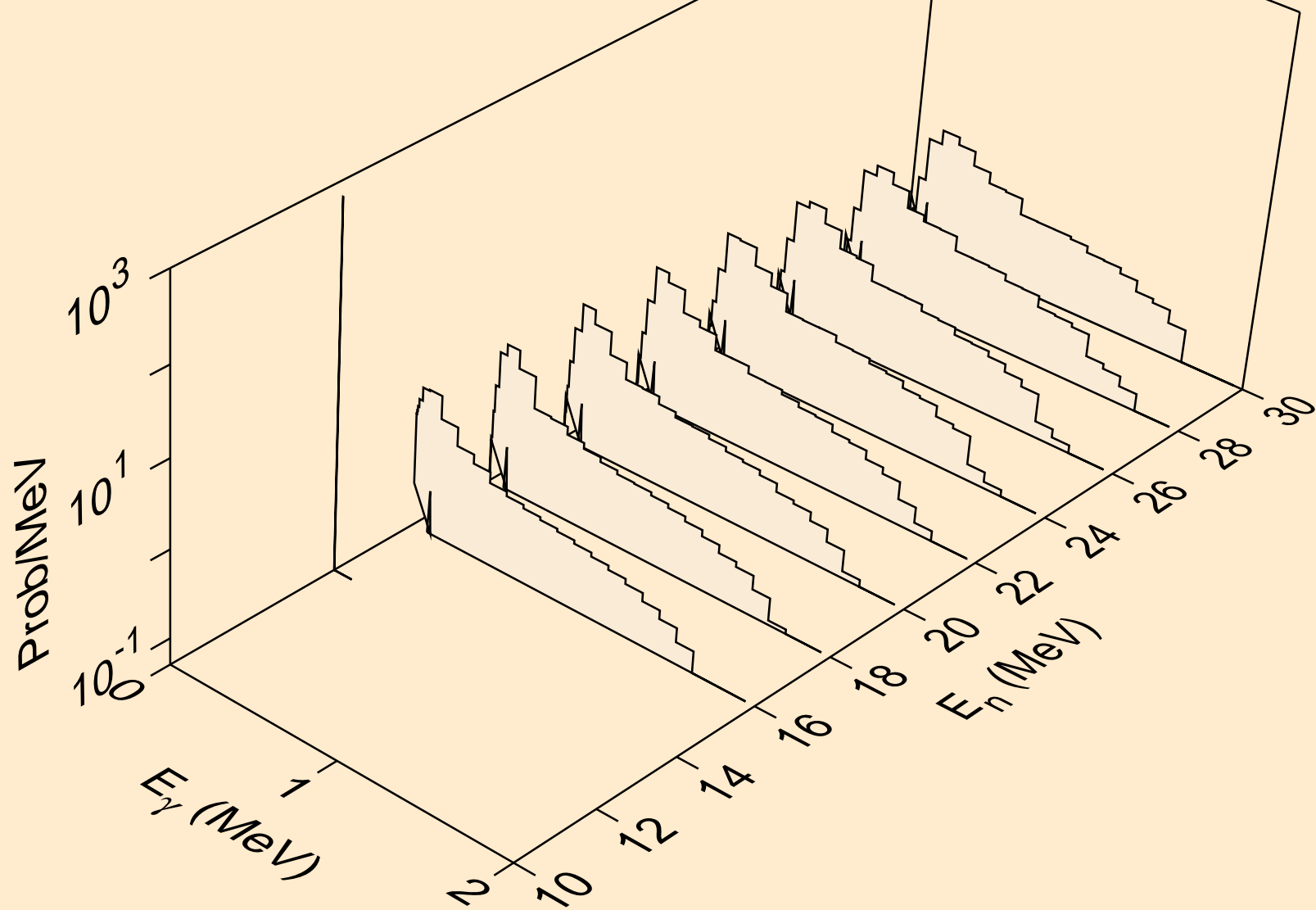

NO264 HELION ACER TENDL-2021 LIBRARY; T=0.K  
Photon emission for (n,n\*)p

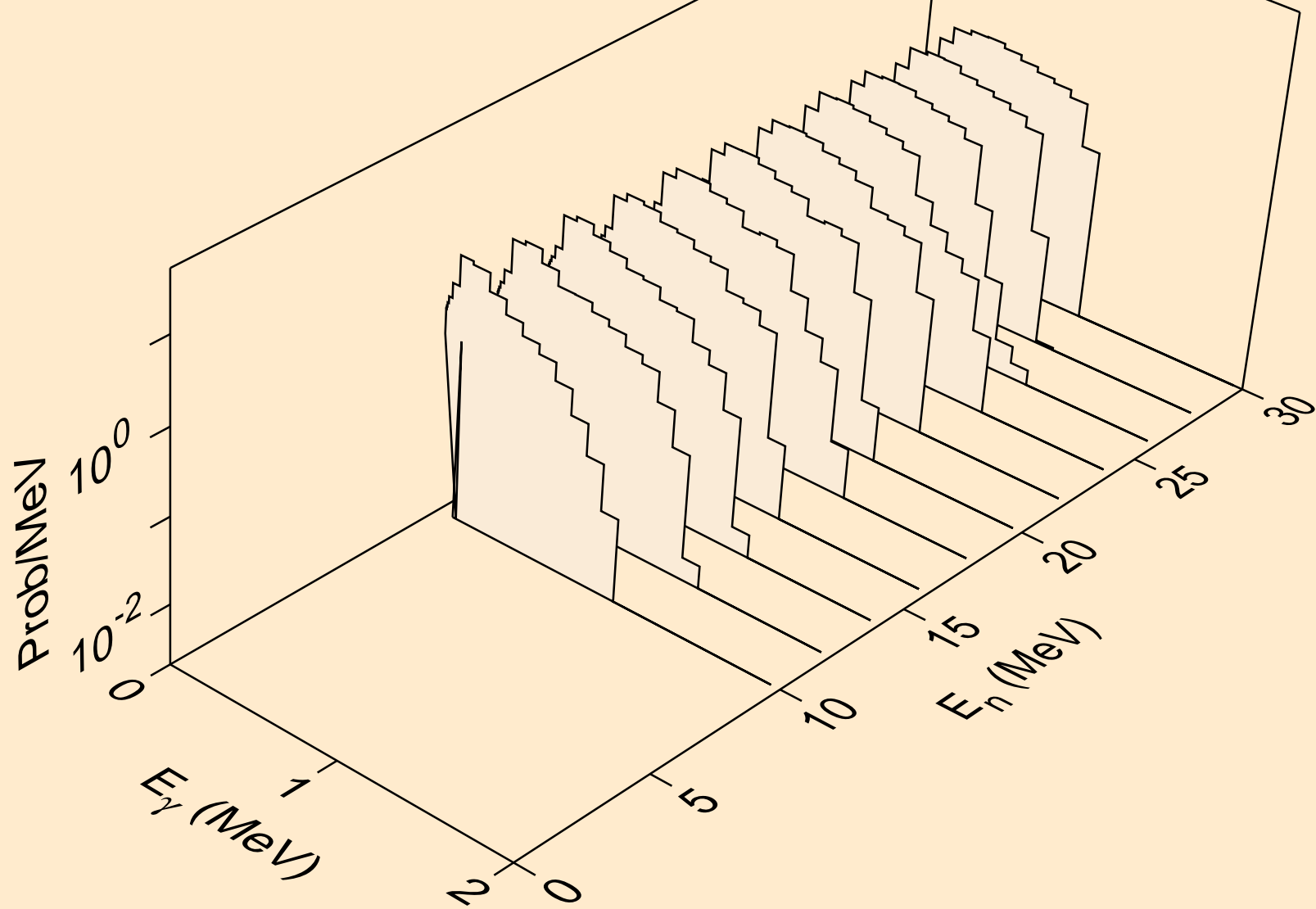



NO264 HELION ACER TENDL-2021 LIBRARY; T=0.K  
Photon emission for (n,n\*)d

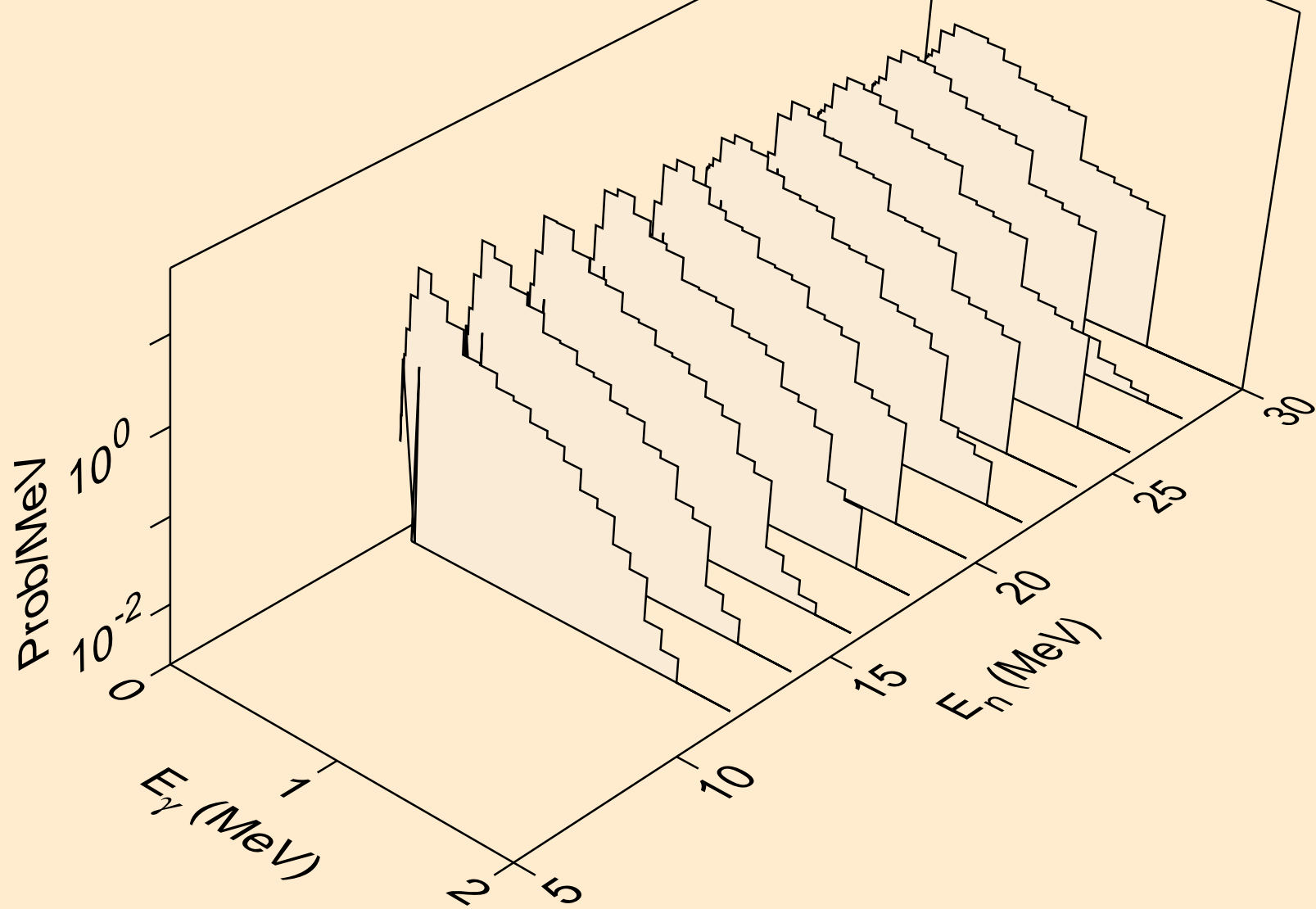

NO264 HELION ACER TENDL-2021 LIBRARY; T=0.K  
Photon emission for (n,n\*)t

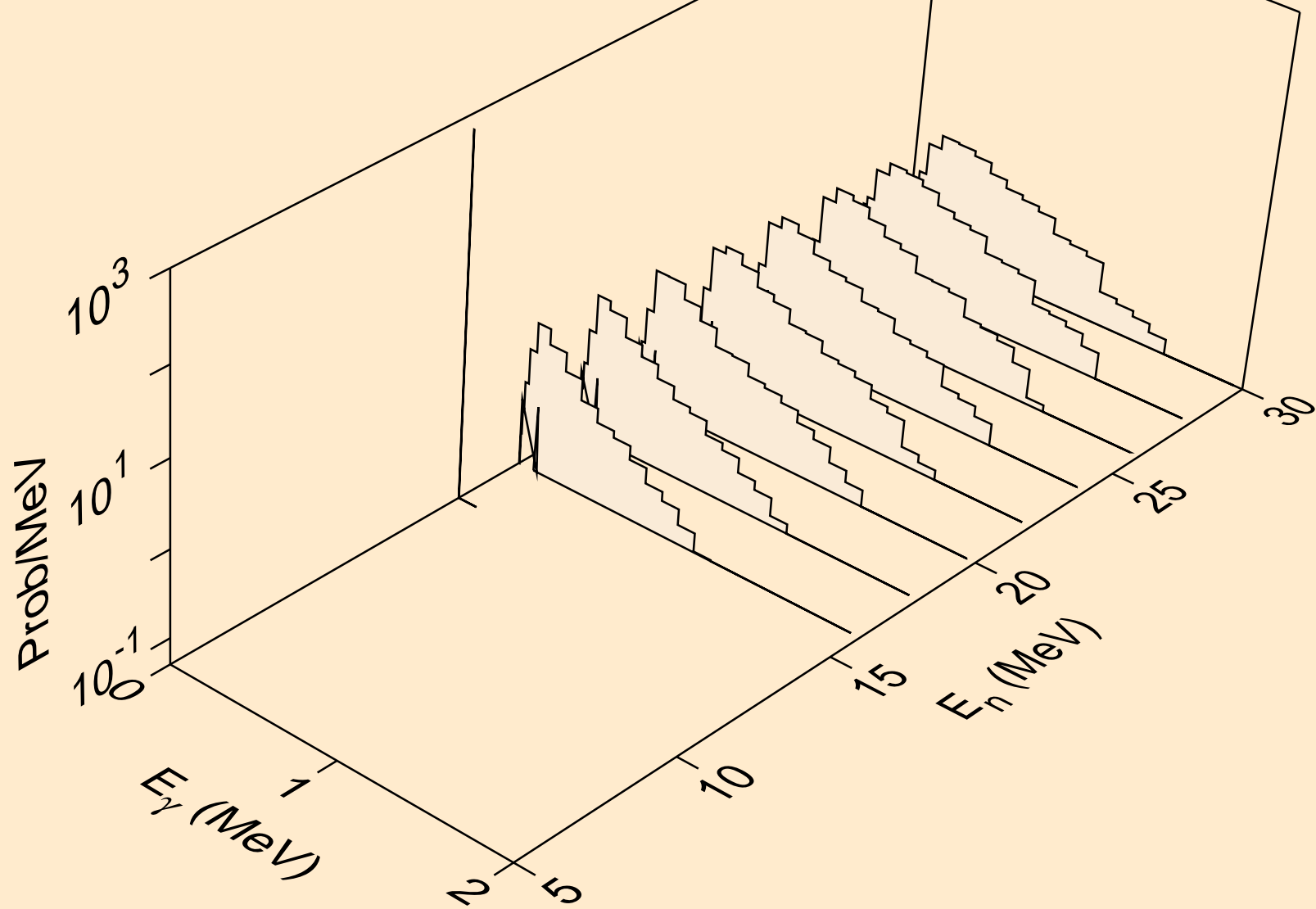

NO264 HELION ACER TENDL-2021 LIBRARY; T=0.K  
Photon emission for (n,2np)

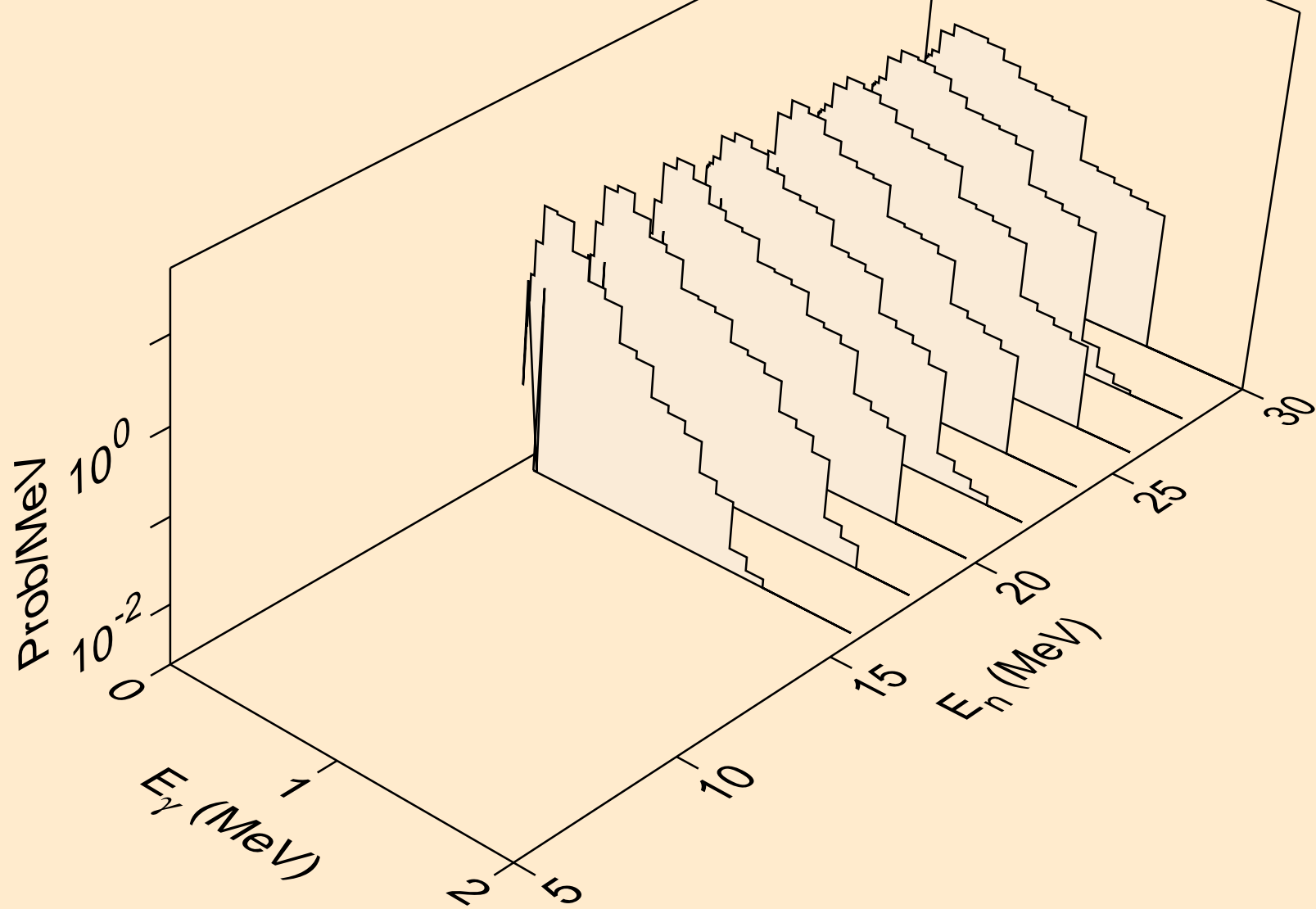

NO264 HELION ACER TENDL-2021 LIBRARY; T=0.K  
Photon emission for (n,p)

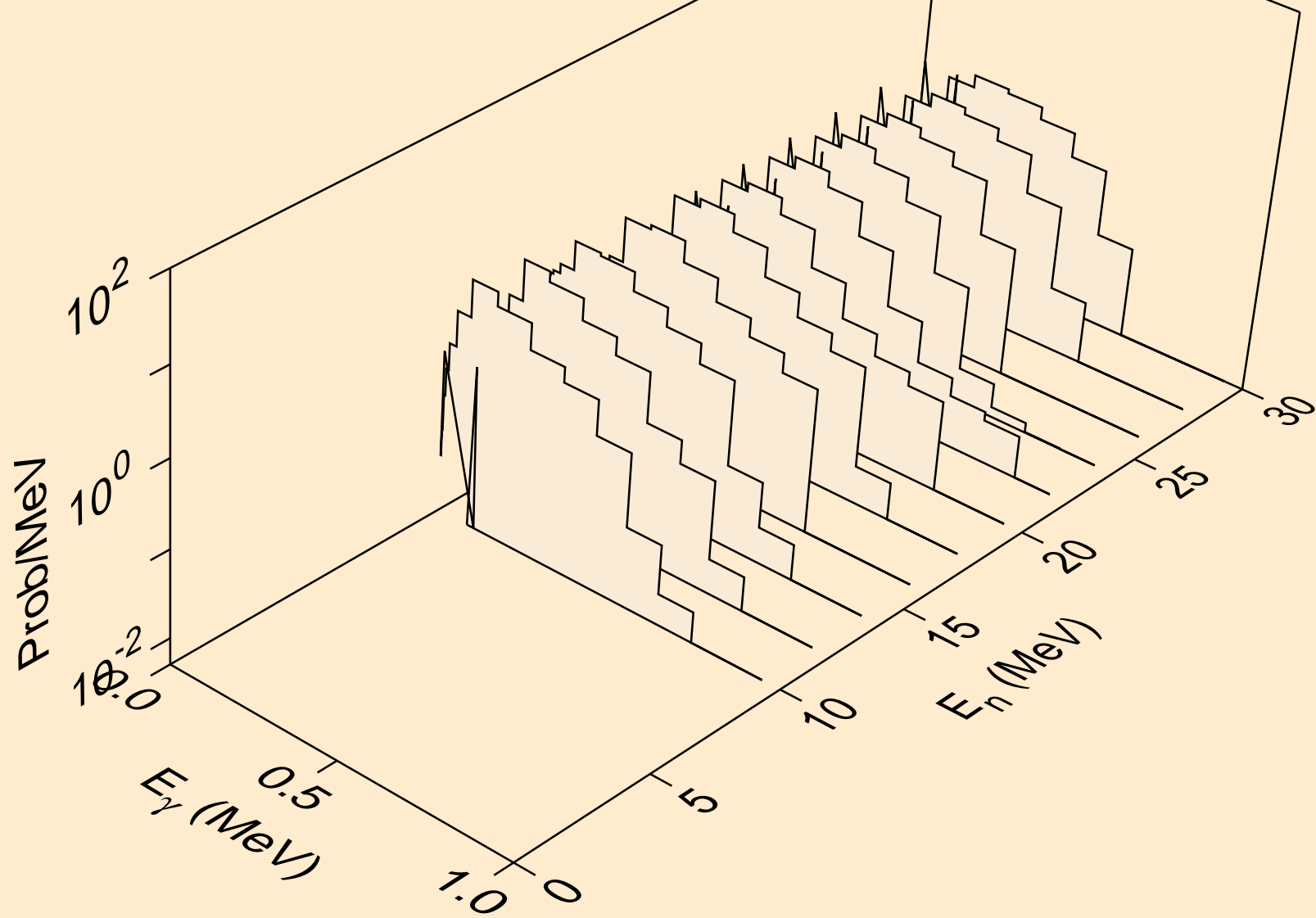

NO264 HELION ACER TENDL-2021 LIBRARY; T=0.K  
Photon emission for (n,d)

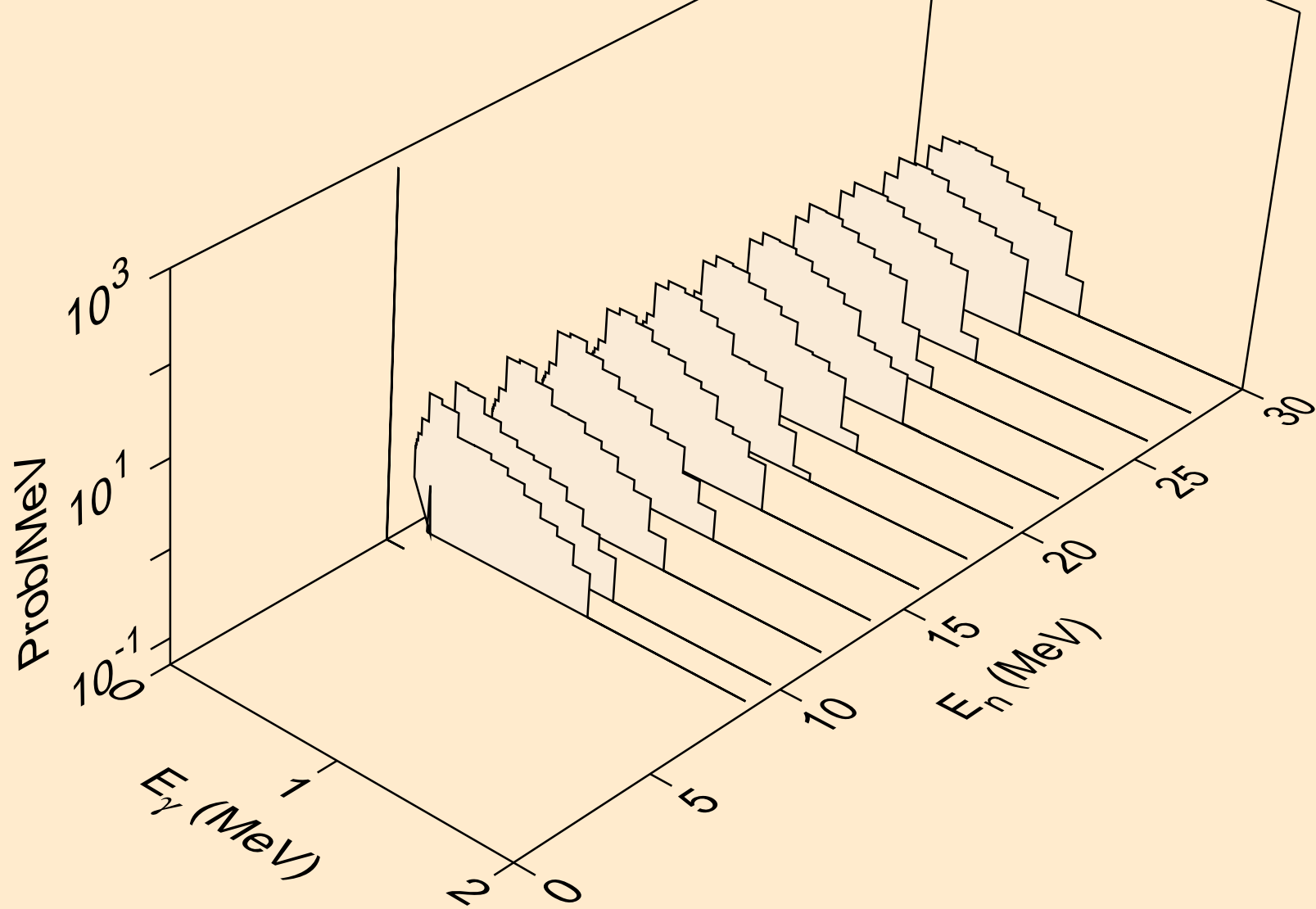

NO264 HELION ACER TENDL-2021 LIBRARY; T=0.K  
Photon emission for (n,t)

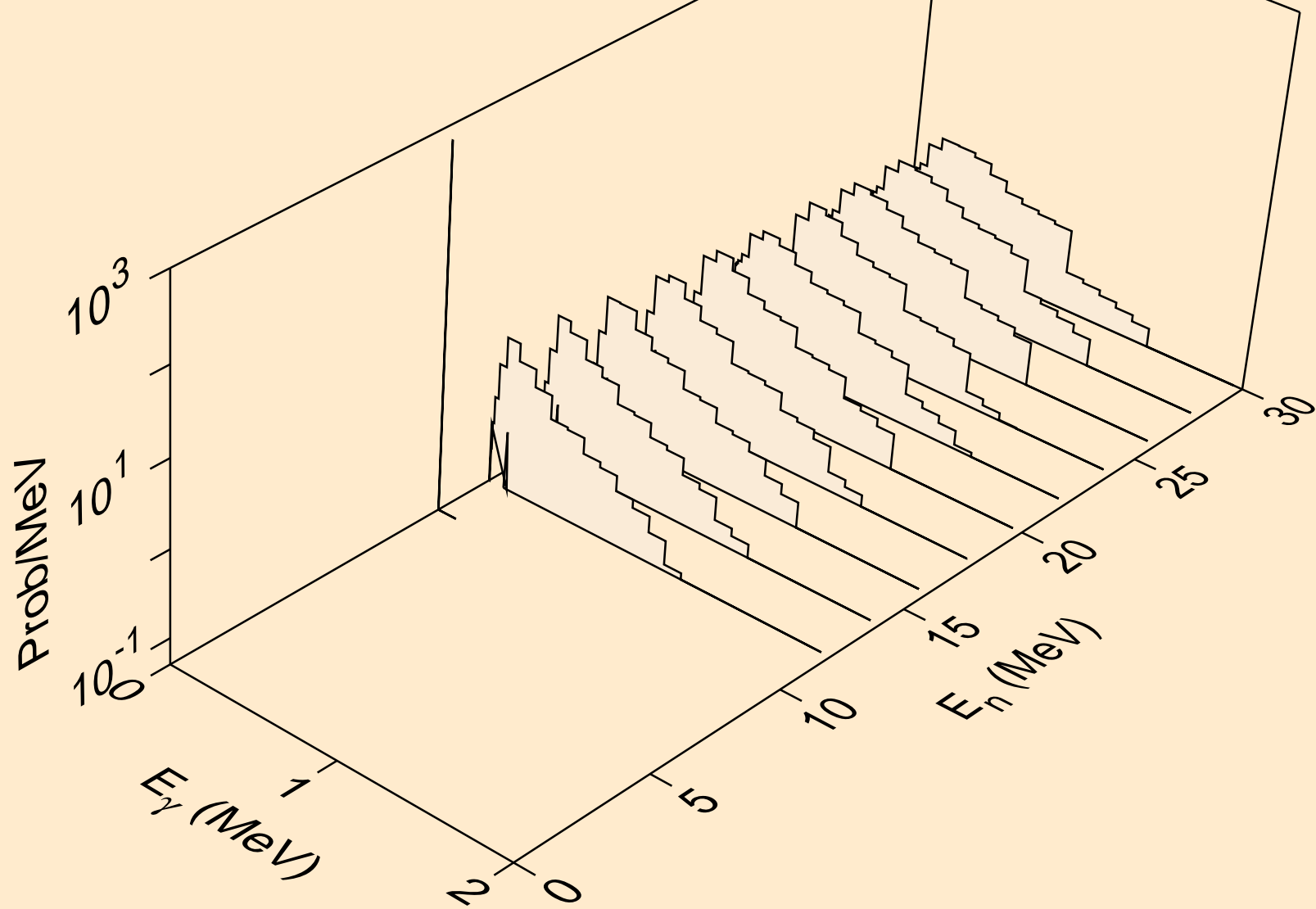

NO264 HELION ACER TENDL-2021 LIBRARY; T=0.K  
Photon emission for inelastic

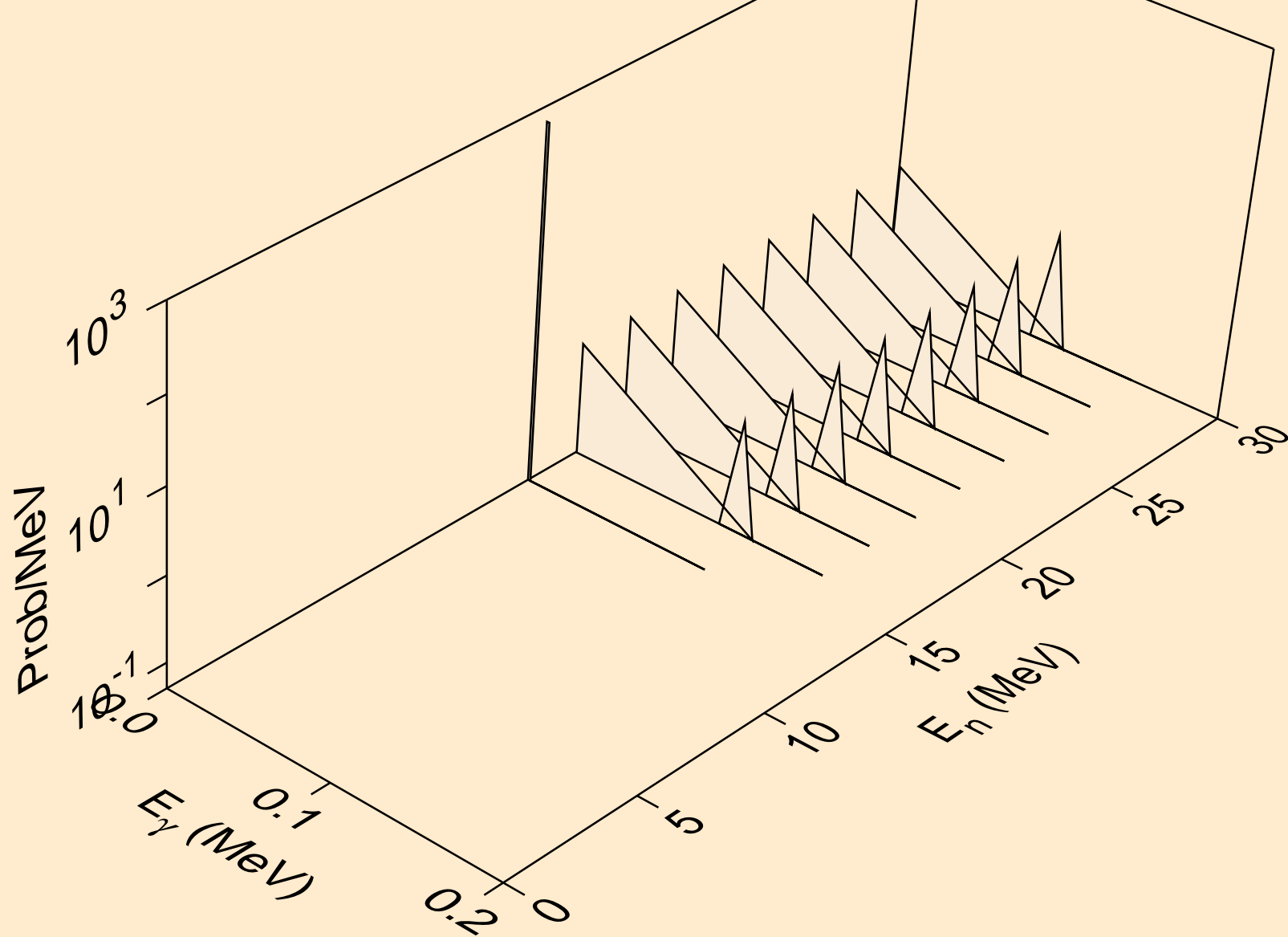

NO264 HELION ACER TENDL-2021 LIBRARY; T=0.K  
Photon emission for (n,a)

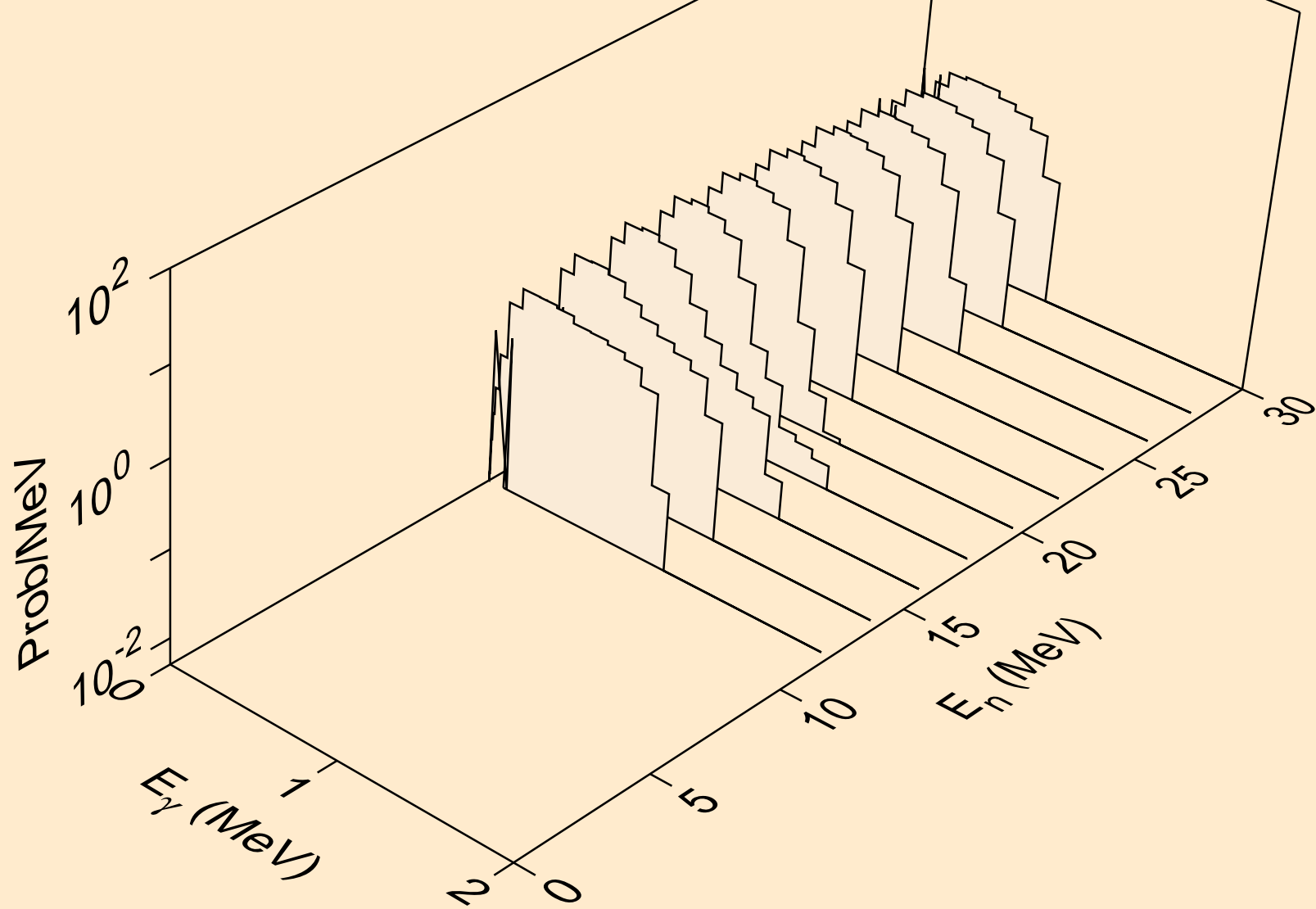



NO264 HELION ACER TENDL-2021 LIBRARY; T=0.K  
Particle heating contributions

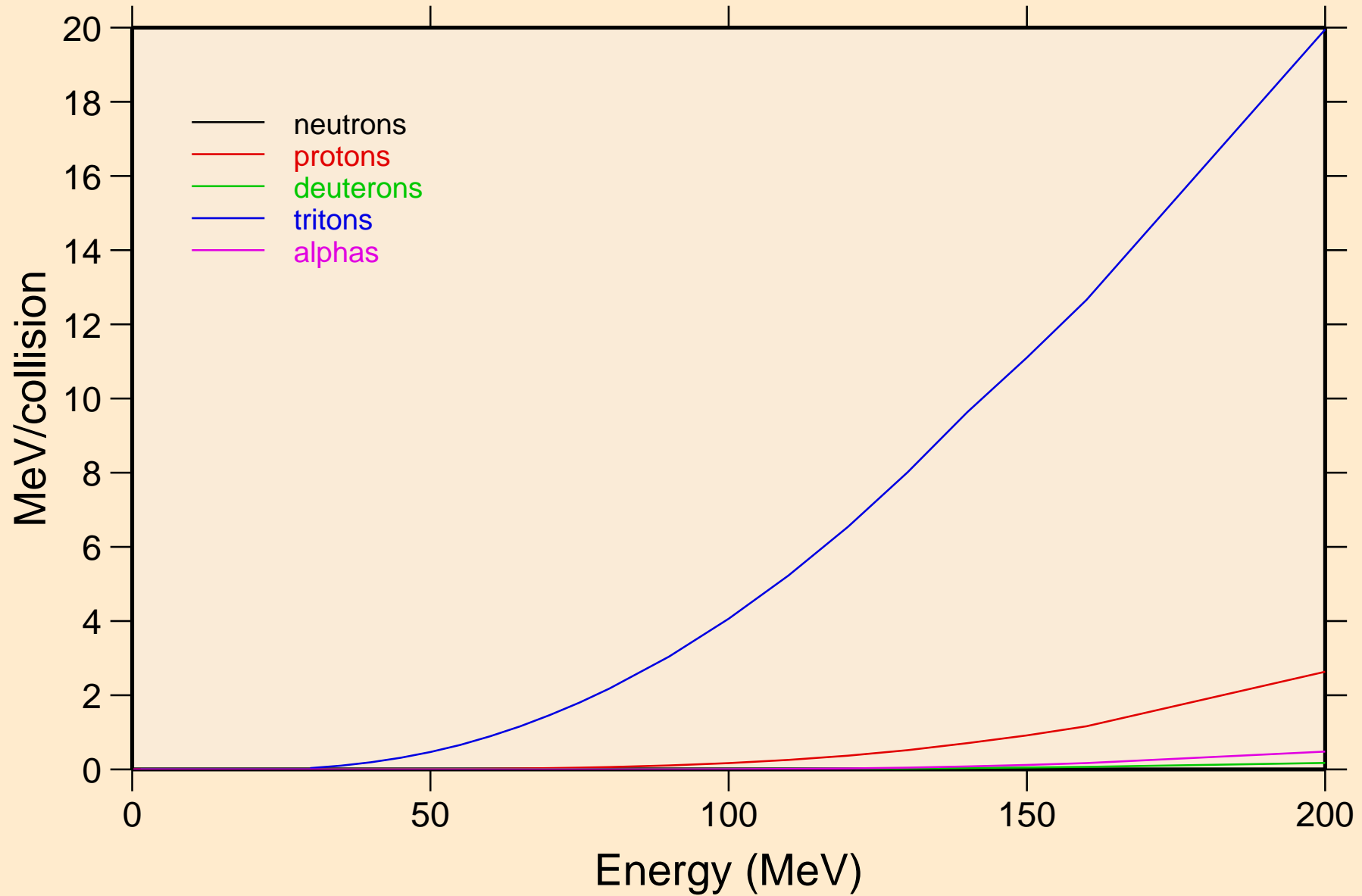

NO264 HELION ACER TENDL-2021 LIBRARY; T=0.K  
Recoil Heating

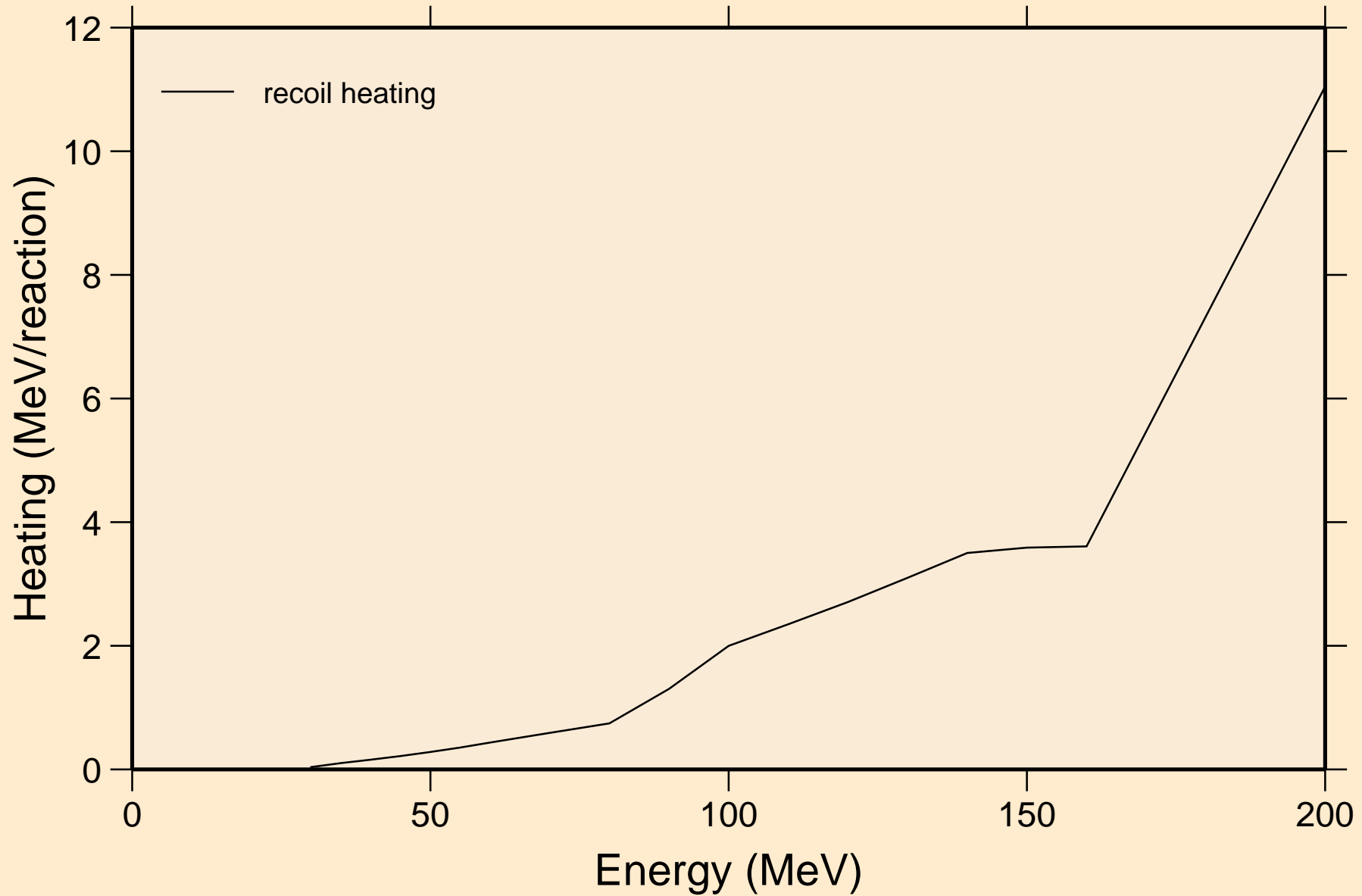

NO264 HELION ACER TENDL-2021 LIBRARY; T=0.K  
Particle production cross sections

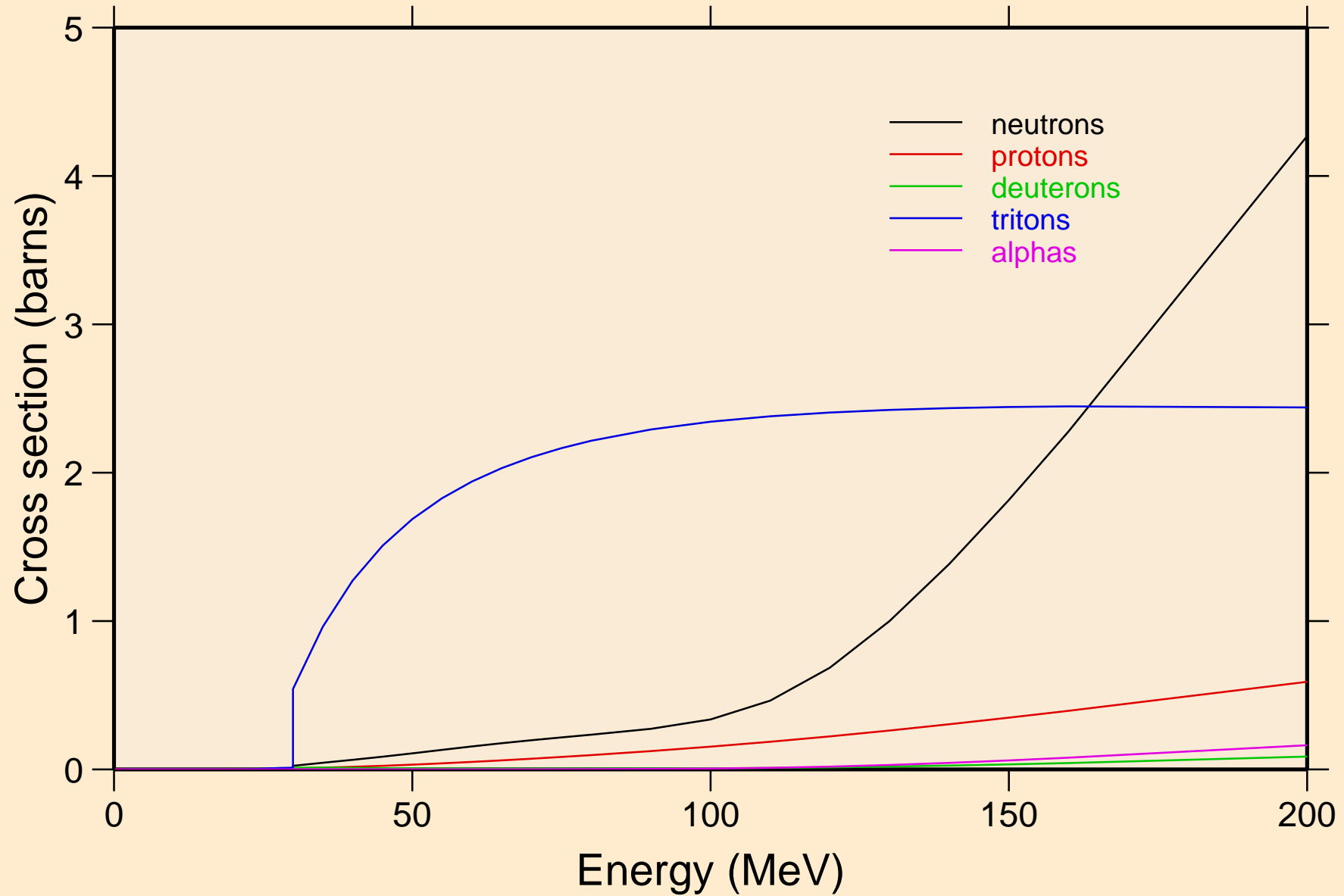

NO264 HELION ACER TENDL-2021 LIBRARY; T=0.K  
neutrons from (s,n)

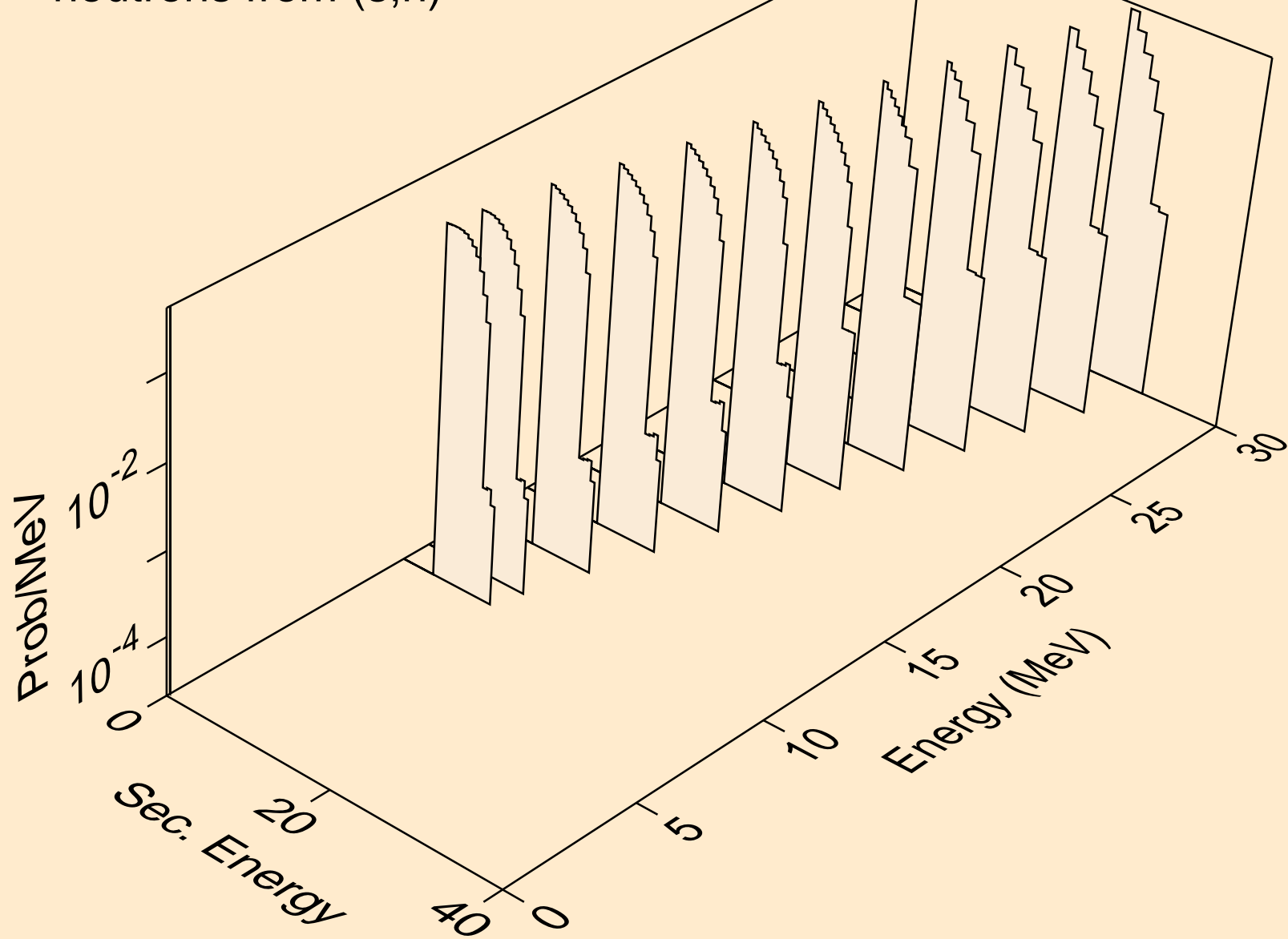

NO264 HELION ACER TENDL-2021 LIBRARY; T=0.K  
neutrons from (s,x)

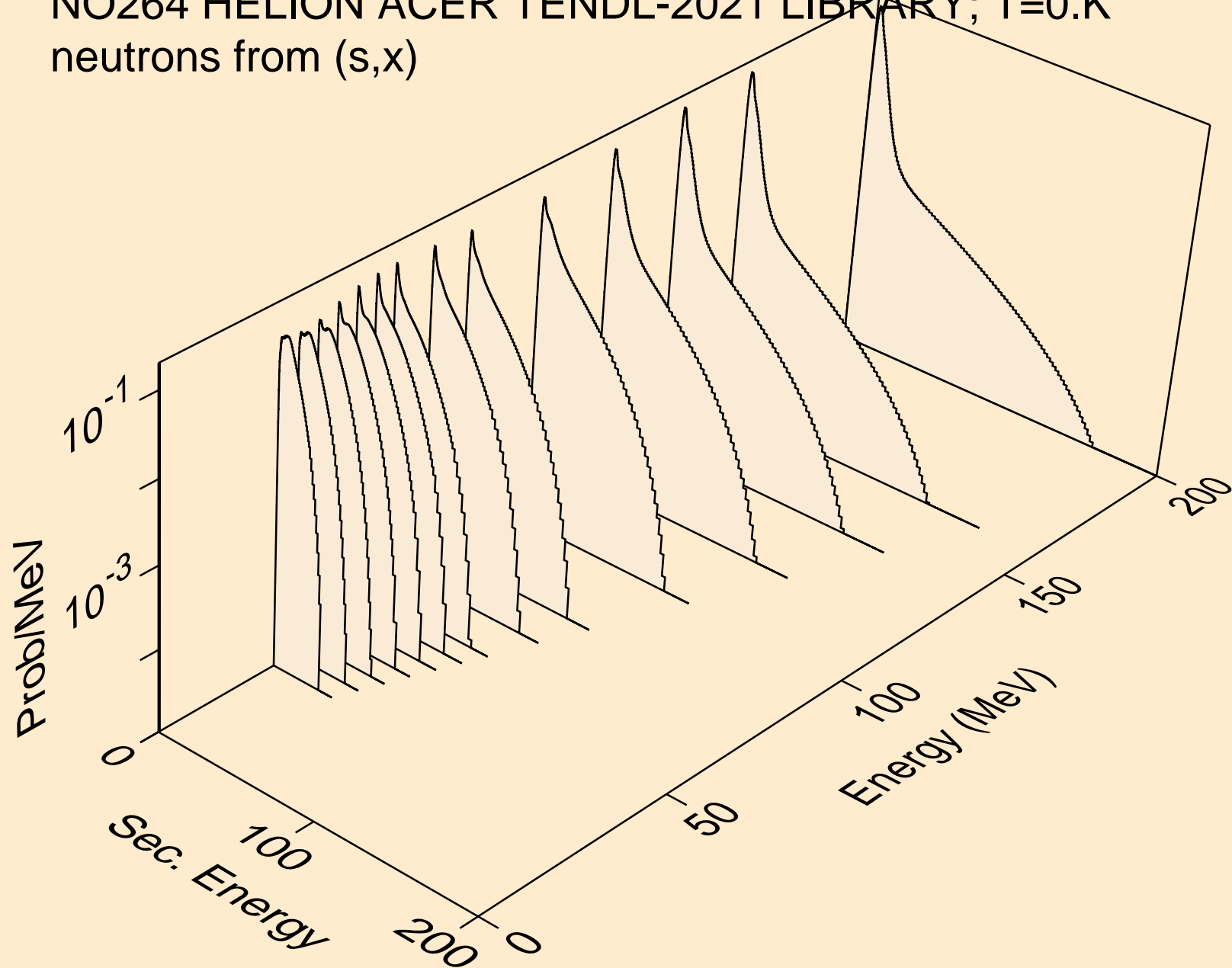

NO264 HELION ACER TENDL-2021 LIBRARY; T=0.K  
neutrons from (s,2n)

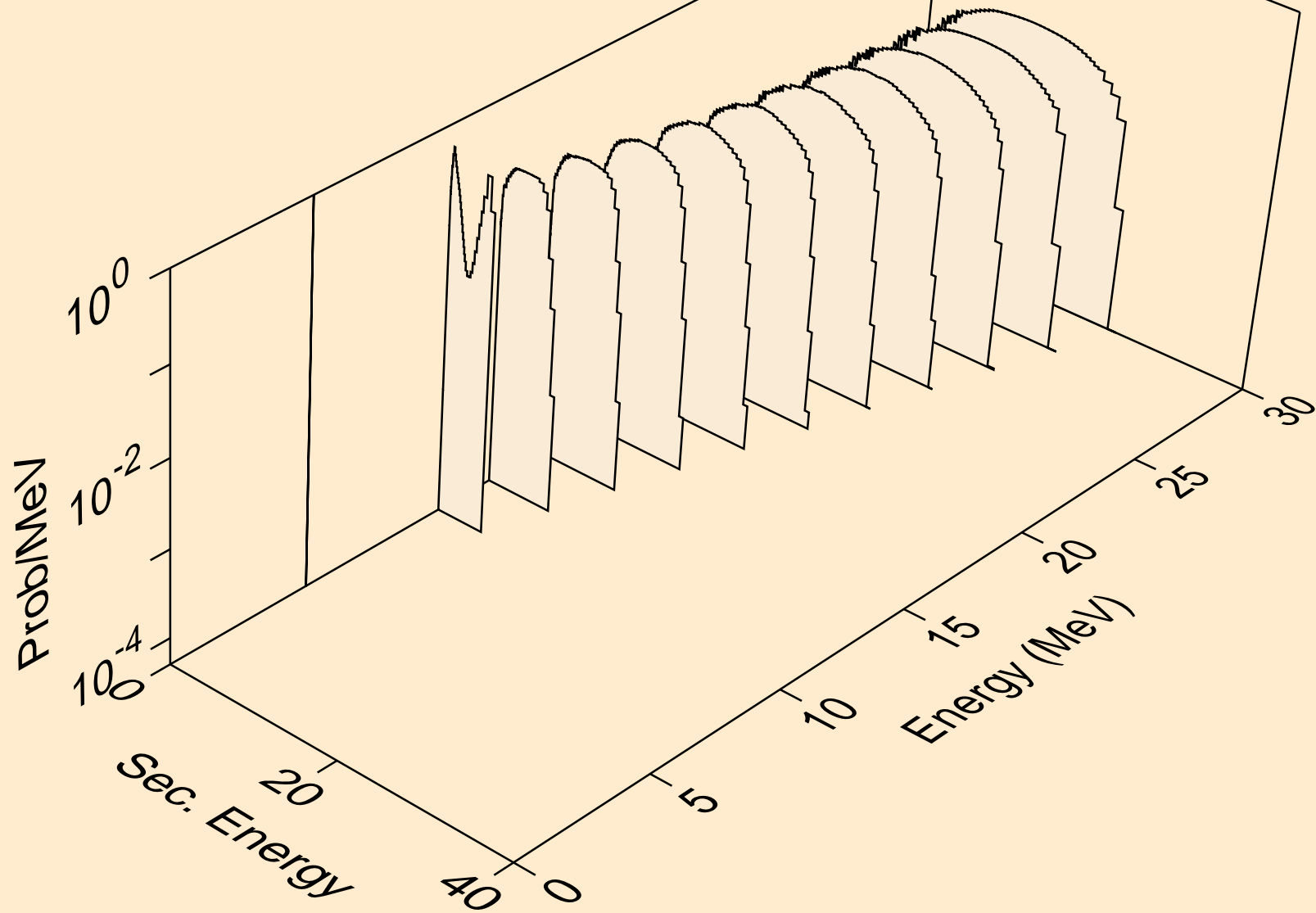

NO264 HELION ACER TENDL-2021 LIBRARY; T=0.K  
neutrons from (s,3n)

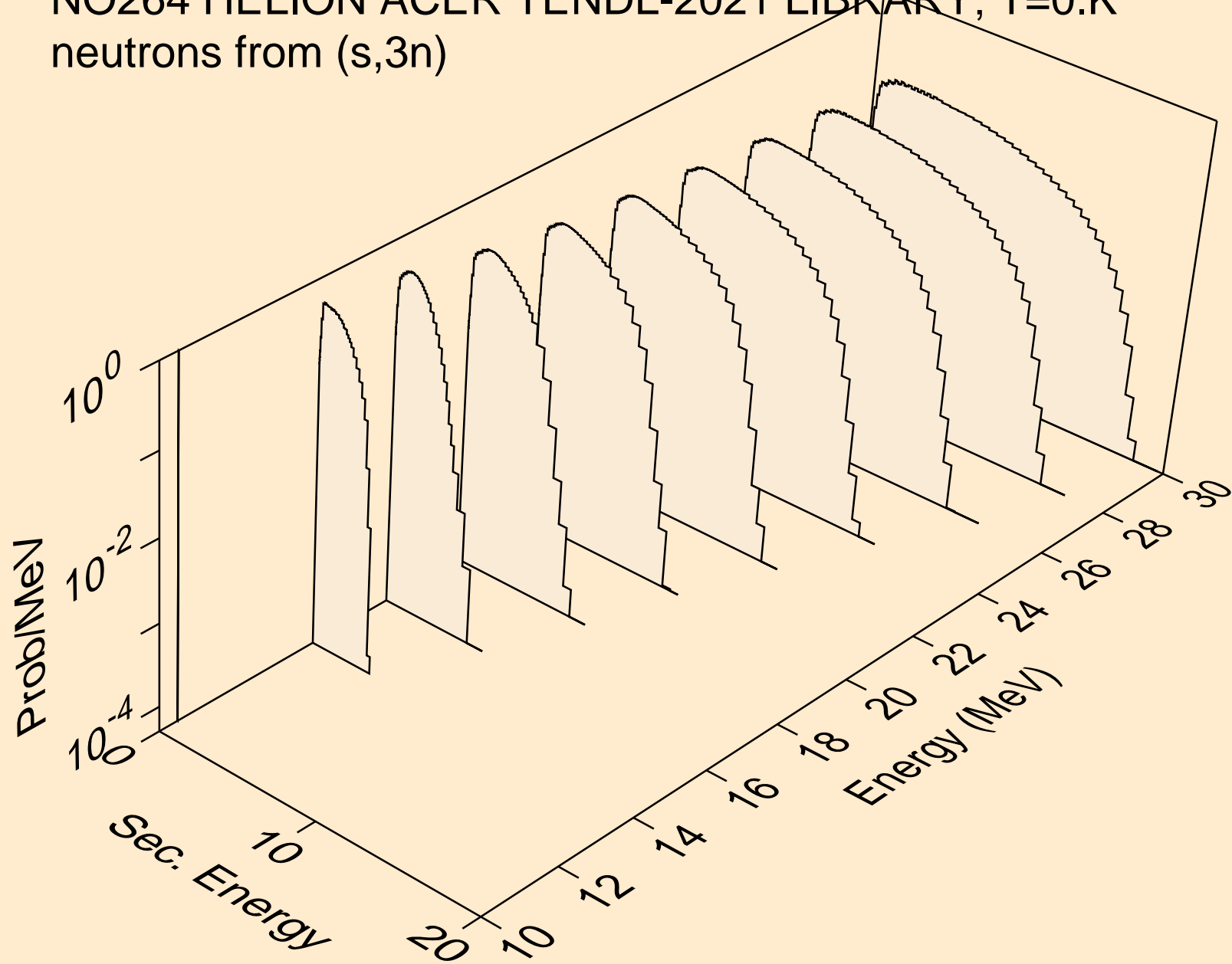

NO264 HELION ACER TENDL-2021 LIBRARY; T=0.K  
neutrons from (s,n\*)p

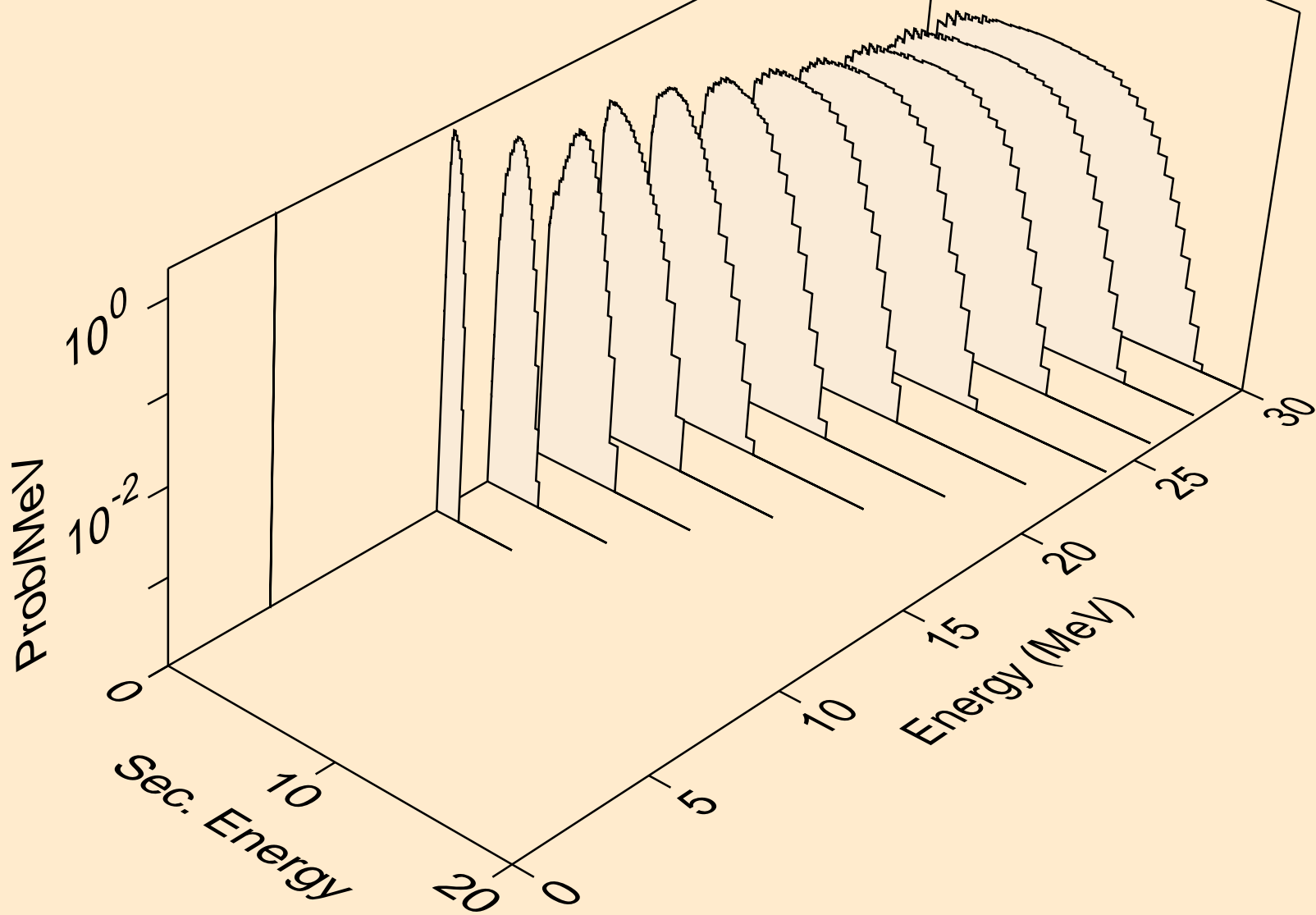



NO264 HELION ACER TENDL-2021 LIBRARY; T=0.K  
neutrons from (s,n\*)d

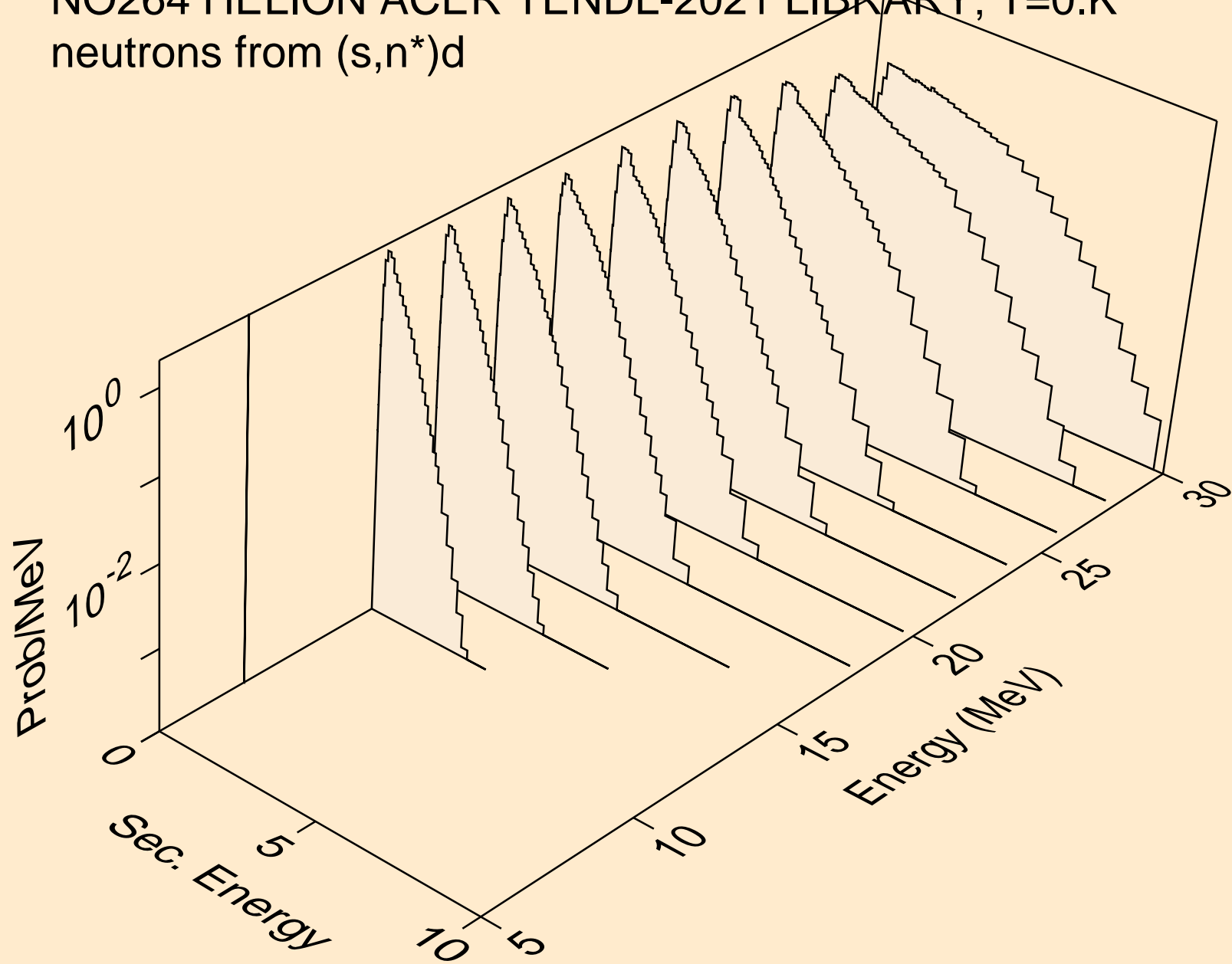

NO264 HELION ACER TENDL-2021 LIBRARY; T=0.K  
neutrons from (s,n\*)t

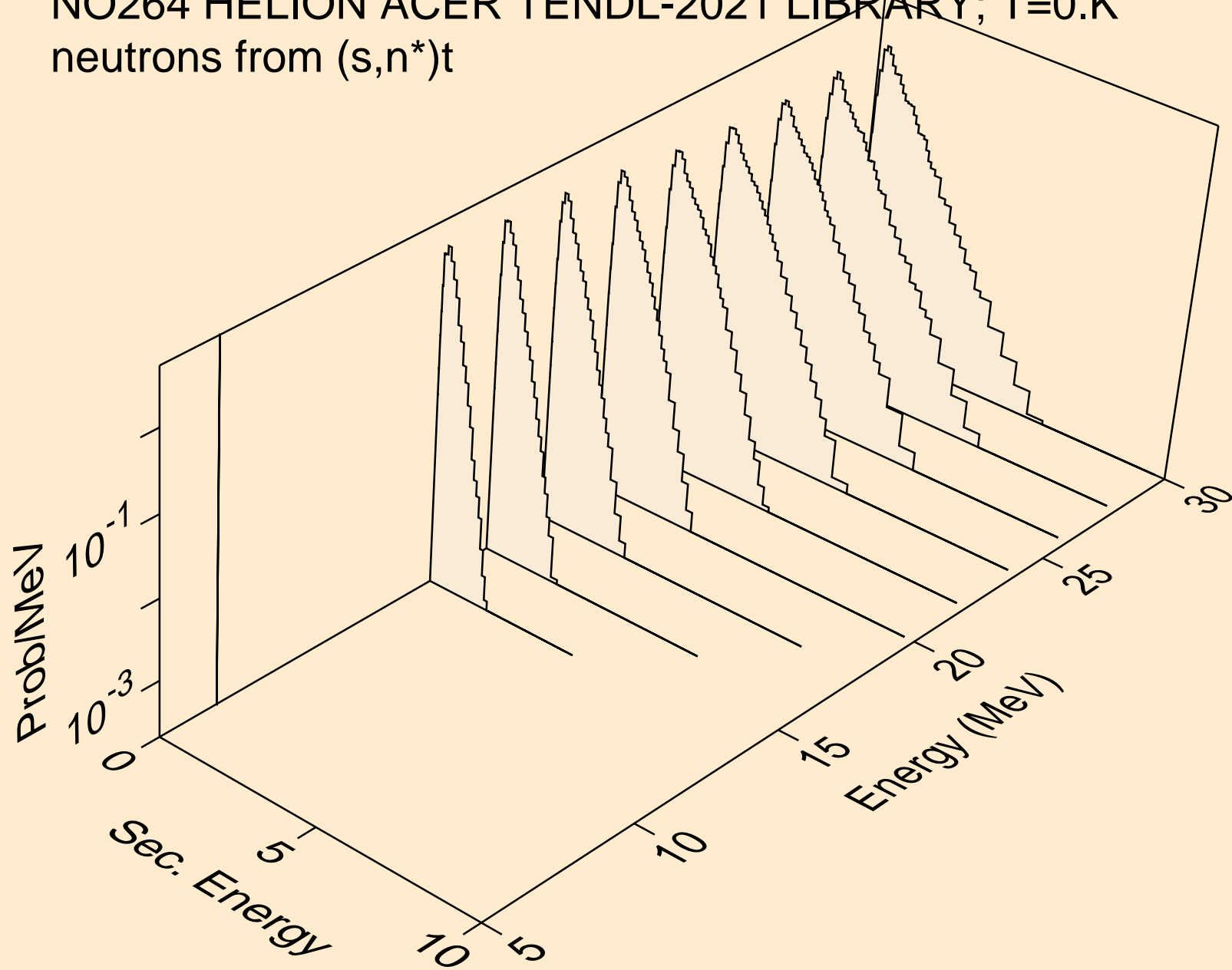

NO264 HELION ACER TENDL-2021 LIBRARY; T=0.K  
neutrons from (s,2np)

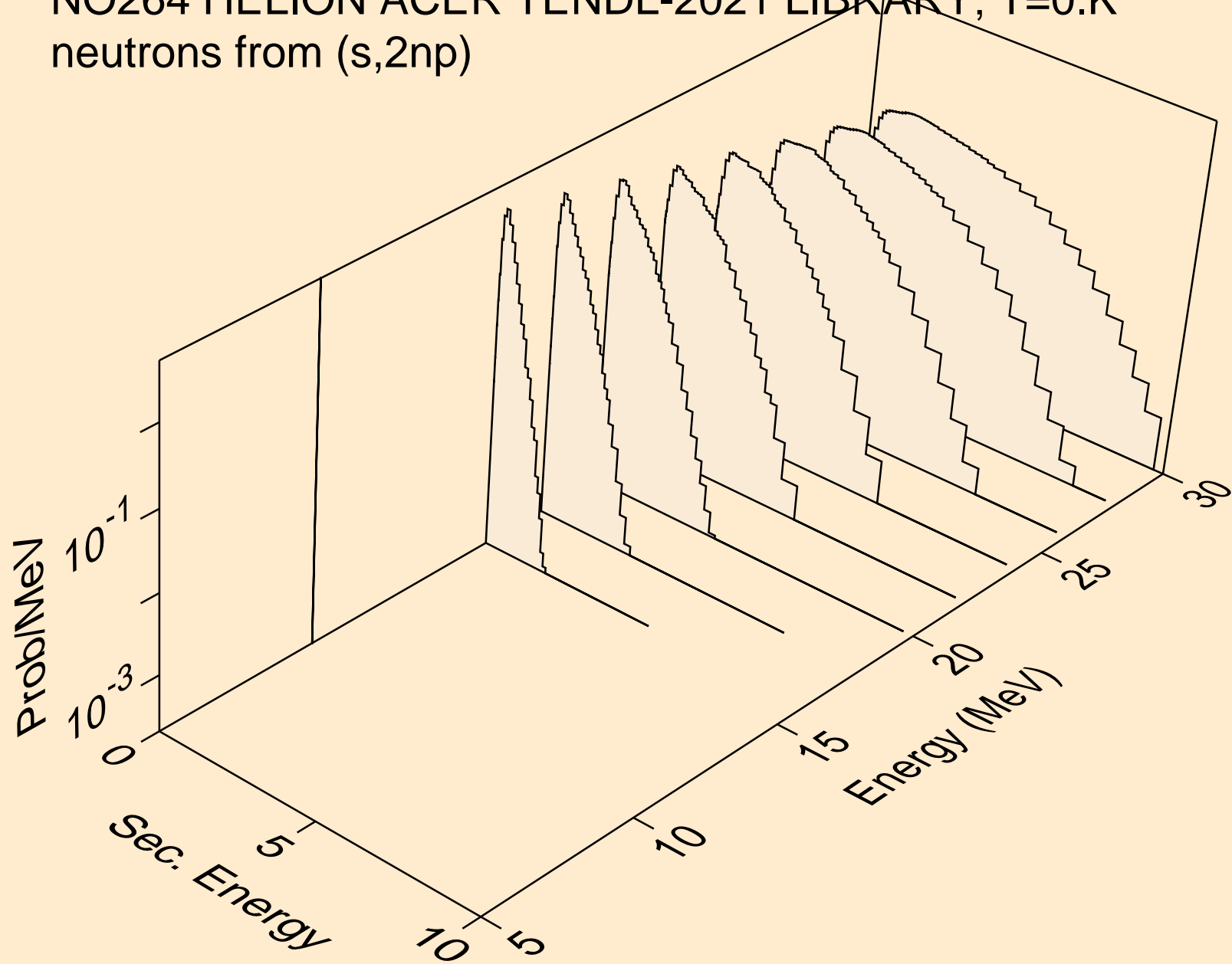

NO264 HELION ACER TENDL-2021 LIBRARY; T=0.K  
protons from (s,x)

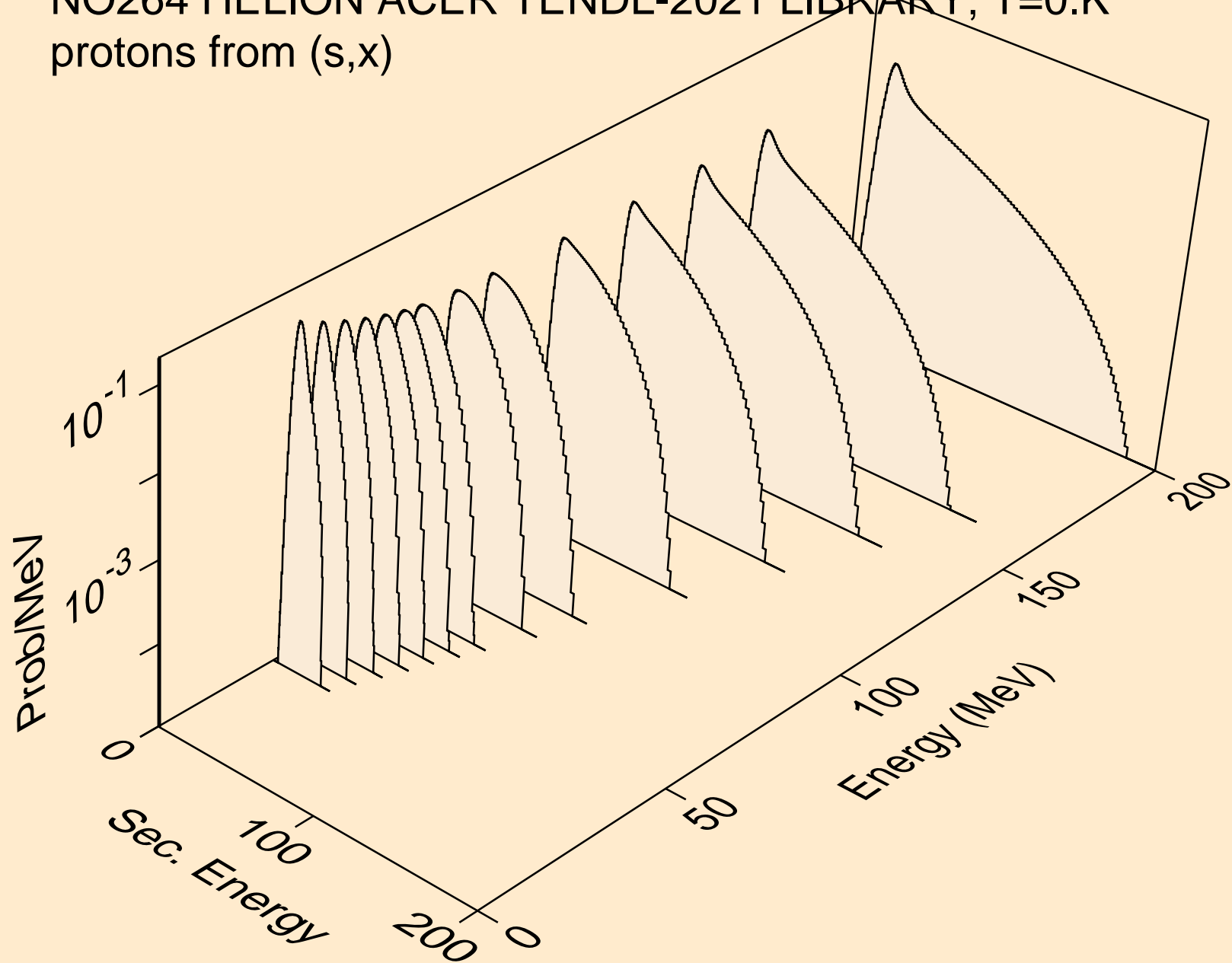

NO264 HELION ACER TENDL-2021 LIBRARY; T=0.K  
protons from (s,n\*)p

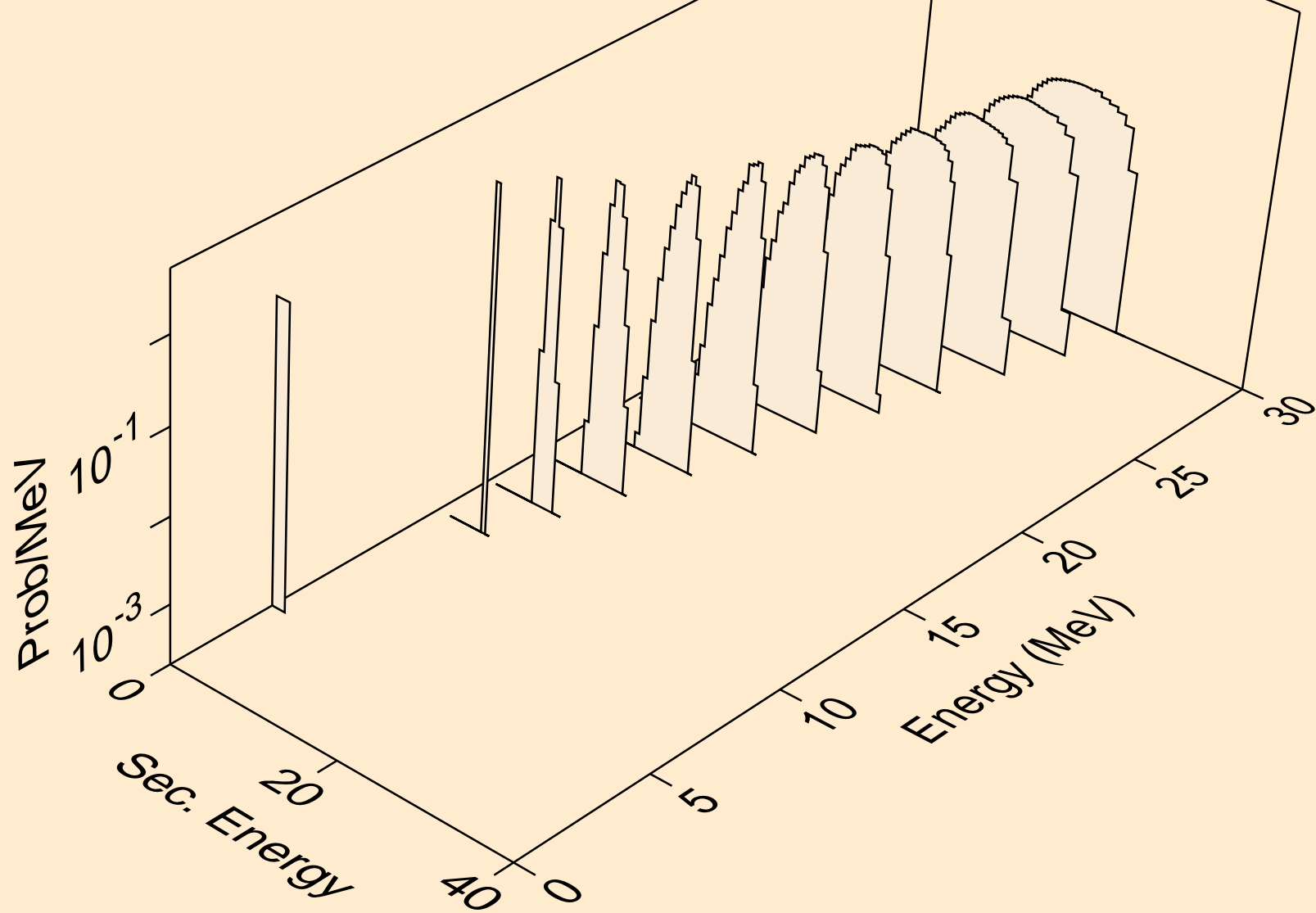

NO264 HELION ACER TENDL-2021 LIBRARY; T=0.K  
protons from (s,2np)

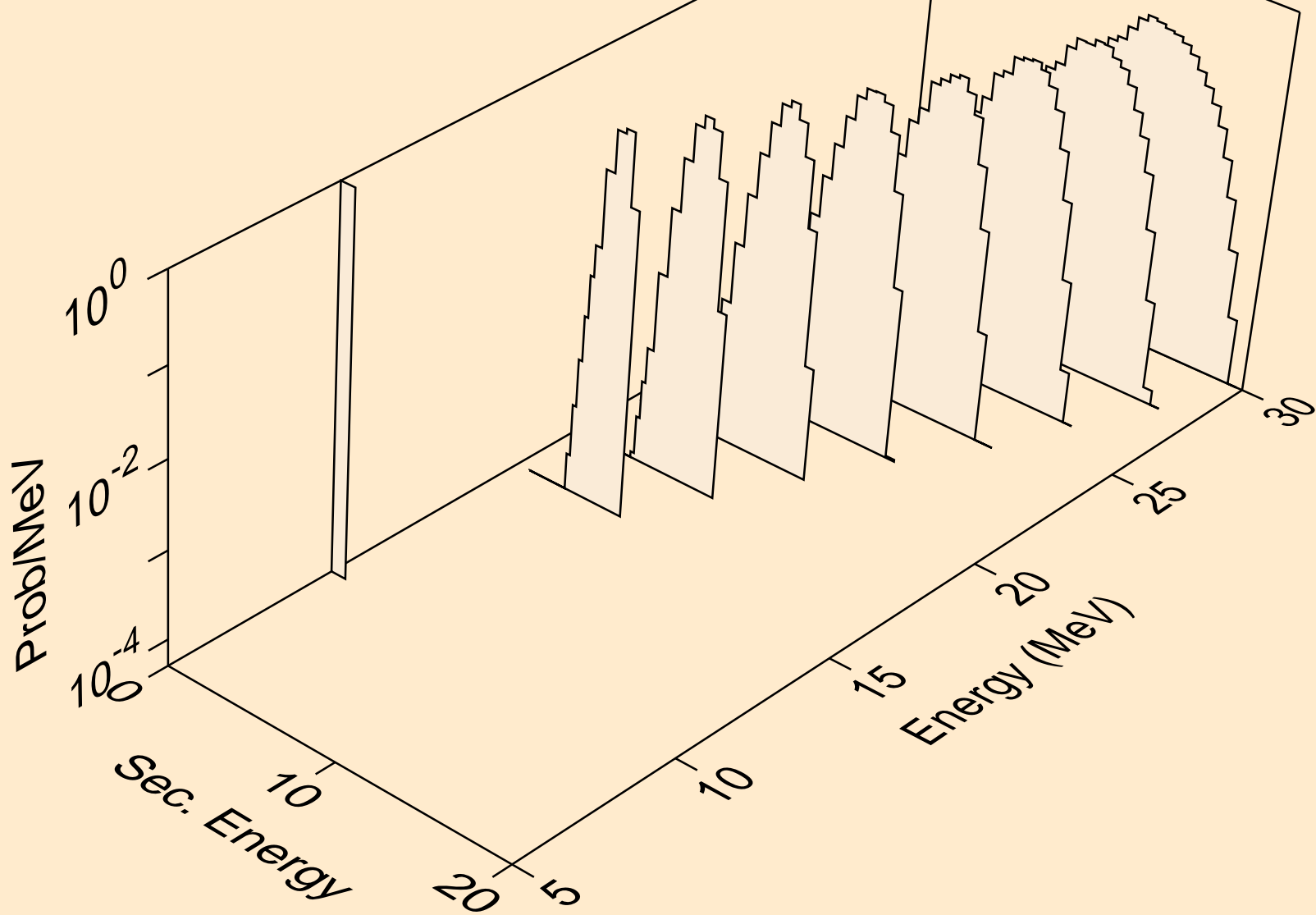

NO264 HELION ACER TENDL-2021 LIBRARY; T=0.K  
protons from (s,p)

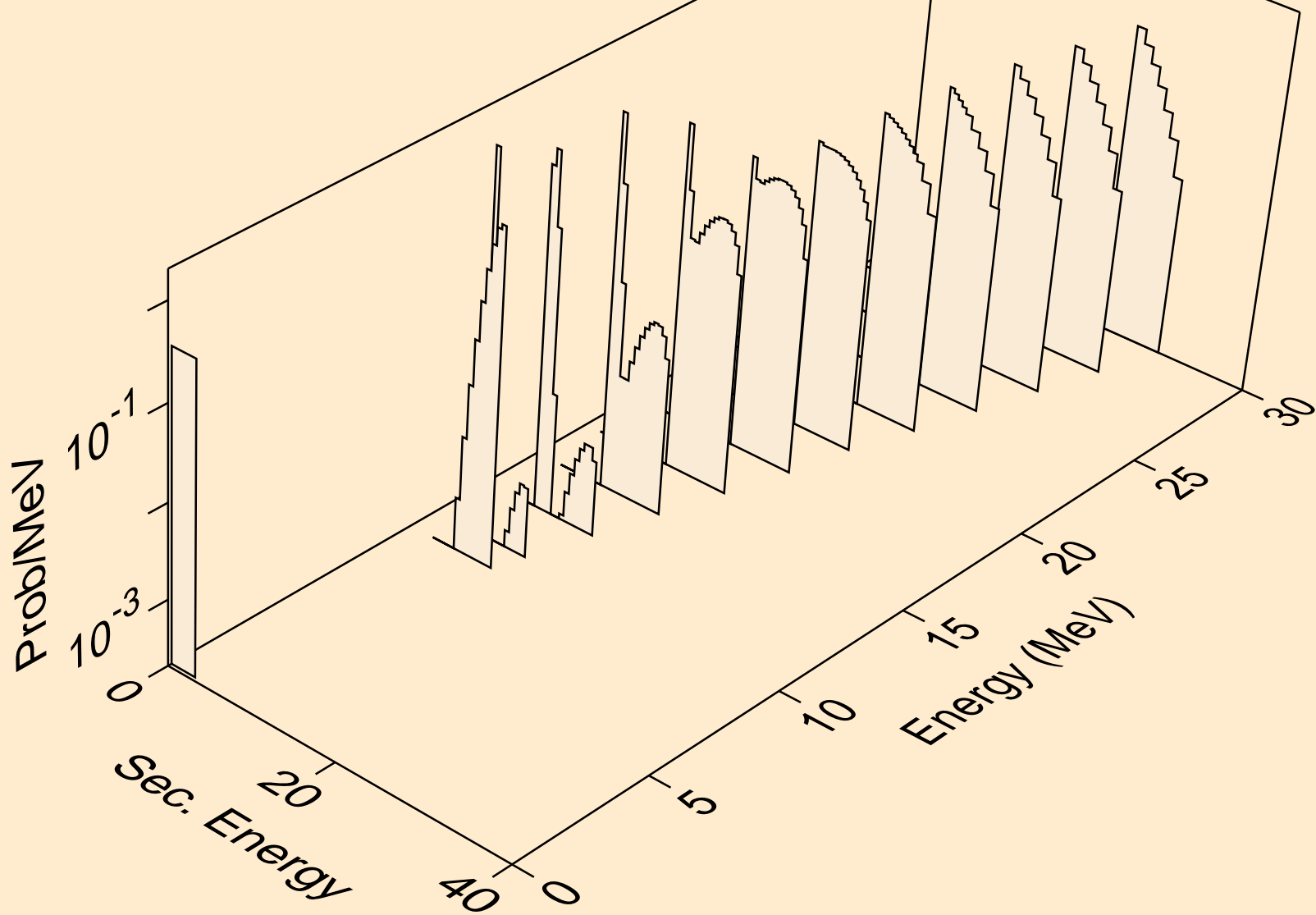

NO264 HELION ACER TENDL-2021 LIBRARY; T=0.K  
deuterons from (s,x)

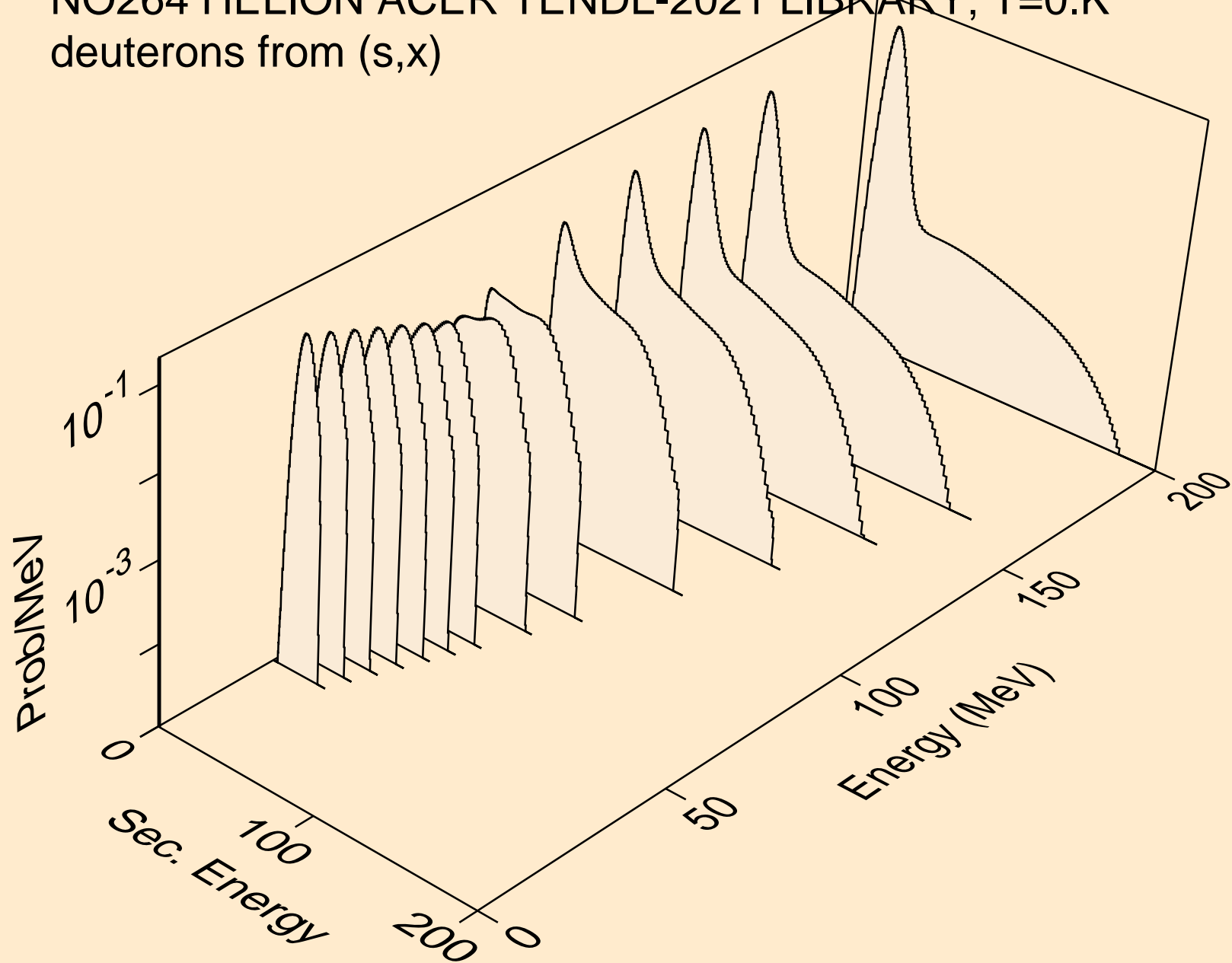



NO264 HELION ACER TENDL-2021 LIBRARY; T=0.K  
deuterons from (s,n\*)d

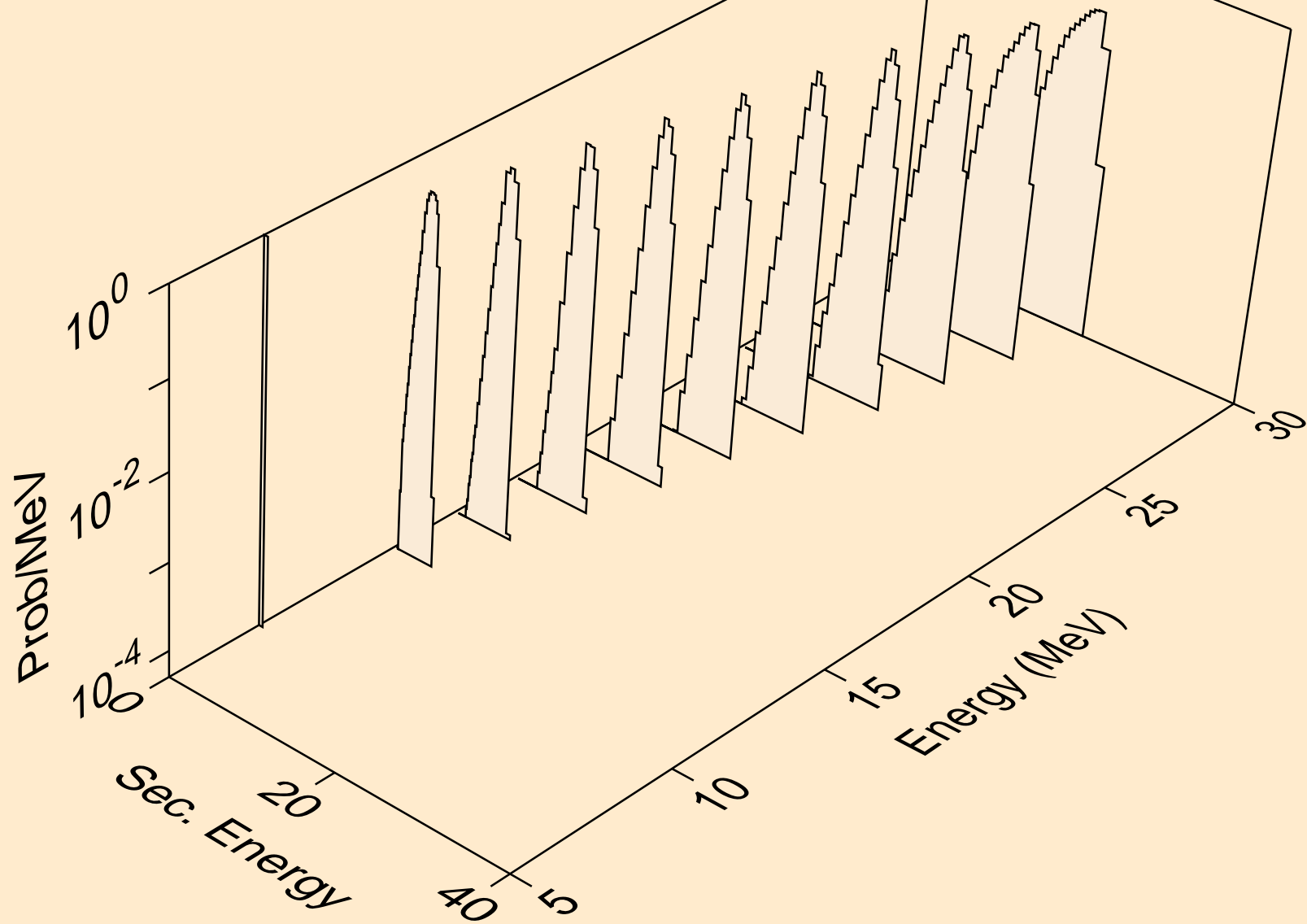

NO264 HELION ACER TENDL-2021 LIBRARY; T=0.K  
deuterons from (s,d)

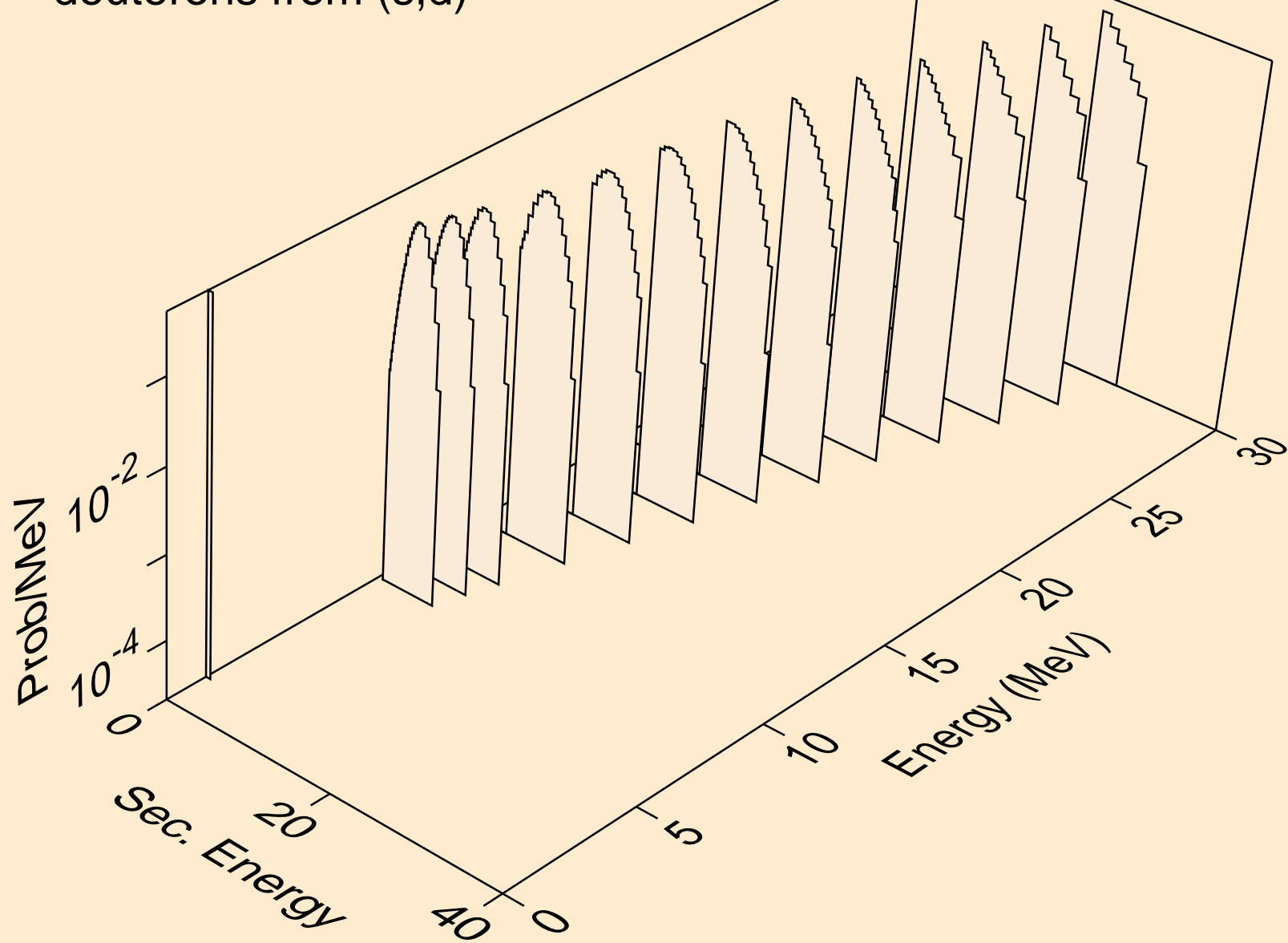

NO264 HELION ACER TENDL-2021 LIBRARY; T=0.K  
tritons from (s,x)

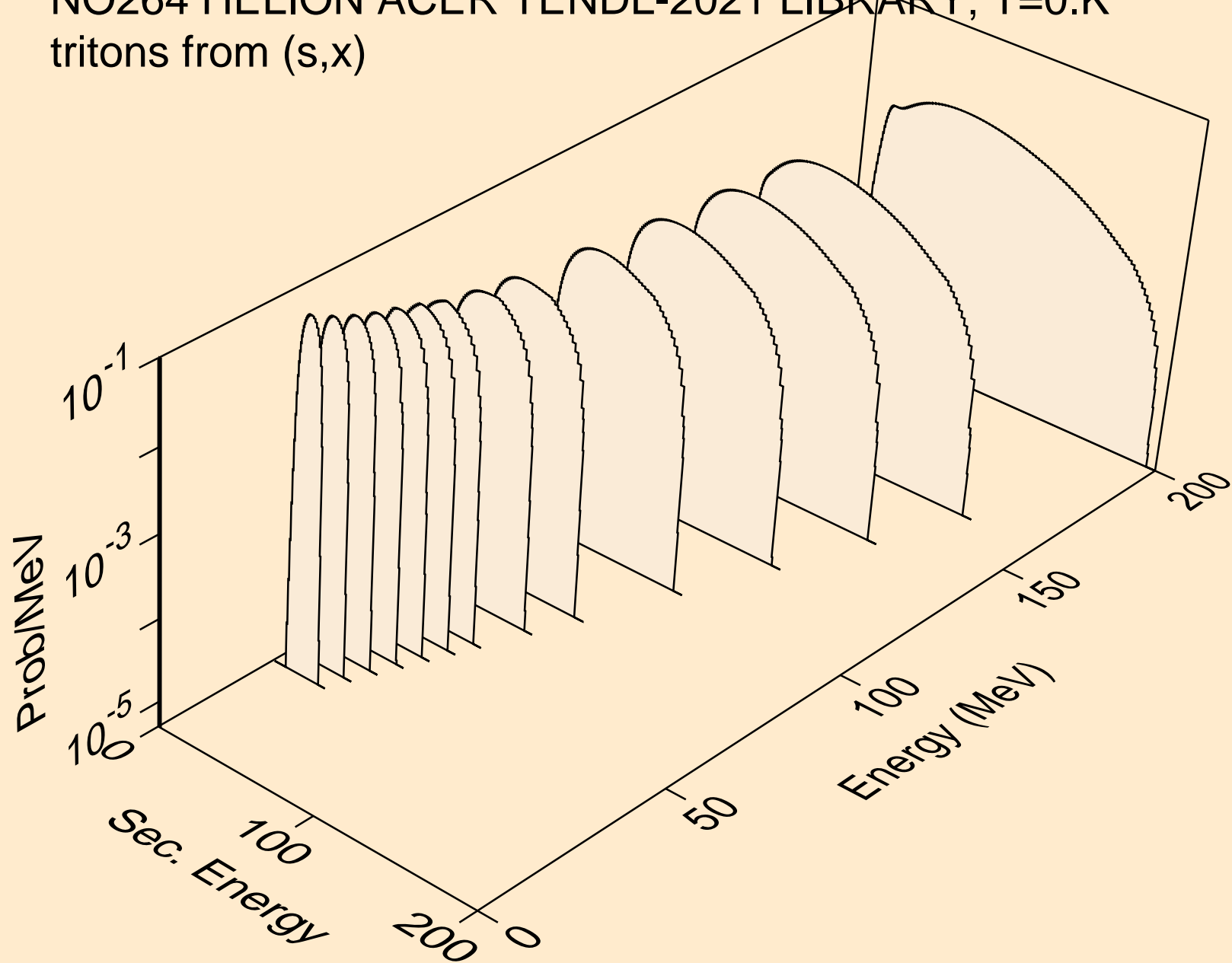

NO264 HELION ACER TENDL-2021 LIBRARY; T=0.K  
tritons from (s,n\*)t

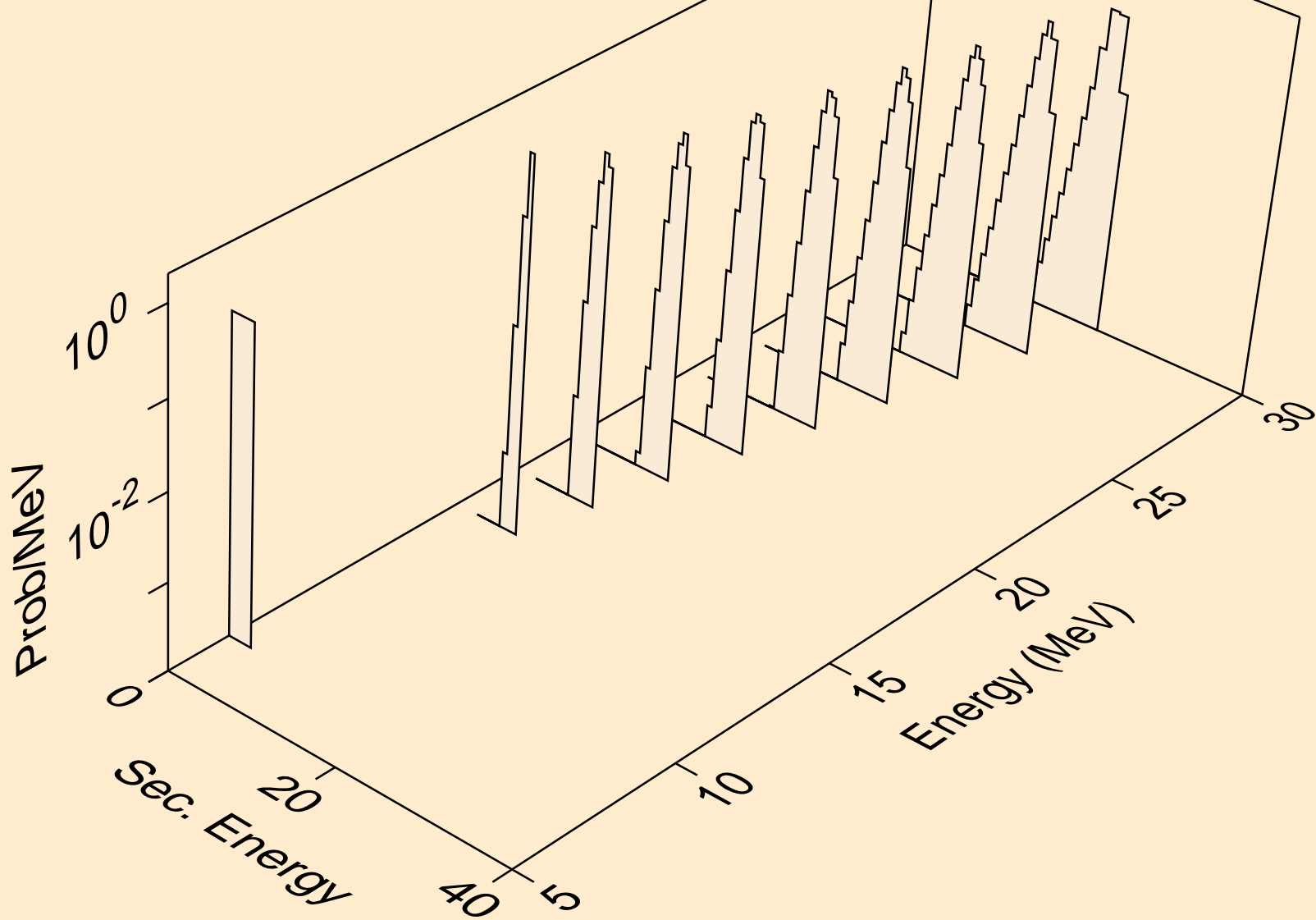

NO264 HELION ACER TENDL-2021 LIBRARY; T=0.K  
tritons from (s,t)

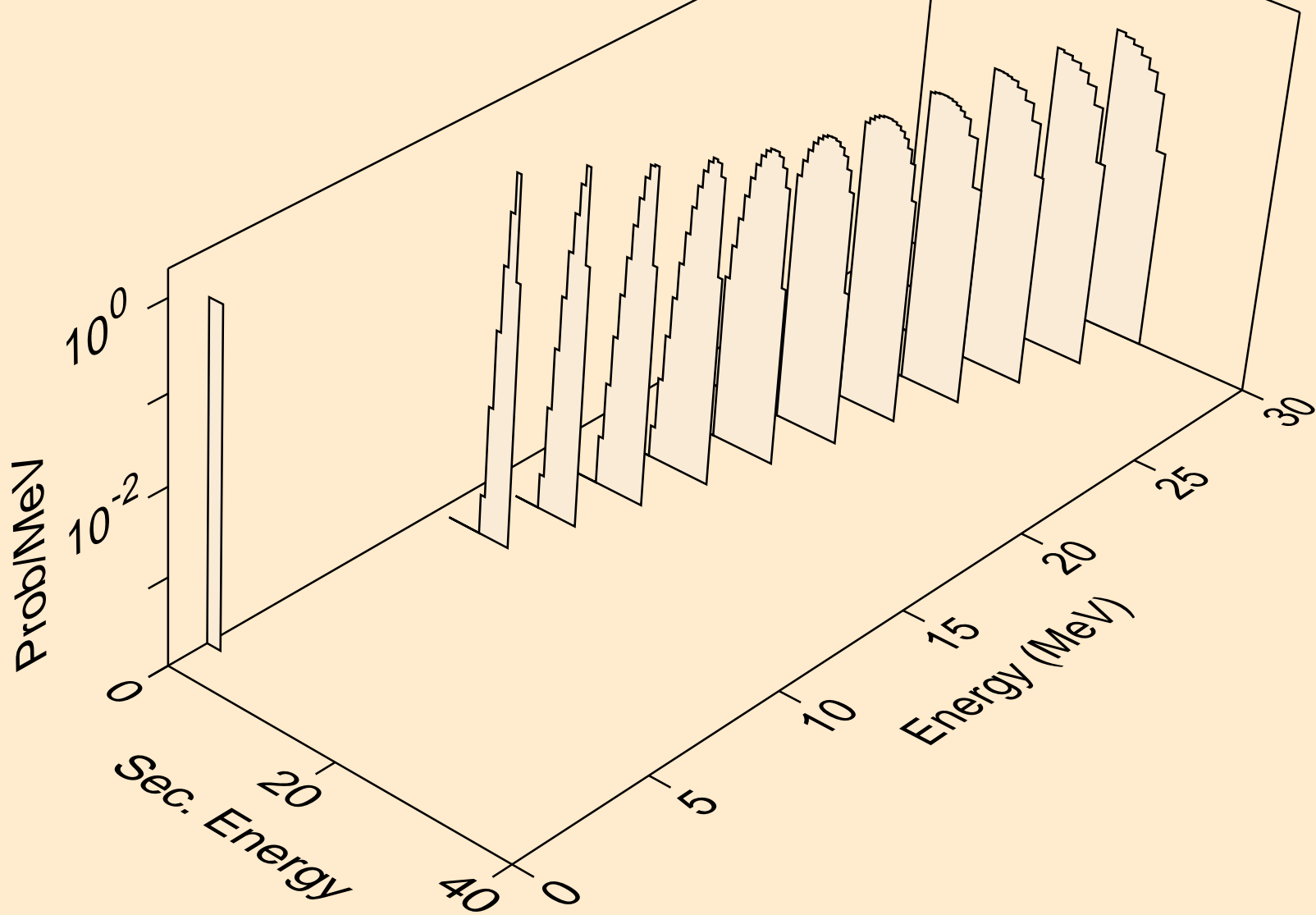

NO264 HELION ACER TENDL-2021 LIBRARY; T=0.K  
alphas from (s,x)

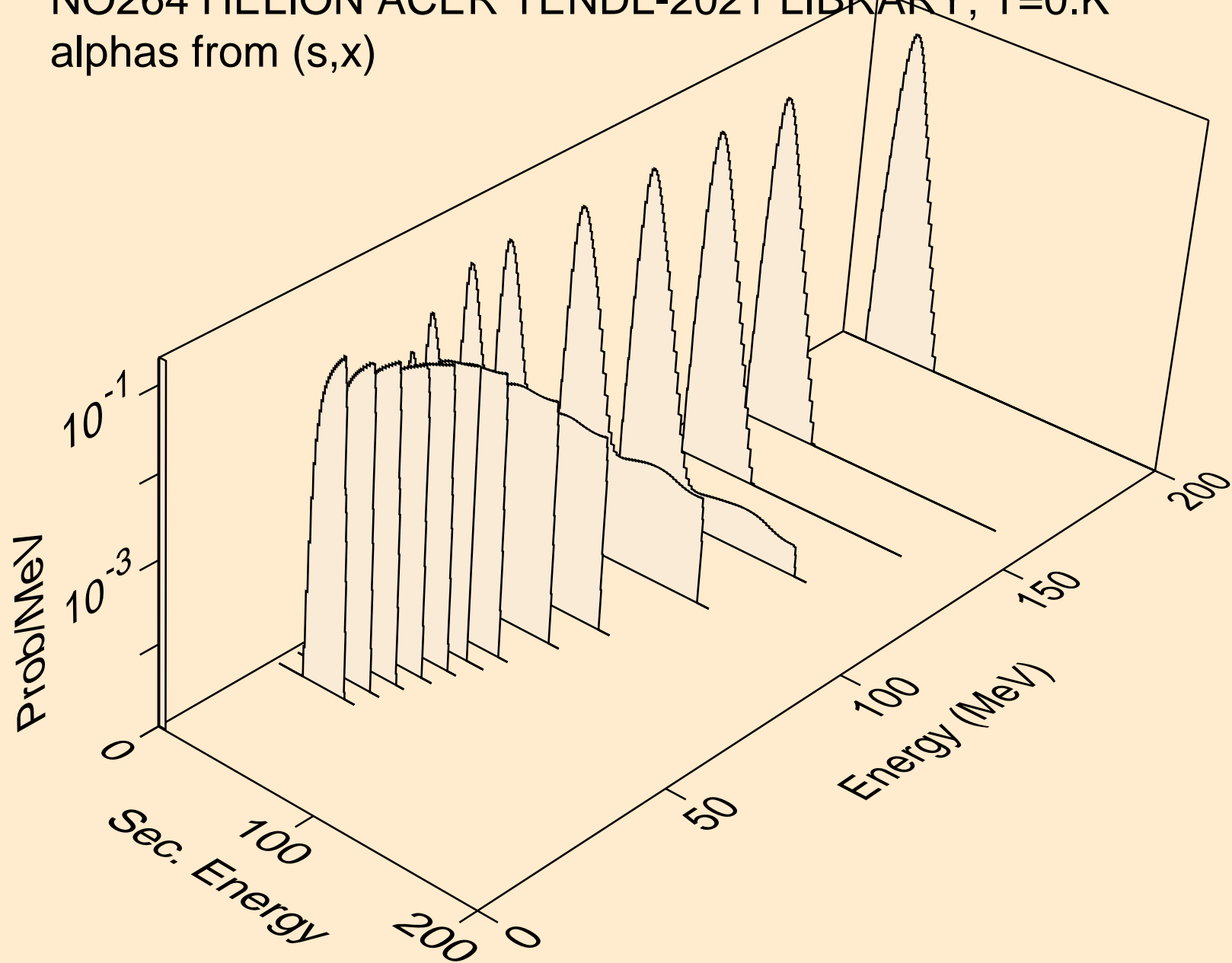

NO264 HELION ACER TENDL-2021 LIBRARY; T=0.K  
alphas from (s,a)

