

SG269 HELION ACER TENDL-2021 LIBRARY; T=0.K  
Principal cross sections

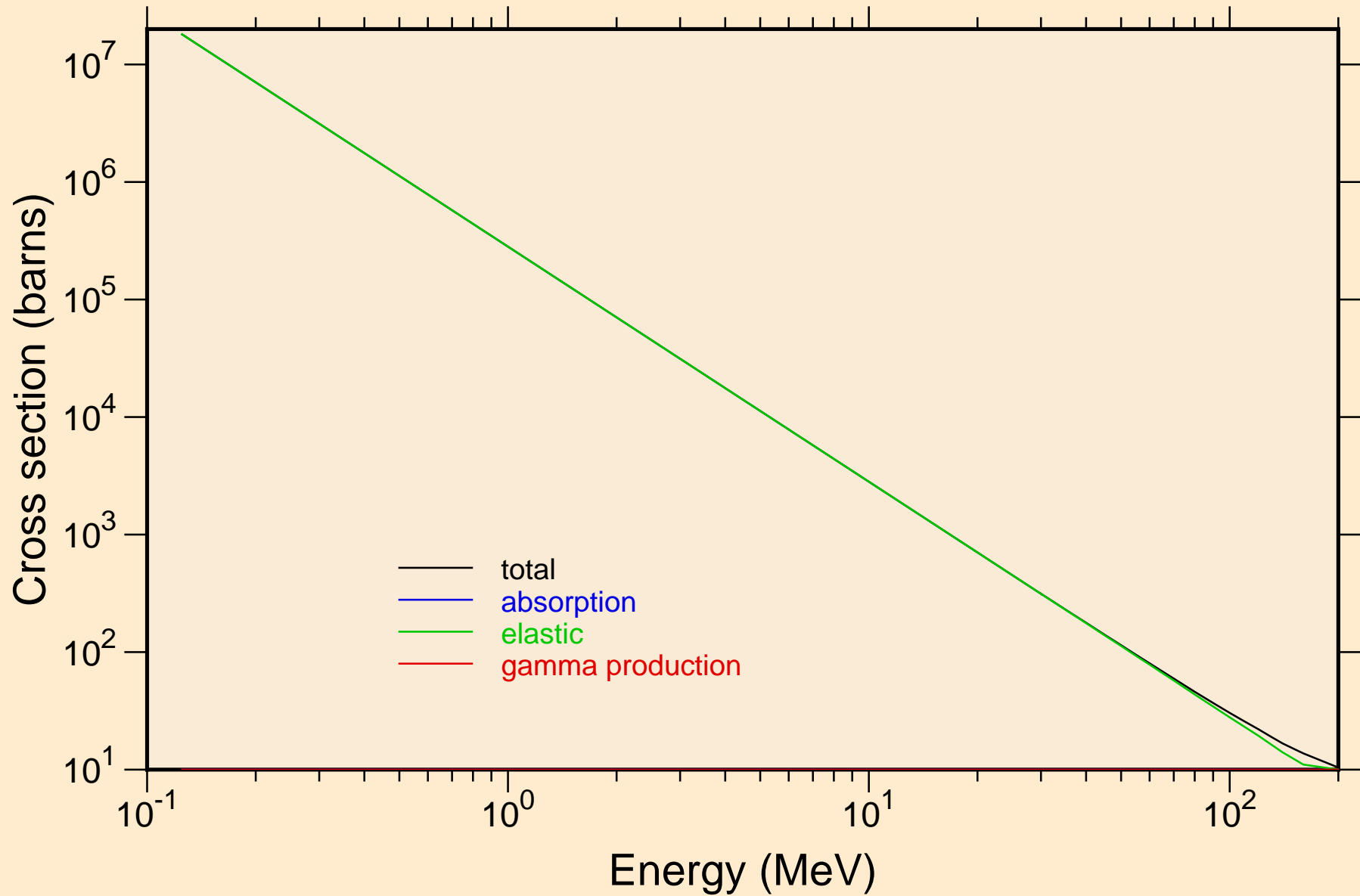

# SG269 HELION ACER TENDL-2021 LIBRARY; T=0.K

## Heating

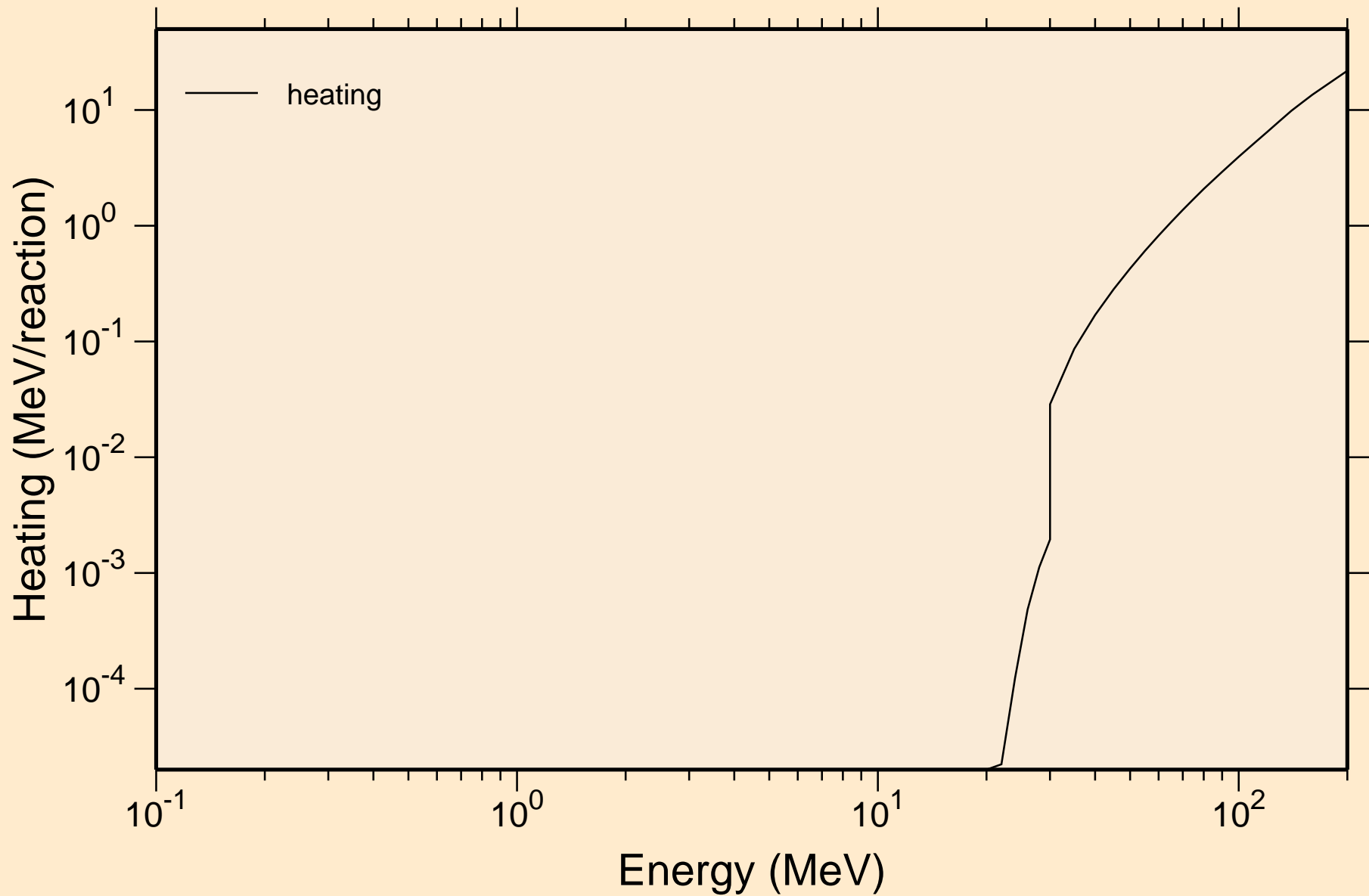

# SG269 HELION ACER TENDL-2021 LIBRARY; T=0.K

## Principal cross sections

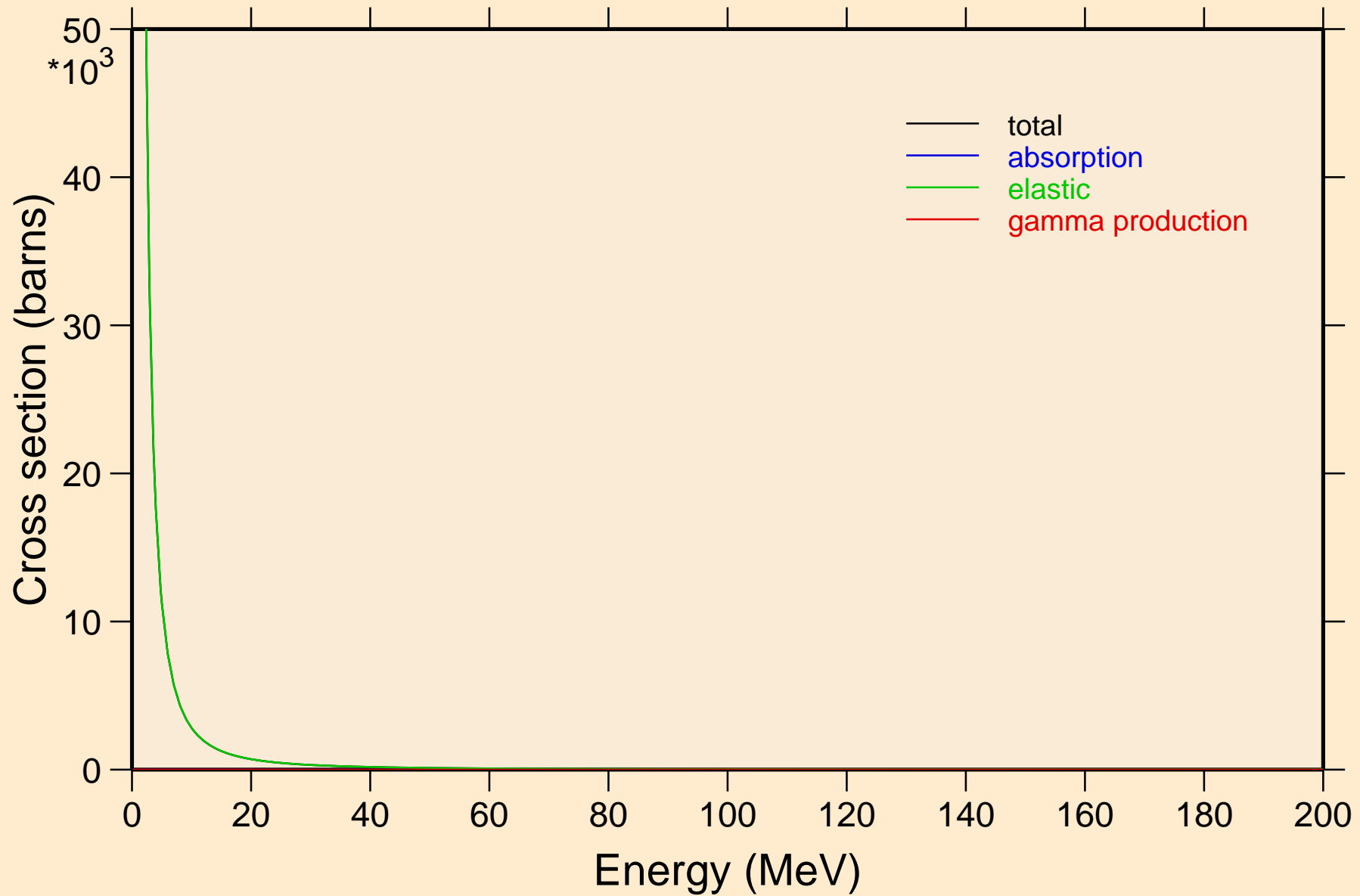

SG269 HELION ACER TENDL-2021 LIBRARY; T=0.K

Heating

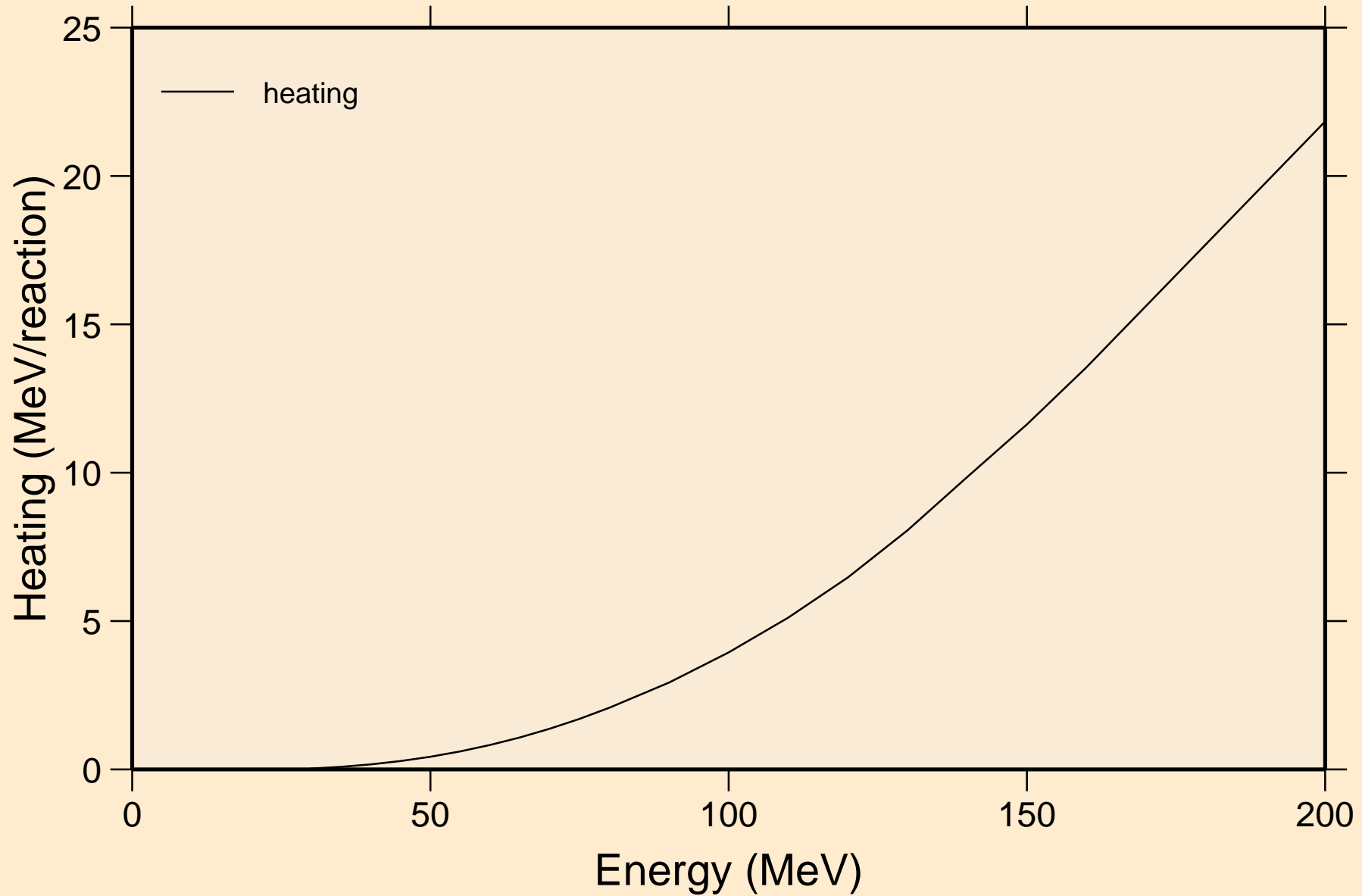

SG269 HELION ACER TENDL-2021 LIBRARY; T=0.K  
Threshold reactions

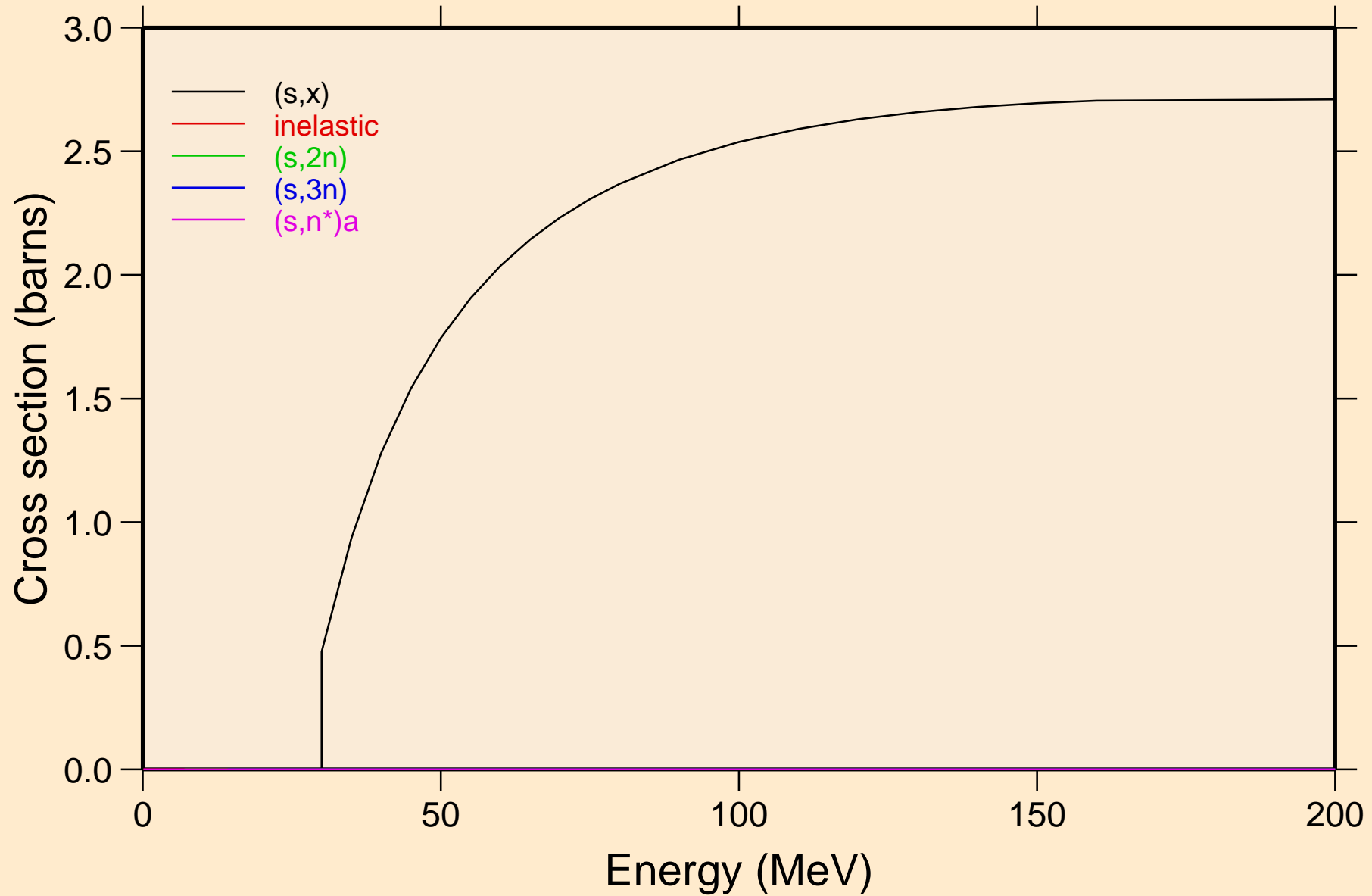

# SG269 HELION ACER TENDL-2021 LIBRARY; T=0.K

## Threshold reactions

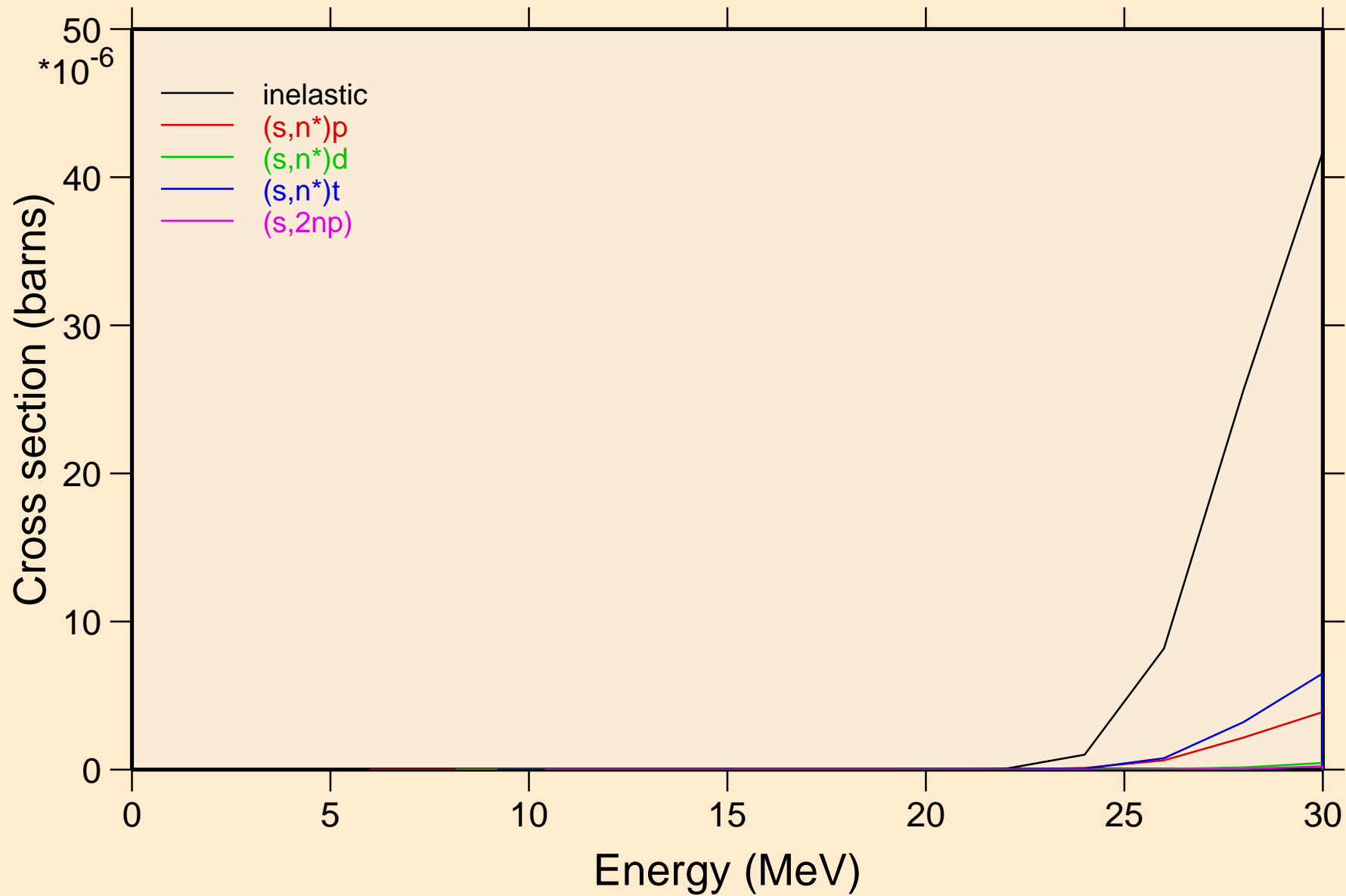

# SG269 HELION ACER TENDL-2021 LIBRARY; T=0.K

## Threshold reactions

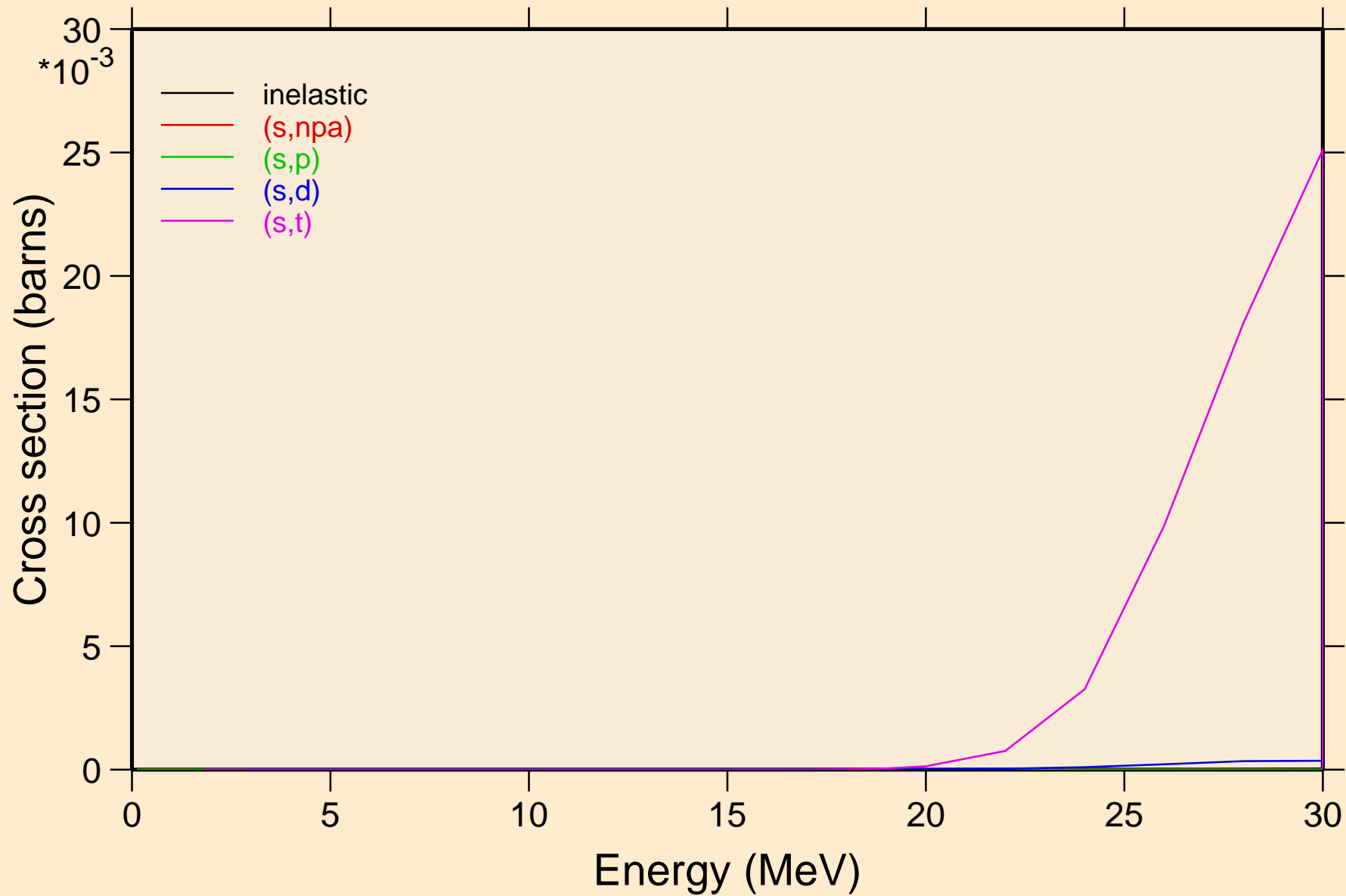

# SG269 HELION ACER TENDL-2021 LIBRARY; T=0.K

## Threshold reactions

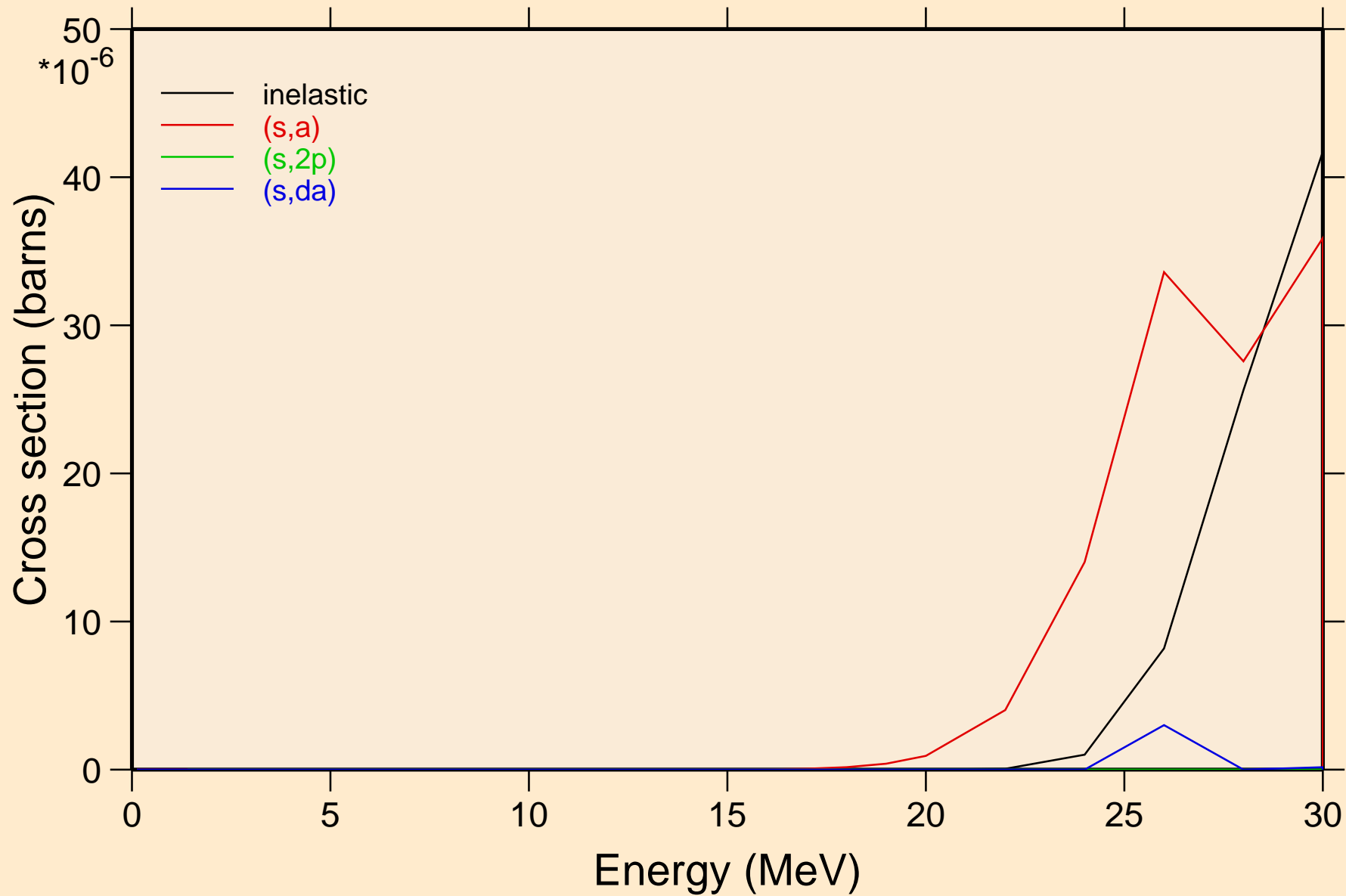



SG269 HELION ACER TENDL-2021 LIBRARY; T=0.K  
angular distribution for elastic

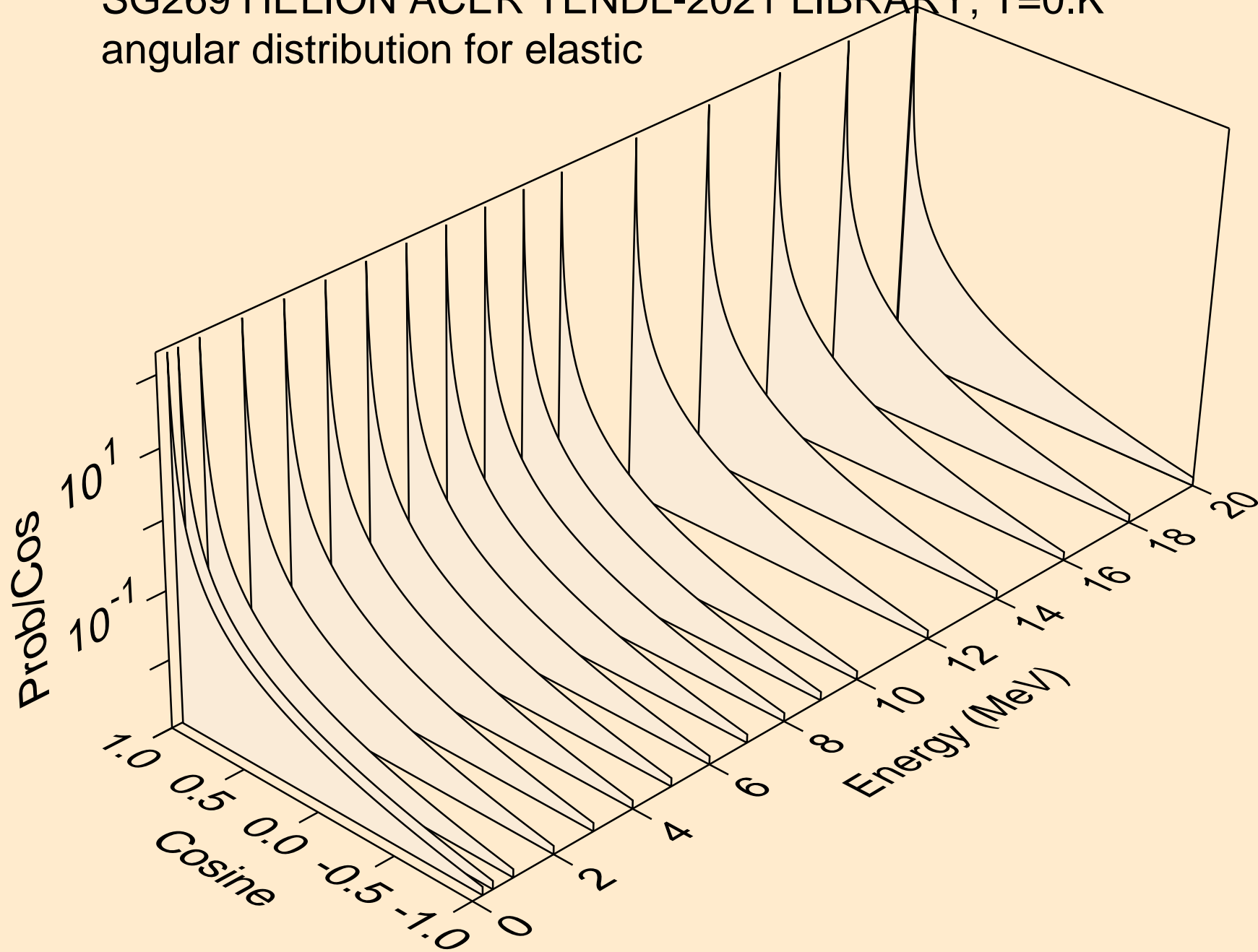

SG269 HELION ACER TENDL-2021 LIBRARY; T=0.K  
angular distribution for elastic

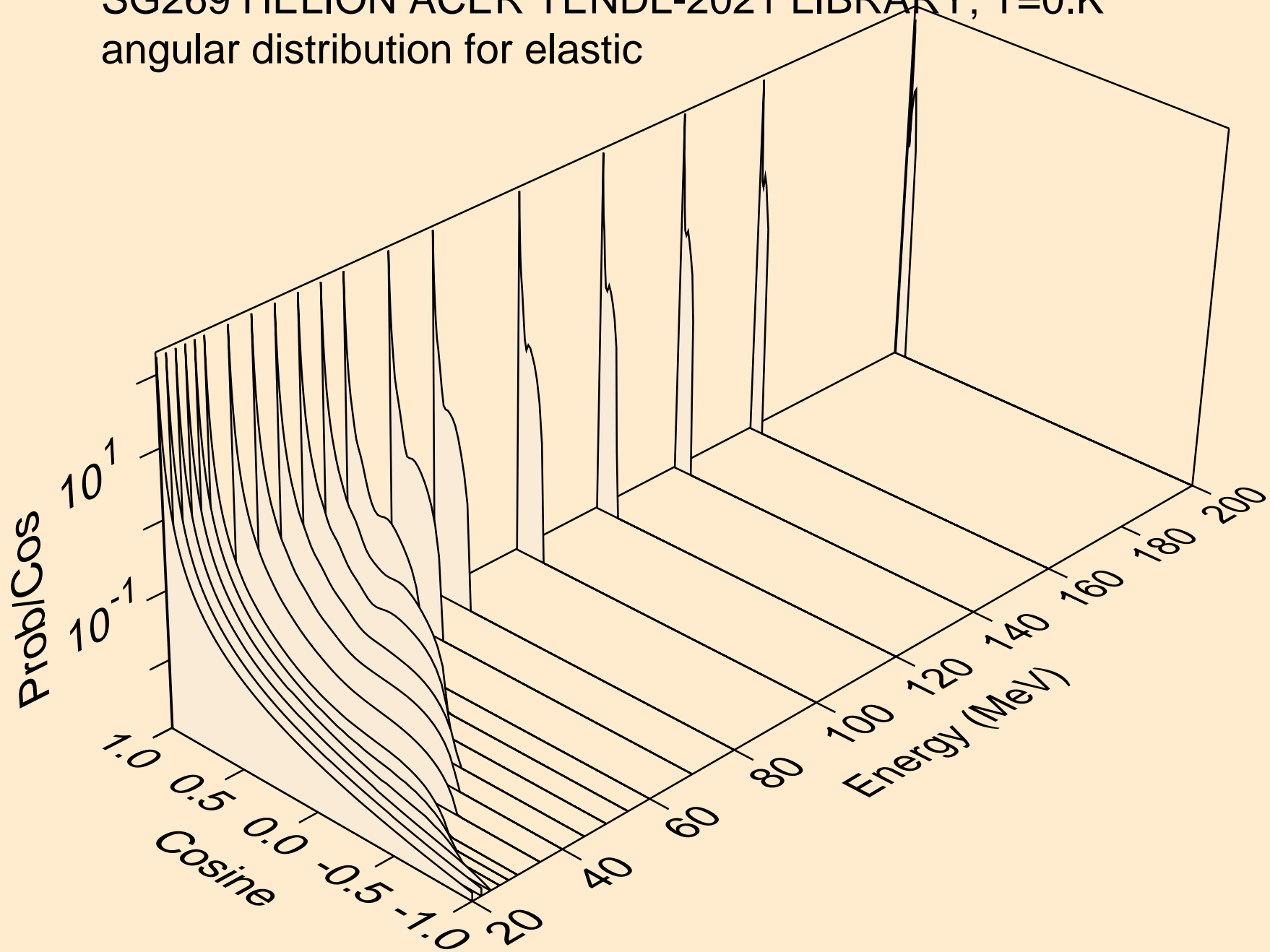

SG269 HELION ACER TENDL-2021 LIBRARY; T=0.K  
He-3 emission for (s,x)

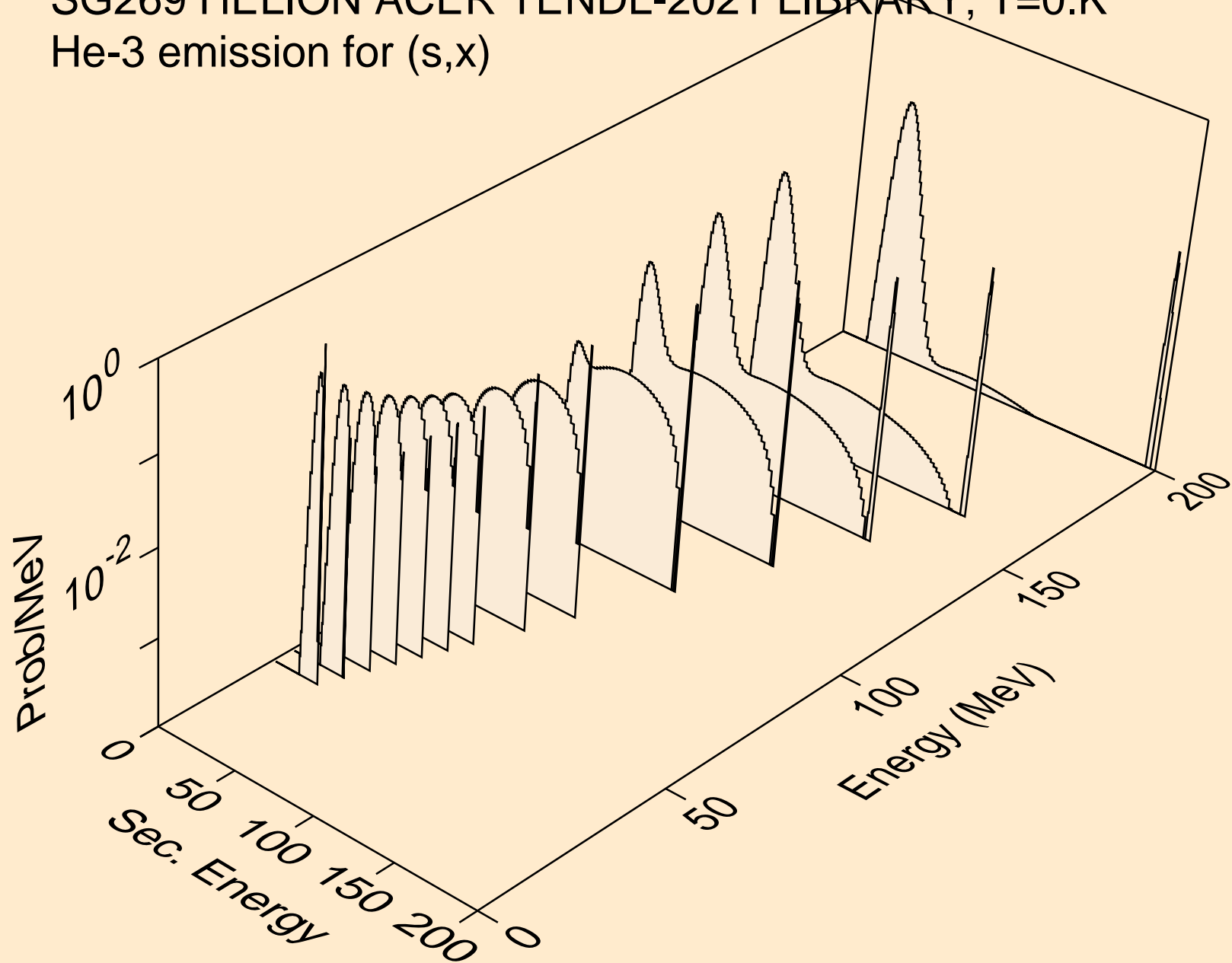

SG269 HELION ACER TENDL-2021 LIBRARY; T=0.K  
He-3 emission for inelastic

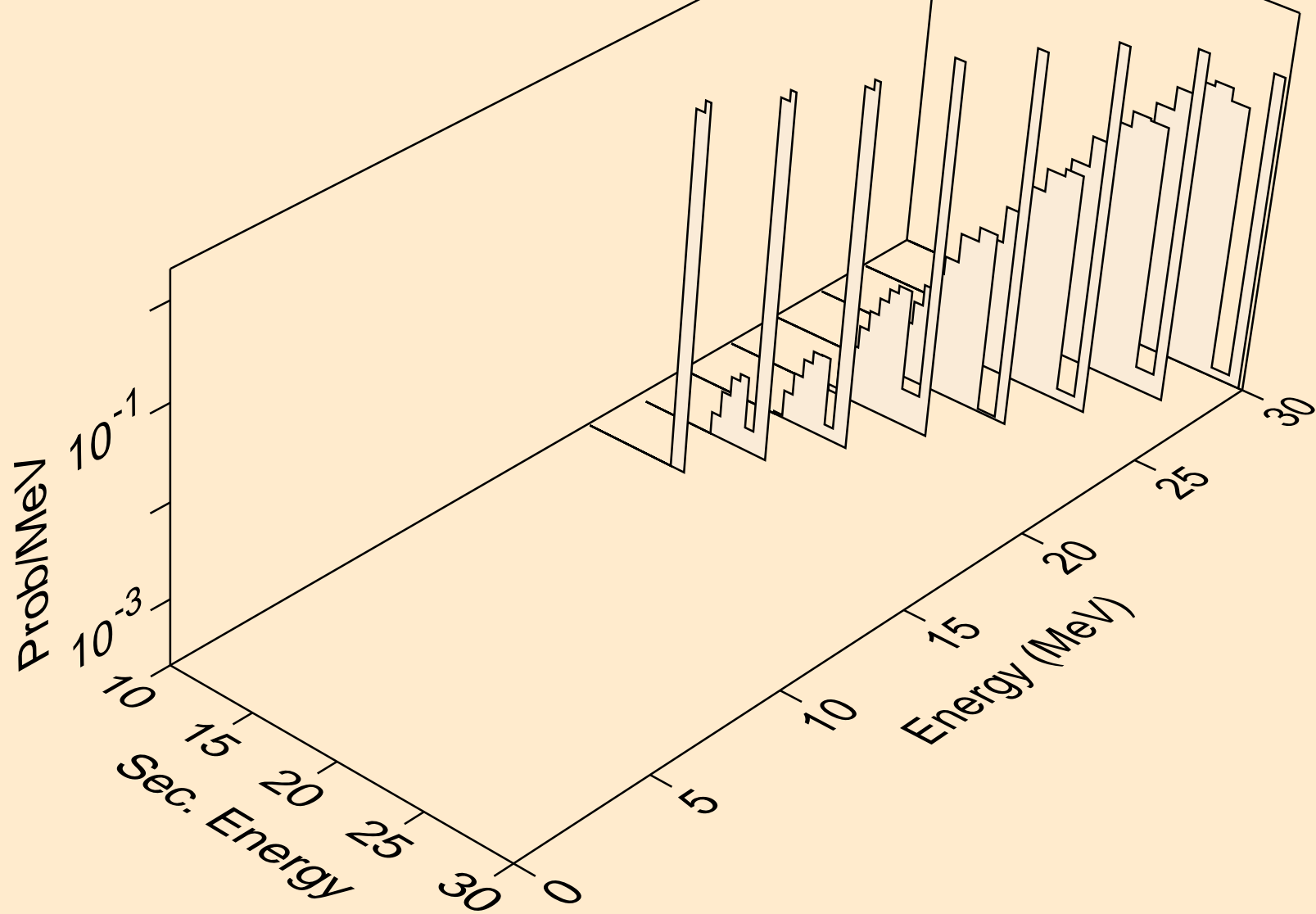

SG269 HELION ACER TENDL-2021 LIBRARY; T=0.K  
Photon emission for (z,n)

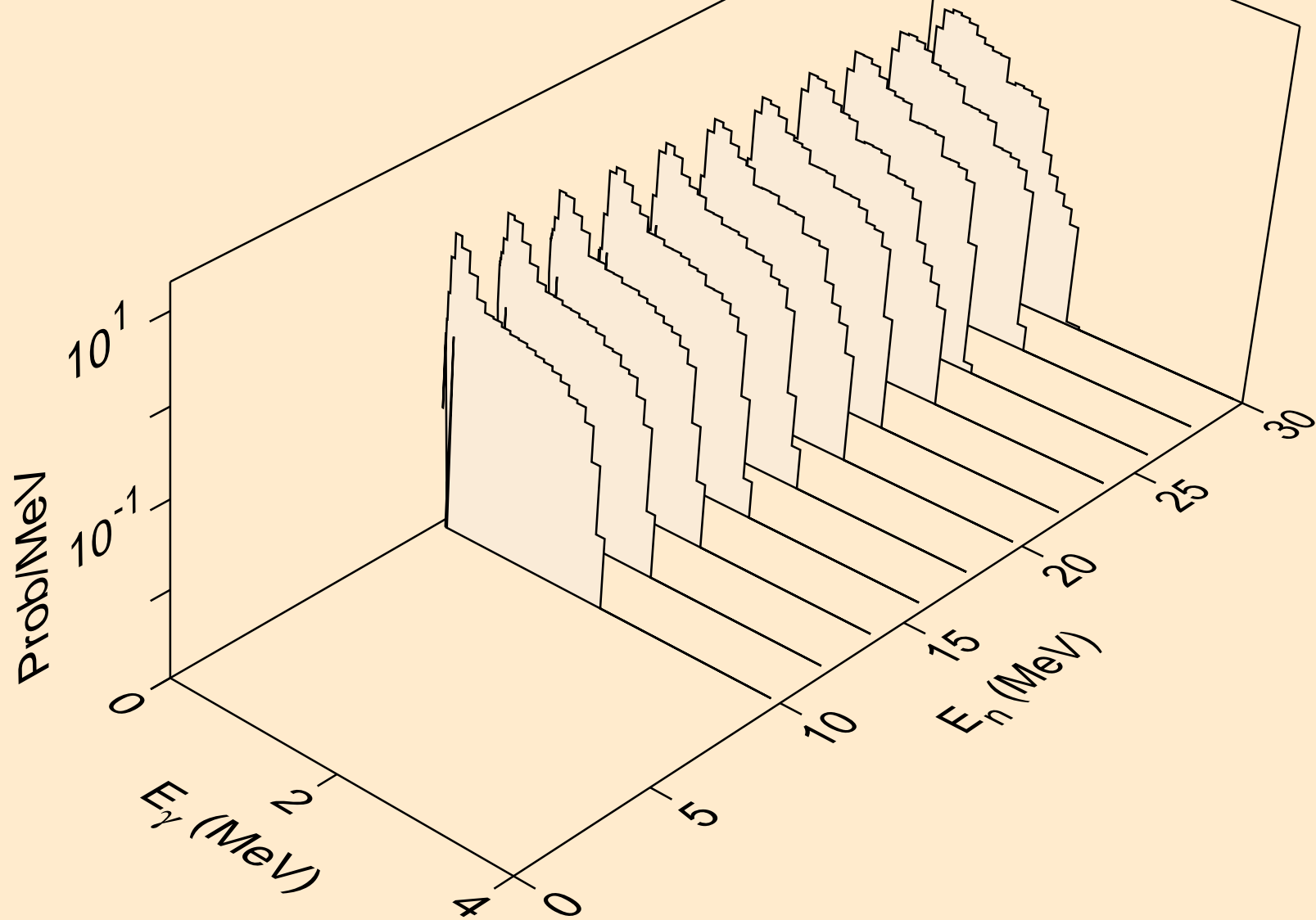

SG269 HELION ACER TENDL-2021 LIBRARY; T=0.K  
Photon emission for (n,x)

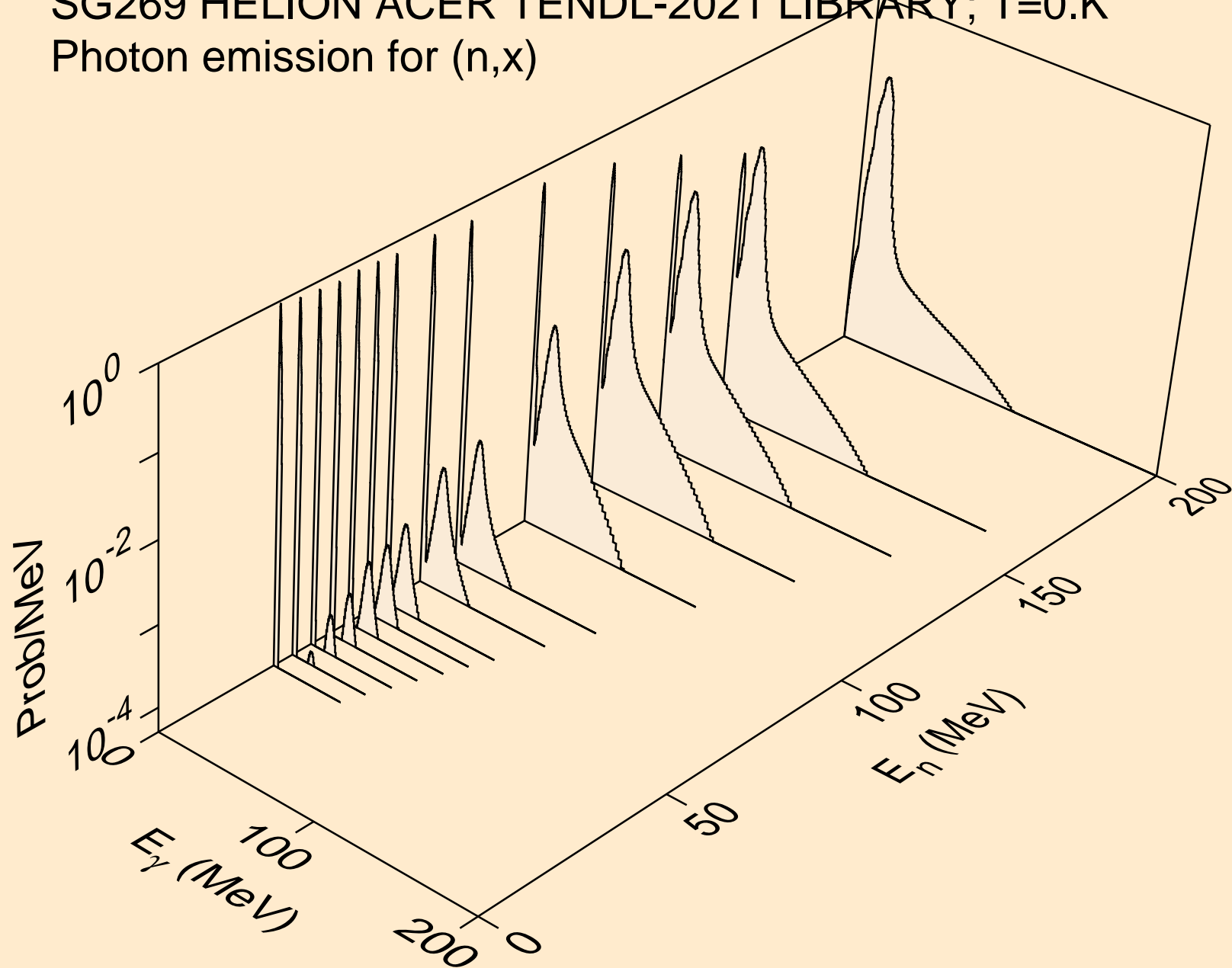

SG269 HELION ACER TENDL-2021 LIBRARY; T=0.K  
Photon emission for (n,2n)

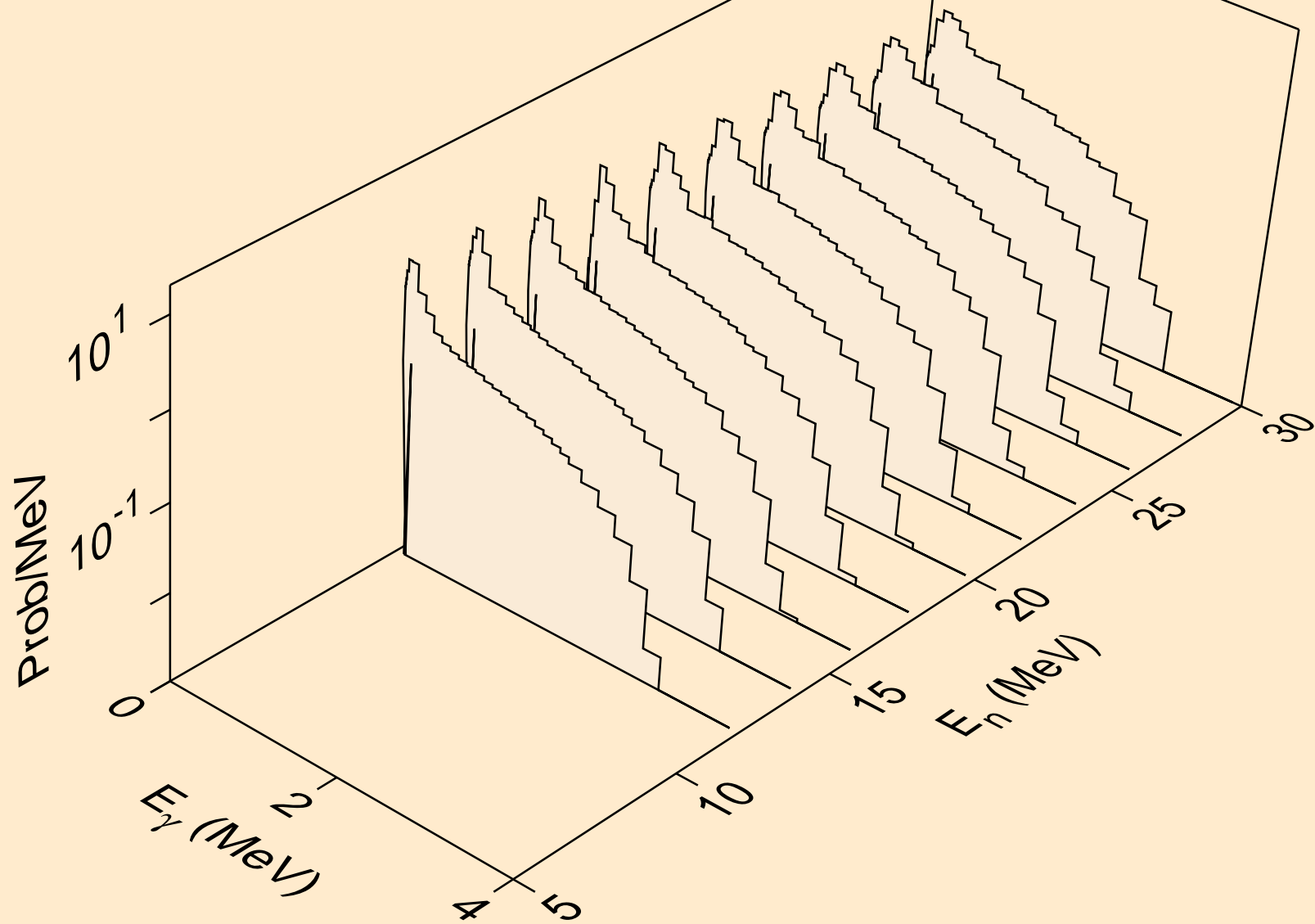

SG269 HELION ACER TENDL-2021 LIBRARY; T=0.K  
Photon emission for (n,3n)

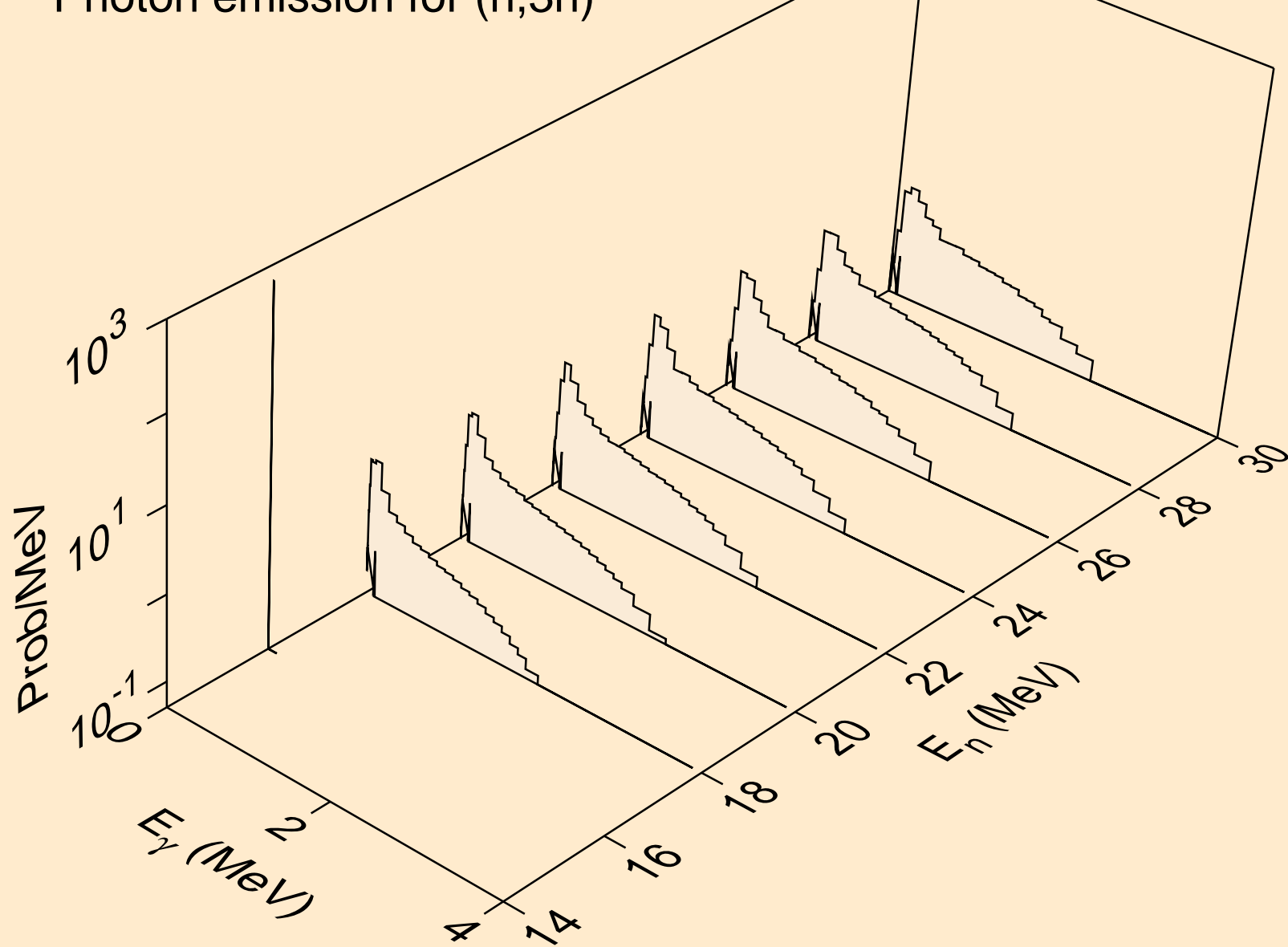



SG269 HELION ACER TENDL-2021 LIBRARY; T=0.K  
Photon emission for (n,n\*)a

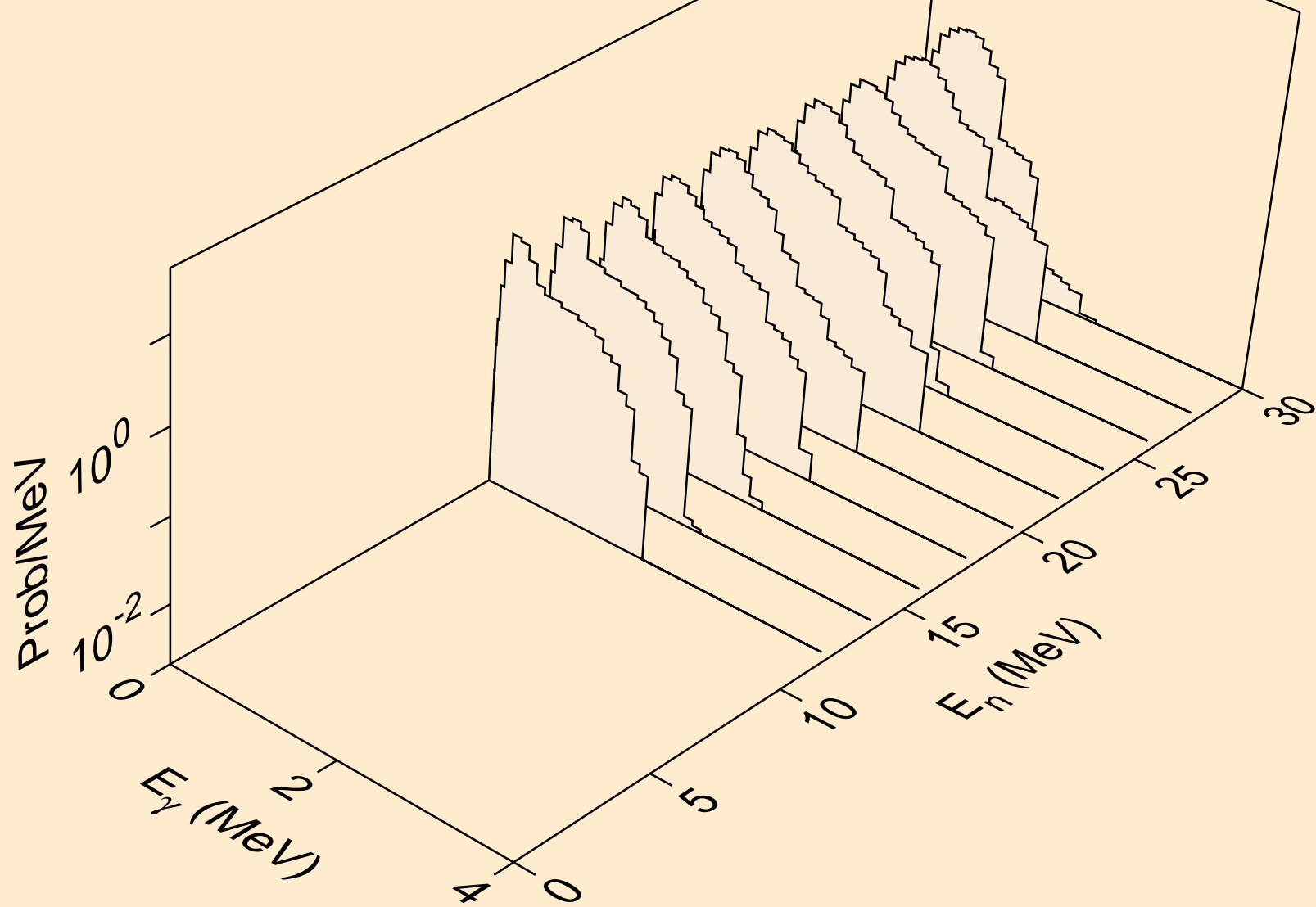

SG269 HELION ACER TENDL-2021 LIBRARY; T=0.K  
Photon emission for (n,n\*)p

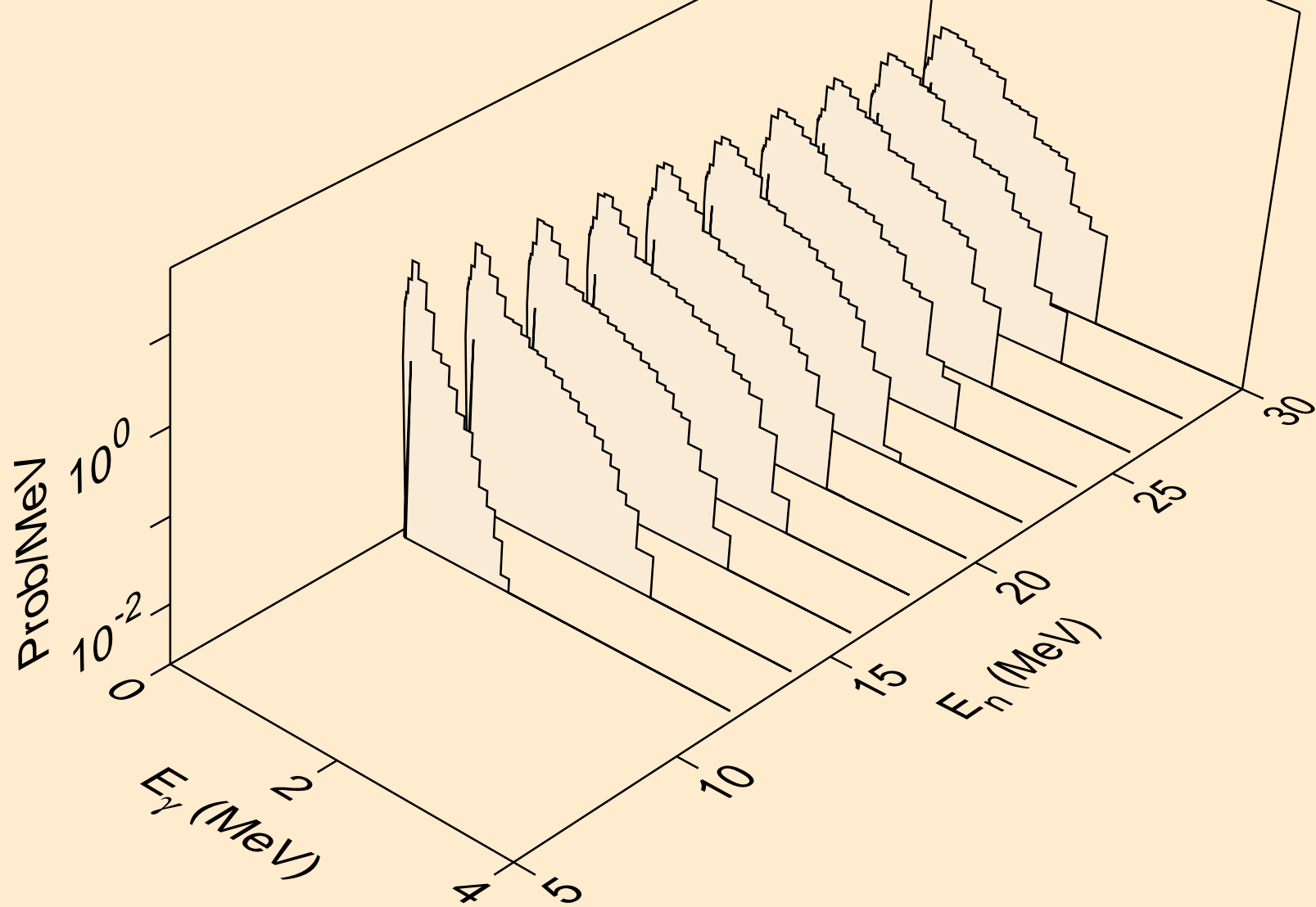

SG269 HELION ACER TENDL-2021 LIBRARY; T=0.K  
Photon emission for (n,n\*)d

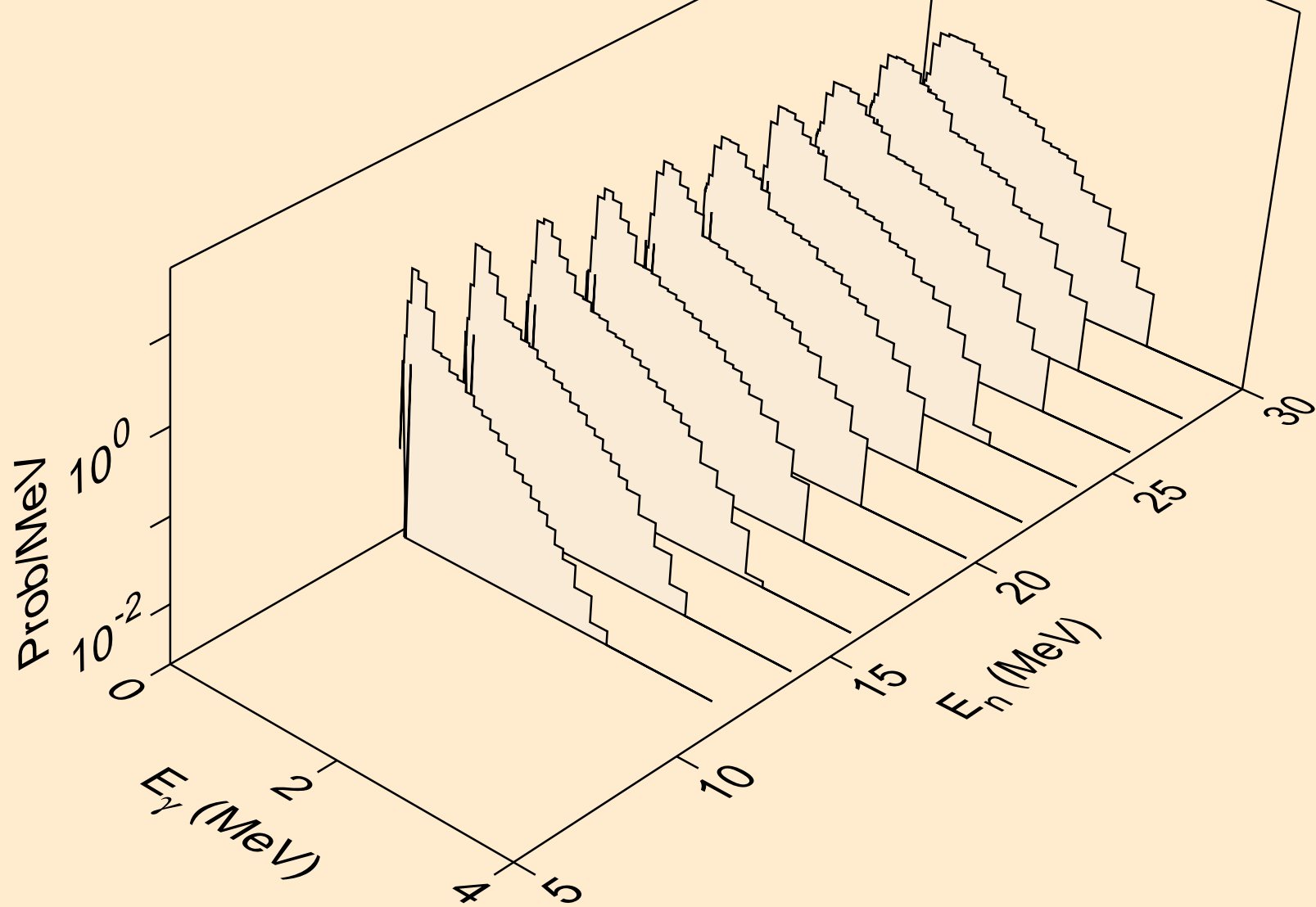

SG269 HELION ACER TENDL-2021 LIBRARY; T=0.K  
Photon emission for (n,n\*)t

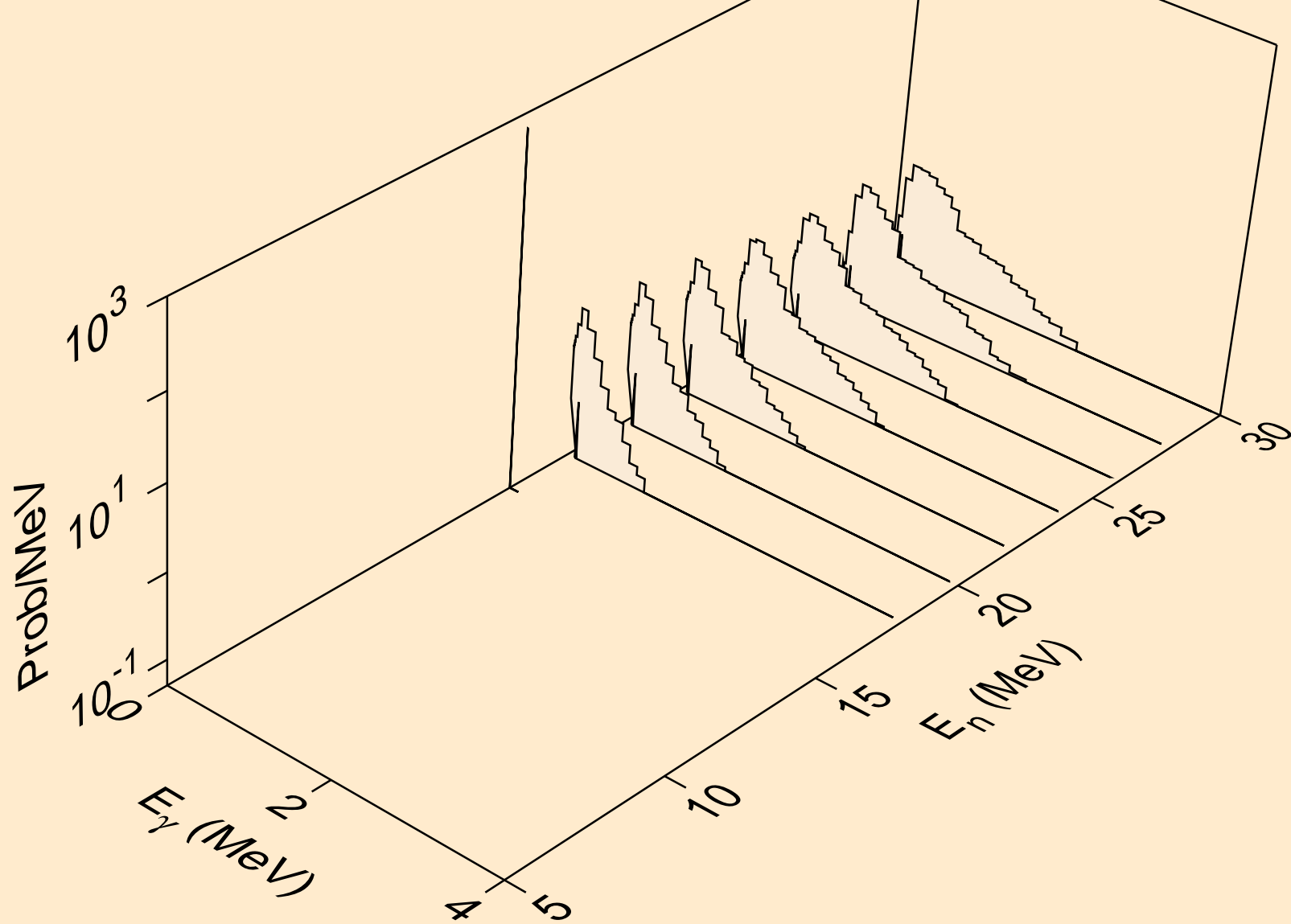

SG269 HELION ACER TENDL-2021 LIBRARY; T=0.K  
Photon emission for (n,2np)

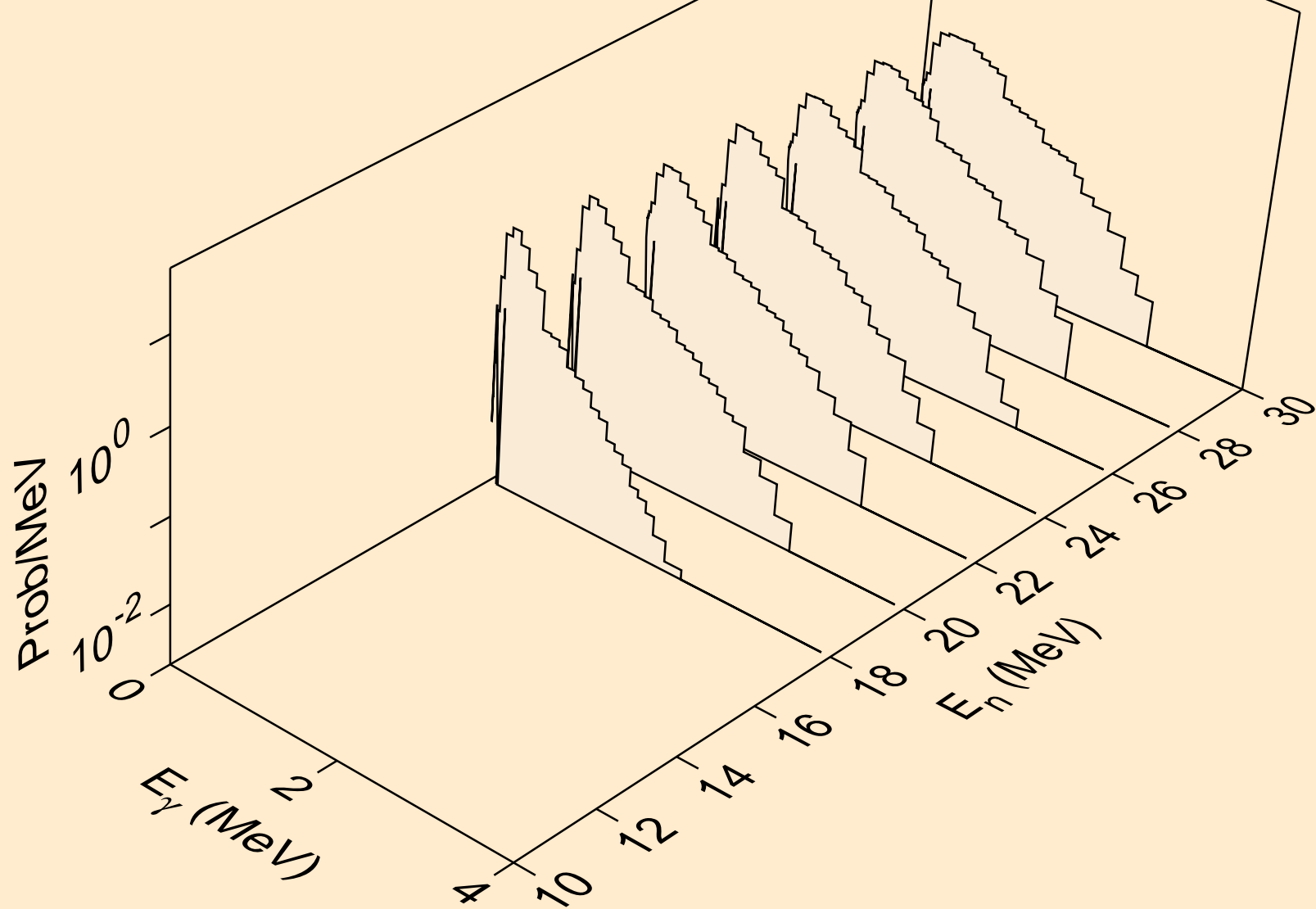

SG269 HELION ACER TENDL-2021 LIBRARY; T=0.K  
Photon emission for (n,npa)

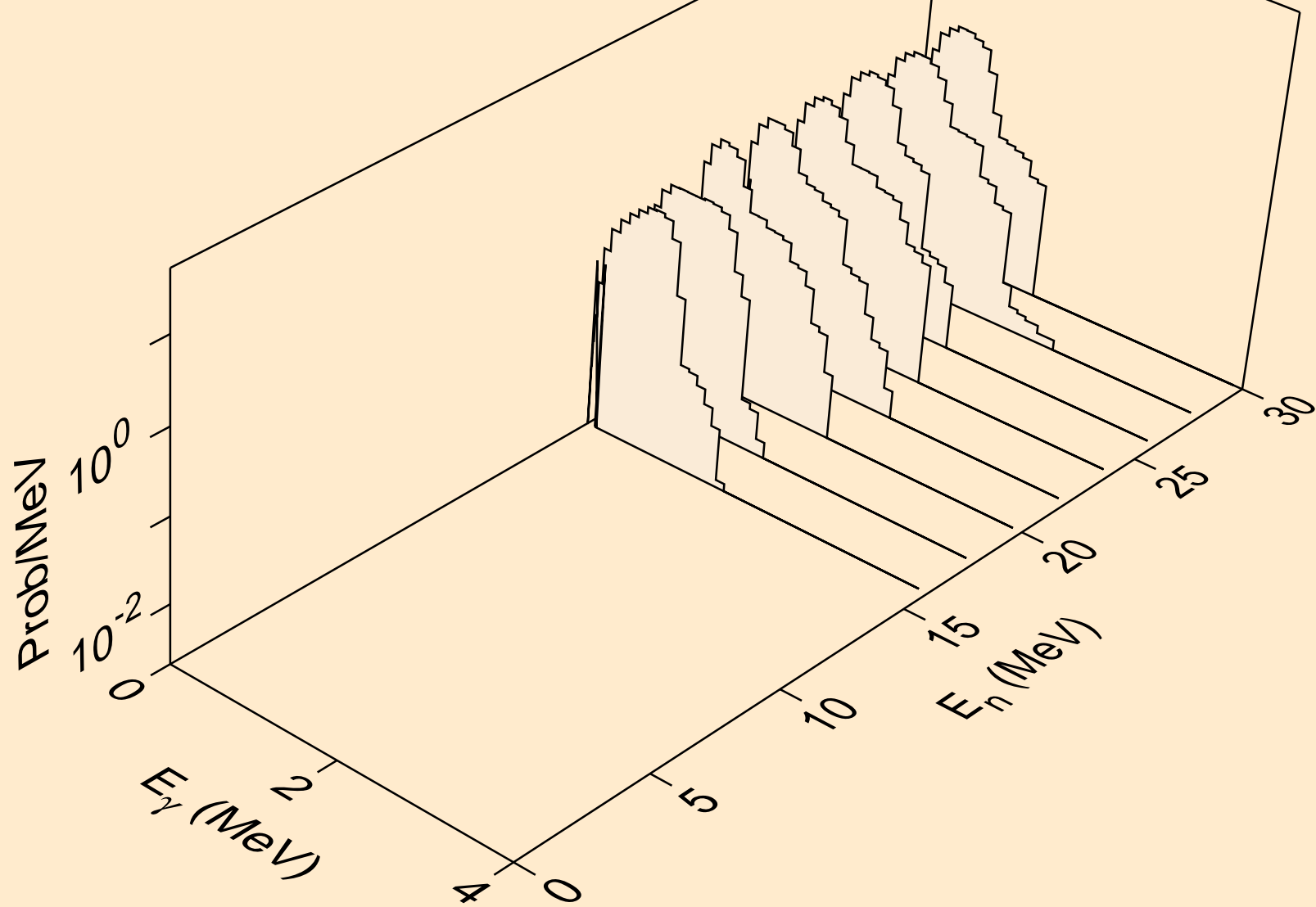

SG269 HELION ACER TENDL-2021 LIBRARY; T=0.K  
Photon emission for (n,p)

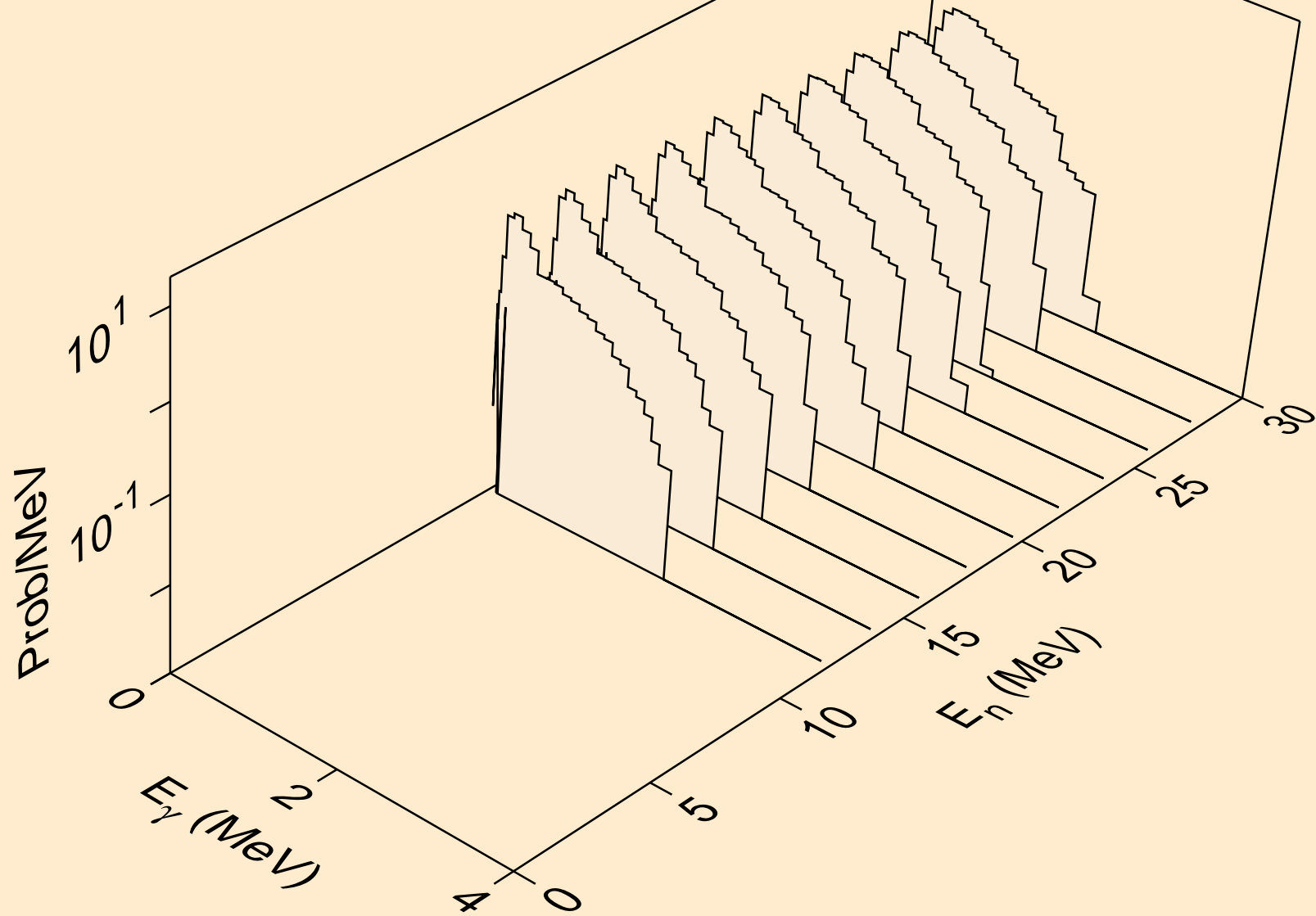

SG269 HELION ACER TENDL-2021 LIBRARY; T=0.K  
Photon emission for (n,d)

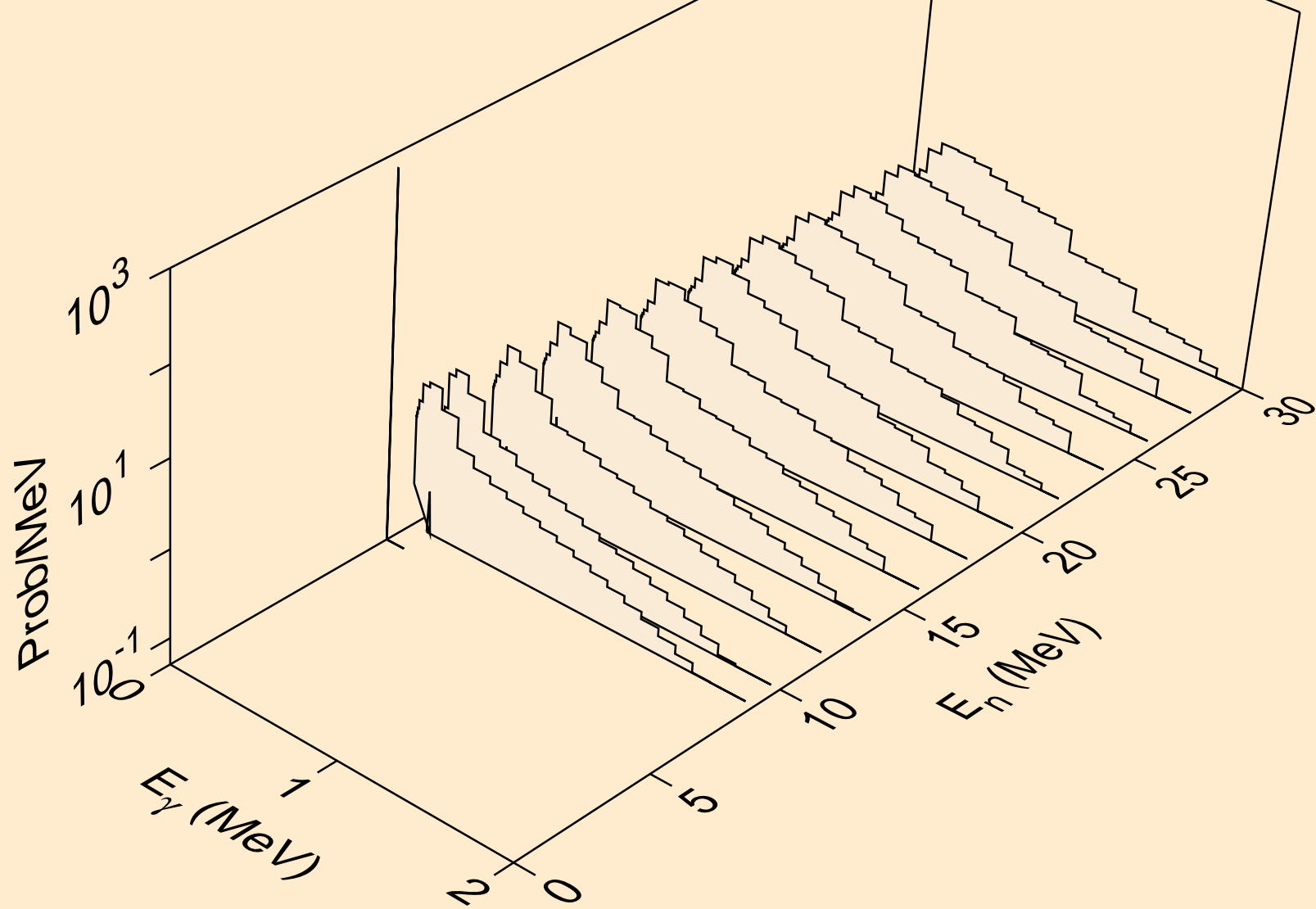



SG269 HELION ACER TENDL-2021 LIBRARY; T=0.K  
Photon emission for (n,t)

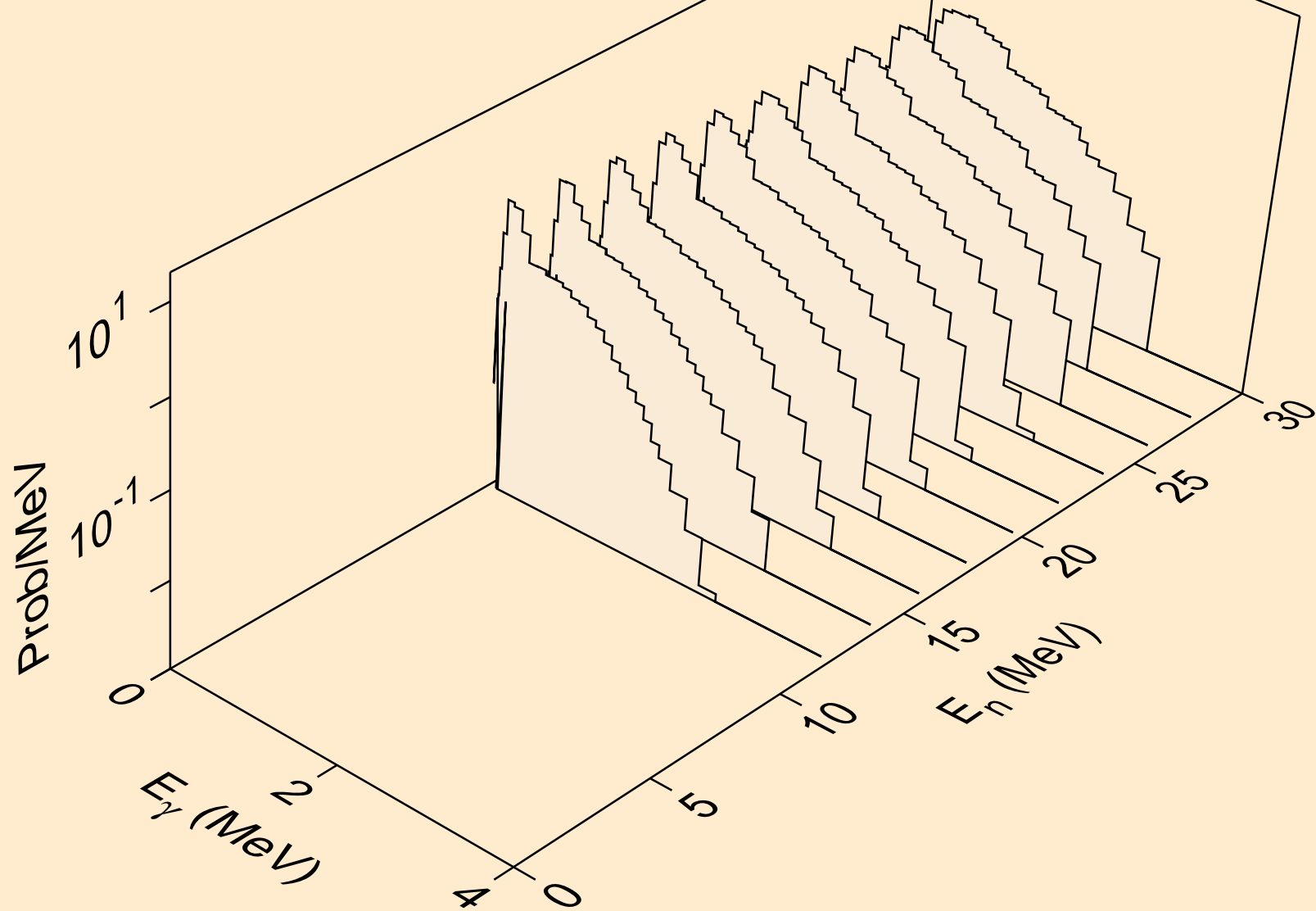

SG269 HELION ACER TENDL-2021 LIBRARY; T=0.K  
Photon emission for inelastic

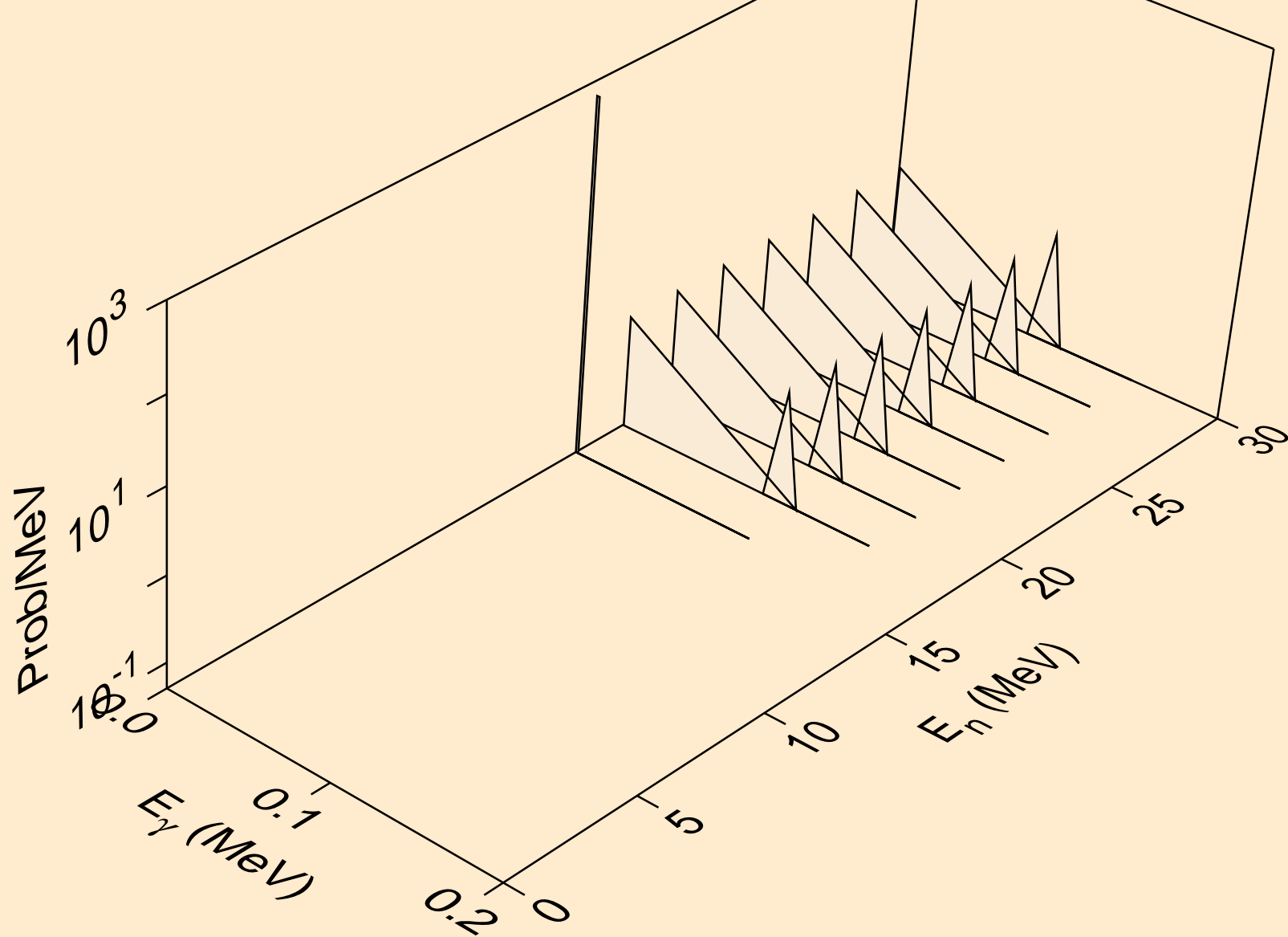

SG269 HELION ACER TENDL-2021 LIBRARY; T=0.K  
Photon emission for (n,a)

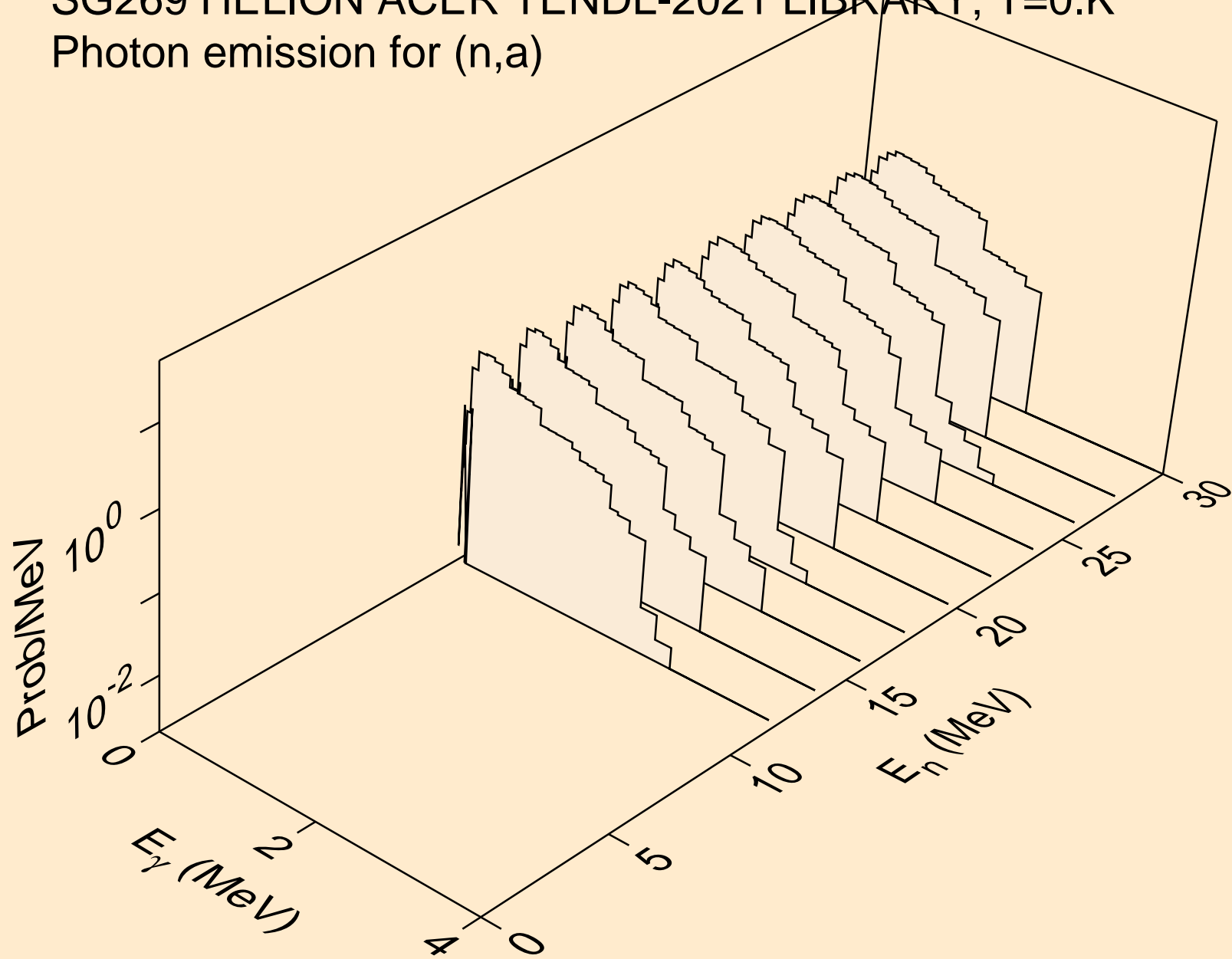

SG269 HELION ACER TENDL-2021 LIBRARY; T=0.K  
Photon emission for (n,2p)

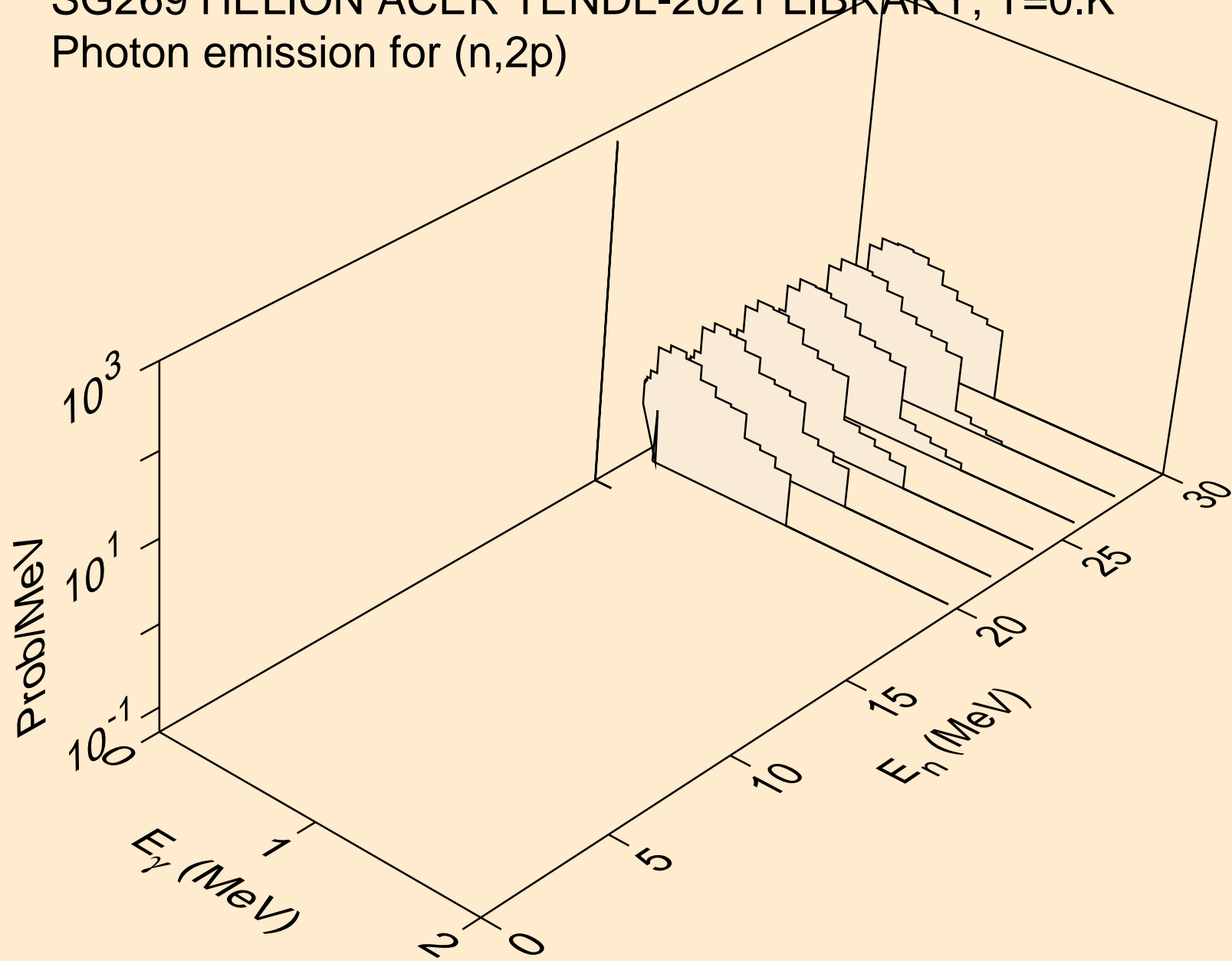

SG269 HELION ACER TENDL-2021 LIBRARY; T=0.K  
Photon emission for (n,da)

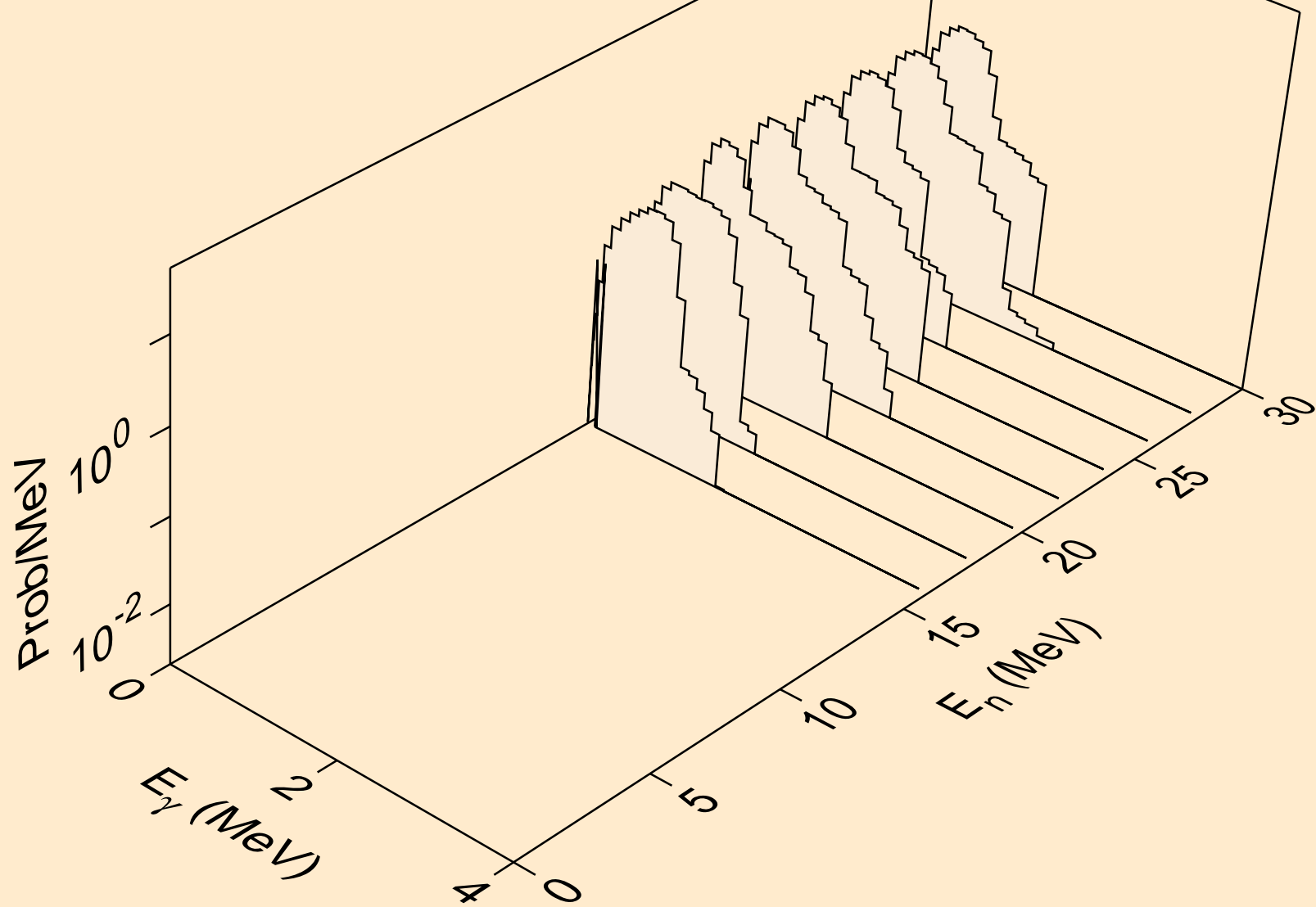

# SG269 HELION ACER TENDL-2021 LIBRARY; T=0.K

## Particle heating contributions

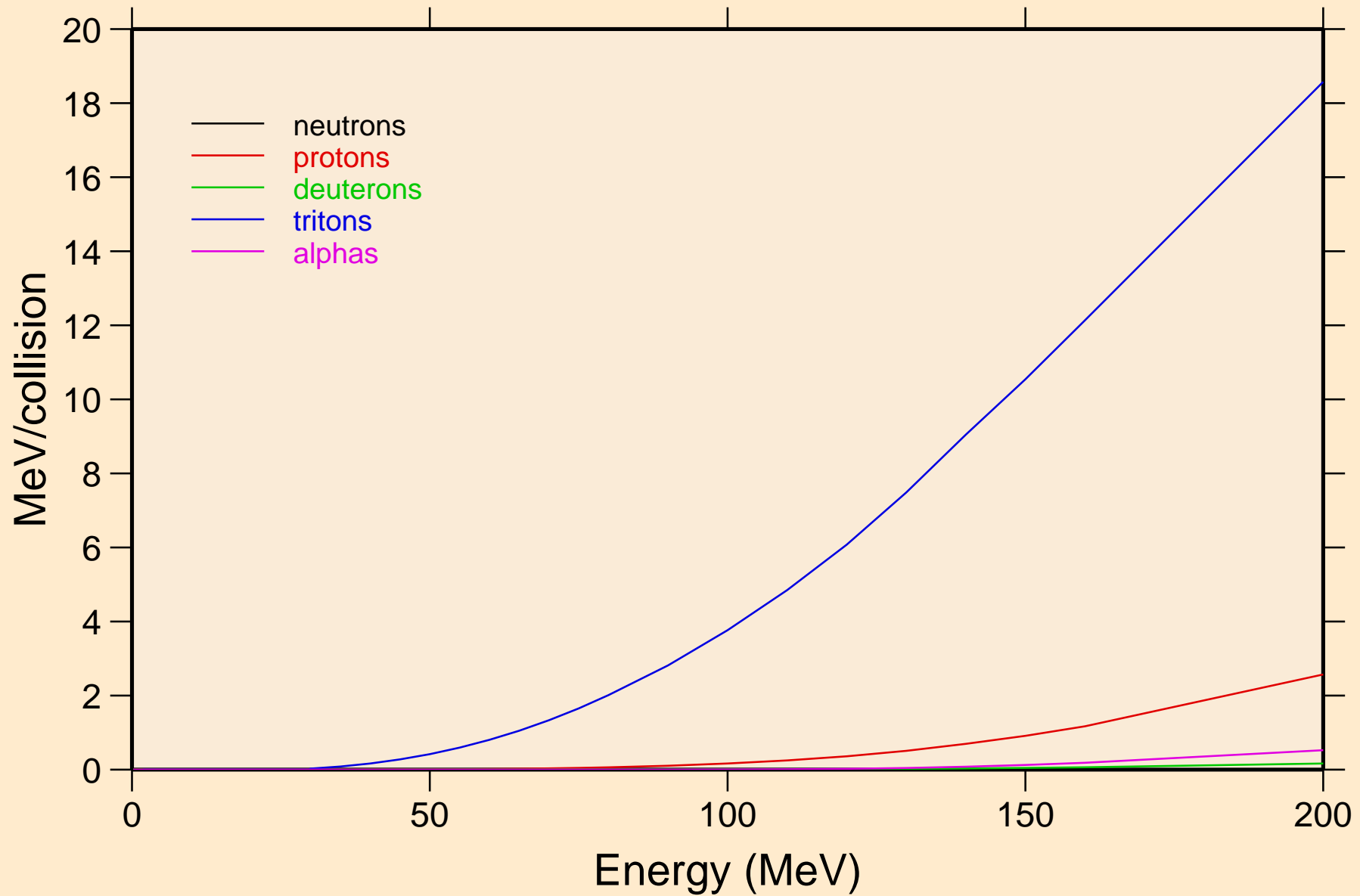

SG269 HELION ACER TENDL-2021 LIBRARY; T=0.K  
Recoil Heating

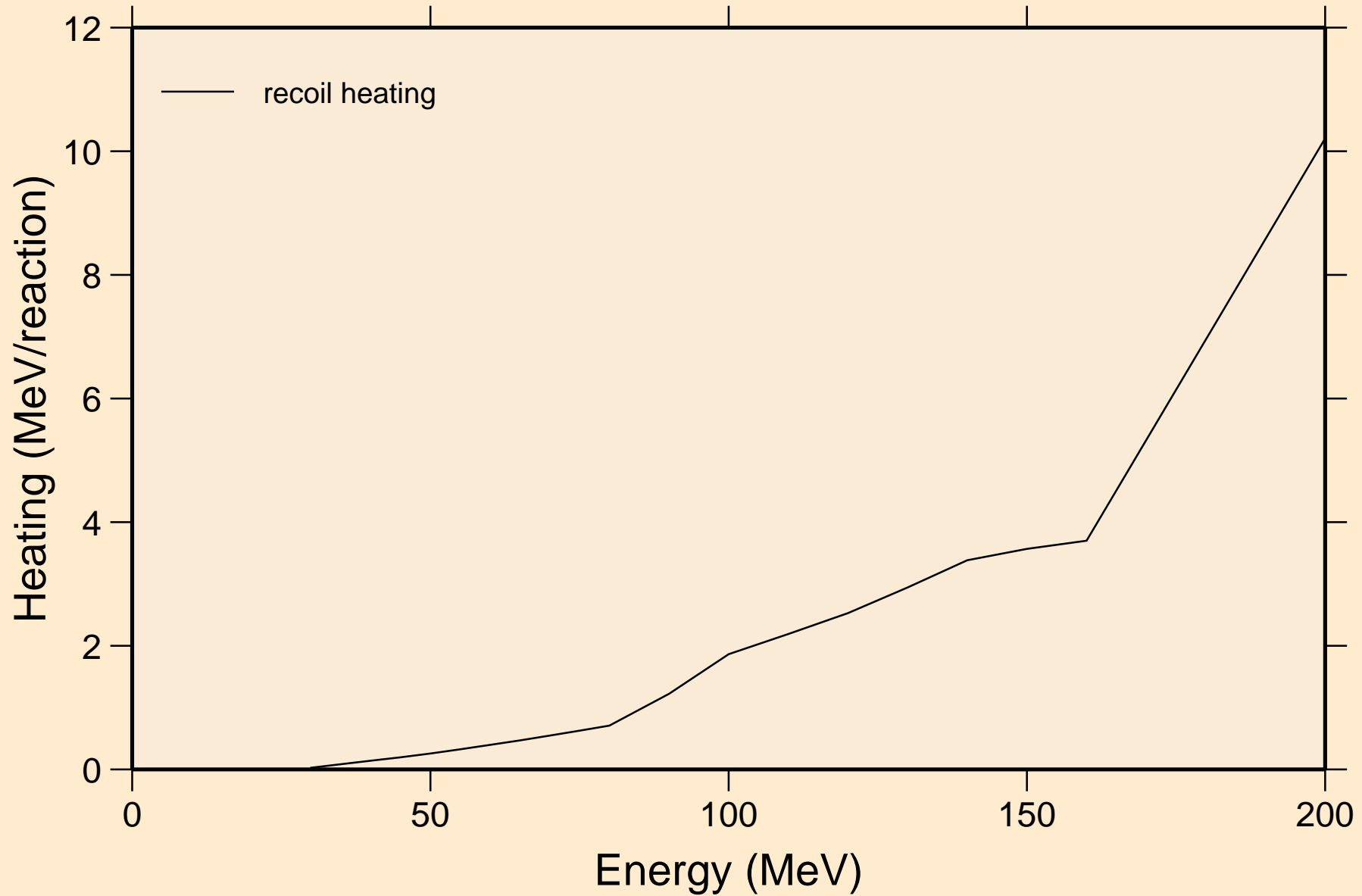

SG269 HELION ACER TENDL-2021 LIBRARY; T=0.K  
Particle production cross sections

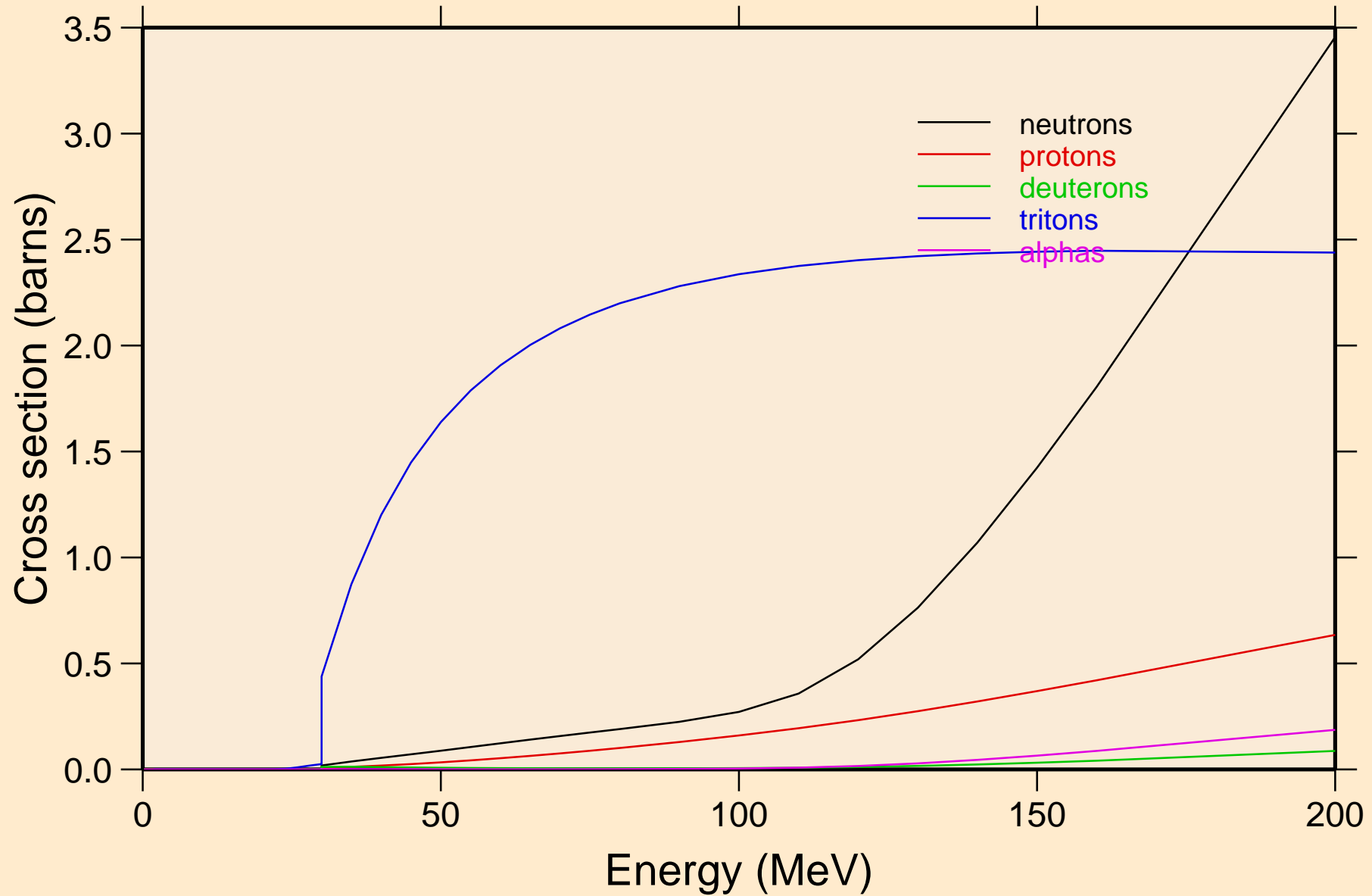



SG269 HELION ACER TENDL-2021 LIBRARY; T=0.K  
neutrons from (s,n)

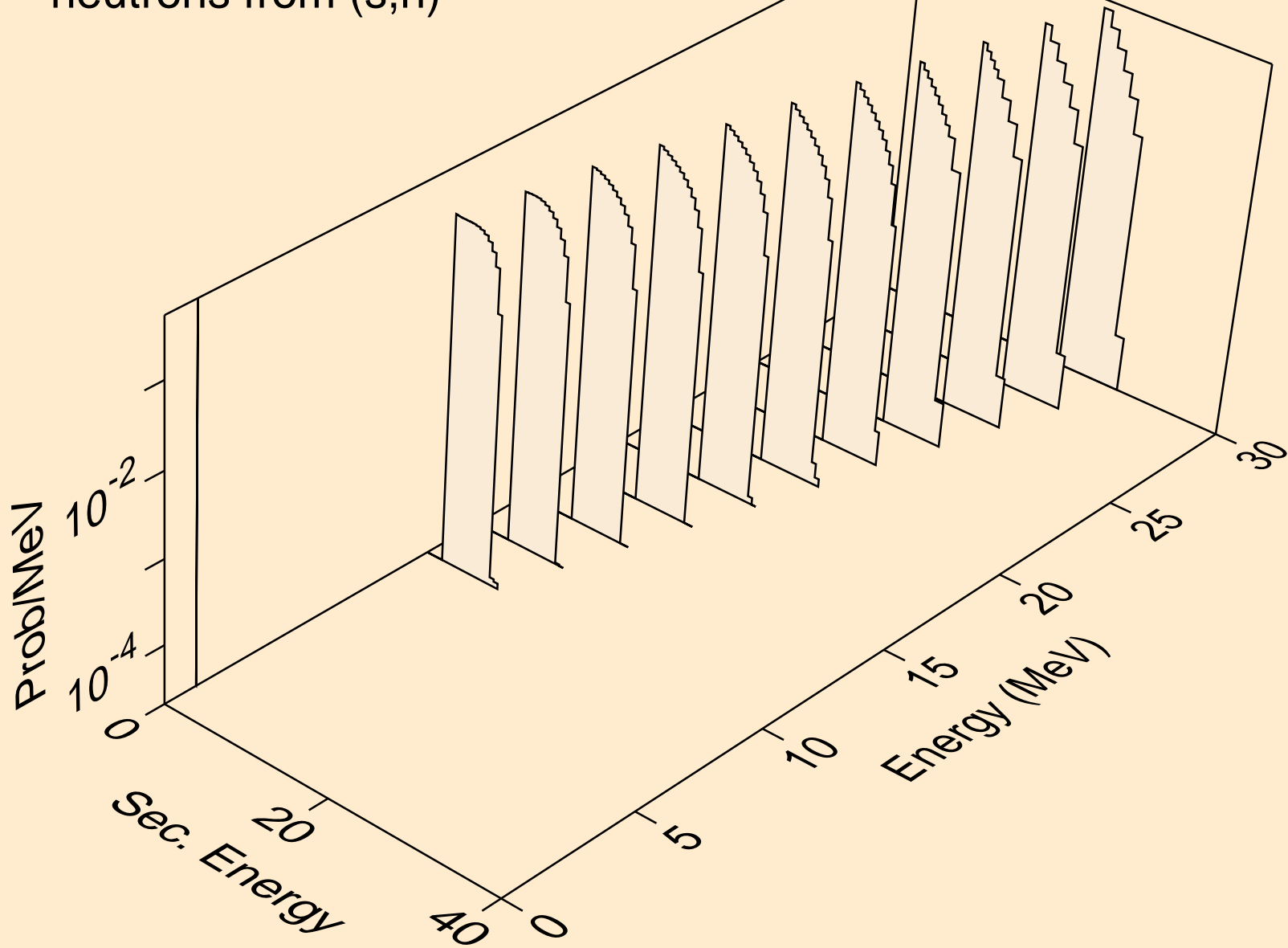

SG269 HELION ACER TENDL-2021 LIBRARY; T=0.K  
neutrons from (s,x)

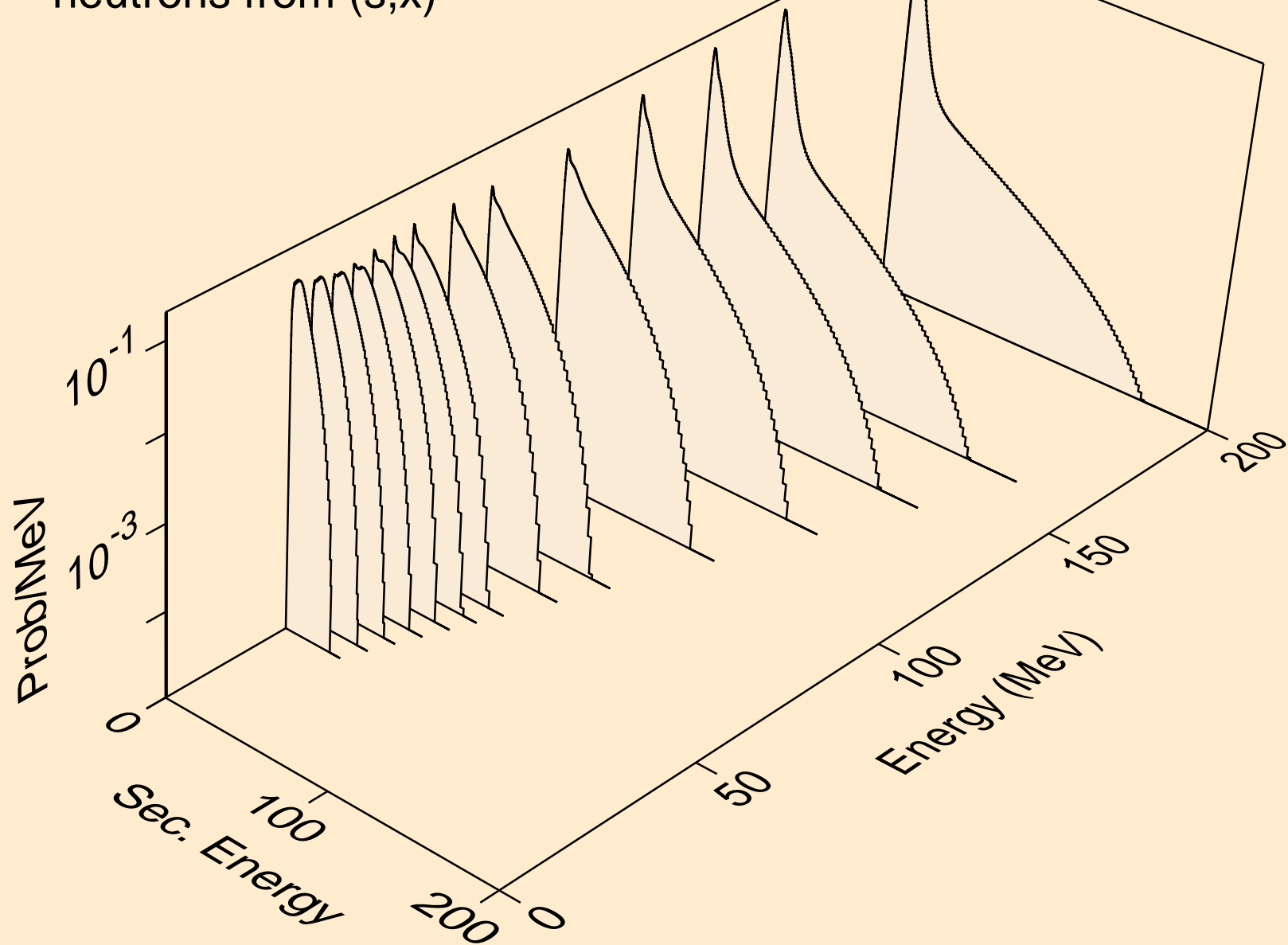

SG269 HELION ACER TENDL-2021 LIBRARY; T=0.K  
neutrons from (s,2n)

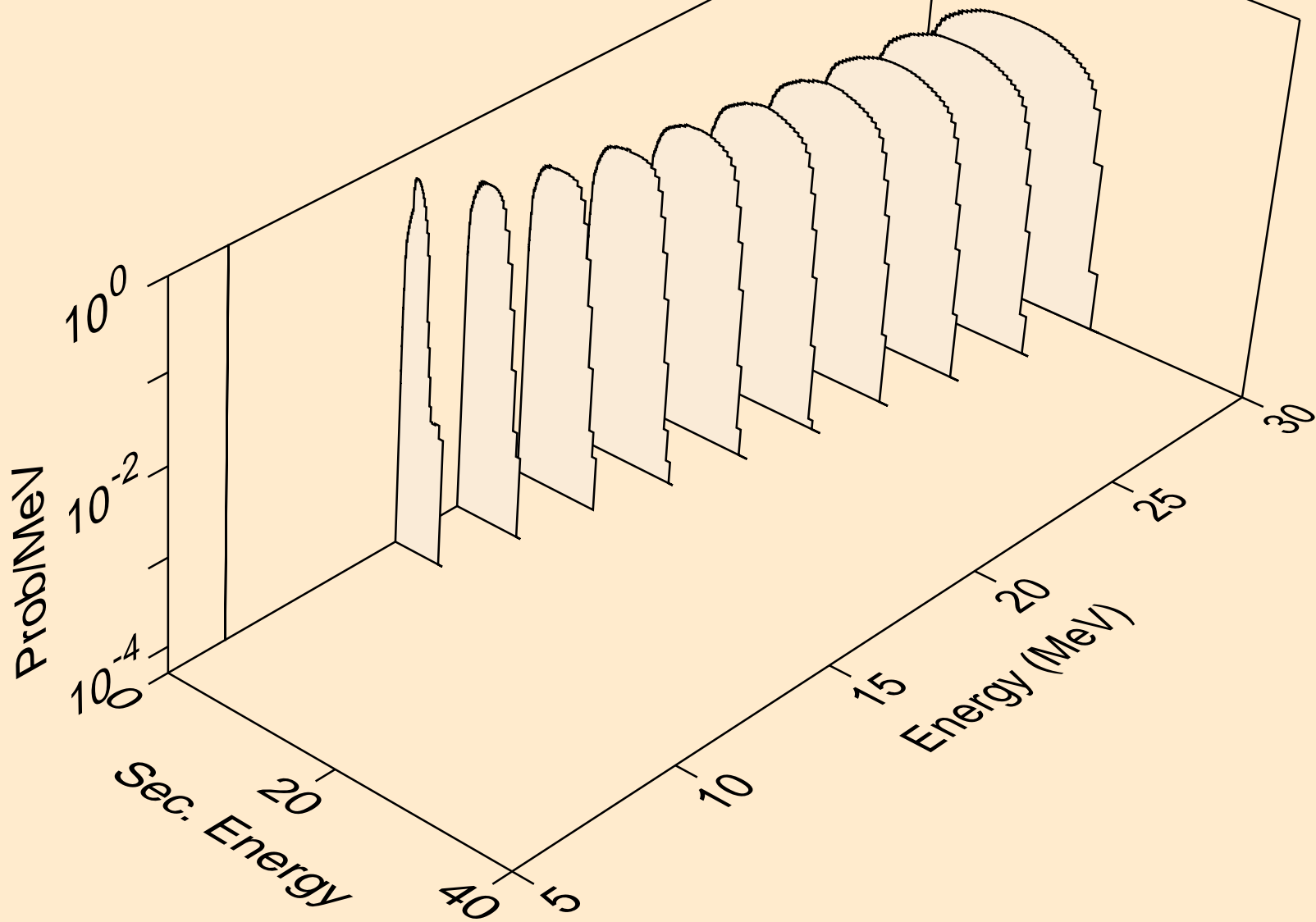

SG269 HELION ACER TENDL-2021 LIBRARY; T=0.K  
neutrons from (s,3n)

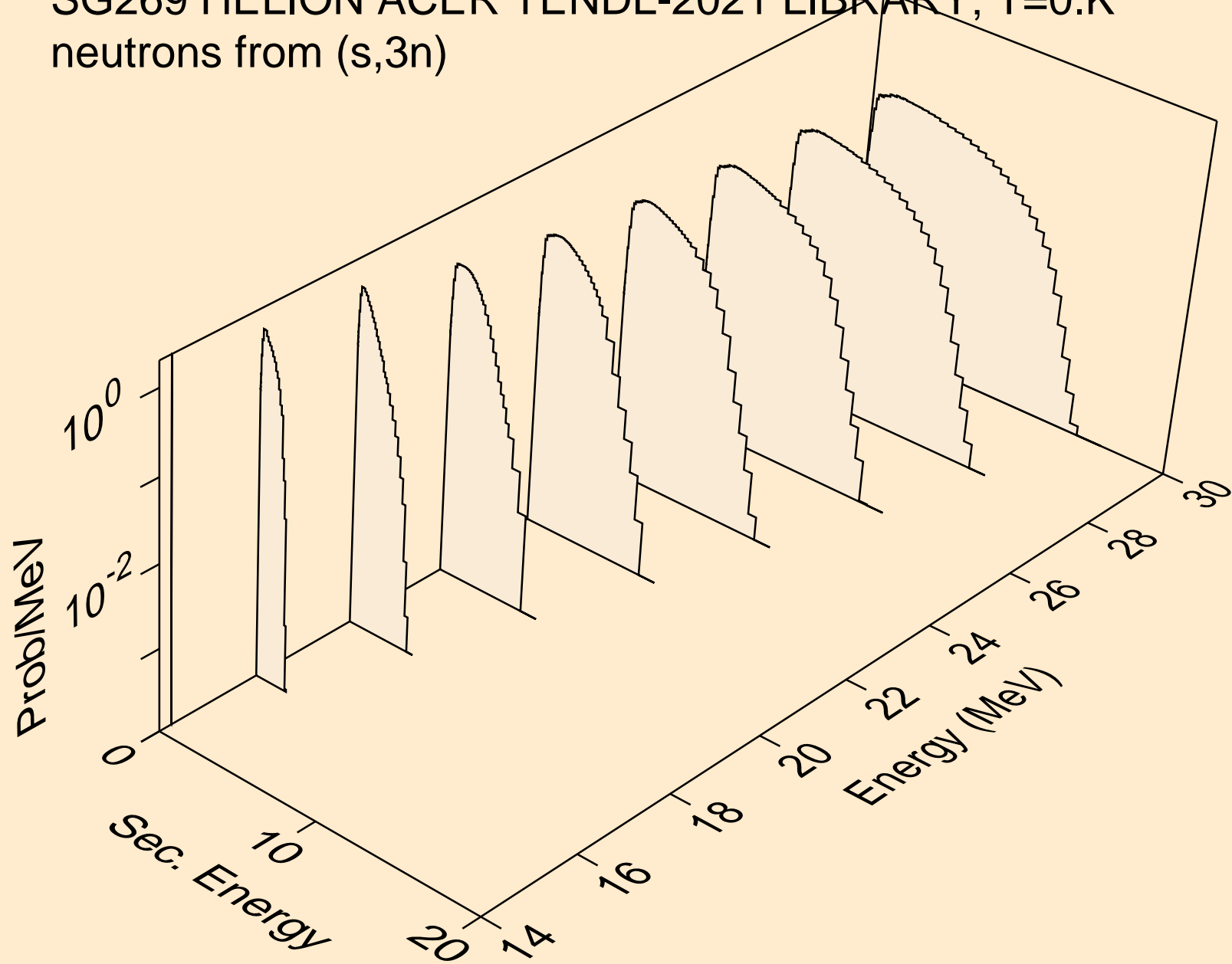

SG269 HELION ACER TENDL-2021 LIBRARY; T=0.K  
neutrons from (s,n\*)a

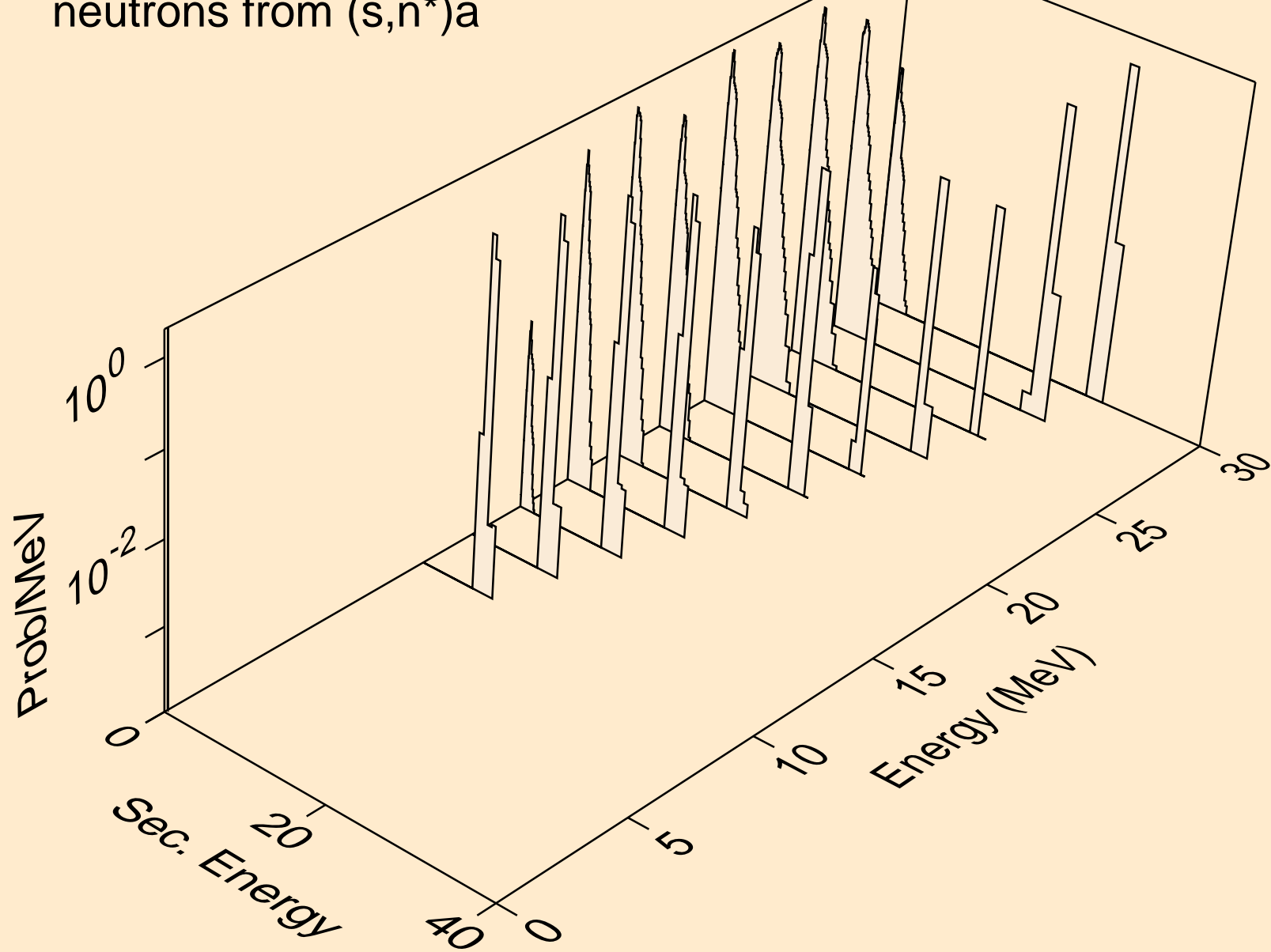

SG269 HELION ACER TENDL-2021 LIBRARY; T=0.K  
neutrons from (s,n\*)p

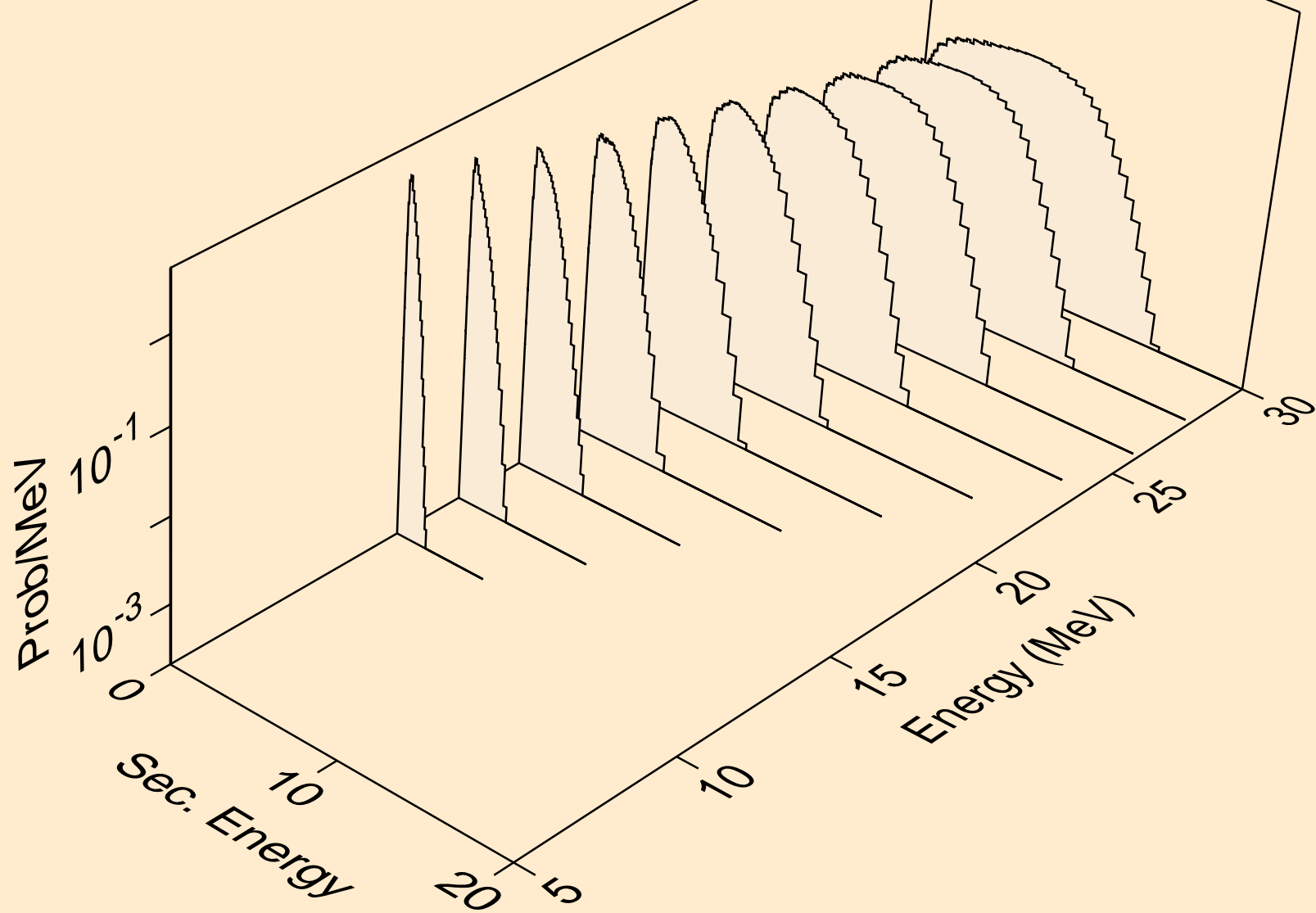

SG269 HELION ACER TENDL-2021 LIBRARY; T=0.K  
neutrons from (s,n\*)d

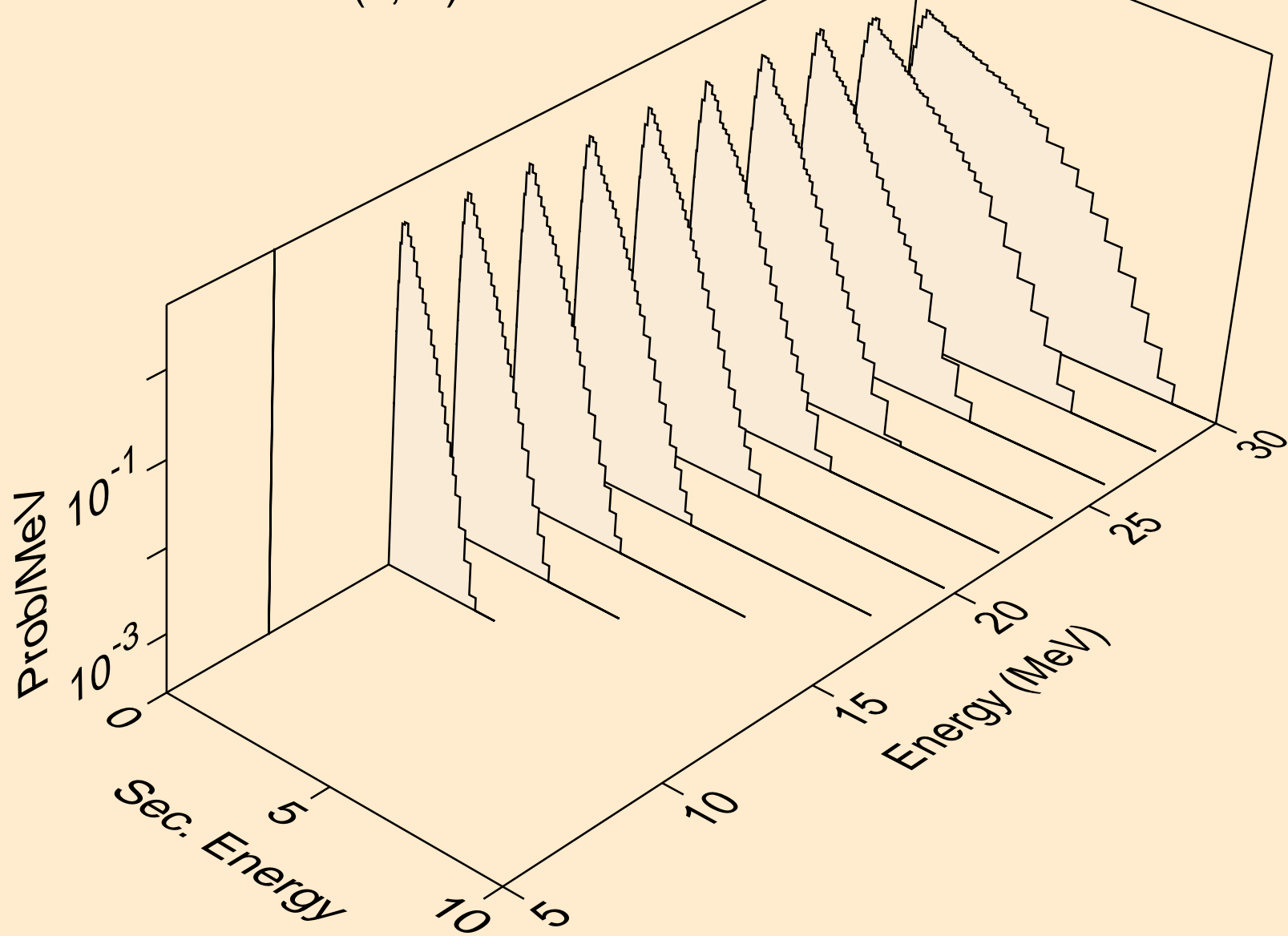

SG269 HELION ACER TENDL-2021 LIBRARY; T=0.K  
neutrons from (s,n\*)t

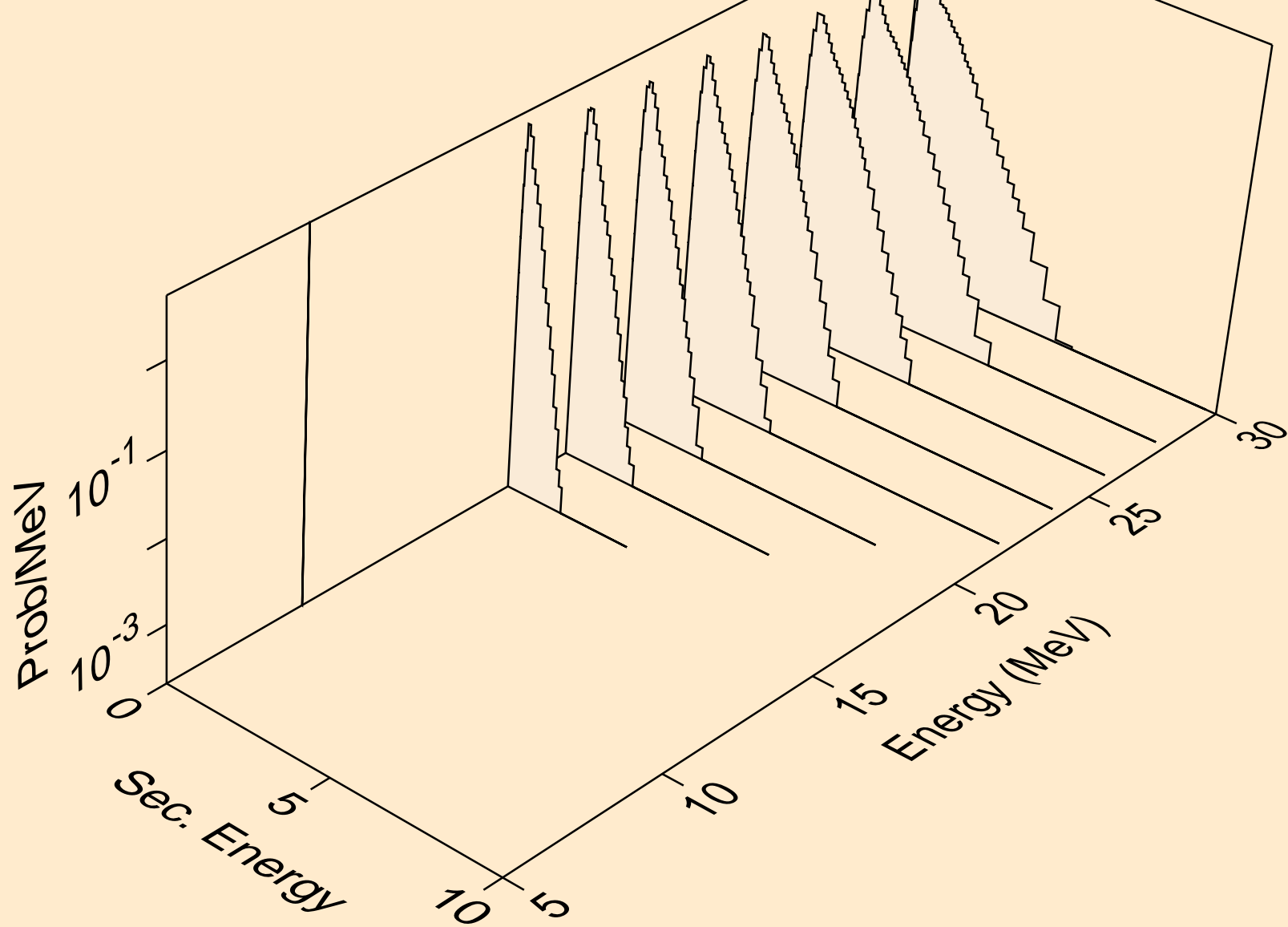



SG269 HELION ACER TENDL-2021 LIBRARY; T=0.K  
neutrons from (s,2np)

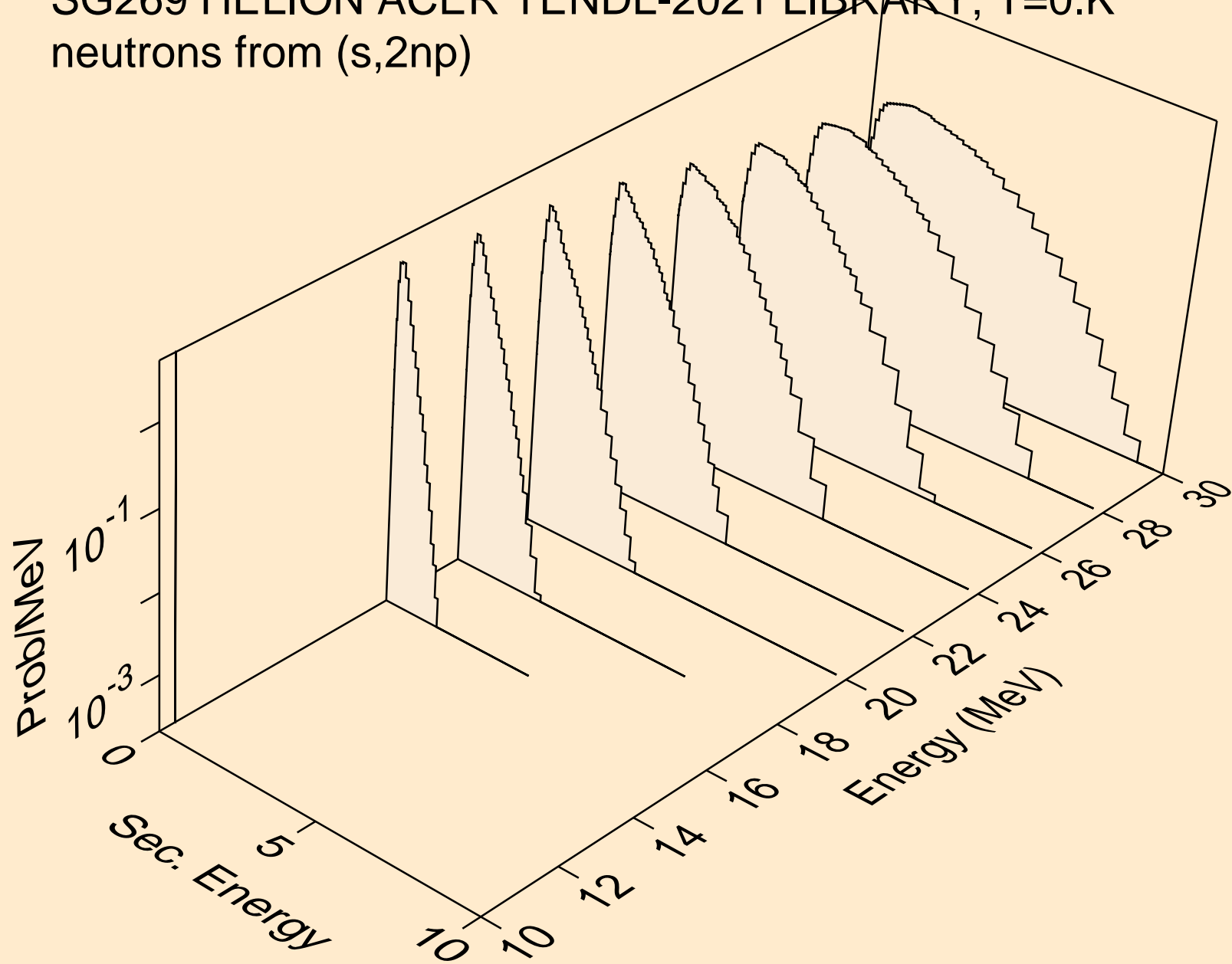

SG269 HELION ACER TENDL-2021 LIBRARY; T=0.K  
neutrons from (s,npa)

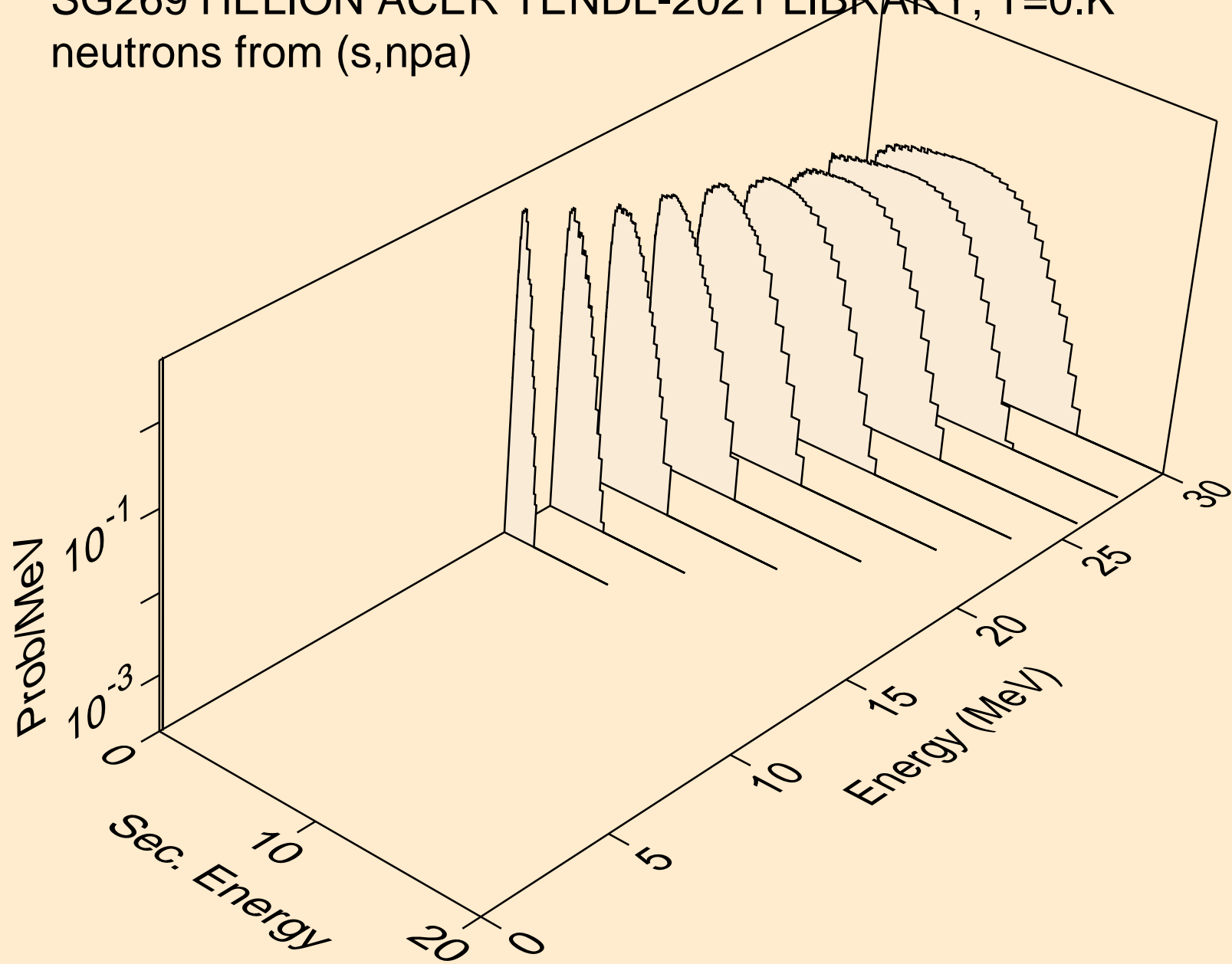

SG269 HELION ACER TENDL-2021 LIBRARY; T=0.K  
protons from (s,x)

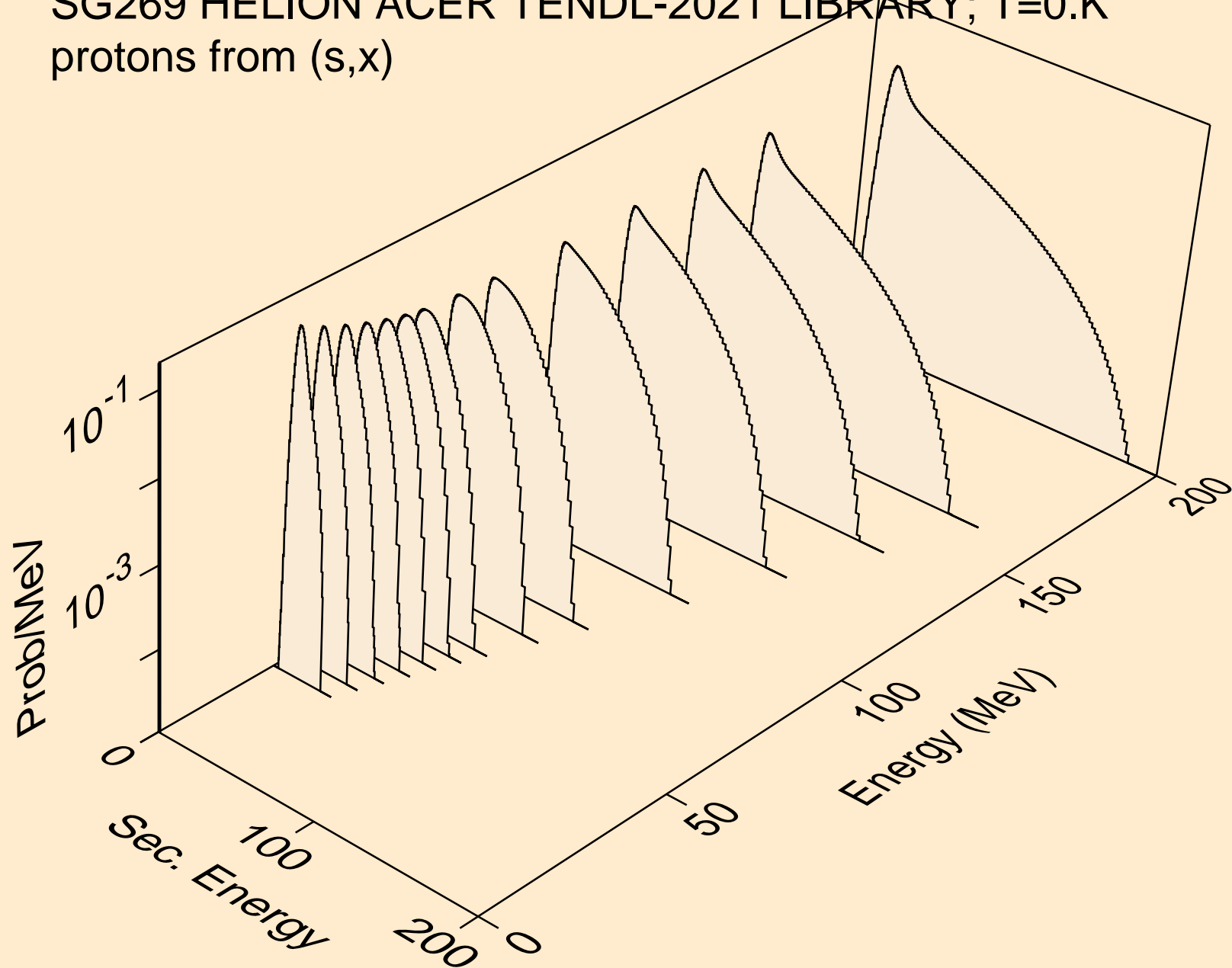

SG269 HELION ACER TENDL-2021 LIBRARY; T=0.K  
protons from (s,n\*)p

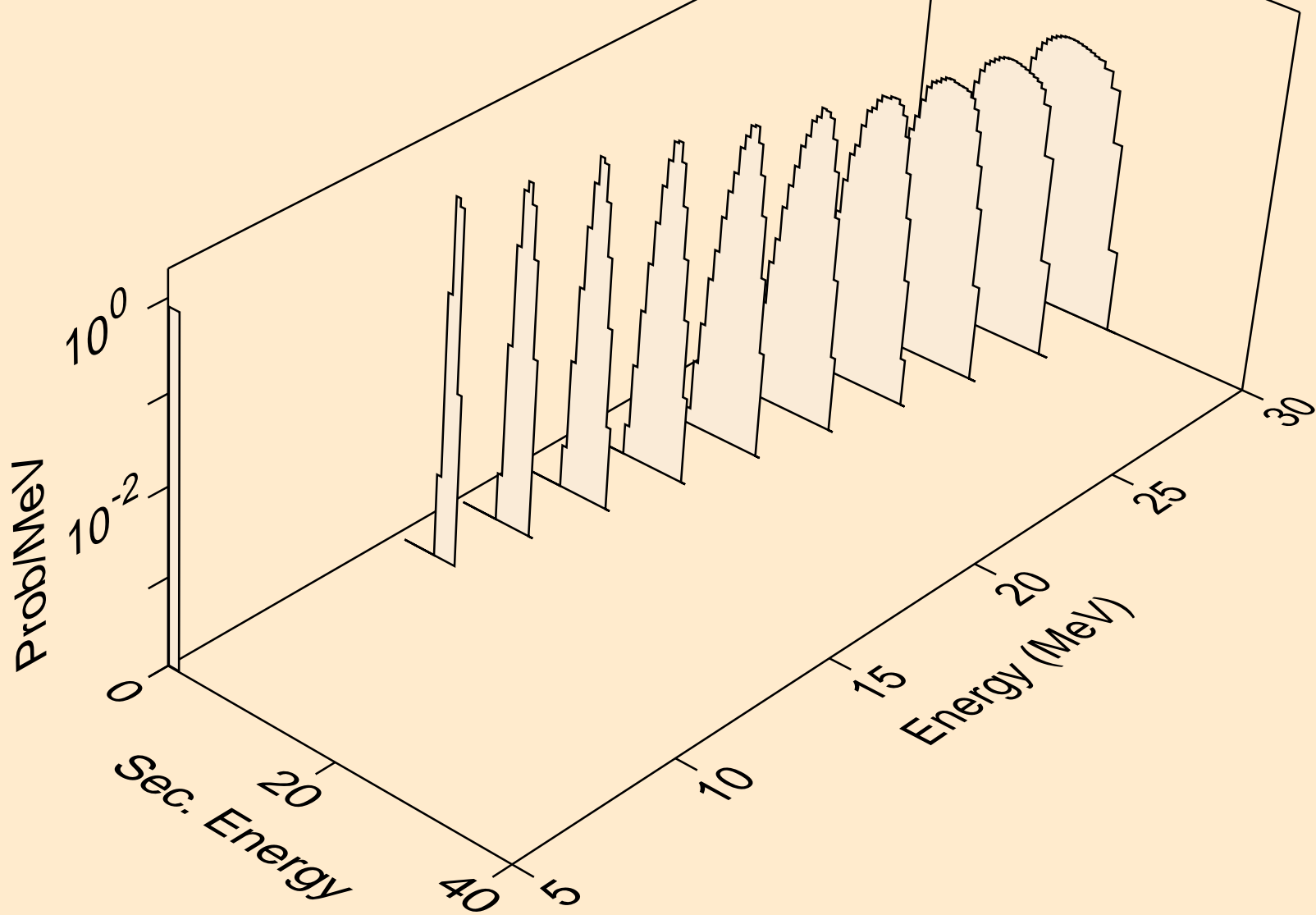

SG269 HELION ACER TENDL-2021 LIBRARY; T=0.K  
protons from (s,2np)

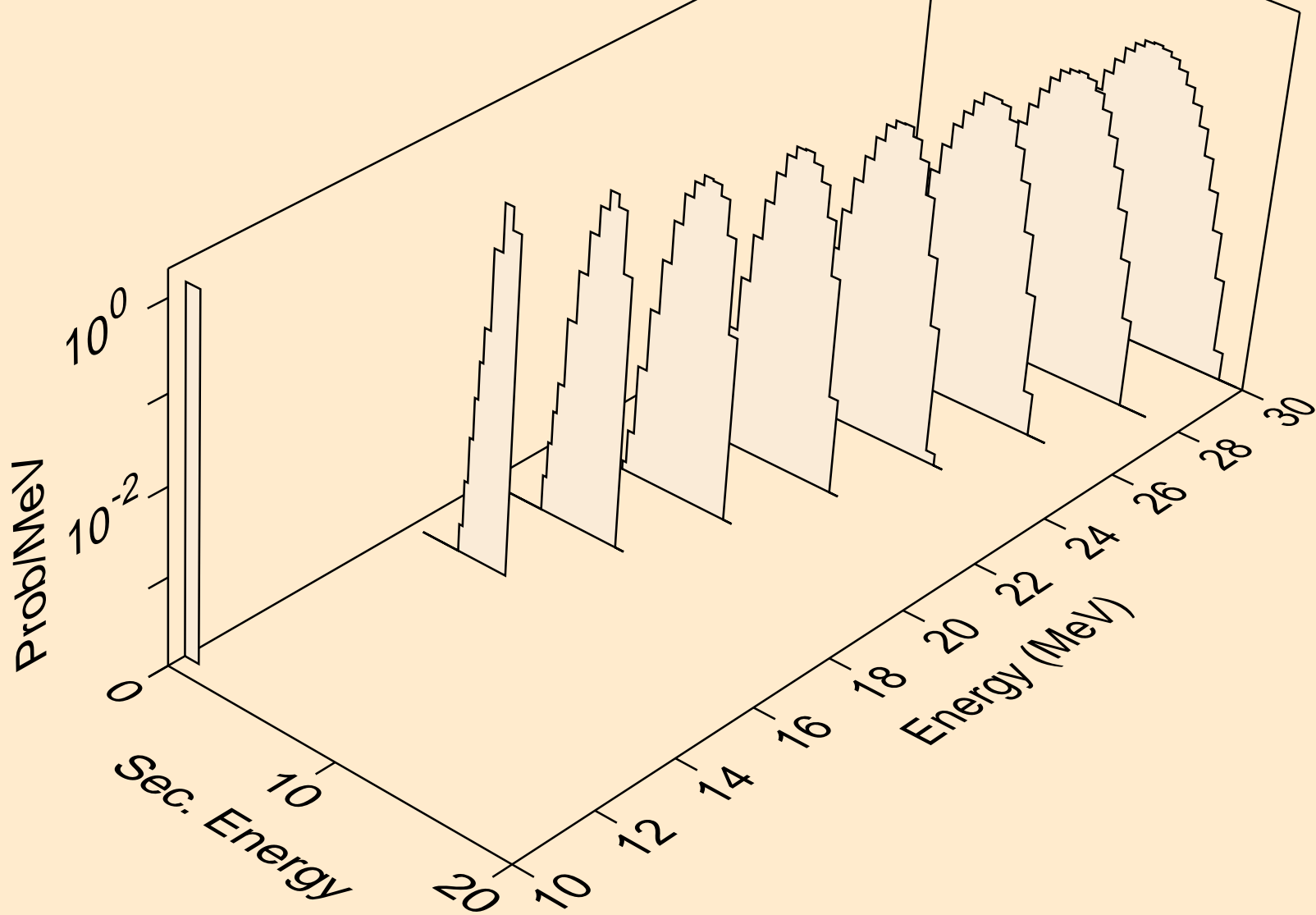

SG269 HELION ACER TENDL-2021 LIBRARY; T=0.K  
protons from (s,npa)

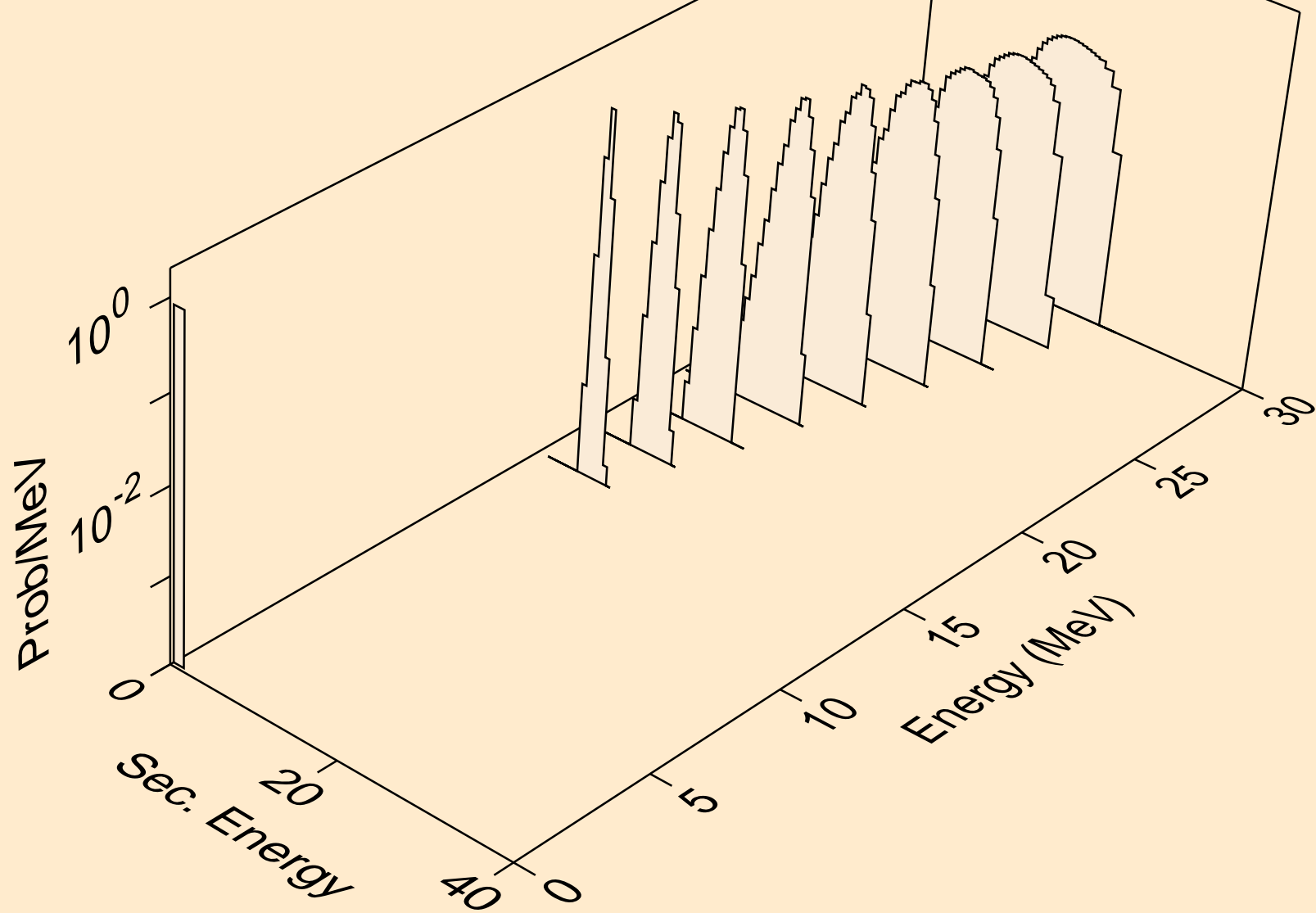

SG269 HELION ACER TENDL-2021 LIBRARY; T=0.K  
protons from (s,p)

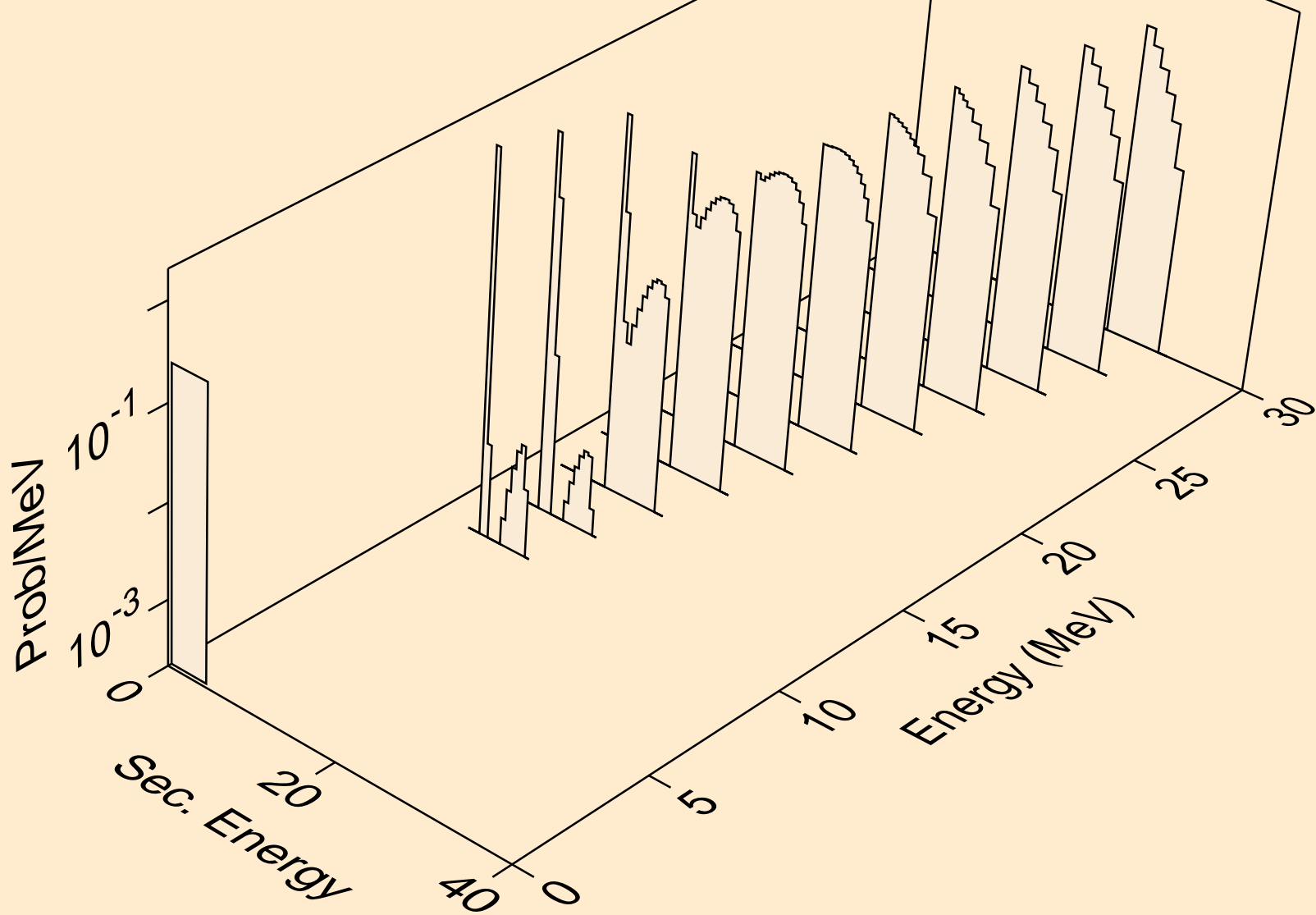

SG269 HELION ACER TENDL-2021 LIBRARY; T=0.K  
protons from (s,2p)

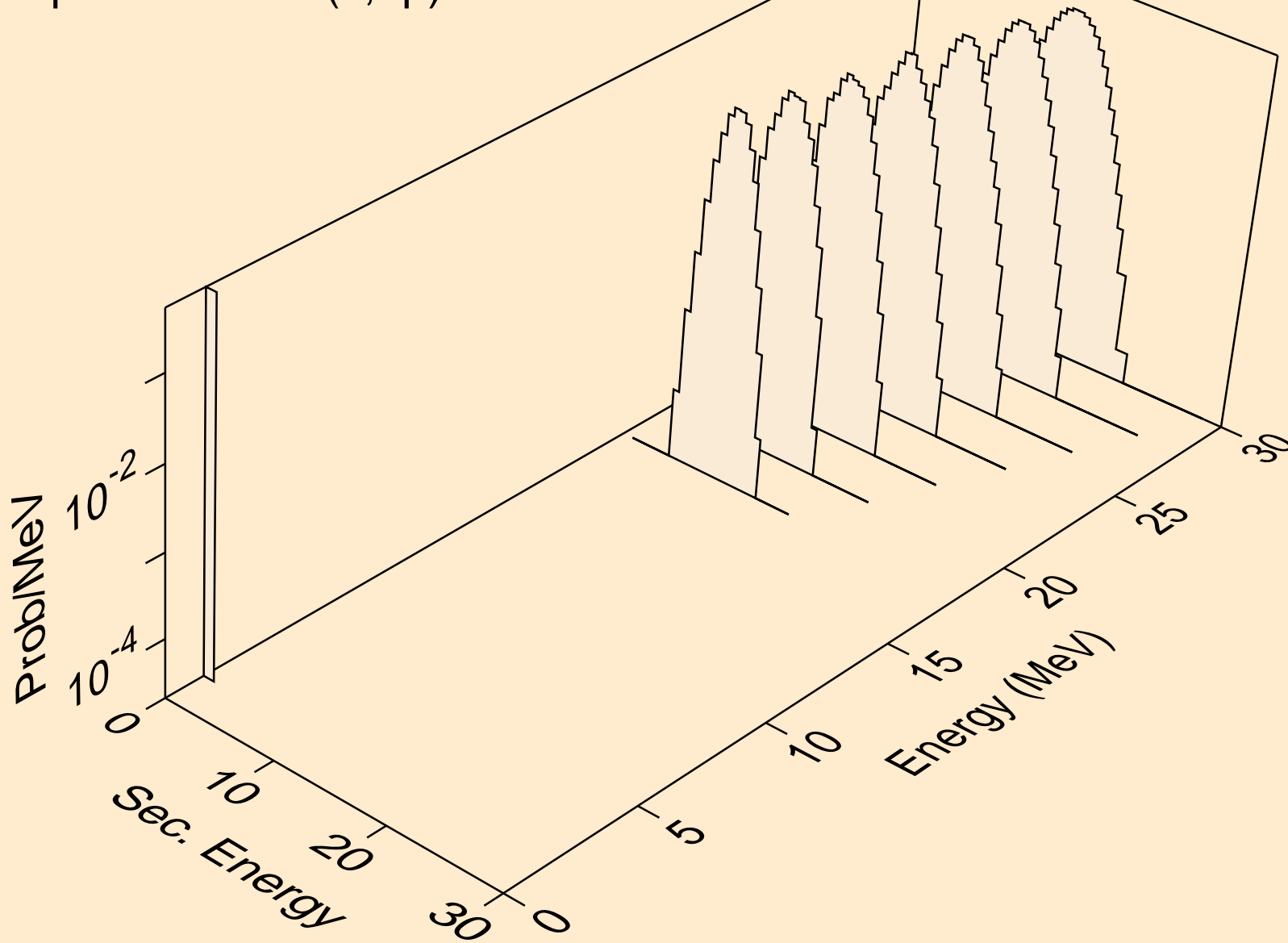



SG269 HELION ACER TENDL-2021 LIBRARY; T=0.K  
deuterons from (s,x)

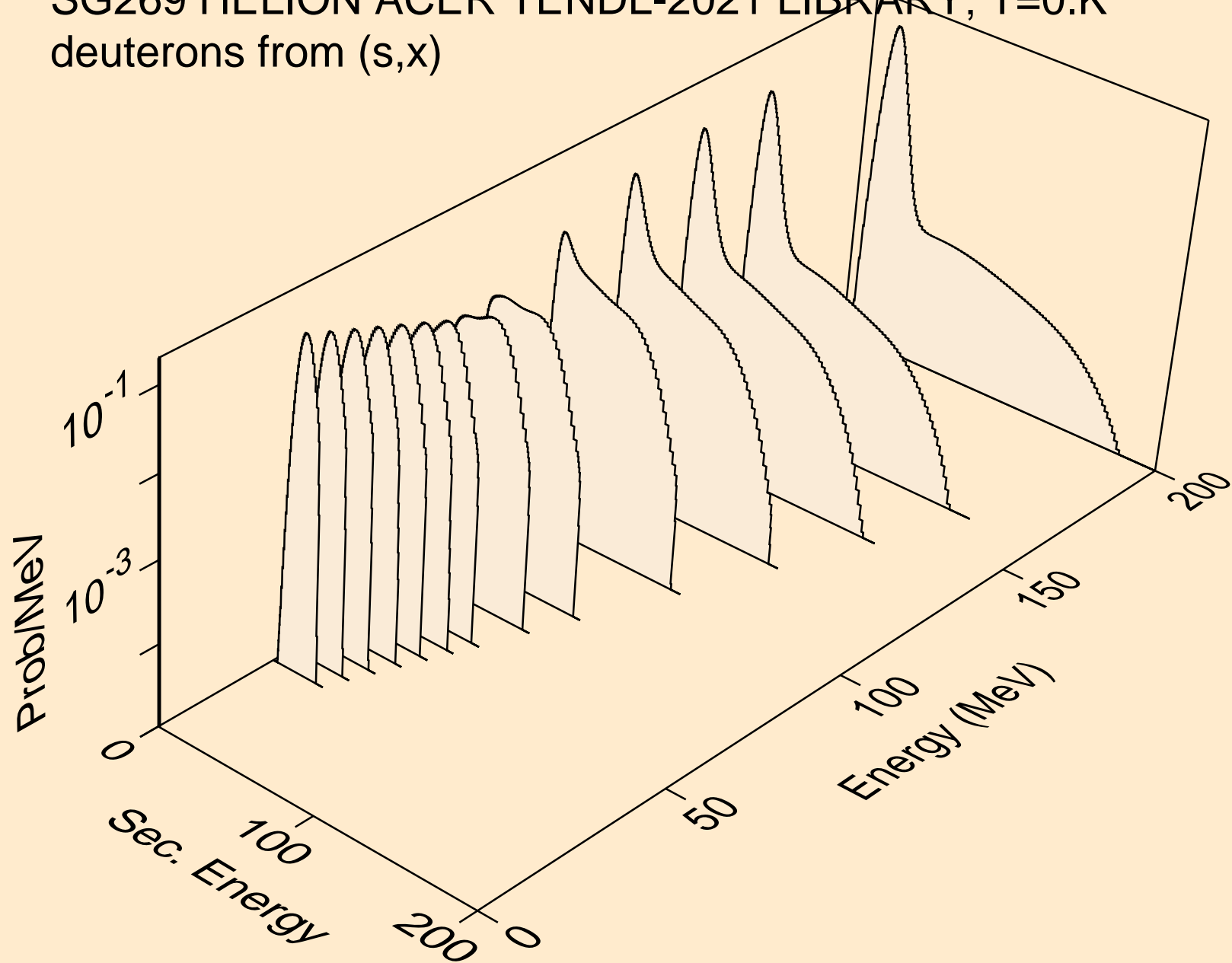

SG269 HELION ACER TENDL-2021 LIBRARY; T=0.K  
deuterons from (s,n\*)d

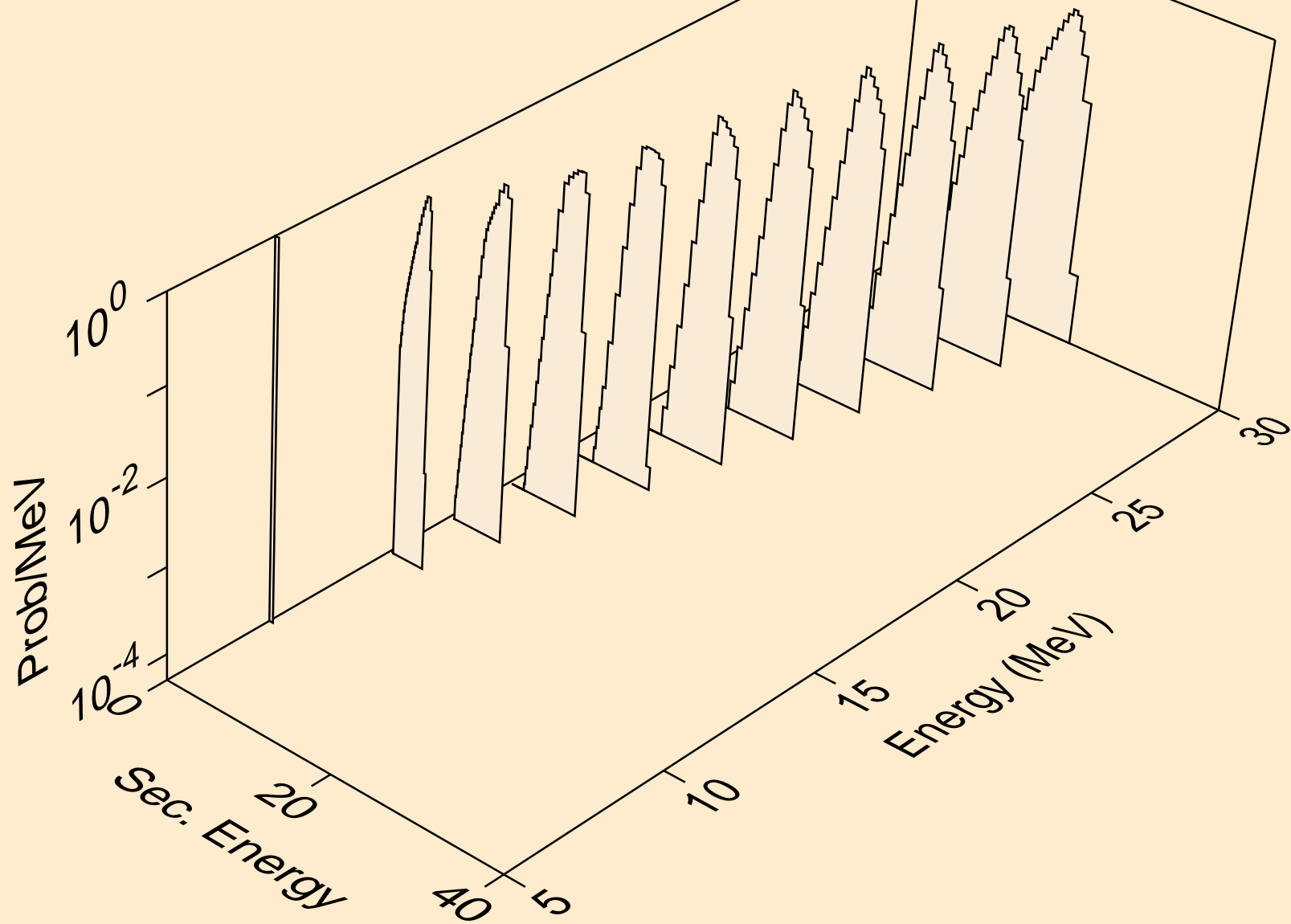

SG269 HELION ACER TENDL-2021 LIBRARY; T=0.K  
deuterons from (s,d)

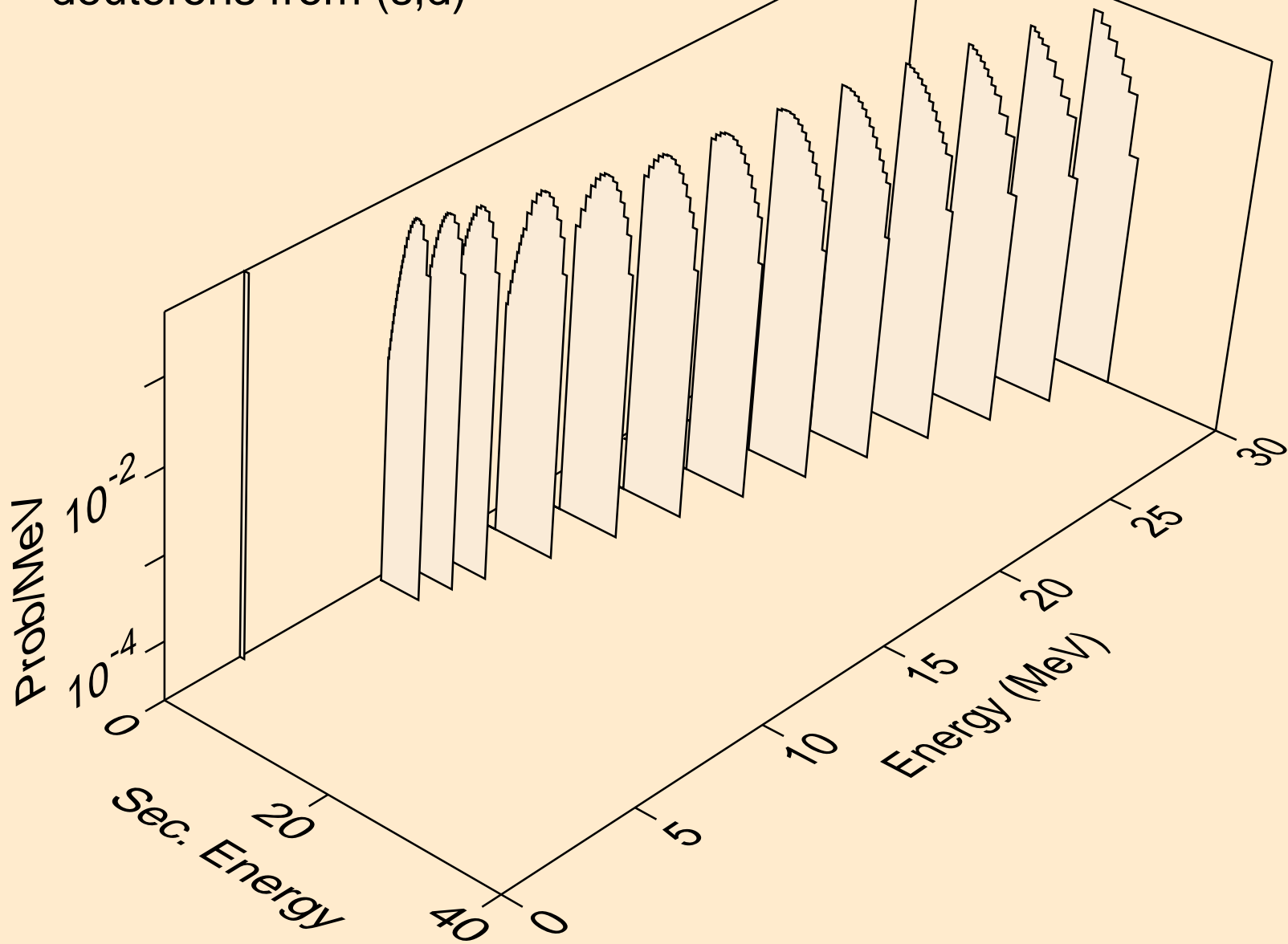

SG269 HELION ACER TENDL-2021 LIBRARY; T=0.K  
deuterons from (s,da)

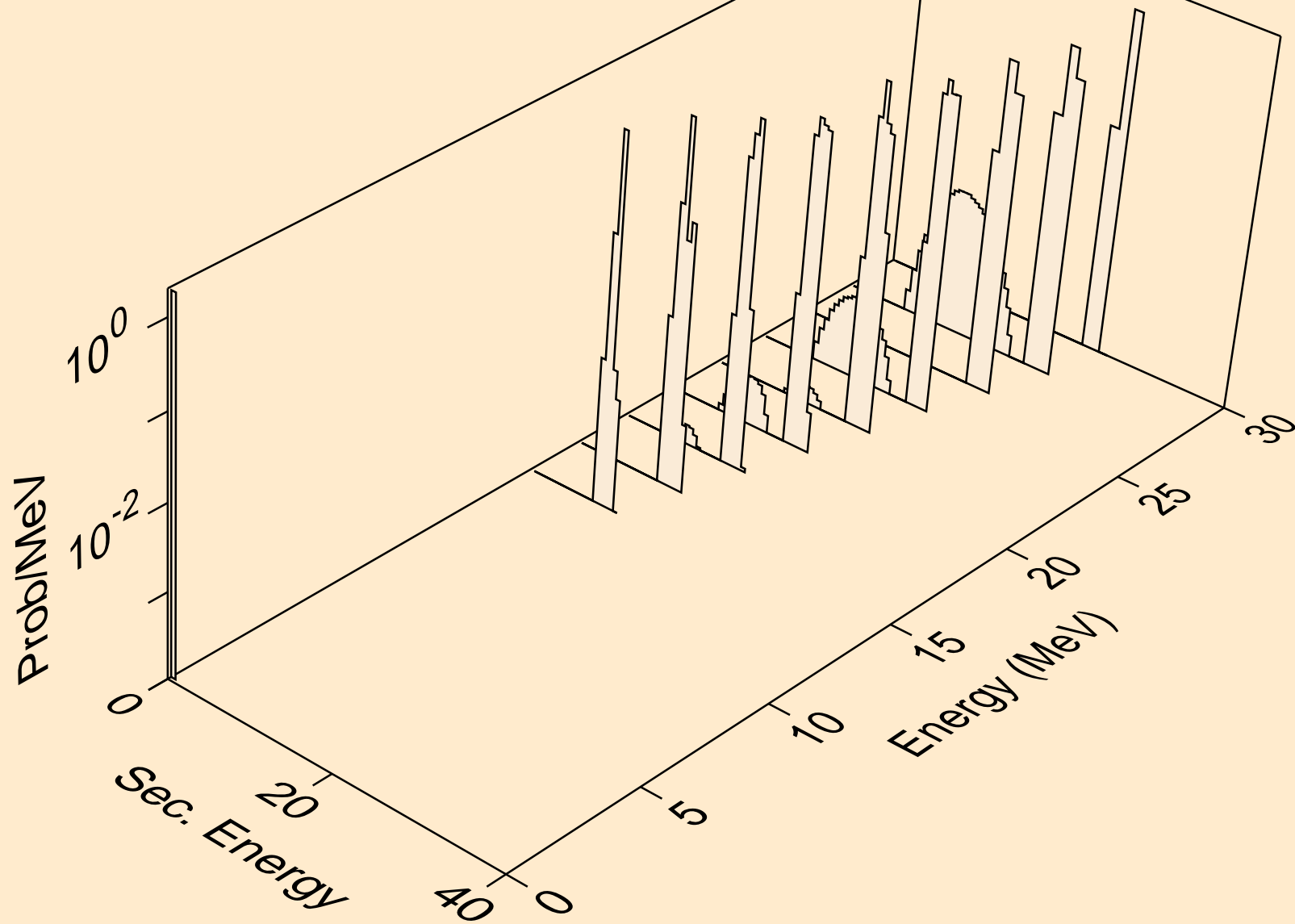

SG269 HELION ACER TENDL-2021 LIBRARY; T=0.K  
tritons from (s,x)

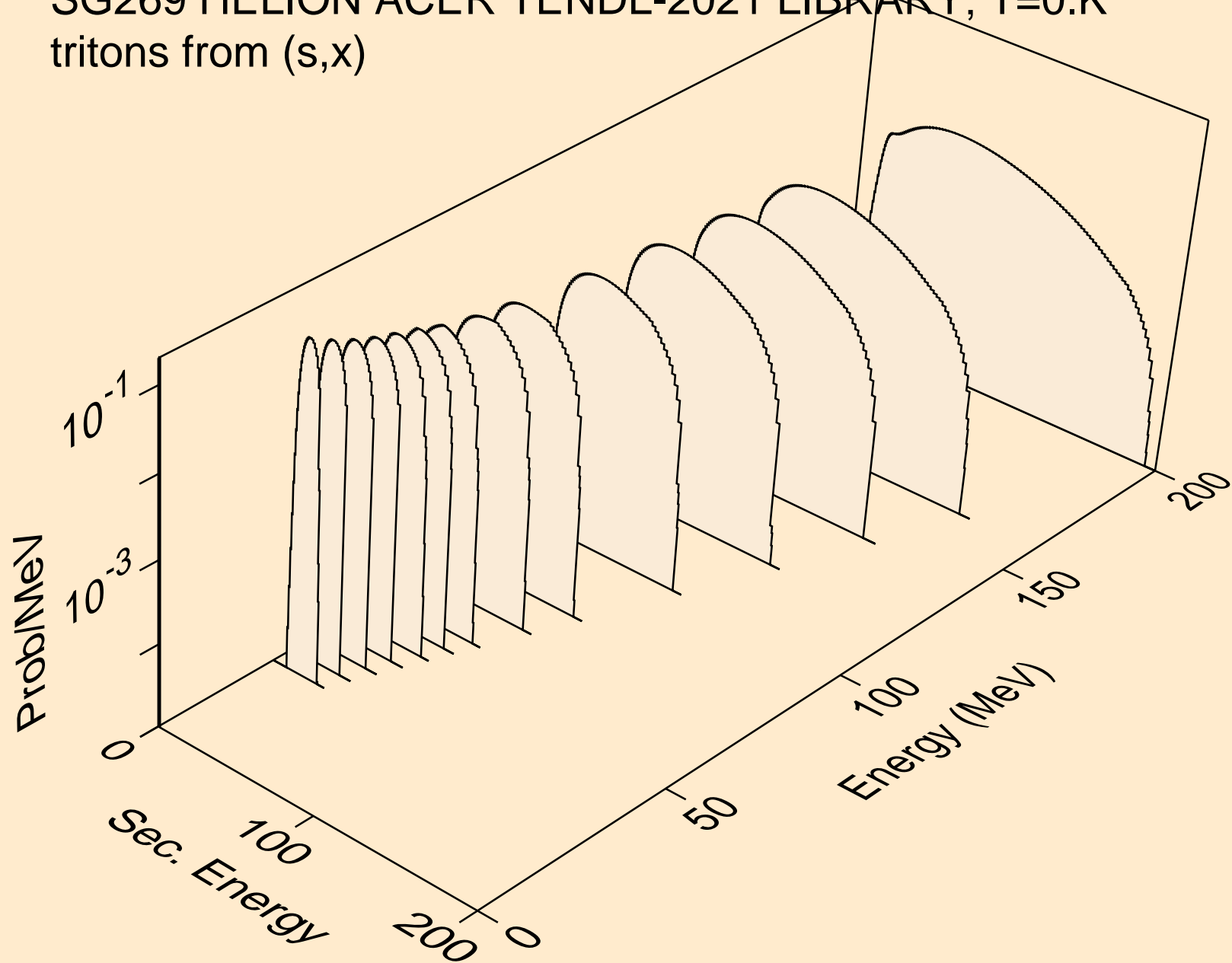

SG269 HELION ACER TENDL-2021 LIBRARY; T=0.K  
tritons from (s,n\*)t

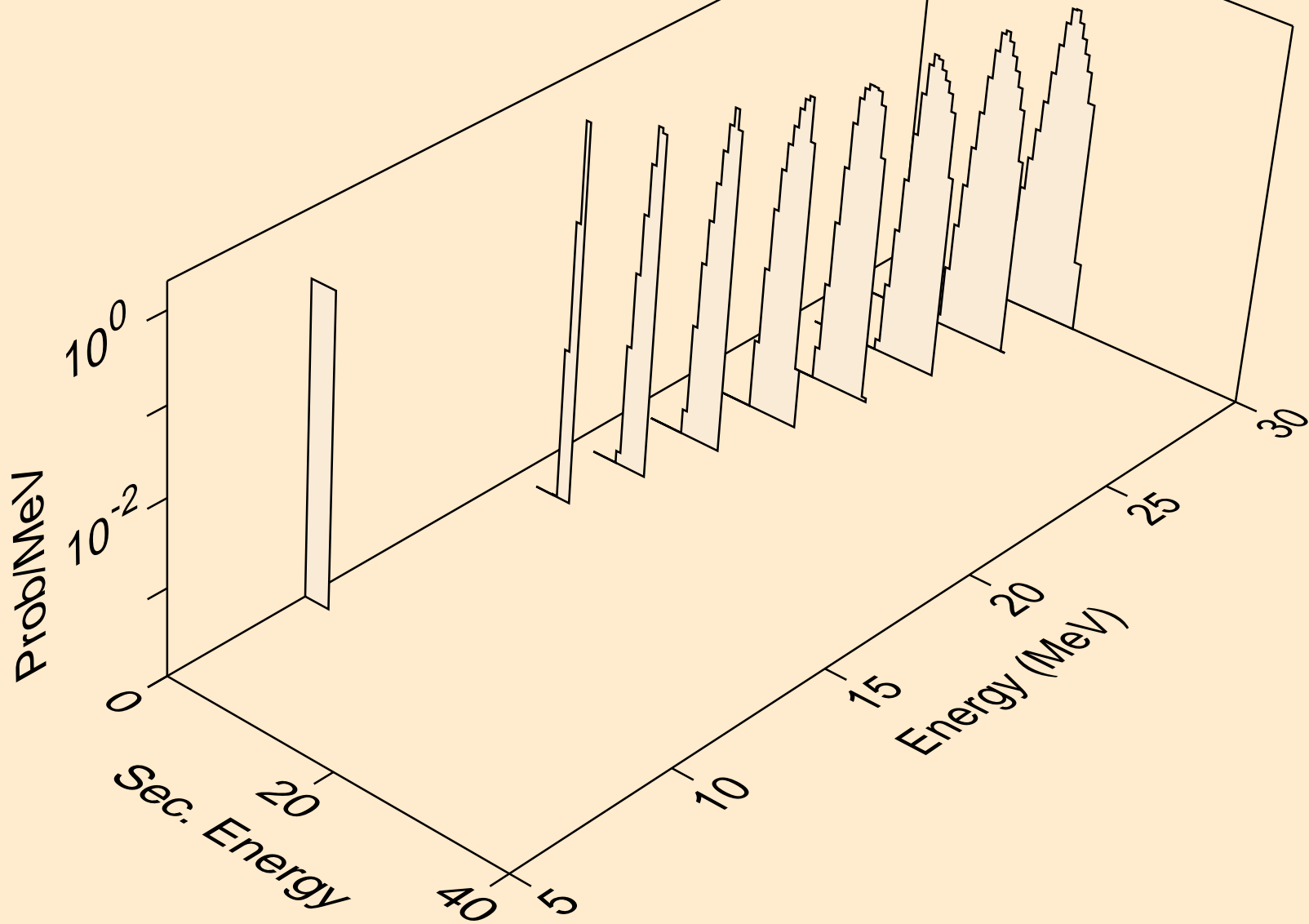

SG269 HELION ACER TENDL-2021 LIBRARY; T=0.K  
tritons from (s,t)

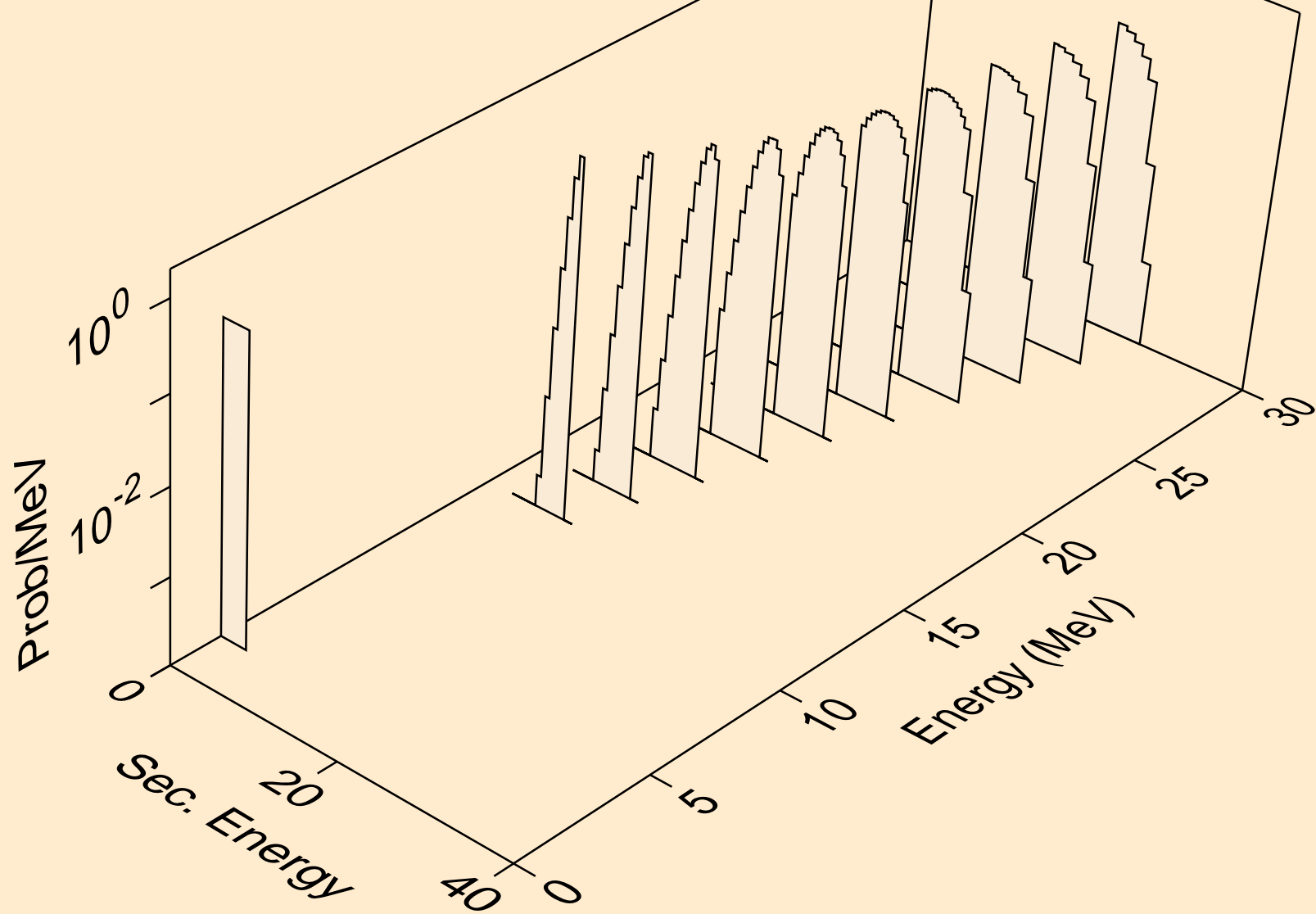

SG269 HELION ACER TENDL-2021 LIBRARY; T=0.K  
alphas from (s,x)

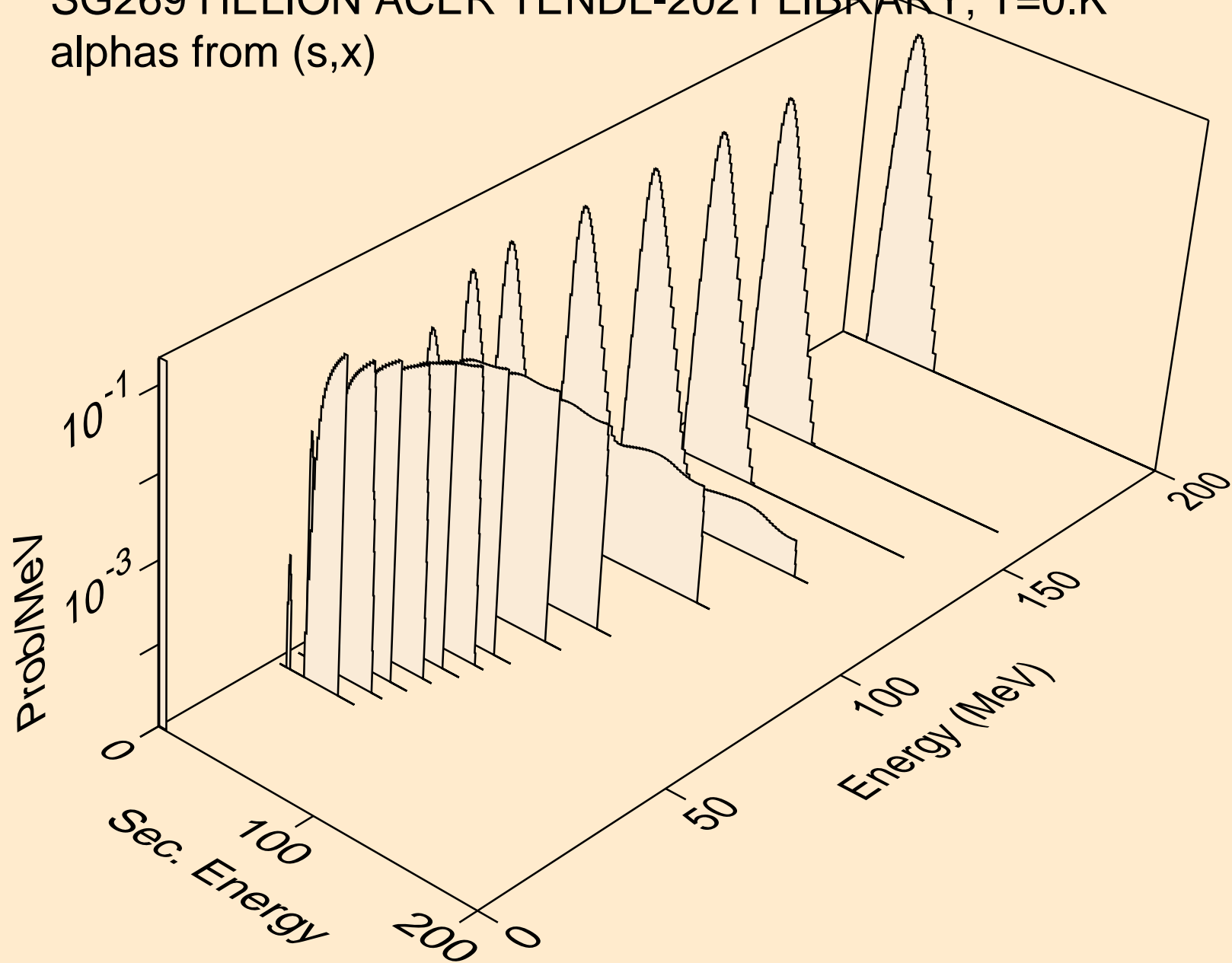



SG269 HELION ACER TENDL-2021 LIBRARY; T=0.K  
alphas from (s,n\*)a

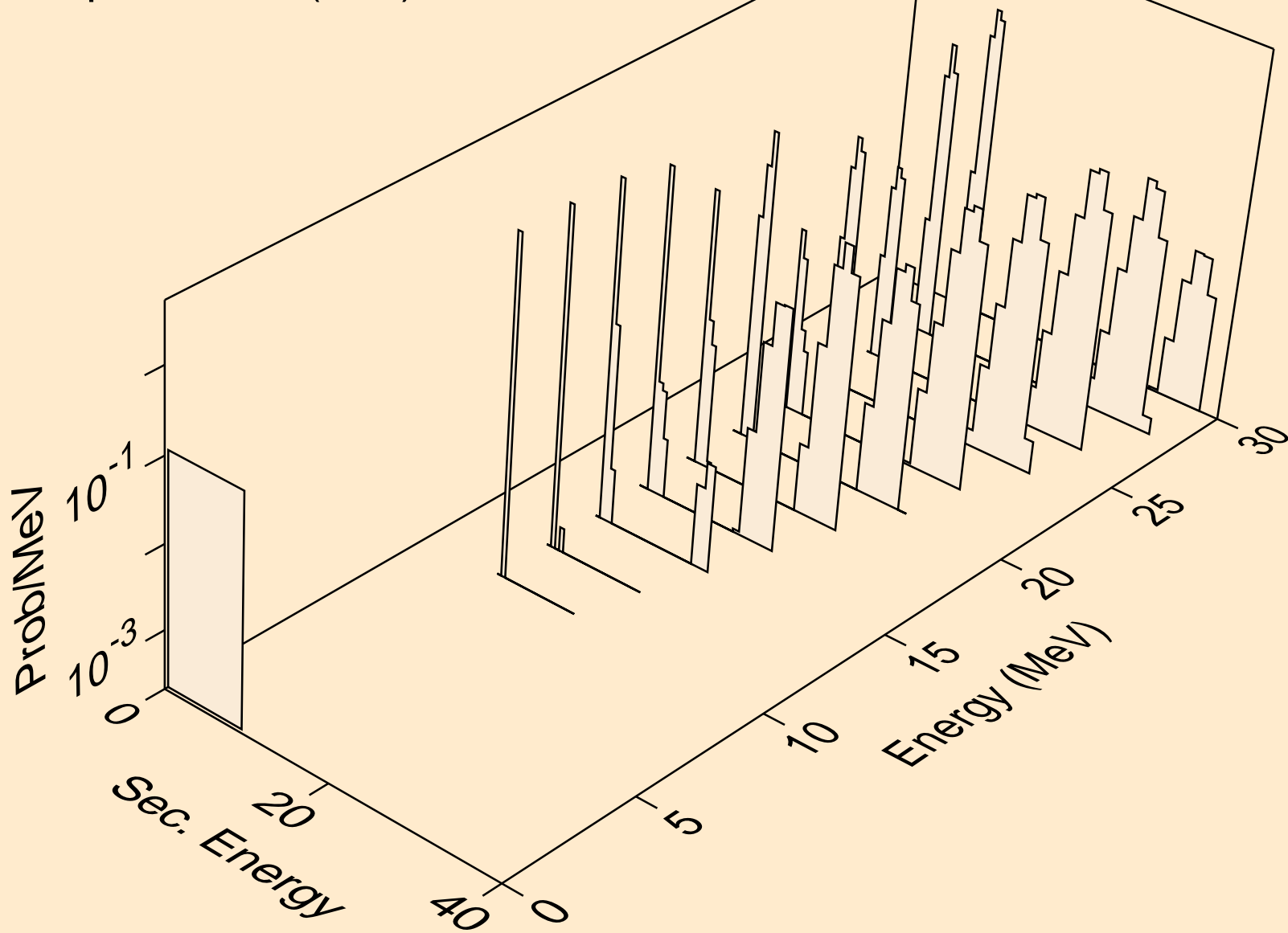

SG269 HELION ACER TENDL-2021 LIBRARY; T=0.K  
alphas from (s,npa)

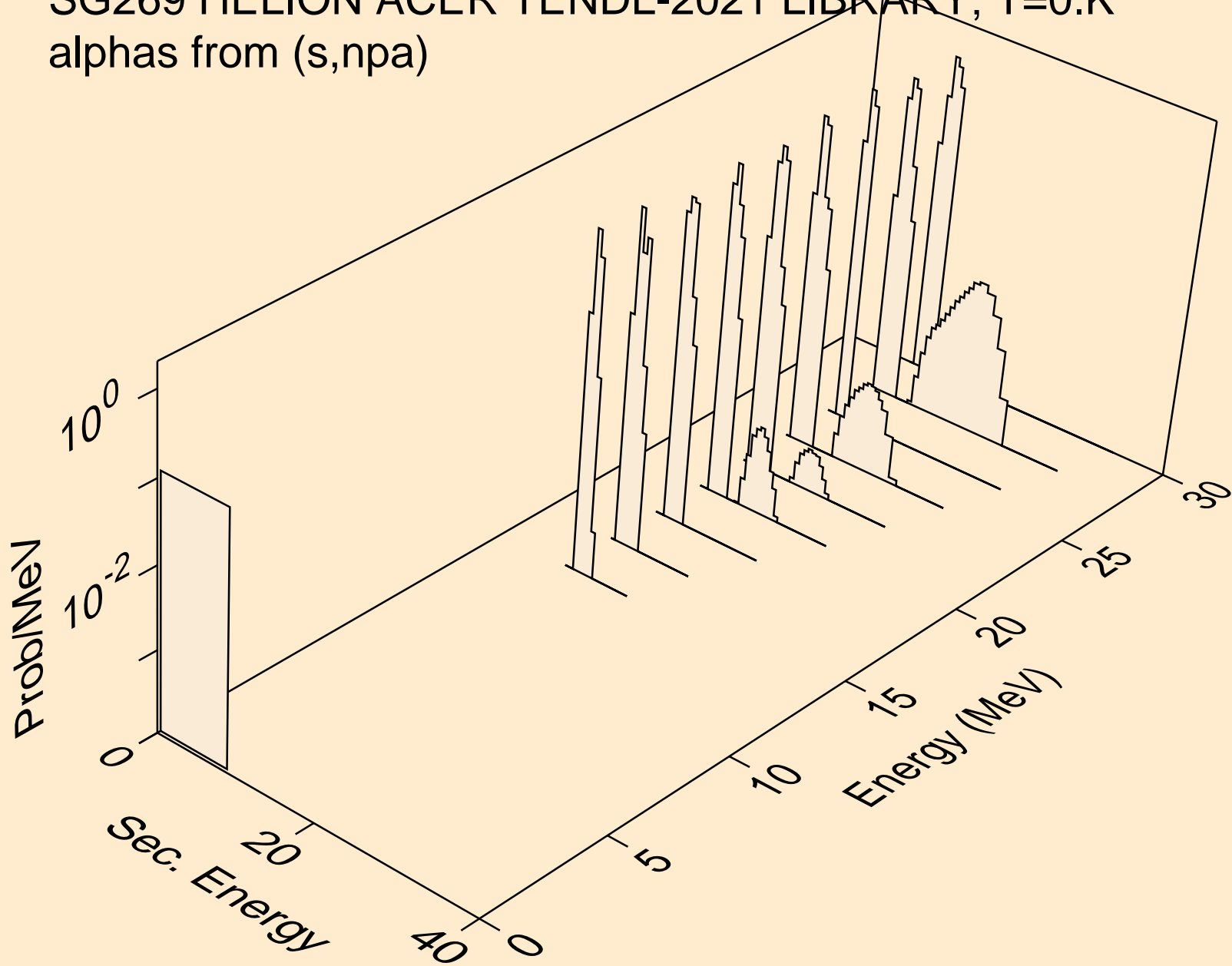

SG269 HELION ACER TENDL-2021 LIBRARY; T=0.K  
alphas from (s,a)

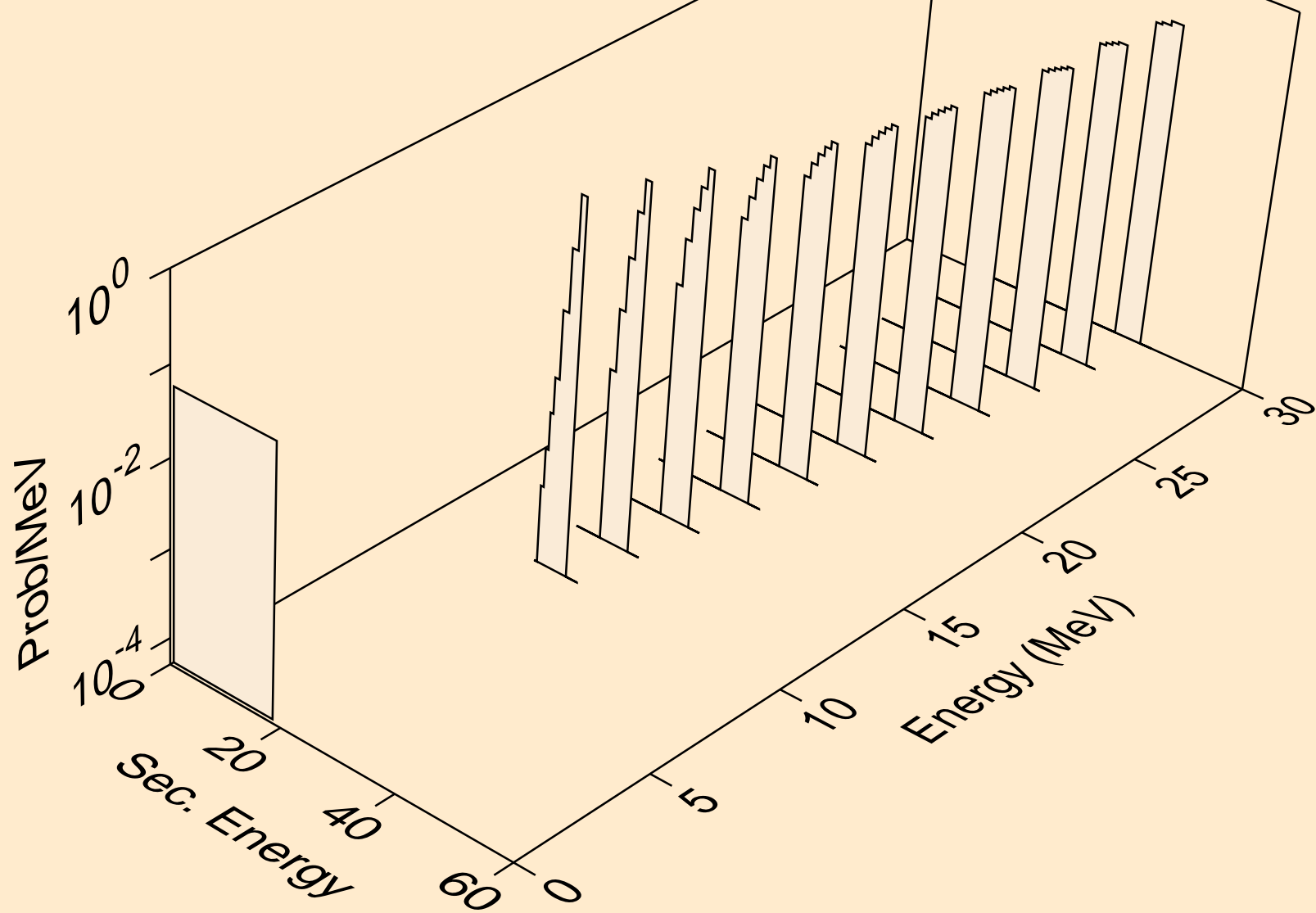

SG269 HELION ACER TENDL-2021 LIBRARY; T=0.K  
alphas from (s,da)

