

# SM163 HELION ACER TENDL-2021 LIBRARY; T=0.K

## Principal cross sections

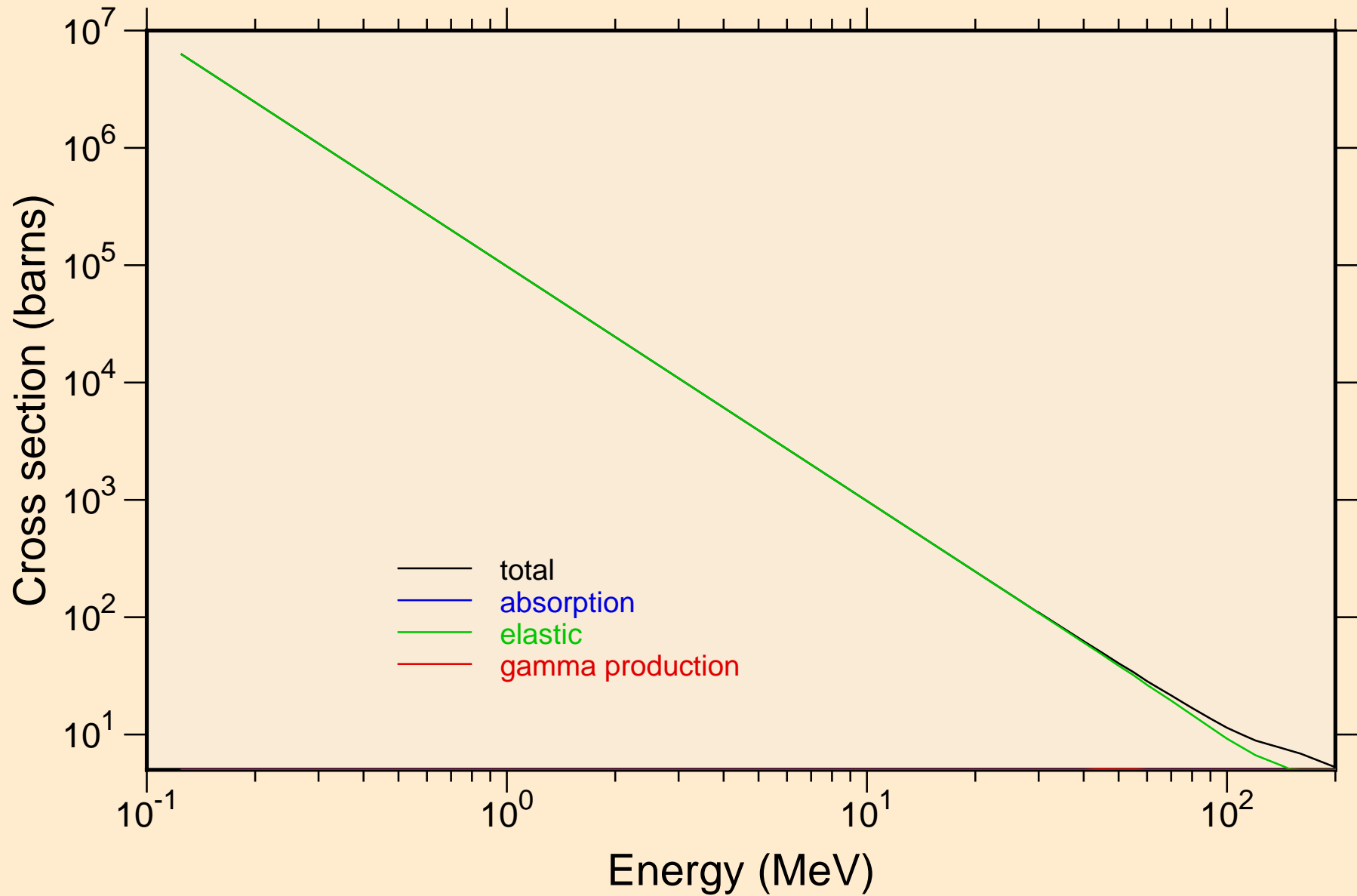

SM163 HELION ACER TENDL-2021 LIBRARY; T=0.K

Heating

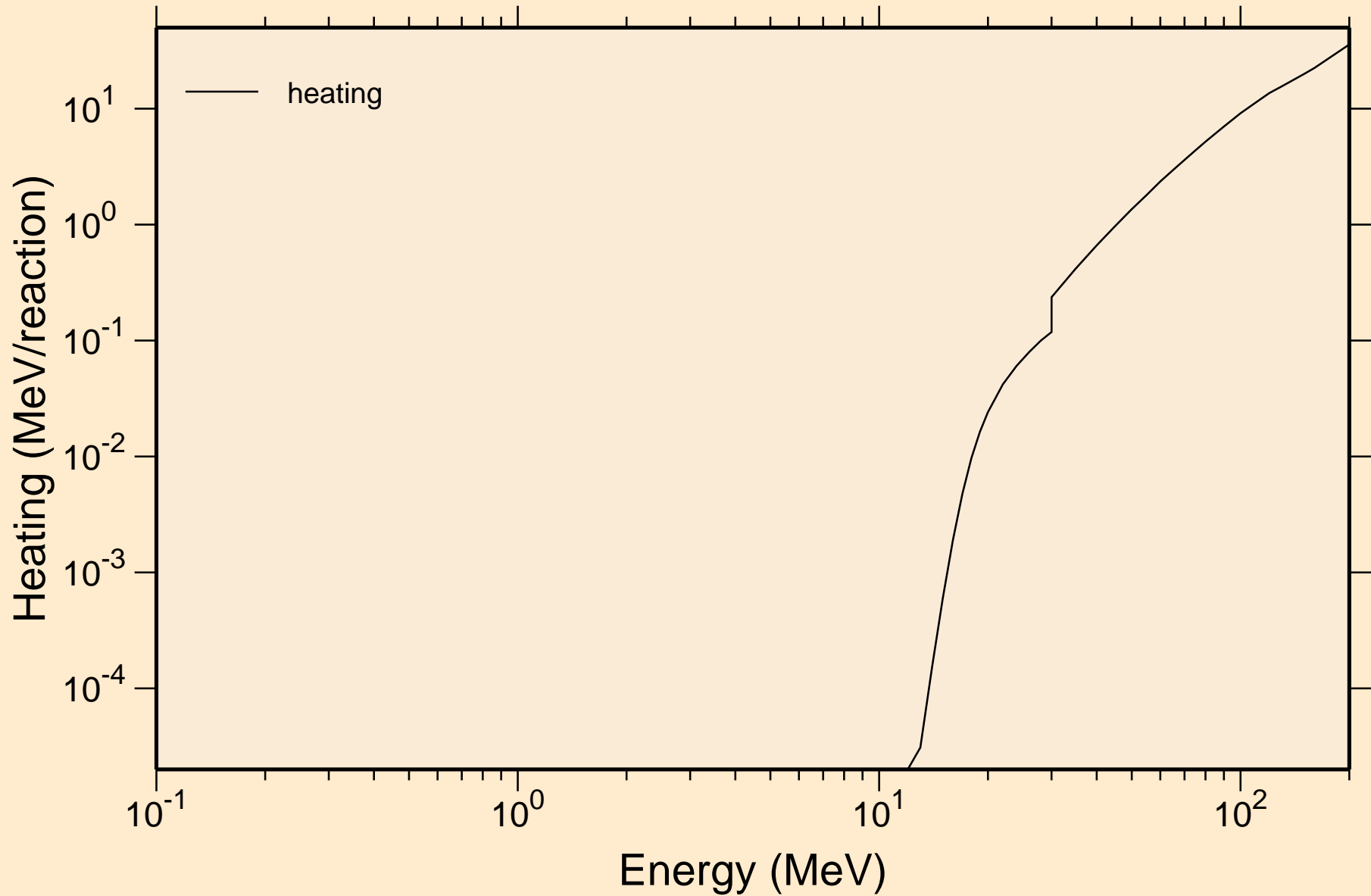

# SM163 HELION ACER TENDL-2021 LIBRARY; T=0.K

## Principal cross sections

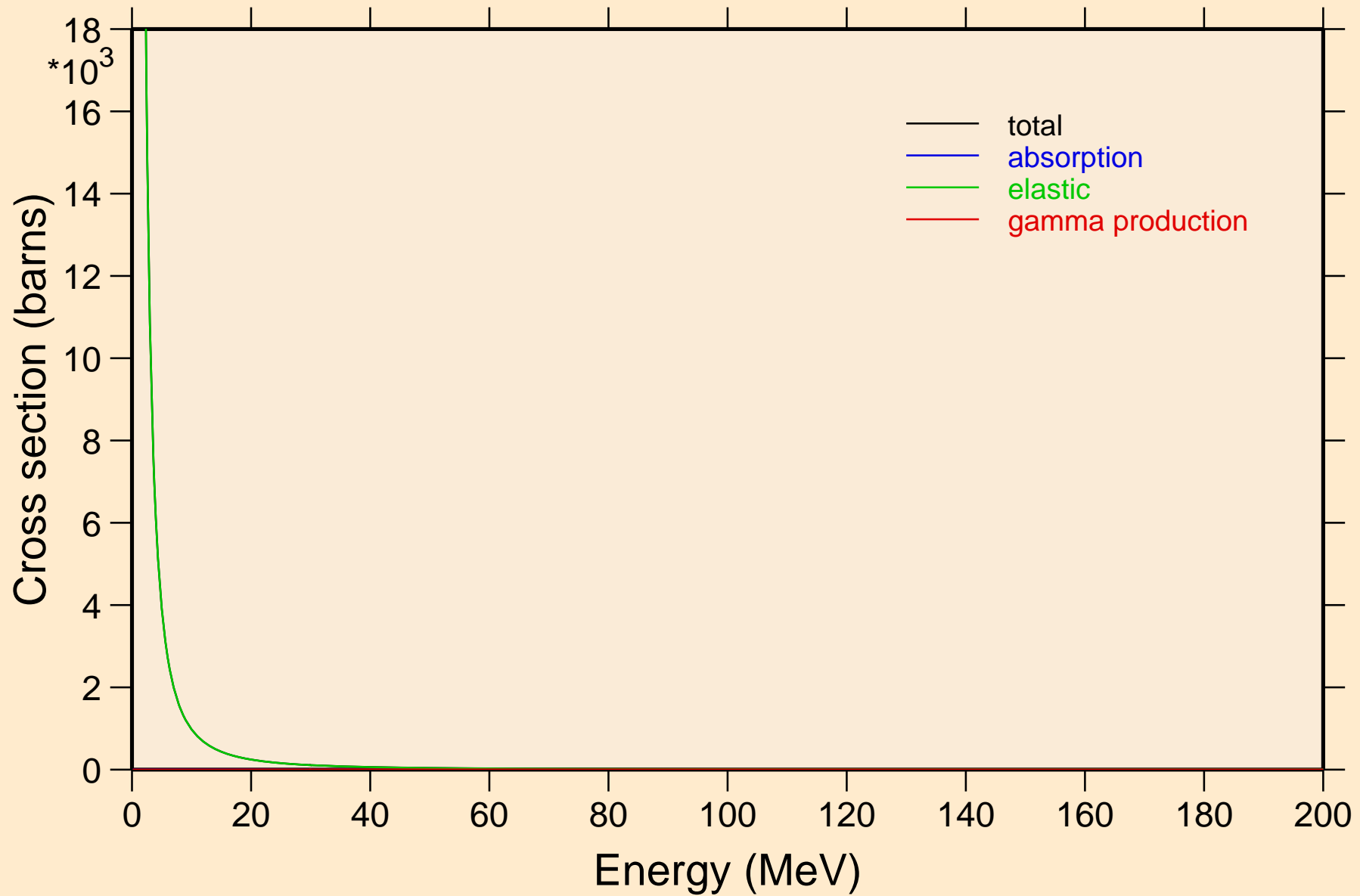

# SM163 HELION ACER TENDL-2021 LIBRARY; T=0.K

## Heating

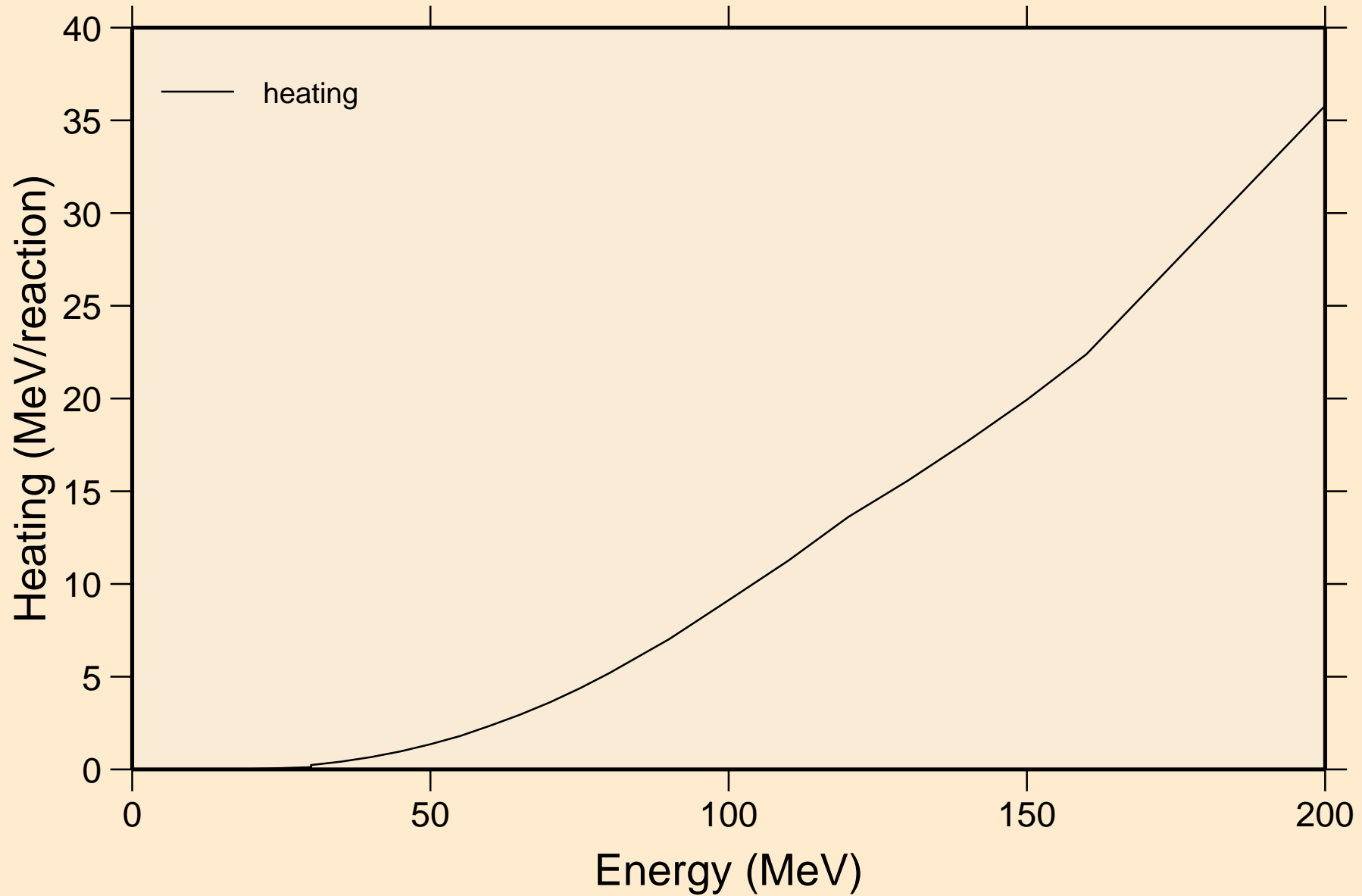

SM163 HELION ACER TENDL-2021 LIBRARY; T=0.K  
Threshold reactions

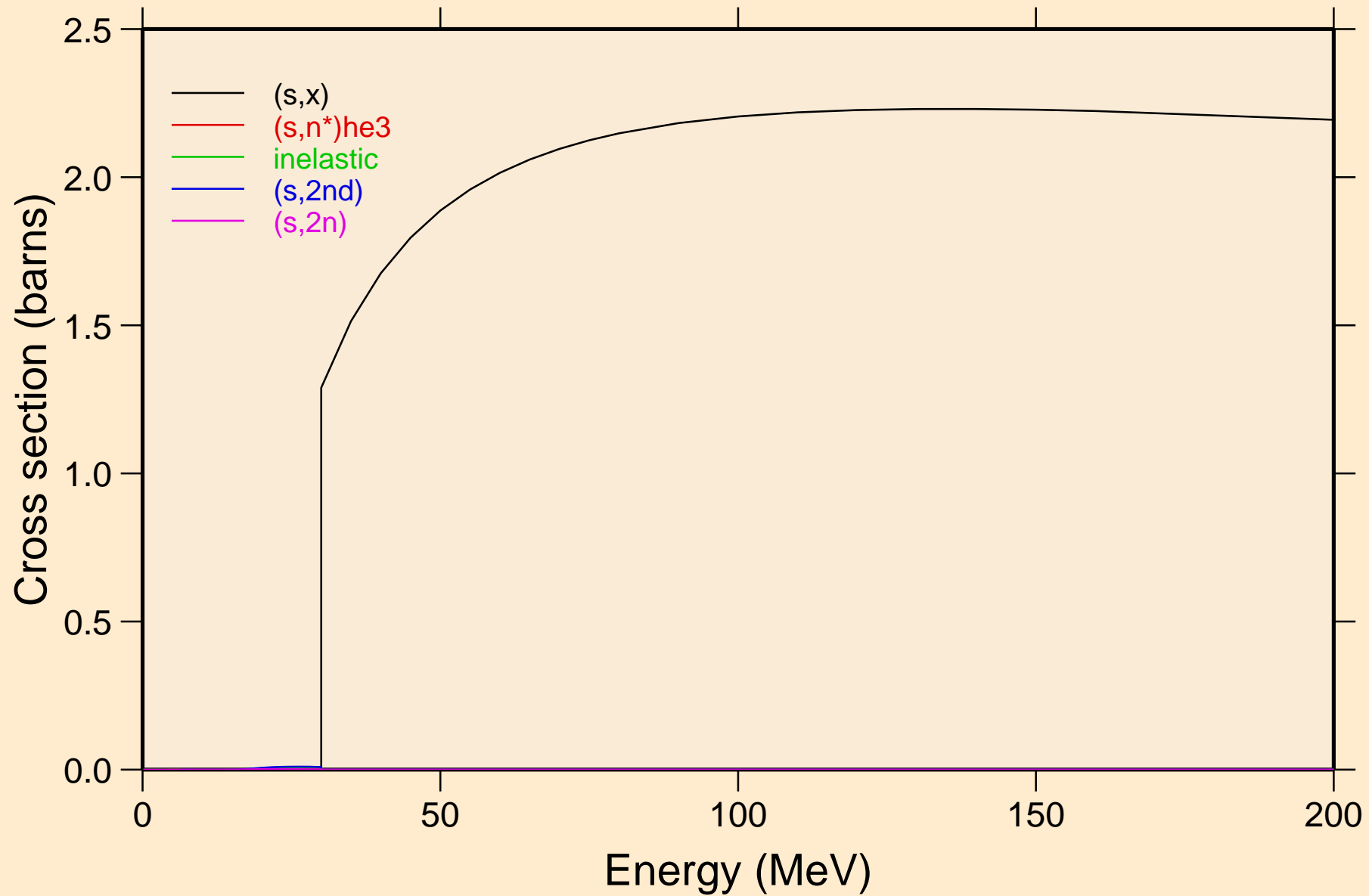

SM163 HELION ACER TENDL-2021 LIBRARY; T=0.K  
Threshold reactions

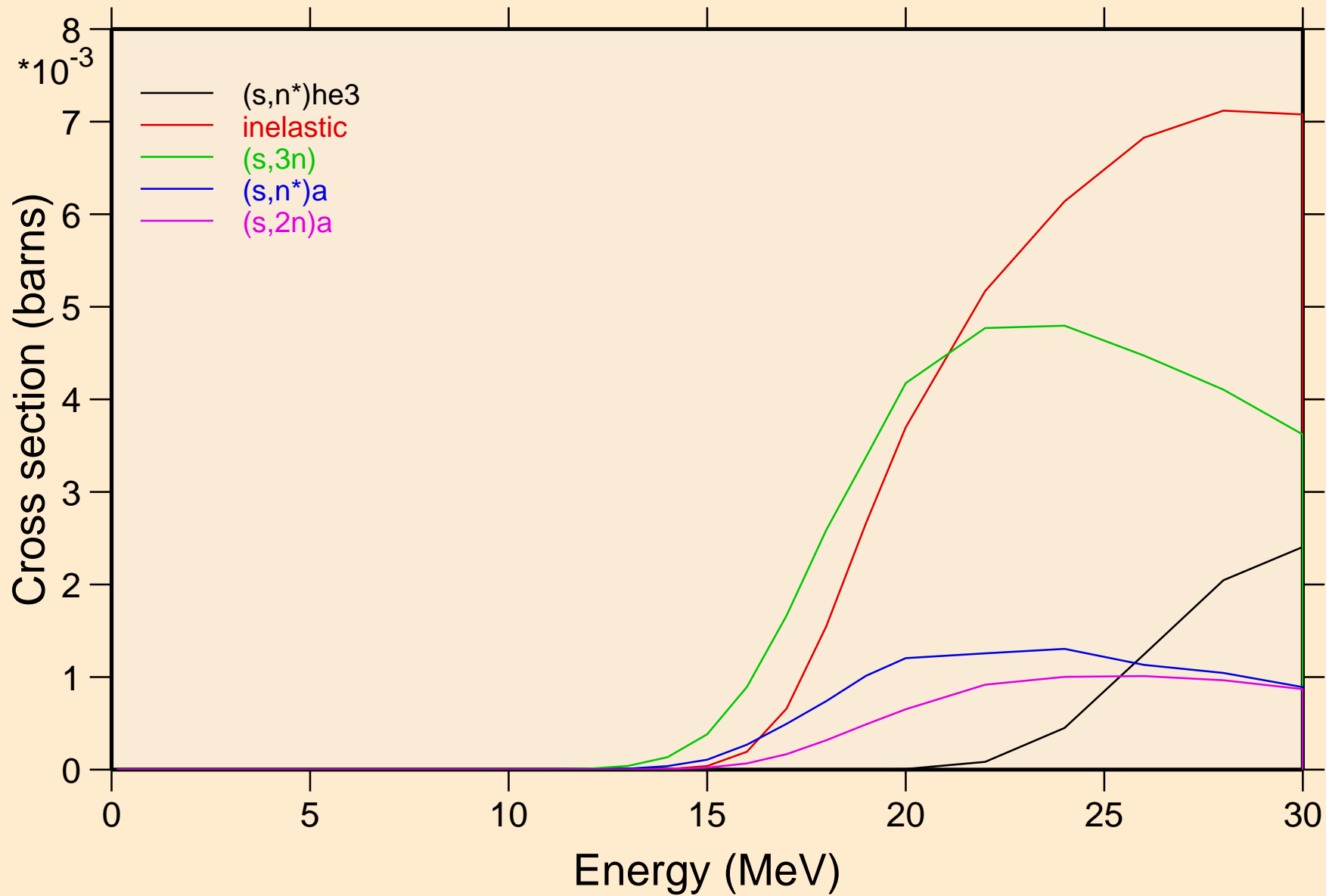

SM163 HELION ACER TENDL-2021 LIBRARY; T=0.K  
Threshold reactions

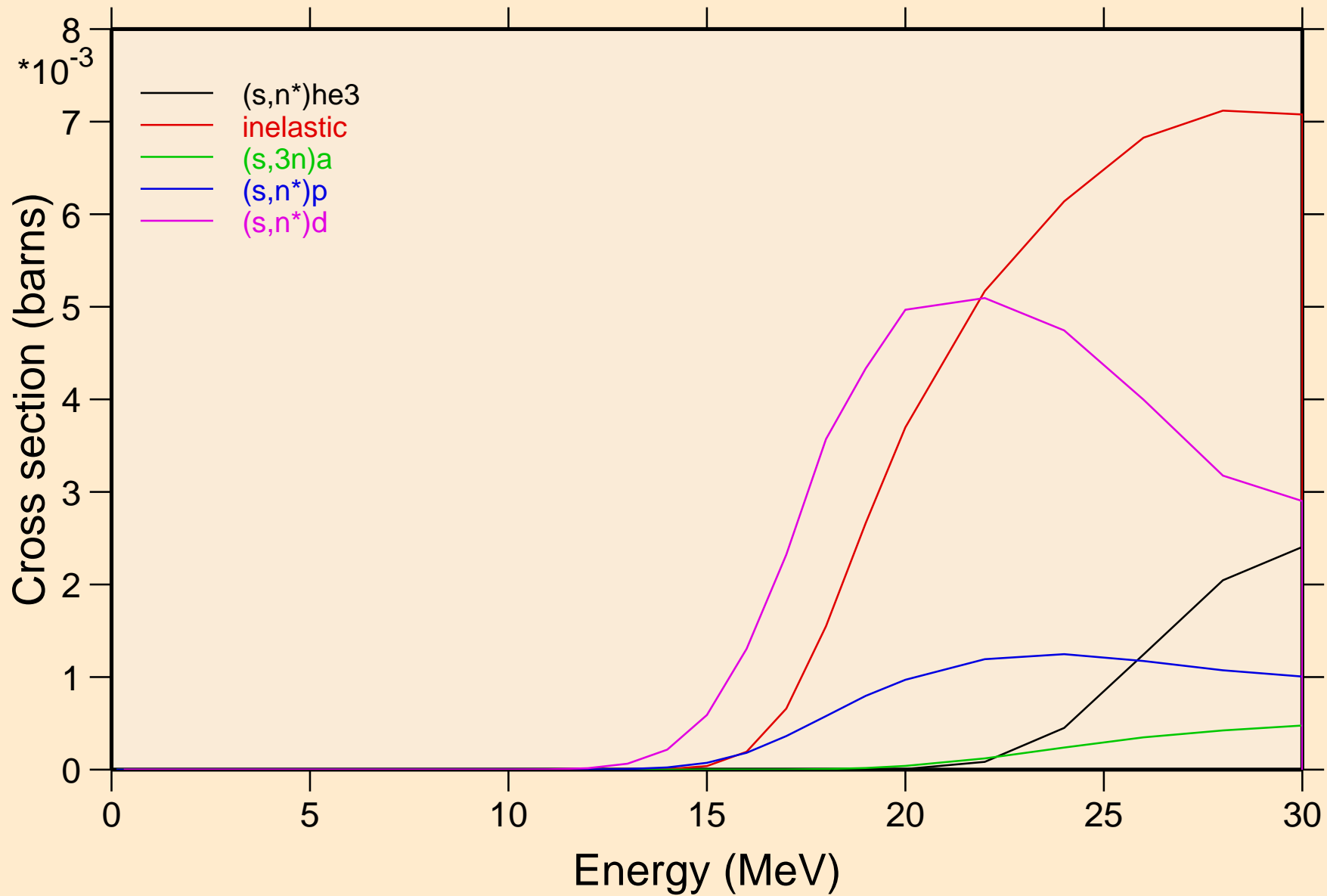

SM163 HELION ACER TENDL-2021 LIBRARY; T=0.K  
Threshold reactions

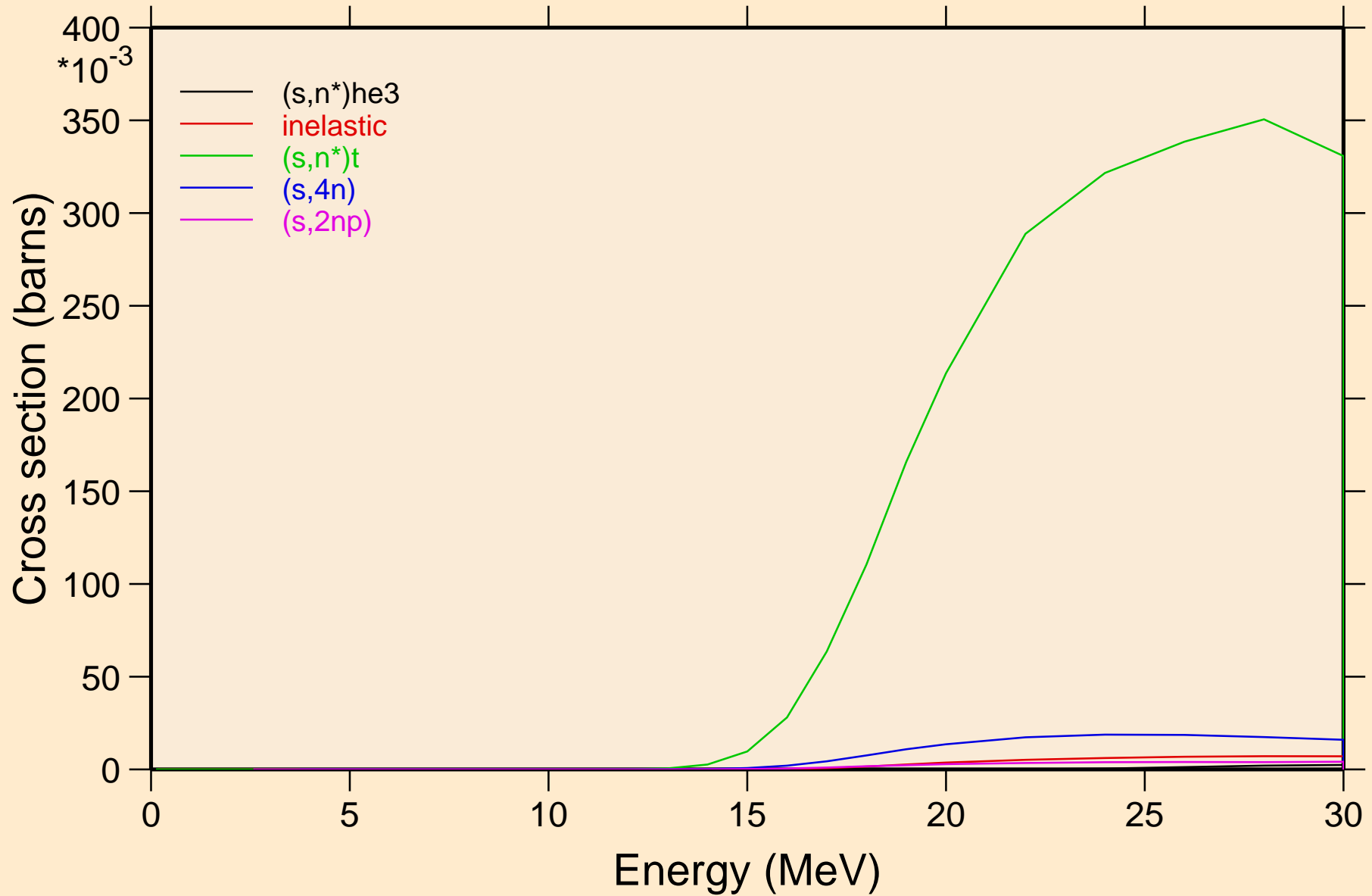



SM163 HELION ACER TENDL-2021 LIBRARY; T=0.K  
Threshold reactions

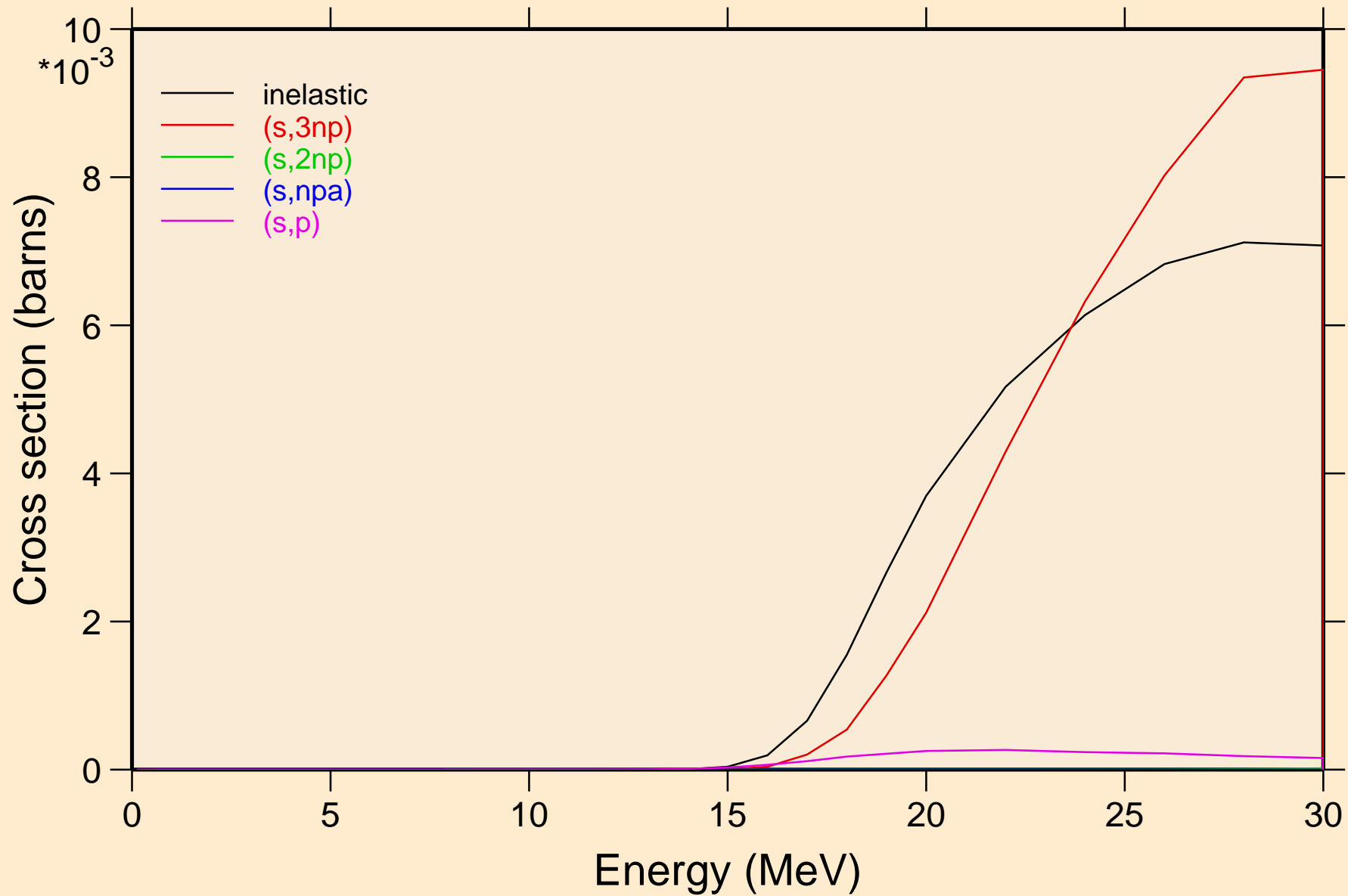

SM163 HELION ACER TENDL-2021 LIBRARY; T=0.K  
Threshold reactions

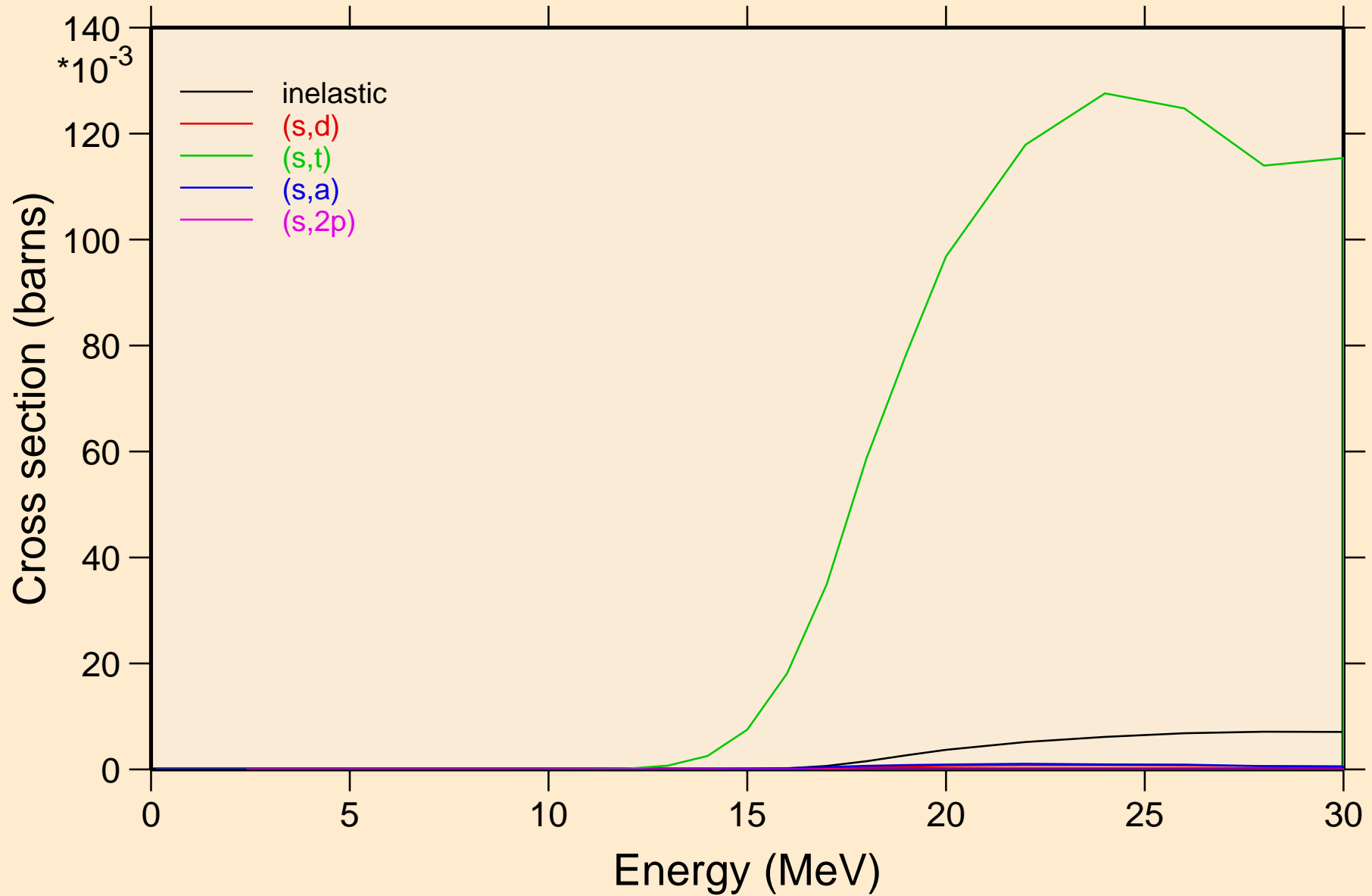

SM163 HELION ACER TENDL-2021 LIBRARY; T=0.K  
Threshold reactions

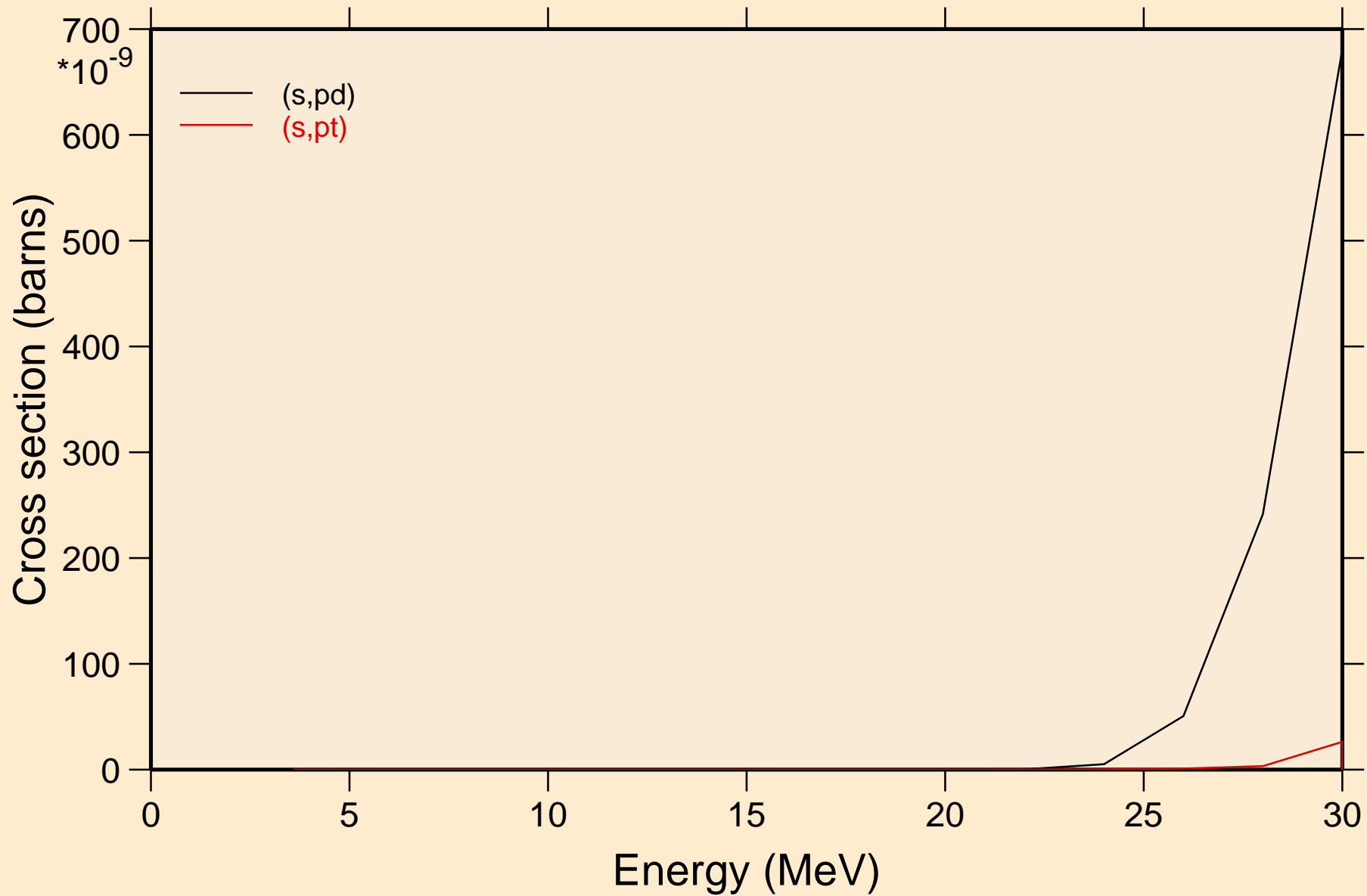

SM163 HELION ACER TENDL-2021 LIBRARY; T=0.K  
angular distribution for elastic

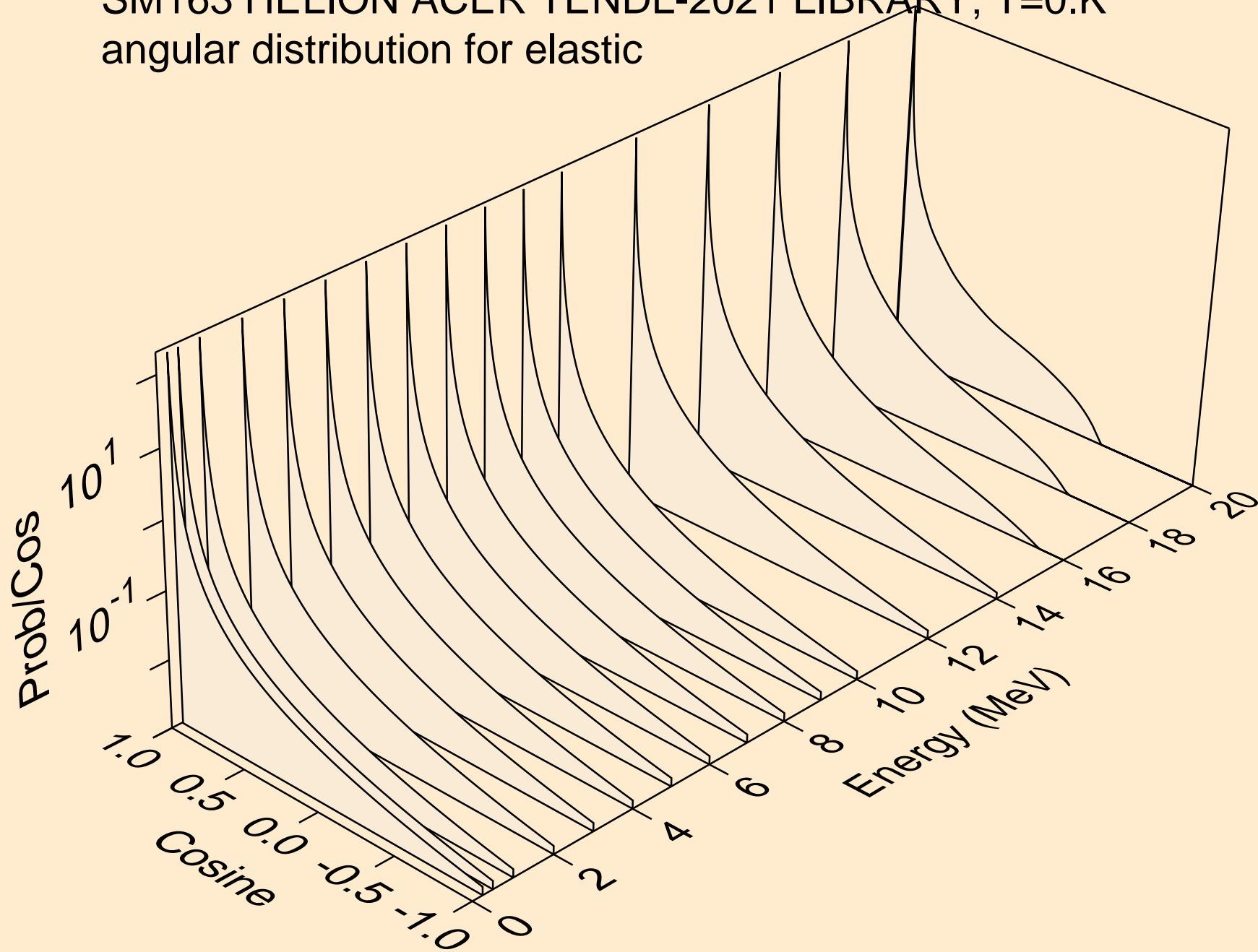

SM163 HELION ACER TENDL-2021 LIBRARY; T=0.K  
angular distribution for elastic

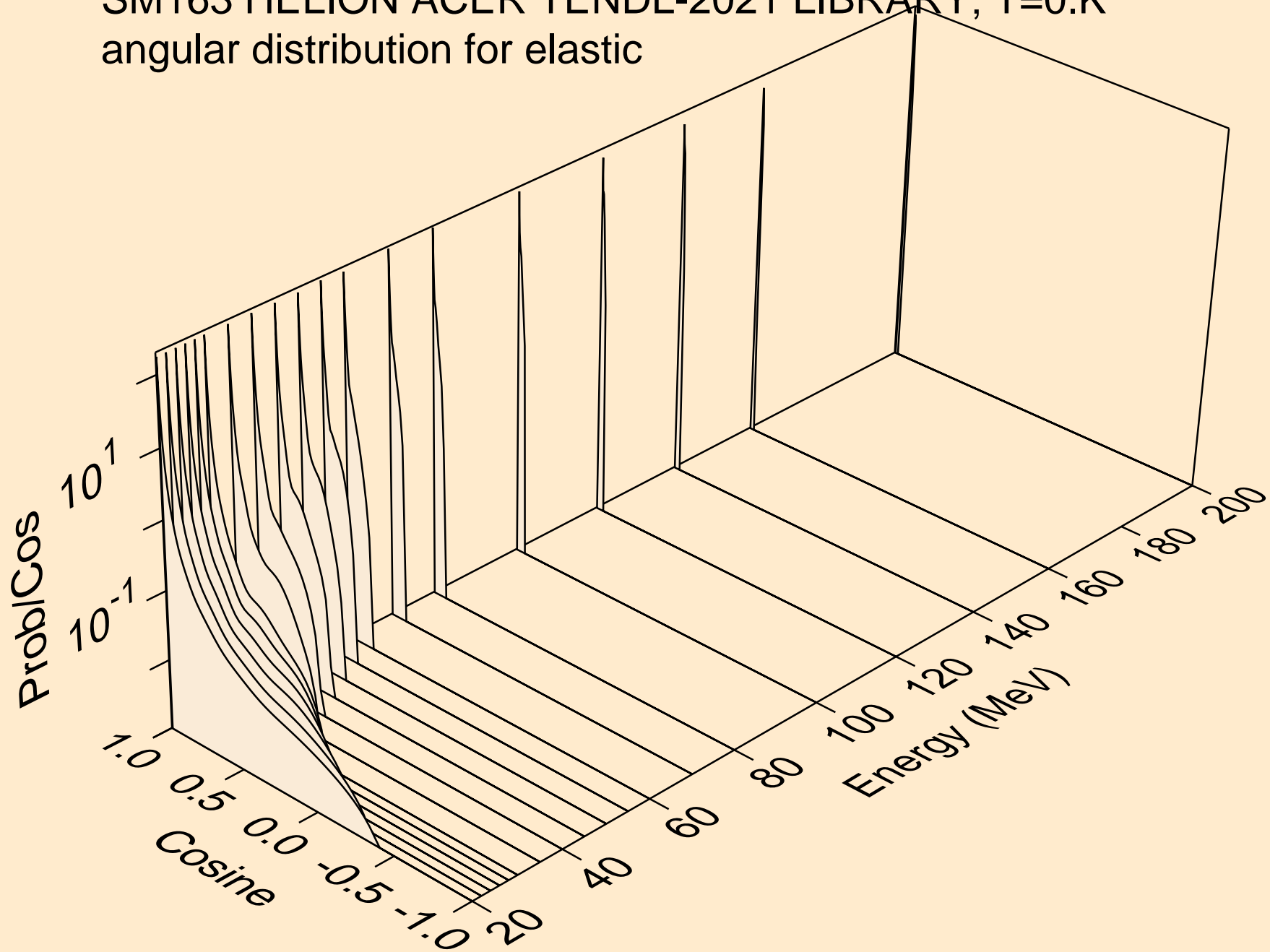

SM163 HELION ACER TENDL-2021 LIBRARY; T=0.K  
He-3 emission for (s,x)

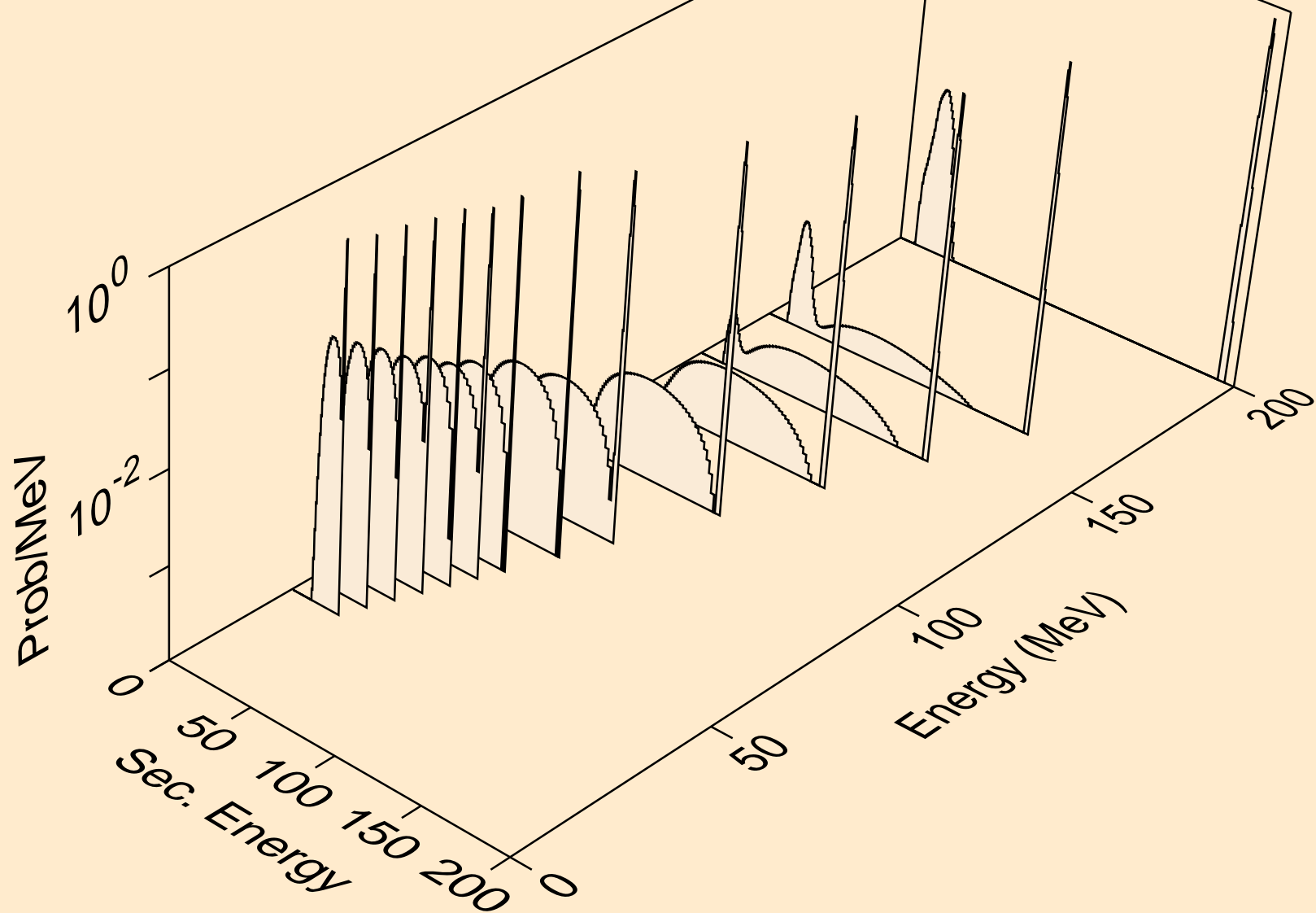

SM163 HELION ACER TENDL-2021 LIBRARY; T=0.K  
He-3 emission for (s,n\*)he3

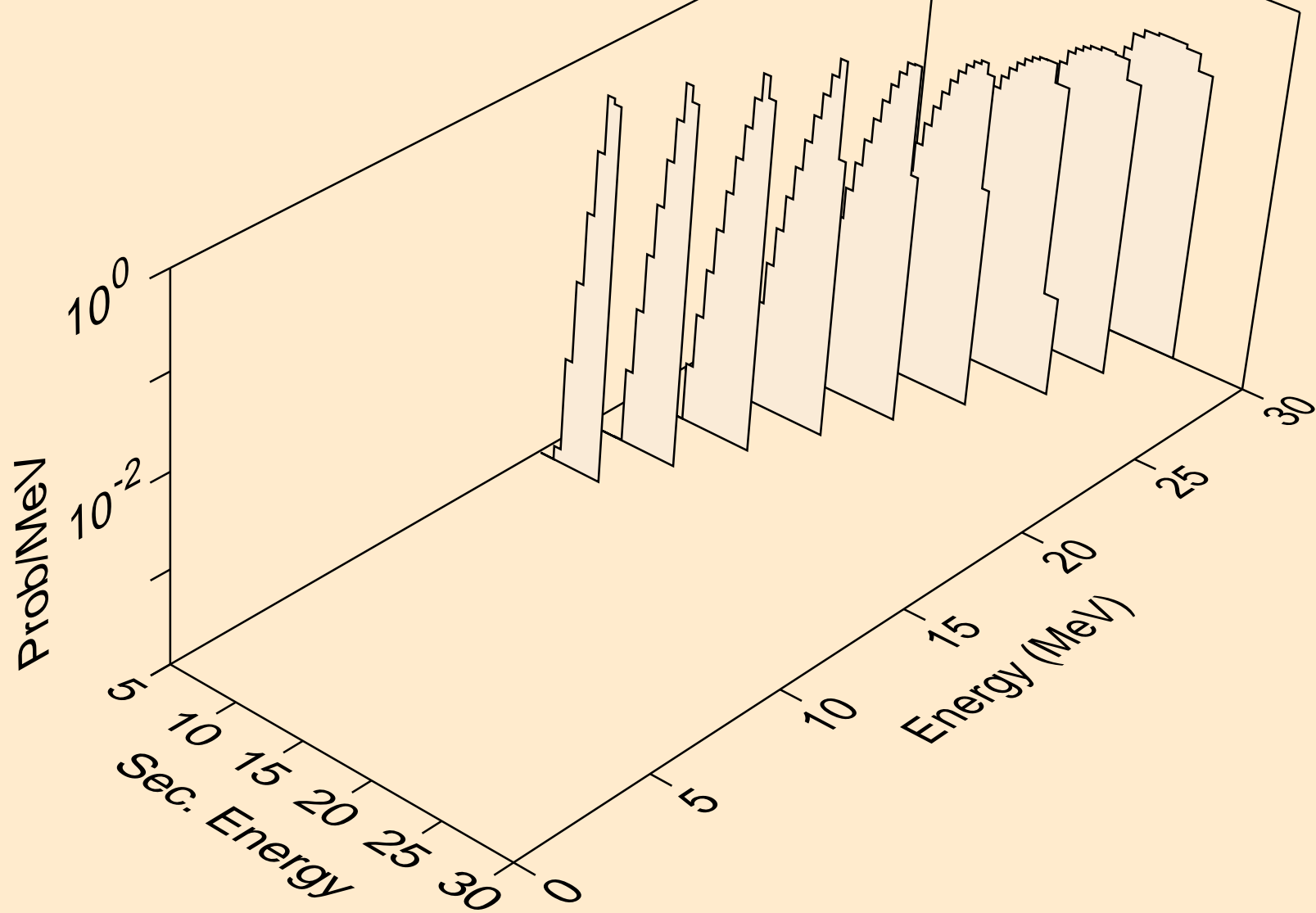

SM163 HELION ACER TENDL-2021 LIBRARY; T=0.K  
He-3 emission for inelastic

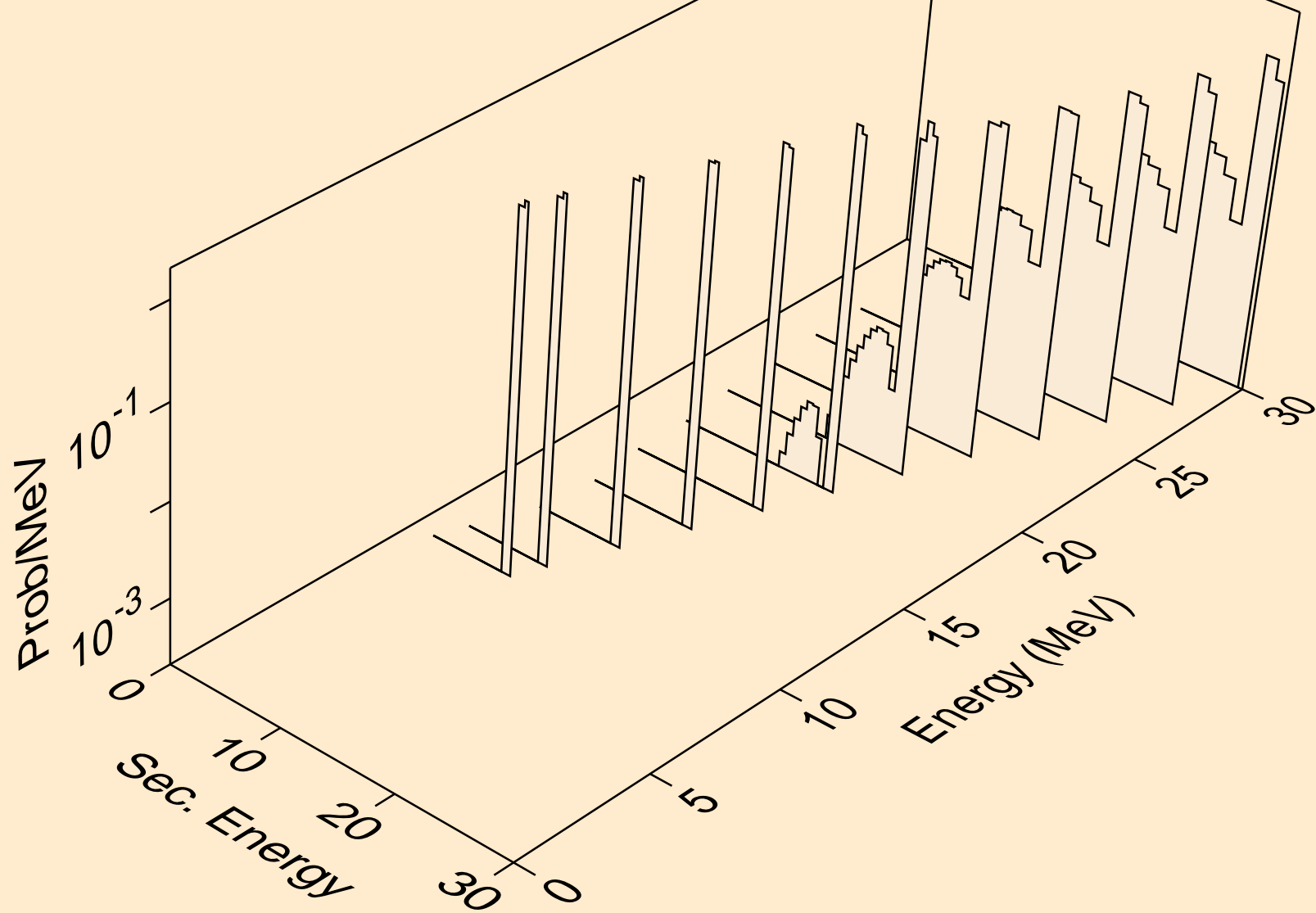



SM163 HELION ACER TENDL-2021 LIBRARY; T=0.K  
Photon emission for (z,n)

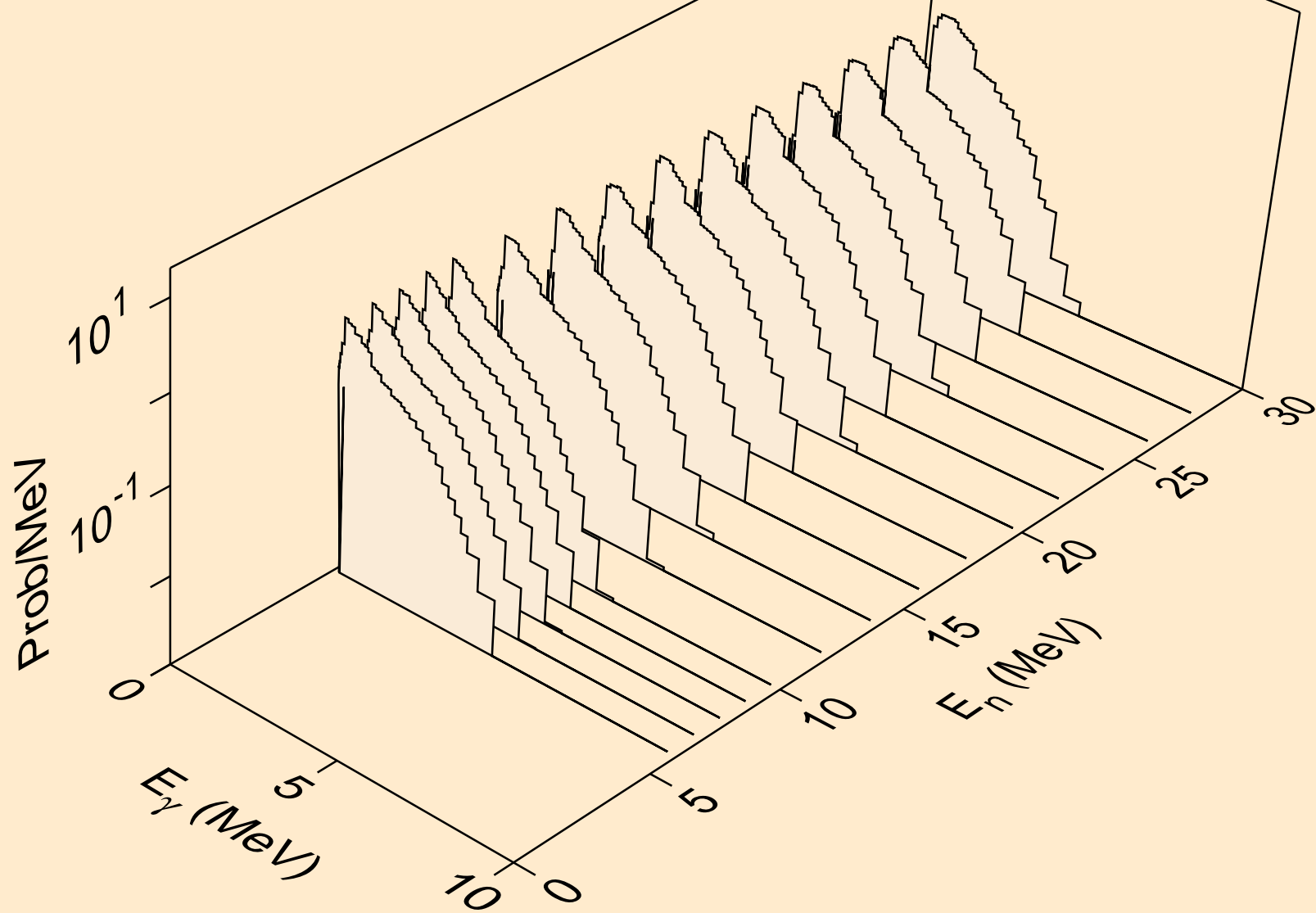

SM163 HELION ACER TENDL-2021 LIBRARY; T=0.K  
Photon emission for (n,x)

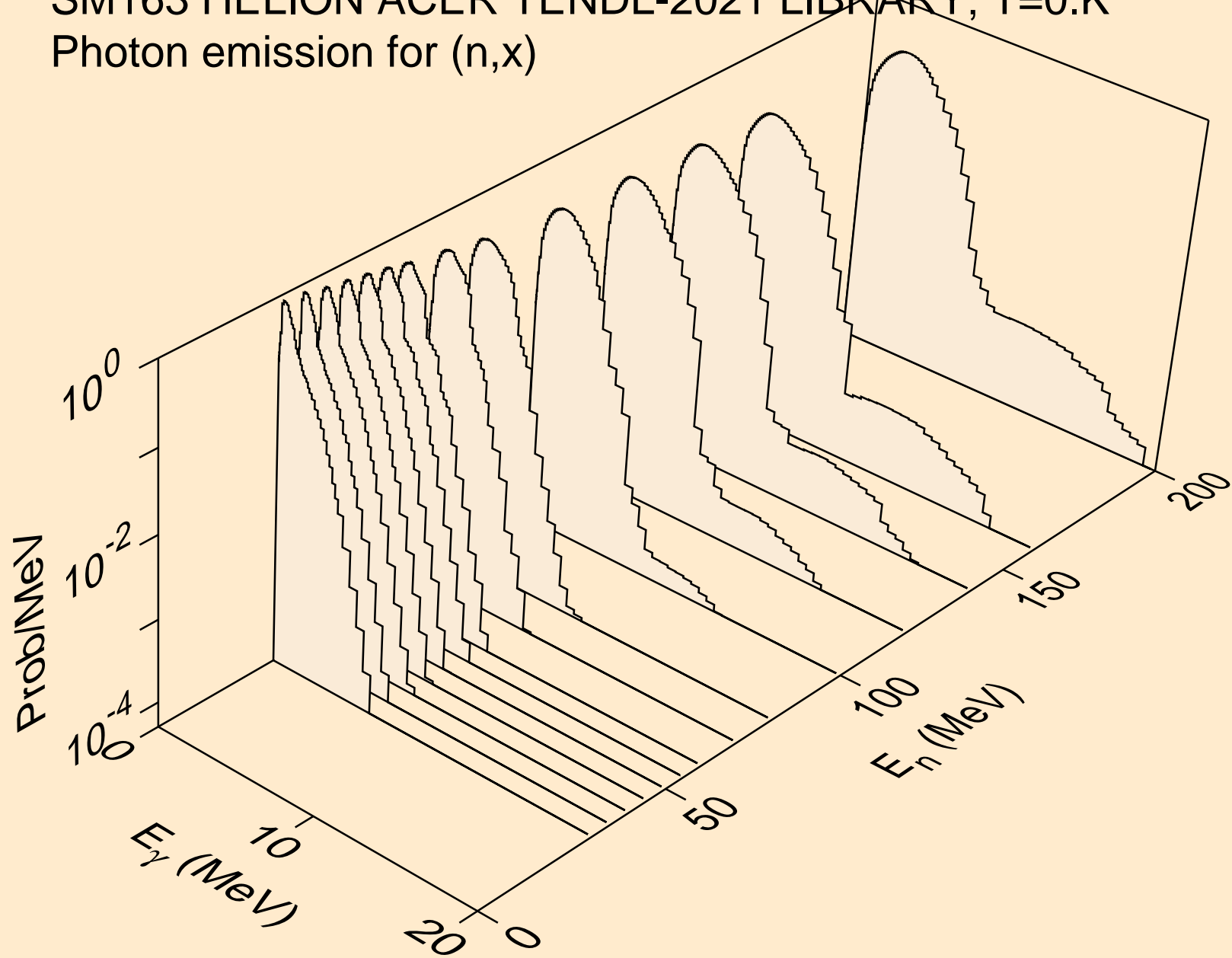

SM163 HELION ACER TENDL-2021 LIBRARY; T=0.K  
Photon emission for (n,2nd)

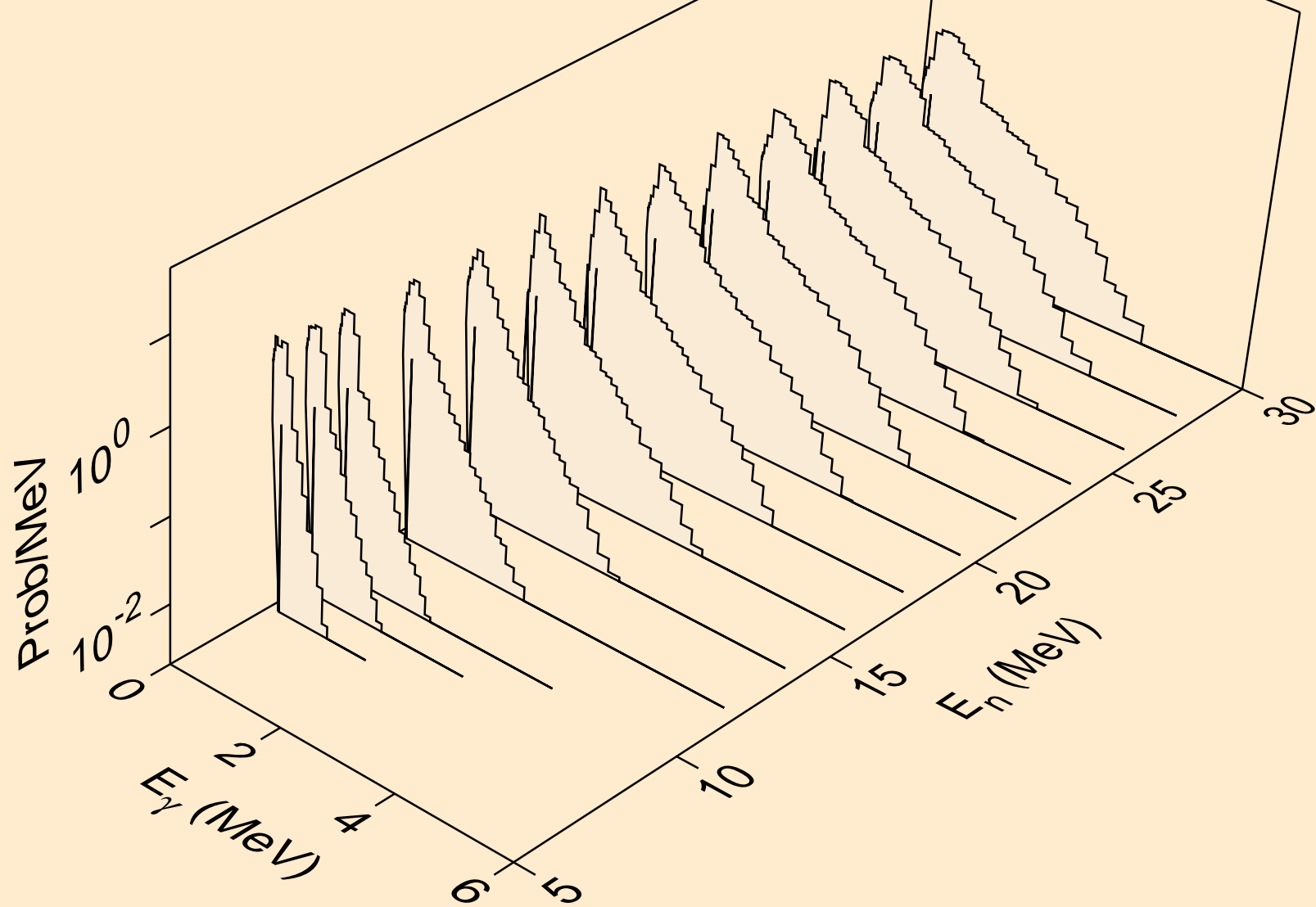

SM163 HELION ACER TENDL-2021 LIBRARY; T=0.K  
Photon emission for (n,2n)

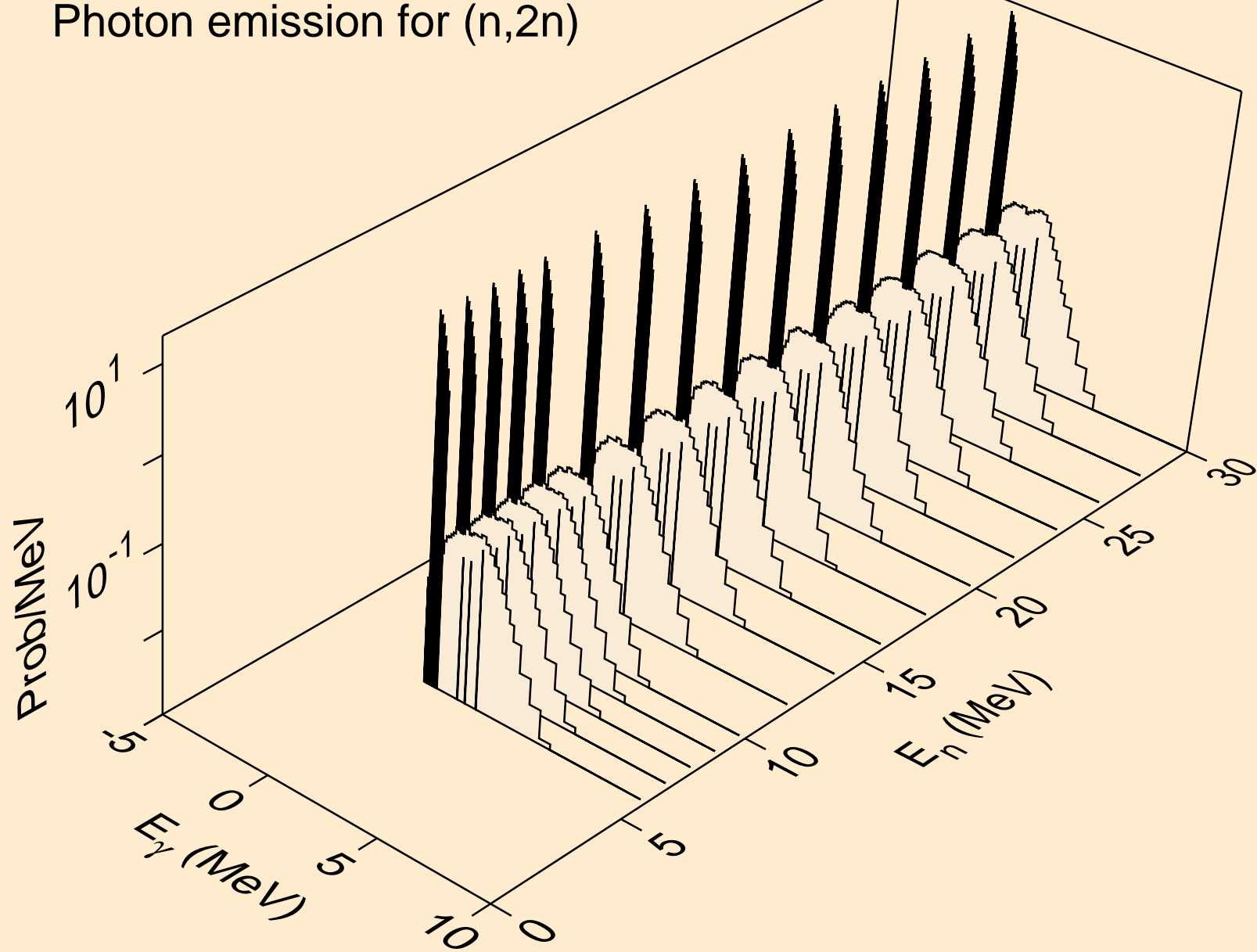

SM163 HELION ACER TENDL-2021 LIBRARY; T=0.K  
Photon emission for (n,3n)

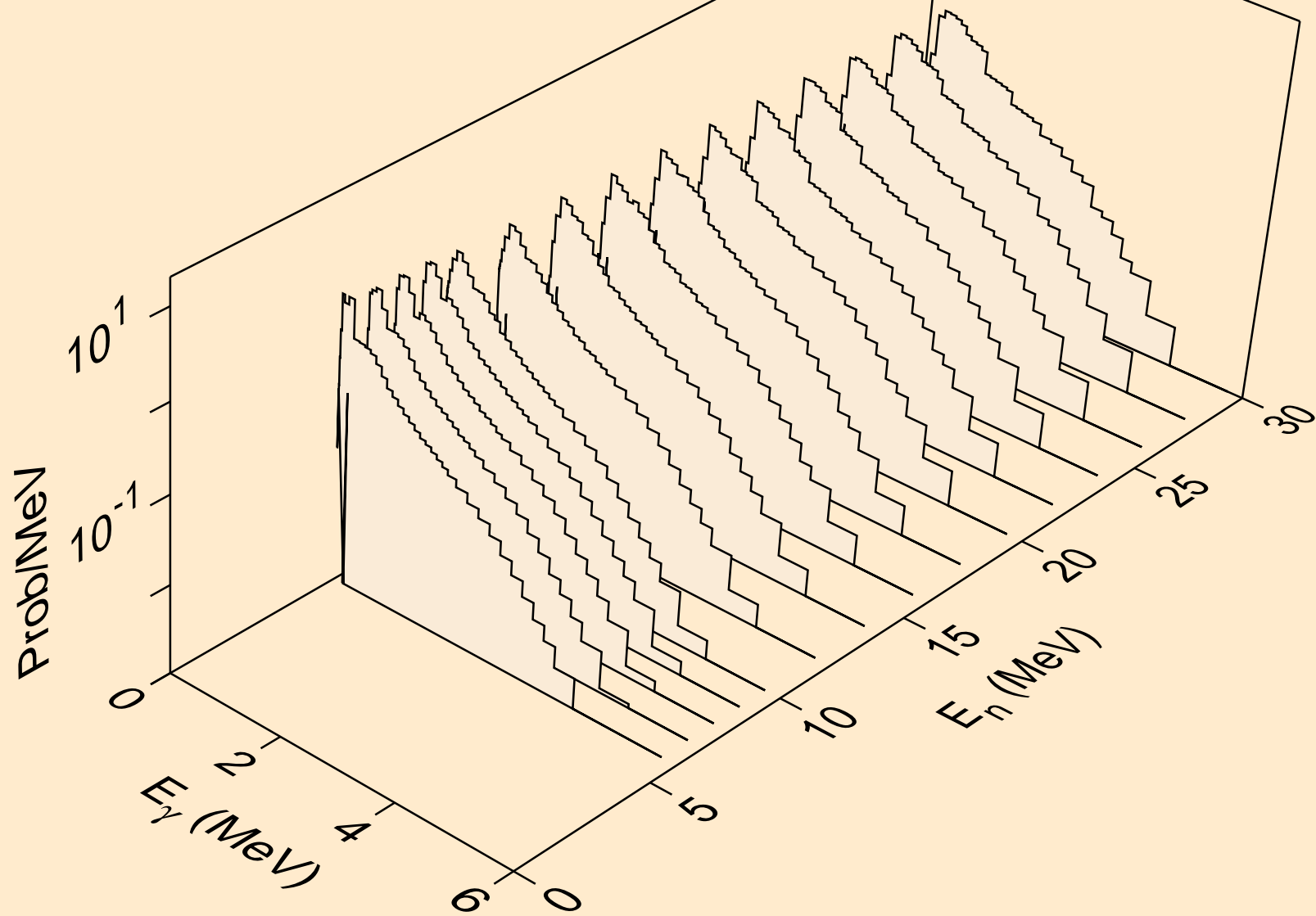

SM163 HELION ACER TENDL-2021 LIBRARY; T=0.K  
Photon emission for (n,n\*)a

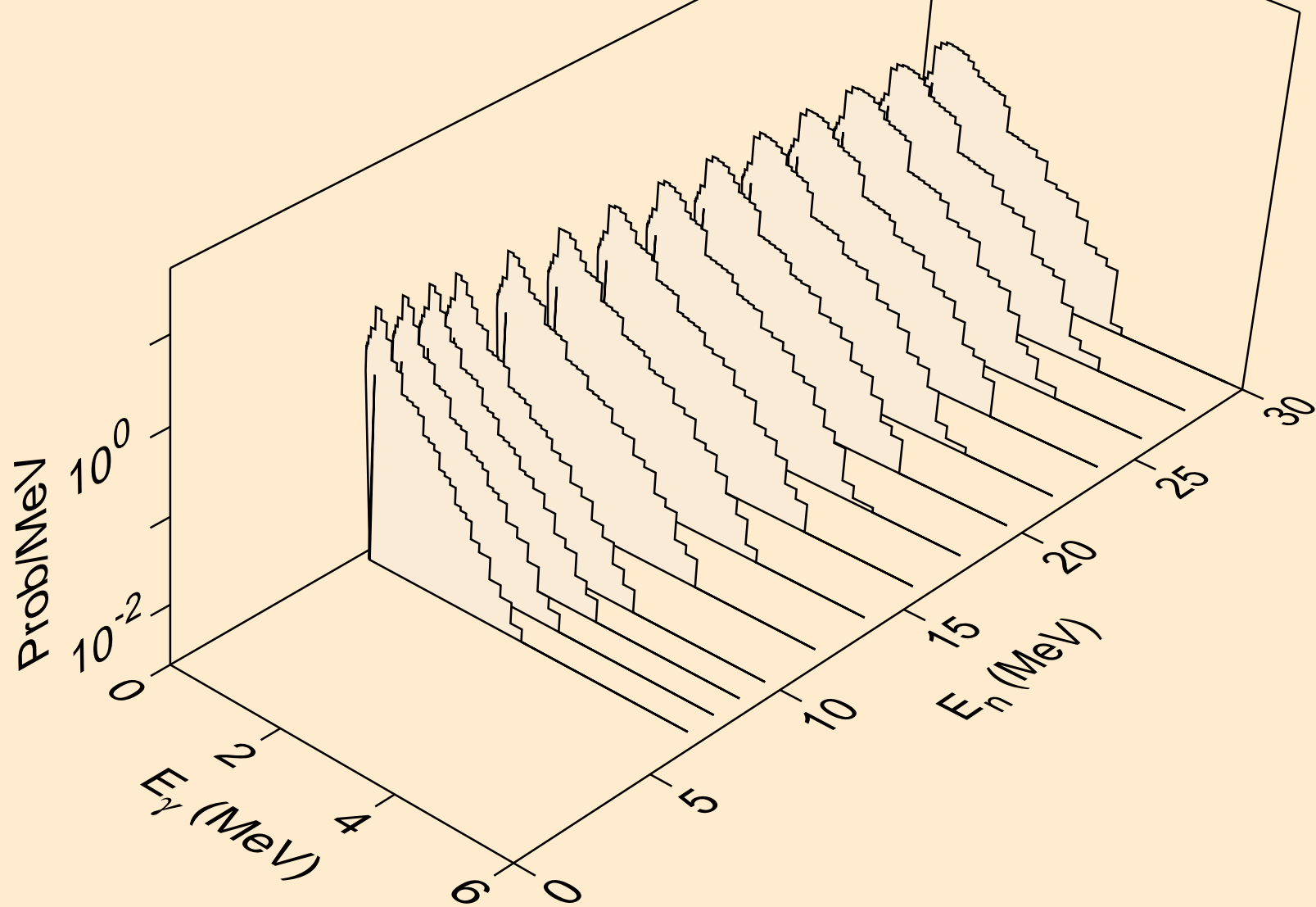

SM163 HELION ACER TENDL-2021 LIBRARY; T=0.K  
Photon emission for (n,2n)a

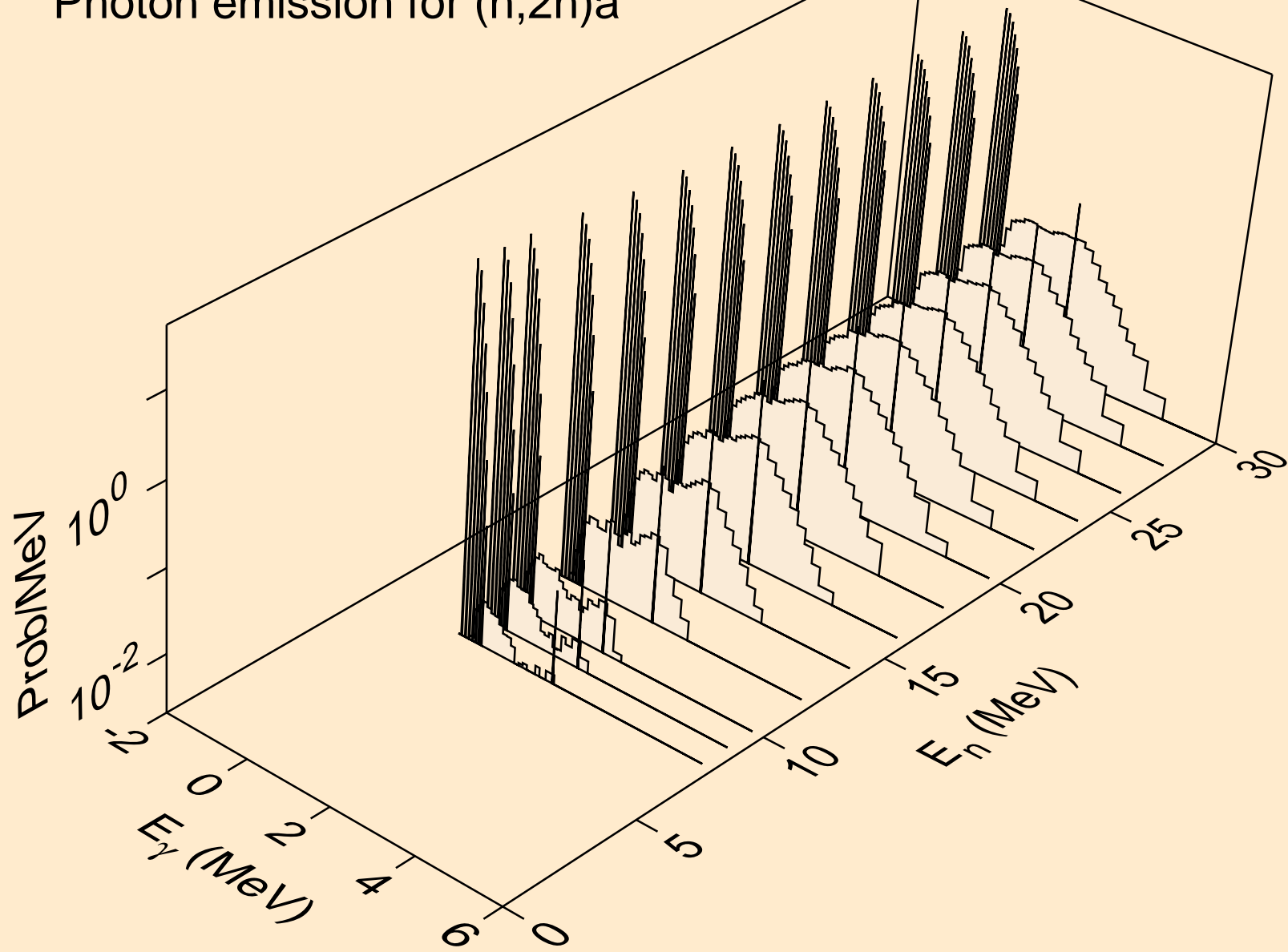

SM163 HELION ACER TENDL-2021 LIBRARY; T=0.K  
Photon emission for (n,3n)a

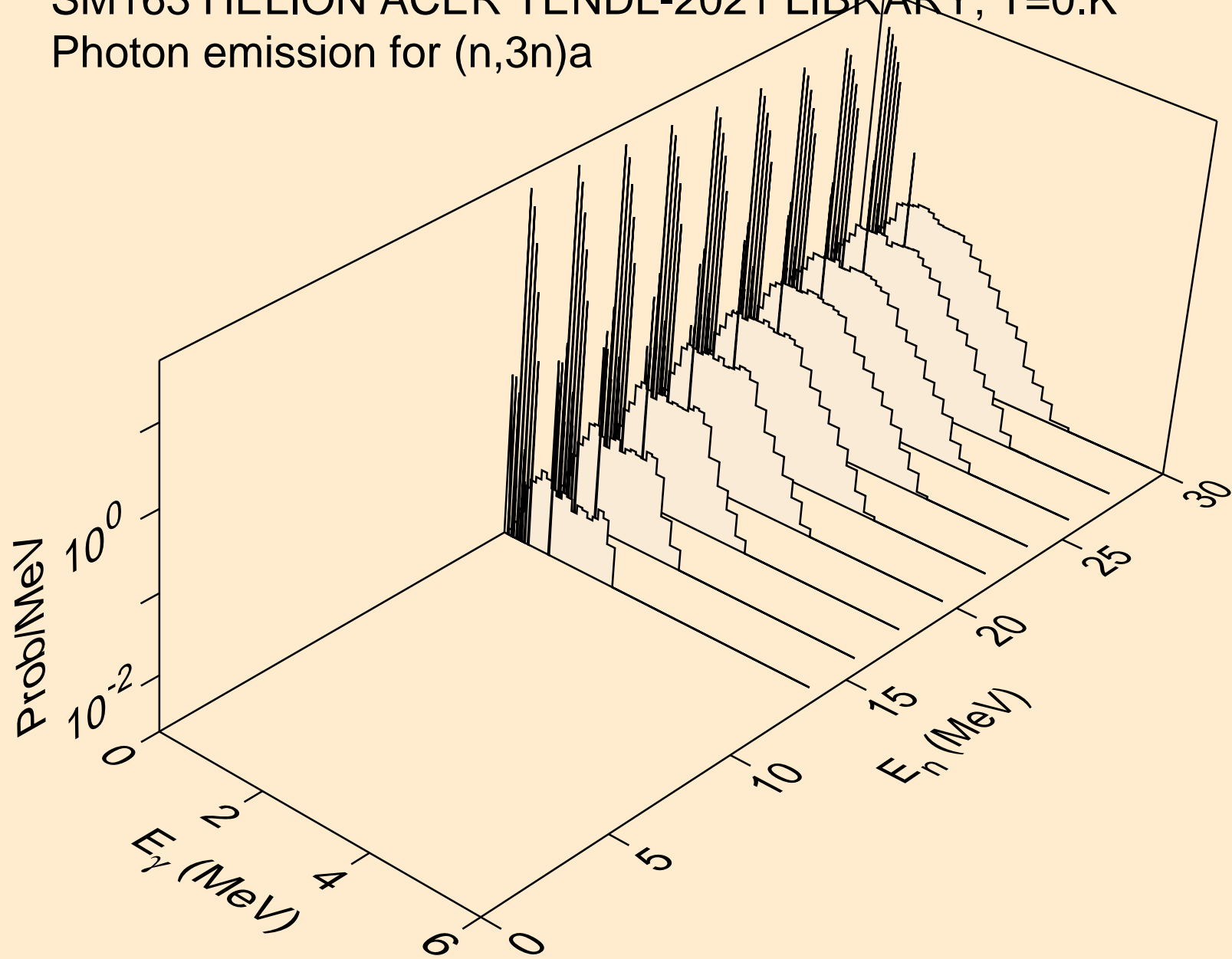



SM163 HELION ACER TENDL-2021 LIBRARY; T=0.K  
Photon emission for (n,n\*)p

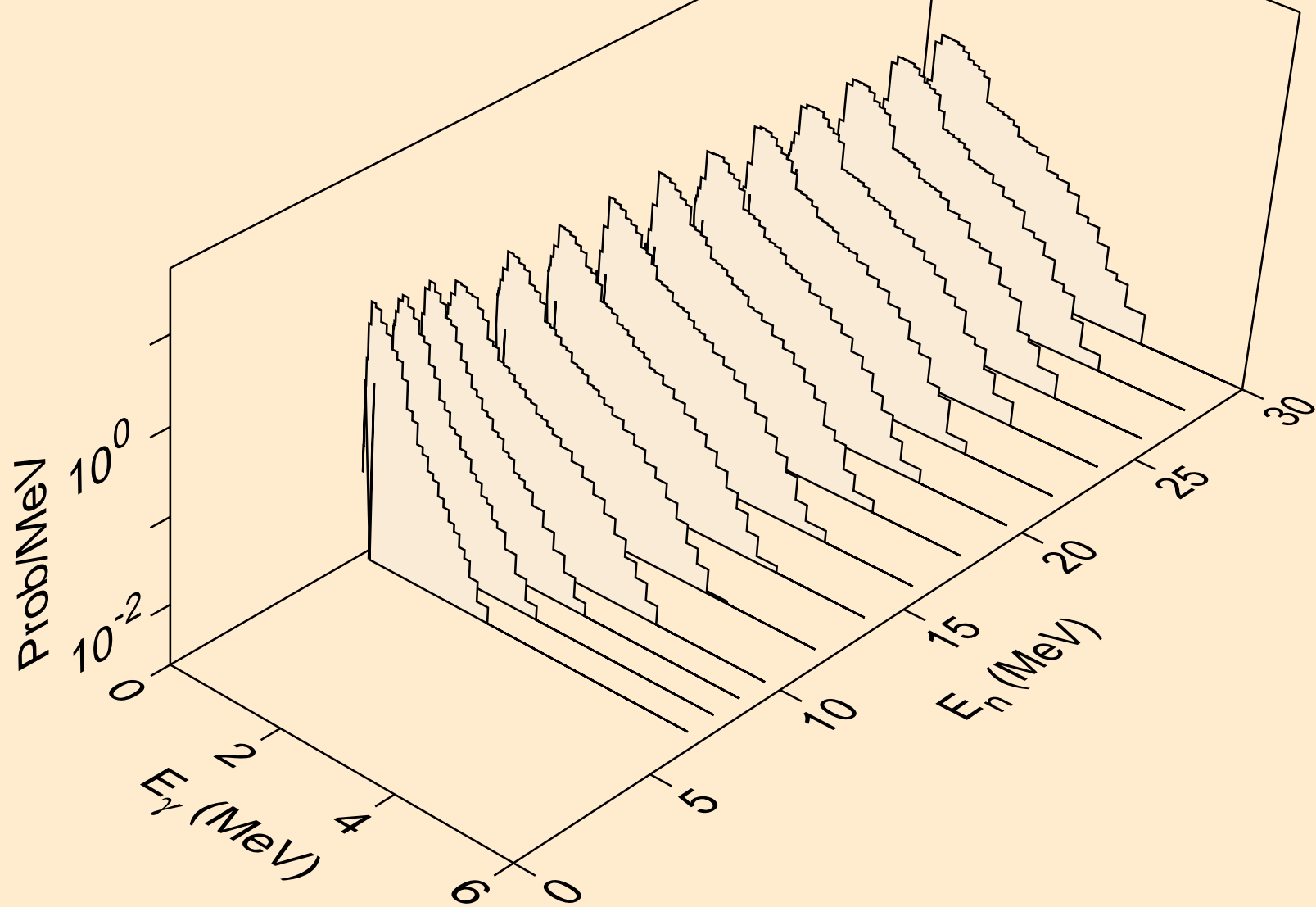

SM163 HELION ACER TENDL-2021 LIBRARY; T=0.K  
Photon emission for (n,n\*)d

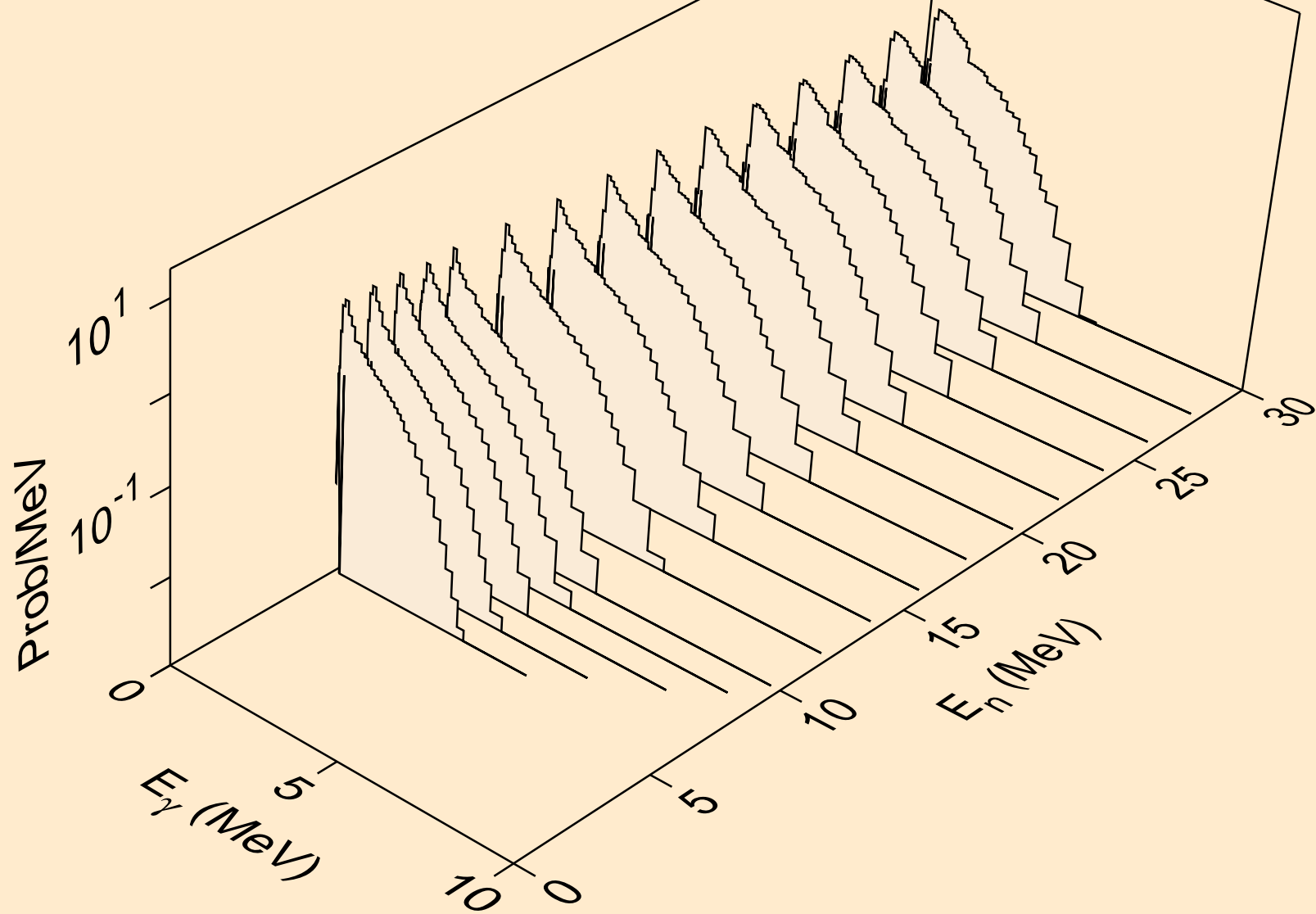

SM163 HELION ACER TENDL-2021 LIBRARY; T=0.K  
Photon emission for (n,n\*)t

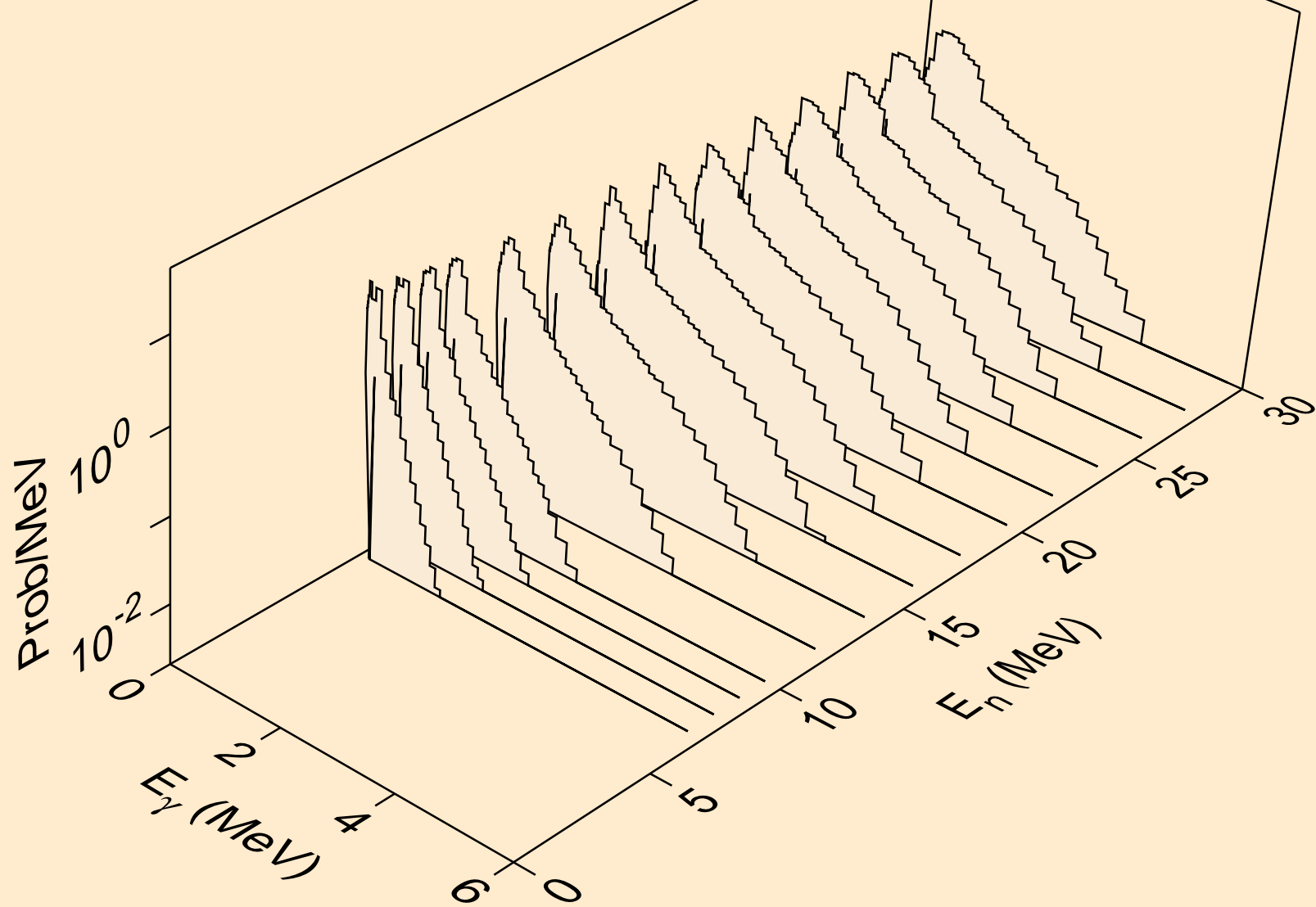

SM163 HELION ACER TENDL-2021 LIBRARY; T=0.K  
Photon emission for (n,n\*)he3

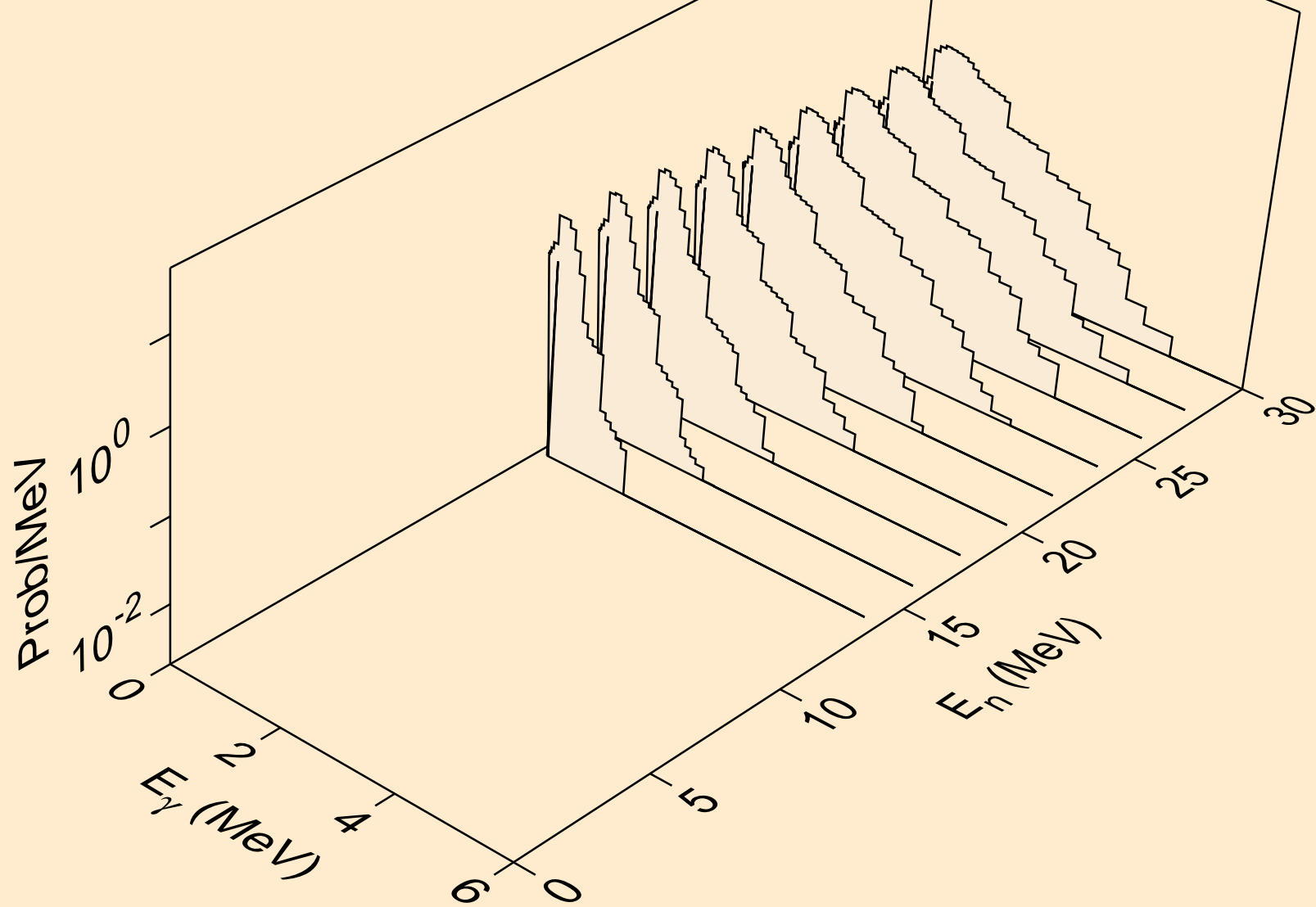

SM163 HELION ACER TENDL-2021 LIBRARY; T=0.K  
Photon emission for (n,4n)

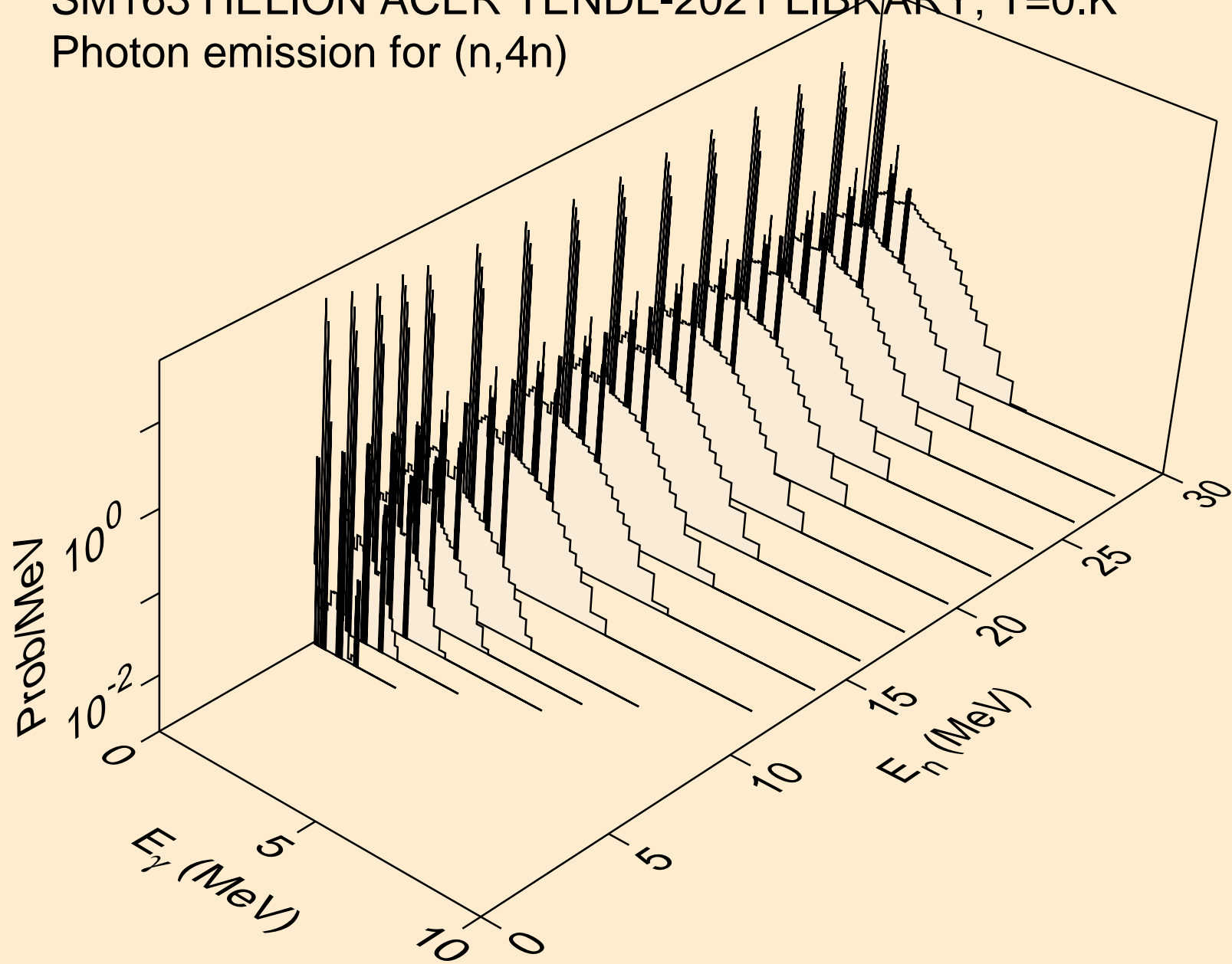

SM163 HELION ACER TENDL-2021 LIBRARY; T=0.K  
Photon emission for (n,2np)

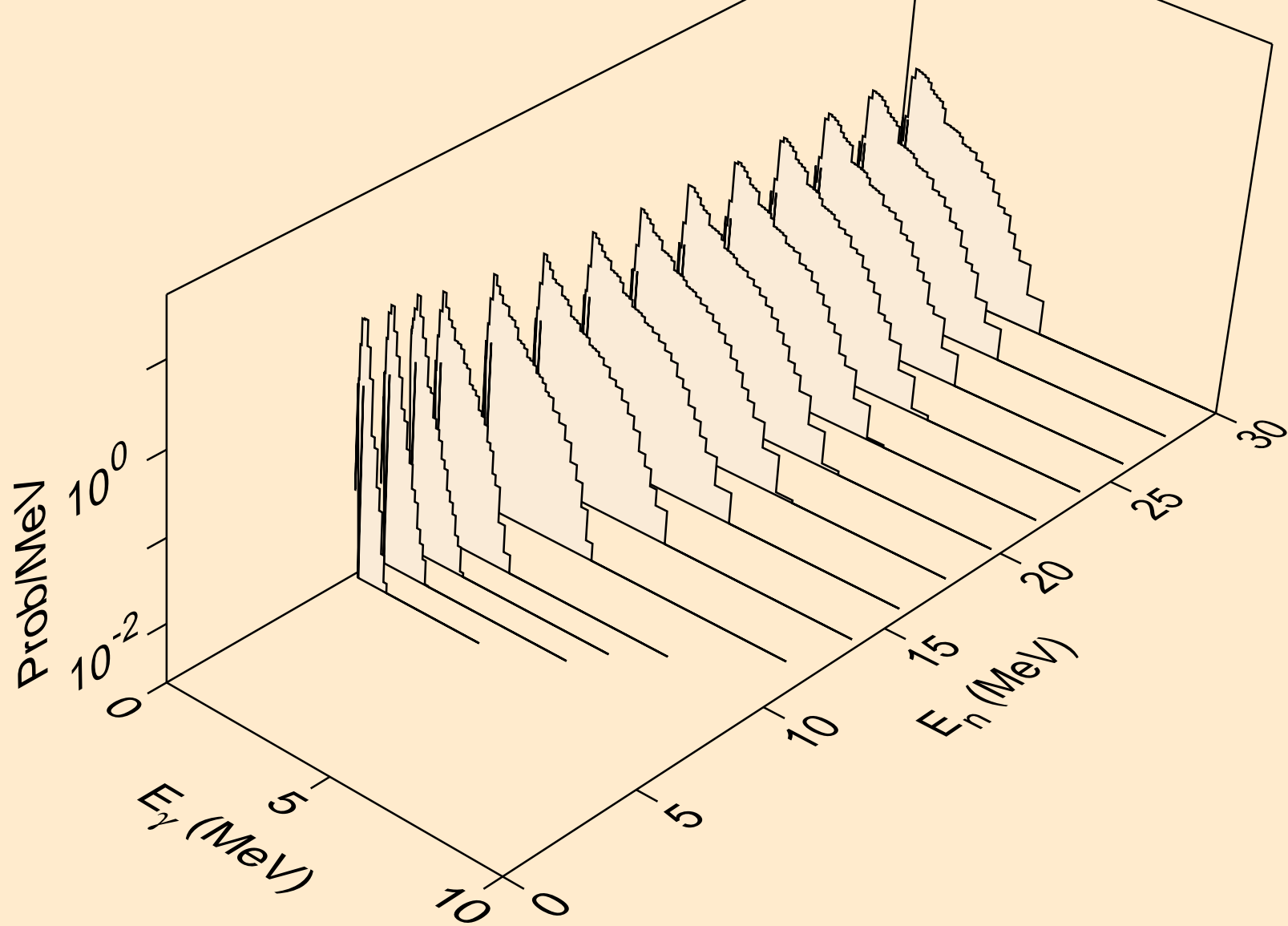

SM163 HELION ACER TENDL-2021 LIBRARY; T=0.K  
Photon emission for (n,3np)

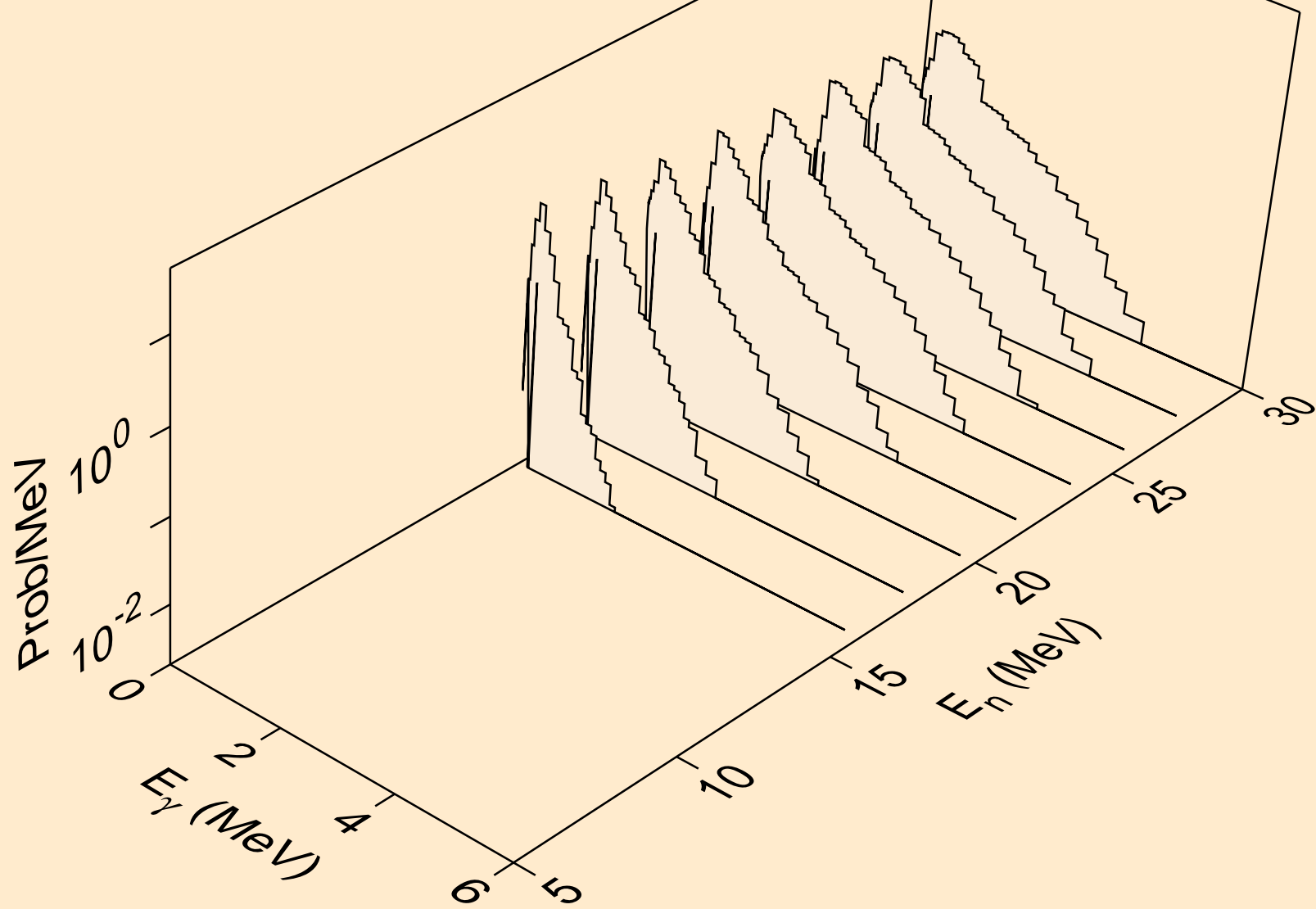

SM163 HELION ACER TENDL-2021 LIBRARY; T=0.K  
Photon emission for (n,2np)

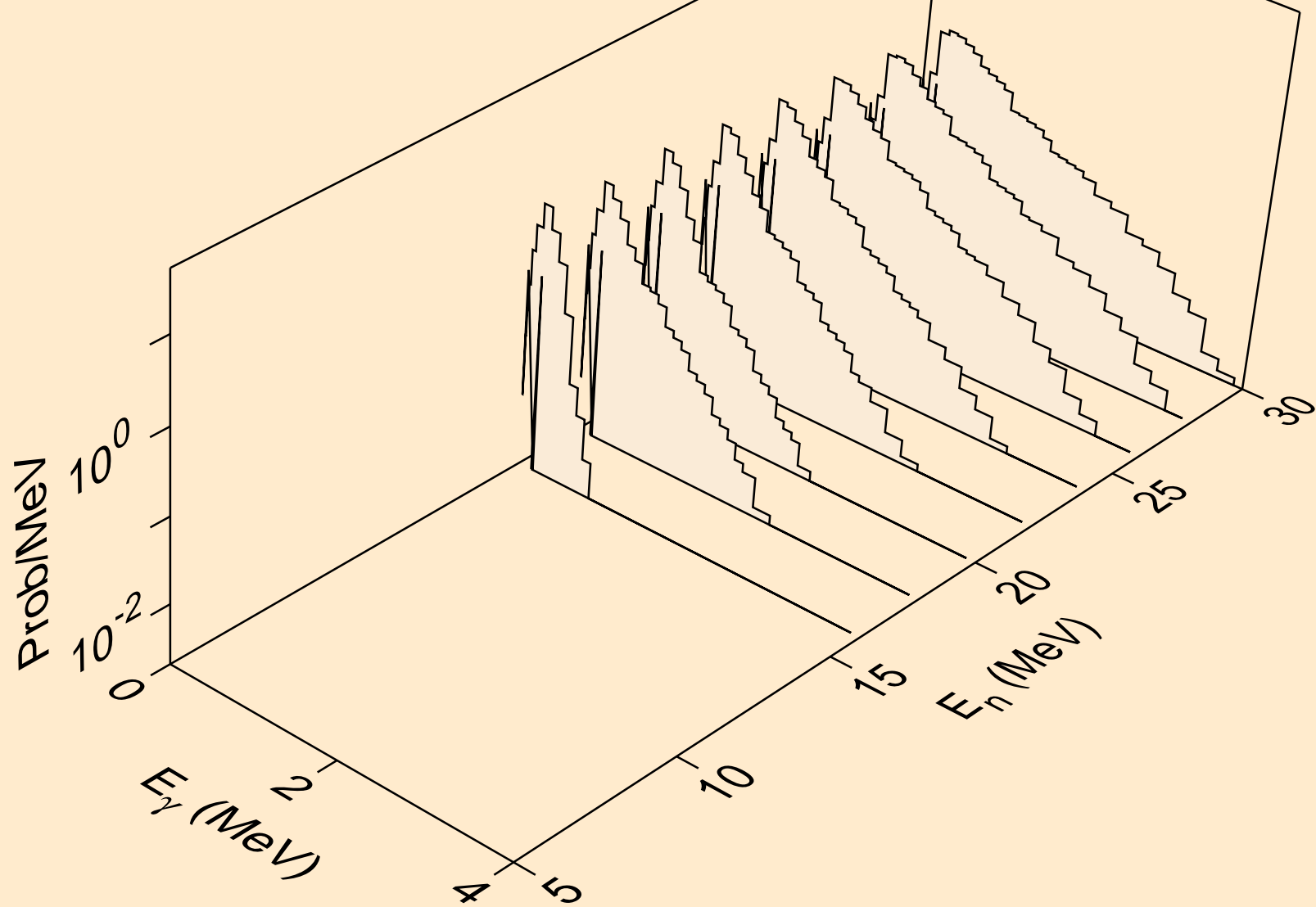



SM163 HELION ACER TENDL-2021 LIBRARY; T=0.K  
Photon emission for (n,npa)

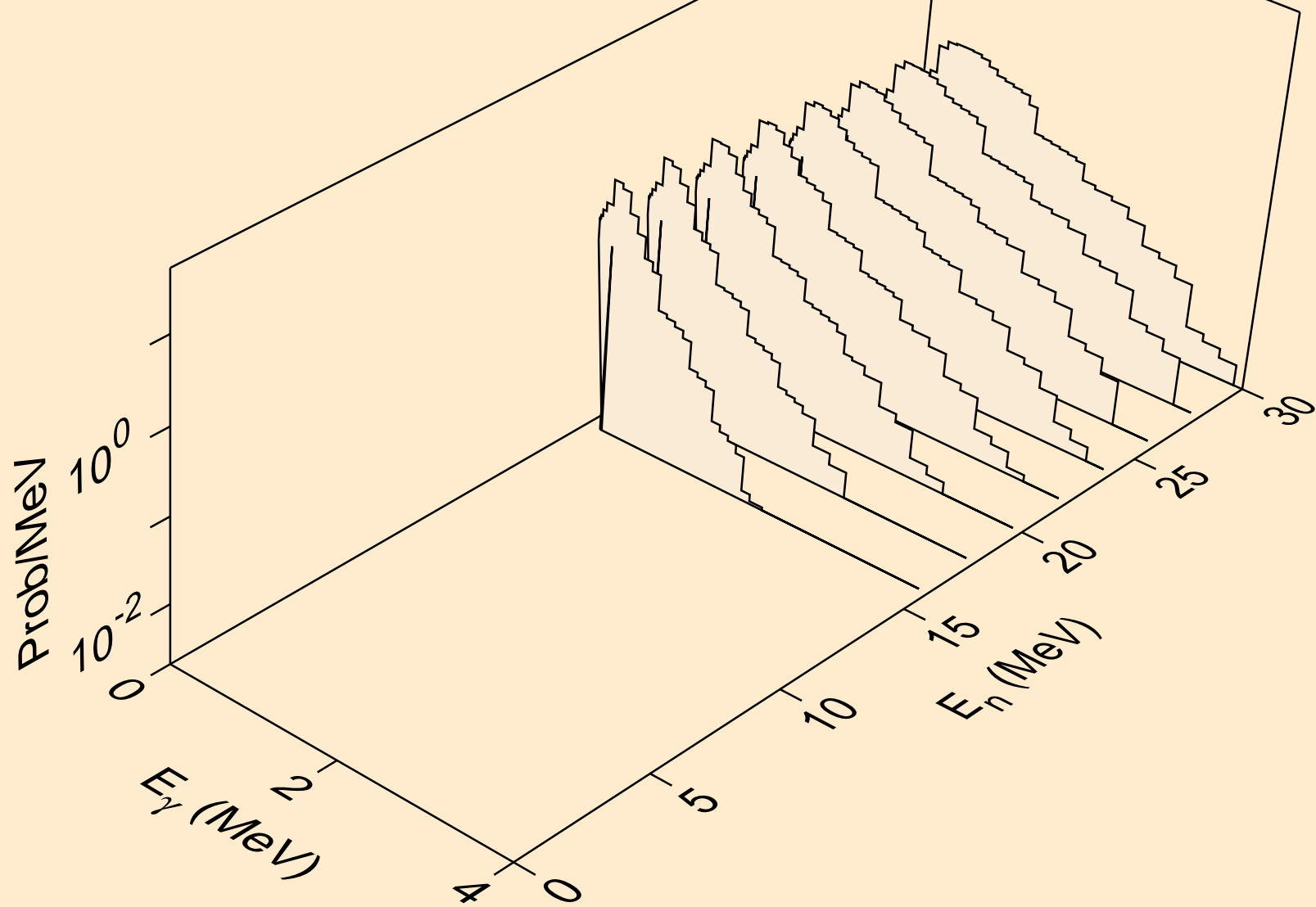

SM163 HELION ACER TENDL-2021 LIBRARY; T=0.K  
Photon emission for (n,p)

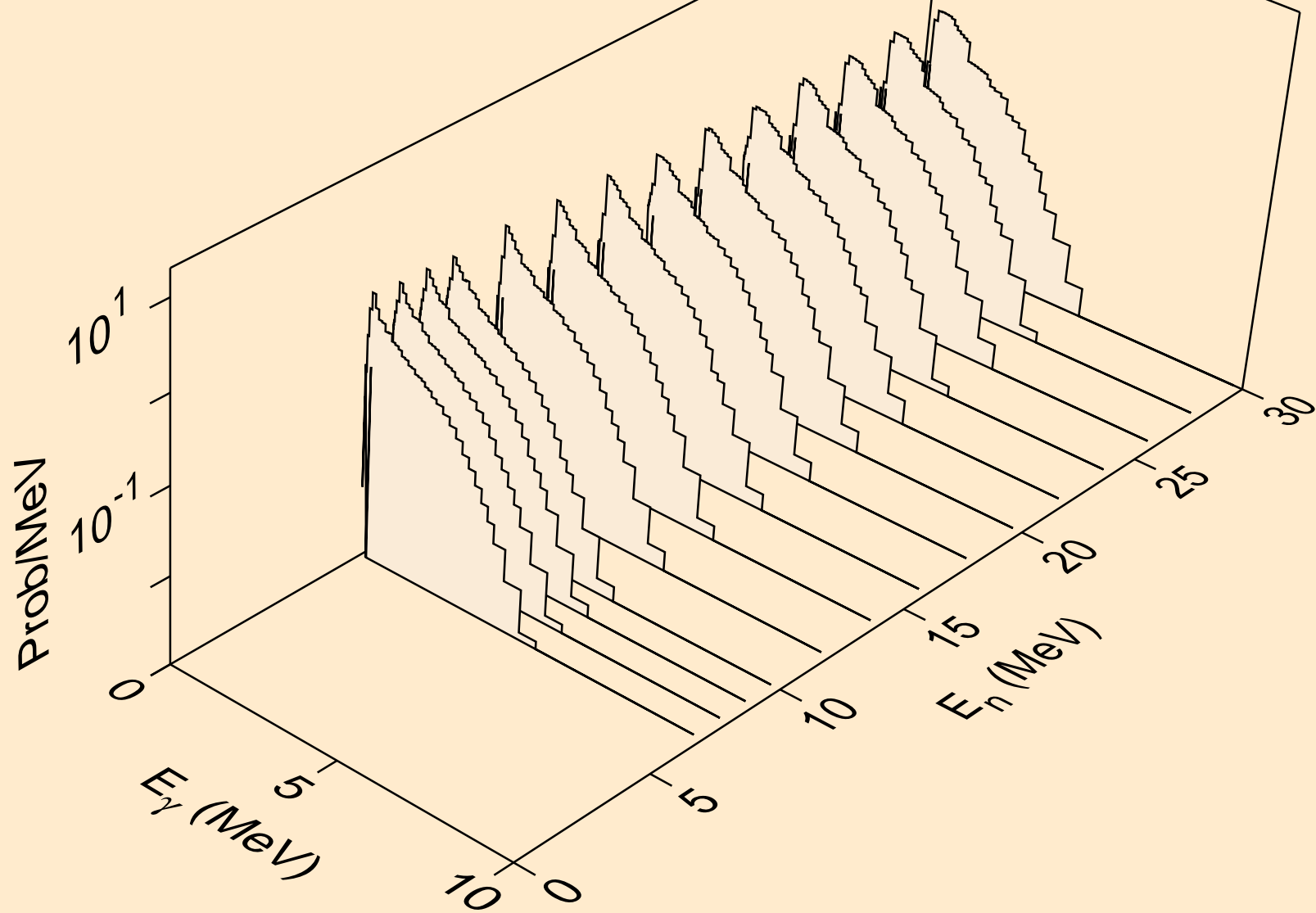

SM163 HELION ACER TENDL-2021 LIBRARY; T=0.K  
Photon emission for (n,d)

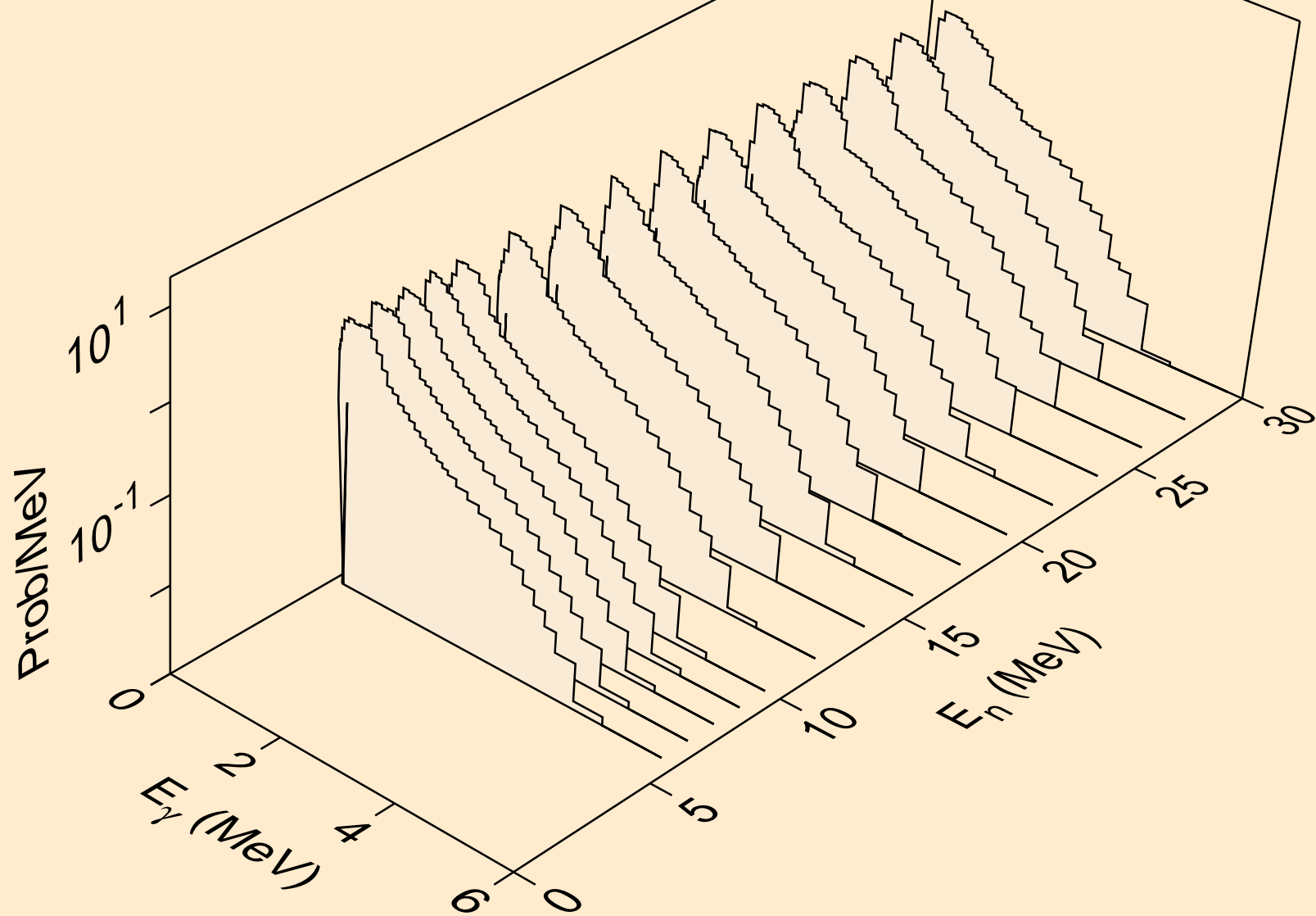

SM163 HELION ACER TENDL-2021 LIBRARY; T=0.K  
Photon emission for (n,t)

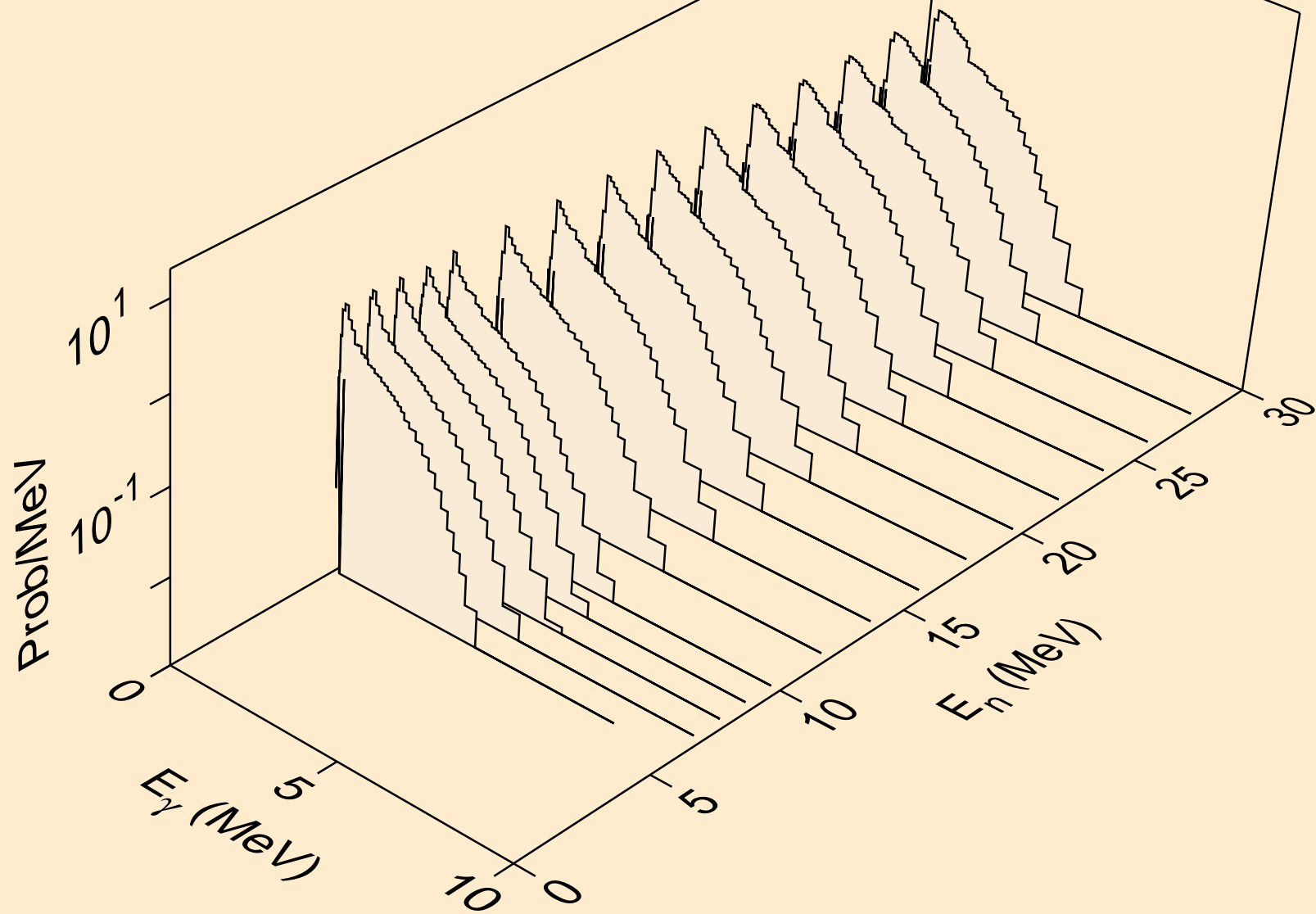

SM163 HELION ACER TENDL-2021 LIBRARY; T=0.K  
Photon emission for inelastic

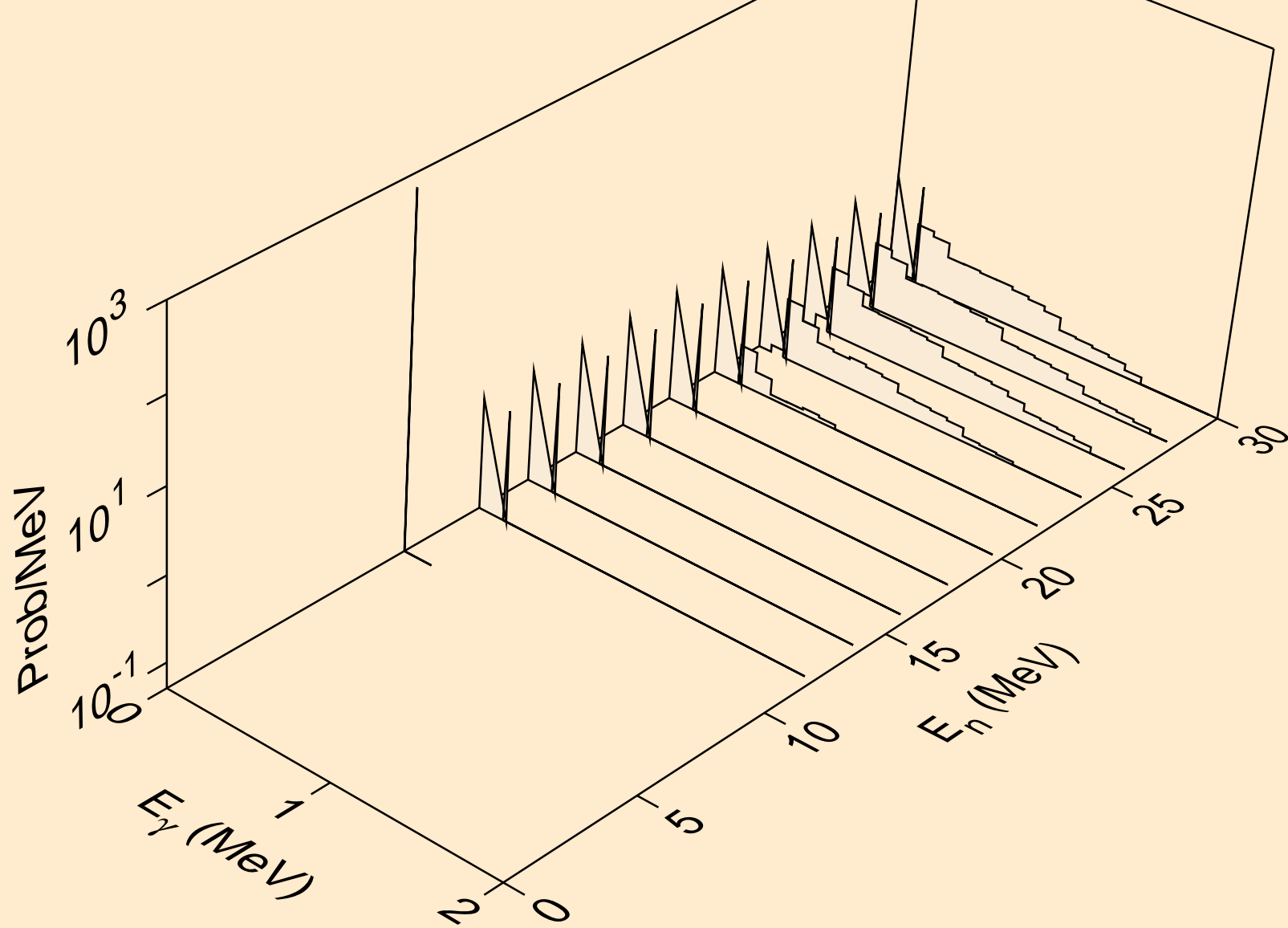

SM163 HELION ACER TENDL-2021 LIBRARY; T=0.K  
Photon emission for (n,a)

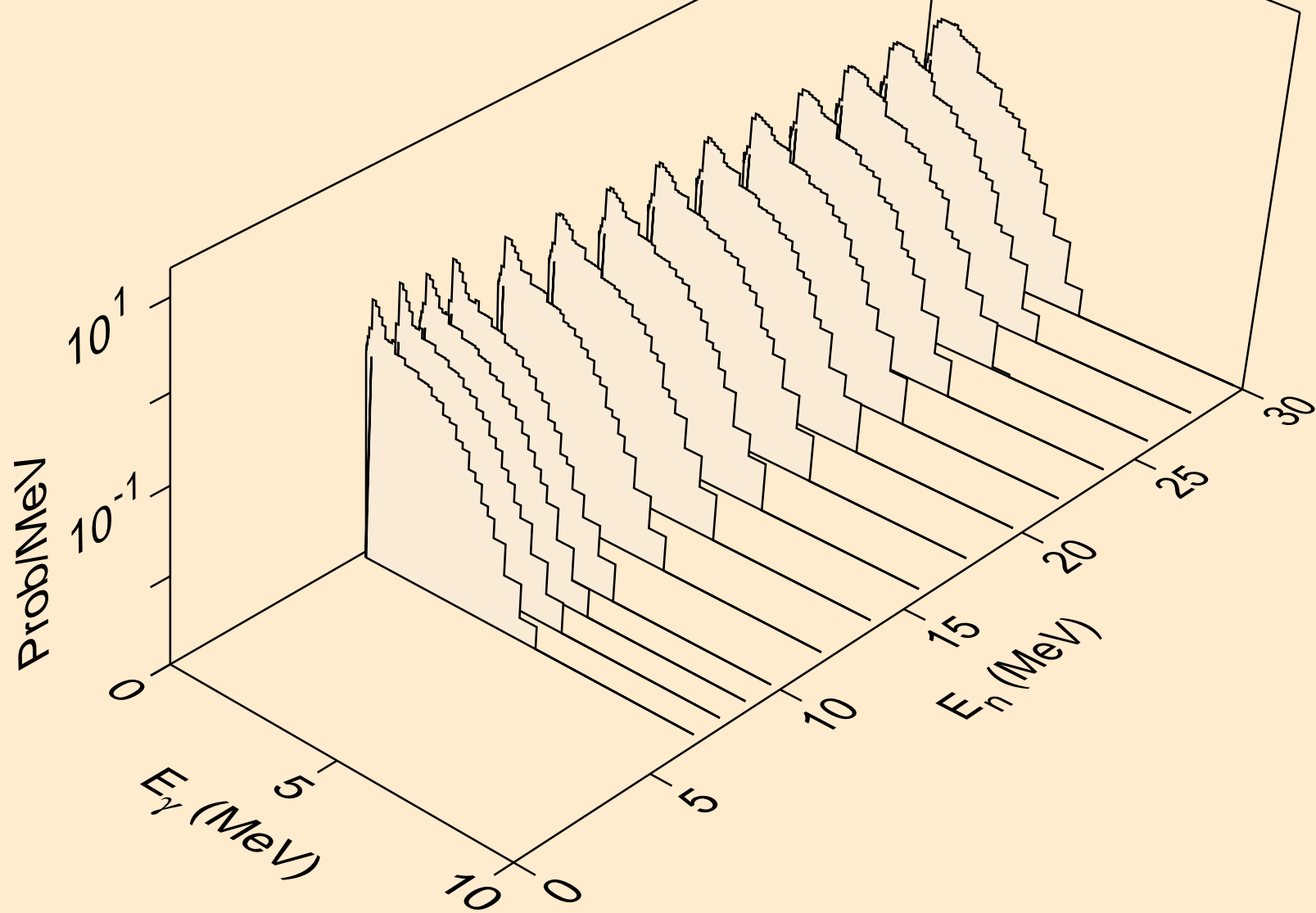

SM163 HELION ACER TENDL-2021 LIBRARY; T=0.K  
Photon emission for (n,2p)

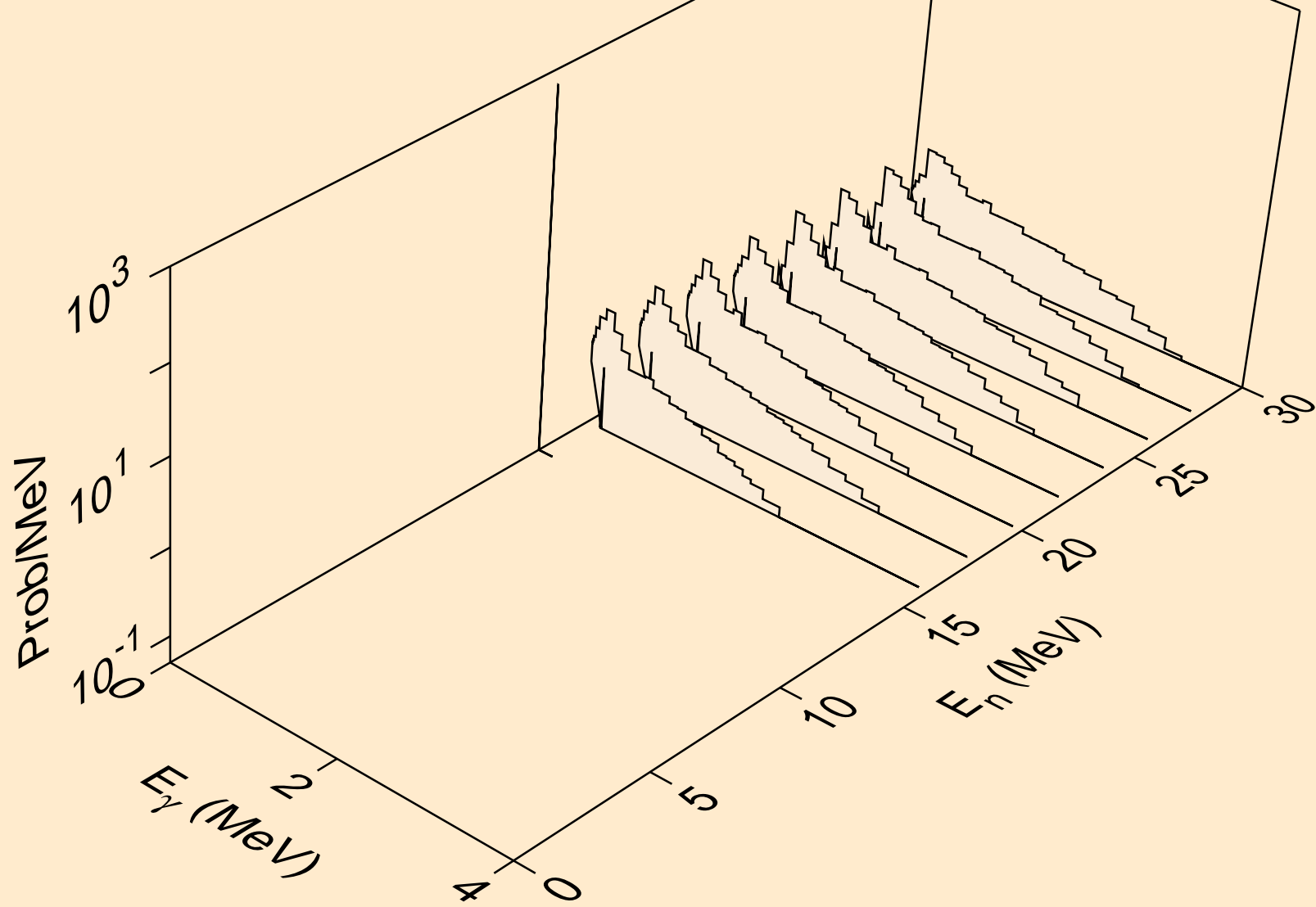

SM163 HELION ACER TENDL-2021 LIBRARY; T=0.K  
Photon emission for (n,pd)

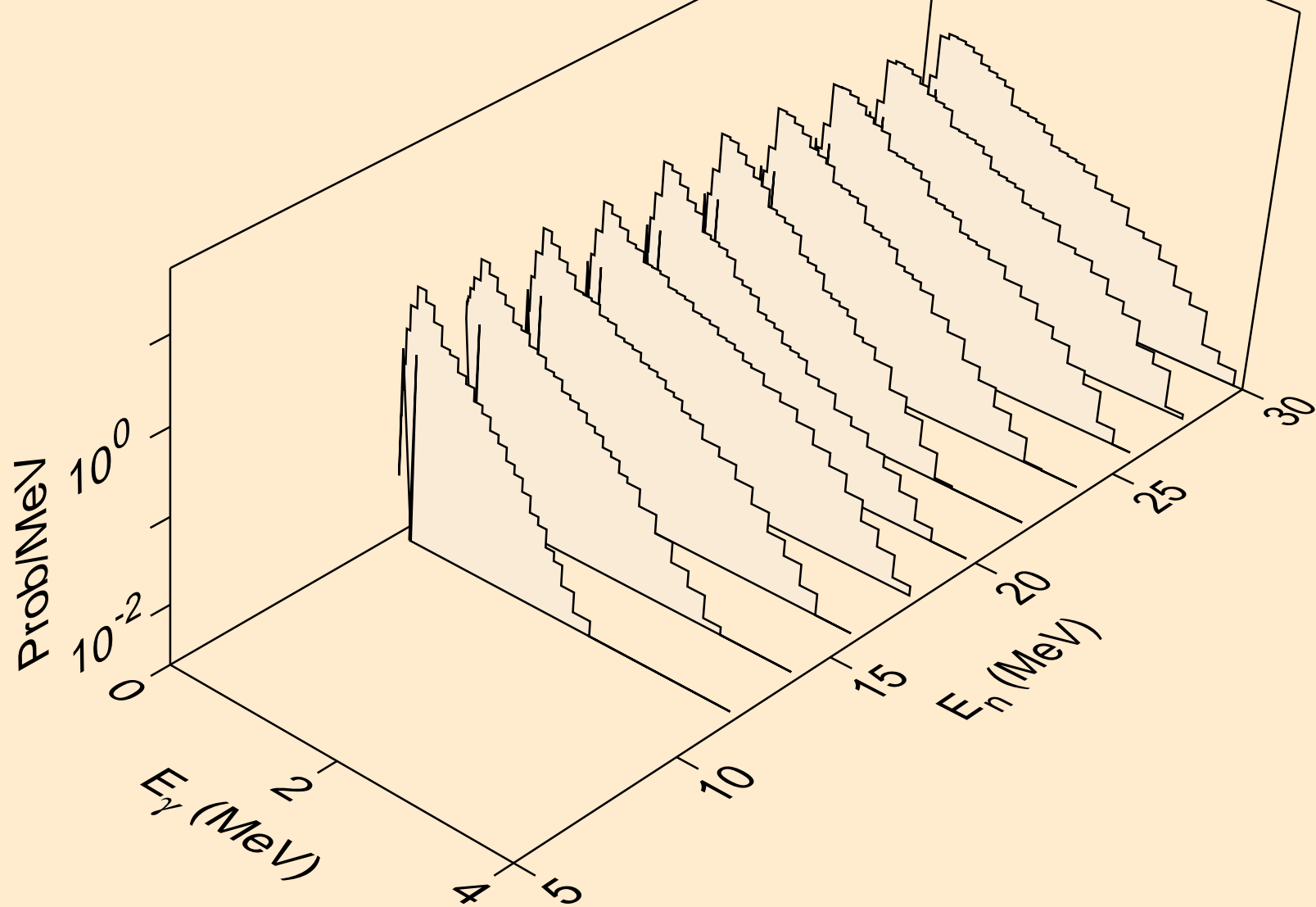



SM163 HELION ACER TENDL-2021 LIBRARY; T=0.K  
Photon emission for (n,pt)

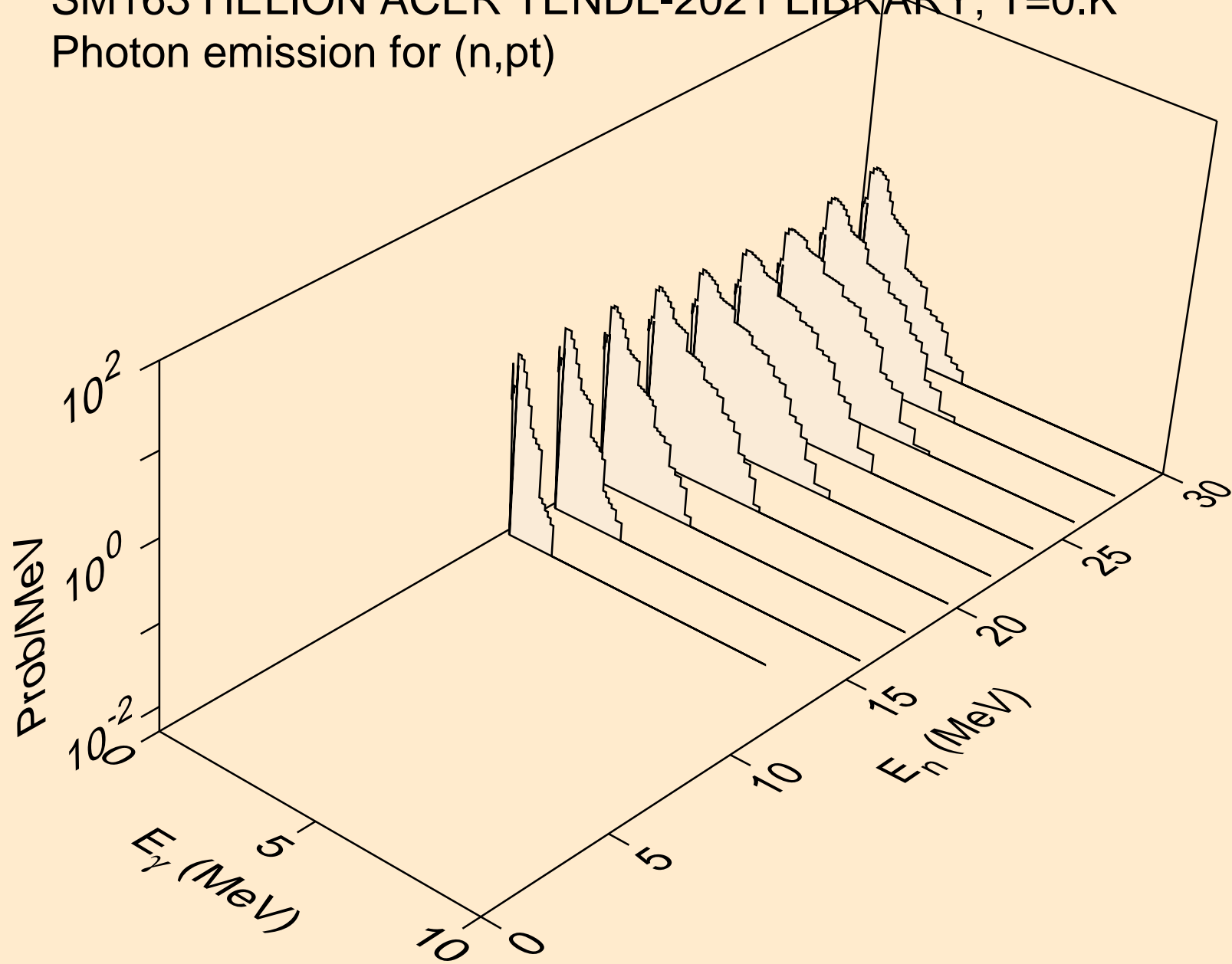

# SM163 HELION ACER TENDL-2021 LIBRARY; T=0.K

## Particle heating contributions

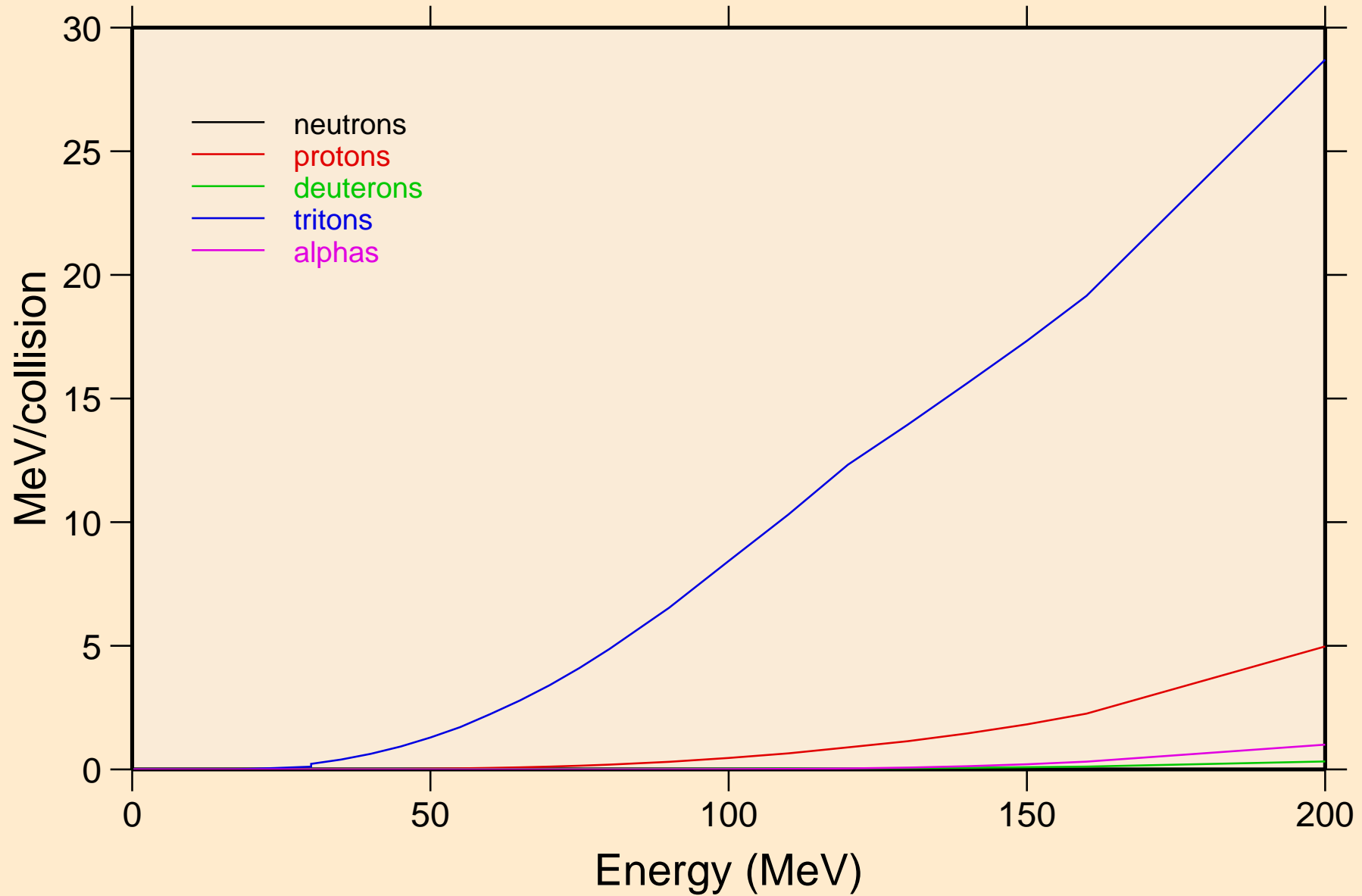

SM163 HELION ACER TENDL-2021 LIBRARY; T=0.K  
Recoil Heating

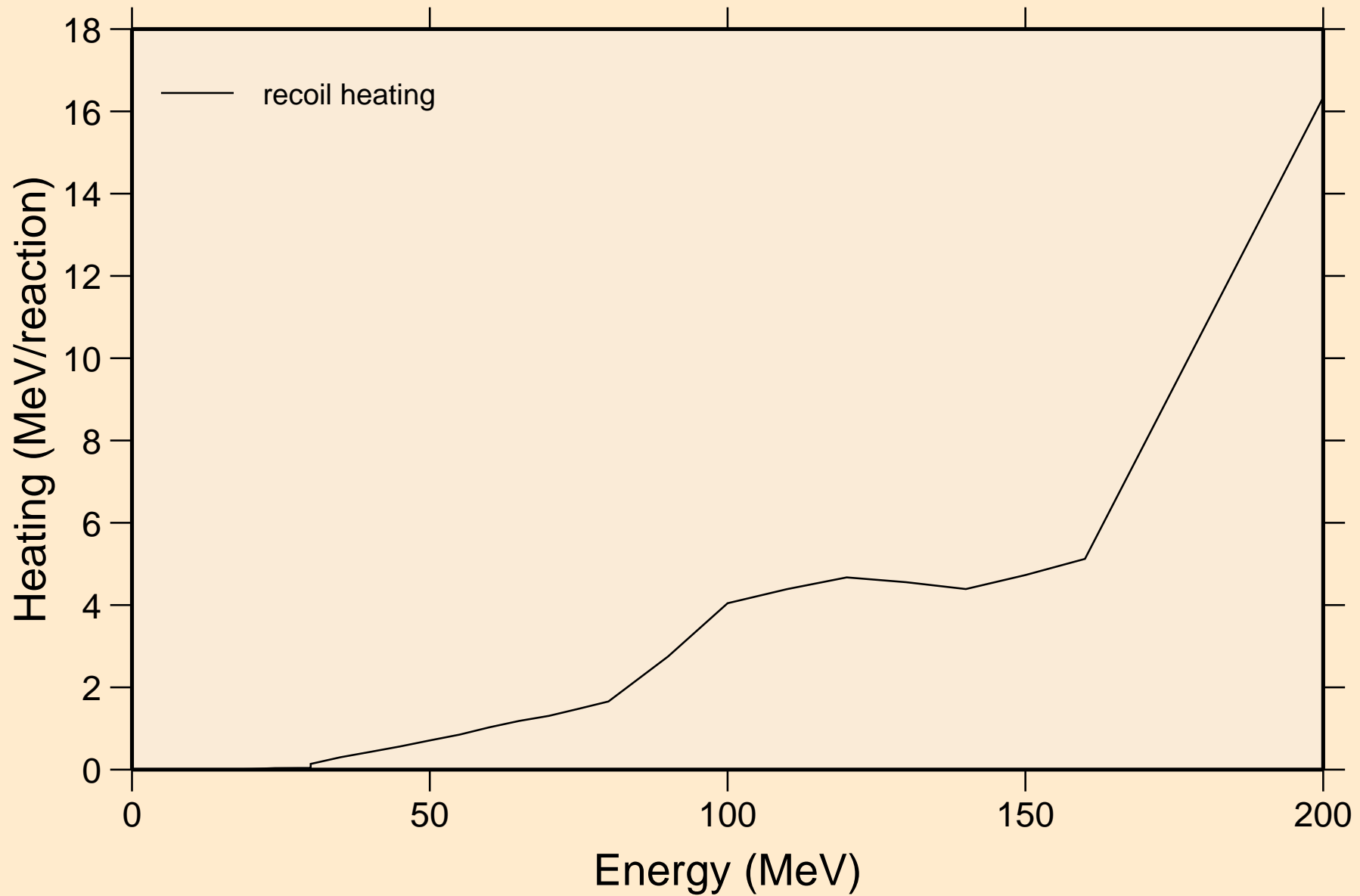

SM163 HELION ACER TENDL-2021 LIBRARY; T=0.K  
Particle production cross sections

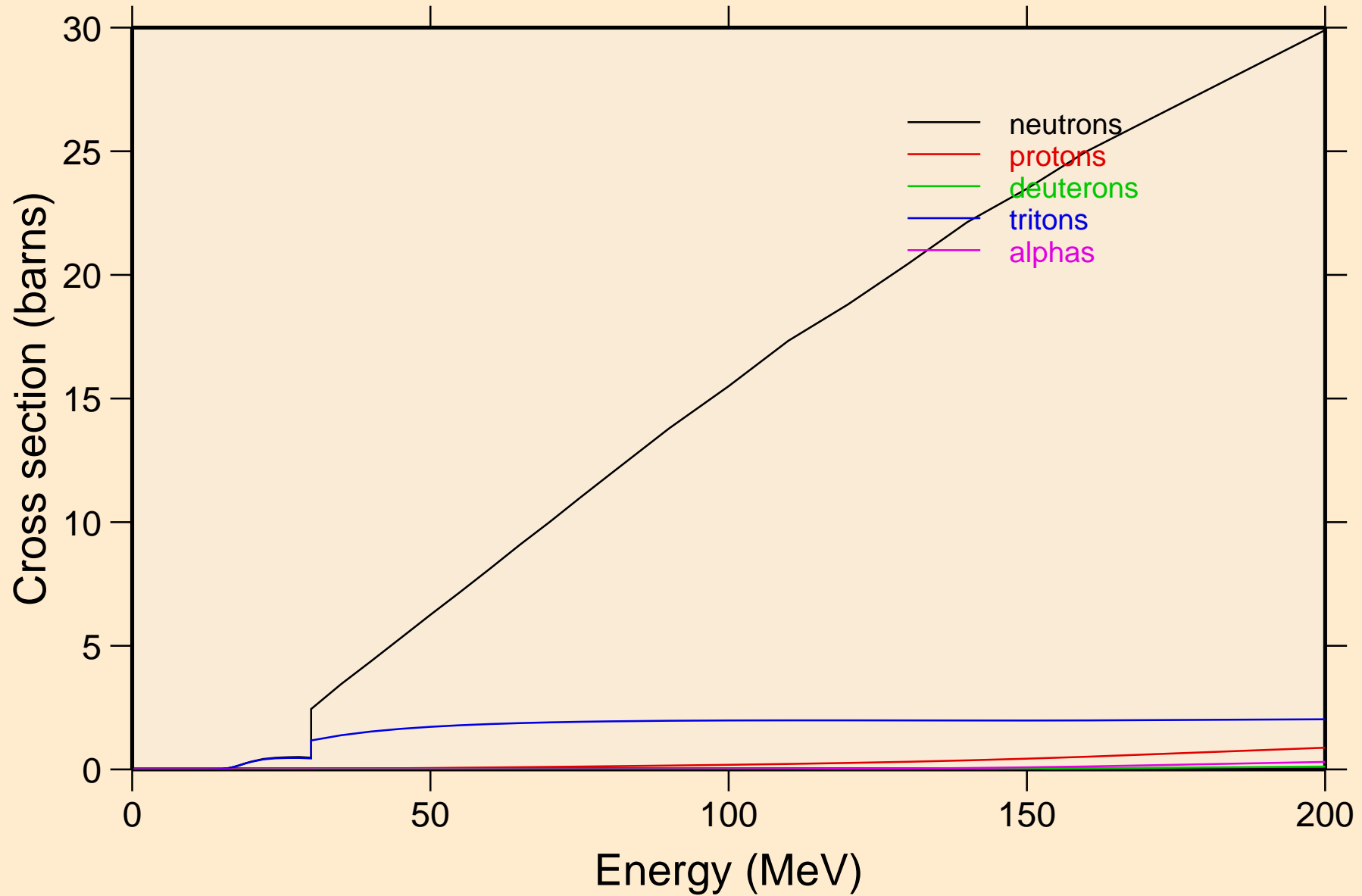

SM163 HELION ACER TENDL-2021 LIBRARY; T=0.K  
neutrons from (s,n)

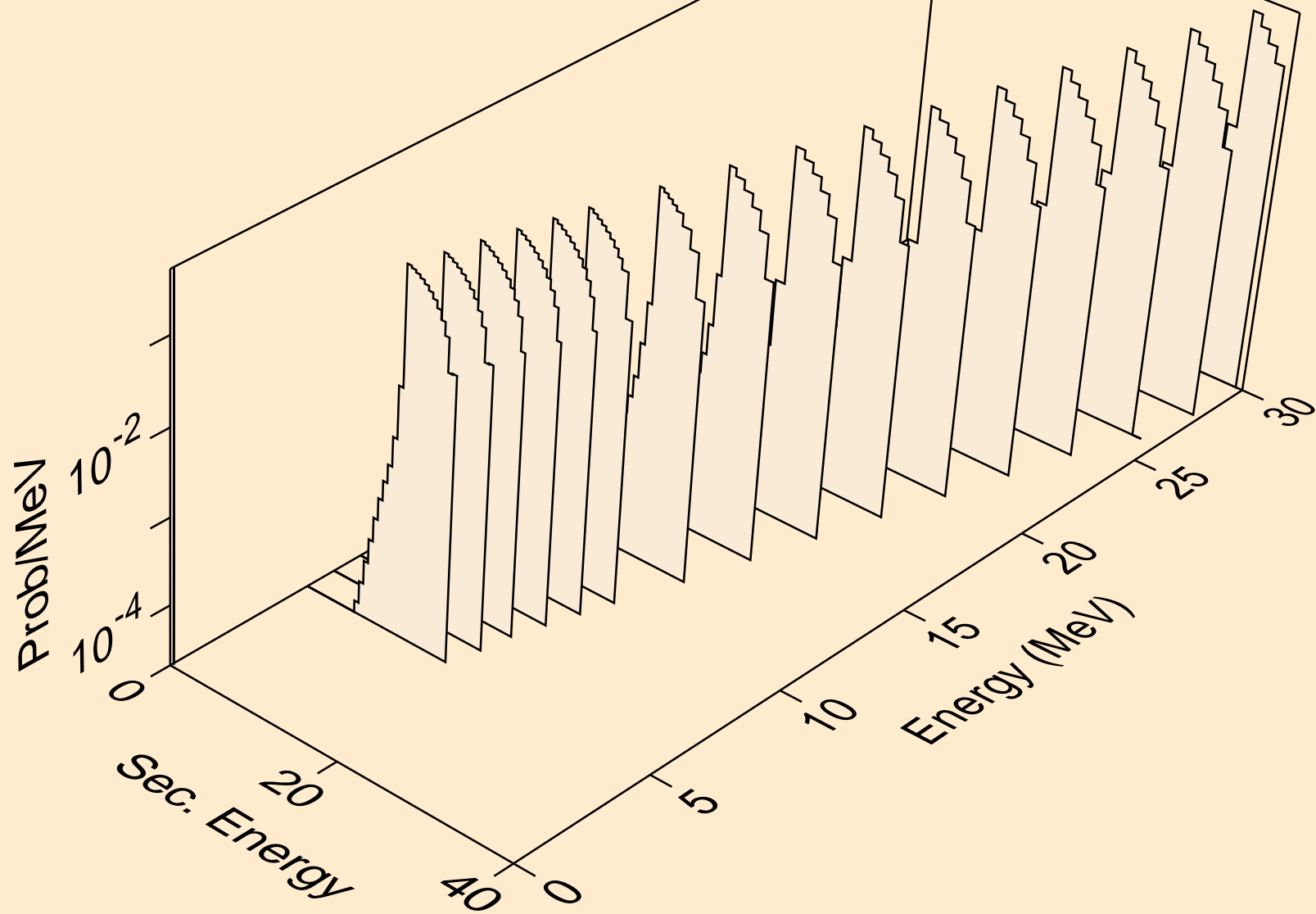

SM163 HELION ACER TENDL-2021 LIBRARY; T=0.K  
neutrons from (s,x)

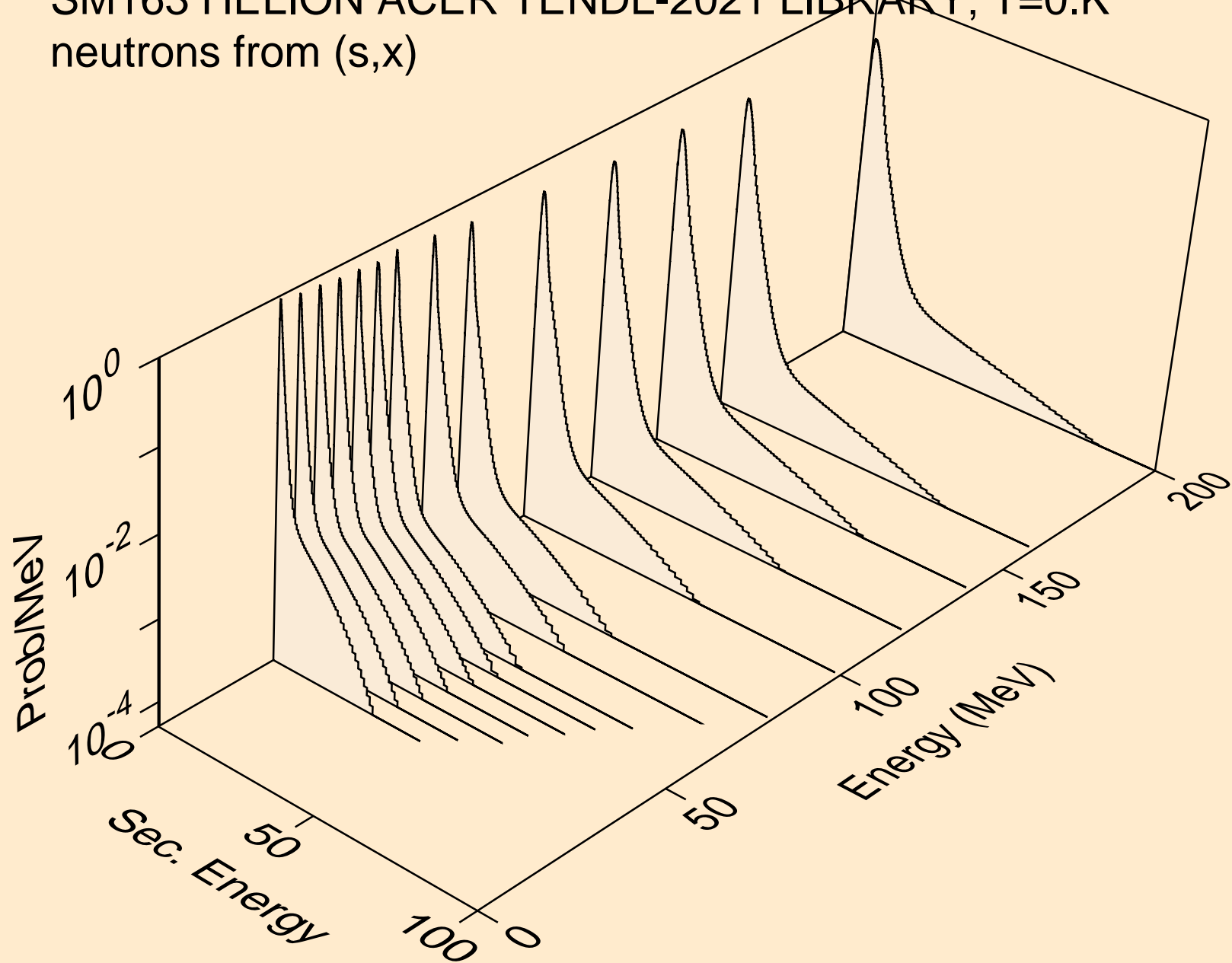

SM163 HELION ACER TENDL-2021 LIBRARY; T=0.K  
neutrons from (s,2nd)

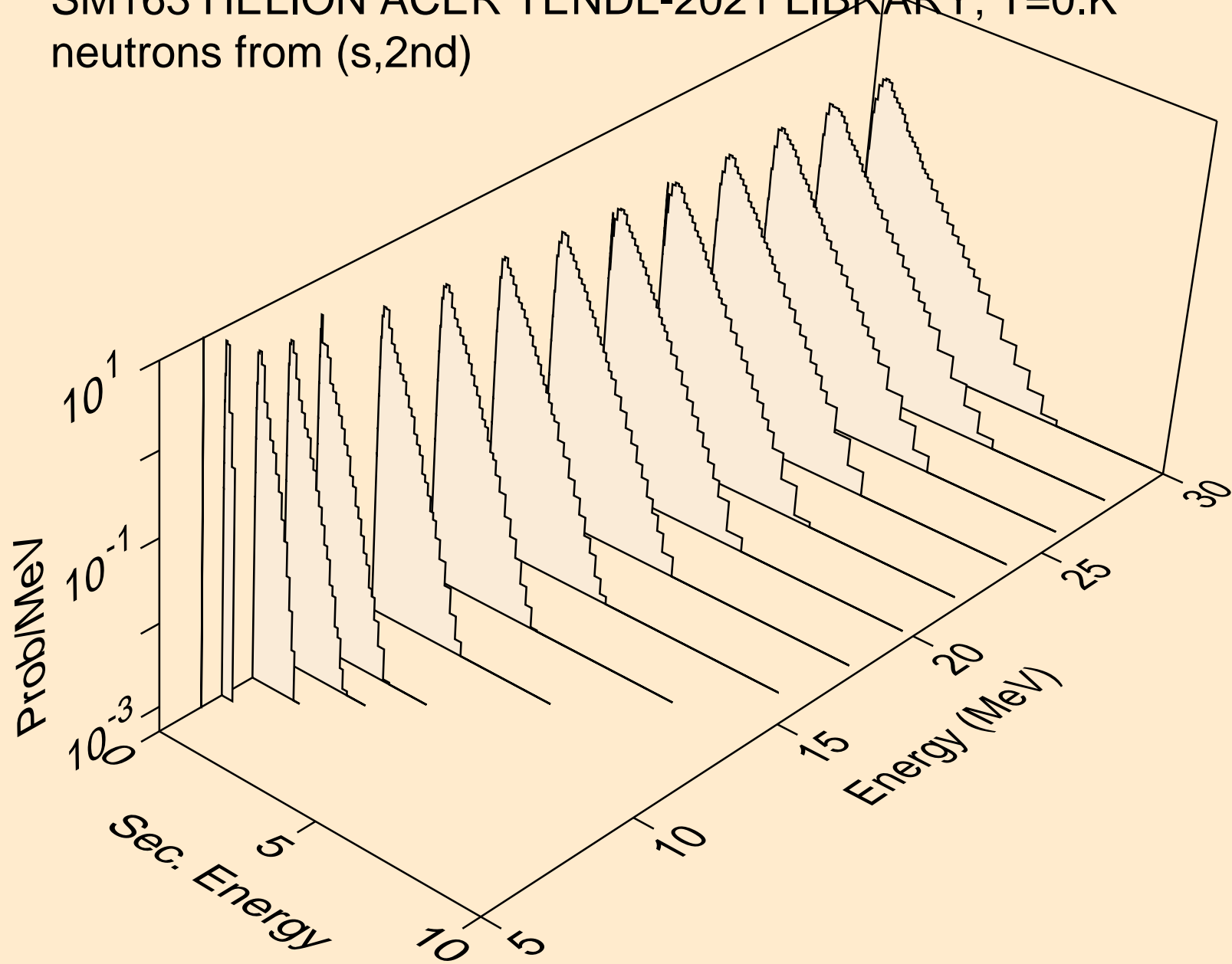

SM163 HELION ACER TENDL-2021 LIBRARY; T=0.K  
neutrons from (s,2n)

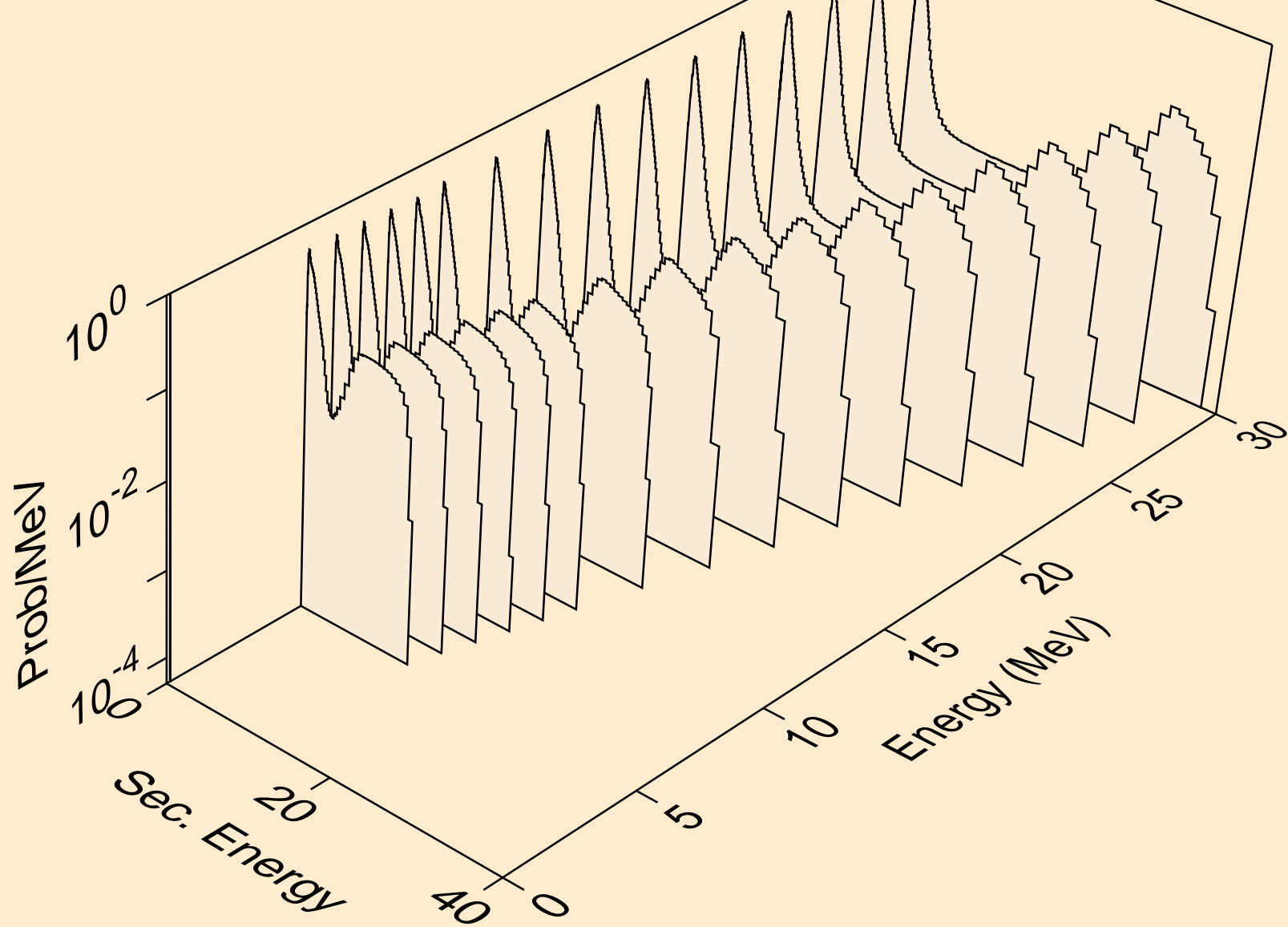



SM163 HELION ACER TENDL-2021 LIBRARY; T=0.K  
neutrons from (s,3n)

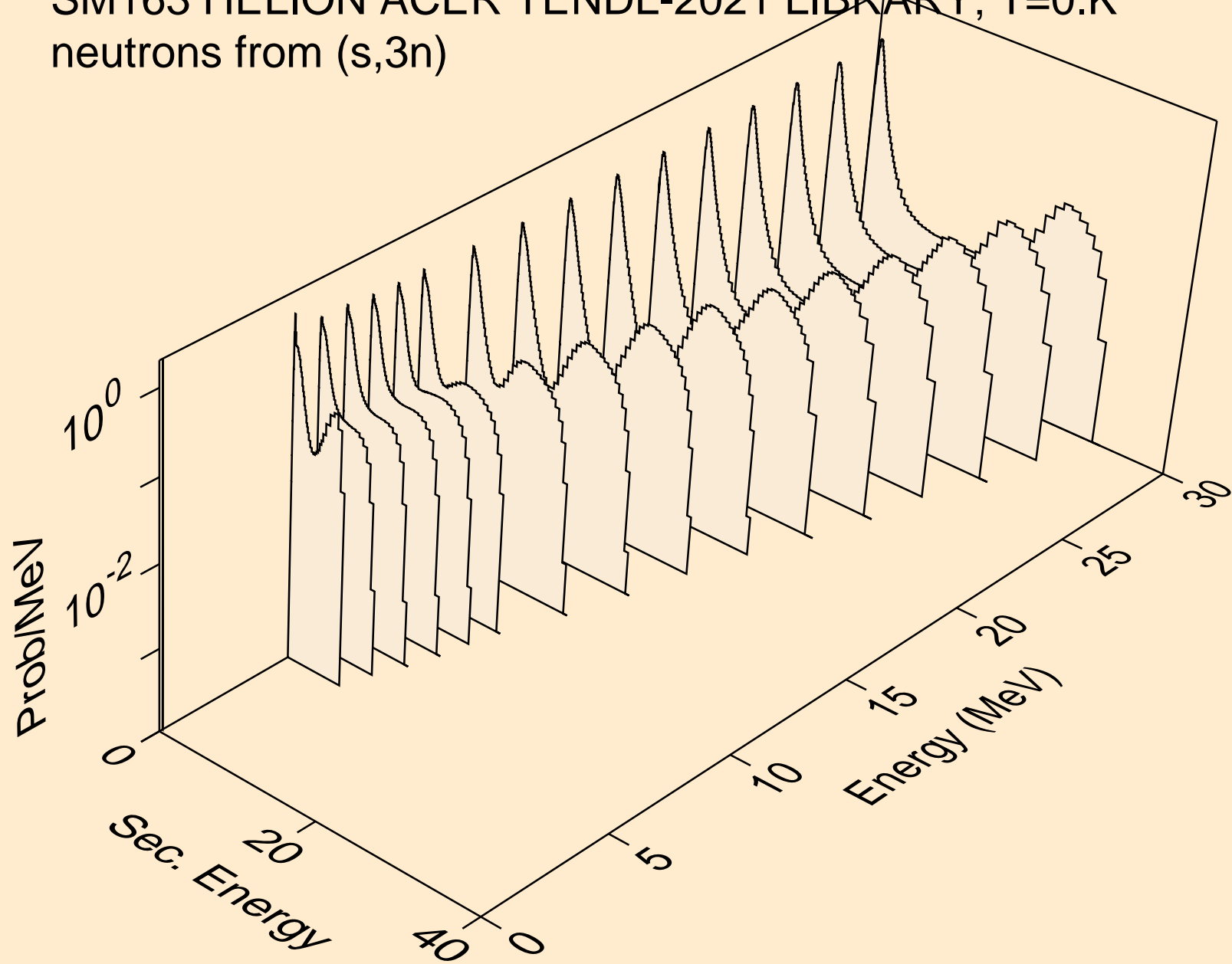

SM163 HELION ACER TENDL-2021 LIBRARY; T=0.K  
neutrons from (s,n\*)a

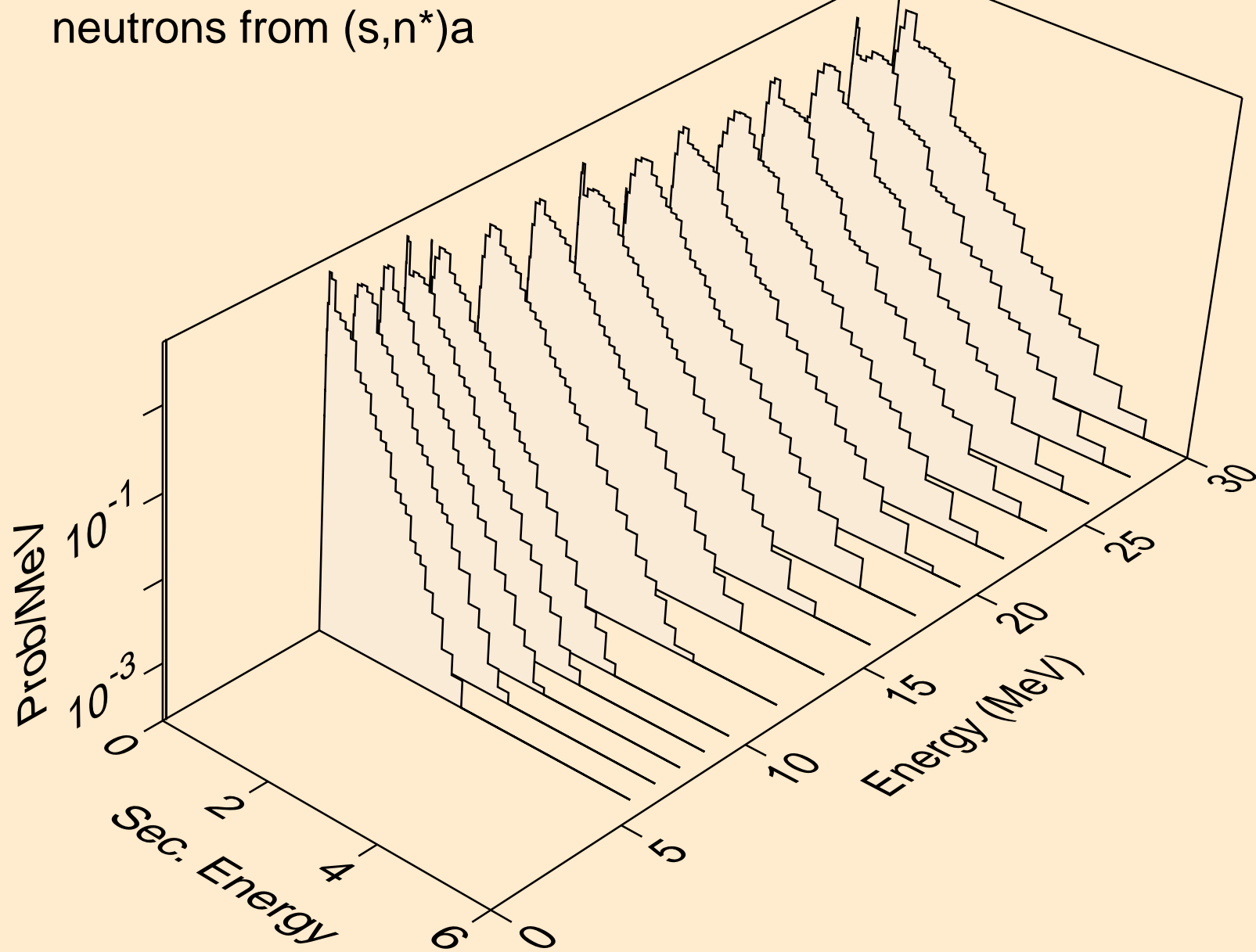

SM163 HELION ACER TENDL-2021 LIBRARY; T=0.K  
neutrons from (s,2n)a

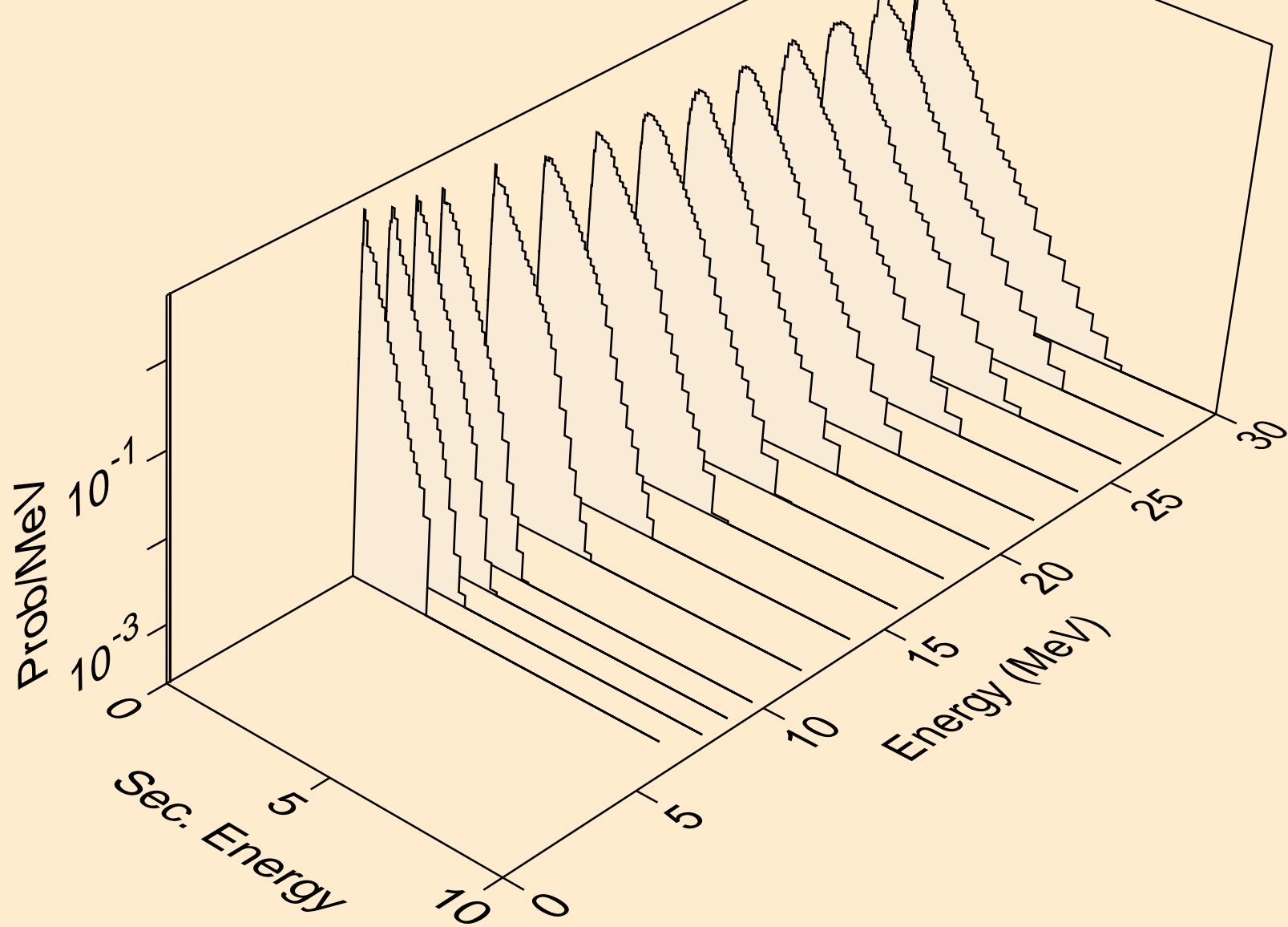

SM163 HELION ACER TENDL-2021 LIBRARY; T=0.K  
neutrons from (s,3n)a

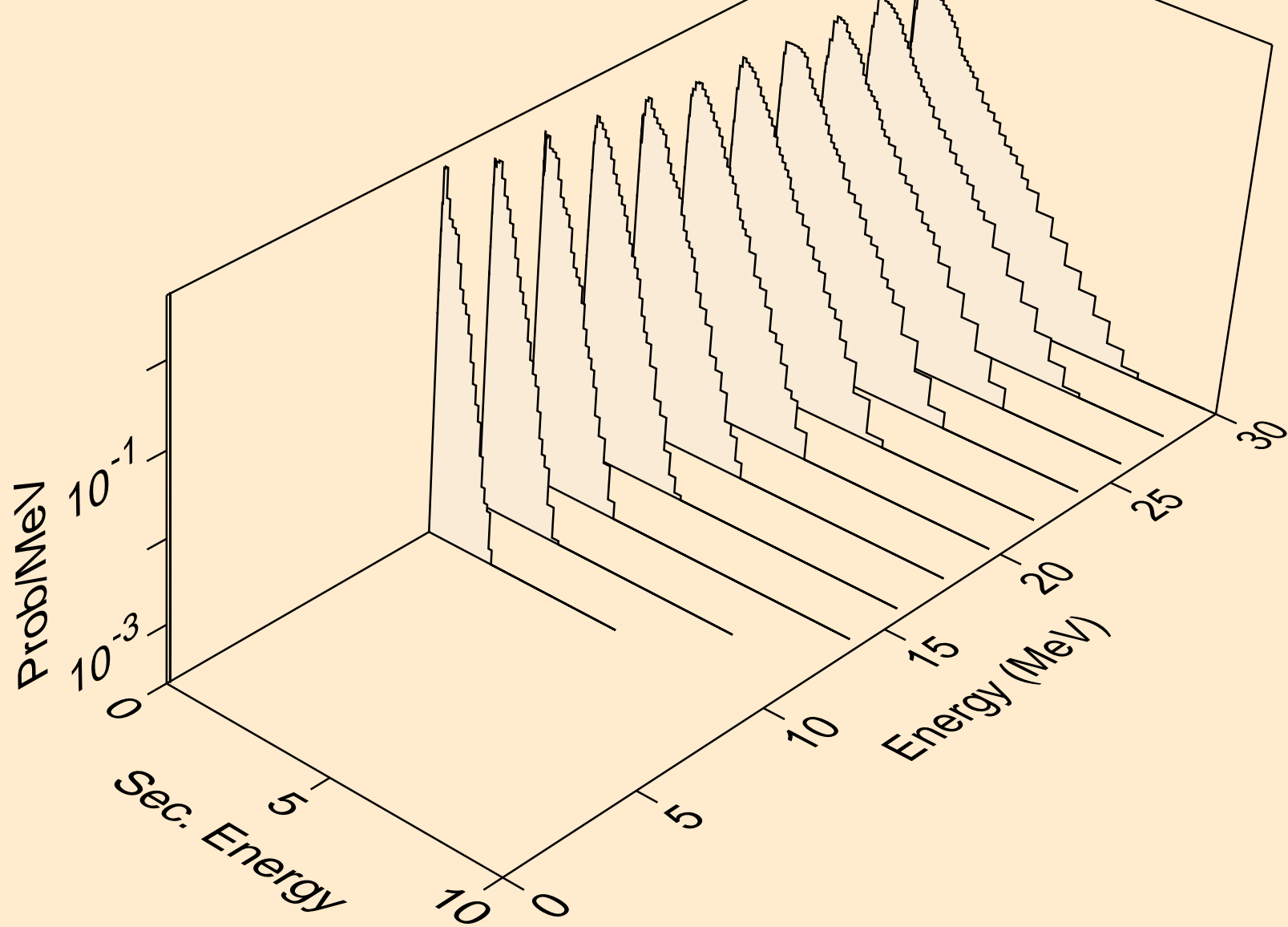

SM163 HELION ACER TENDL-2021 LIBRARY; T=0.K  
neutrons from (s,n\*)p

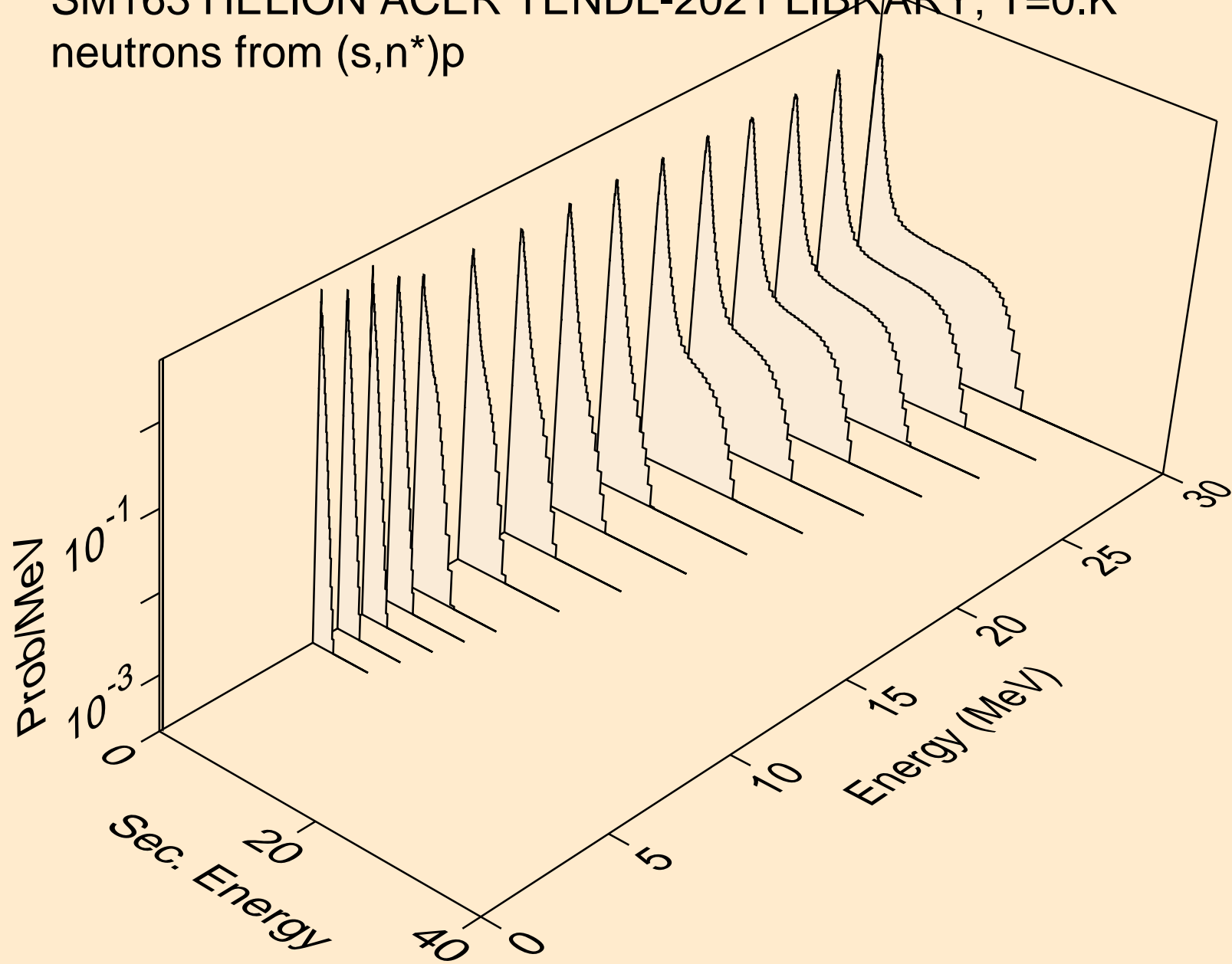

SM163 HELION ACER TENDL-2021 LIBRARY; T=0.K  
neutrons from (s,n\*)d

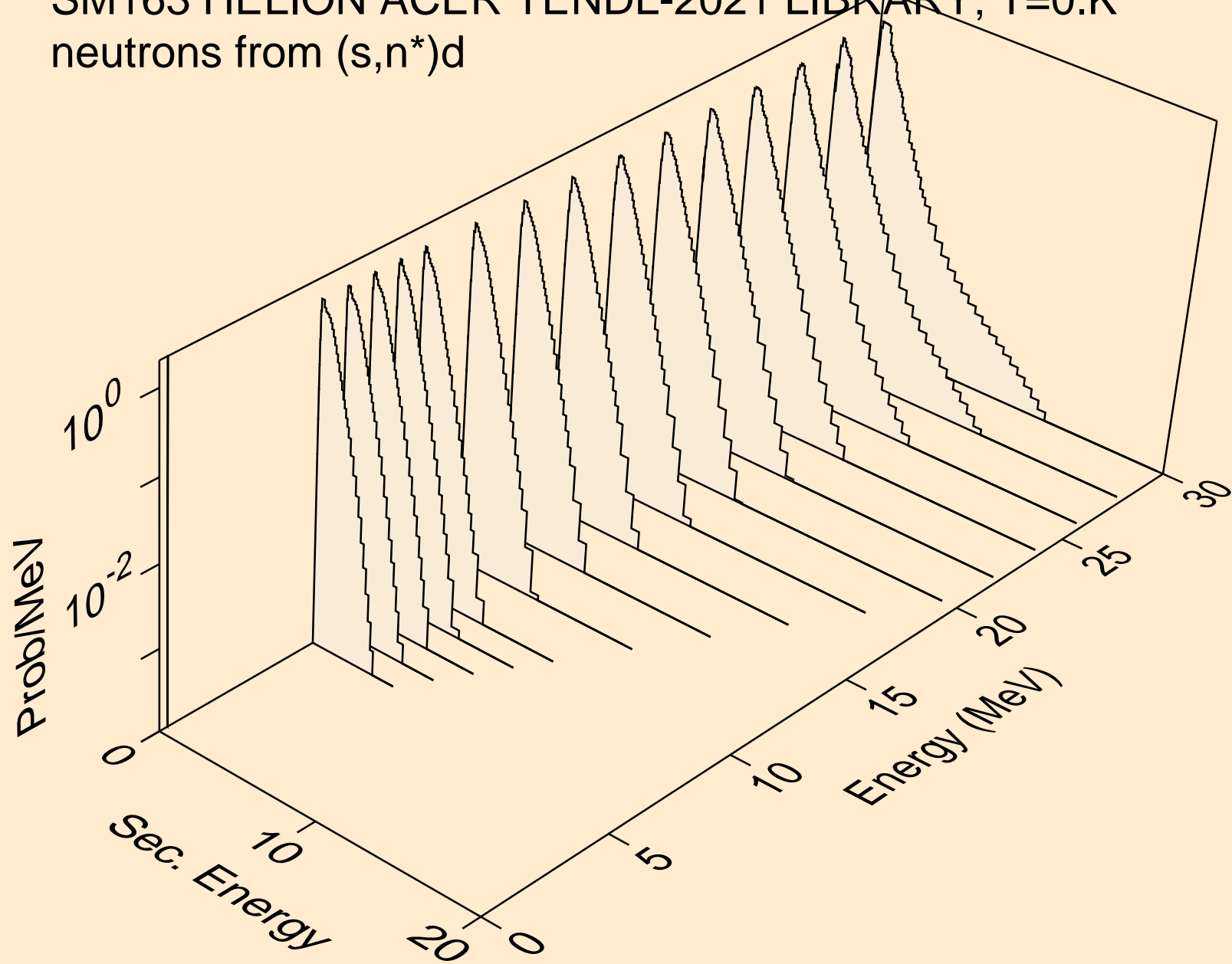

SM163 HELION ACER TENDL-2021 LIBRARY; T=0.K  
neutrons from (s,n\*)t

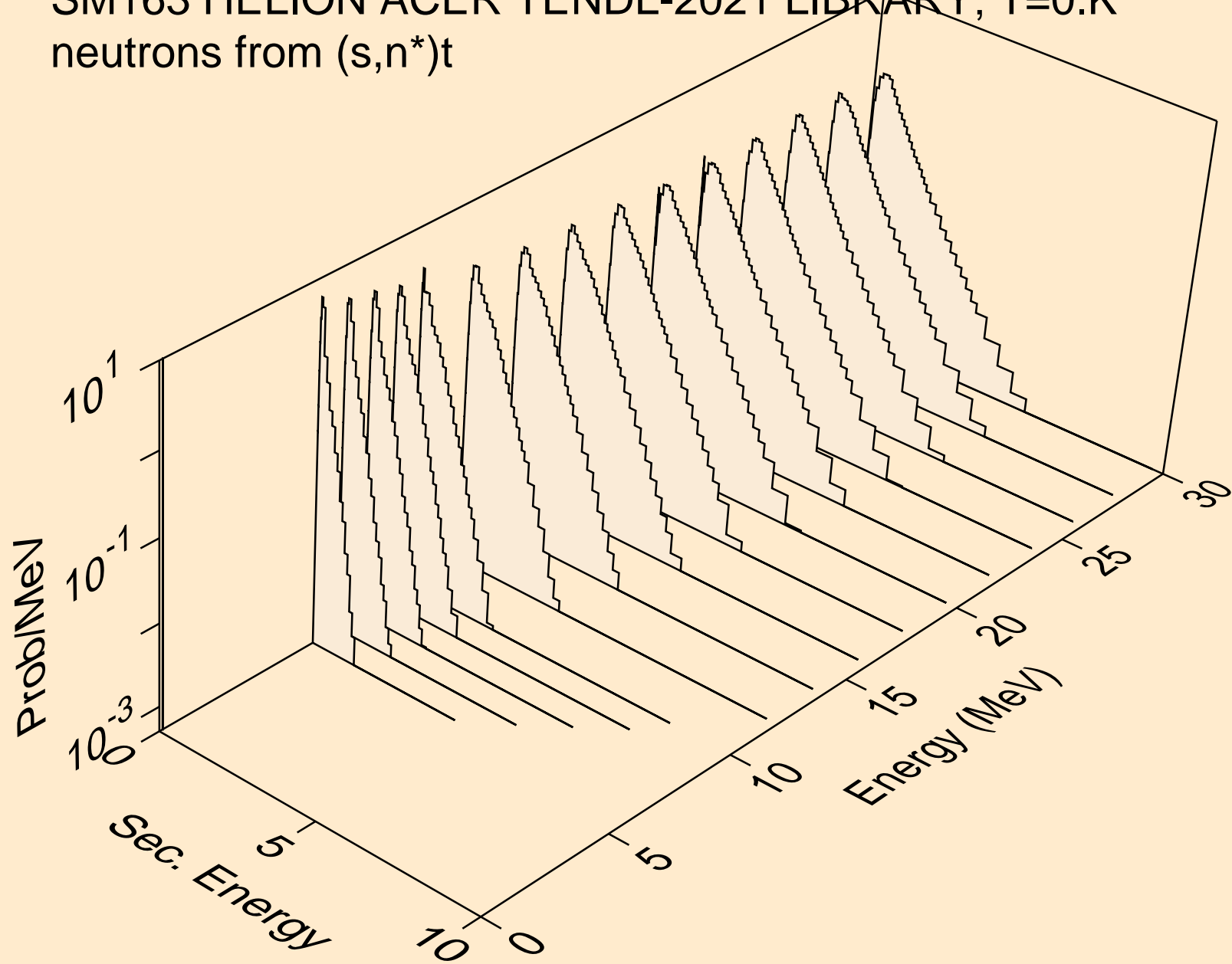

SM163 HELION ACER TENDL-2021 LIBRARY; T=0.K  
neutrons from (s,n\*)he3

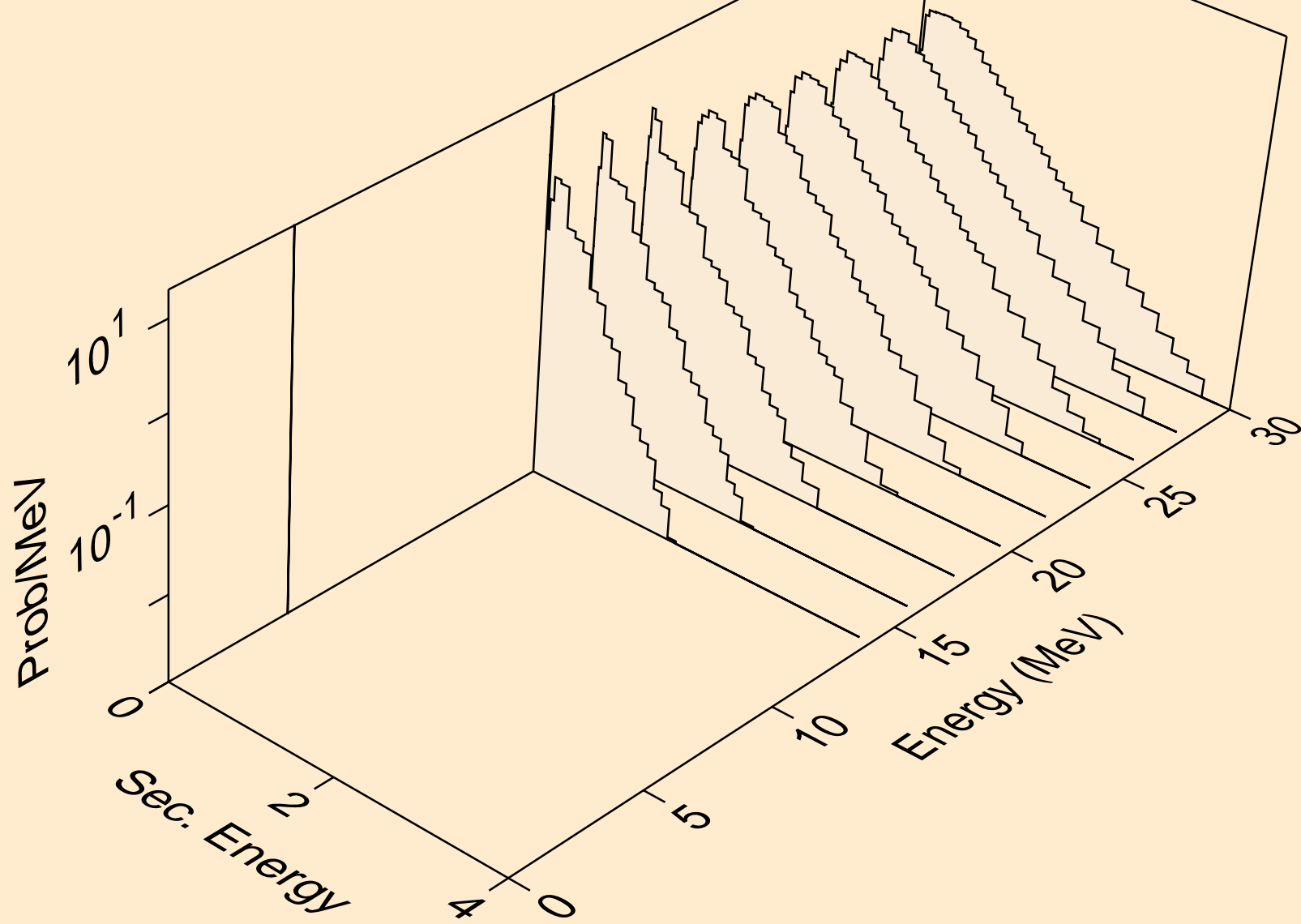



SM163 HELION ACER TENDL-2021 LIBRARY; T=0.K  
neutrons from (s,4n)

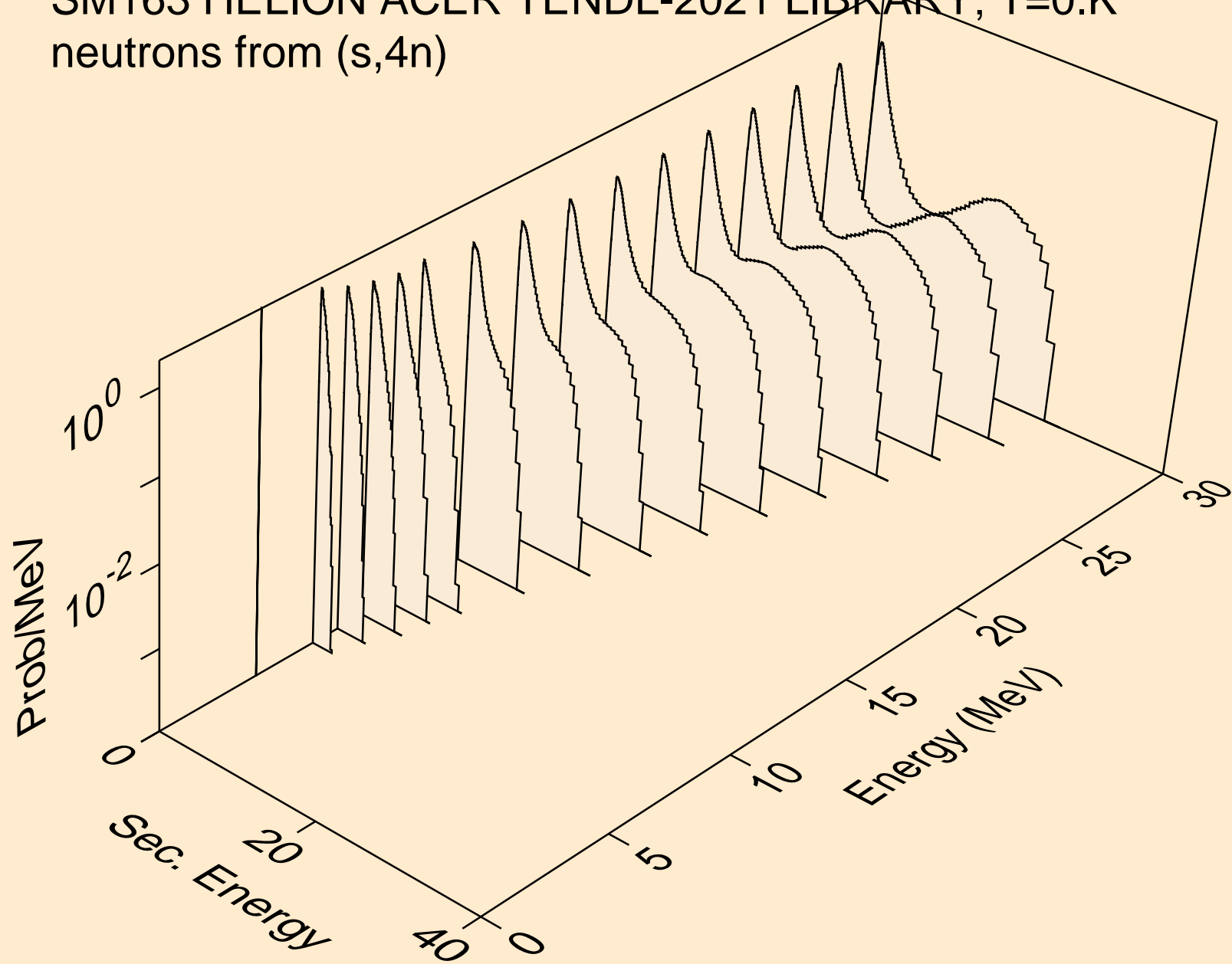

SM163 HELION ACER TENDL-2021 LIBRARY; T=0.K  
neutrons from (s,2np)

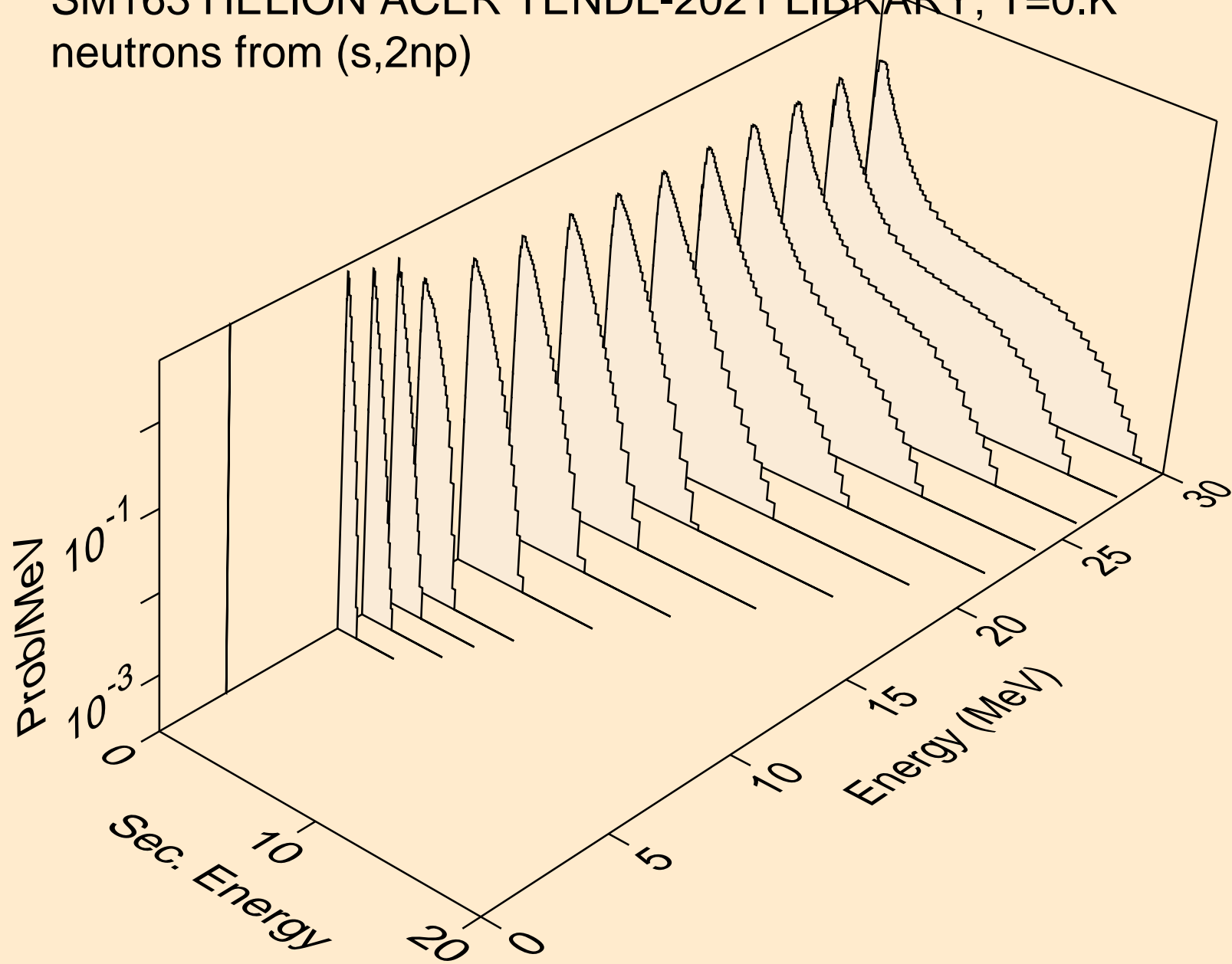

SM163 HELION ACER TENDL-2021 LIBRARY; T=0.K  
neutrons from (s,3np)

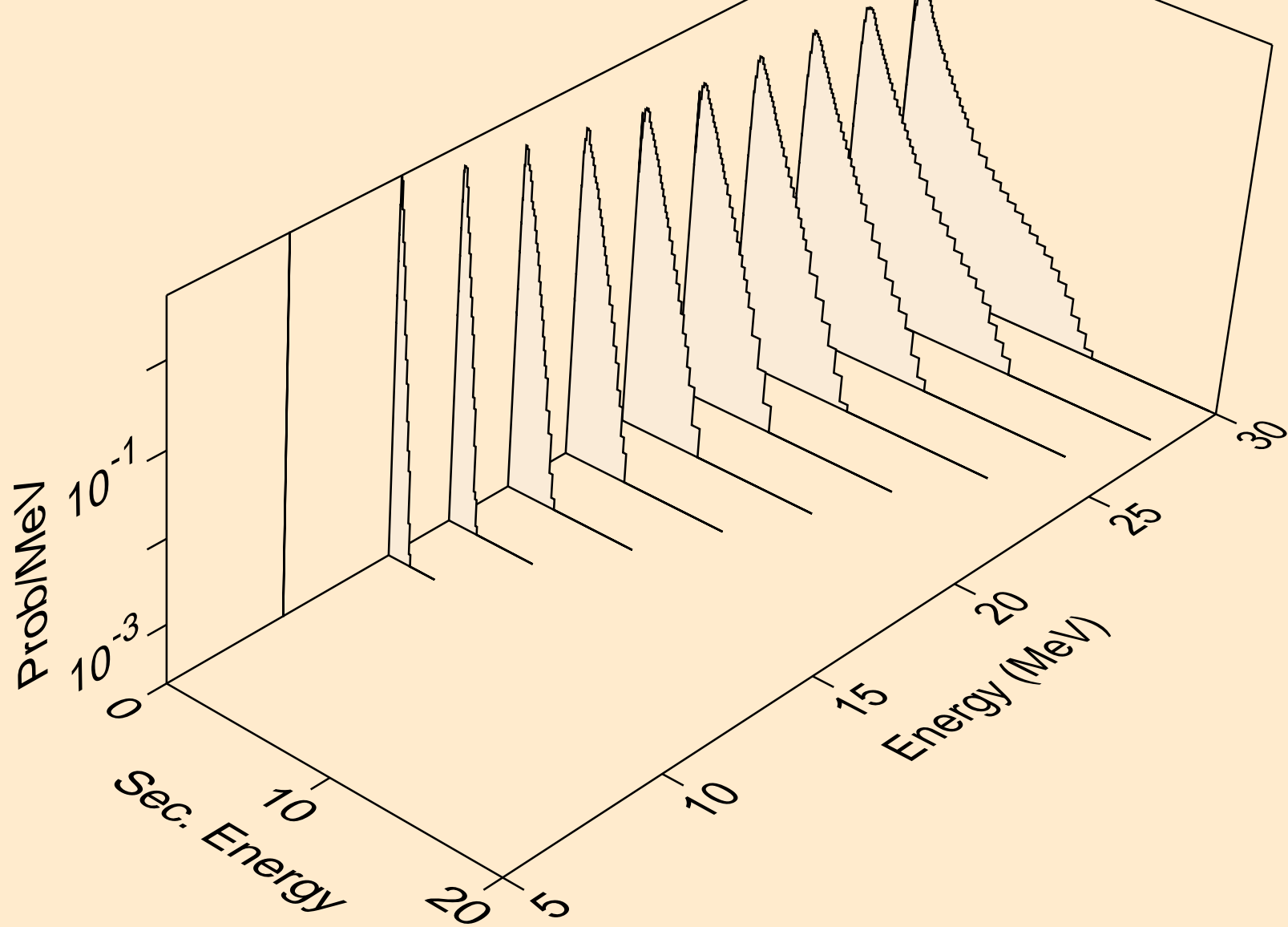

SM163 HELION ACER TENDL-2021 LIBRARY; T=0.K  
neutrons from (s,2np)

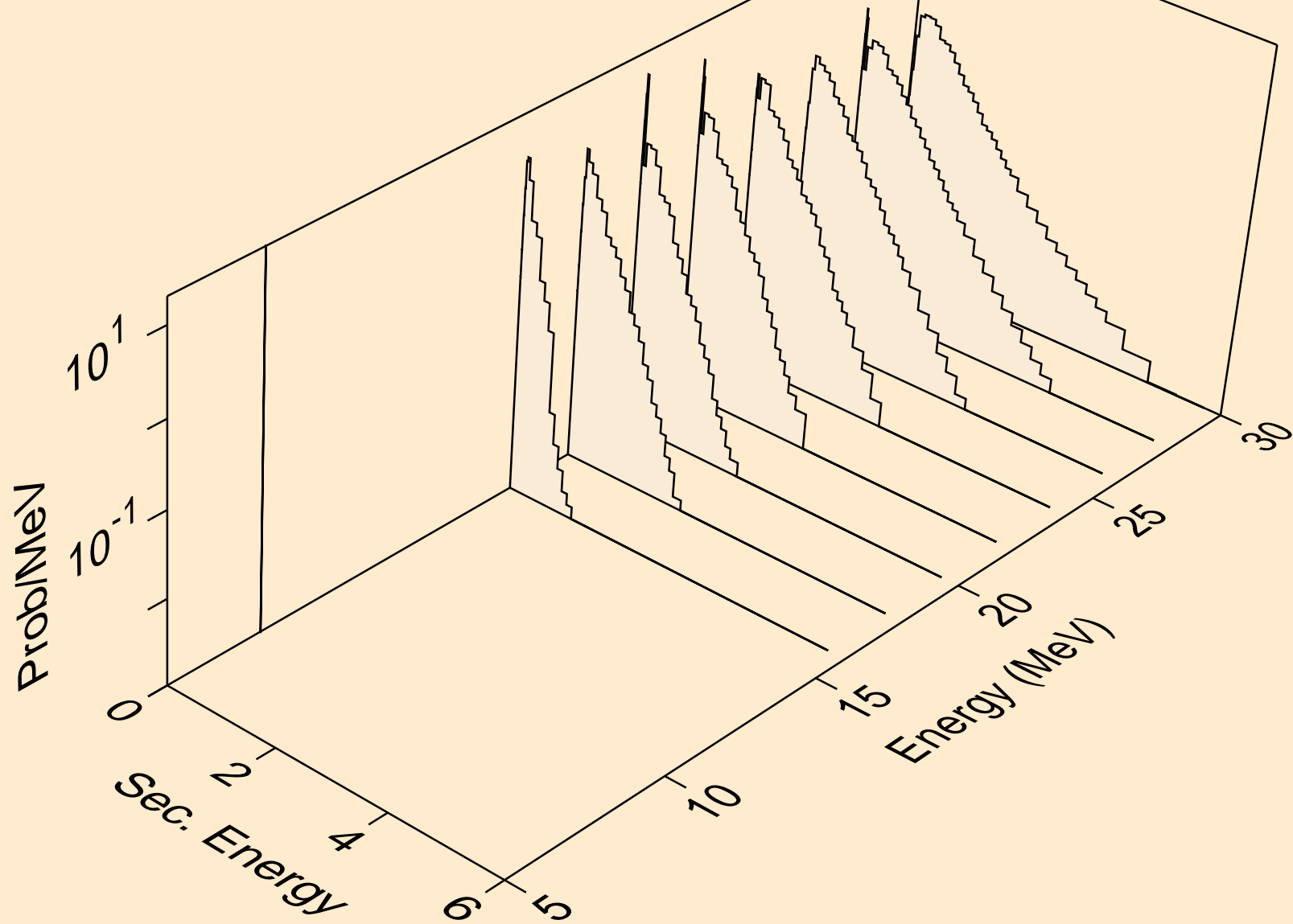

SM163 HELION ACER TENDL-2021 LIBRARY; T=0.K  
neutrons from (s,npa)

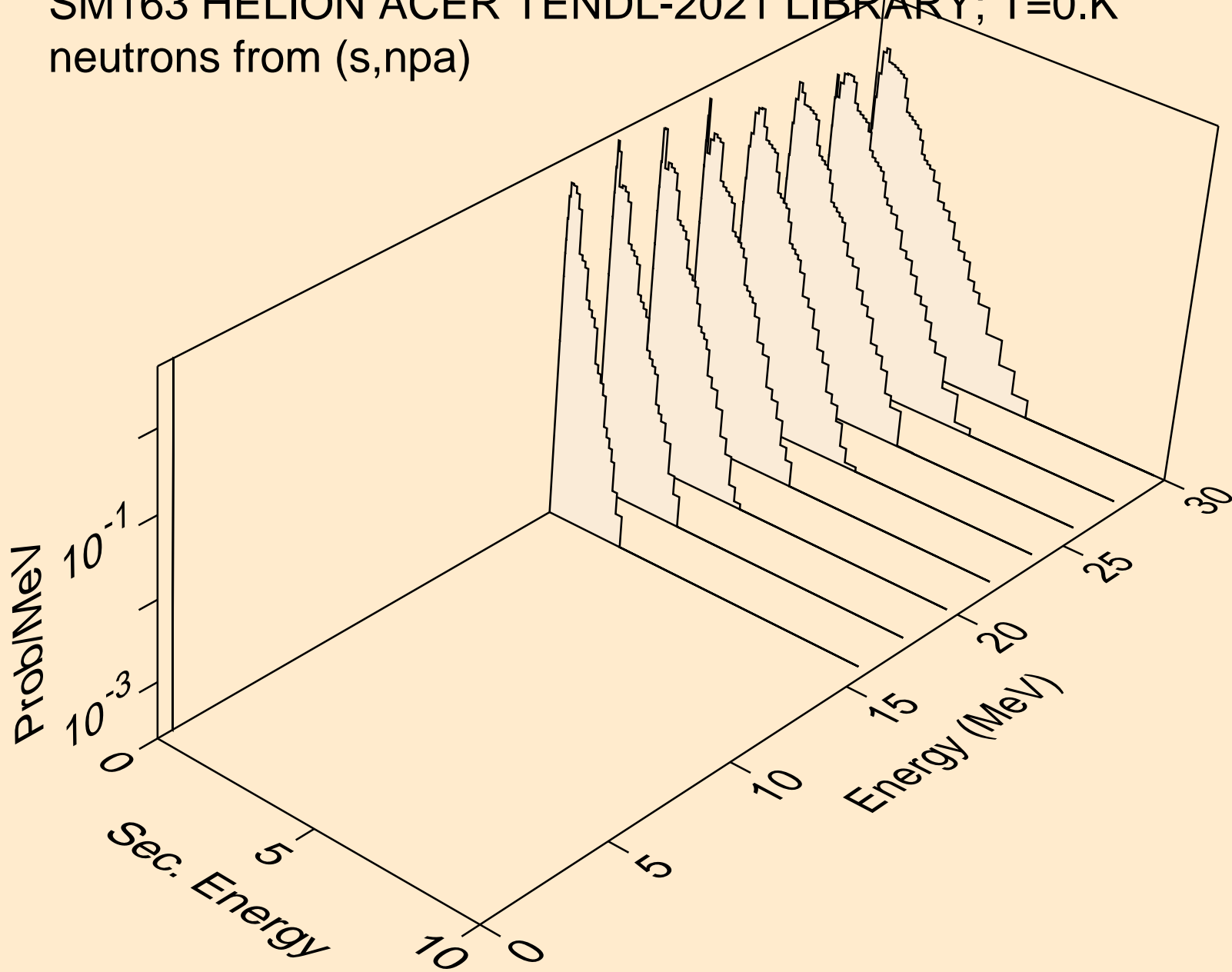

SM163 HELION ACER TENDL-2021 LIBRARY; T=0.K  
protons from (s,x)

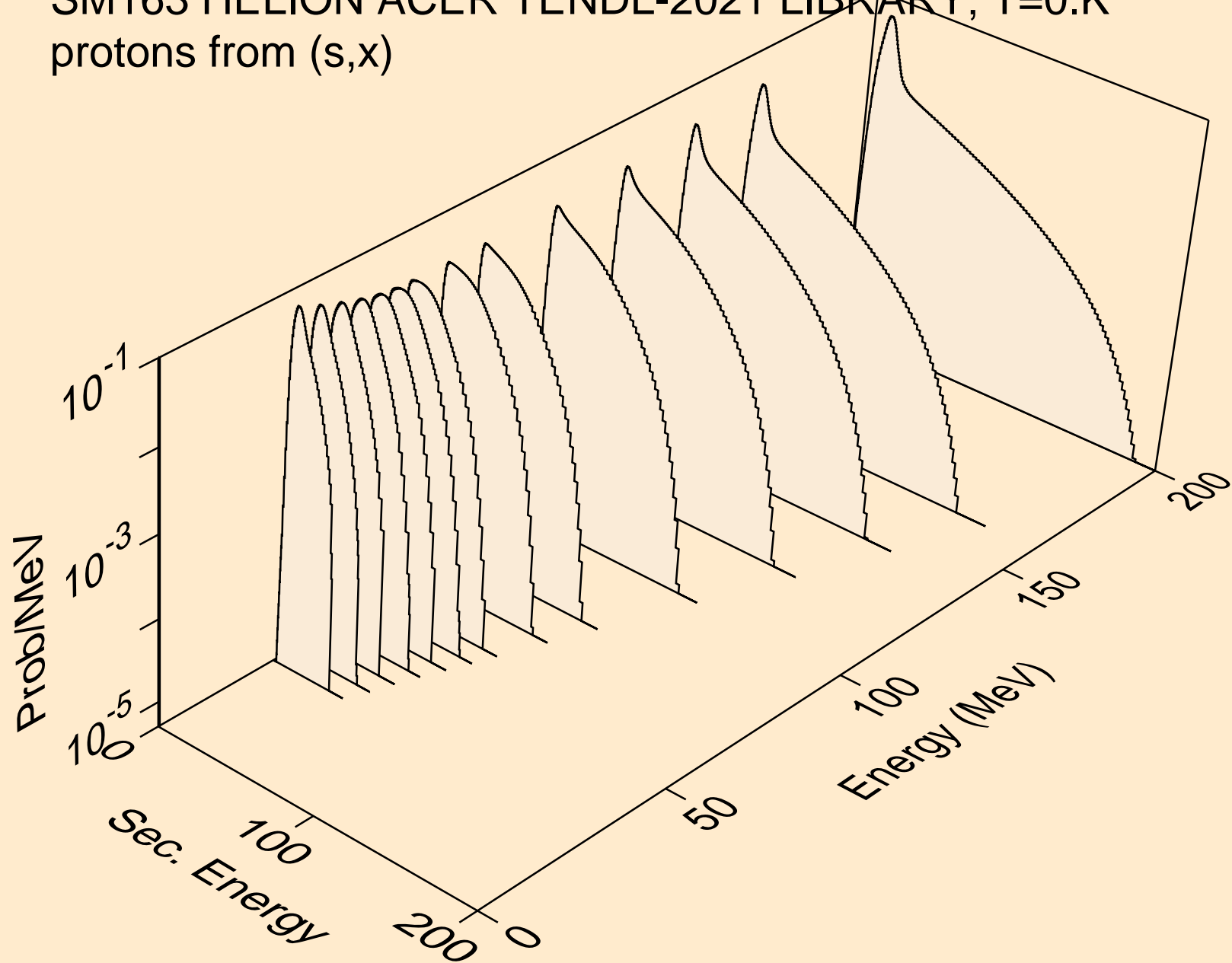

SM163 HELION ACER TENDL-2021 LIBRARY; T=0.K  
protons from (s,n\*)p

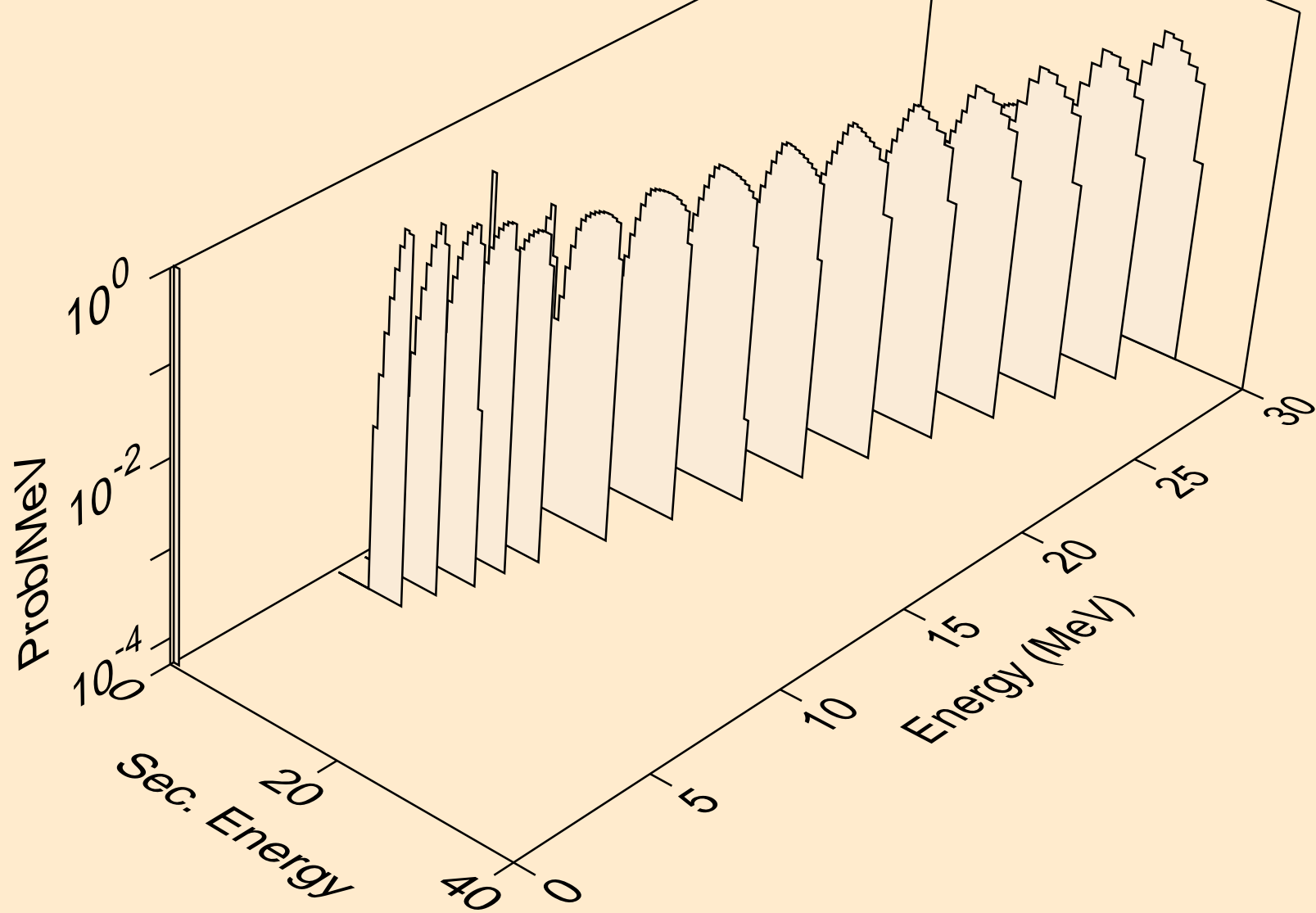

SM163 HELION ACER TENDL-2021 LIBRARY; T=0.K  
protons from (s,2np)

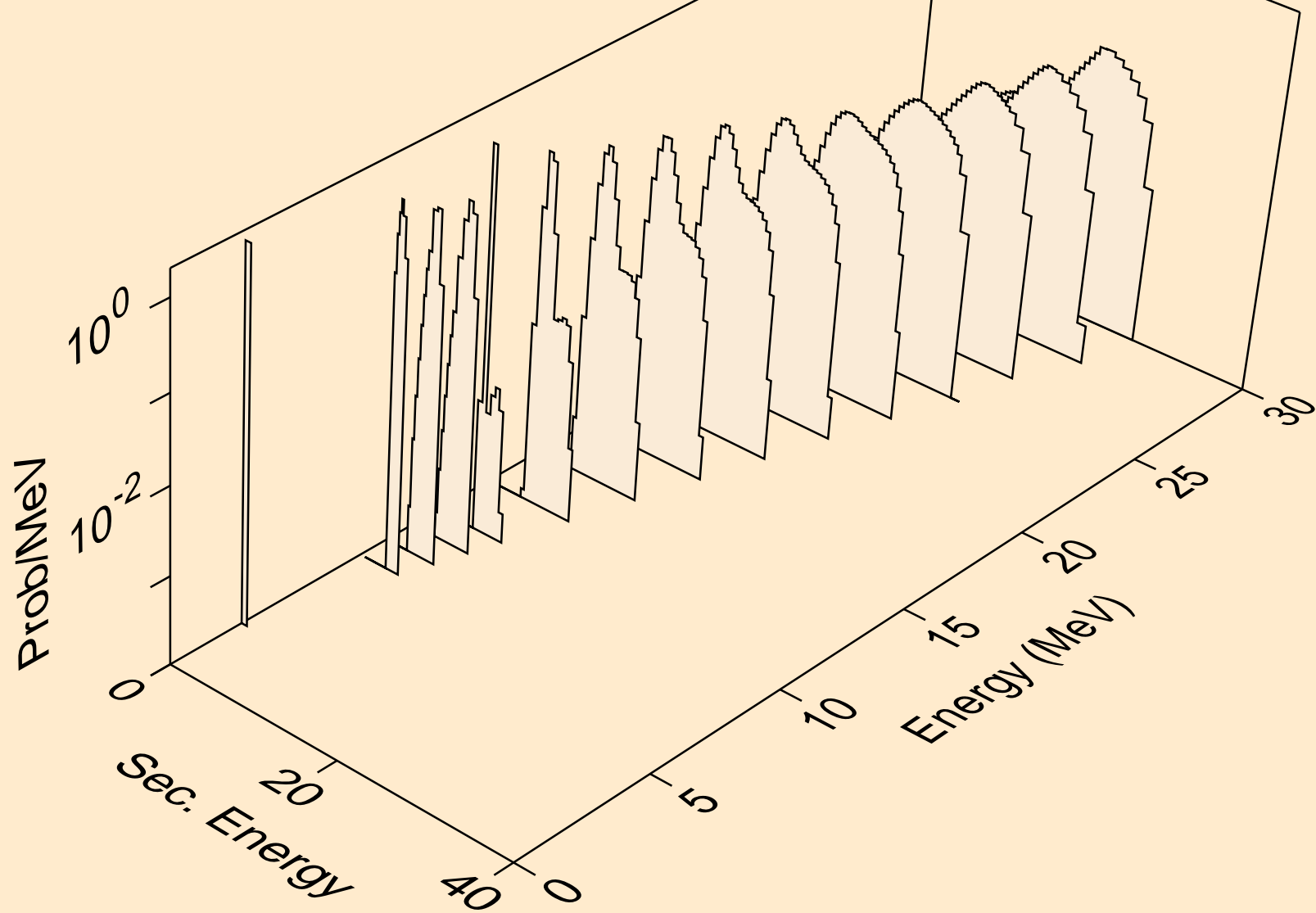



SM163 HELION ACER TENDL-2021 LIBRARY; T=0.K  
protons from (s,3np)

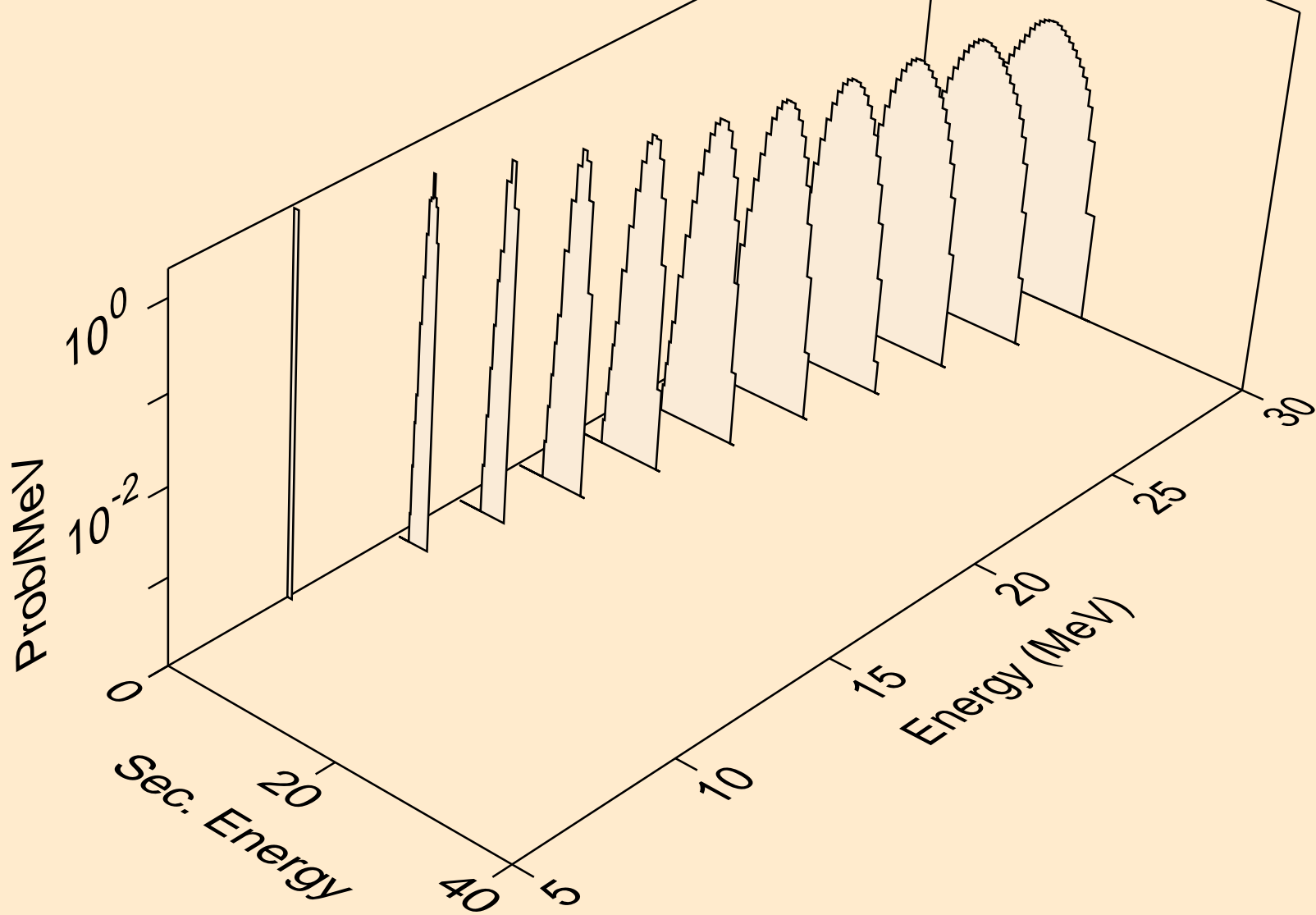

SM163 HELION ACER TENDL-2021 LIBRARY; T=0.K  
protons from (s,2np)

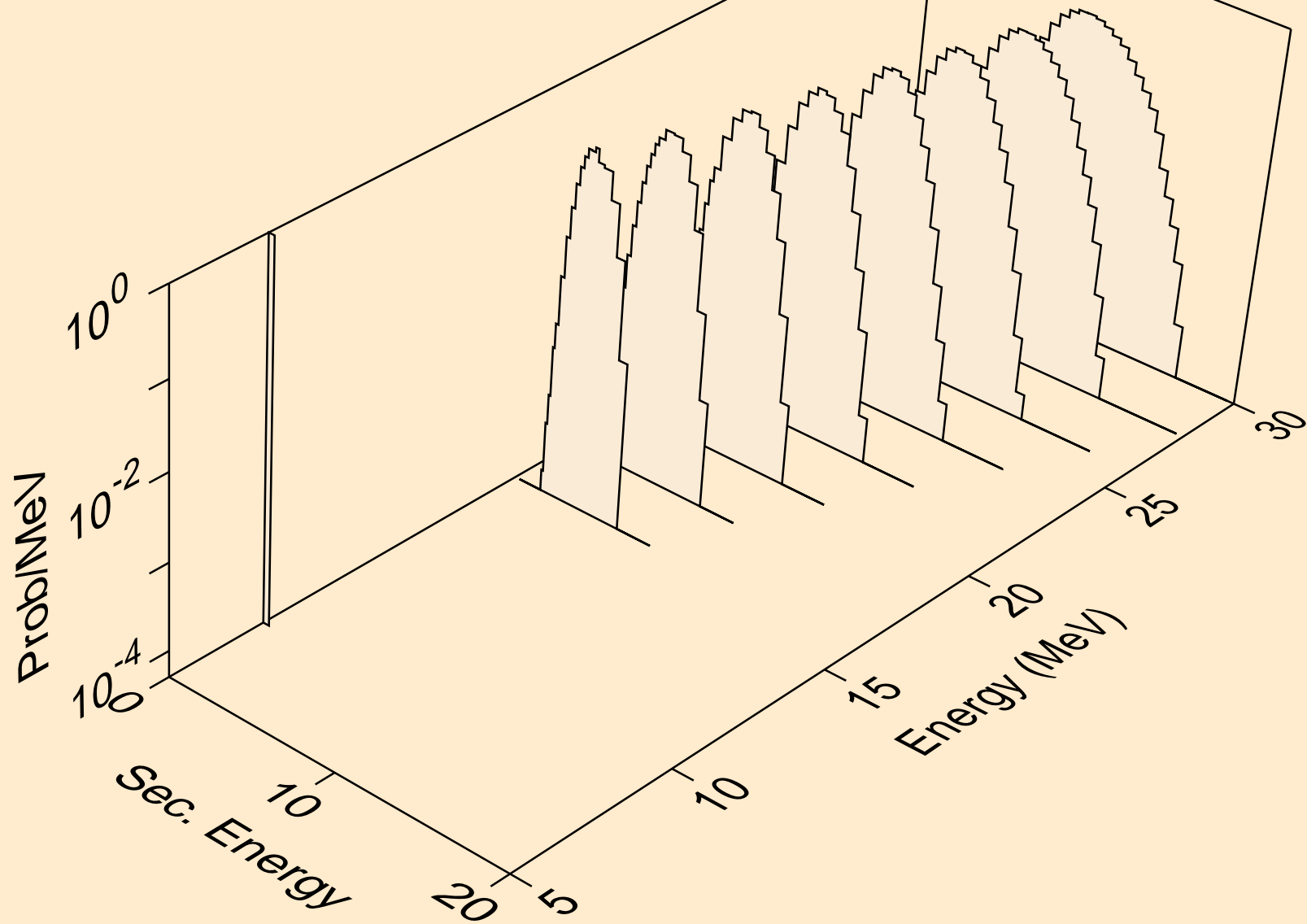

SM163 HELION ACER TENDL-2021 LIBRARY; T=0.K  
protons from (s,npa)

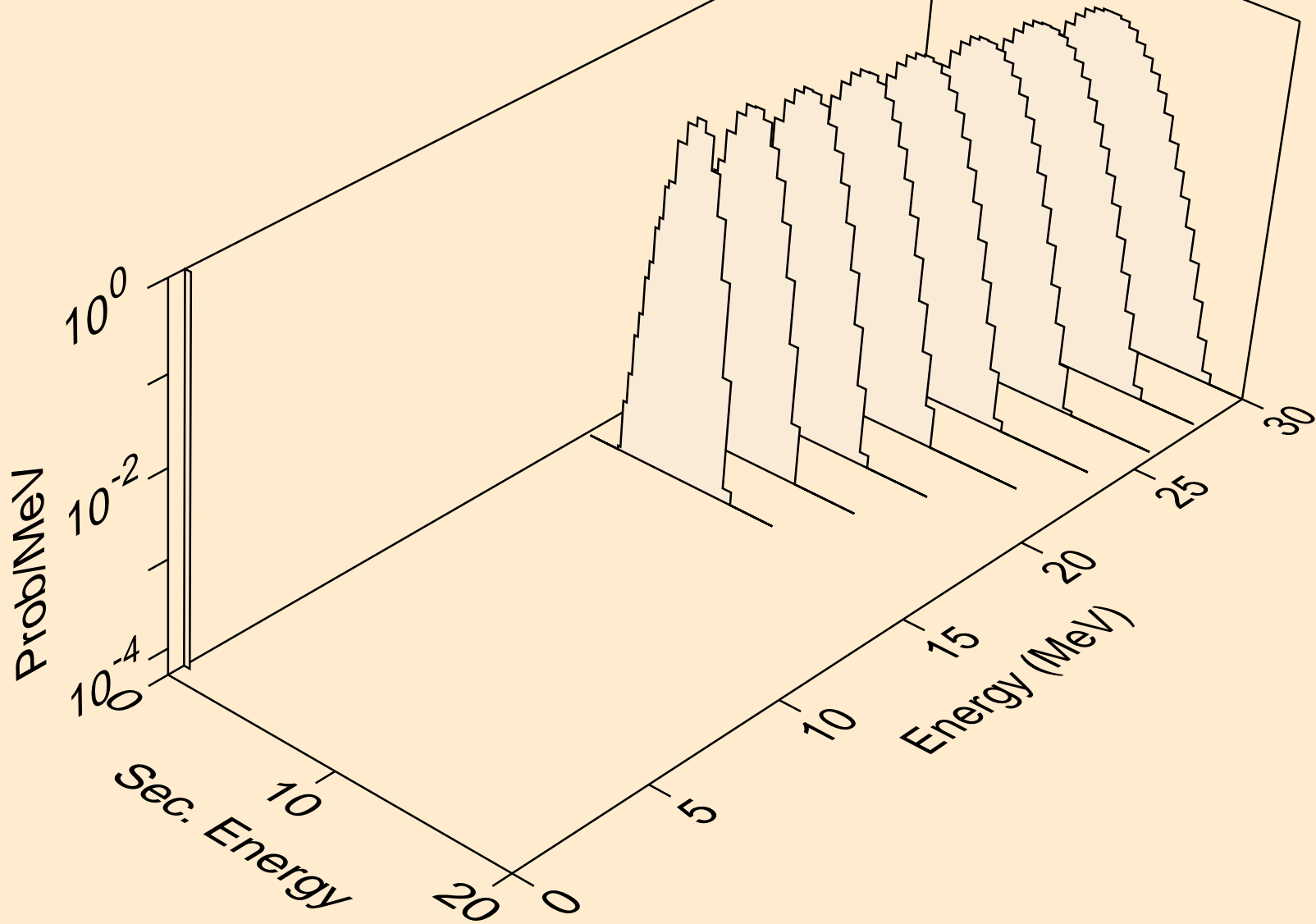

SM163 HELION ACER TENDL-2021 LIBRARY; T=0.K  
protons from (s,p)

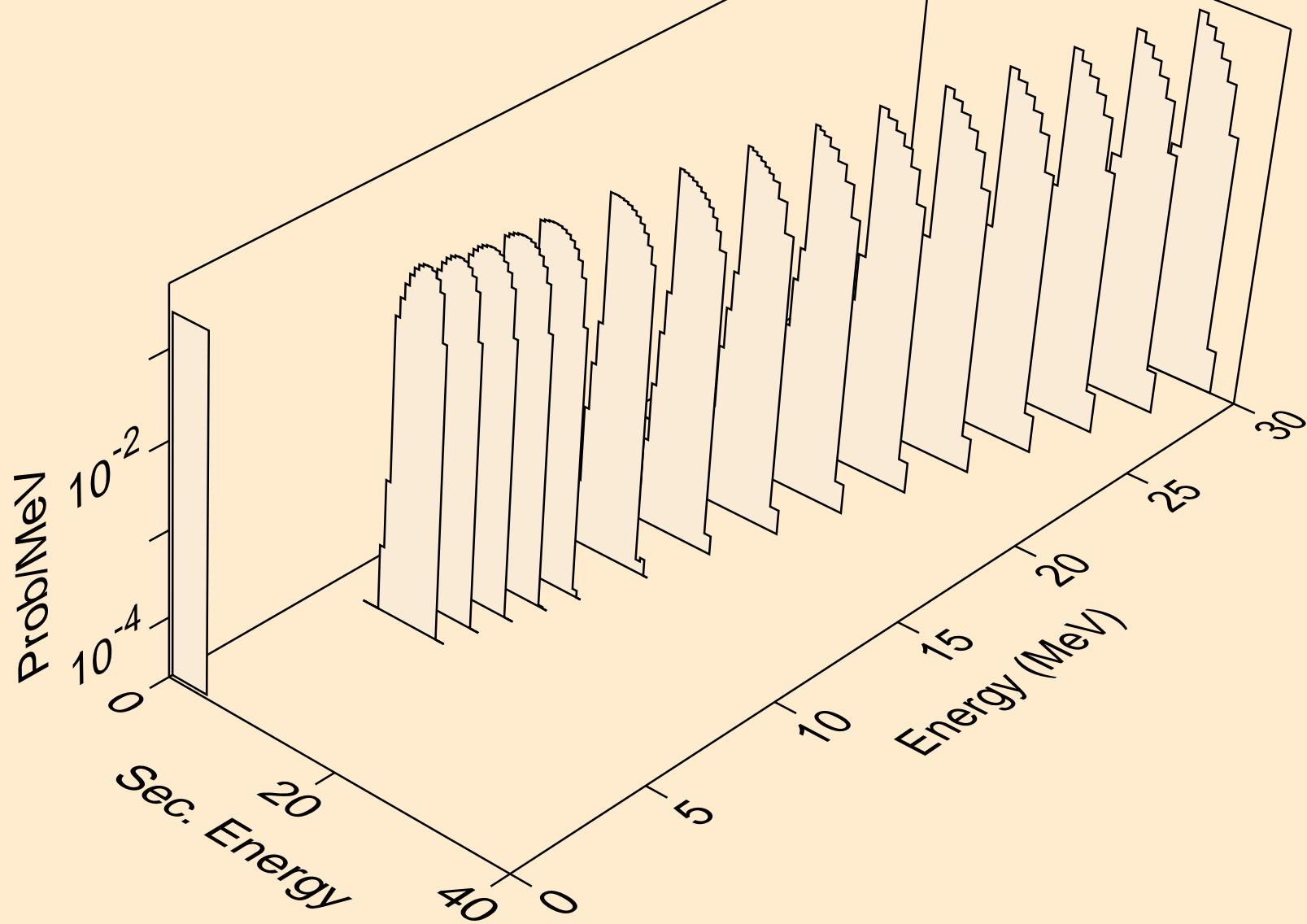

SM163 HELION ACER TENDL-2021 LIBRARY; T=0.K  
protons from (s,2p)

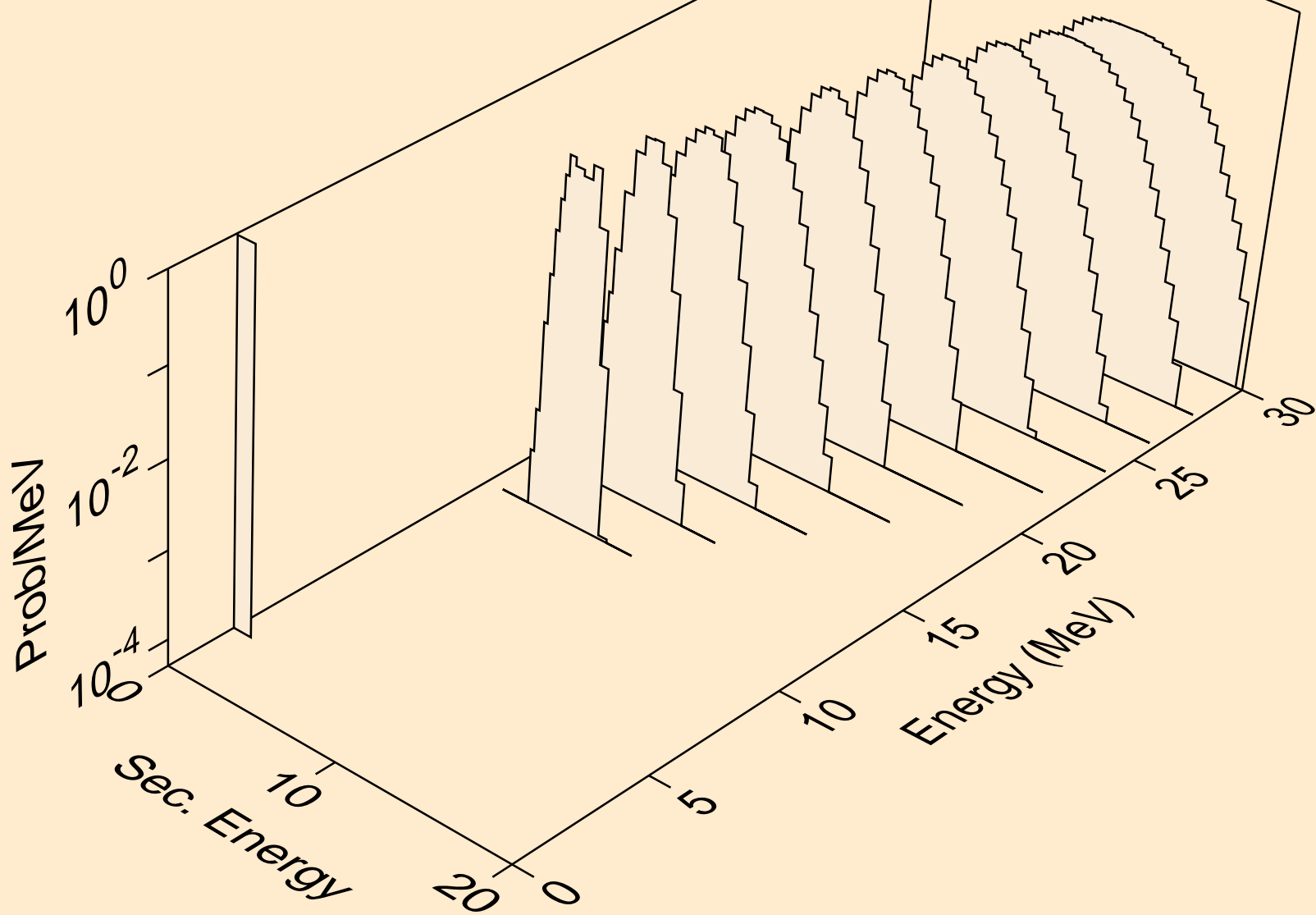

SM163 HELION ACER TENDL-2021 LIBRARY; T=0.K  
protons from (s,pd)

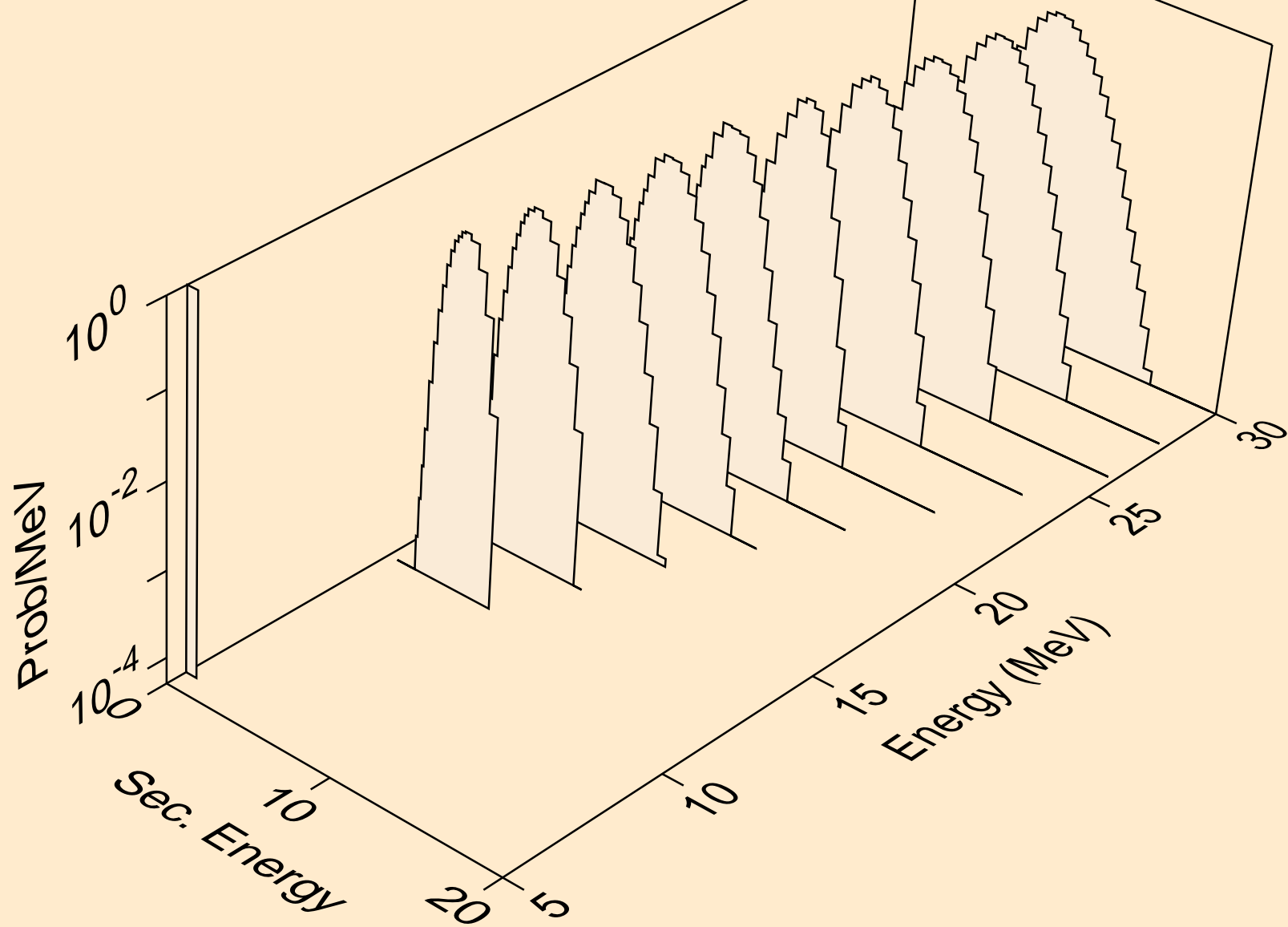

SM163 HELION ACER TENDL-2021 LIBRARY; T=0.K  
protons from (s,pt)

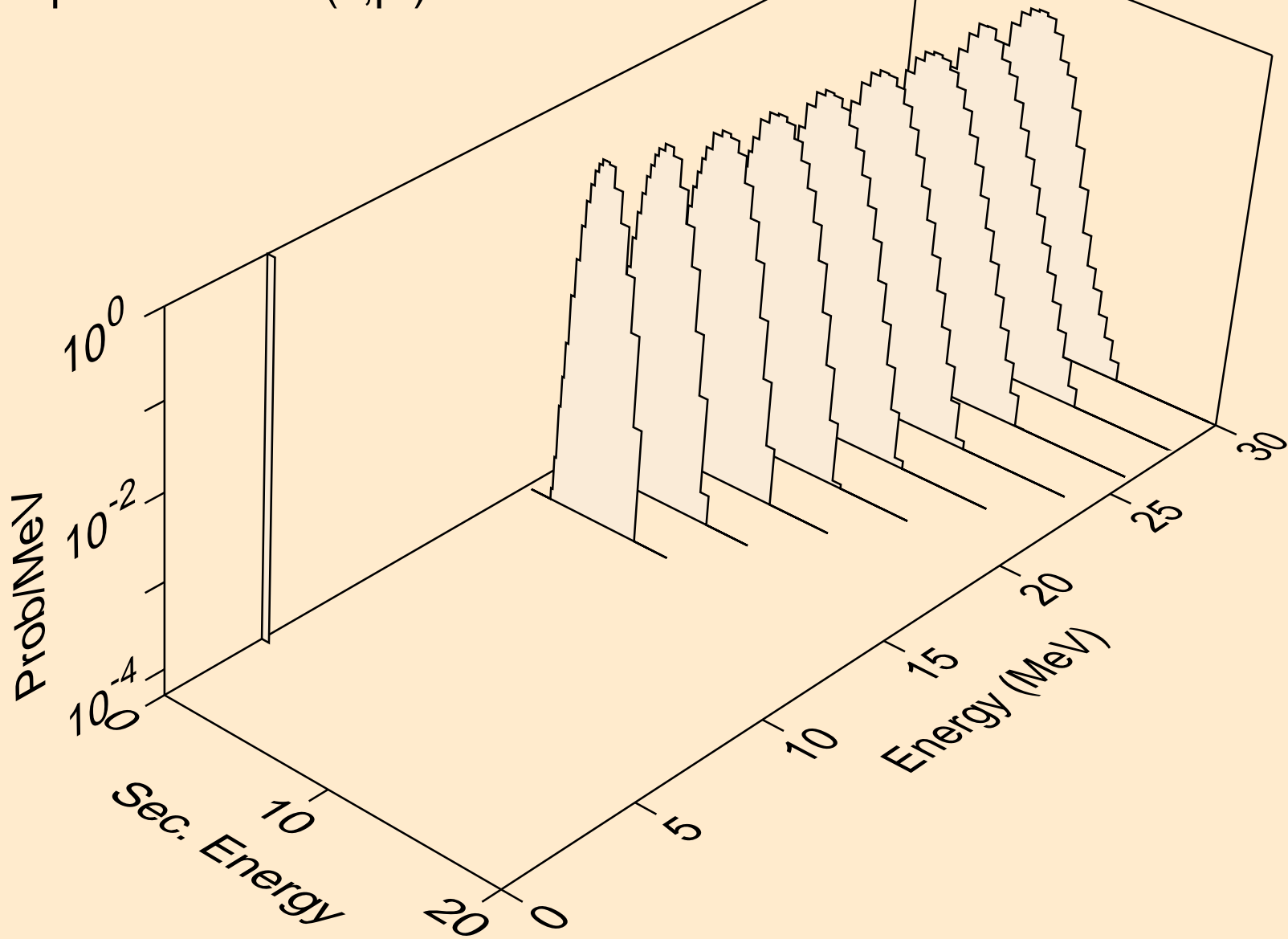

SM163 HELION ACER TENDL-2021 LIBRARY; T=0.K  
deuterons from (s,x)

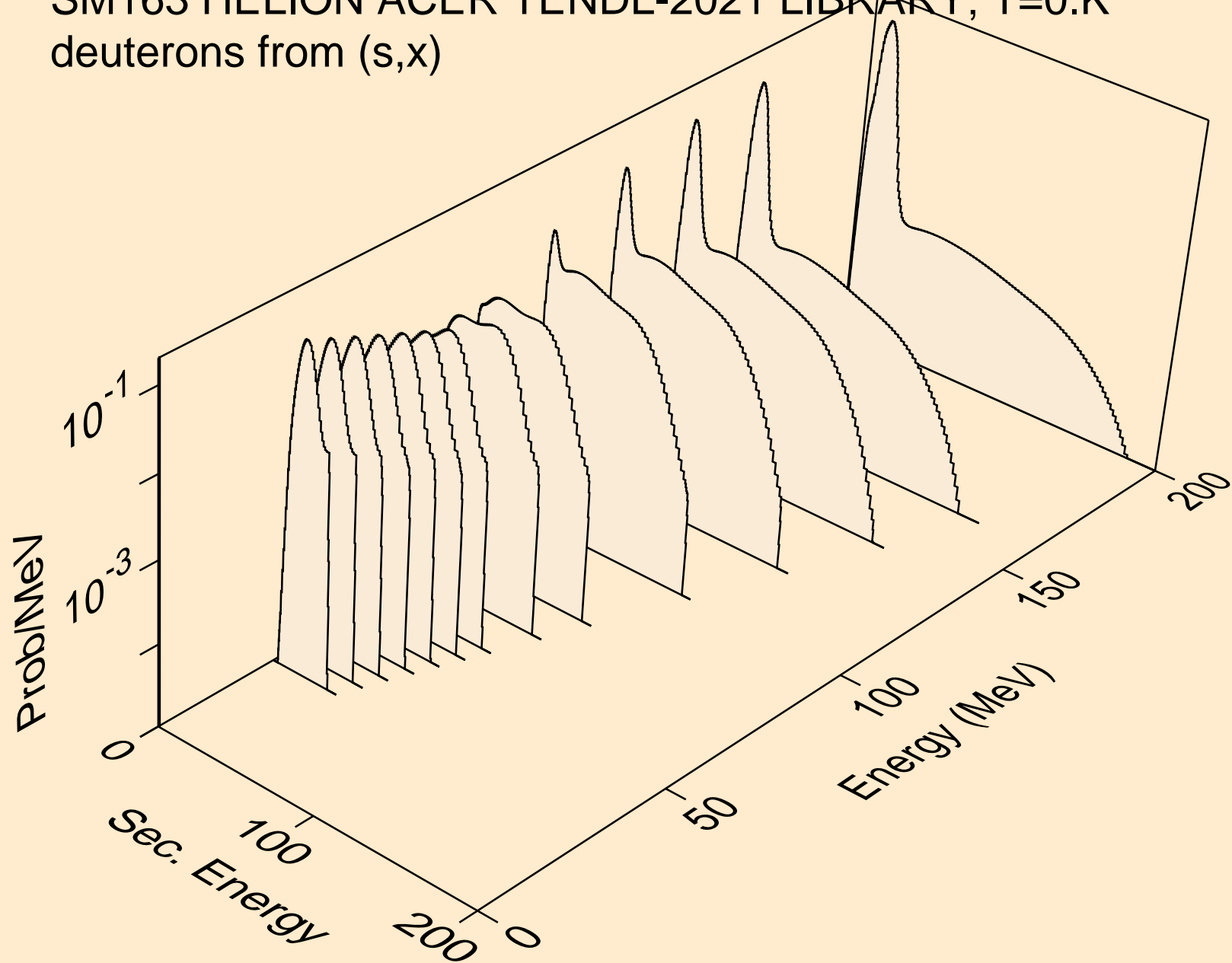



SM163 HELION ACER TENDL-2021 LIBRARY; T=0.K  
deuterons from (s,2nd)

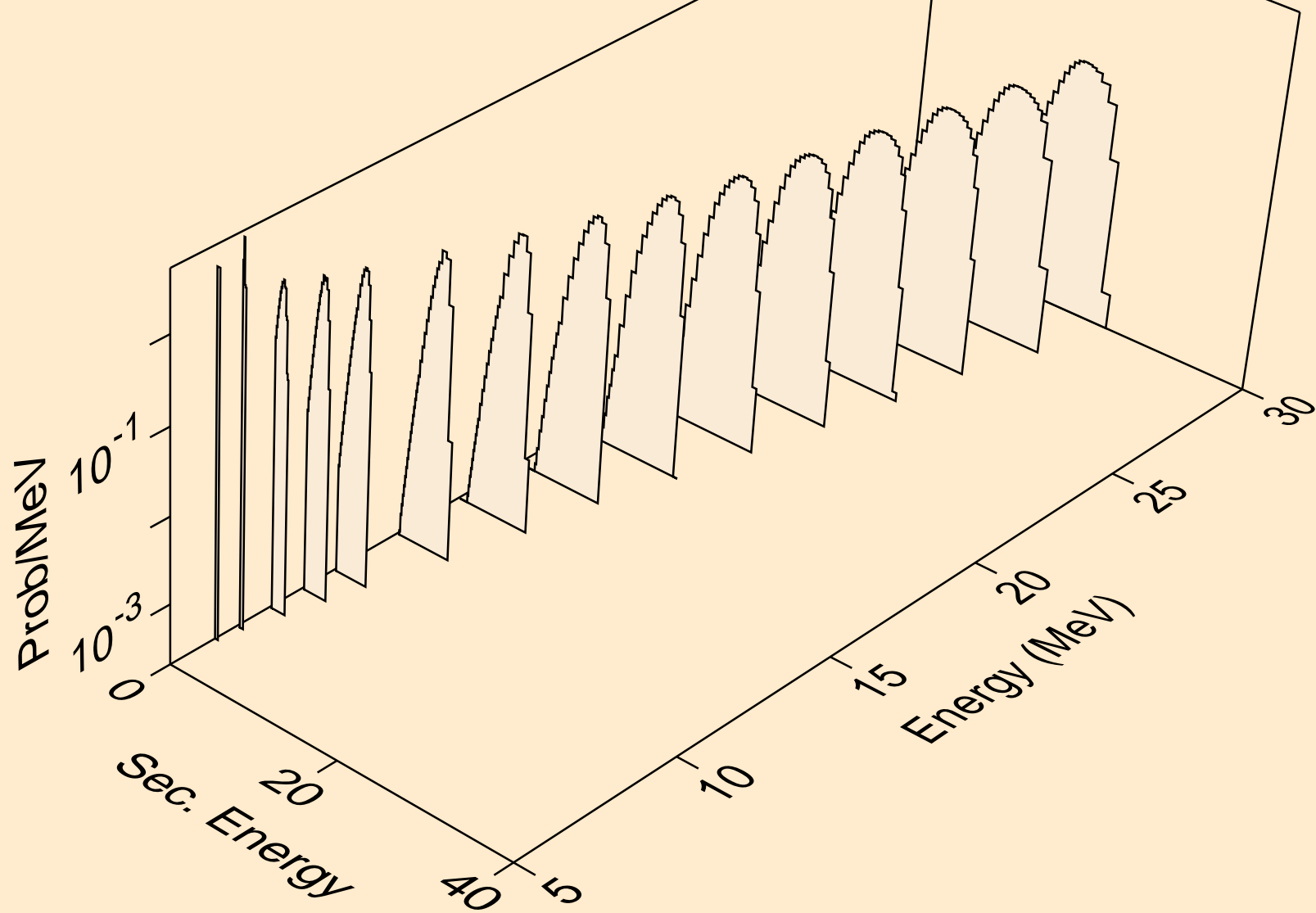

SM163 HELION ACER TENDL-2021 LIBRARY; T=0.K  
deuterons from (s,n\*)d

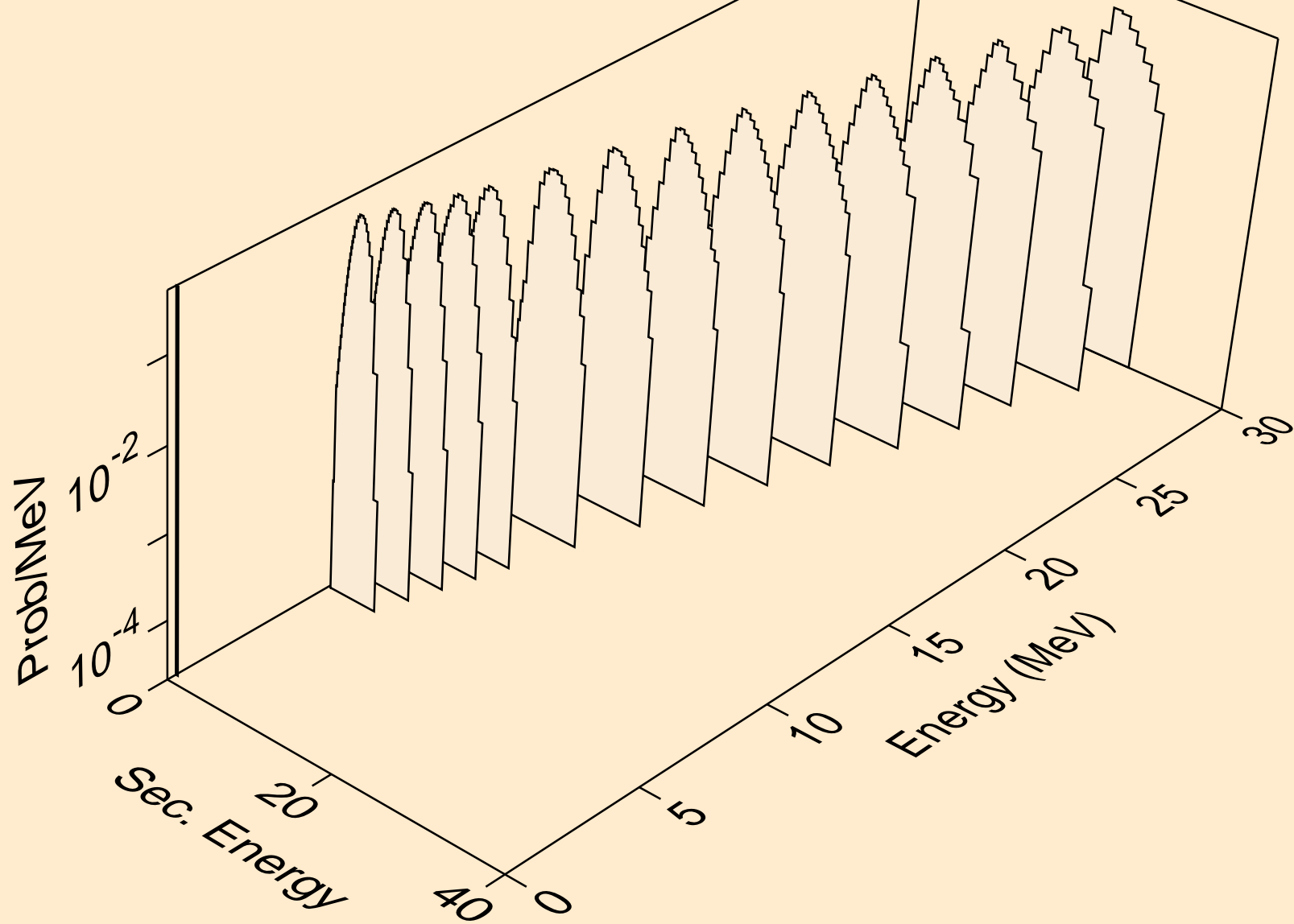

SM163 HELION ACER TENDL-2021 LIBRARY; T=0.K  
deuterons from (s,d)

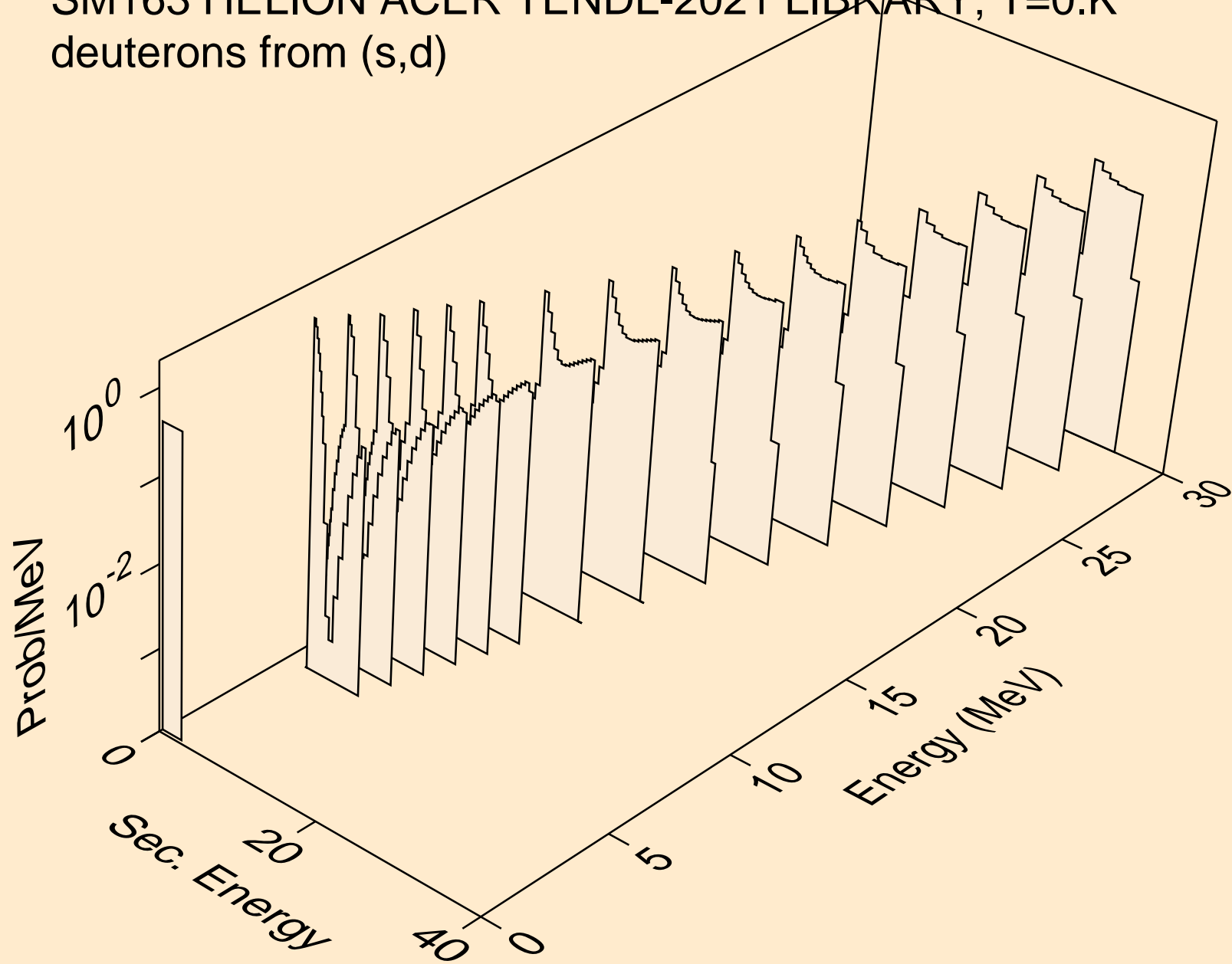

SM163 HELION ACER TENDL-2021 LIBRARY; T=0.K  
deuterons from (s,pd)

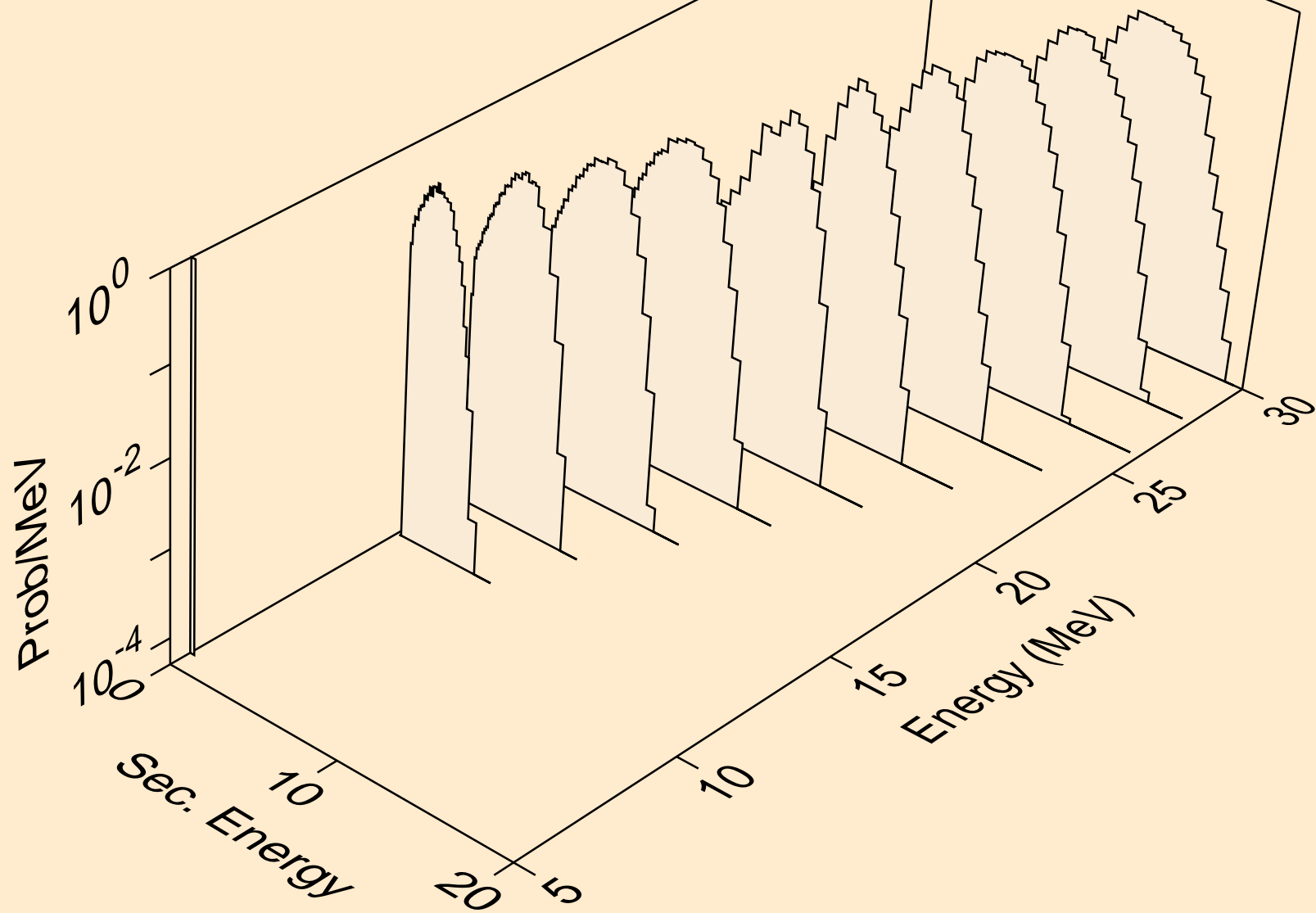

SM163 HELION ACER TENDL-2021 LIBRARY; T=0.K  
tritons from (s,x)

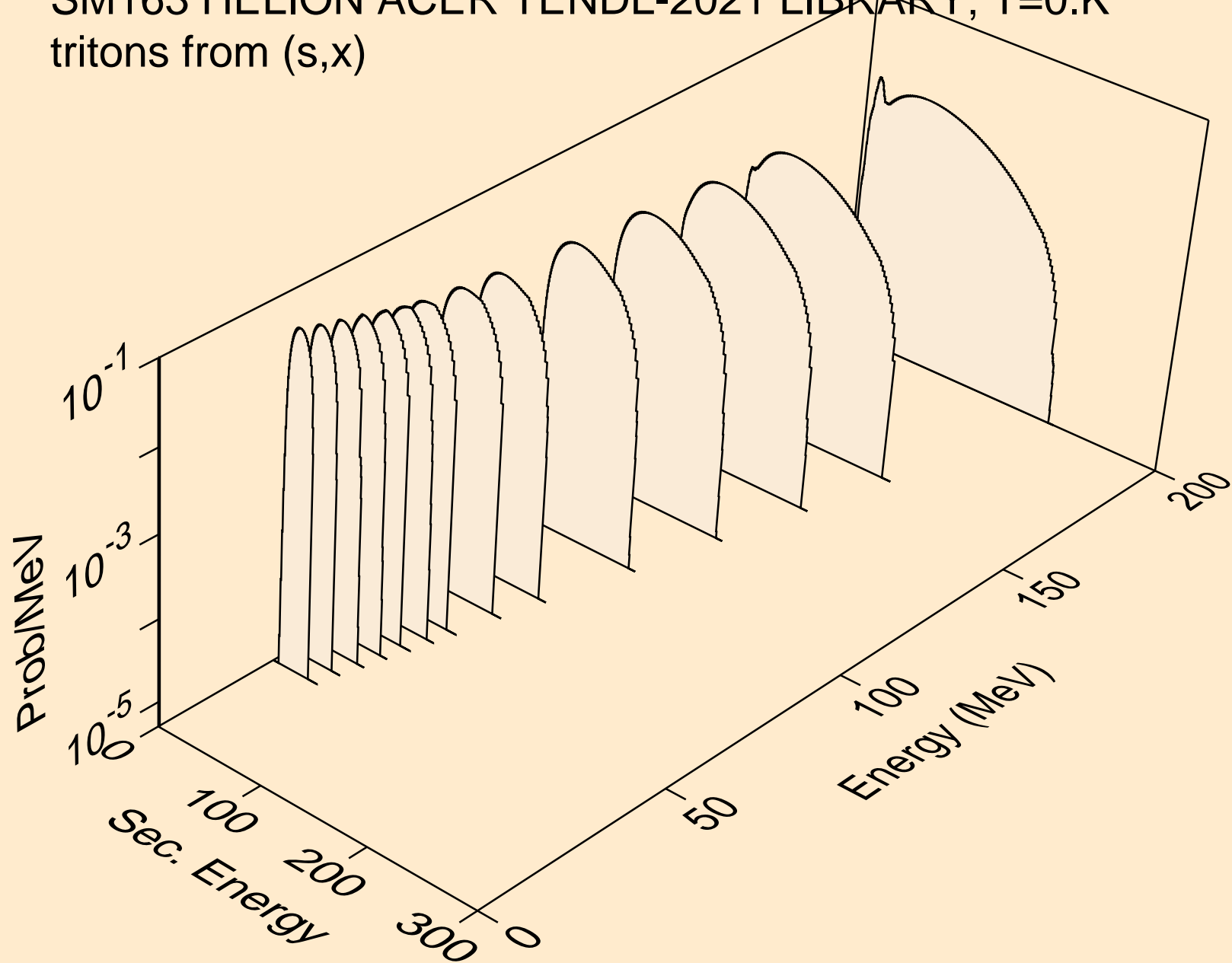

SM163 HELION ACER TENDL-2021 LIBRARY; T=0.K  
tritons from (s,n\*)t

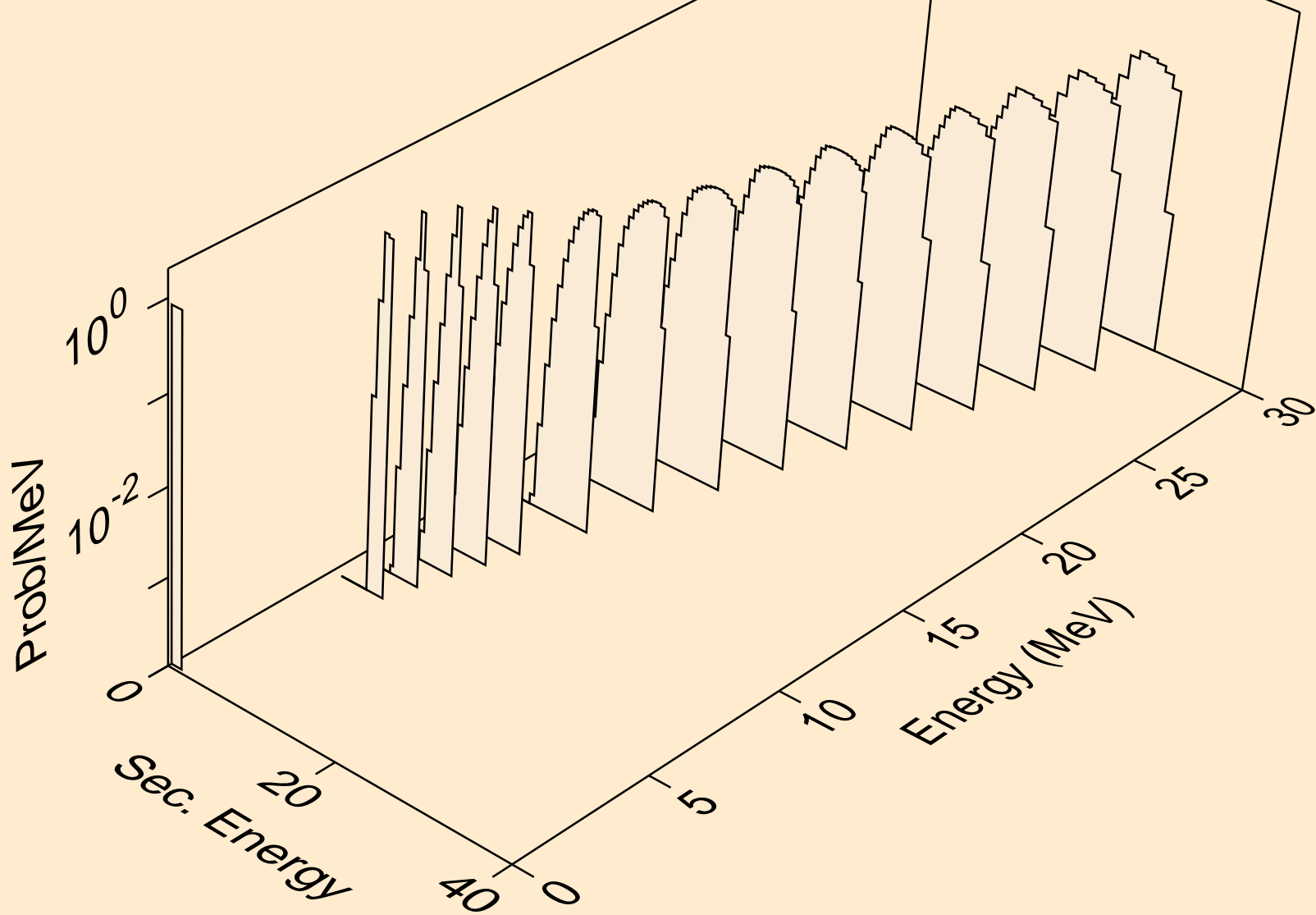

SM163 HELION ACER TENDL-2021 LIBRARY; T=0.K  
tritons from (s,t)

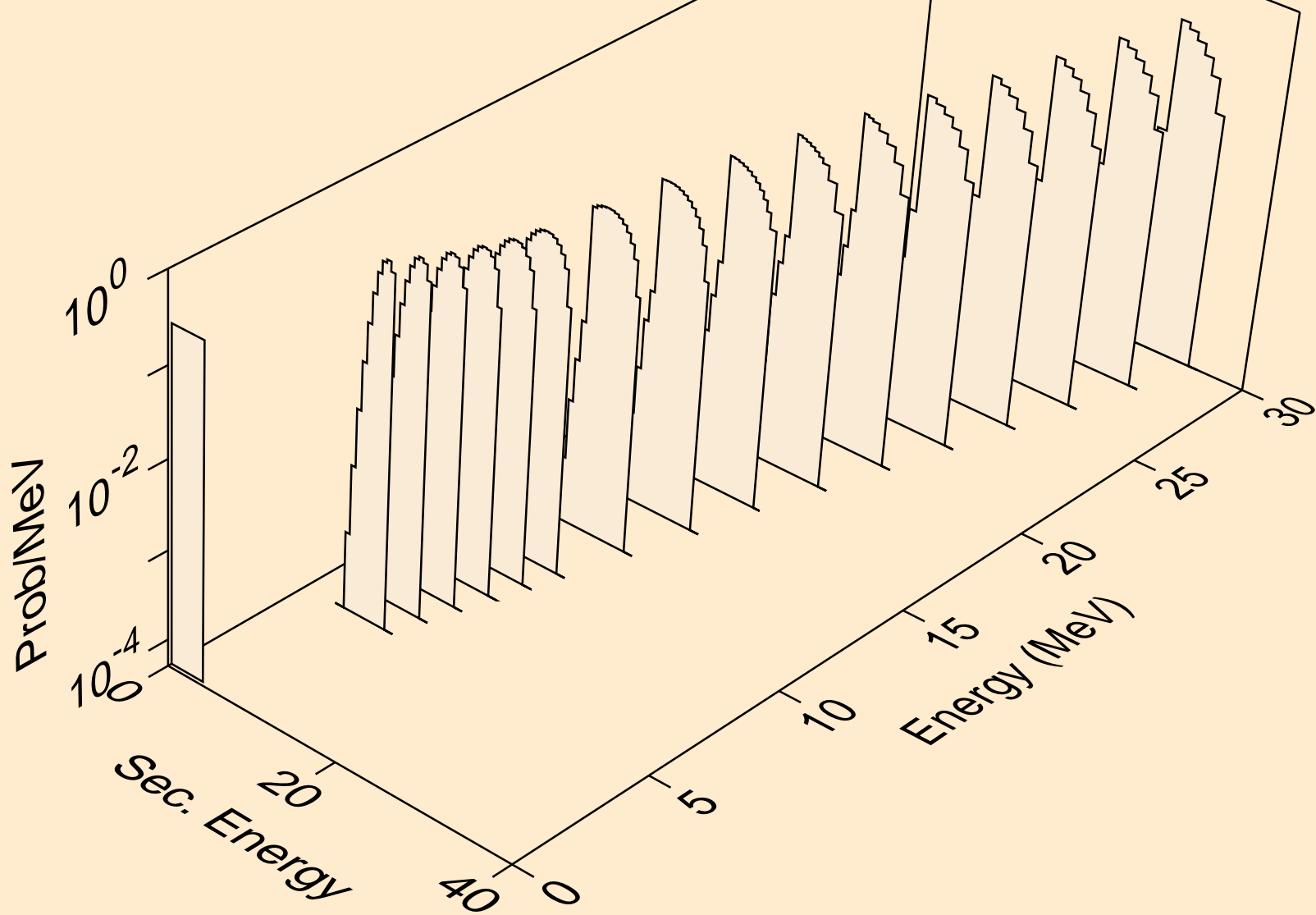

SM163 HELION ACER TENDL-2021 LIBRARY; T=0.K  
tritons from (s,pt)

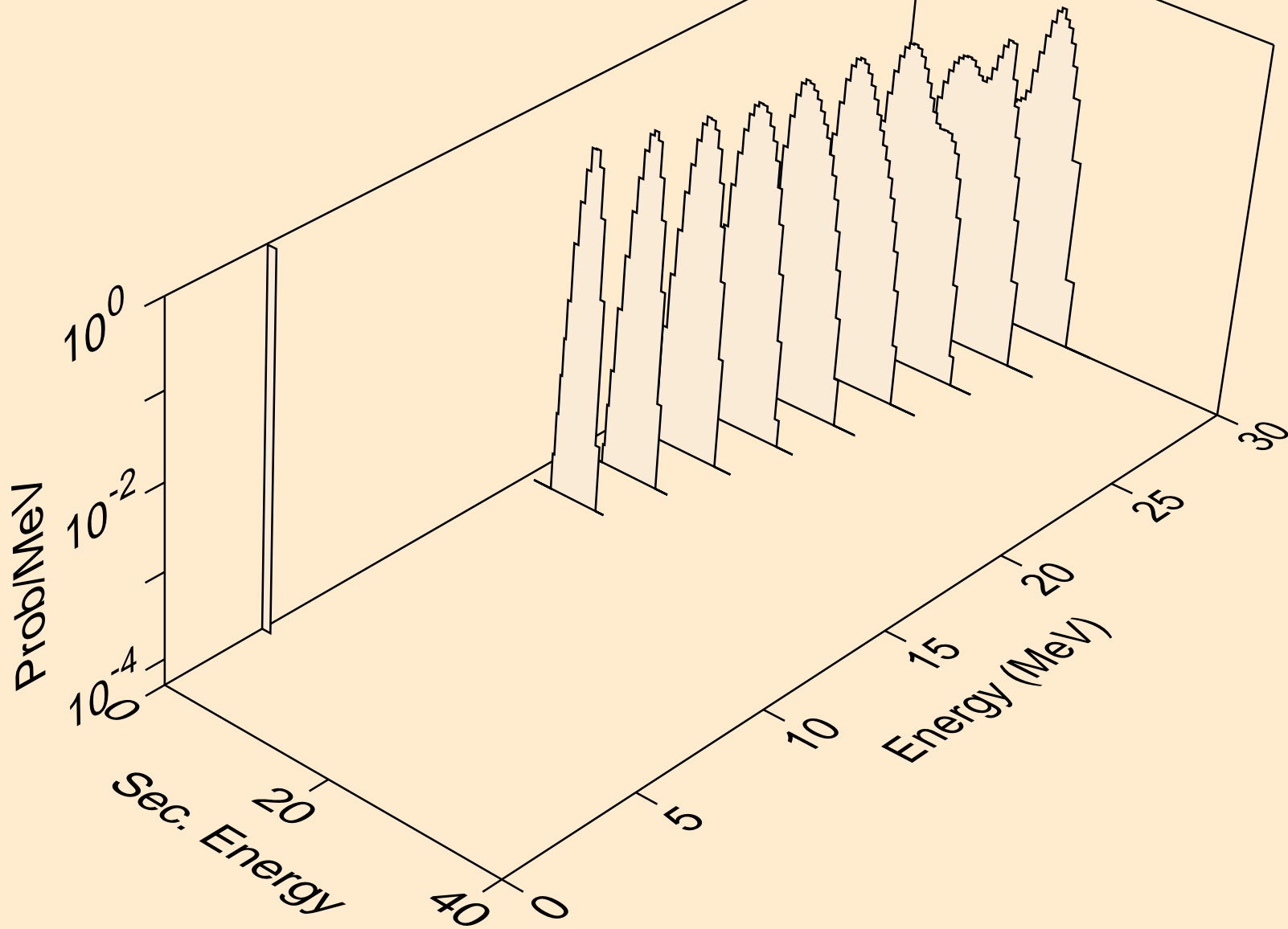



SM163 HELION ACER TENDL-2021 LIBRARY; T=0.K  
alphas from (s,x)

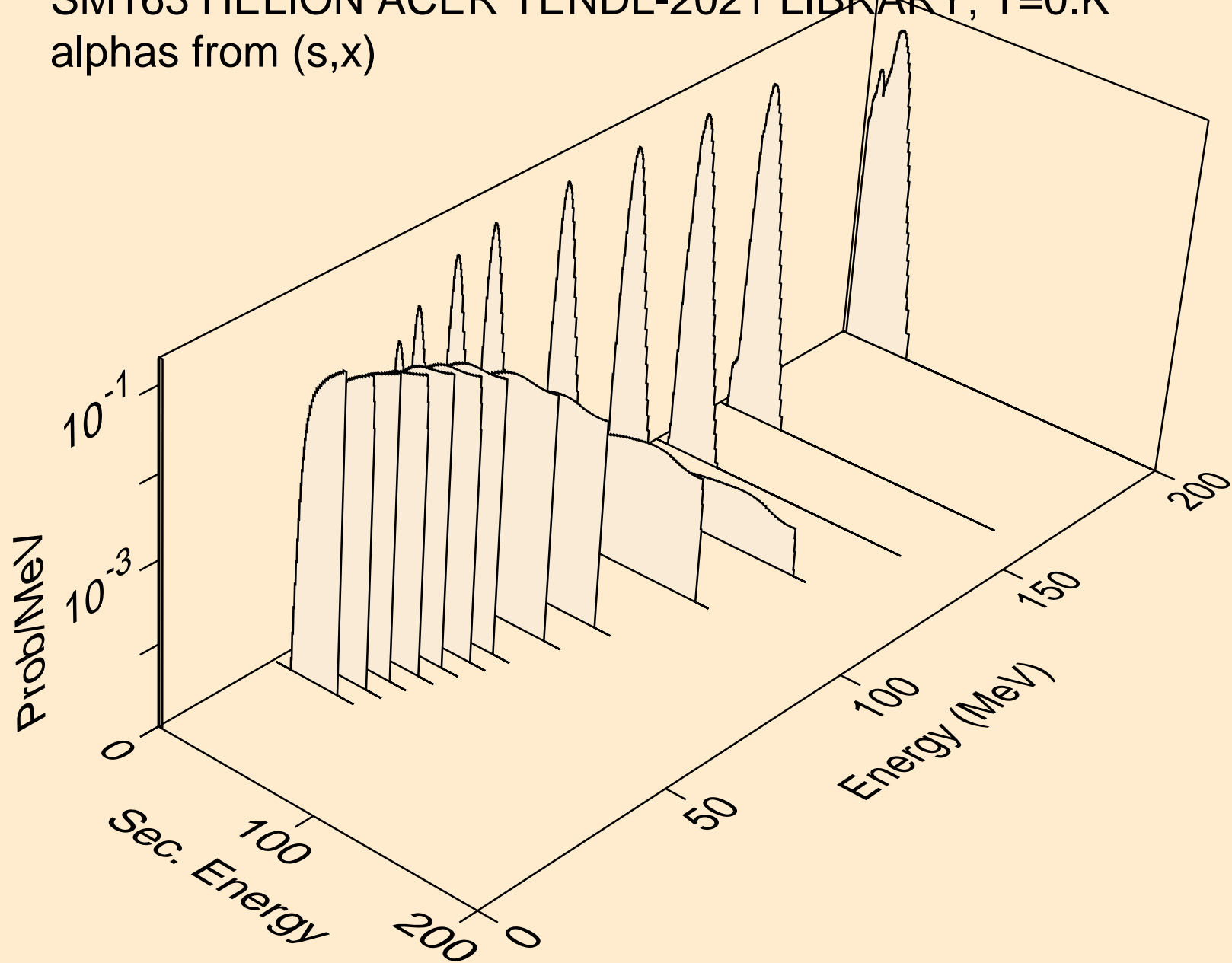

SM163 HELION ACER TENDL-2021 LIBRARY; T=0.K  
alphas from (s,n\*)a

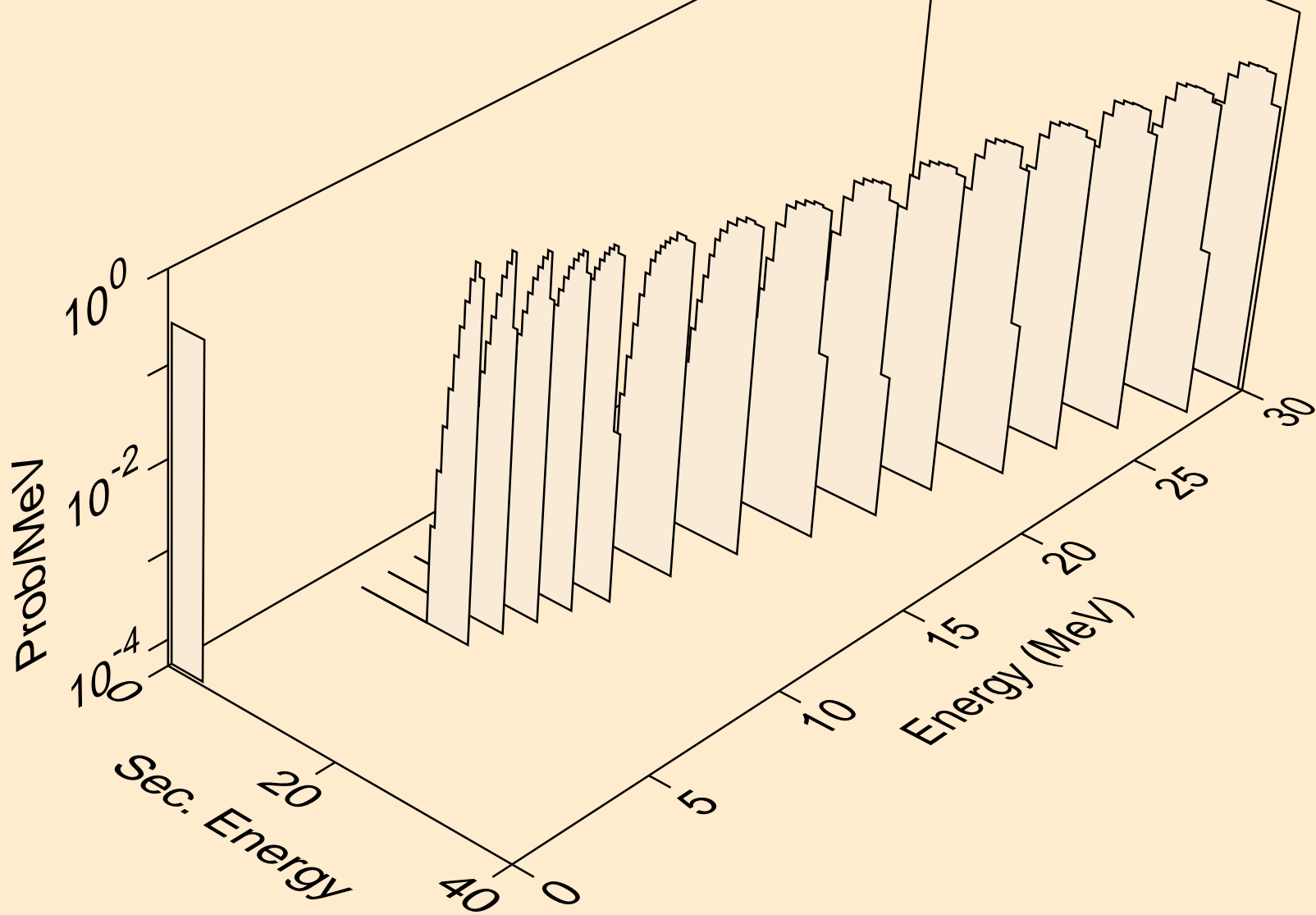

SM163 HELION ACER TENDL-2021 LIBRARY; T=0.K  
alphas from (s,2n)a

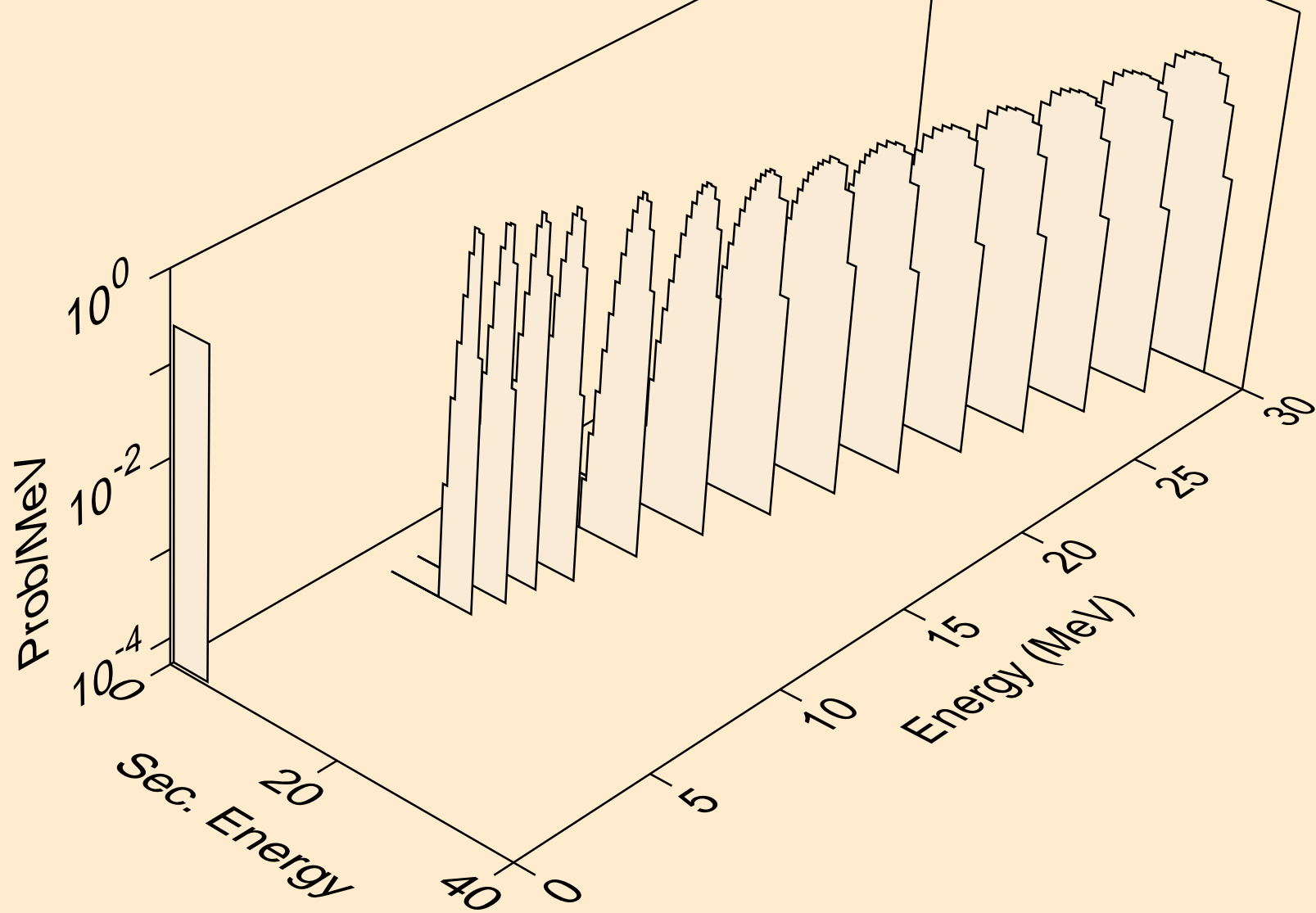

SM163 HELION ACER TENDL-2021 LIBRARY; T=0.K  
alphas from (s,3n)a

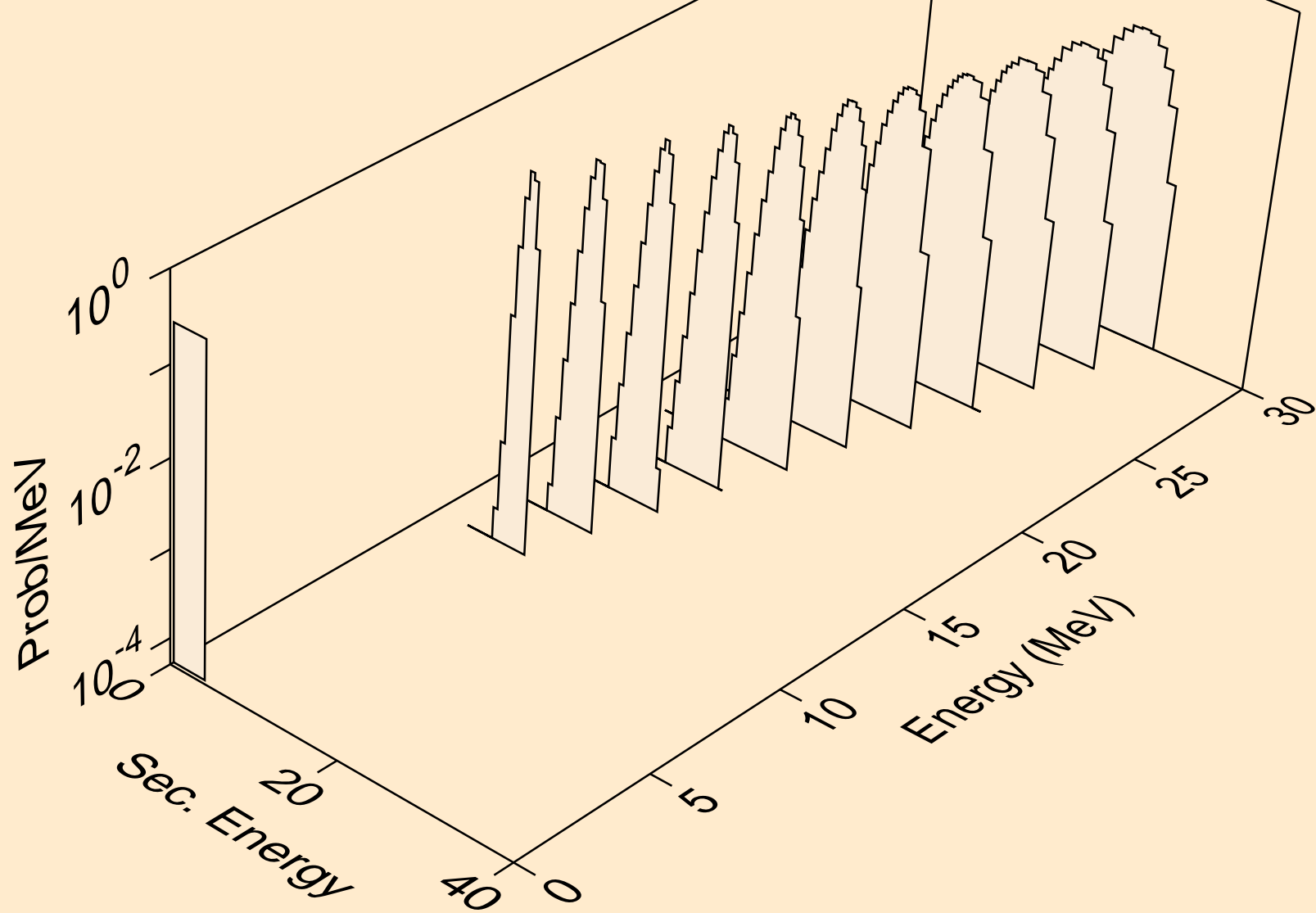

SM163 HELION ACER TENDL-2021 LIBRARY; T=0.K  
alphas from (s,npa)

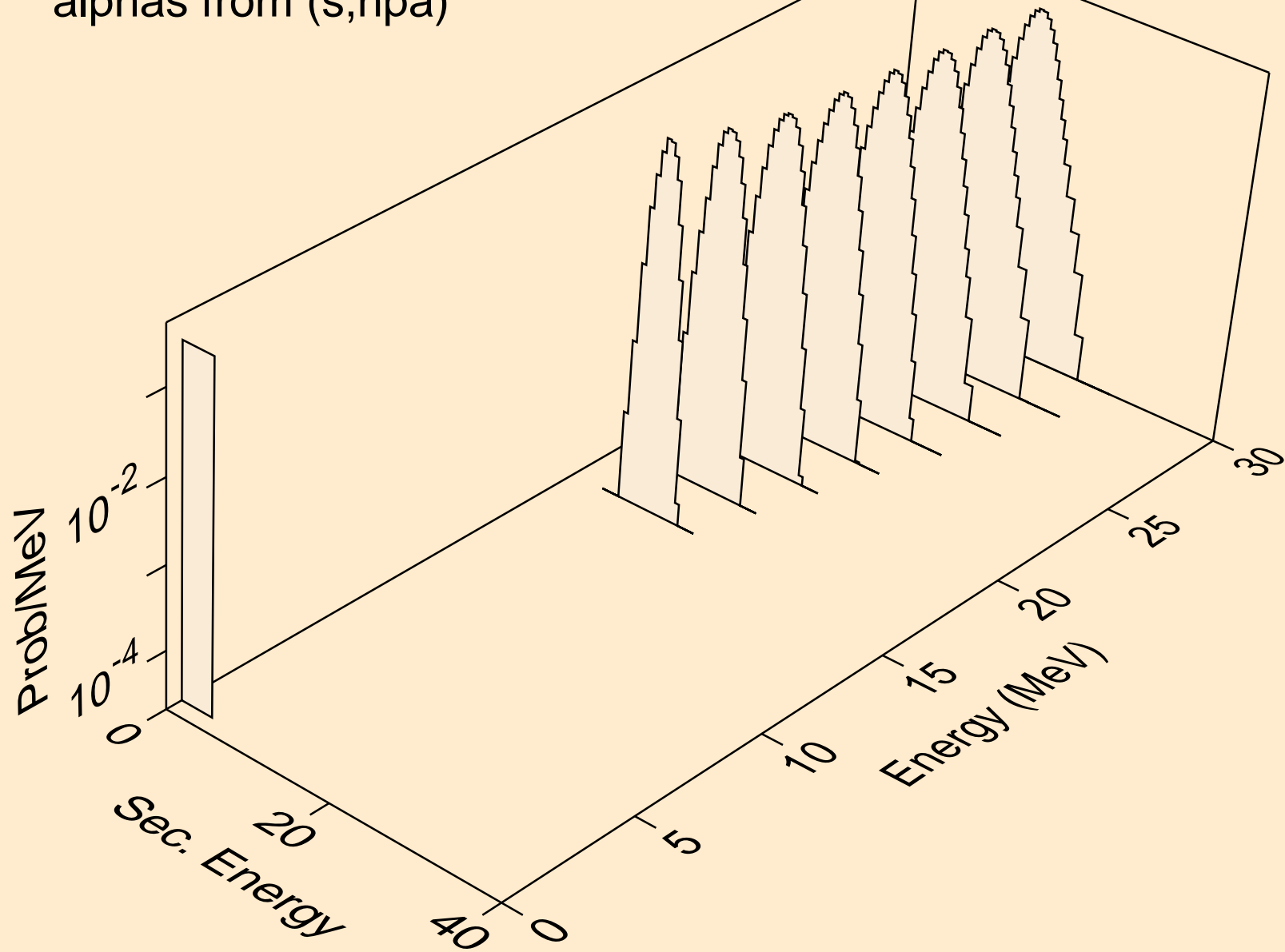

SM163 HELION ACER TENDL-2021 LIBRARY; T=0.K  
alphas from (s,a)

