

ZR083 HELION ACER TENDL-2021 LIBRARY; T=0.K  
Principal cross sections

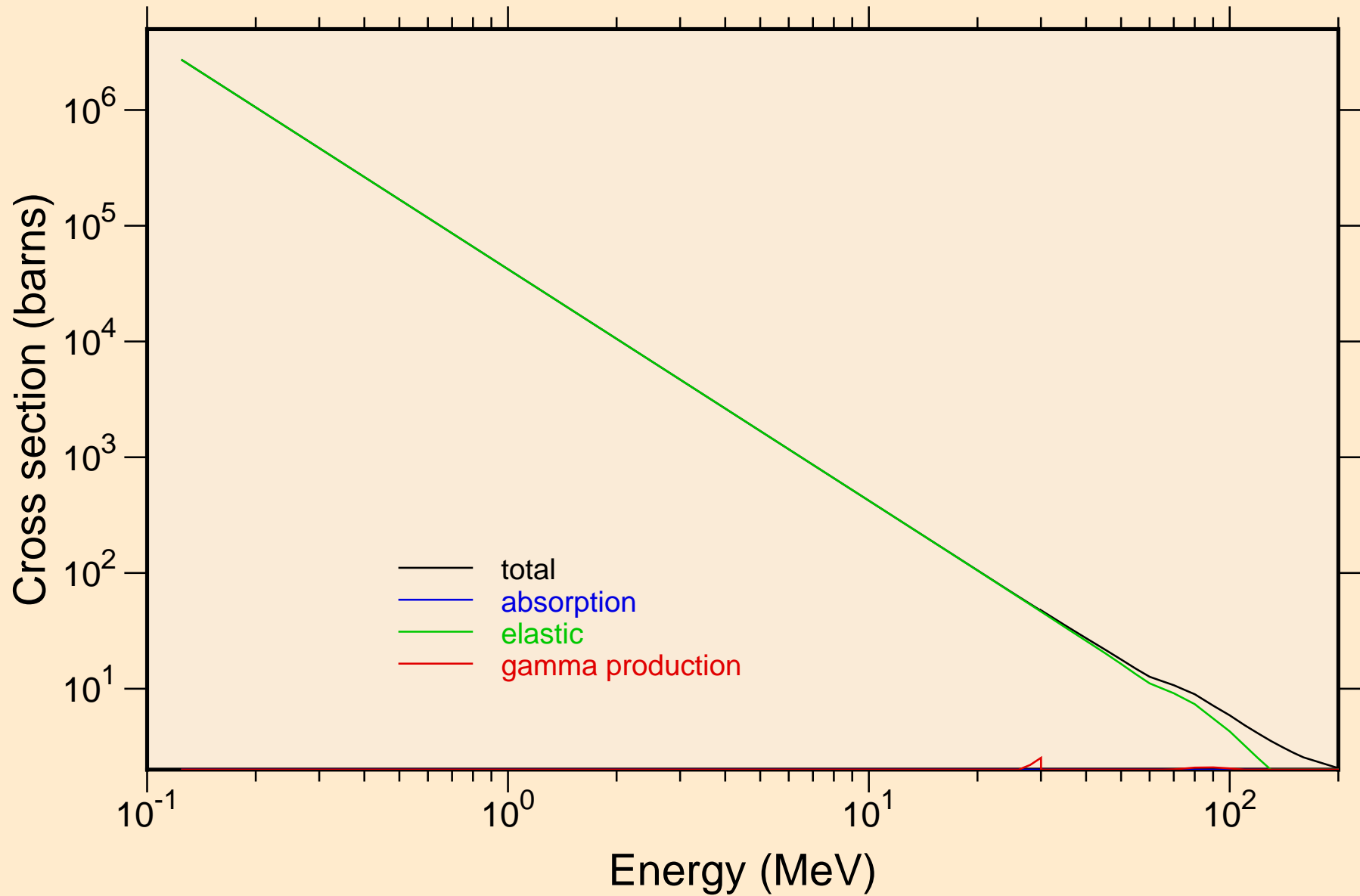

ZR083 HELION ACER TENDL-2021 LIBRARY; T=0.K

Heating

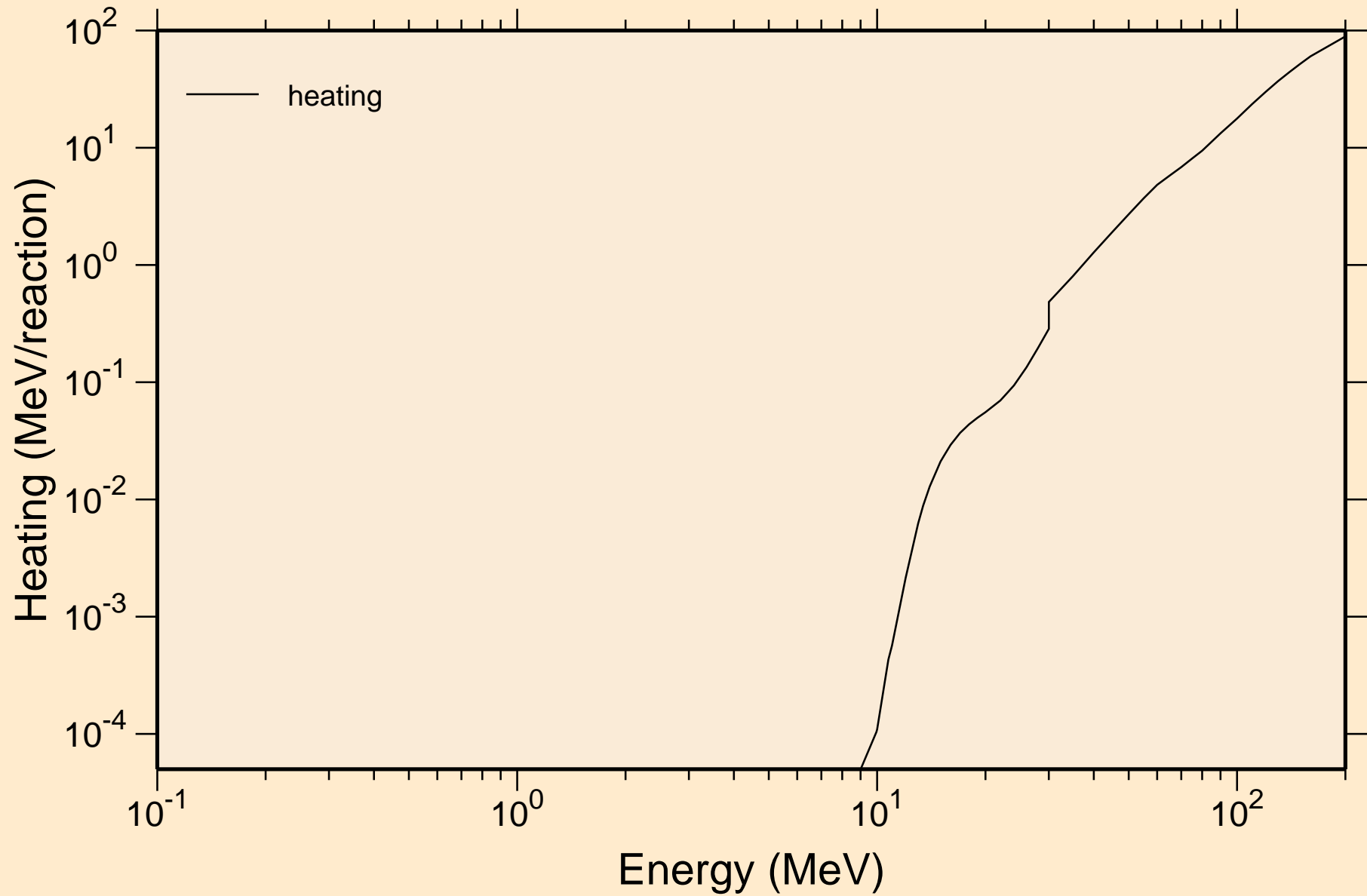

# ZR083 HELION ACER TENDL-2021 LIBRARY; T=0.K

## Principal cross sections

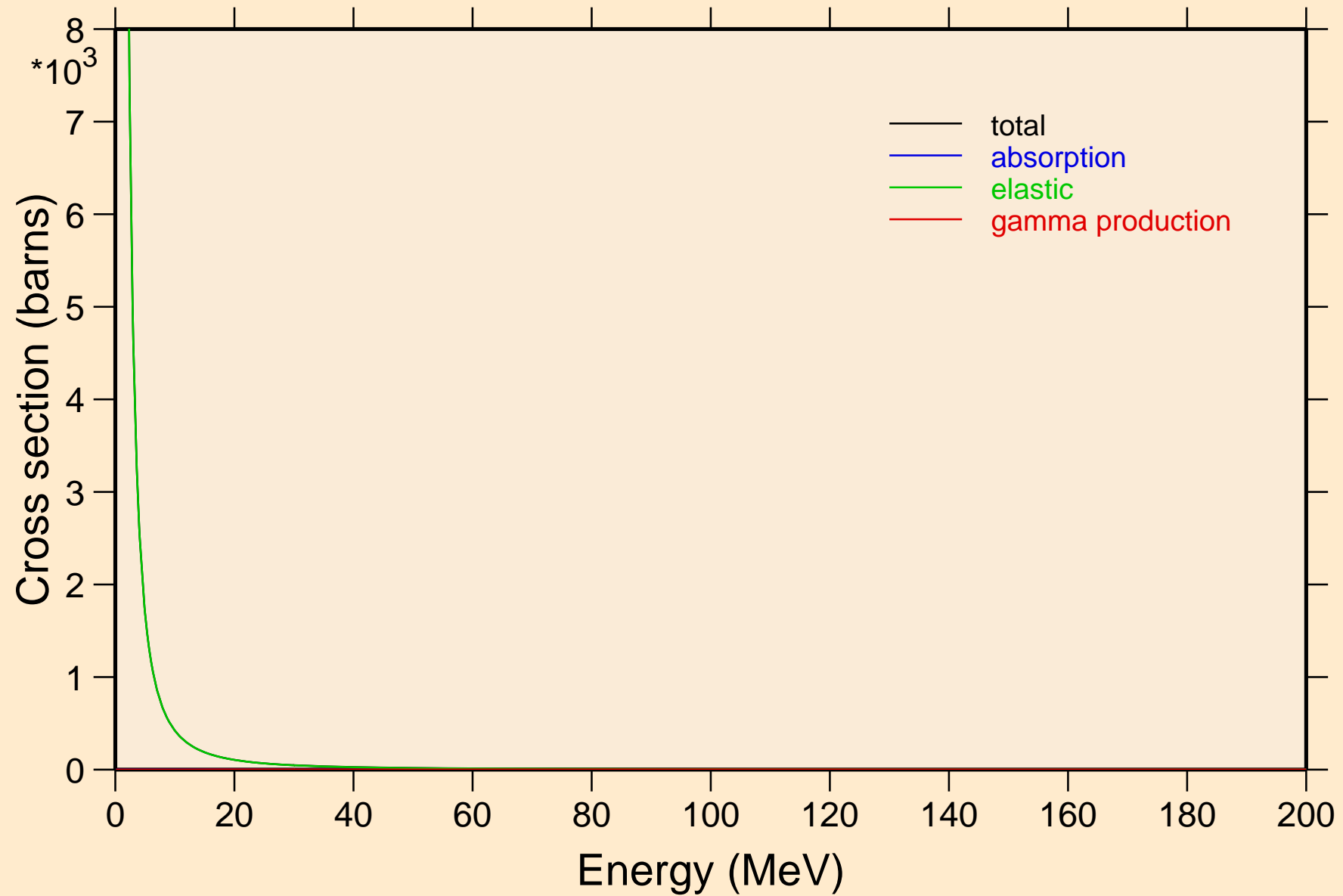

ZR083 HELION ACER TENDL-2021 LIBRARY; T=0.K

Heating

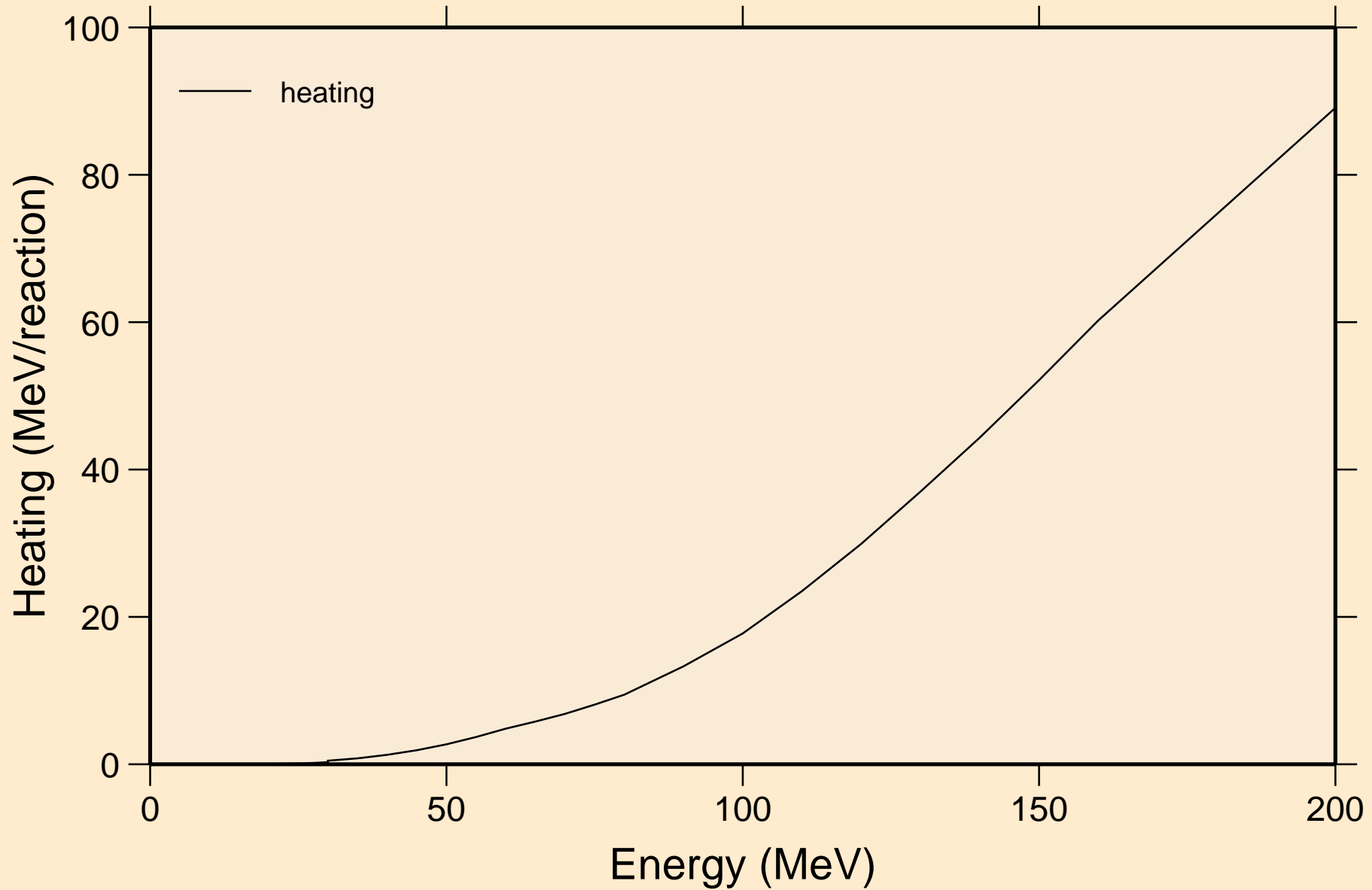

# ZR083 HELION ACER TENDL-2021 LIBRARY; T=0.K

## Threshold reactions

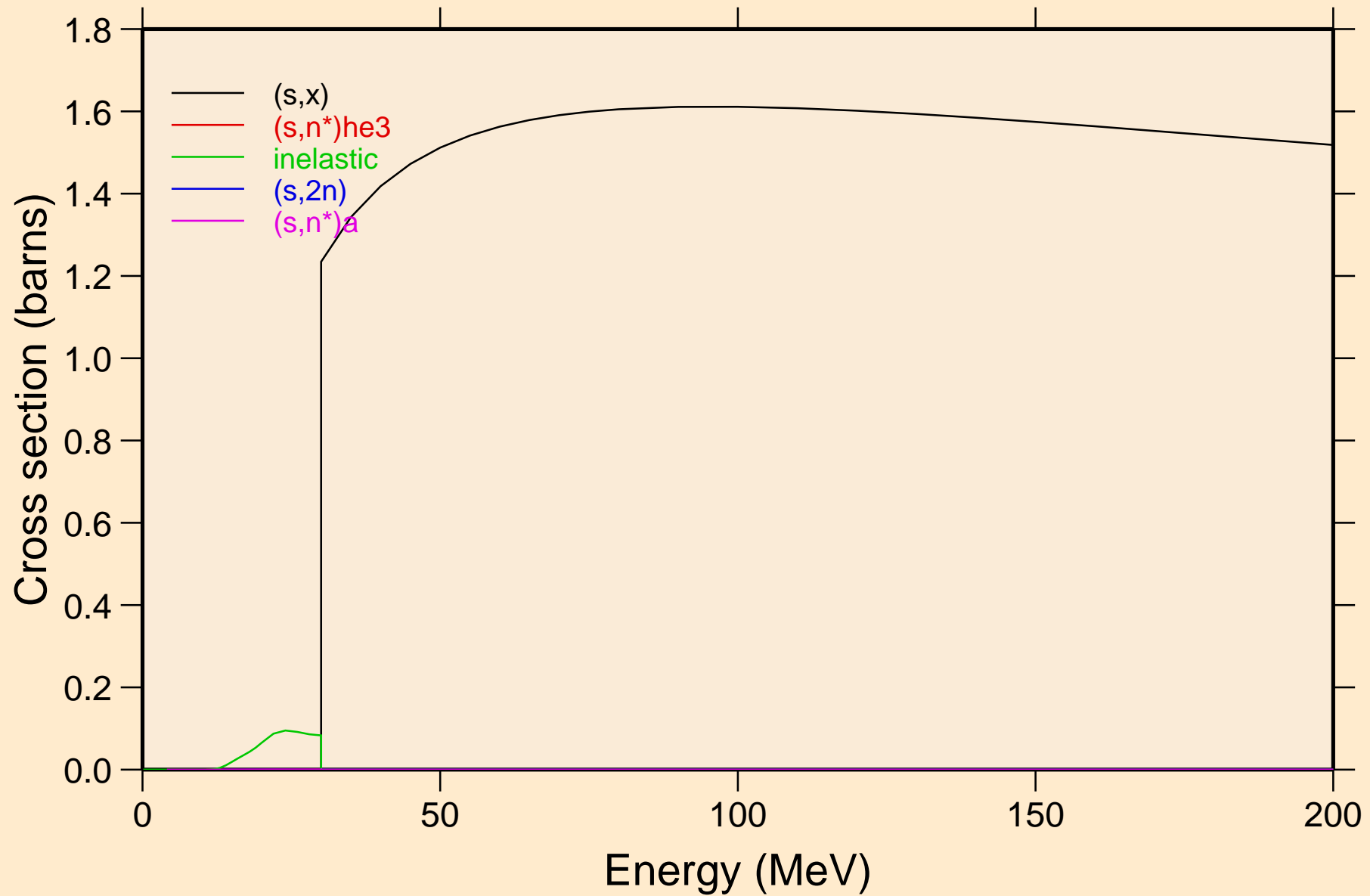

ZR083 HELION ACER TENDL-2021 LIBRARY; T=0.K  
Threshold reactions

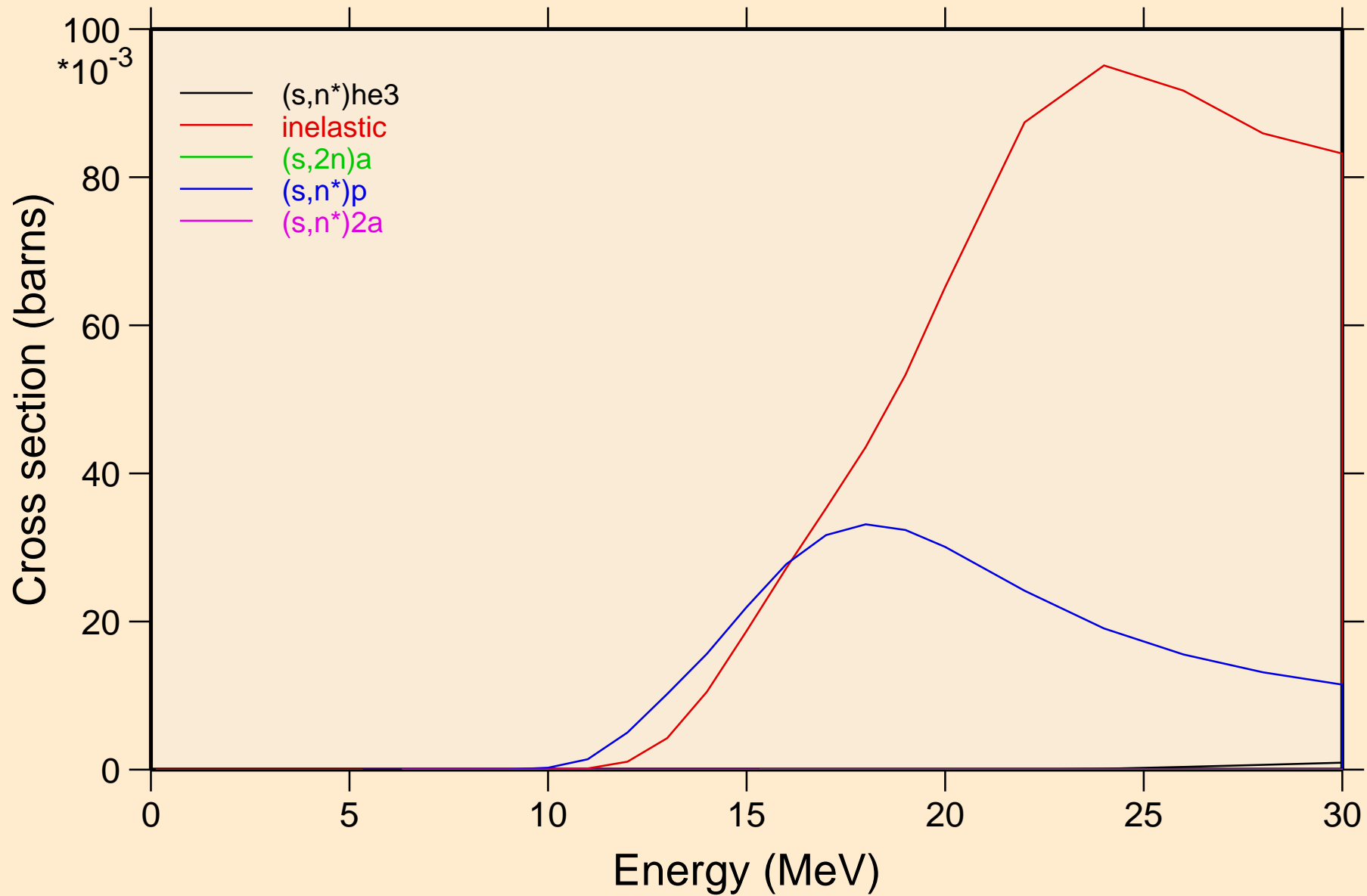

ZR083 HELION ACER TENDL-2021 LIBRARY; T=0.K  
Threshold reactions

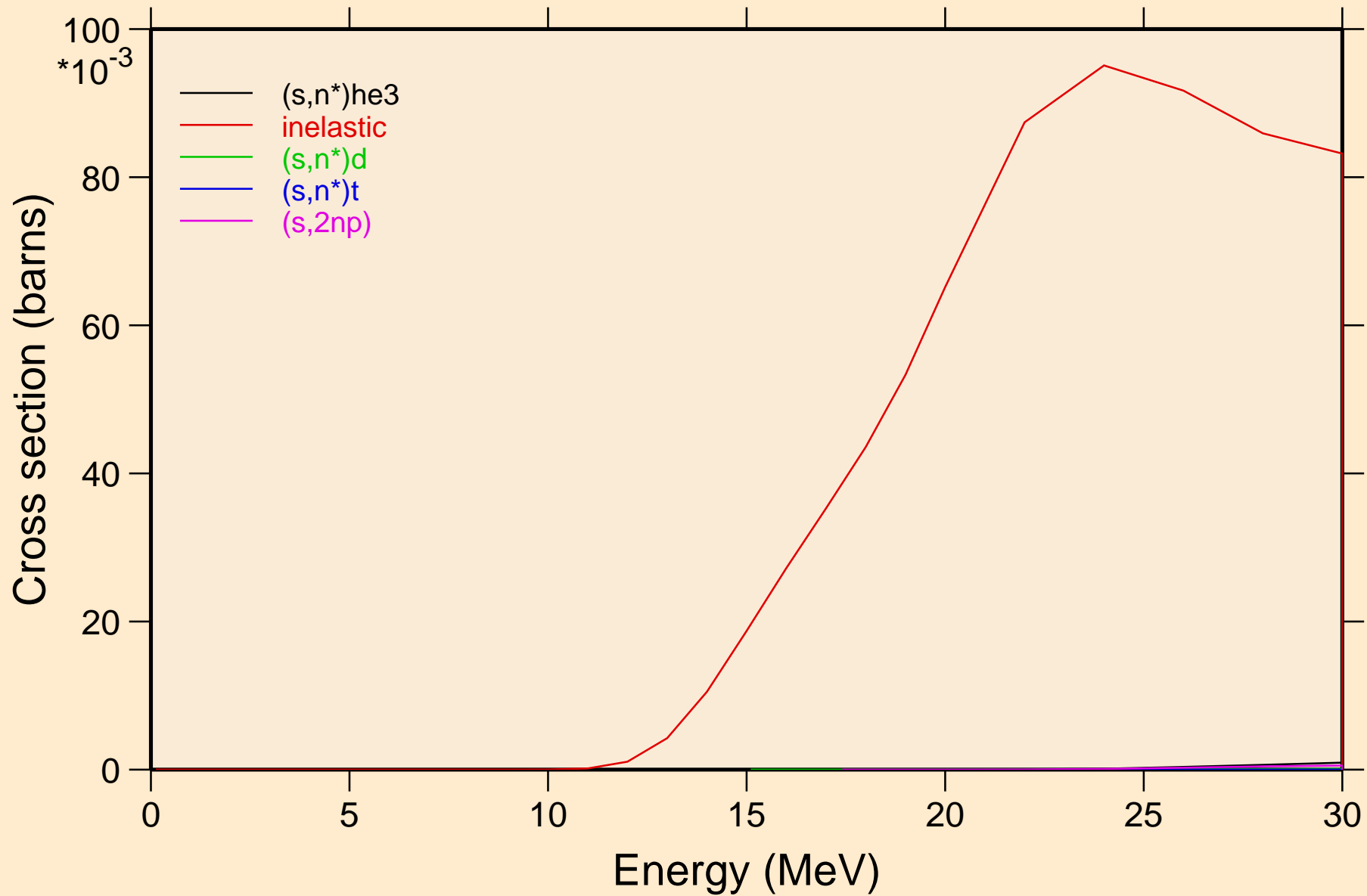

ZR083 HELION ACER TENDL-2021 LIBRARY; T=0.K  
Threshold reactions

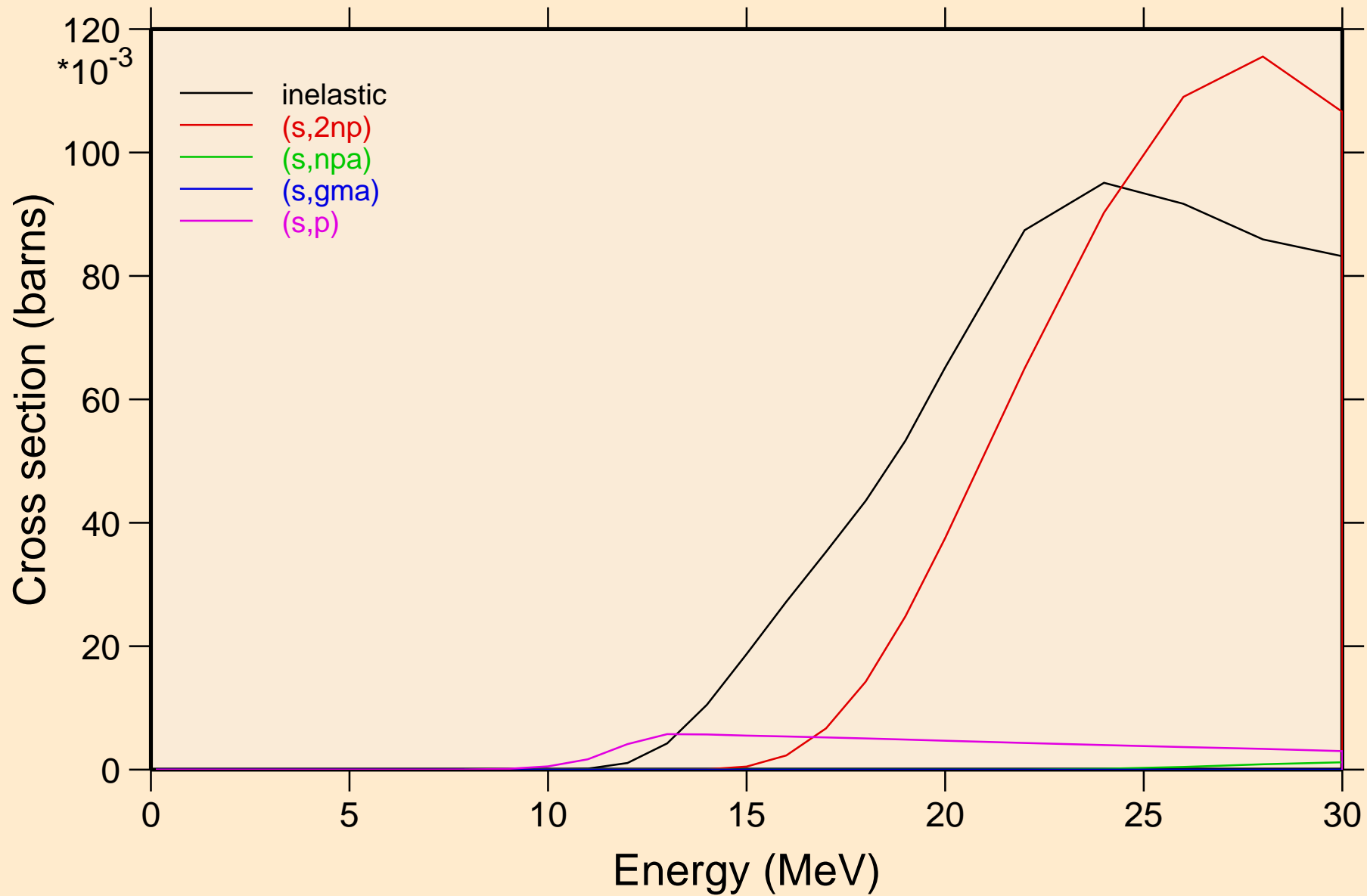



ZR083 HELION ACER TENDL-2021 LIBRARY; T=0.K  
Threshold reactions

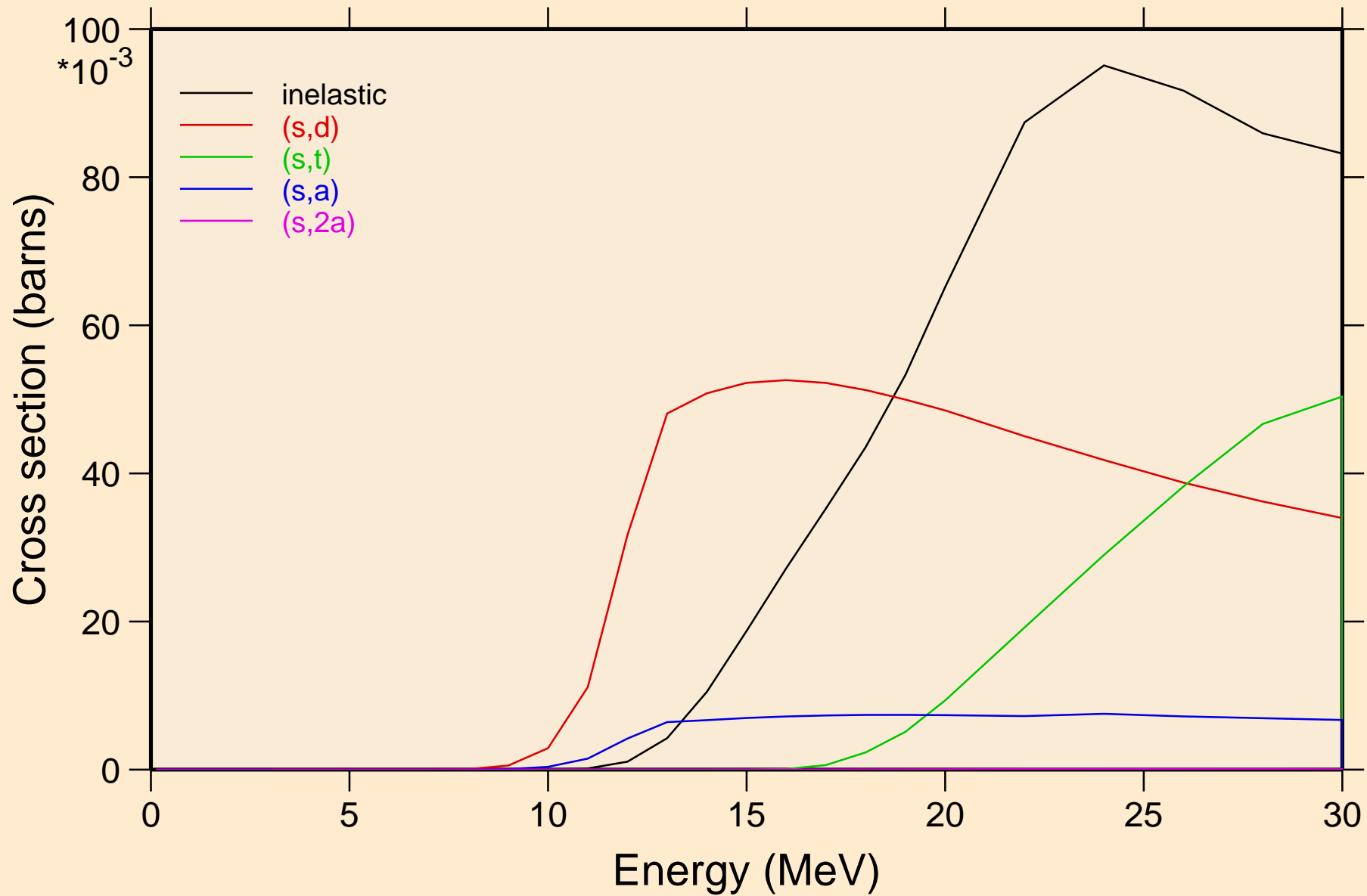

ZR083 HELION ACER TENDL-2021 LIBRARY; T=0.K  
Threshold reactions

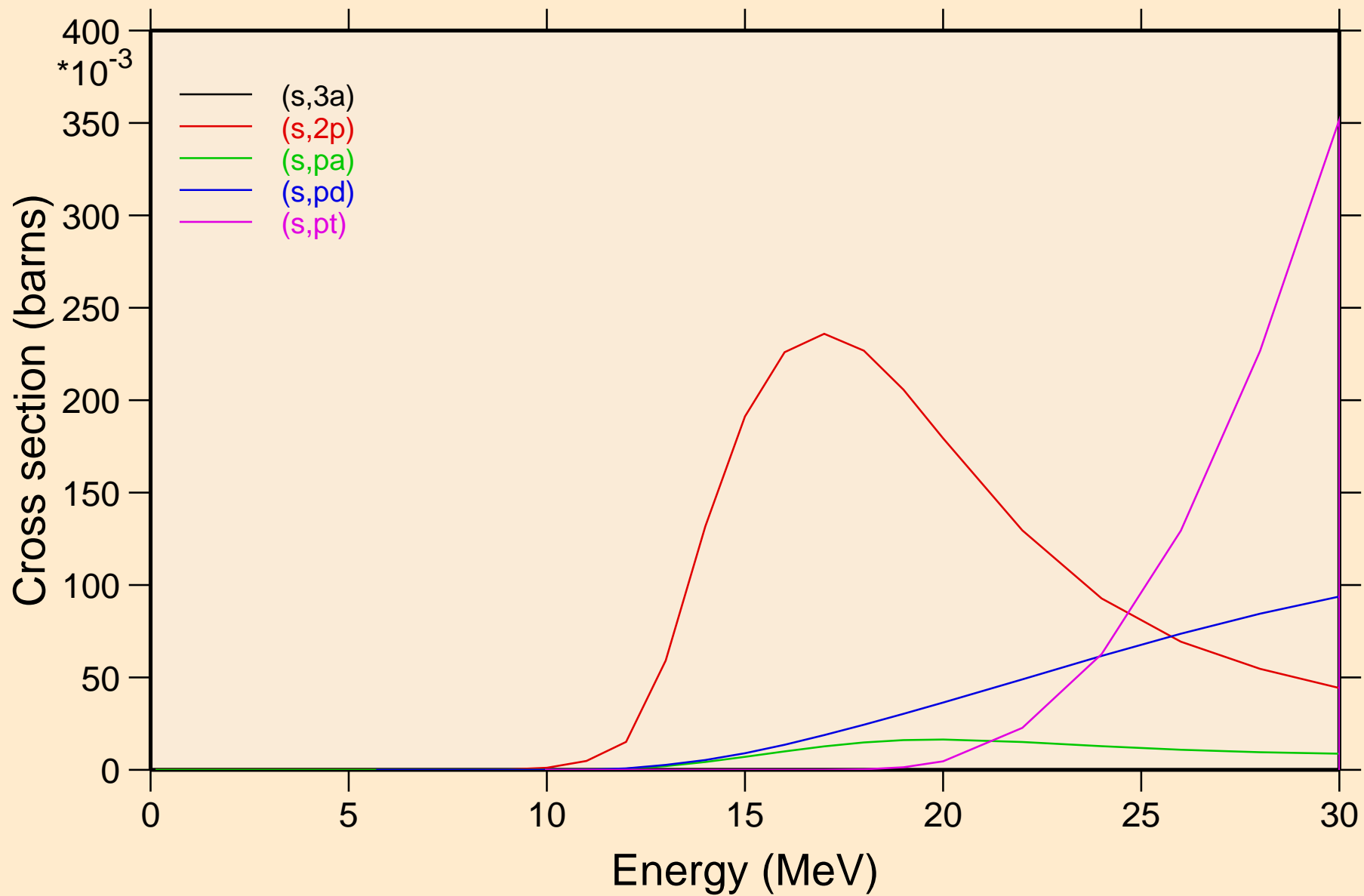

ZR083 HELION ACER TENDL-2021 LIBRARY; T=0.K  
Threshold reactions

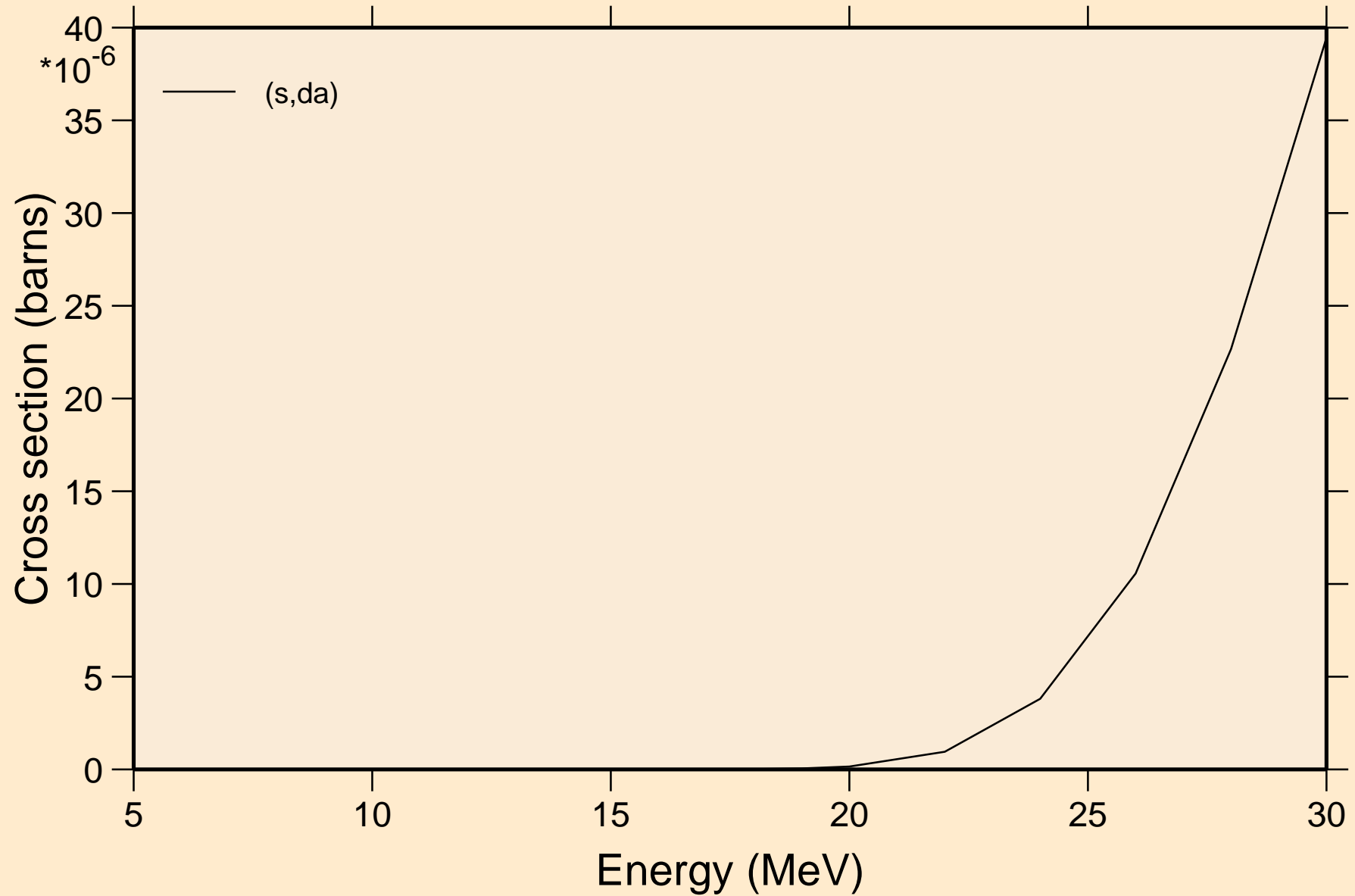

ZR083 HELION ACER TENDL-2021 LIBRARY; T=0.K  
angular distribution for elastic

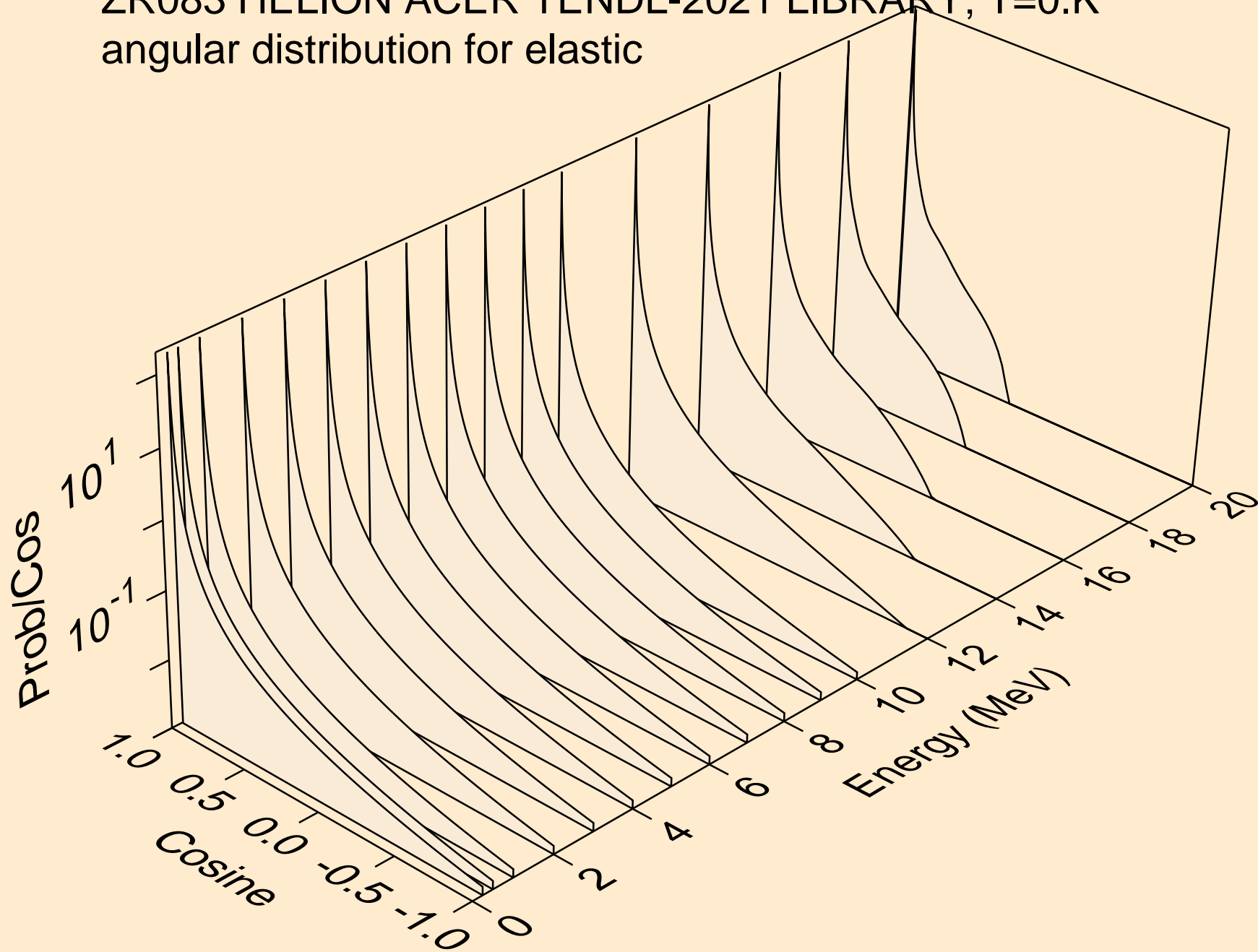

ZR083 HELION ACER TENDL-2021 LIBRARY; T=0.K  
angular distribution for elastic

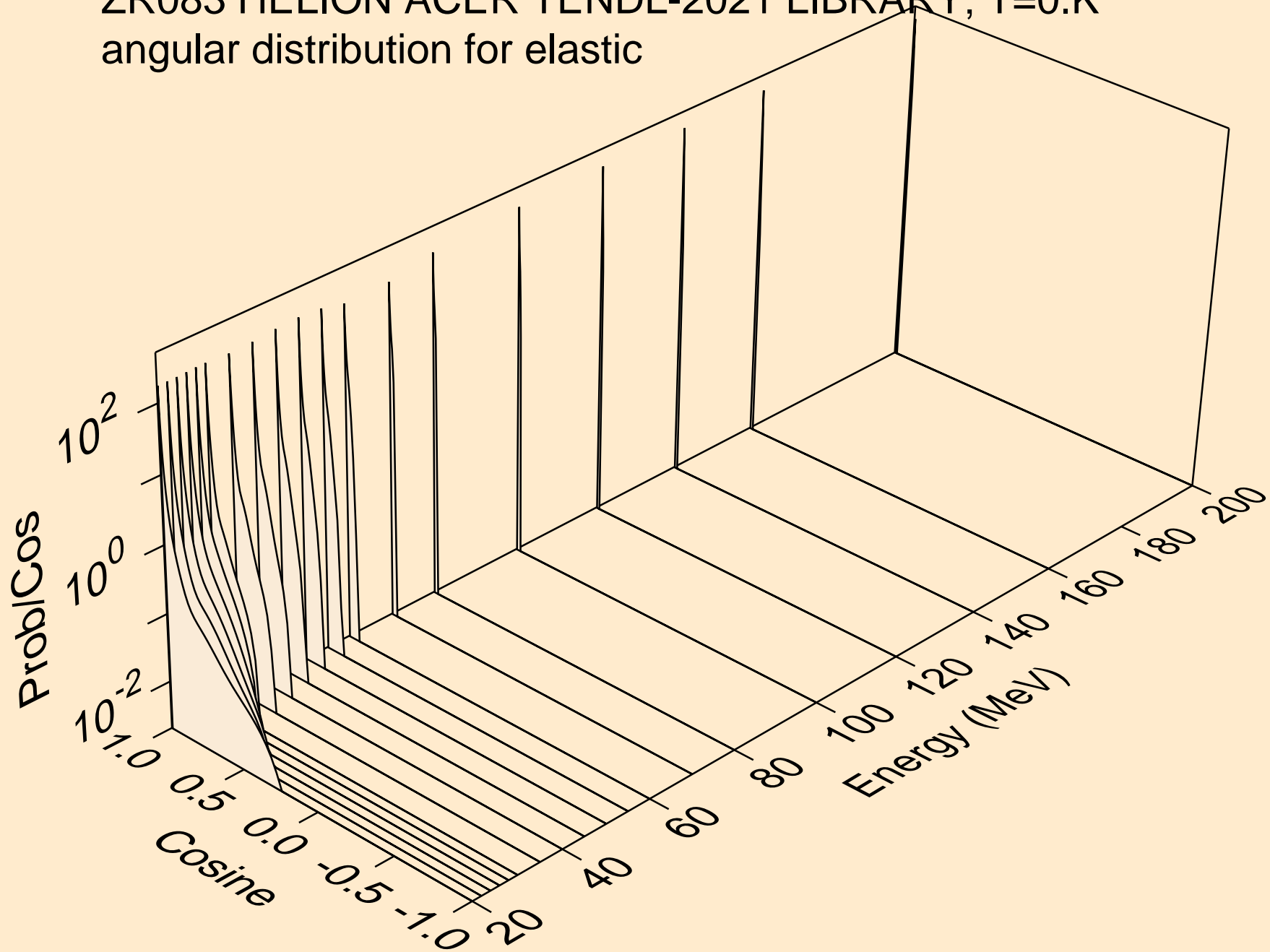

ZR083 HELION ACER TENDL-2021 LIBRARY; T=0.K  
He-3 emission for (s,x)

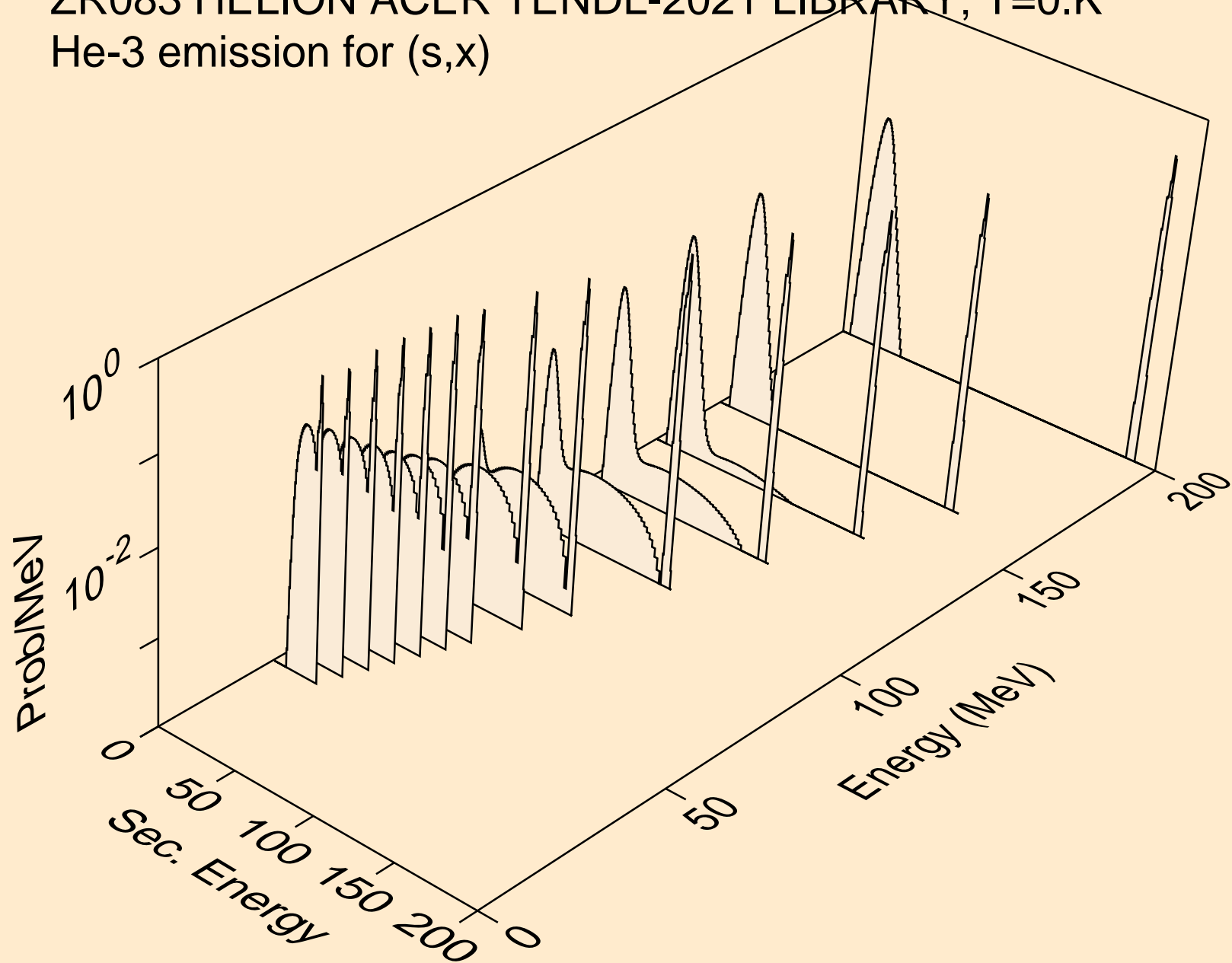

ZR083 HELION ACER TENDL-2021 LIBRARY; T=0.K  
He-3 emission for (s,n\*)he3

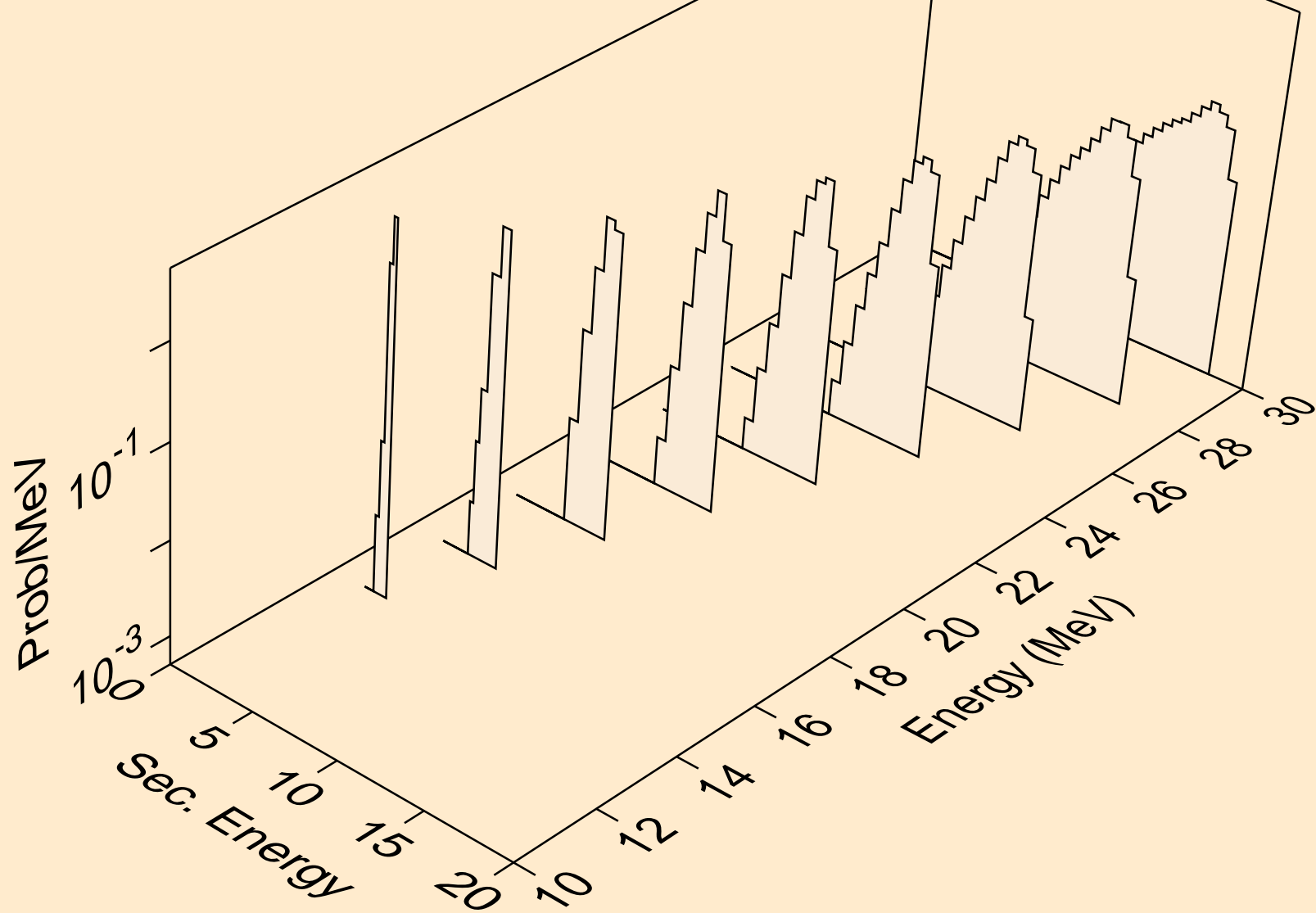

ZR083 HELION ACER TENDL-2021 LIBRARY; T=0.K  
He-3 emission for inelastic

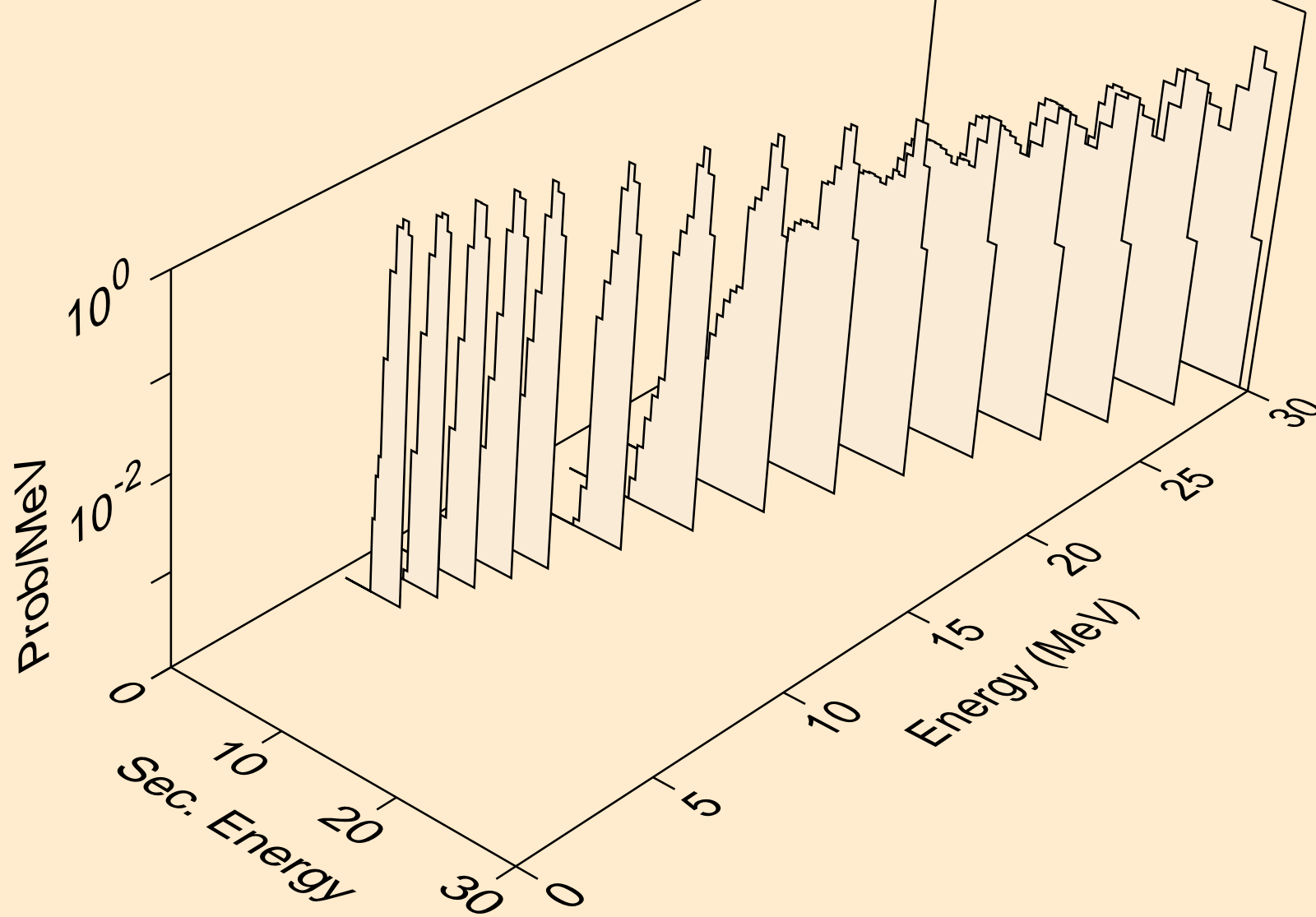



ZR083 HELION ACER TENDL-2021 LIBRARY; T=0.K  
Photon emission for (z,n)

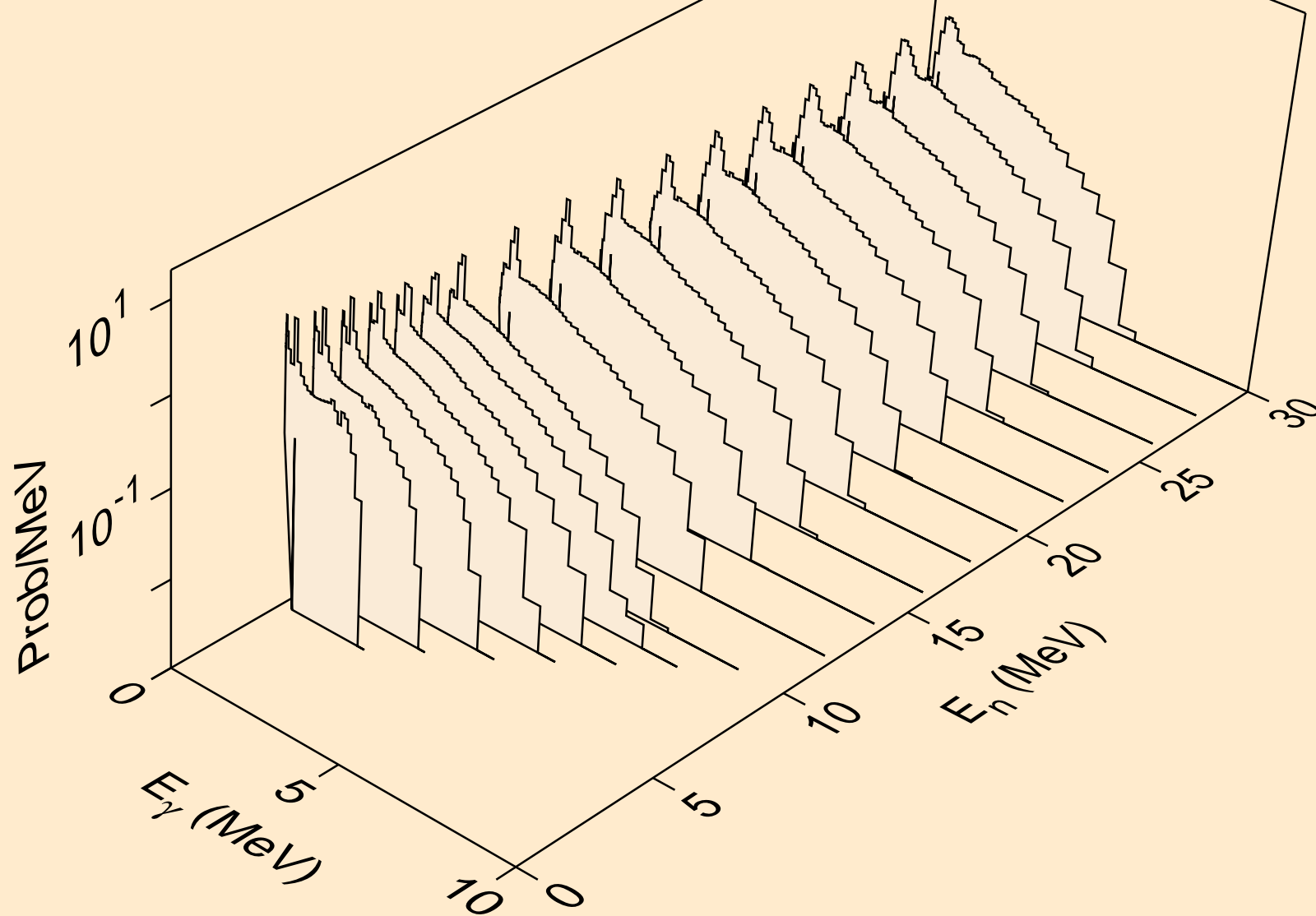

ZR083 HELION ACER TENDL-2021 LIBRARY; T=0.K  
Photon emission for (n,x)

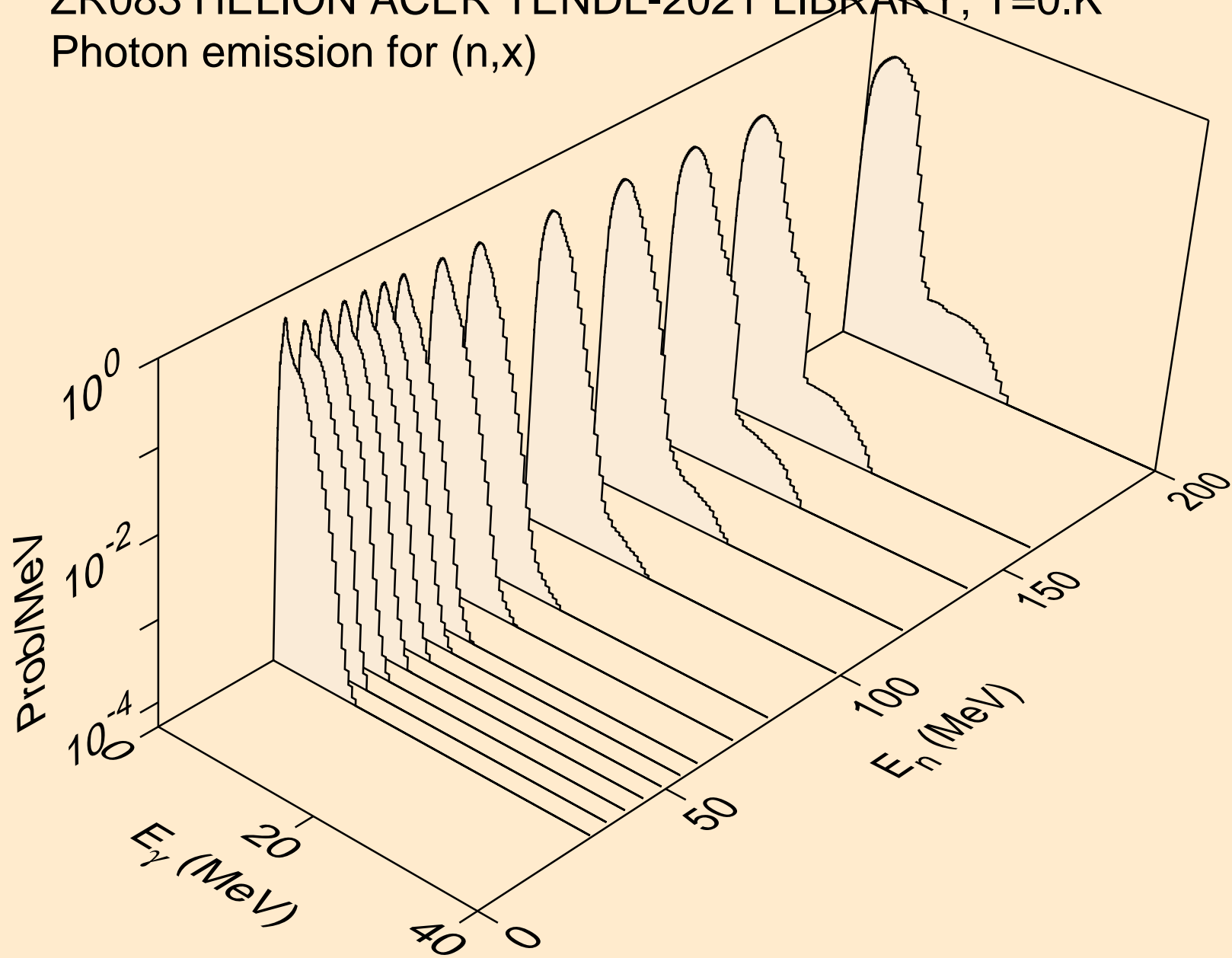

ZR083 HELION ACER TENDL-2021 LIBRARY; T=0.K  
Photon emission for (n,2n)

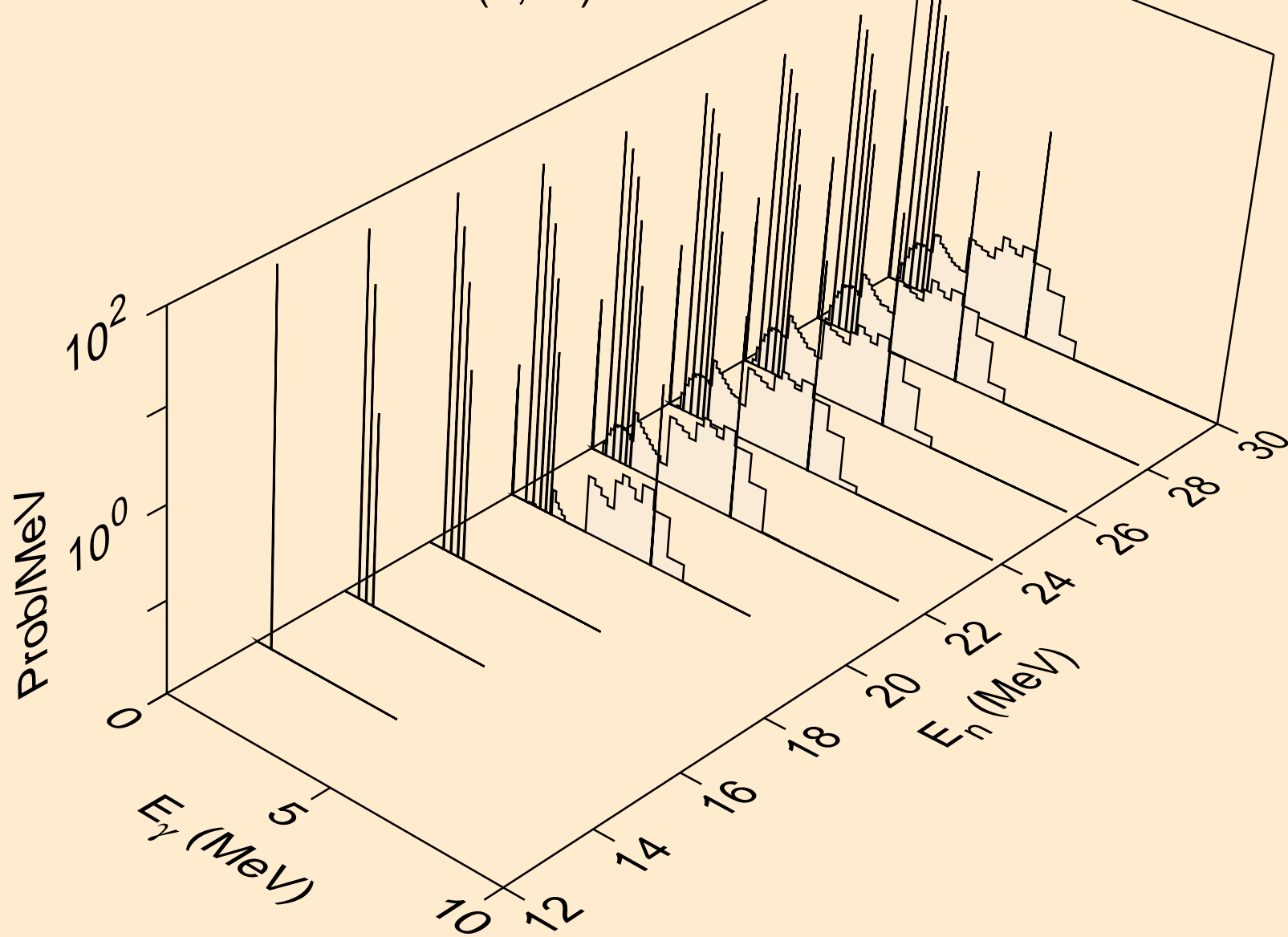

ZR083 HELION ACER TENDL-2021 LIBRARY; T=0.K  
Photon emission for (n,n\*)a

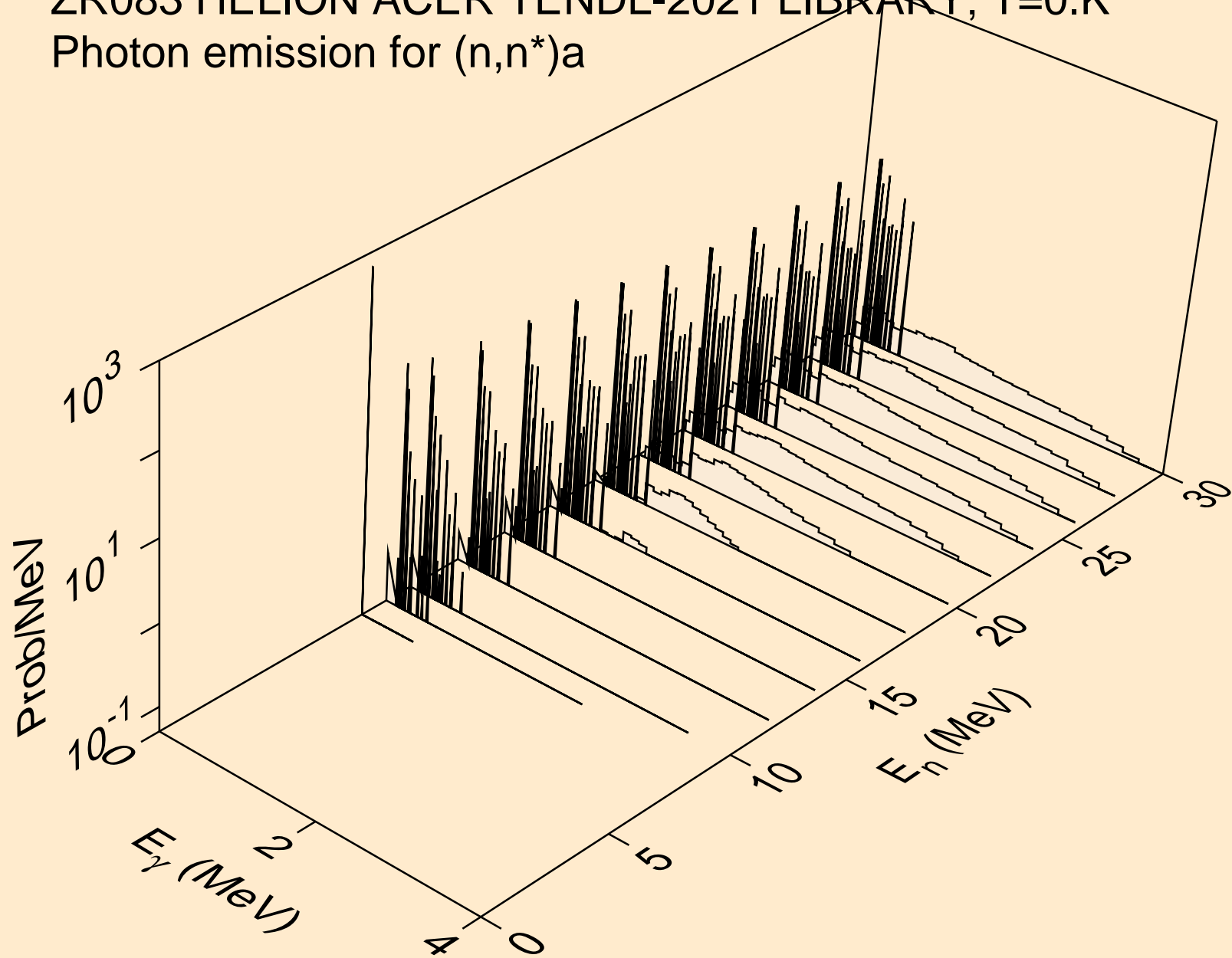

ZR083 HELION ACER TENDL-2021 LIBRARY; T=0.K  
Photon emission for (n,2n)a

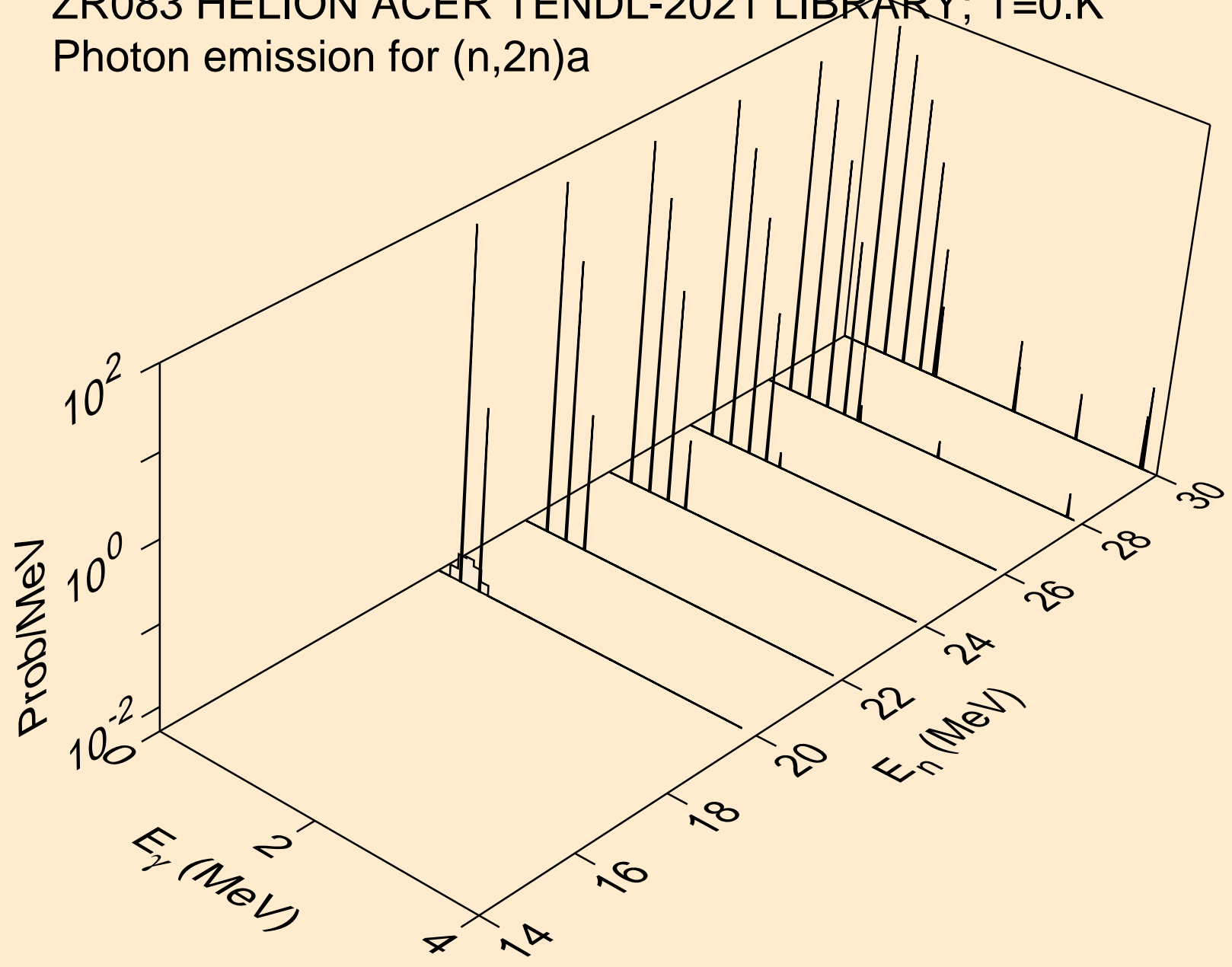

ZR083 HELION ACER TENDL-2021 LIBRARY; T=0.K  
Photon emission for (n,n\*)p

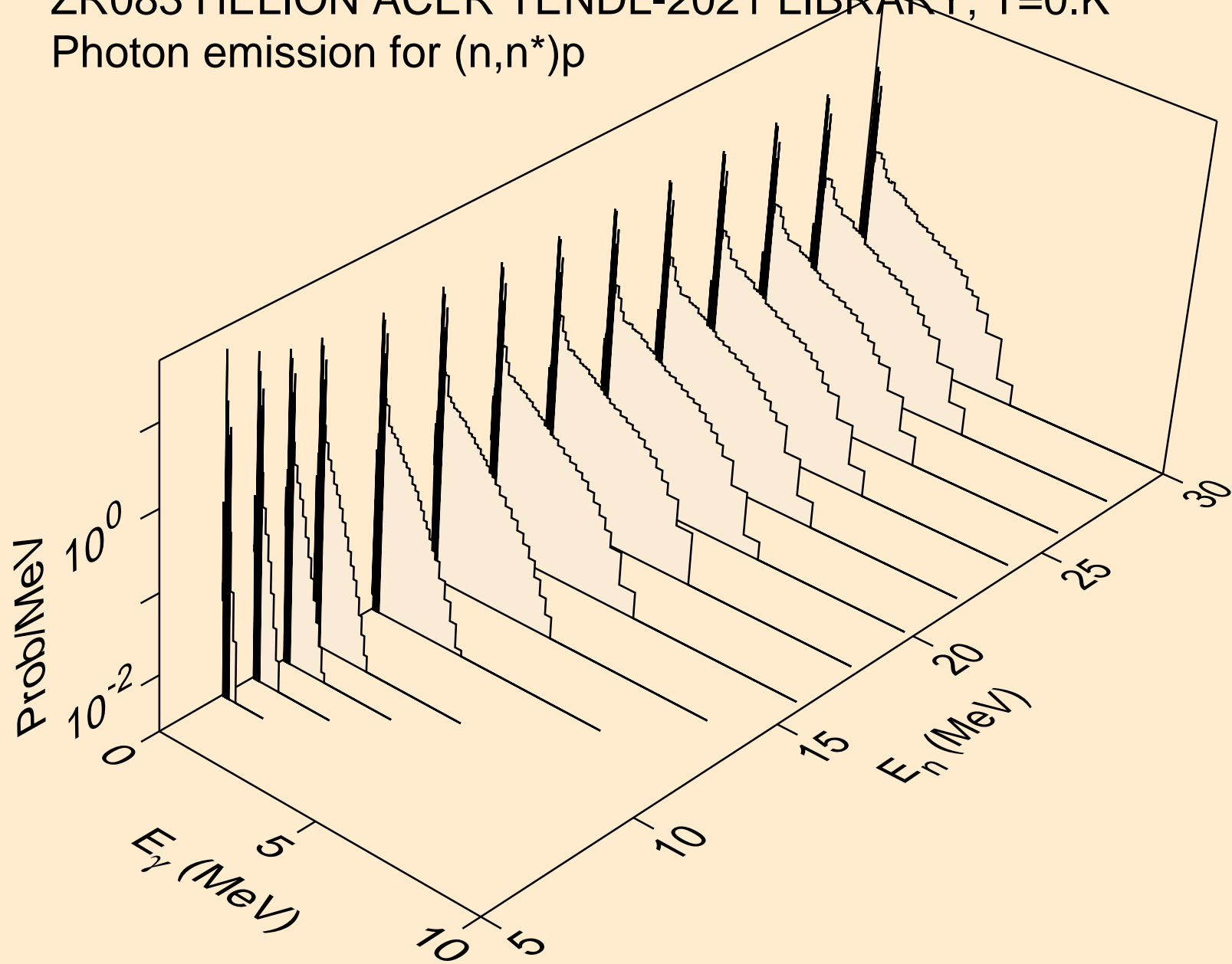

ZR083 HELION ACER TENDL-2021 LIBRARY; T=0.K  
Photon emission for (n,n\*)2a

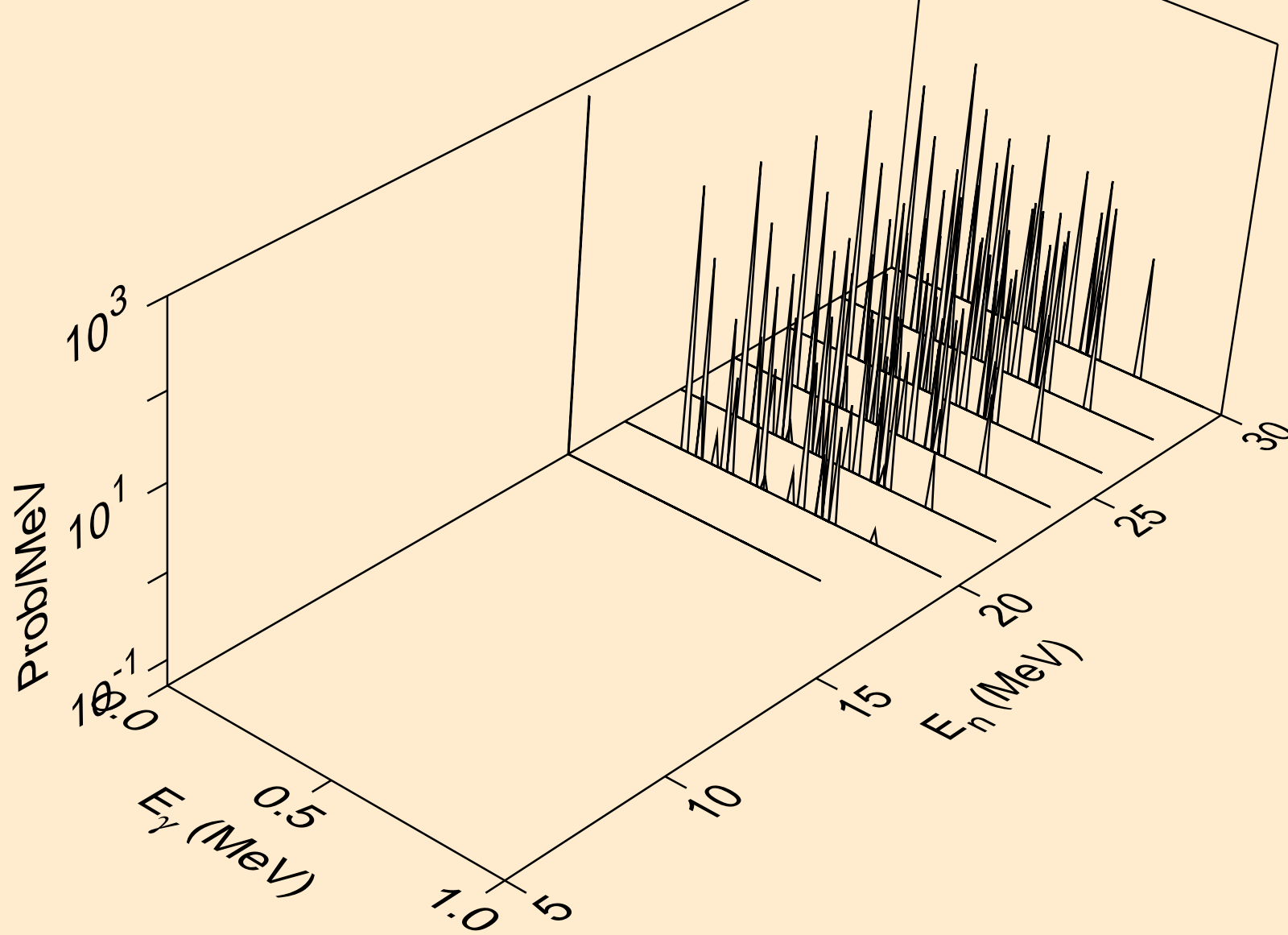

ZR083 HELION ACER TENDL-2021 LIBRARY; T=0.K  
Photon emission for (n,n\*)d

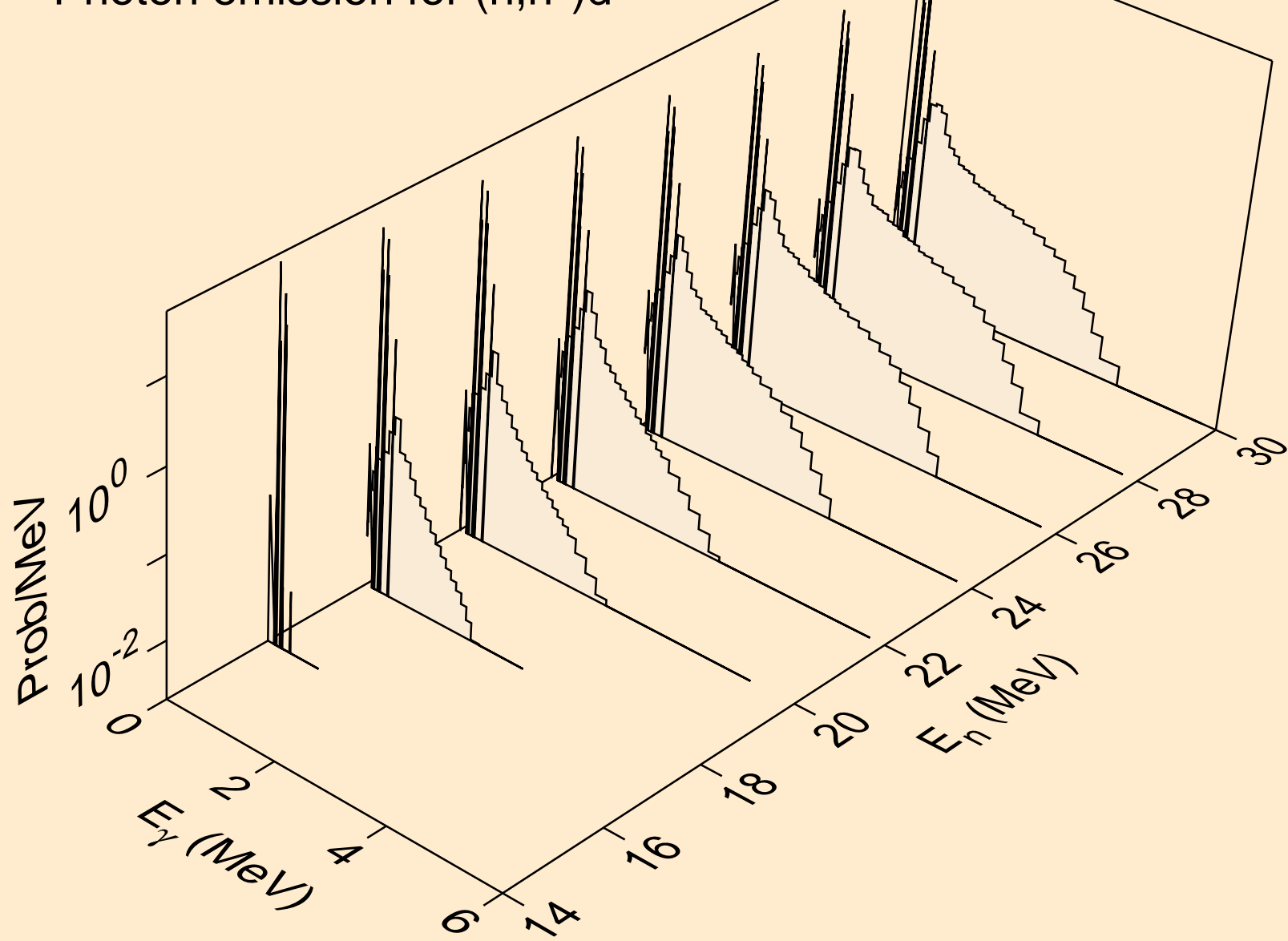



ZR083 HELION ACER TENDL-2021 LIBRARY; T=0.K  
Photon emission for (n,n\*)t

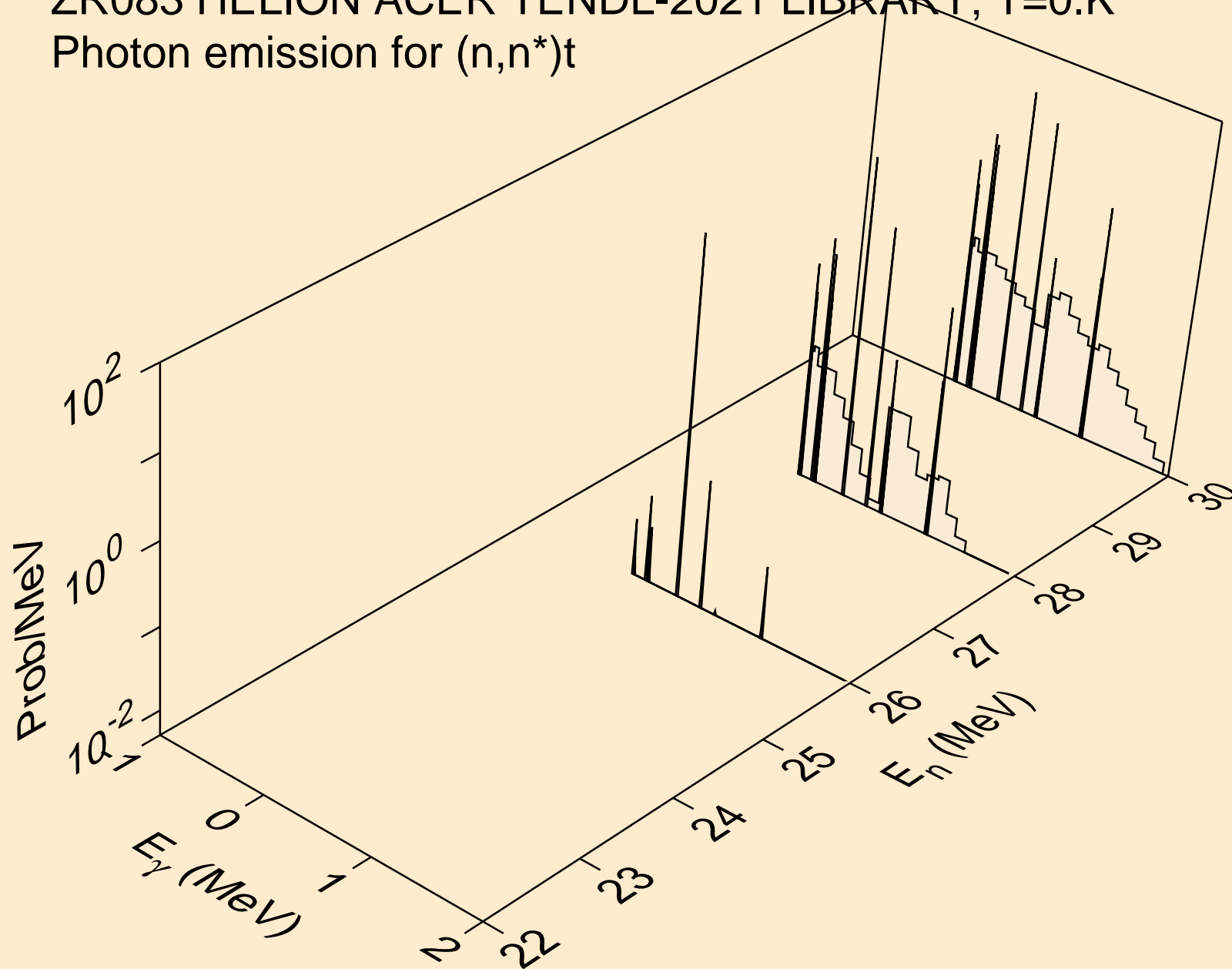

ZR083 HELION ACER TENDL-2021 LIBRARY; T=0.K  
Photon emission for (n,n\*)he3

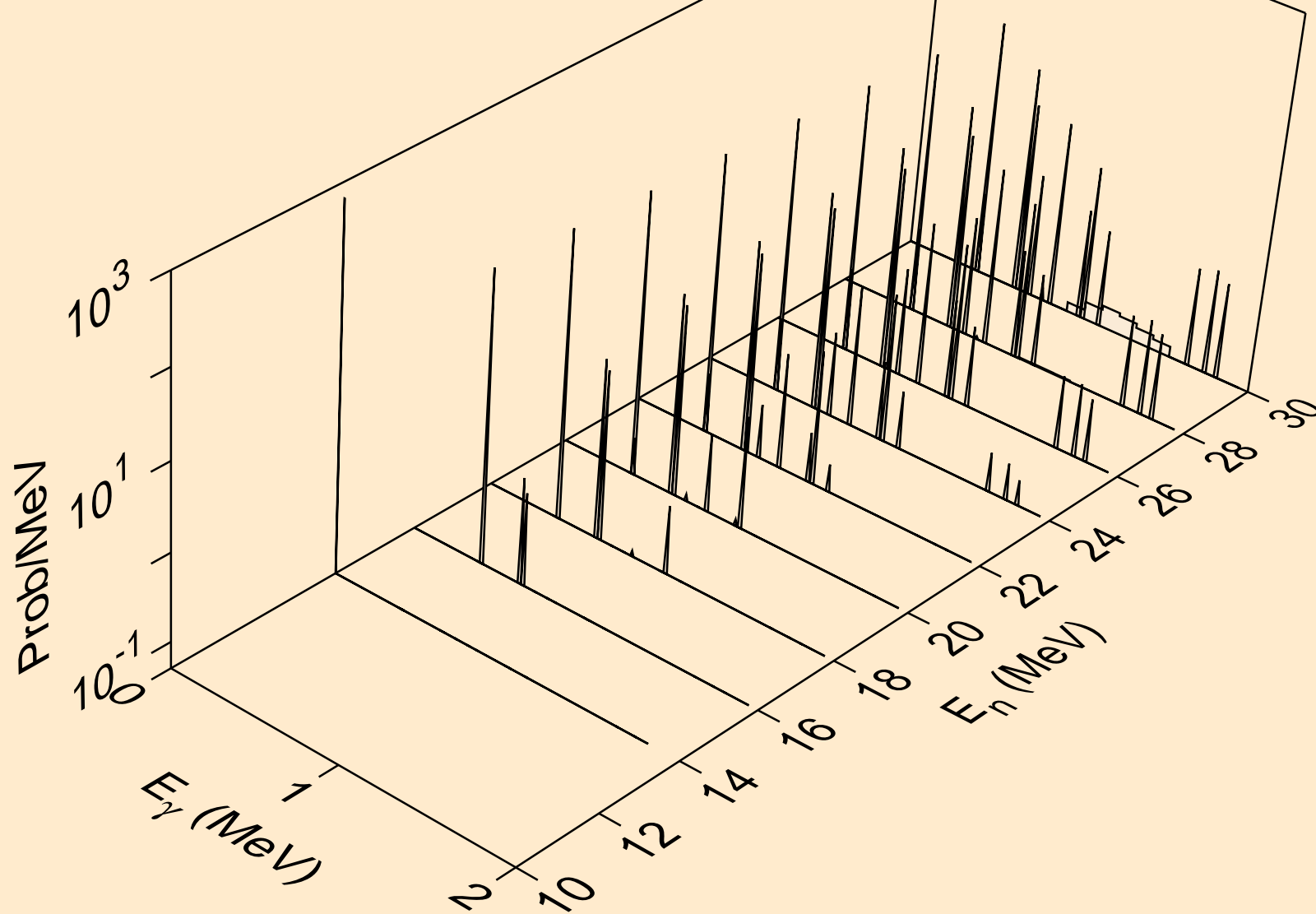

ZR083 HELION ACER TENDL-2021 LIBRARY; T=0.K  
Photon emission for (n,2np)

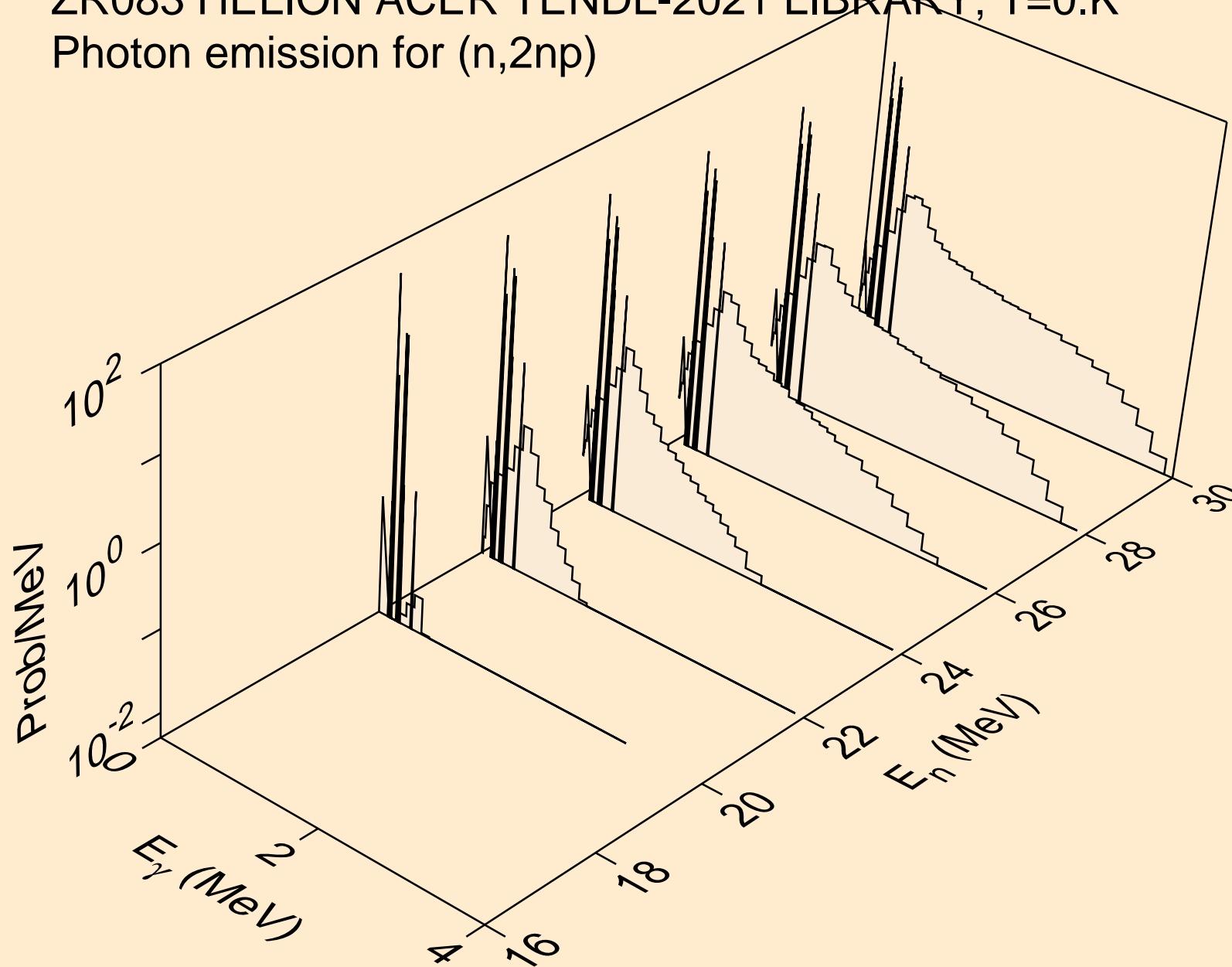

ZR083 HELION ACER TENDL-2021 LIBRARY; T=0.K  
Photon emission for (n,2np)

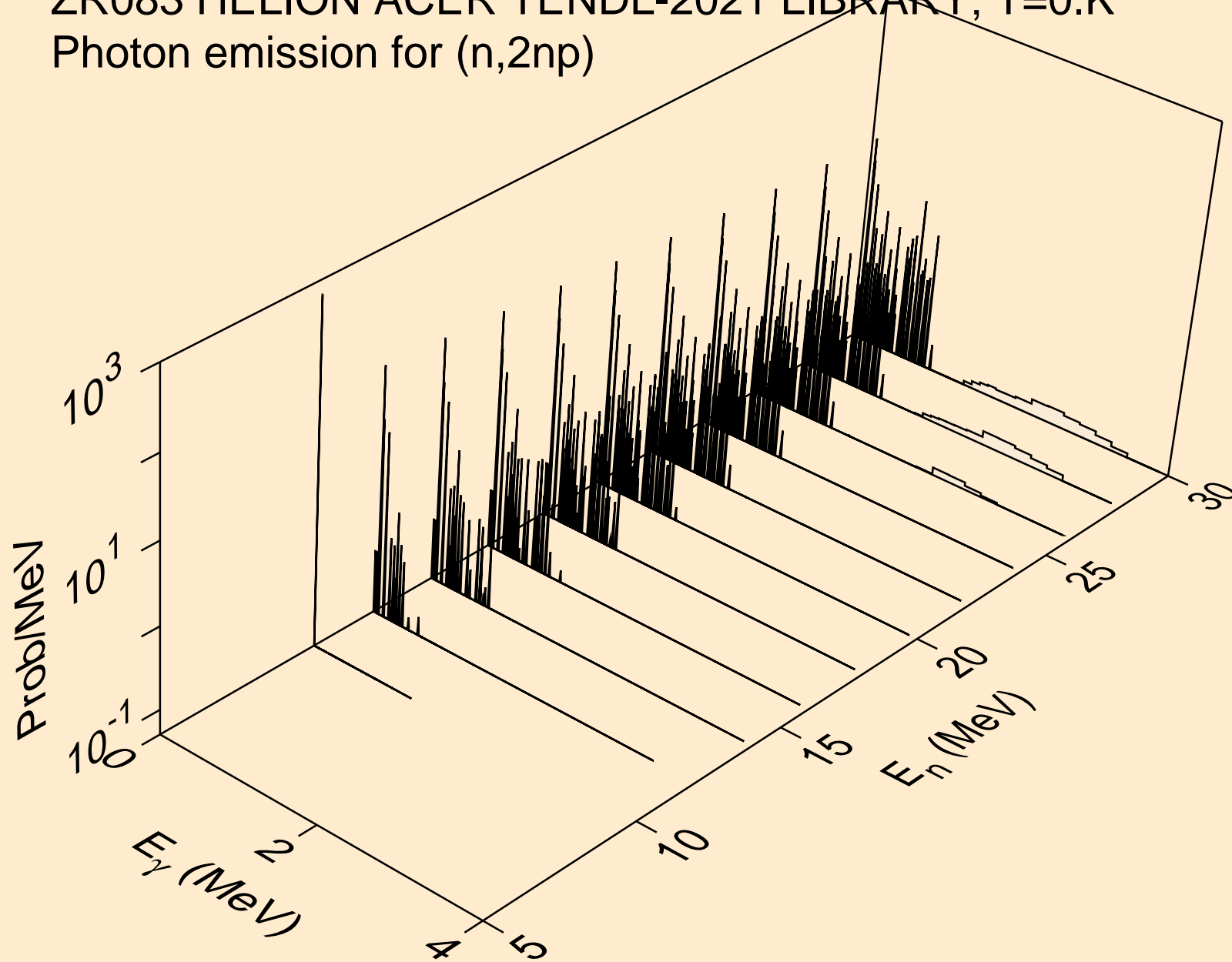

ZR083 HELION ACER TENDL-2021 LIBRARY; T=0.K  
Photon emission for (n,npa)

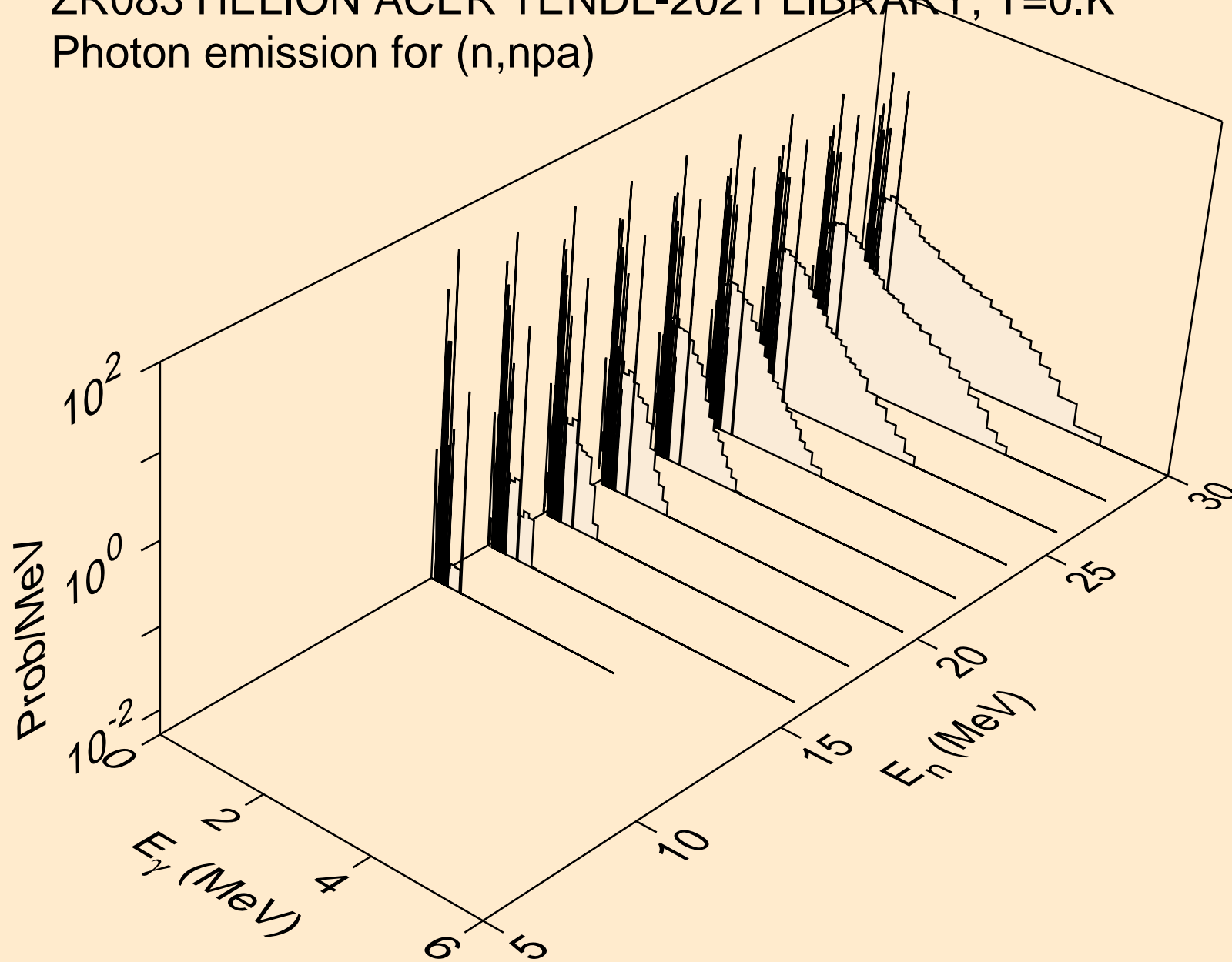

ZR083 HELION ACER TENDL-2021 LIBRARY; T=0.K  
Photon emission for (n,gma)

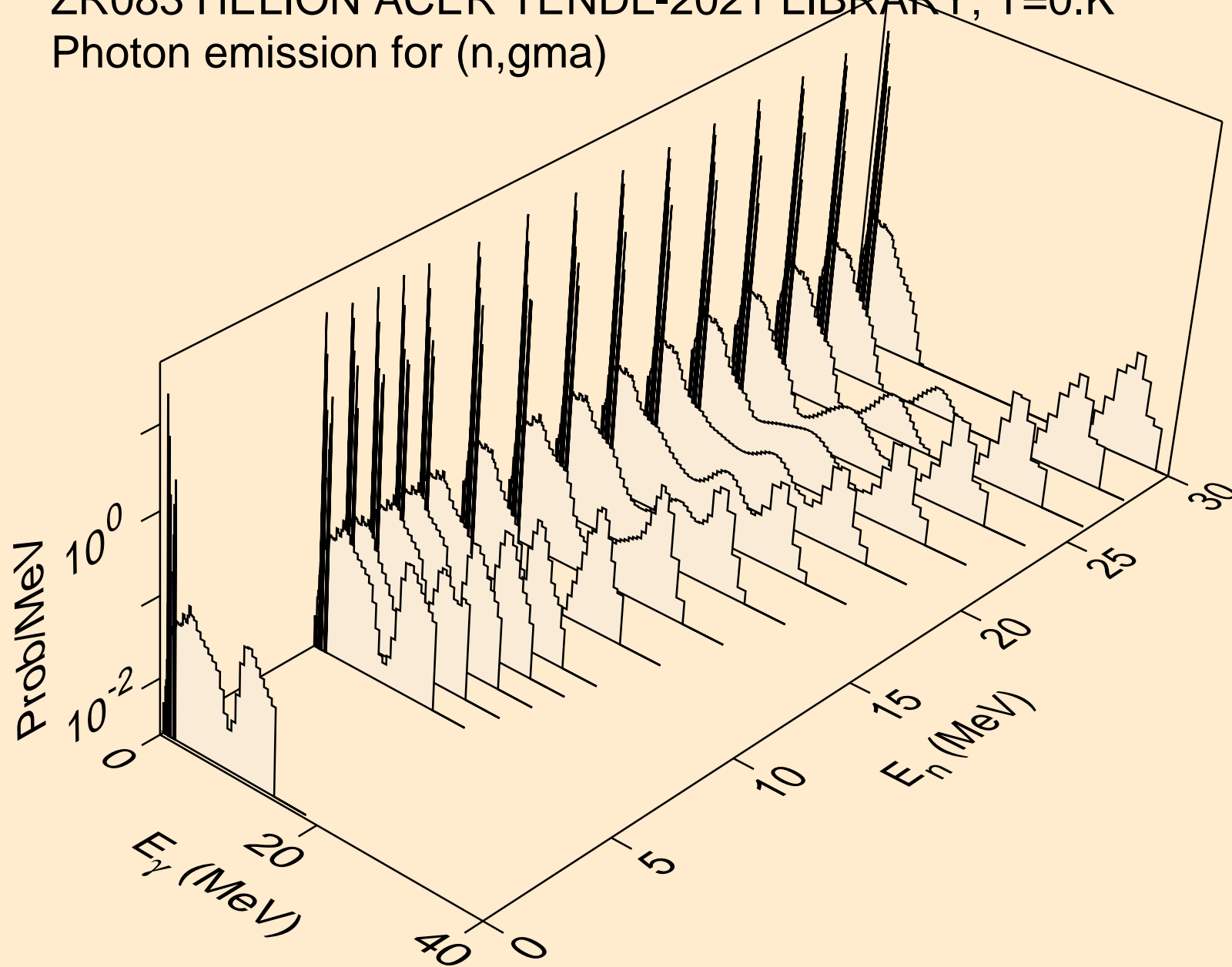

ZR083 HELION ACER TENDL-2021 LIBRARY; T=0.K  
Photon emission for (n,p)

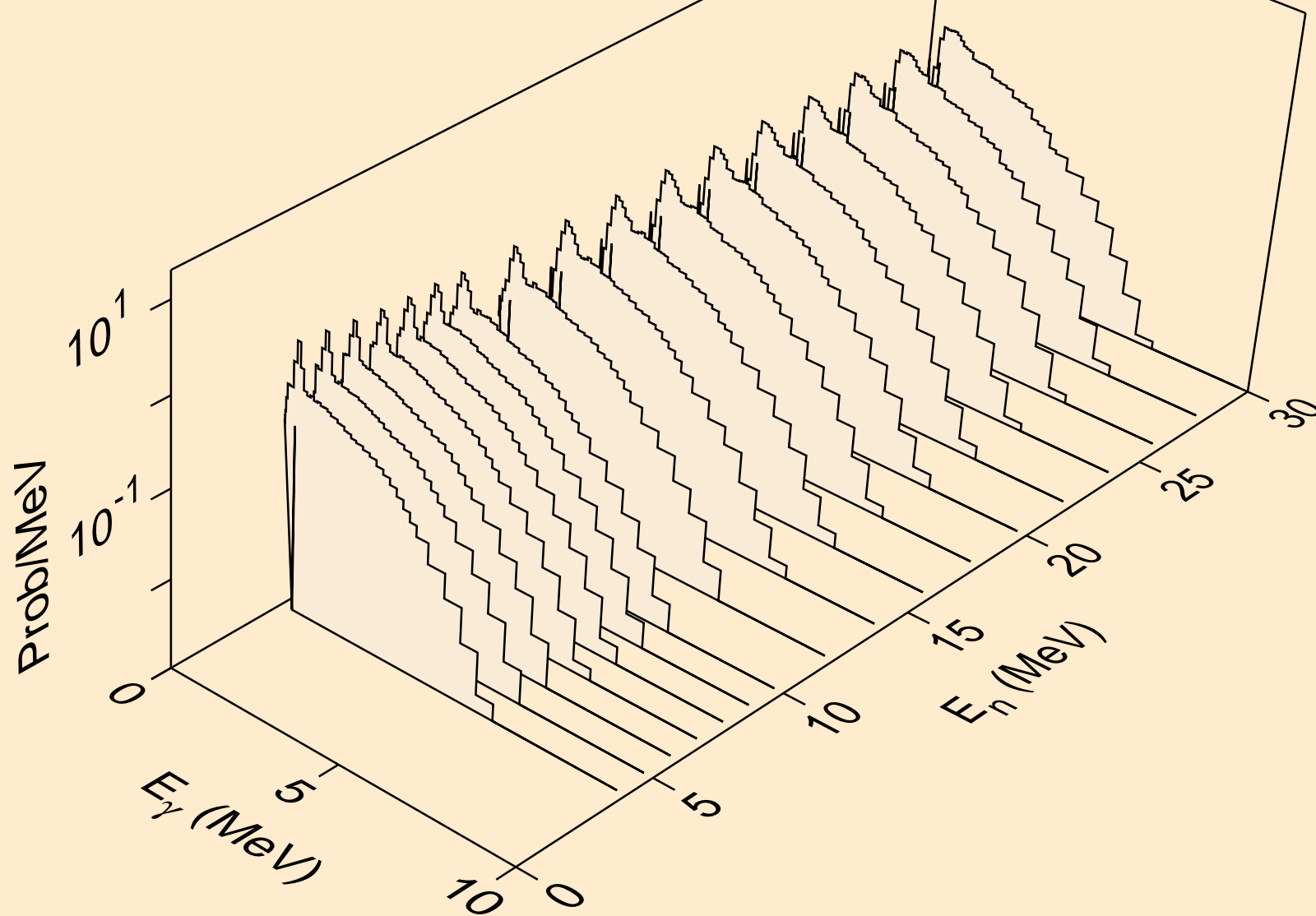

ZR083 HELION ACER TENDL-2021 LIBRARY; T=0.K  
Photon emission for (n,d)

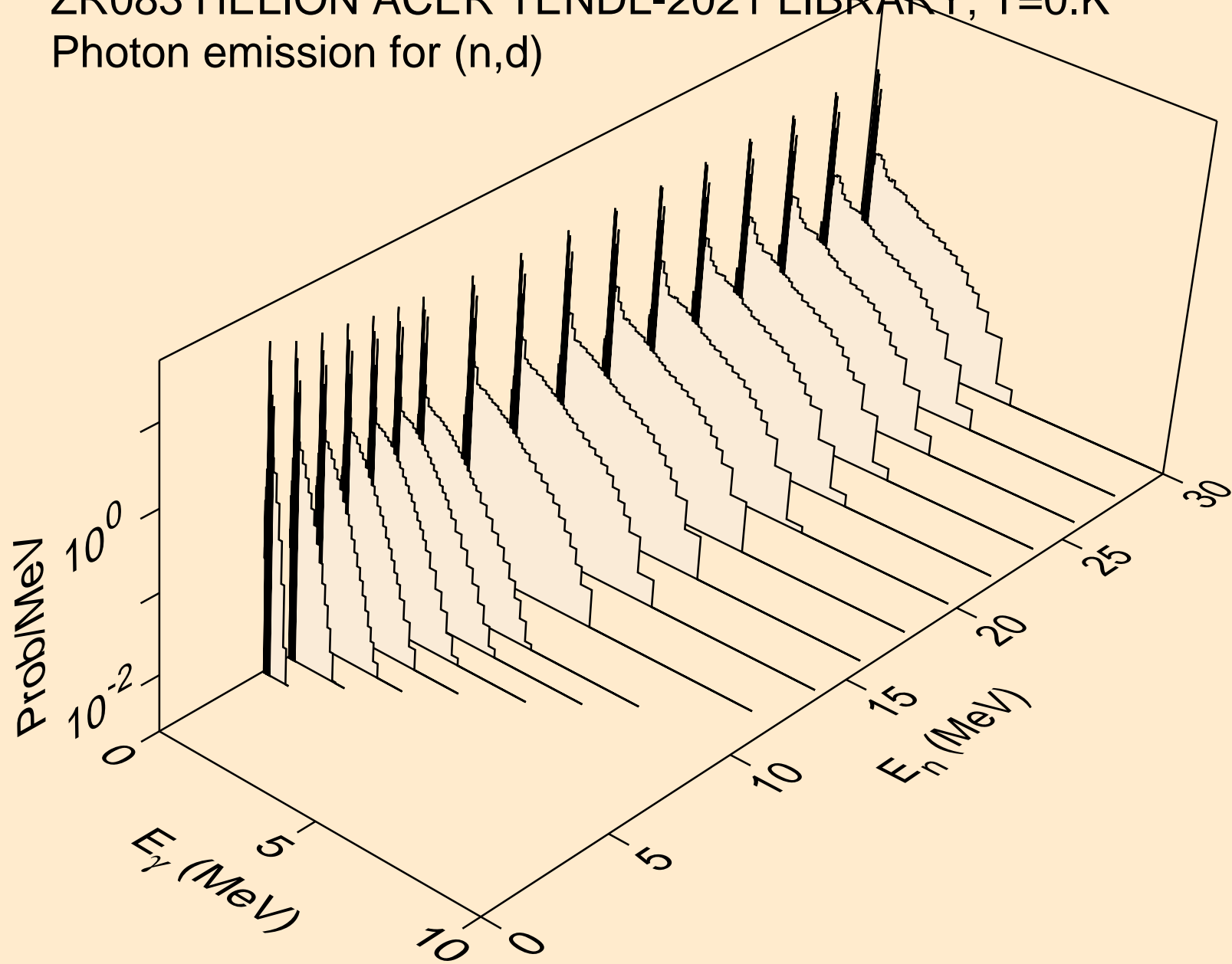



ZR083 HELION ACER TENDL-2021 LIBRARY; T=0.K  
Photon emission for (n,t)

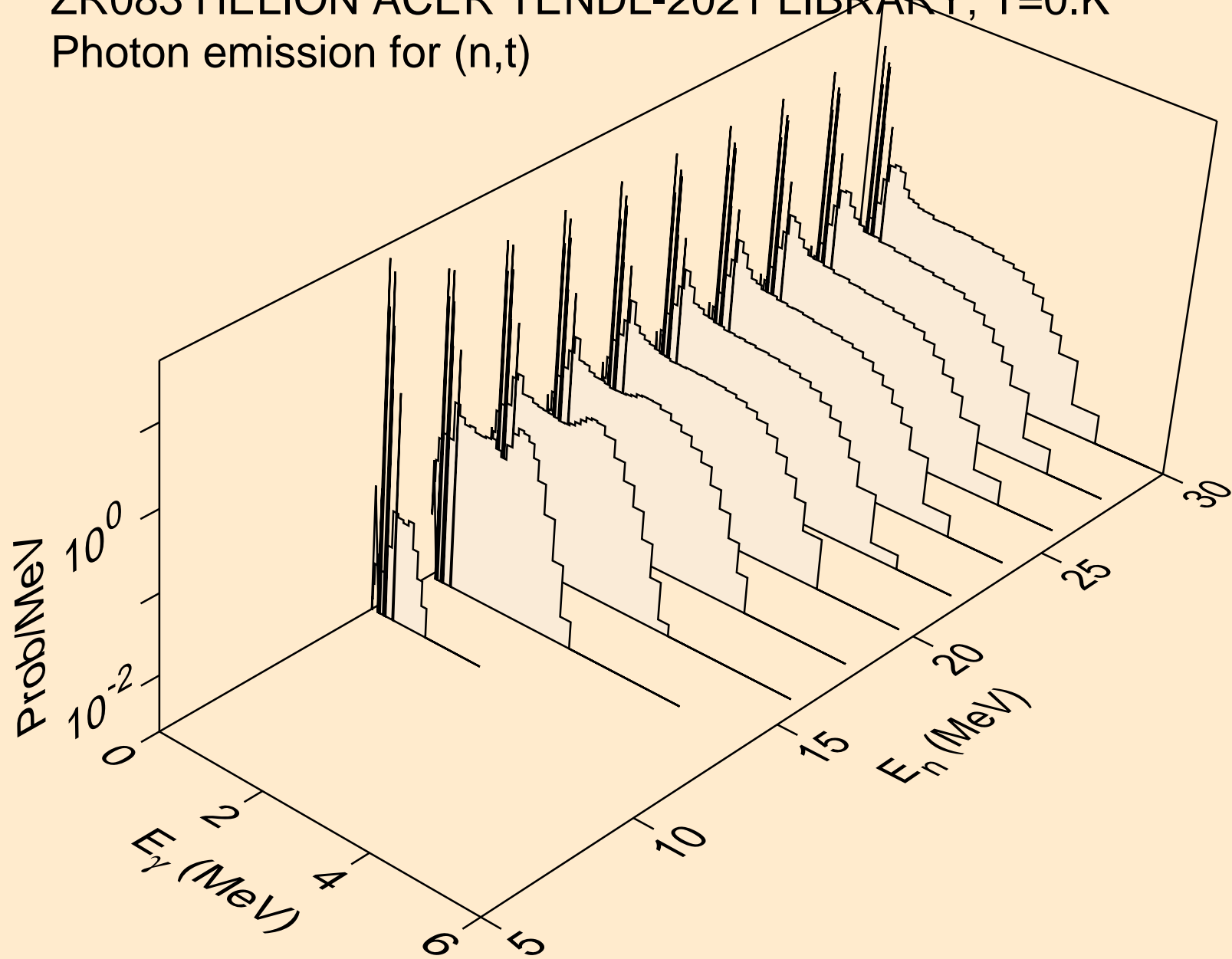

ZR083 HELION ACER TENDL-2021 LIBRARY; T=0.K  
Photon emission for inelastic

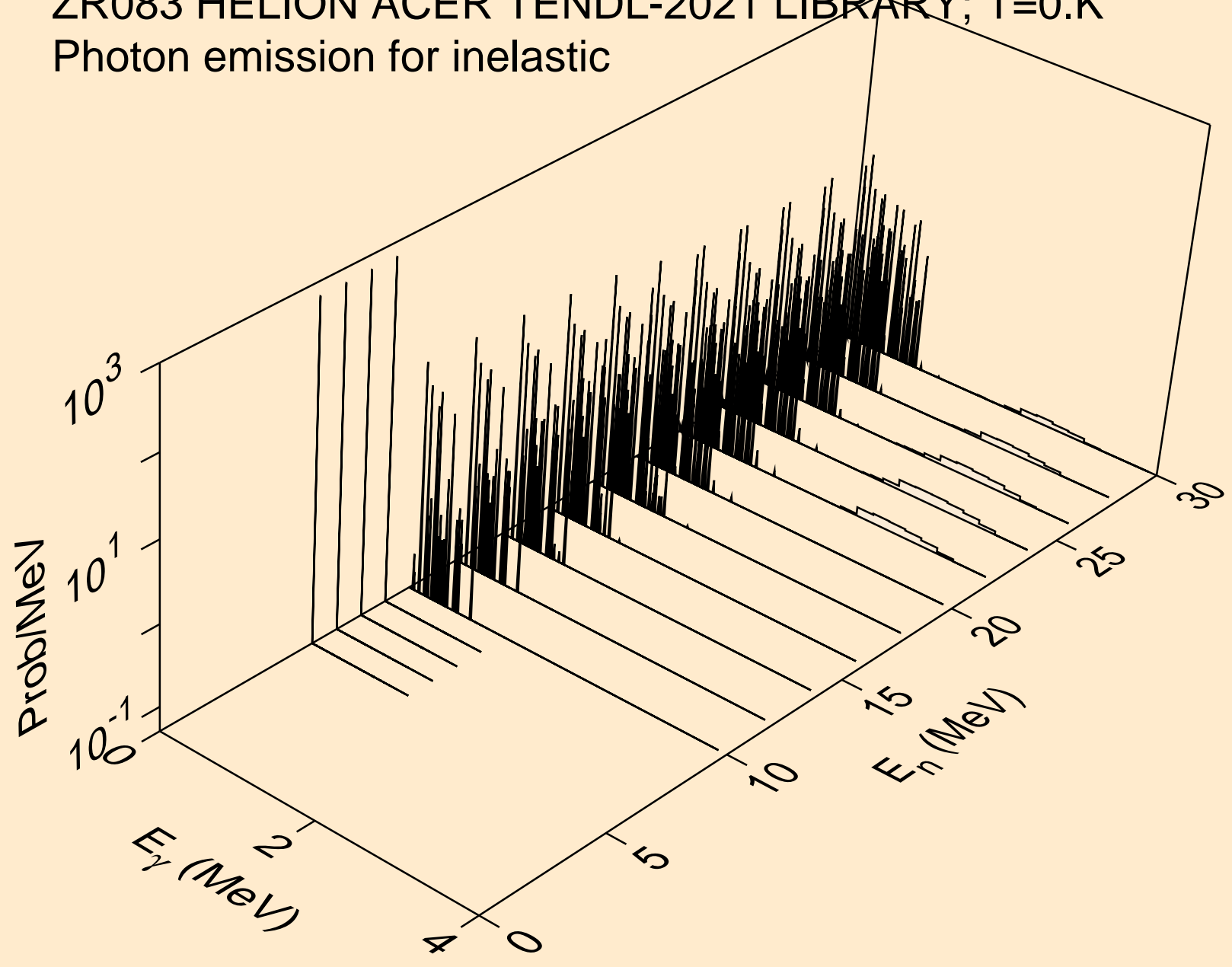

ZR083 HELION ACER TENDL-2021 LIBRARY; T=0.K  
Photon emission for (n,a)

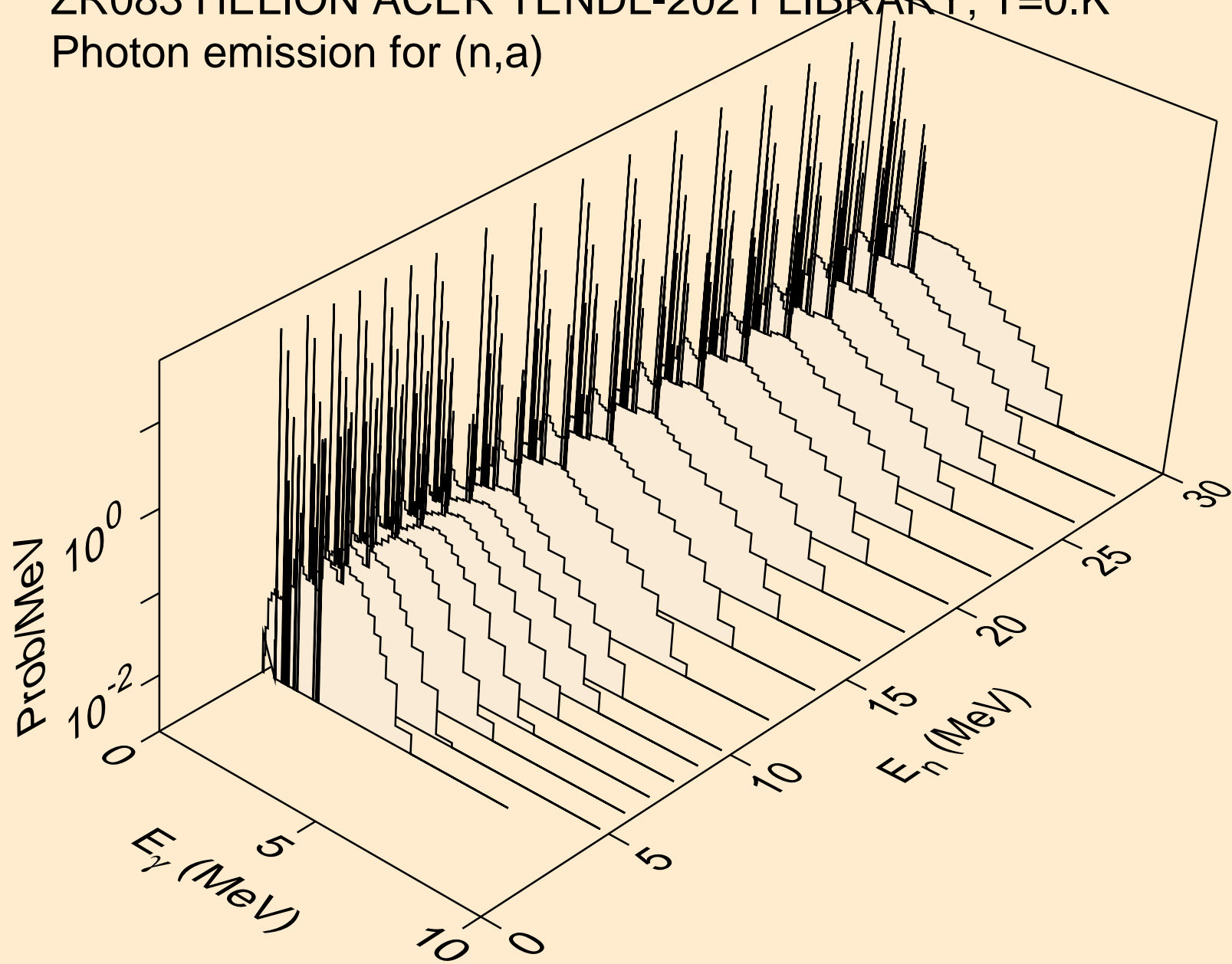

ZR083 HELION ACER TENDL-2021 LIBRARY; T=0.K  
Photon emission for (n,2a)

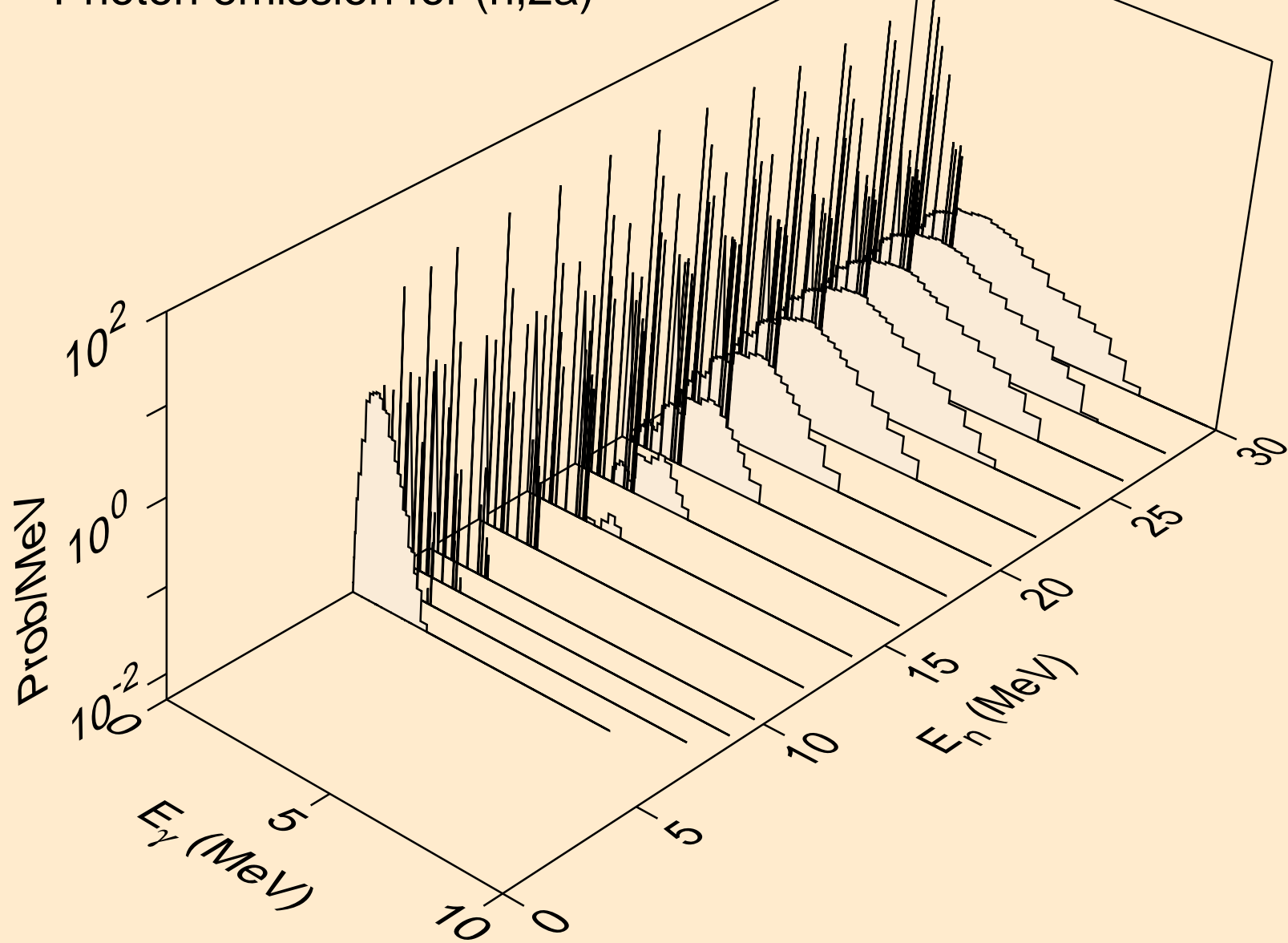

ZR083 HELION ACER TENDL-2021 LIBRARY; T=0.K  
Photon emission for (n,3a)

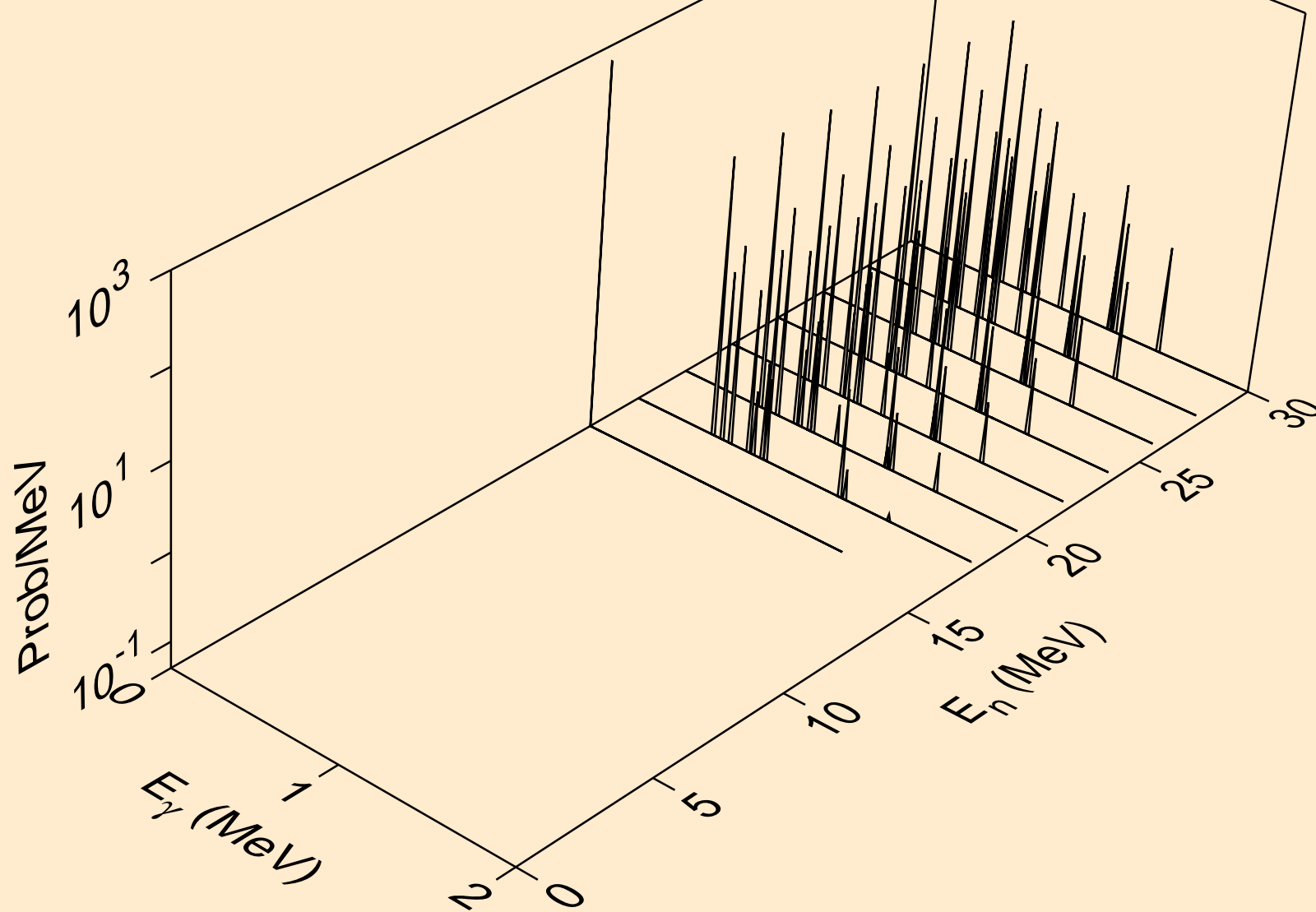

ZR083 HELION ACER TENDL-2021 LIBRARY; T=0.K  
Photon emission for (n,2p)

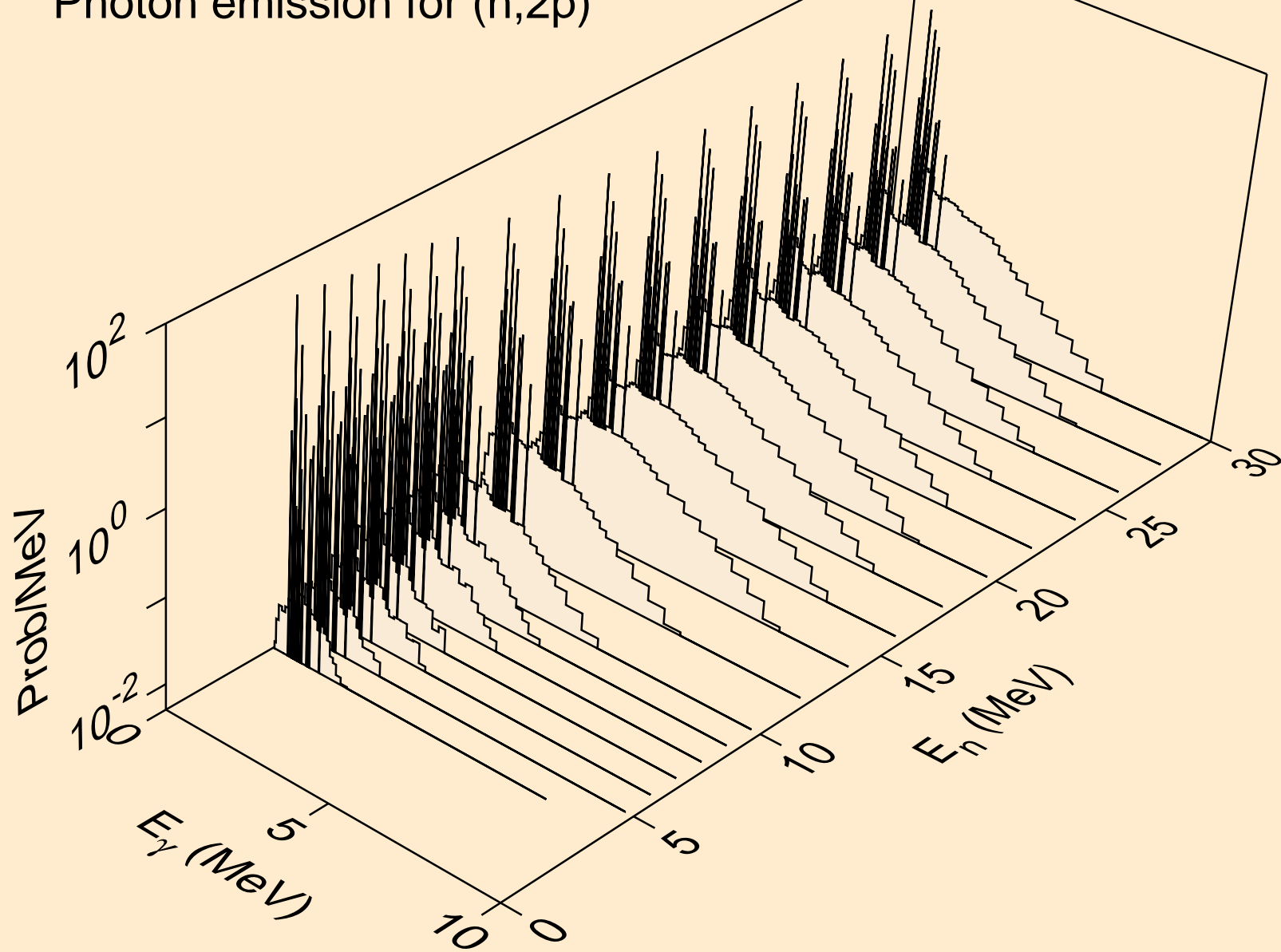

ZR083 HELION ACER TENDL-2021 LIBRARY; T=0.K  
Photon emission for (n,p $\alpha$ )

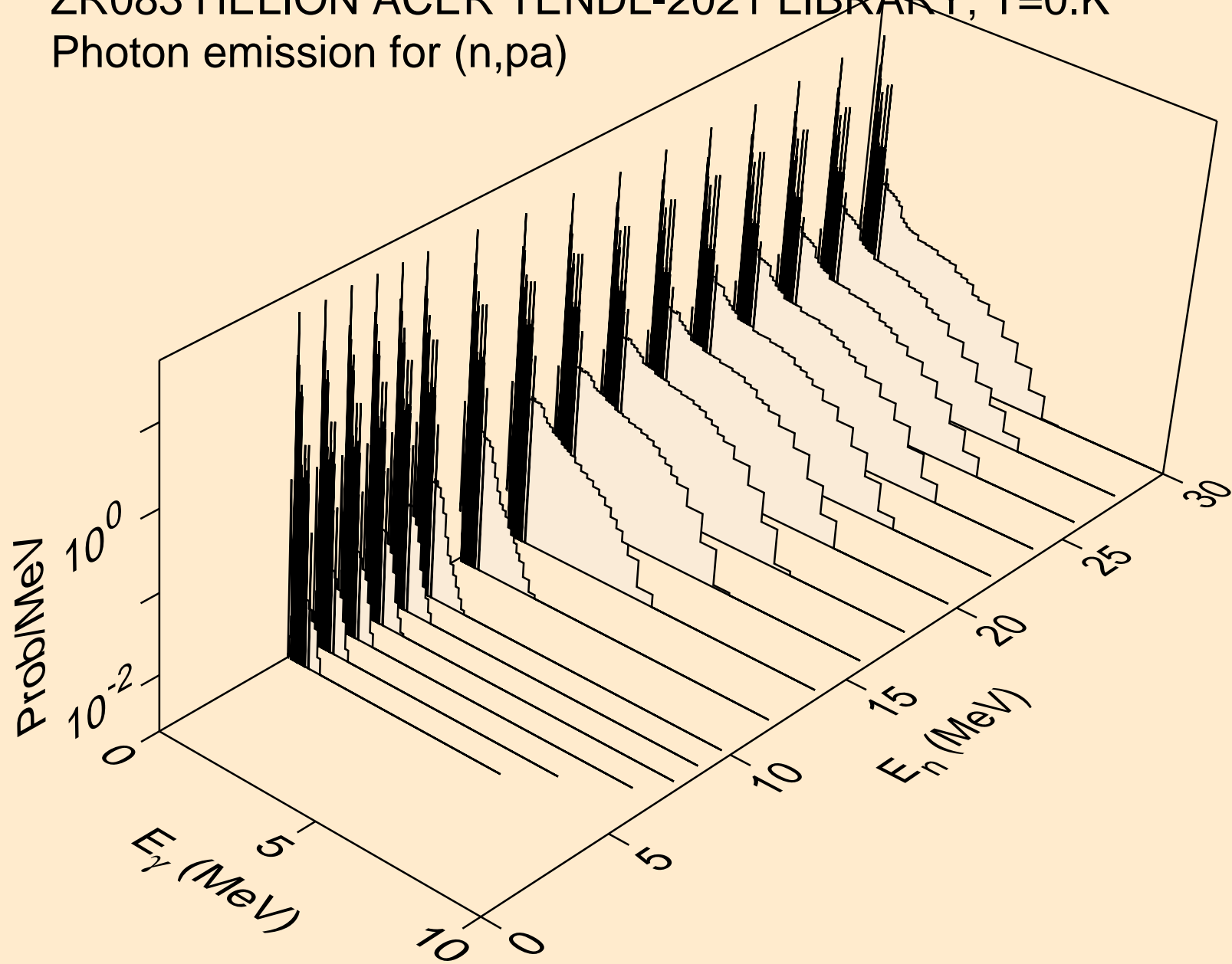

ZR083 HELION ACER TENDL-2021 LIBRARY; T=0.K  
Photon emission for (n,pd)

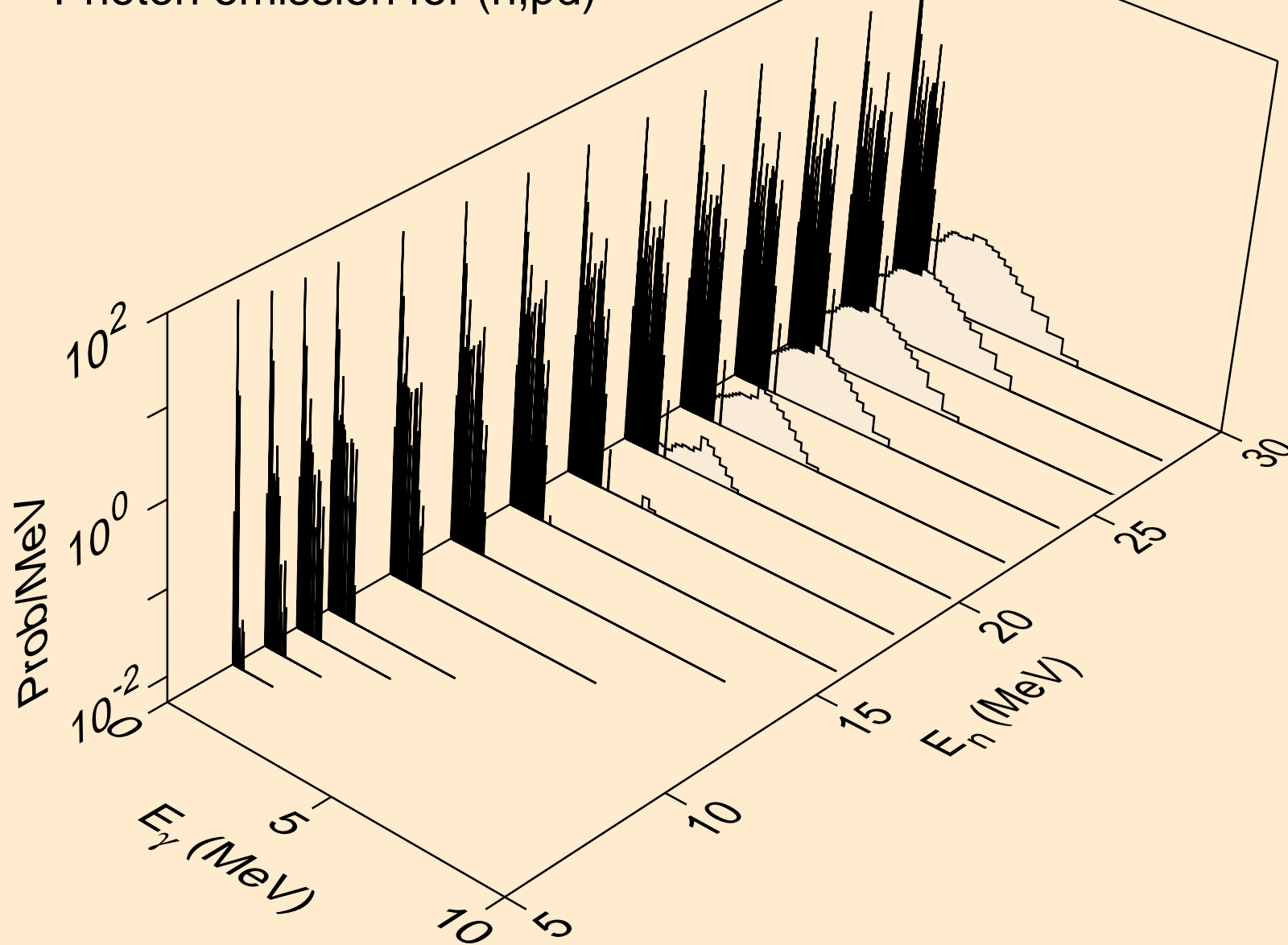



ZR083 HELION ACER TENDL-2021 LIBRARY; T=0.K  
Photon emission for (n,pt)

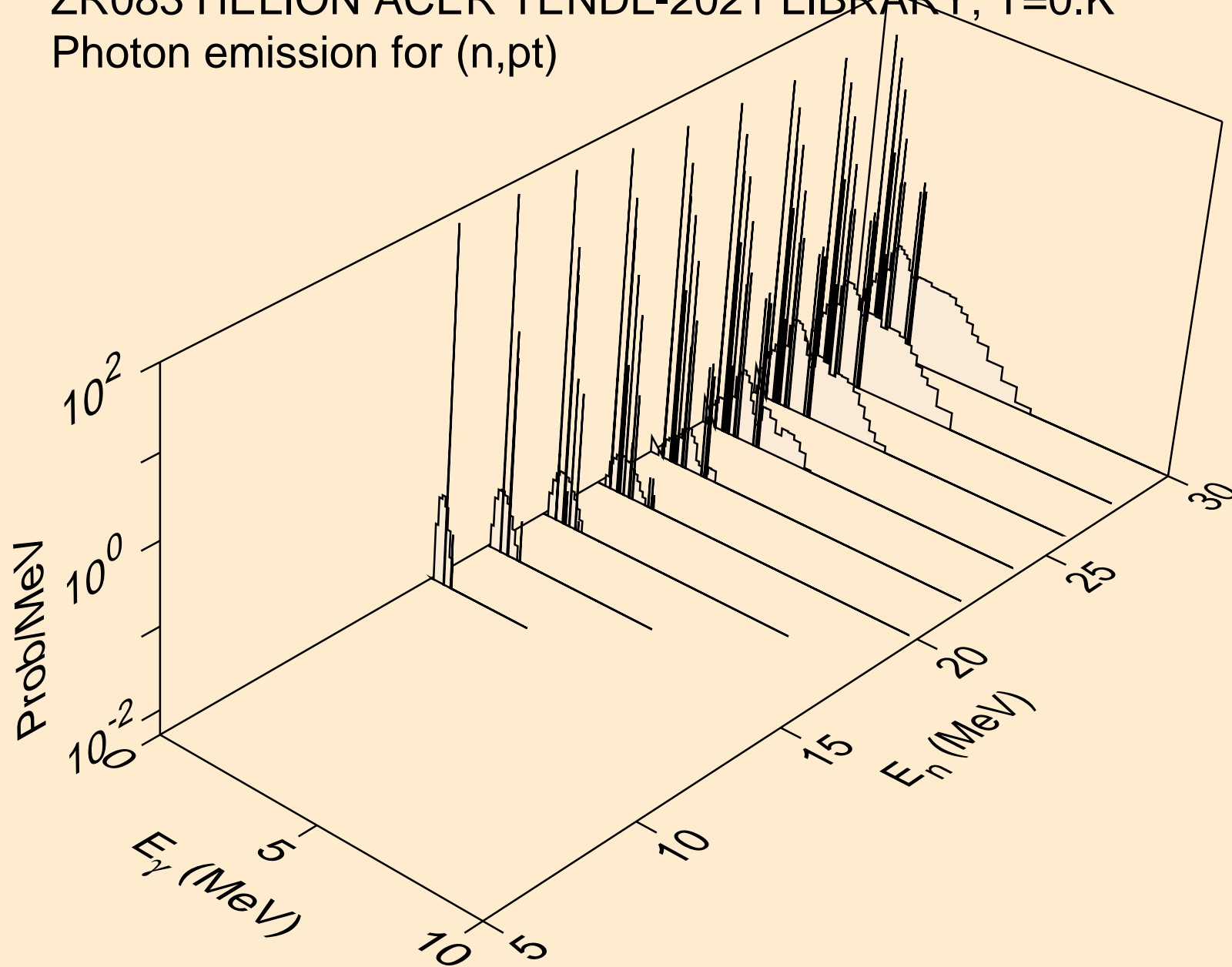

ZR083 HELION ACER TENDL-2021 LIBRARY; T=0.K  
Photon emission for (n,da)

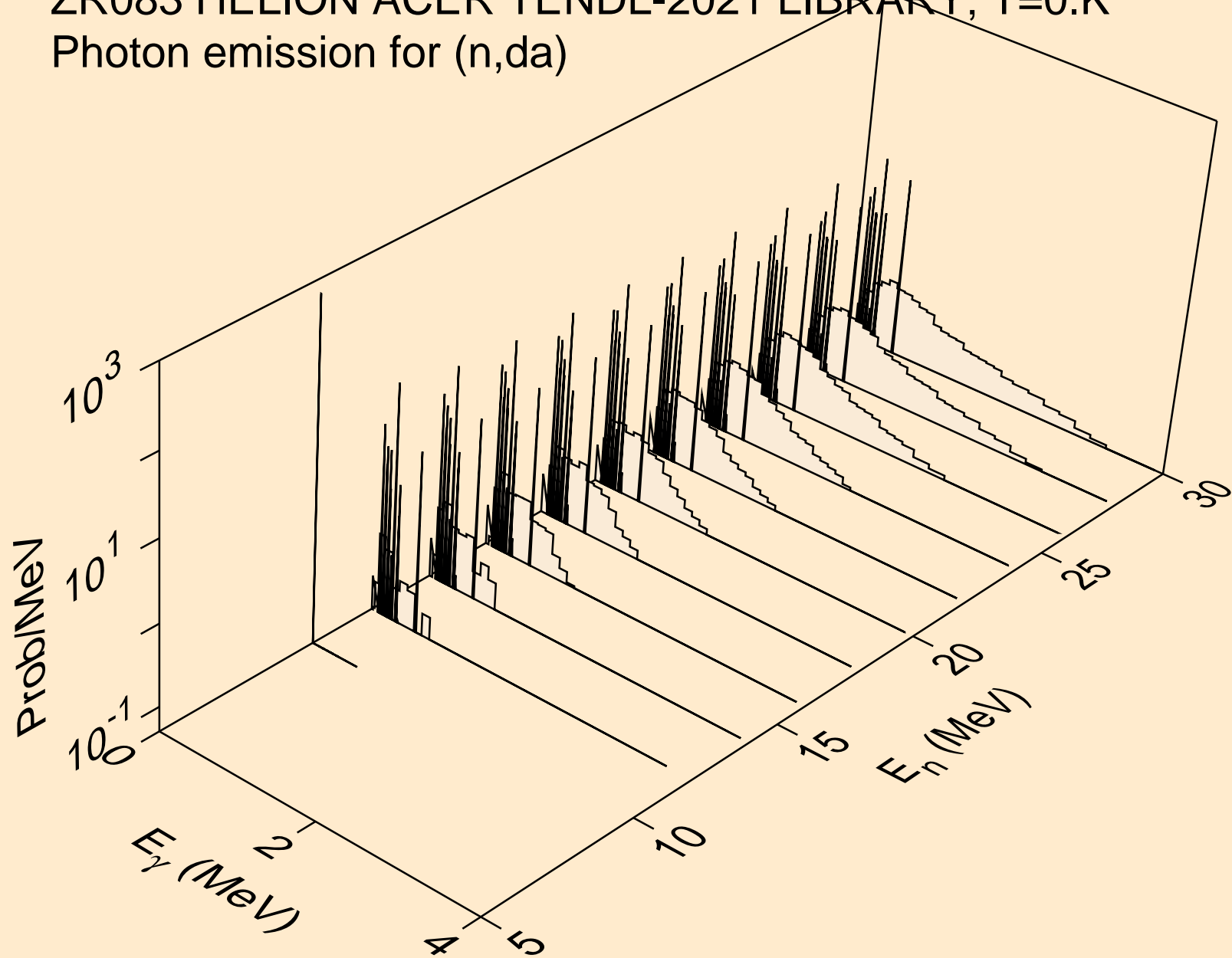

ZR083 HELION ACER TENDL-2021 LIBRARY; T=0.K  
Particle heating contributions

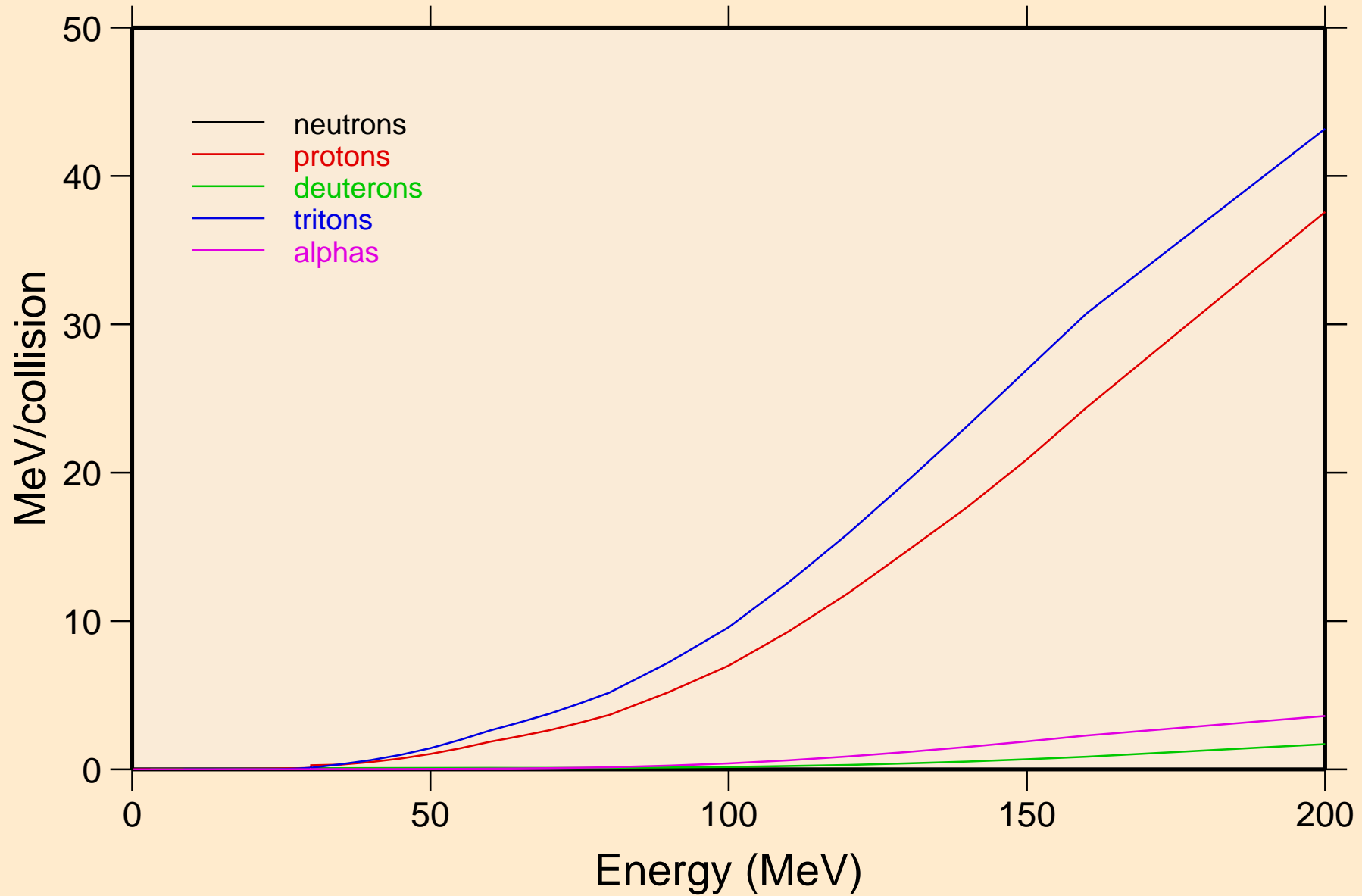

ZR083 HELION ACER TENDL-2021 LIBRARY; T=0.K  
Recoil Heating

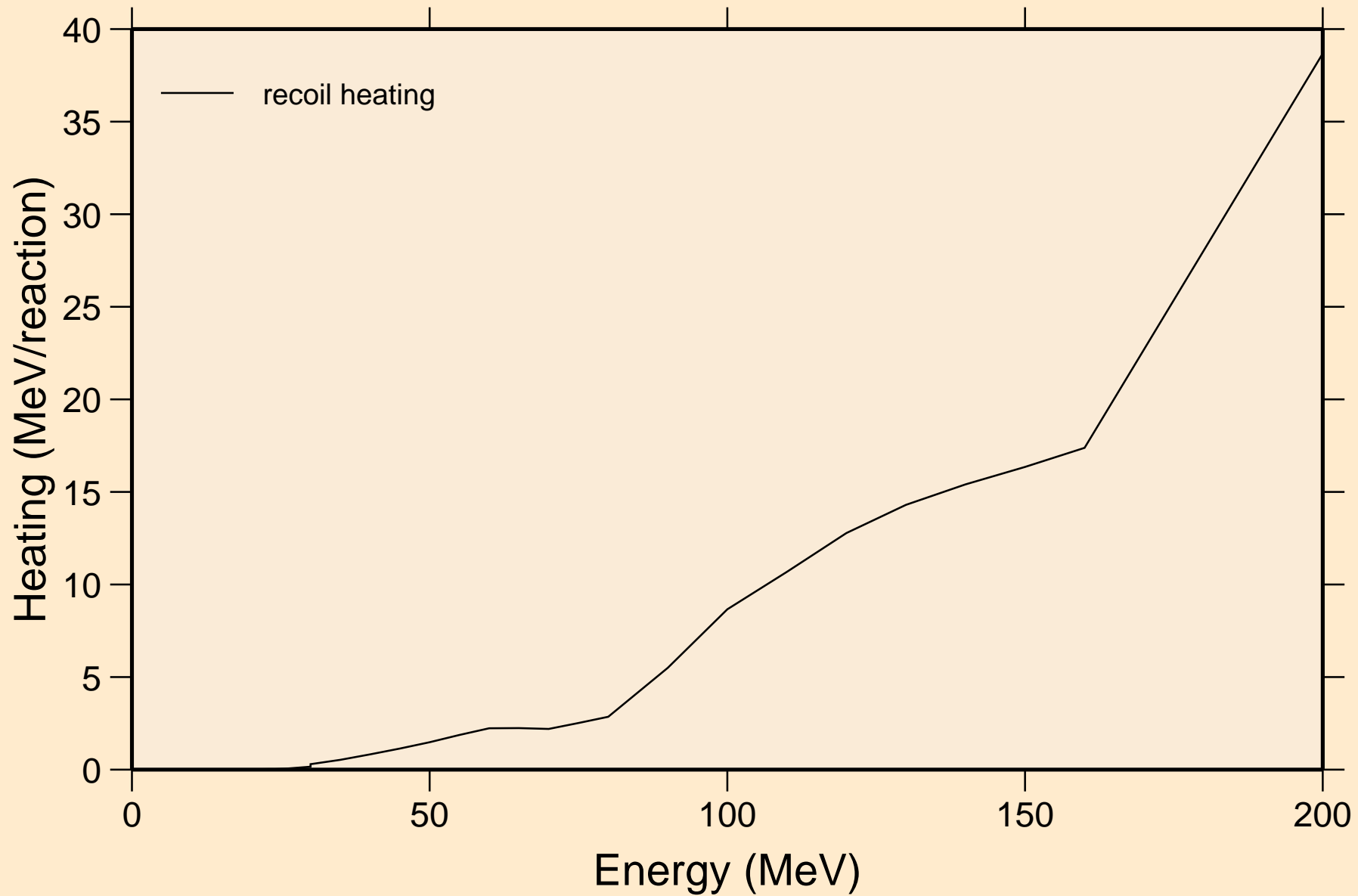

ZR083 HELION ACER TENDL-2021 LIBRARY; T=0.K  
Particle production cross sections

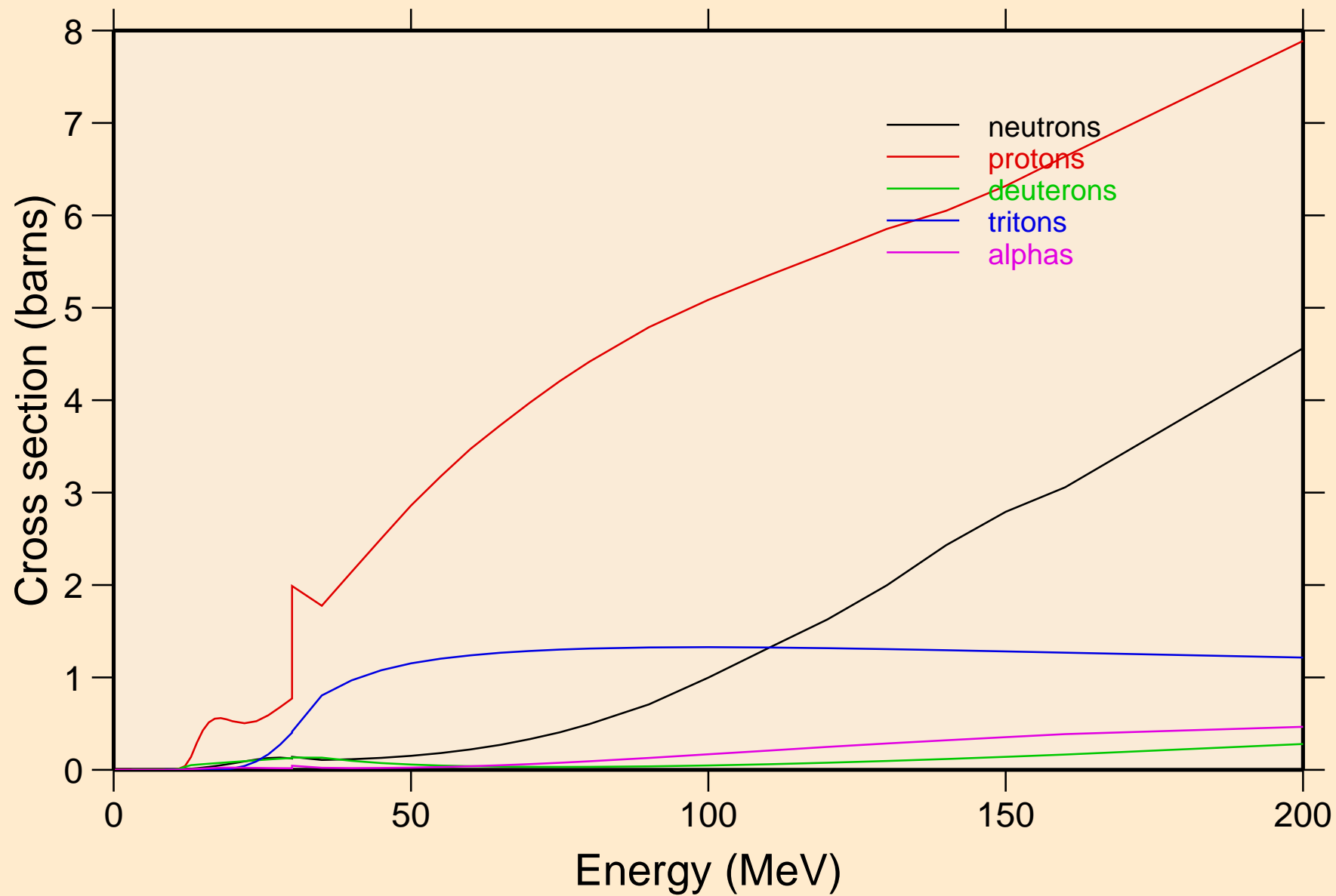

ZR083 HELION ACER TENDL-2021 LIBRARY; T=0.K  
neutrons from (s,n)

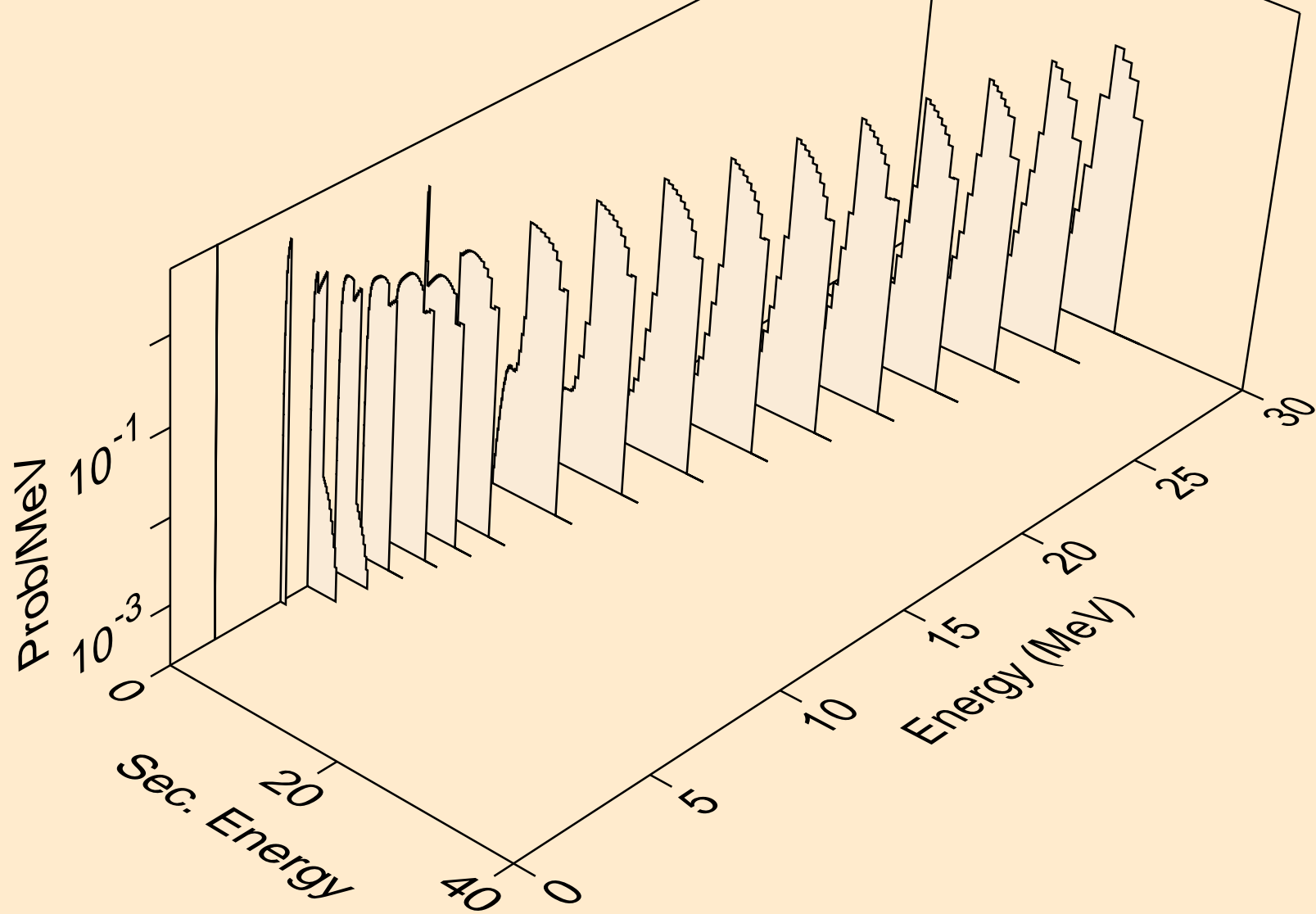

ZR083 HELION ACER TENDL-2021 LIBRARY; T=0.K  
neutrons from (s,x)

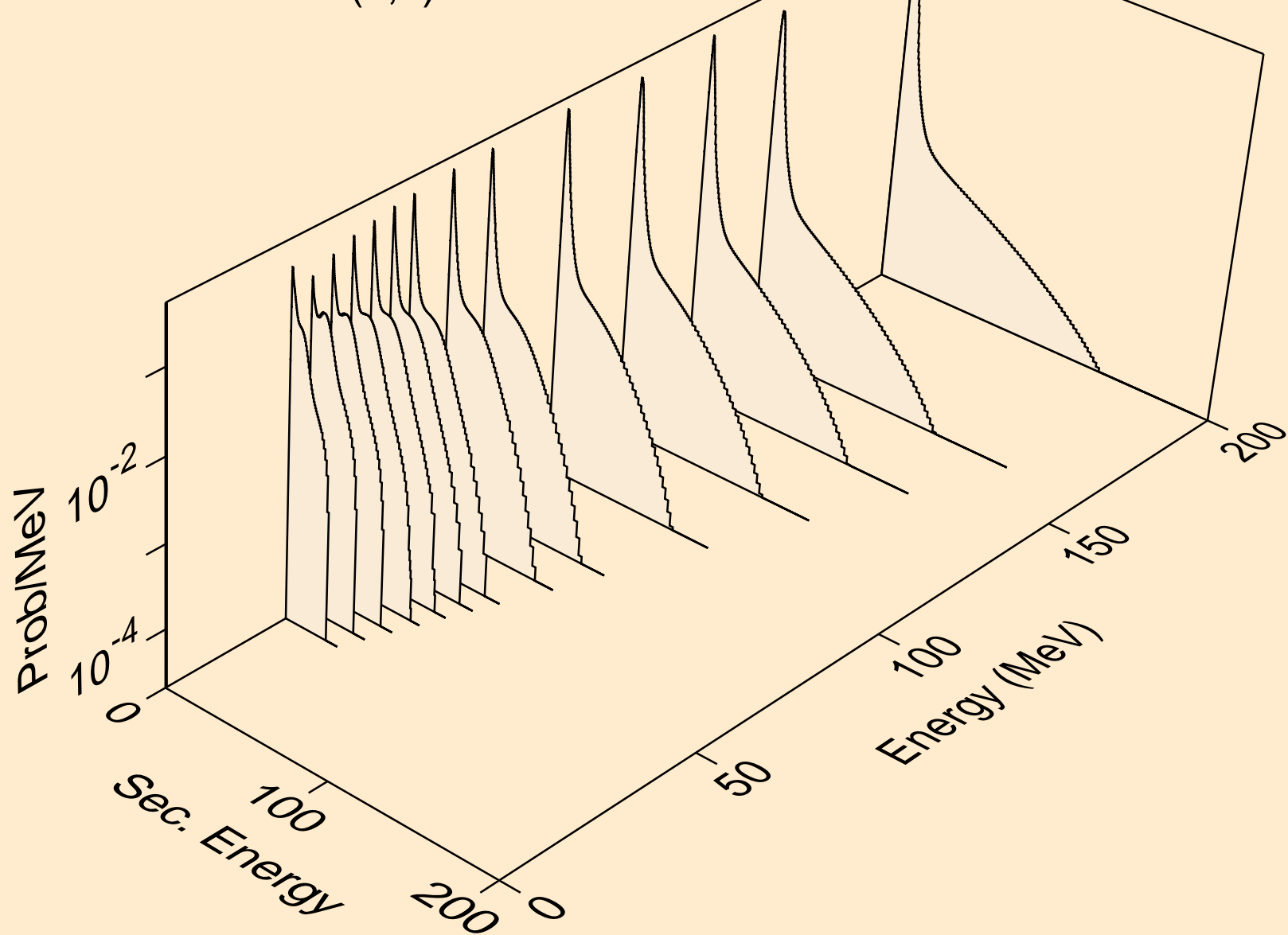

ZR083 HELION ACER TENDL-2021 LIBRARY; T=0.K  
neutrons from (s,2n)

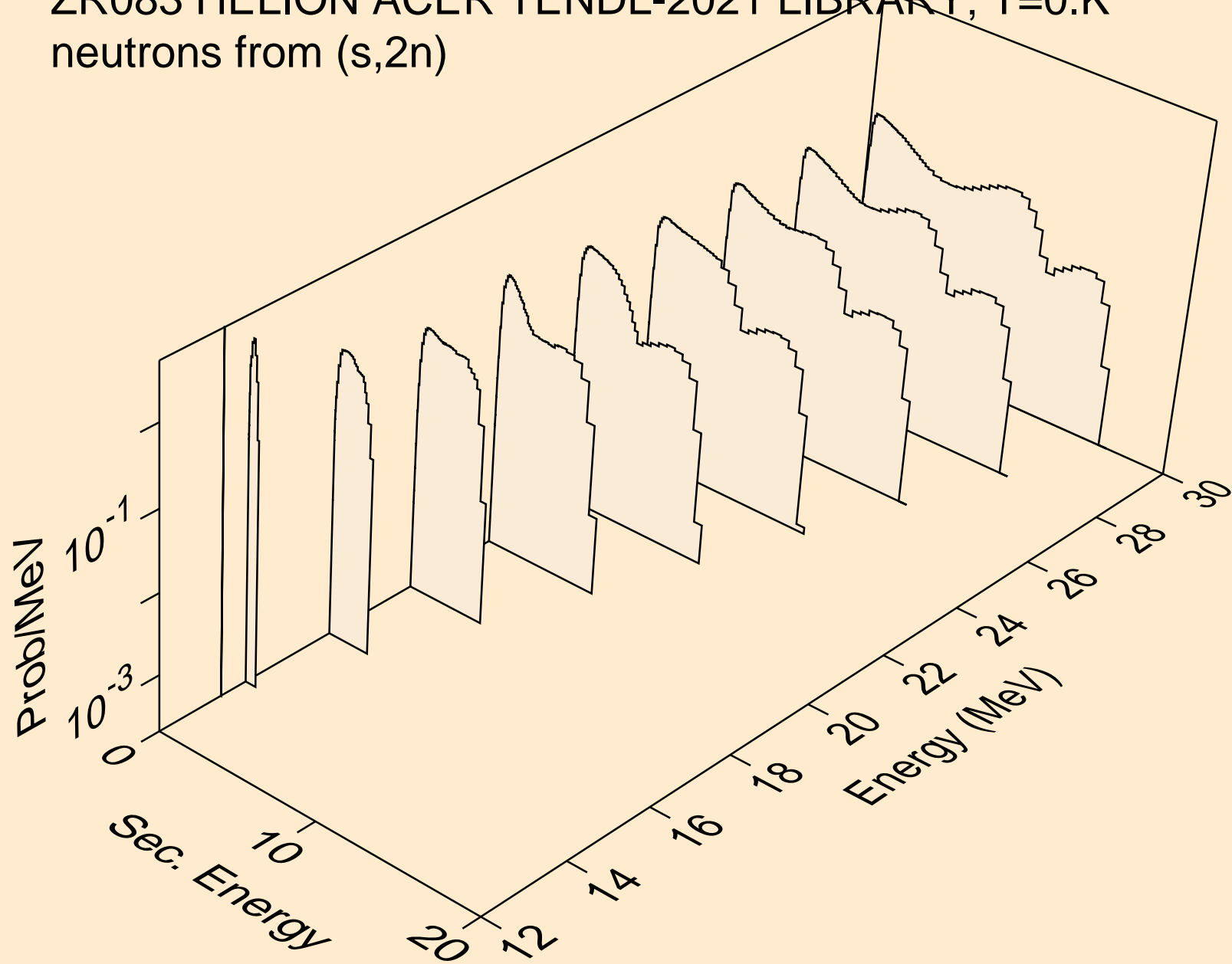



ZR083 HELION ACER TENDL-2021 LIBRARY; T=0.K  
neutrons from (s,n\*)a

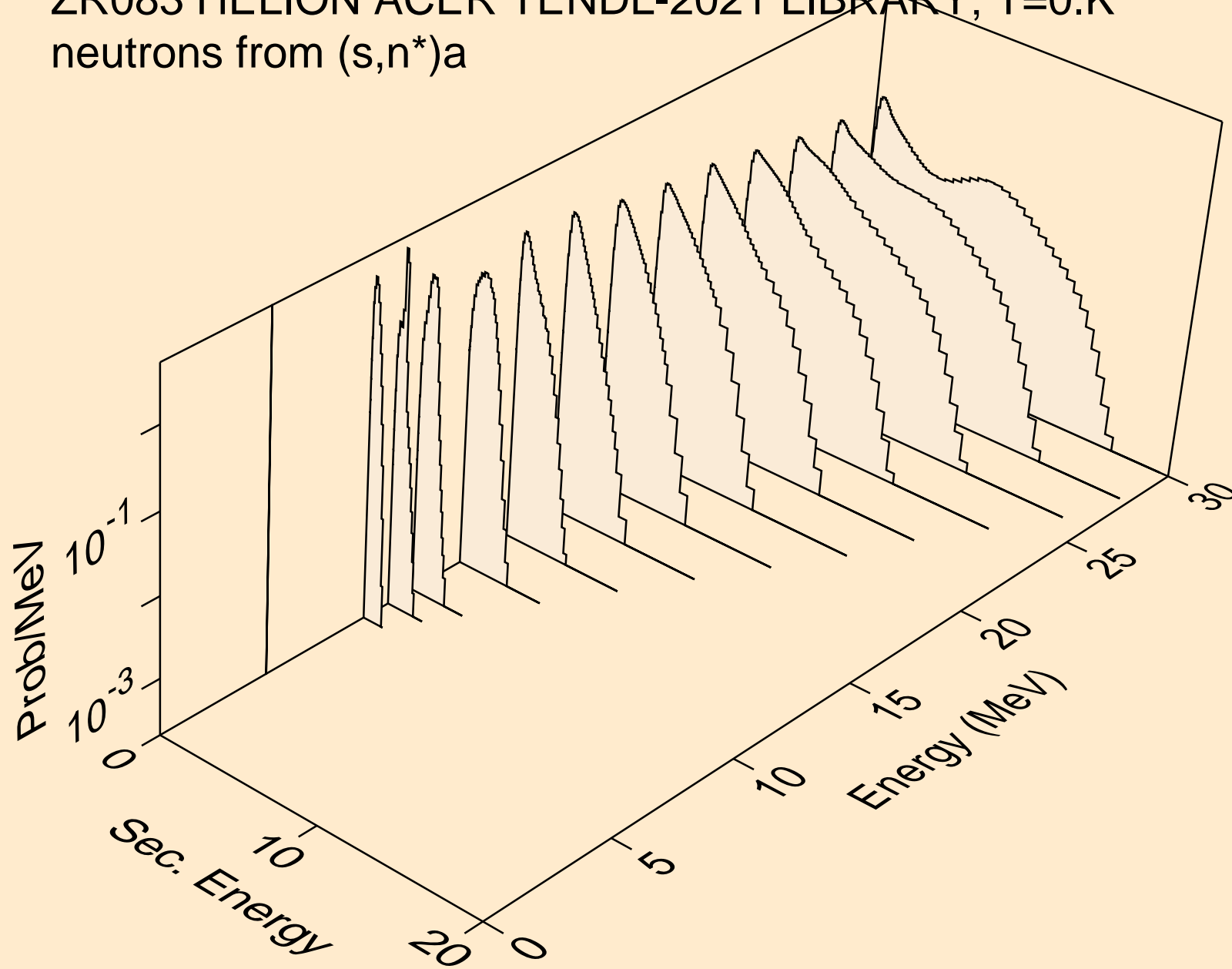

ZR083 HELION ACER TENDL-2021 LIBRARY; T=0.K  
neutrons from (s,2n)a

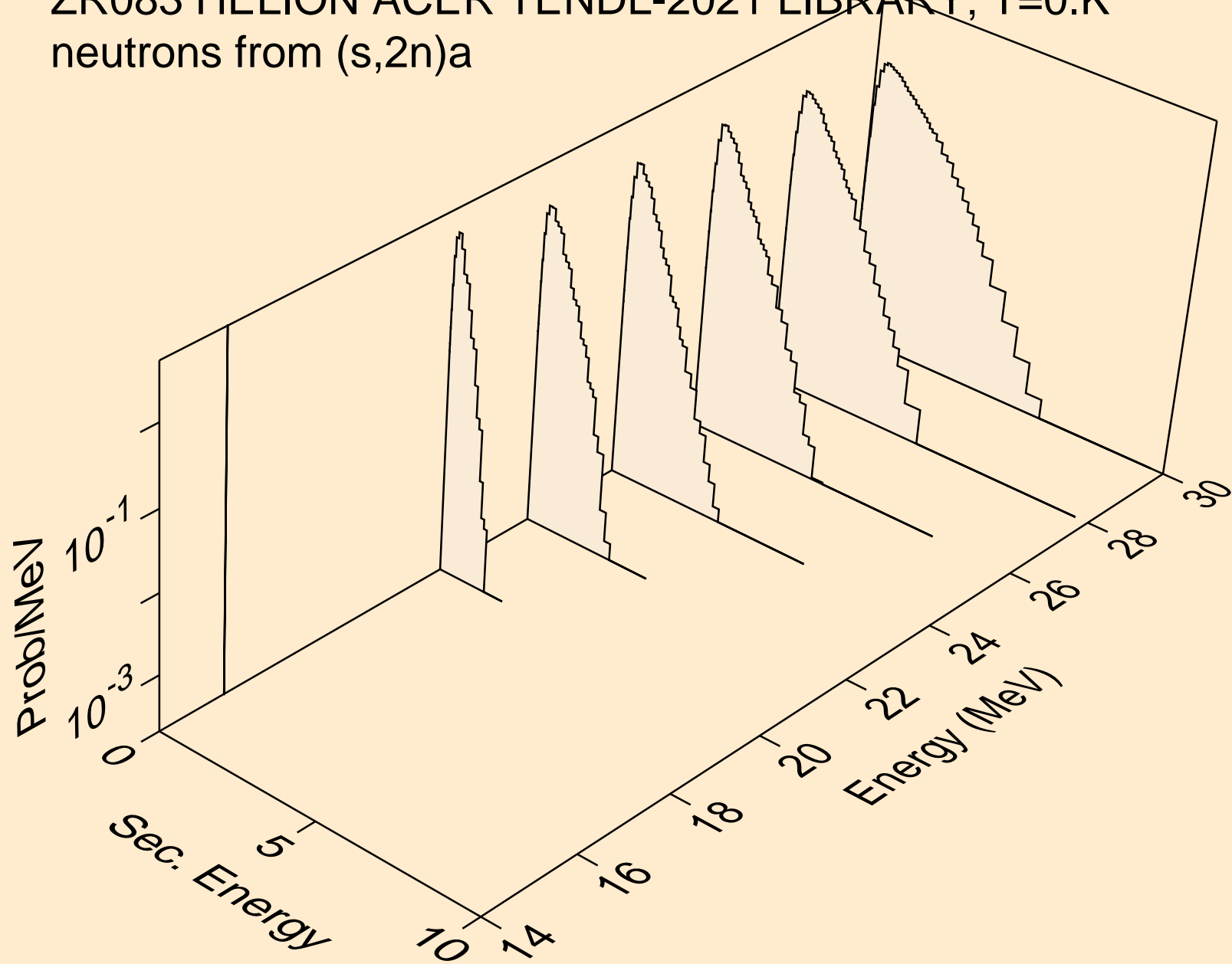

ZR083 HELION ACER TENDL-2021 LIBRARY; T=0.K  
neutrons from (s,n\*)p

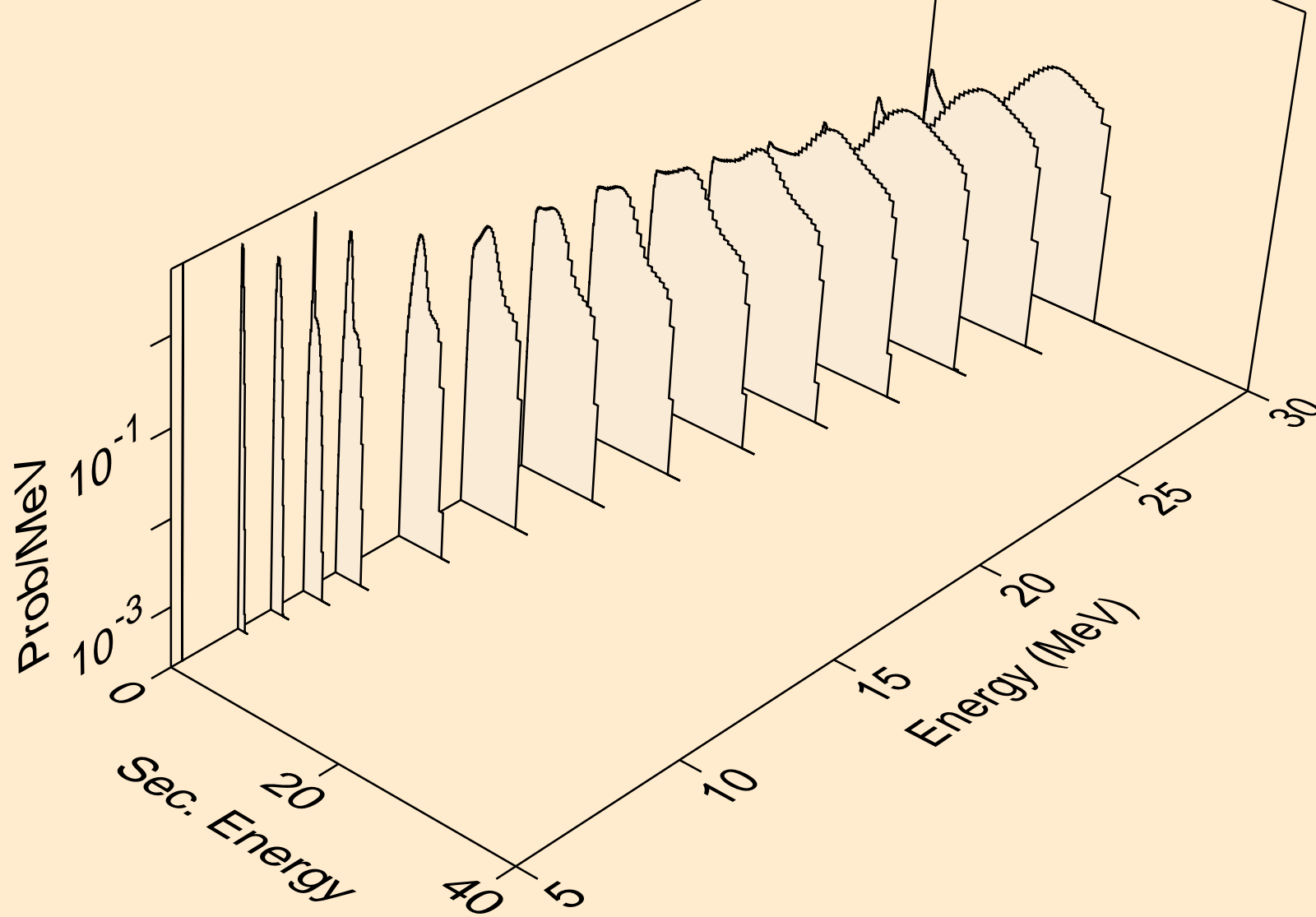

ZR083 HELION ACER TENDL-2021 LIBRARY; T=0.K  
neutrons from (s,n\*)2a

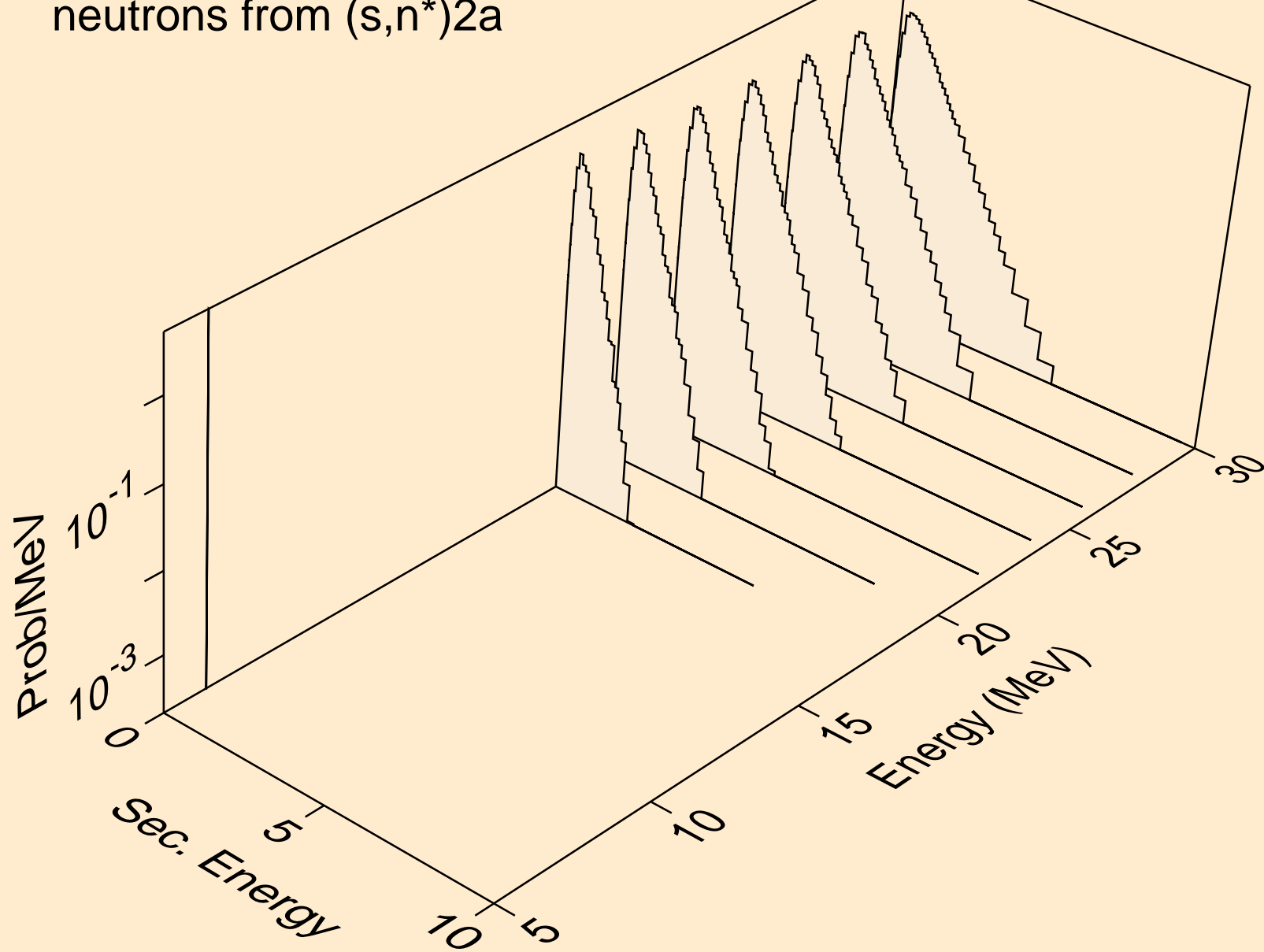

ZR083 HELION ACER TENDL-2021 LIBRARY; T=0.K  
neutrons from (s,n\*)d

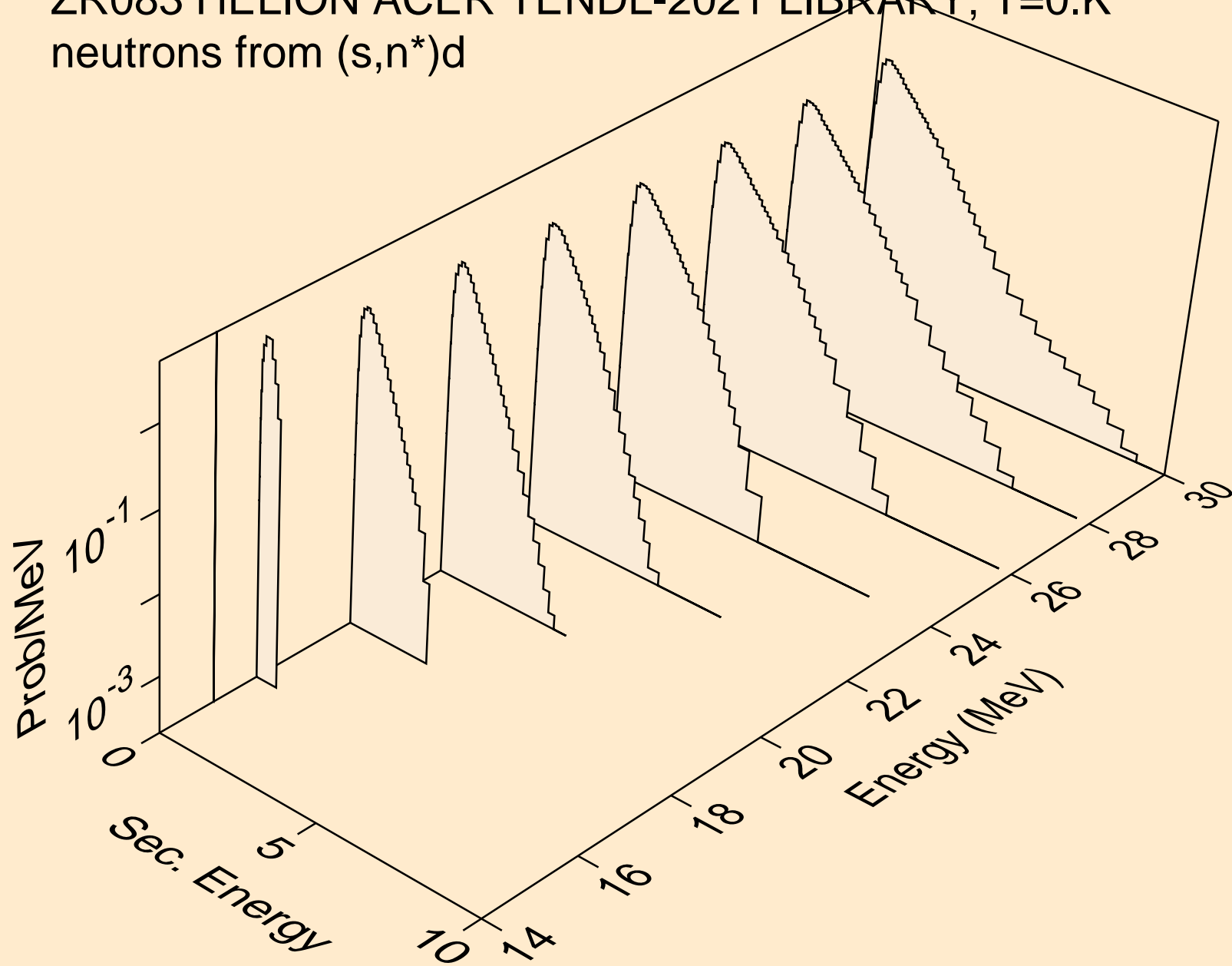

ZR083 HELION ACER TENDL-2021 LIBRARY; T=0.K  
neutrons from (s,n\*)t

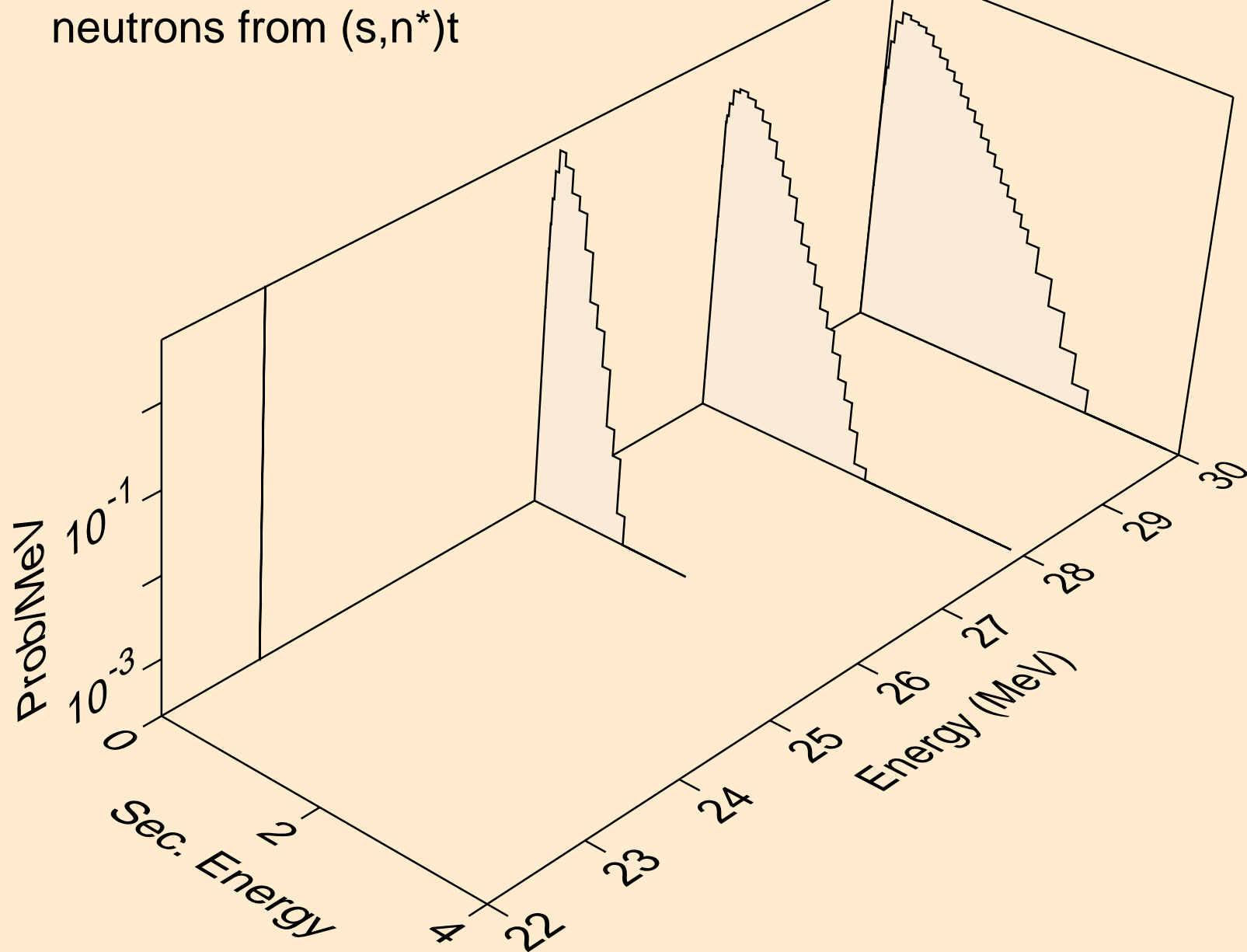

ZR083 HELION ACER TENDL-2021 LIBRARY; T=0.K  
neutrons from (s,n\*)he3

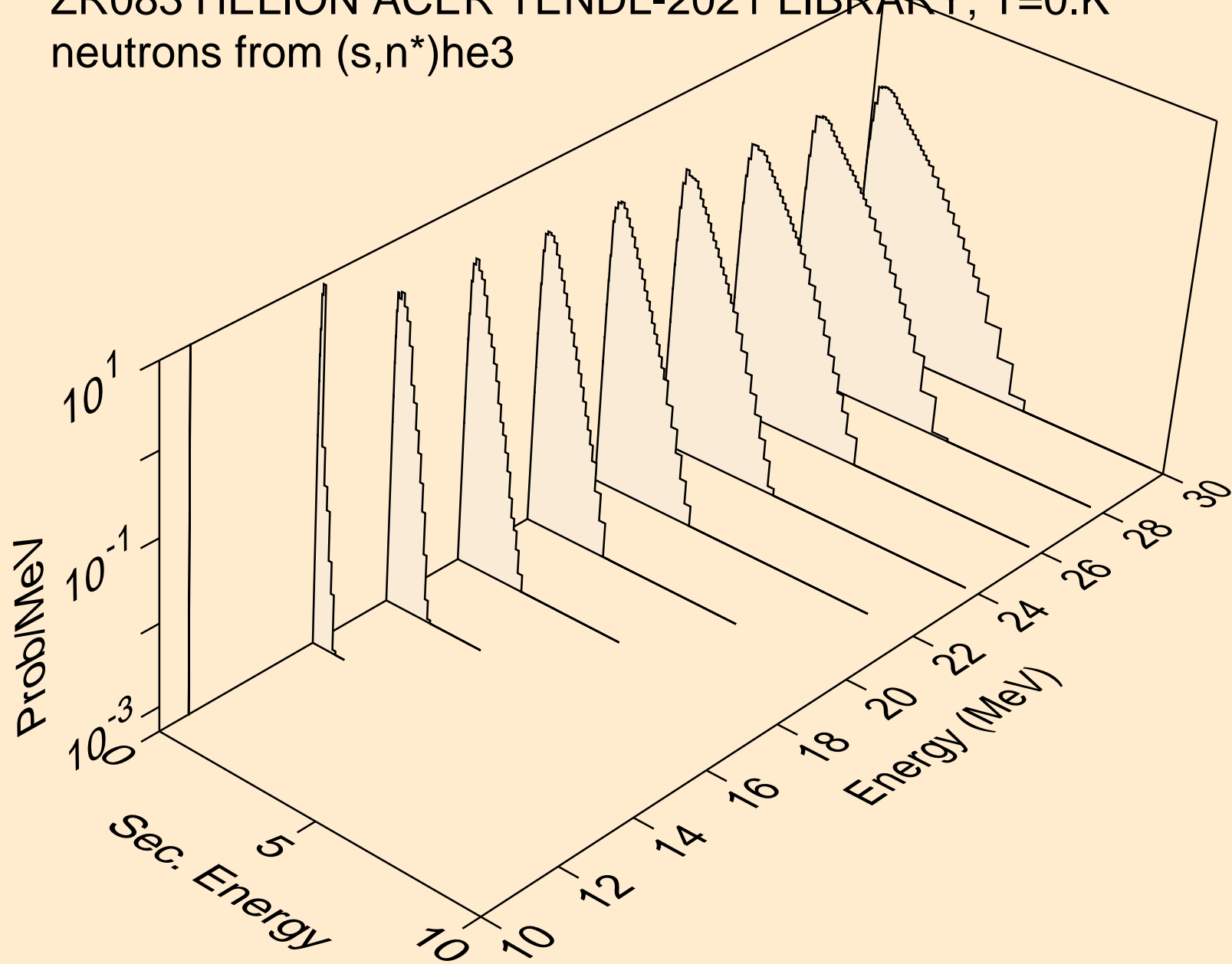

ZR083 HELION ACER TENDL-2021 LIBRARY; T=0.K  
neutrons from (s,2np)

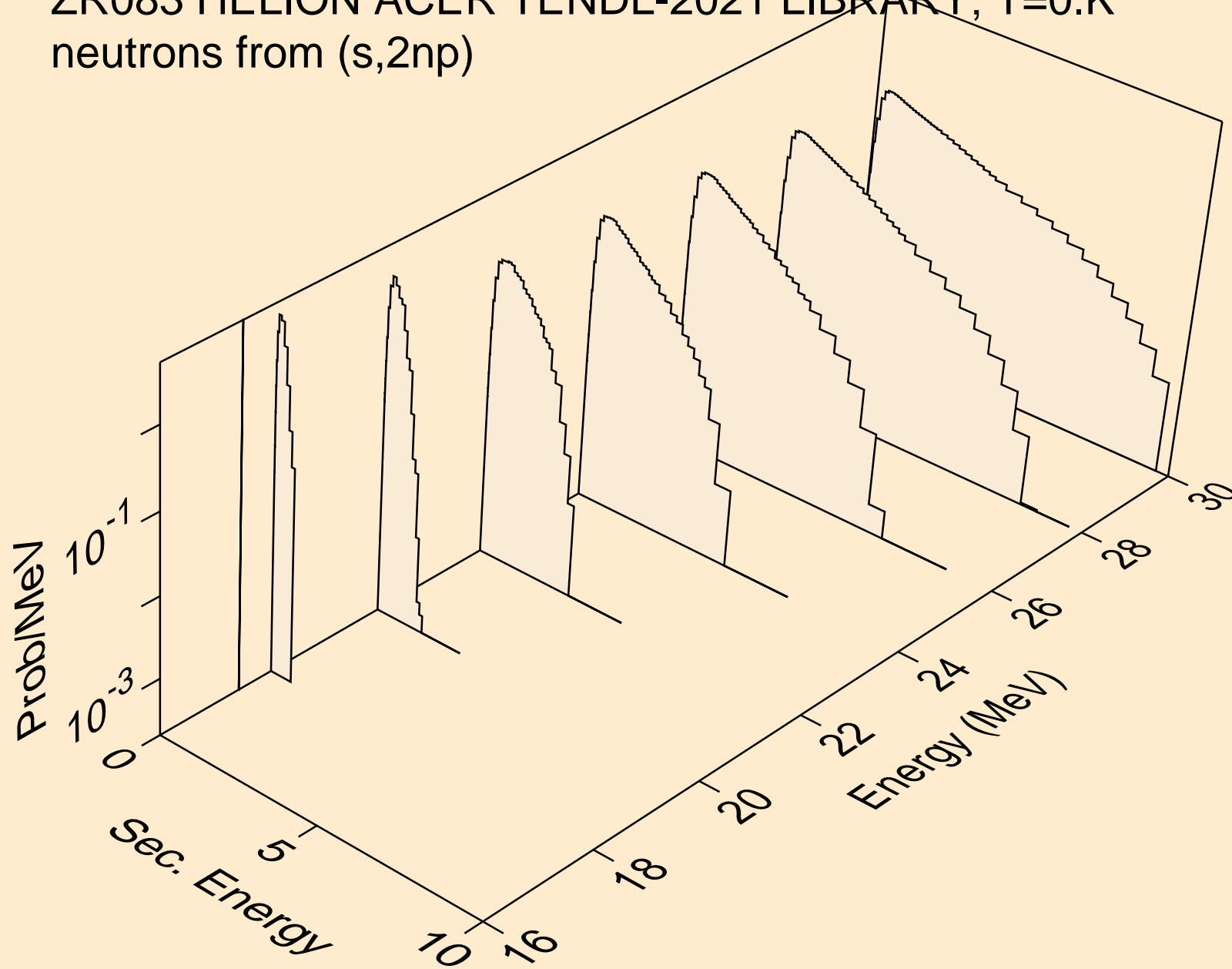



ZR083 HELION ACER TENDL-2021 LIBRARY; T=0.K  
neutrons from (s,2np)

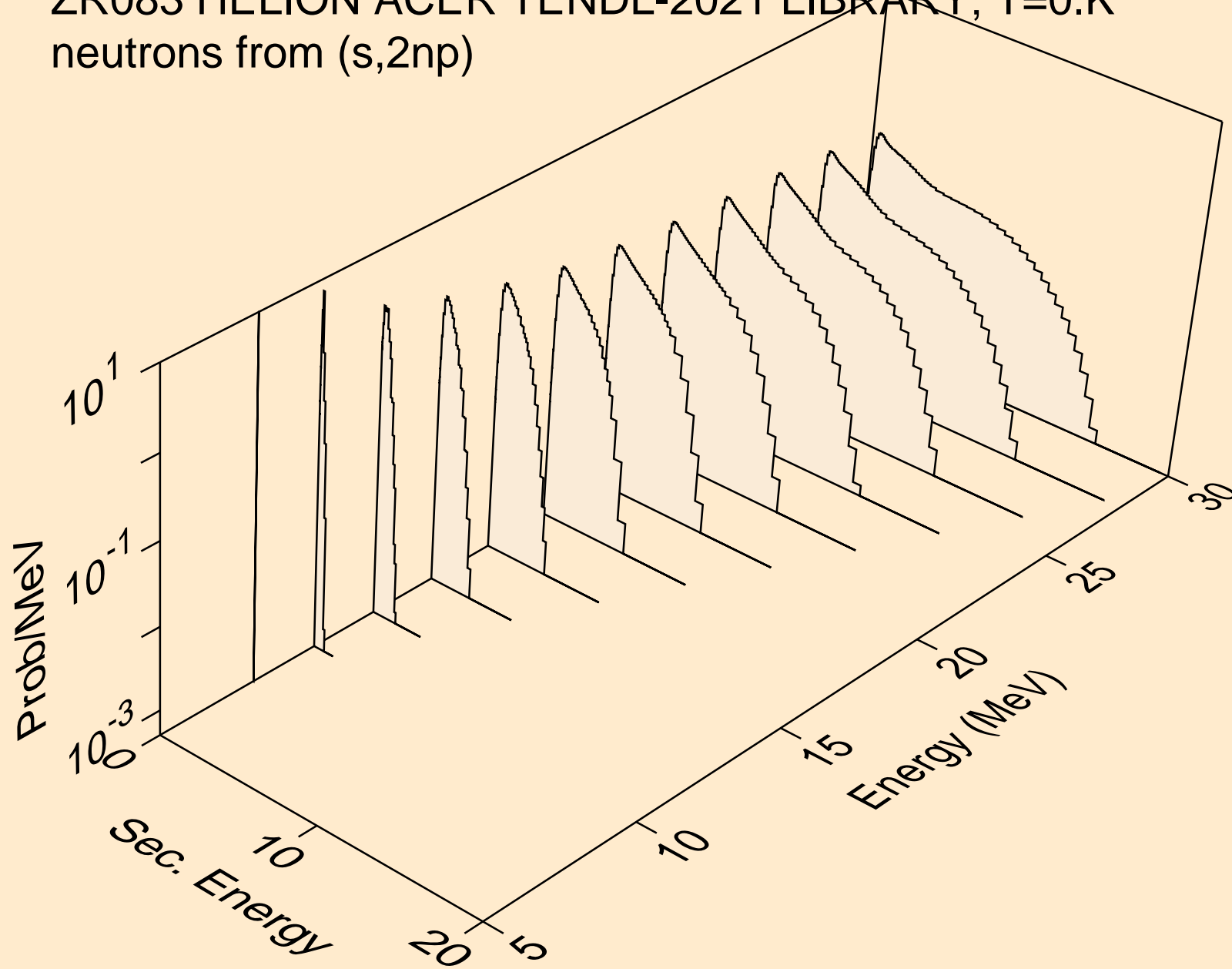

ZR083 HELION ACER TENDL-2021 LIBRARY; T=0.K  
neutrons from (s,npa)

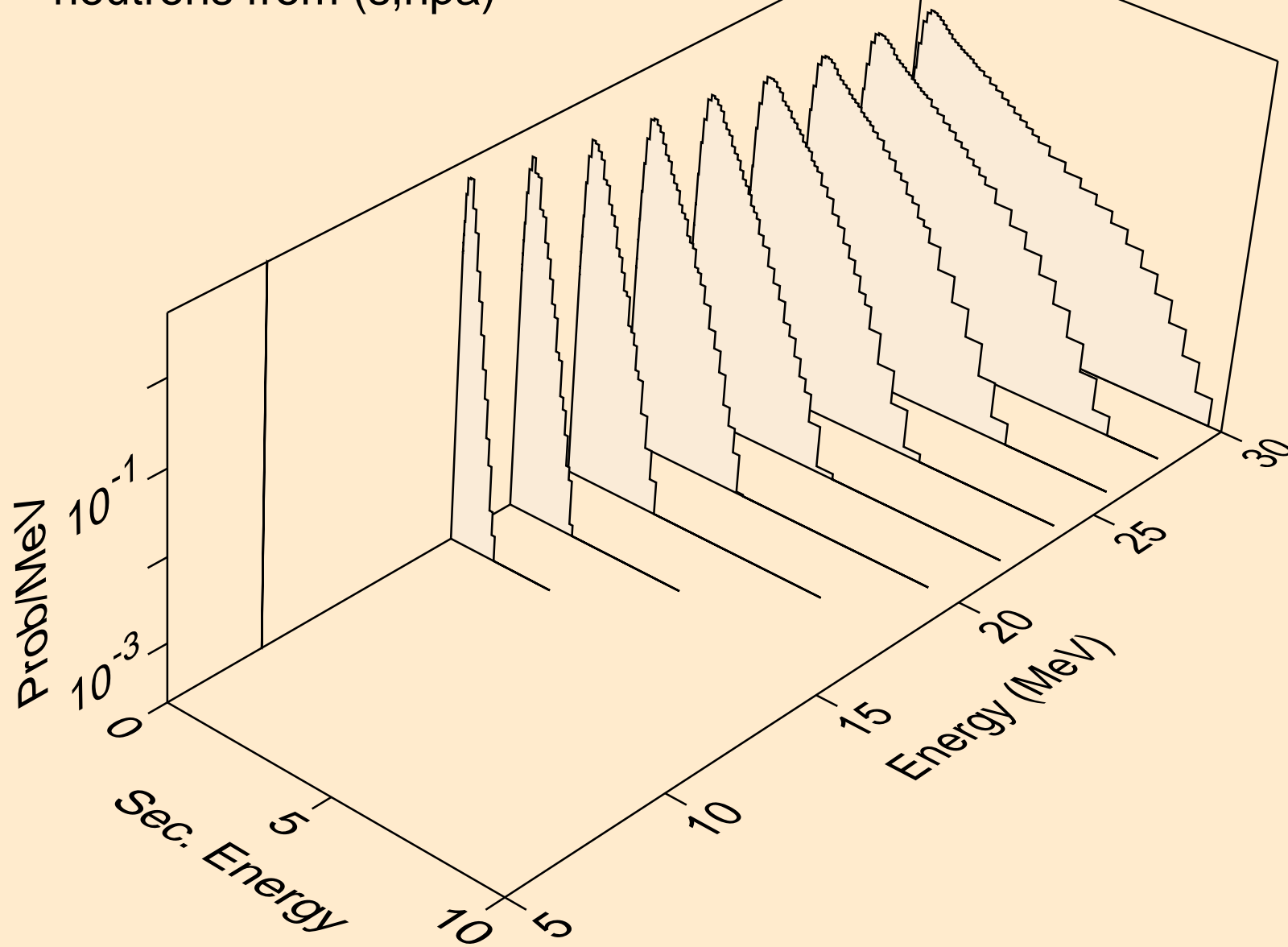

ZR083 HELION ACER TENDL-2021 LIBRARY; T=0.K  
protons from (s,x)

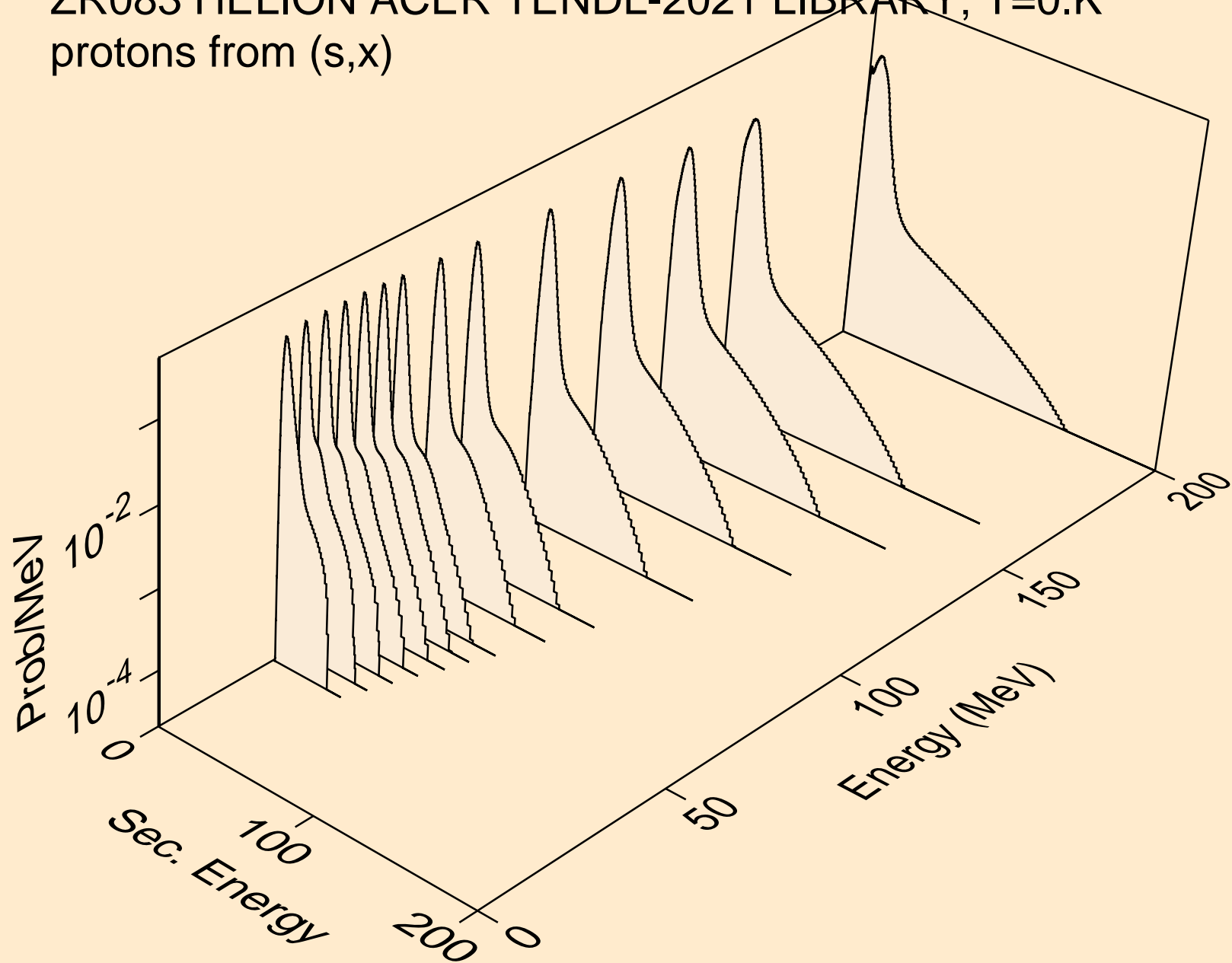

ZR083 HELION ACER TENDL-2021 LIBRARY; T=0.K  
protons from (s,n\*)p

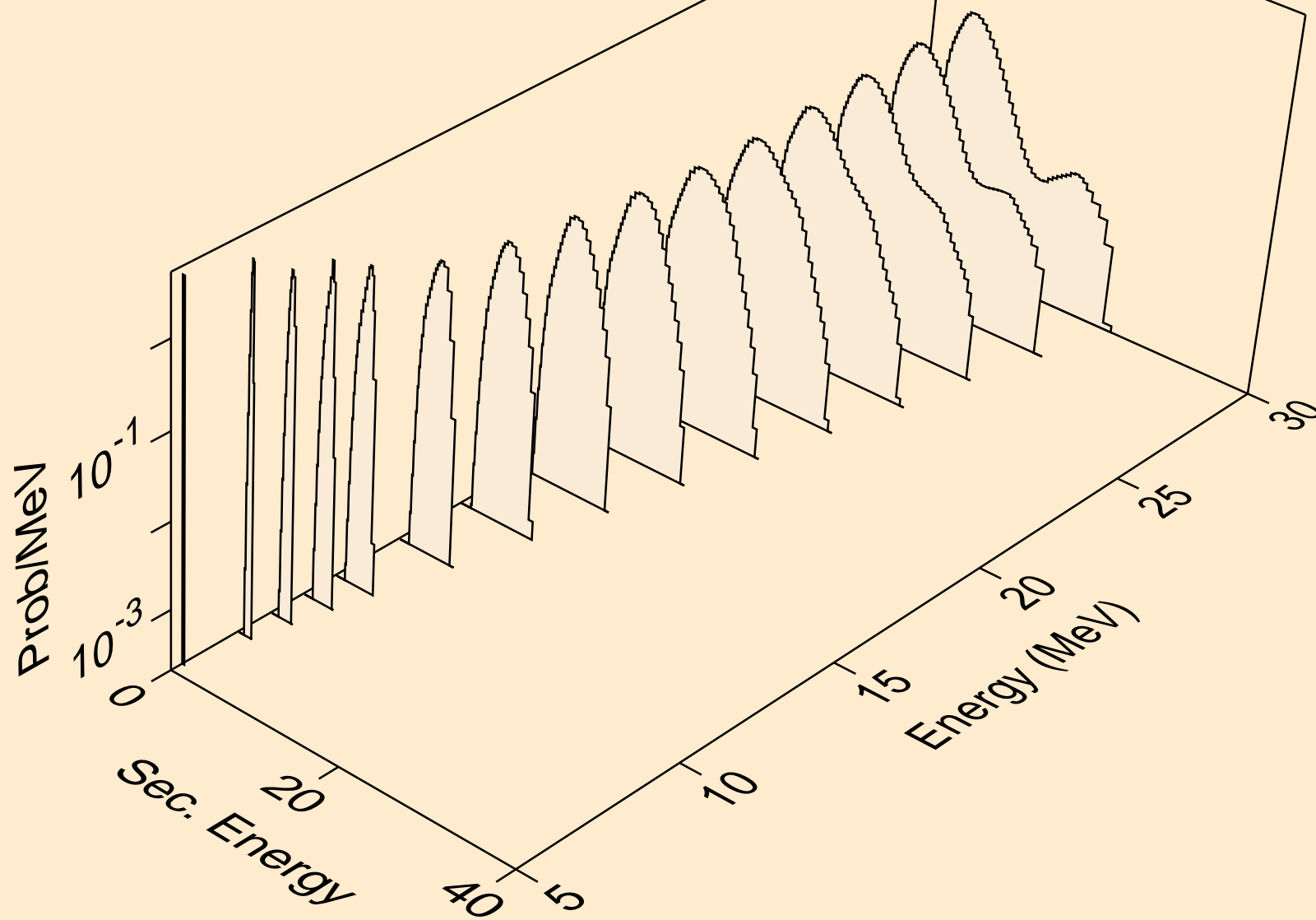

ZR083 HELION ACER TENDL-2021 LIBRARY; T=0.K  
protons from (s,2np)

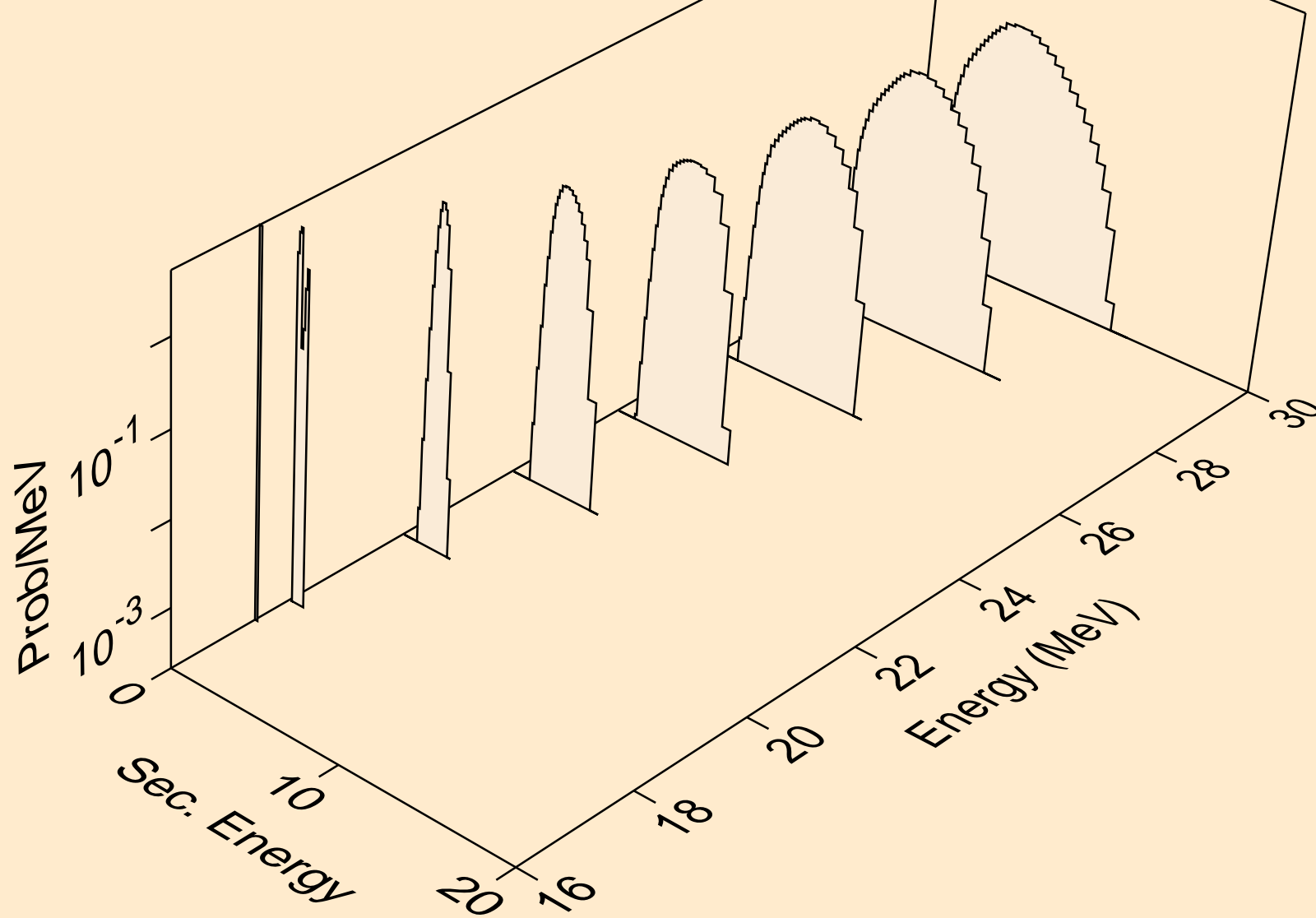

ZR083 HELION ACER TENDL-2021 LIBRARY; T=0.K  
protons from (s,2np)

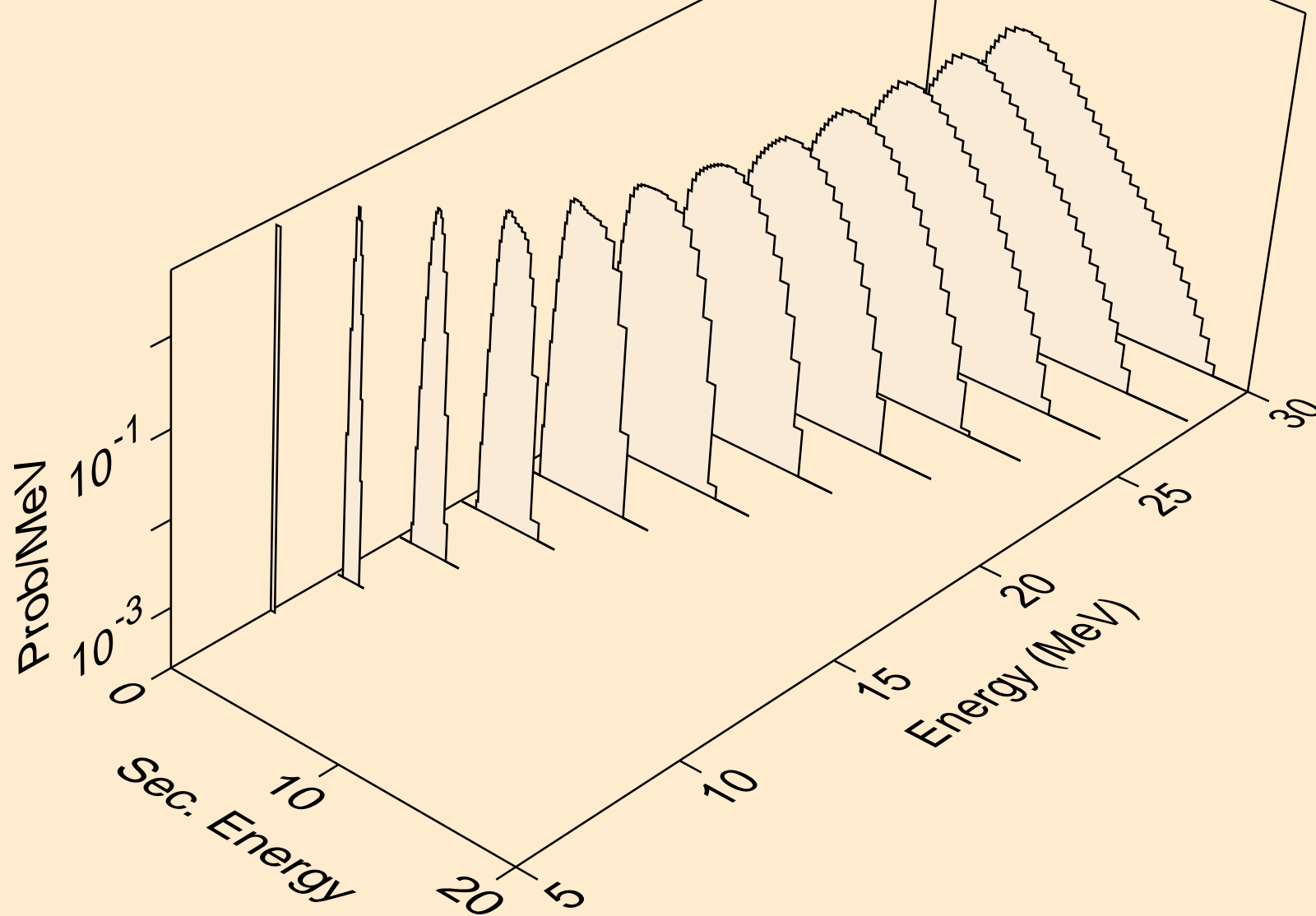

ZR083 HELION ACER TENDL-2021 LIBRARY; T=0.K  
protons from (s,npa)

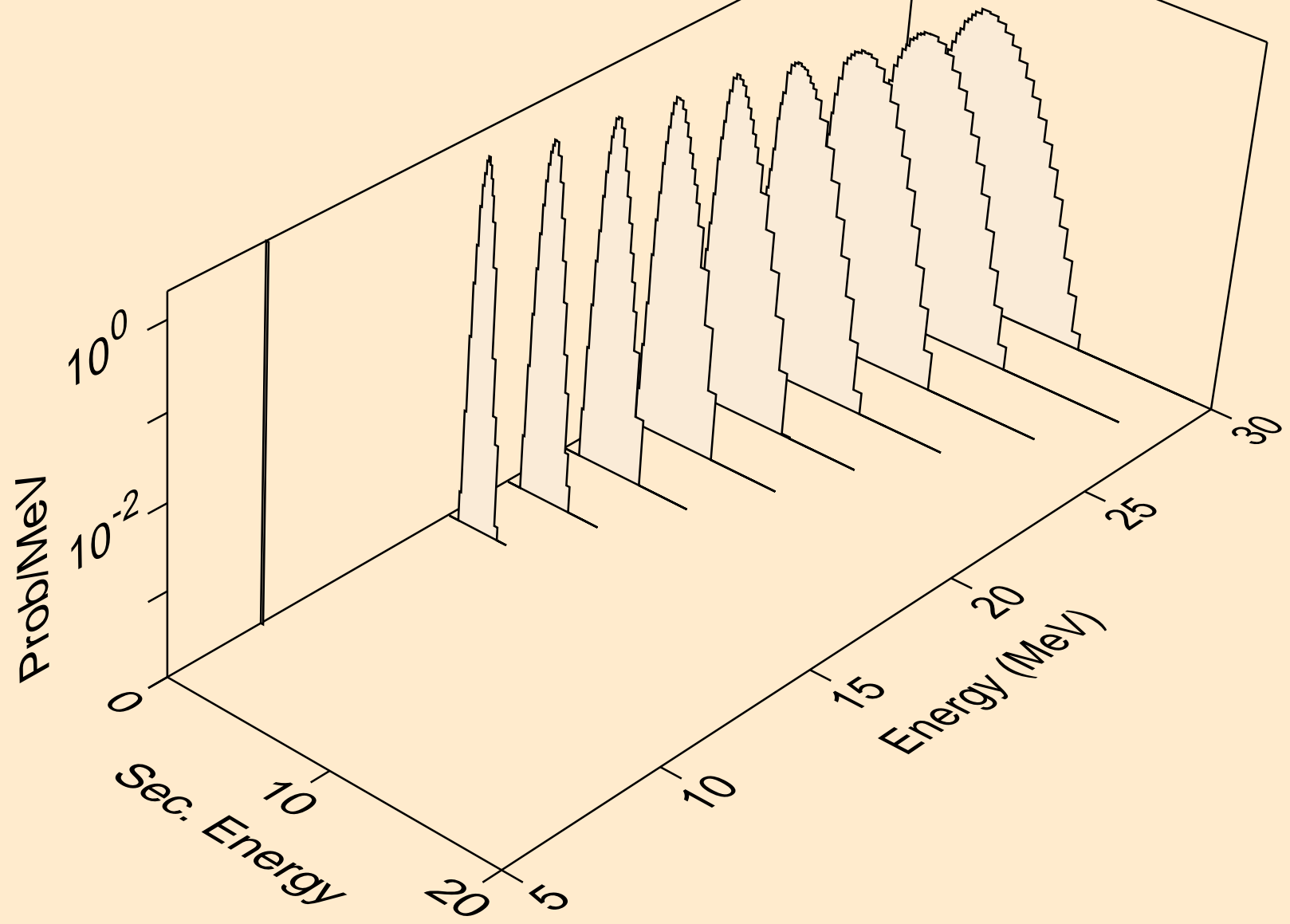

ZR083 HELION ACER TENDL-2021 LIBRARY; T=0.K  
protons from (s,p)

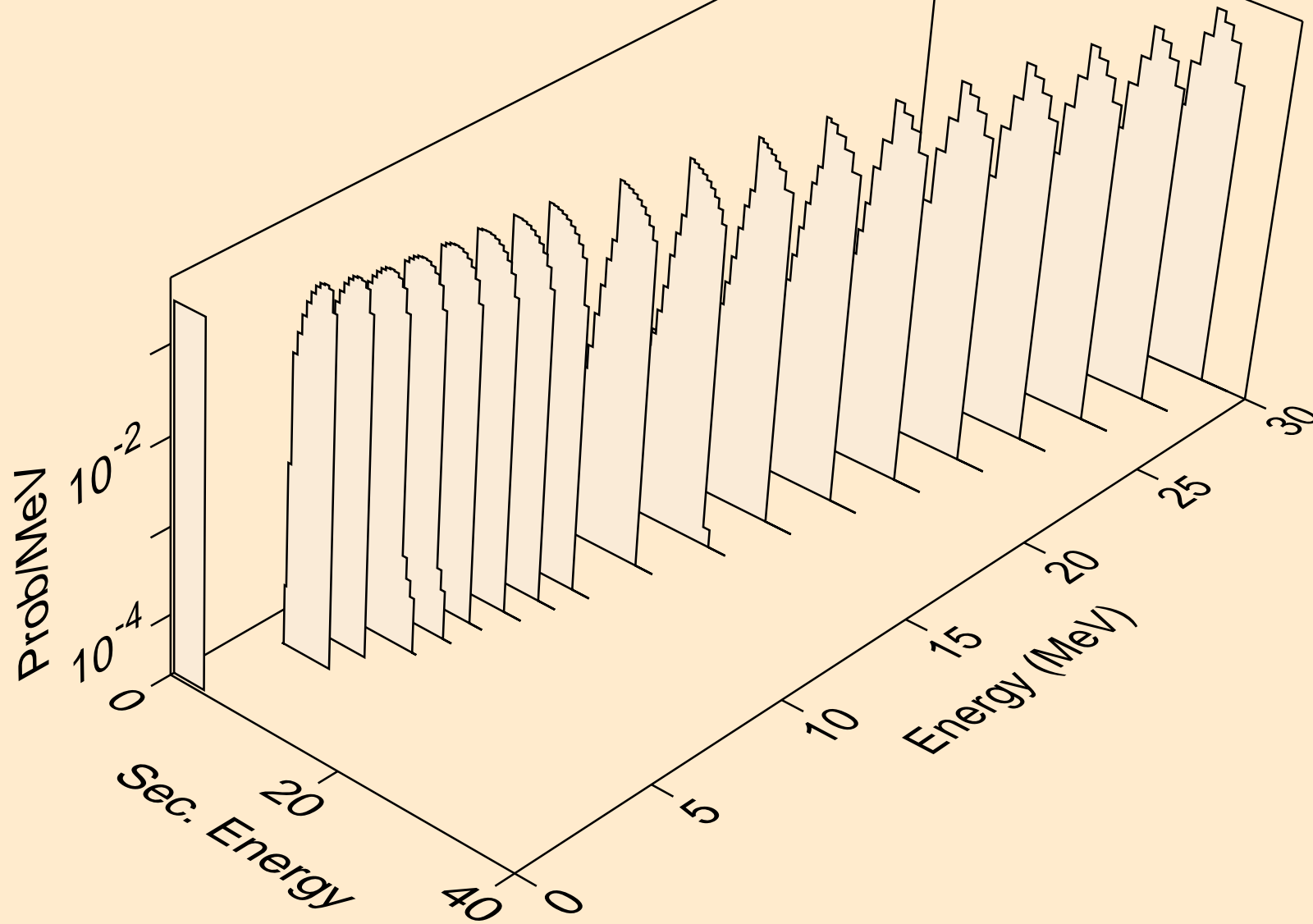



ZR083 HELION ACER TENDL-2021 LIBRARY; T=0.K  
protons from (s,2p)

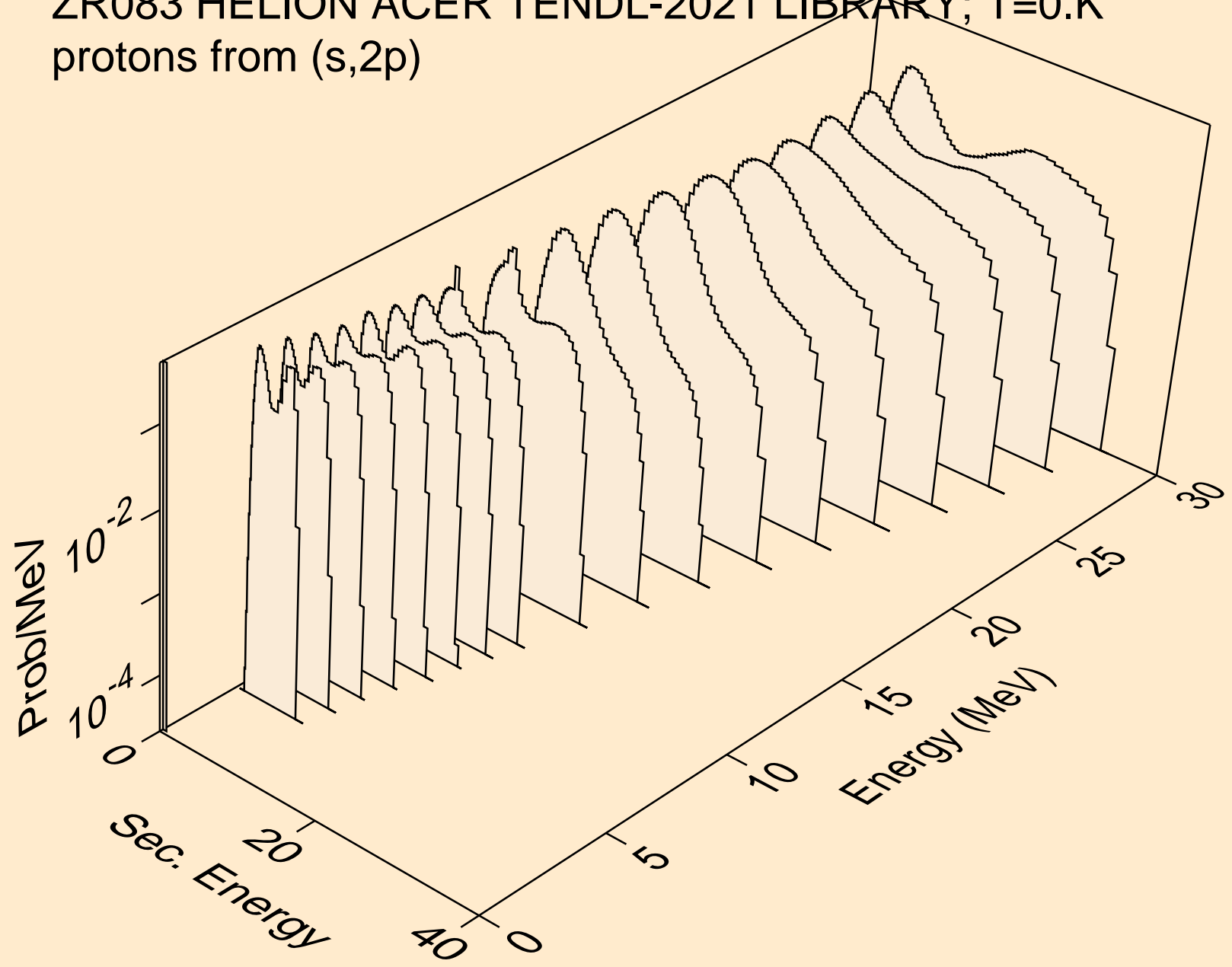

ZR083 HELION ACER TENDL-2021 LIBRARY; T=0.K  
protons from (s,pa)

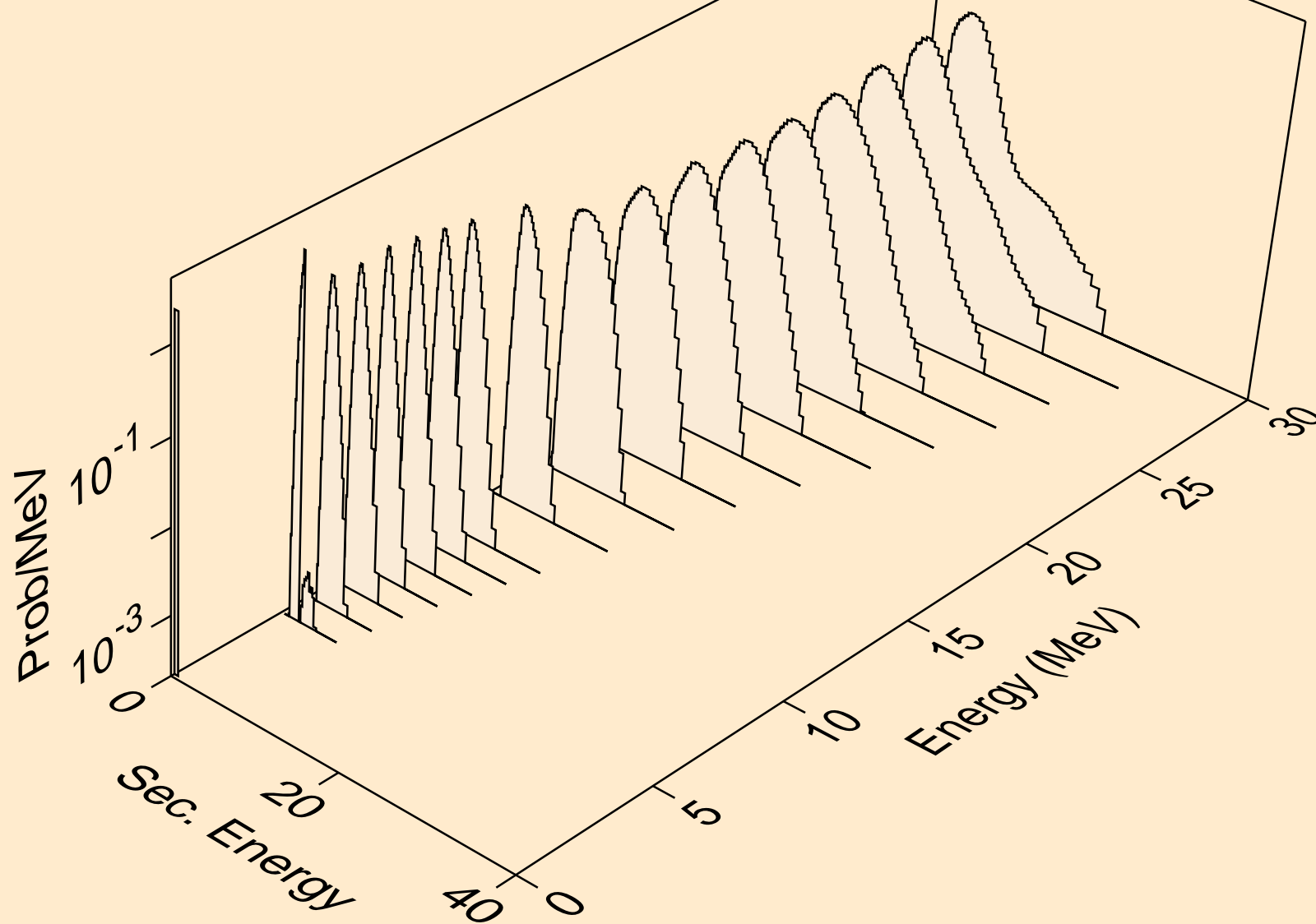

ZR083 HELION ACER TENDL-2021 LIBRARY; T=0.K  
protons from (s,pd)

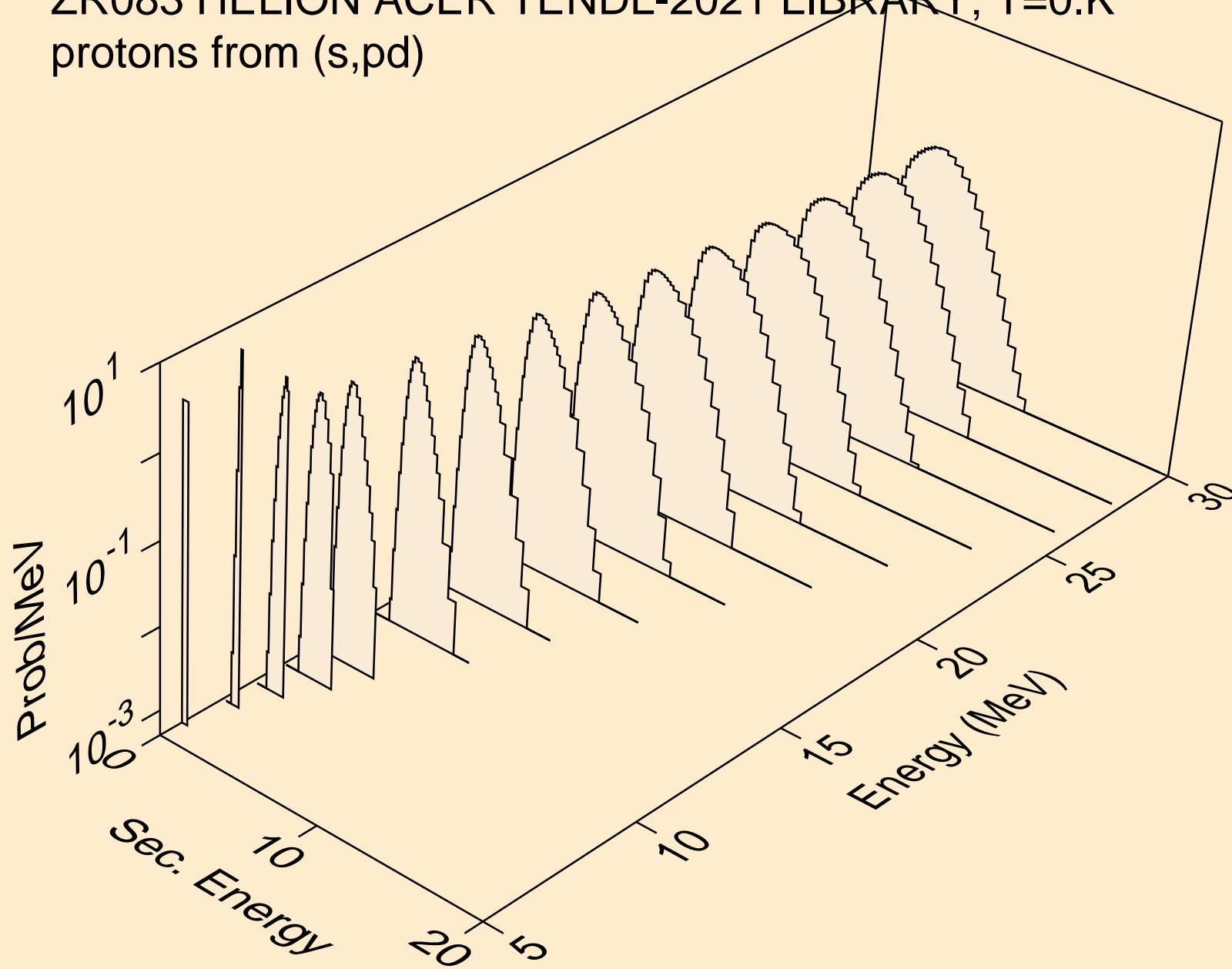

ZR083 HELION ACER TENDL-2021 LIBRARY; T=0.K  
protons from (s,pt)

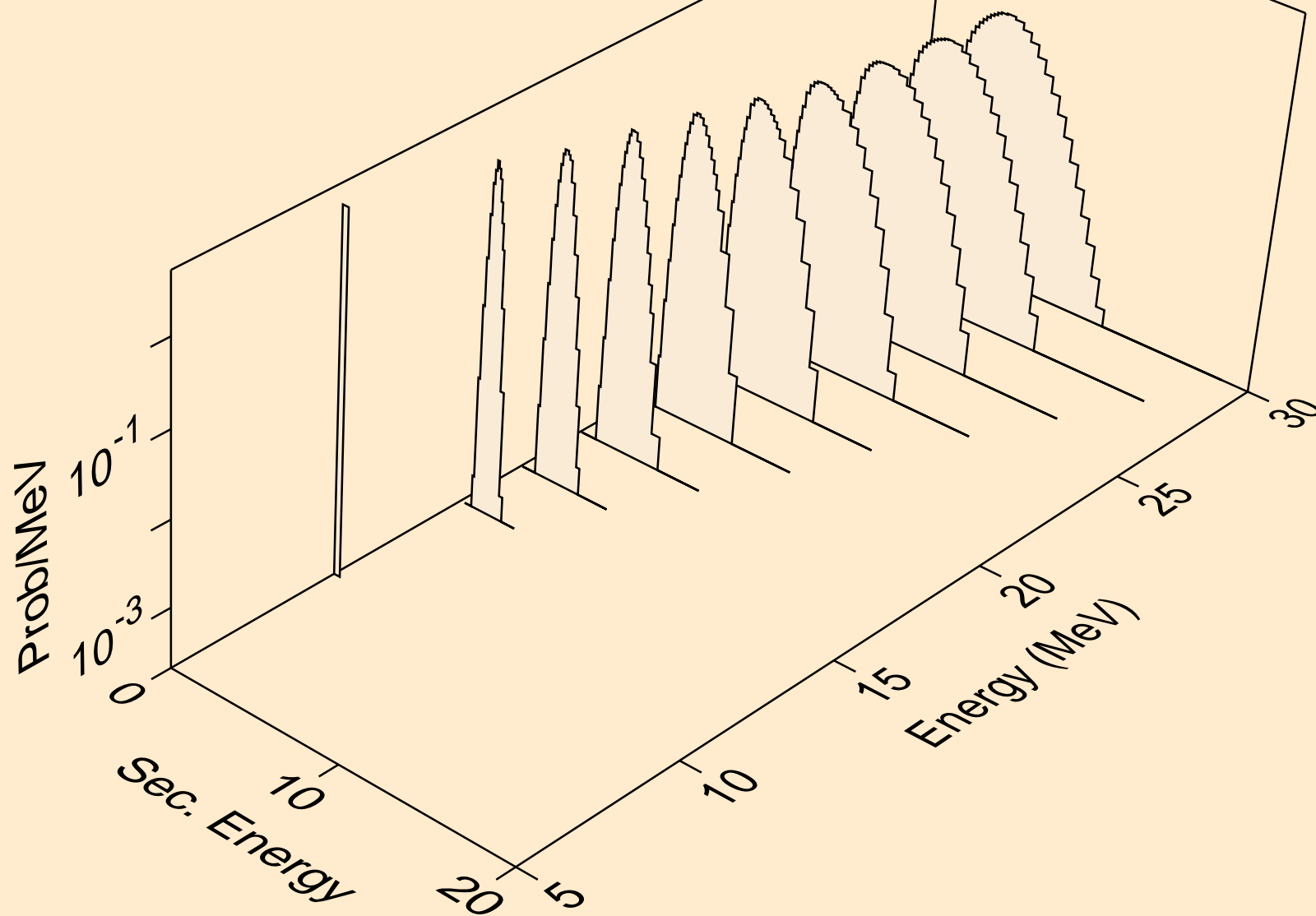

ZR083 HELION ACER TENDL-2021 LIBRARY; T=0.K  
deuterons from (s,x)

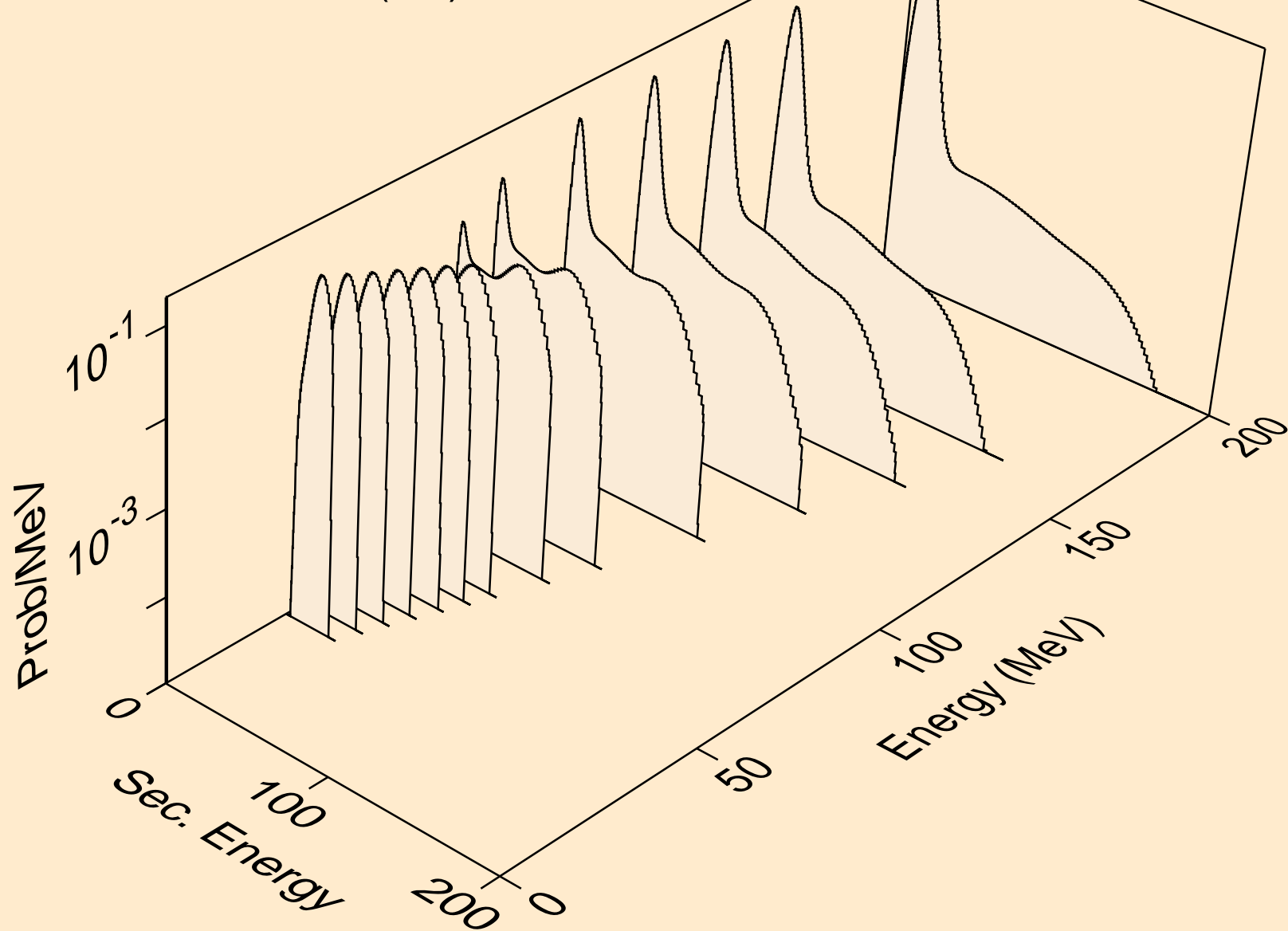

ZR083 HELION ACER TENDL-2021 LIBRARY; T=0.K  
deuterons from (s,n\*)d

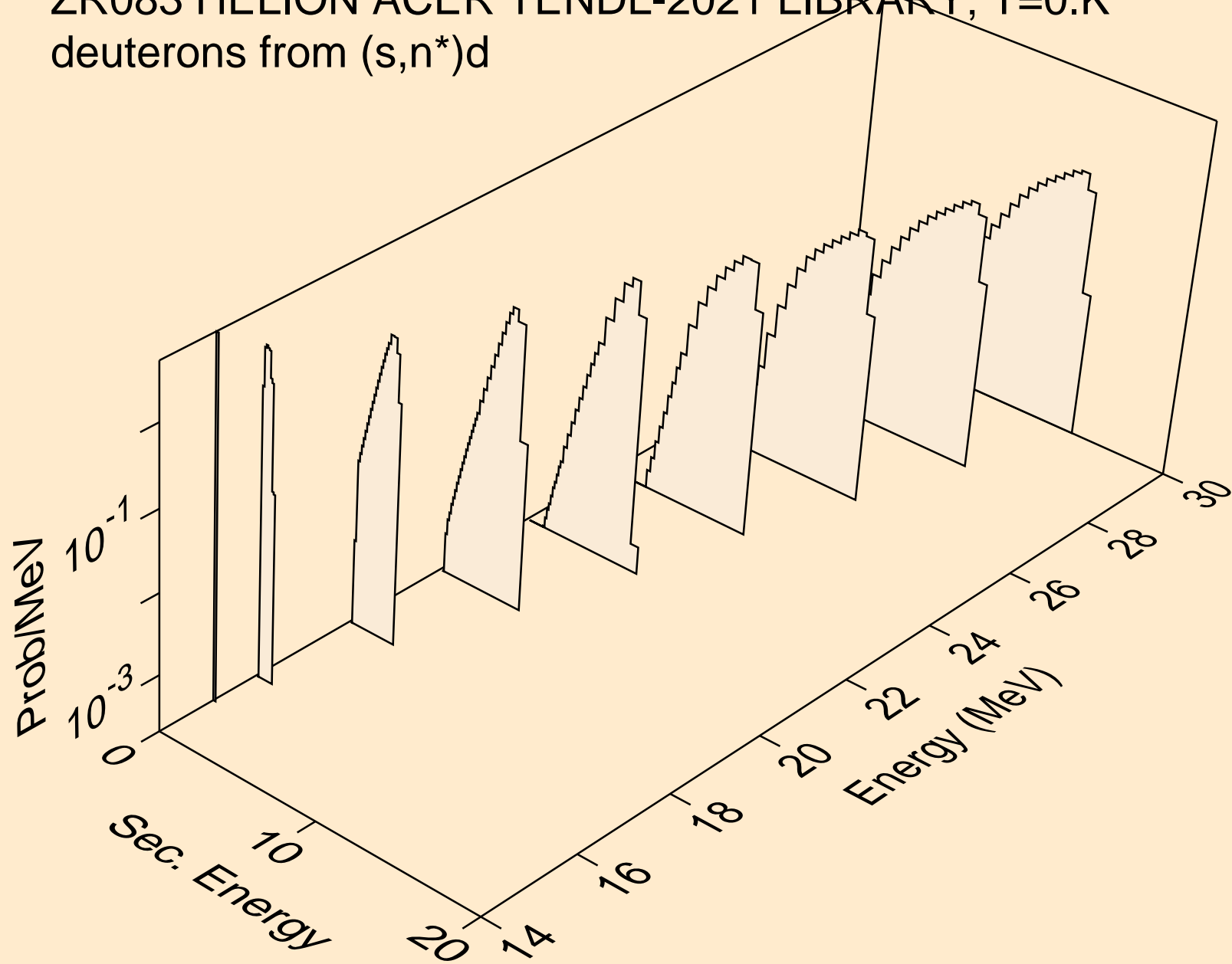

ZR083 HELION ACER TENDL-2021 LIBRARY; T=0.K  
deuterons from (s,d)

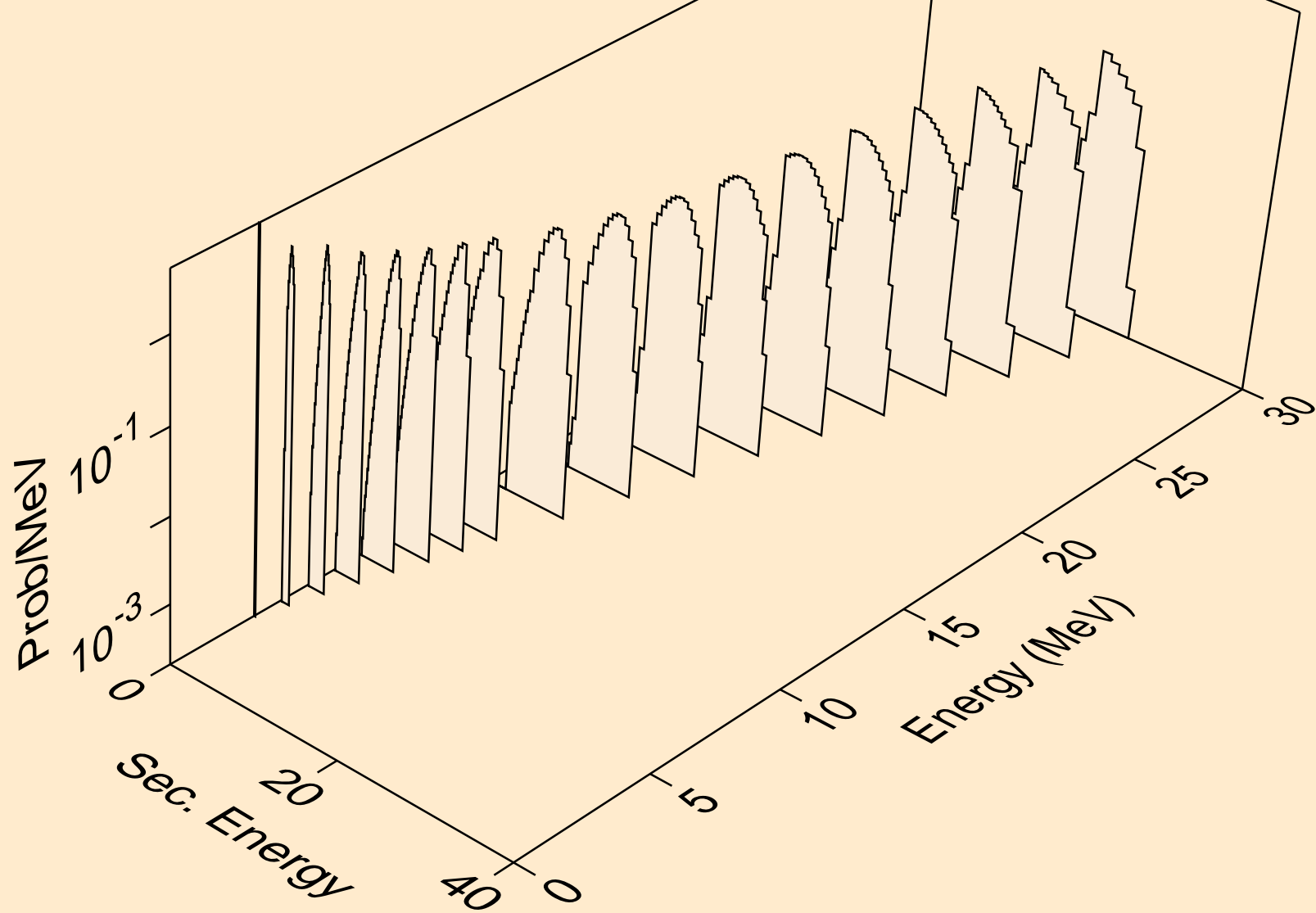

ZR083 HELION ACER TENDL-2021 LIBRARY; T=0.K  
deuterons from (s,pd)

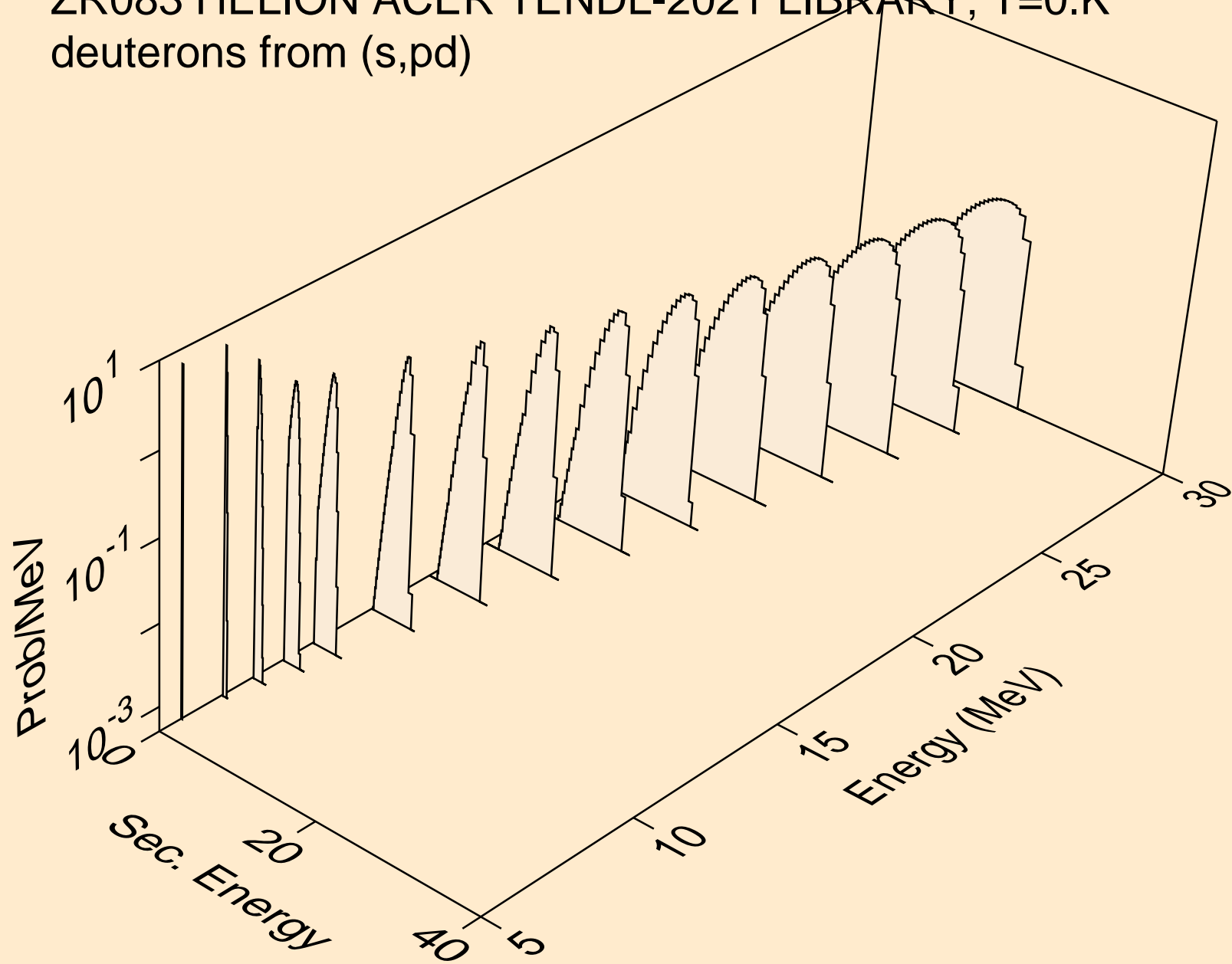



ZR083 HELION ACER TENDL-2021 LIBRARY; T=0.K  
deuterons from (s,da)

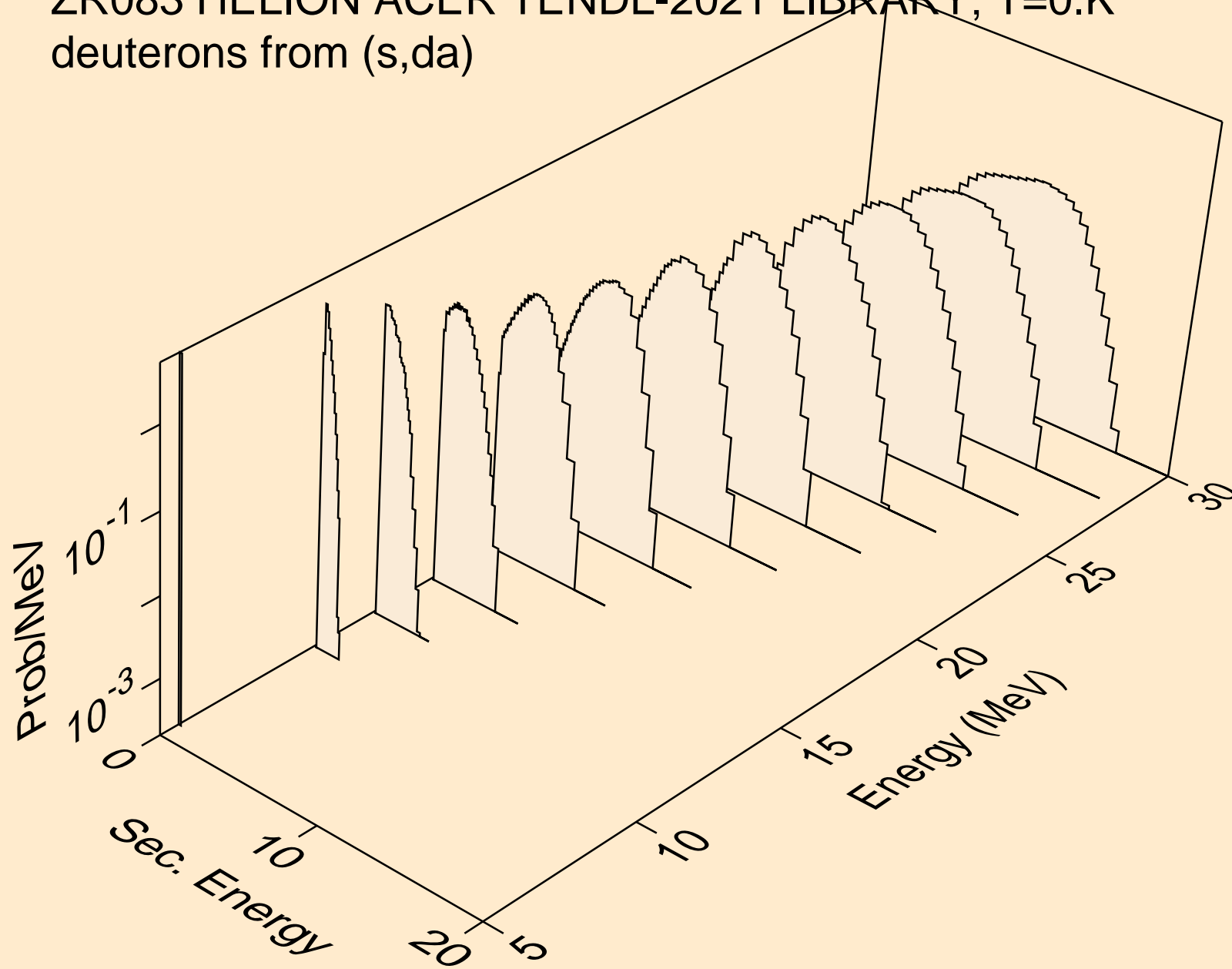

ZR083 HELION ACER TENDL-2021 LIBRARY; T=0.K  
tritons from (s,x)

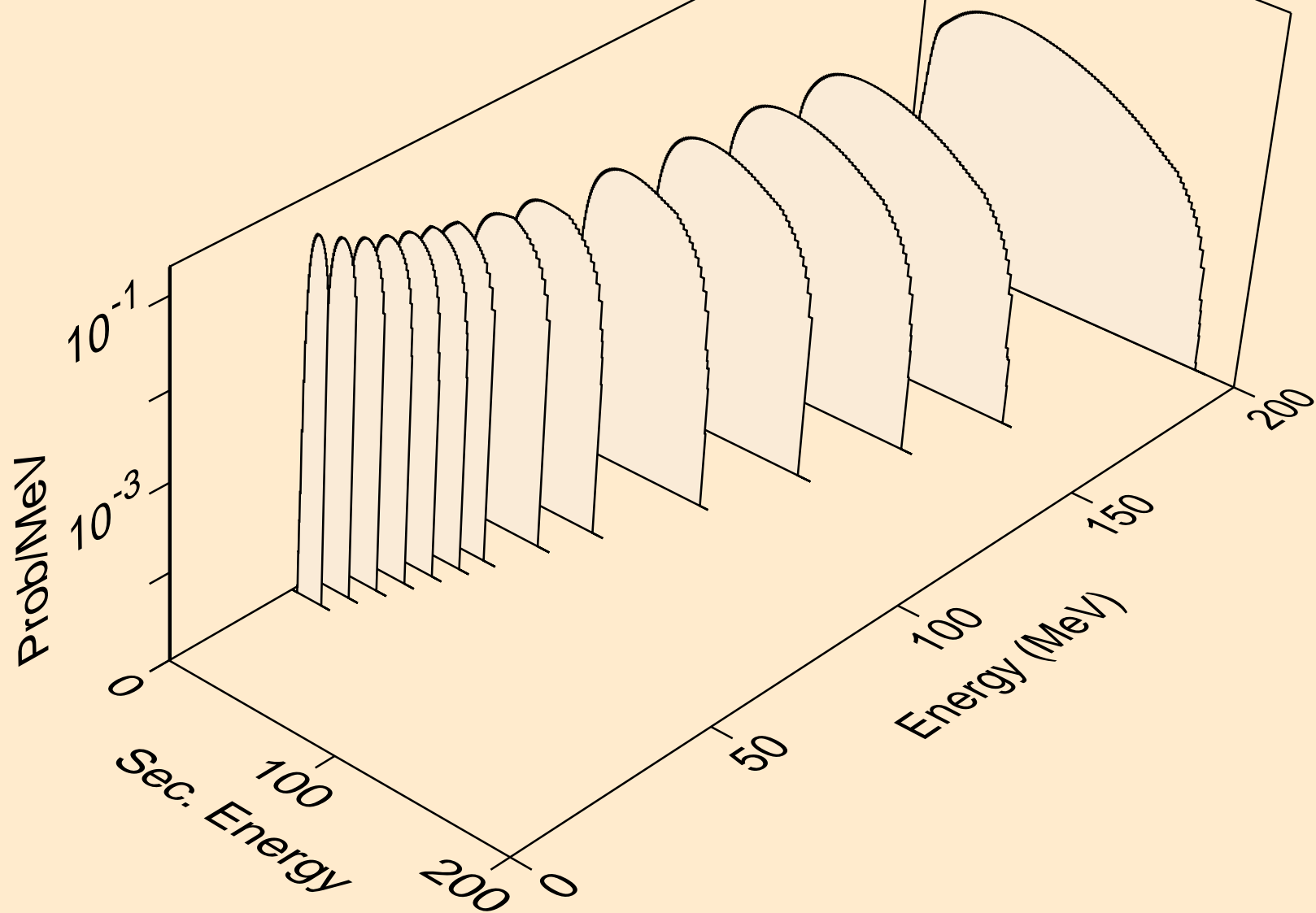

ZR083 HELION ACER TENDL-2021 LIBRARY; T=0.K

tritons from (s,n\*)t

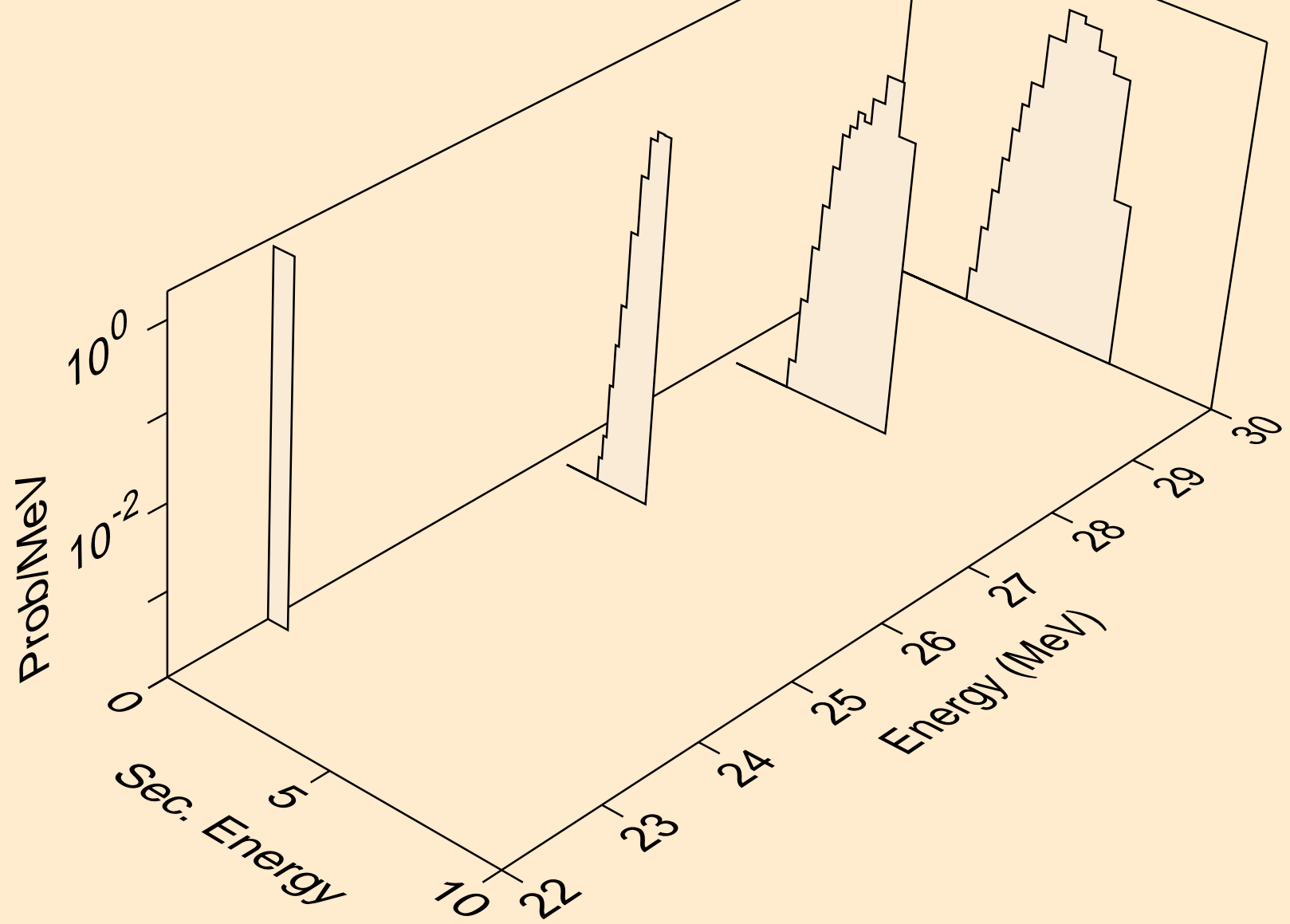

ZR083 HELION ACER TENDL-2021 LIBRARY; T=0.K  
tritons from (s,t)

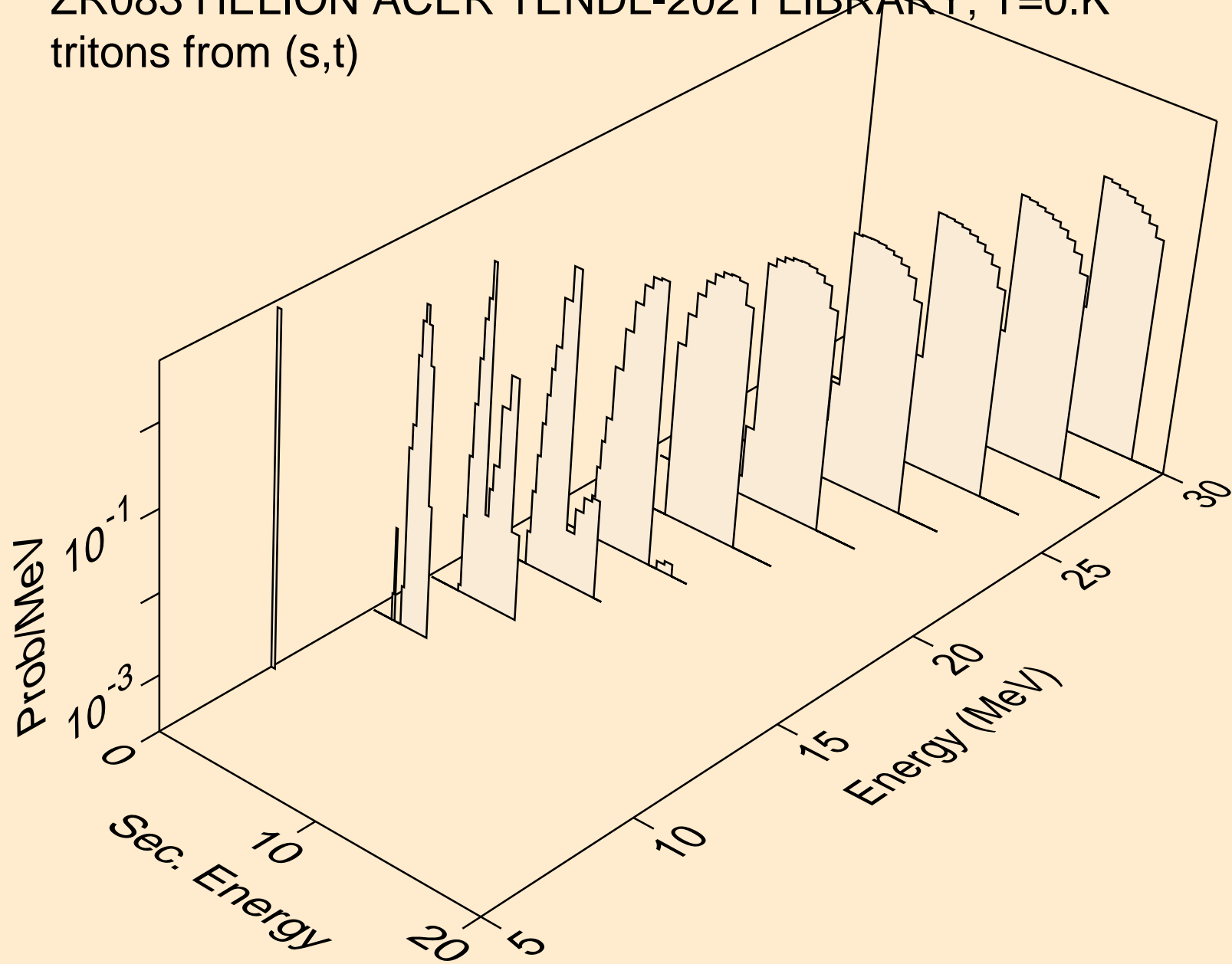

ZR083 HELION ACER TENDL-2021 LIBRARY; T=0.K  
tritons from (s,pt)

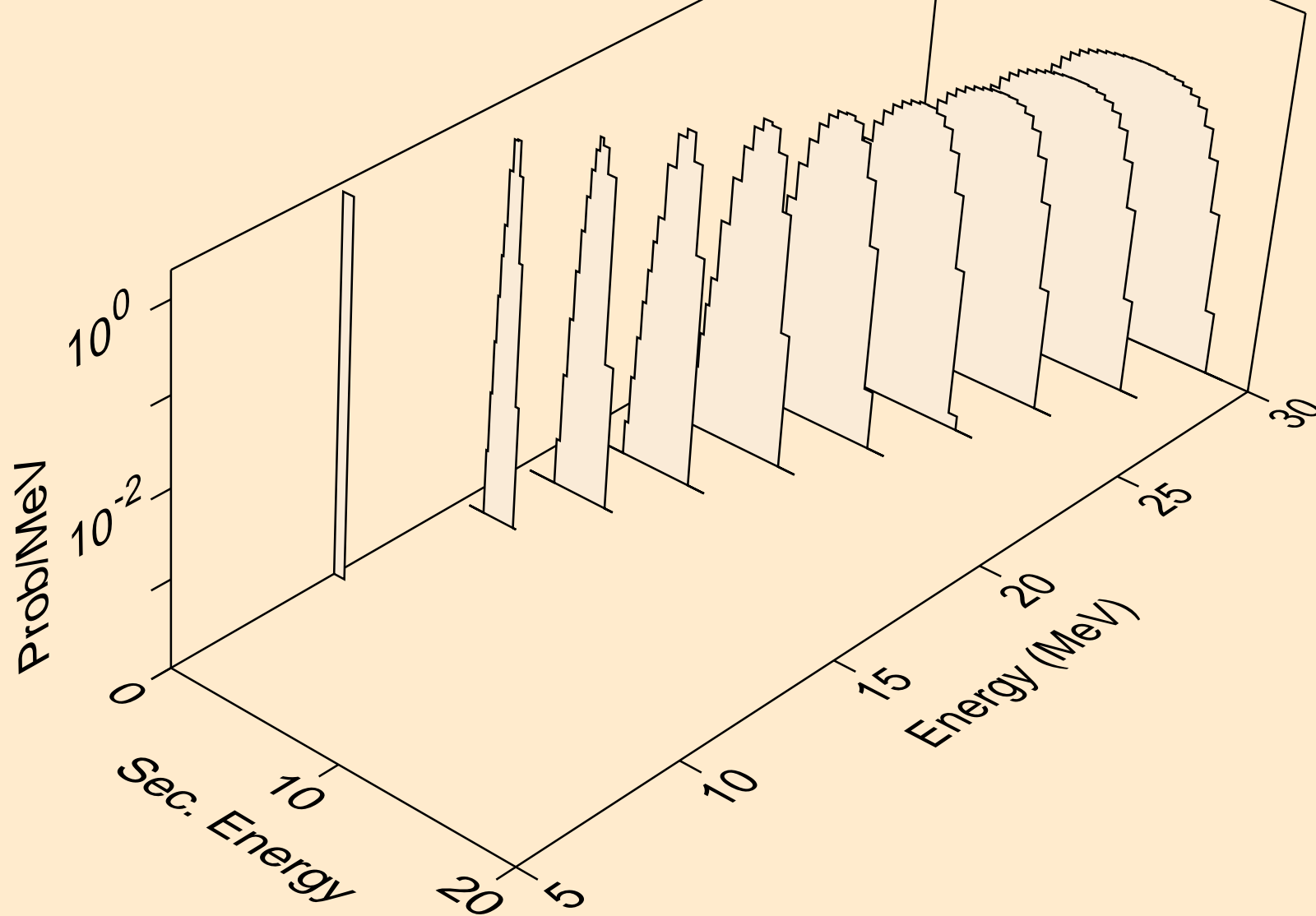

ZR083 HELION ACER TENDL-2021 LIBRARY; T=0.K  
alphas from (s,x)

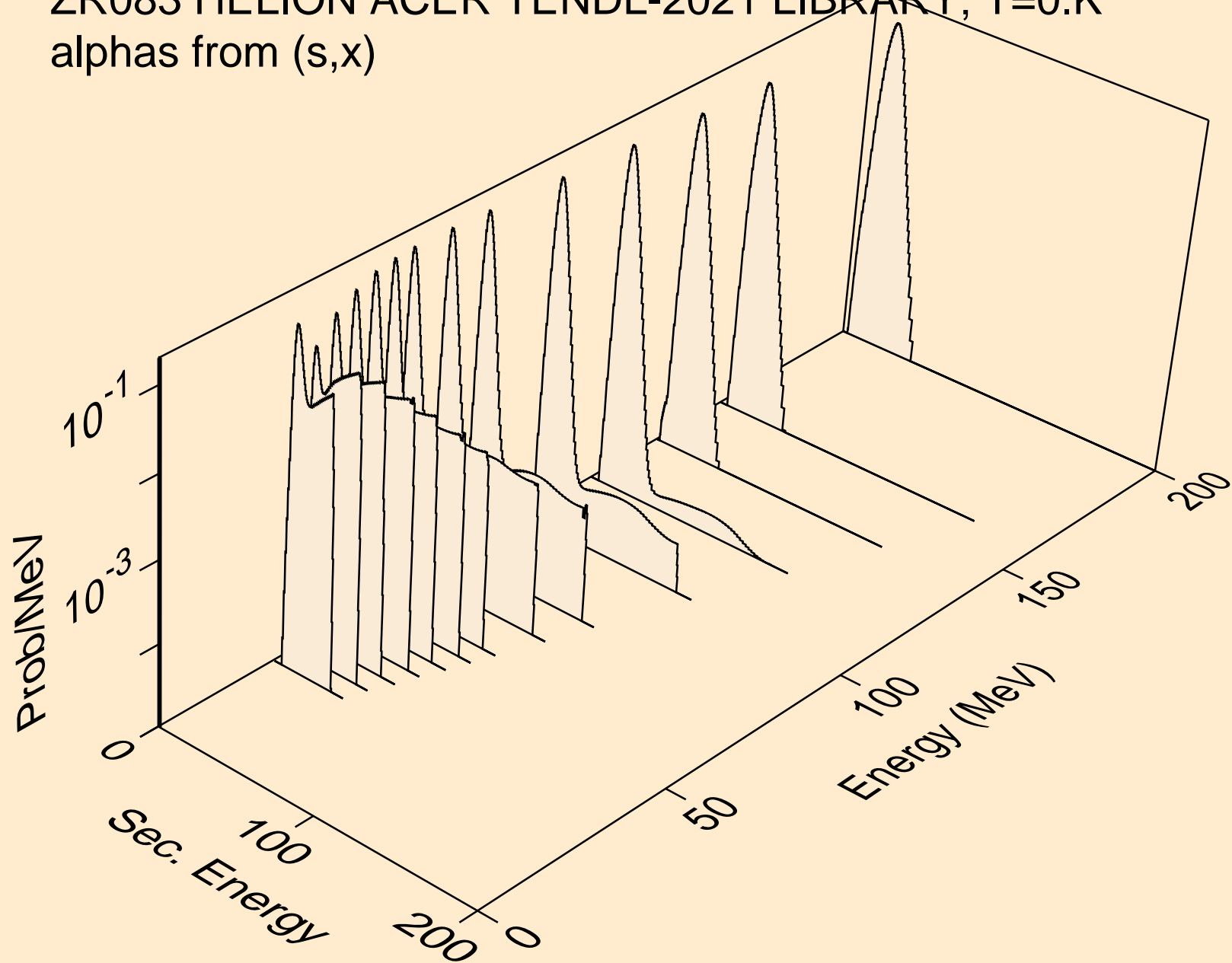

ZR083 HELION ACER TENDL-2021 LIBRARY; T=0.K  
alphas from (s,n\*)a

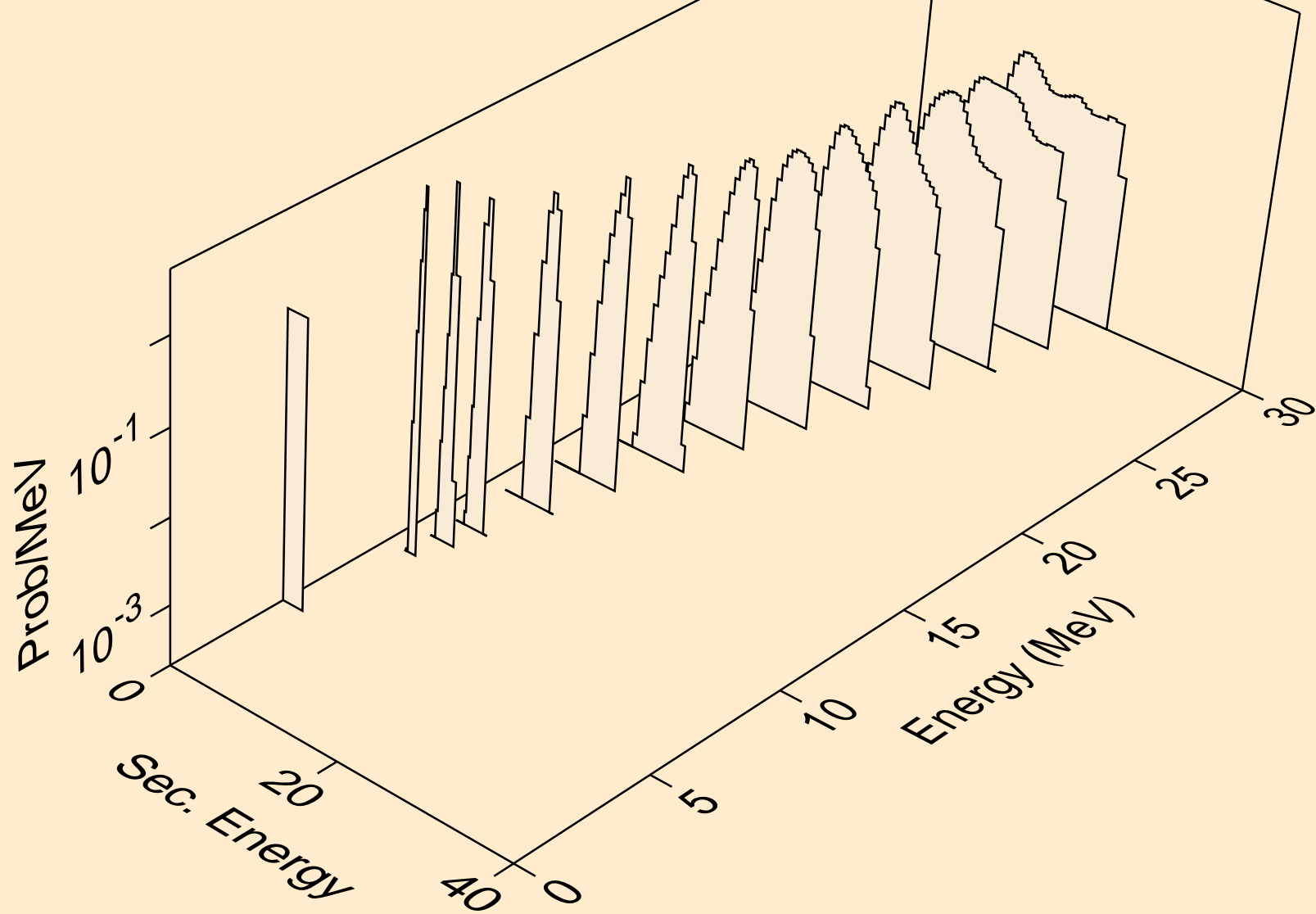

ZR083 HELION ACER TENDL-2021 LIBRARY; T=0.K  
alphas from (s,2n)a

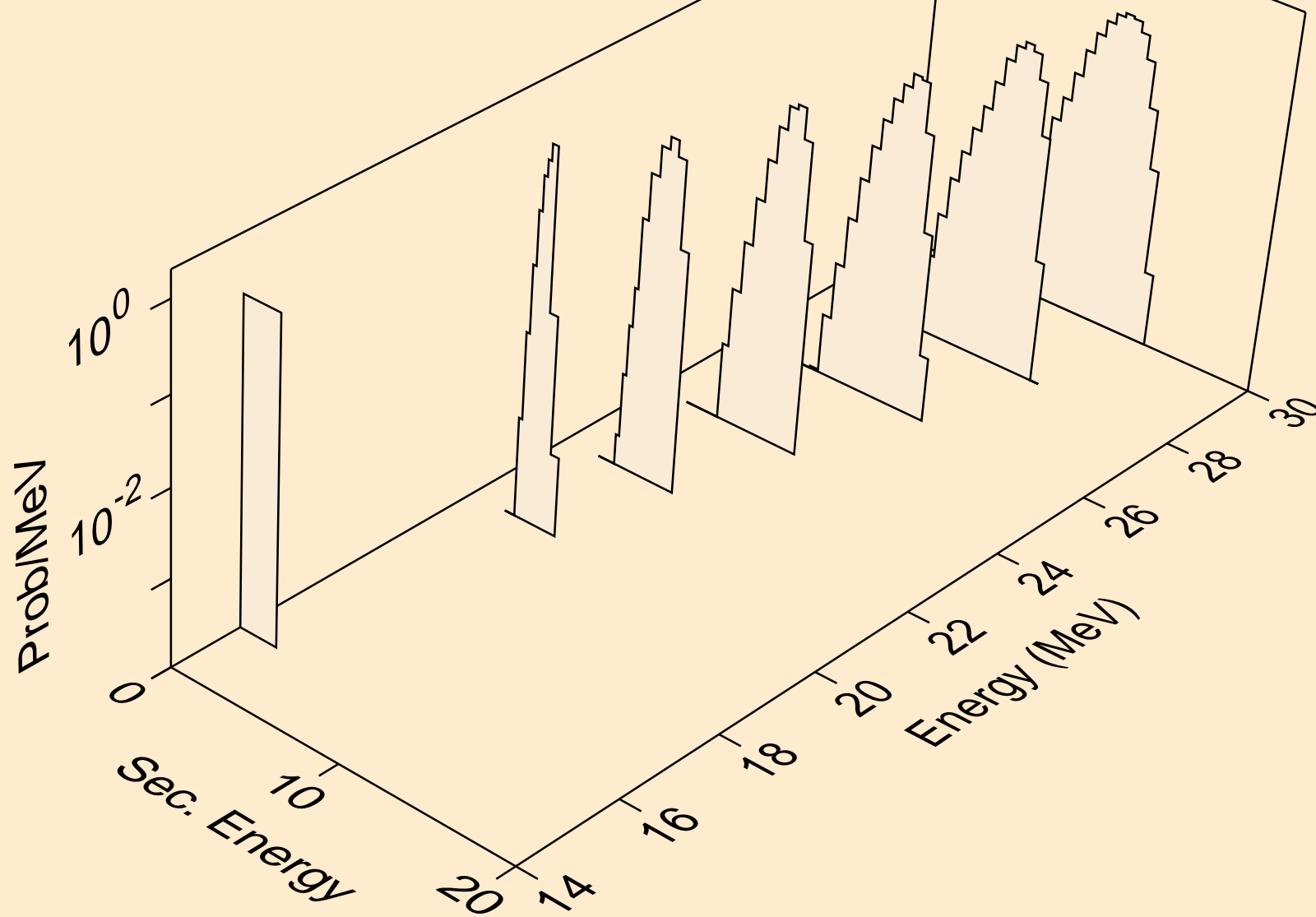



ZR083 HELION ACER TENDL-2021 LIBRARY; T=0.K  
alphas from (s,n\*)2a

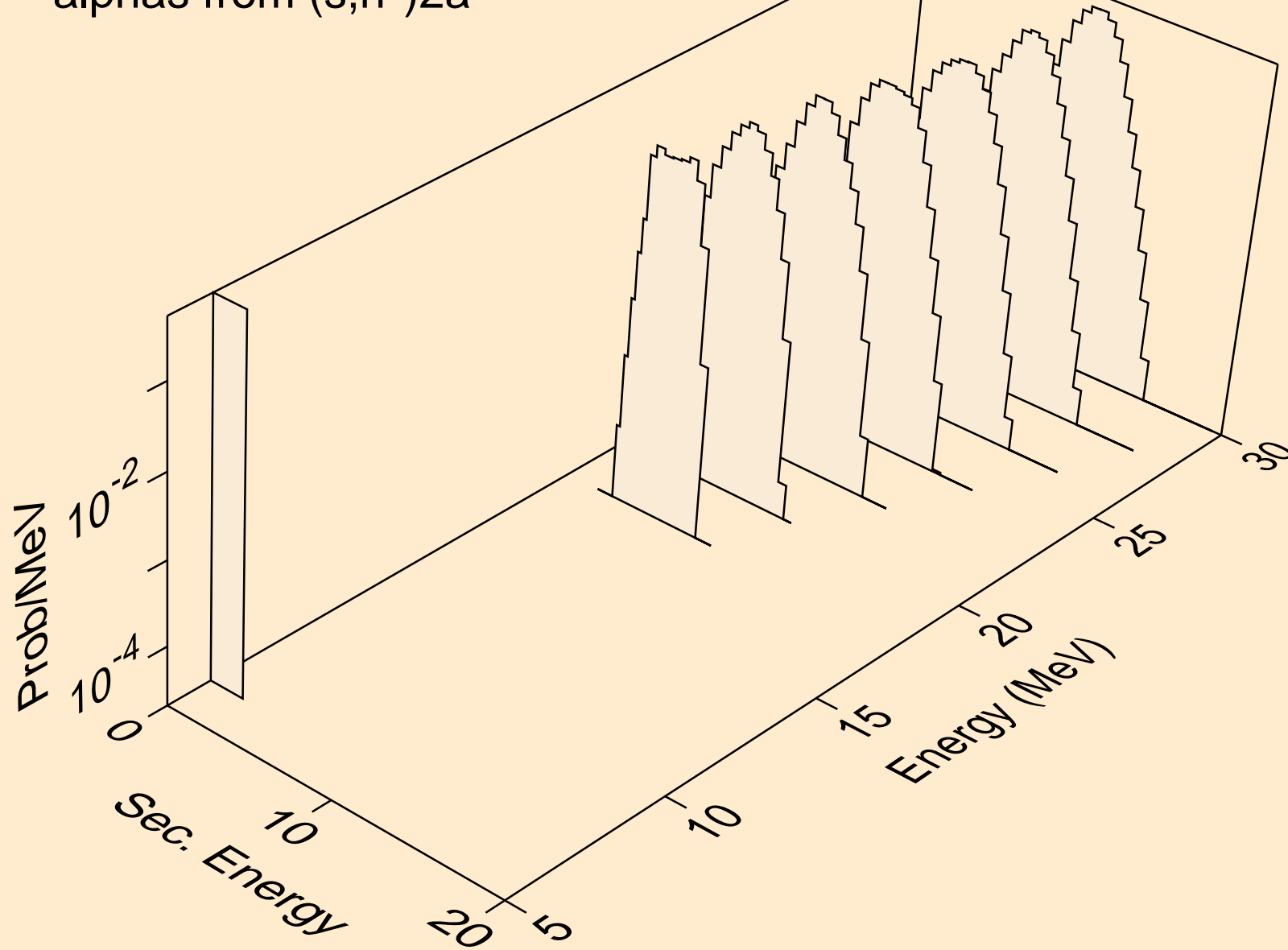

ZR083 HELION ACER TENDL-2021 LIBRARY; T=0.K  
alphas from (s,npa)

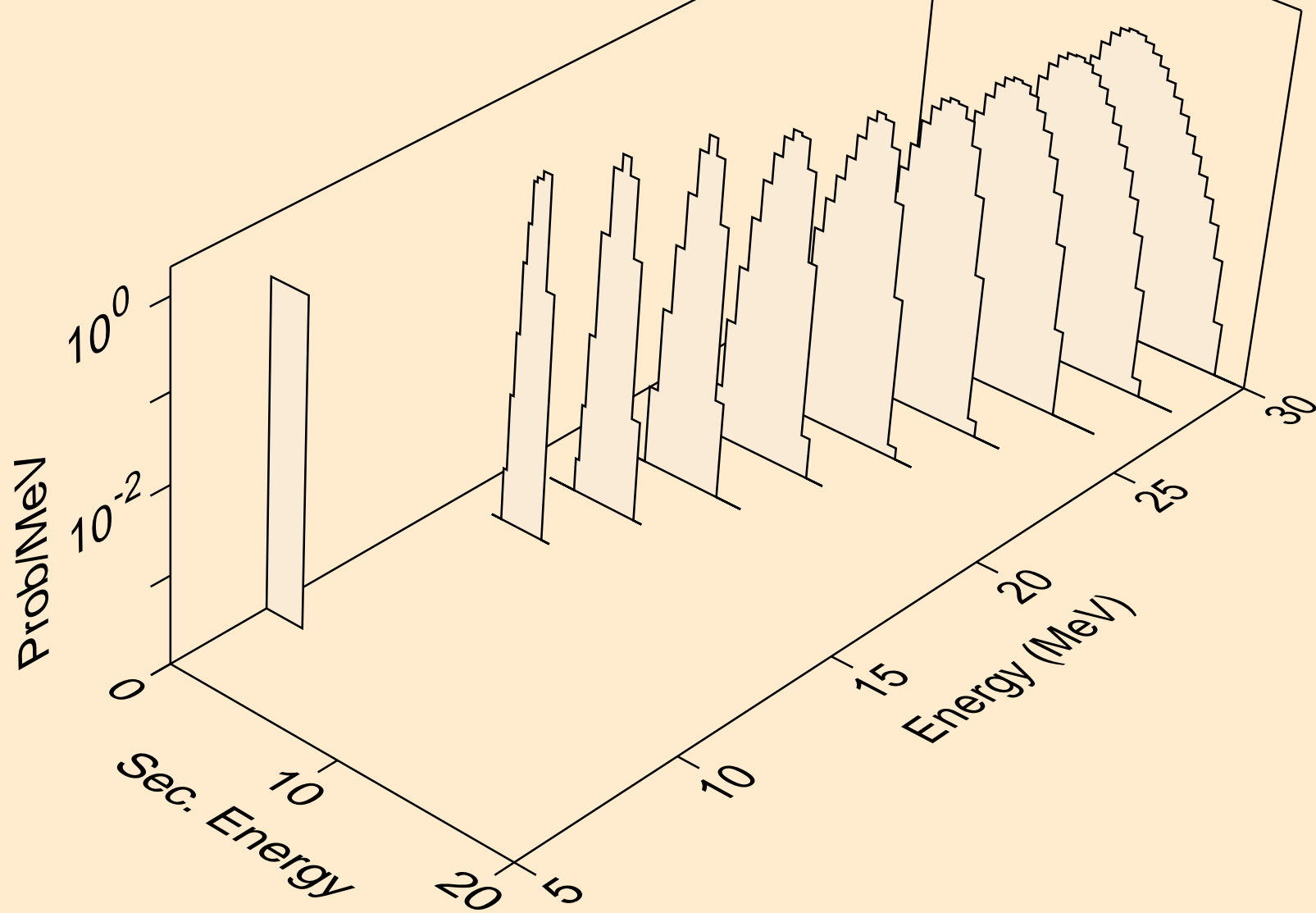

ZR083 HELION ACER TENDL-2021 LIBRARY; T=0.K  
alphas from (s,a)

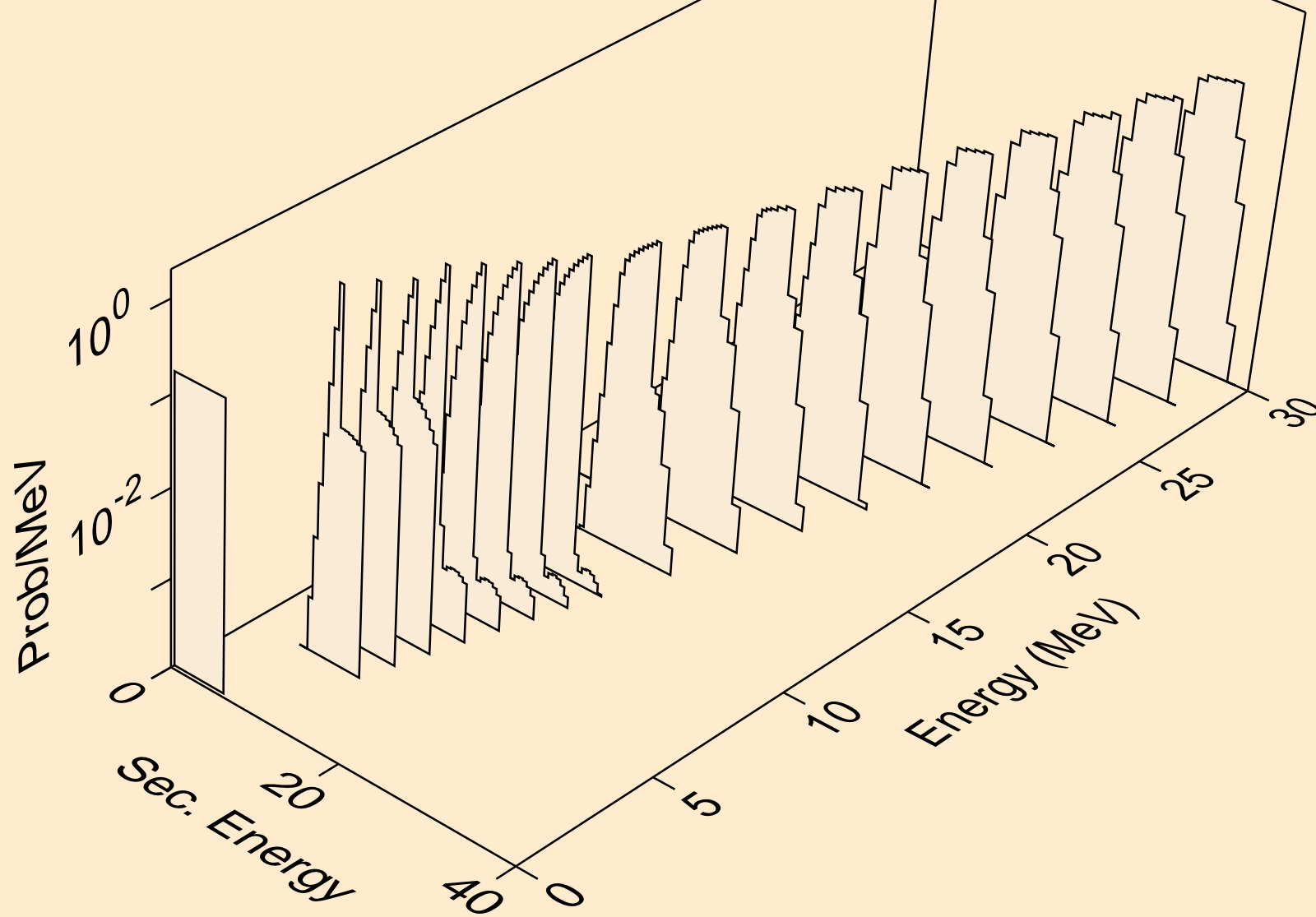

ZR083 HELION ACER TENDL-2021 LIBRARY; T=0.K  
alphas from (s,2a)

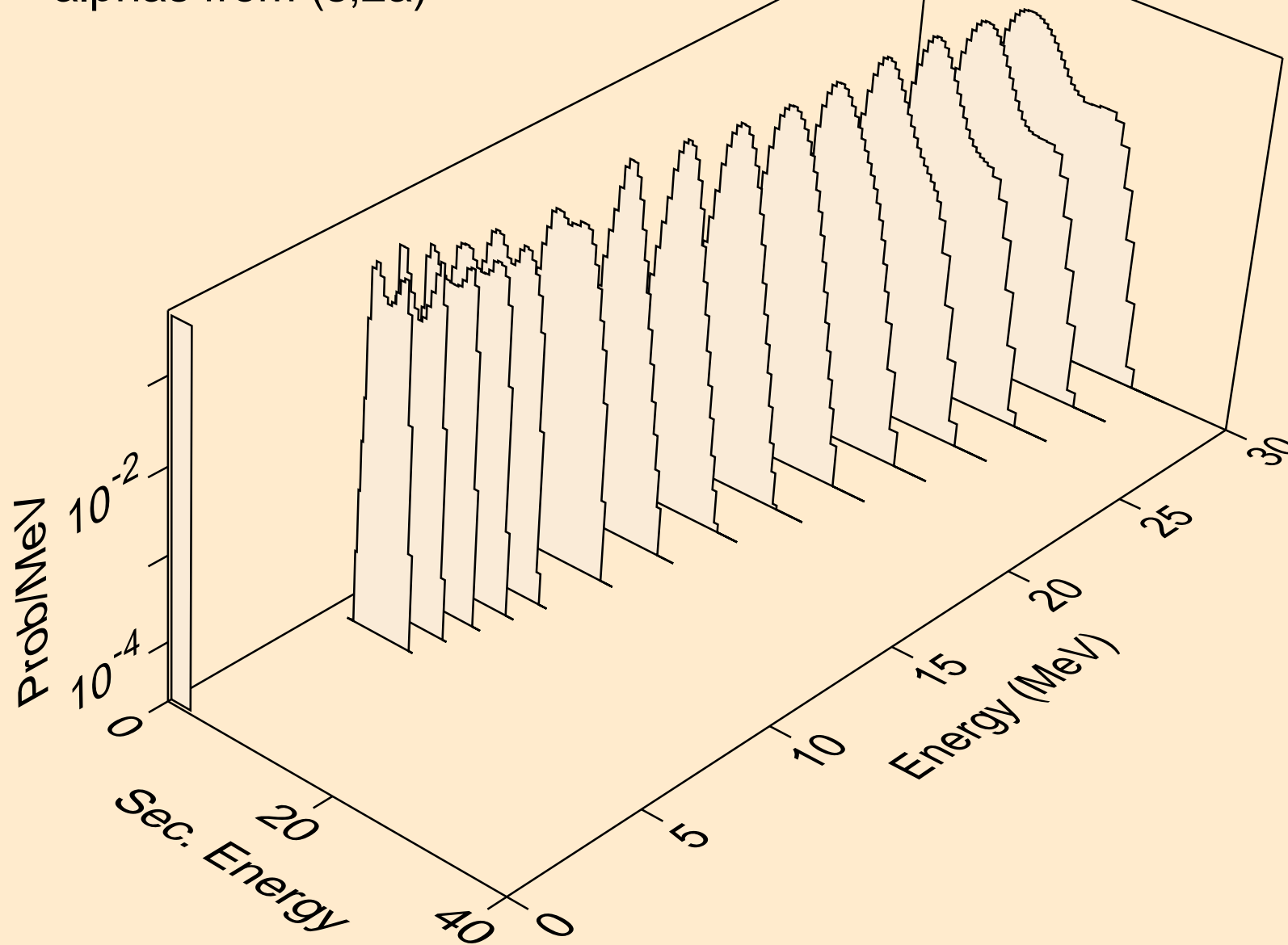

ZR083 HELION ACER TENDL-2021 LIBRARY; T=0.K  
alphas from (s,3a)

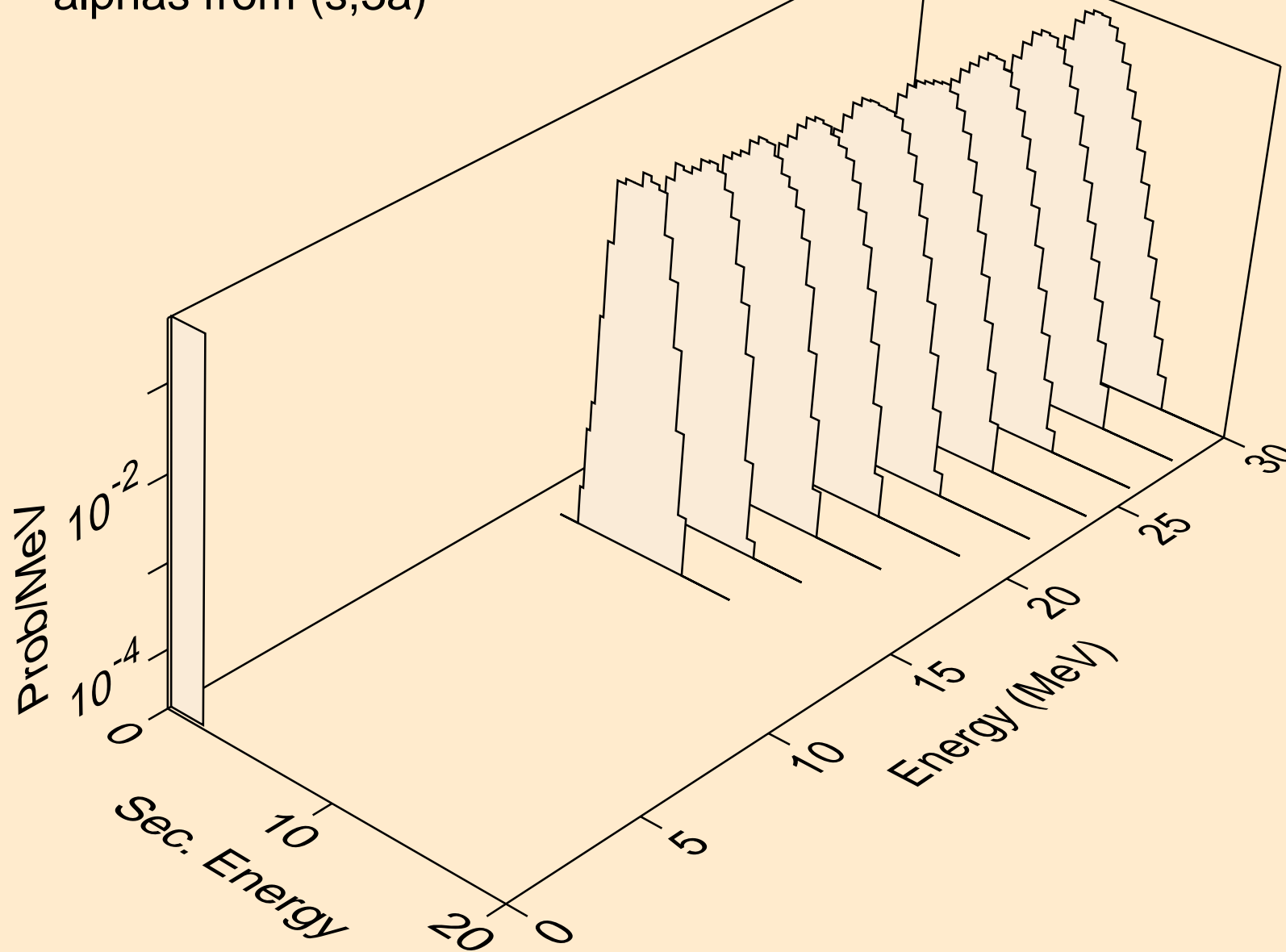

ZR083 HELION ACER TENDL-2021 LIBRARY; T=0.K  
alphas from (s,pa)

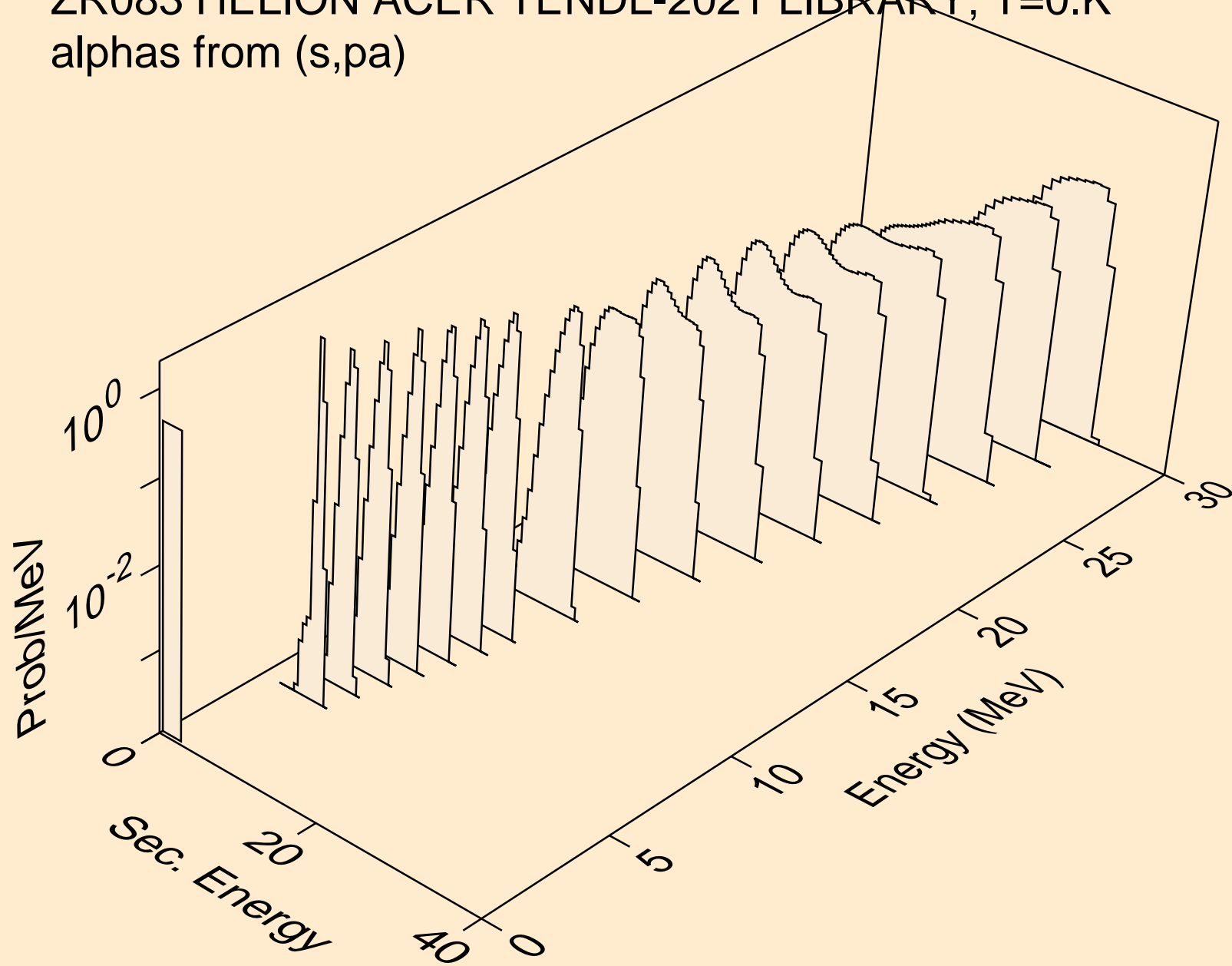

ZR083 HELION ACER TENDL-2021 LIBRARY; T=0.K  
alphas from (s,da)

