

AC229 NEUTRON ACER TENDL-2021 LIBRARY; T=293.6K

Principal cross sections

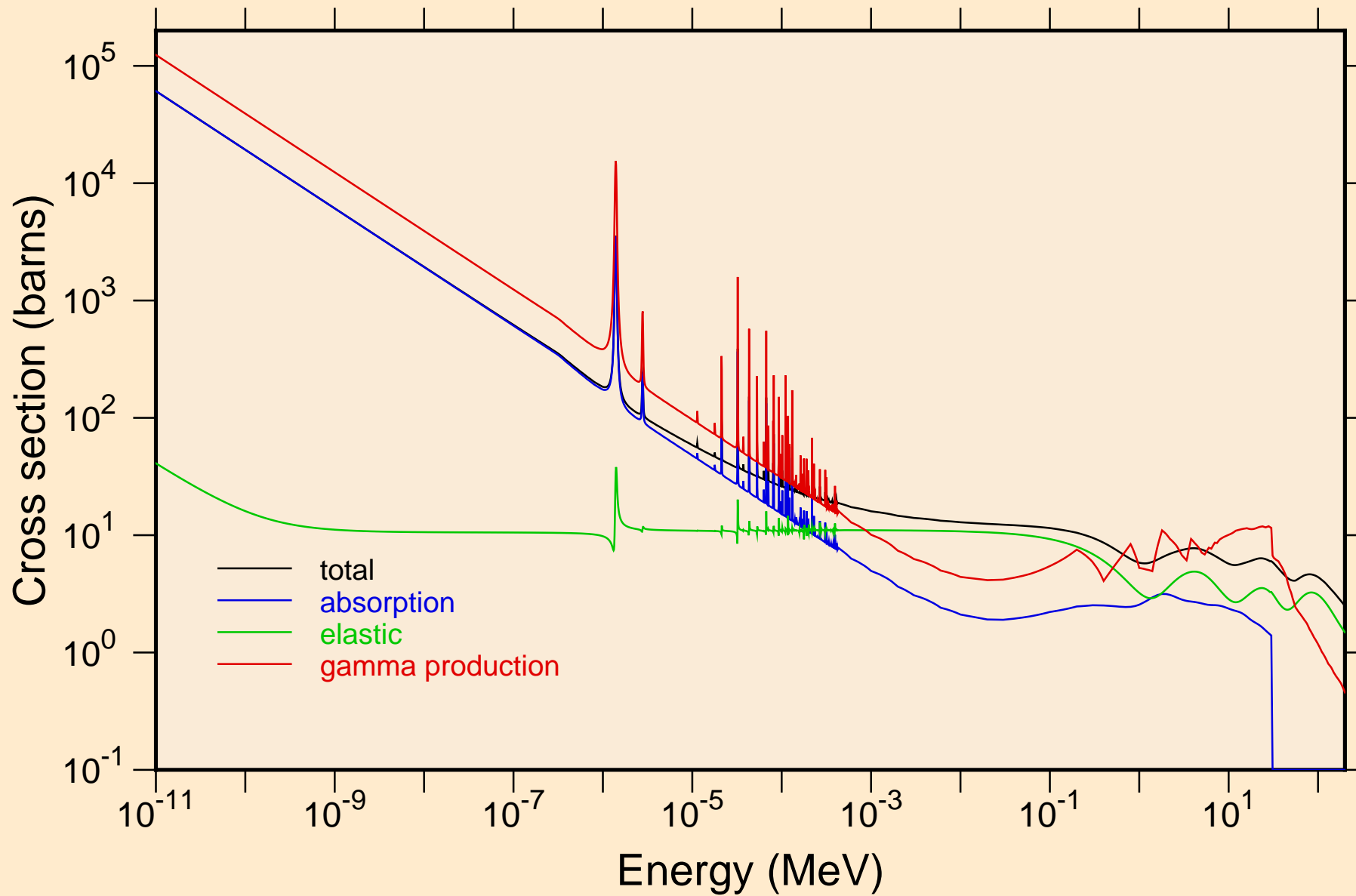

AC229 NEUTRON ACER TENDL-2021 LIBRARY; T=293.6K
resonance total cross section

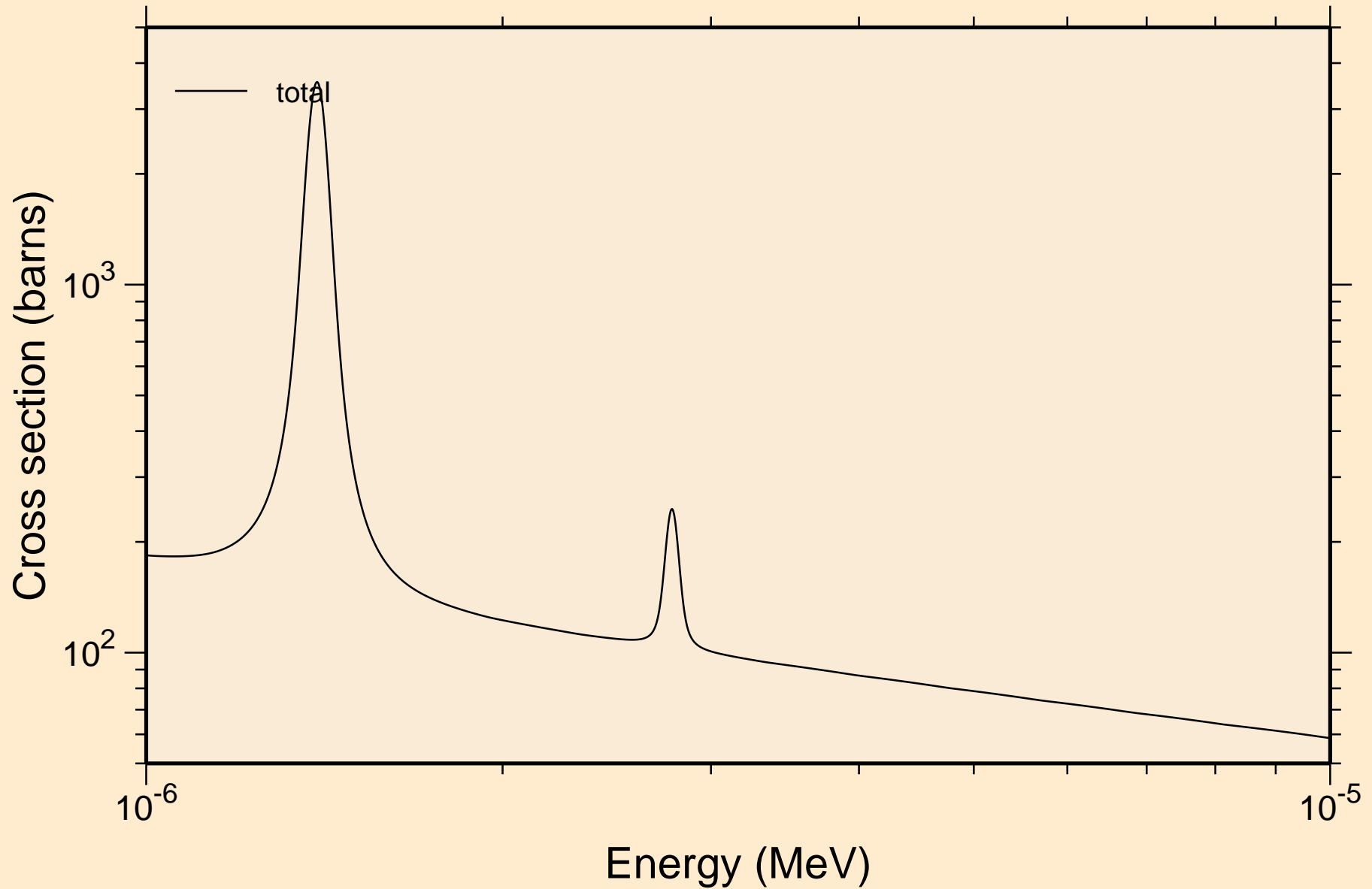

AC229 NEUTRON ACER TENDL-2021 LIBRARY; T=293.6K
resonance total cross section

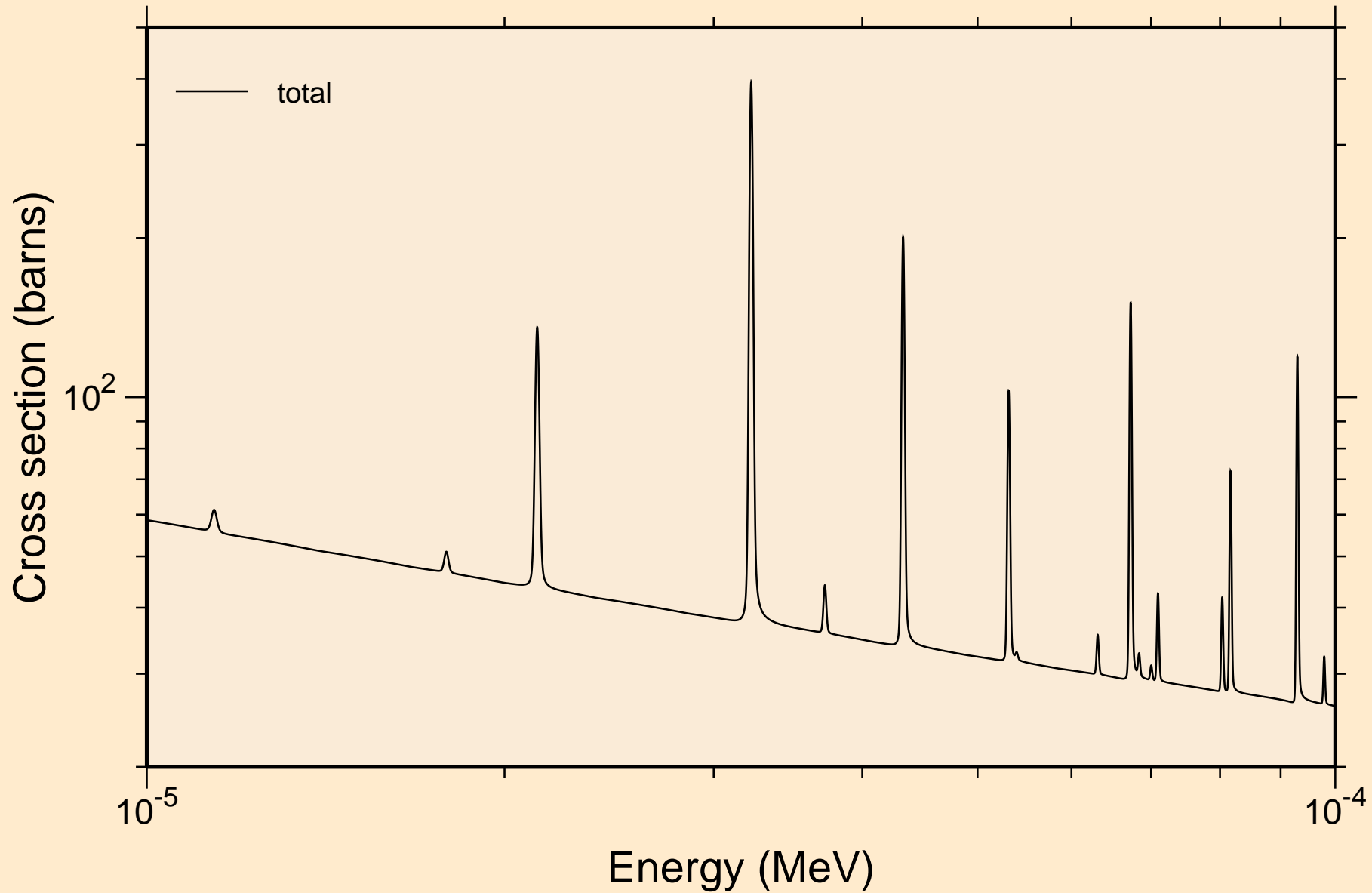

AC229 NEUTRON ACER TENDL-2021 LIBRARY; T=293.6K
resonance total cross section

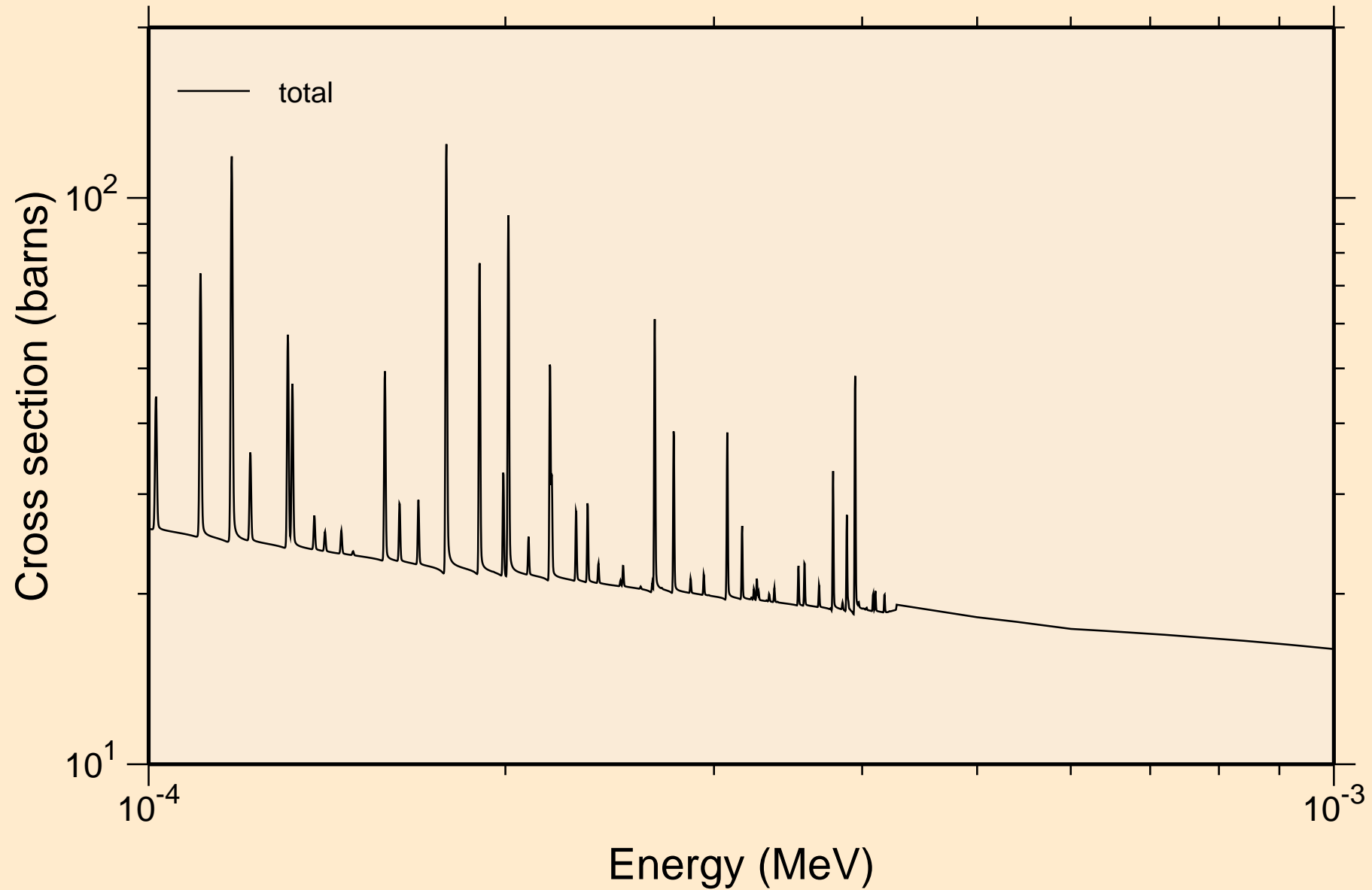

AC229 NEUTRON ACER TENDL-2021 LIBRARY; T=293.6K
resonance total cross section

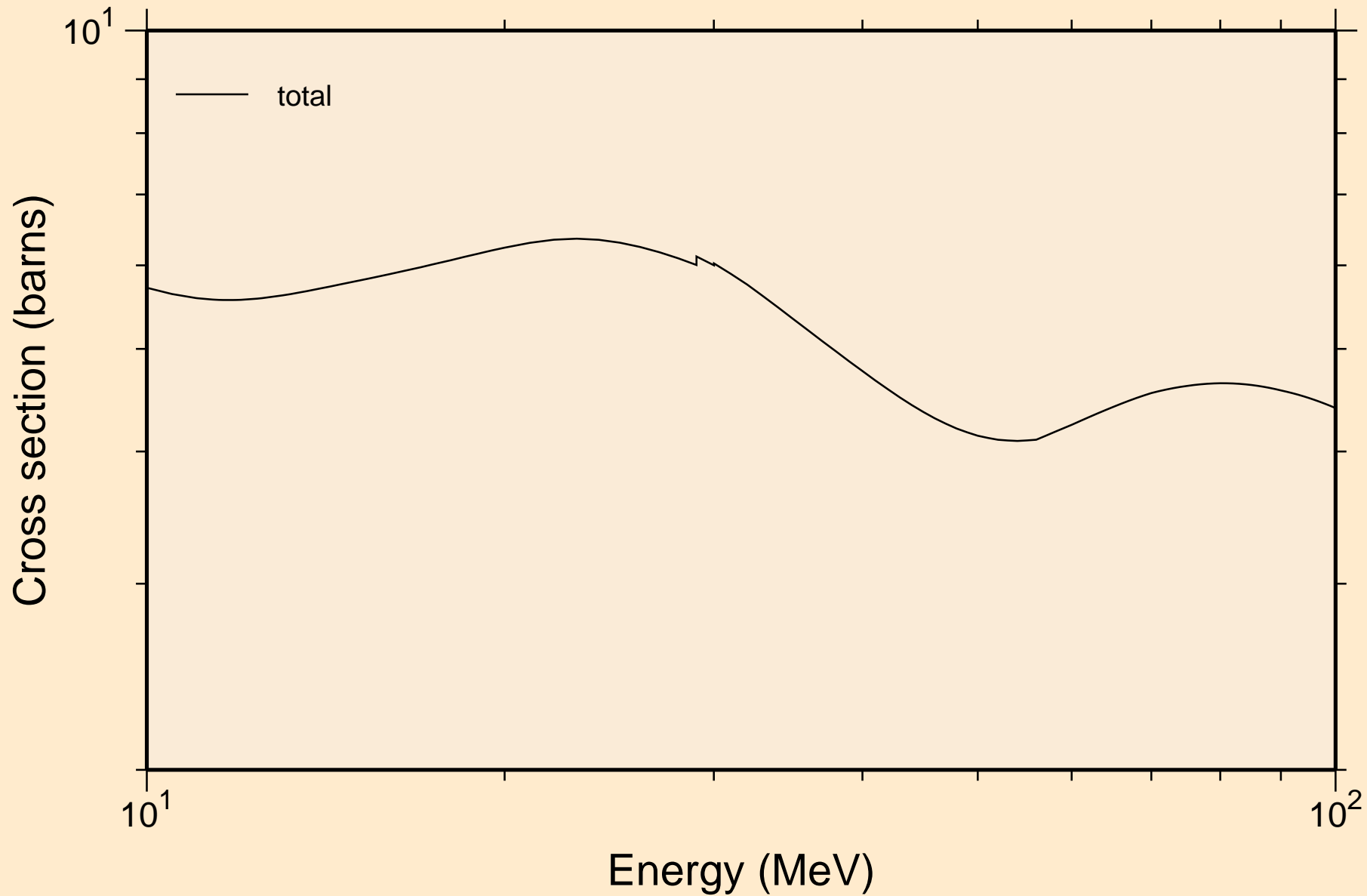

AC229 NEUTRON ACER TENDL-2021 LIBRARY; T=293.6K
resonance absorption cross sections

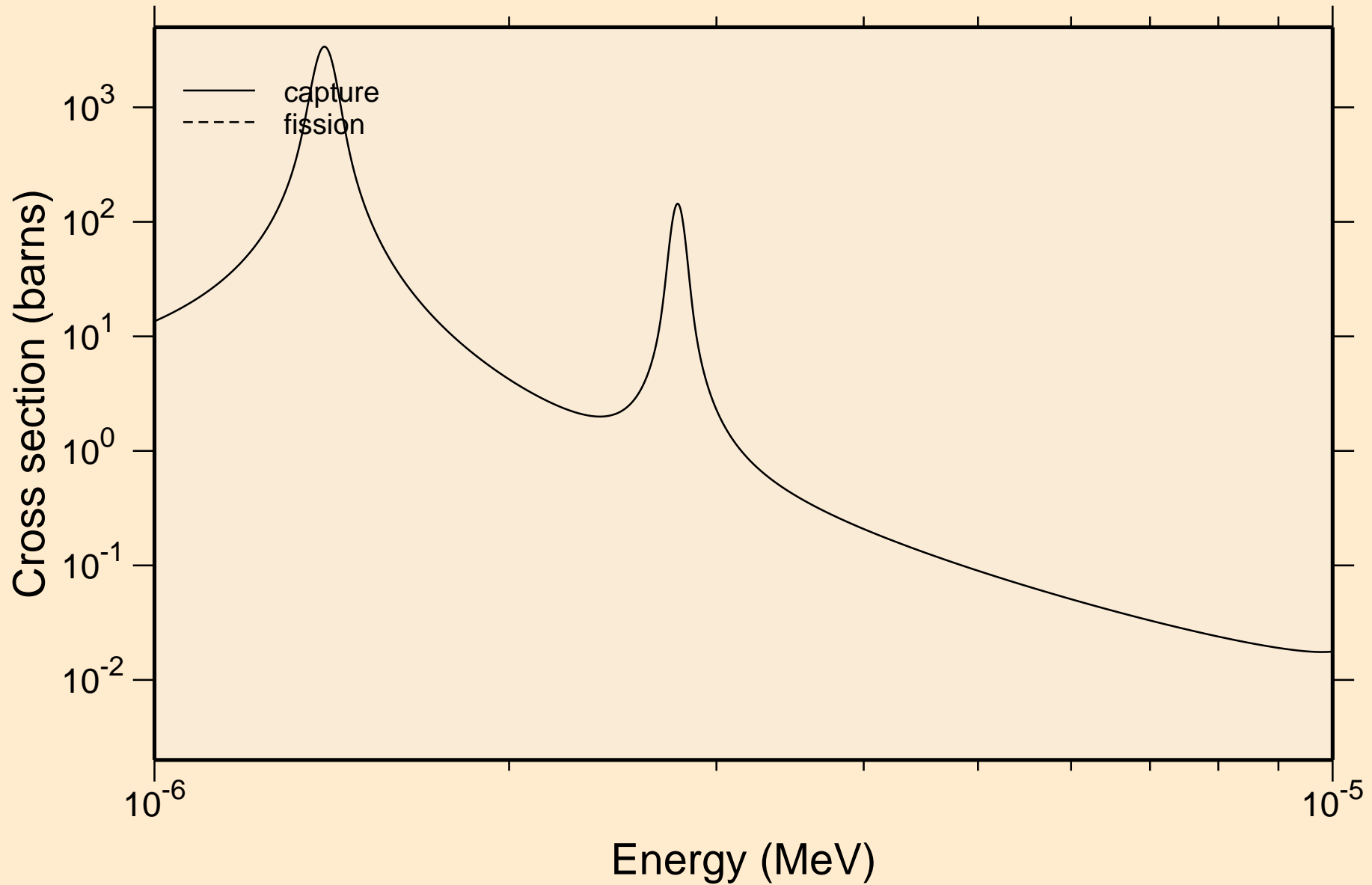

AC229 NEUTRON ACER TENDL-2021 LIBRARY; T=293.6K
resonance absorption cross sections

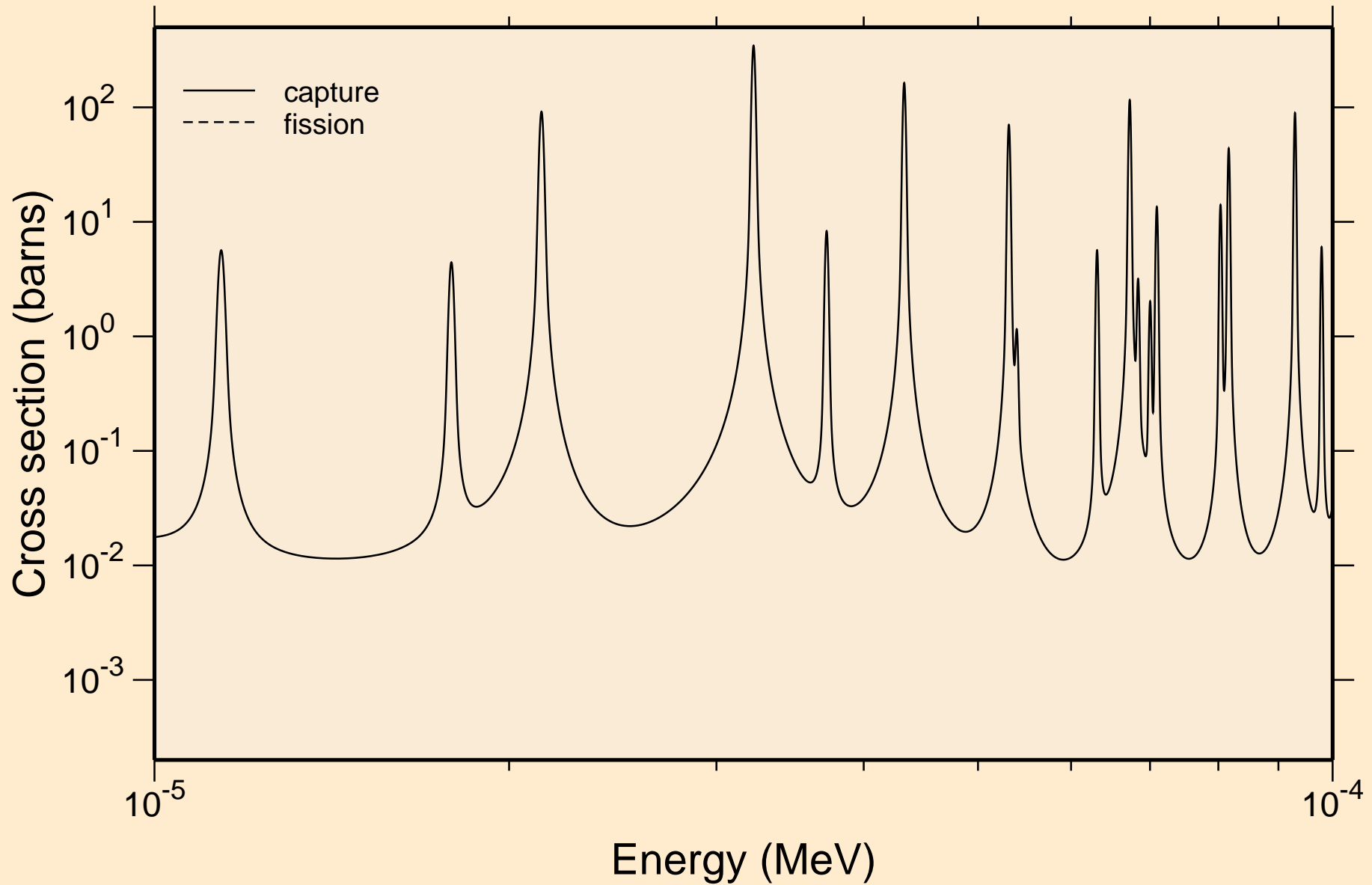

AC229 NEUTRON ACER TENDL-2021 LIBRARY; T=293.6K
resonance absorption cross sections

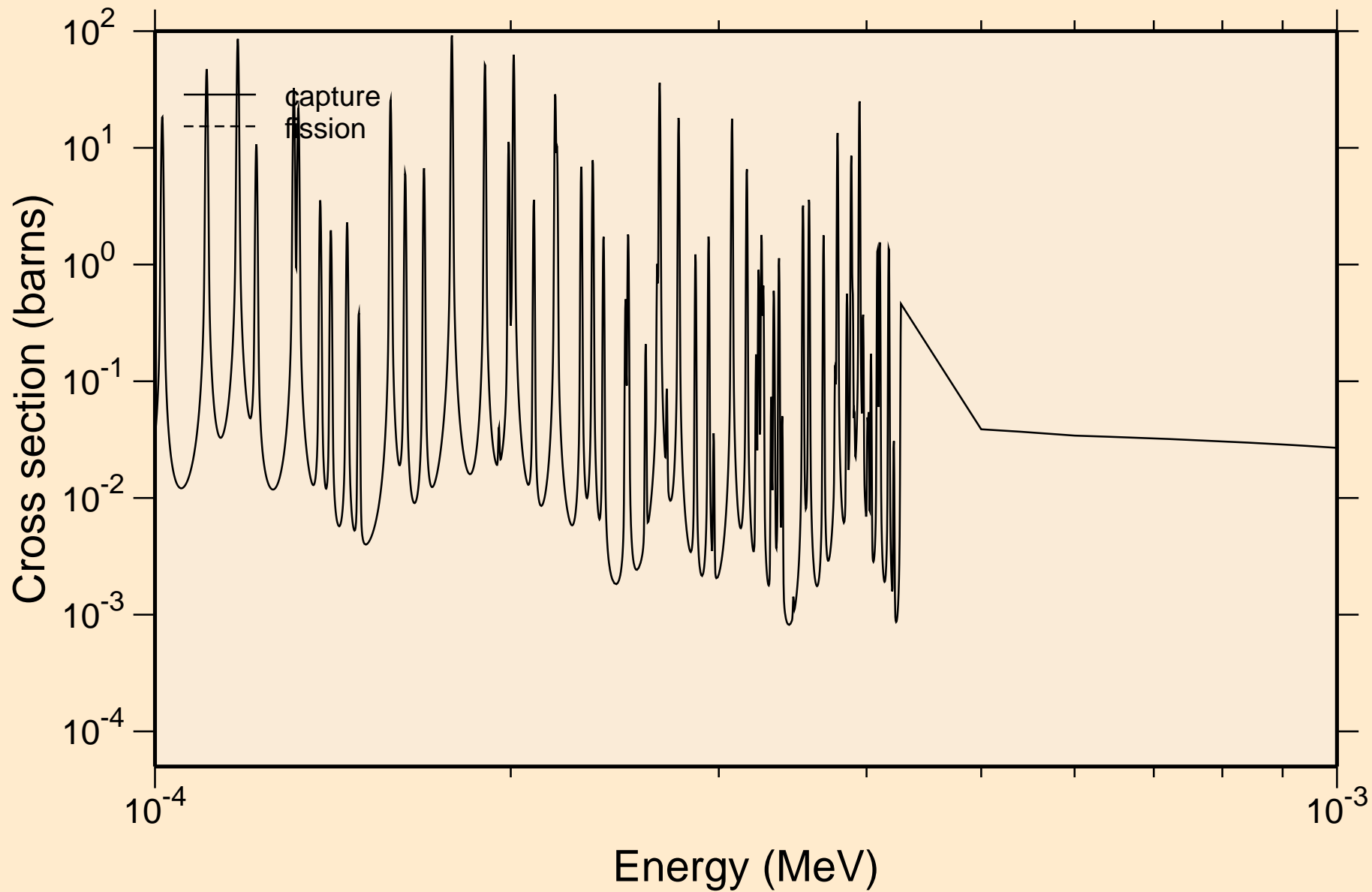

AC229 NEUTRON ACER TENDL-2021 LIBRARY; T=293.6K
resonance absorption cross sections

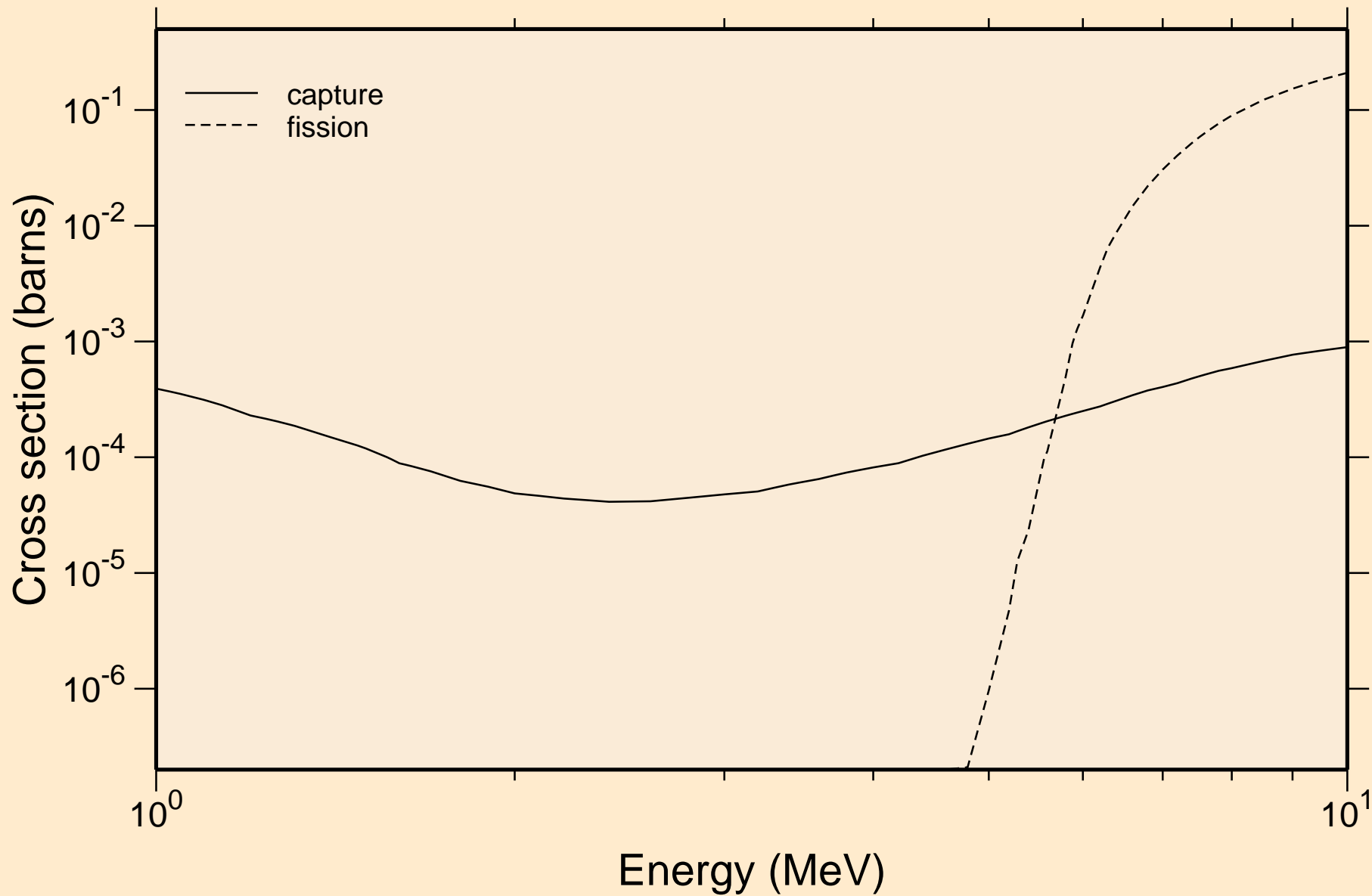

AC229 NEUTRON ACER TENDL-2021 LIBRARY; T=293.6K
Heating

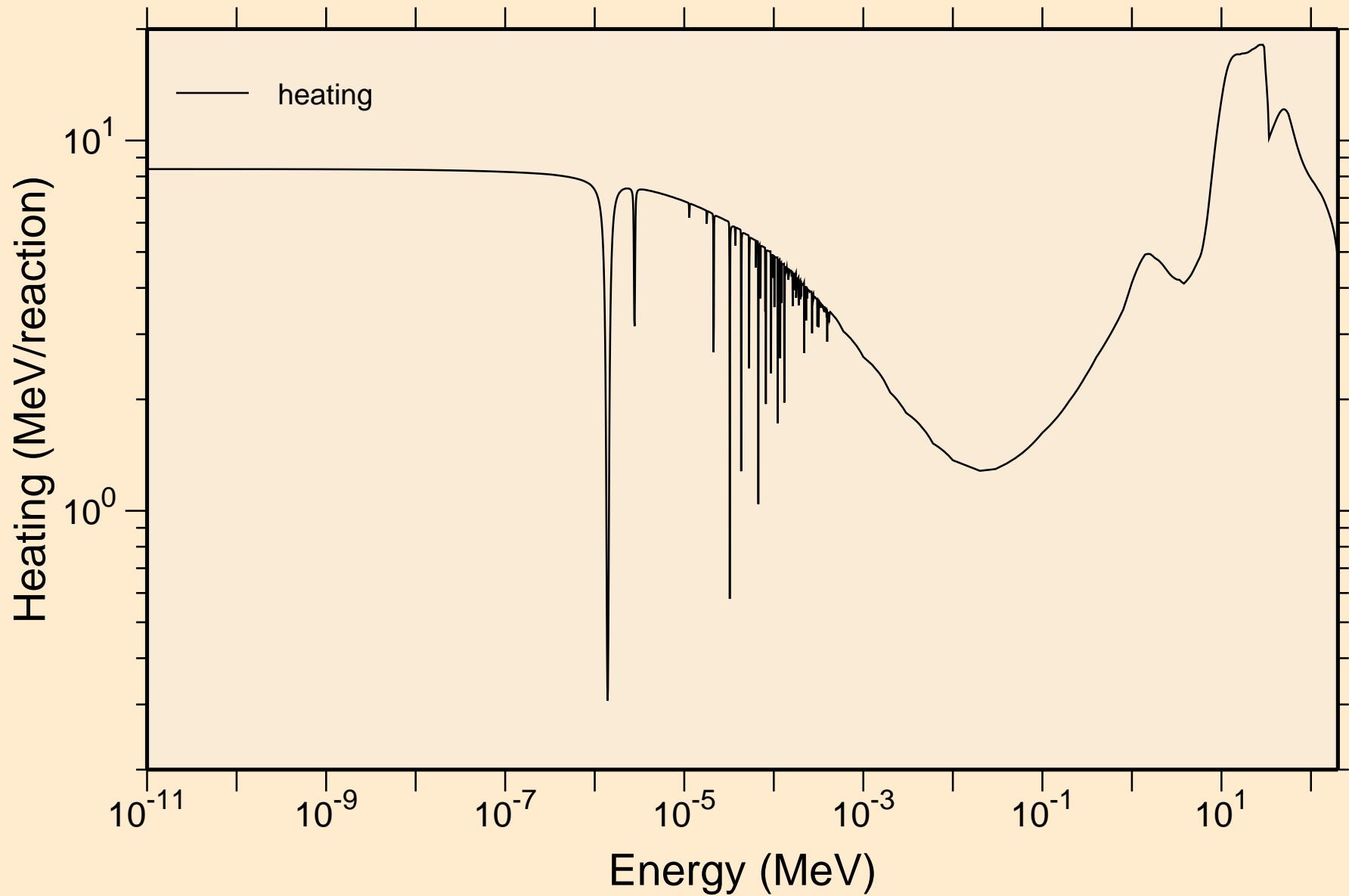

AC229 NEUTRON ACER TENDL-2021 LIBRARY; T=293.6K
Damage

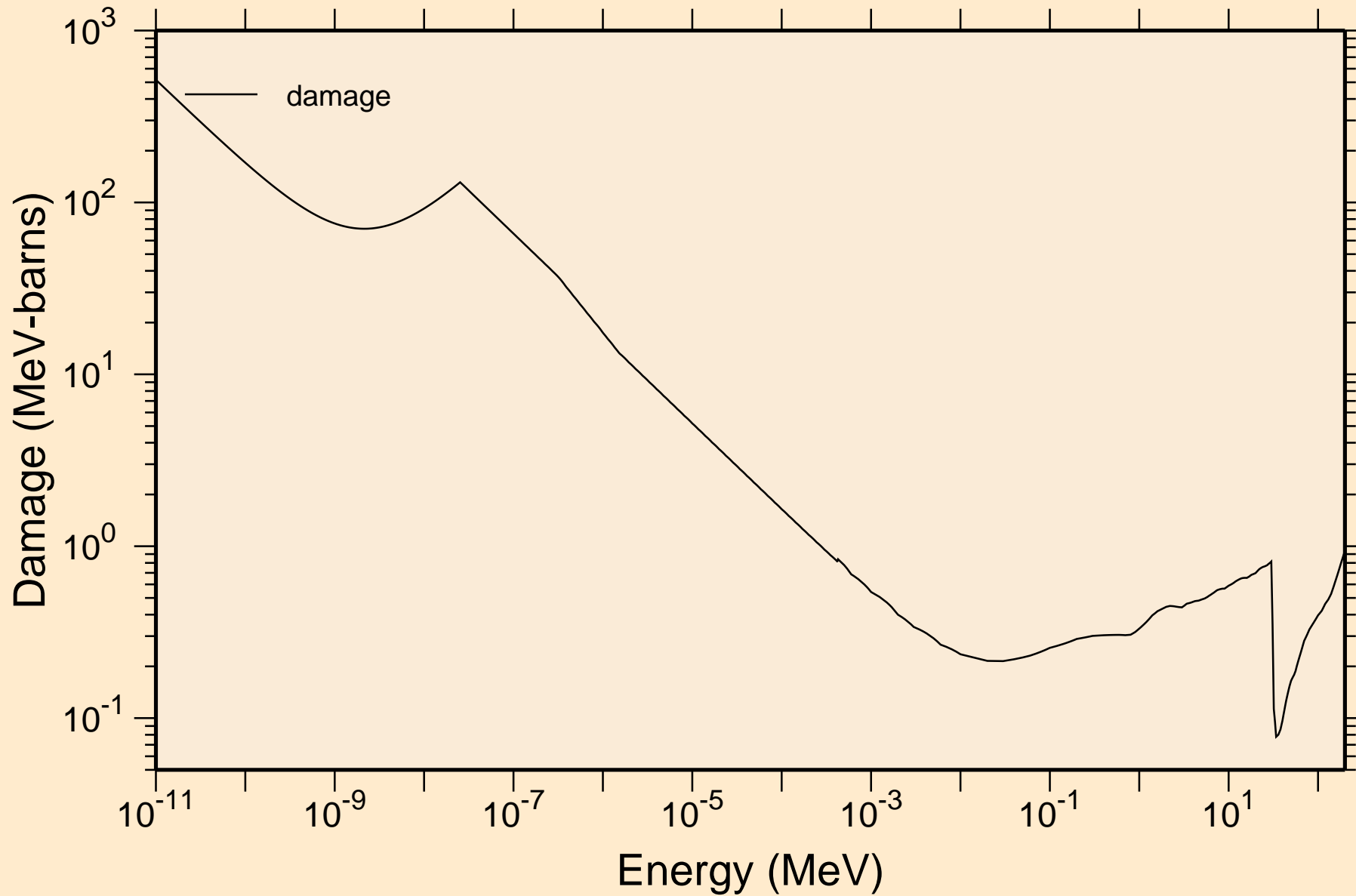

AC229 NEUTRON ACER TENDL-2021 LIBRARY; T=293.6K
Non-threshold reactions

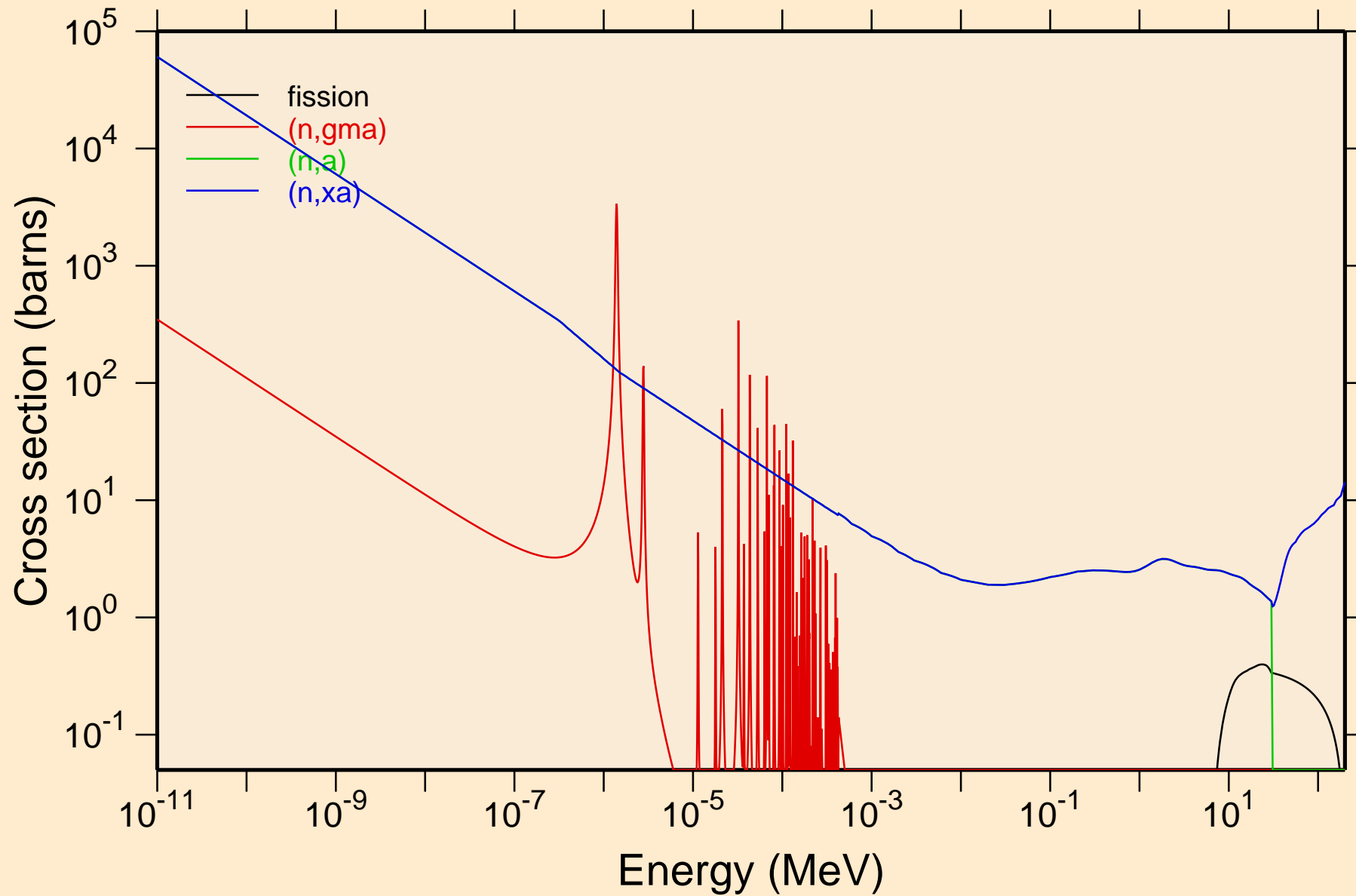

AC229 NEUTRON ACER TENDL-2021 LIBRARY; T=293.6K

Principal cross sections

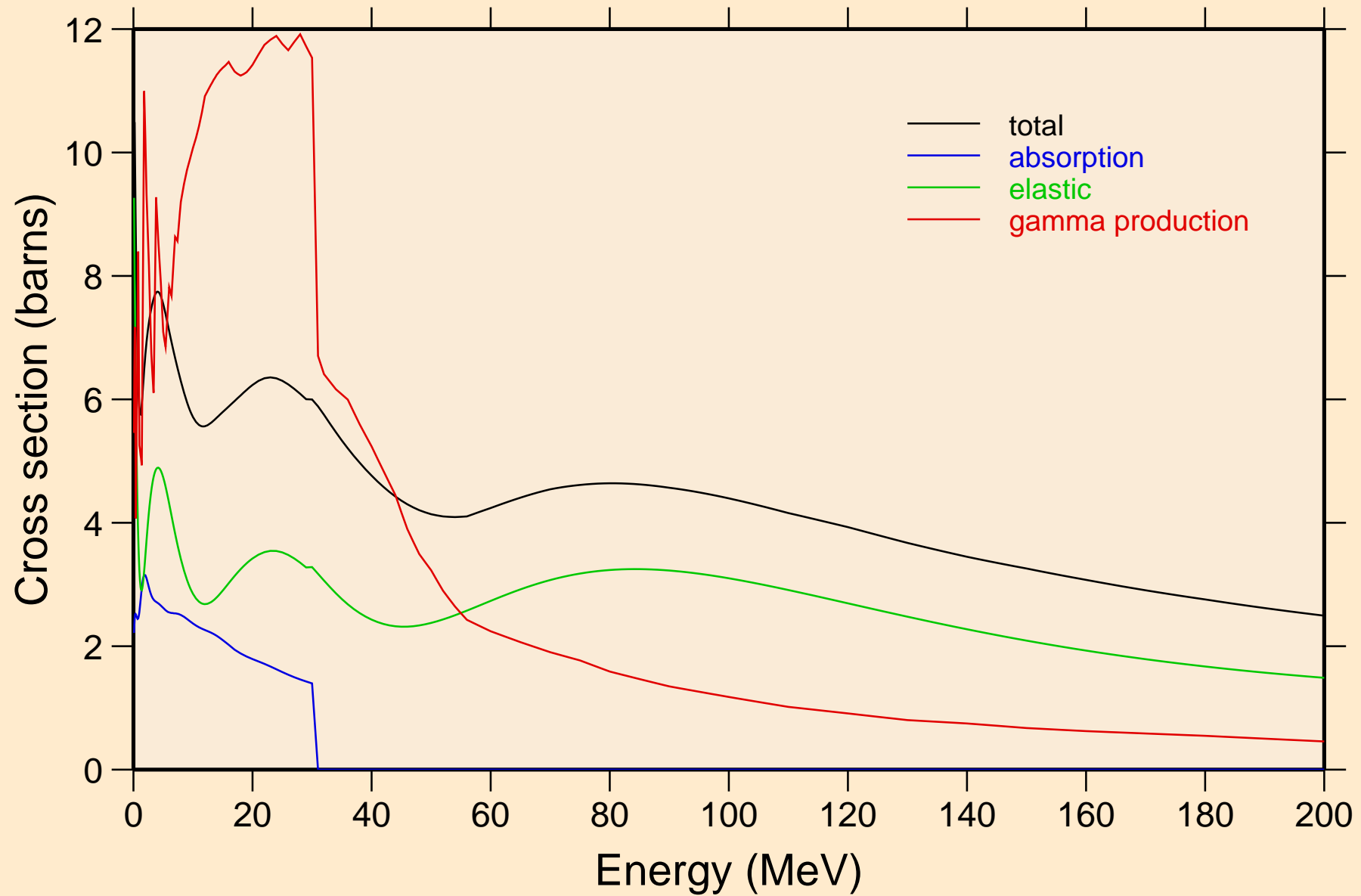

AC229 NEUTRON ACER TENDL-2021 LIBRARY; T=293.6K
Heating

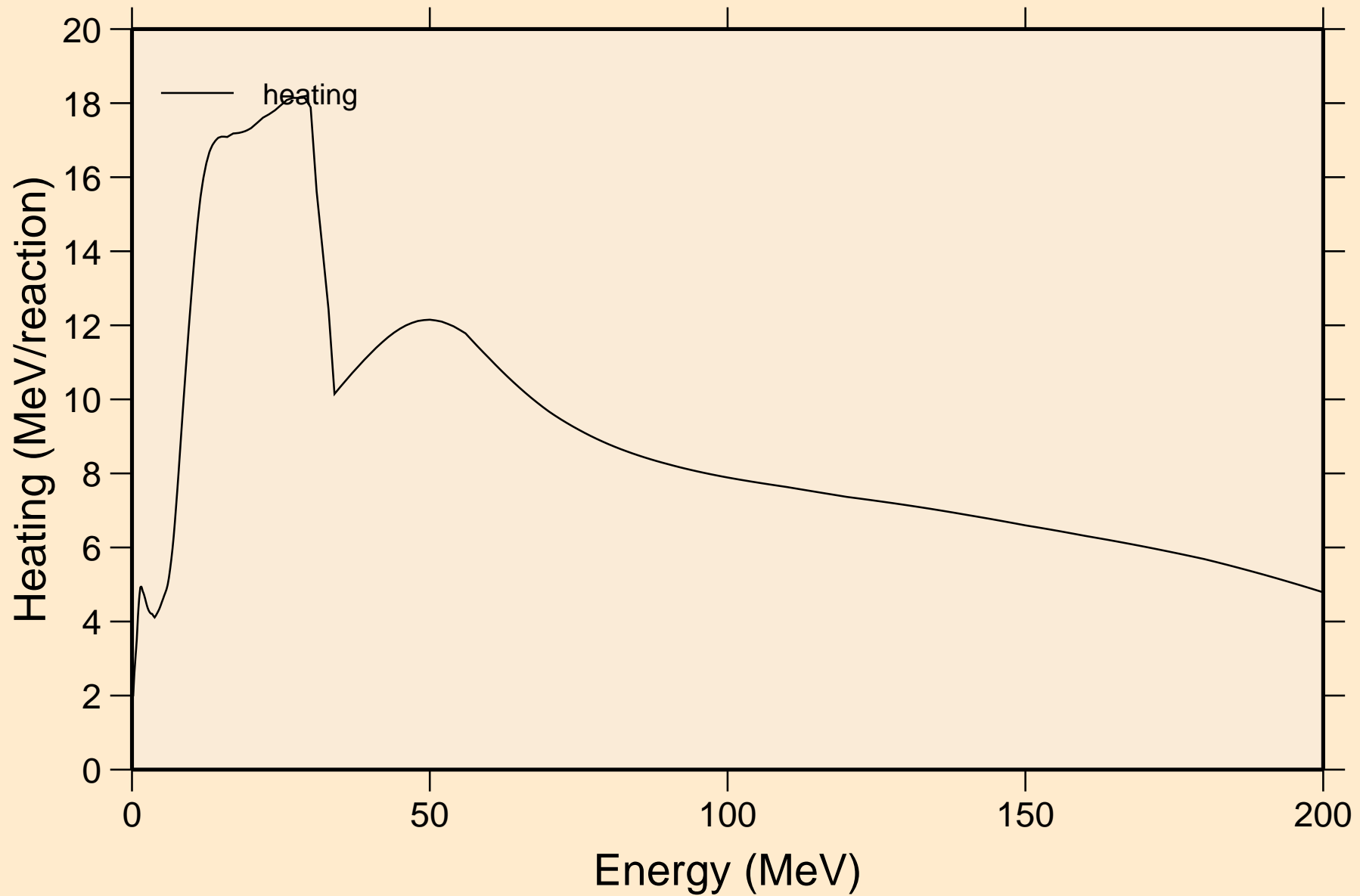

AC229 NEUTRON ACER TENDL-2021 LIBRARY; T=293.6K
Damage

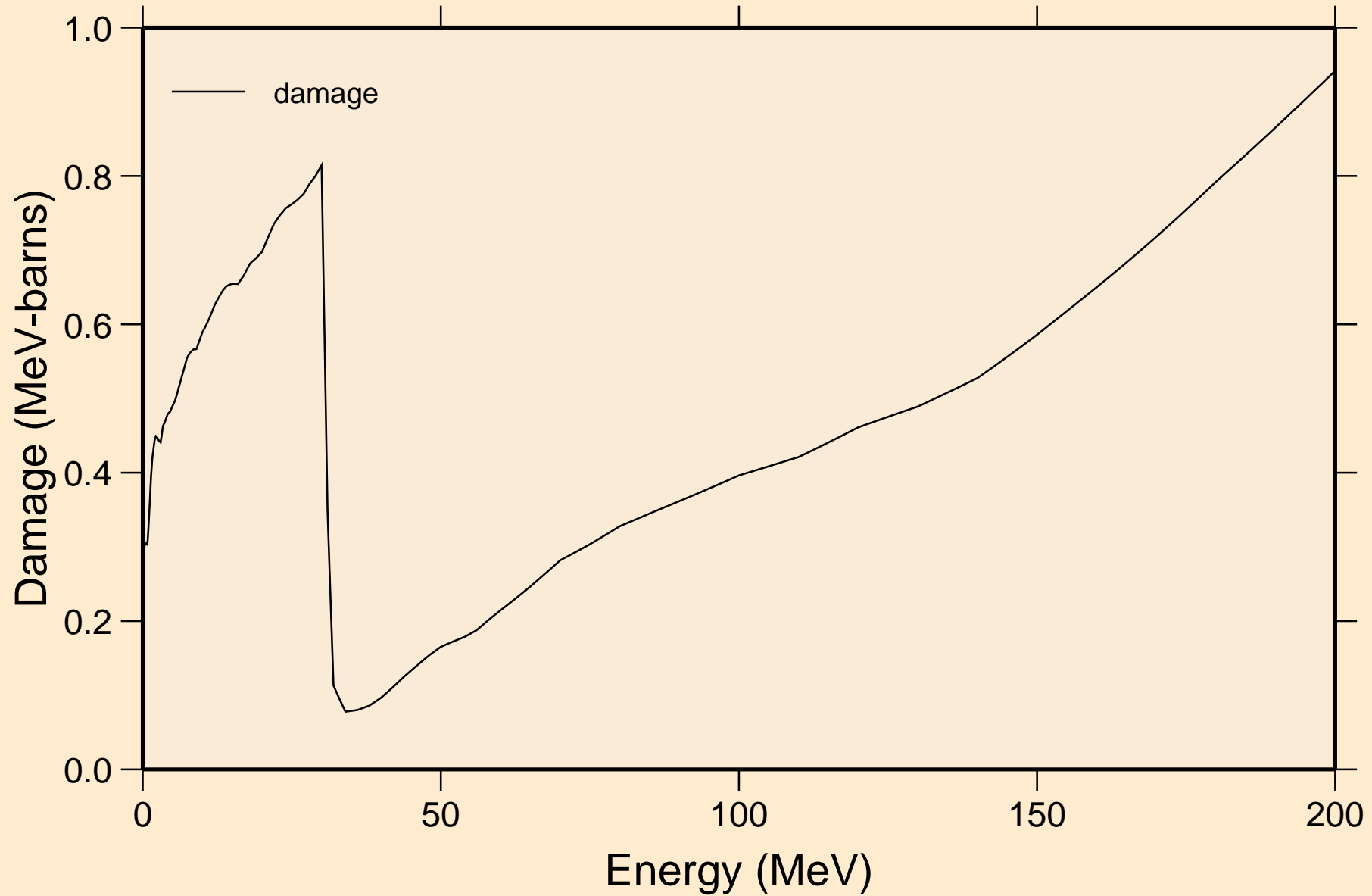

AC229 NEUTRON ACER TENDL-2021 LIBRARY; T=293.6K
Non-threshold reactions

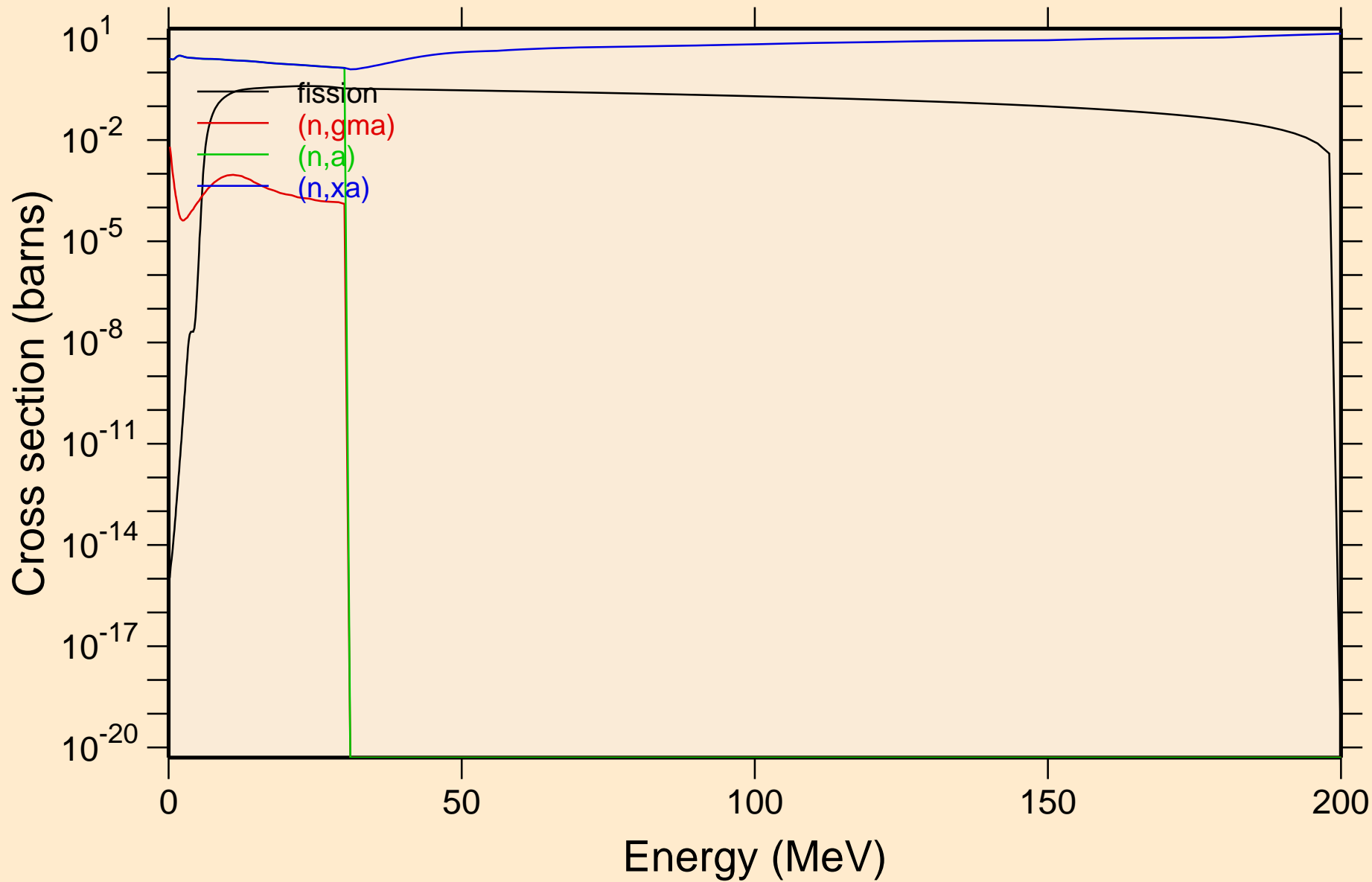

AC229 NEUTRON ACER TENDL-2021 LIBRARY; T=293.6K
Inelastic levels

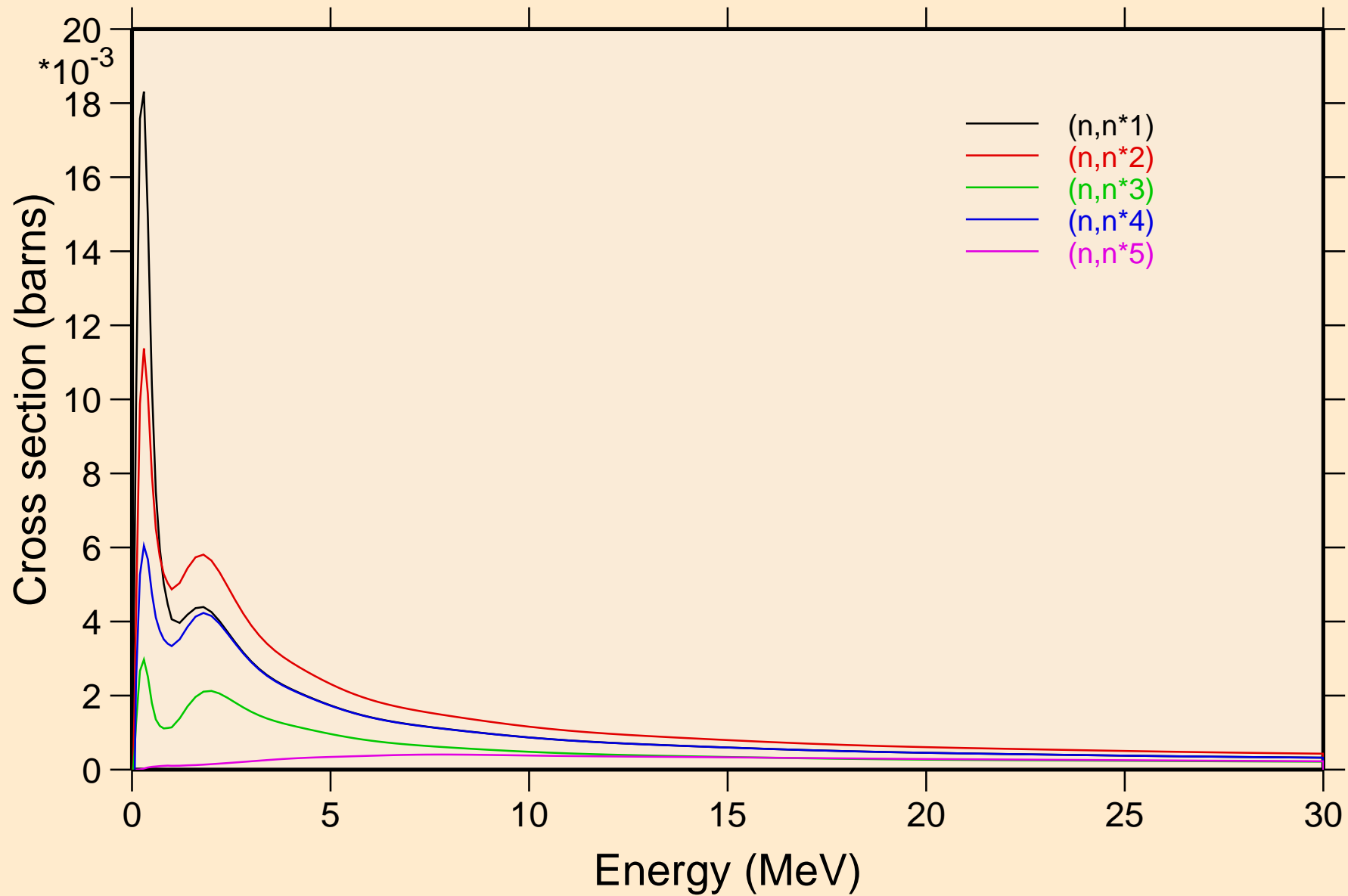

AC229 NEUTRON ACER TENDL-2021 LIBRARY; T=293.6K
Inelastic levels

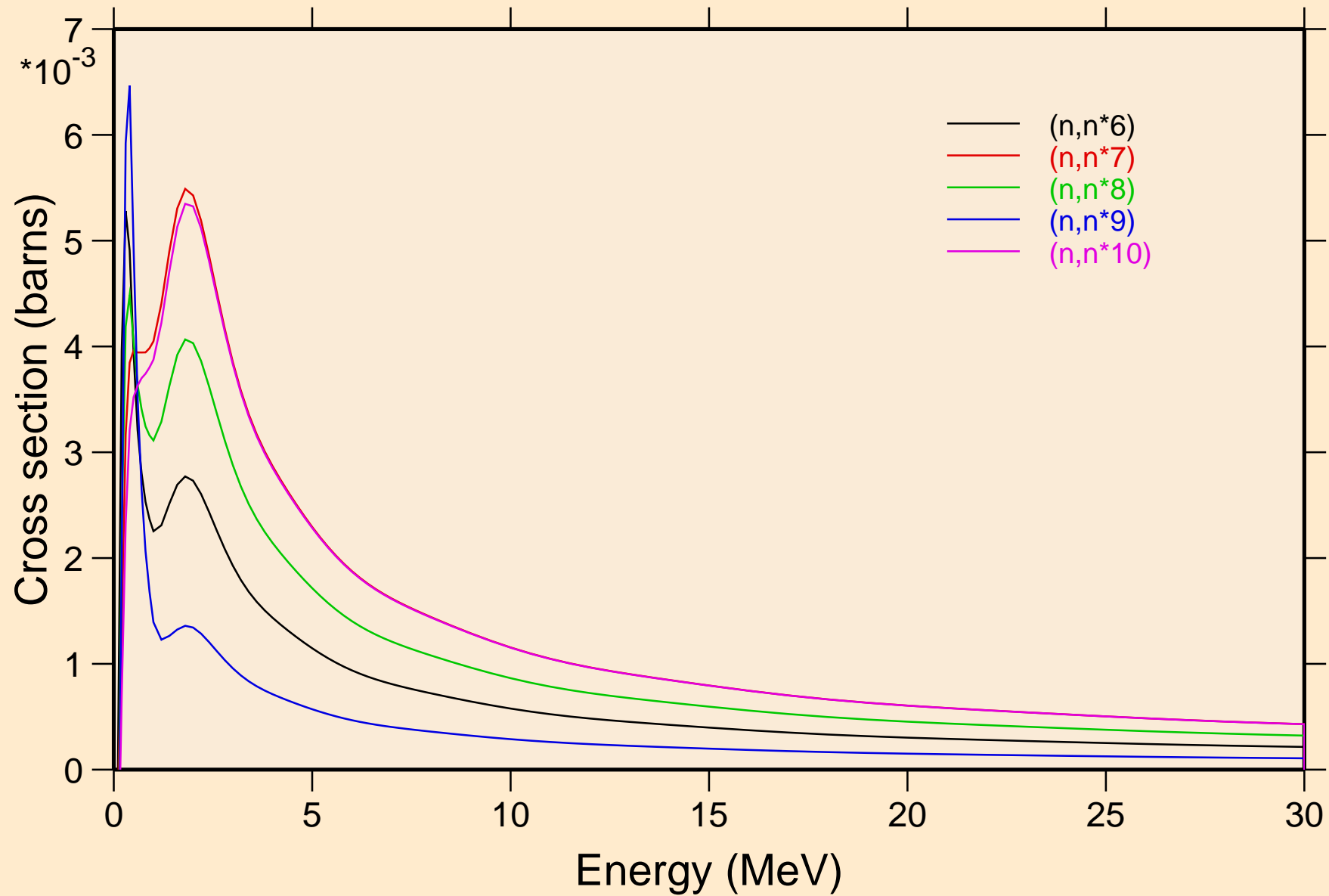

AC229 NEUTRON ACER TENDL-2021 LIBRARY; T=293.6K
Inelastic levels

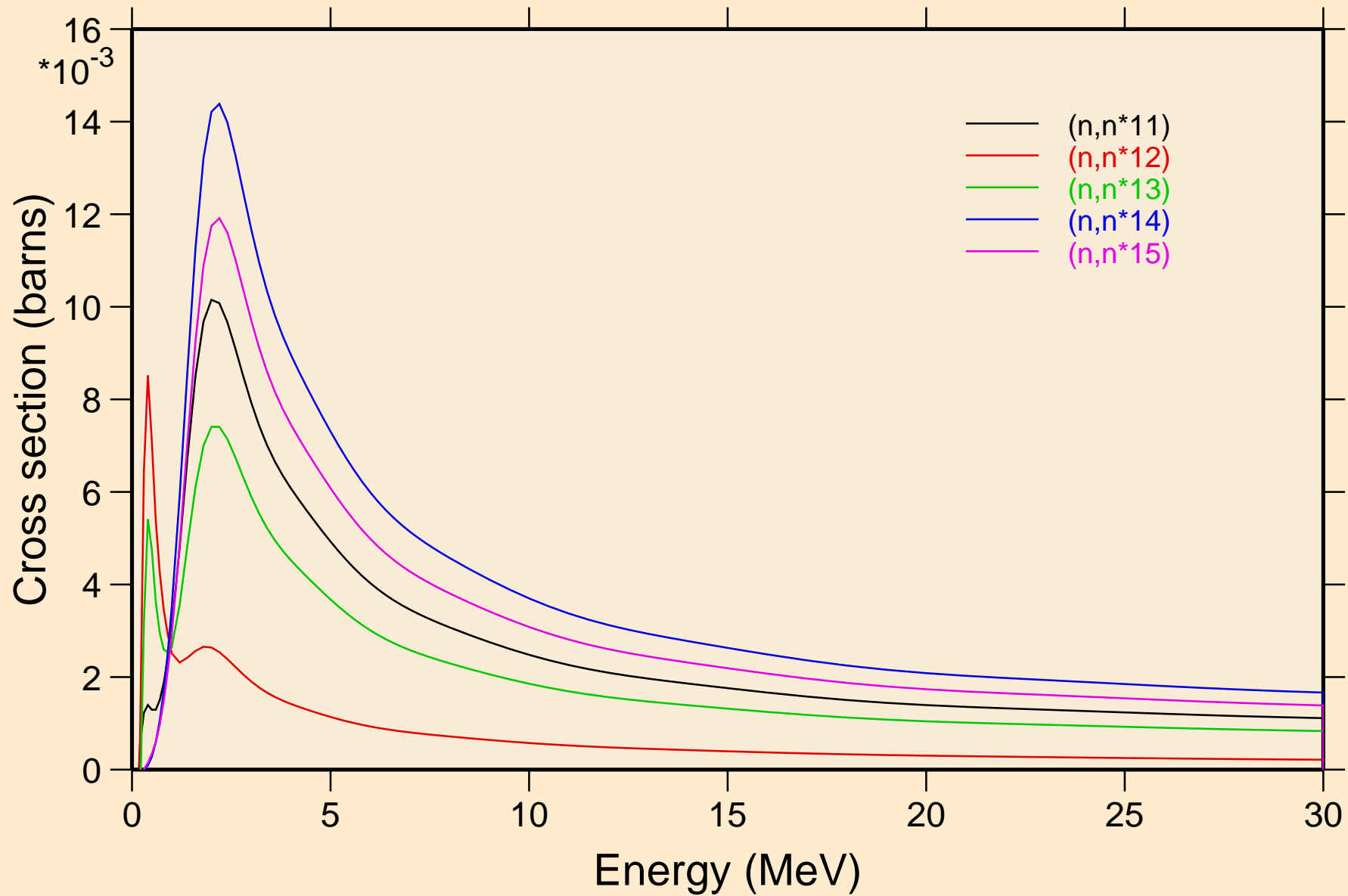

AC229 NEUTRON ACER TENDL-2021 LIBRARY; T=293.6K
Threshold reactions

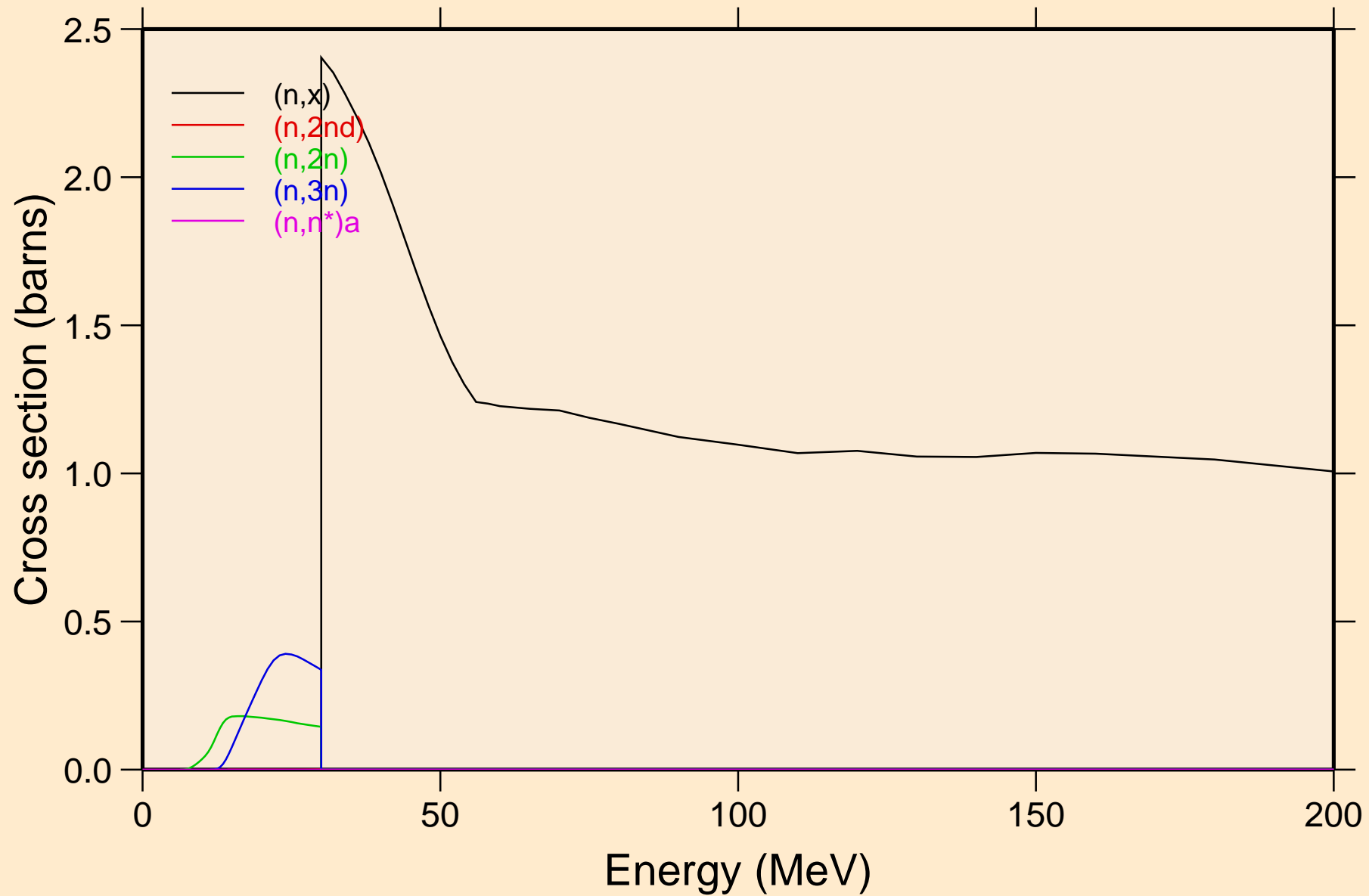

AC229 NEUTRON ACER TENDL-2021 LIBRARY; T=293.6K
Threshold reactions

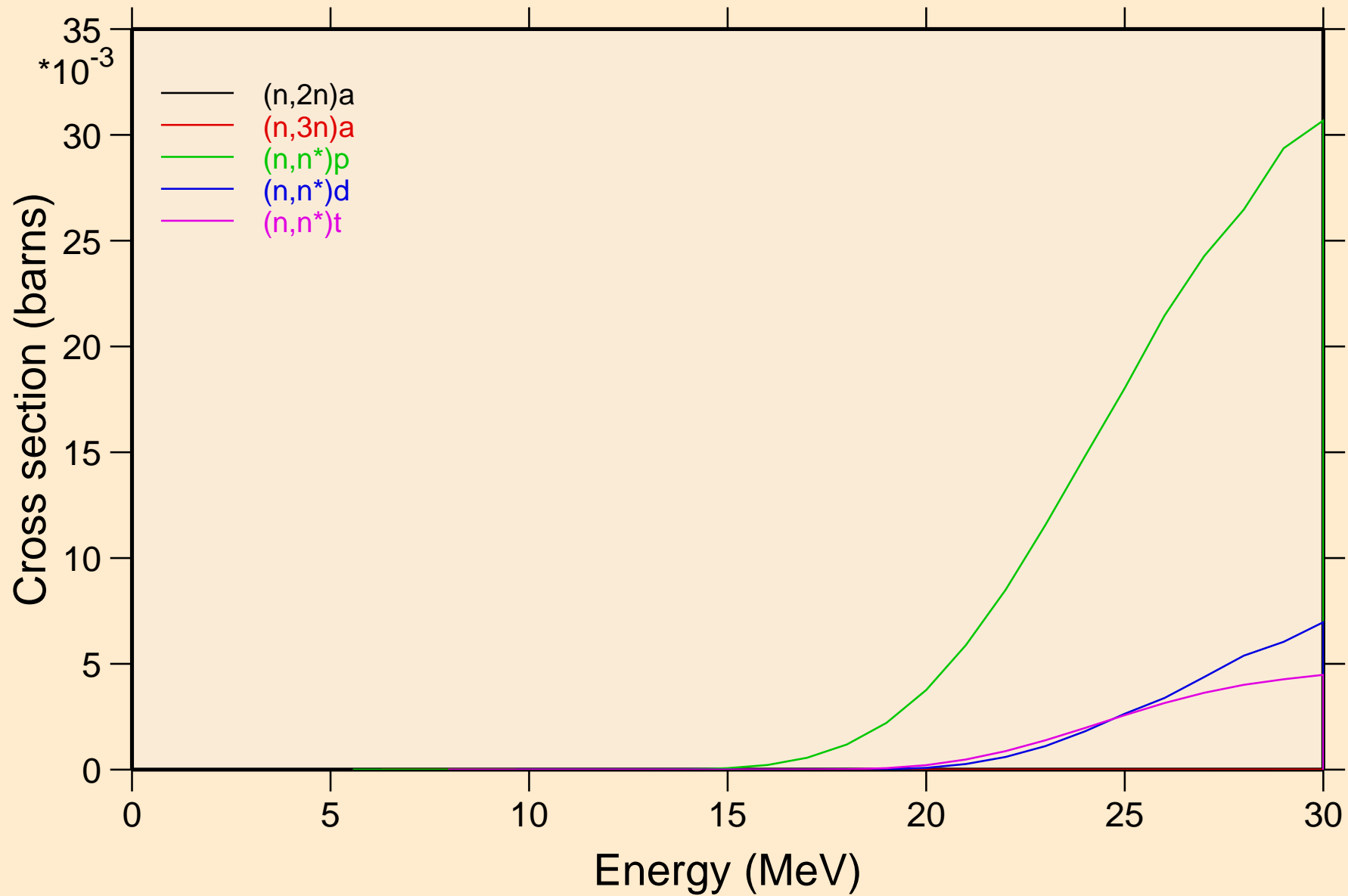

AC229 NEUTRON ACER TENDL-2021 LIBRARY; T=293.6K
Threshold reactions

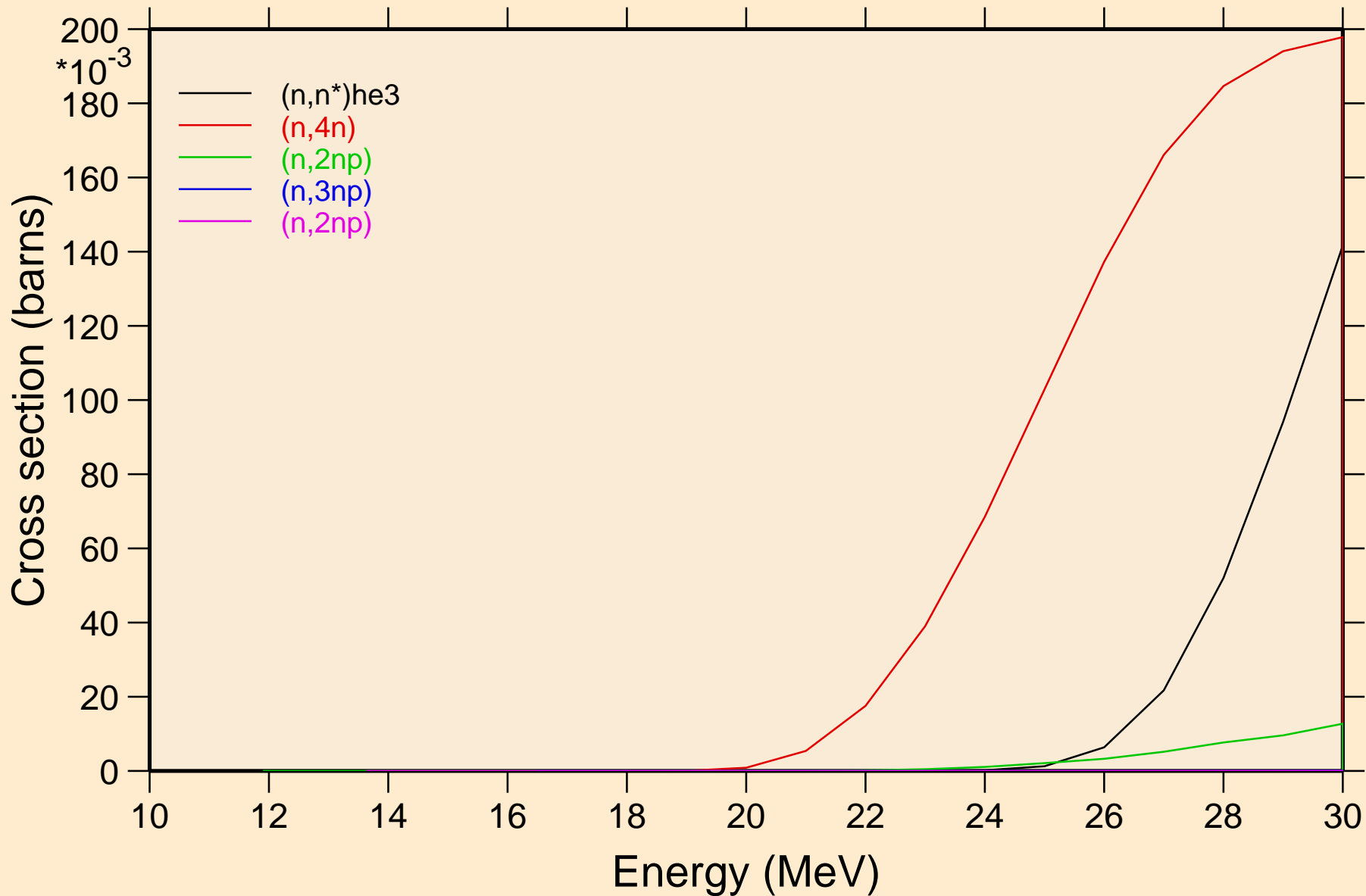

AC229 NEUTRON ACER TENDL-2021 LIBRARY; T=293.6K
Threshold reactions

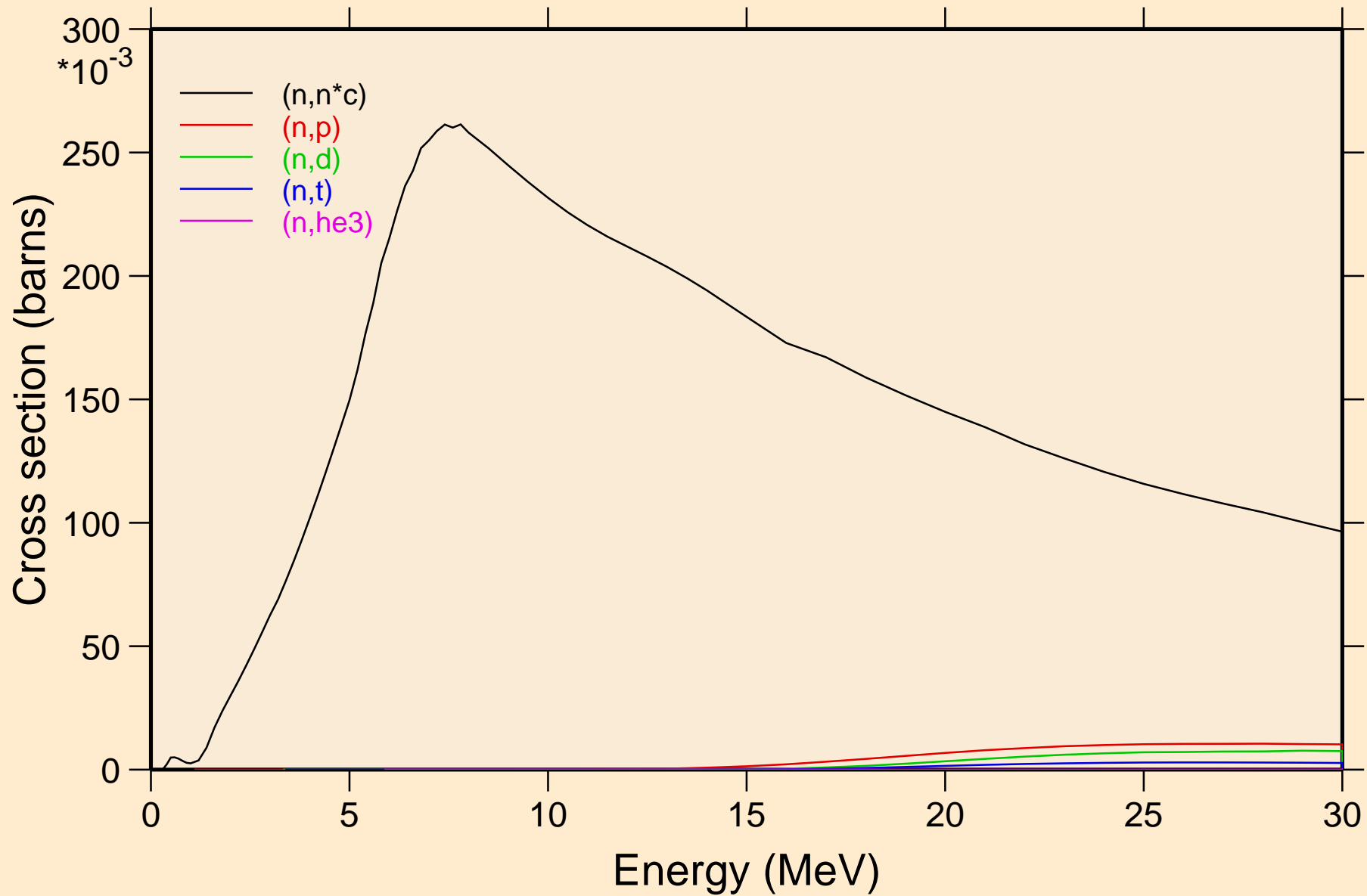

AC229 NEUTRON ACER TENDL-2021 LIBRARY; T=293.6K
Threshold reactions

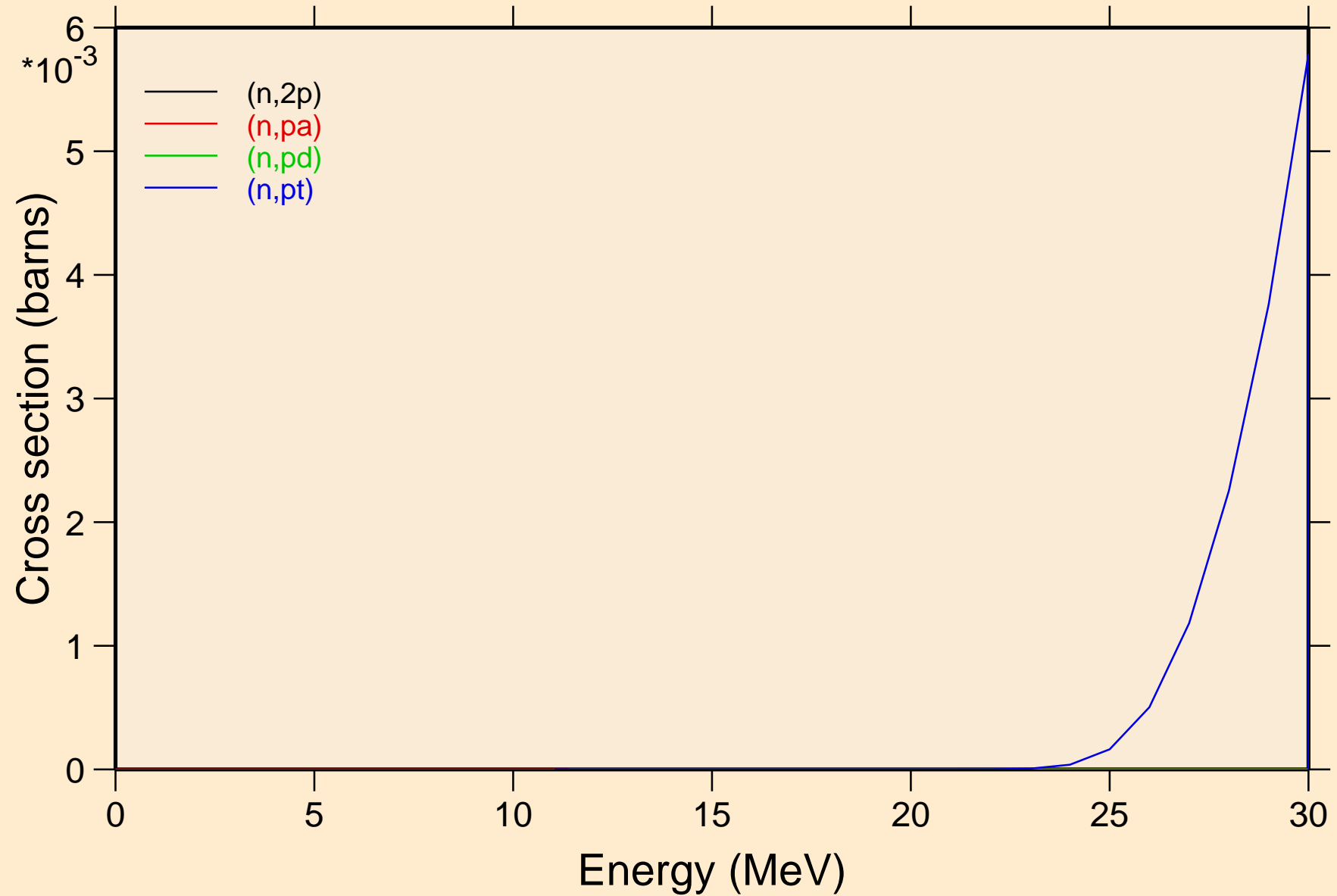

AC229 NEUTRON ACER TENDL-2021 LIBRARY; T=293.6K
Threshold reactions

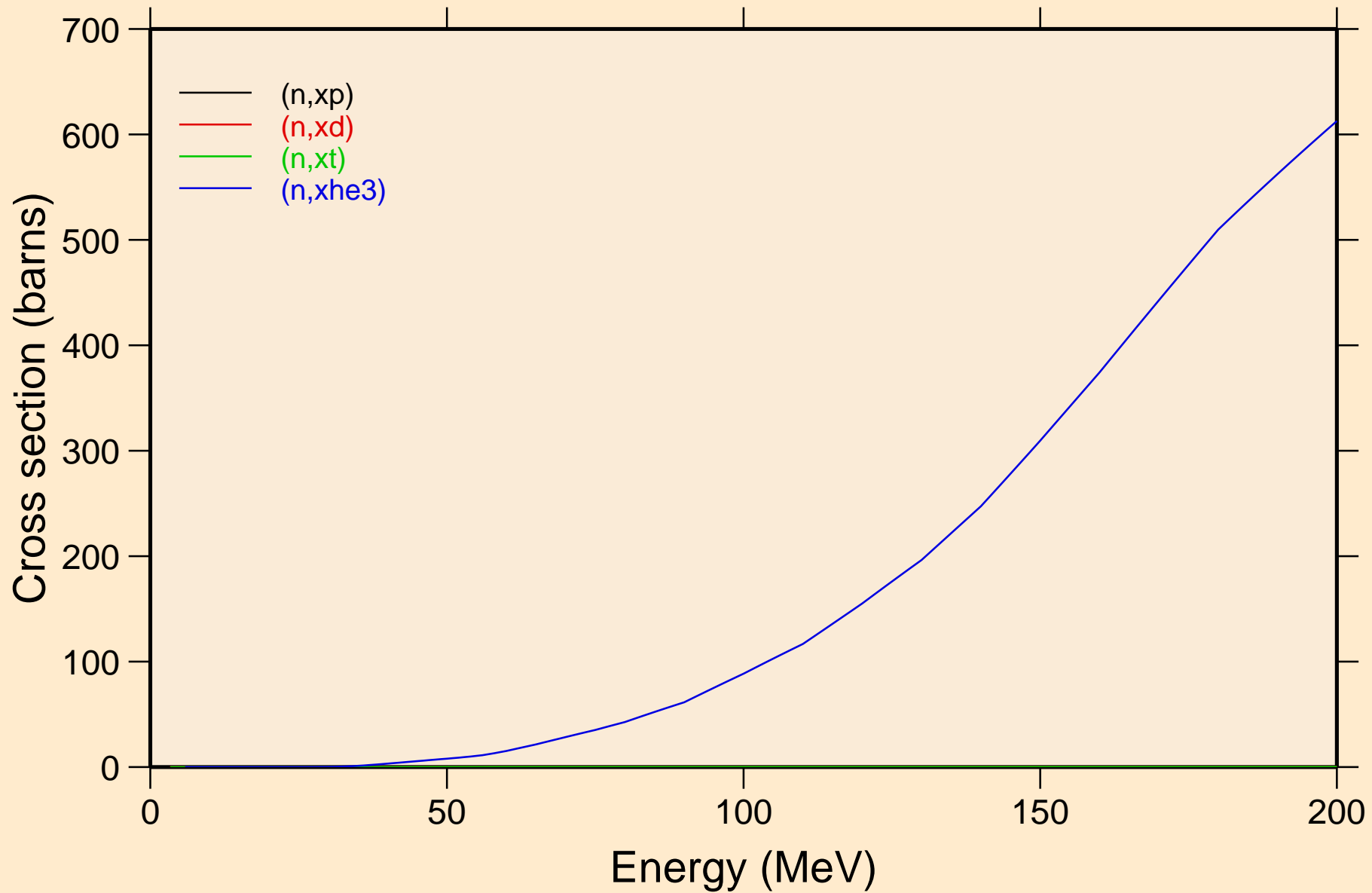

AC229 NEUTRON ACER TENDL-2021 LIBRARY; T=293.6K
angular distribution for elastic

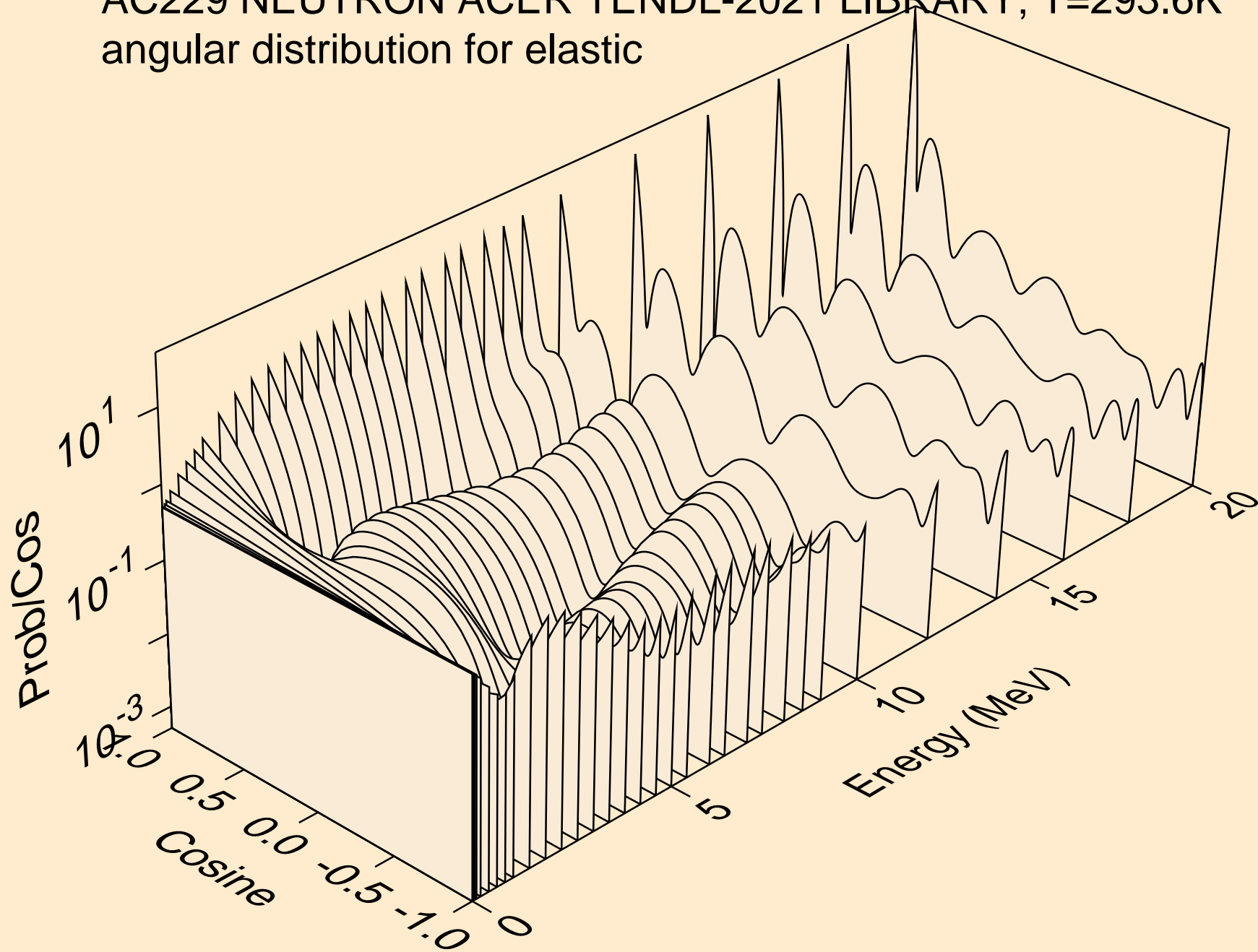

AC229 NEUTRON ACER TENDL-2021 LIBRARY; T=293.6K
angular distribution for elastic

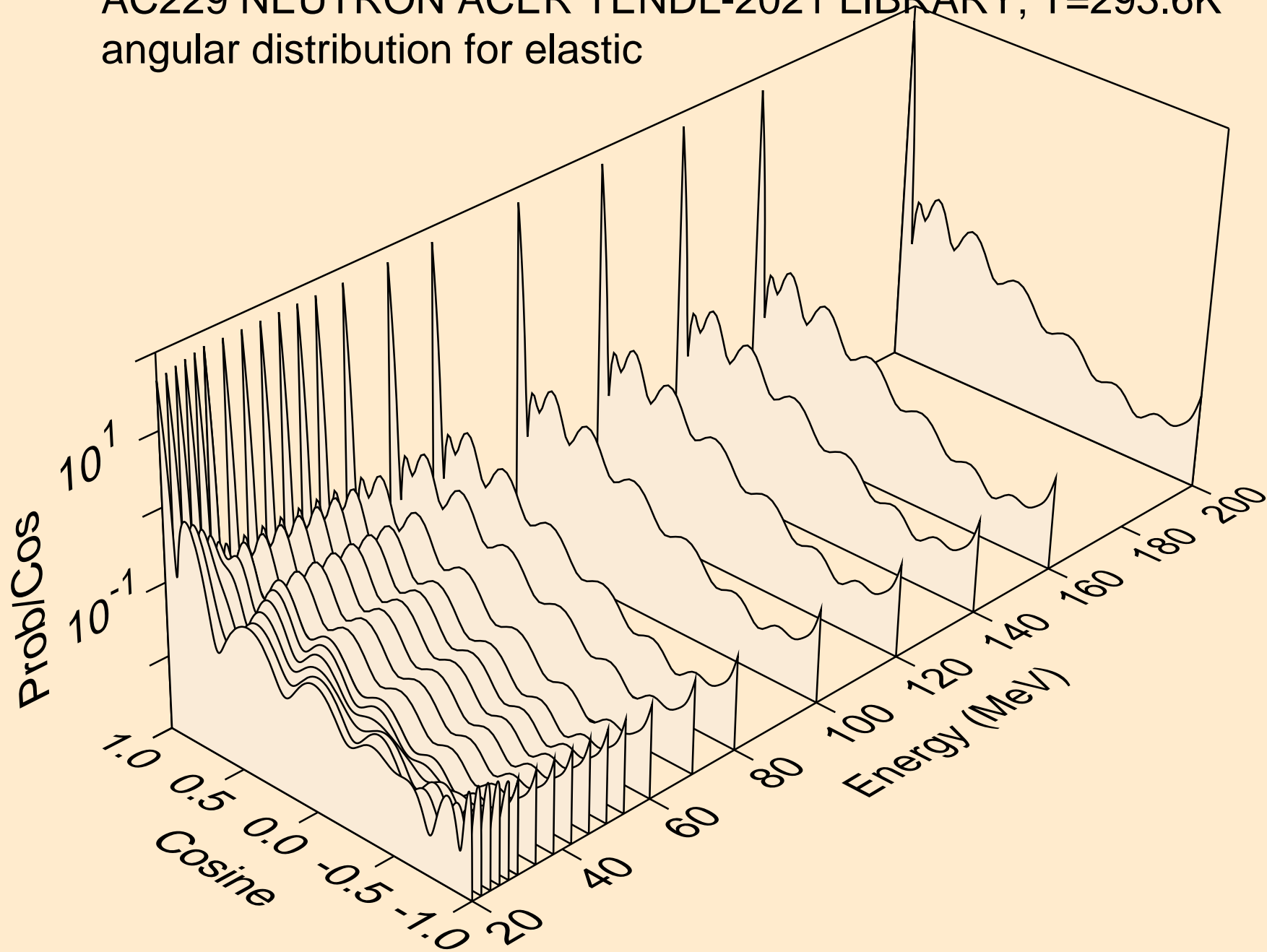

AC229 NEUTRON ACER TENDL-2021 LIBRARY; T=293.6K
angular distribution for (n,n*1)

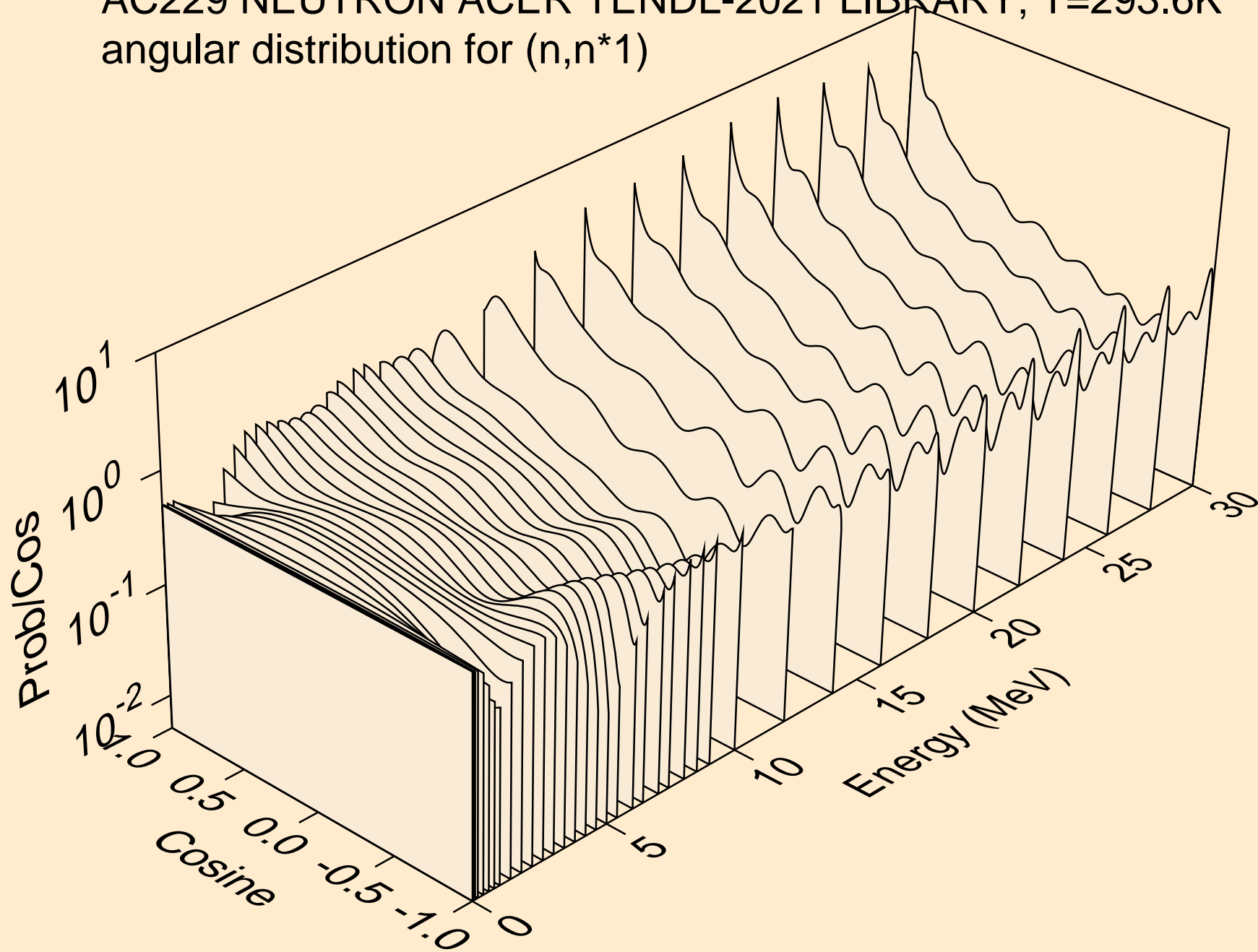

AC229 NEUTRON ACER TENDL-2021 LIBRARY; T=293.6K
angular distribution for (n,n*2)

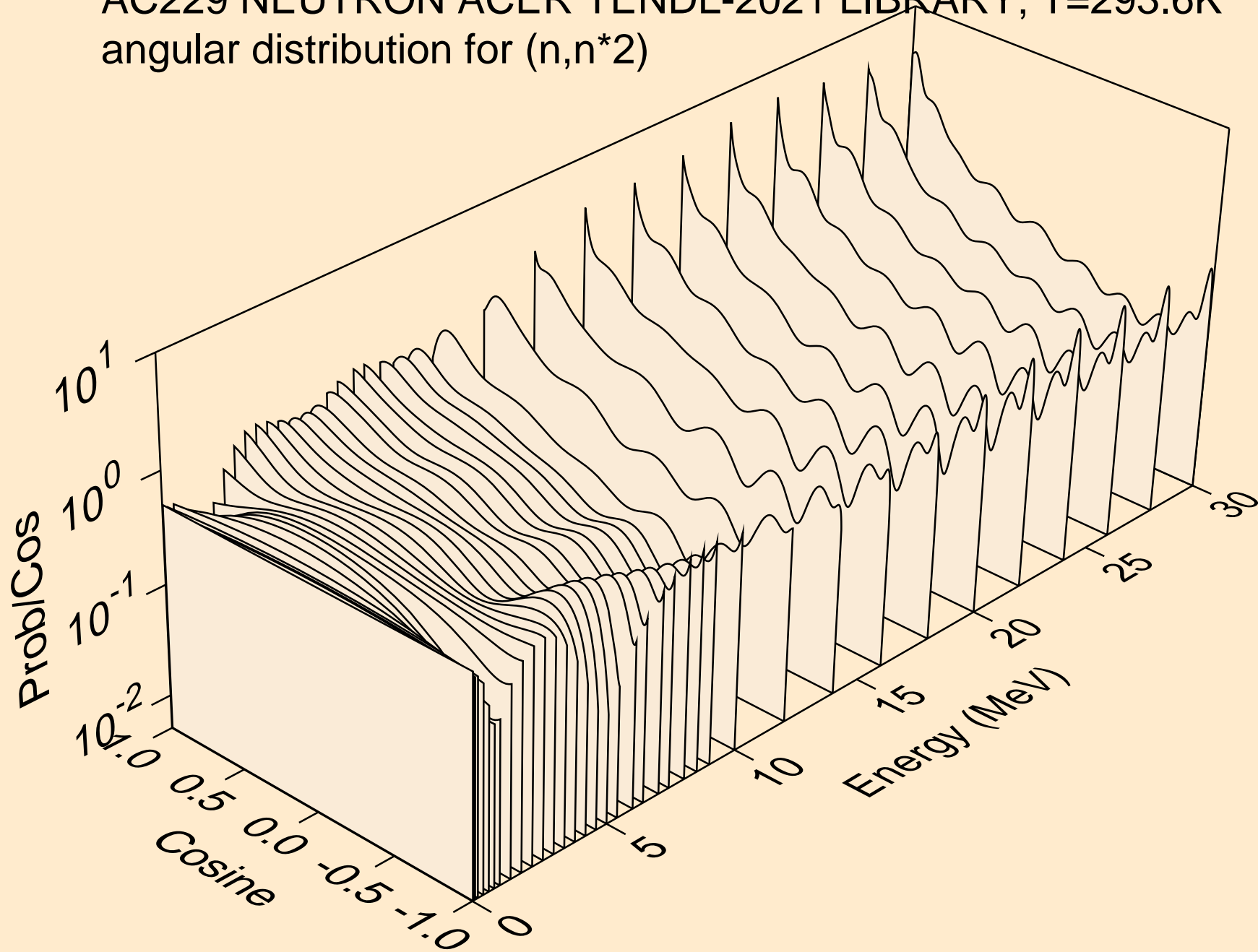

AC229 NEUTRON ACER TENDL-2021 LIBRARY; T=293.6K
angular distribution for (n,n*3)

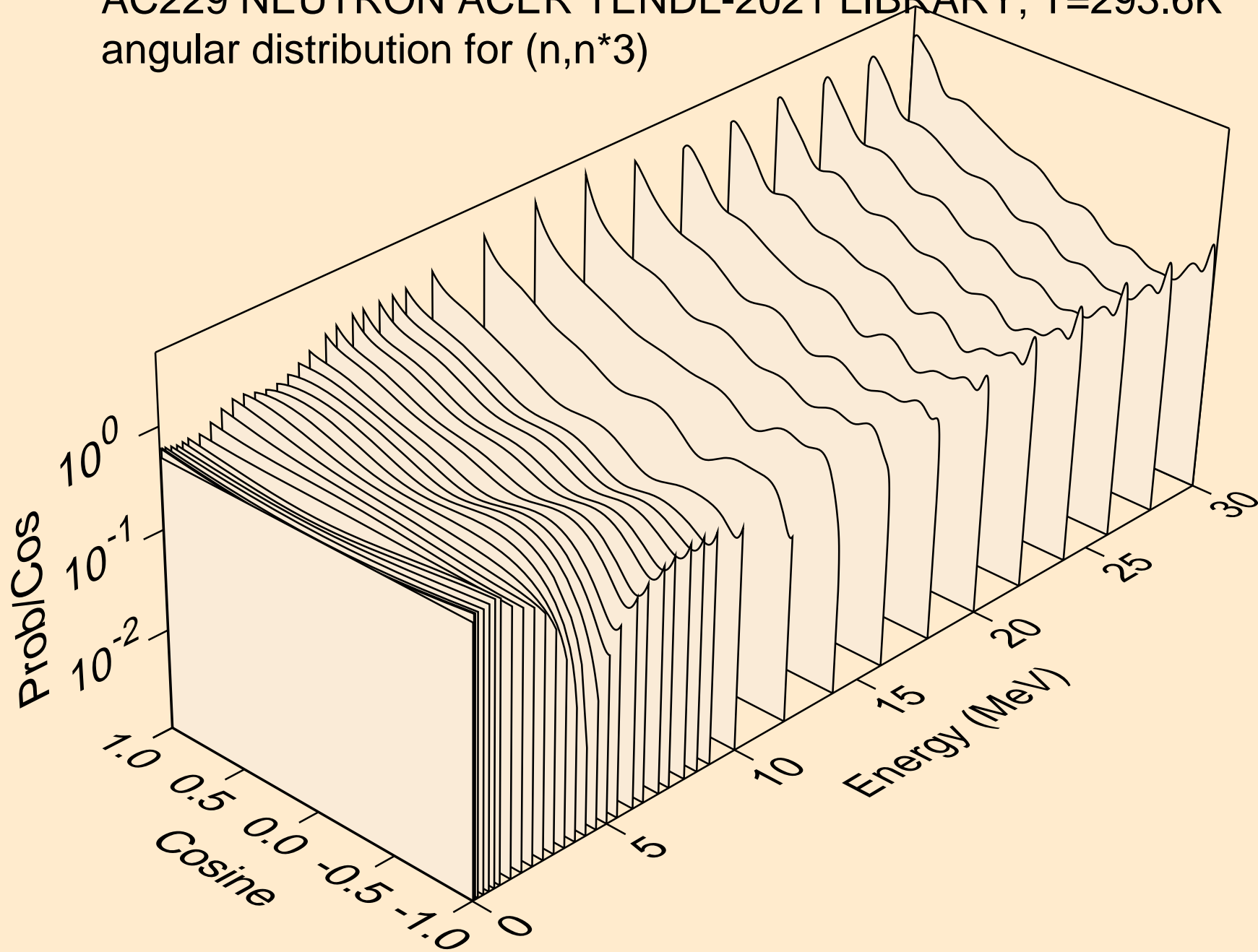

AC229 NEUTRON ACER TENDL-2021 LIBRARY; T=293.6K
angular distribution for (n,n*4)

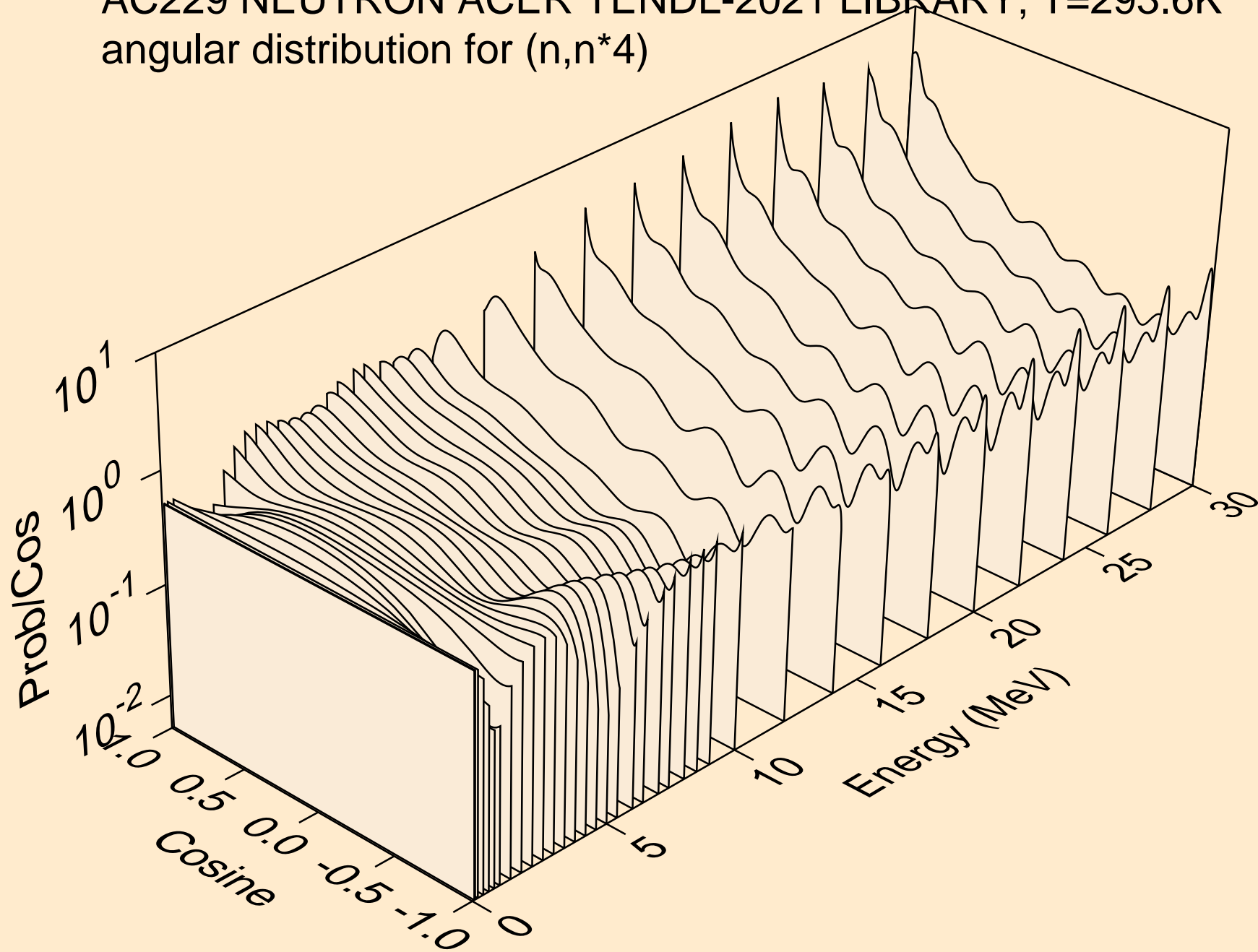

AC229 NEUTRON ACER TENDL-2021 LIBRARY; T=293.6K
angular distribution for (n,n*5)

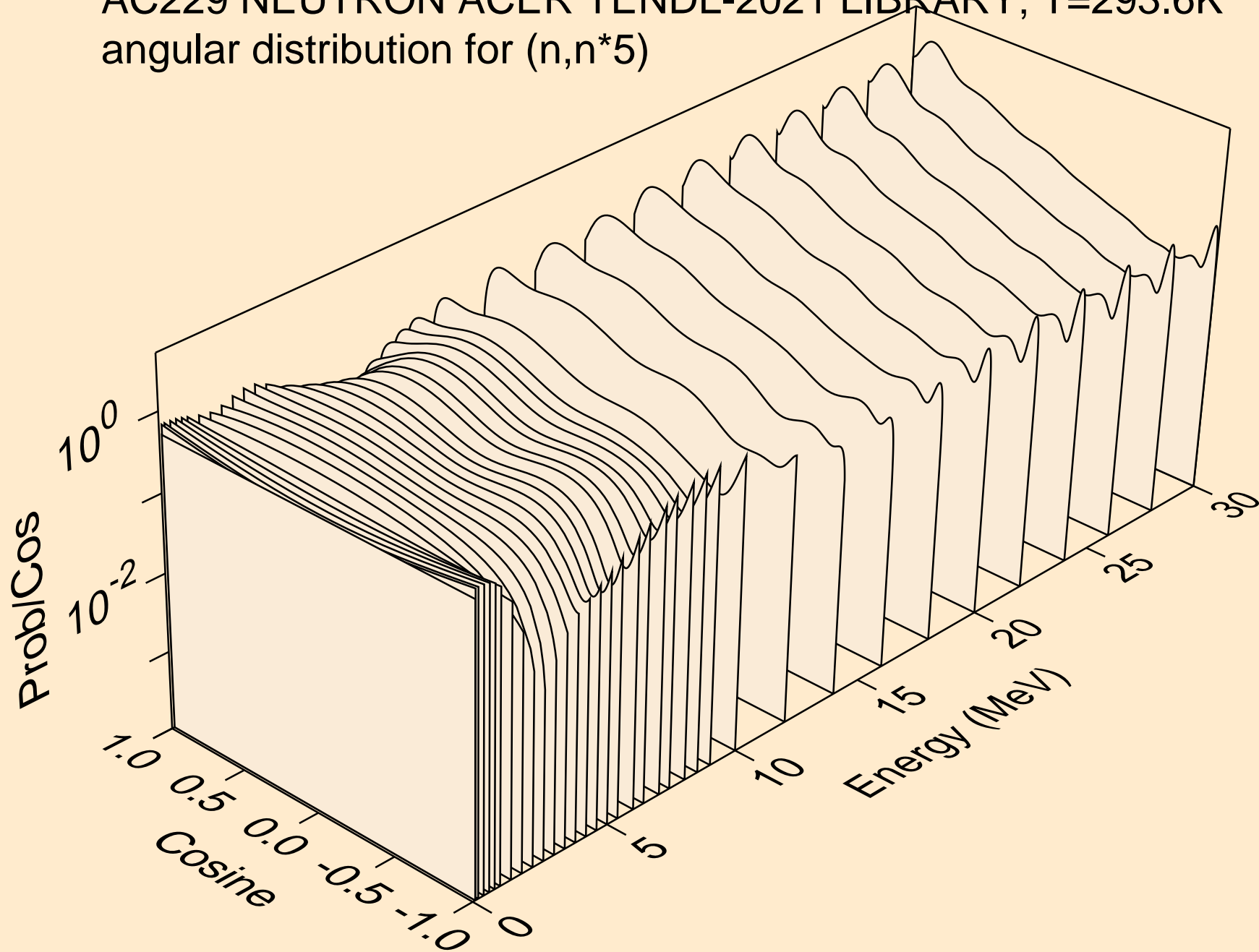

AC229 NEUTRON ACER TENDL-2021 LIBRARY; T=293.6K
angular distribution for (n,n*6)

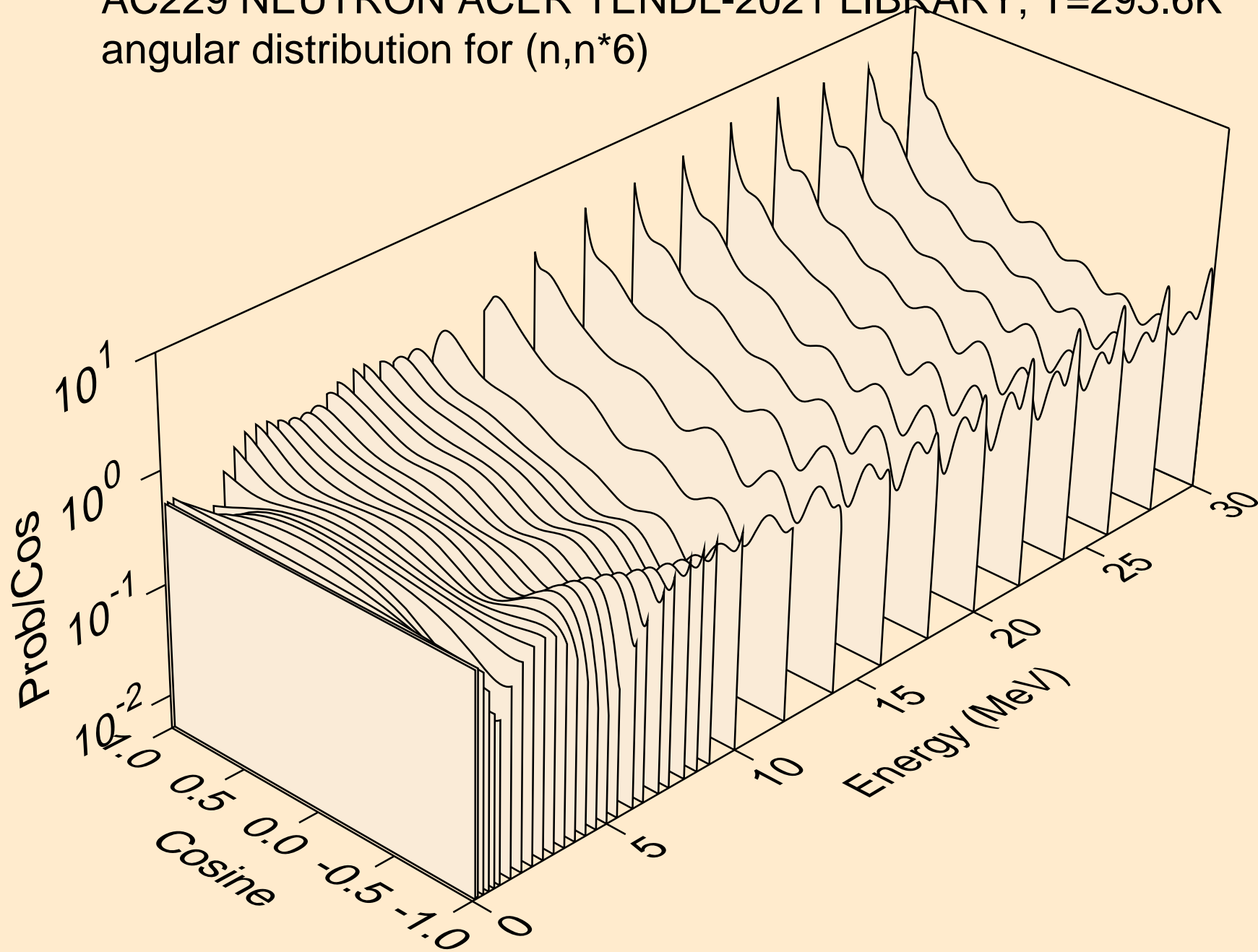

AC229 NEUTRON ACER TENDL-2021 LIBRARY; T=293.6K
angular distribution for (n,n*7)

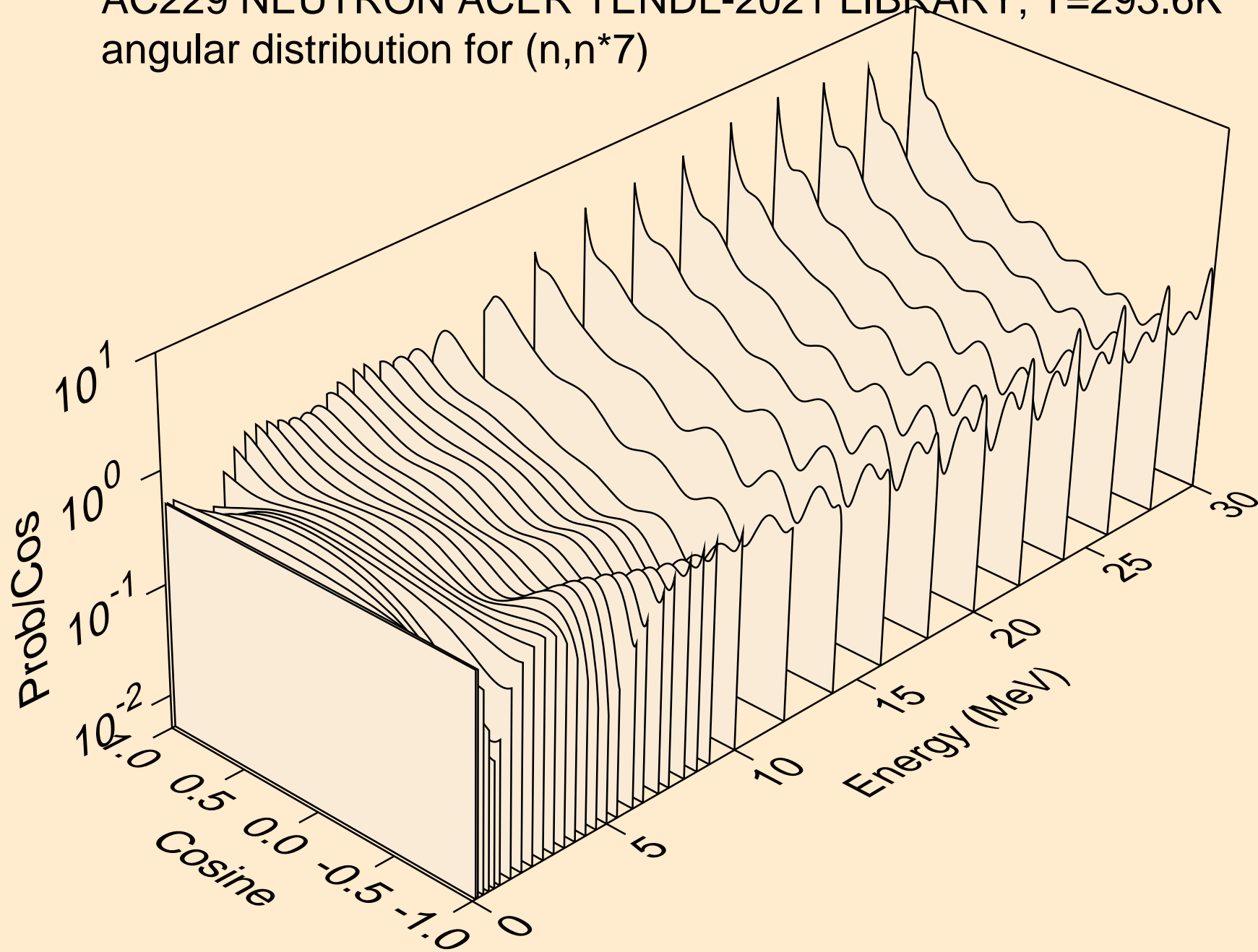

AC229 NEUTRON ACER TENDL-2021 LIBRARY; T=293.6K
angular distribution for (n,n*8)

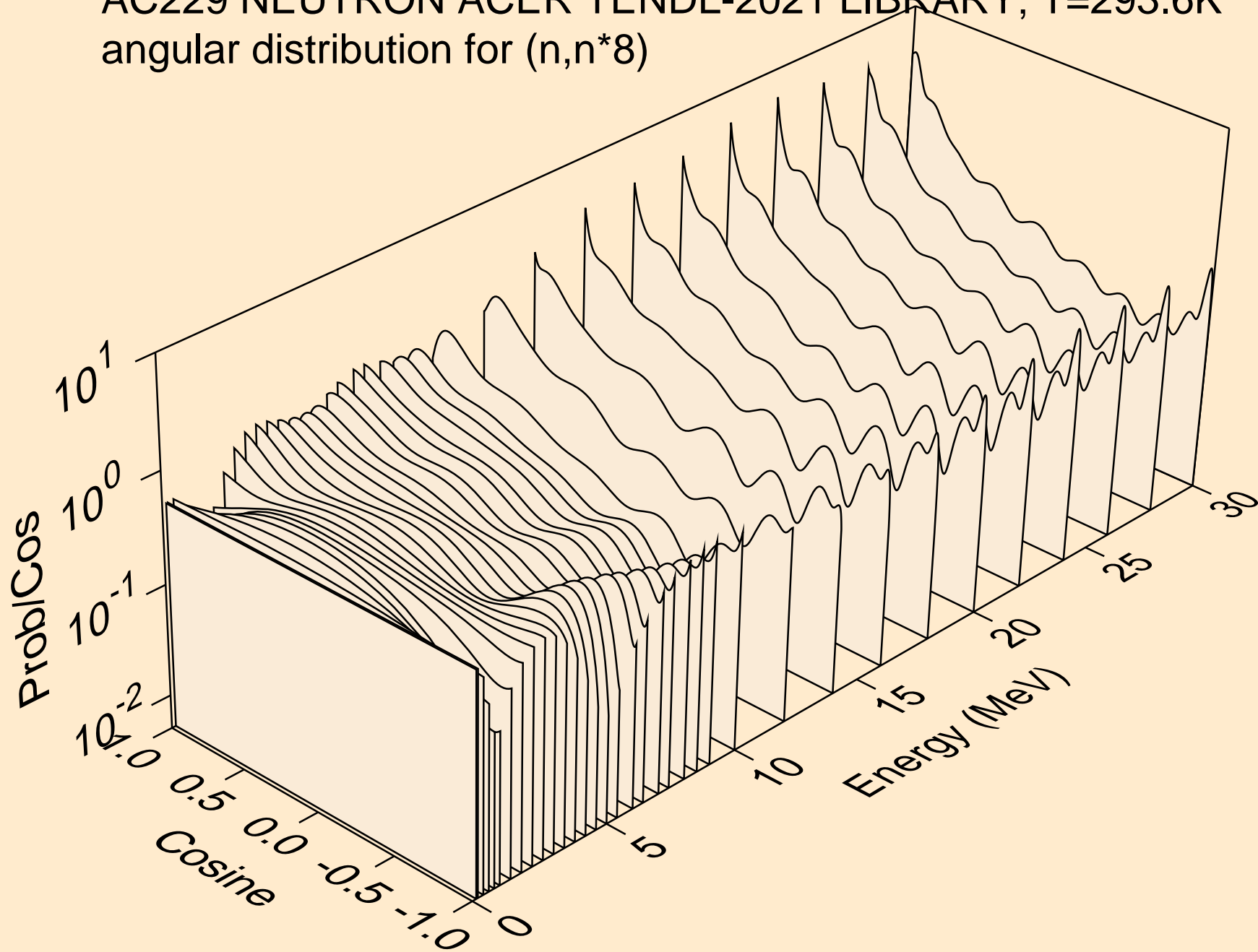

AC229 NEUTRON ACER TENDL-2021 LIBRARY; T=293.6K
angular distribution for (n,n*9)

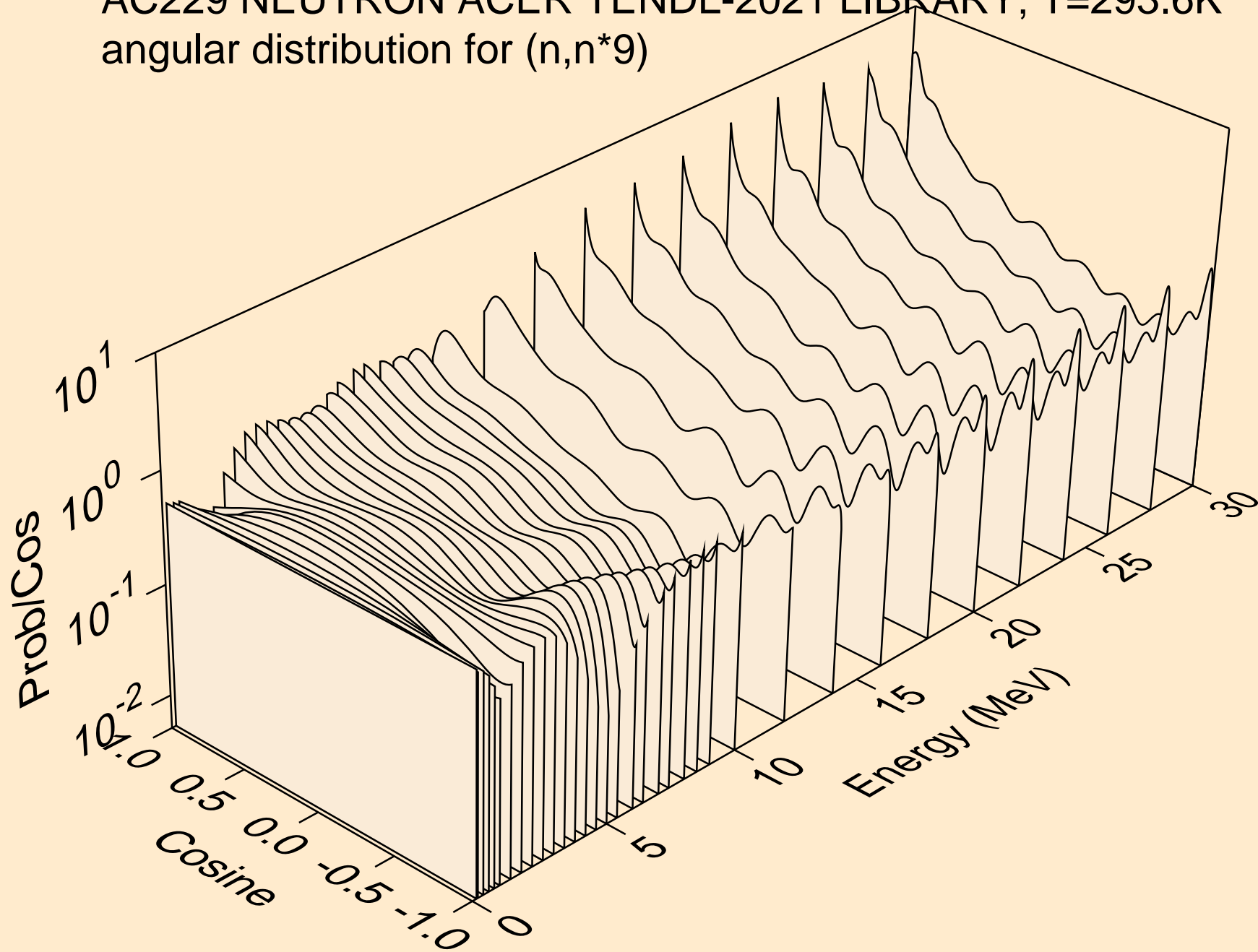

AC229 NEUTRON ACER TENDL-2021 LIBRARY; T=293.6K
angular distribution for (n,n*10)

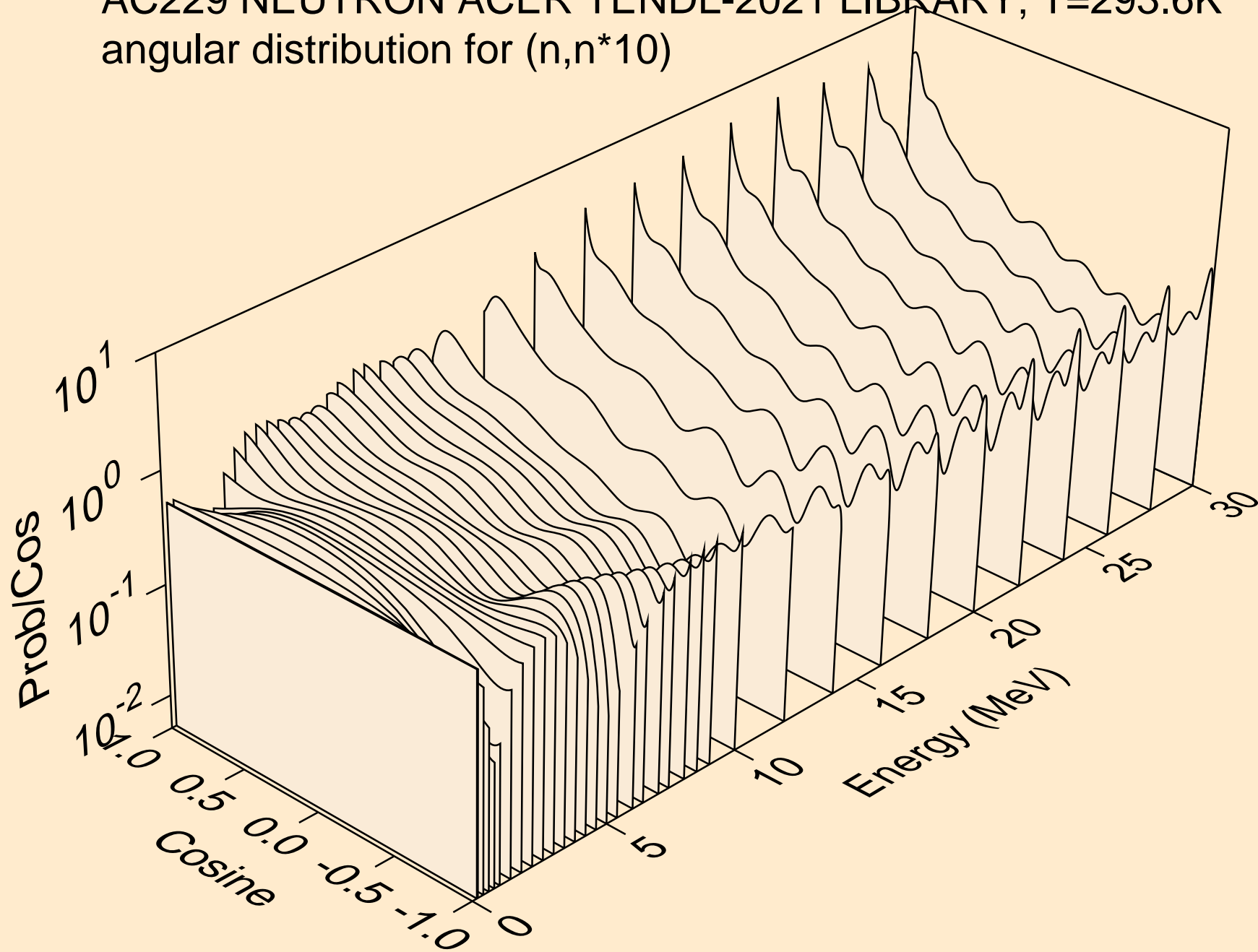

AC229 NEUTRON ACER TENDL-2021 LIBRARY; T=293.6K
angular distribution for (n,n*11)

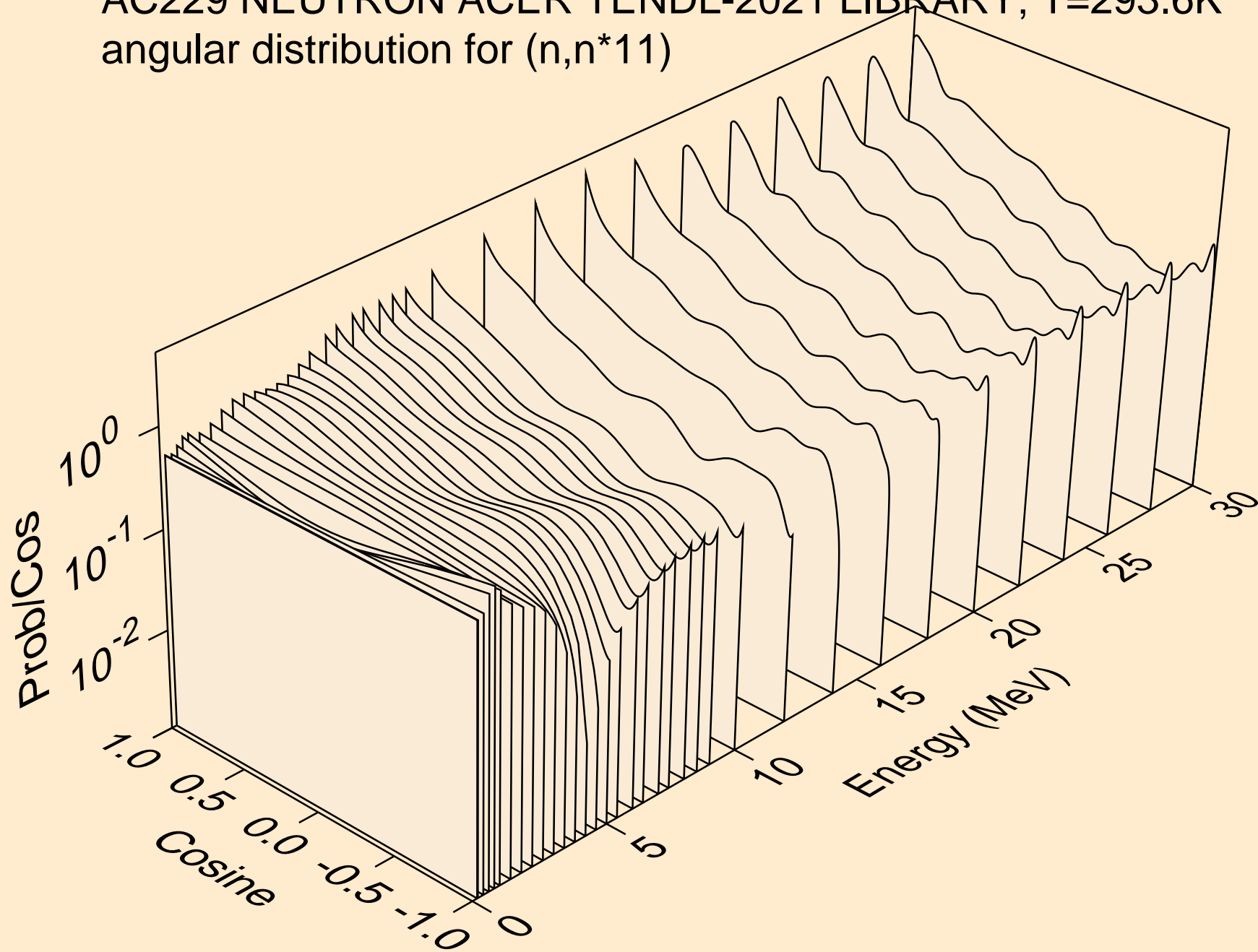

AC229 NEUTRON ACER TENDL-2021 LIBRARY; T=293.6K
angular distribution for (n,n*12)

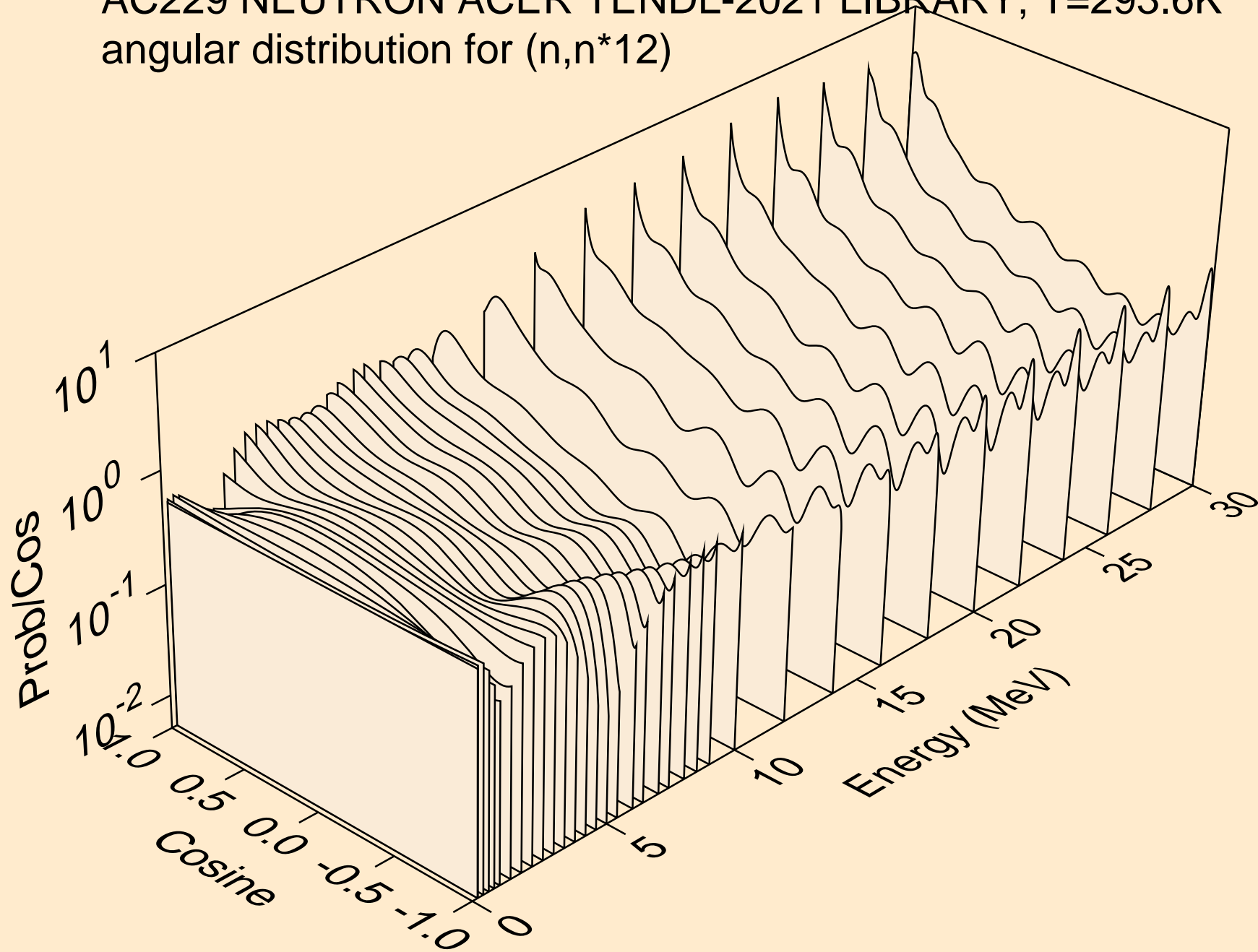

AC229 NEUTRON ACER TENDL-2021 LIBRARY; T=293.6K
angular distribution for (n,n*13)

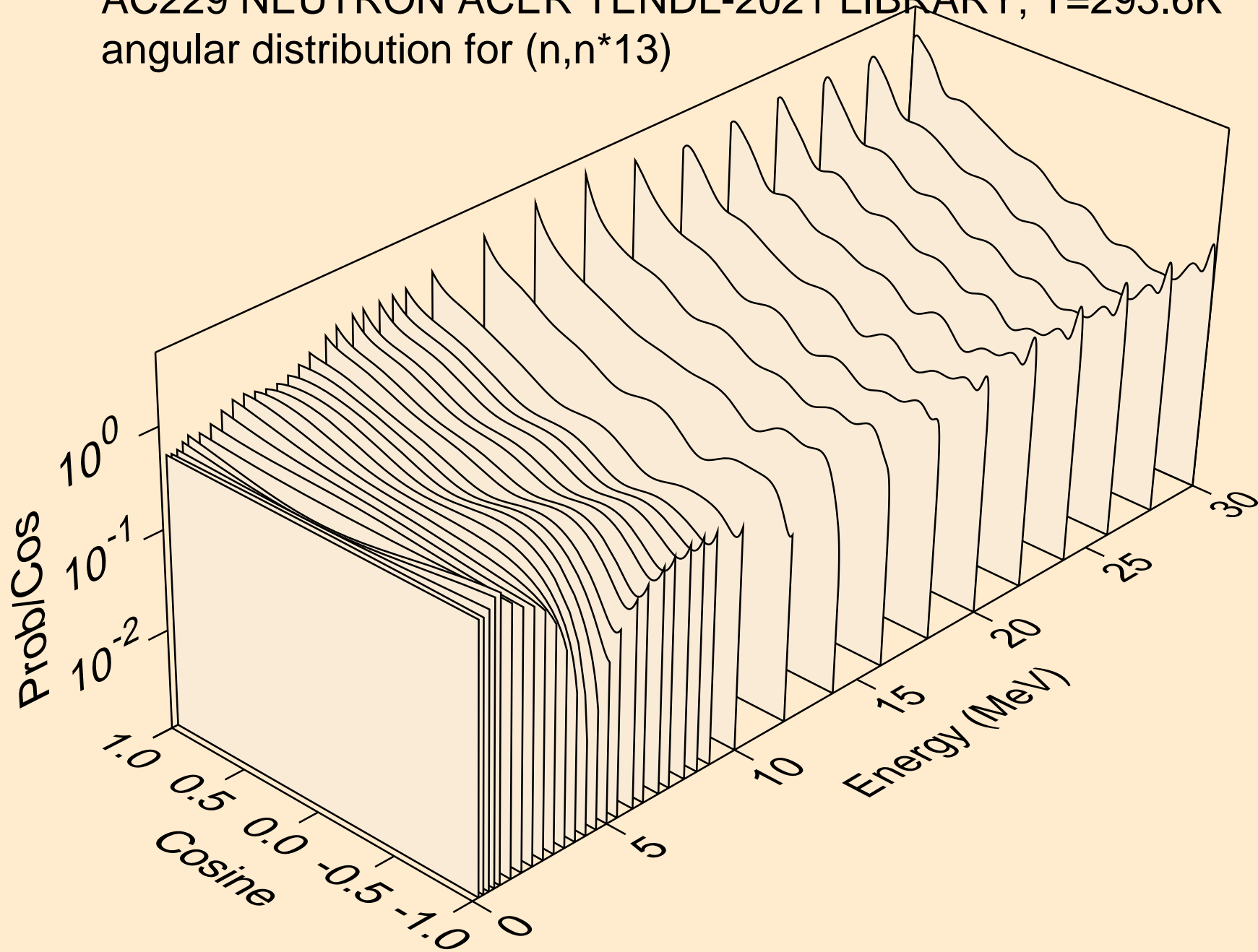

AC229 NEUTRON ACER TENDL-2021 LIBRARY; T=293.6K
angular distribution for (n,n*14)

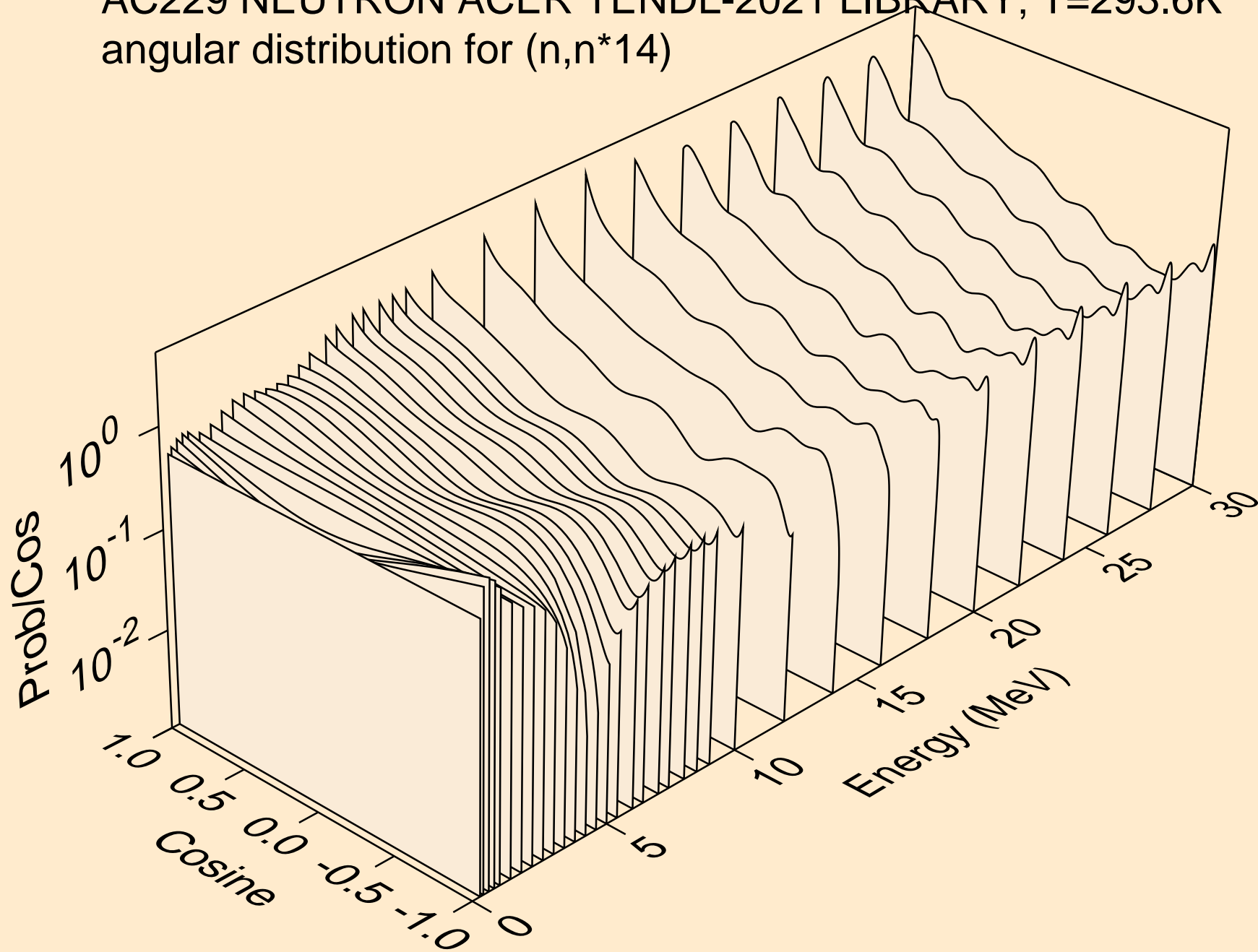

AC229 NEUTRON ACER TENDL-2021 LIBRARY; T=293.6K
angular distribution for (n,n*15)

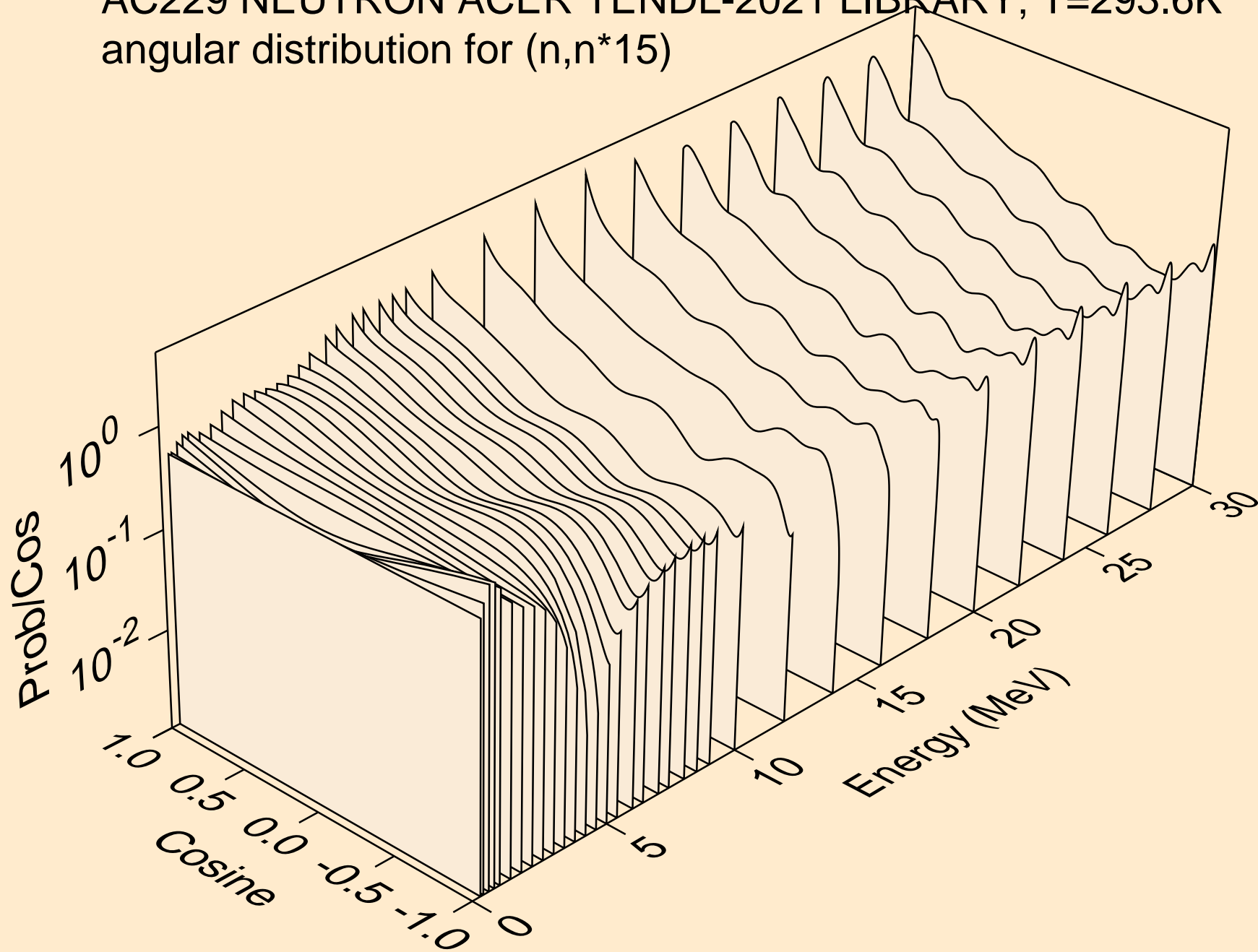

AC229 NEUTRON ACER TENDL-2021 LIBRARY; T=293.6K
Total fission nubar

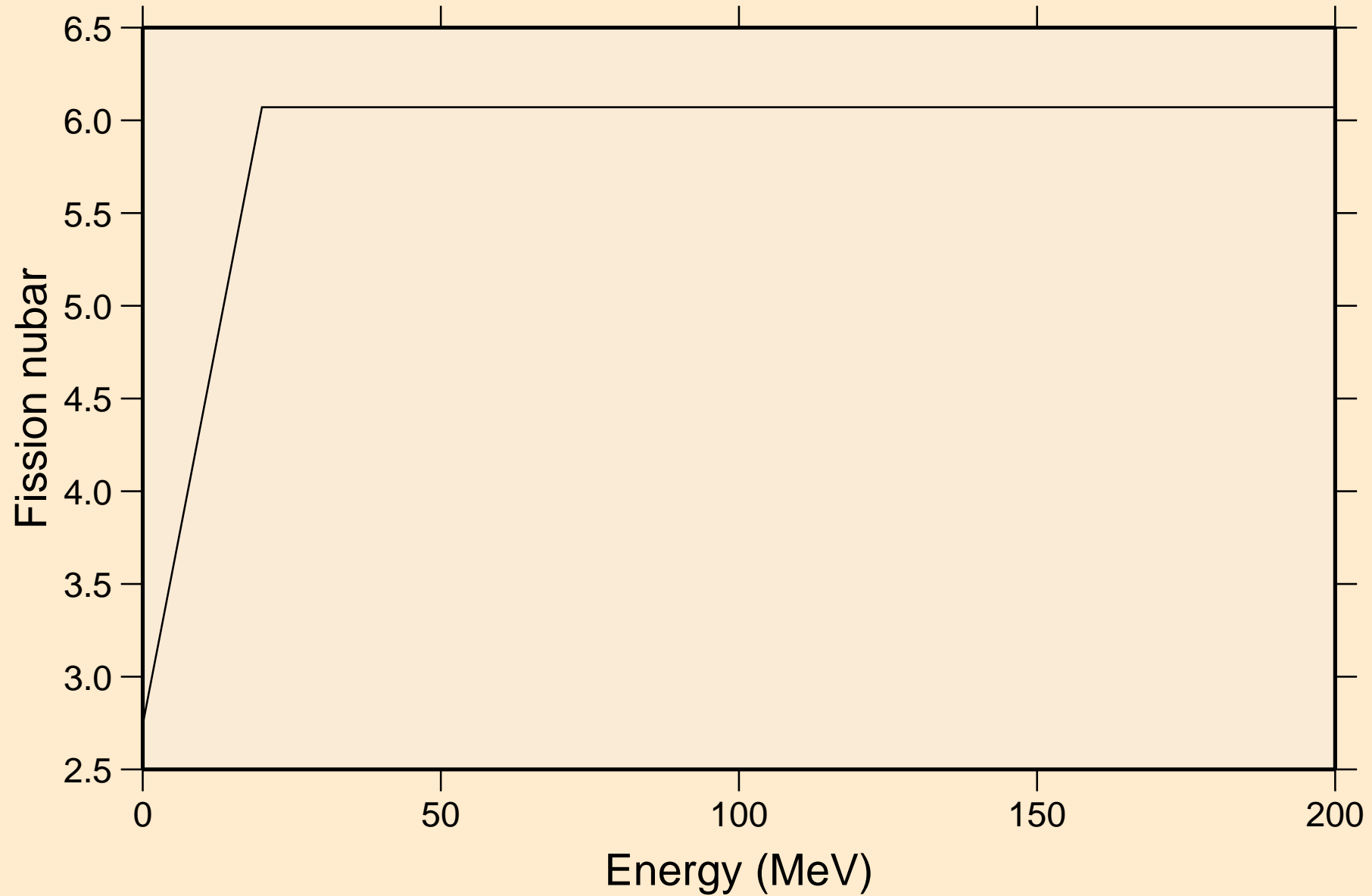

AC229 NEUTRON ACER TENDL-2021 LIBRARY; T=293.6K
Neutron emission for (n,x)

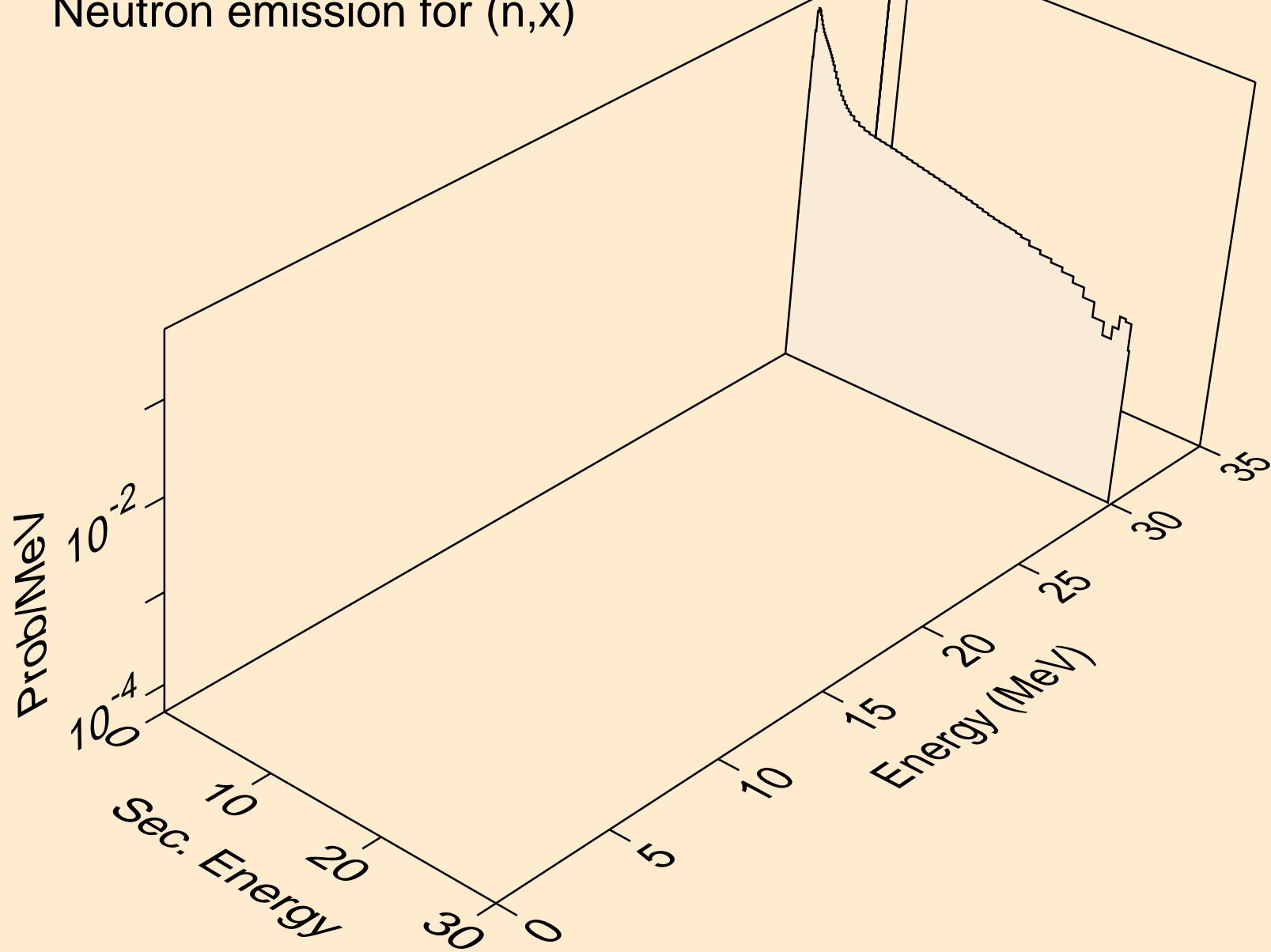

AC229 NEUTRON ACER TENDL-2021 LIBRARY; T=293.6K
Neutron emission for (n,2nd)

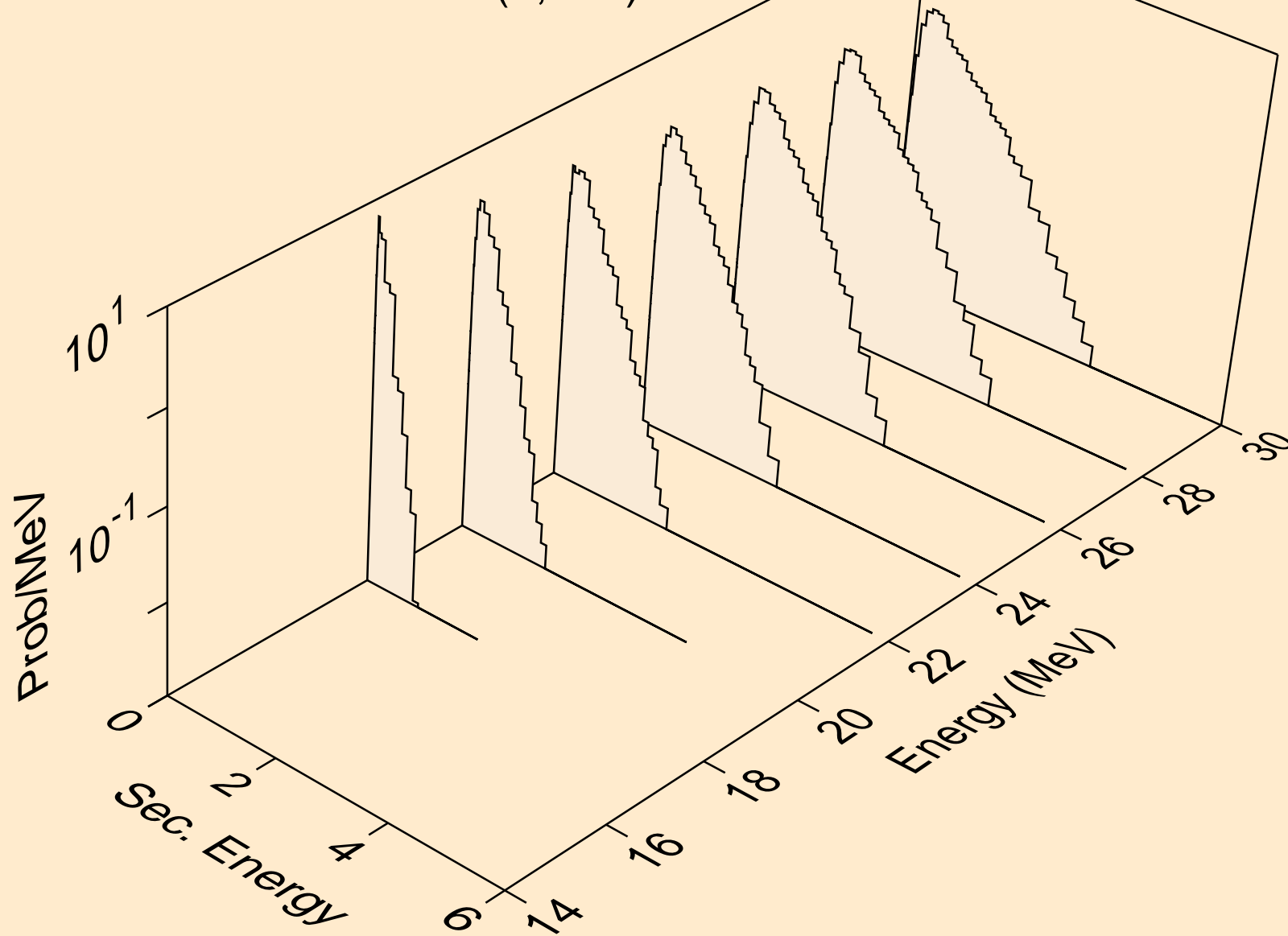

AC229 NEUTRON ACER TENDL-2021 LIBRARY; T=293.6K
Neutron emission for (n,2n)

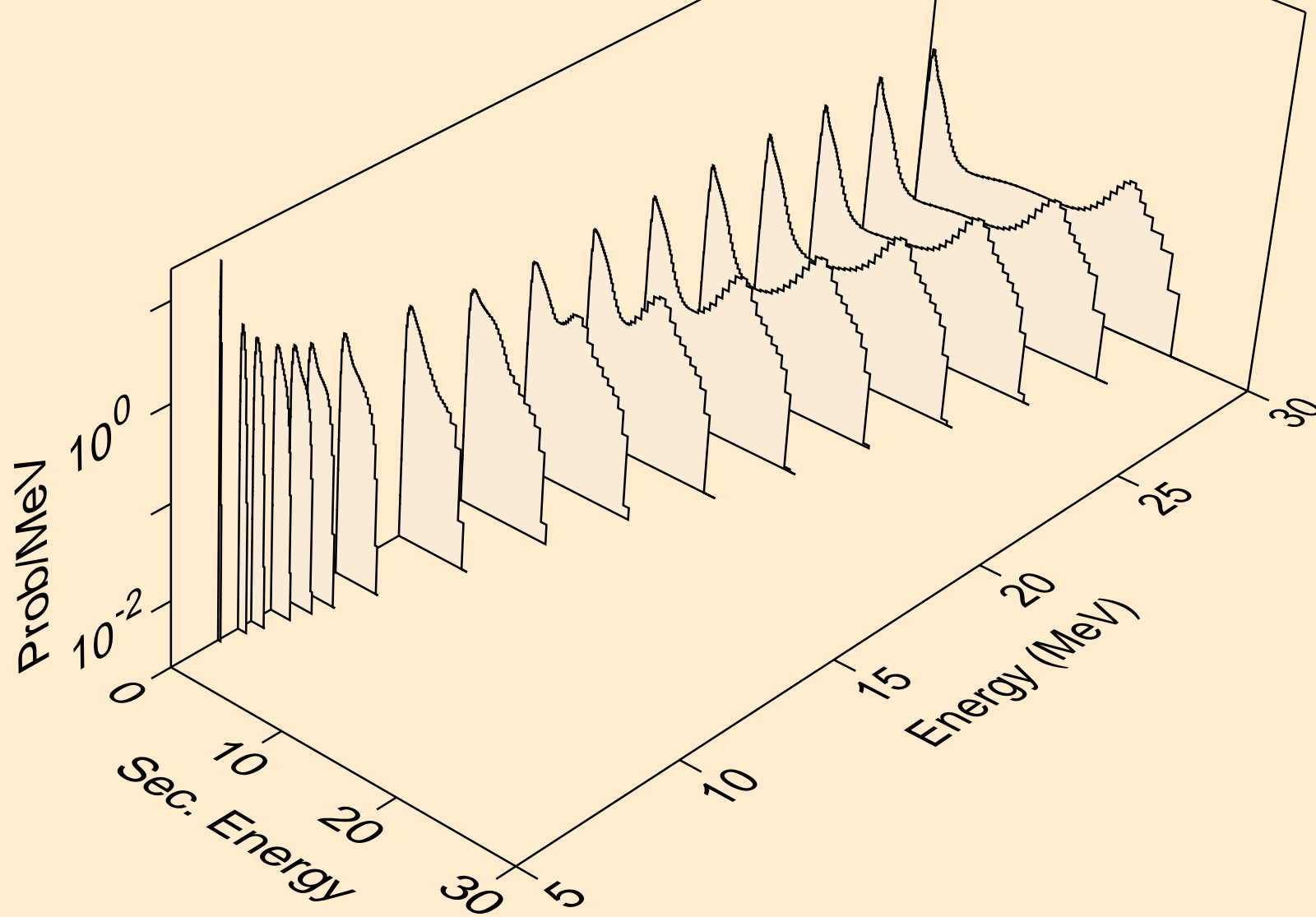

AC229 NEUTRON ACER TENDL-2021 LIBRARY; T=293.6K
Neutron emission for (n,3n)

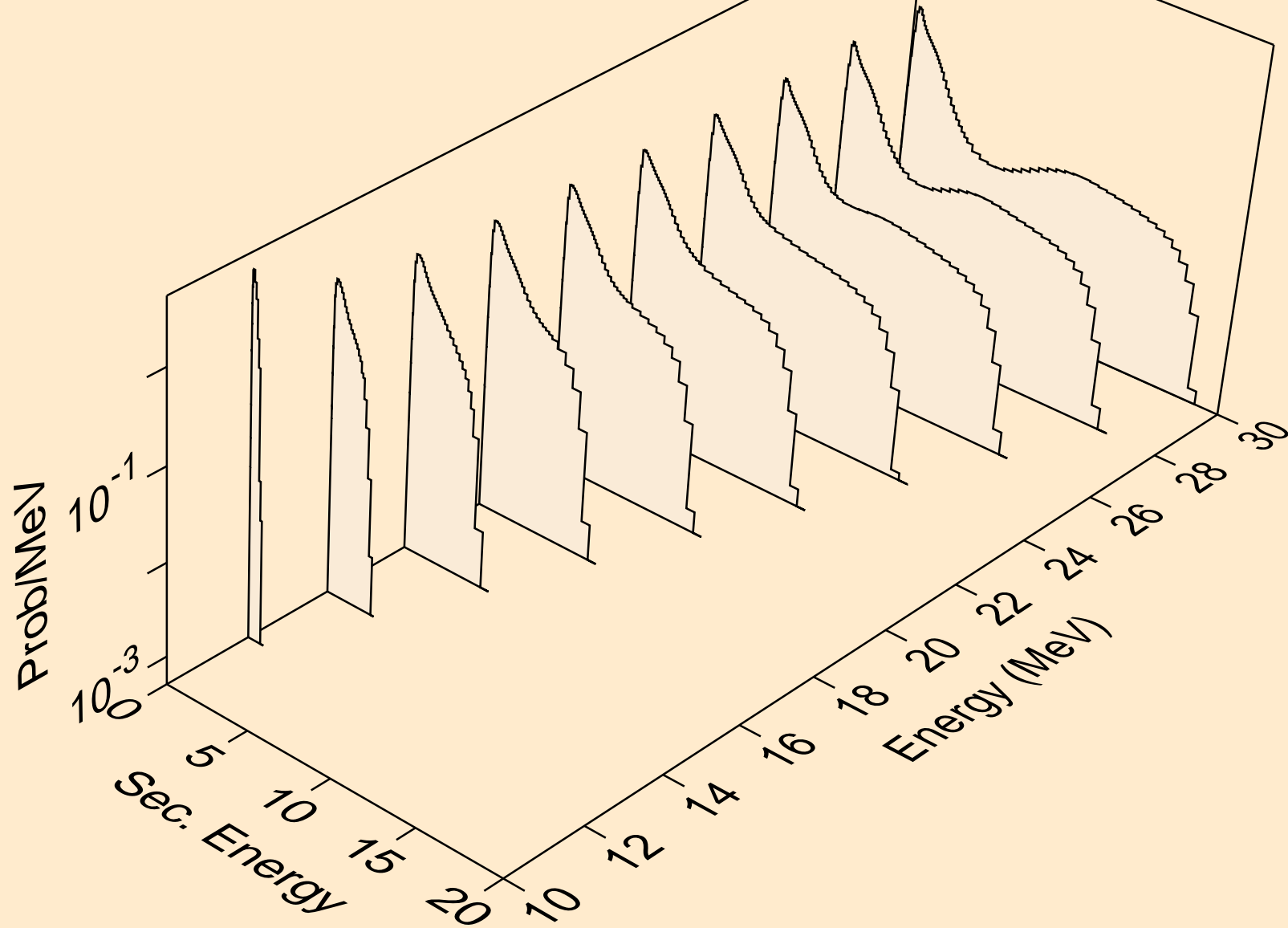

AC229 NEUTRON ACER TENDL-2021 LIBRARY; T=293.6K
Neutron emission for fission

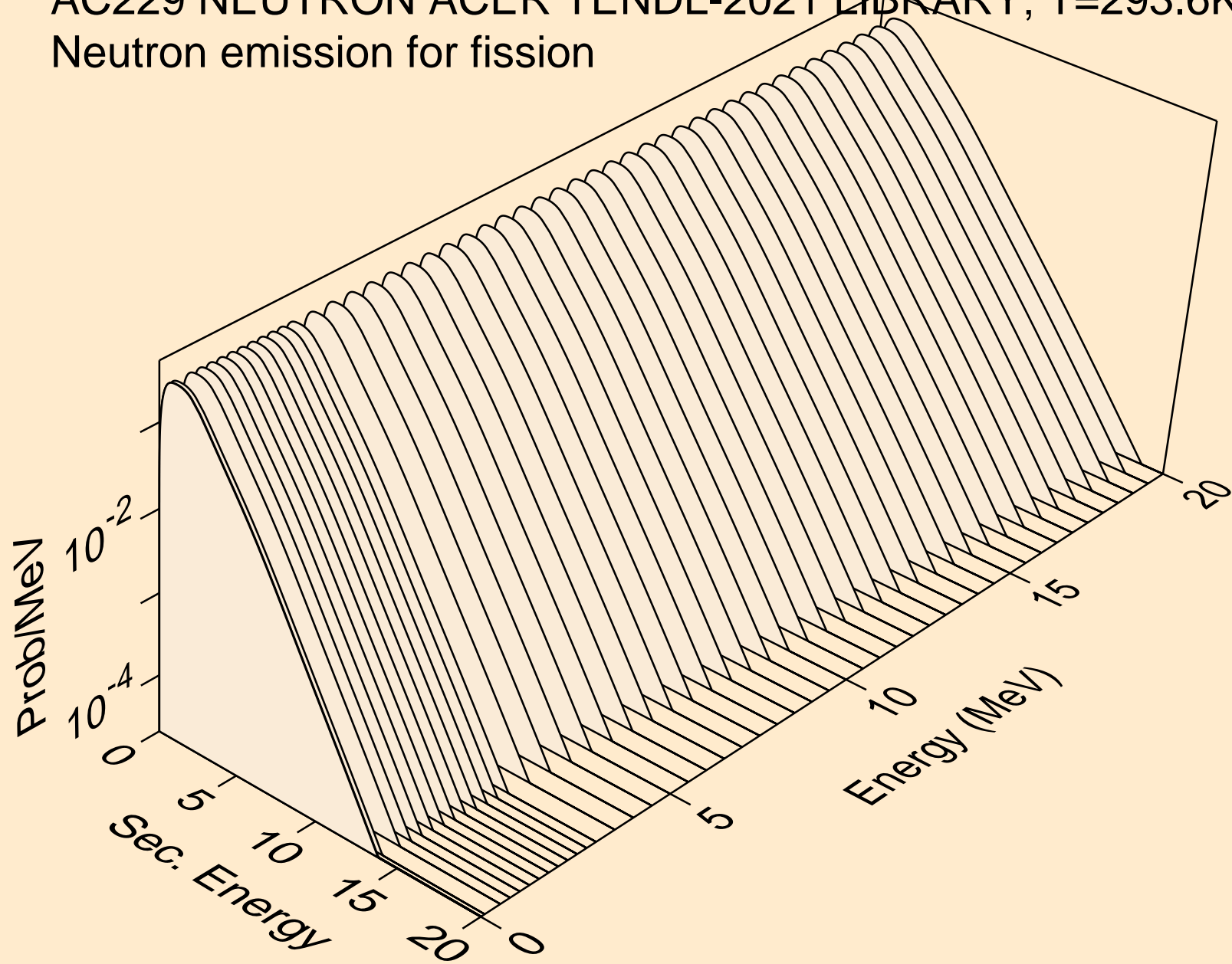

AC229 NEUTRON ACER TENDL-2021 LIBRARY; T=293.6K
Neutron emission for (n,n*)a

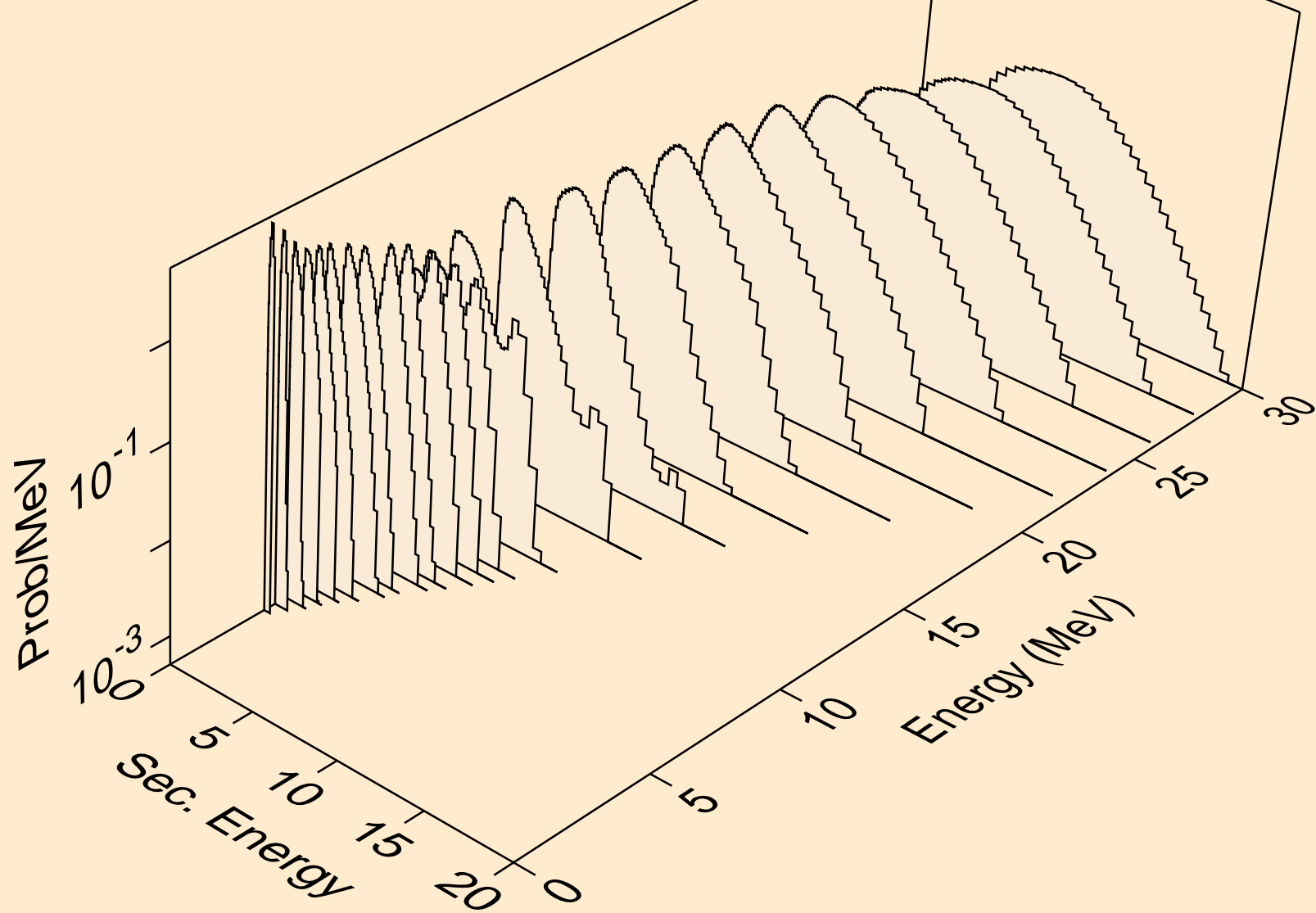

AC229 NEUTRON ACER TENDL-2021 LIBRARY; T=293.6K
Neutron emission for (n,2n)_a

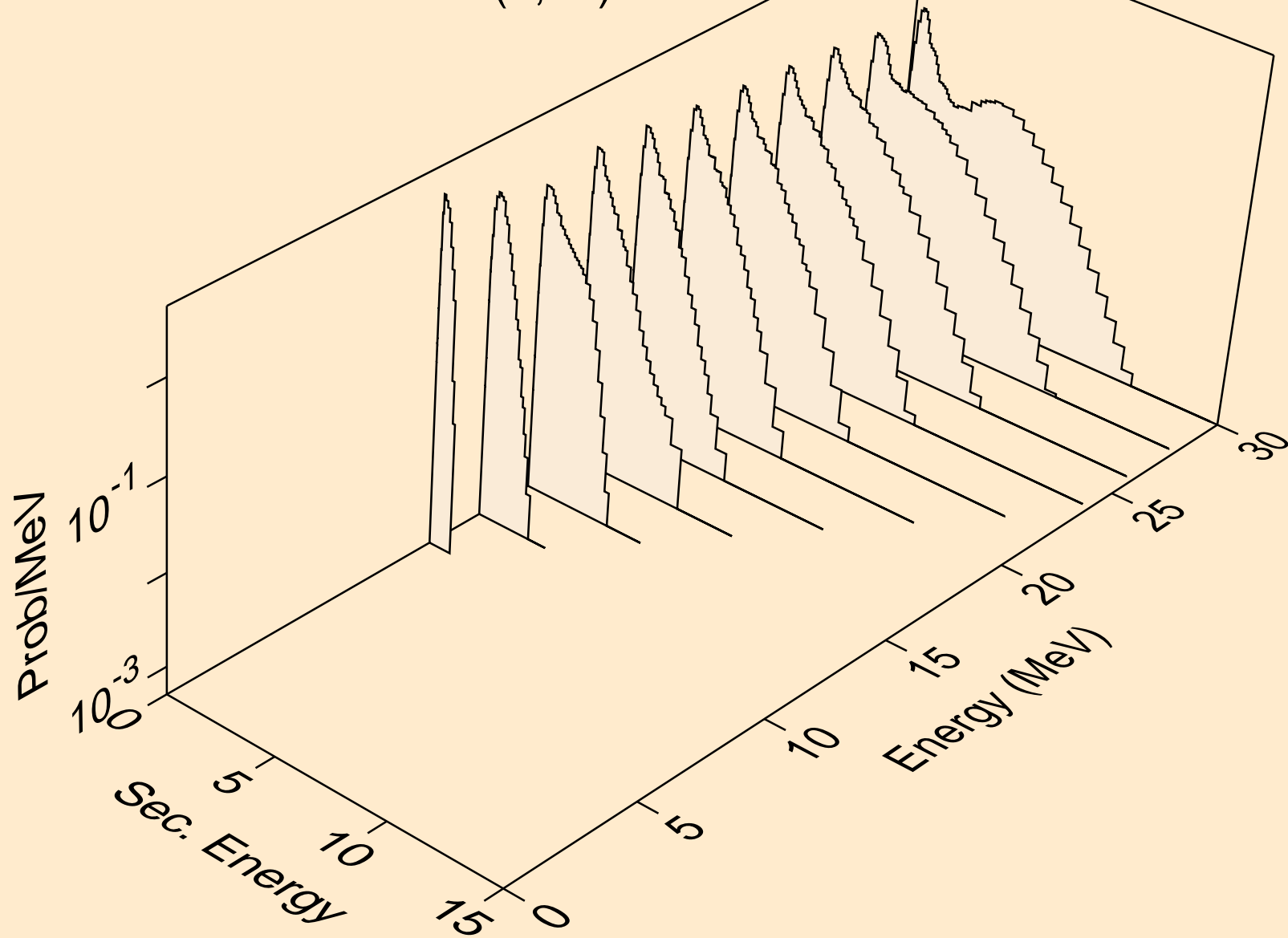

AC229 NEUTRON ACER TENDL-2021 LIBRARY; T=293.6K
Neutron emission for (n,3n)a

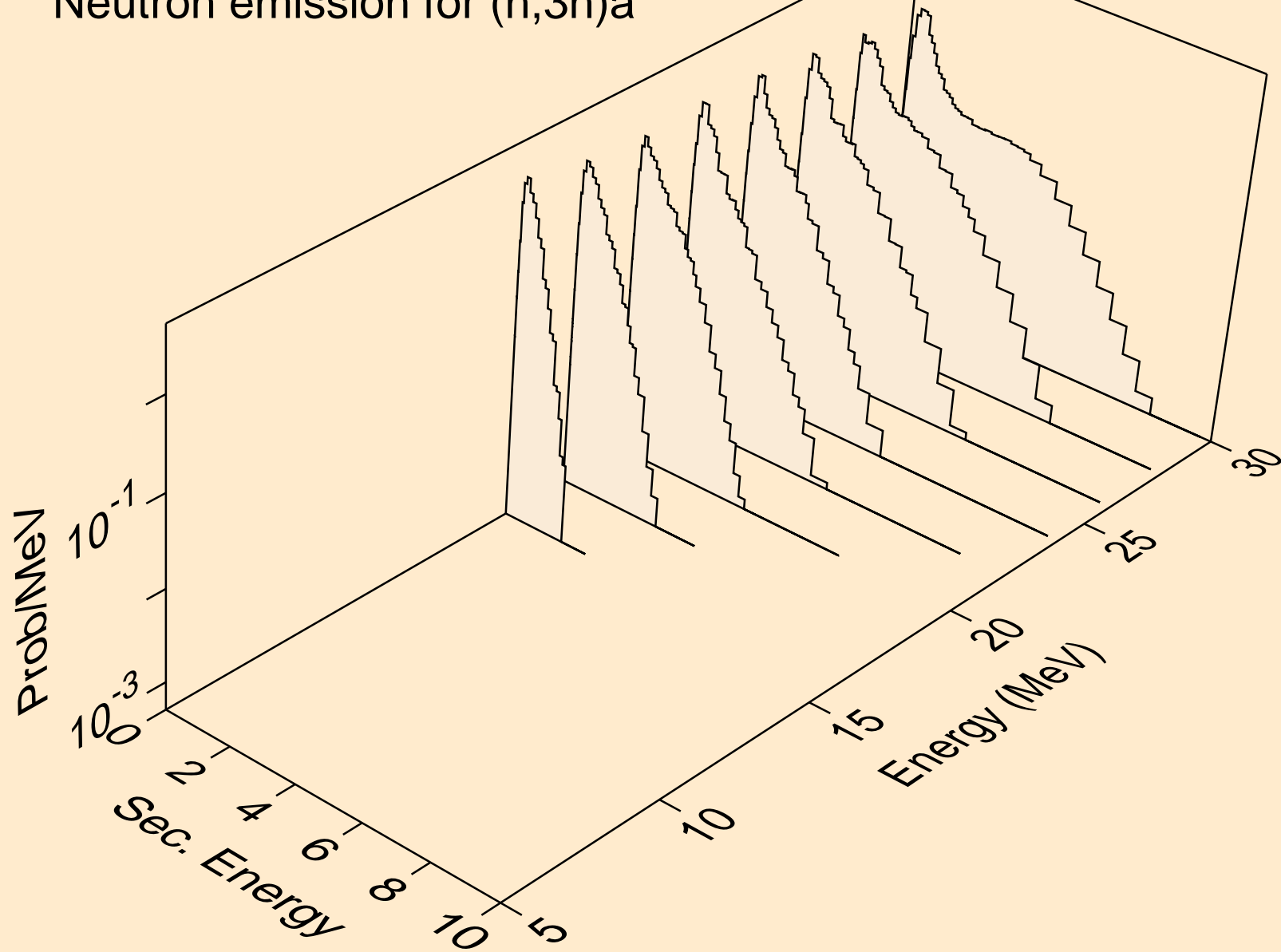

AC229 NEUTRON ACER TENDL-2021 LIBRARY; T=293.6K
Neutron emission for (n,n*)p

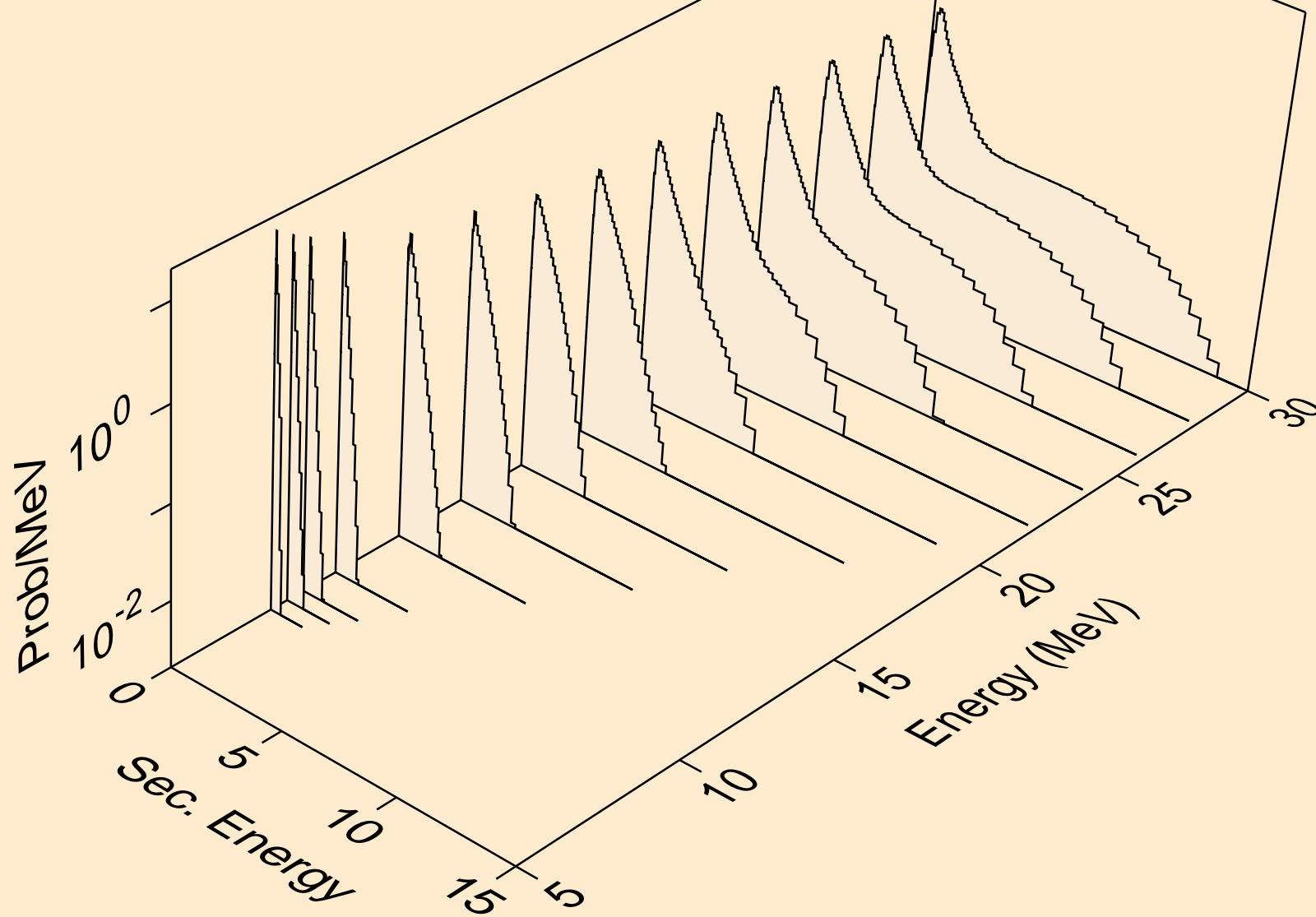

AC229 NEUTRON ACER TENDL-2021 LIBRARY; T=293.6K
Neutron emission for (n,n*)d

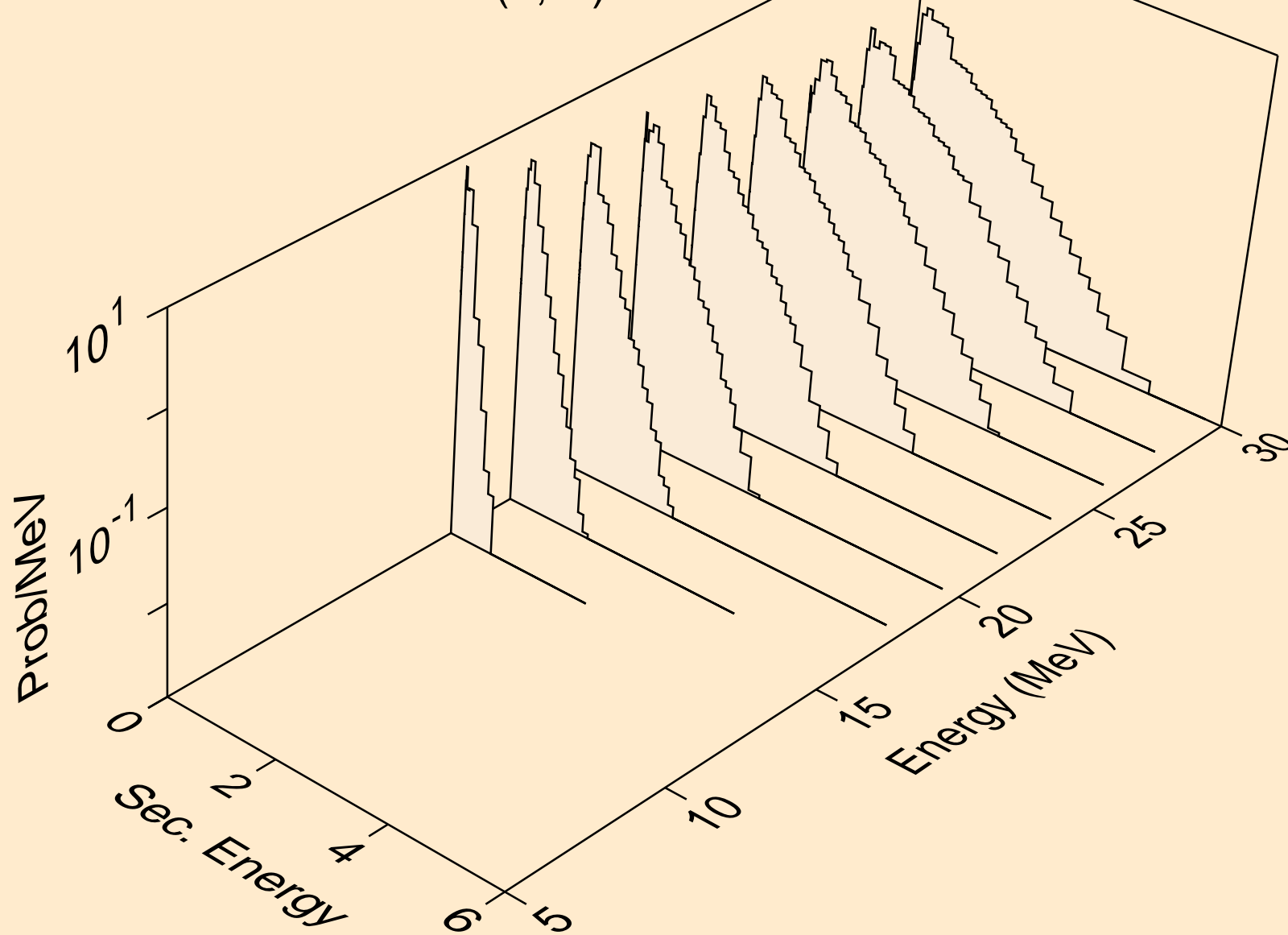

AC229 NEUTRON ACER TENDL-2021 LIBRARY; T=293.6K
Neutron emission for (n,n*)t

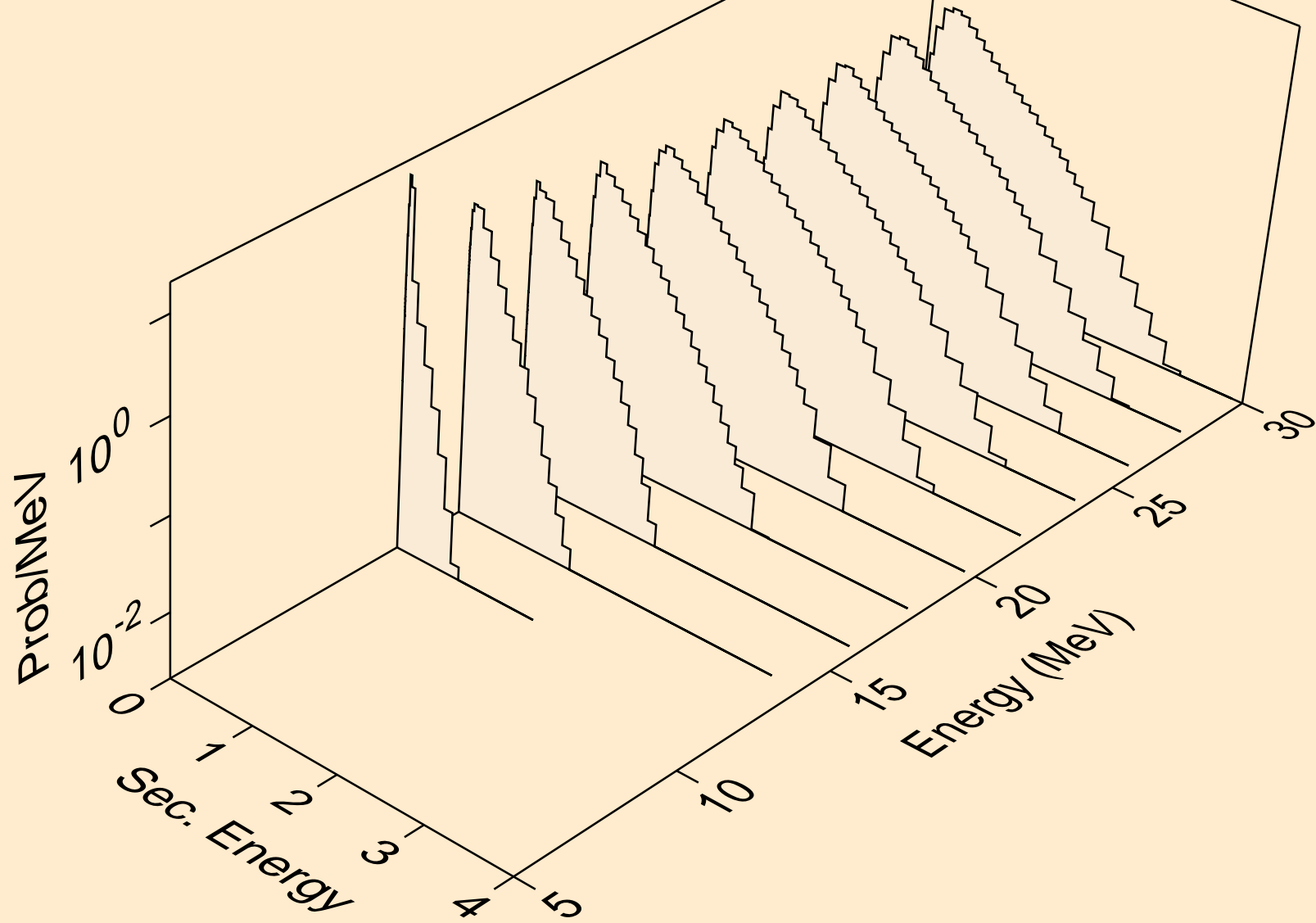

AC229 NEUTRON ACER TENDL-2021 LIBRARY; T=293.6K
Neutron emission for (n,n*)he3

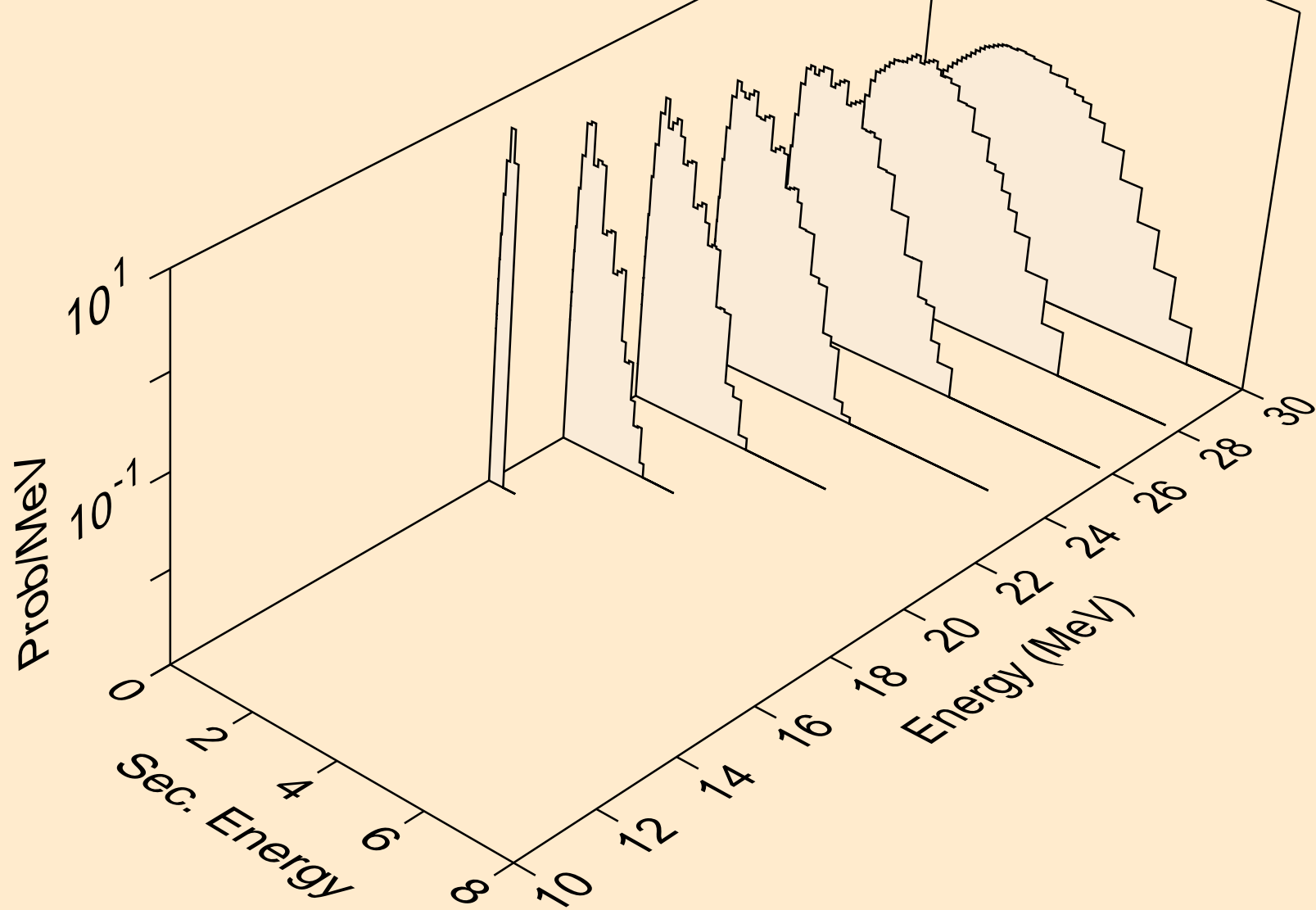

AC229 NEUTRON ACER TENDL-2021 LIBRARY; T=293.6K
Neutron emission for (n,4n)

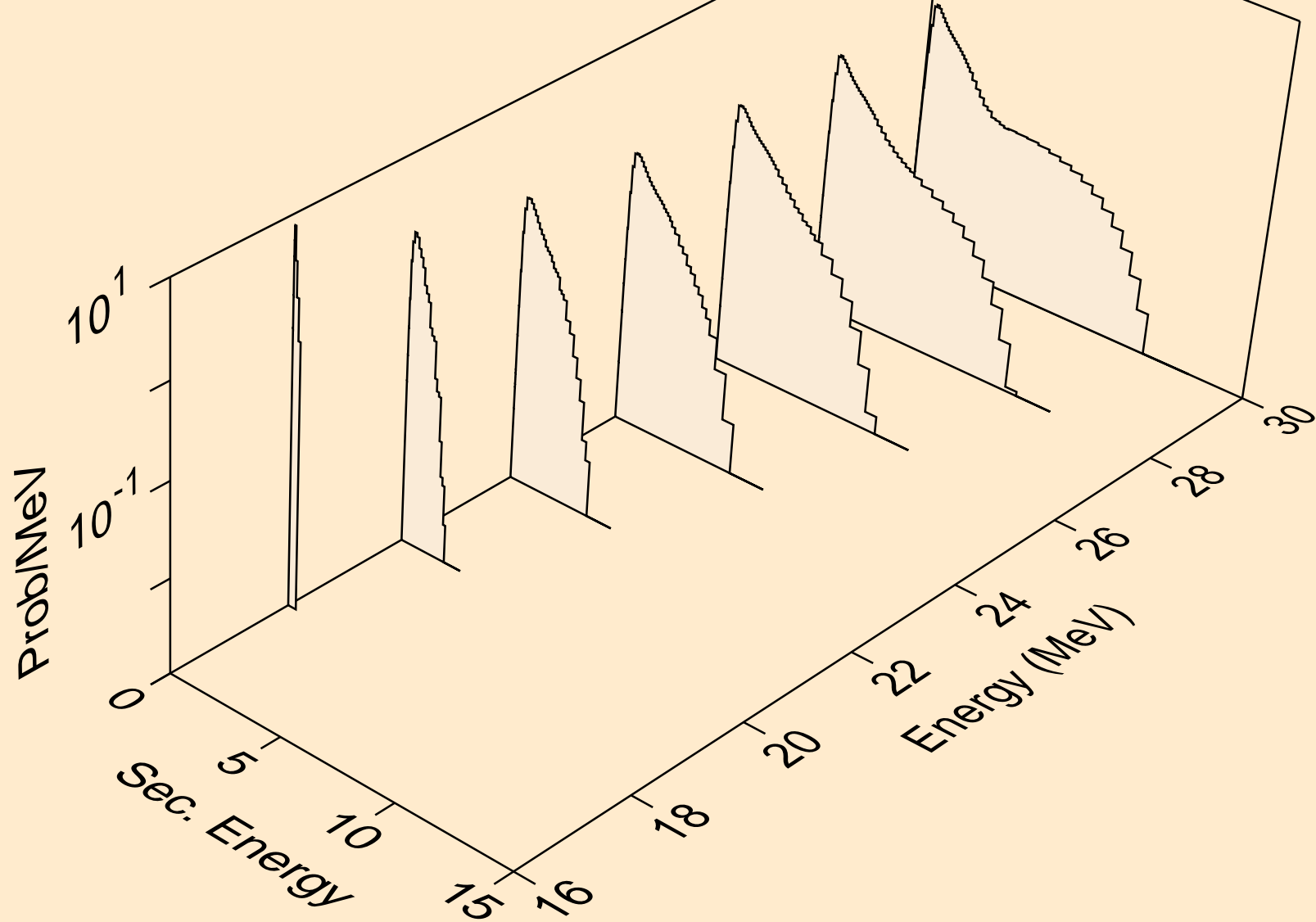

AC229 NEUTRON ACER TENDL-2021 LIBRARY; T=293.6K
Neutron emission for (n,2np)

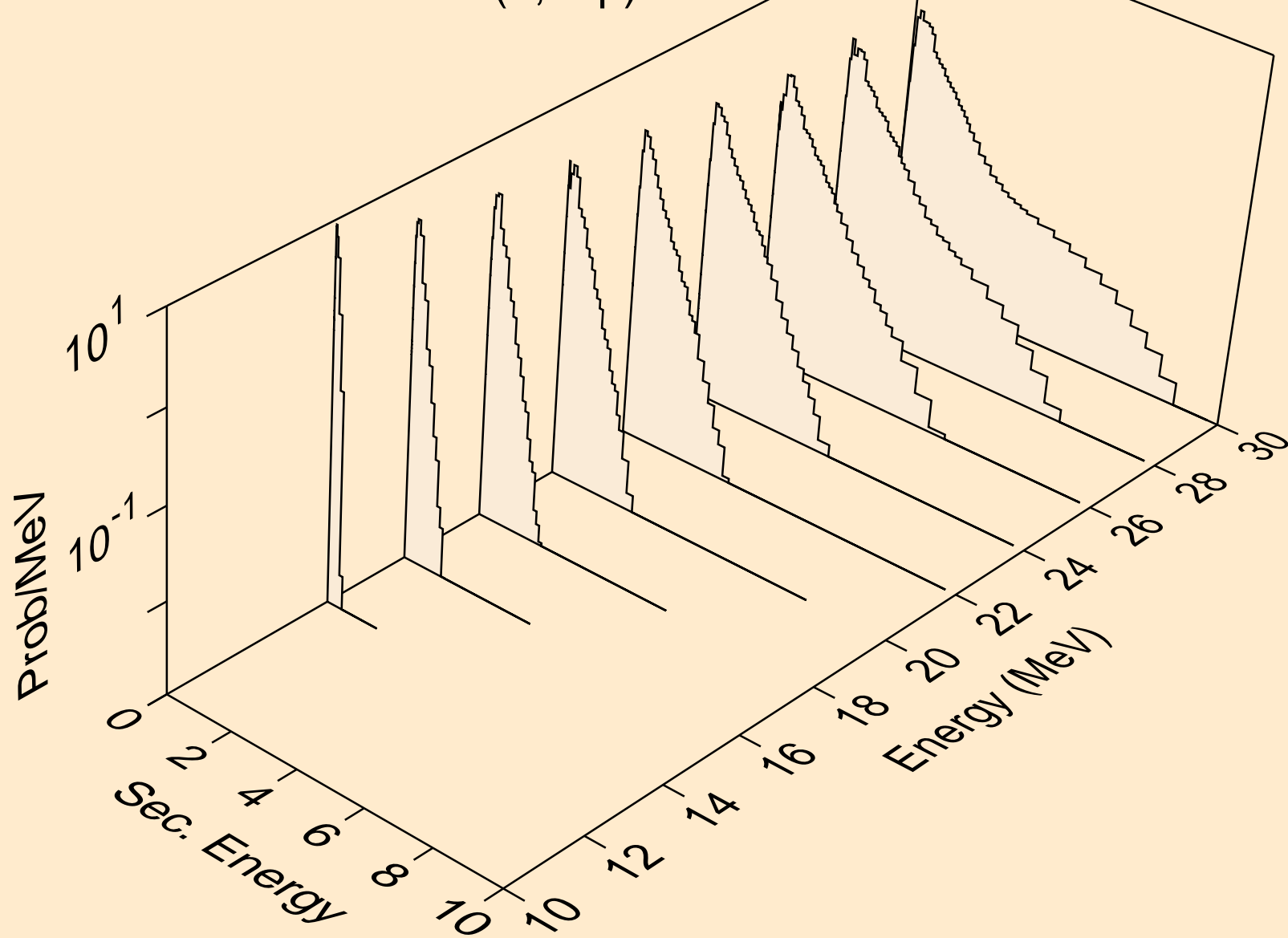

AC229 NEUTRON ACER TENDL-2021 LIBRARY; T=293.6K
Neutron emission for (n,3np)

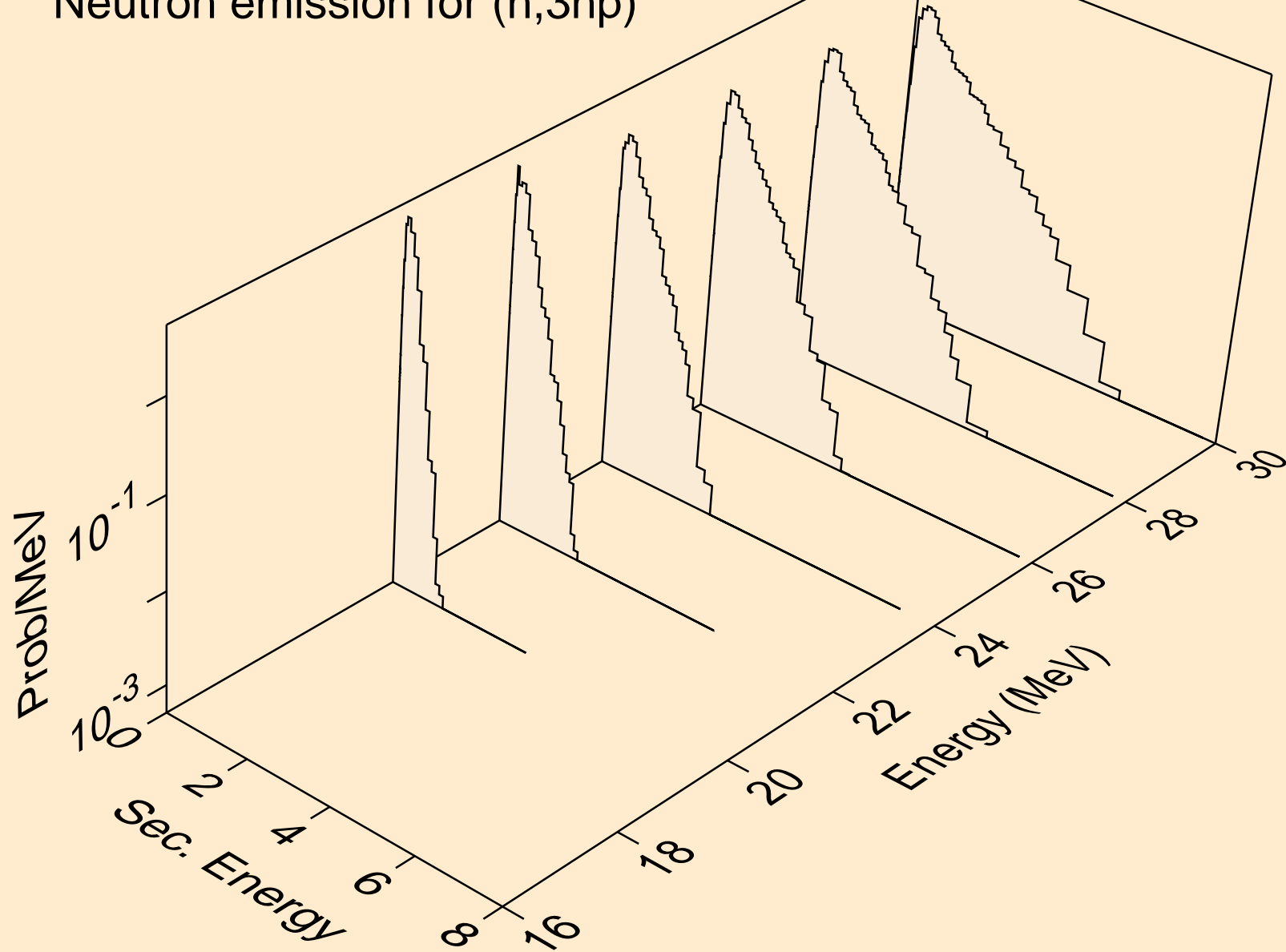

AC229 NEUTRON ACER TENDL-2021 LIBRARY; T=293.6K
Neutron emission for (n,2np)

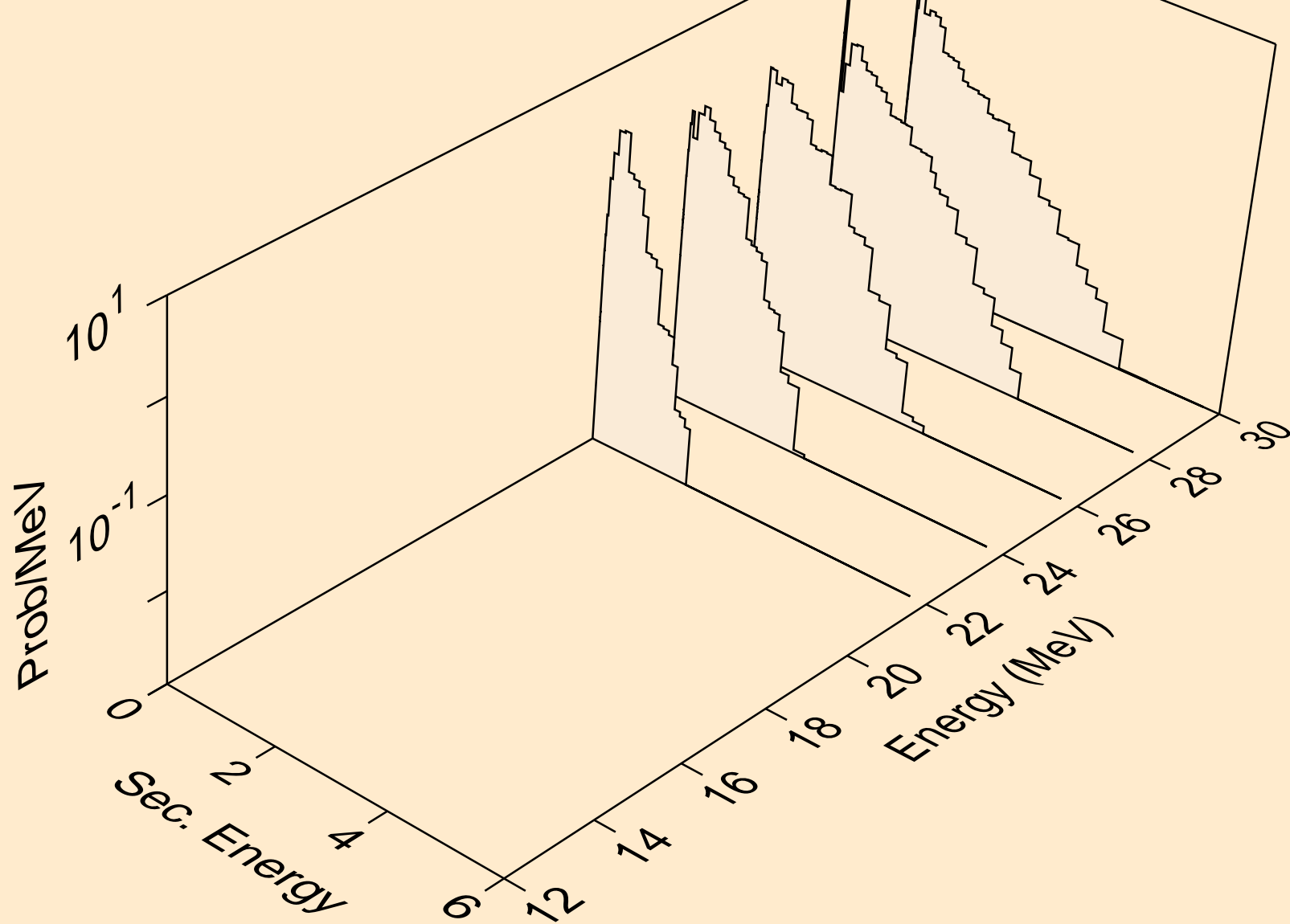

AC229 NEUTRON ACER TENDL-2021 LIBRARY; T=293.6K
Neutron emission for (n,n*c)

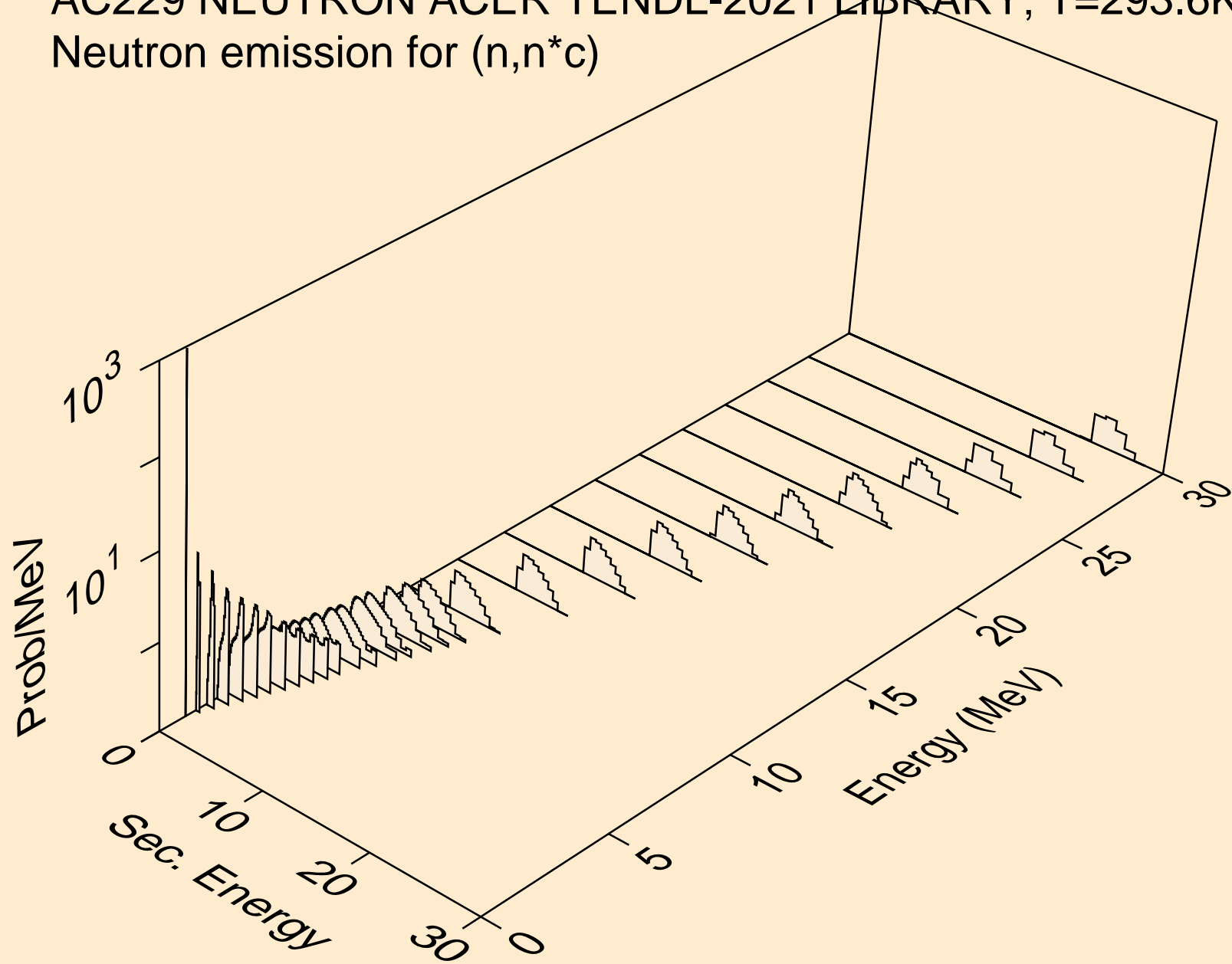

AC229 NEUTRON ACER TENDL-2021 LIBRARY; T=293.6K

Delayed nubar

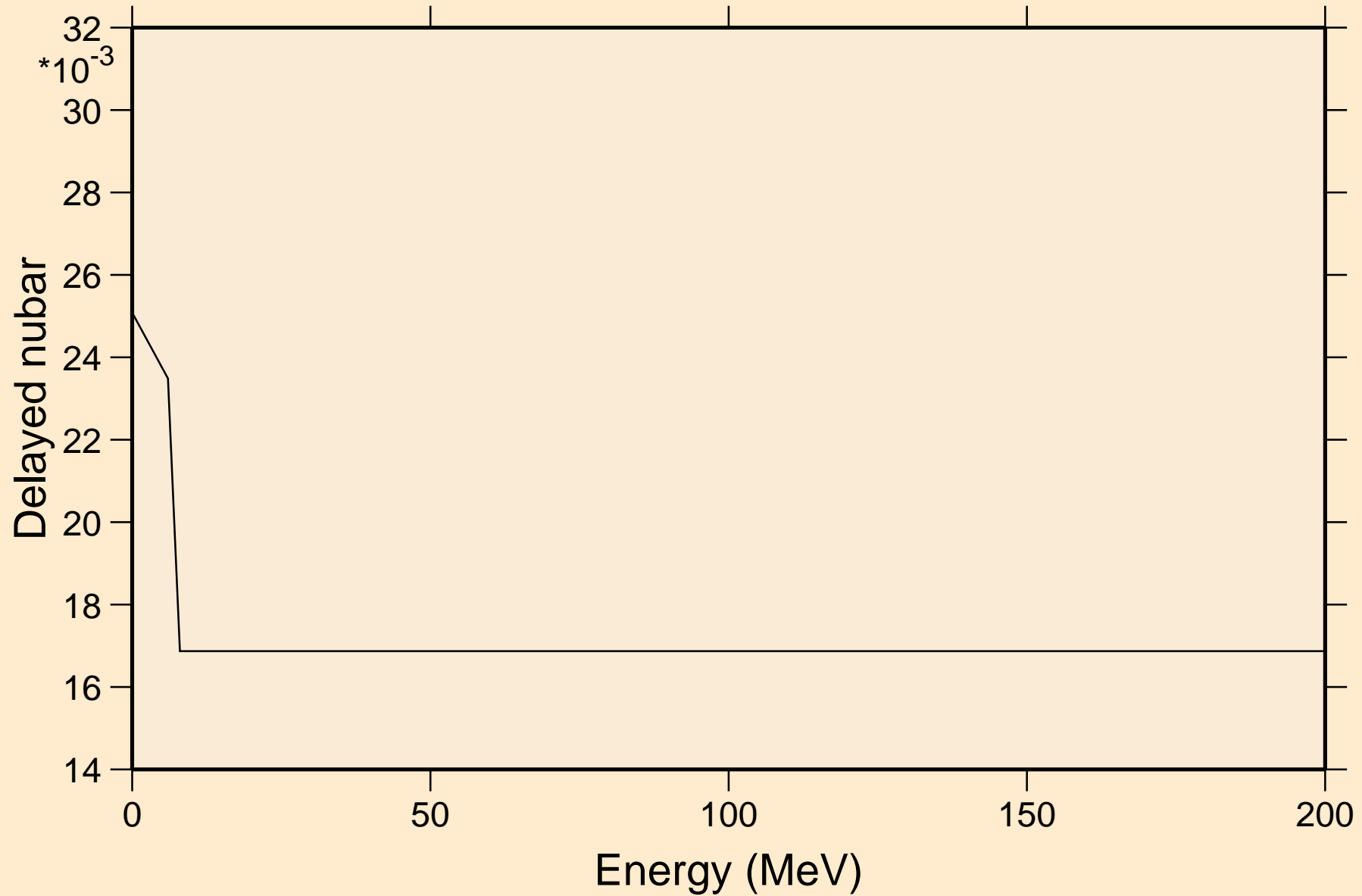

AC229 NEUTRON ACER TENDL-2021 LIBRARY; T=293.6K

Delayed neutron spectra

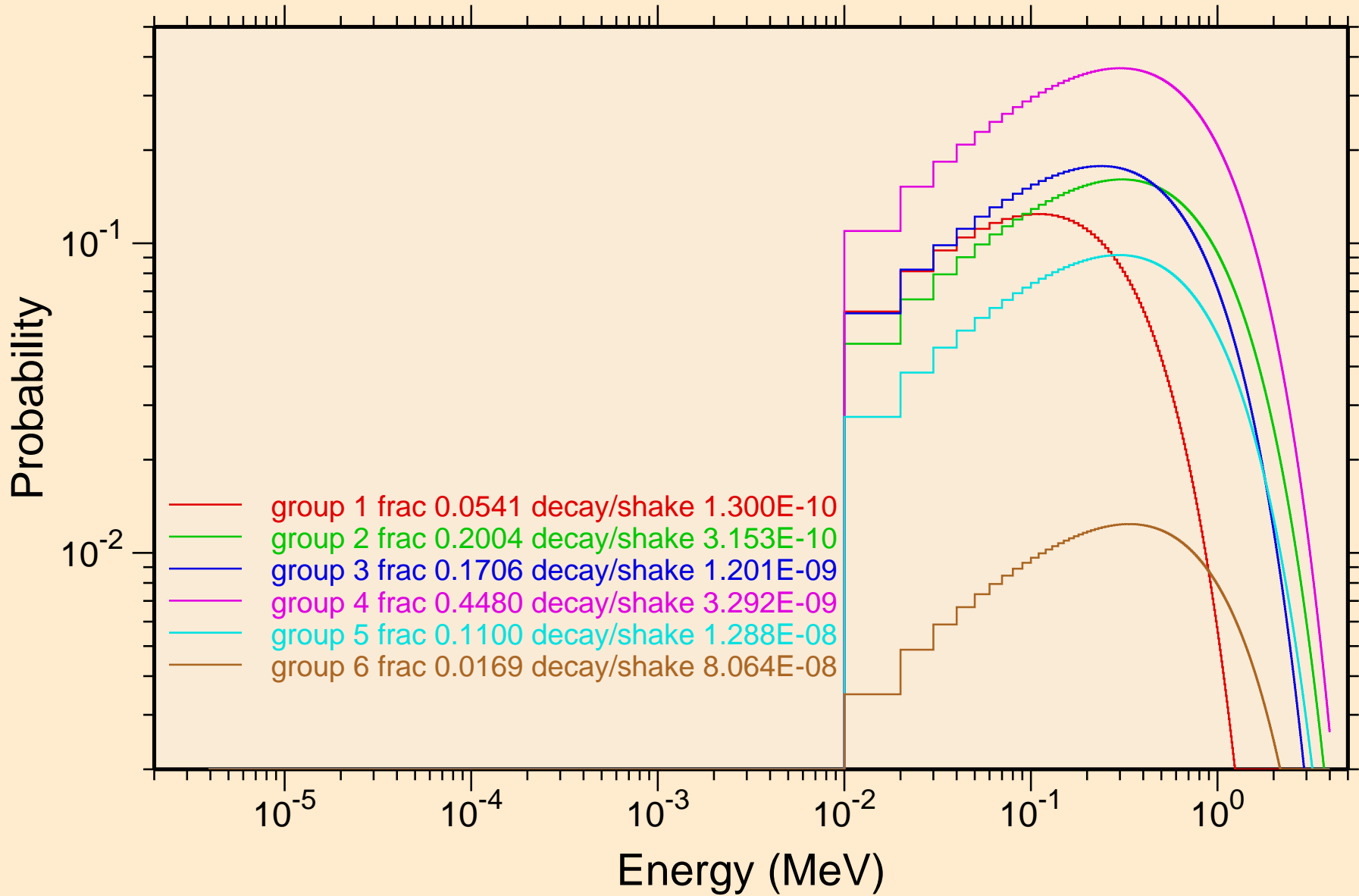

AC229 NEUTRON ACER TENDL-2021 LIBRARY; T=293.6K
Photon emission for (n,x)

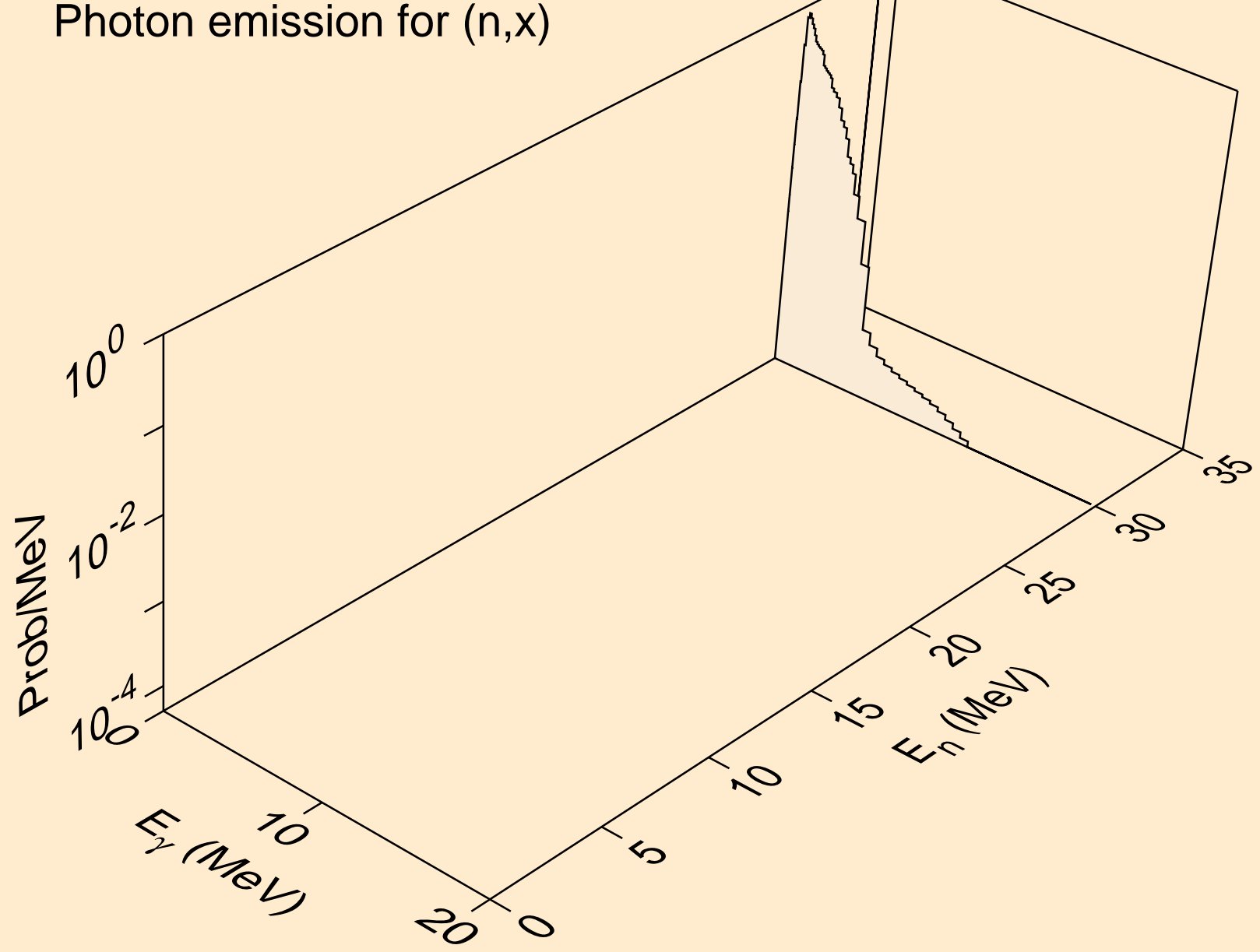

AC229 NEUTRON ACER TENDL-2021 LIBRARY; T=293.6K
Photon emission for (n,2nd)

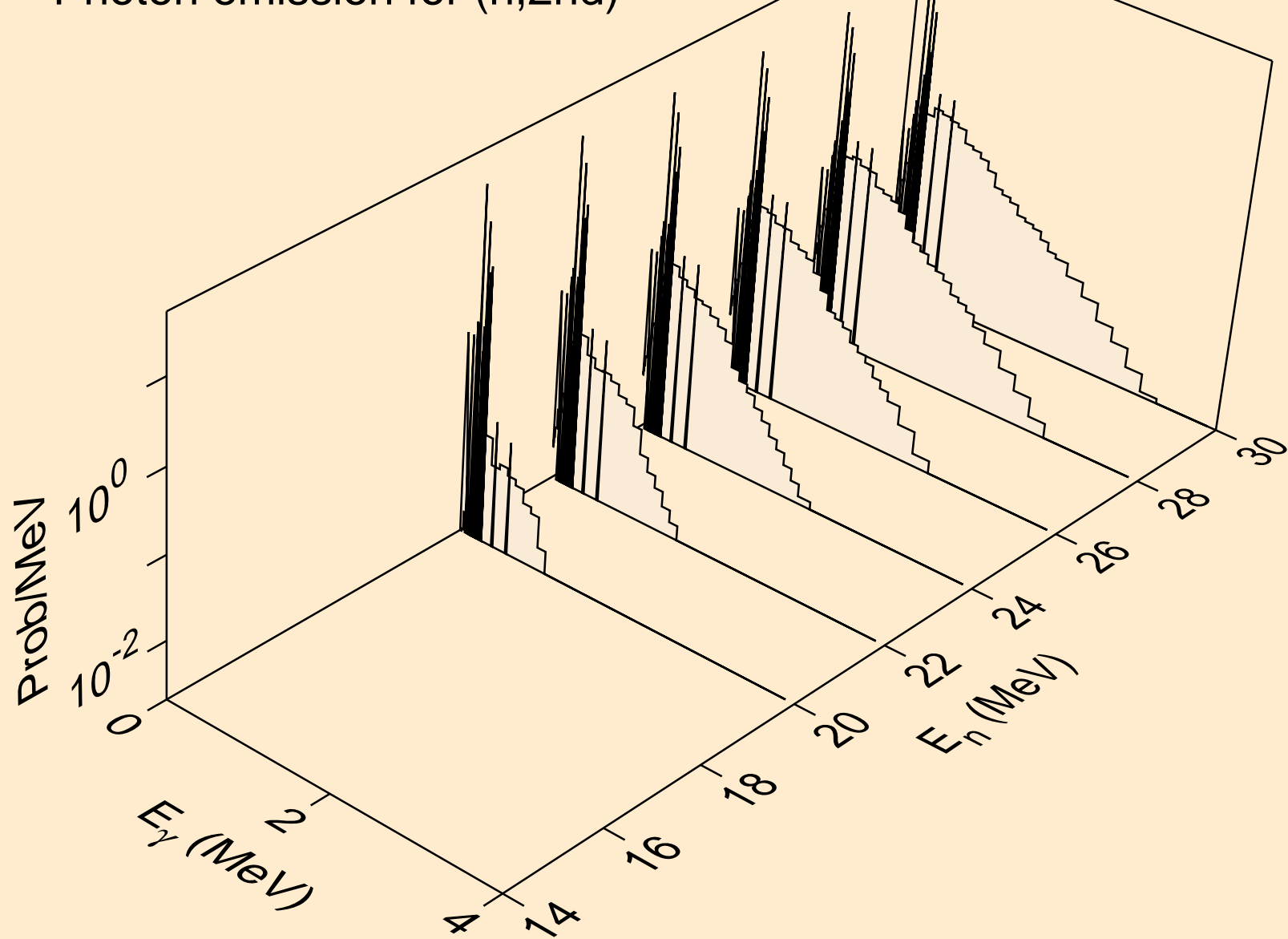

AC229 NEUTRON ACER TENDL-2021 LIBRARY; T=293.6K
Photon emission for (n,2n)

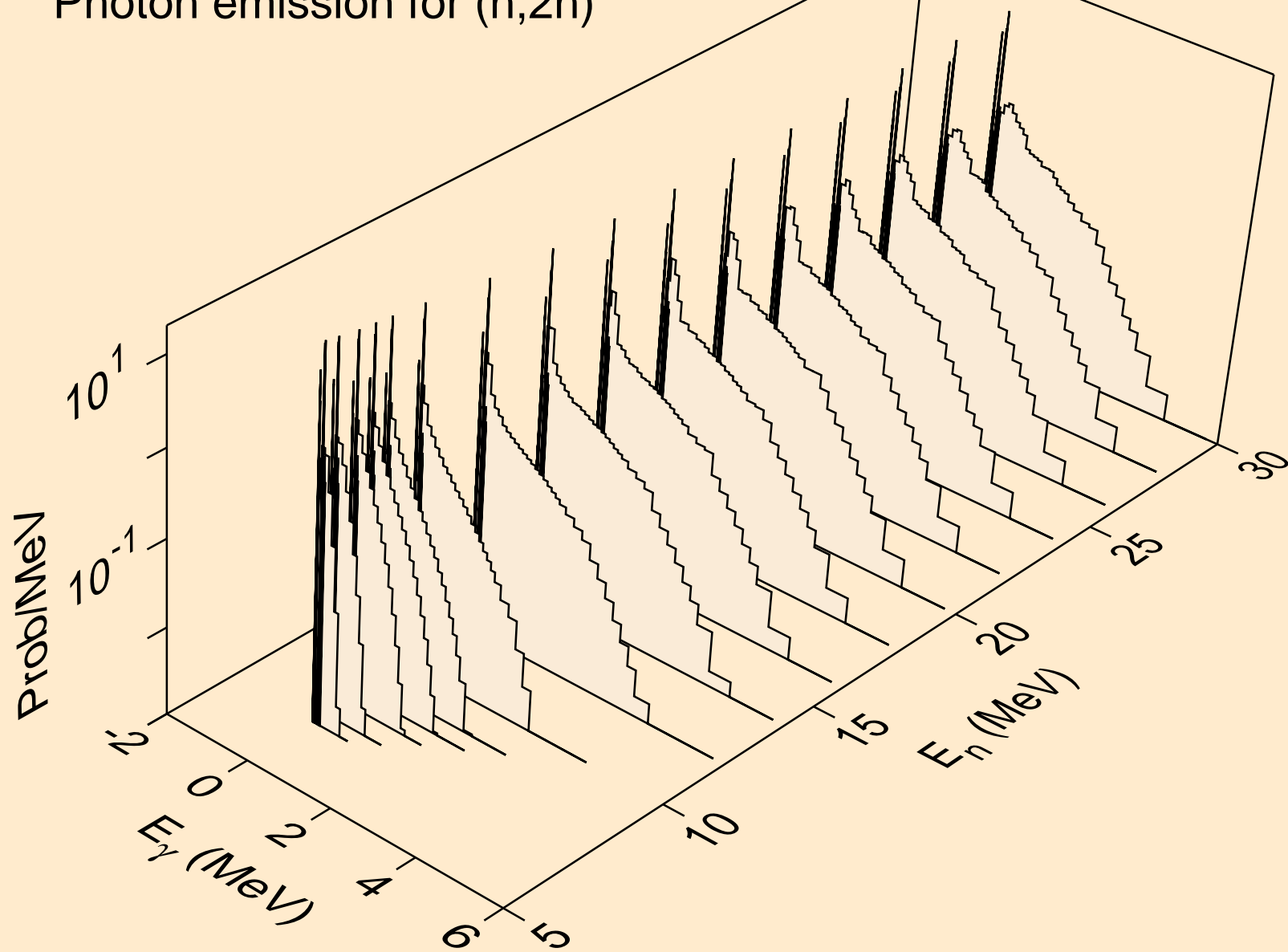

AC229 NEUTRON ACER TENDL-2021 LIBRARY; T=293.6K
Photon emission for (n,3n)

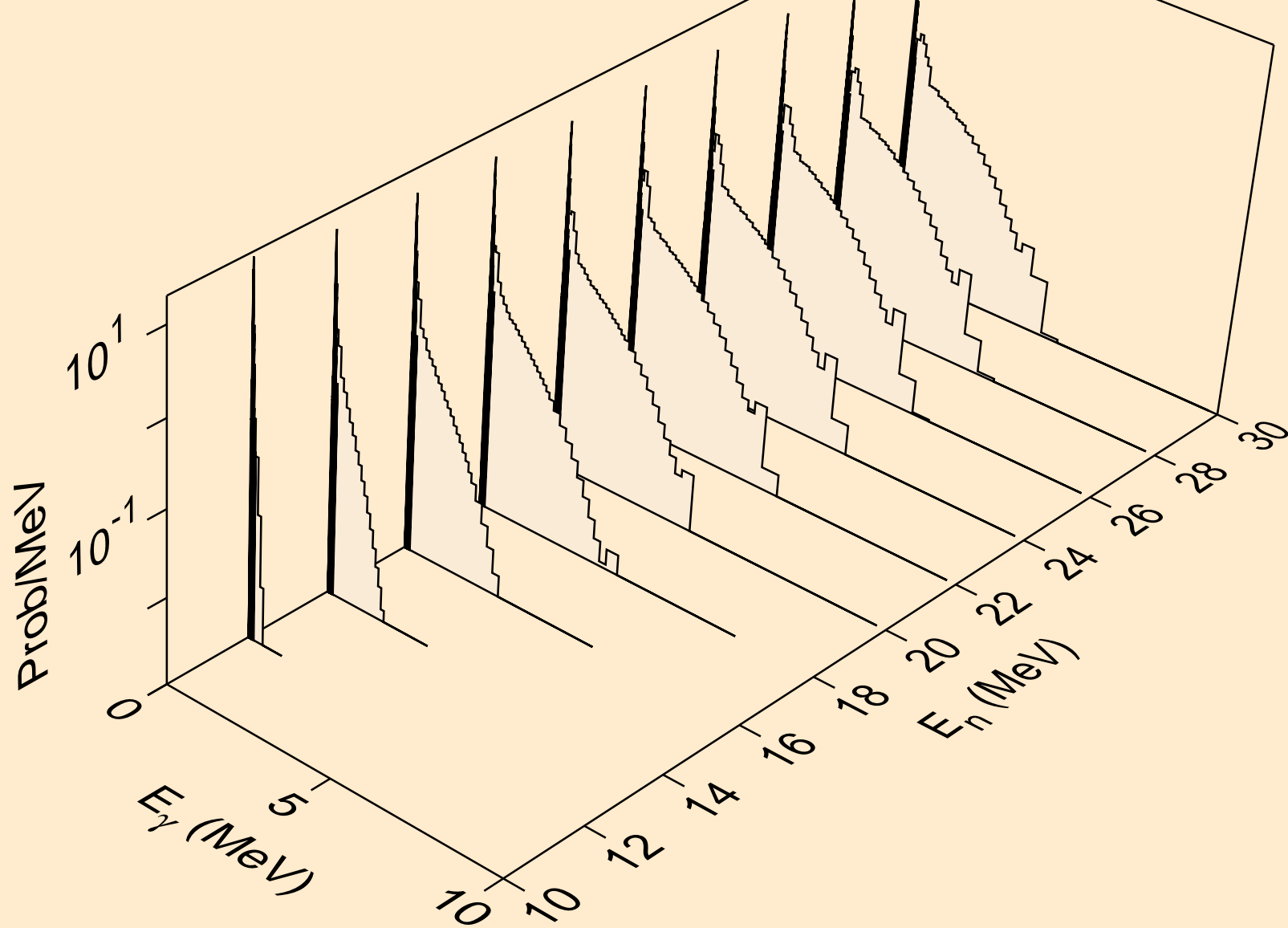

AC229 NEUTRON ACER TENDL-2021 LIBRARY; T=293.6K
Photon emission for (n,n*)a

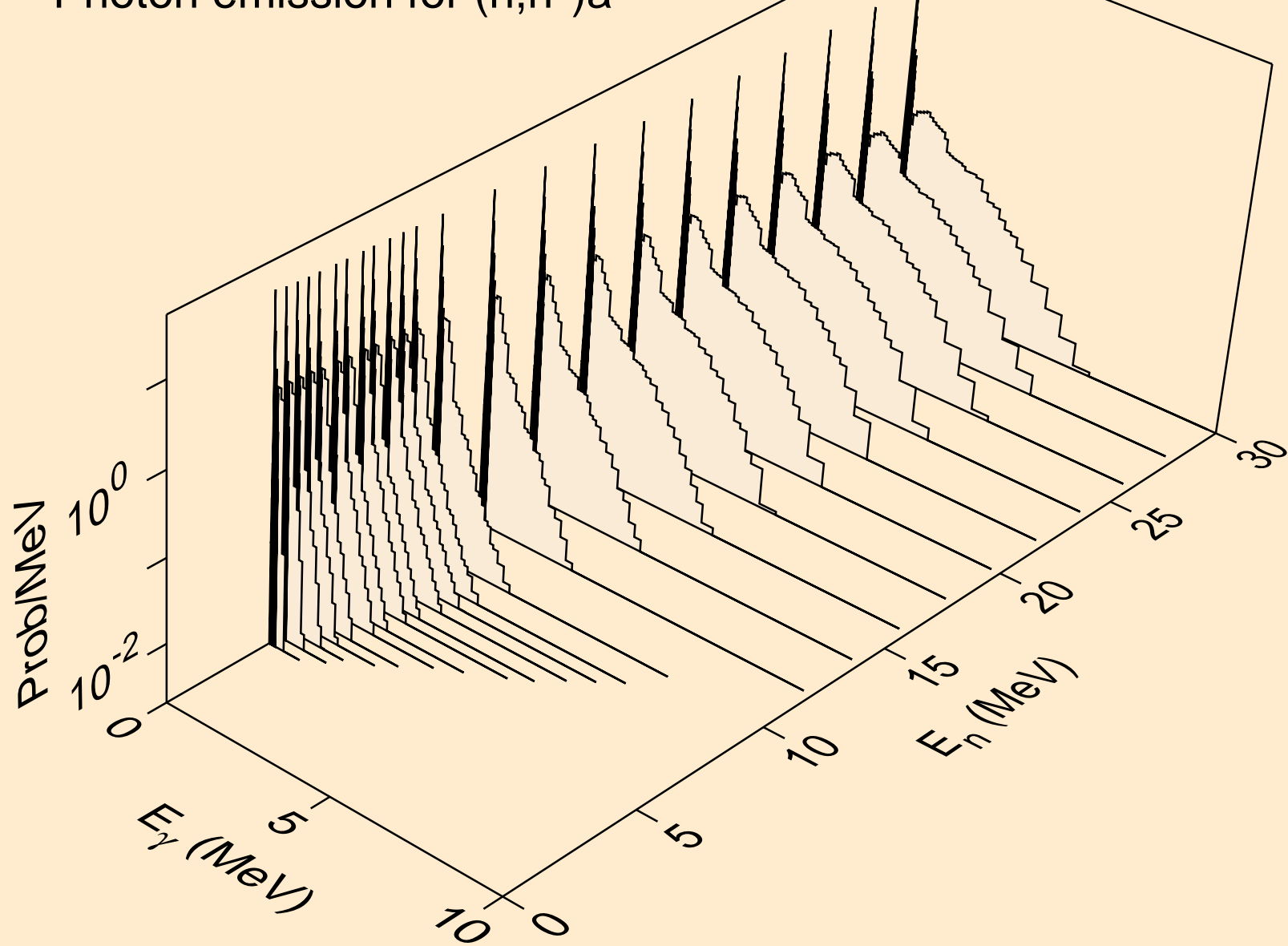

AC229 NEUTRON ACER TENDL-2021 LIBRARY; T=293.6K
Photon emission for (n,2n) α

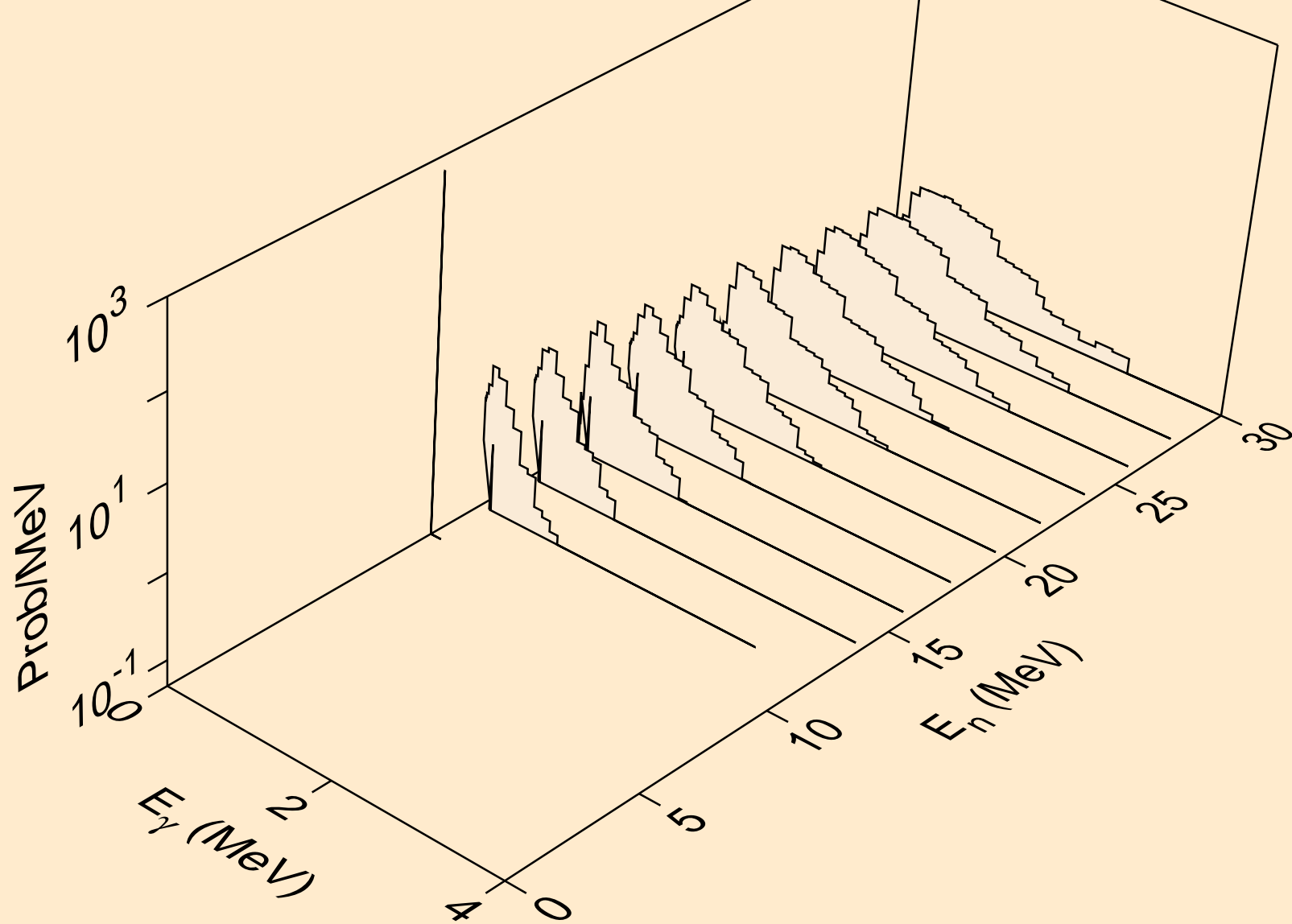

AC229 NEUTRON ACER TENDL-2021 LIBRARY; T=293.6K
Photon emission for (n,3n)a

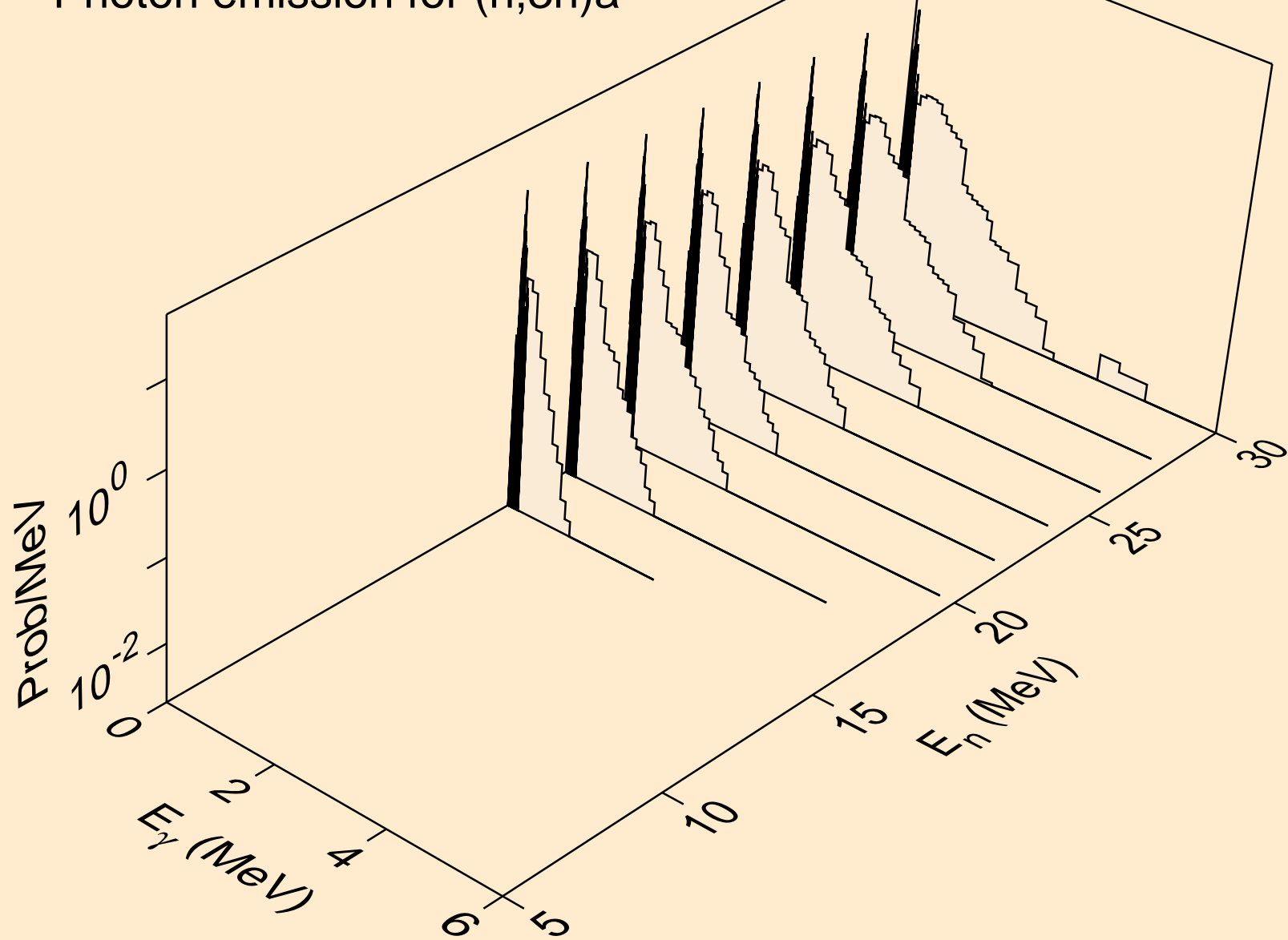

AC229 NEUTRON ACER TENDL-2021 LIBRARY; T=293.6K
Photon emission for (n,n*)p

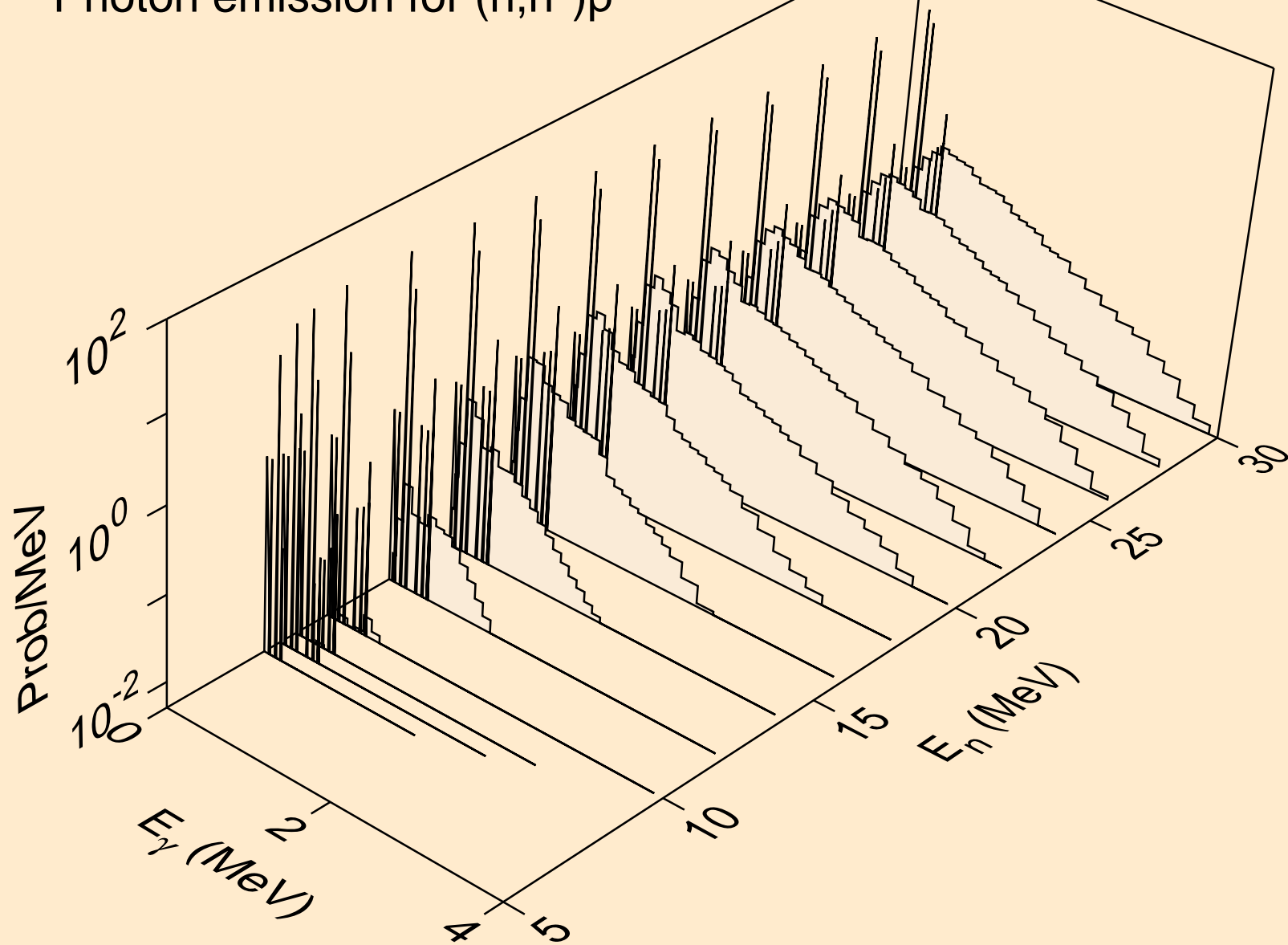

AC229 NEUTRON ACER TENDL-2021 LIBRARY; T=293.6K
Photon emission for (n,n*)d

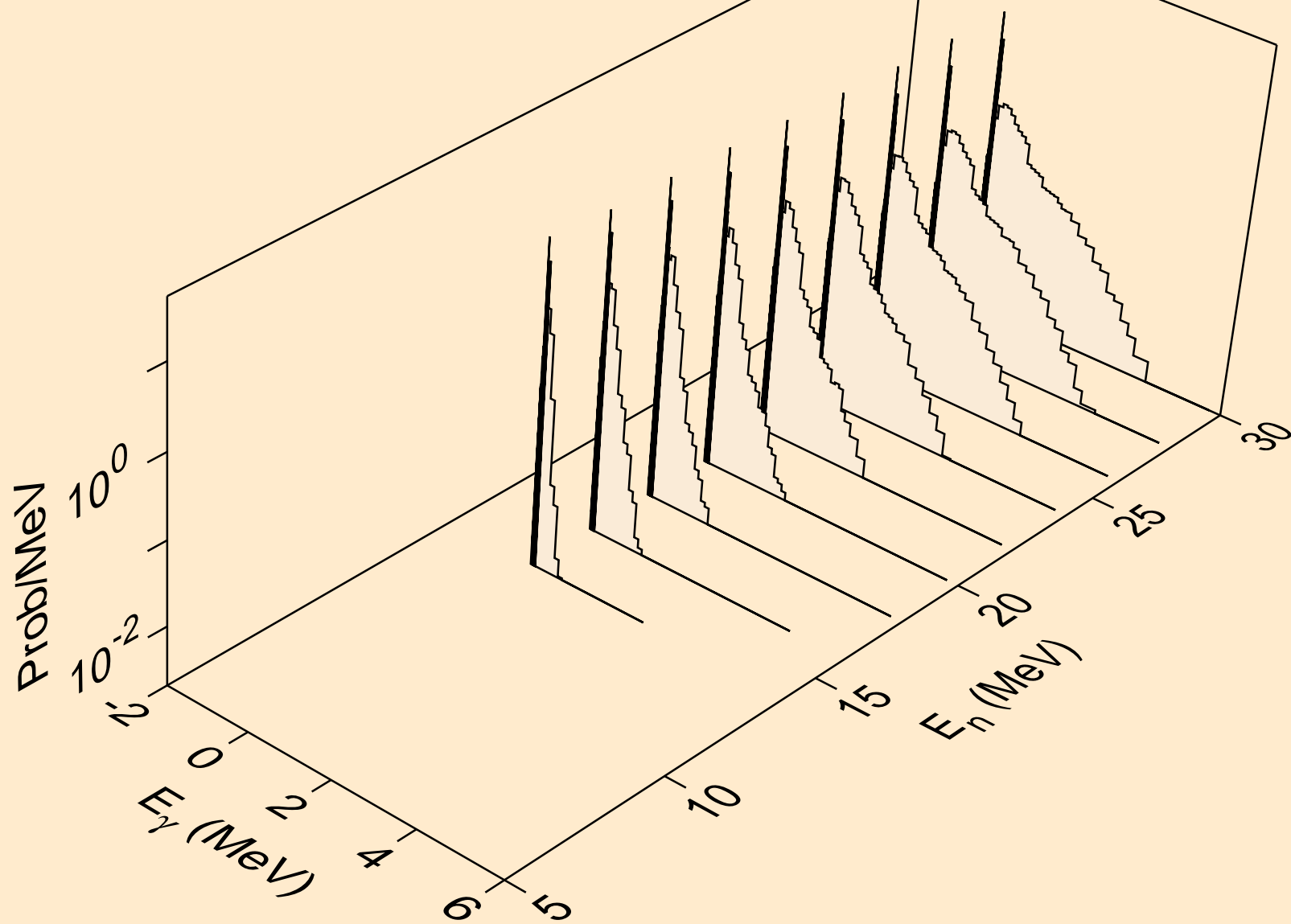

AC229 NEUTRON ACER TENDL-2021 LIBRARY; T=293.6K
Photon emission for (n,n*)t

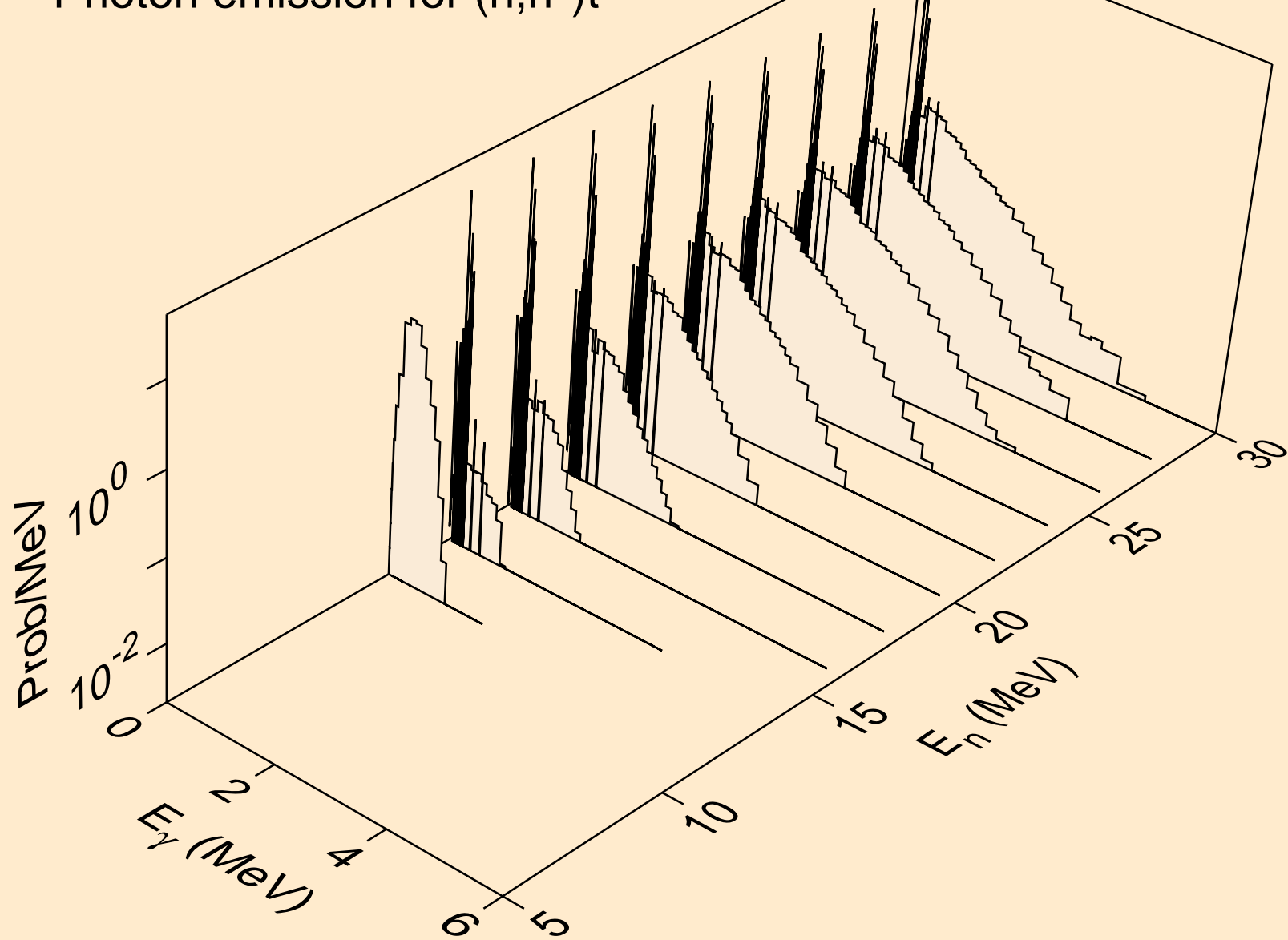

AC229 NEUTRON ACER TENDL-2021 LIBRARY; T=293.6K
Photon emission for (n,n*)he3

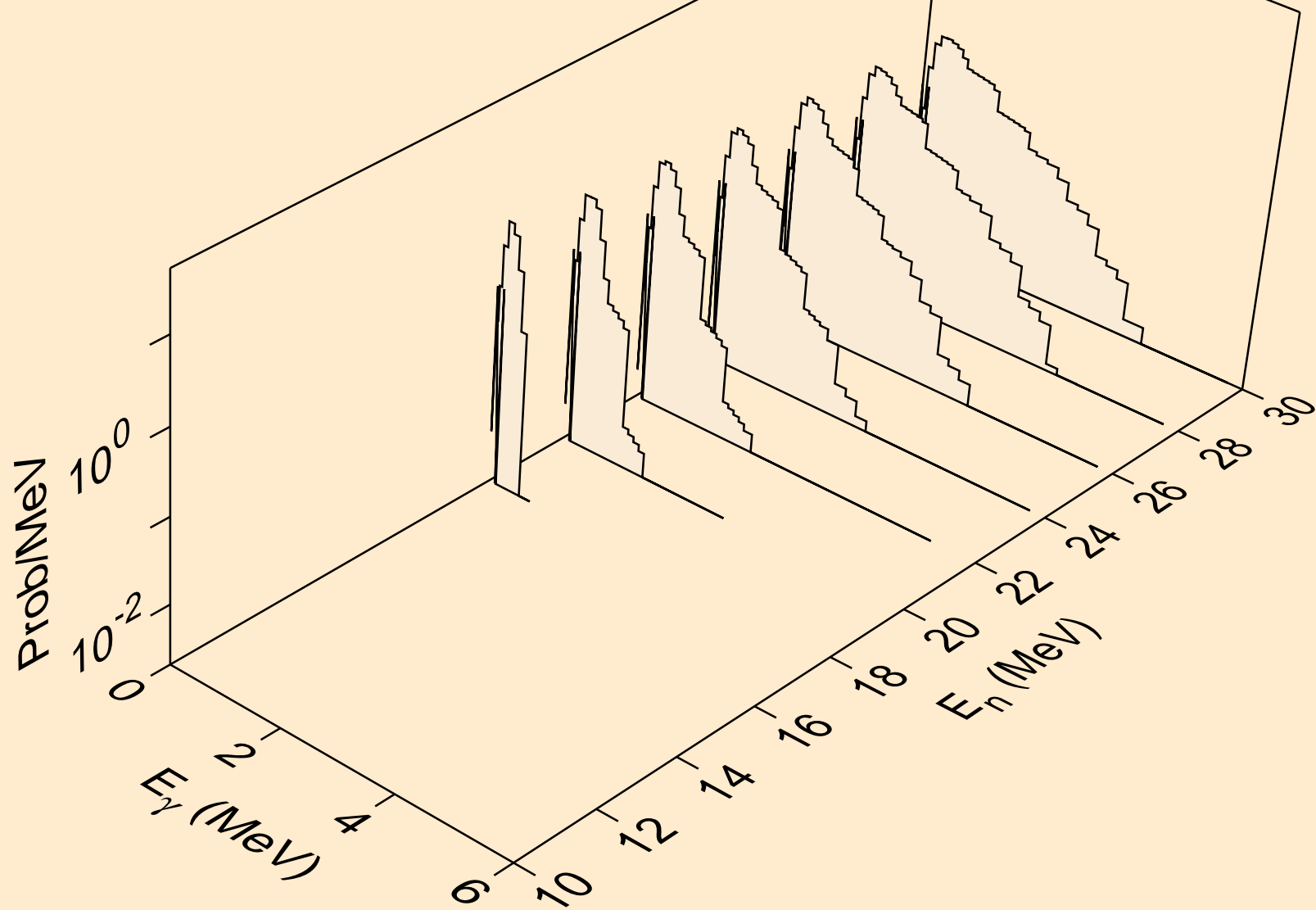

AC229 NEUTRON ACER TENDL-2021 LIBRARY; T=293.6K
Photon emission for (n,4n)

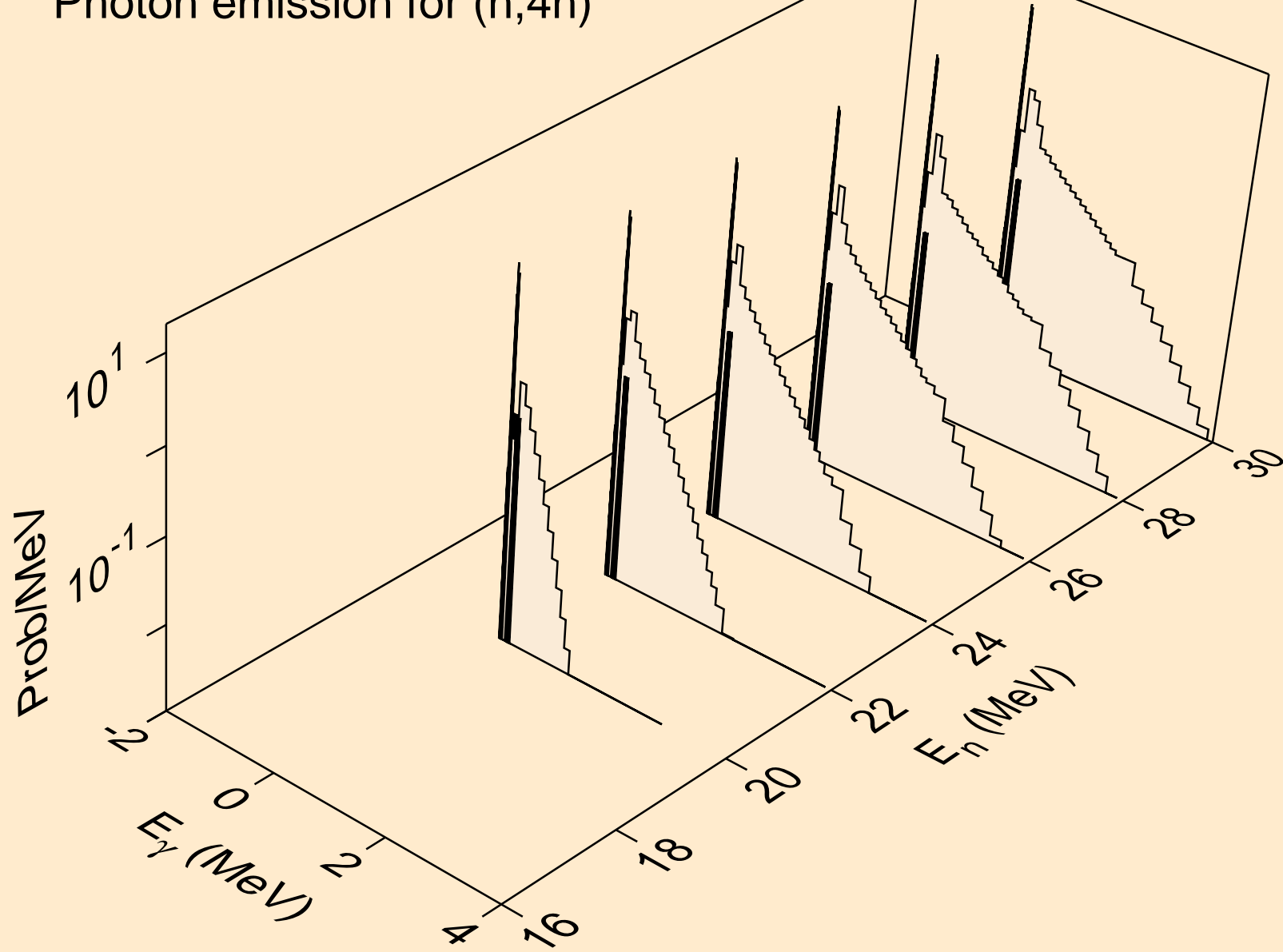

AC229 NEUTRON ACER TENDL-2021 LIBRARY; T=293.6K
Photon emission for (n,2np)

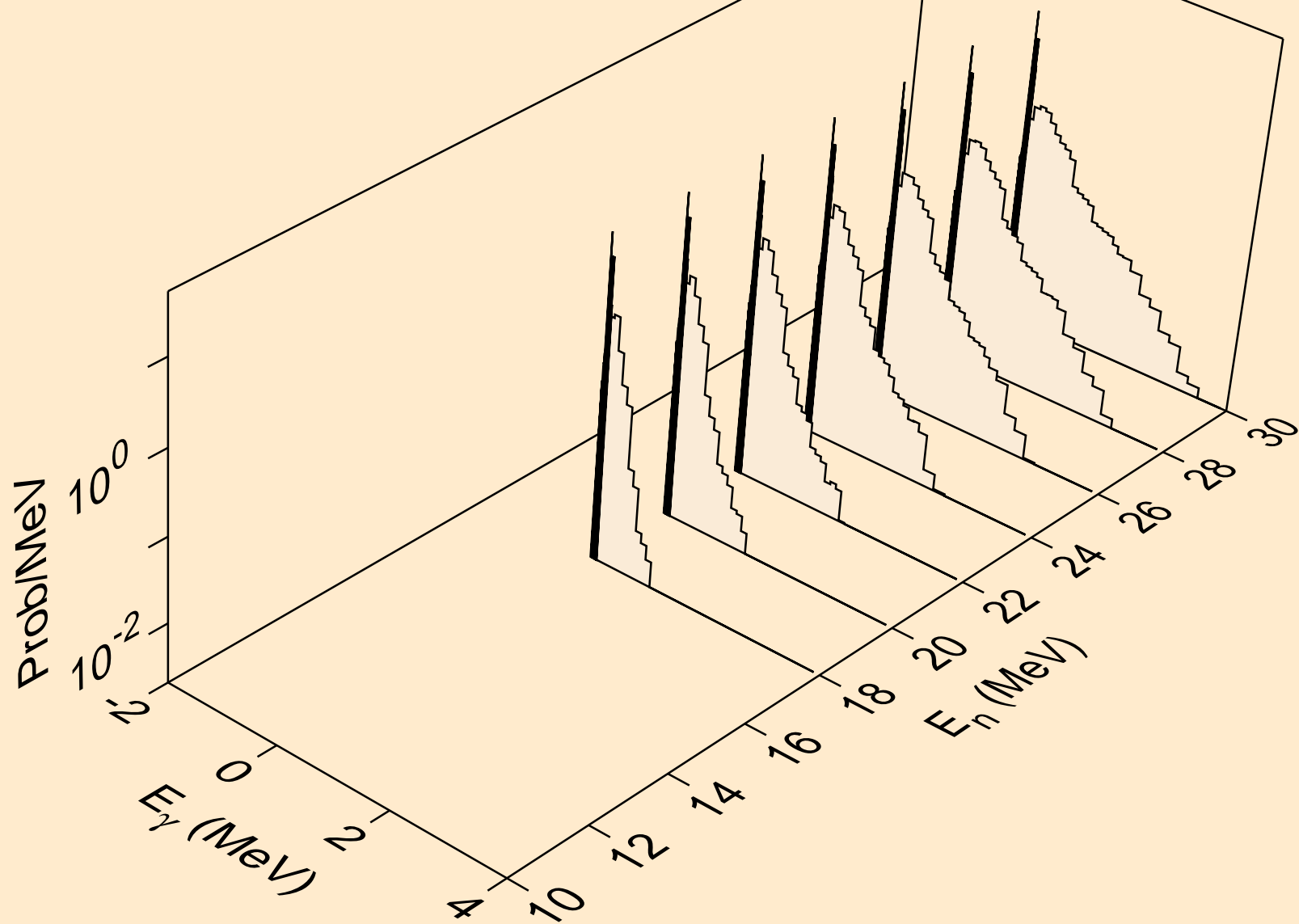

AC229 NEUTRON ACER TENDL-2021 LIBRARY; T=293.6K
Photon emission for (n,3np)

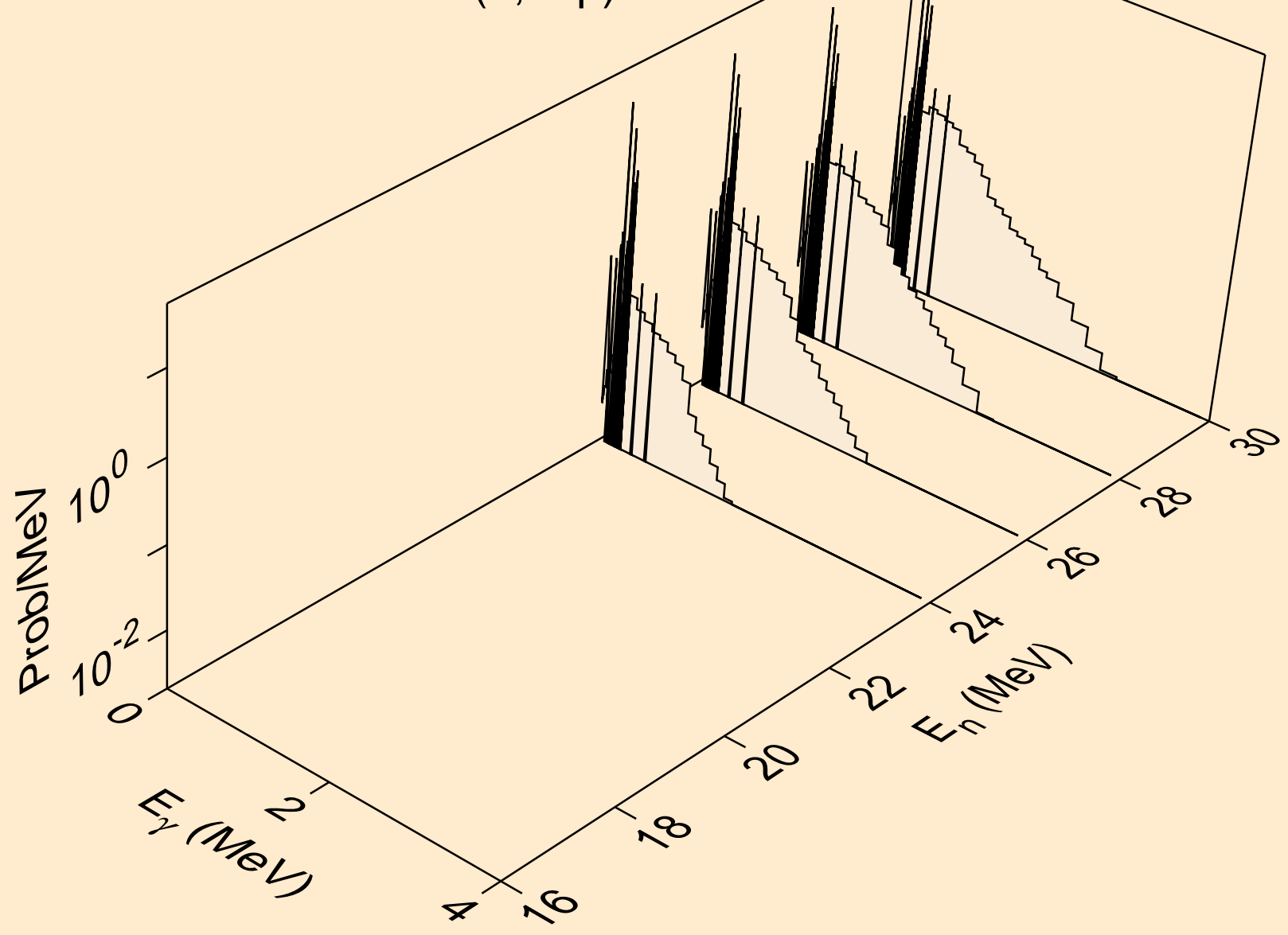

AC229 NEUTRON ACER TENDL-2021 LIBRARY; T=293.6K
Photon emission for (n,2np)

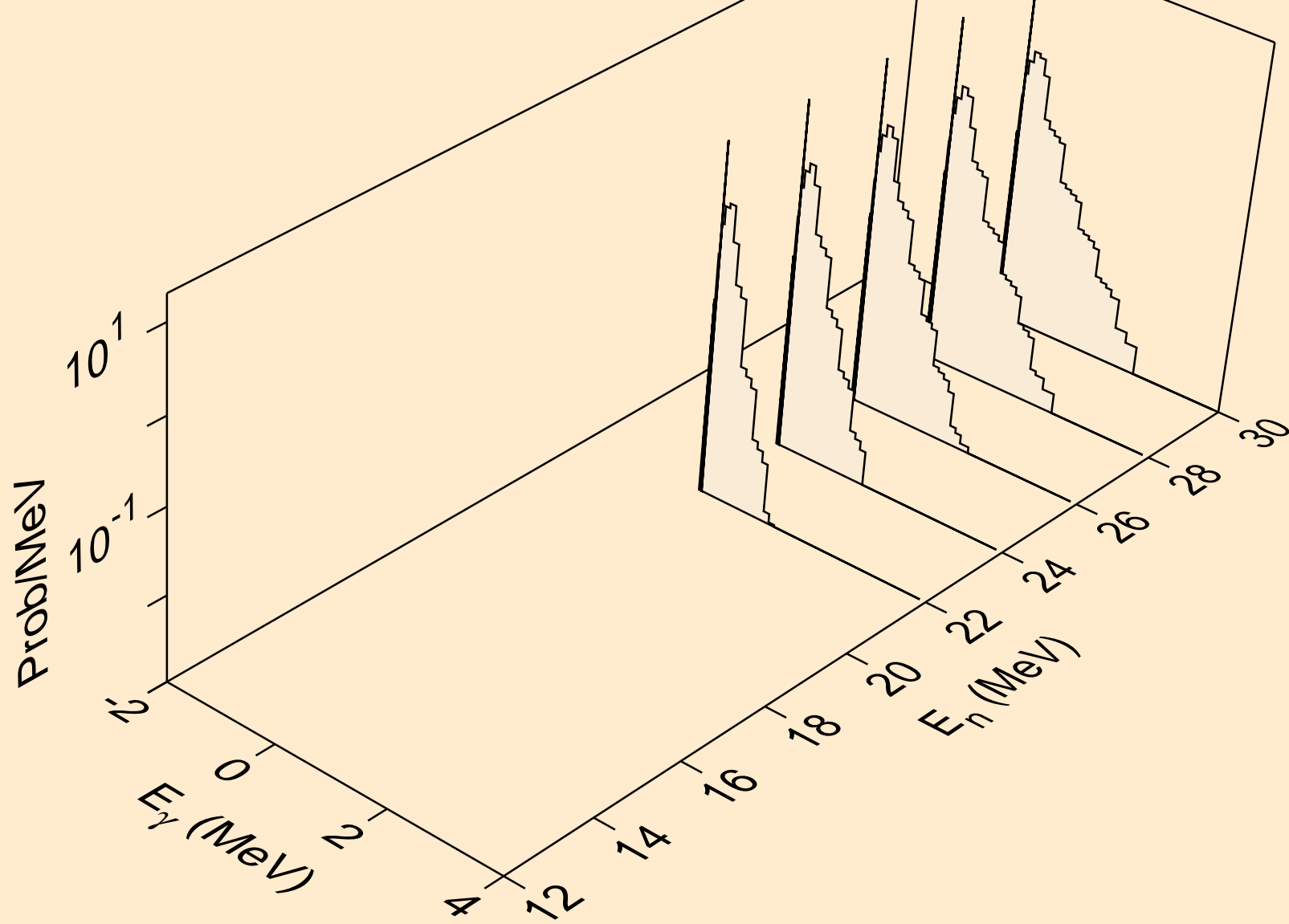

AC229 NEUTRON ACER TENDL-2021 LIBRARY; T=293.6K
Photon emission for (n,n*c)

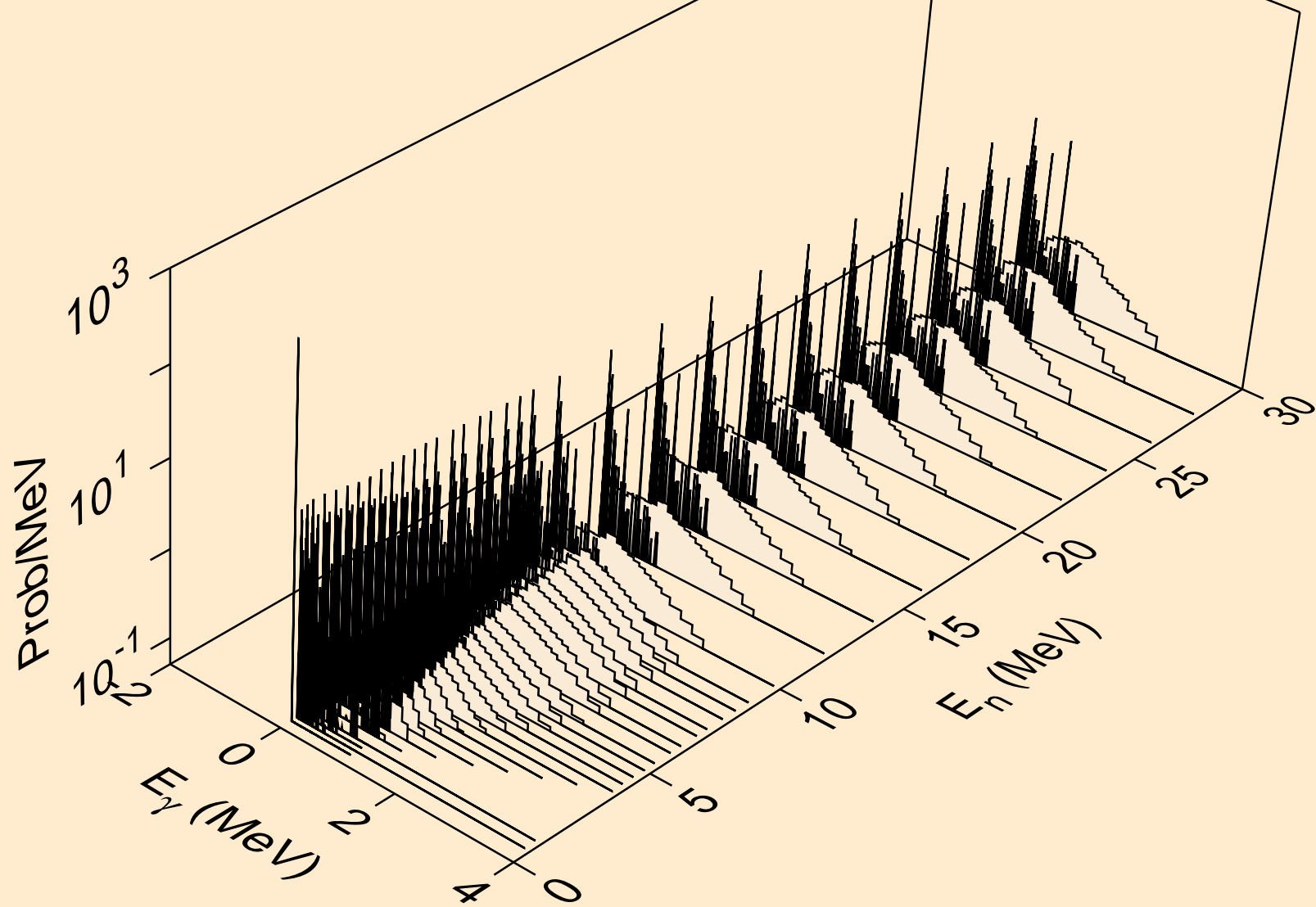

AC229 NEUTRON ACER TENDL-2021 LIBRARY; T=293.6K
Photon emission for (n,gma)

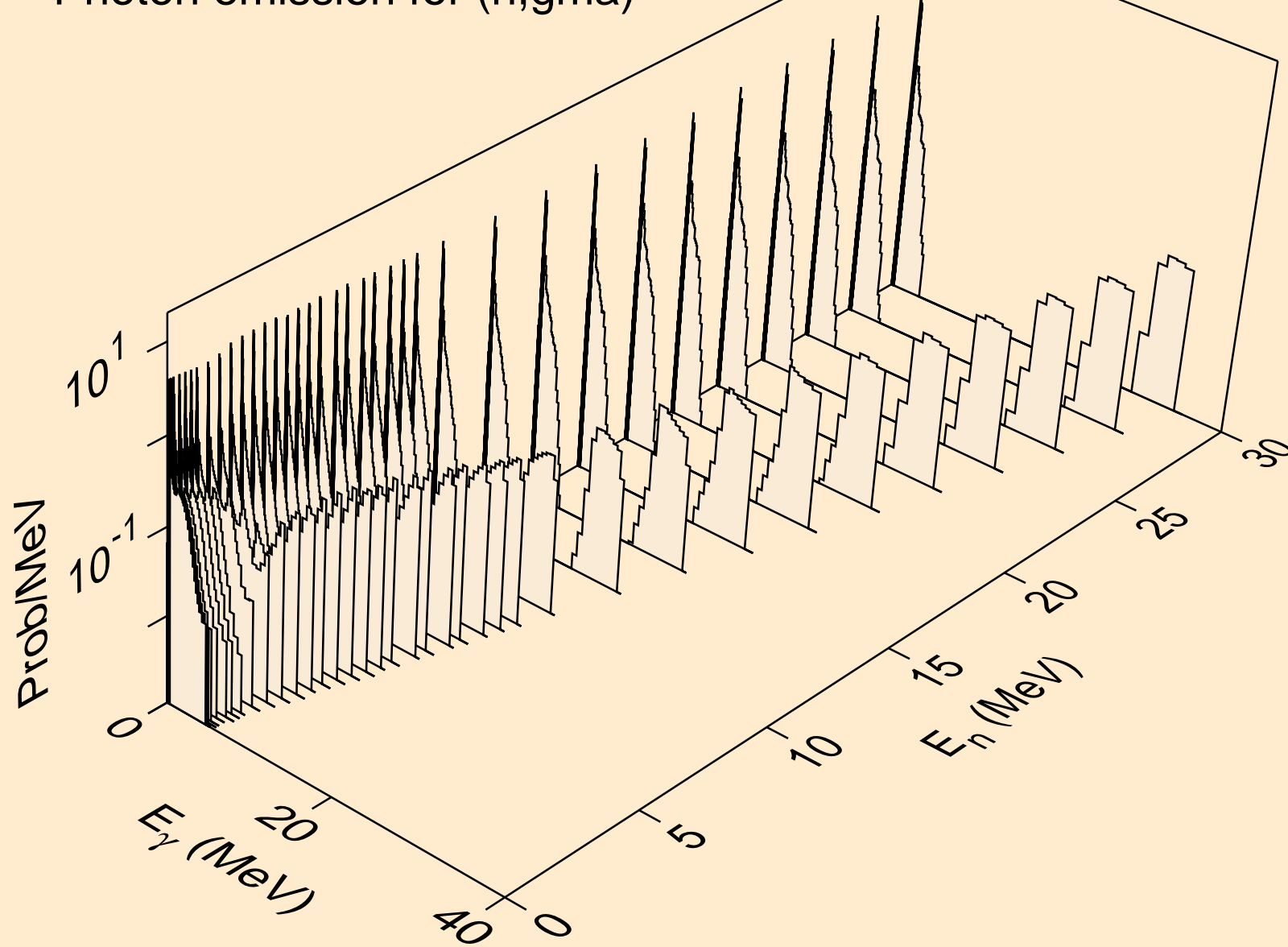

AC229 NEUTRON ACER TENDL-2021 LIBRARY; T=293.6K
Photon emission for (n,p)

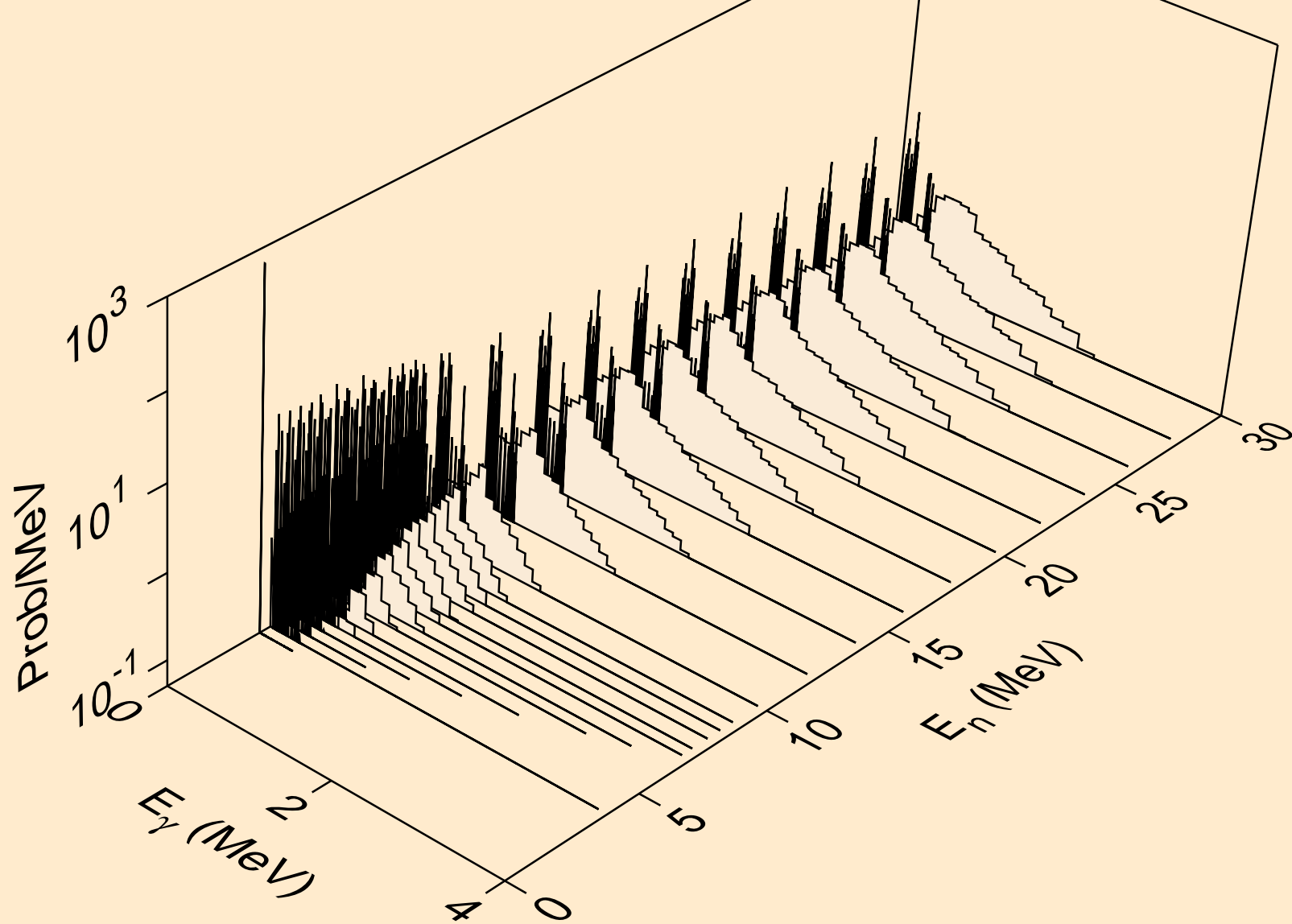

AC229 NEUTRON ACER TENDL-2021 LIBRARY; T=293.6K
Photon emission for (n,d)

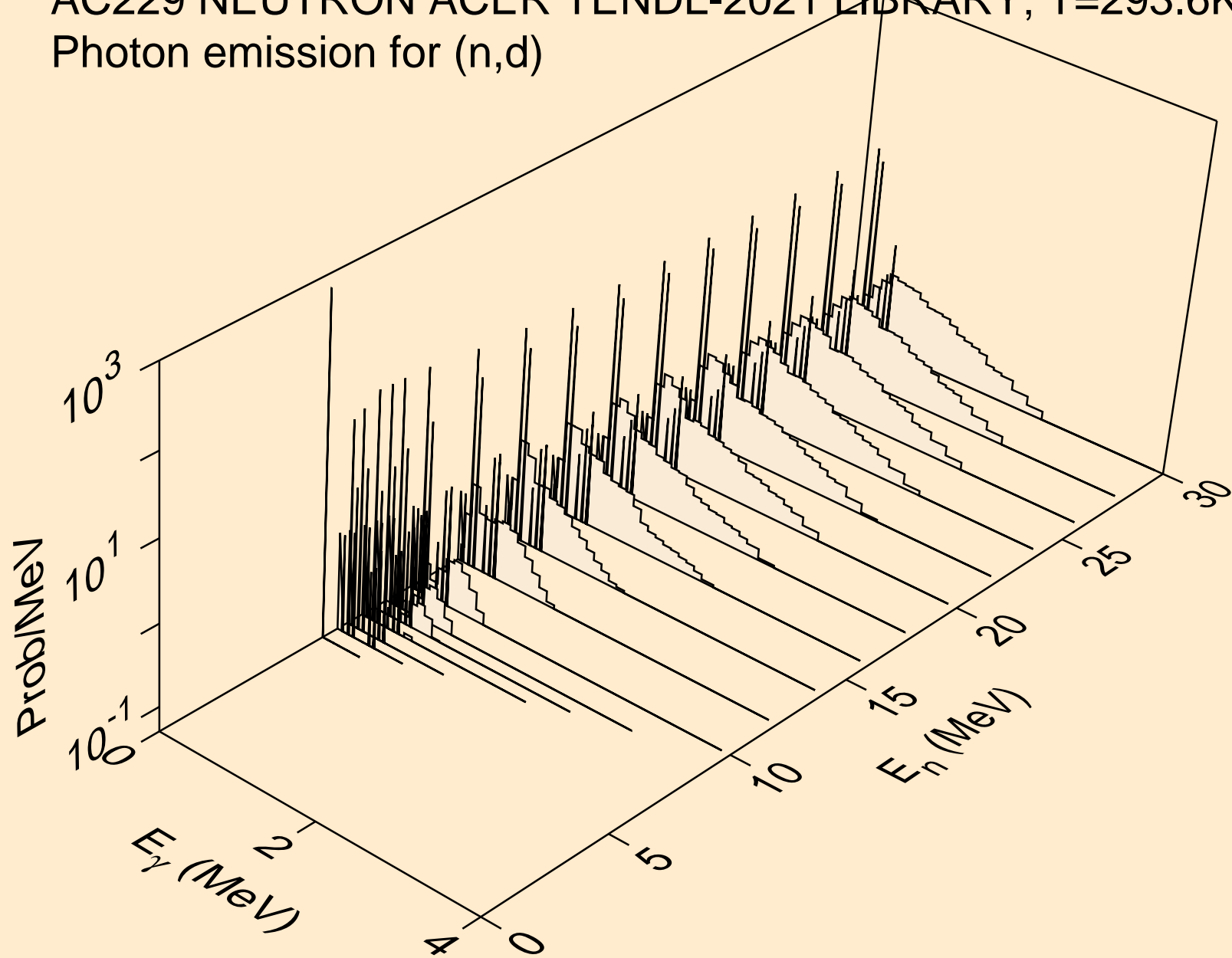

AC229 NEUTRON ACER TENDL-2021 LIBRARY; T=293.6K
Photon emission for (n,t)

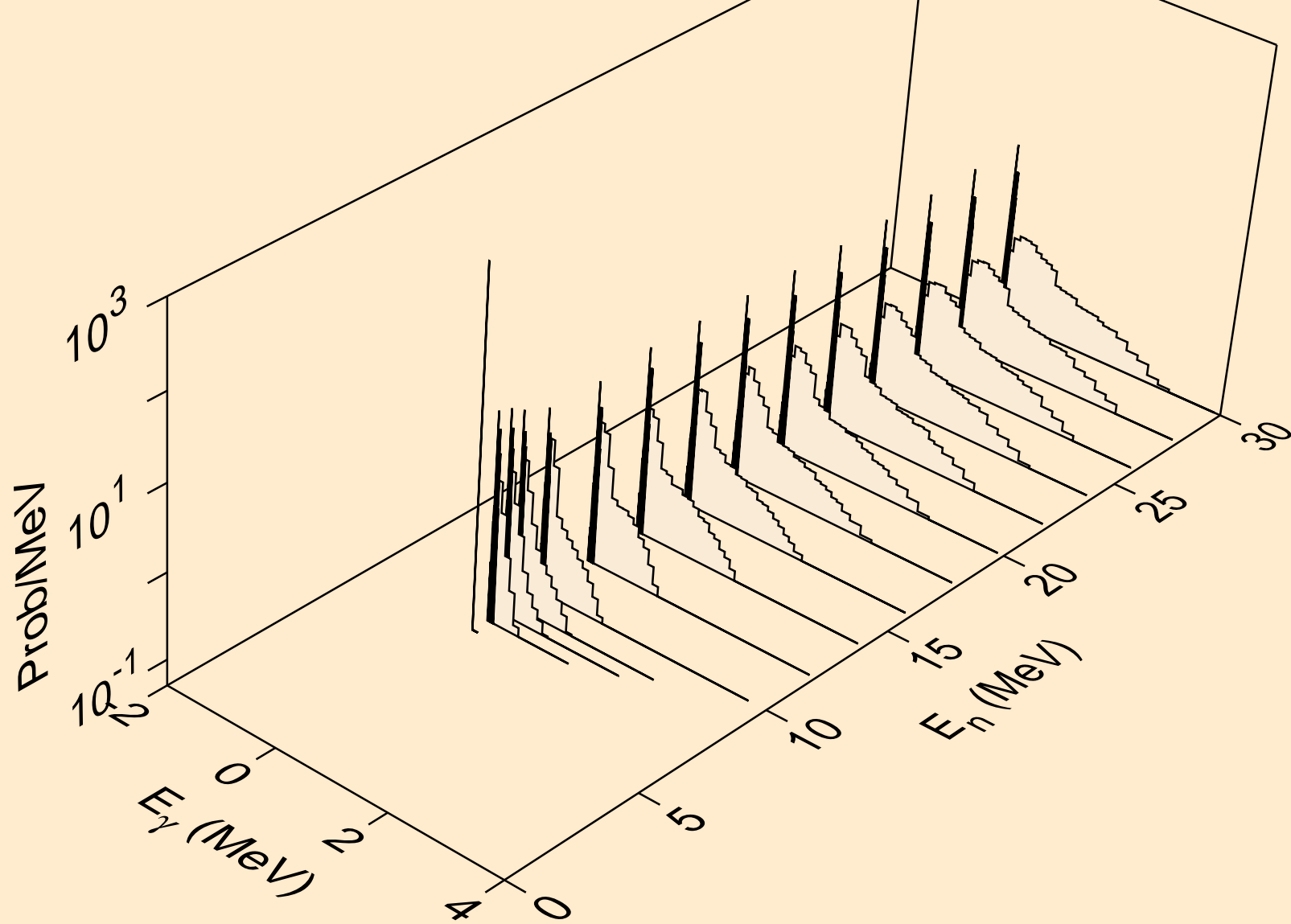

AC229 NEUTRON ACER TENDL-2021 LIBRARY; T=293.6K
Photon emission for (n,he3)

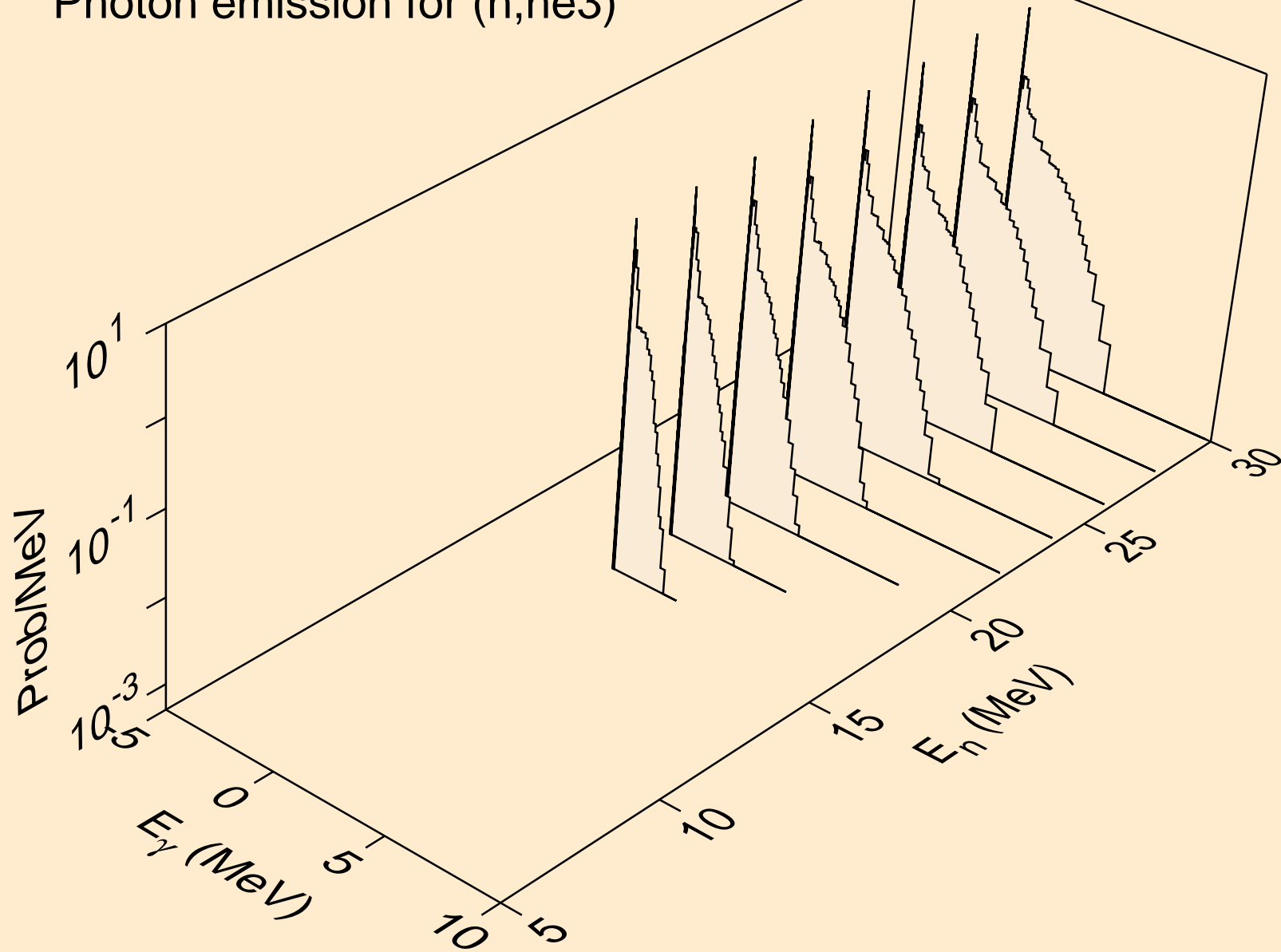

AC229 NEUTRON ACER TENDL-2021 LIBRARY; T=293.6K
Photon emission for (n,a)

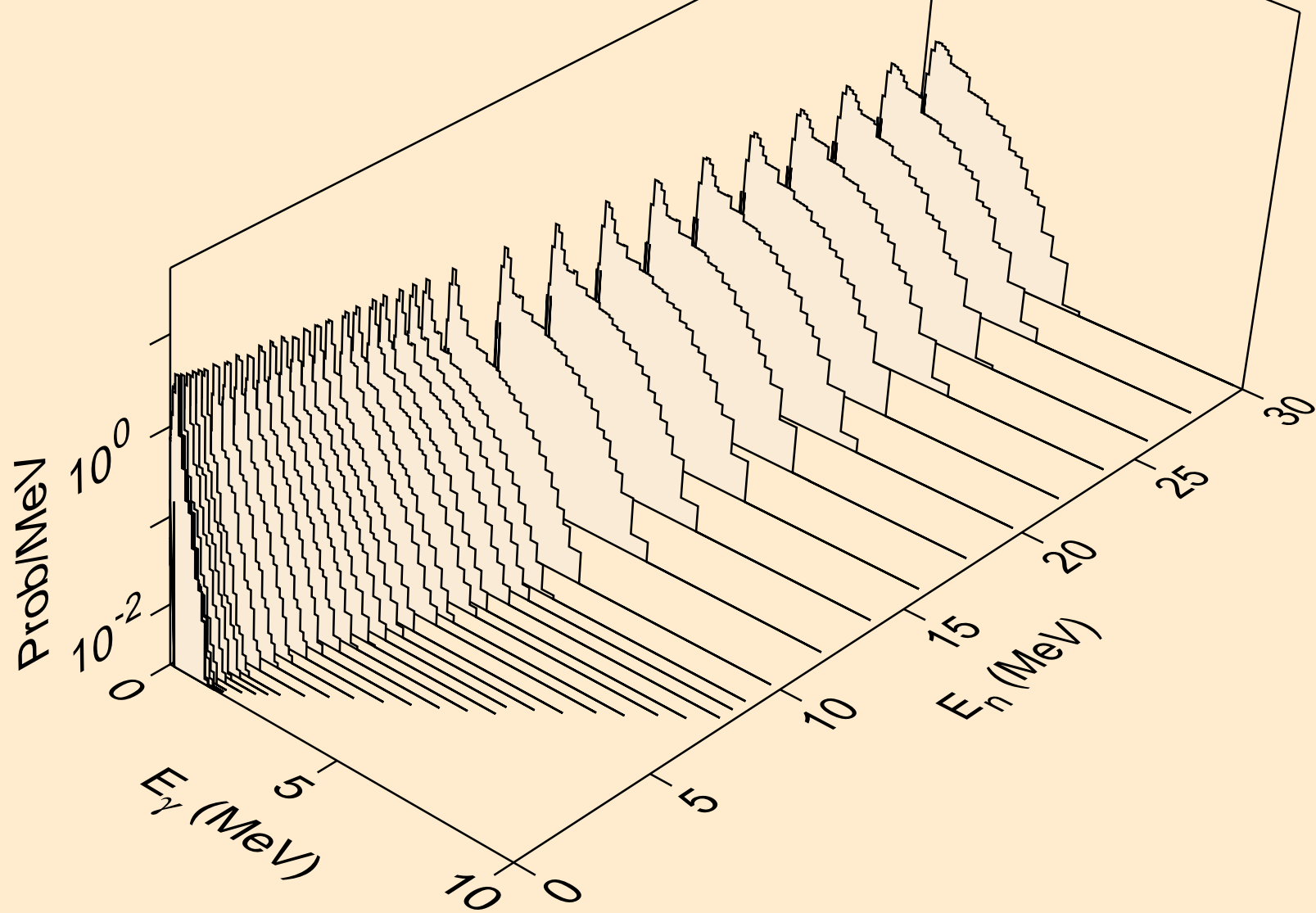

AC229 NEUTRON ACER TENDL-2021 LIBRARY; T=293.6K
Photon emission for (n,2p)

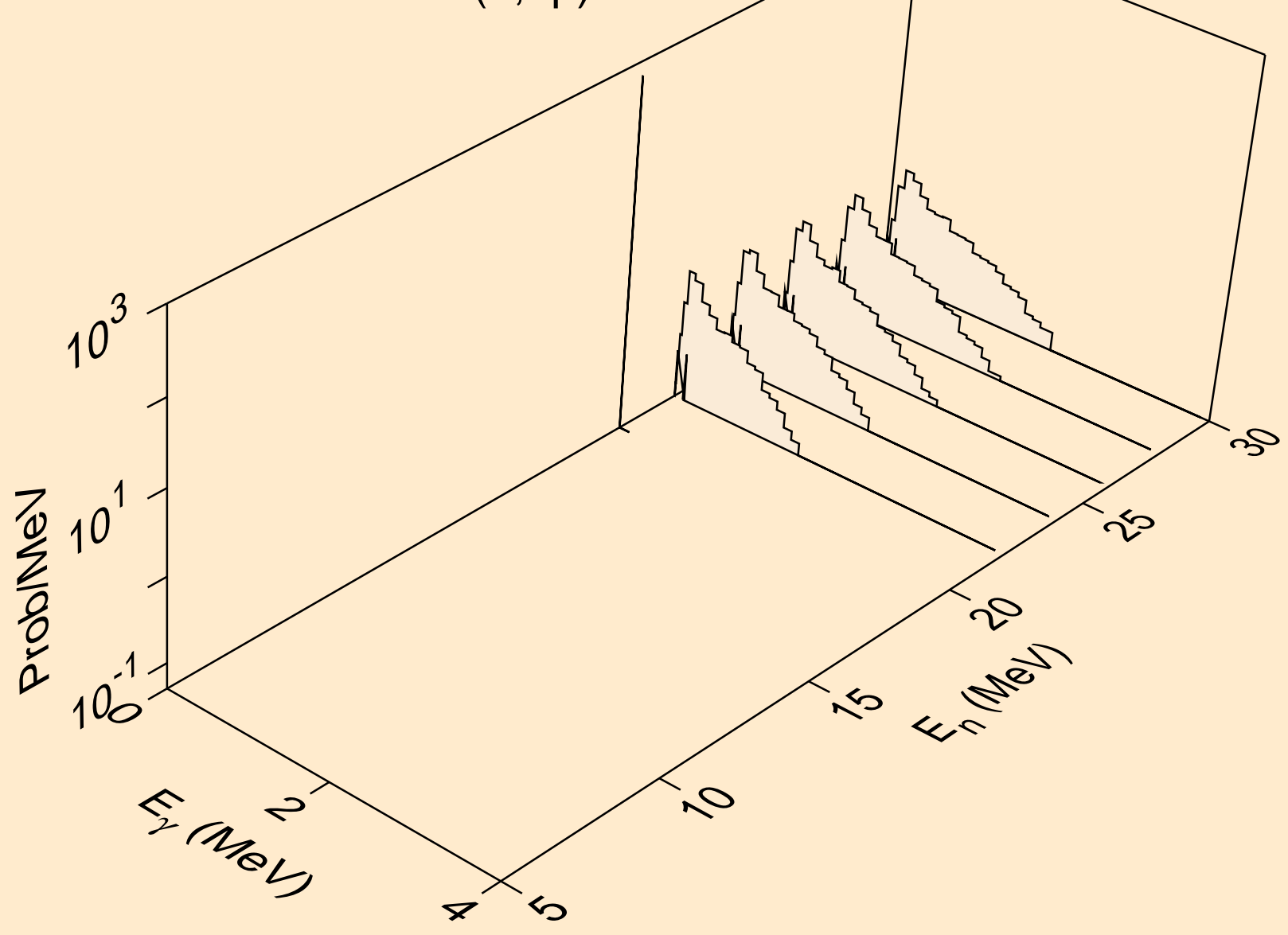

AC229 NEUTRON ACER TENDL-2021 LIBRARY; T=293.6K
Photon emission for (n,p)

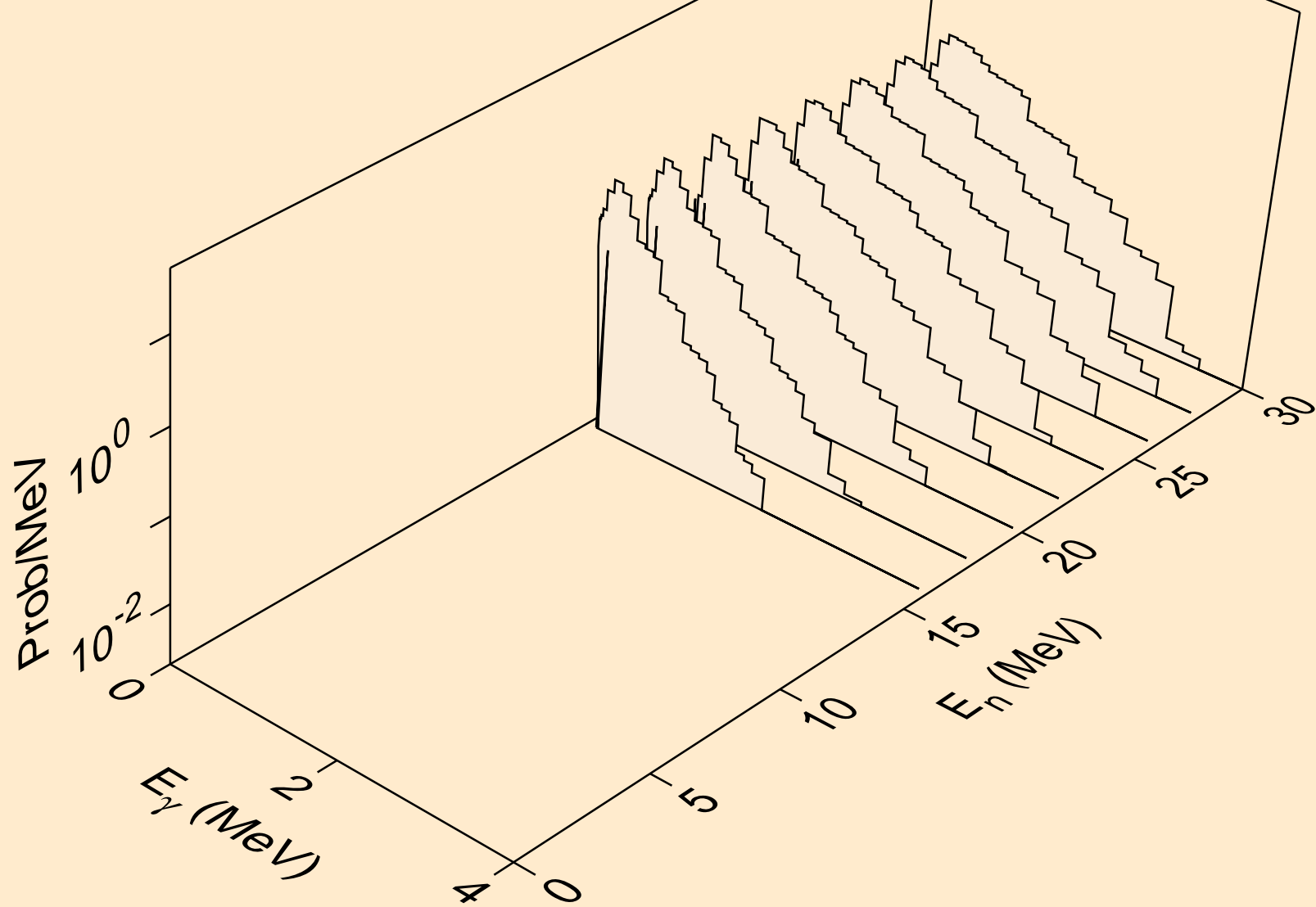

AC229 NEUTRON ACER TENDL-2021 LIBRARY; T=293.6K
Photon emission for (n,pd)

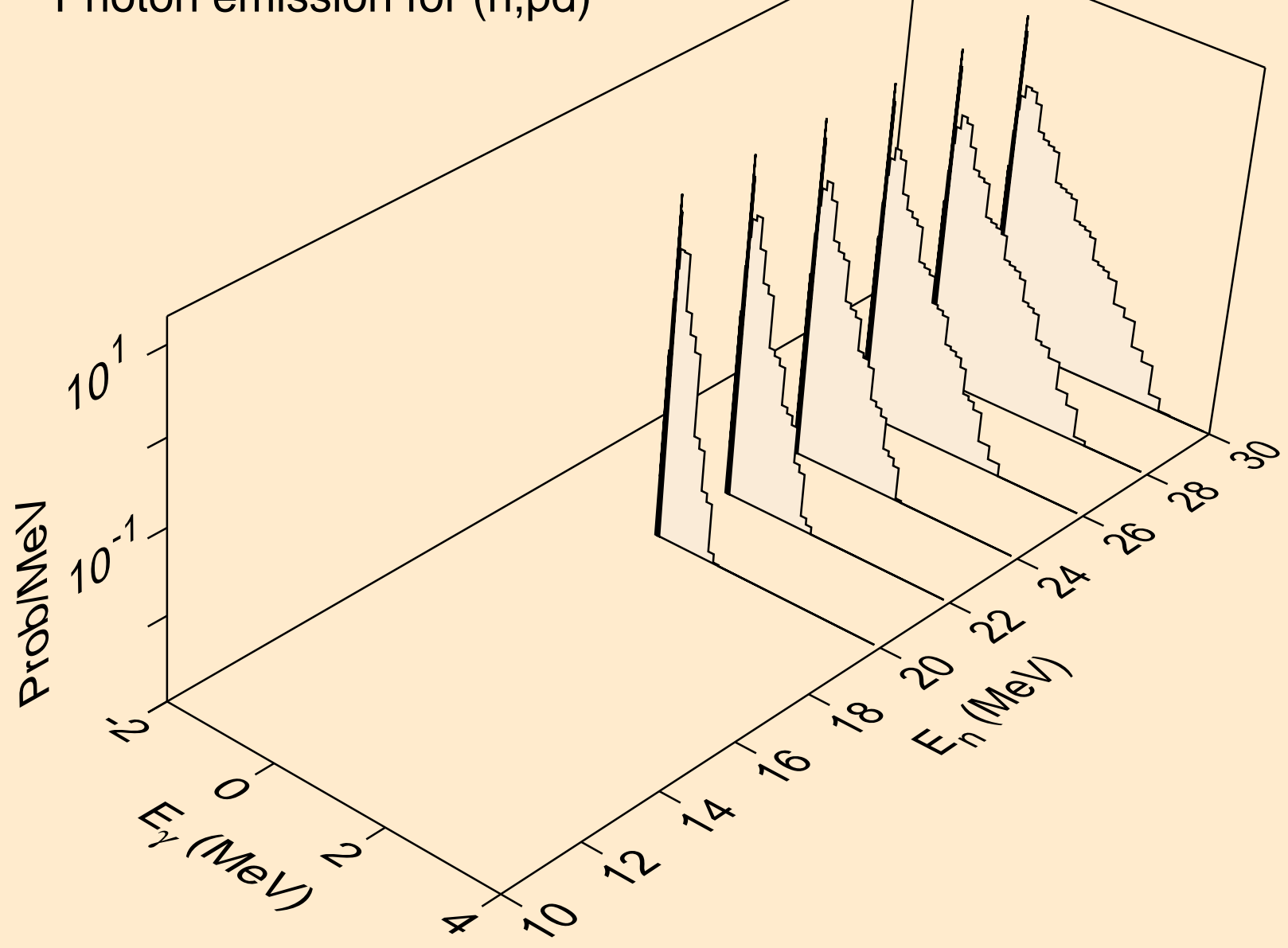

AC229 NEUTRON ACER TENDL-2021 LIBRARY; T=293.6K
Photon emission for (n,pt)

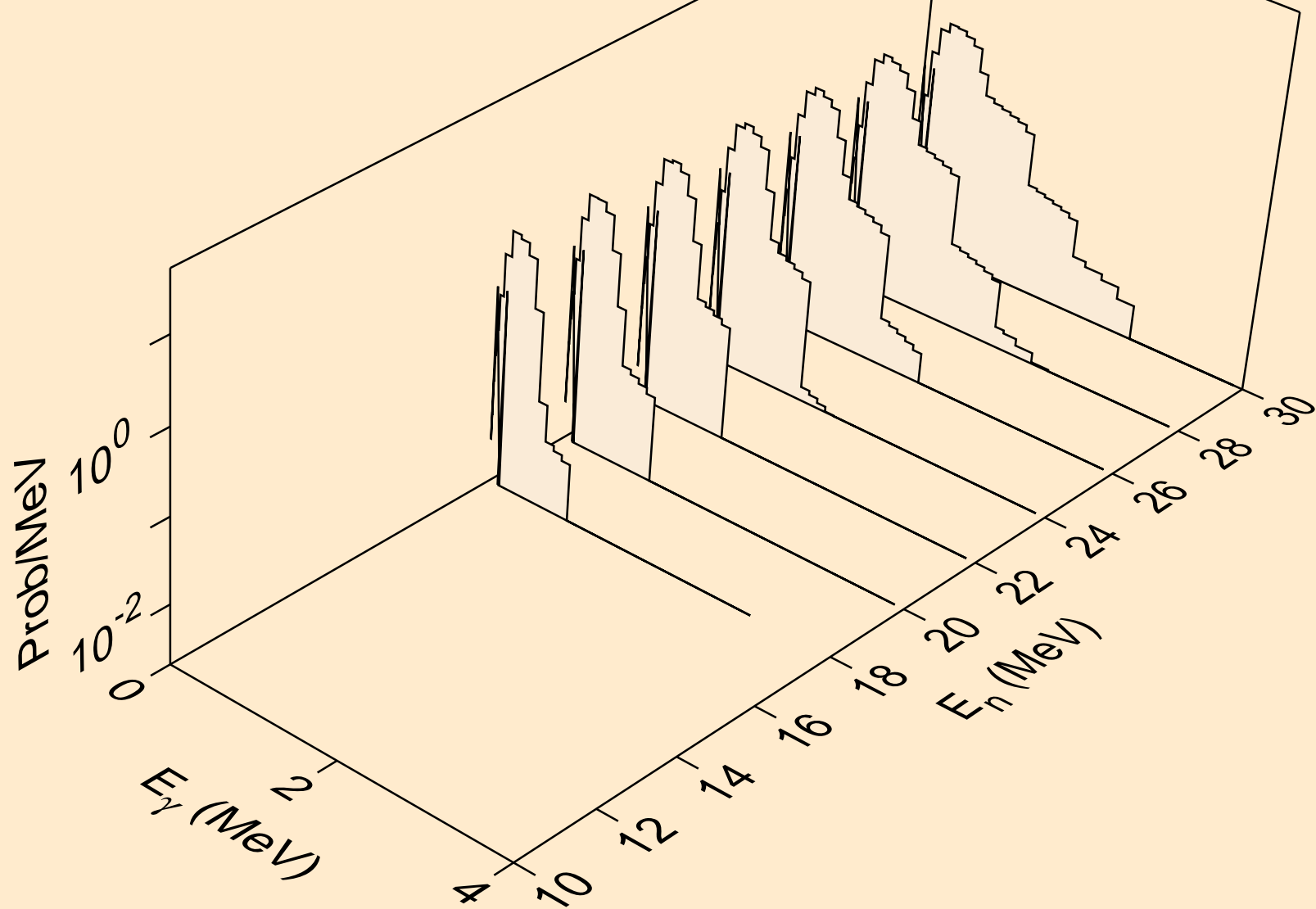

AC229 NEUTRON ACER TENDL-2021 LIBRARY; T=293.6K
thermal capture photon spectrum

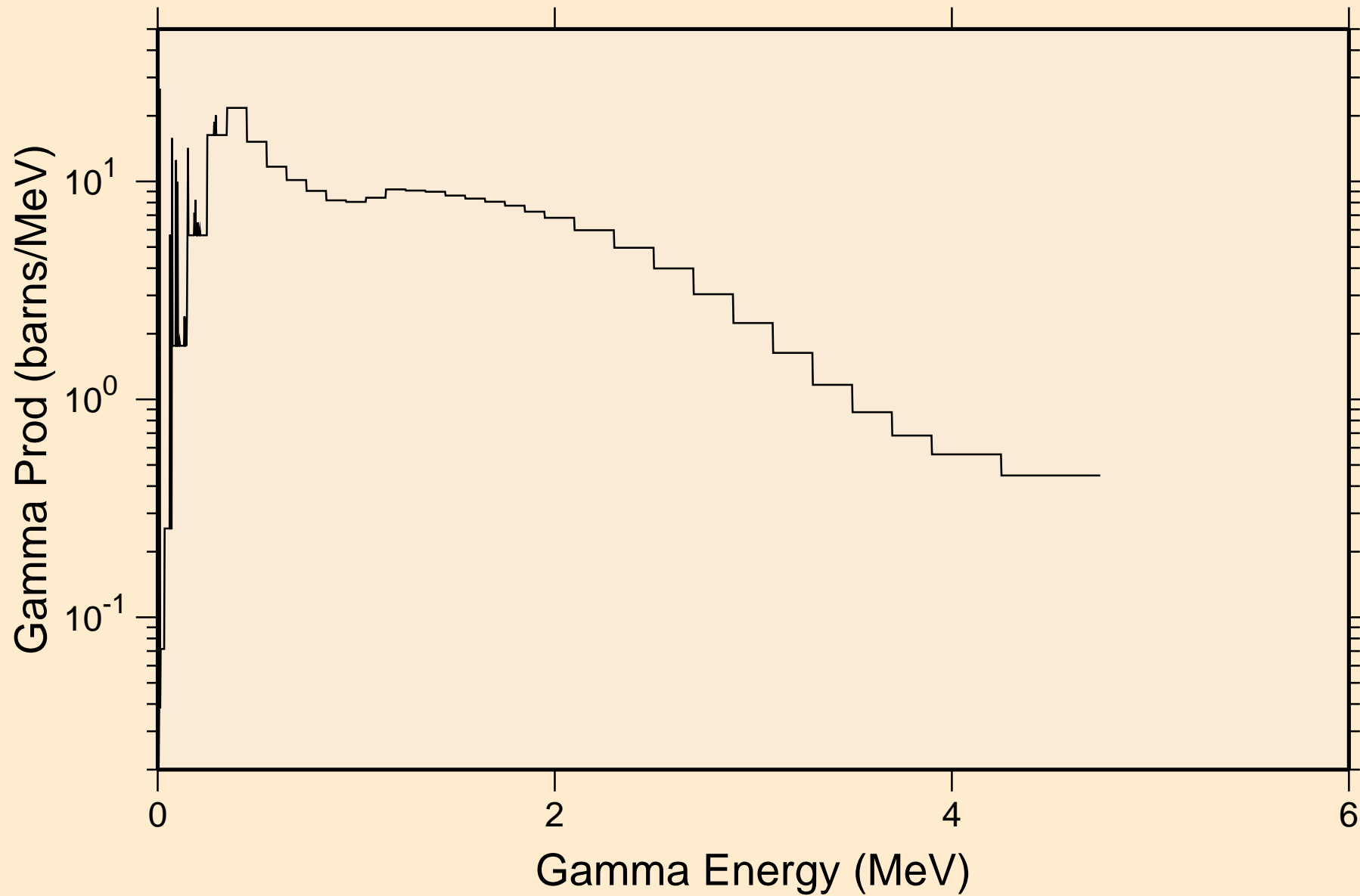

AC229 NEUTRON ACER TENDL-2021 LIBRARY; T=293.6K
14 MeV photon spectrum

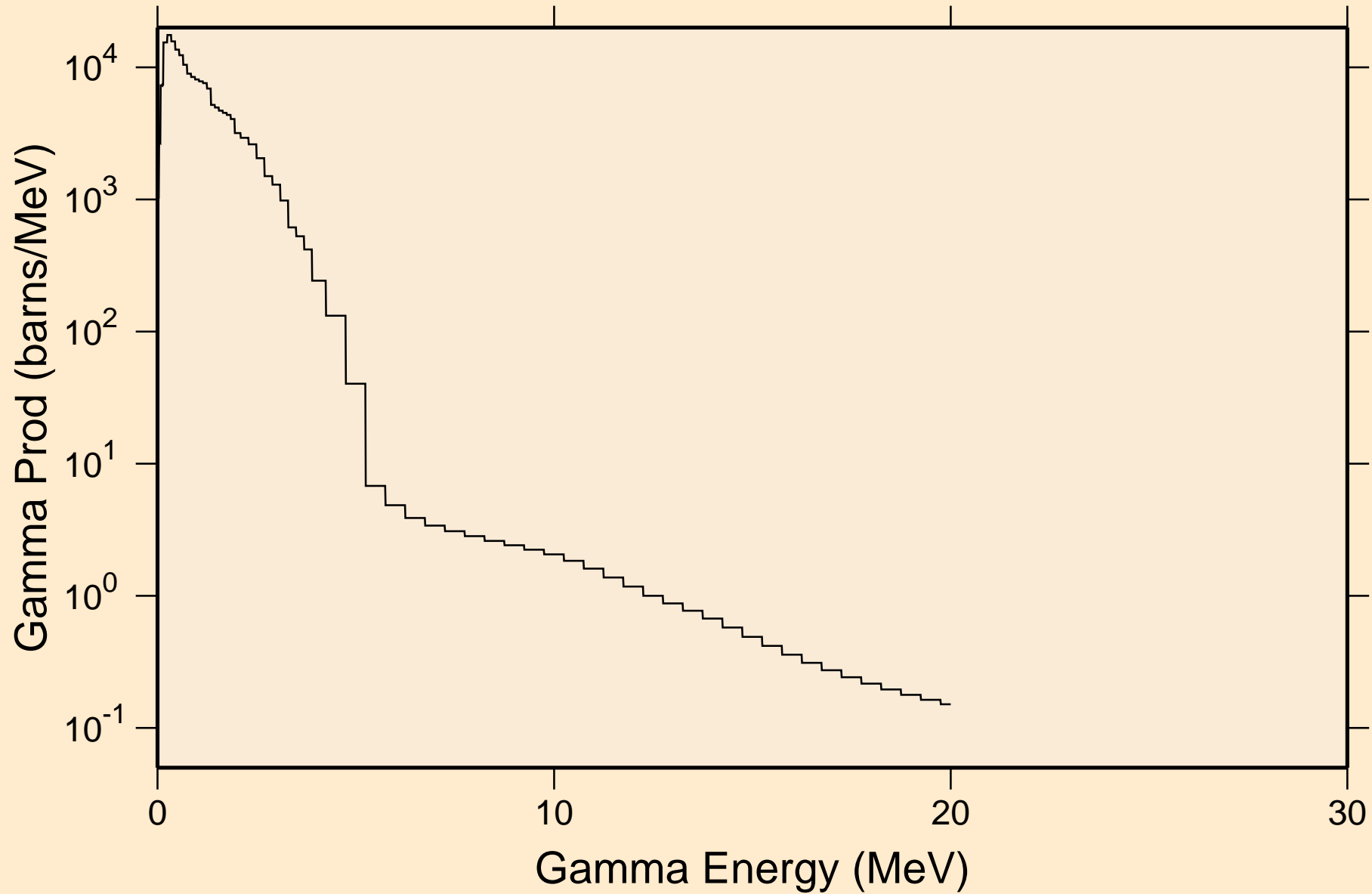

AC229 NEUTRON ACER TENDL-2021 LIBRARY; T=293.6K

Particle heating contributions

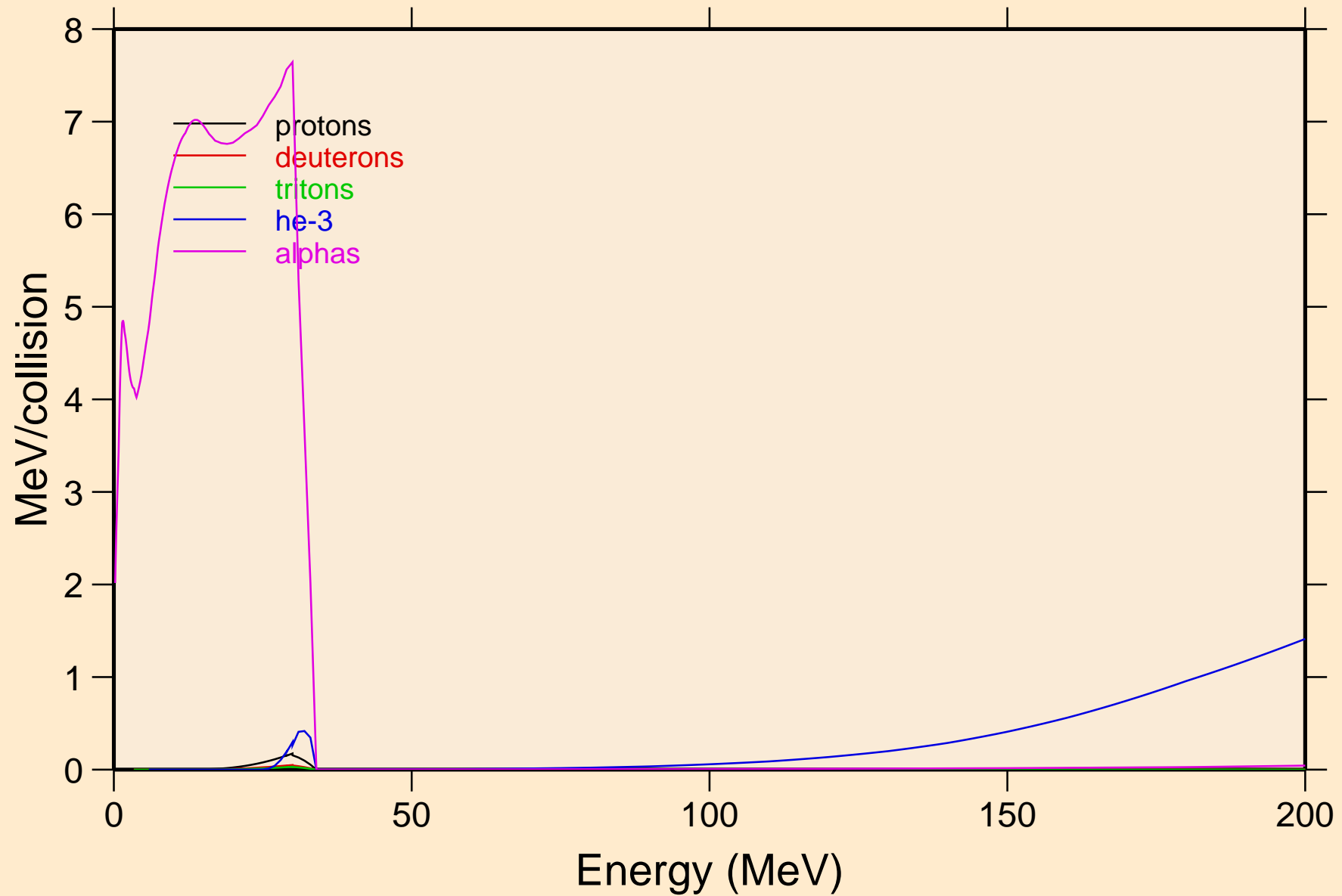

AC229 NEUTRON ACER TENDL-2021 LIBRARY; T=293.6K
Recoil Heating

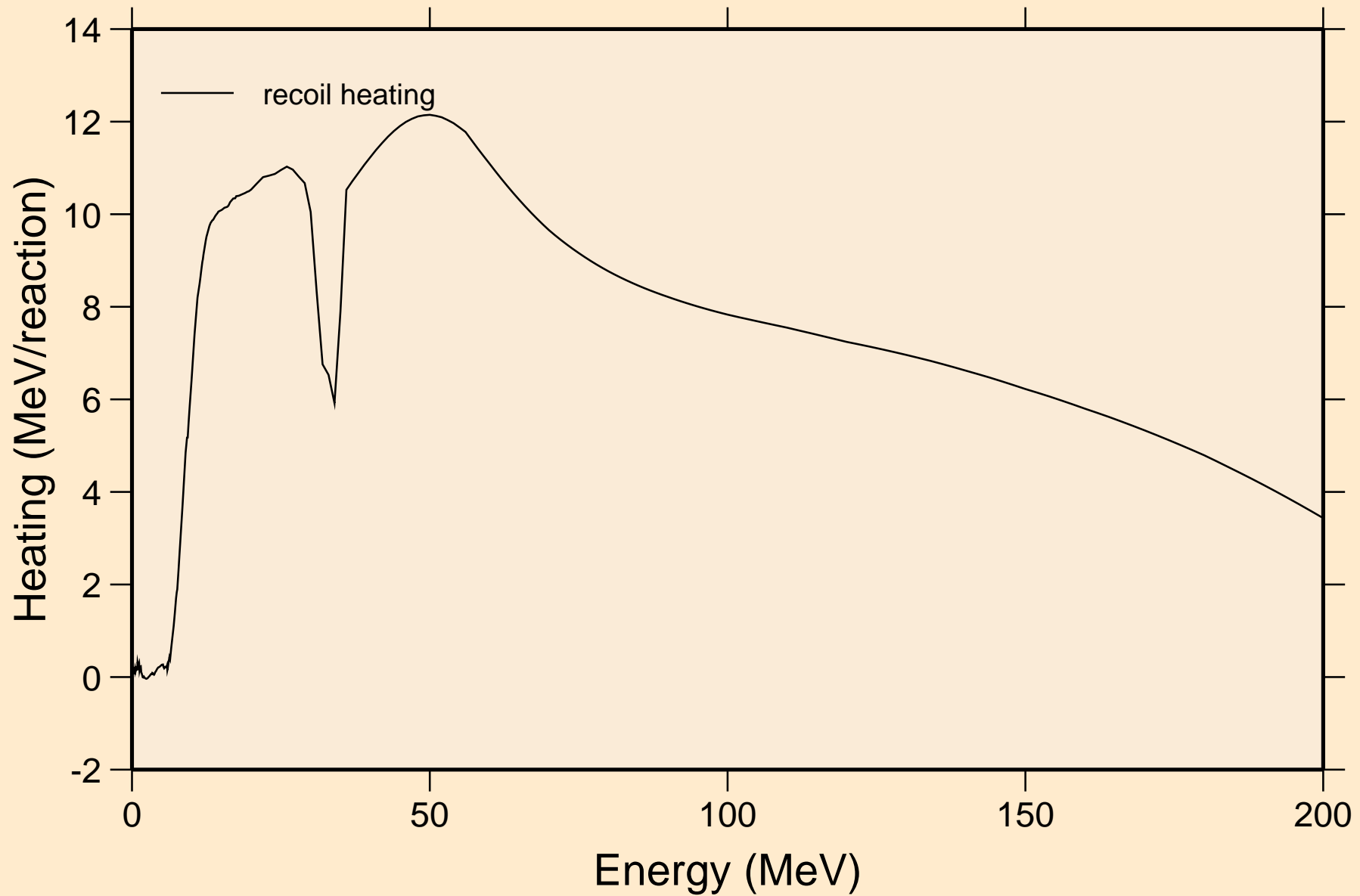

AC229 NEUTRON ACER TENDL-2021 LIBRARY; T=293.6K
Particle production cross sections

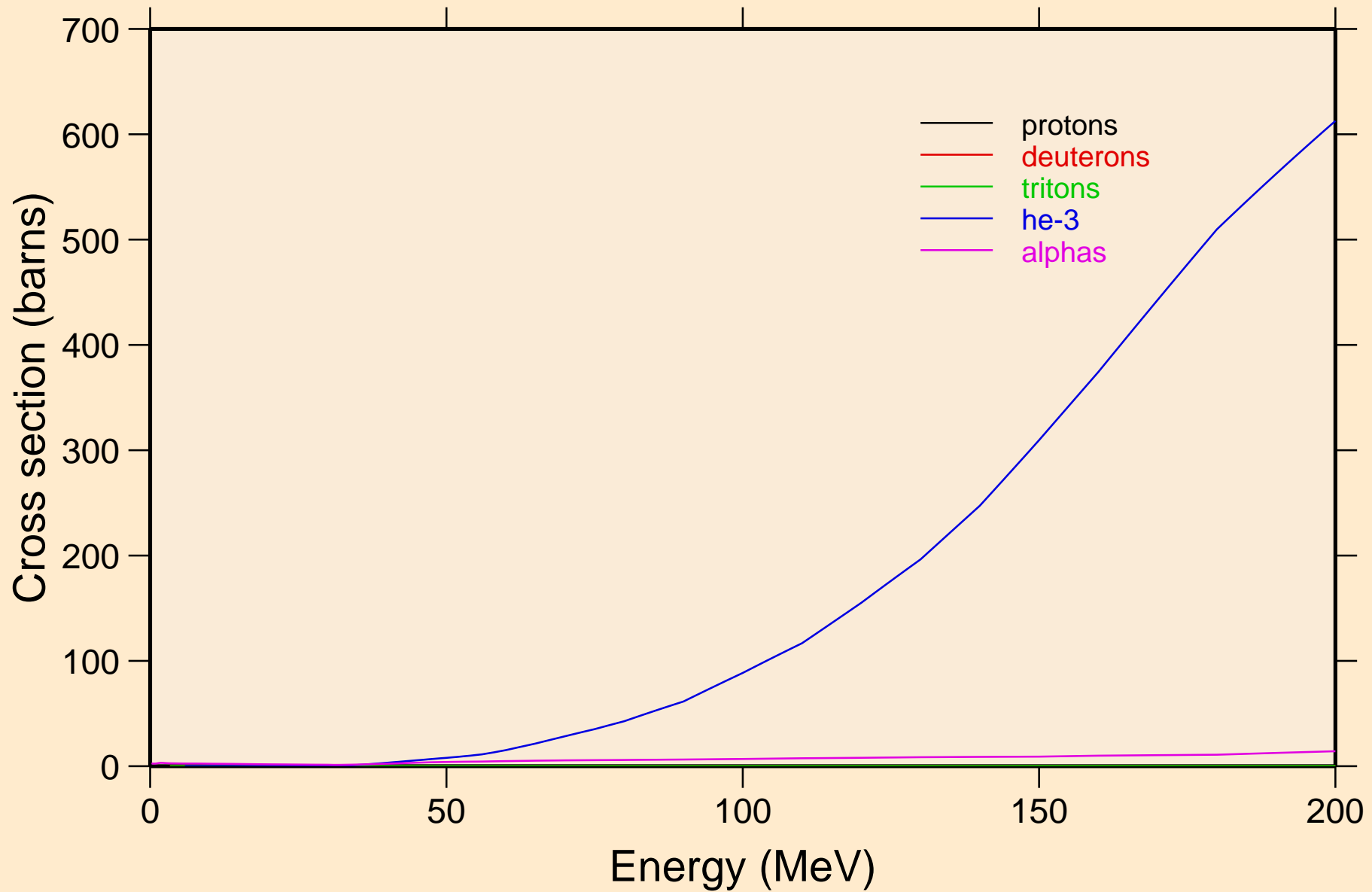

AC229 NEUTRON ACER TENDL-2021 LIBRARY; T=293.6K
protons from (n,x)

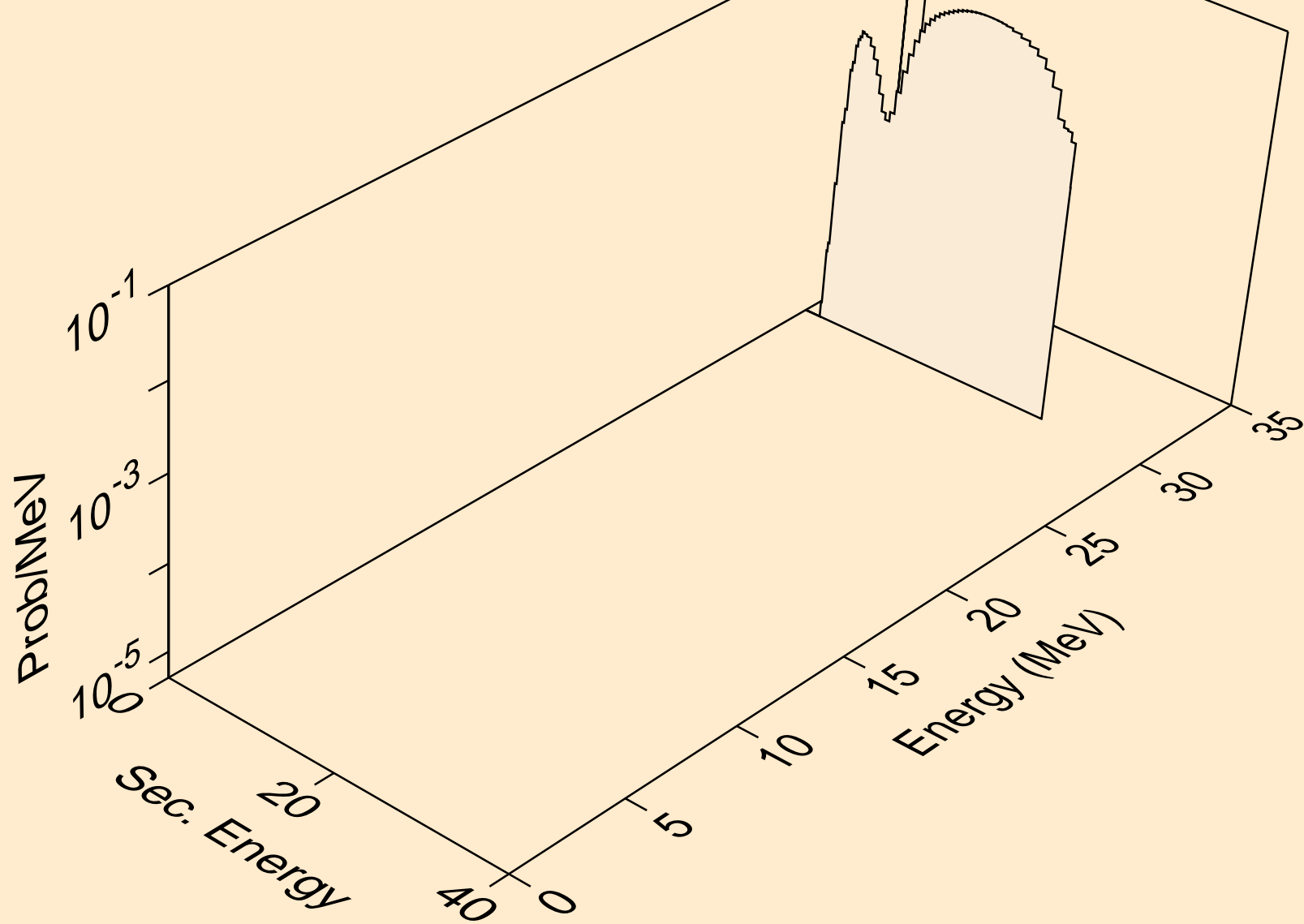

AC229 NEUTRON ACER TENDL-2021 LIBRARY; T=293.6K
protons from (n,n*)p

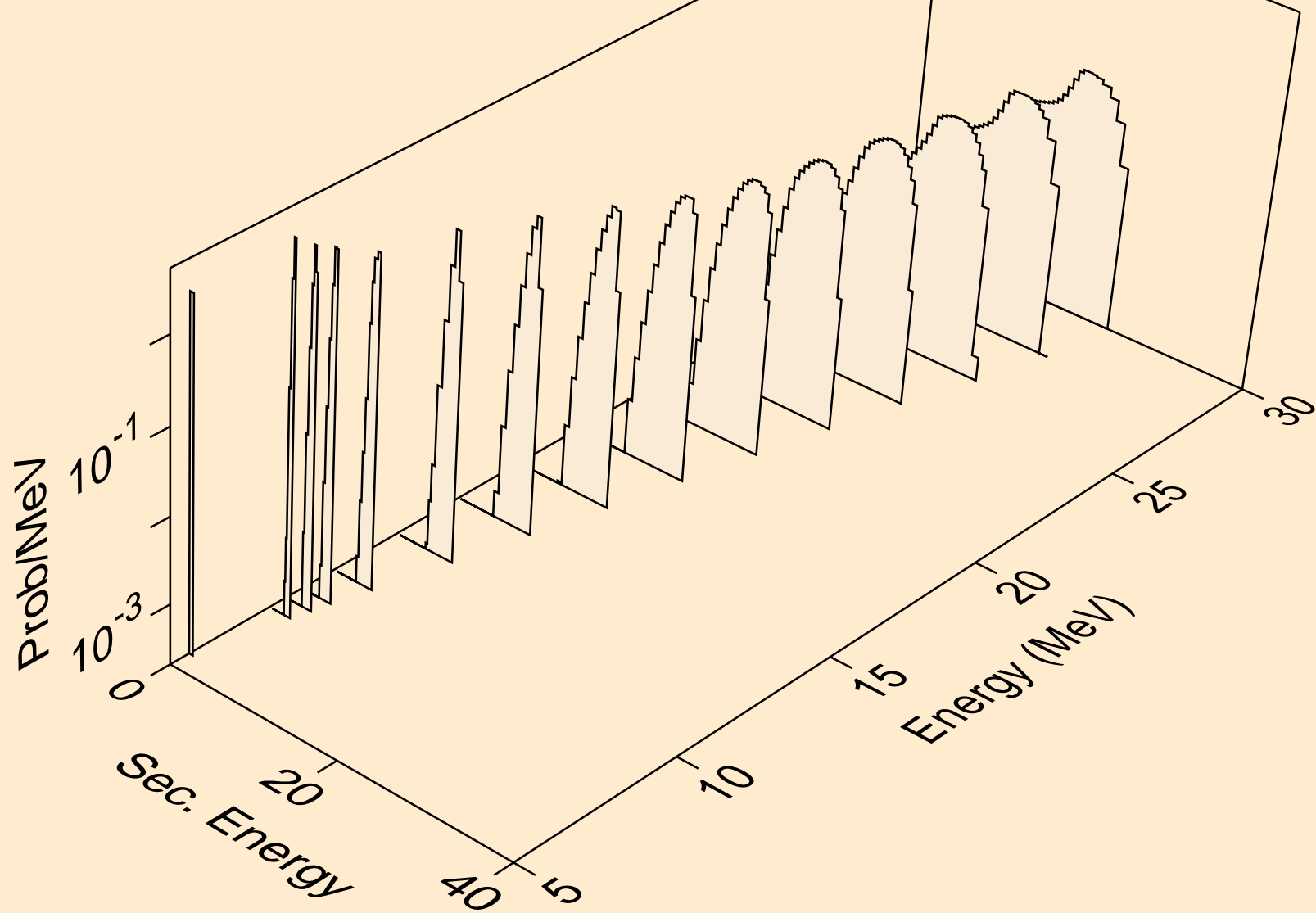

AC229 NEUTRON ACER TENDL-2021 LIBRARY; T=293.6K
protons from (n,2np)

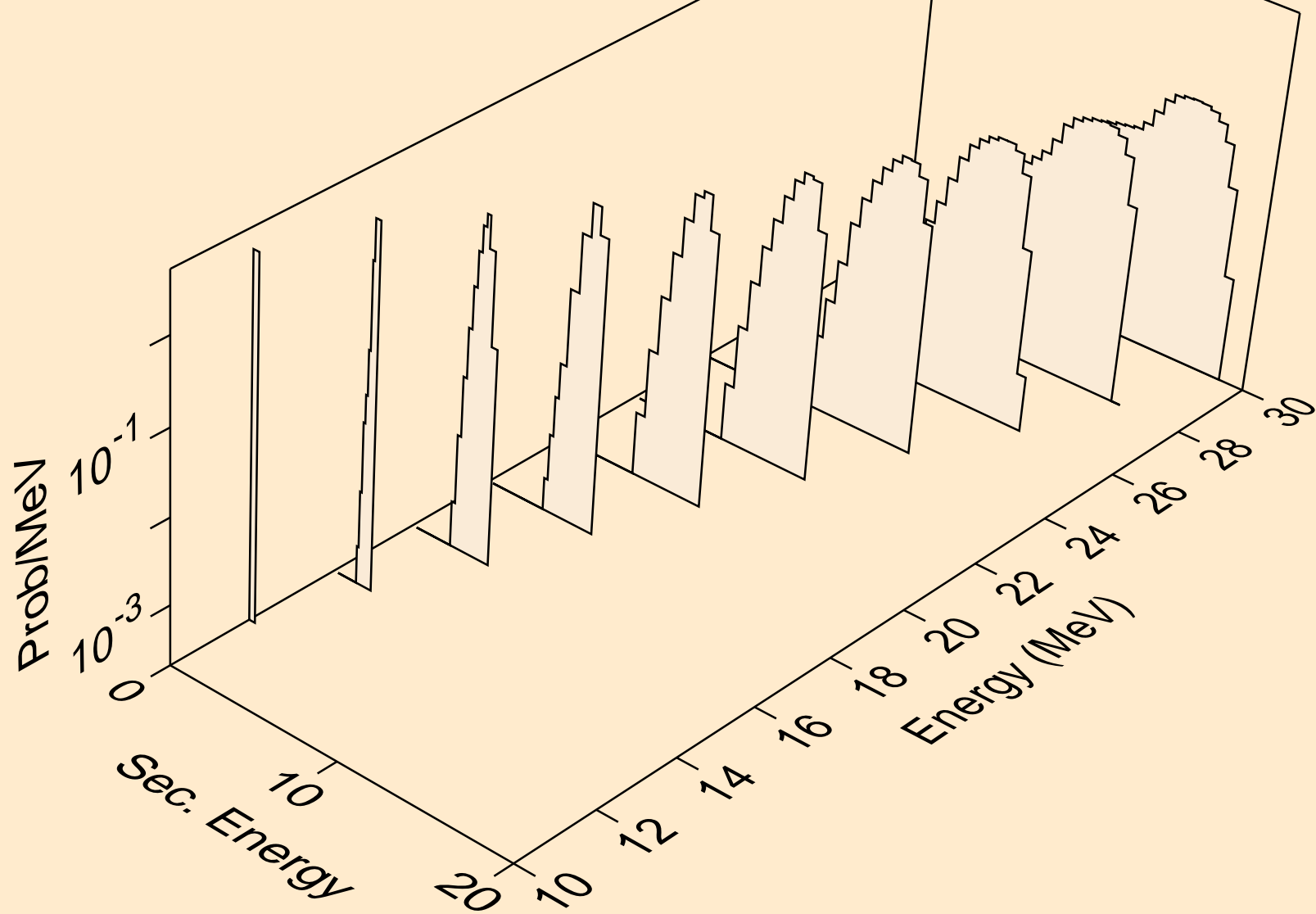

AC229 NEUTRON ACER TENDL-2021 LIBRARY; T=293.6K
protons from (n,3np)

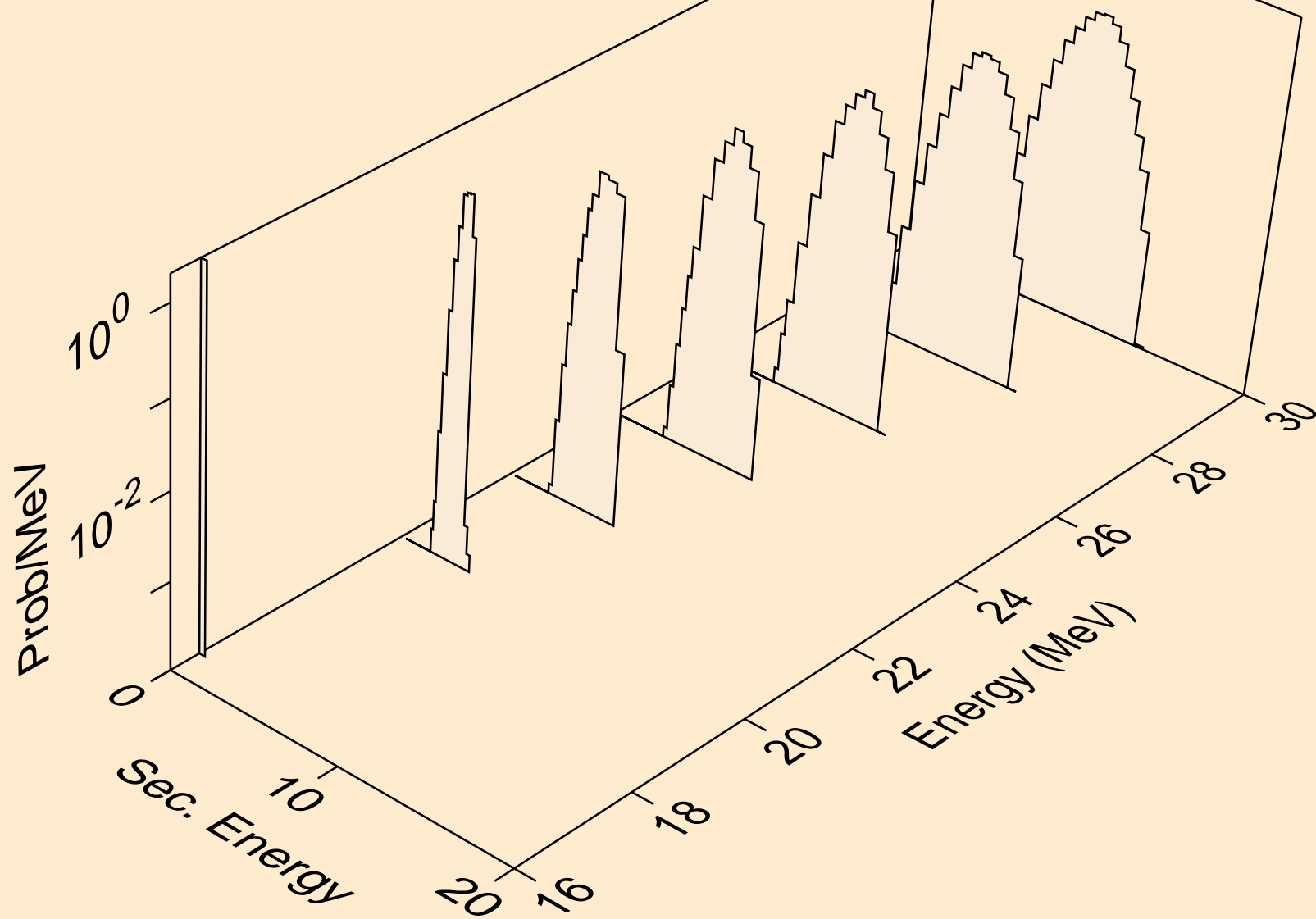

AC229 NEUTRON ACER TENDL-2021 LIBRARY; T=293.6K
protons from (n,2np)

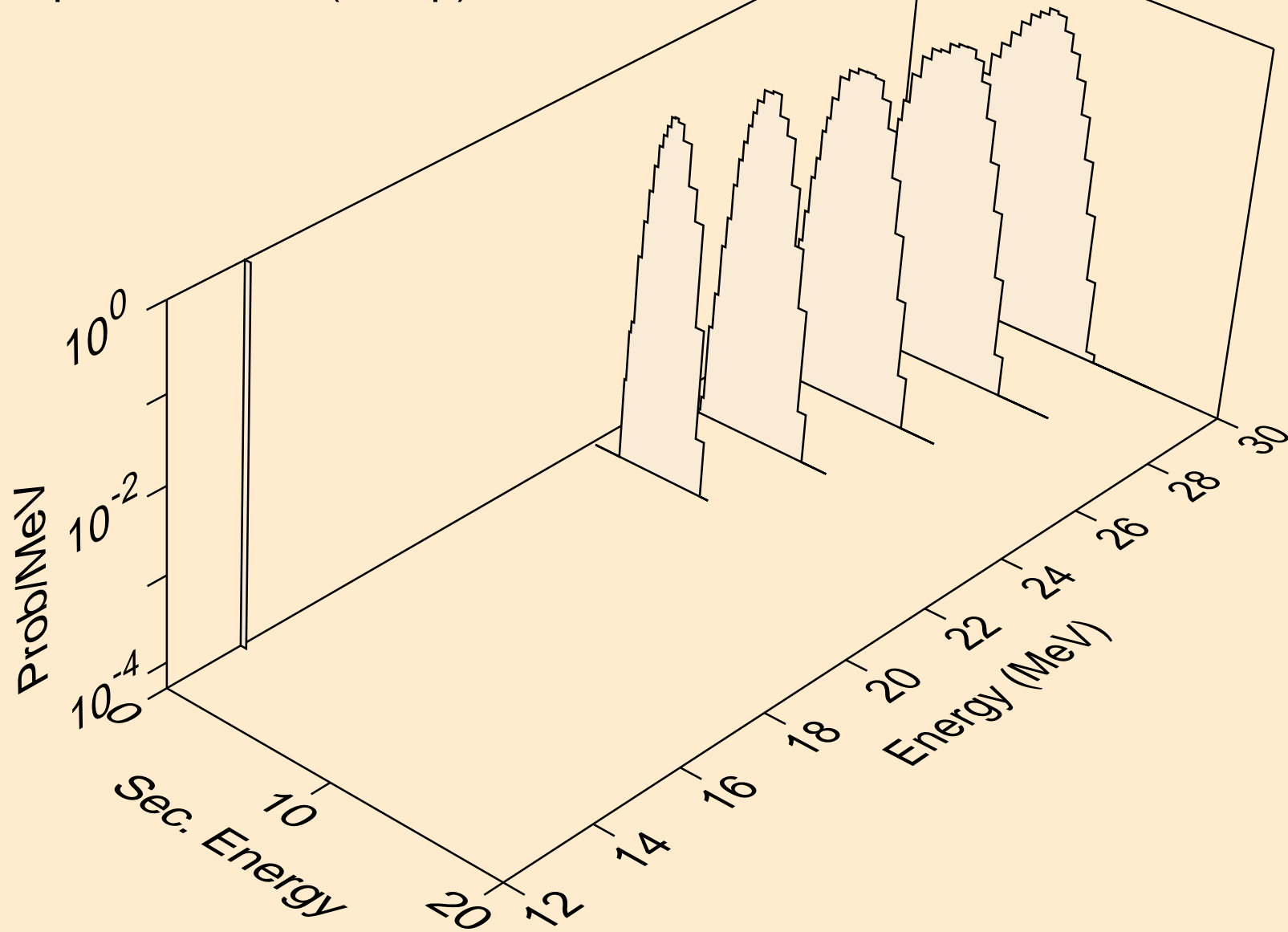

AC229 NEUTRON ACER TENDL-2021 LIBRARY; T=293.6K
protons from (n,p)

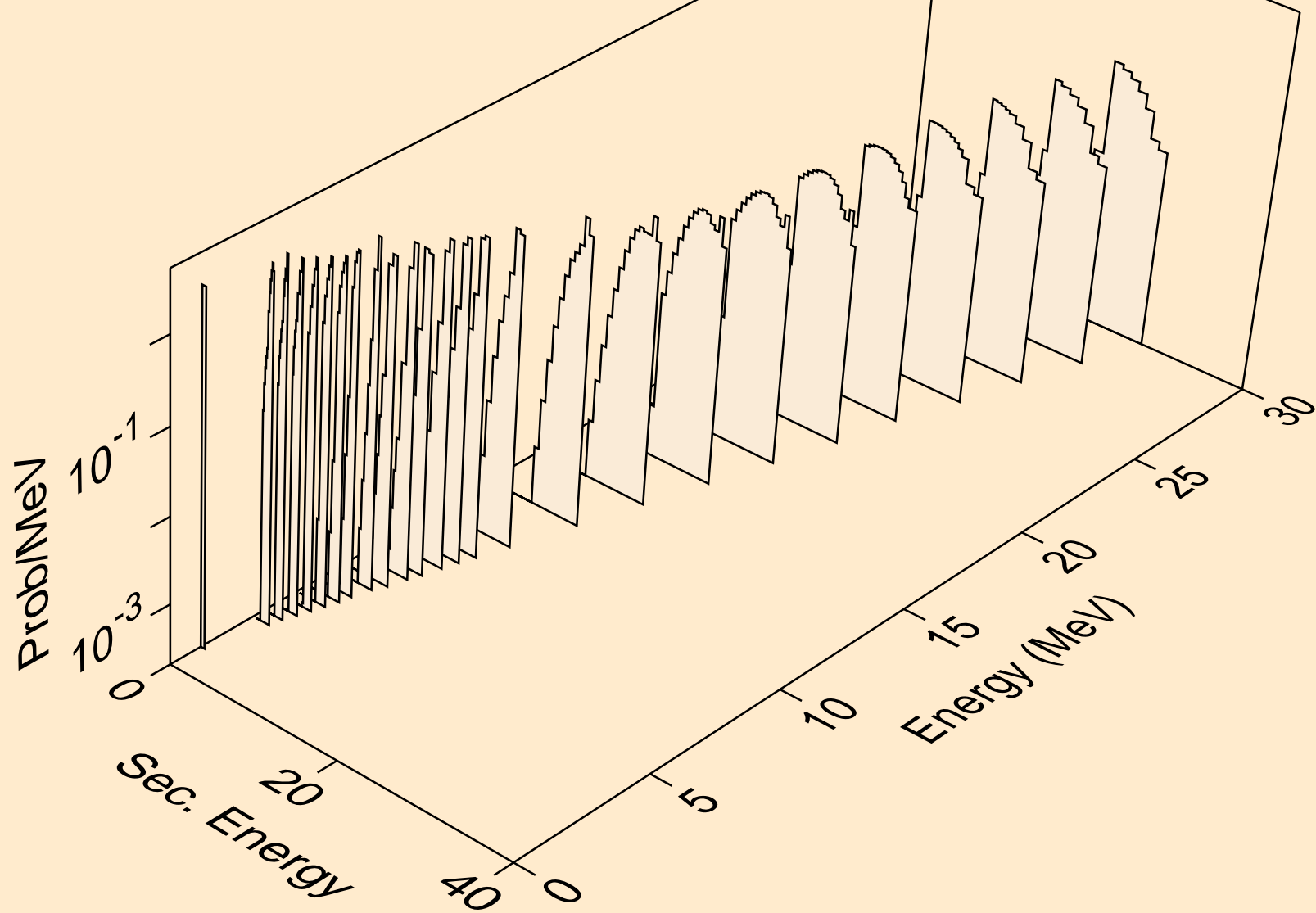

AC229 NEUTRON ACER TENDL-2021 LIBRARY; T=293.6K
protons from (n,2p)

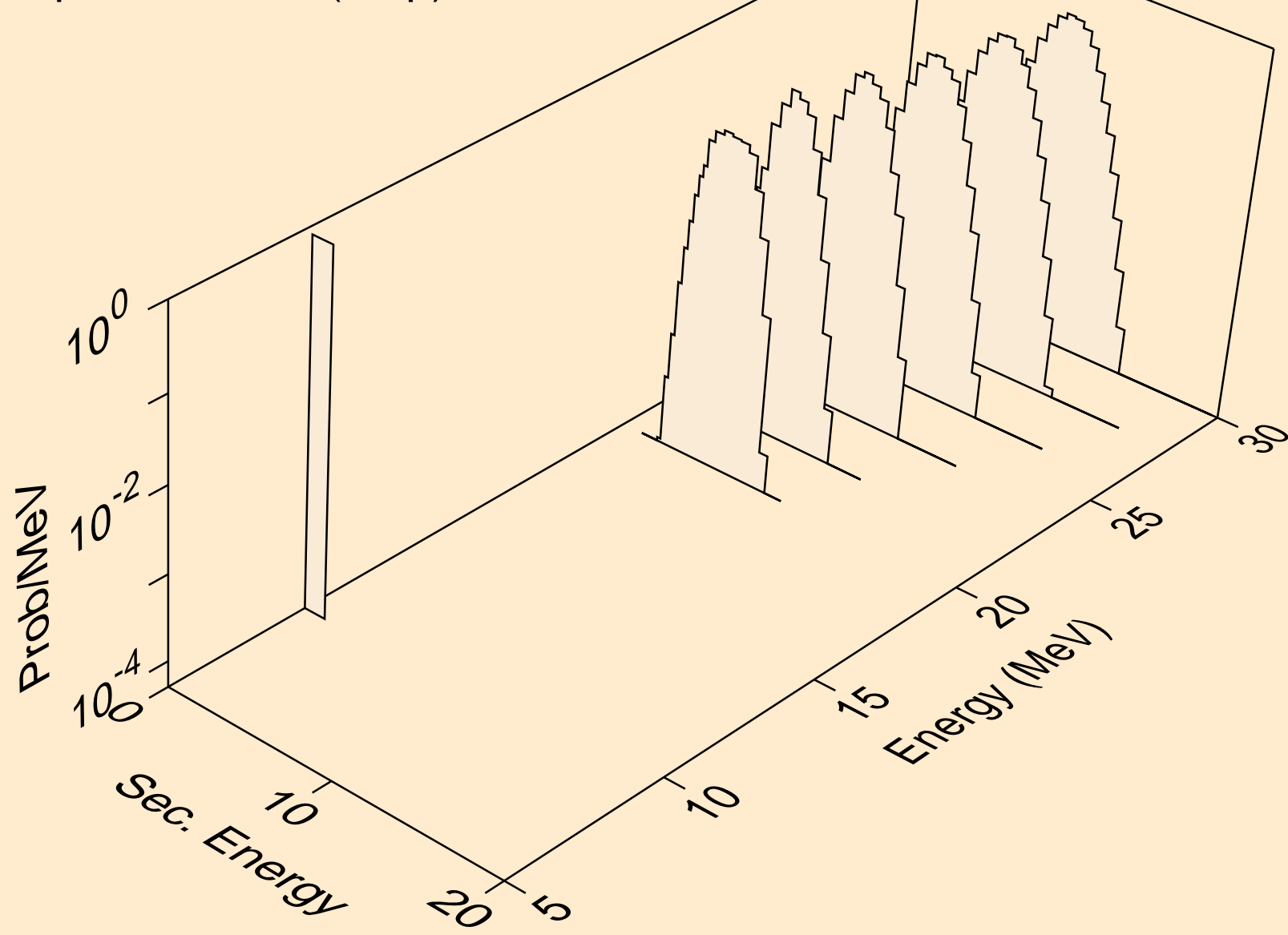

AC229 NEUTRON ACER TENDL-2021 LIBRARY; T=293.6K
protons from (n,p)

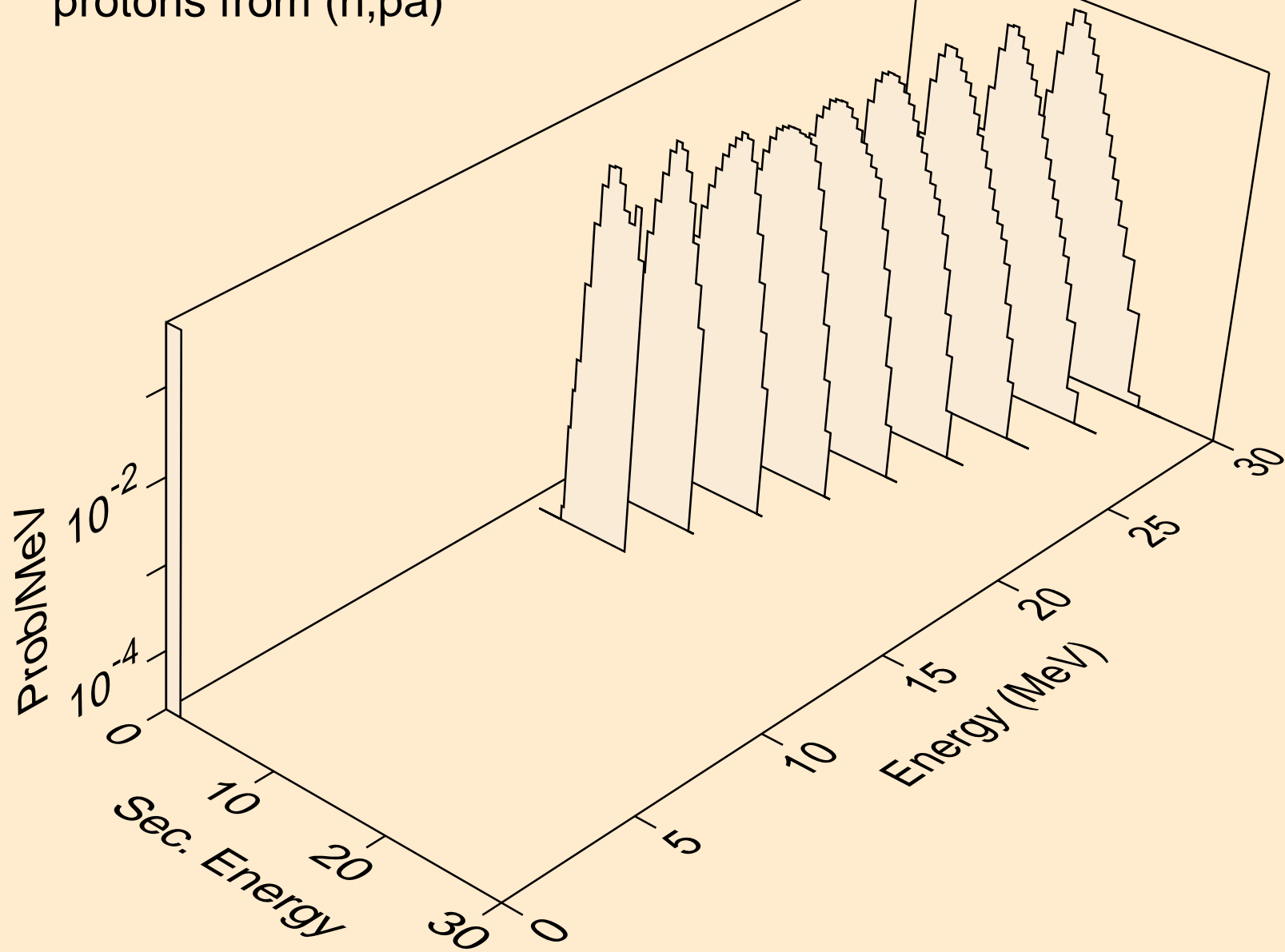

AC229 NEUTRON ACER TENDL-2021 LIBRARY; T=293.6K
protons from (n,pd)

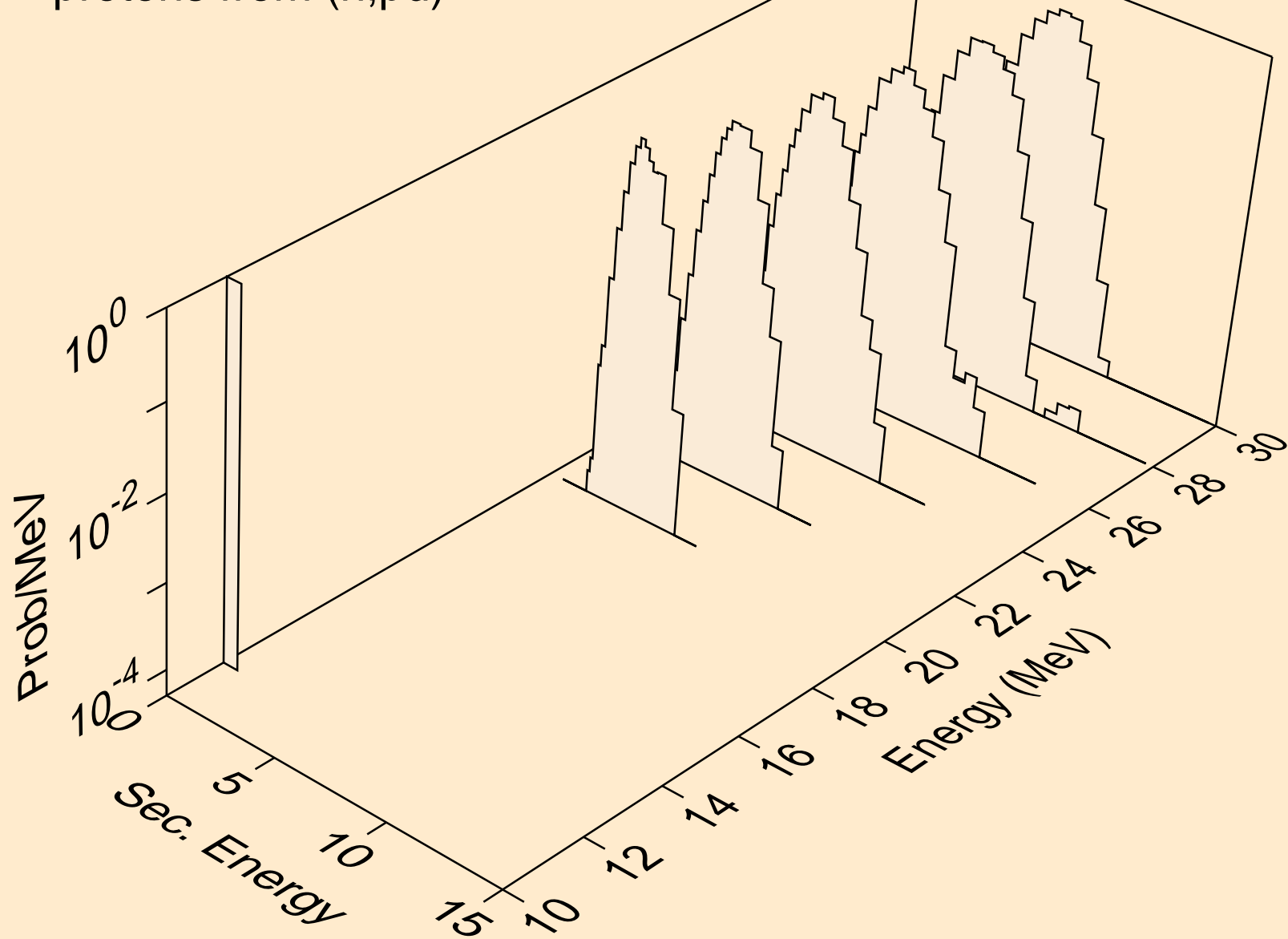

AC229 NEUTRON ACER TENDL-2021 LIBRARY; T=293.6K
protons from (n,pt)

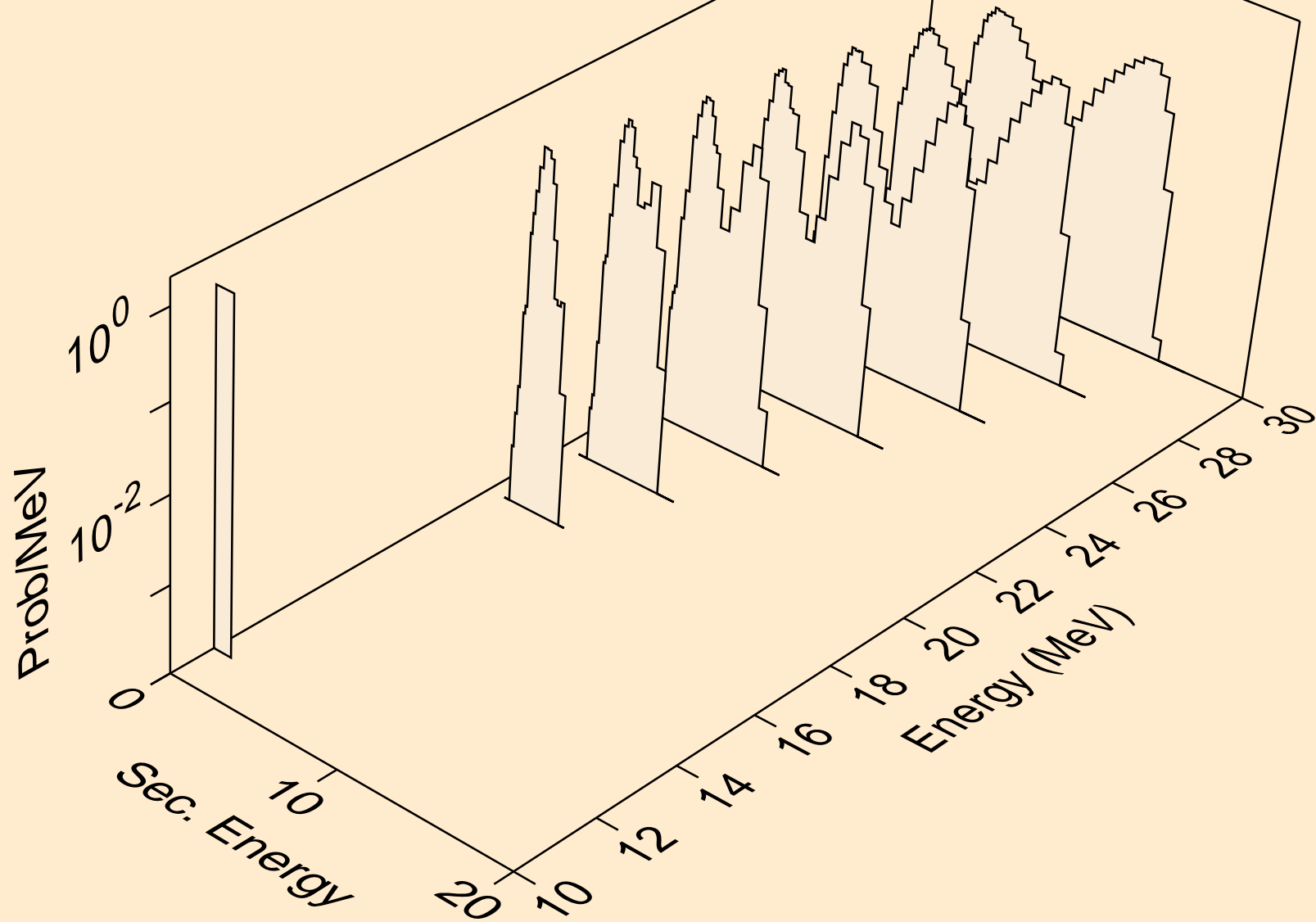

AC229 NEUTRON ACER TENDL-2021 LIBRARY; T=293.6K
deuterons from (n,x)

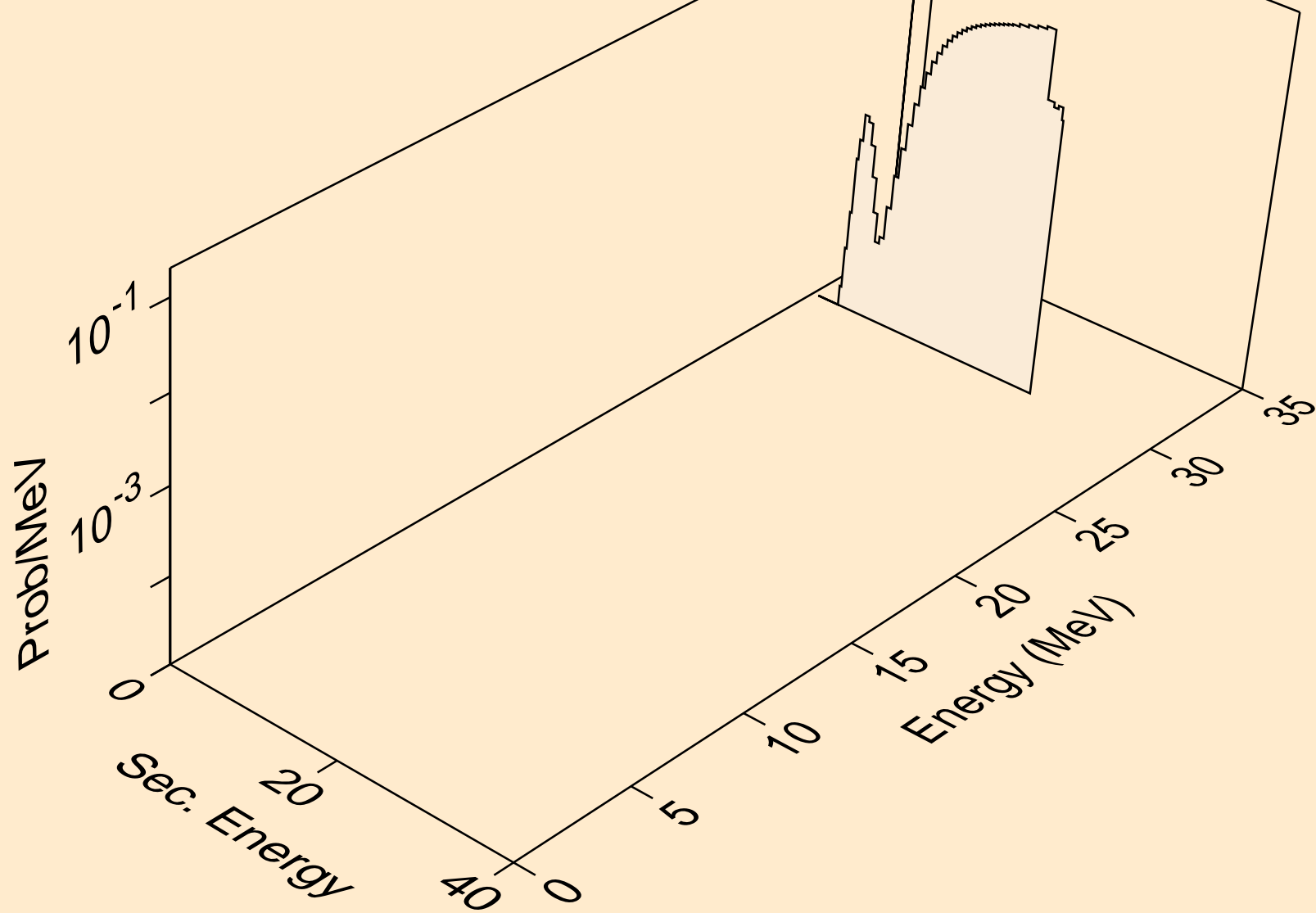

AC229 NEUTRON ACER TENDL-2021 LIBRARY; T=293.6K
deuterons from (n,2nd)

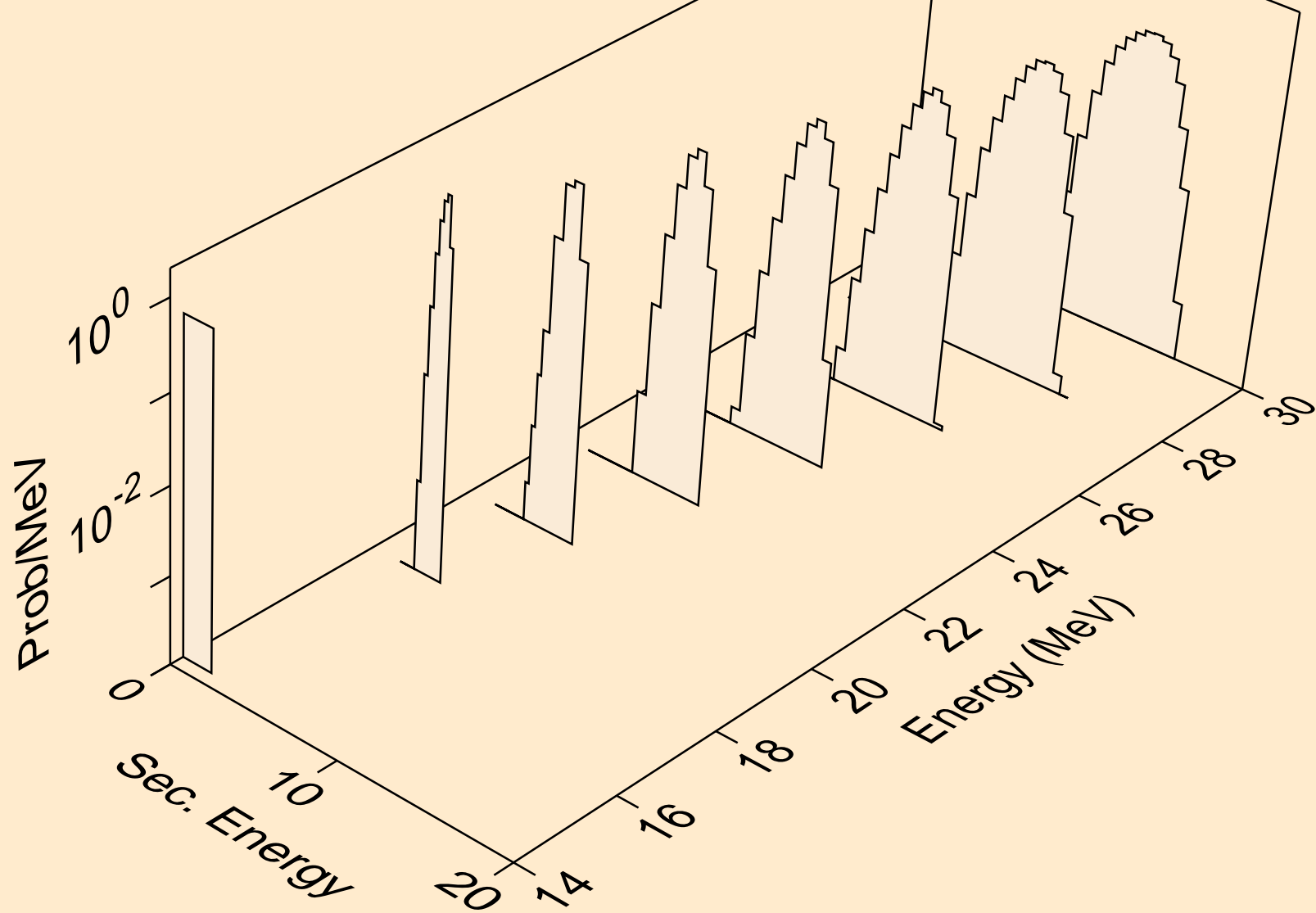

AC229 NEUTRON ACER TENDL-2021 LIBRARY; T=293.6K
deuterons from (n,n*)d

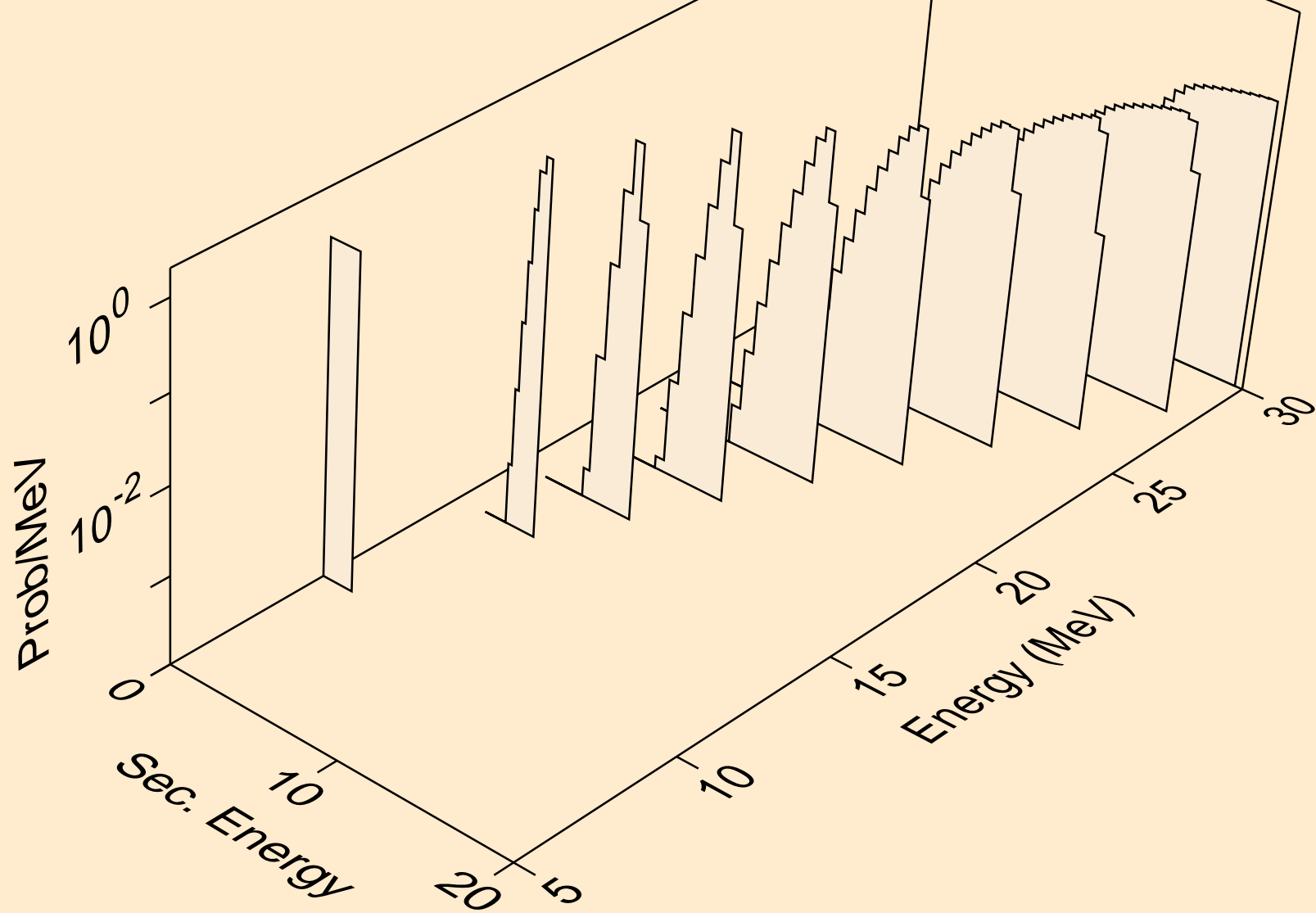

AC229 NEUTRON ACER TENDL-2021 LIBRARY; T=293.6K
deuterons from (n,d)

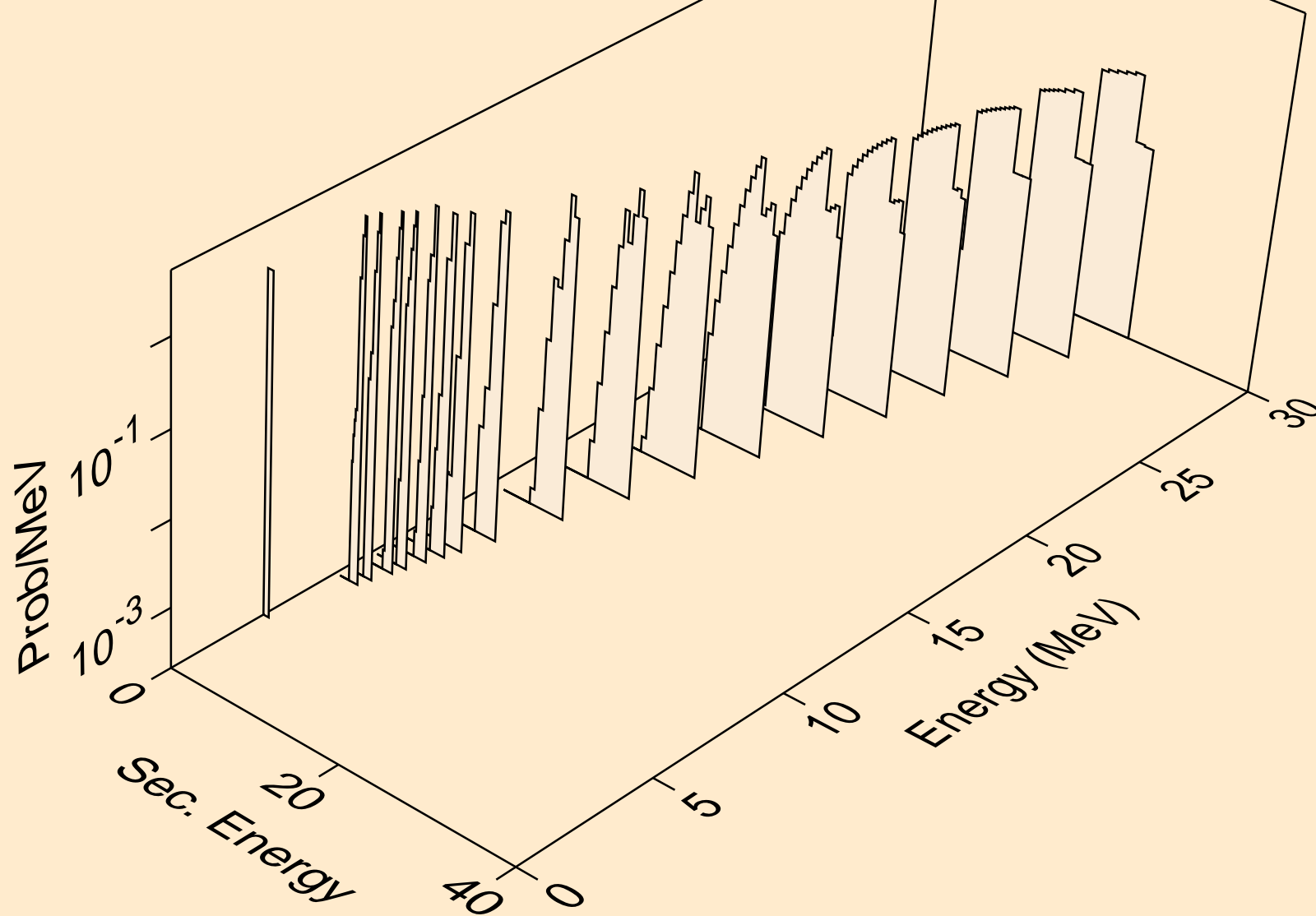

AC229 NEUTRON ACER TENDL-2021 LIBRARY; T=293.6K
deuterons from (n,pd)

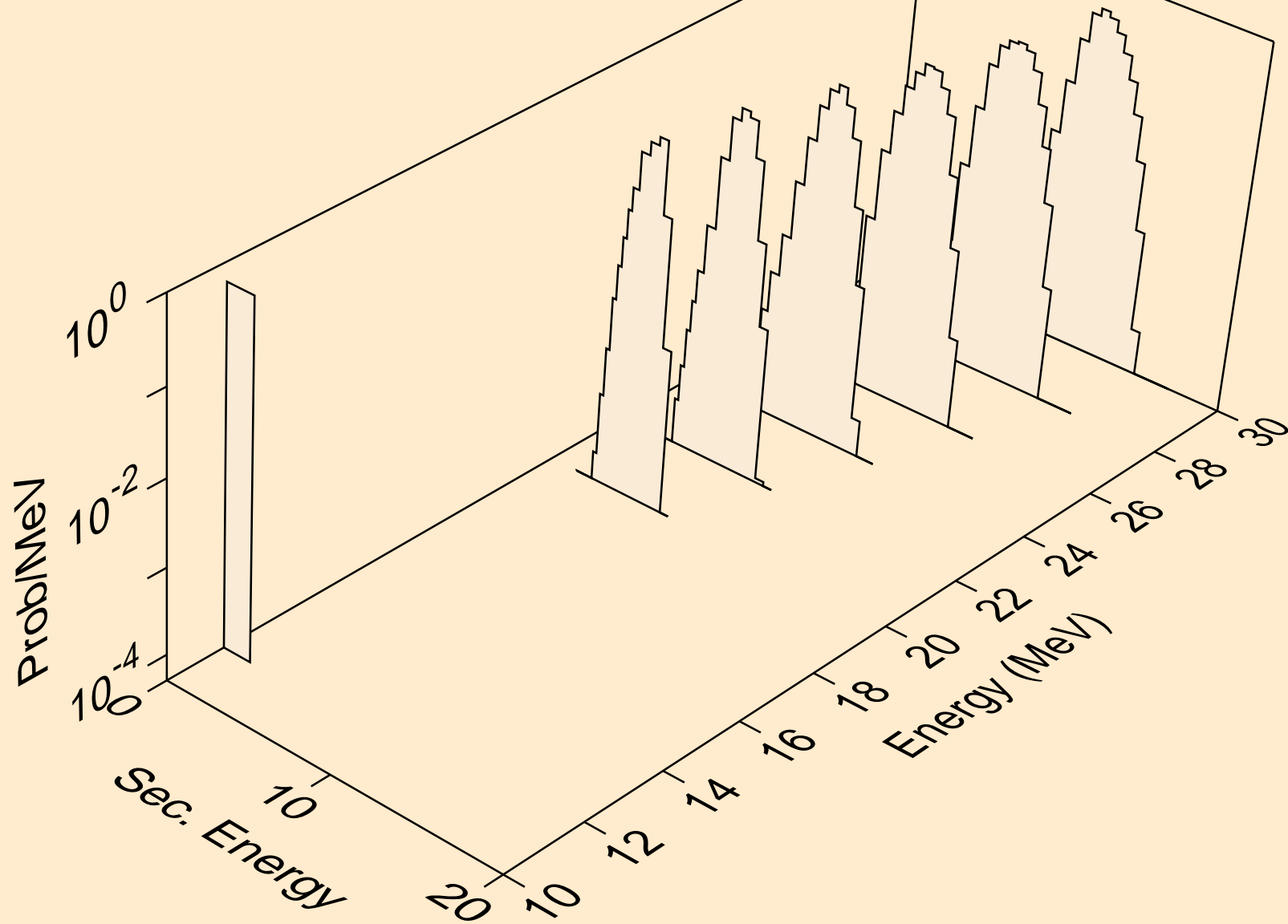

AC229 NEUTRON ACER TENDL-2021 LIBRARY; T=293.6K
tritons from (n,x)

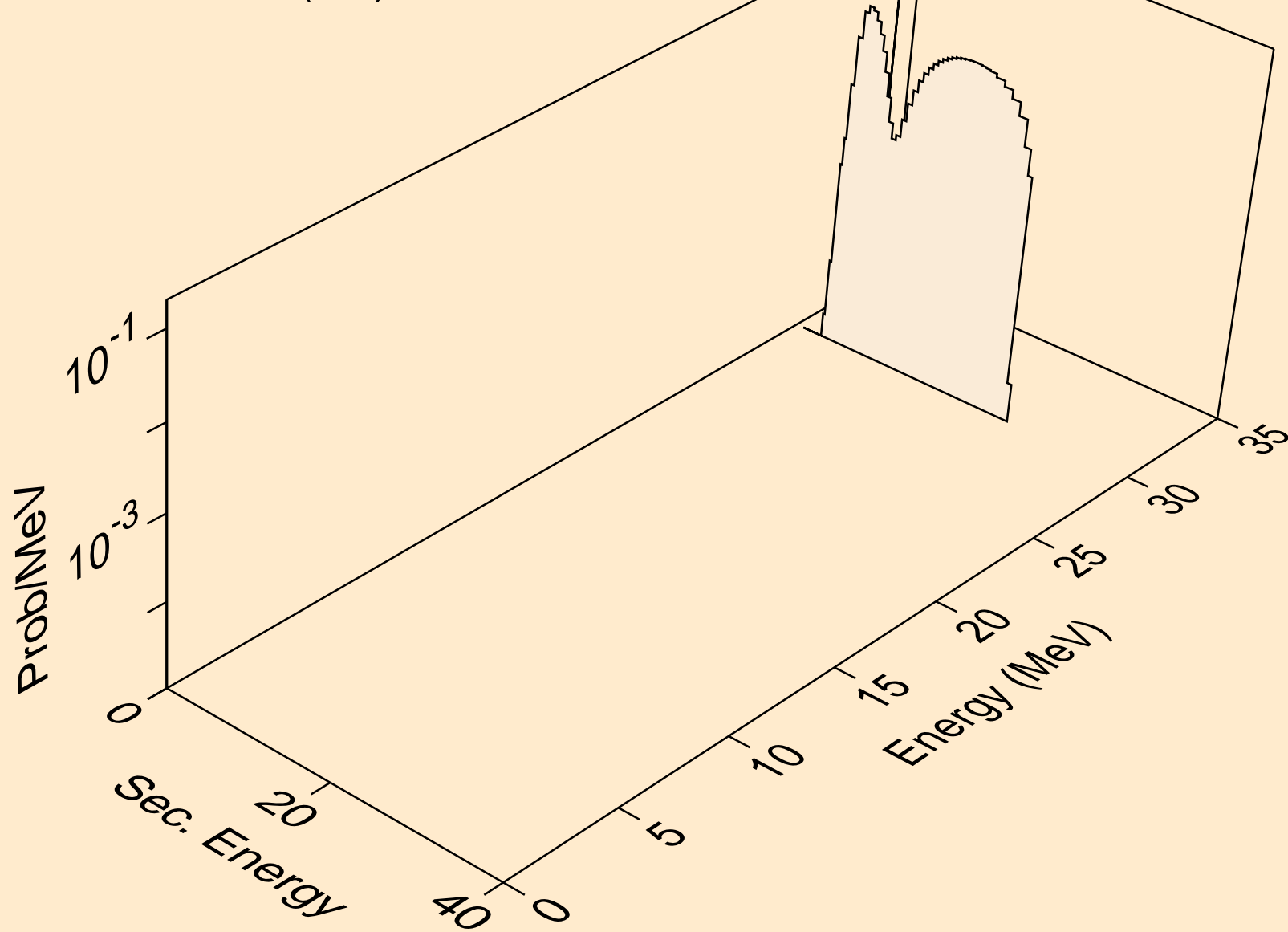

AC229 NEUTRON ACER TENDL-2021 LIBRARY; T=293.6K
tritons from (n,n*)t

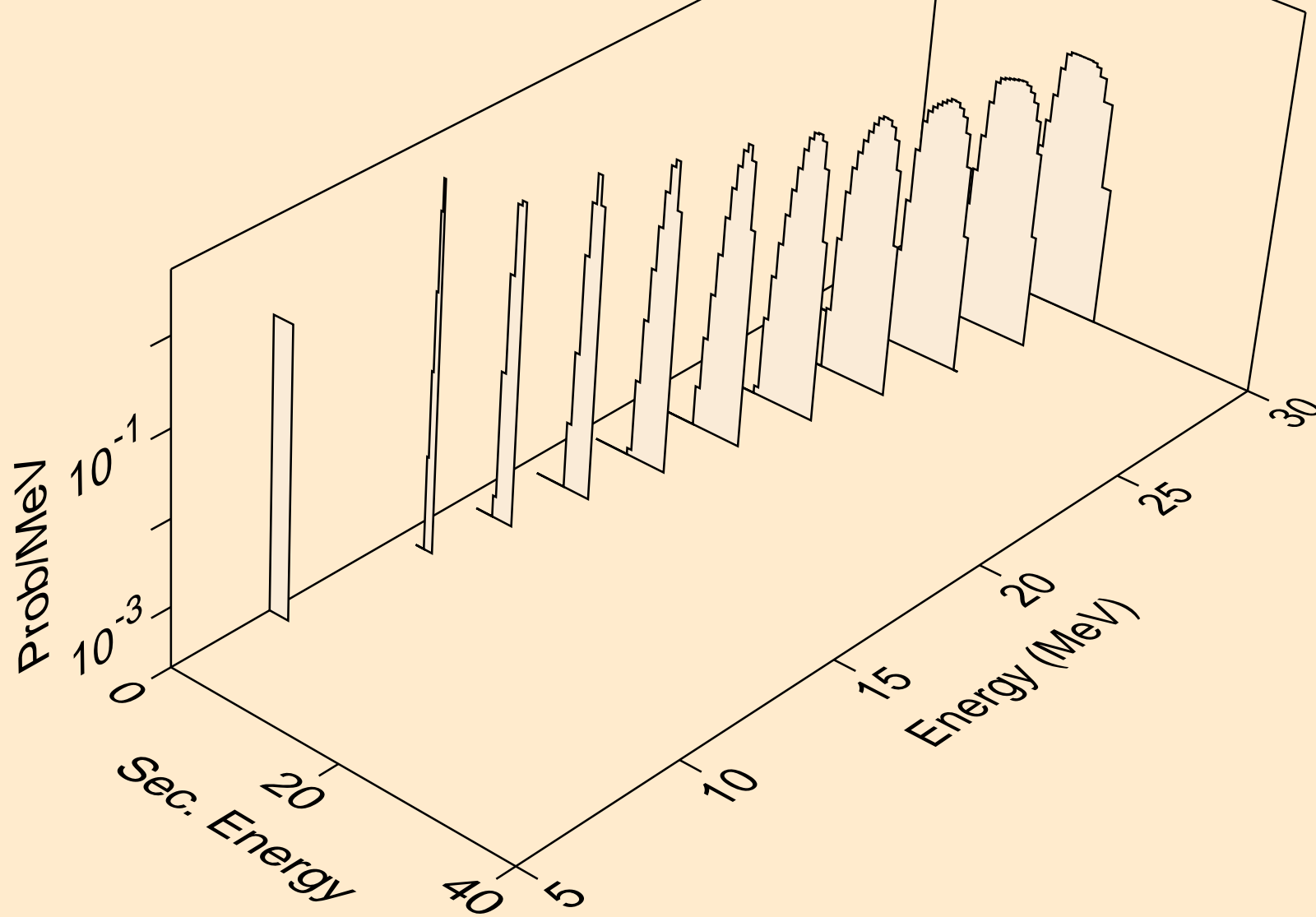

AC229 NEUTRON ACER TENDL-2021 LIBRARY; T=293.6K
tritons from (n,t)

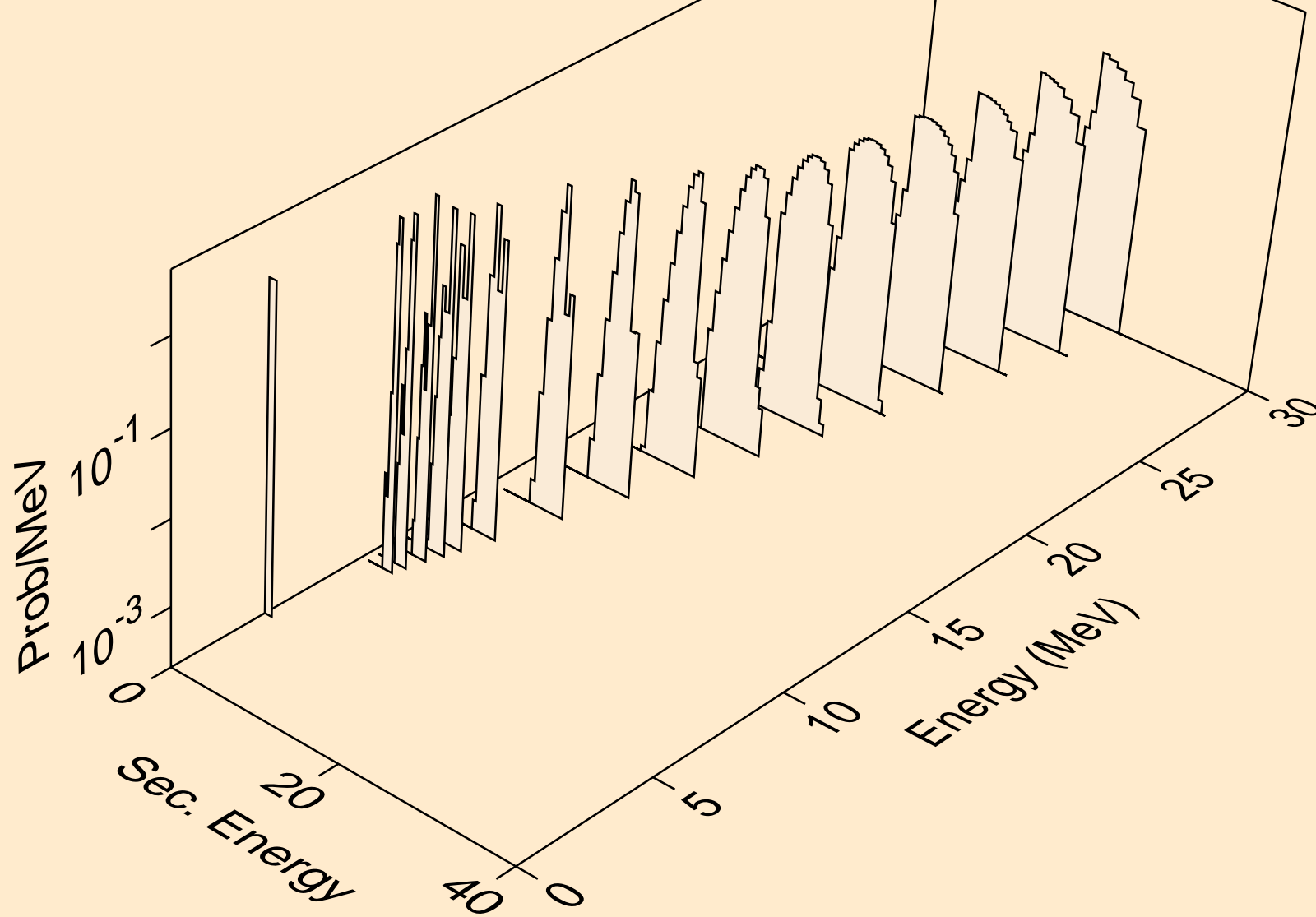

AC229 NEUTRON ACER TENDL-2021 LIBRARY; T=293.6K
tritons from (n,pt)

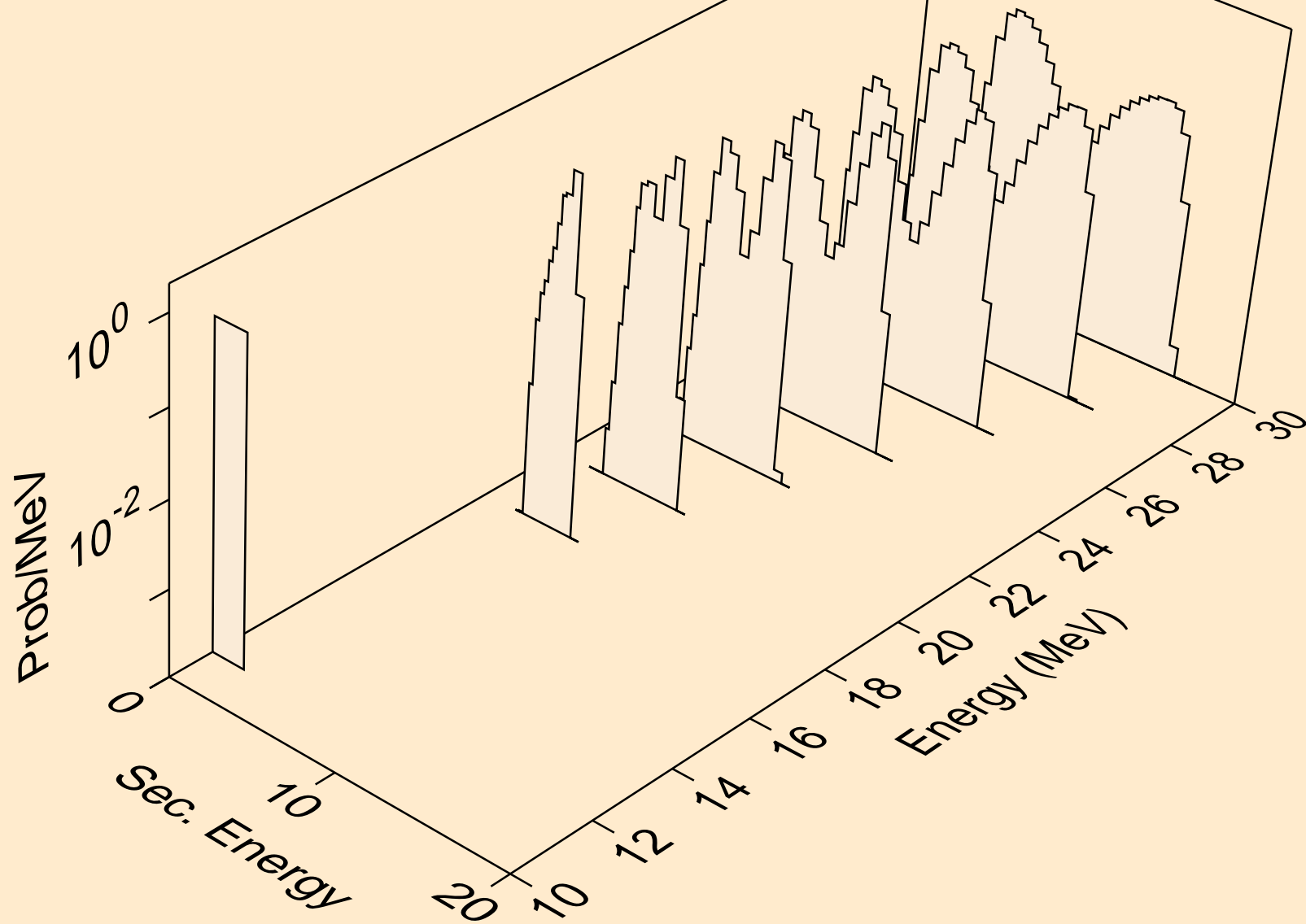

AC229 NEUTRON ACER TENDL-2021 LIBRARY; T=293.6K
he3s from (n,x)

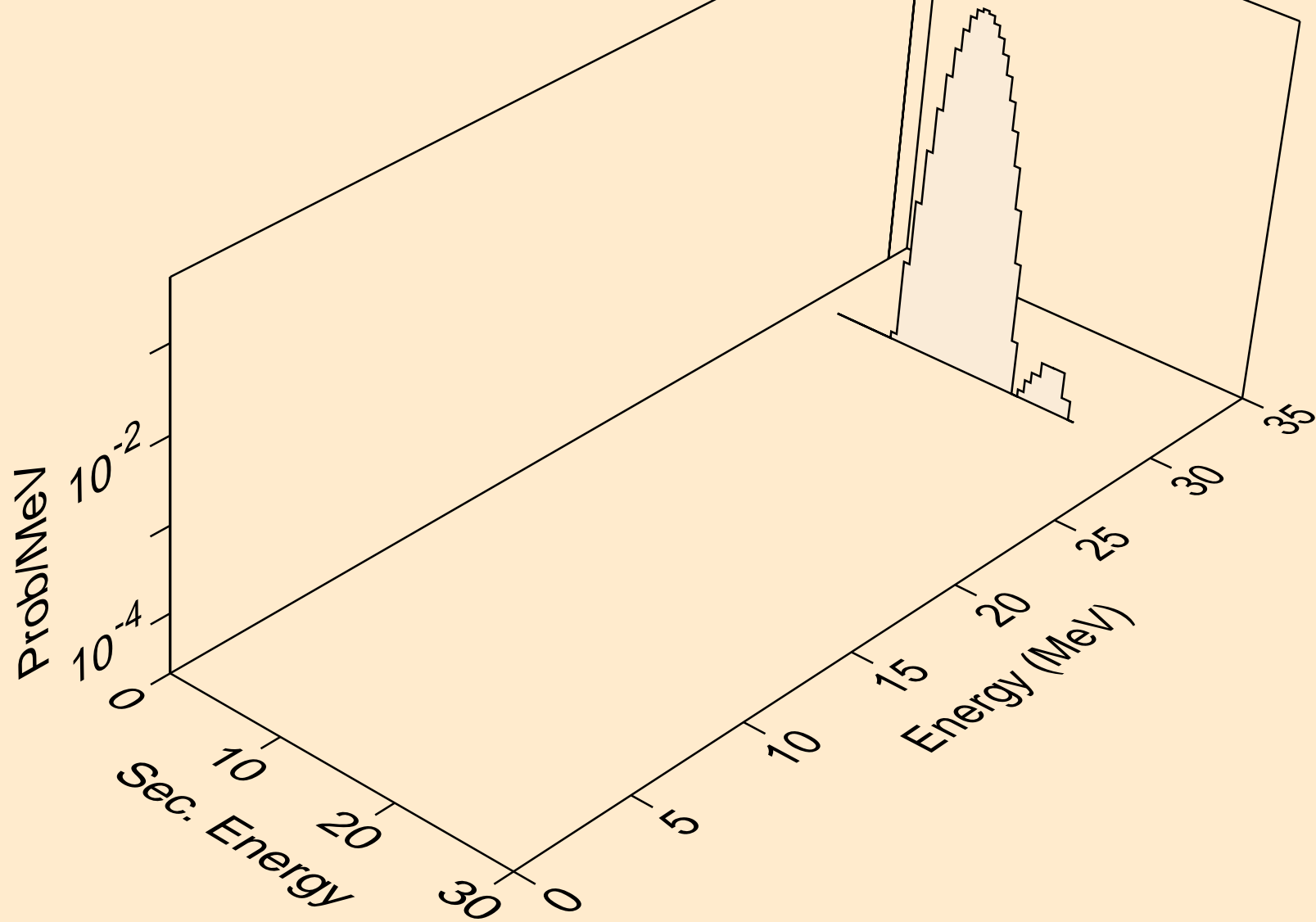

AC229 NEUTRON ACER TENDL-2021 LIBRARY; T=293.6K
he3s from (n,n*)he3

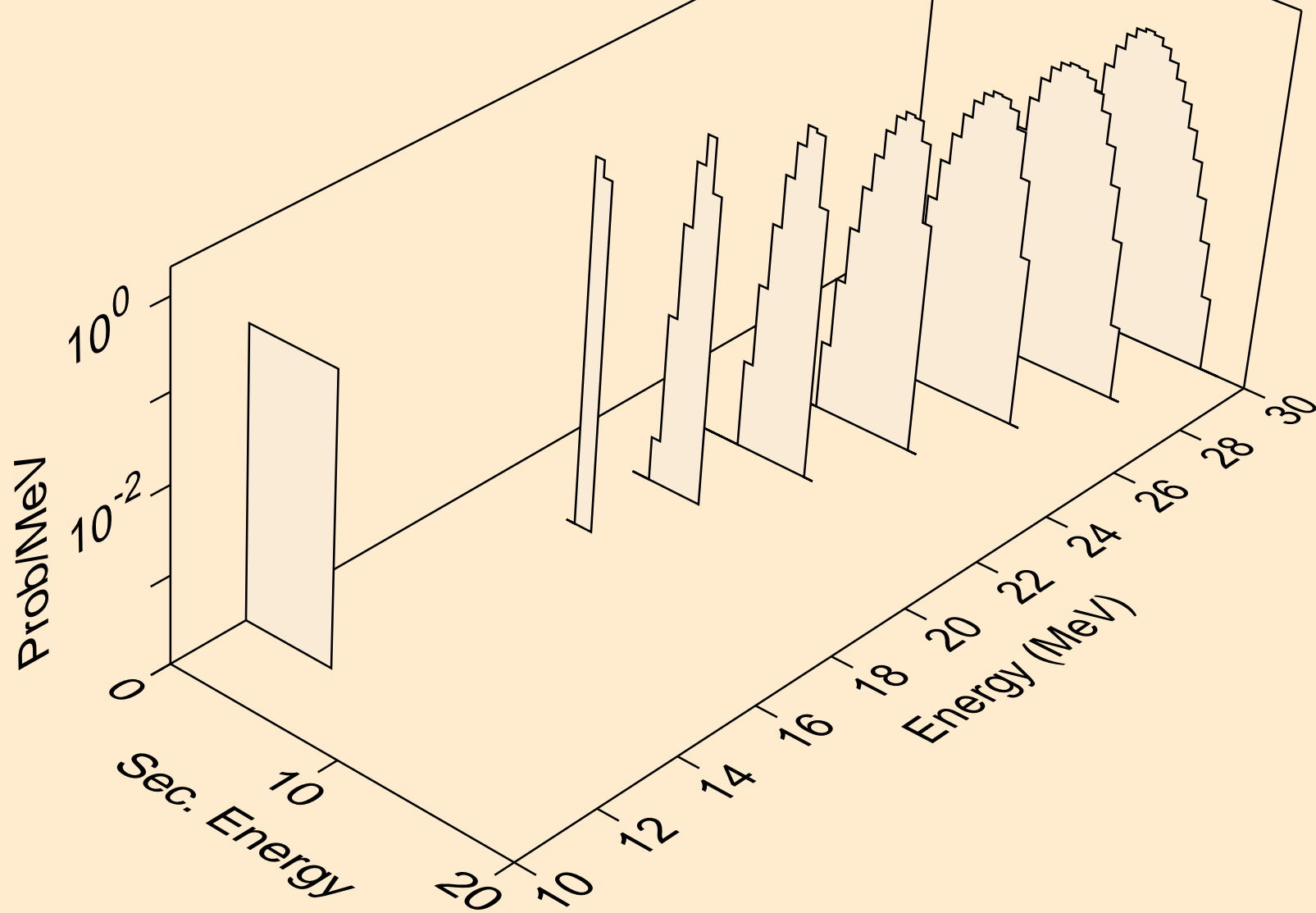

AC229 NEUTRON ACER TENDL-2021 LIBRARY; T=293.6K
he3s from (n,he3)

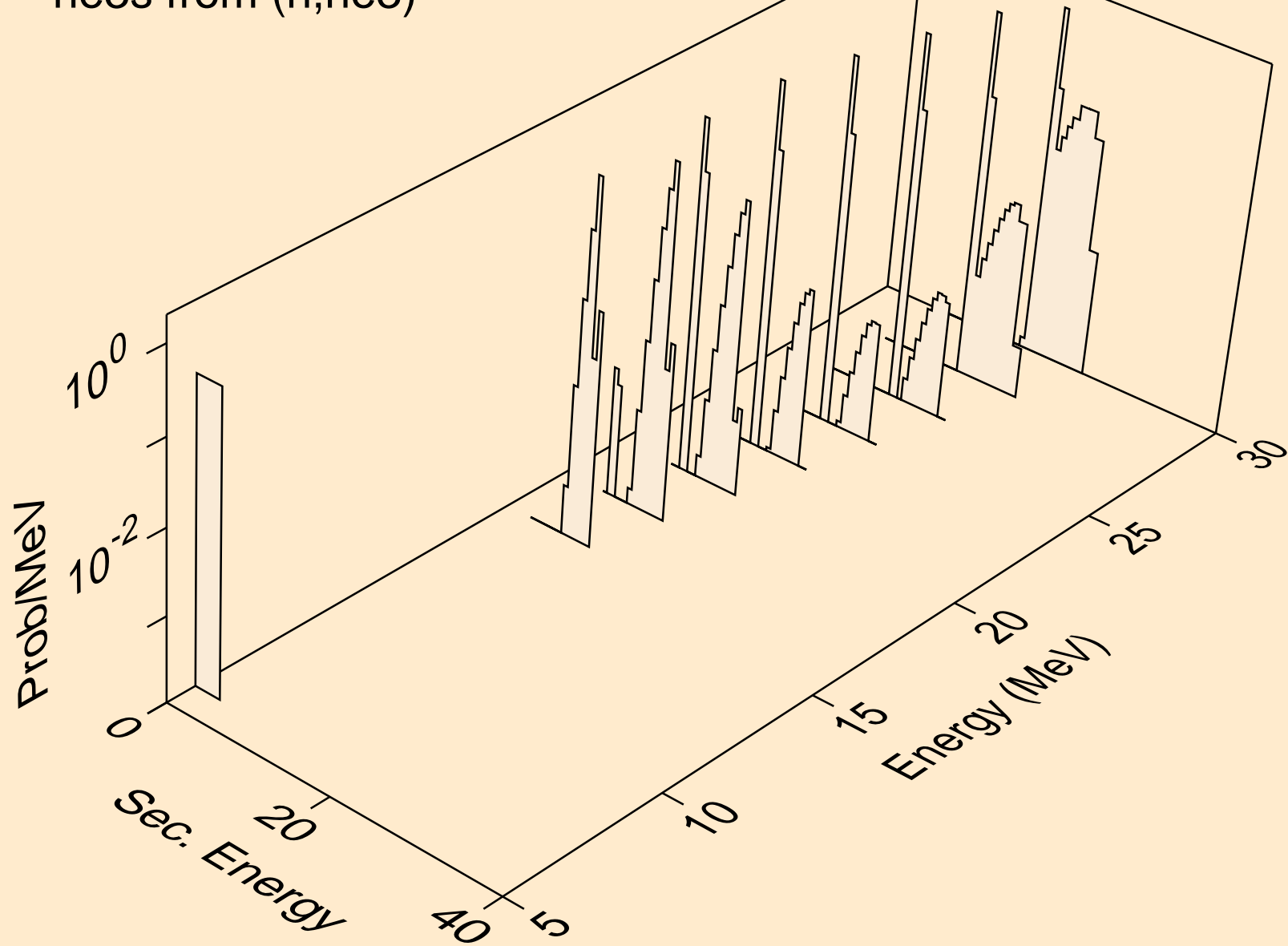

AC229 NEUTRON ACER TENDL-2021 LIBRARY; T=293.6K
alphas from (n,x)

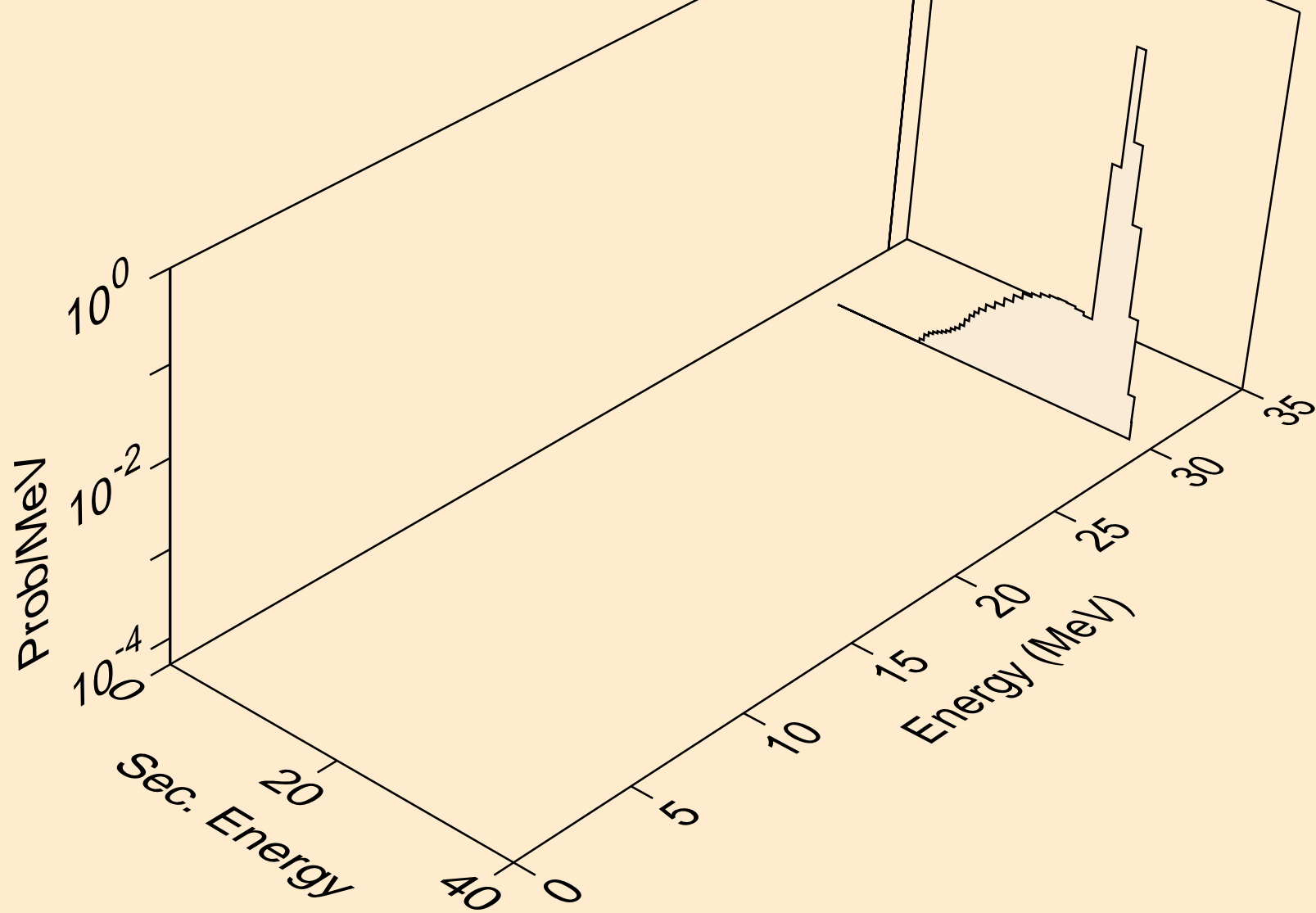

AC229 NEUTRON ACER TENDL-2021 LIBRARY; T=293.6K
alphas from (n,n*)a

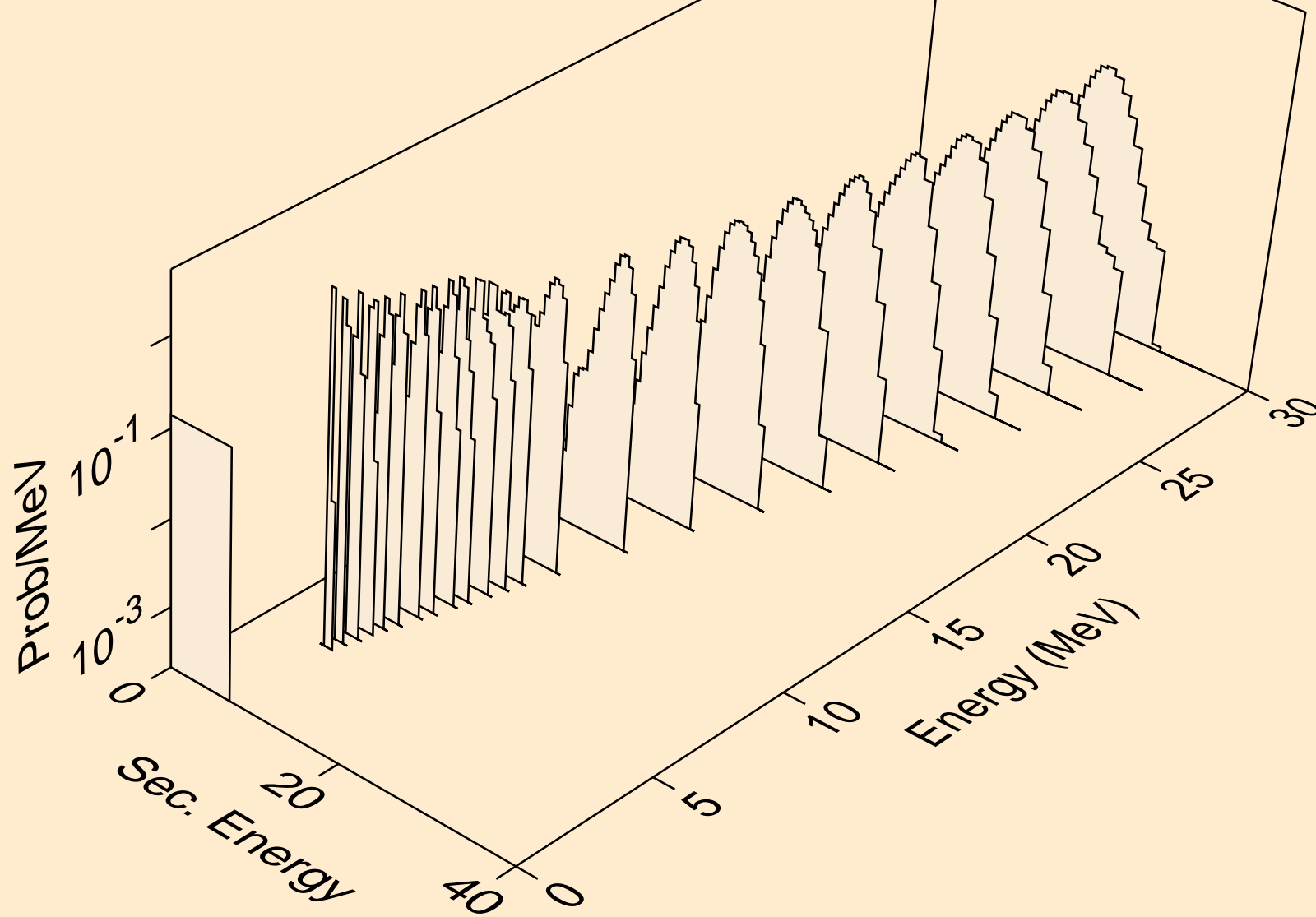

AC229 NEUTRON ACER TENDL-2021 LIBRARY; T=293.6K
alphas from (n,2n)a

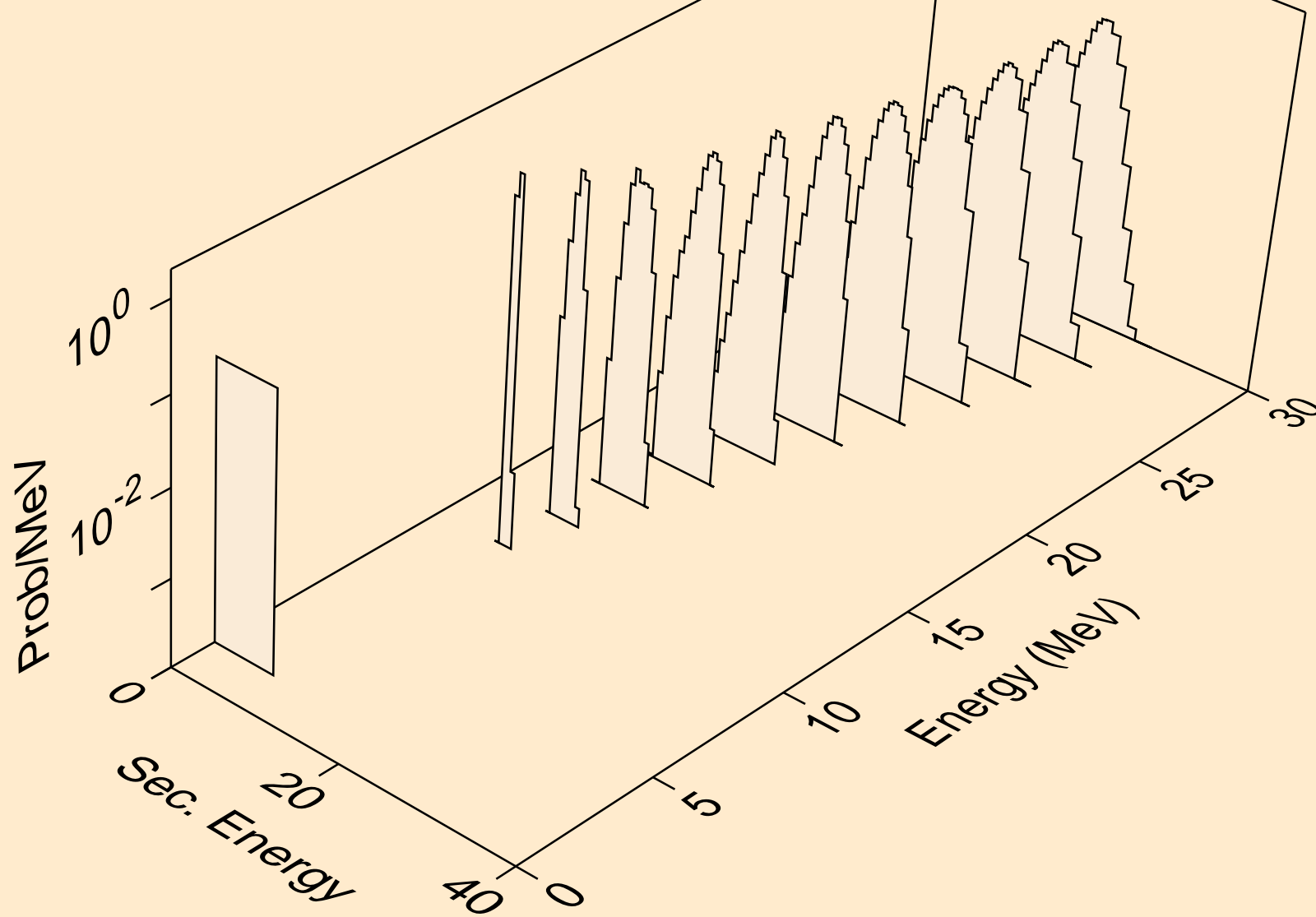

AC229 NEUTRON ACER TENDL-2021 LIBRARY; T=293.6K
alphas from (n,3n)a

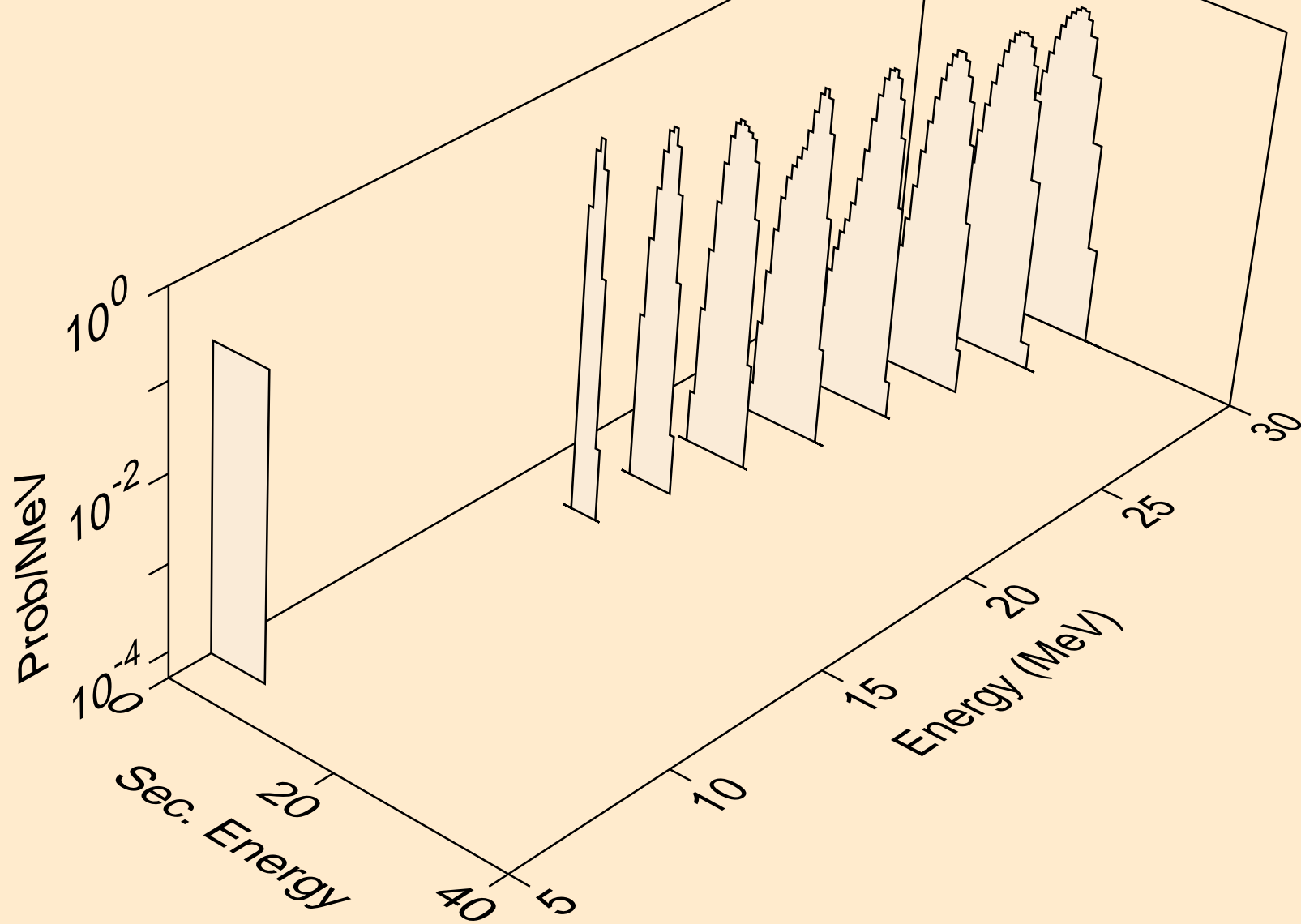

AC229 NEUTRON ACER TENDL-2021 LIBRARY; T=293.6K
alphas from (n,a)

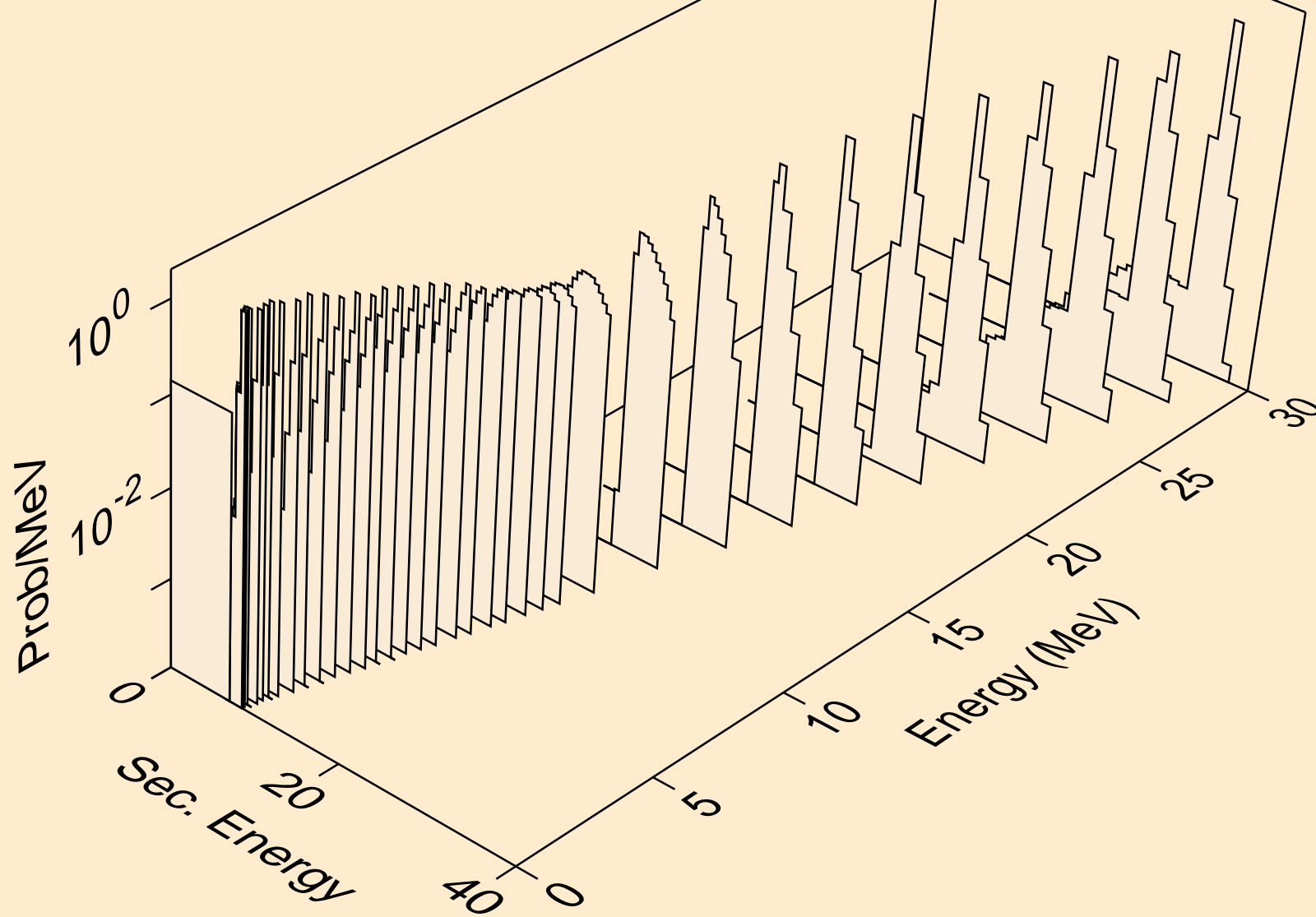

AC229 NEUTRON ACER TENDL-2021 LIBRARY; T=293.6K
alphas from (n,pa)

