

BH273 NEUTRON ACER TENDL-2021 LIBRARY; T=293.6K

Principal cross sections

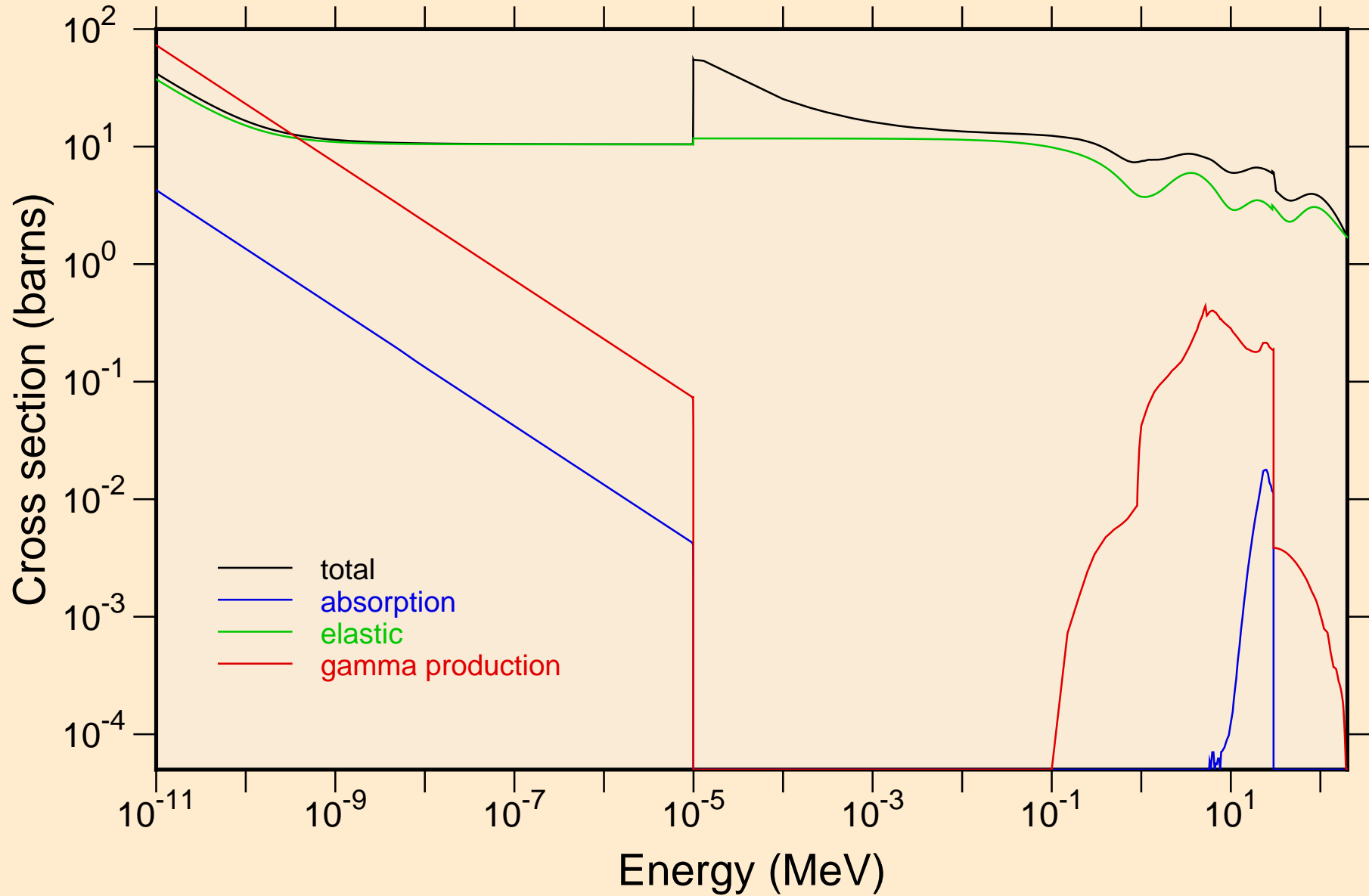

BH273 NEUTRON ACER TENDL-2021 LIBRARY; T=293.6K
Heating

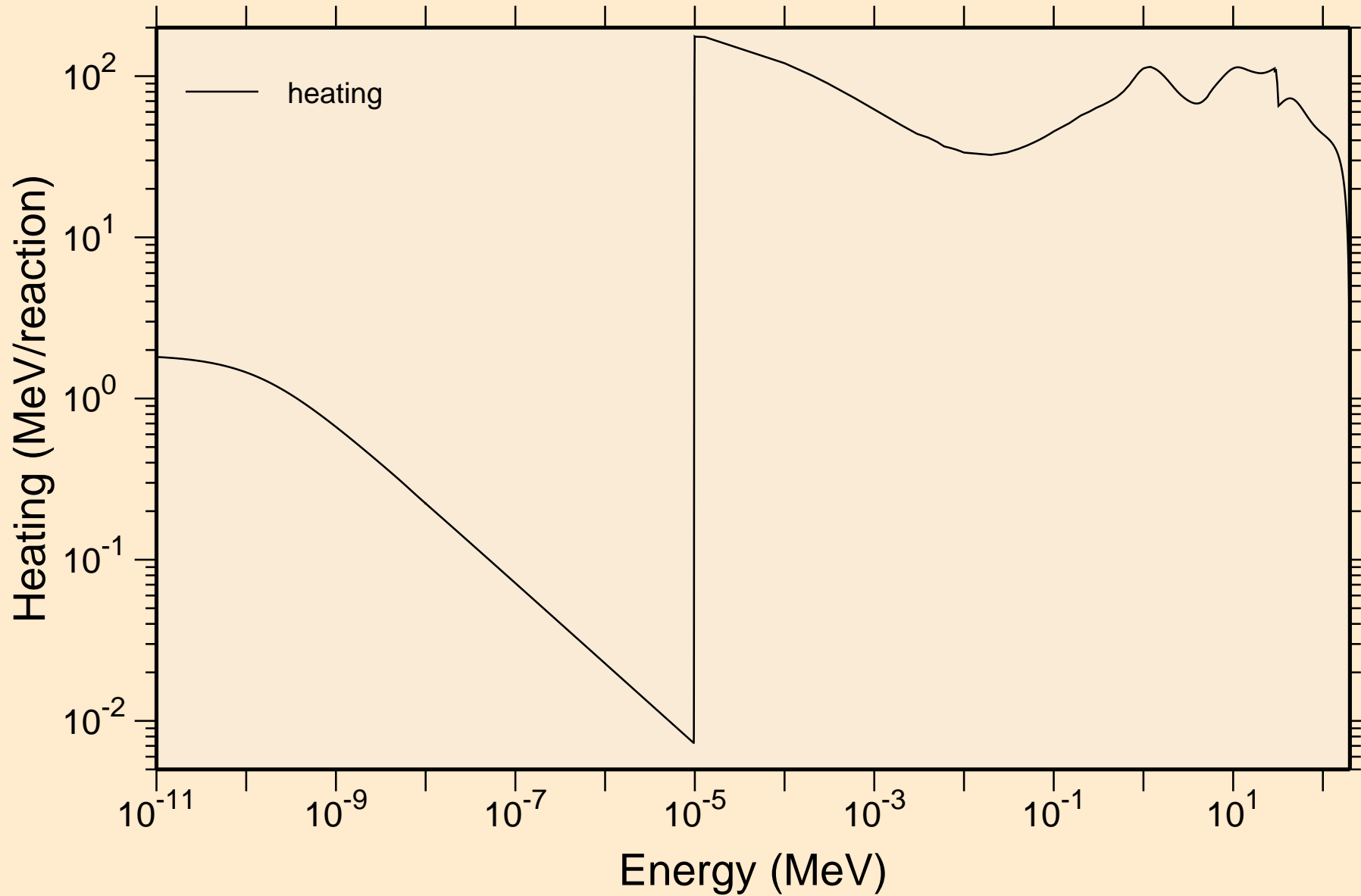

BH273 NEUTRON ACER TENDL-2021 LIBRARY; T=293.6K
Damage

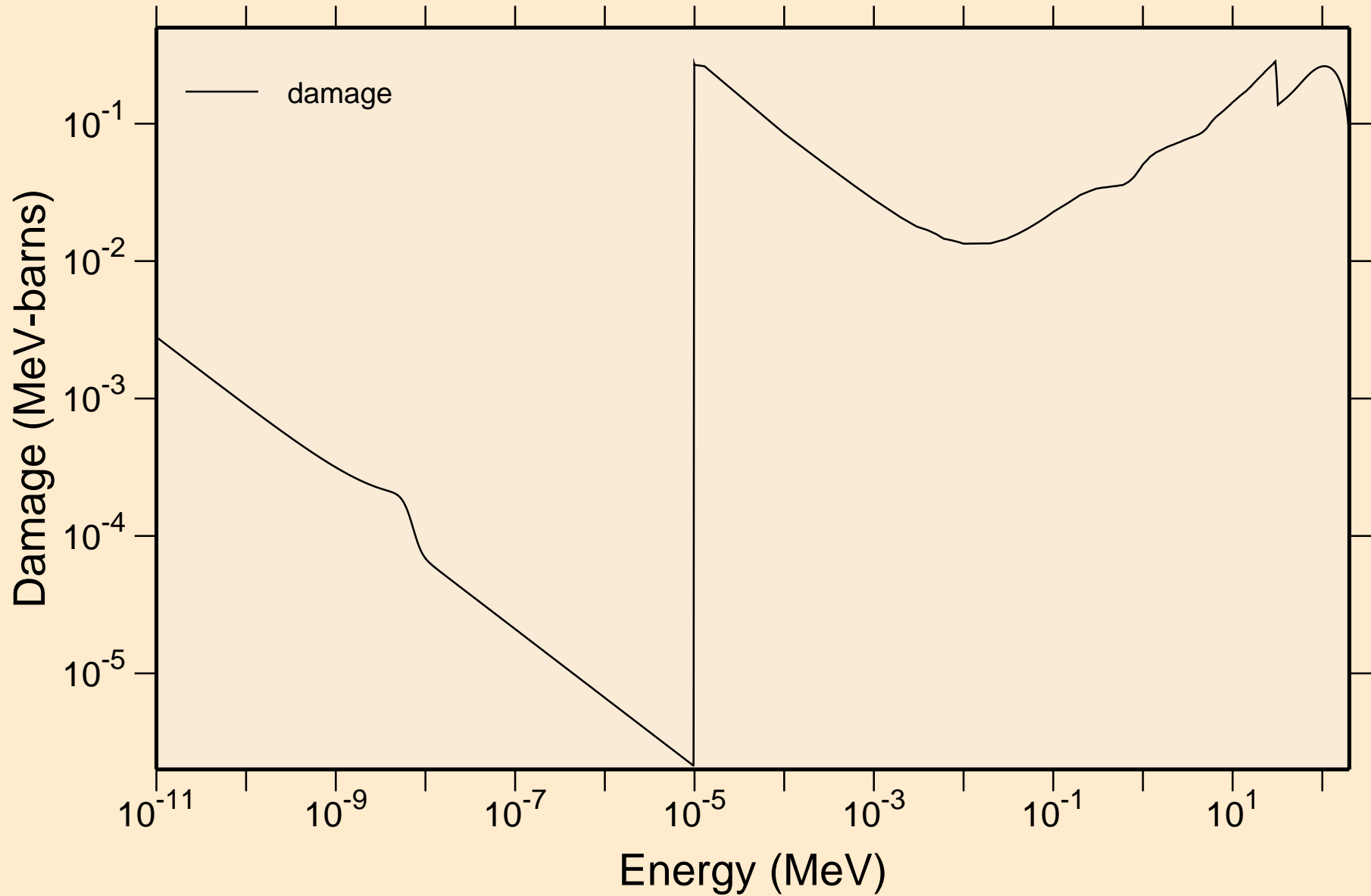

BH273 NEUTRON ACER TENDL-2021 LIBRARY; T=293.6K
Non-threshold reactions

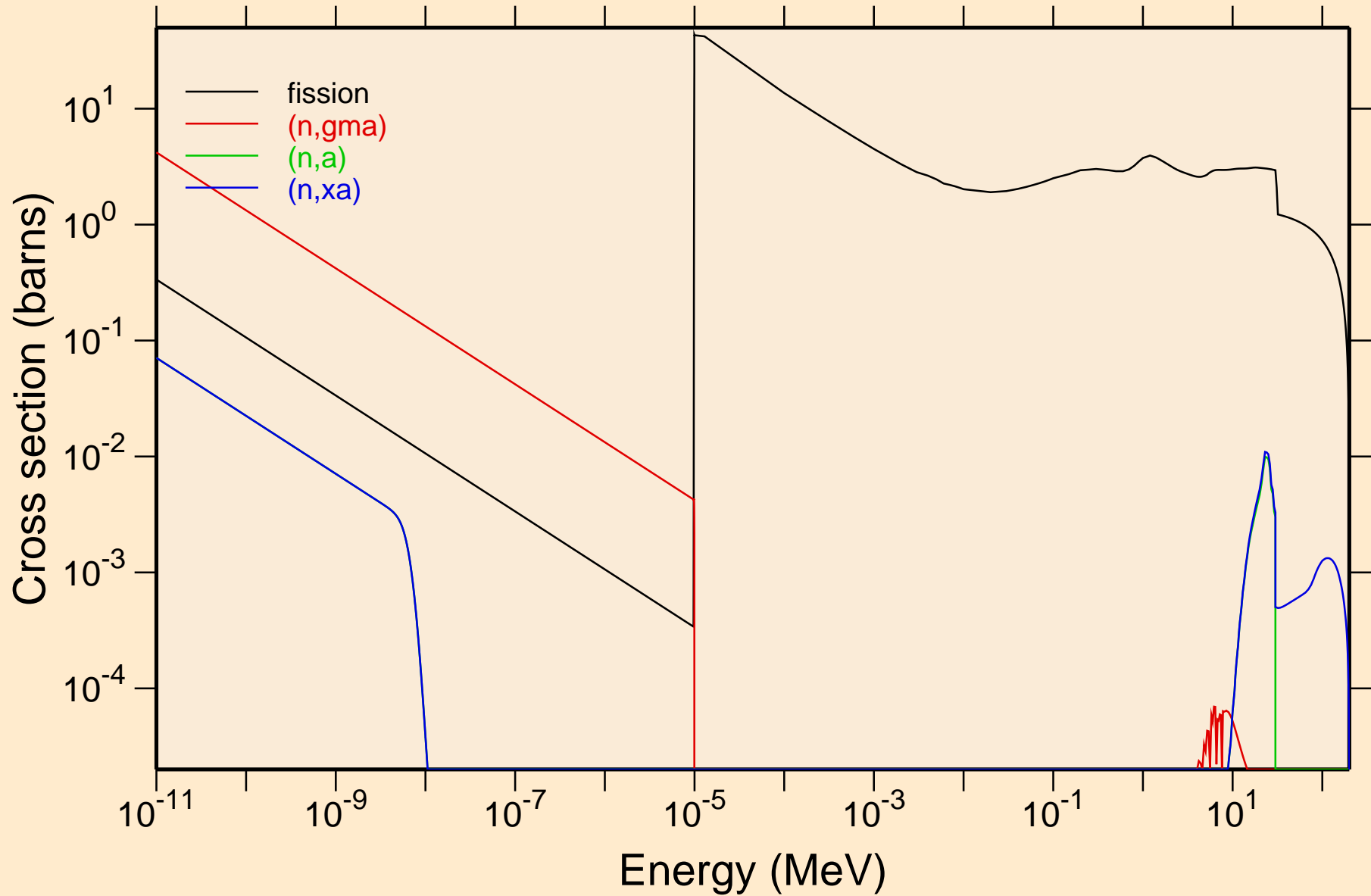

BH273 NEUTRON ACER TENDL-2021 LIBRARY; T=293.6K
Principal cross sections

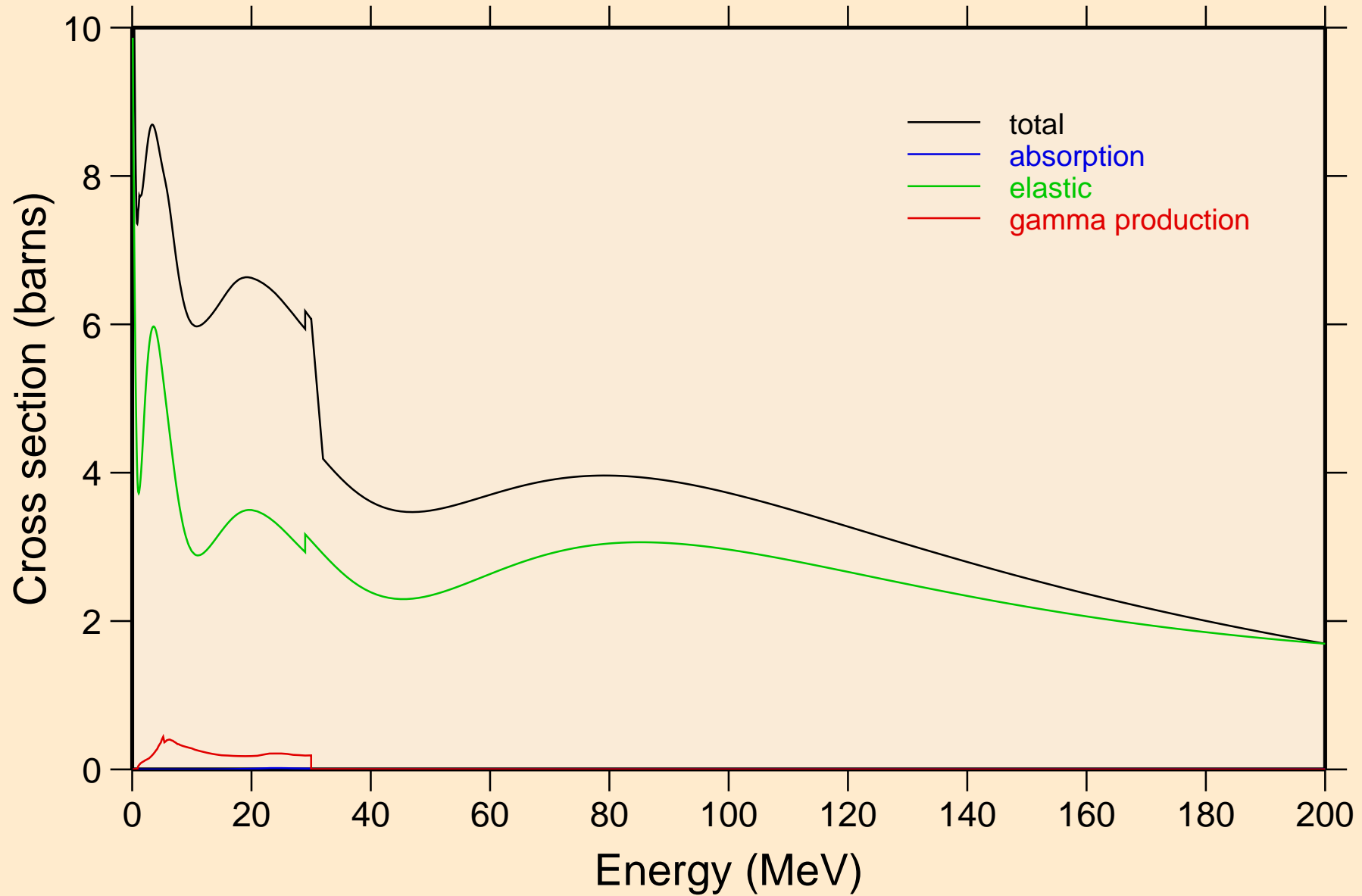

BH273 NEUTRON ACER TENDL-2021 LIBRARY; T=293.6K
Heating

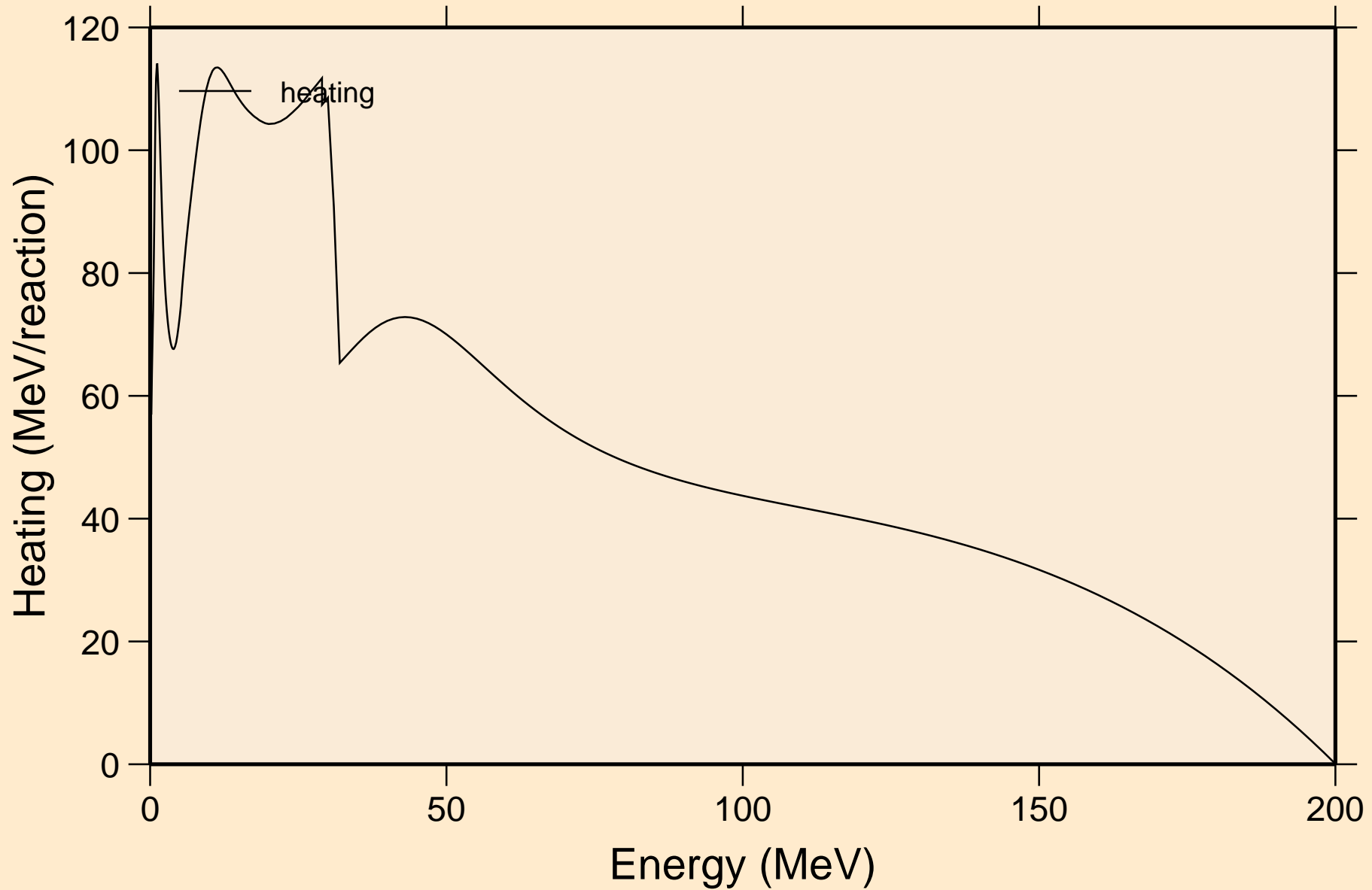

BH273 NEUTRON ACER TENDL-2021 LIBRARY; T=293.6K
Damage

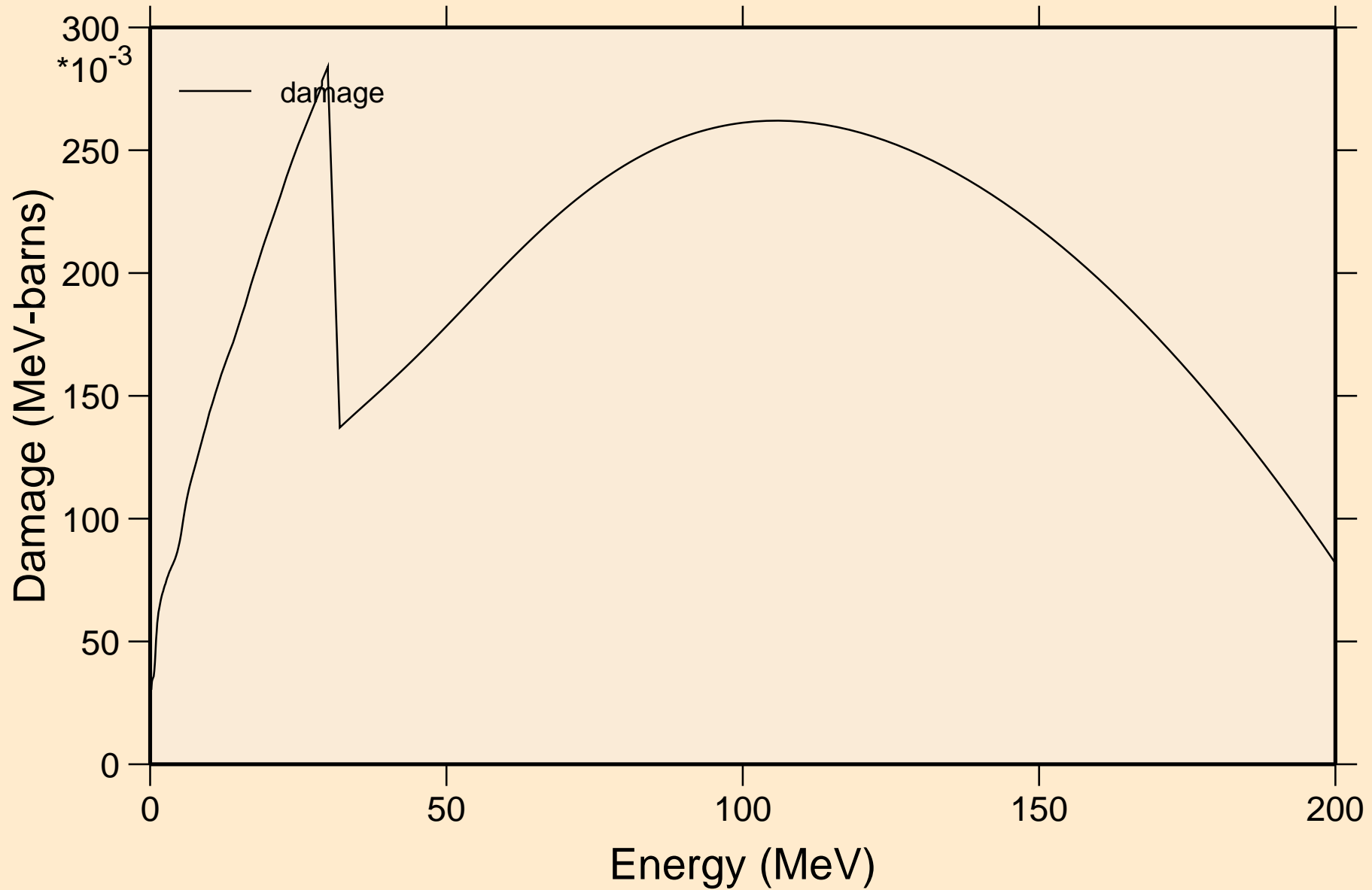

BH273 NEUTRON ACER TENDL-2021 LIBRARY; T=293.6K
Non-threshold reactions

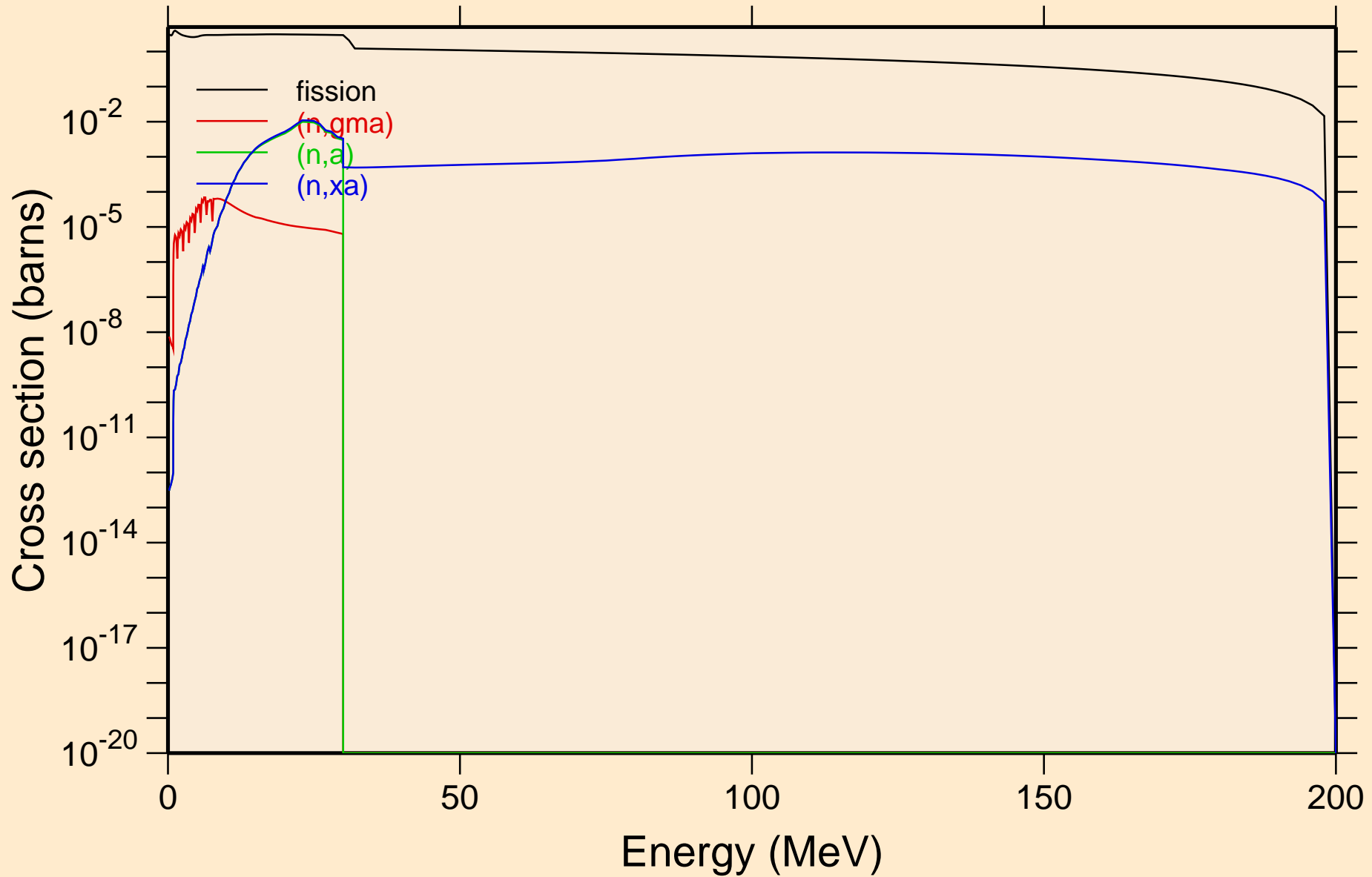

BH273 NEUTRON ACER TENDL-2021 LIBRARY; T=293.6K
Inelastic levels

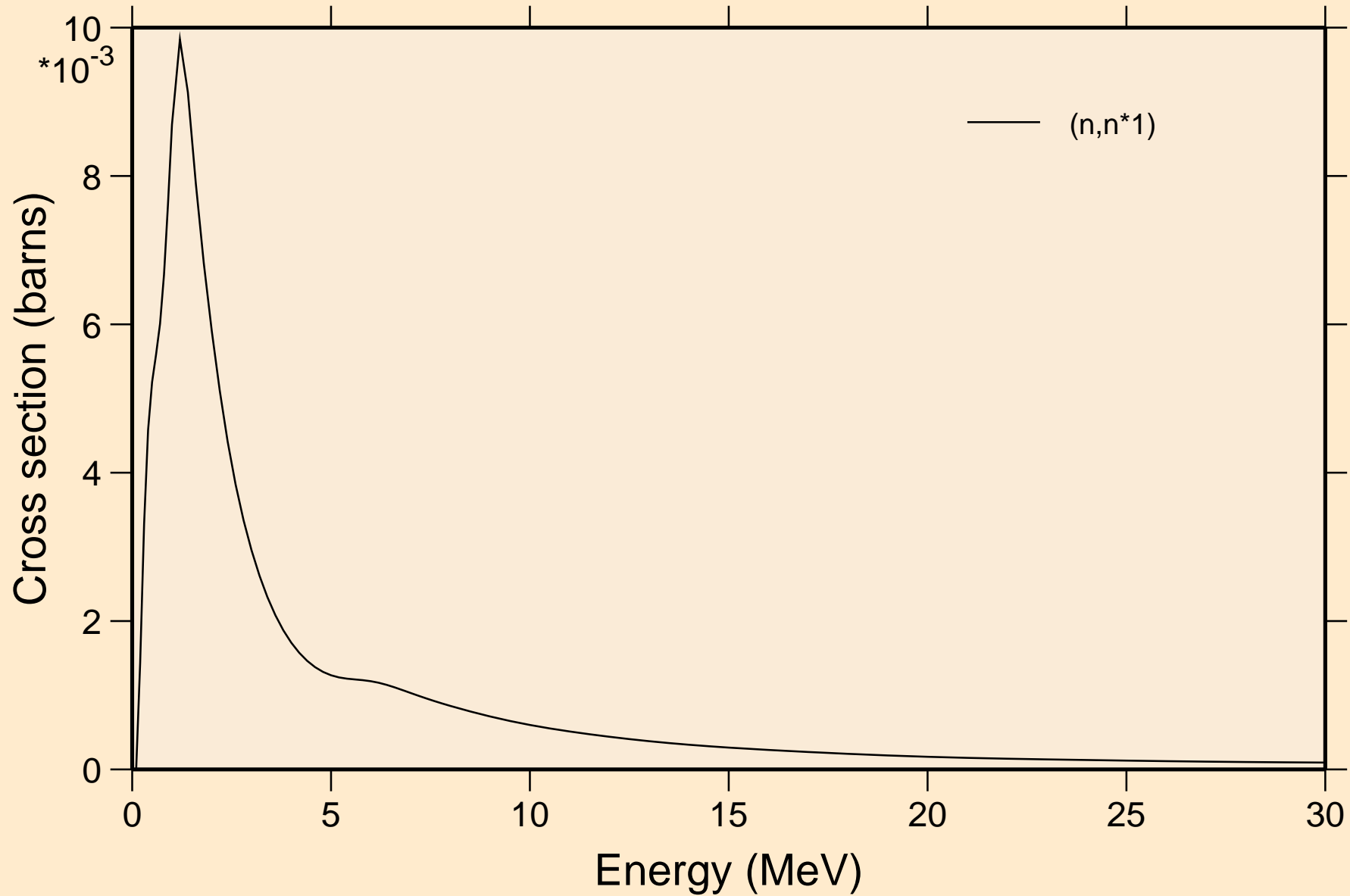

BH273 NEUTRON ACER TENDL-2021 LIBRARY; T=293.6K
Threshold reactions

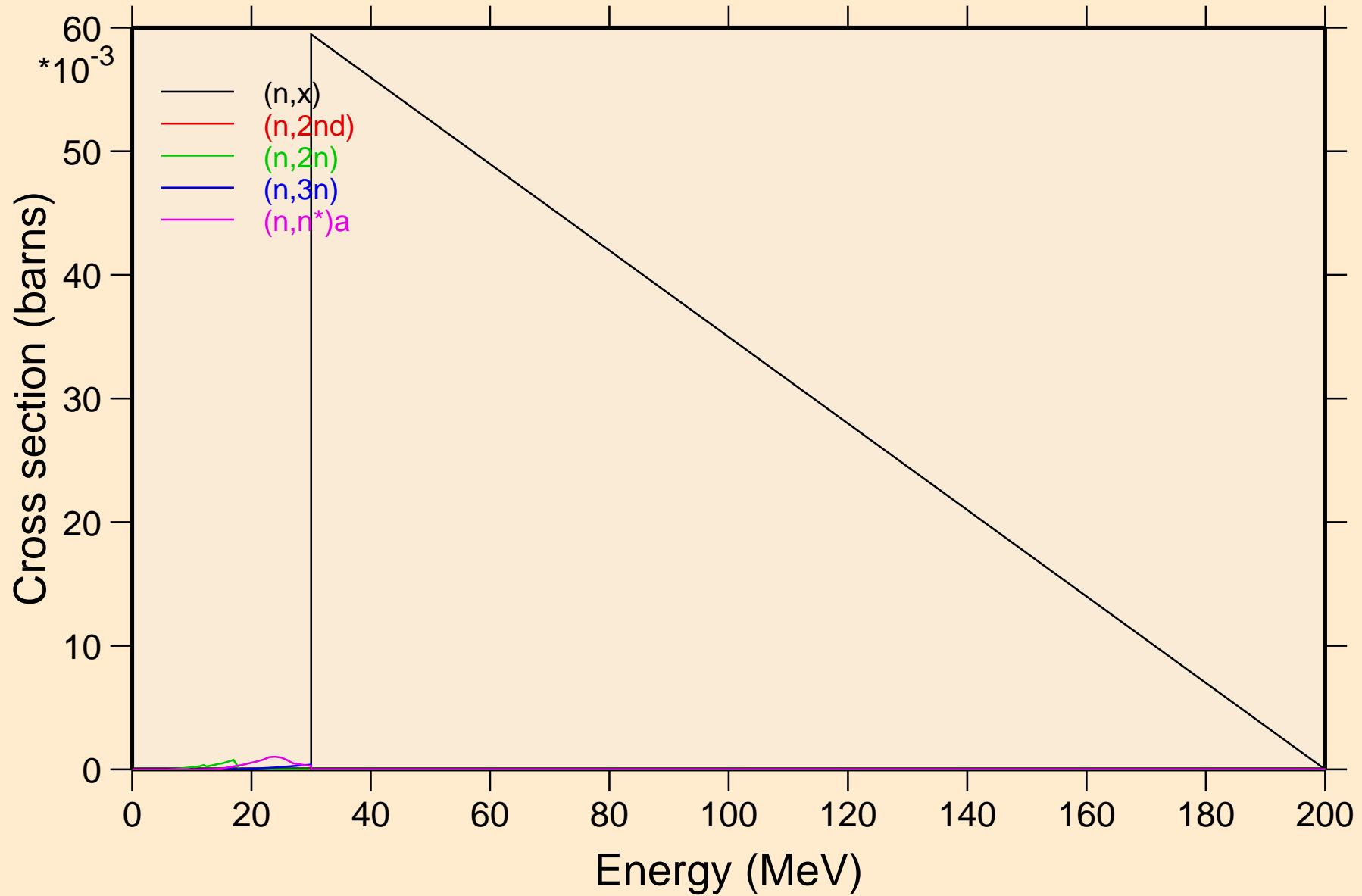

BH273 NEUTRON ACER TENDL-2021 LIBRARY; T=293.6K
Threshold reactions

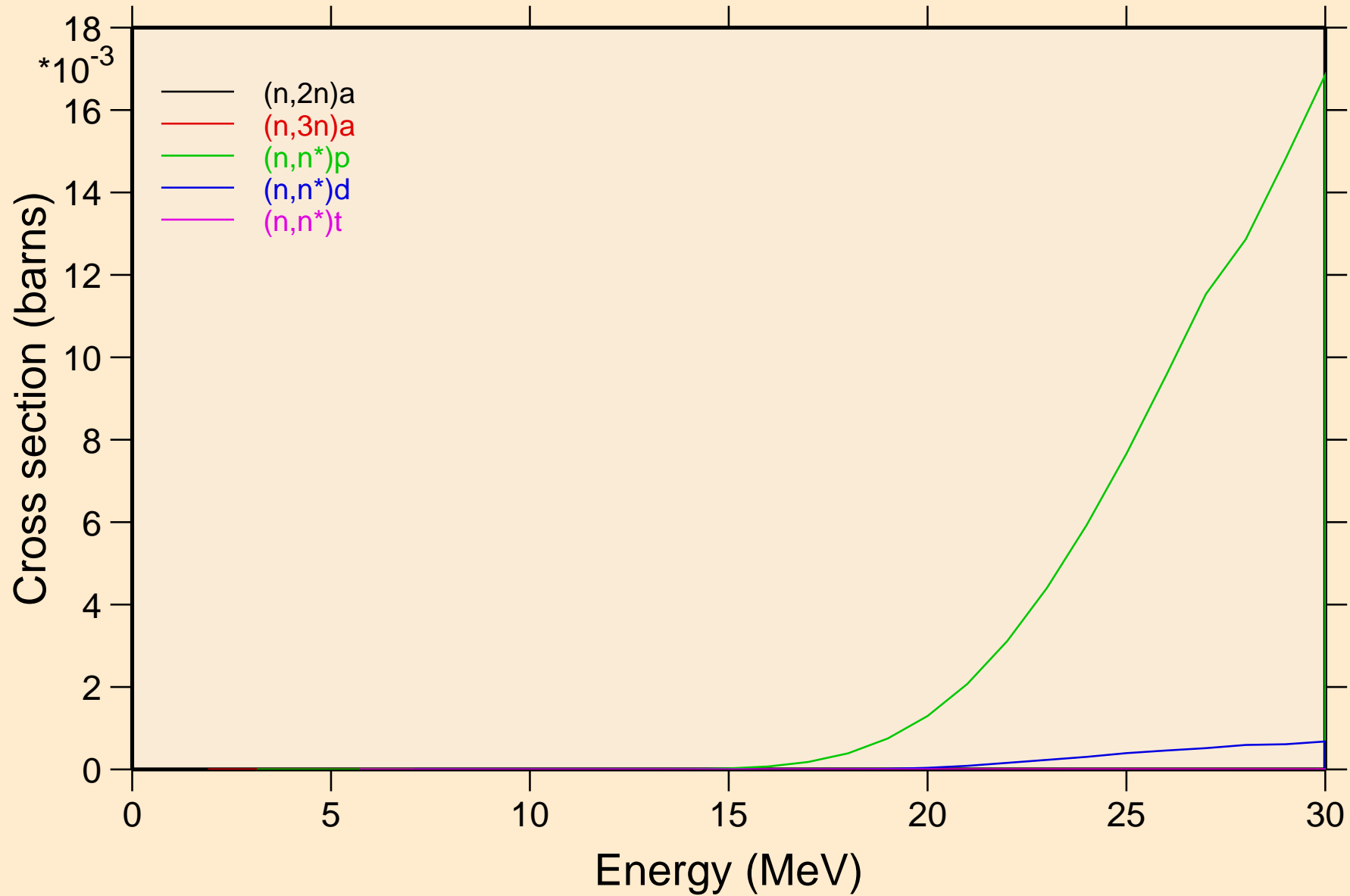

BH273 NEUTRON ACER TENDL-2021 LIBRARY; T=293.6K
Threshold reactions

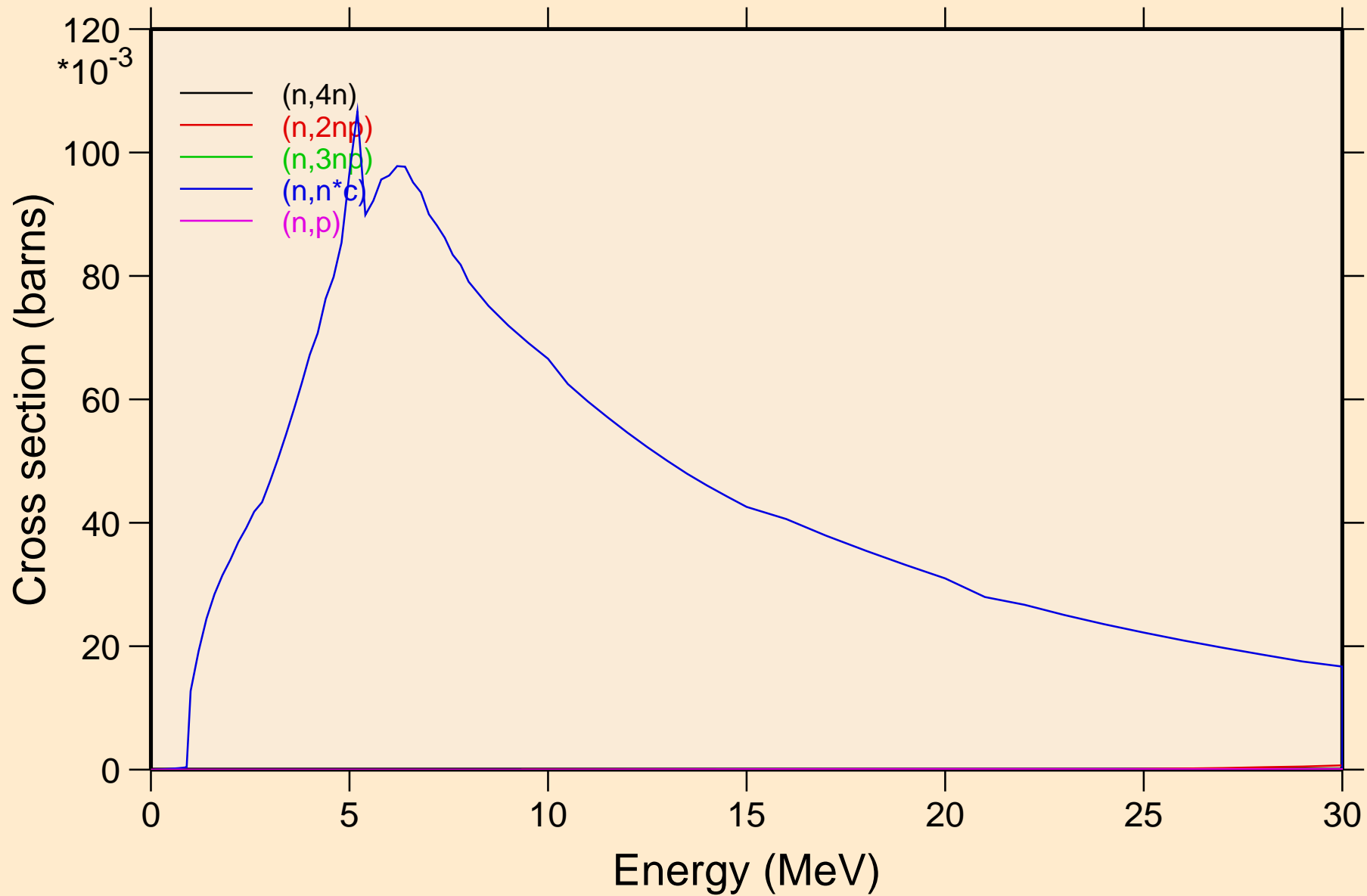

BH273 NEUTRON ACER TENDL-2021 LIBRARY; T=293.6K
Threshold reactions

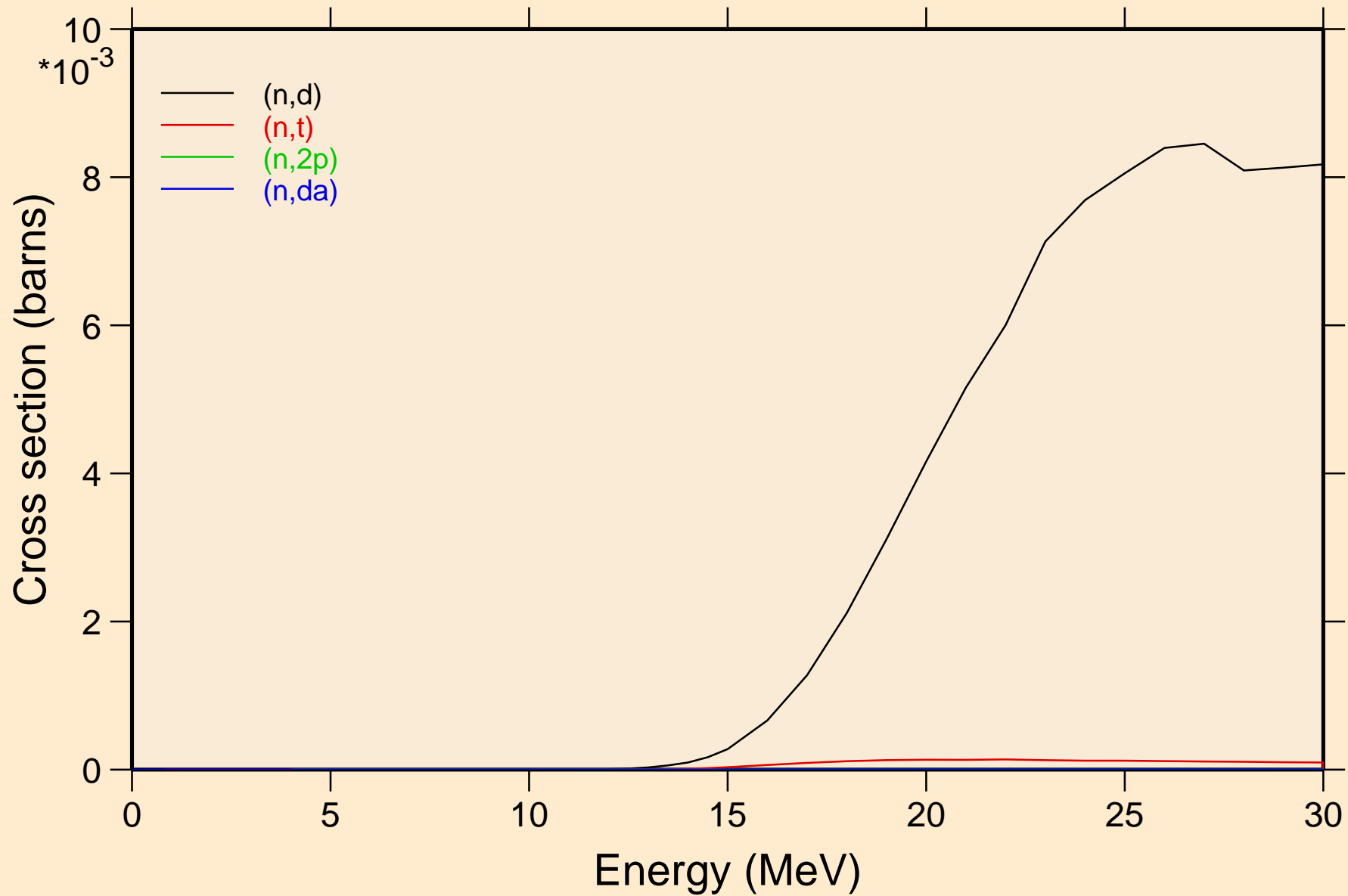

BH273 NEUTRON ACER TENDL-2021 LIBRARY; T=293.6K
Threshold reactions

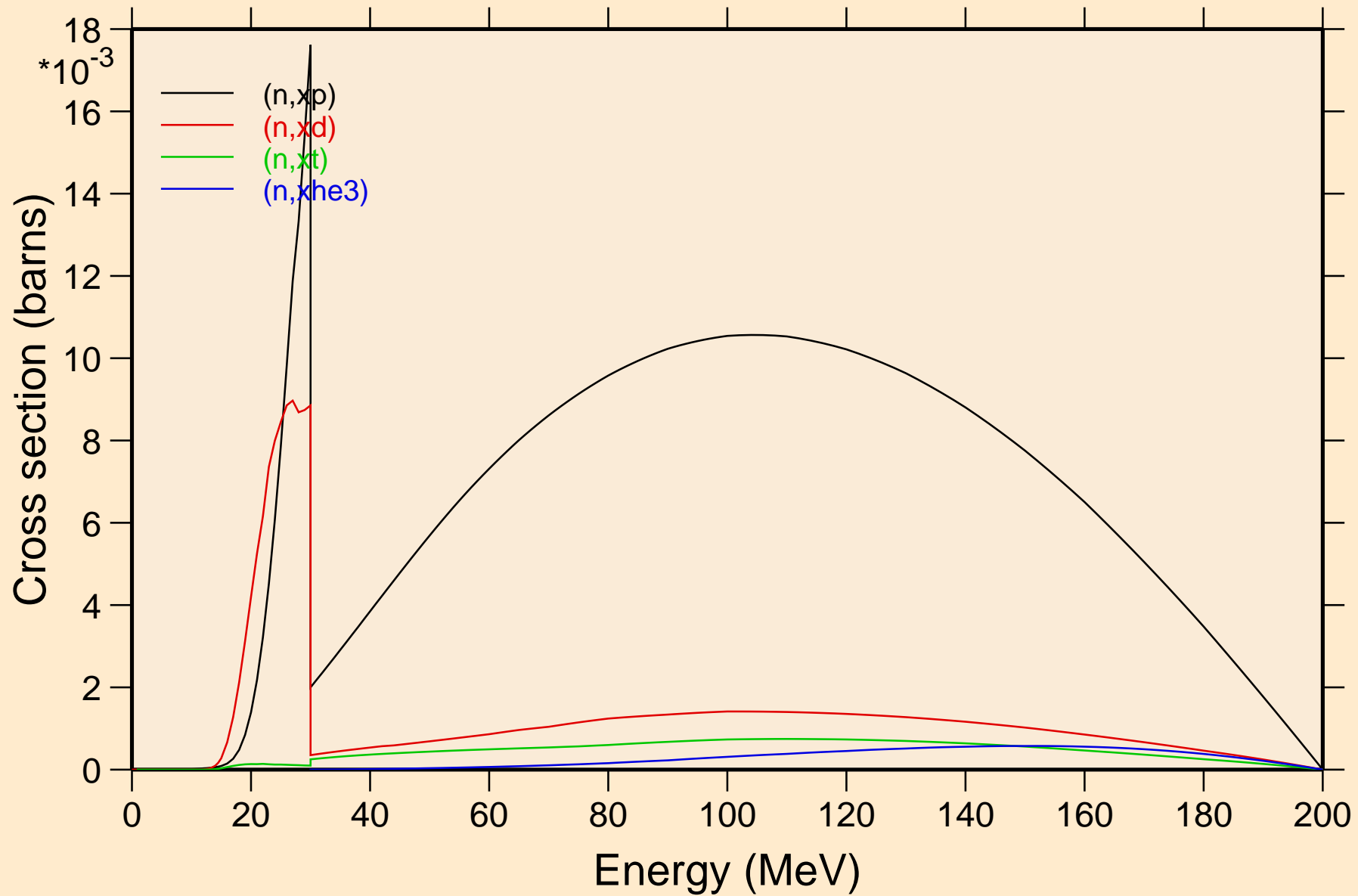

BH273 NEUTRON ACER TENDL-2021 LIBRARY; T=293.6K
angular distribution for elastic

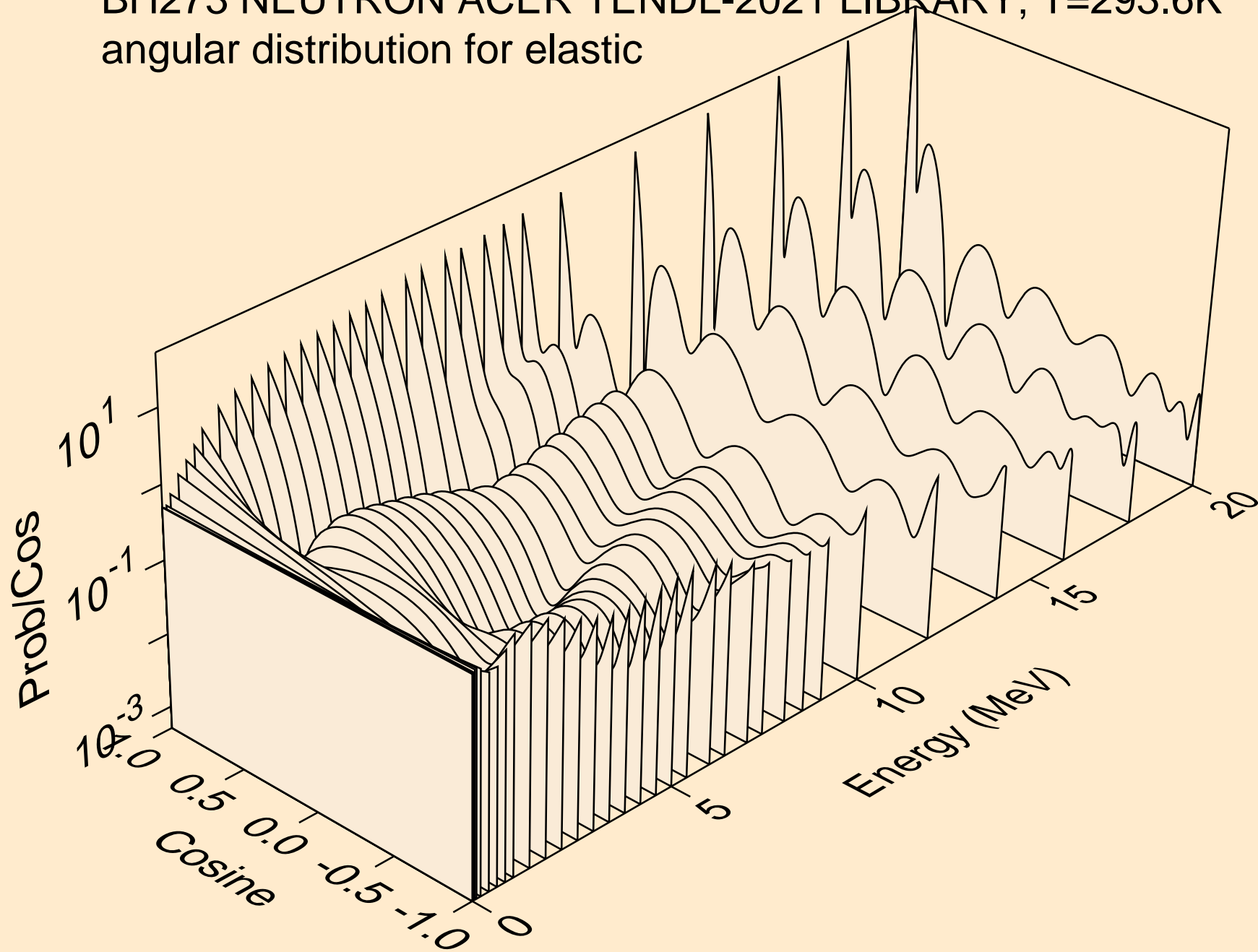

BH273 NEUTRON ACER TENDL-2021 LIBRARY; T=293.6K
angular distribution for elastic

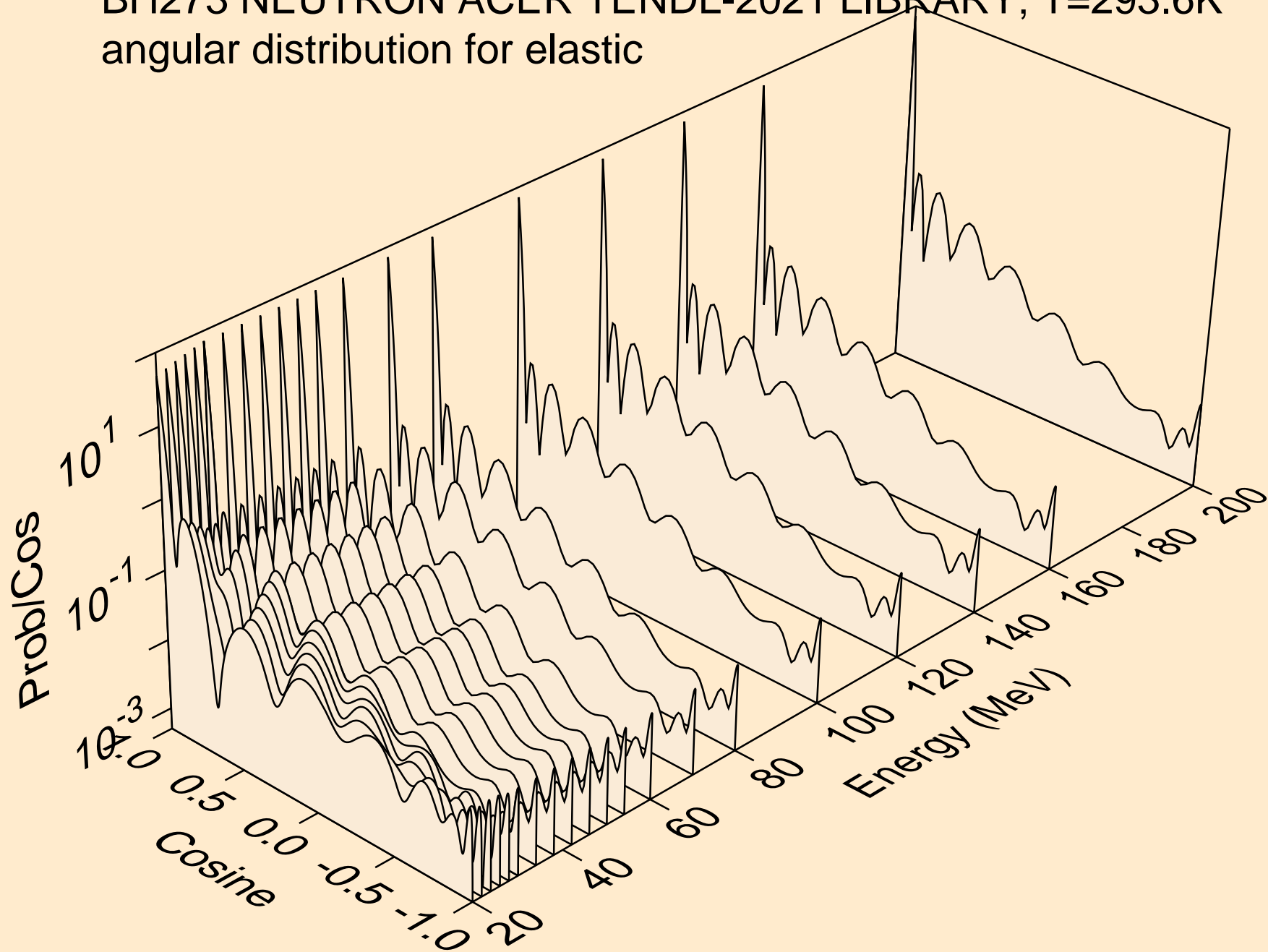

BH273 NEUTRON ACER TENDL-2021 LIBRARY; T=293.6K
angular distribution for (n,n*1)

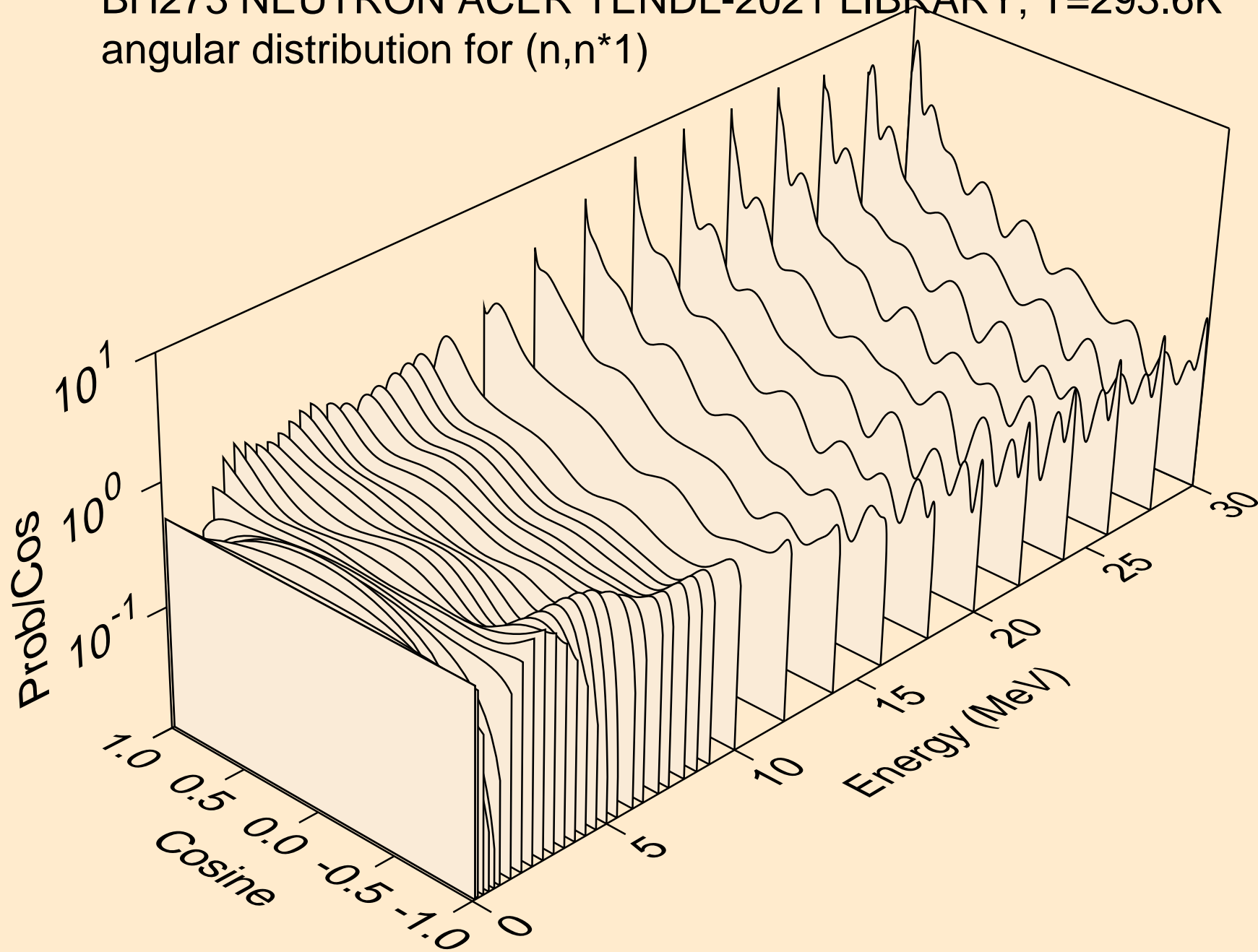

BH273 NEUTRON ACER TENDL-2021 LIBRARY; T=293.6K
Total fission nubar

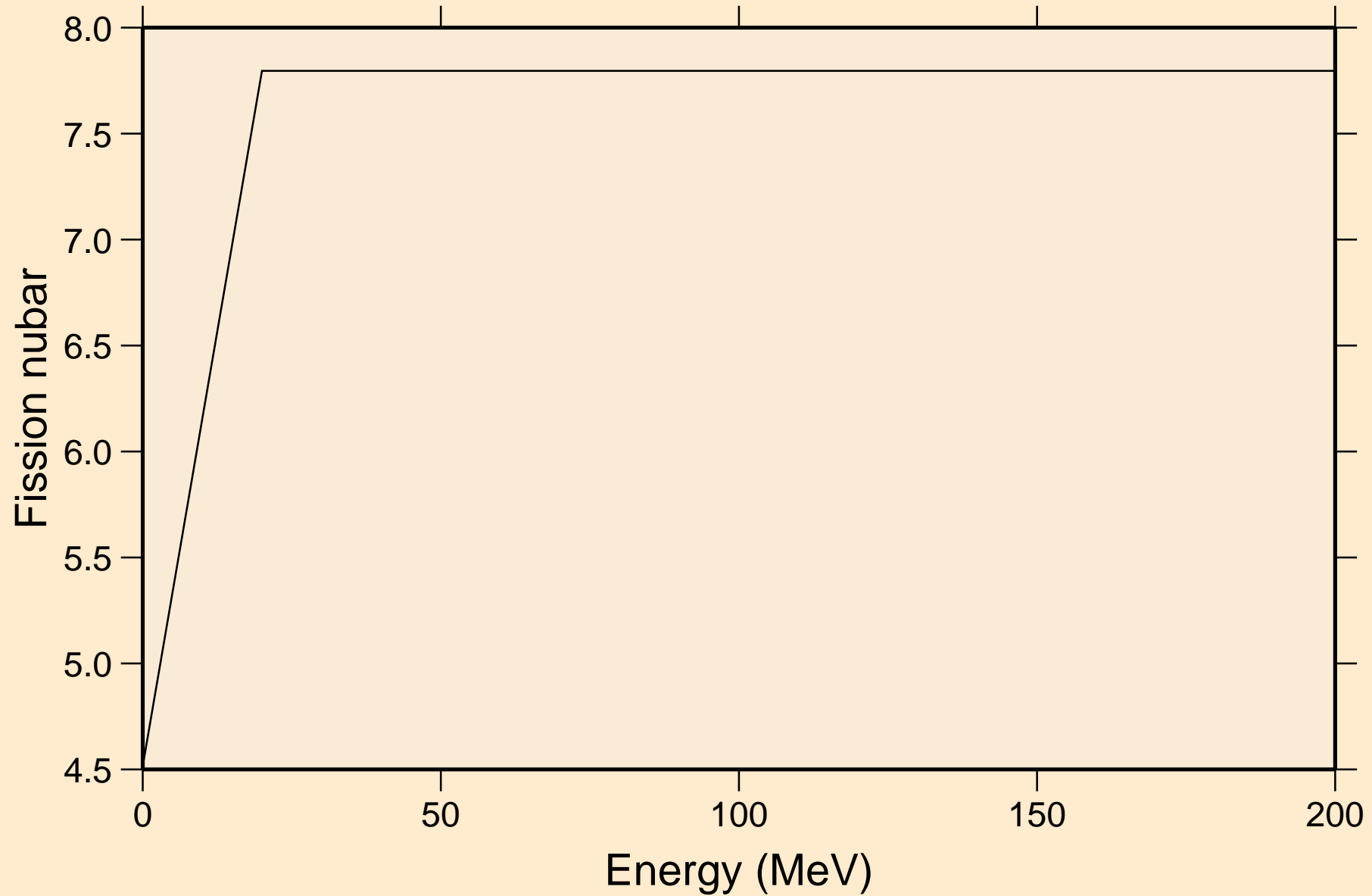

BH273 NEUTRON ACER TENDL-2021 LIBRARY; T=293.6K
Neutron emission for (n,x)

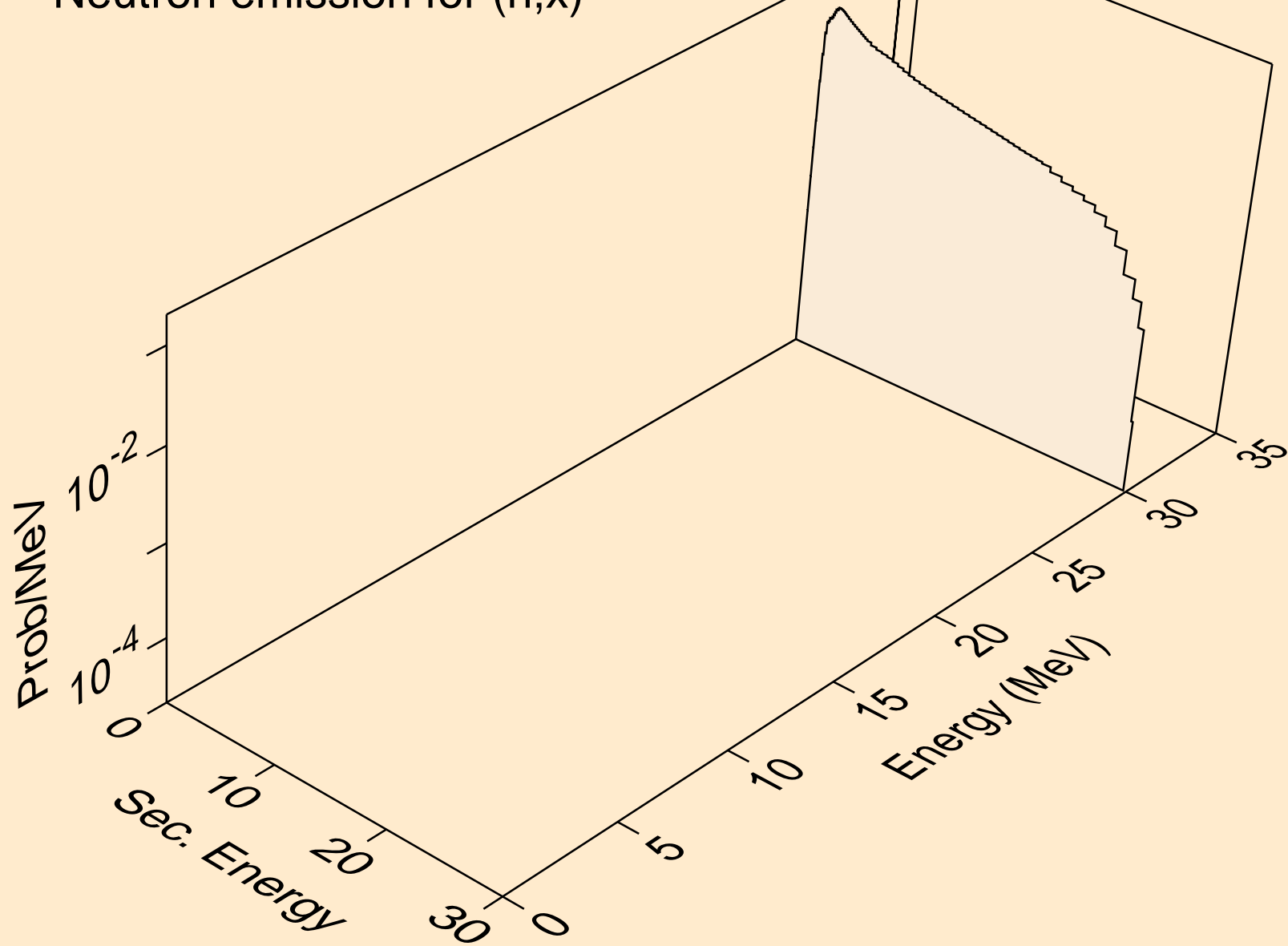

BH273 NEUTRON ACER TENDL-2021 LIBRARY; T=293.6K
Neutron emission for (n,2nd)

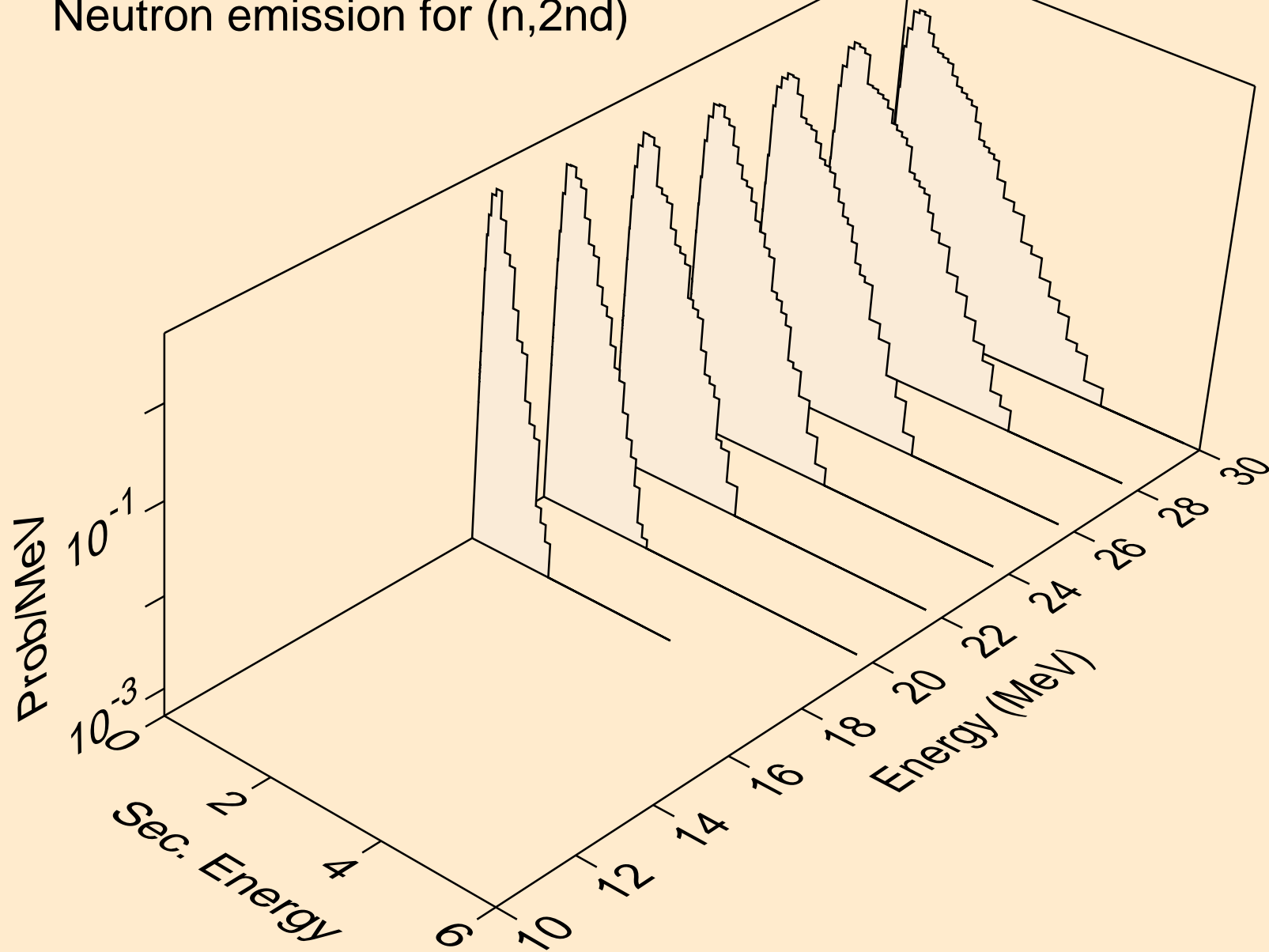

BH273 NEUTRON ACER TENDL-2021 LIBRARY; T=293.6K
Neutron emission for (n,2n)

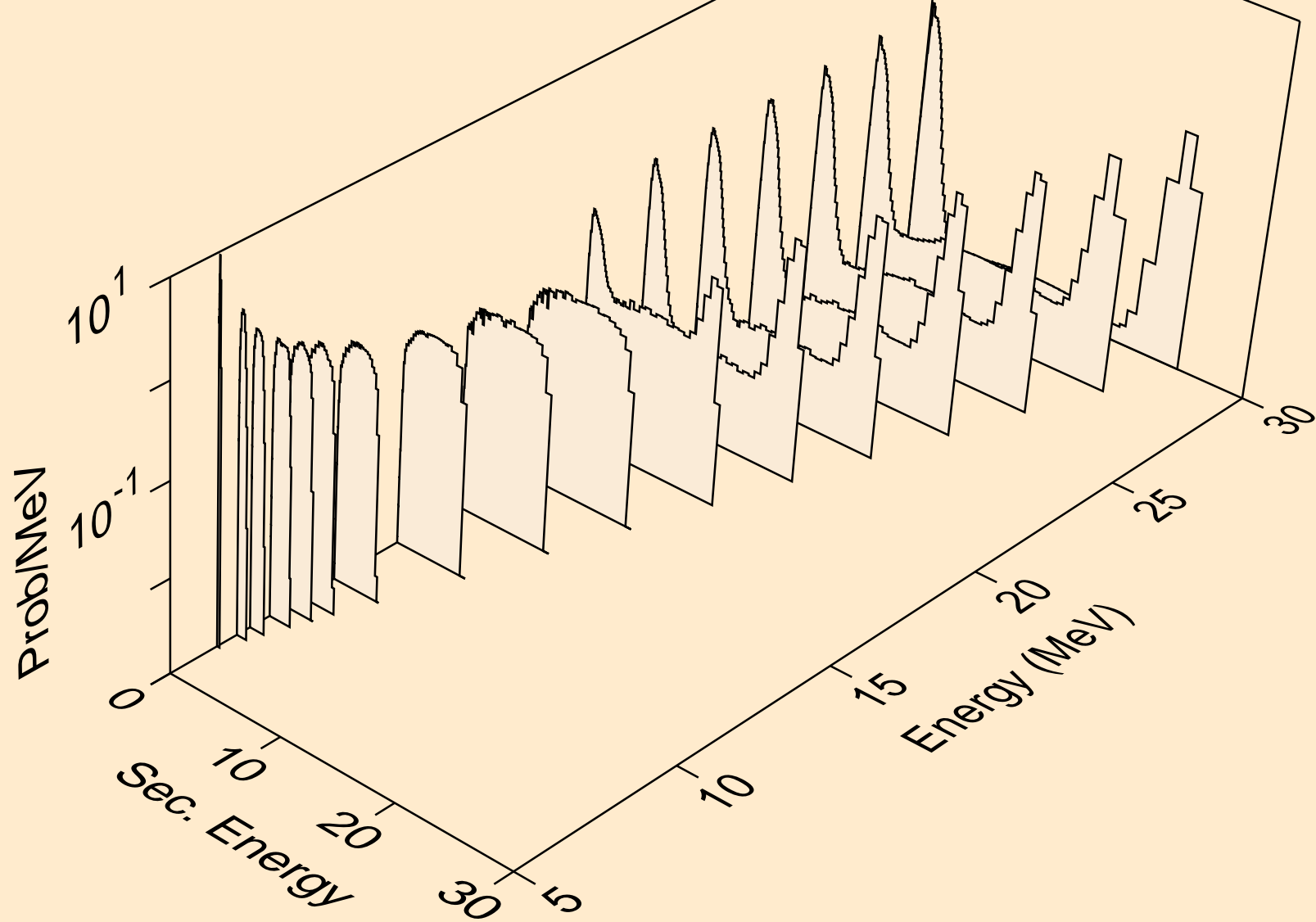

BH273 NEUTRON ACER TENDL-2021 LIBRARY; T=293.6K
Neutron emission for (n,3n)

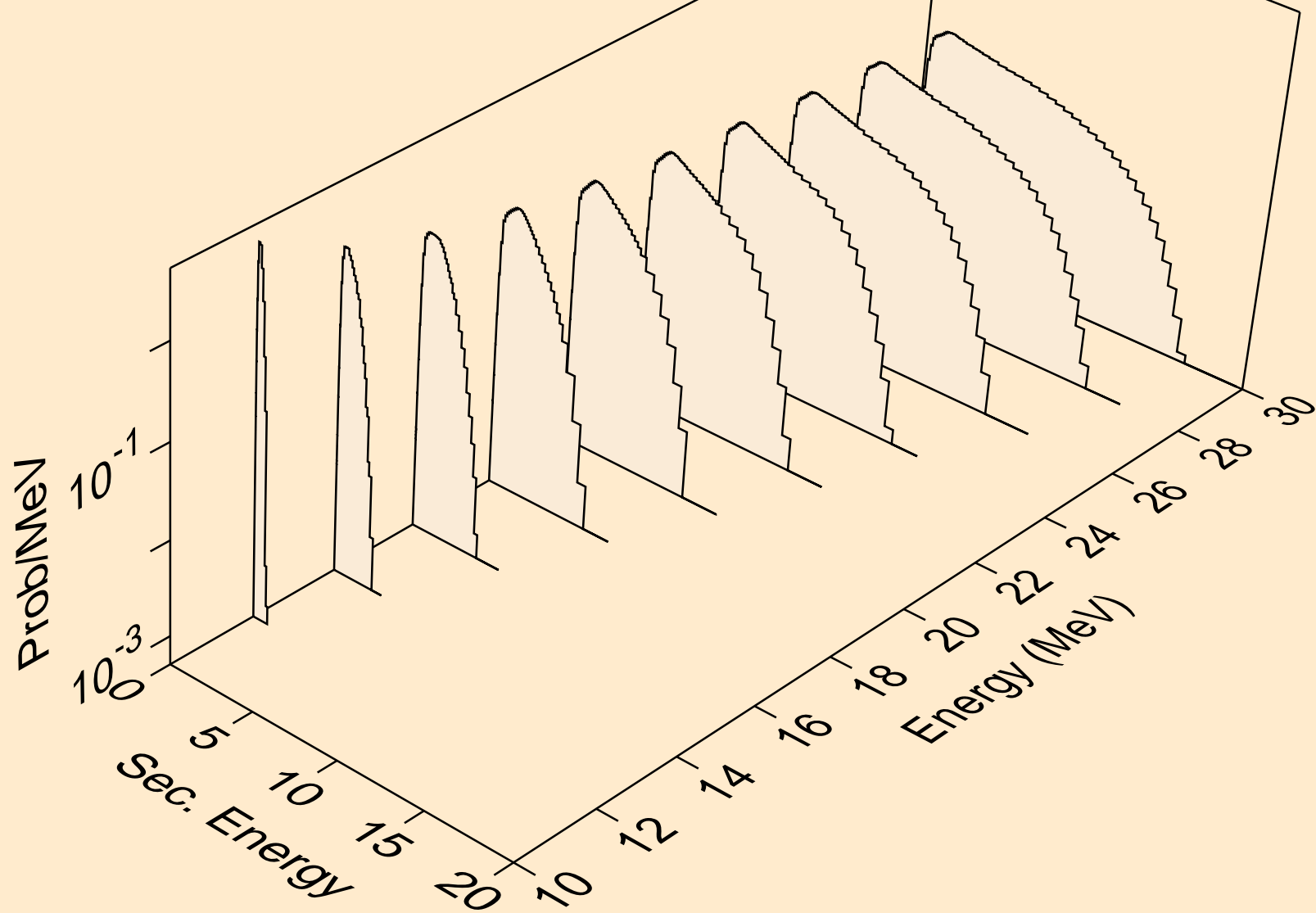

BH273 NEUTRON ACER TENDL-2021 LIBRARY; T=293.6K
Neutron emission for fission

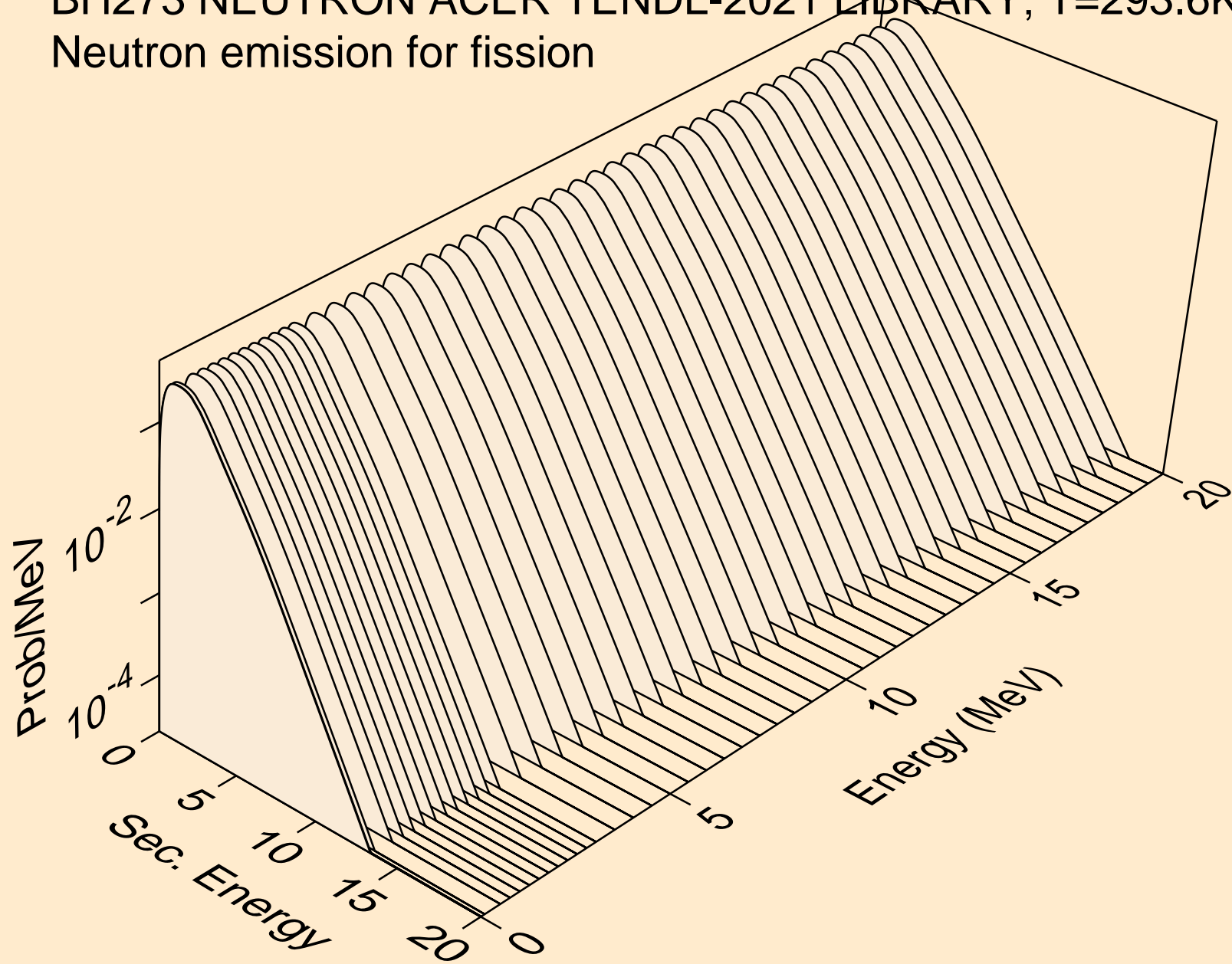

BH273 NEUTRON ACER TENDL-2021 LIBRARY; T=293.6K
Neutron emission for (n,n*)a

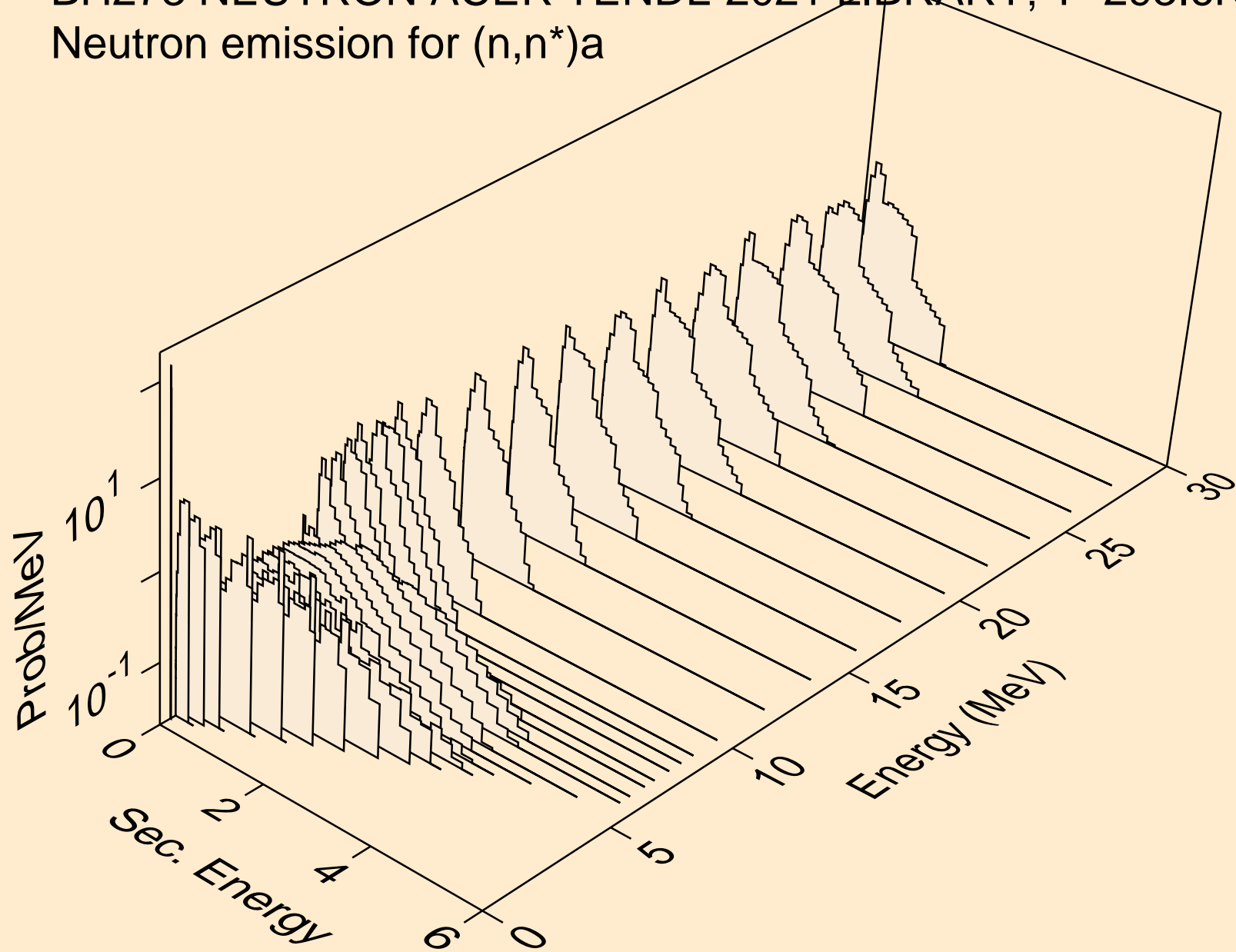

BH273 NEUTRON ACER TENDL-2021 LIBRARY; T=293.6K
Neutron emission for (n,2n)a

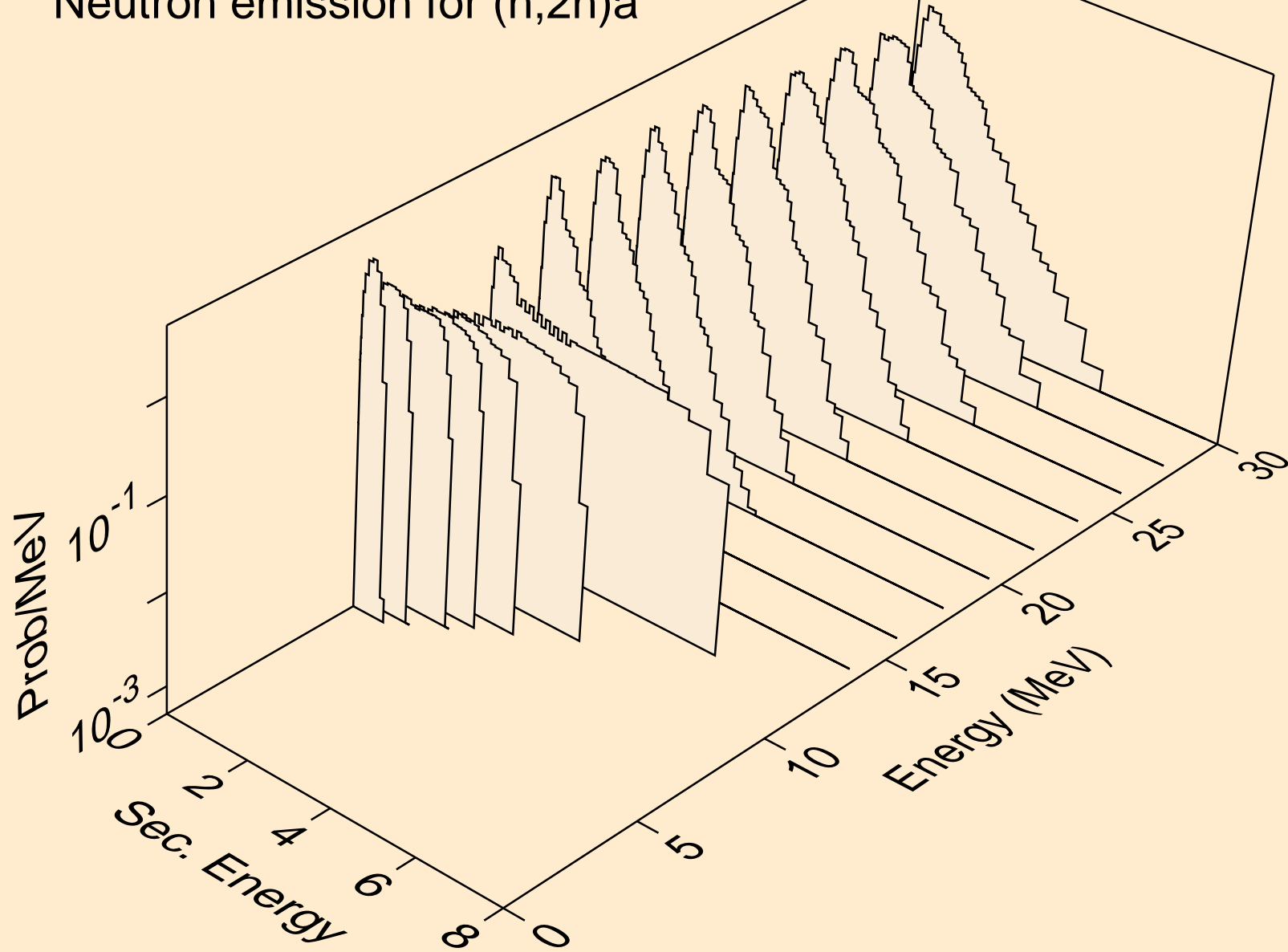

BH273 NEUTRON ACER TENDL-2021 LIBRARY; T=293.6K
Neutron emission for (n,3n)a

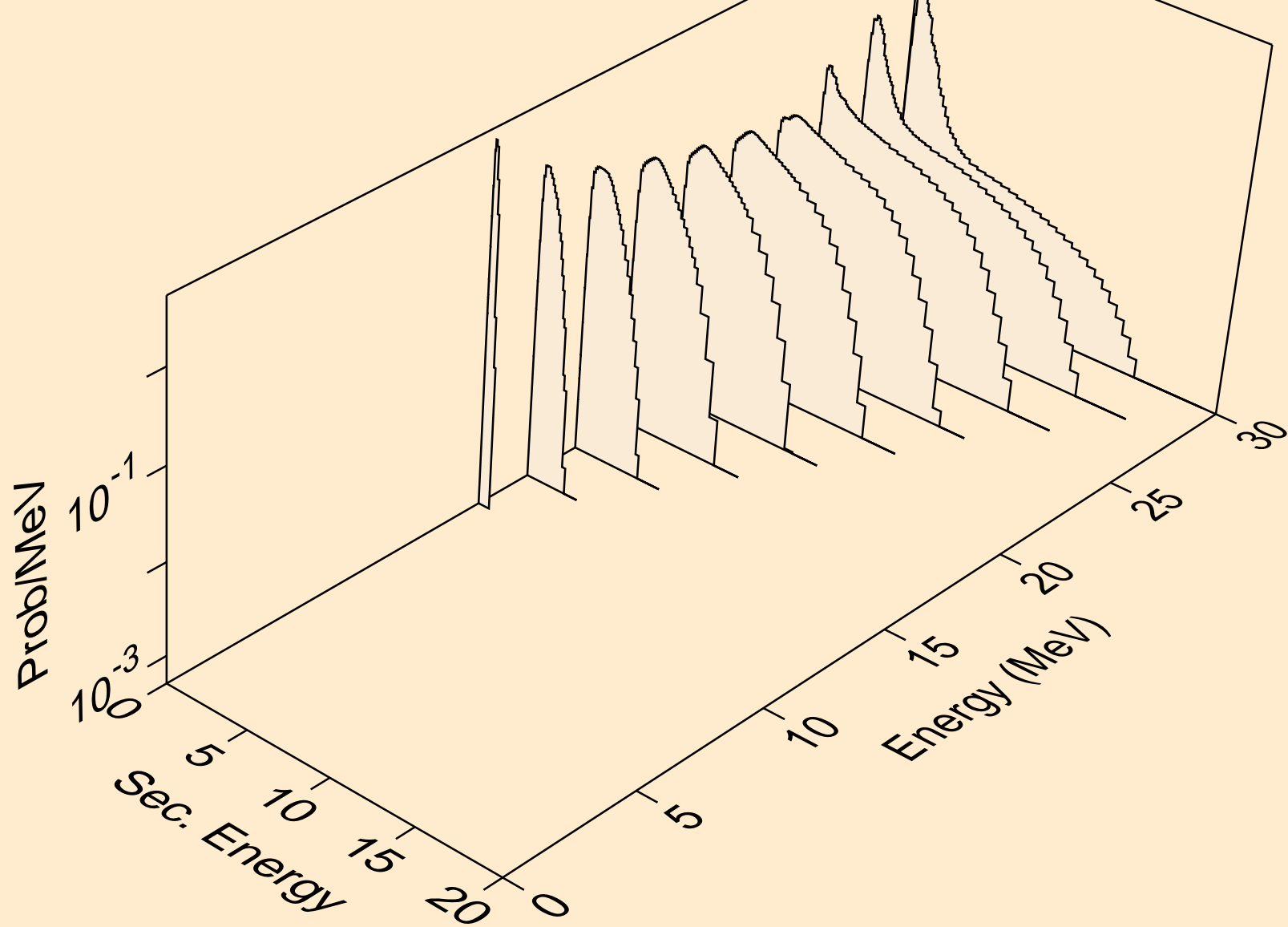

BH273 NEUTRON ACER TENDL-2021 LIBRARY; T=293.6K
Neutron emission for (n,n*)p

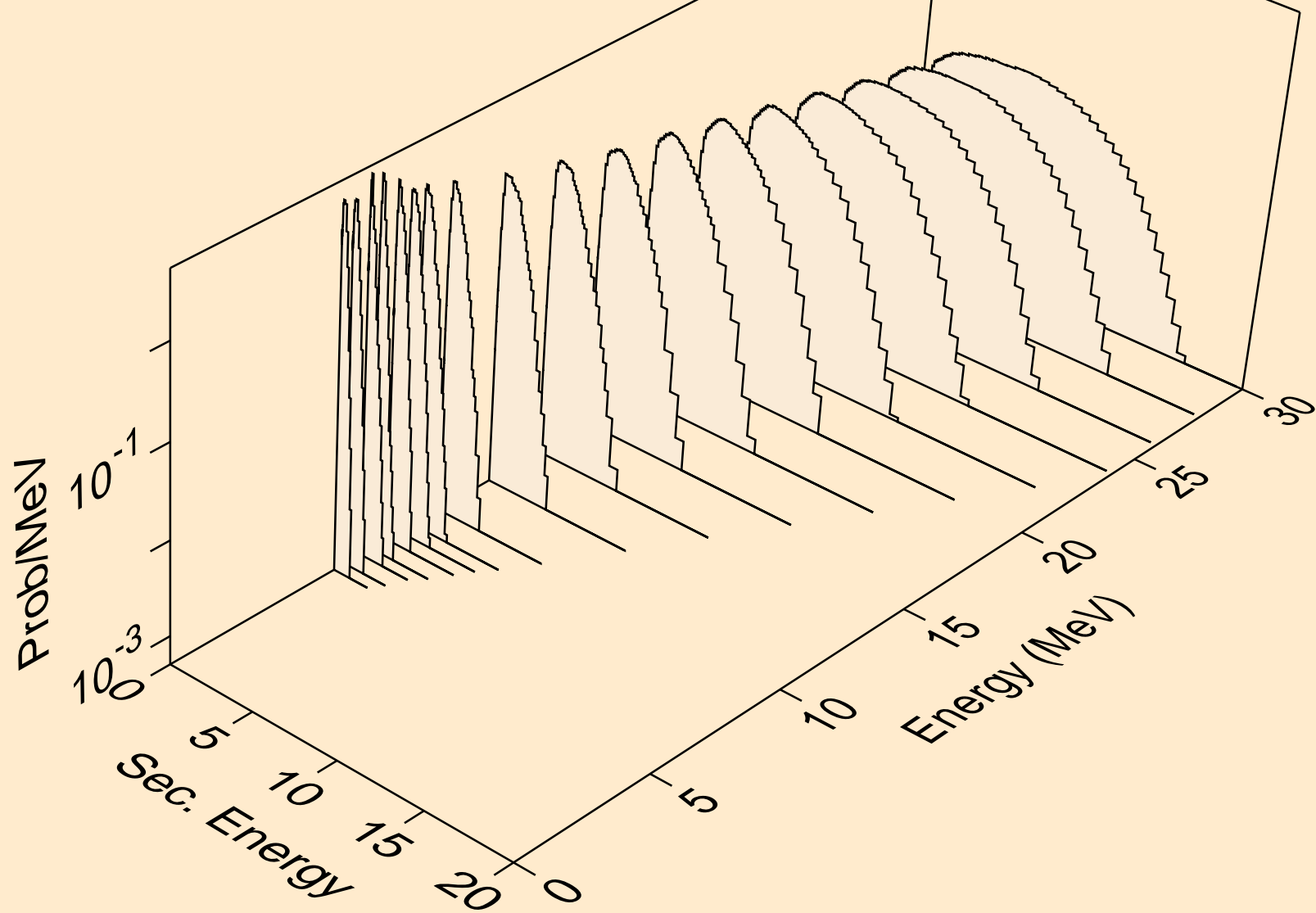

BH273 NEUTRON ACER TENDL-2021 LIBRARY; T=293.6K
Neutron emission for (n,n*)d

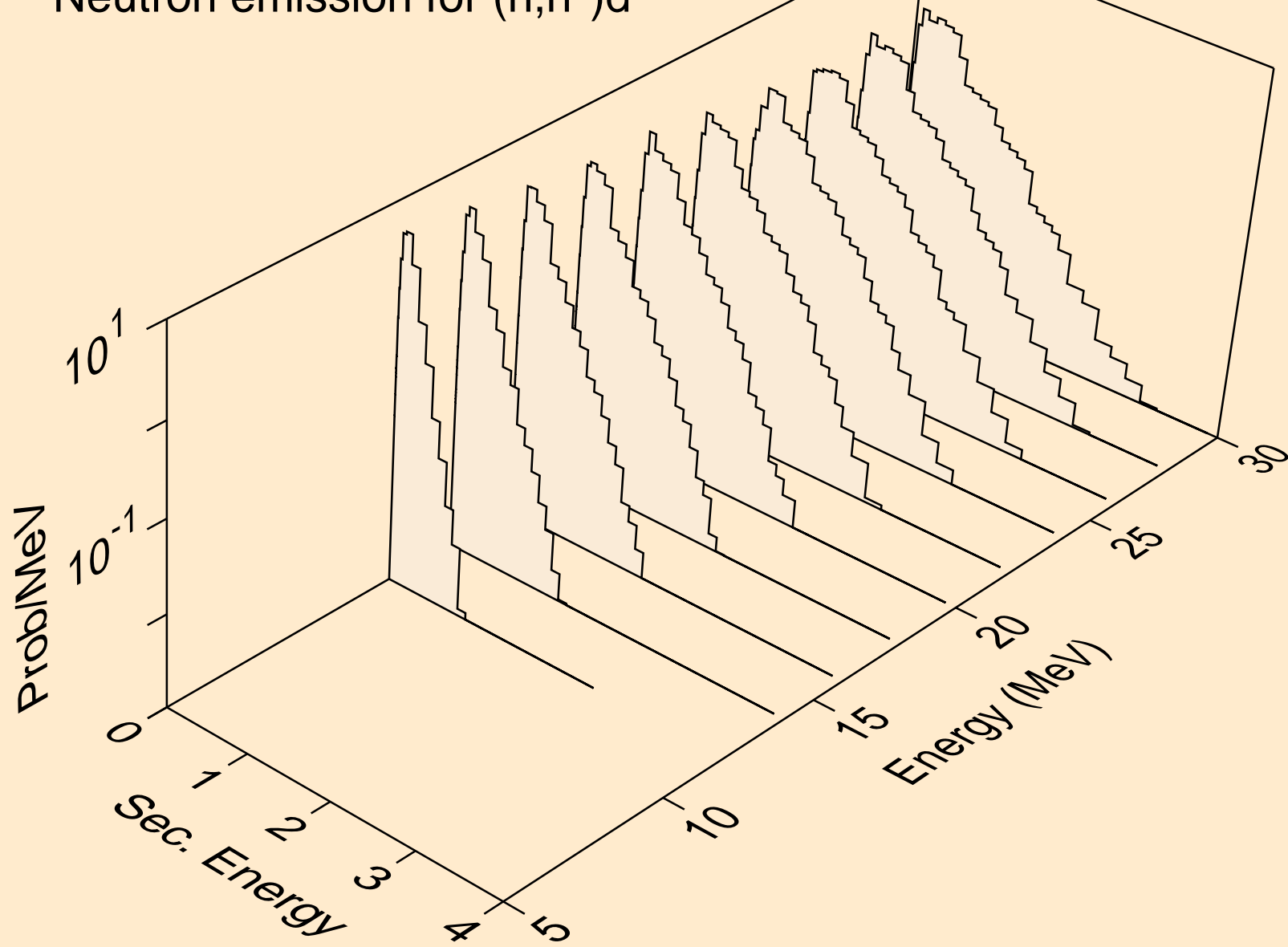

BH273 NEUTRON ACER TENDL-2021 LIBRARY; T=293.6K
Neutron emission for (n,n*)t

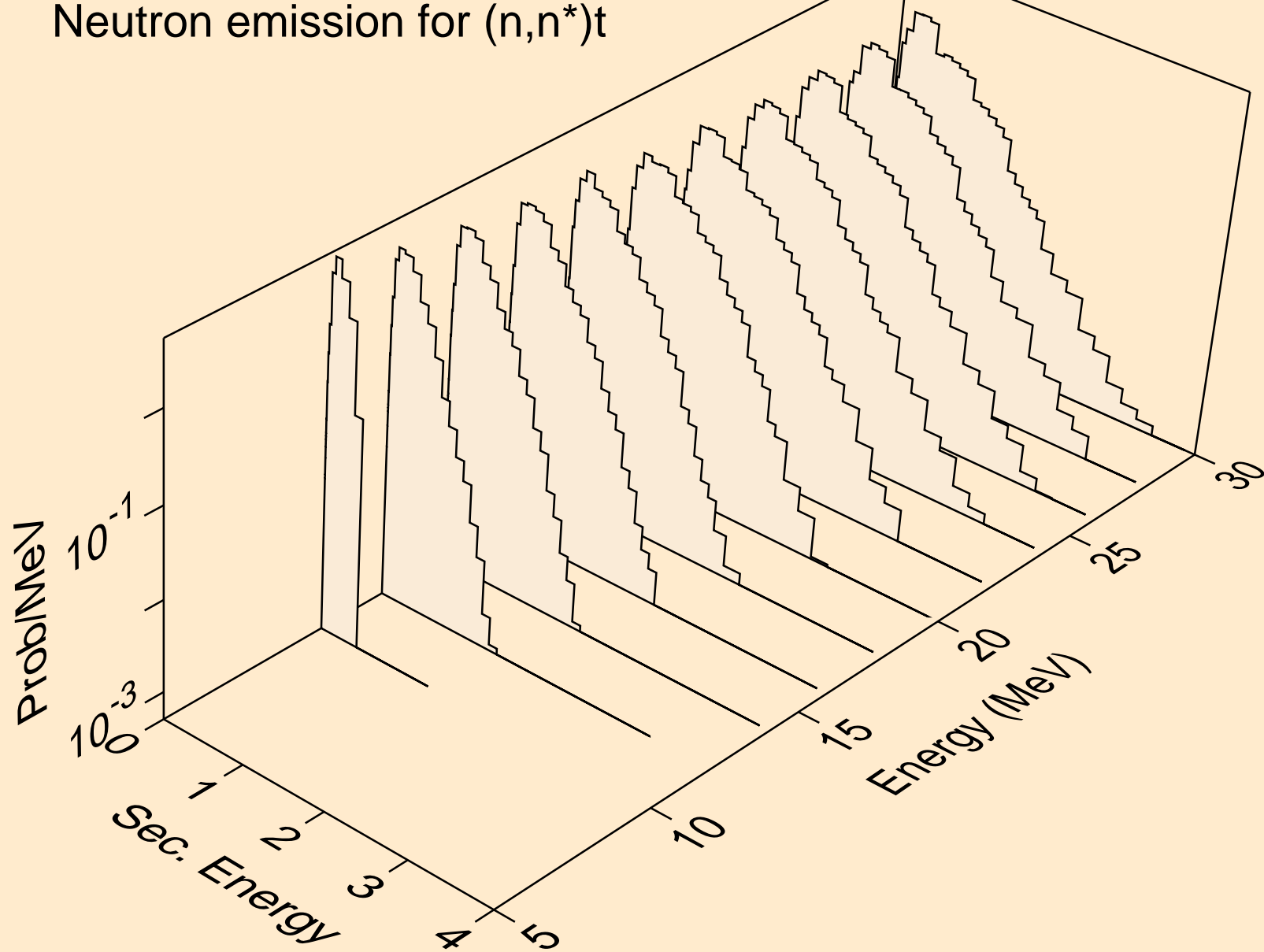

BH273 NEUTRON ACER TENDL-2021 LIBRARY; T=293.6K
Neutron emission for (n,4n)

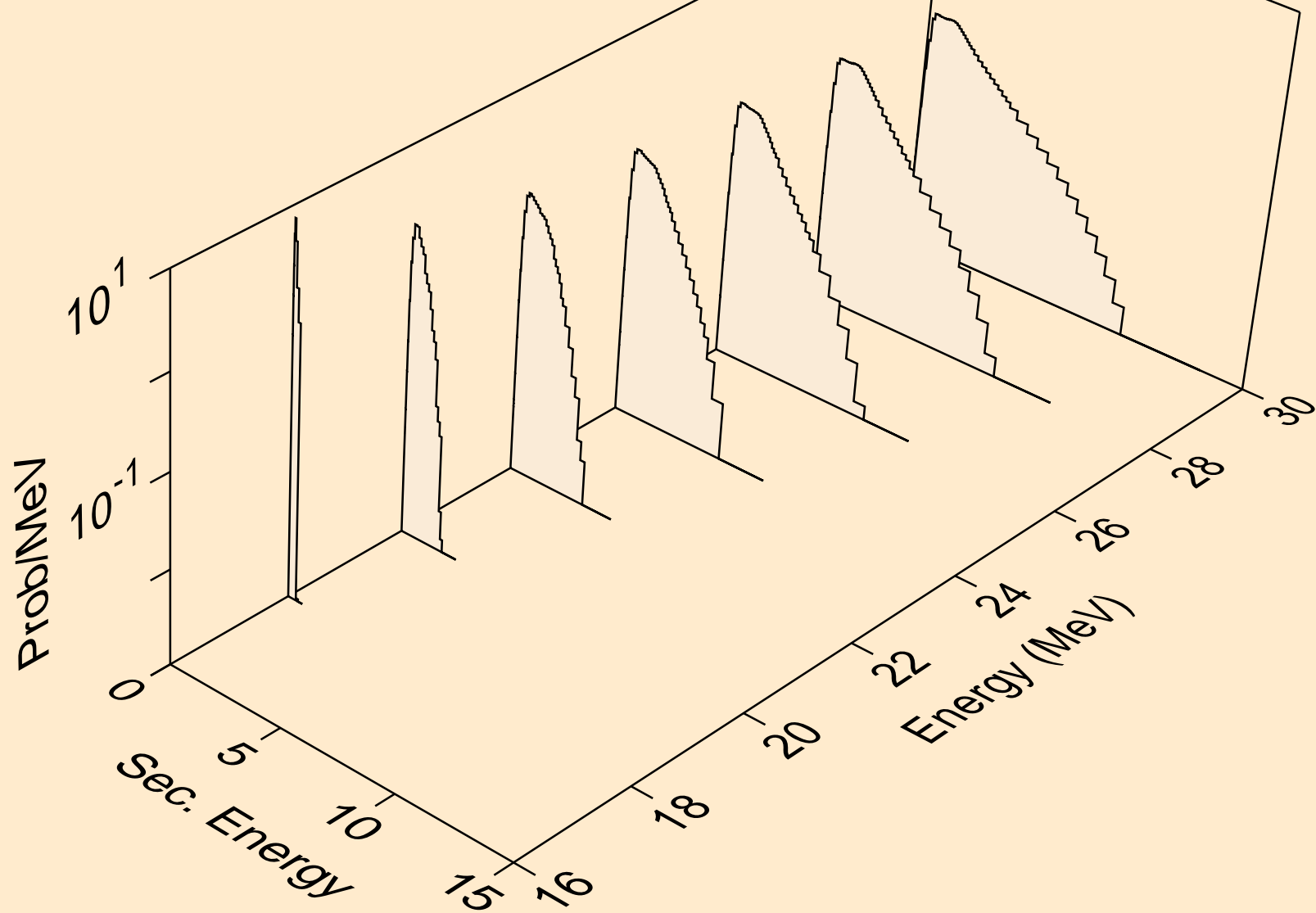

BH273 NEUTRON ACER TENDL-2021 LIBRARY; T=293.6K
Neutron emission for (n,2np)

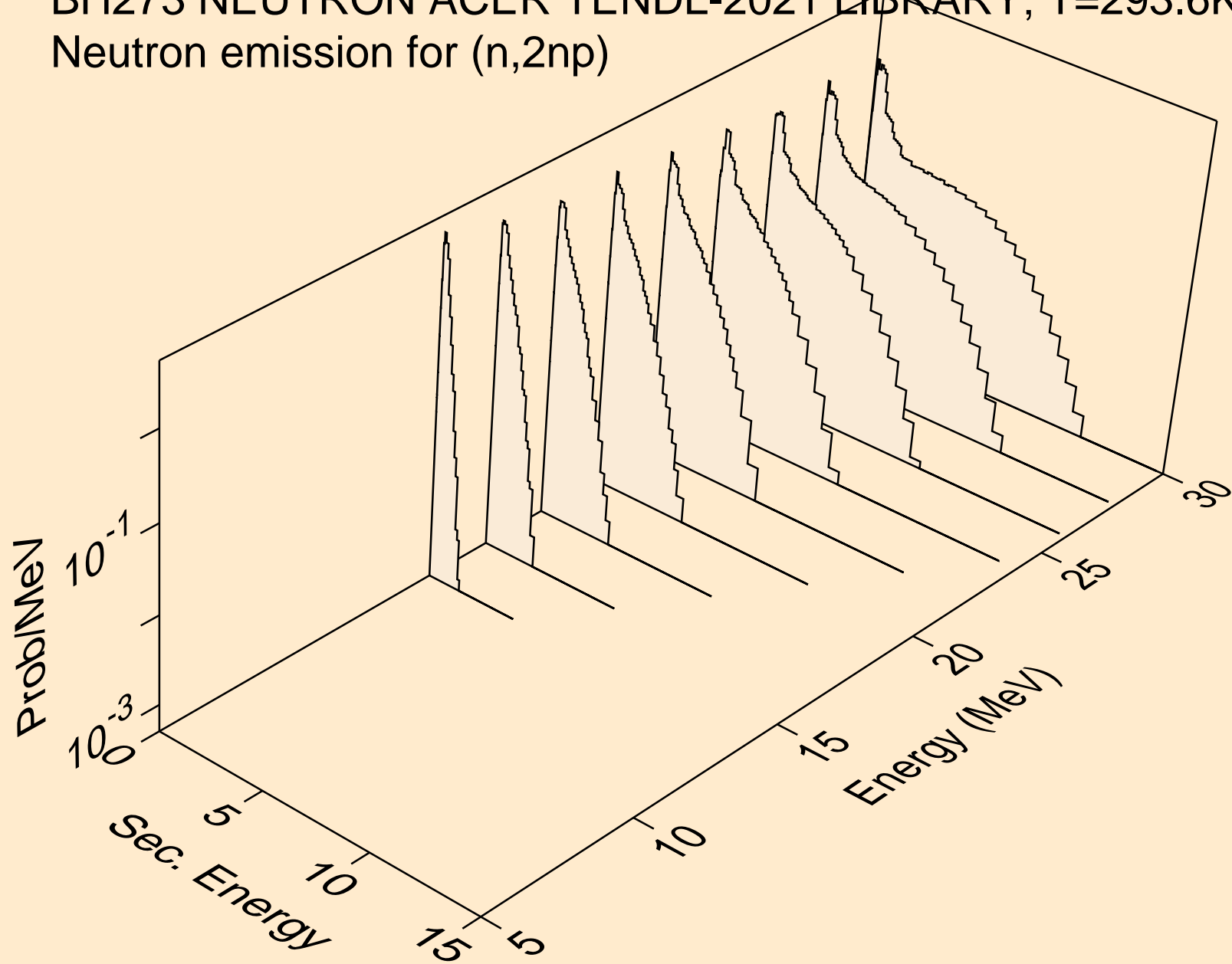

BH273 NEUTRON ACER TENDL-2021 LIBRARY; T=293.6K
Neutron emission for (n,3np)

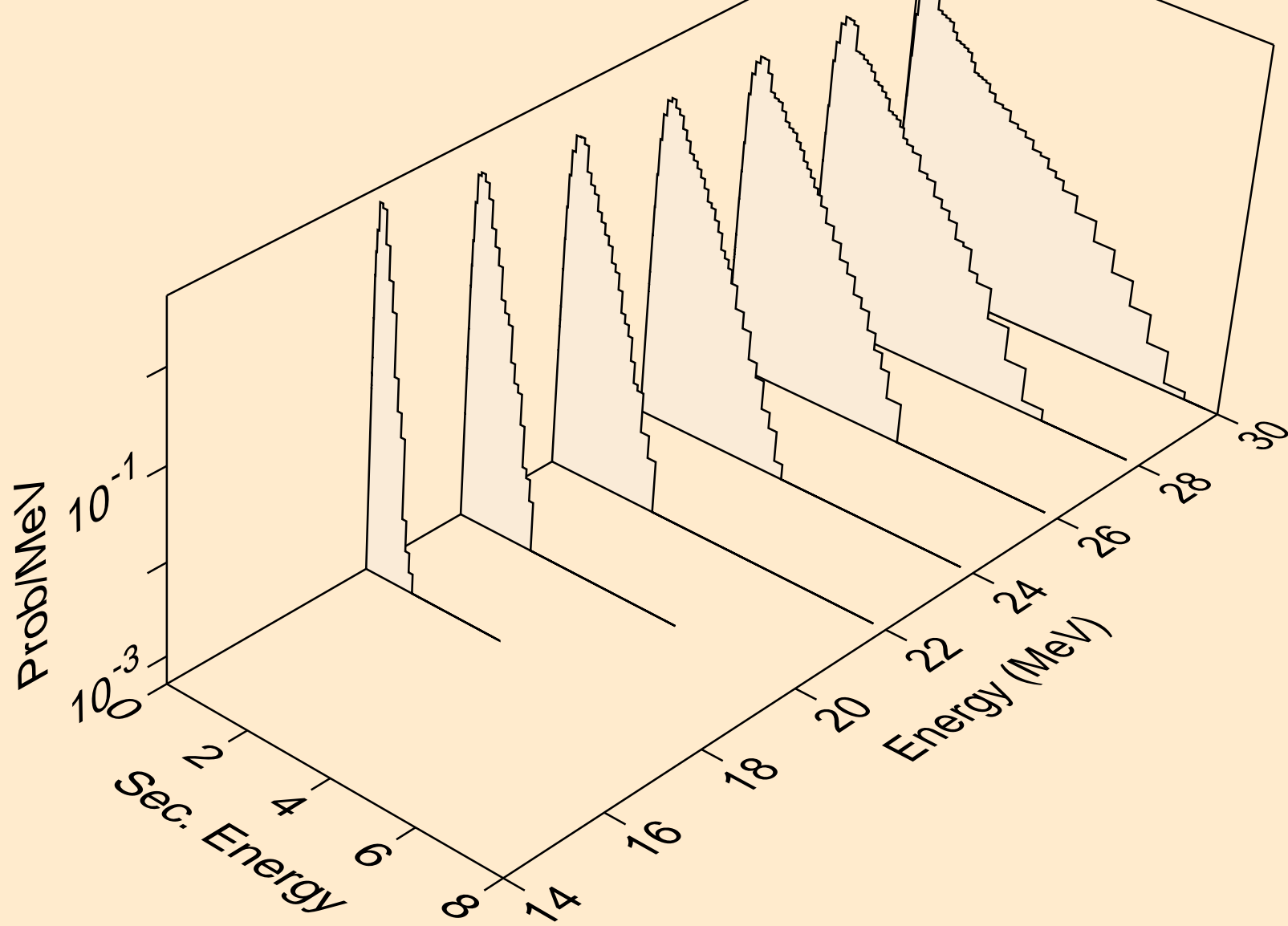

BH273 NEUTRON ACER TENDL-2021 LIBRARY; T=293.6K
Neutron emission for (n,n*c)

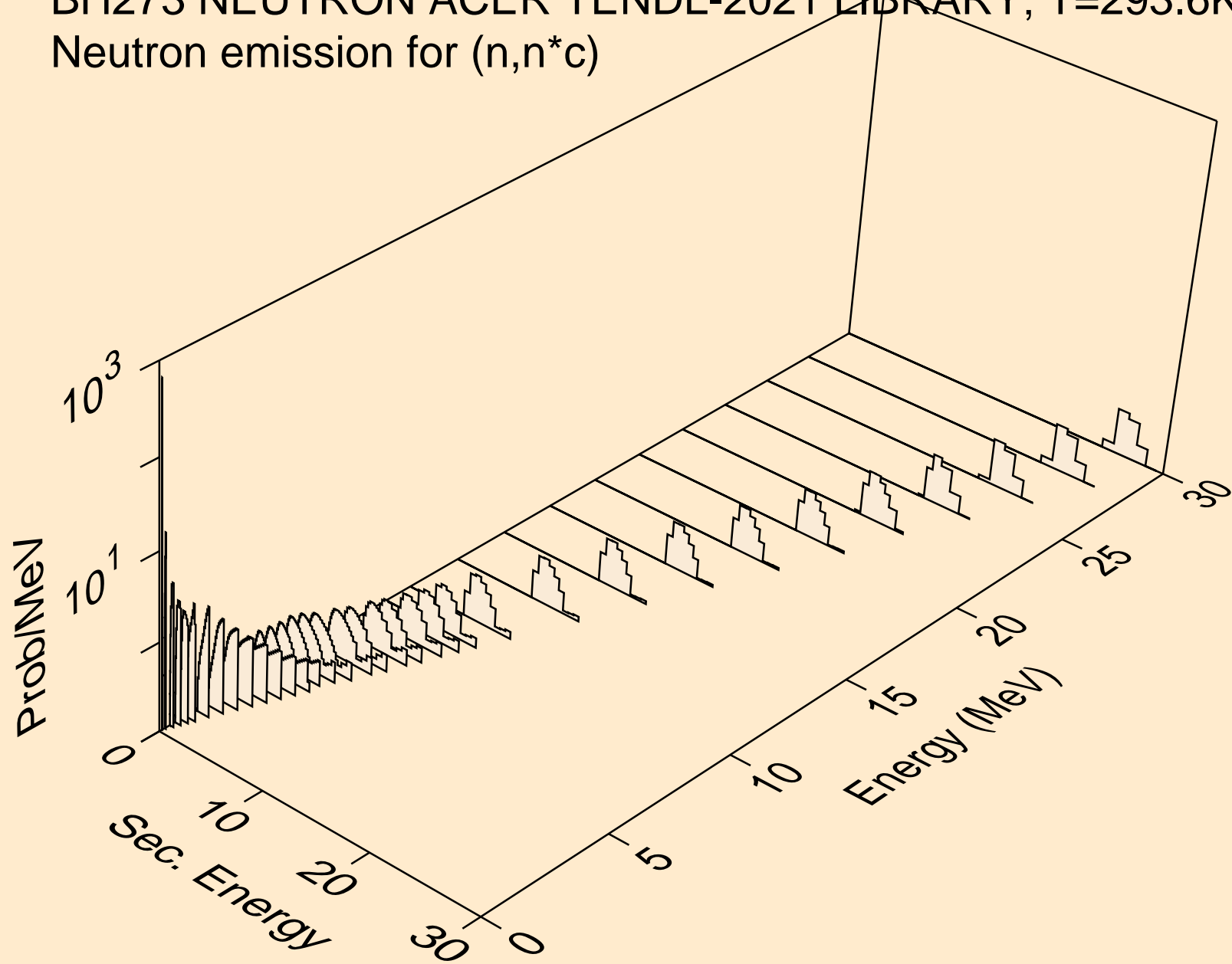

BH273 NEUTRON ACER TENDL-2021 LIBRARY; T=293.6K

Delayed nubar

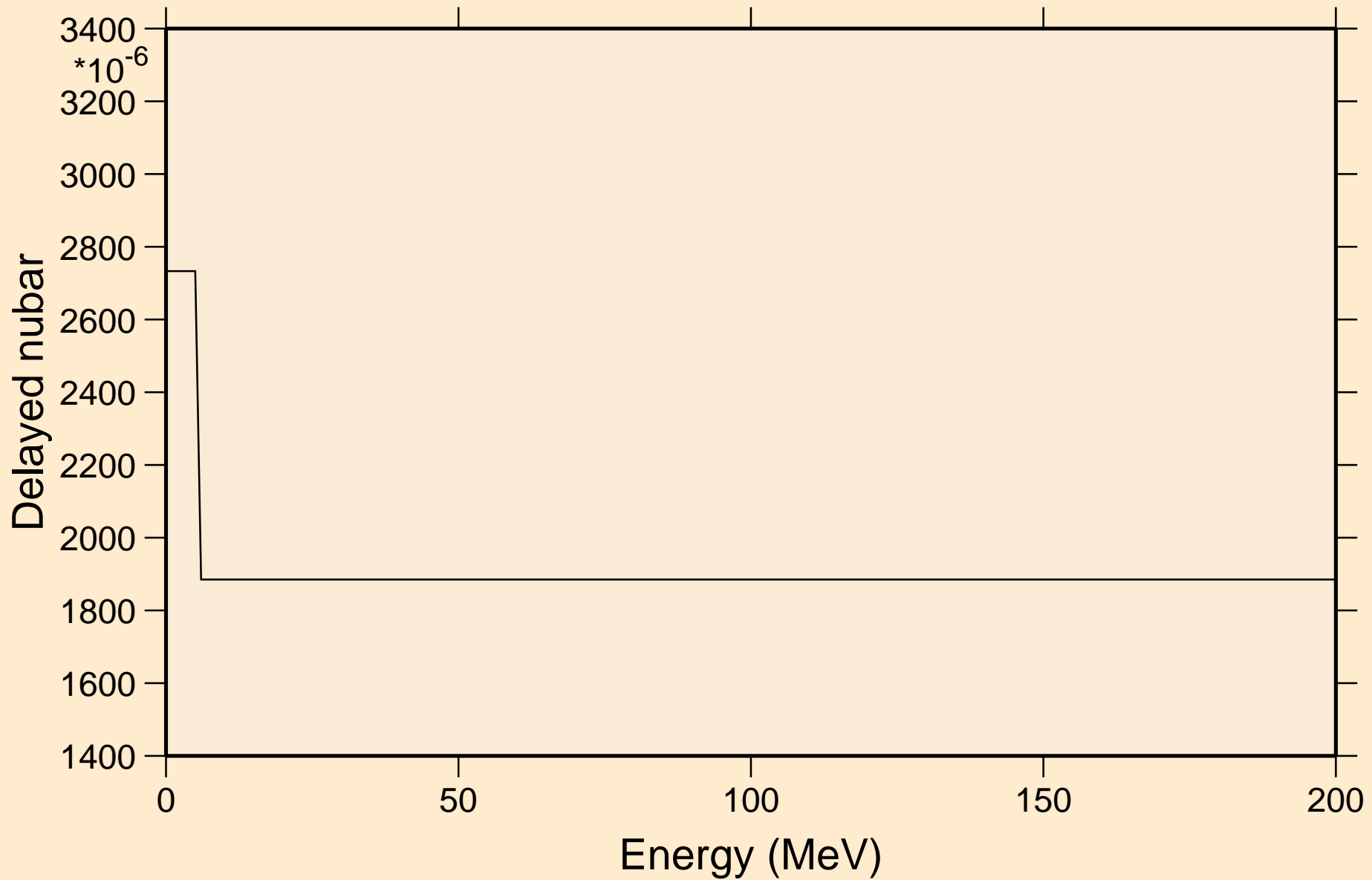

BH273 NEUTRON ACER TENDL-2021 LIBRARY; T=293.6K

Delayed neutron spectra

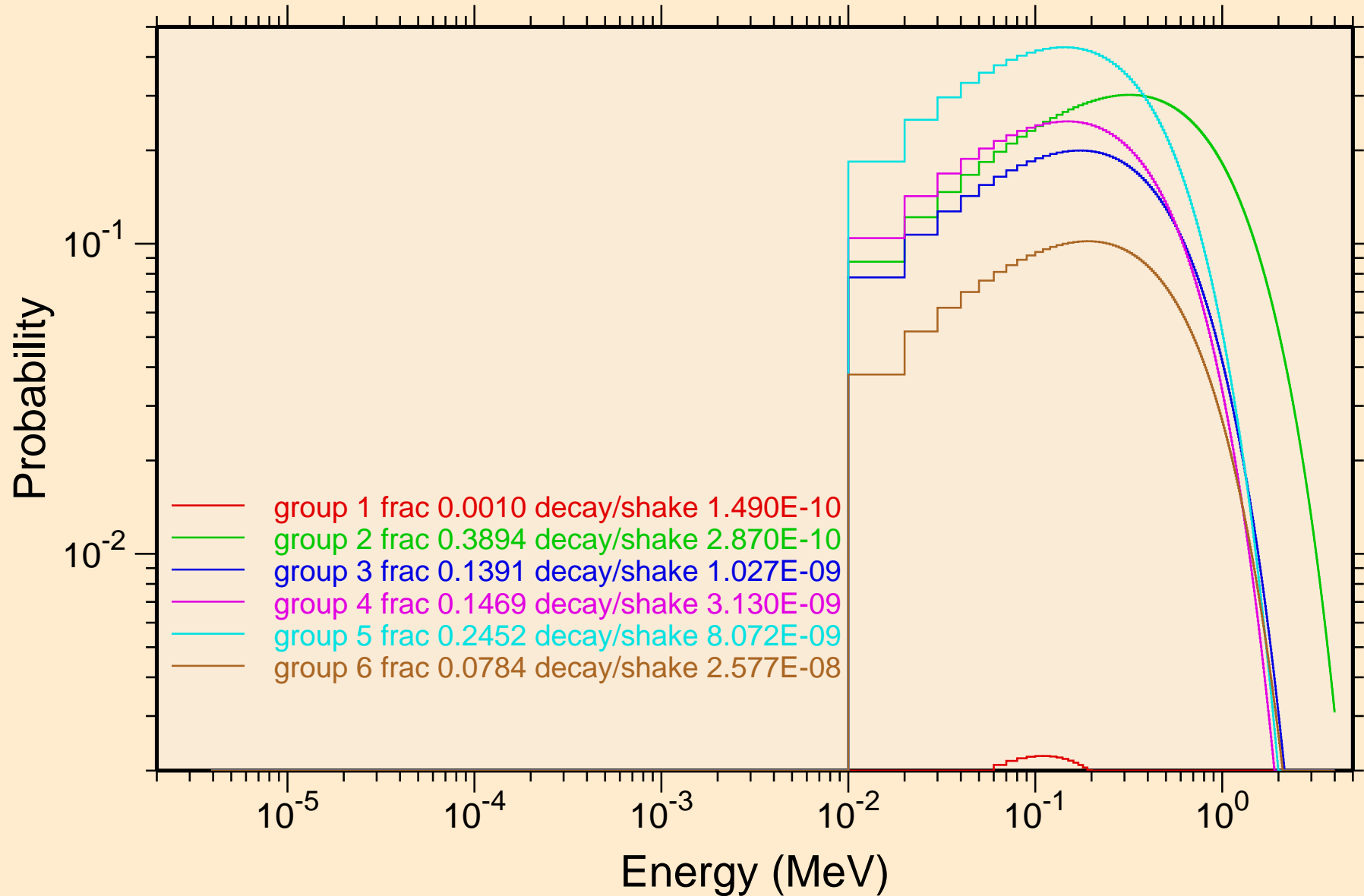

BH273 NEUTRON ACER TENDL-2021 LIBRARY; T=293.6K
Photon emission for (n,x)

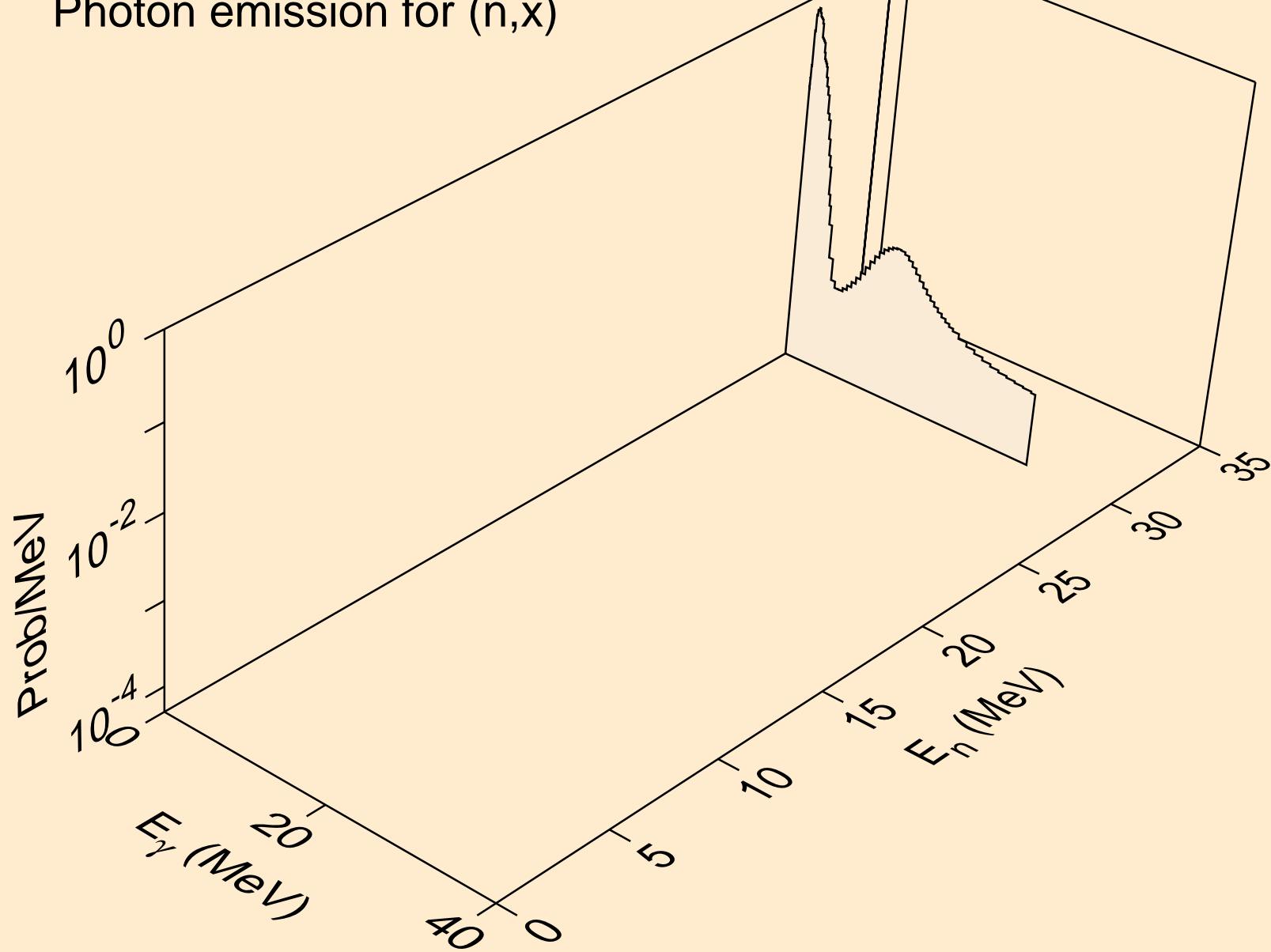

BH273 NEUTRON ACER TENDL-2021 LIBRARY; T=293.6K
Photon emission for (n,2nd)

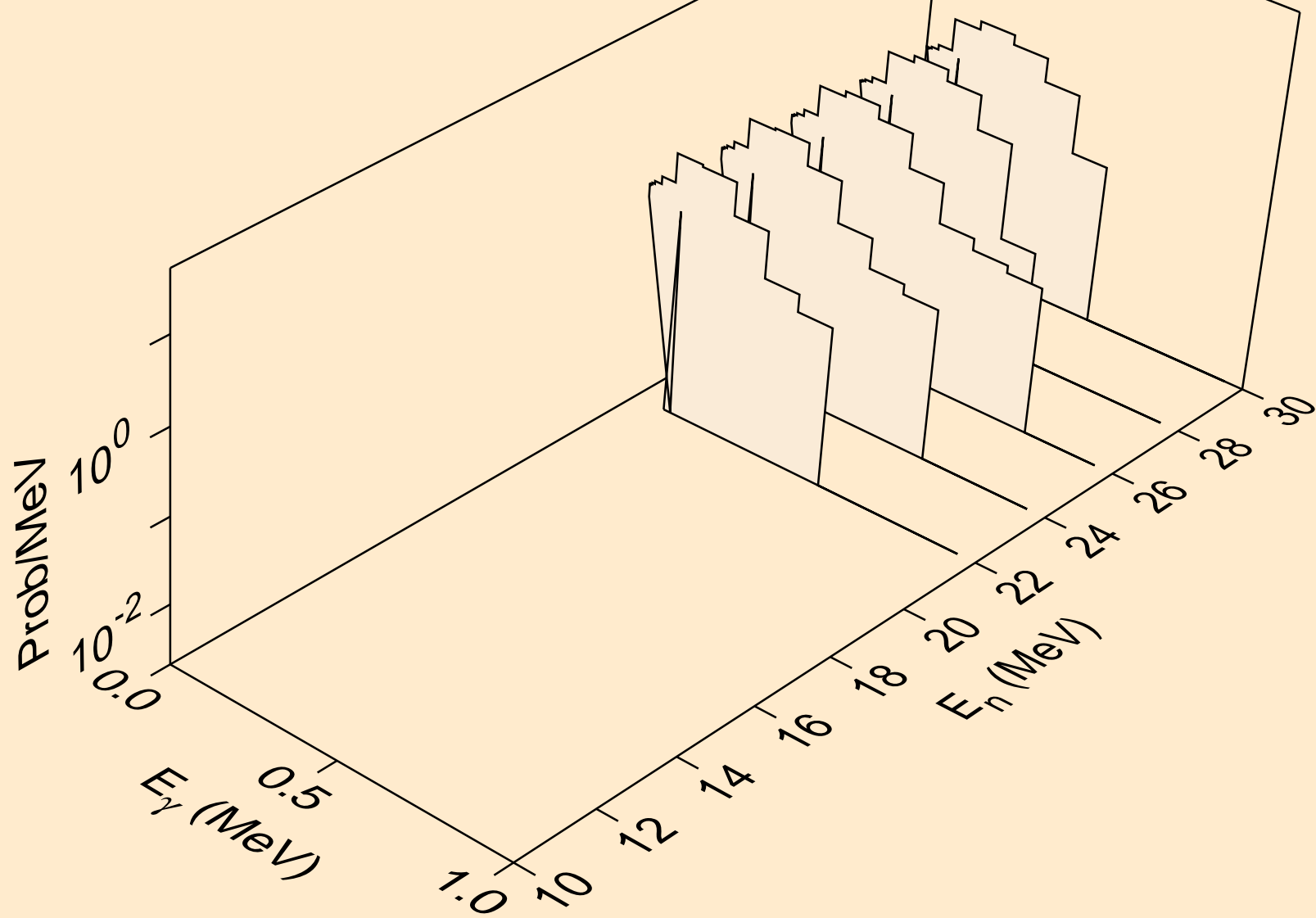

BH273 NEUTRON ACER TENDL-2021 LIBRARY; T=293.6K
Photon emission for (n,2n)

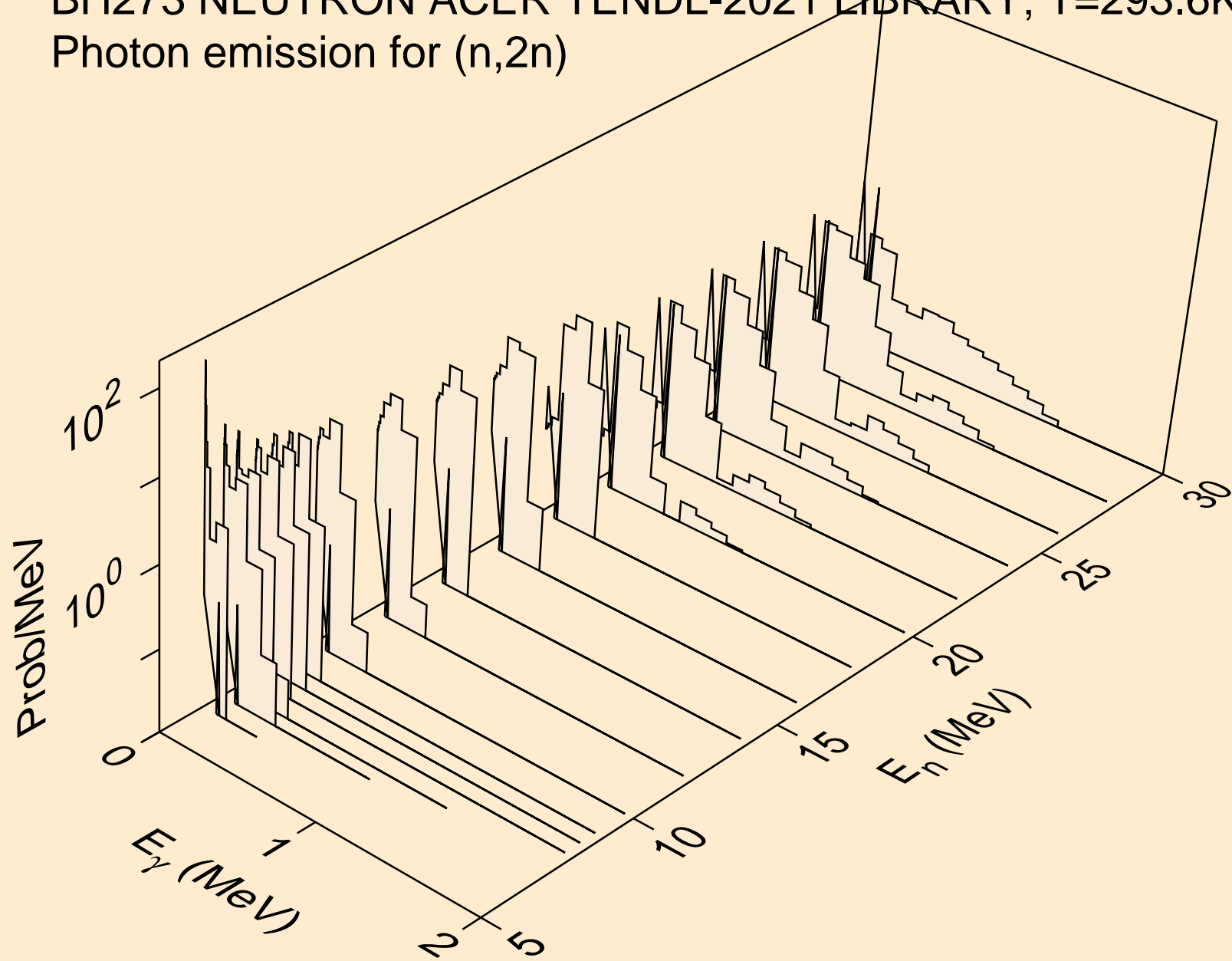

BH273 NEUTRON ACER TENDL-2021 LIBRARY; T=293.6K
Photon emission for (n,3n)

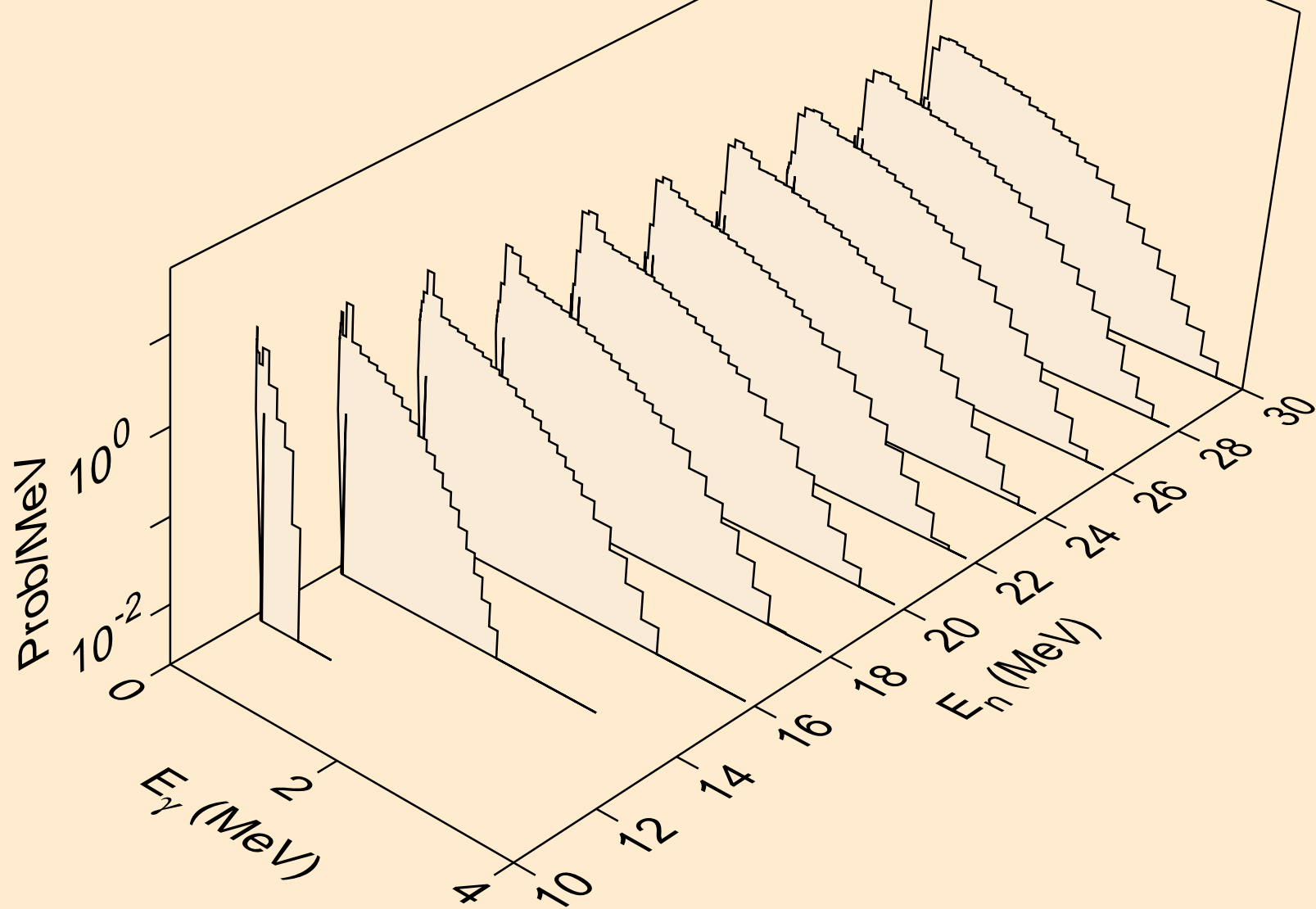

BH273 NEUTRON ACER TENDL-2021 LIBRARY; T=293.6K
Photon emission for (n,n*)a

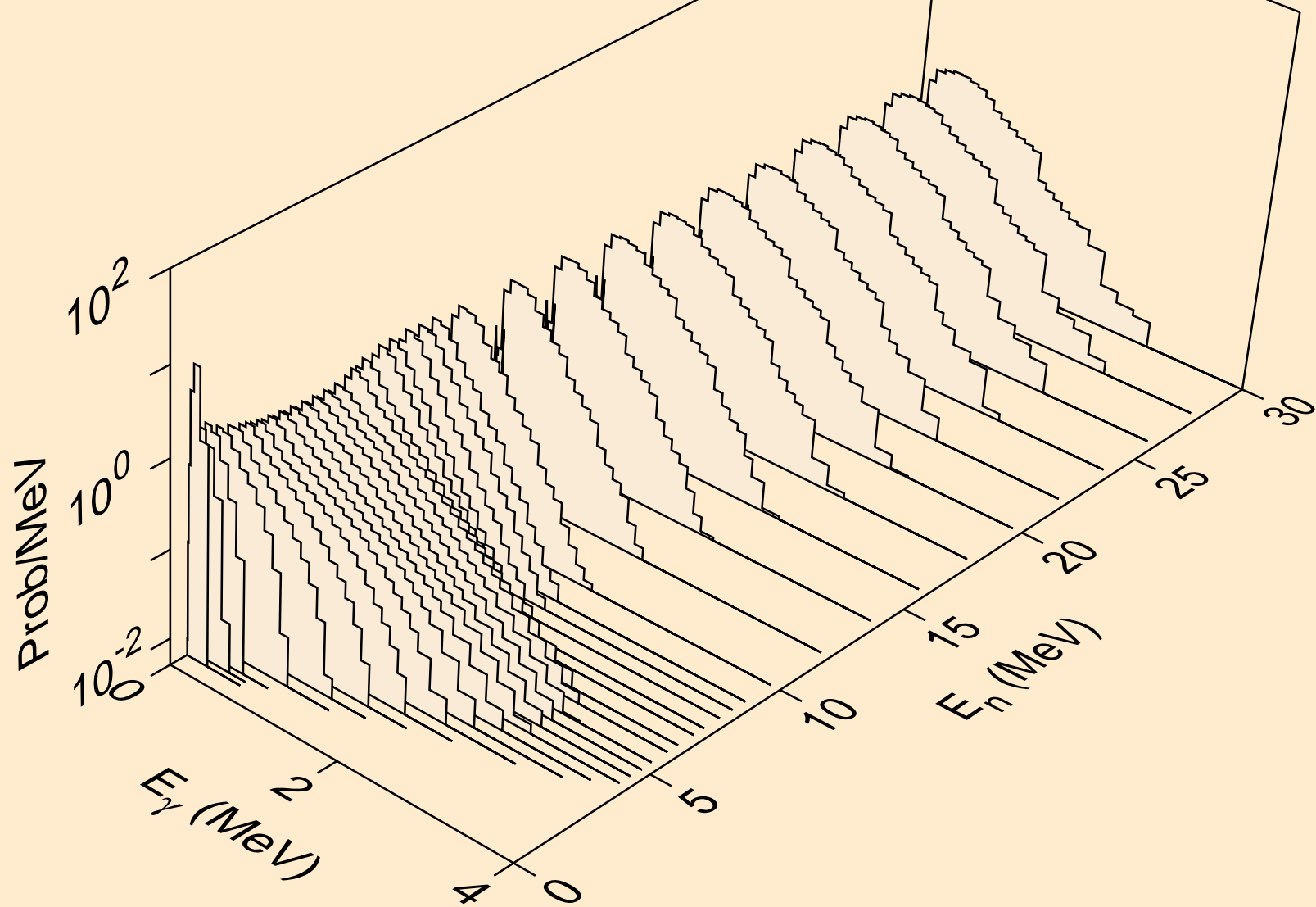

BH273 NEUTRON ACER TENDL-2021 LIBRARY; T=293.6K
Photon emission for (n,2n)a

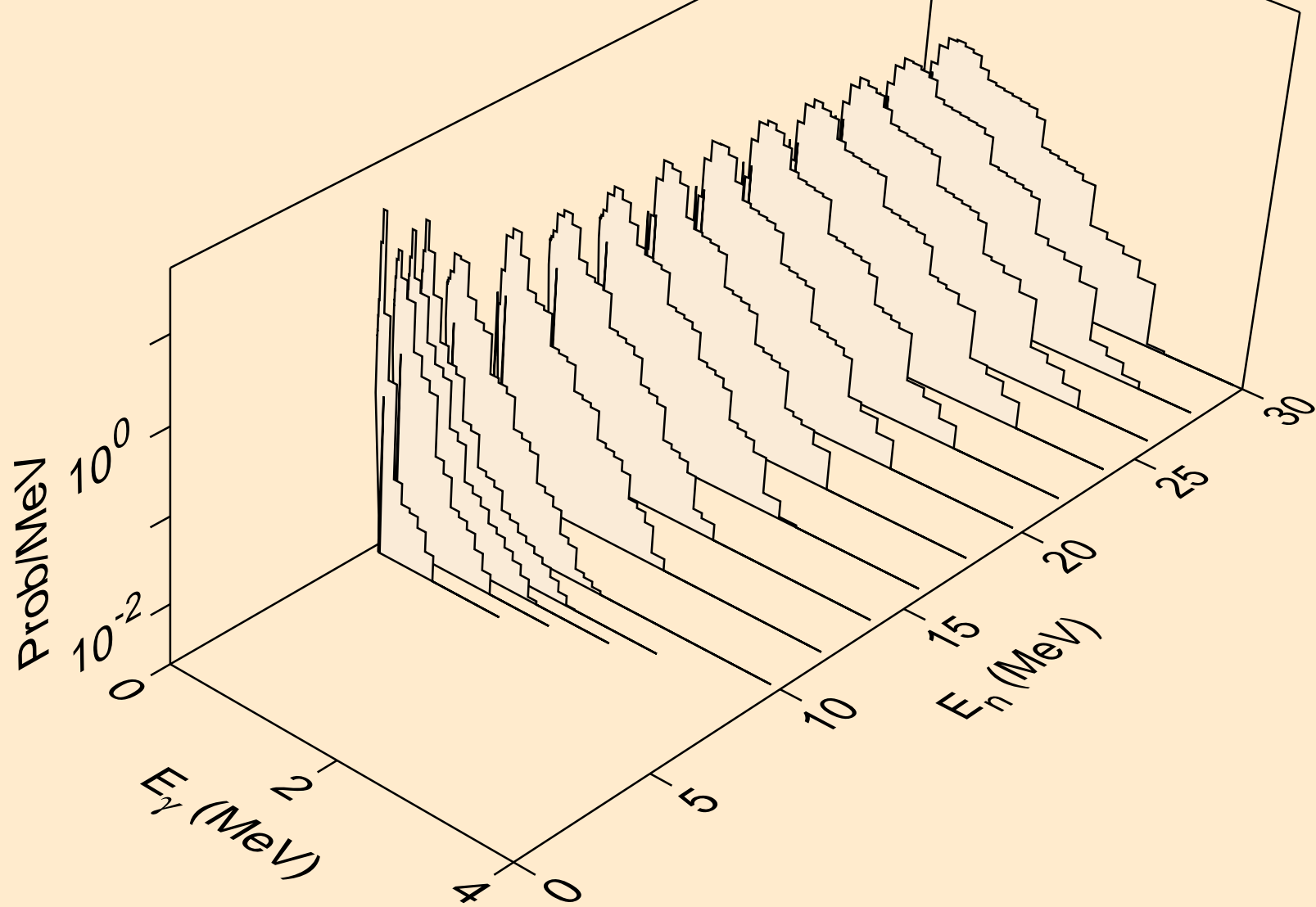

BH273 NEUTRON ACER TENDL-2021 LIBRARY; T=293.6K
Photon emission for (n,3n)a

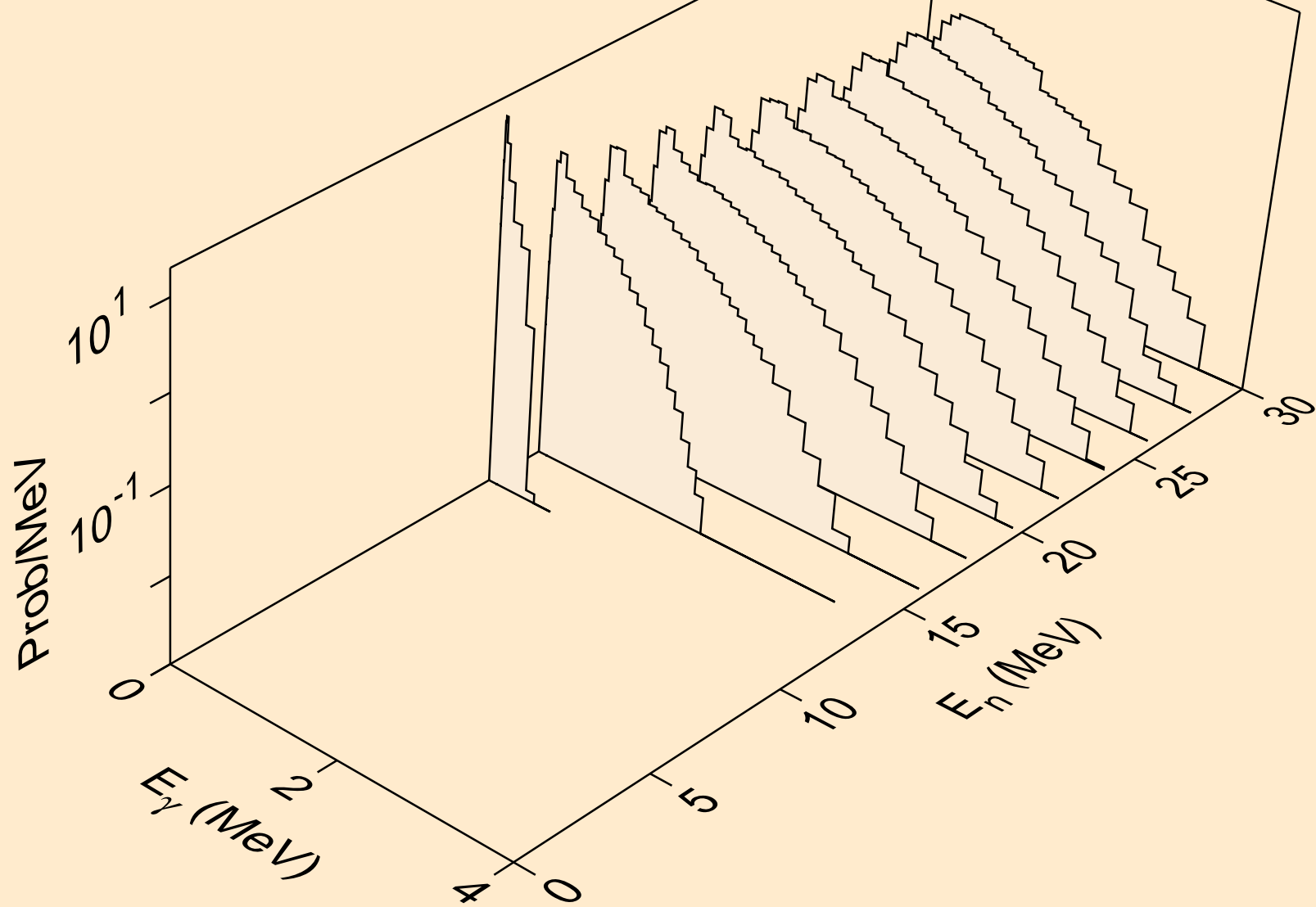

BH273 NEUTRON ACER TENDL-2021 LIBRARY; T=293.6K
Photon emission for (n,n*)p

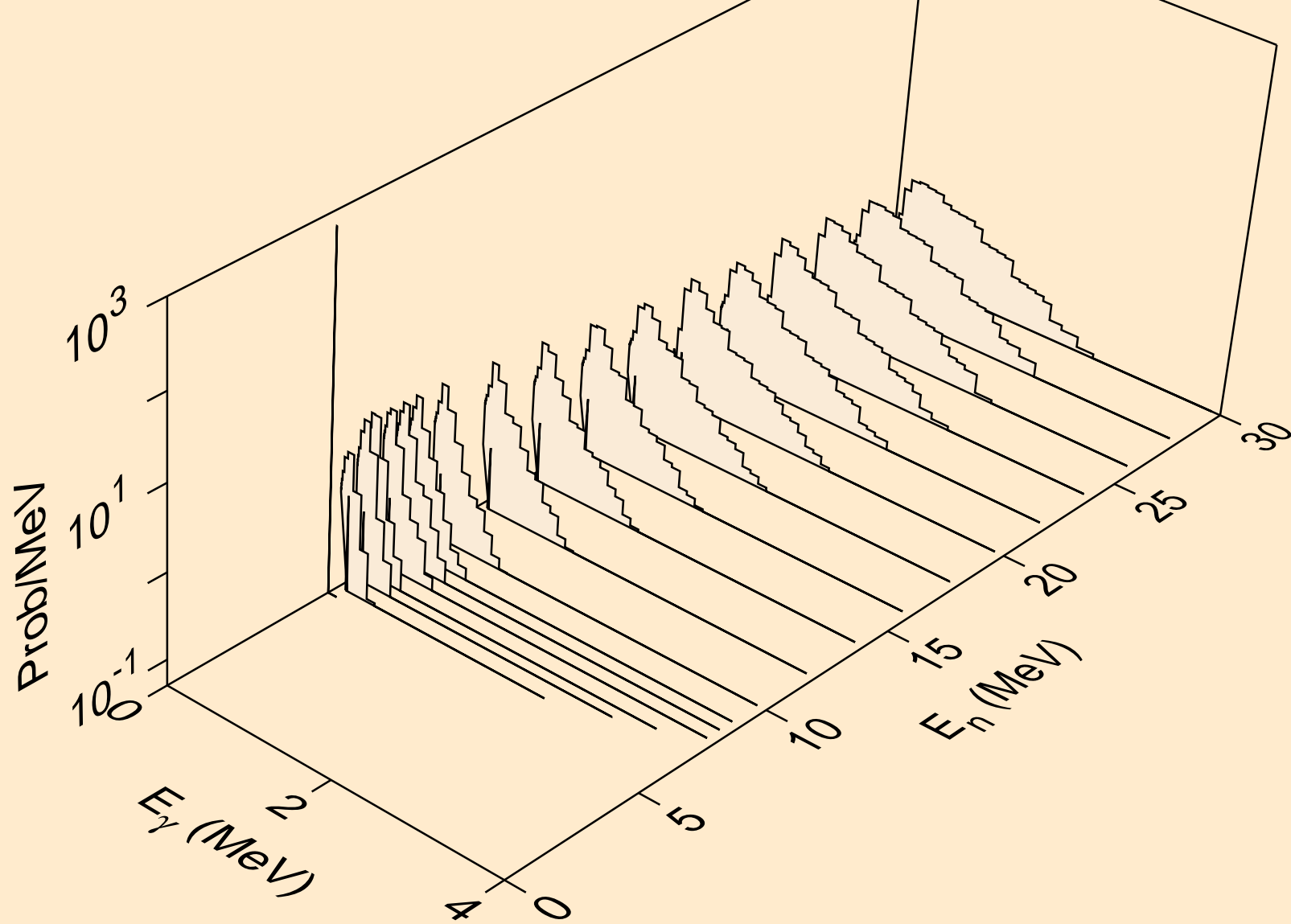

BH273 NEUTRON ACER TENDL-2021 LIBRARY; T=293.6K
Photon emission for (n,n*)d

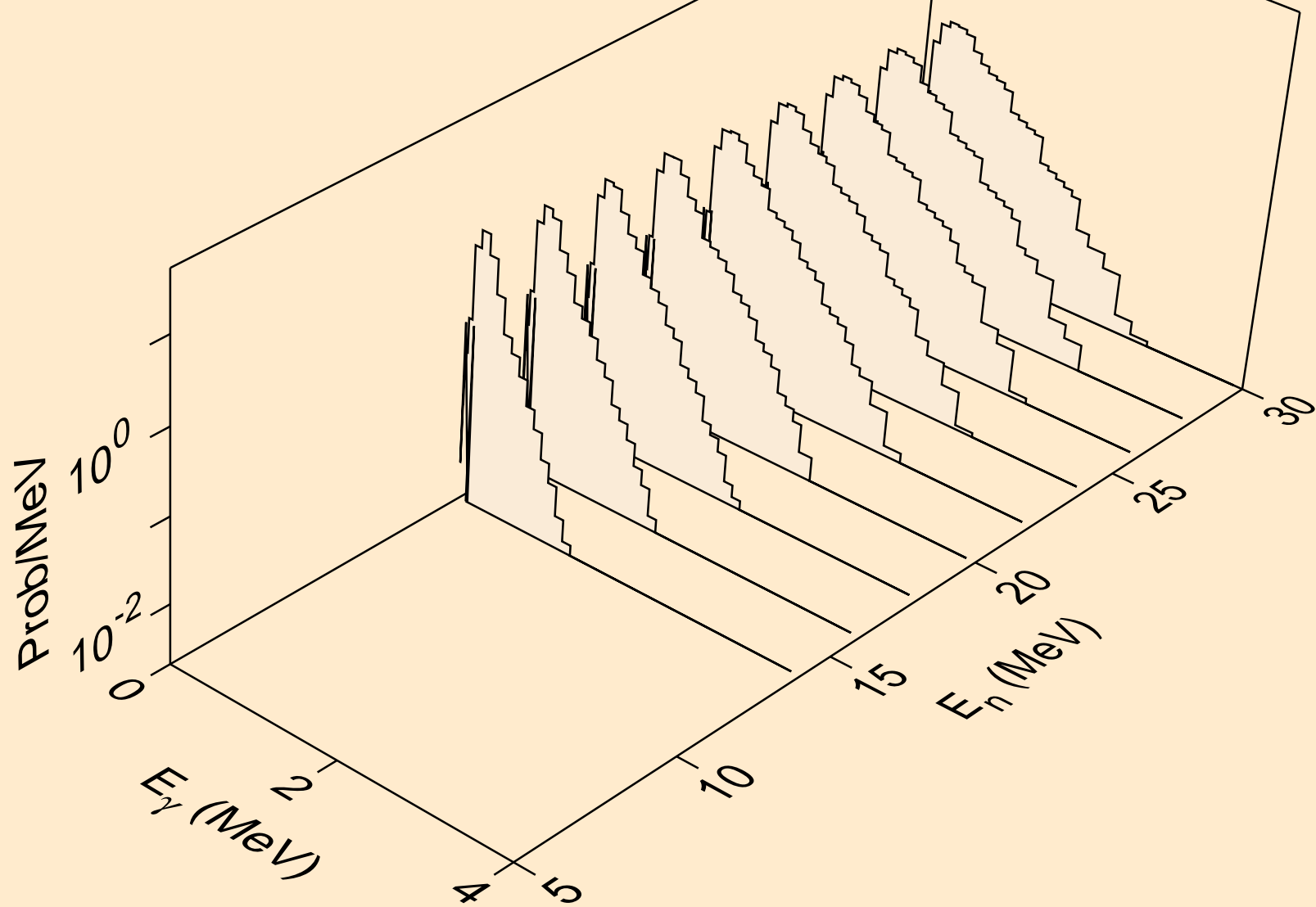

BH273 NEUTRON ACER TENDL-2021 LIBRARY; T=293.6K
Photon emission for (n,n*)t

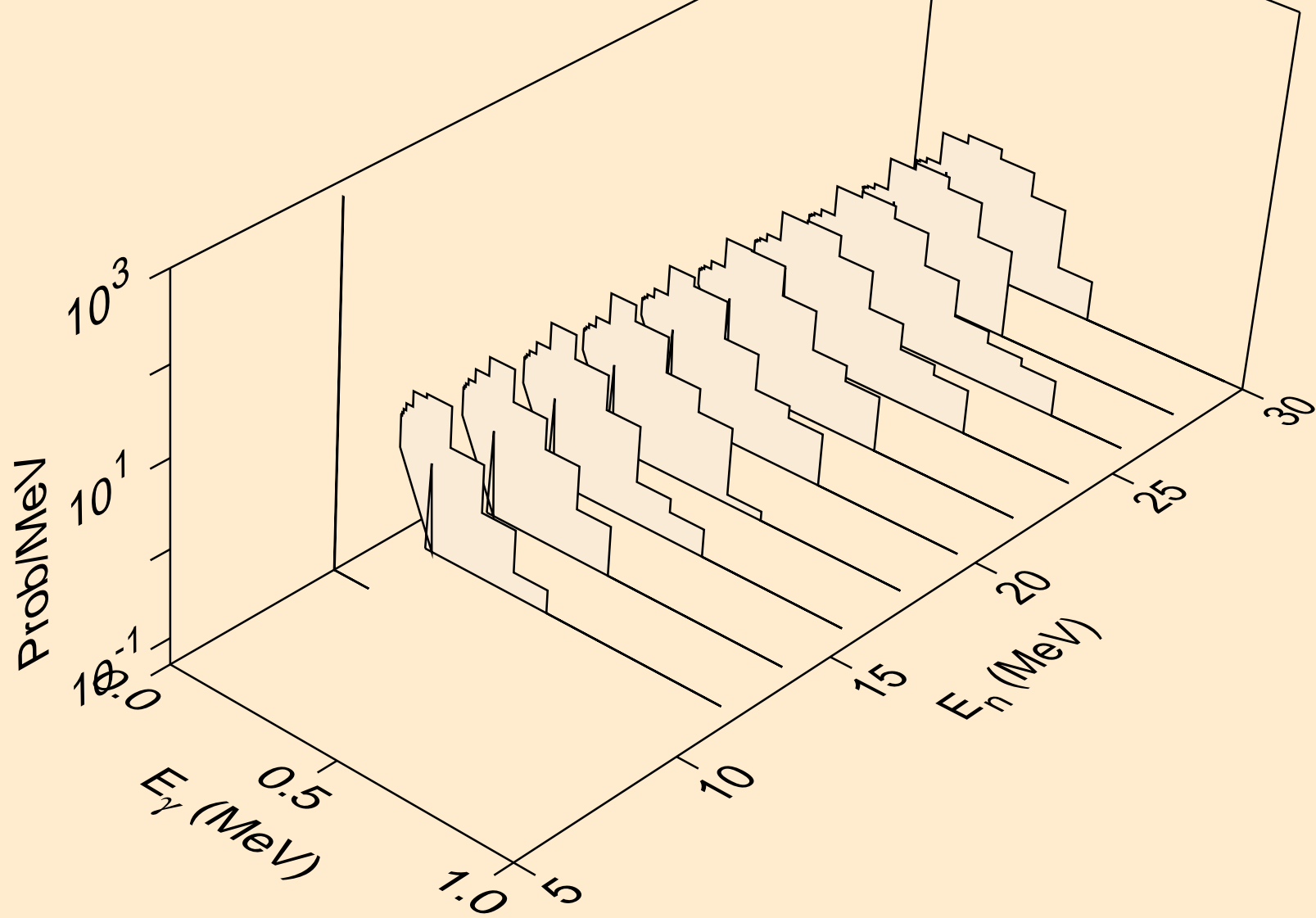

BH273 NEUTRON ACER TENDL-2021 LIBRARY; T=293.6K
Photon emission for (n,4n)

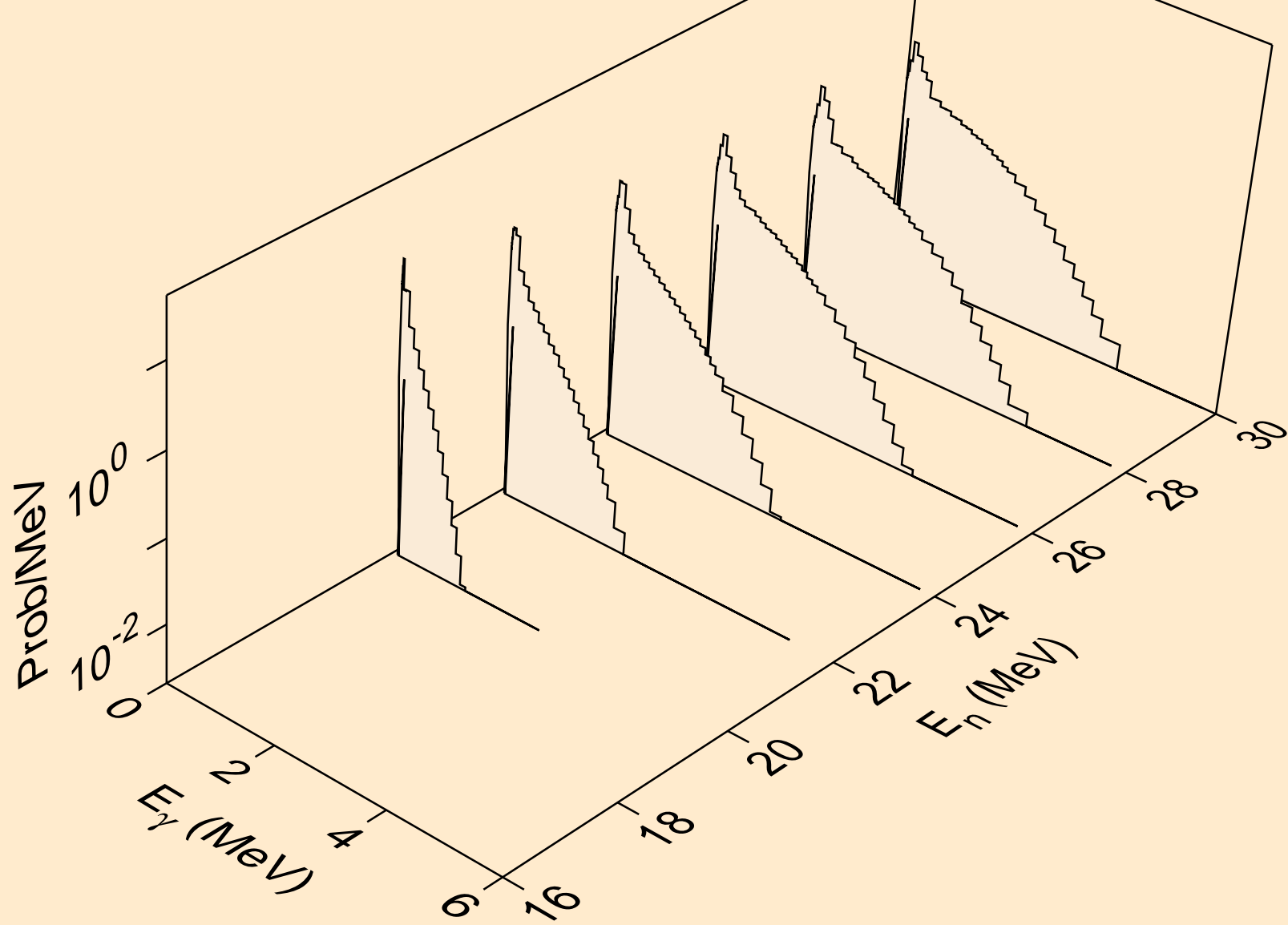

BH273 NEUTRON ACER TENDL-2021 LIBRARY; T=293.6K
Photon emission for (n,2np)

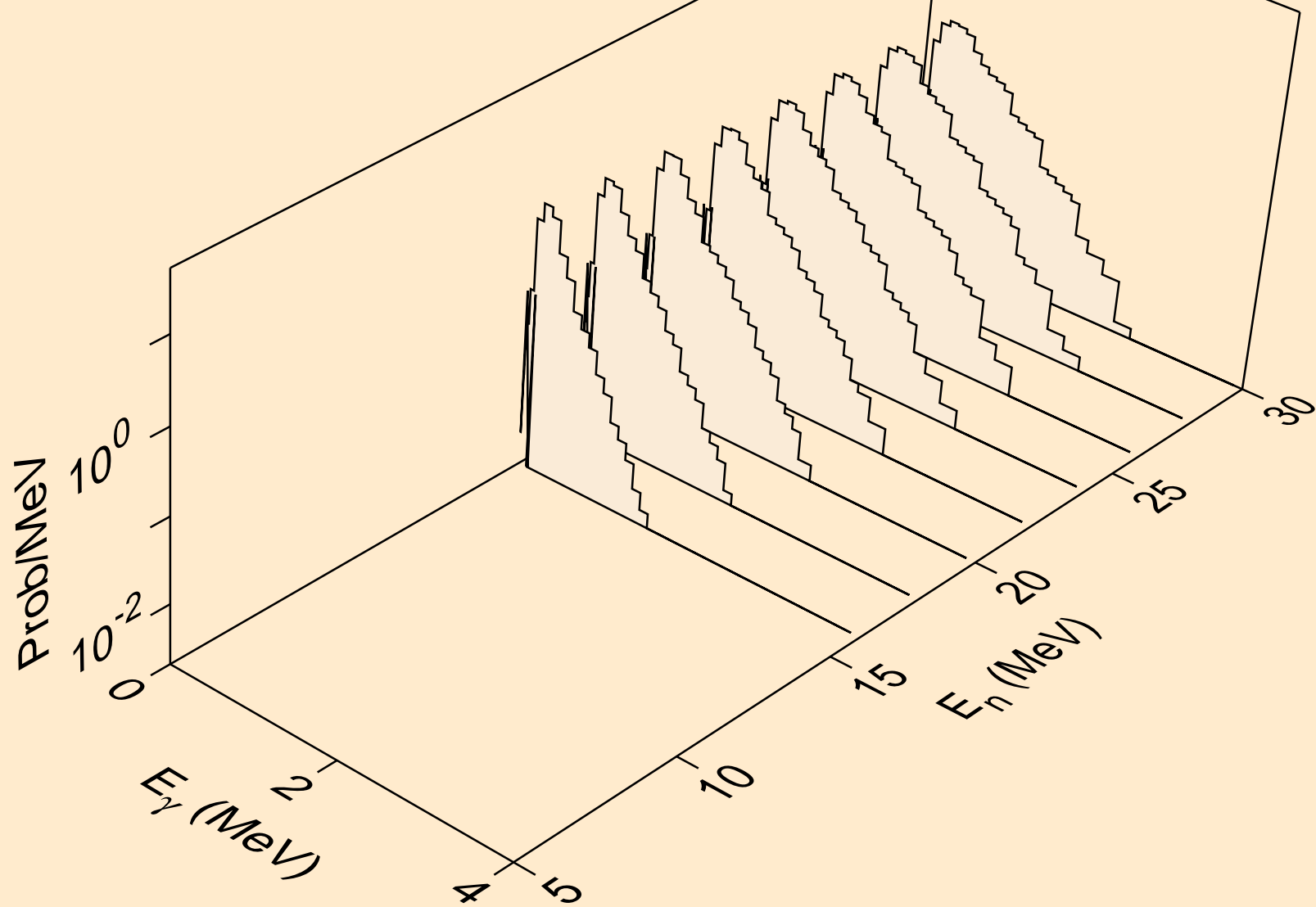

BH273 NEUTRON ACER TENDL-2021 LIBRARY; T=293.6K
Photon emission for (n,3np)

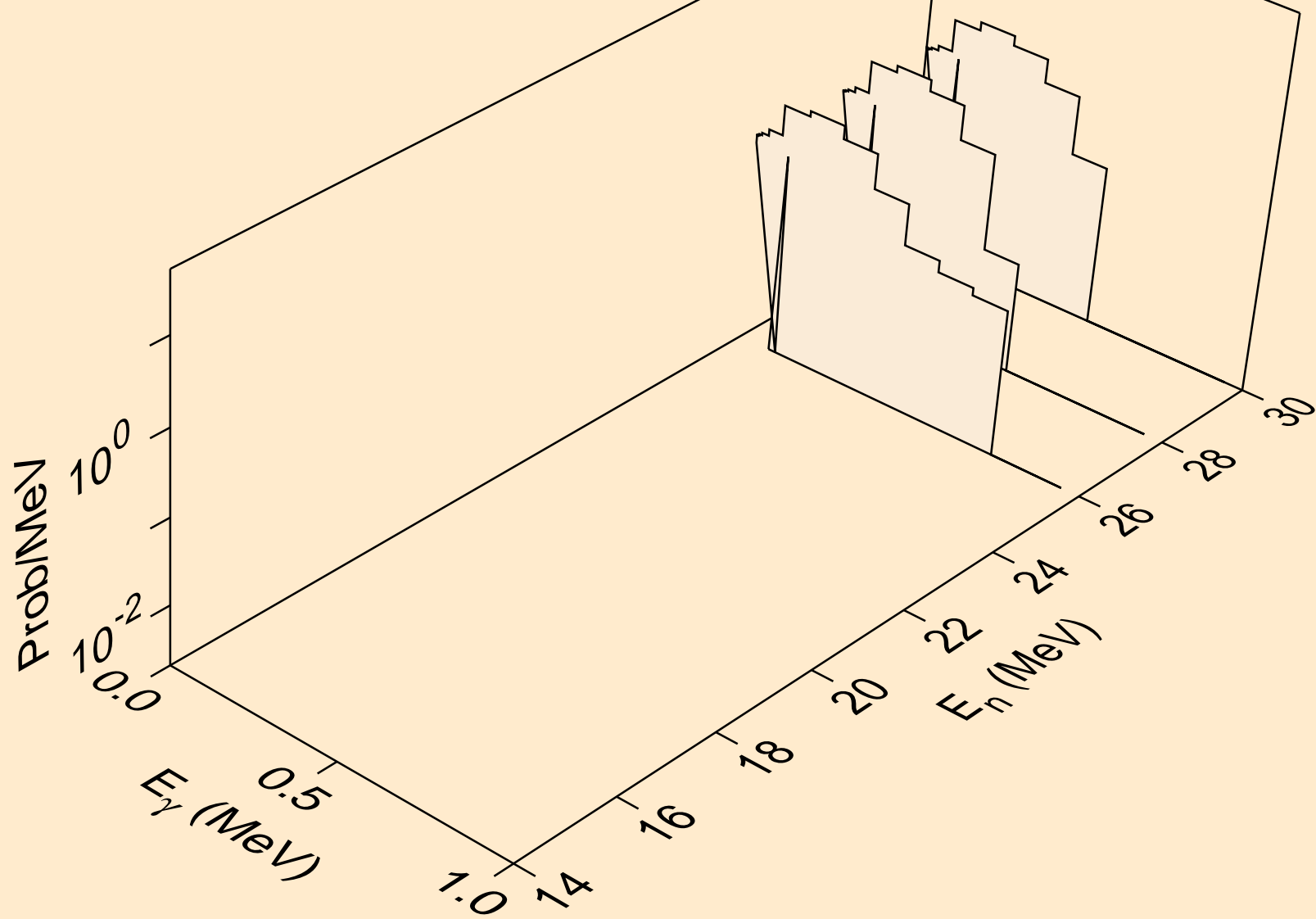

BH273 NEUTRON ACER TENDL-2021 LIBRARY; T=293.6K
Photon emission for (n,n*c)

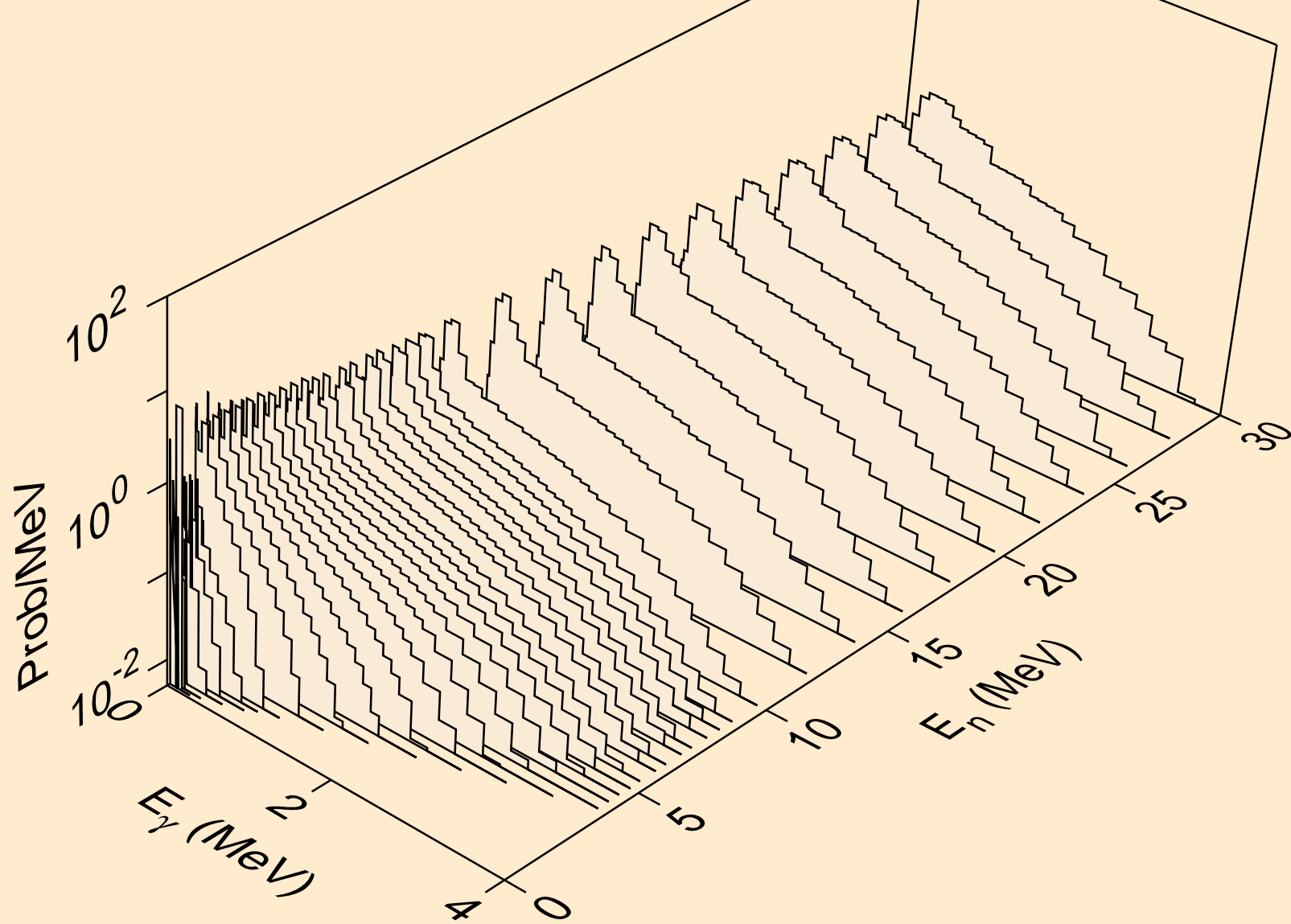

BH273 NEUTRON ACER TENDL-2021 LIBRARY; T=293.6K
Photon emission for (n,gma)

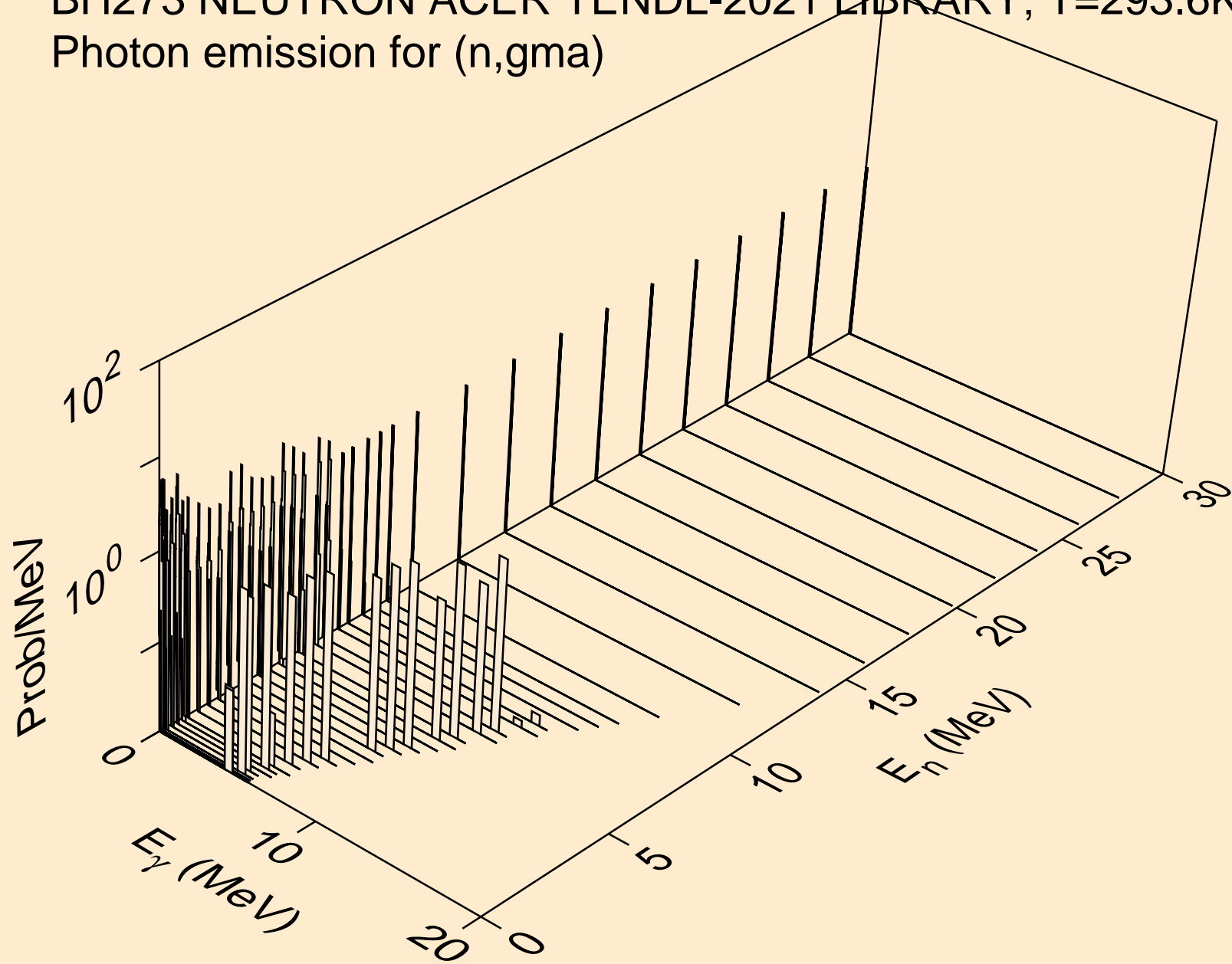

BH273 NEUTRON ACER TENDL-2021 LIBRARY; T=293.6K
Photon emission for (n,p)

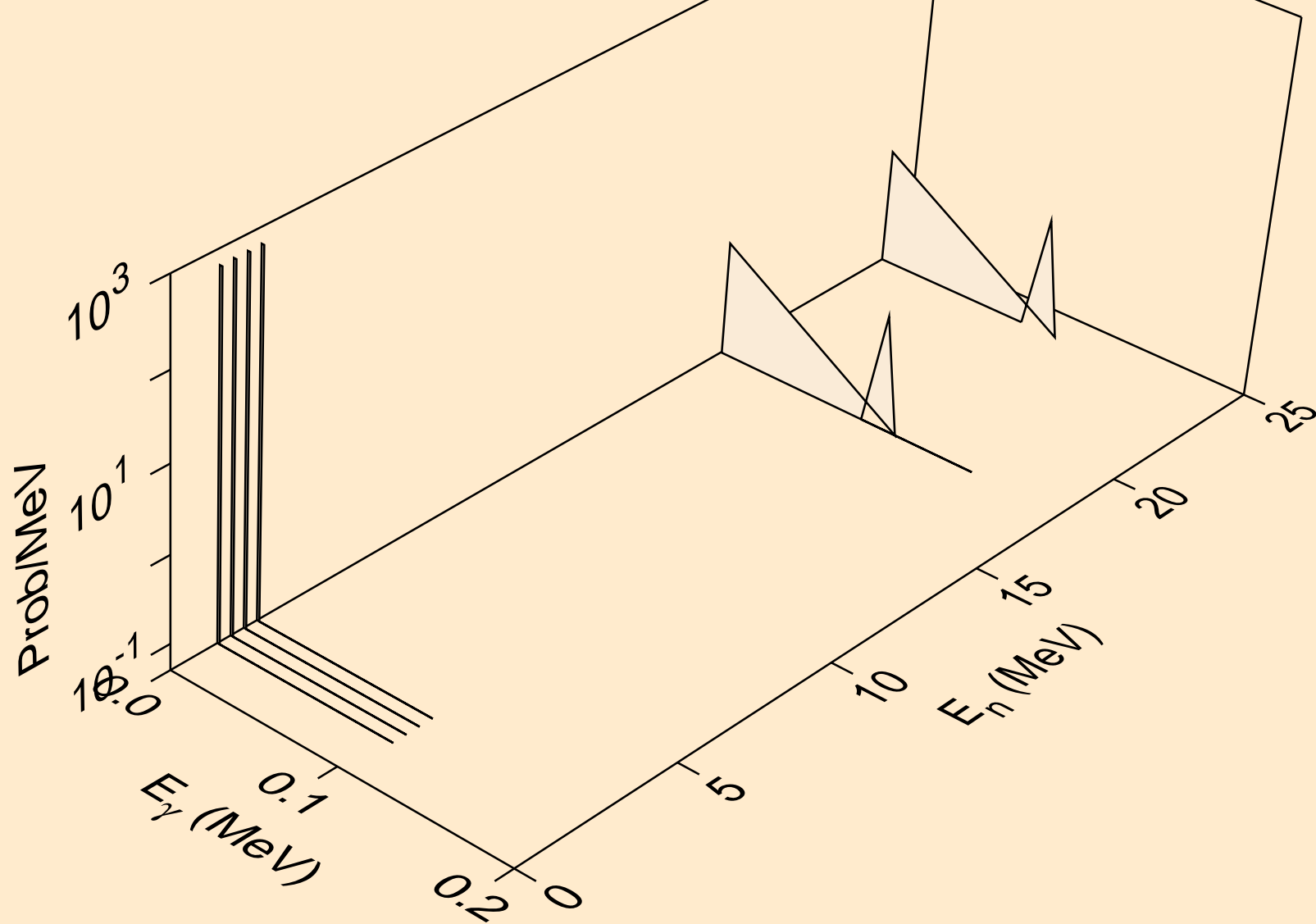

BH273 NEUTRON ACER TENDL-2021 LIBRARY; T=293.6K
Photon emission for (n,d)

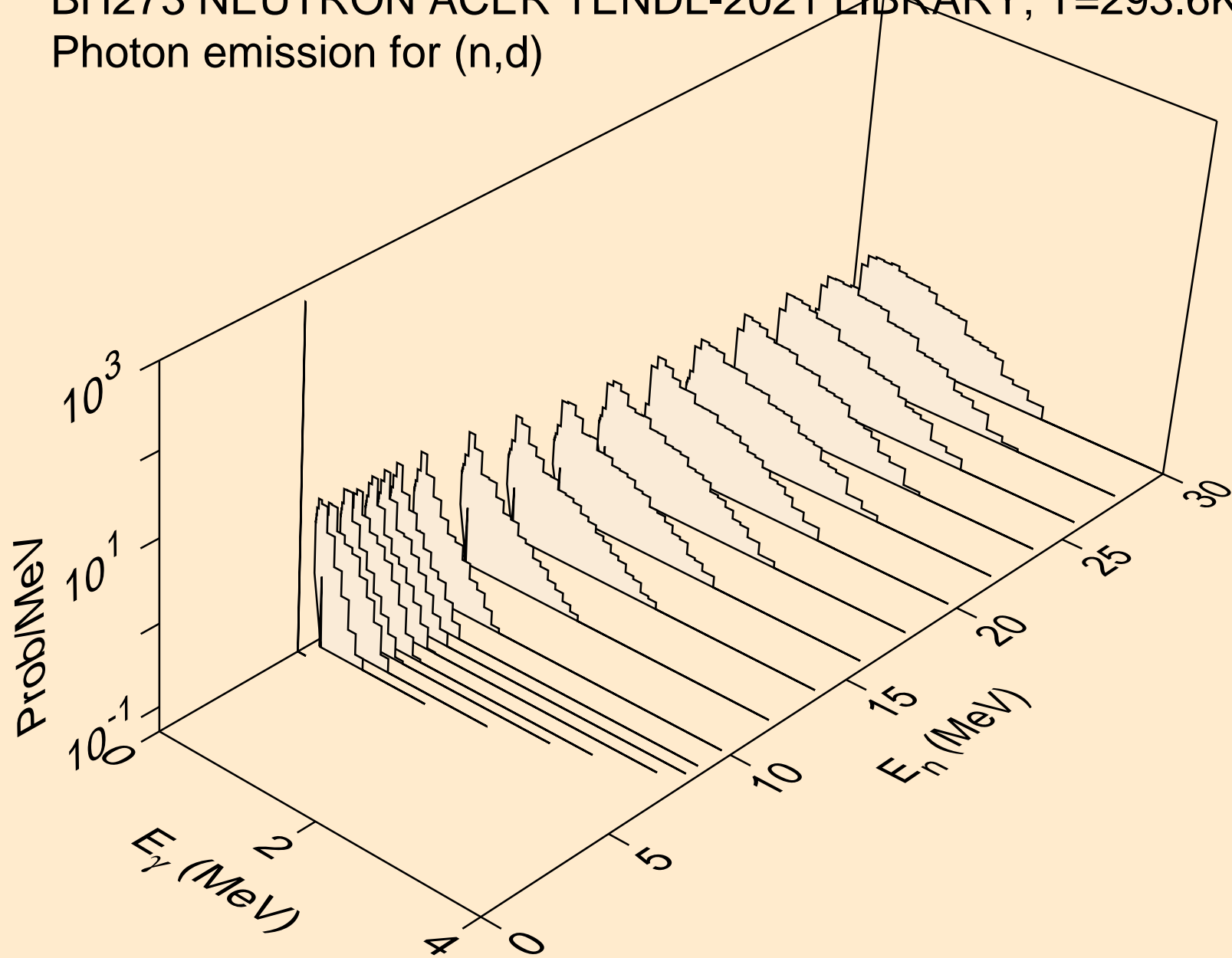

BH273 NEUTRON ACER TENDL-2021 LIBRARY; T=293.6K
Photon emission for (n,t)

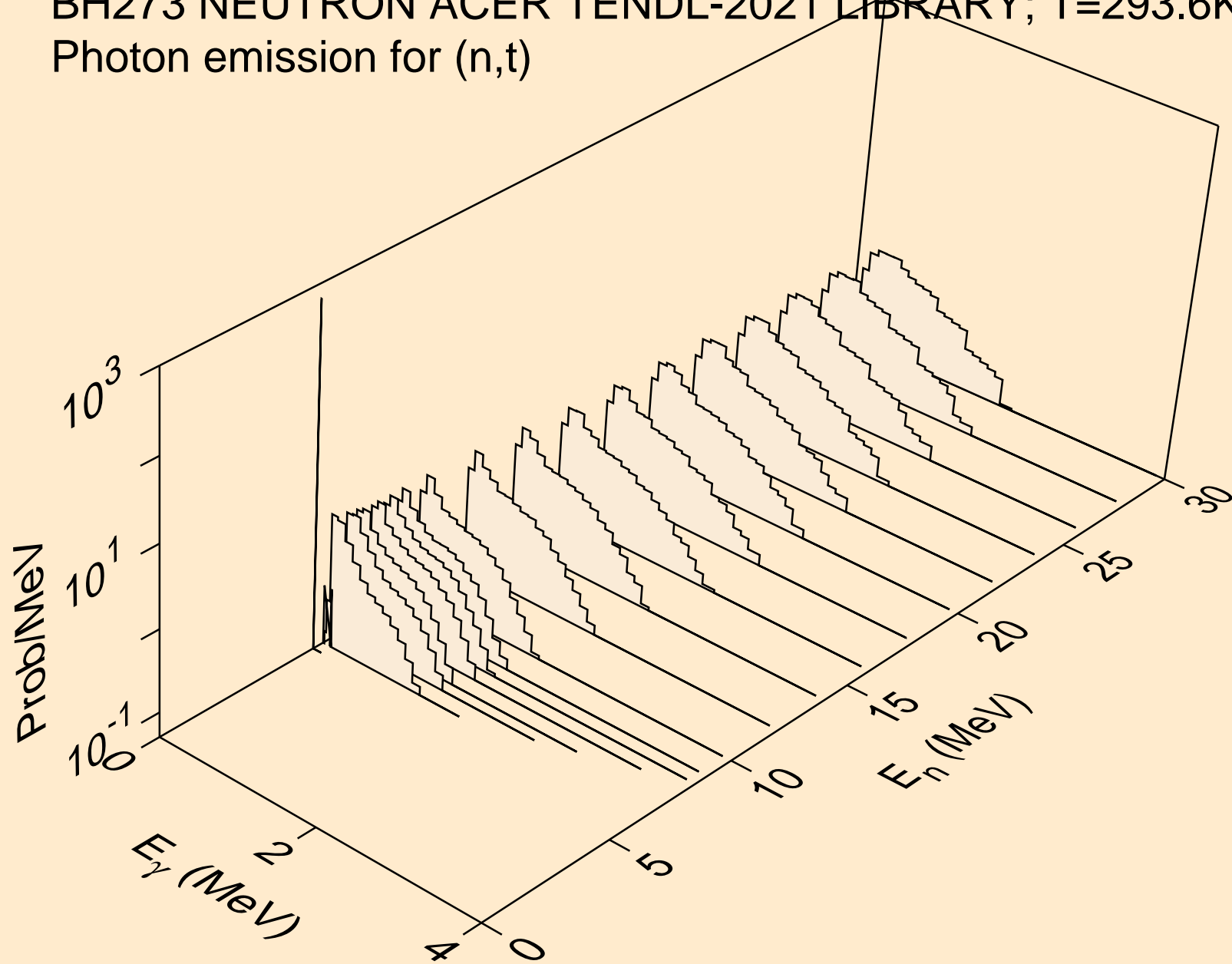

BH273 NEUTRON ACER TENDL-2021 LIBRARY; T=293.6K
Photon emission for (n,a)

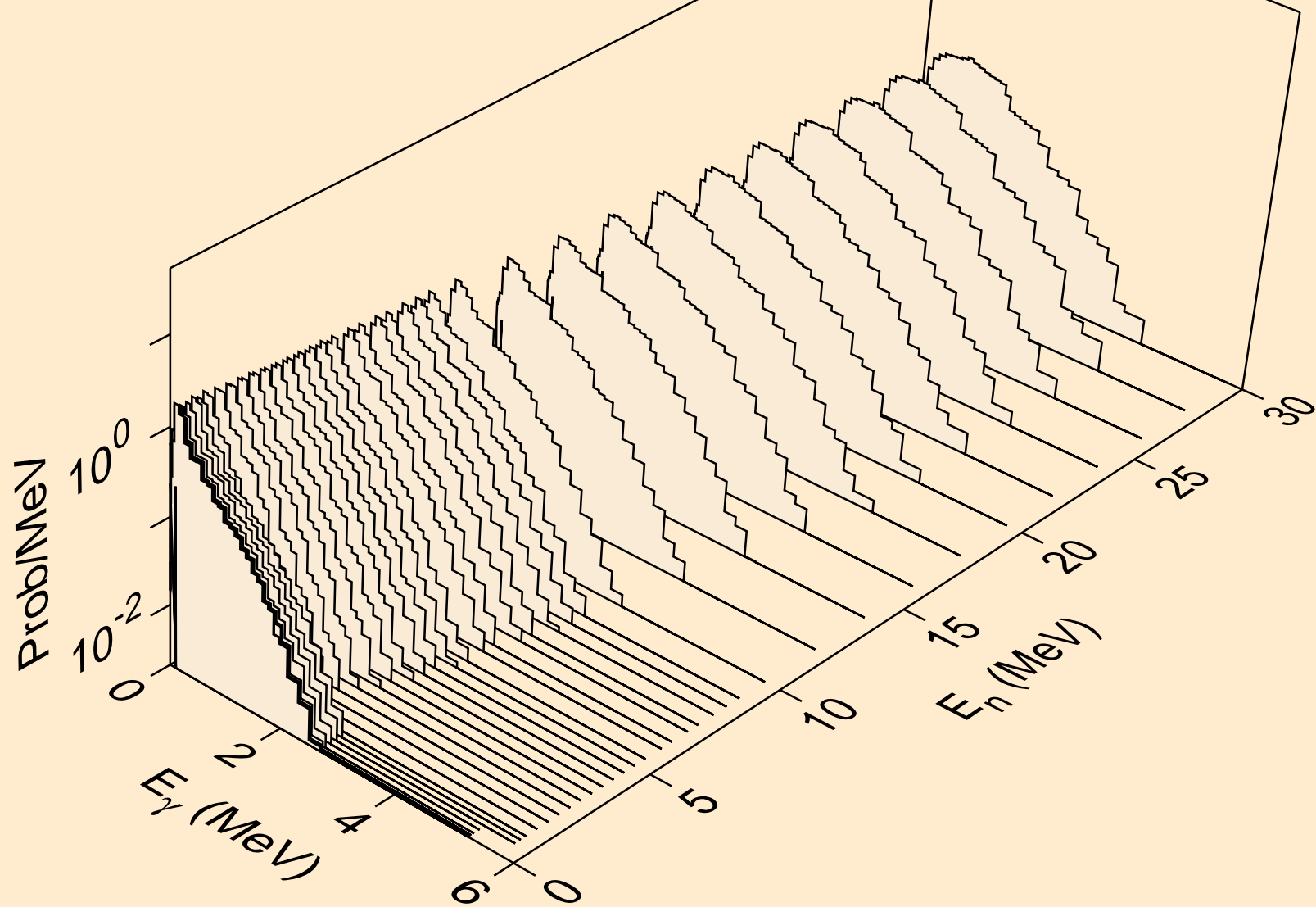

BH273 NEUTRON ACER TENDL-2021 LIBRARY; T=293.6K
Photon emission for (n,2p)

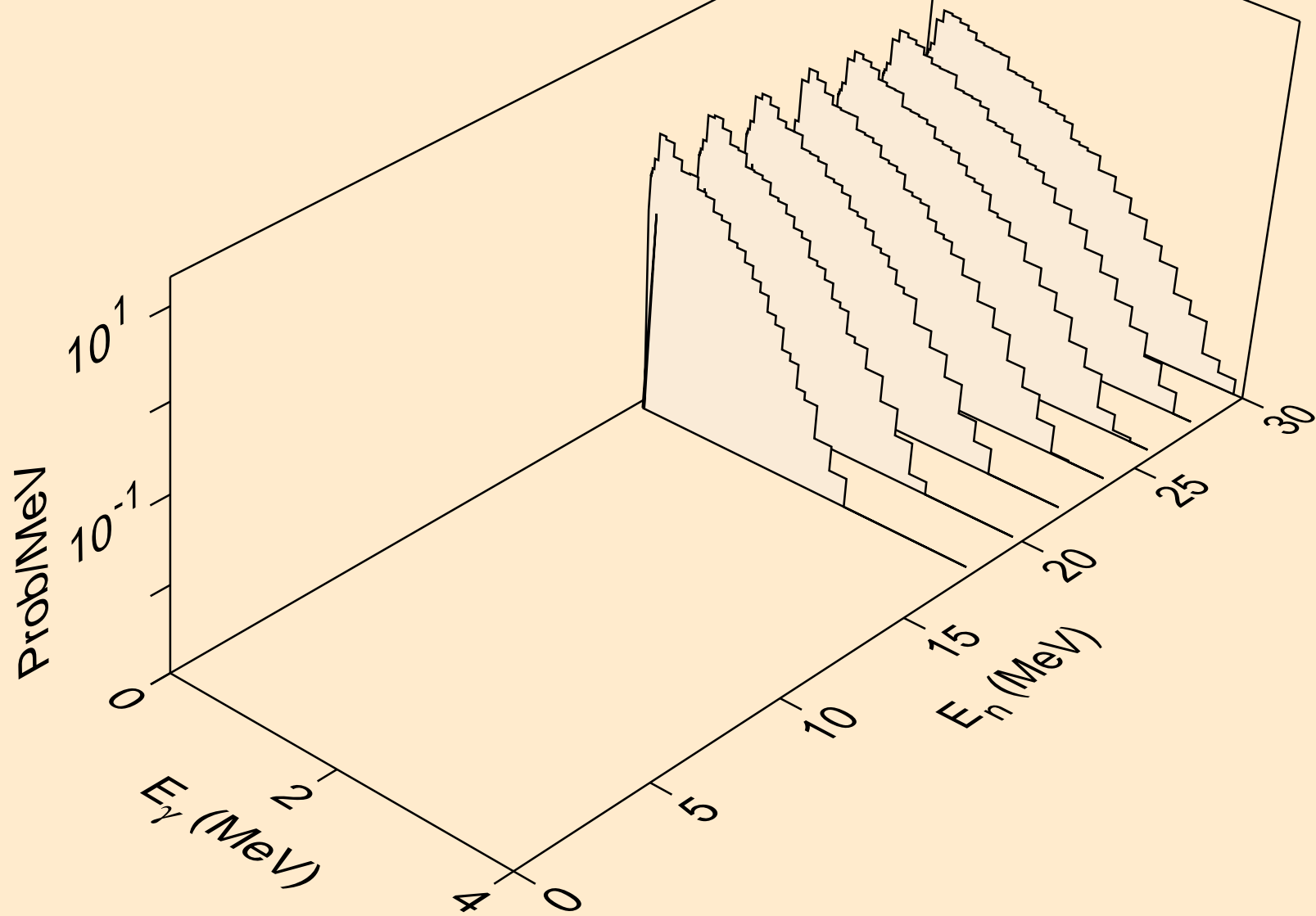

BH273 NEUTRON ACER TENDL-2021 LIBRARY; T=293.6K
Photon emission for (n,da)

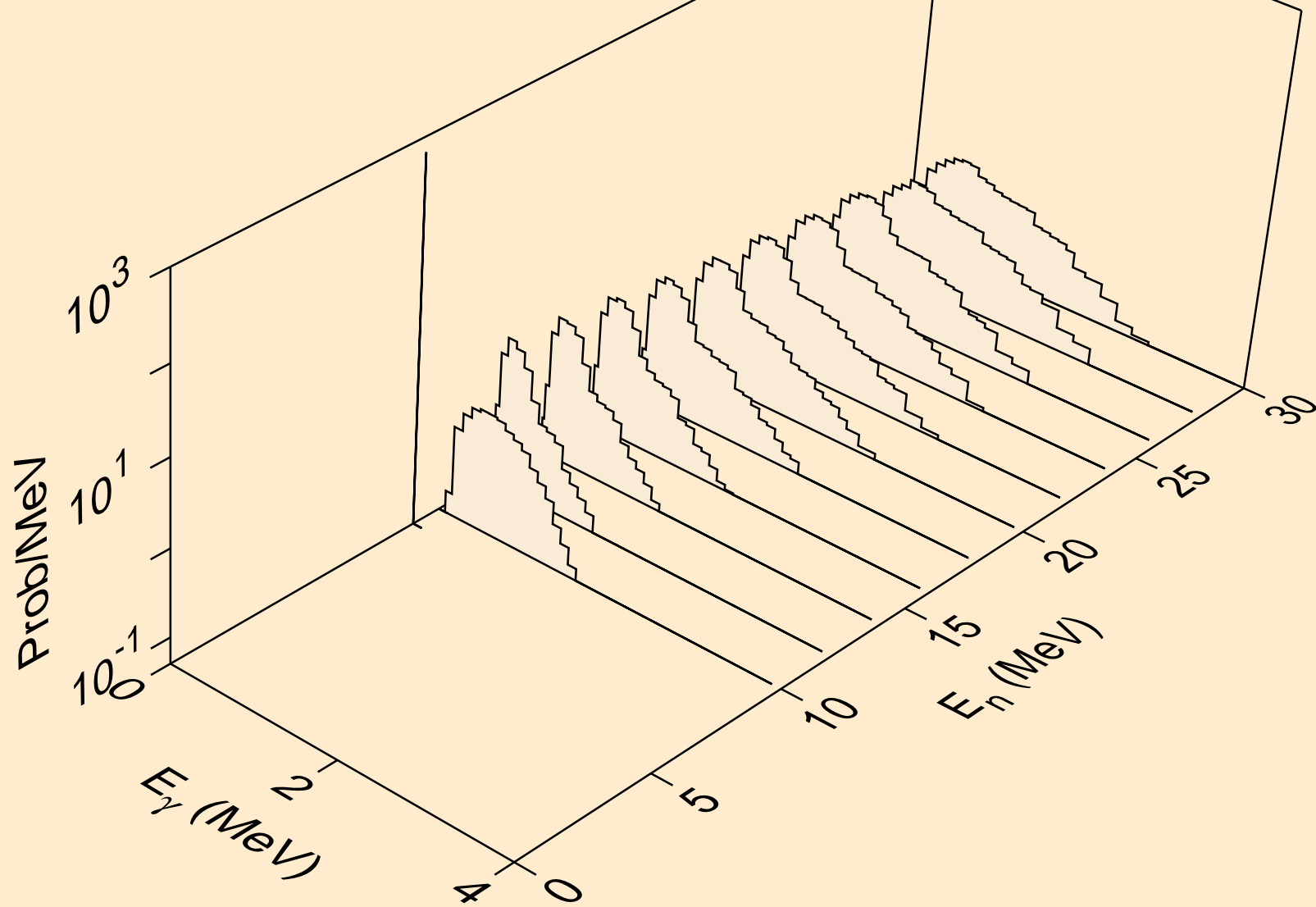

BH273 NEUTRON ACER TENDL-2021 LIBRARY; T=293.6K
thermal capture photon spectrum

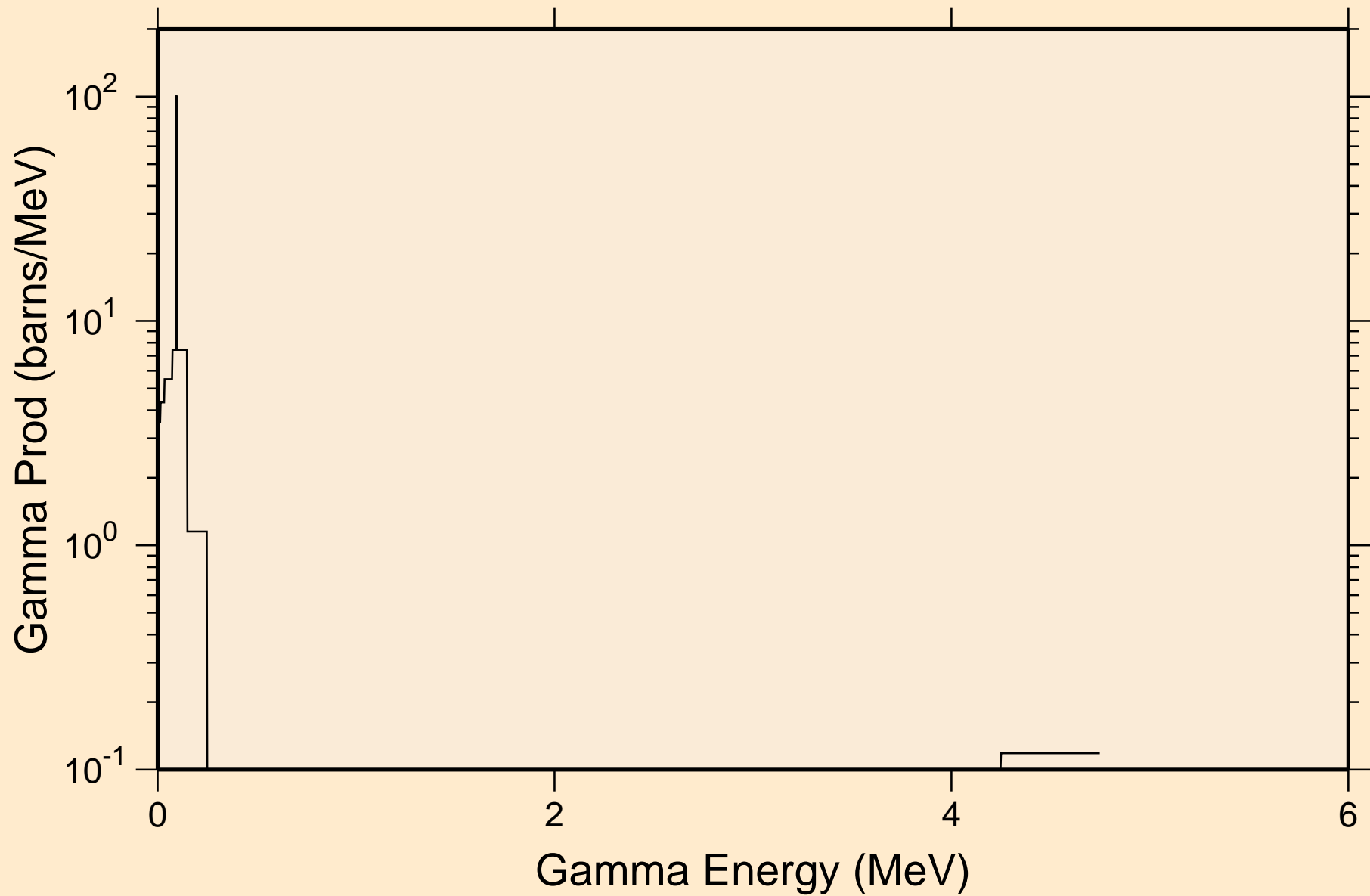

BH273 NEUTRON ACER TENDL-2021 LIBRARY; T=293.6K
14 MeV photon spectrum

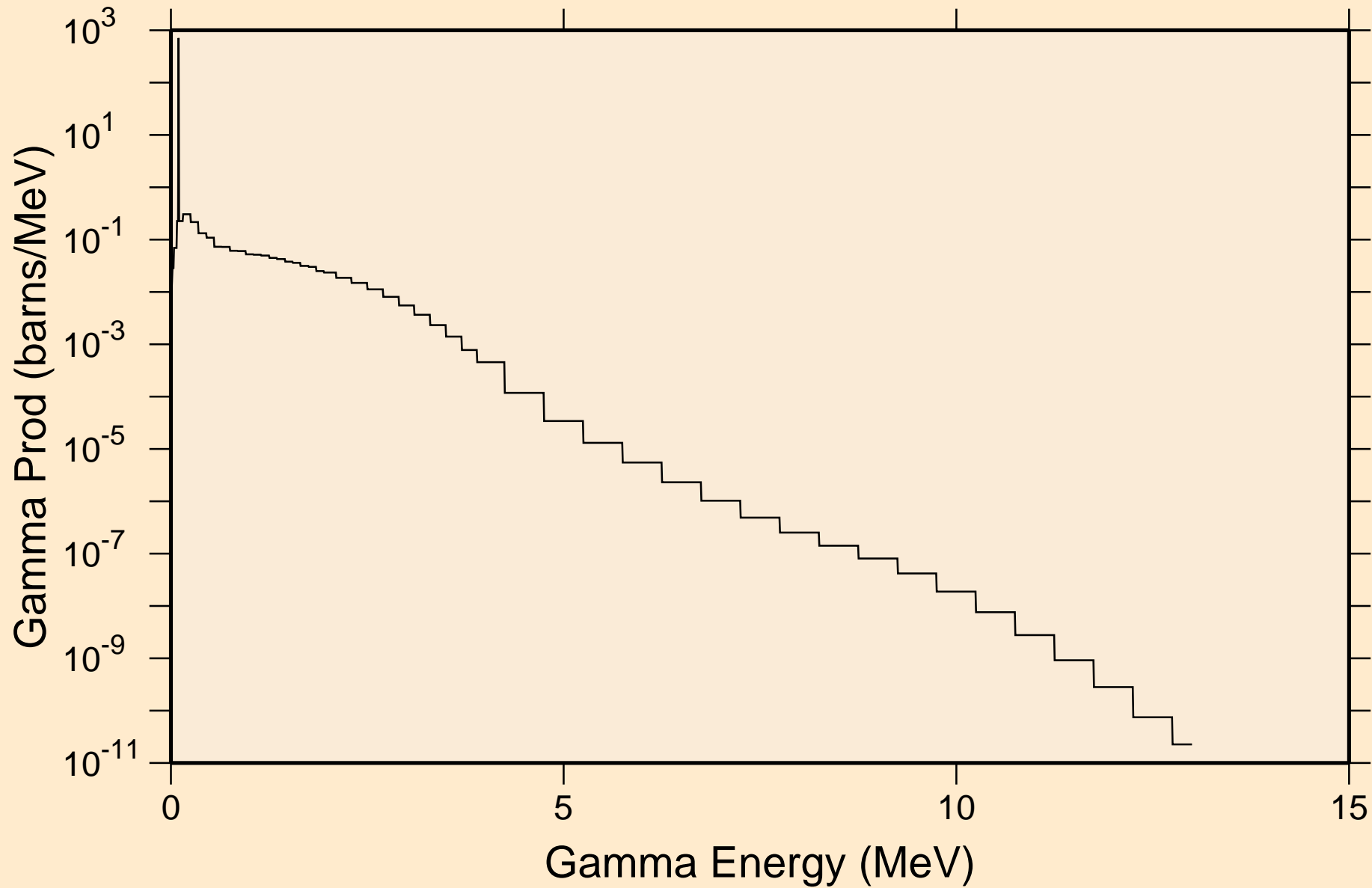

BH273 NEUTRON ACER TENDL-2021 LIBRARY; T=293.6K

Particle heating contributions

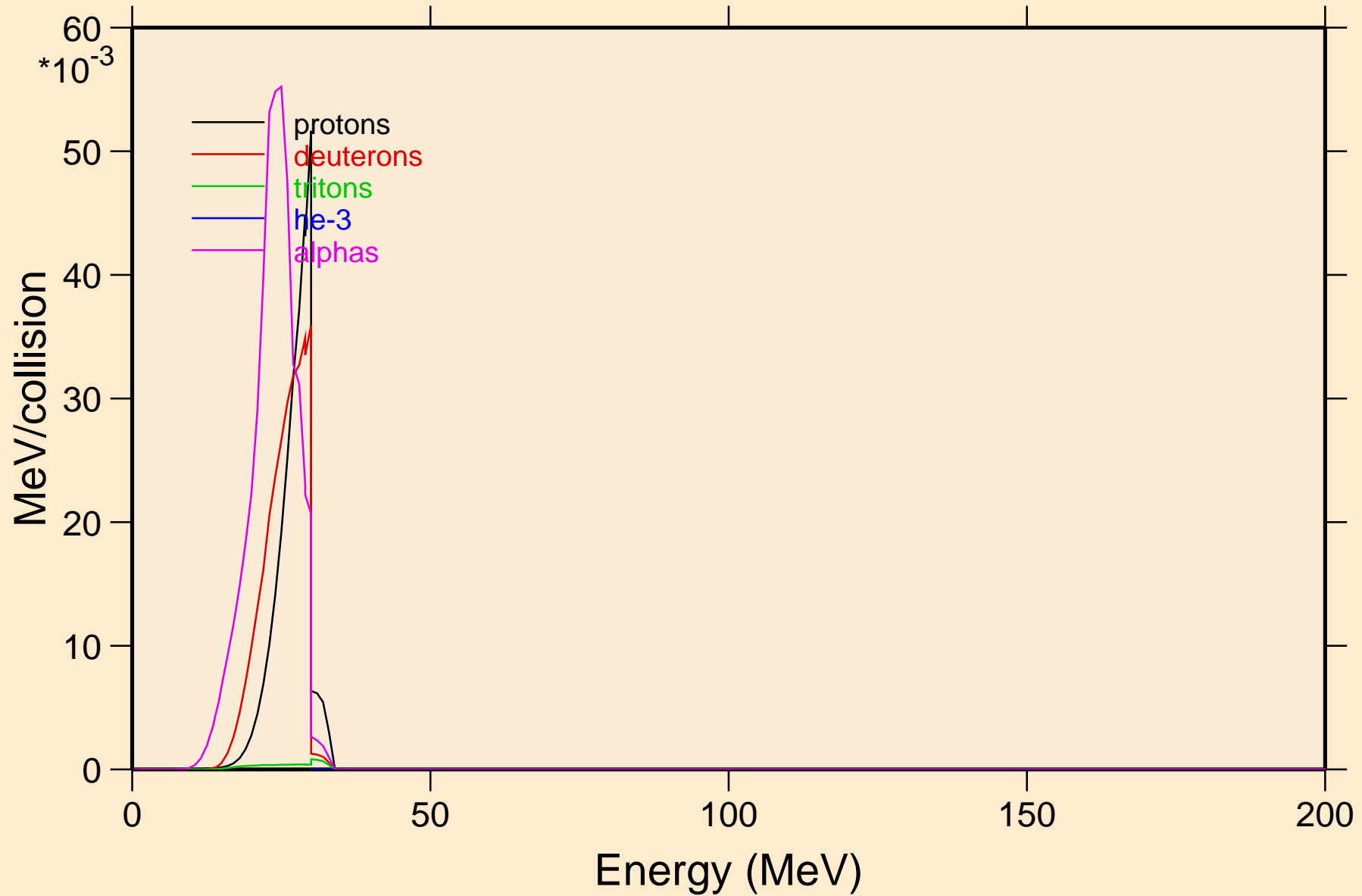

BH273 NEUTRON ACER TENDL-2021 LIBRARY; T=293.6K
Recoil Heating

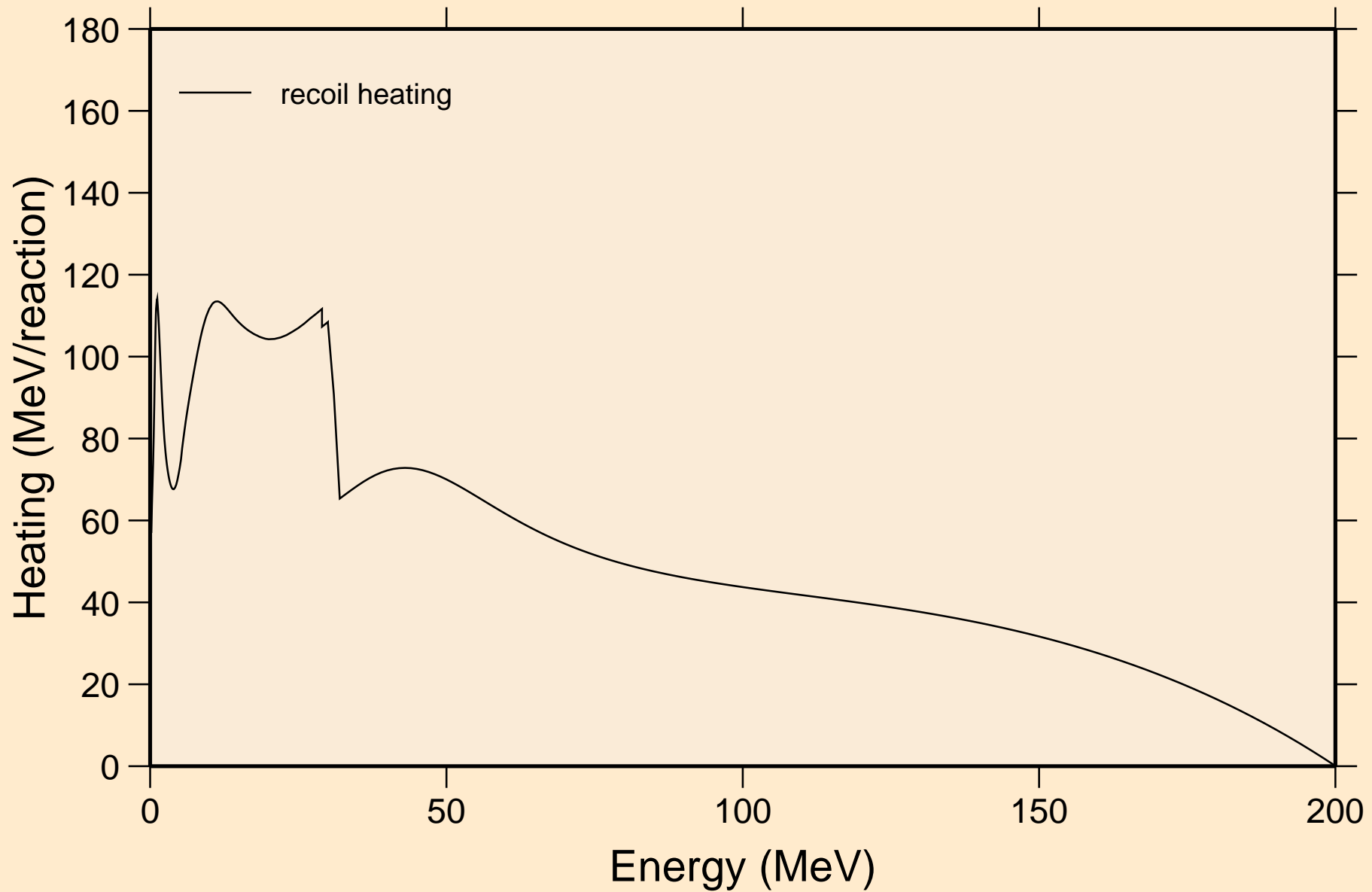

BH273 NEUTRON ACER TENDL-2021 LIBRARY; T=293.6K

Particle production cross sections

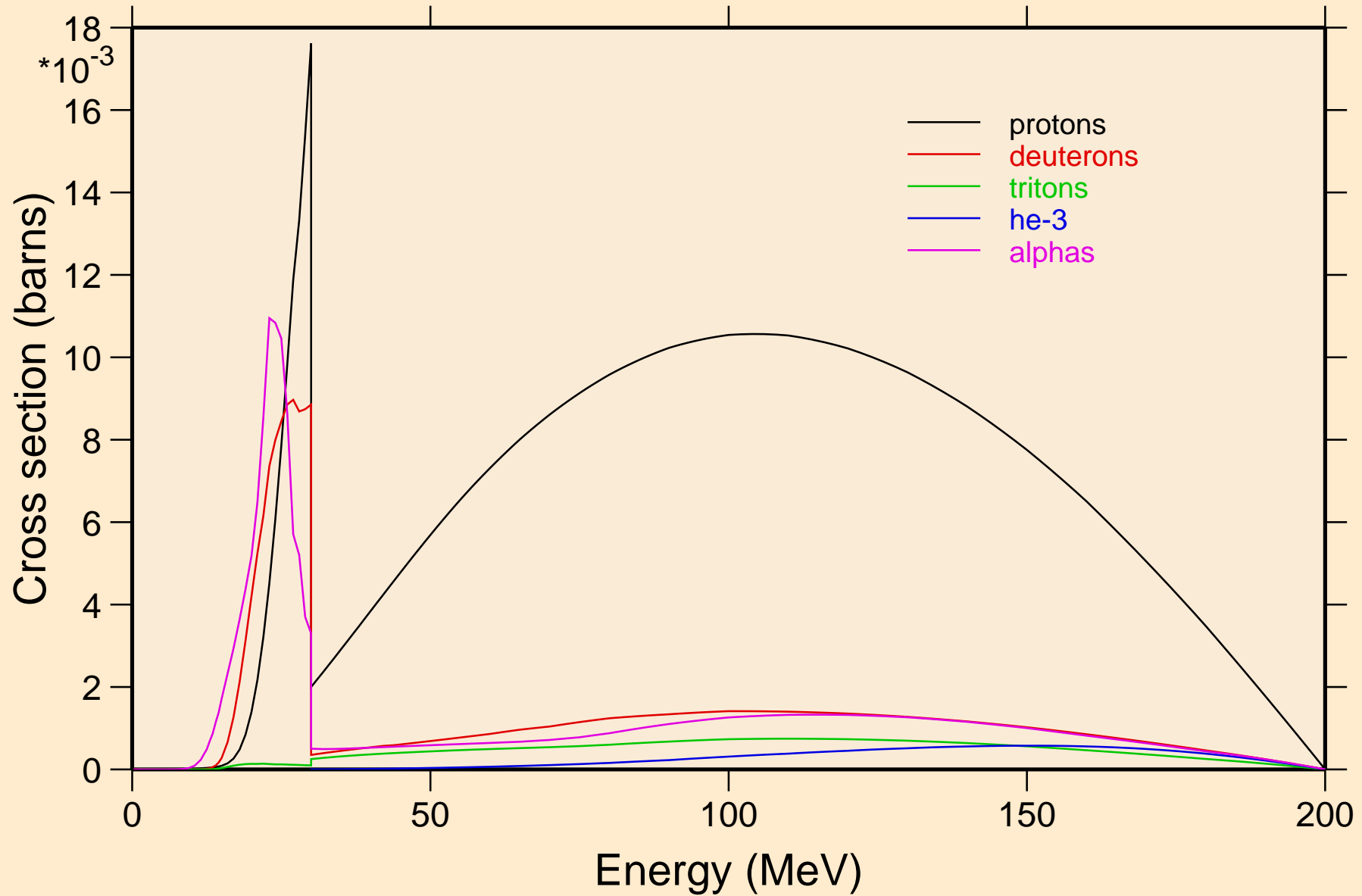

BH273 NEUTRON ACER TENDL-2021 LIBRARY; T=293.6K
protons from (n,x)

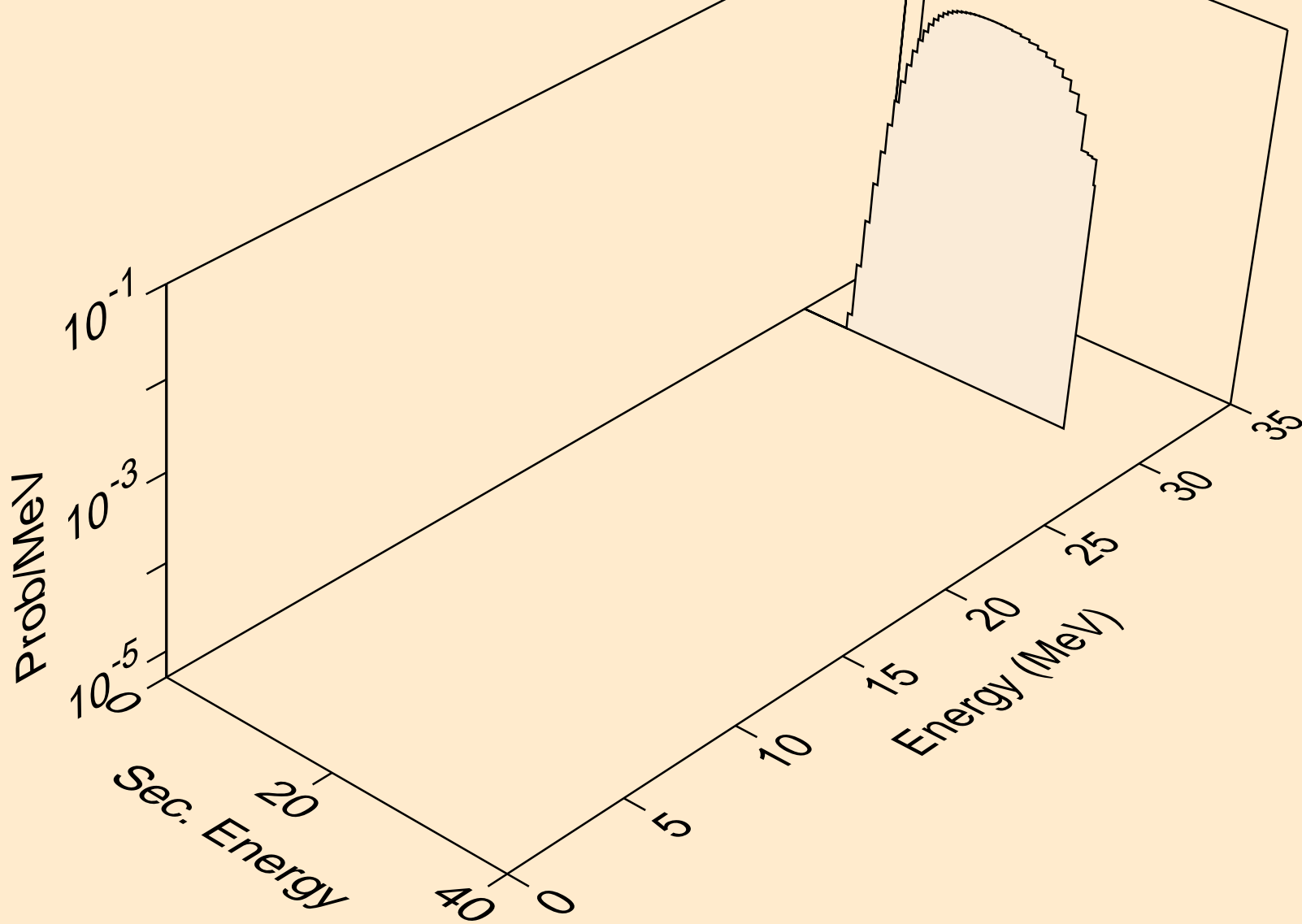

BH273 NEUTRON ACER TENDL-2021 LIBRARY; T=293.6K
protons from (n,n*)p

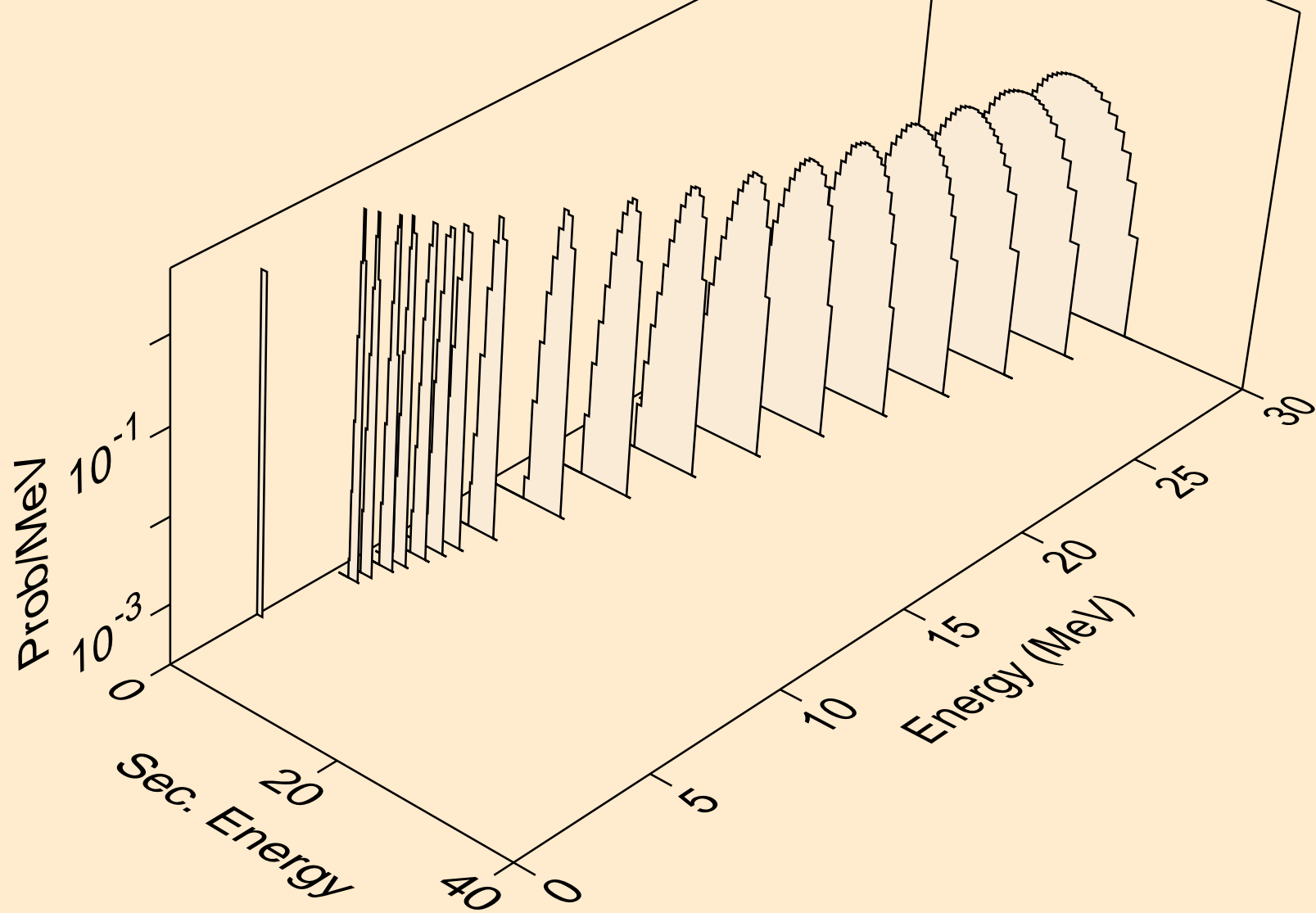

BH273 NEUTRON ACER TENDL-2021 LIBRARY; T=293.6K
protons from (n,2np)

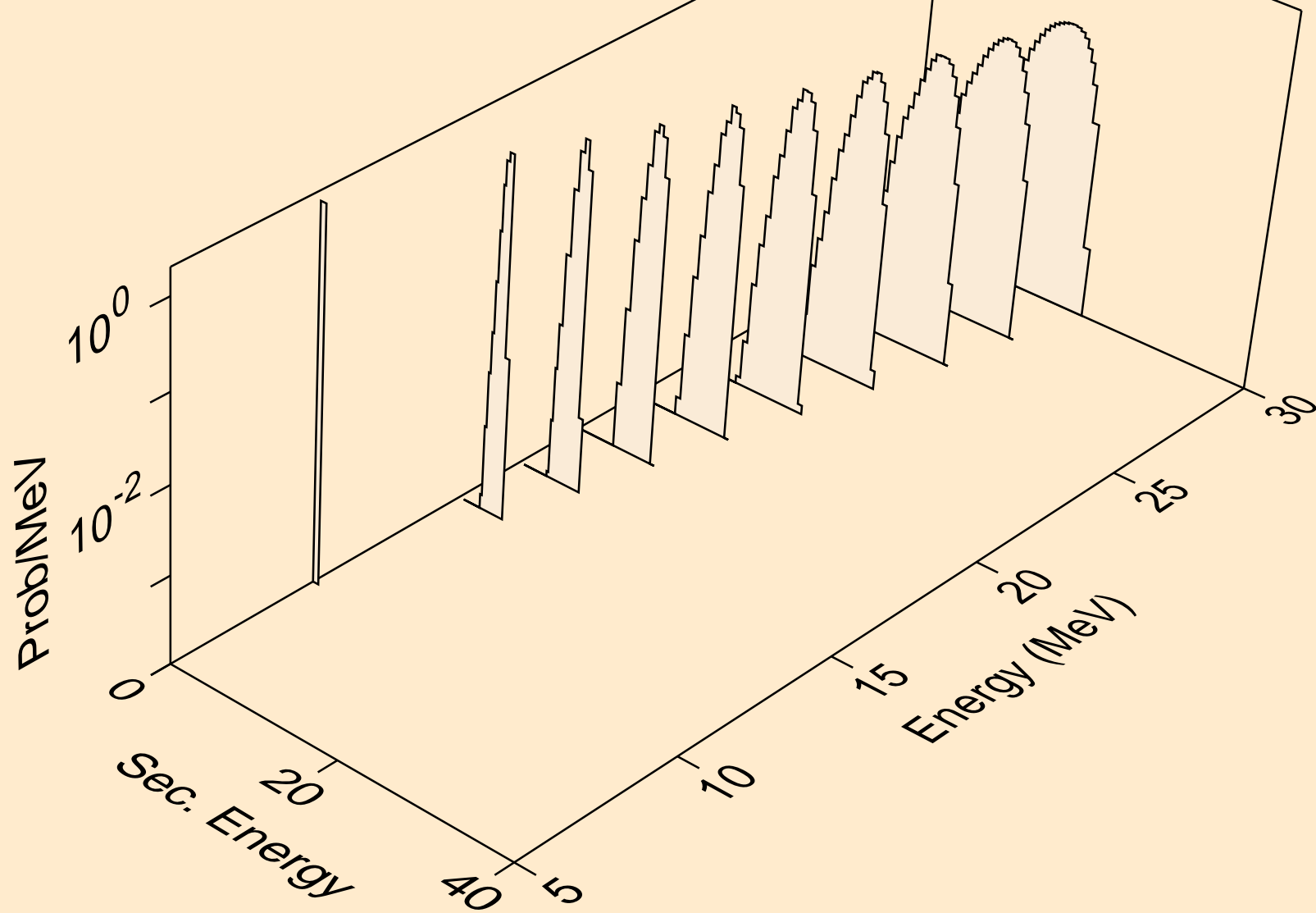

BH273 NEUTRON ACER TENDL-2021 LIBRARY; T=293.6K
protons from (n,3np)

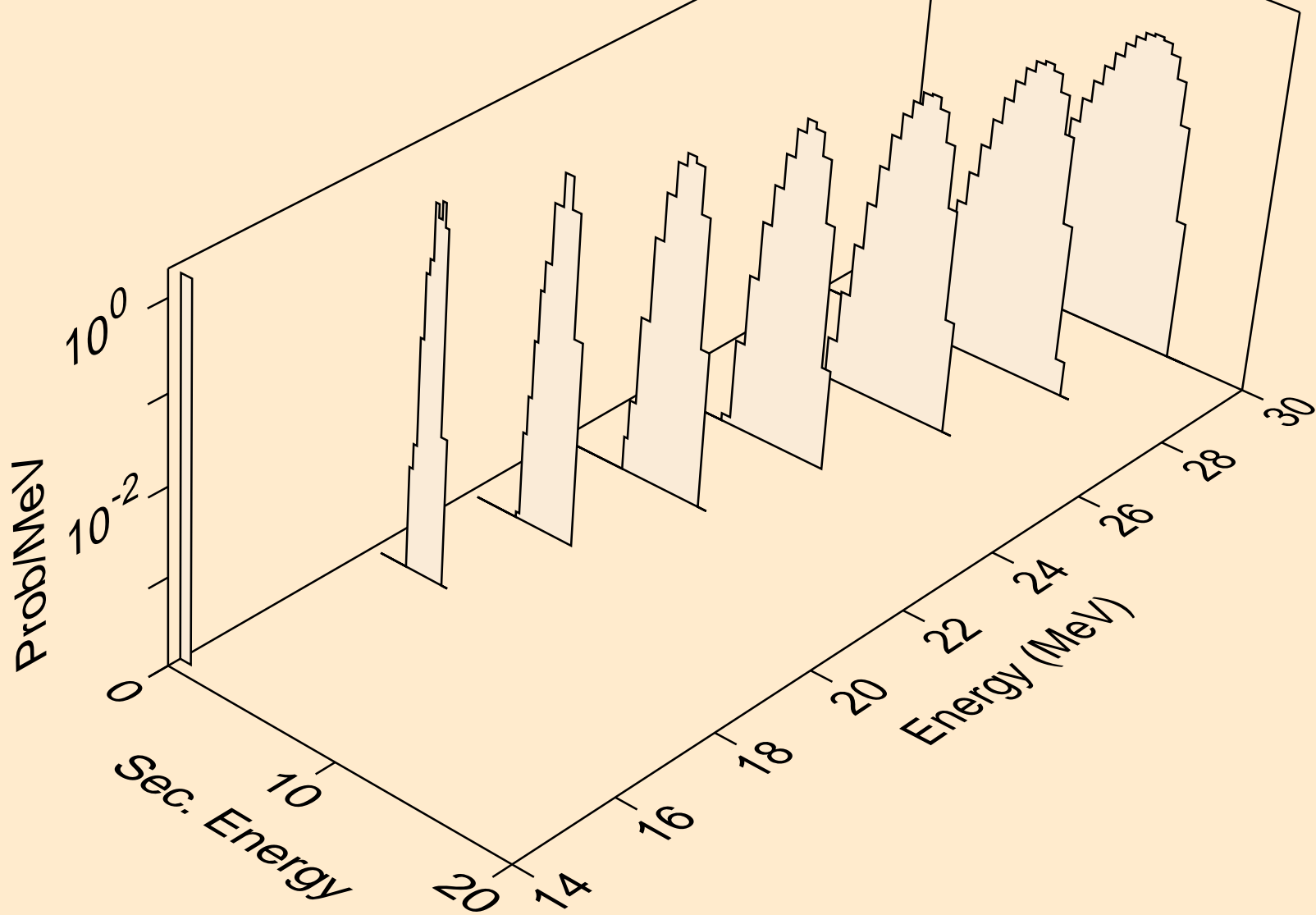

BH273 NEUTRON ACER TENDL-2021 LIBRARY; T=293.6K
protons from (n,p)

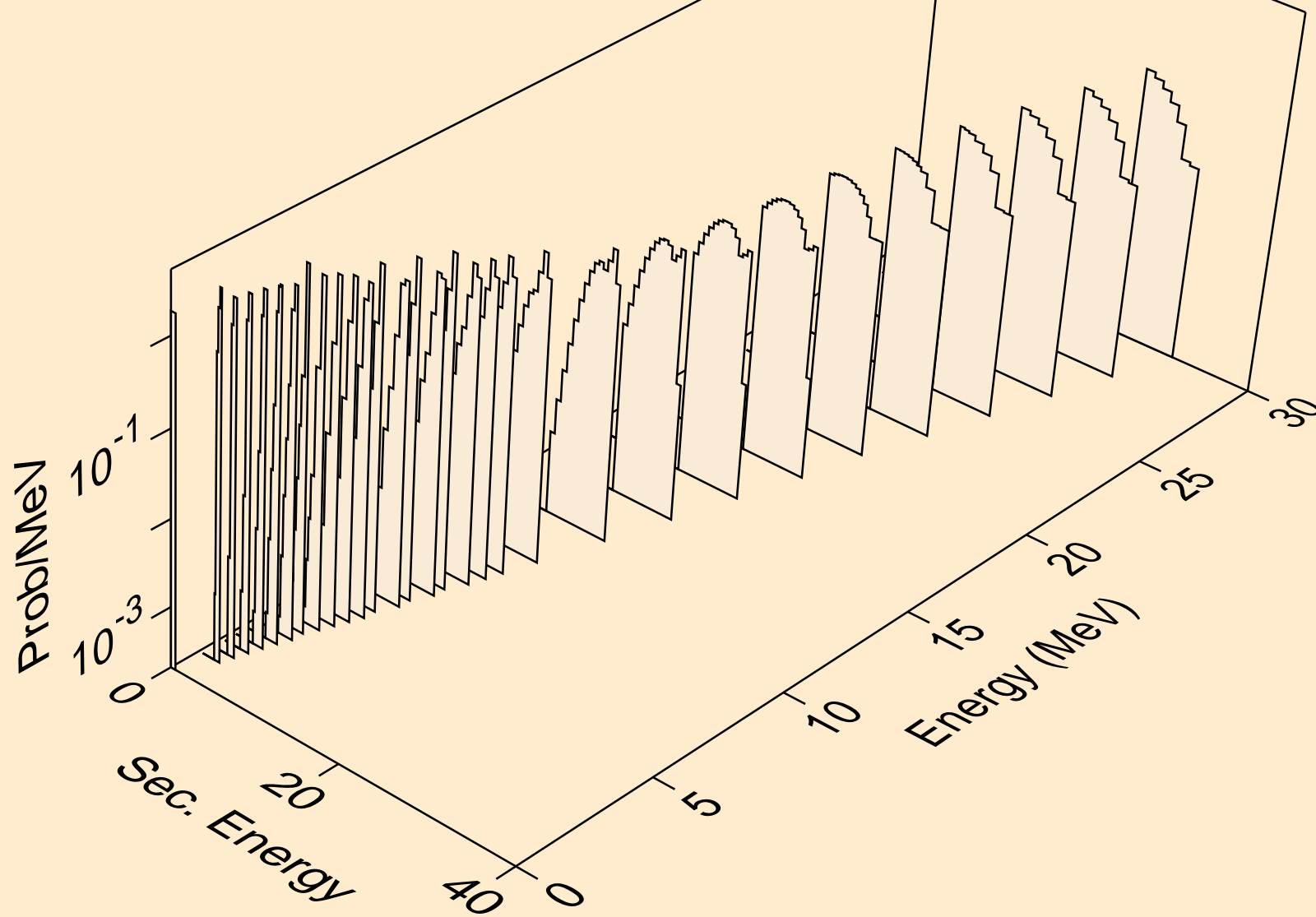

BH273 NEUTRON ACER TENDL-2021 LIBRARY; T=293.6K
protons from (n,2p)

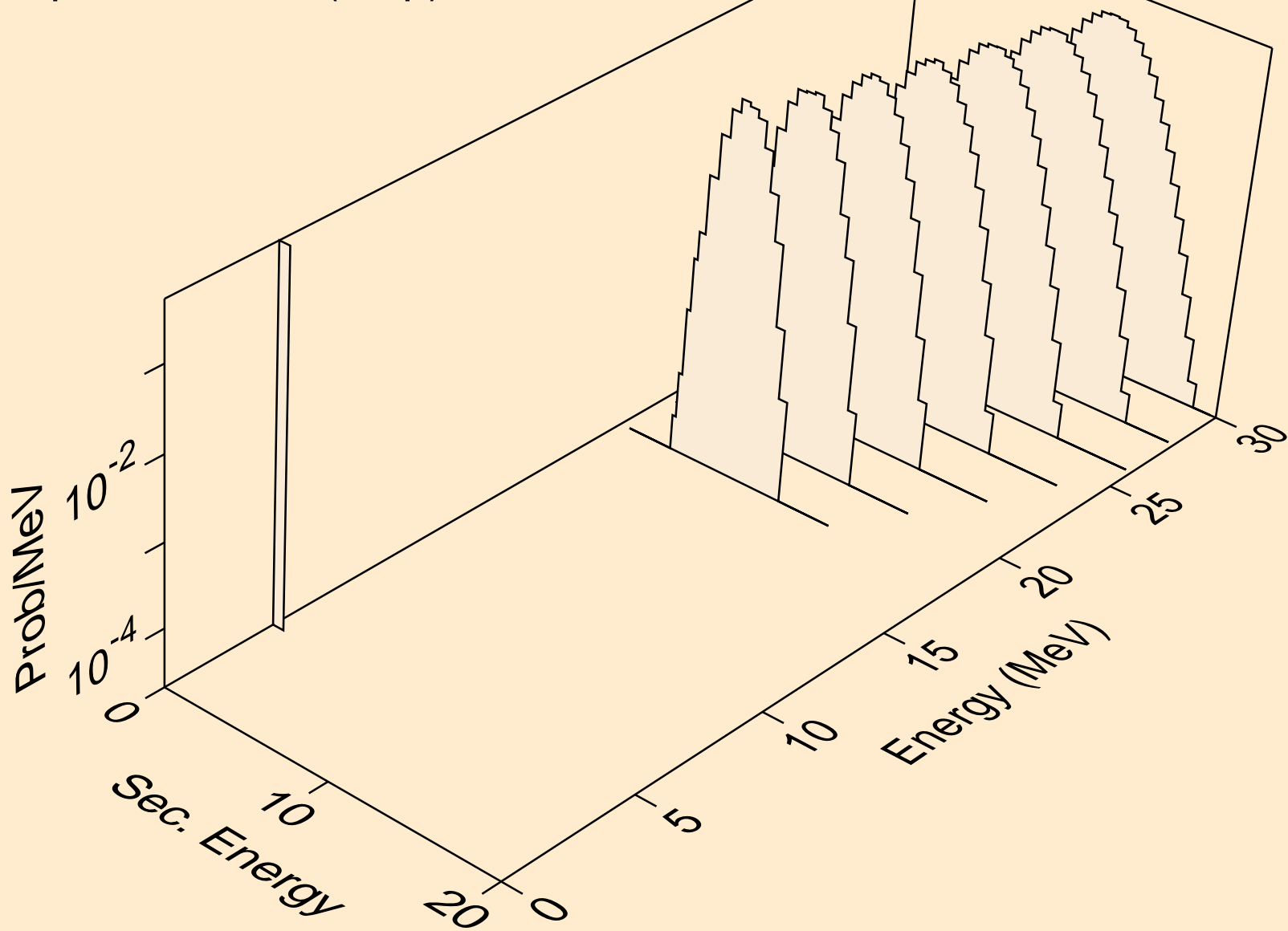

BH273 NEUTRON ACER TENDL-2021 LIBRARY; T=293.6K
deuterons from (n,x)

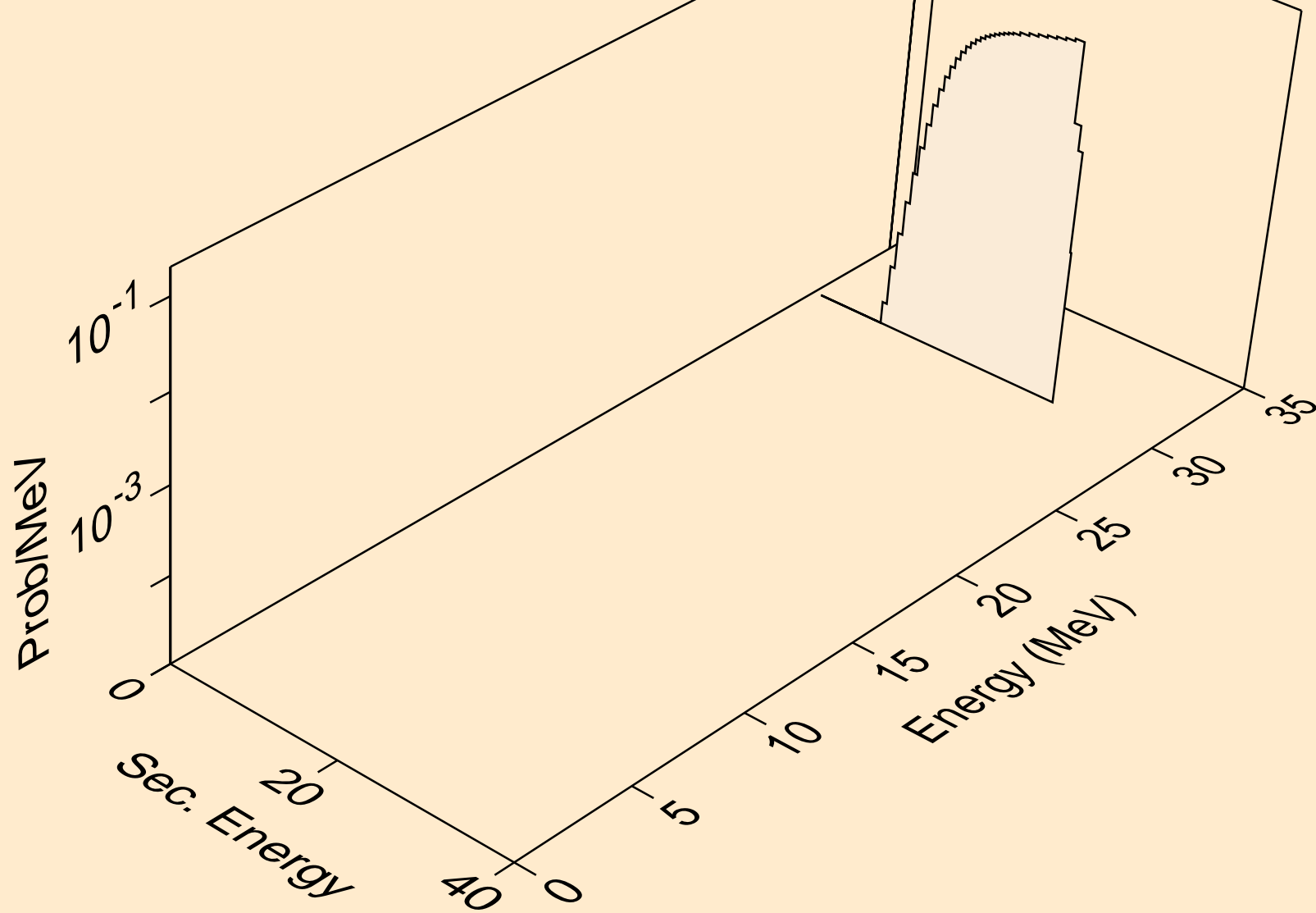

BH273 NEUTRON ACER TENDL-2021 LIBRARY; T=293.6K
deuterons from (n,2nd)

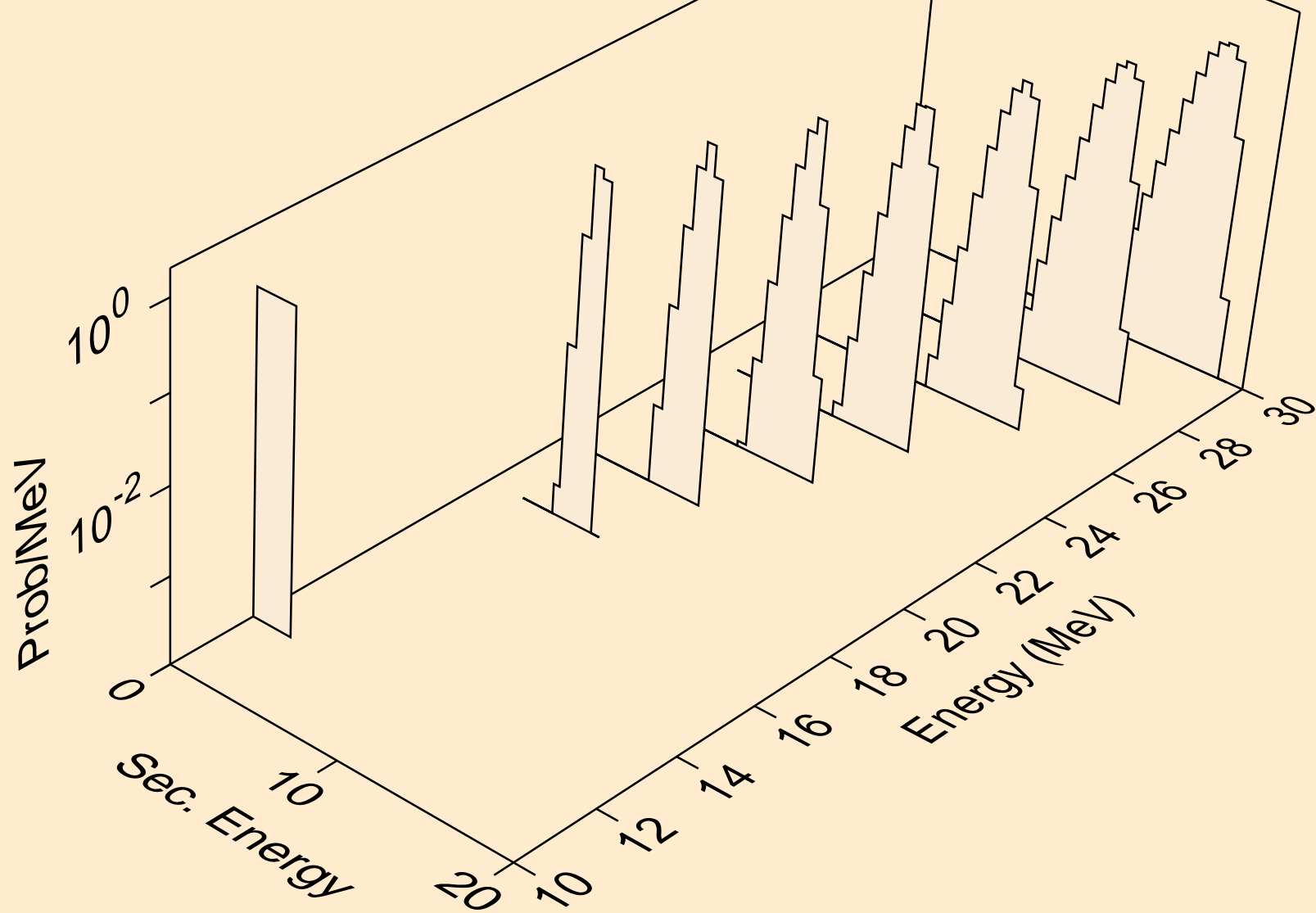

BH273 NEUTRON ACER TENDL-2021 LIBRARY; T=293.6K
deuterons from (n,n*)d

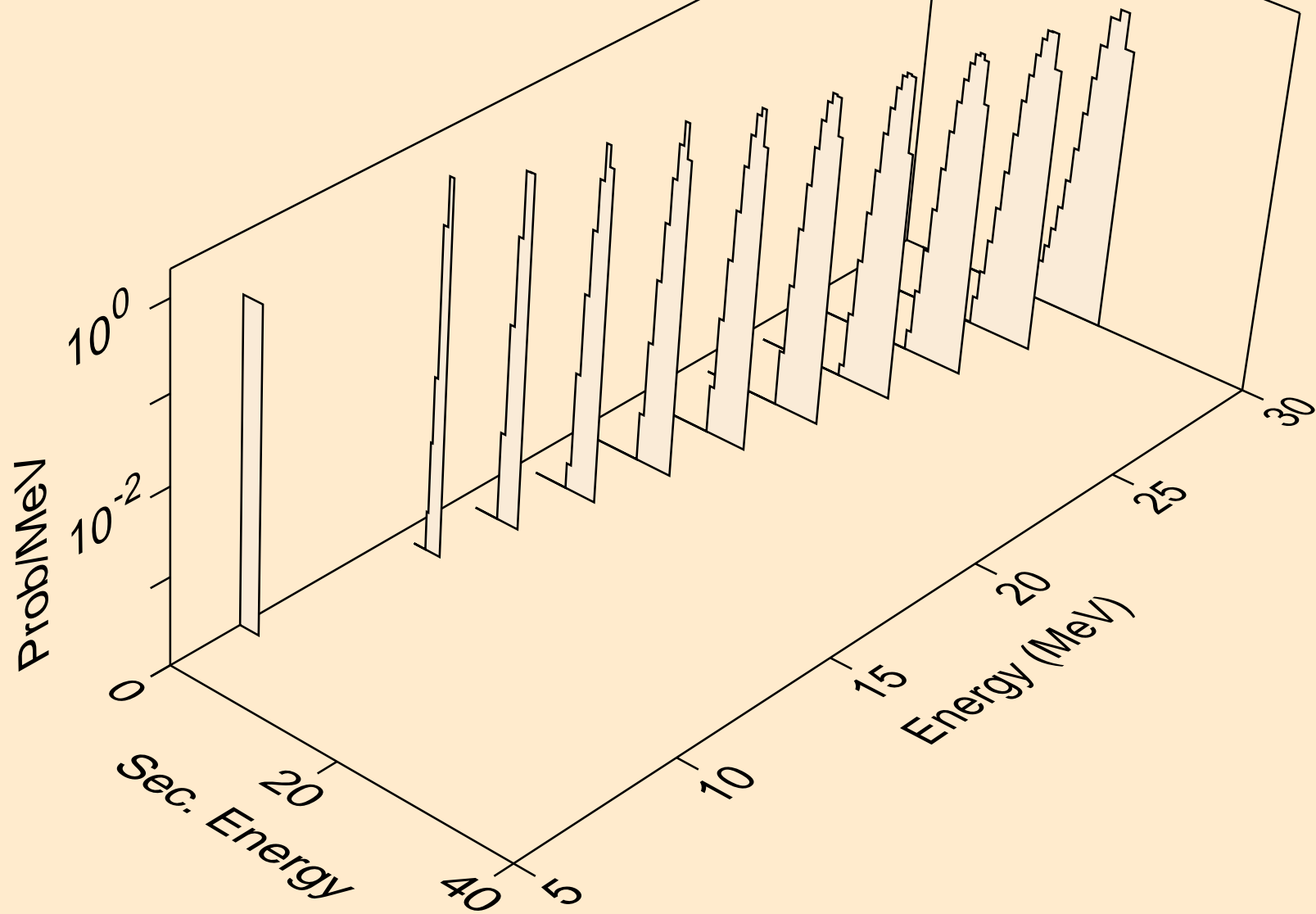

BH273 NEUTRON ACER TENDL-2021 LIBRARY; T=293.6K
deuterons from (n,d)

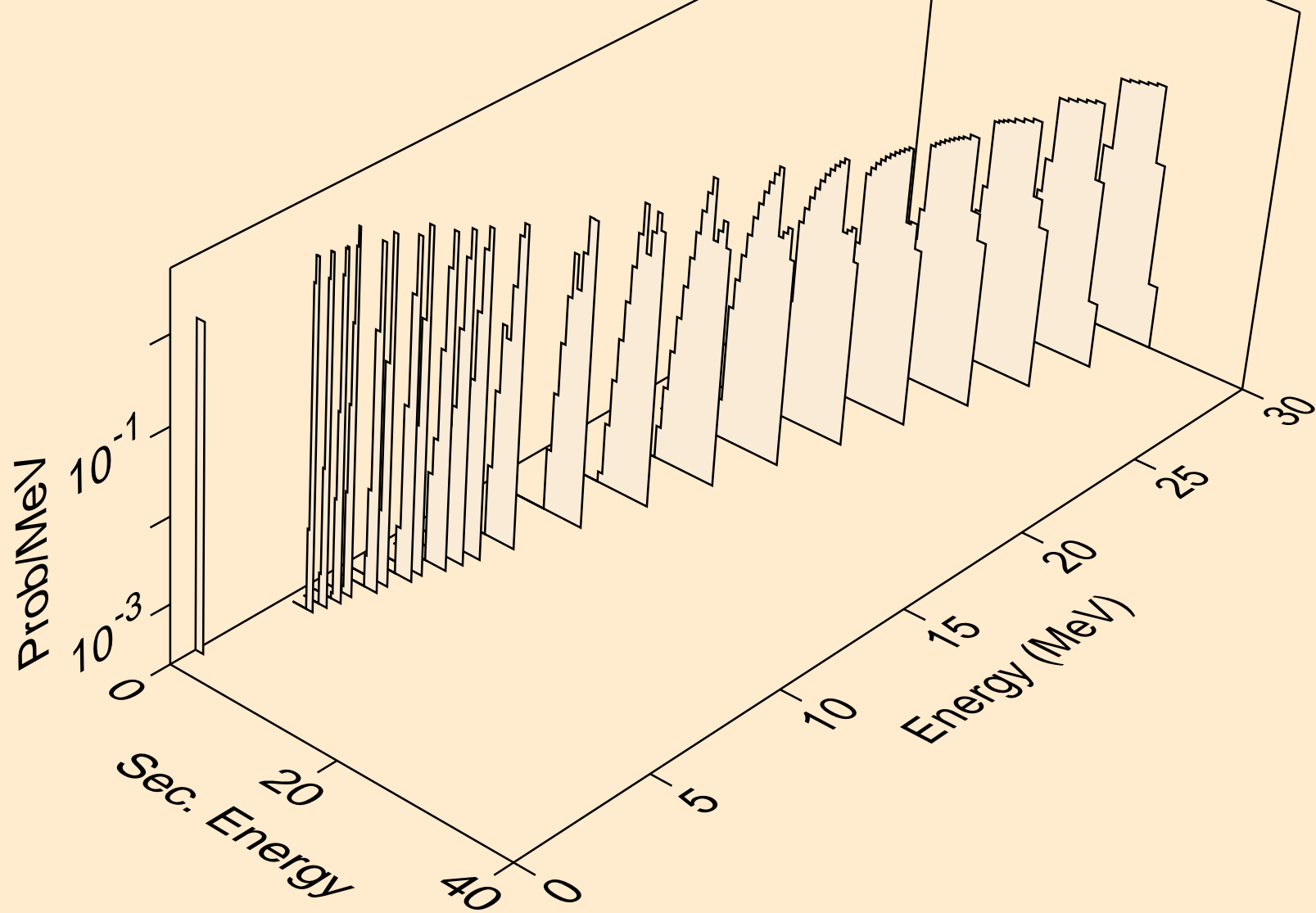

BH273 NEUTRON ACER TENDL-2021 LIBRARY; T=293.6K
deuterons from (n,da)

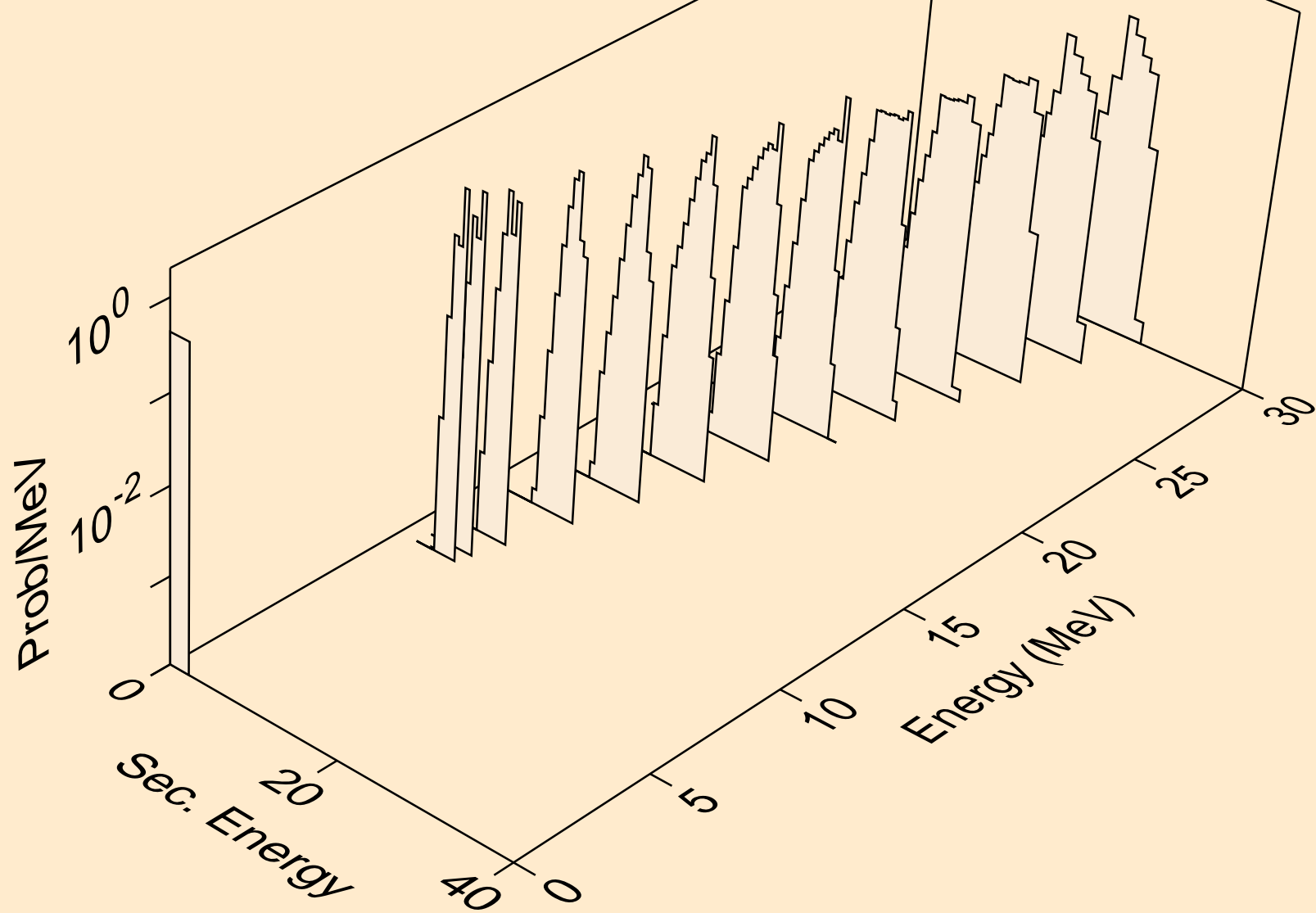

BH273 NEUTRON ACER TENDL-2021 LIBRARY; T=293.6K
tritons from (n,x)

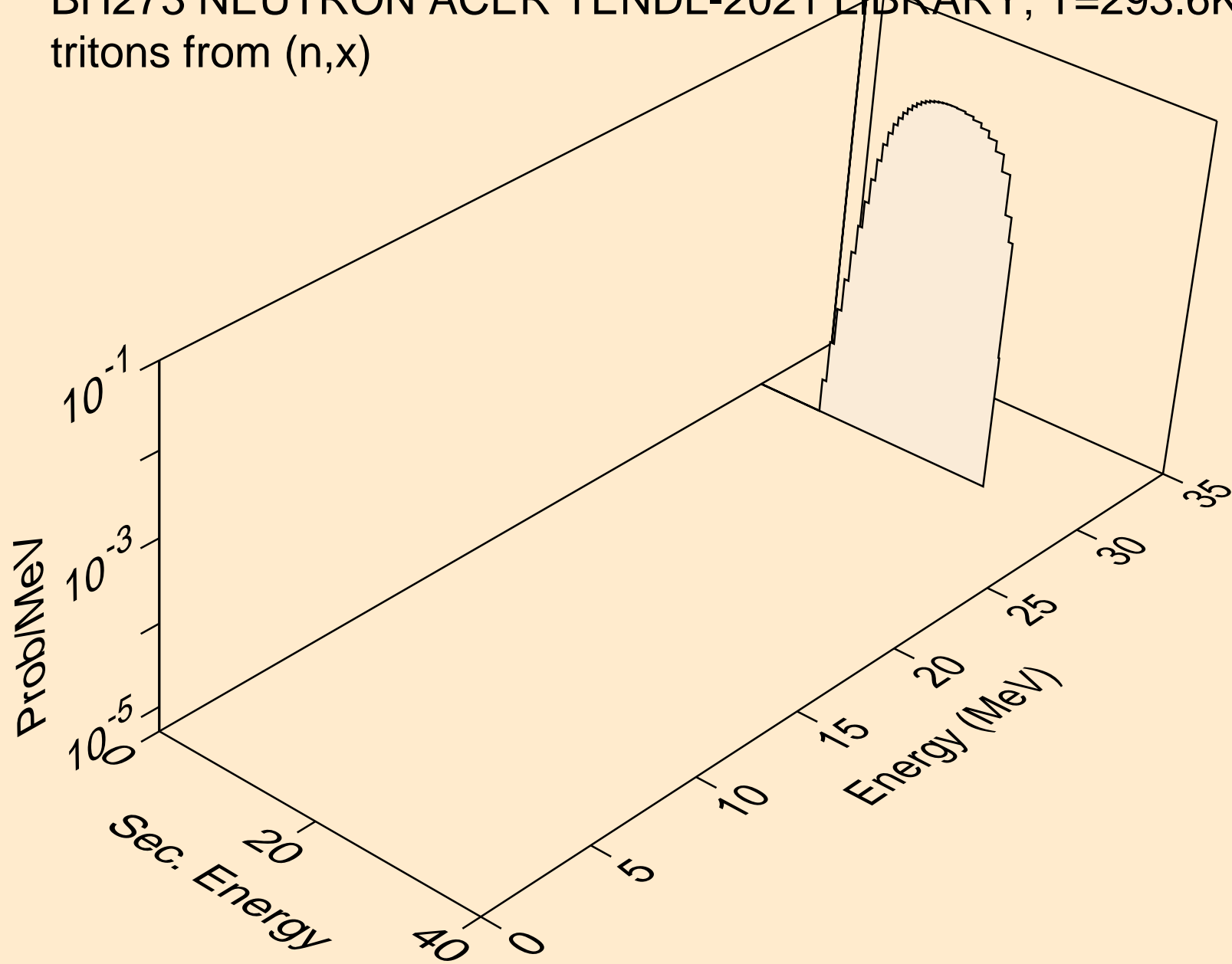

BH273 NEUTRON ACER TENDL-2021 LIBRARY; T=293.6K
tritons from (n,n*)t

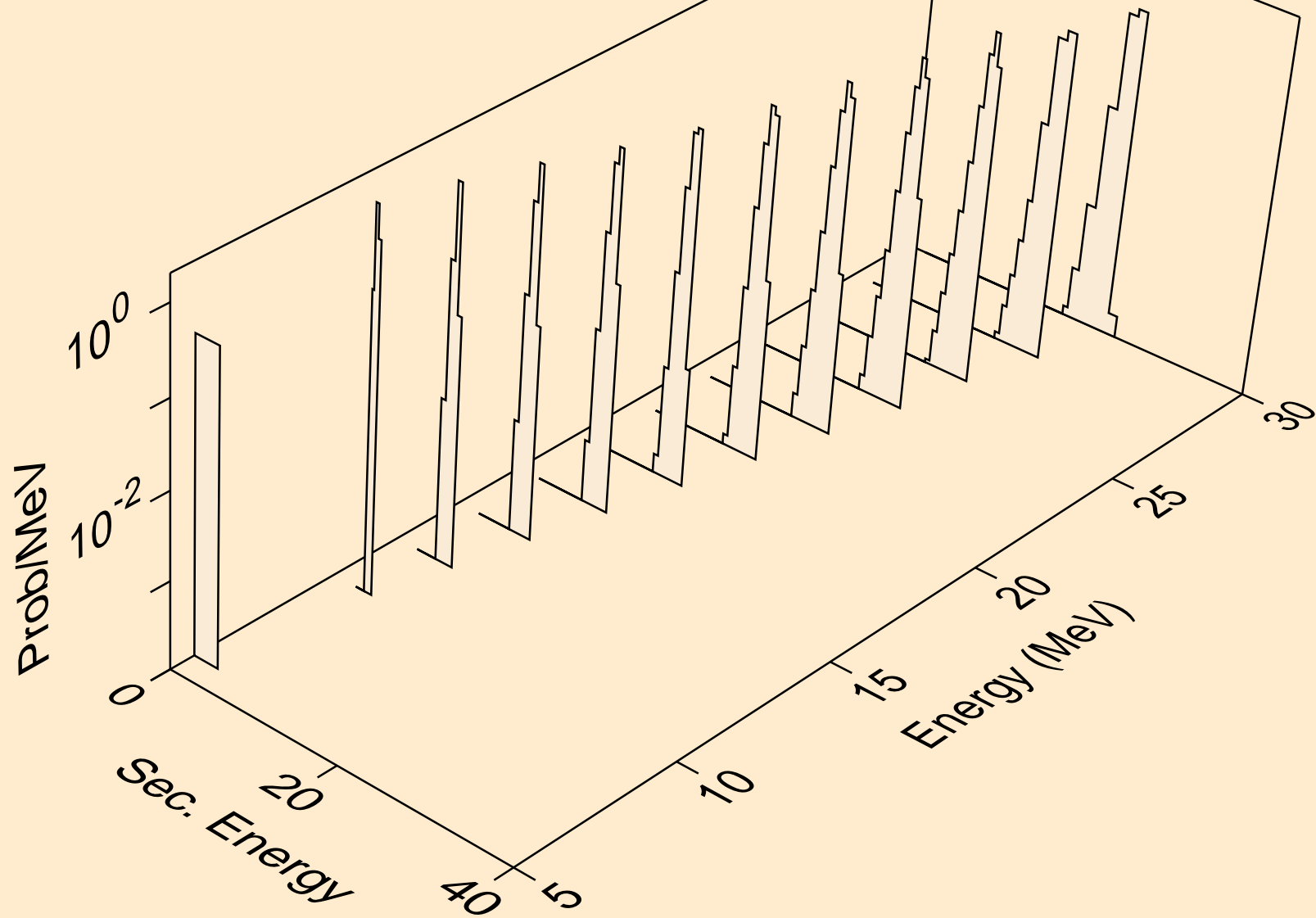

BH273 NEUTRON ACER TENDL-2021 LIBRARY; T=293.6K
tritons from (n,t)

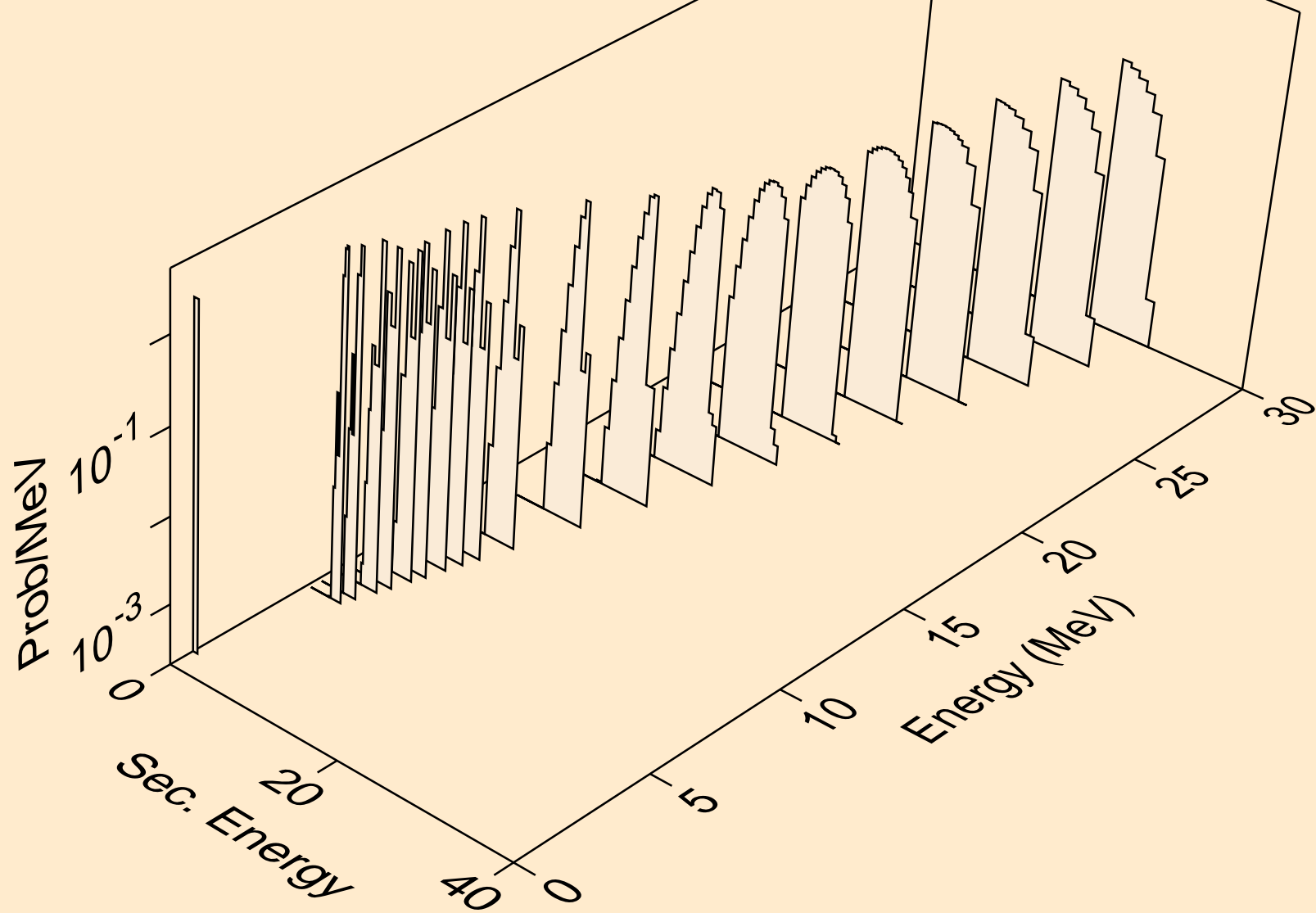

BH273 NEUTRON ACER TENDL-2021 LIBRARY; T=293.6K
he3s from (n,x)

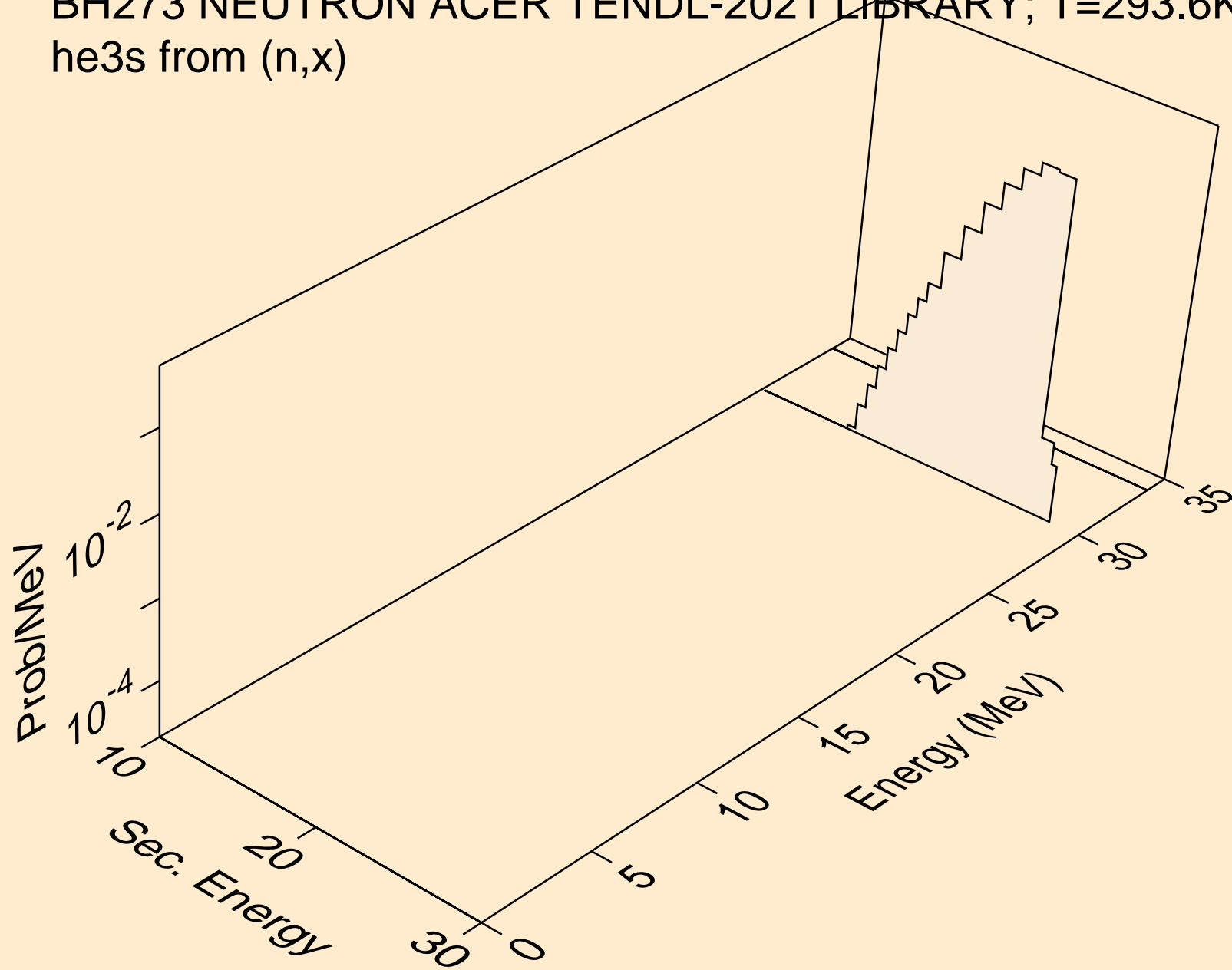

BH273 NEUTRON ACER TENDL-2021 LIBRARY; T=293.6K
alphas from (n,x)

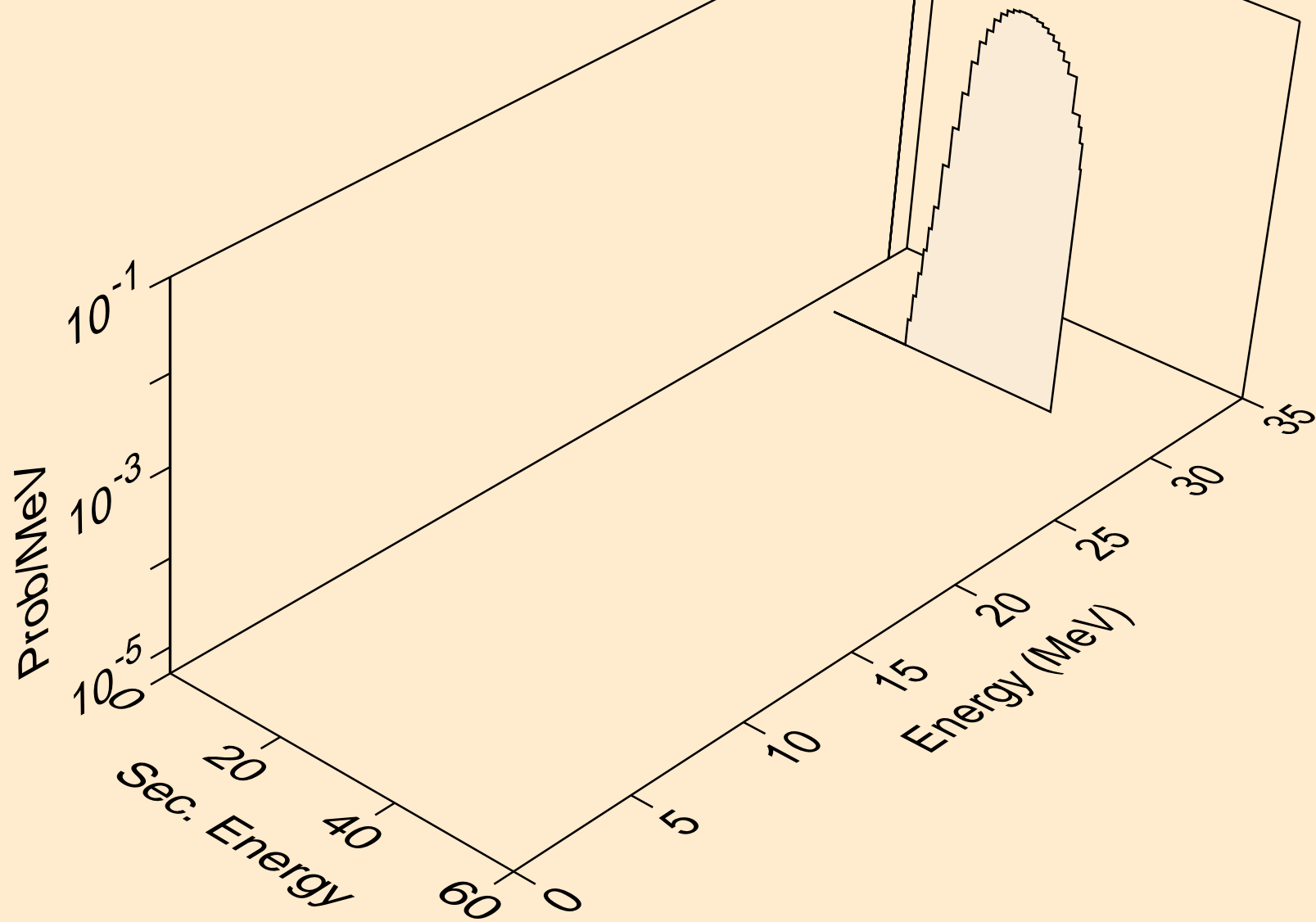

BH273 NEUTRON ACER TENDL-2021 LIBRARY; T=293.6K
alphas from (n,n*)a

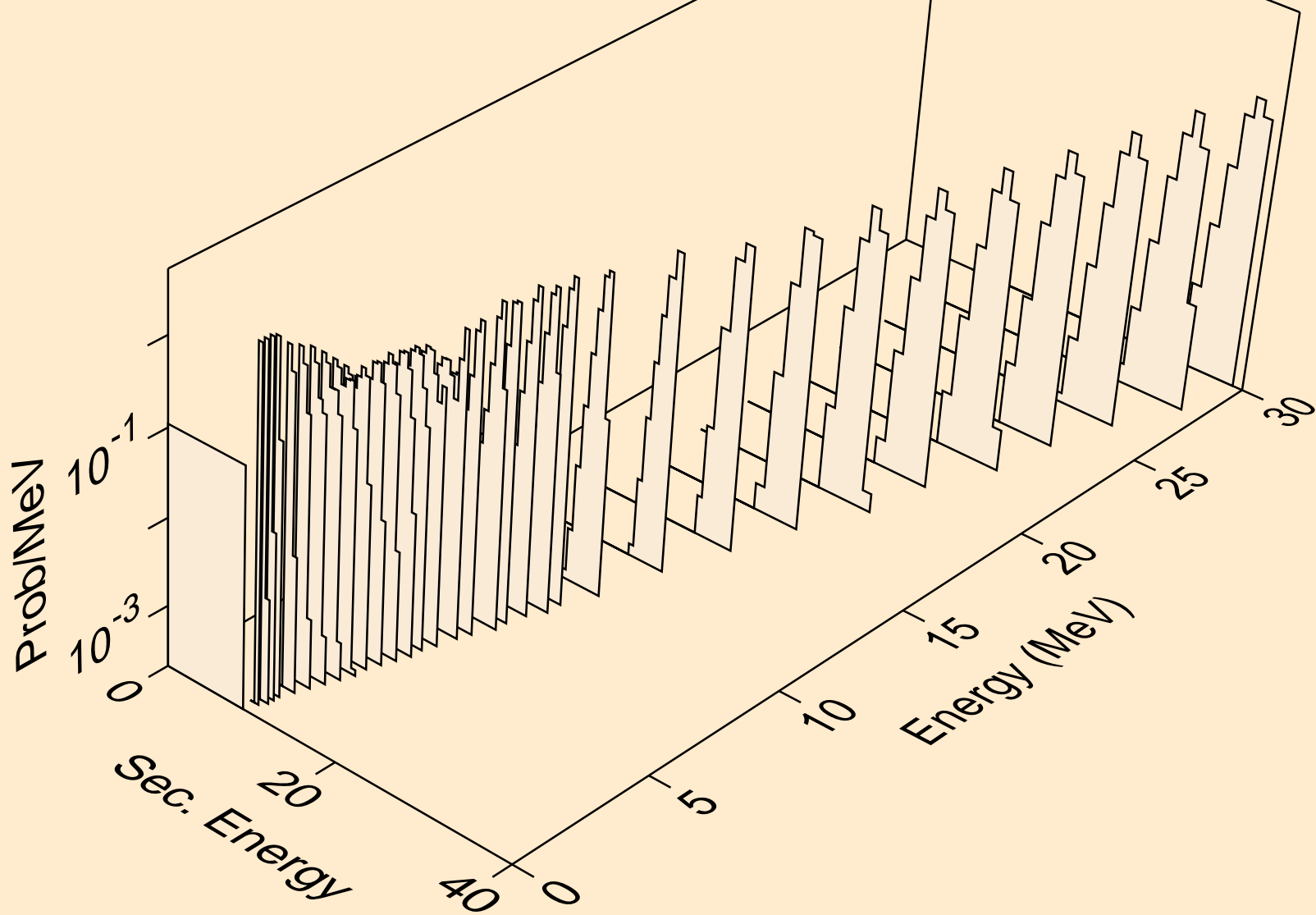

BH273 NEUTRON ACER TENDL-2021 LIBRARY; T=293.6K
alphas from (n,2n)a

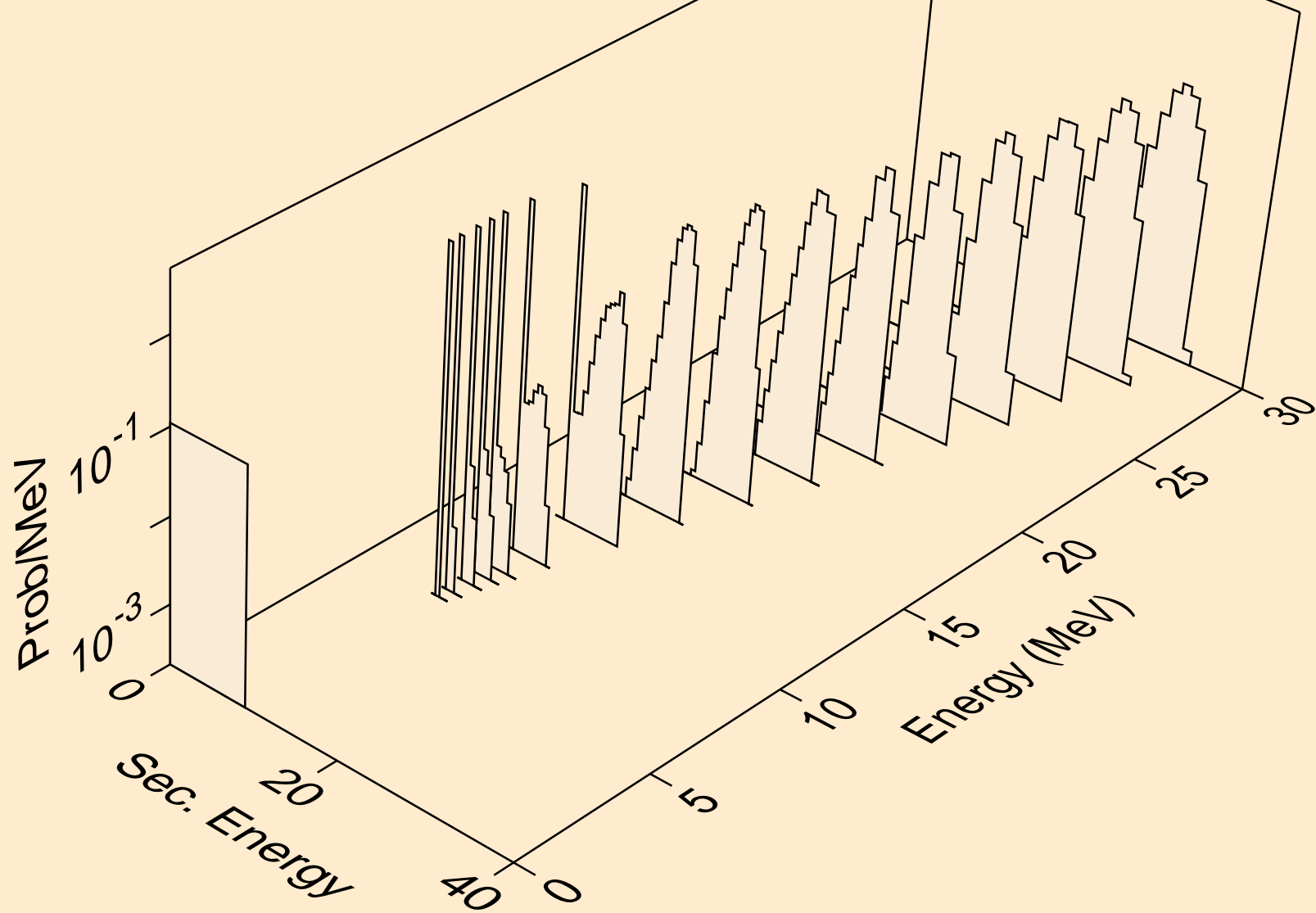

BH273 NEUTRON ACER TENDL-2021 LIBRARY; T=293.6K
alphas from (n,3n)a

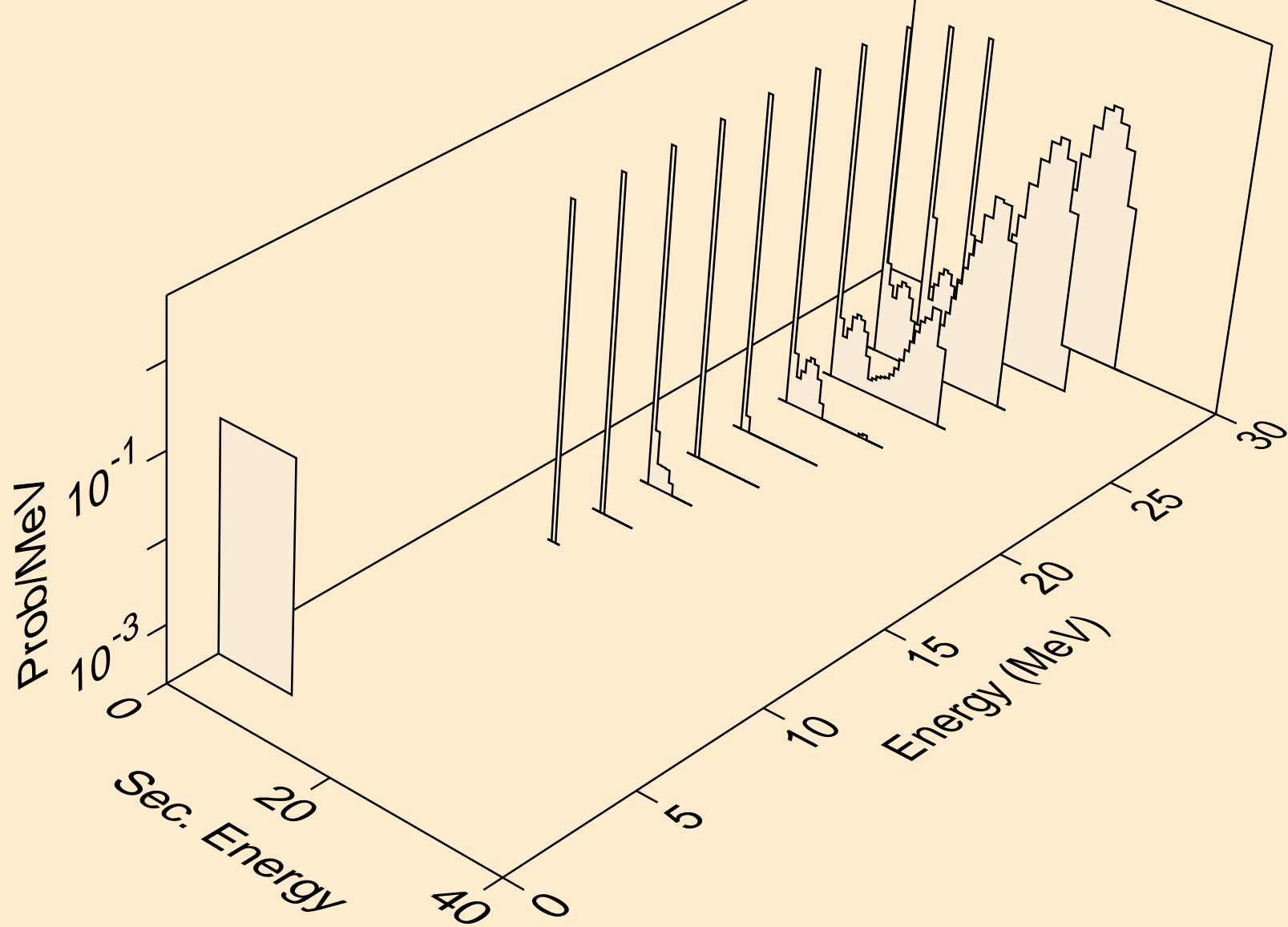

BH273 NEUTRON ACER TENDL-2021 LIBRARY; T=293.6K
alphas from (n,a)

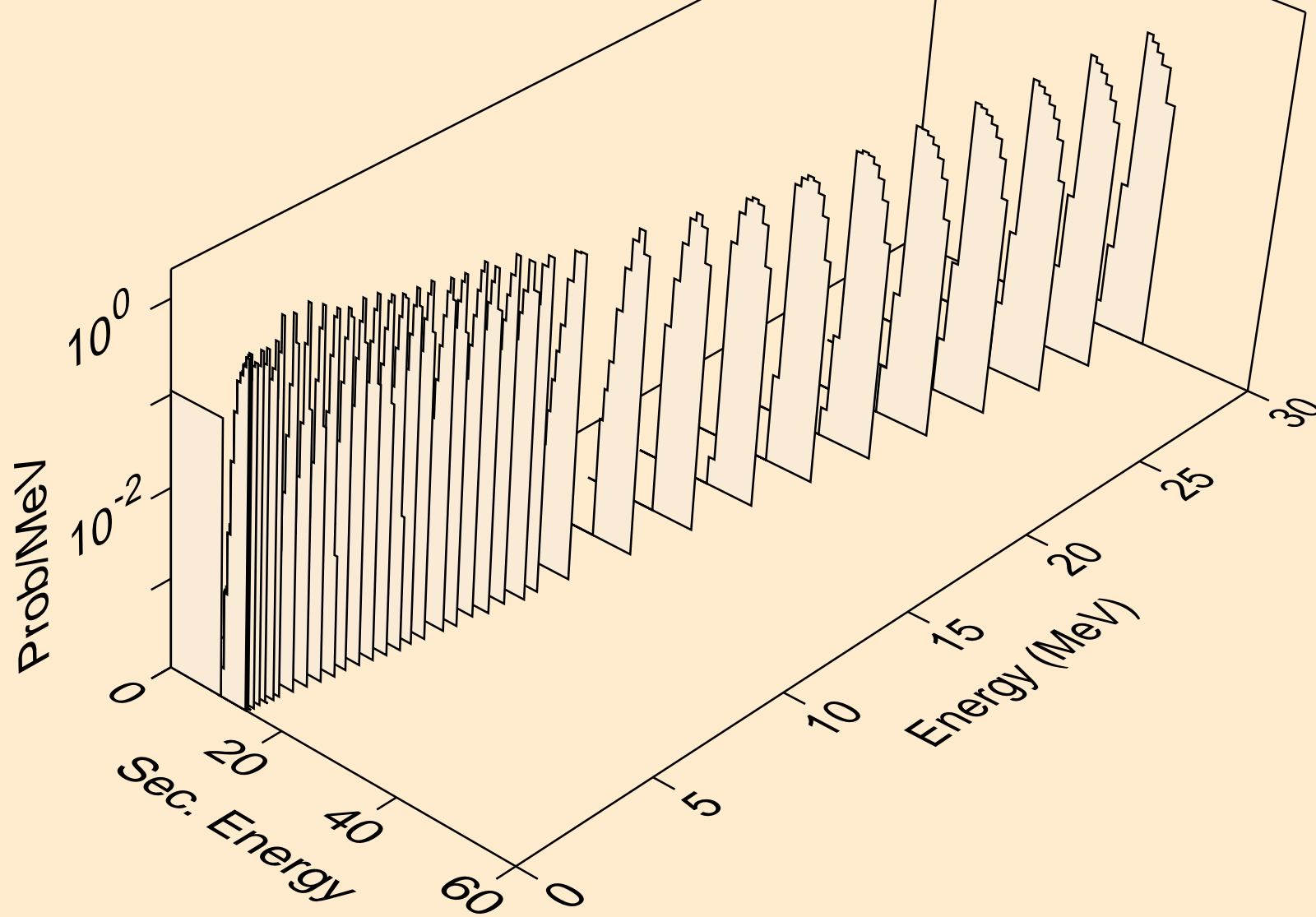

BH273 NEUTRON ACER TENDL-2021 LIBRARY; T=293.6K
alphas from (n,da)

