

FM247M NEUTRON ACER TENDL-2021 LIBRARY; T=293.6K

Principal cross sections

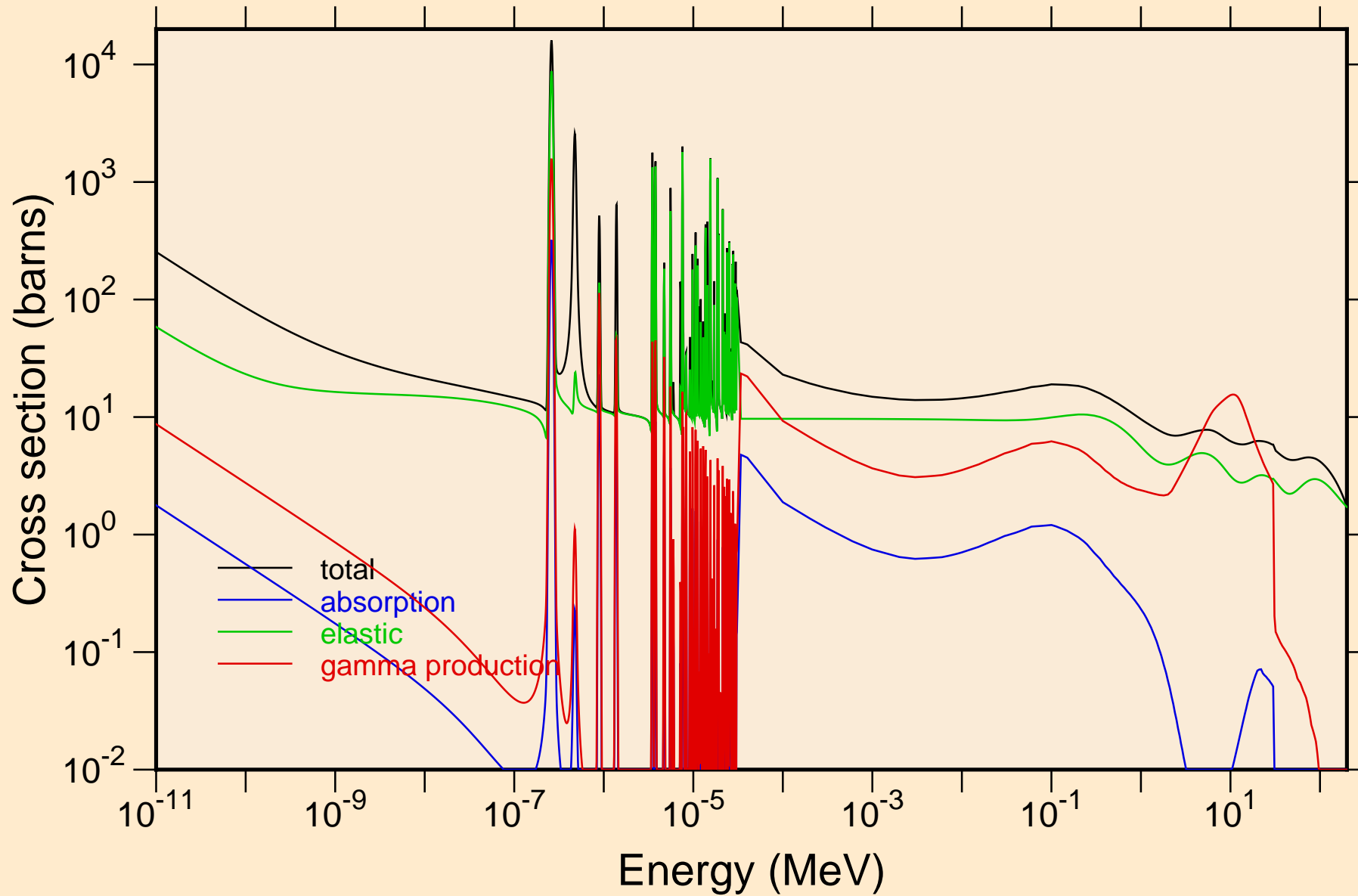

FM247M NEUTRON ACER TENDL-2021 LIBRARY; T=293.6K
resonance total cross section

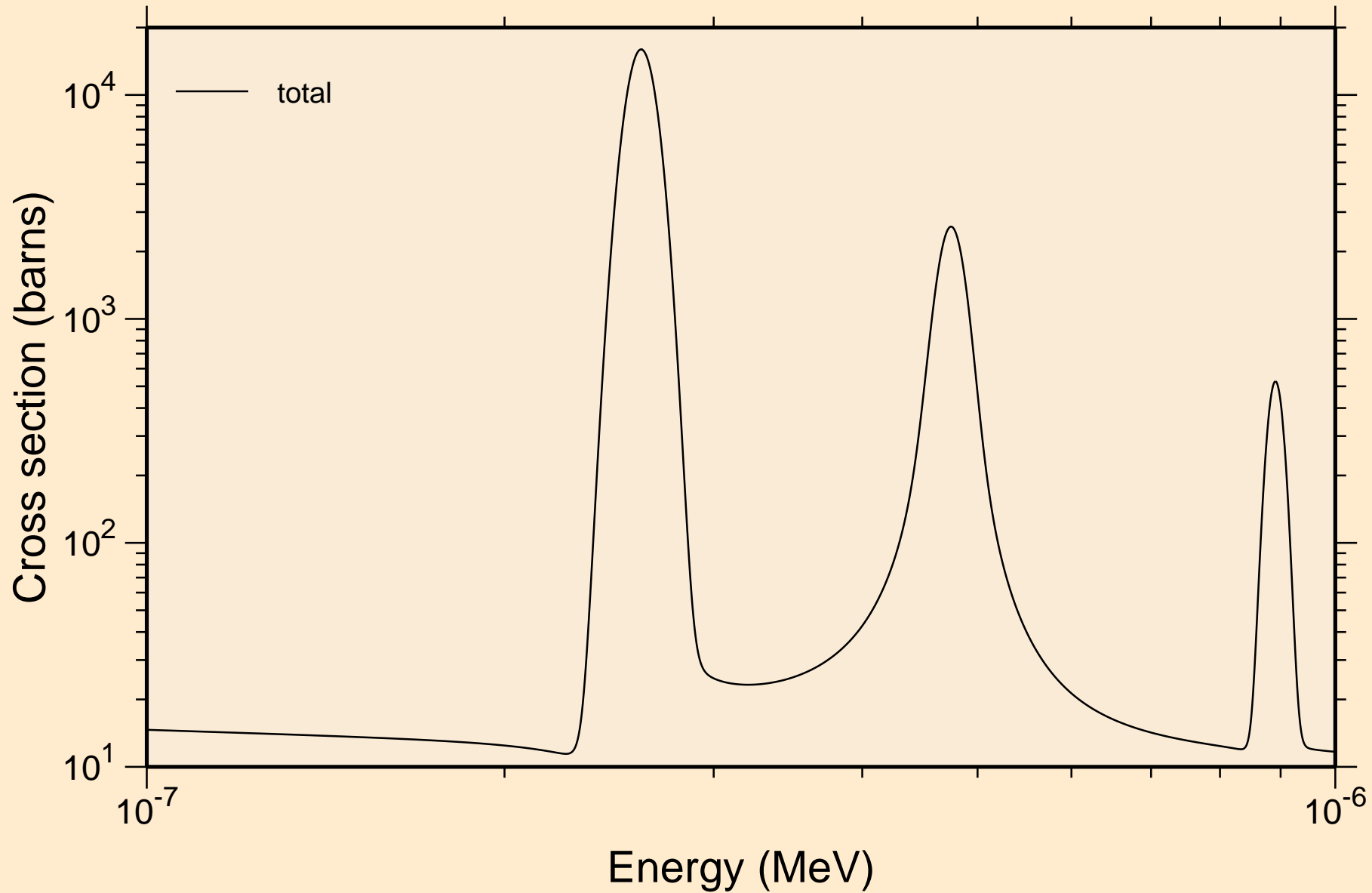

FM247M NEUTRON ACER TENDL-2021 LIBRARY; T=293.6K
resonance total cross section

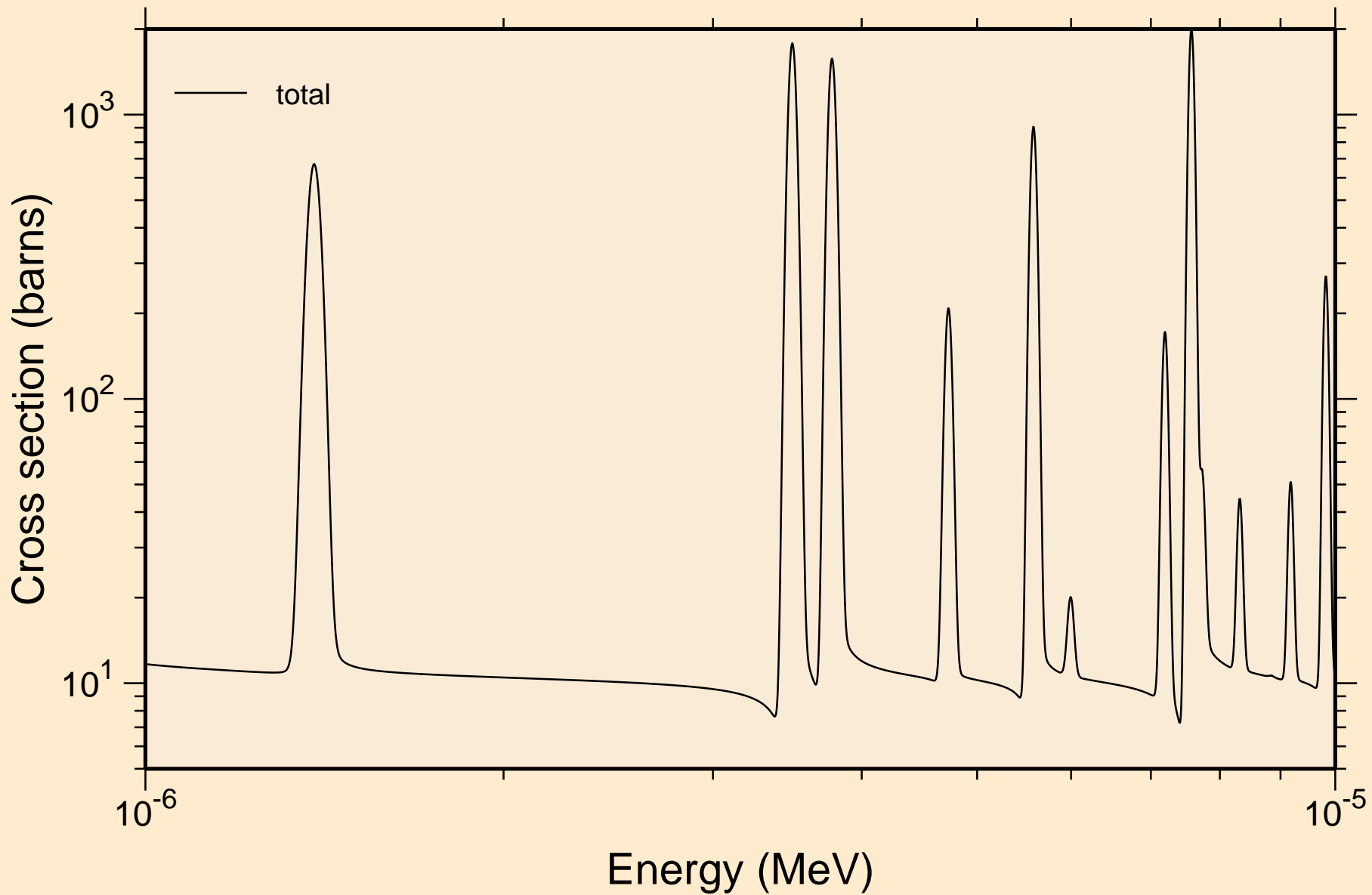

FM247M NEUTRON ACER TENDL-2021 LIBRARY; T=293.6K
resonance total cross section

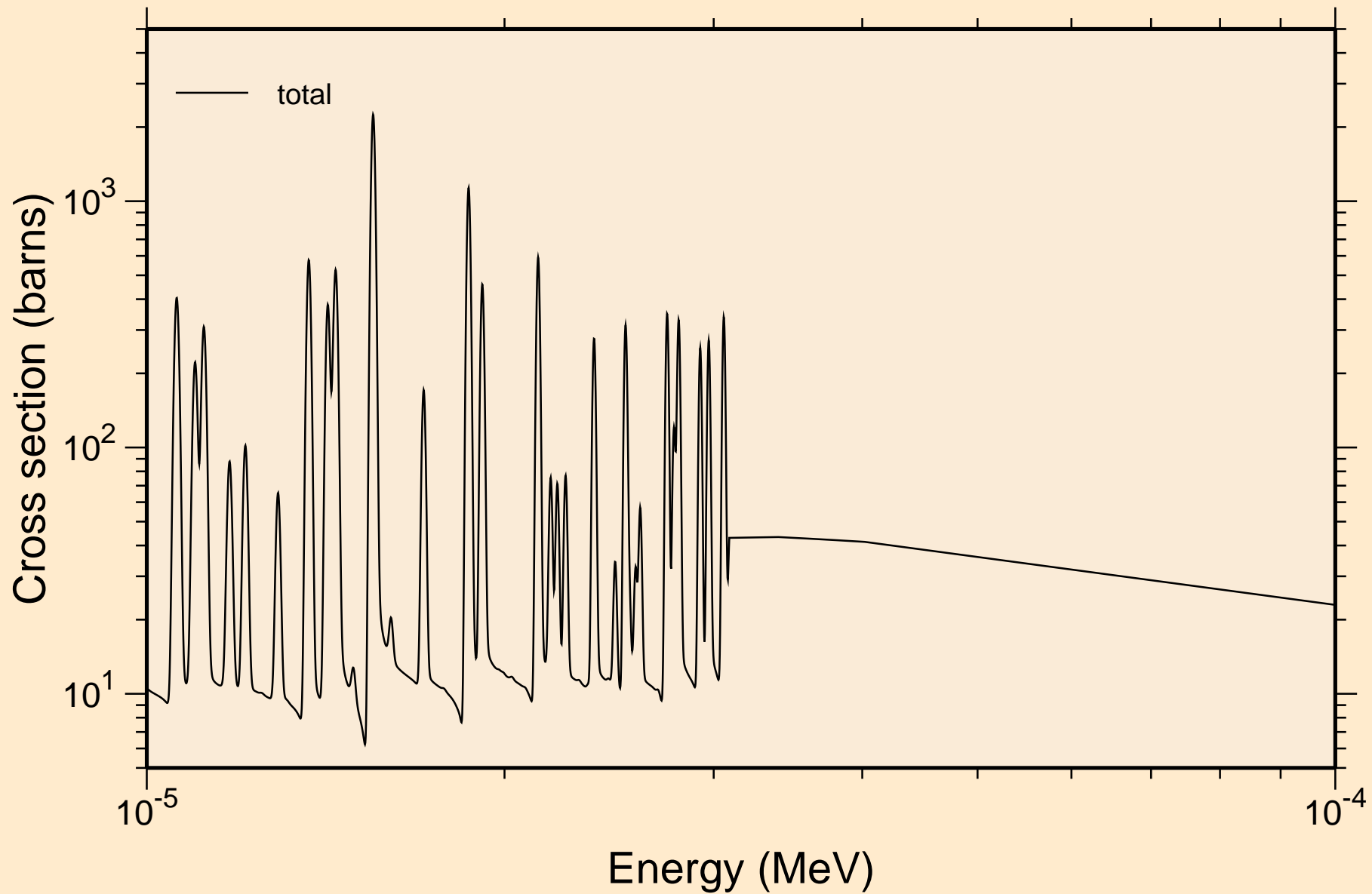

FM247M NEUTRON ACER TENDL-2021 LIBRARY; T=293.6K
resonance total cross section

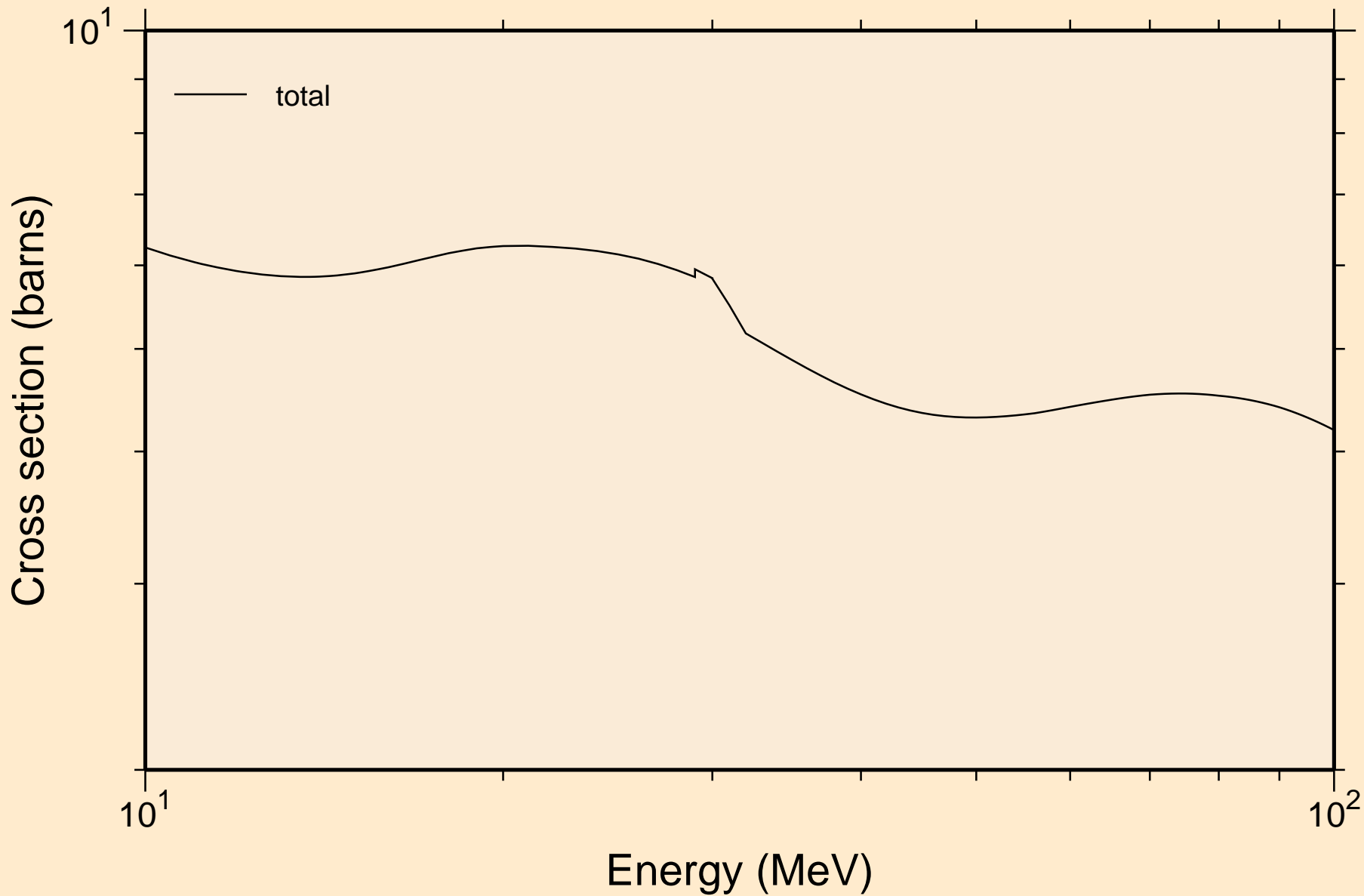

FM247M NEUTRON ACER TENDL-2021 LIBRARY; T=293.6K
resonance absorption cross sections

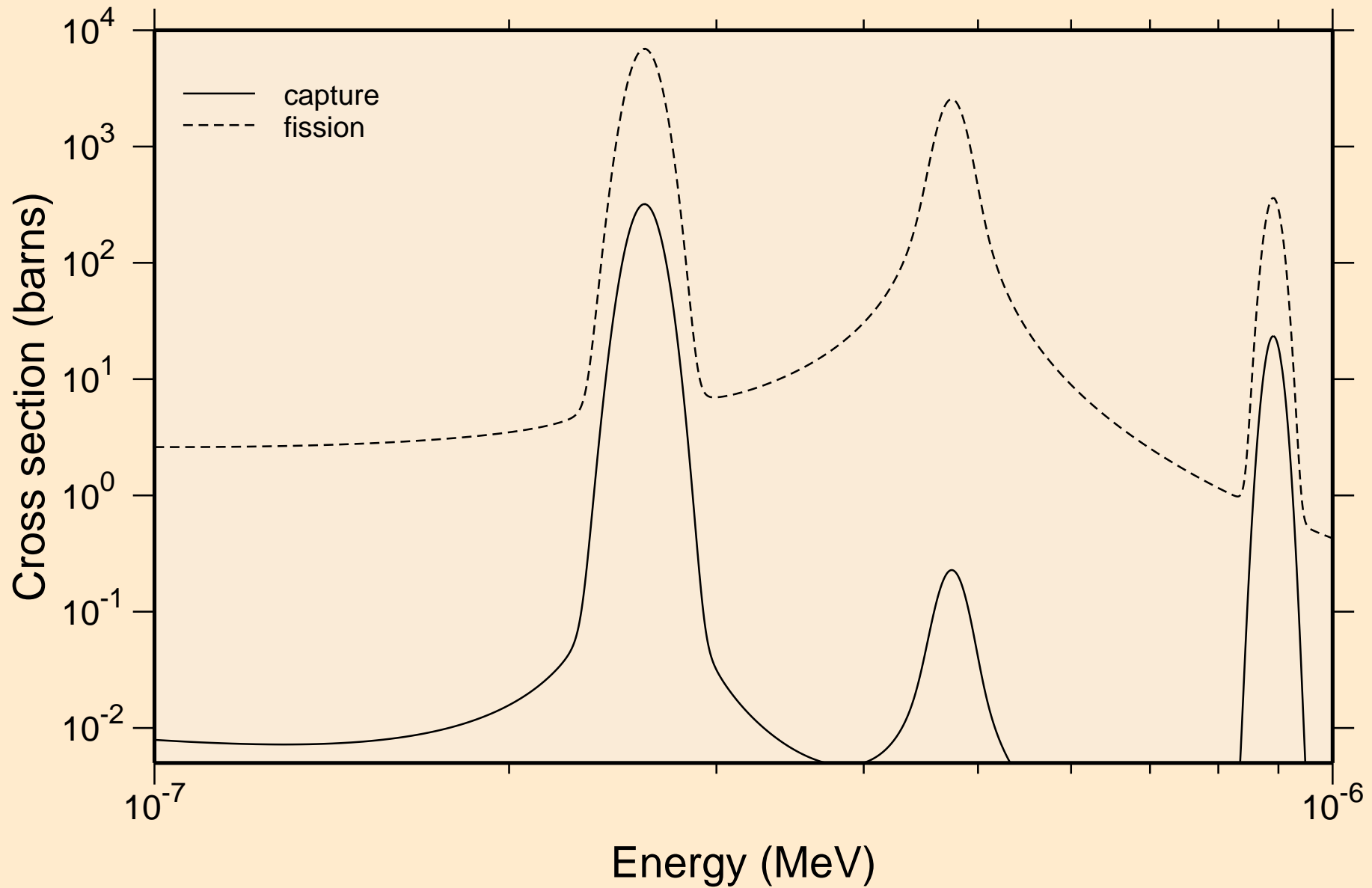

FM247M NEUTRON ACER TENDL-2021 LIBRARY; T=293.6K
resonance absorption cross sections

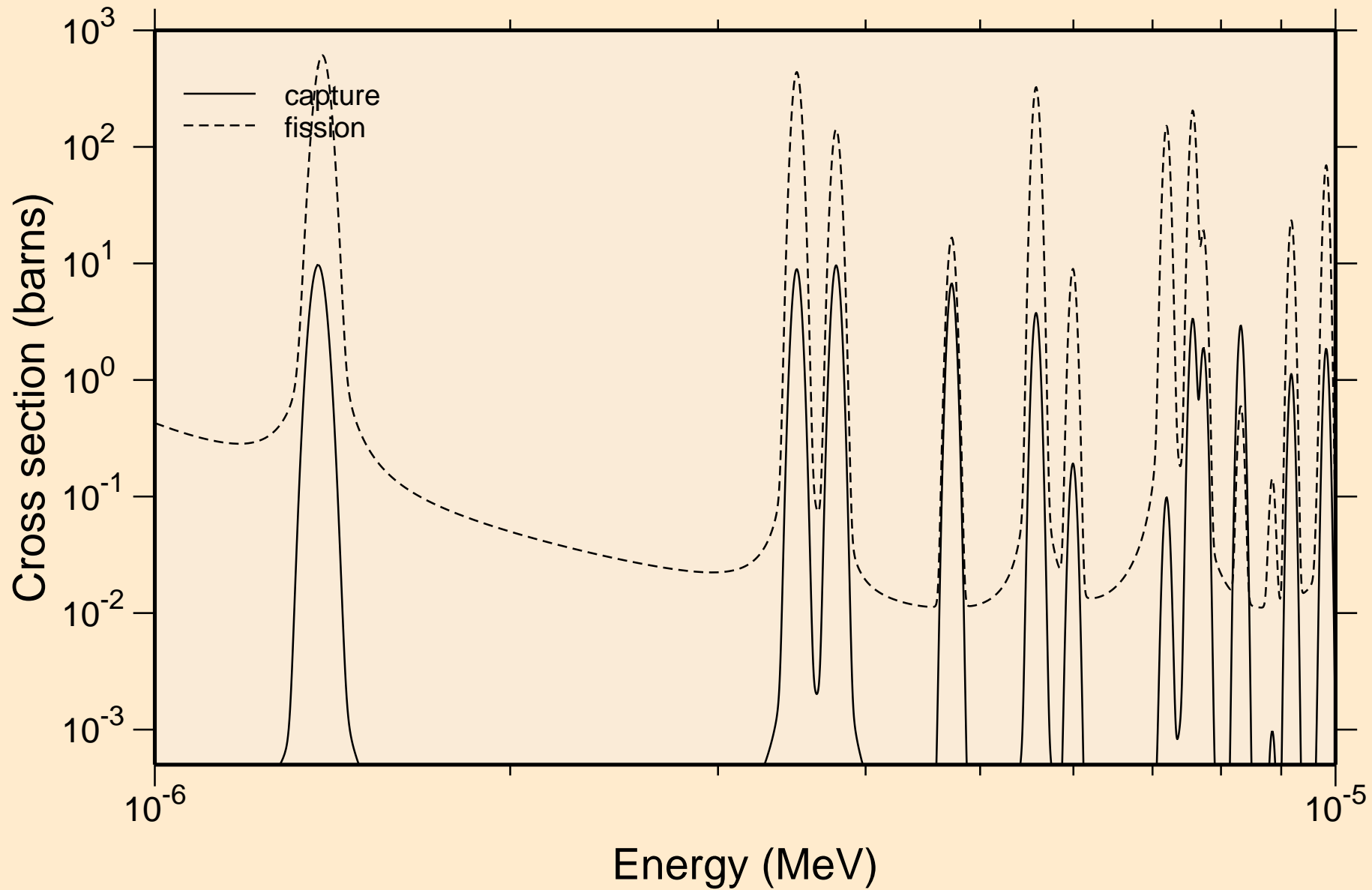

FM247M NEUTRON ACER TENDL-2021 LIBRARY; T=293.6K
resonance absorption cross sections

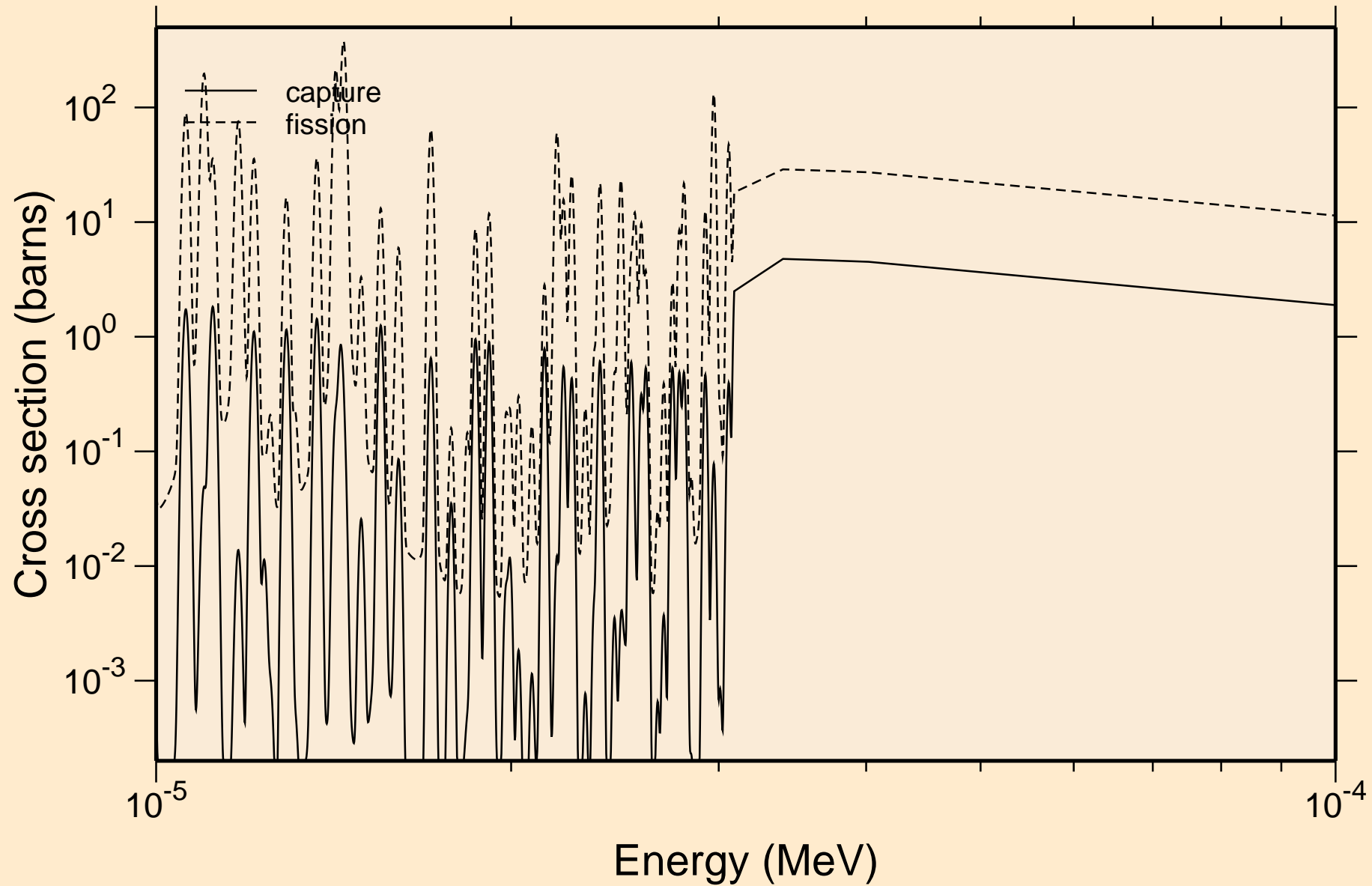

FM247M NEUTRON ACER TENDL-2021 LIBRARY; T=293.6K
resonance absorption cross sections

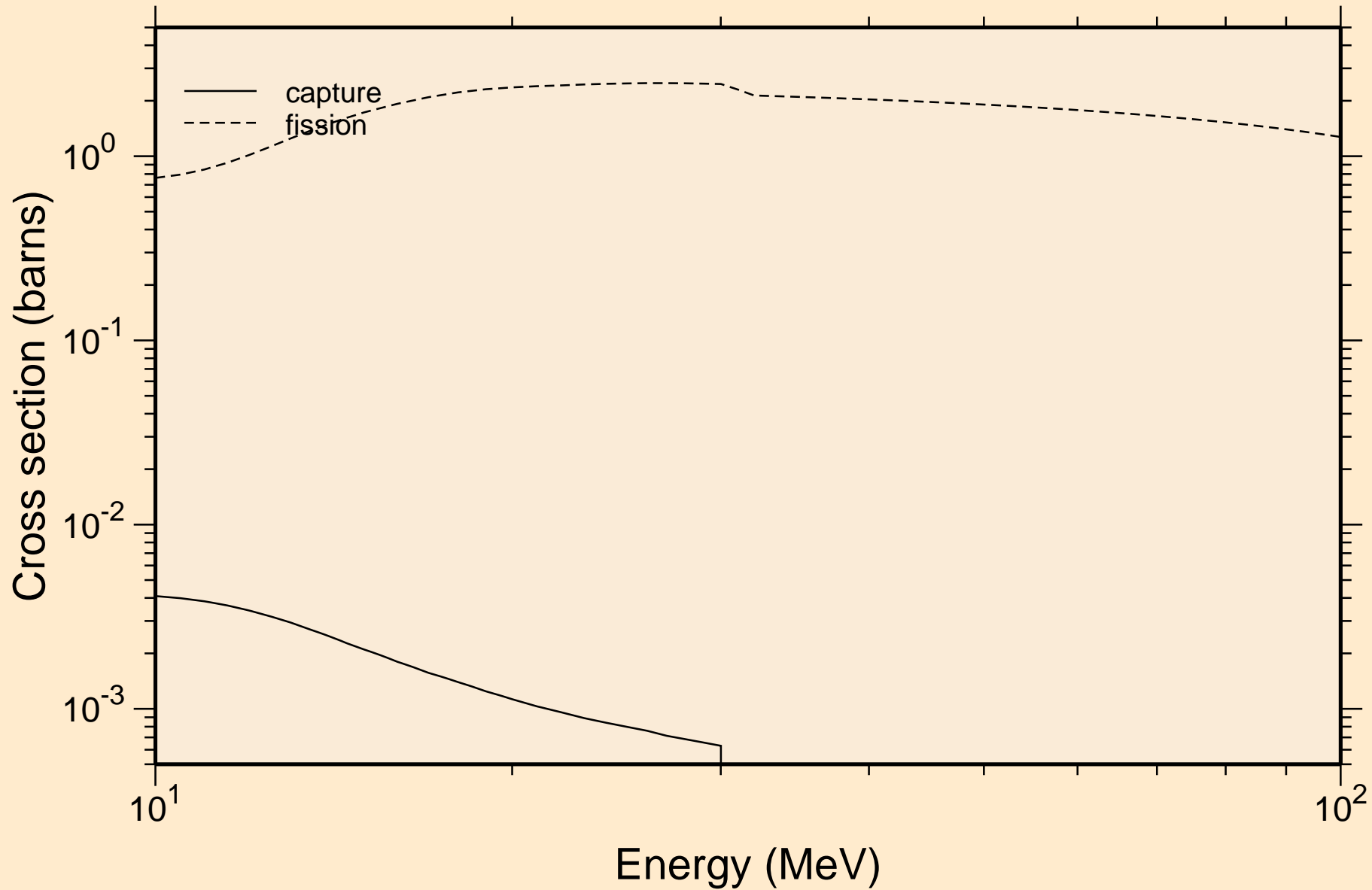

FM247M NEUTRON ACER TENDL-2021 LIBRARY; T=293.6K
Heating

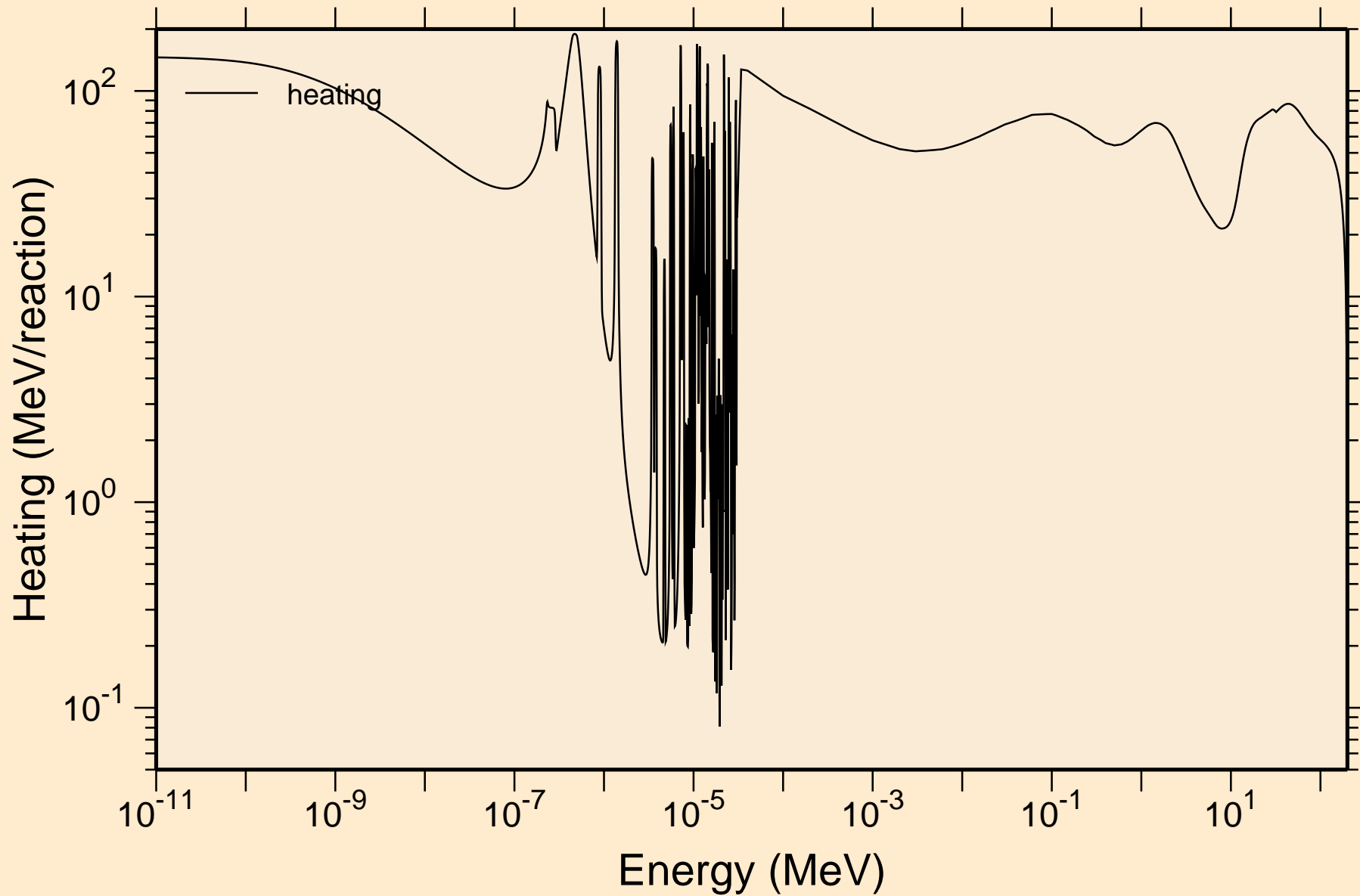

FM247M NEUTRON ACER TENDL-2021 LIBRARY; T=293.6K Damage

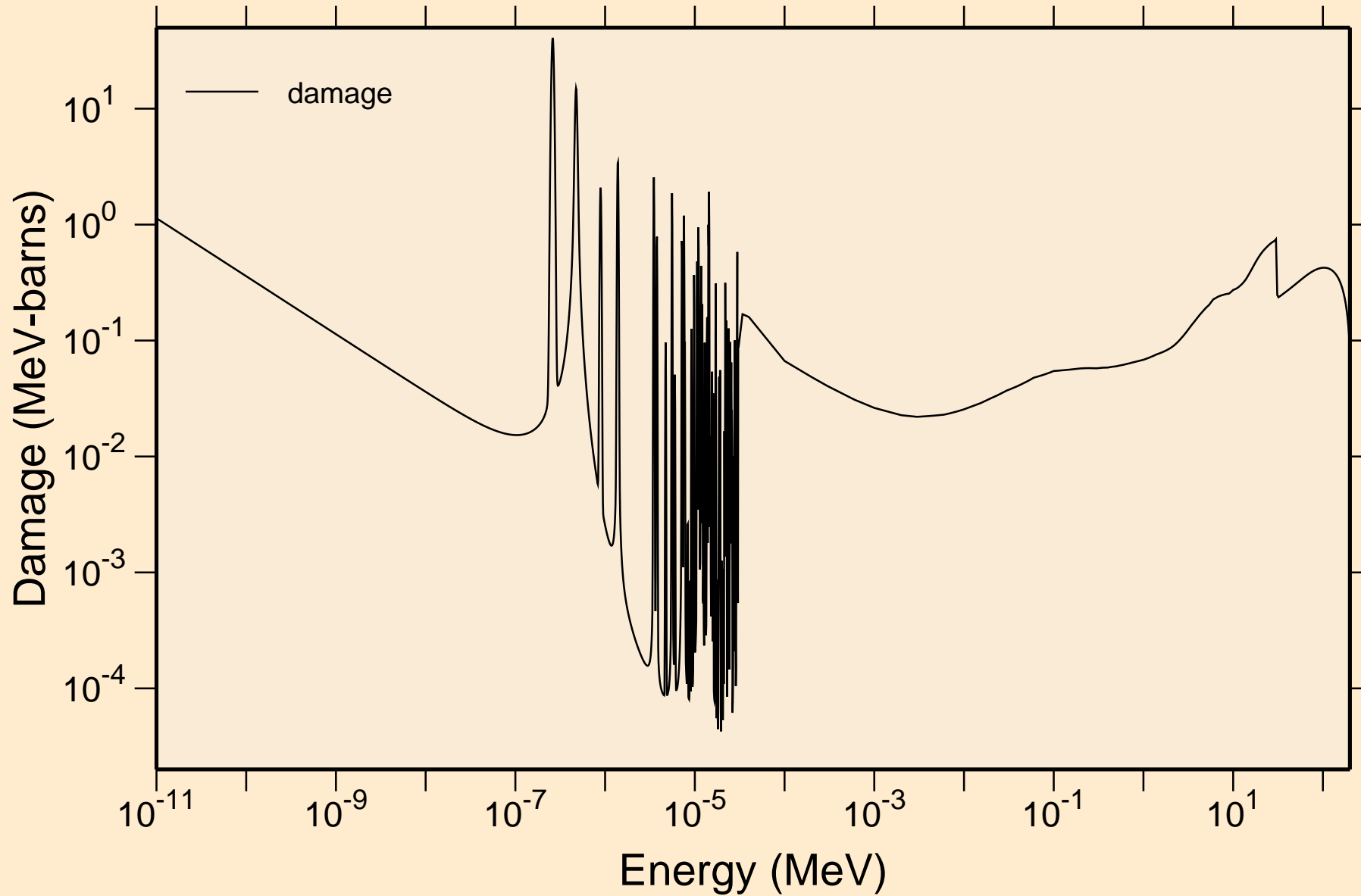

FM247M NEUTRON ACER TENDL-2021 LIBRARY; T=293.6K

Non-threshold reactions

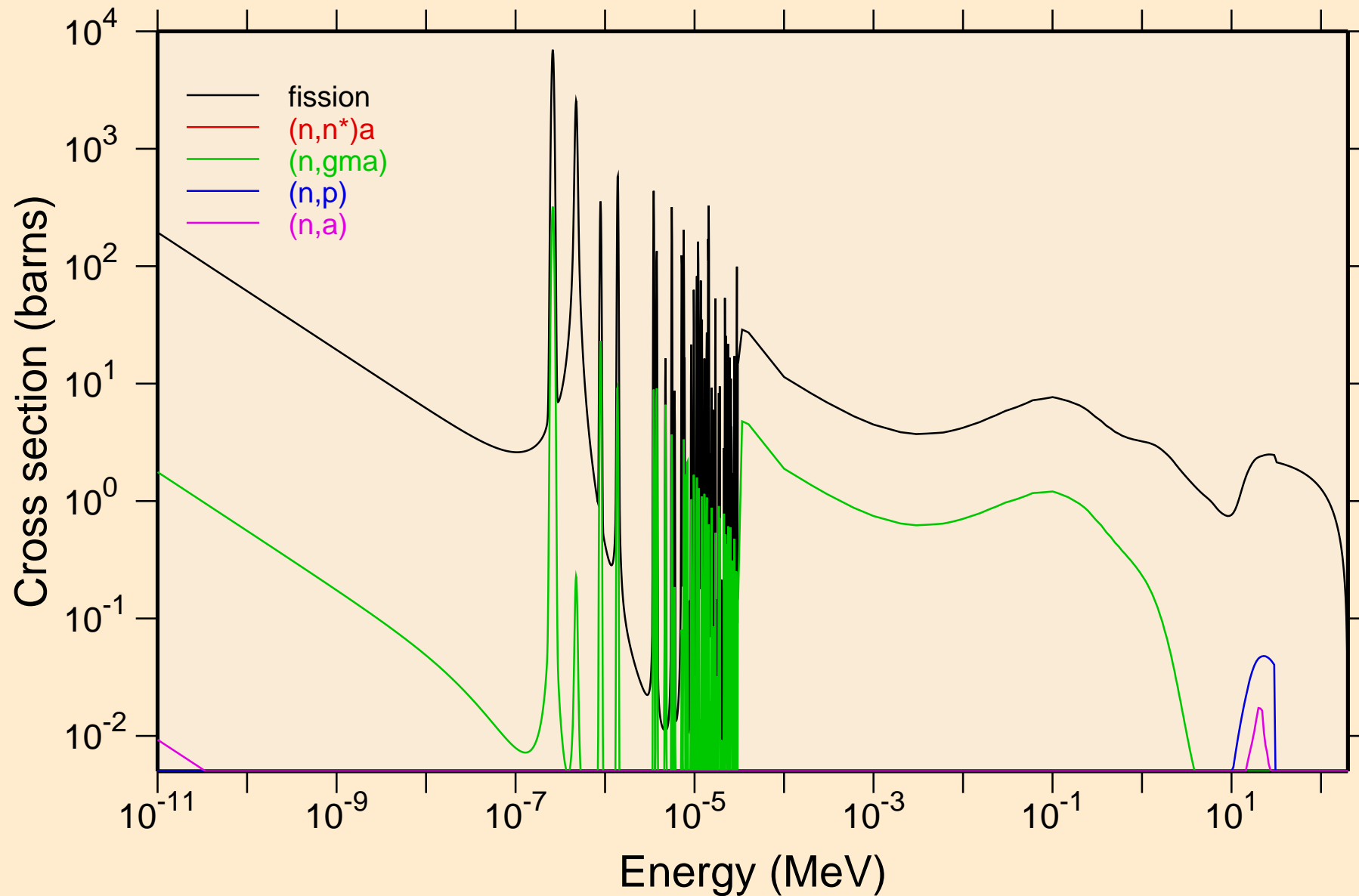

FM247M NEUTRON ACER TENDL-2021 LIBRARY; T=293.6K
Non-threshold reactions

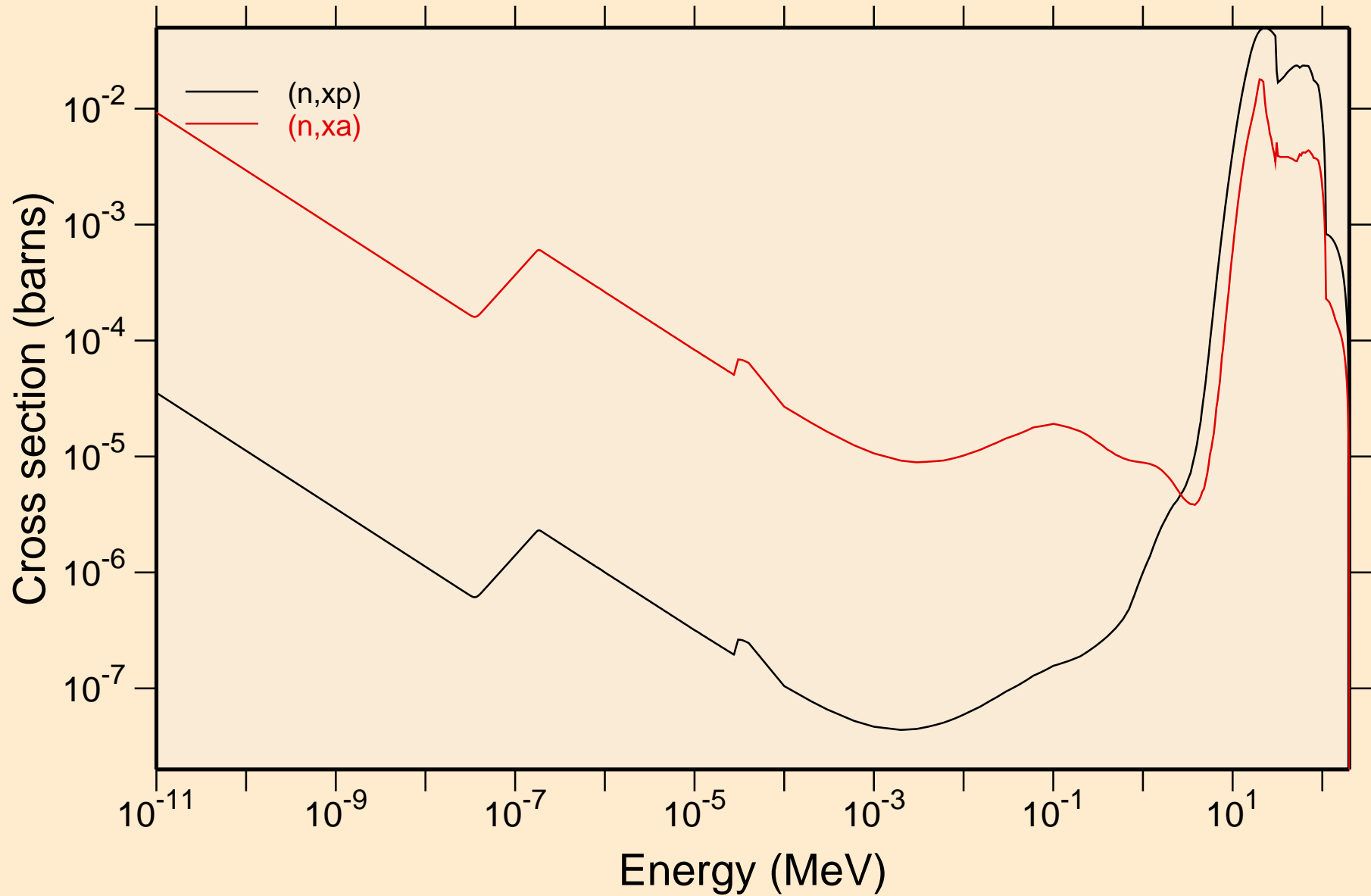

FM247M NEUTRON ACER TENDL-2021 LIBRARY; T=293.6K
Principal cross sections

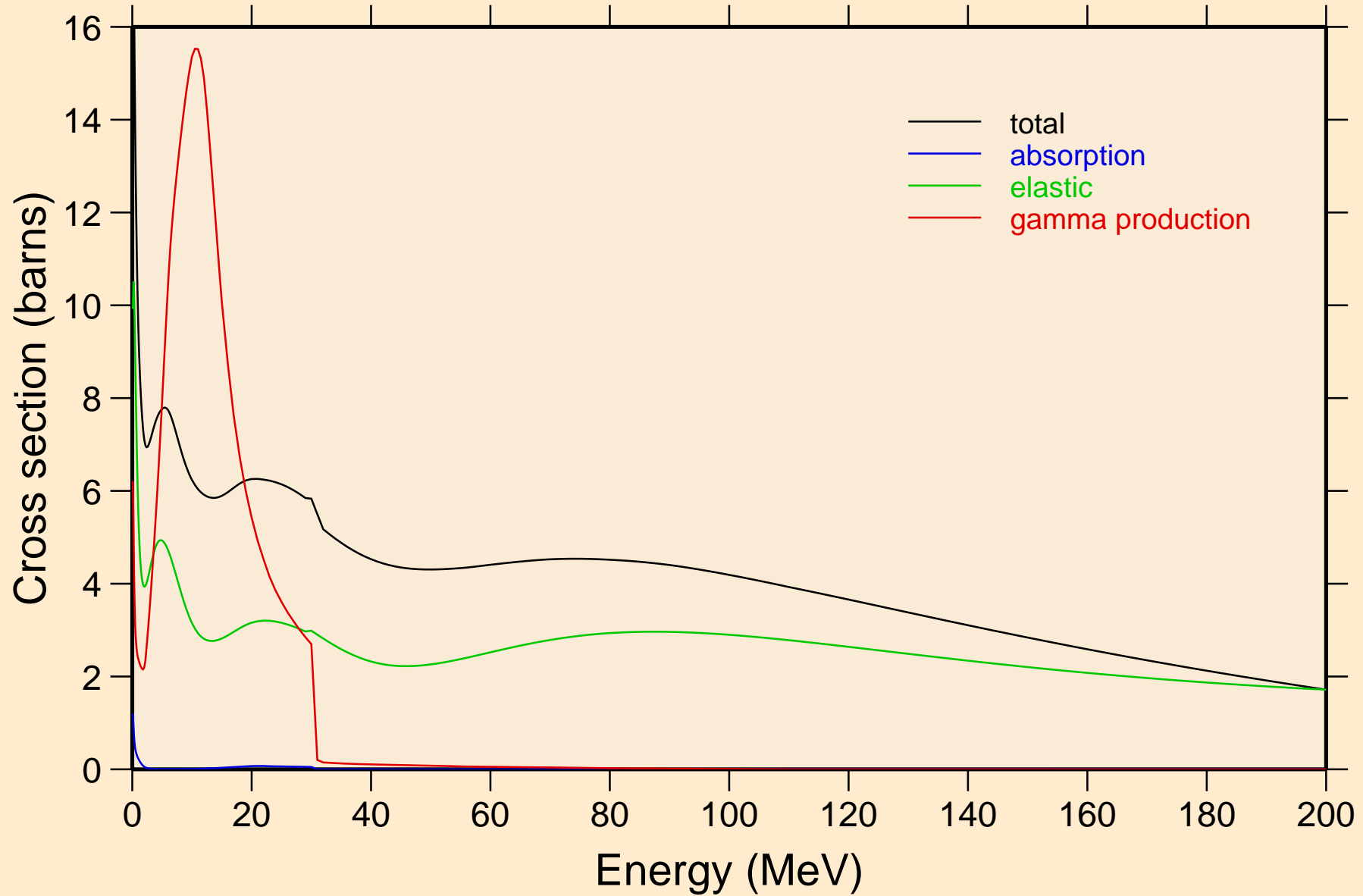

FM247M NEUTRON ACER TENDL-2021 LIBRARY; T=293.6K
Heating

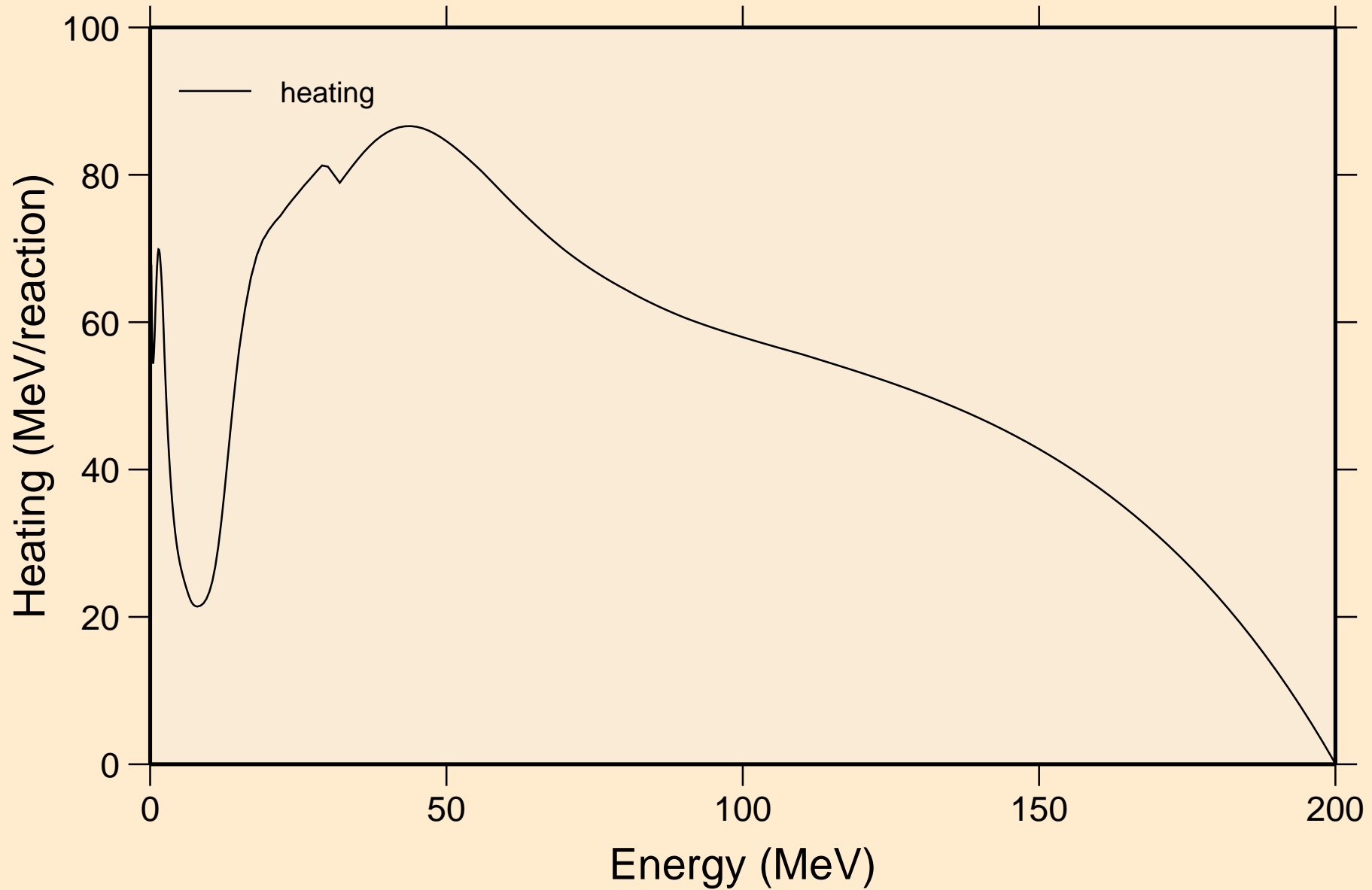

FM247M NEUTRON ACER TENDL-2021 LIBRARY; T=293.6K
Damage

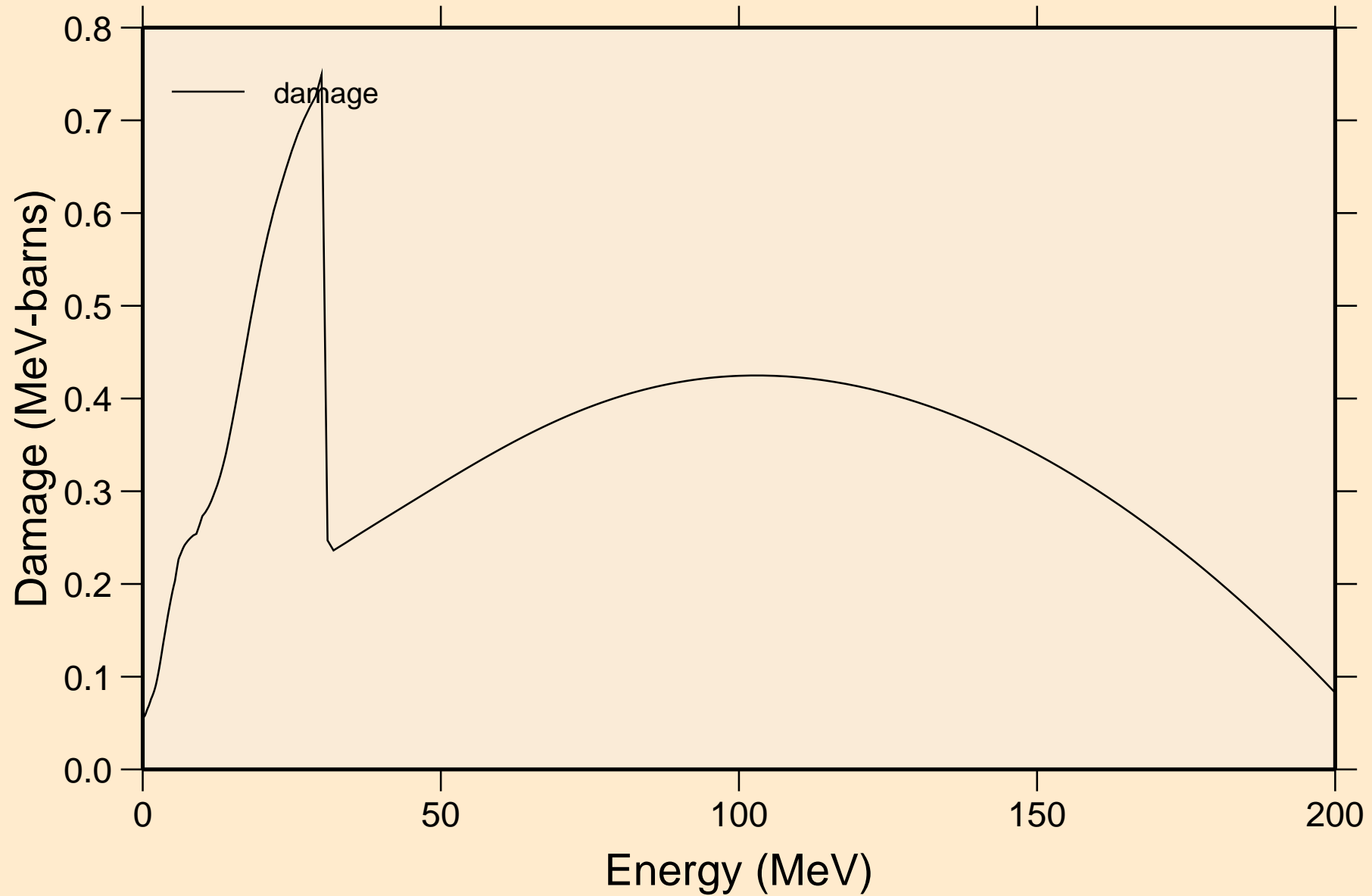

FM247M NEUTRON ACER TENDL-2021 LIBRARY; T=293.6K

Non-threshold reactions

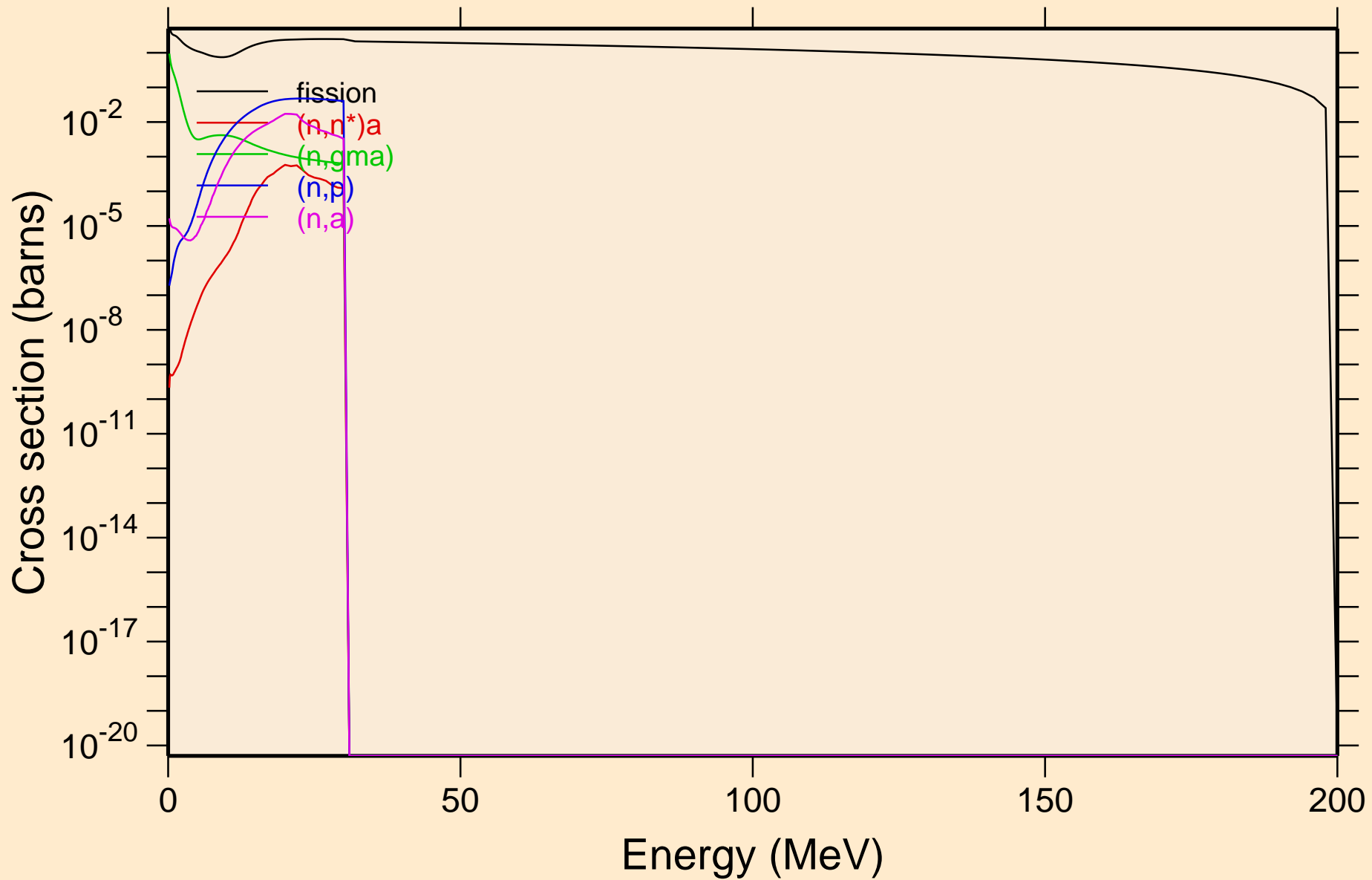

FM247M NEUTRON ACER TENDL-2021 LIBRARY; T=293.6K
Non-threshold reactions

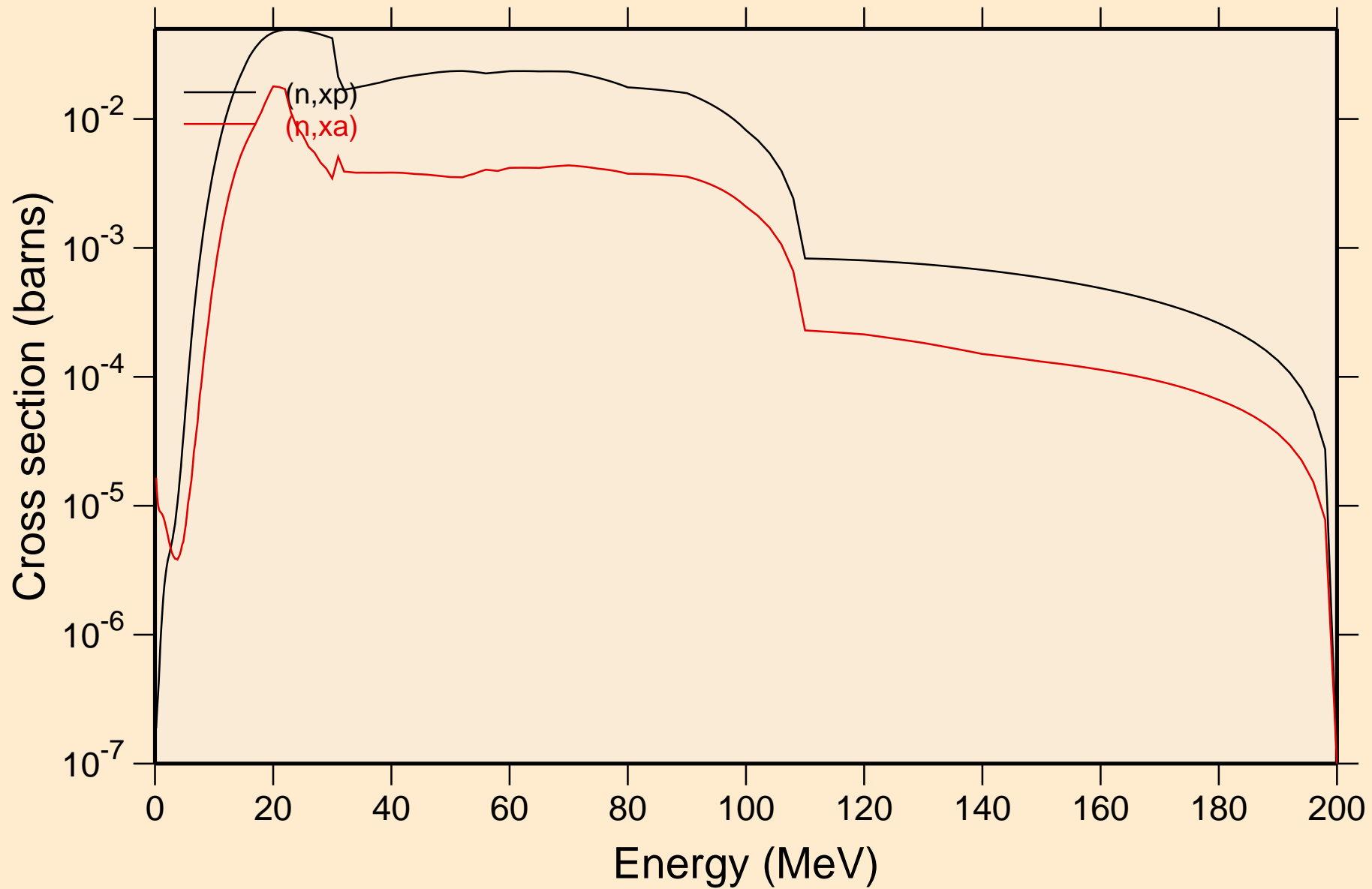

FM247M NEUTRON ACER TENDL-2021 LIBRARY; T=293.6K
Inelastic levels

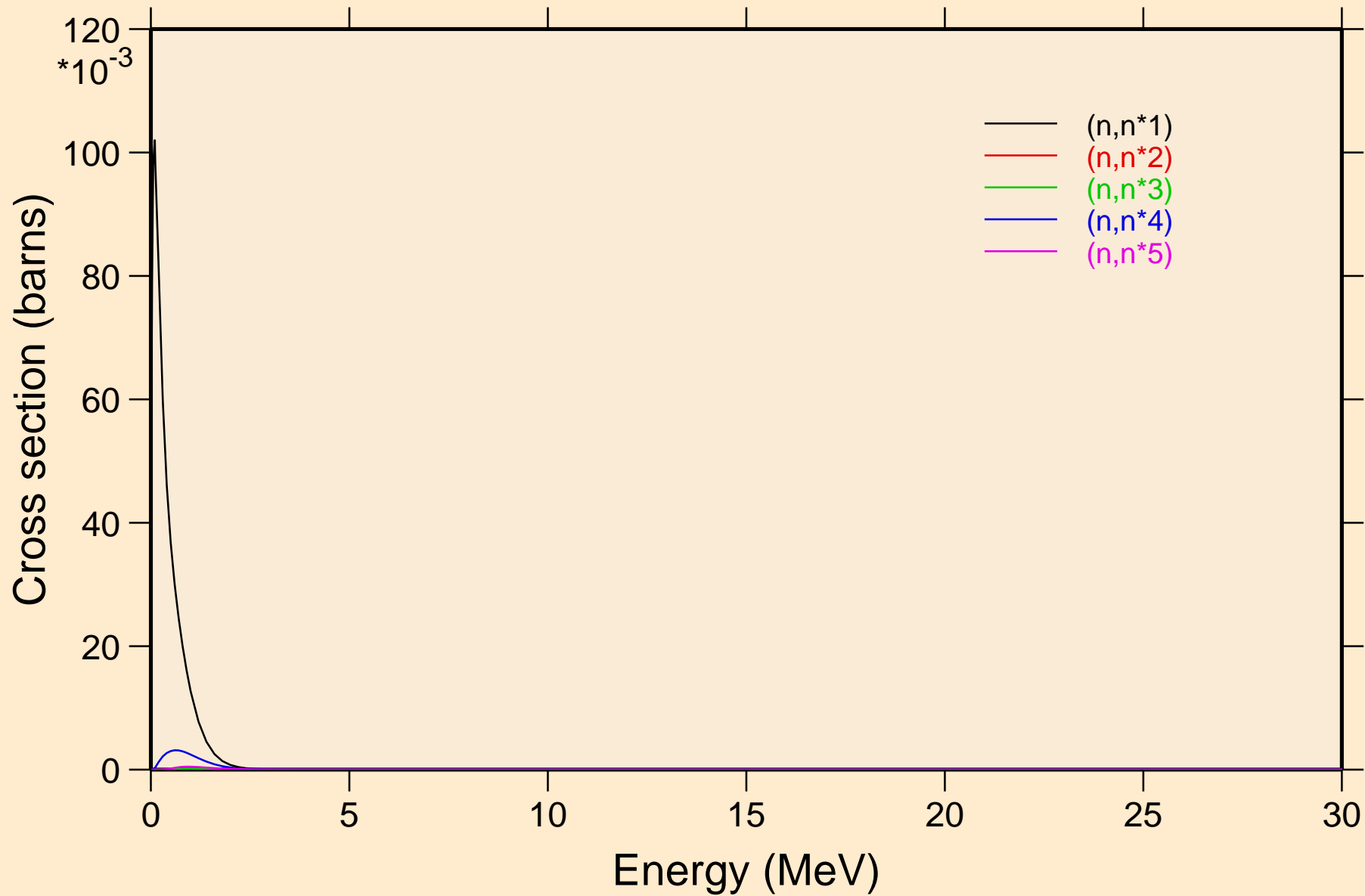

FM247M NEUTRON ACER TENDL-2021 LIBRARY; T=293.6K
Inelastic levels

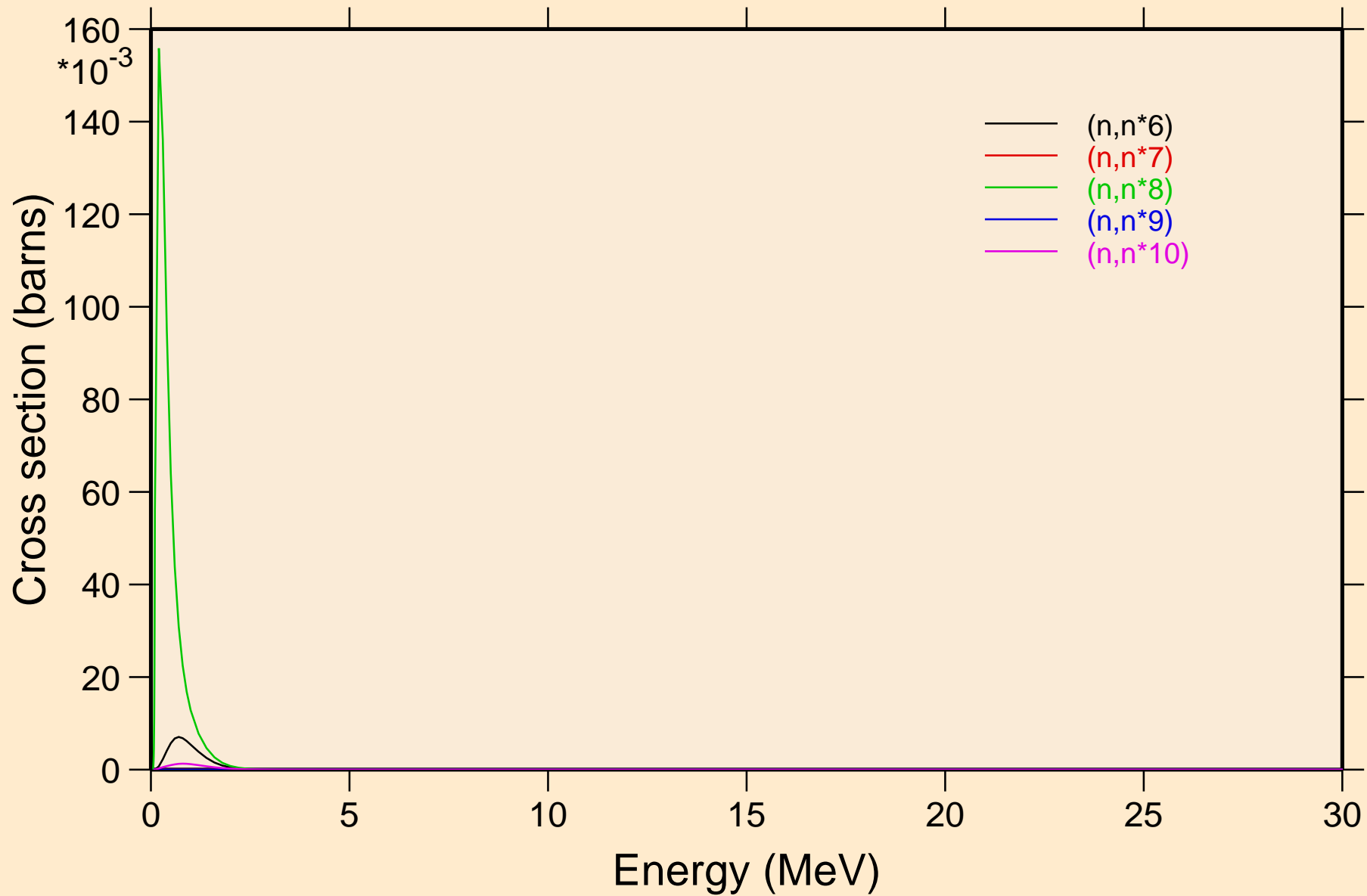

FM247M NEUTRON ACER TENDL-2021 LIBRARY; T=293.6K
Inelastic levels

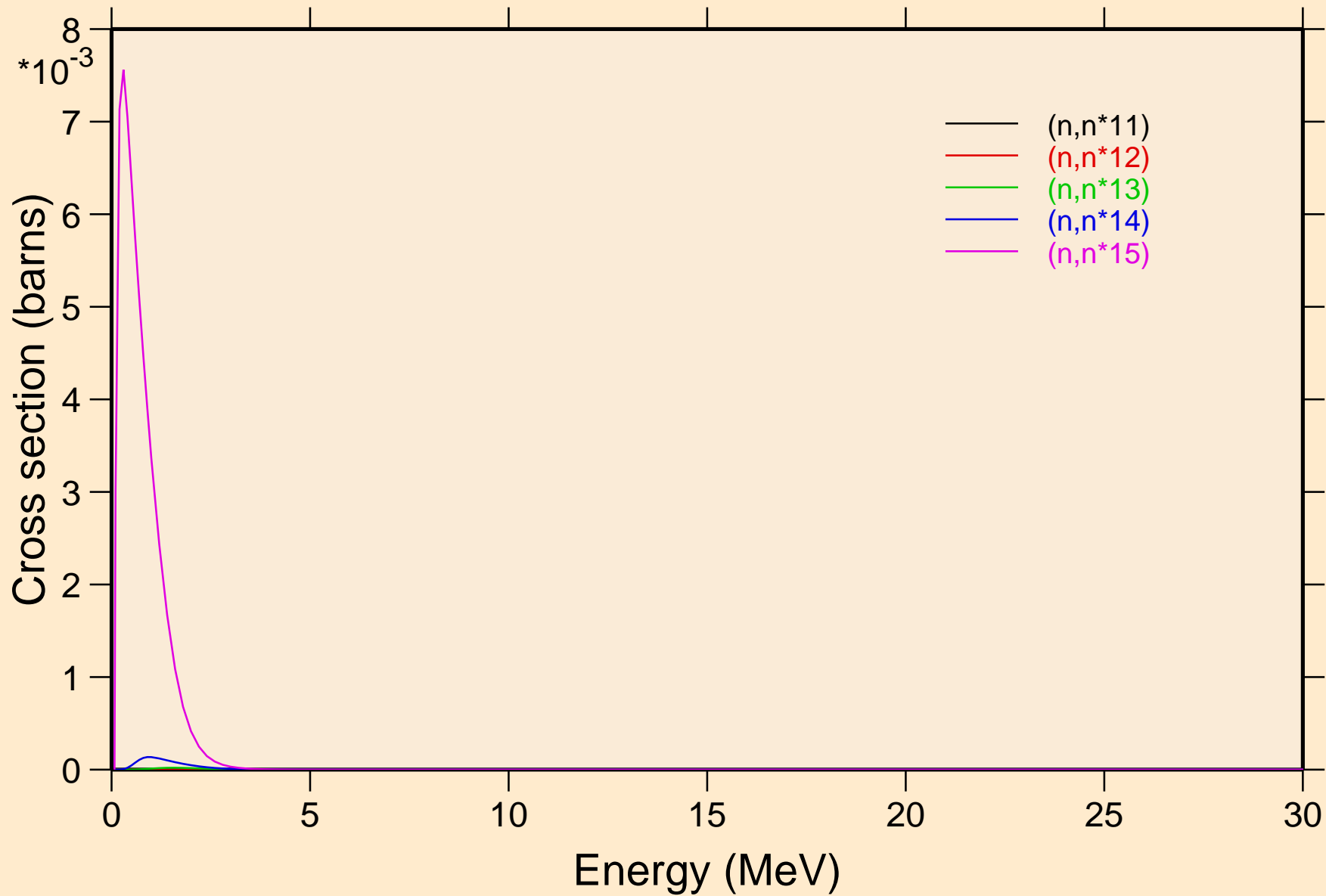

FM247M NEUTRON ACER TENDL-2021 LIBRARY; T=293.6K
Inelastic levels

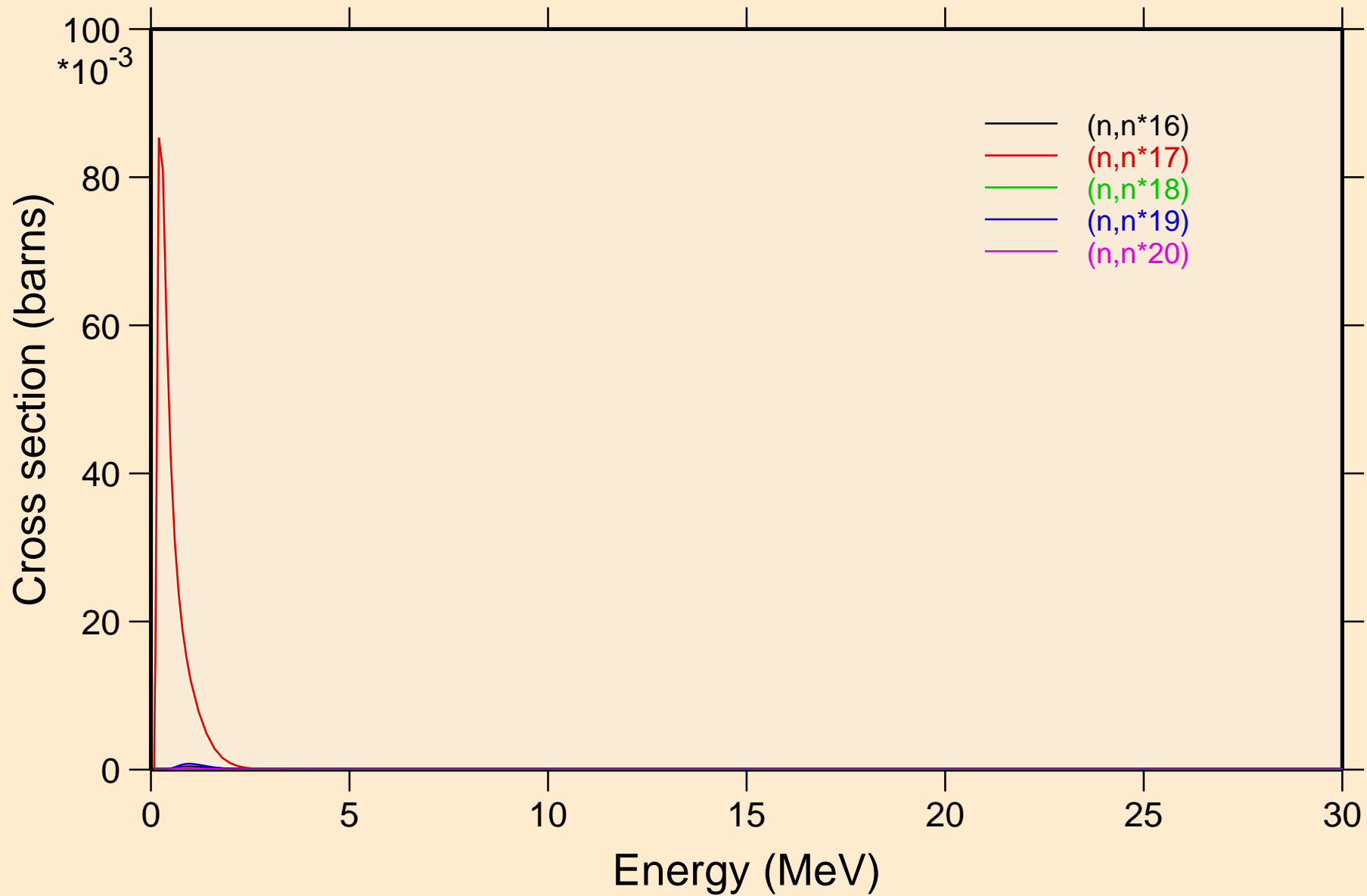

FM247M NEUTRON ACER TENDL-2021 LIBRARY; T=293.6K
Inelastic levels

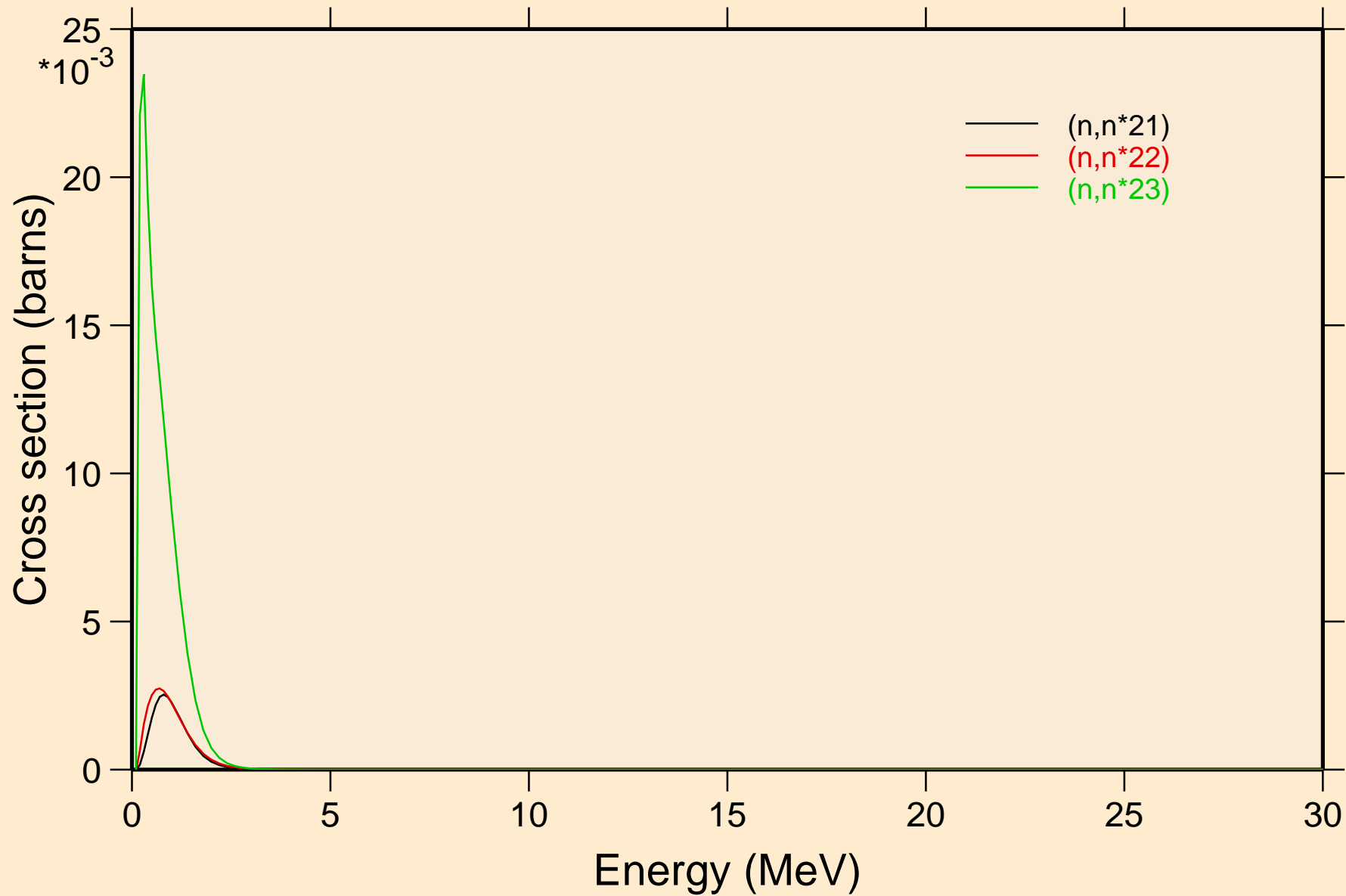

FM247M NEUTRON ACER TENDL-2021 LIBRARY; T=293.6K

Threshold reactions

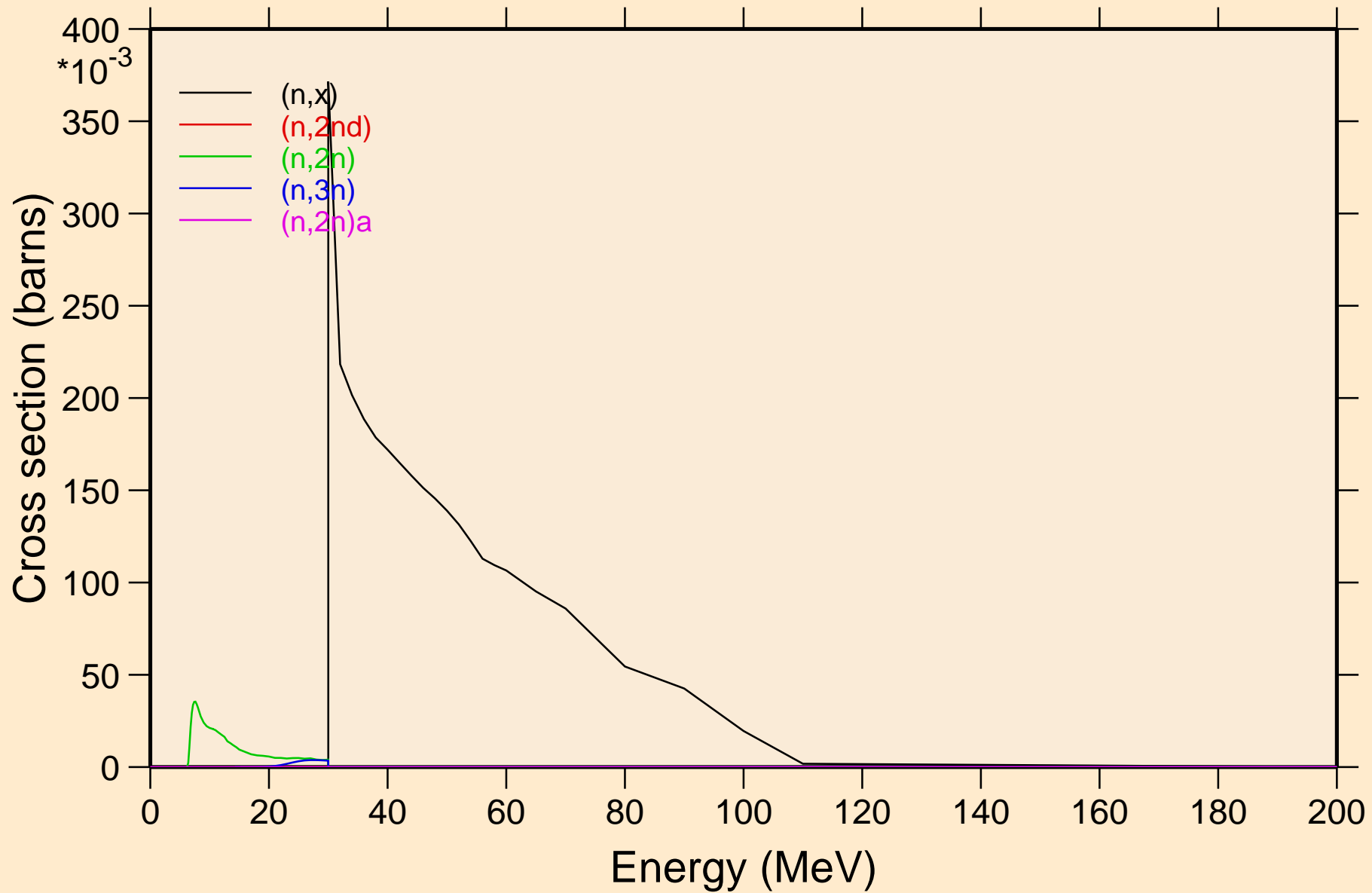

FM247M NEUTRON ACER TENDL-2021 LIBRARY; T=293.6K
Threshold reactions

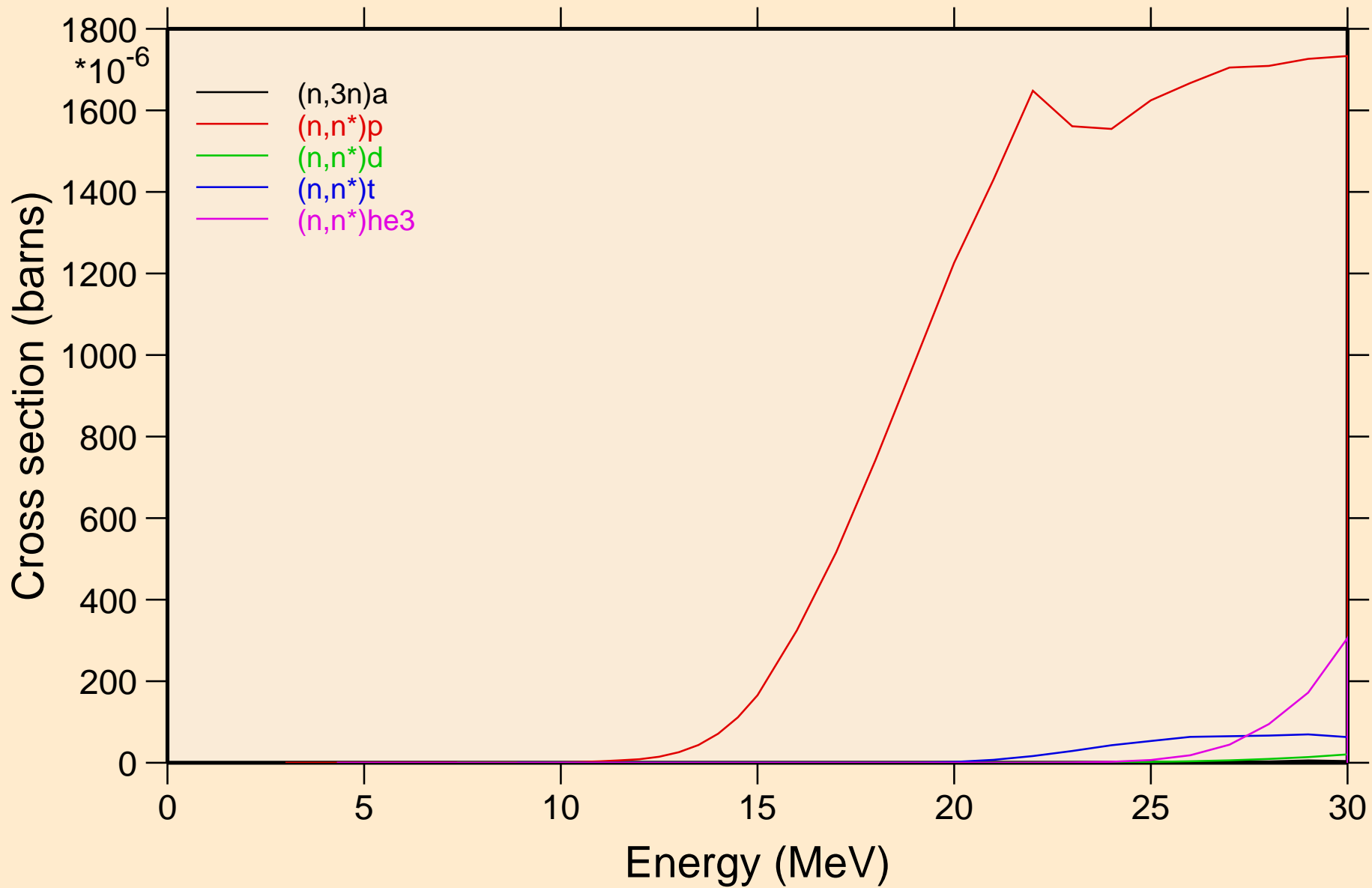

FM247M NEUTRON ACER TENDL-2021 LIBRARY; T=293.6K
Threshold reactions

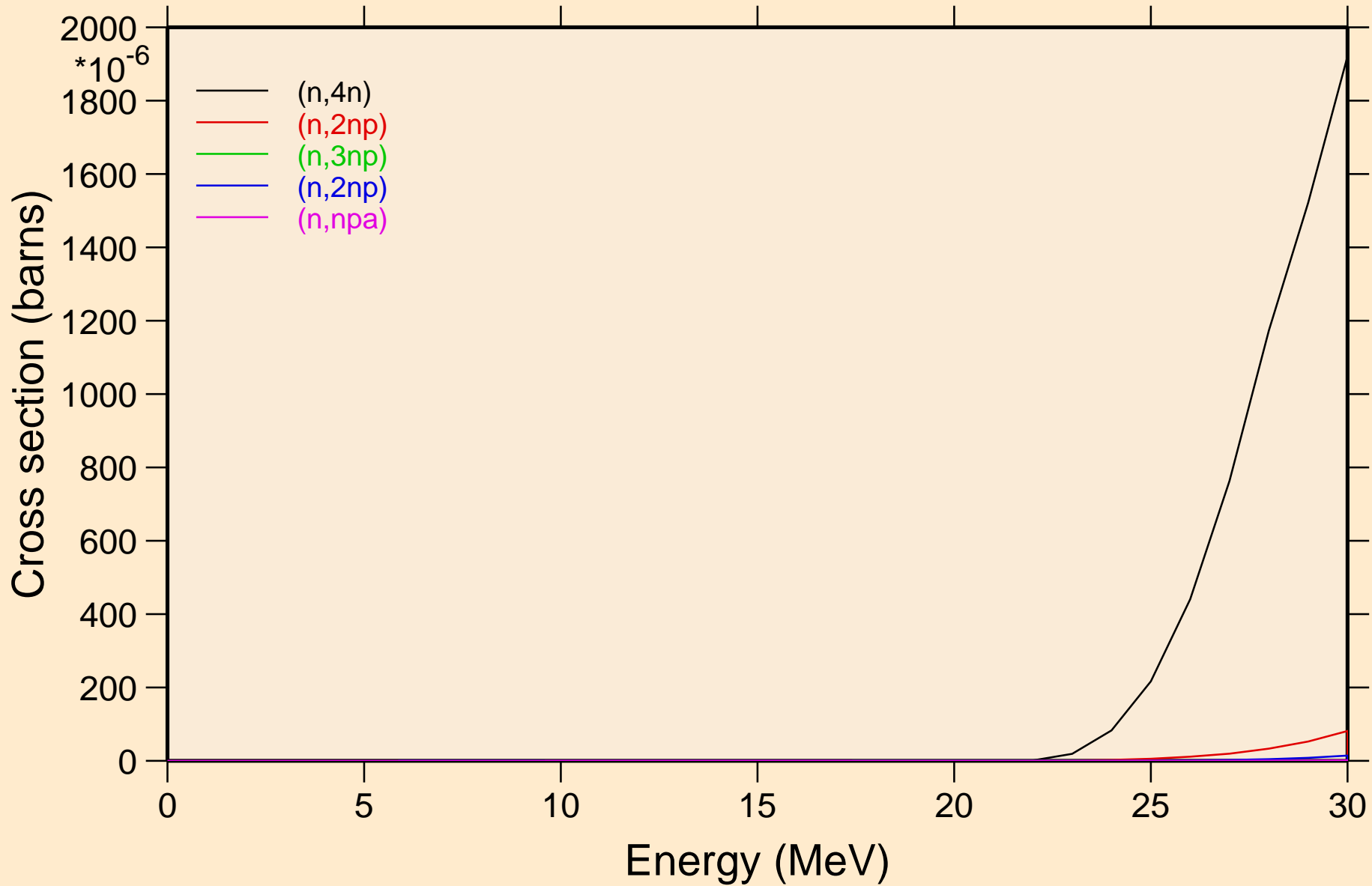

FM247M NEUTRON ACER TENDL-2021 LIBRARY; T=293.6K
Threshold reactions

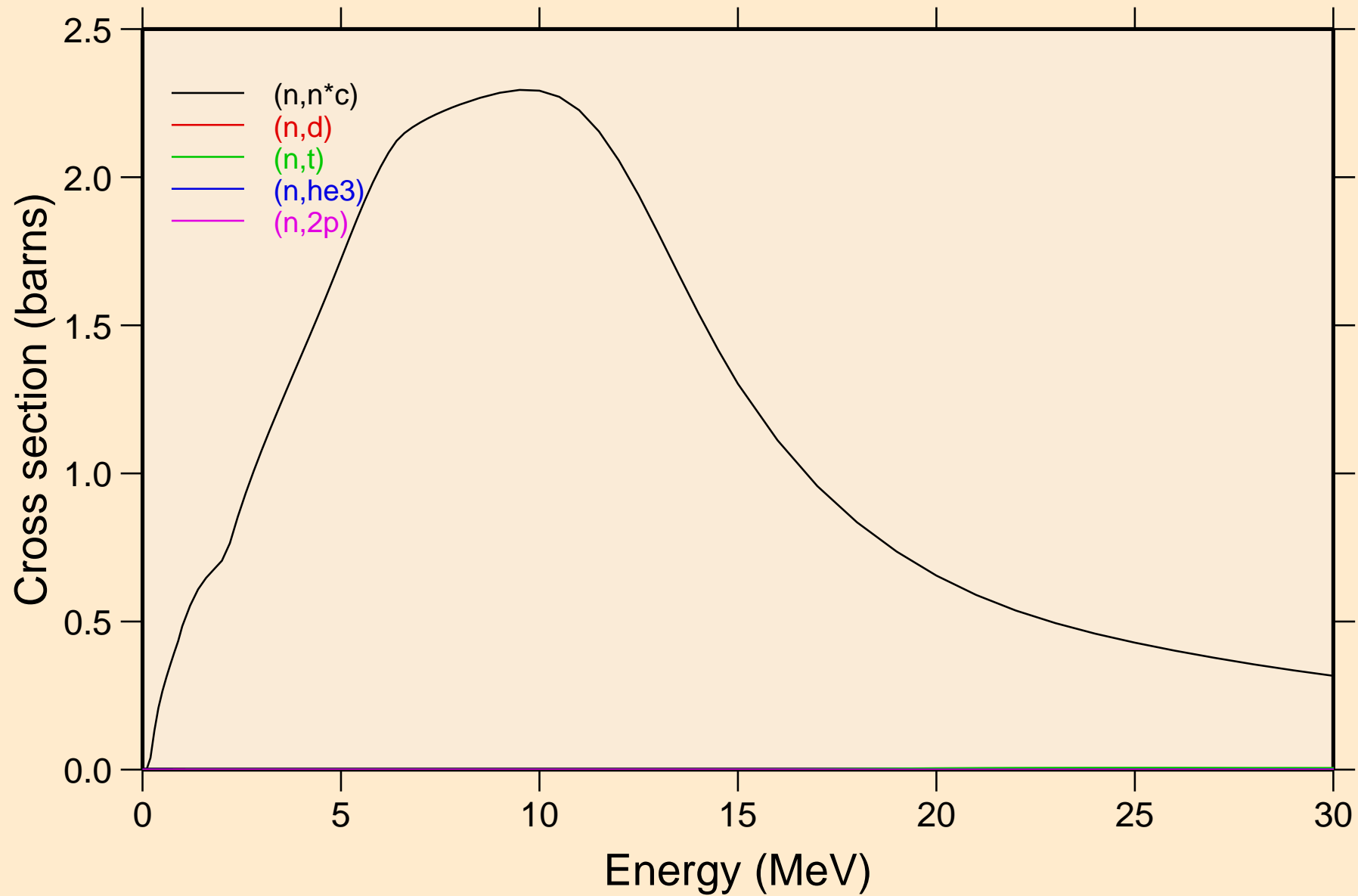

FM247M NEUTRON ACER TENDL-2021 LIBRARY; T=293.6K
Threshold reactions

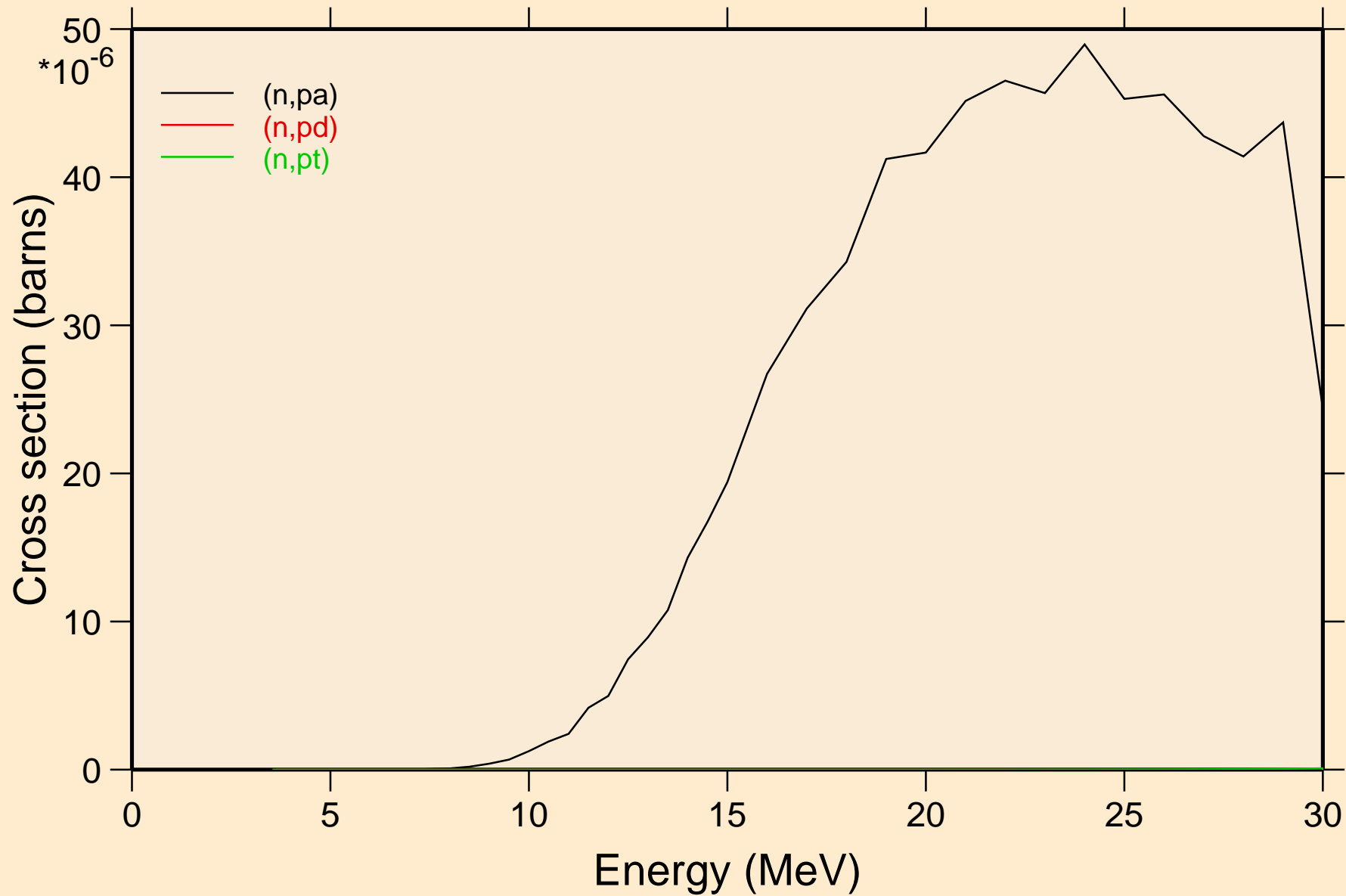

FM247M NEUTRON ACER TENDL-2021 LIBRARY; T=293.6K
Threshold reactions

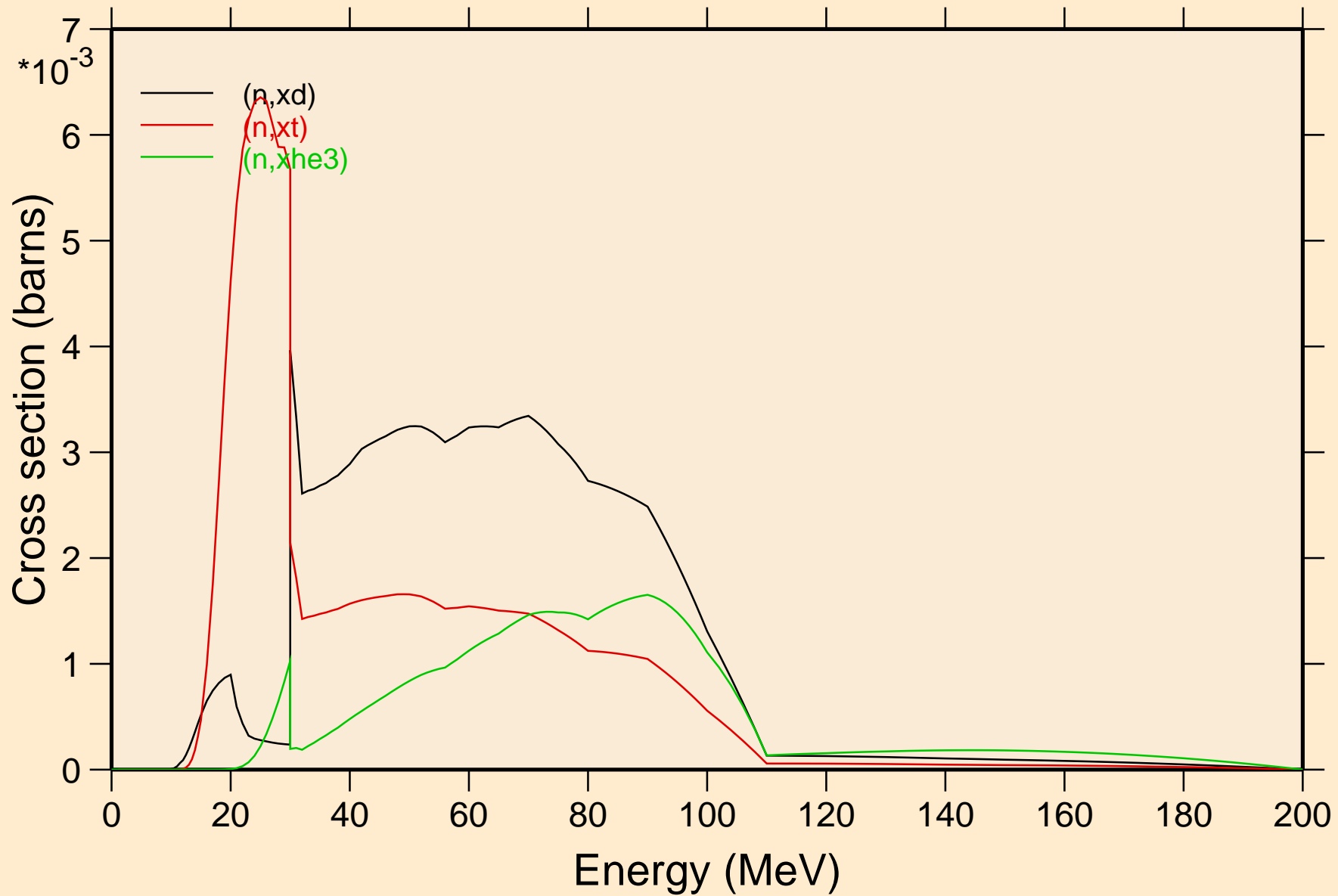

FM247M NEUTRON ACER TENDL-2021 LIBRARY; T=293.6K
angular distribution for elastic

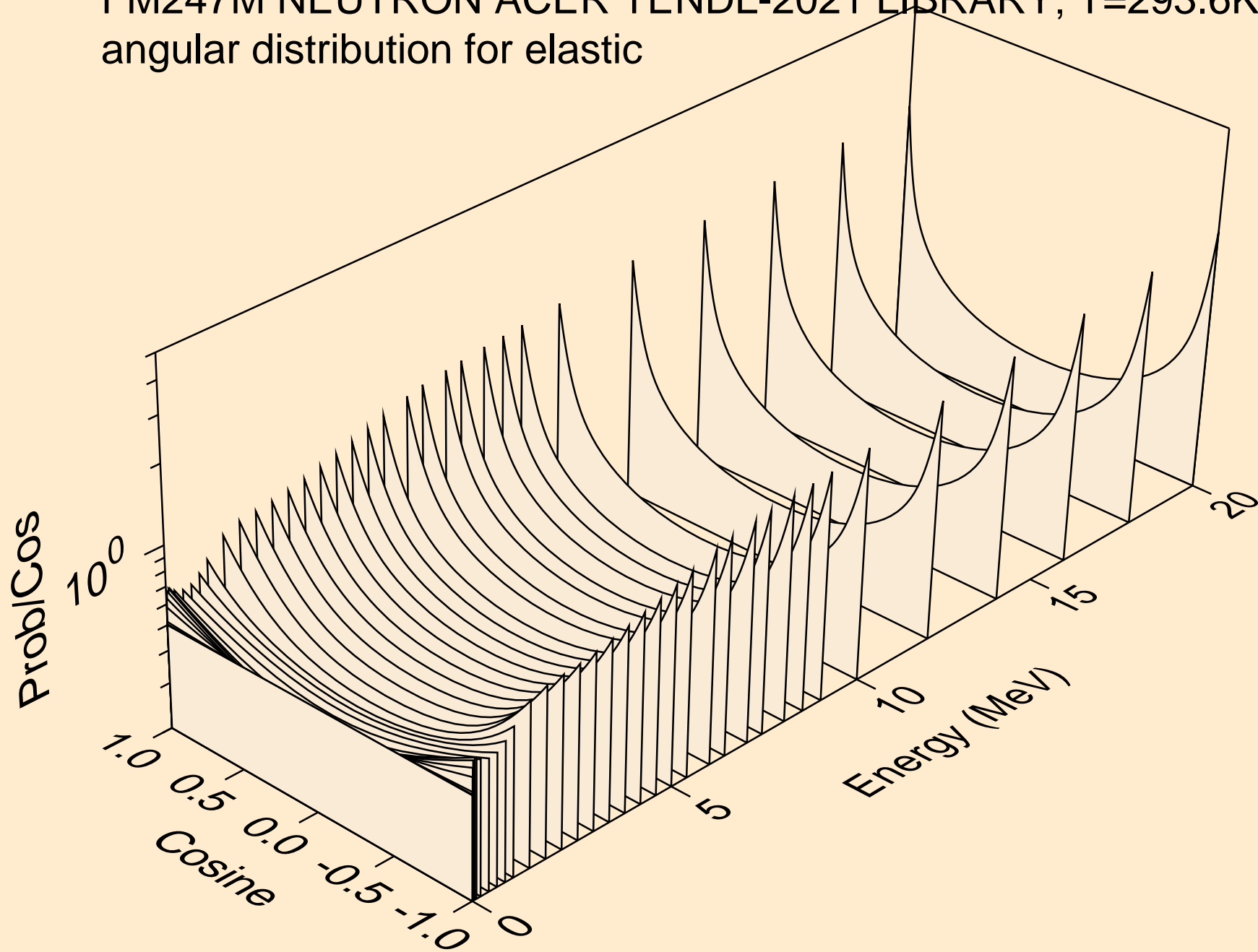

FM247M NEUTRON ACER TENDL-2021 LIBRARY; T=293.6K
angular distribution for elastic

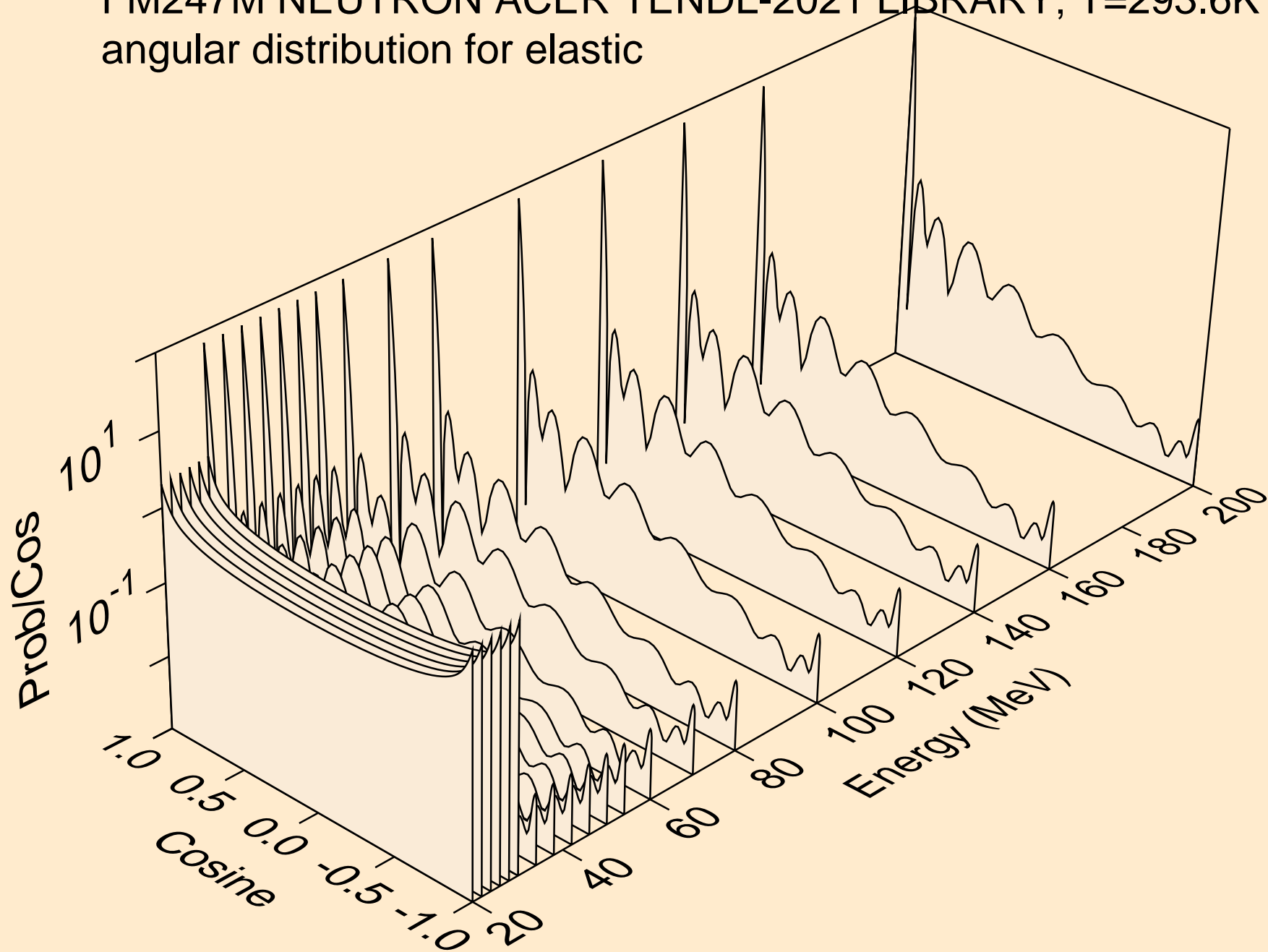

FM247M NEUTRON ACER TENDL-2021 LIBRARY; T=293.6K
angular distribution for (n,n*1)

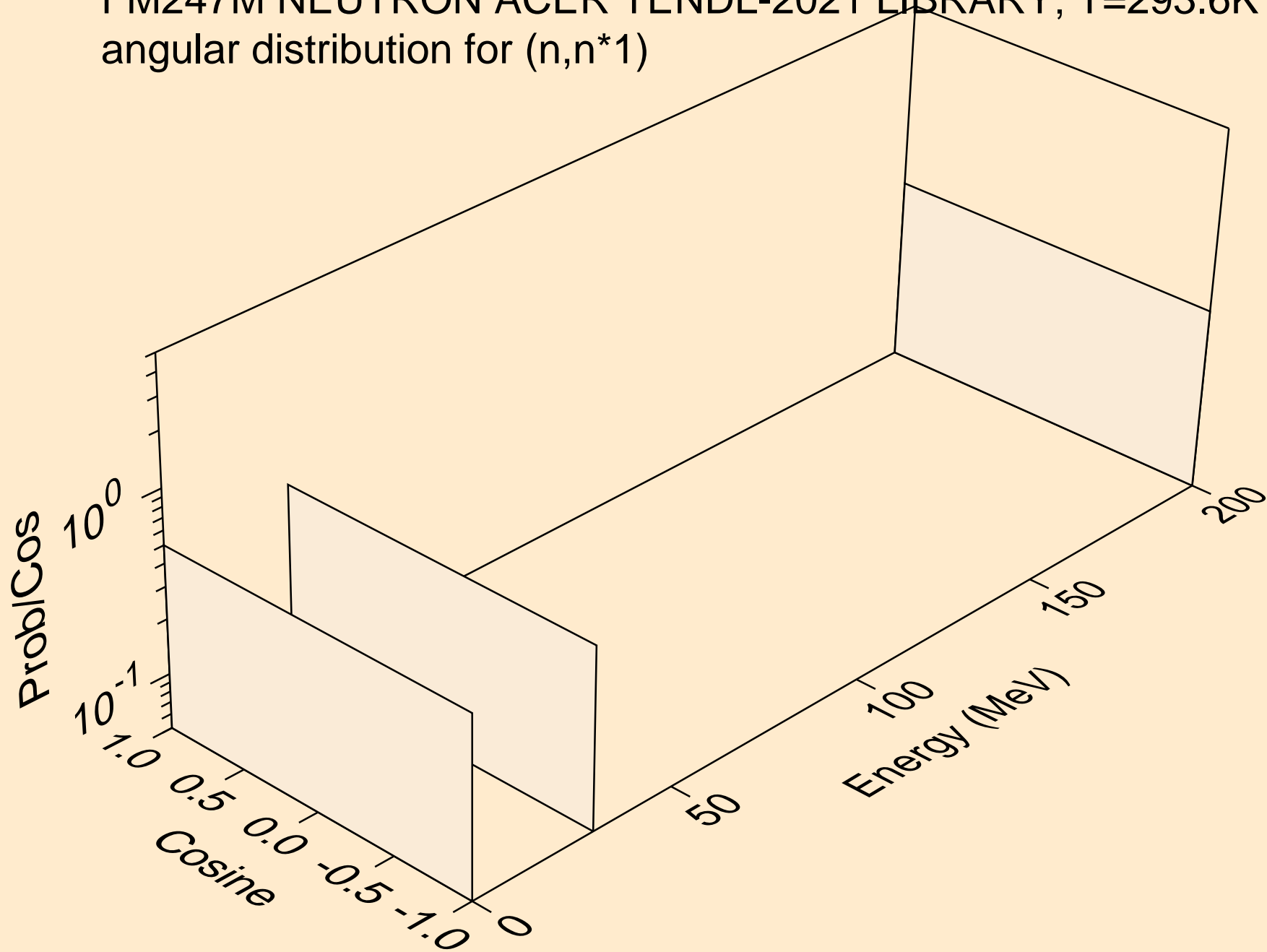

FM247M NEUTRON ACER TENDL-2021 LIBRARY; T=293.6K
angular distribution for (n,n*2)

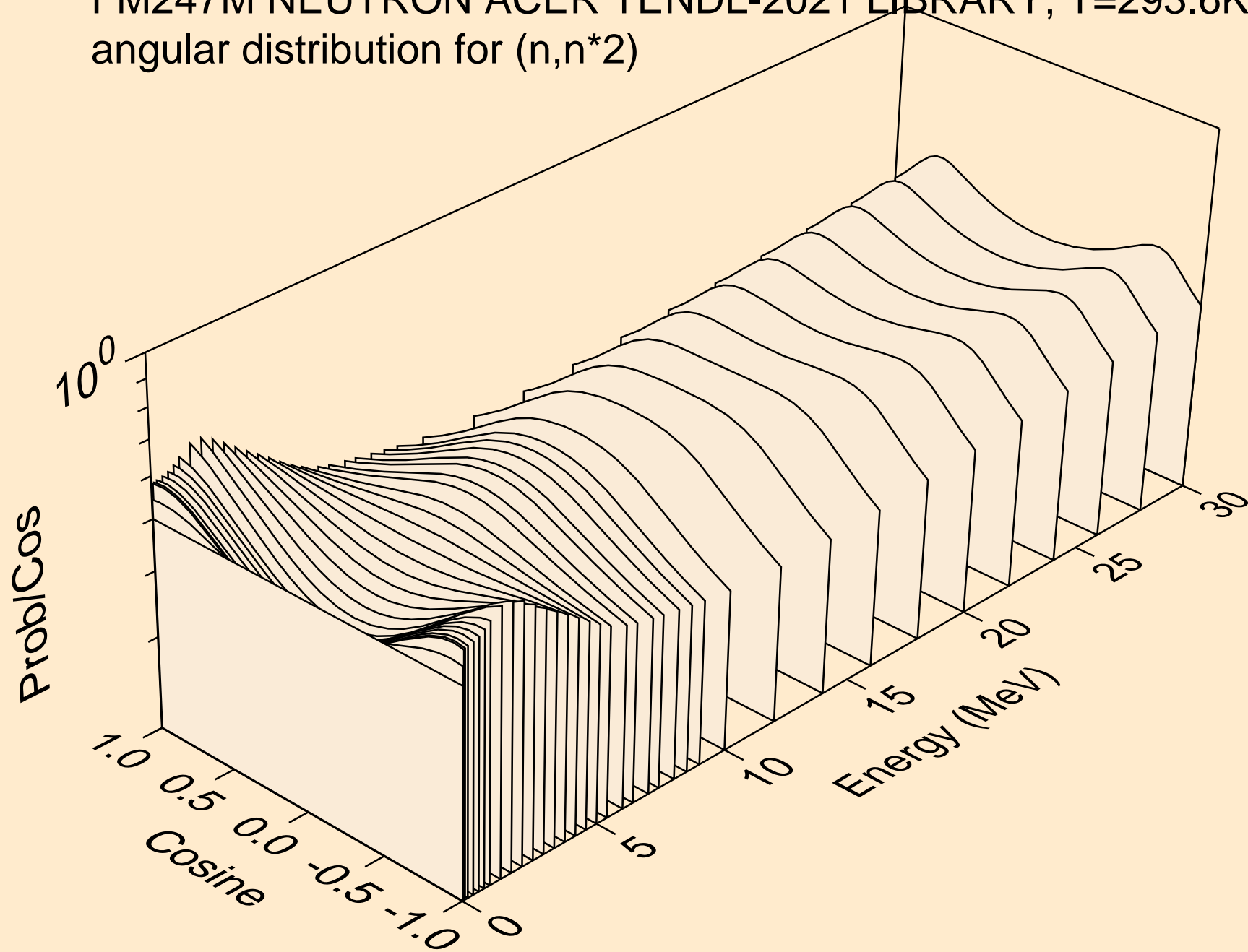

FM247M NEUTRON ACER TENDL-2021 LIBRARY; T=293.6K
angular distribution for (n,n*3)

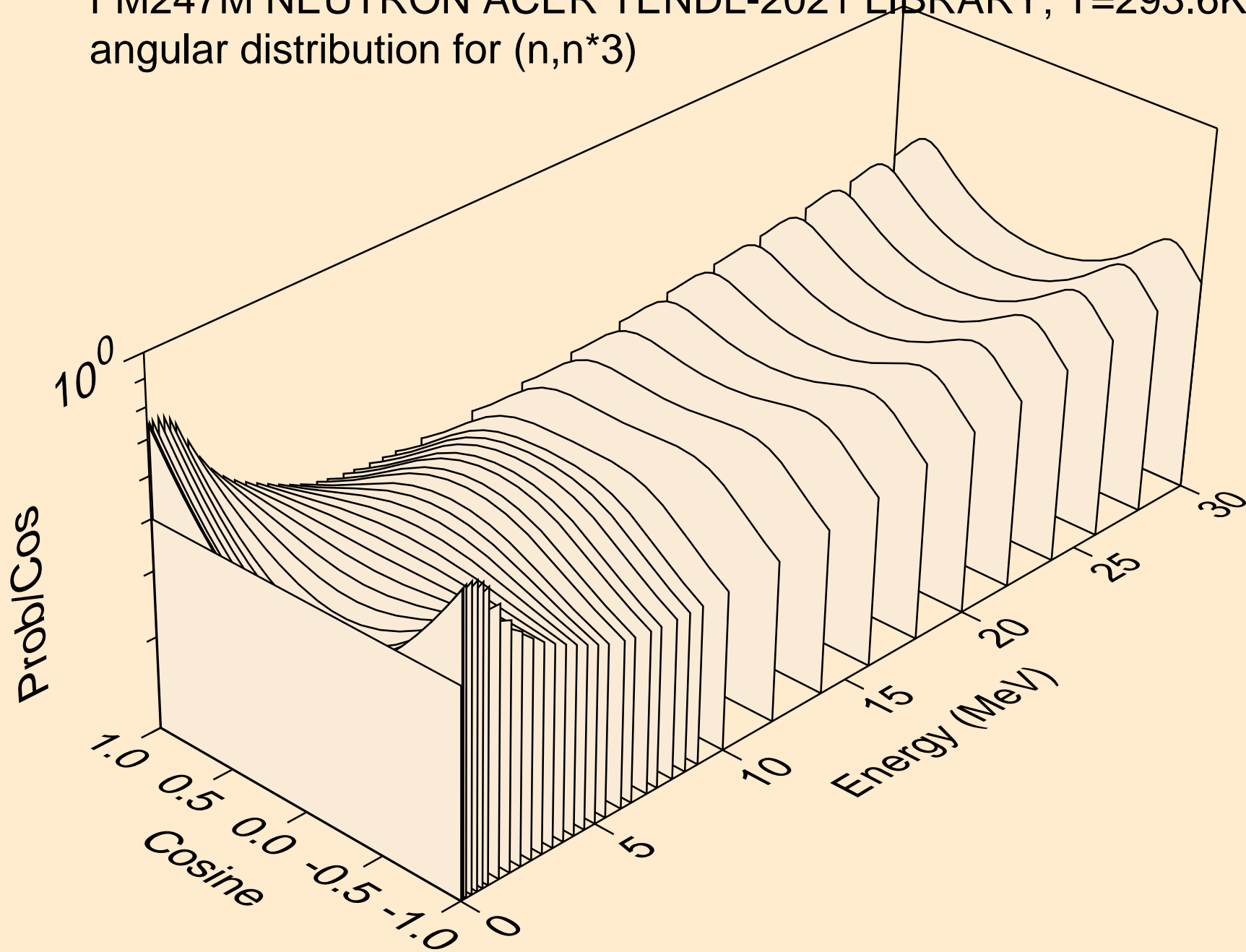

FM247M NEUTRON ACER TENDL-2021 LIBRARY; T=293.6K
angular distribution for (n,n*4)

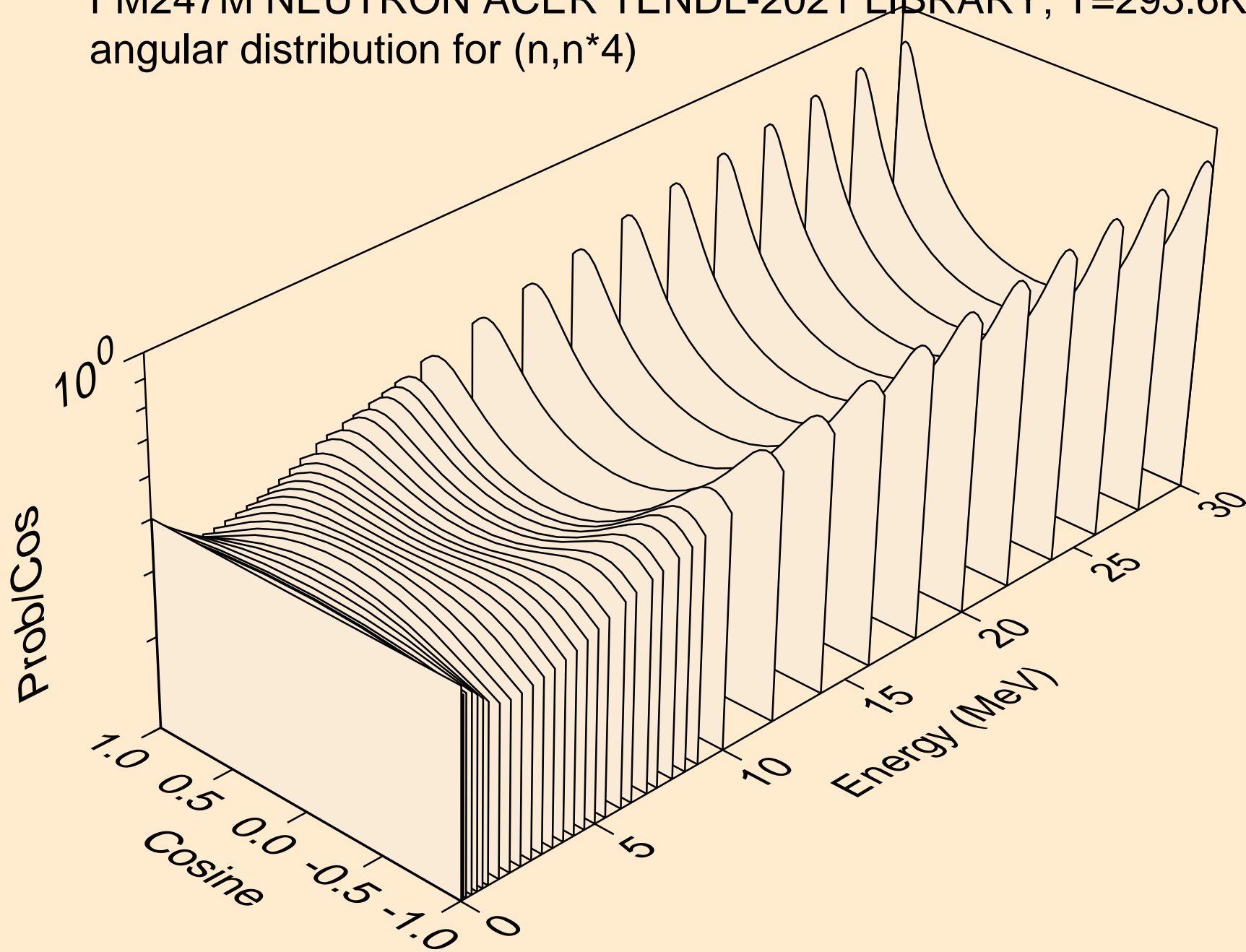

FM247M NEUTRON ACER TENDL-2021 LIBRARY; T=293.6K
angular distribution for (n,n*5)

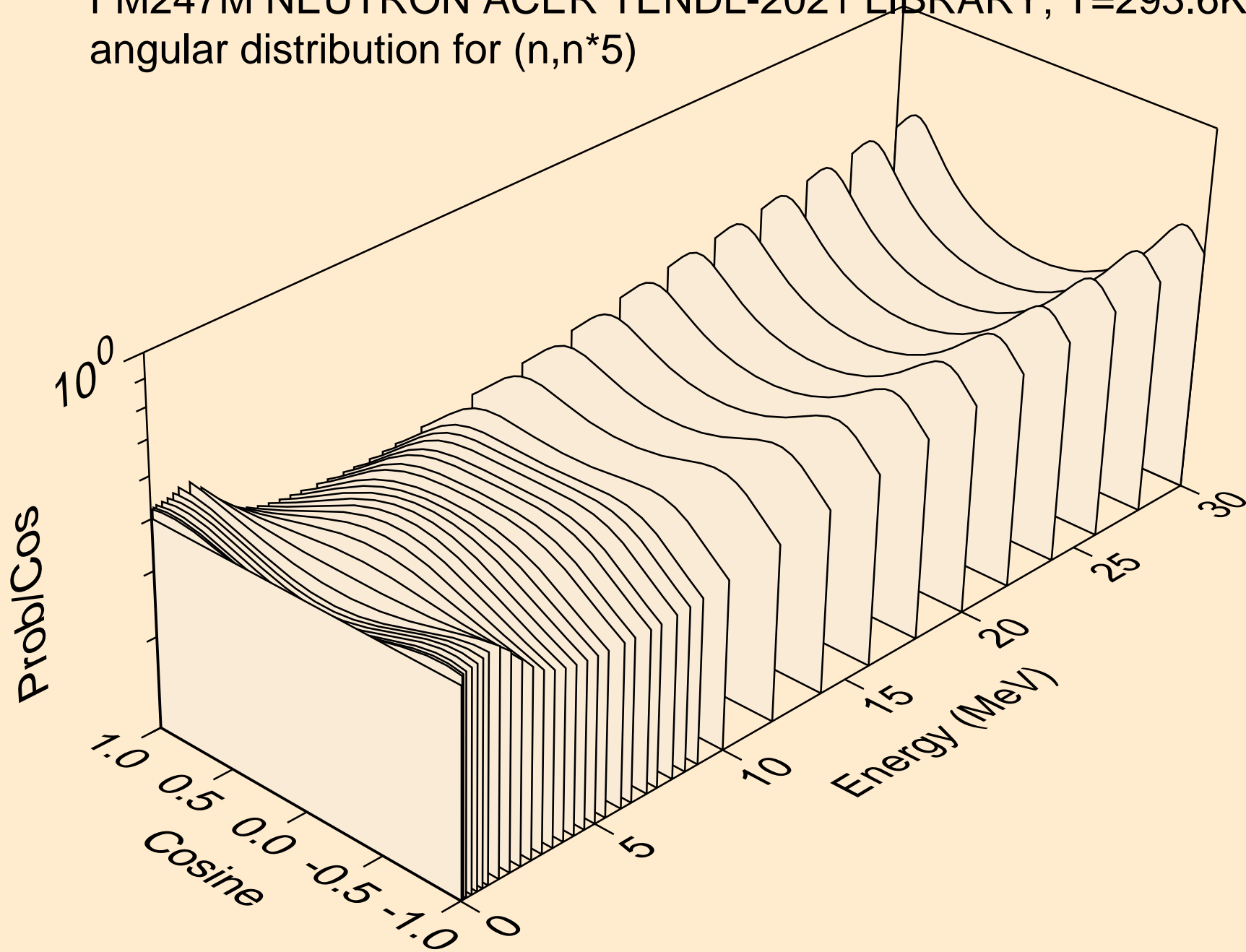

FM247M NEUTRON ACER TENDL-2021 LIBRARY; T=293.6K
angular distribution for (n,n*6)

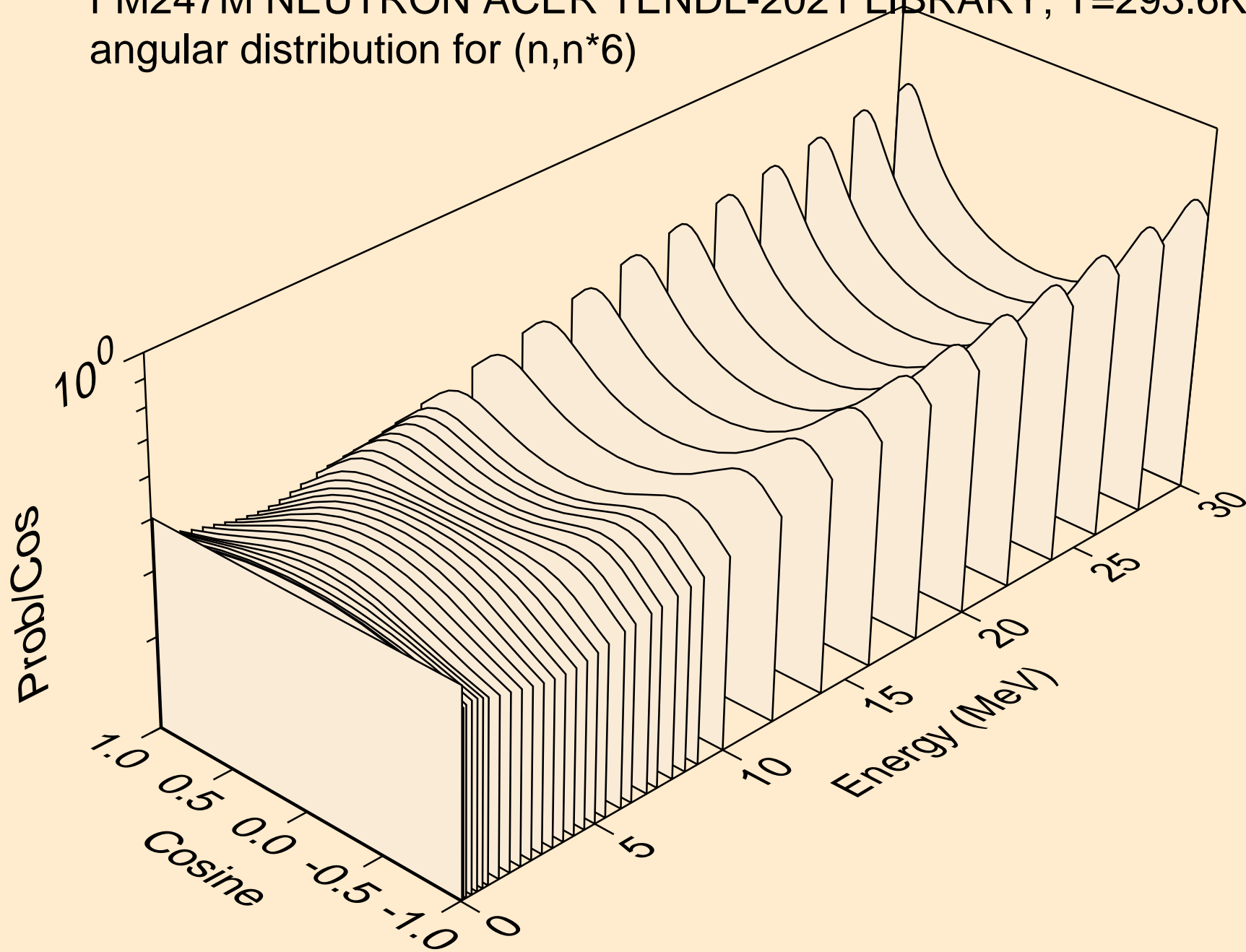

FM247M NEUTRON ACER TENDL-2021 LIBRARY; T=293.6K
angular distribution for (n,n*7)

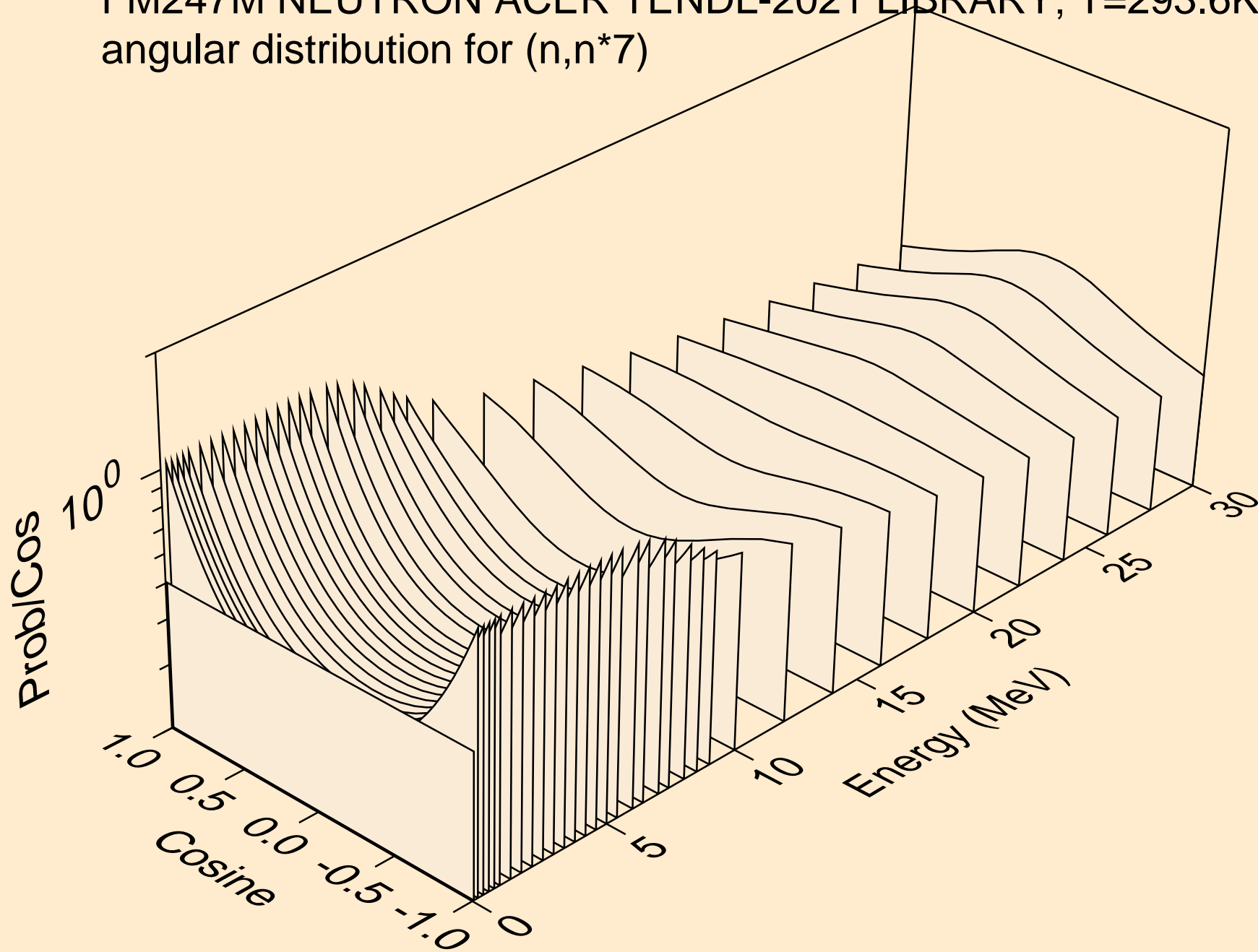

FM247M NEUTRON ACER TENDL-2021 LIBRARY; T=293.6K
angular distribution for (n,n*8)

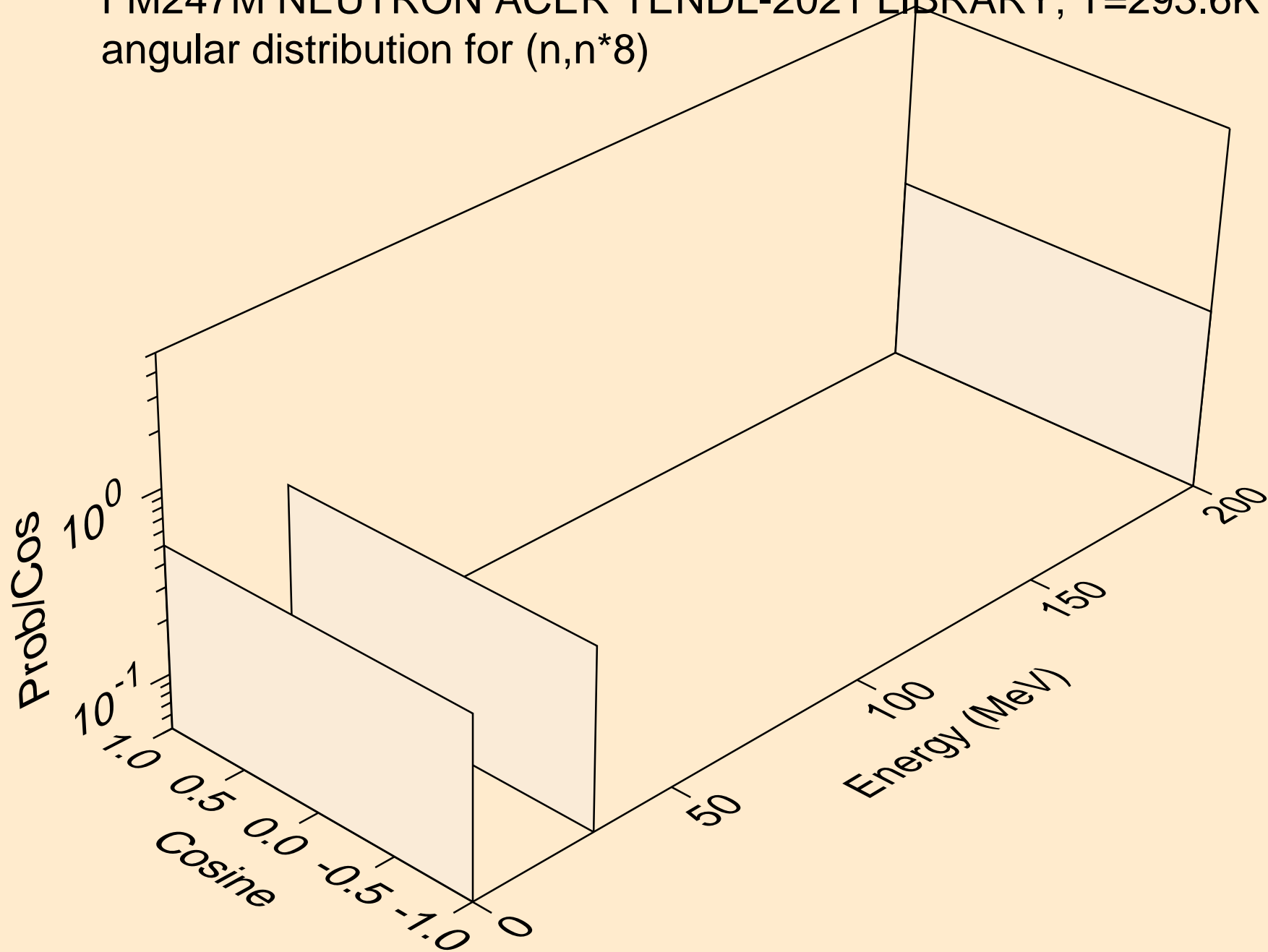

FM247M NEUTRON ACER TENDL-2021 LIBRARY; T=293.6K
angular distribution for (n,n*9)

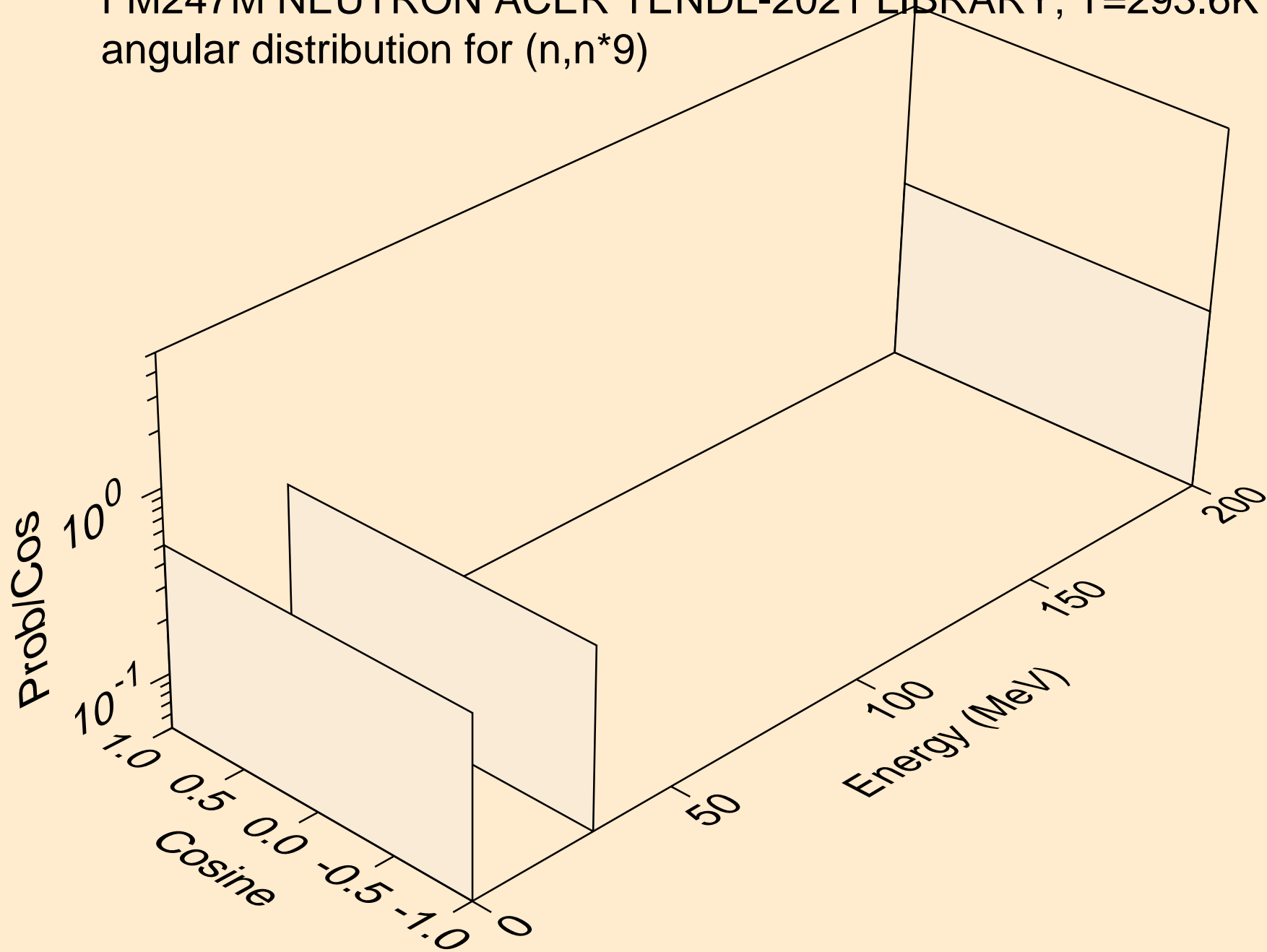

FM247M NEUTRON ACER TENDL-2021 LIBRARY; T=293.6K
angular distribution for (n,n*10)

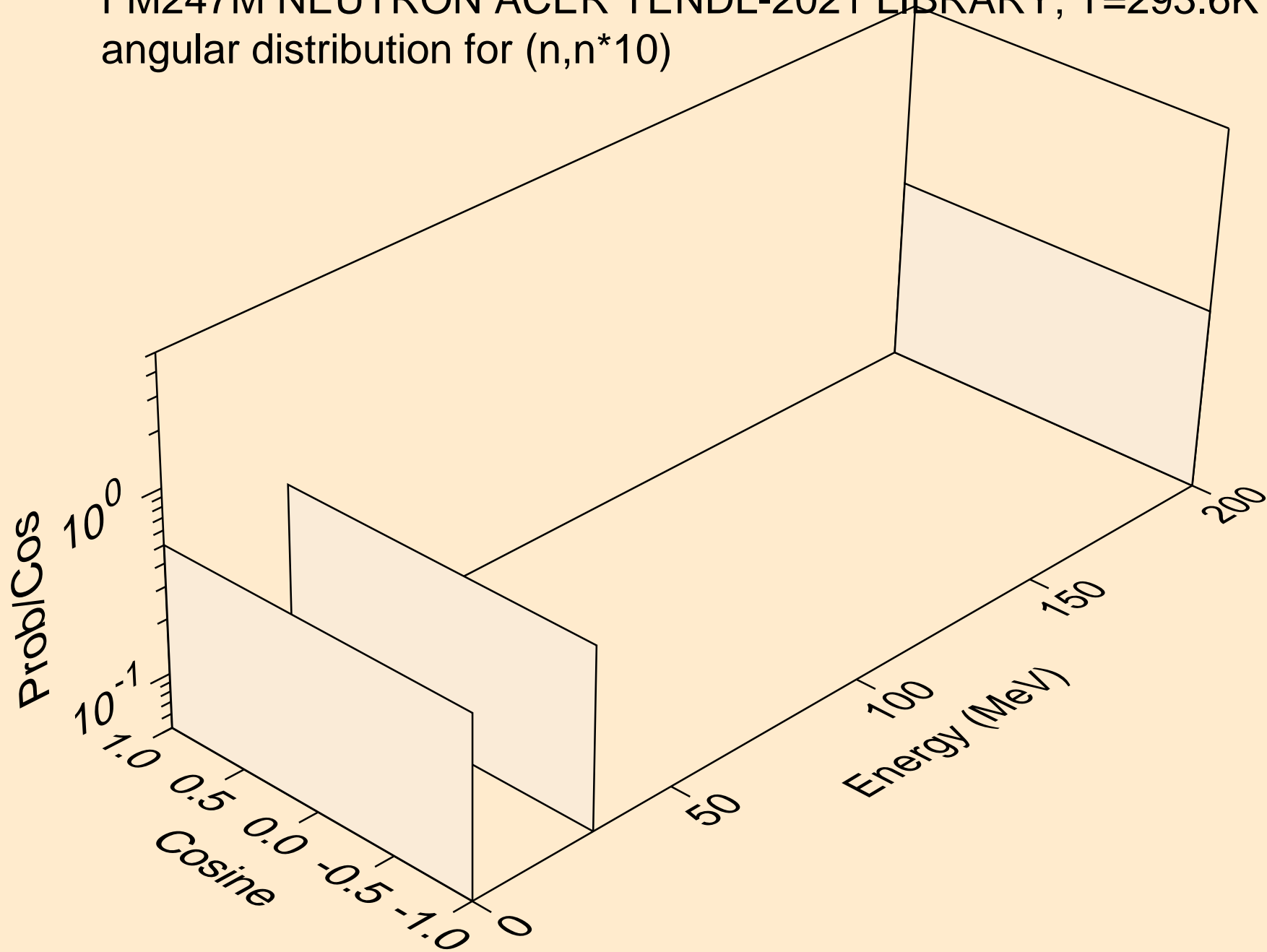

FM247M NEUTRON ACER TENDL-2021 LIBRARY; T=293.6K
angular distribution for (n,n*11)

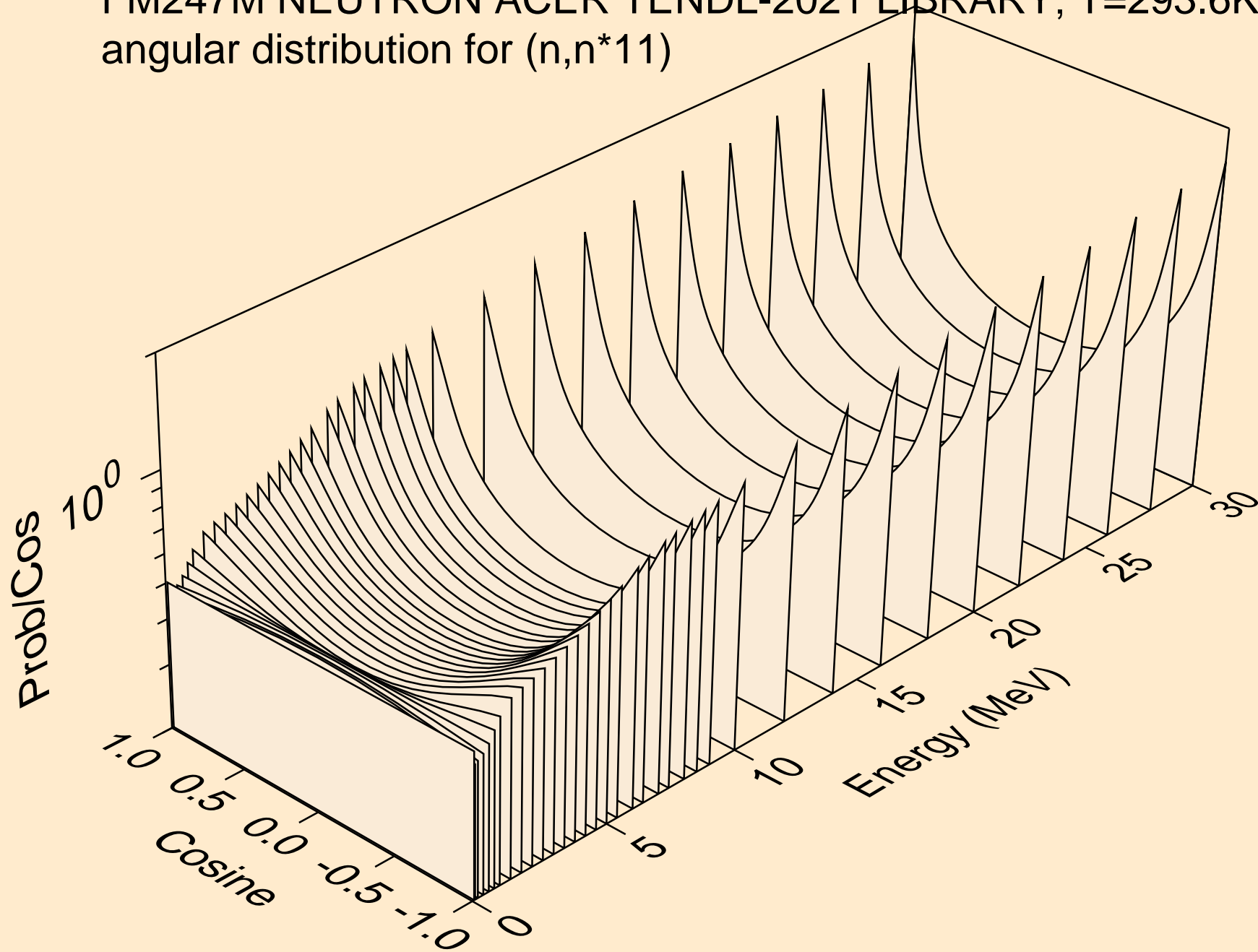

FM247M NEUTRON ACER TENDL-2021 LIBRARY; T=293.6K
angular distribution for (n,n*12)

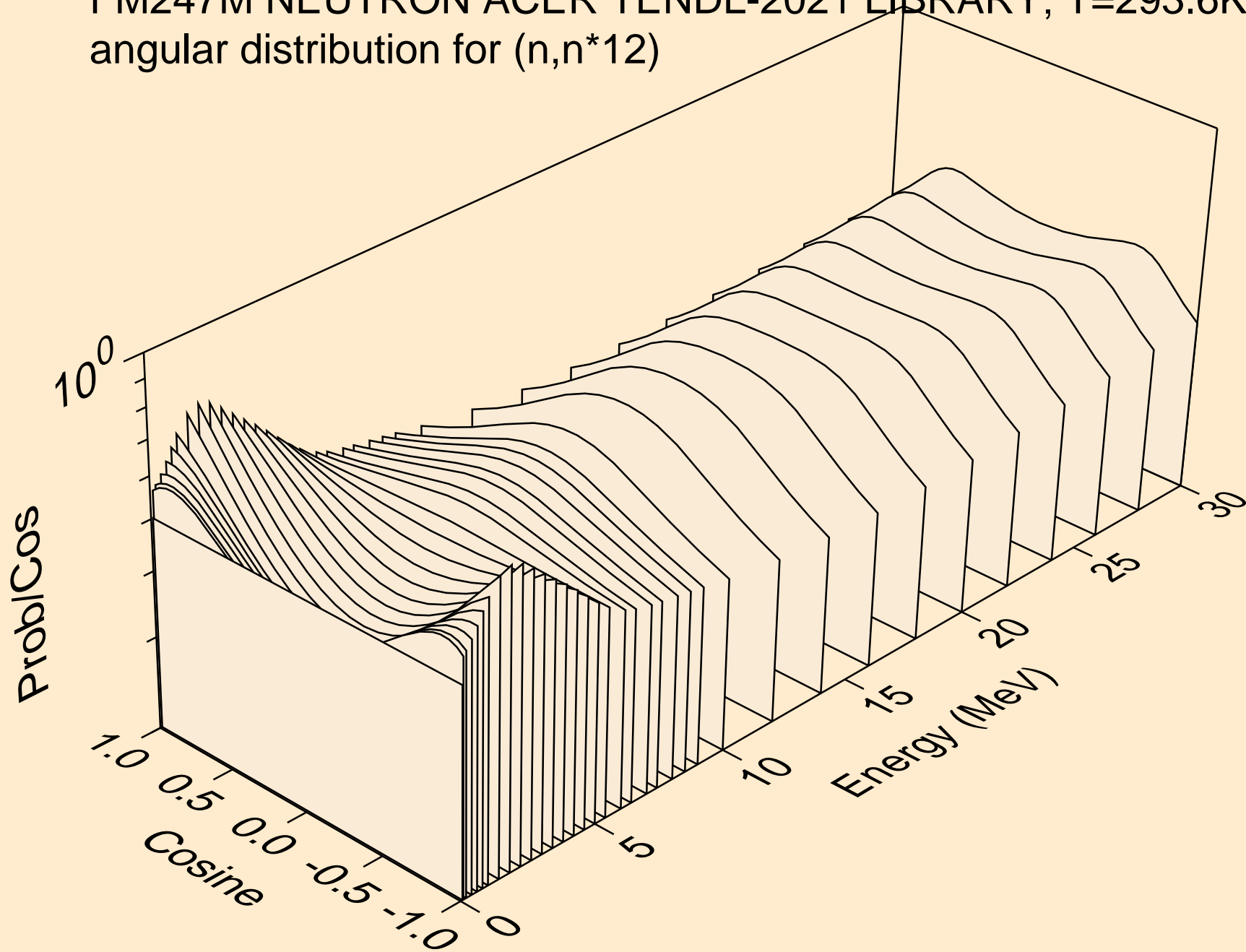

FM247M NEUTRON ACER TENDL-2021 LIBRARY; T=293.6K
angular distribution for (n,n*13)

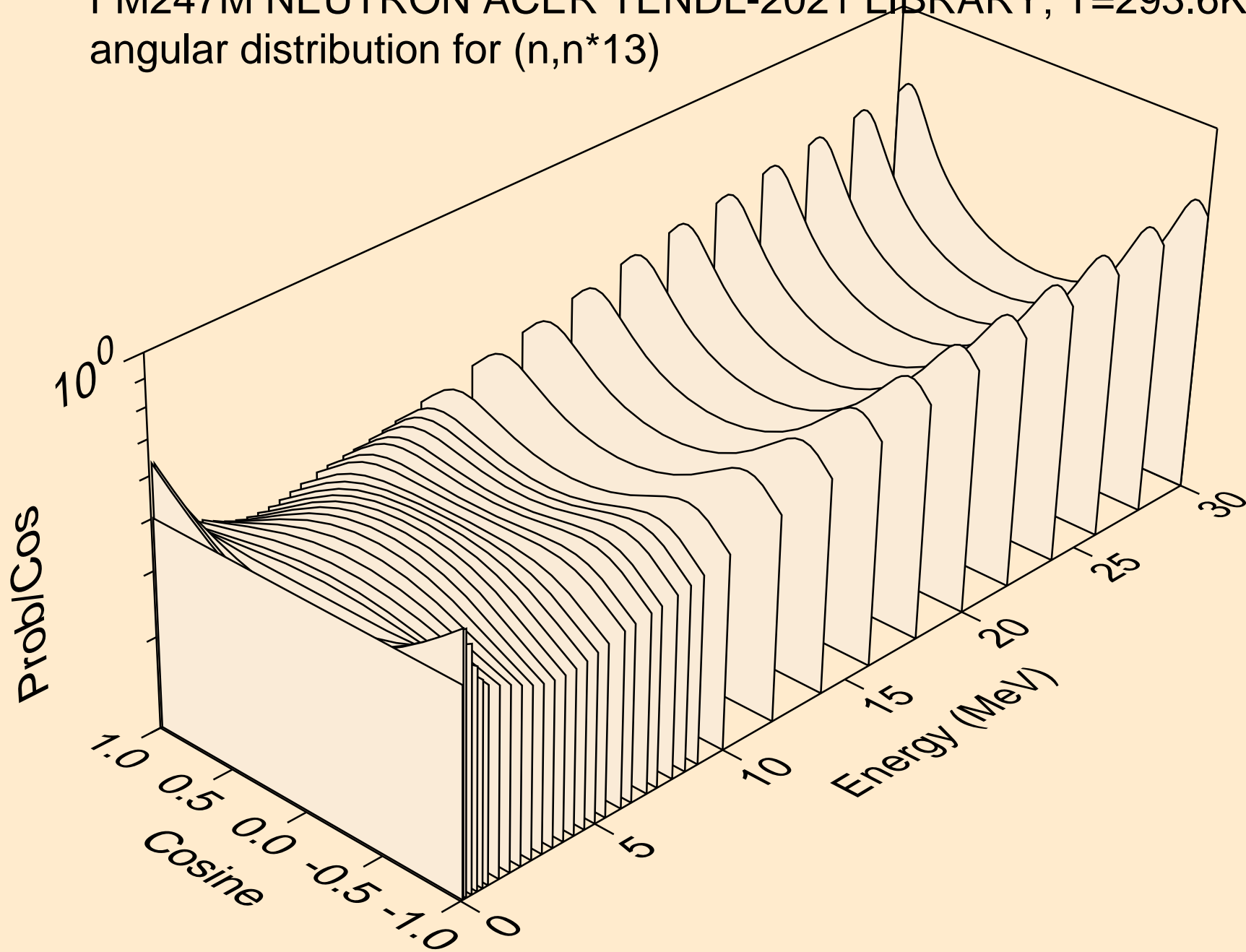

FM247M NEUTRON ACER TENDL-2021 LIBRARY; T=293.6K
angular distribution for (n,n*14)

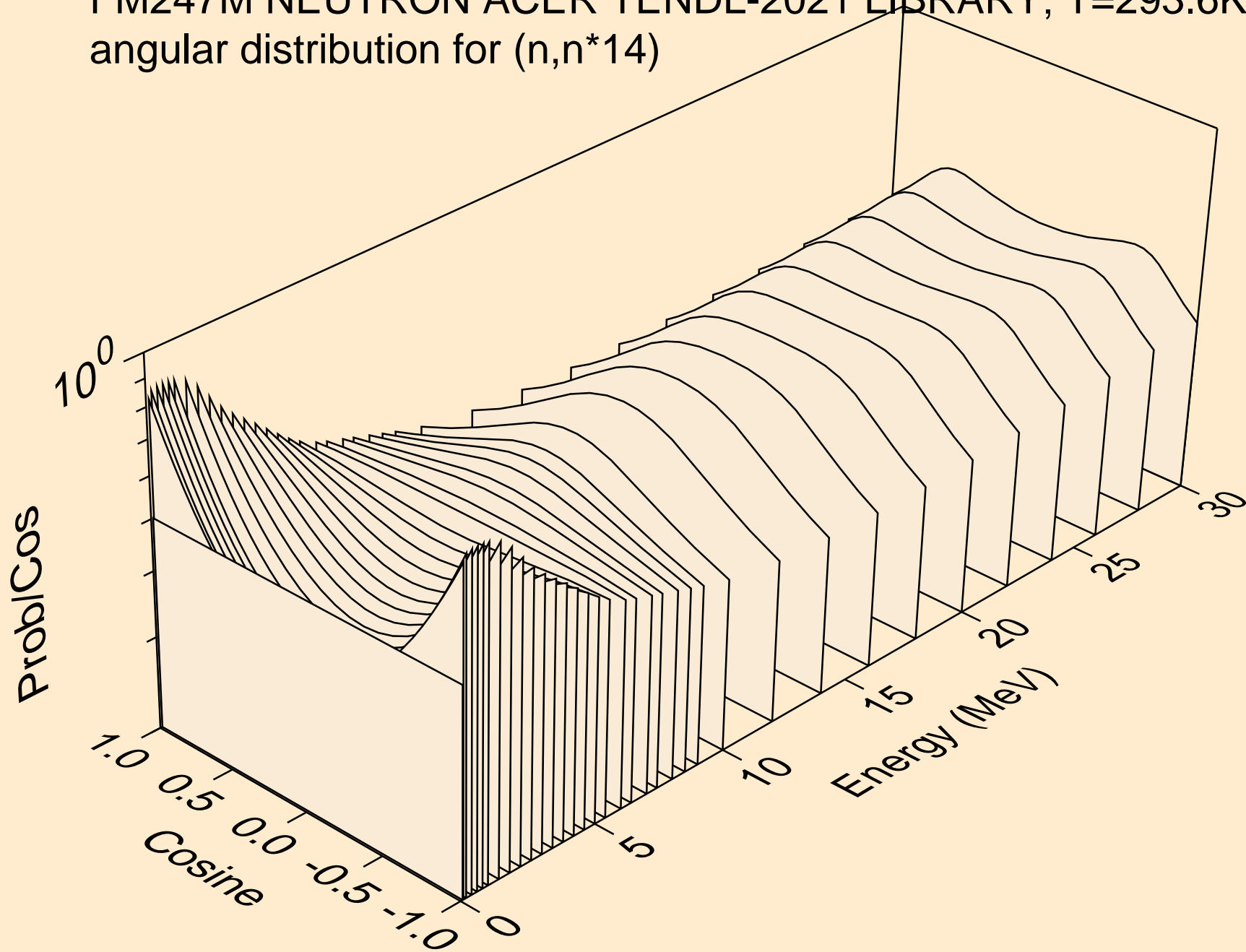

FM247M NEUTRON ACER TENDL-2021 LIBRARY; T=293.6K
angular distribution for (n,n*15)

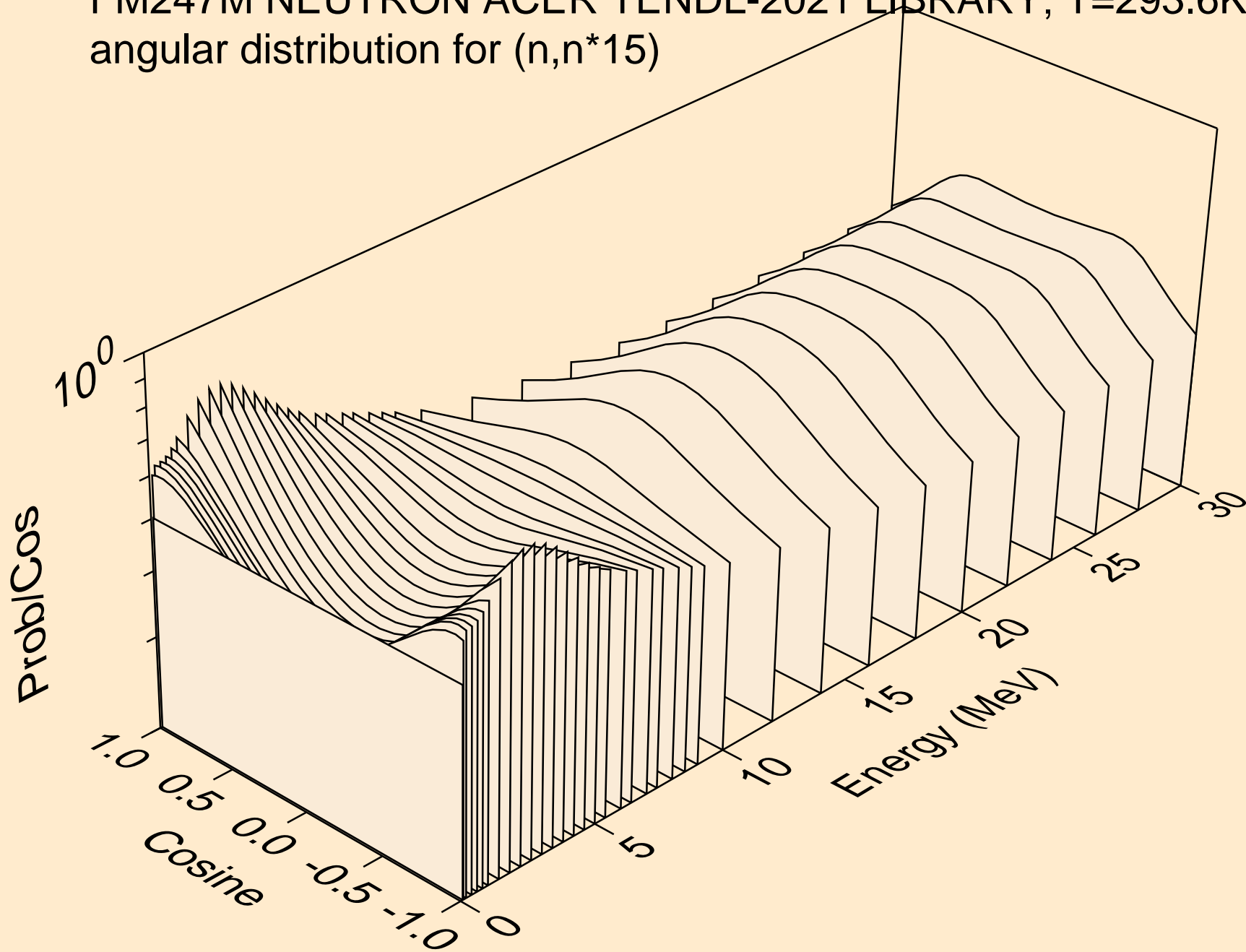

FM247M NEUTRON ACER TENDL-2021 LIBRARY; T=293.6K
angular distribution for (n,n*16)

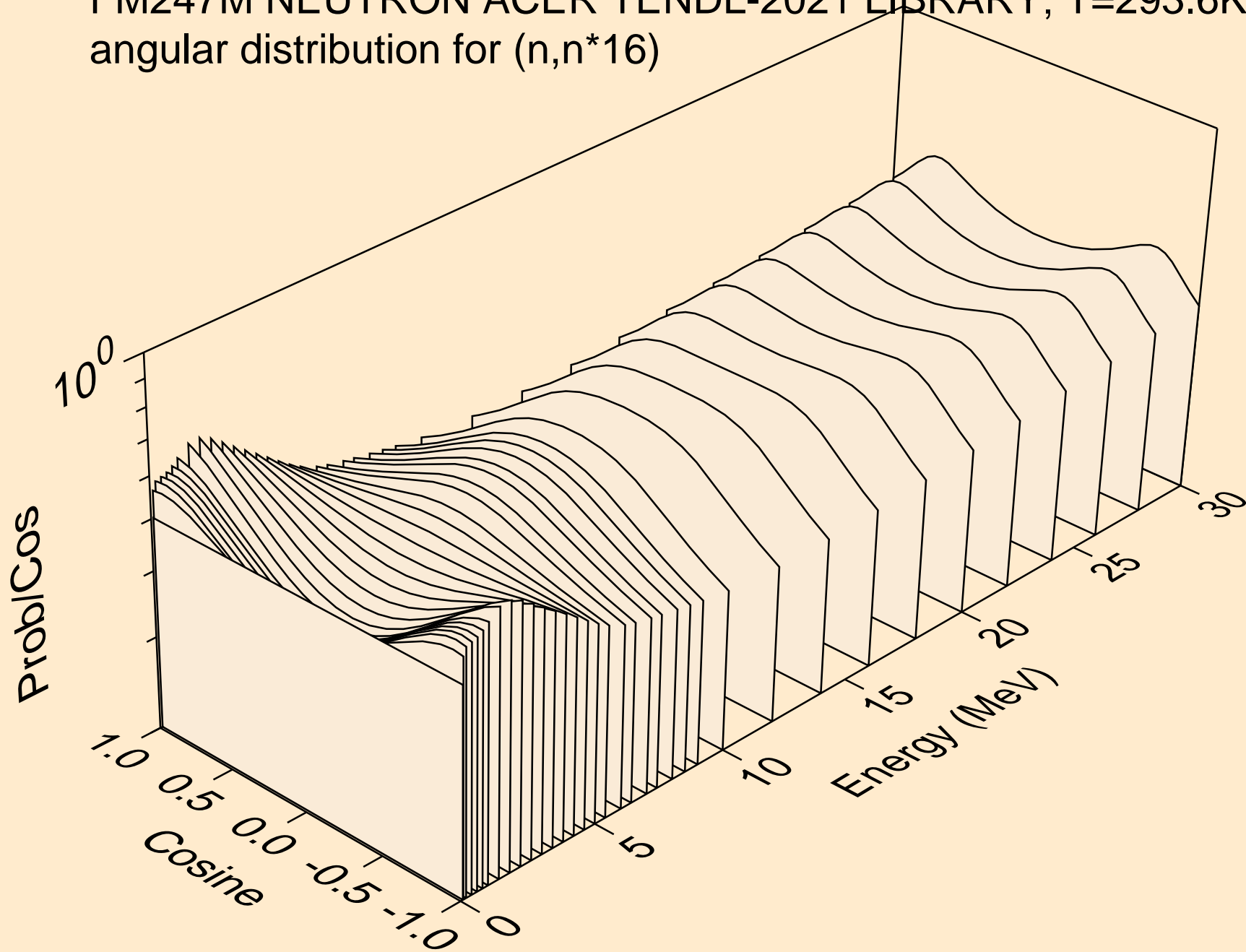

FM247M NEUTRON ACER TENDL-2021 LIBRARY; T=293.6K
angular distribution for (n,n*17)

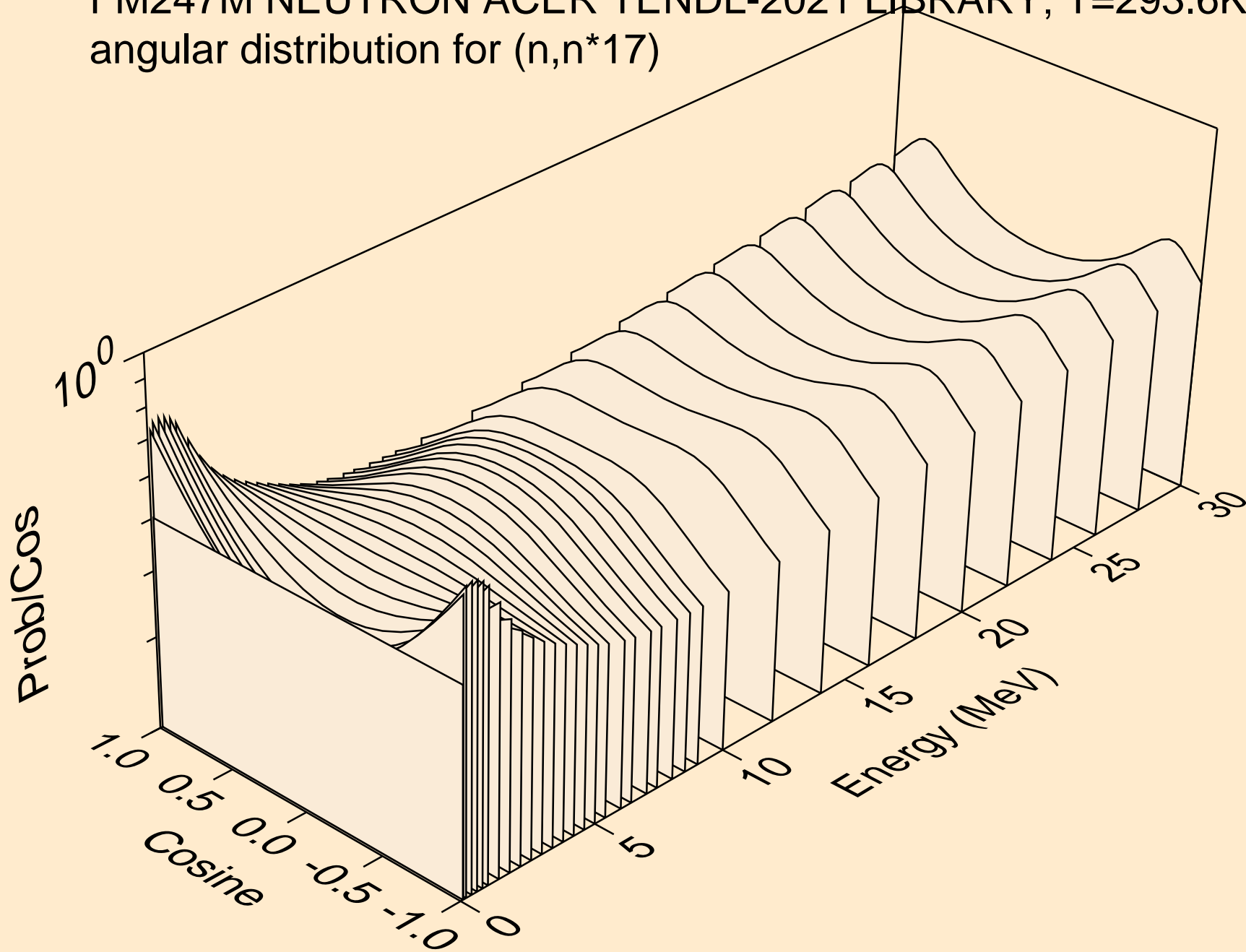

FM247M NEUTRON ACER TENDL-2021 LIBRARY; T=293.6K
angular distribution for (n,n*18)

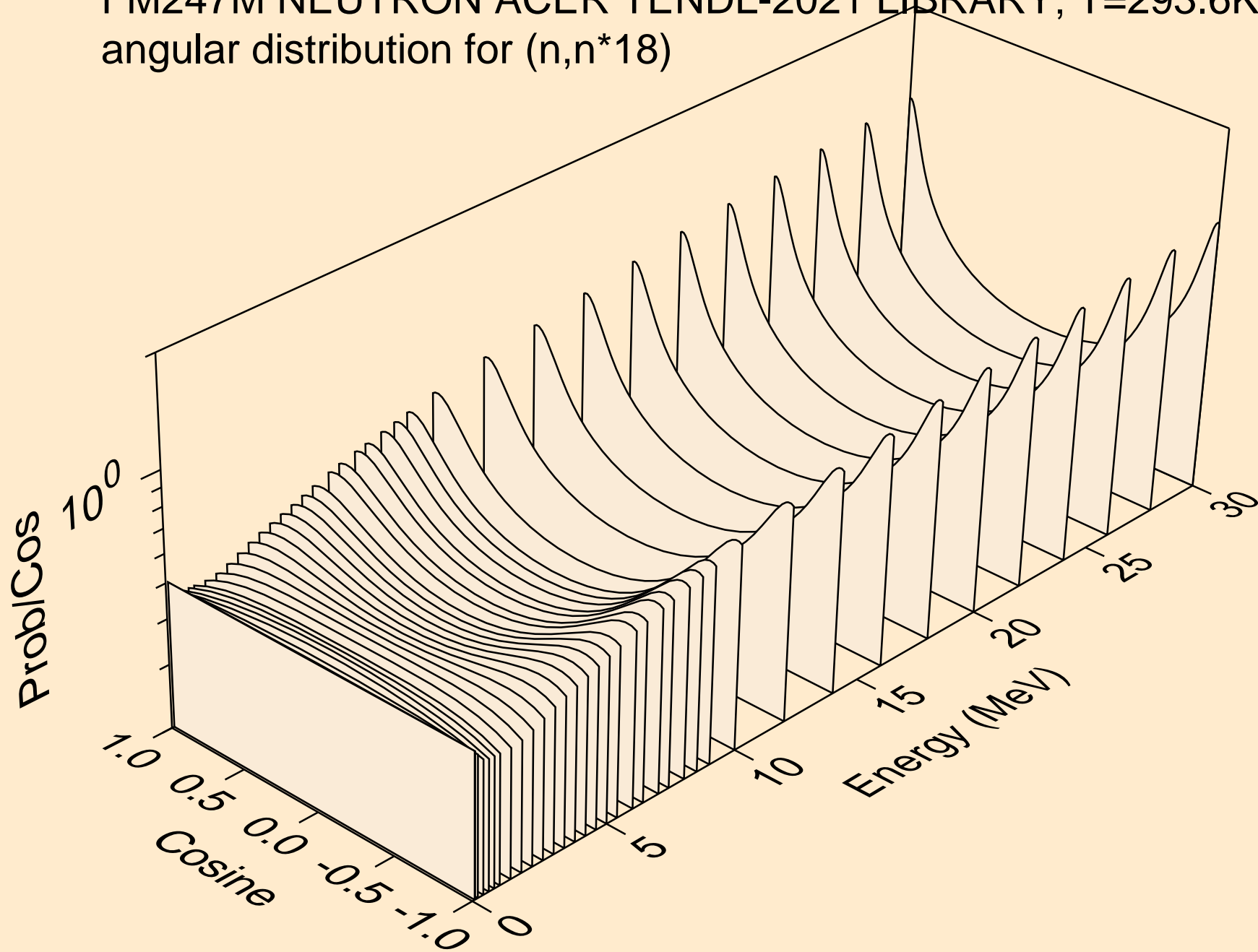

FM247M NEUTRON ACER TENDL-2021 LIBRARY; T=293.6K
angular distribution for (n,n*19)

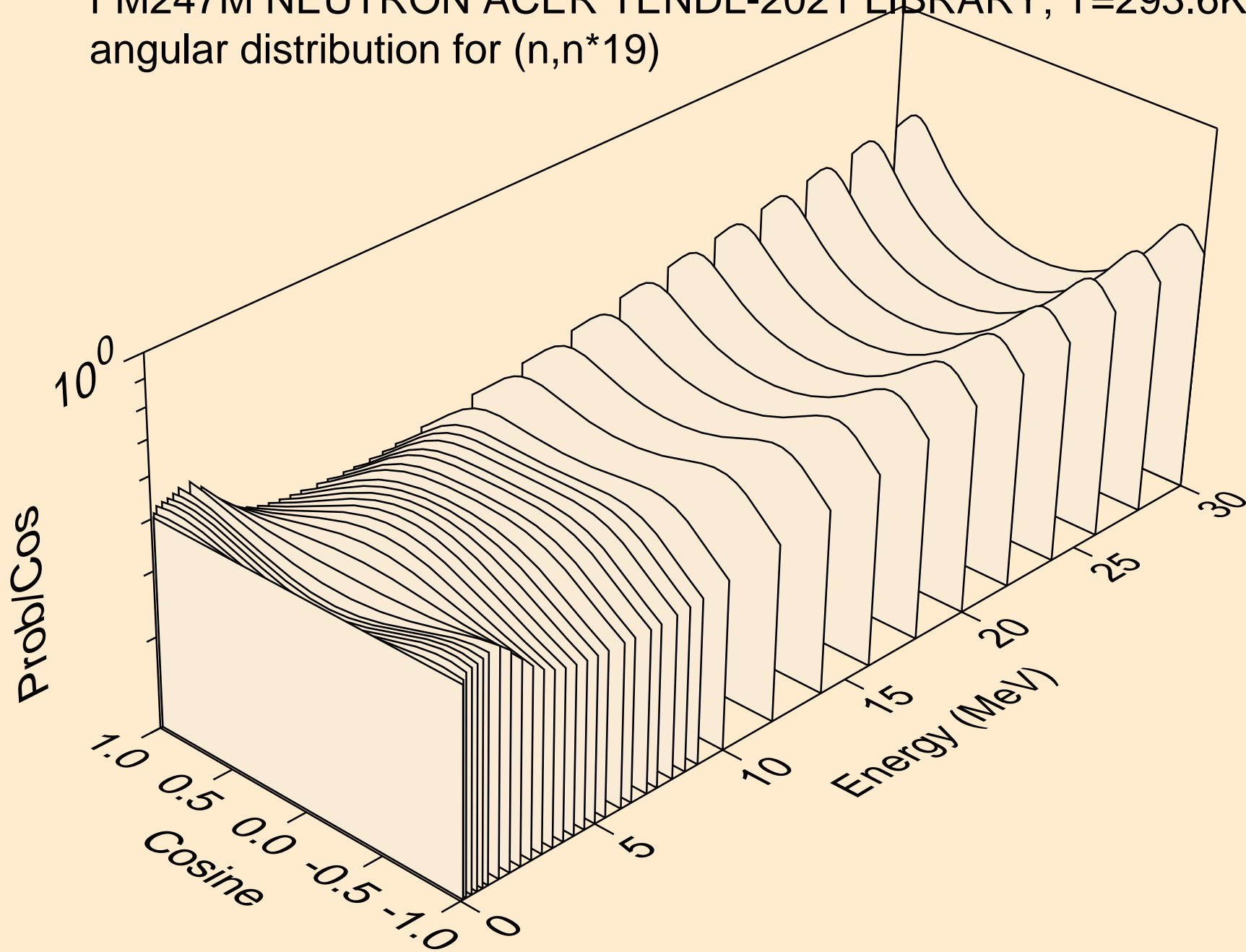

FM247M NEUTRON ACER TENDL-2021 LIBRARY; T=293.6K
angular distribution for (n,n*20)

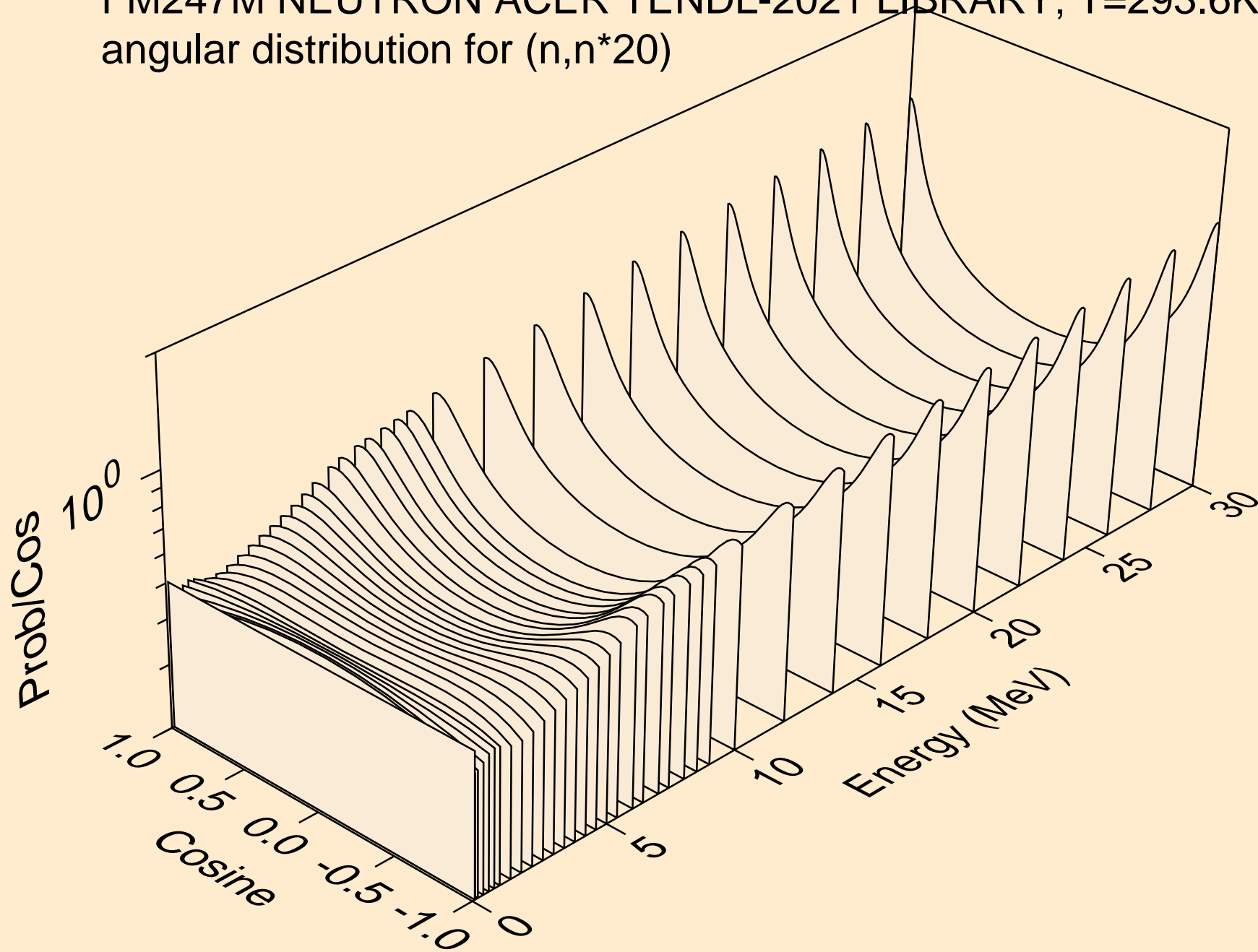

FM247M NEUTRON ACER TENDL-2021 LIBRARY; T=293.6K
angular distribution for (n,n*21)

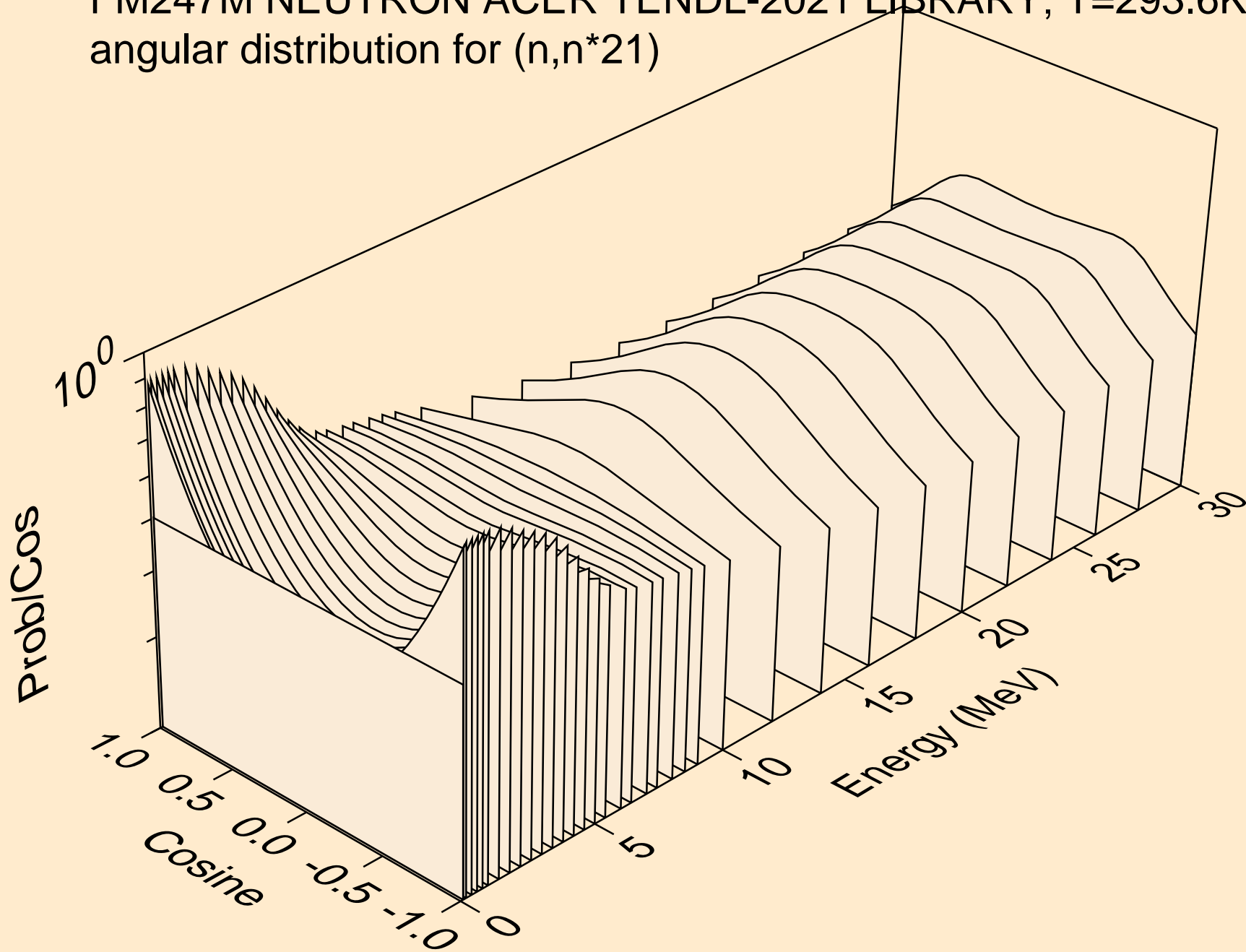

FM247M NEUTRON ACER TENDL-2021 LIBRARY; T=293.6K
angular distribution for (n,n*22)

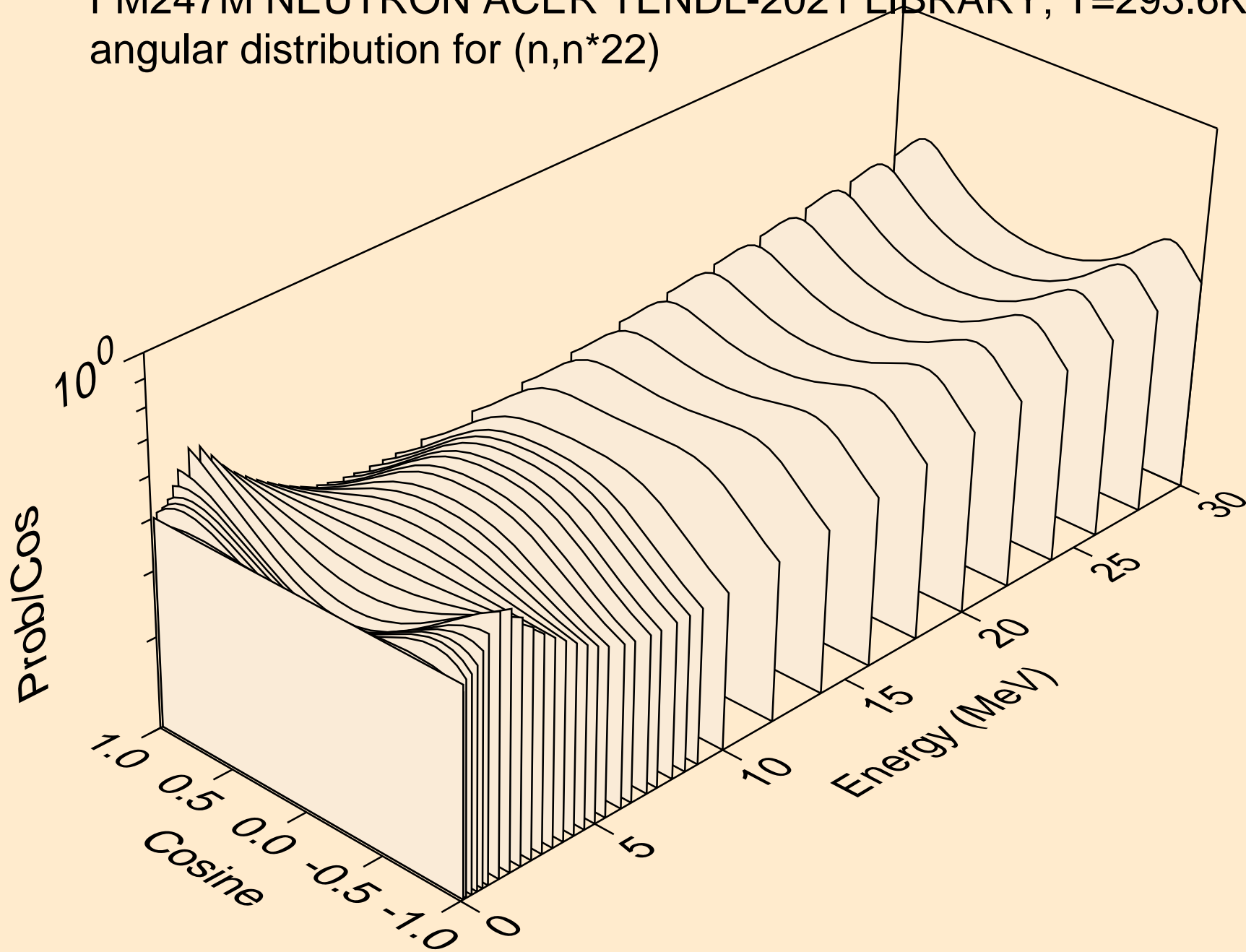

FM247M NEUTRON ACER TENDL-2021 LIBRARY; T=293.6K
angular distribution for (n,n*23)

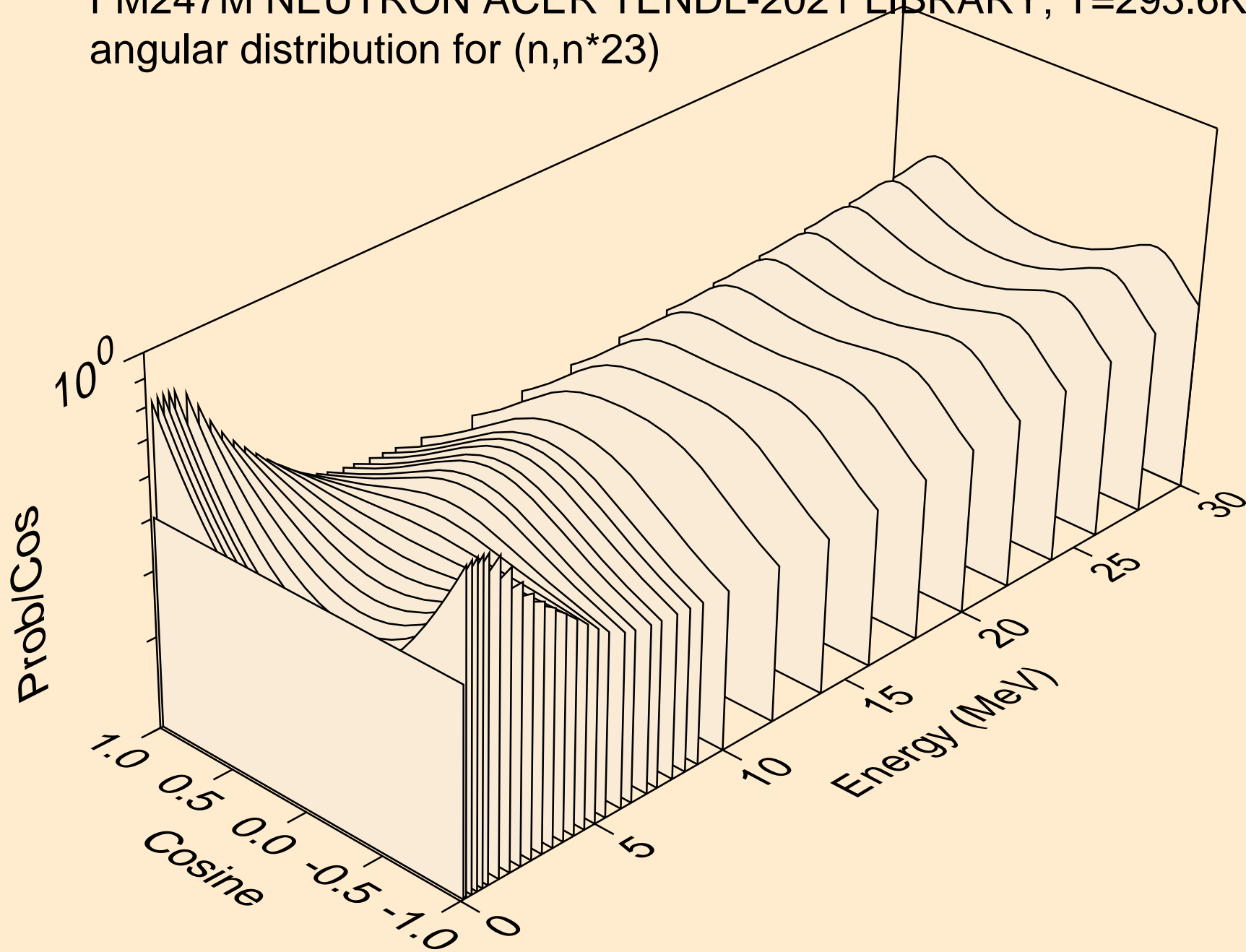

FM247M NEUTRON ACER TENDL-2021 LIBRARY; T=293.6K
Total fission nubar

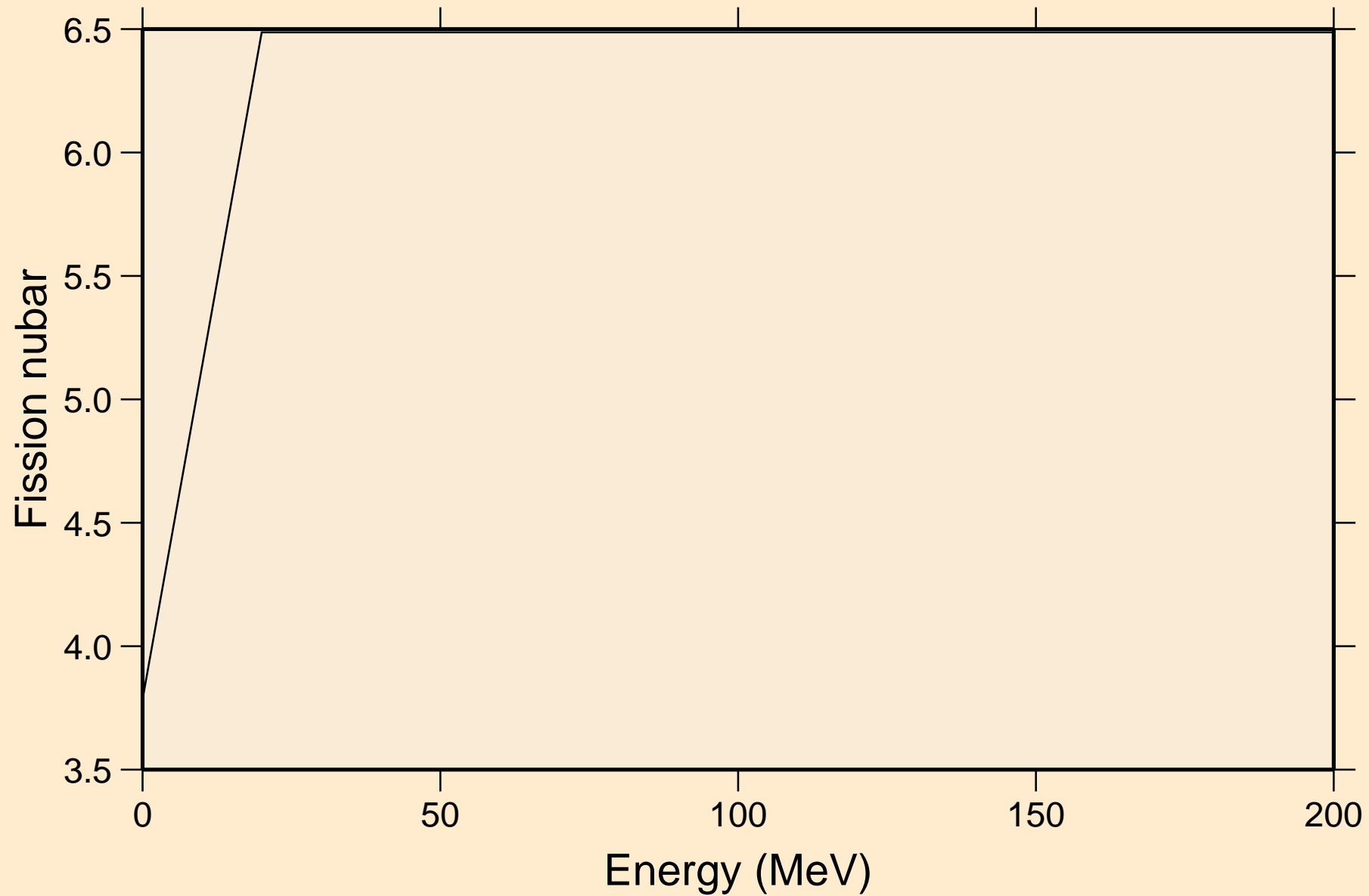

FM247M NEUTRON ACER TENDL-2021 LIBRARY; T=293.6K
Neutron emission for (n,x)

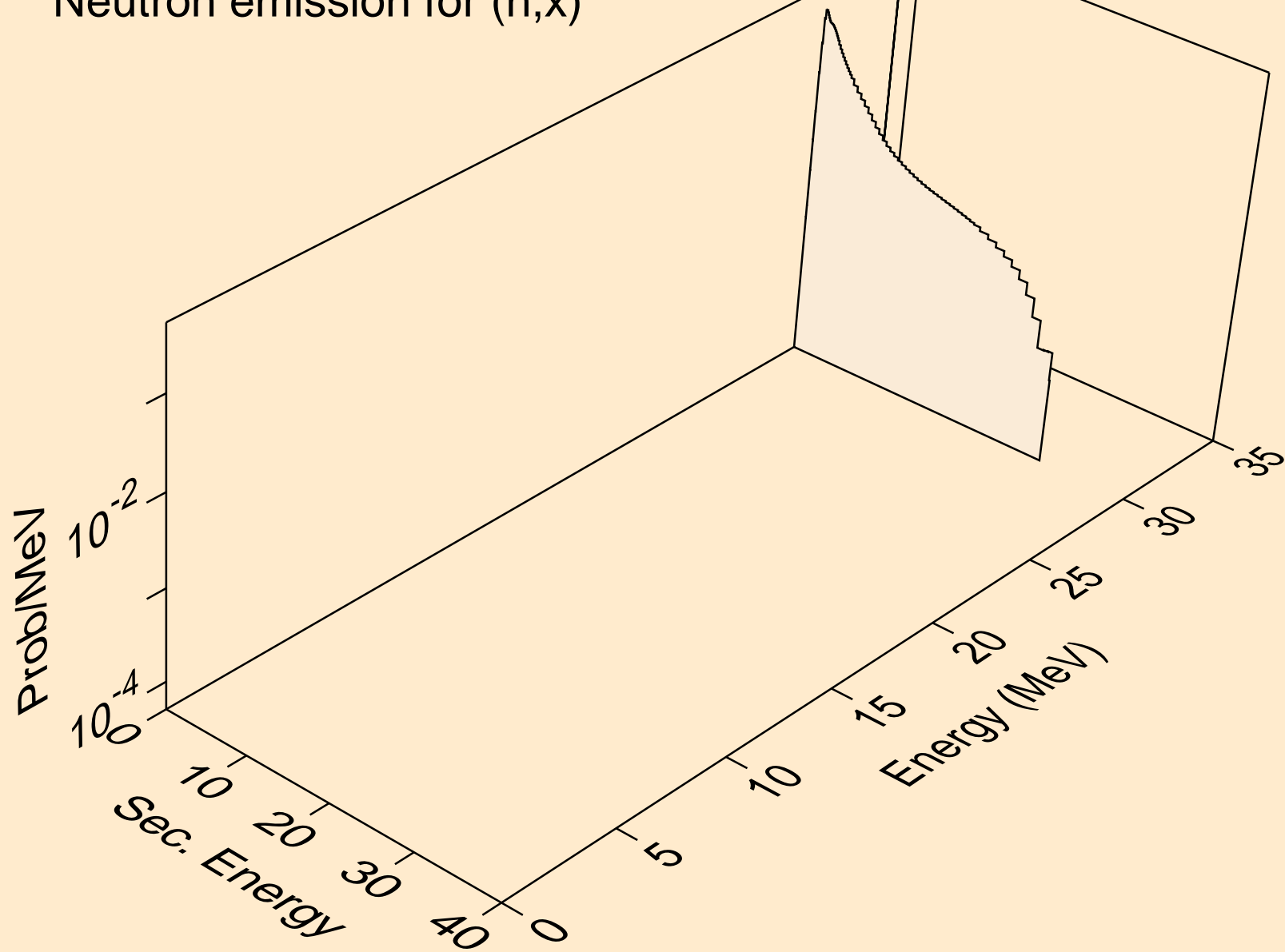

FM247M NEUTRON ACER TENDL-2021 LIBRARY; T=293.6K
Neutron emission for (n,2nd)

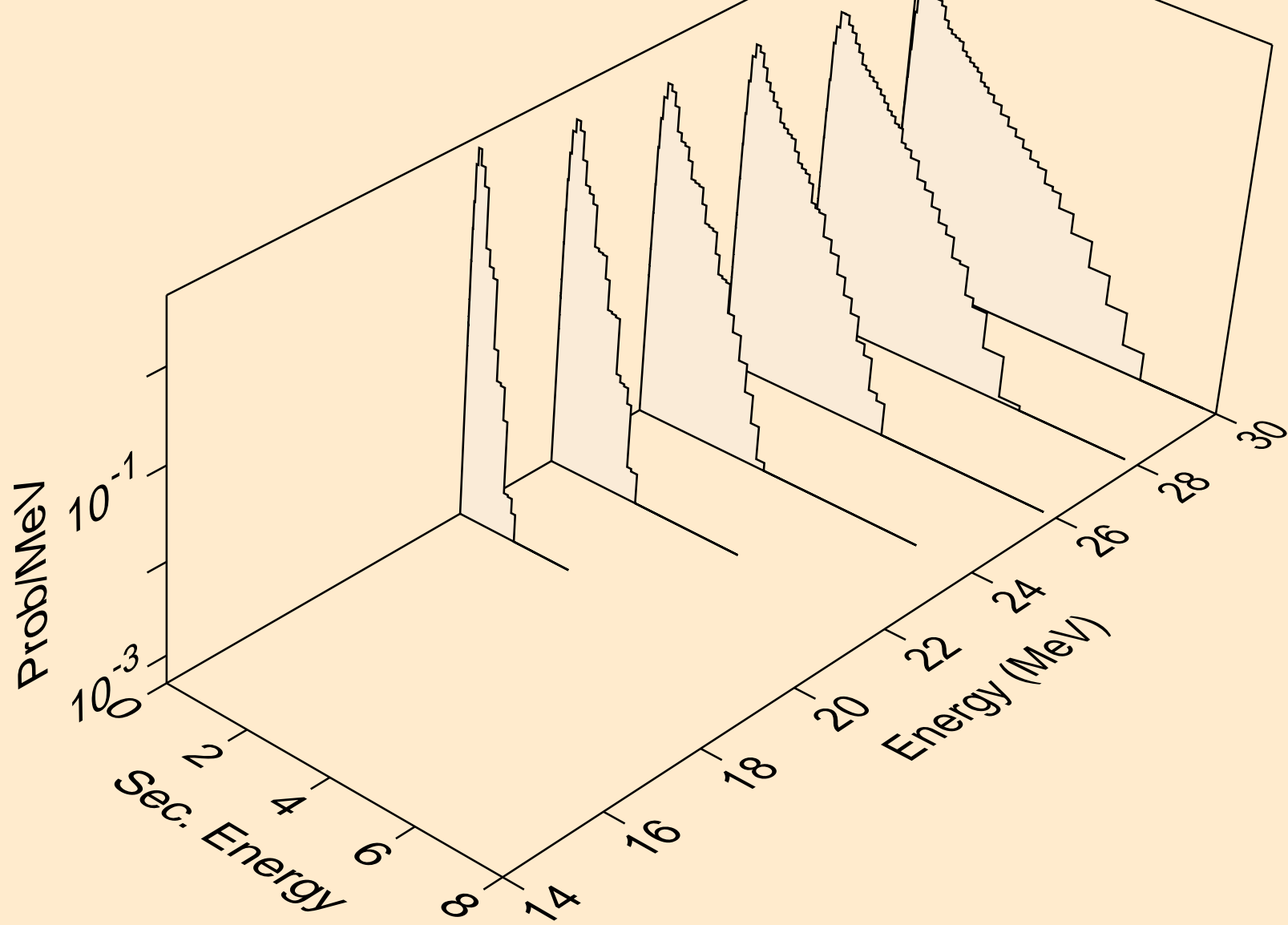

FM247M NEUTRON ACER TENDL-2021 LIBRARY; T=293.6K
Neutron emission for (n,2n)

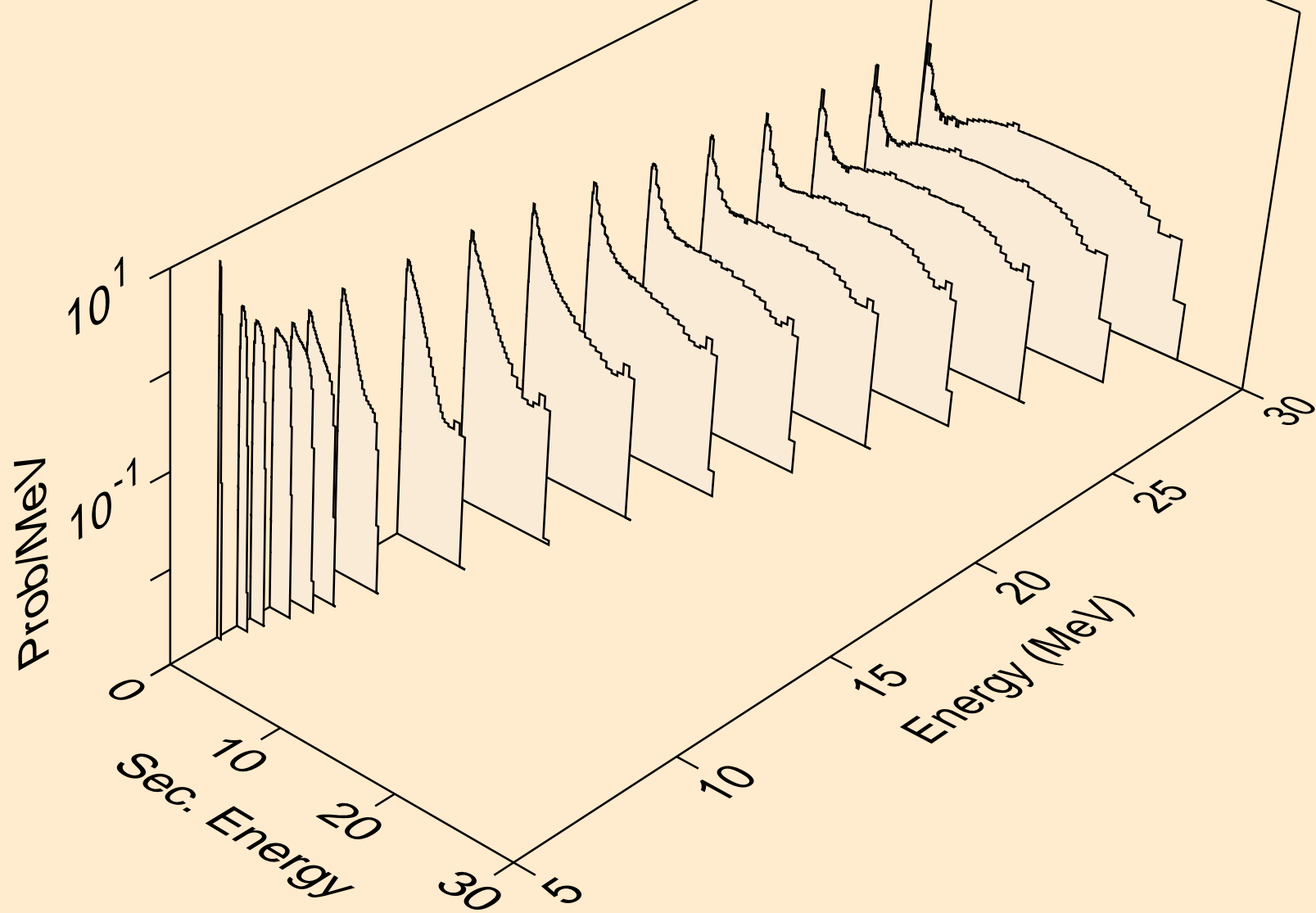

FM247M NEUTRON ACER TENDL-2021 LIBRARY; T=293.6K
Neutron emission for (n,3n)

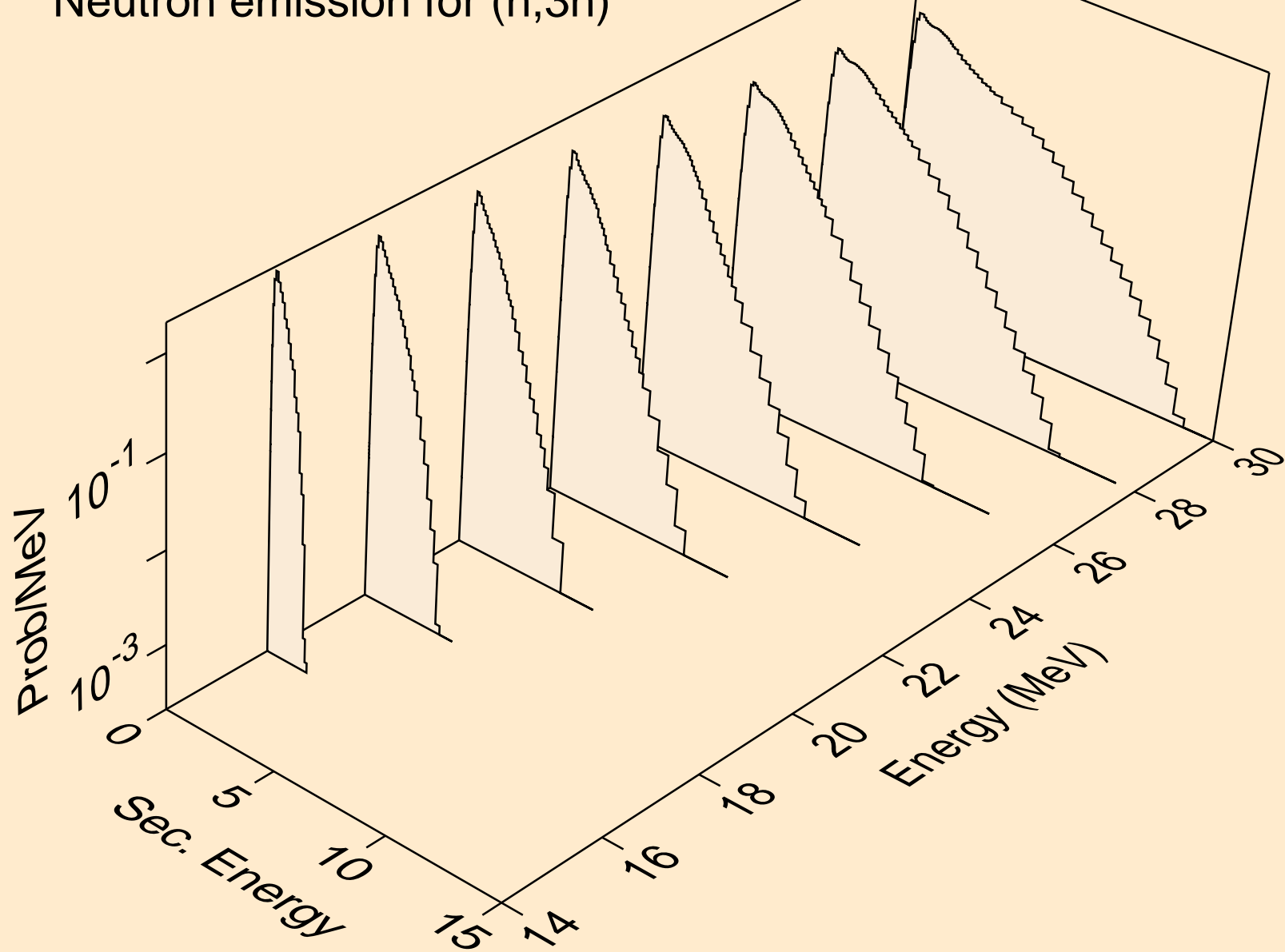

FM247M NEUTRON ACER TENDL-2021 LIBRARY; T=293.6K
Neutron emission for fission

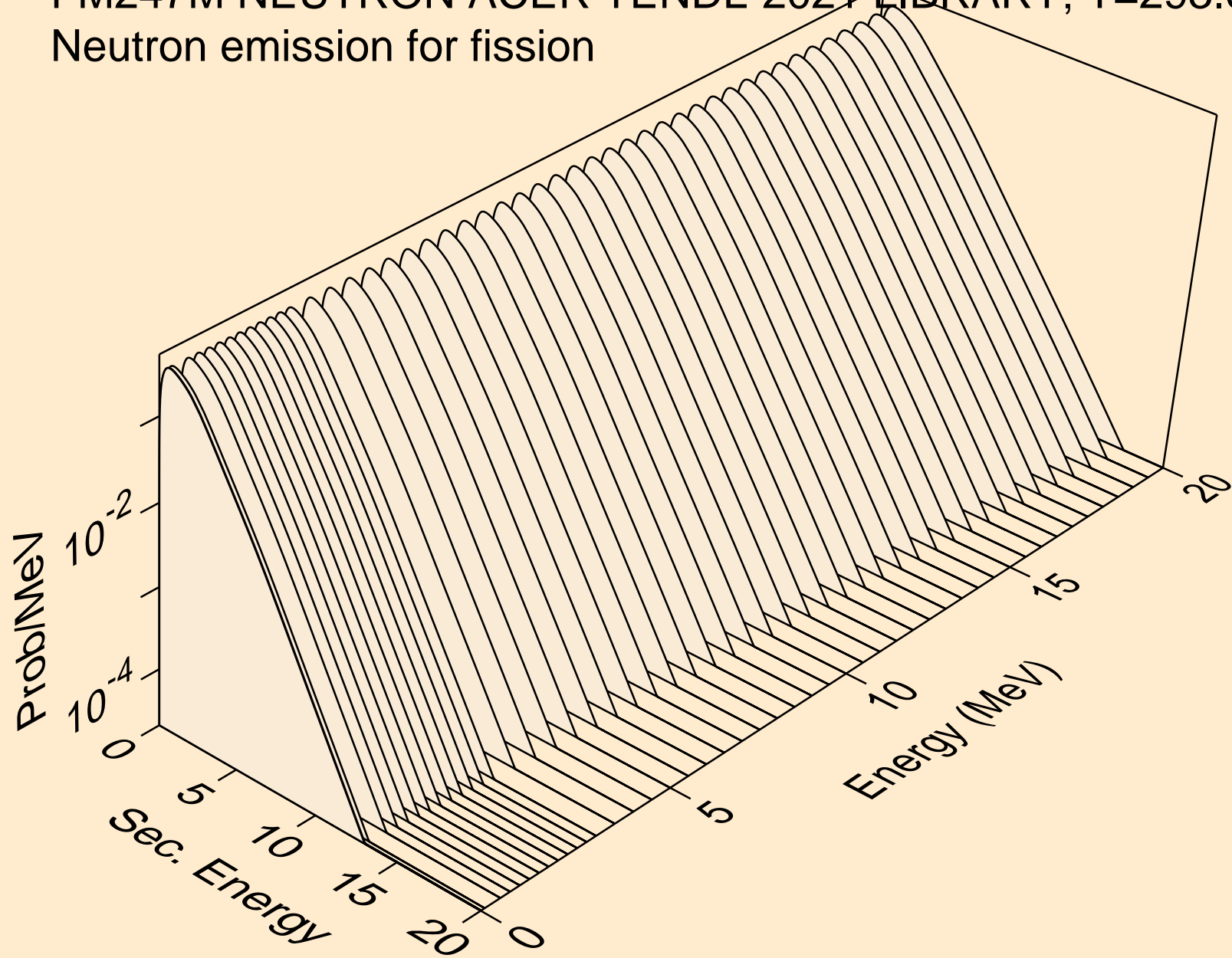

FM247M NEUTRON ACER TENDL-2021 LIBRARY; T=293.6K
Neutron emission for (n,n*)a

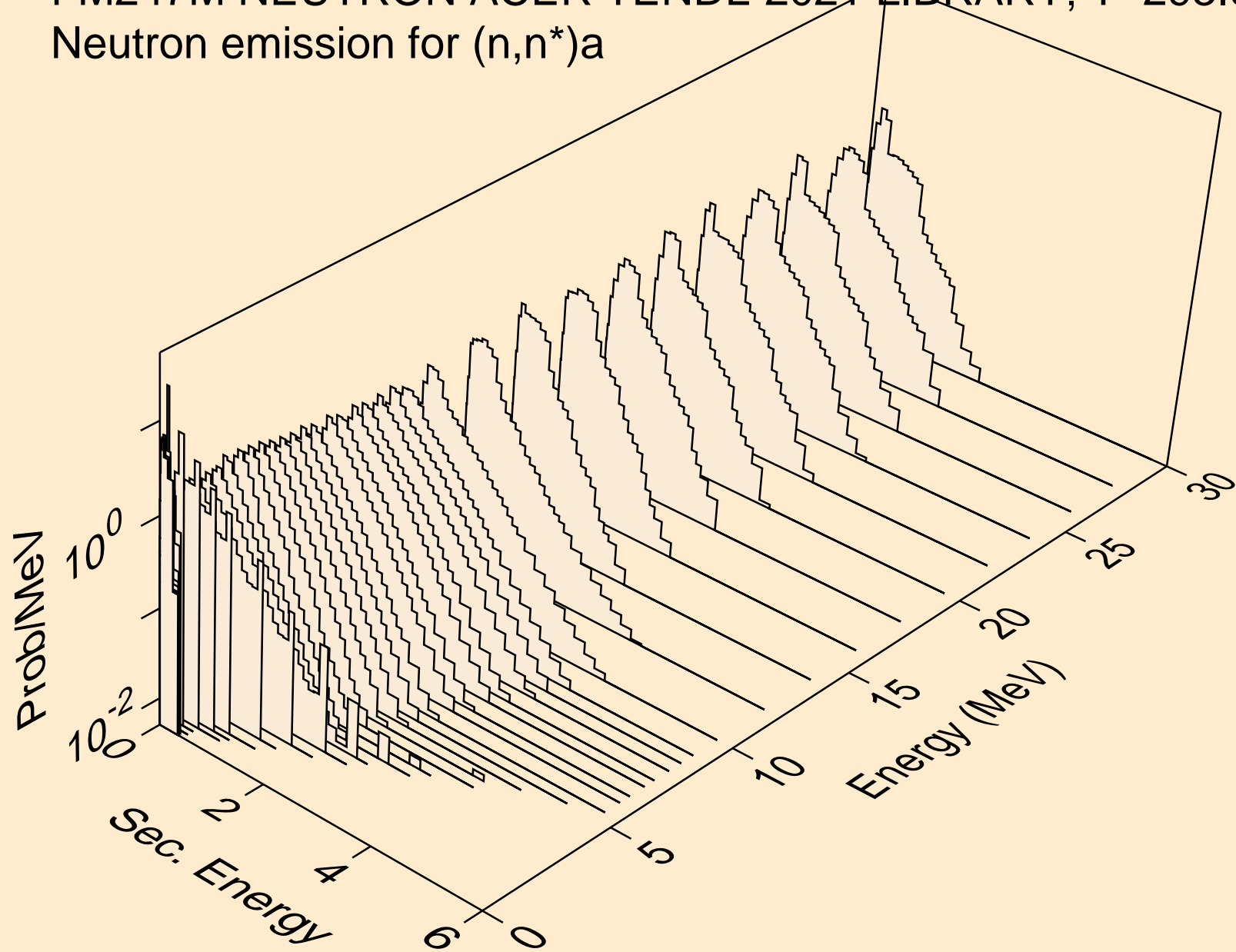

FM247M NEUTRON ACER TENDL-2021 LIBRARY; T=293.6K
Neutron emission for (n,2n)a

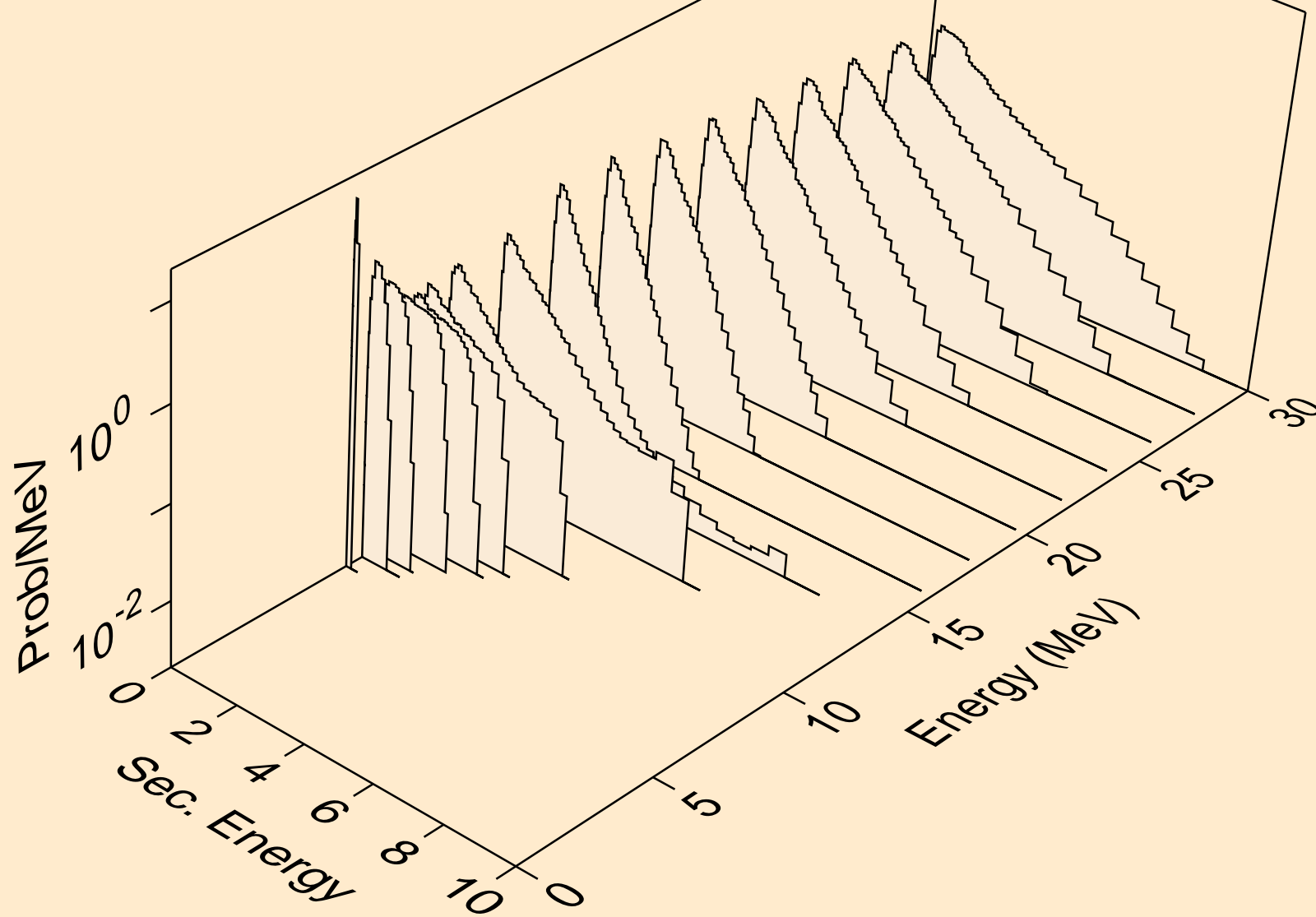

FM247M NEUTRON ACER TENDL-2021 LIBRARY; T=293.6K
Neutron emission for (n,3n)a

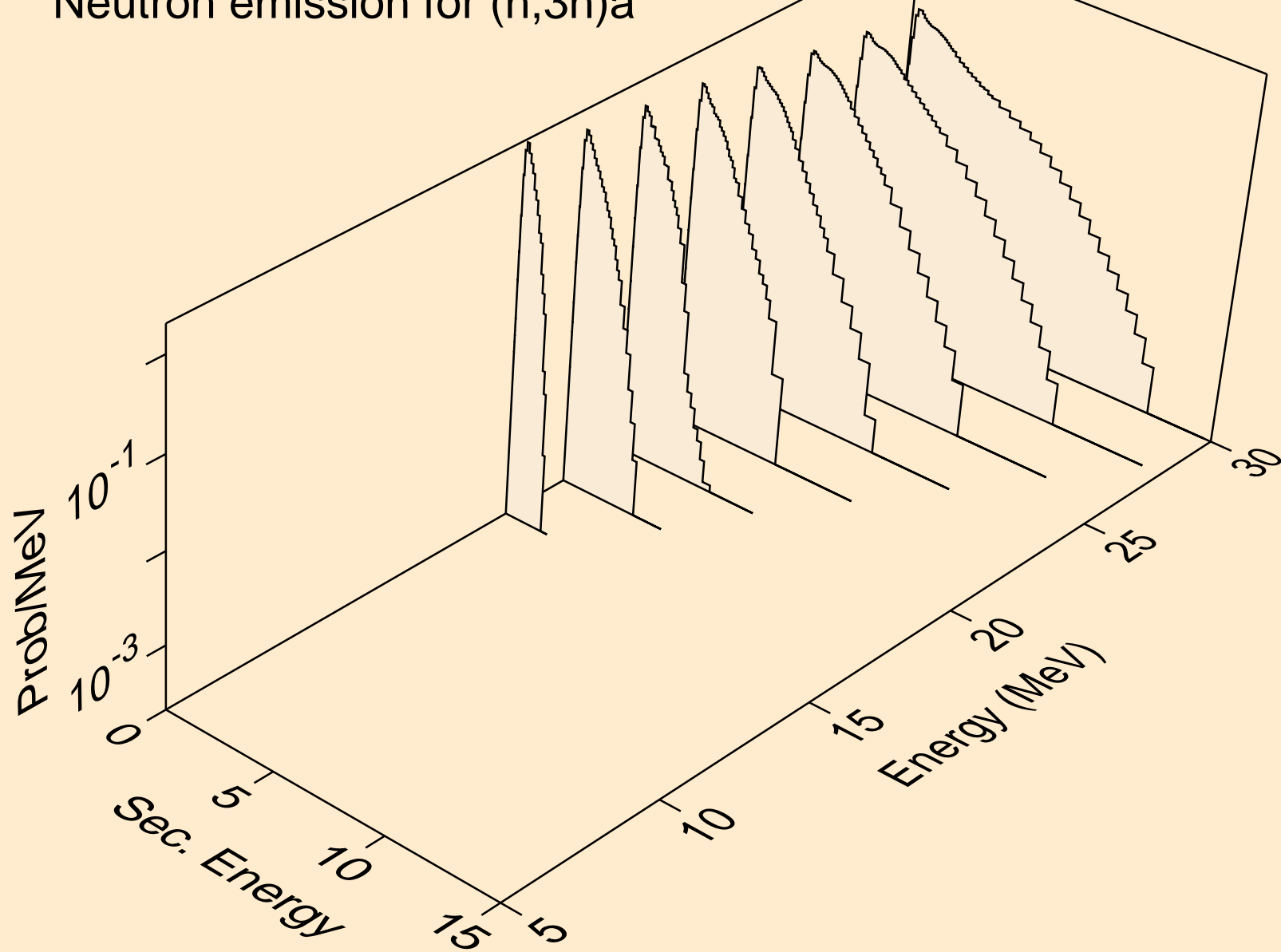

FM247M NEUTRON ACER TENDL-2021 LIBRARY; T=293.6K
Neutron emission for (n,n*)p

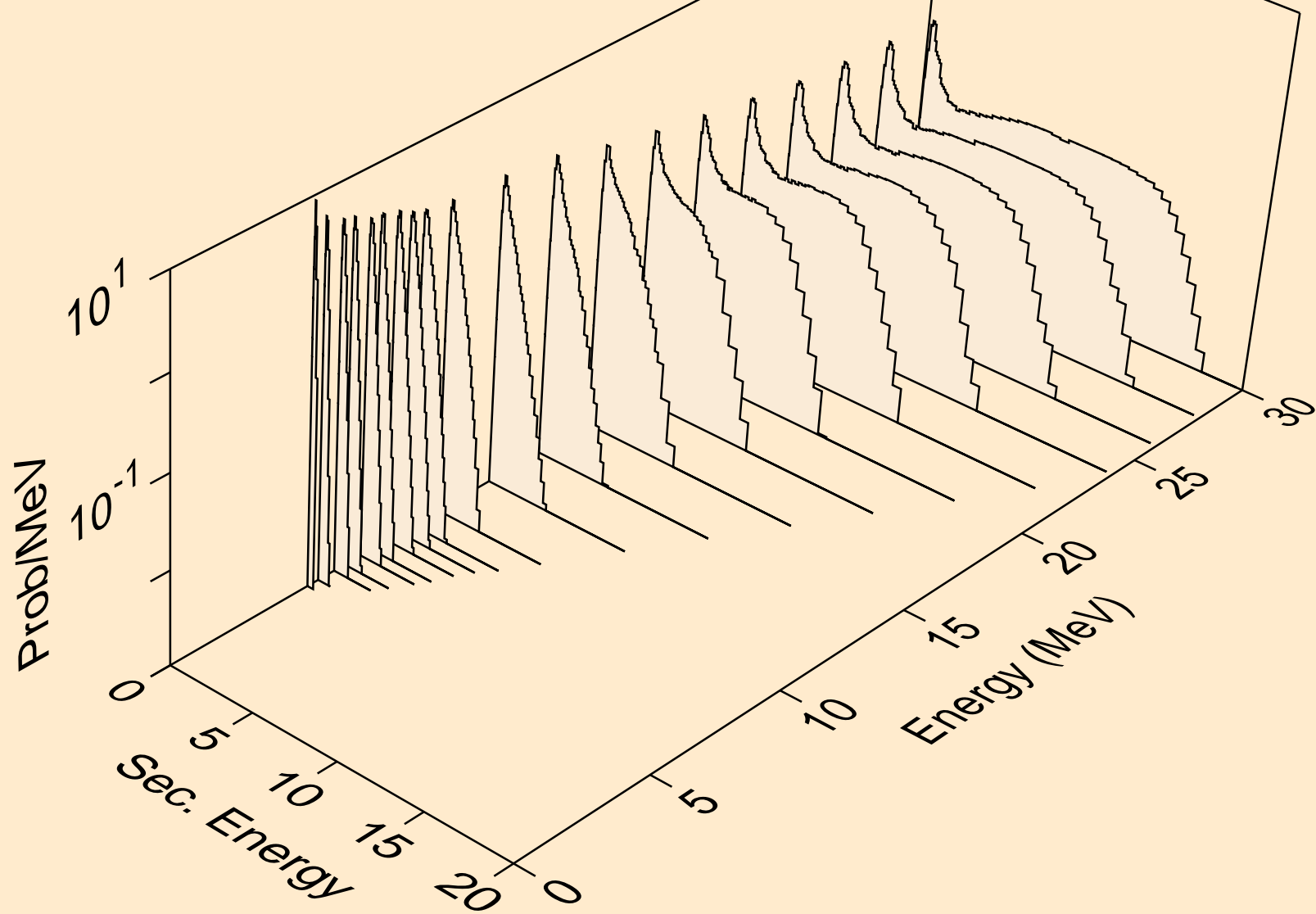

FM247M NEUTRON ACER TENDL-2021 LIBRARY; T=293.6K
Neutron emission for (n,n*)d

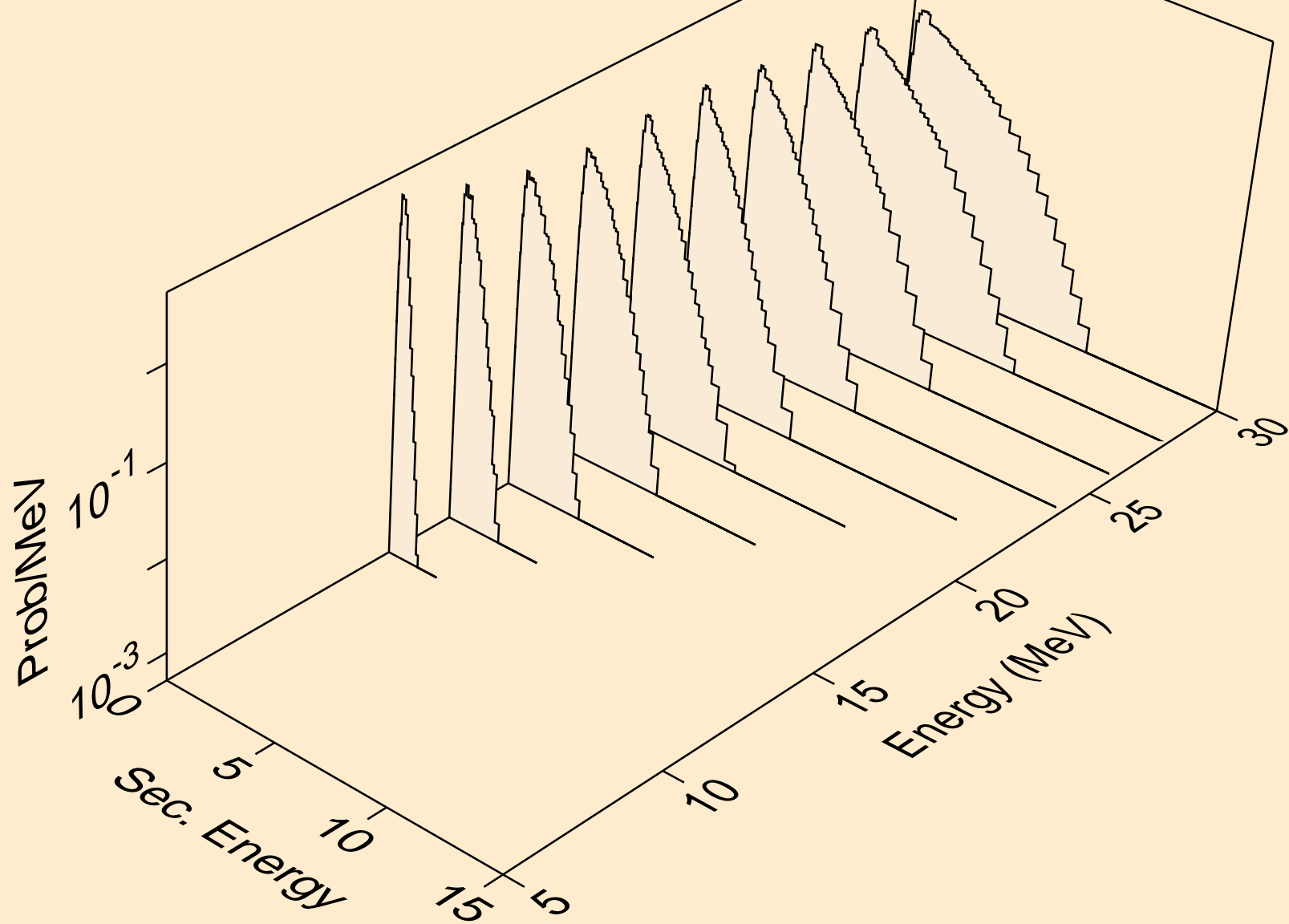

FM247M NEUTRON ACER TENDL-2021 LIBRARY; T=293.6K
Neutron emission for (n,n*)t

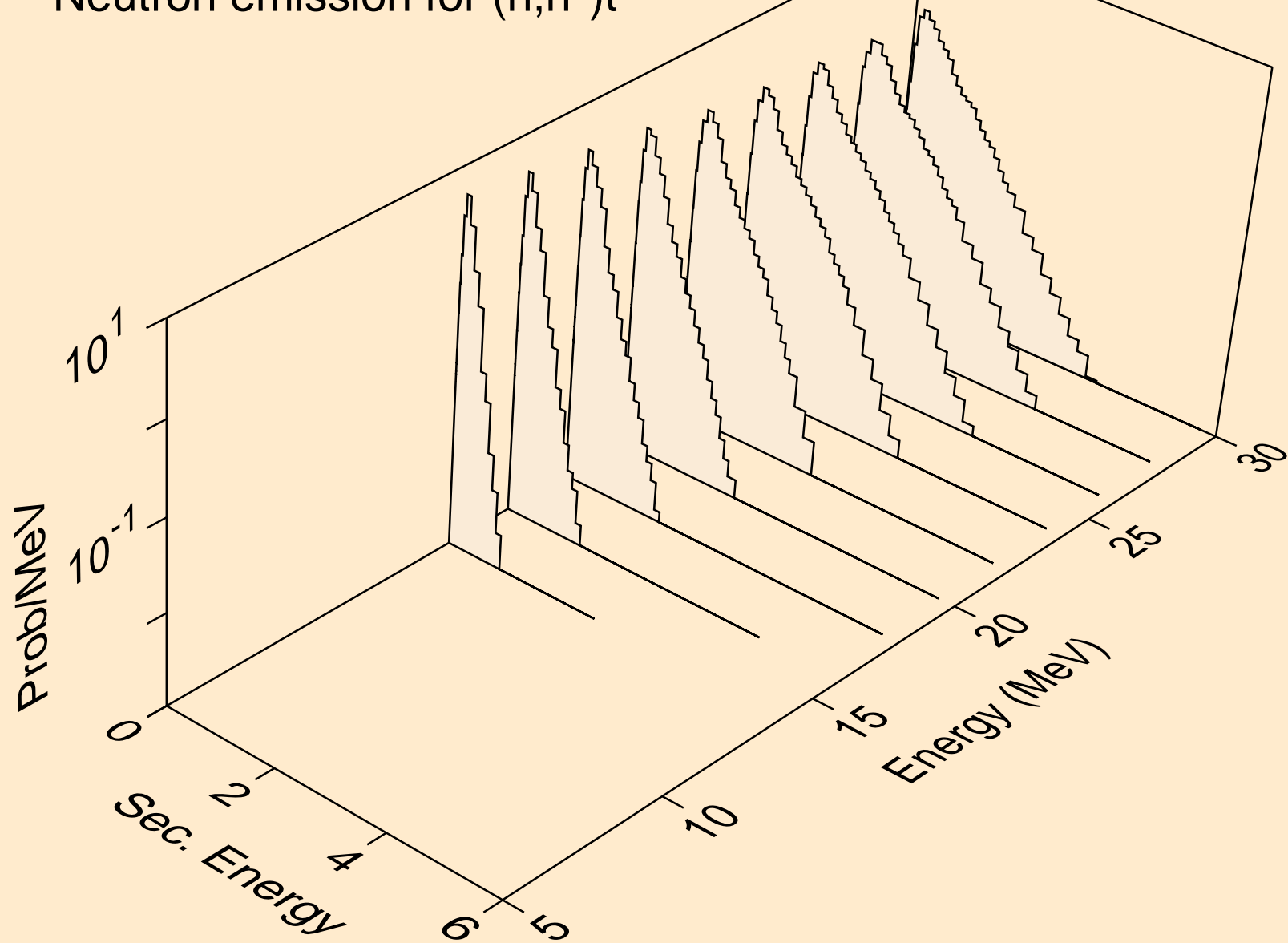

FM247M NEUTRON ACER TENDL-2021 LIBRARY; T=293.6K
Neutron emission for (n,n*)he3

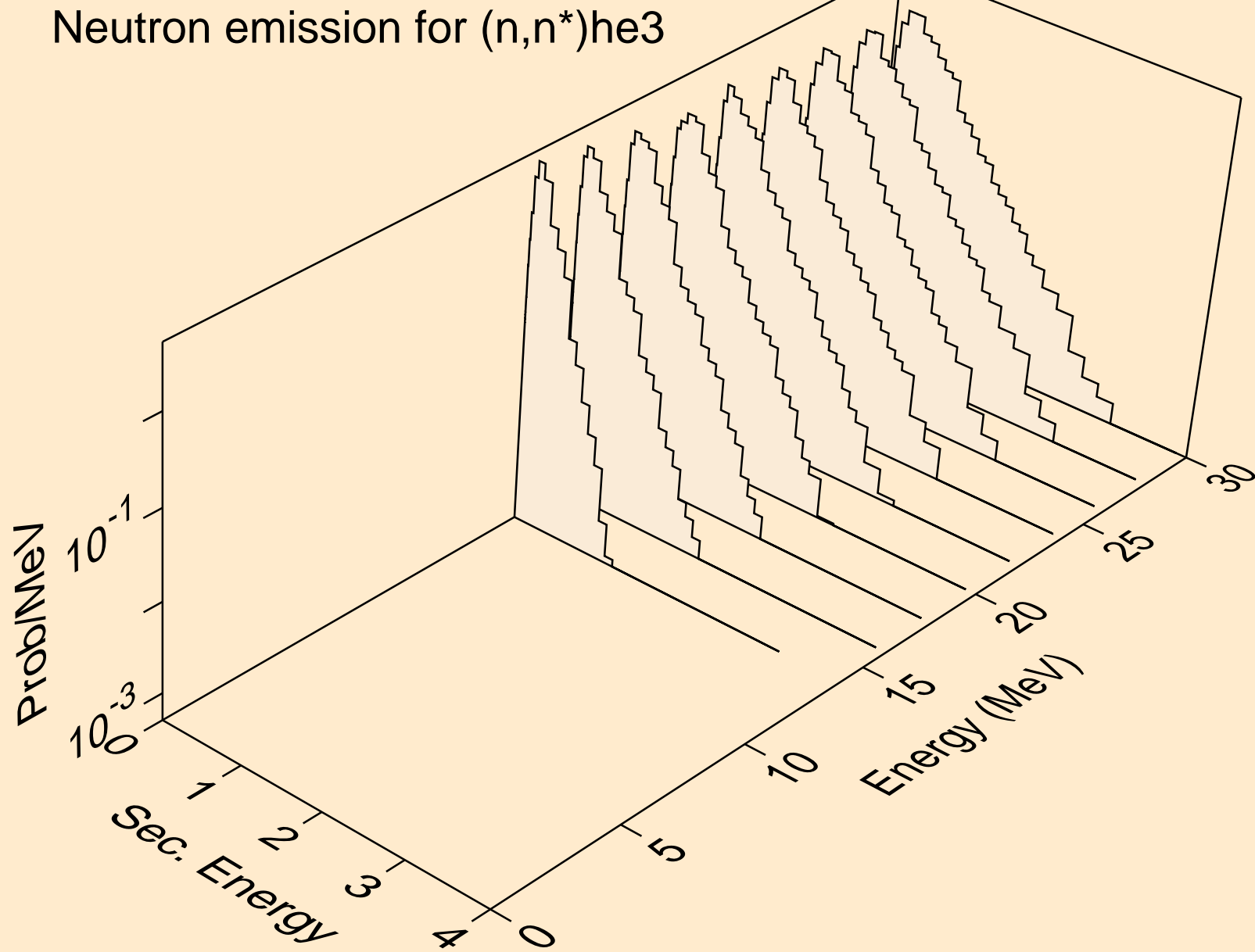

FM247M NEUTRON ACER TENDL-2021 LIBRARY; T=293.6K
Neutron emission for (n,4n)

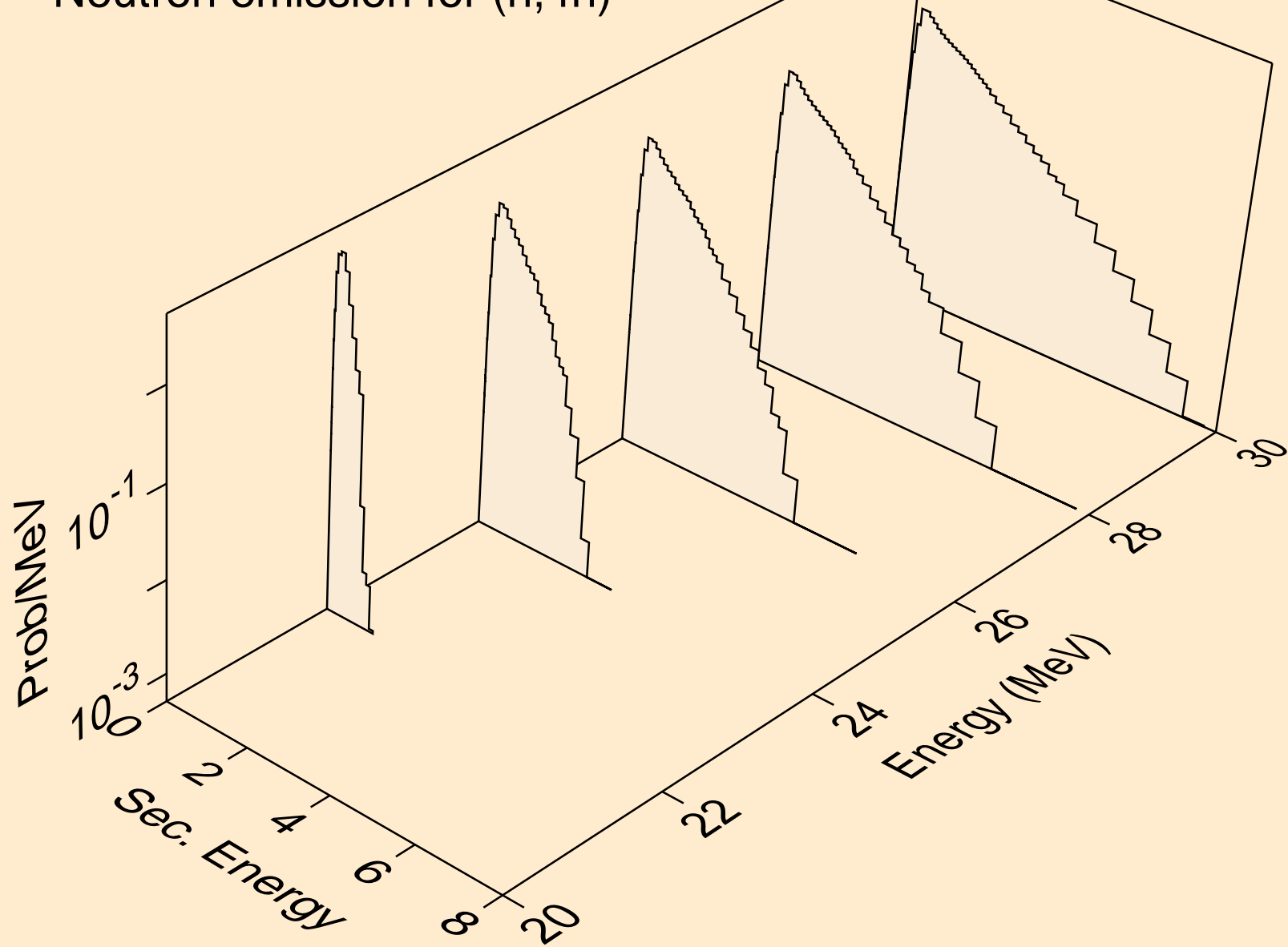

FM247M NEUTRON ACER TENDL-2021 LIBRARY; T=293.6K
Neutron emission for (n,2np)

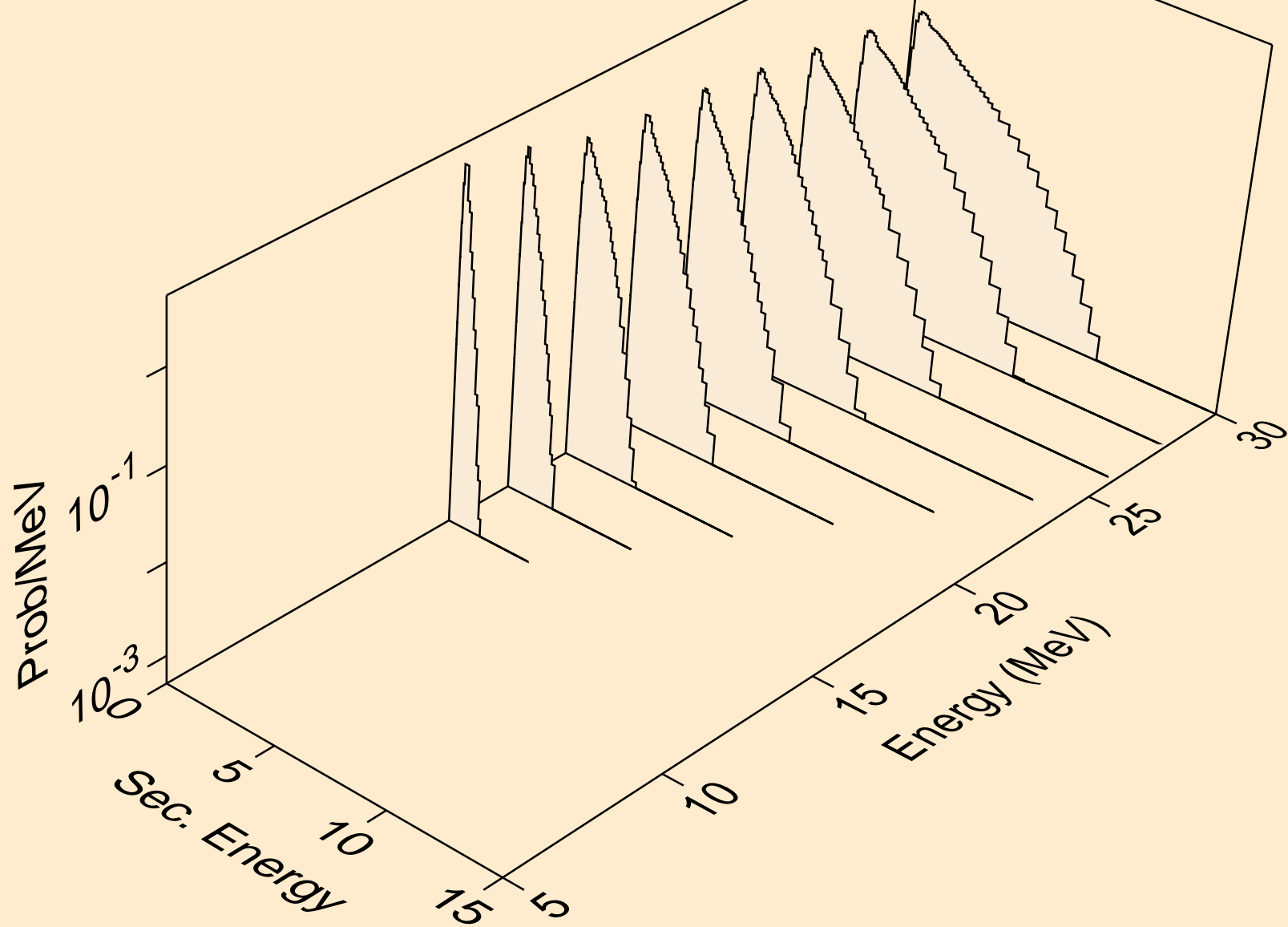

FM247M NEUTRON ACER TENDL-2021 LIBRARY; T=293.6K
Neutron emission for (n,3np)

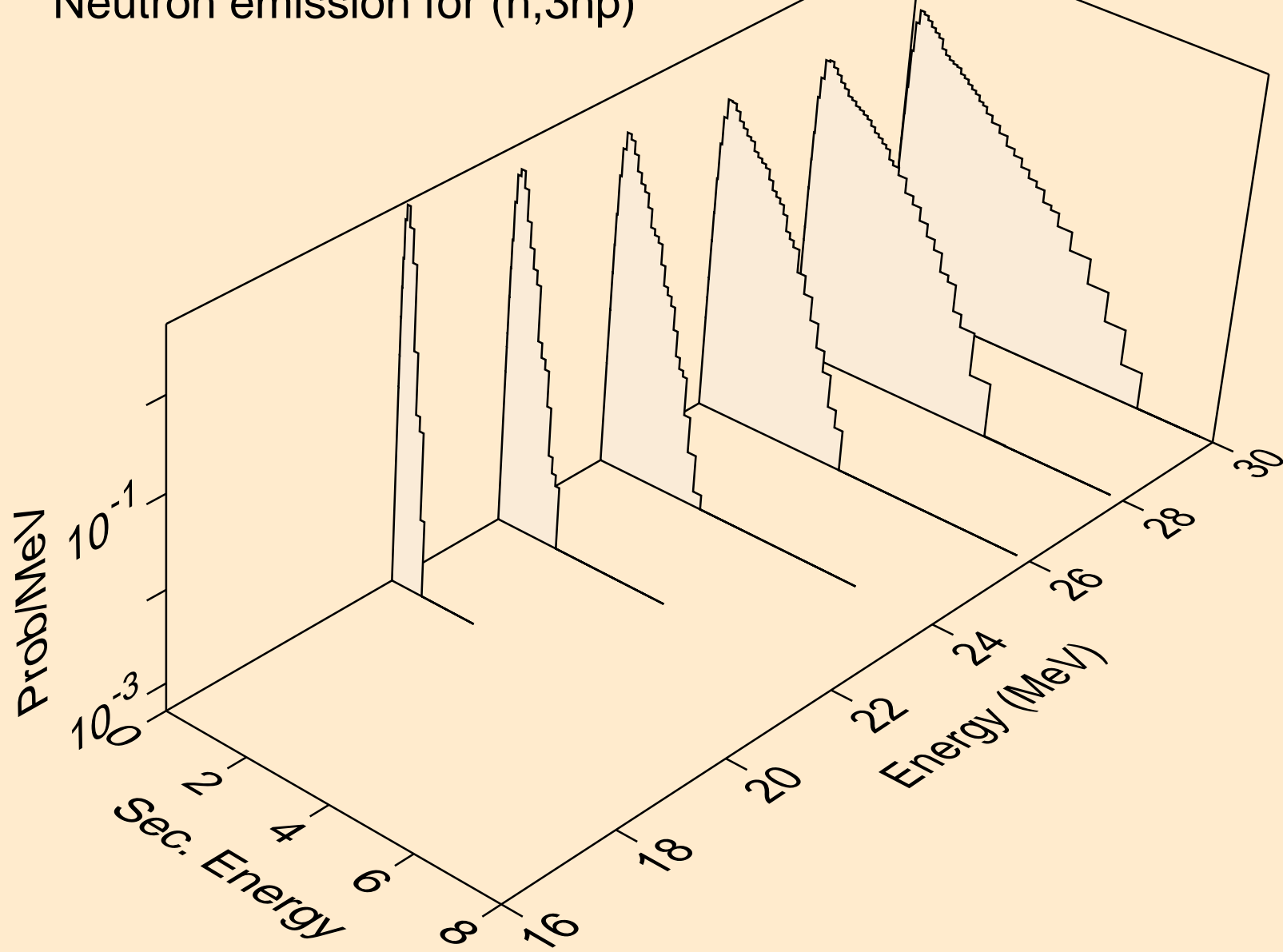

FM247M NEUTRON ACER TENDL-2021 LIBRARY; T=293.6K
Neutron emission for (n,2np)

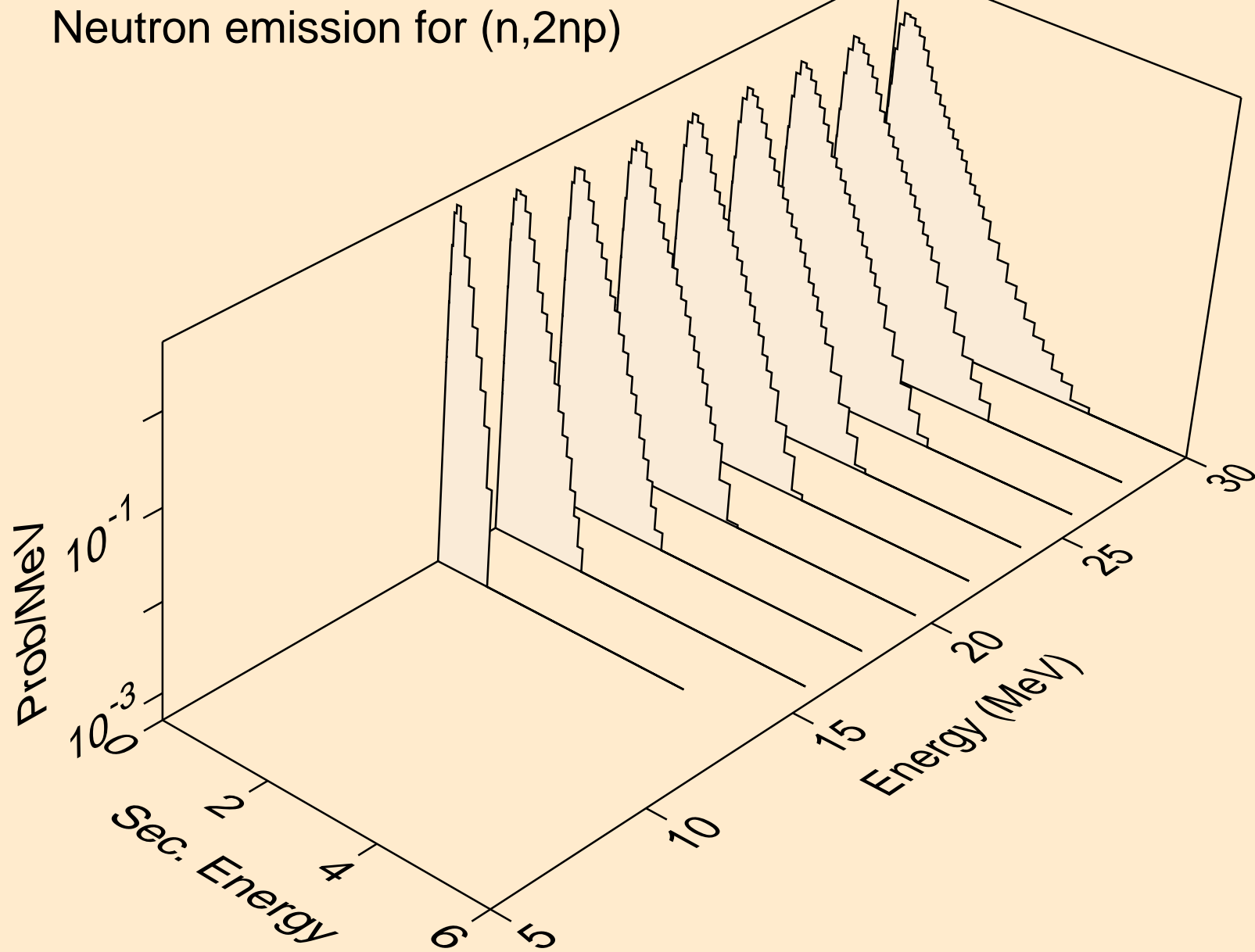

FM247M NEUTRON ACER TENDL-2021 LIBRARY; T=293.6K
Neutron emission for (n,npa)

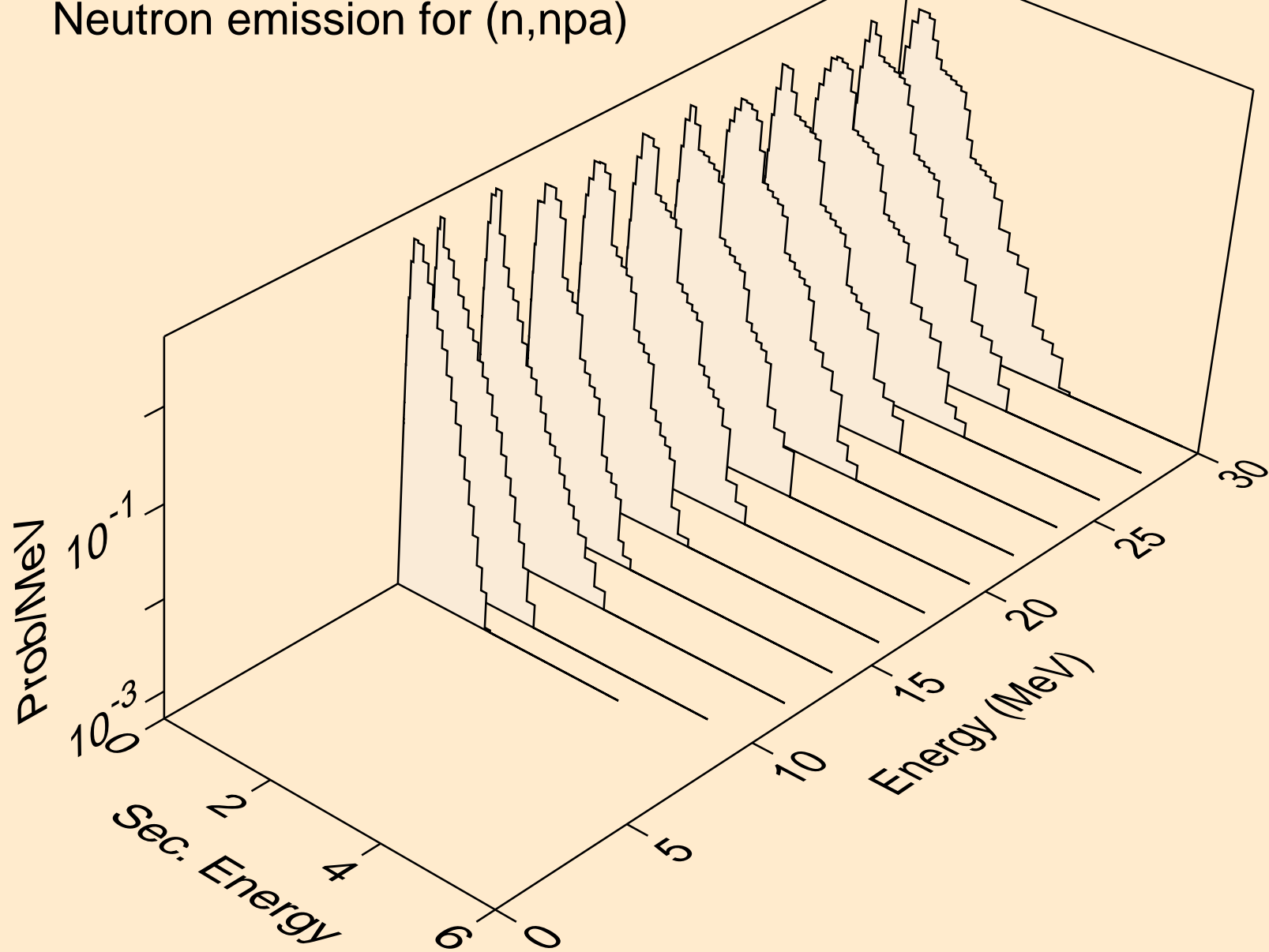

FM247M NEUTRON ACER TENDL-2021 LIBRARY; T=293.6K
Neutron emission for (n,n*c)

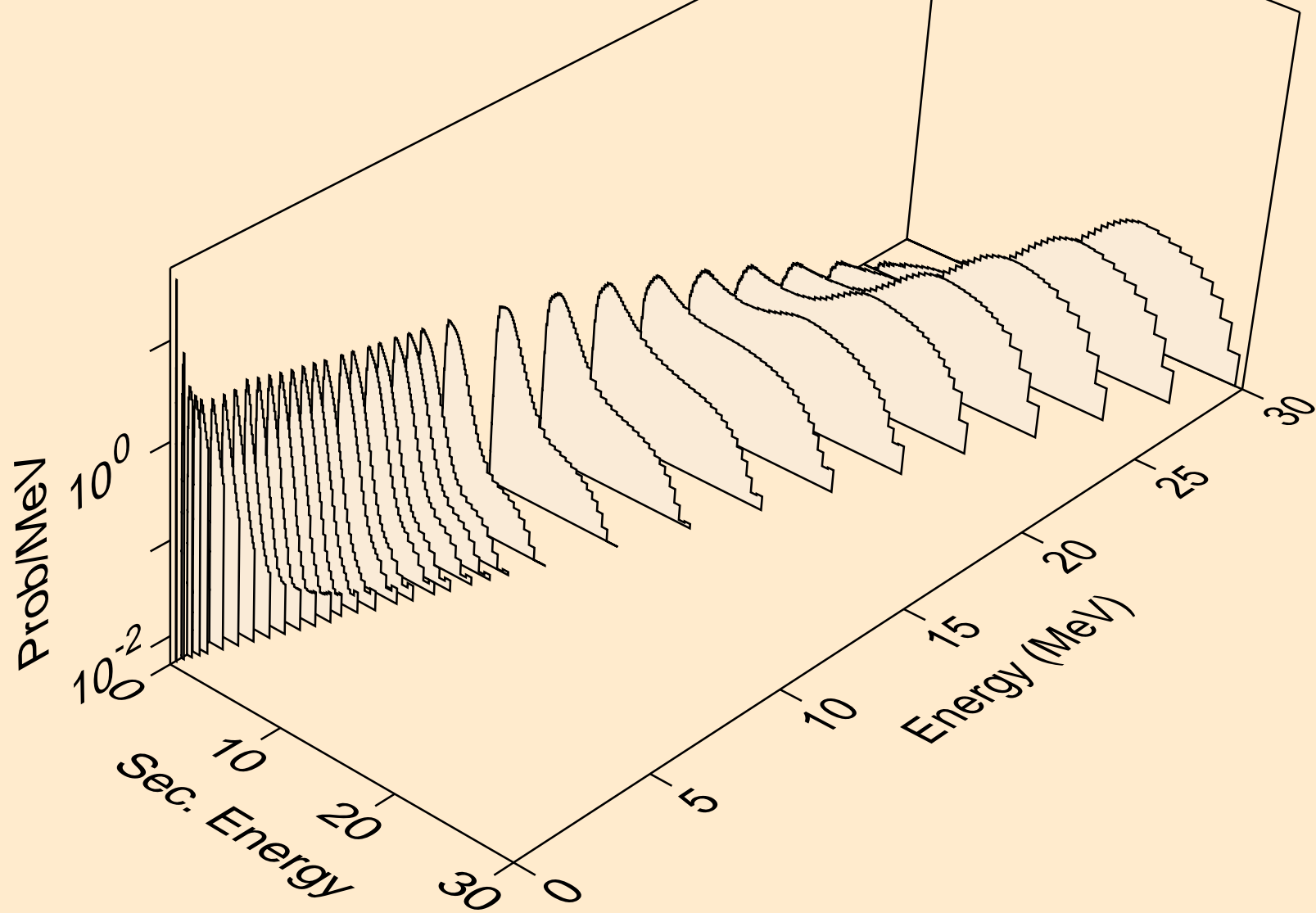

FM247M NEUTRON ACER TENDL-2021 LIBRARY; T=293.6K
Delayed nubar

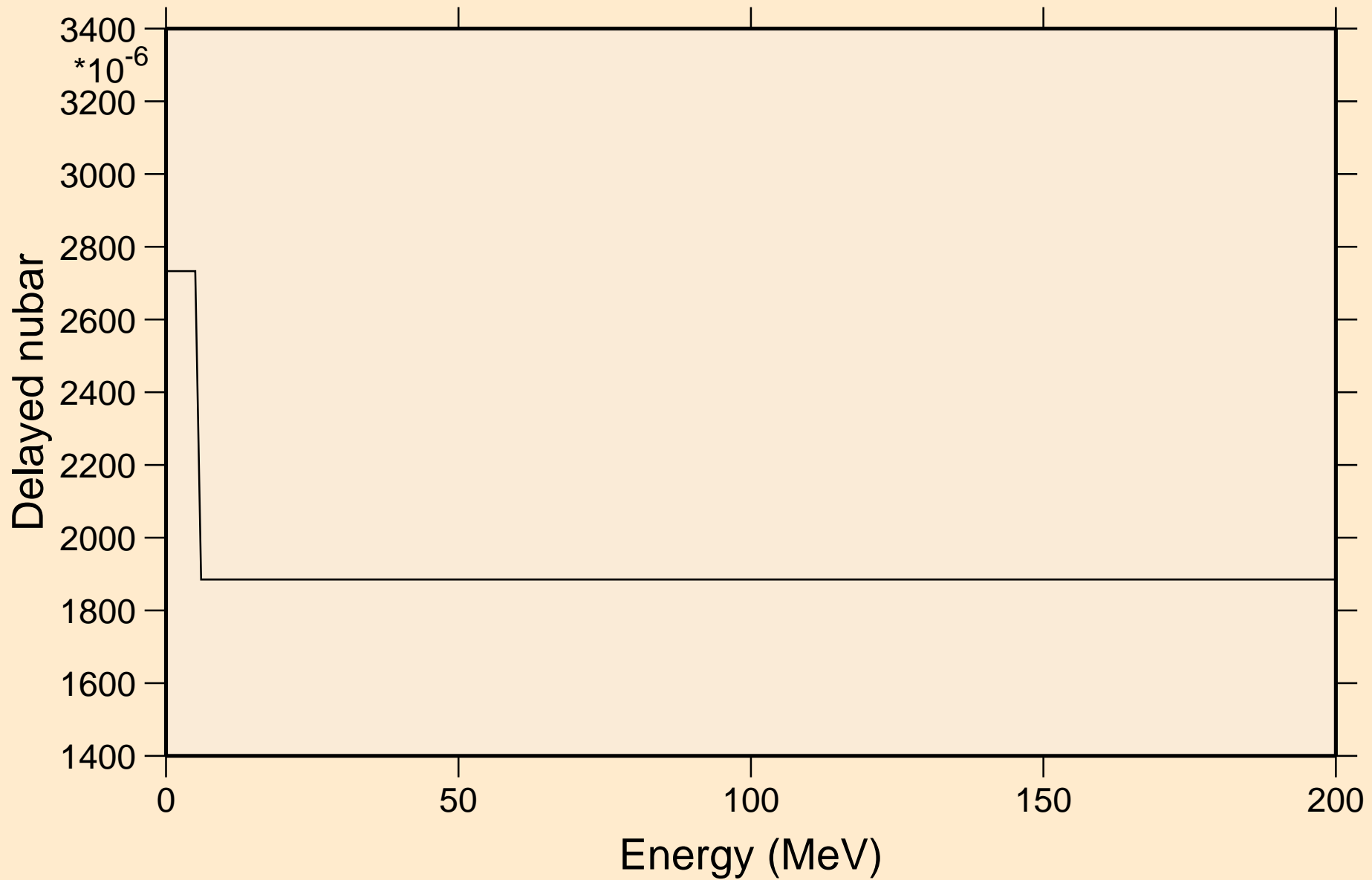

FM247M NEUTRON ACER TENDL-2021 LIBRARY; T=293.6K

Delayed neutron spectra

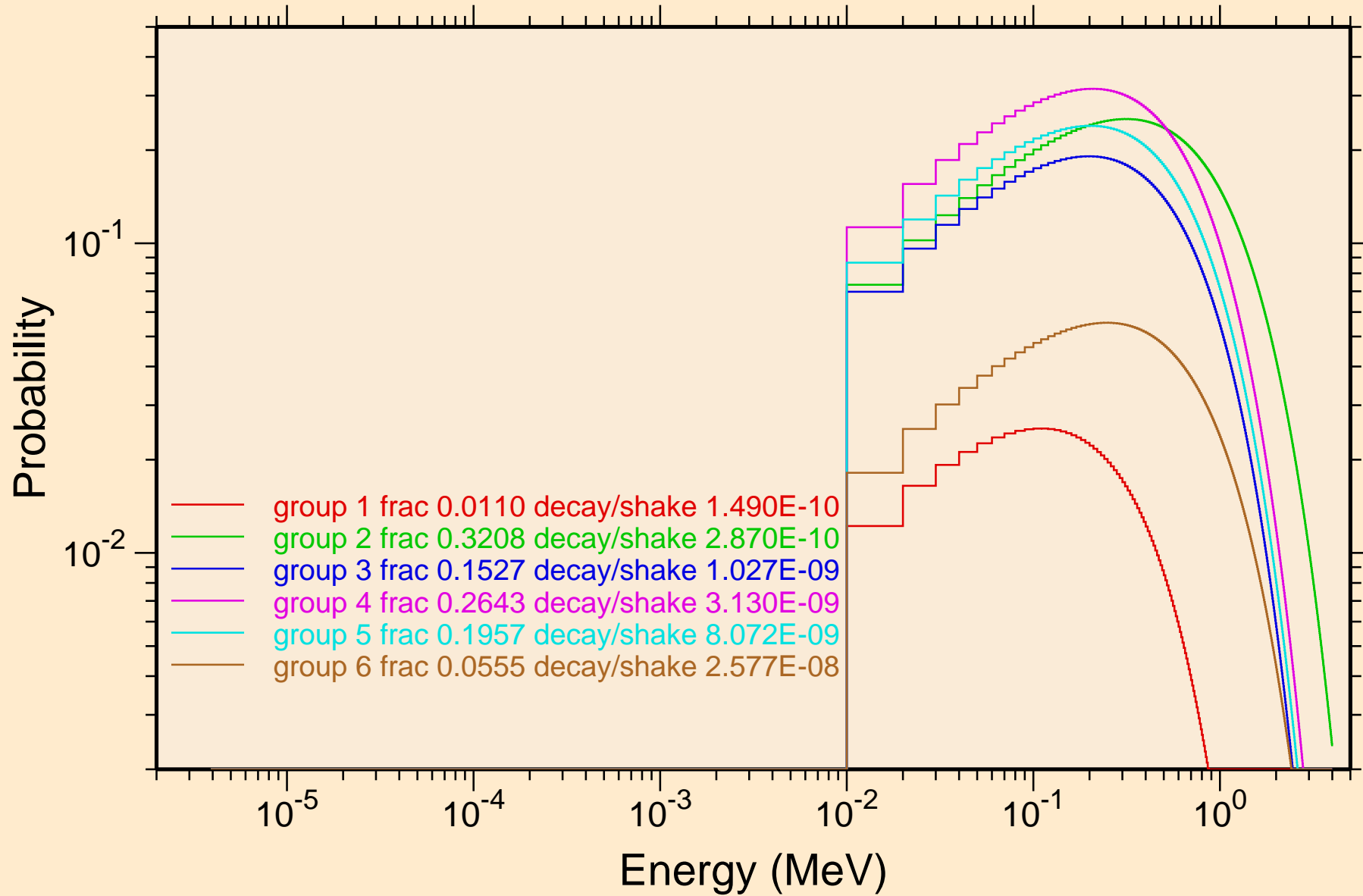

FM247M NEUTRON ACER TENDL-2021 LIBRARY; T=293.6K
Photon emission for (n,x)

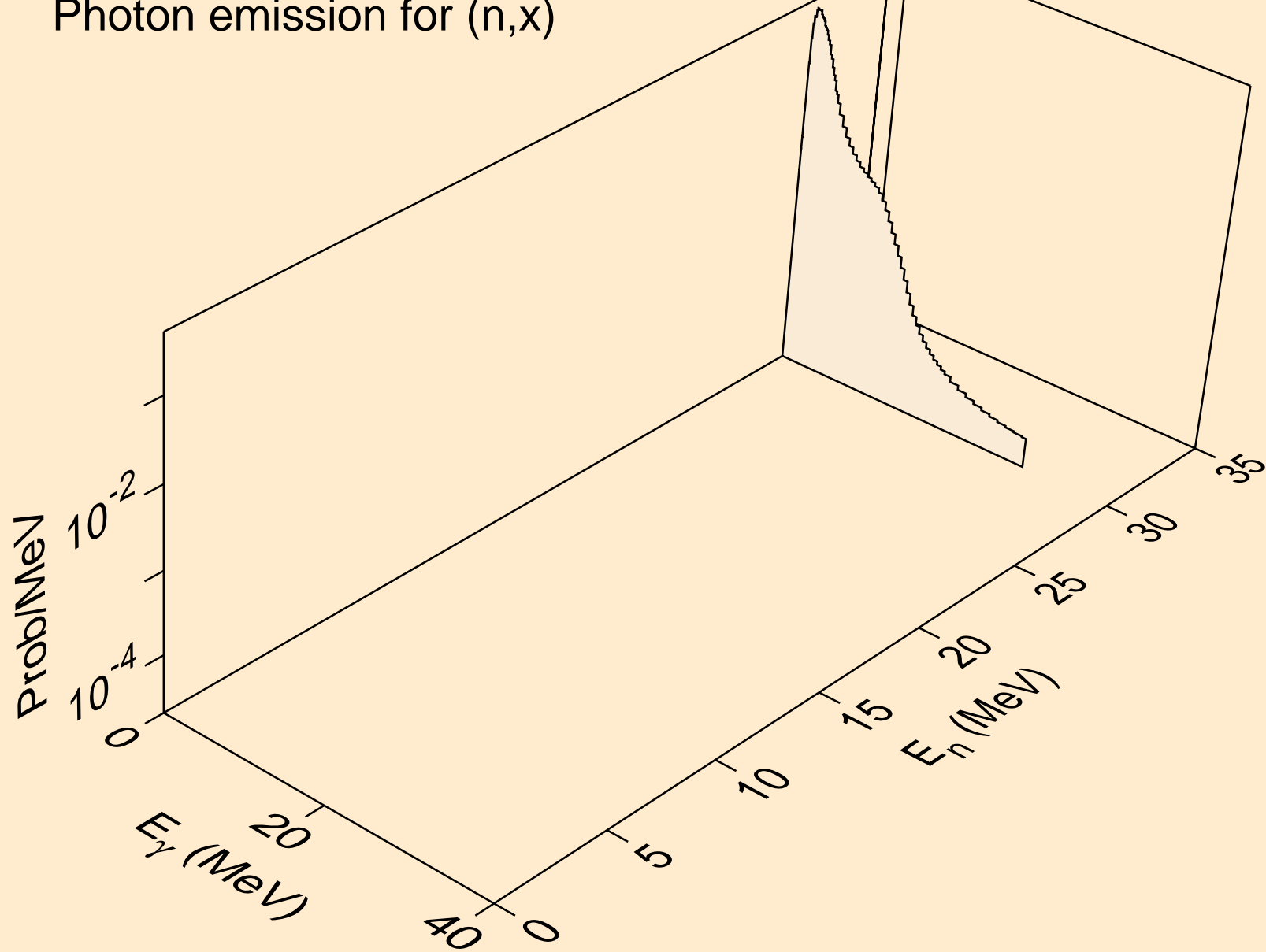

FM247M NEUTRON ACER TENDL-2021 LIBRARY; T=293.6K
Photon emission for (n,2nd)

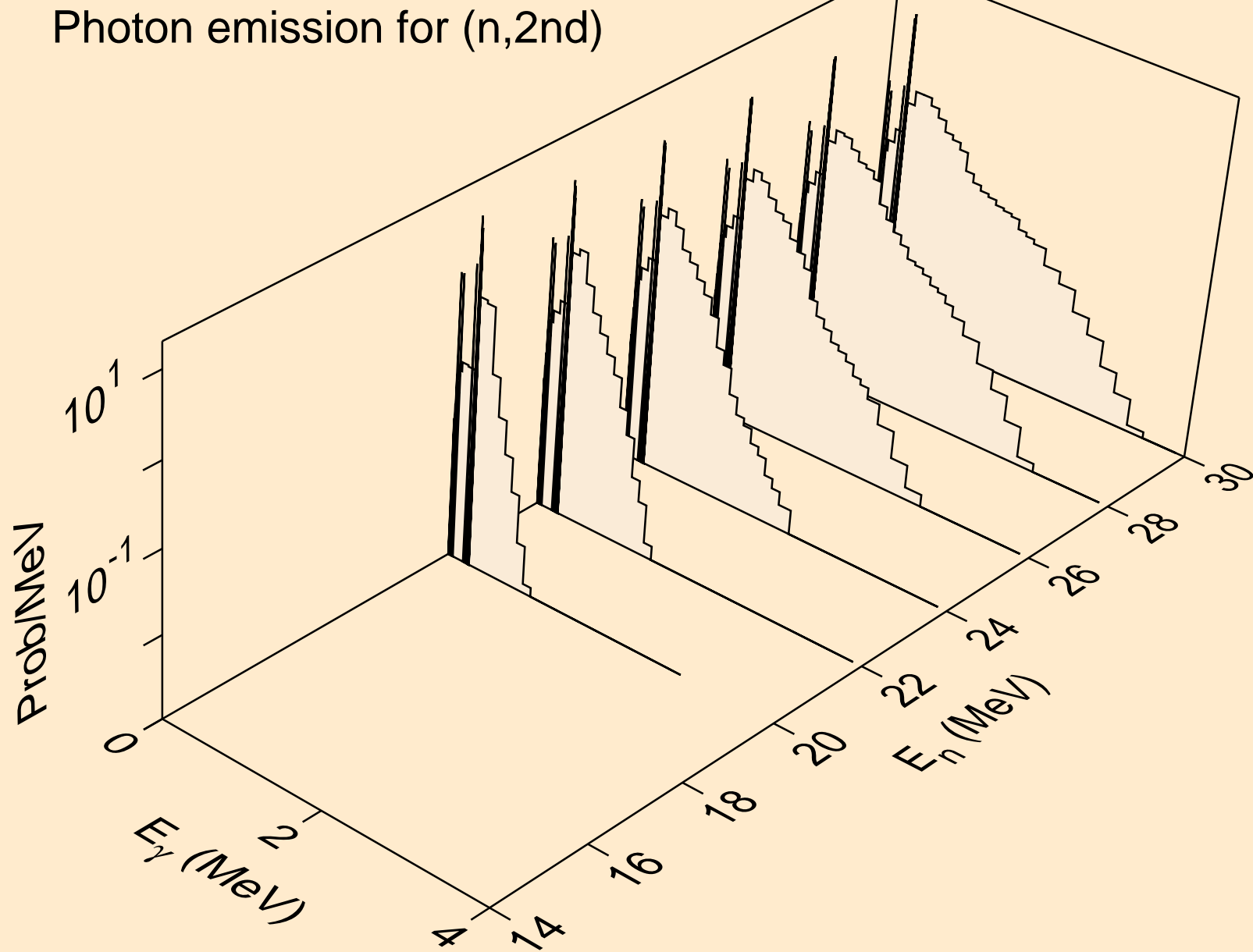

FM247M NEUTRON ACER TENDL-2021 LIBRARY; T=293.6K
Photon emission for (n,2n)

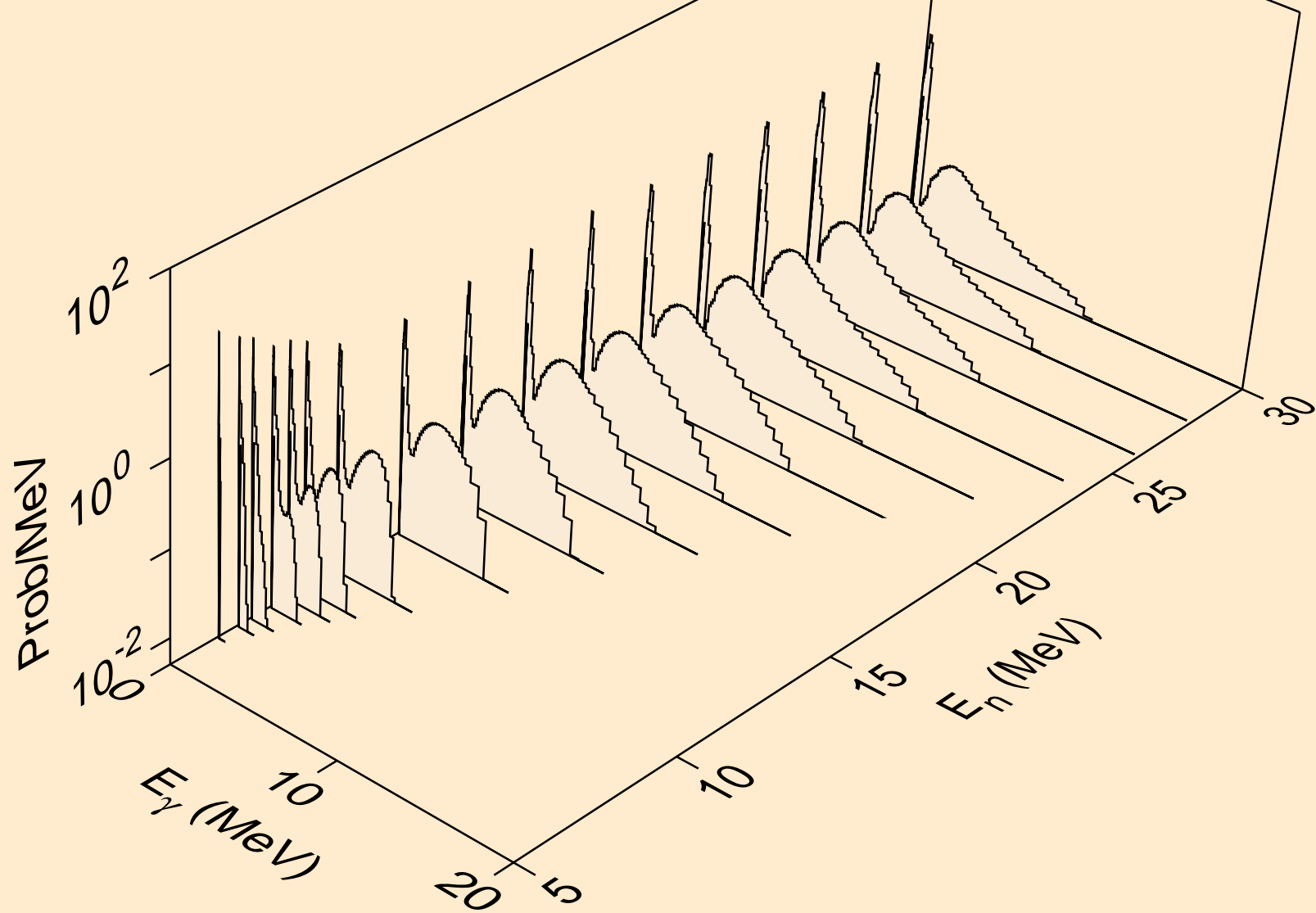

FM247M NEUTRON ACER TENDL-2021 LIBRARY; T=293.6K
Photon emission for (n,3n)

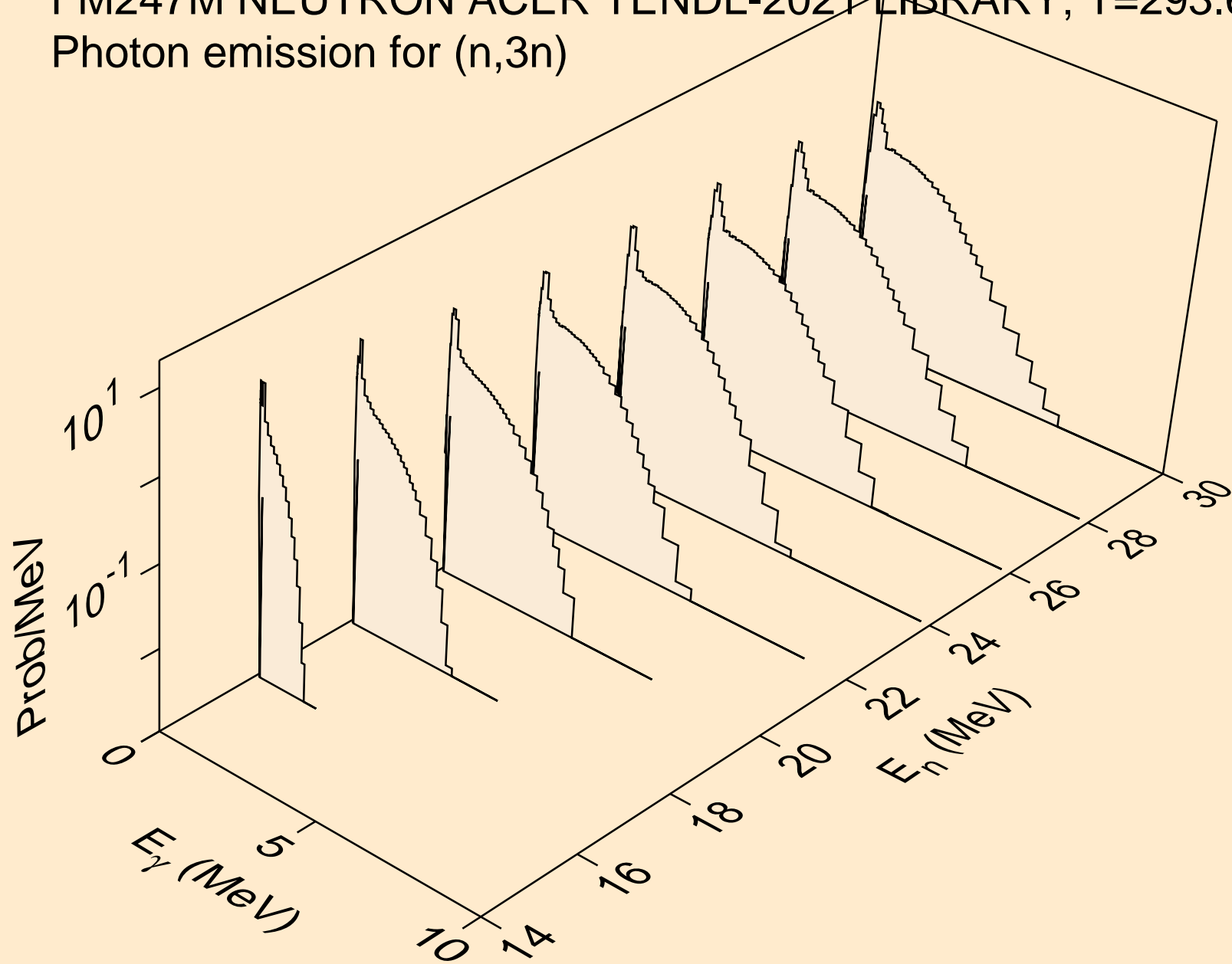

FM247M NEUTRON ACER TENDL-2021 LIBRARY; T=293.6K
Photon emission for (n,n*)a

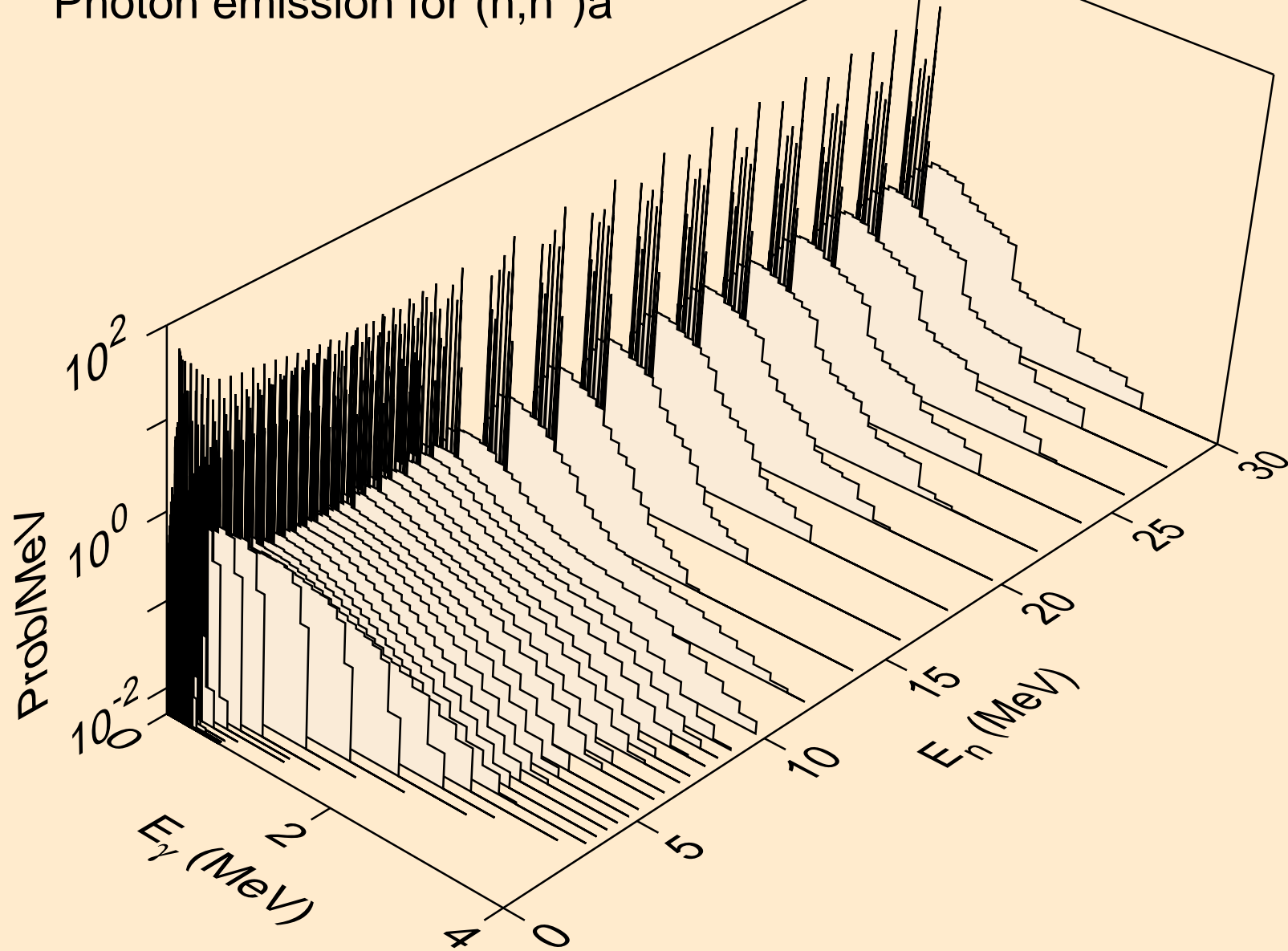

FM247M NEUTRON ACER TENDL-2021 LIBRARY; T=293.6K
Photon emission for (n,2n)a

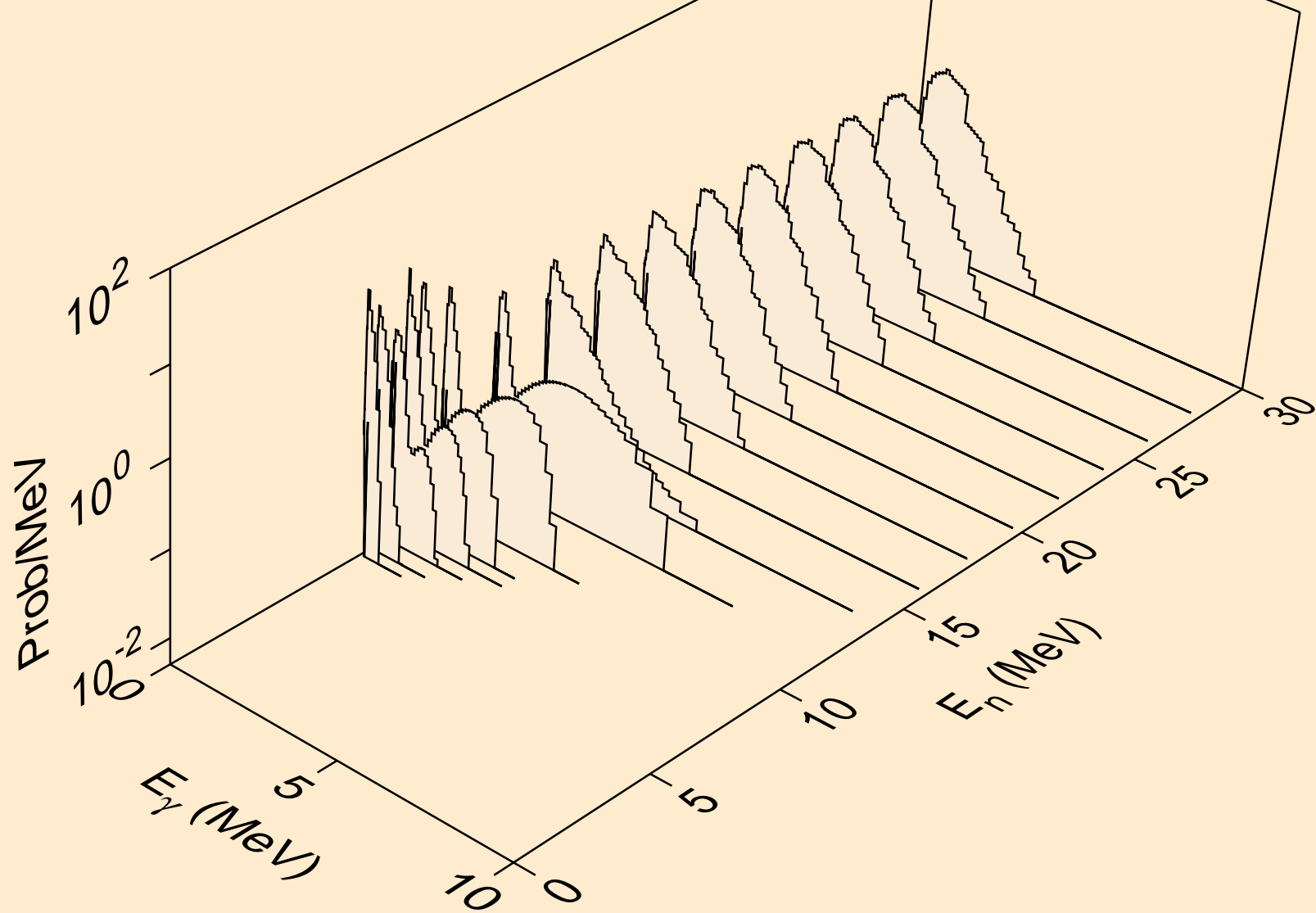

FM247M NEUTRON ACER TENDL-2021 LIBRARY; T=293.6K
Photon emission for (n,3n)a

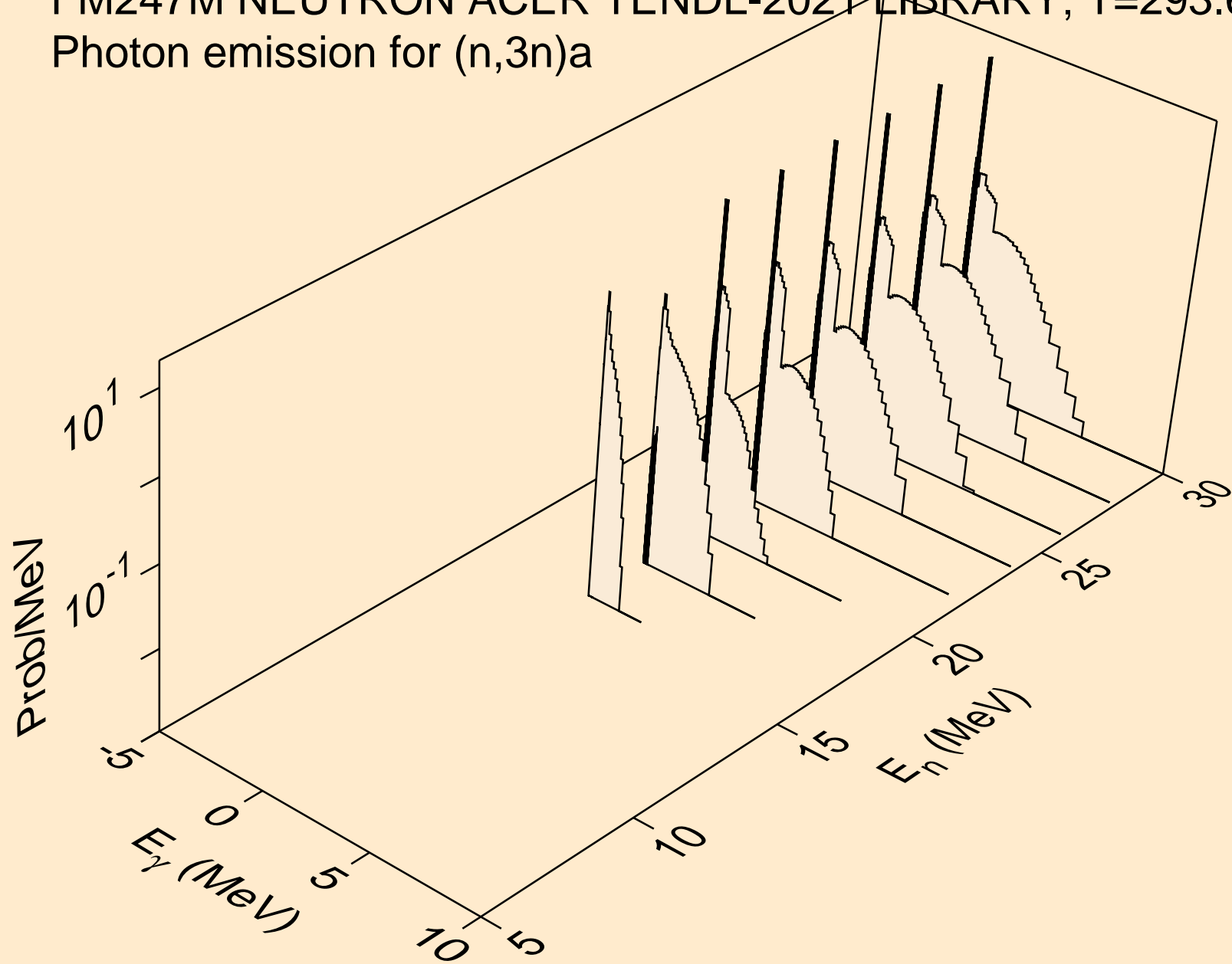

FM247M NEUTRON ACER TENDL-2021 LIBRARY; T=293.6K
Photon emission for (n,n*)p

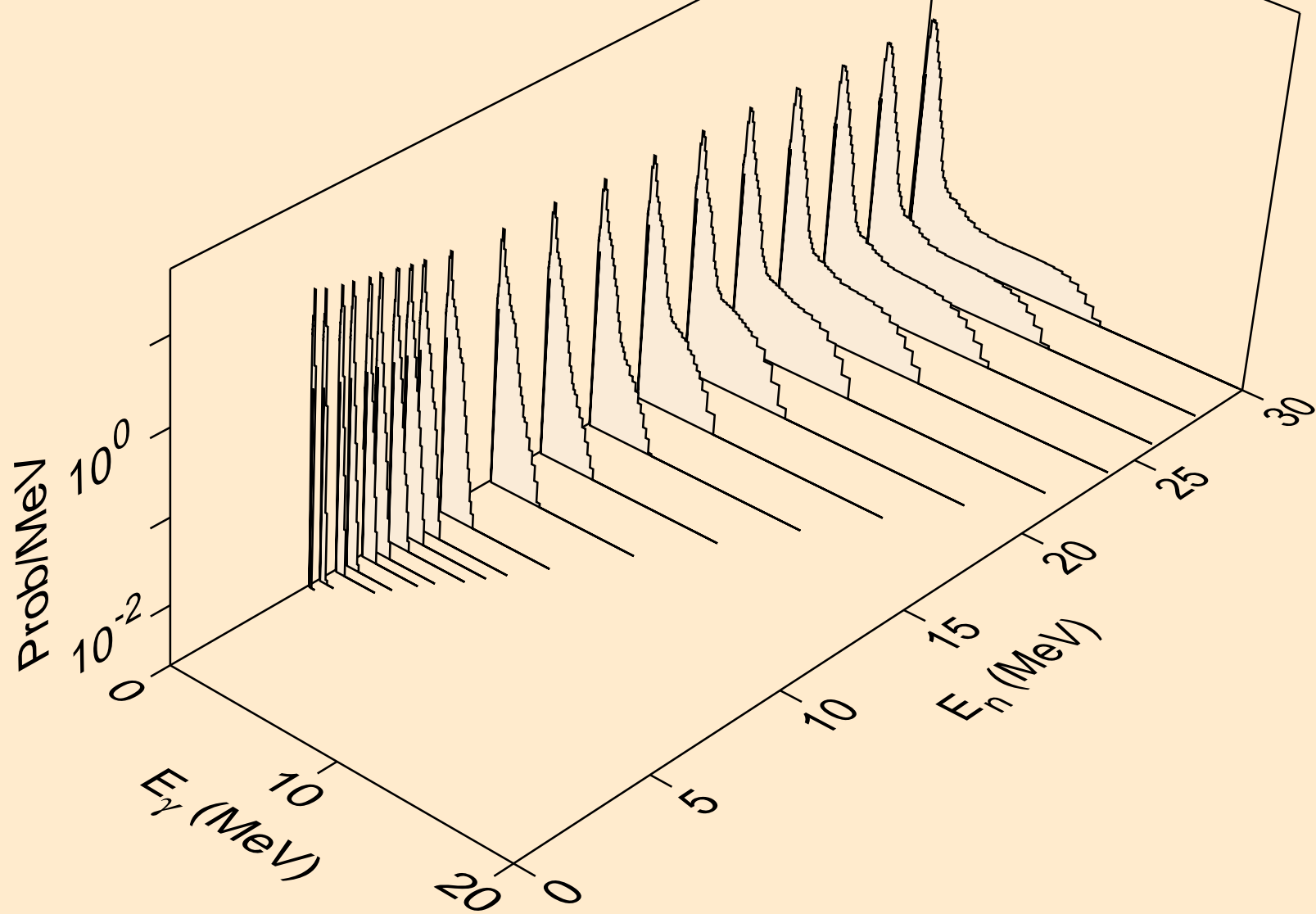

FM247M NEUTRON ACER TENDL-2021 LIBRARY; T=293.6K
Photon emission for (n,n*)d

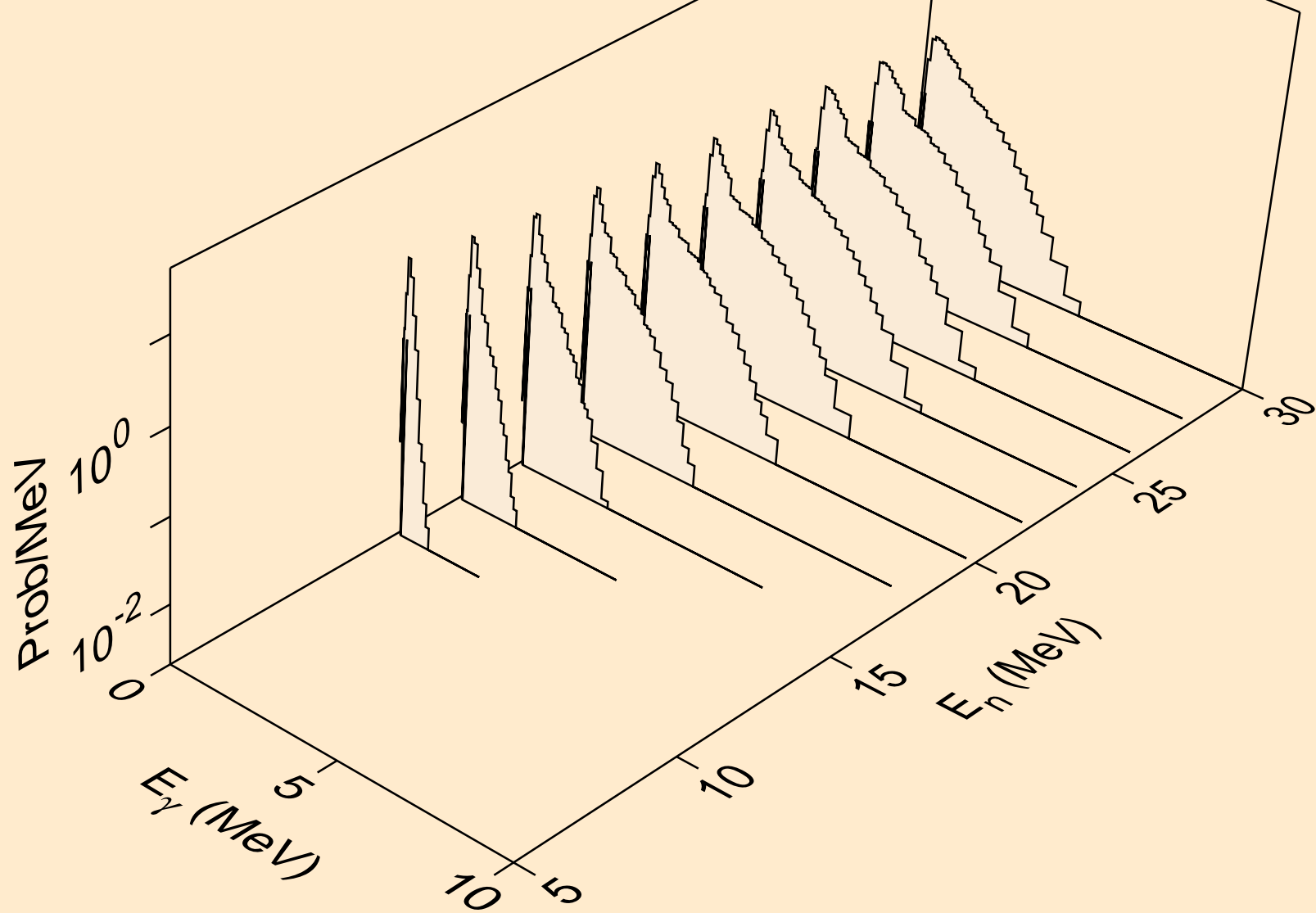

FM247M NEUTRON ACER TENDL-2021 LIBRARY; T=293.6K
Photon emission for (n,n*)t

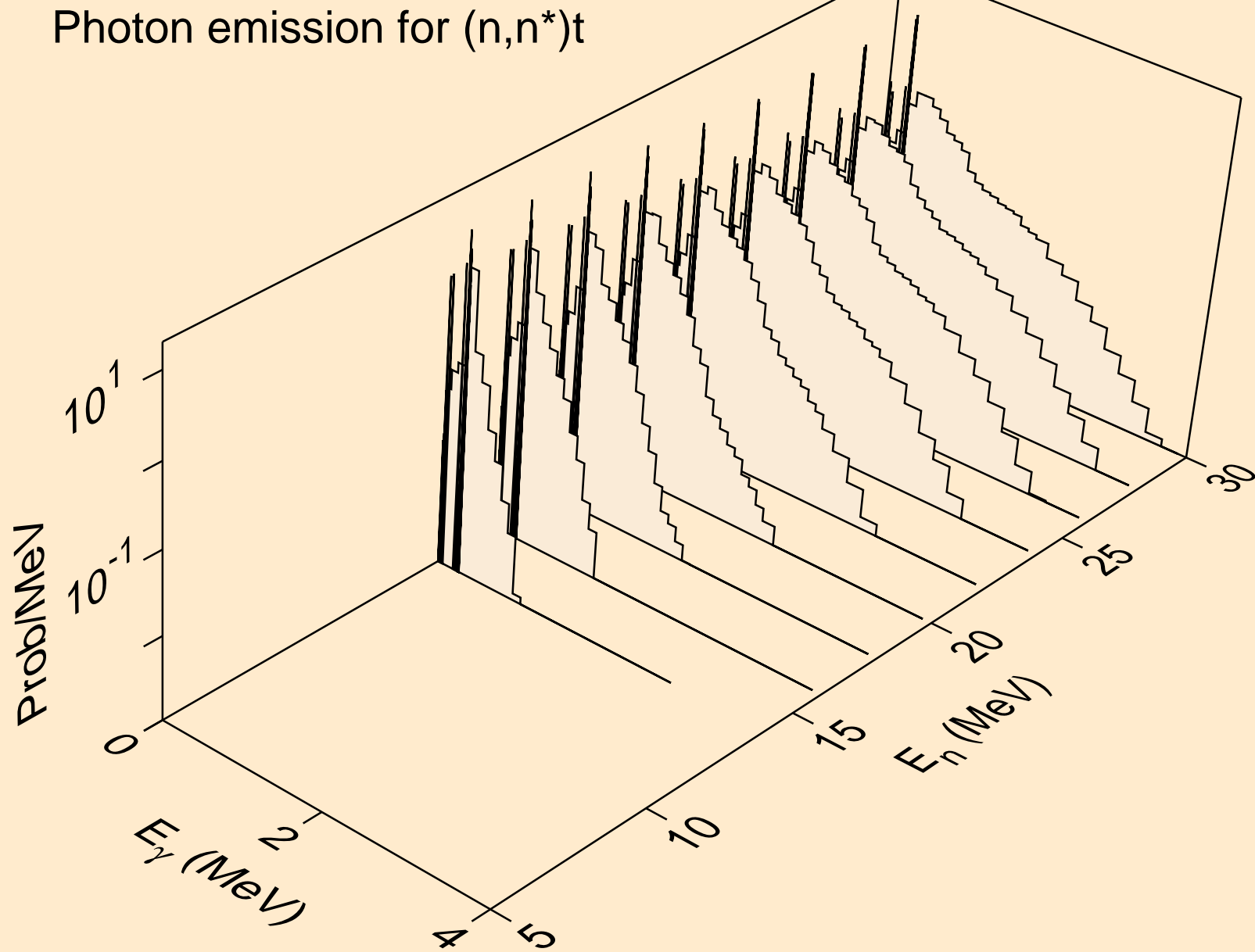

FM247M NEUTRON ACER TENDL-2021 LIBRARY; T=293.6K
Photon emission for (n,n*)he3

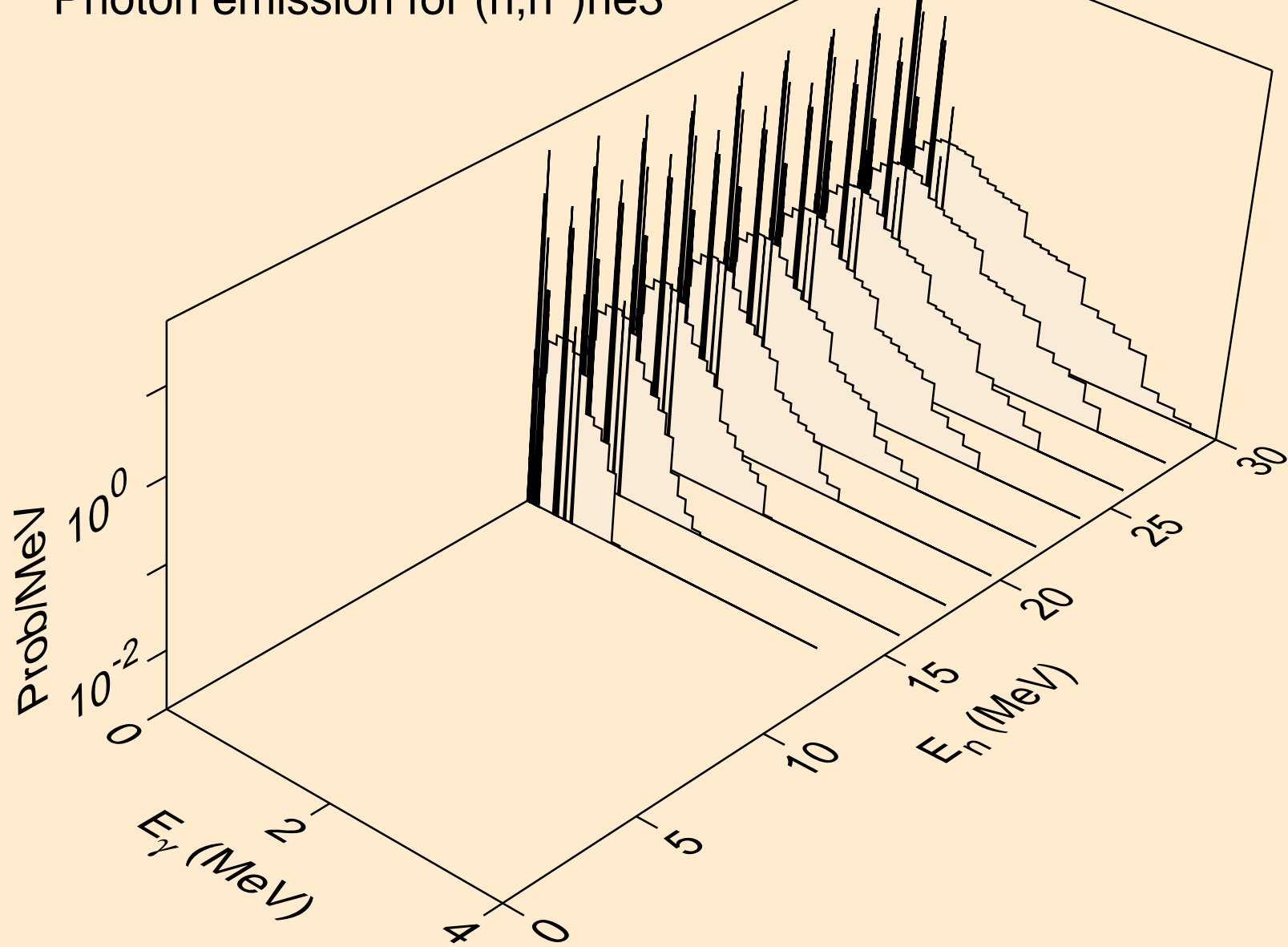

FM247M NEUTRON ACER TENDL-2021 LIBRARY; T=293.6K
Photon emission for (n,4n)

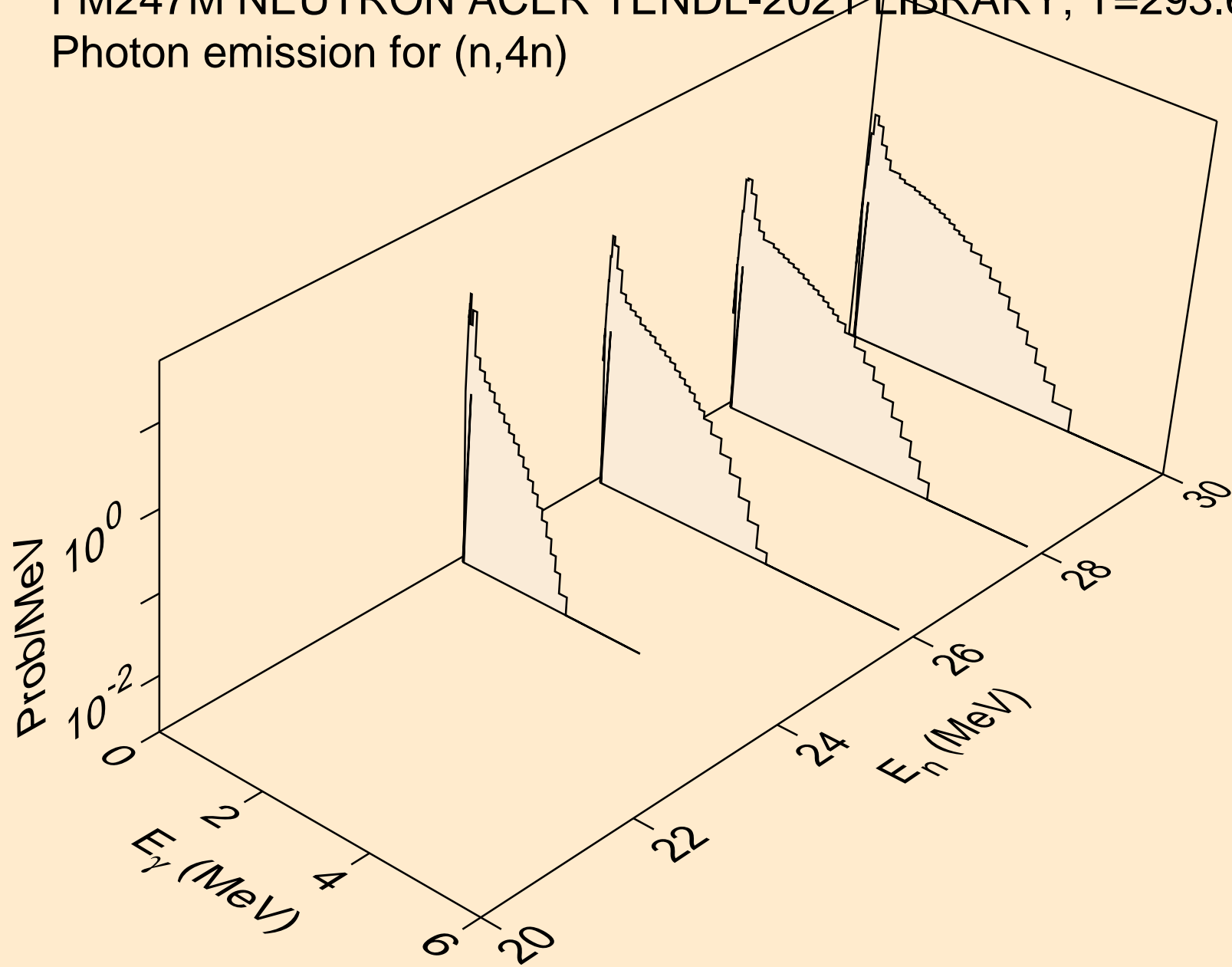

FM247M NEUTRON ACER TENDL-2021 LIBRARY; T=293.6K
Photon emission for (n,2np)

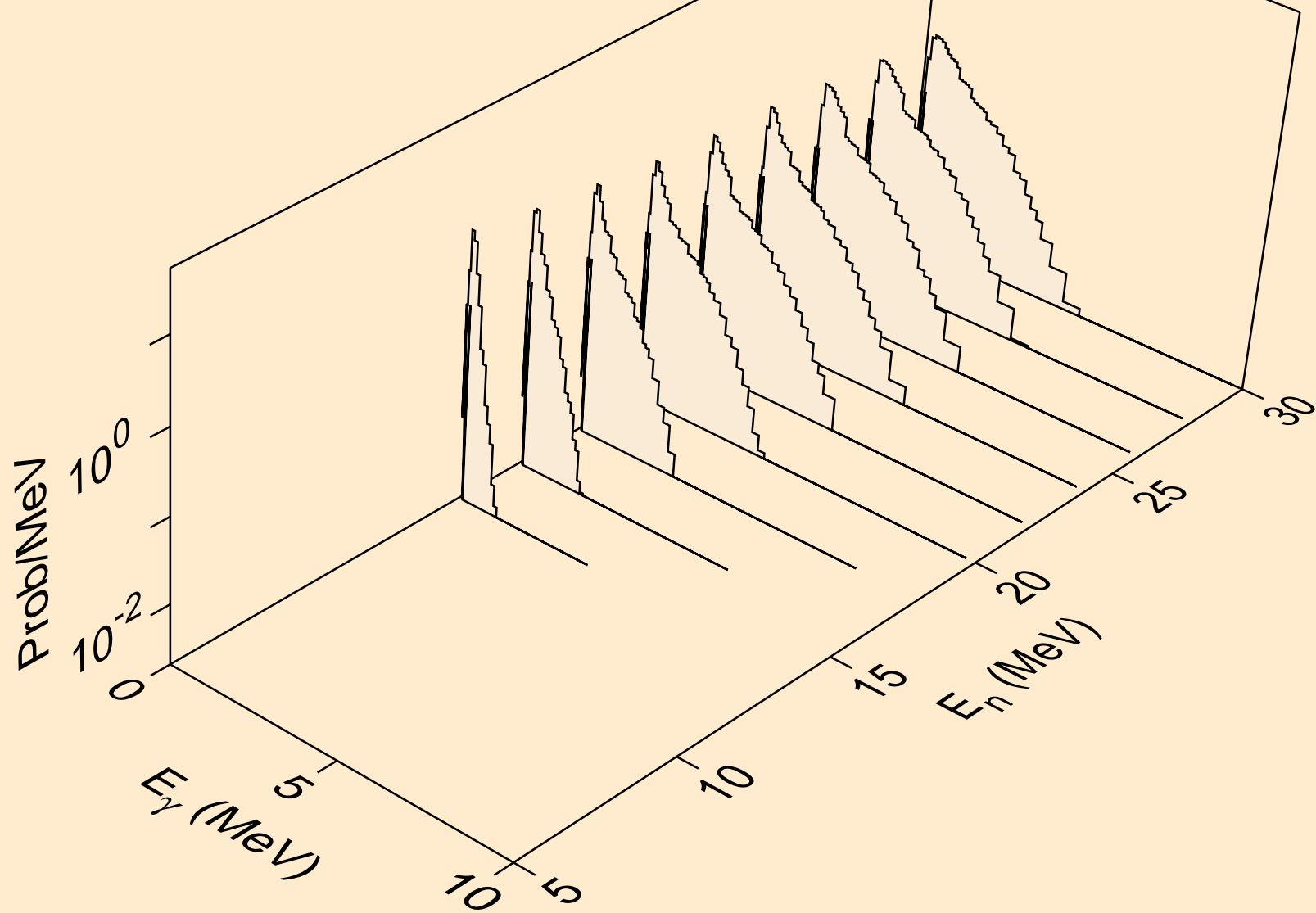

FM247M NEUTRON ACER TENDL-2021 LIBRARY; T=293.6K
Photon emission for (n,3np)

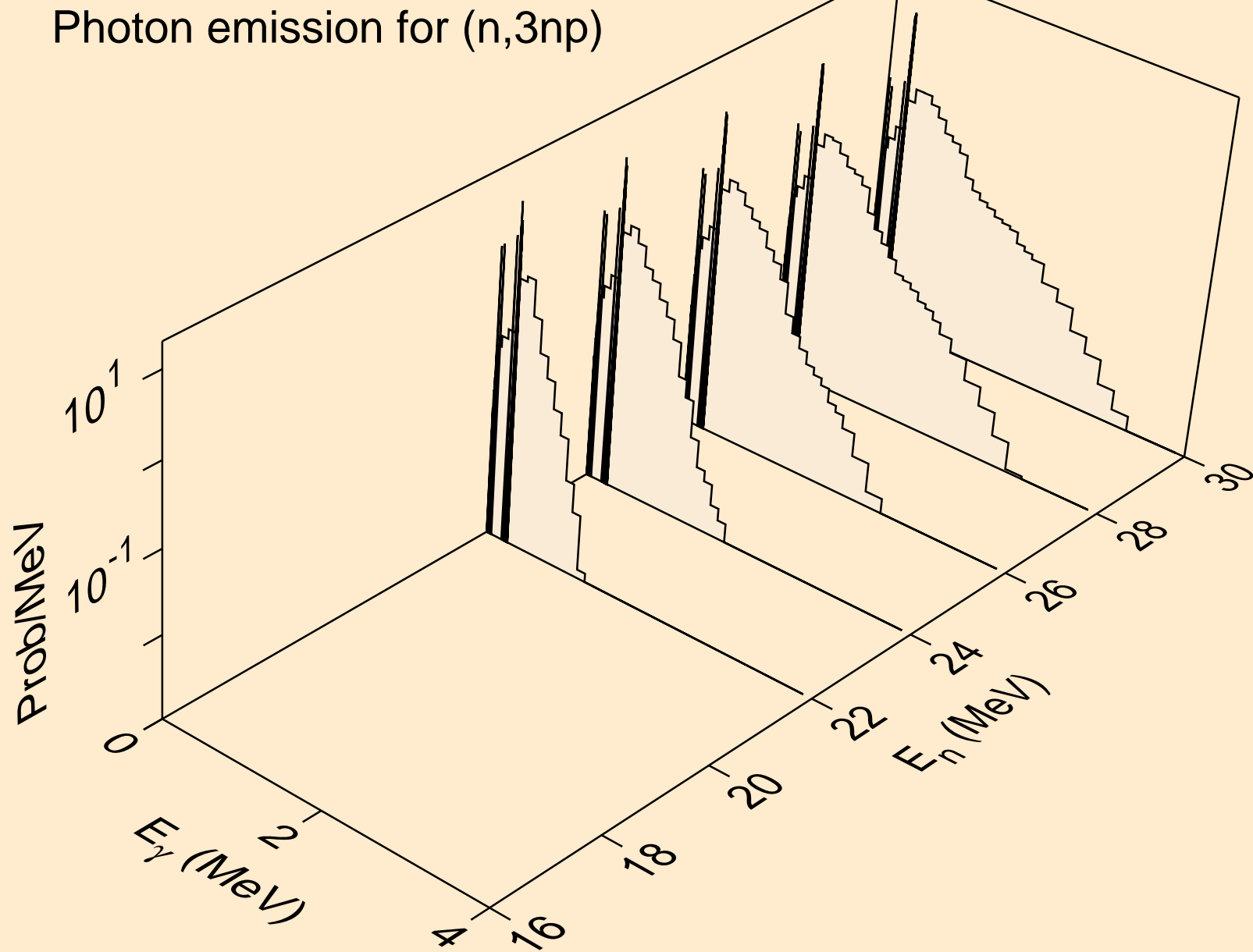

FM247M NEUTRON ACER TENDL-2021 LIBRARY; T=293.6K
Photon emission for (n,2np)

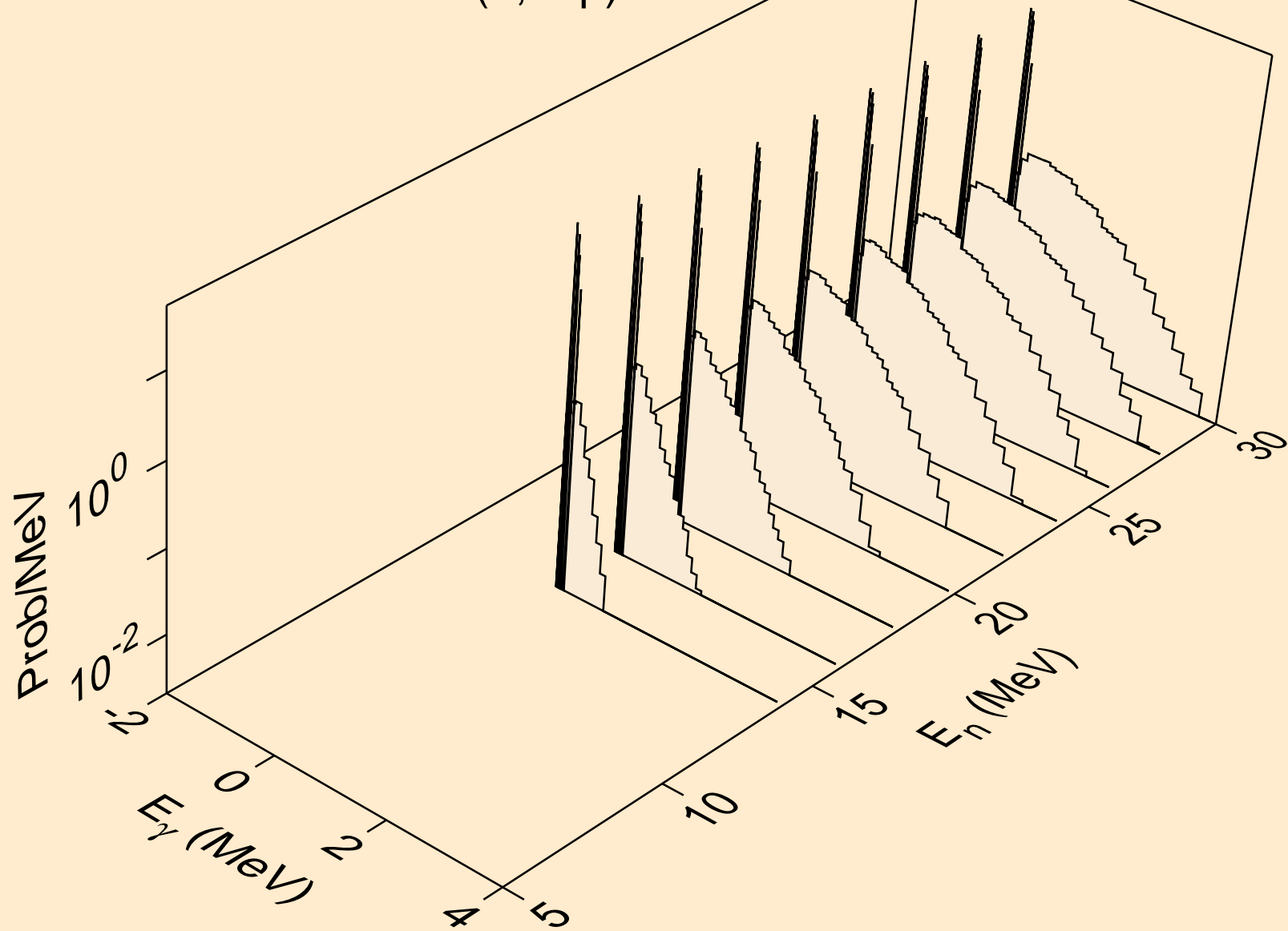

FM247M NEUTRON ACER TENDL-2021 LIBRARY; T=293.6K
Photon emission for (n,npa)

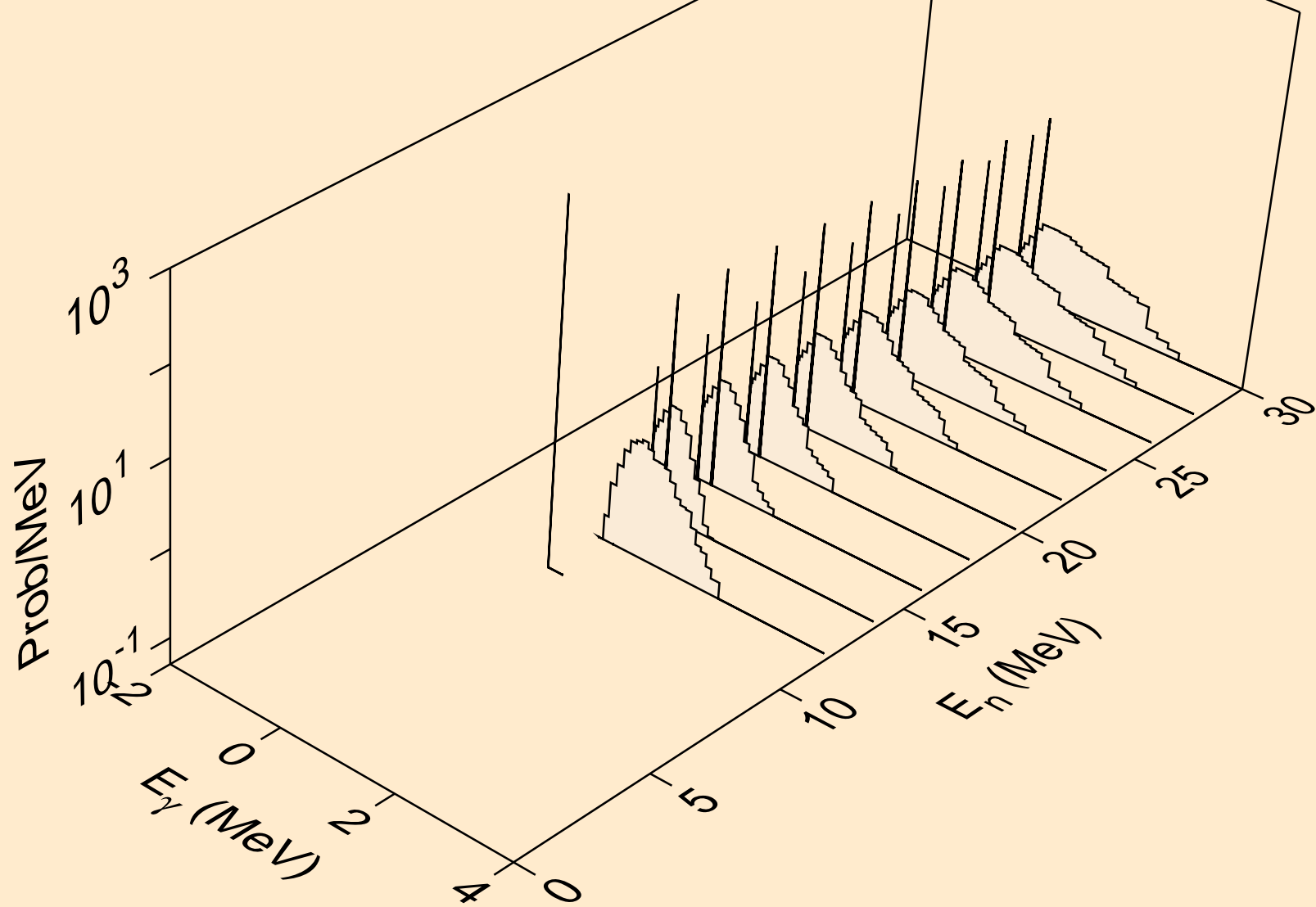

FM247M NEUTRON ACER TENDL-2021 LIBRARY; T=293.6K
Photon emission for (n,n*2)

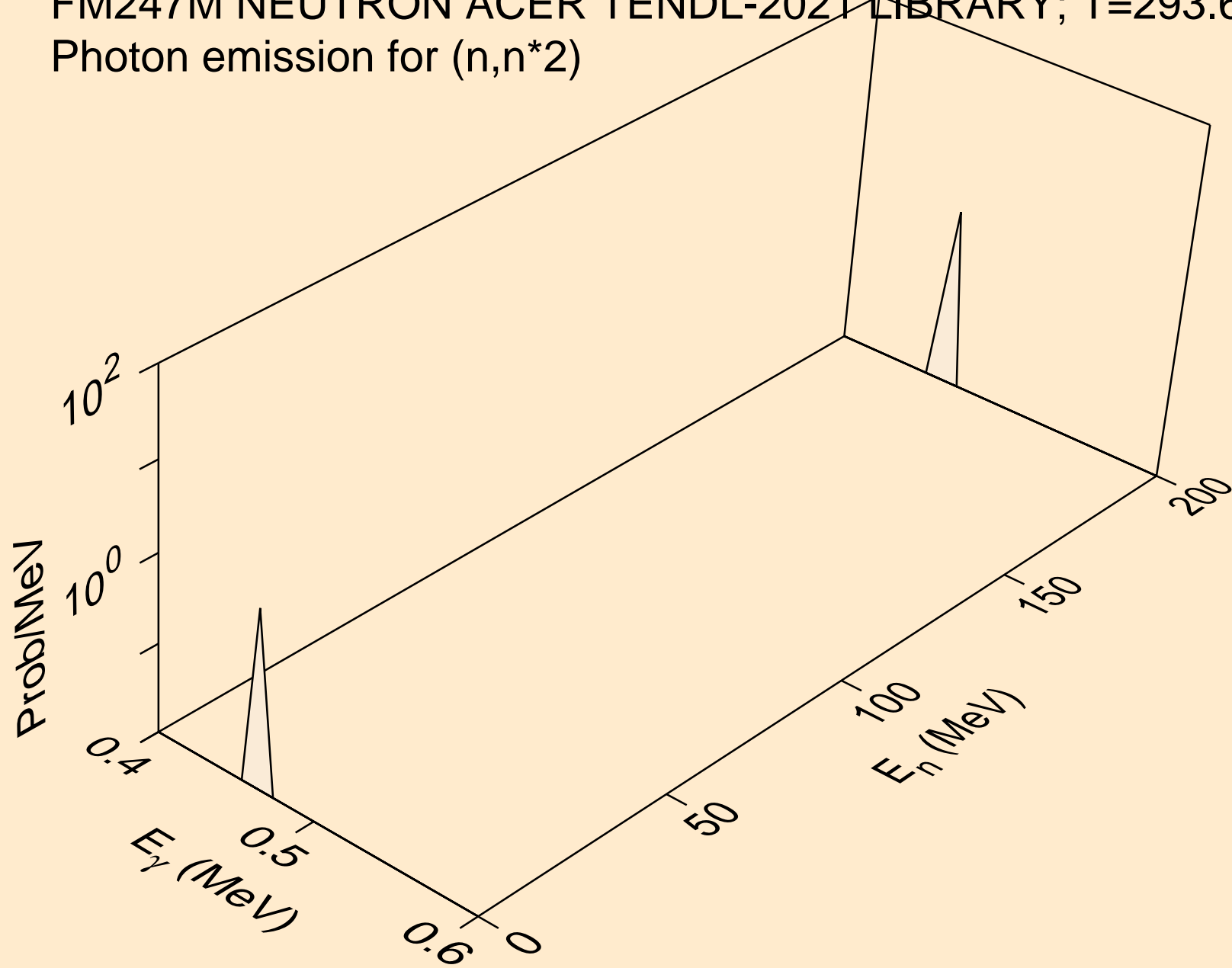

FM247M NEUTRON ACER TENDL-2021 LIBRARY; T=293.6K
Photon emission for (n,n*3)

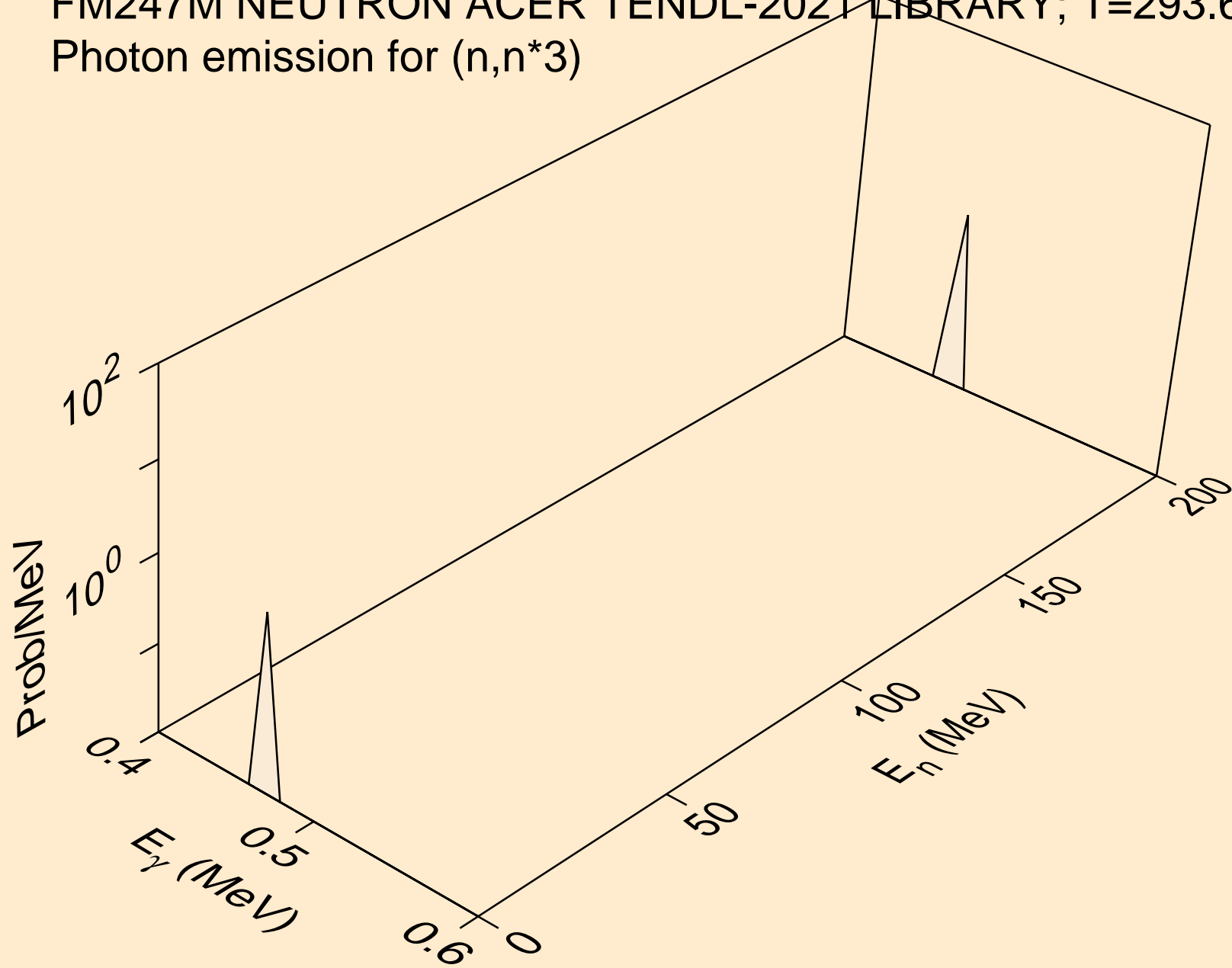

FM247M NEUTRON ACER TENDL-2021 LIBRARY; T=293.6K
Photon emission for (n,n*4)

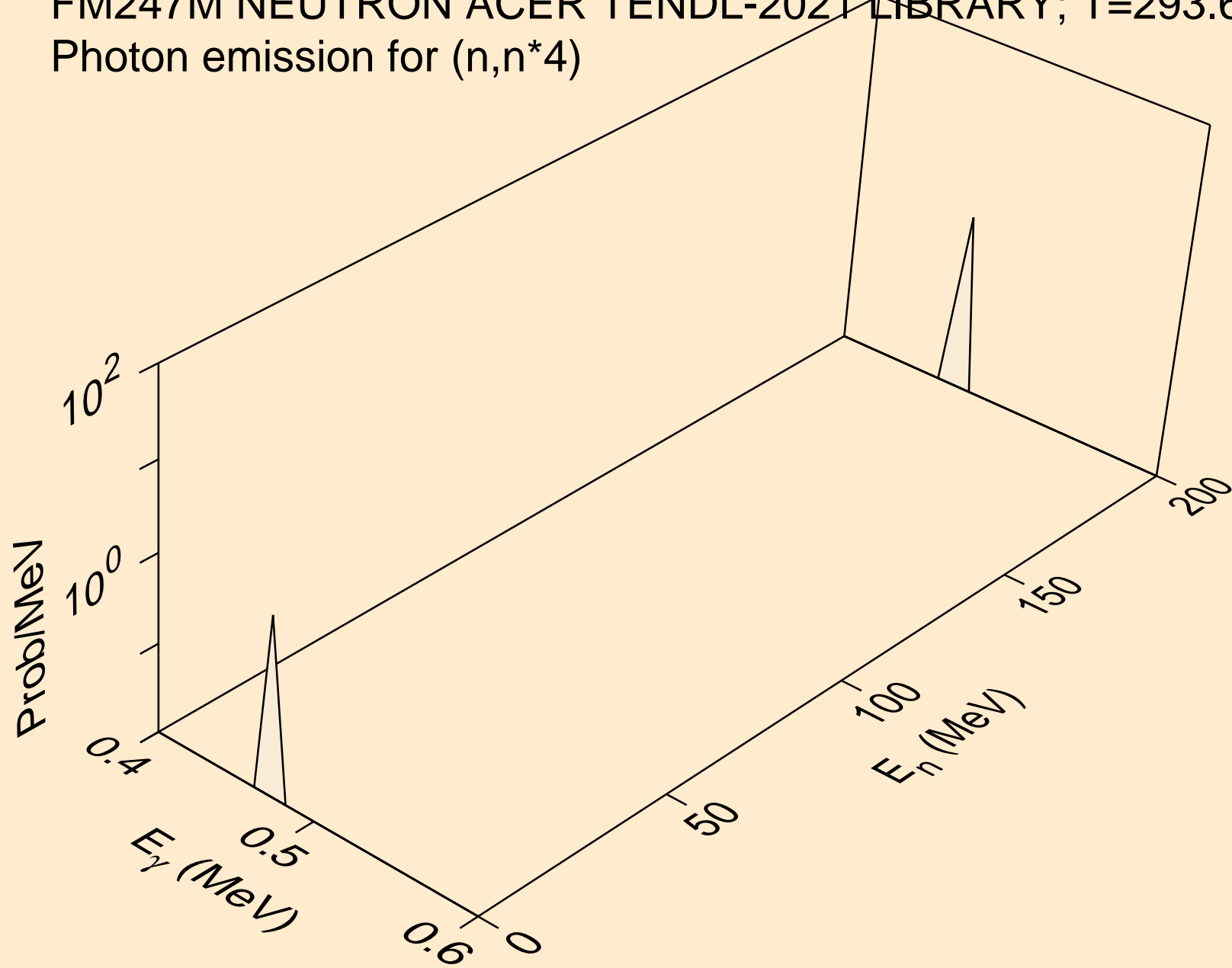

FM247M NEUTRON ACER TENDL-2021 LIBRARY; T=293.6K
Photon emission for (n,n*5)

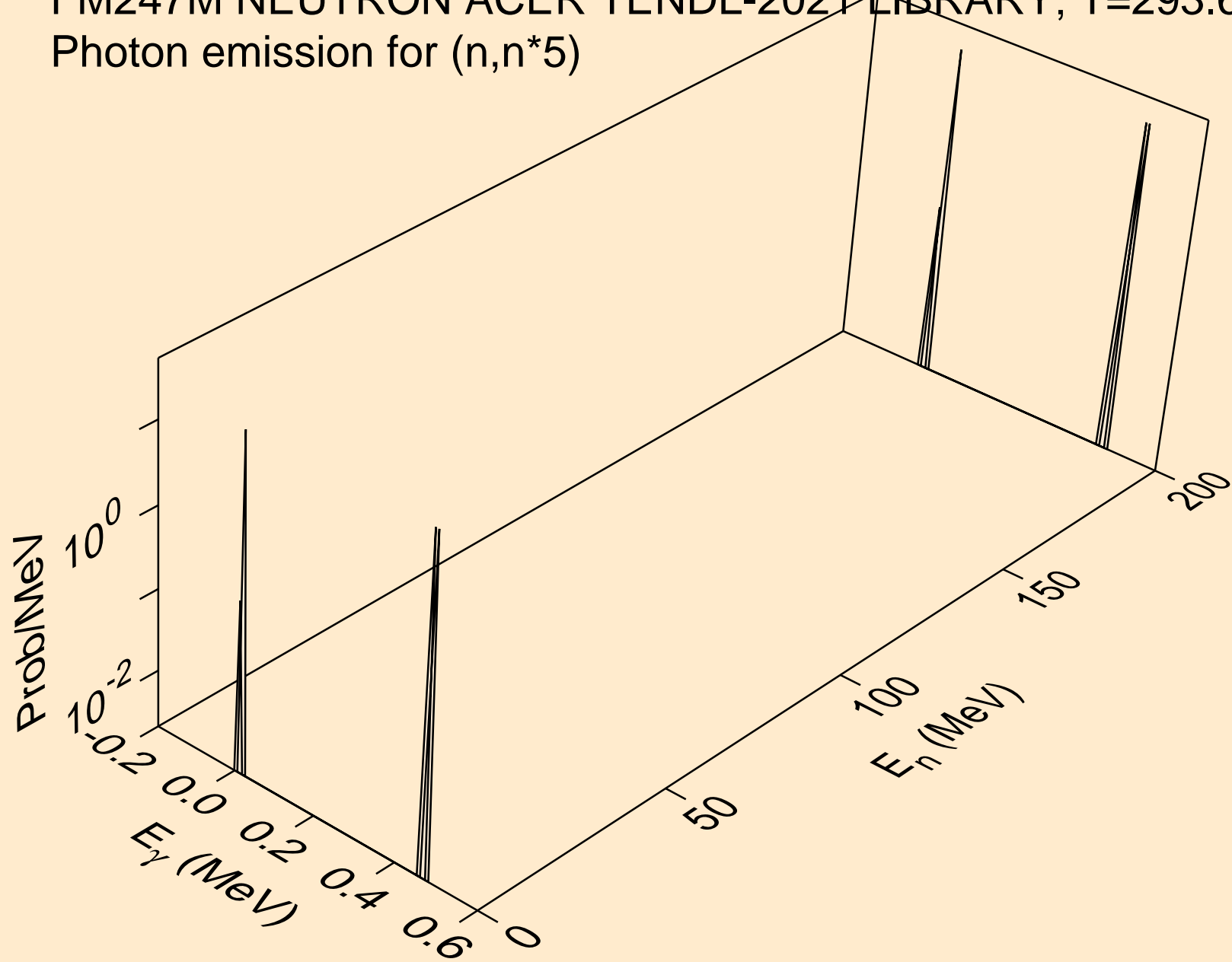

FM247M NEUTRON ACER TENDL-2021 LIBRARY; T=293.6K
Photon emission for (n,n*6)

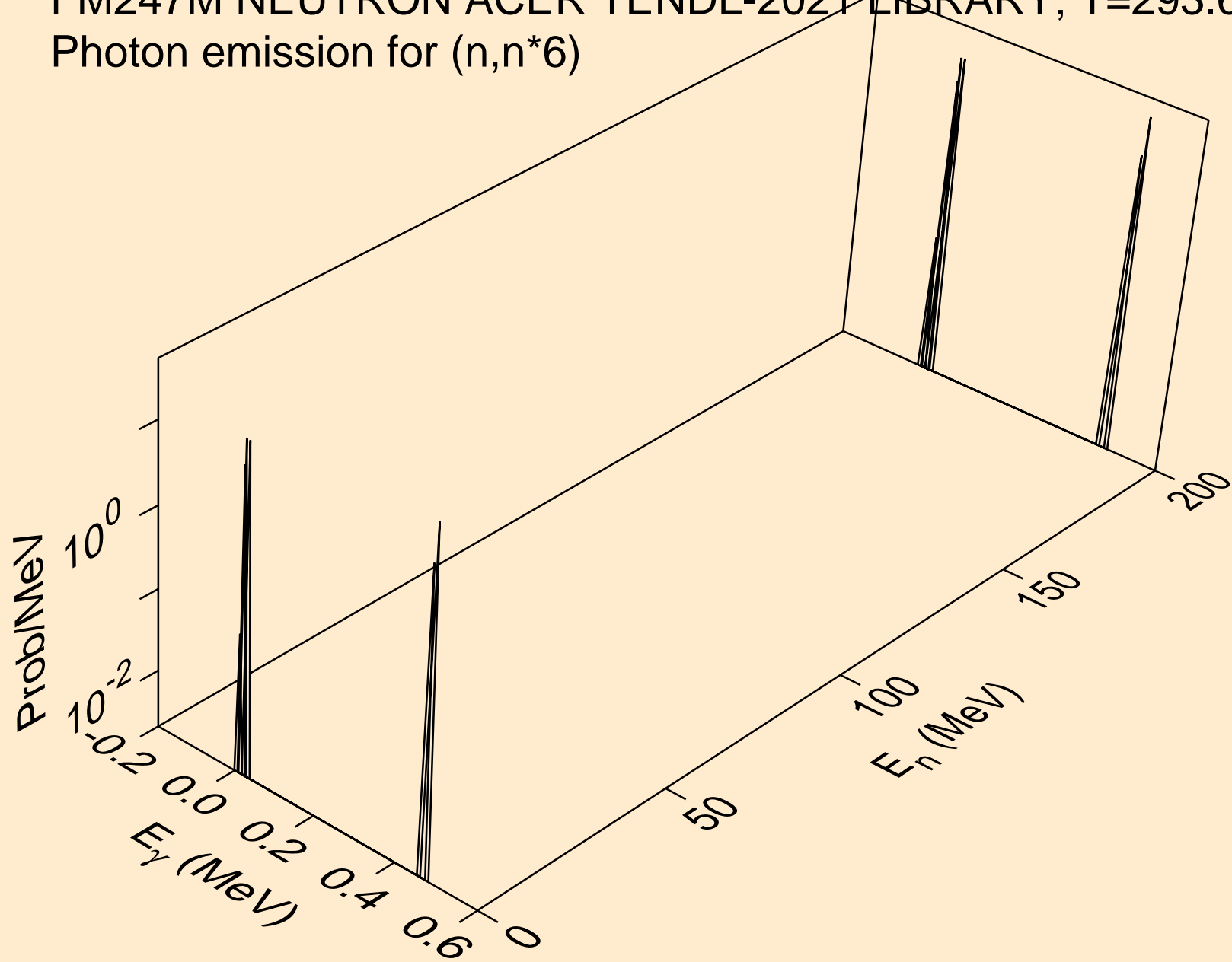

FM247M NEUTRON ACER TENDL-2021 LIBRARY; T=293.6K
Photon emission for (n,n*7)

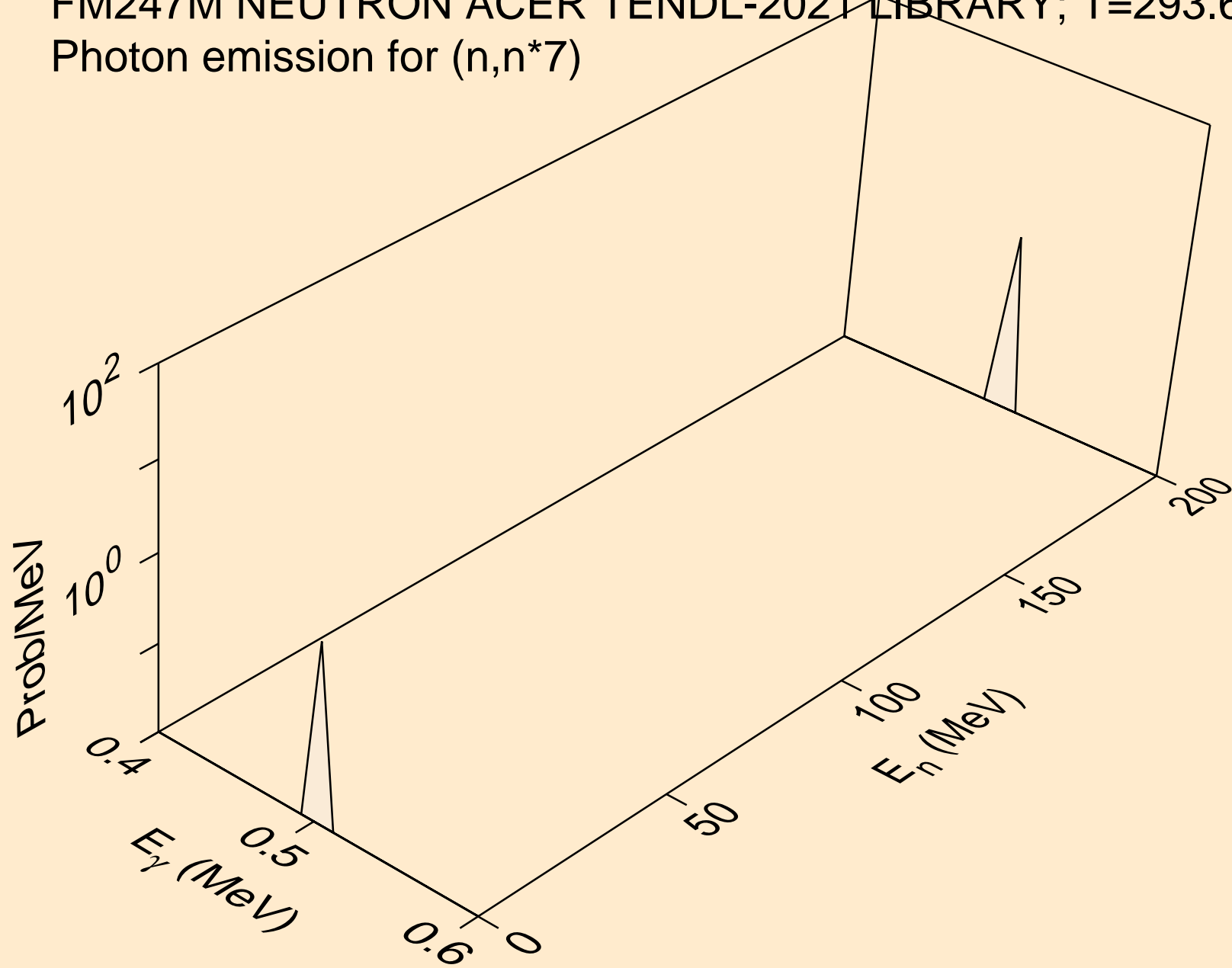

FM247M NEUTRON ACER TENDL-2021 LIBRARY; T=293.6K
Photon emission for (n,n*8)

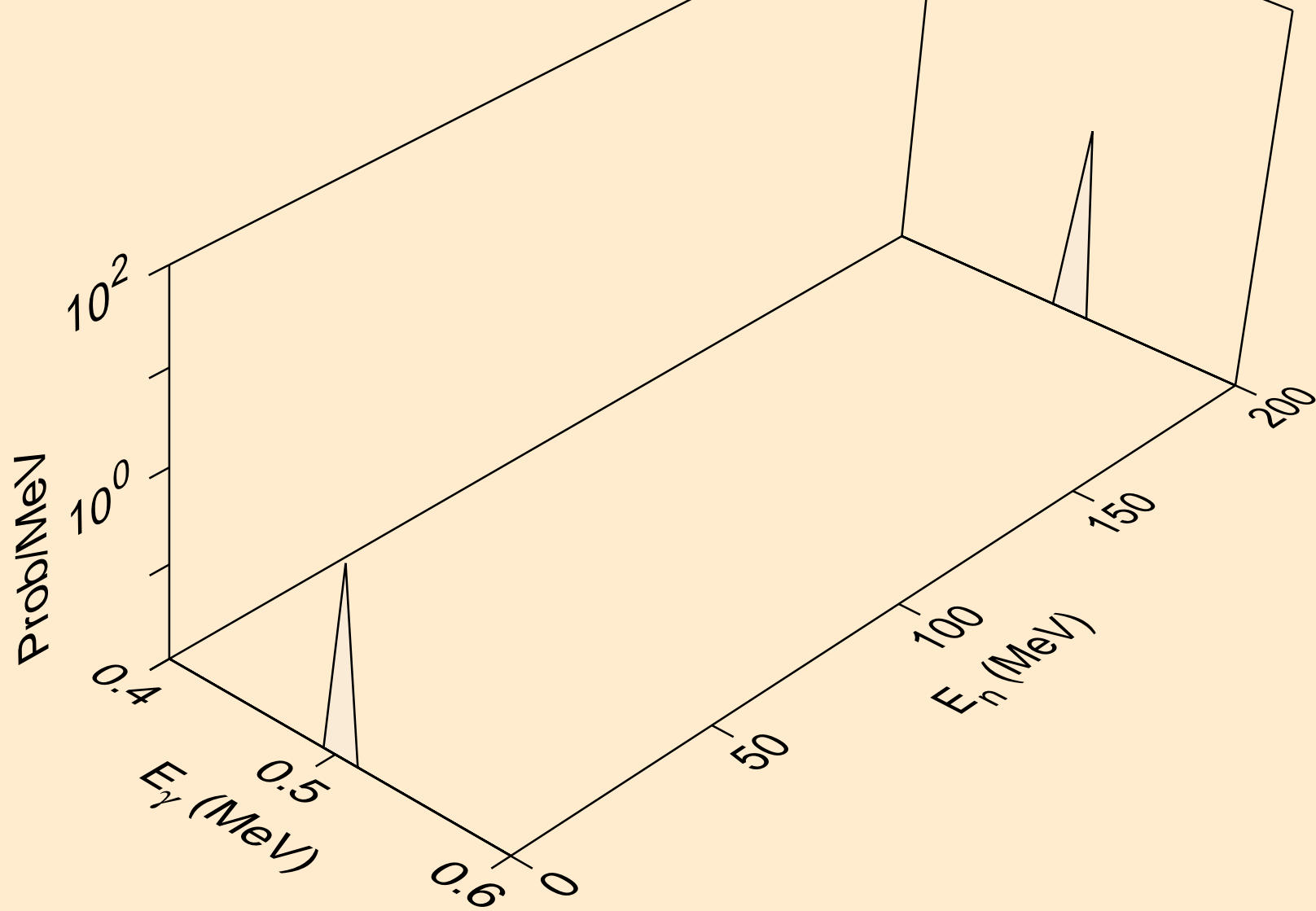

FM247M NEUTRON ACER TENDL-2021 LIBRARY; T=293.6K
Photon emission for (n,n*9)

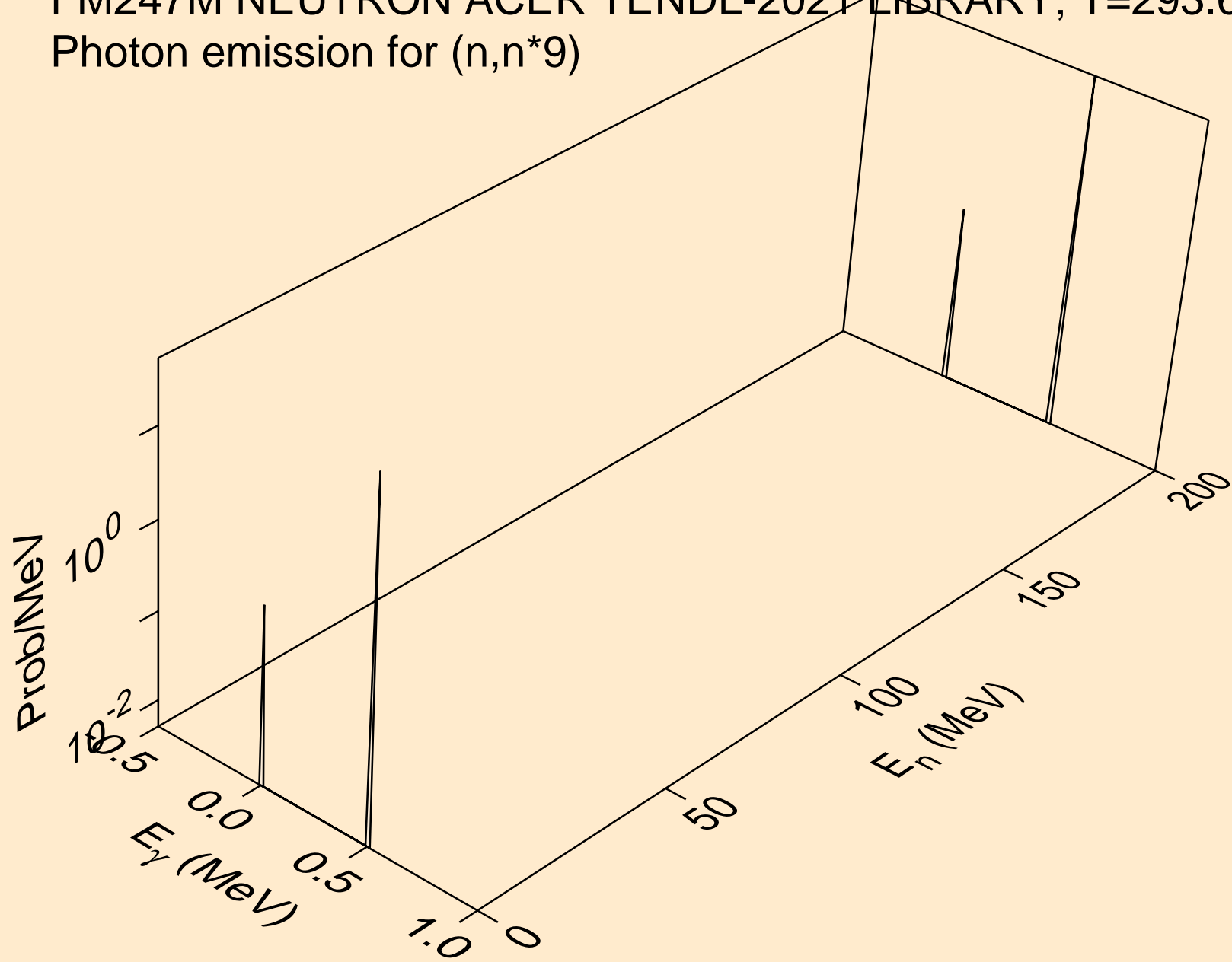

FM247M NEUTRON ACER TENDL-2021 LIBRARY; T=293.6K
Photon emission for (n,n*10)

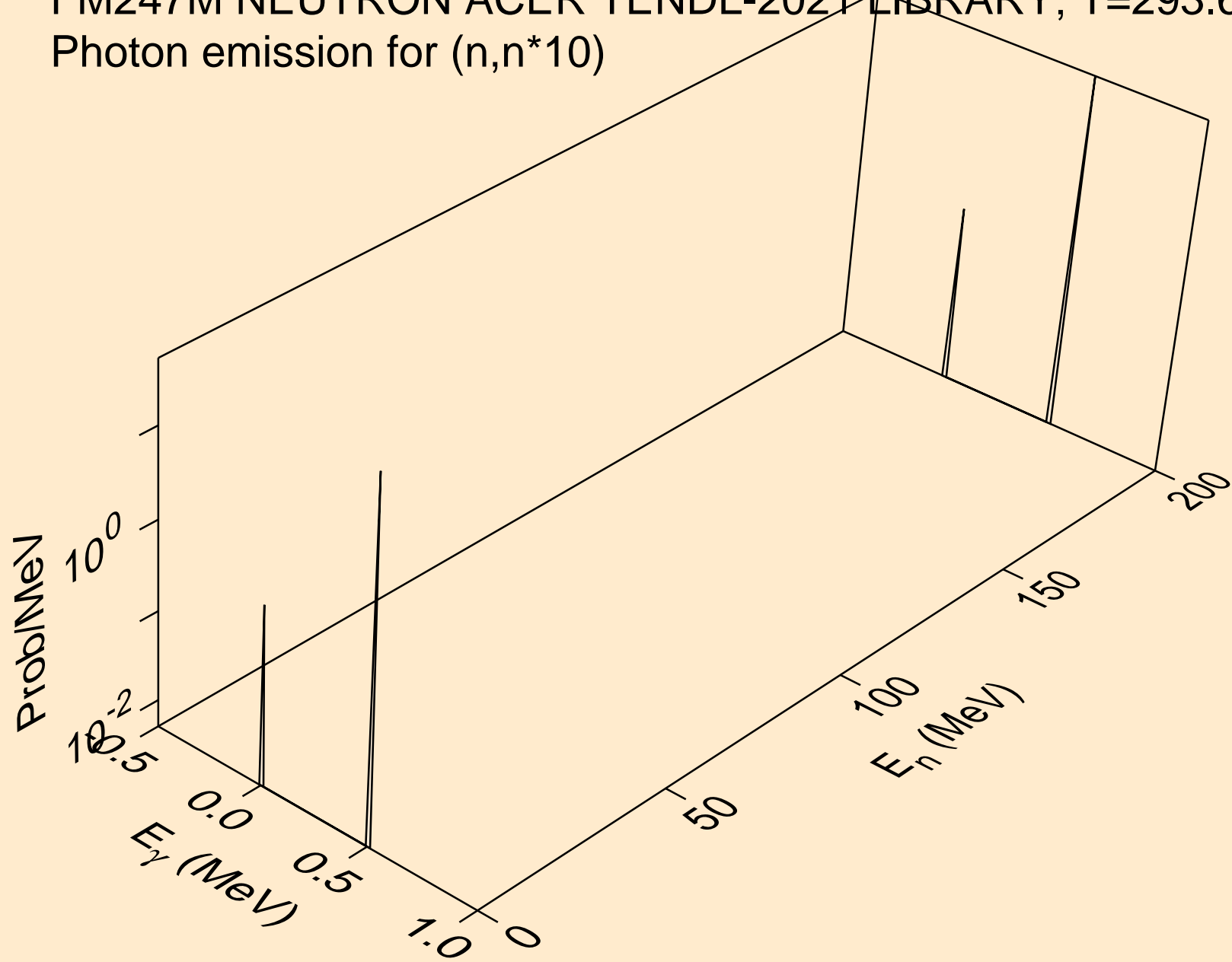

FM247M NEUTRON ACER TENDL-2021 LIBRARY; T=293.6K
Photon emission for (n,n*11)

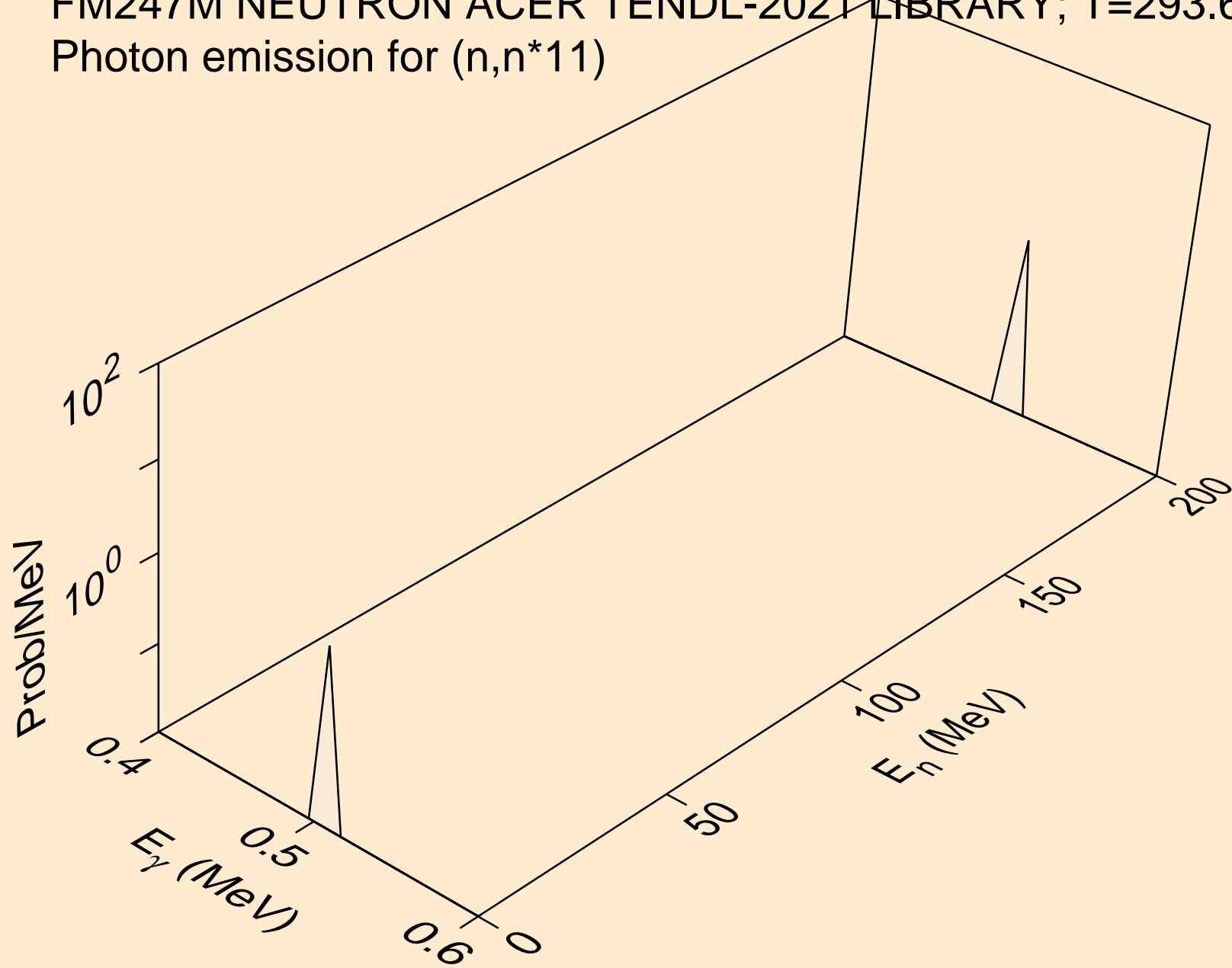

FM247M NEUTRON ACER TENDL-2021 LIBRARY; T=293.6K
Photon emission for (n,n*12)

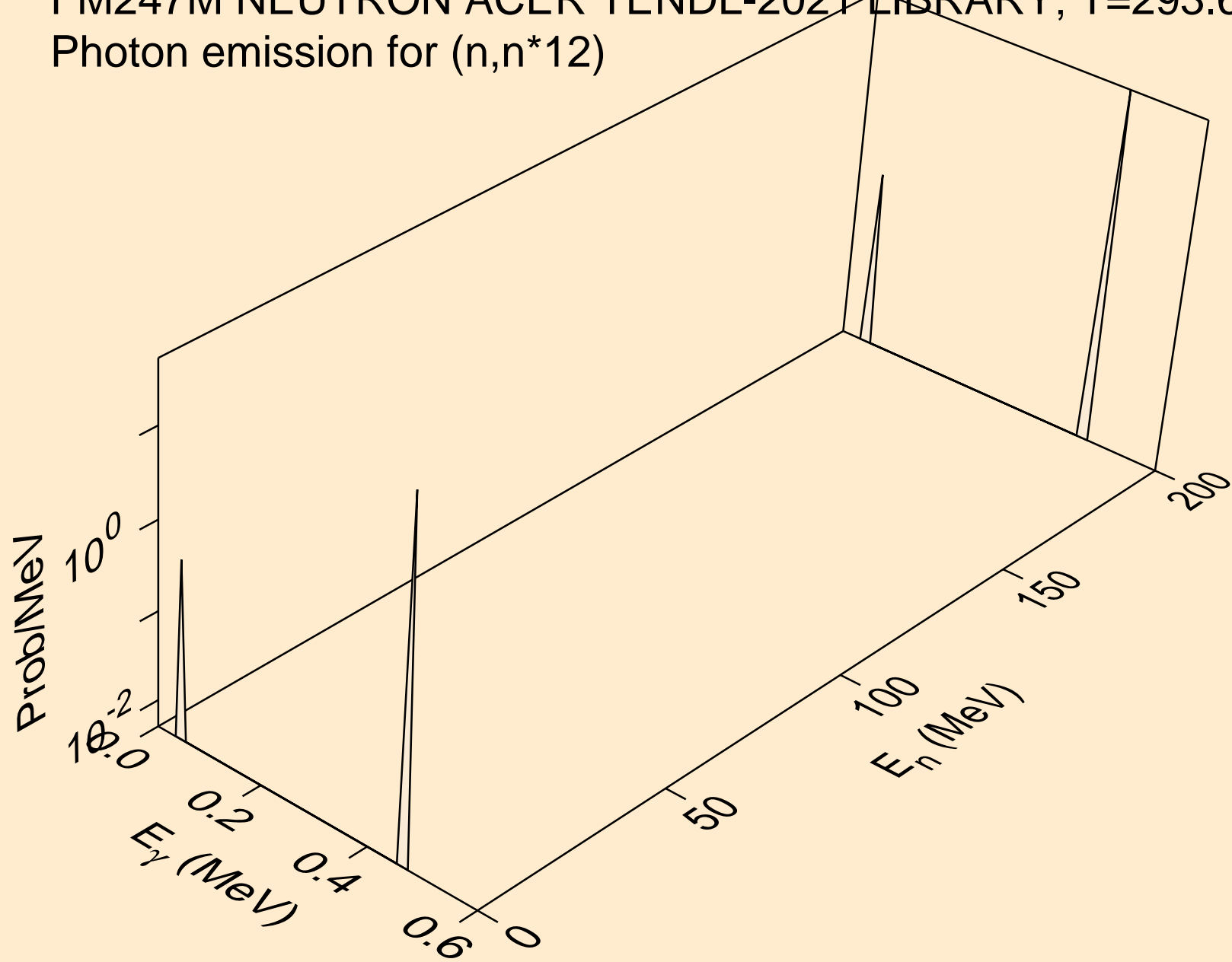

FM247M NEUTRON ACER TENDL-2021 LIBRARY; T=293.6K
Photon emission for (n,n*13)

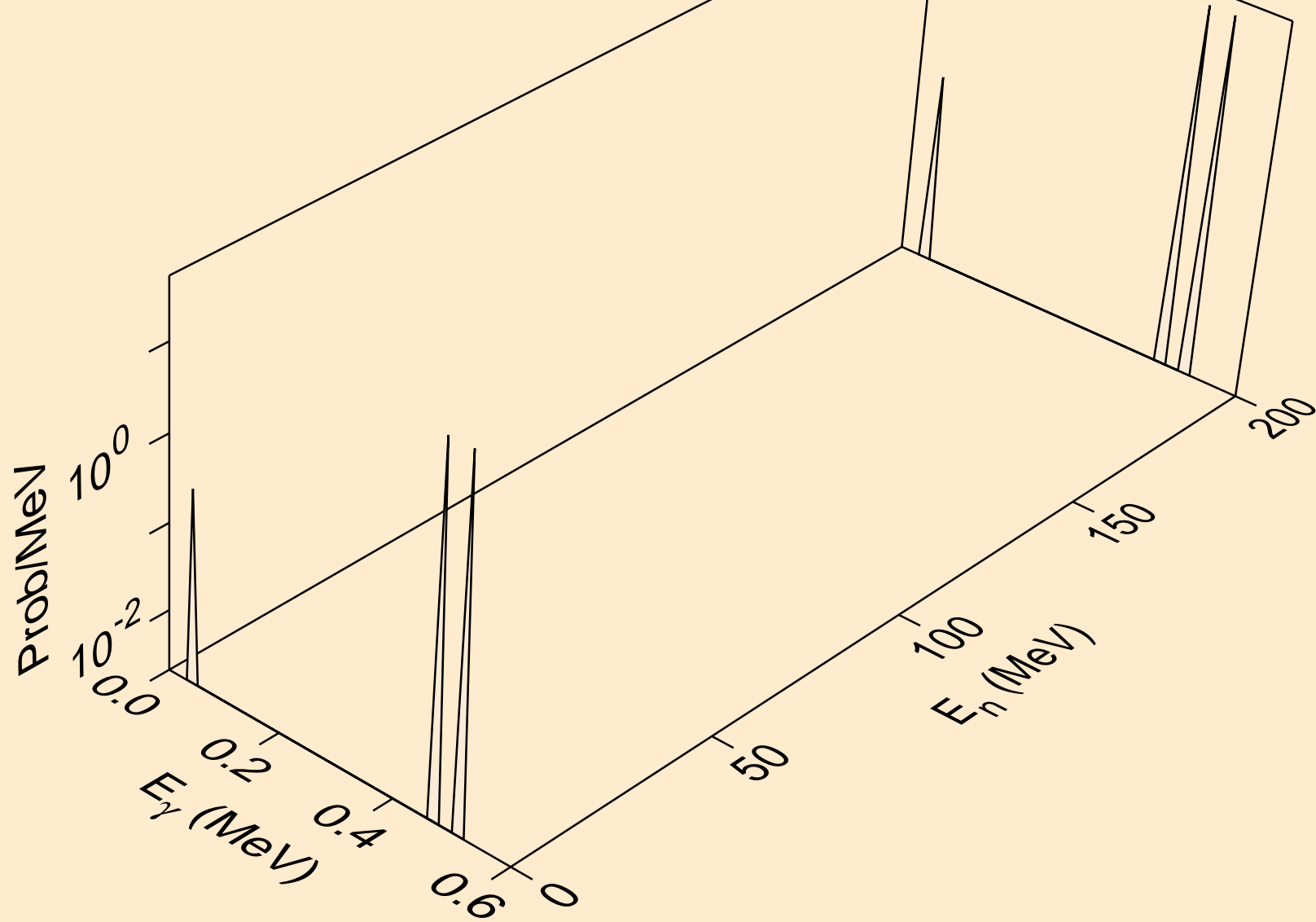

FM247M NEUTRON ACER TENDL-2021 LIBRARY; T=293.6K
Photon emission for (n,n*14)

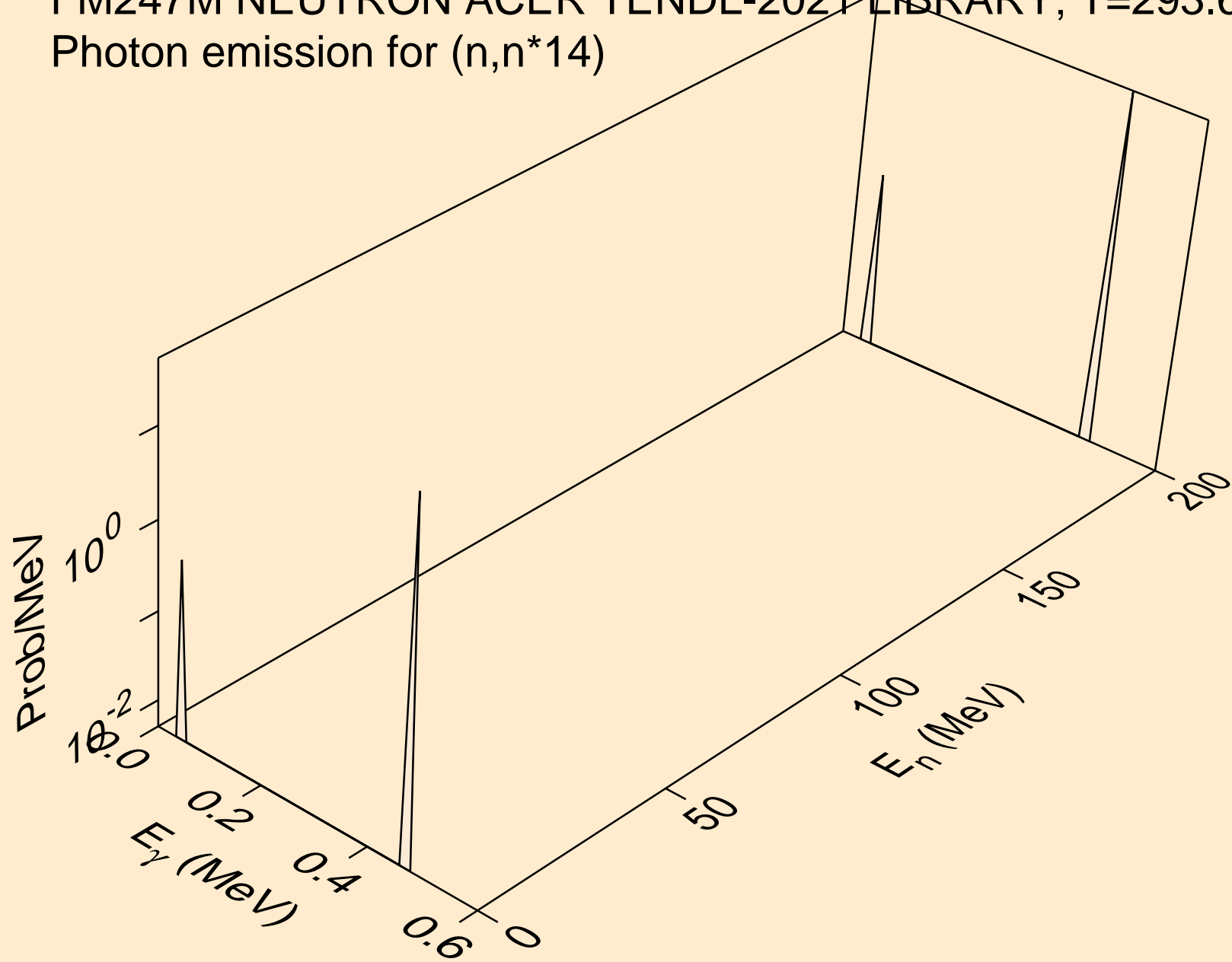

FM247M NEUTRON ACER TENDL-2021 LIBRARY; T=293.6K
Photon emission for (n,n*15)

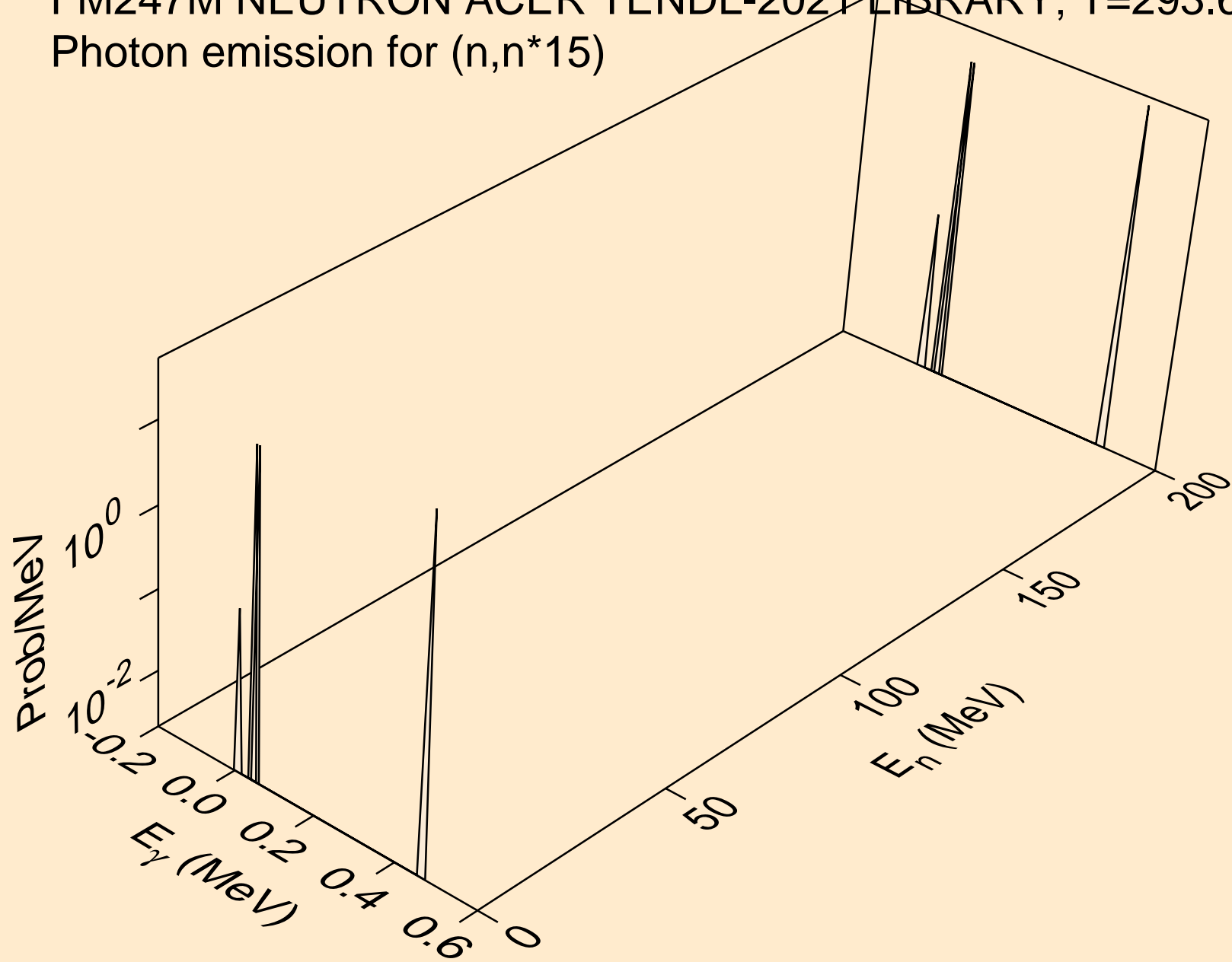

FM247M NEUTRON ACER TENDL-2021 LIBRARY; T=293.6K
Photon emission for (n,n*16)

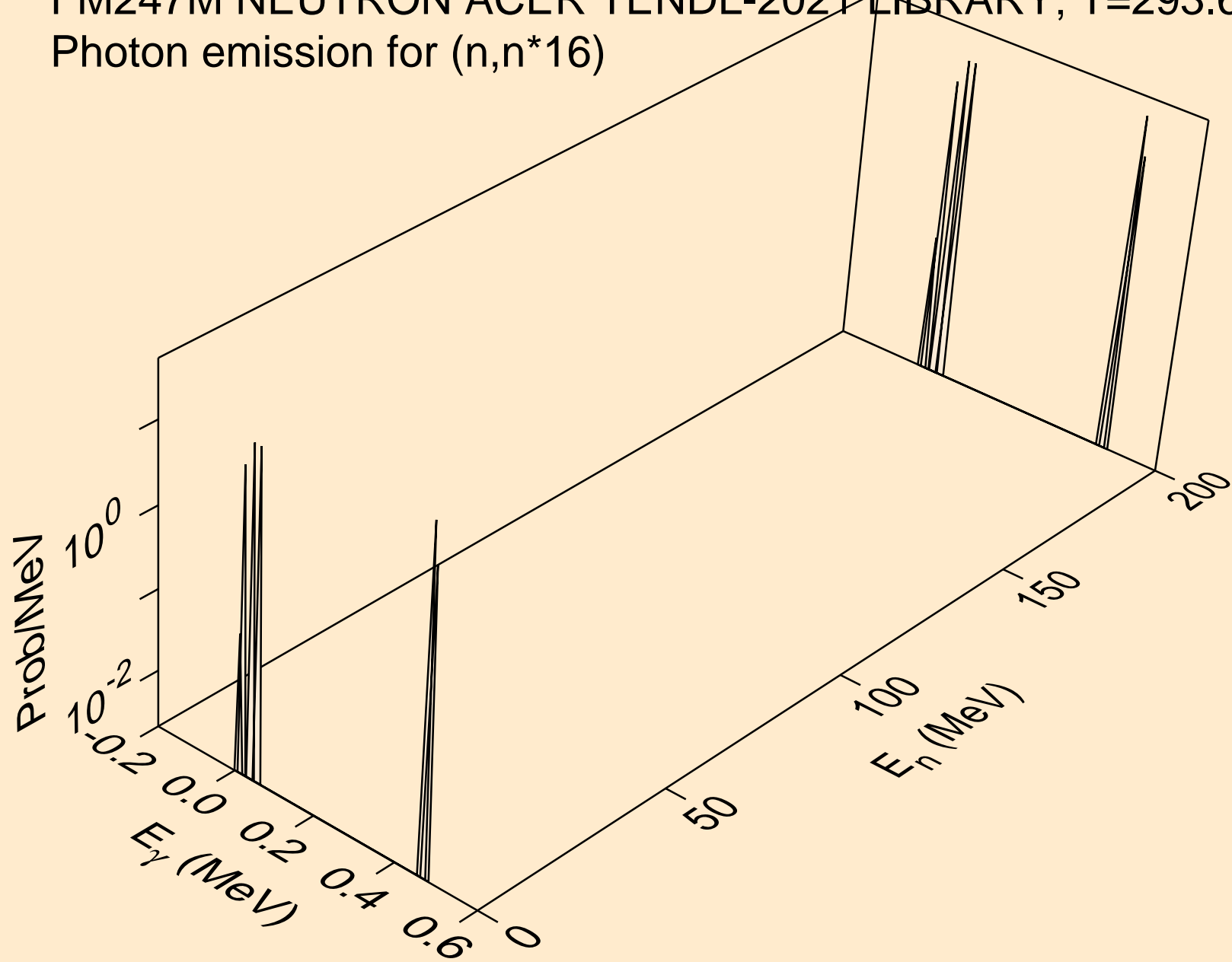

FM247M NEUTRON ACER TENDL-2021 LIBRARY; T=293.6K
Photon emission for (n,n*17)

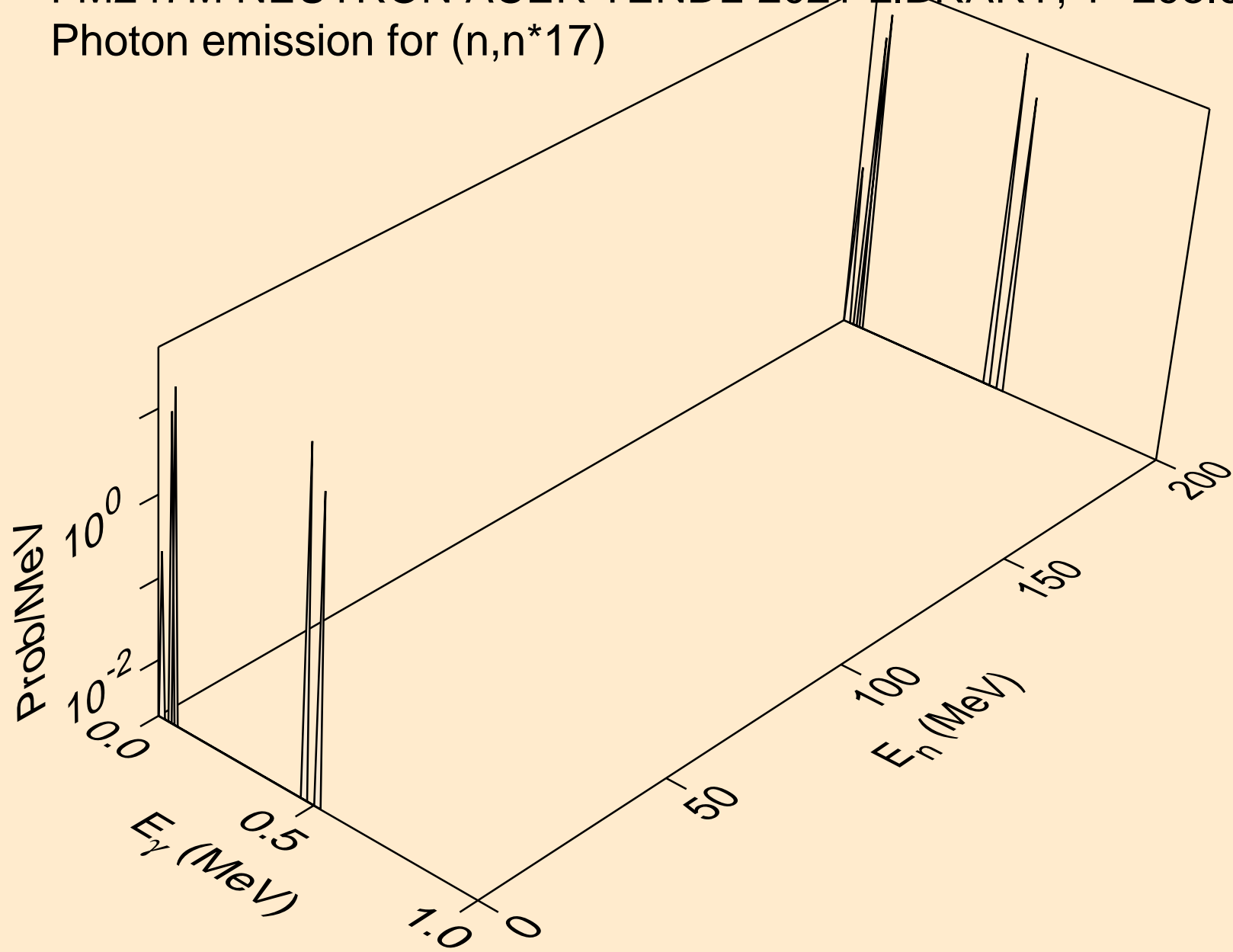

FM247M NEUTRON ACER TENDL-2021 LIBRARY; T=293.6K
Photon emission for (n,n*18)

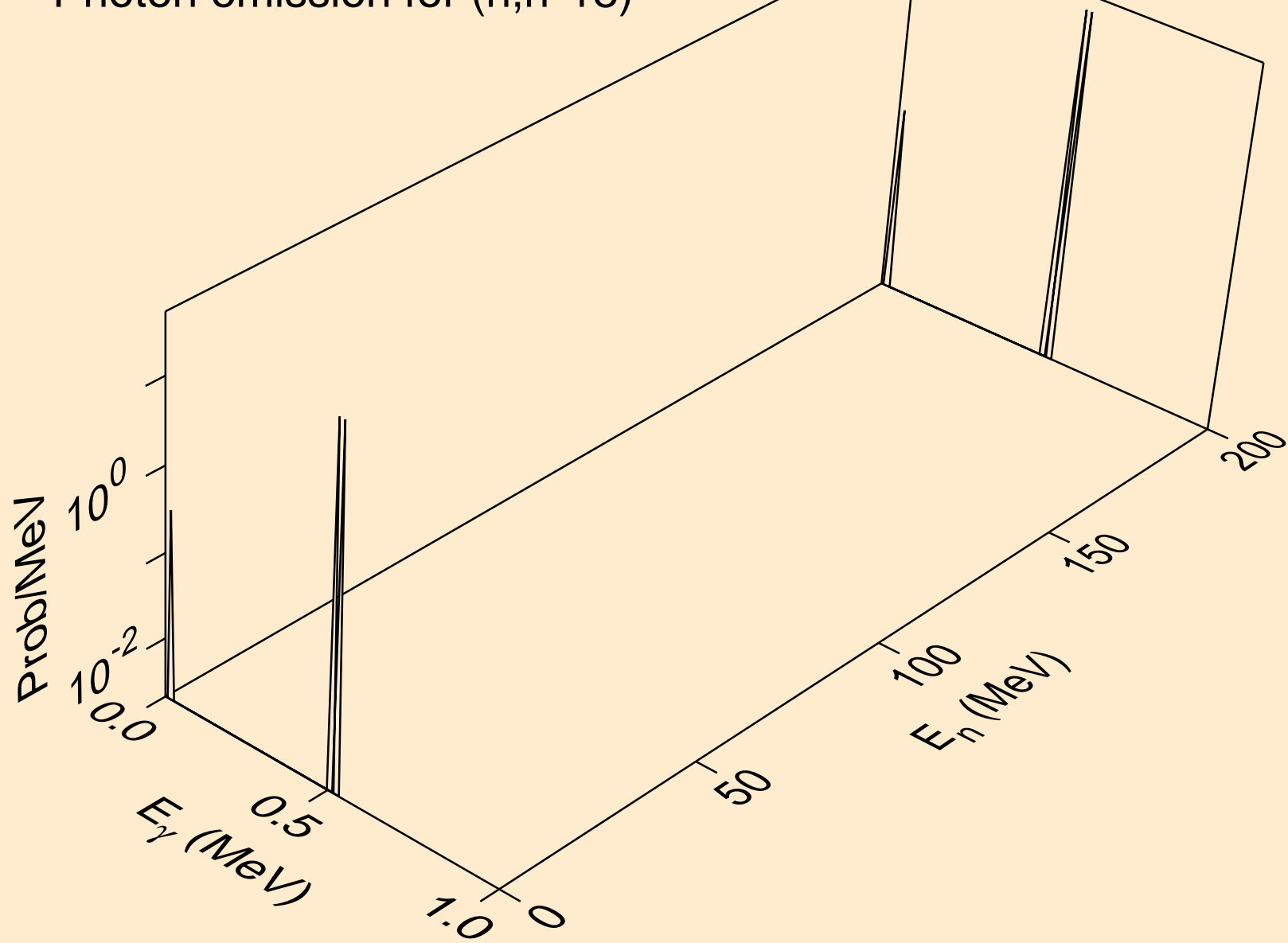

FM247M NEUTRON ACER TENDL-2021 LIBRARY; T=293.6K
Photon emission for (n,n*19)

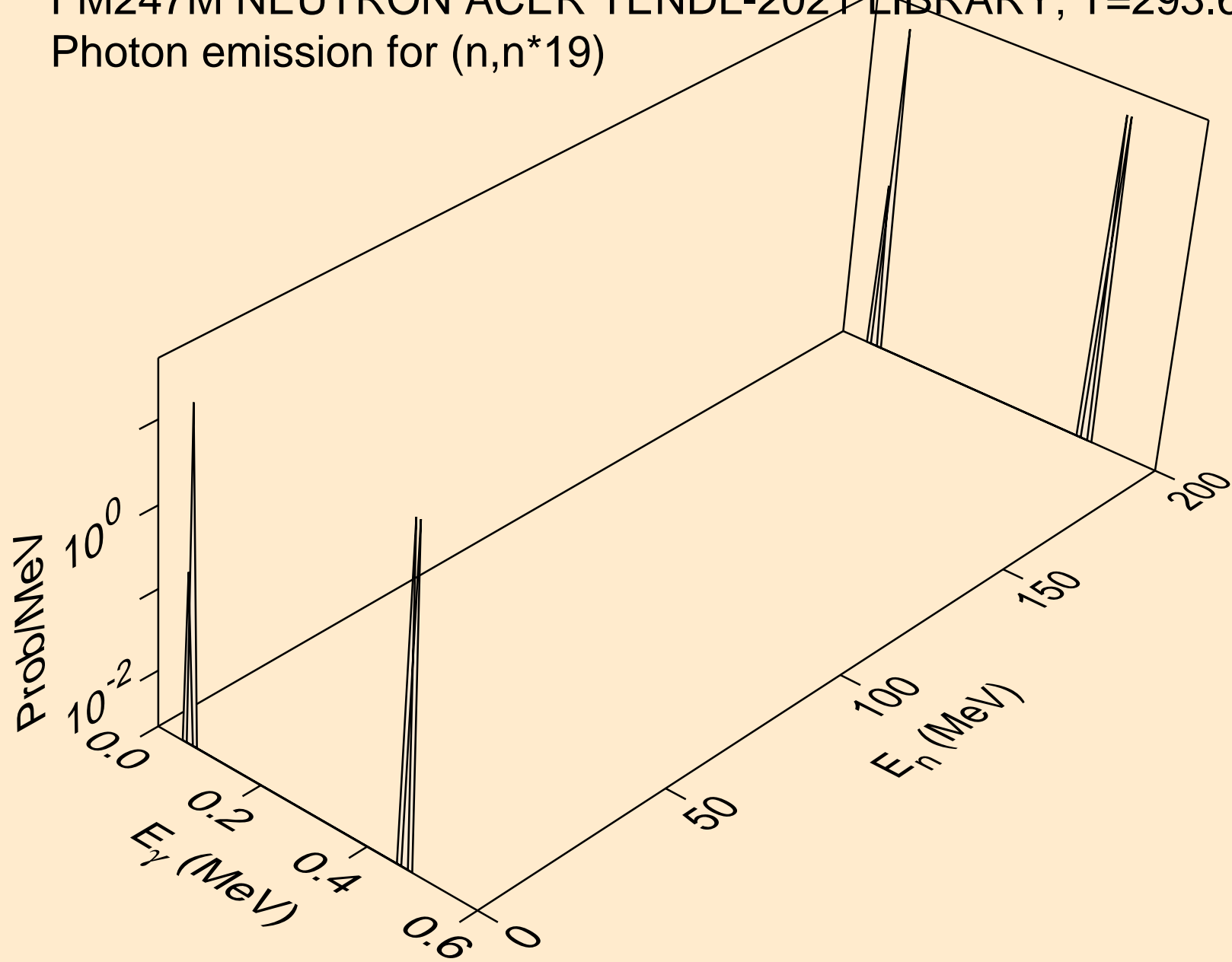

FM247M NEUTRON ACER TENDL-2021 LIBRARY; T=293.6K
Photon emission for (n,n*20)

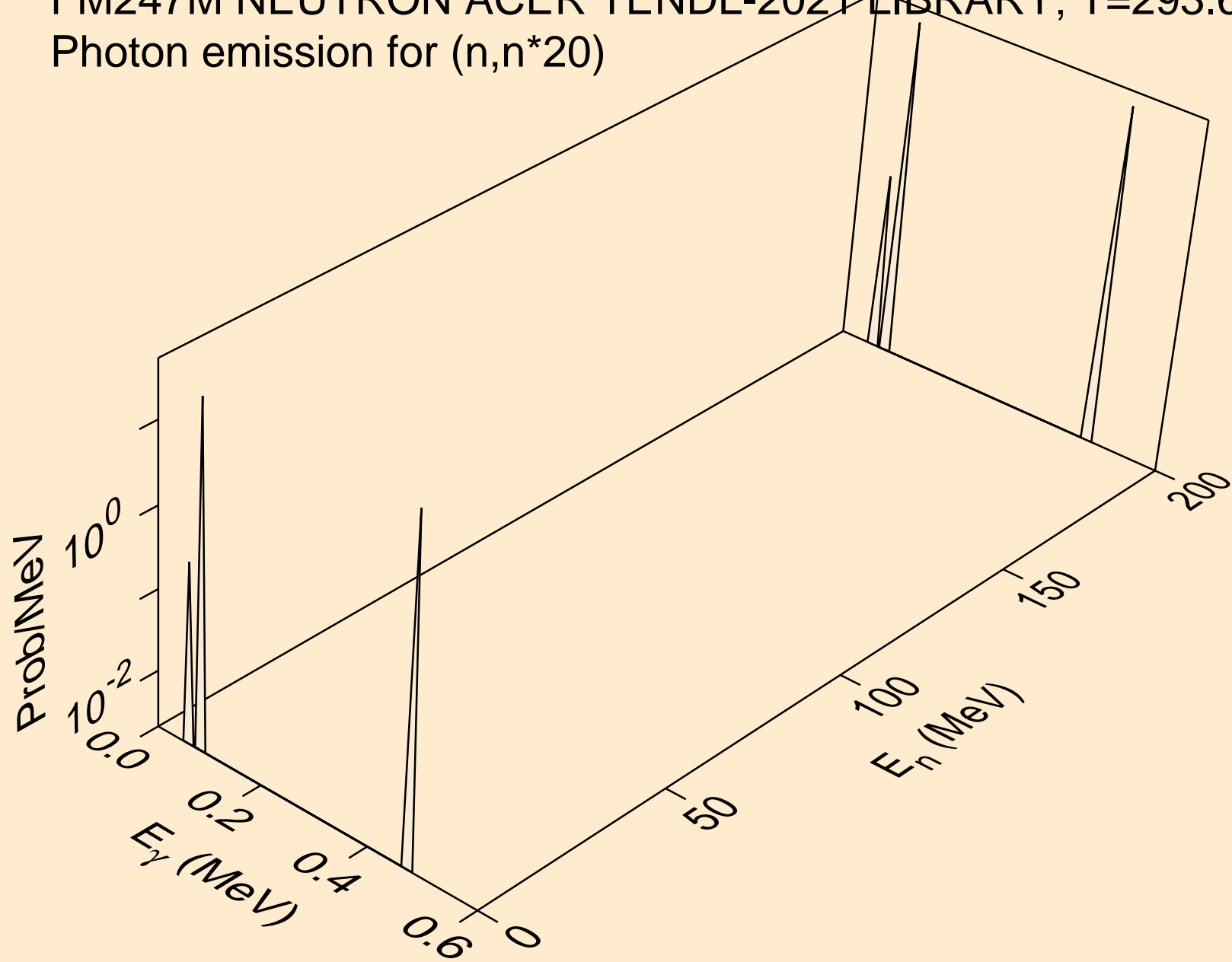

FM247M NEUTRON ACER TENDL-2021 LIBRARY; T=293.6K
Photon emission for (n,n*21)

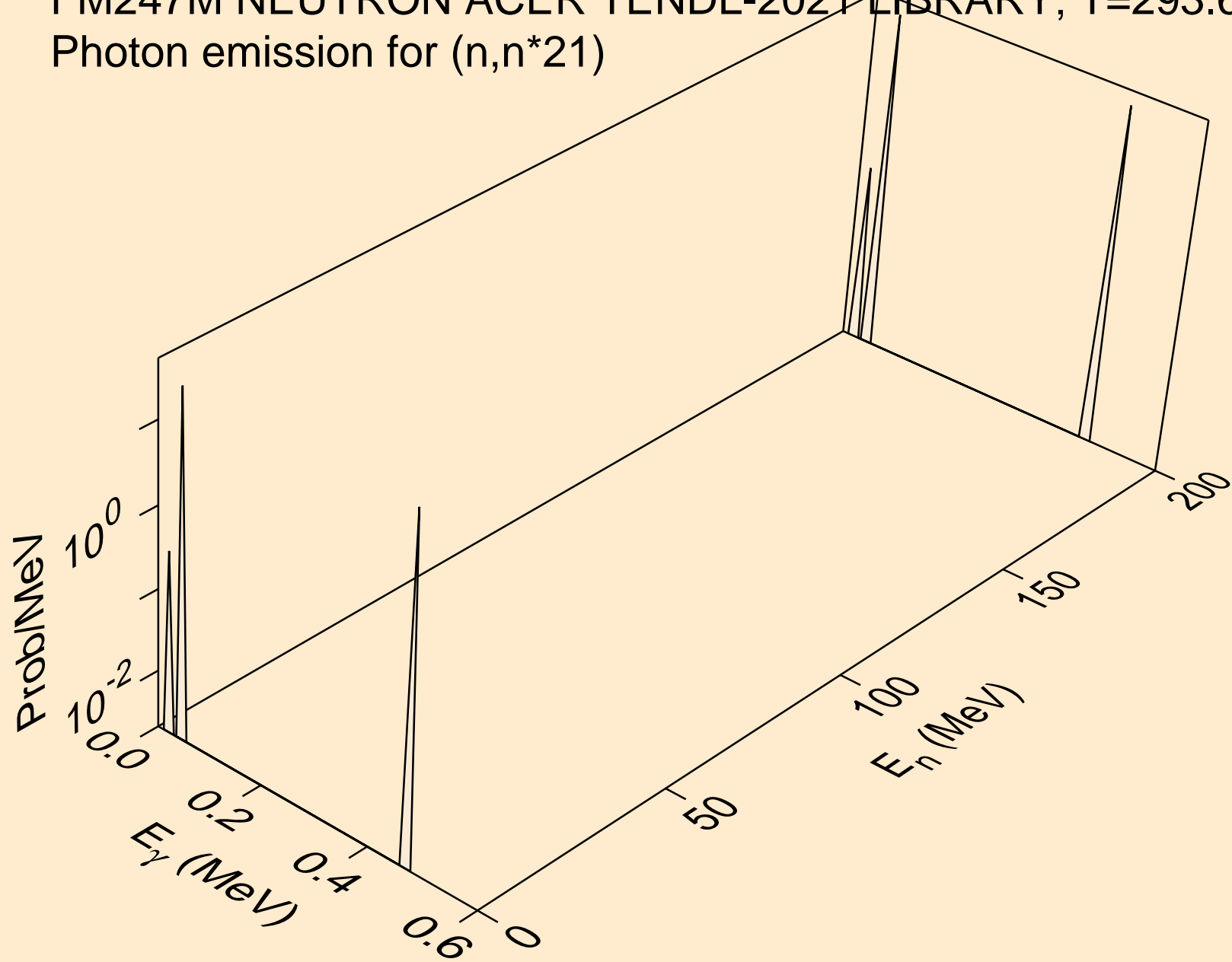

FM247M NEUTRON ACER TENDL-2021 LIBRARY; T=293.6K
Photon emission for (n,n*22)

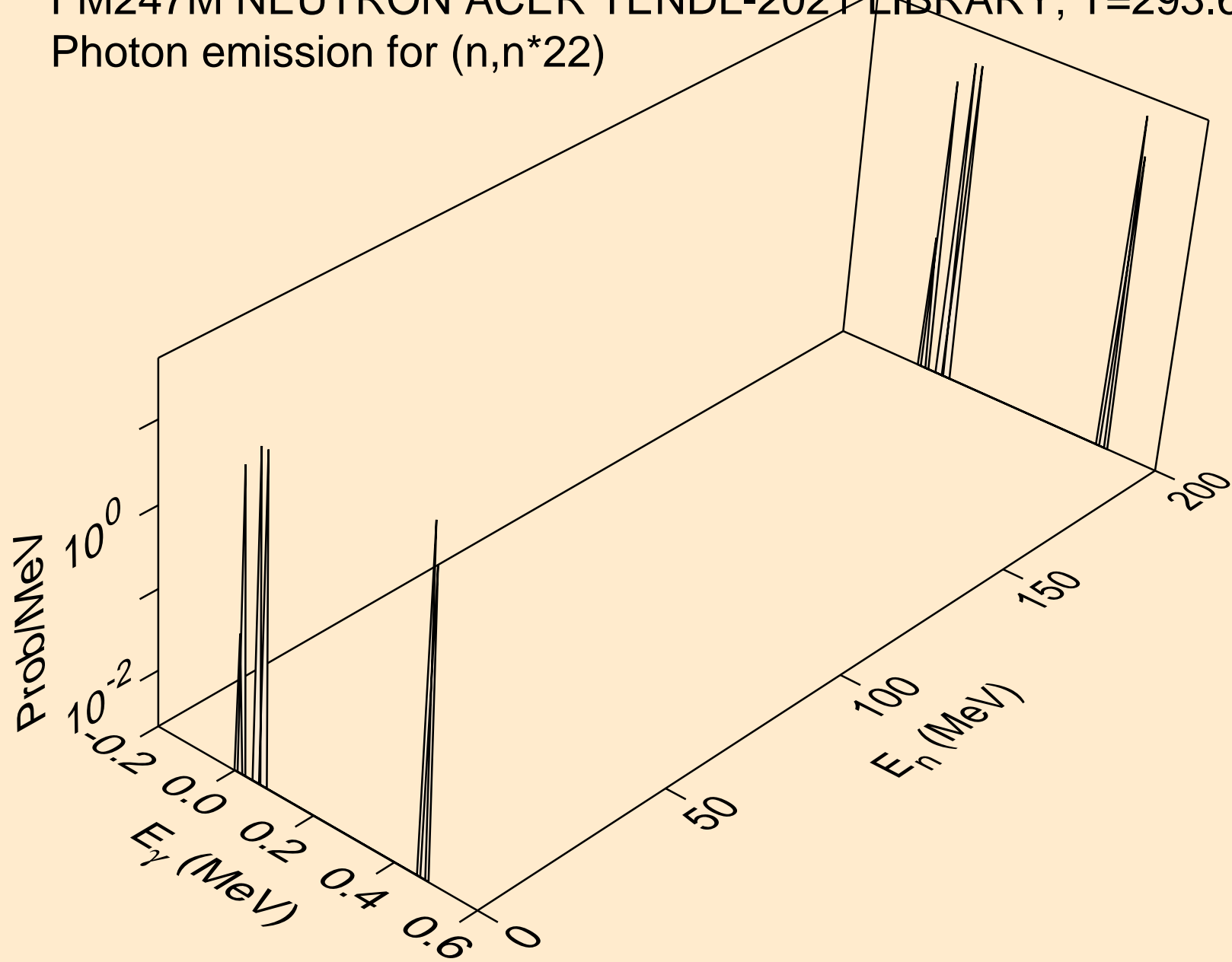

FM247M NEUTRON ACER TENDL-2021 LIBRARY; T=293.6K
Photon emission for (n,n*23)

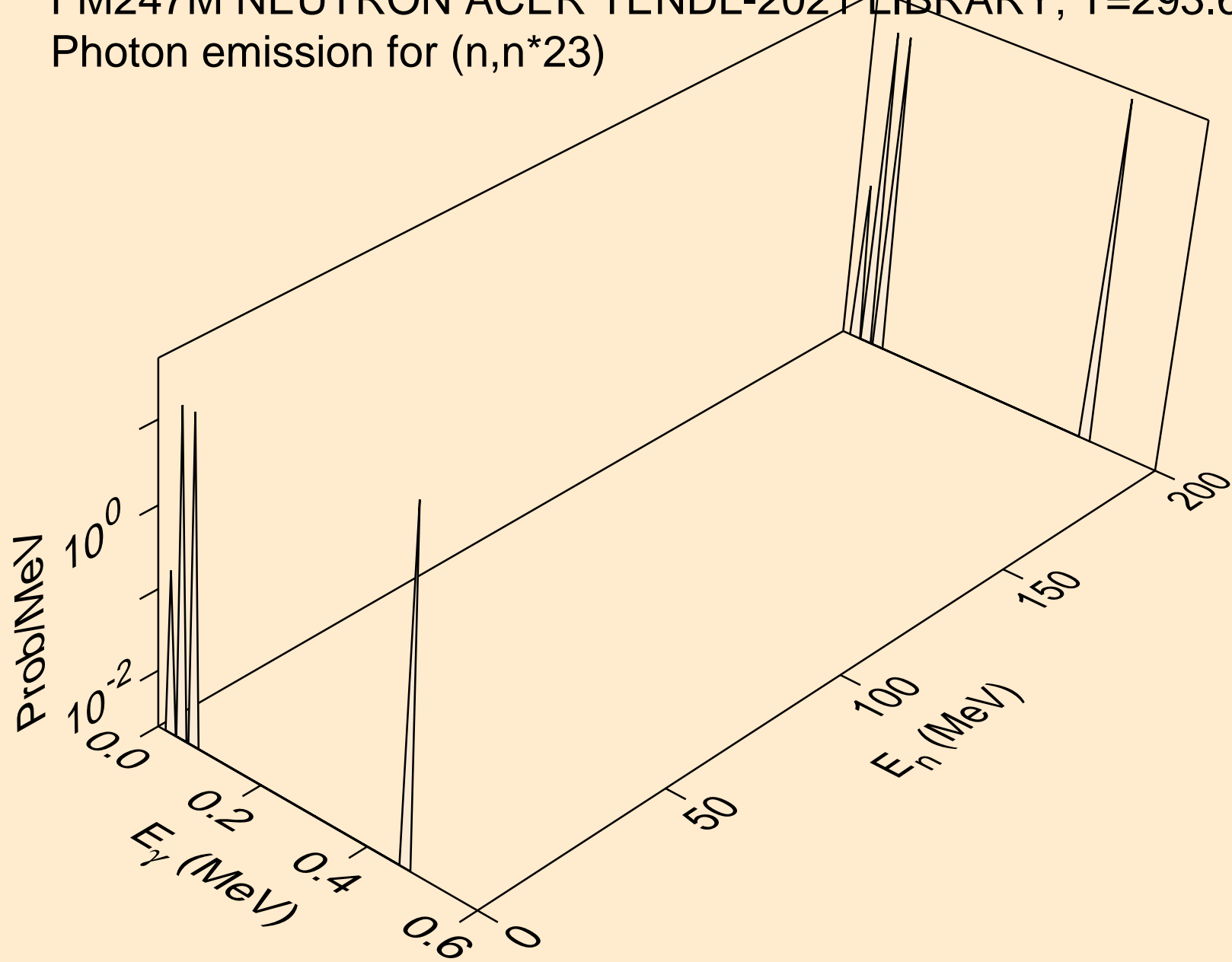

FM247M NEUTRON ACER TENDL-2021 LIBRARY; T=293.6K
Photon emission for (n,n*c)

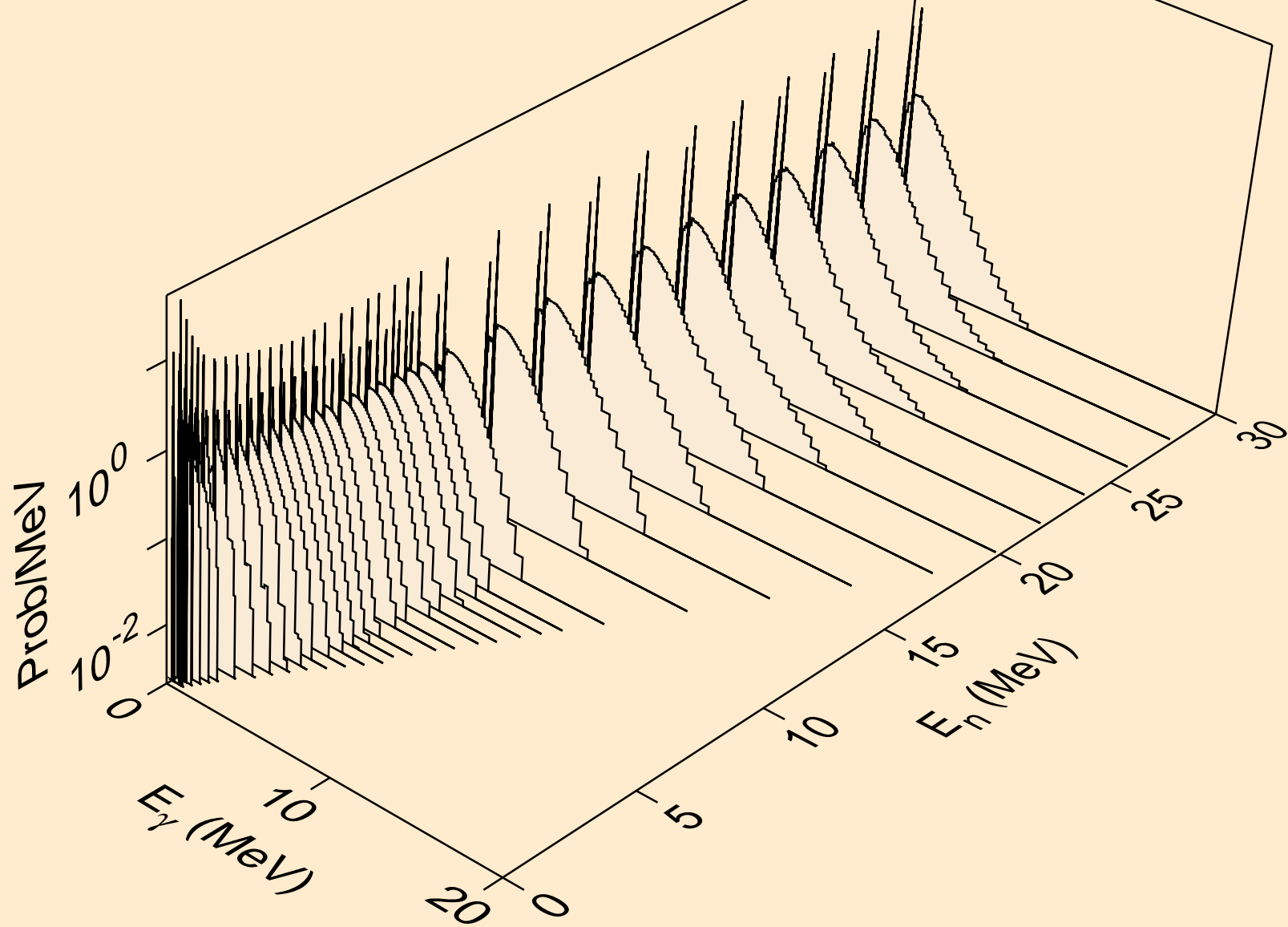

FM247M NEUTRON ACER TENDL-2021 LIBRARY; T=293.6K
Photon emission for (n,gma)

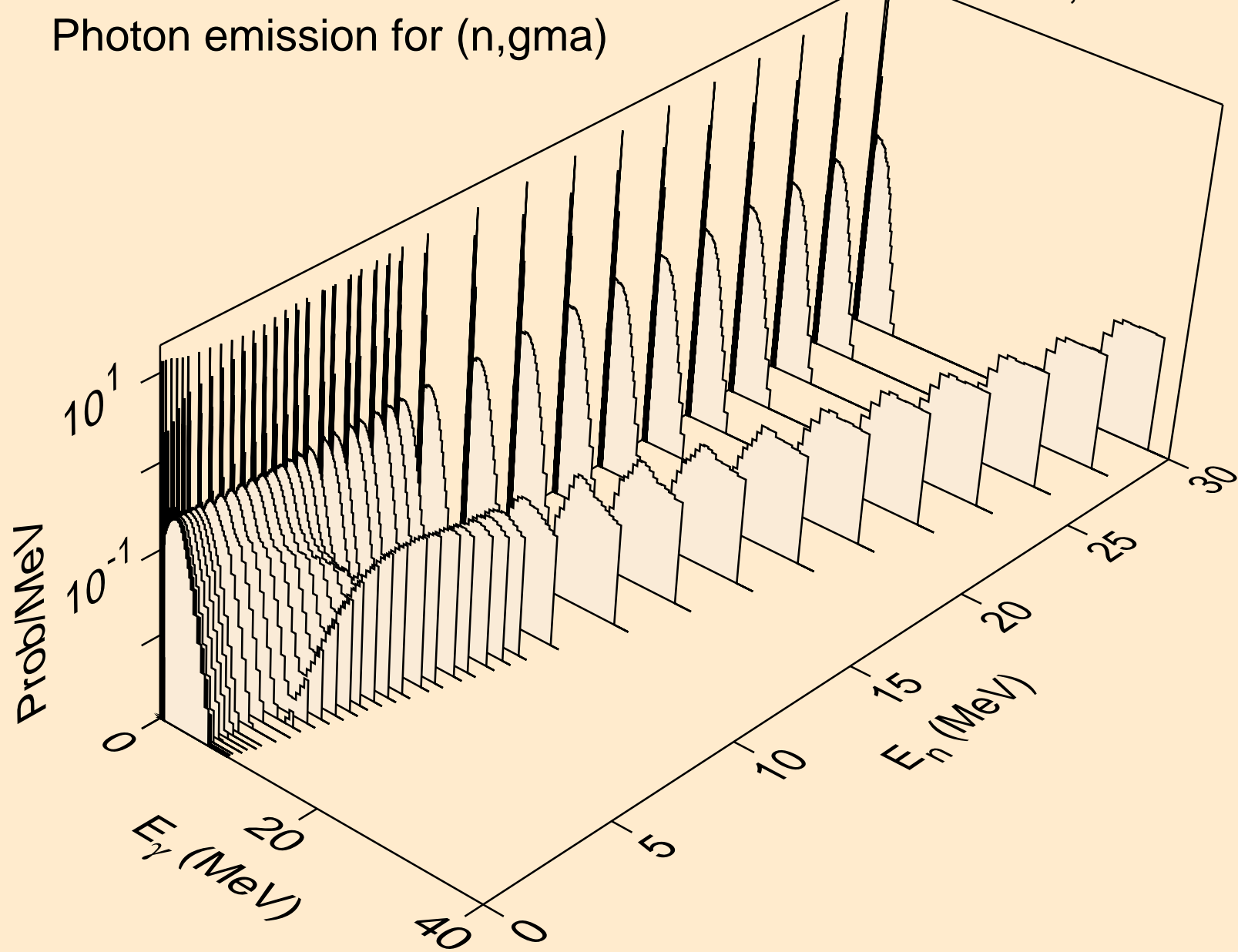

FM247M NEUTRON ACER TENDL-2021 LIBRARY; T=293.6K
Photon emission for (n,p)

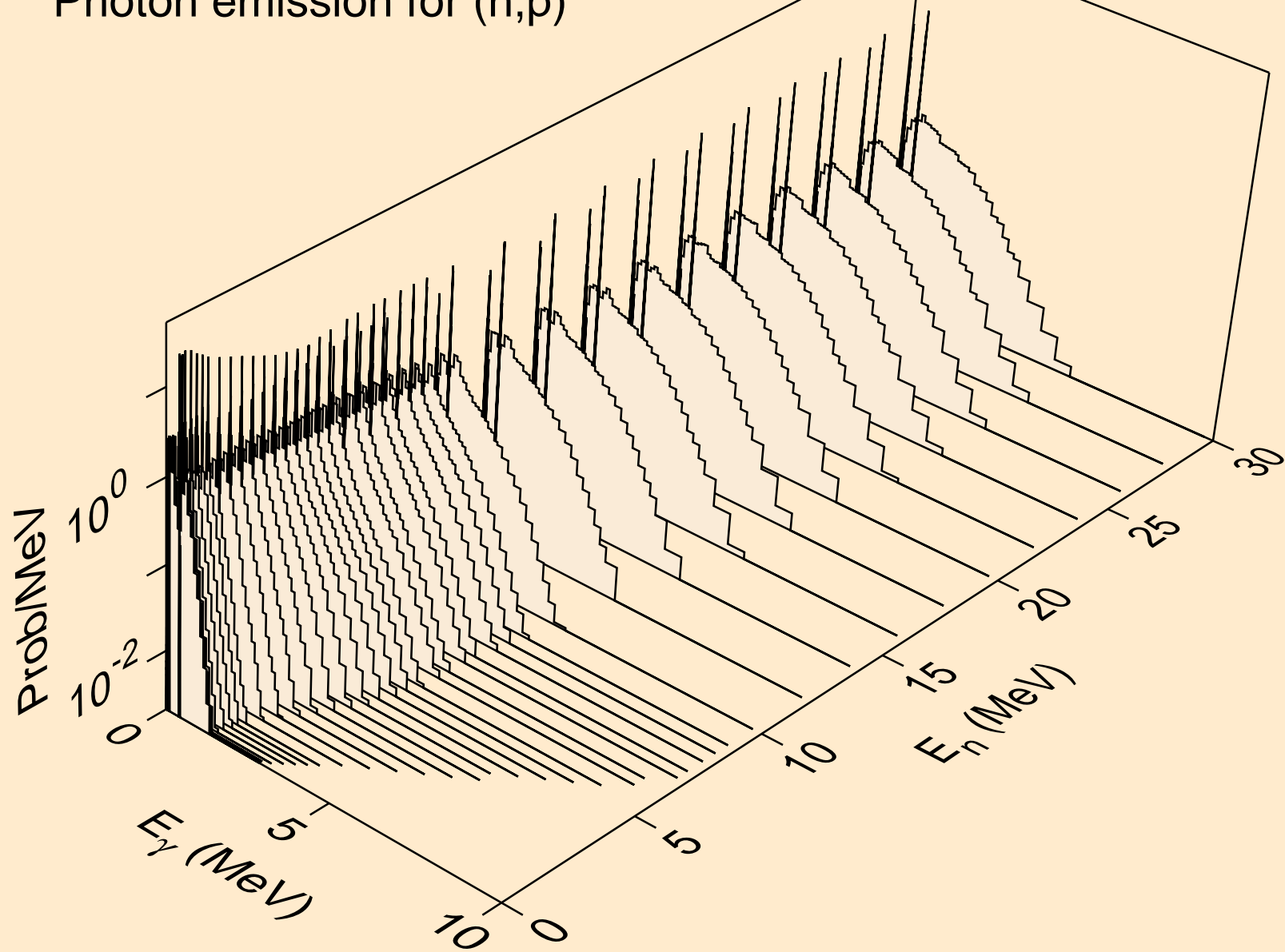

FM247M NEUTRON ACER TENDL-2021 LIBRARY; T=293.6K
Photon emission for (n,d)

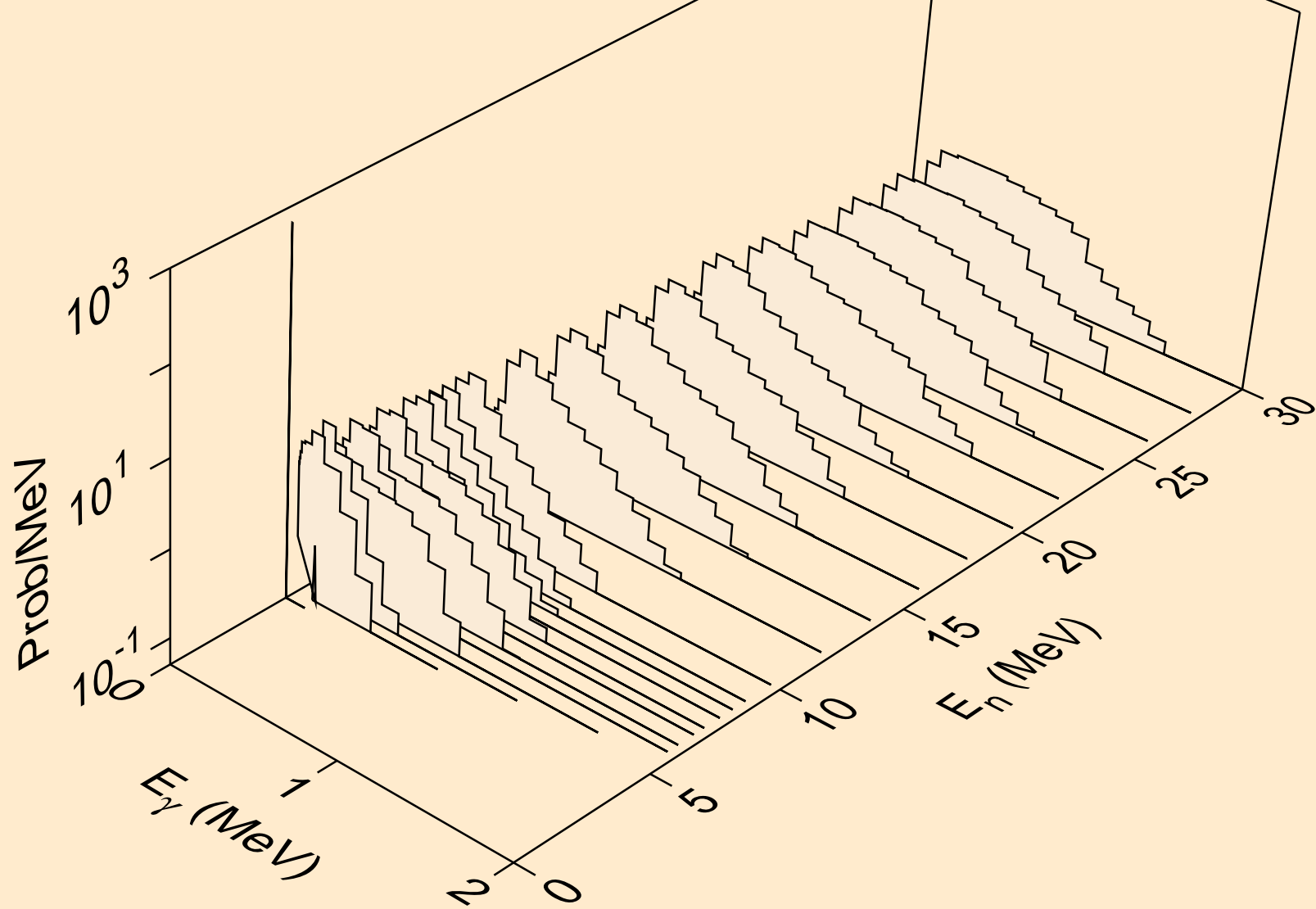

FM247M NEUTRON ACER TENDL-2021 LIBRARY; T=293.6K
Photon emission for (n,t)

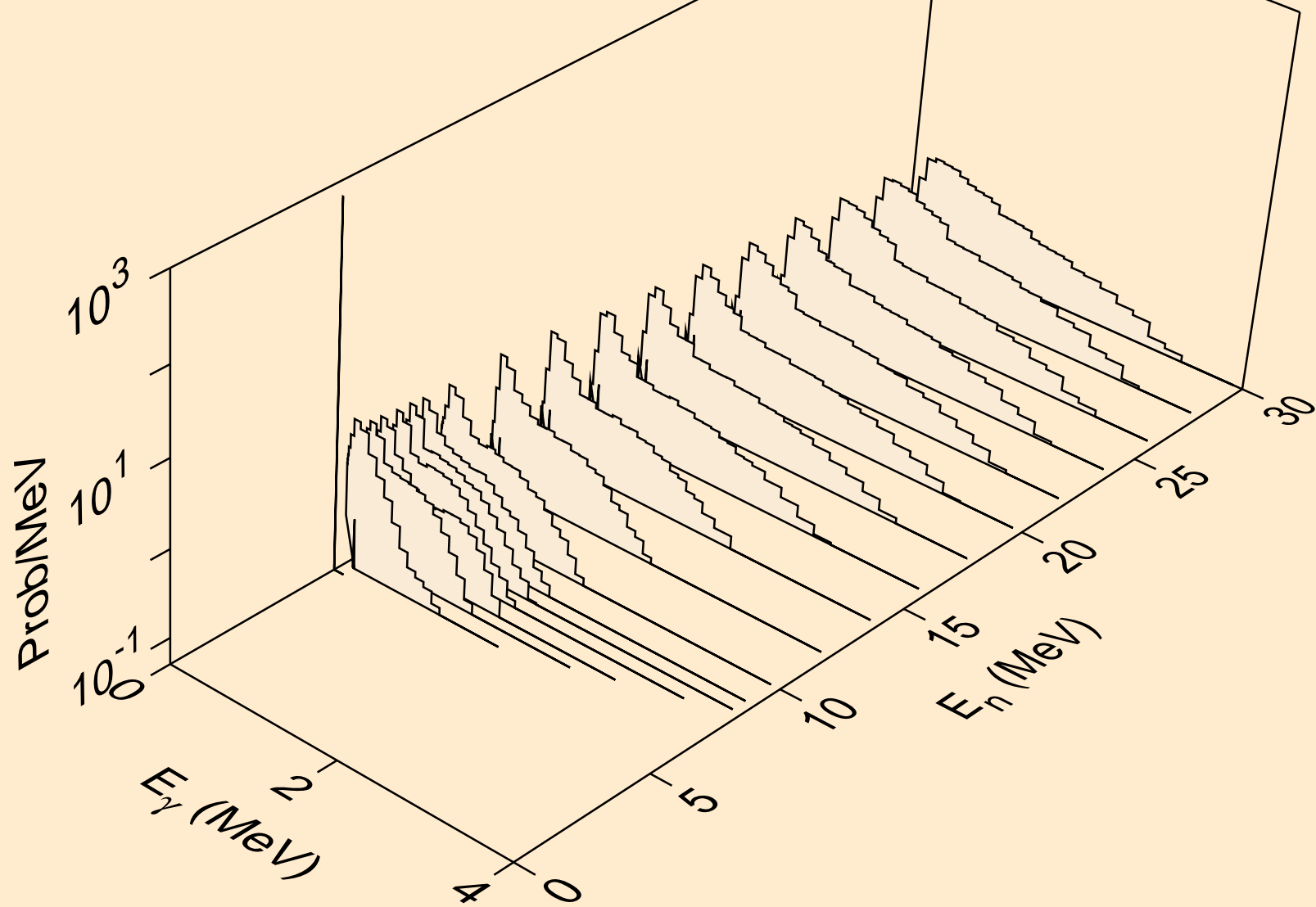

FM247M NEUTRON ACER TENDL-2021 LIBRARY; T=293.6K
Photon emission for (n,he3)

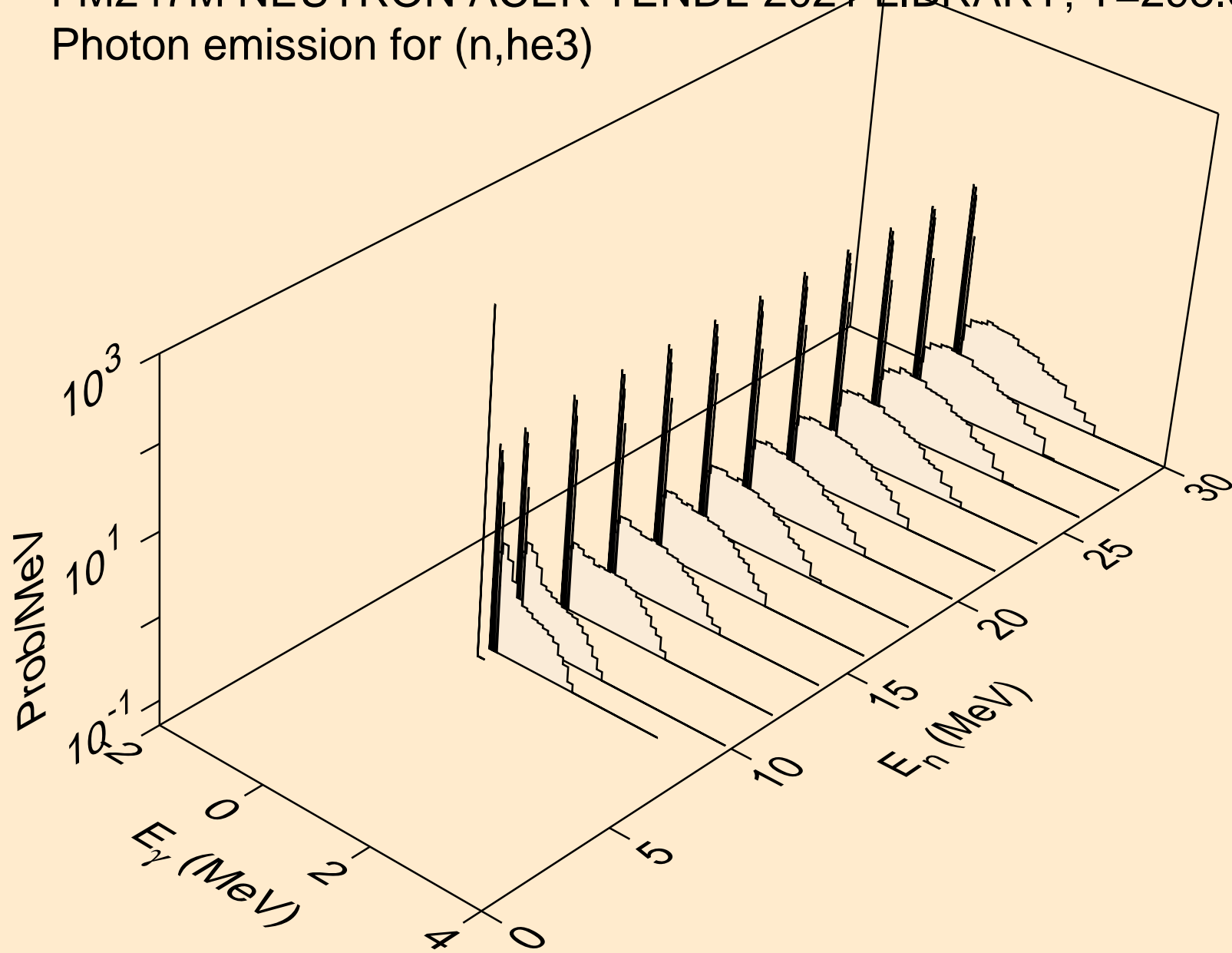

FM247M NEUTRON ACER TENDL-2021 LIBRARY; T=293.6K
Photon emission for (n,a)

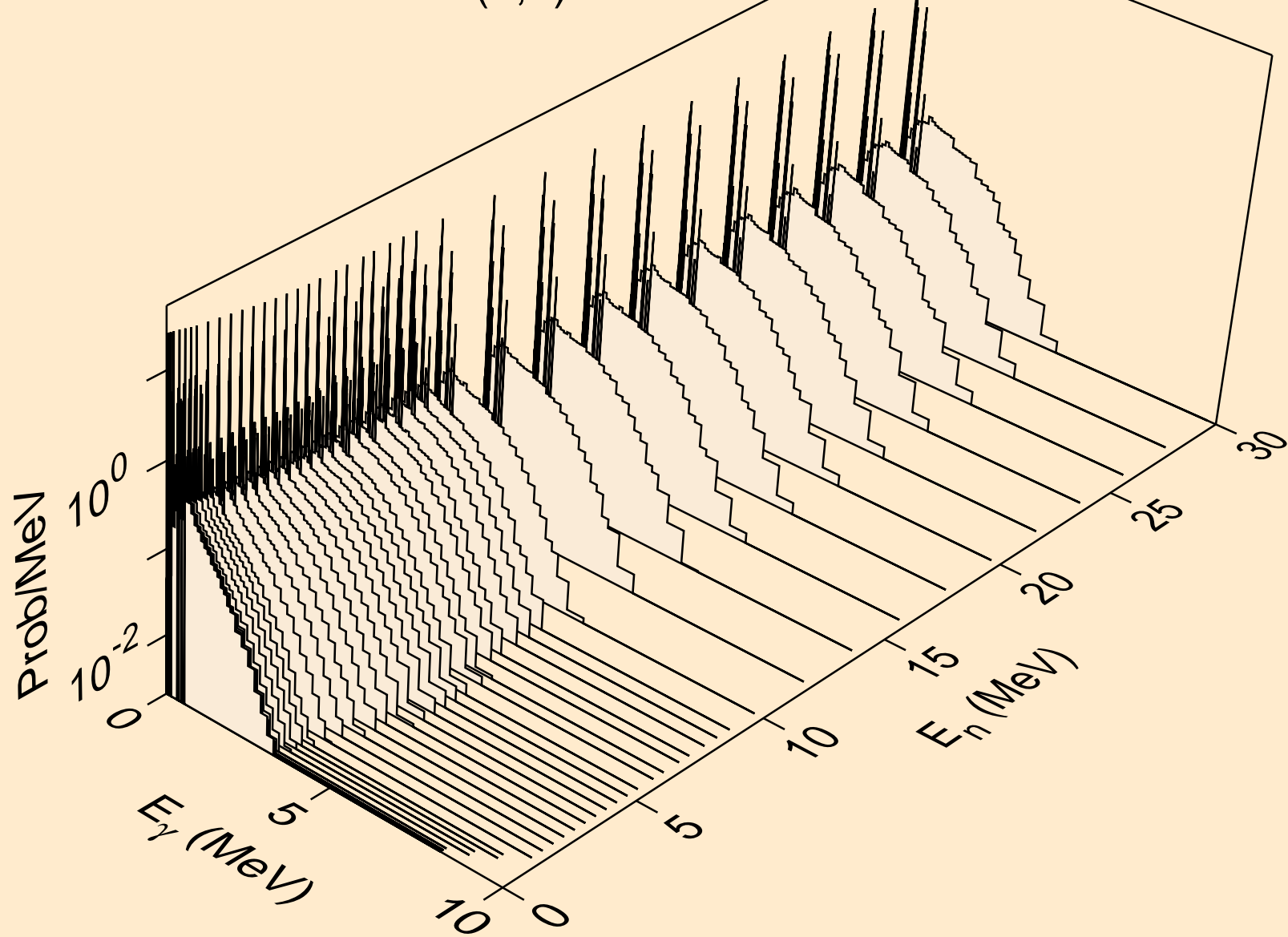

FM247M NEUTRON ACER TENDL-2021 LIBRARY; T=293.6K
Photon emission for (n,2p)

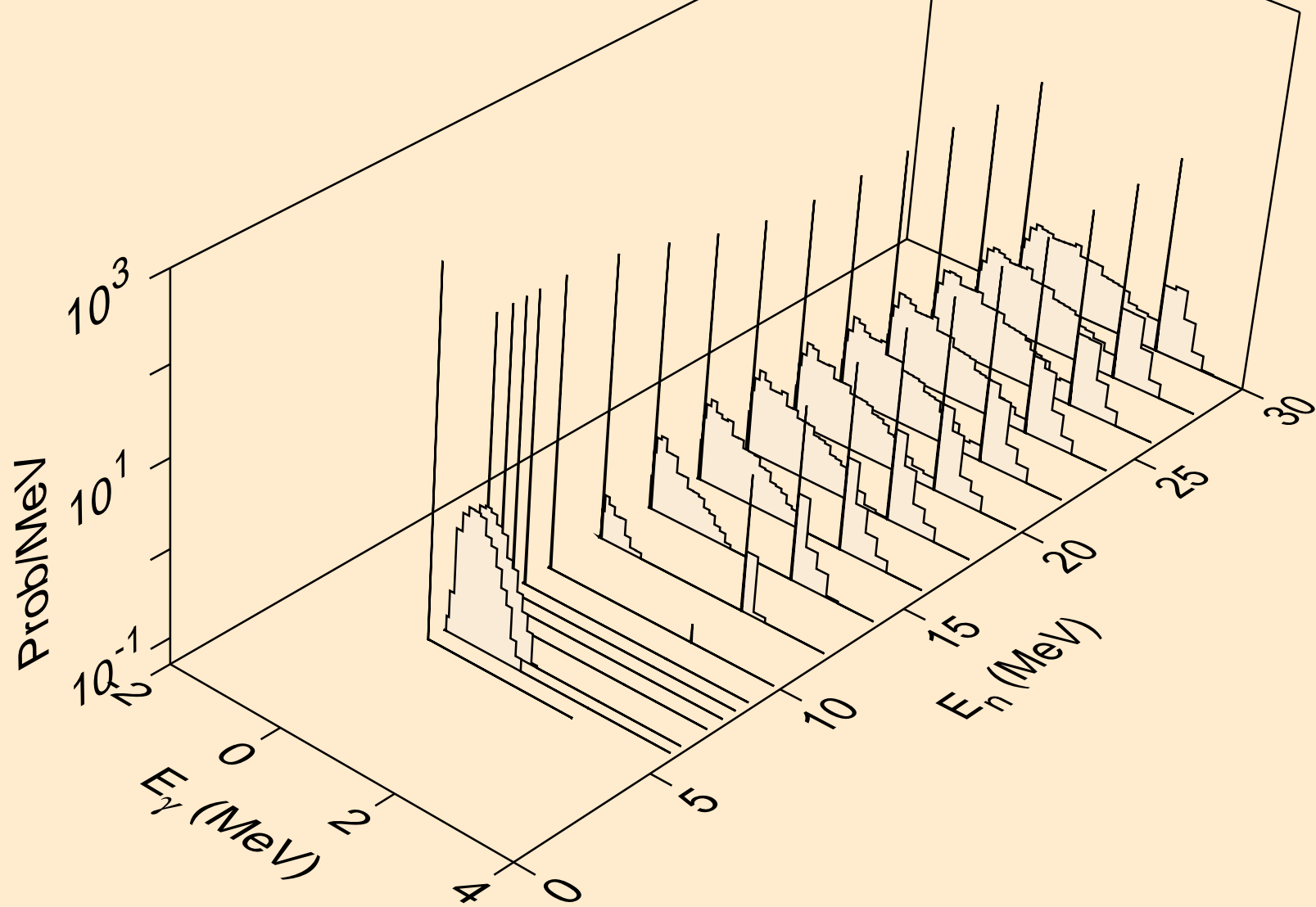

FM247M NEUTRON ACER TENDL-2021 LIBRARY; T=293.6K
Photon emission for (n,p)

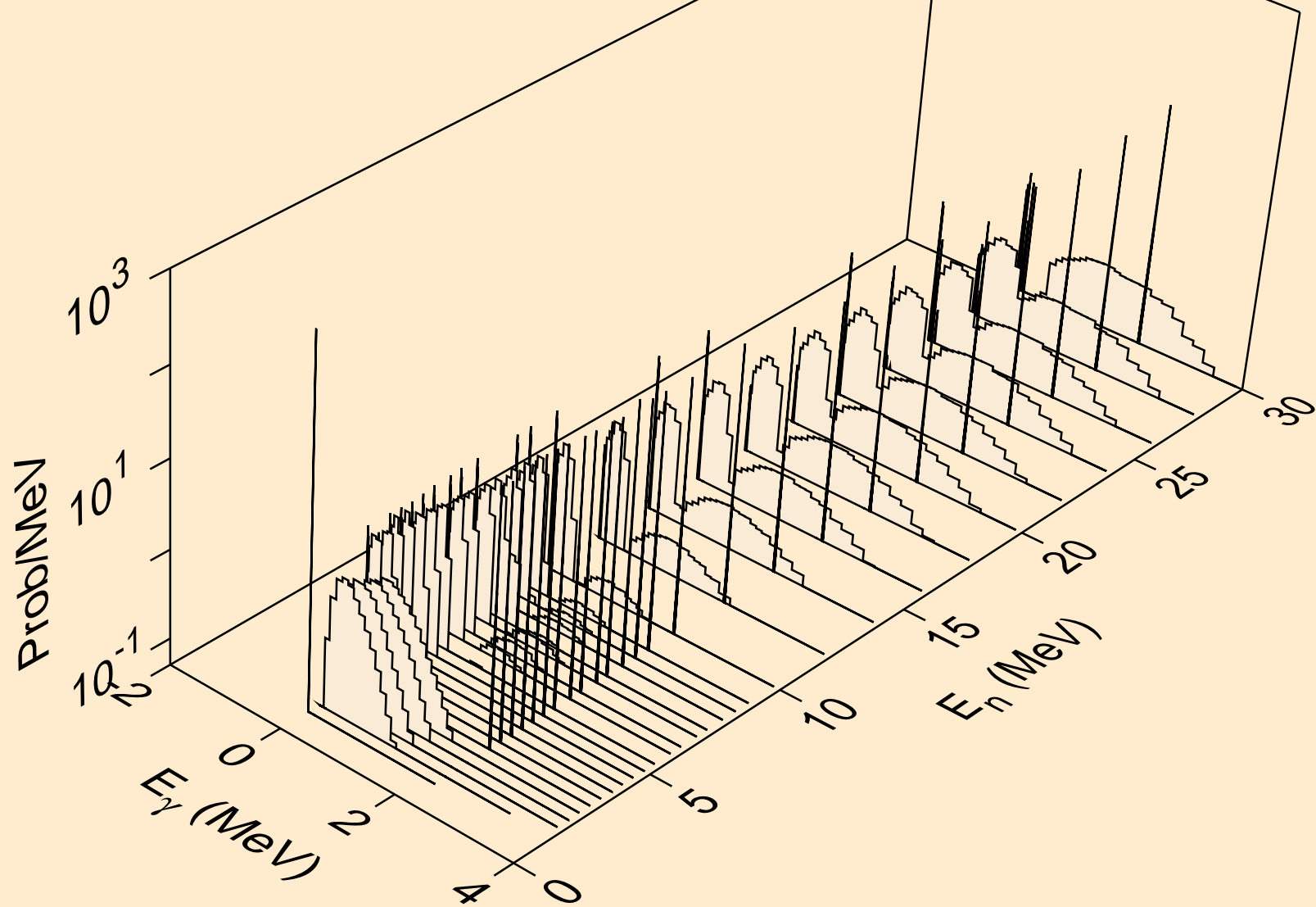

FM247M NEUTRON ACER TENDL-2021 LIBRARY; T=293.6K
Photon emission for (n,pd)

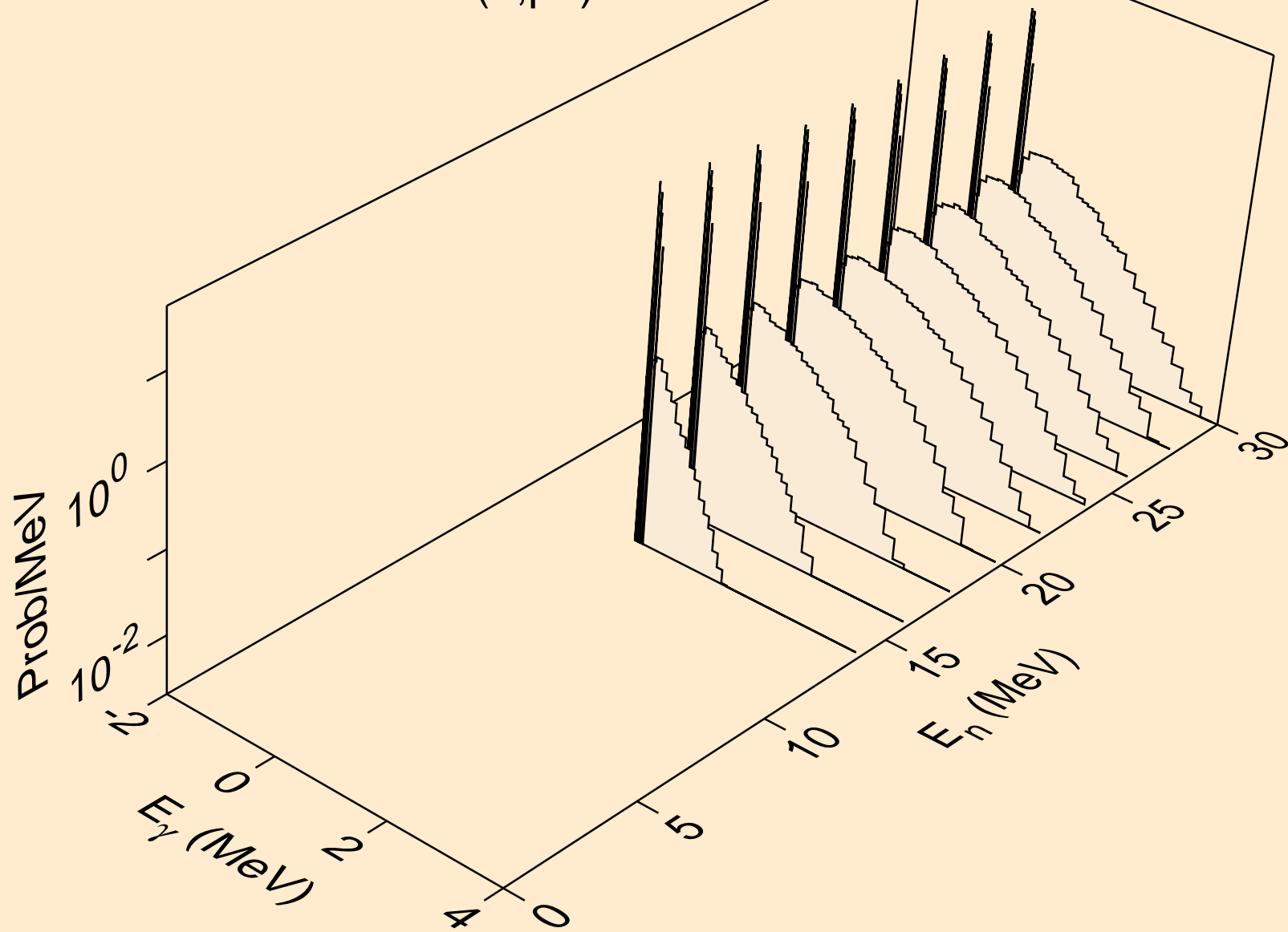

FM247M NEUTRON ACER TENDL-2021 LIBRARY; T=293.6K
Photon emission for (n,pt)

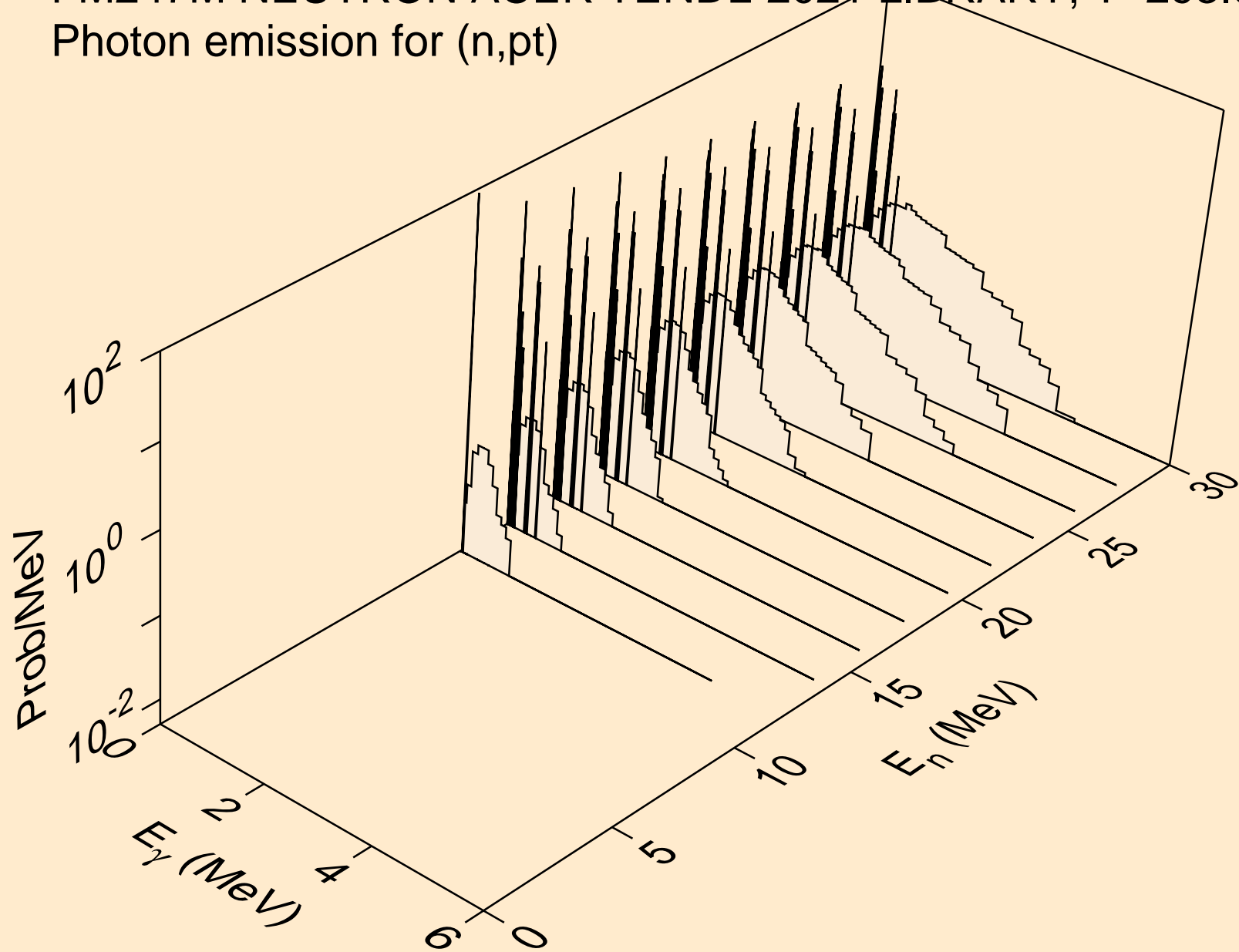

FM247M NEUTRON ACER TENDL-2021 LIBRARY; T=293.6K
thermal capture photon spectrum

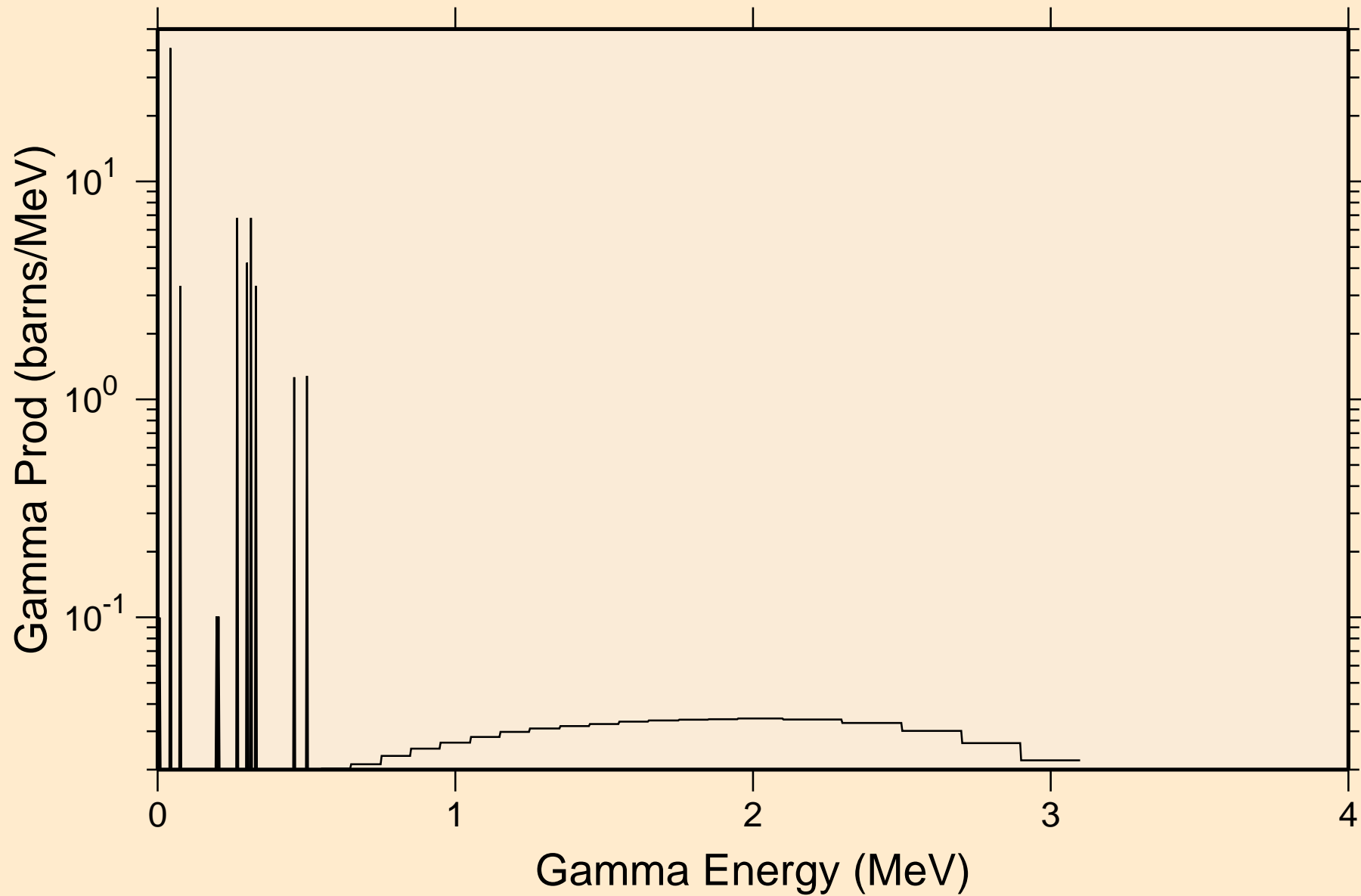

FM247M NEUTRON ACER TENDL-2021 LIBRARY; T=293.6K
14 MeV photon spectrum

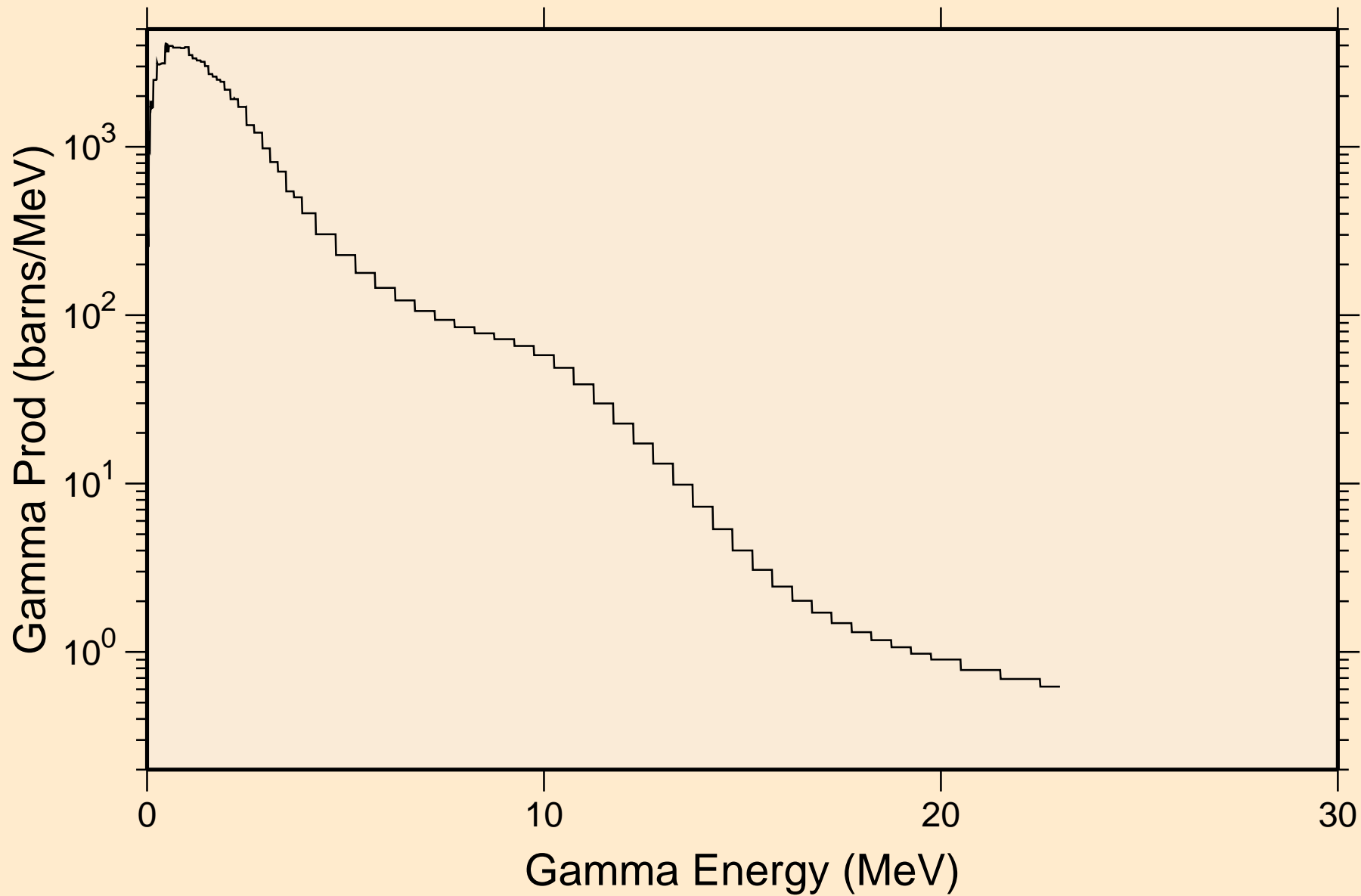

FM247M NEUTRON ACER TENDL-2021 LIBRARY; T=293.6K

Particle heating contributions

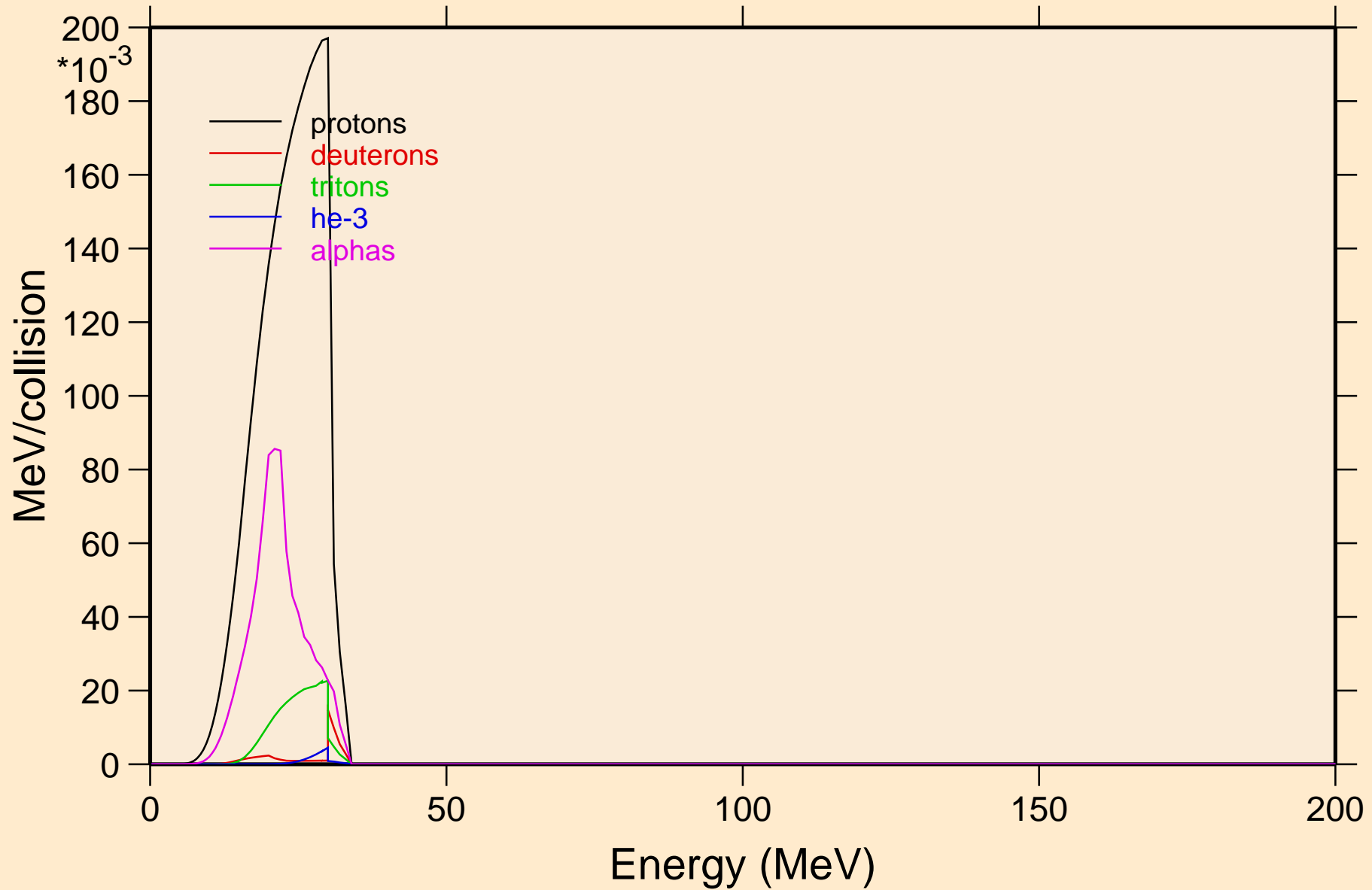

FM247M NEUTRON ACER TENDL-2021 LIBRARY; T=293.6K
Recoil Heating

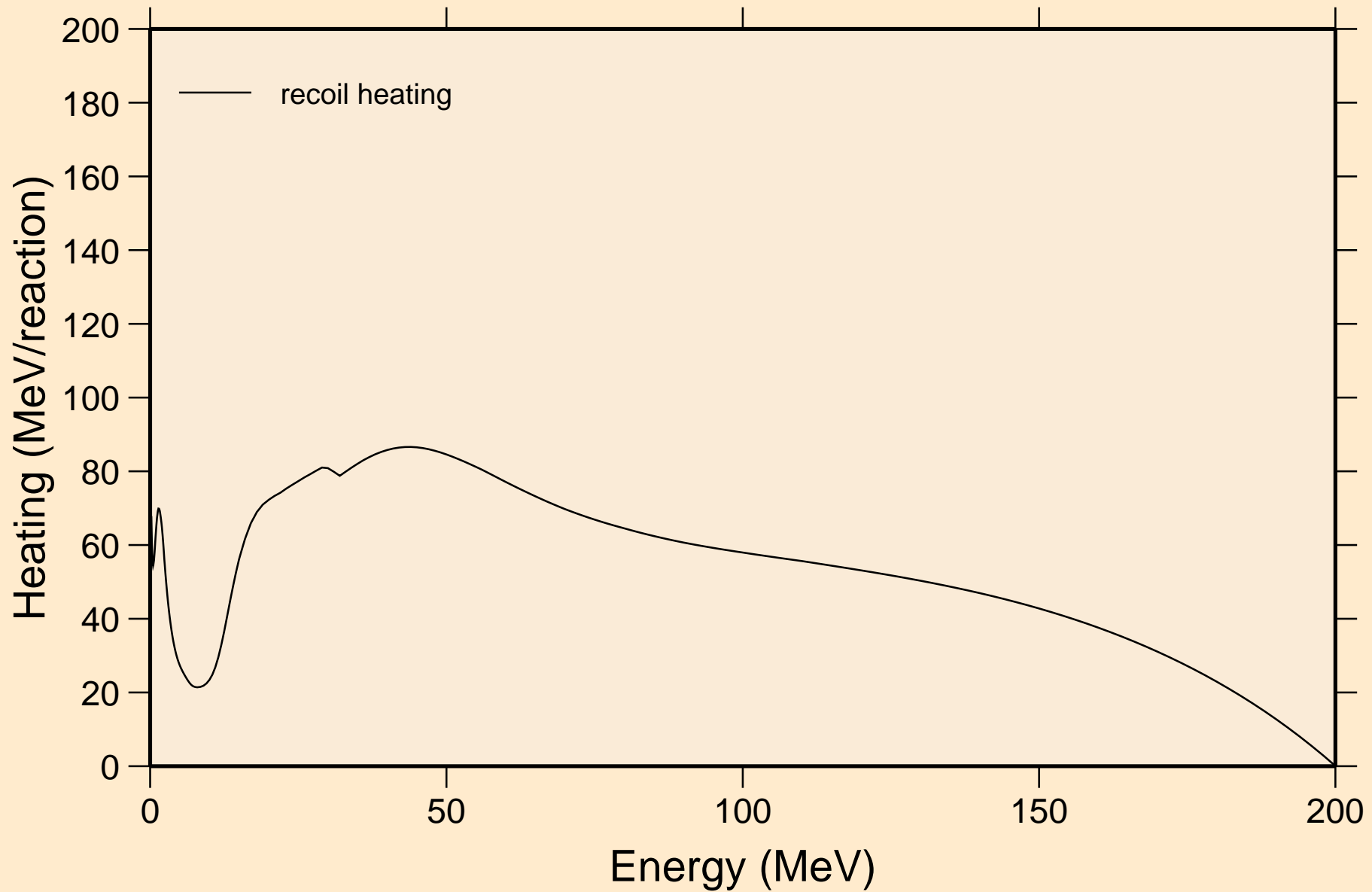

FM247M NEUTRON ACER TENDL-2021 LIBRARY; T=293.6K

Particle production cross sections

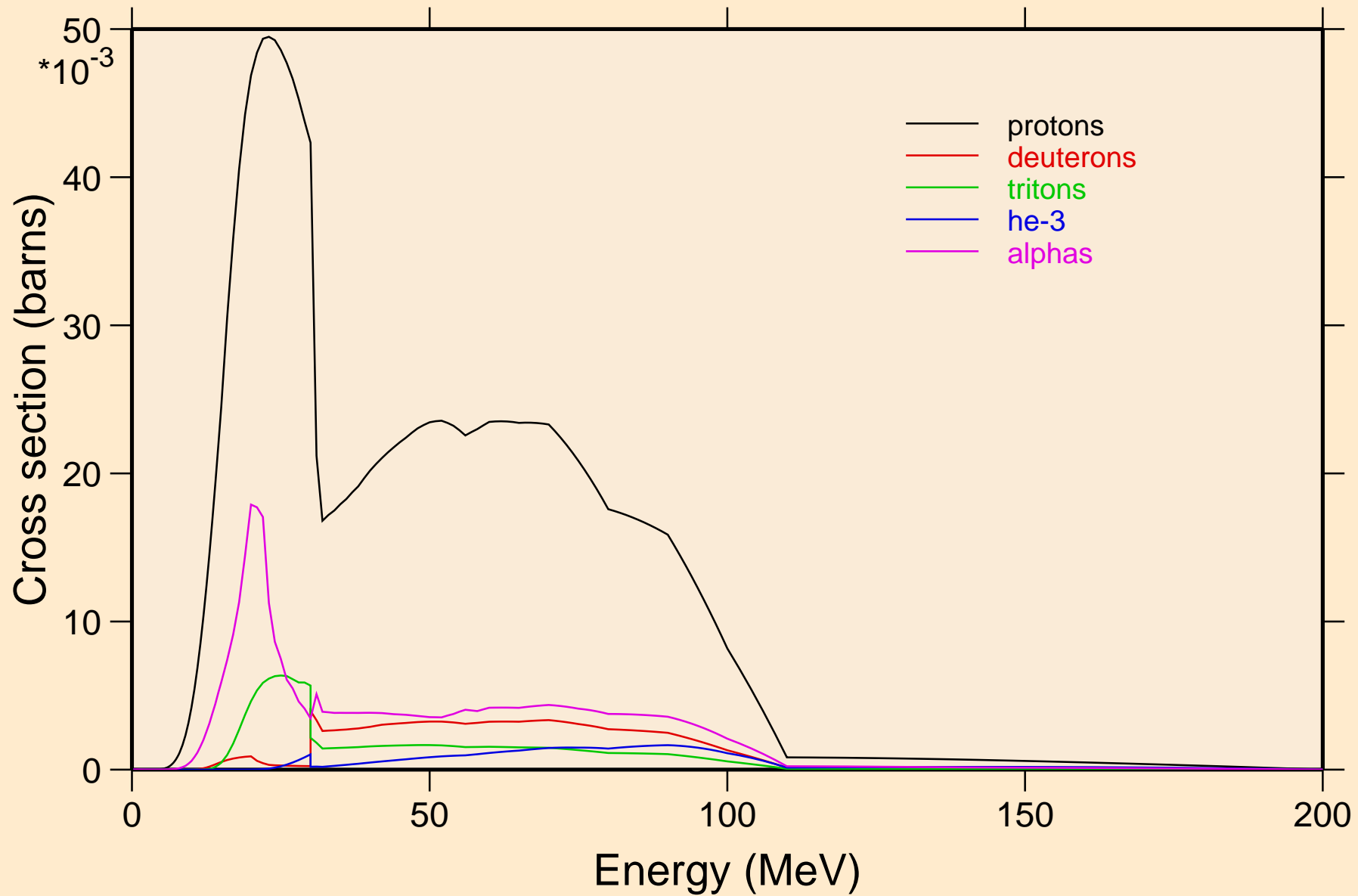

FM247M NEUTRON ACER TENDL-2021 LIBRARY; T=293.6K
protons from (n,x)

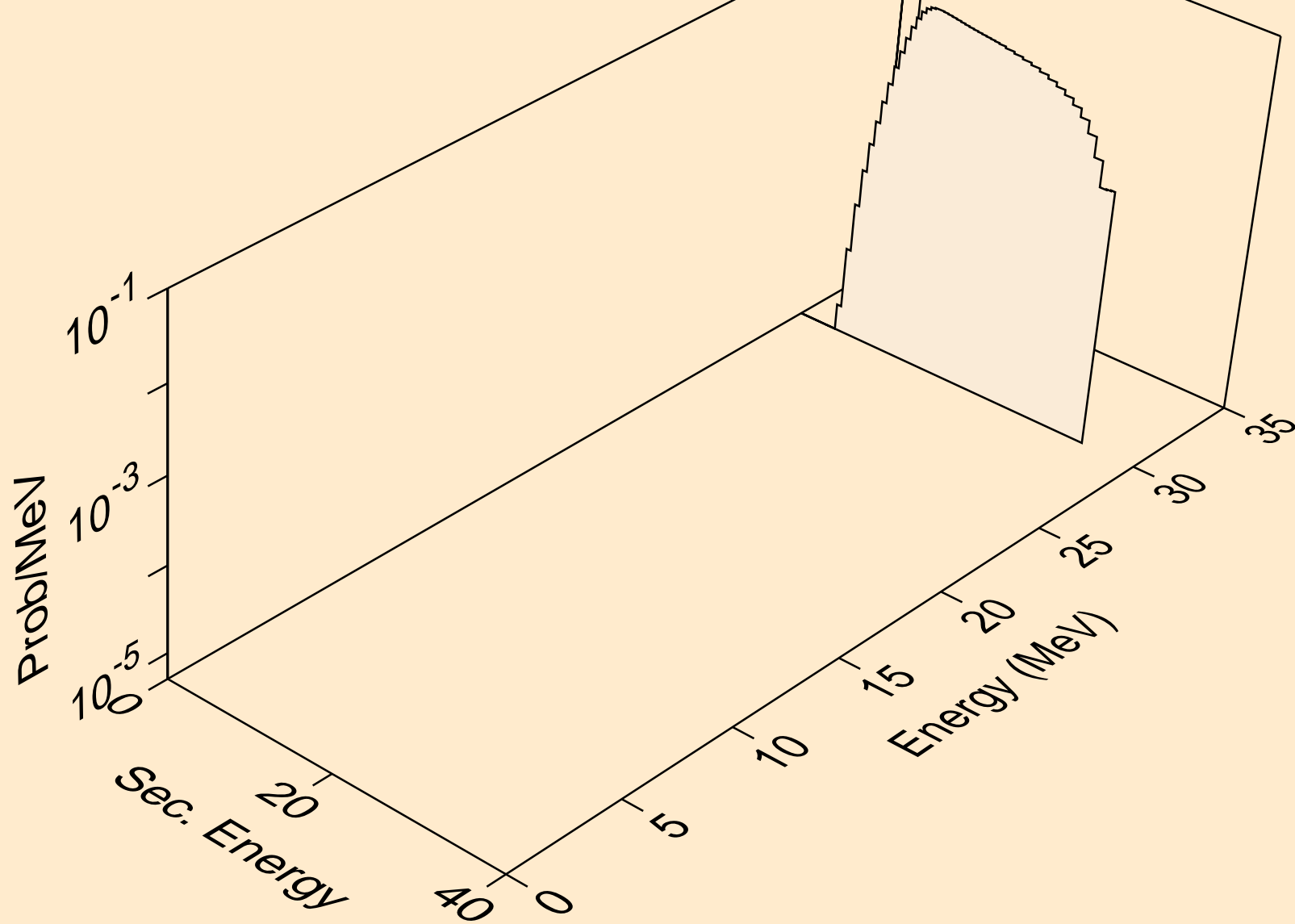

FM247M NEUTRON ACER TENDL-2021 LIBRARY; T=293.6K
protons from (n,n*)p

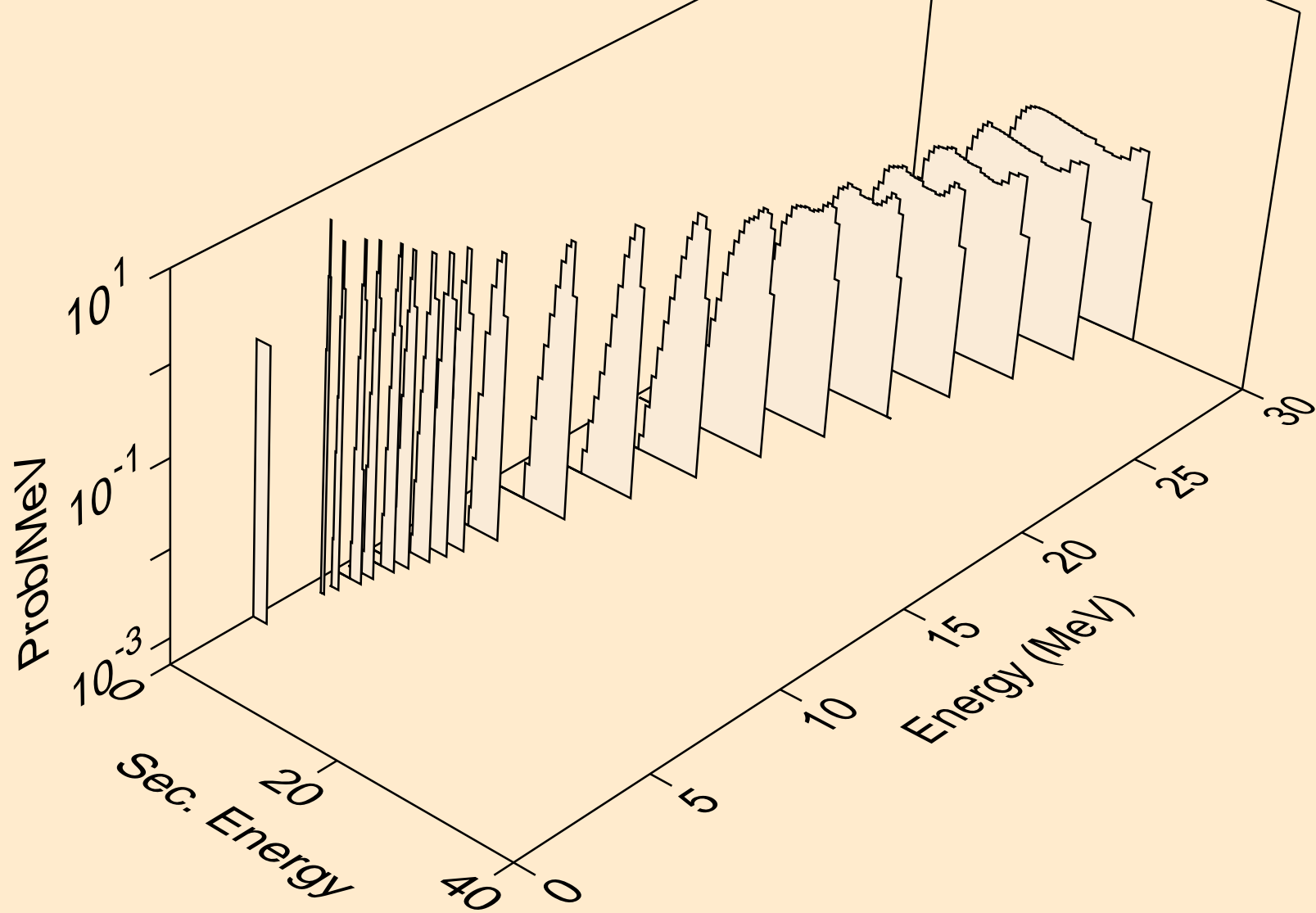

FM247M NEUTRON ACER TENDL-2021 LIBRARY; T=293.6K
protons from (n,2np)

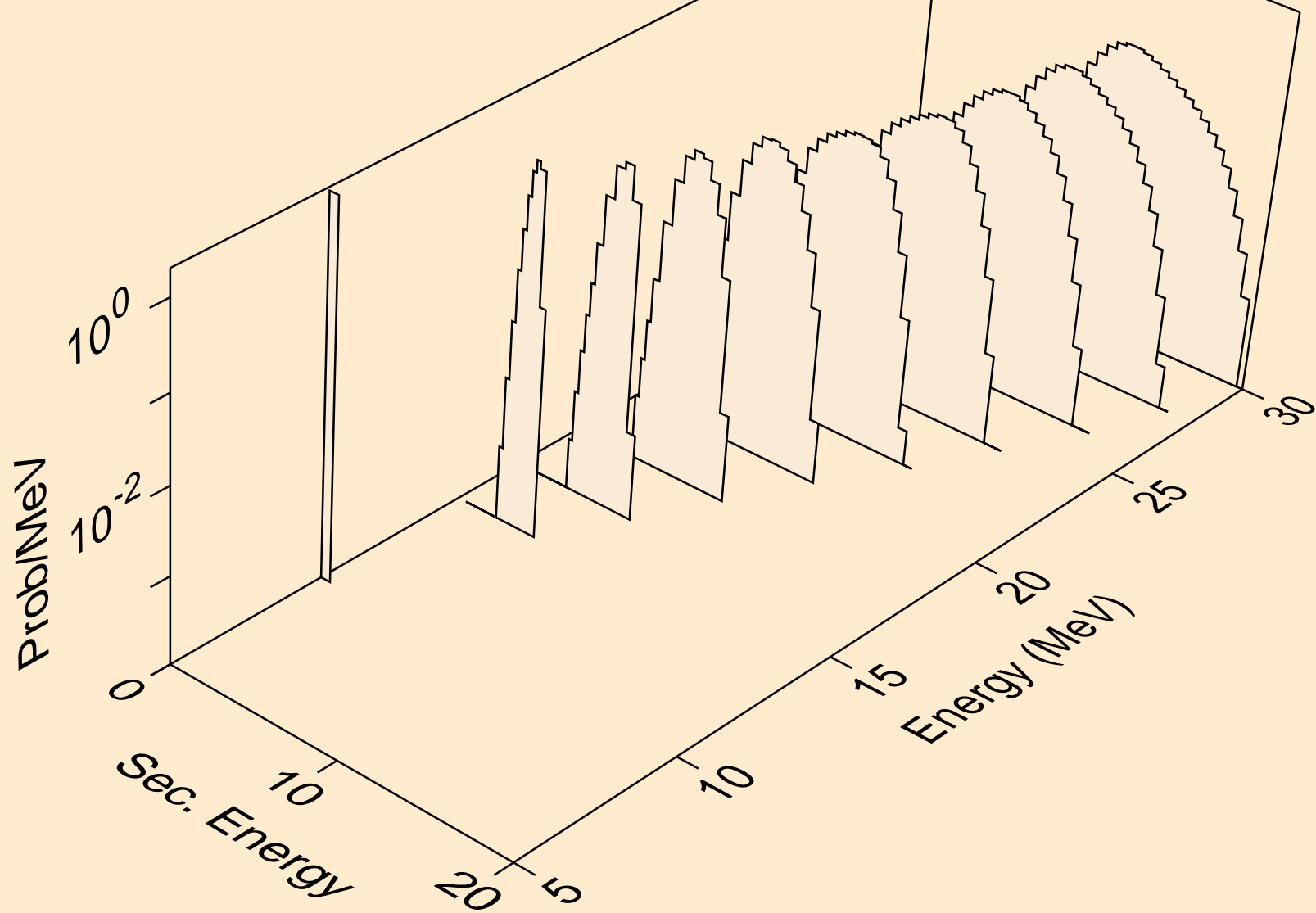

FM247M NEUTRON ACER TENDL-2021 LIBRARY; T=293.6K
protons from (n,3np)

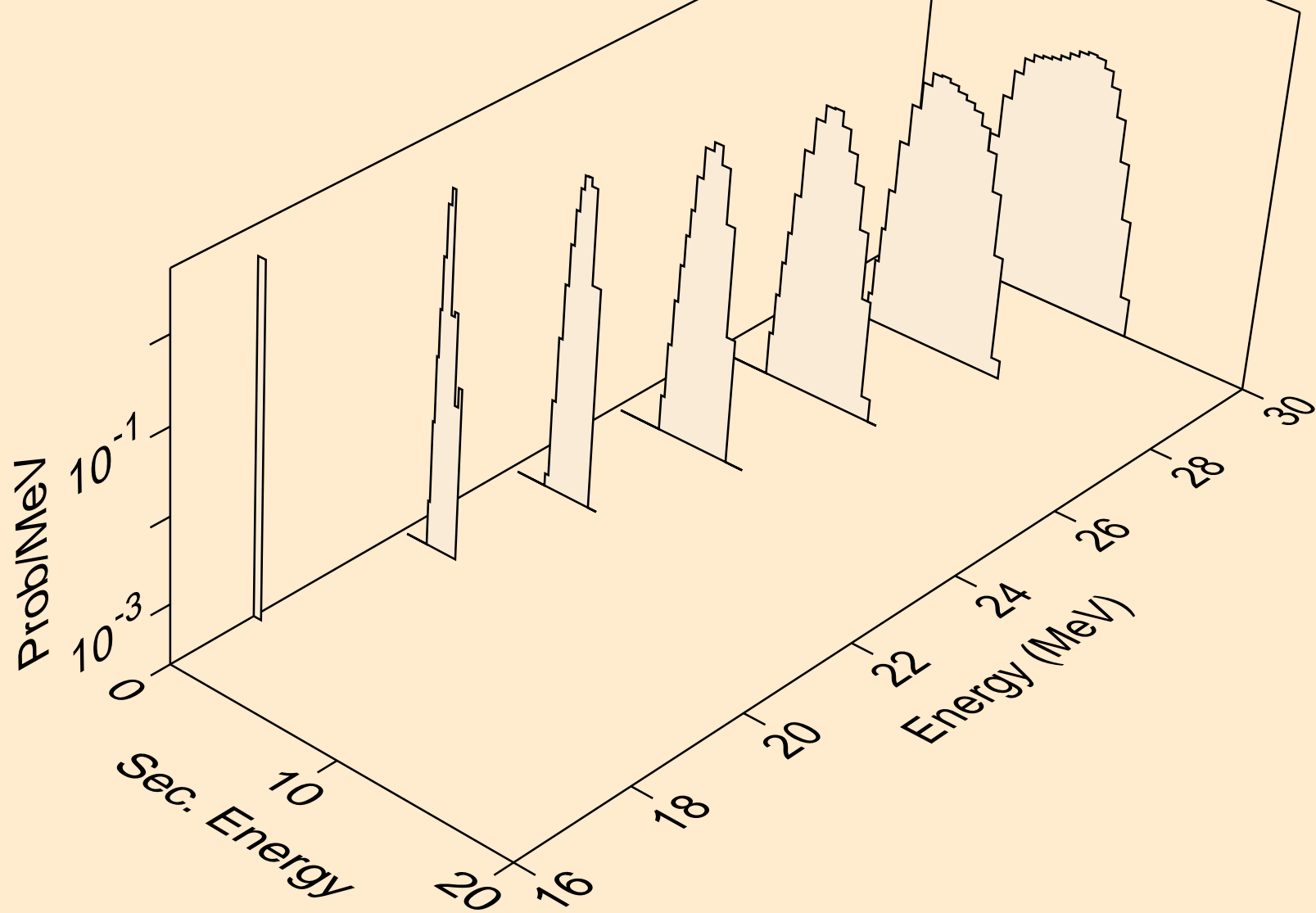

FM247M NEUTRON ACER TENDL-2021 LIBRARY; T=293.6K
protons from (n,2np)

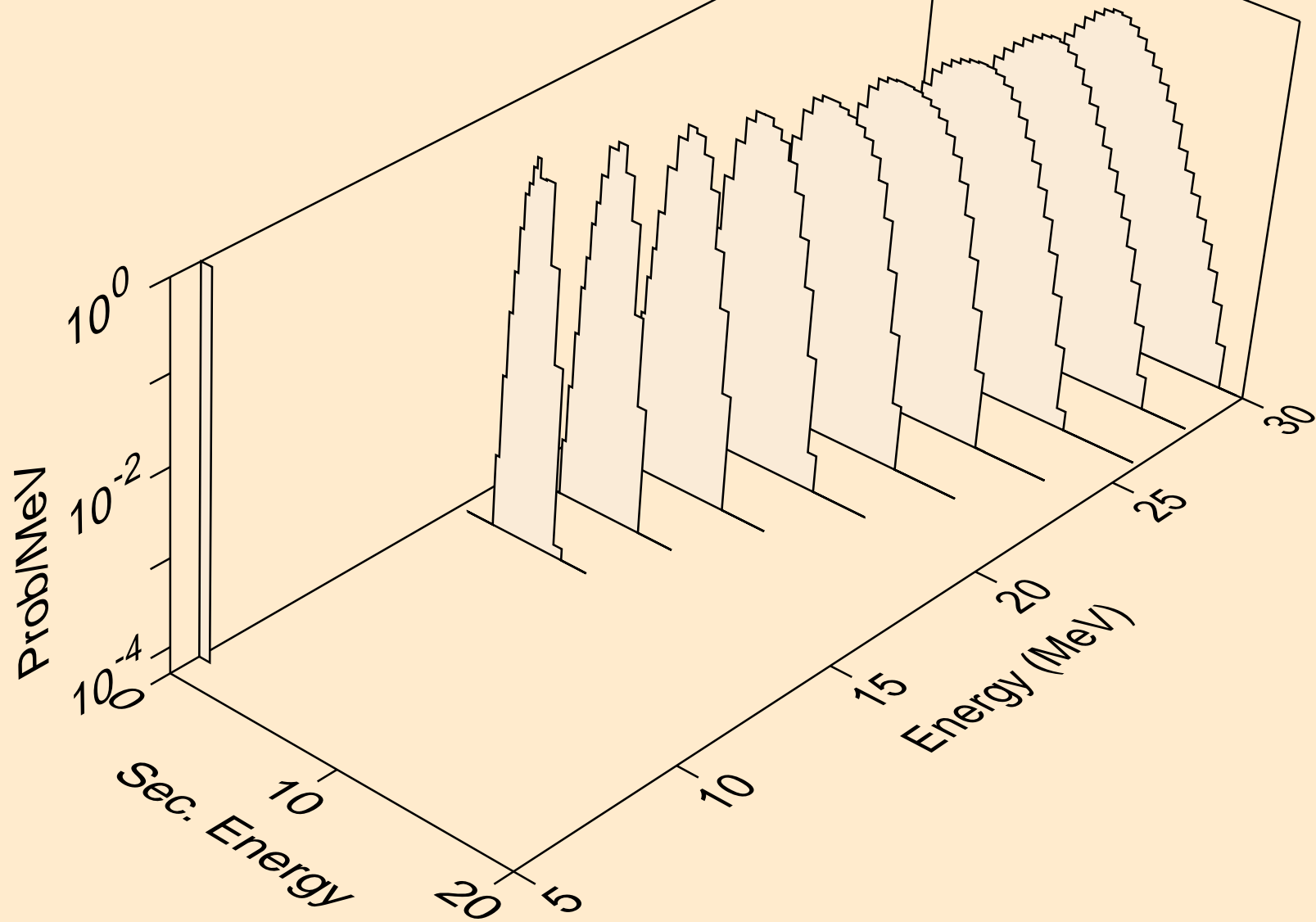

FM247M NEUTRON ACER TENDL-2021 LIBRARY; T=293.6K
protons from (n,npa)

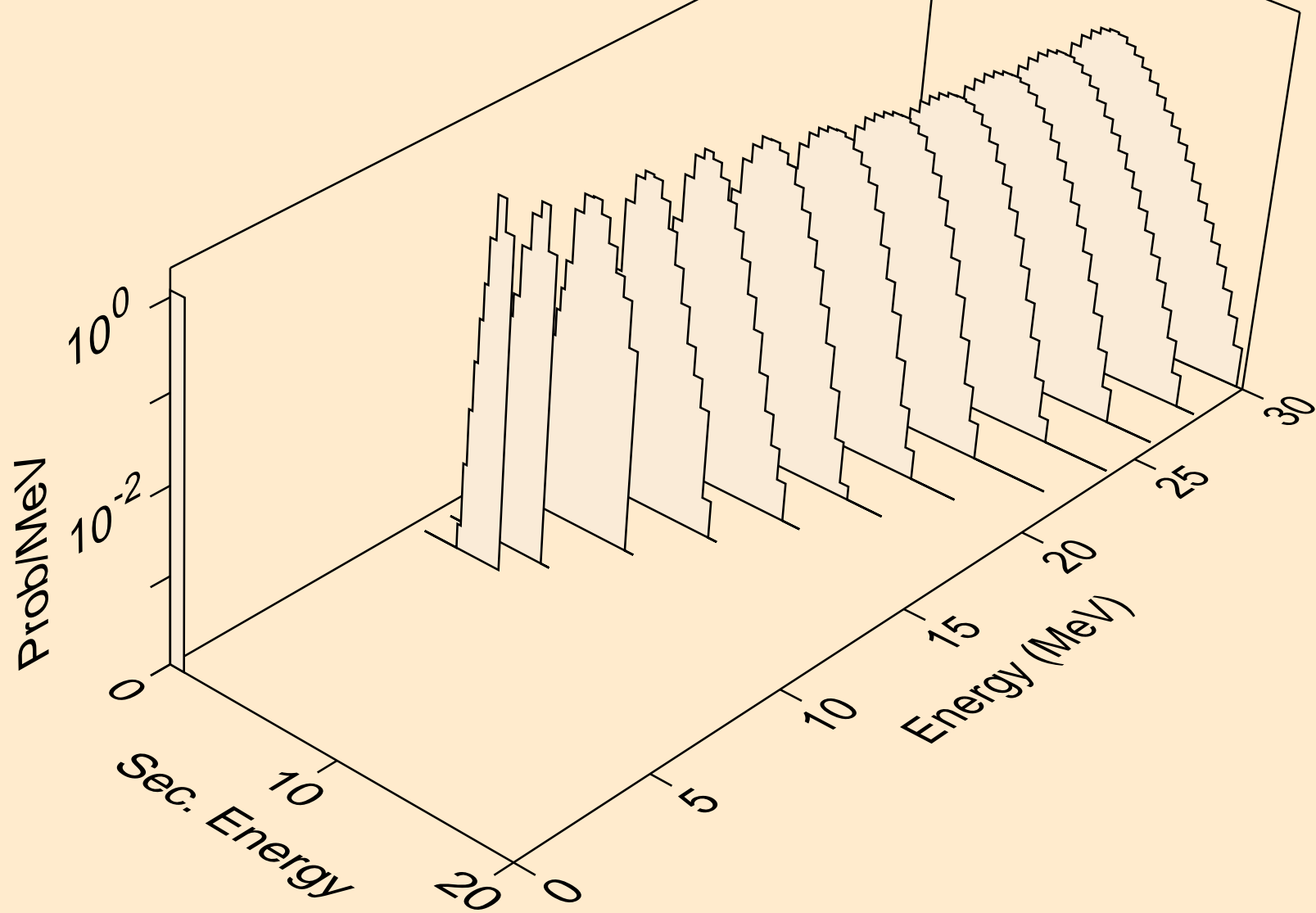

FM247M NEUTRON ACER TENDL-2021 LIBRARY; T=293.6K
protons from (n,p)

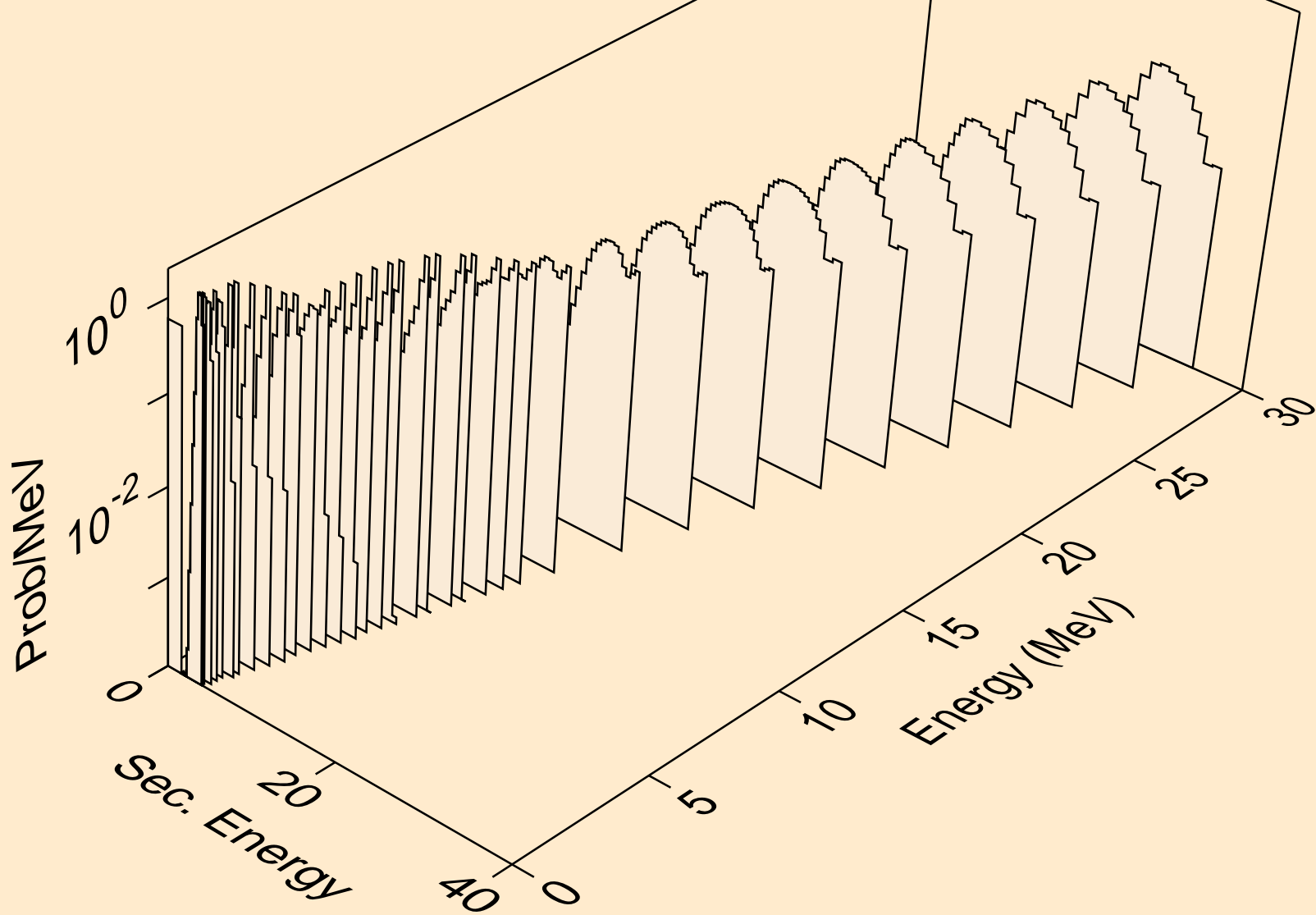

FM247M NEUTRON ACER TENDL-2021 LIBRARY; T=293.6K
protons from (n,2p)

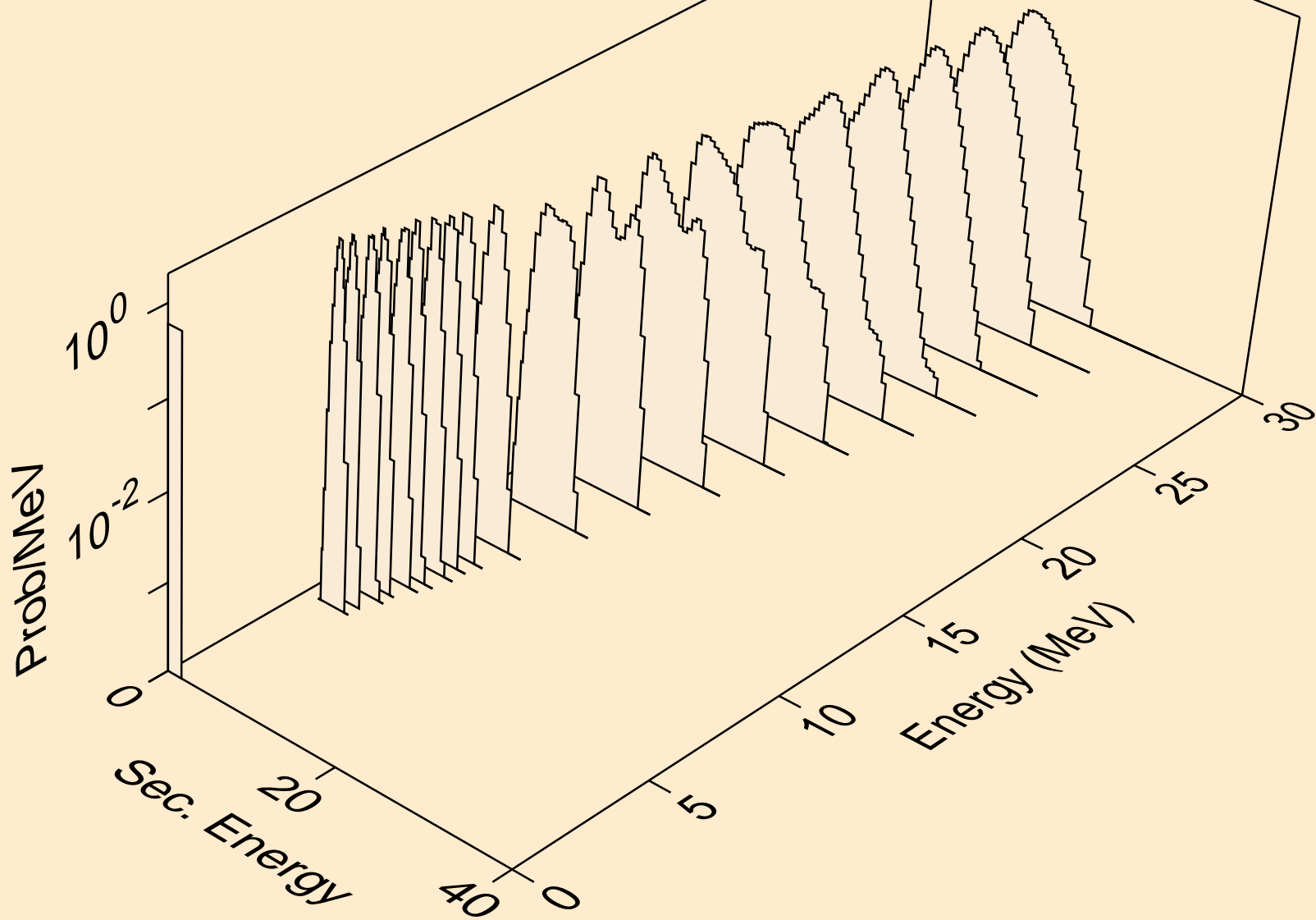

FM247M NEUTRON ACER TENDL-2021 LIBRARY; T=293.6K
protons from (n,p)

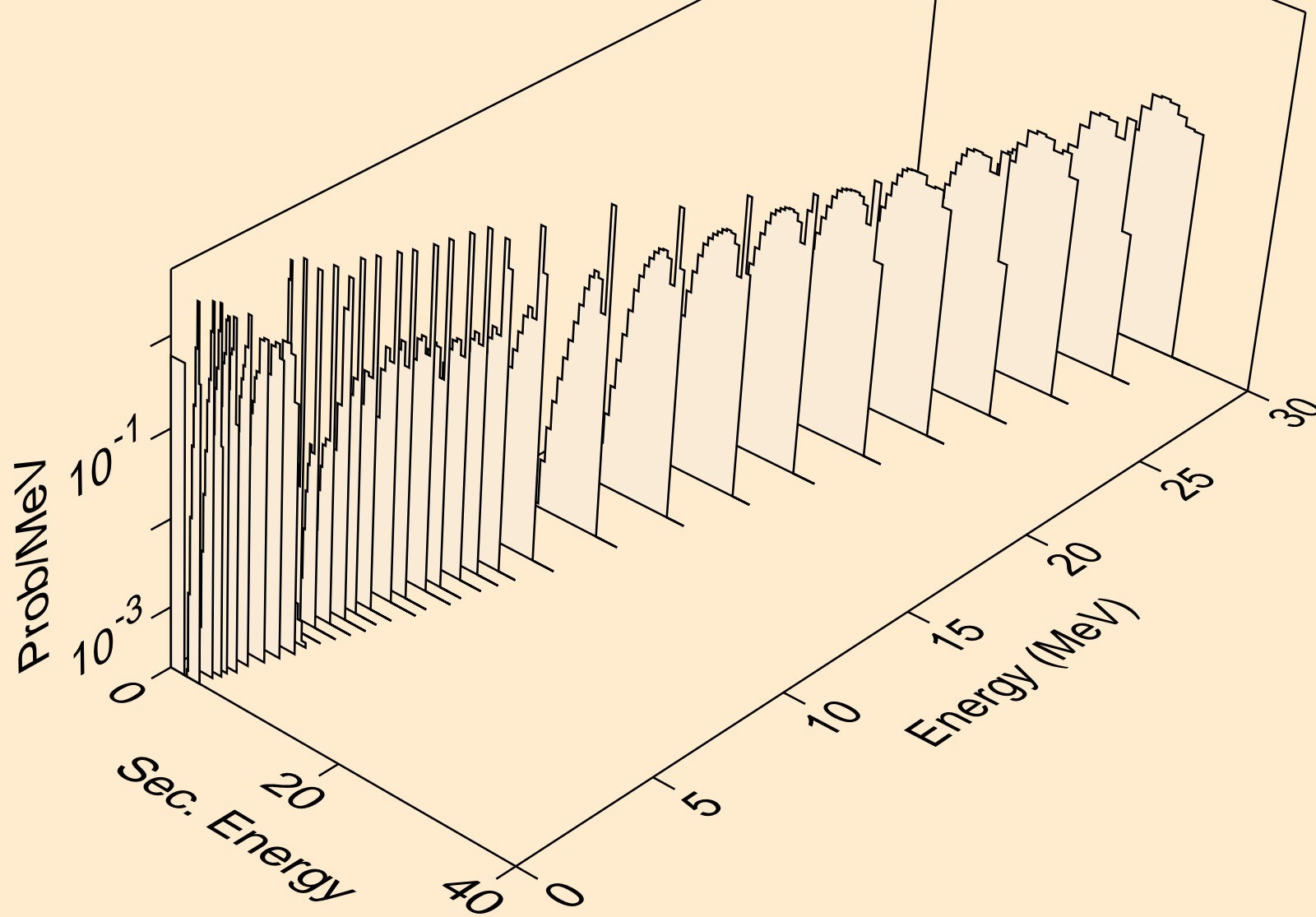

FM247M NEUTRON ACER TENDL-2021 LIBRARY; T=293.6K
protons from (n,pd)

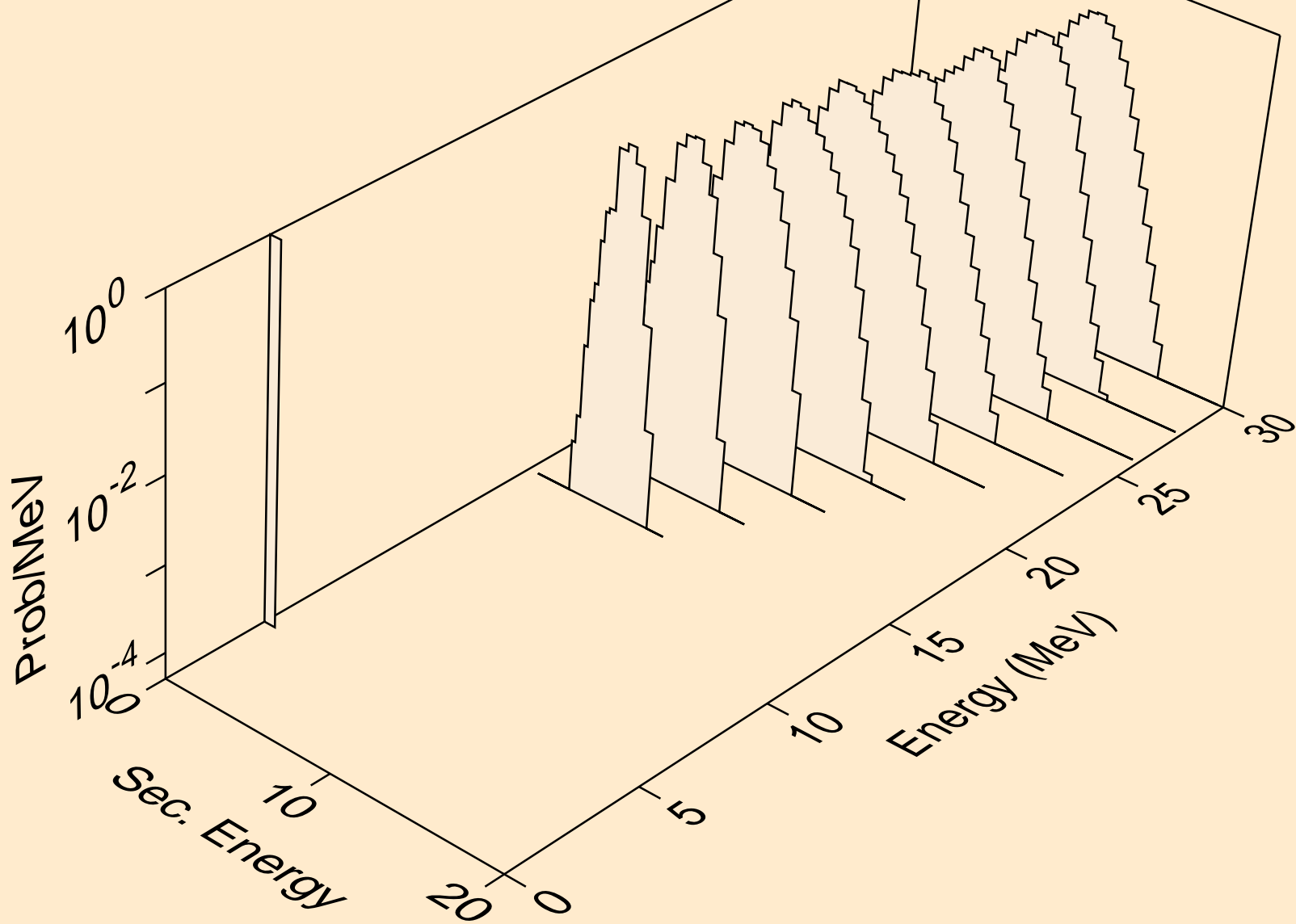

FM247M NEUTRON ACER TENDL-2021 LIBRARY; T=293.6K
protons from (n,pt)

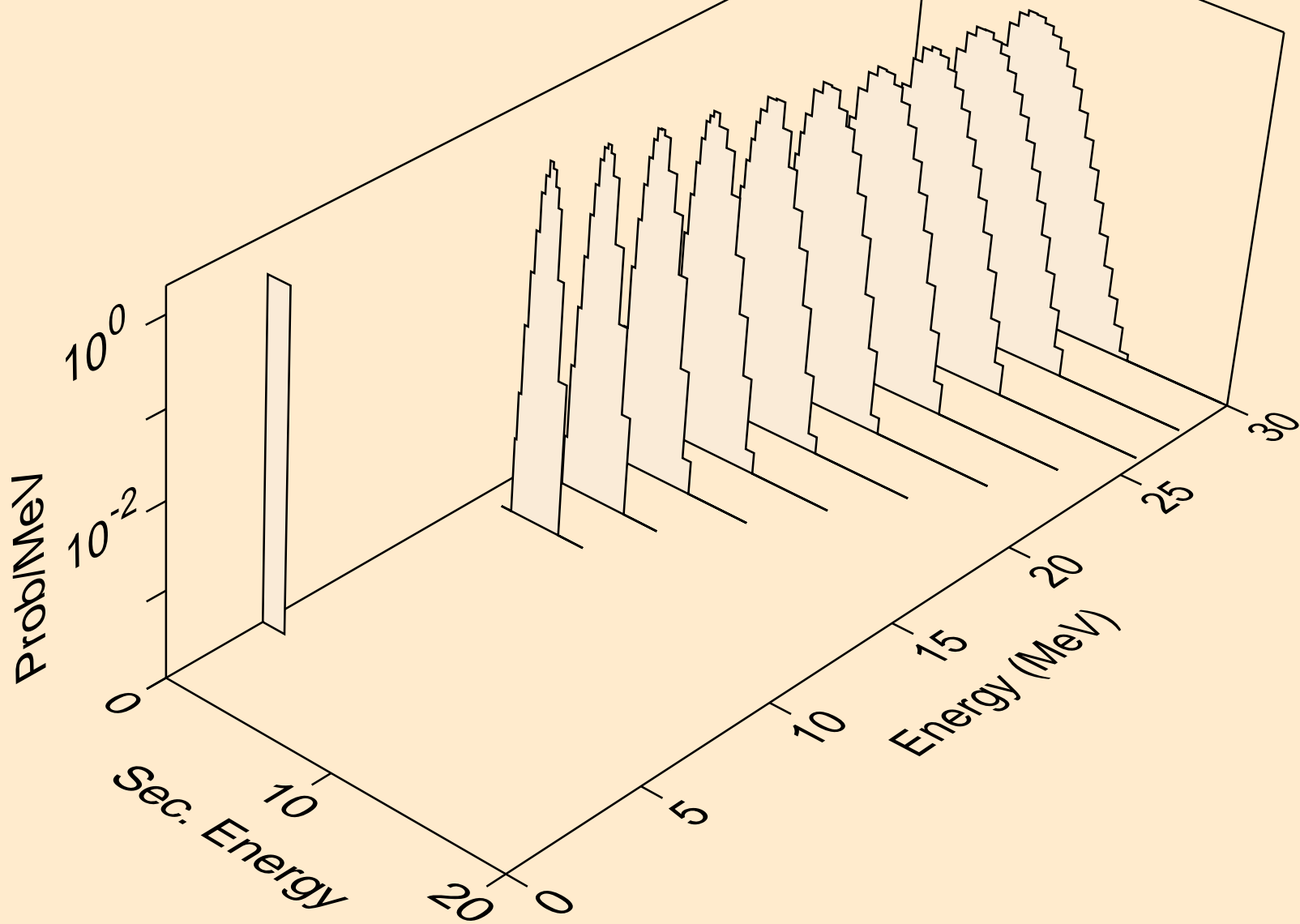

FM247M NEUTRON ACER TENDL-2021 LIBRARY; T=293.6K
deuterons from (n,x)

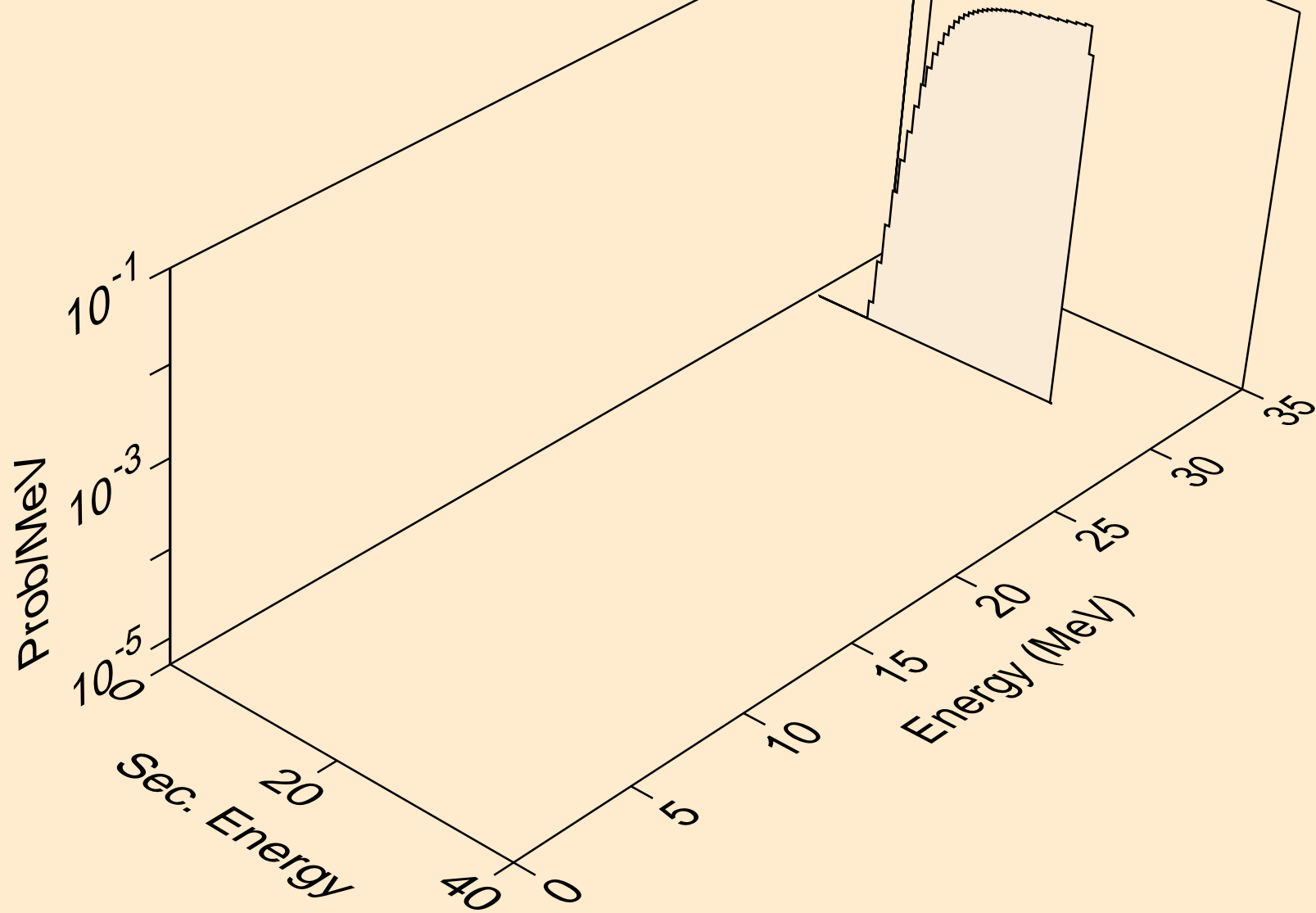

FM247M NEUTRON ACER TENDL-2021 LIBRARY; T=293.6K
deuterons from (n,2nd)

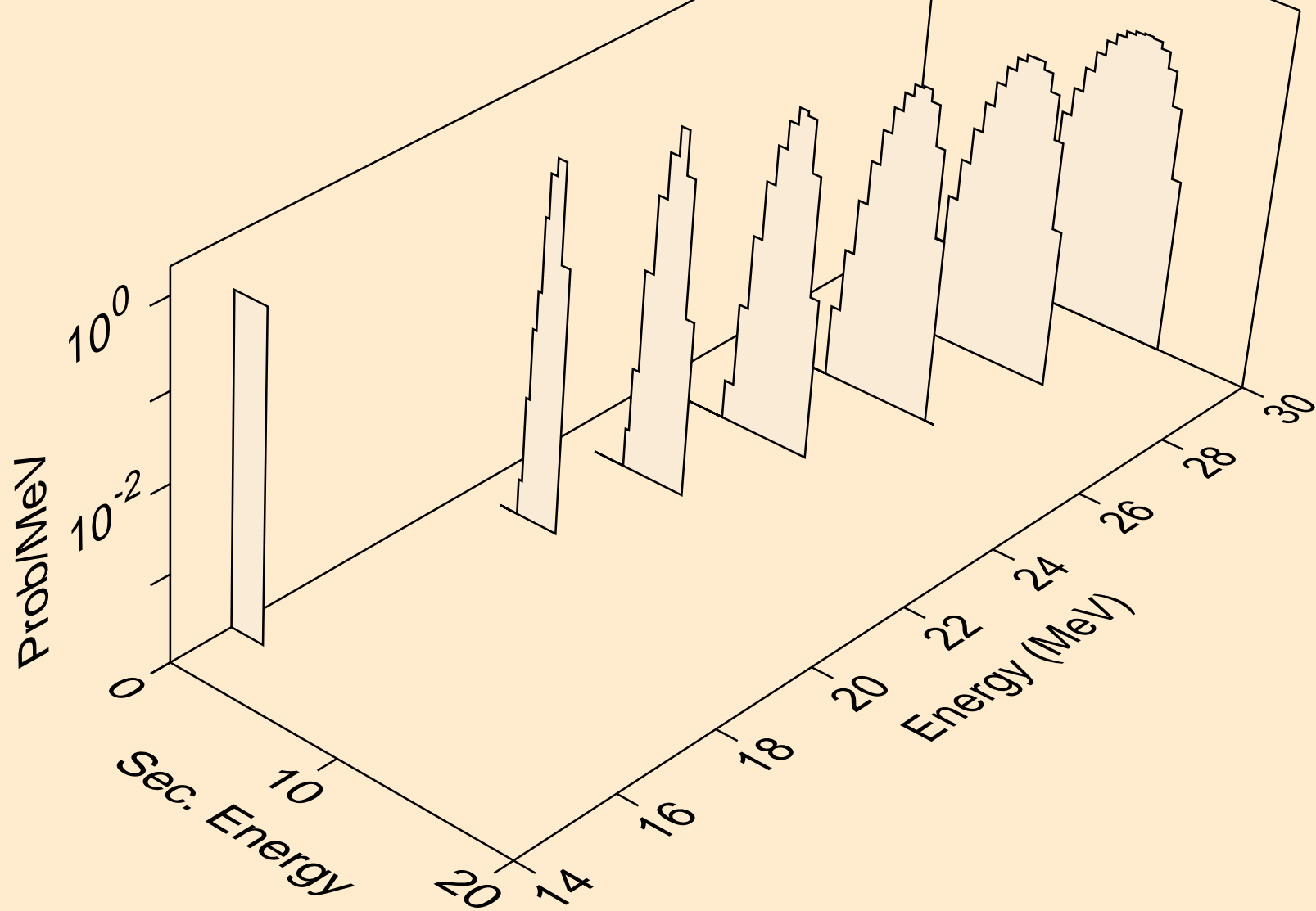

FM247M NEUTRON ACER TENDL-2021 LIBRARY; T=293.6K
deuterons from (n,n*)d

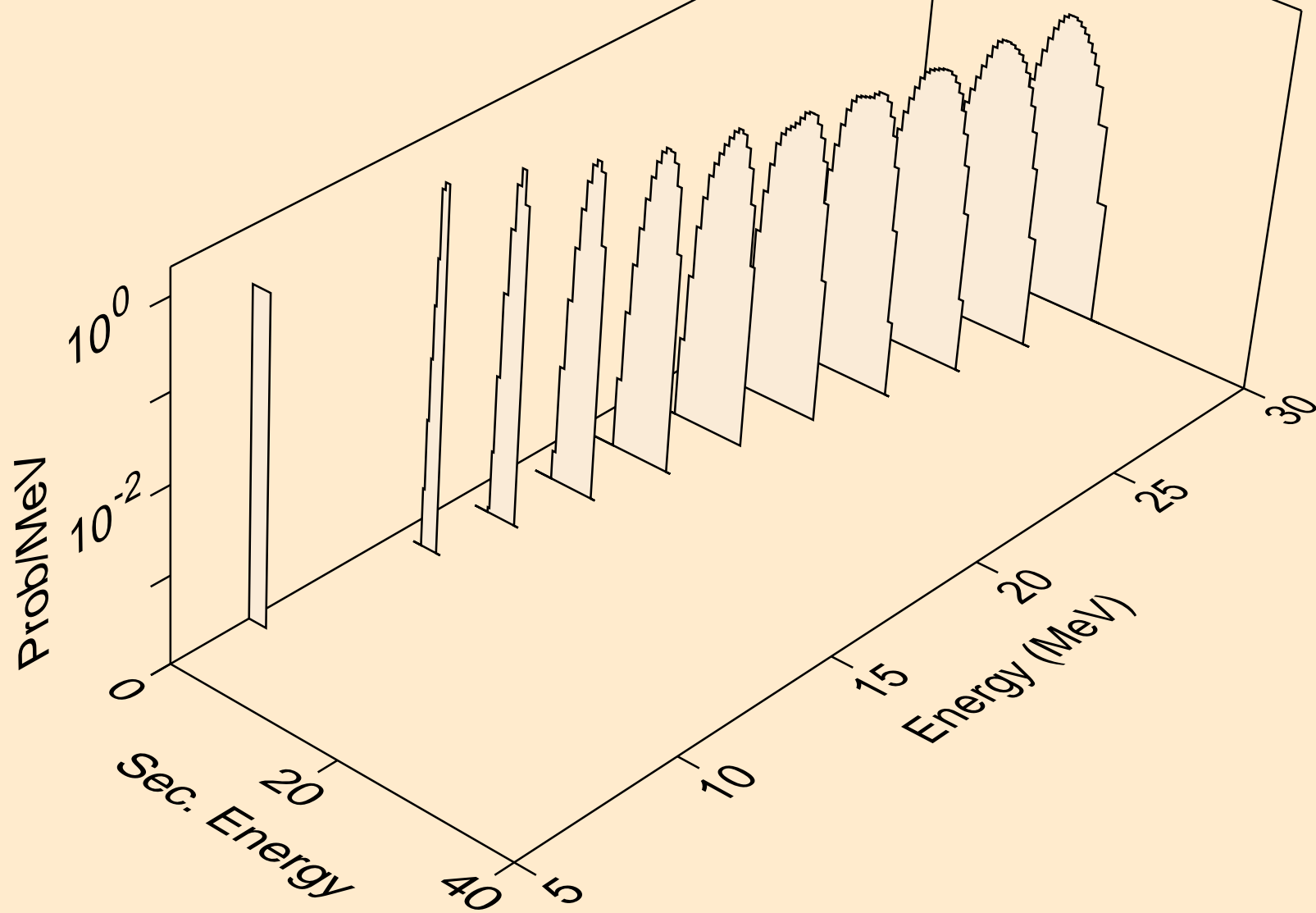

FM247M NEUTRON ACER TENDL-2021 LIBRARY; T=293.6K
deuterons from (n,d)

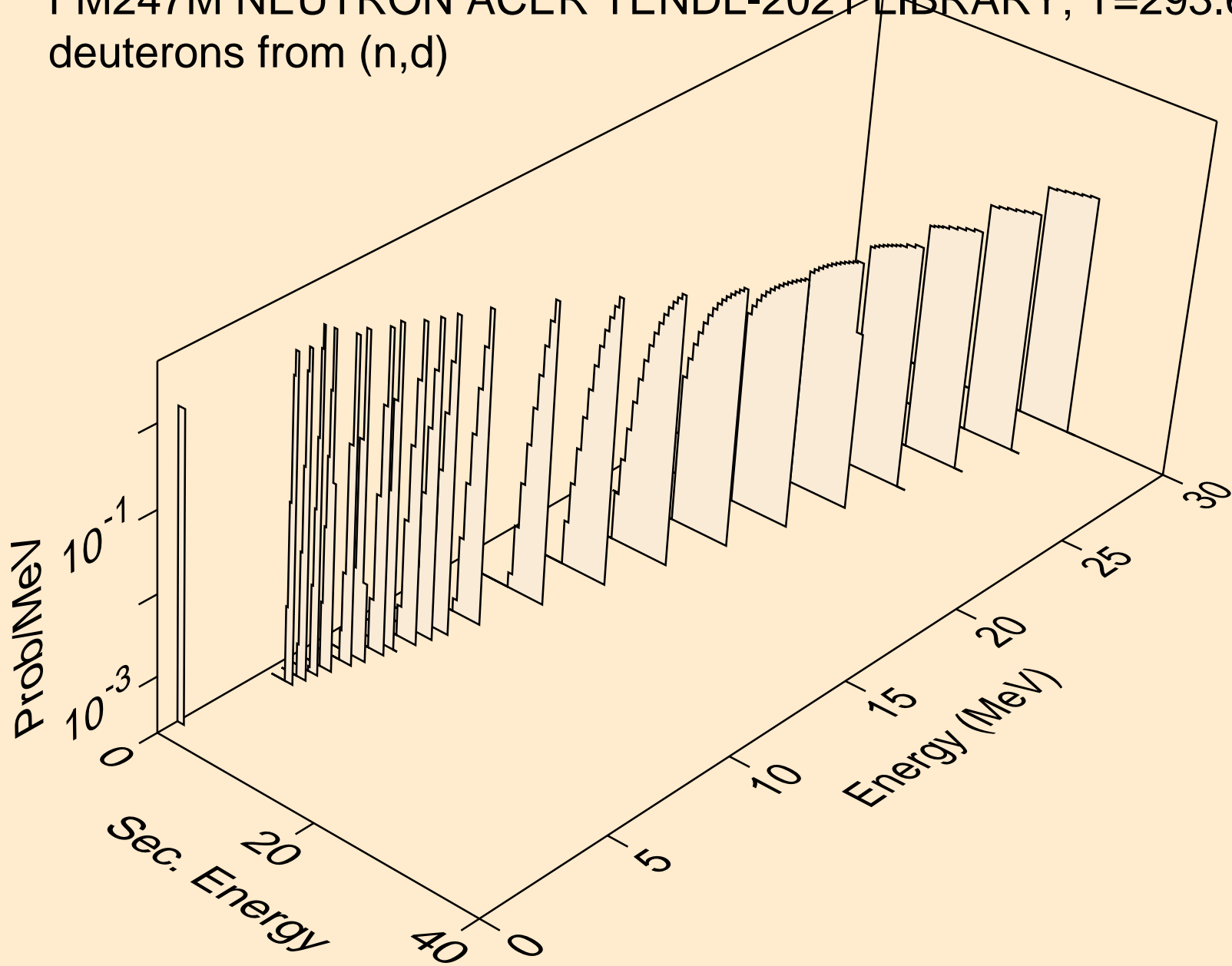

FM247M NEUTRON ACER TENDL-2021 LIBRARY; T=293.6K
deuterons from (n,pd)

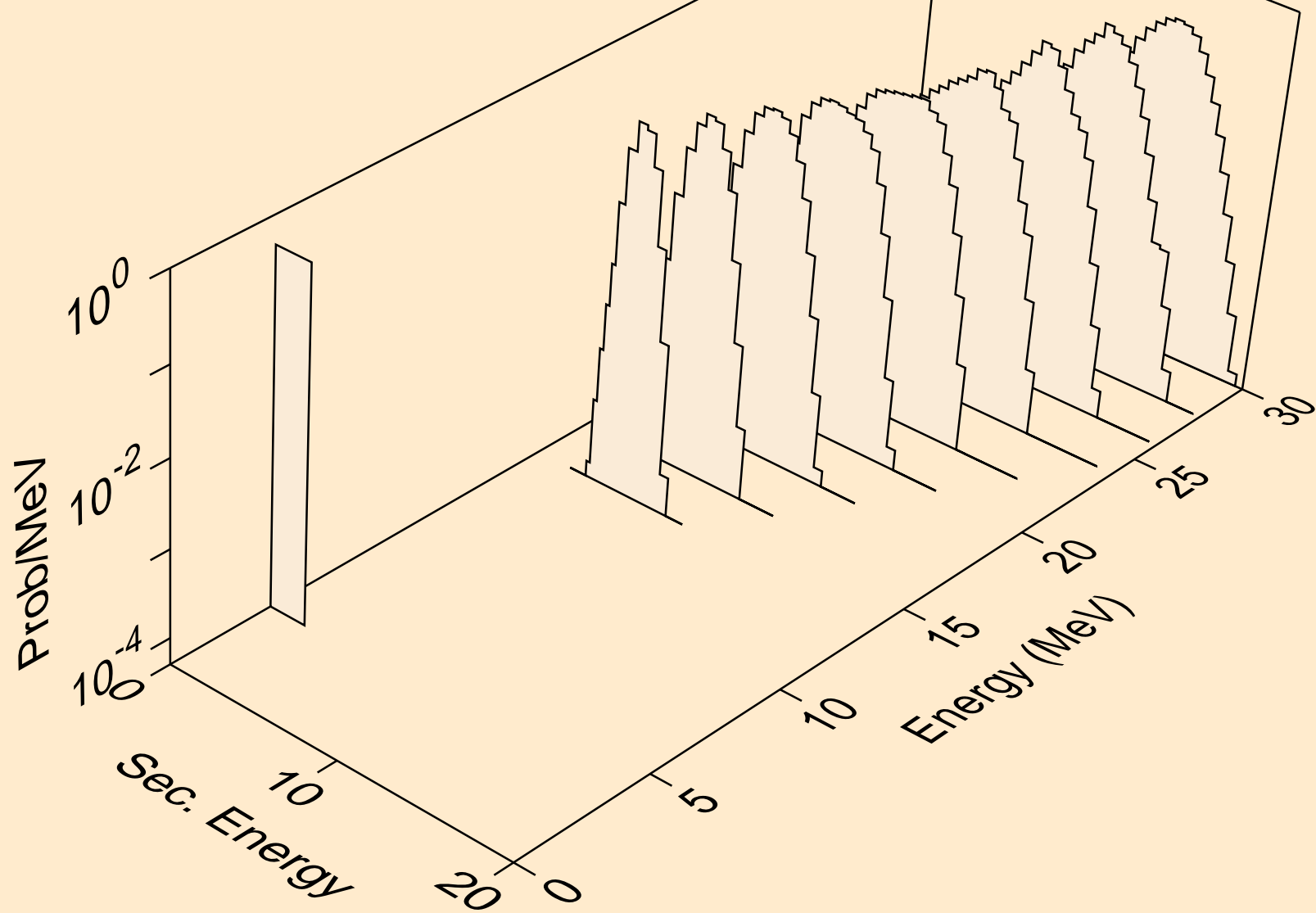

FM247M NEUTRON ACER TENDL-2021 LIBRARY; T=293.6K
tritons from (n,x)

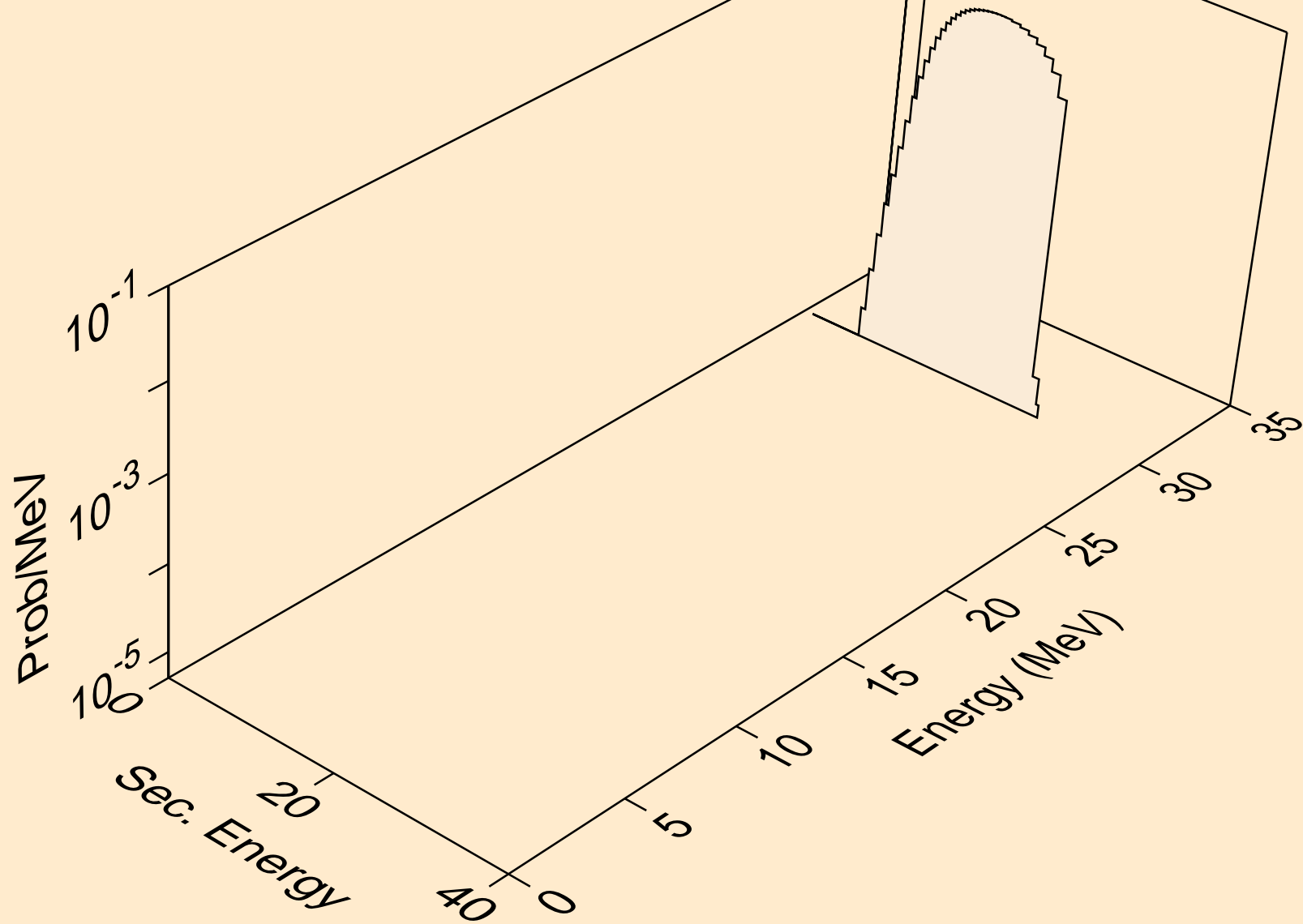

FM247M NEUTRON ACER TENDL-2021 LIBRARY; T=293.6K
tritons from (n,n*)t

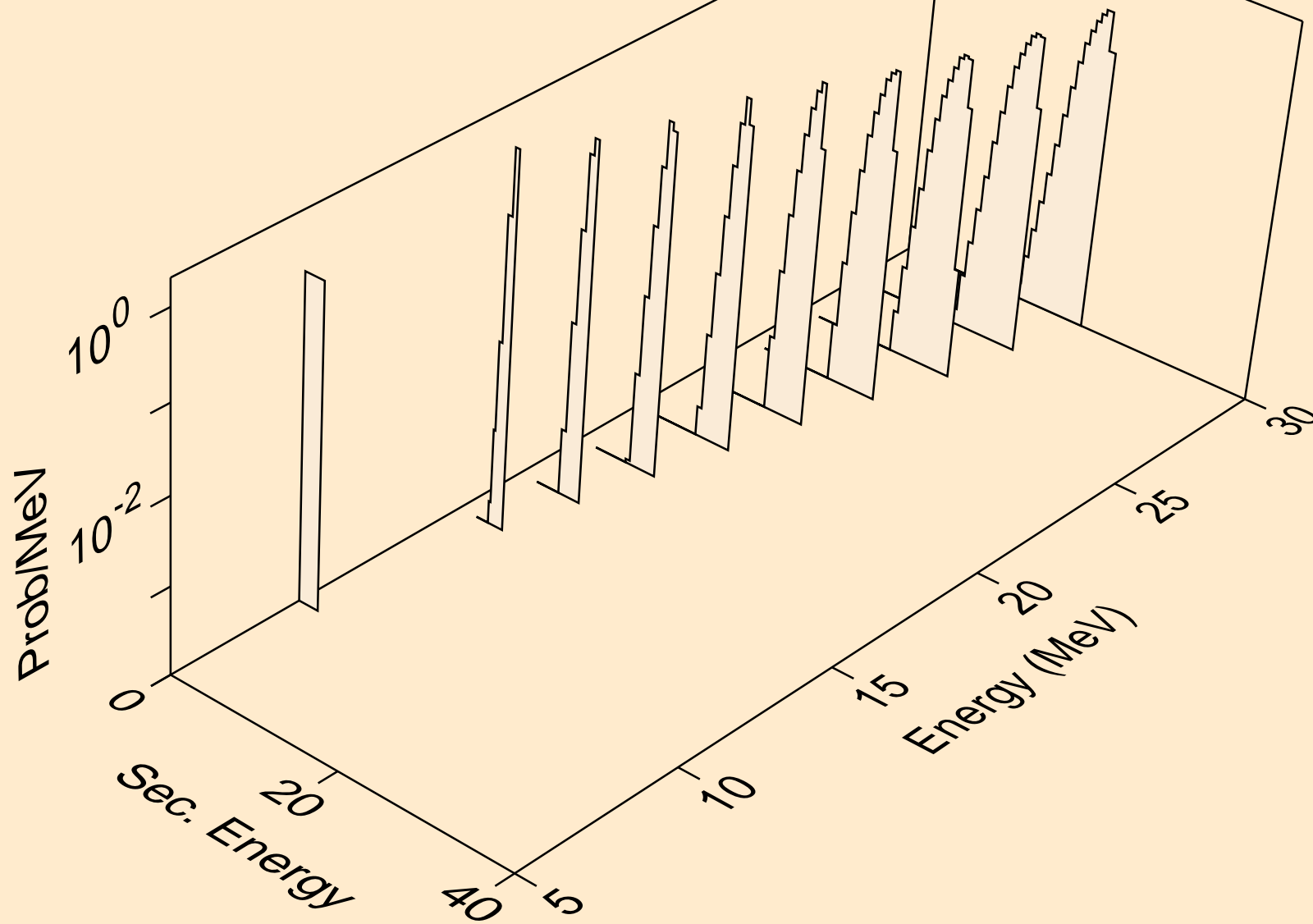

FM247M NEUTRON ACER TENDL-2021 LIBRARY; T=293.6K
tritons from (n,t)

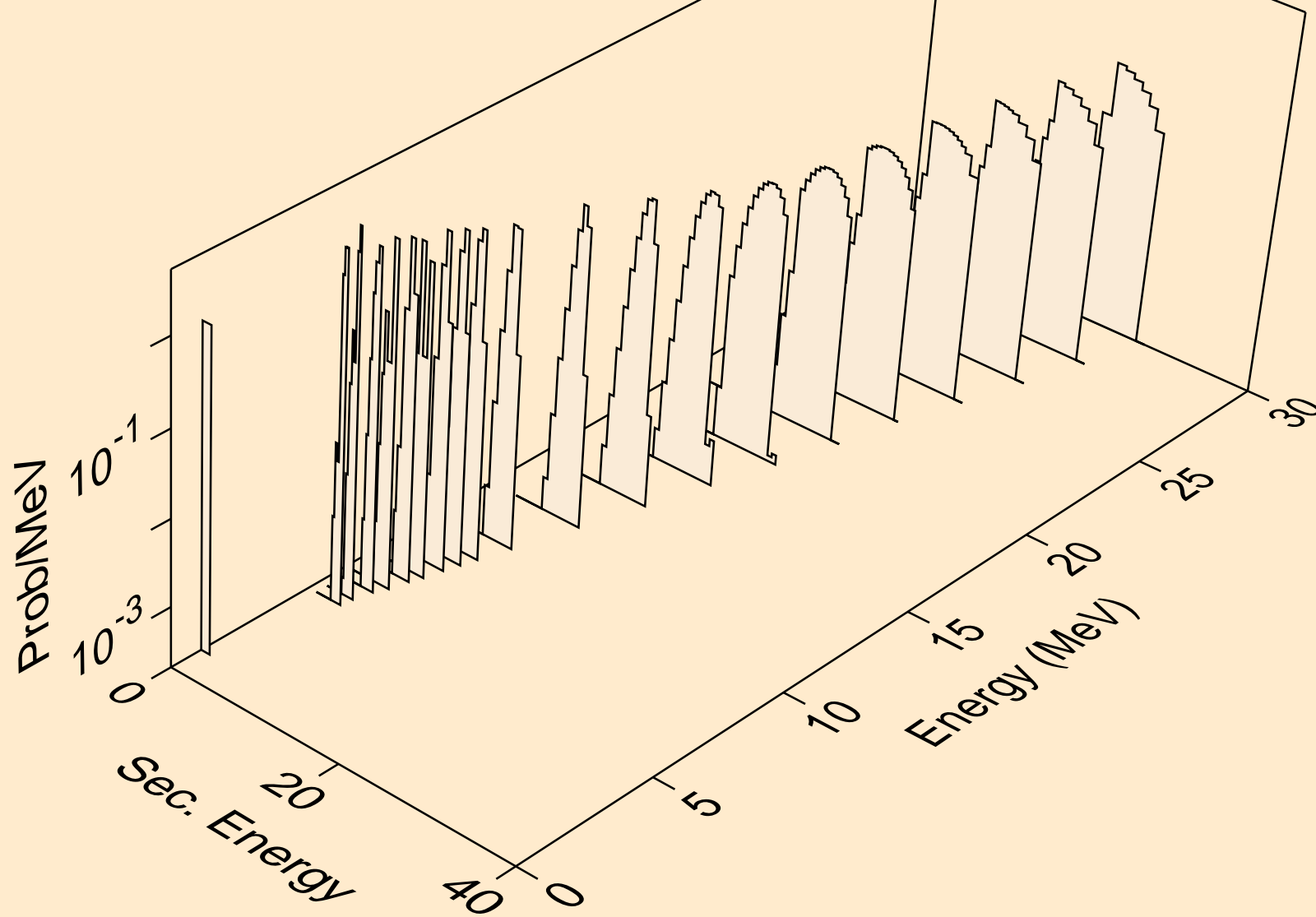

FM247M NEUTRON ACER TENDL-2021 LIBRARY; T=293.6K
tritons from (n,pt)

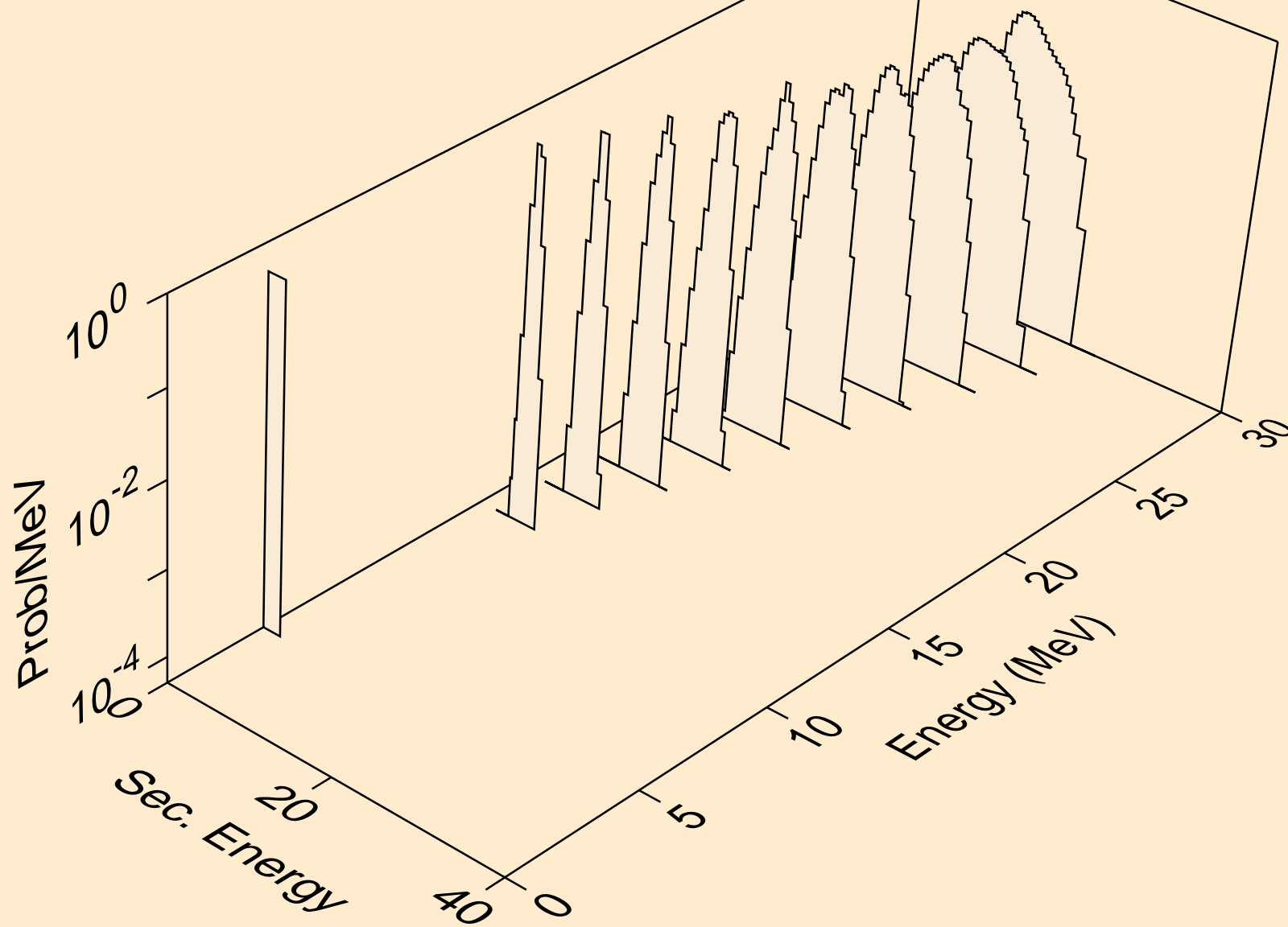

FM247M NEUTRON ACER TENDL-2021 LIBRARY; T=293.6K
he3s from (n,x)

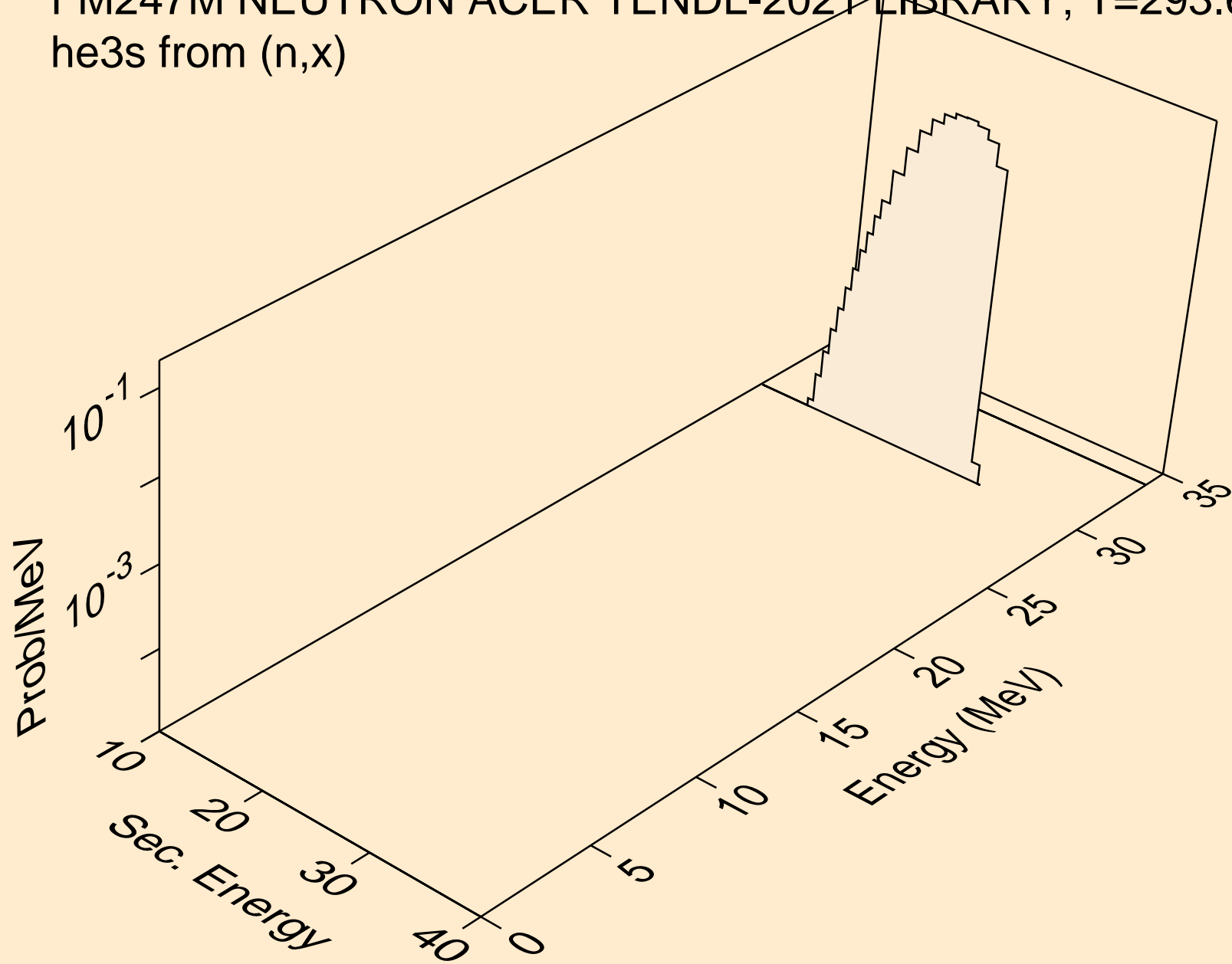

FM247M NEUTRON ACER TENDL-2021 LIBRARY; T=293.6K
he3s from (n,n*)he3

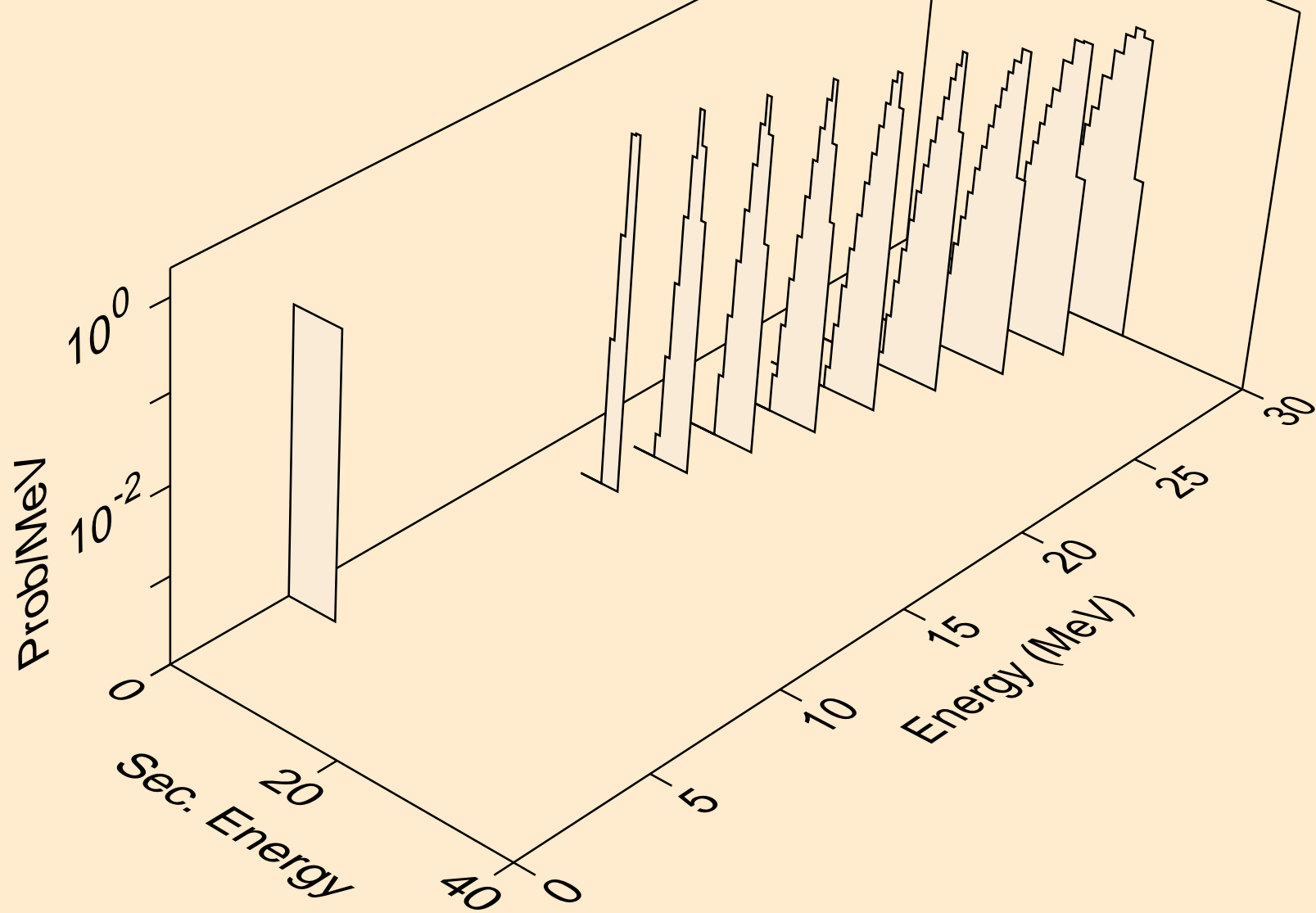

FM247M NEUTRON ACER TENDL-2021 LIBRARY; T=293.6K
he3s from (n,he3)

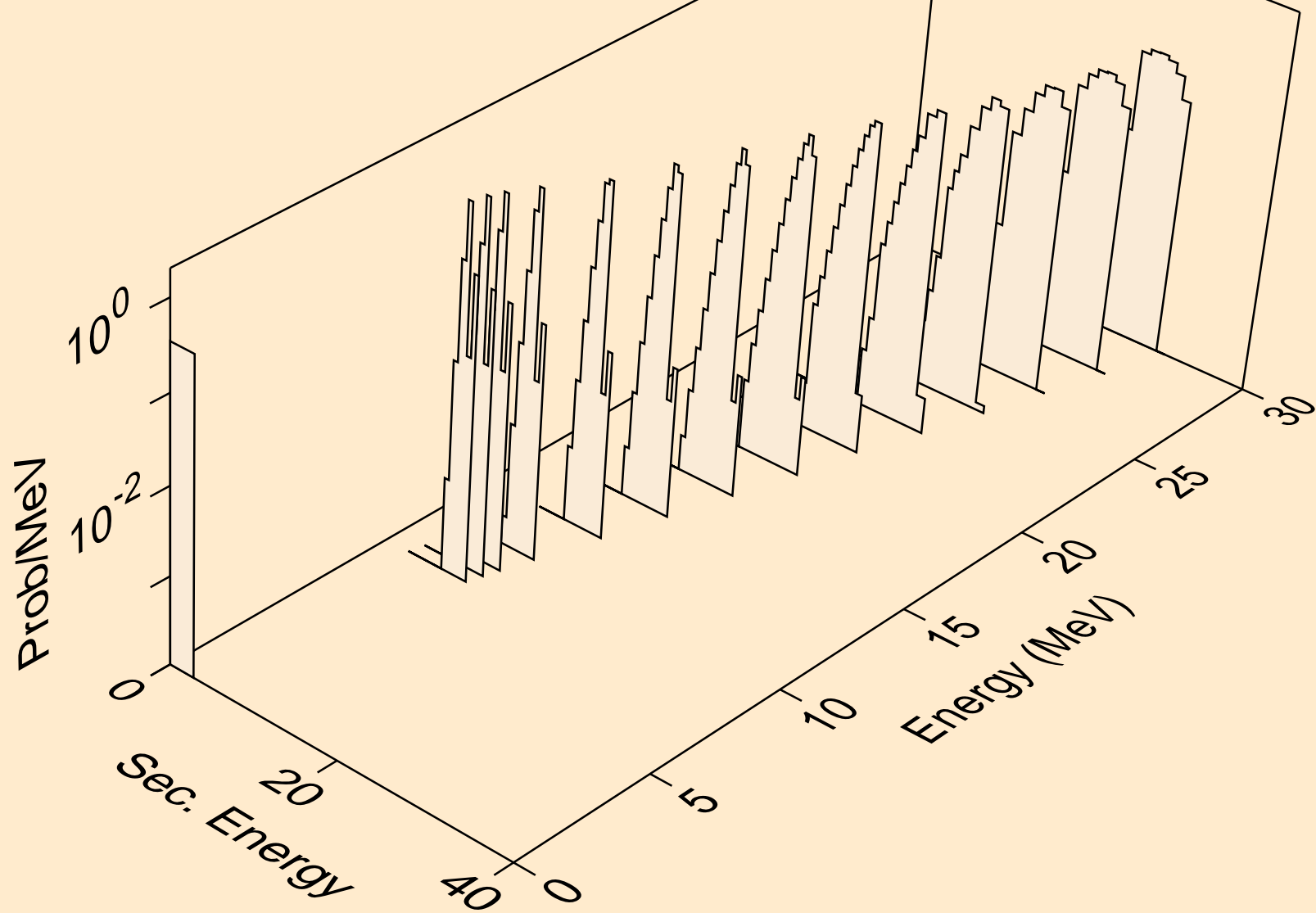

FM247M NEUTRON ACER TENDL-2021 LIBRARY; T=293.6K
alphas from (n,x)

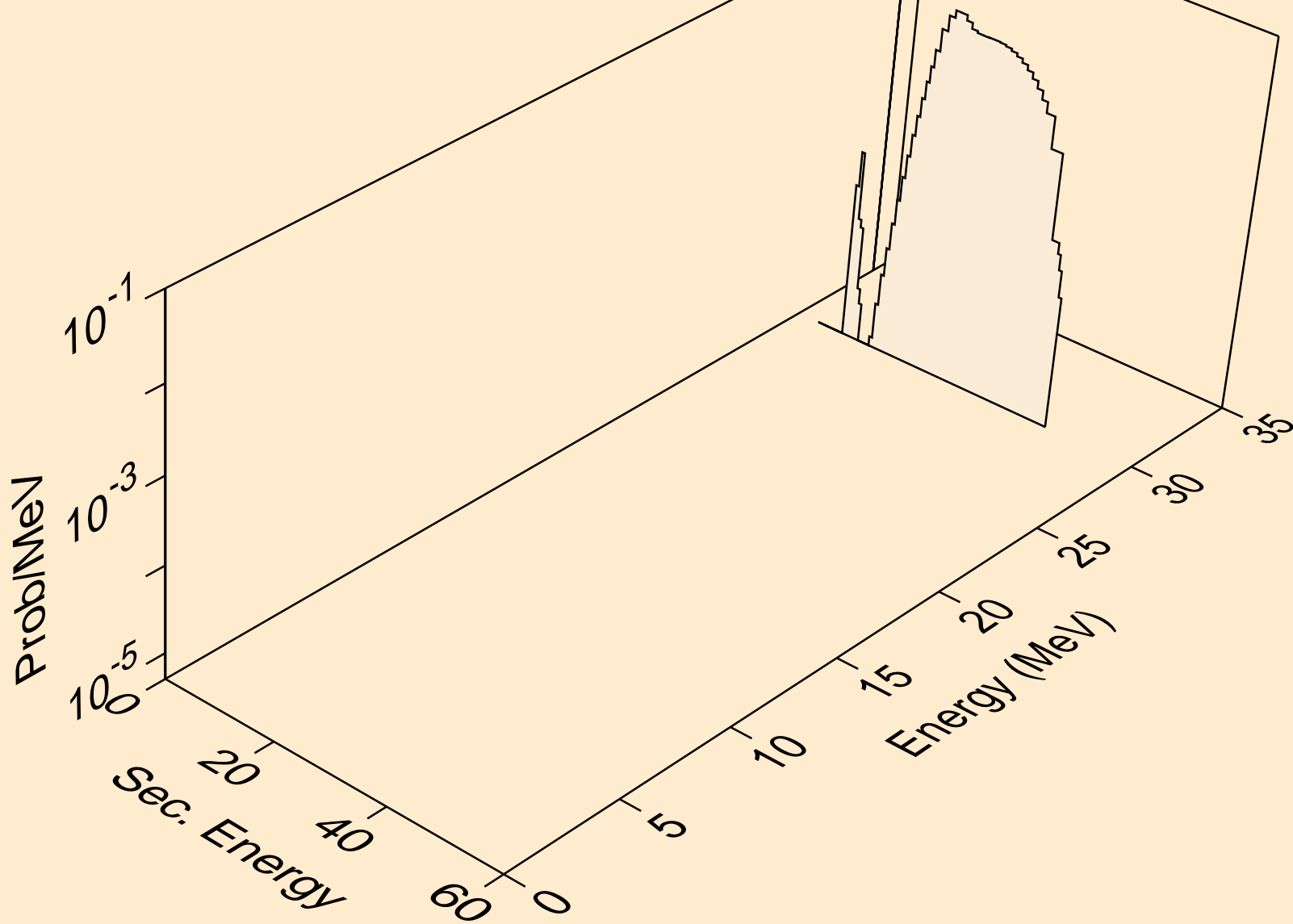

FM247M NEUTRON ACER TENDL-2021 LIBRARY; T=293.6K
alphas from (n,n*)a

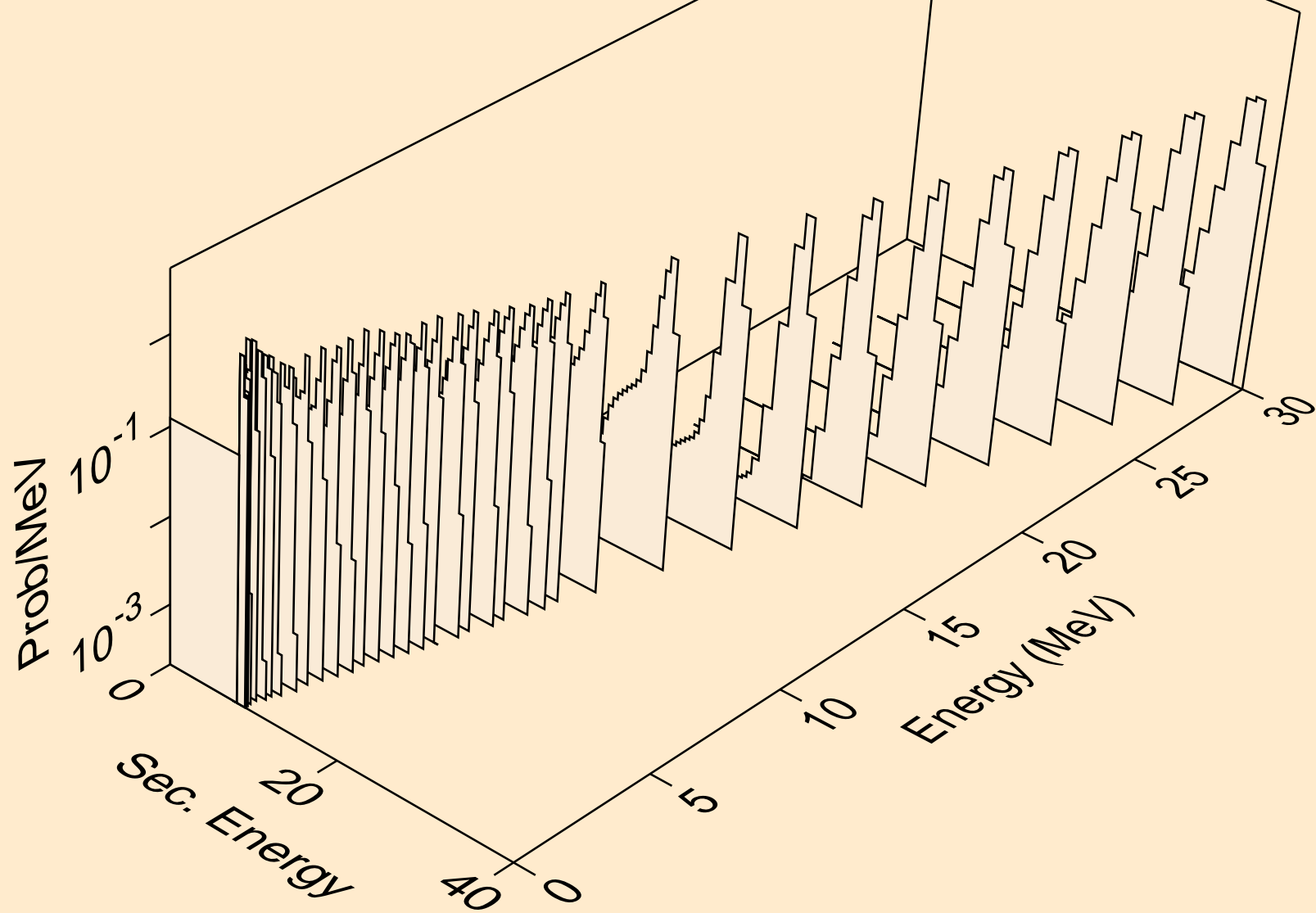

FM247M NEUTRON ACER TENDL-2021 LIBRARY; T=293.6K
alphas from (n,2n)a

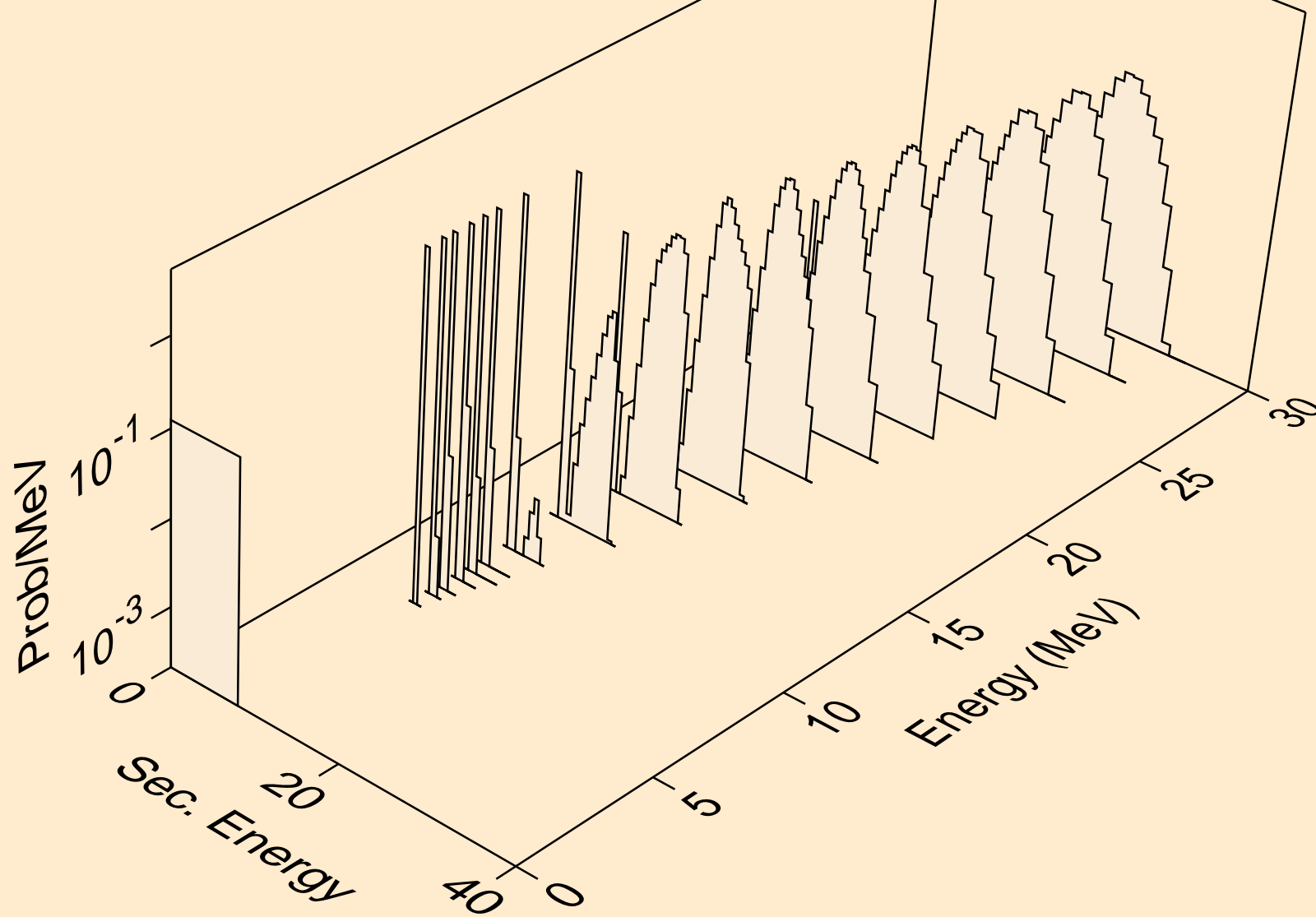

FM247M NEUTRON ACER TENDL-2021 LIBRARY; T=293.6K
alphas from (n,3n)a

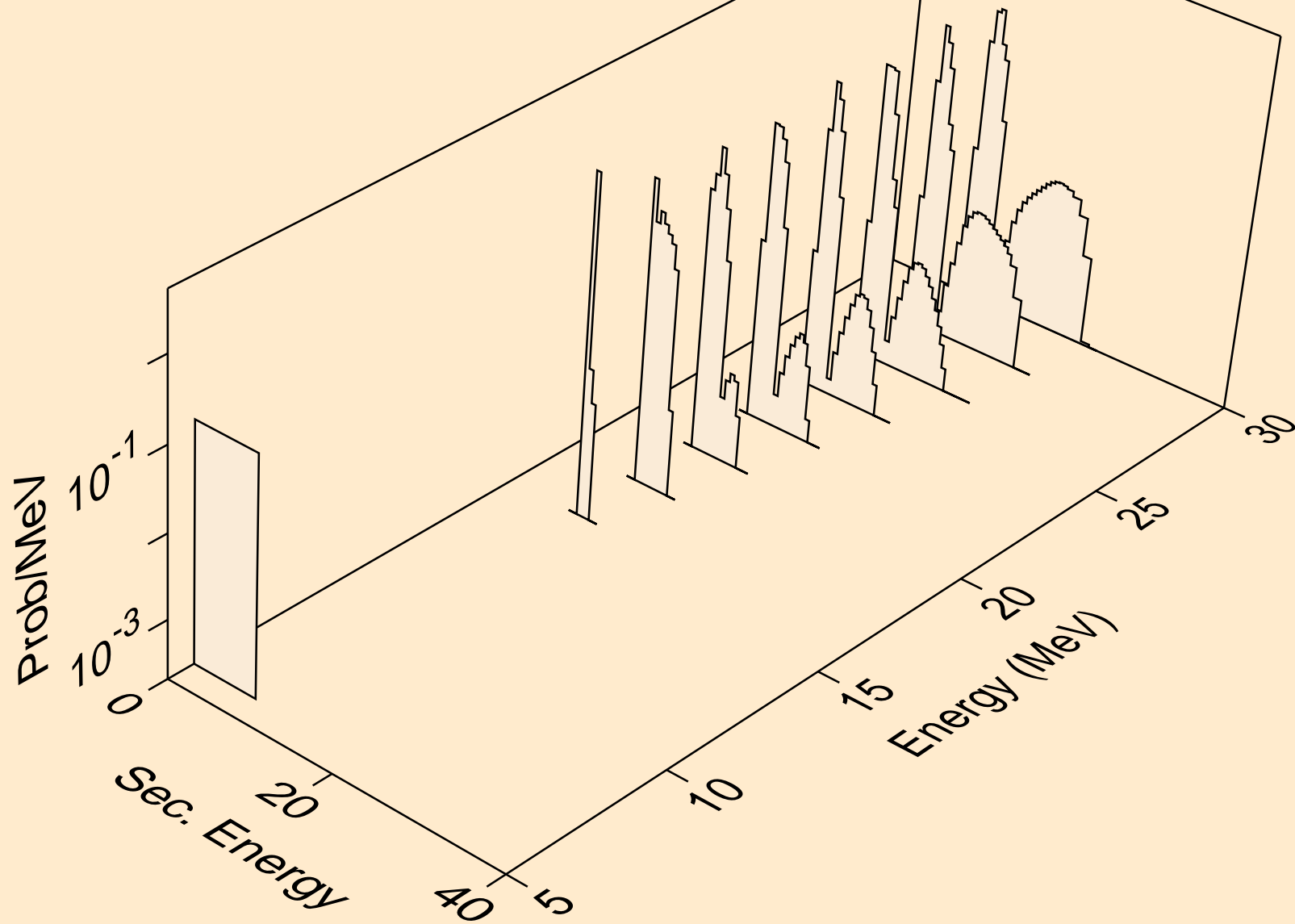

FM247M NEUTRON ACER TENDL-2021 LIBRARY; T=293.6K
alphas from (n,npa)

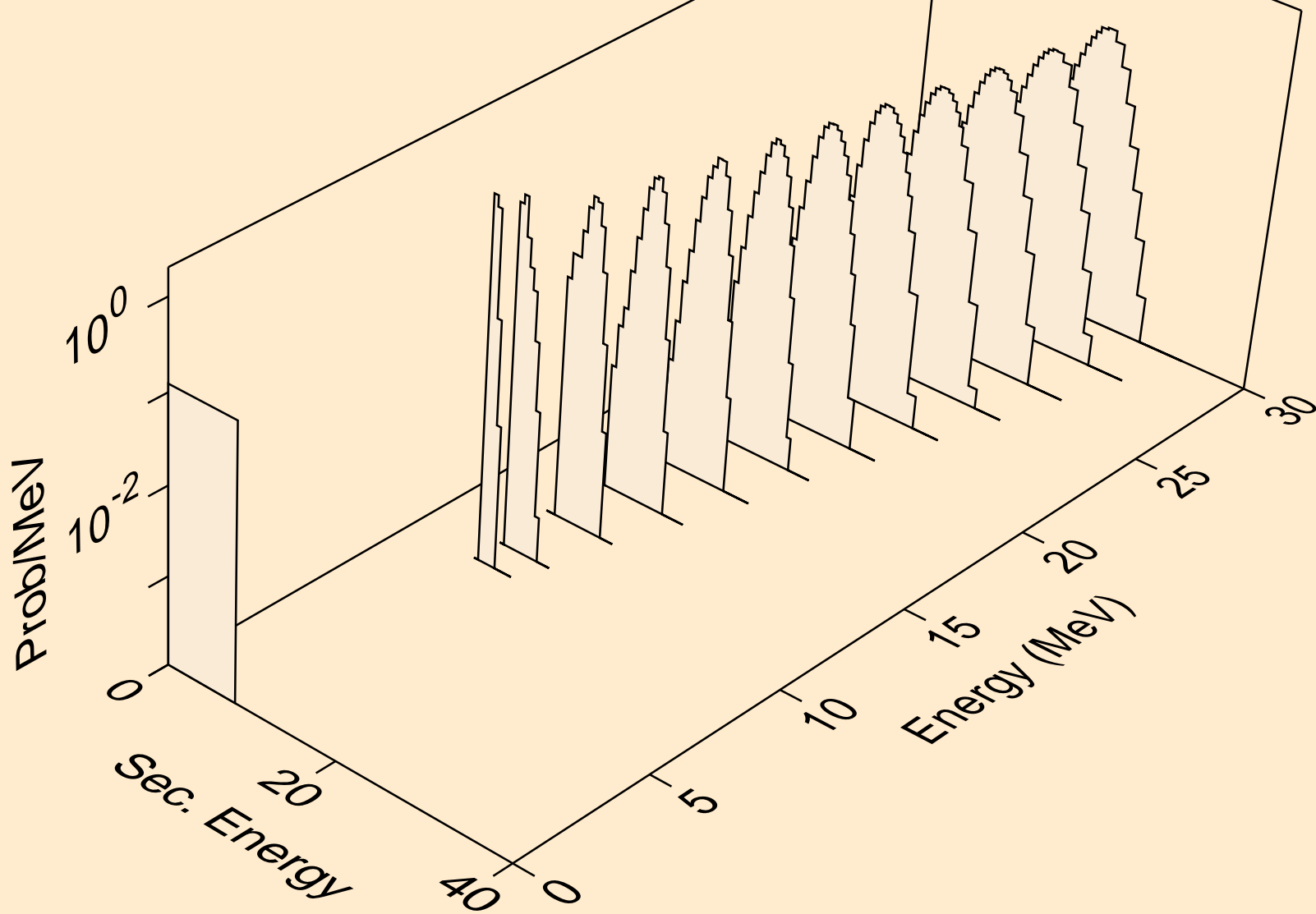

FM247M NEUTRON ACER TENDL-2021 LIBRARY; T=293.6K
alphas from (n,a)

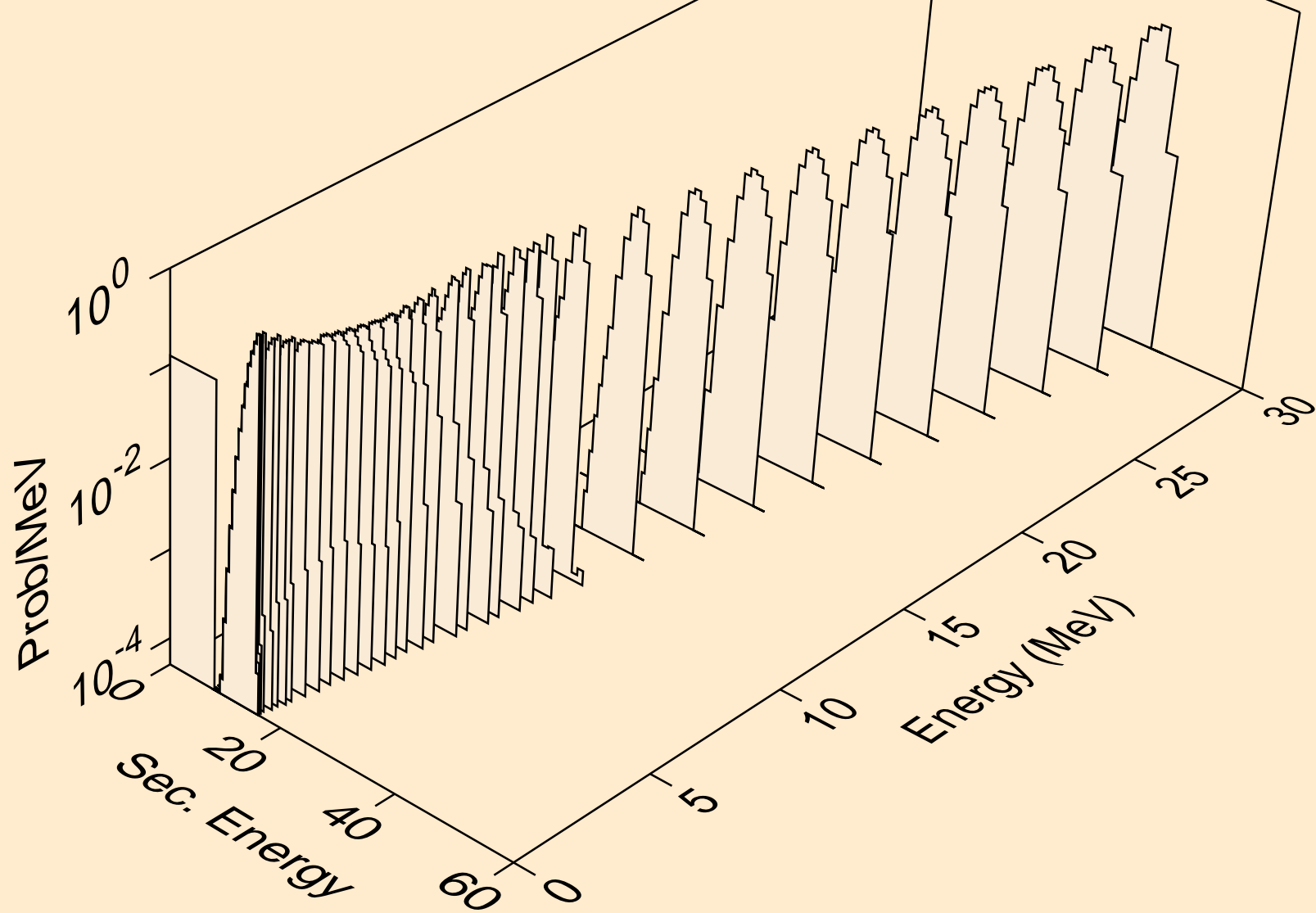

FM247M NEUTRON ACER TENDL-2021 LIBRARY; T=293.6K
alphas from (n,pa)

