

RA232 NEUTRON ACER TENDL-2021 LIBRARY; T=293.6K

Principal cross sections

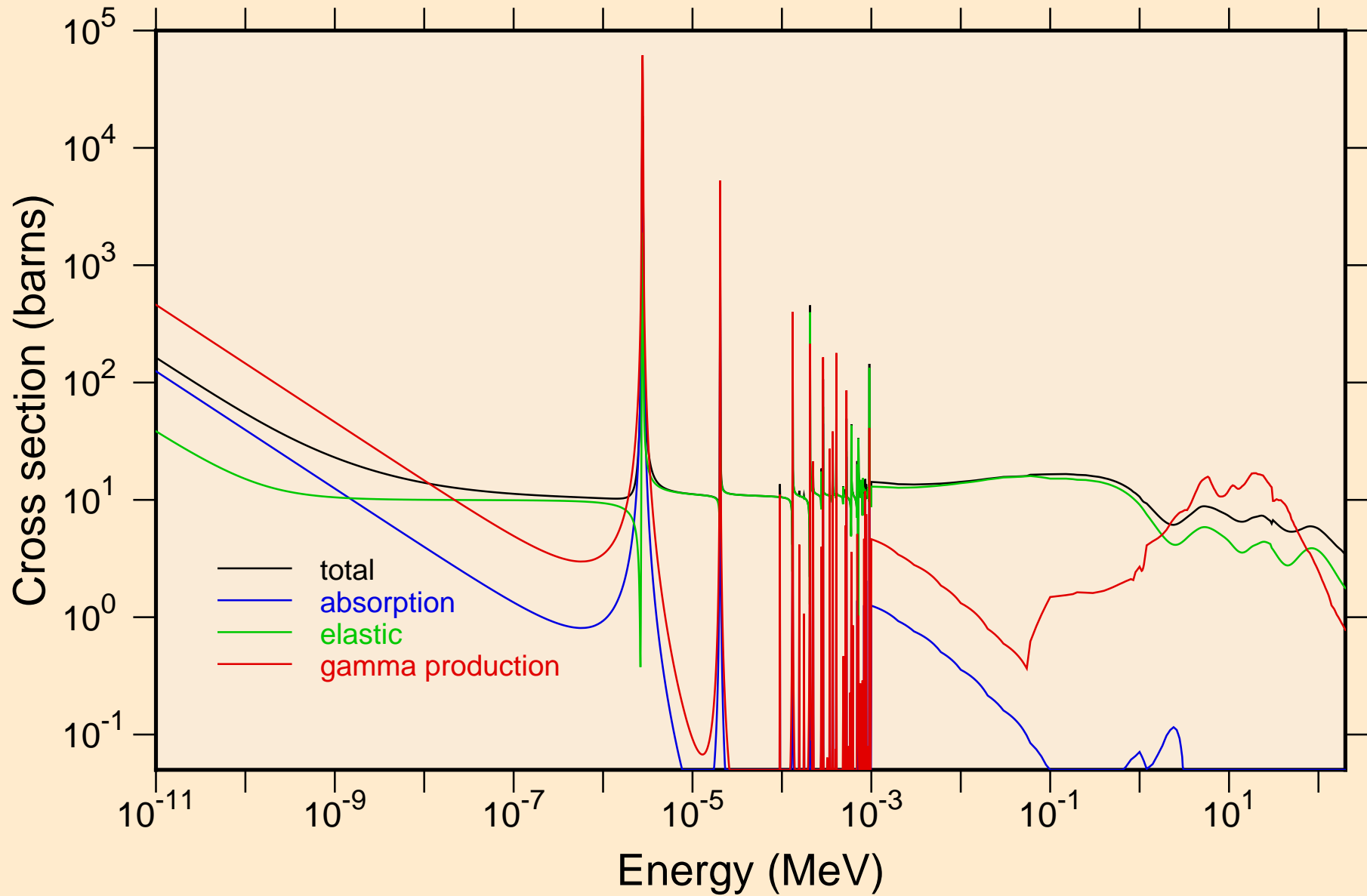

RA232 NEUTRON ACER TENDL-2021 LIBRARY; T=293.6K
resonance total cross section

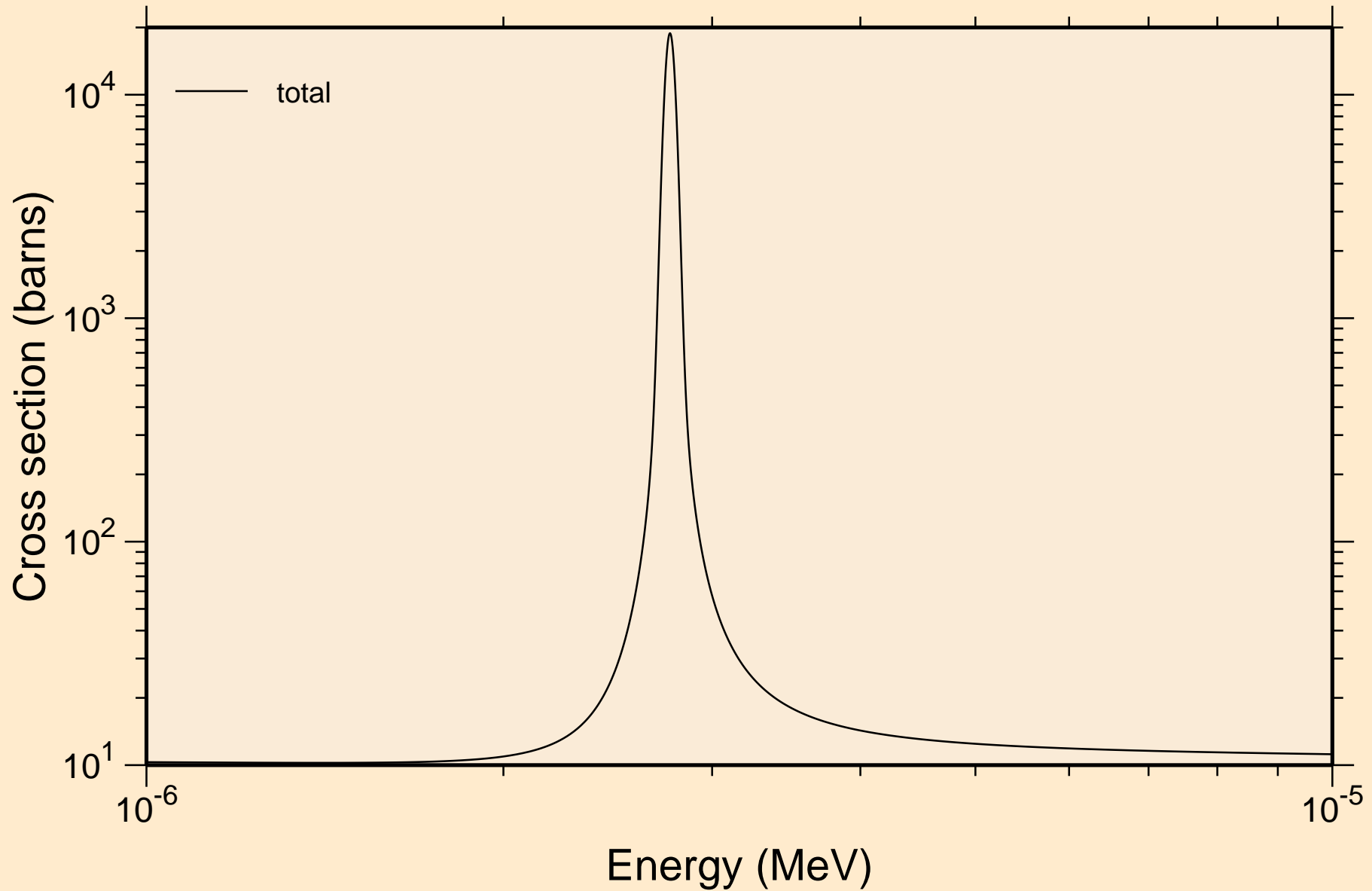

RA232 NEUTRON ACER TENDL-2021 LIBRARY; T=293.6K
resonance total cross section

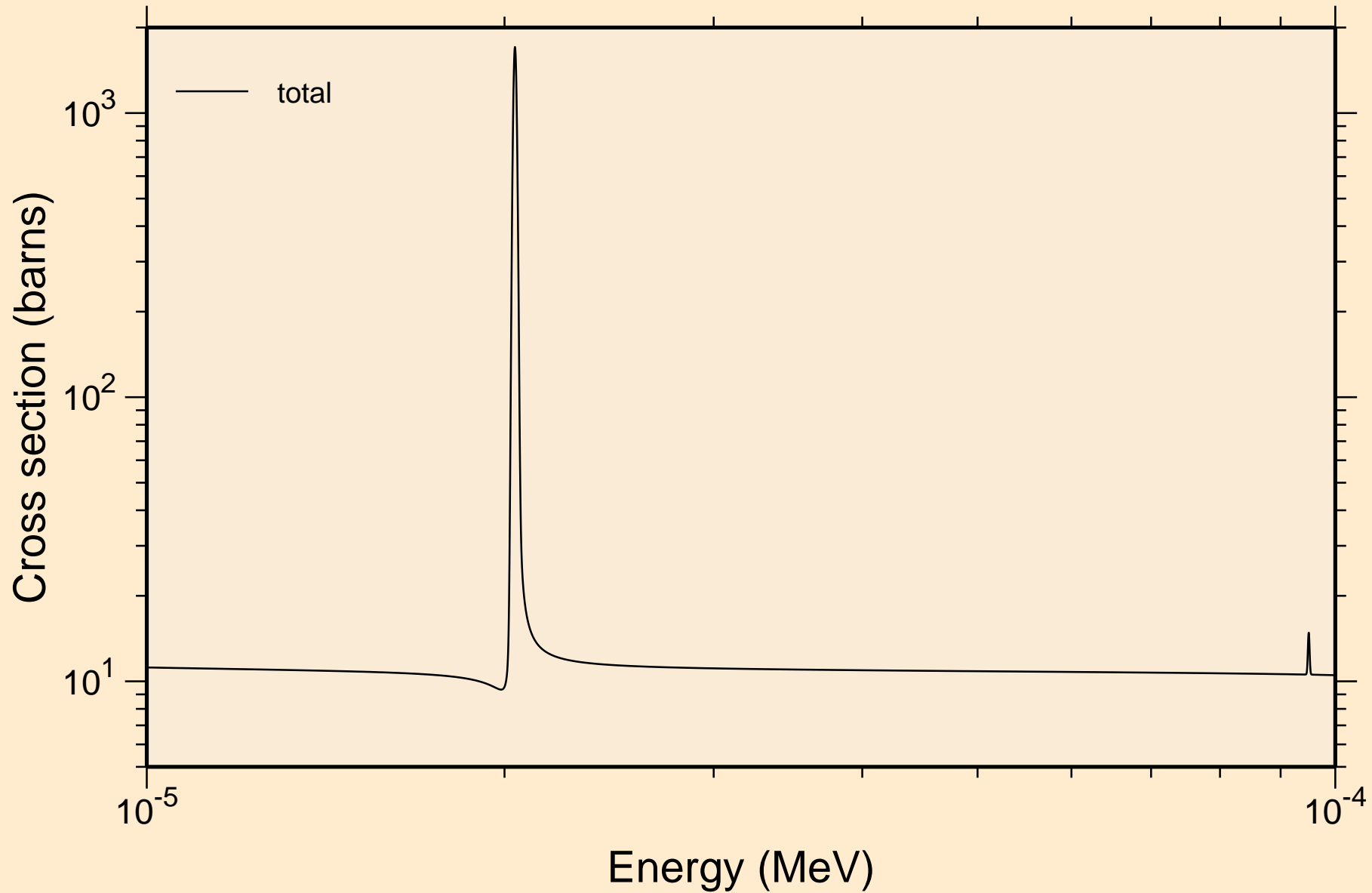

RA232 NEUTRON ACER TENDL-2021 LIBRARY; T=293.6K
resonance total cross section

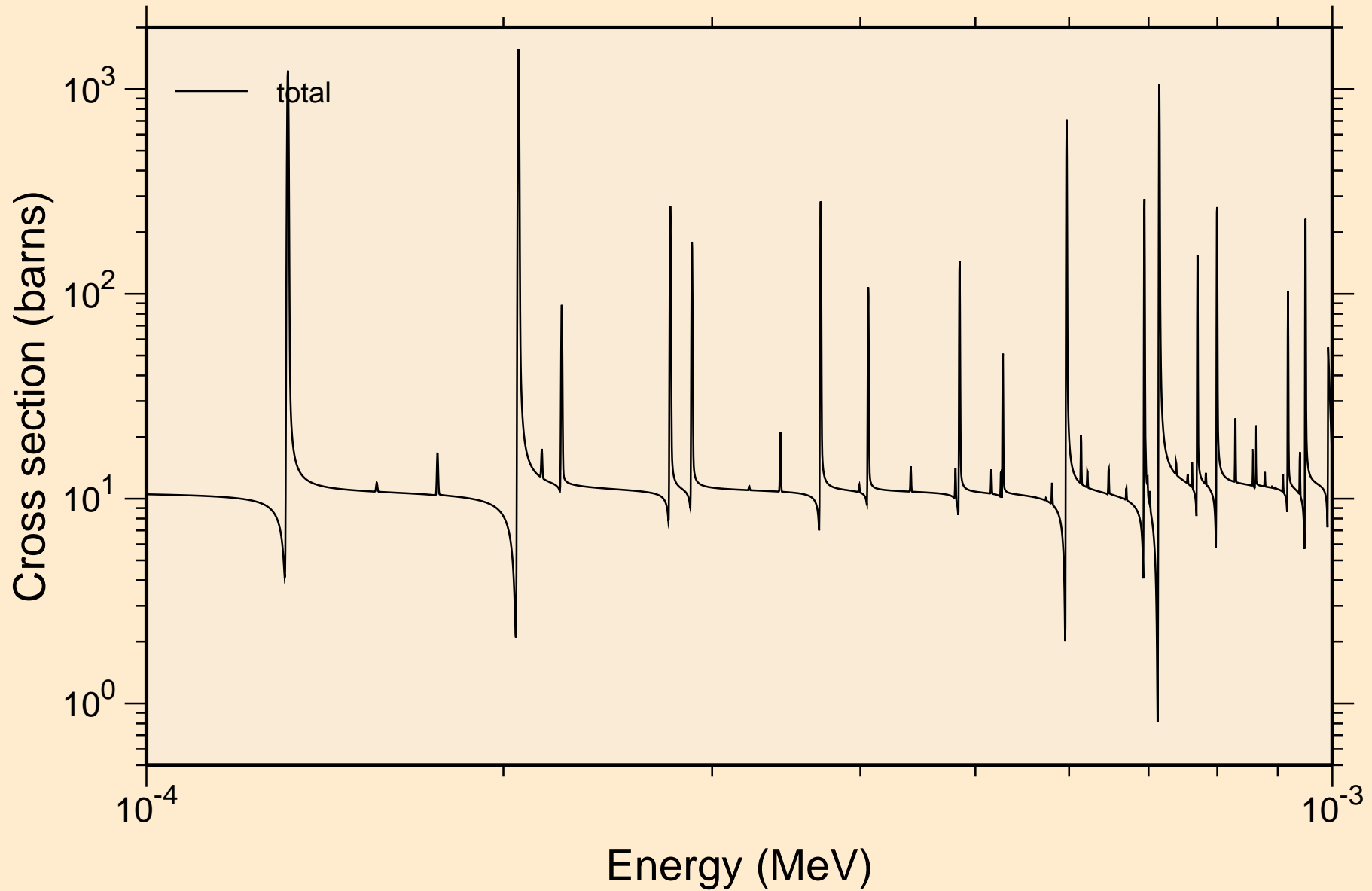

RA232 NEUTRON ACER TENDL-2021 LIBRARY; T=293.6K
resonance total cross section

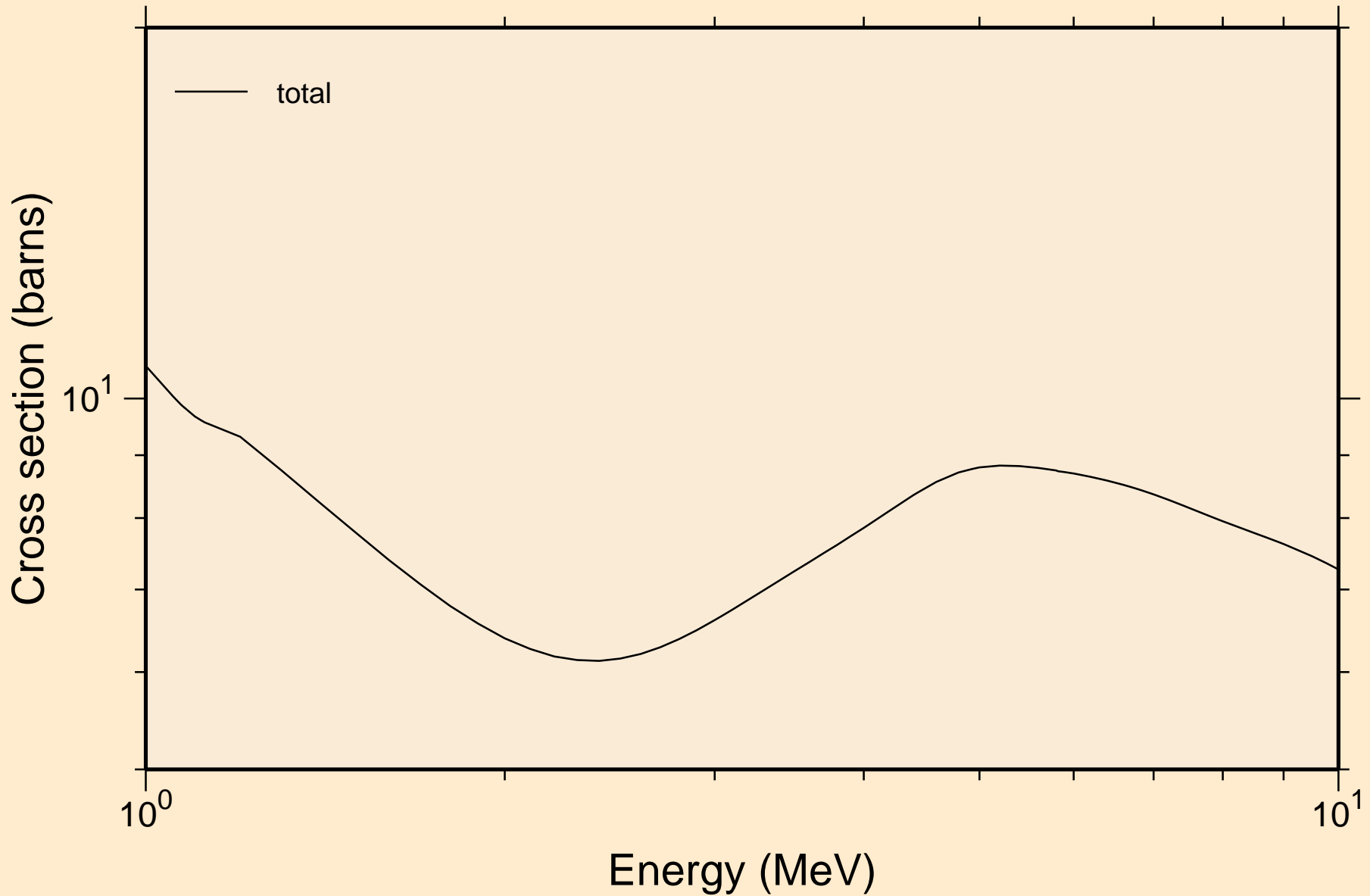

RA232 NEUTRON ACER TENDL-2021 LIBRARY; T=293.6K
resonance absorption cross sections

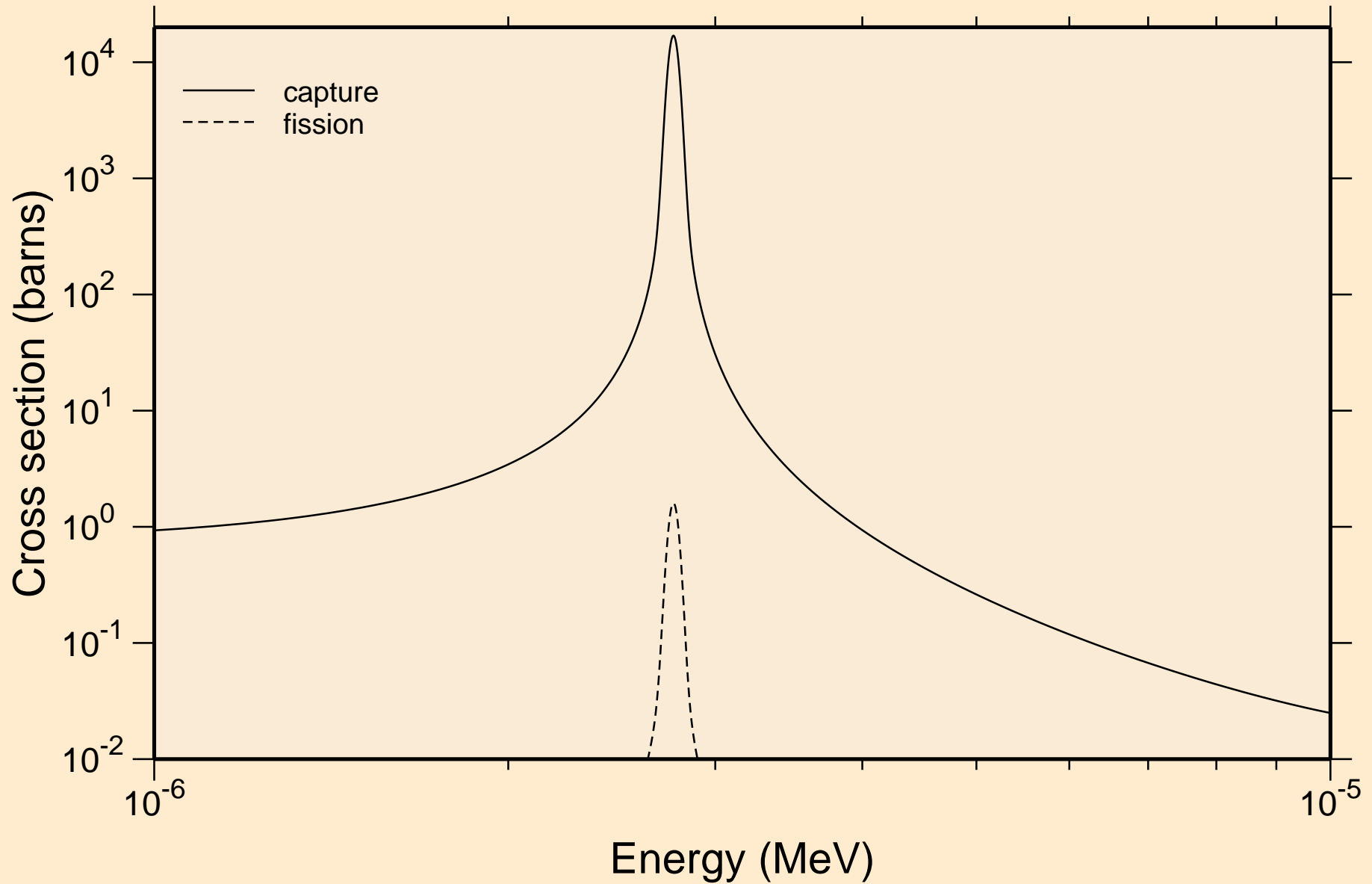

RA232 NEUTRON ACER TENDL-2021 LIBRARY; T=293.6K
resonance absorption cross sections

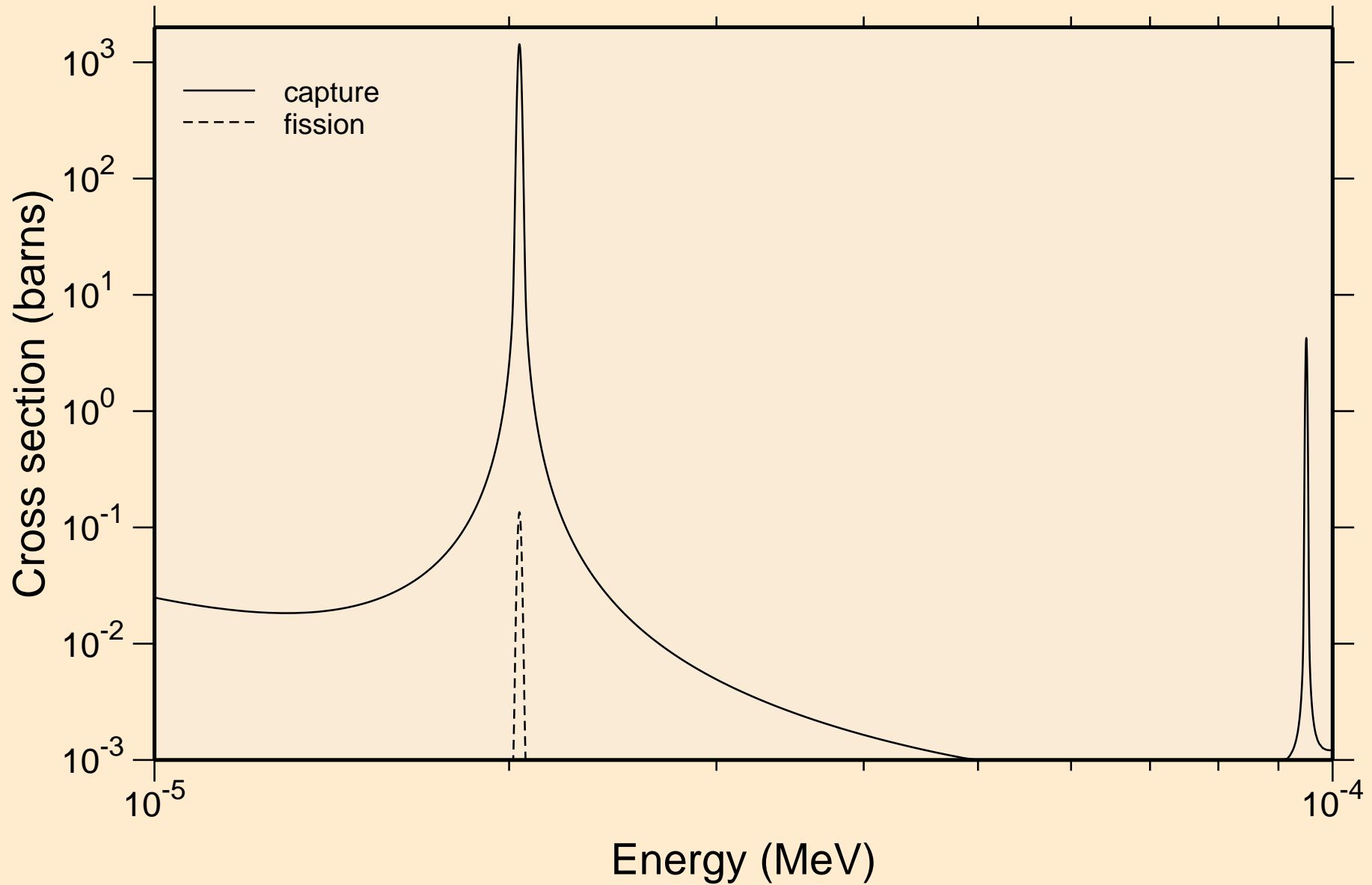

RA232 NEUTRON ACER TENDL-2021 LIBRARY; T=293.6K
resonance absorption cross sections

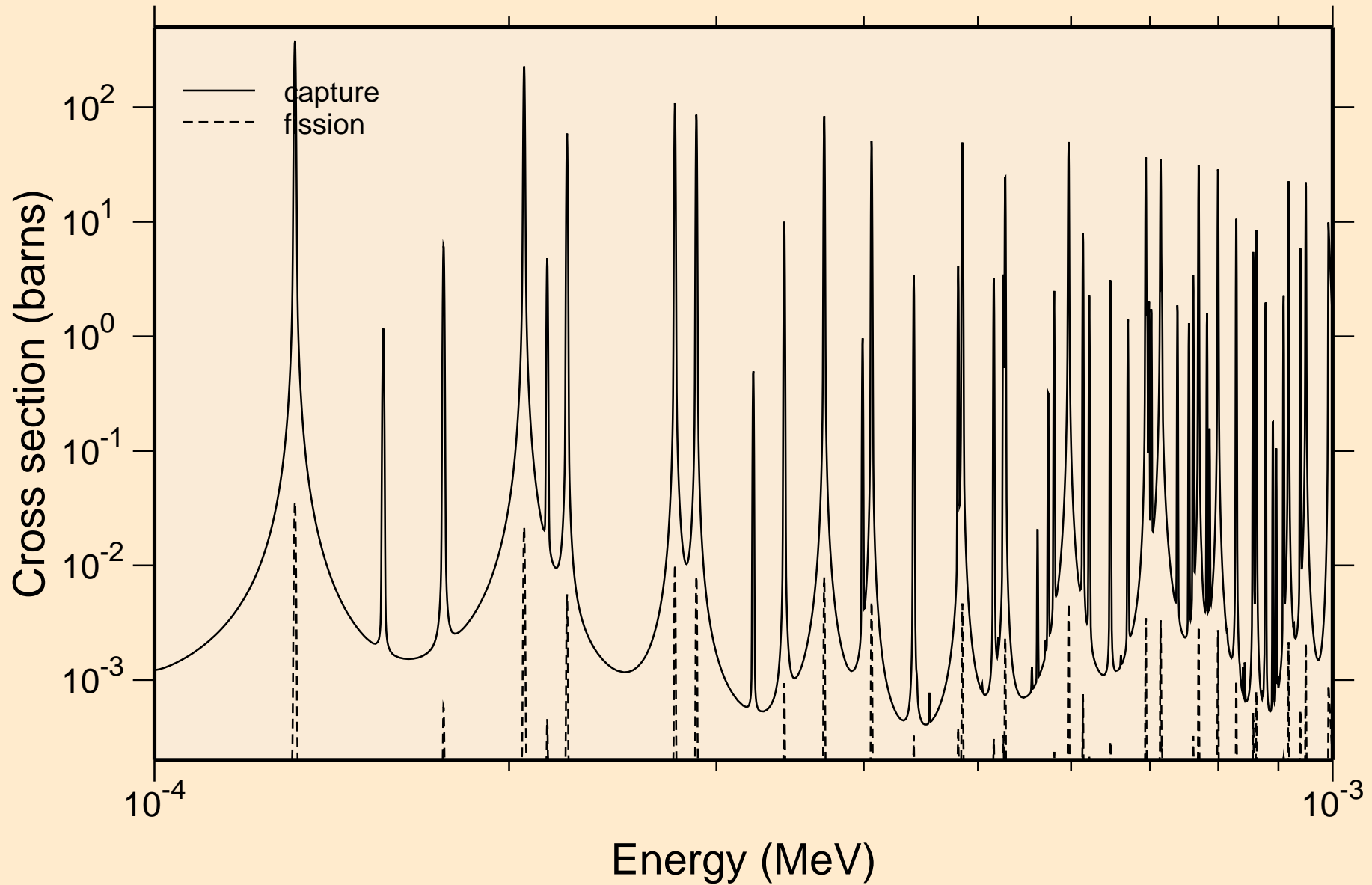

RA232 NEUTRON ACER TENDL-2021 LIBRARY; T=293.6K
resonance absorption cross sections

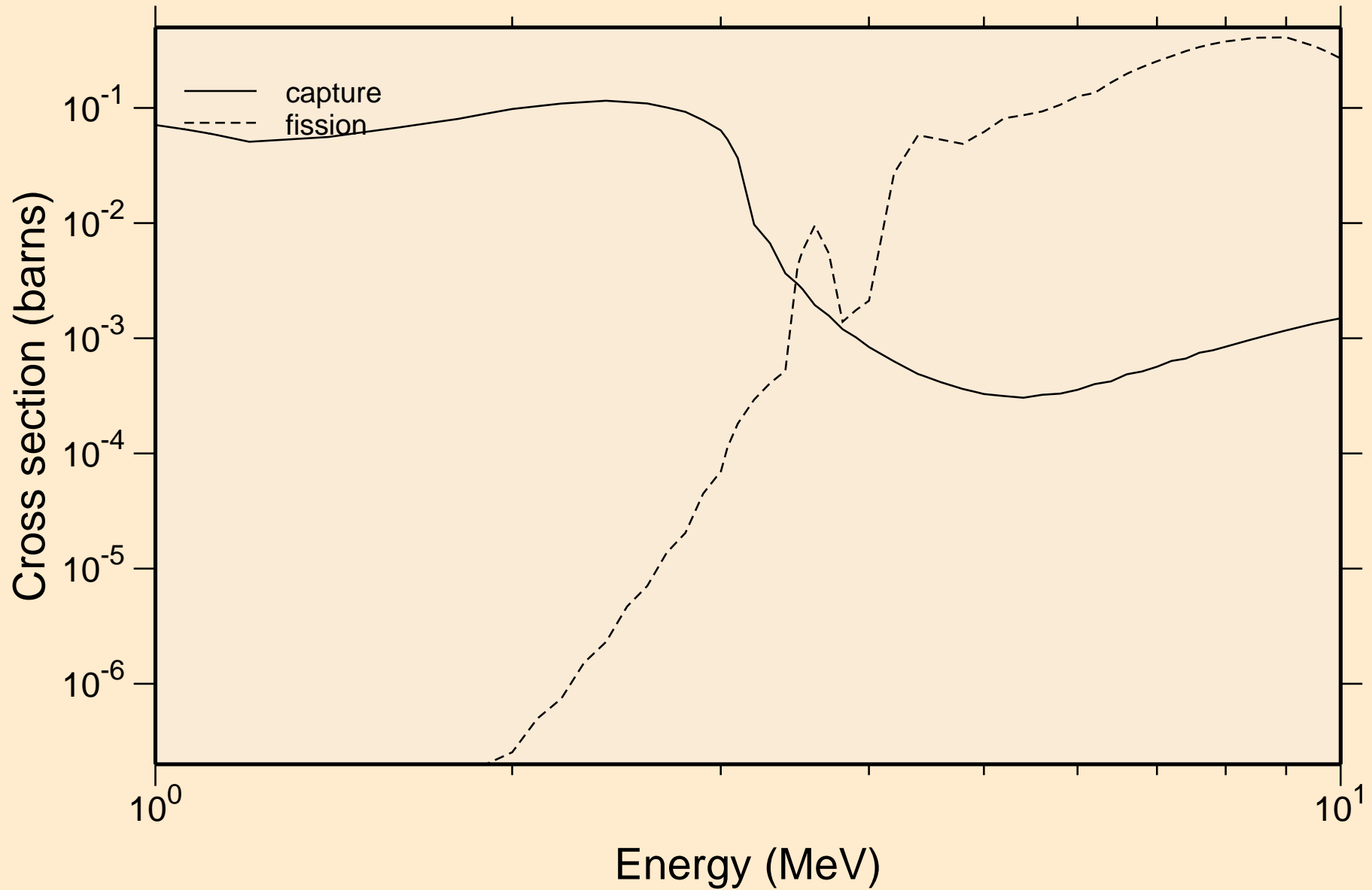

RA232 NEUTRON ACER TENDL-2021 LIBRARY; T=293.6K
Heating

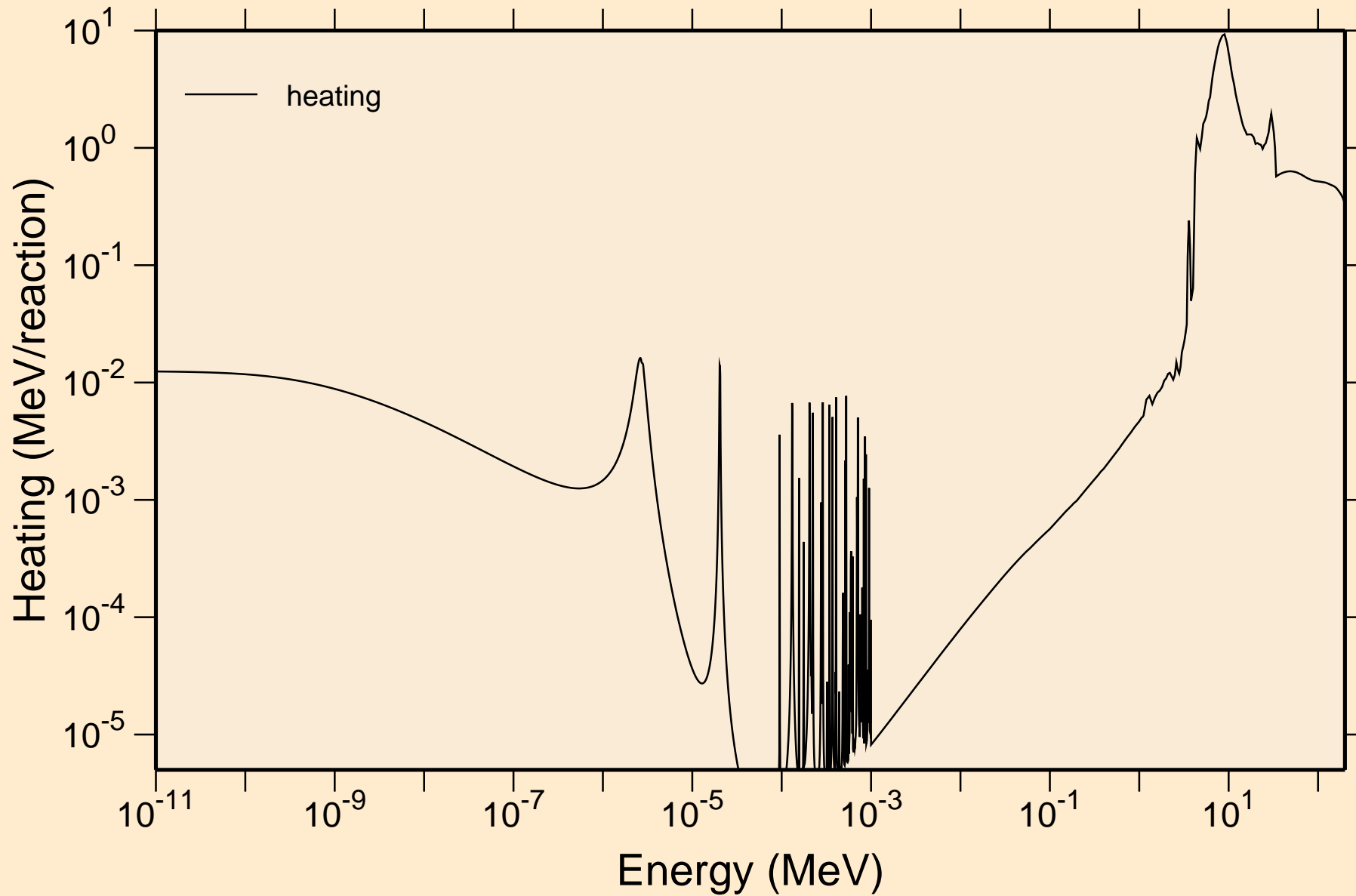

RA232 NEUTRON ACER TENDL-2021 LIBRARY; T=293.6K
Damage

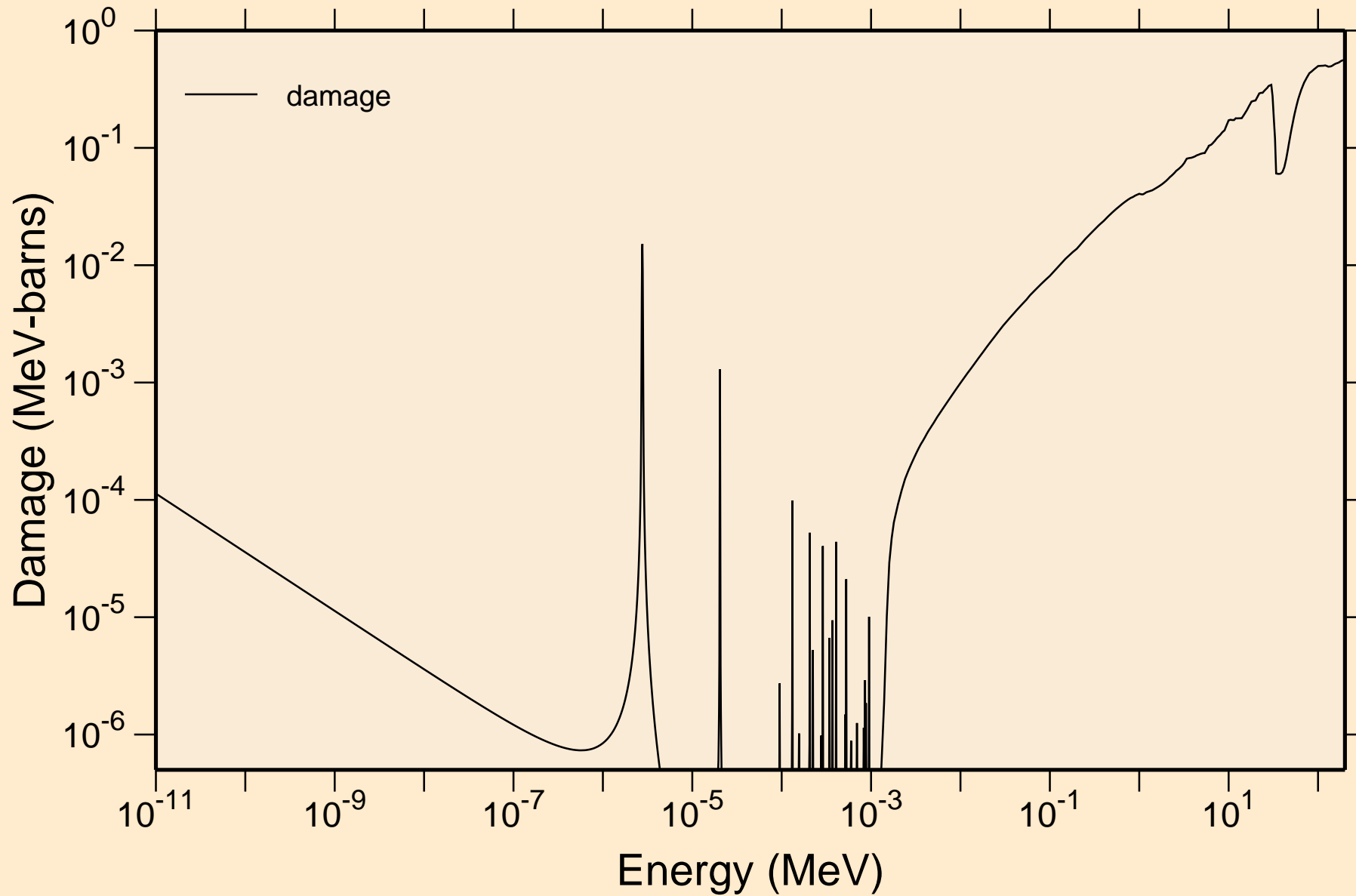

RA232 NEUTRON ACER TENDL-2021 LIBRARY; T=293.6K
Non-threshold reactions

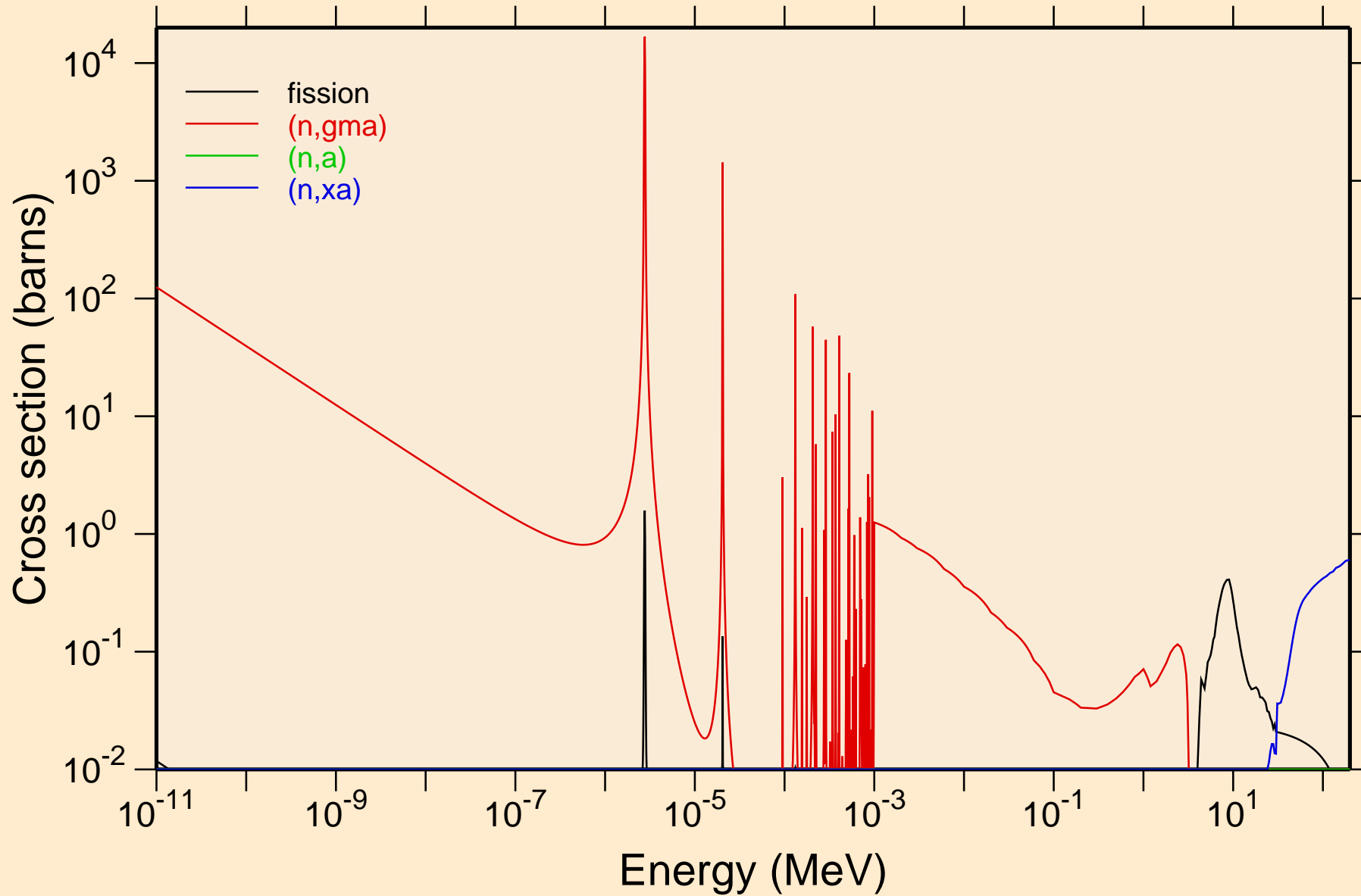

RA232 NEUTRON ACER TENDL-2021 LIBRARY; T=293.6K

Principal cross sections

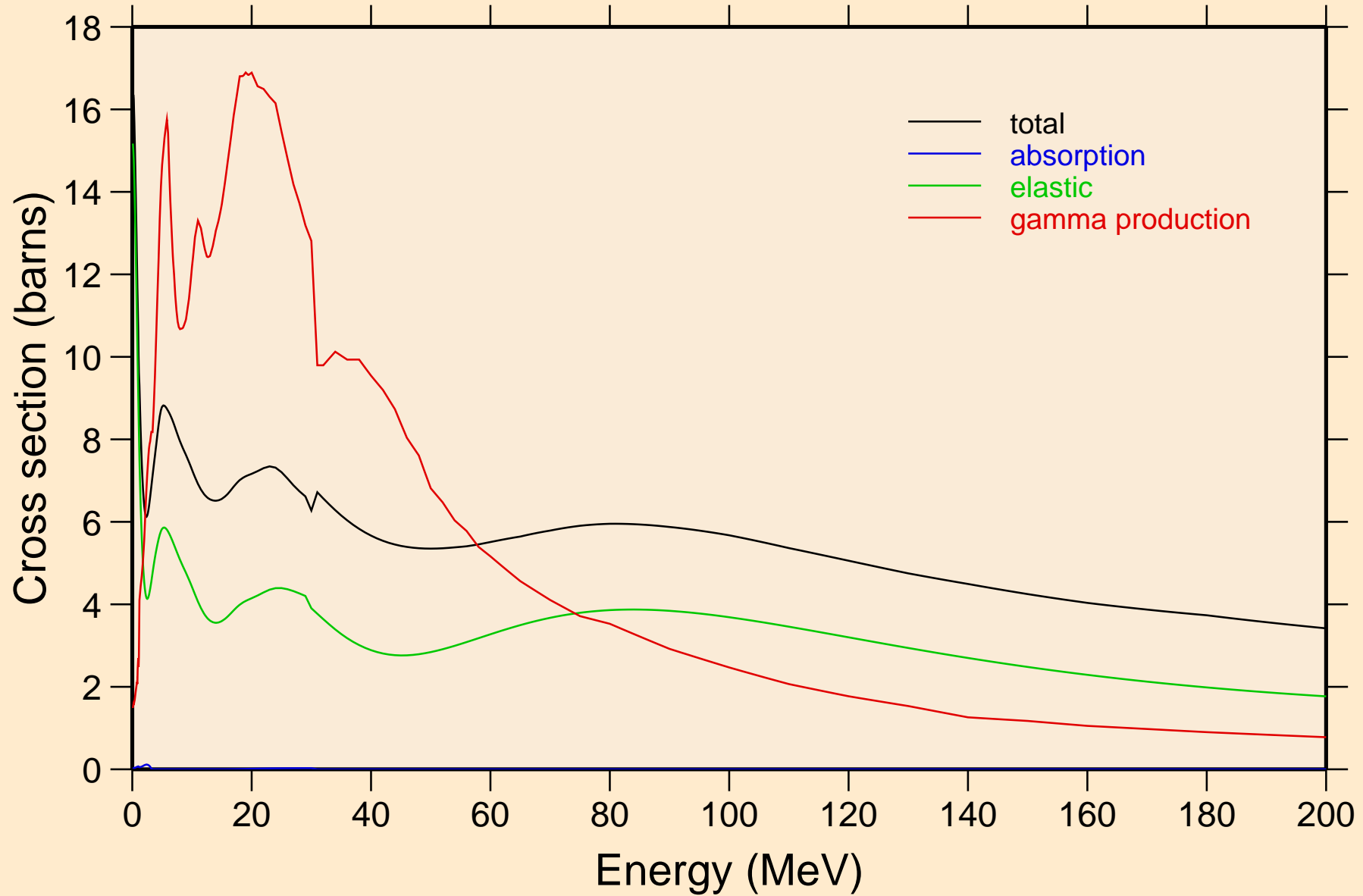

RA232 NEUTRON ACER TENDL-2021 LIBRARY; T=293.6K

Heating

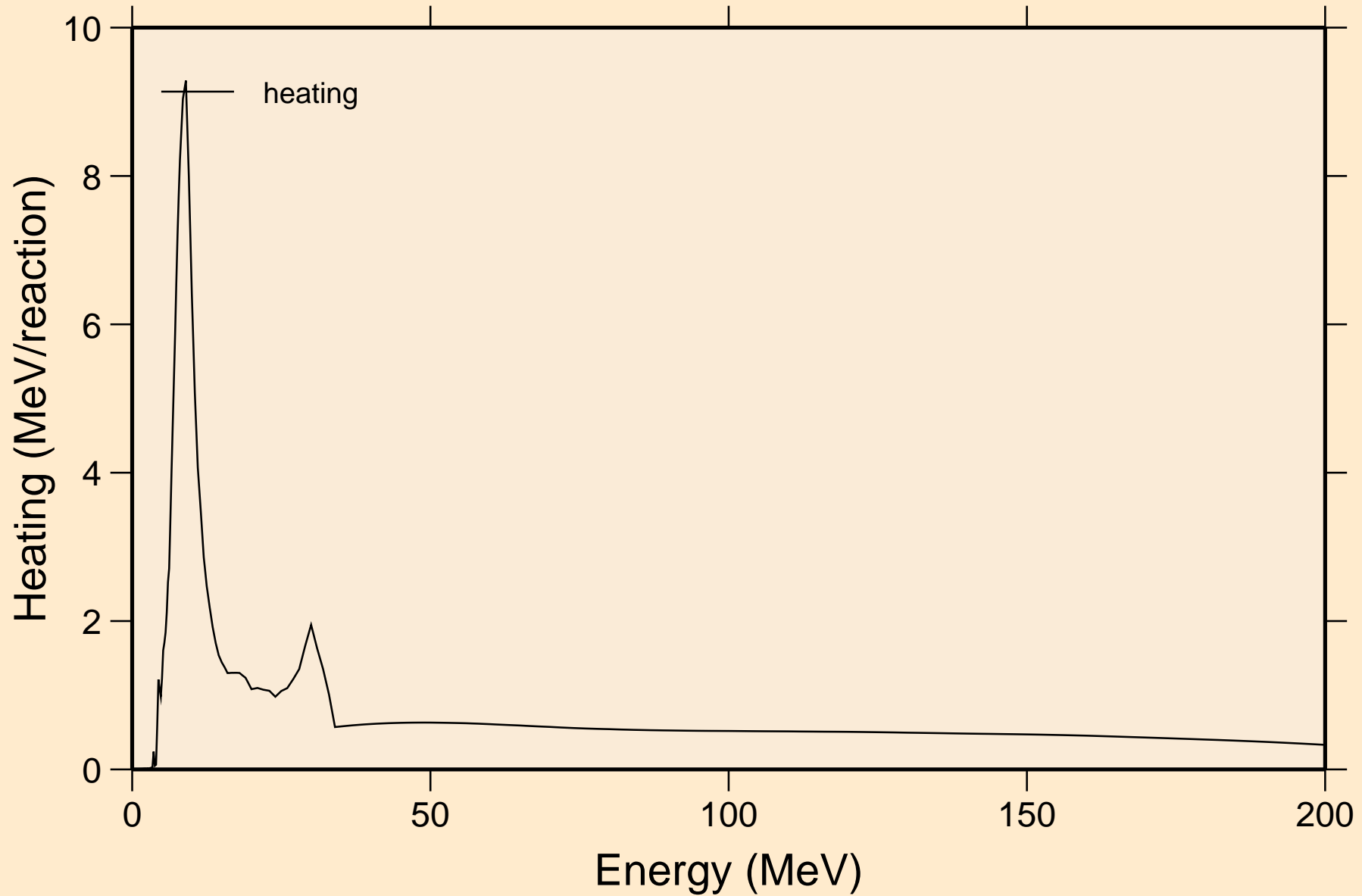

RA232 NEUTRON ACER TENDL-2021 LIBRARY; T=293.6K
Damage

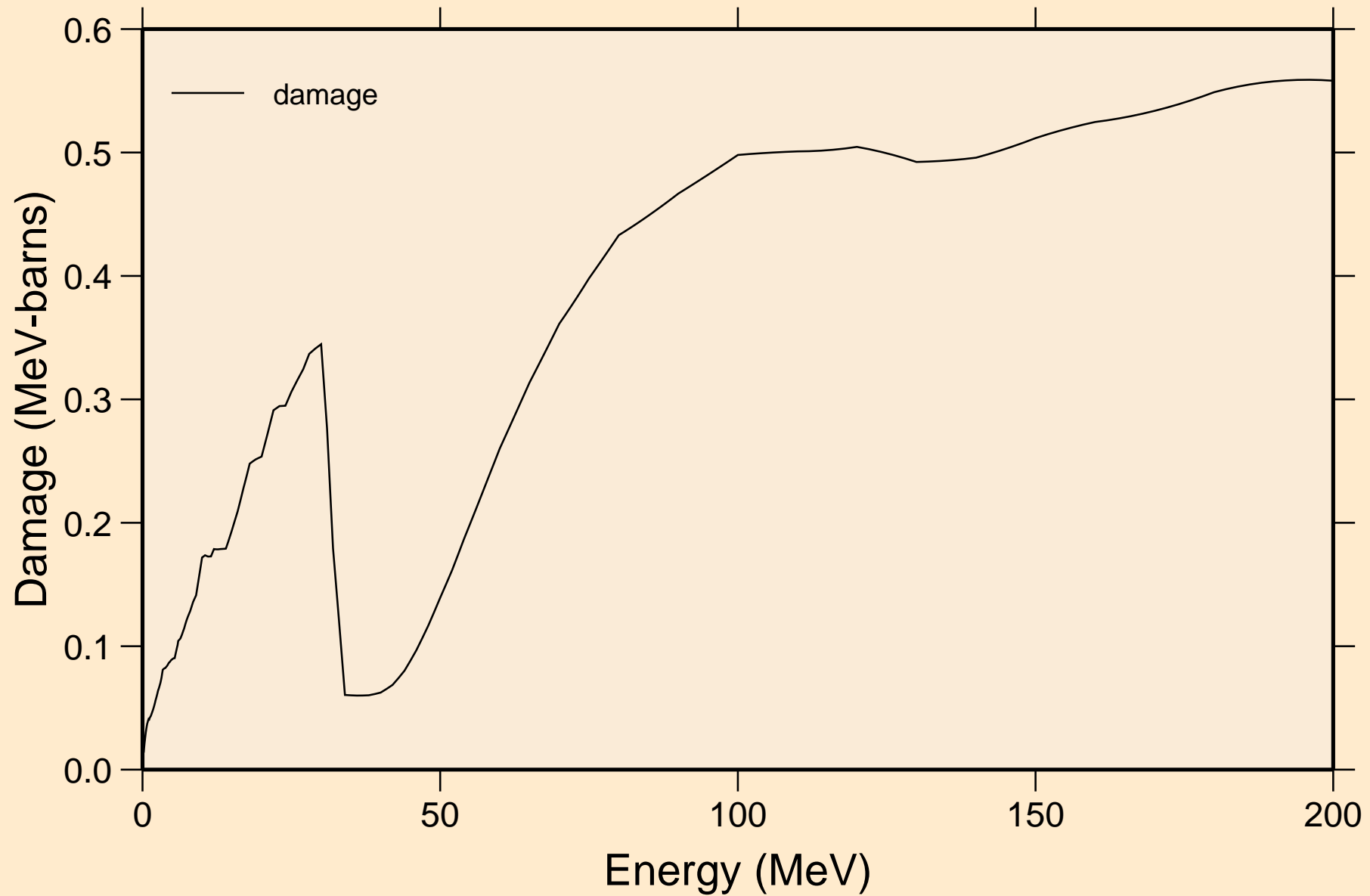

RA232 NEUTRON ACER TENDL-2021 LIBRARY; T=293.6K
Non-threshold reactions

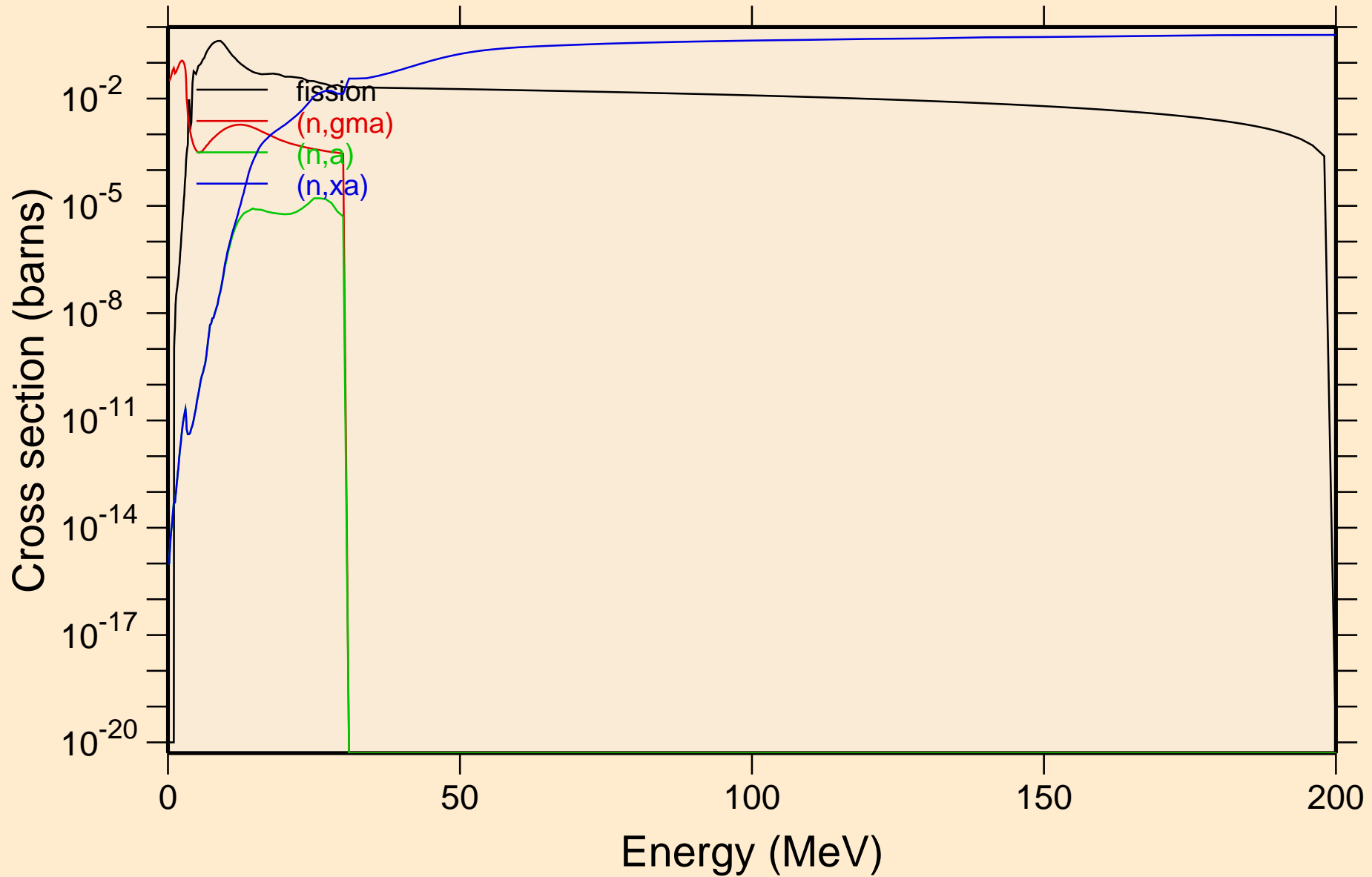

RA232 NEUTRON ACER TENDL-2021 LIBRARY; T=293.6K
Inelastic levels

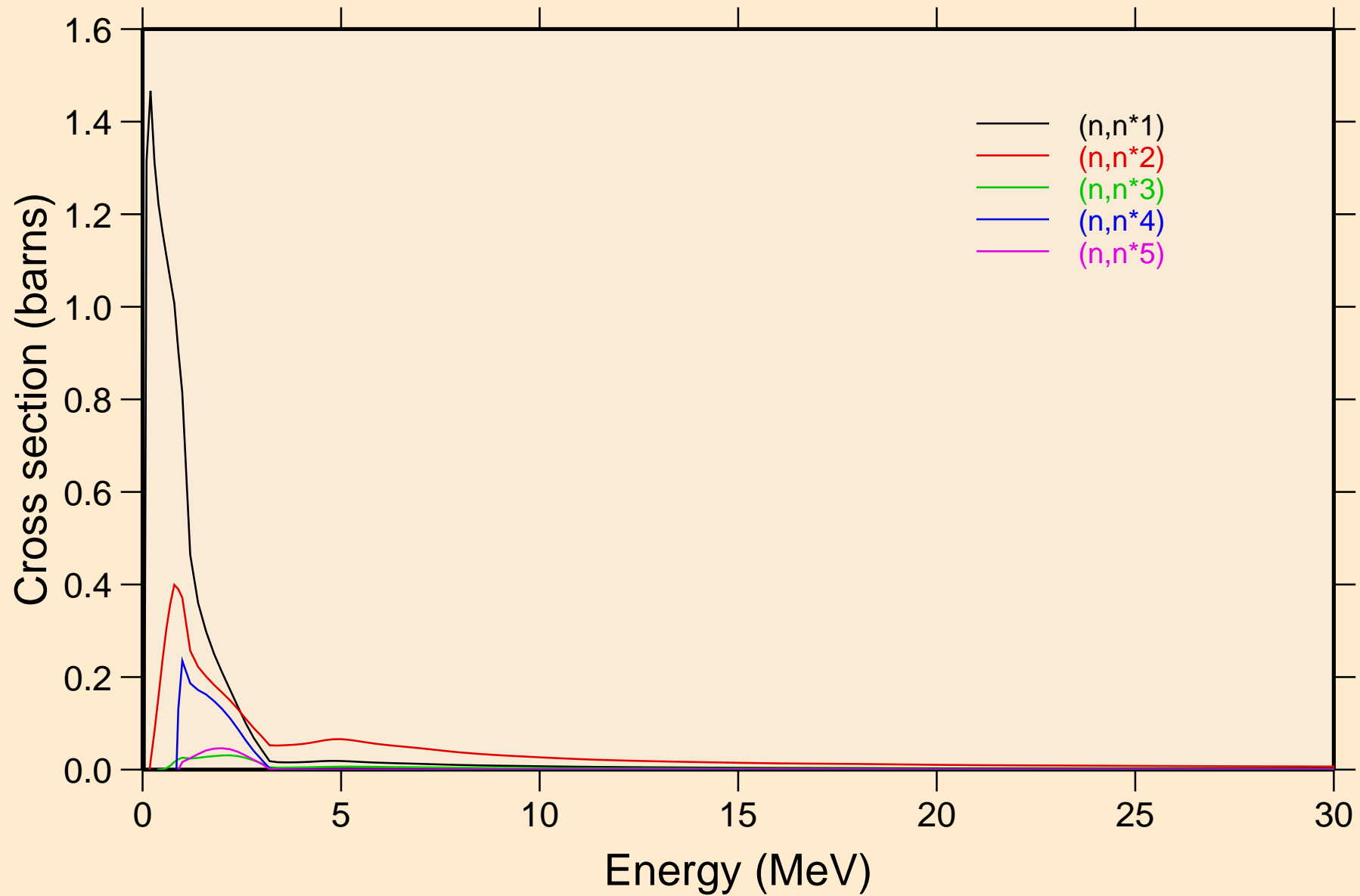

RA232 NEUTRON ACER TENDL-2021 LIBRARY; T=293.6K
Inelastic levels

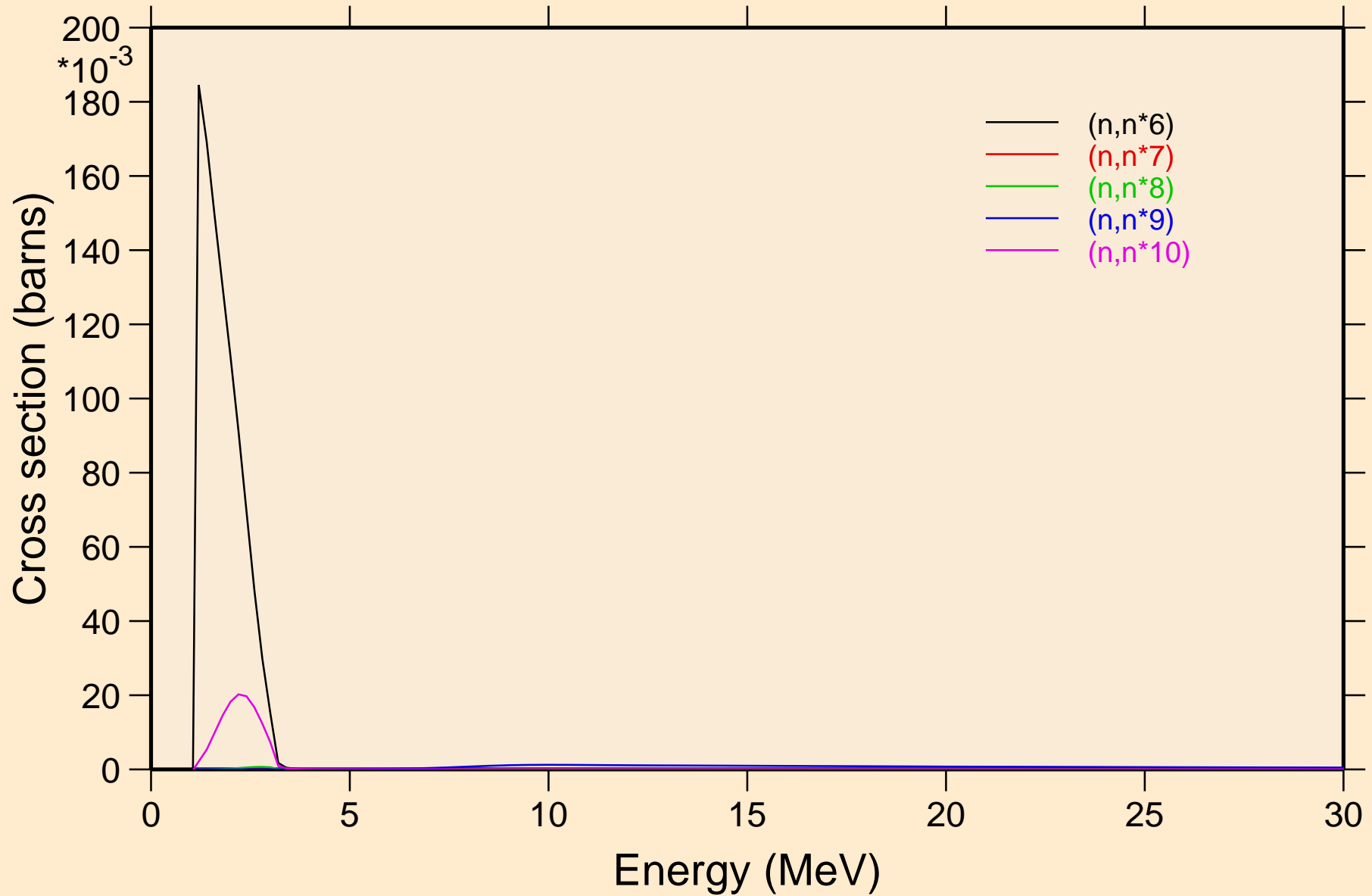

RA232 NEUTRON ACER TENDL-2021 LIBRARY; T=293.6K
Inelastic levels

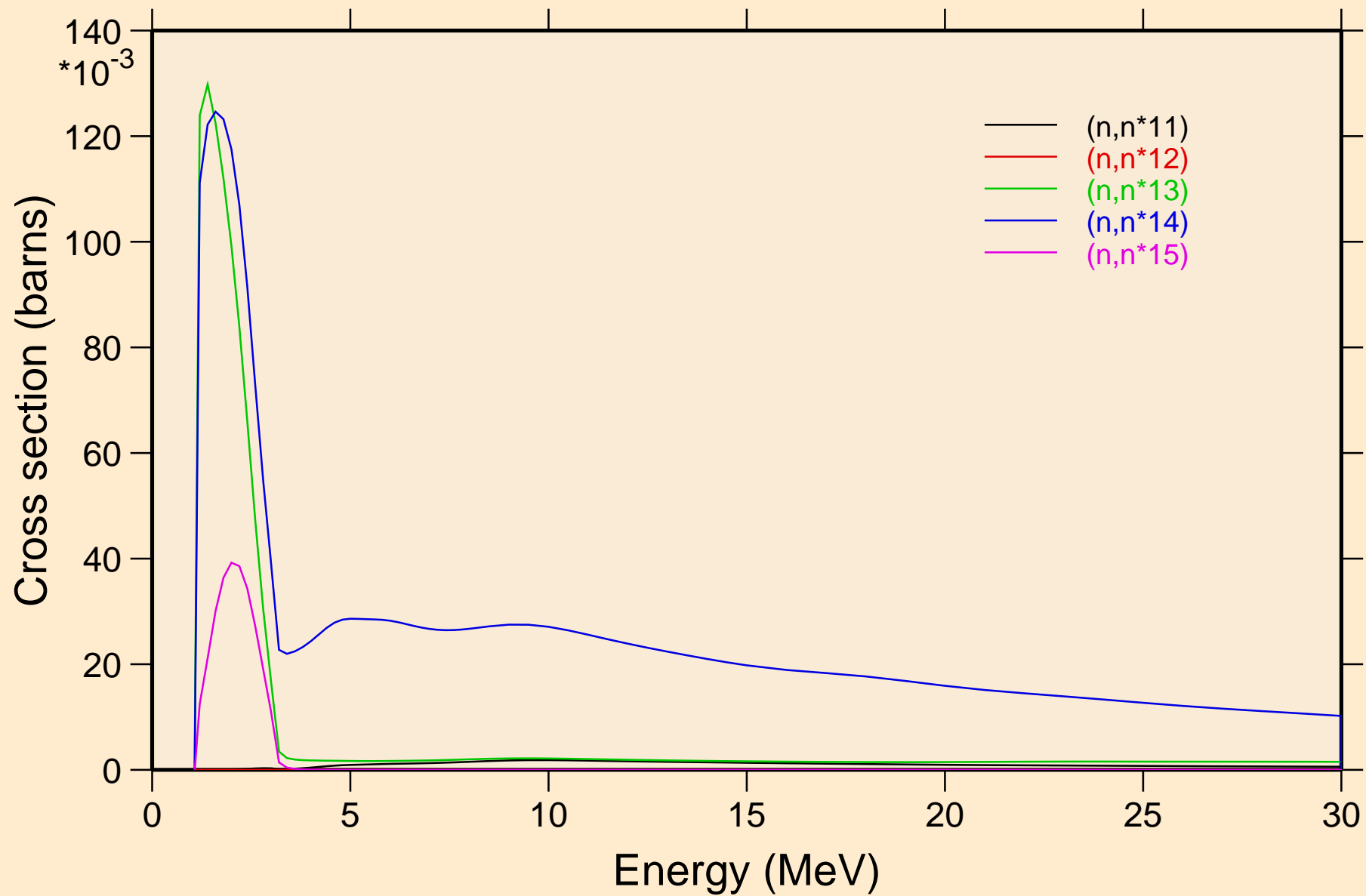

RA232 NEUTRON ACER TENDL-2021 LIBRARY; T=293.6K
Inelastic levels

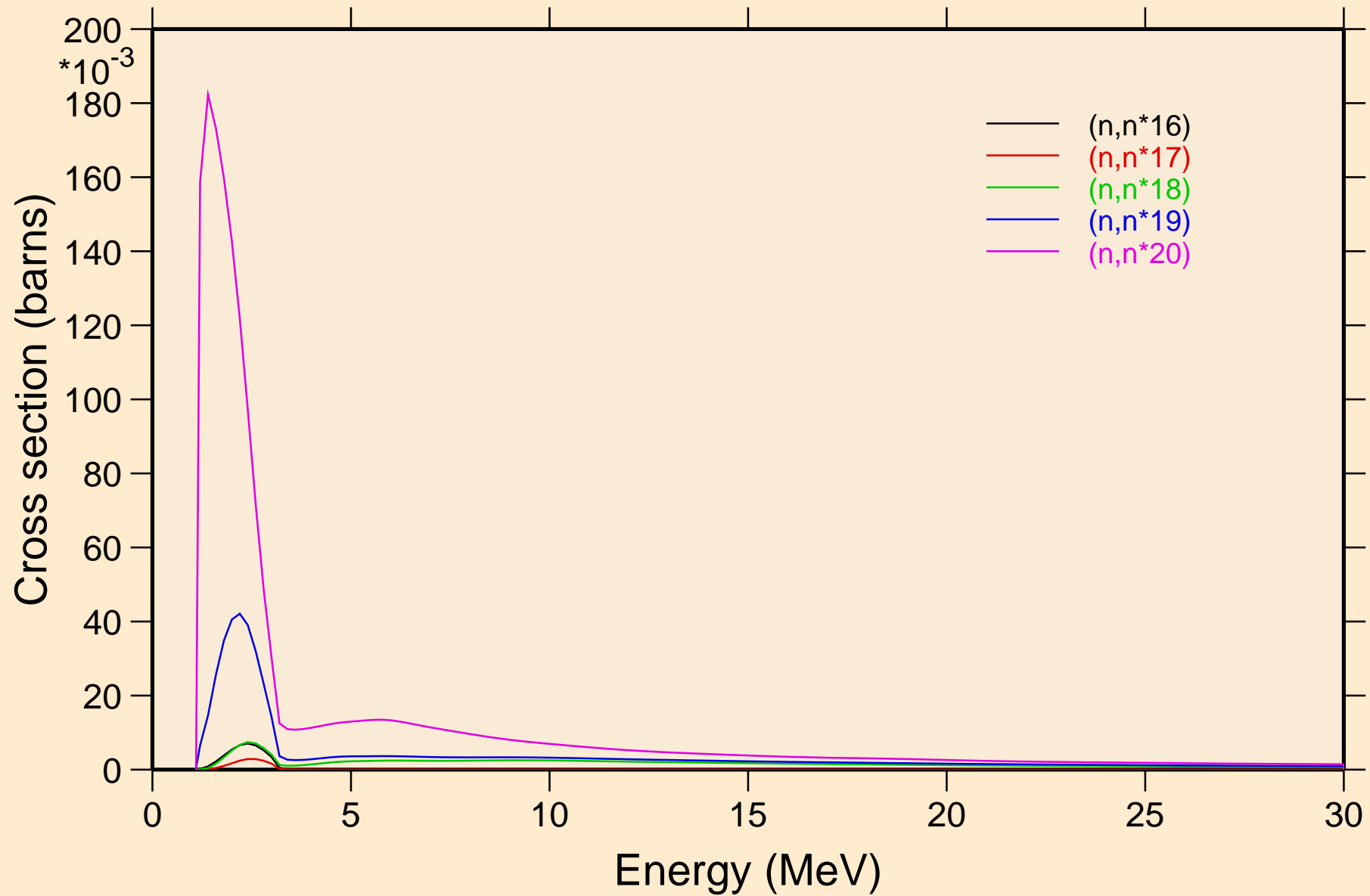

RA232 NEUTRON ACER TENDL-2021 LIBRARY; T=293.6K
Inelastic levels

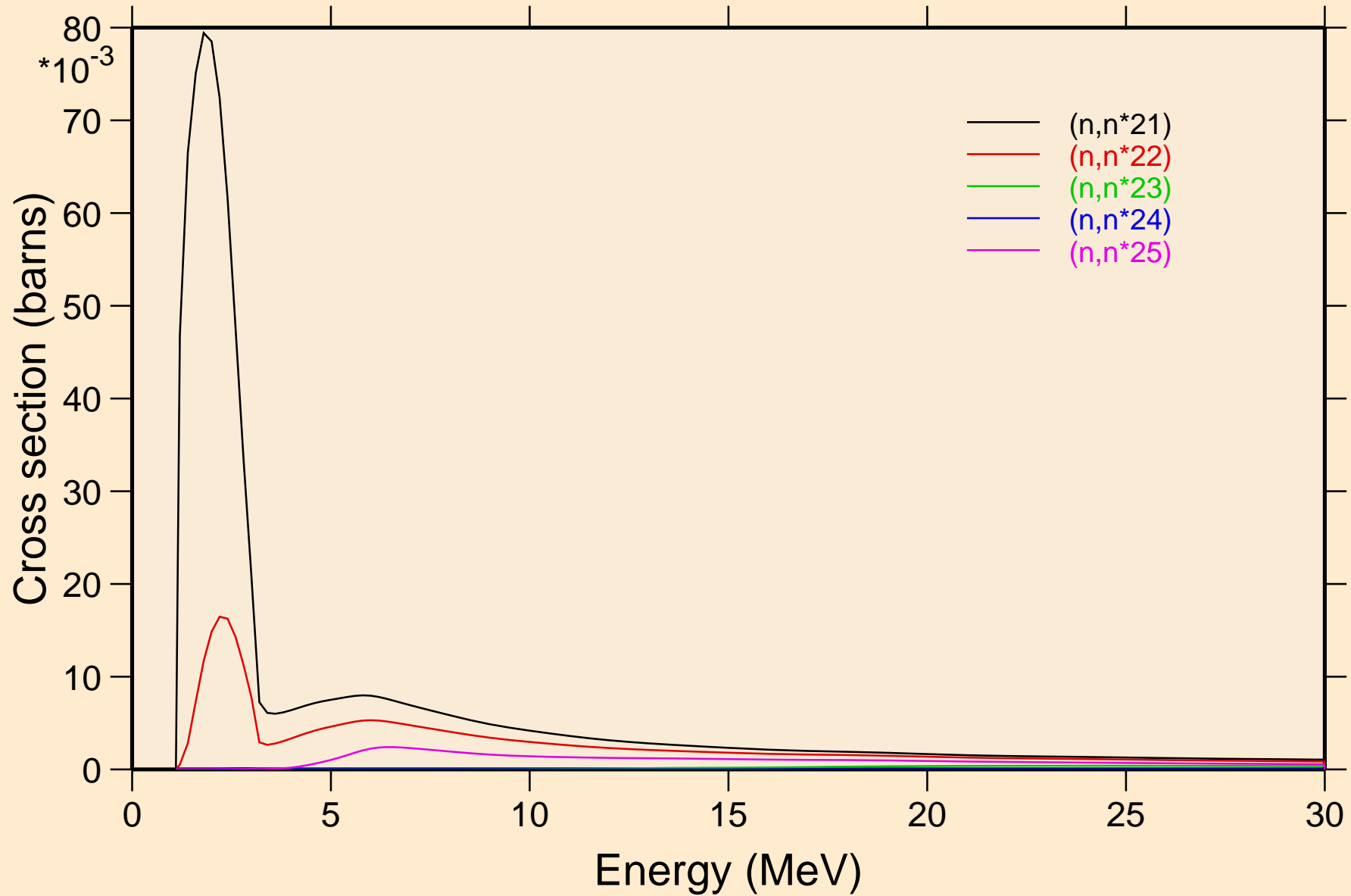

RA232 NEUTRON ACER TENDL-2021 LIBRARY; T=293.6K
Inelastic levels

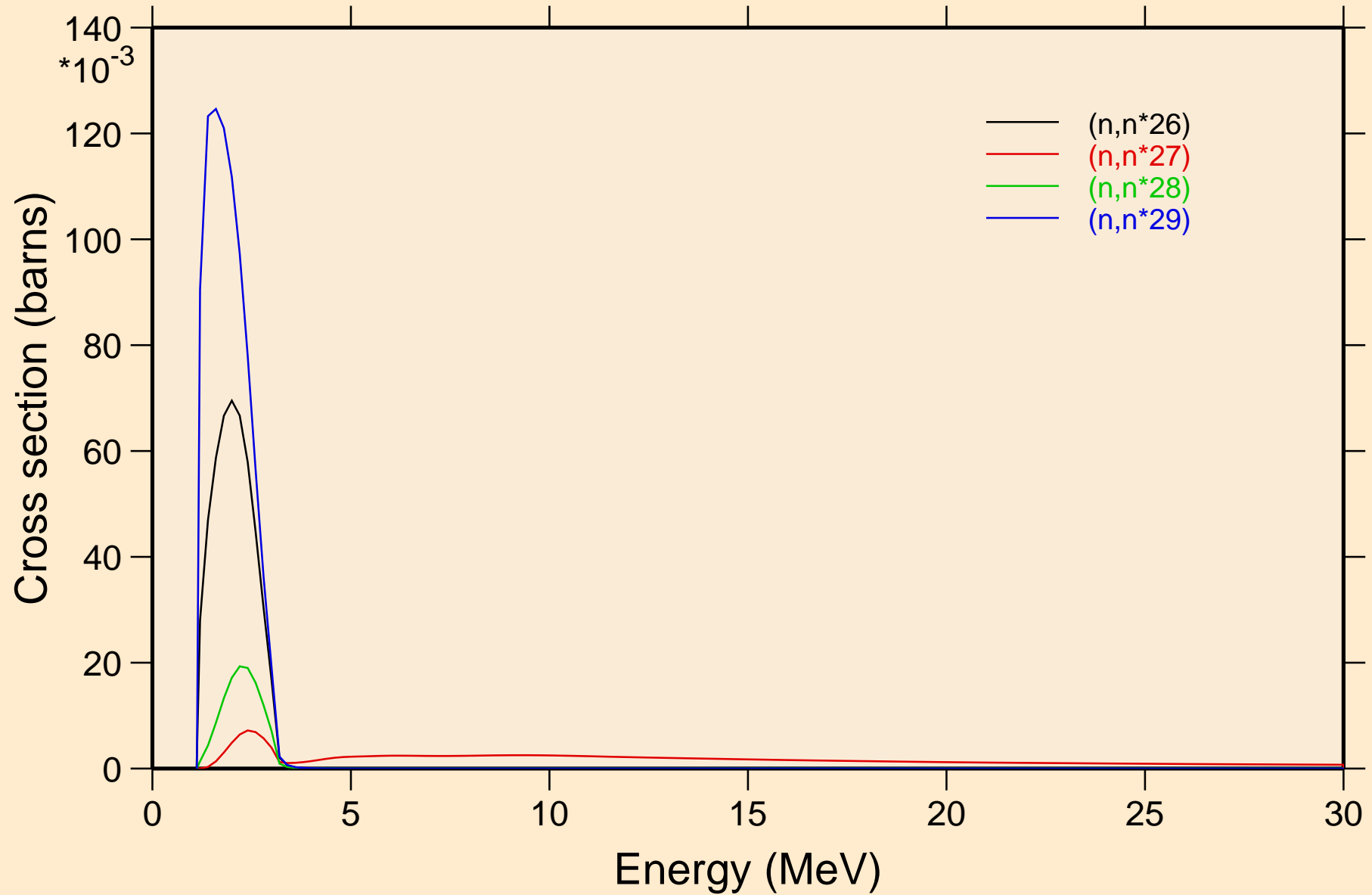

RA232 NEUTRON ACER TENDL-2021 LIBRARY; T=293.6K
Threshold reactions

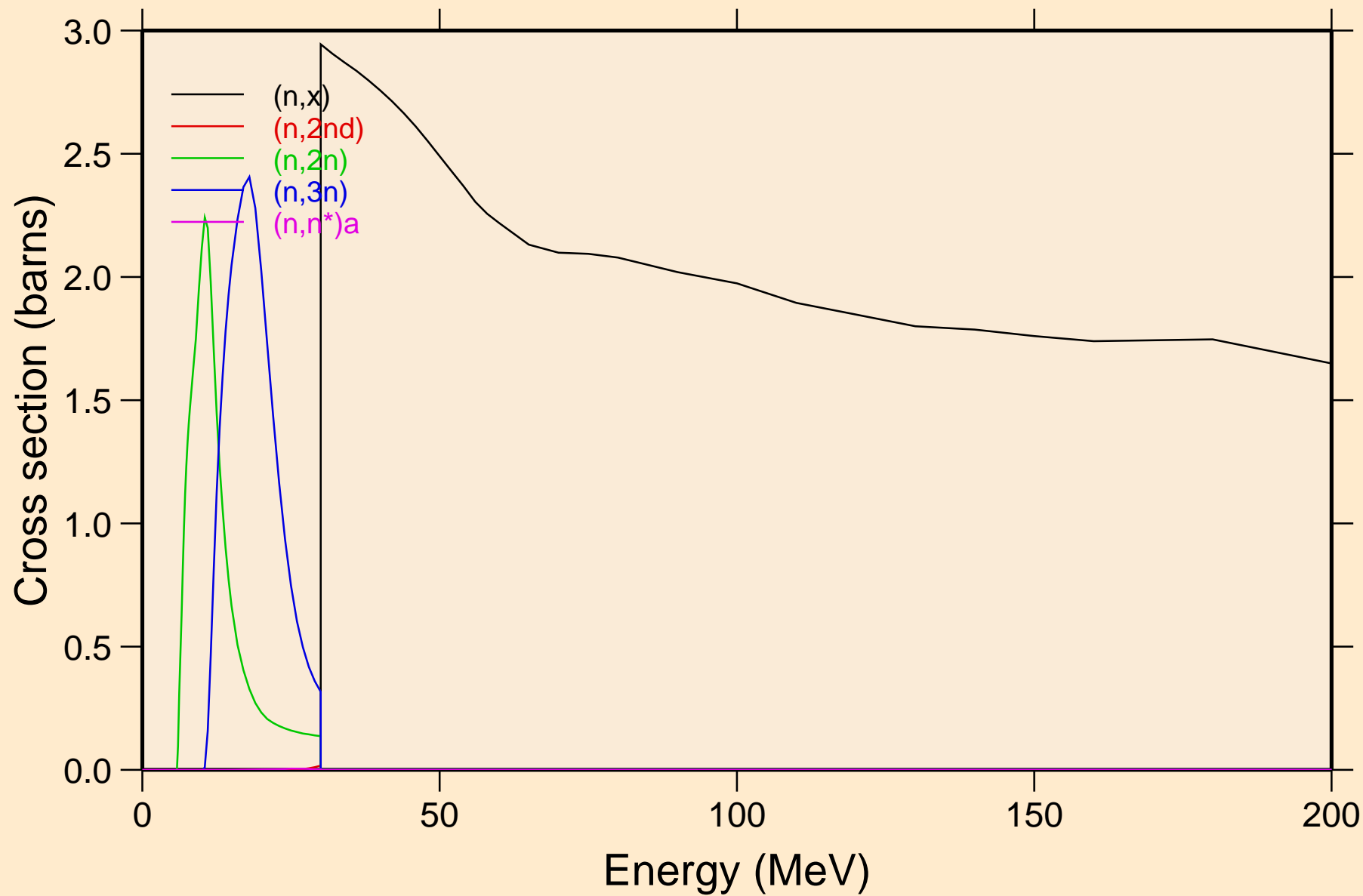

RA232 NEUTRON ACER TENDL-2021 LIBRARY; T=293.6K
Threshold reactions

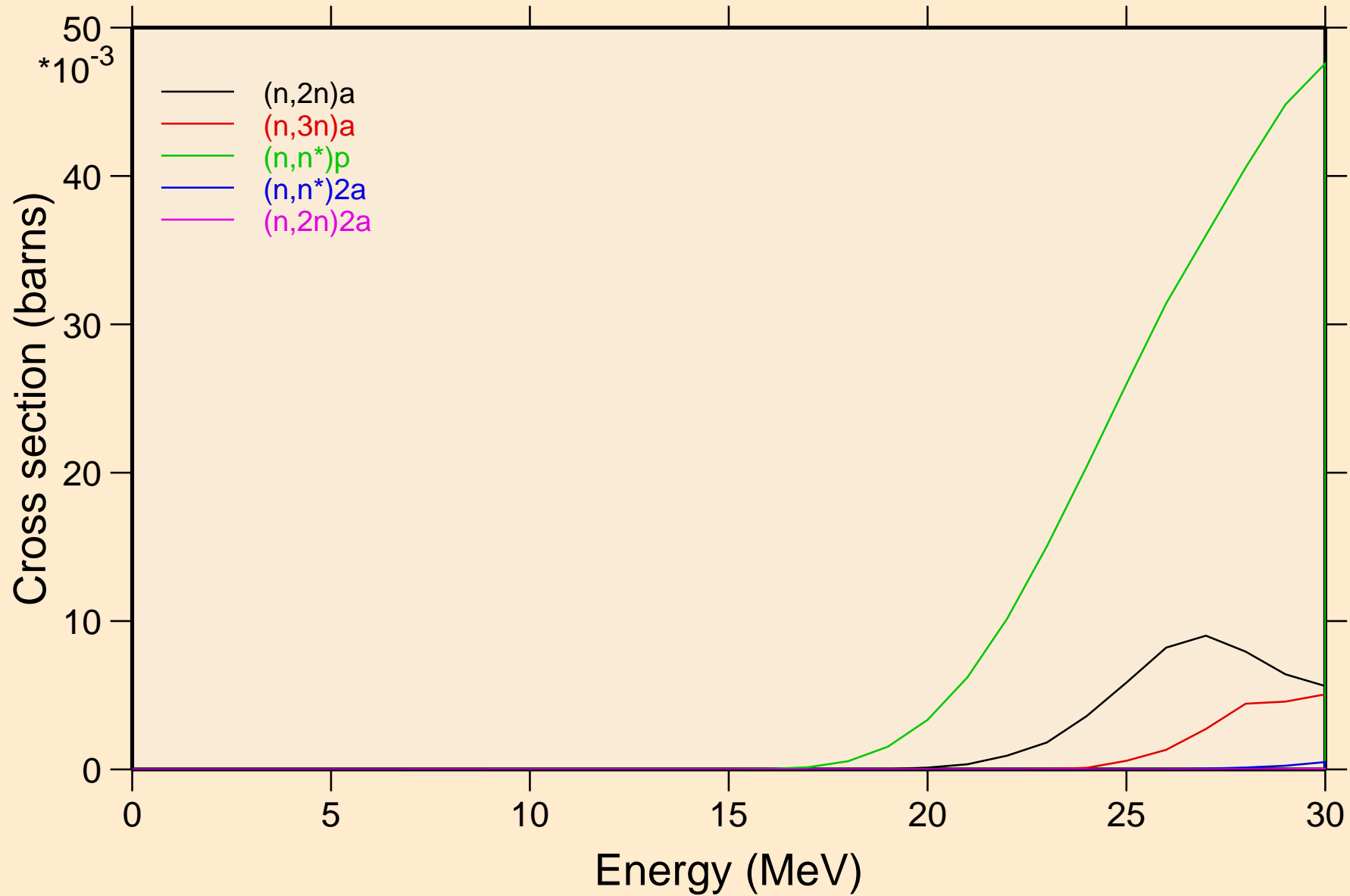

RA232 NEUTRON ACER TENDL-2021 LIBRARY; T=293.6K
Threshold reactions

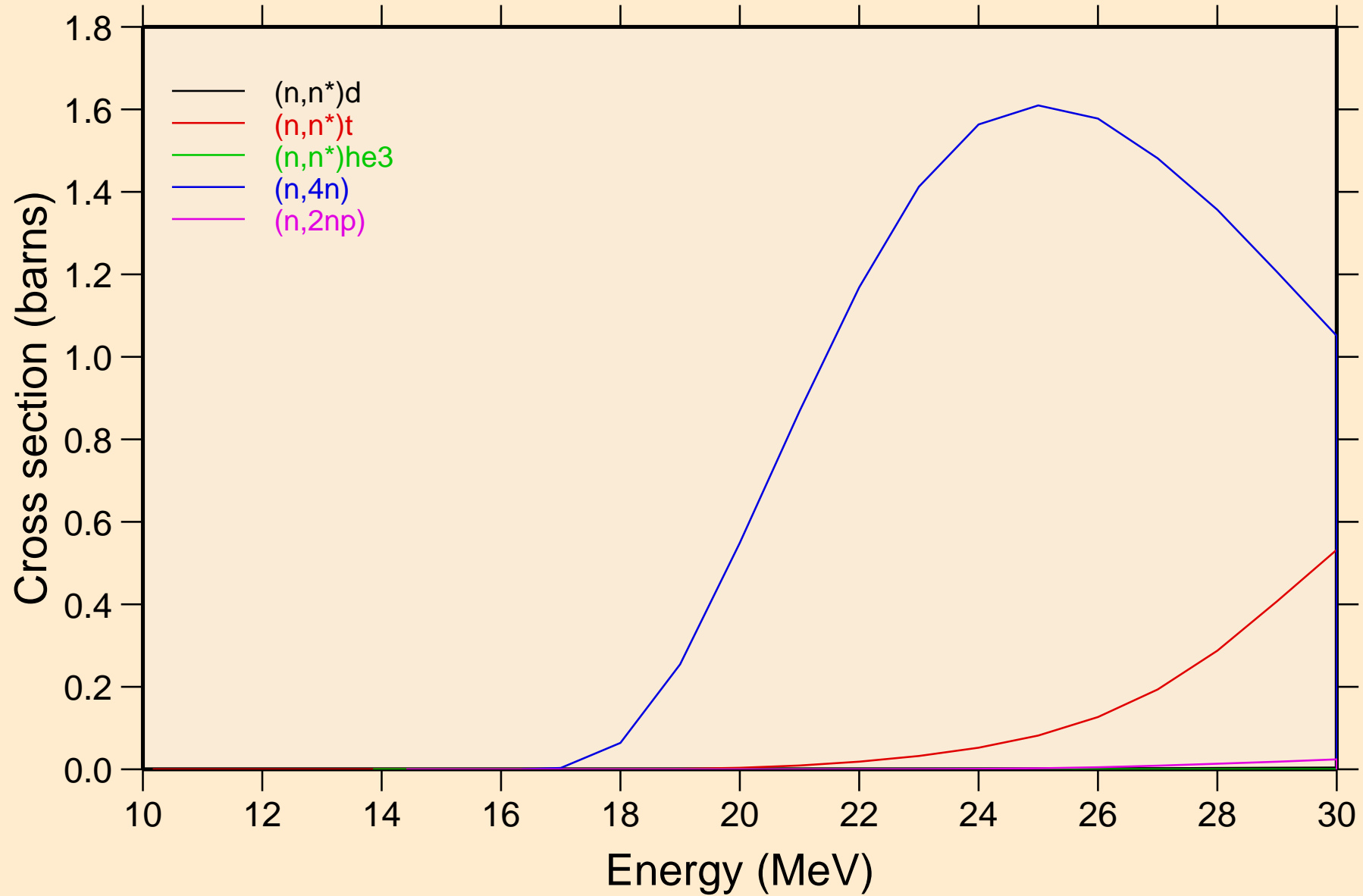

RA232 NEUTRON ACER TENDL-2021 LIBRARY; T=293.6K
Threshold reactions

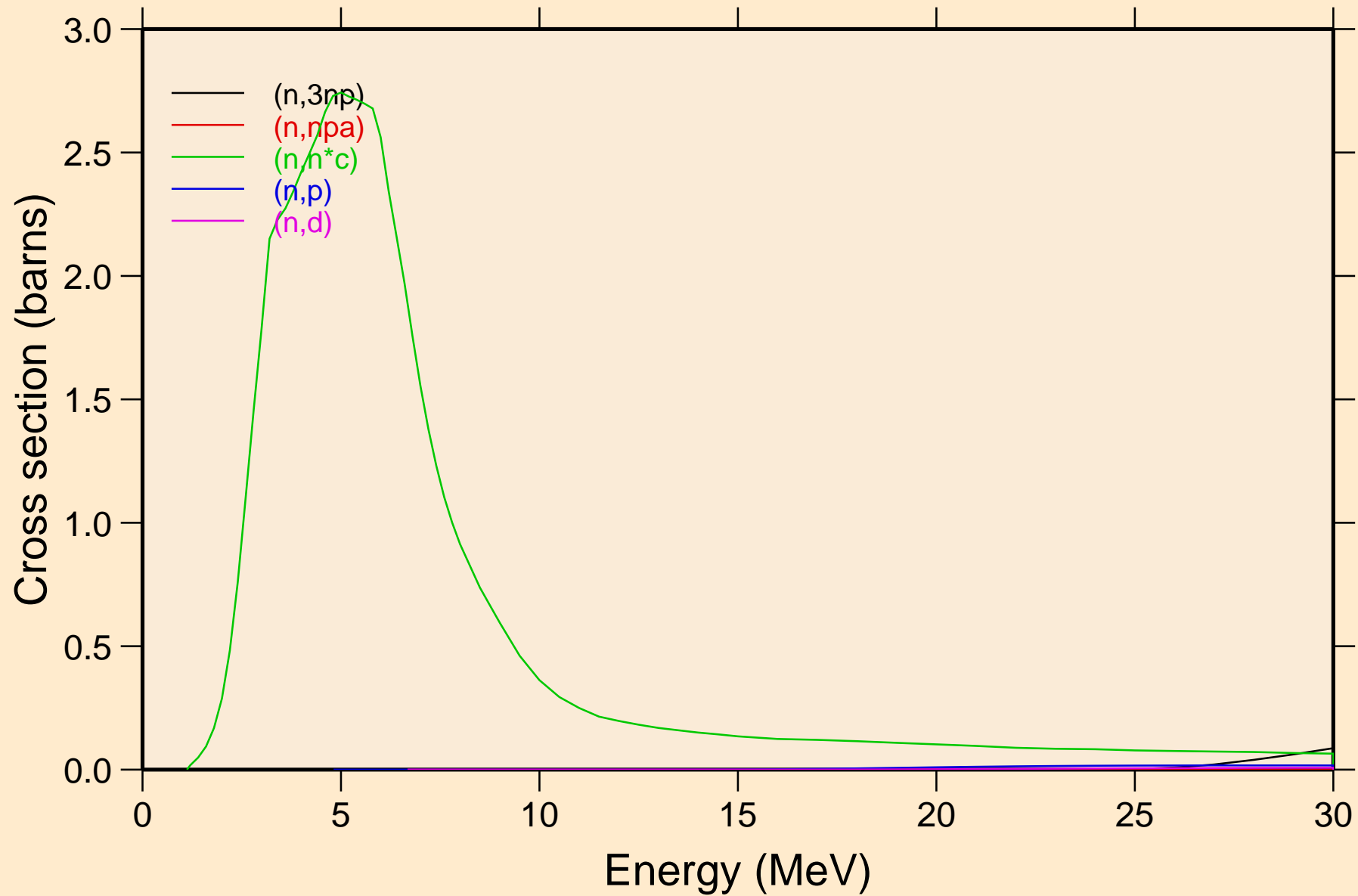

RA232 NEUTRON ACER TENDL-2021 LIBRARY; T=293.6K
Threshold reactions

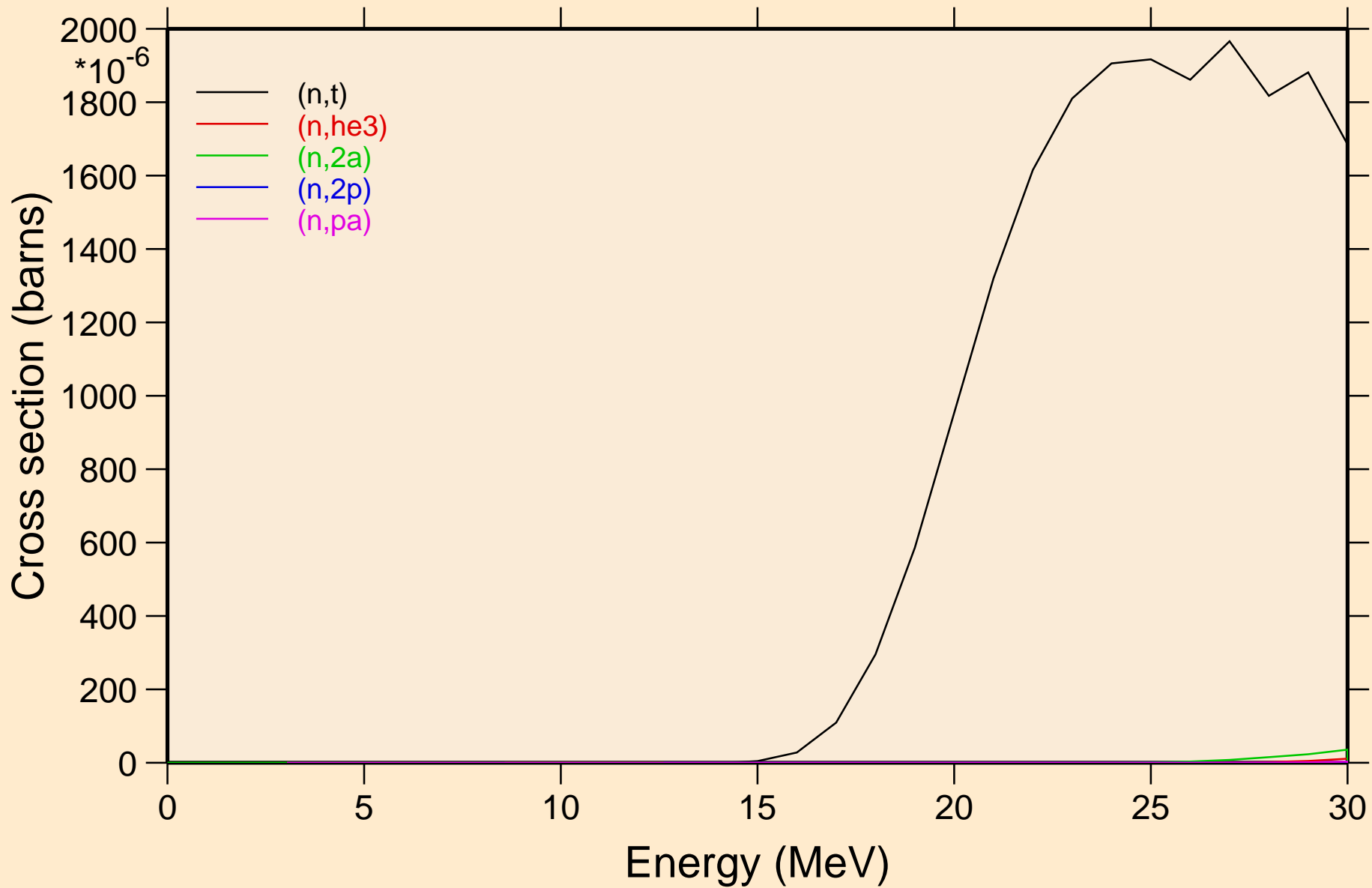

RA232 NEUTRON ACER TENDL-2021 LIBRARY; T=293.6K
Threshold reactions

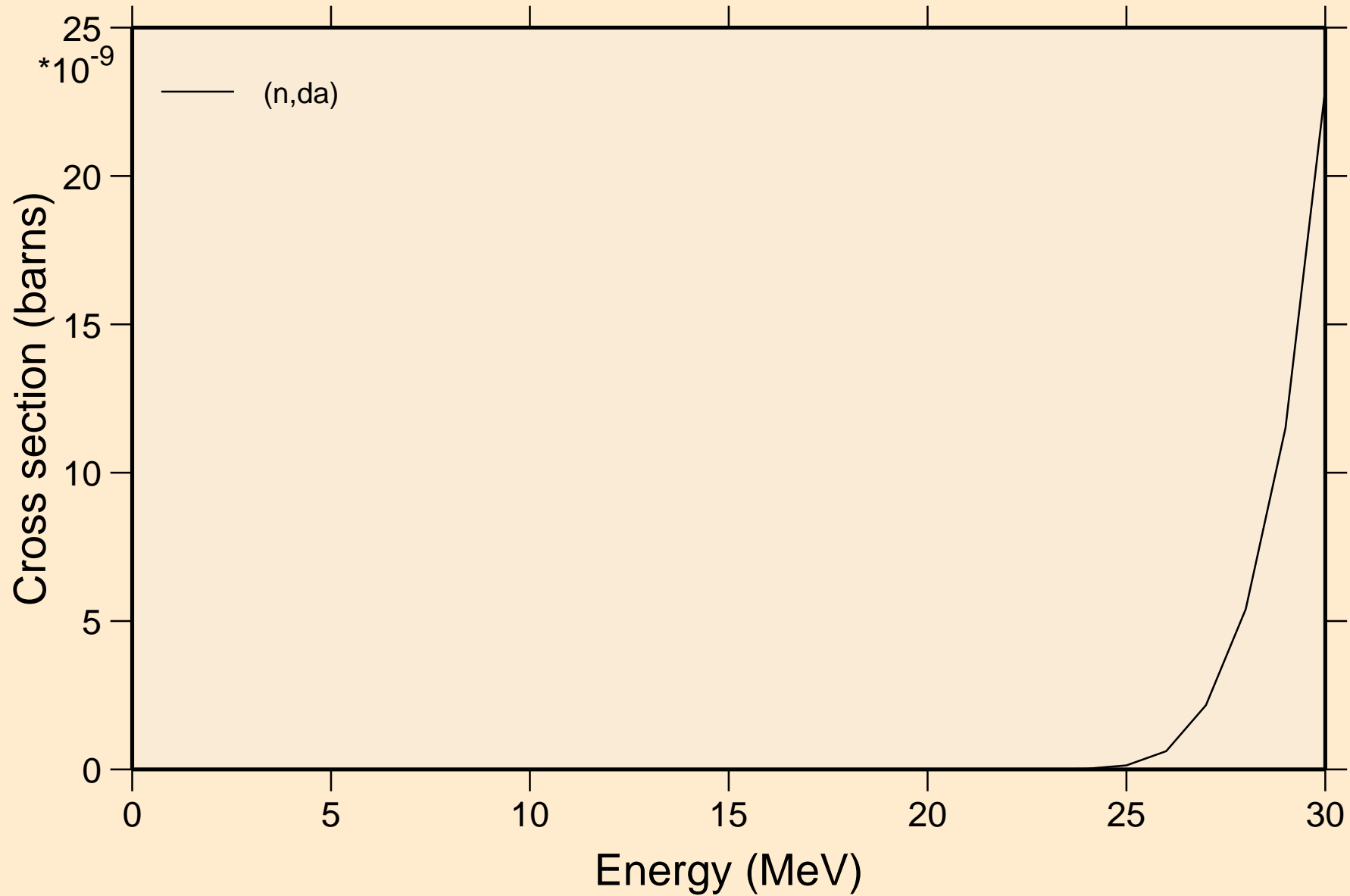

RA232 NEUTRON ACER TENDL-2021 LIBRARY; T=293.6K
Threshold reactions

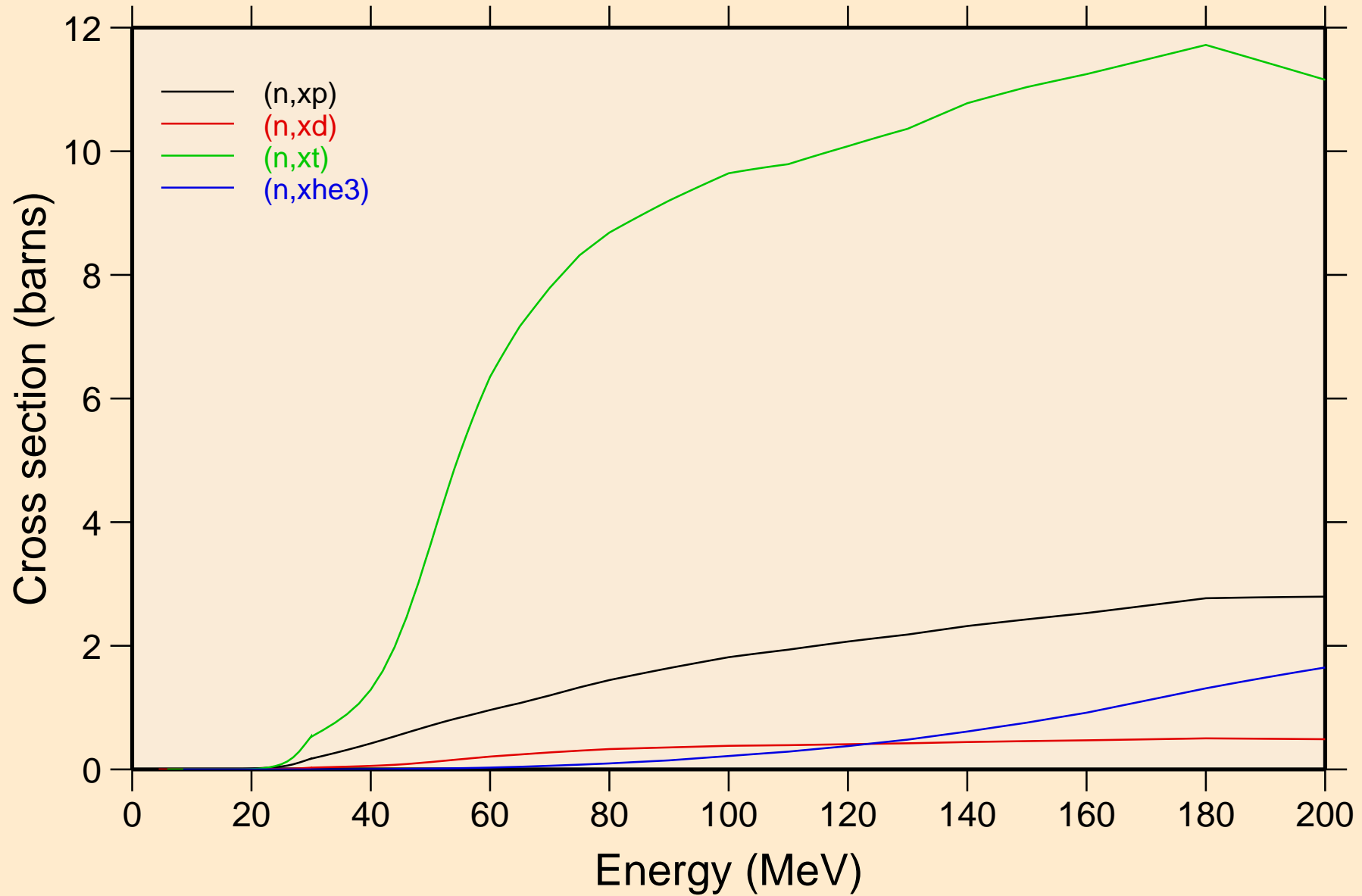

RA232 NEUTRON ACER TENDL-2021 LIBRARY; T=293.6K
angular distribution for elastic

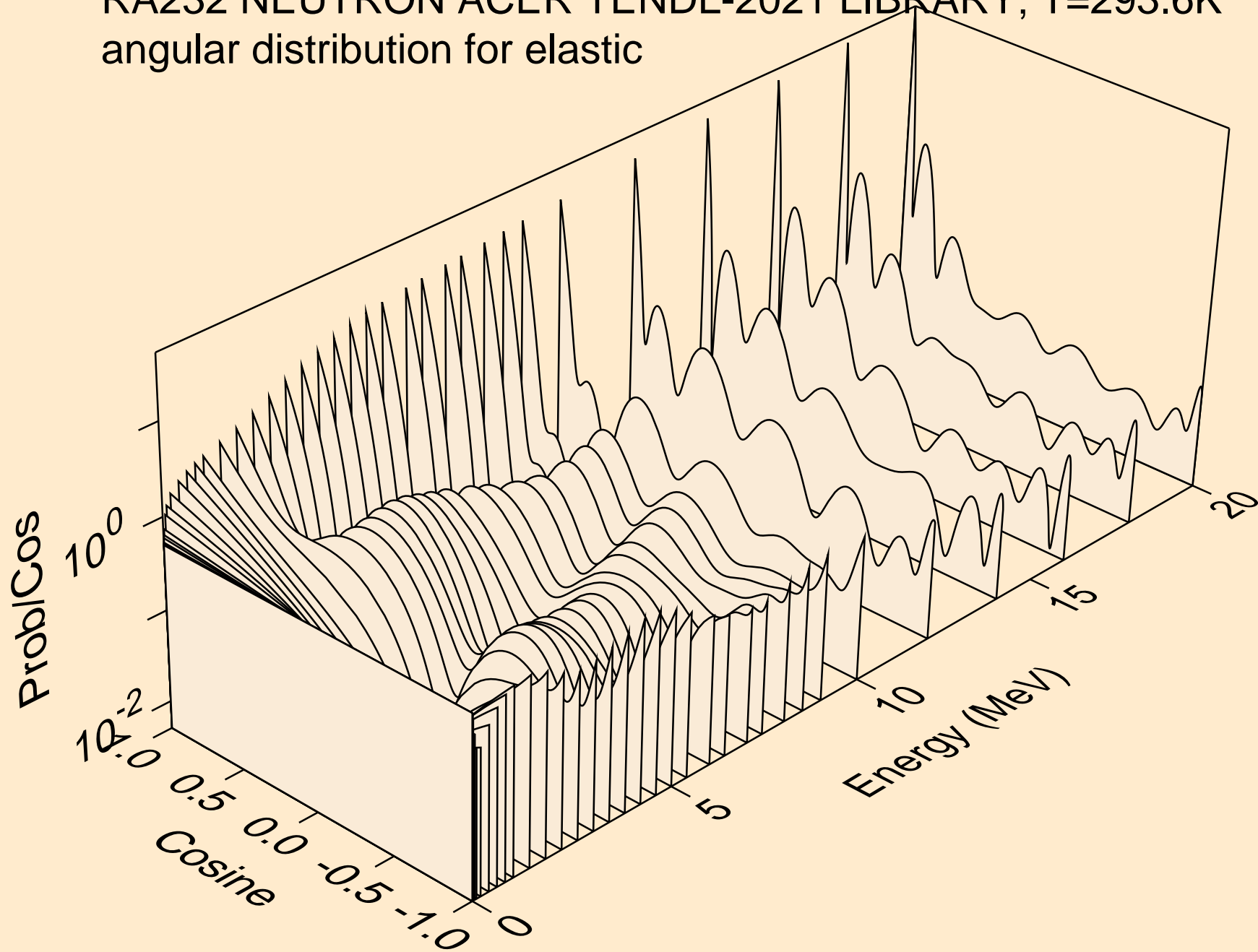

RA232 NEUTRON ACER TENDL-2021 LIBRARY; T=293.6K
angular distribution for elastic

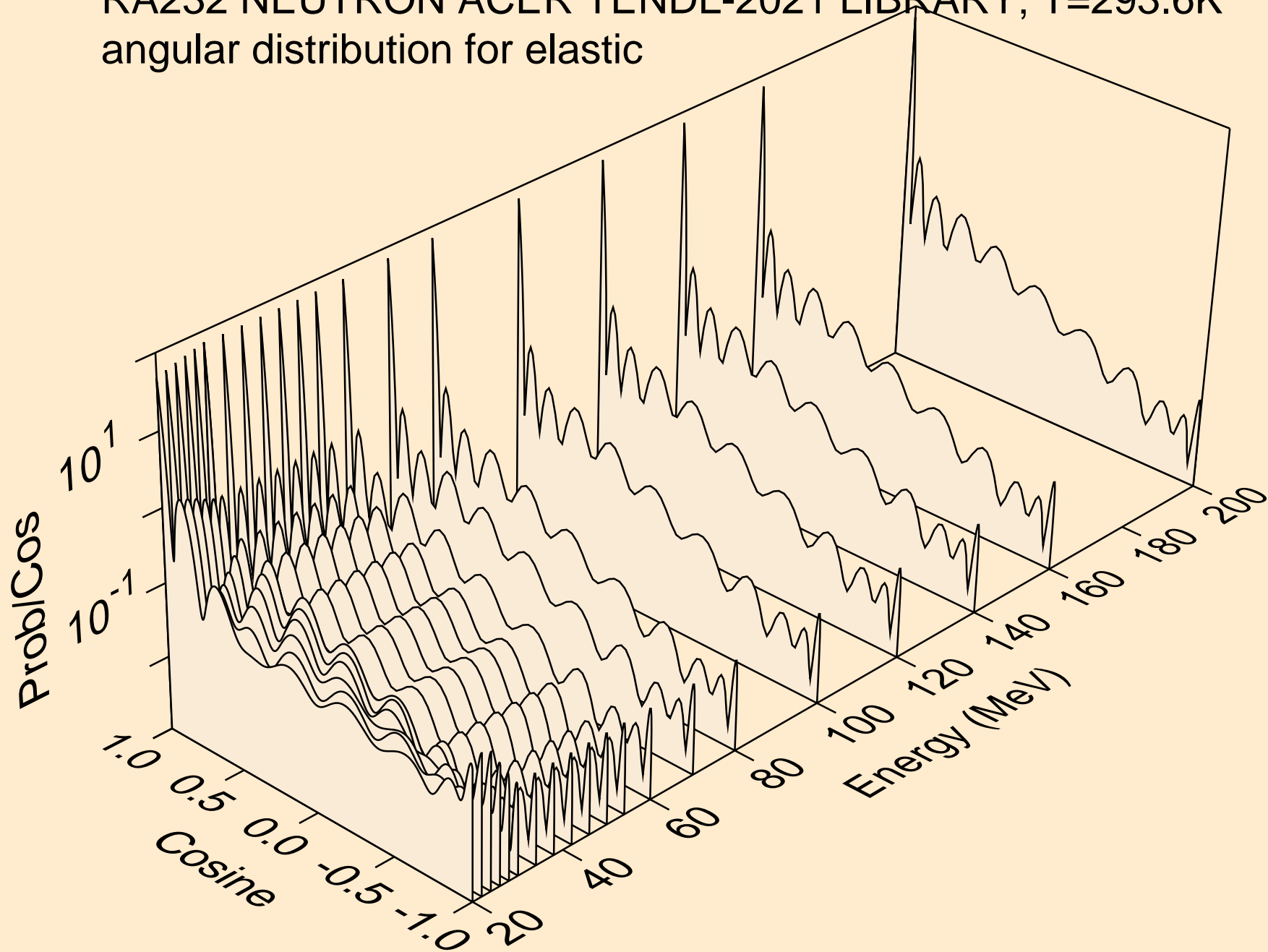

RA232 NEUTRON ACER TENDL-2021 LIBRARY; T=293.6K
angular distribution for (n,n*1)

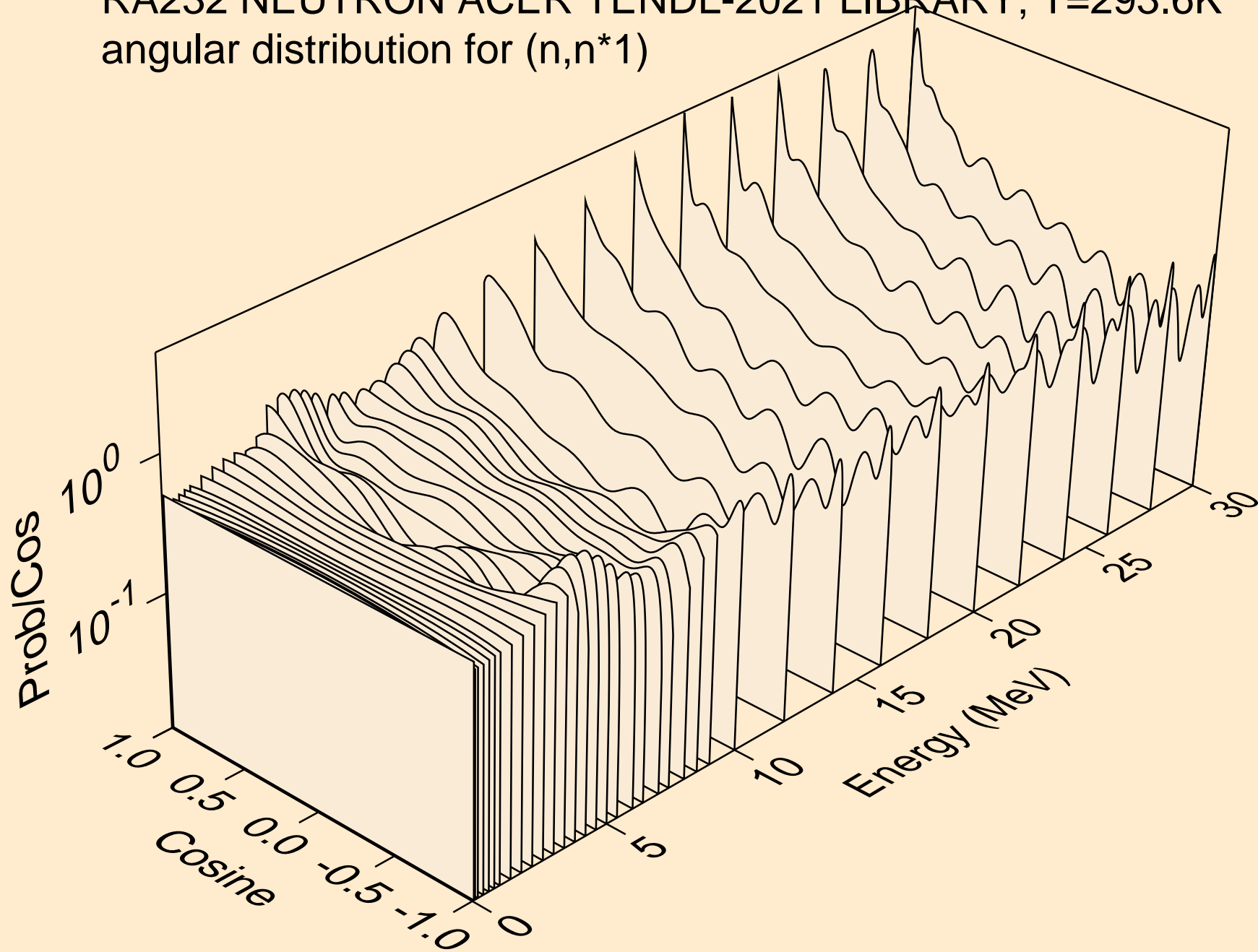

RA232 NEUTRON ACER TENDL-2021 LIBRARY; T=293.6K
angular distribution for (n,n*2)

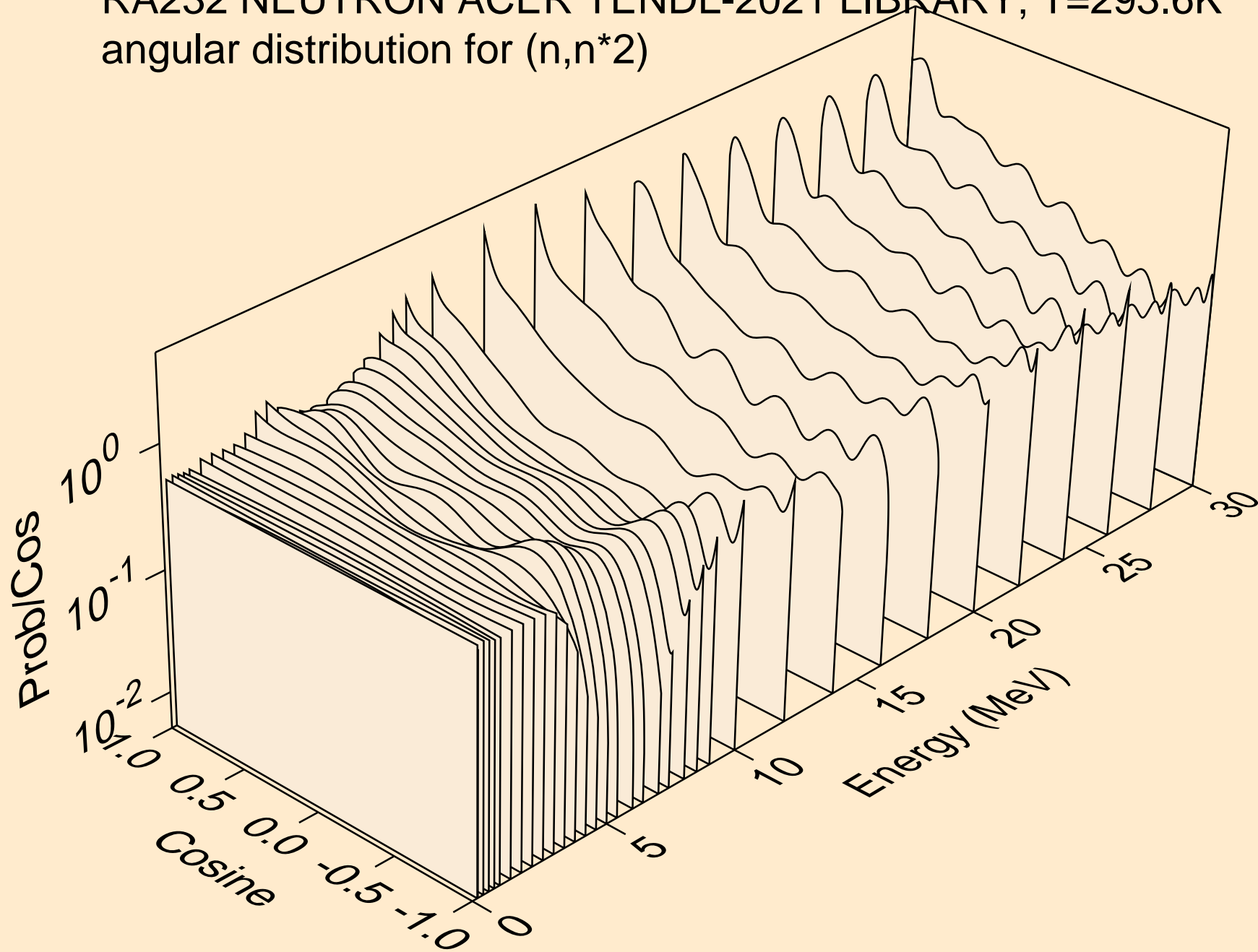

RA232 NEUTRON ACER TENDL-2021 LIBRARY; T=293.6K
angular distribution for (n,n*3)

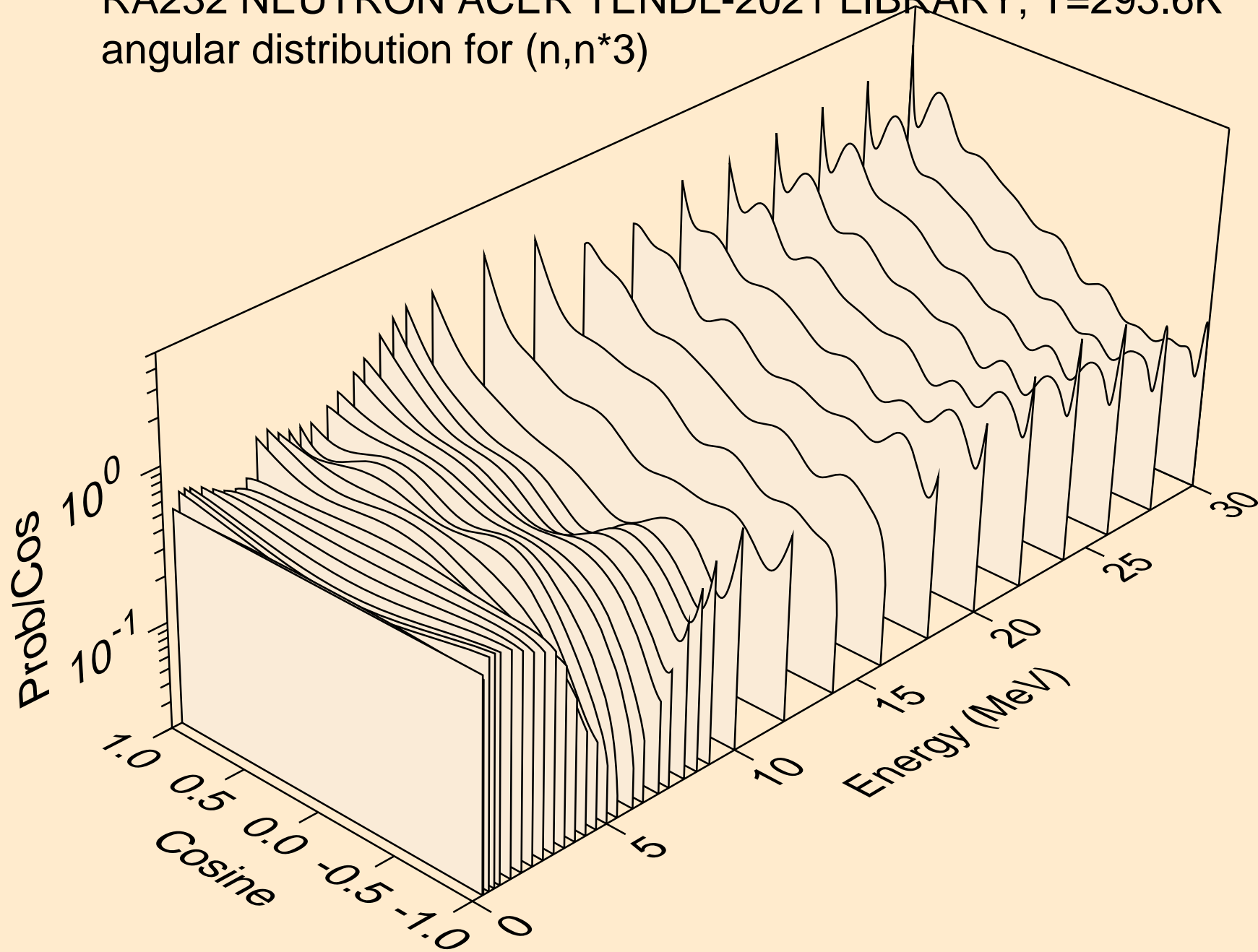

RA232 NEUTRON ACER TENDL-2021 LIBRARY; T=293.6K
angular distribution for (n,n*4)

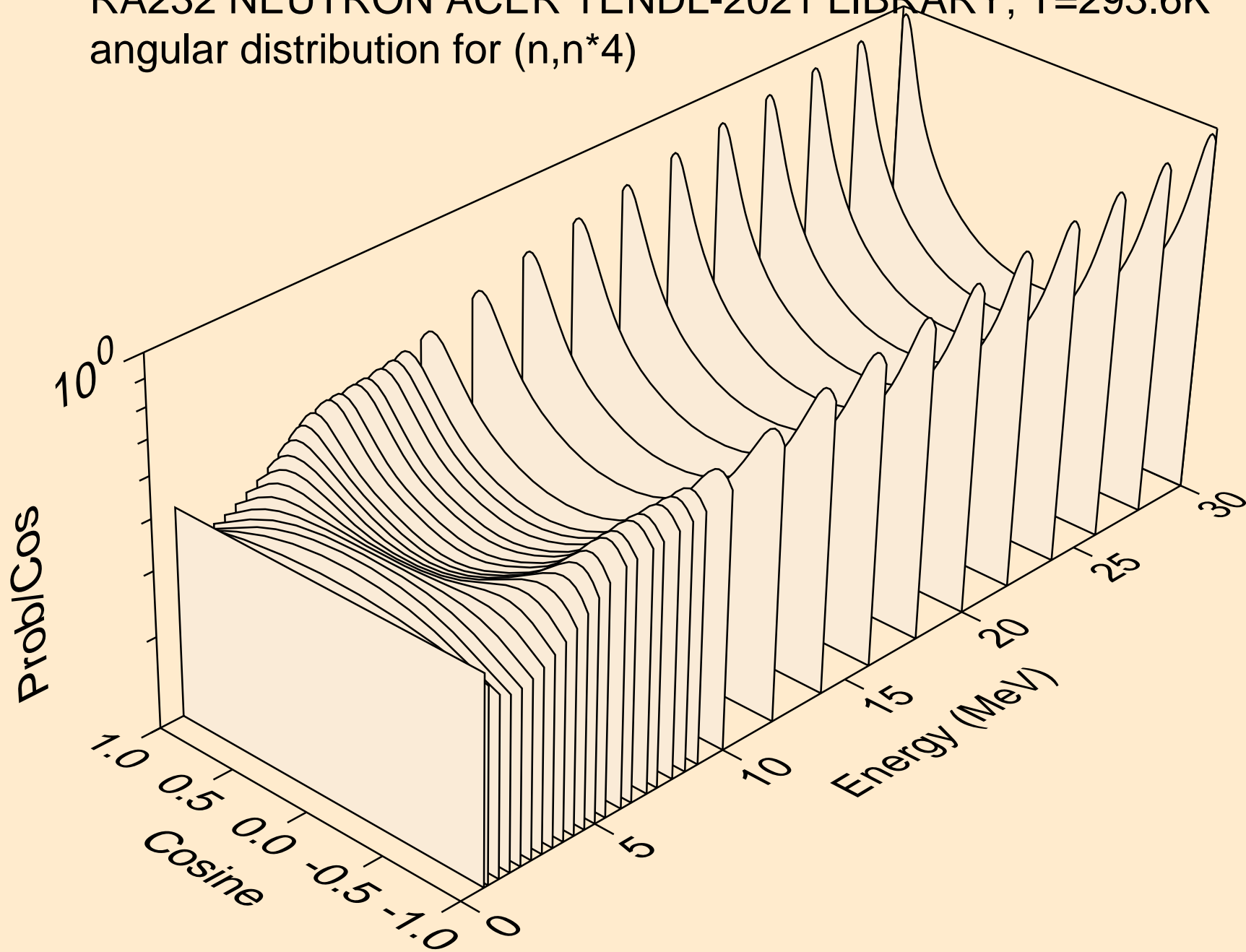

RA232 NEUTRON ACER TENDL-2021 LIBRARY; T=293.6K
angular distribution for (n,n*5)

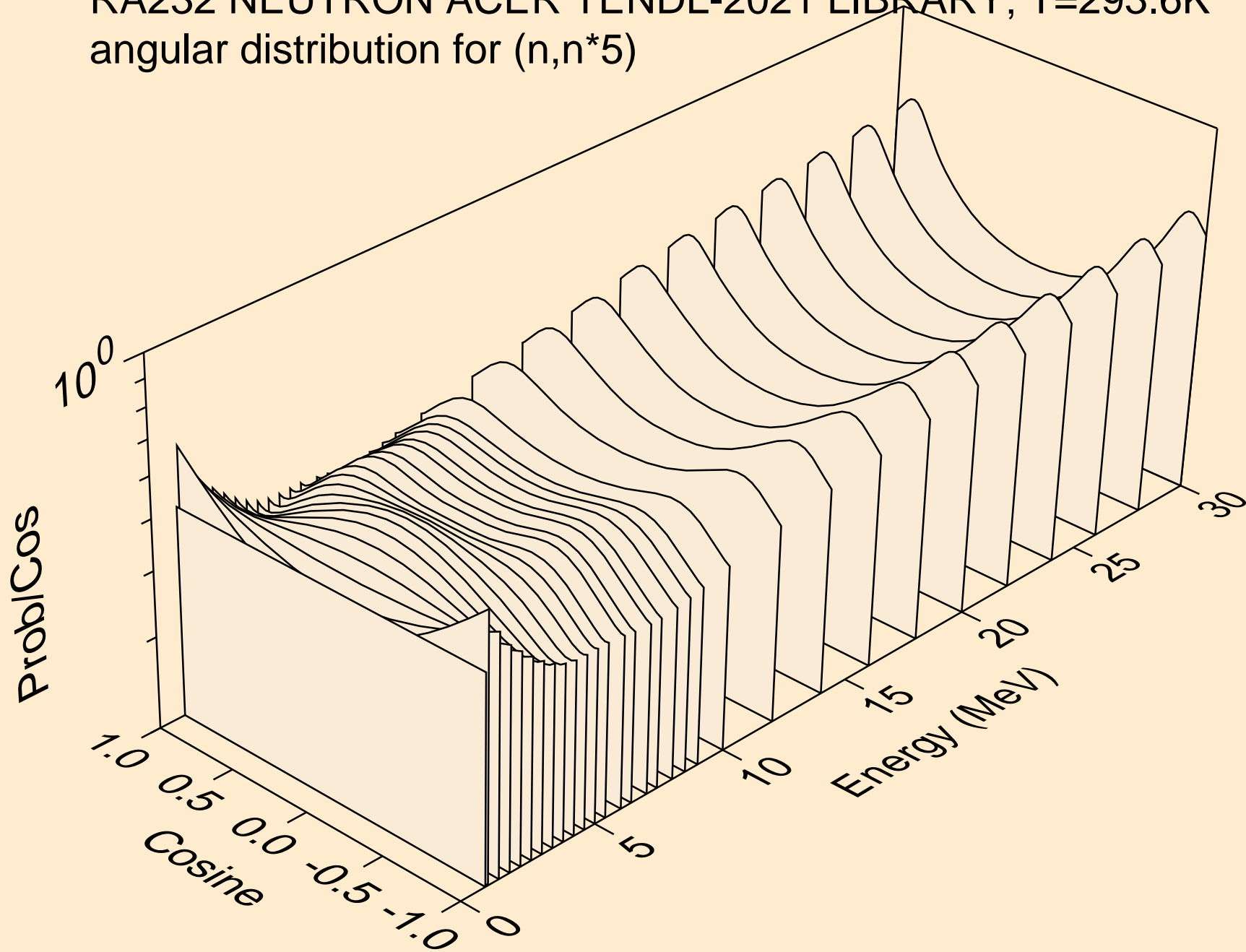

RA232 NEUTRON ACER TENDL-2021 LIBRARY; T=293.6K
angular distribution for (n,n*6)

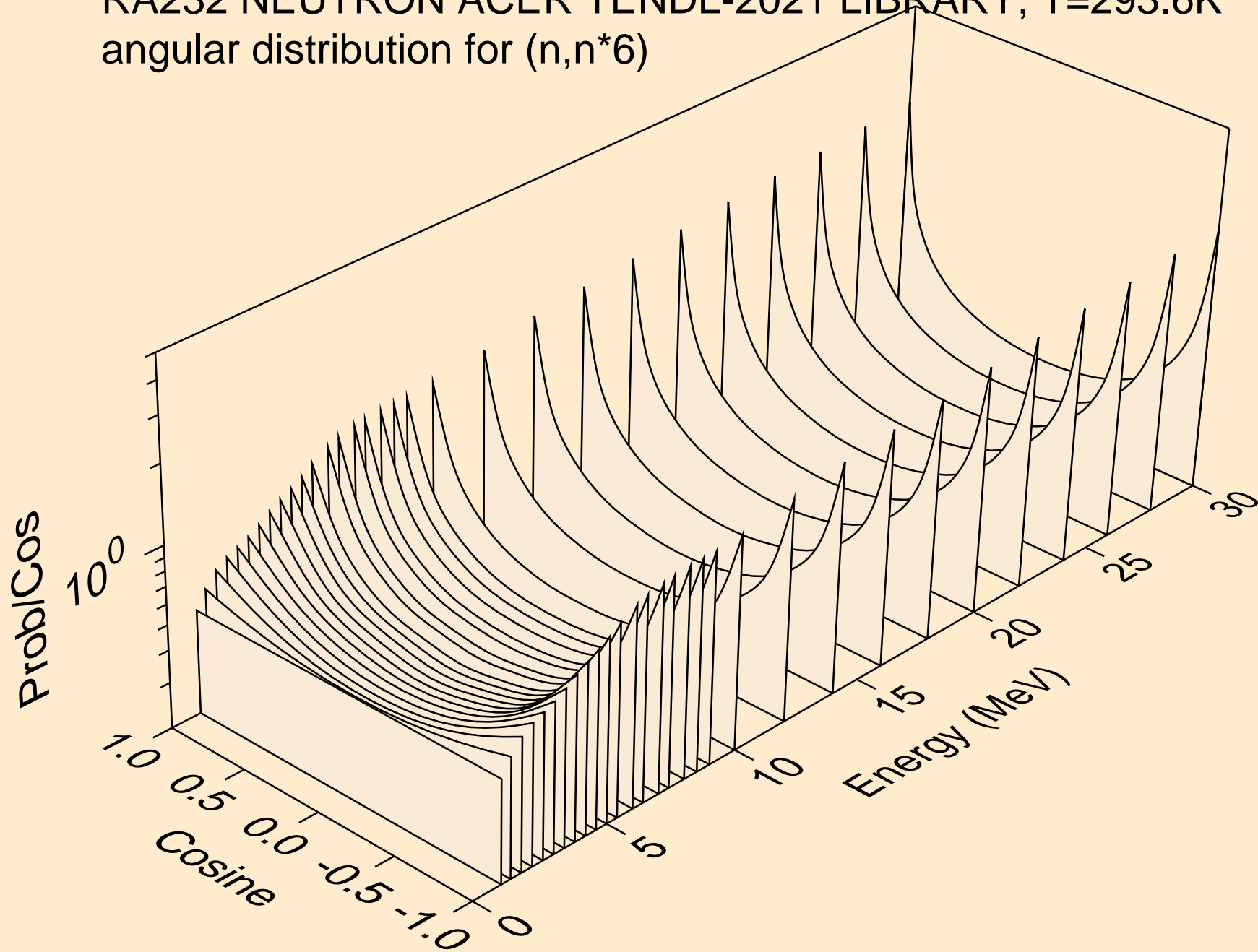

RA232 NEUTRON ACER TENDL-2021 LIBRARY; T=293.6K
angular distribution for (n,n*7)

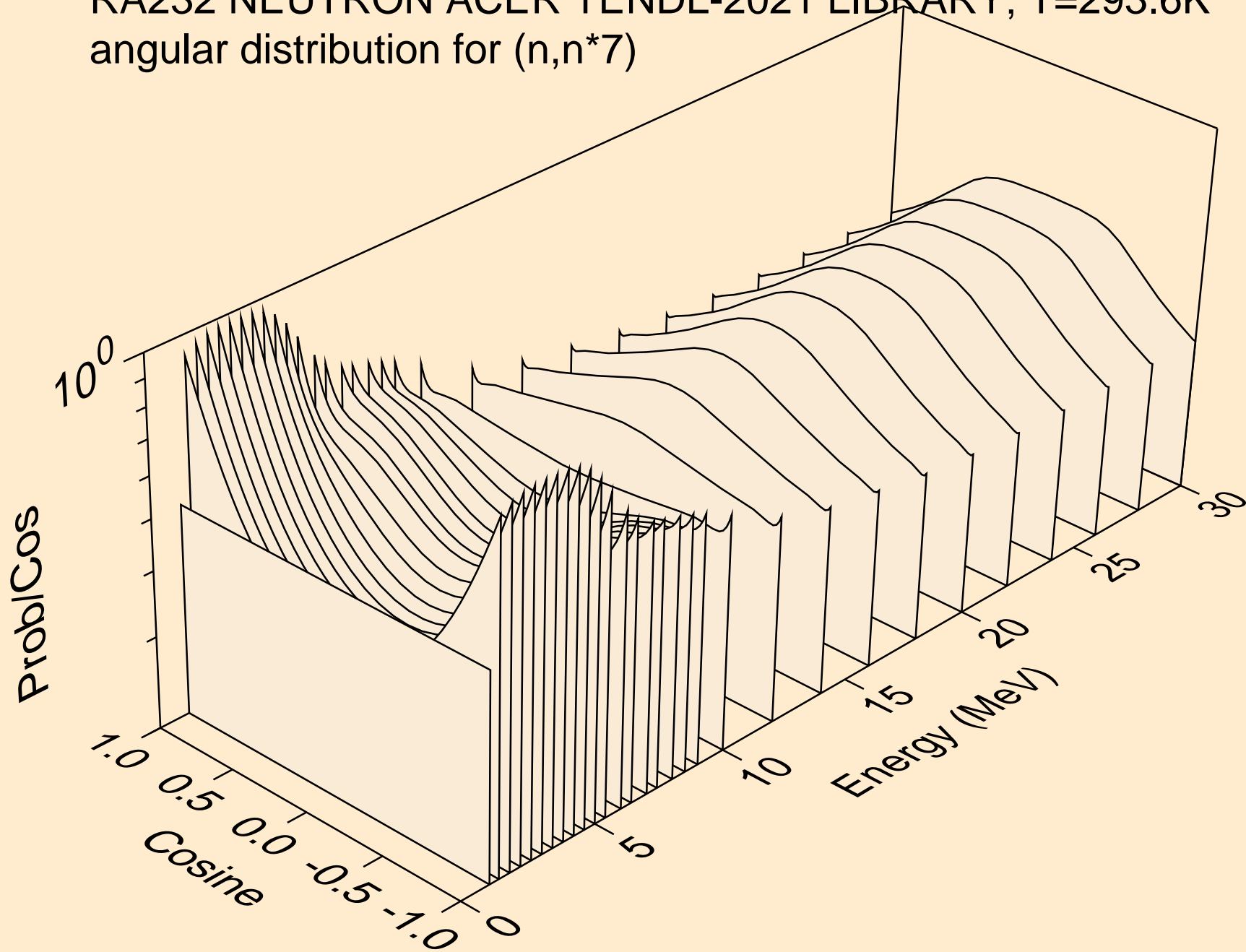

RA232 NEUTRON ACER TENDL-2021 LIBRARY; T=293.6K
angular distribution for (n,n*8)

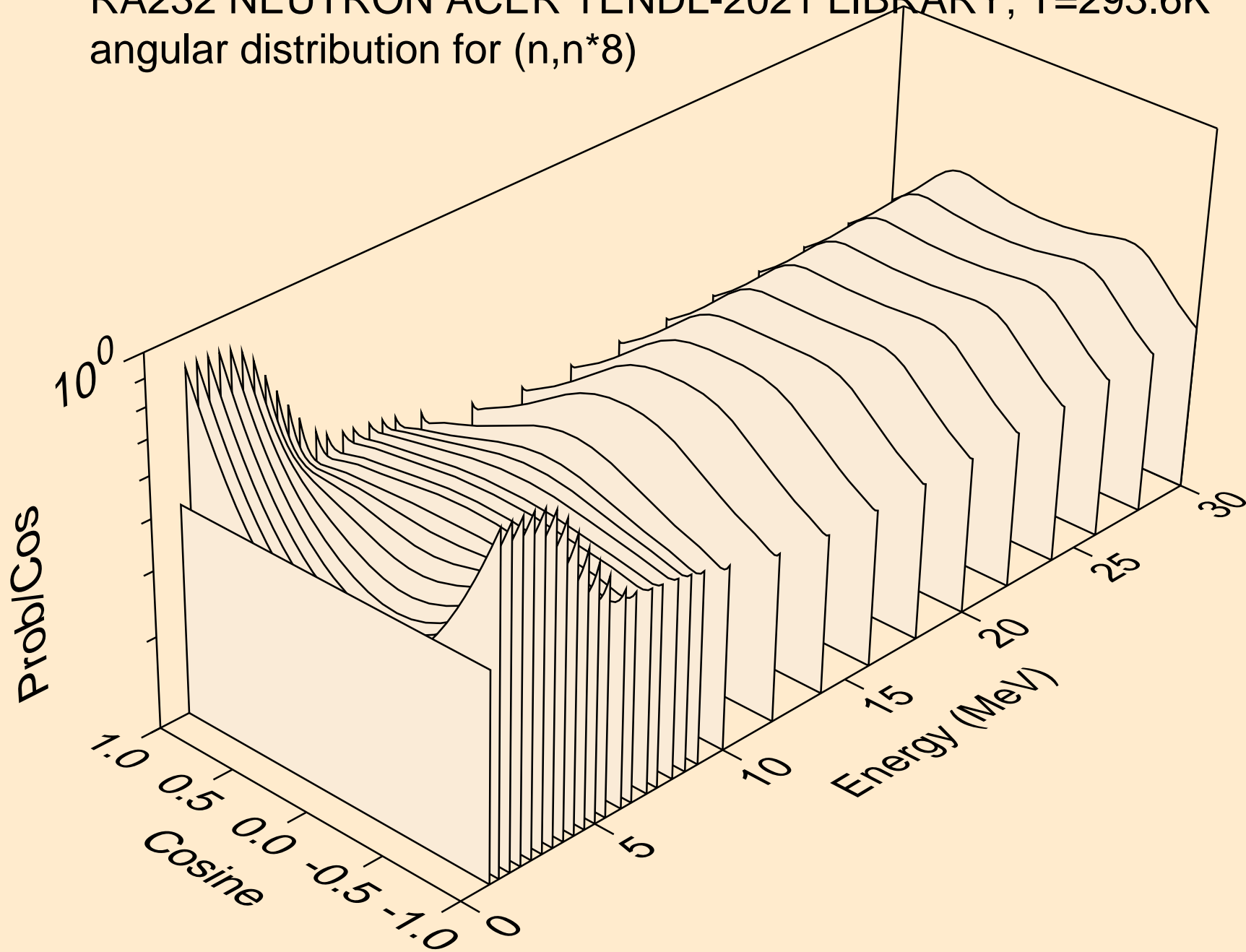

RA232 NEUTRON ACER TENDL-2021 LIBRARY; T=293.6K
angular distribution for (n,n*9)

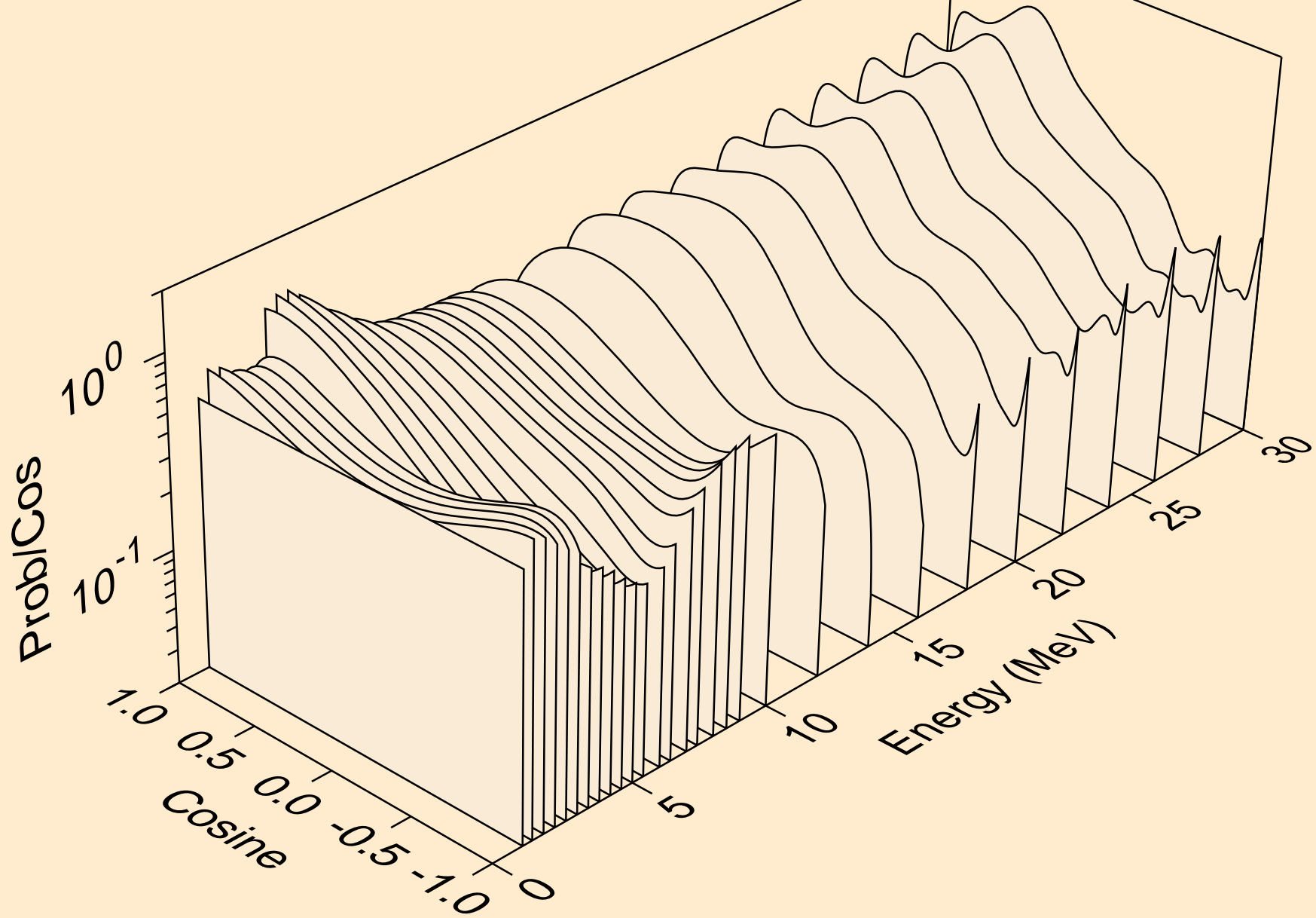

RA232 NEUTRON ACER TENDL-2021 LIBRARY; T=293.6K
angular distribution for (n,n*10)

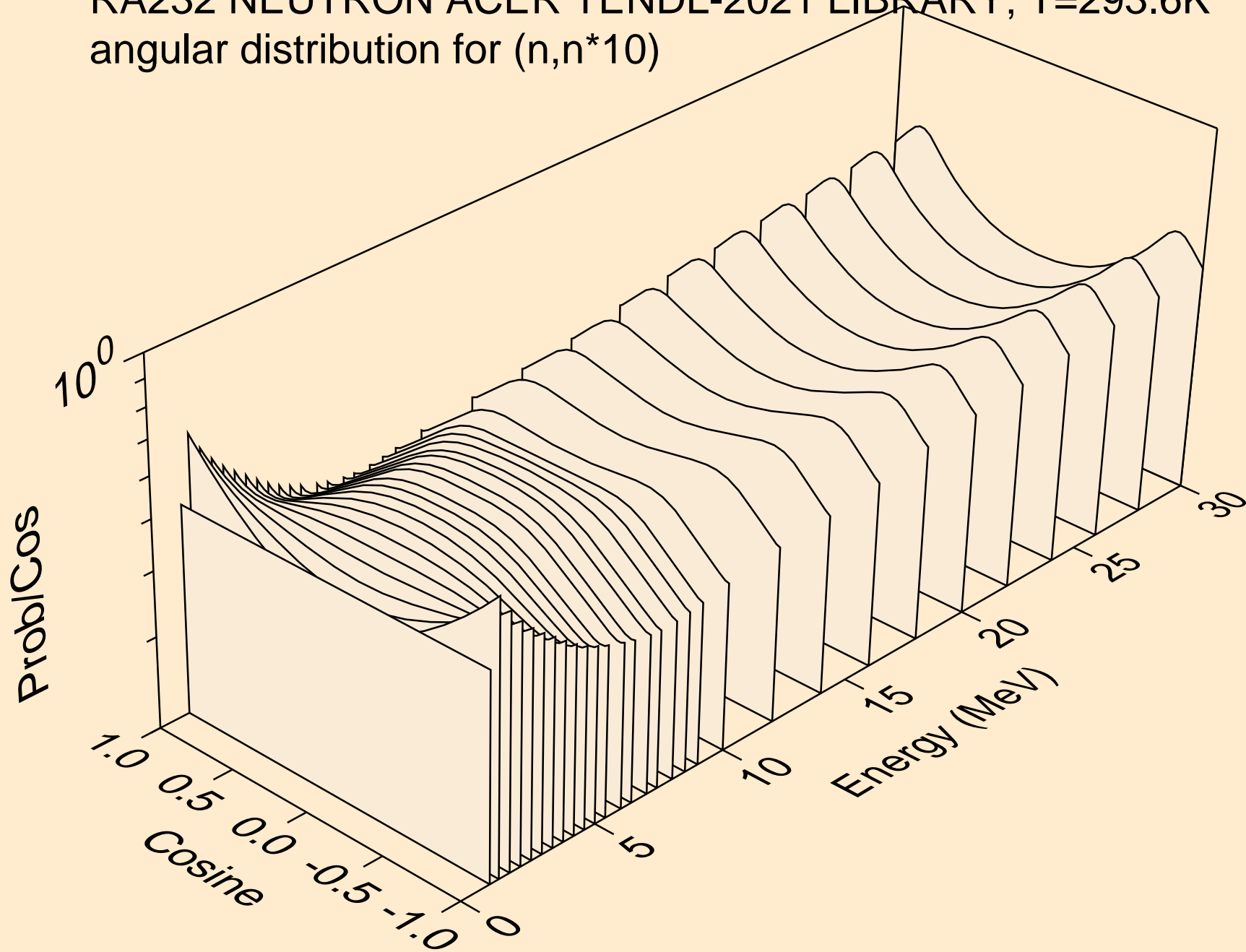

RA232 NEUTRON ACER TENDL-2021 LIBRARY; T=293.6K
angular distribution for (n,n*11)

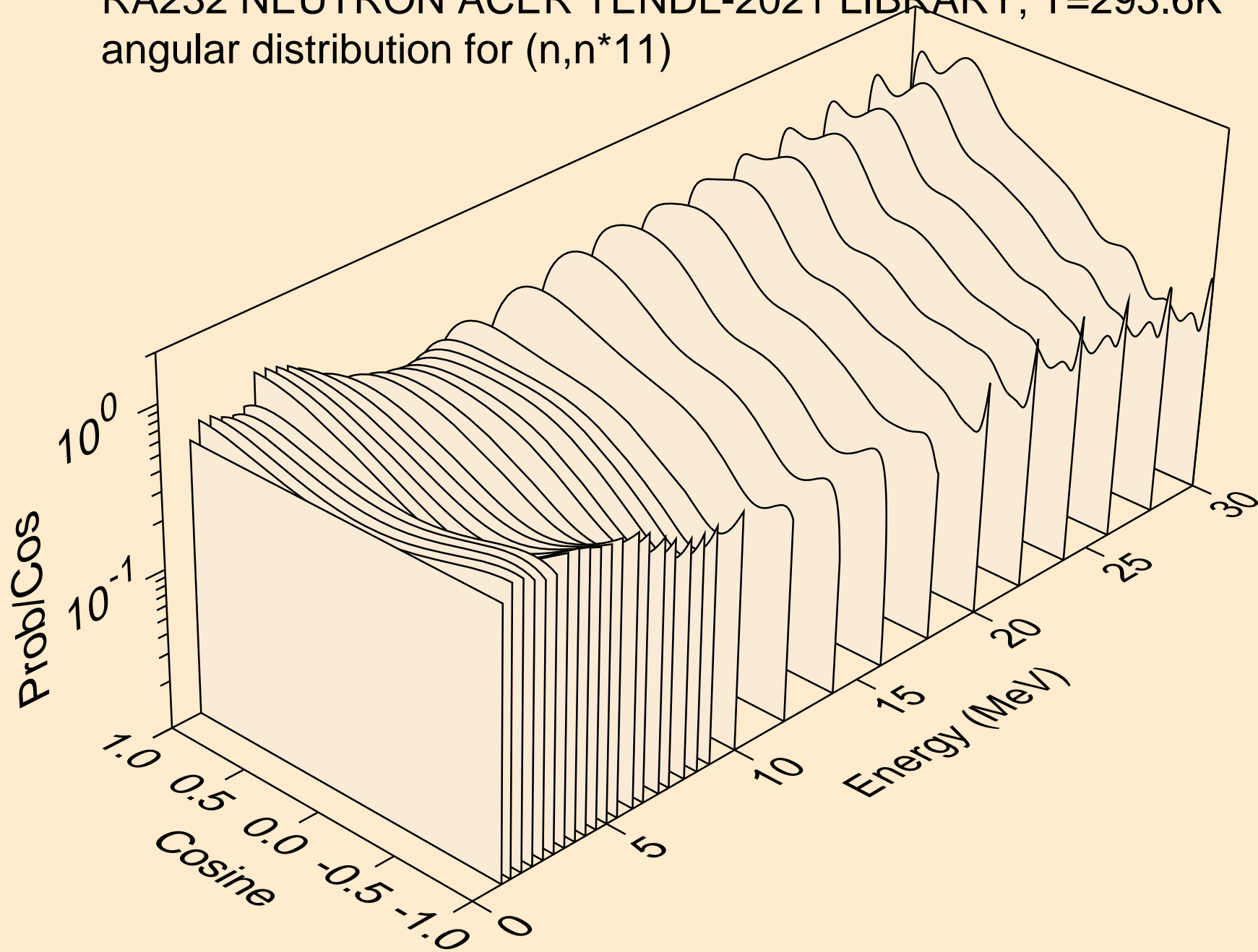

RA232 NEUTRON ACER TENDL-2021 LIBRARY; T=293.6K
angular distribution for (n,n*12)

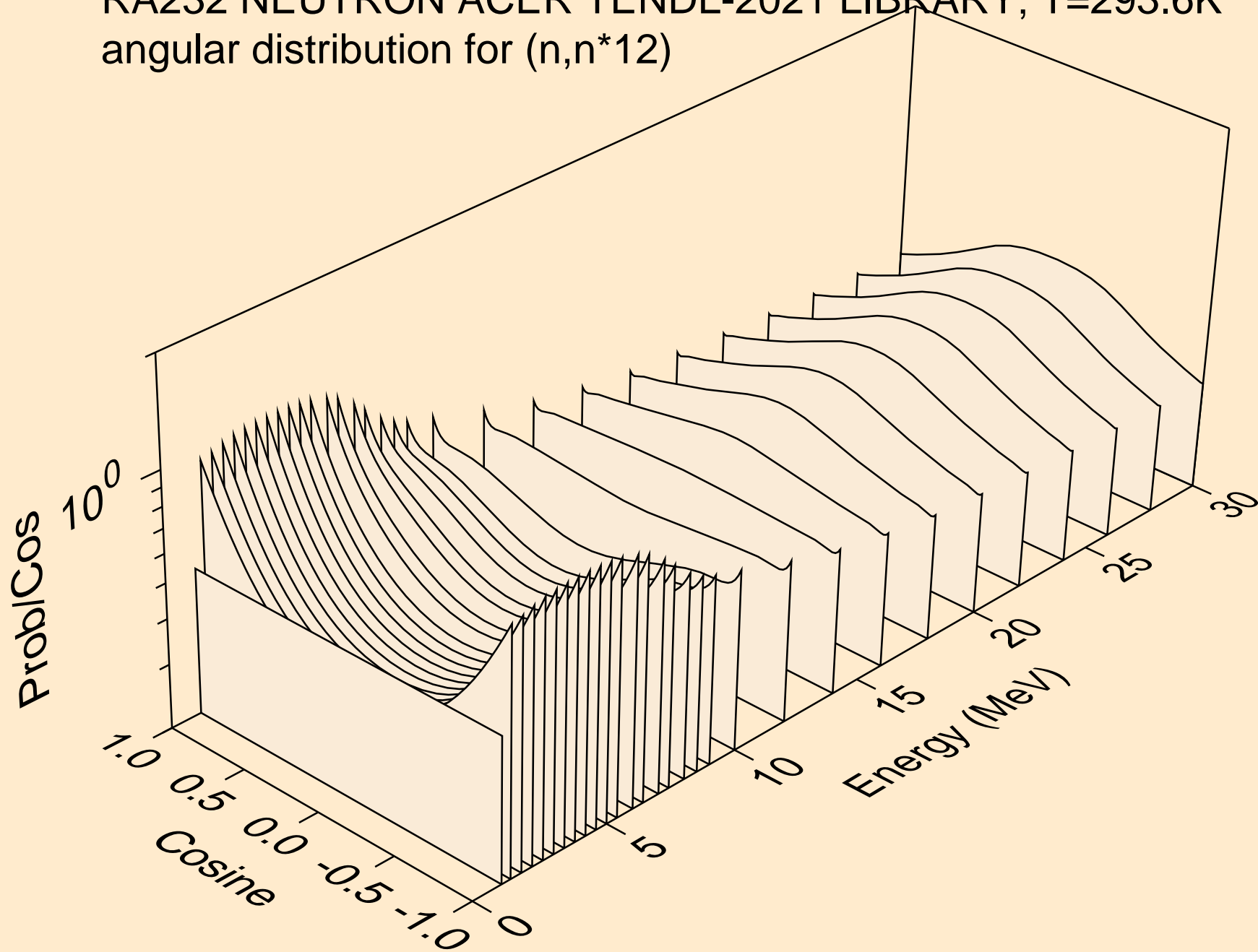

RA232 NEUTRON ACER TENDL-2021 LIBRARY; T=293.6K
angular distribution for (n,n*13)

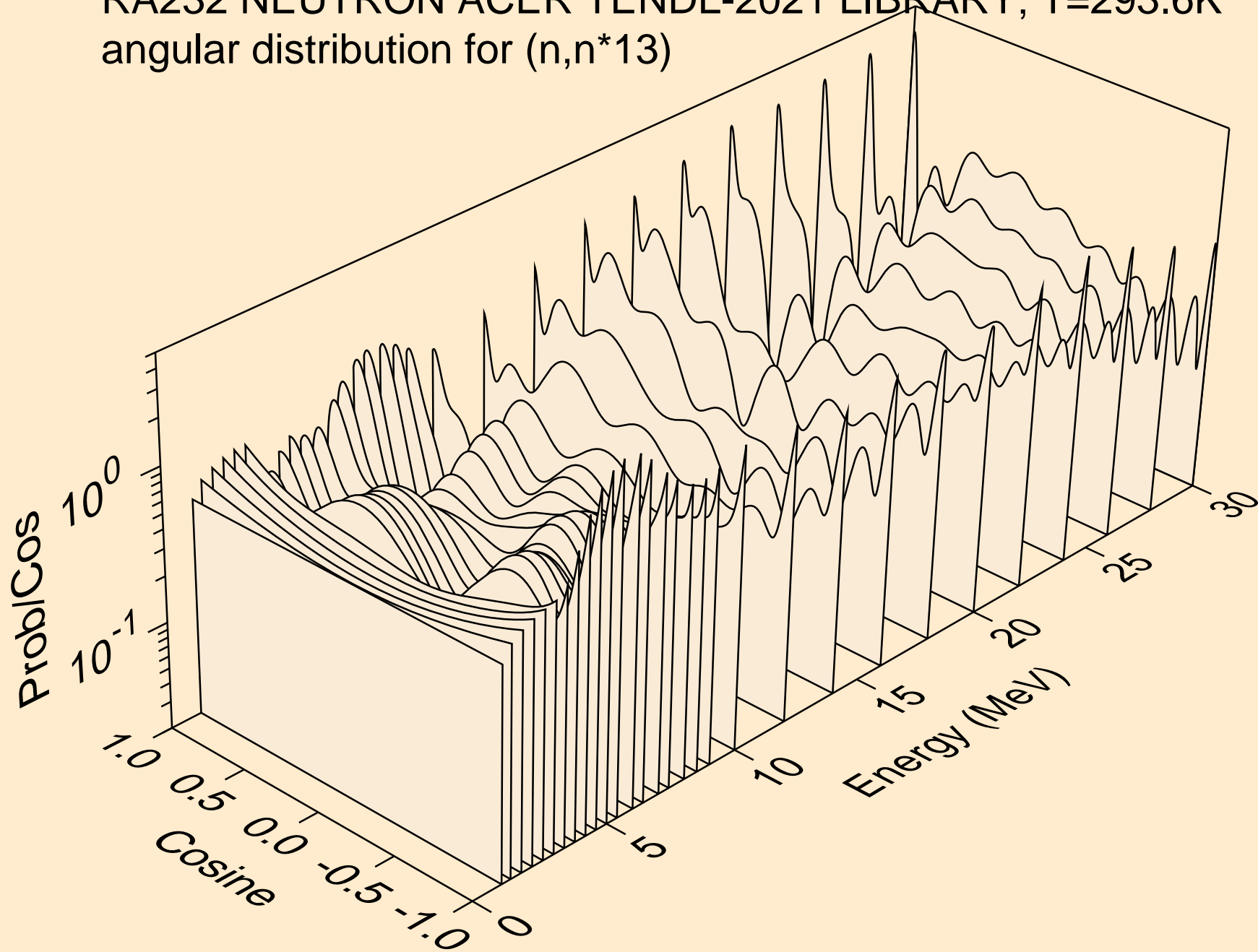

RA232 NEUTRON ACER TENDL-2021 LIBRARY; T=293.6K
angular distribution for (n,n*14)

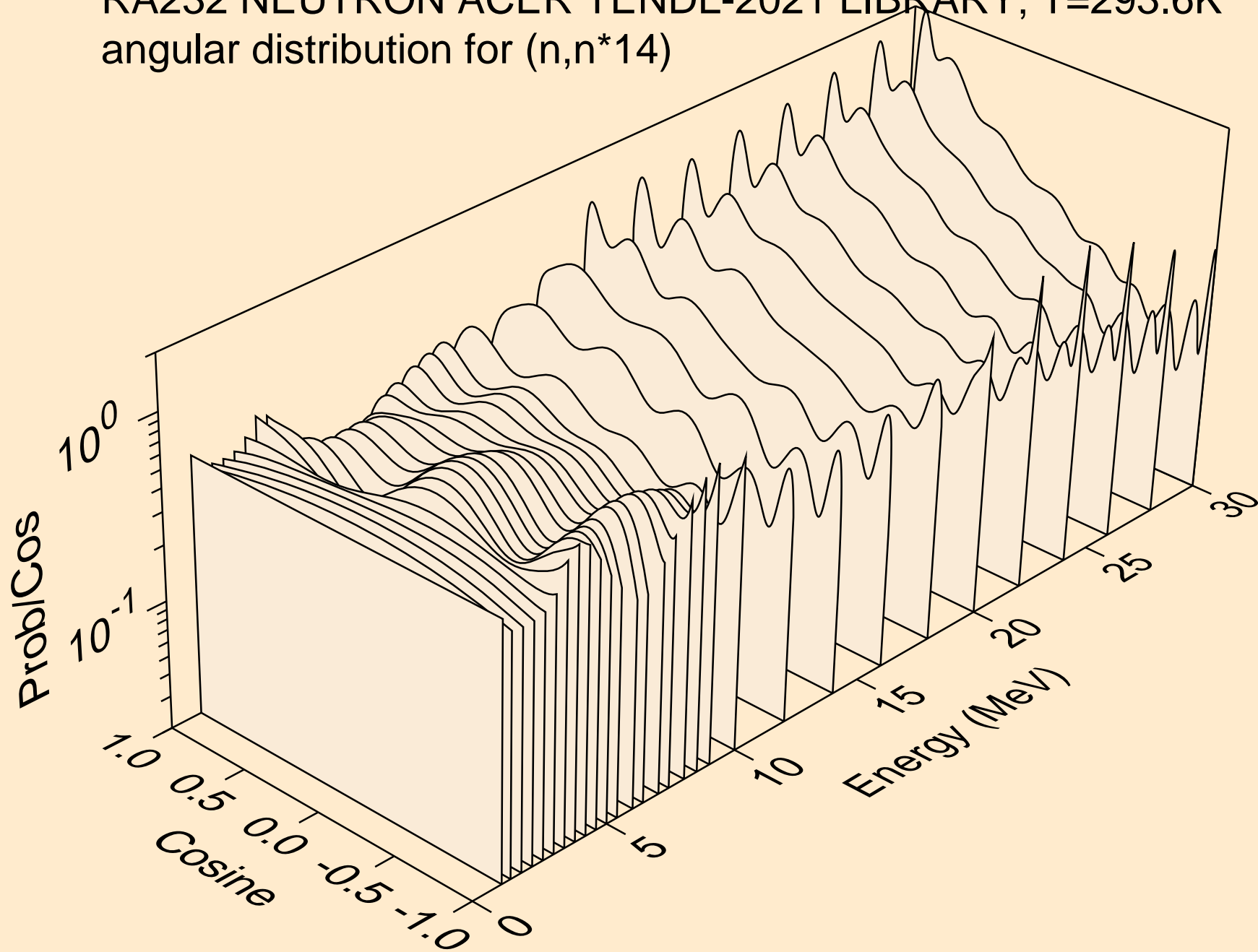

RA232 NEUTRON ACER TENDL-2021 LIBRARY; T=293.6K
angular distribution for (n,n*15)

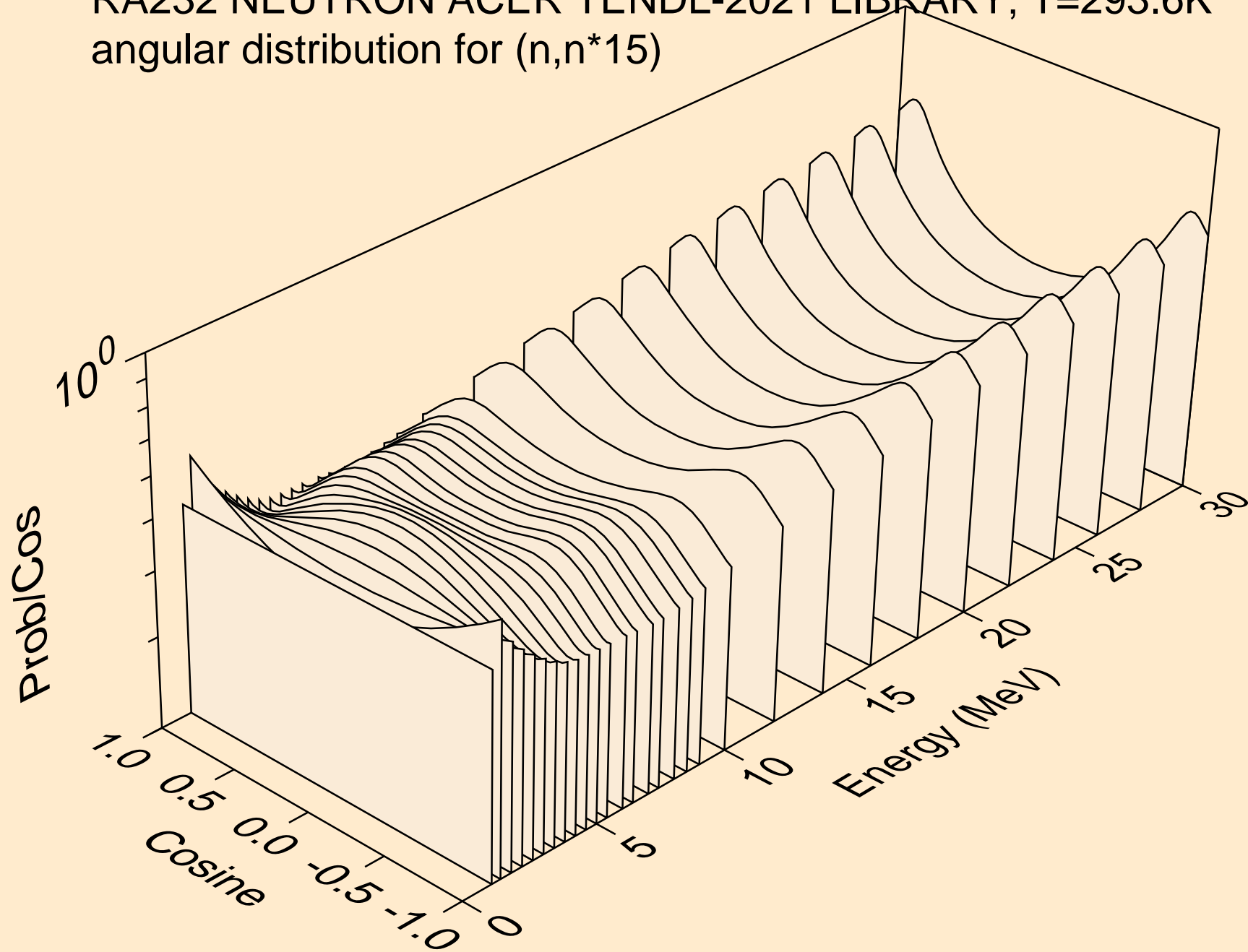

RA232 NEUTRON ACER TENDL-2021 LIBRARY; T=293.6K
angular distribution for (n,n*16)

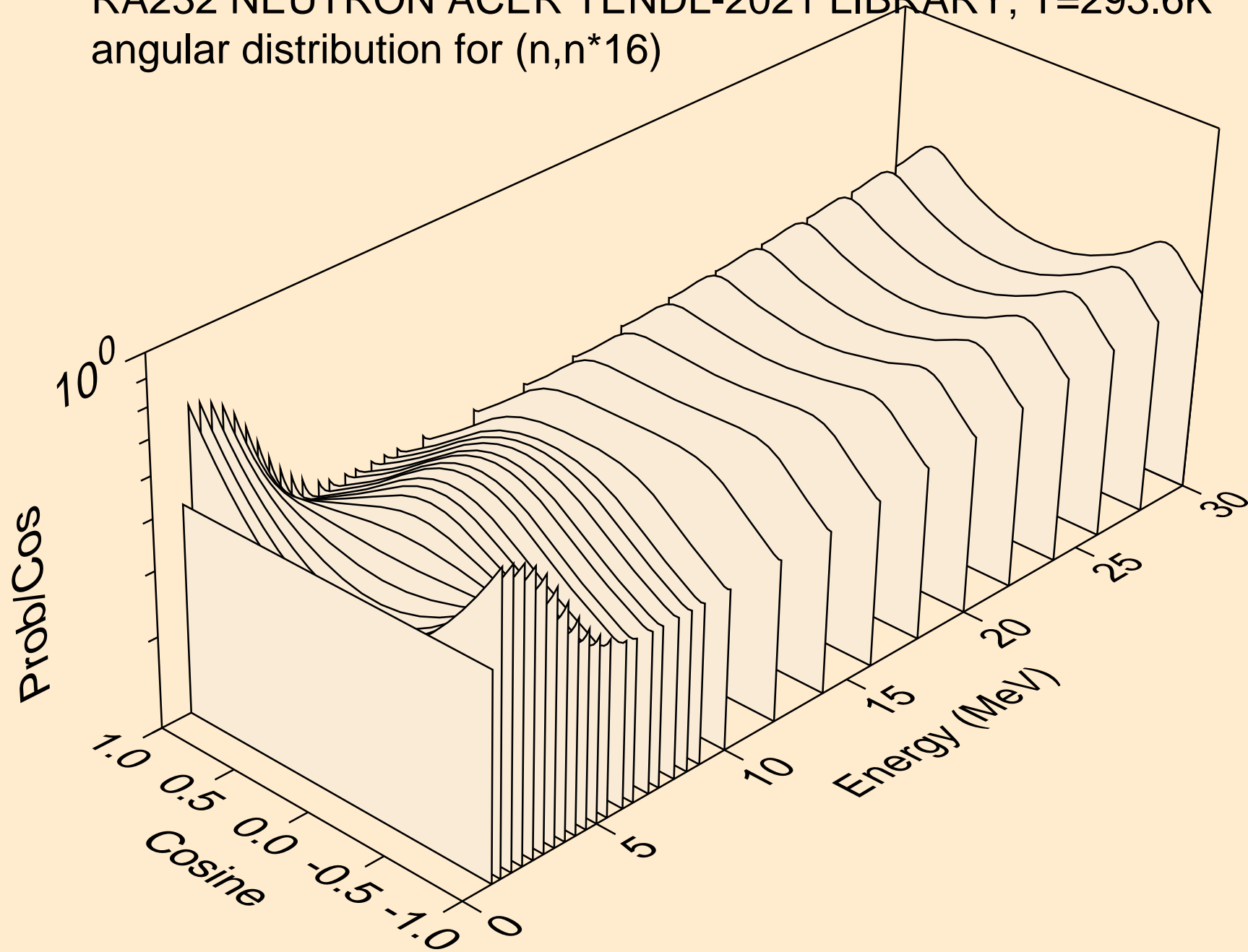

RA232 NEUTRON ACER TENDL-2021 LIBRARY; T=293.6K
angular distribution for (n,n*17)

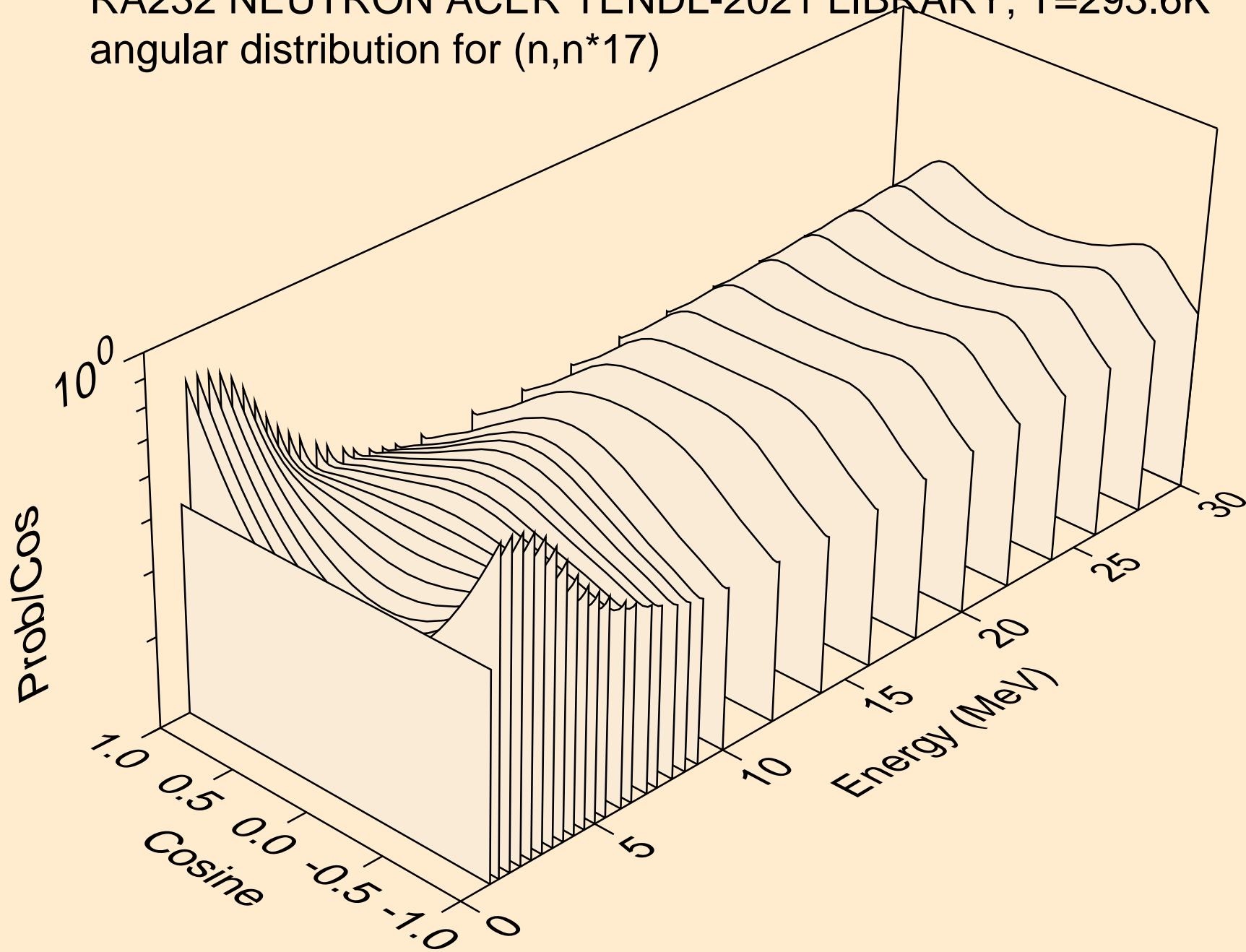

RA232 NEUTRON ACER TENDL-2021 LIBRARY; T=293.6K
angular distribution for (n,n*18)

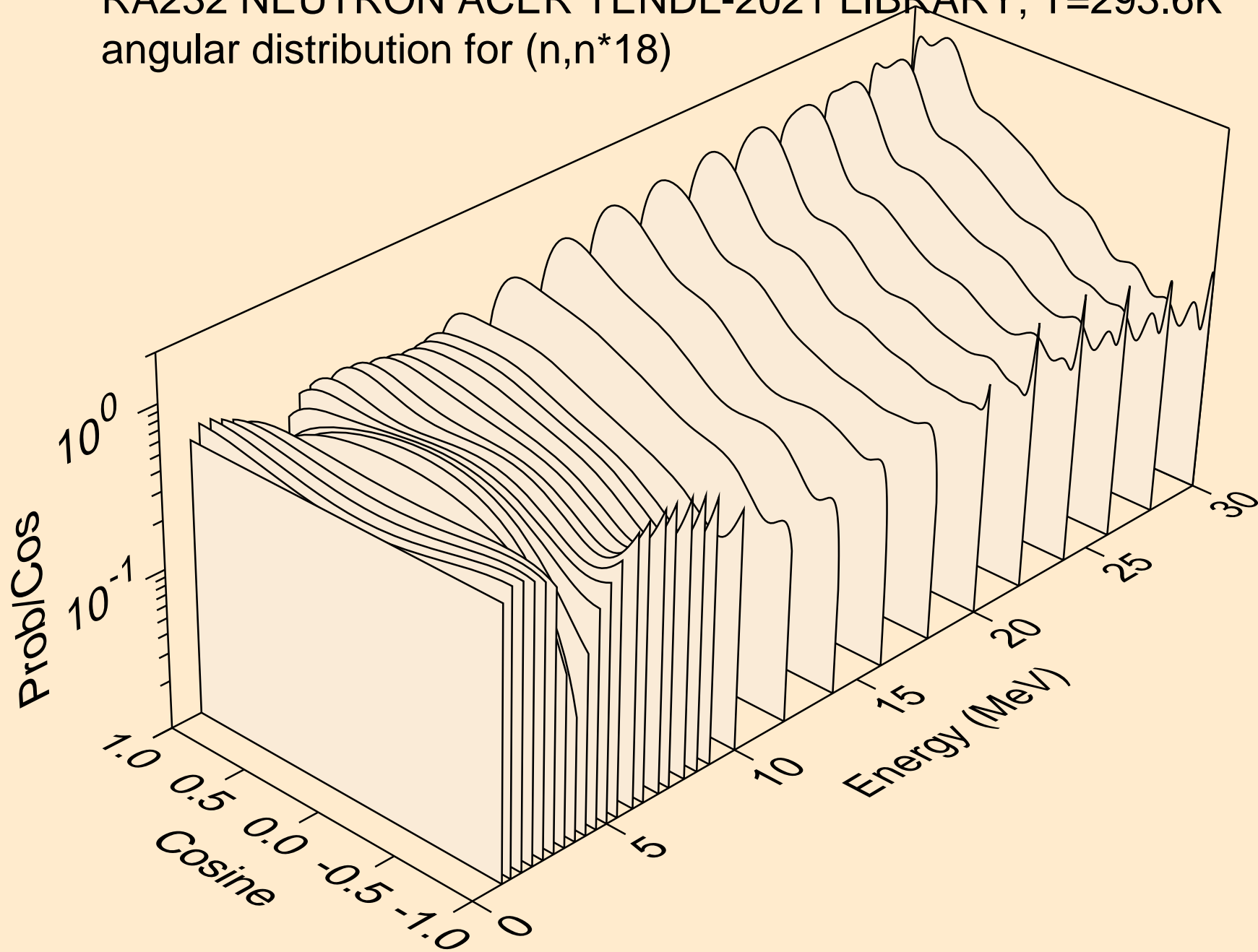

RA232 NEUTRON ACER TENDL-2021 LIBRARY; T=293.6K
angular distribution for (n,n*19)

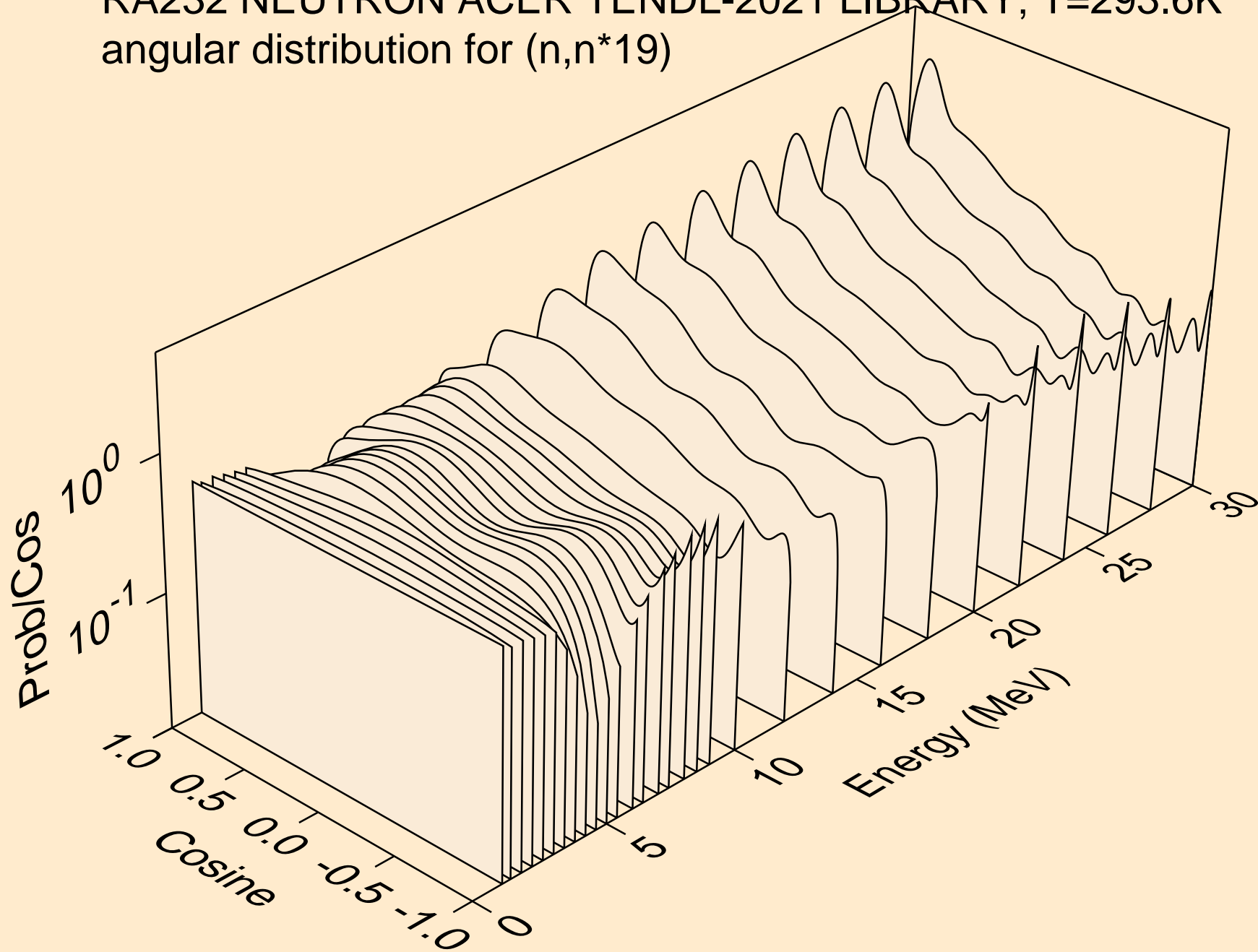

RA232 NEUTRON ACER TENDL-2021 LIBRARY; T=293.6K
angular distribution for (n,n*20)

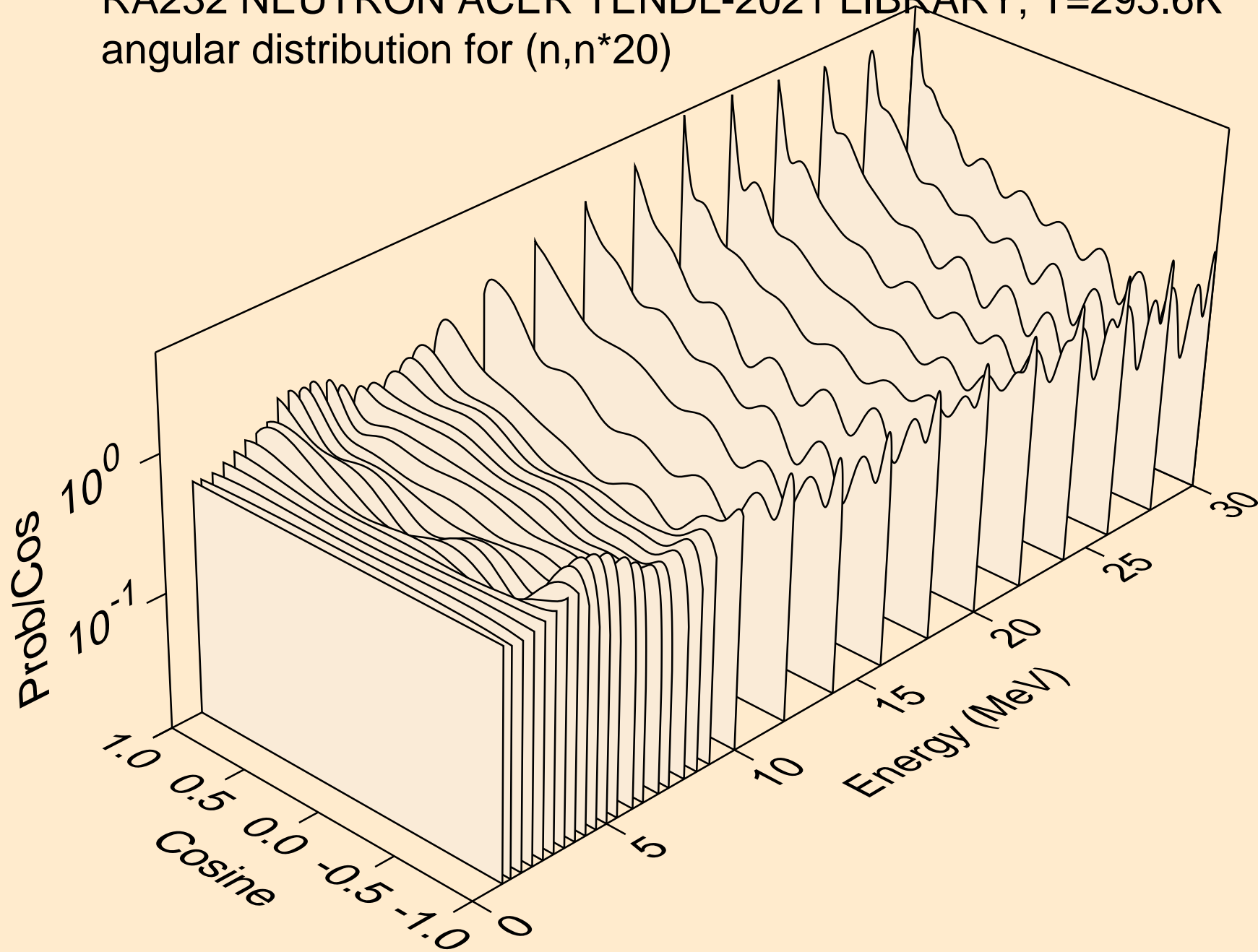

RA232 NEUTRON ACER TENDL-2021 LIBRARY; T=293.6K
angular distribution for (n,n*21)

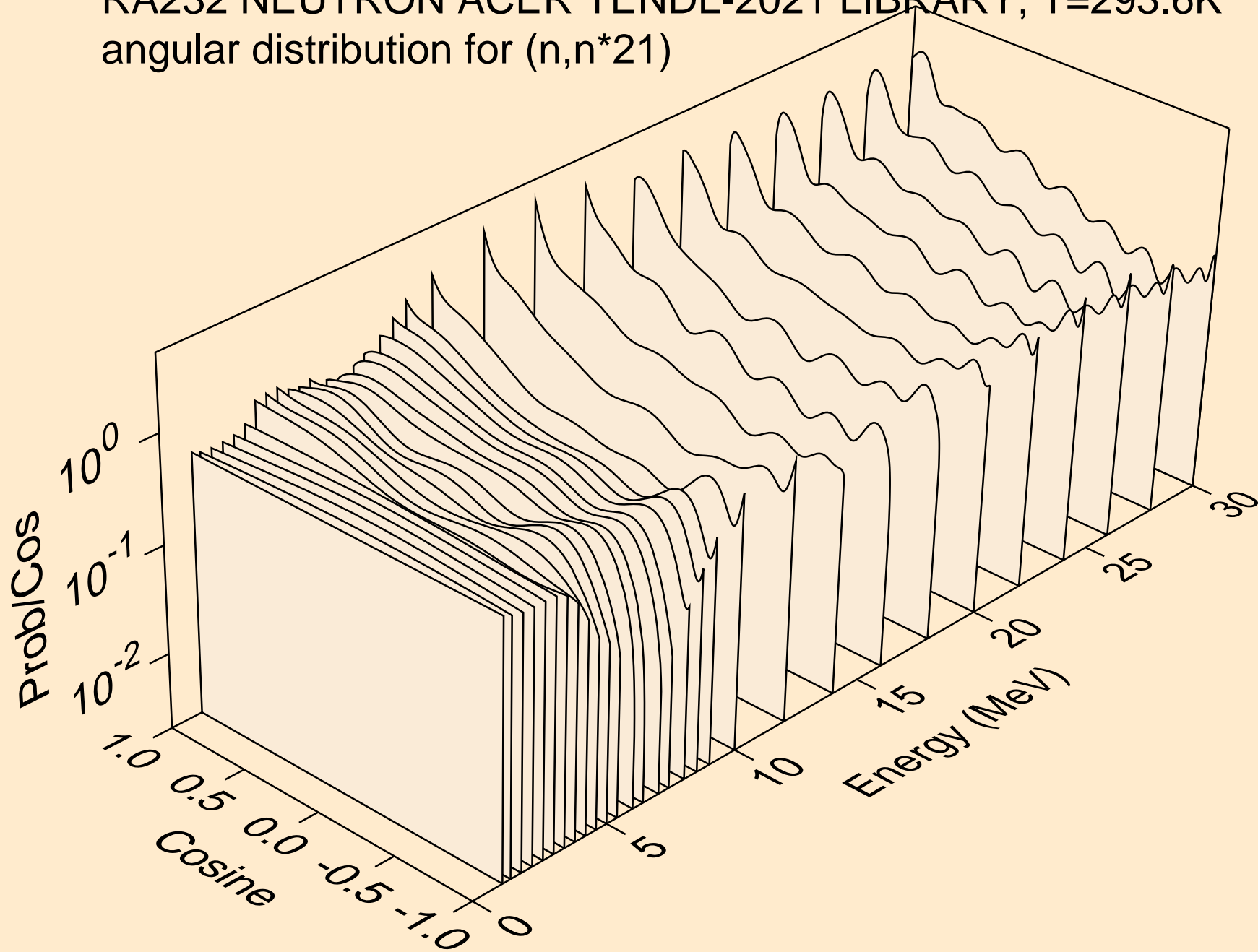

RA232 NEUTRON ACER TENDL-2021 LIBRARY; T=293.6K
angular distribution for (n,n*22)

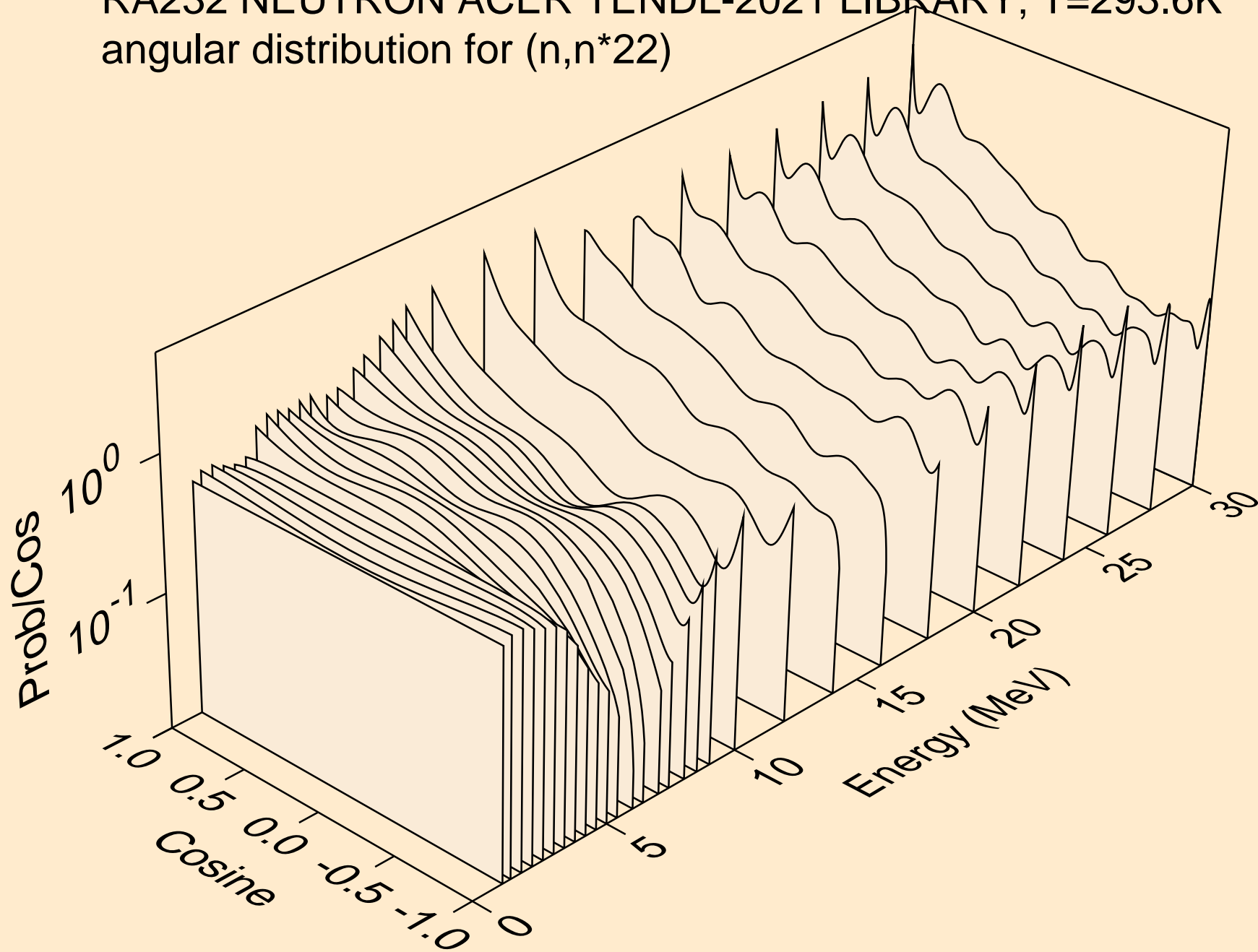

RA232 NEUTRON ACER TENDL-2021 LIBRARY; T=293.6K
angular distribution for (n,n*23)

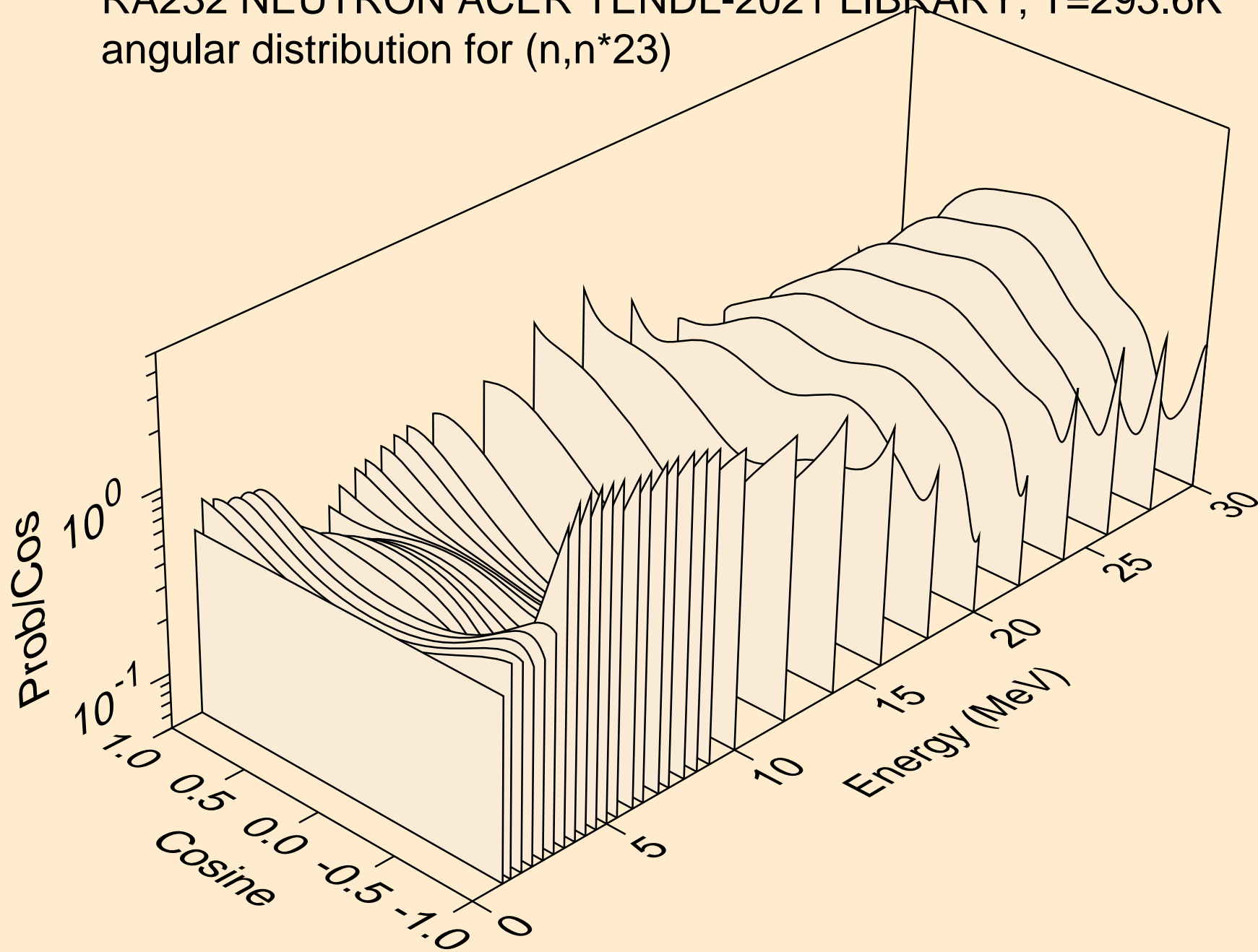

RA232 NEUTRON ACER TENDL-2021 LIBRARY; T=293.6K
angular distribution for (n,n*24)

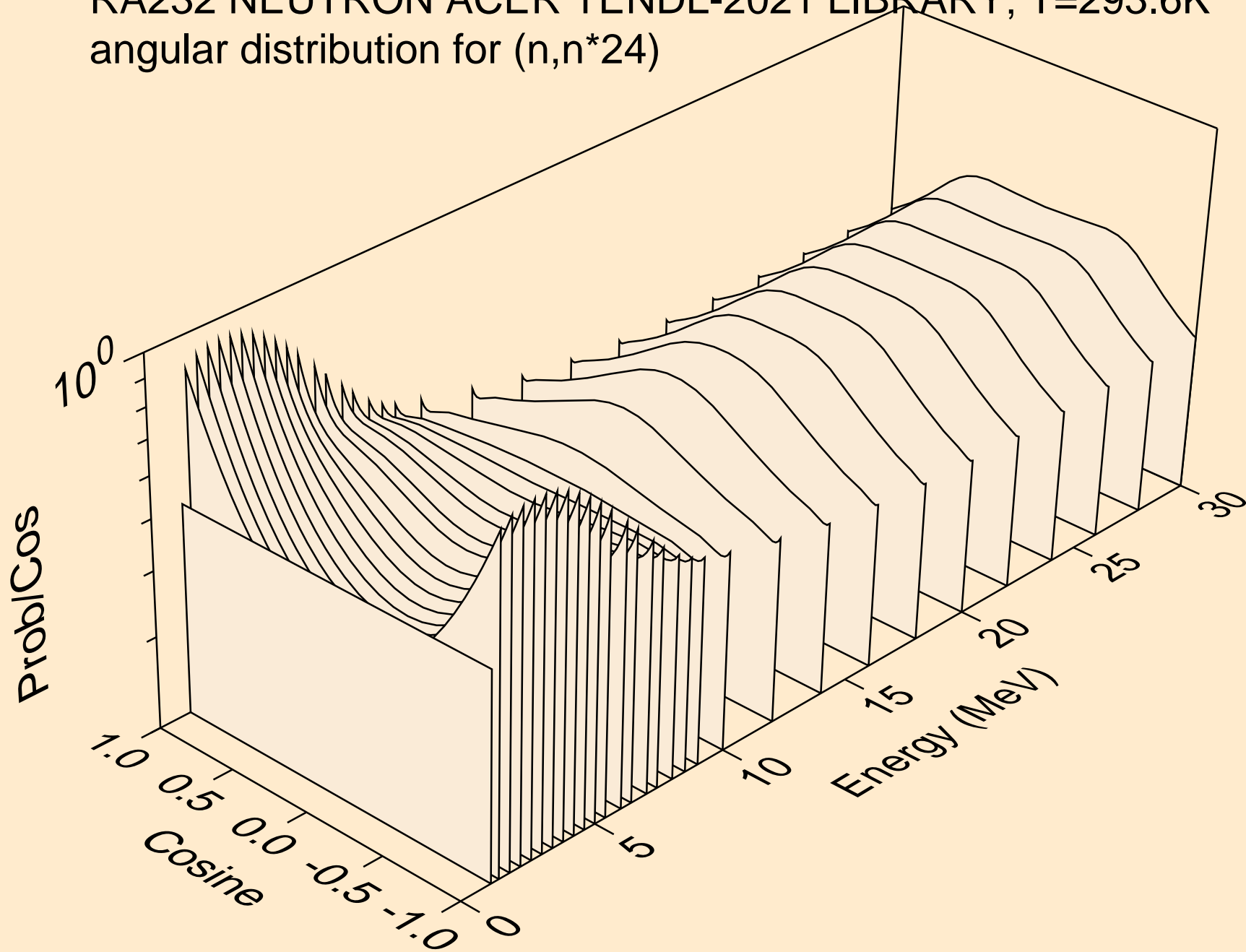

RA232 NEUTRON ACER TENDL-2021 LIBRARY; T=293.6K
angular distribution for (n,n*25)

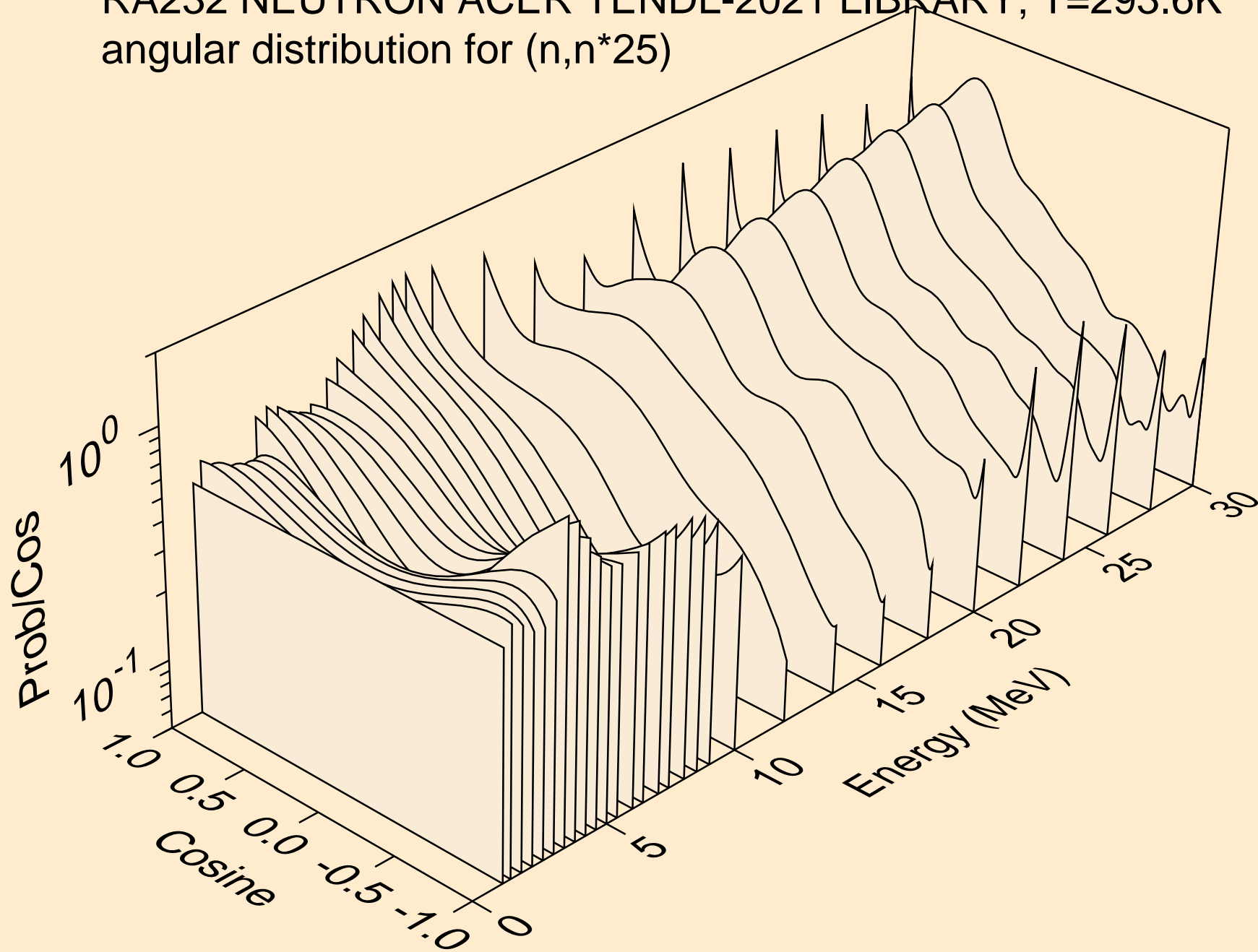

RA232 NEUTRON ACER TENDL-2021 LIBRARY; T=293.6K
angular distribution for (n,n*26)

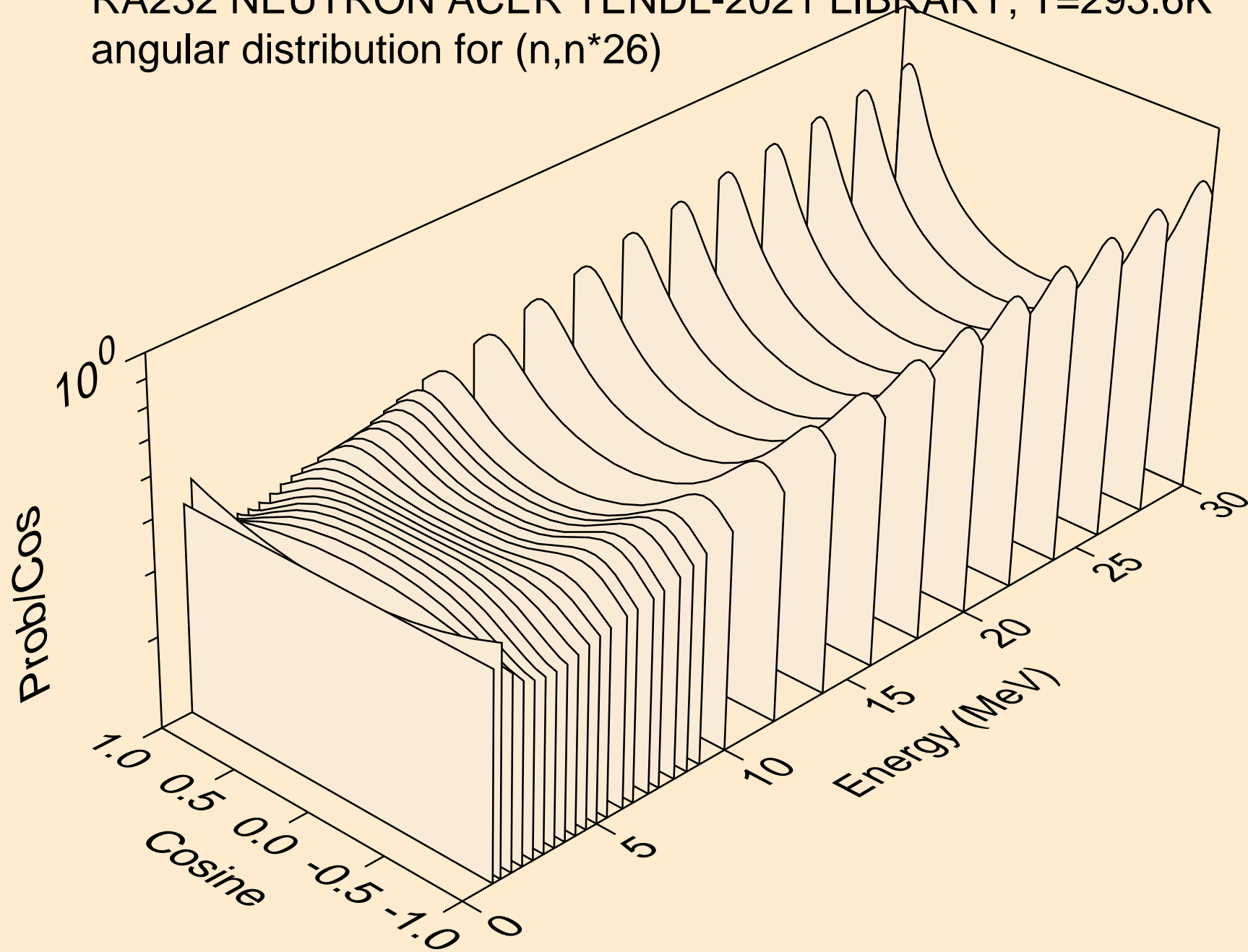

RA232 NEUTRON ACER TENDL-2021 LIBRARY; T=293.6K
angular distribution for (n,n*27)

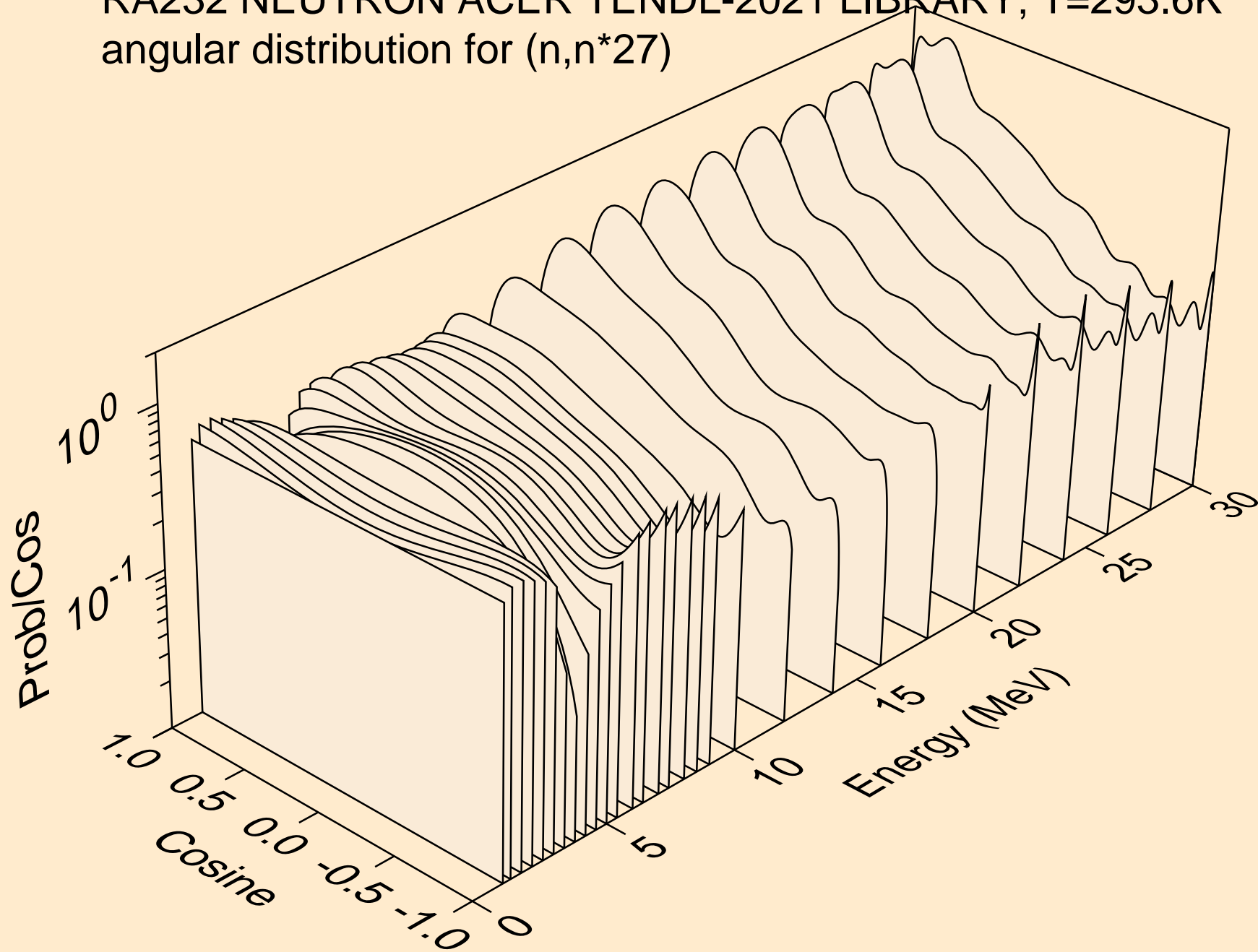

RA232 NEUTRON ACER TENDL-2021 LIBRARY; T=293.6K
angular distribution for (n,n*28)

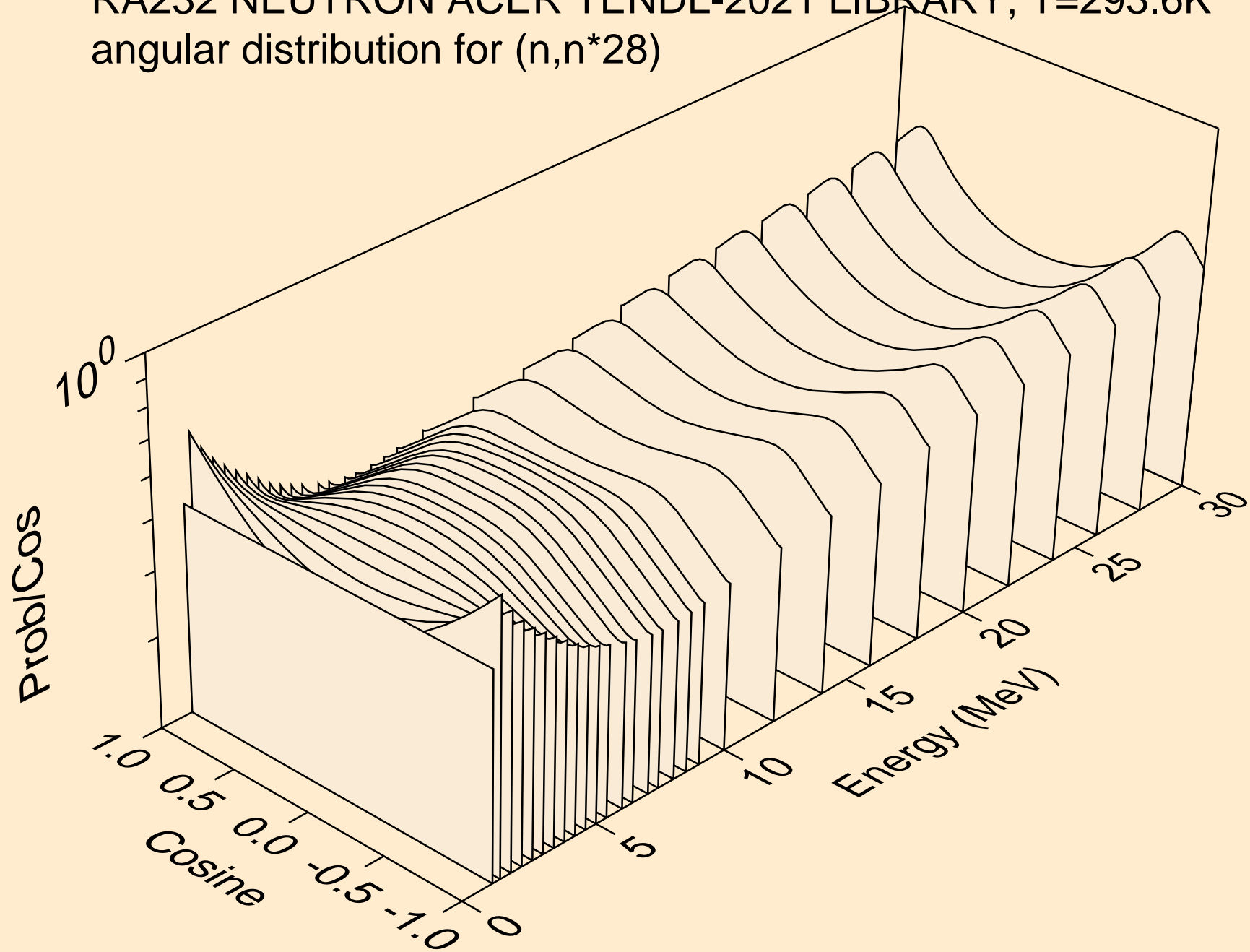

RA232 NEUTRON ACER TENDL-2021 LIBRARY; T=293.6K
angular distribution for (n,n*29)

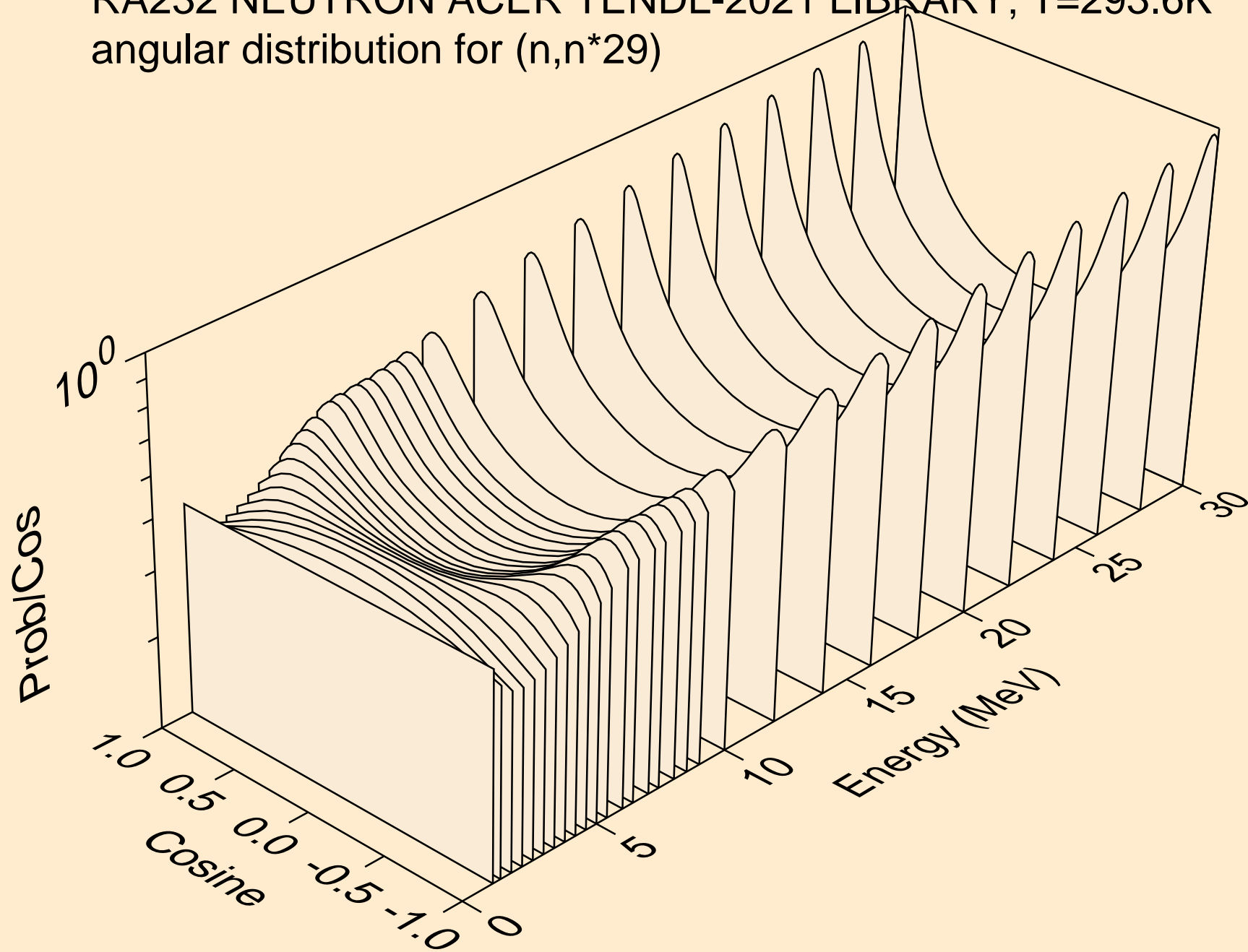

RA232 NEUTRON ACER TENDL-2021 LIBRARY; T=293.6K
Total fission nubar

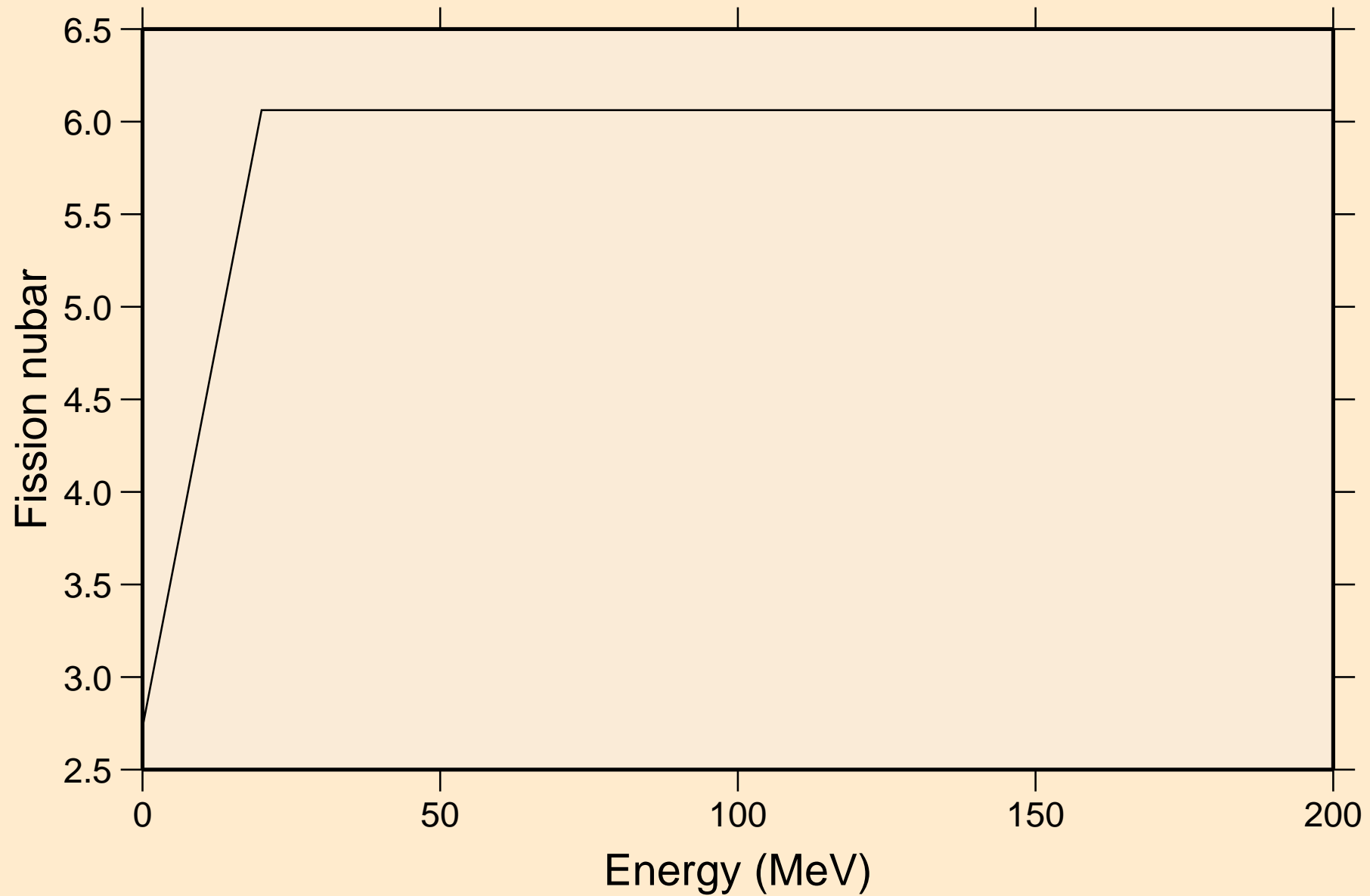

RA232 NEUTRON ACER TENDL-2021 LIBRARY; T=293.6K
Neutron emission for (n,x)

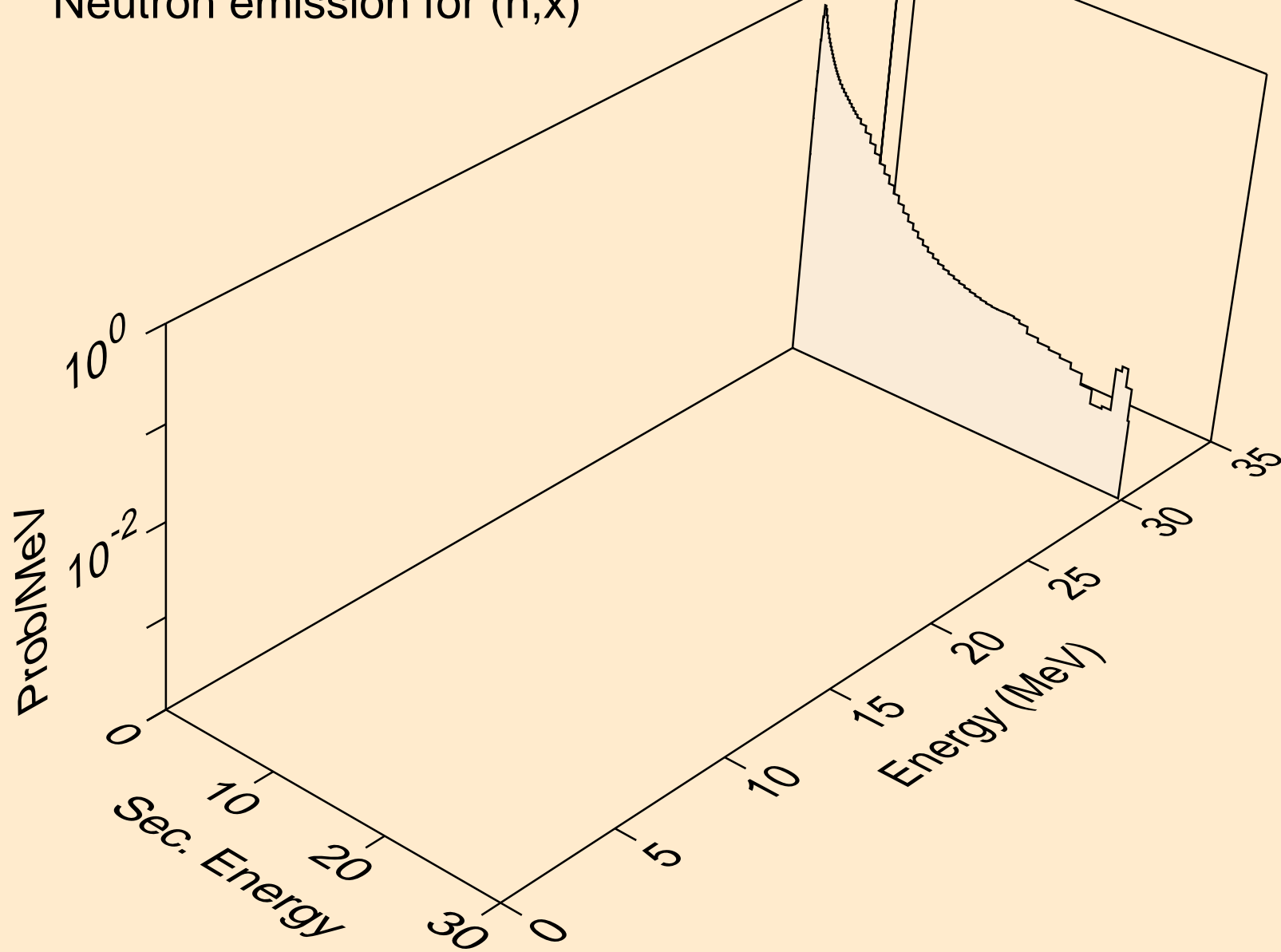

RA232 NEUTRON ACER TENDL-2021 LIBRARY; T=293.6K
Neutron emission for (n,2nd)

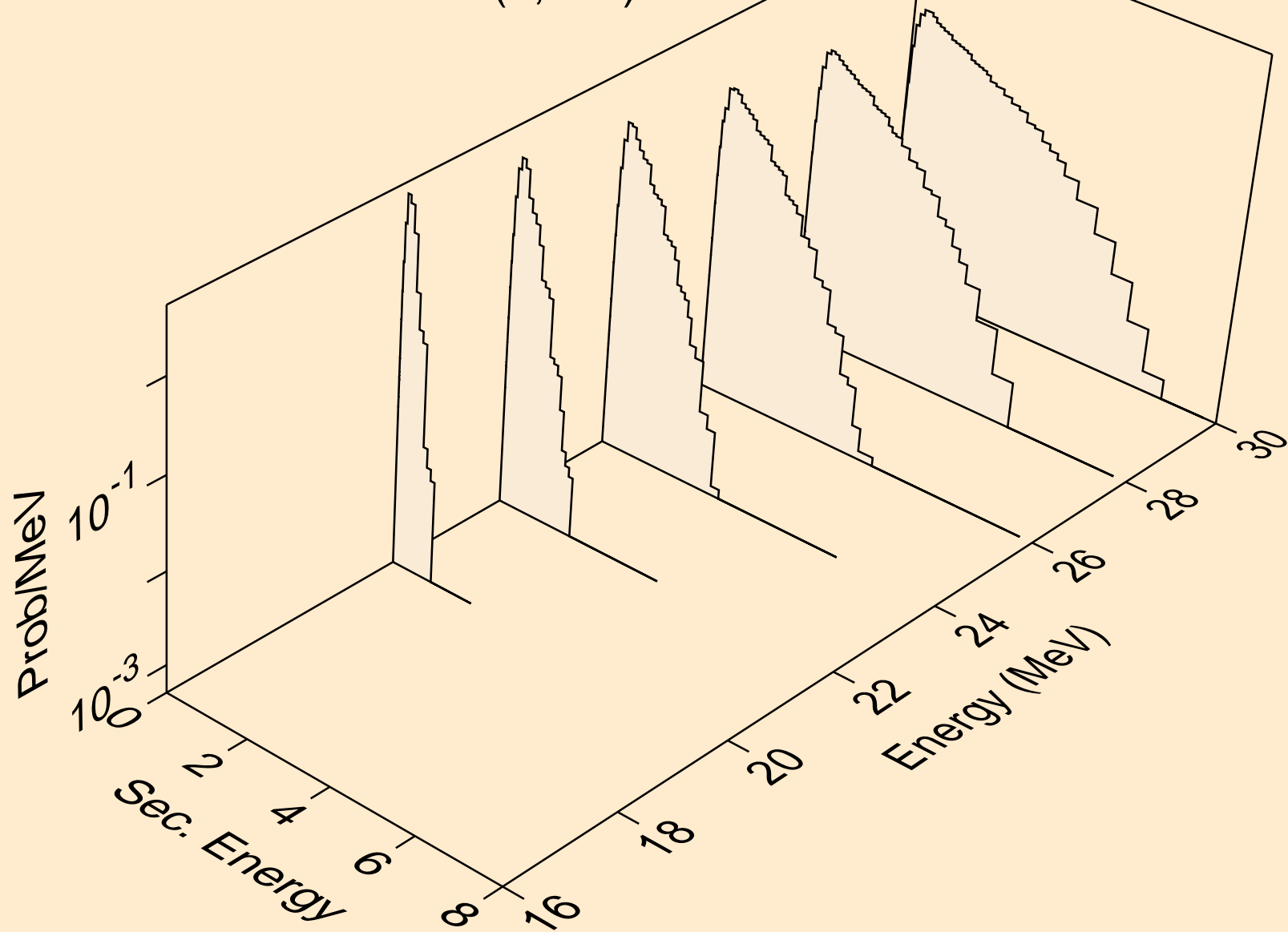

RA232 NEUTRON ACER TENDL-2021 LIBRARY; T=293.6K
Neutron emission for (n,2n)

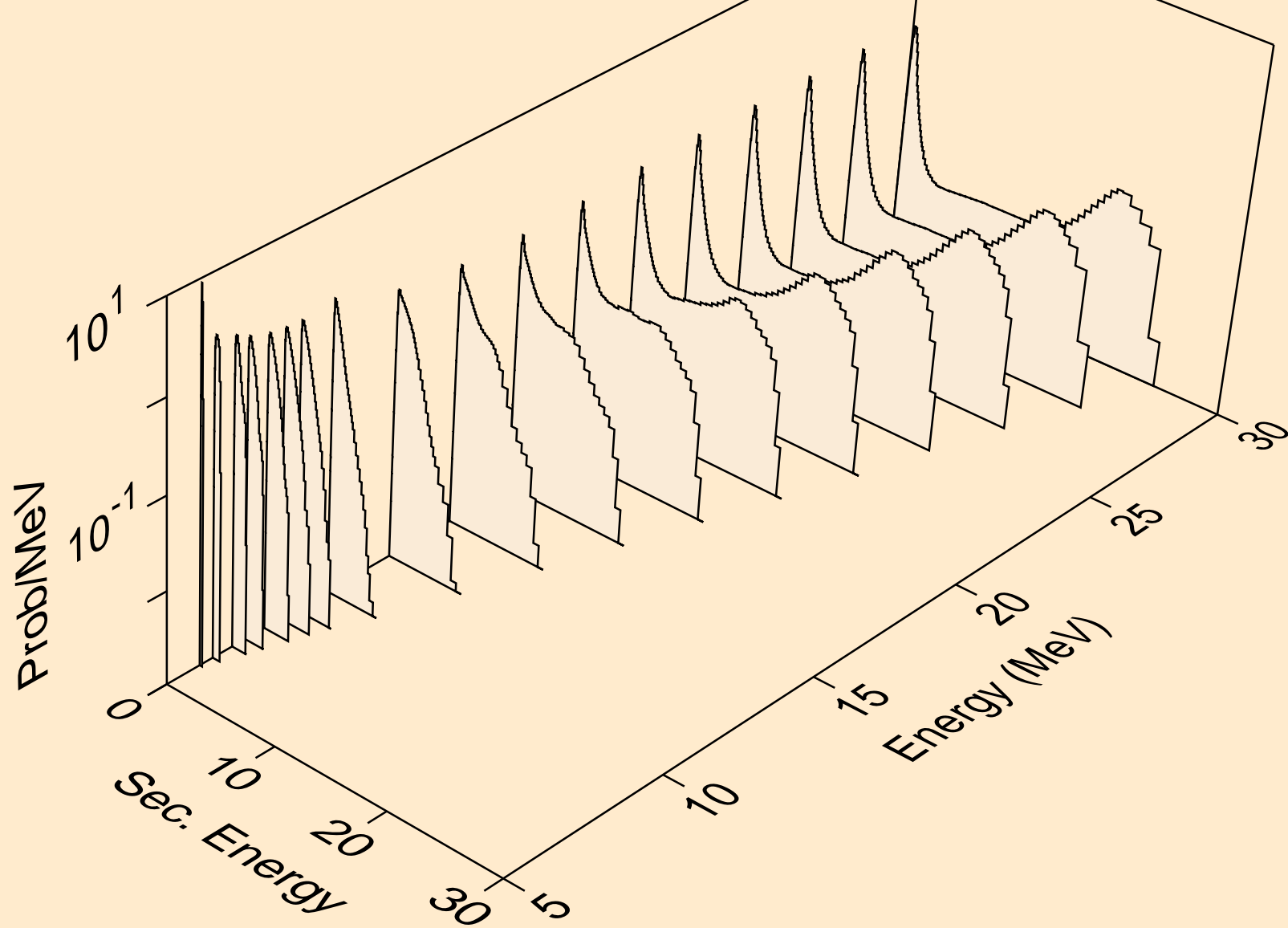

RA232 NEUTRON ACER TENDL-2021 LIBRARY; T=293.6K
Neutron emission for (n,3n)

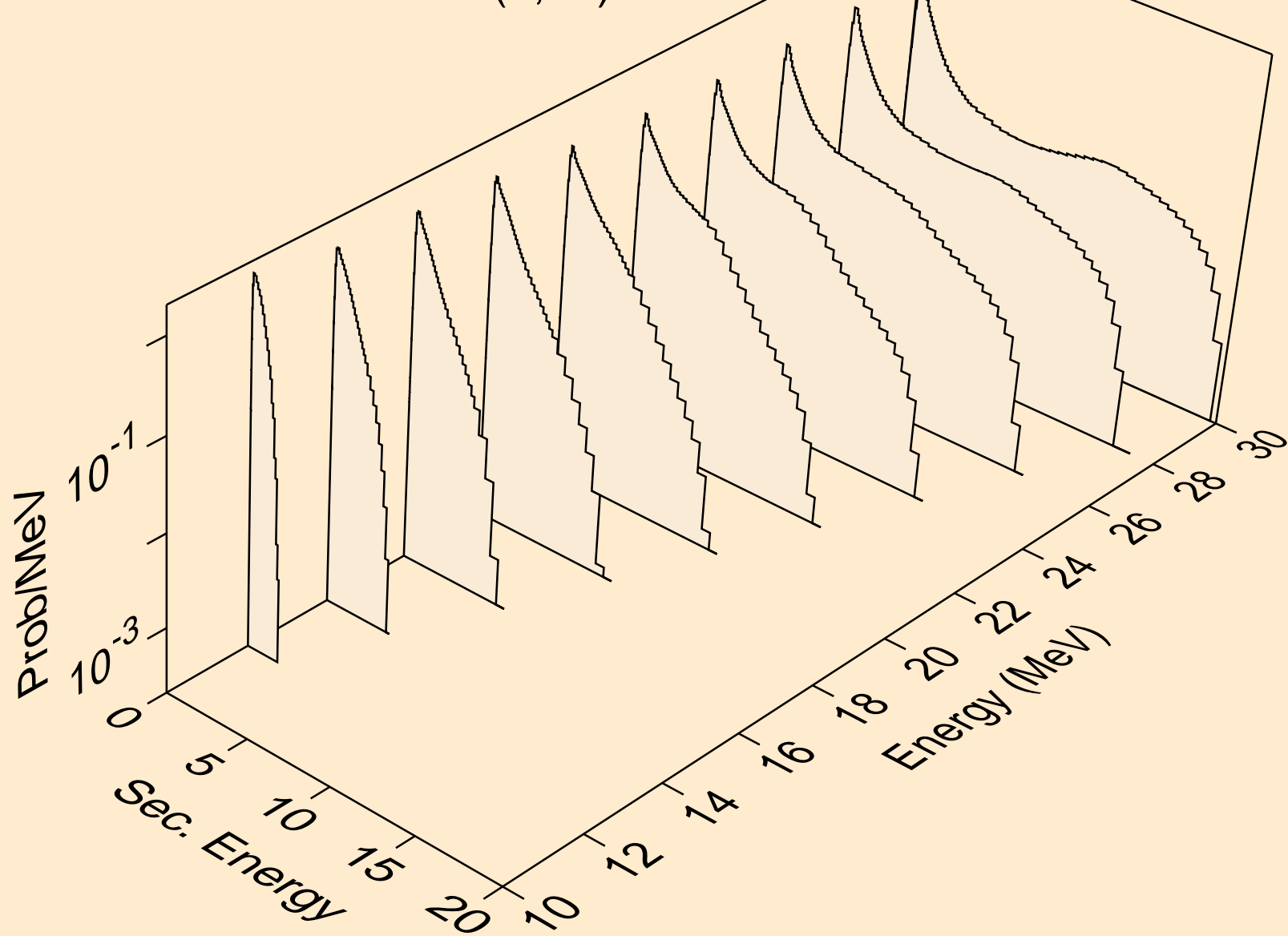

RA232 NEUTRON ACER TENDL-2021 LIBRARY; T=293.6K
Neutron emission for fission

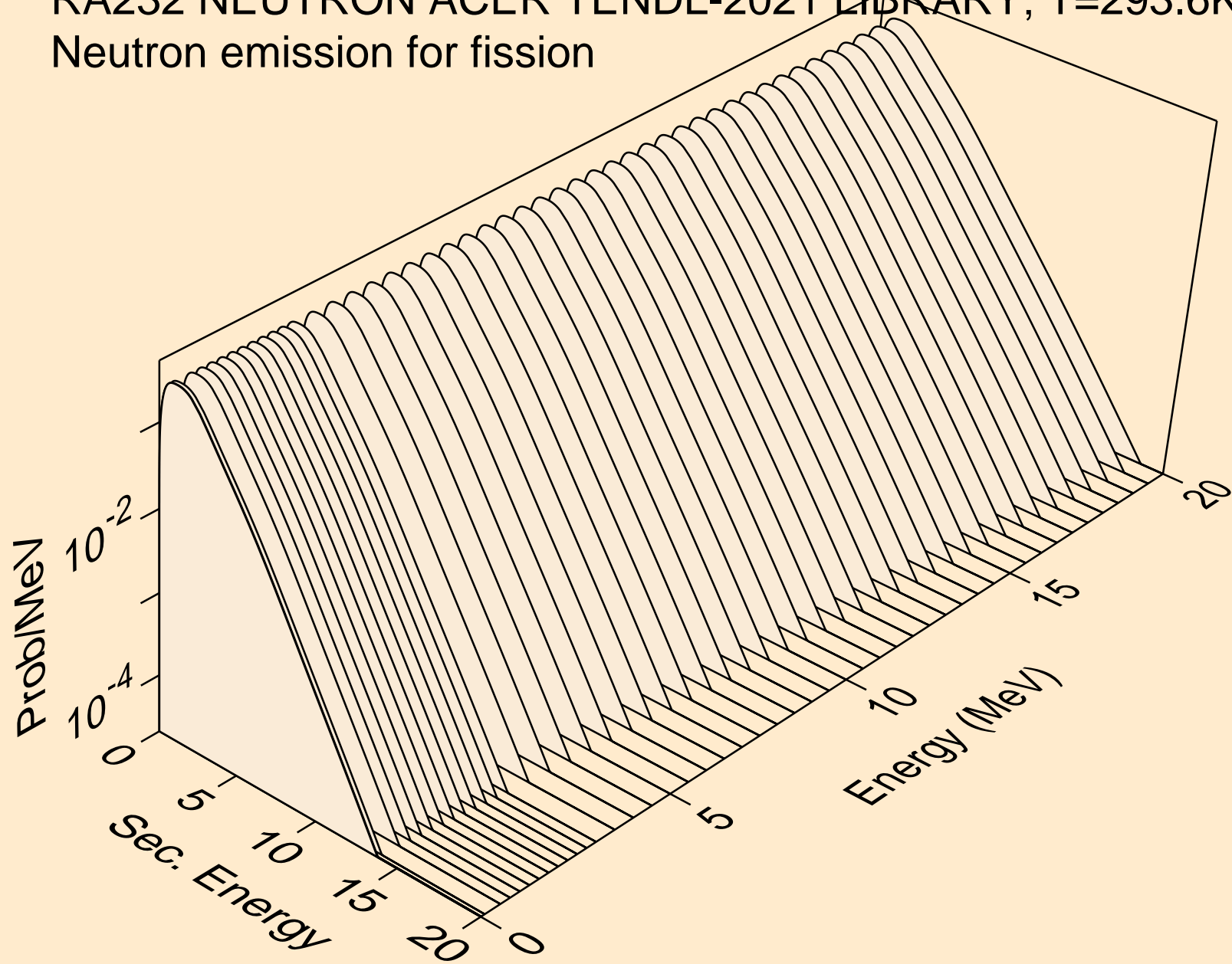

RA232 NEUTRON ACER TENDL-2021 LIBRARY; T=293.6K
Neutron emission for (n,n*)a

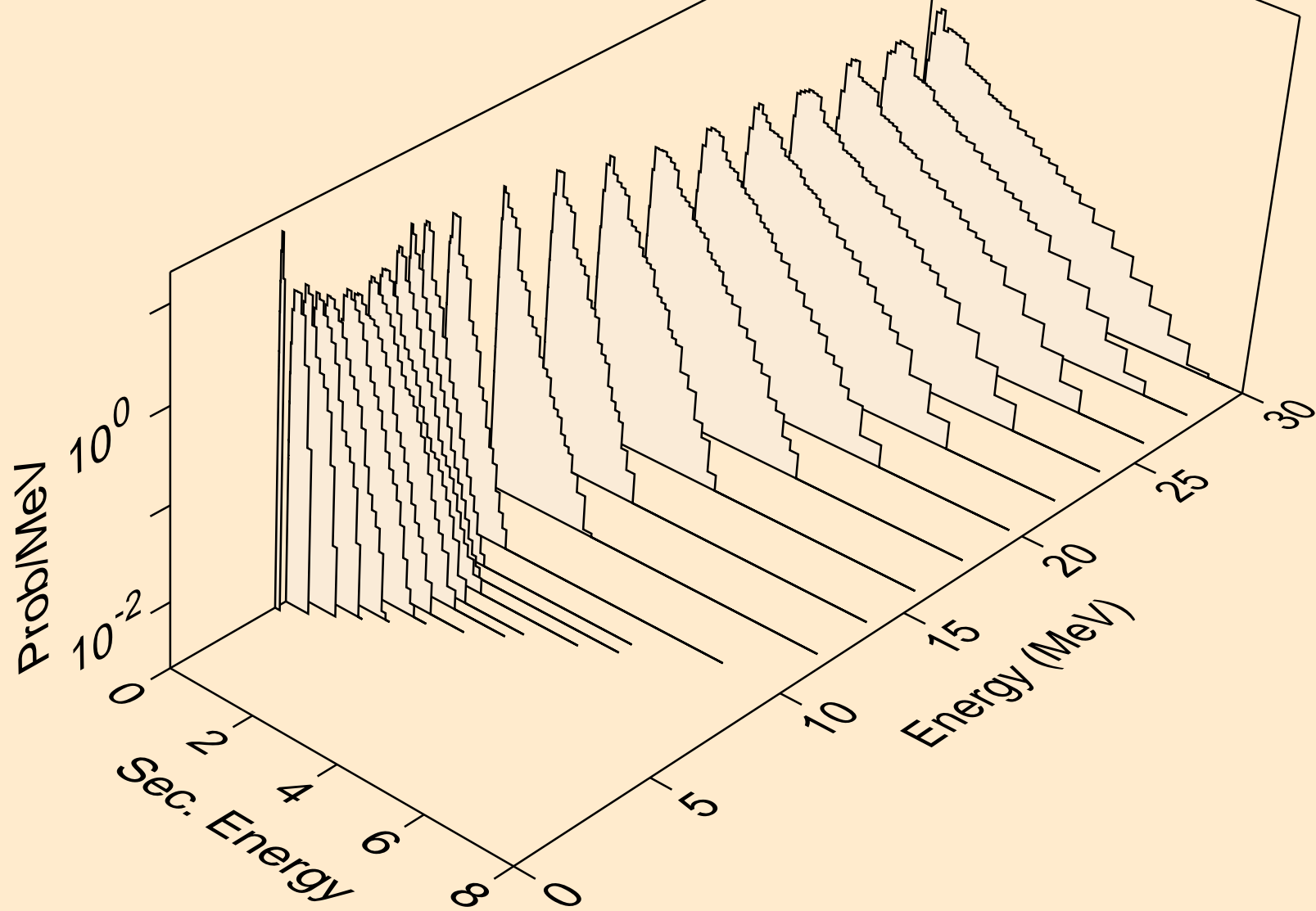

RA232 NEUTRON ACER TENDL-2021 LIBRARY; T=293.6K
Neutron emission for (n,2n)a

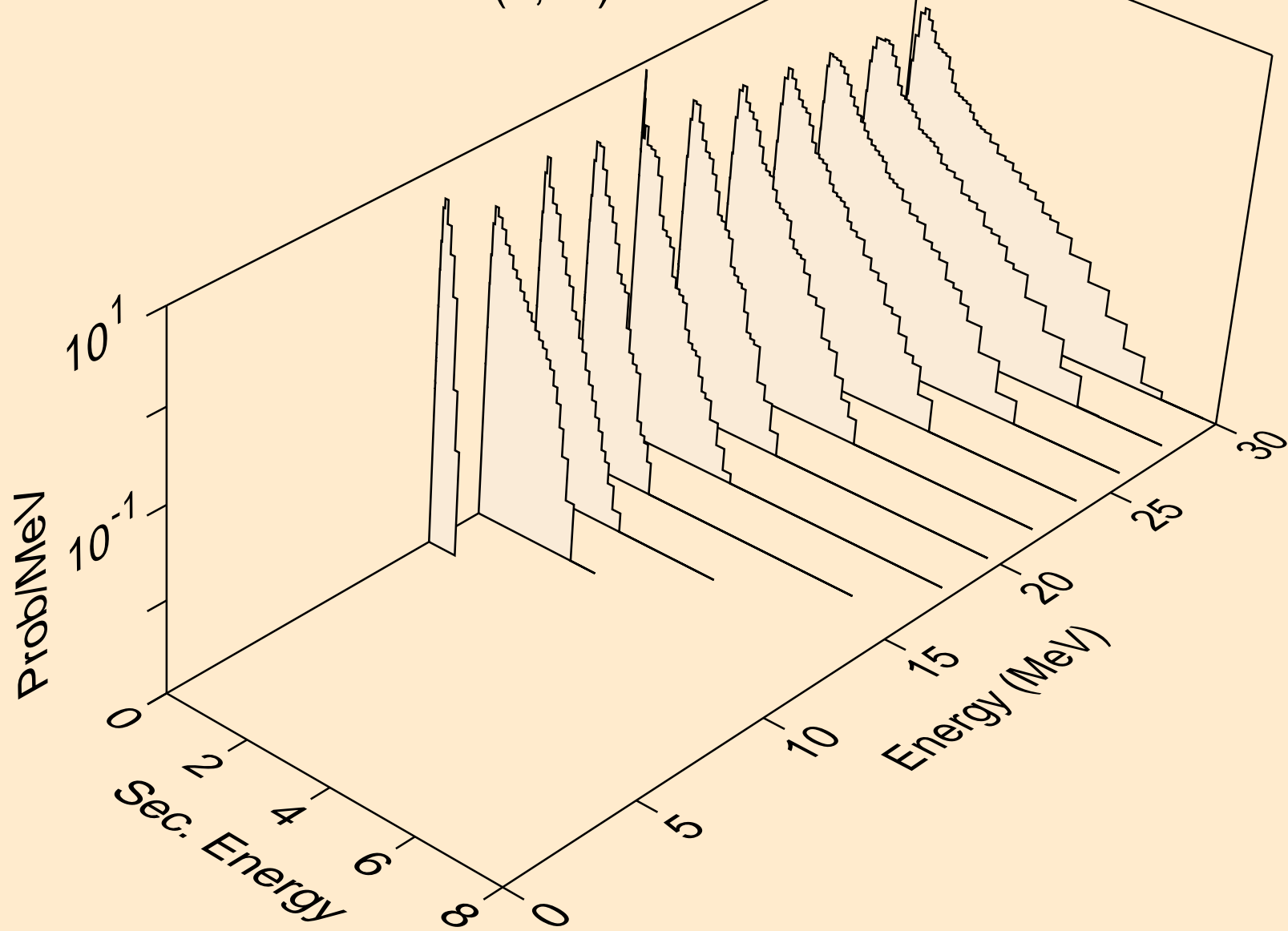

RA232 NEUTRON ACER TENDL-2021 LIBRARY; T=293.6K
Neutron emission for (n,3n)a

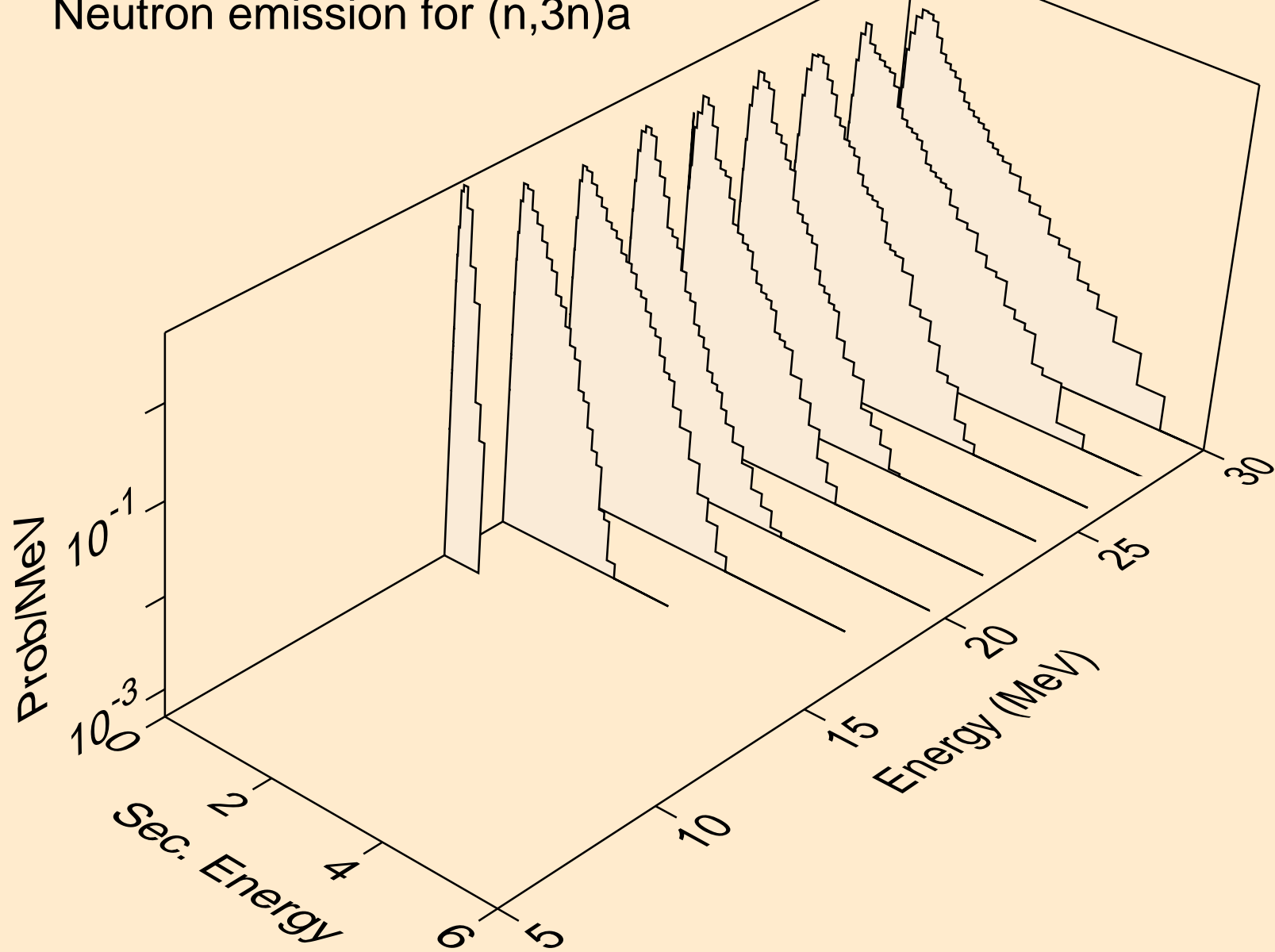

RA232 NEUTRON ACER TENDL-2021 LIBRARY; T=293.6K
Neutron emission for (n,n*)p

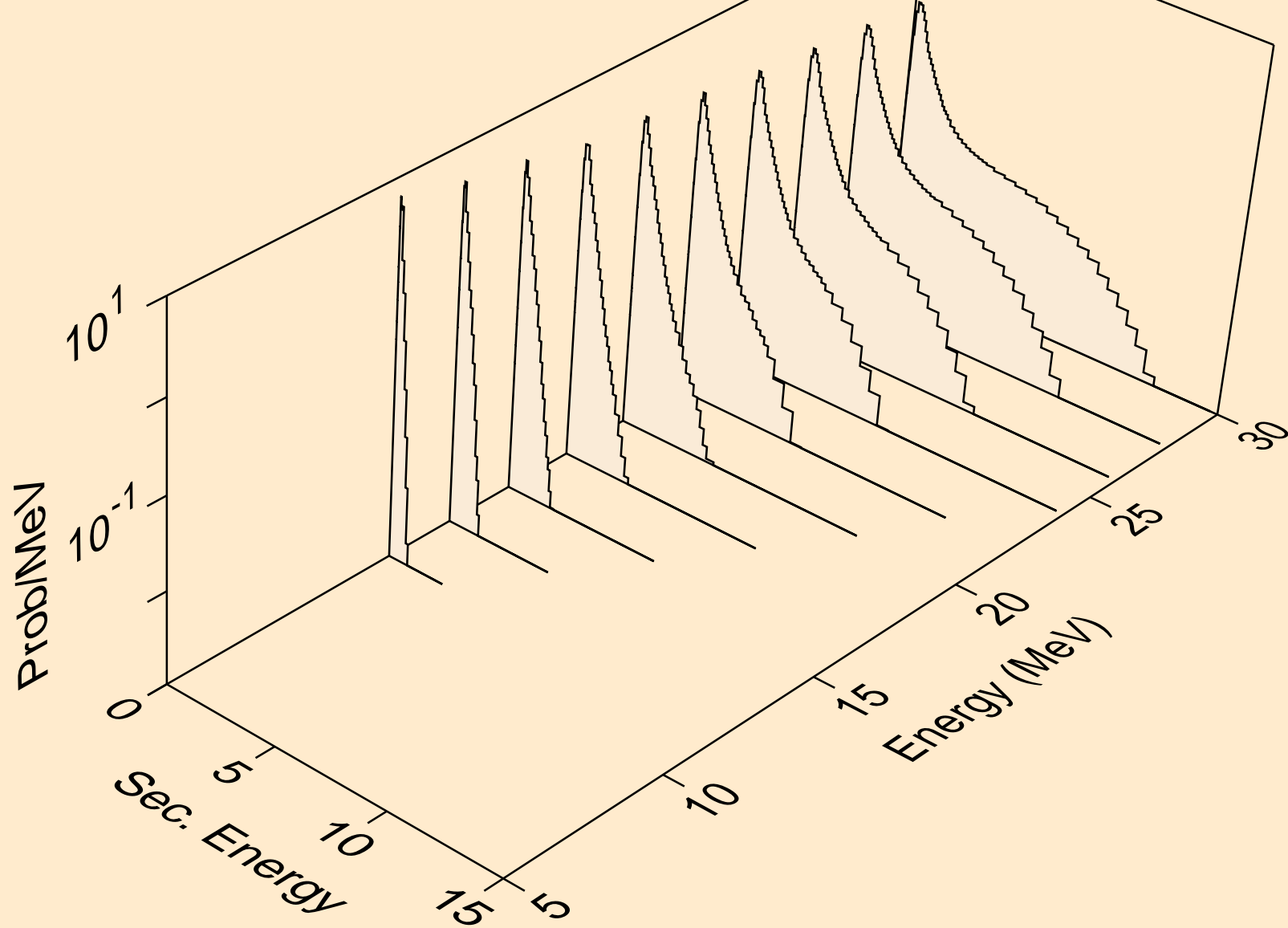

RA232 NEUTRON ACER TENDL-2021 LIBRARY; T=293.6K
Neutron emission for (n,n*)2a

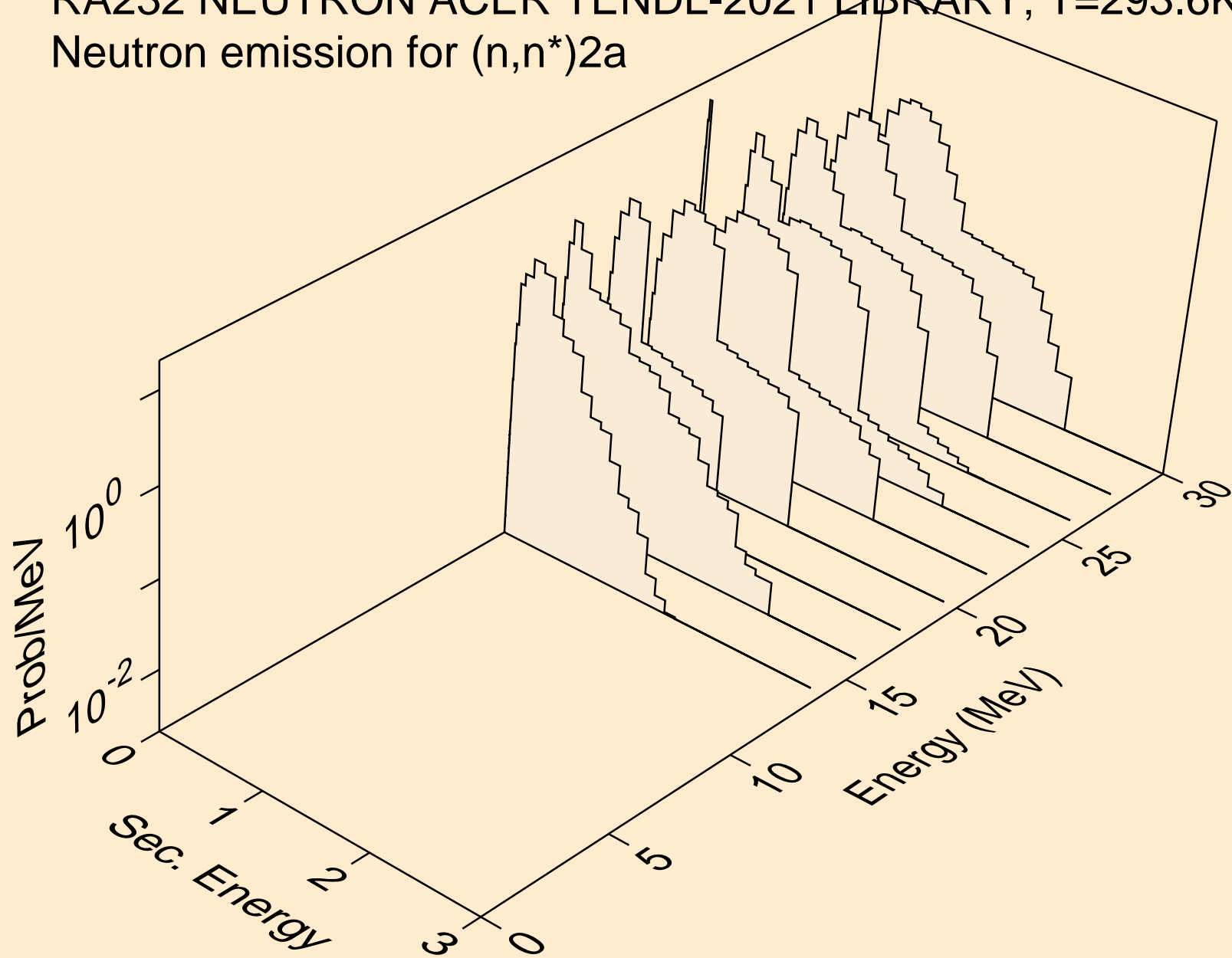

RA232 NEUTRON ACER TENDL-2021 LIBRARY; T=293.6K
Neutron emission for (n,2n)2a

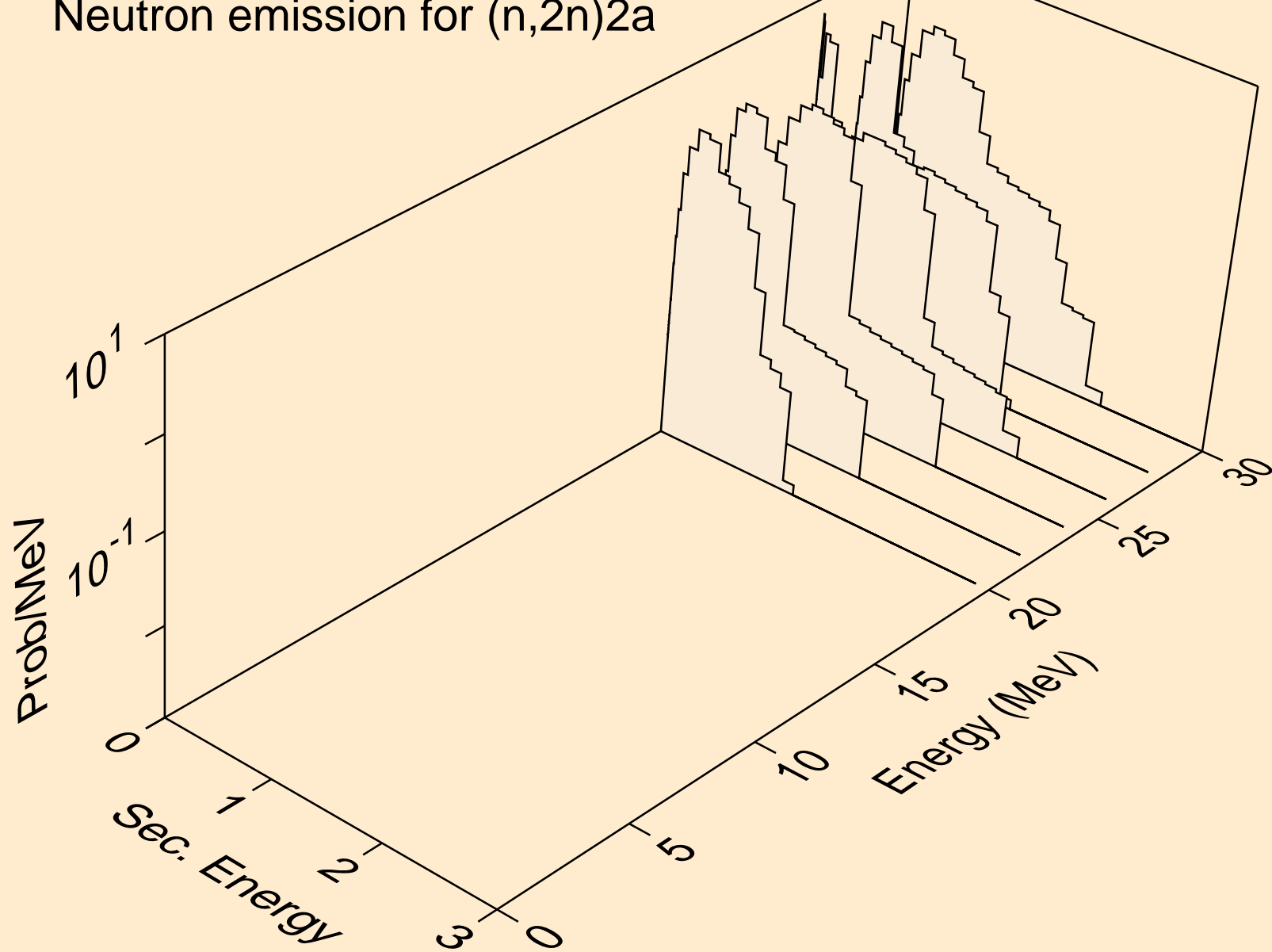

RA232 NEUTRON ACER TENDL-2021 LIBRARY; T=293.6K
Neutron emission for (n,n*)d

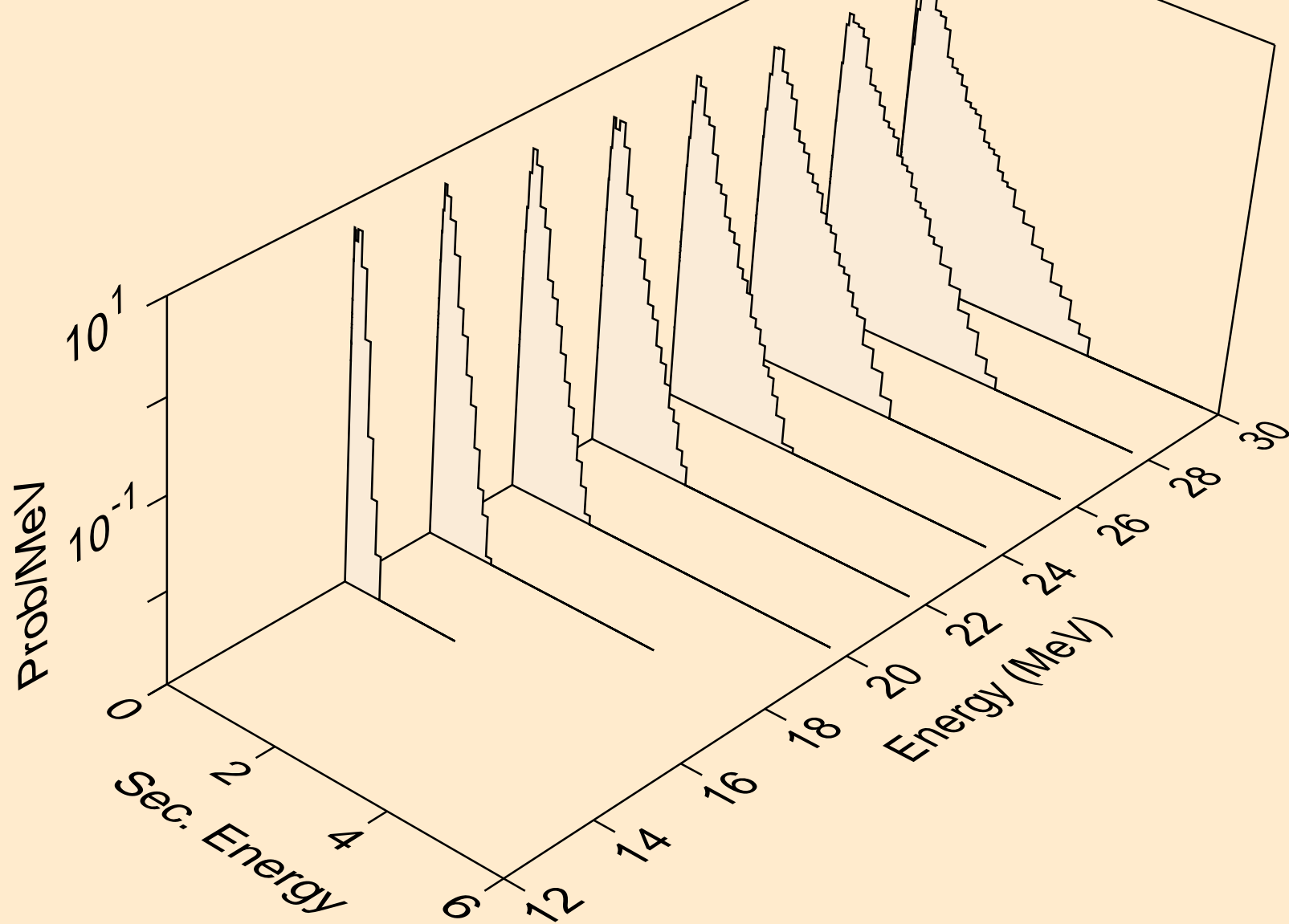

RA232 NEUTRON ACER TENDL-2021 LIBRARY; T=293.6K
Neutron emission for (n,n*)t

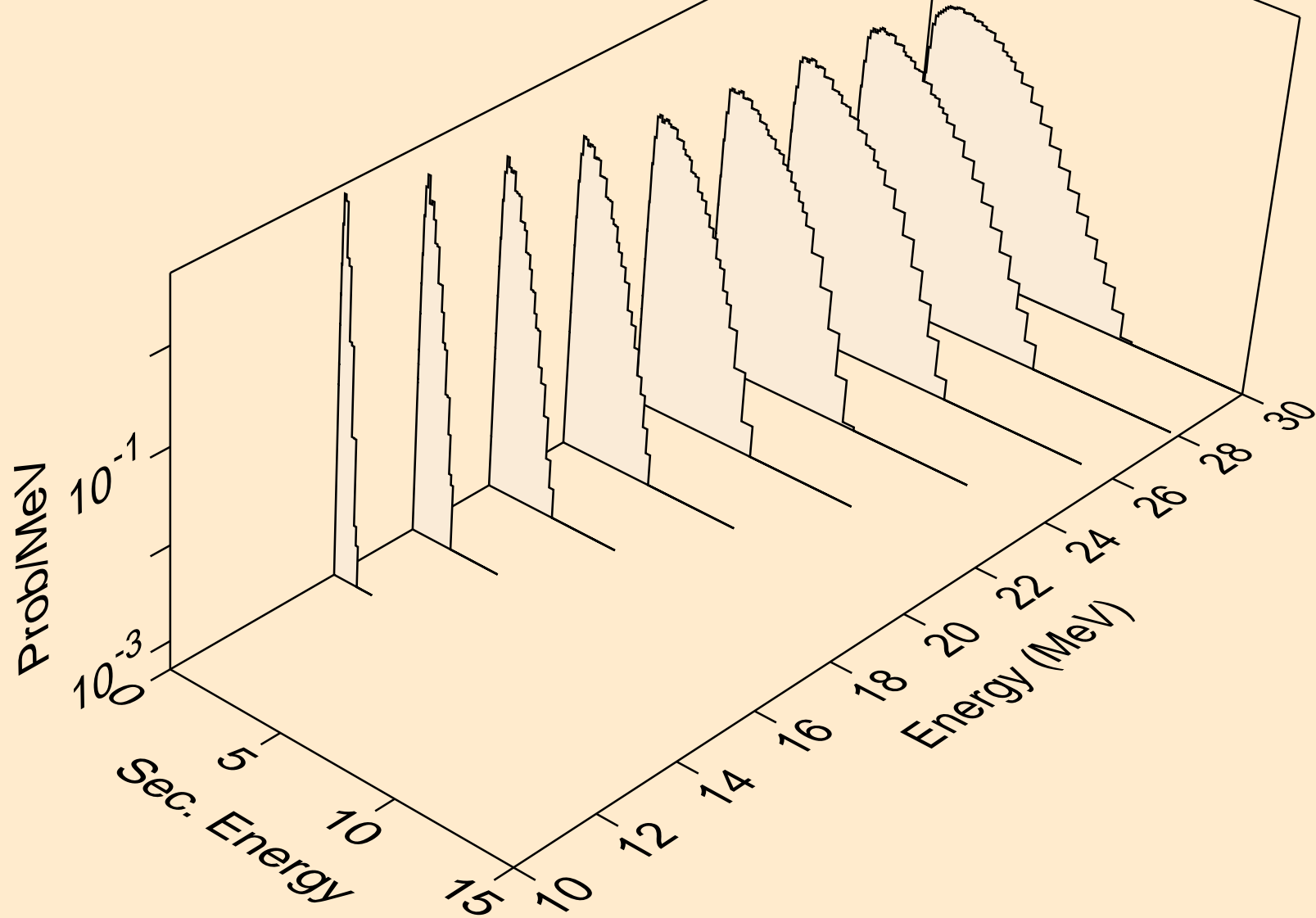

RA232 NEUTRON ACER TENDL-2021 LIBRARY; T=293.6K
Neutron emission for (n,n*)he3

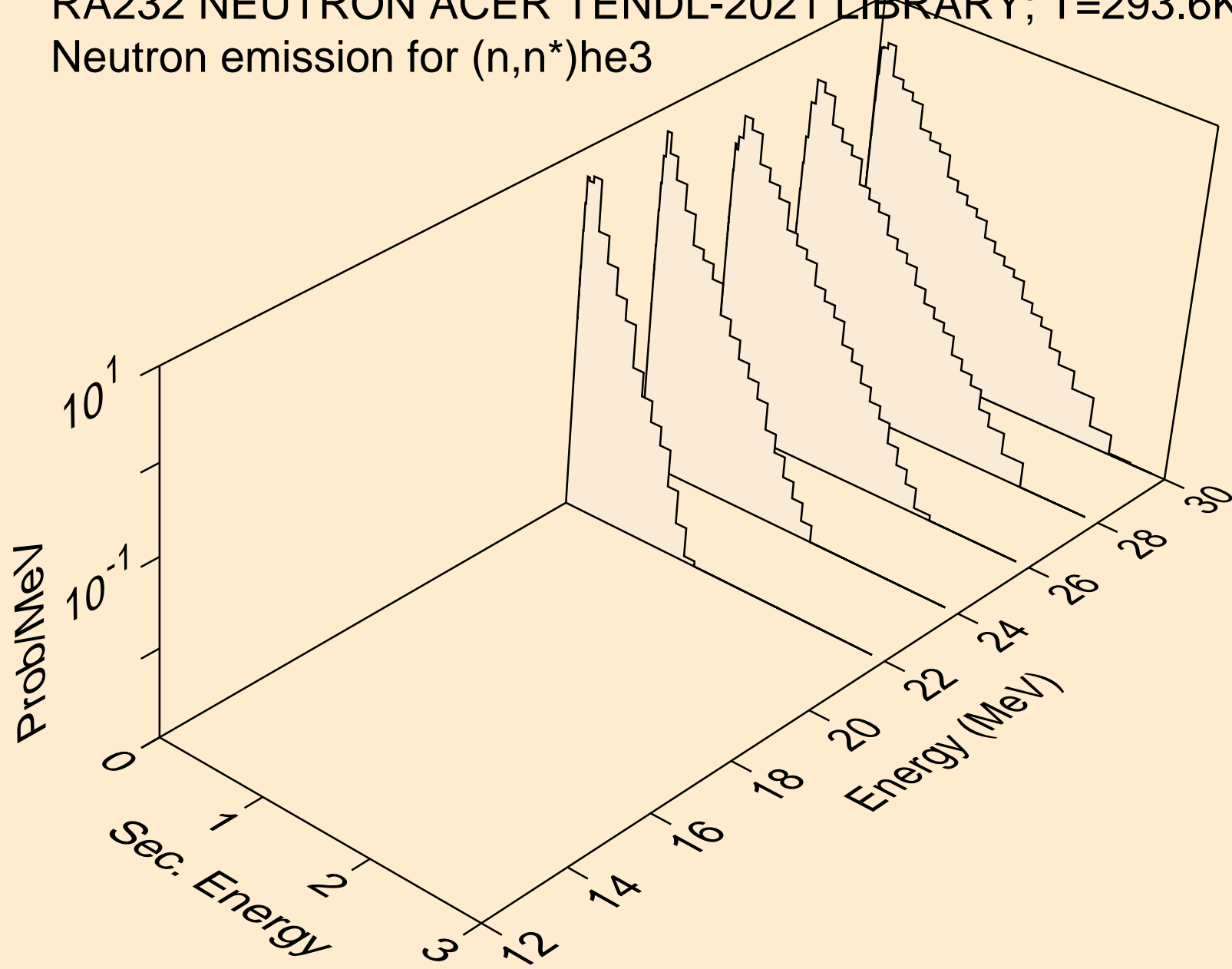

RA232 NEUTRON ACER TENDL-2021 LIBRARY; T=293.6K
Neutron emission for (n,4n)

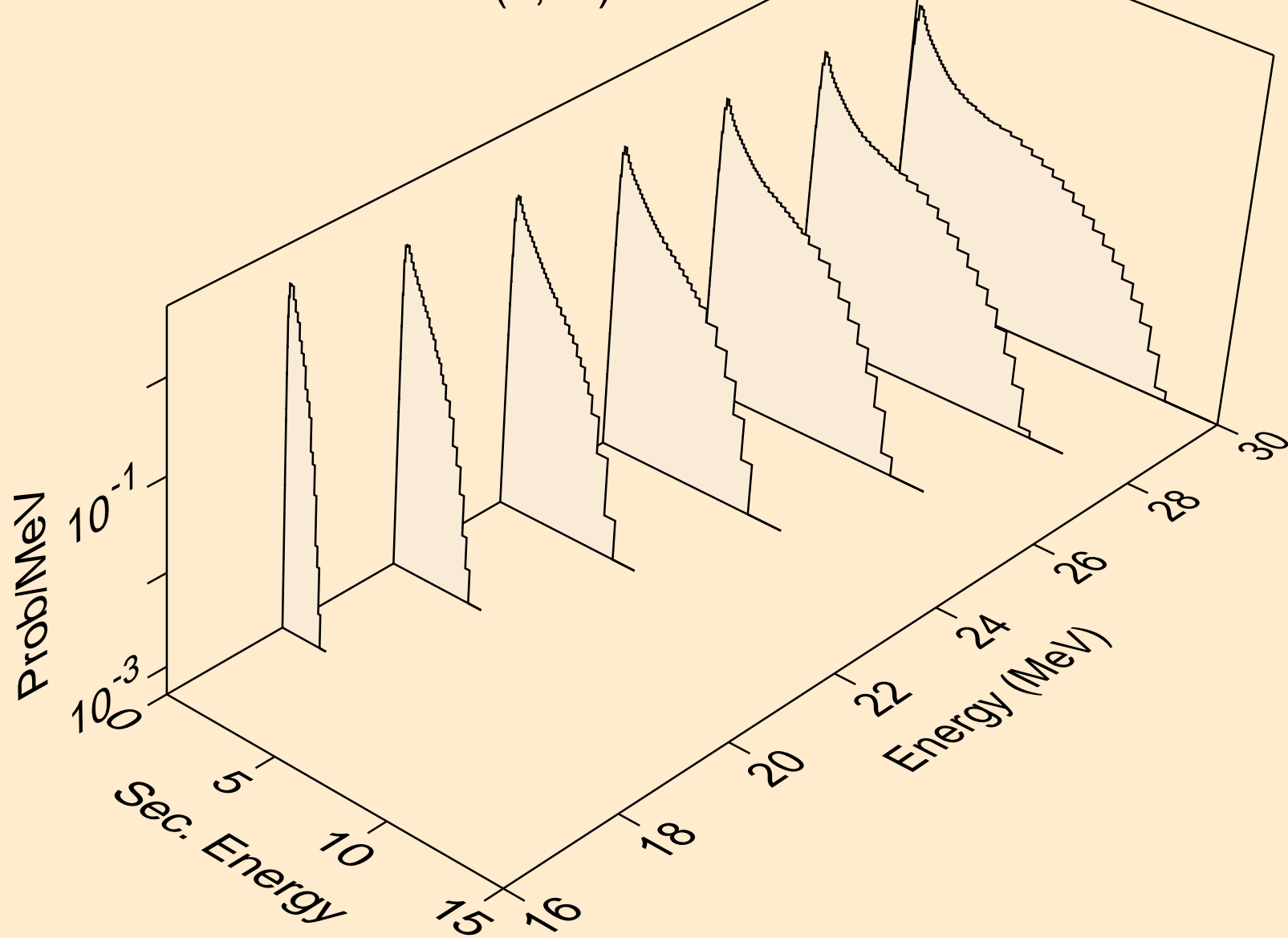

RA232 NEUTRON ACER TENDL-2021 LIBRARY; T=293.6K
Neutron emission for (n,2np)

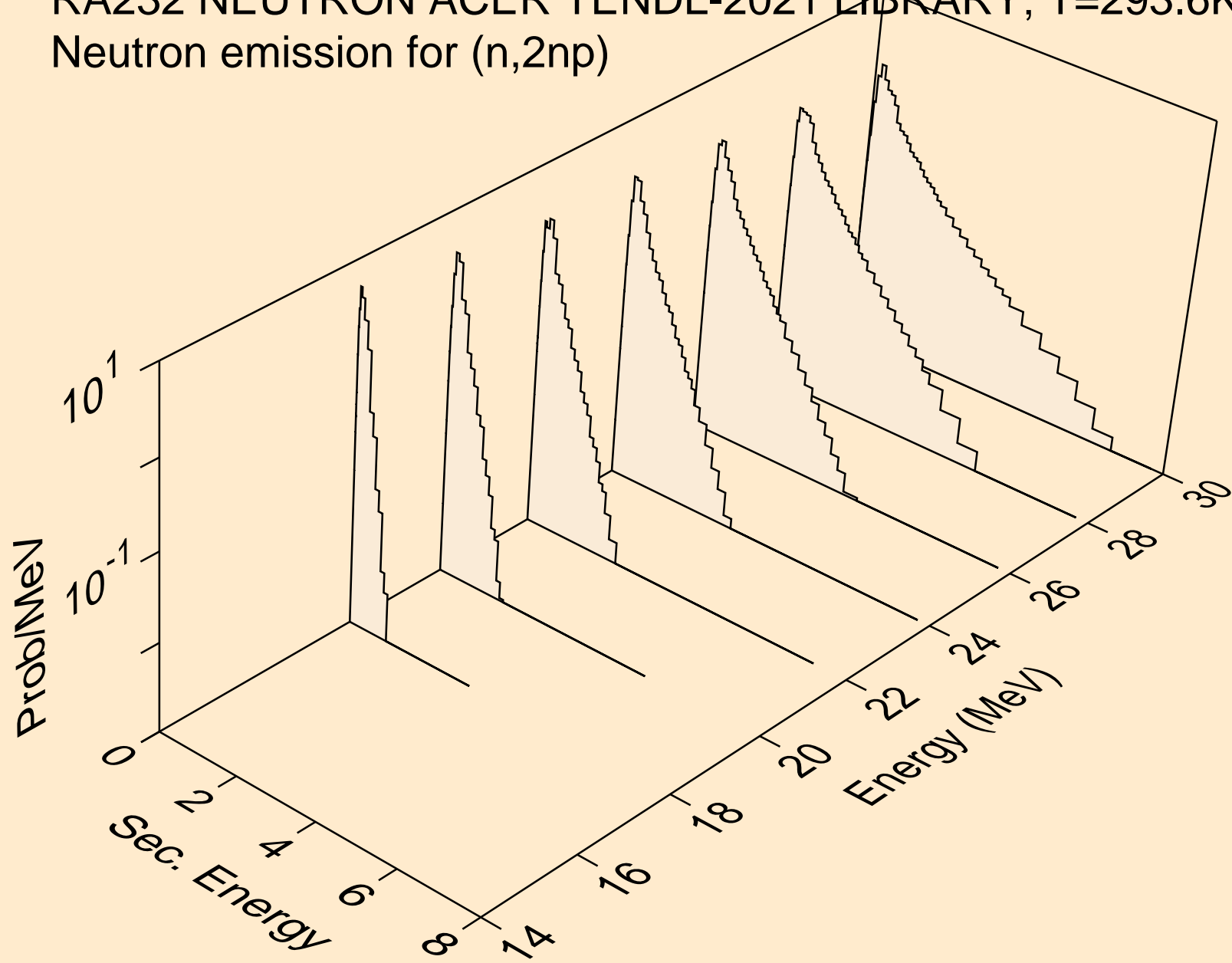

RA232 NEUTRON ACER TENDL-2021 LIBRARY; T=293.6K
Neutron emission for (n,3np)

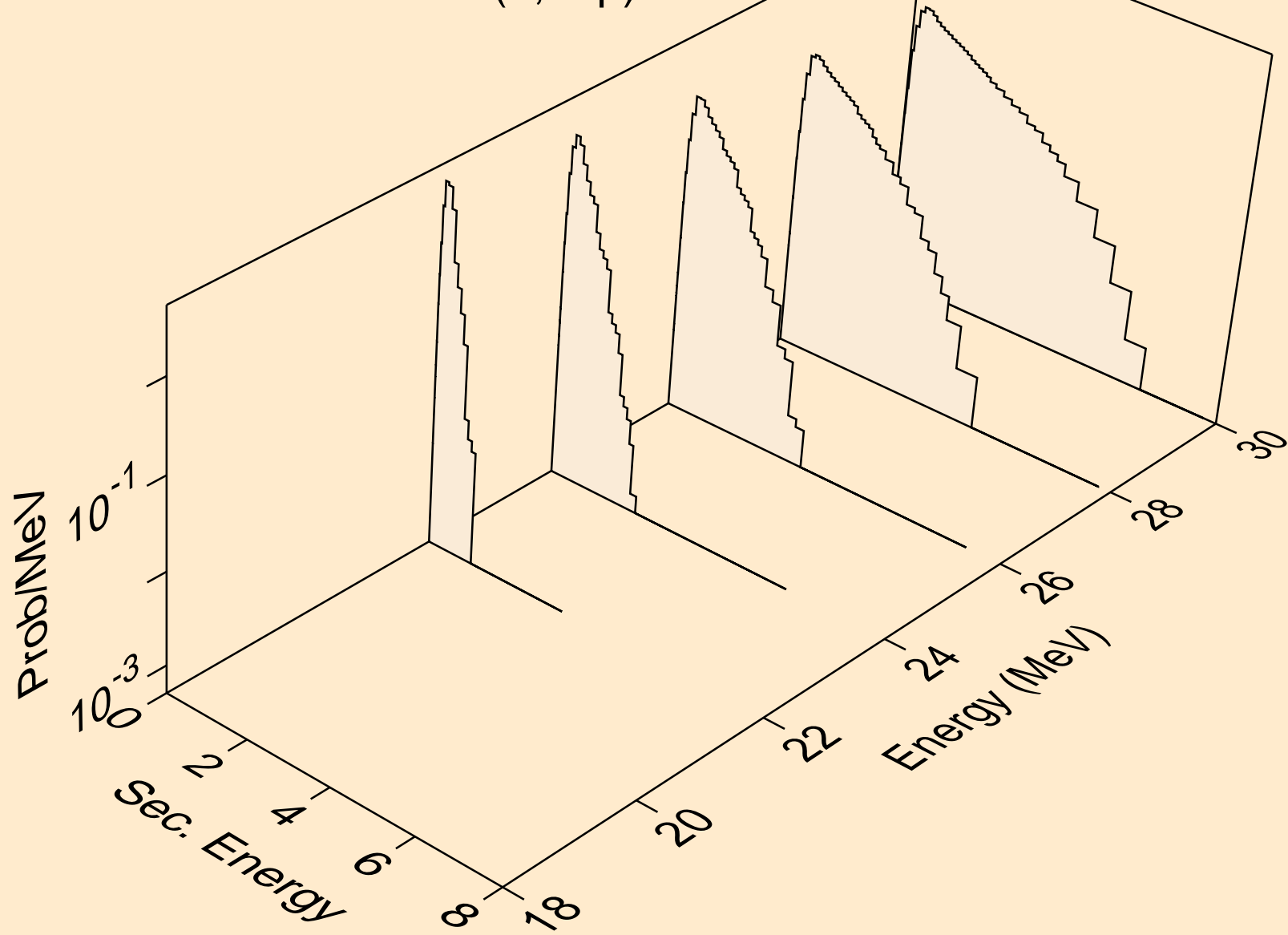

RA232 NEUTRON ACER TENDL-2021 LIBRARY; T=293.6K
Neutron emission for (n,npa)

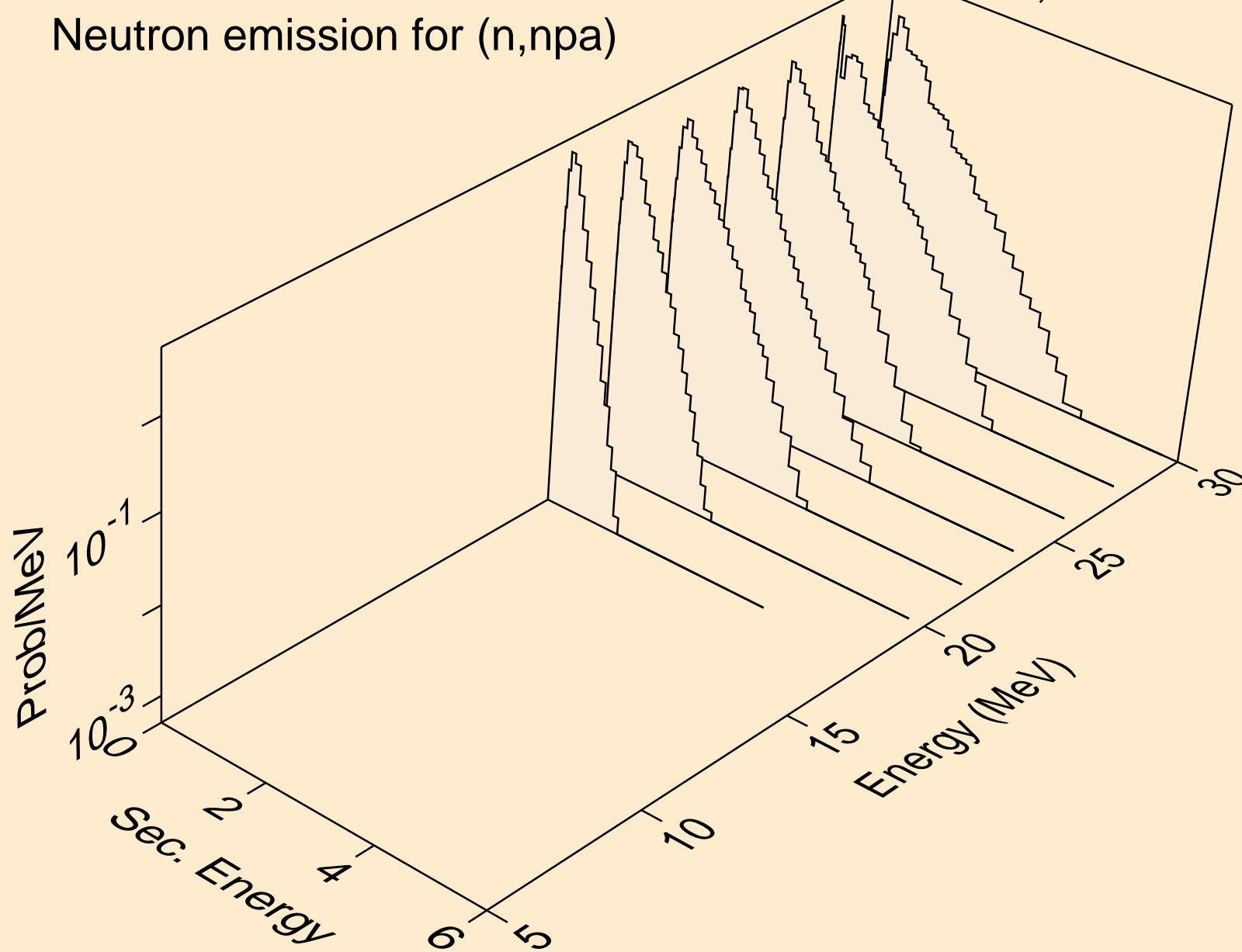

RA232 NEUTRON ACER TENDL-2021 LIBRARY; T=293.6K
Neutron emission for (n,n*c)

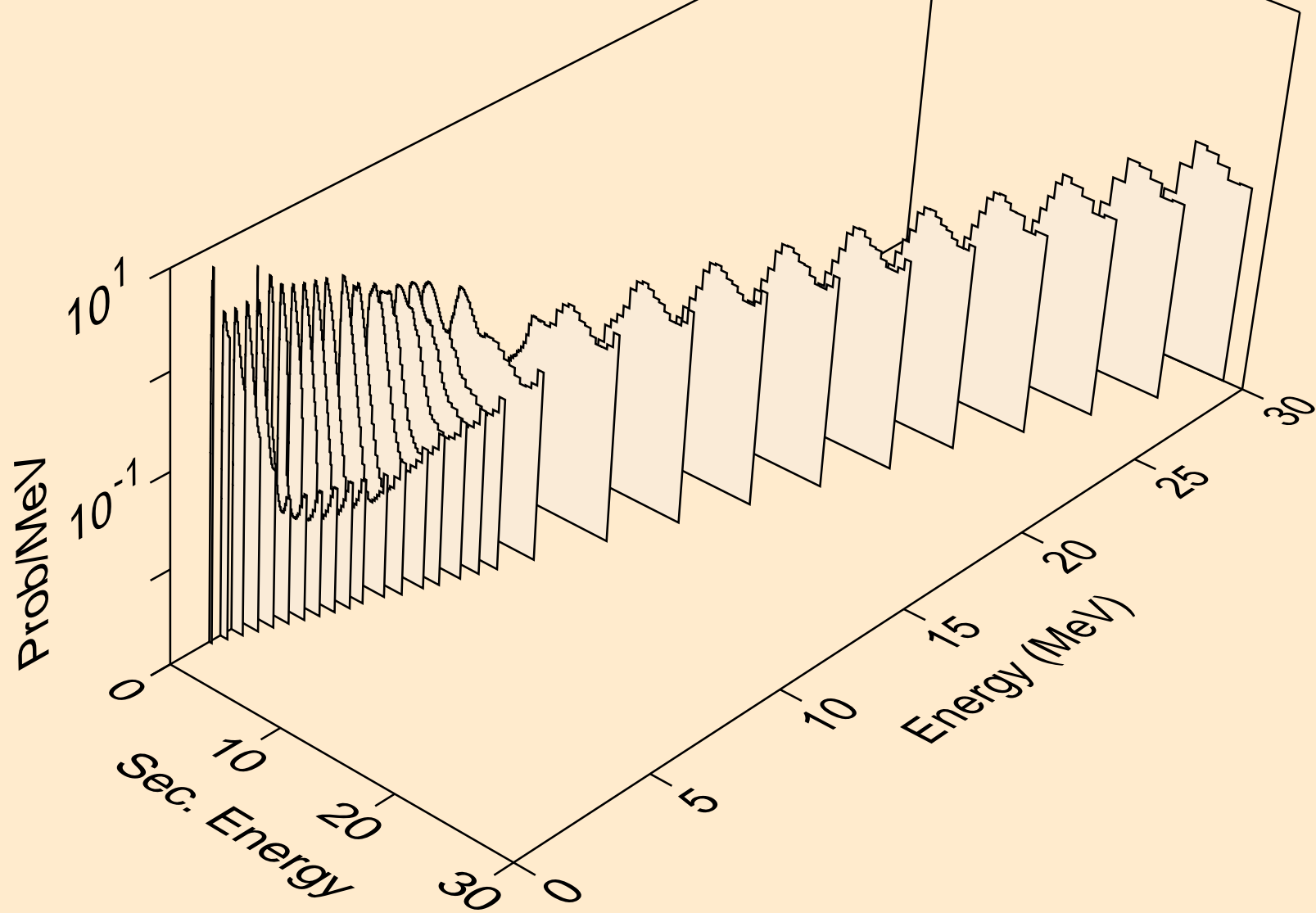

RA232 NEUTRON ACER TENDL-2021 LIBRARY; T=293.6K

Delayed nubar

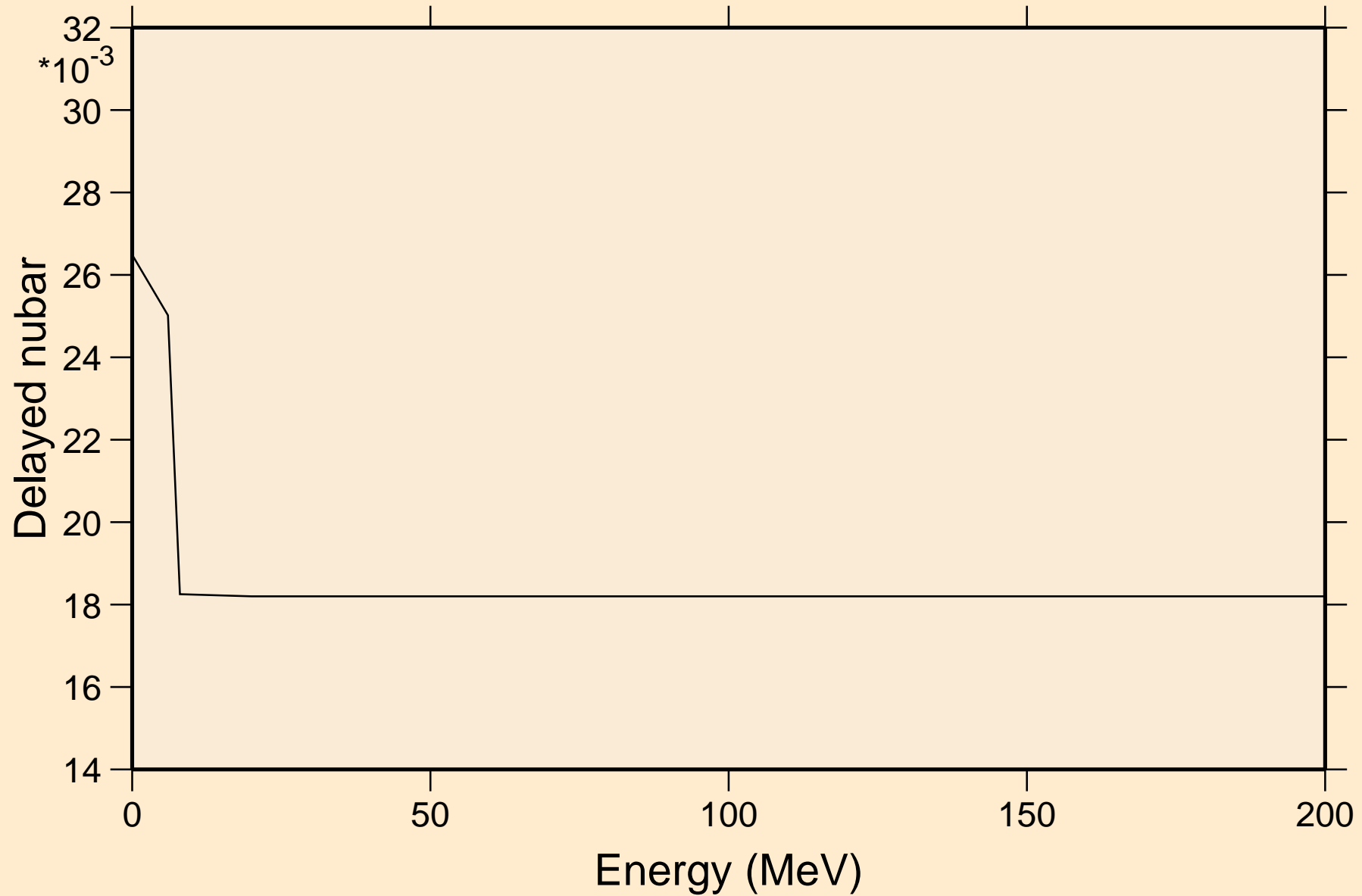

RA232 NEUTRON ACER TENDL-2021 LIBRARY; T=293.6K

Delayed neutron spectra

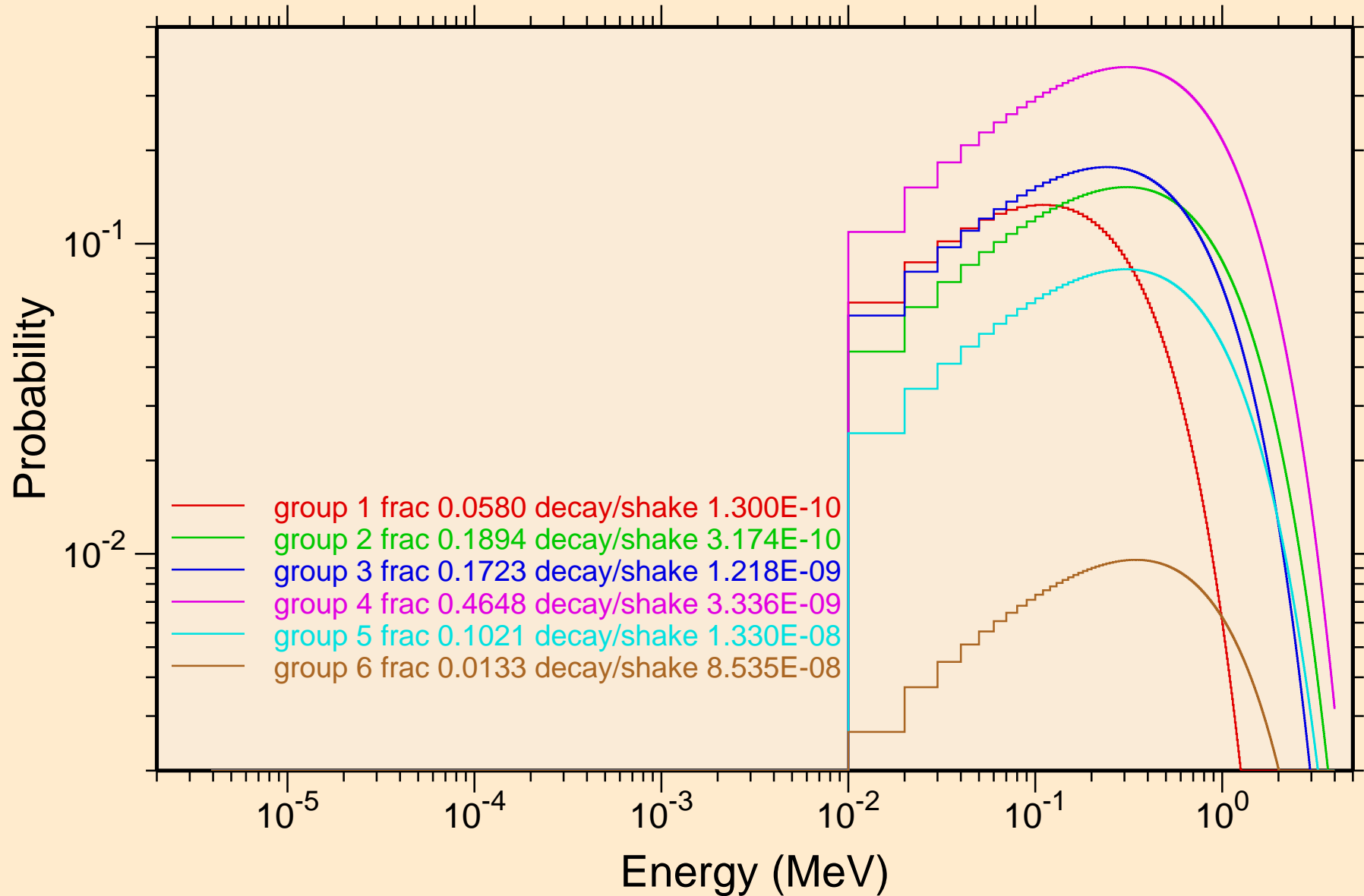

RA232 NEUTRON ACER TENDL-2021 LIBRARY; T=293.6K
Photon emission for (n,x)

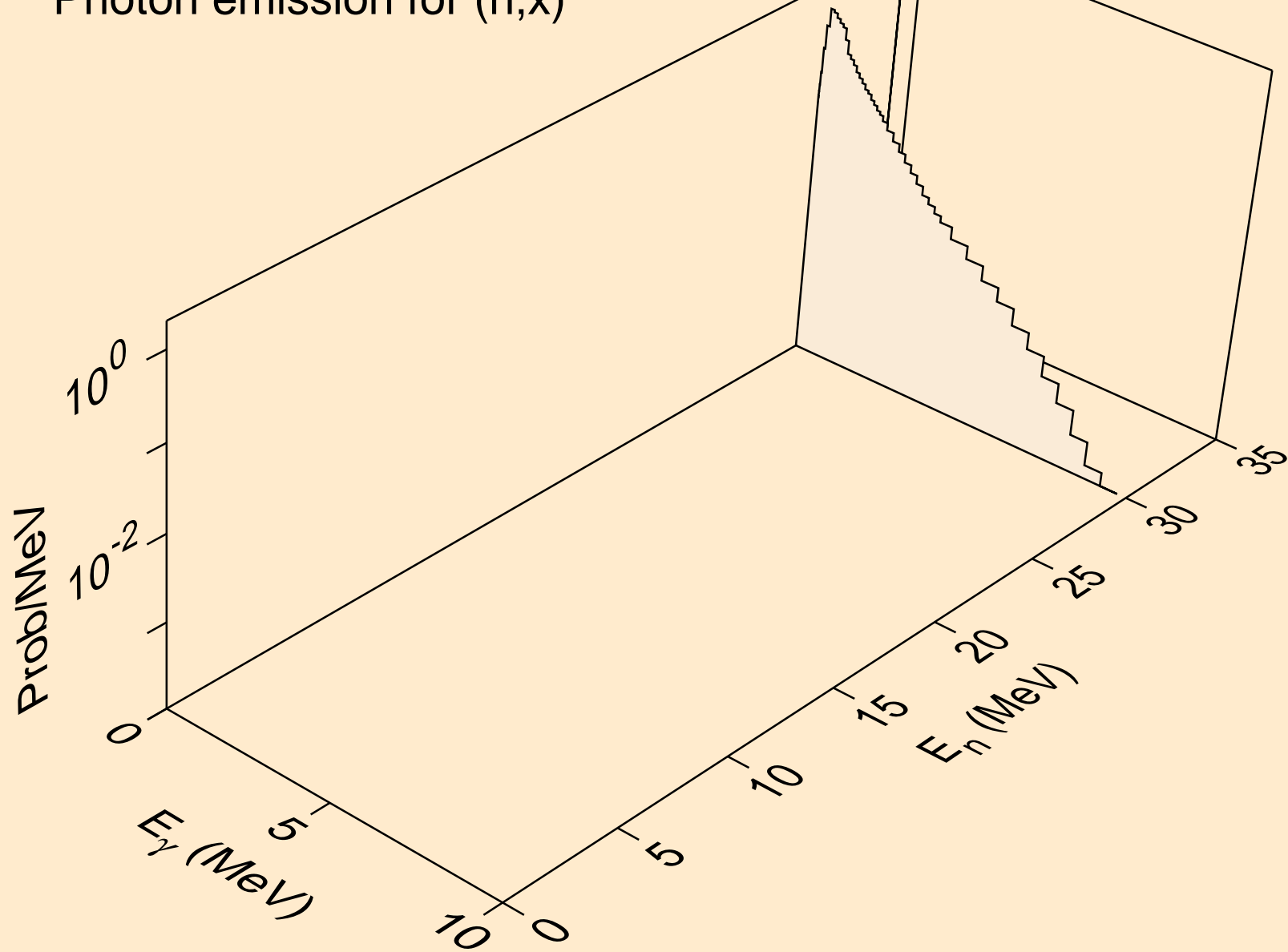

RA232 NEUTRON ACER TENDL-2021 LIBRARY; T=293.6K
Photon emission for (n,2nd)

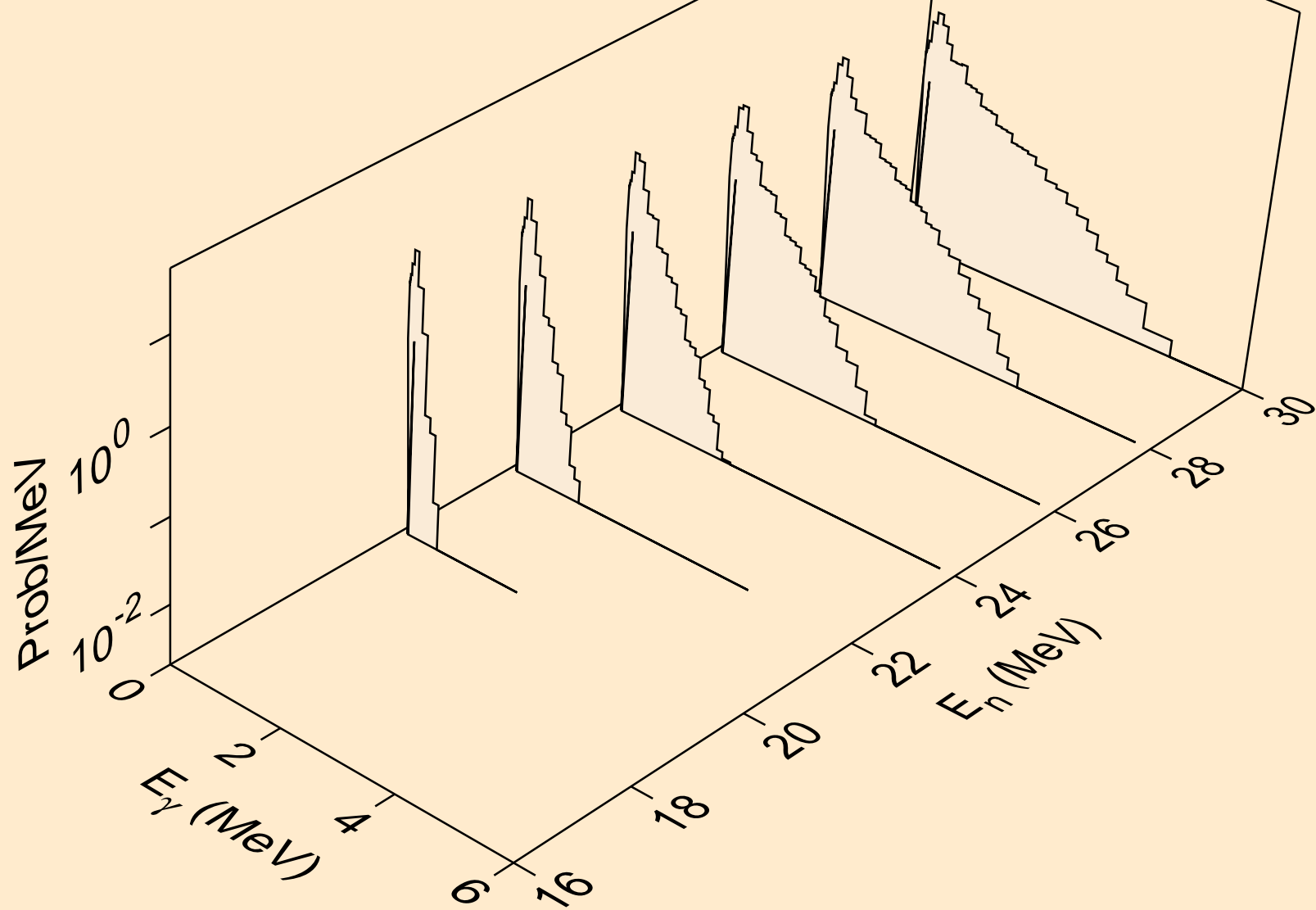

RA232 NEUTRON ACER TENDL-2021 LIBRARY; T=293.6K
Photon emission for (n,2n)

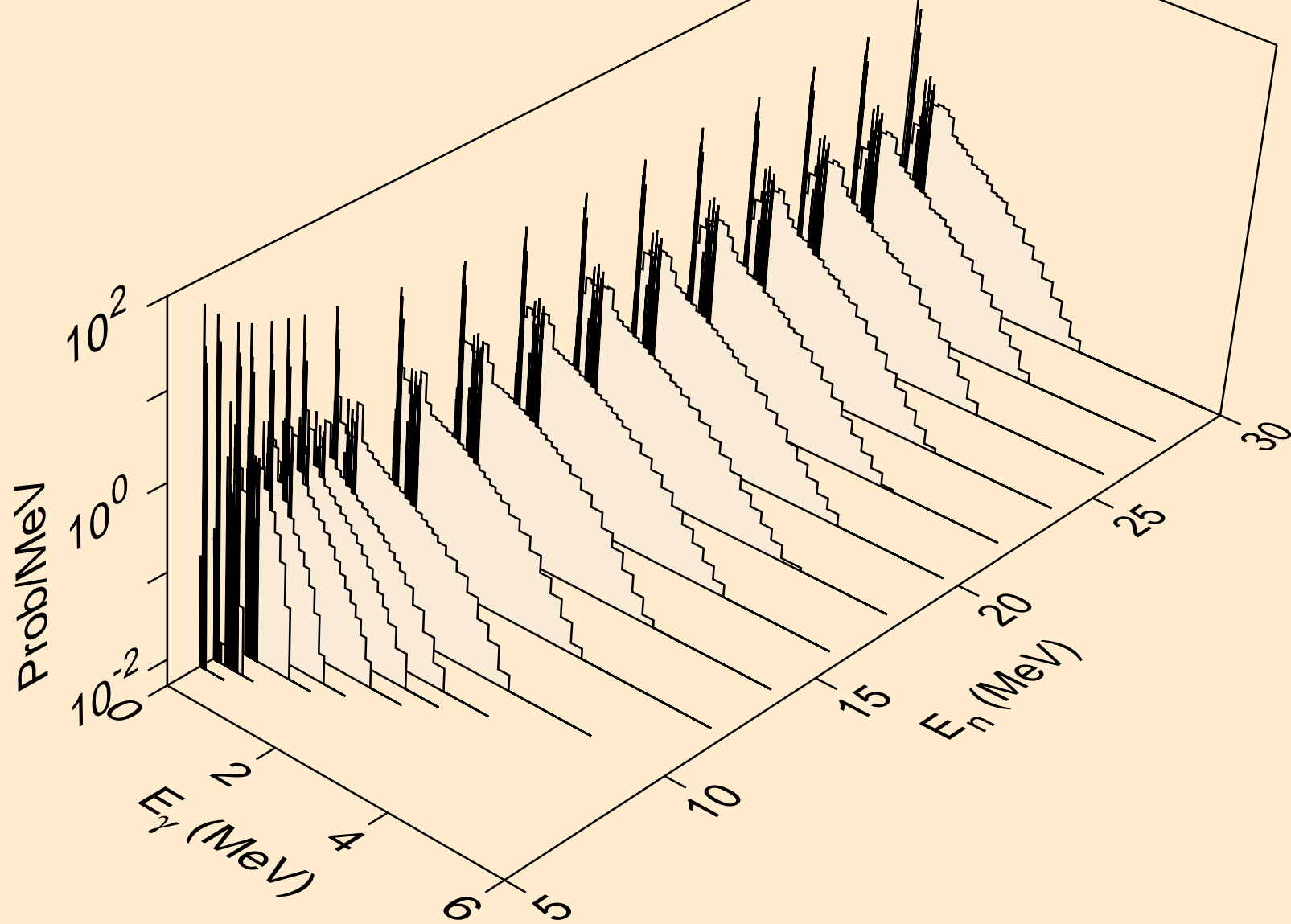

RA232 NEUTRON ACER TENDL-2021 LIBRARY; T=293.6K
Photon emission for (n,3n)

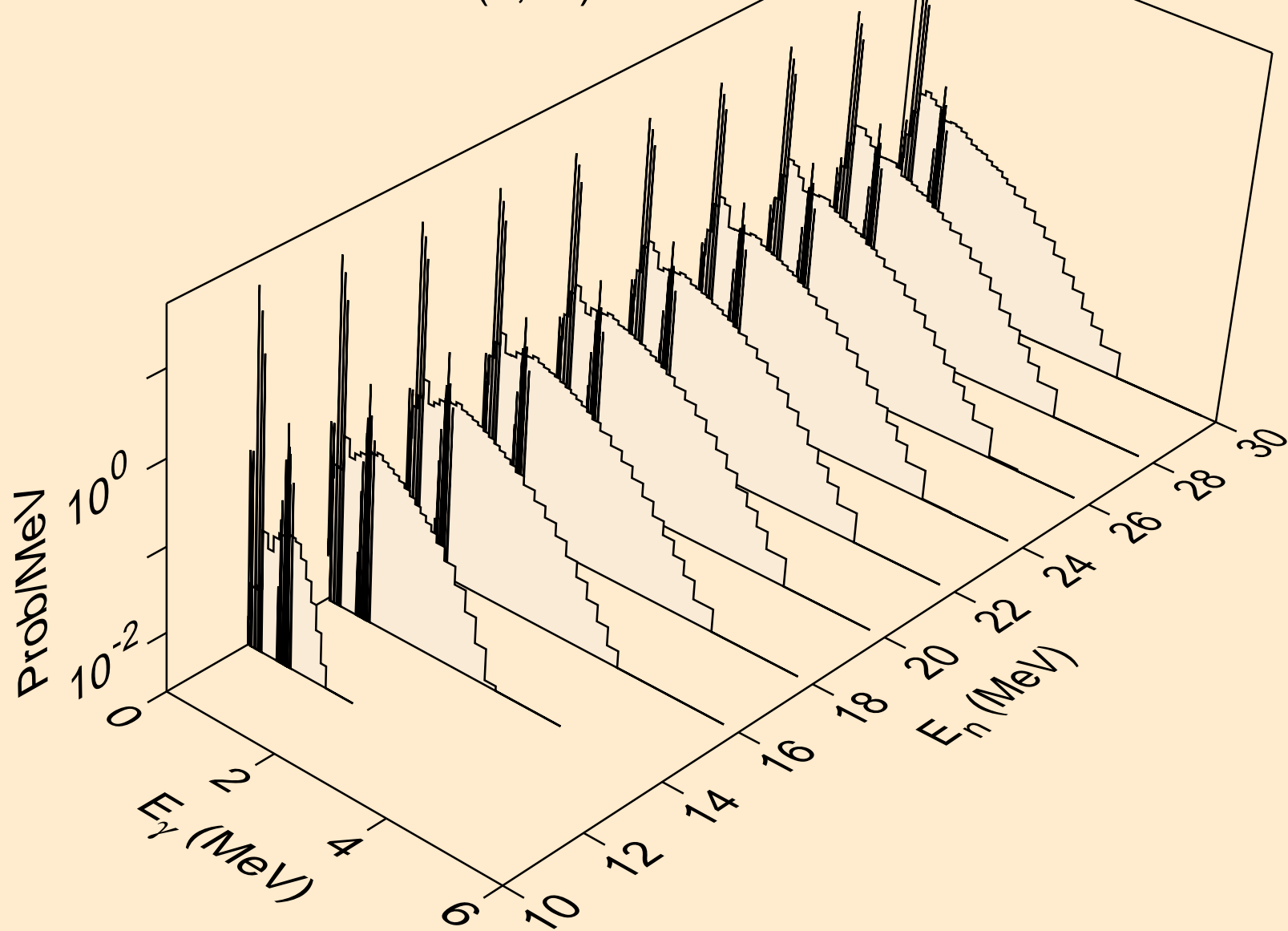

RA232 NEUTRON ACER TENDL-2021 LIBRARY; T=293.6K
Photon emission for (n,n*)a

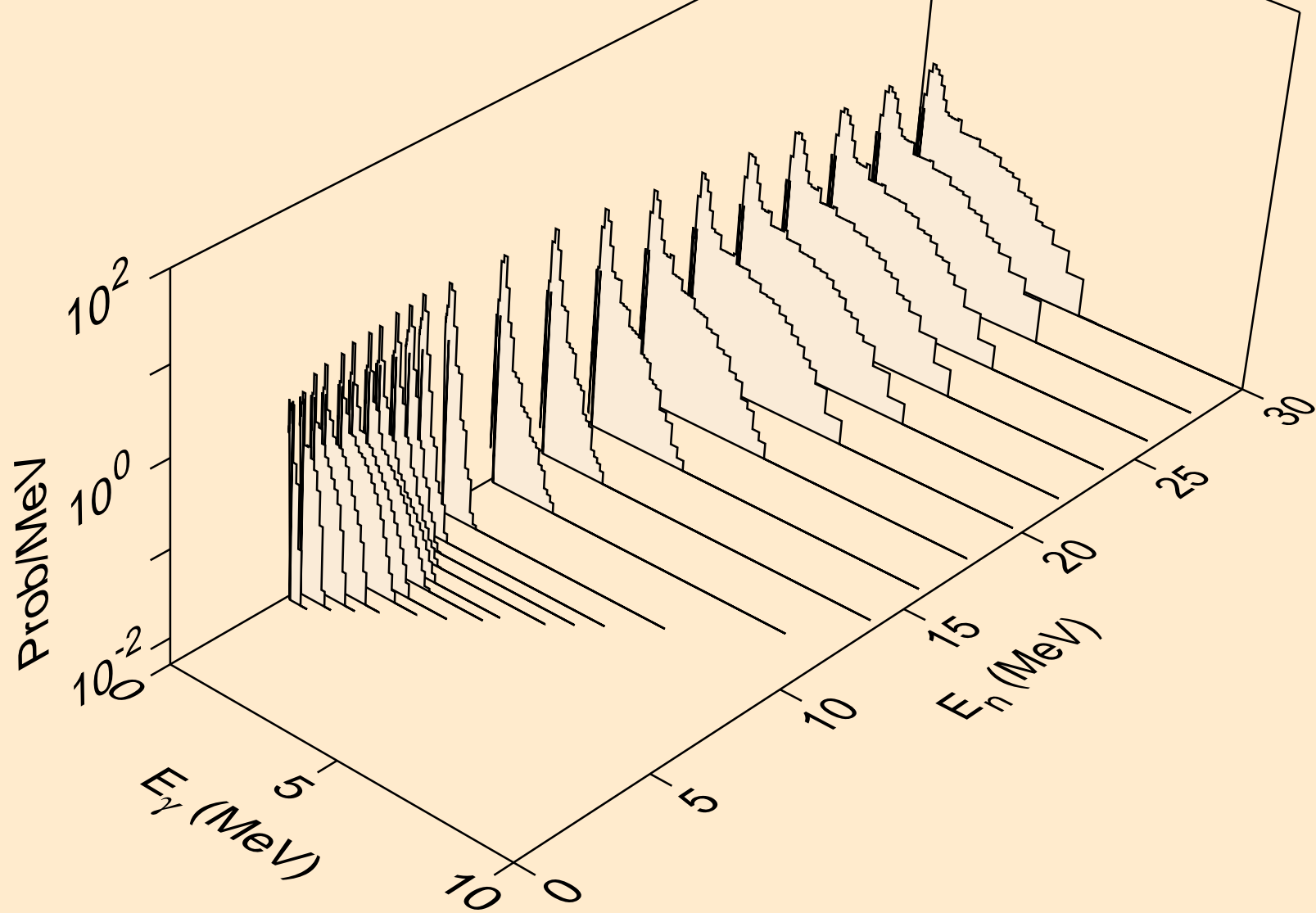

RA232 NEUTRON ACER TENDL-2021 LIBRARY; T=293.6K
Photon emission for (n,2n)a

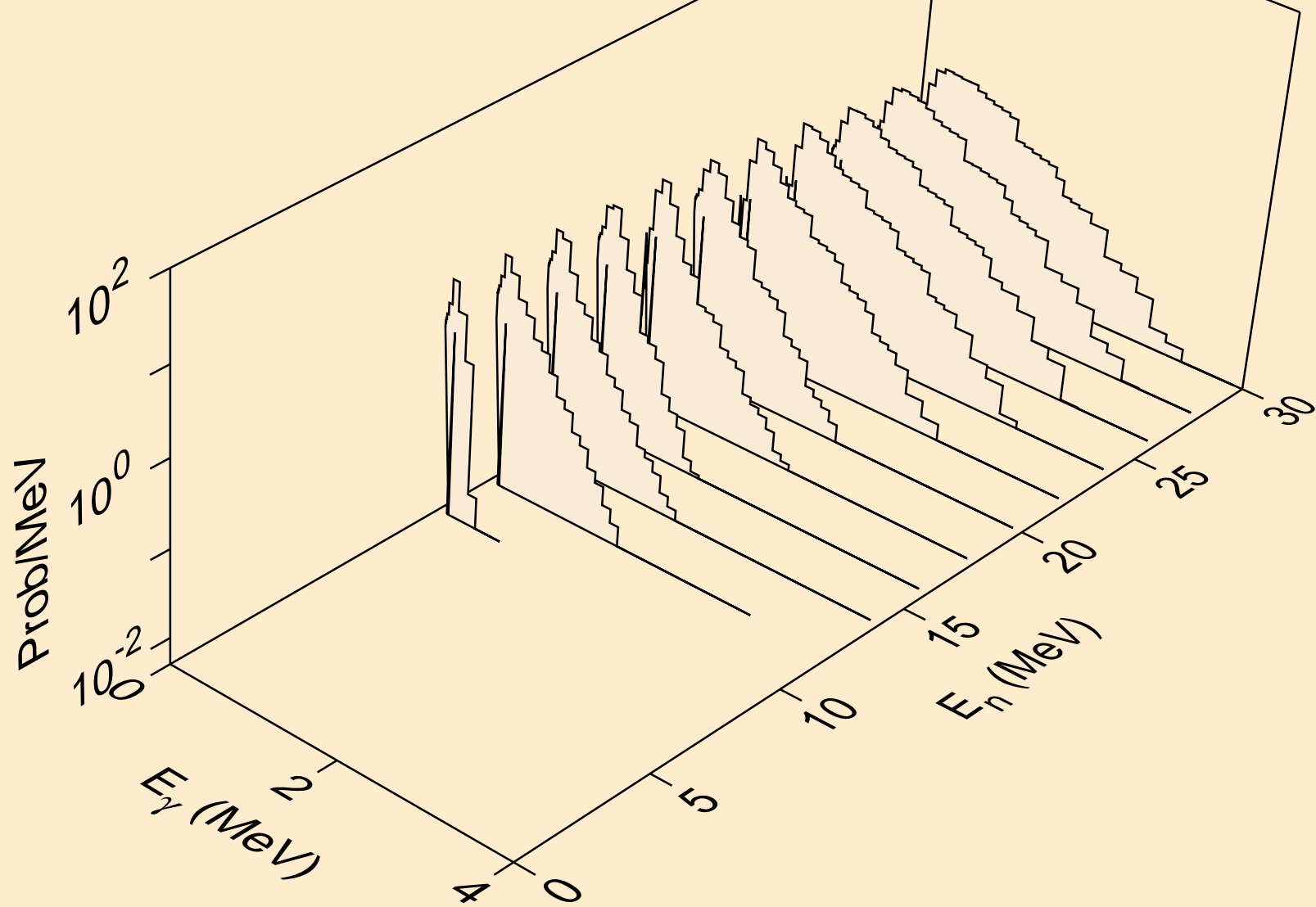

RA232 NEUTRON ACER TENDL-2021 LIBRARY; T=293.6K
Photon emission for (n,3n)a

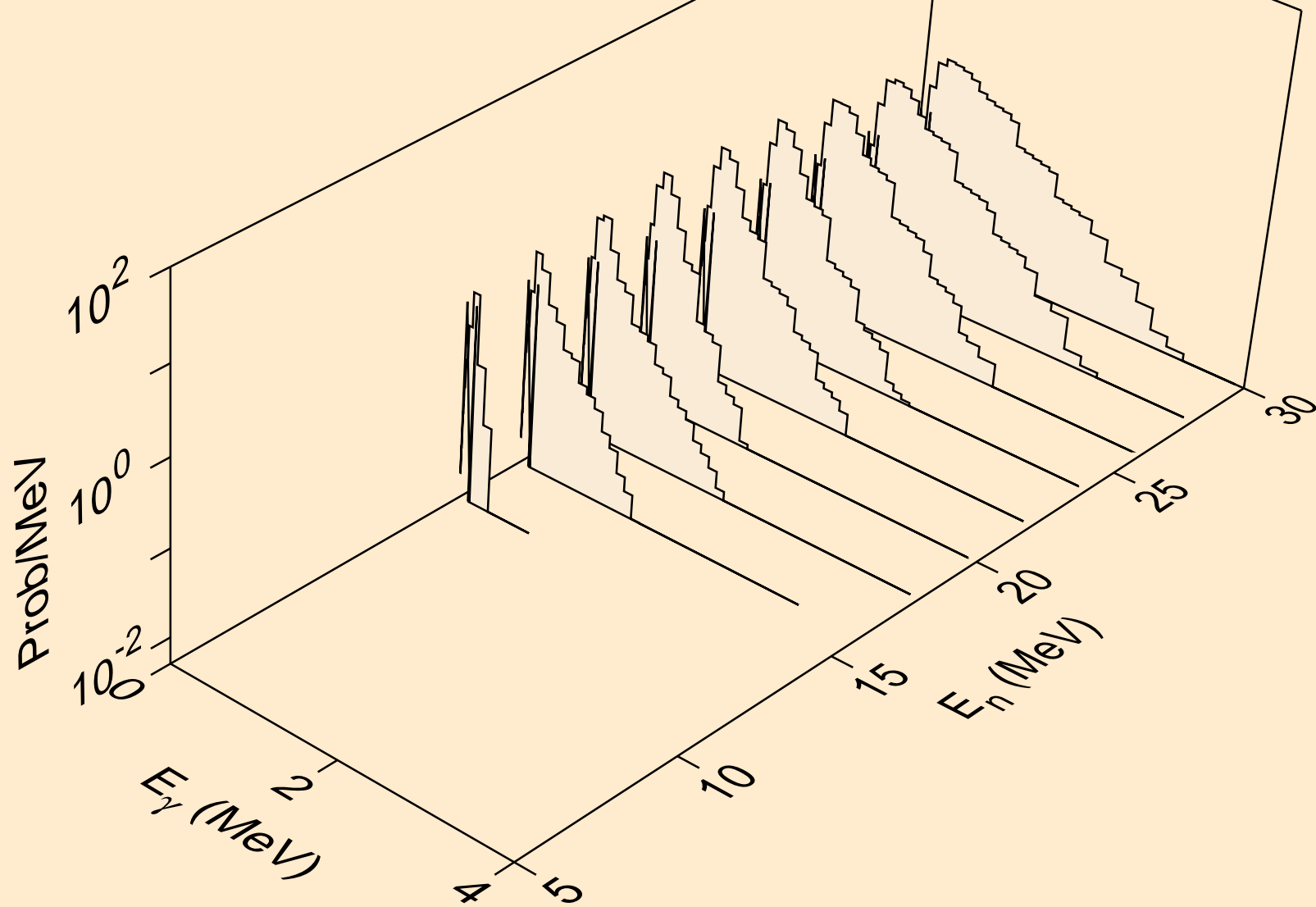

RA232 NEUTRON ACER TENDL-2021 LIBRARY; T=293.6K
Photon emission for (n,n*)p

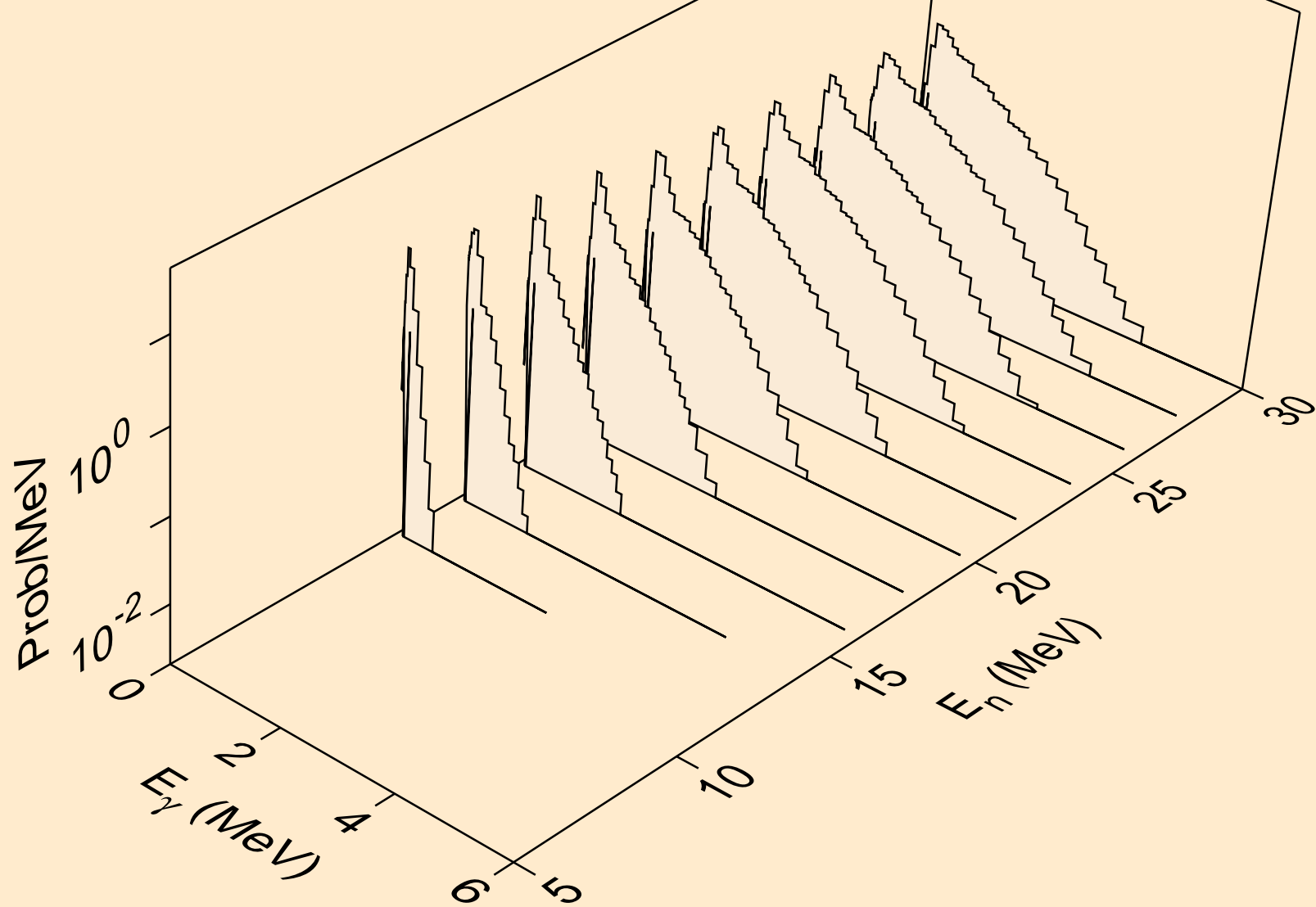

RA232 NEUTRON ACER TENDL-2021 LIBRARY; T=293.6K
Photon emission for (n,n*)2a

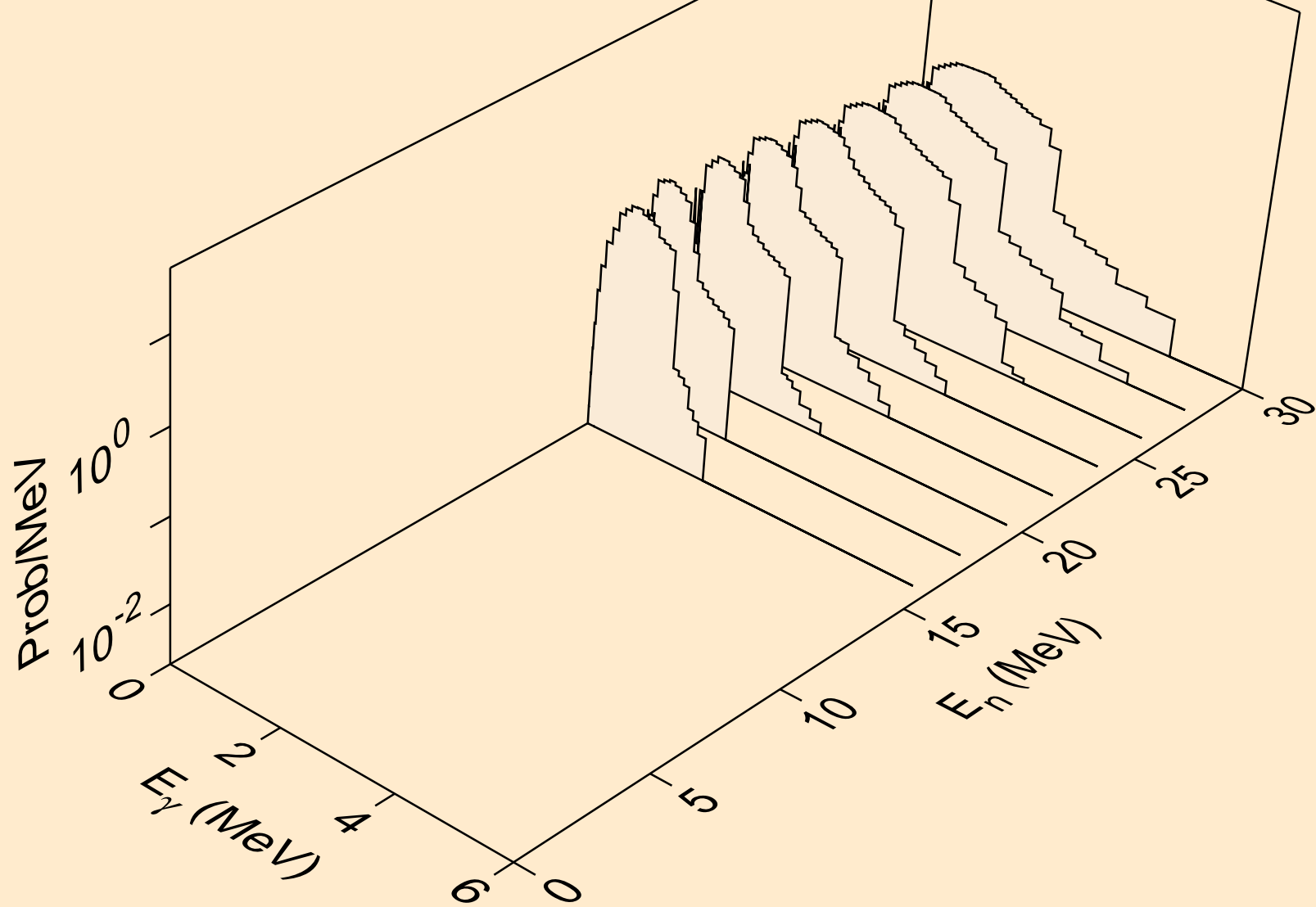

RA232 NEUTRON ACER TENDL-2021 LIBRARY; T=293.6K
Photon emission for (n,2n)2a

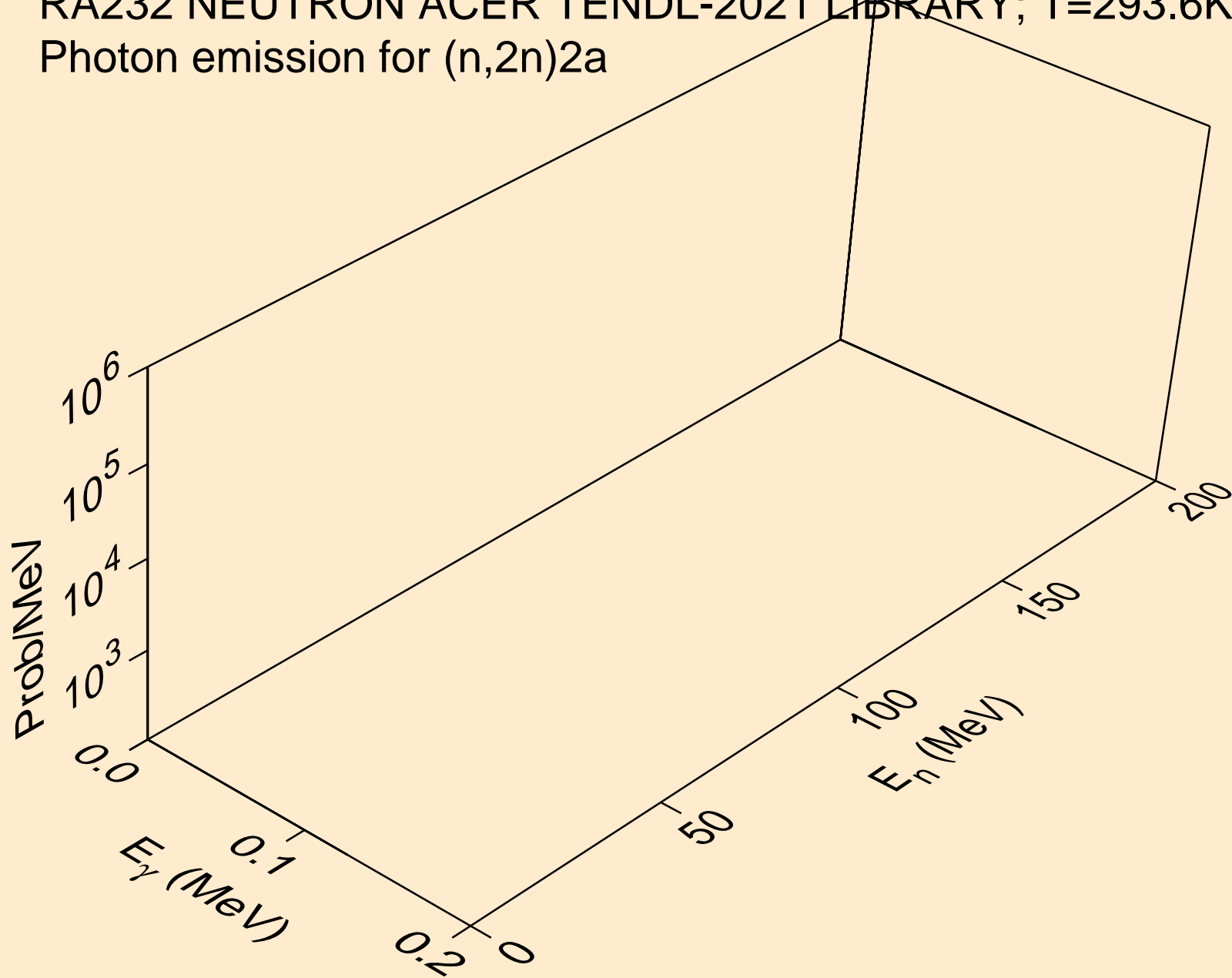

RA232 NEUTRON ACER TENDL-2021 LIBRARY; T=293.6K
Photon emission for (n,n*)d

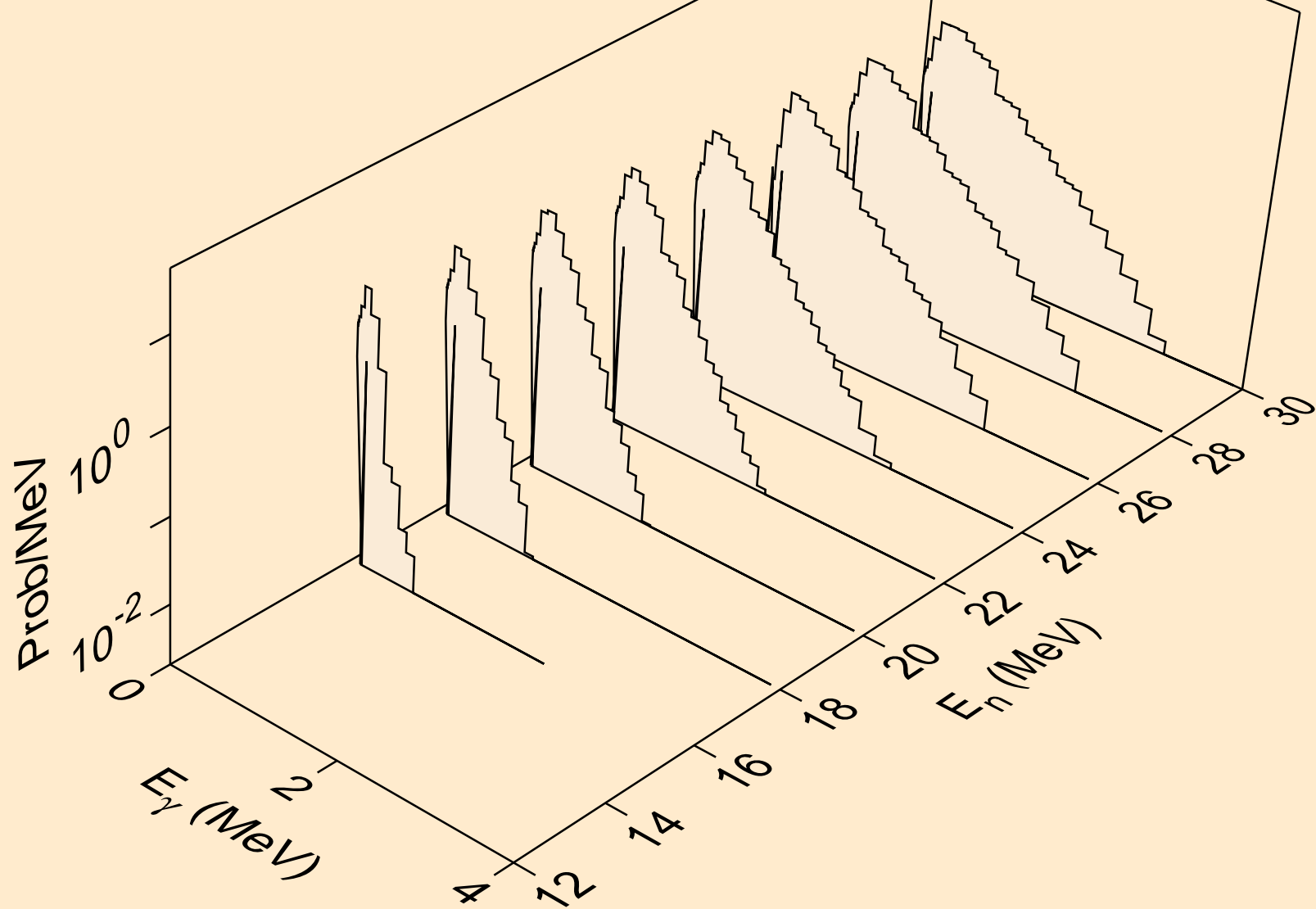

RA232 NEUTRON ACER TENDL-2021 LIBRARY; T=293.6K
Photon emission for (n,n*)t

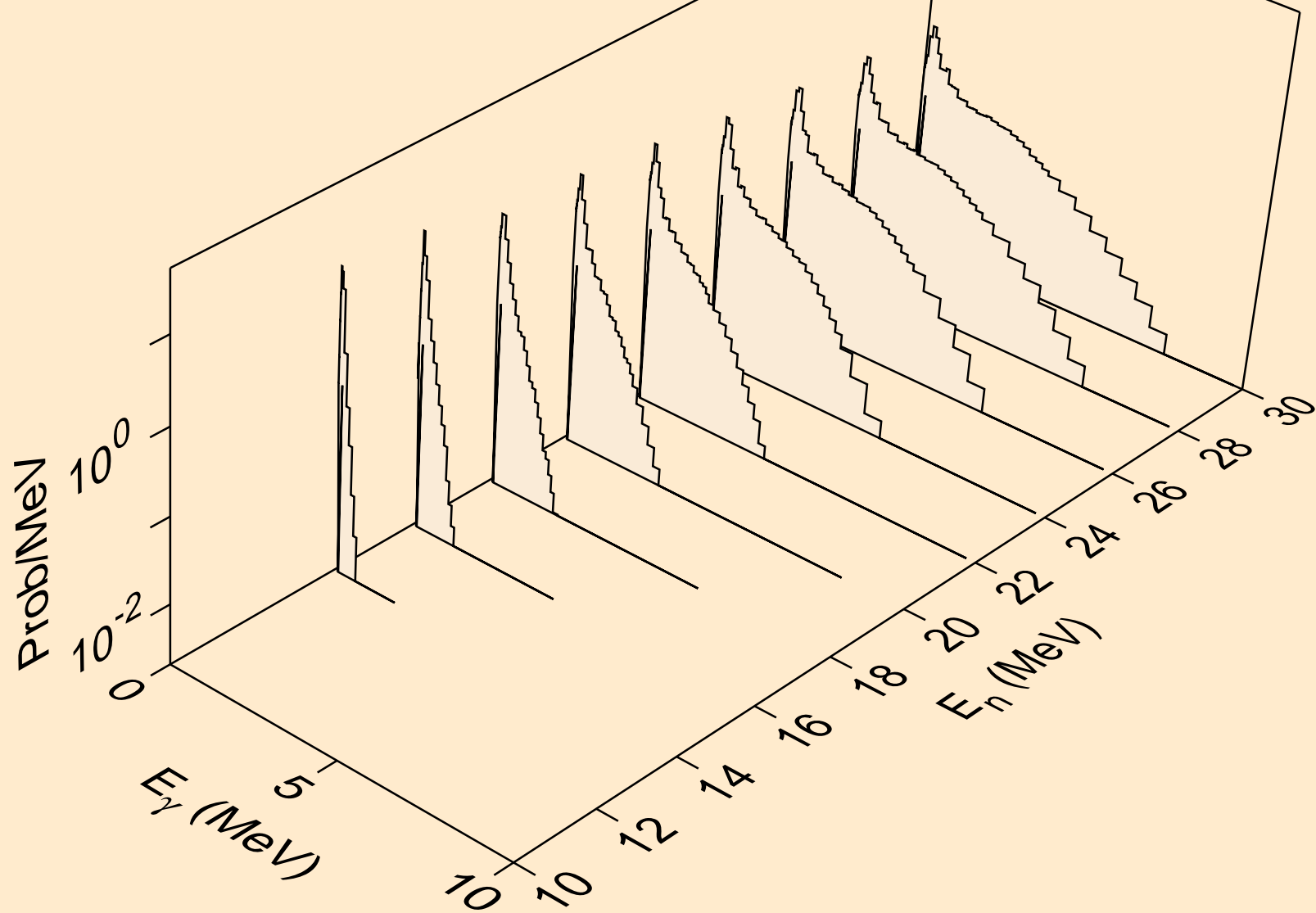

RA232 NEUTRON ACER TENDL-2021 LIBRARY; T=293.6K
Photon emission for (n,n*)he3

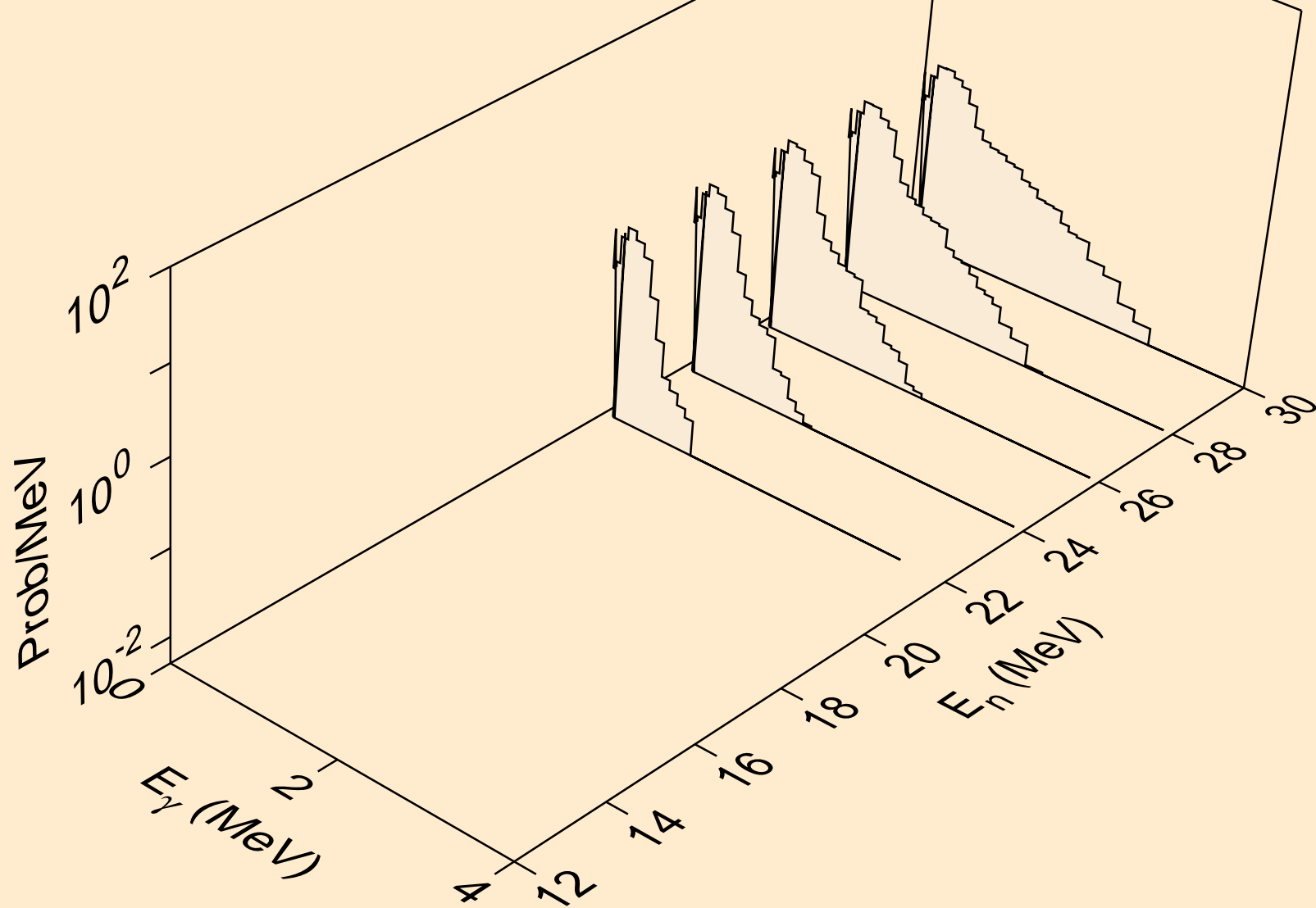

RA232 NEUTRON ACER TENDL-2021 LIBRARY; T=293.6K
Photon emission for (n,4n)

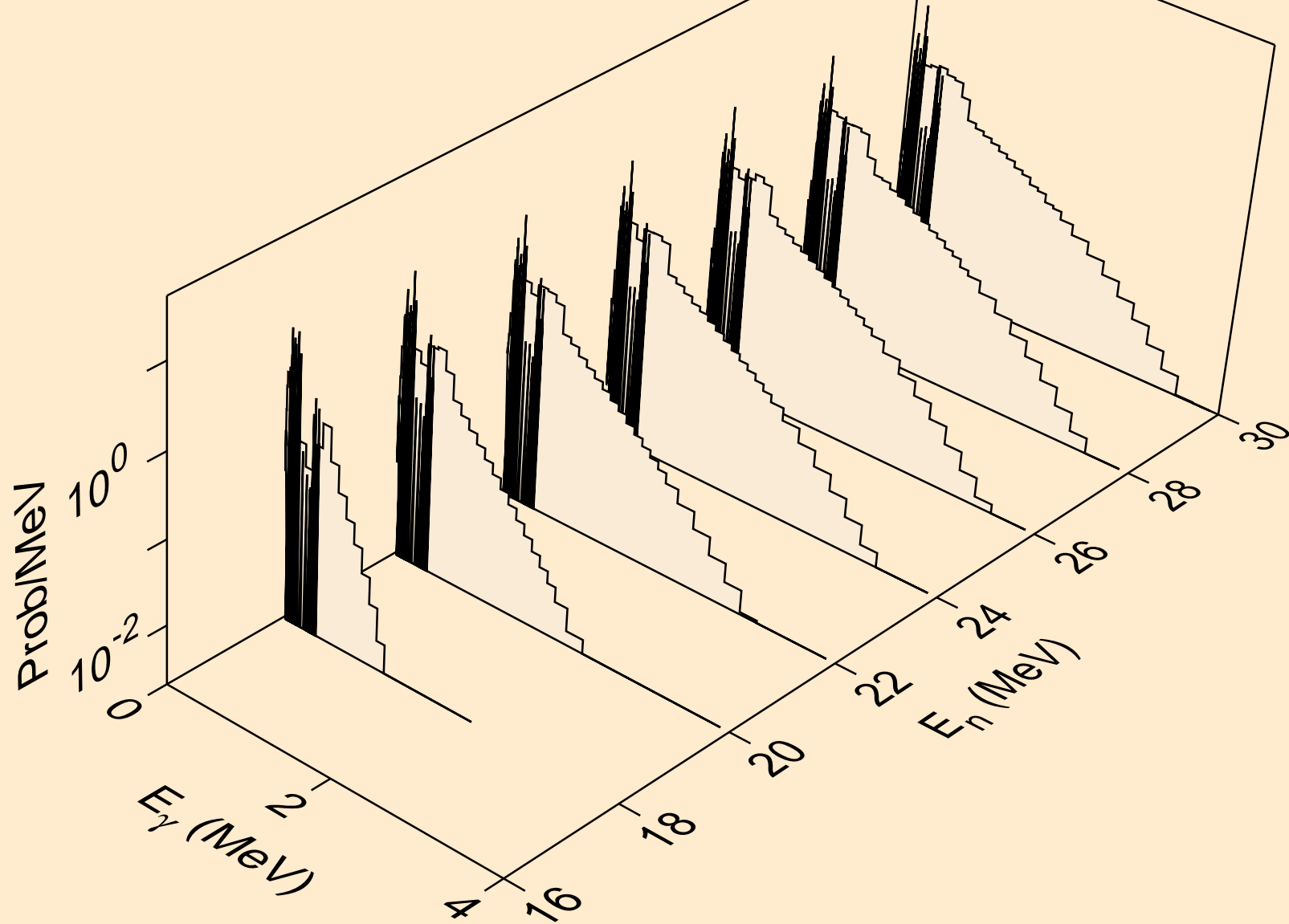

RA232 NEUTRON ACER TENDL-2021 LIBRARY; T=293.6K
Photon emission for (n,2np)

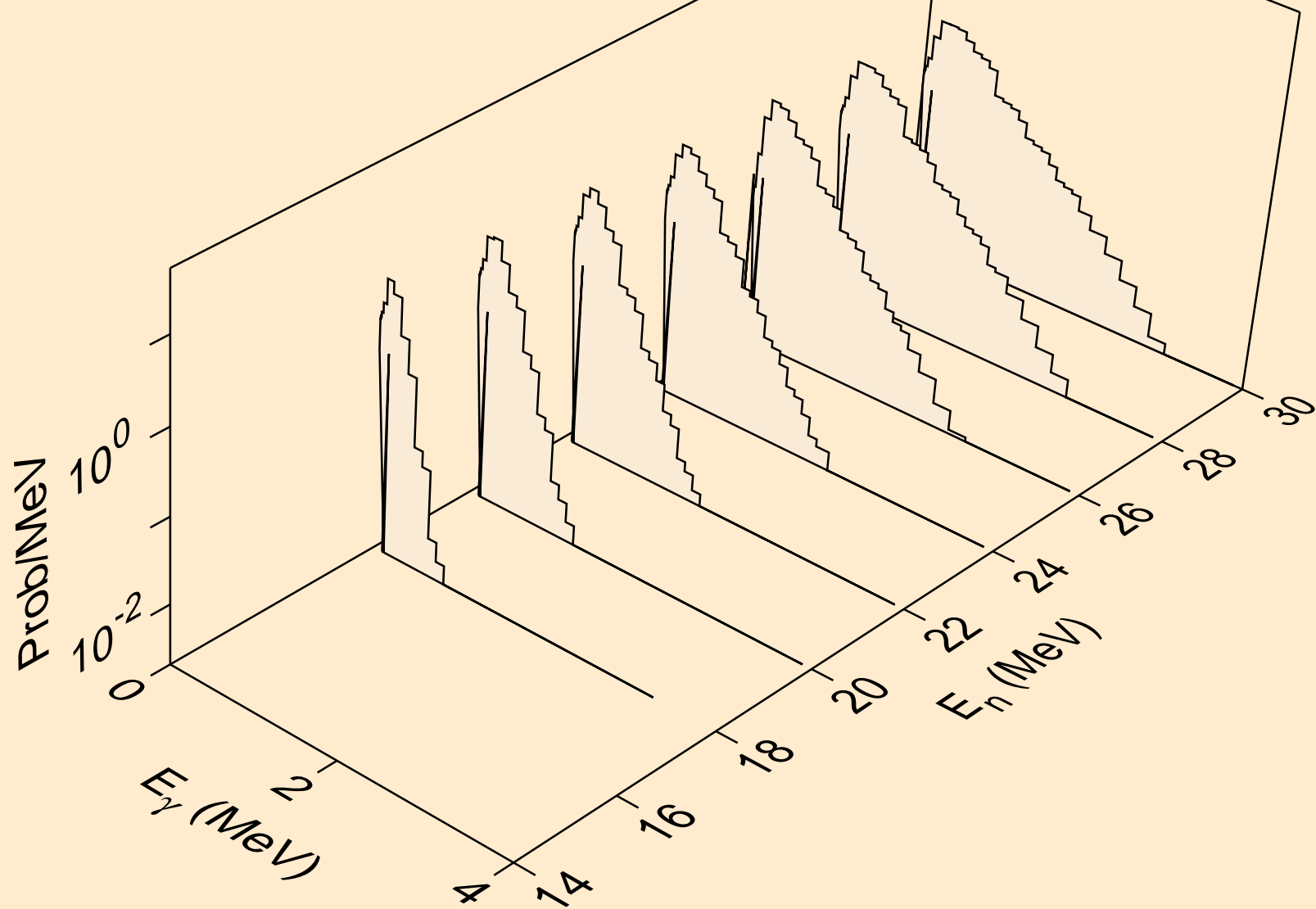

RA232 NEUTRON ACER TENDL-2021 LIBRARY; T=293.6K
Photon emission for (n,3np)

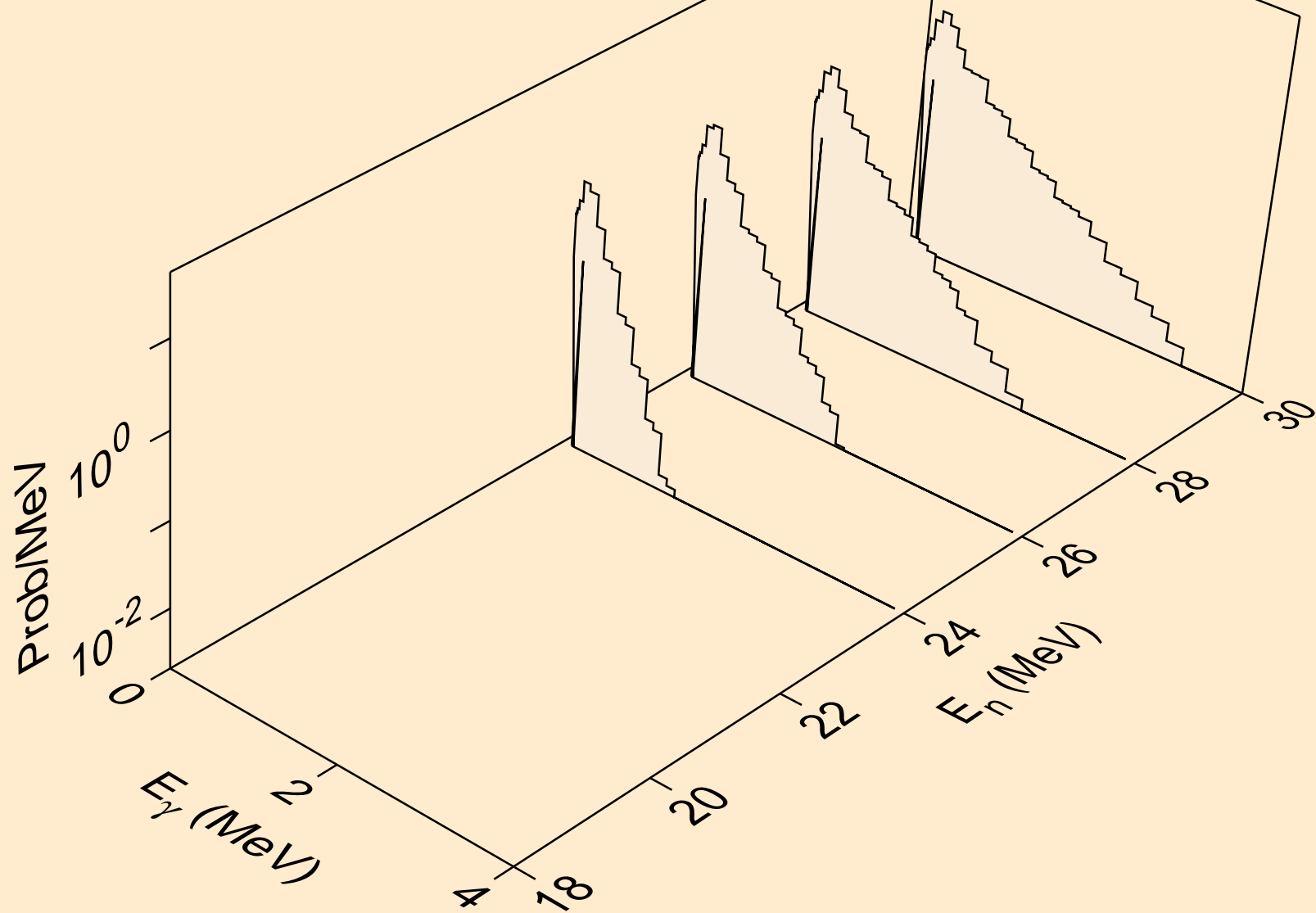

RA232 NEUTRON ACER TENDL-2021 LIBRARY; T=293.6K
Photon emission for (n,npa)

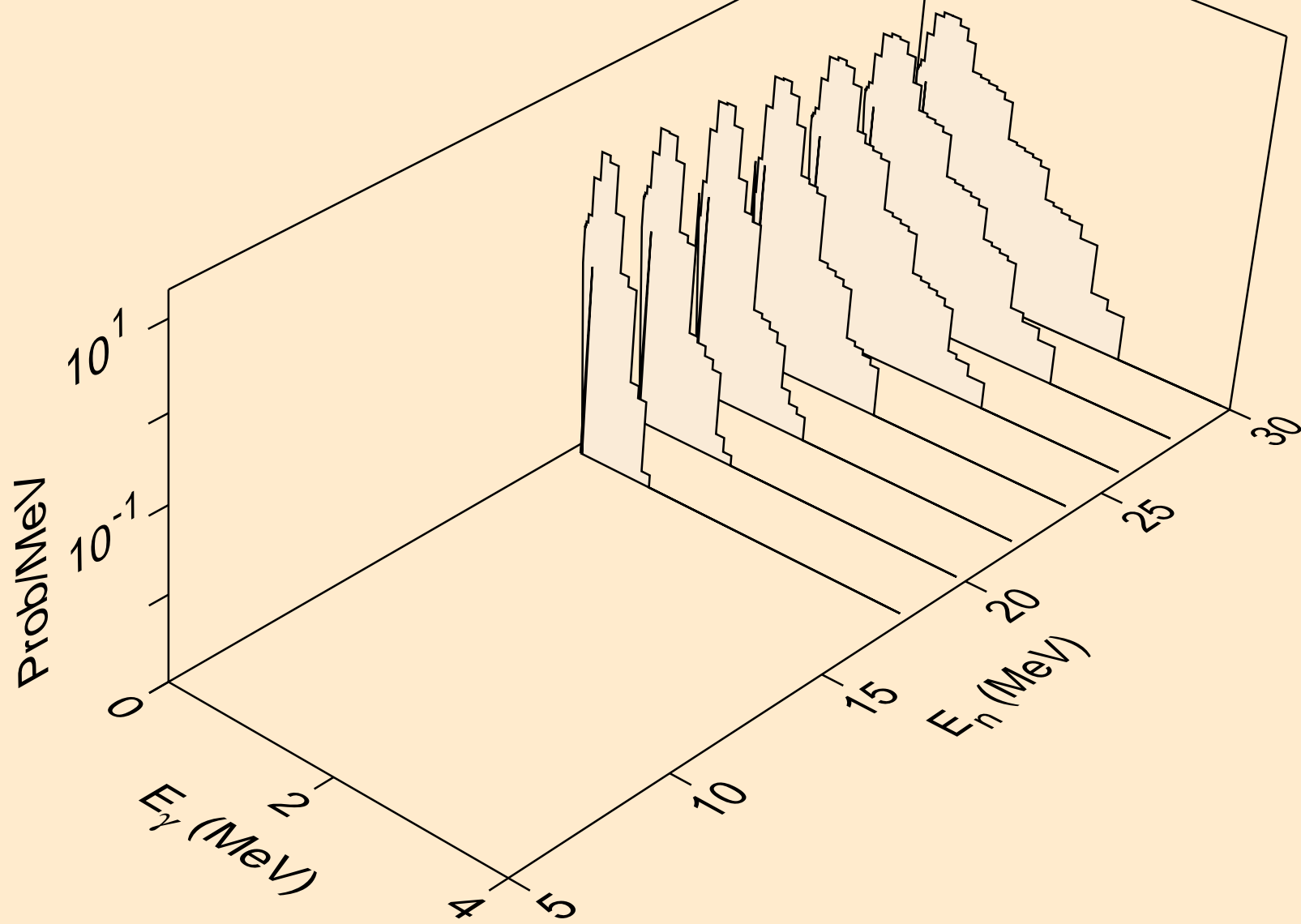

RA232 NEUTRON ACER TENDL-2021 LIBRARY; T=293.6K
Photon emission for (n,n*c)

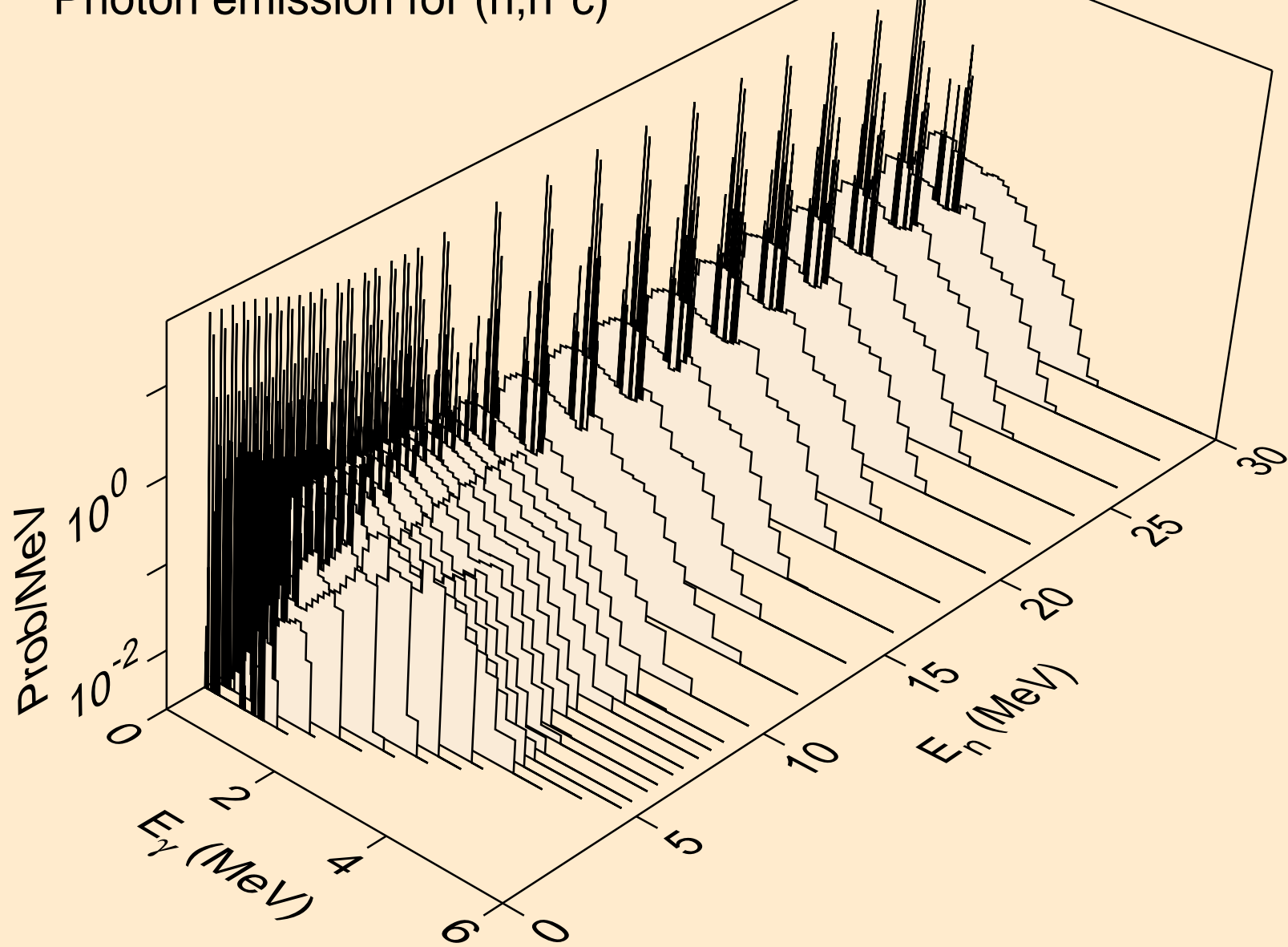

RA232 NEUTRON ACER TENDL-2021 LIBRARY; T=293.6K
Photon emission for (n,gma)

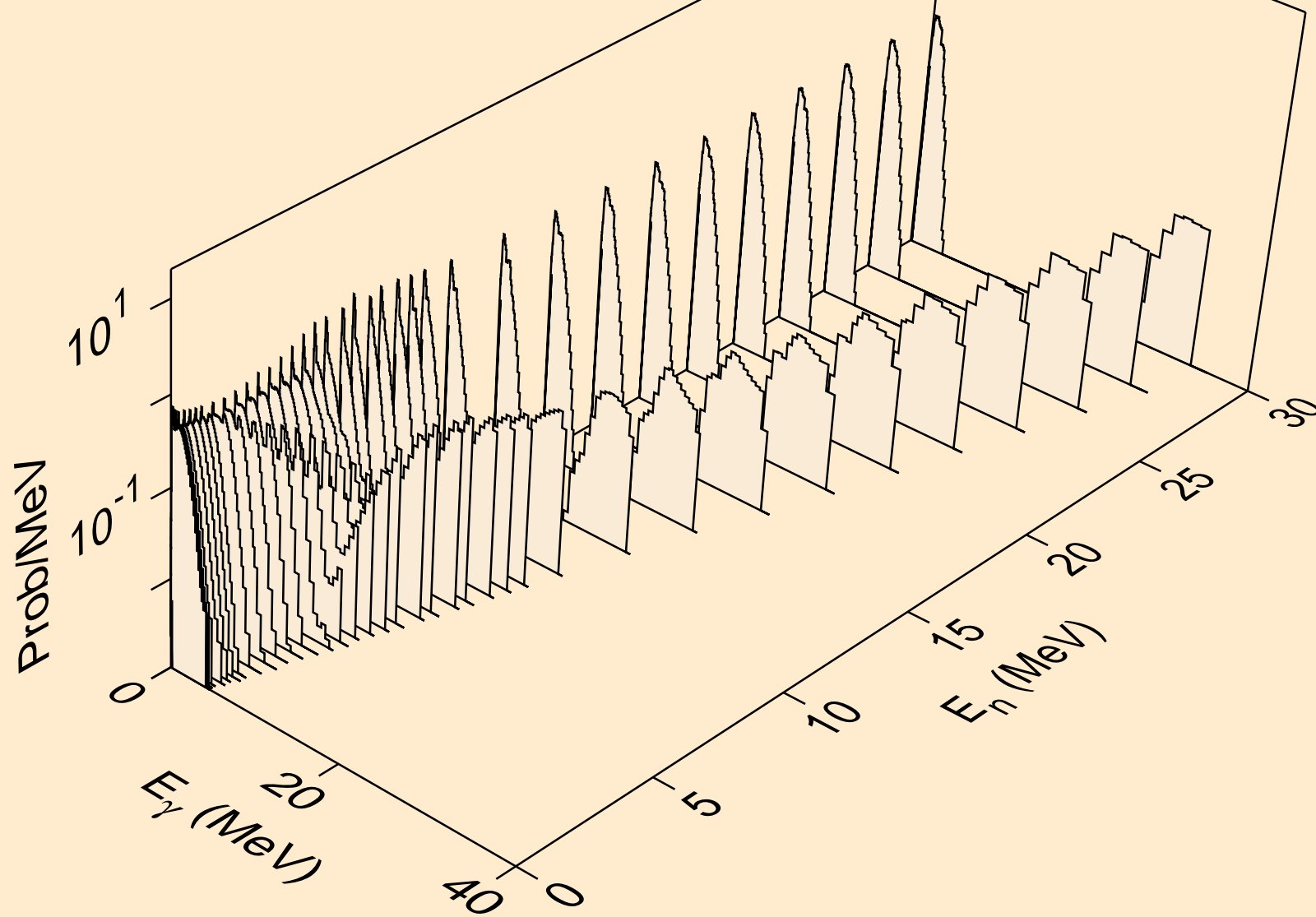

RA232 NEUTRON ACER TENDL-2021 LIBRARY; T=293.6K
Photon emission for (n,p)

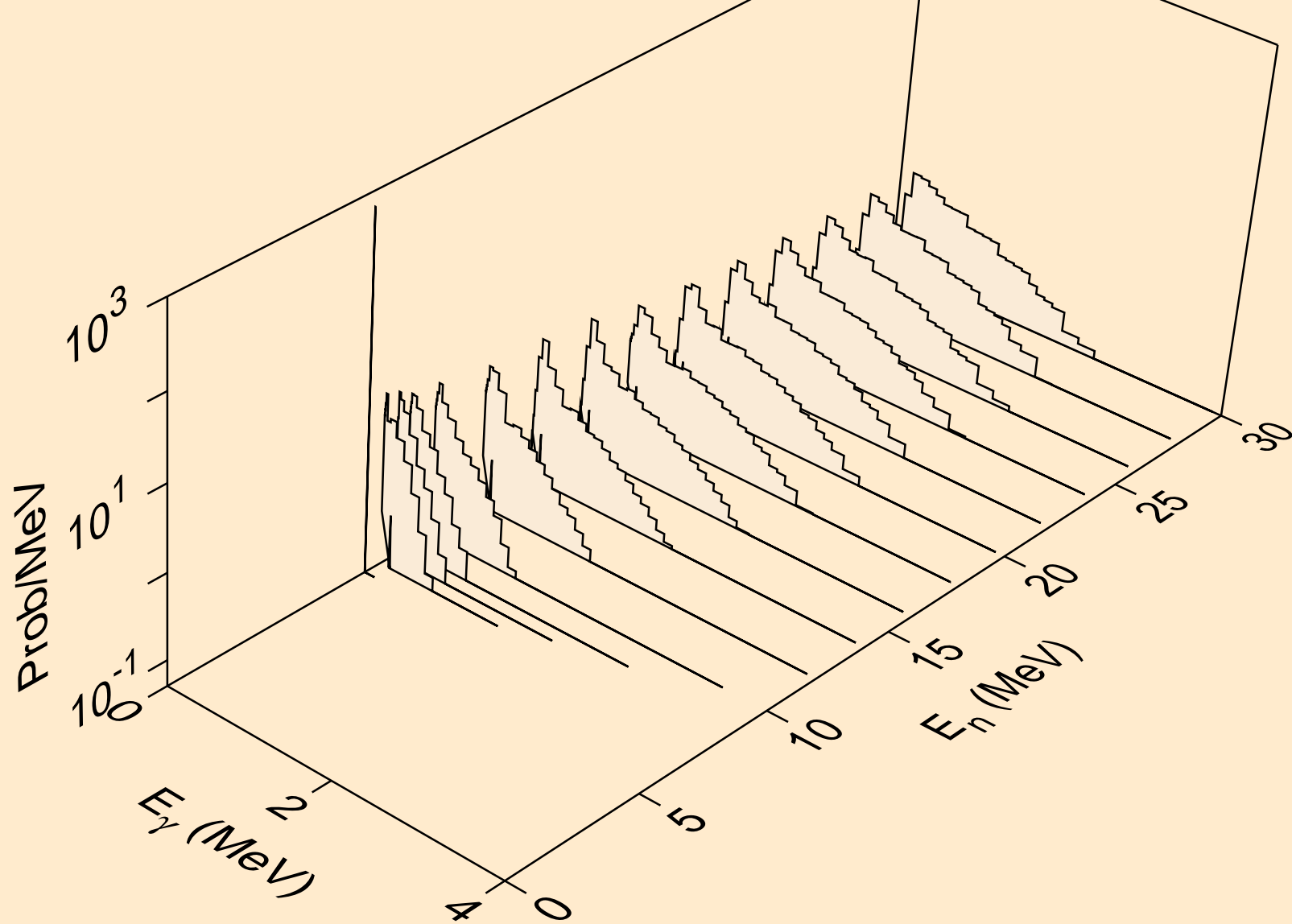

RA232 NEUTRON ACER TENDL-2021 LIBRARY; T=293.6K
Photon emission for (n,d)

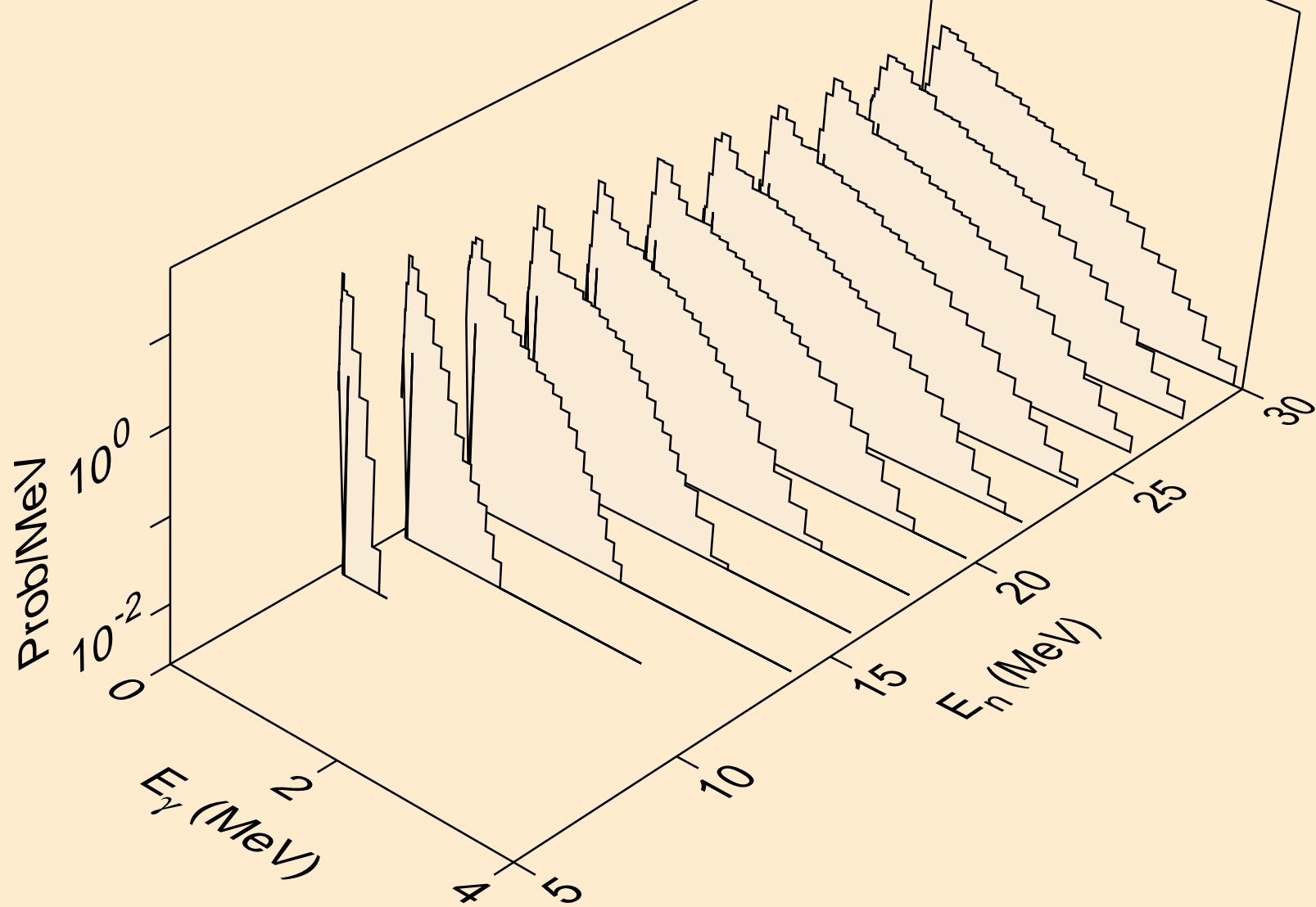

RA232 NEUTRON ACER TENDL-2021 LIBRARY; T=293.6K
Photon emission for (n,t)

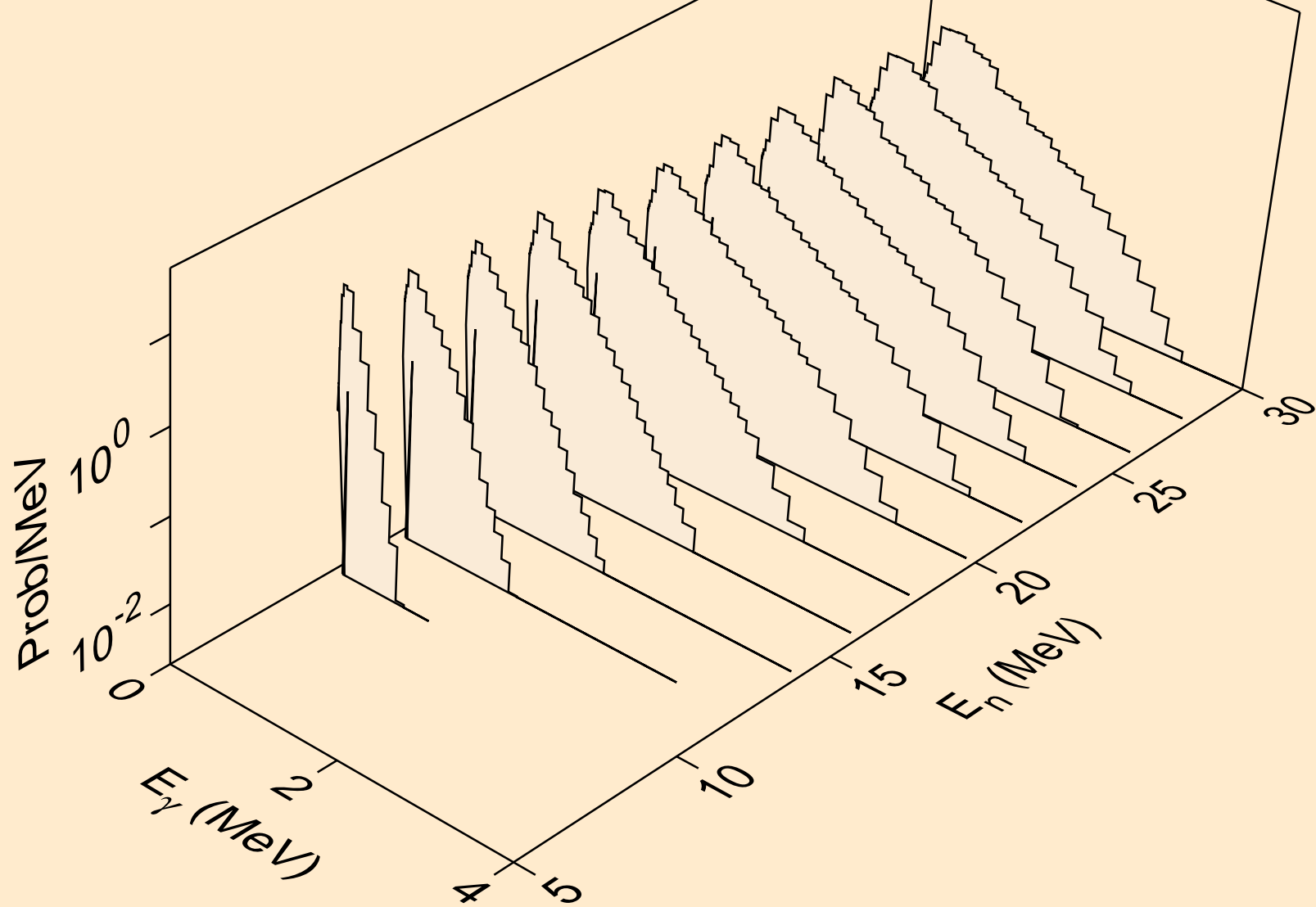

RA232 NEUTRON ACER TENDL-2021 LIBRARY; T=293.6K
Photon emission for (n,he3)

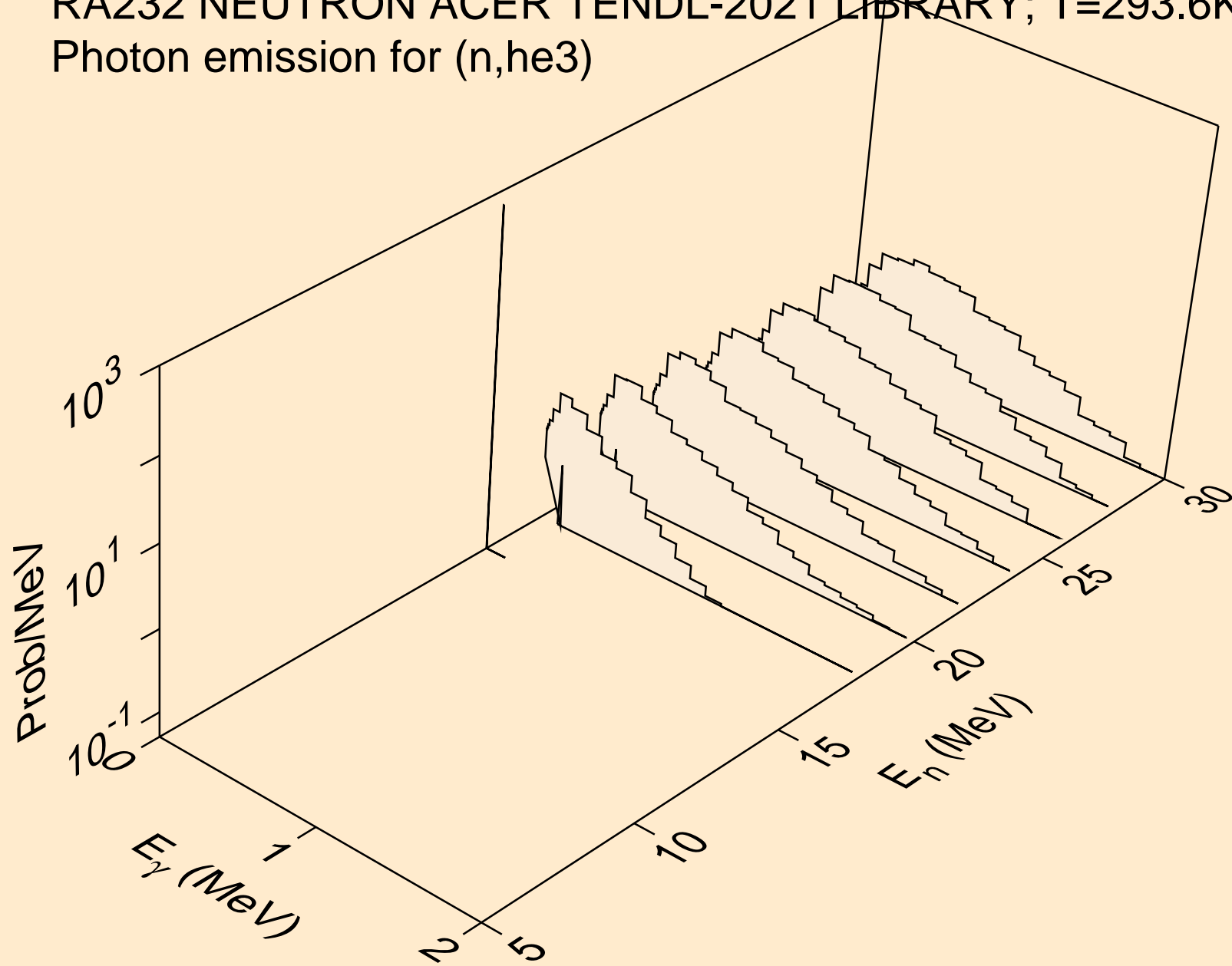

RA232 NEUTRON ACER TENDL-2021 LIBRARY; T=293.6K
Photon emission for (n,a)

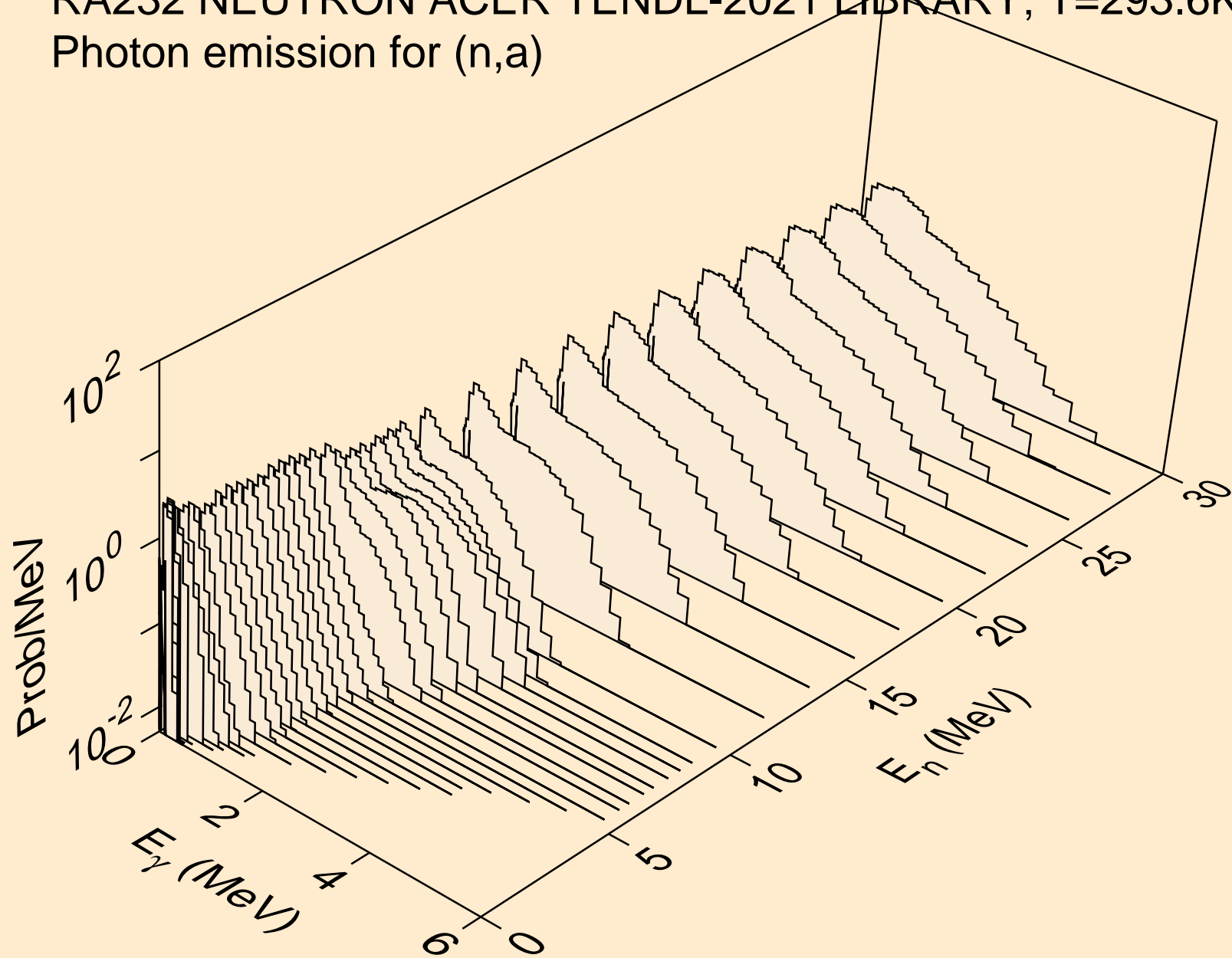

RA232 NEUTRON ACER TENDL-2021 LIBRARY; T=293.6K
Photon emission for (n,2a)

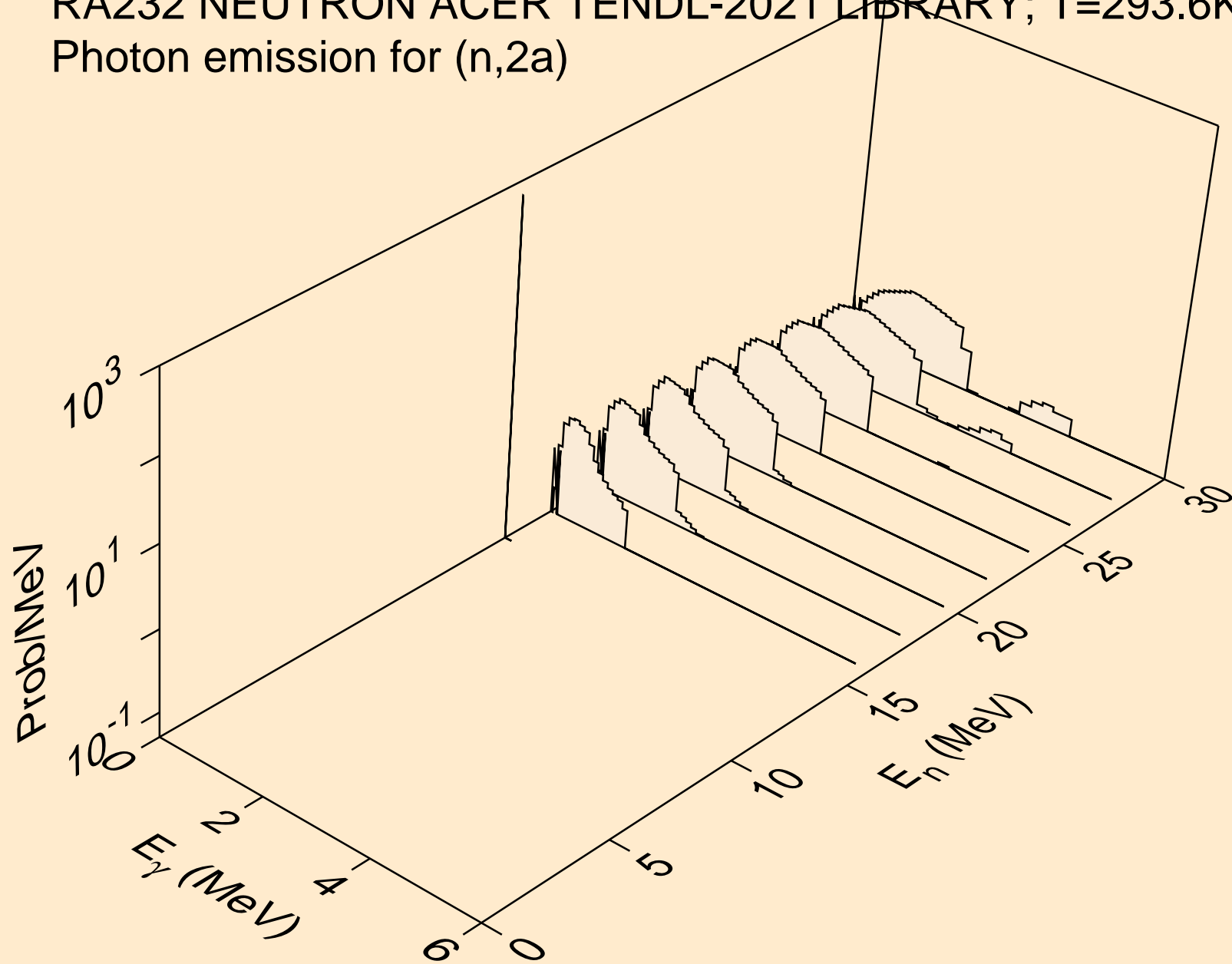

RA232 NEUTRON ACER TENDL-2021 LIBRARY; T=293.6K
Photon emission for (n,2p)

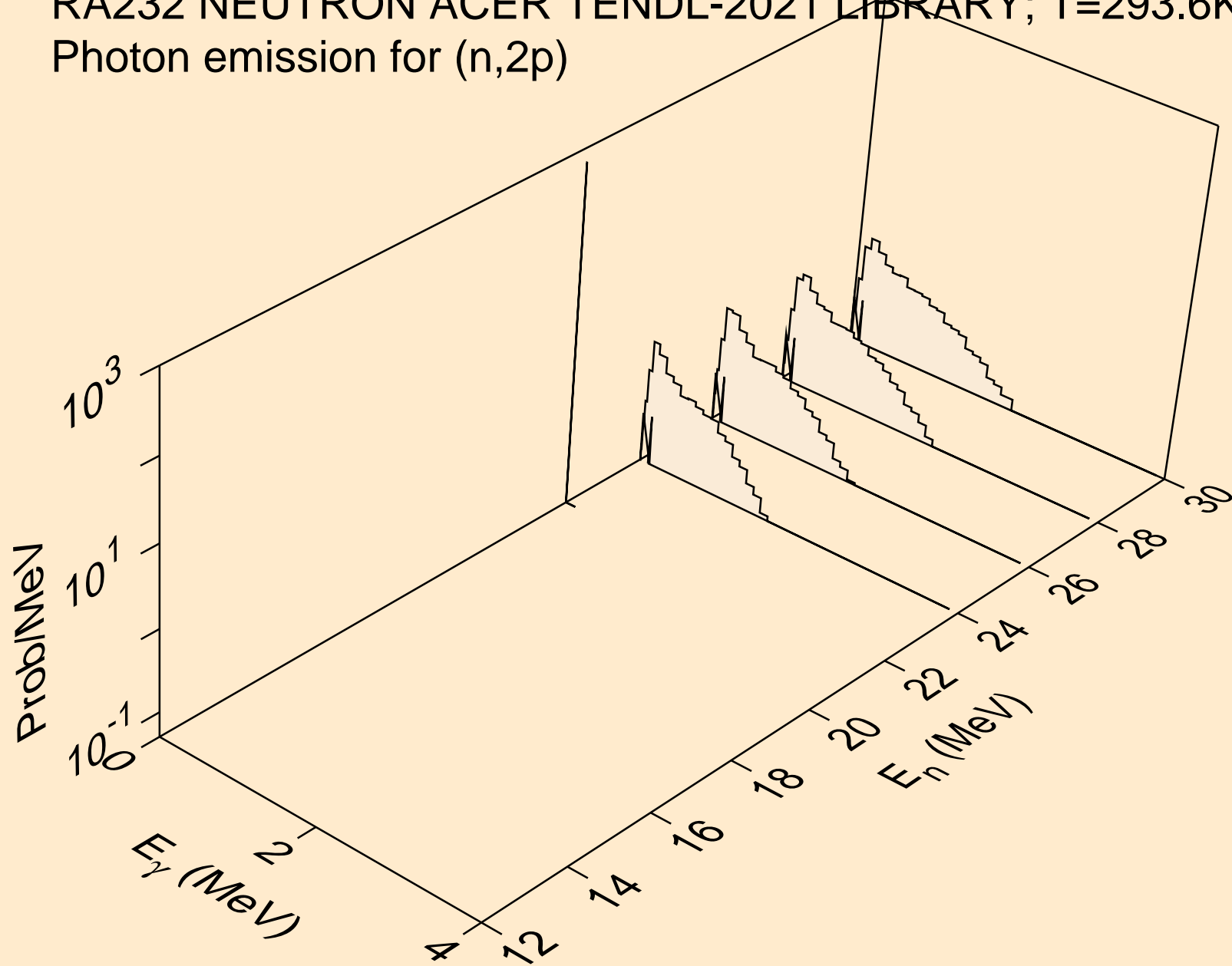

RA232 NEUTRON ACER TENDL-2021 LIBRARY; T=293.6K
Photon emission for (n,p α)

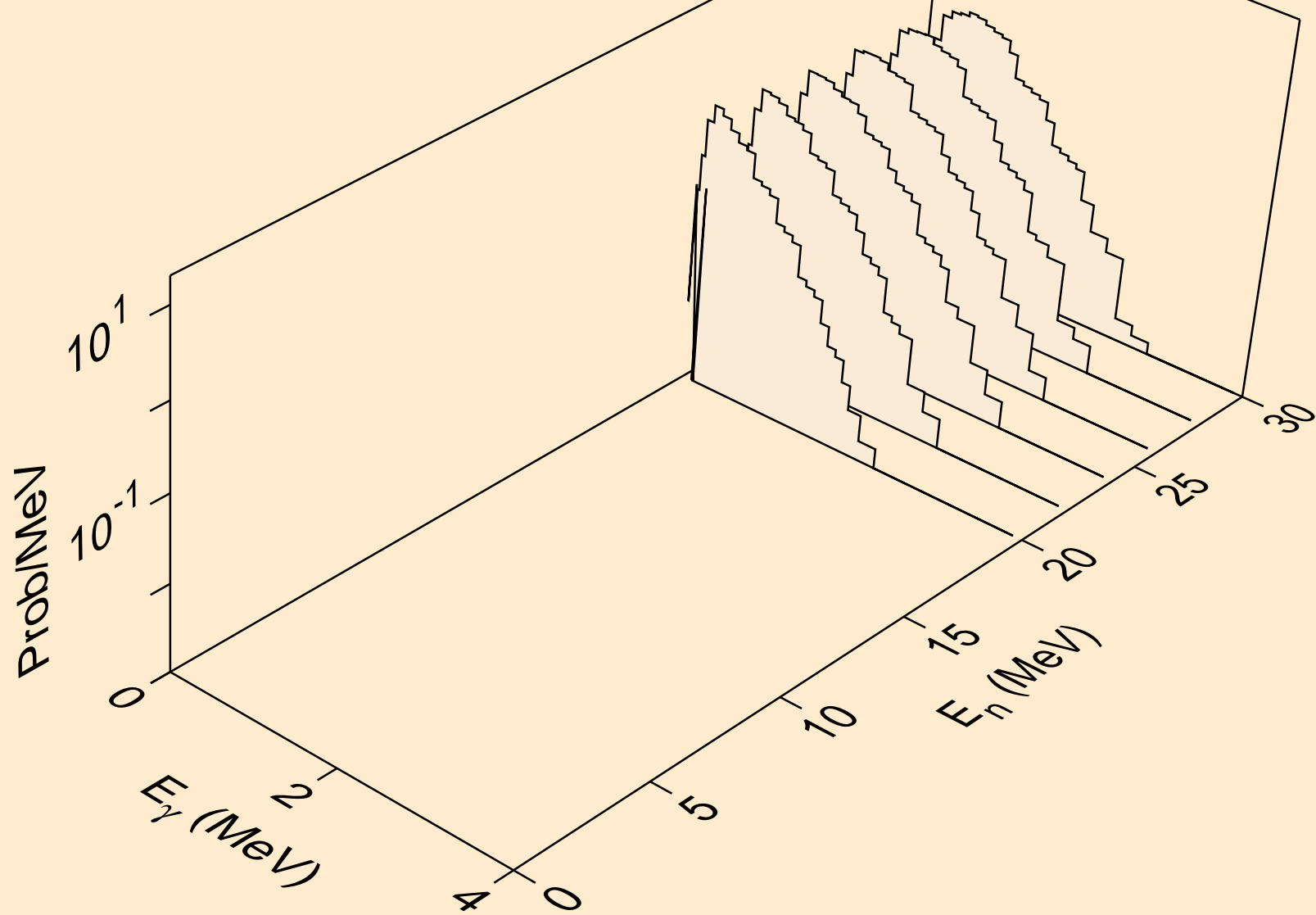

RA232 NEUTRON ACER TENDL-2021 LIBRARY; T=293.6K
Photon emission for (n,da)

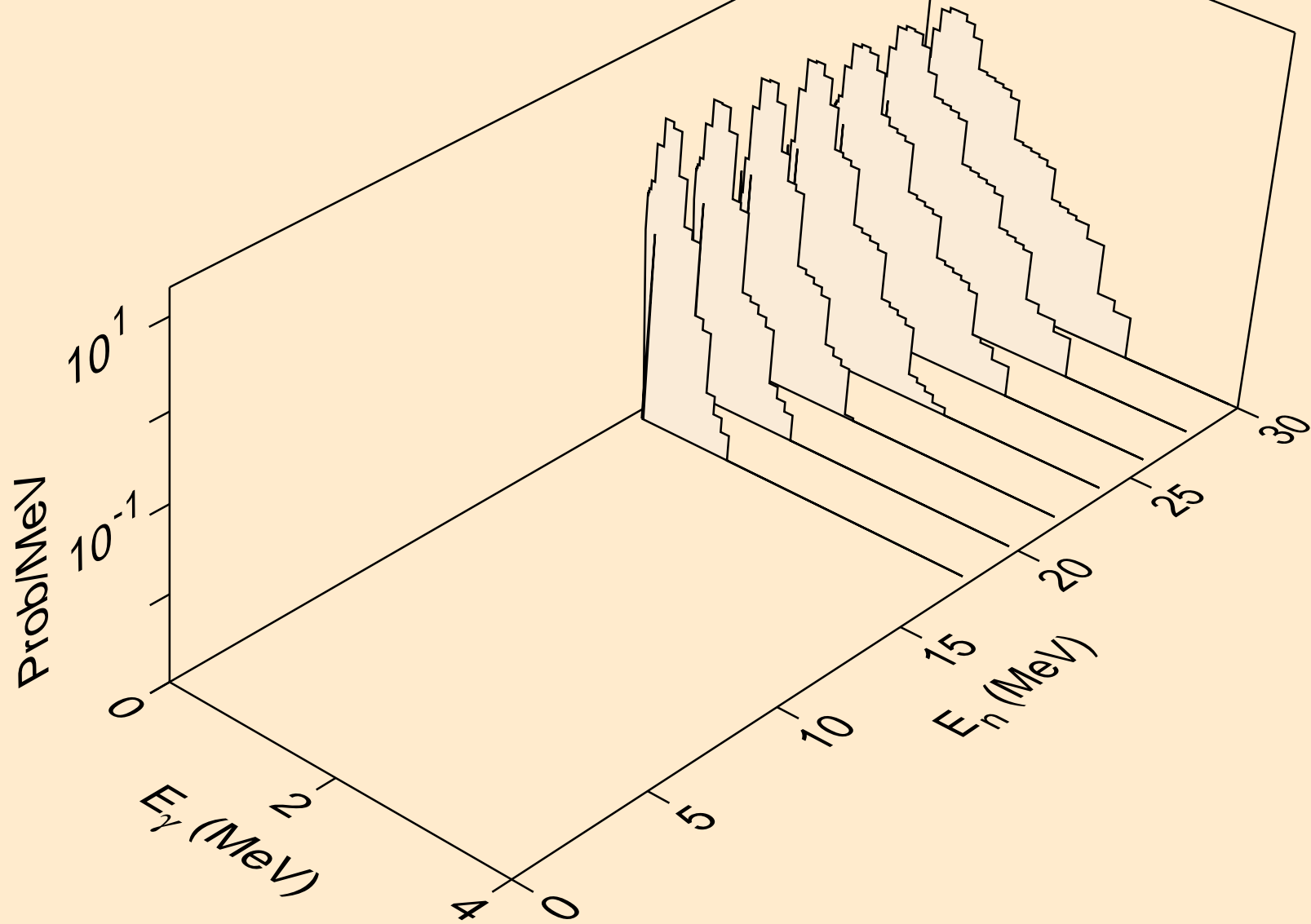

RA232 NEUTRON ACER TENDL-2021 LIBRARY; T=293.6K
thermal capture photon spectrum

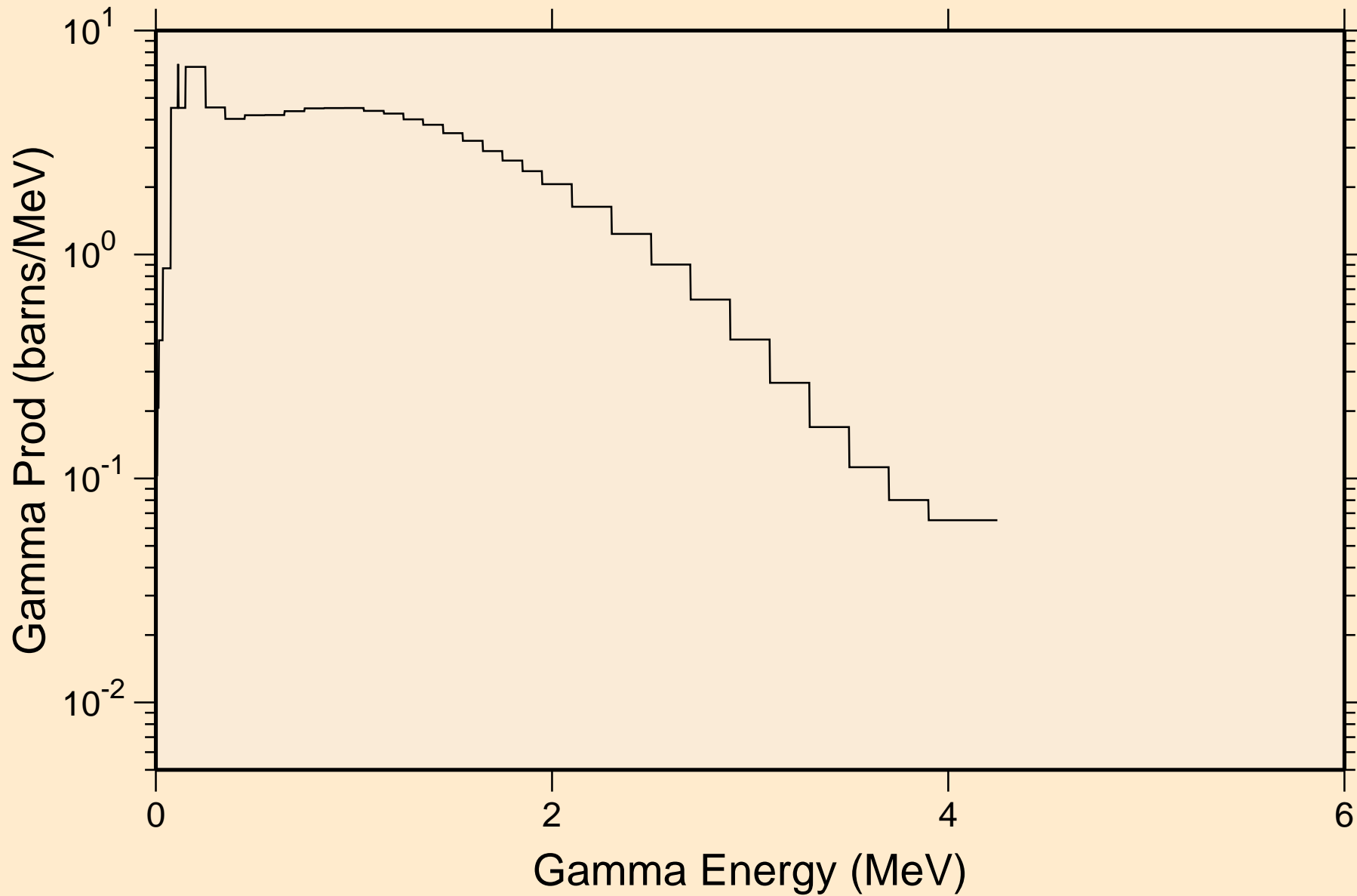

RA232 NEUTRON ACER TENDL-2021 LIBRARY; T=293.6K
14 MeV photon spectrum

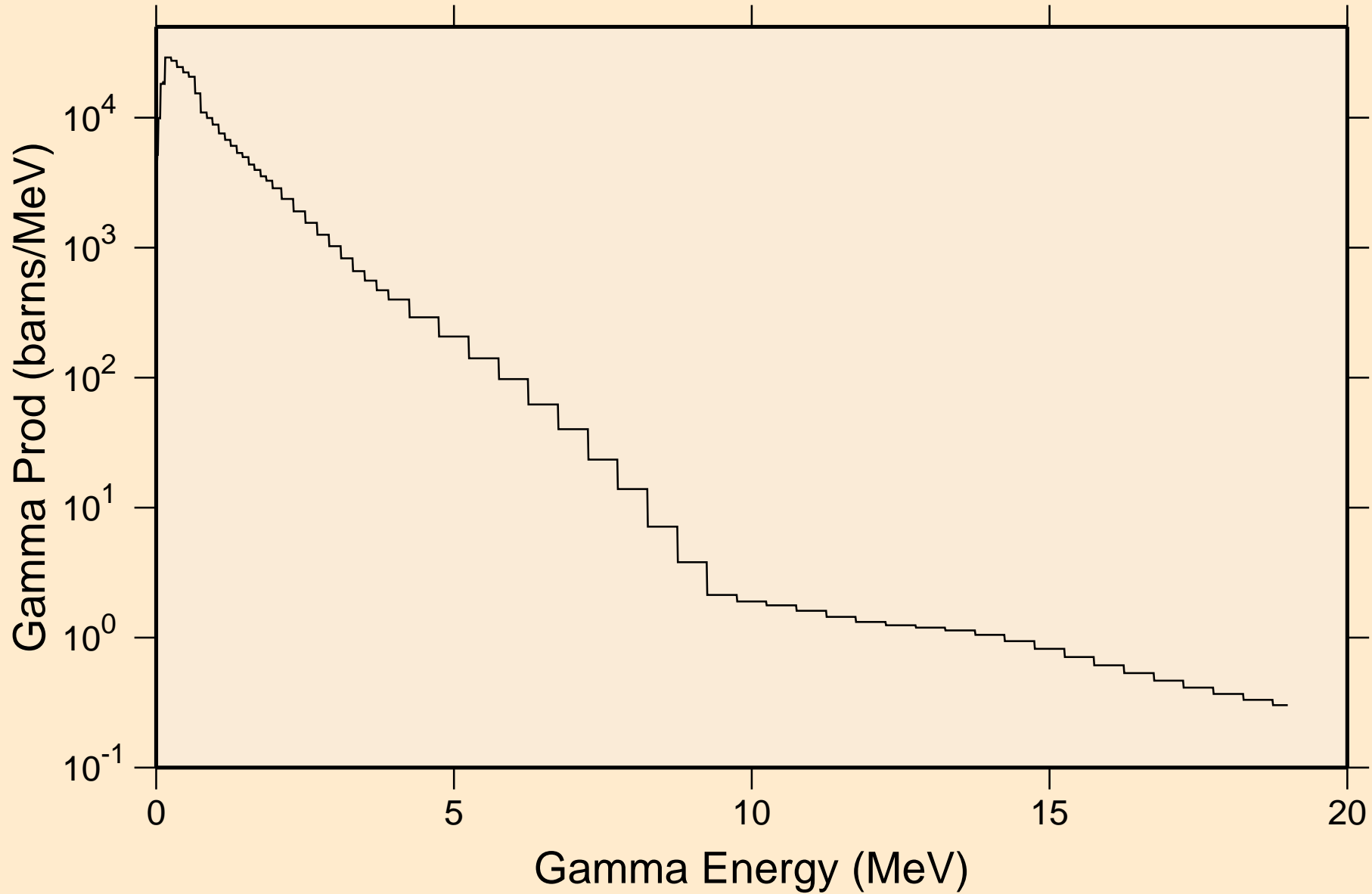

RA232 NEUTRON ACER TENDL-2021 LIBRARY; T=293.6K
Particle heating contributions

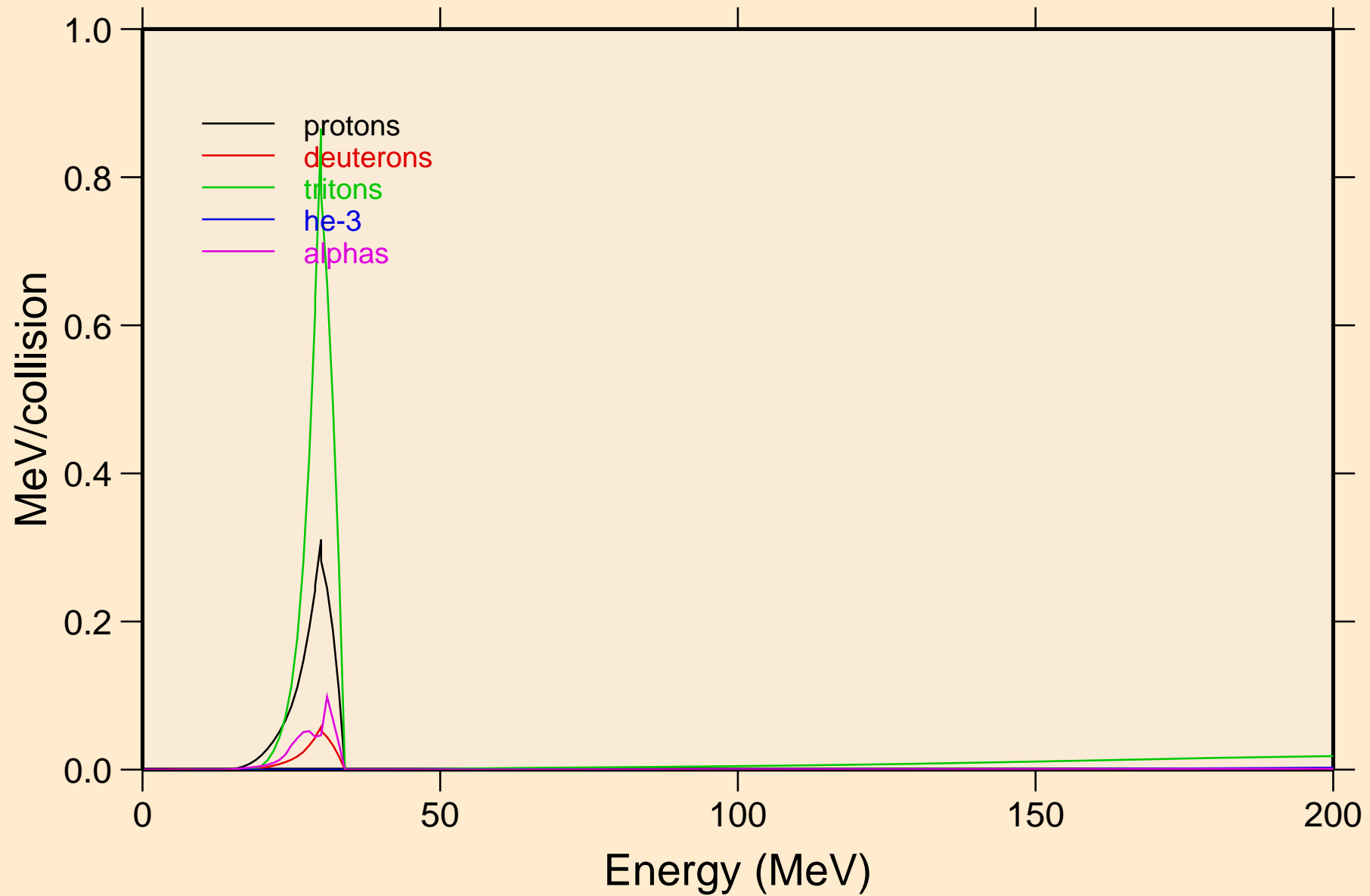

RA232 NEUTRON ACER TENDL-2021 LIBRARY; T=293.6K
Recoil Heating

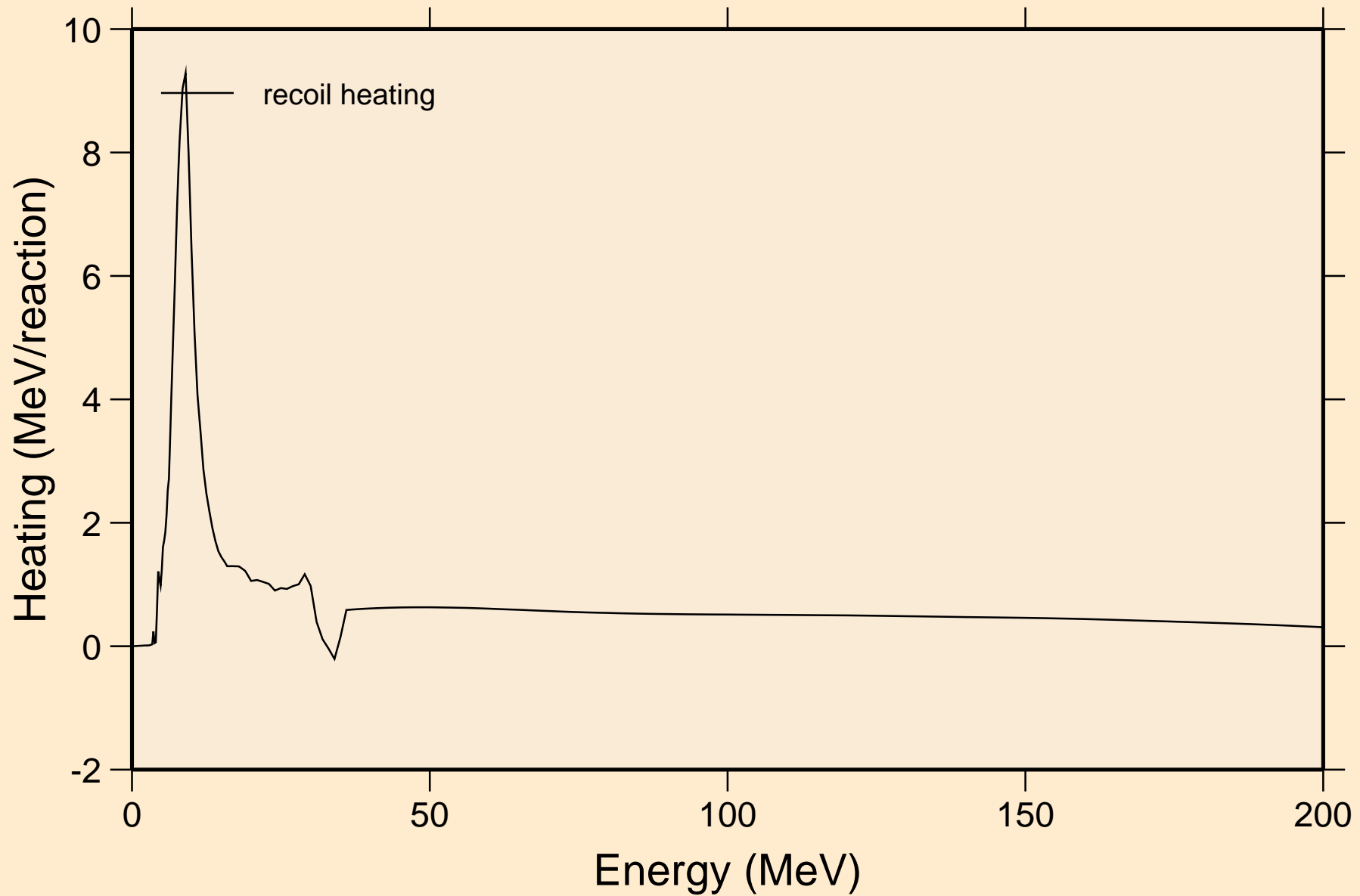

RA232 NEUTRON ACER TENDL-2021 LIBRARY; T=293.6K
Particle production cross sections

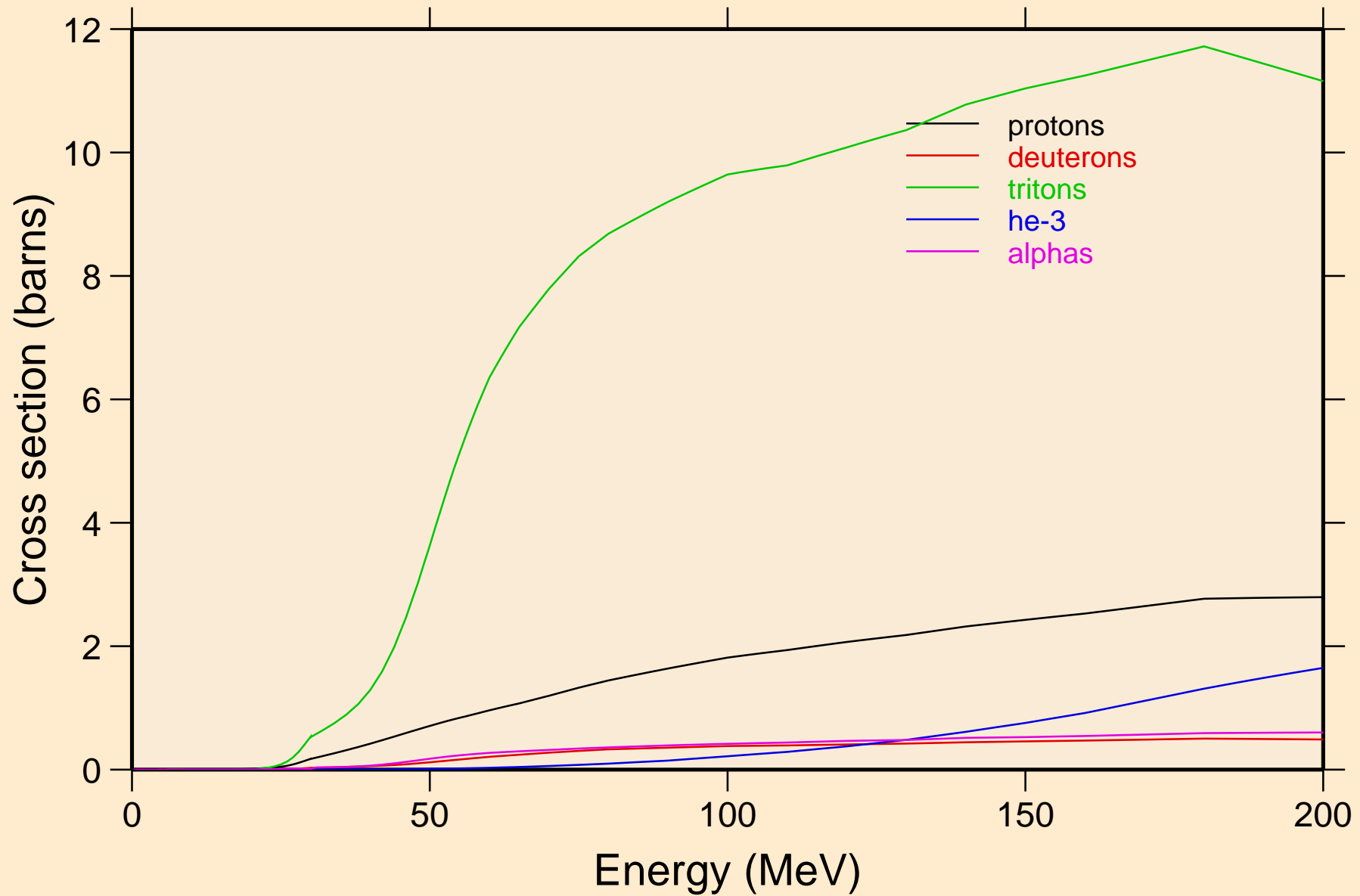

RA232 NEUTRON ACER TENDL-2021 LIBRARY; T=293.6K
protons from (n,x)

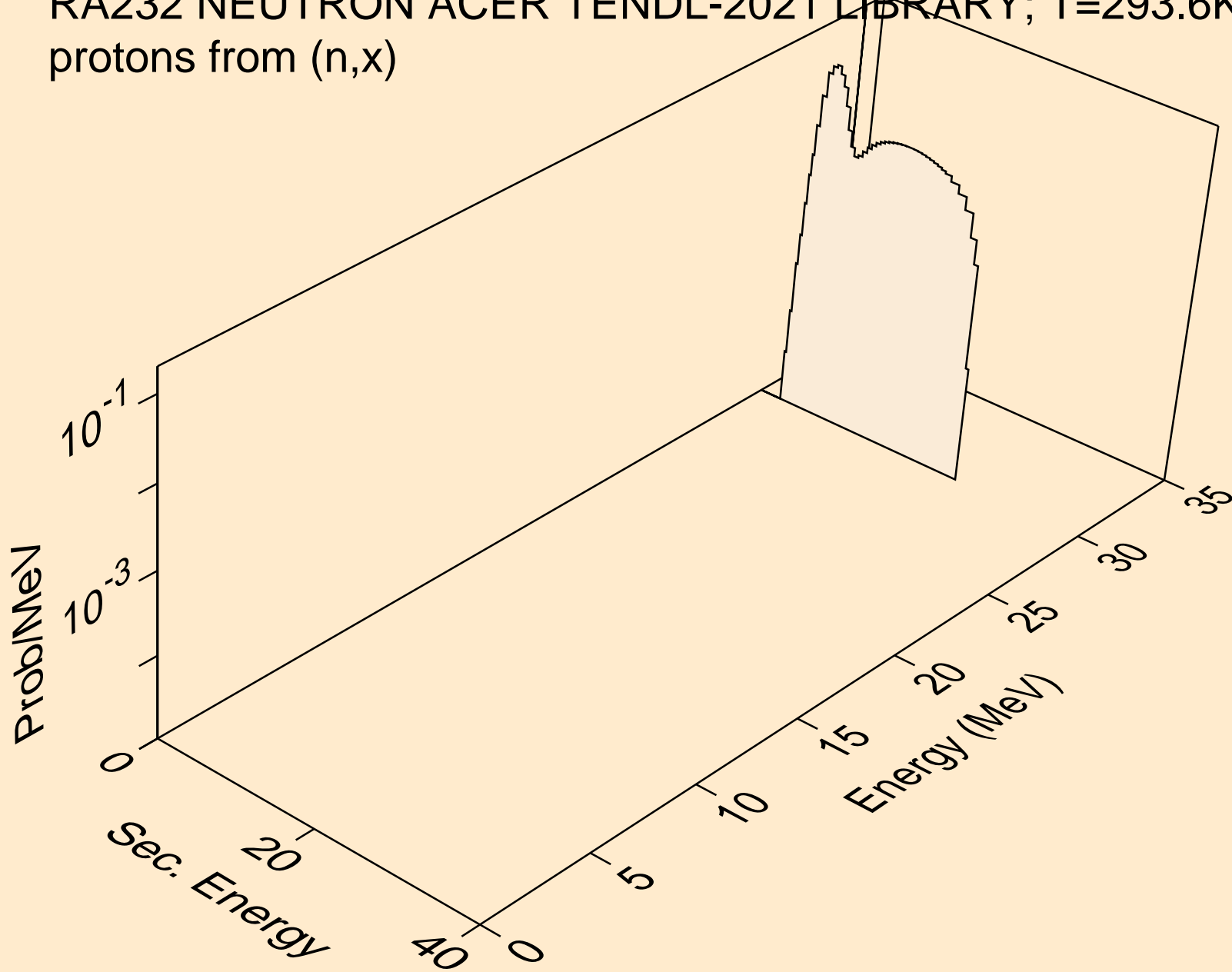

RA232 NEUTRON ACER TENDL-2021 LIBRARY; T=293.6K
protons from (n,n*)p

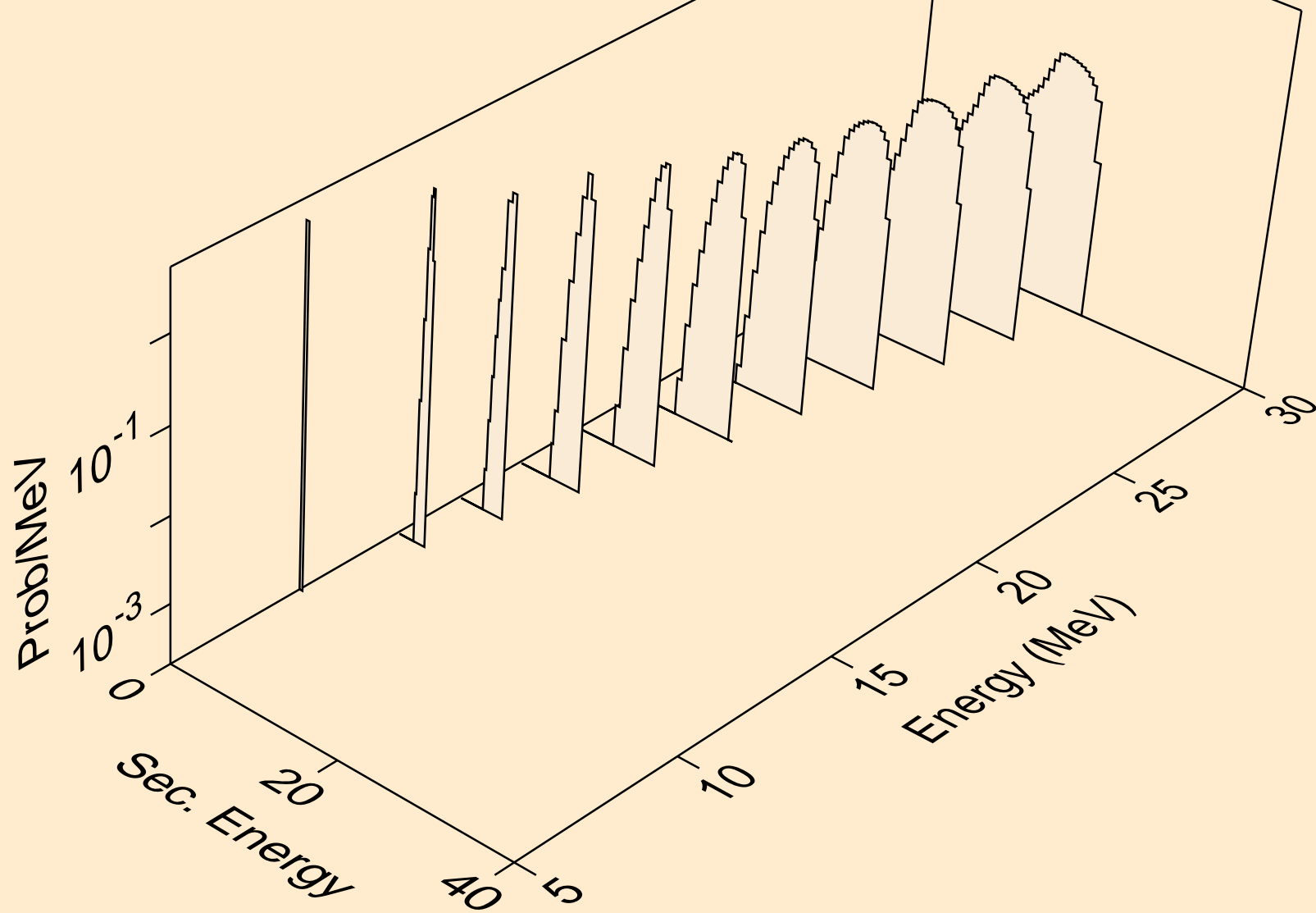

RA232 NEUTRON ACER TENDL-2021 LIBRARY; T=293.6K
protons from (n,2np)

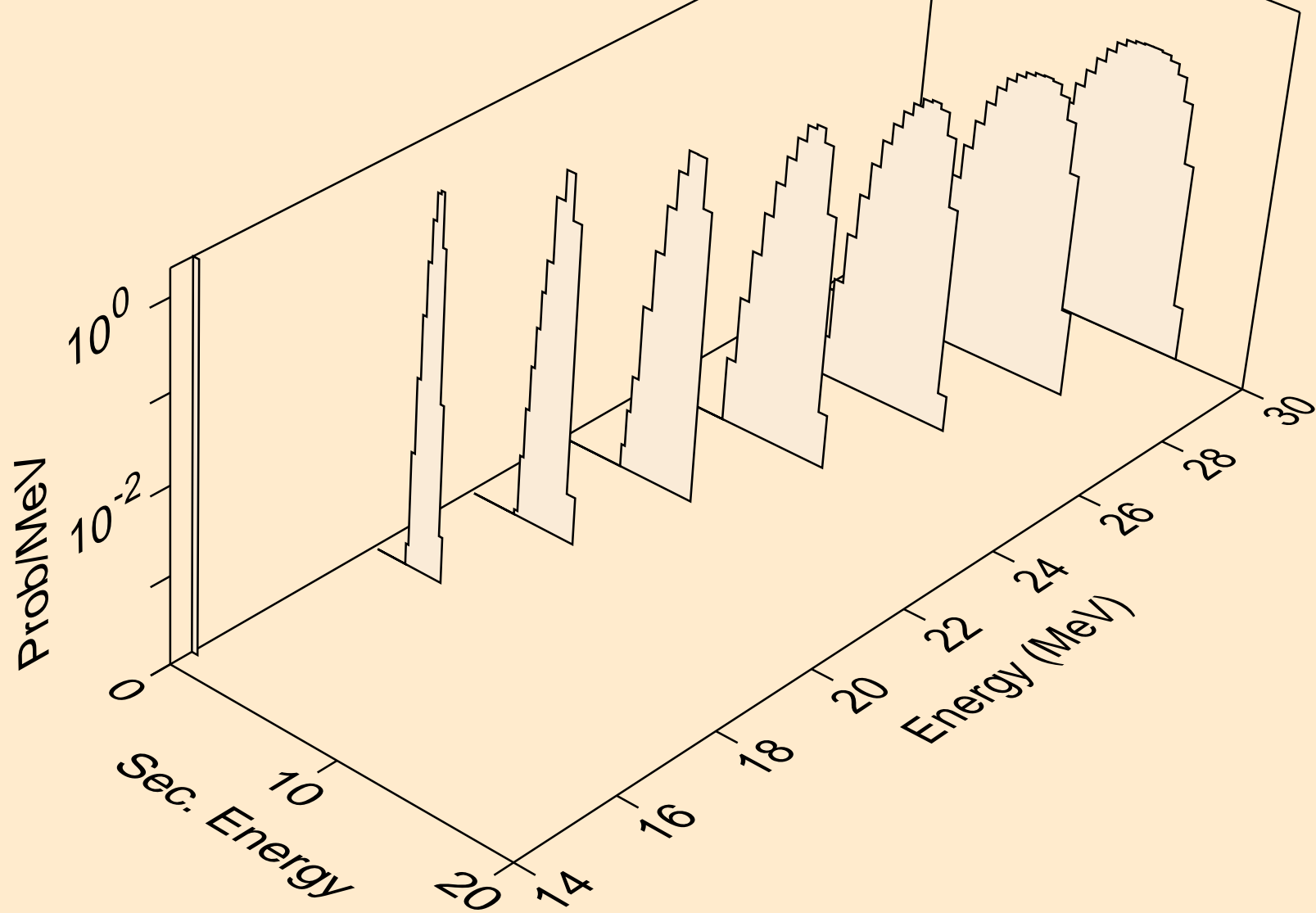

RA232 NEUTRON ACER TENDL-2021 LIBRARY; T=293.6K
protons from (n,3np)

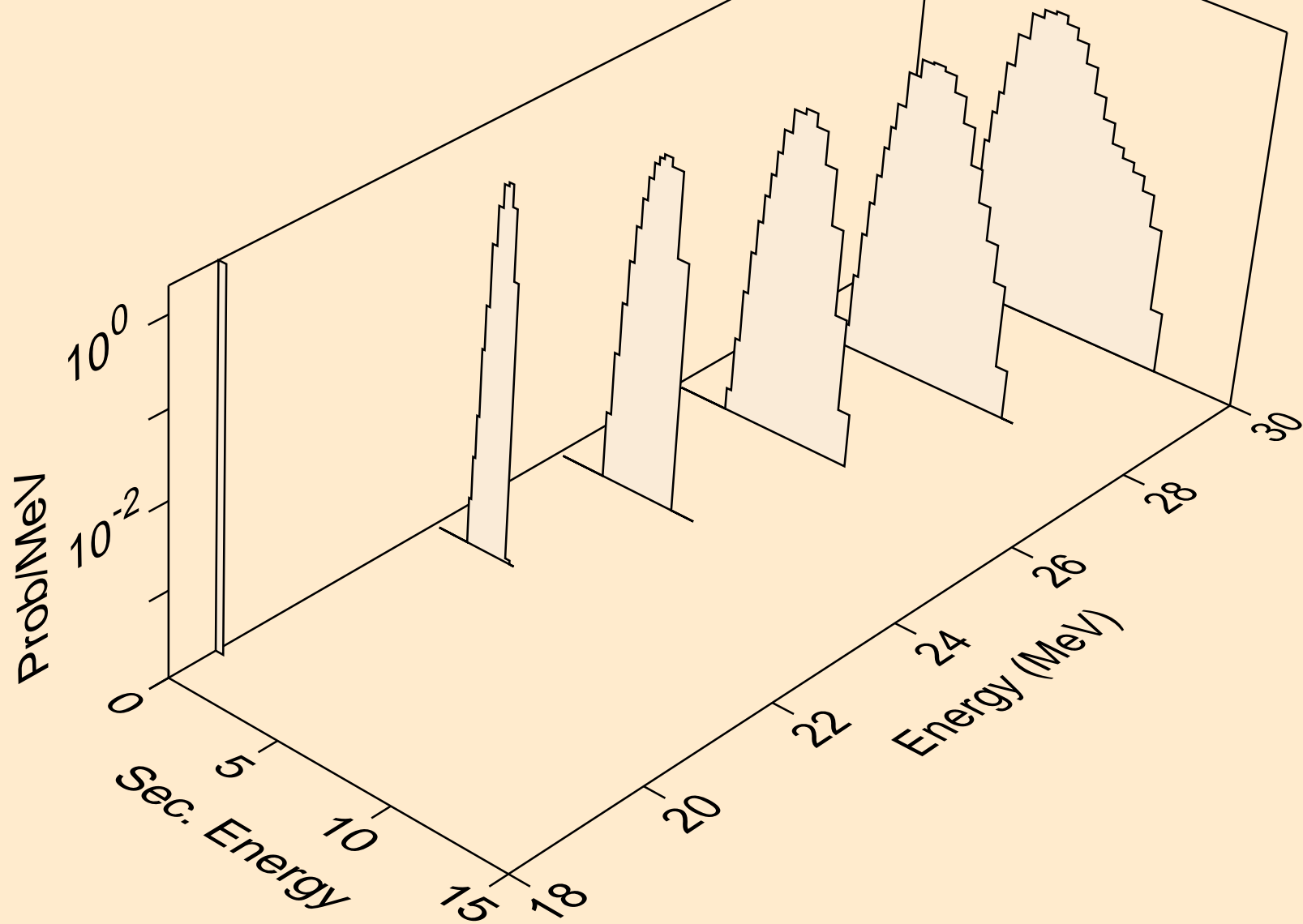

RA232 NEUTRON ACER TENDL-2021 LIBRARY; T=293.6K
protons from (n,npa)

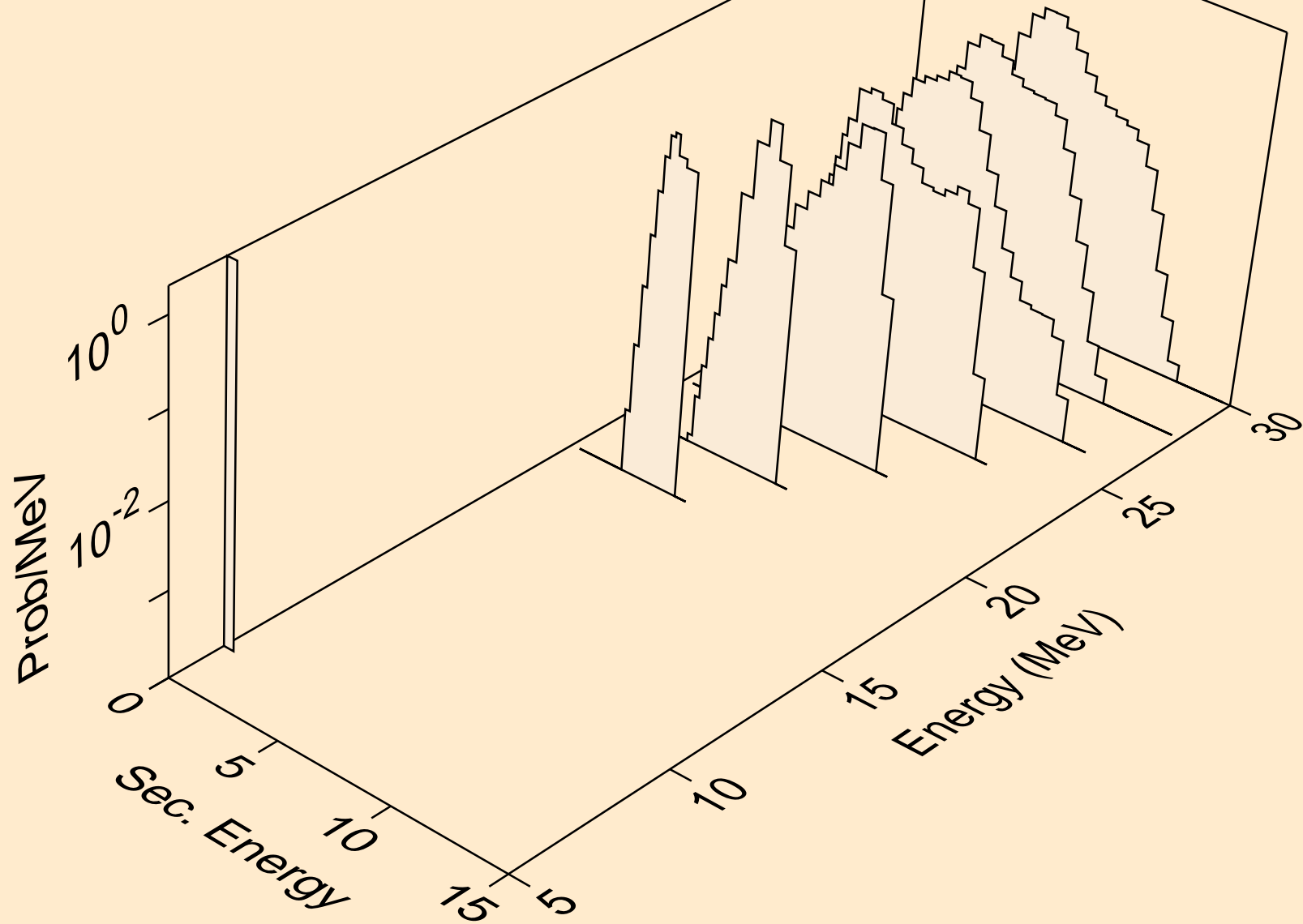

RA232 NEUTRON ACER TENDL-2021 LIBRARY; T=293.6K
protons from (n,p)

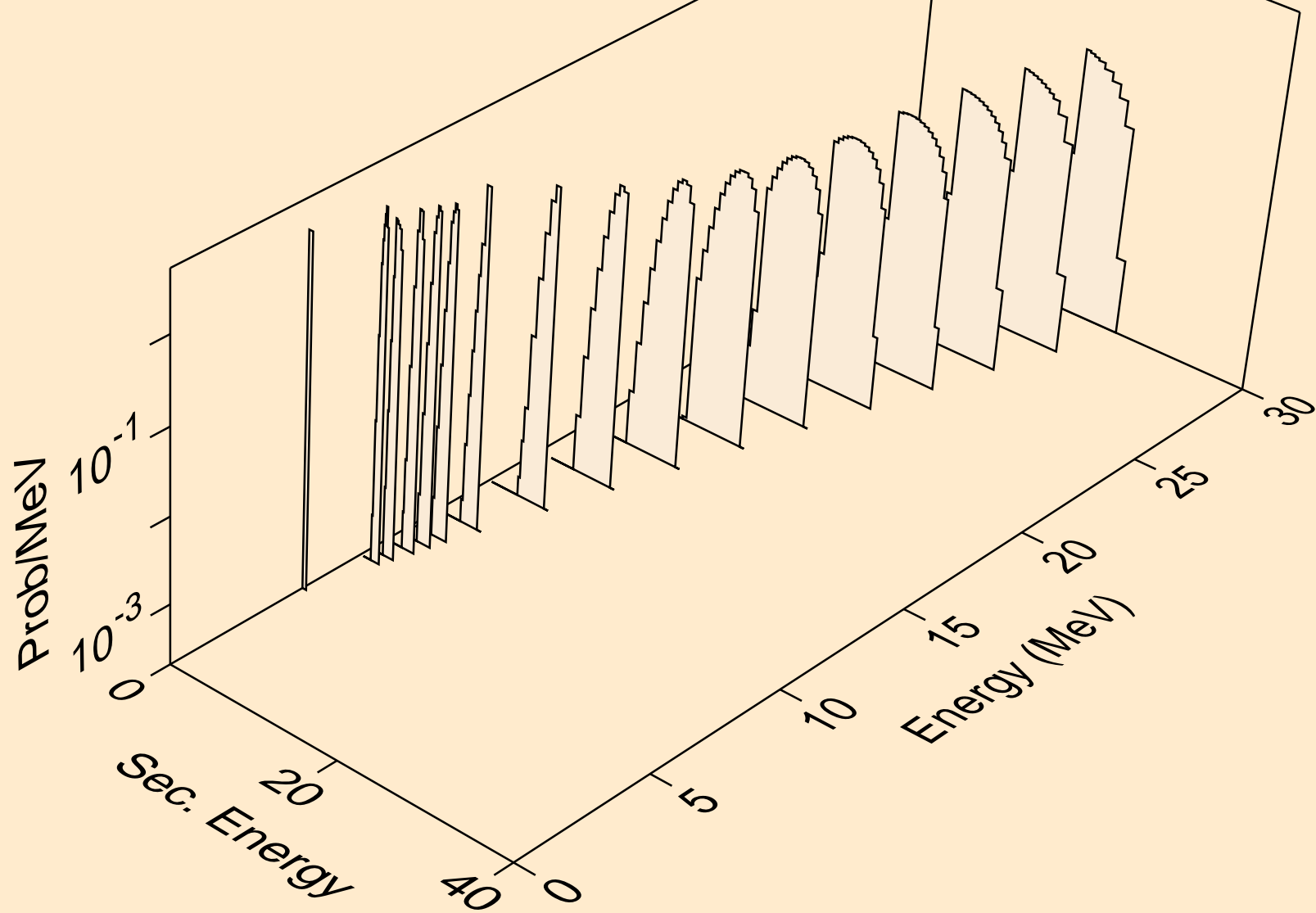

RA232 NEUTRON ACER TENDL-2021 LIBRARY; T=293.6K
protons from (n,2p)

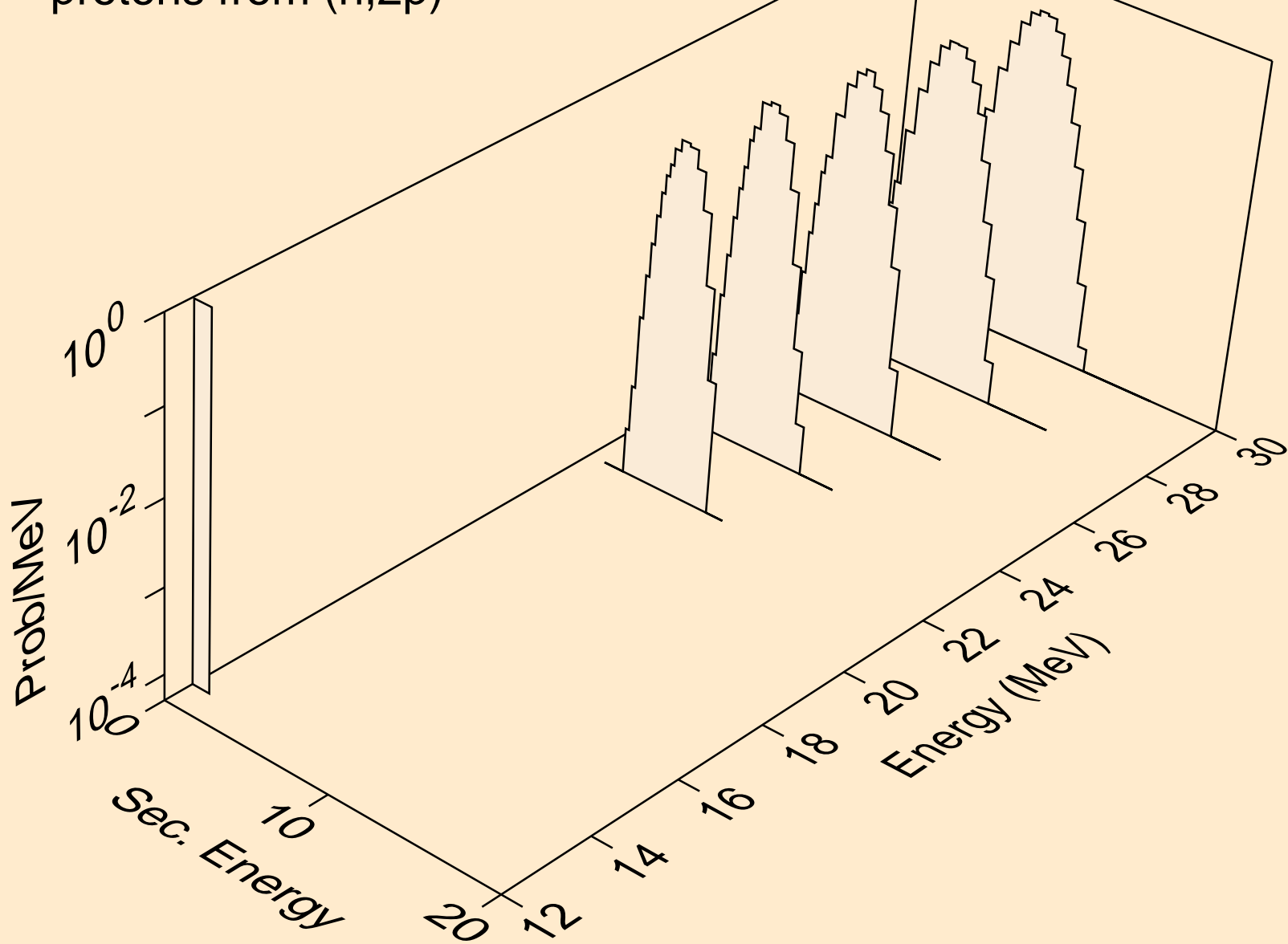

RA232 NEUTRON ACER TENDL-2021 LIBRARY; T=293.6K
protons from (n,pa)

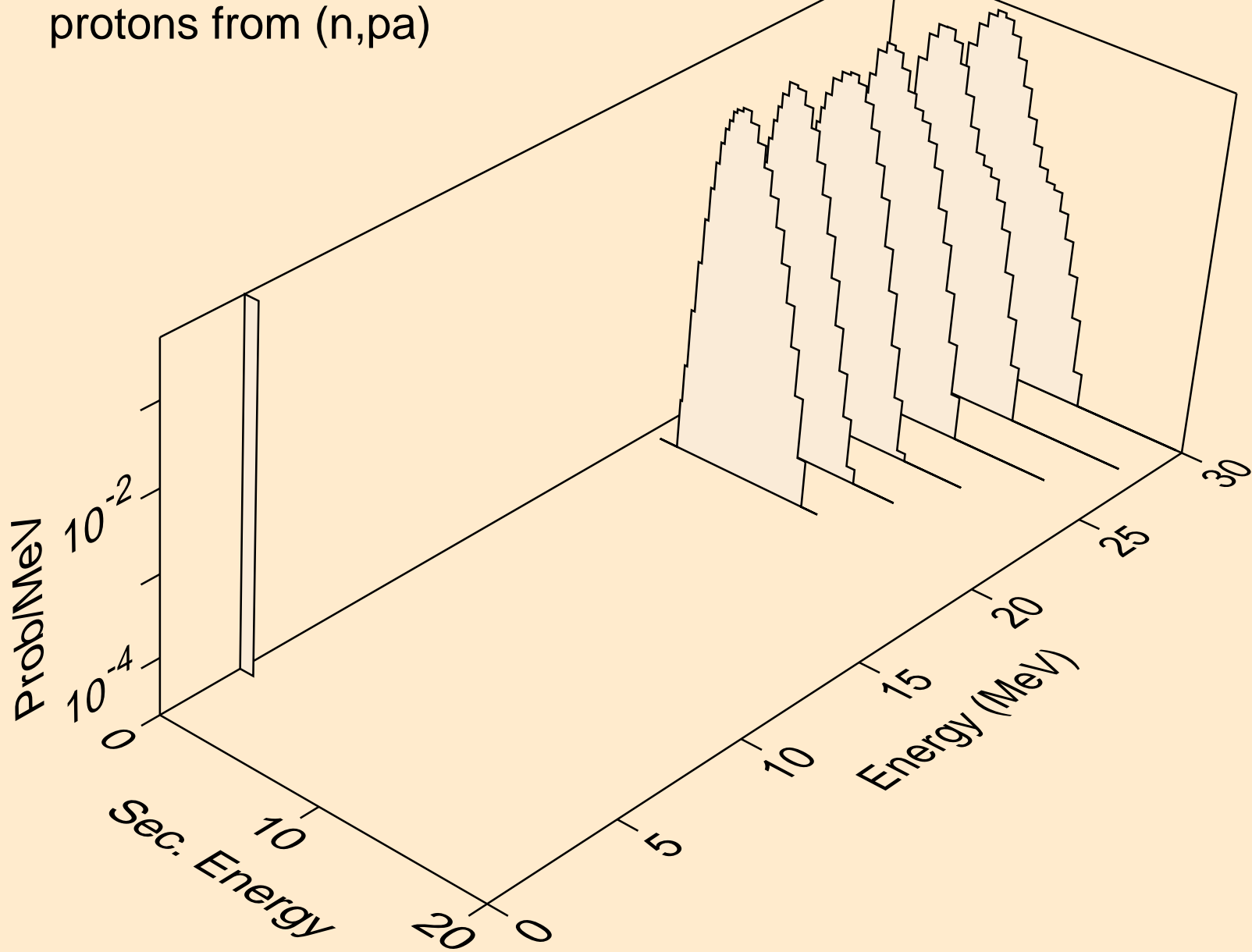

RA232 NEUTRON ACER TENDL-2021 LIBRARY; T=293.6K
deuterons from (n,x)

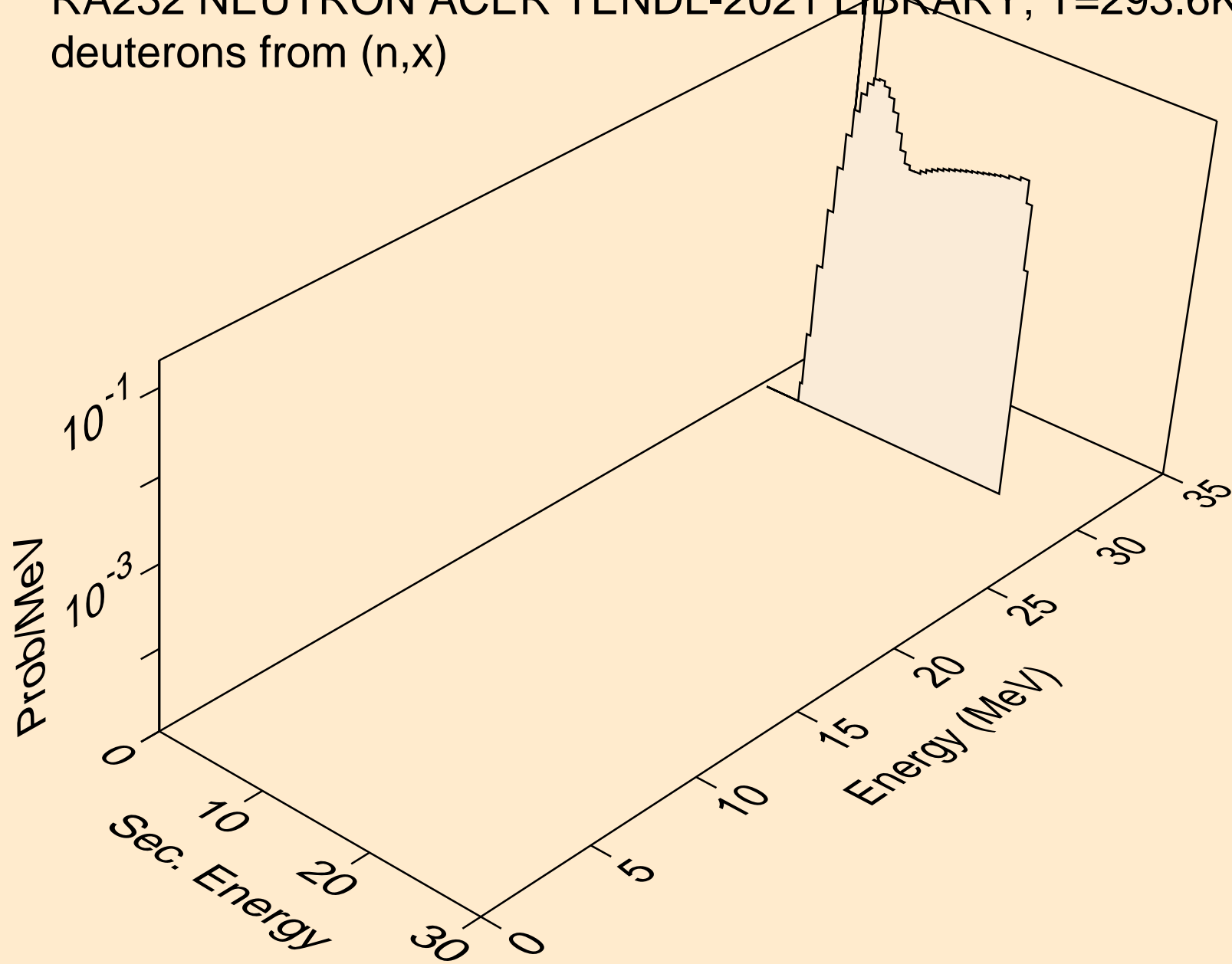

RA232 NEUTRON ACER TENDL-2021 LIBRARY; T=293.6K
deuterons from (n,2nd)

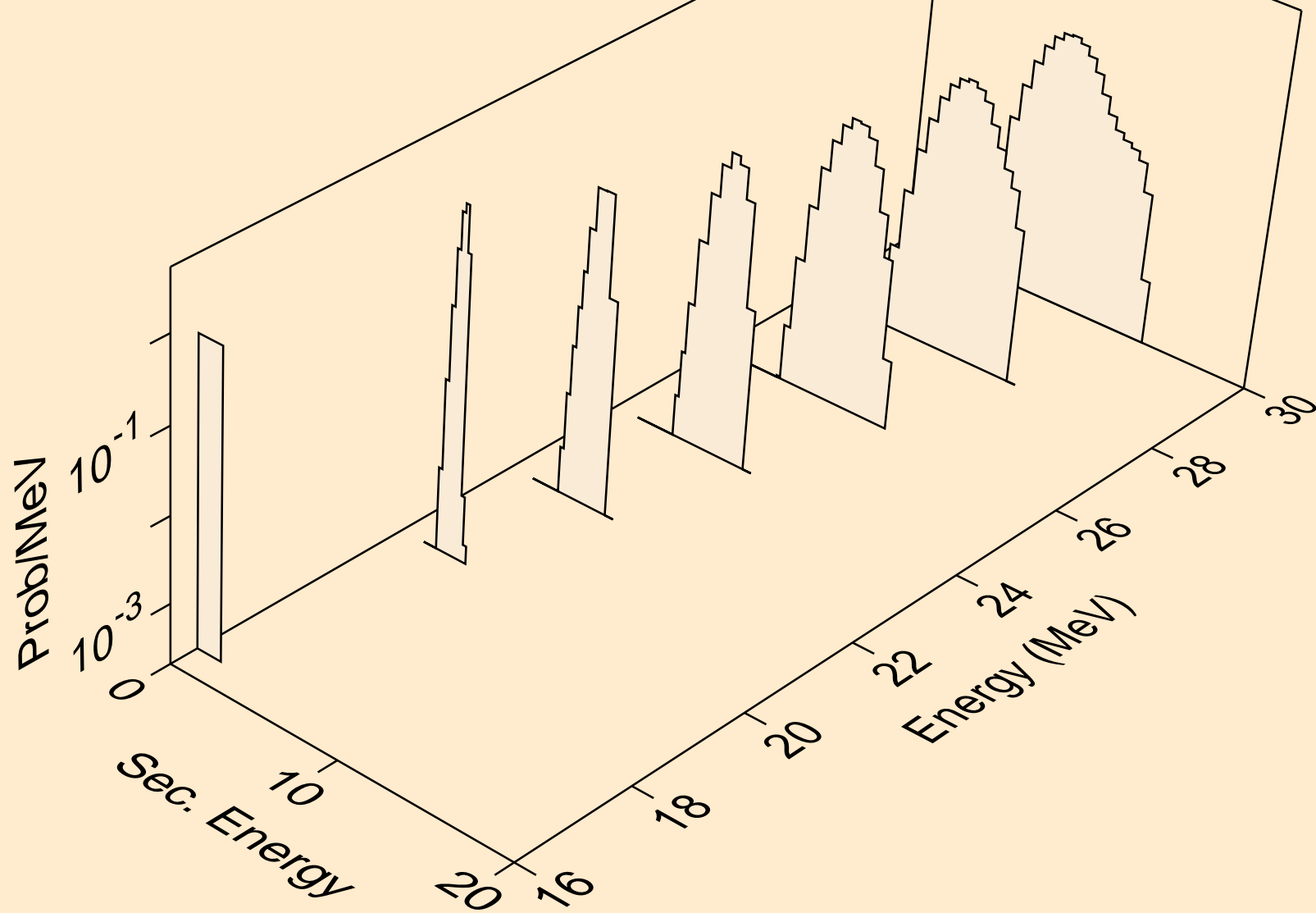

RA232 NEUTRON ACER TENDL-2021 LIBRARY; T=293.6K
deuterons from (n,n*)d

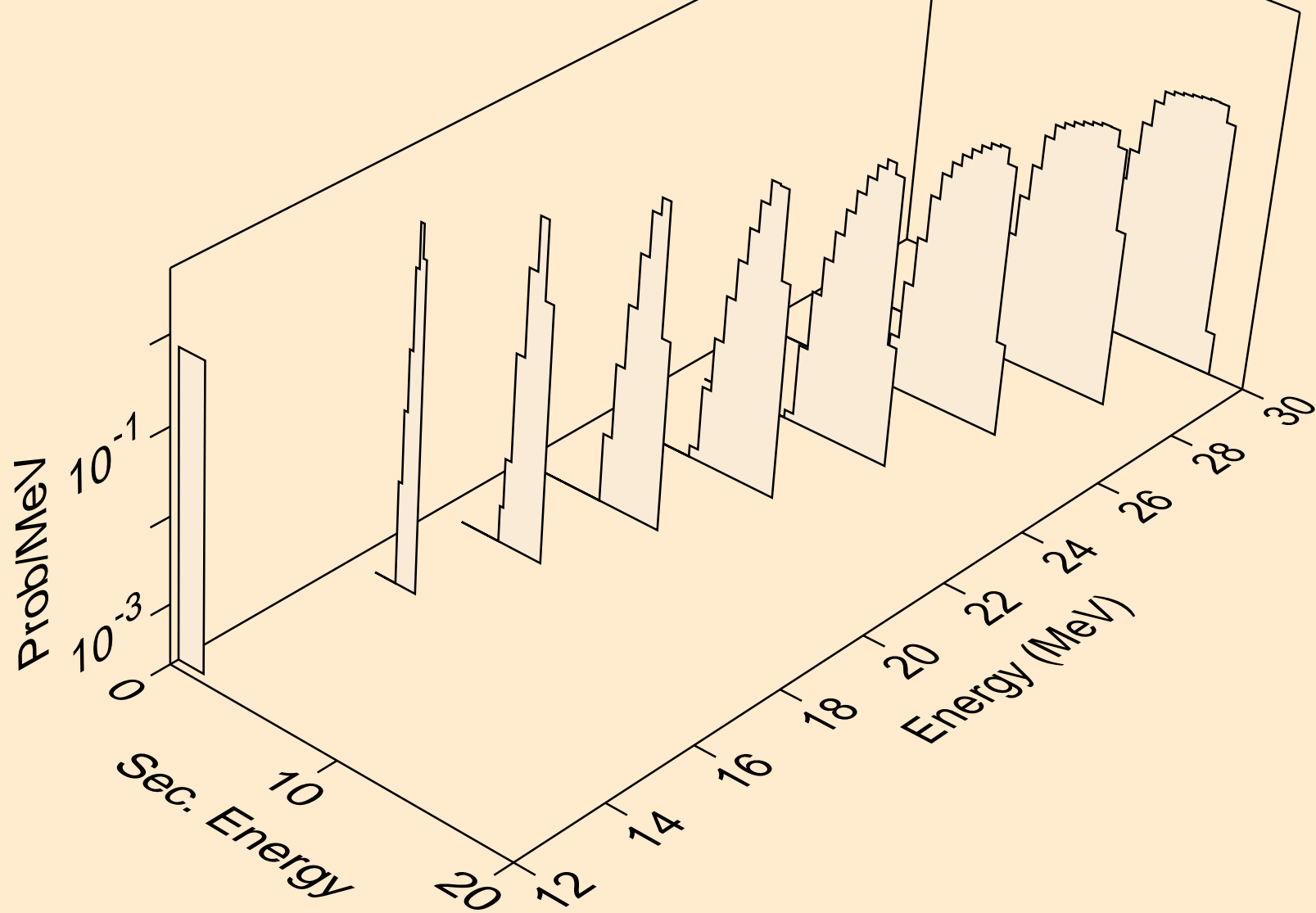

RA232 NEUTRON ACER TENDL-2021 LIBRARY; T=293.6K
deuterons from (n,d)

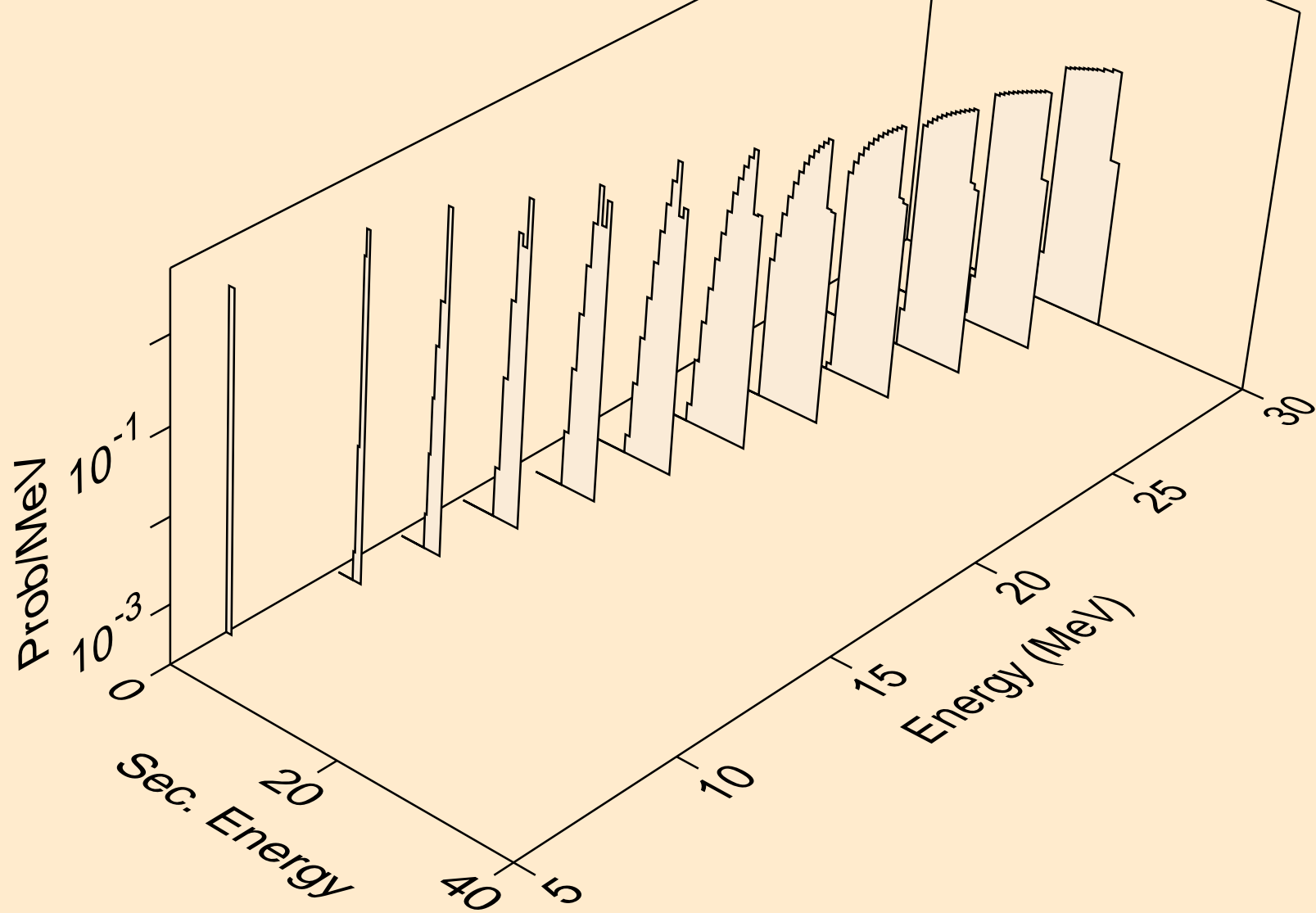

RA232 NEUTRON ACER TENDL-2021 LIBRARY; T=293.6K
deuterons from (n,da)

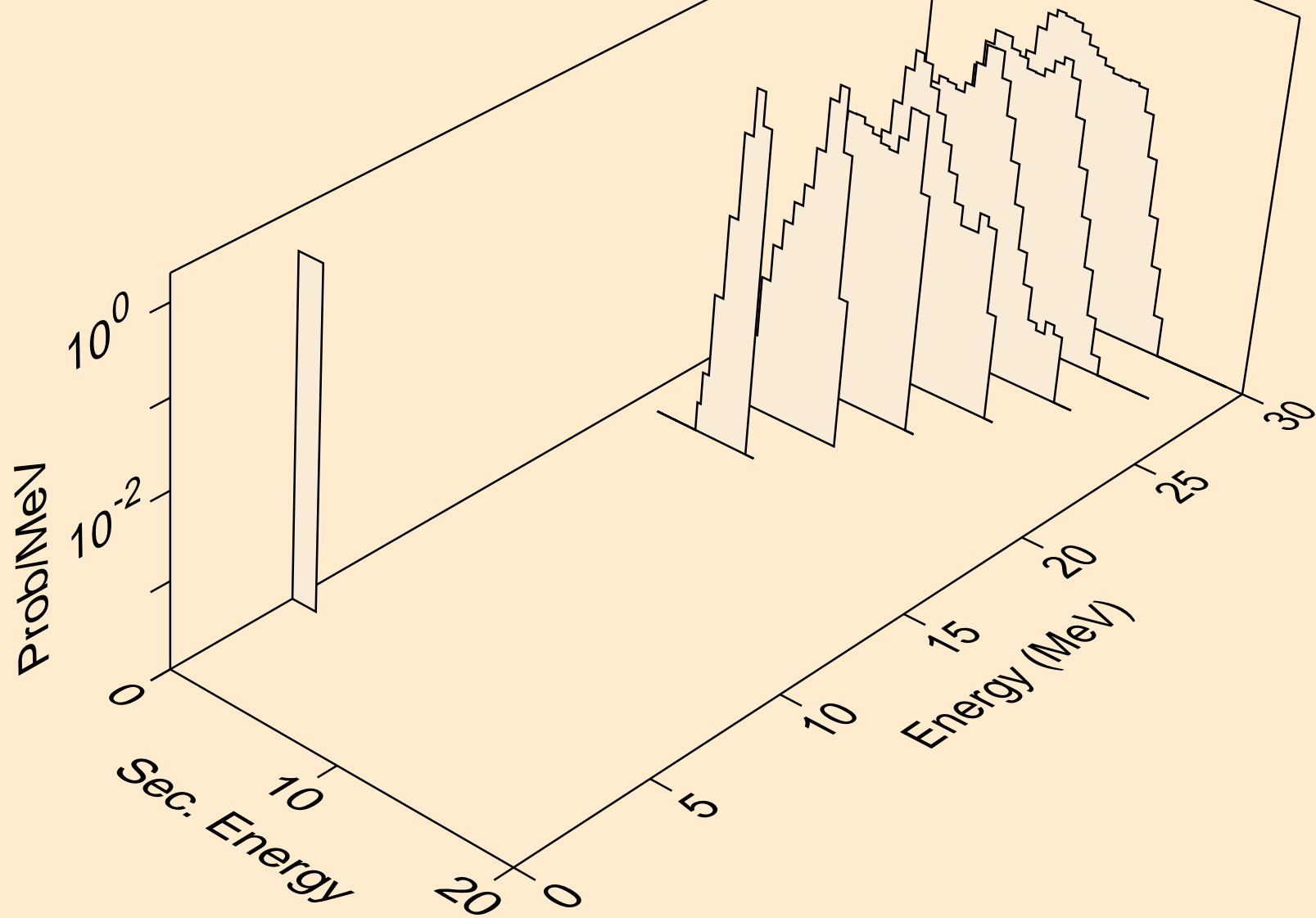

RA232 NEUTRON ACER TENDL-2021 LIBRARY; T=293.6K
tritons from (n,x)

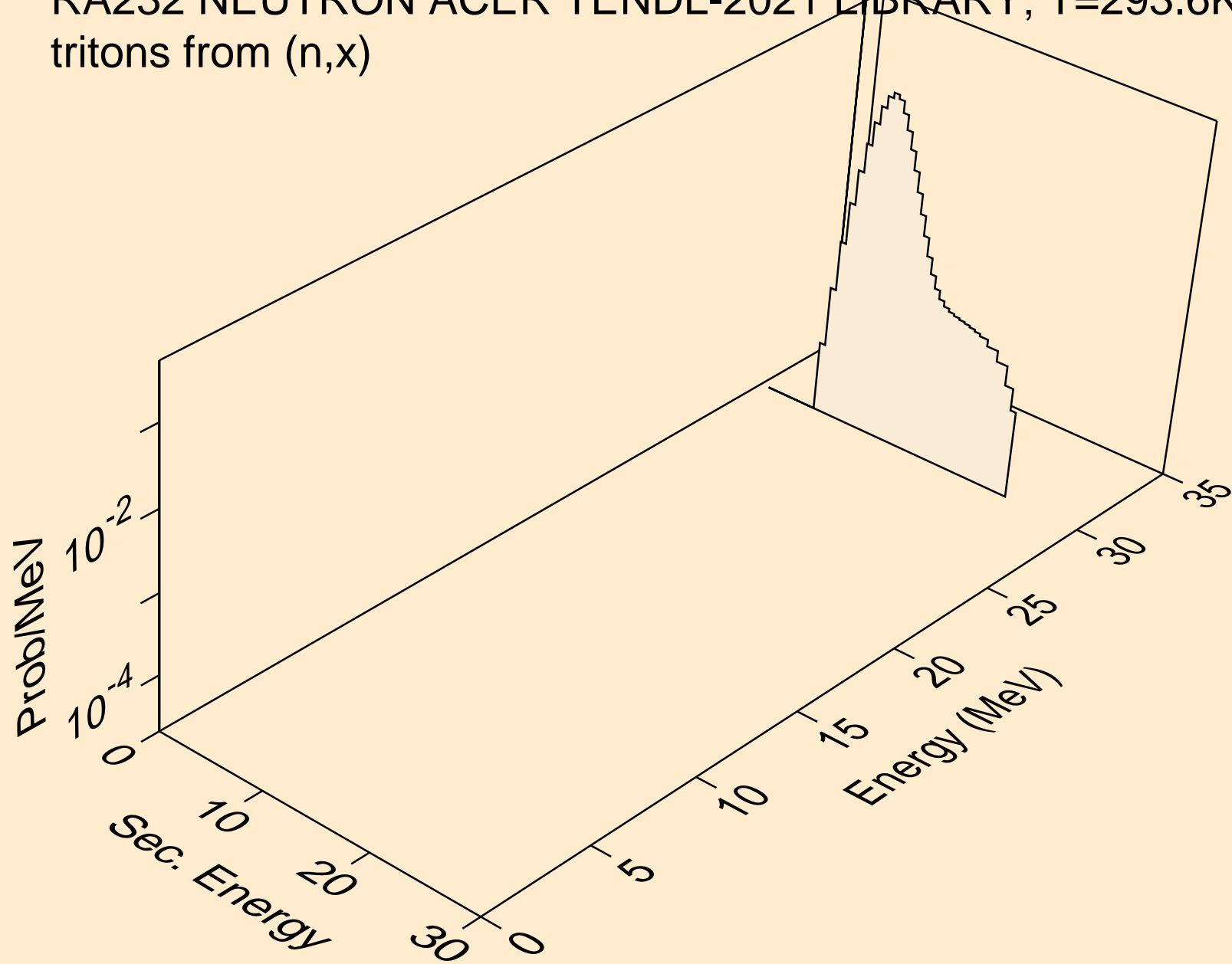

RA232 NEUTRON ACER TENDL-2021 LIBRARY; T=293.6K
tritons from (n,n*)t

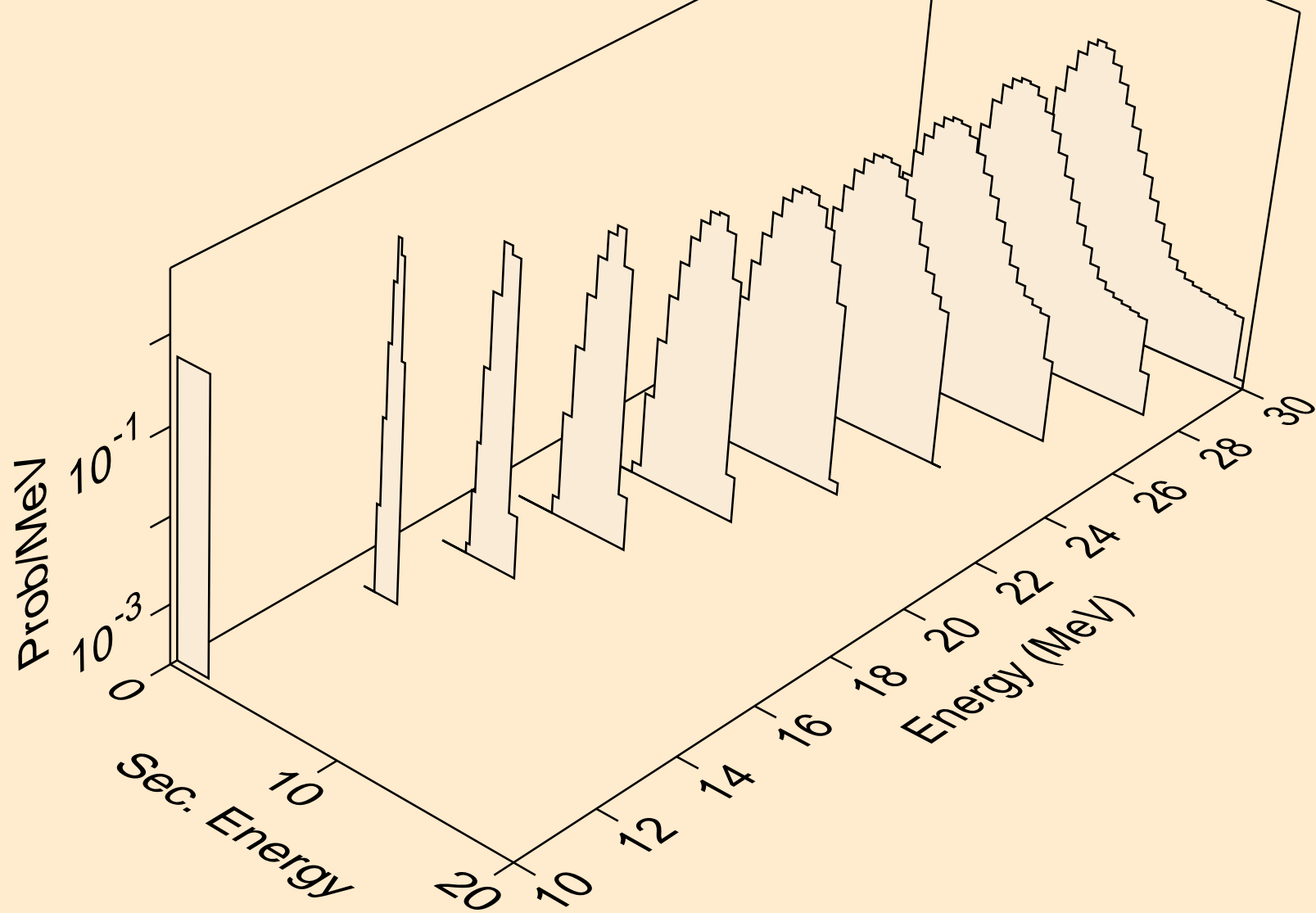

RA232 NEUTRON ACER TENDL-2021 LIBRARY; T=293.6K
tritons from (n,t)

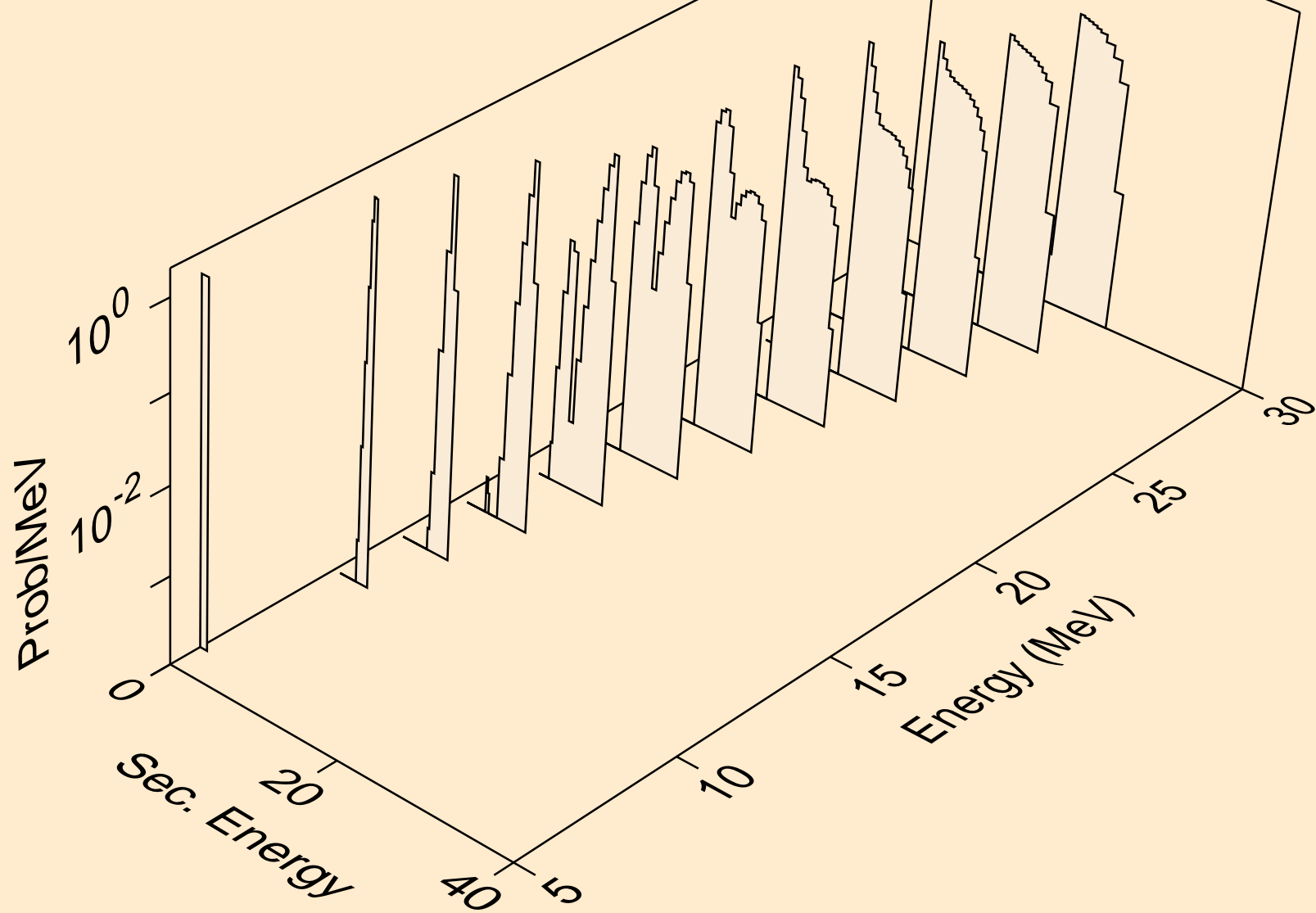

RA232 NEUTRON ACER TENDL-2021 LIBRARY; T=293.6K
he3s from (n,x)

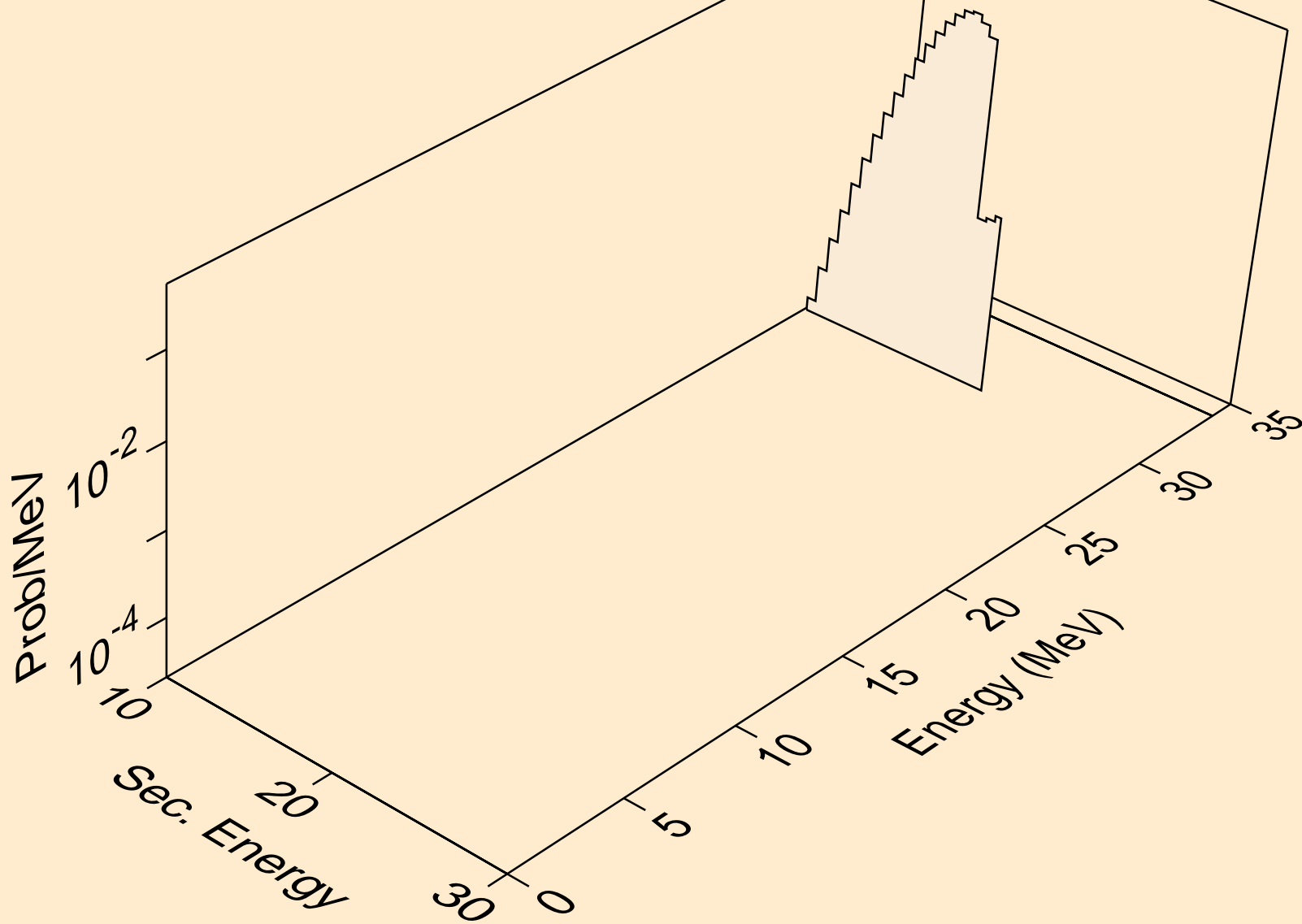

RA232 NEUTRON ACER TENDL-2021 LIBRARY; T=293.6K
he3s from (n,n*)he3

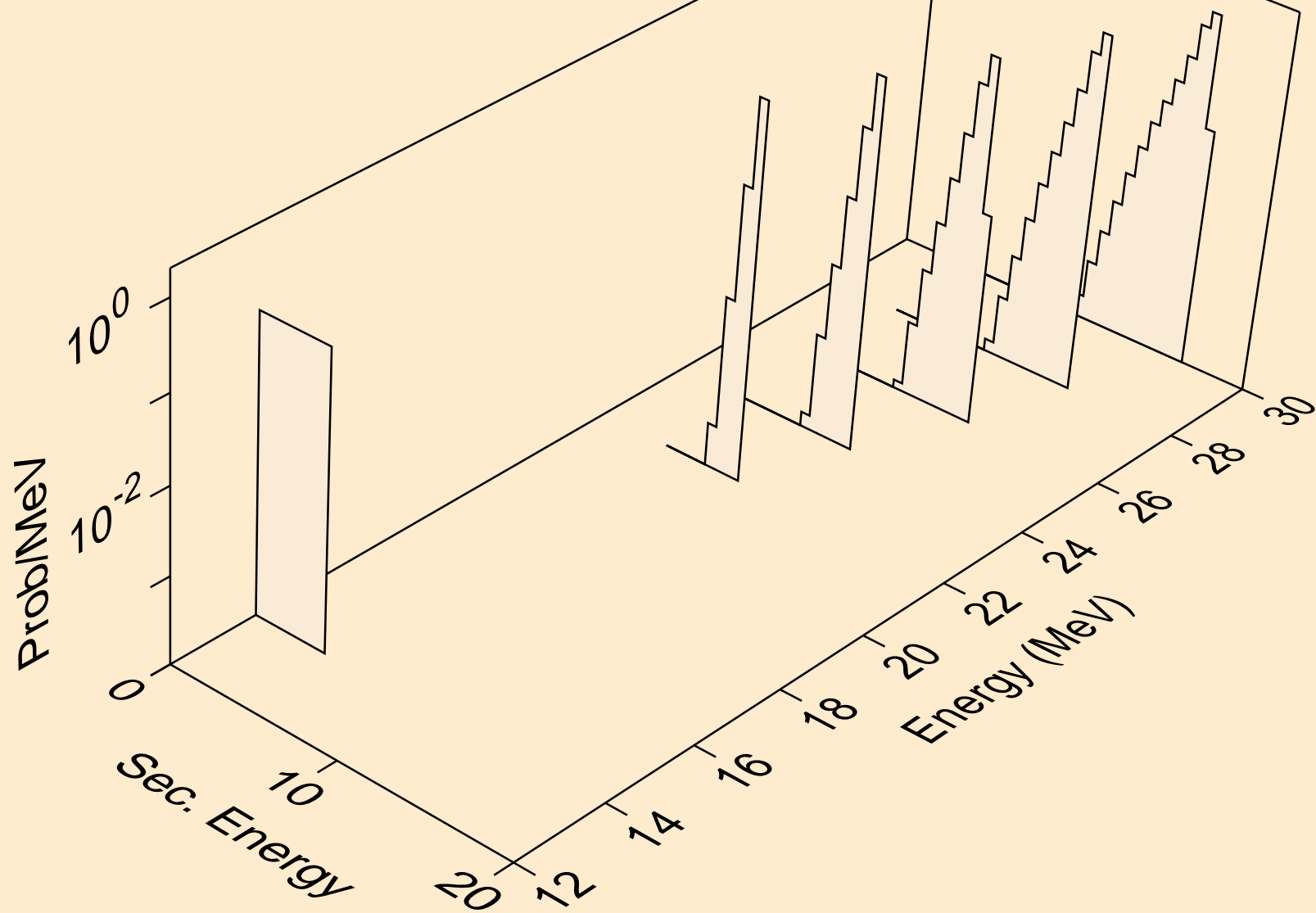

RA232 NEUTRON ACER TENDL-2021 LIBRARY; T=293.6K
he3s from (n,he3)

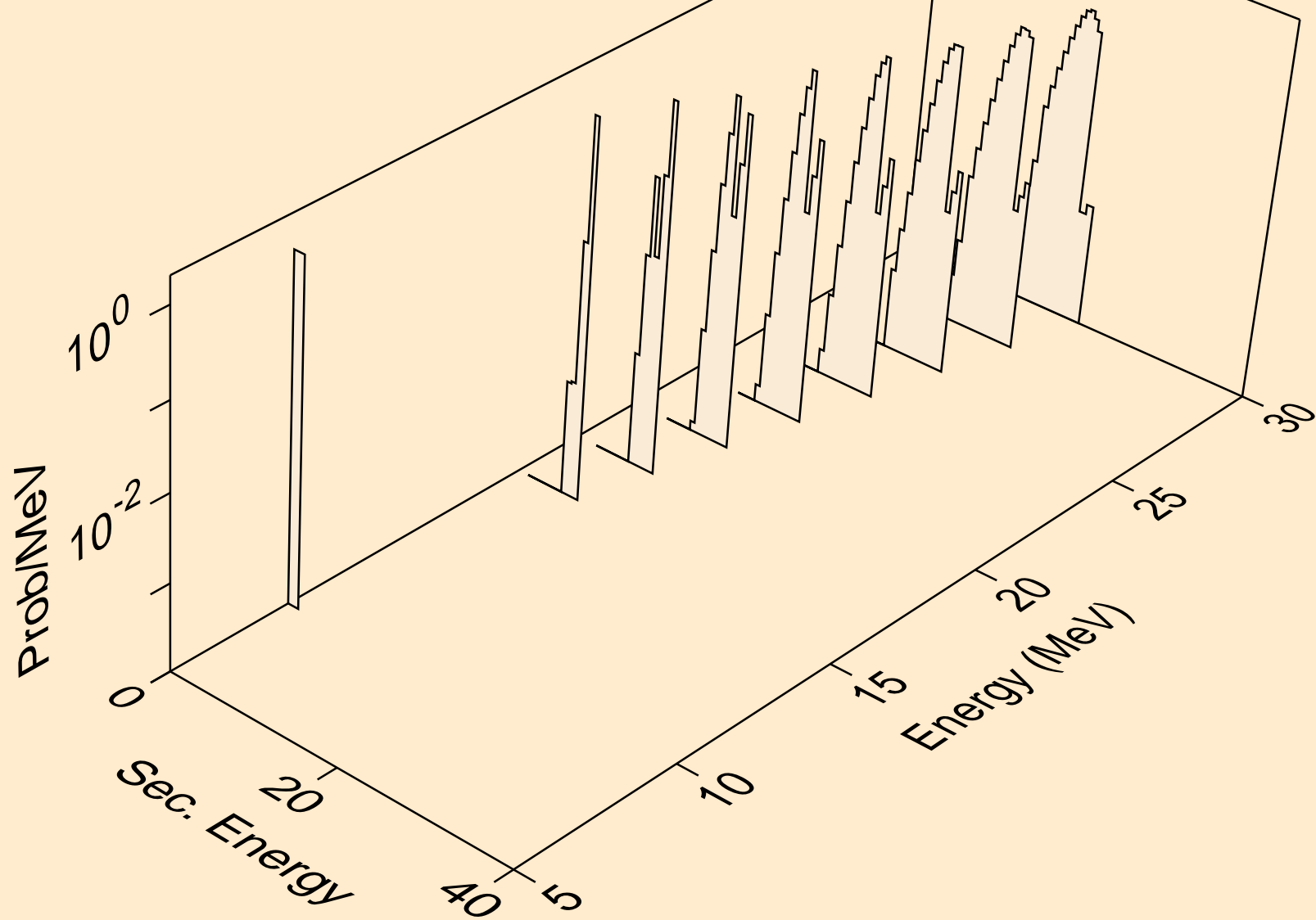

RA232 NEUTRON ACER TENDL-2021 LIBRARY; T=293.6K
alphas from (n,x)

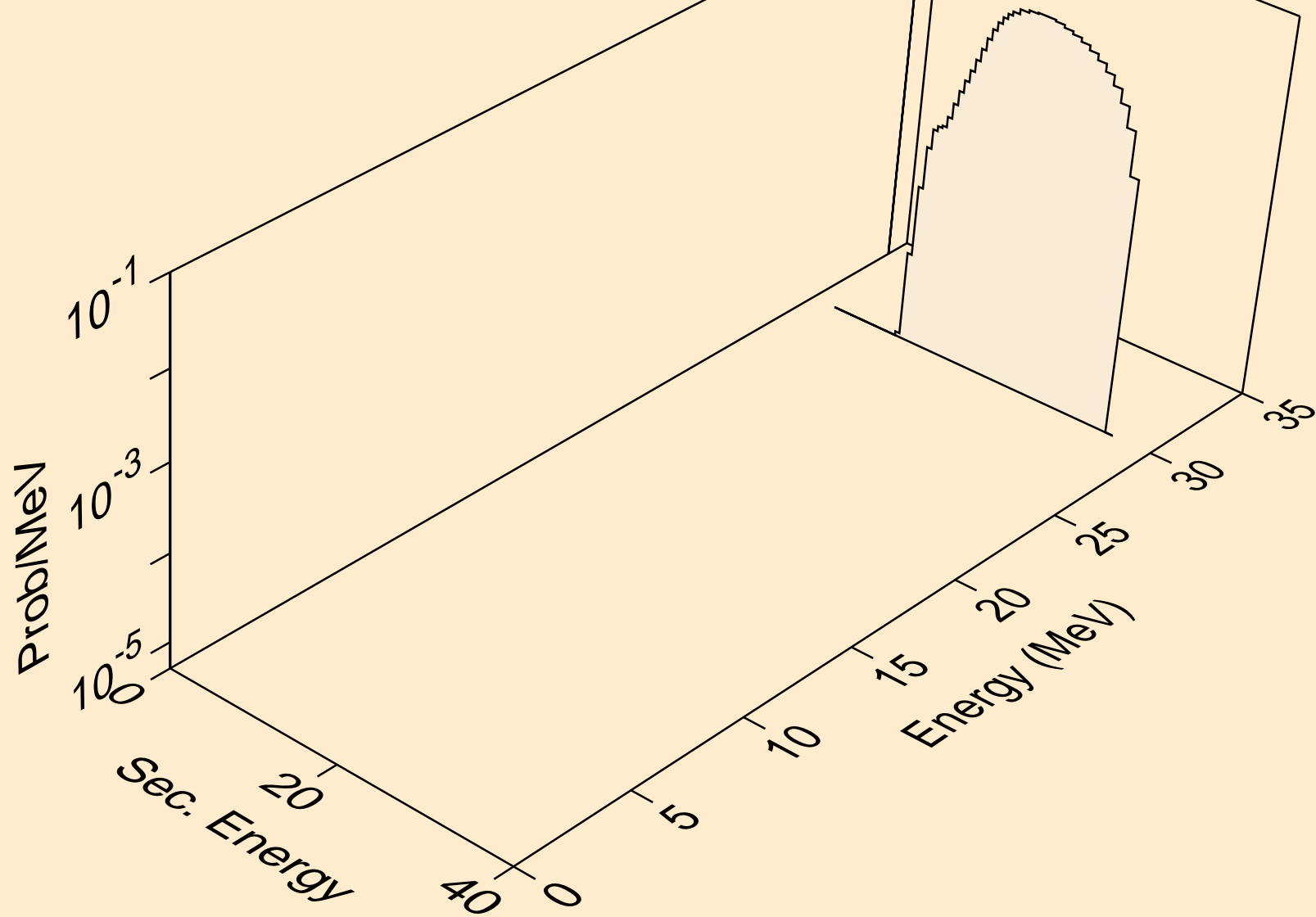

RA232 NEUTRON ACER TENDL-2021 LIBRARY; T=293.6K
alphas from (n,n*)a

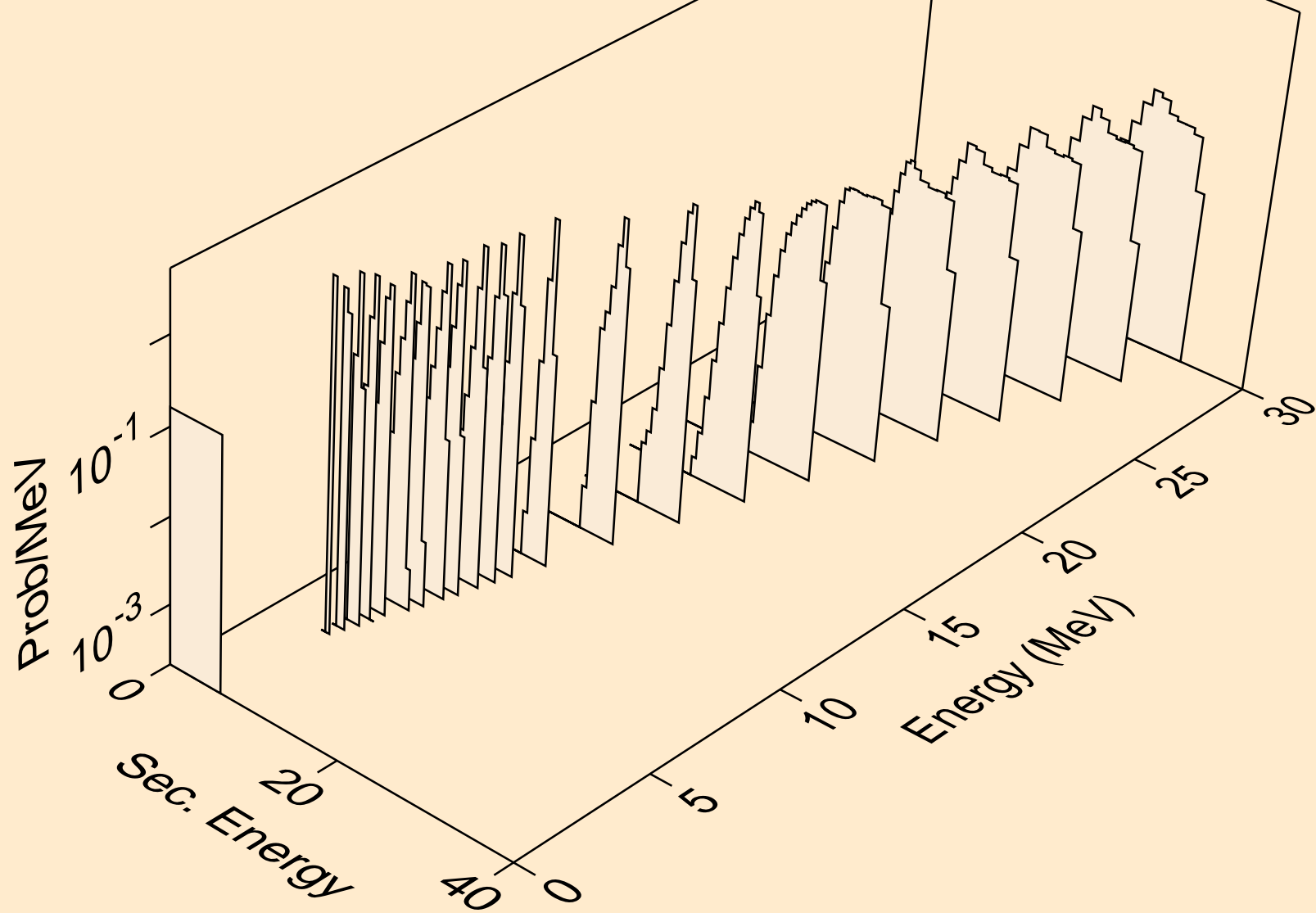

RA232 NEUTRON ACER TENDL-2021 LIBRARY; T=293.6K
alphas from (n,2n)a

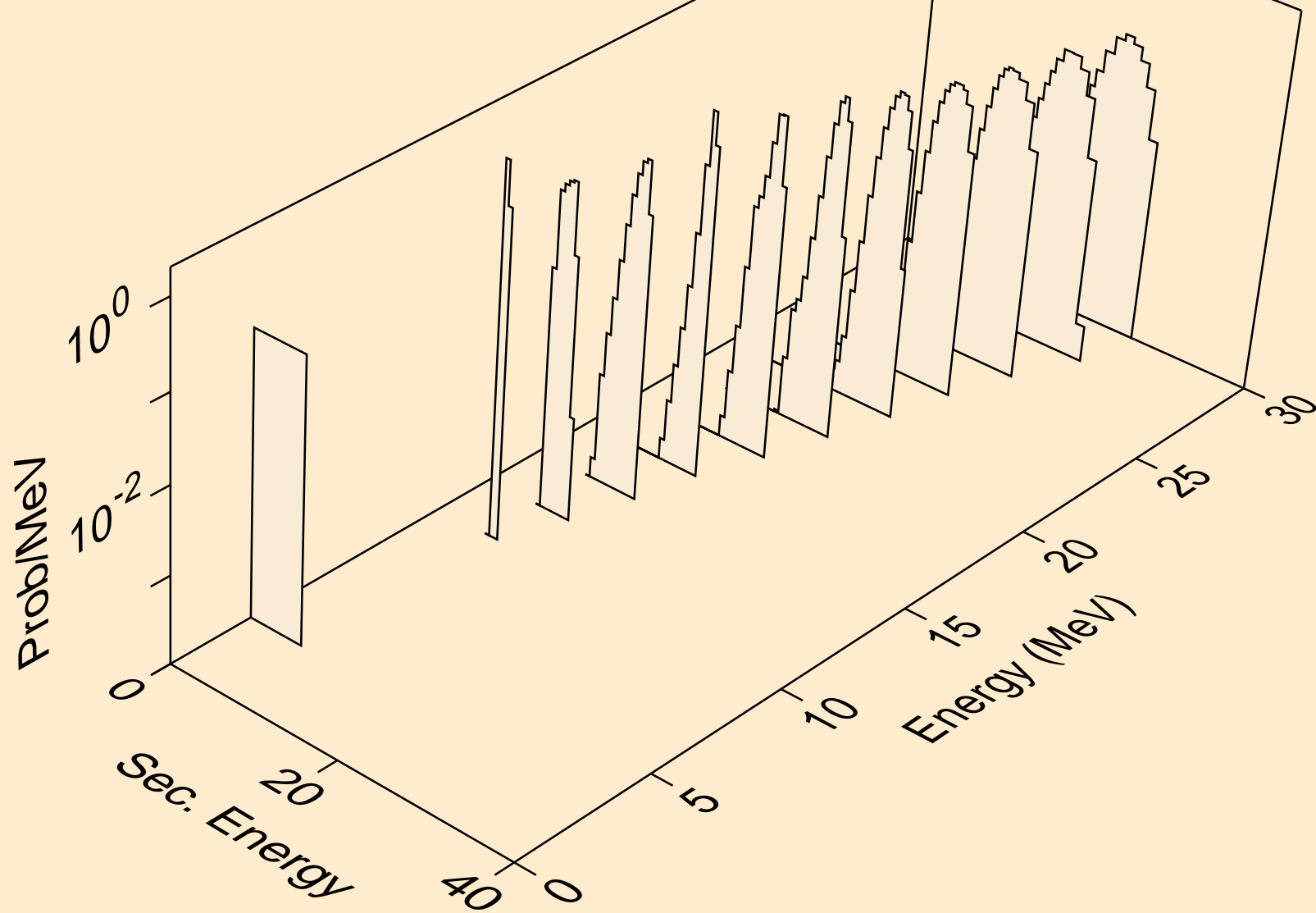

RA232 NEUTRON ACER TENDL-2021 LIBRARY; T=293.6K
alphas from (n,3n)a

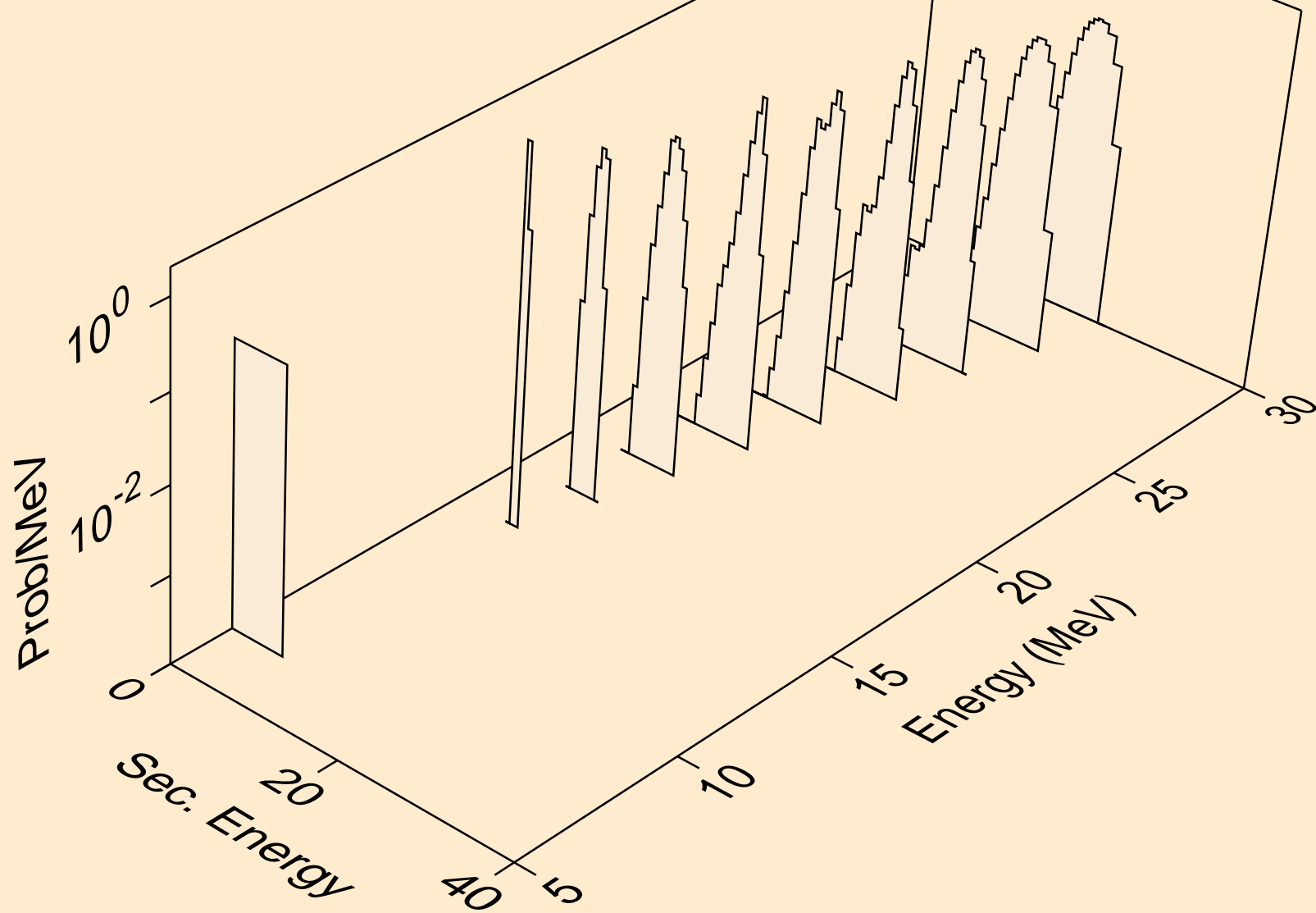

RA232 NEUTRON ACER TENDL-2021 LIBRARY; T=293.6K
alphas from (n,n*)2a

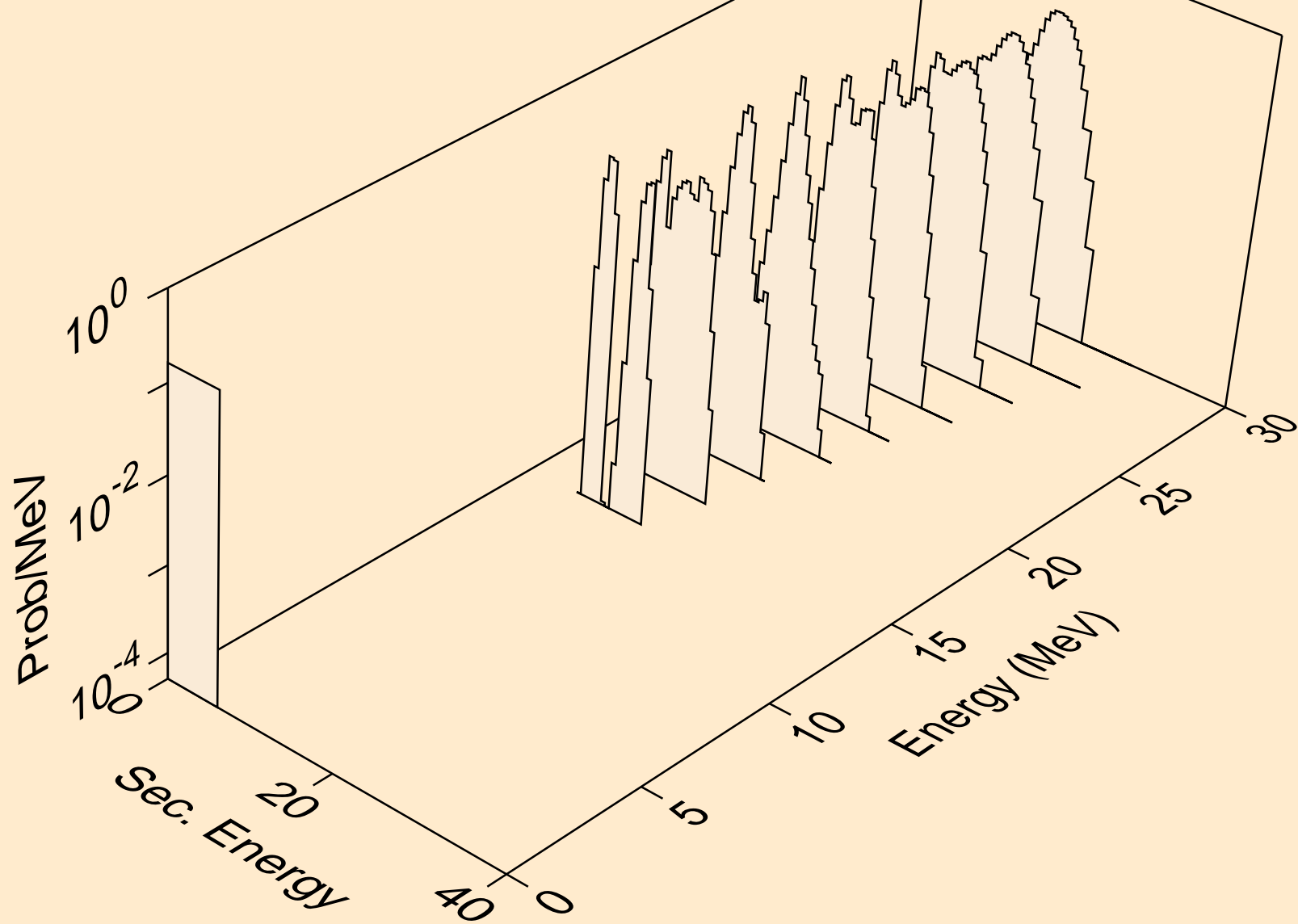

RA232 NEUTRON ACER TENDL-2021 LIBRARY; T=293.6K
alphas from (n,2n)2a

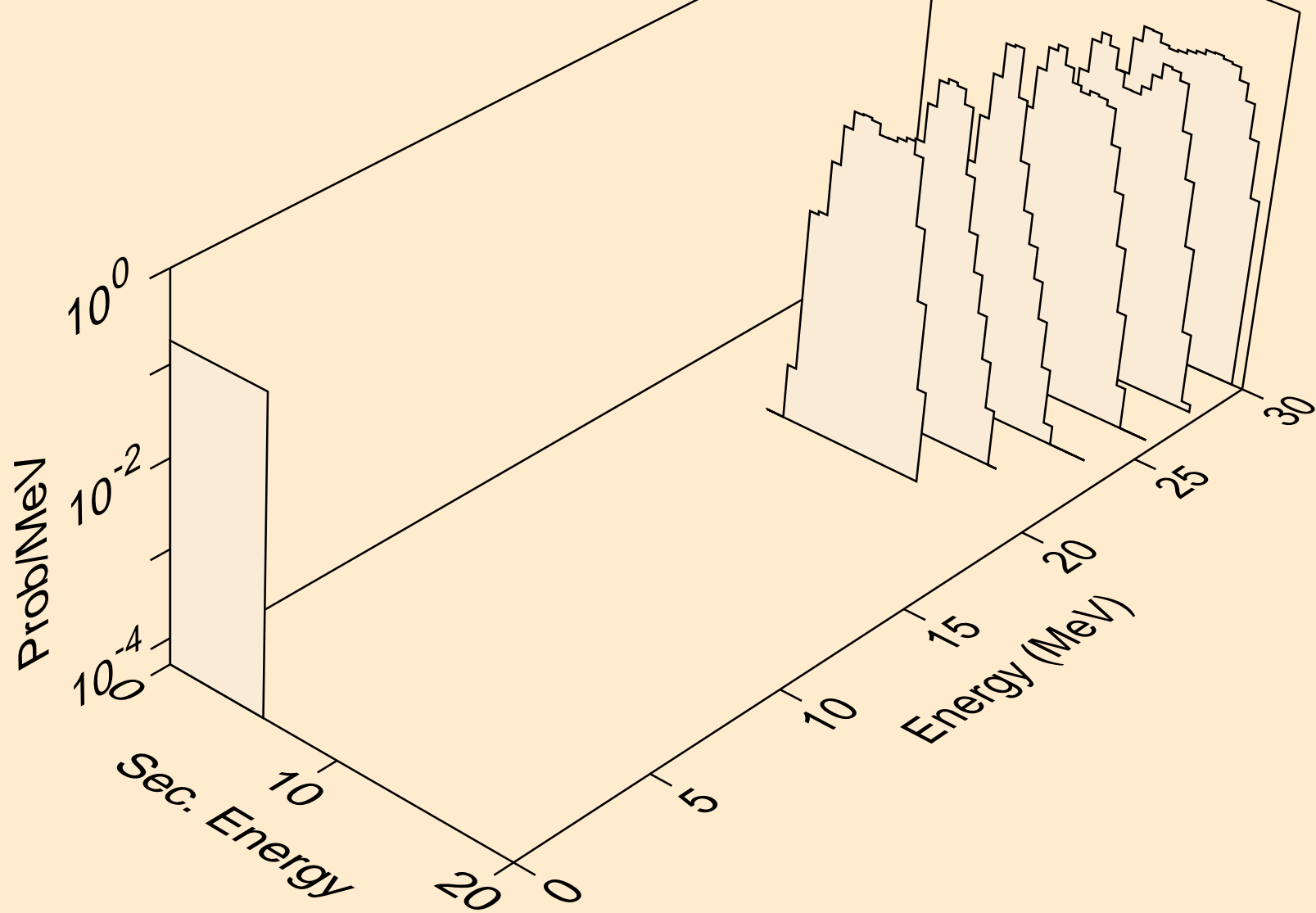

RA232 NEUTRON ACER TENDL-2021 LIBRARY; T=293.6K
alphas from (n,npa)

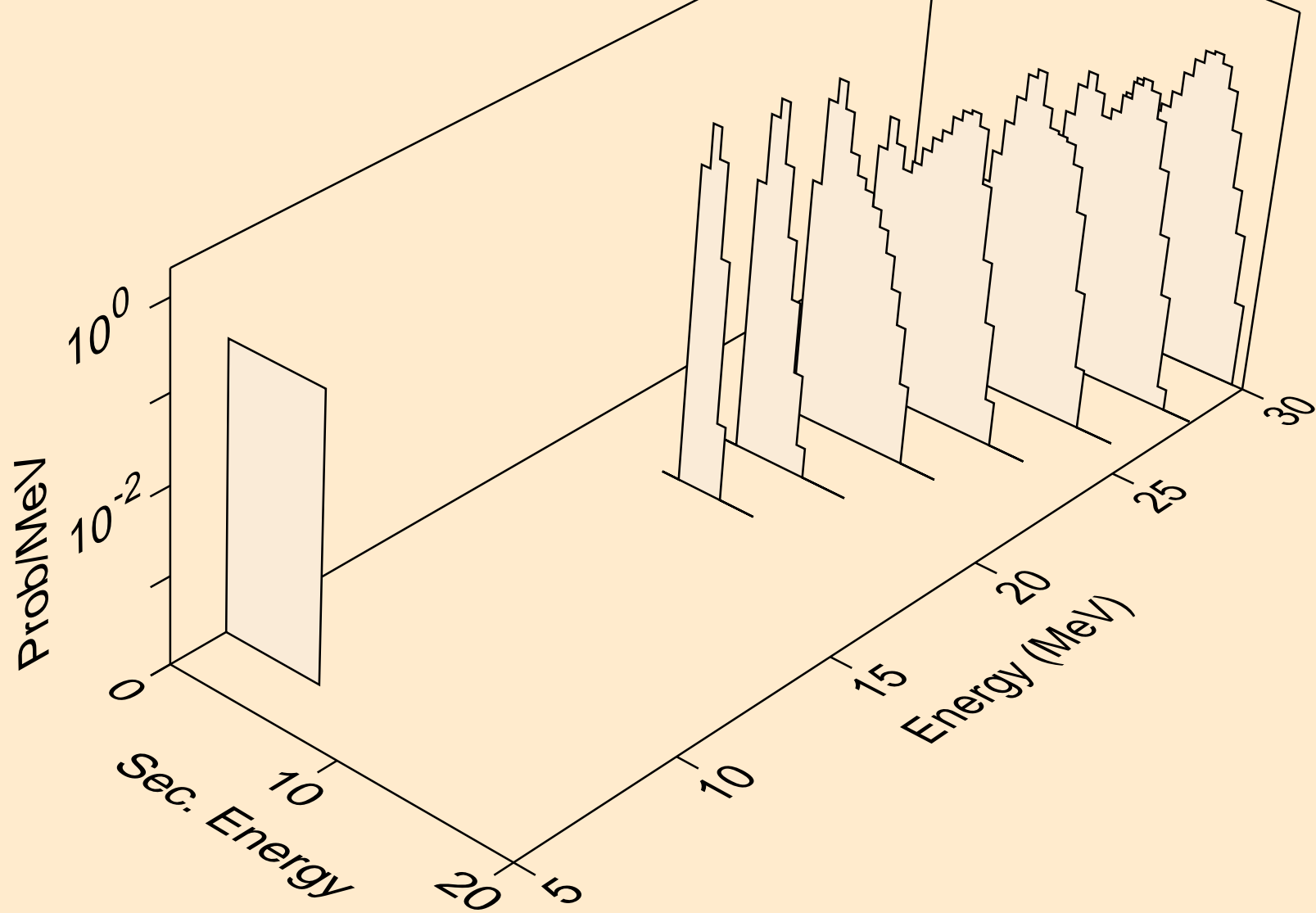

RA232 NEUTRON ACER TENDL-2021 LIBRARY; T=293.6K
alphas from (n,a)

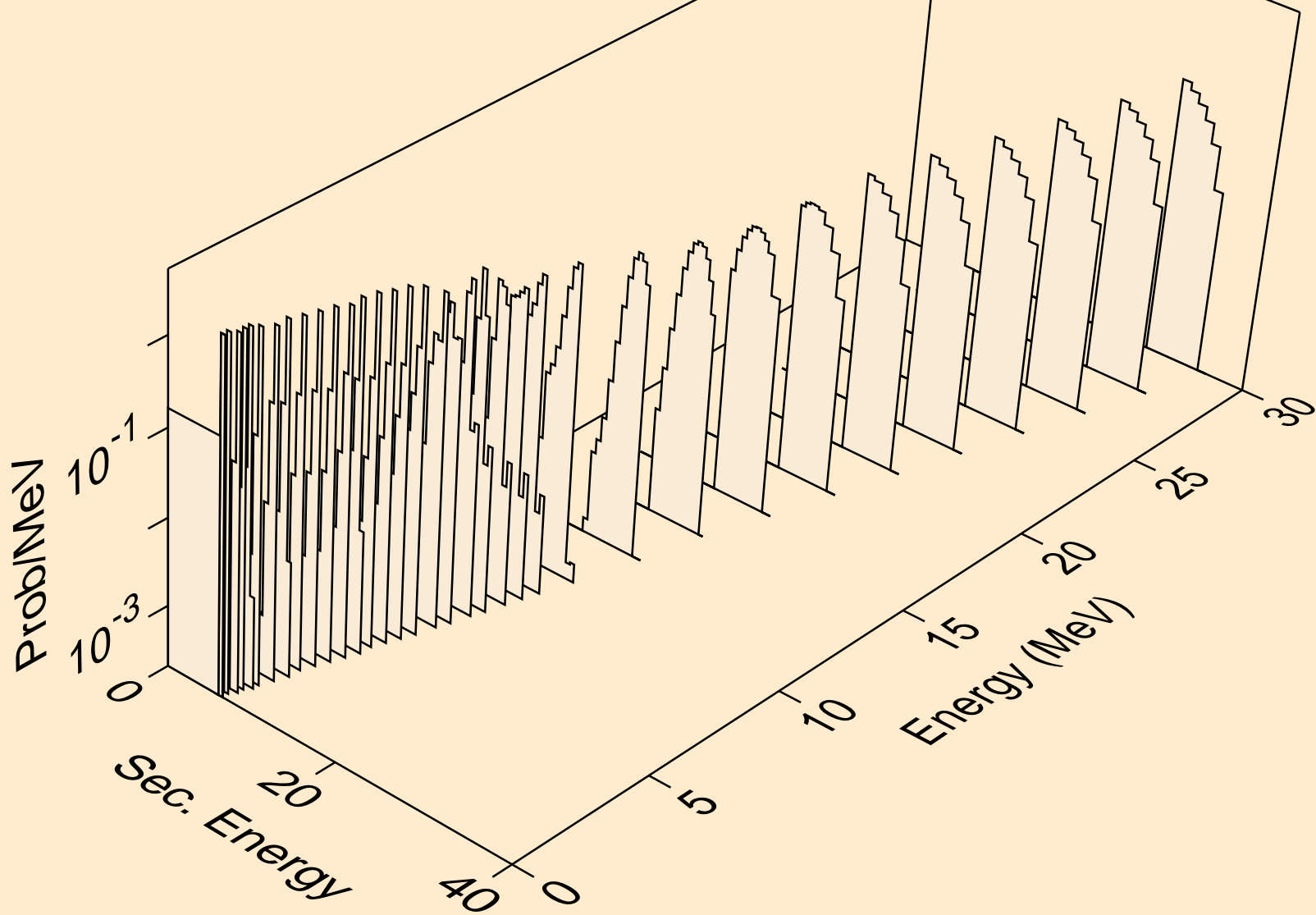

RA232 NEUTRON ACER TENDL-2021 LIBRARY; T=293.6K
alphas from (n,2a)

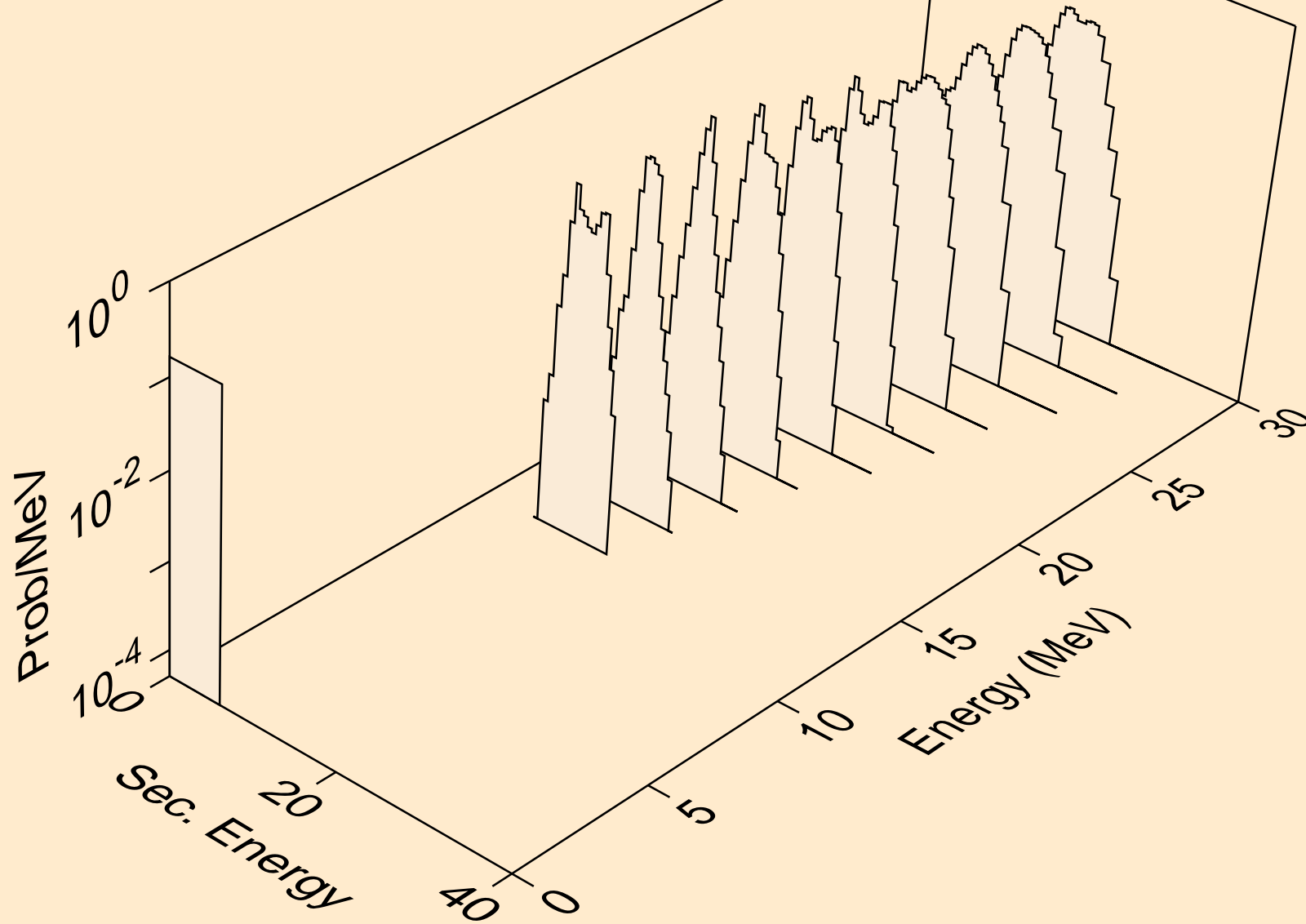

RA232 NEUTRON ACER TENDL-2021 LIBRARY; T=293.6K
alphas from (n,pa)

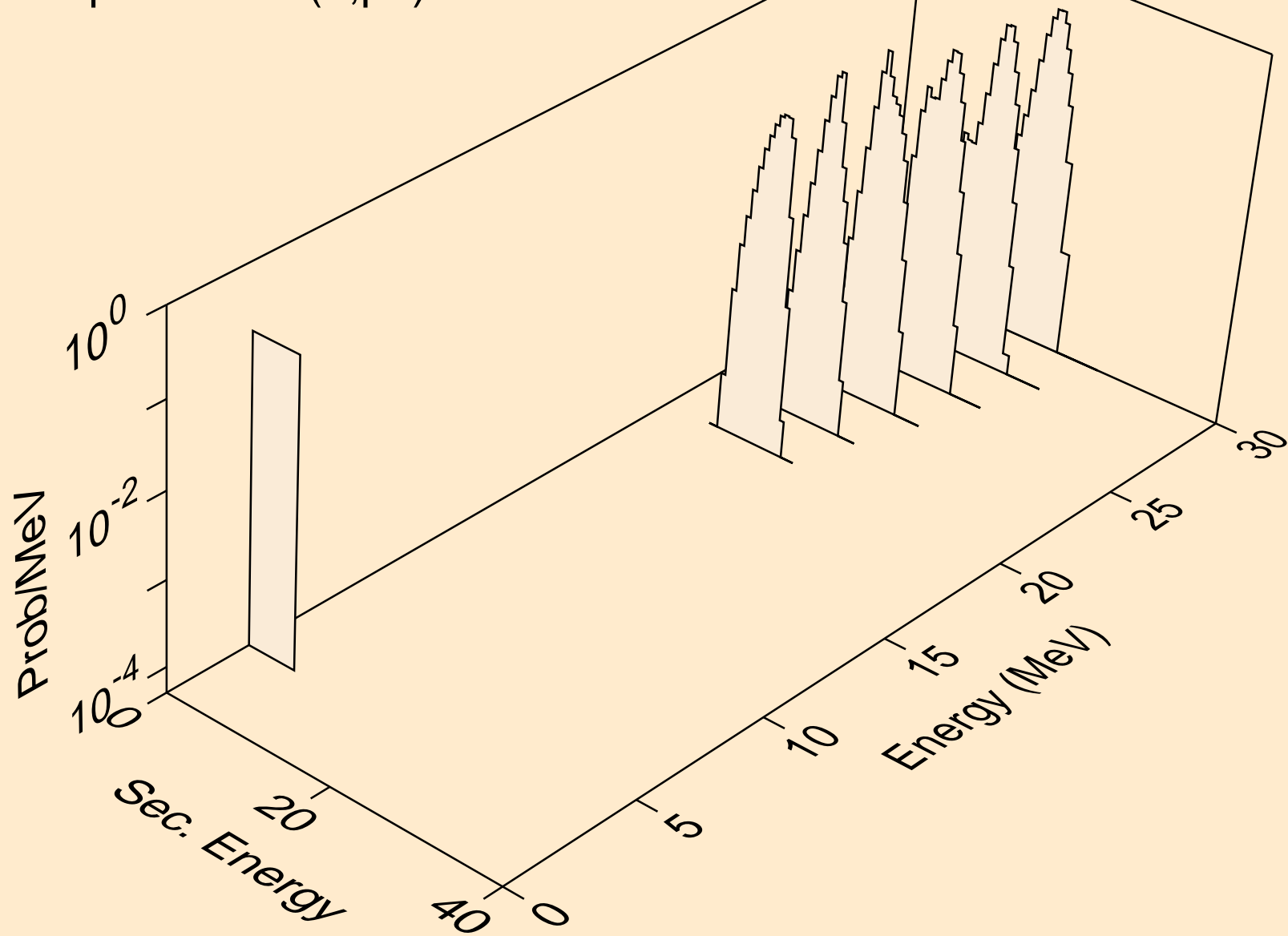

RA232 NEUTRON ACER TENDL-2021 LIBRARY; T=293.6K
alphas from (n,da)

