

# ZN073M NEUTRON ACER TENDL-2021 LIBRARY; T=293.6K

## Principal cross sections

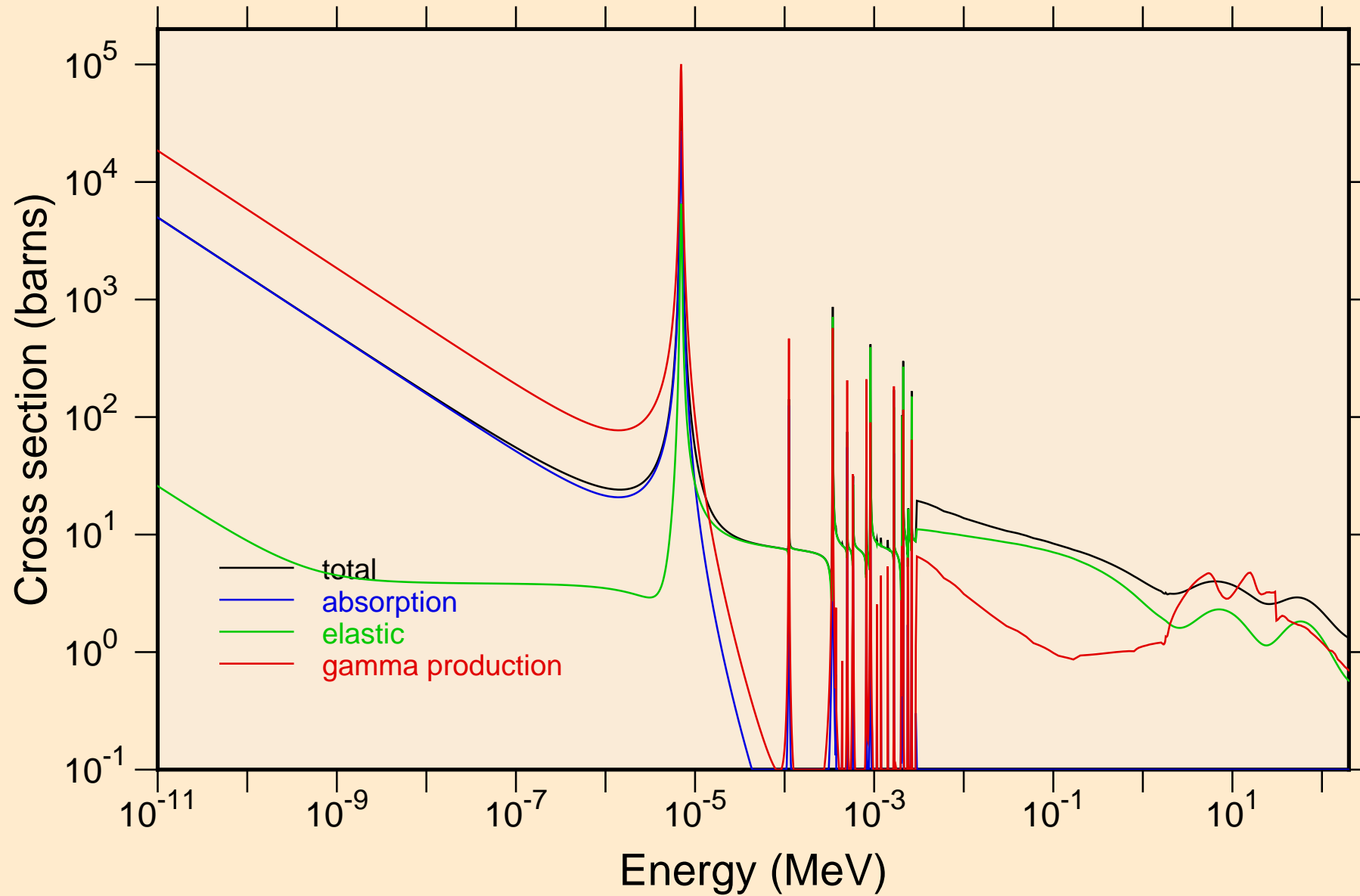

ZN073M NEUTRON ACER TENDL-2021 LIBRARY; T=293.6K  
resonance total cross section

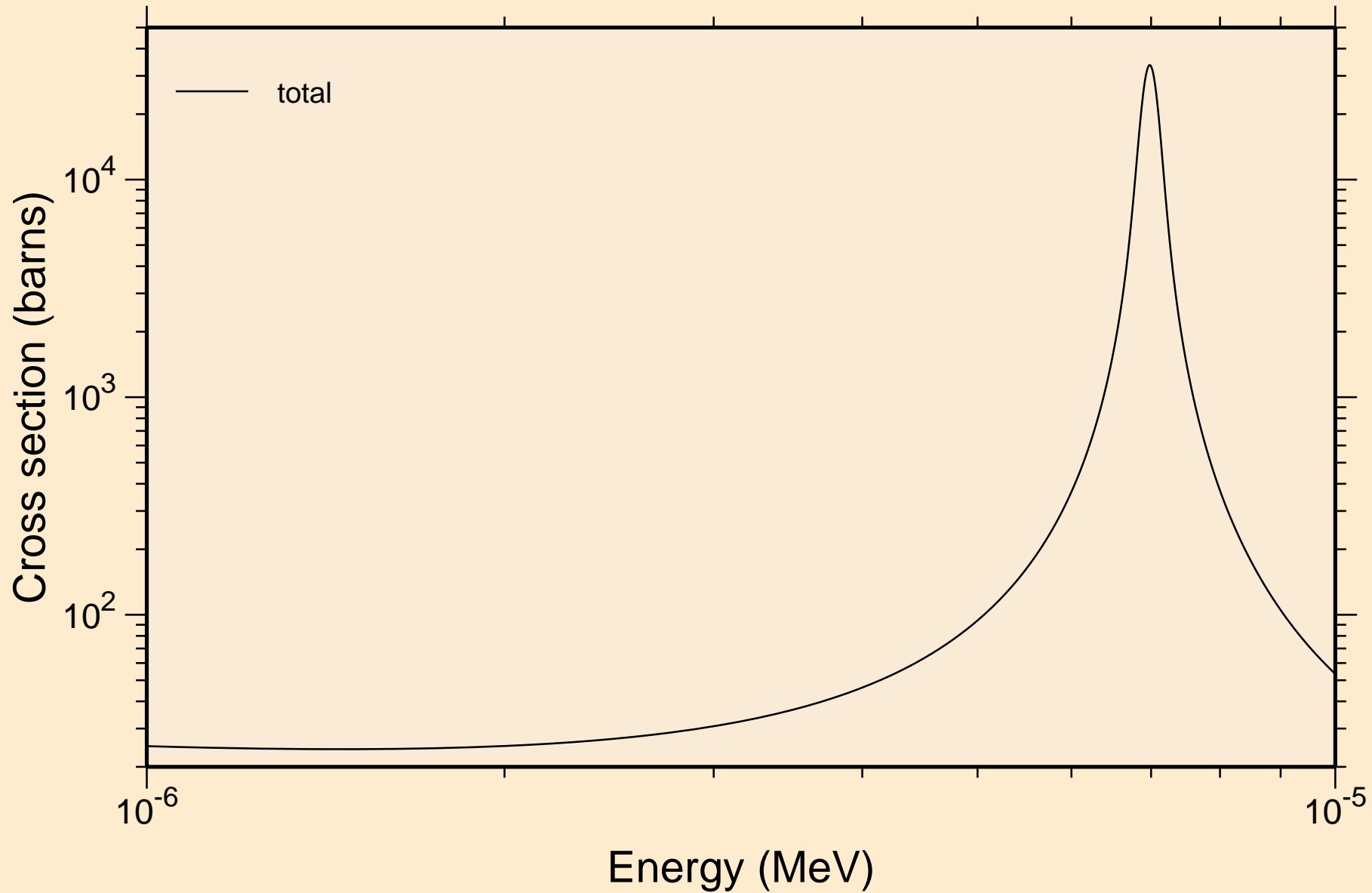

ZN073M NEUTRON ACER TENDL-2021 LIBRARY; T=293.6K  
resonance total cross section

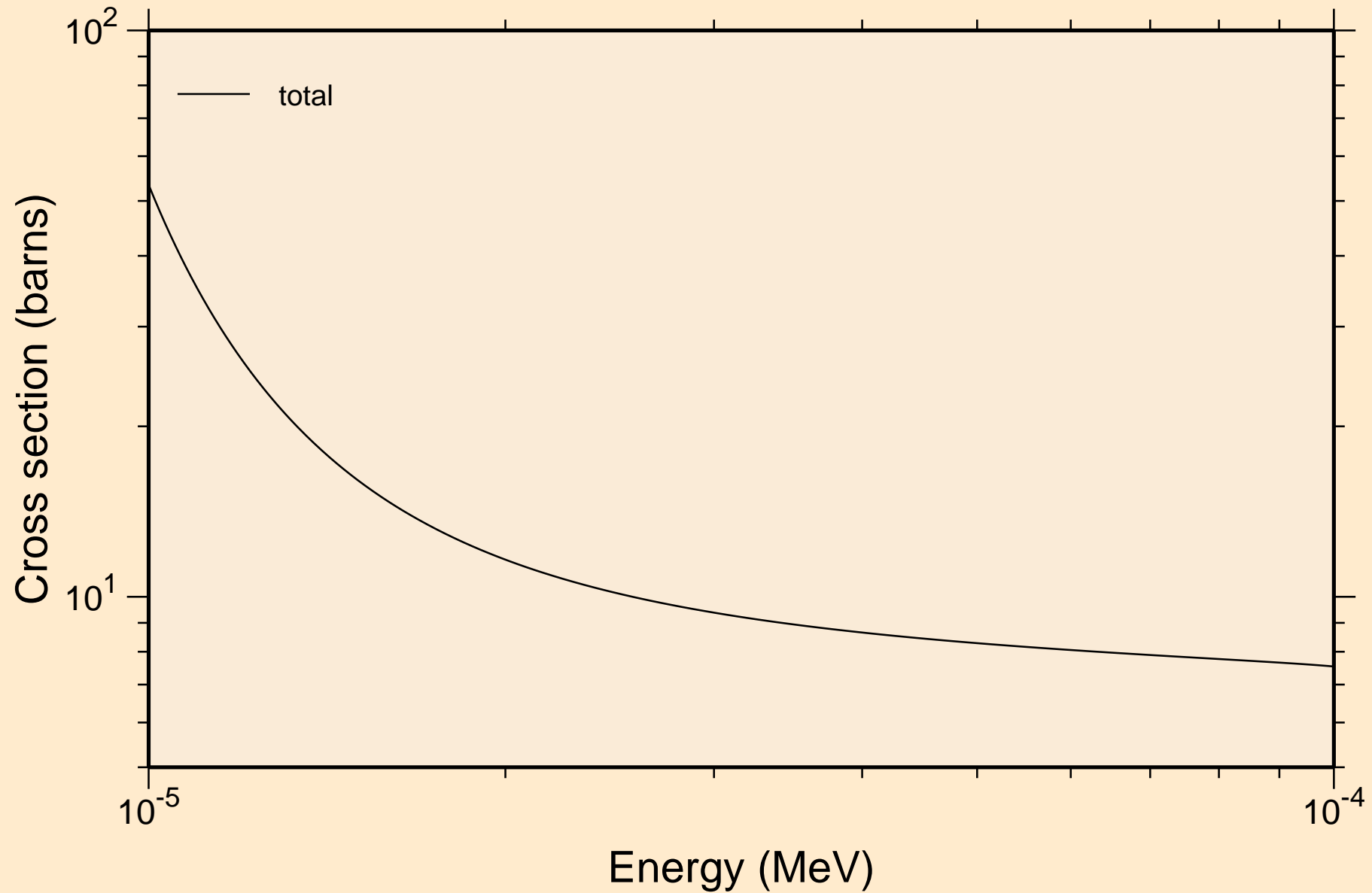

ZN073M NEUTRON ACER TENDL-2021 LIBRARY; T=293.6K  
resonance total cross section

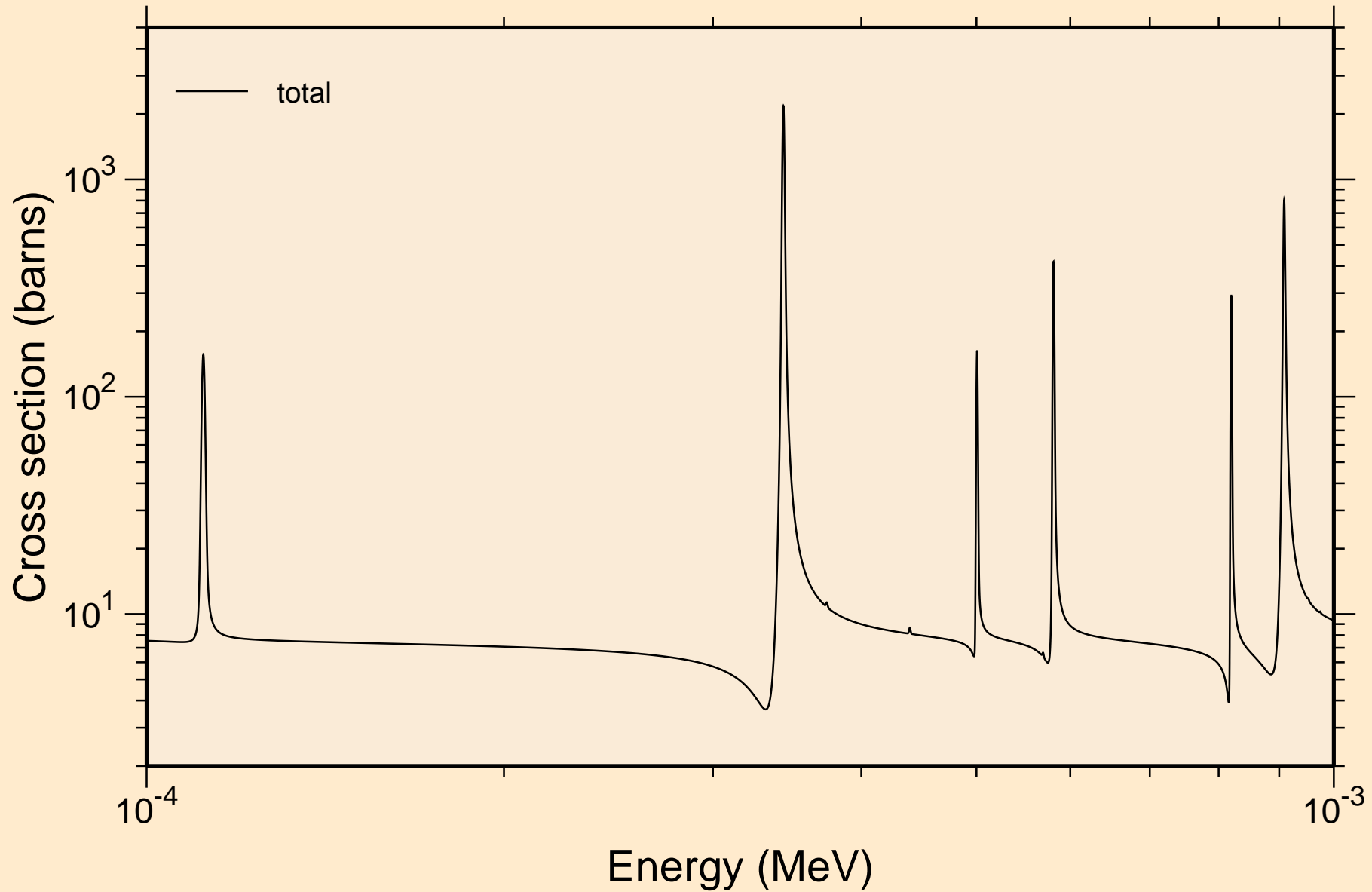

ZN073M NEUTRON ACER TENDL-2021 LIBRARY; T=293.6K  
resonance total cross section

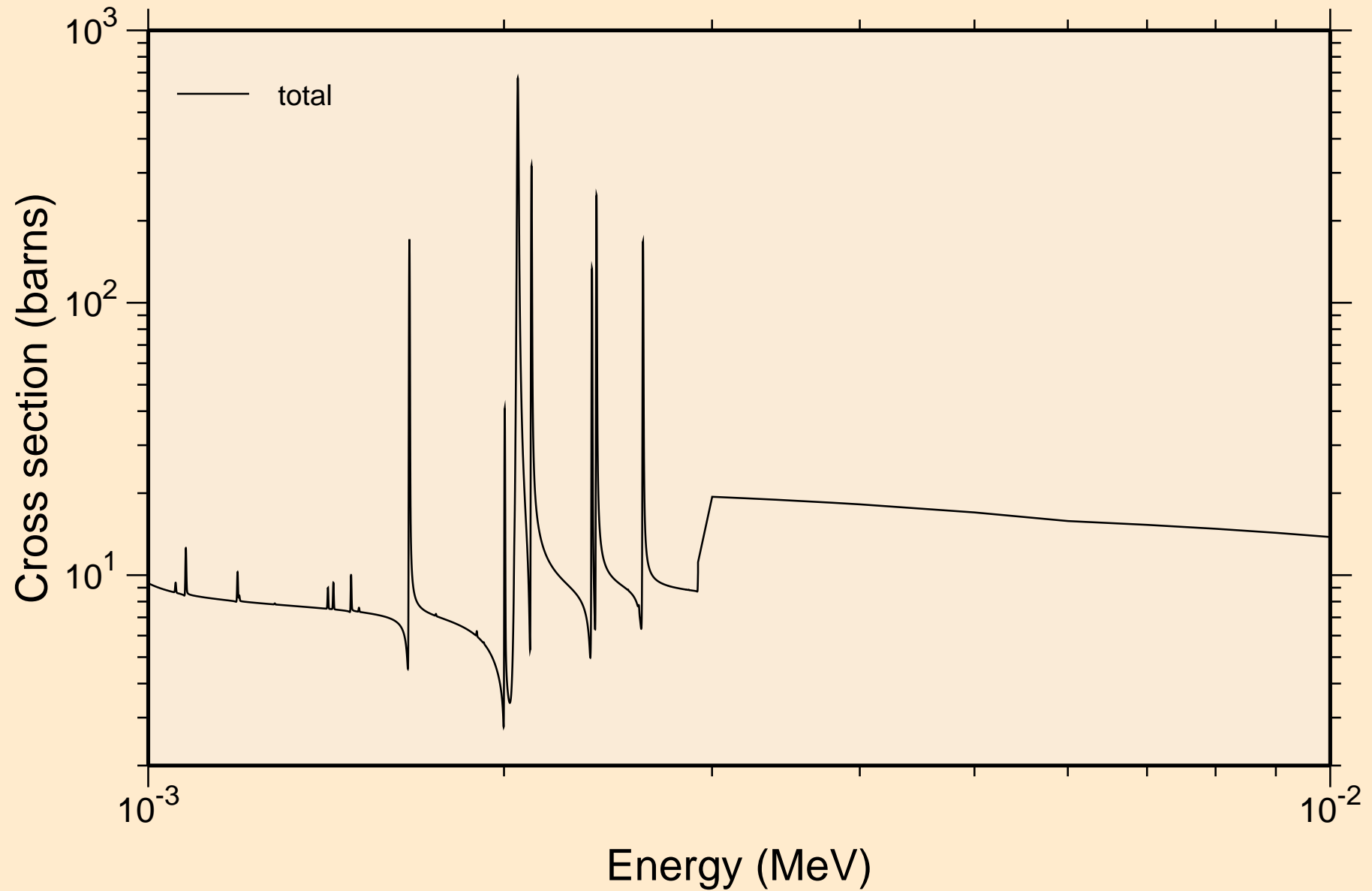

ZN073M NEUTRON ACER TENDL-2021 LIBRARY; T=293.6K  
resonance total cross section

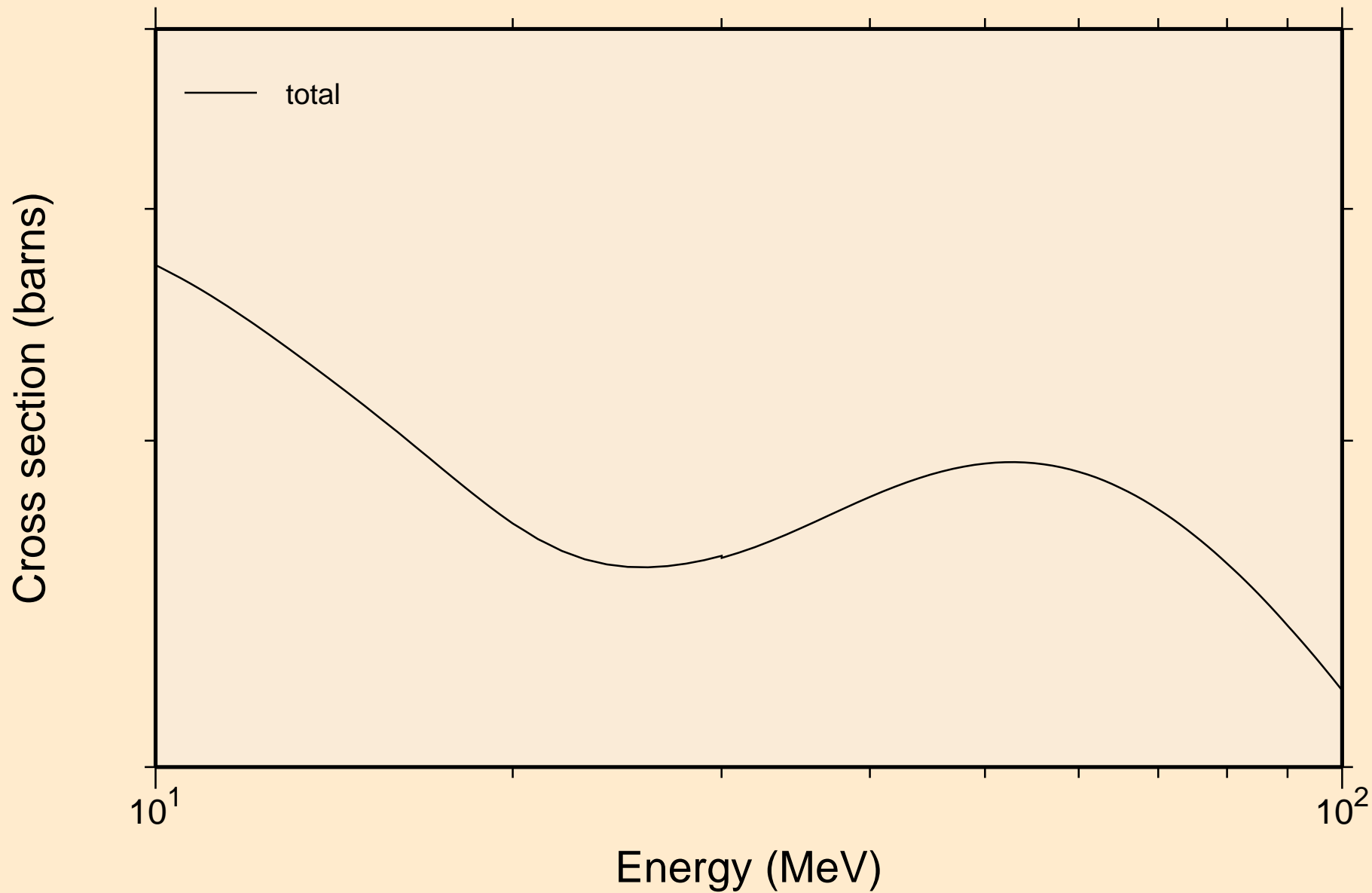

ZN073M NEUTRON ACER TENDL-2021 LIBRARY; T=293.6K  
resonance absorption cross sections

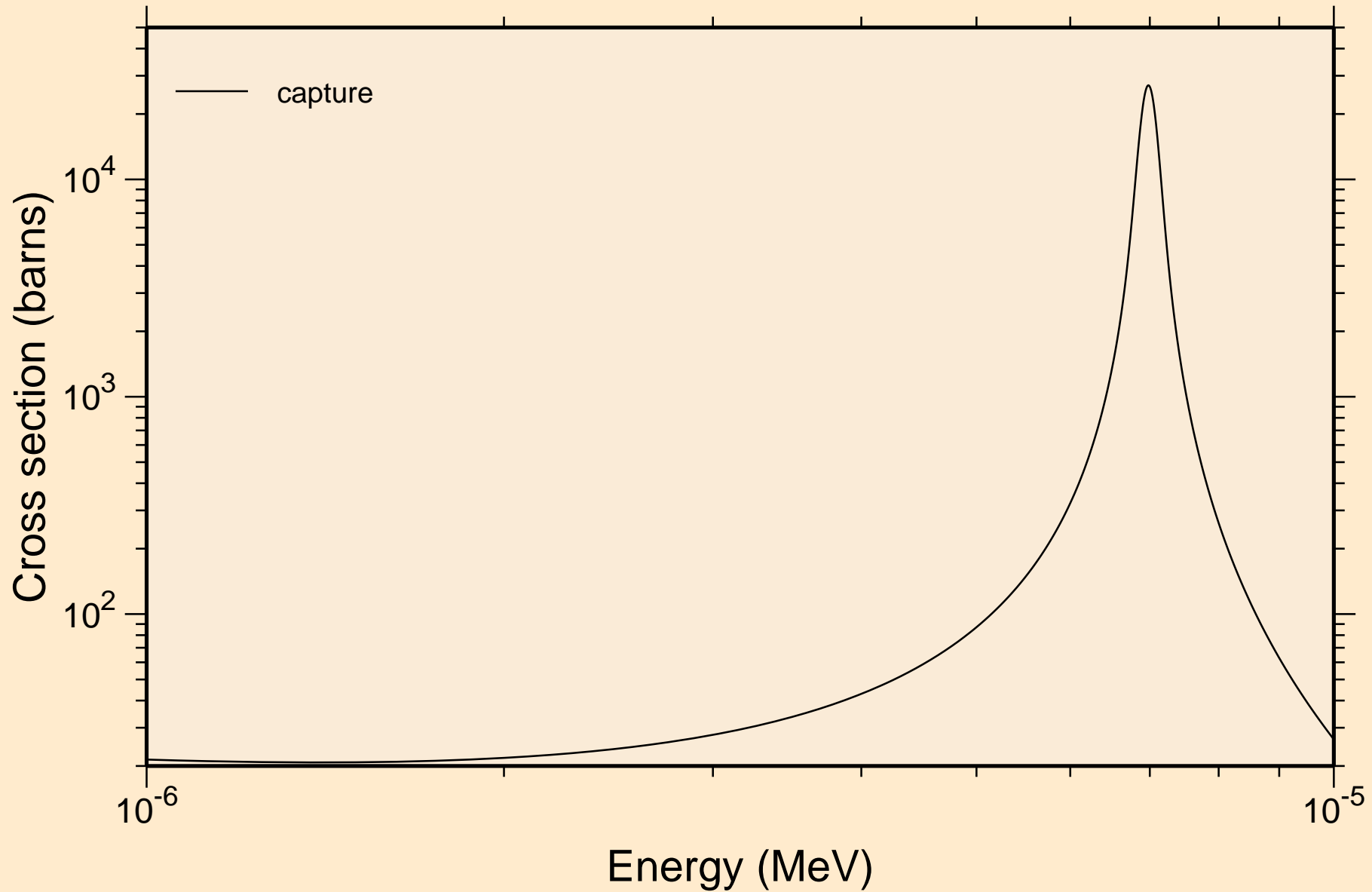

ZN073M NEUTRON ACER TENDL-2021 LIBRARY; T=293.6K  
resonance absorption cross sections

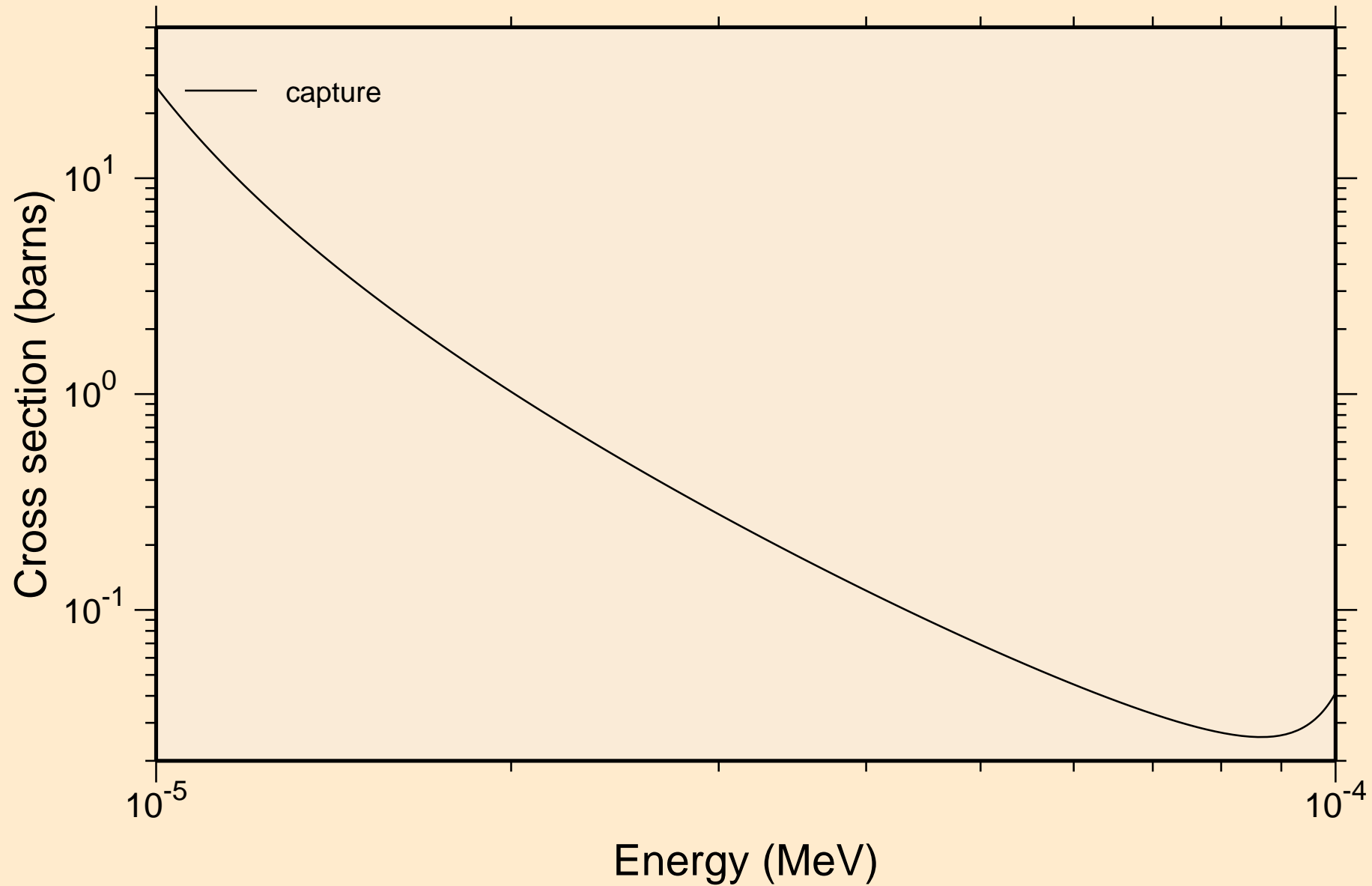



ZN073M NEUTRON ACER TENDL-2021 LIBRARY; T=293.6K  
resonance absorption cross sections

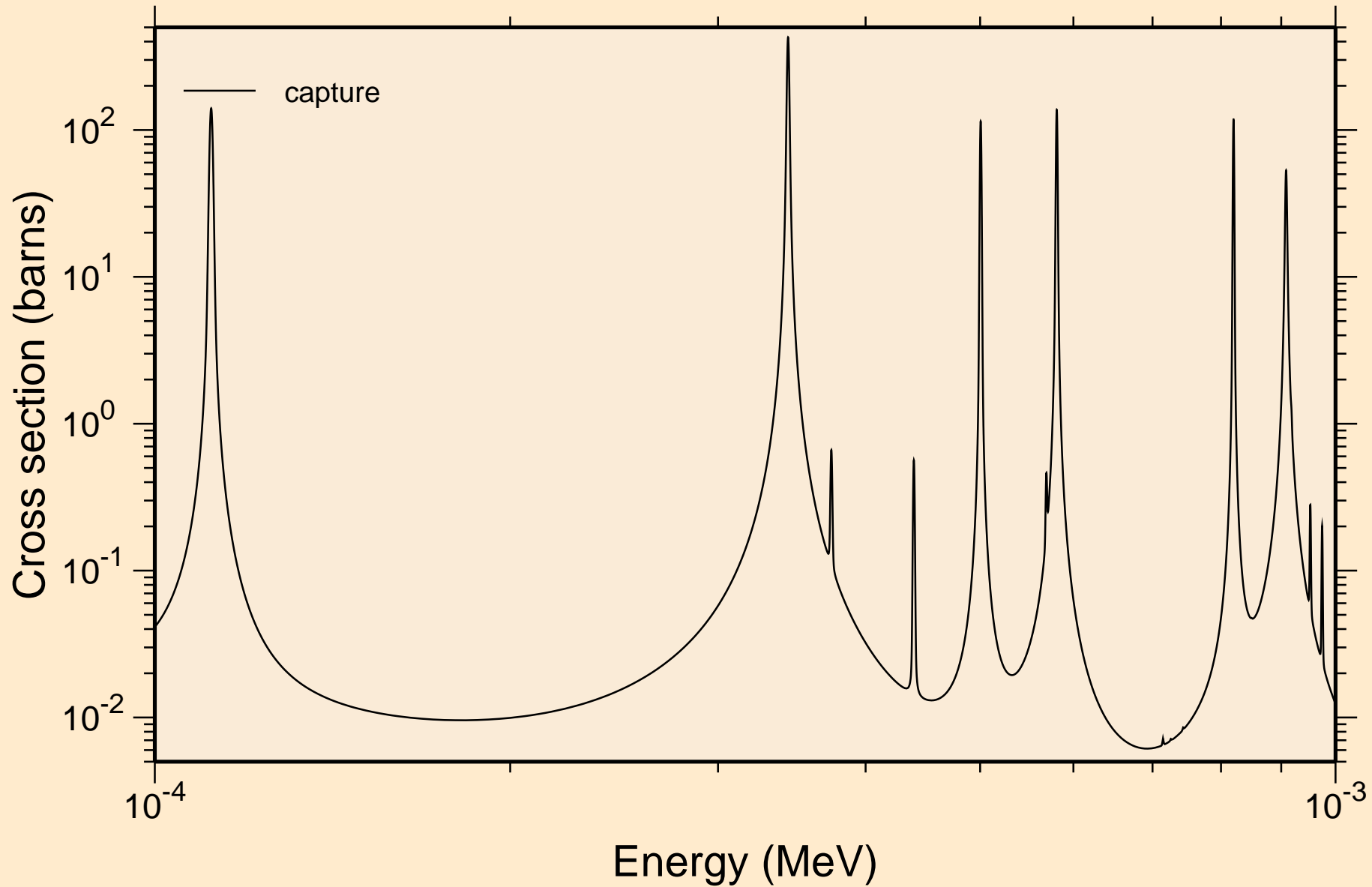

ZN073M NEUTRON ACER TENDL-2021 LIBRARY; T=293.6K  
resonance absorption cross sections

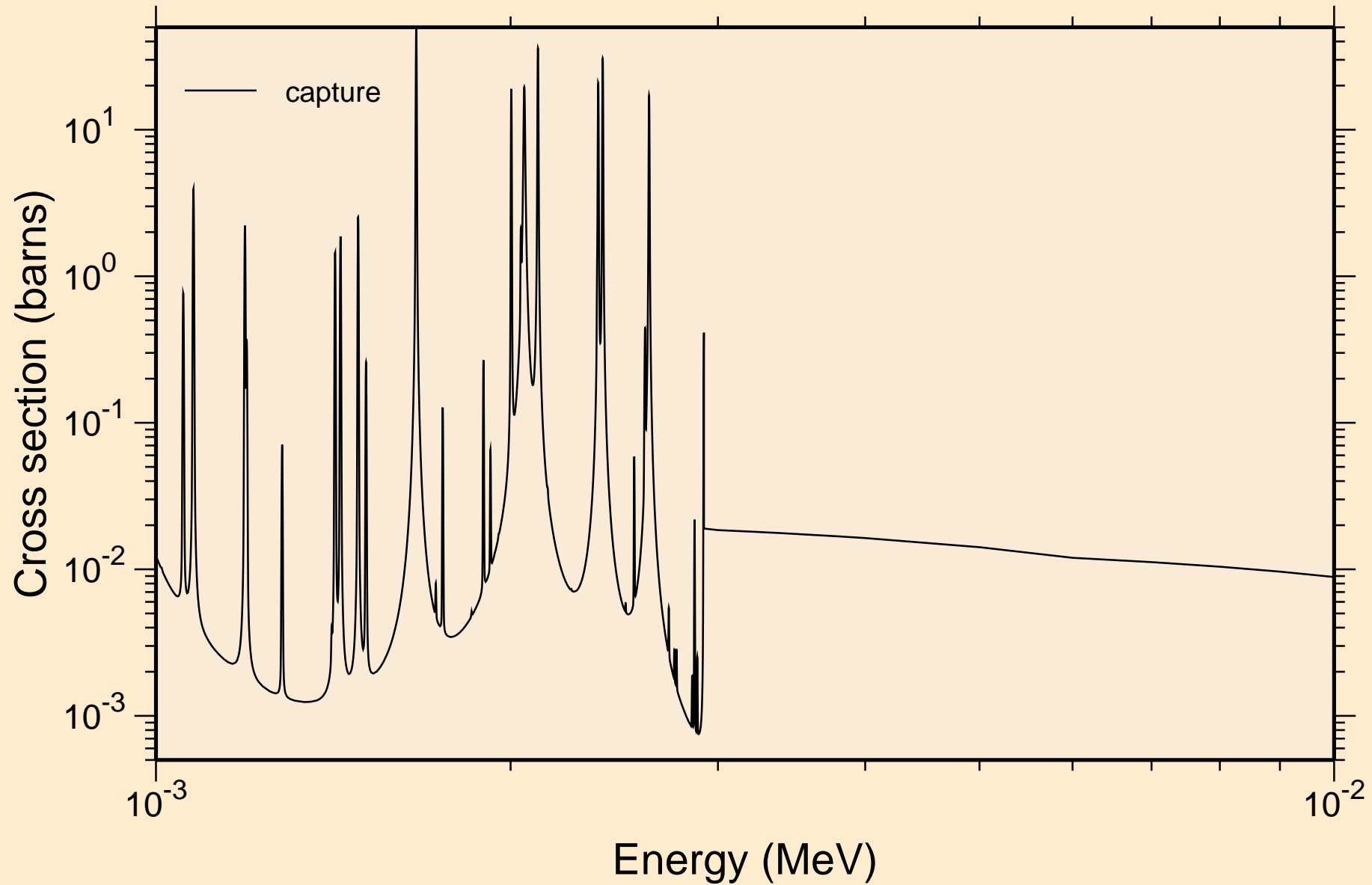

ZN073M NEUTRON ACER TENDL-2021 LIBRARY; T=293.6K  
resonance absorption cross sections

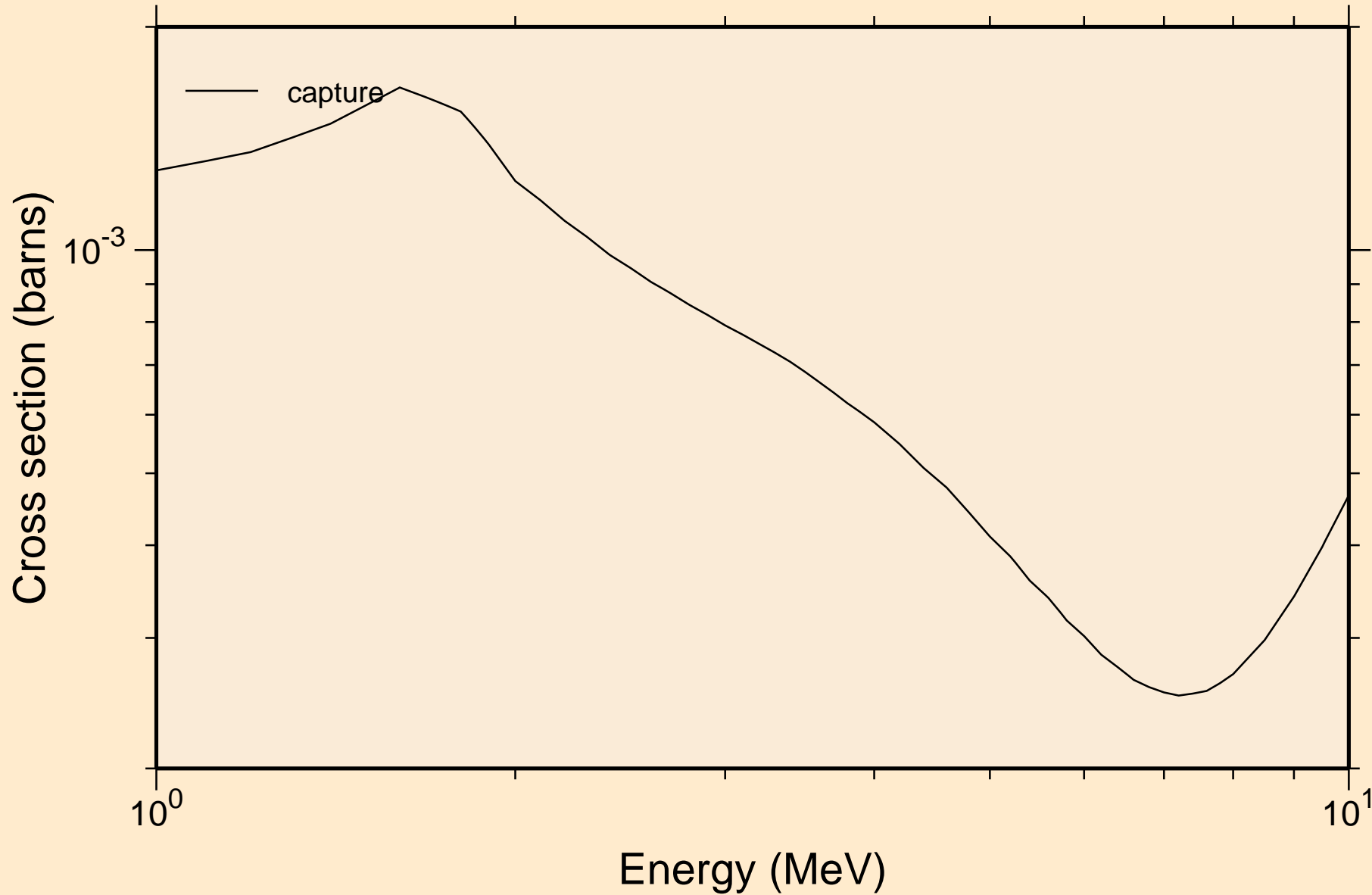

ZN073M NEUTRON ACER TENDL-2021 LIBRARY; T=293.6K  
Heating

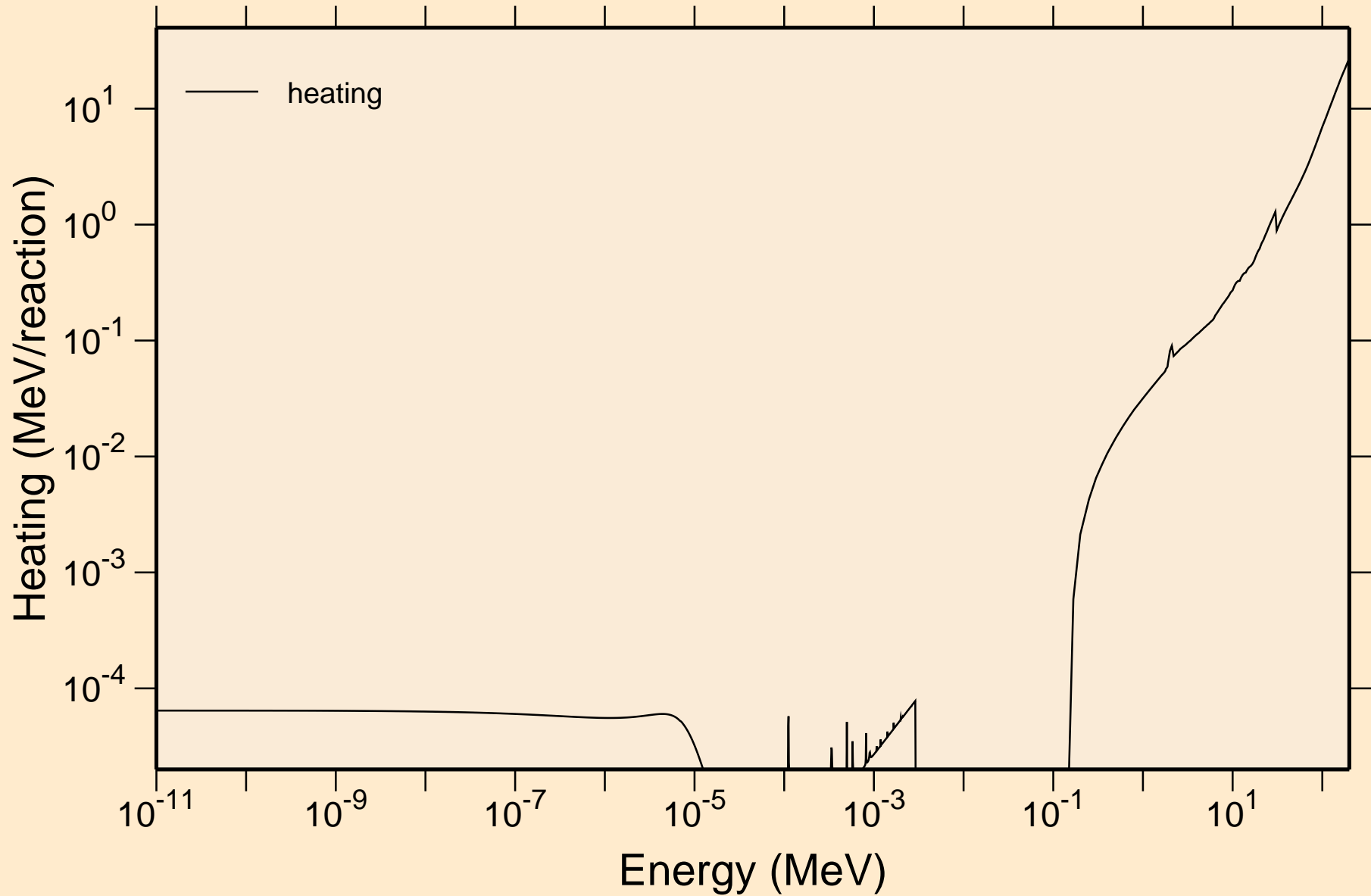

# ZN073M NEUTRON ACER TENDL-2021 LIBRARY; T=293.6K Damage

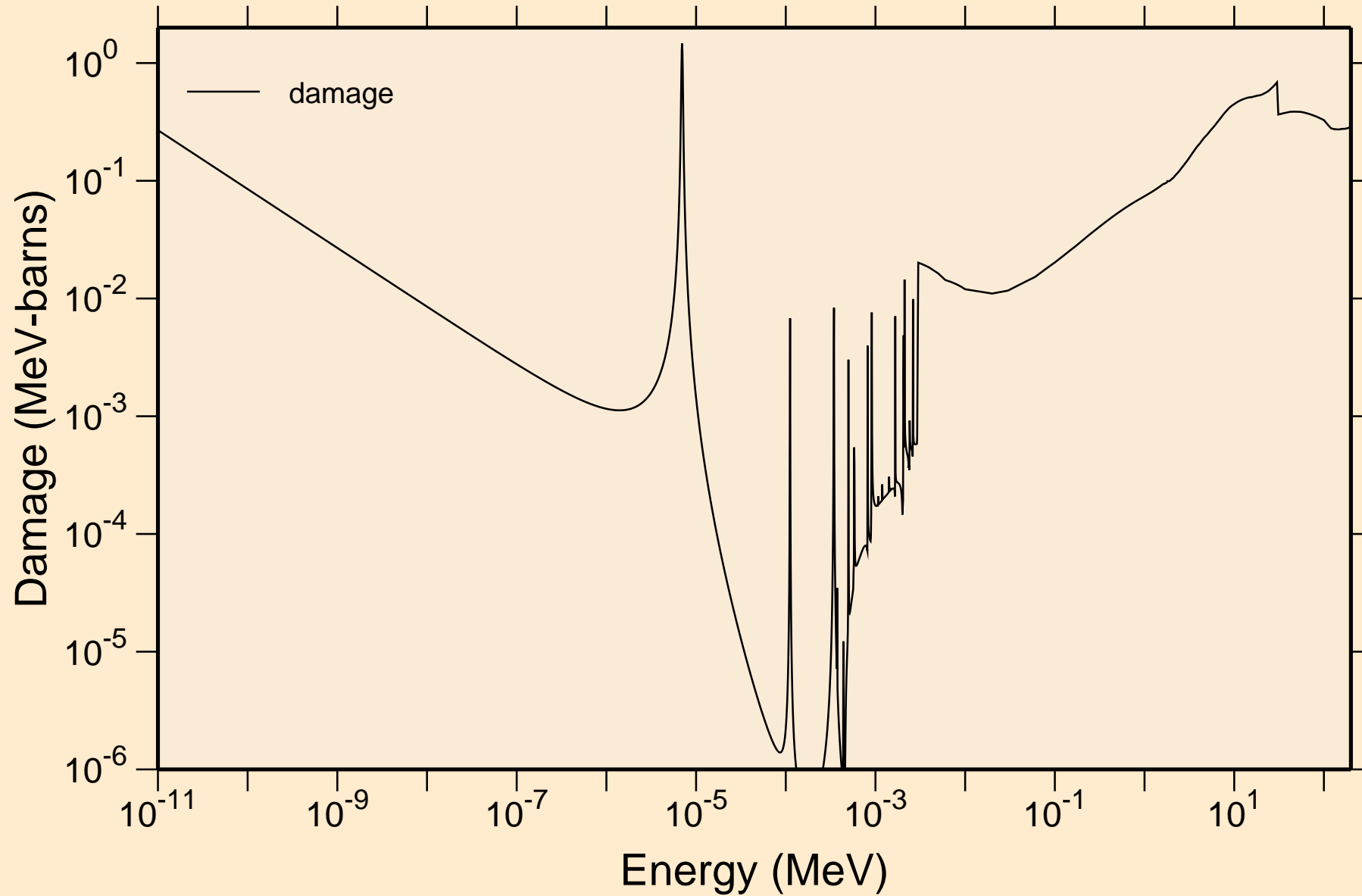

ZN073M NEUTRON ACER TENDL-2021 LIBRARY; T=293.6K  
Non-threshold reactions

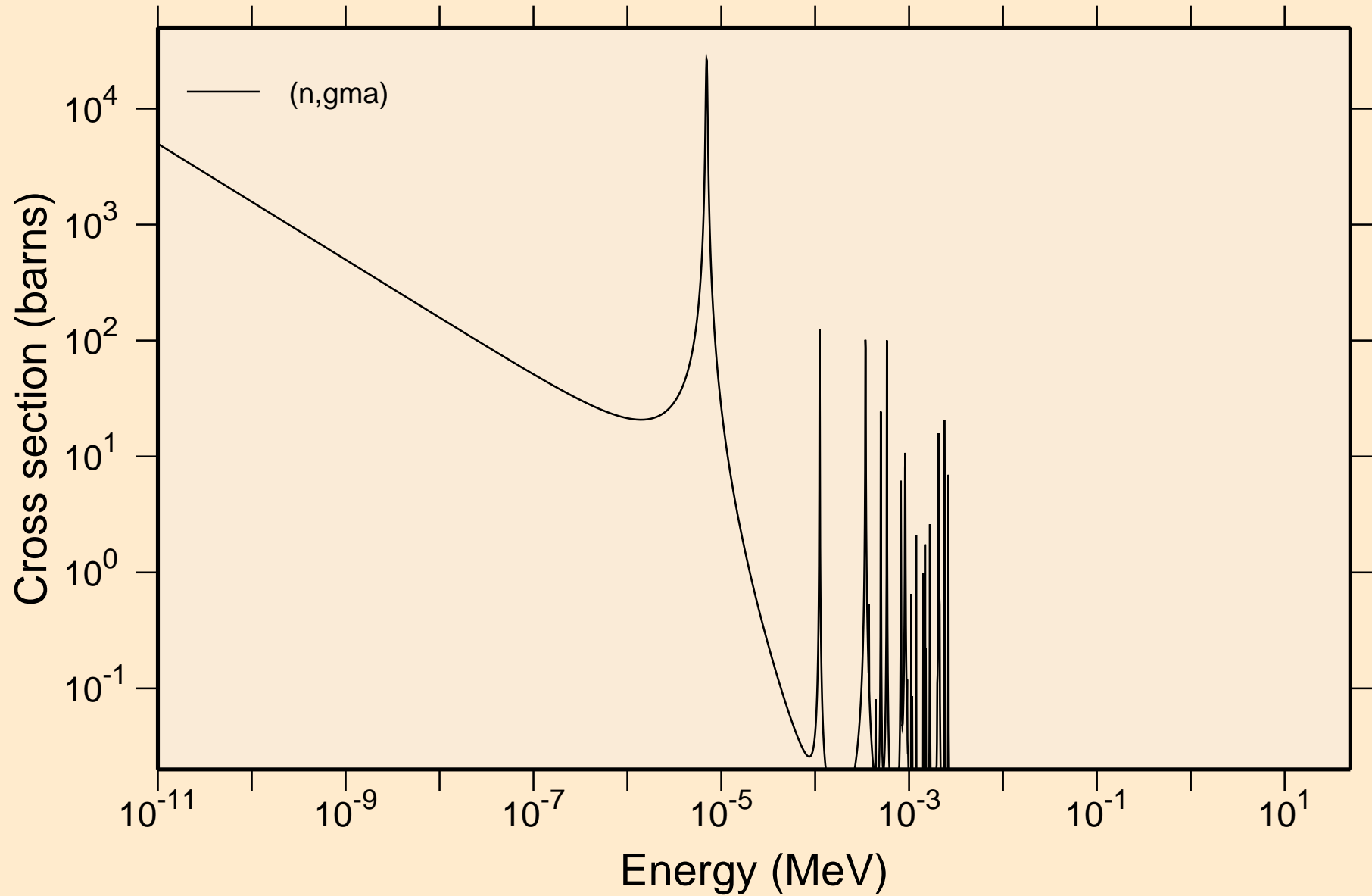

# ZN073M NEUTRON ACER TENDL-2021 LIBRARY; T=293.6K

## Principal cross sections

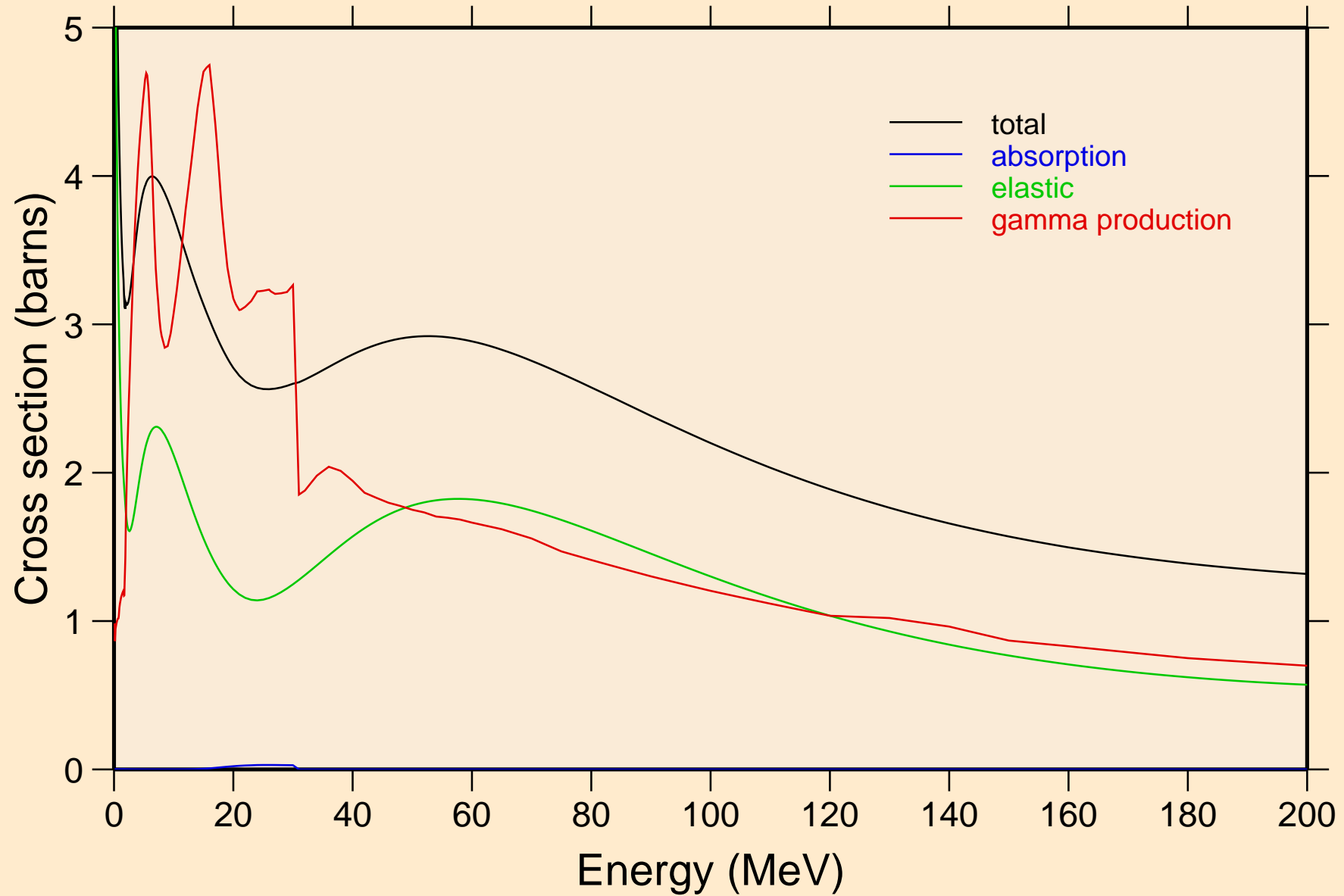

ZN073M NEUTRON ACER TENDL-2021 LIBRARY; T=293.6K  
Heating

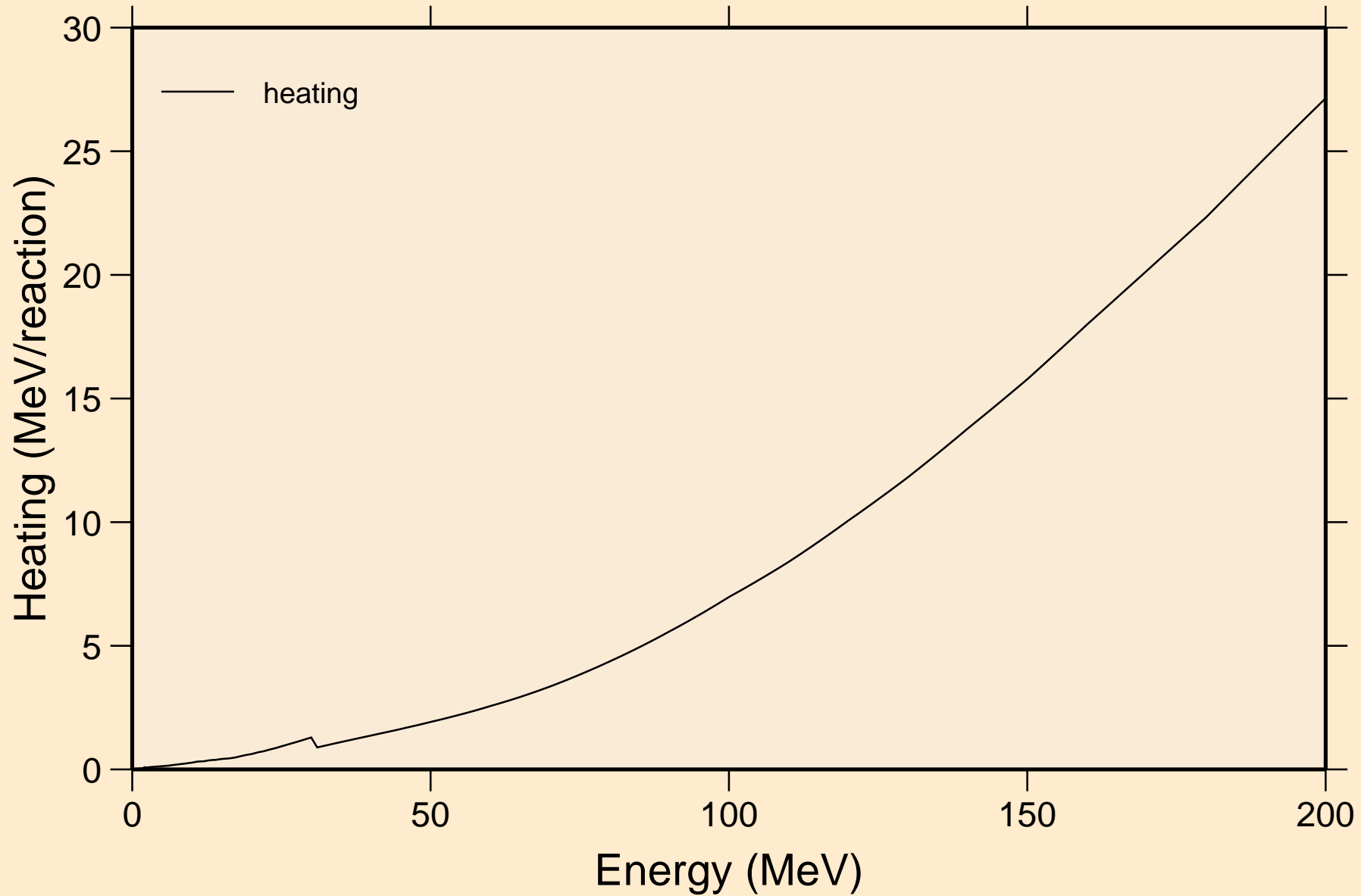



ZN073M NEUTRON ACER TENDL-2021 LIBRARY; T=293.6K  
Damage

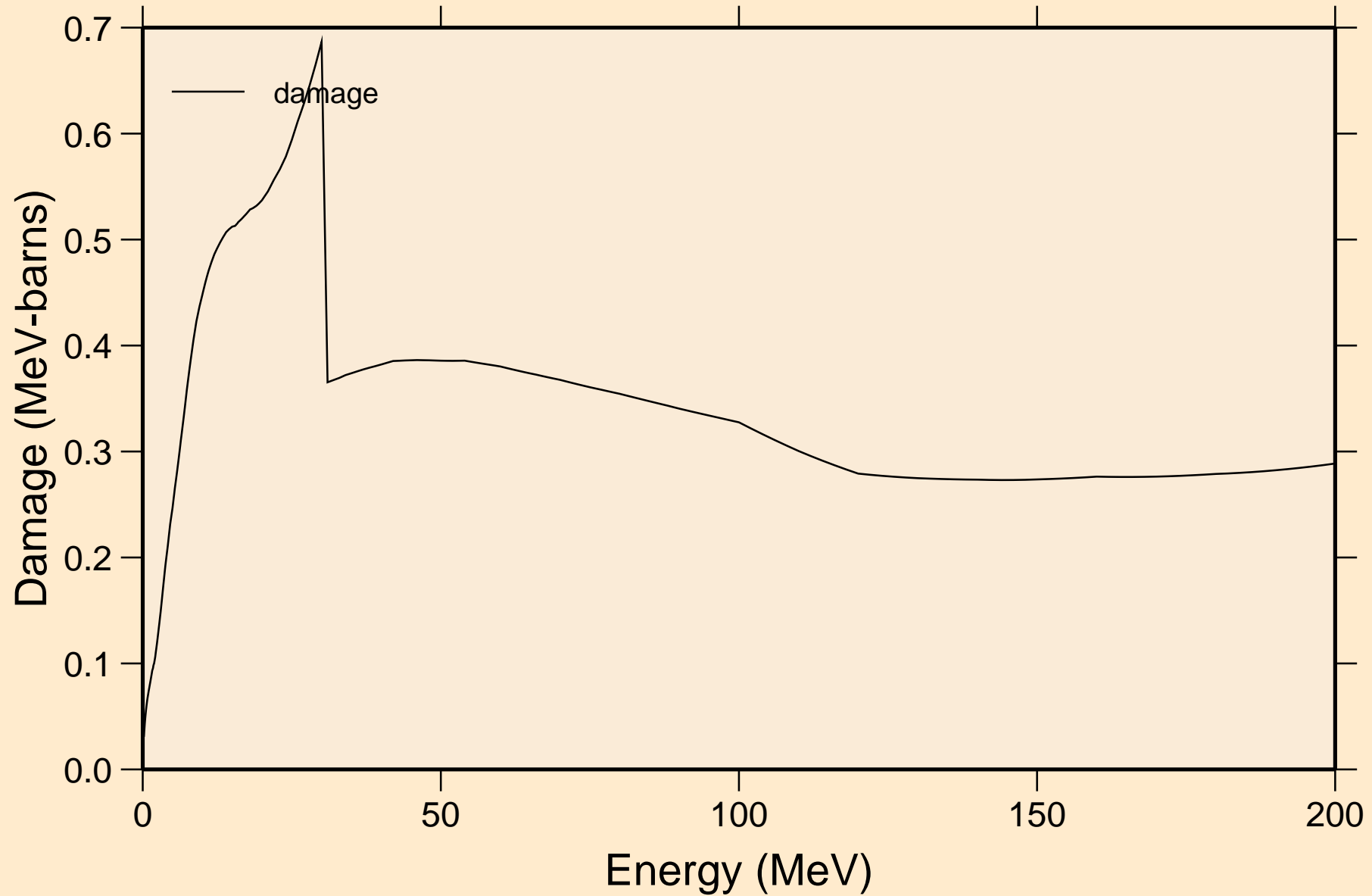

ZN073M NEUTRON ACER TENDL-2021 LIBRARY; T=293.6K  
Non-threshold reactions

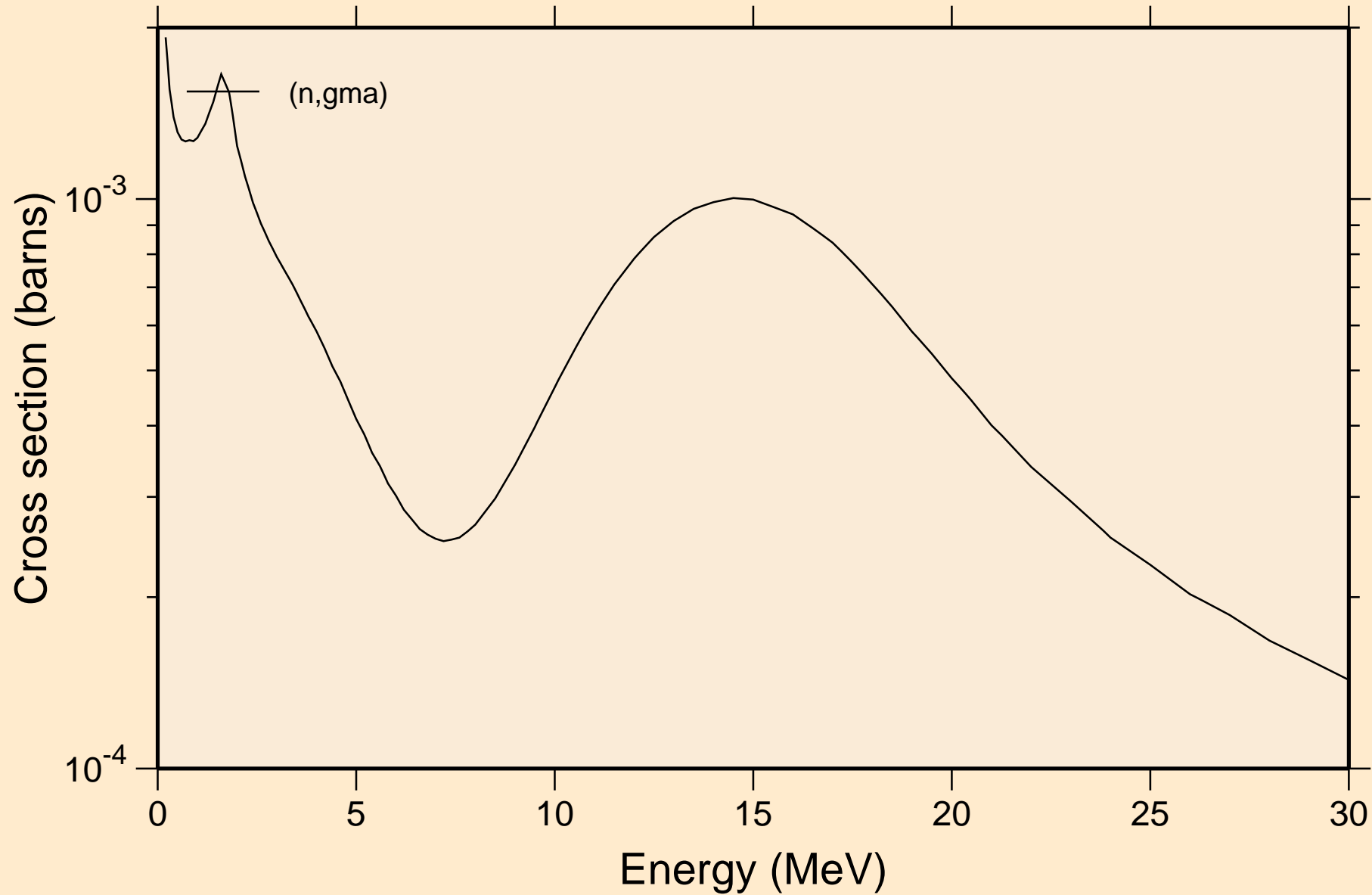

ZN073M NEUTRON ACER TENDL-2021 LIBRARY; T=293.6K  
Inelastic levels

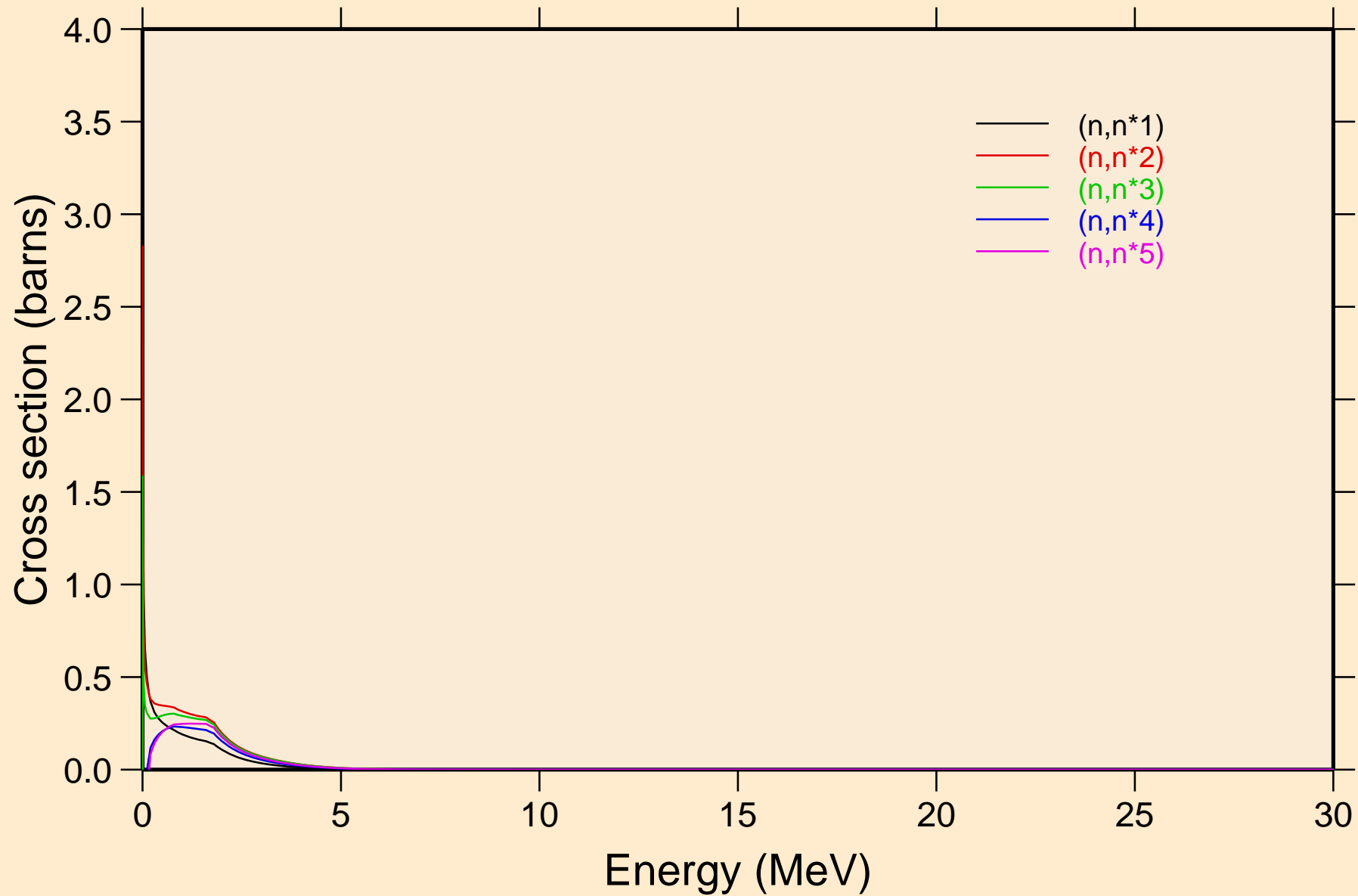

ZN073M NEUTRON ACER TENDL-2021 LIBRARY; T=293.6K  
Inelastic levels

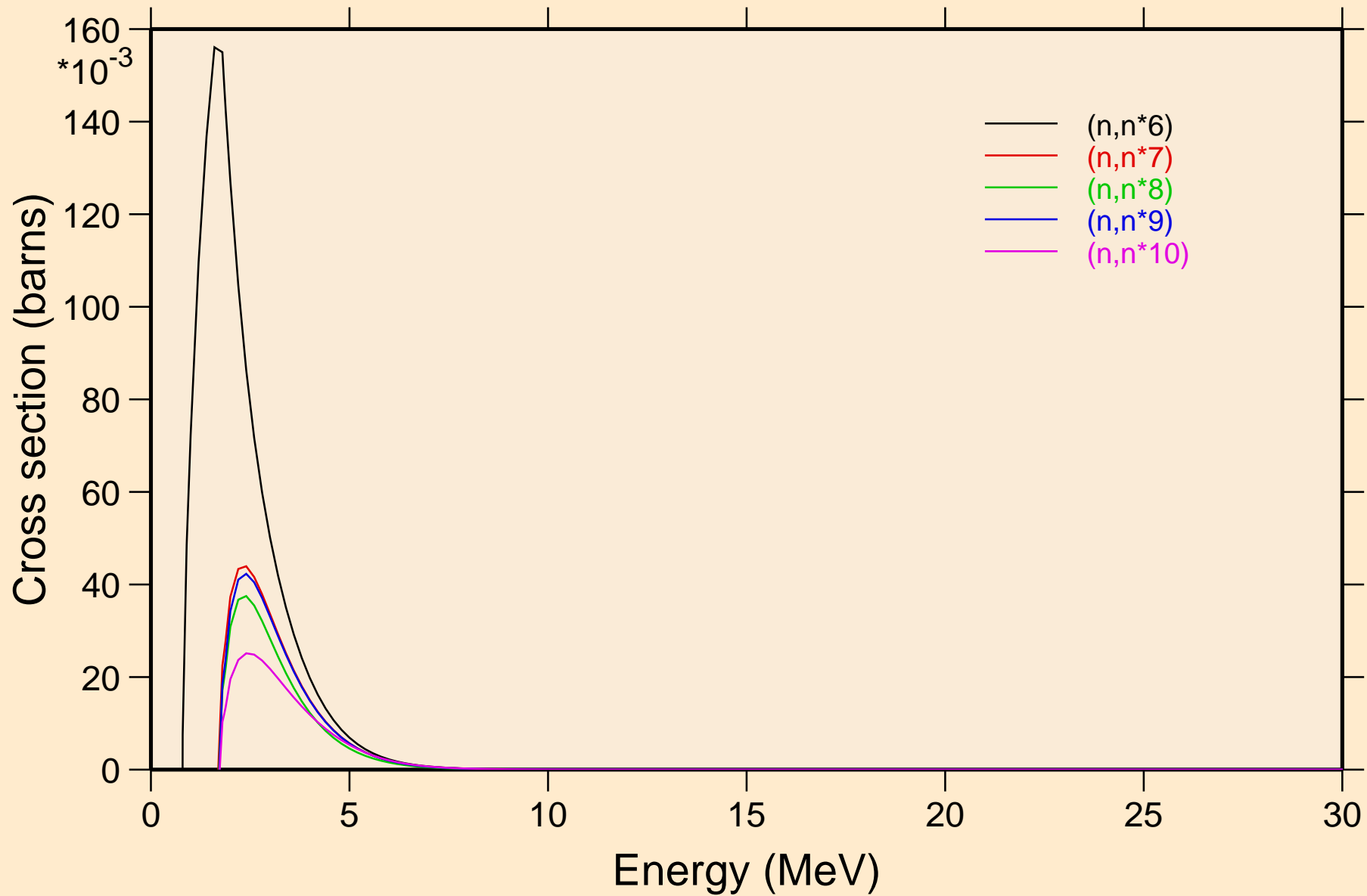

ZN073M NEUTRON ACER TENDL-2021 LIBRARY; T=293.6K  
Inelastic levels

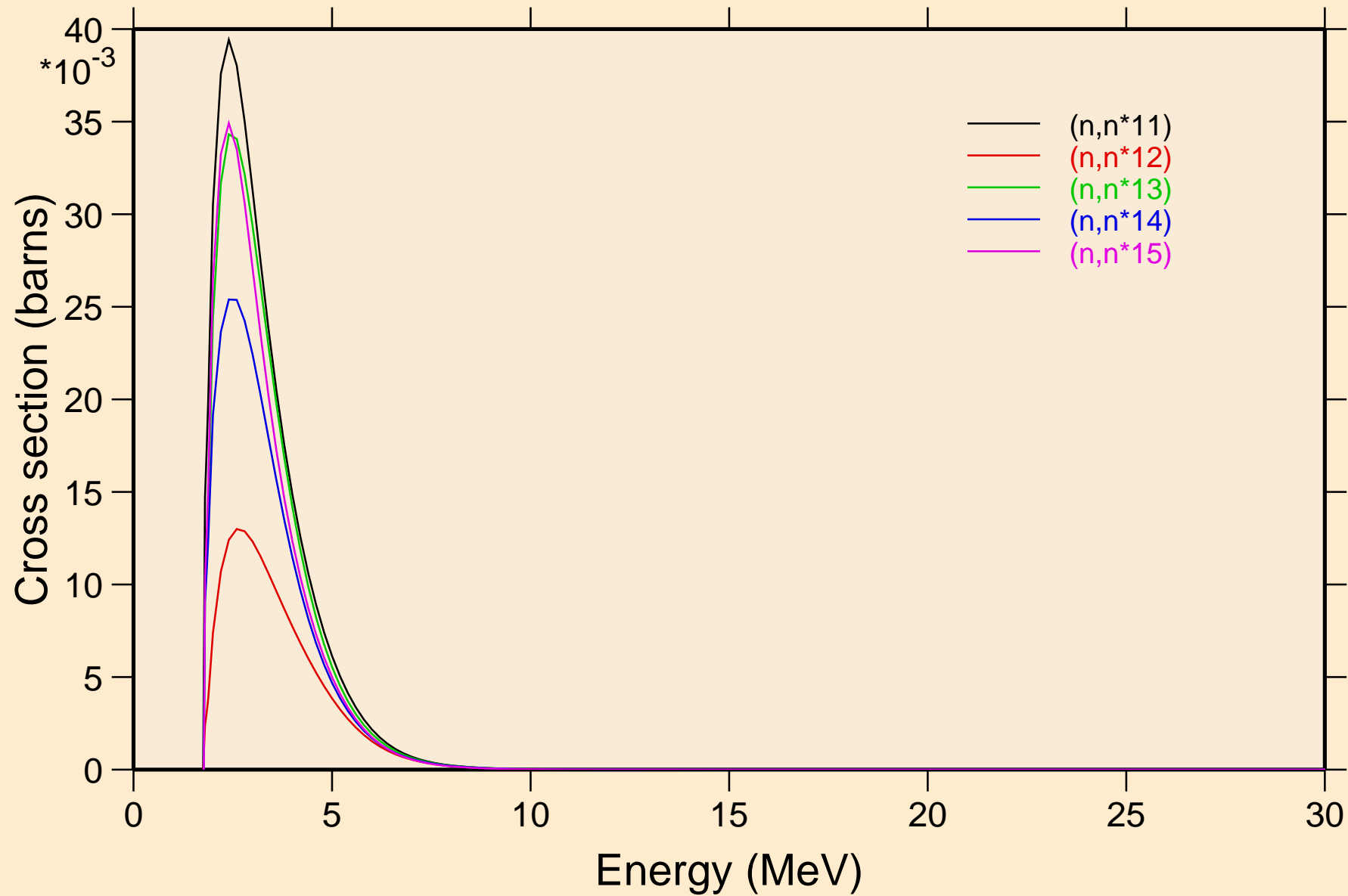

ZN073M NEUTRON ACER TENDL-2021 LIBRARY; T=293.6K  
Inelastic levels

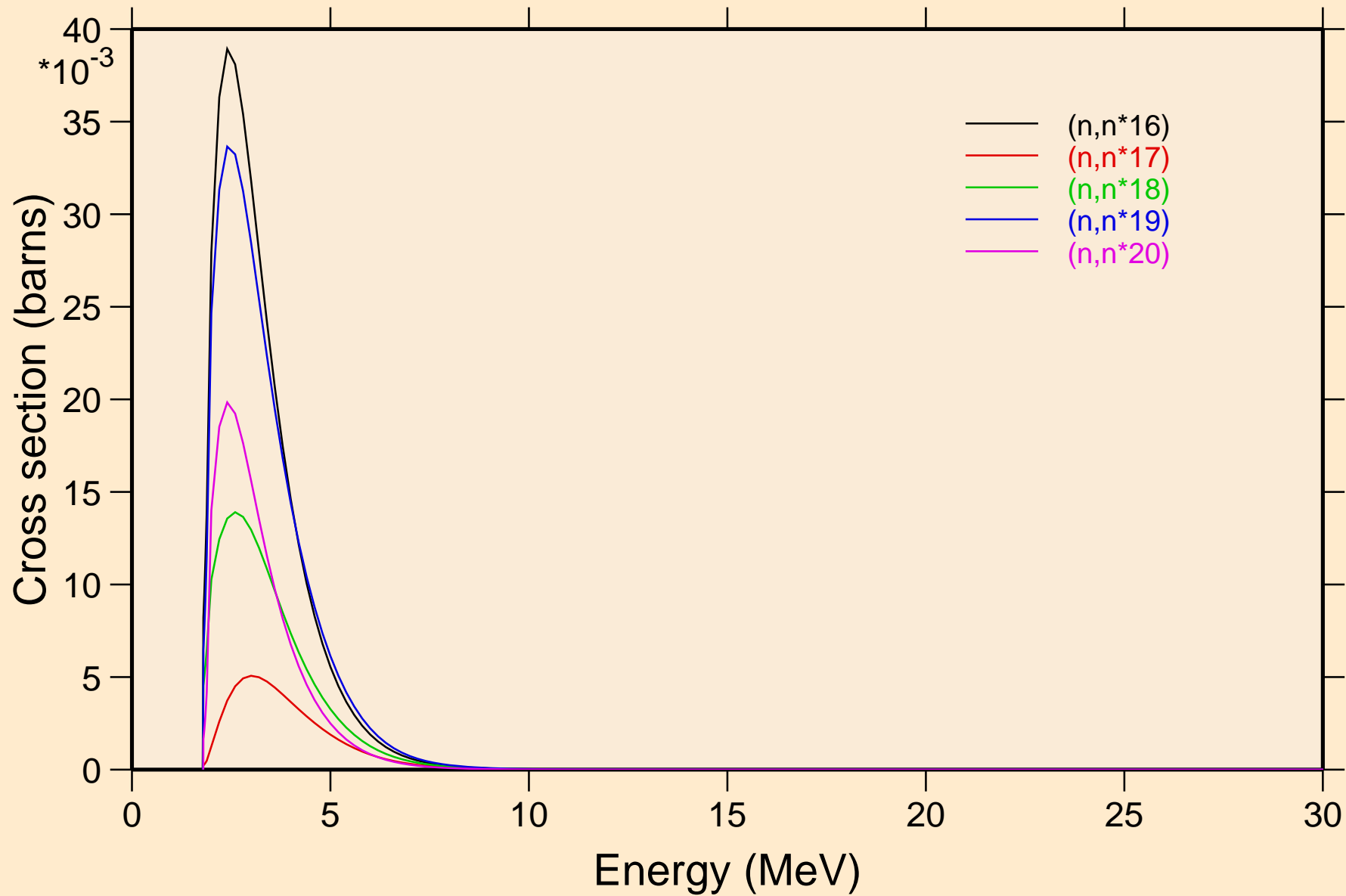

ZN073M NEUTRON ACER TENDL-2021 LIBRARY; T=293.6K  
Inelastic levels

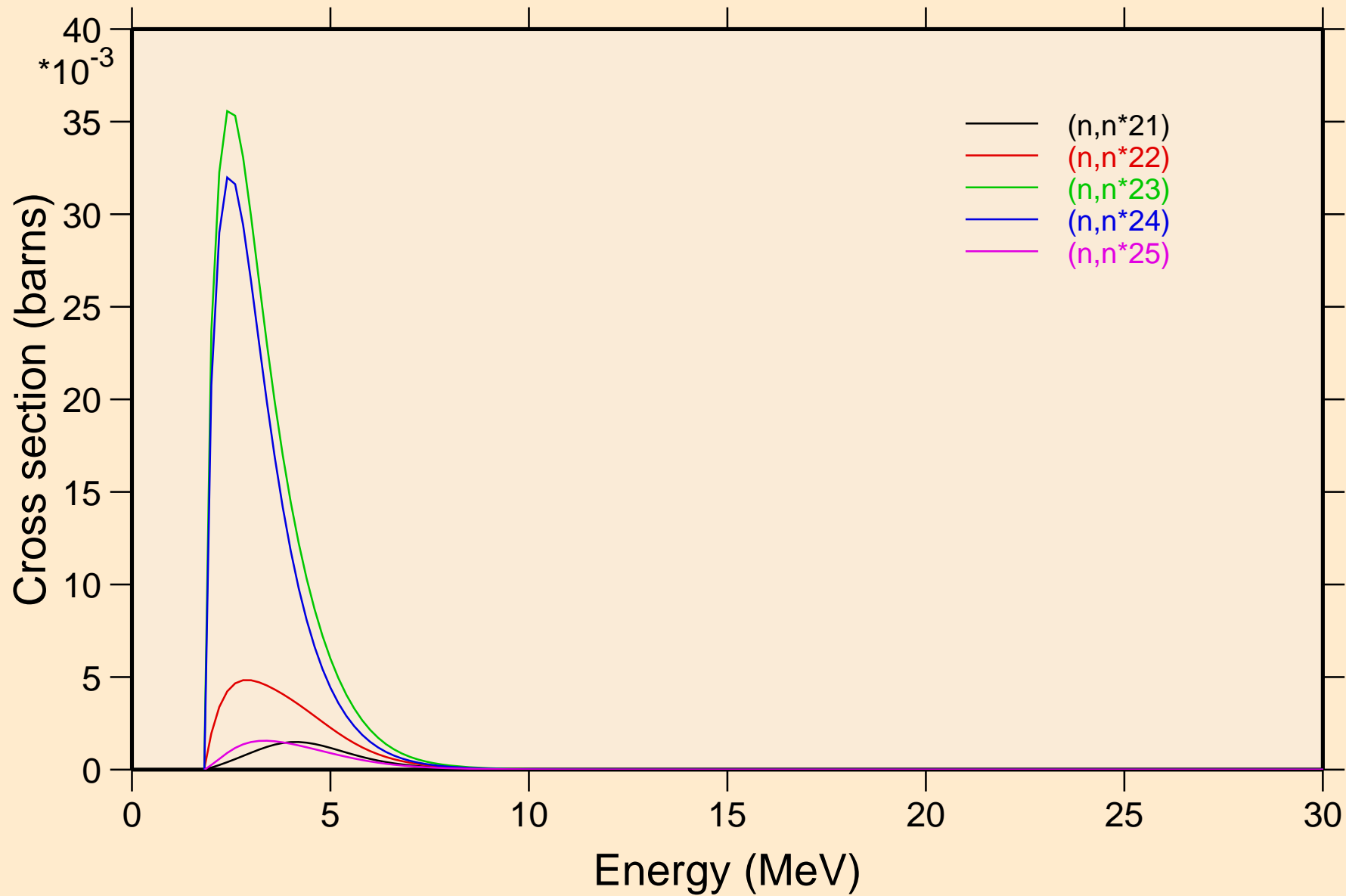

ZN073M NEUTRON ACER TENDL-2021 LIBRARY; T=293.6K  
Inelastic levels

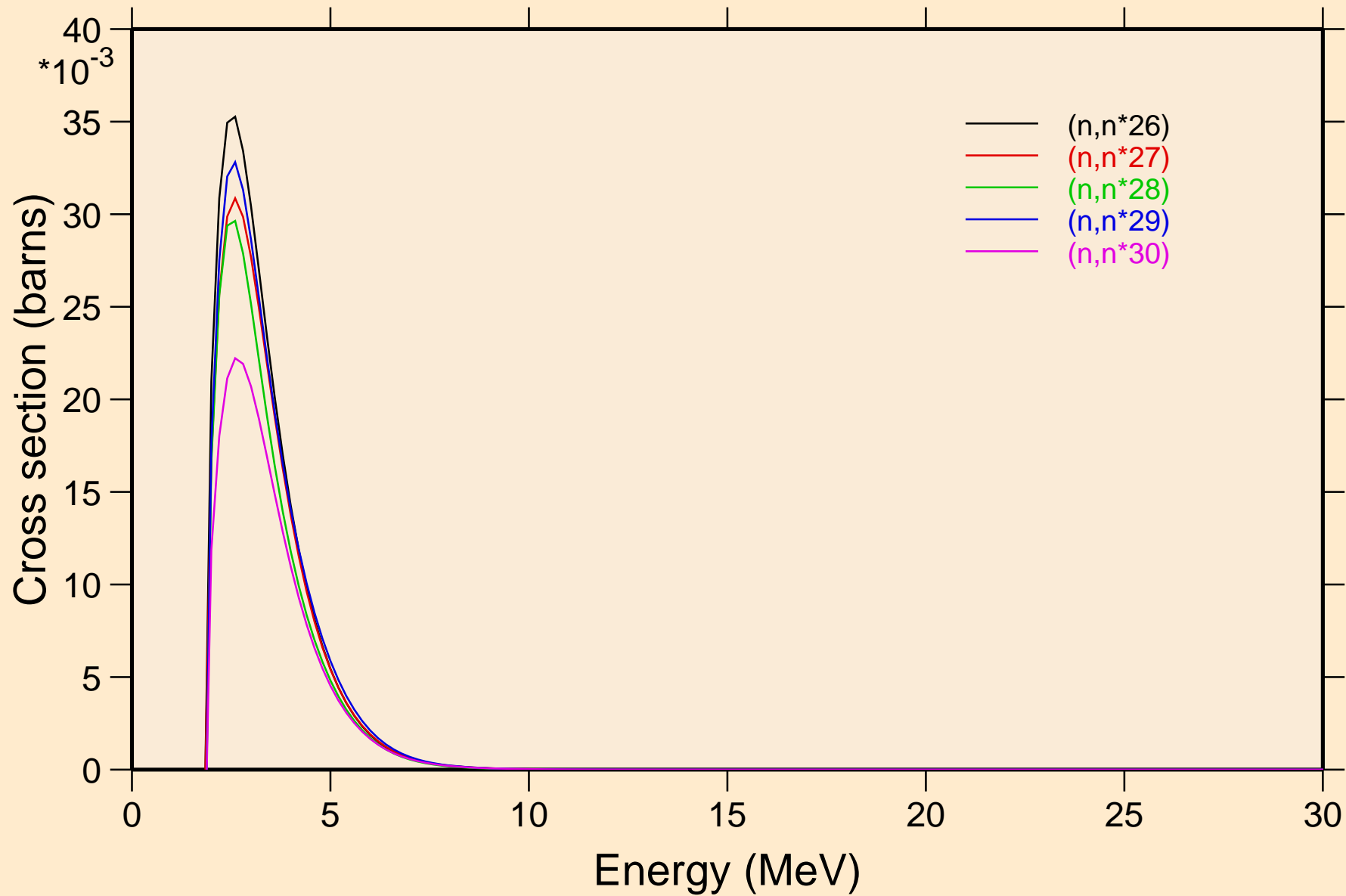



ZN073M NEUTRON ACER TENDL-2021 LIBRARY; T=293.6K  
Threshold reactions

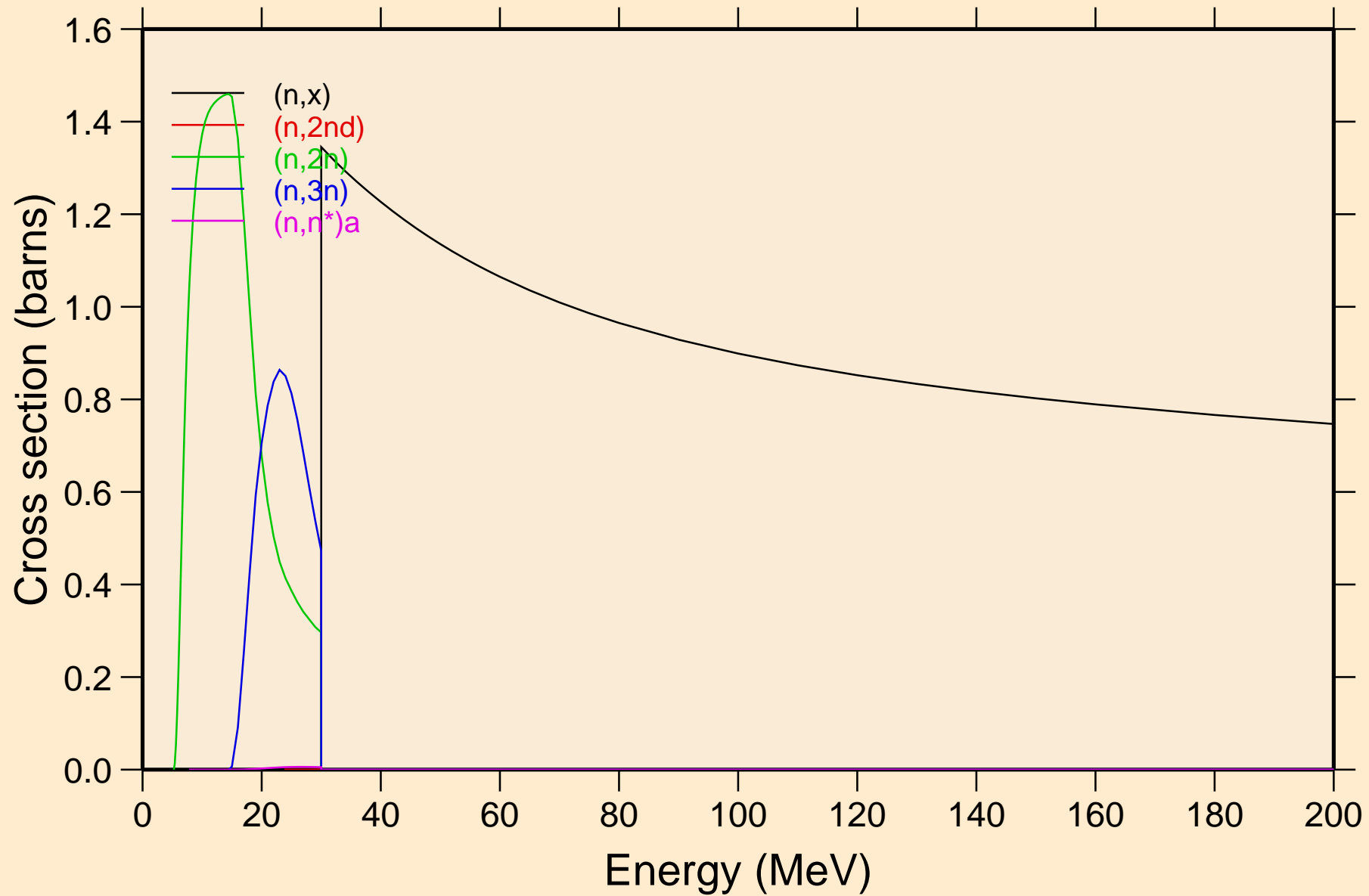

# ZN073M NEUTRON ACER TENDL-2021 LIBRARY; T=293.6K

## Threshold reactions

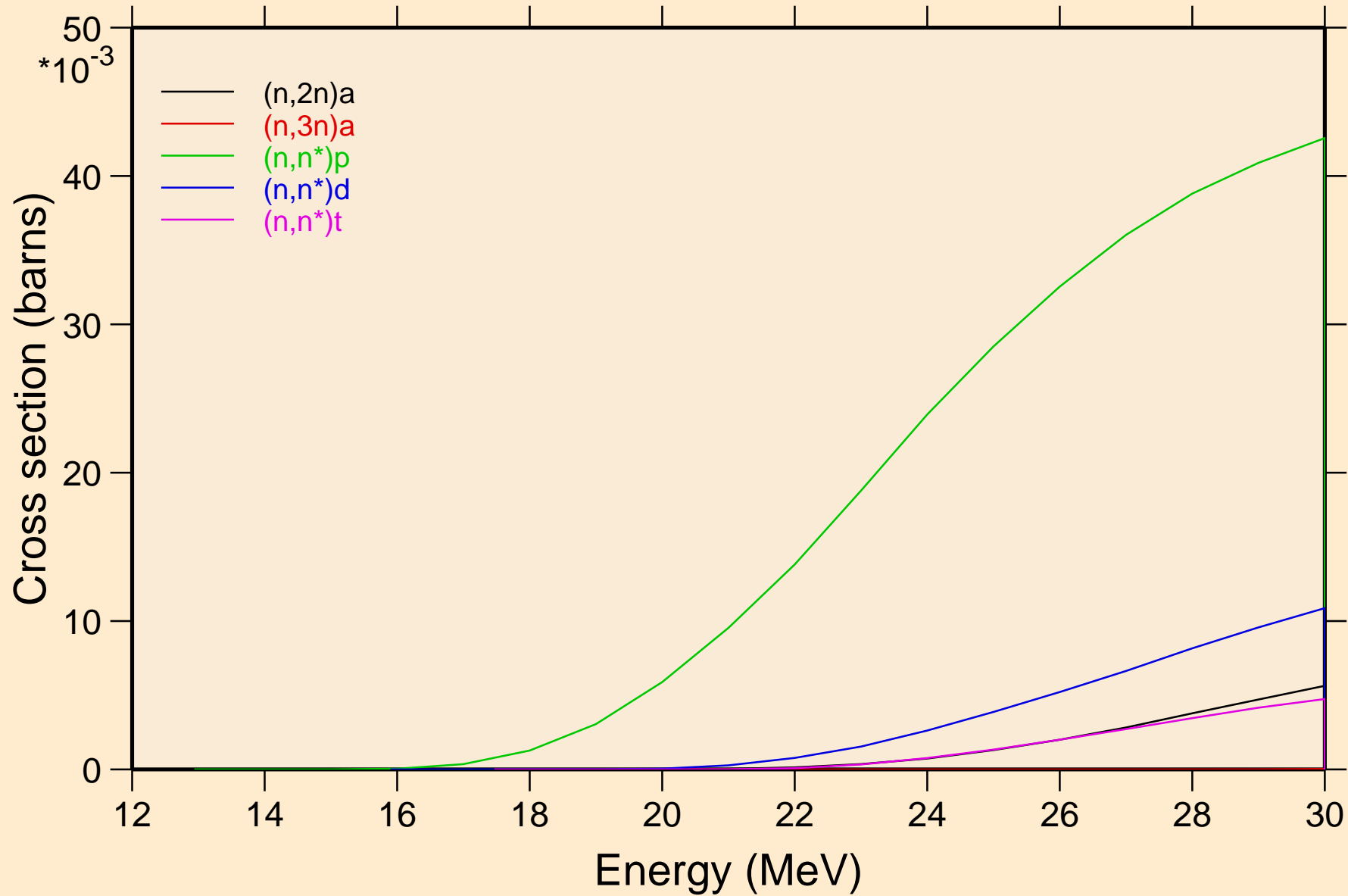

ZN073M NEUTRON ACER TENDL-2021 LIBRARY; T=293.6K  
Threshold reactions

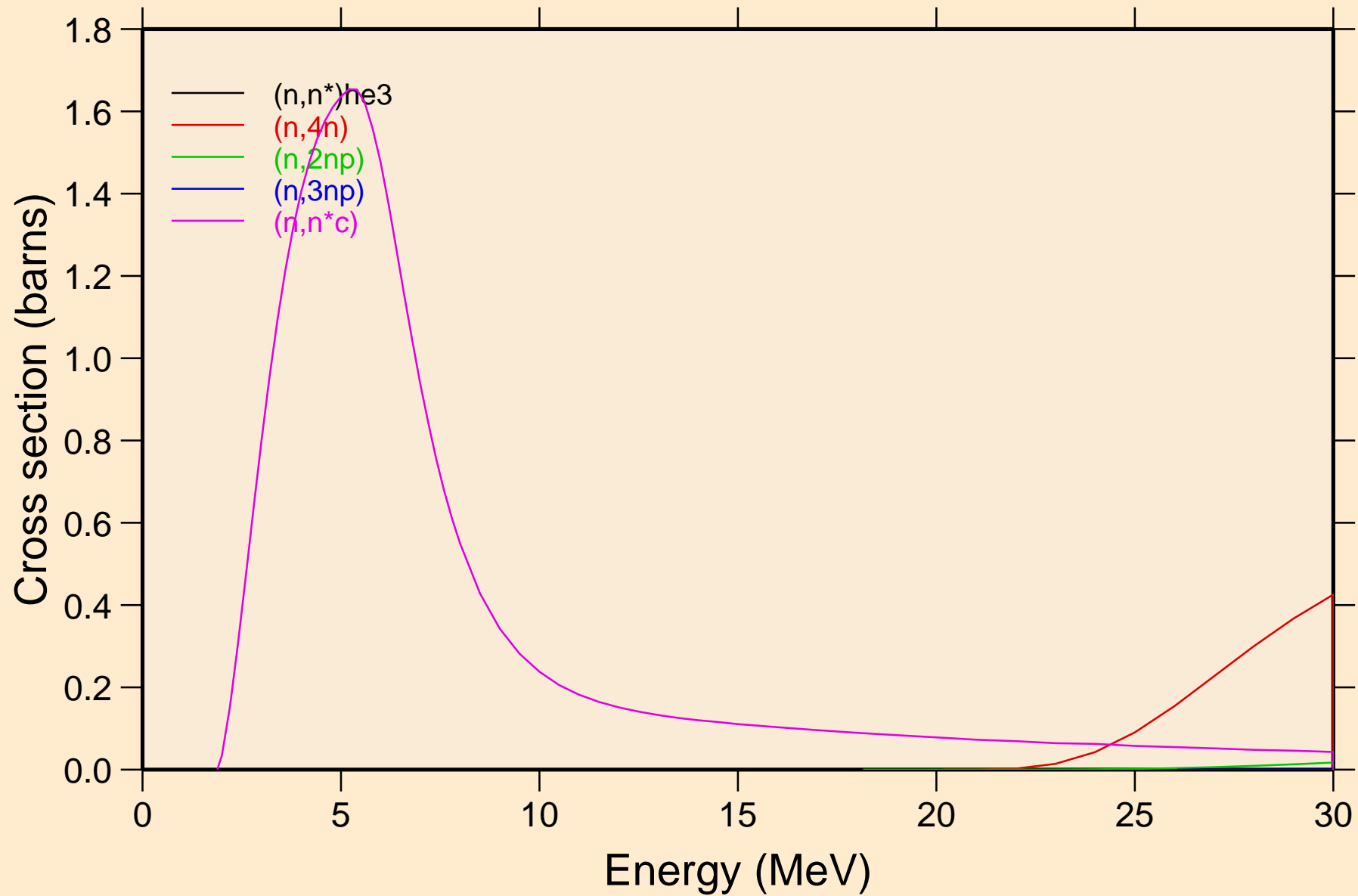

ZN073M NEUTRON ACER TENDL-2021 LIBRARY; T=293.6K  
Threshold reactions

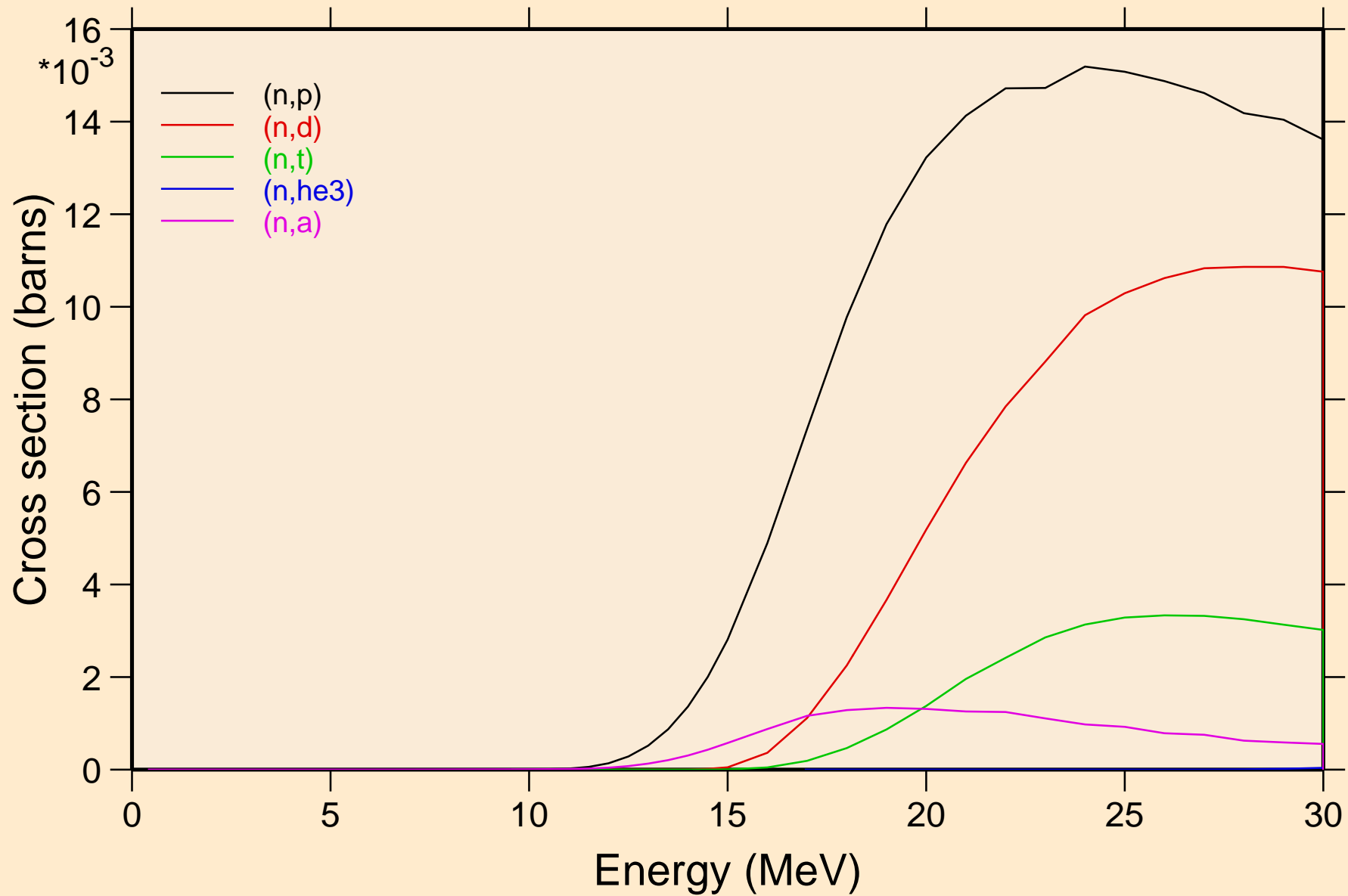

ZN073M NEUTRON ACER TENDL-2021 LIBRARY; T=293.6K  
Threshold reactions

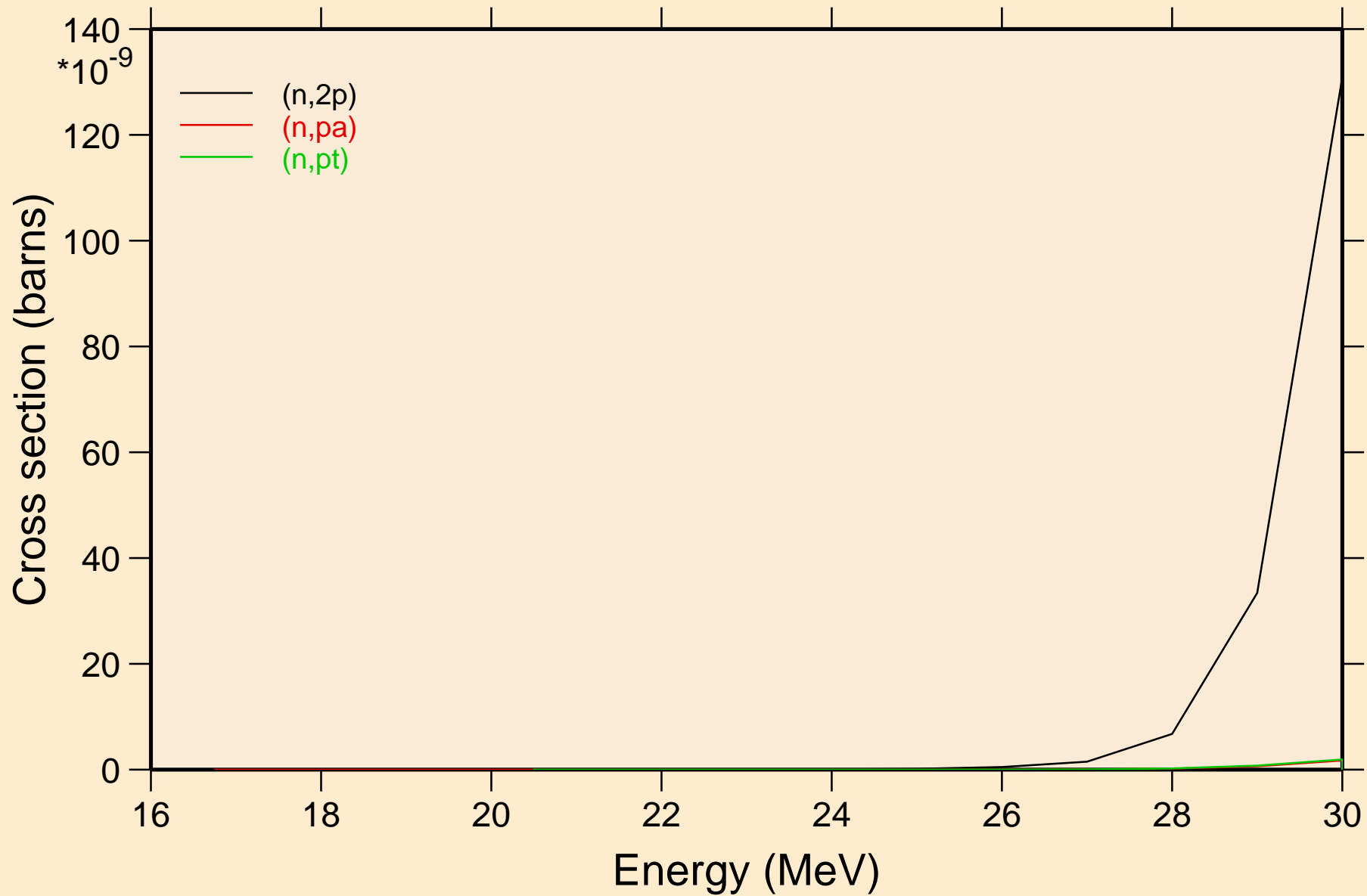

# ZN073M NEUTRON ACER TENDL-2021 LIBRARY; T=293.6K

## Threshold reactions

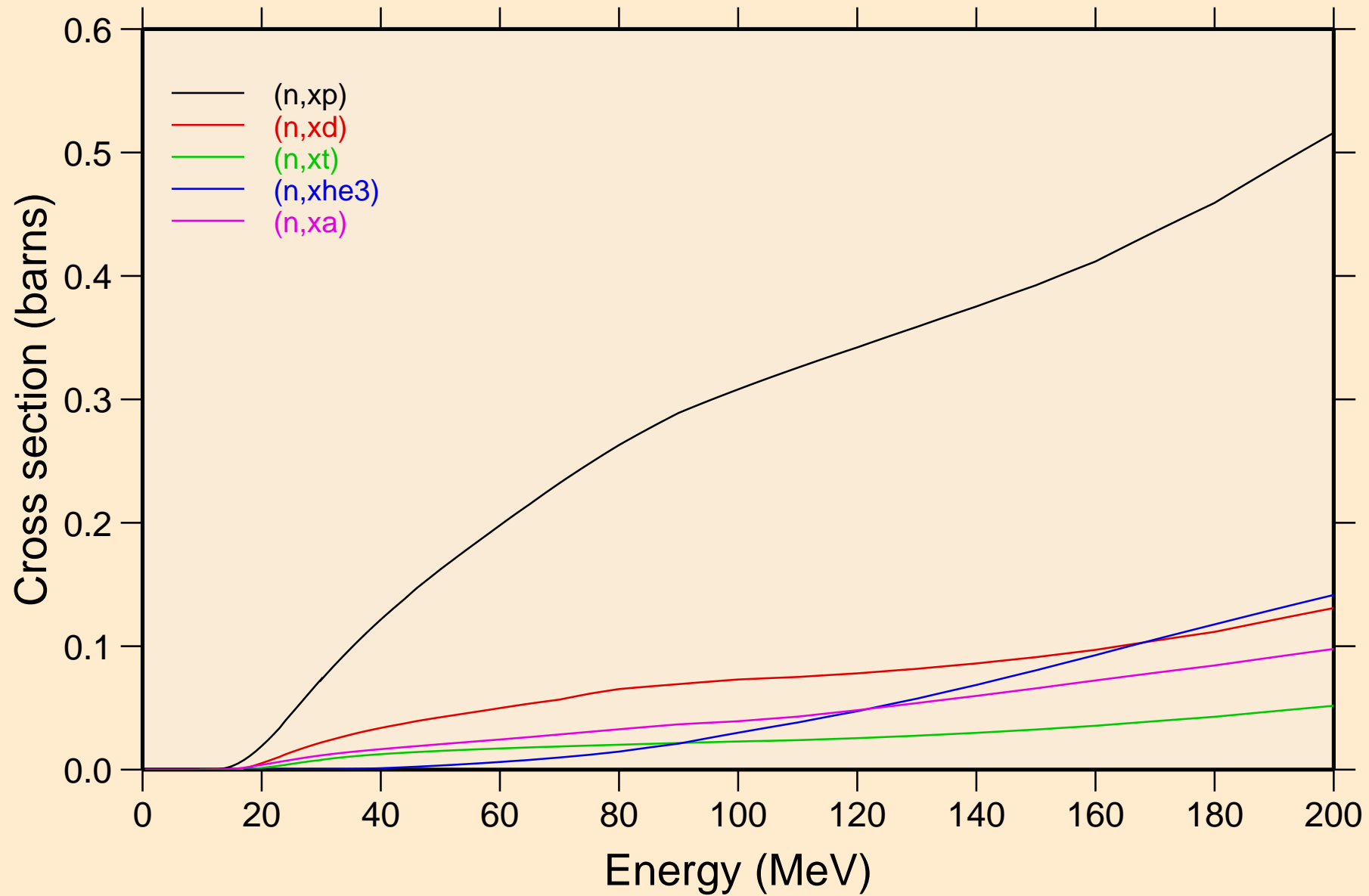

ZN073M NEUTRON ACER TENDL-2021 LIBRARY; T=293.6K  
angular distribution for elastic

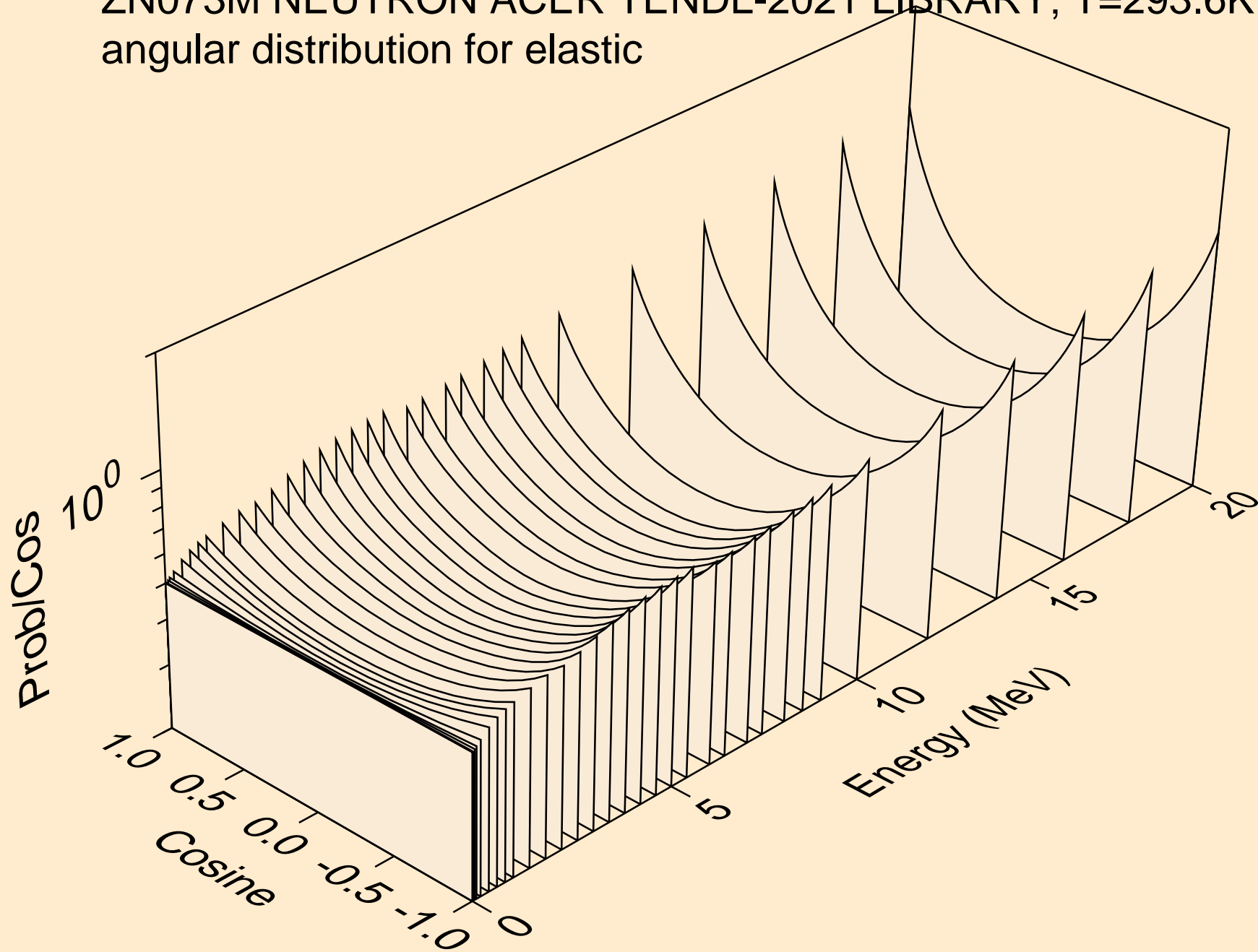

ZN073M NEUTRON ACER TENDL-2021 LIBRARY; T=293.6K  
angular distribution for elastic

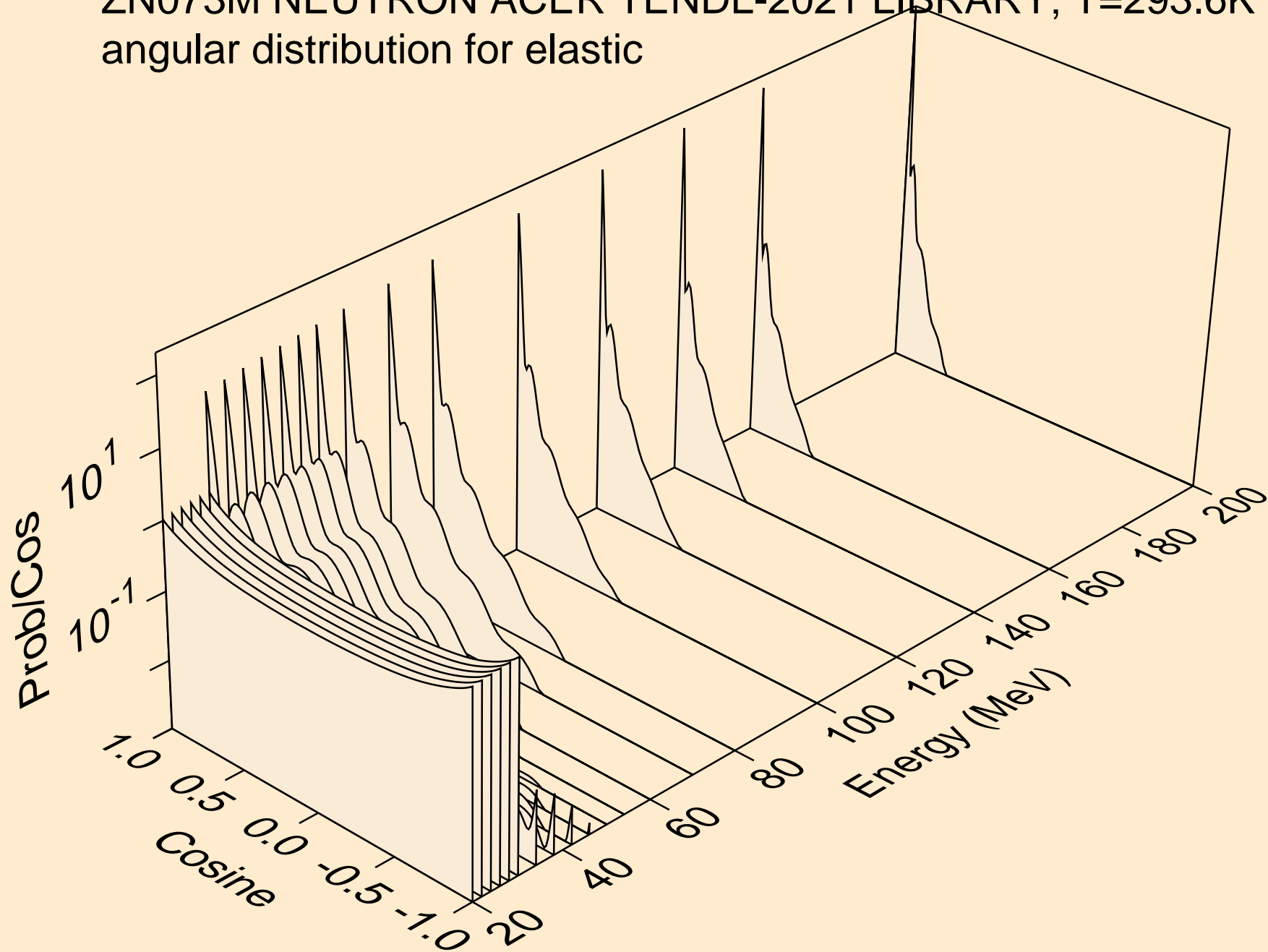



ZN073M NEUTRON ACER TENDL-2021 LIBRARY; T=293.6K  
angular distribution for (n,n\*1)

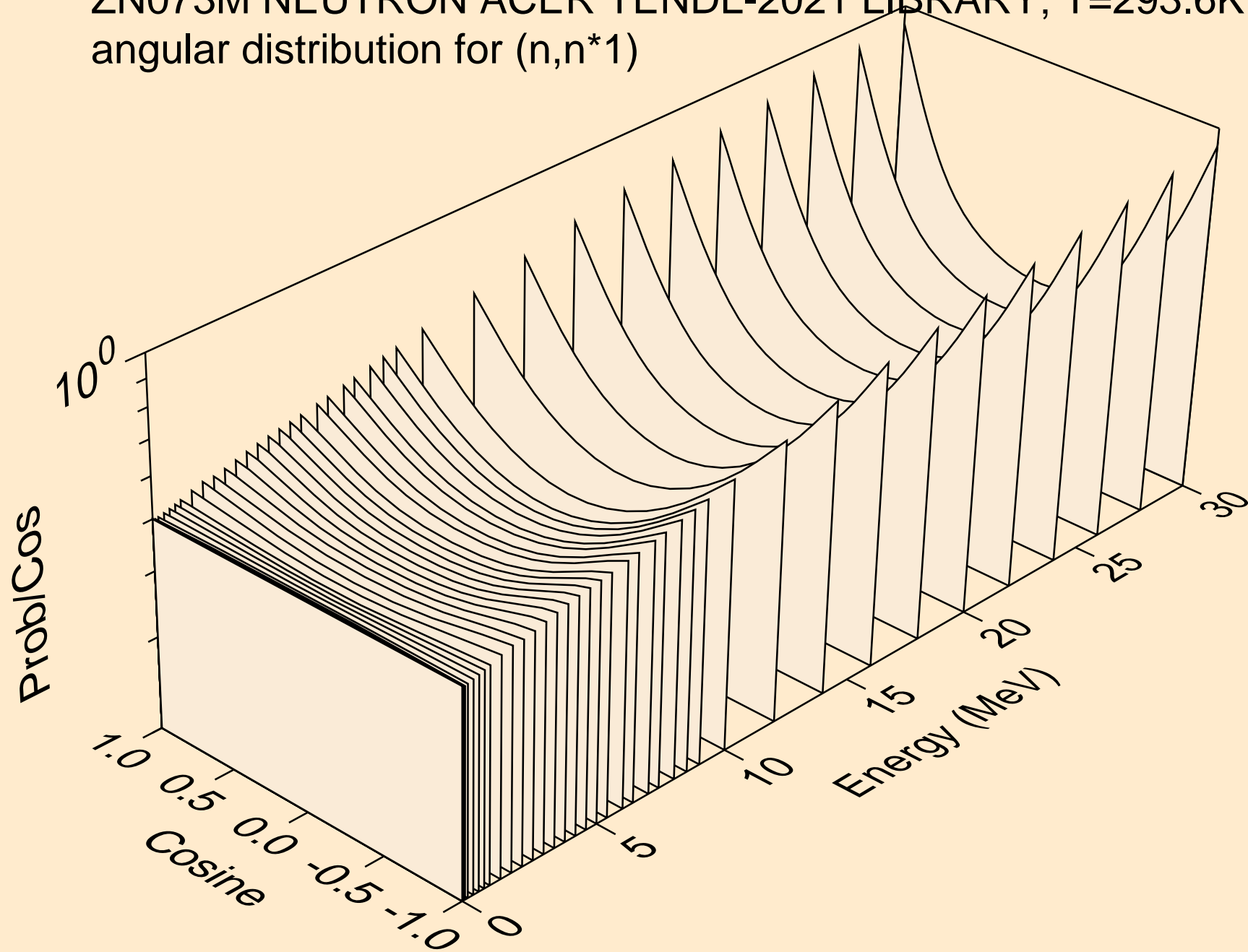

ZN073M NEUTRON ACER TENDL-2021 LIBRARY; T=293.6K  
angular distribution for (n,n\*2)

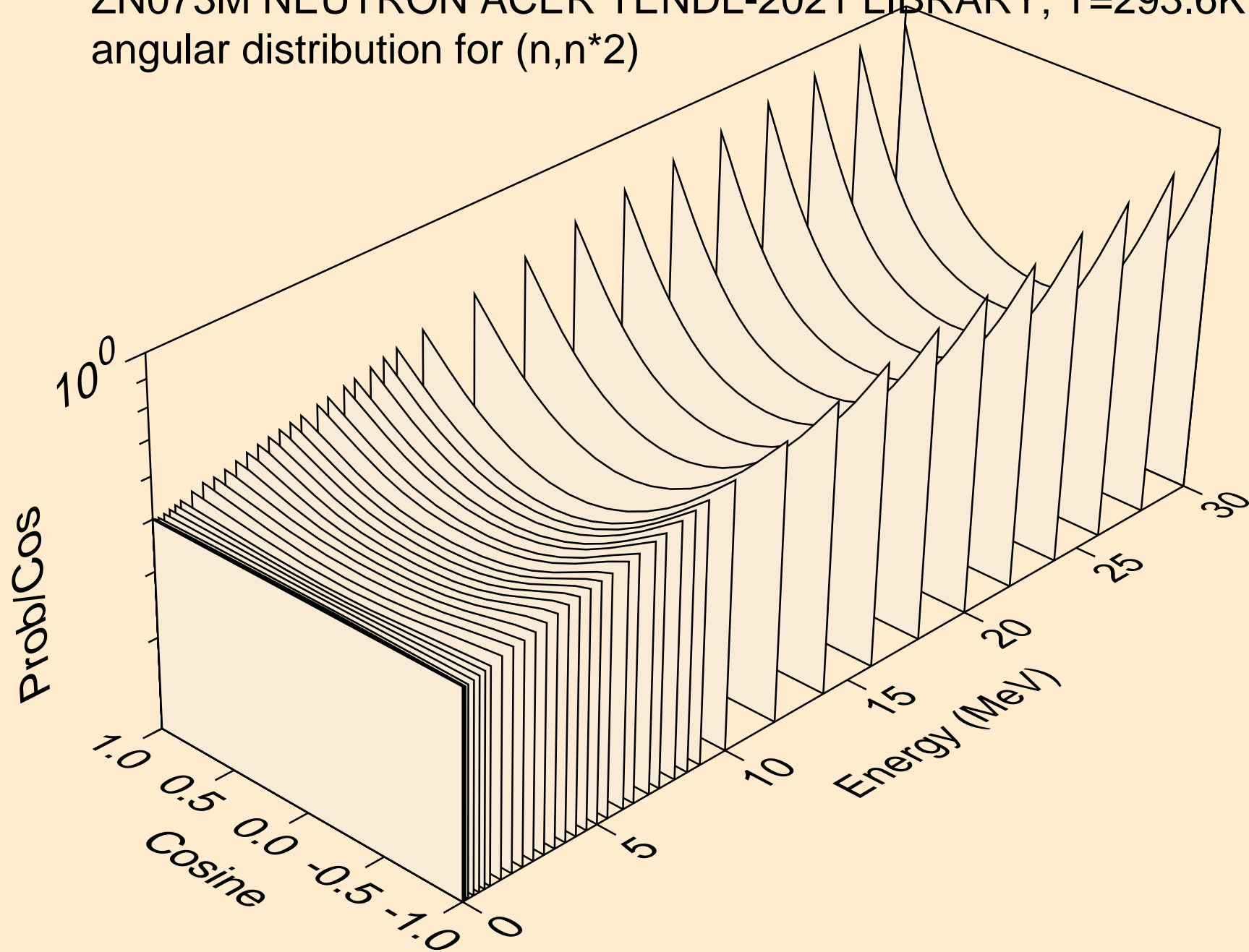

ZN073M NEUTRON ACER TENDL-2021 LIBRARY; T=293.6K  
angular distribution for (n,n\*3)

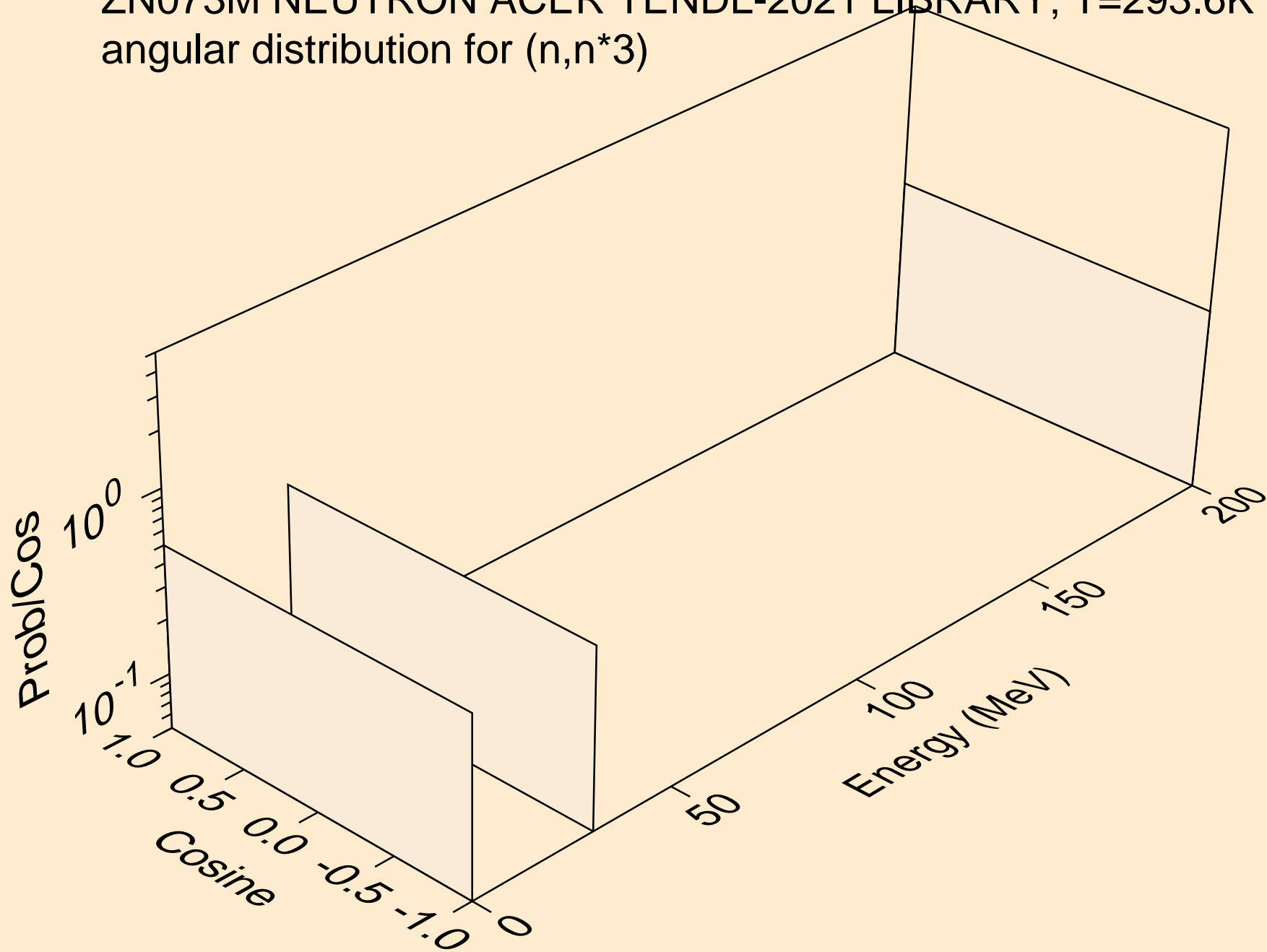

ZN073M NEUTRON ACER TENDL-2021 LIBRARY; T=293.6K  
angular distribution for (n,n\*4)

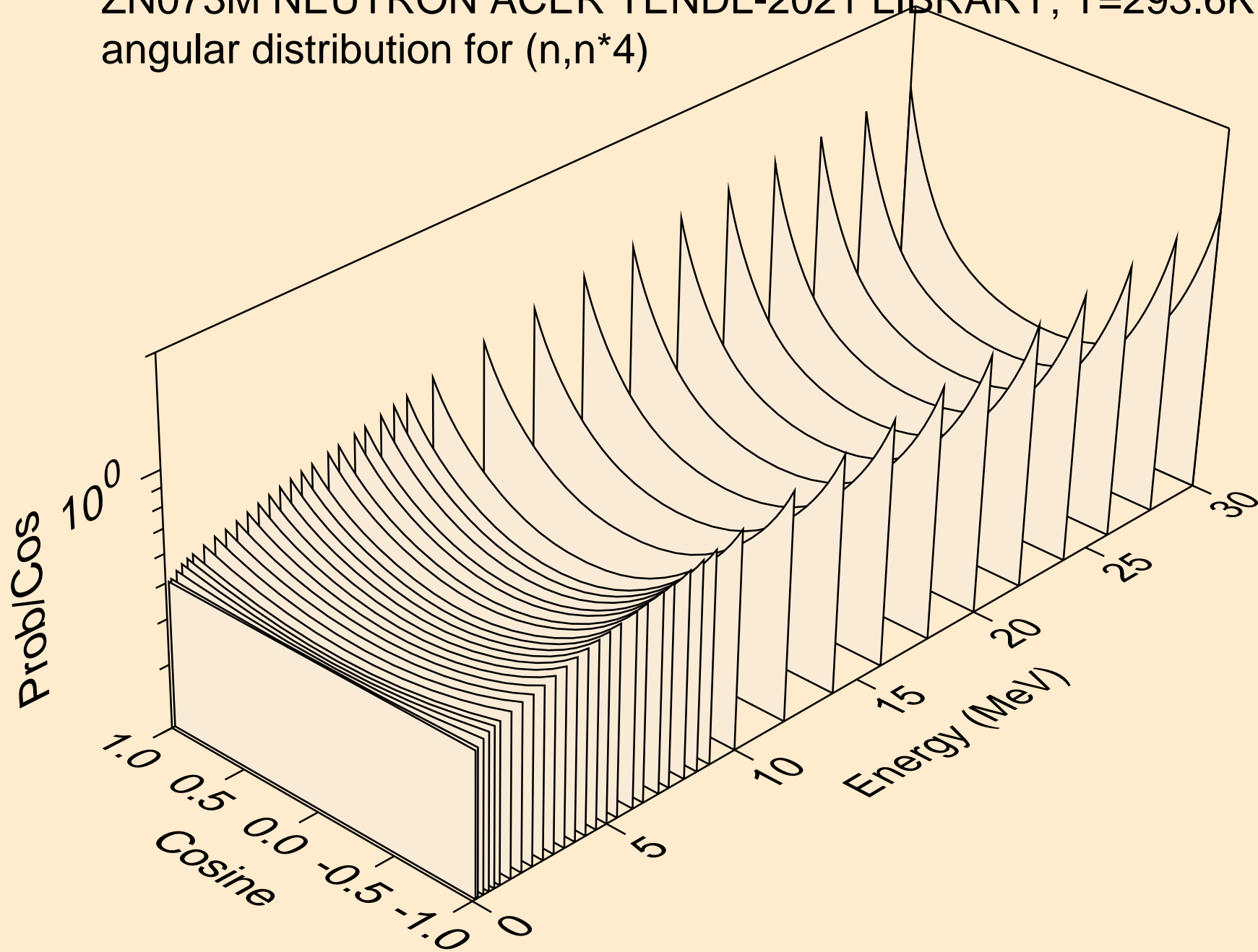

ZN073M NEUTRON ACER TENDL-2021 LIBRARY; T=293.6K  
angular distribution for (n,n\*5)

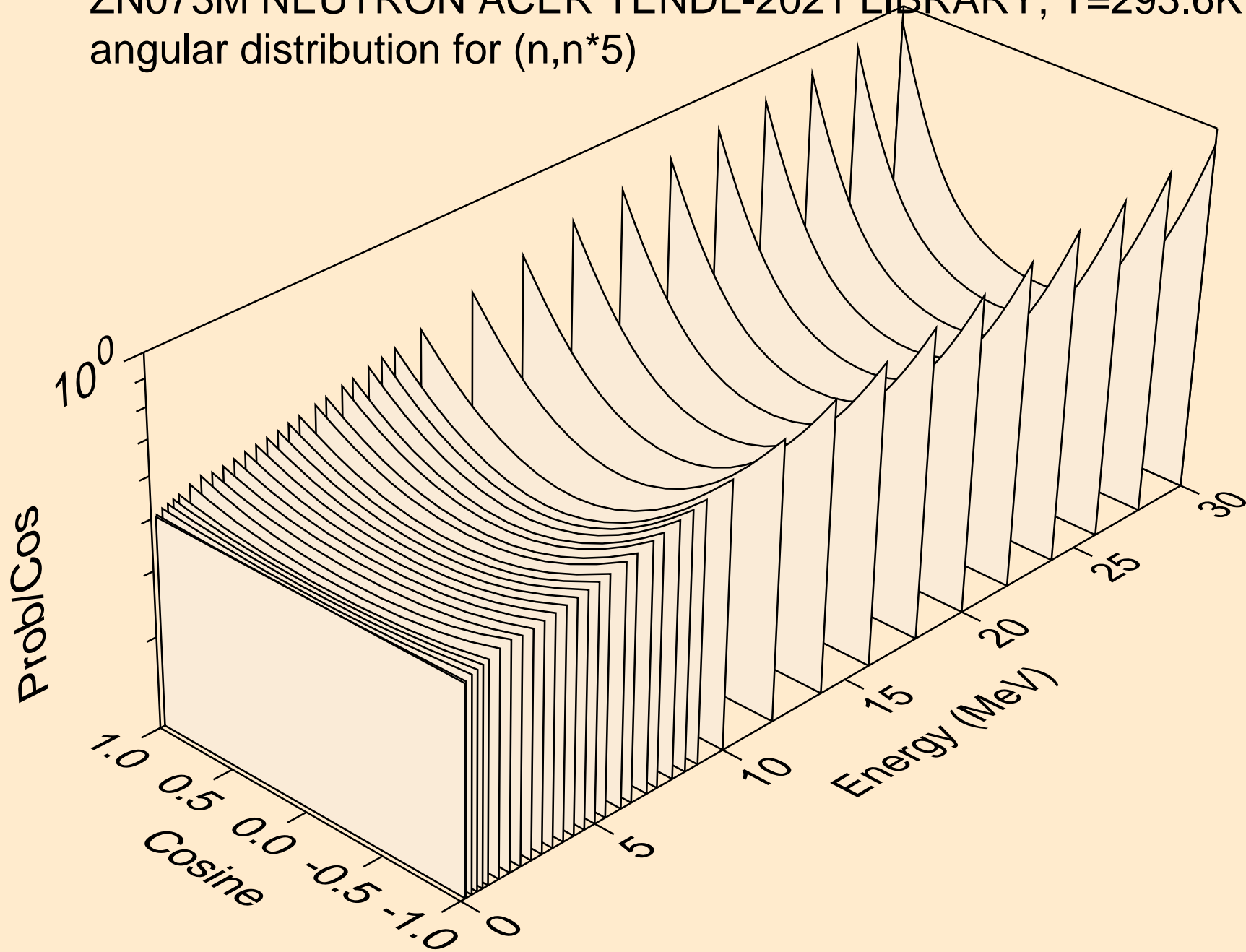

ZN073M NEUTRON ACER TENDL-2021 LIBRARY; T=293.6K  
angular distribution for (n,n\*6)

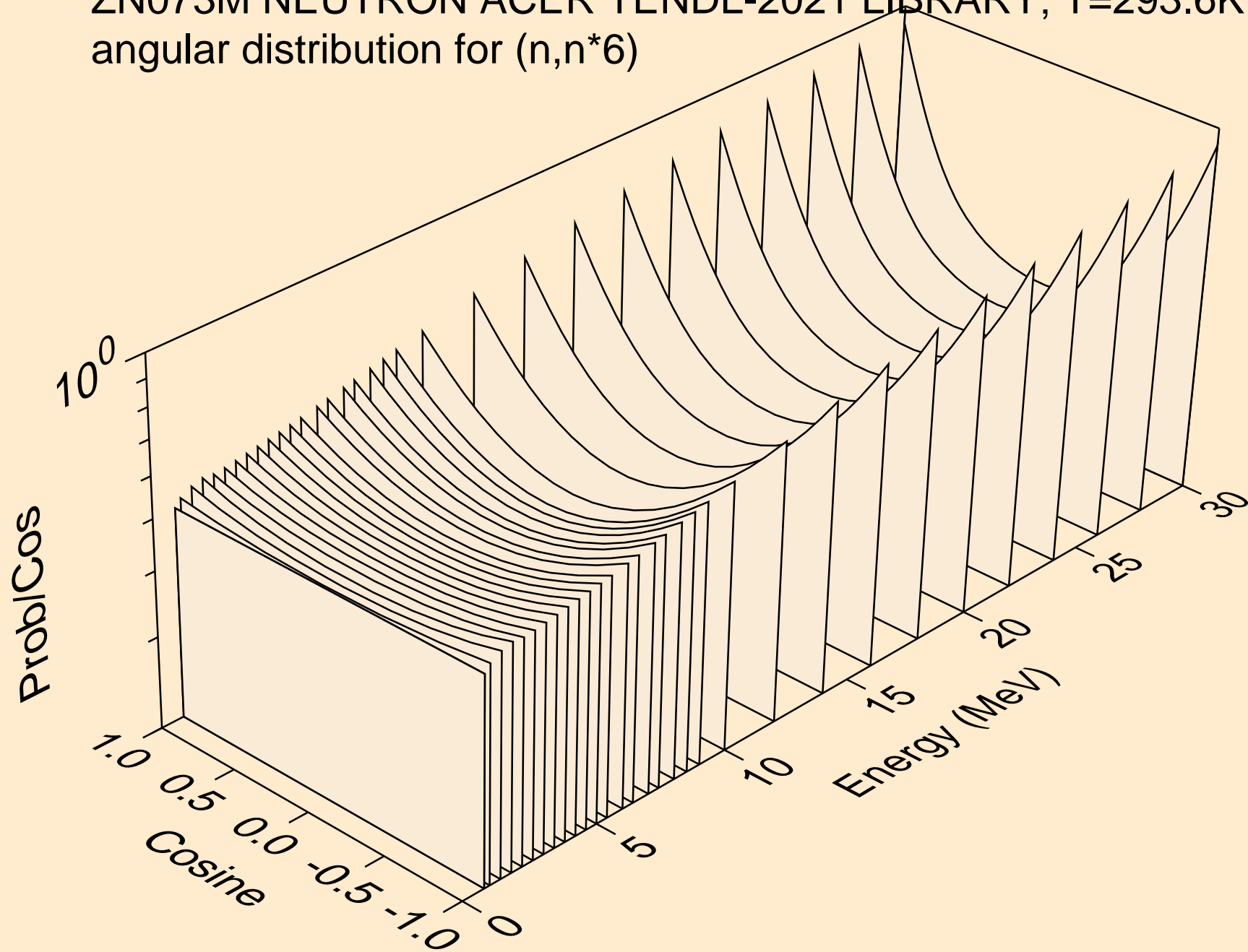

ZN073M NEUTRON ACER TENDL-2021 LIBRARY; T=293.6K  
angular distribution for (n,n\*7)

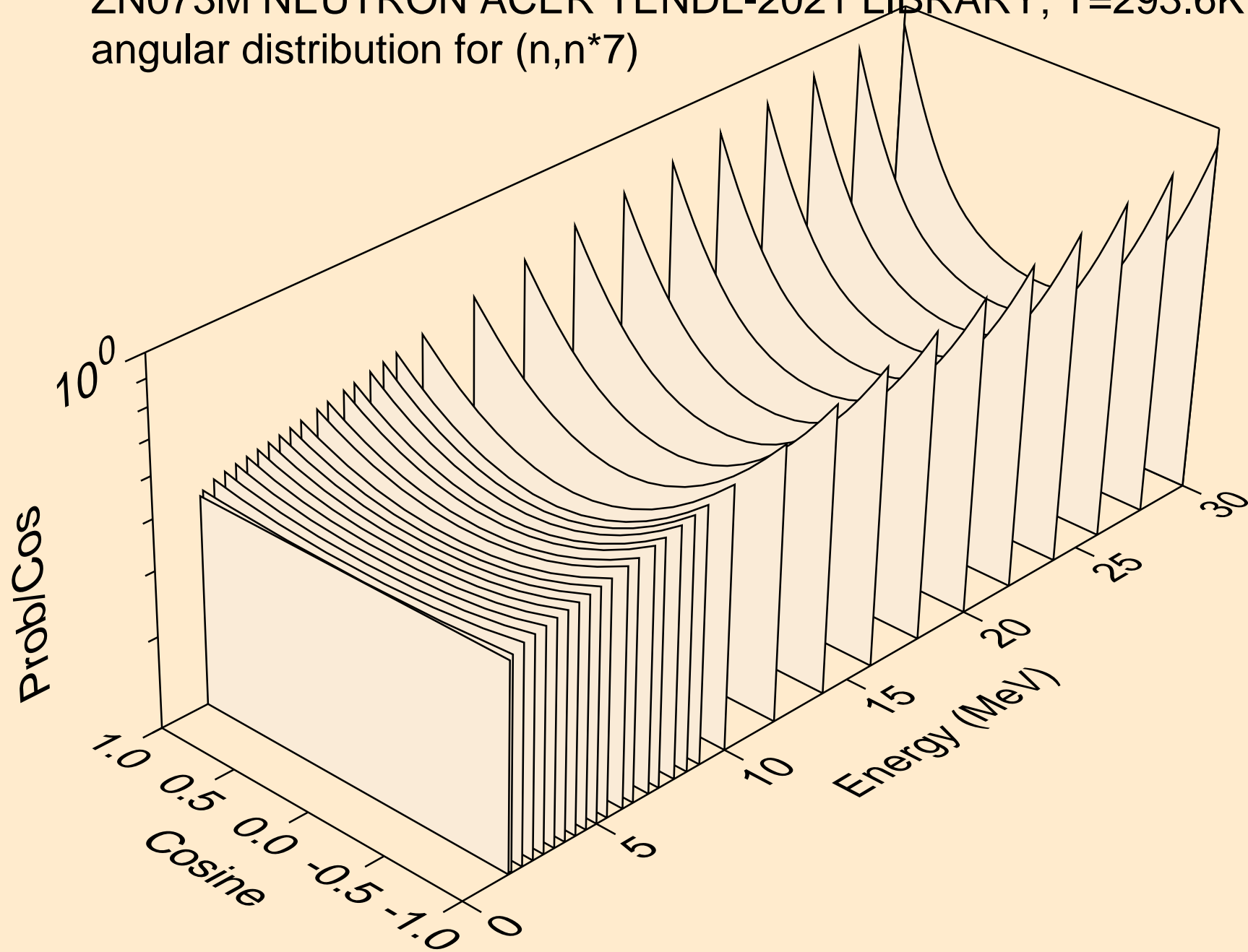

ZN073M NEUTRON ACER TENDL-2021 LIBRARY; T=293.6K  
angular distribution for (n,n\*8)

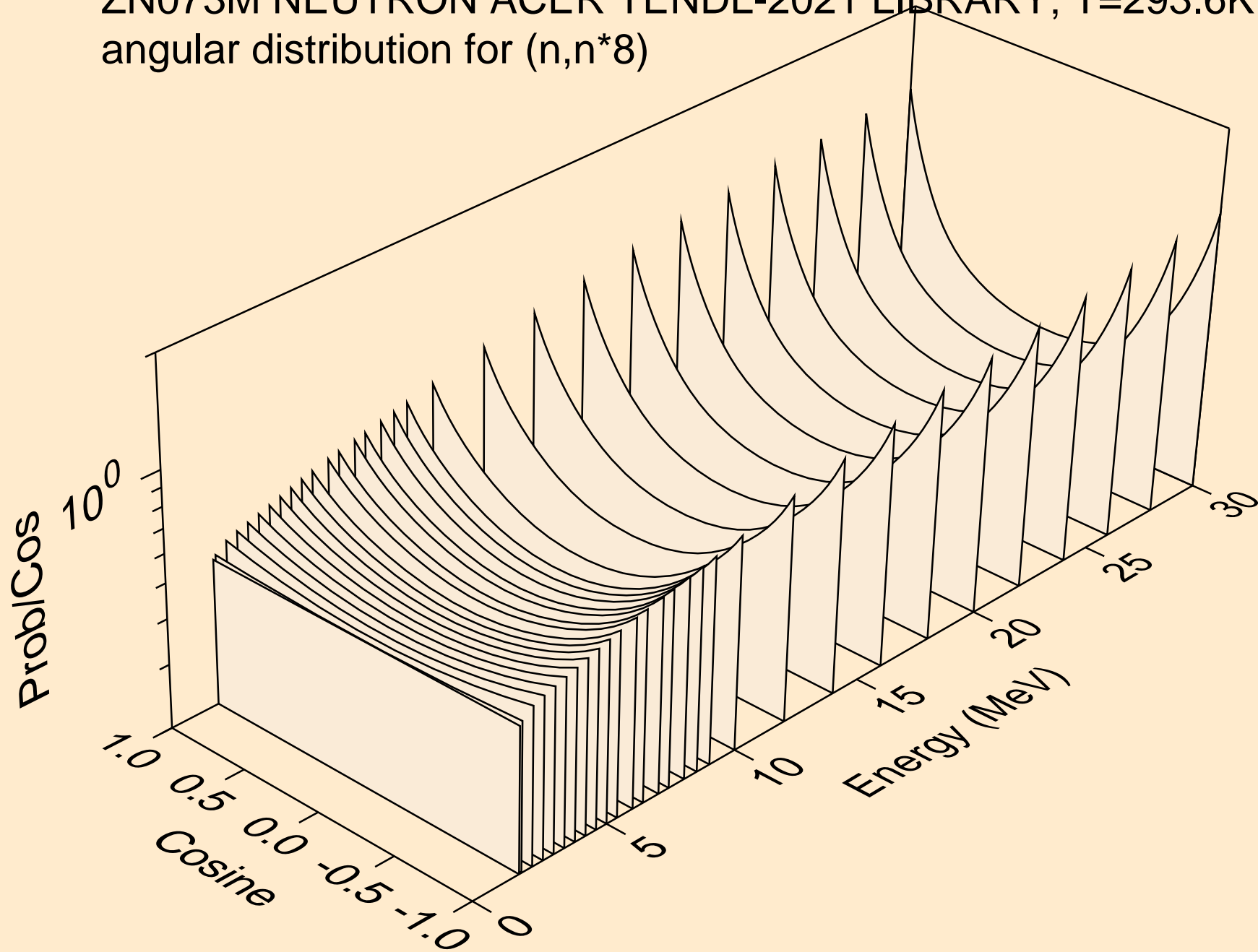



ZN073M NEUTRON ACER TENDL-2021 LIBRARY; T=293.6K  
angular distribution for (n,n\*9)

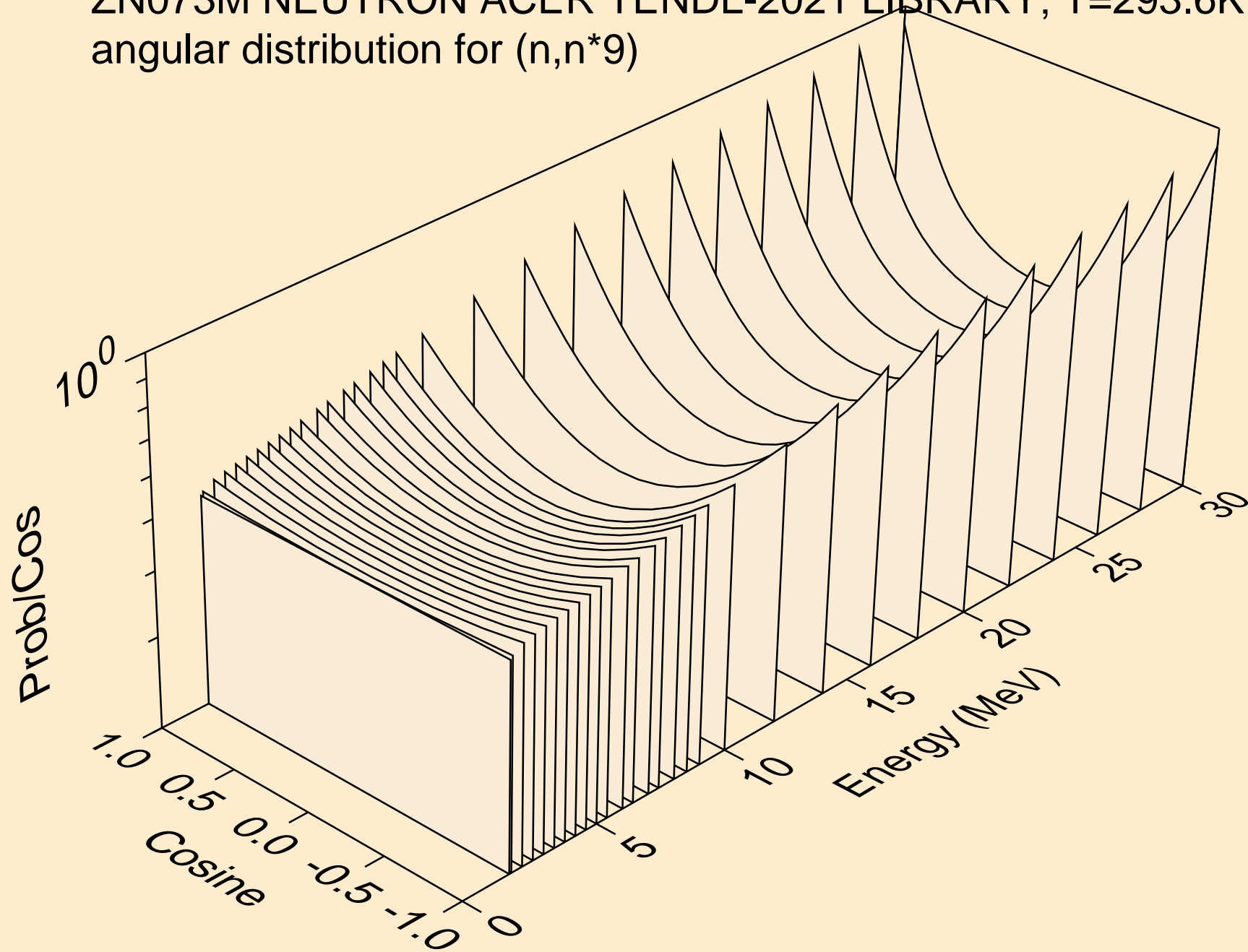

ZN073M NEUTRON ACER TENDL-2021 LIBRARY; T=293.6K  
angular distribution for (n,n\*10)

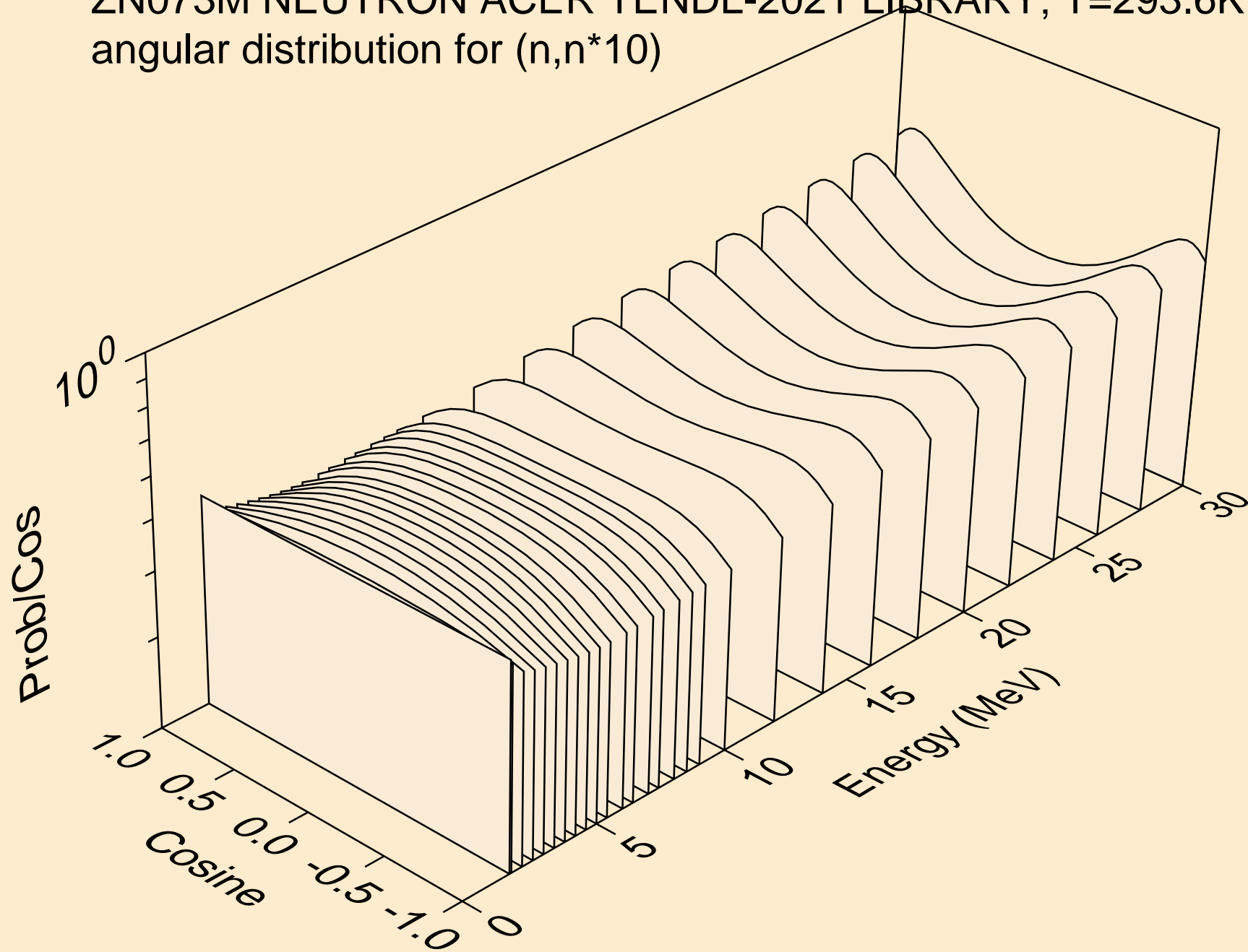

ZN073M NEUTRON ACER TENDL-2021 LIBRARY; T=293.6K  
angular distribution for (n,n\*11)

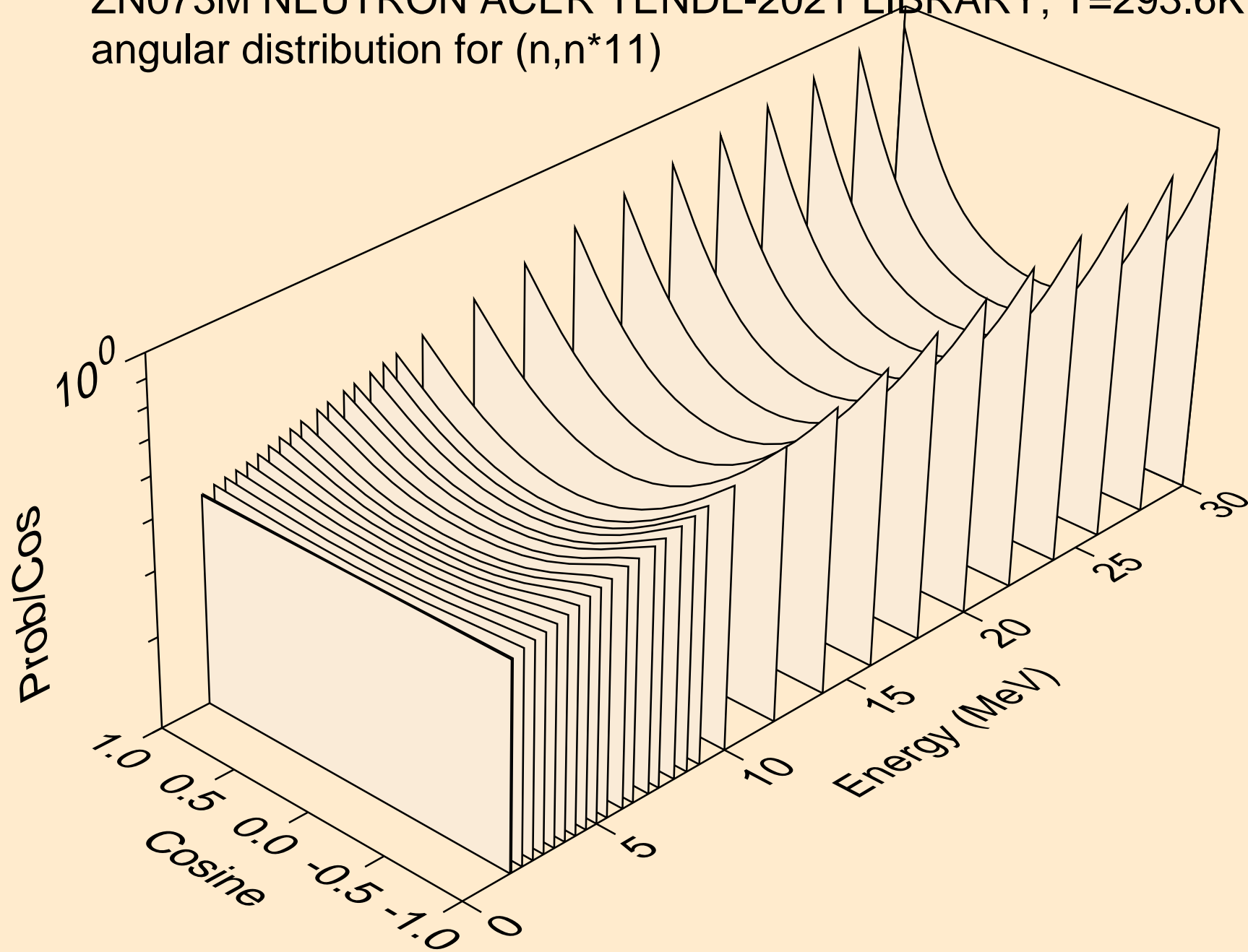

ZN073M NEUTRON ACER TENDL-2021 LIBRARY; T=293.6K  
angular distribution for (n,n\*12)

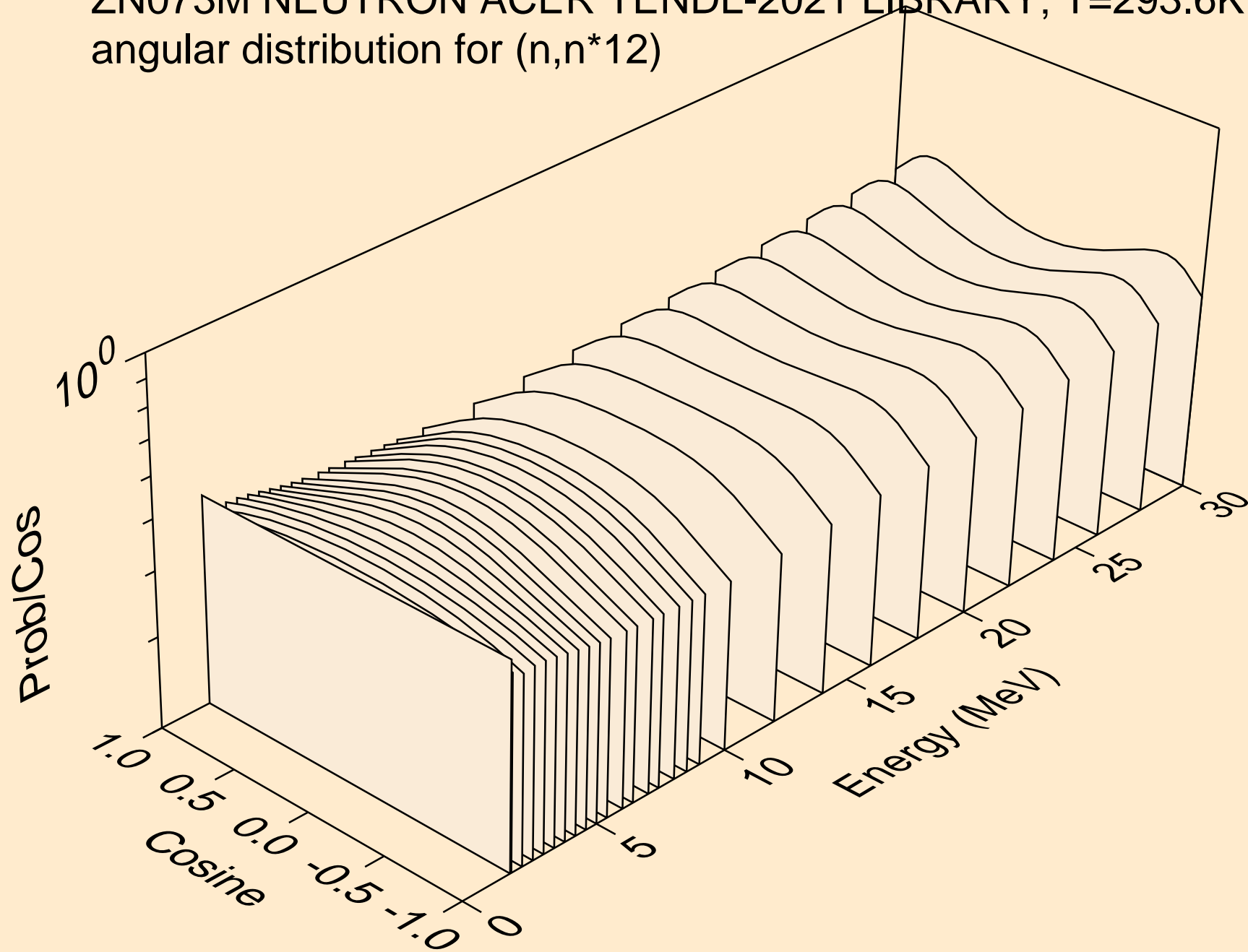

ZN073M NEUTRON ACER TENDL-2021 LIBRARY; T=293.6K  
angular distribution for (n,n\*13)

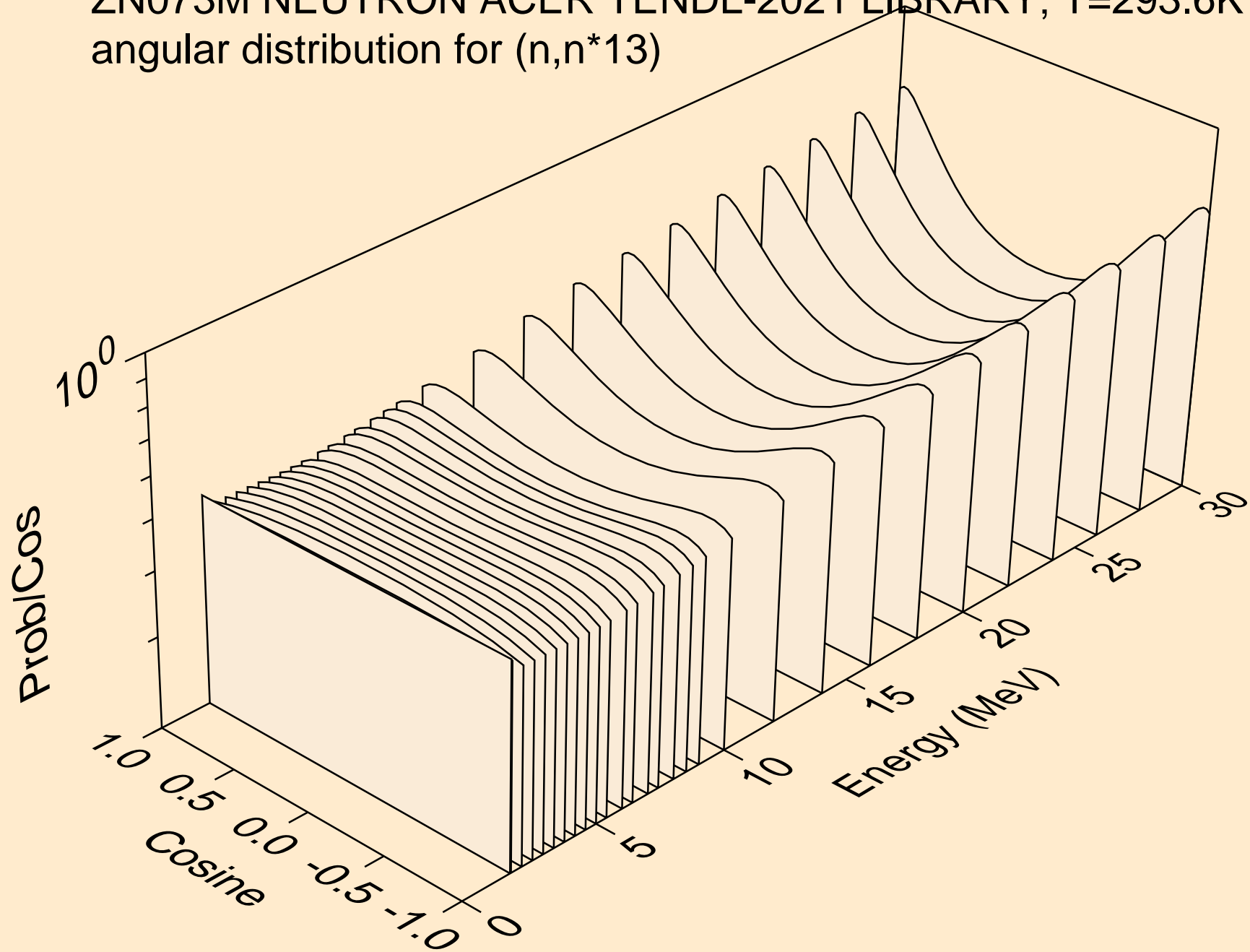

ZN073M NEUTRON ACER TENDL-2021 LIBRARY; T=293.6K  
angular distribution for (n,n\*14)

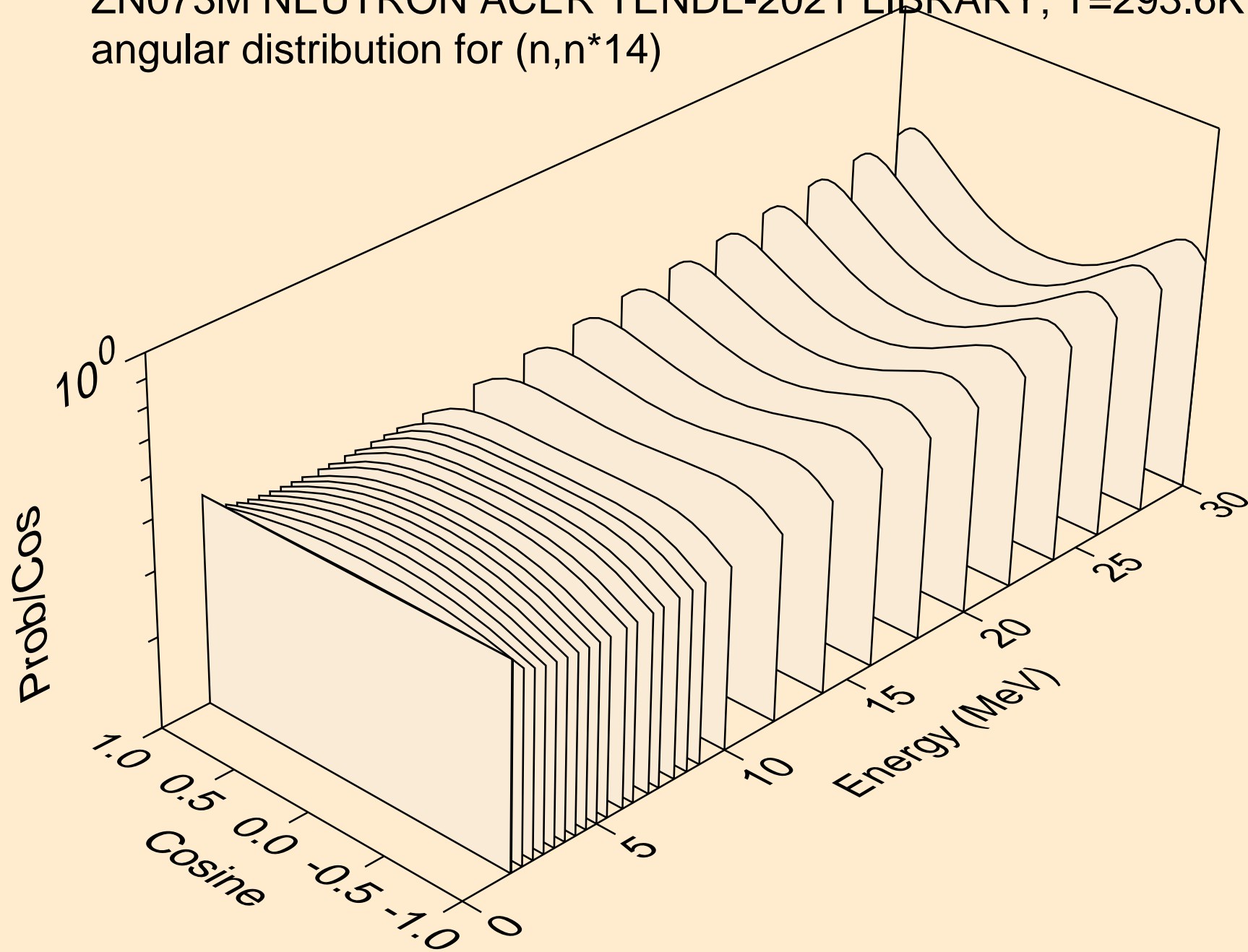

ZN073M NEUTRON ACER TENDL-2021 LIBRARY; T=293.6K  
angular distribution for (n,n\*15)

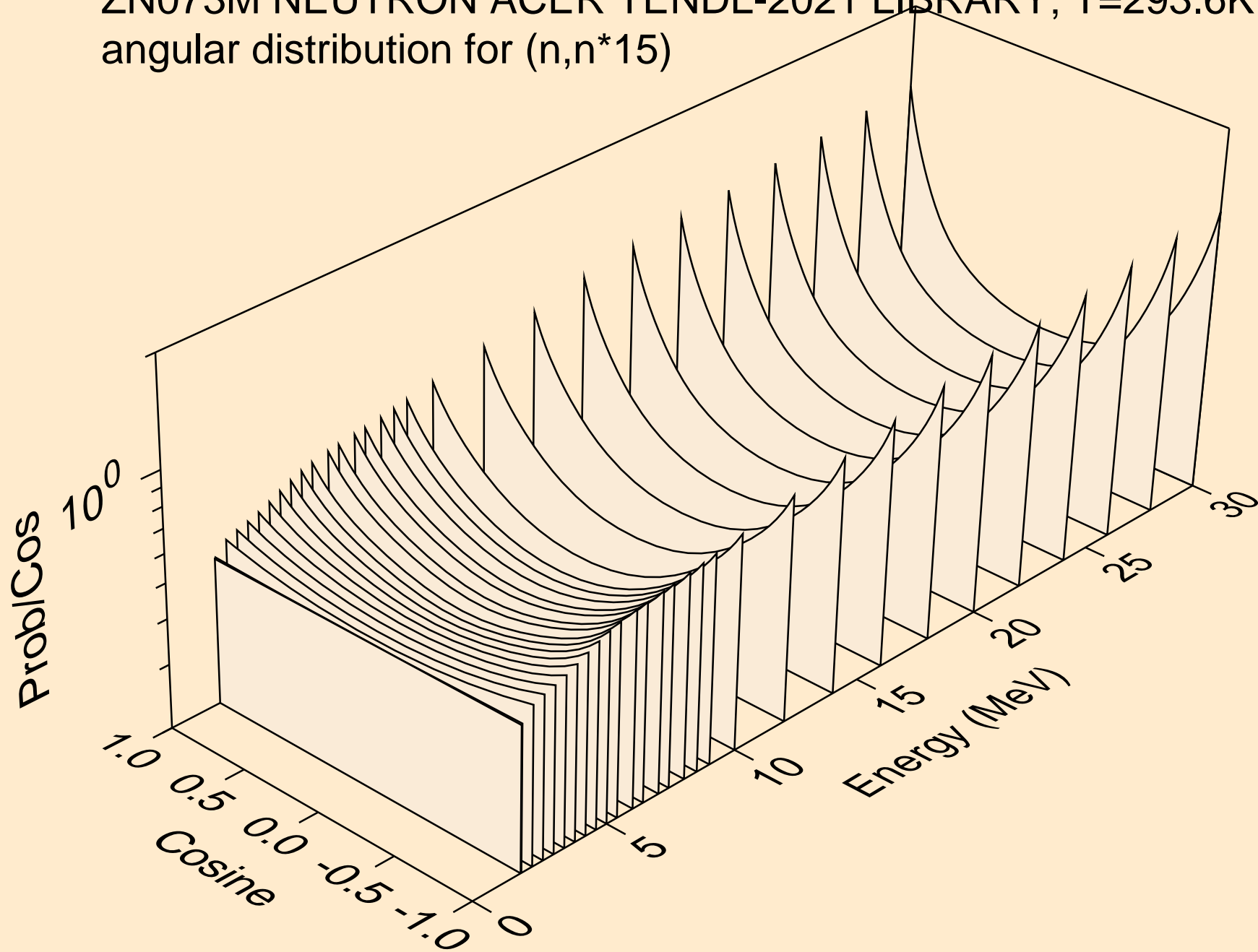

ZN073M NEUTRON ACER TENDL-2021 LIBRARY; T=293.6K  
angular distribution for (n,n\*16)

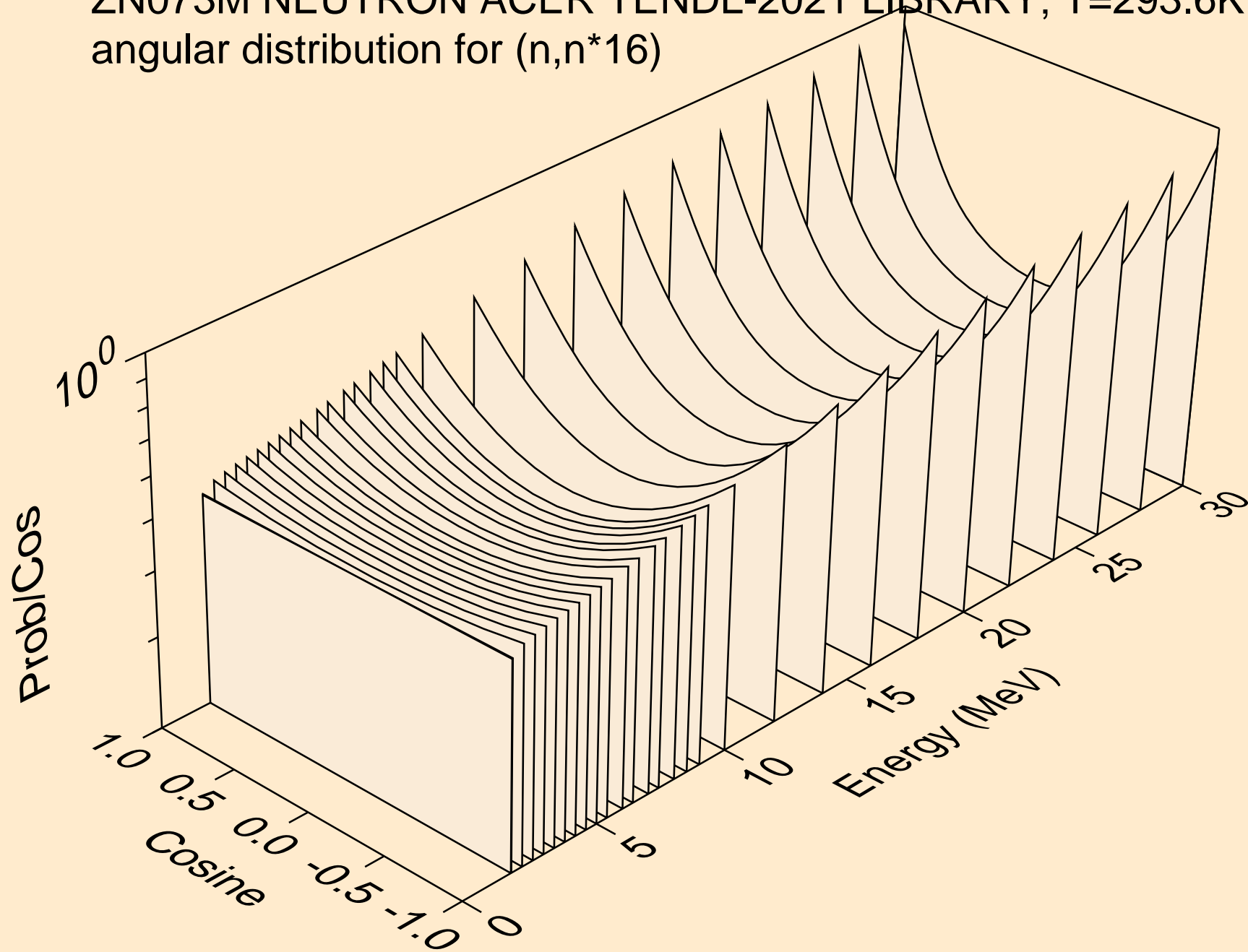



ZN073M NEUTRON ACER TENDL-2021 LIBRARY; T=293.6K  
angular distribution for (n,n\*17)

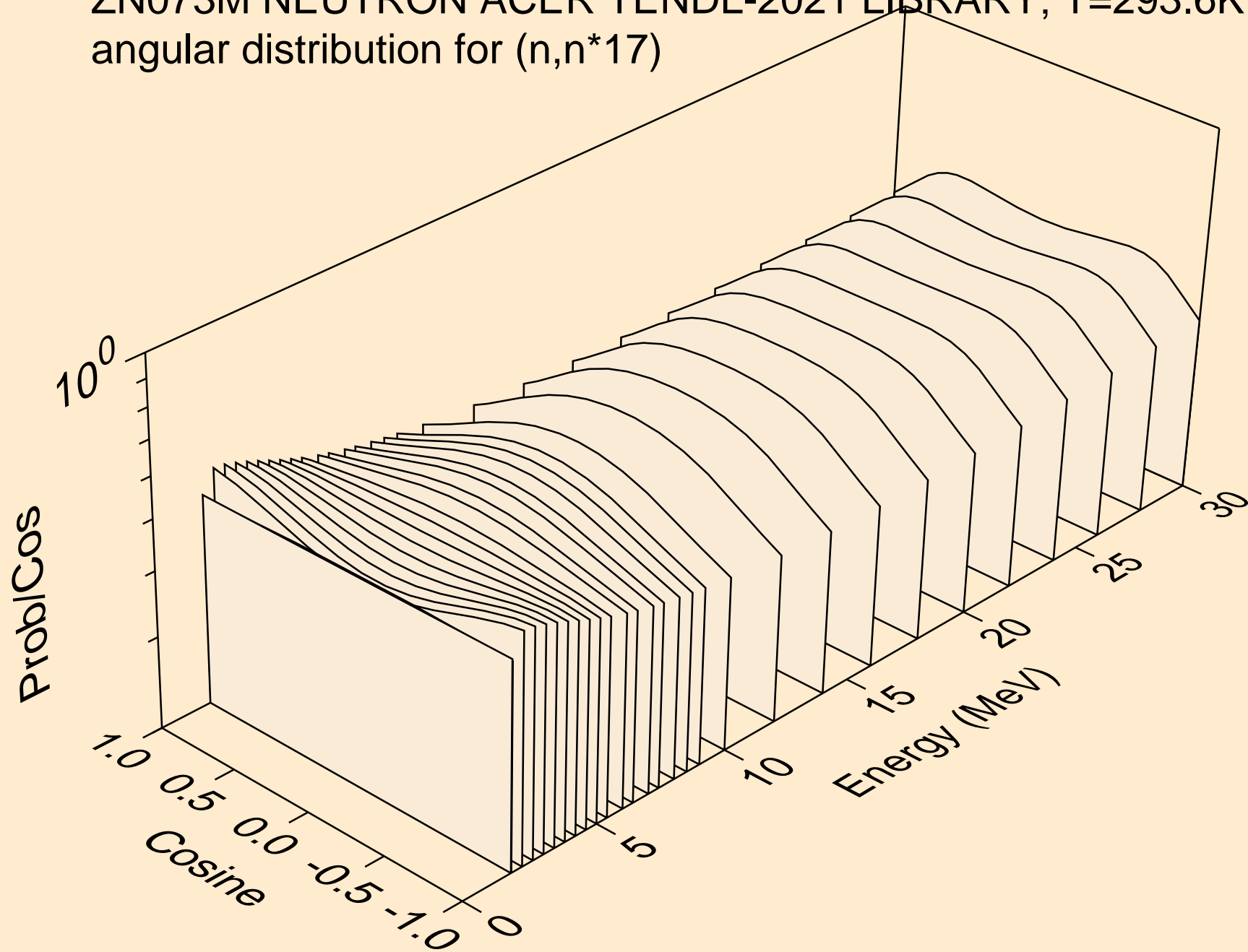

ZN073M NEUTRON ACER TENDL-2021 LIBRARY; T=293.6K  
angular distribution for (n,n\*18)

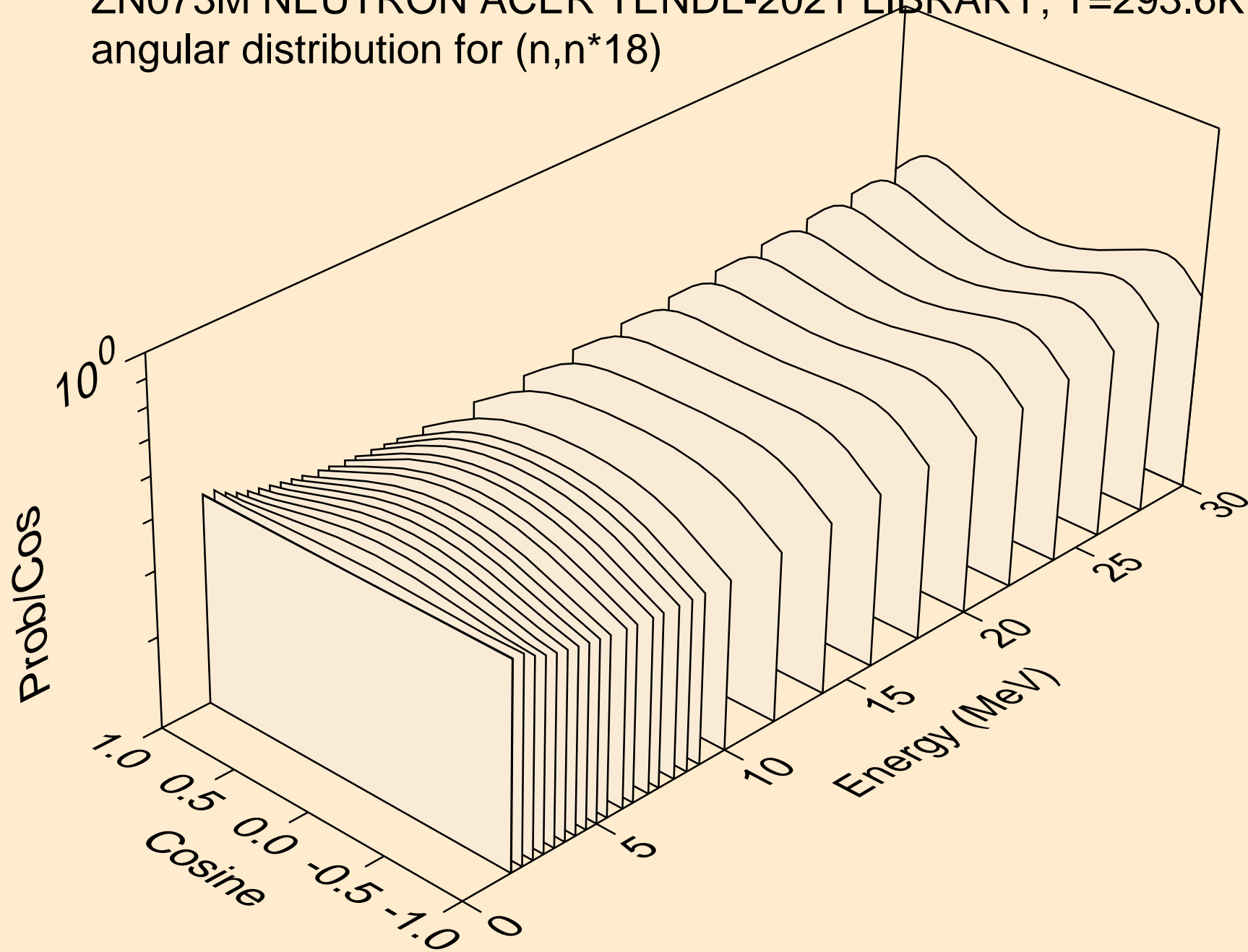

ZN073M NEUTRON ACER TENDL-2021 LIBRARY; T=293.6K  
angular distribution for (n,n\*19)

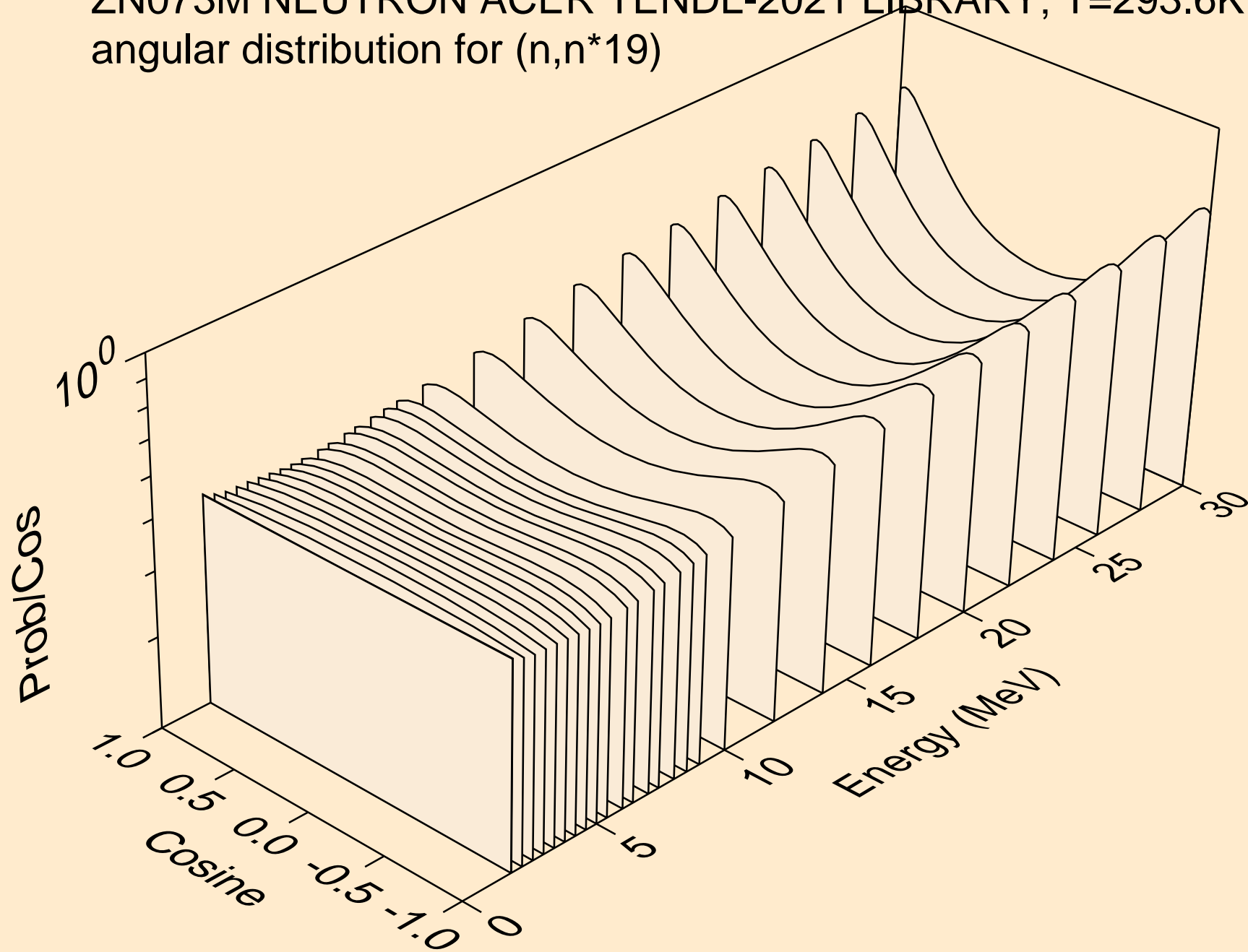

ZN073M NEUTRON ACER TENDL-2021 LIBRARY; T=293.6K  
angular distribution for (n,n\*20)

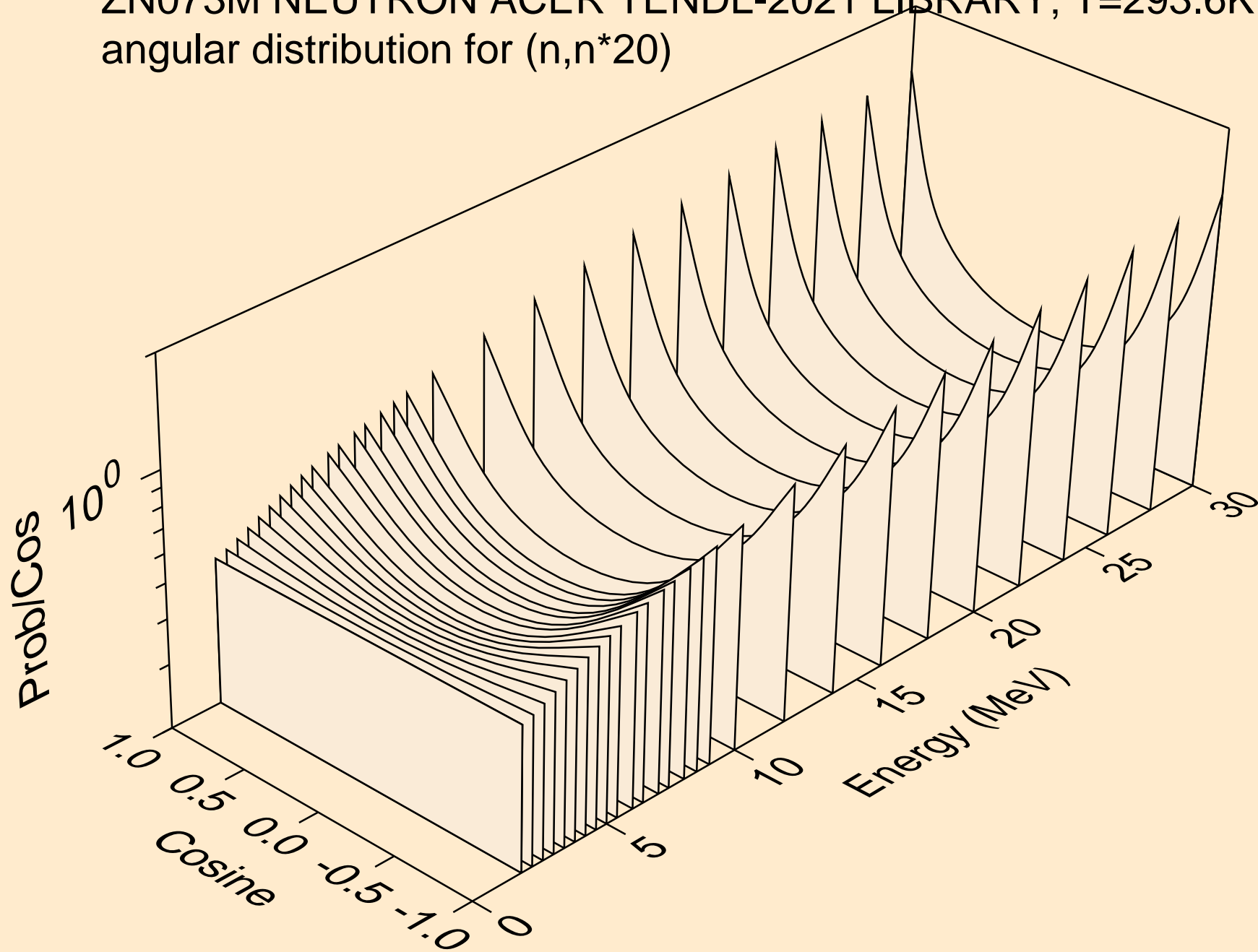

ZN073M NEUTRON ACER TENDL-2021 LIBRARY; T=293.6K  
angular distribution for (n,n\*21)

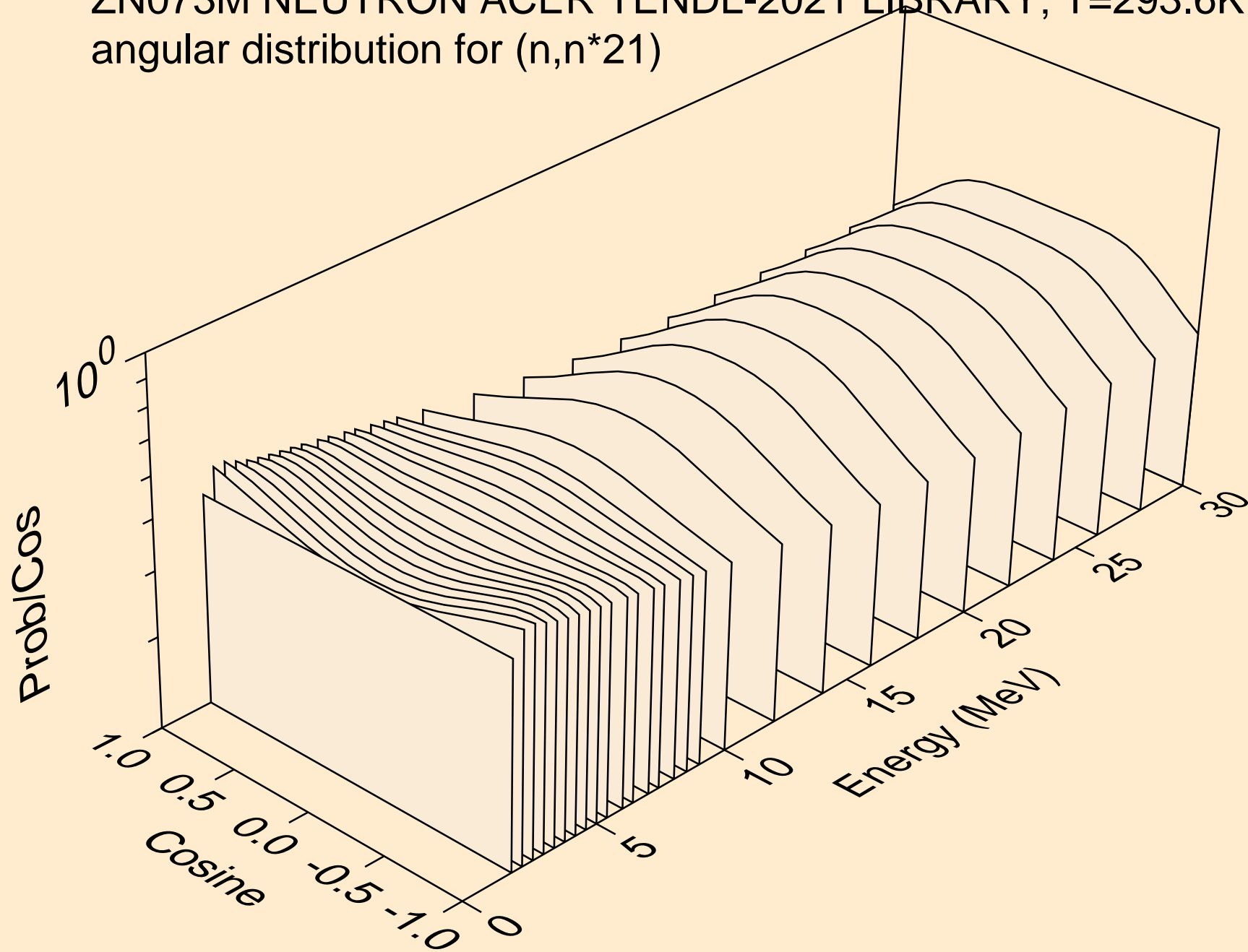

ZN073M NEUTRON ACER TENDL-2021 LIBRARY; T=293.6K  
angular distribution for (n,n\*22)

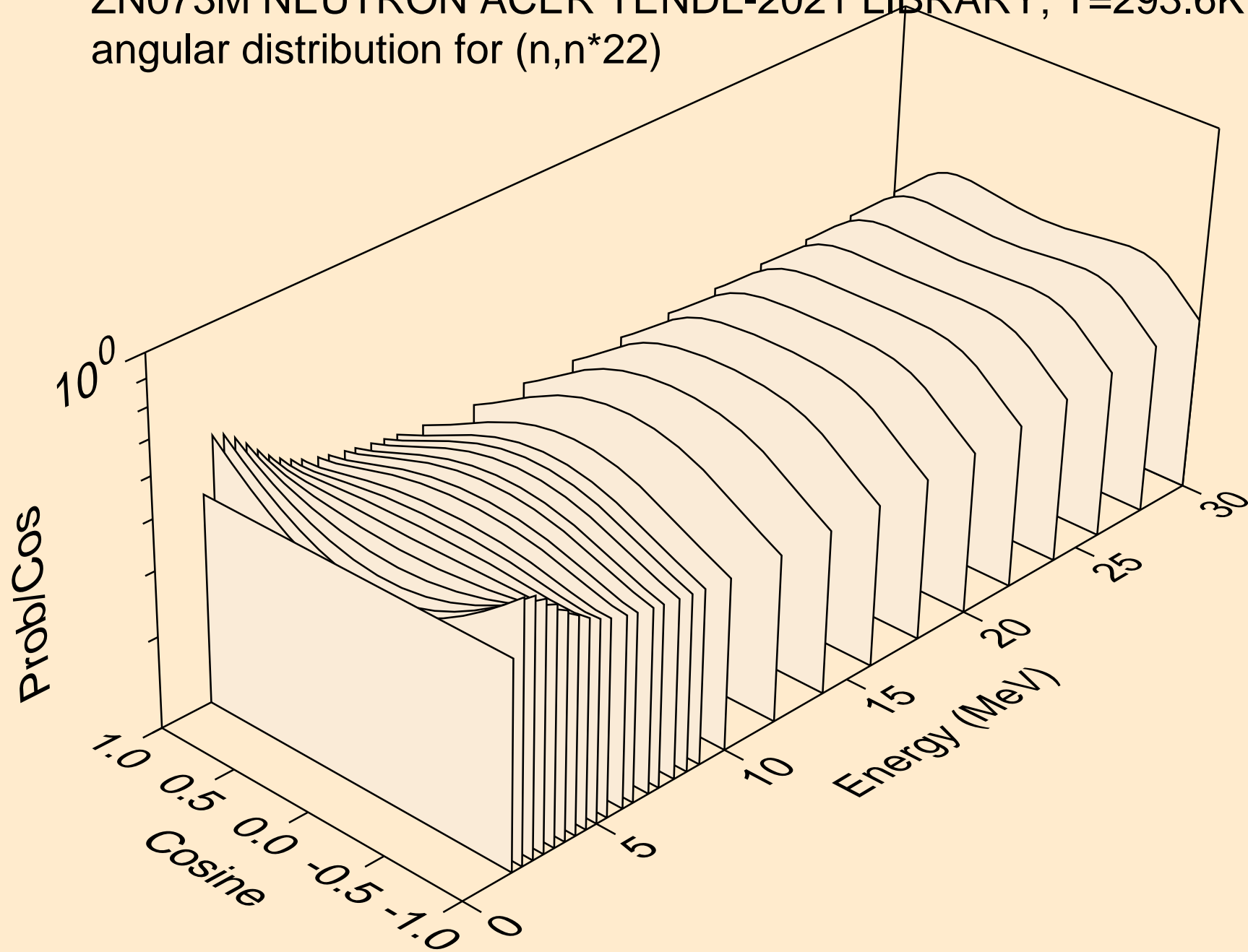

ZN073M NEUTRON ACER TENDL-2021 LIBRARY; T=293.6K  
angular distribution for (n,n\*23)

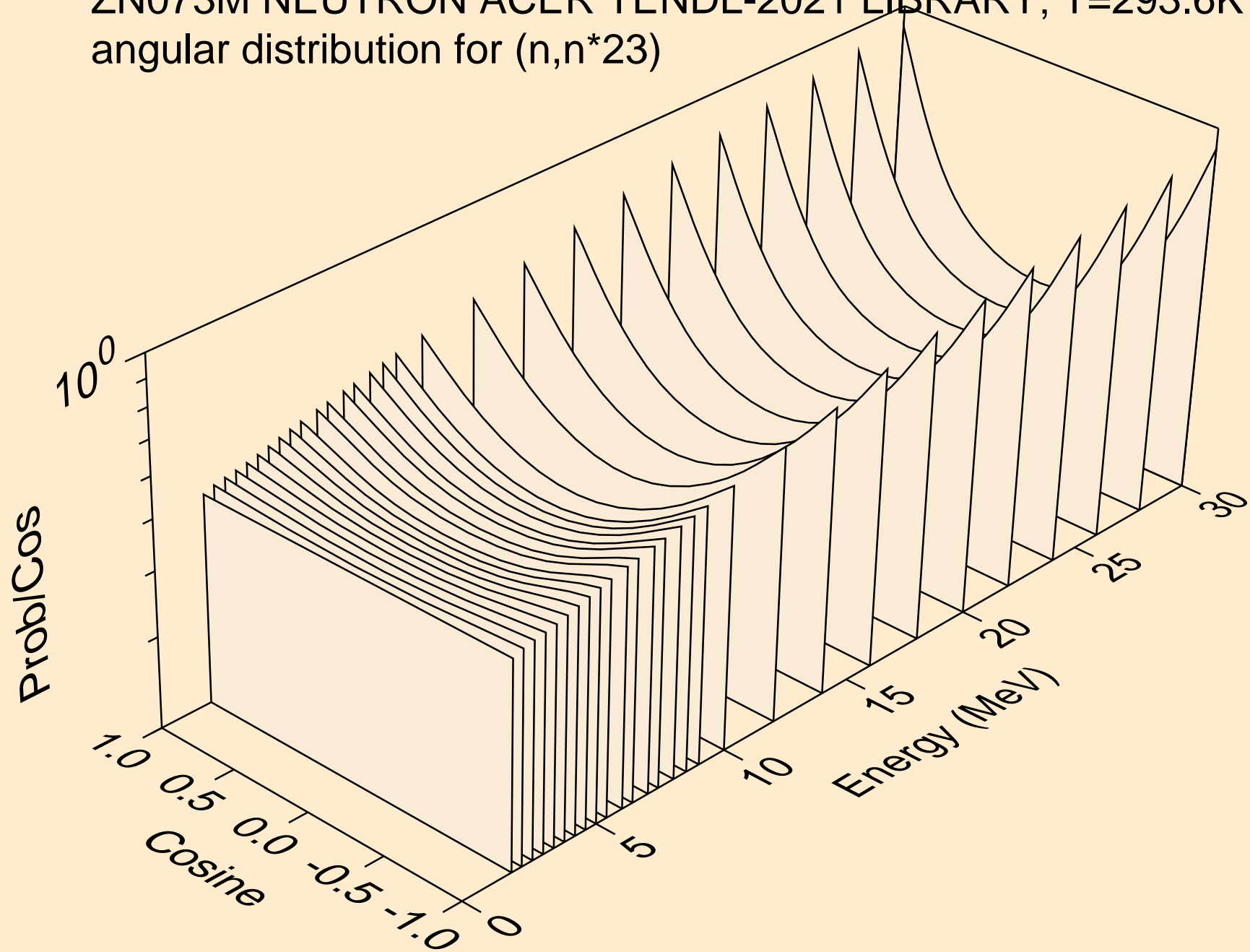

ZN073M NEUTRON ACER TENDL-2021 LIBRARY; T=293.6K  
angular distribution for (n,n\*24)

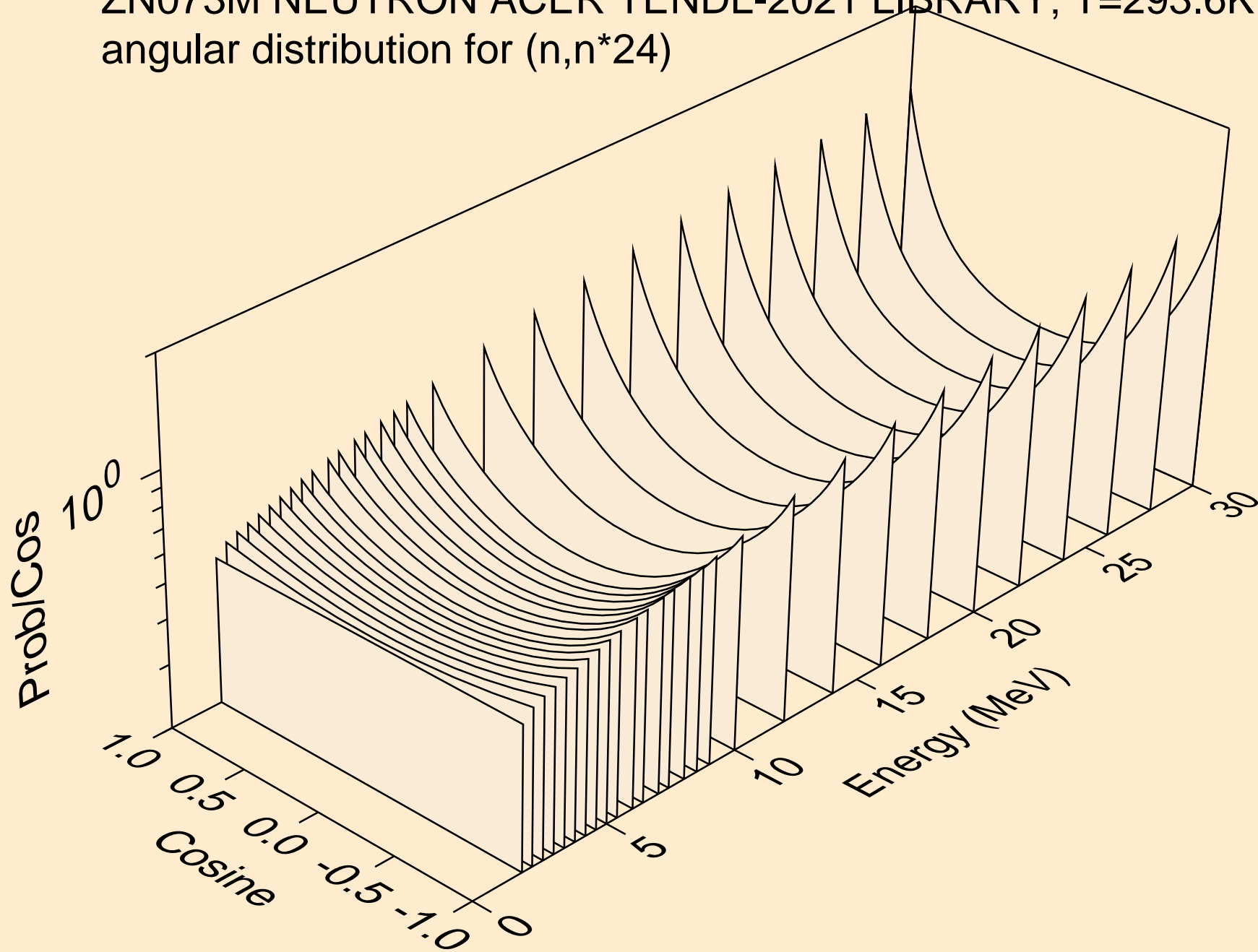



ZN073M NEUTRON ACER TENDL-2021 LIBRARY; T=293.6K  
angular distribution for (n,n\*25)

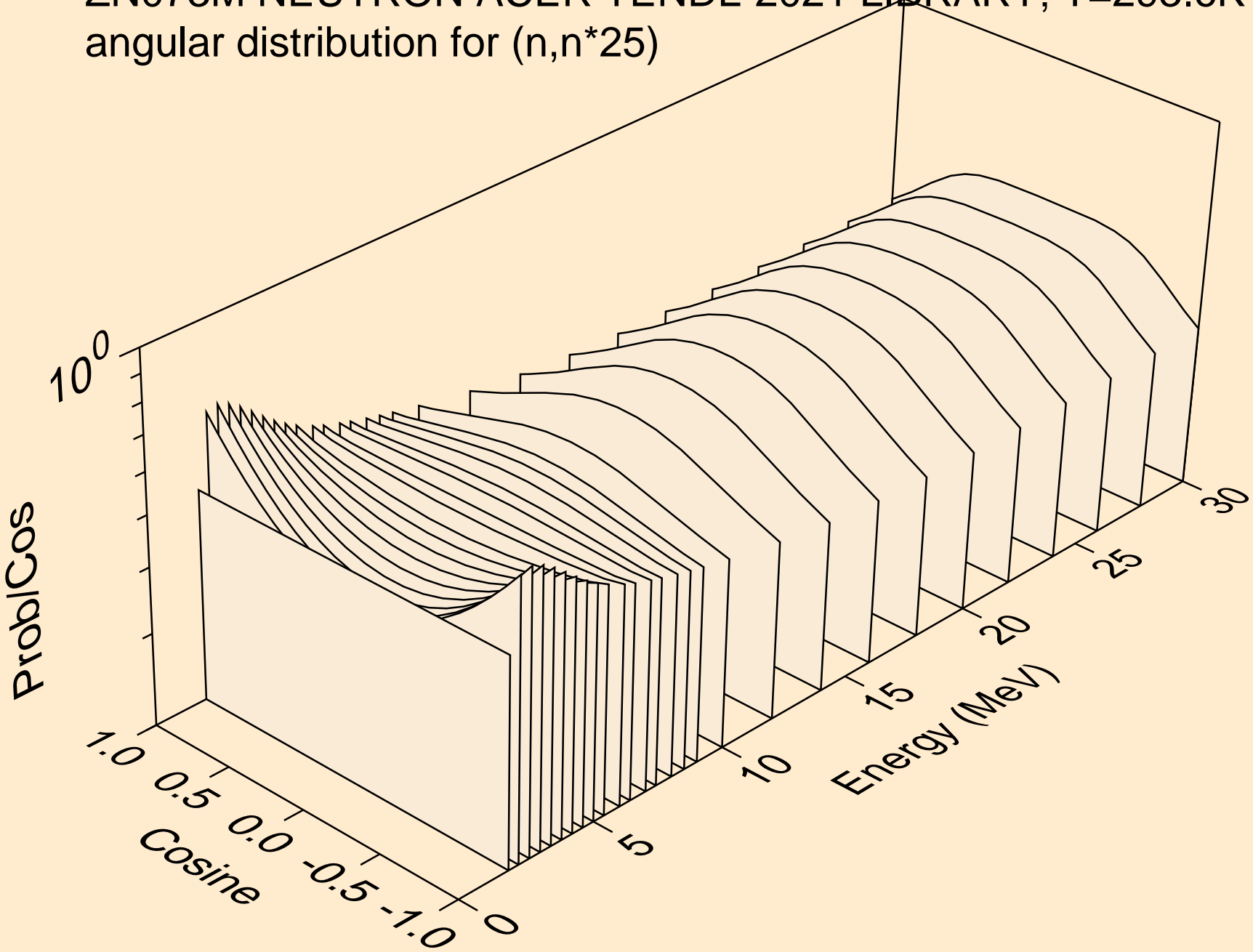

ZN073M NEUTRON ACER TENDL-2021 LIBRARY; T=293.6K  
angular distribution for (n,n\*26)

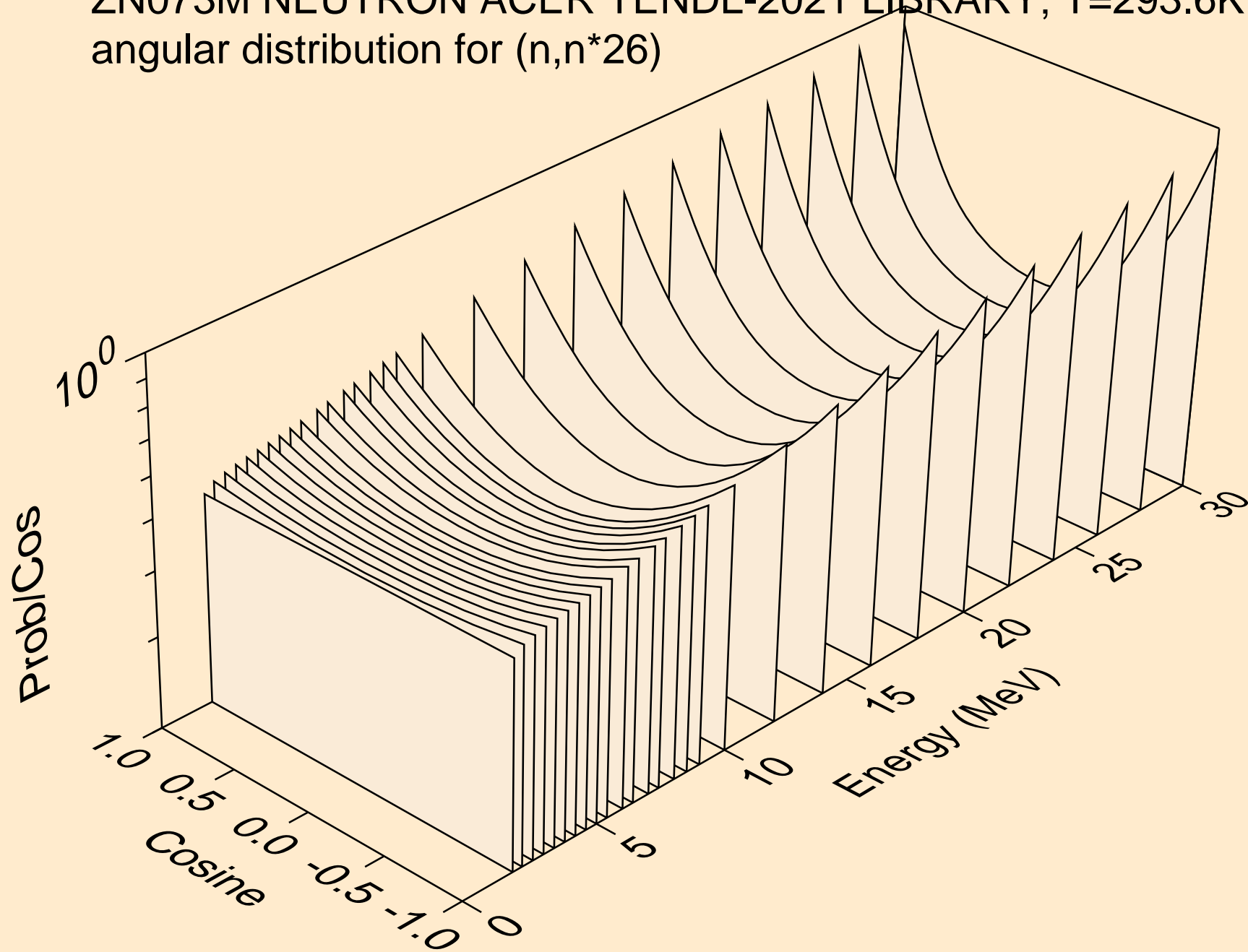

ZN073M NEUTRON ACER TENDL-2021 LIBRARY; T=293.6K  
angular distribution for (n,n\*27)

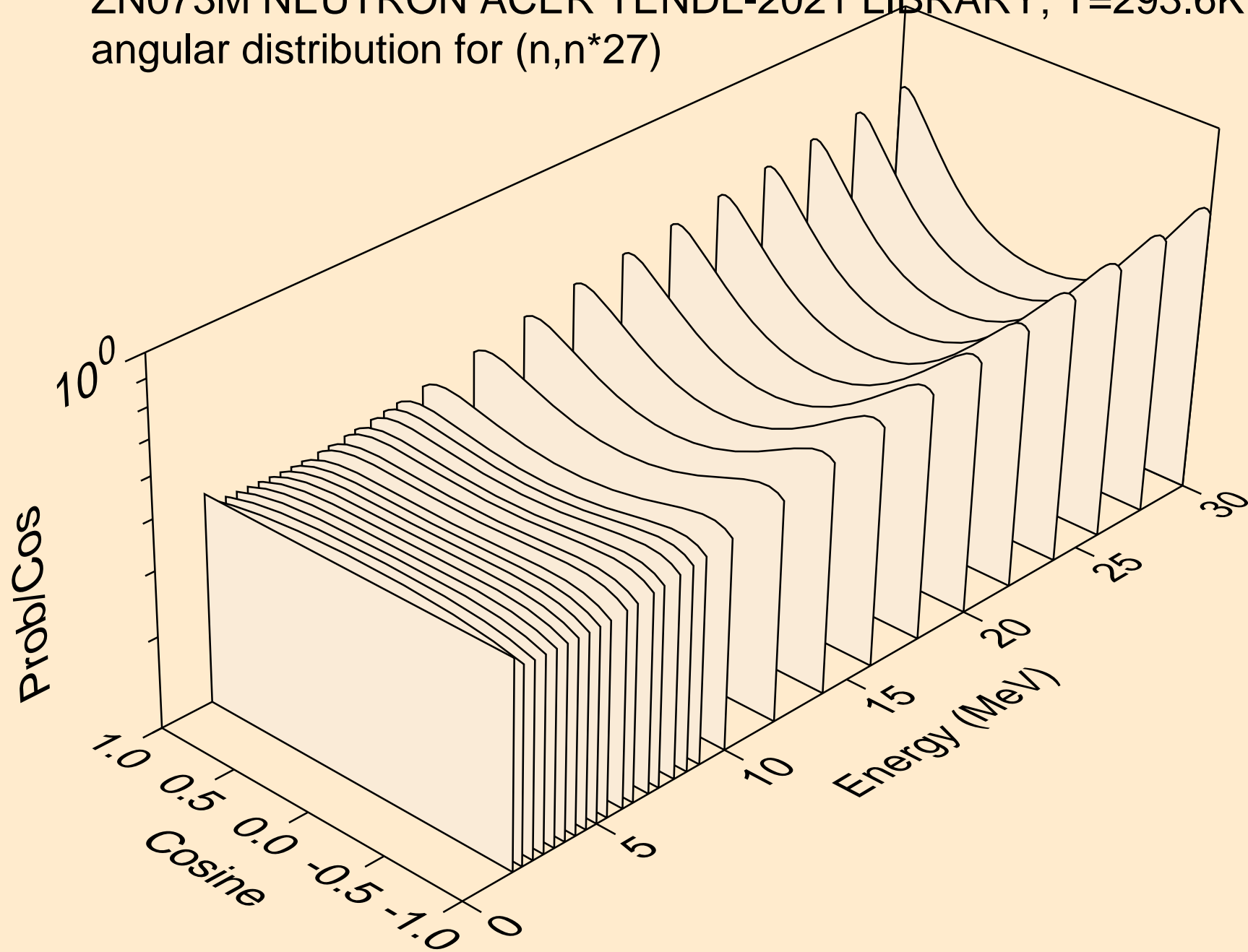

ZN073M NEUTRON ACER TENDL-2021 LIBRARY; T=293.6K  
angular distribution for (n,n\*28)

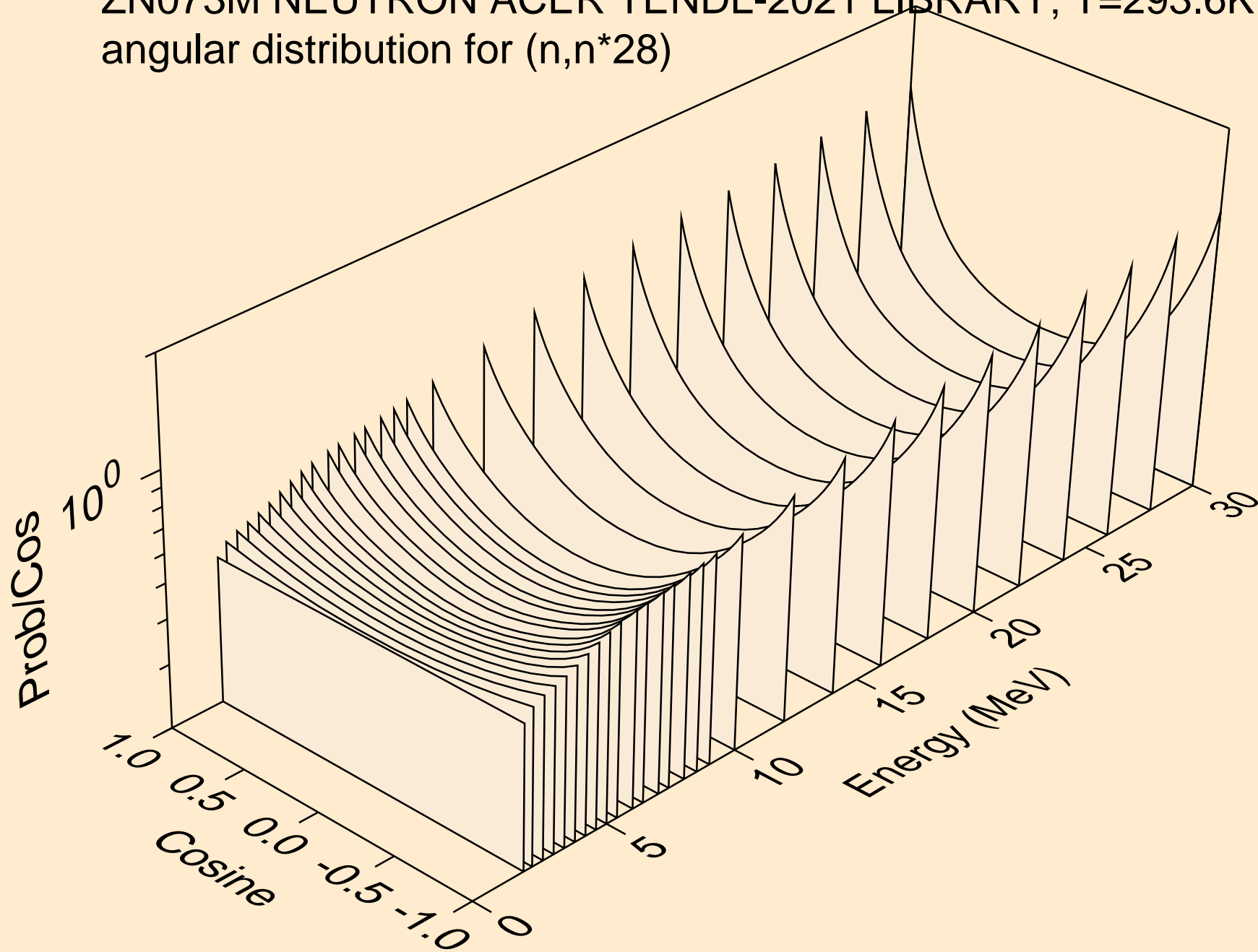

ZN073M NEUTRON ACER TENDL-2021 LIBRARY; T=293.6K  
angular distribution for (n,n\*29)

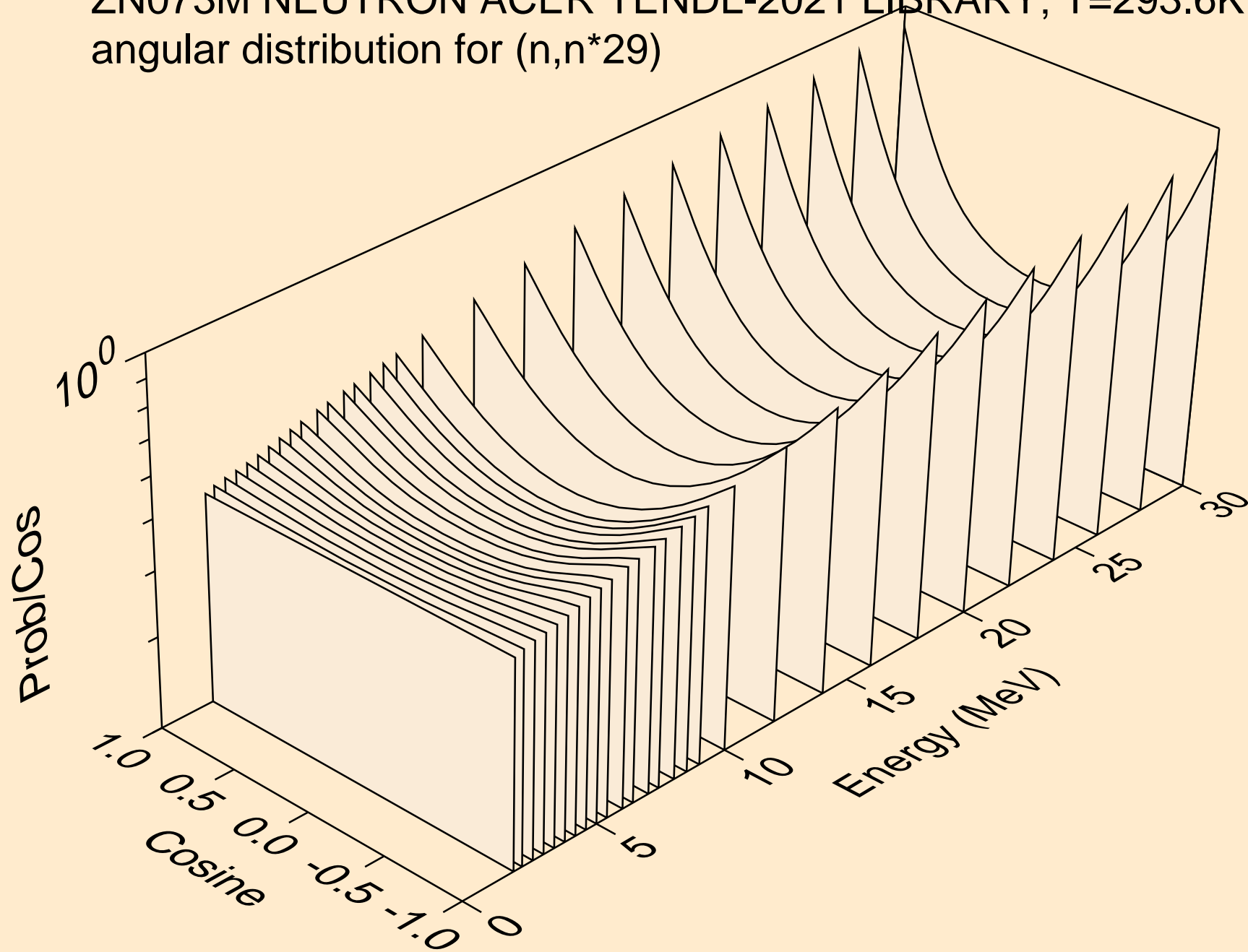

ZN073M NEUTRON ACER TENDL-2021 LIBRARY; T=293.6K  
angular distribution for (n,n\*30)

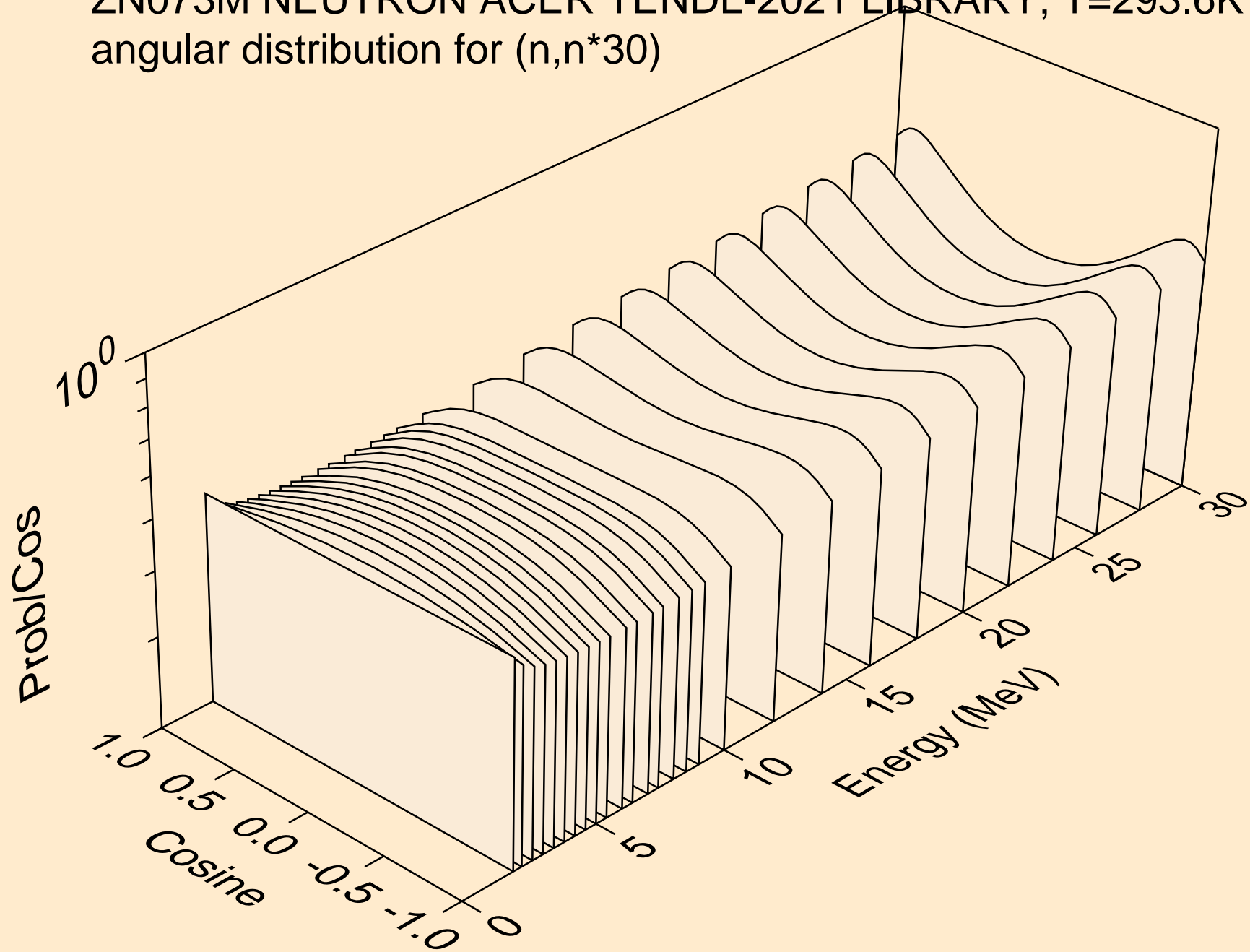

ZN073M NEUTRON ACER TENDL-2021 LIBRARY; T=293.6K  
Neutron emission for (n,x)

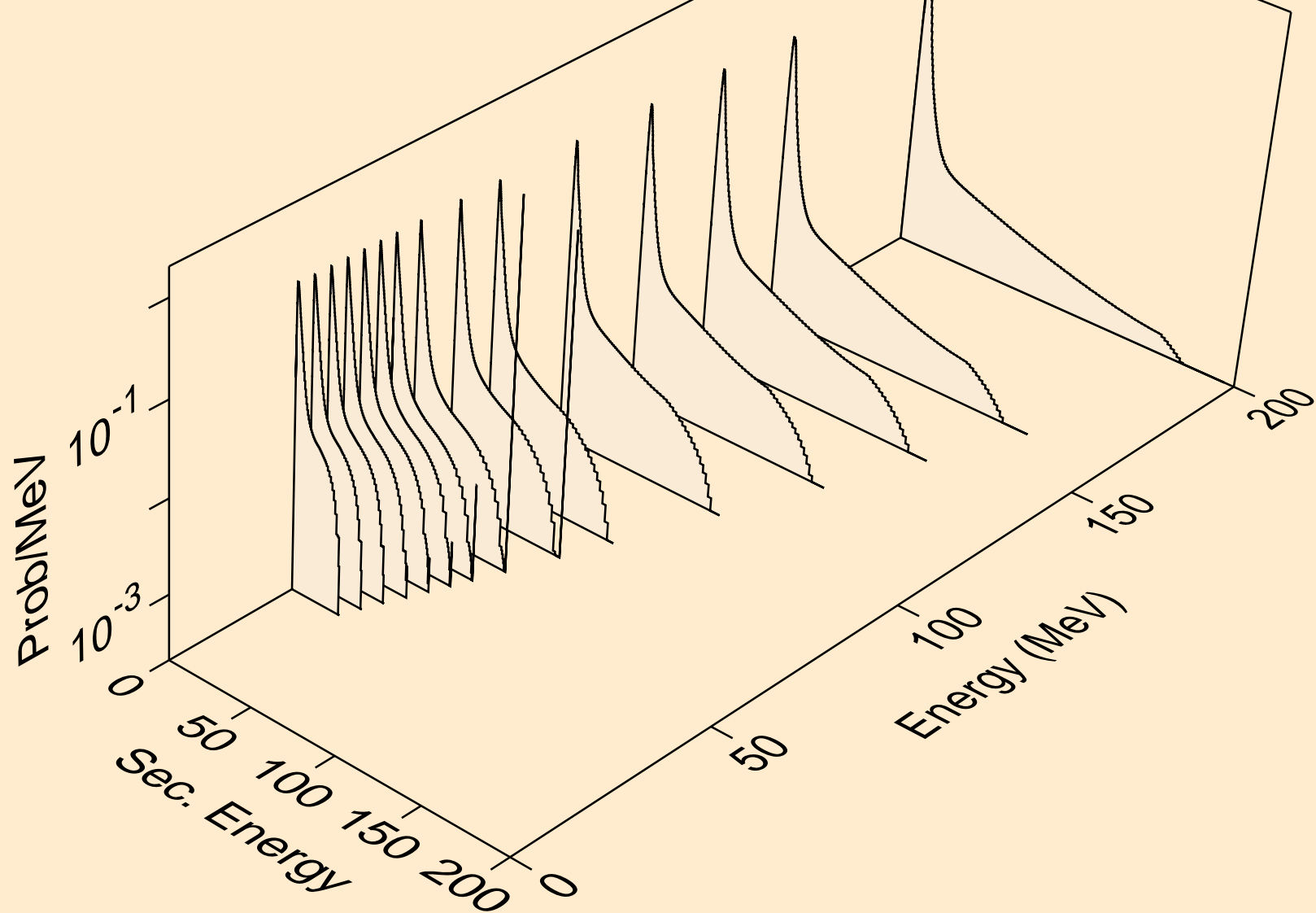

ZN073M NEUTRON ACER TENDL-2021 LIBRARY; T=293.6K  
Neutron emission for (n,2nd)

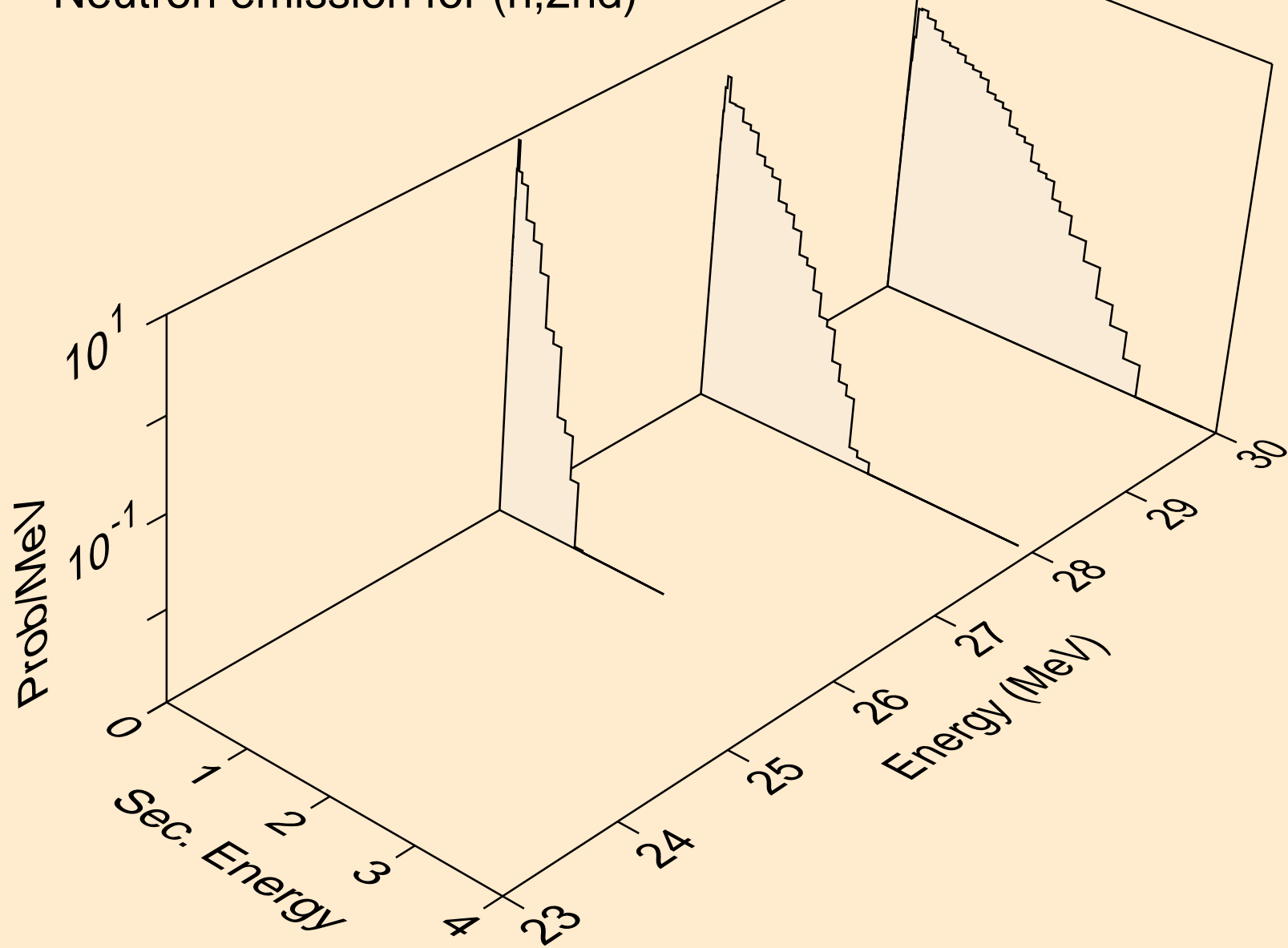



ZN073M NEUTRON ACER TENDL-2021 LIBRARY; T=293.6K  
Neutron emission for (n,2n)

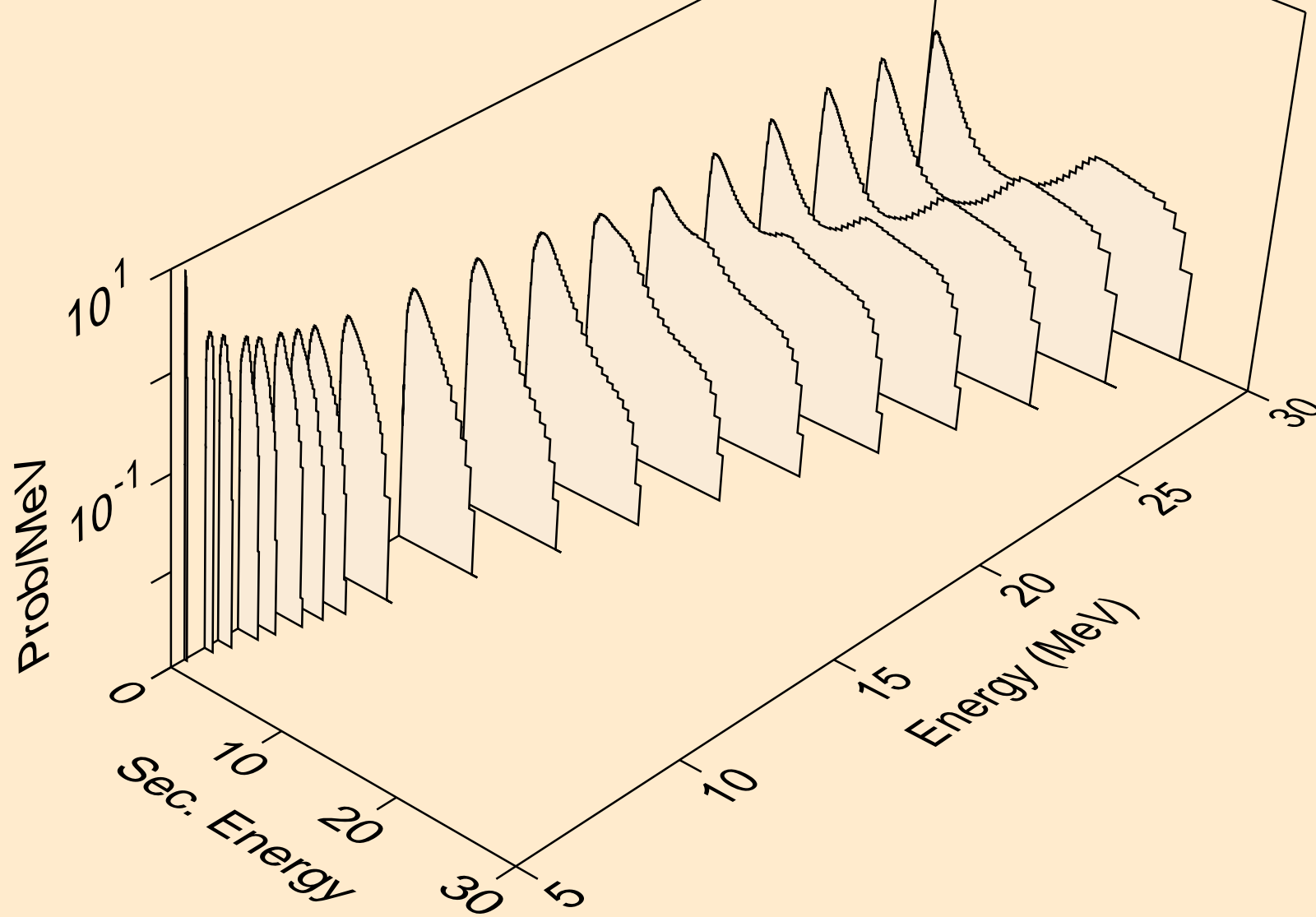

ZN073M NEUTRON ACER TENDL-2021 LIBRARY; T=293.6K  
Neutron emission for (n,3n)

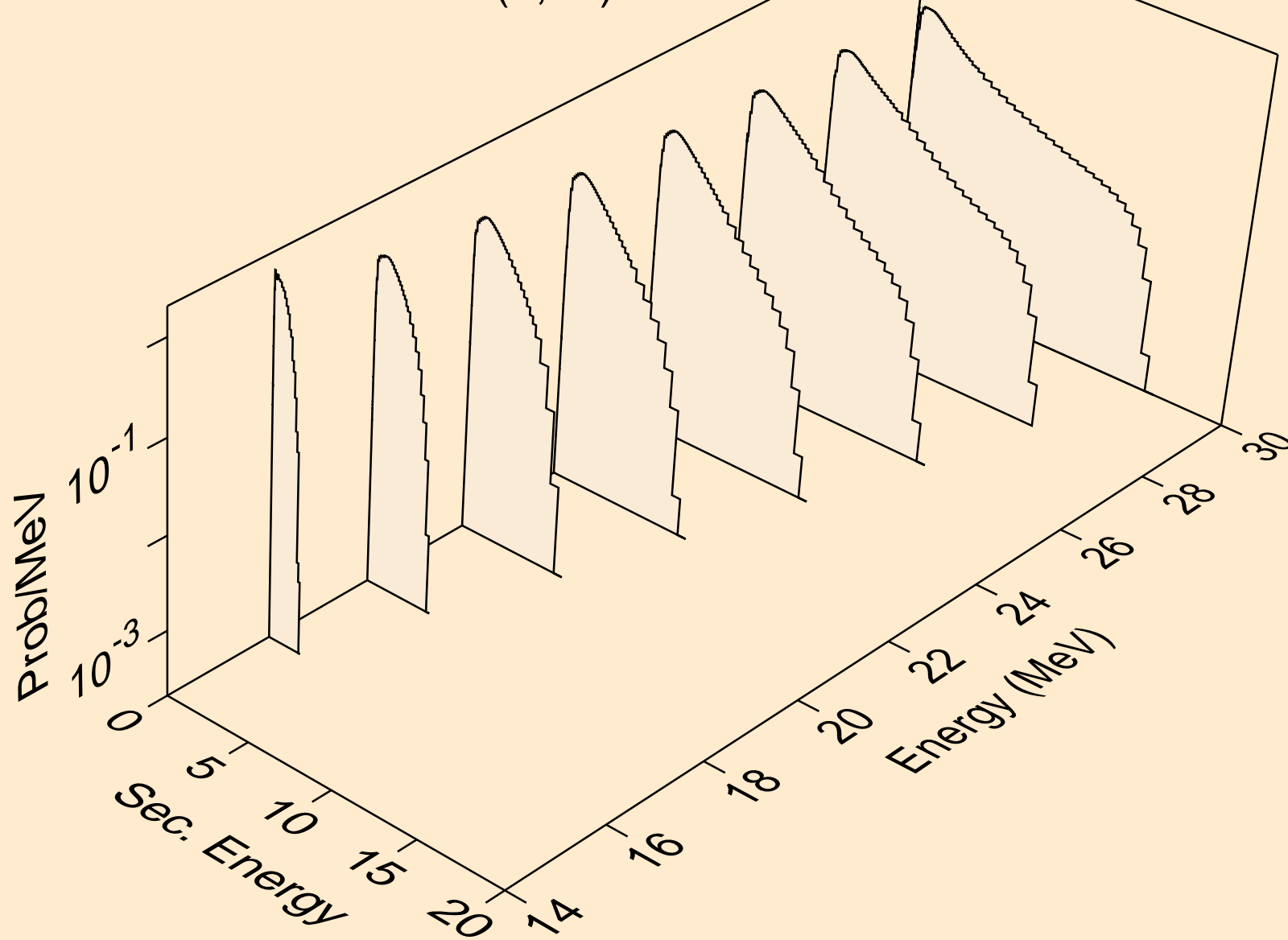

ZN073M NEUTRON ACER TENDL-2021 LIBRARY; T=293.6K  
Neutron emission for (n,n\*)a

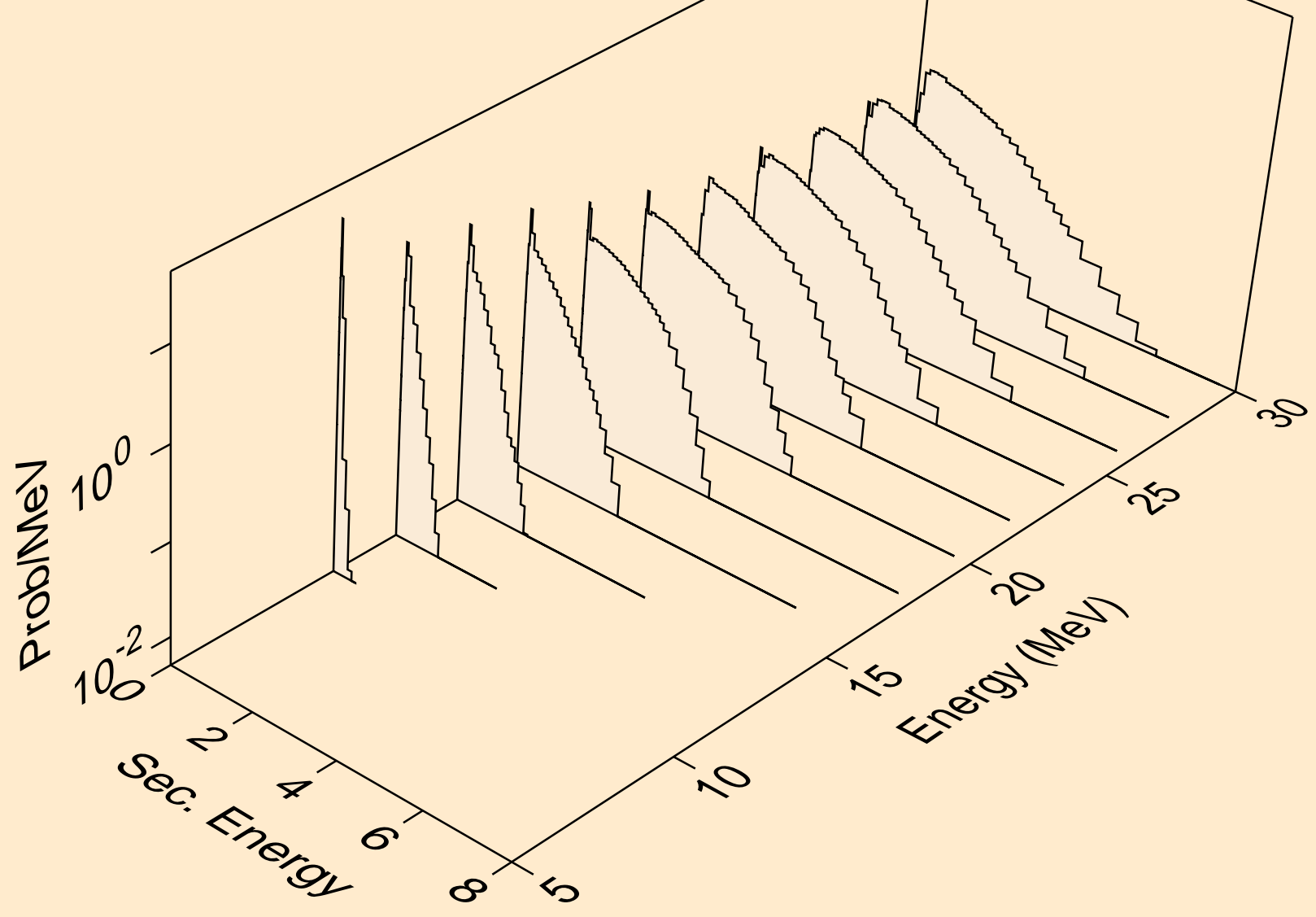

ZN073M NEUTRON ACER TENDL-2021 LIBRARY; T=293.6K  
Neutron emission for (n,2n)<sub>a</sub>

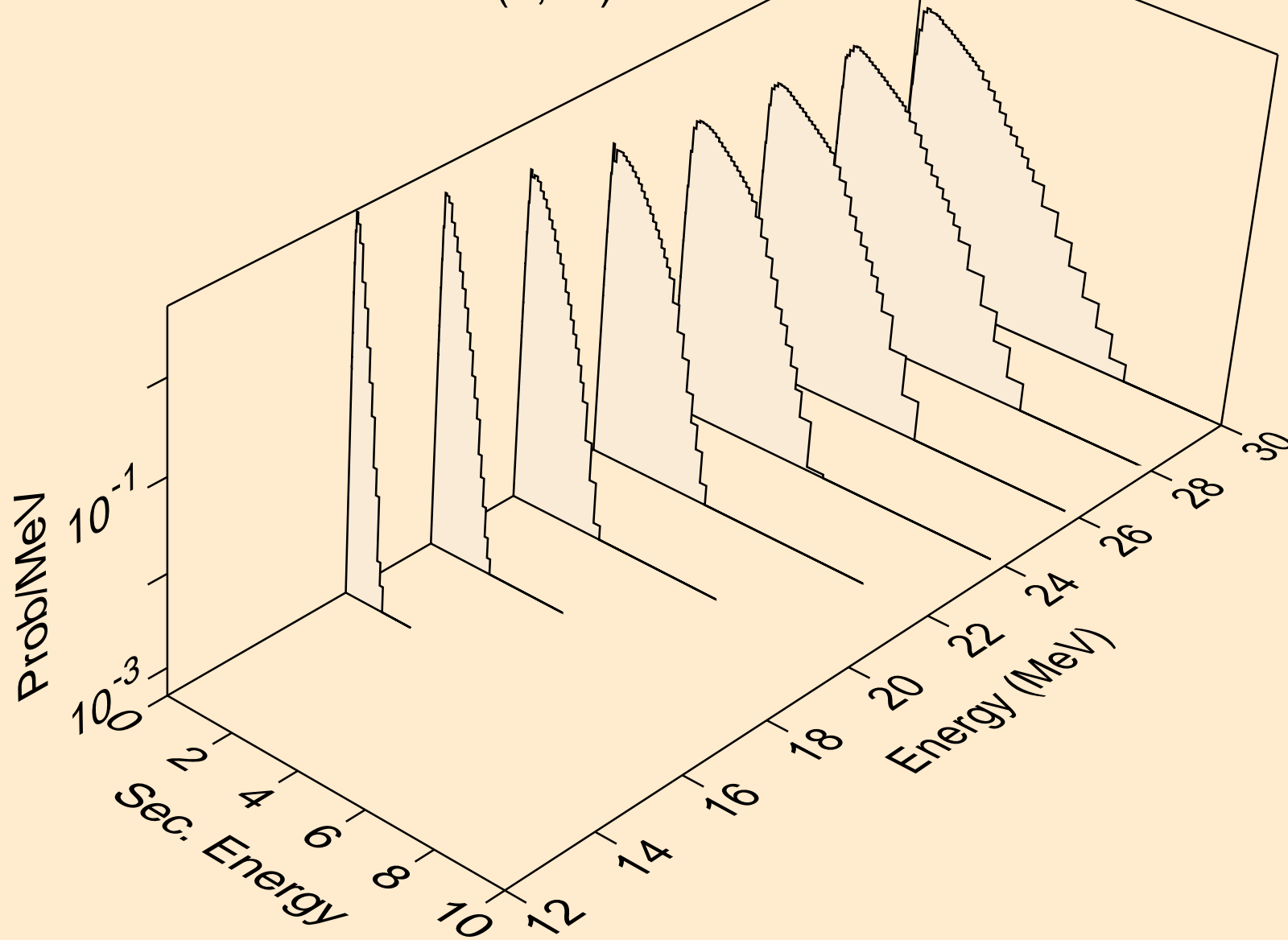

ZN073M NEUTRON ACER TENDL-2021 LIBRARY; T=293.6K  
Neutron emission for (n,3n)a

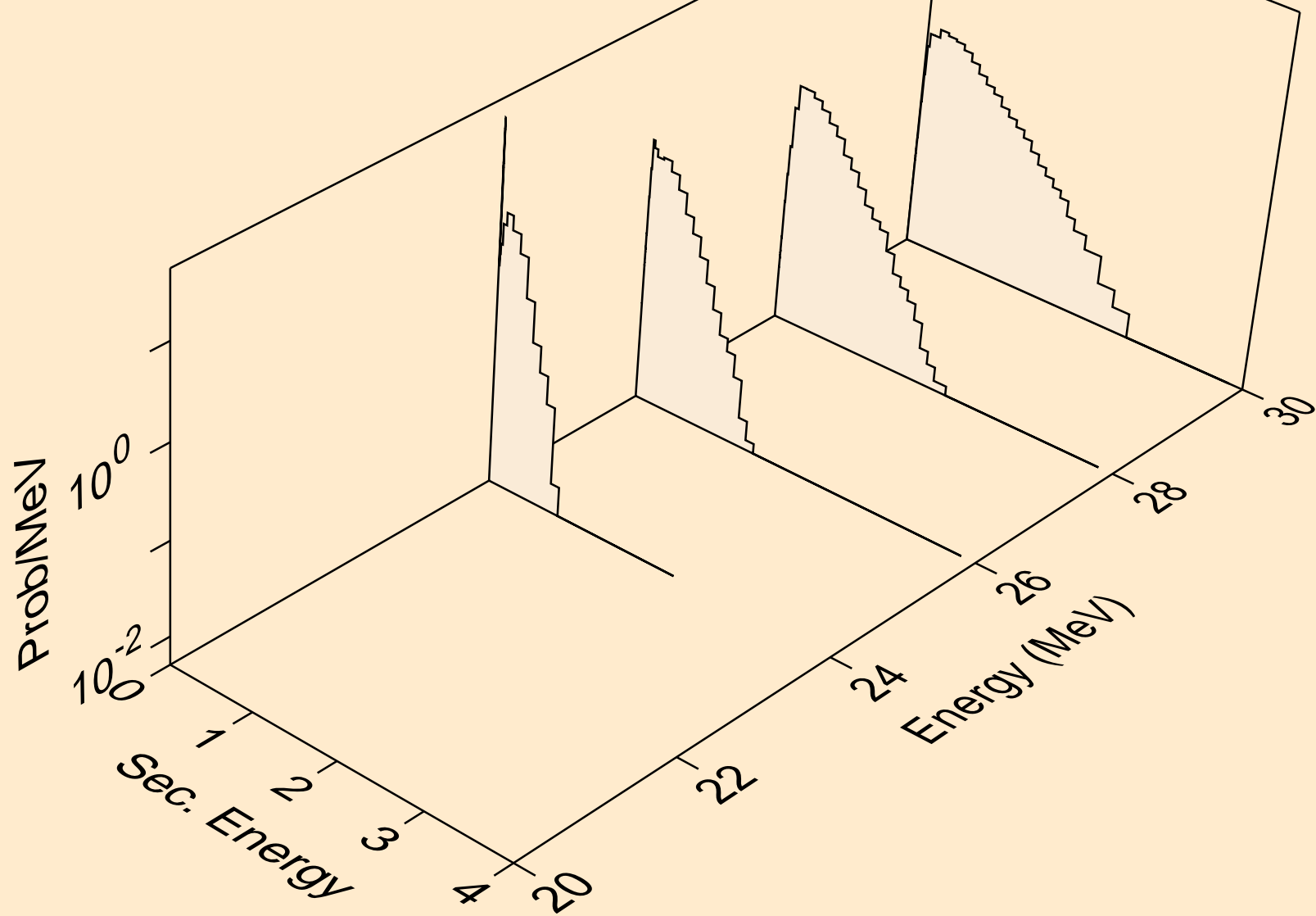

ZN073M NEUTRON ACER TENDL-2021 LIBRARY; T=293.6K  
Neutron emission for (n,n\*)p

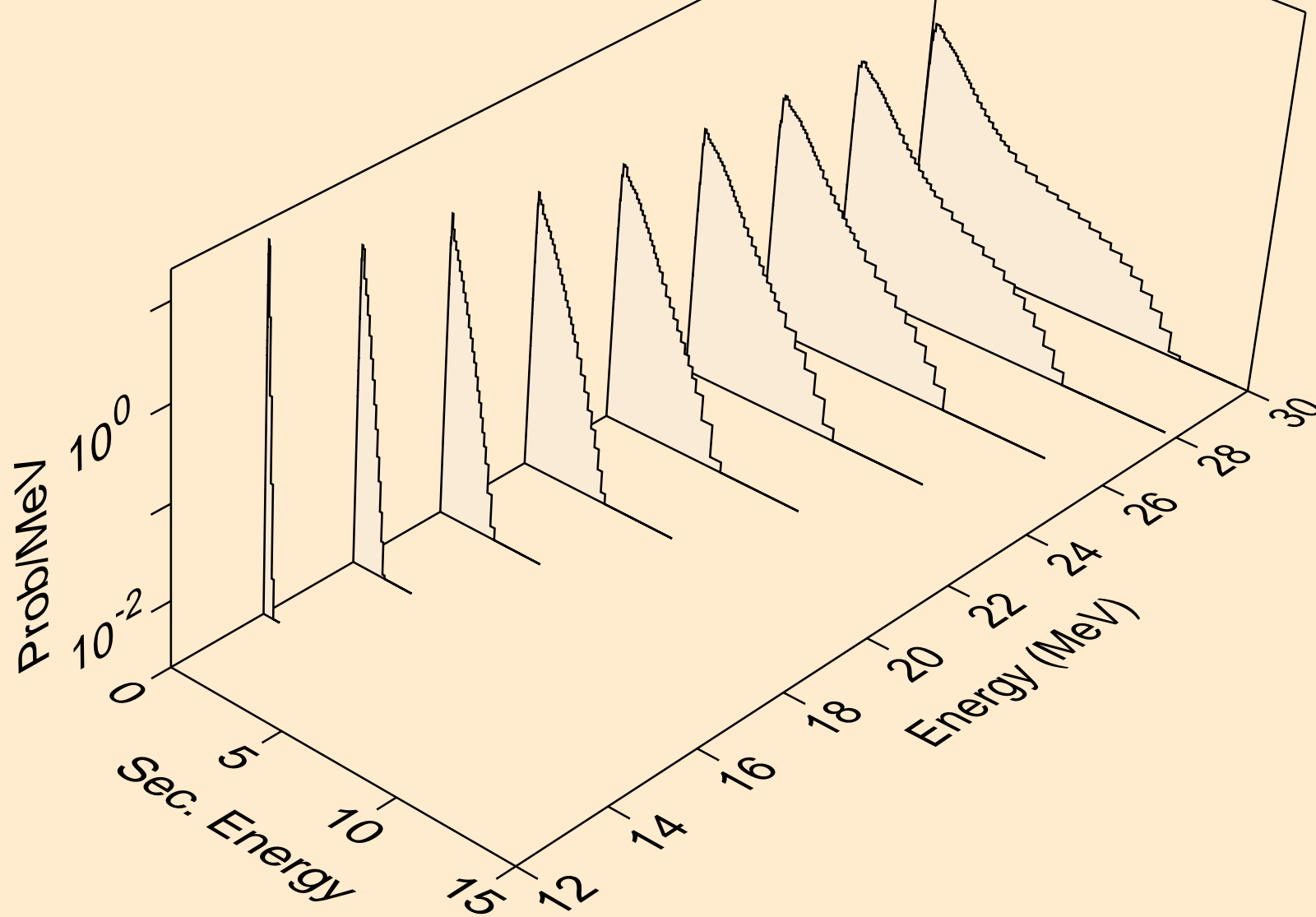

ZN073M NEUTRON ACER TENDL-2021 LIBRARY; T=293.6K  
Neutron emission for (n,n\*)d

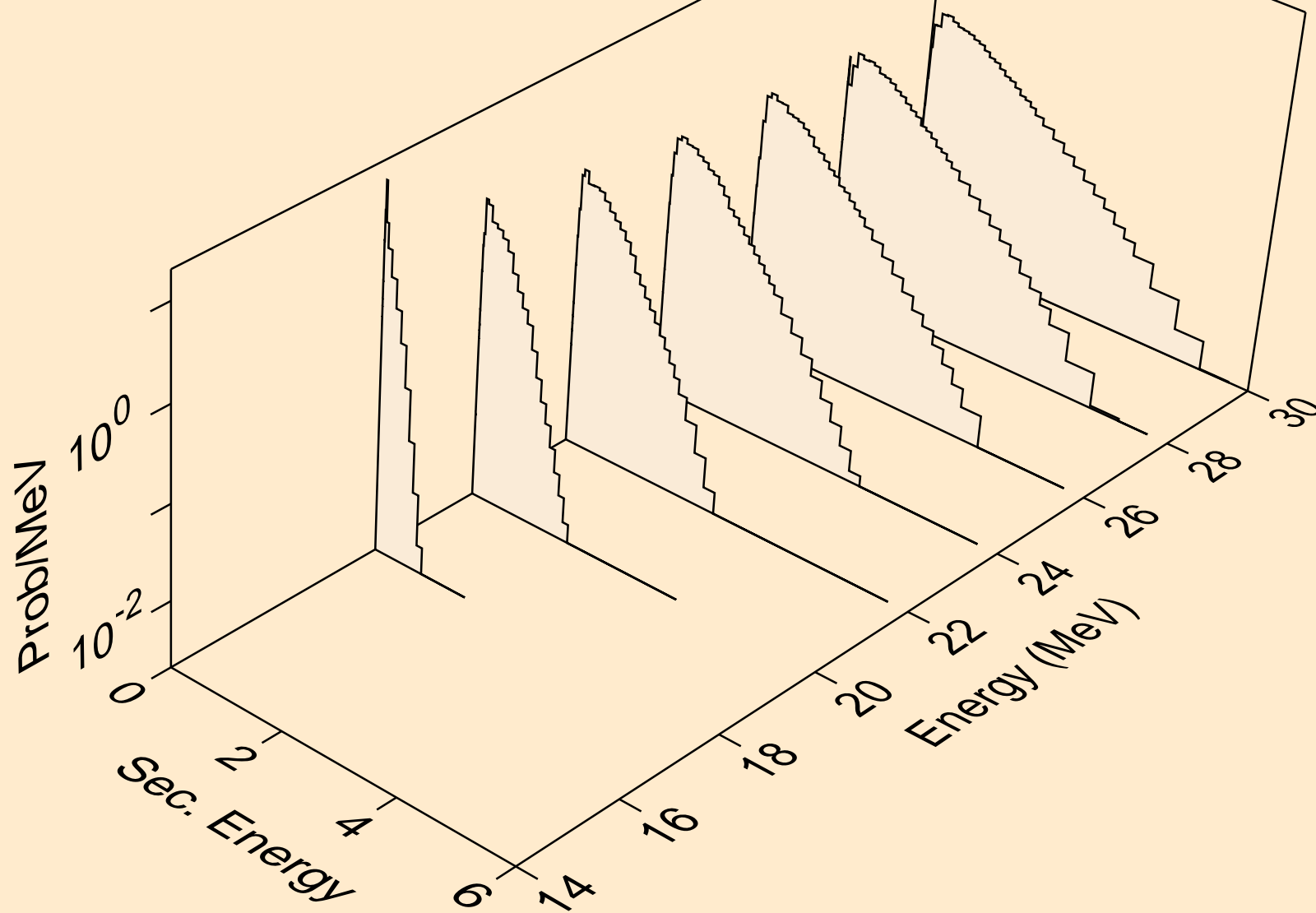

ZN073M NEUTRON ACER TENDL-2021 LIBRARY; T=293.6K  
Neutron emission for (n,n\*)t

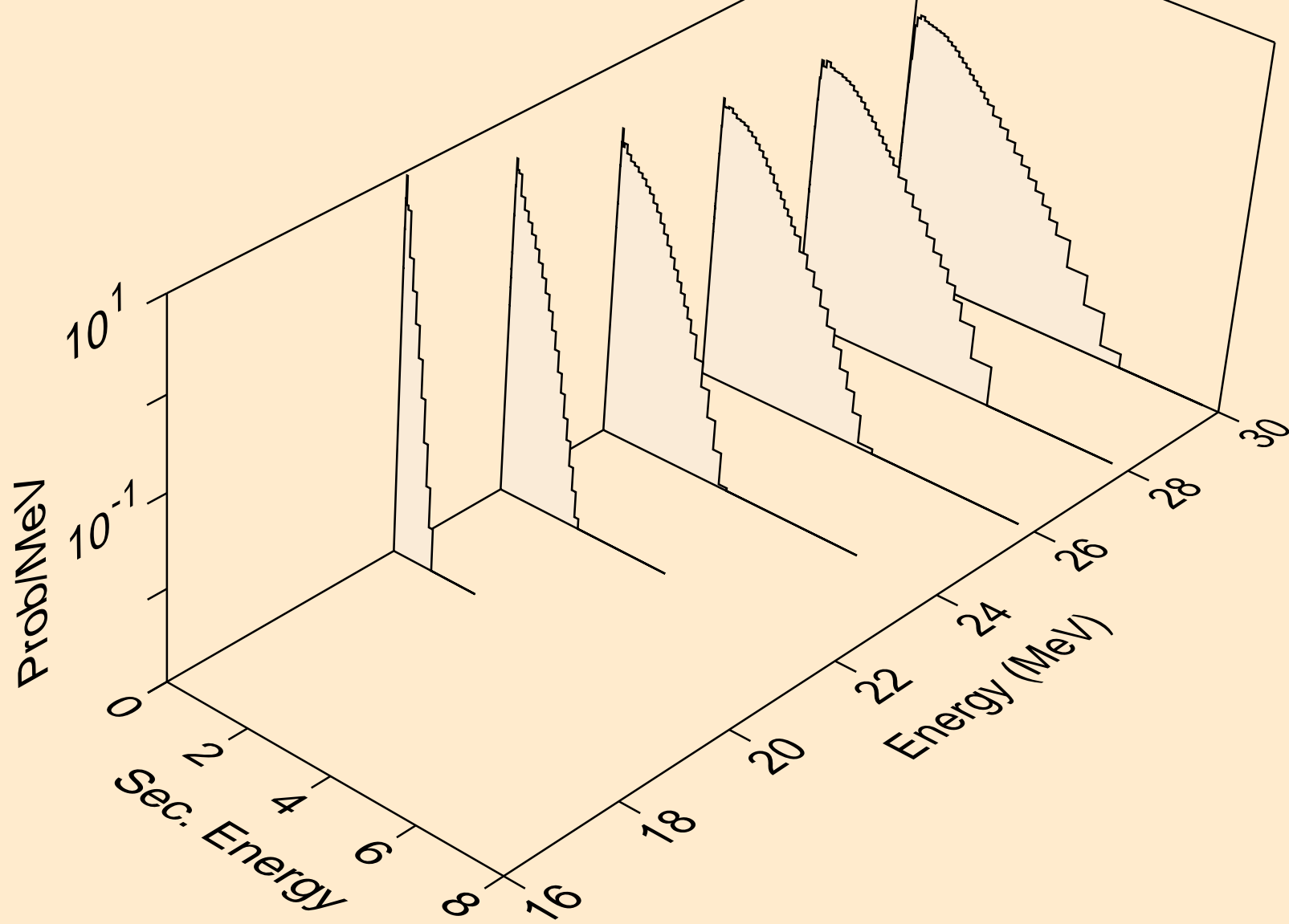



ZN073M NEUTRON ACER TENDL-2021 LIBRARY; T=293.6K  
Neutron emission for (n,n\*)he3

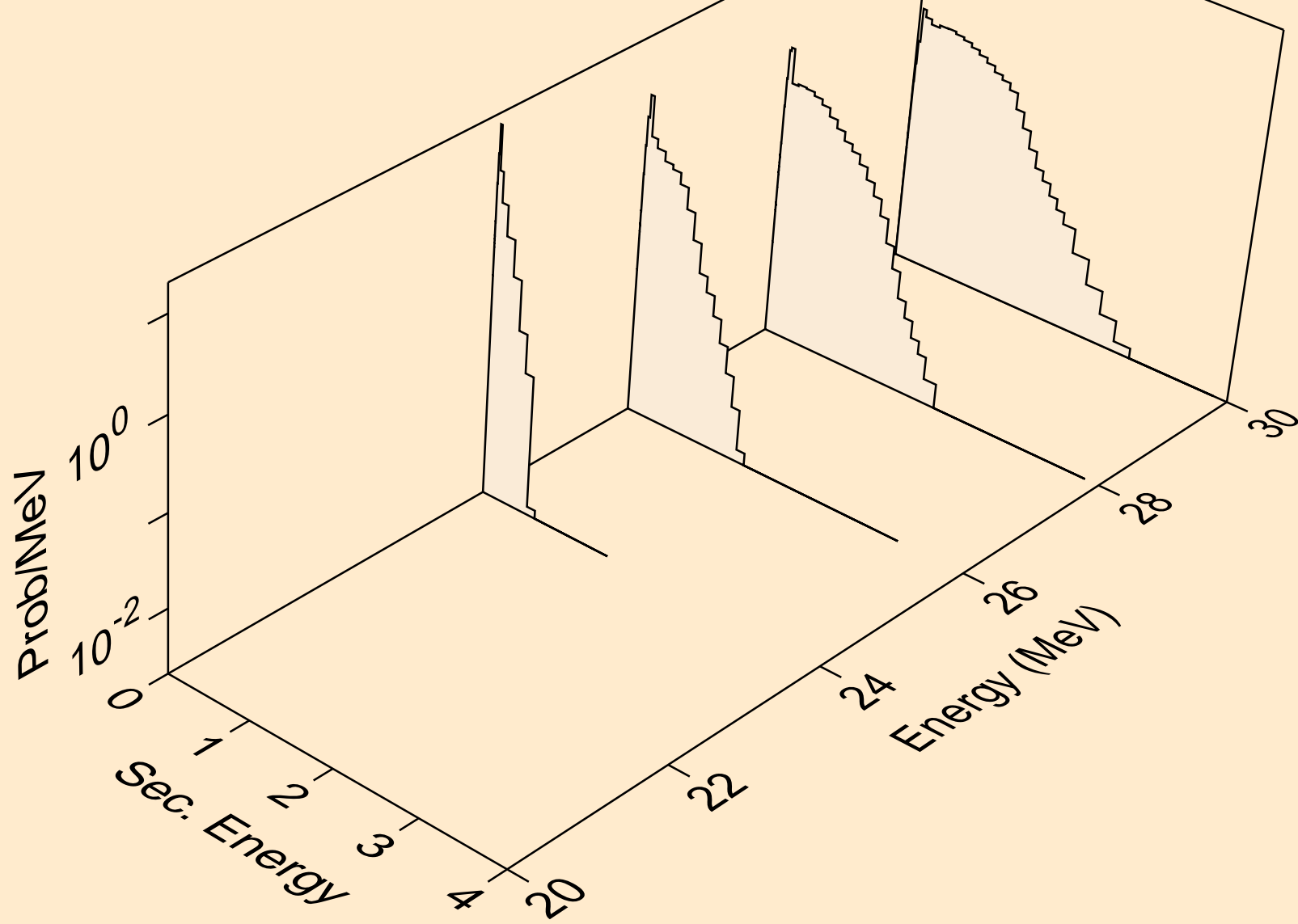

ZN073M NEUTRON ACER TENDL-2021 LIBRARY; T=293.6K  
Neutron emission for (n,4n)

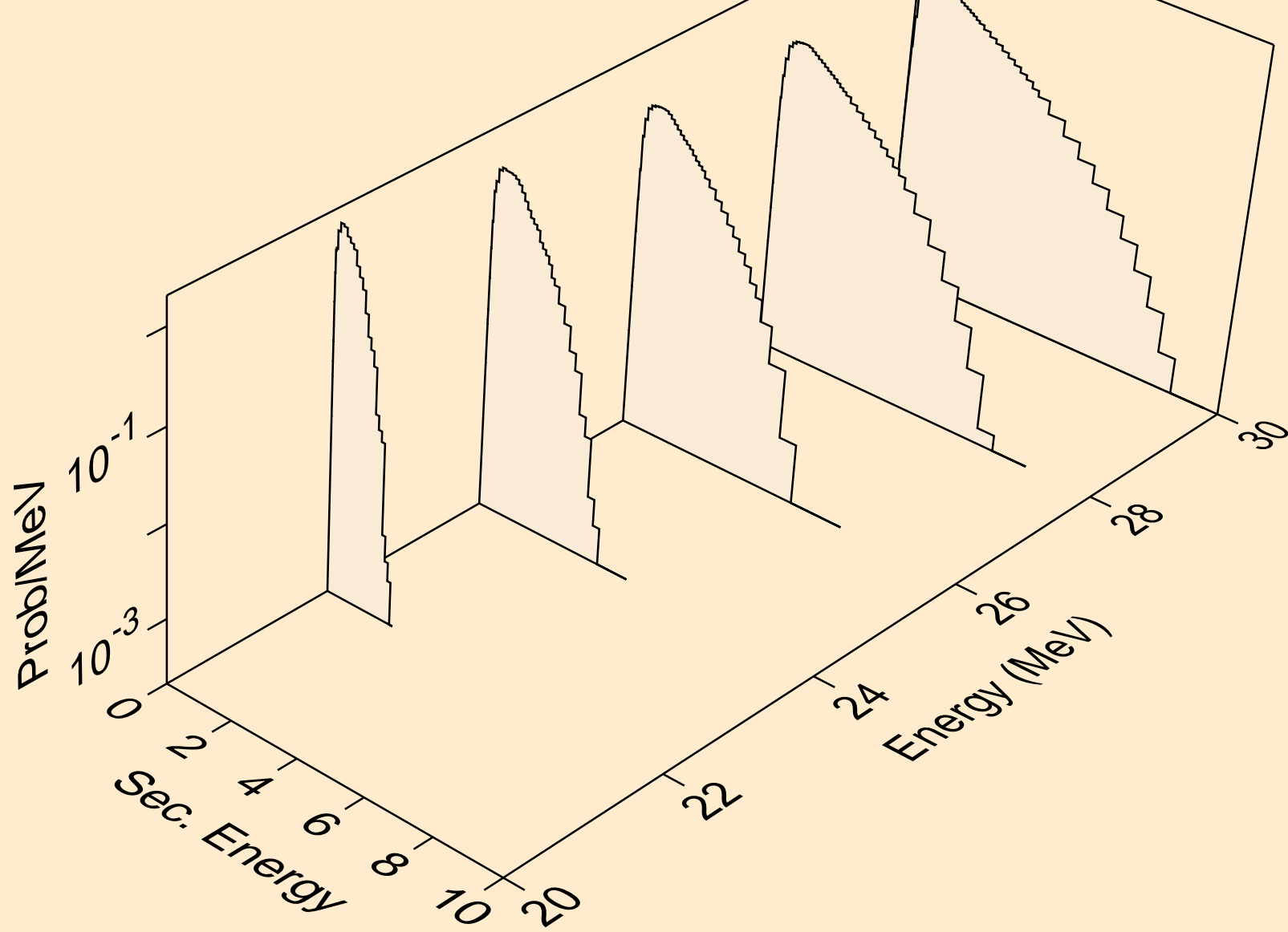

ZN073M NEUTRON ACER TENDL-2021 LIBRARY; T=293.6K  
Neutron emission for (n,2np)

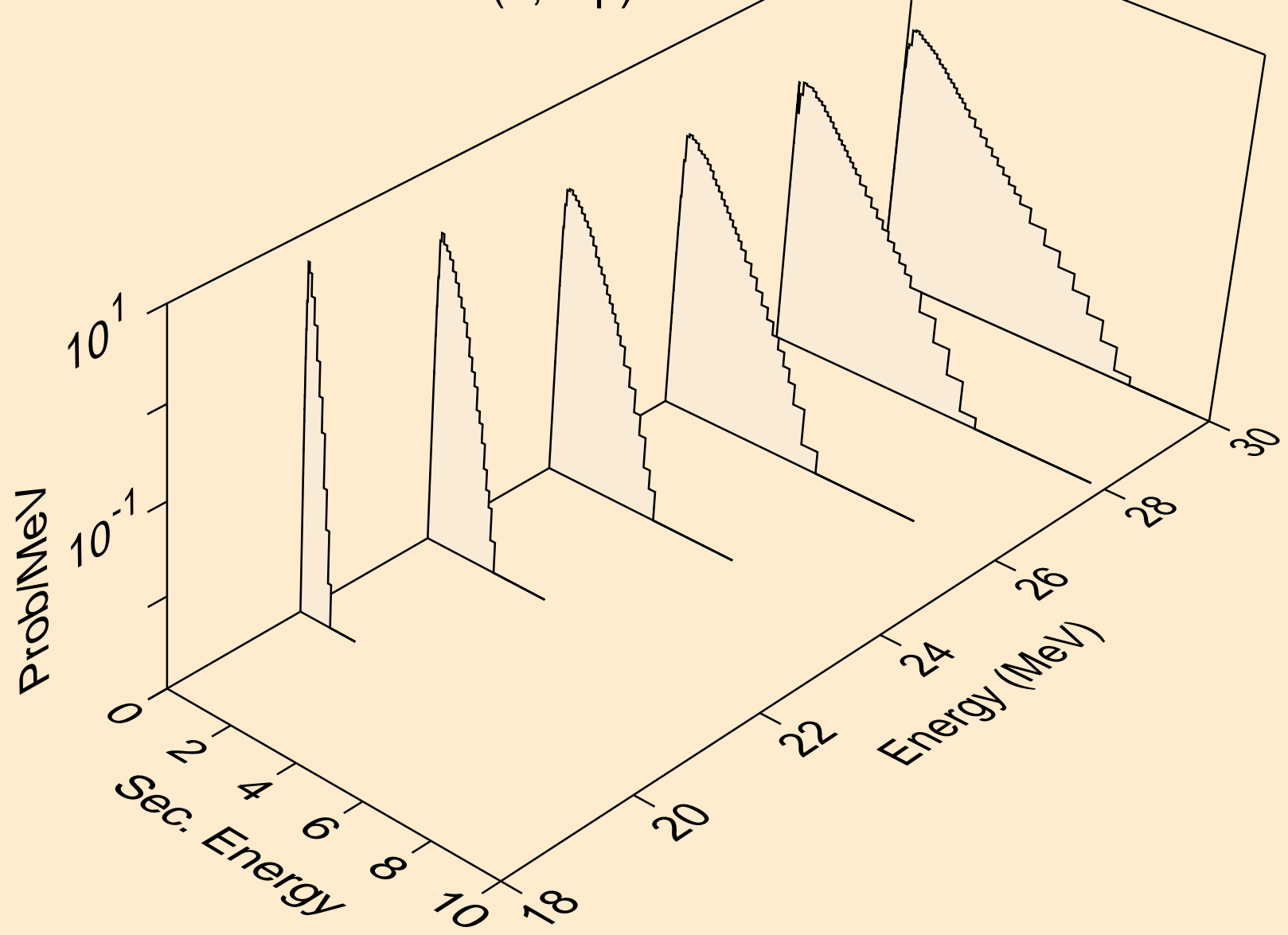

ZN073M NEUTRON ACER TENDL-2021 LIBRARY; T=293.6K  
Neutron emission for (n,3np)

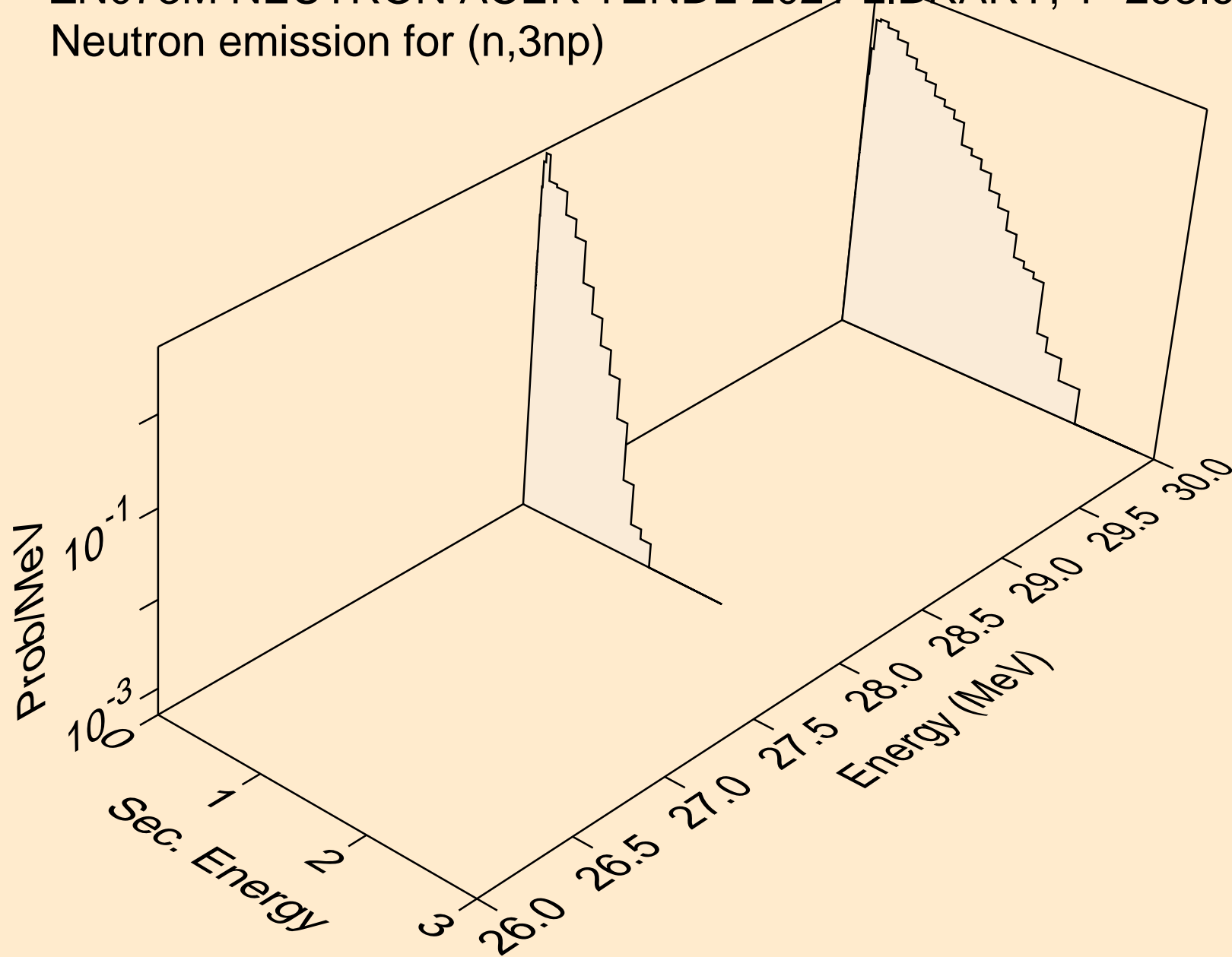

ZN073M NEUTRON ACER TENDL-2021 LIBRARY; T=293.6K  
Neutron emission for (n,n\*c)

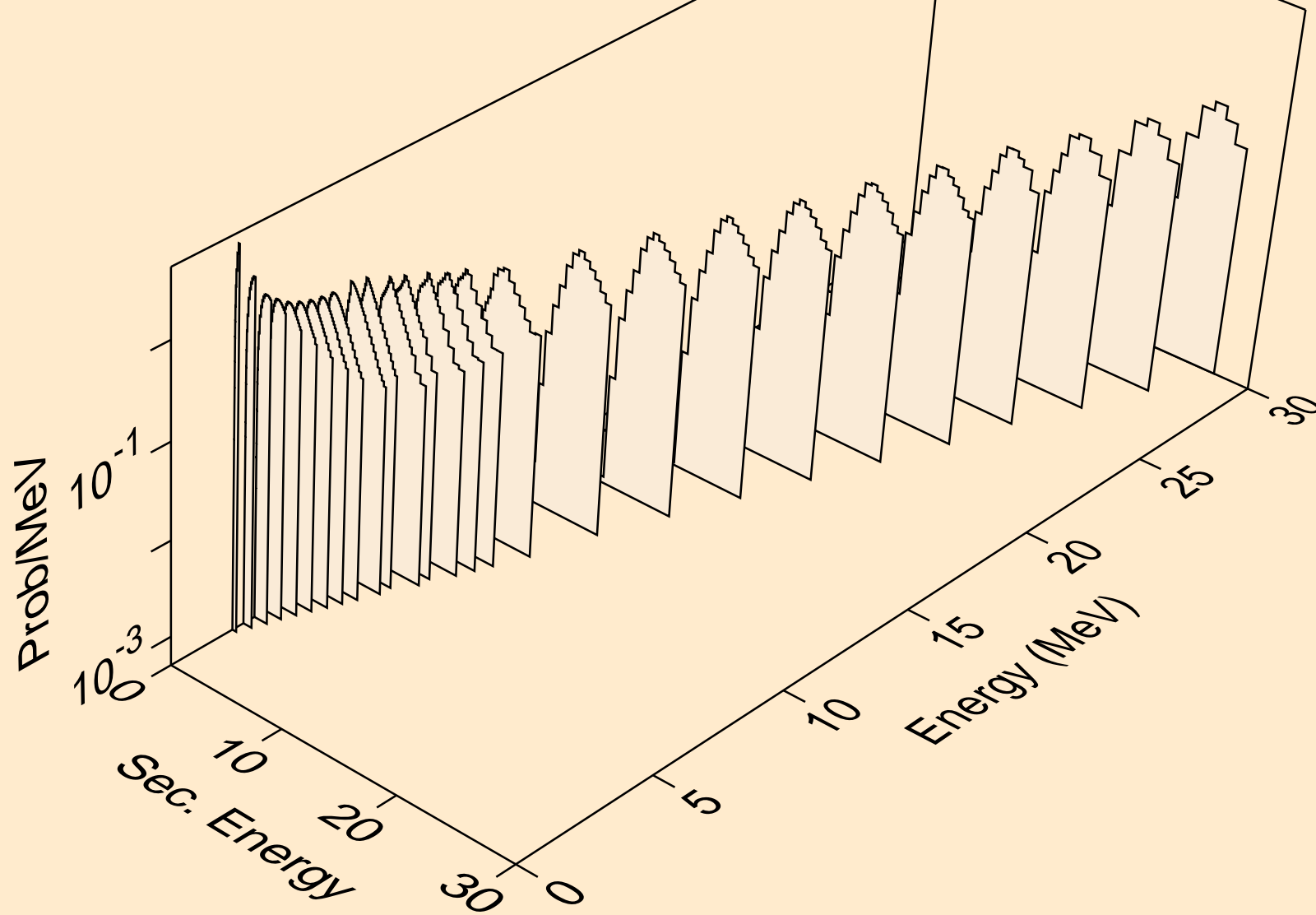

ZN073M NEUTRON ACER TENDL-2021 LIBRARY; T=293.6K  
Photon emission for (n,x)

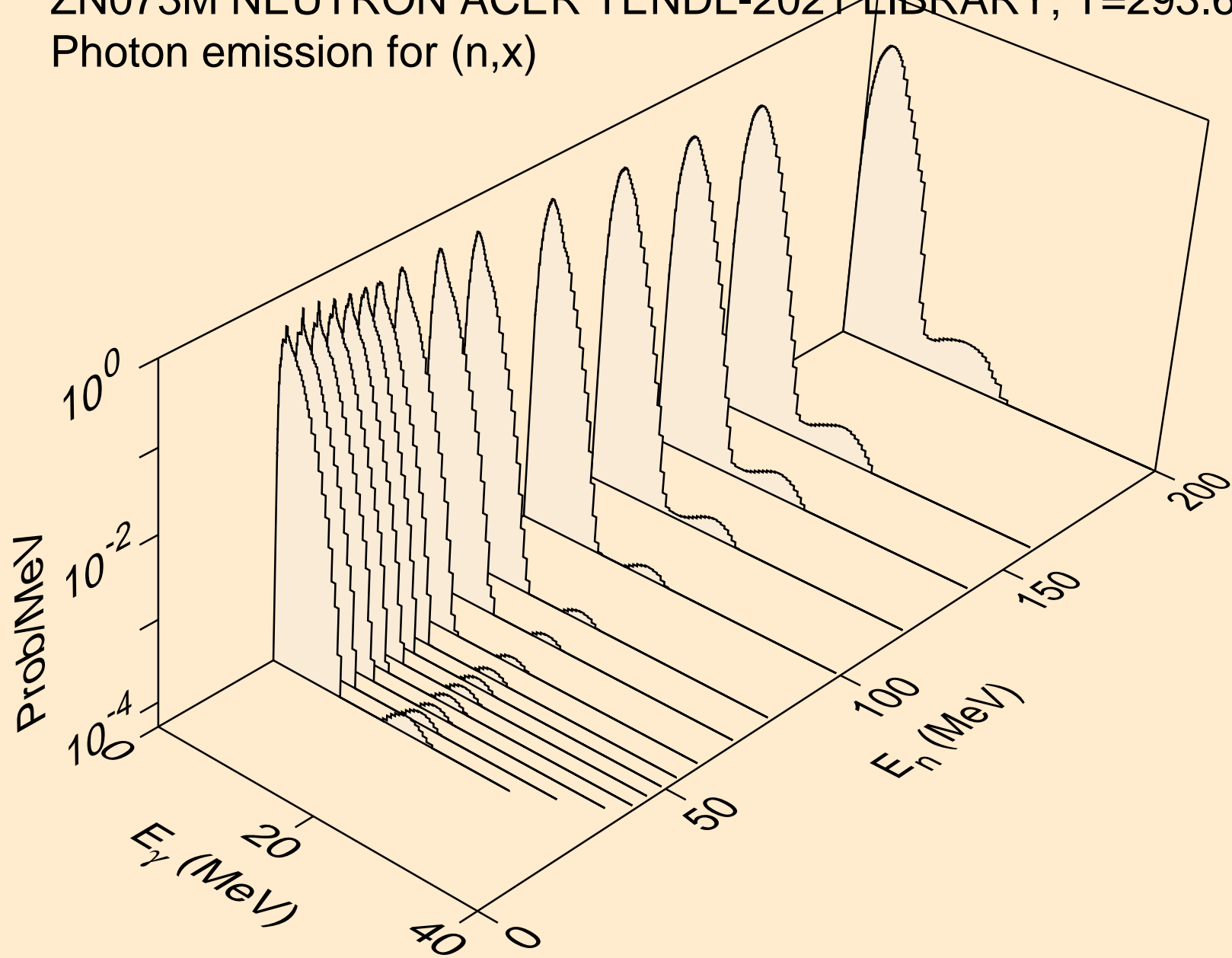

ZN073M NEUTRON ACER TENDL-2021 LIBRARY; T=293.6K  
Photon emission for (n,2nd)

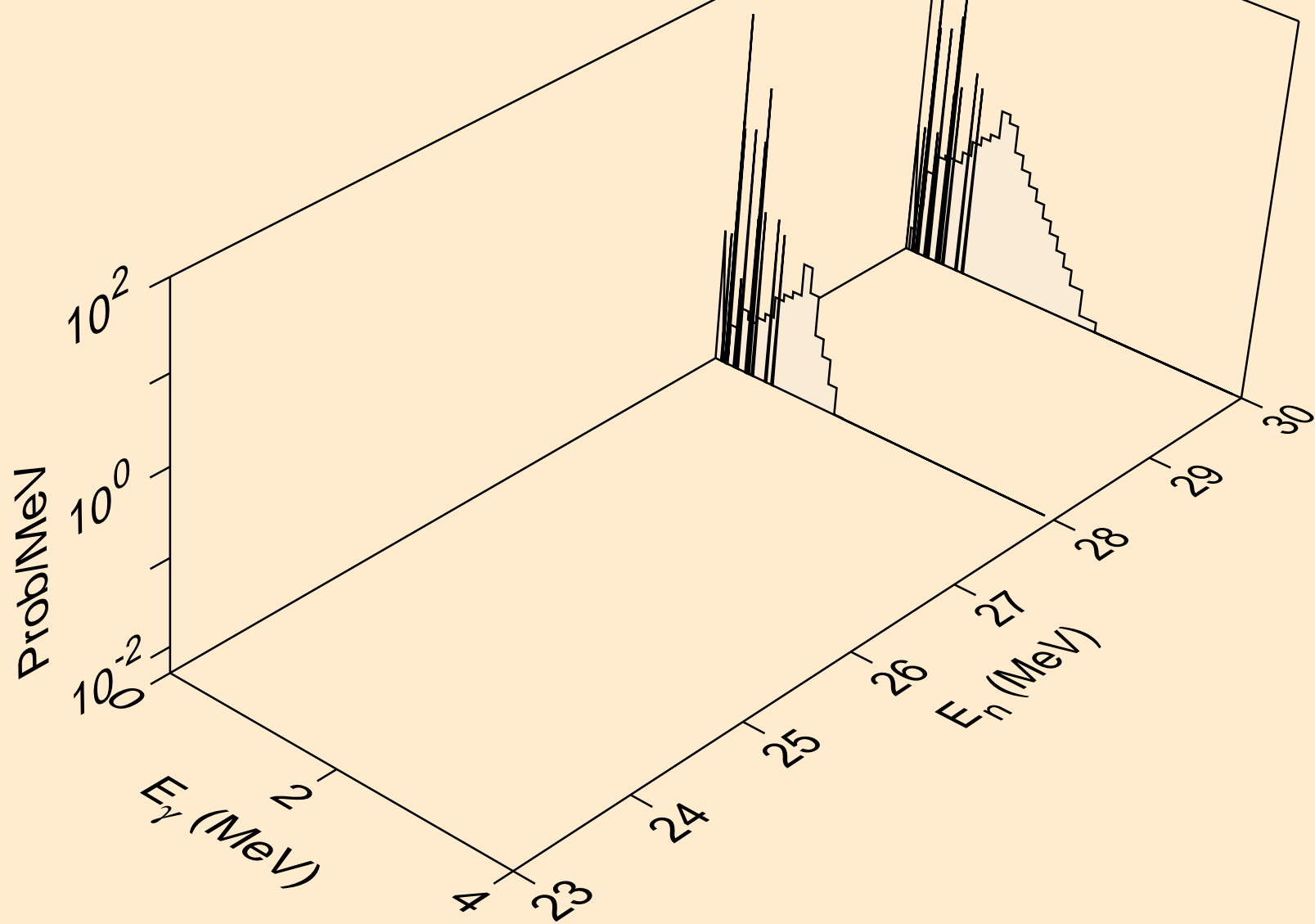

ZN073M NEUTRON ACER TENDL-2021 LIBRARY; T=293.6K  
Photon emission for (n,2n)

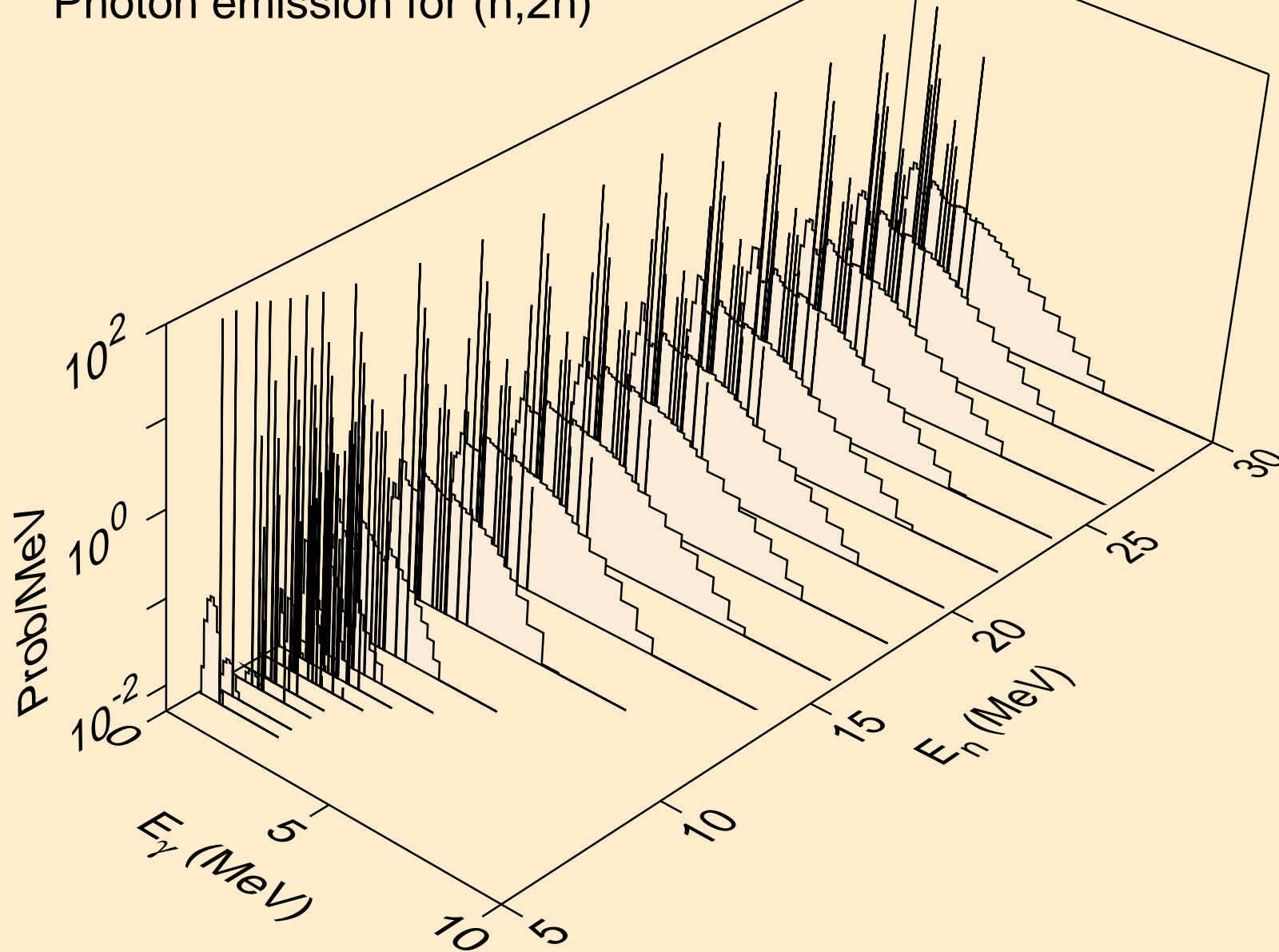



ZN073M NEUTRON ACER TENDL-2021 LIBRARY; T=293.6K  
Photon emission for (n,3n)

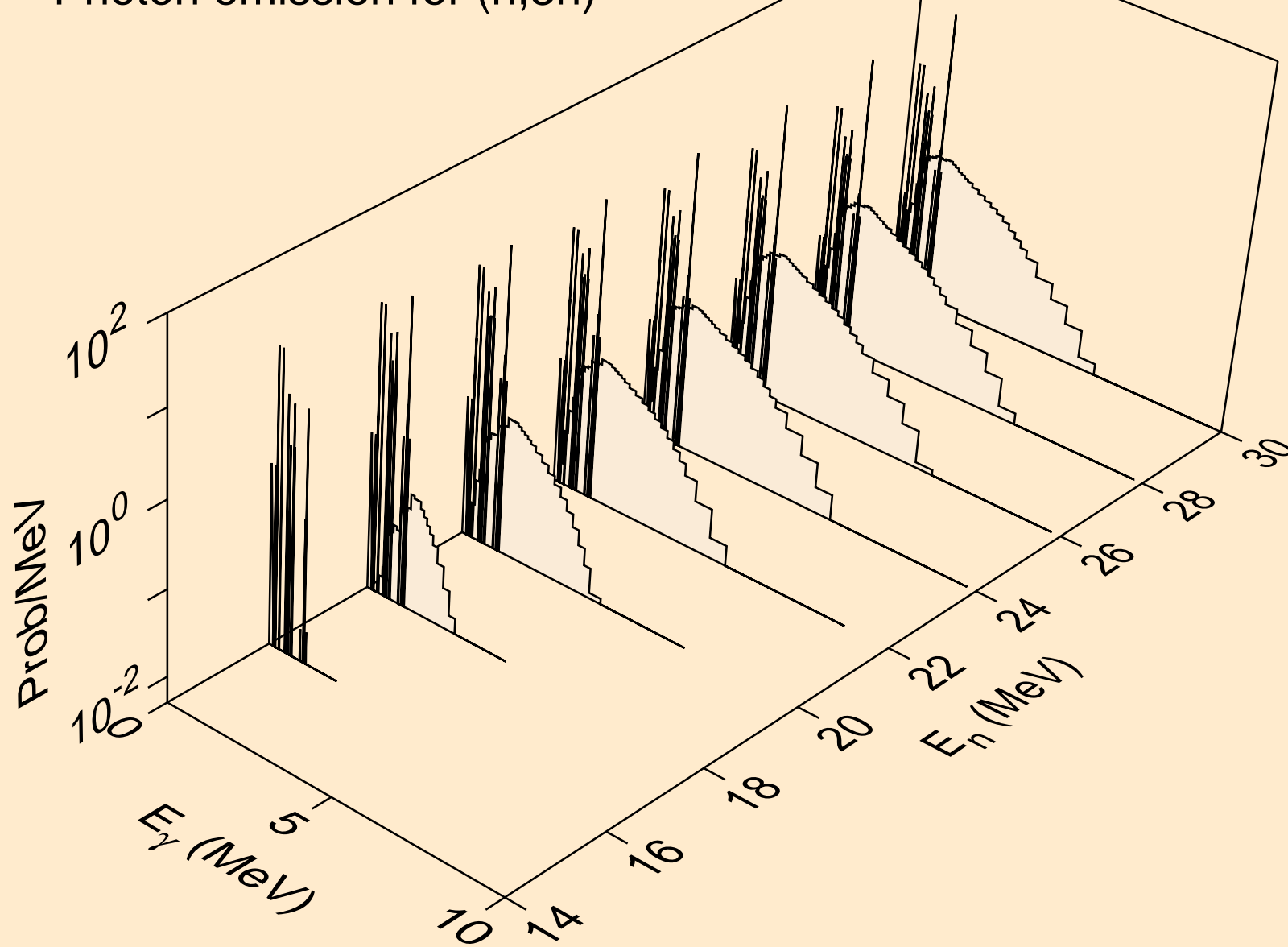

ZN073M NEUTRON ACER TENDL-2021 LIBRARY; T=293.6K  
Photon emission for (n,n\*)a

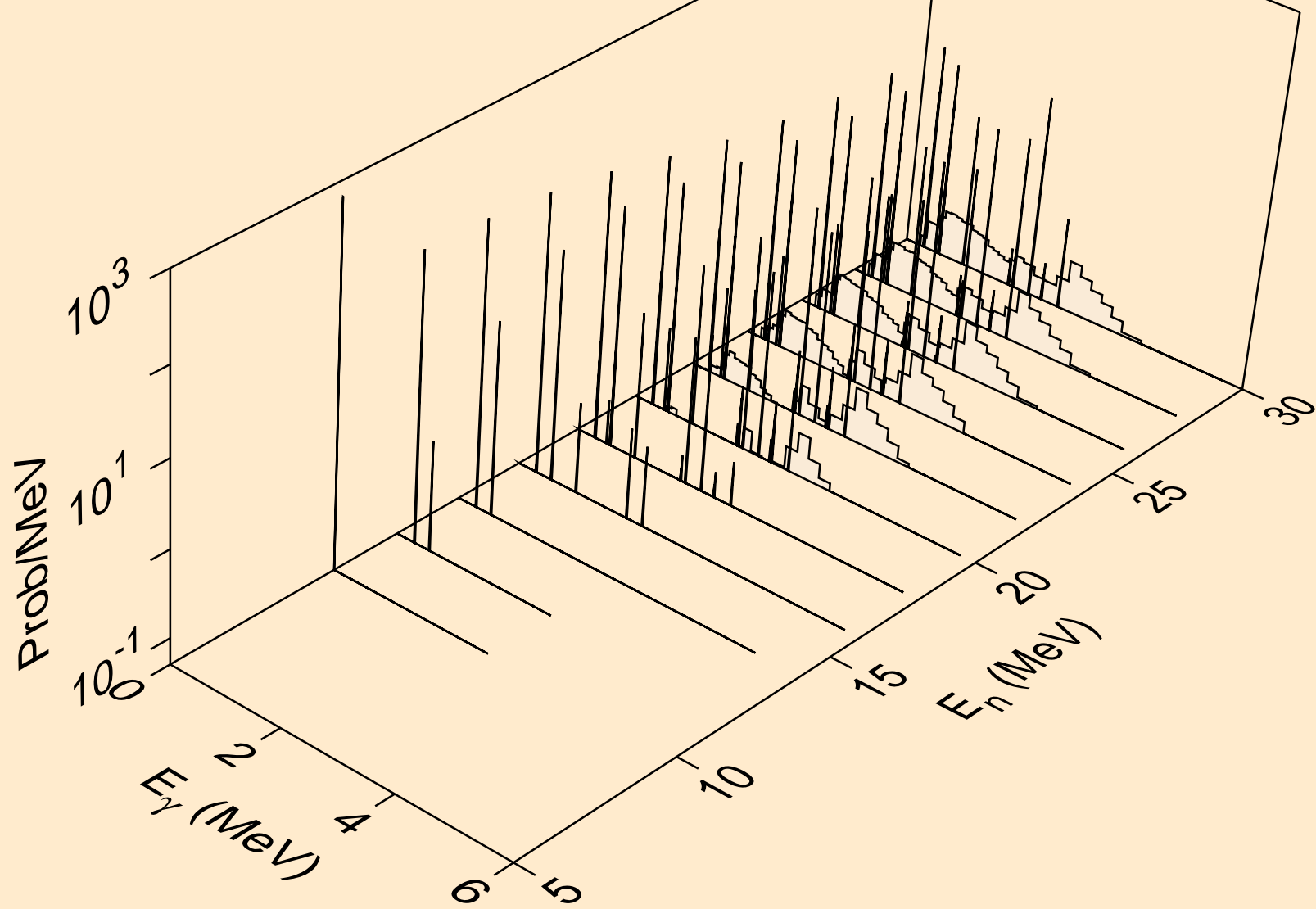

ZN073M NEUTRON ACER TENDL-2021 LIBRARY; T=293.6K  
Photon emission for (n,2n)a

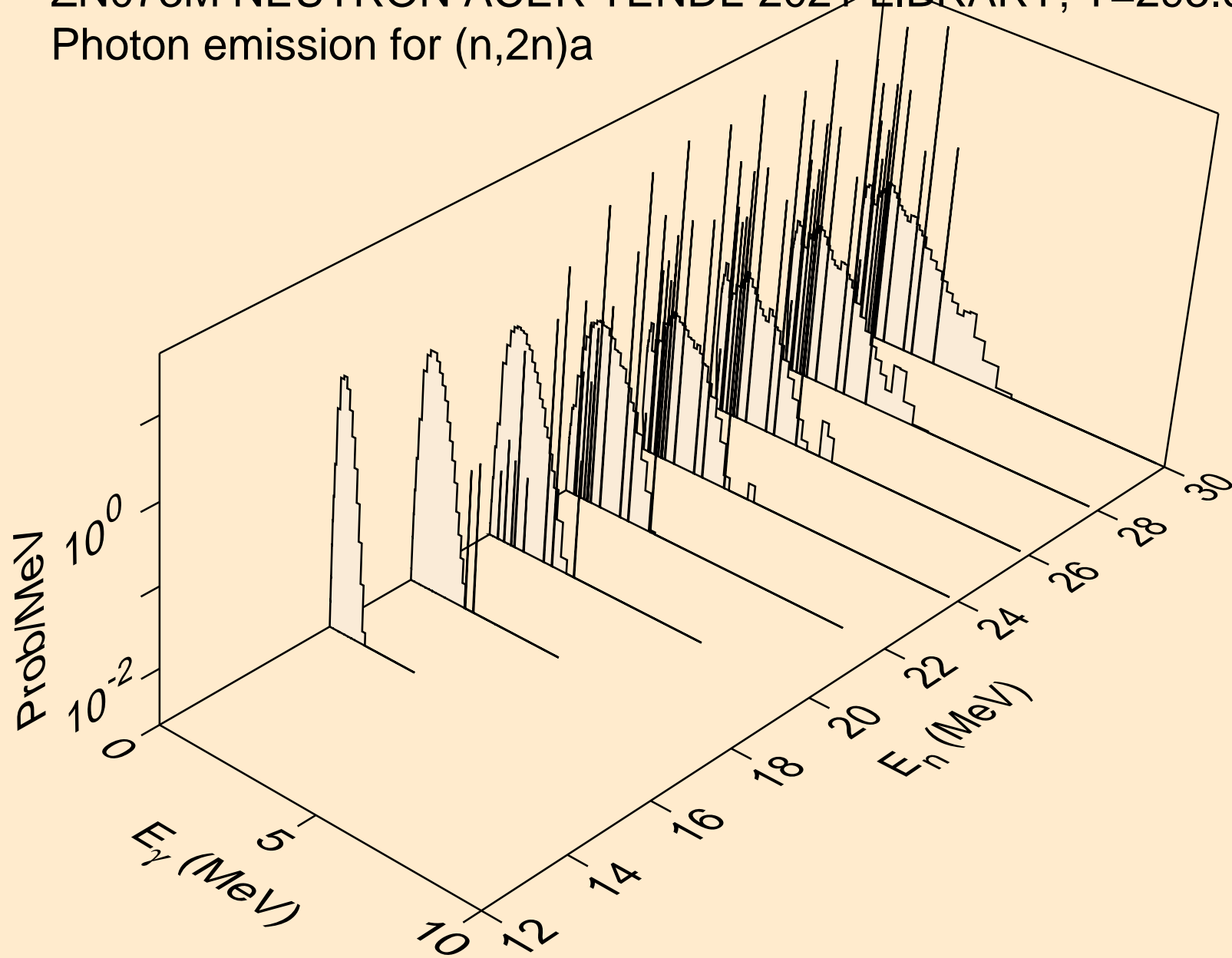

ZN073M NEUTRON ACER TENDL-2021 LIBRARY; T=293.6K  
Photon emission for (n,3n)a

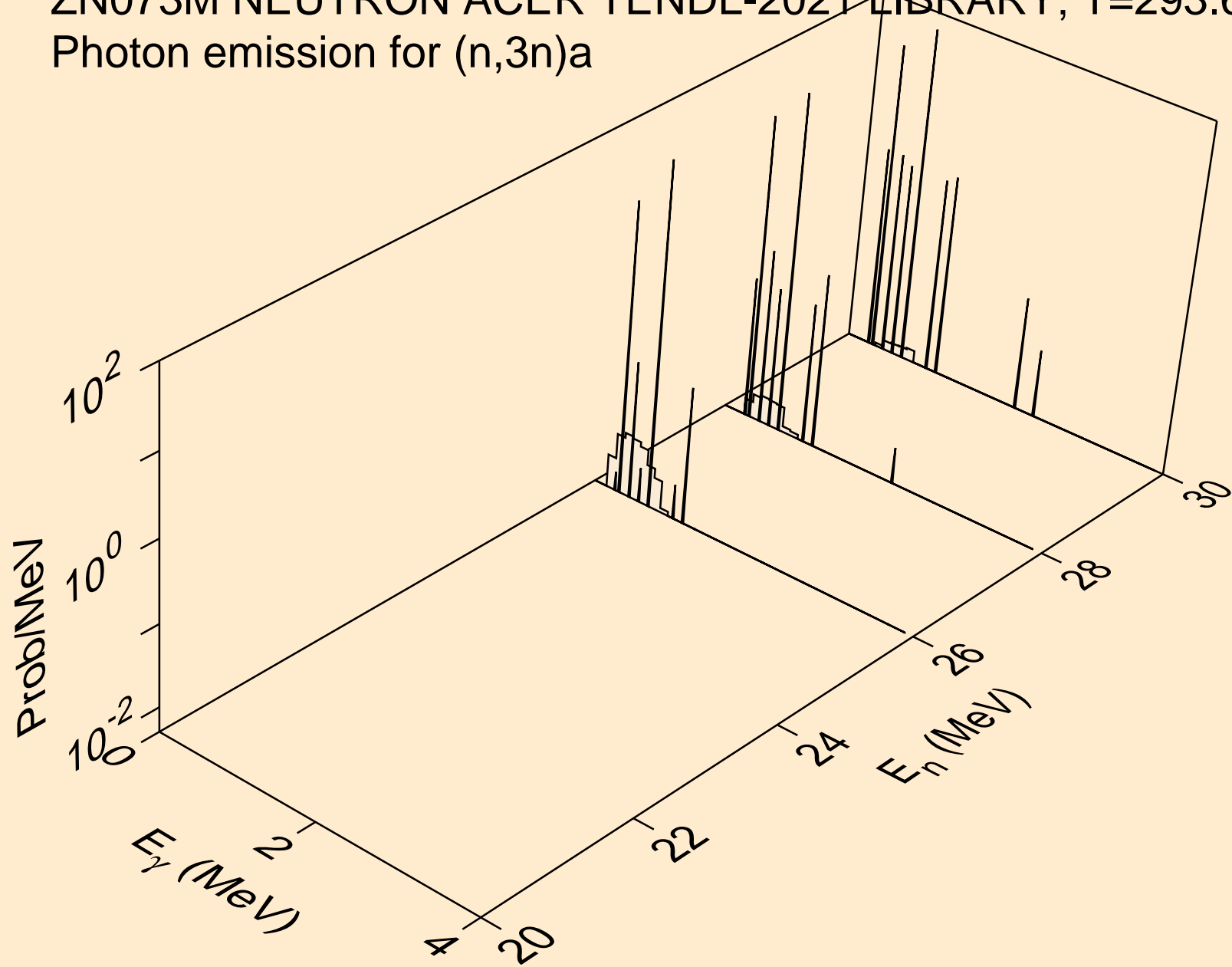

ZN073M NEUTRON ACER TENDL-2021 LIBRARY; T=293.6K  
Photon emission for (n,n\*)p

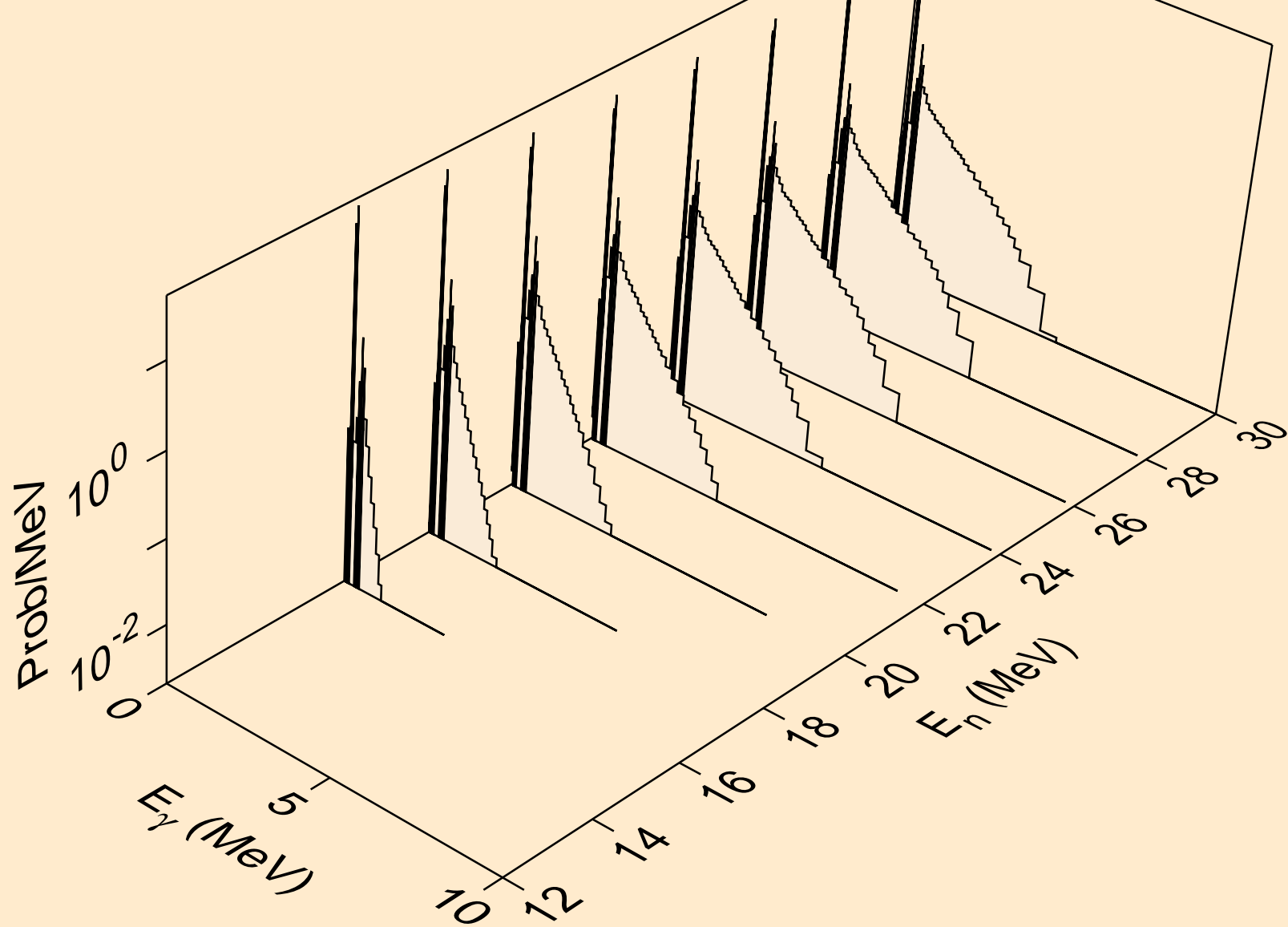

ZN073M NEUTRON ACER TENDL-2021 LIBRARY; T=293.6K  
Photon emission for (n,n\*)d

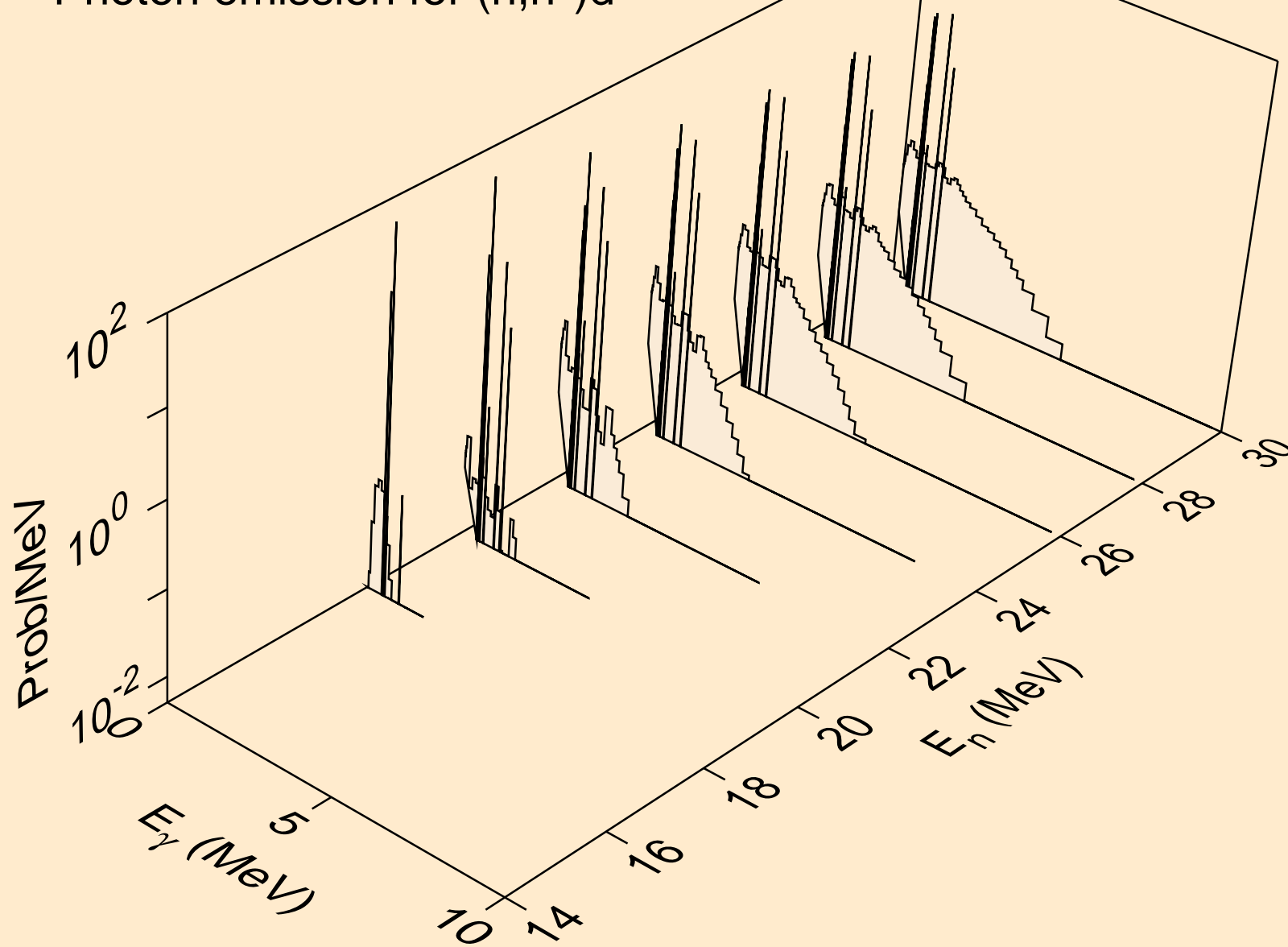

ZN073M NEUTRON ACER TENDL-2021 LIBRARY; T=293.6K  
Photon emission for (n,n\*)t

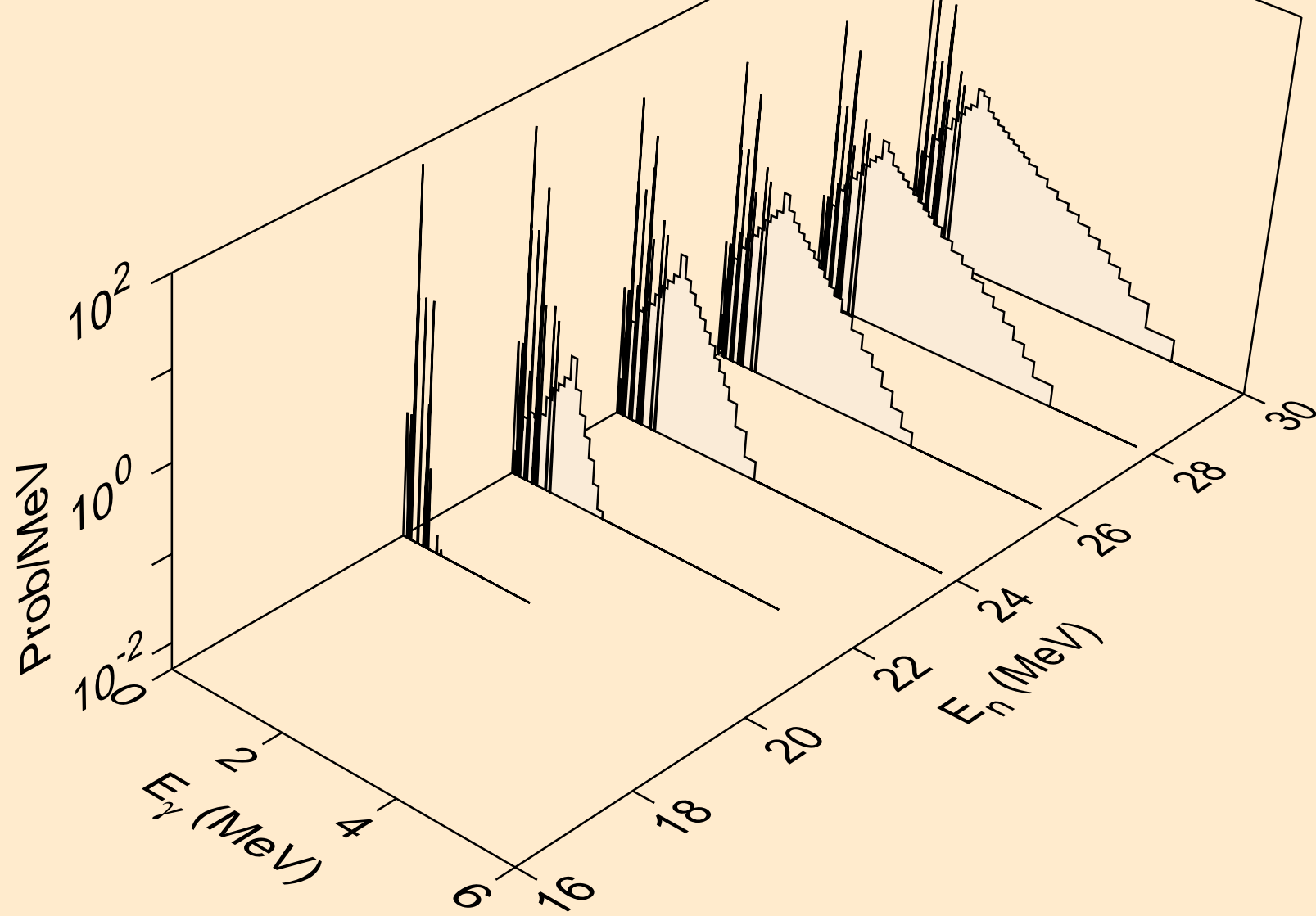

ZN073M NEUTRON ACER TENDL-2021 LIBRARY; T=293.6K  
Photon emission for (n,n\*)he3

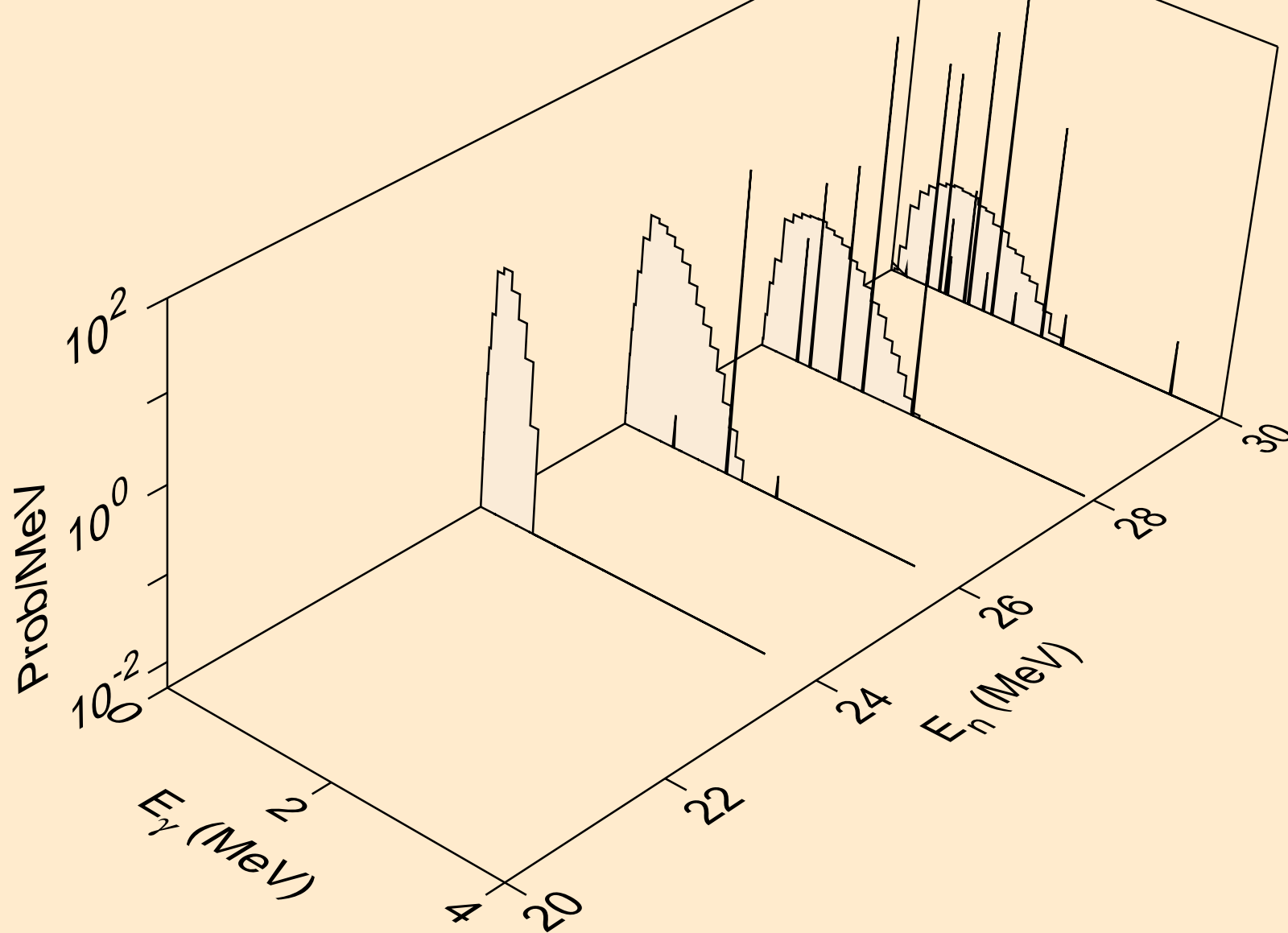



ZN073M NEUTRON ACER TENDL-2021 LIBRARY; T=293.6K  
Photon emission for (n,4n)

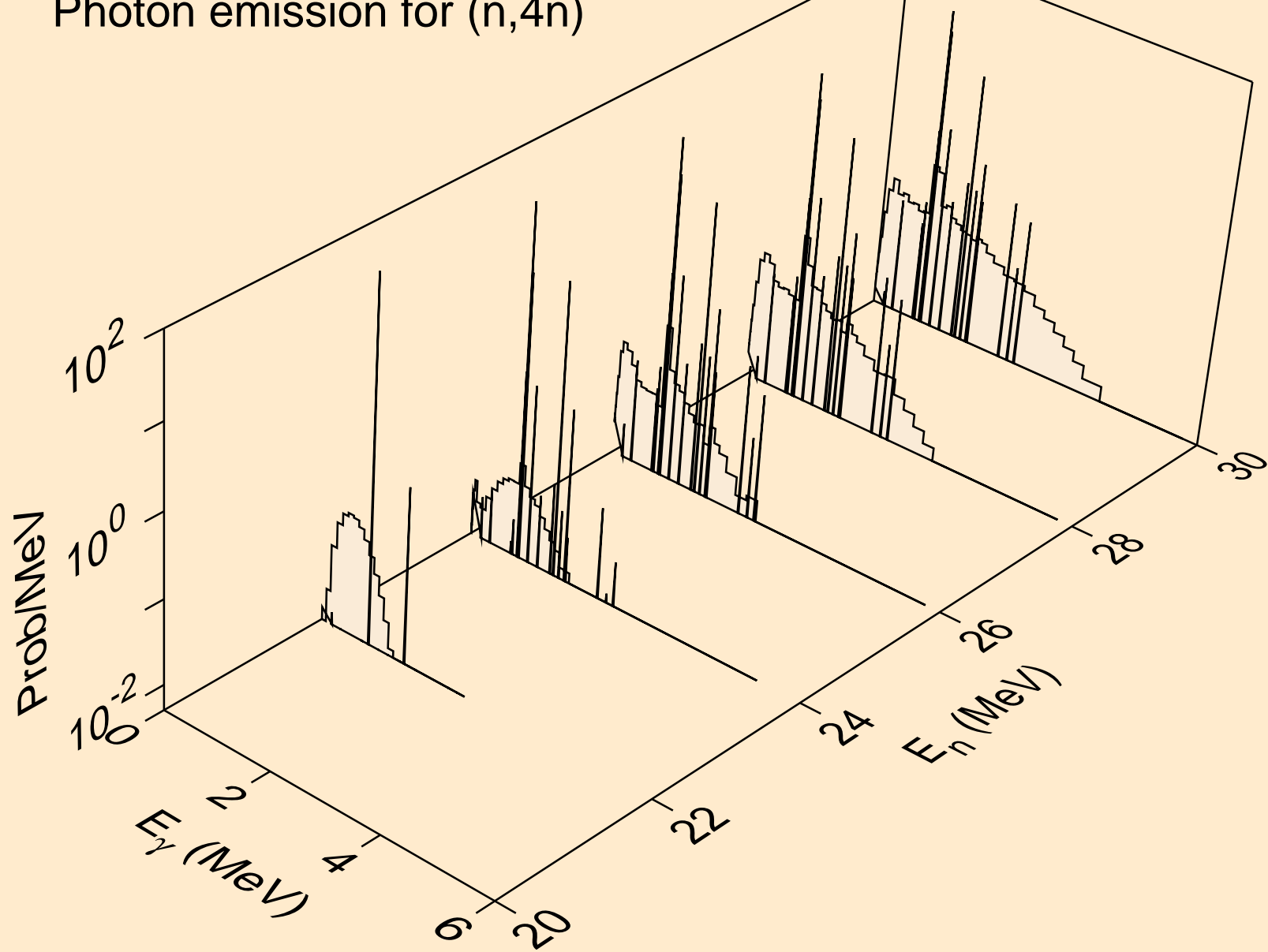

ZN073M NEUTRON ACER TENDL-2021 LIBRARY; T=293.6K  
Photon emission for (n,2np)

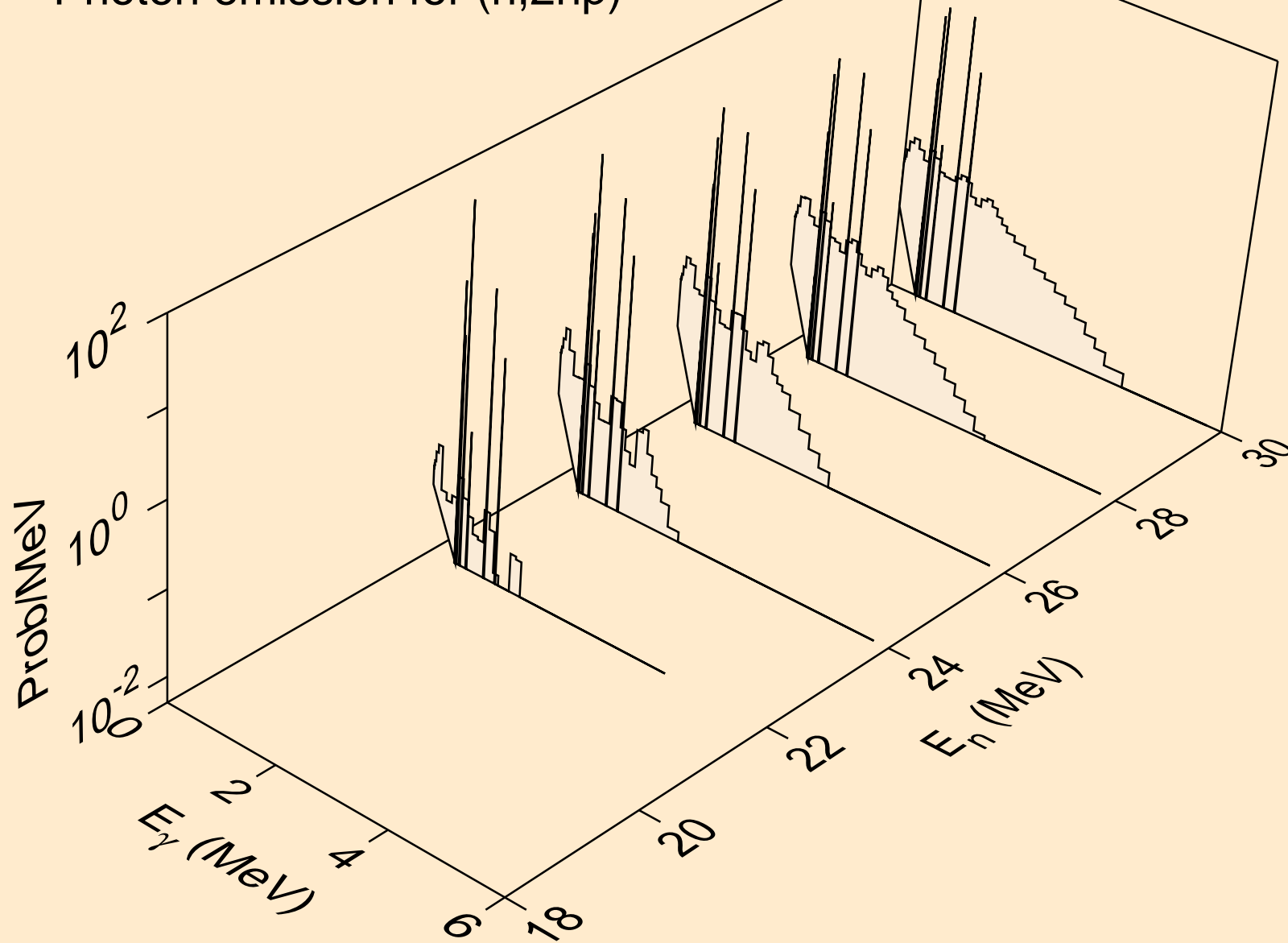

ZN073M NEUTRON ACER TENDL-2021 LIBRARY; T=293.6K  
Photon emission for (n,3np)

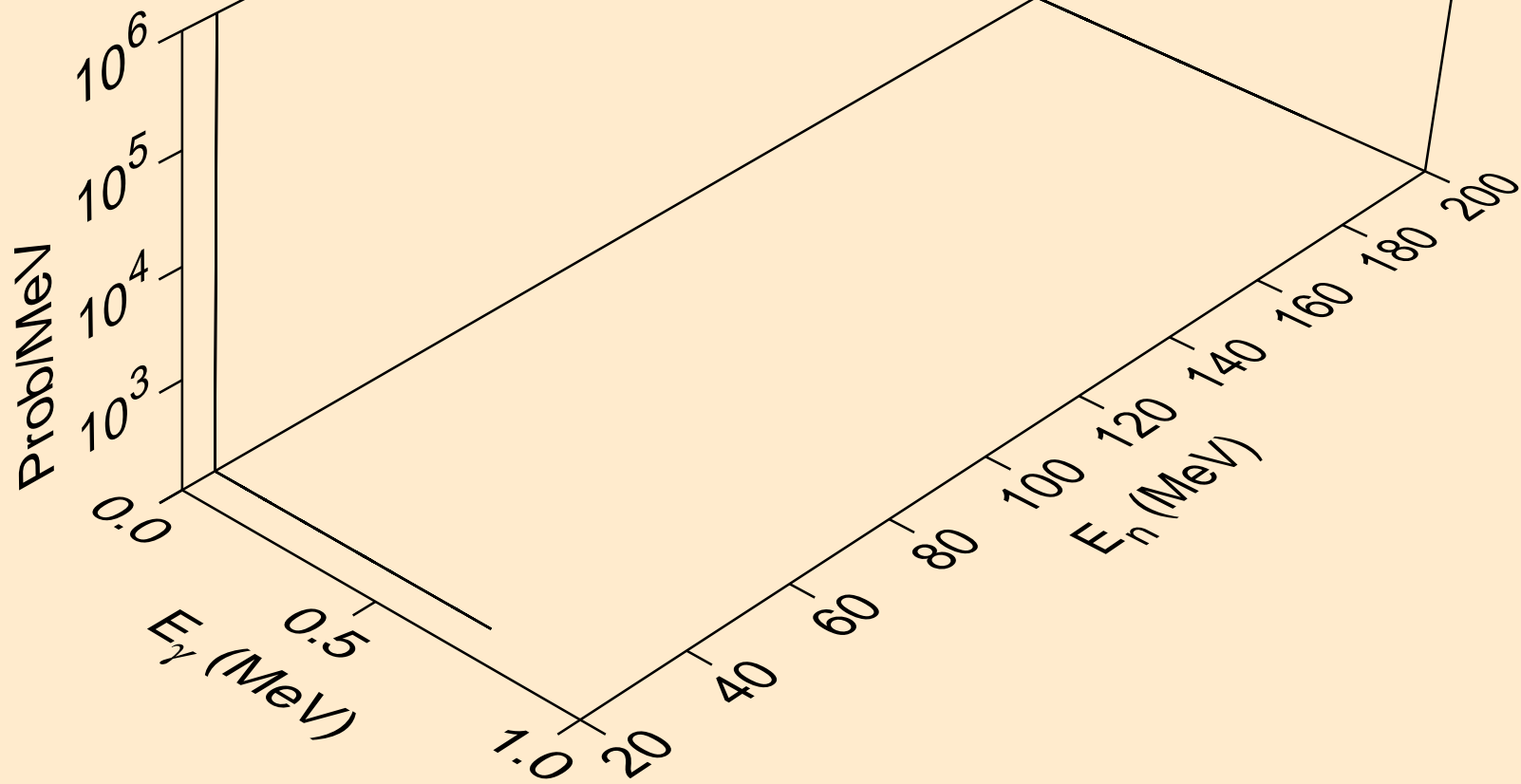

ZN073M NEUTRON ACER TENDL-2021 LIBRARY; T=293.6K  
Photon emission for (n,n\*1)

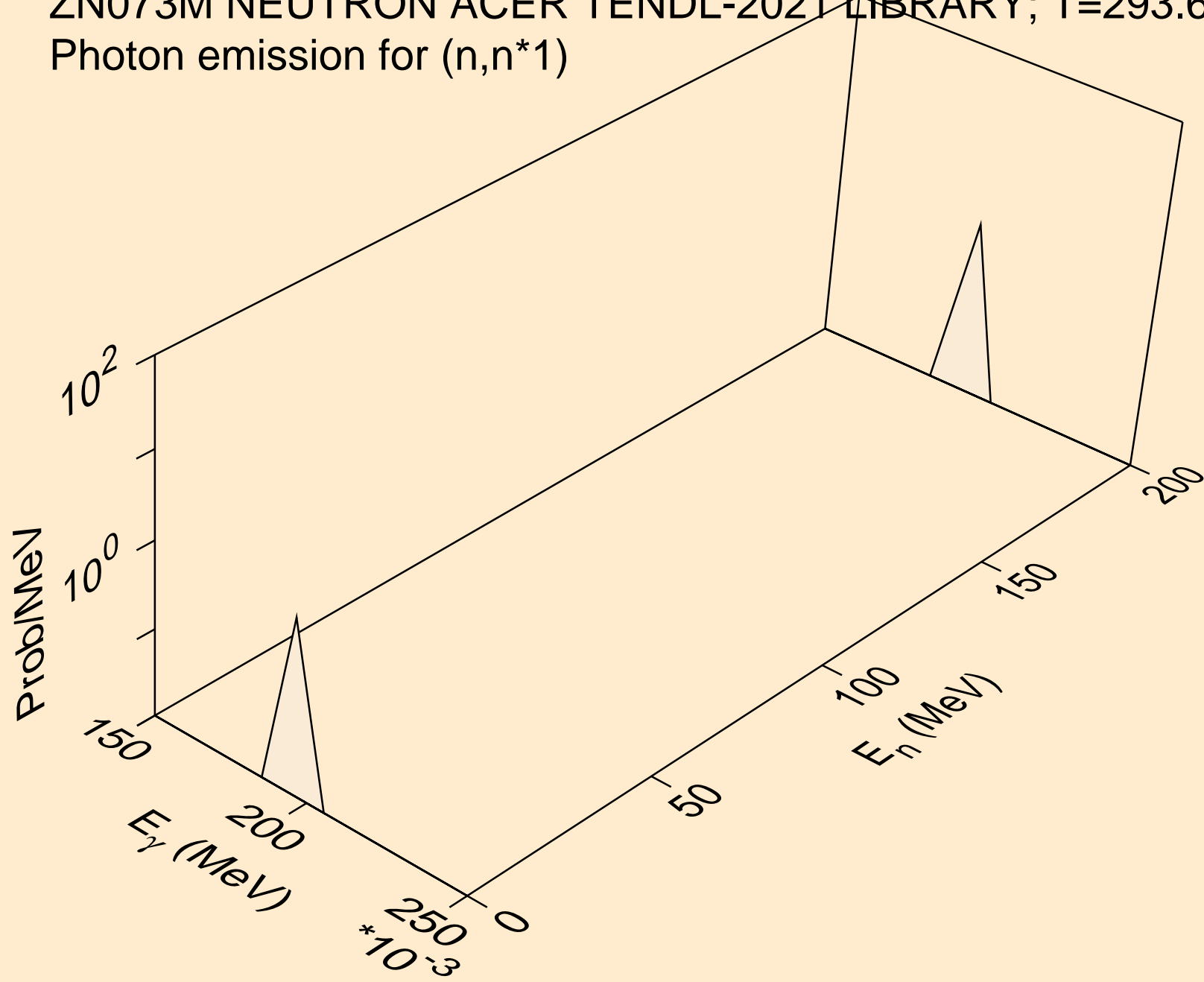

ZN073M NEUTRON ACER TENDL-2021 LIBRARY; T=293.6K  
Photon emission for (n,n\*2)

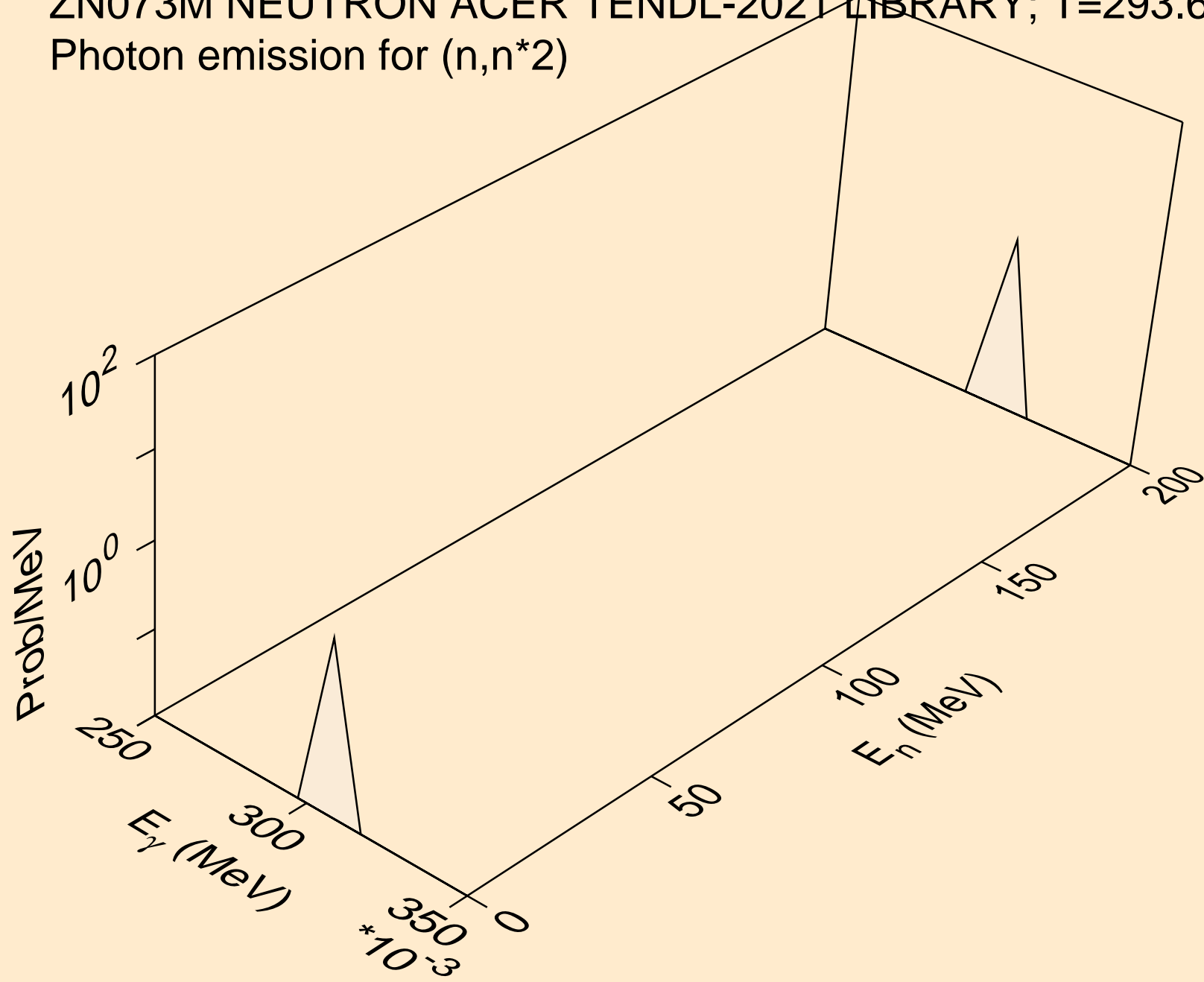

ZN073M NEUTRON ACER TENDL-2021 LIBRARY; T=293.6K  
Photon emission for (n,n\*4)

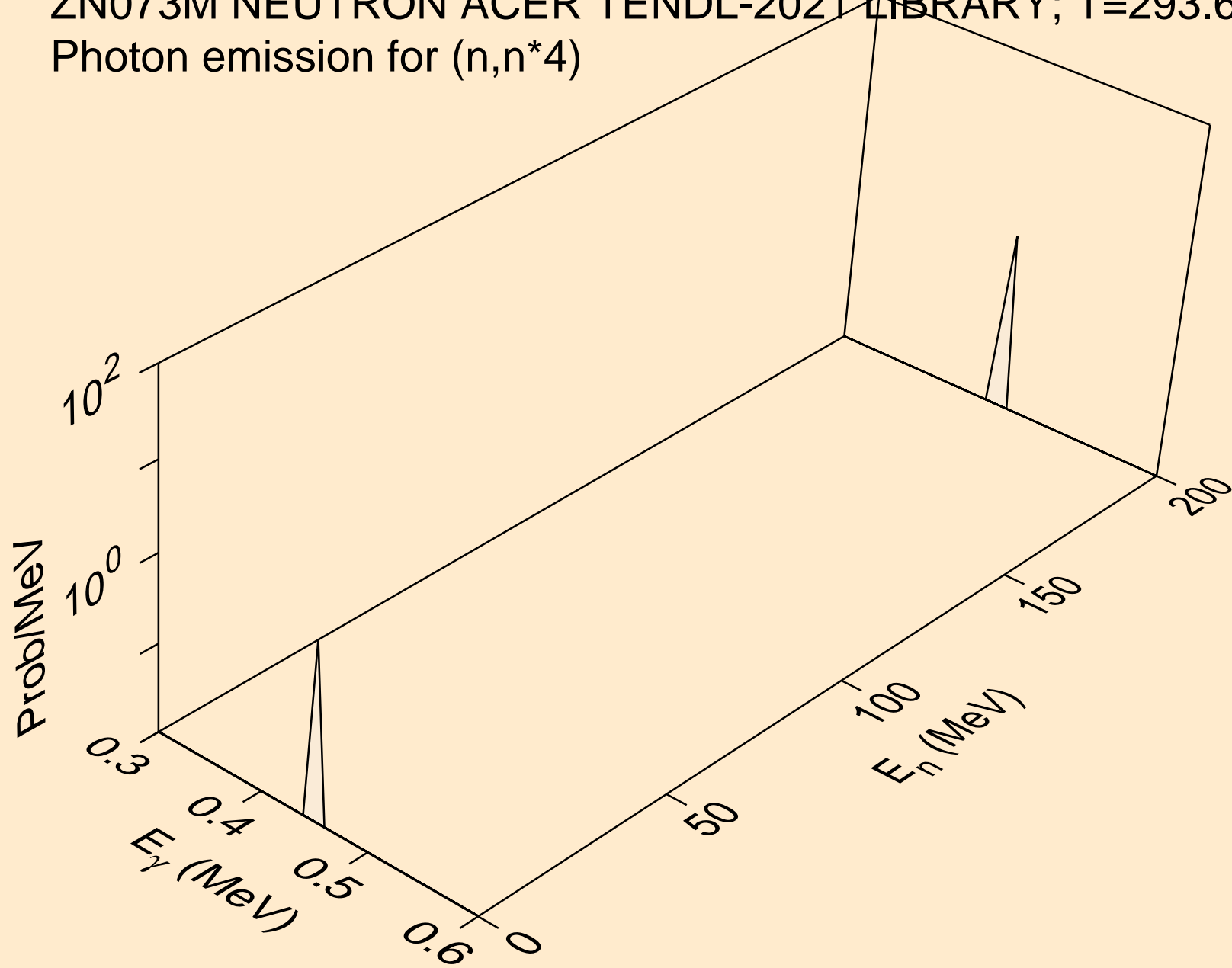

ZN073M NEUTRON ACER TENDL-2021 LIBRARY; T=293.6K  
Photon emission for (n,n\*5)

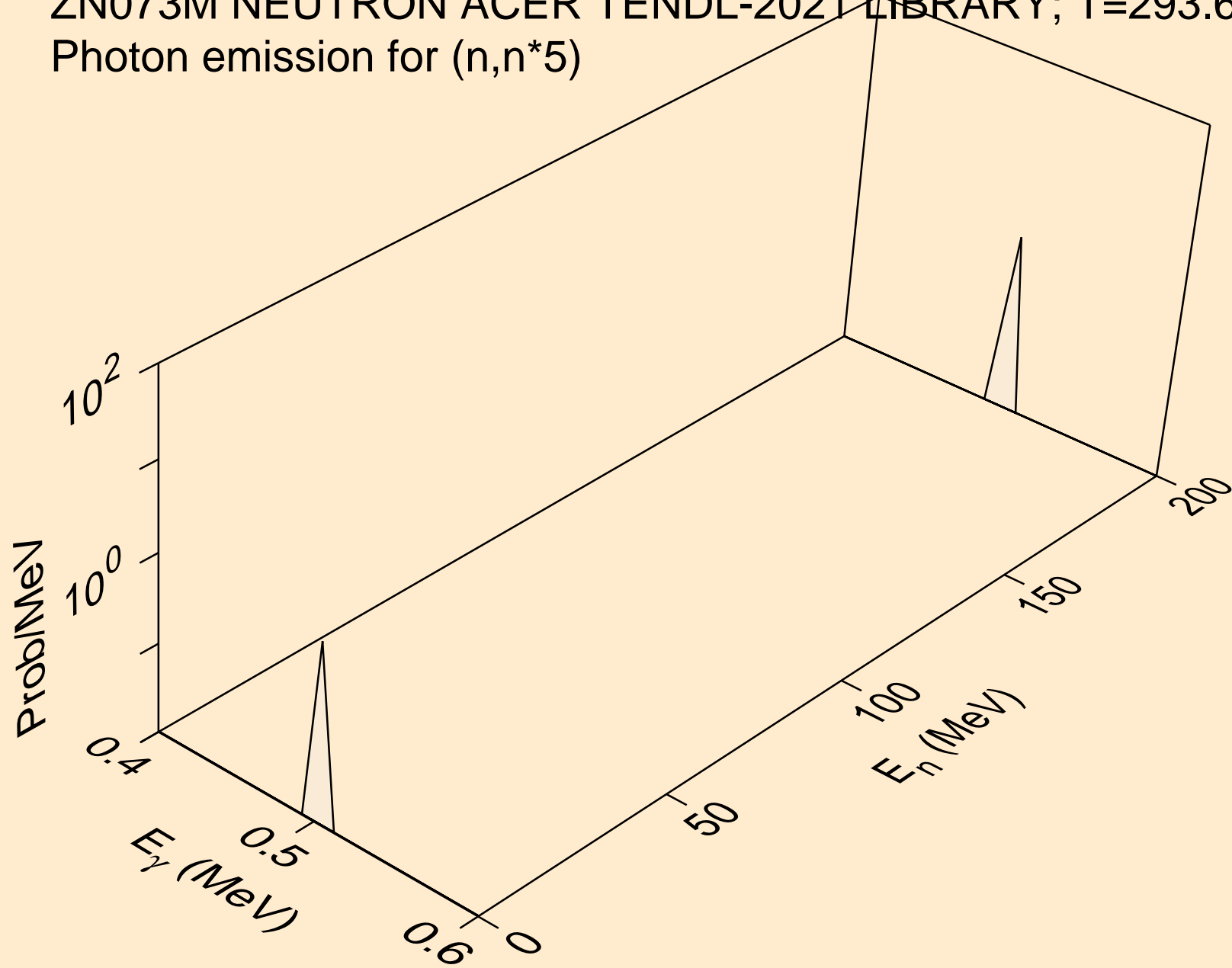

ZN073M NEUTRON ACER TENDL-2021 LIBRARY; T=293.6K  
Photon emission for (n,n\*6)

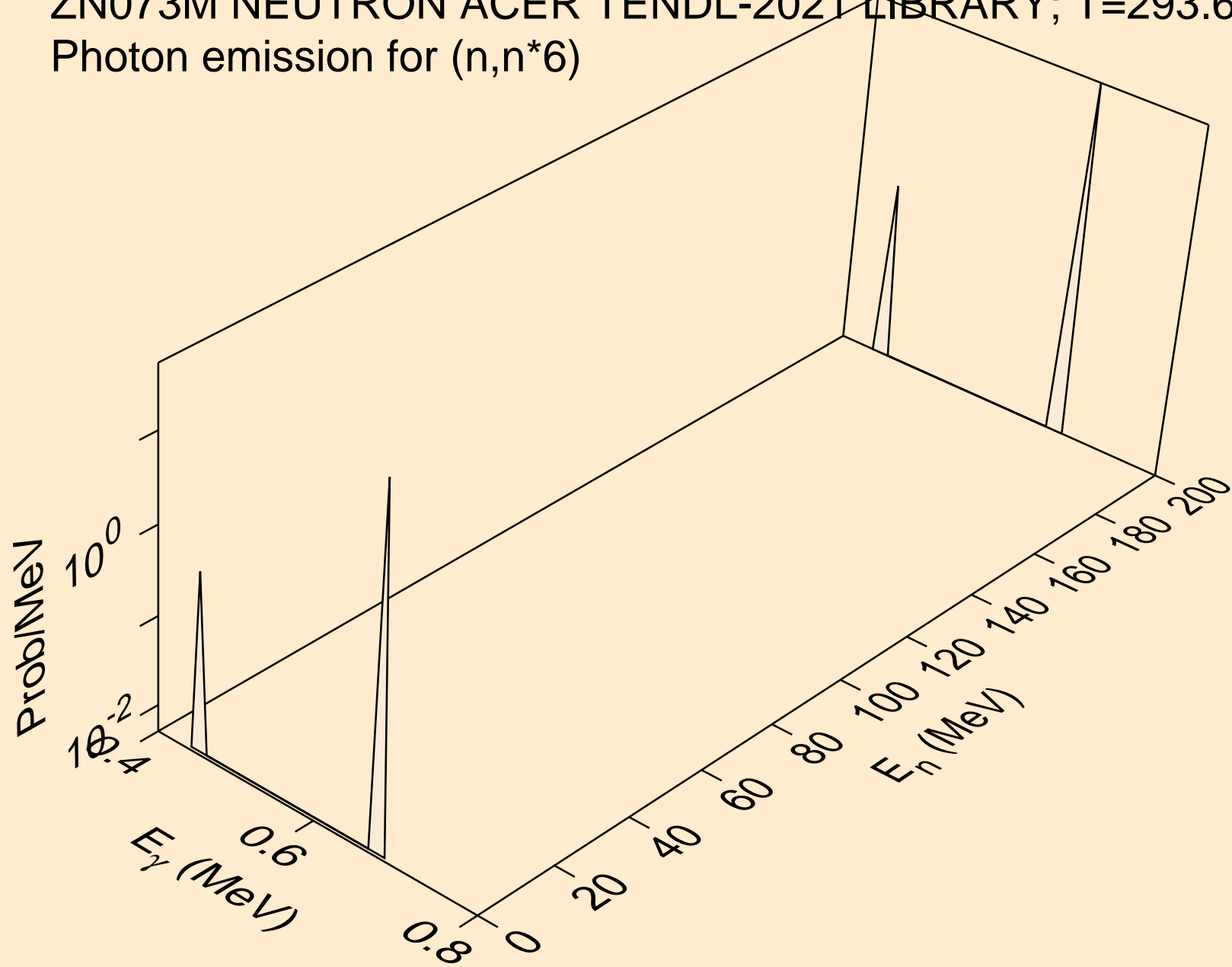



ZN073M NEUTRON ACER TENDL-2021 LIBRARY; T=293.6K  
Photon emission for (n,n\*7)

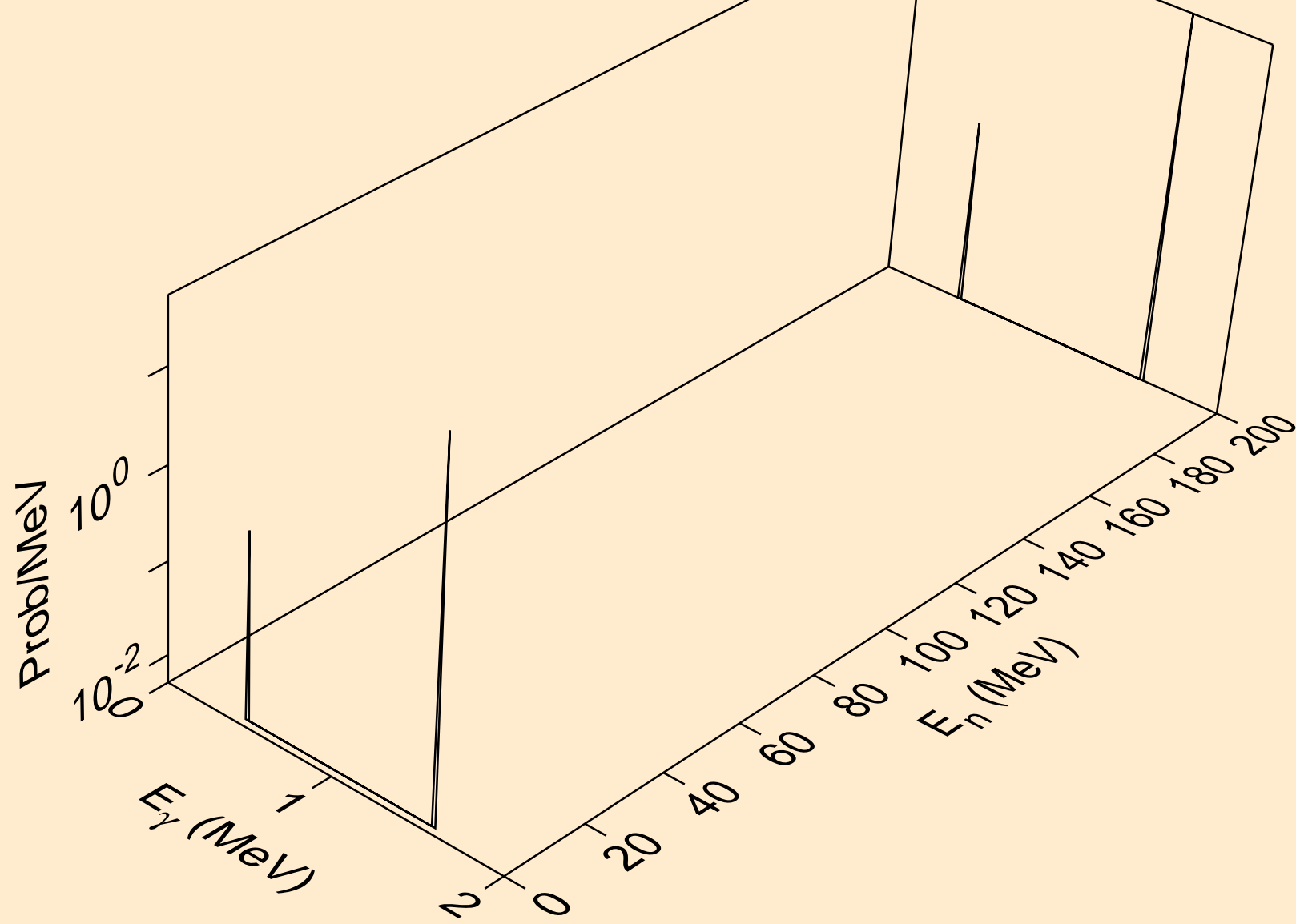

ZN073M NEUTRON ACER TENDL-2021 LIBRARY; T=293.6K  
Photon emission for (n,n\*8)

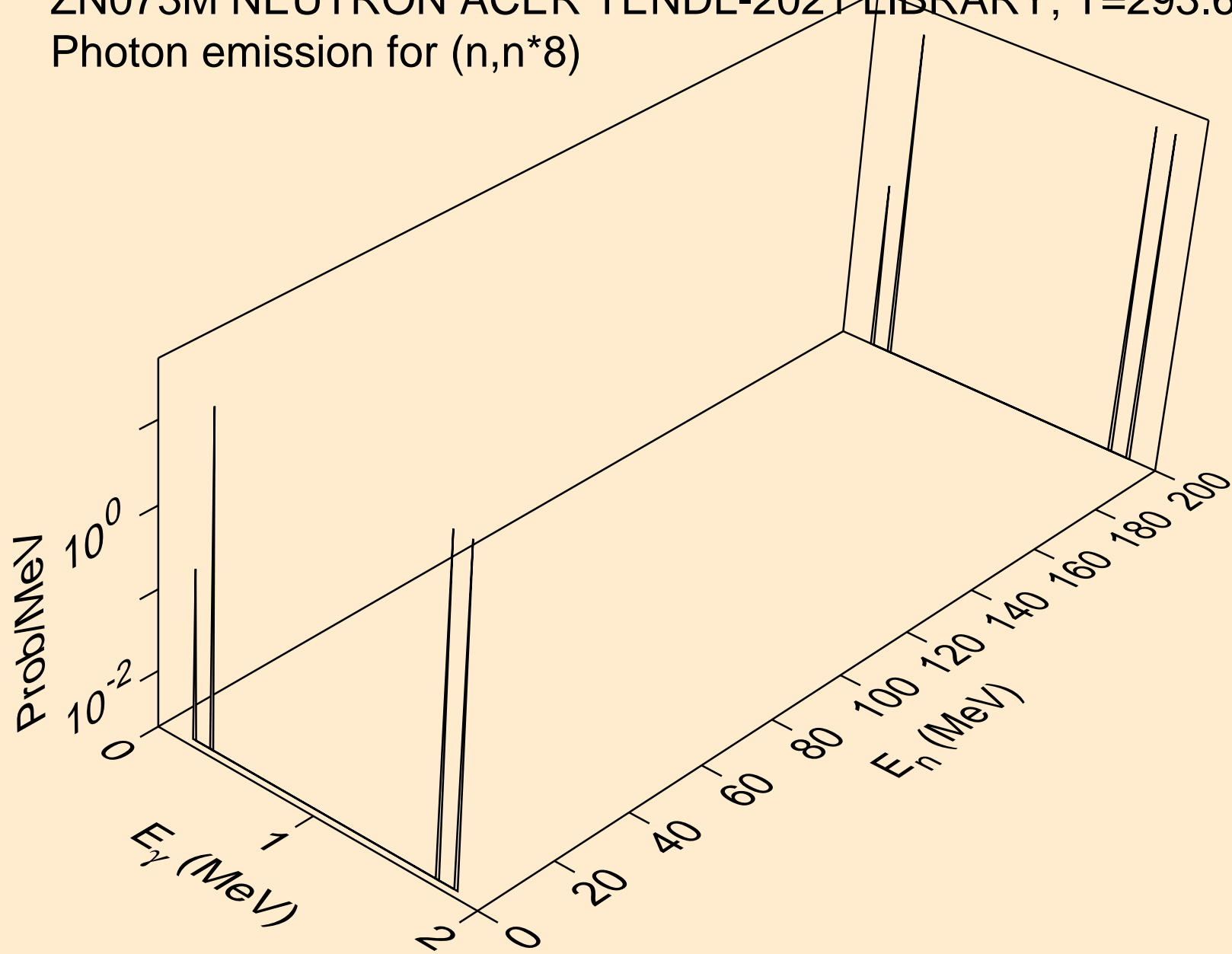

ZN073M NEUTRON ACER TENDL-2021 LIBRARY; T=293.6K  
Photon emission for (n,n\*9)

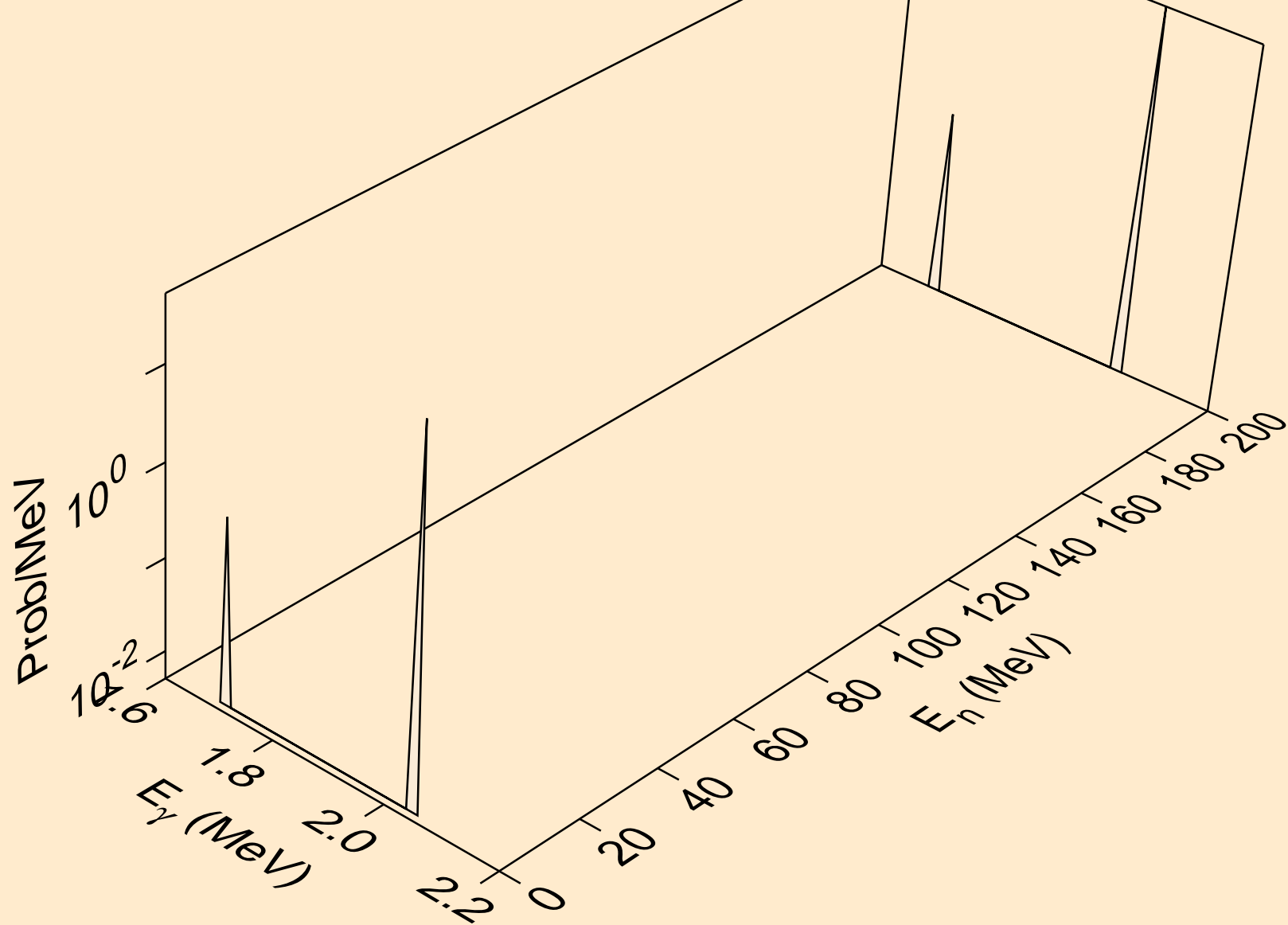

ZN073M NEUTRON ACER TENDL-2021 LIBRARY; T=293.6K  
Photon emission for (n,n\*10)

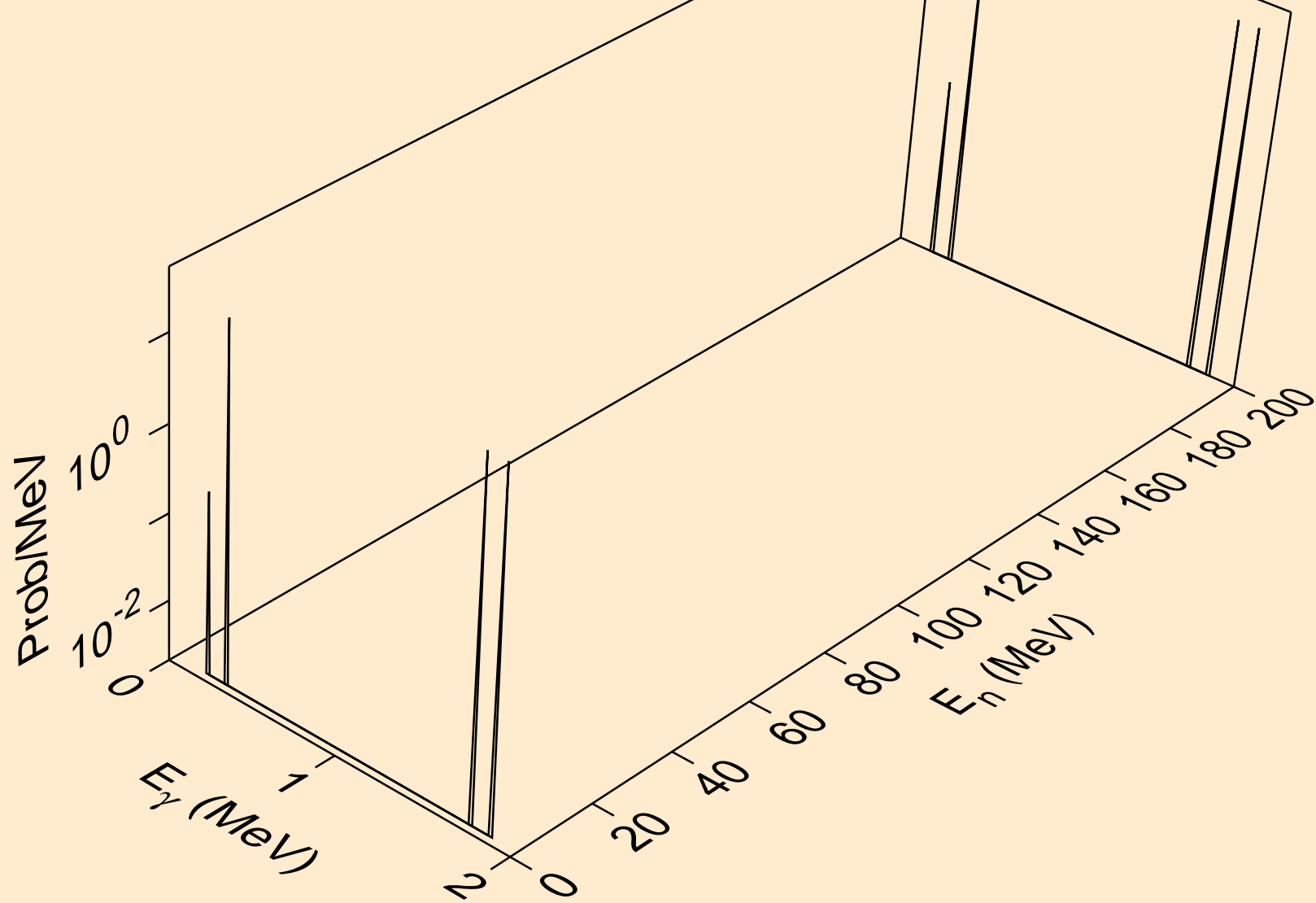

ZN073M NEUTRON ACER TENDL-2021 LIBRARY; T=293.6K  
Photon emission for (n,n\*11)

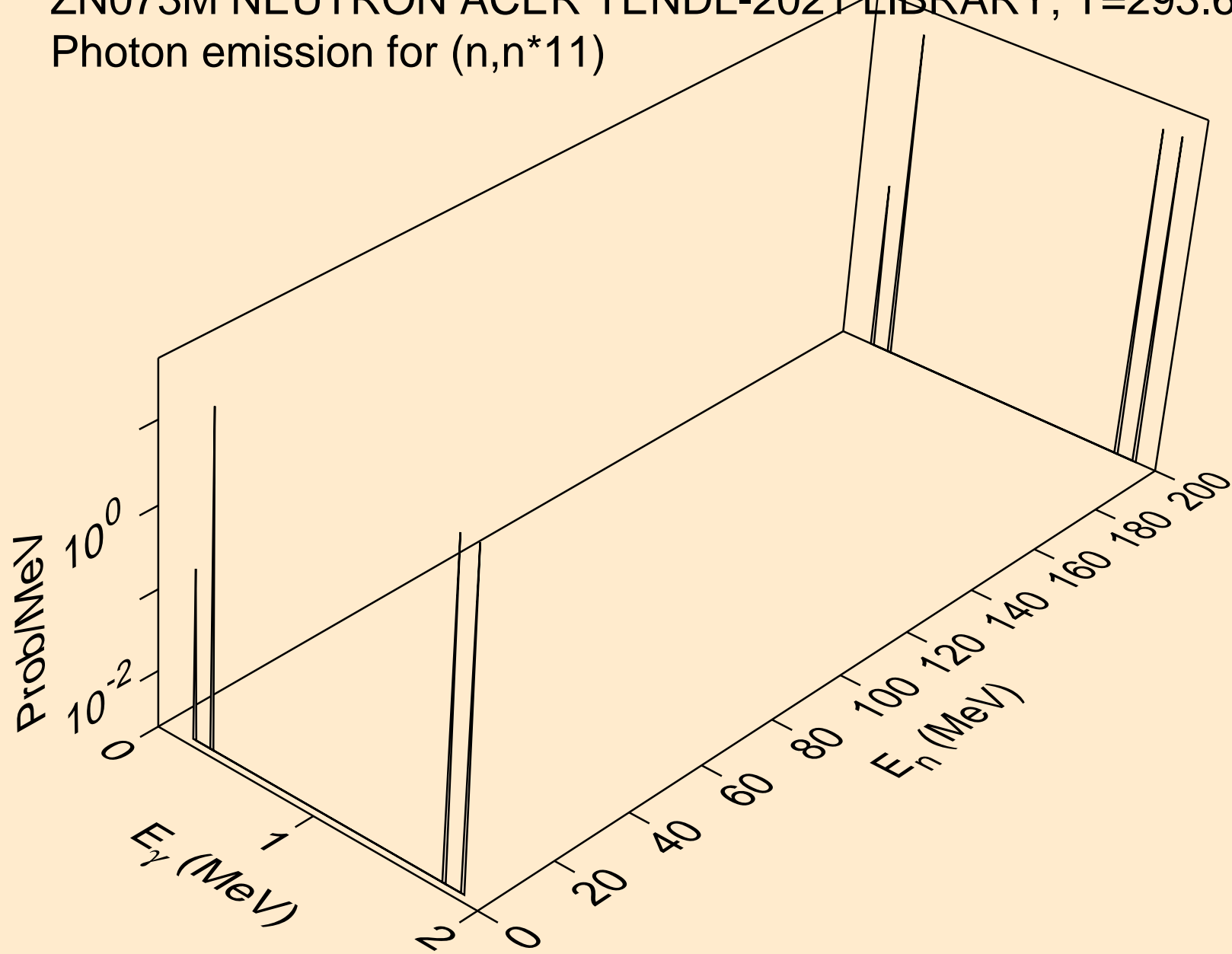

ZN073M NEUTRON ACER TENDL-2021 LIBRARY; T=293.6K  
Photon emission for (n,n\*12)

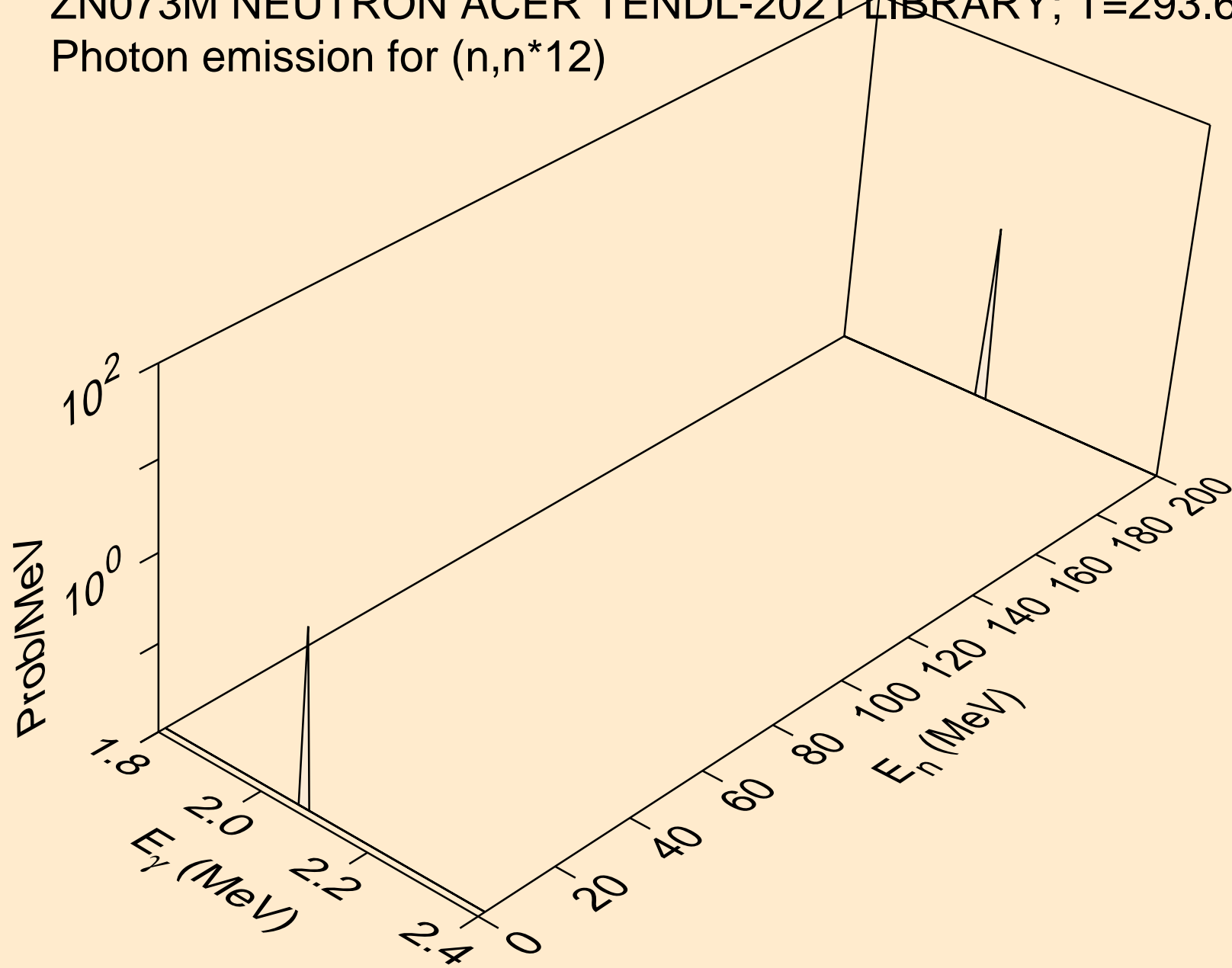

ZN073M NEUTRON ACER TENDL-2021 LIBRARY; T=293.6K  
Photon emission for (n,n\*13)

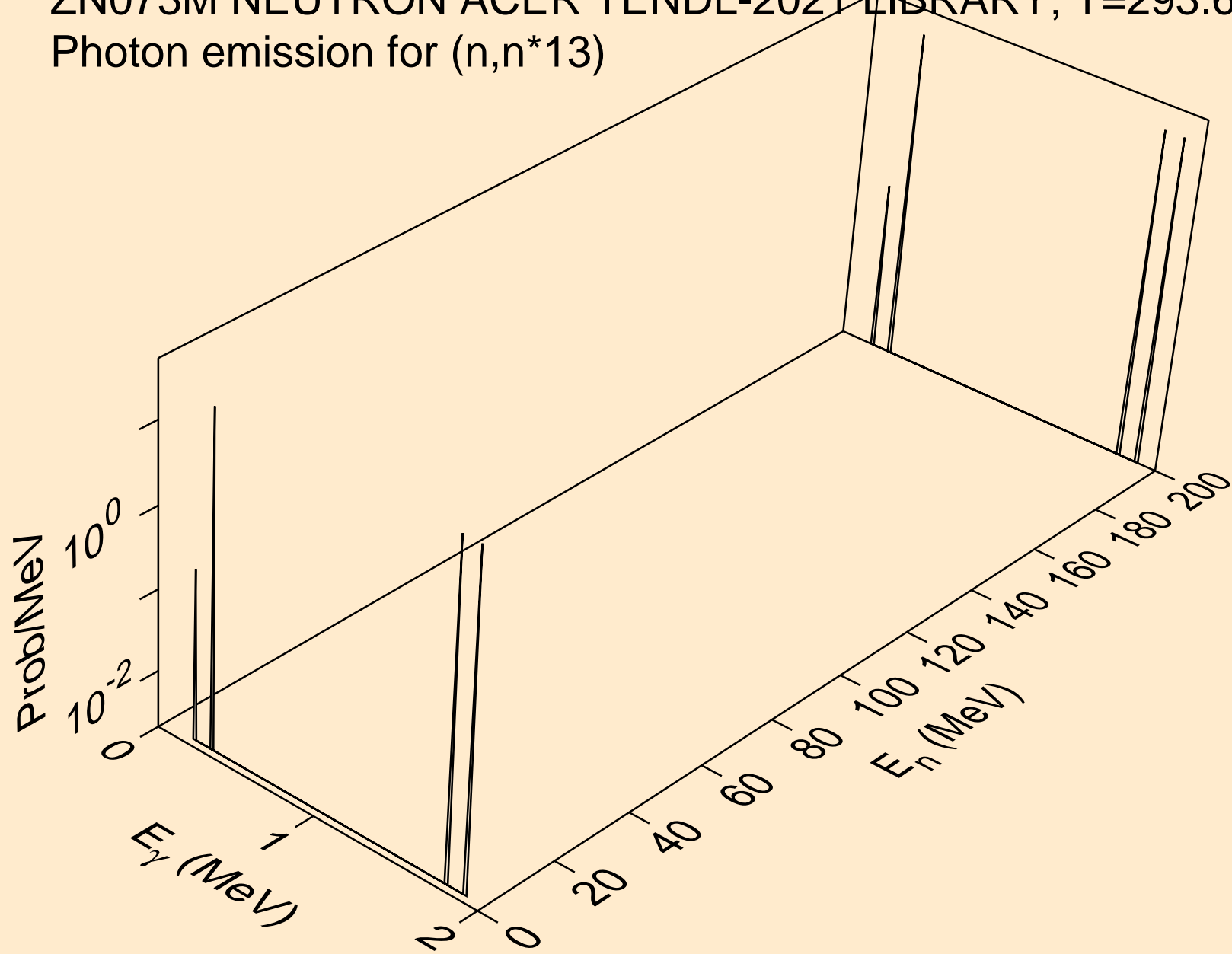

ZN073M NEUTRON ACER TENDL-2021 LIBRARY; T=293.6K  
Photon emission for (n,n\*14)

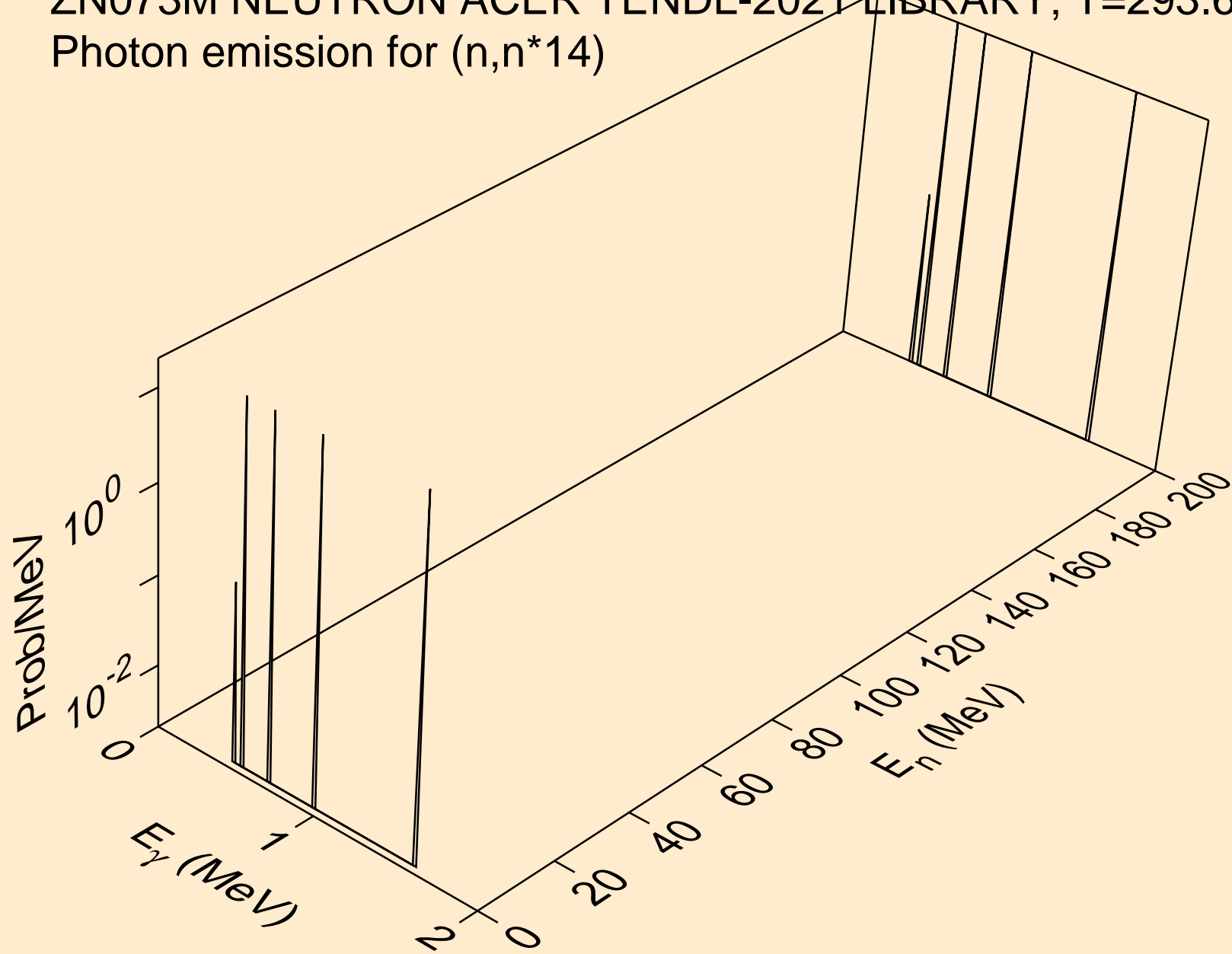



ZN073M NEUTRON ACER TENDL-2021 LIBRARY; T=293.6K  
Photon emission for (n,n\*15)

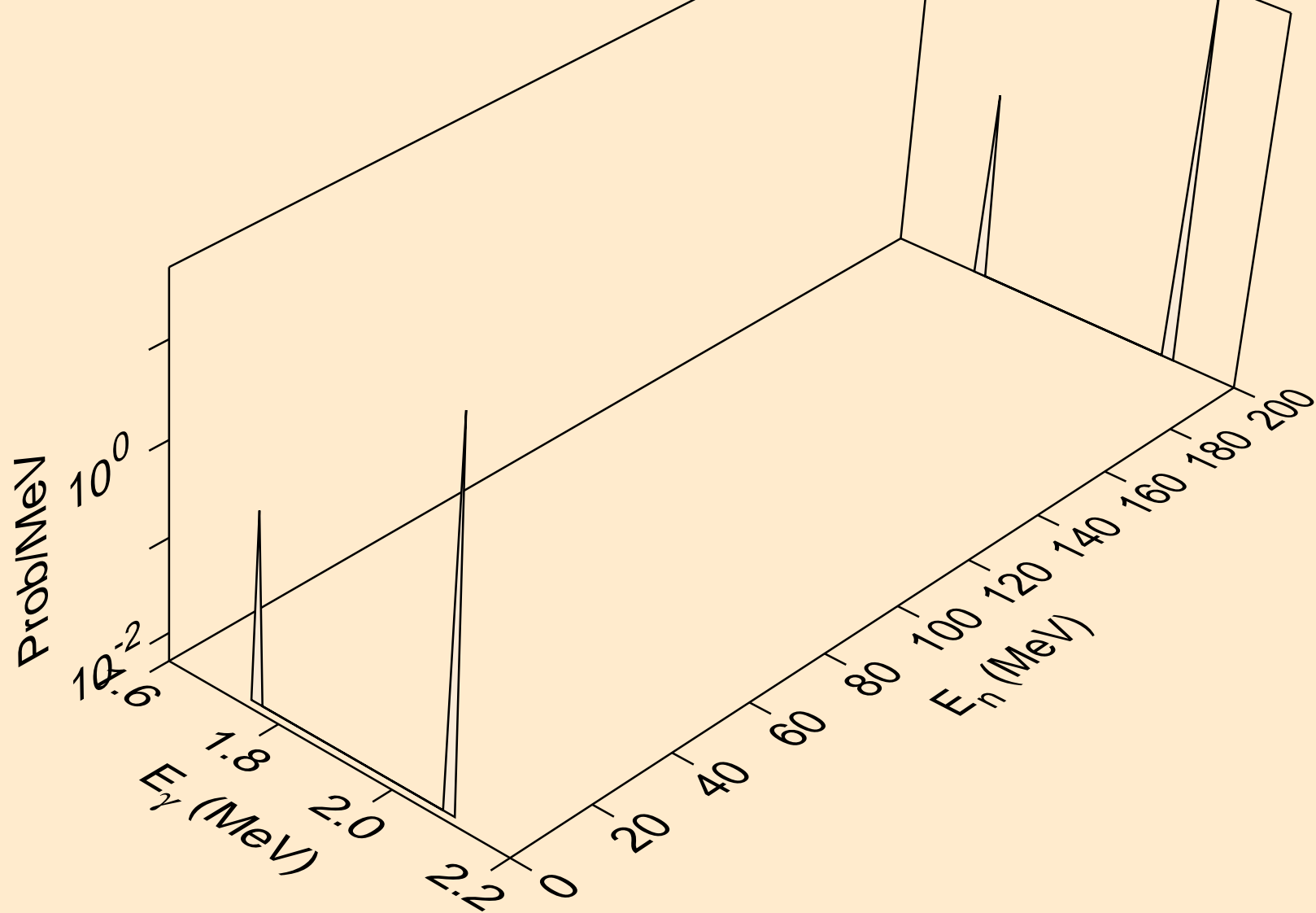

ZN073M NEUTRON ACER TENDL-2021 LIBRARY; T=293.6K  
Photon emission for (n,n\*16)

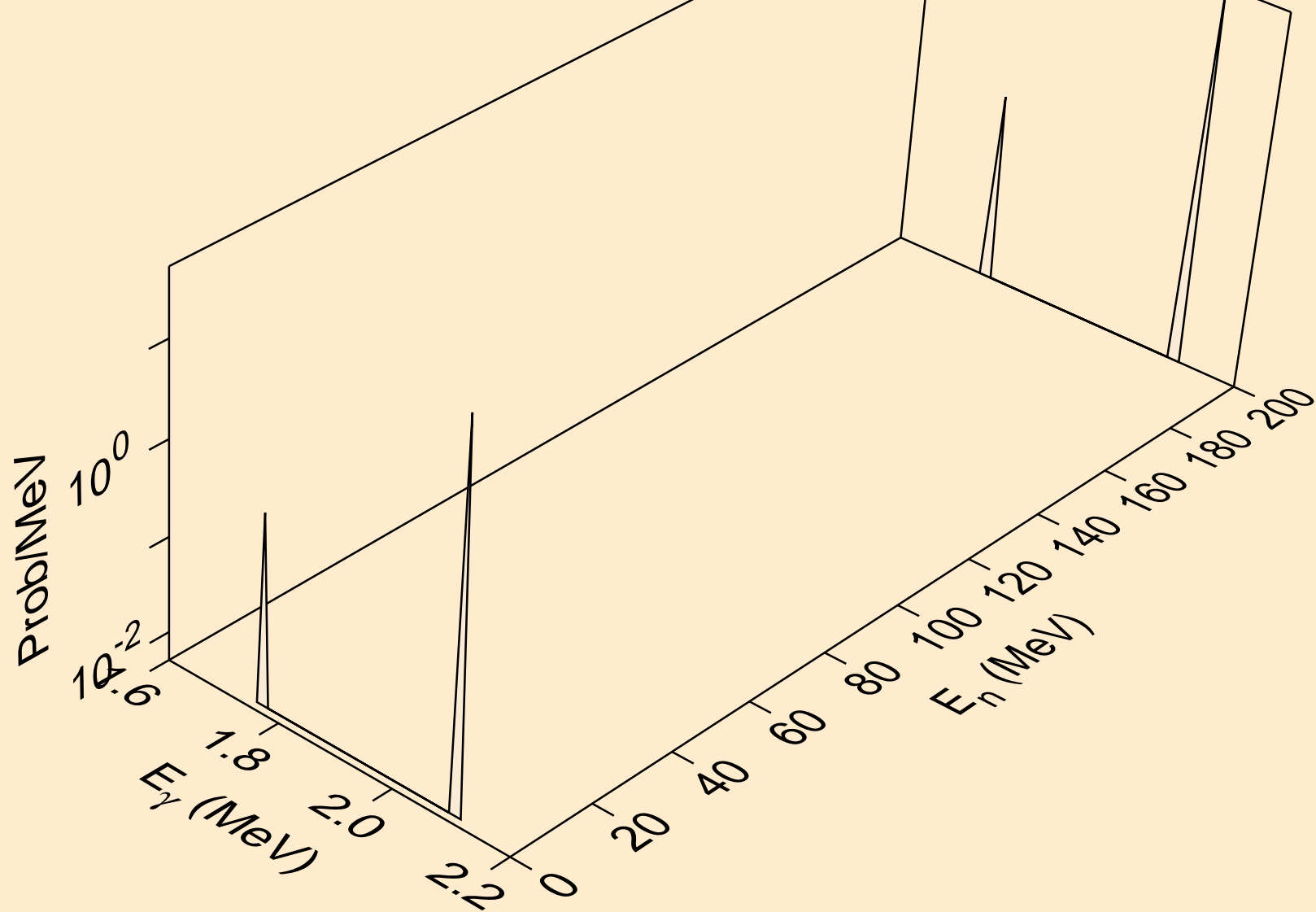

ZN073M NEUTRON ACER TENDL-2021 LIBRARY; T=293.6K  
Photon emission for (n,n\*17)

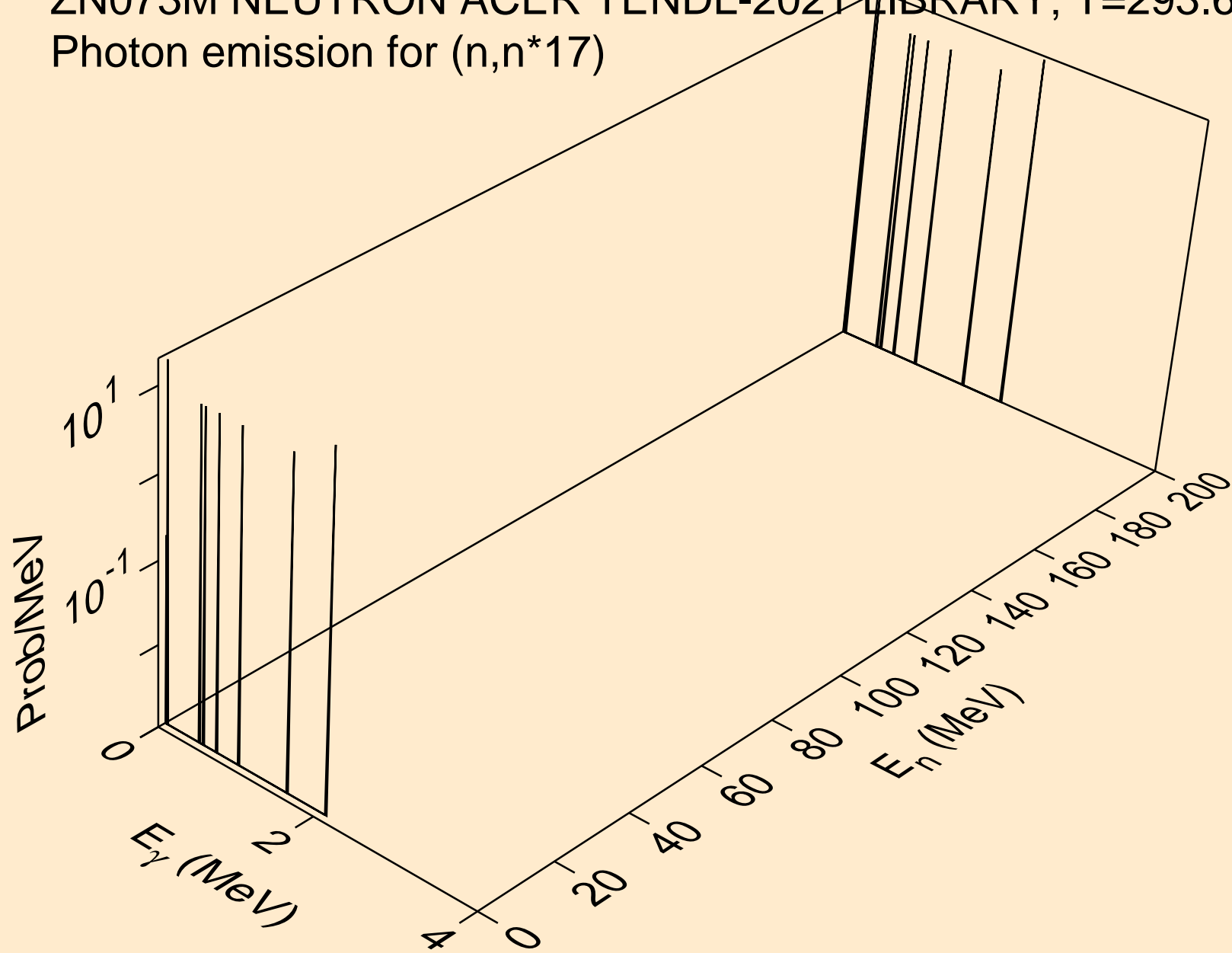

ZN073M NEUTRON ACER TENDL-2021 LIBRARY; T=293.6K  
Photon emission for (n,n\*18)

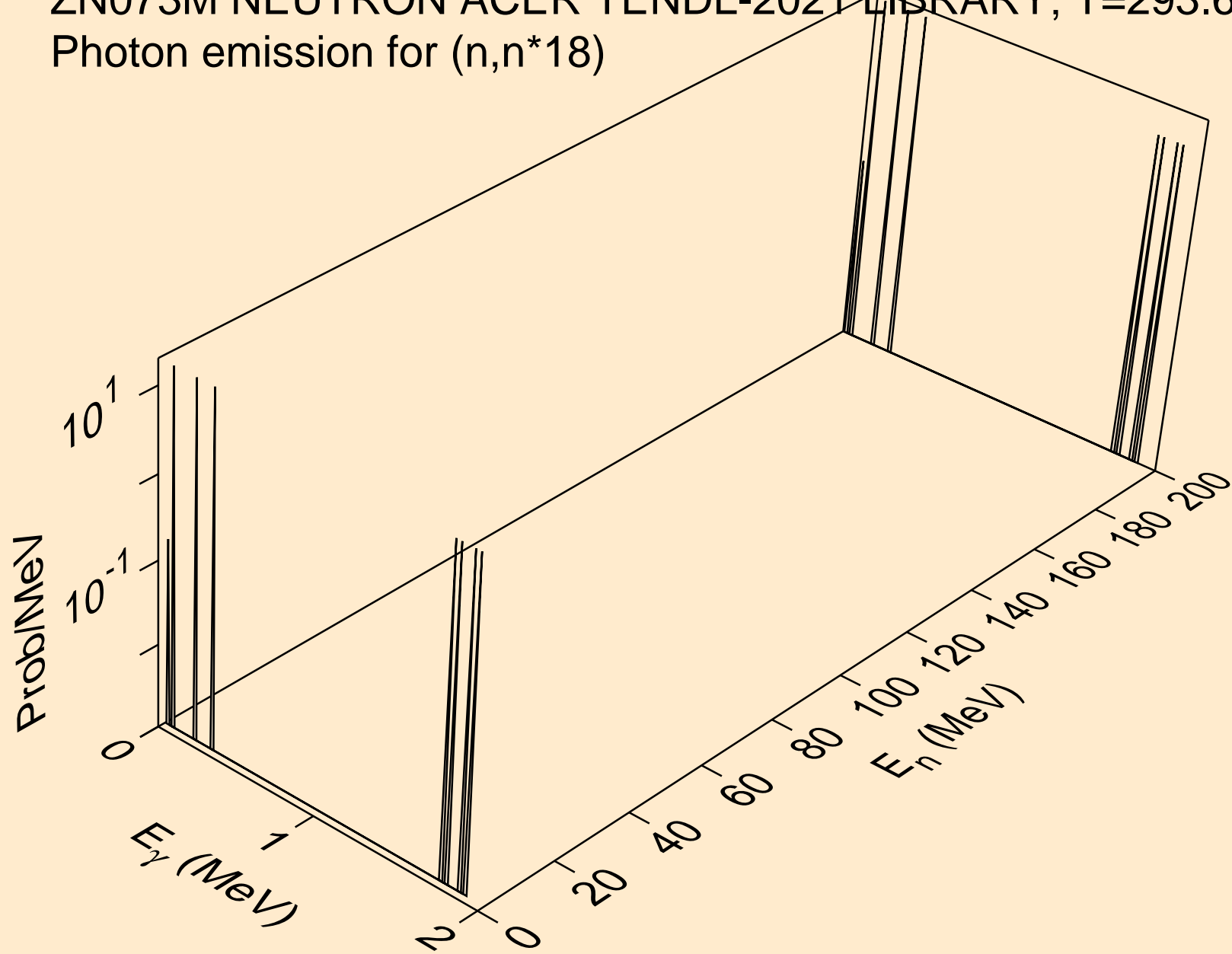

ZN073M NEUTRON ACER TENDL-2021 LIBRARY; T=293.6K  
Photon emission for (n,n\*19)

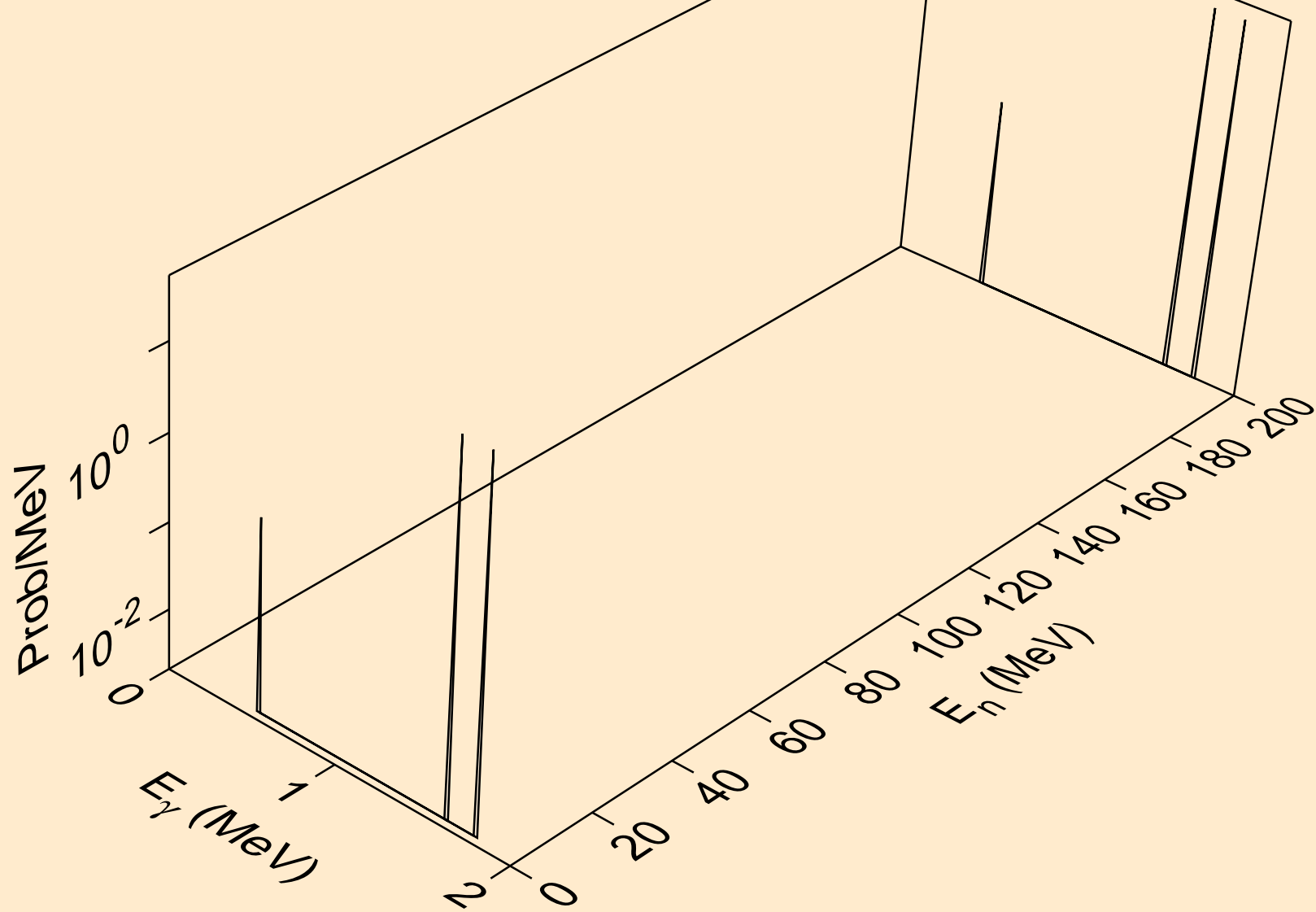

ZN073M NEUTRON ACER TENDL-2021 LIBRARY; T=293.6K  
Photon emission for (n,n\*20)

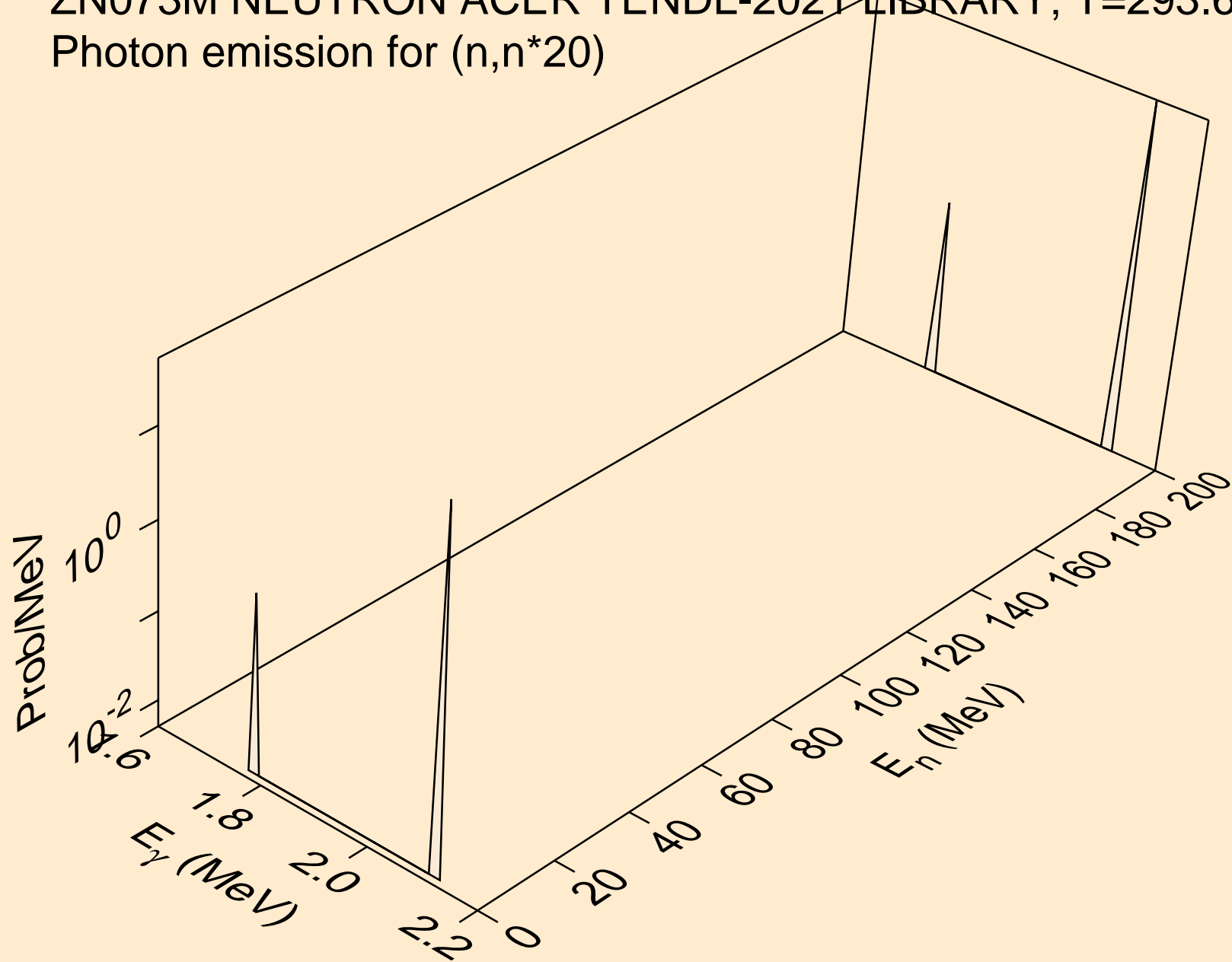

ZN073M NEUTRON ACER TENDL-2021 LIBRARY; T=293.6K  
Photon emission for (n,n\*21)

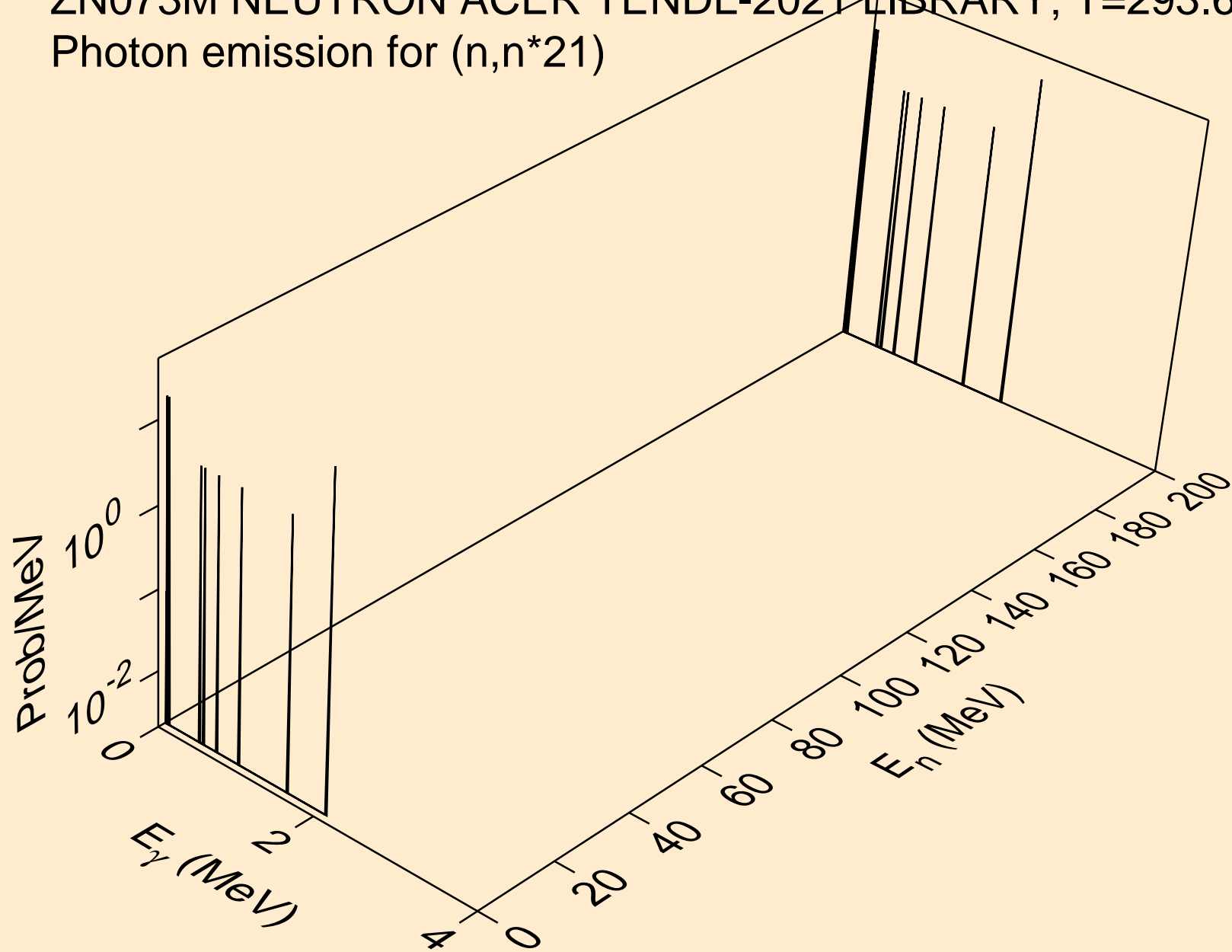

ZN073M NEUTRON ACER TENDL-2021 LIBRARY; T=293.6K  
Photon emission for (n,n\*22)

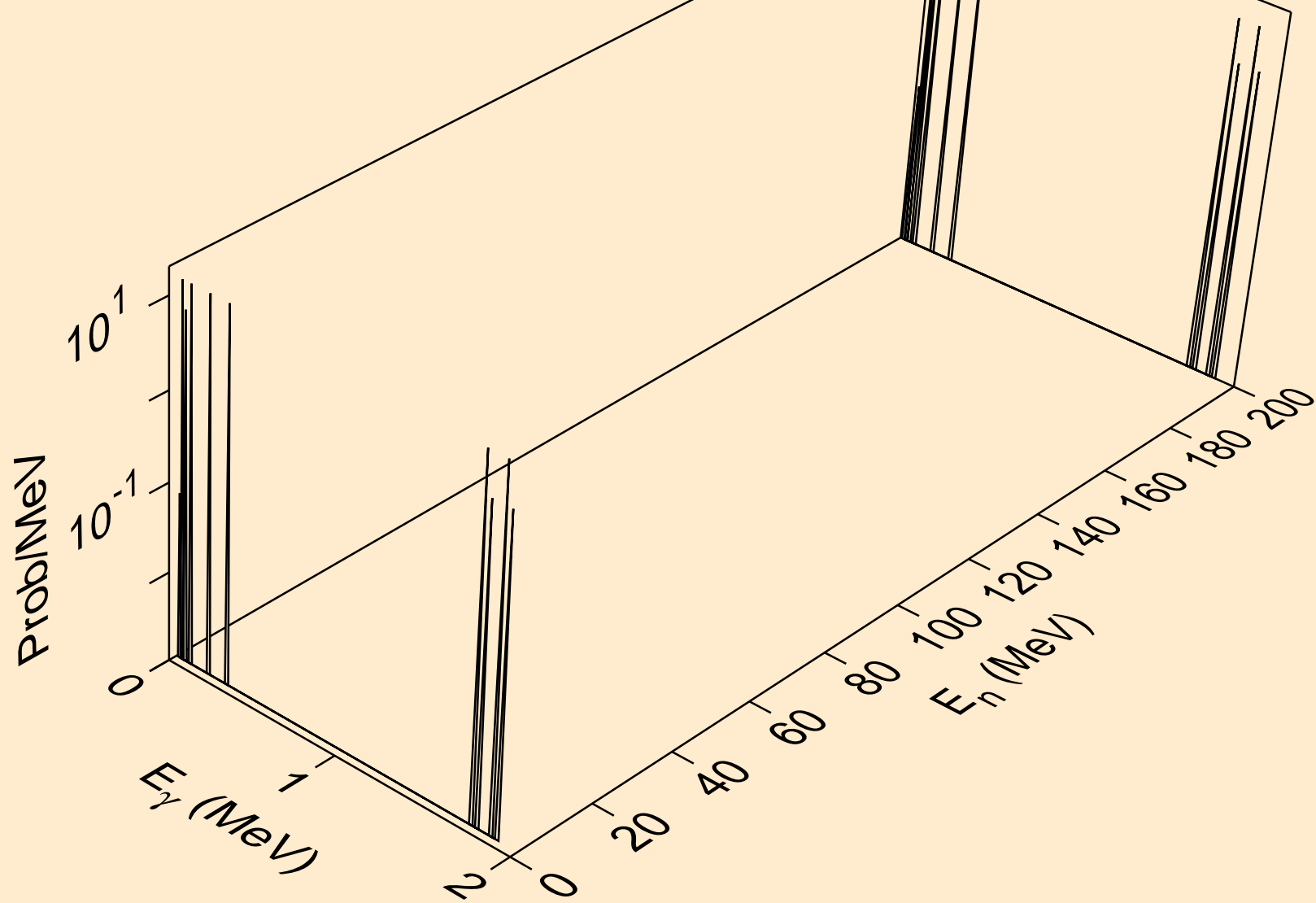



ZN073M NEUTRON ACER TENDL-2021 LIBRARY; T=293.6K  
Photon emission for (n,n\*23)

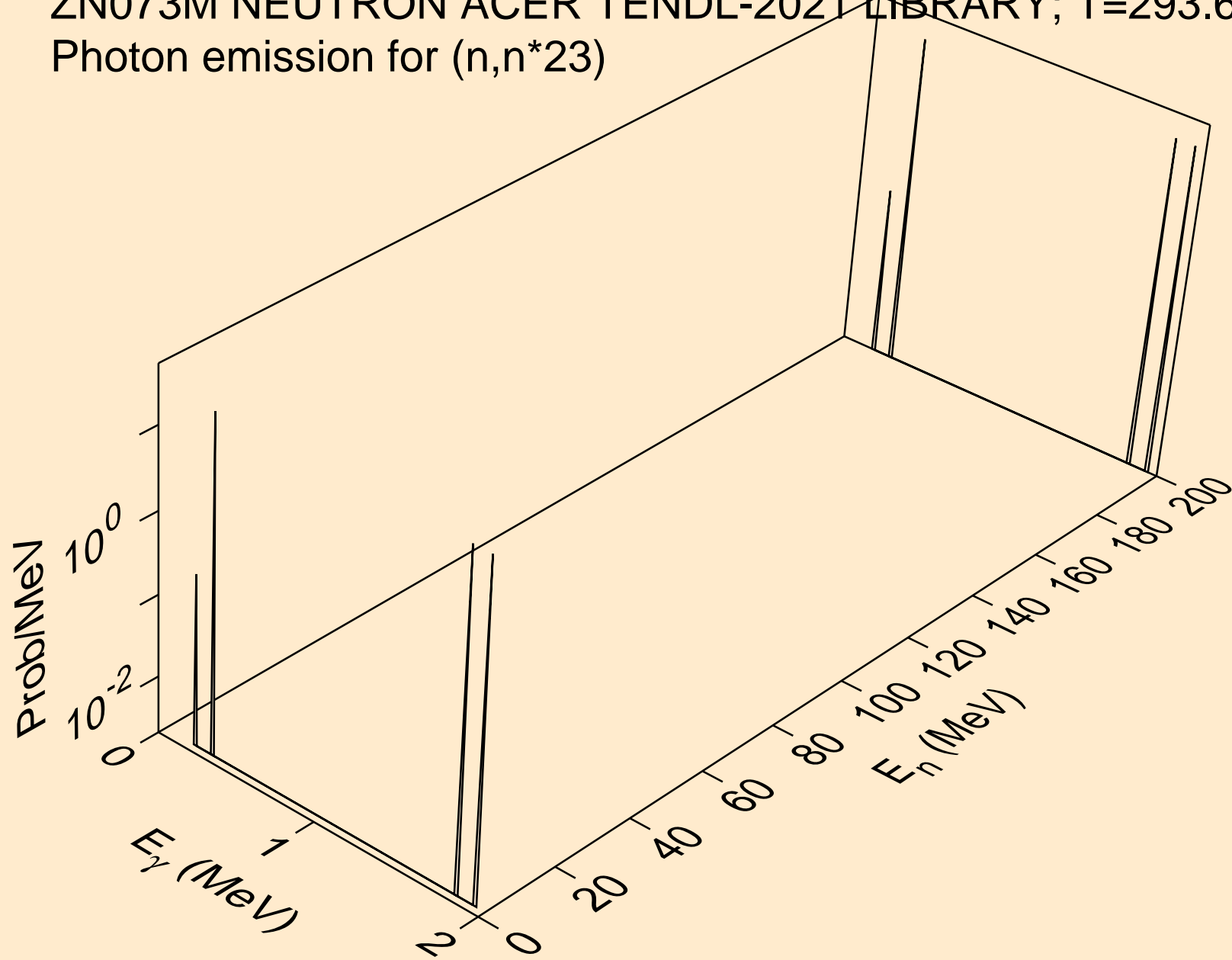

ZN073M NEUTRON ACER TENDL-2021 LIBRARY; T=293.6K  
Photon emission for (n,n\*24)

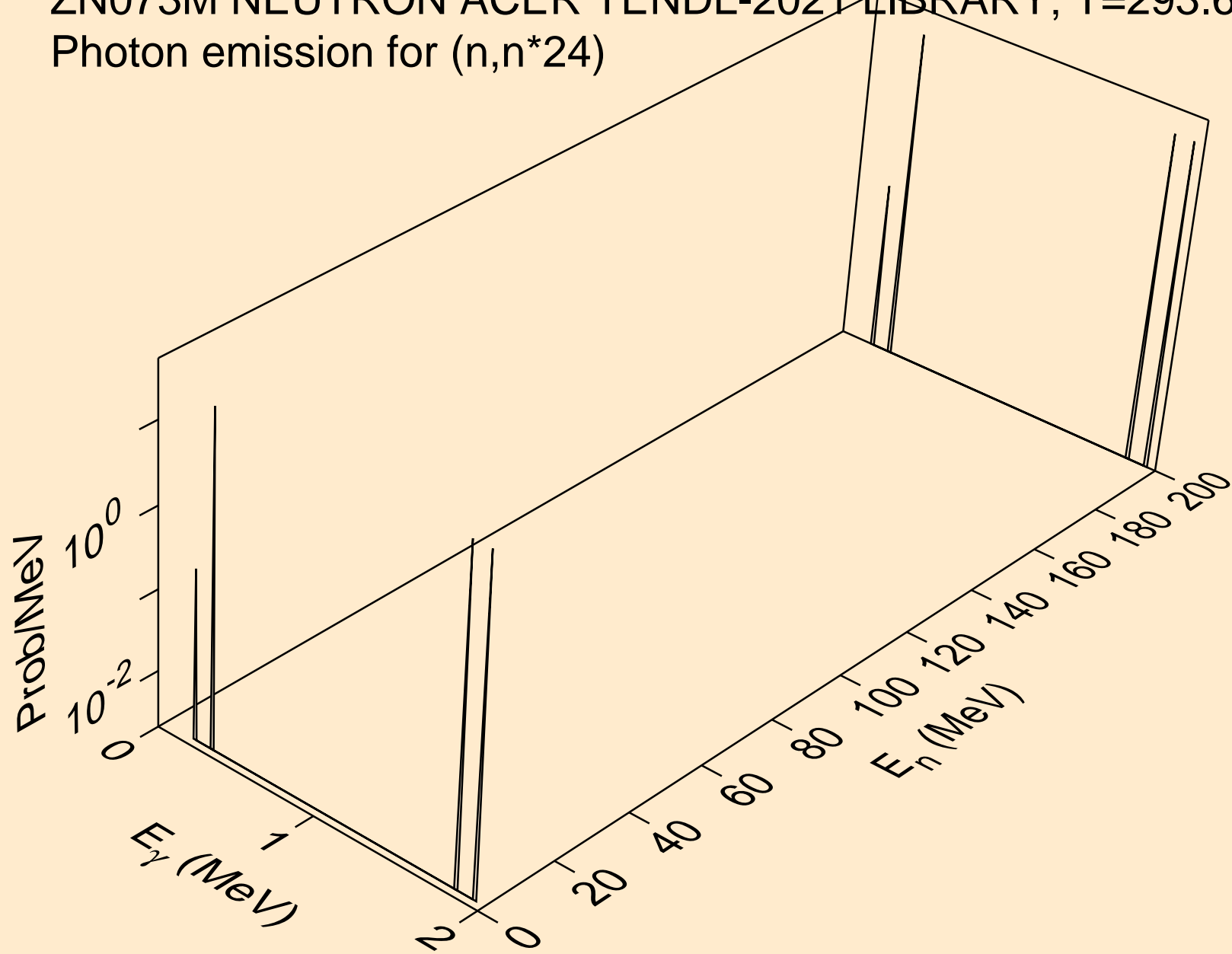

ZN073M NEUTRON ACER TENDL-2021 LIBRARY; T=293.6K  
Photon emission for (n,n\*25)

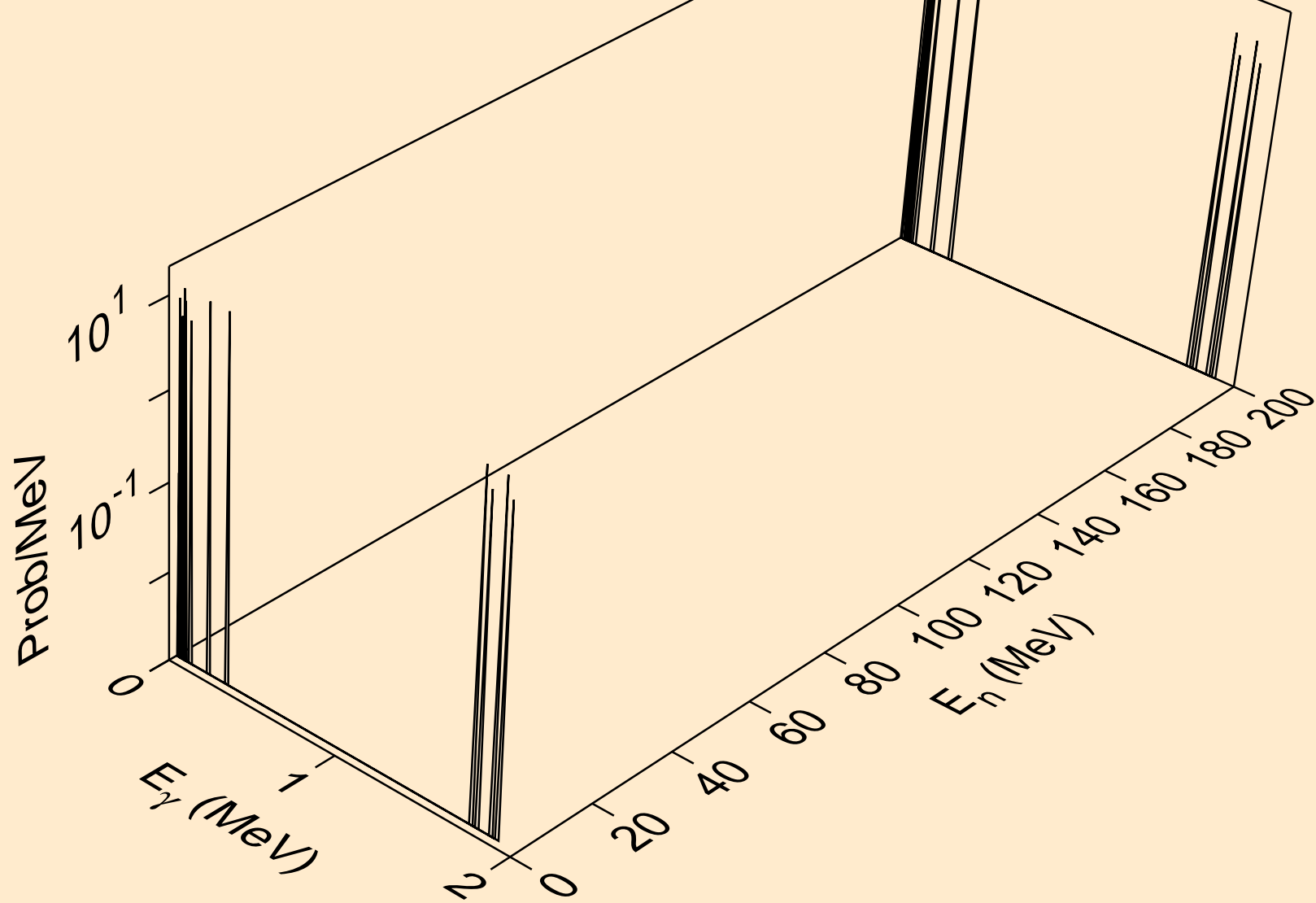

ZN073M NEUTRON ACER TENDL-2021 LIBRARY; T=293.6K  
Photon emission for (n,n\*26)

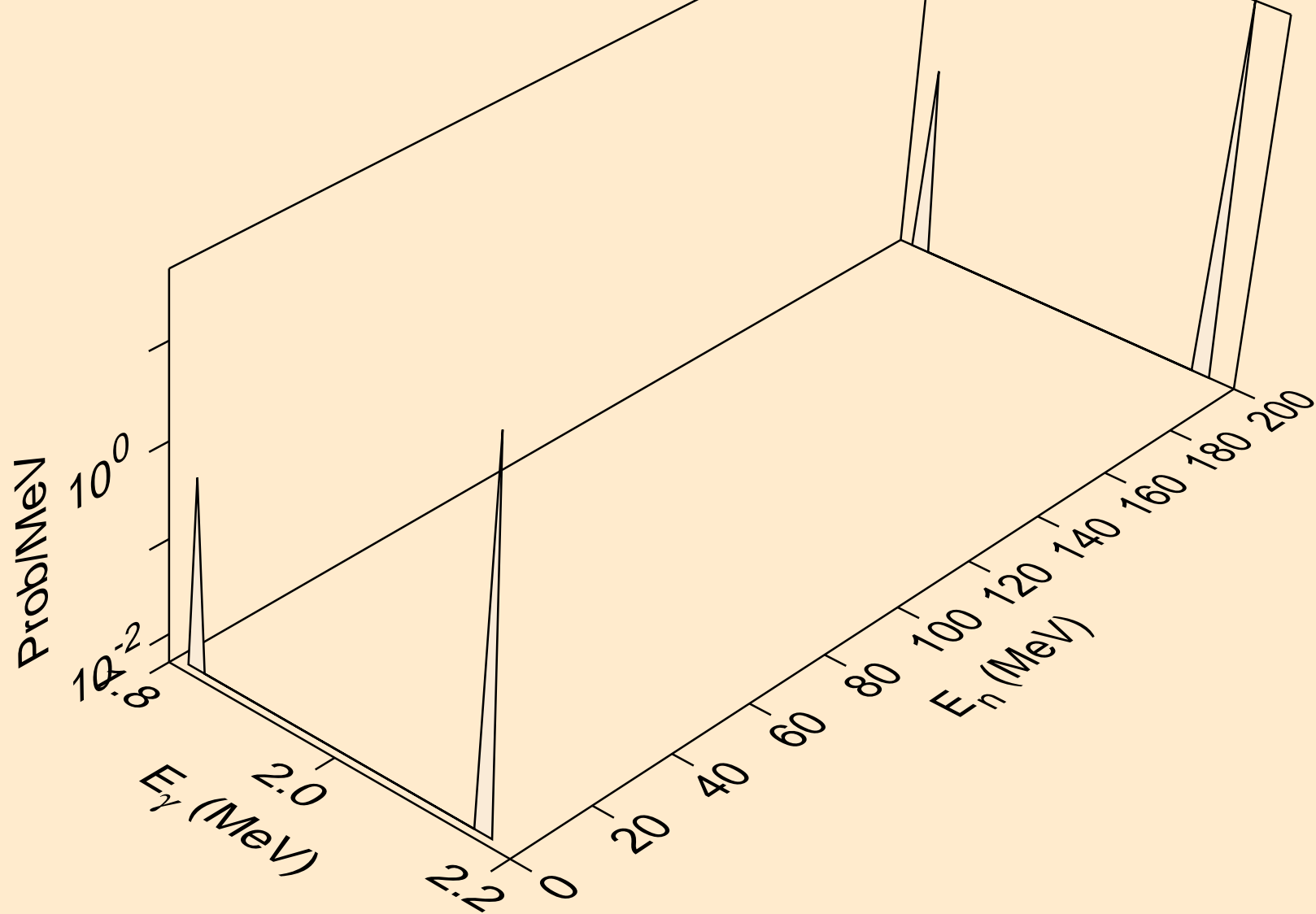

ZN073M NEUTRON ACER TENDL-2021 LIBRARY; T=293.6K  
Photon emission for (n,n\*27)

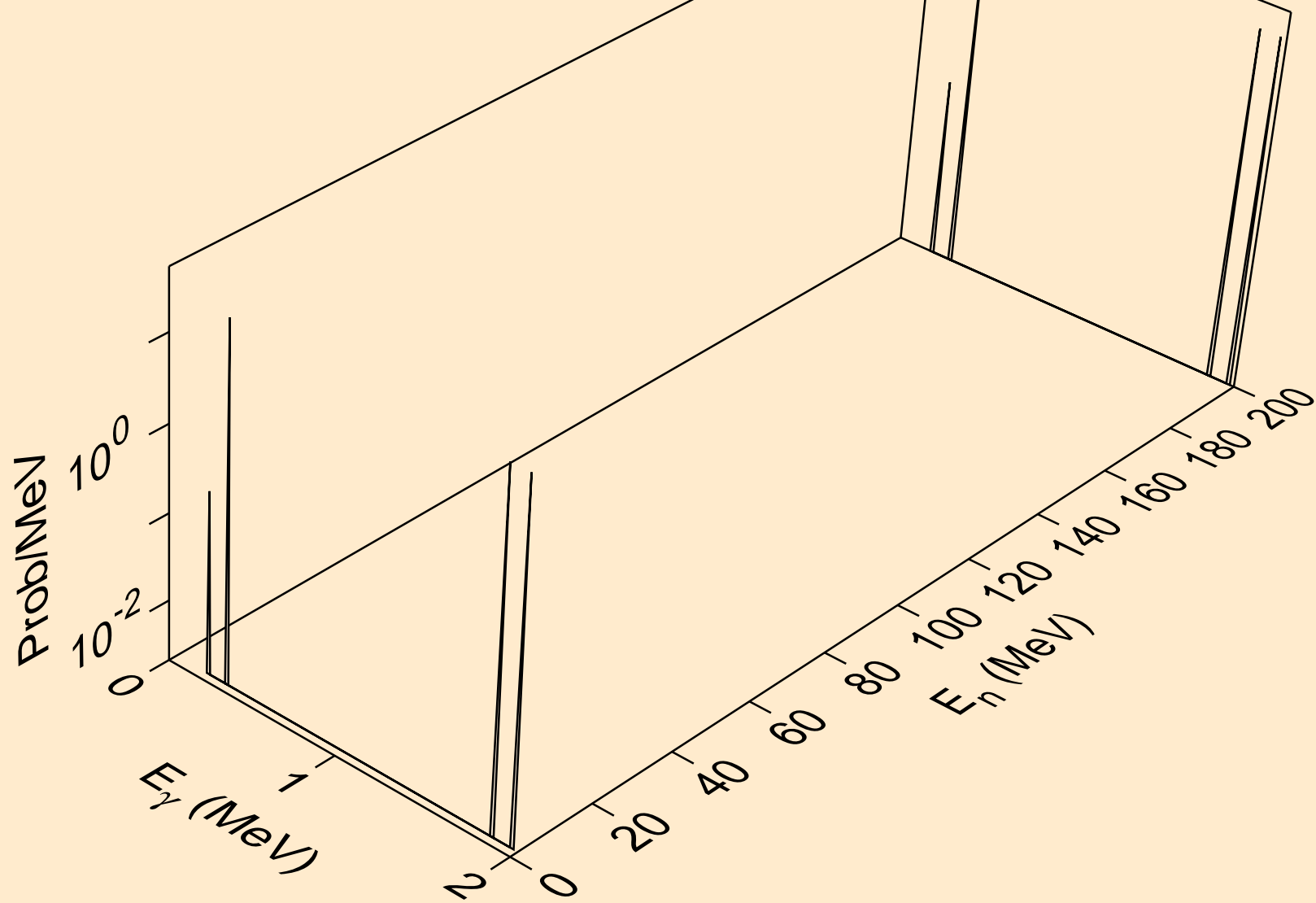

ZN073M NEUTRON ACER TENDL-2021 LIBRARY; T=293.6K  
Photon emission for (n,n\*28)

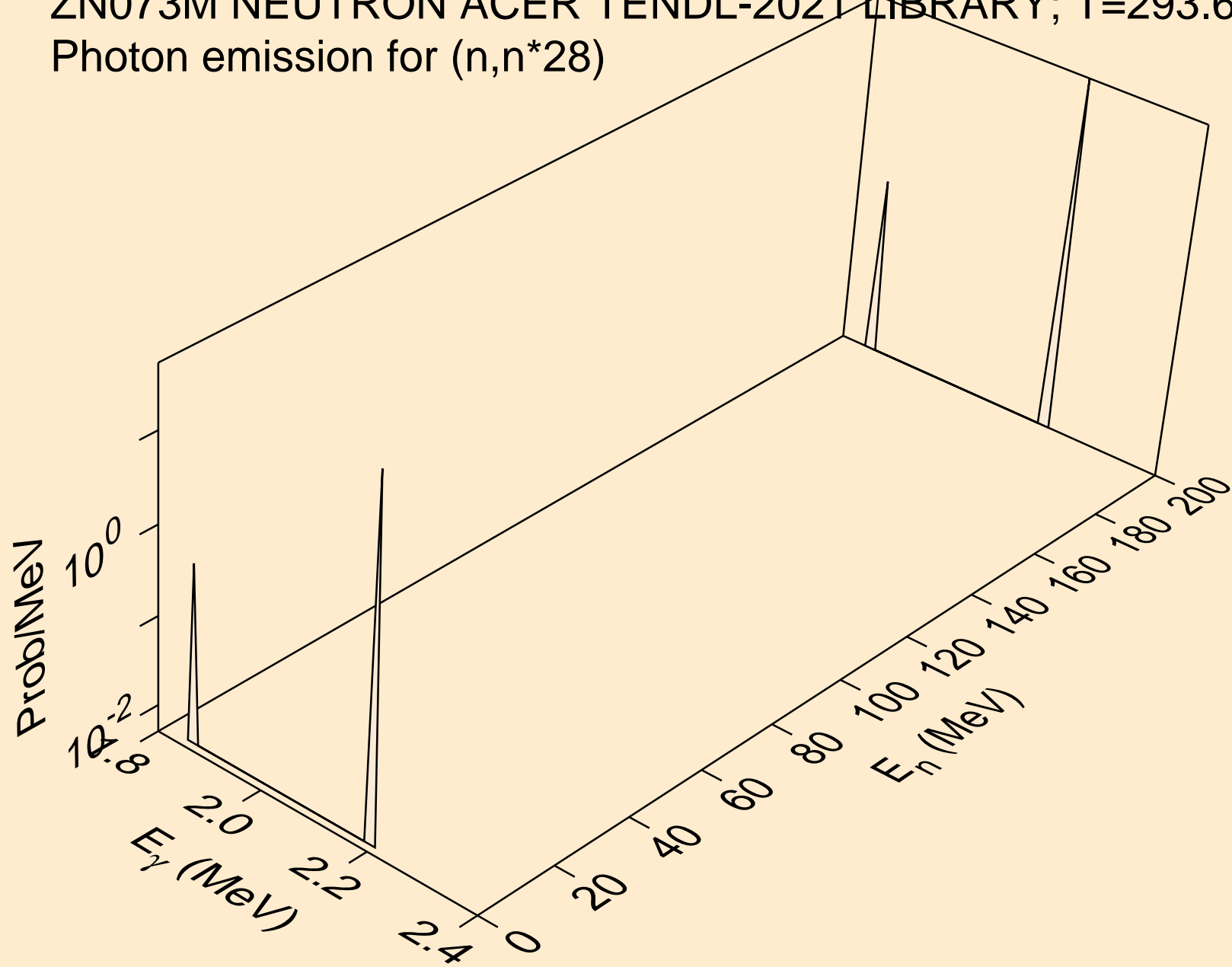

ZN073M NEUTRON ACER TENDL-2021 LIBRARY; T=293.6K  
Photon emission for (n,n\*29)

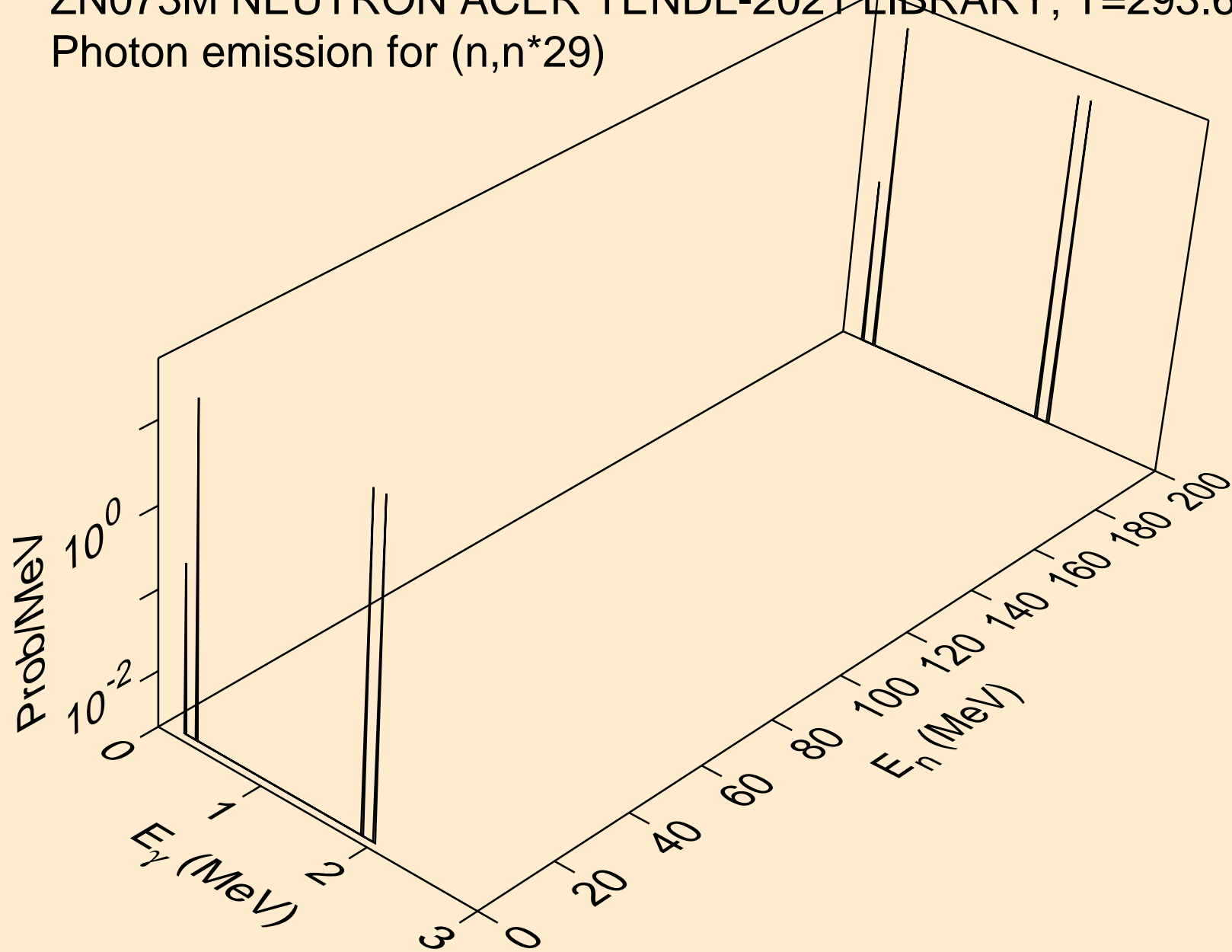

ZN073M NEUTRON ACER TENDL-2021 LIBRARY; T=293.6K  
Photon emission for (n,n\*30)

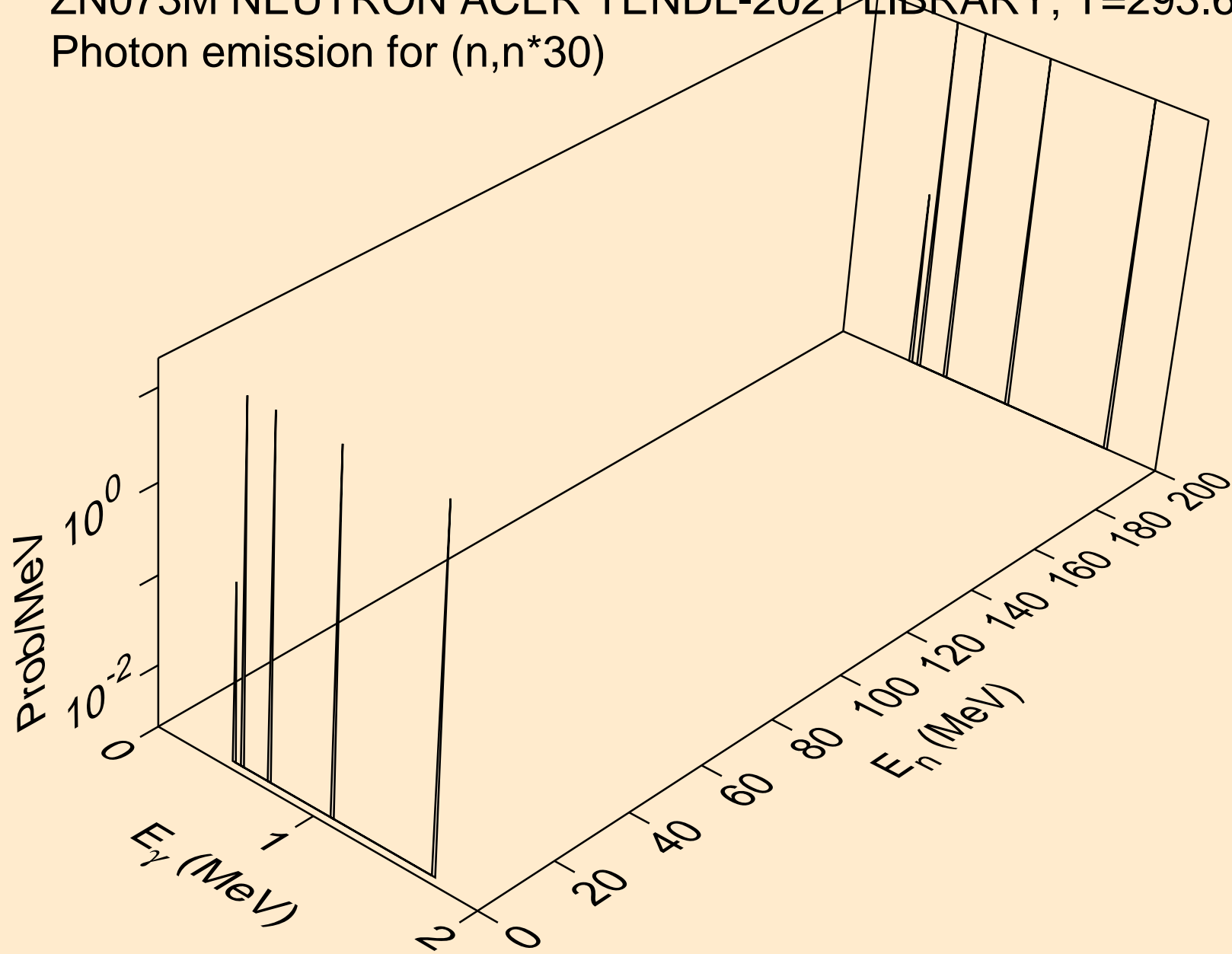



ZN073M NEUTRON ACER TENDL-2021 LIBRARY; T=293.6K  
Photon emission for (n,n\*c)

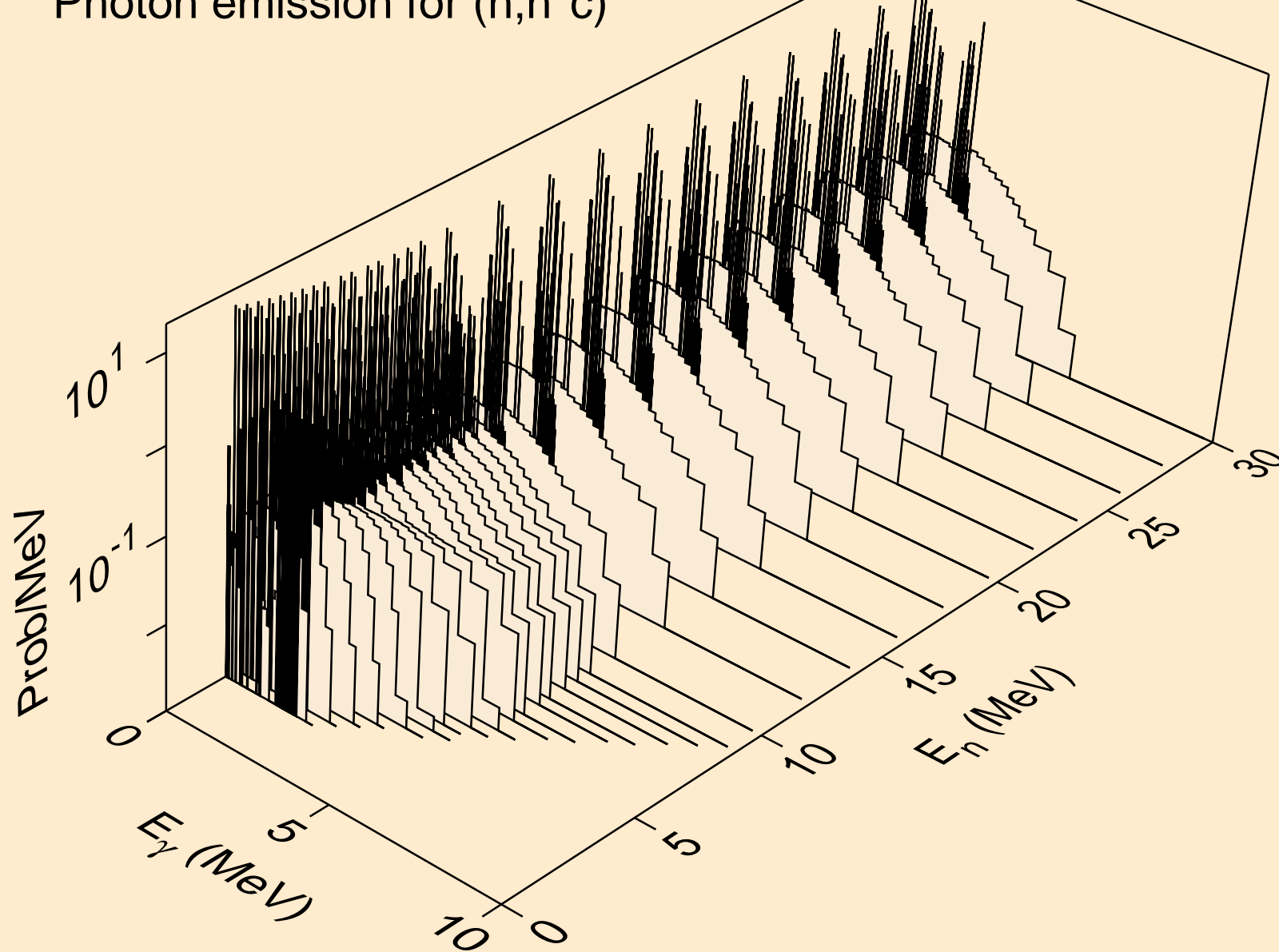

ZN073M NEUTRON ACER TENDL-2021 LIBRARY; T=293.6K  
Photon emission for (n,gma)

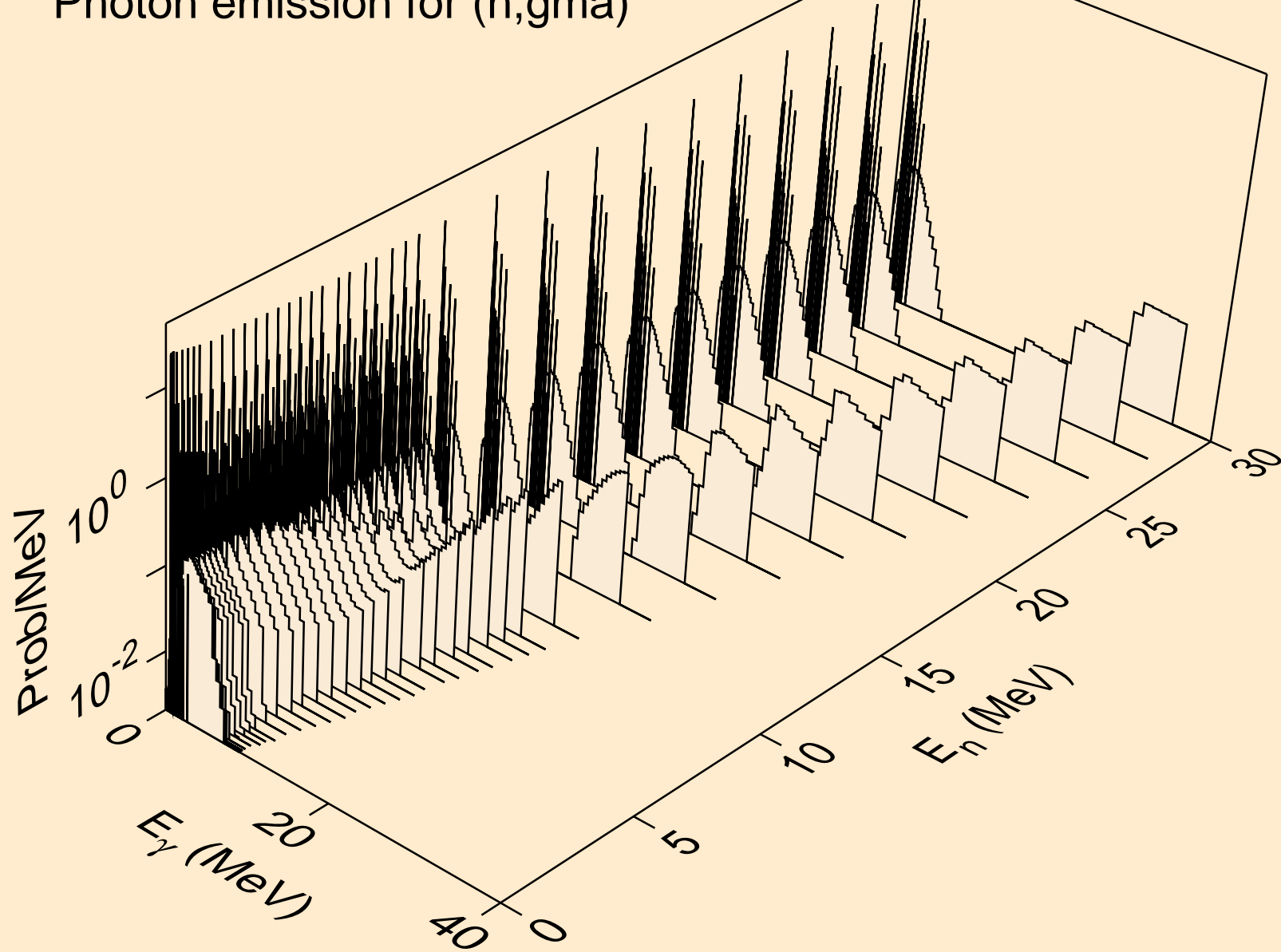

ZN073M NEUTRON ACER TENDL-2021 LIBRARY; T=293.6K  
Photon emission for (n,p)

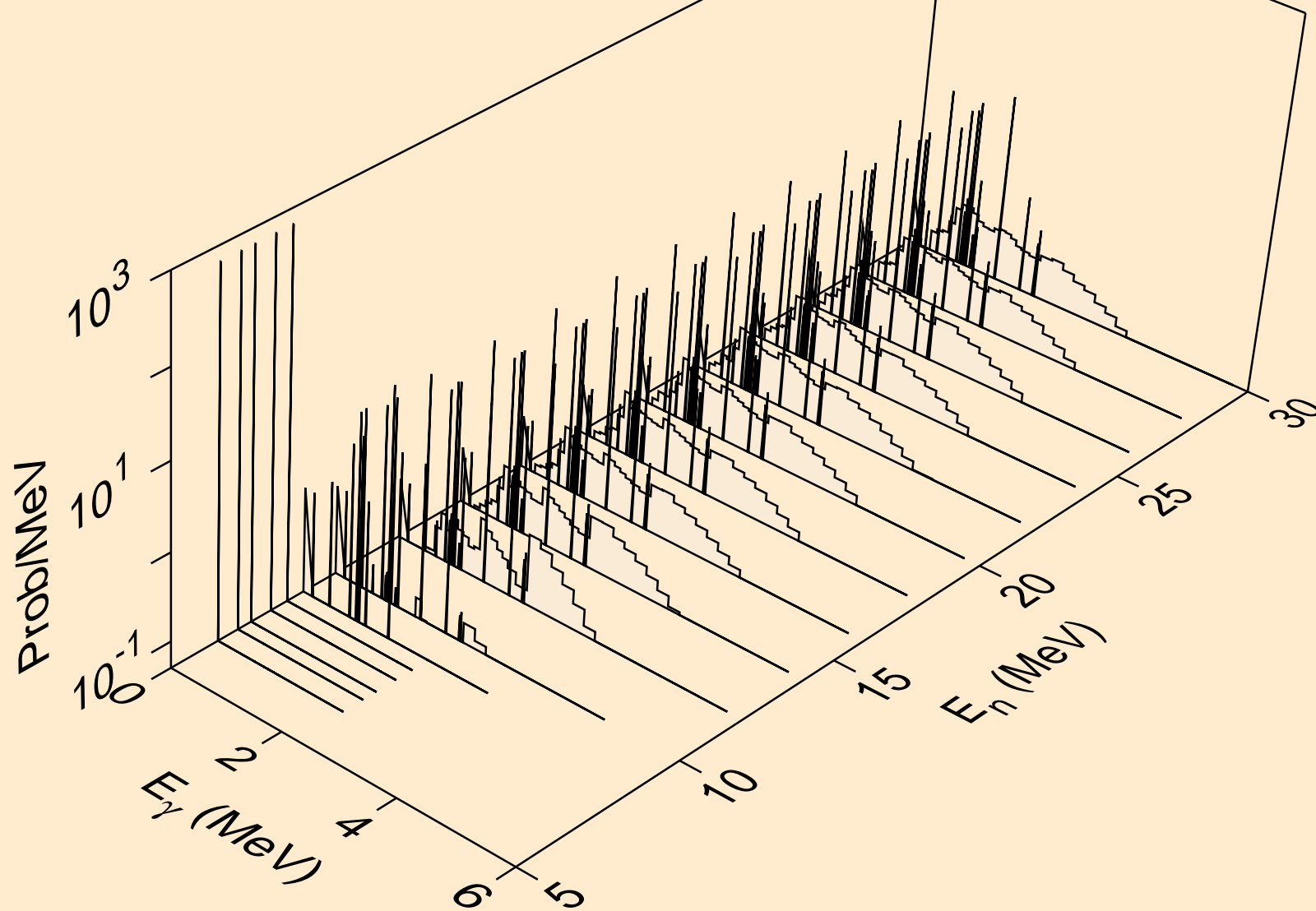

ZN073M NEUTRON ACER TENDL-2021 LIBRARY; T=293.6K  
Photon emission for (n,d)

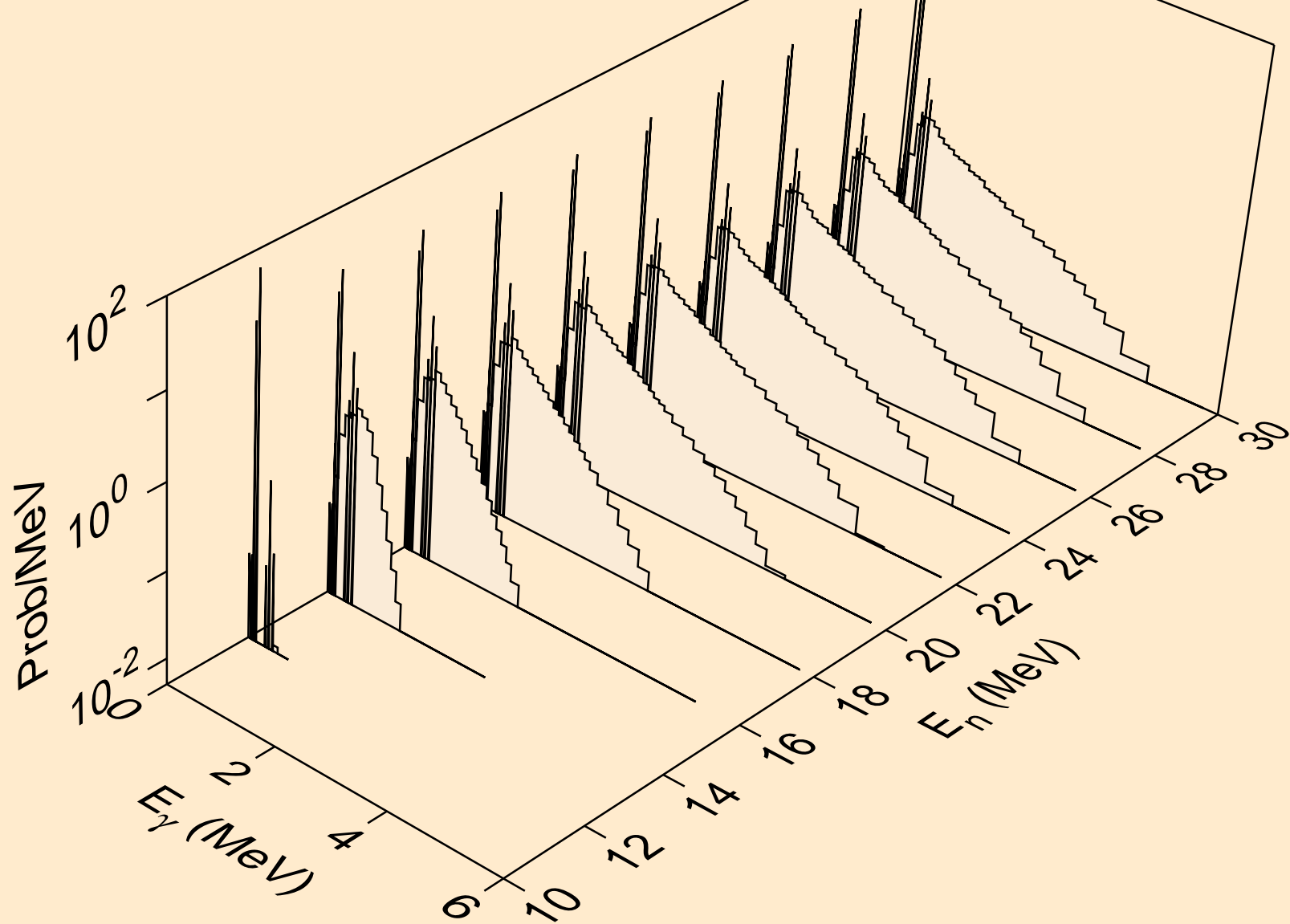

ZN073M NEUTRON ACER TENDL-2021 LIBRARY; T=293.6K  
Photon emission for (n,t)

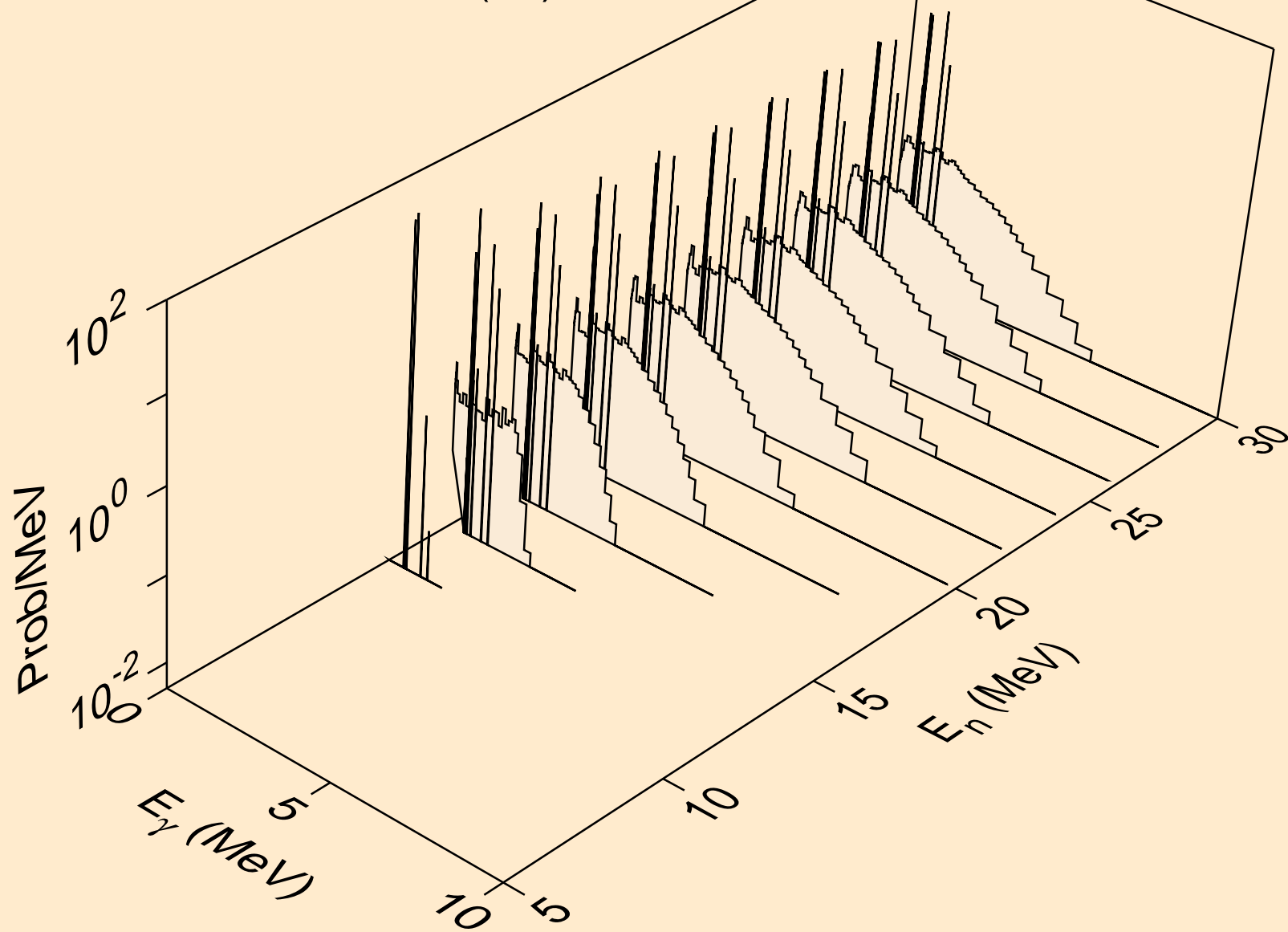

ZN073M NEUTRON ACER TENDL-2021 LIBRARY; T=293.6K  
Photon emission for (n,he3)

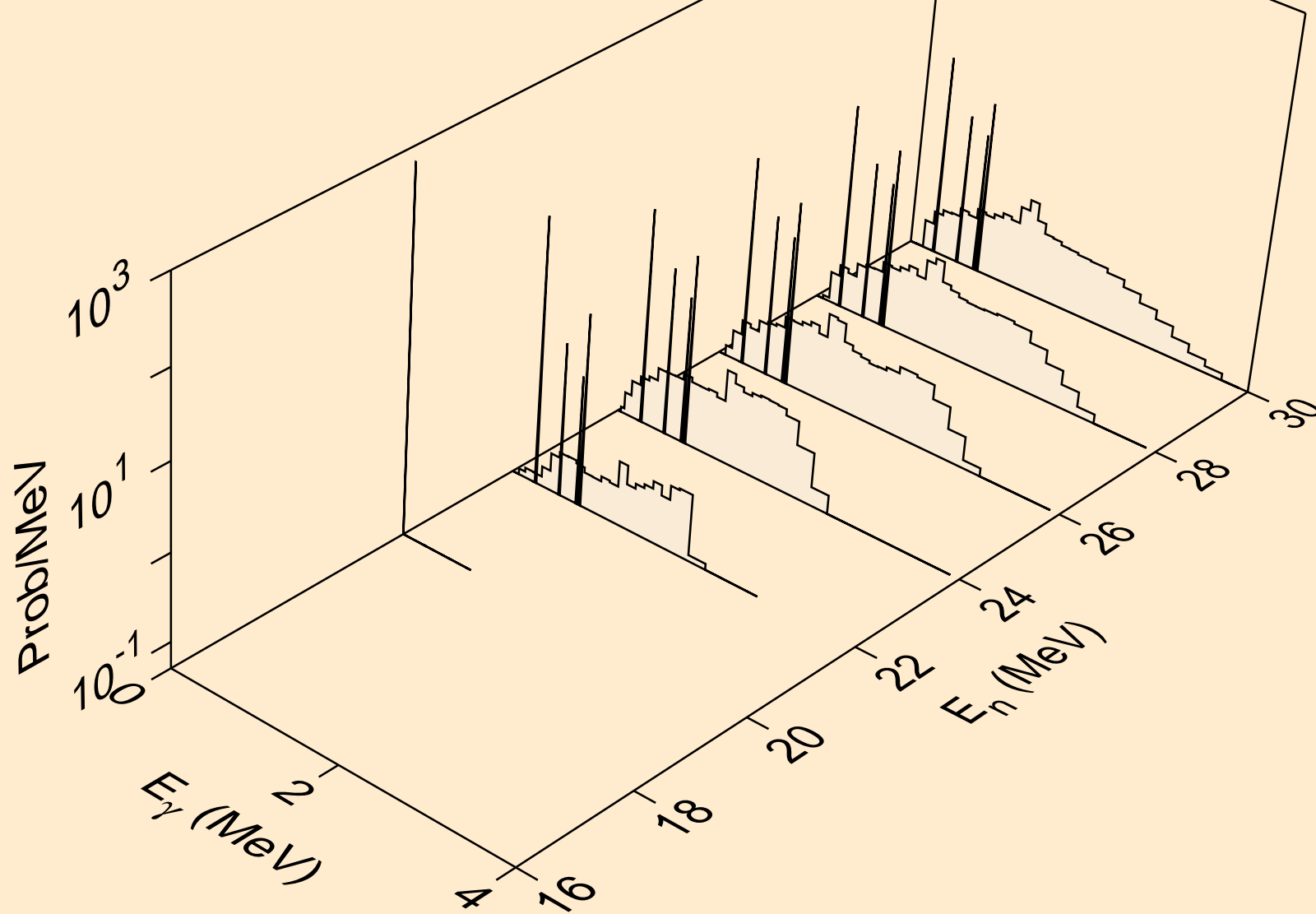

ZN073M NEUTRON ACER TENDL-2021 LIBRARY; T=293.6K  
Photon emission for (n,a)

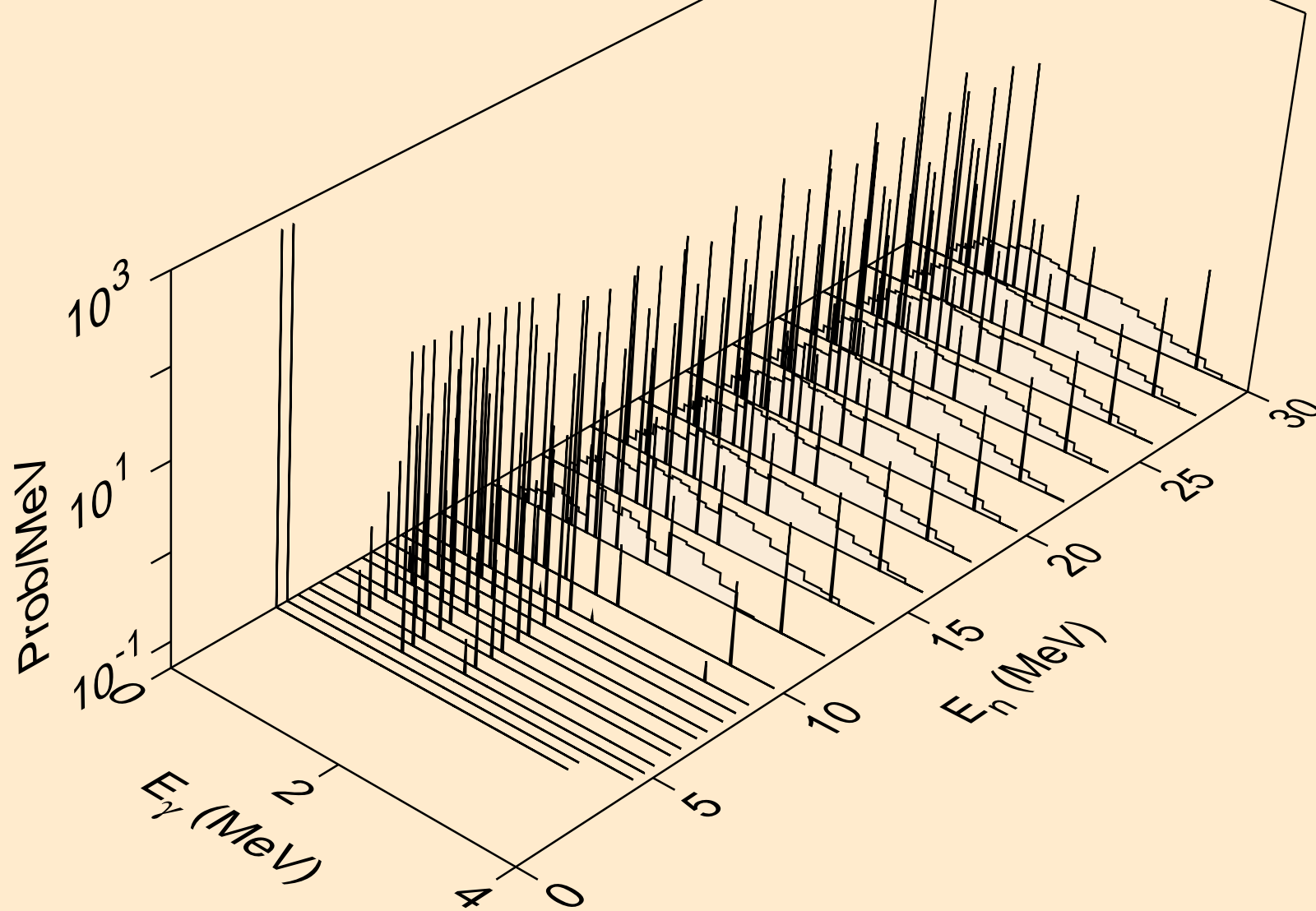

ZN073M NEUTRON ACER TENDL-2021 LIBRARY; T=293.6K  
Photon emission for (n,2p)

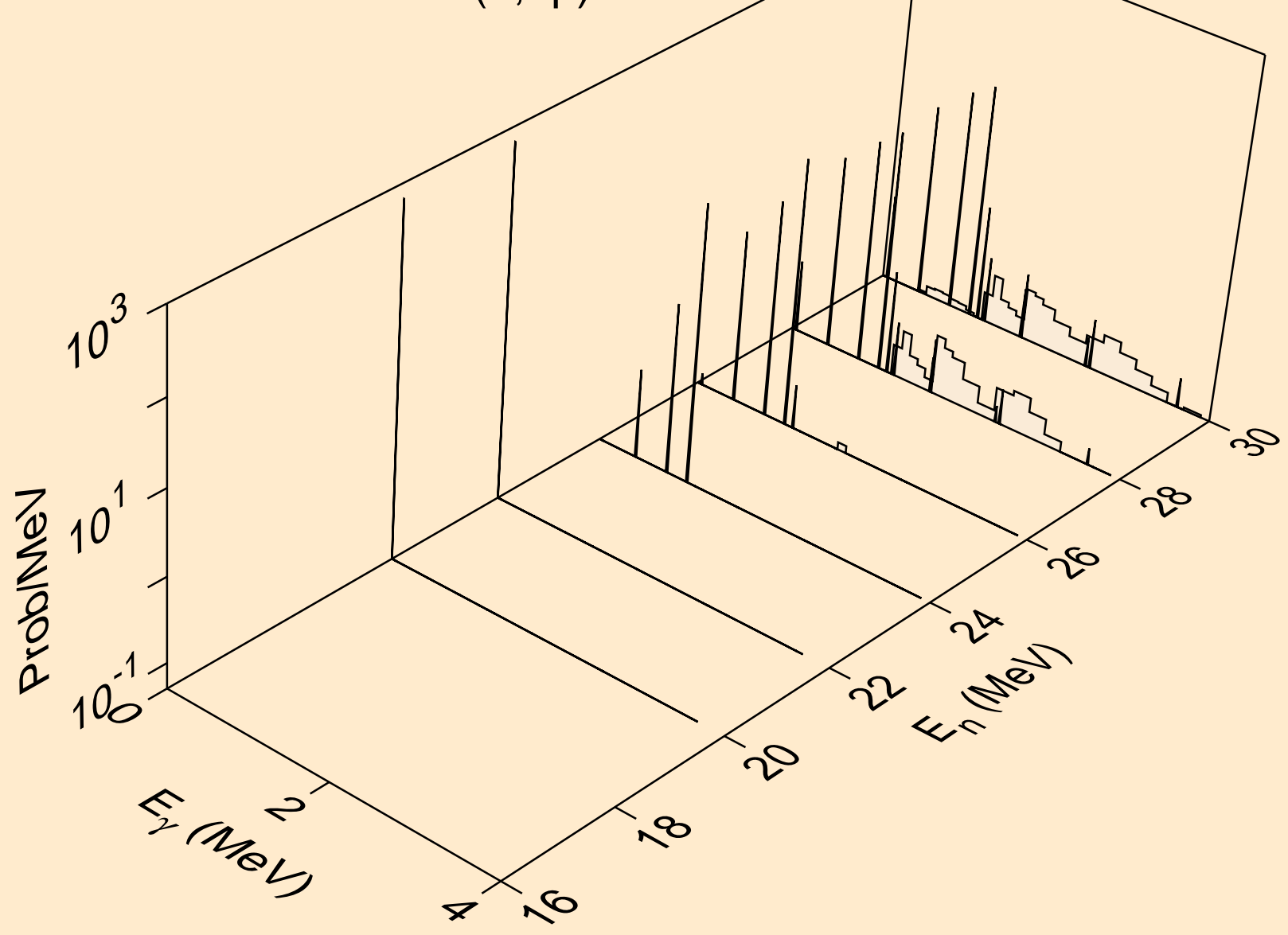



ZN073M NEUTRON ACER TENDL-2021 LIBRARY; T=293.6K  
Photon emission for (n,p $\alpha$ )

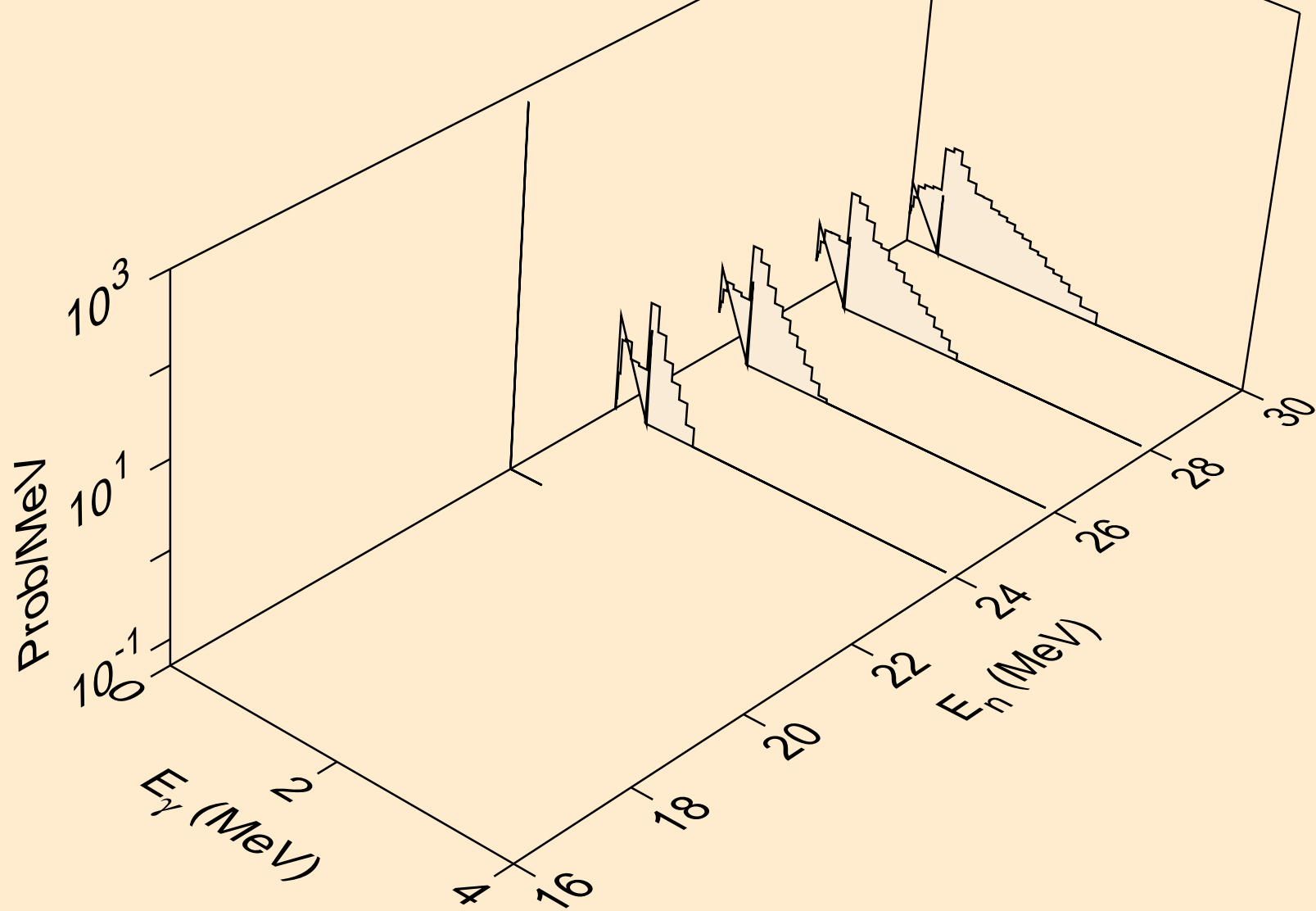

ZN073M NEUTRON ACER TENDL-2021 LIBRARY; T=293.6K  
Photon emission for (n,pt)

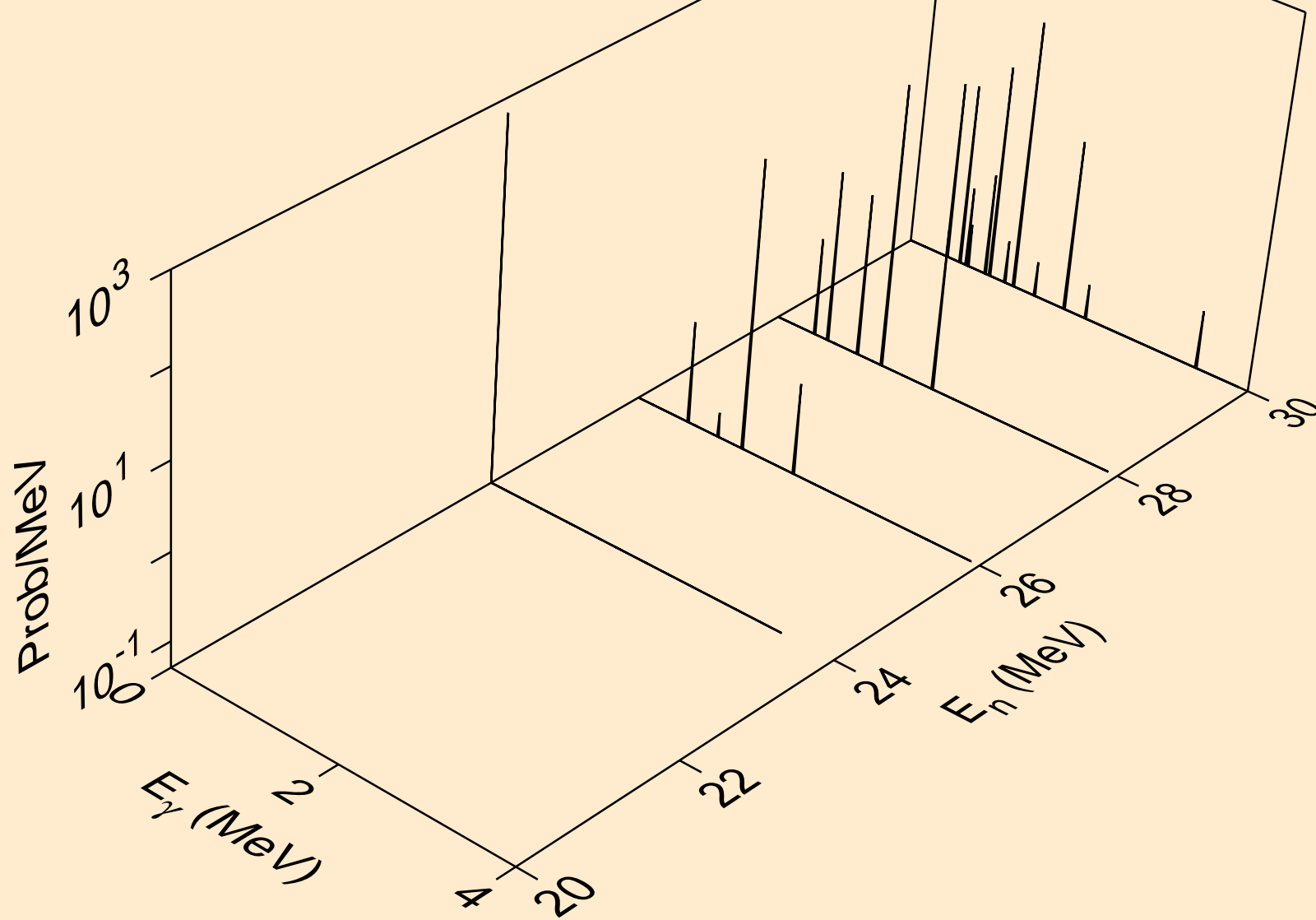

ZN073M NEUTRON ACER TENDL-2021 LIBRARY; T=293.6K  
thermal capture photon spectrum

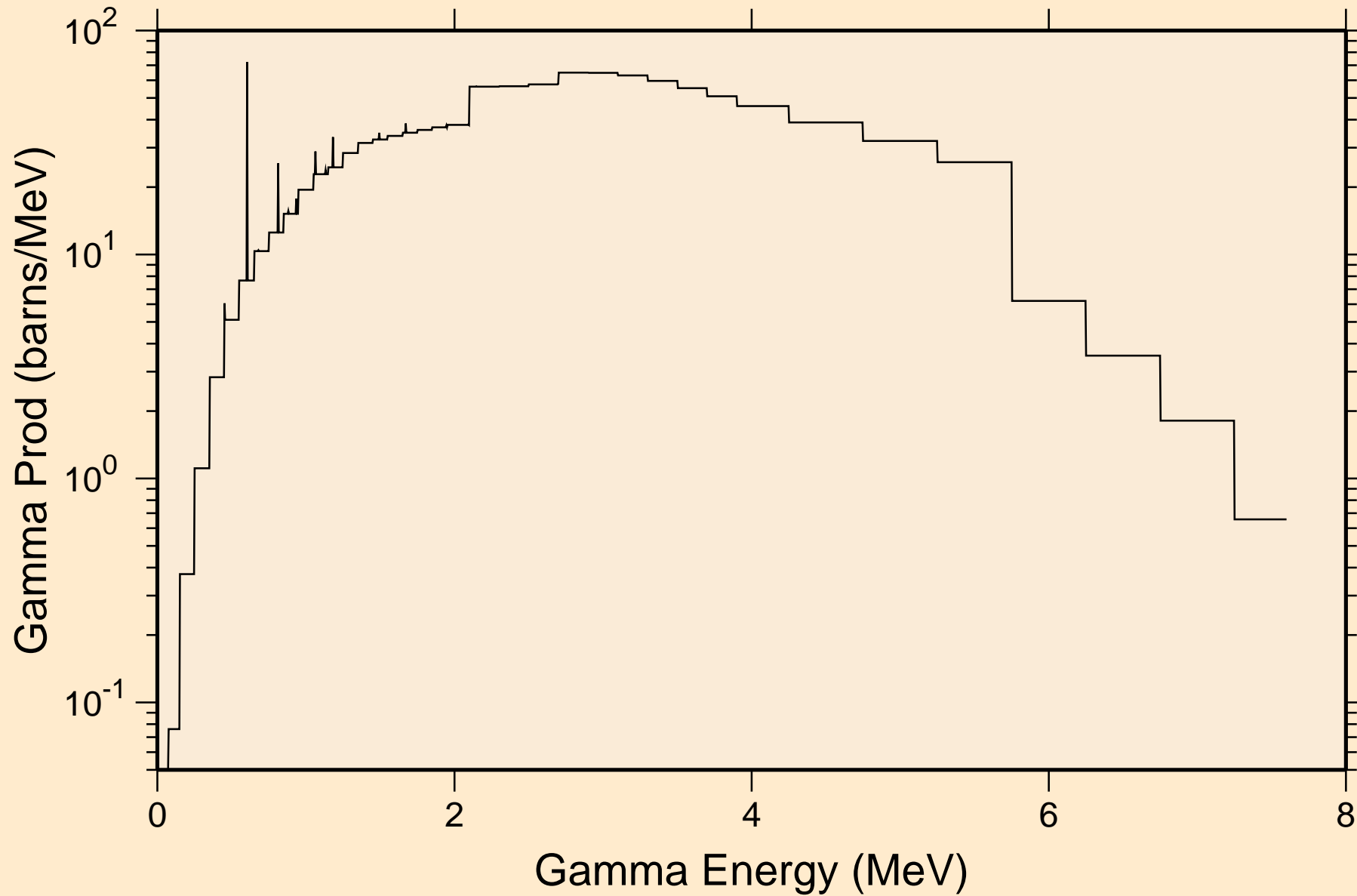

ZN073M NEUTRON ACER TENDL-2021 LIBRARY; T=293.6K  
14 MeV photon spectrum

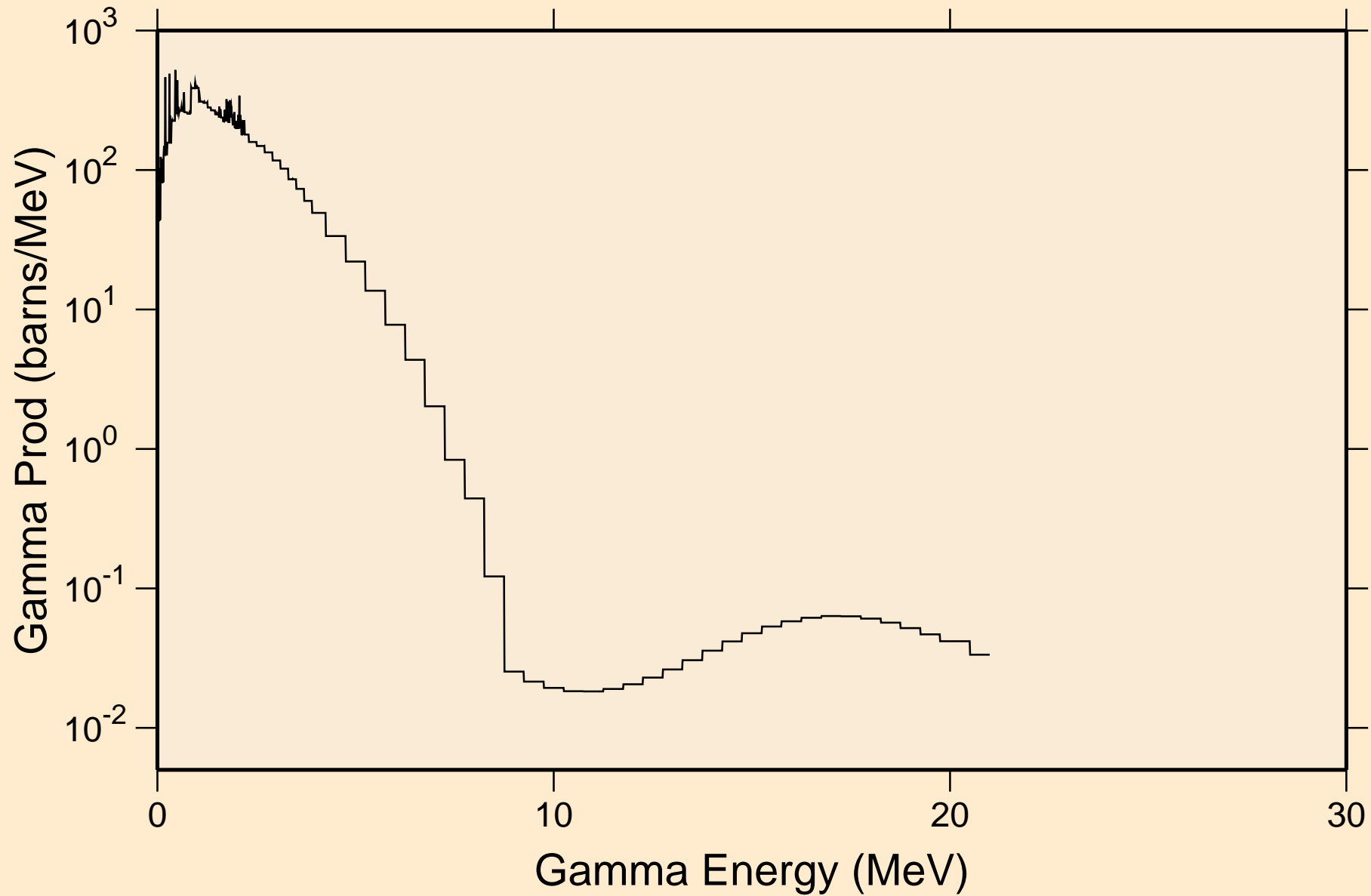

# ZN073M NEUTRON ACER TENDL-2021 LIBRARY; T=293.6K

## Particle heating contributions

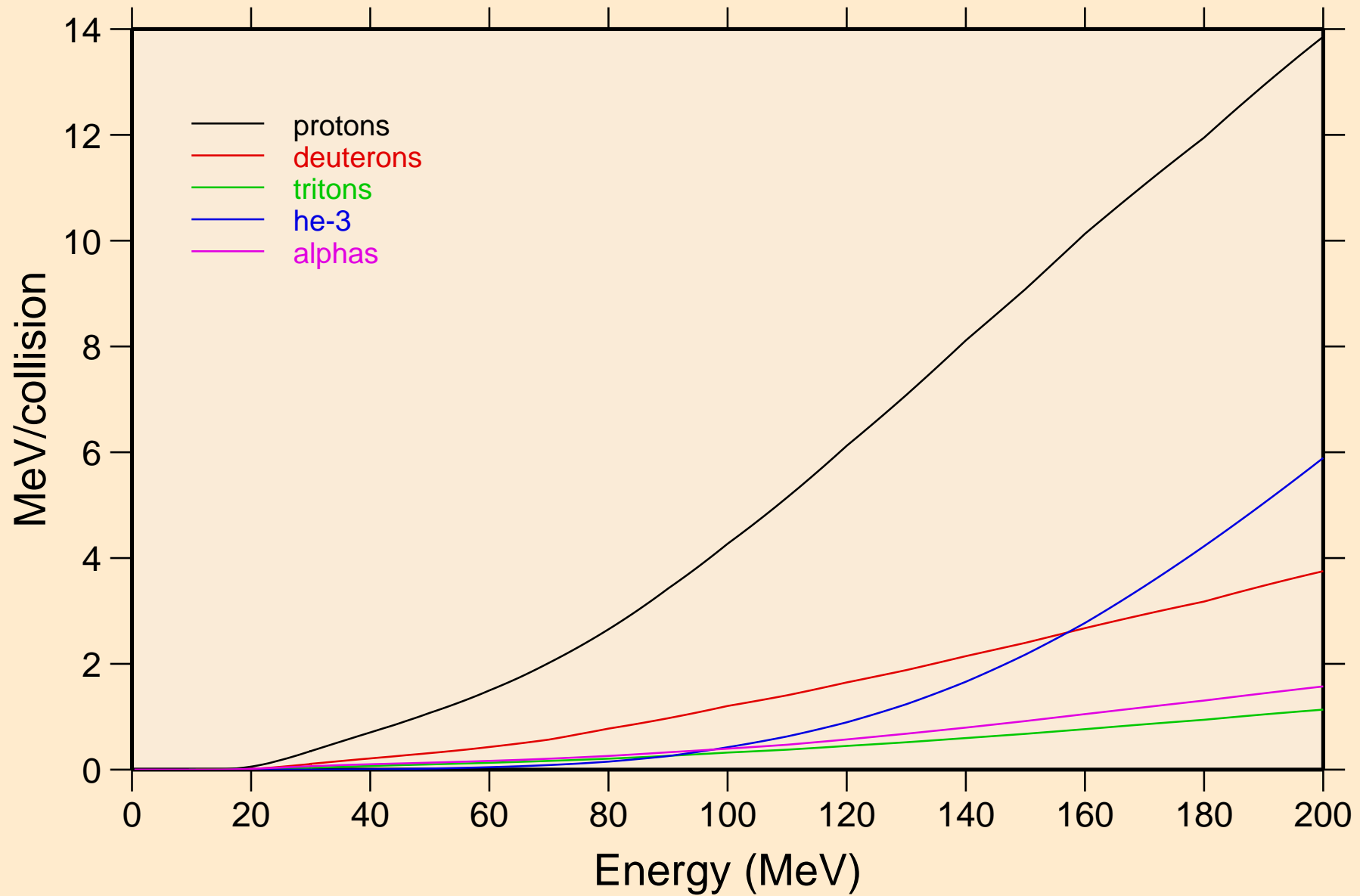

ZN073M NEUTRON ACER TENDL-2021 LIBRARY; T=293.6K  
Recoil Heating

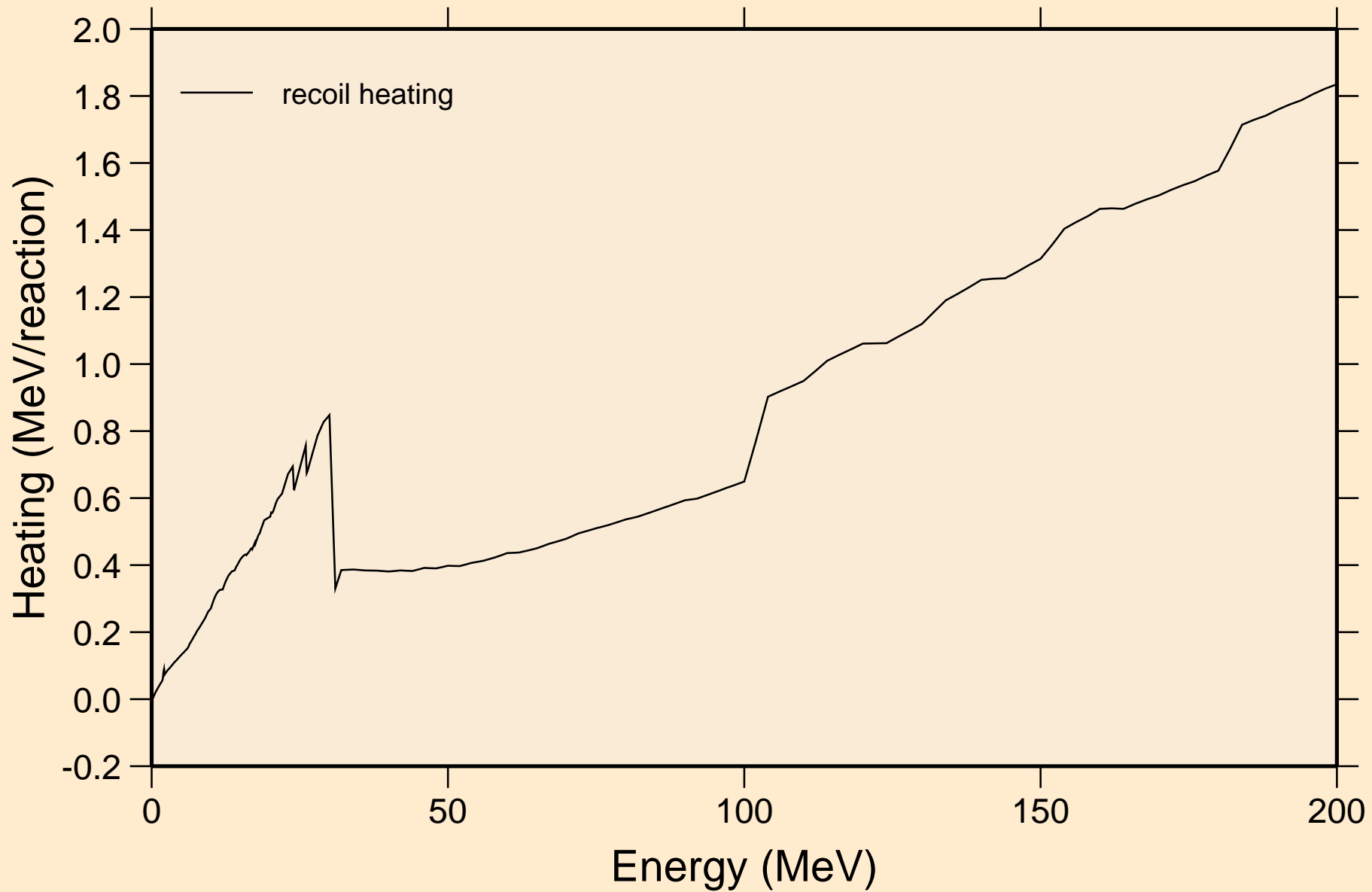

ZN073M NEUTRON ACER TENDL-2021 LIBRARY; T=293.6K  
Particle production cross sections

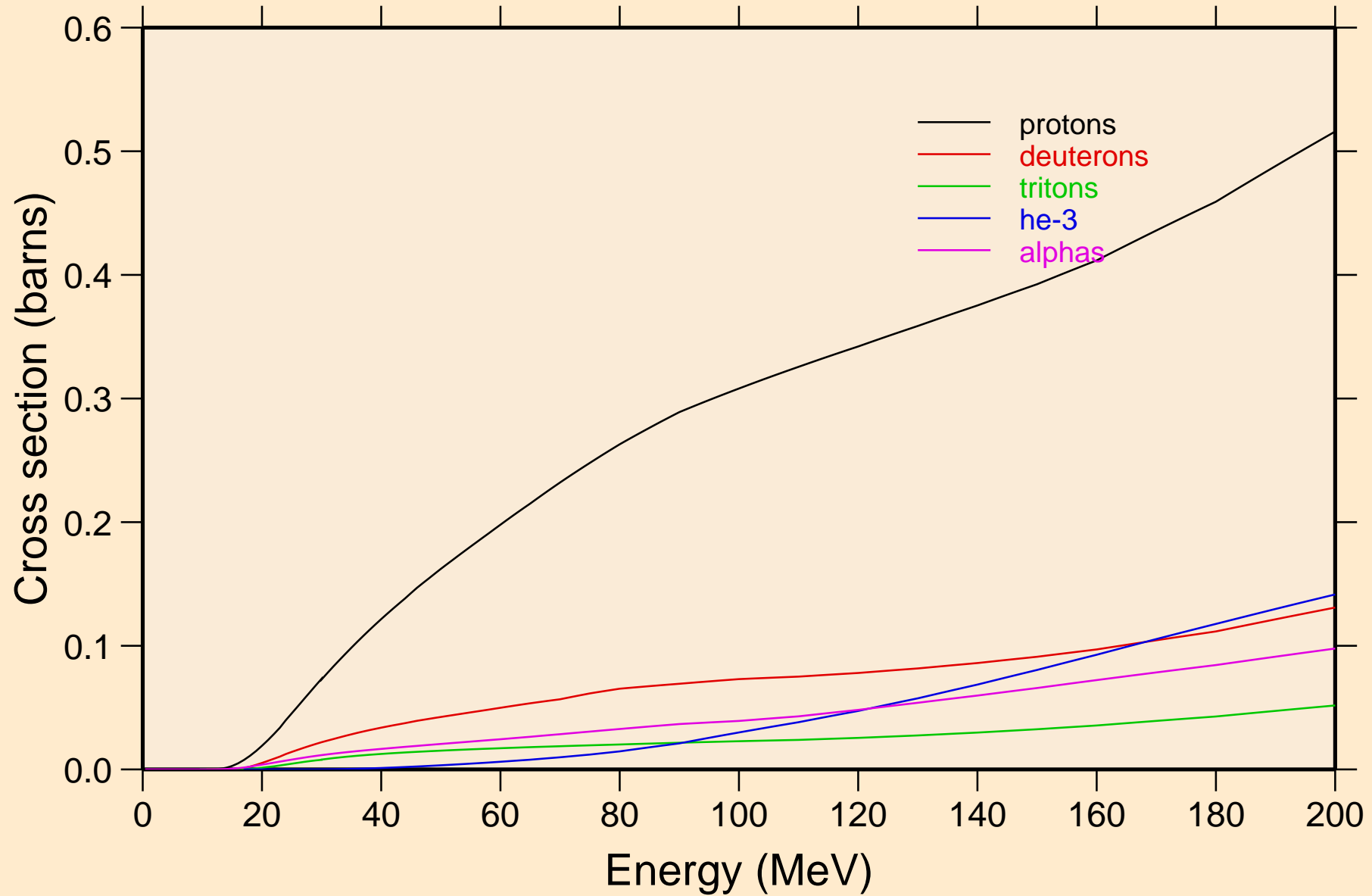

ZN073M NEUTRON ACER TENDL-2021 LIBRARY; T=293.6K  
protons from (n,x)

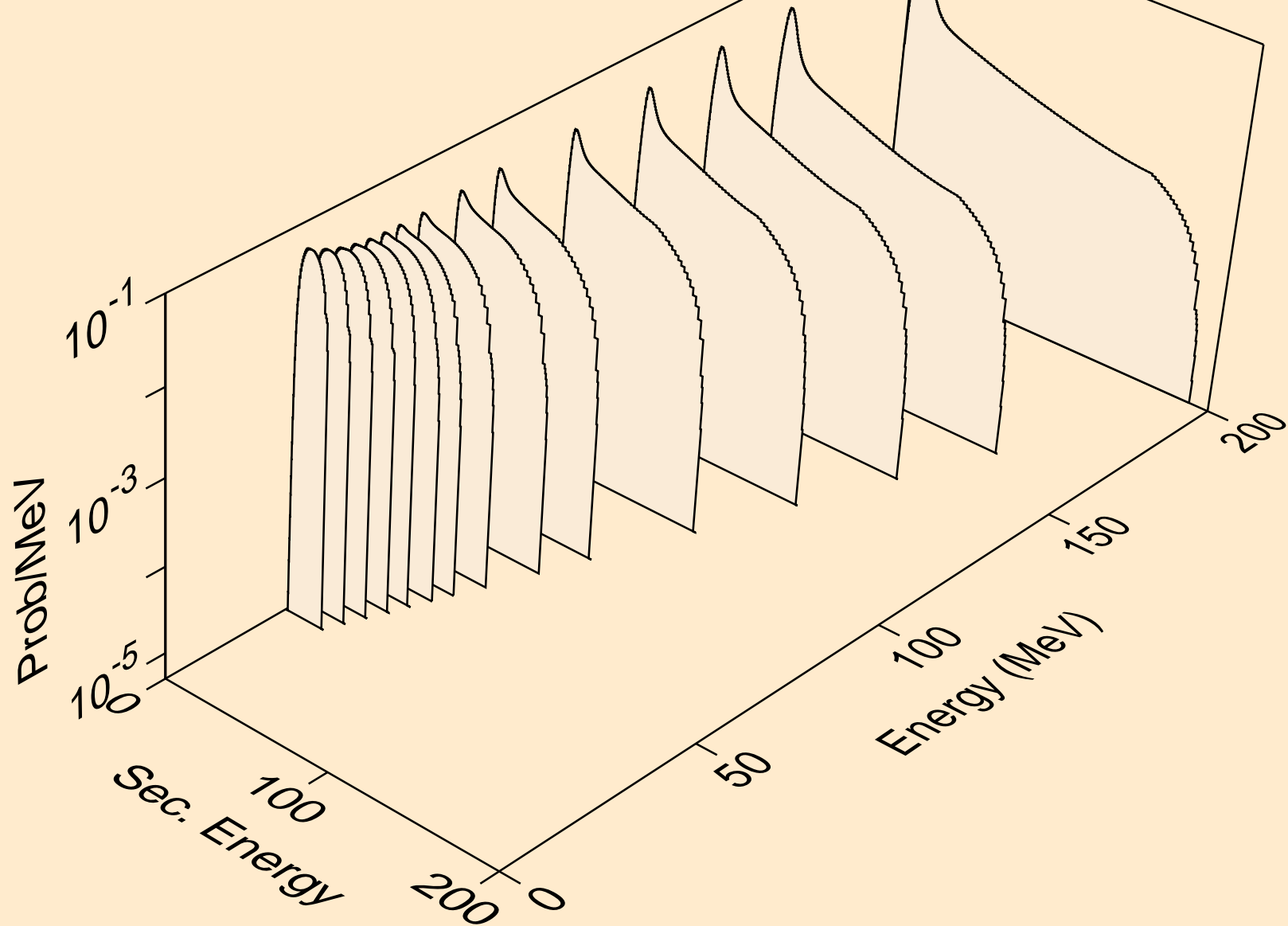



ZN073M NEUTRON ACER TENDL-2021 LIBRARY; T=293.6K  
protons from (n,n\*)p

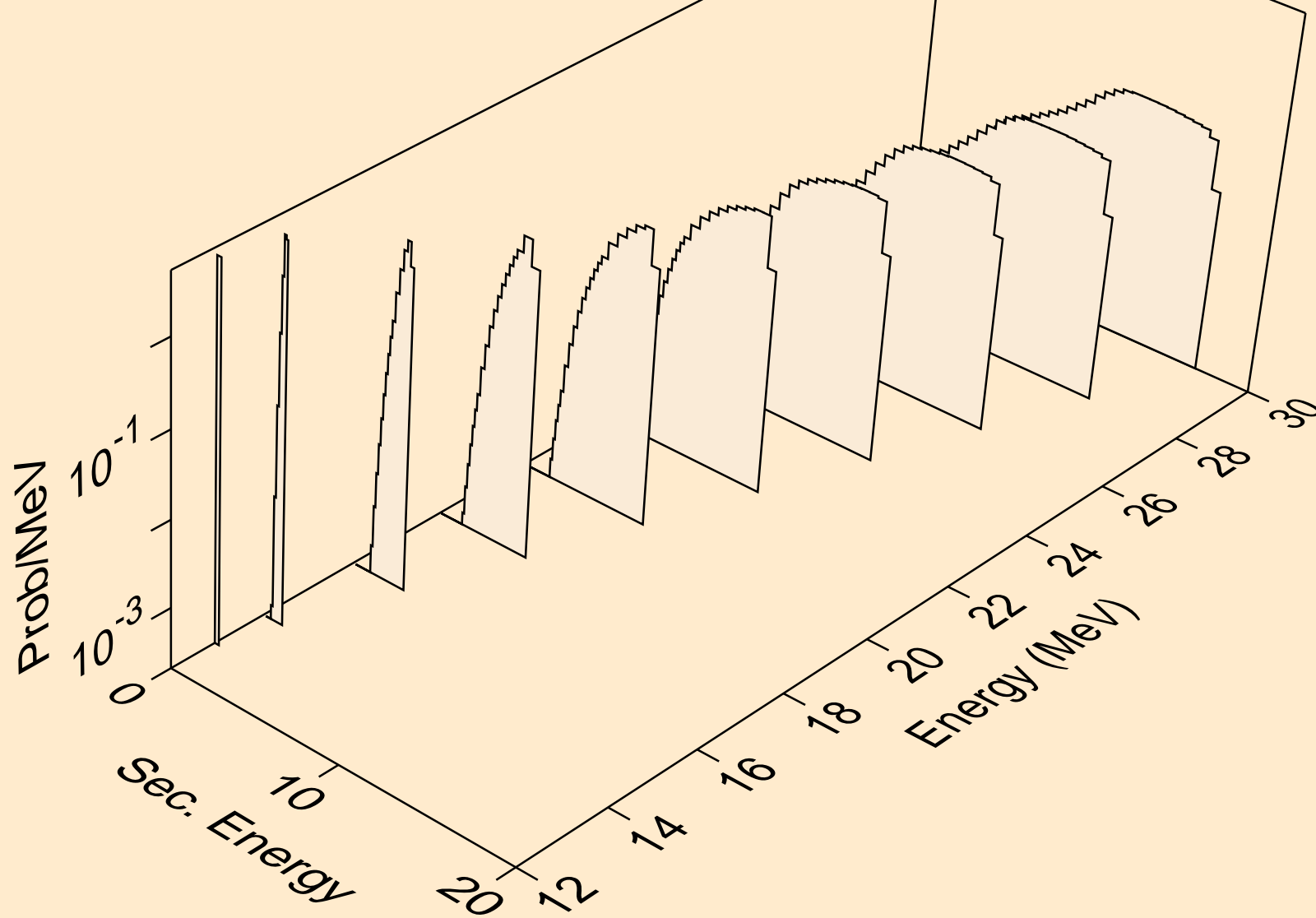

ZN073M NEUTRON ACER TENDL-2021 LIBRARY; T=293.6K  
protons from (n,2np)

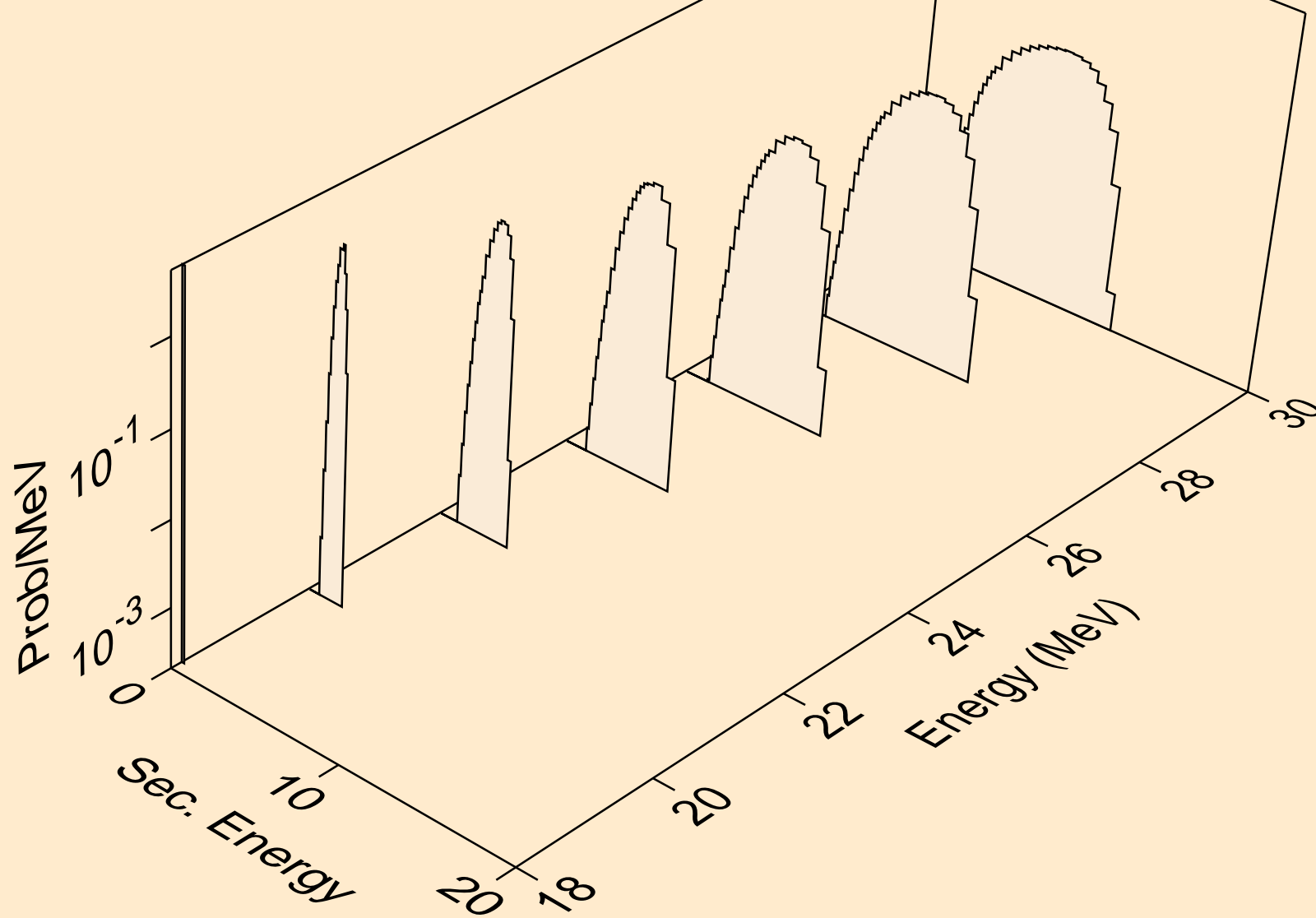

ZN073M NEUTRON ACER TENDL-2021 LIBRARY; T=293.6K  
protons from (n,3np)

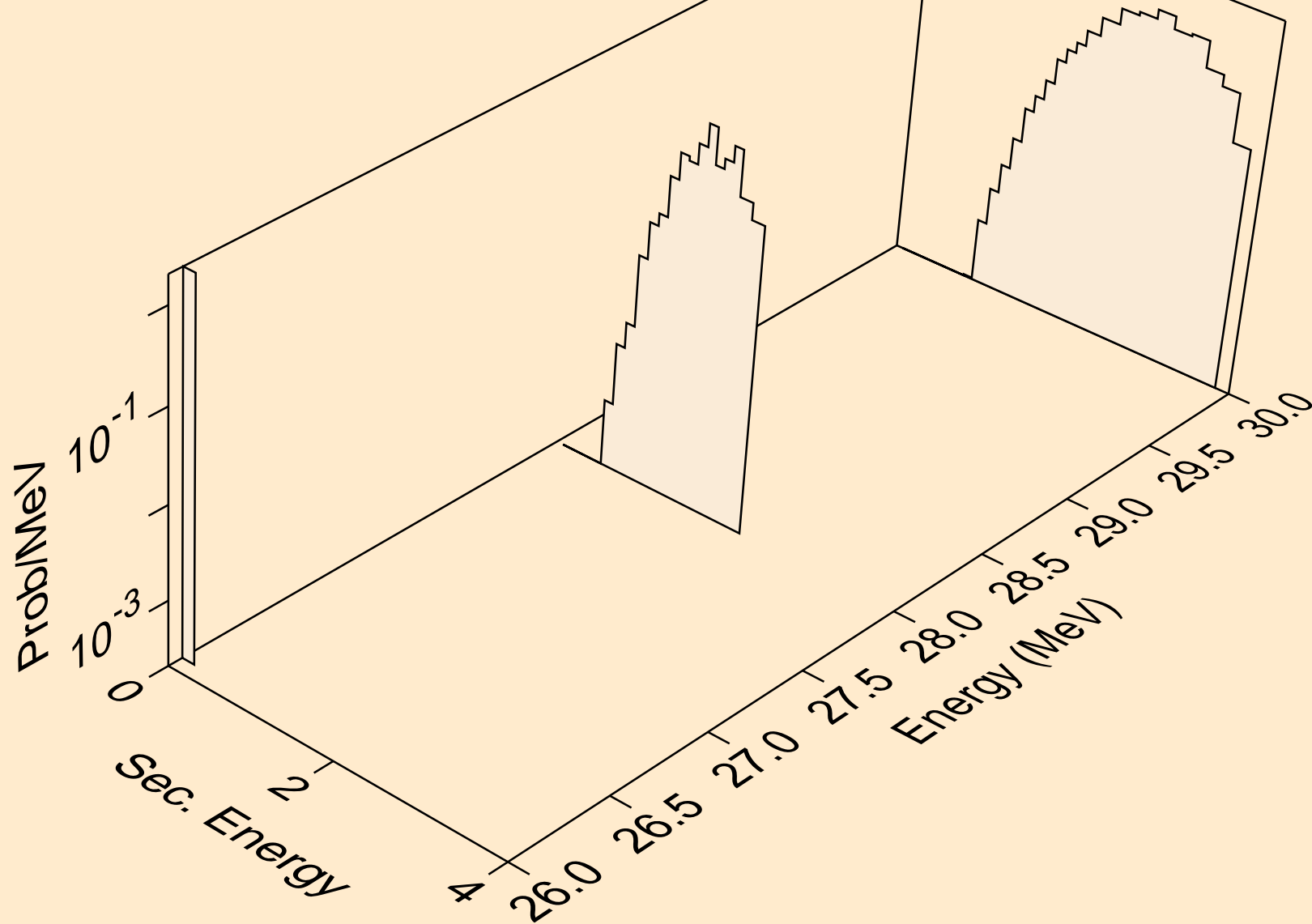

ZN073M NEUTRON ACER TENDL-2021 LIBRARY; T=293.6K  
protons from (n,p)

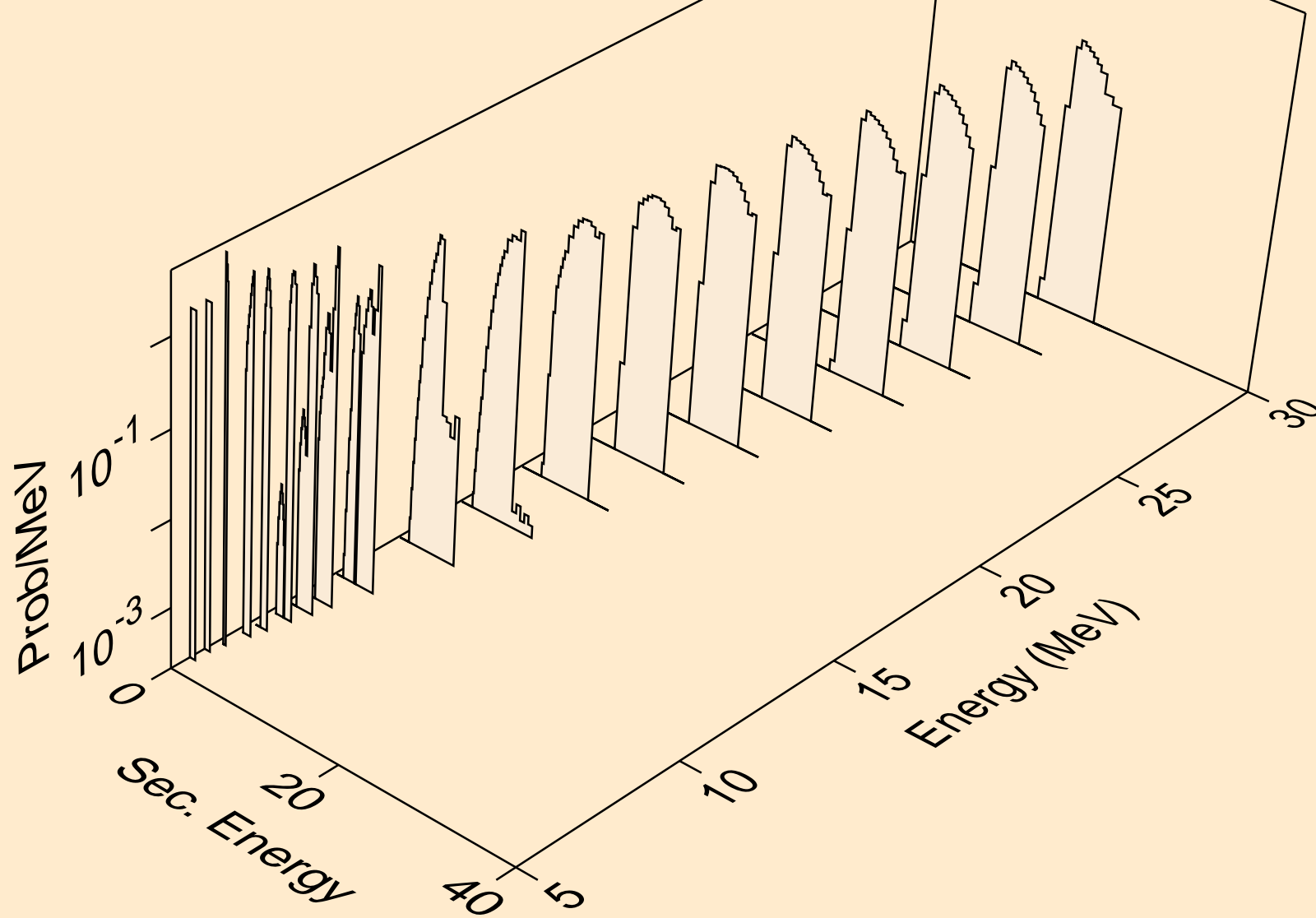

ZN073M NEUTRON ACER TENDL-2021 LIBRARY; T=293.6K  
protons from (n,2p)

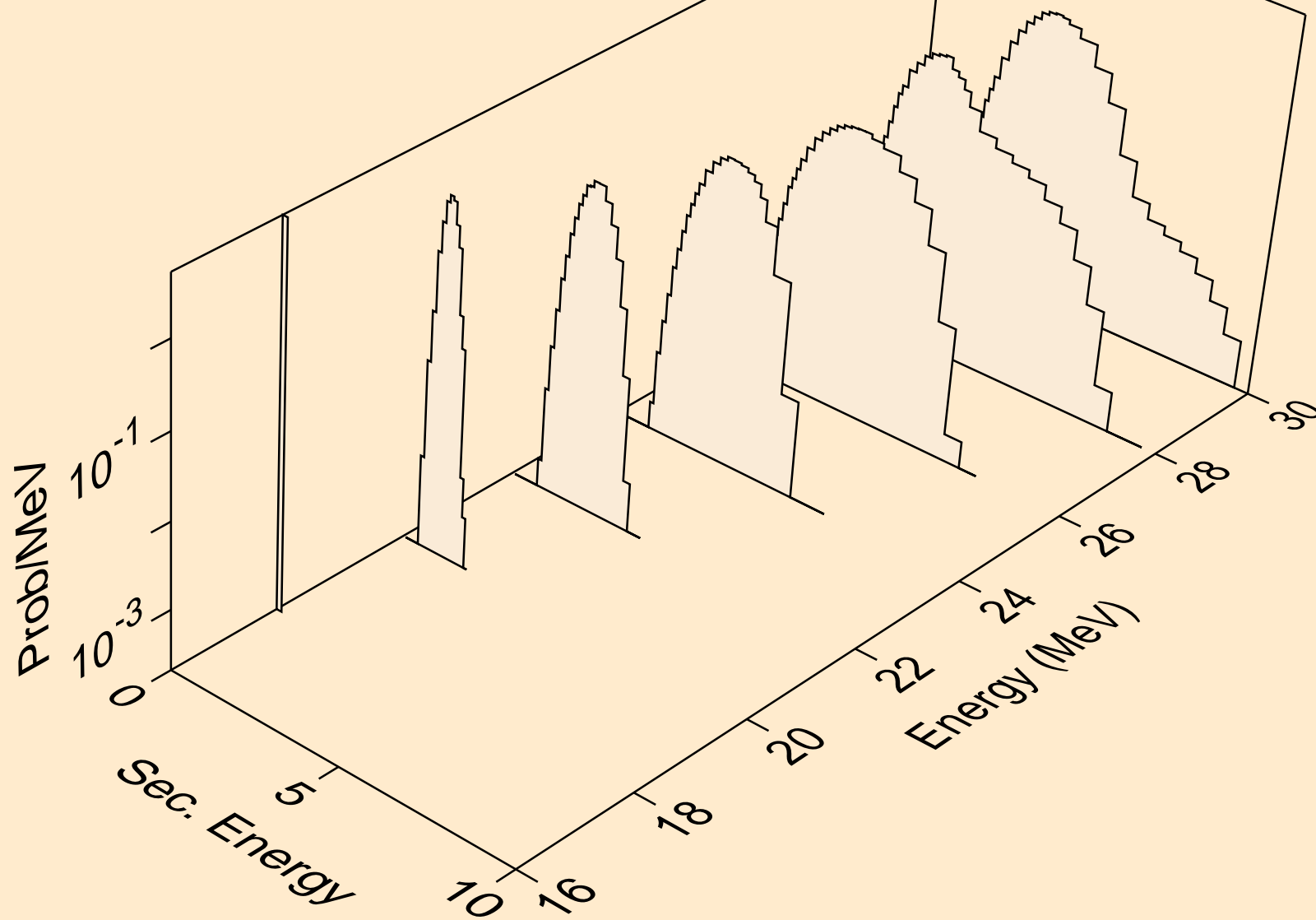

ZN073M NEUTRON ACER TENDL-2021 LIBRARY; T=293.6K  
protons from (n,p)

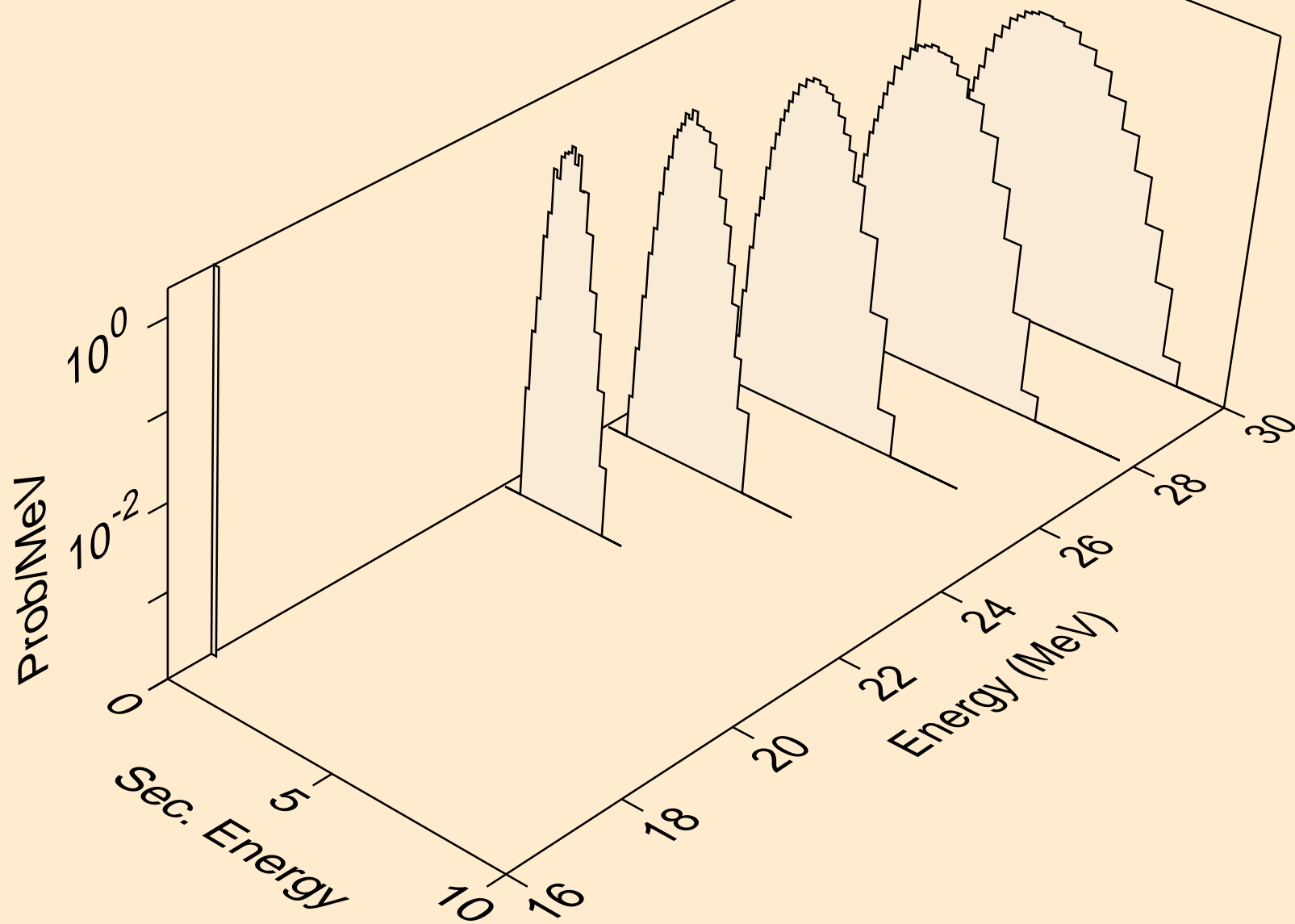

ZN073M NEUTRON ACER TENDL-2021 LIBRARY; T=293.6K  
protons from (n,pt)

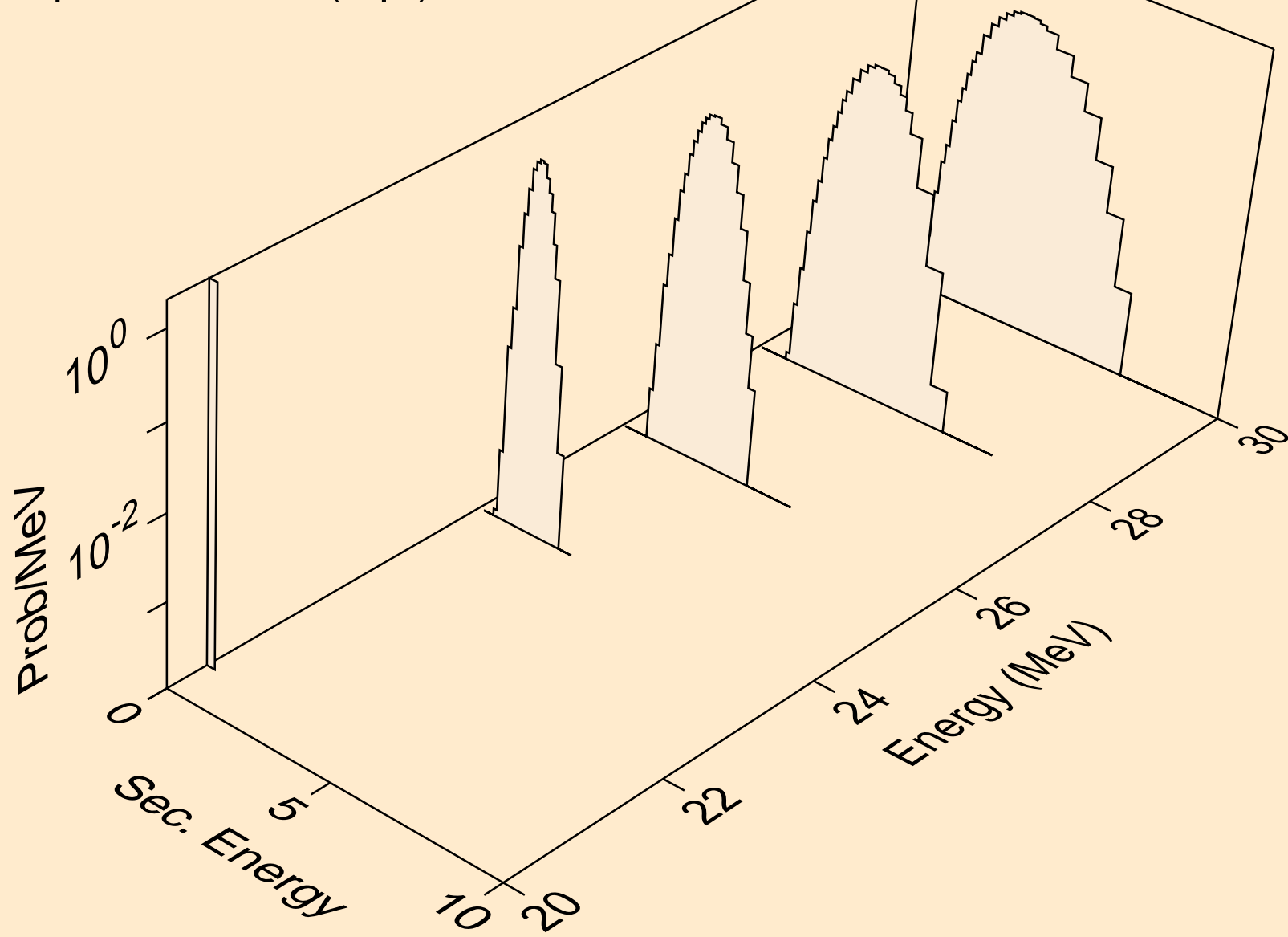

ZN073M NEUTRON ACER TENDL-2021 LIBRARY; T=293.6K  
deuterons from (n,x)

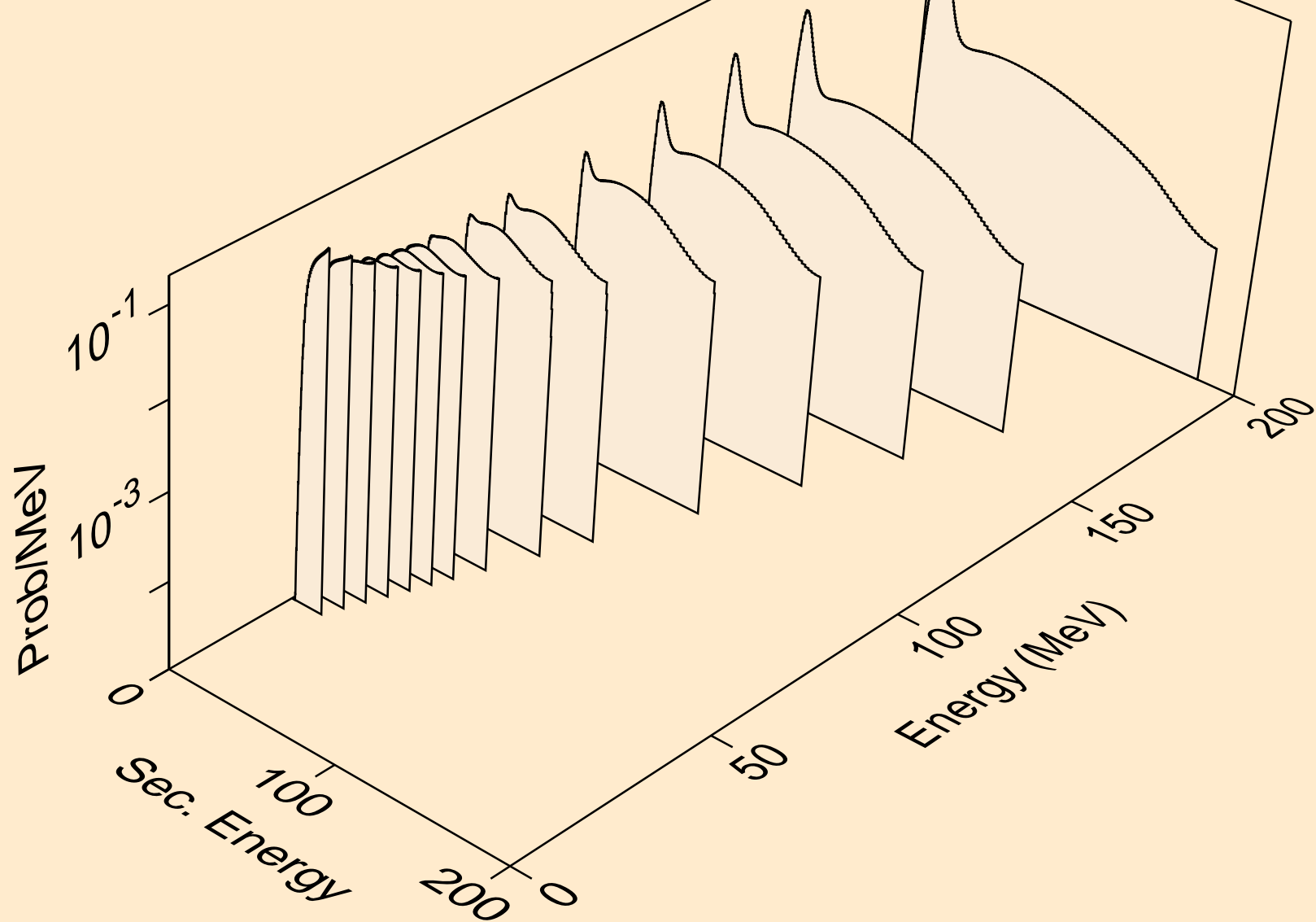



ZN073M NEUTRON ACER TENDL-2021 LIBRARY; T=293.6K  
deuterons from (n,2nd)

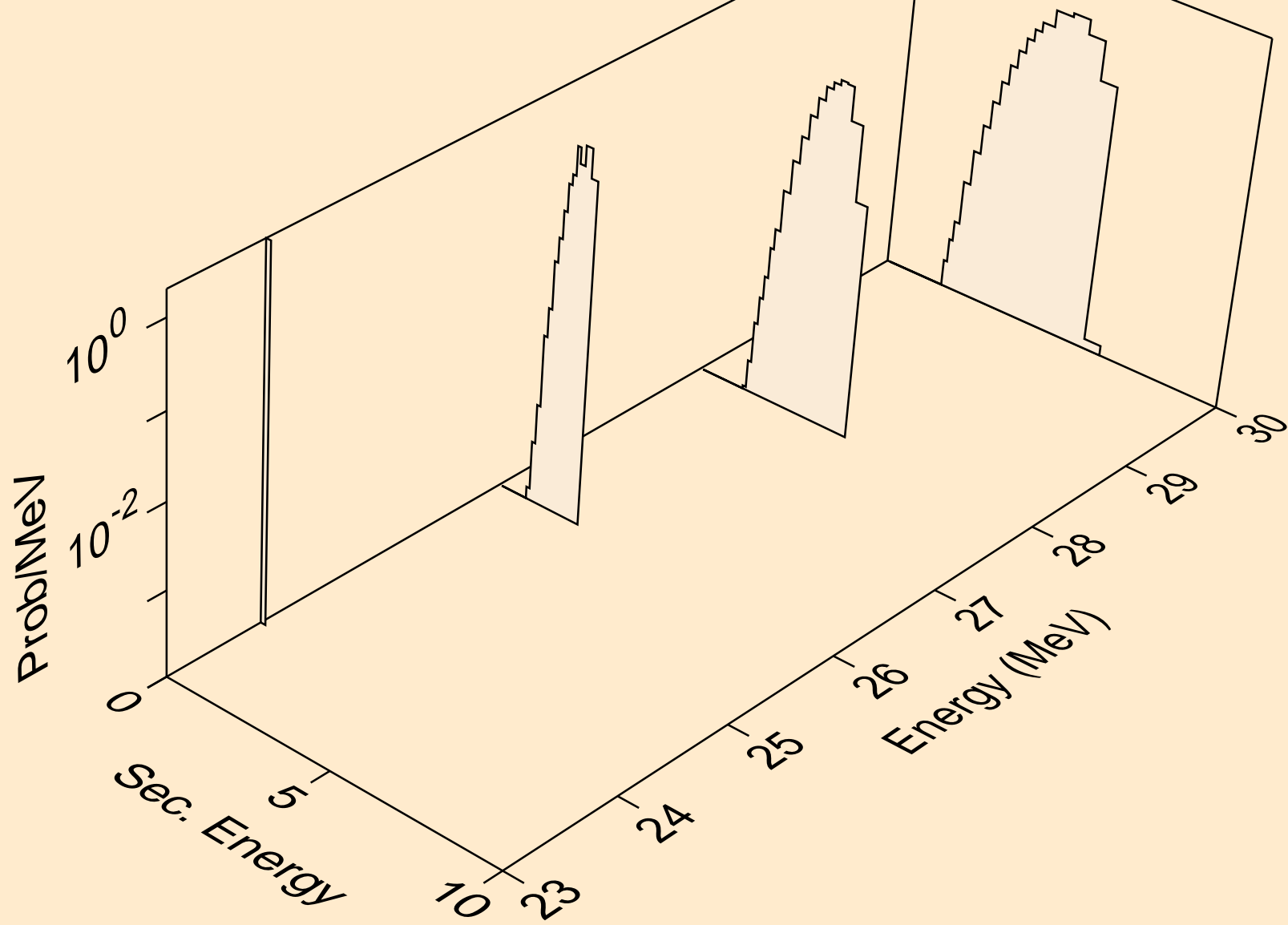

ZN073M NEUTRON ACER TENDL-2021 LIBRARY; T=293.6K  
deuterons from (n,n\*)d

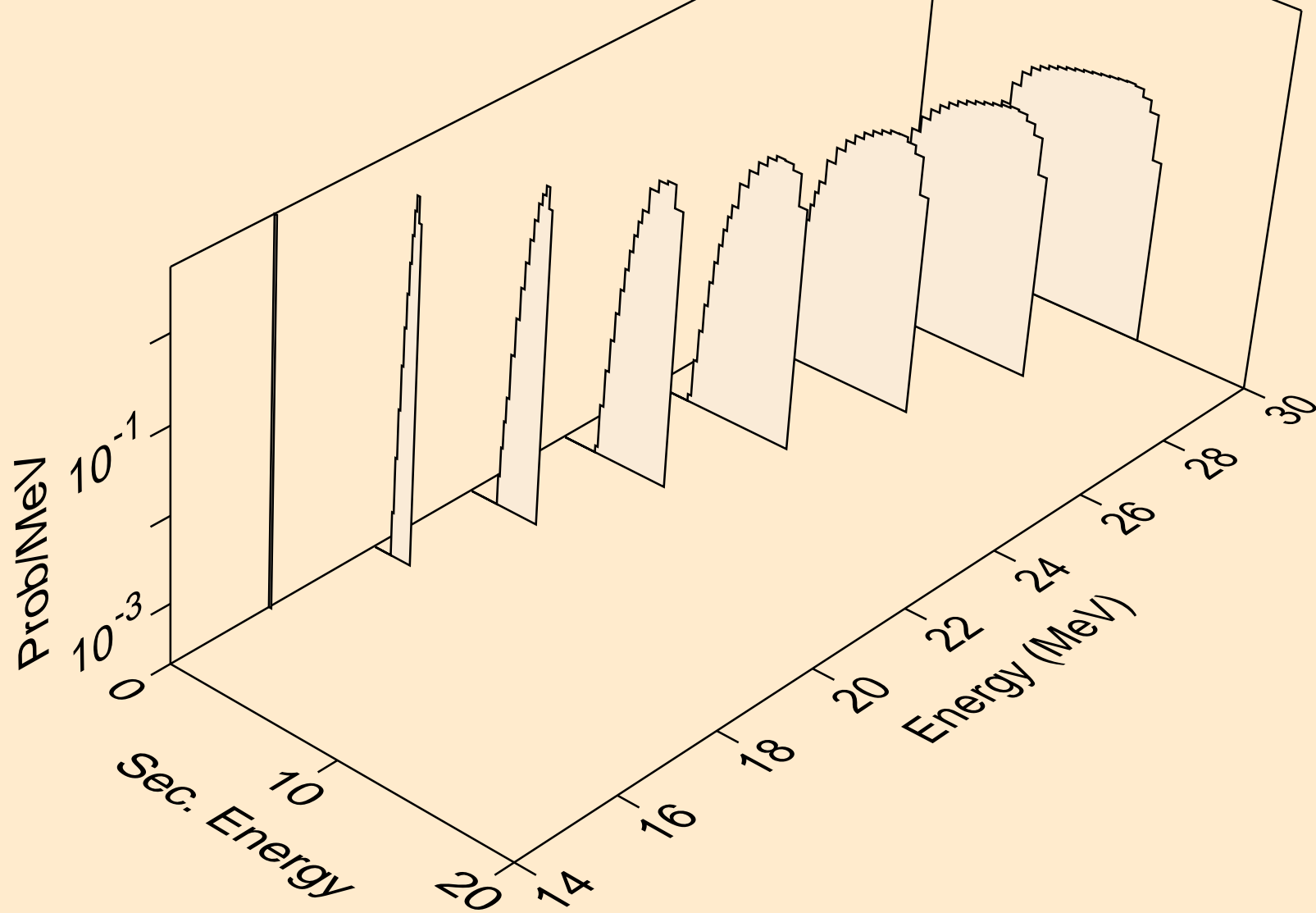

ZN073M NEUTRON ACER TENDL-2021 LIBRARY; T=293.6K  
deuterons from (n,d)

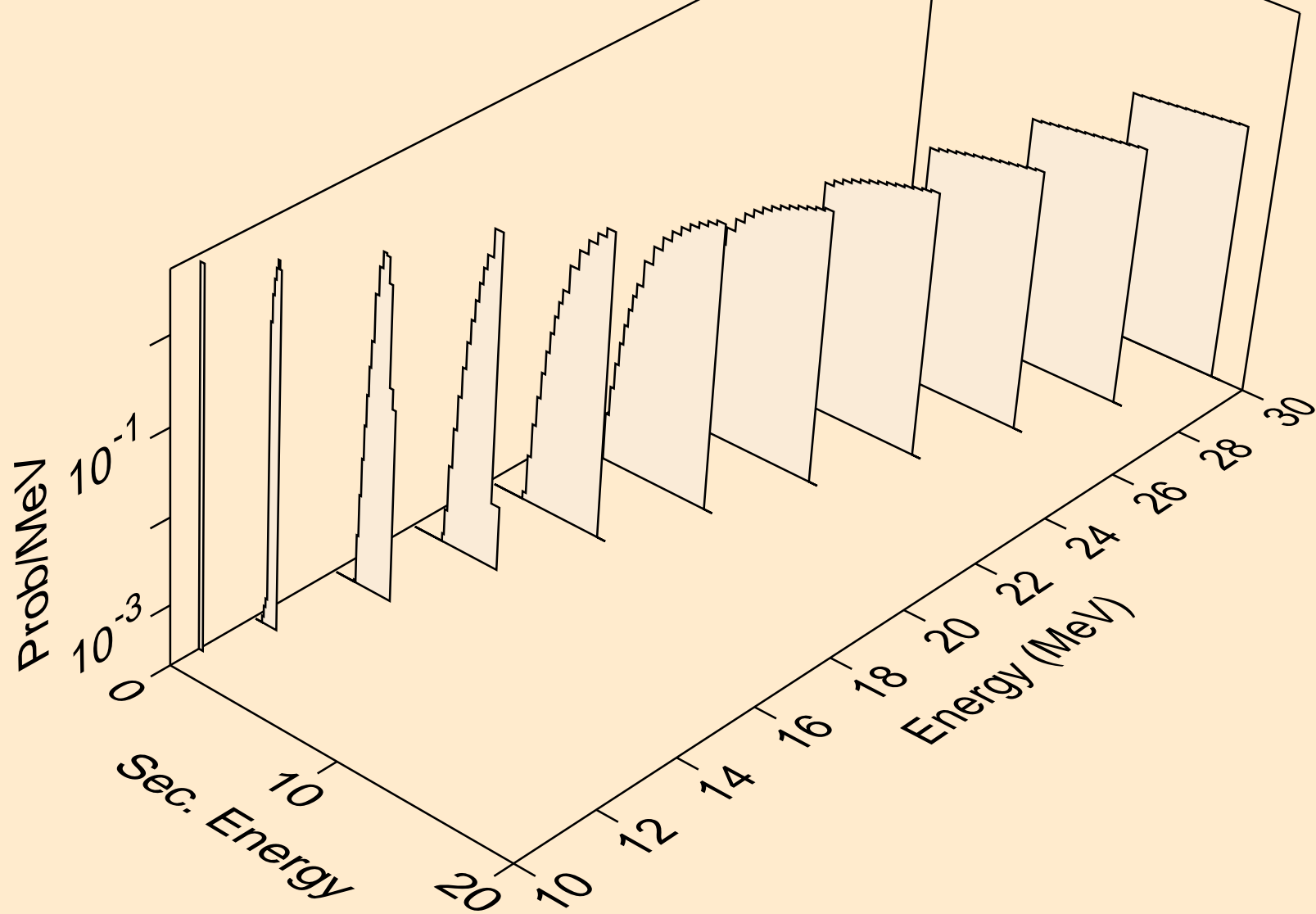

ZN073M NEUTRON ACER TENDL-2021 LIBRARY; T=293.6K  
tritons from (n,x)

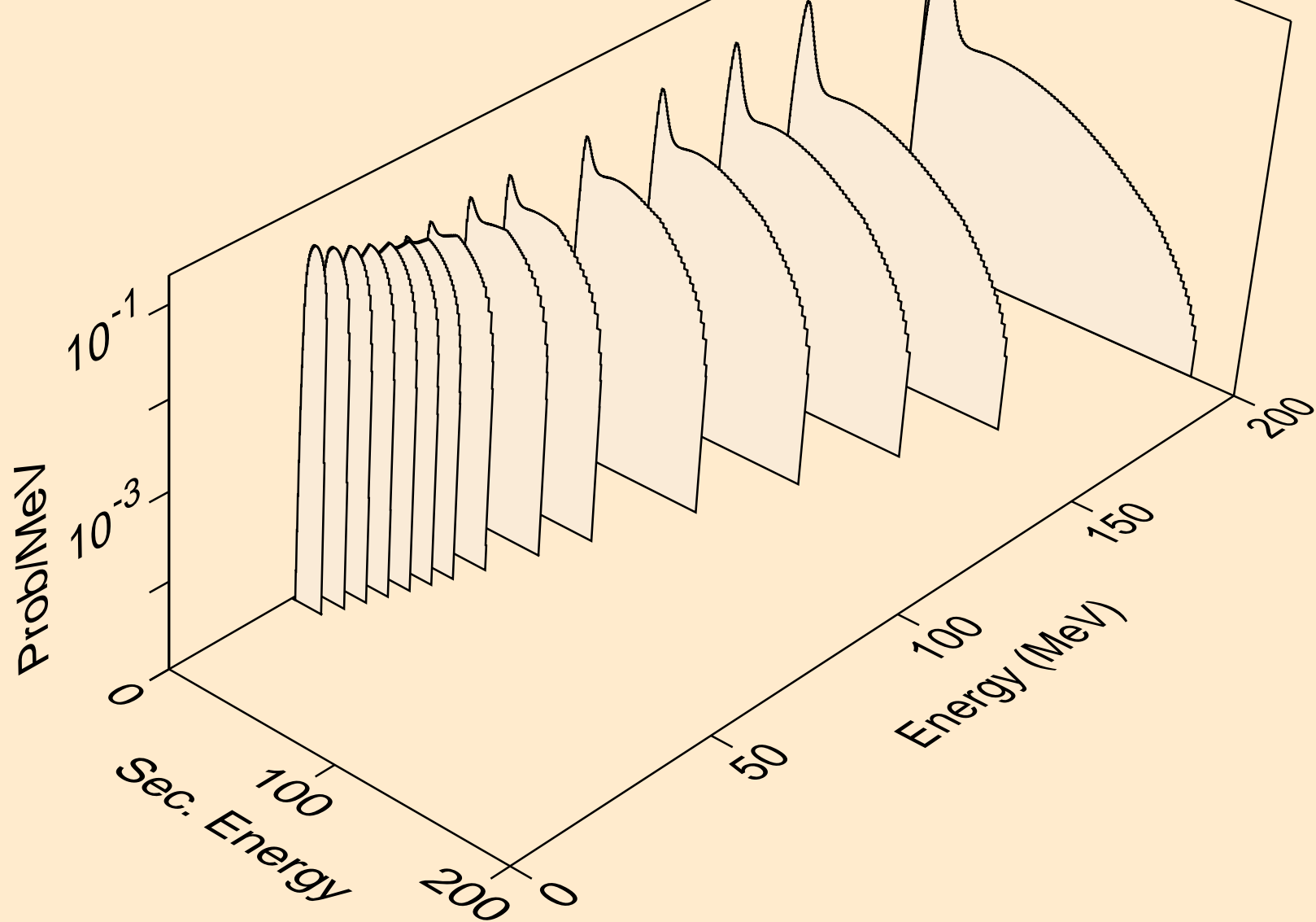

ZN073M NEUTRON ACER TENDL-2021 LIBRARY; T=293.6K  
tritons from (n,n\*)t

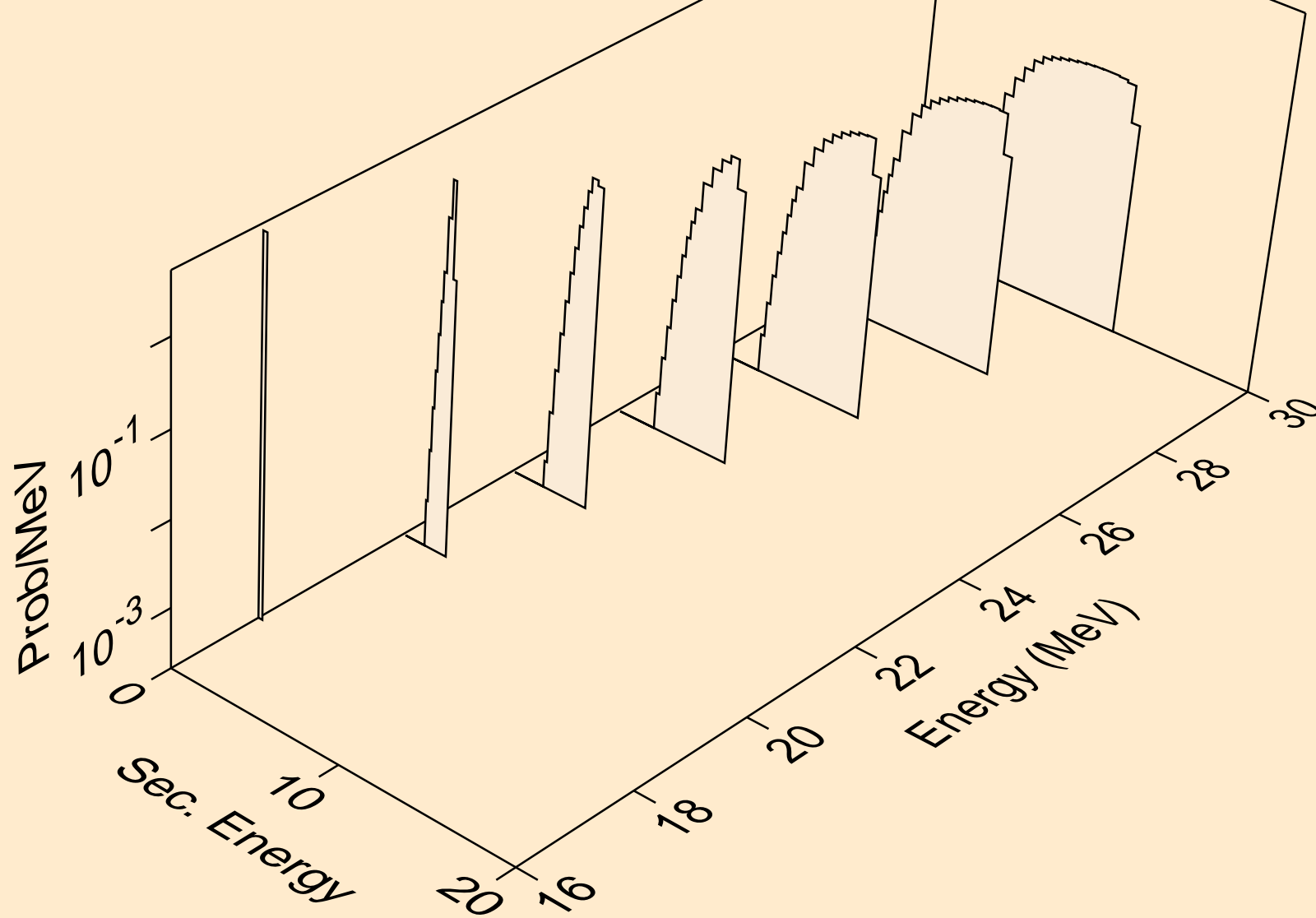

ZN073M NEUTRON ACER TENDL-2021 LIBRARY; T=293.6K  
tritons from (n,t)

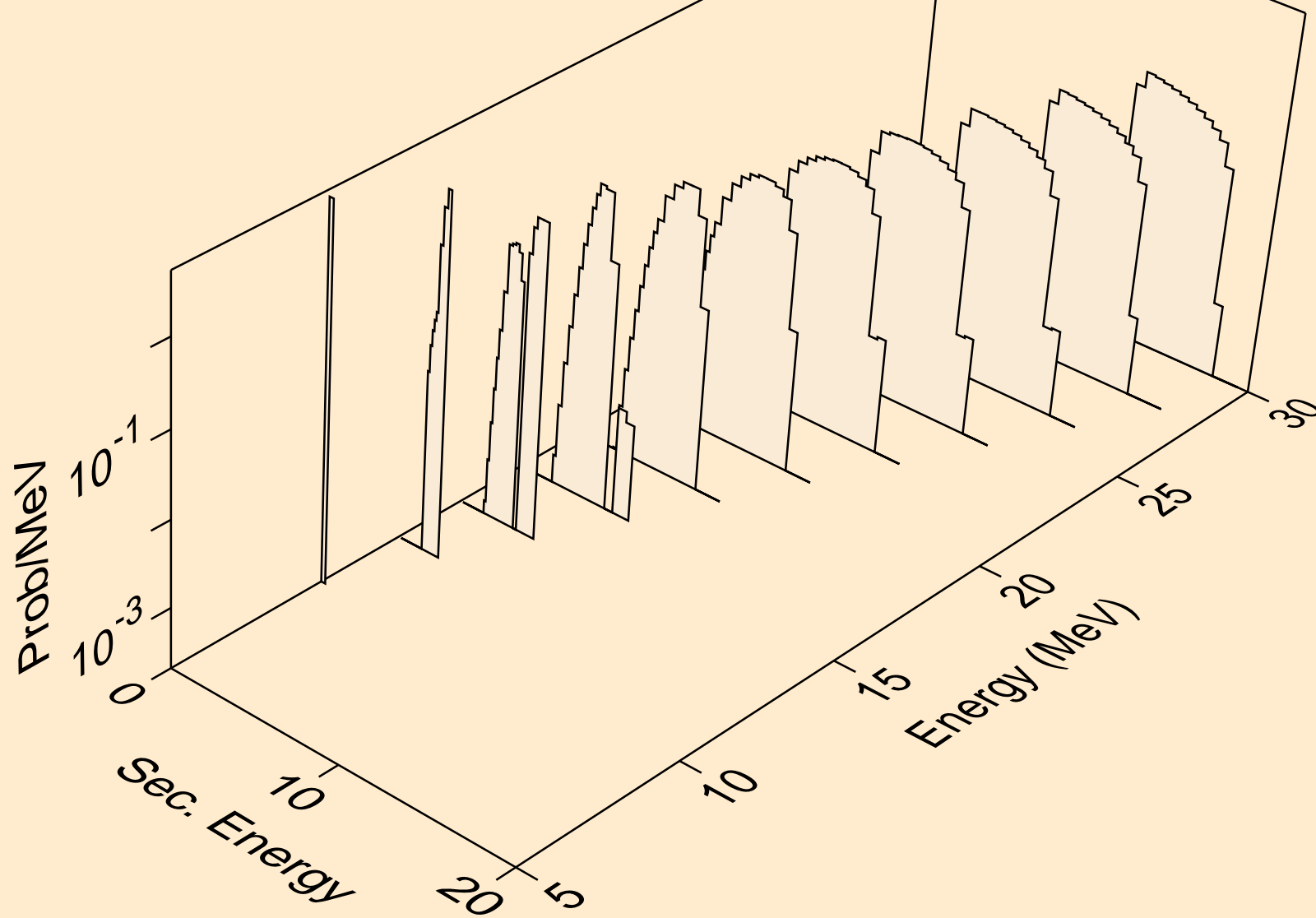

ZN073M NEUTRON ACER TENDL-2021 LIBRARY; T=293.6K  
tritons from (n,pt)

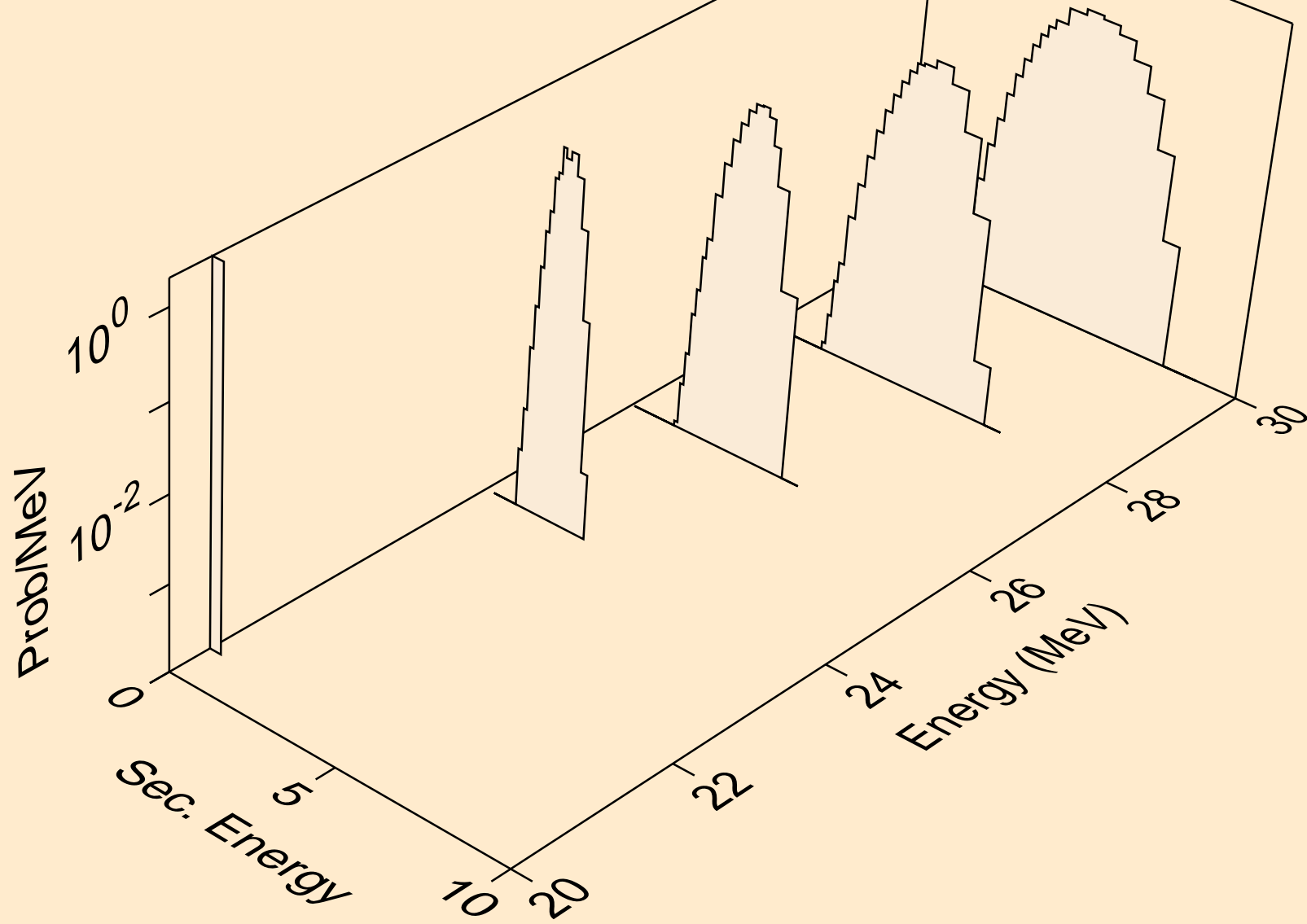

ZN073M NEUTRON ACER TENDL-2021 LIBRARY; T=293.6K  
he3s from (n,x)

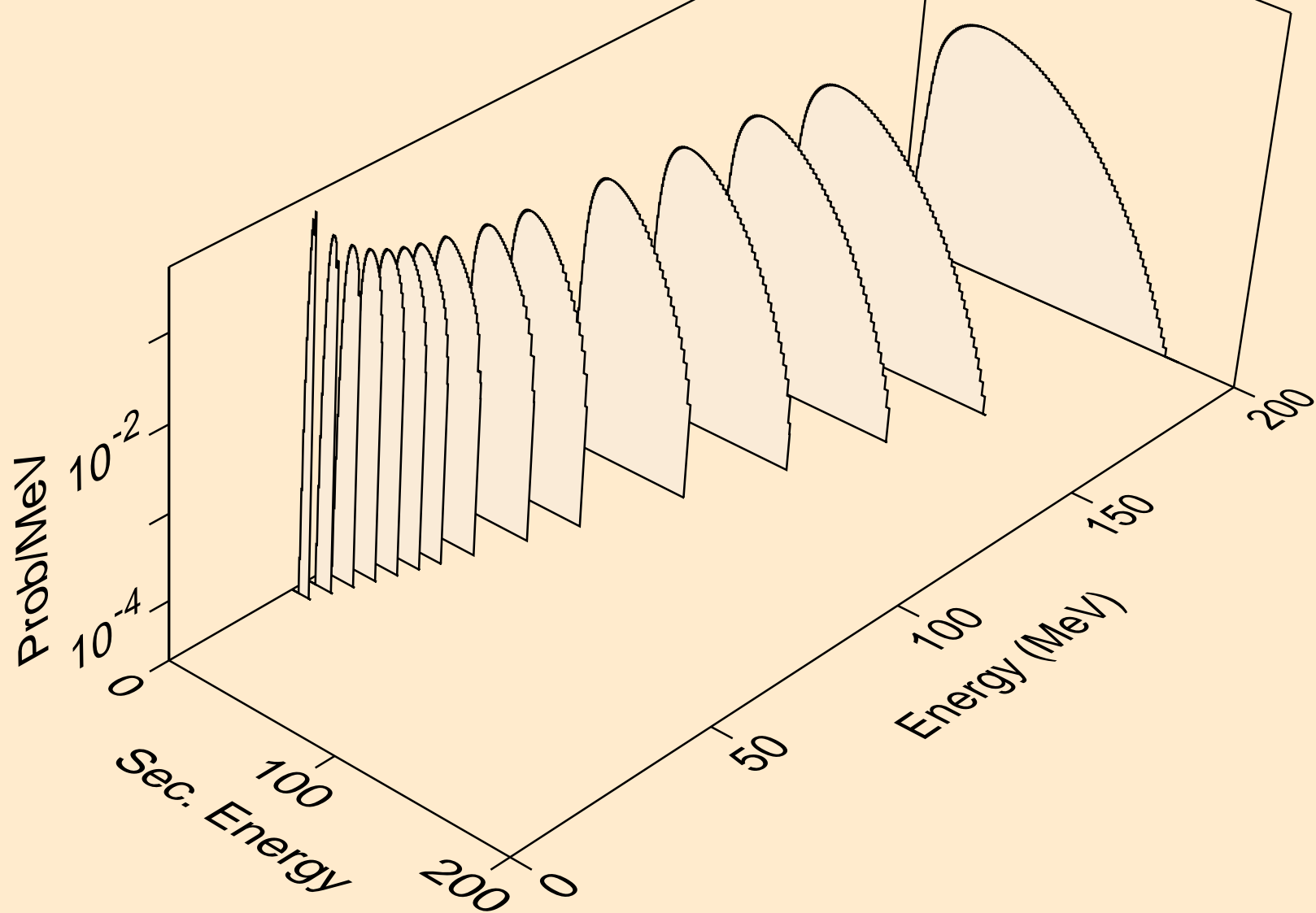



ZN073M NEUTRON ACER TENDL-2021 LIBRARY; T=293.6K  
he3s from (n,n\*)he3

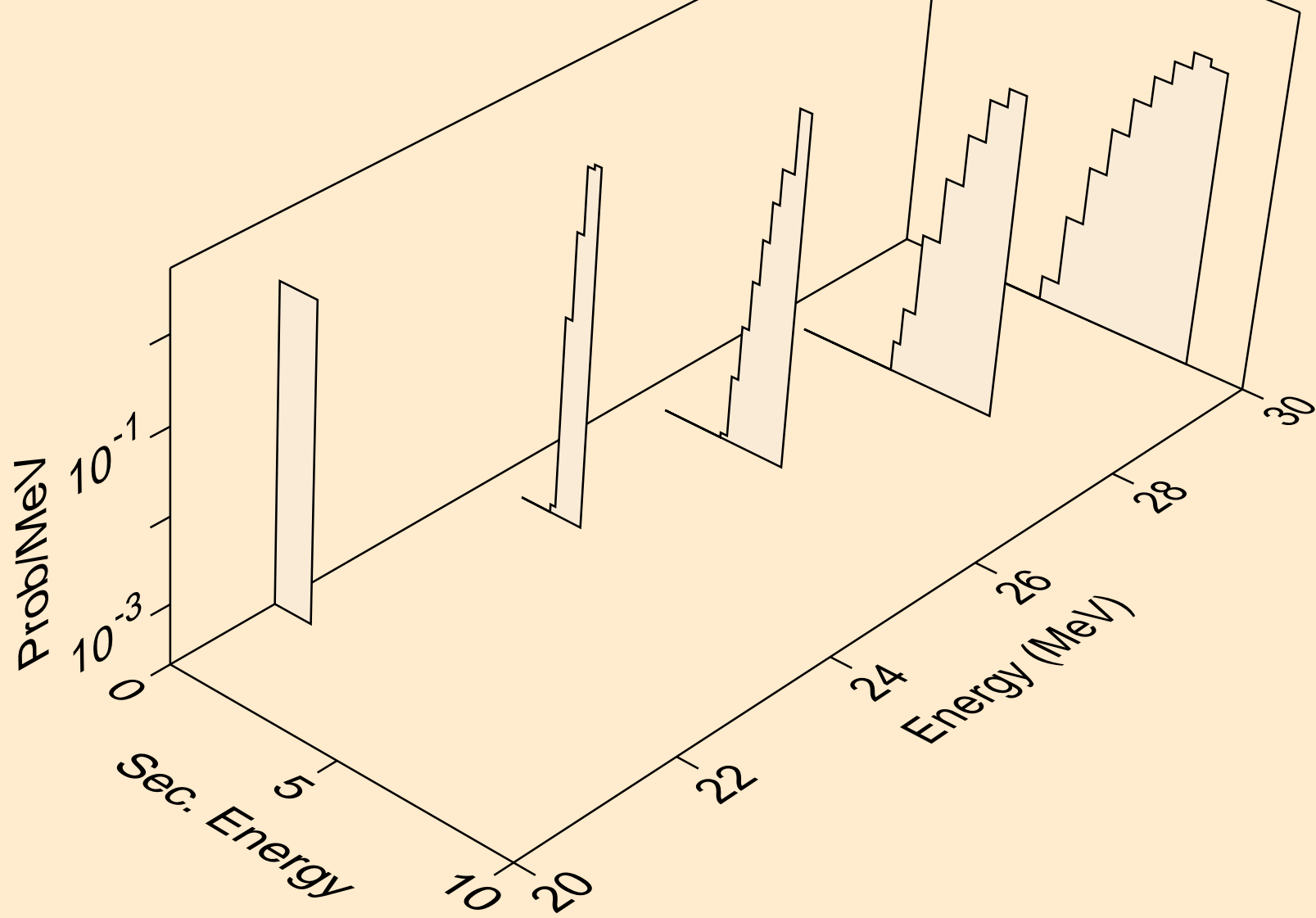

ZN073M NEUTRON ACER TENDL-2021 LIBRARY; T=293.6K  
he3s from (n,he3)

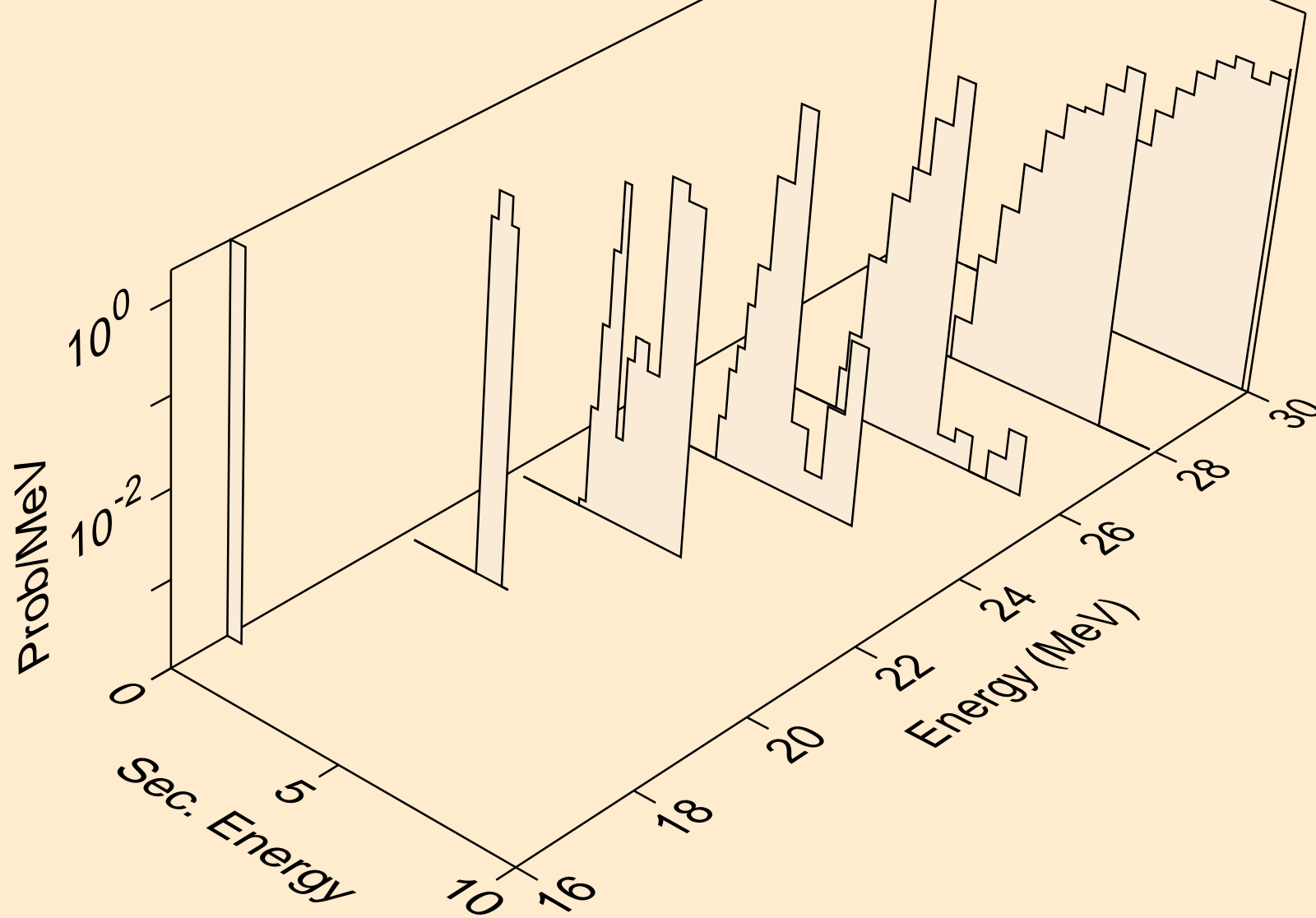

ZN073M NEUTRON ACER TENDL-2021 LIBRARY; T=293.6K  
alphas from (n,x)

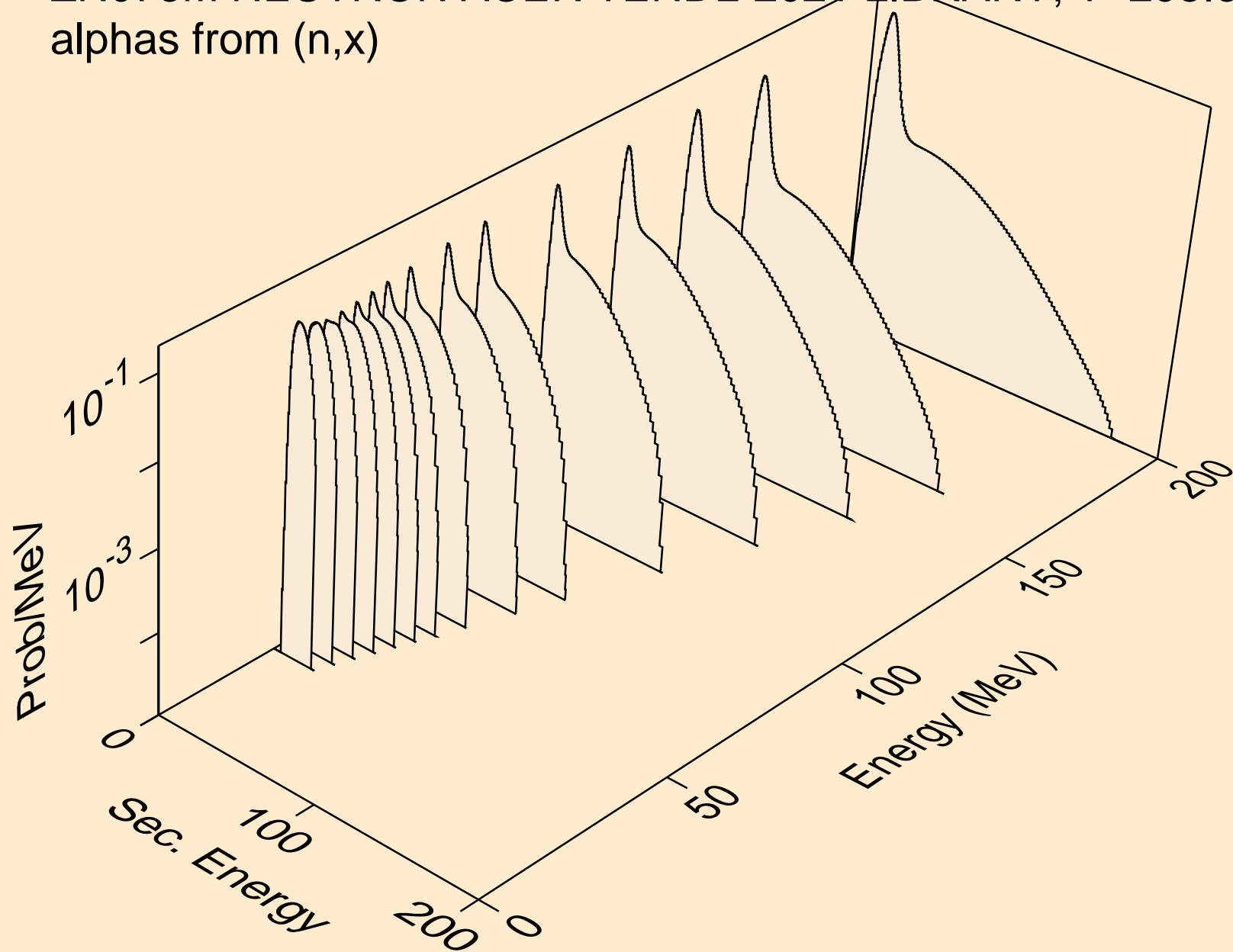

ZN073M NEUTRON ACER TENDL-2021 LIBRARY; T=293.6K  
alphas from (n,n\*)a

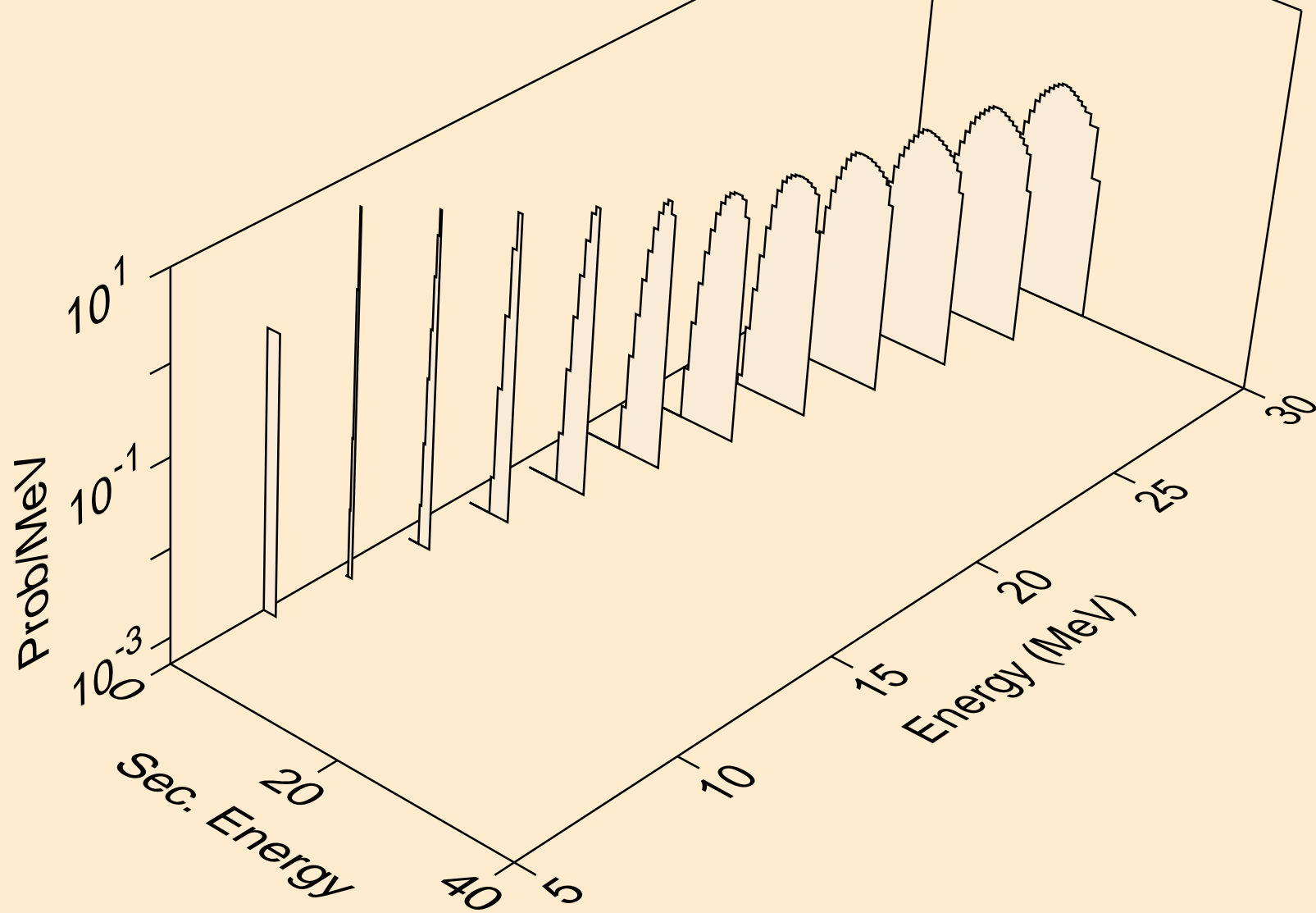

ZN073M NEUTRON ACER TENDL-2021 LIBRARY; T=293.6K  
alphas from (n,2n)a

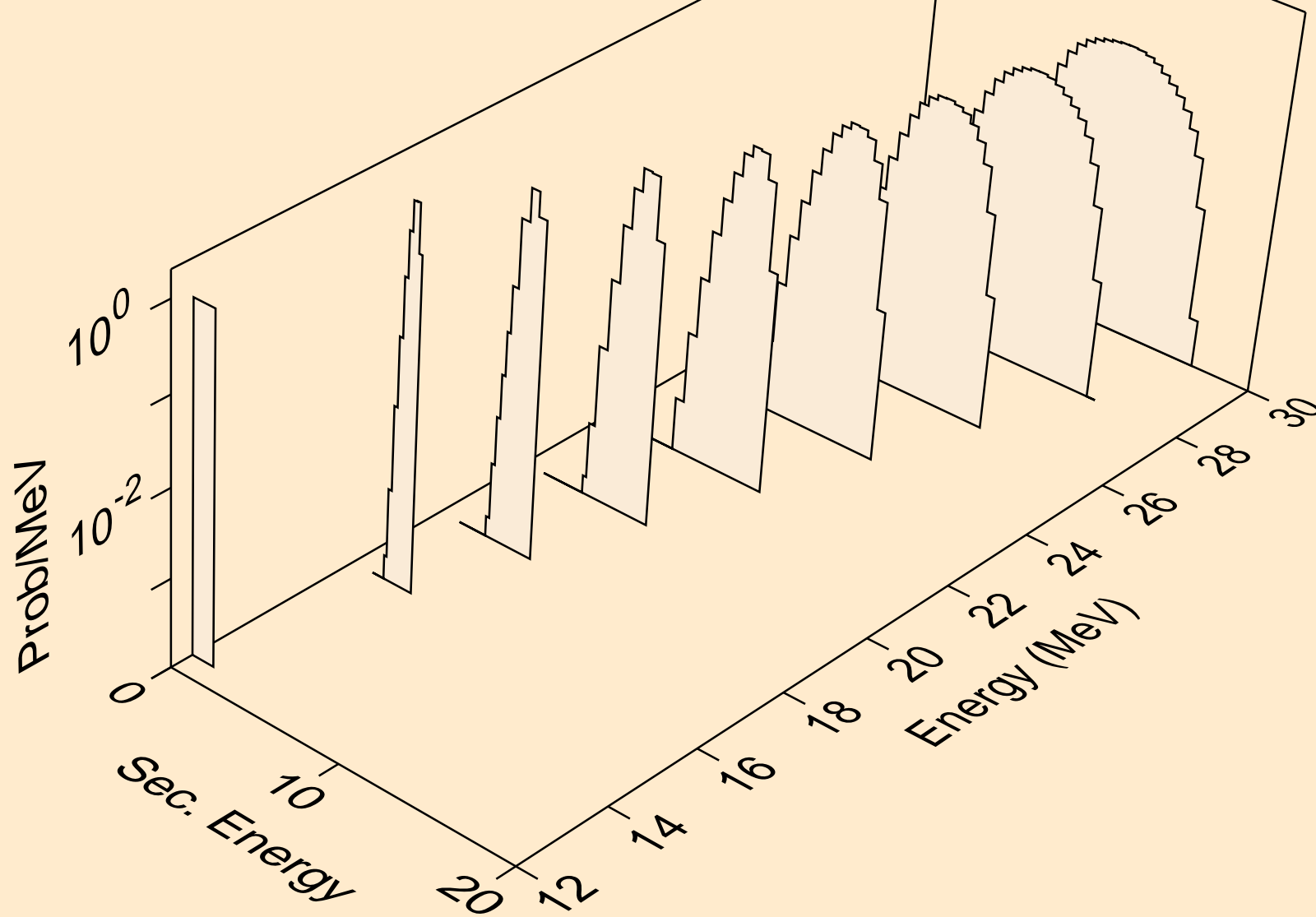

ZN073M NEUTRON ACER TENDL-2021 LIBRARY; T=293.6K  
alphas from (n,3n)a

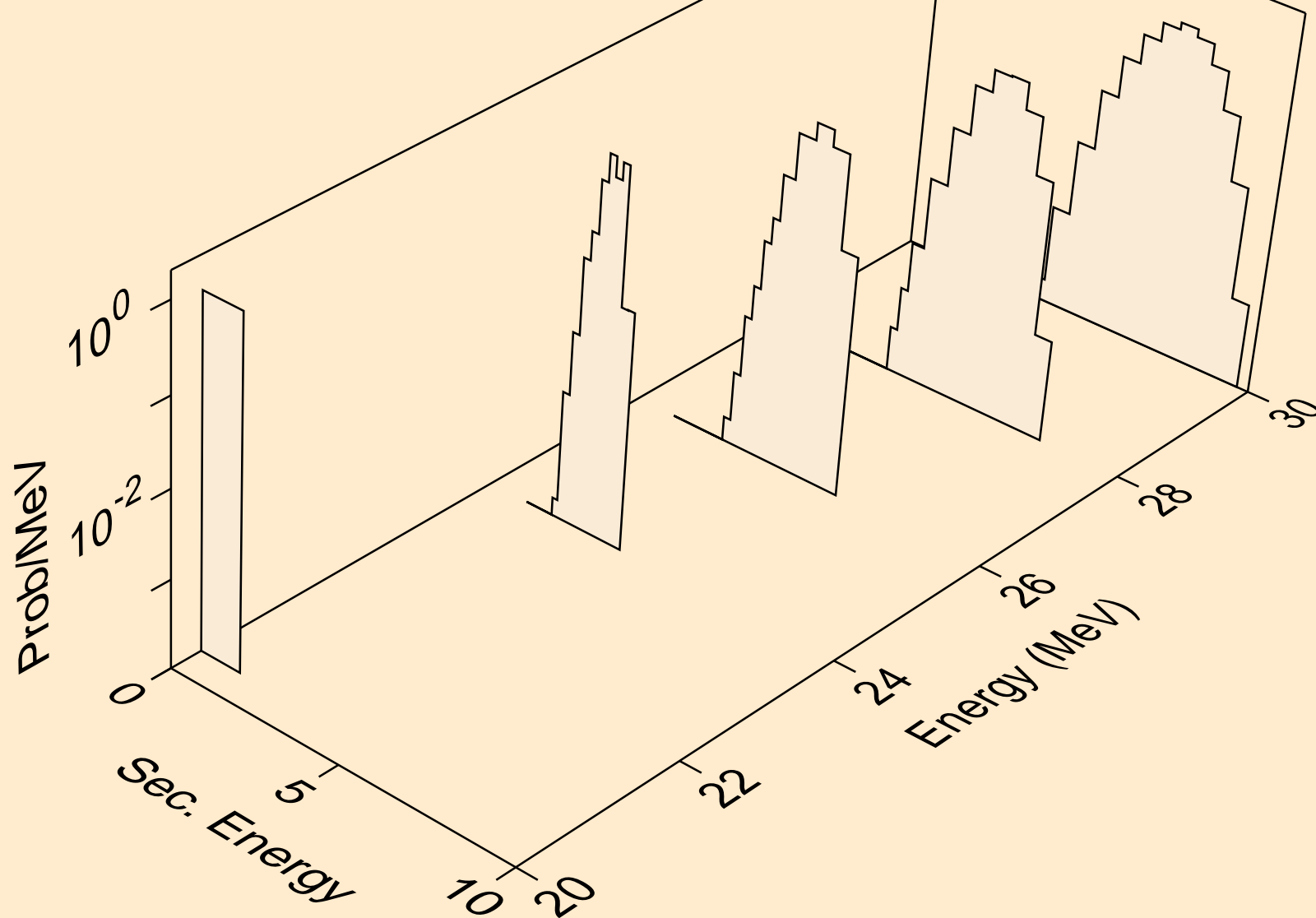

ZN073M NEUTRON ACER TENDL-2021 LIBRARY; T=293.6K  
alphas from (n,a)

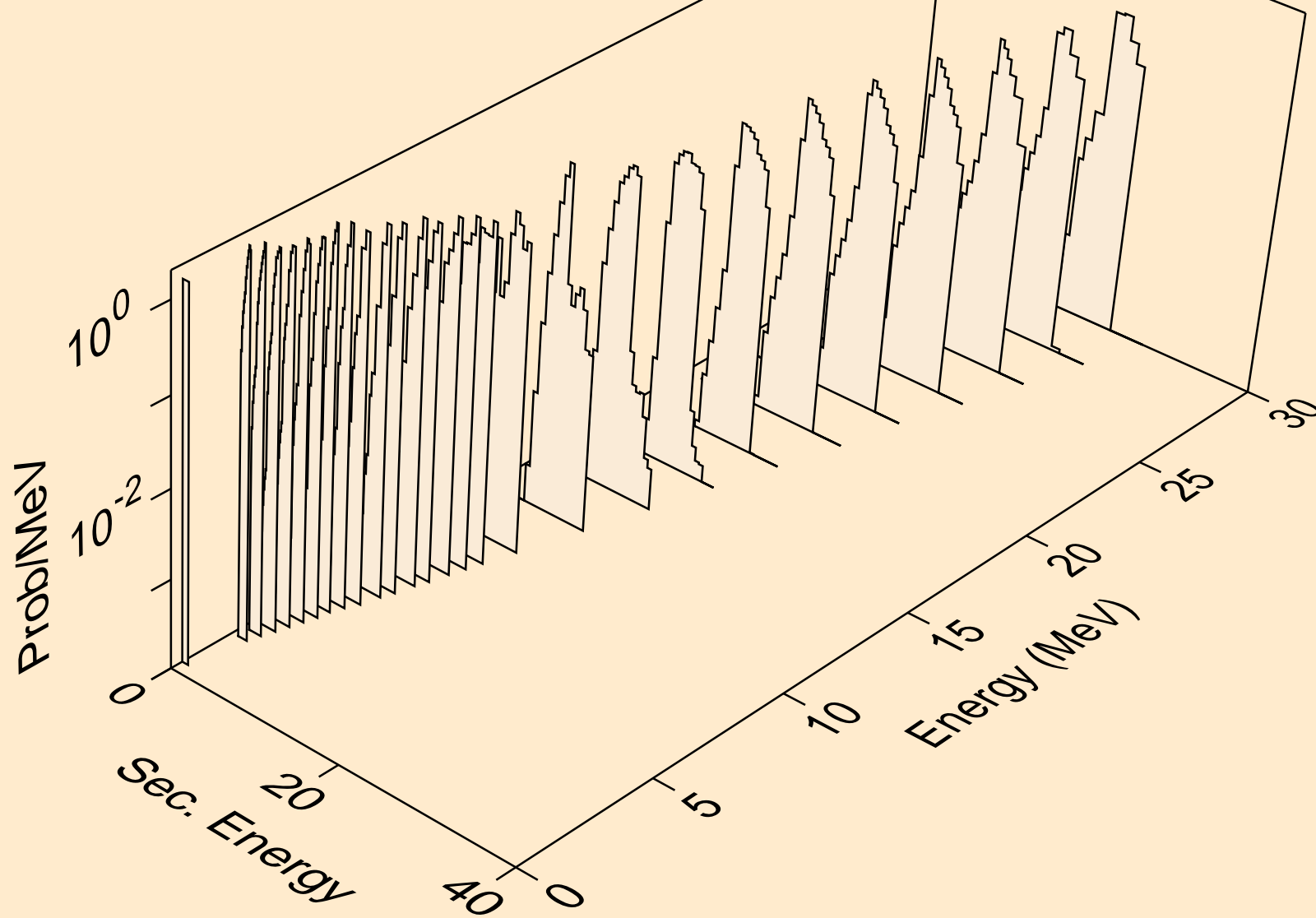

ZN073M NEUTRON ACER TENDL-2021 LIBRARY; T=293.6K  
alphas from (n,pa)

