

BH269 PROTON ACER TENDL-2021 LIBRARY; T=0.K  
Principal cross sections

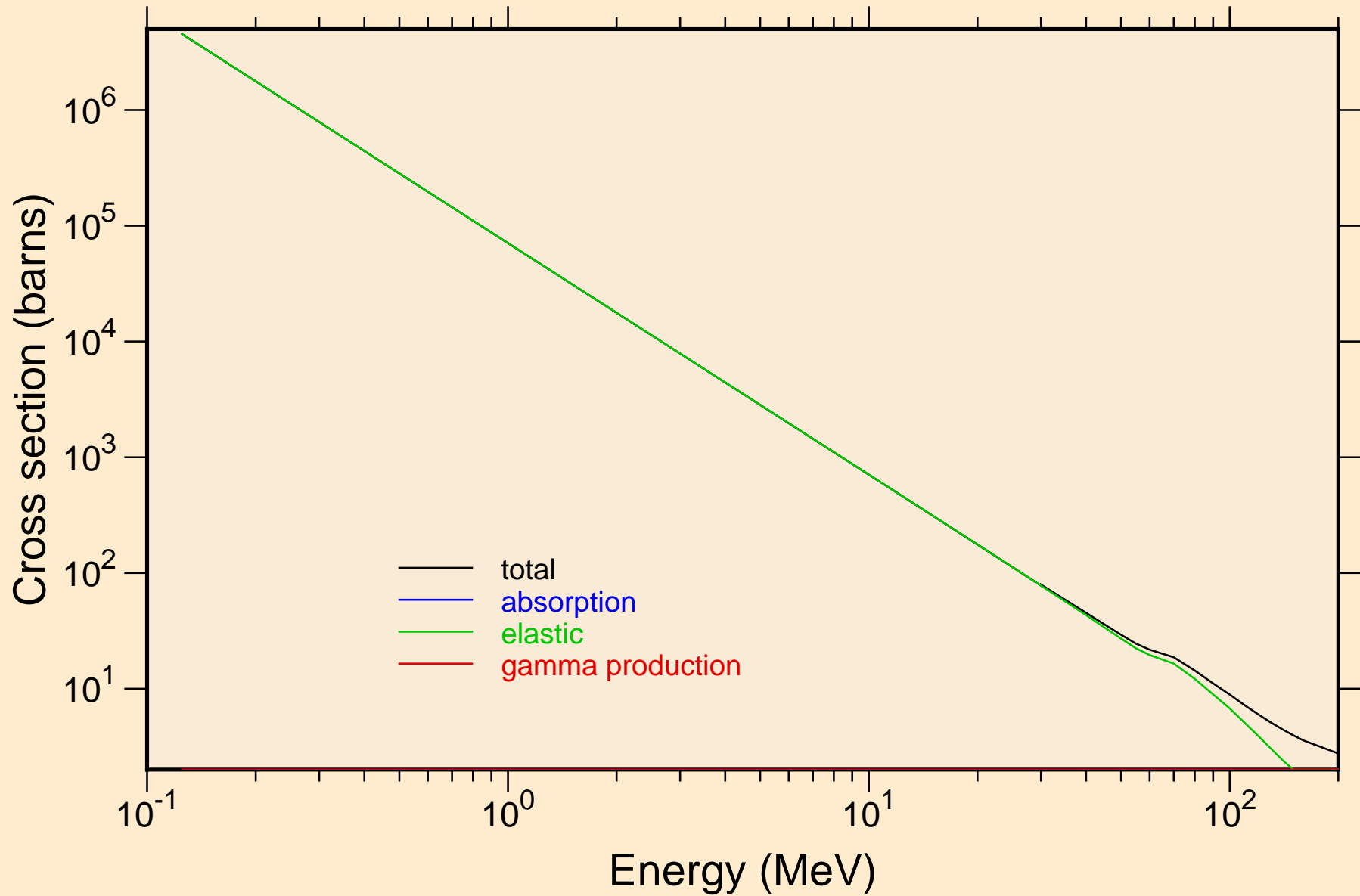

# BH269 PROTON ACER TENDL-2021 LIBRARY; T=0.K

## Heating

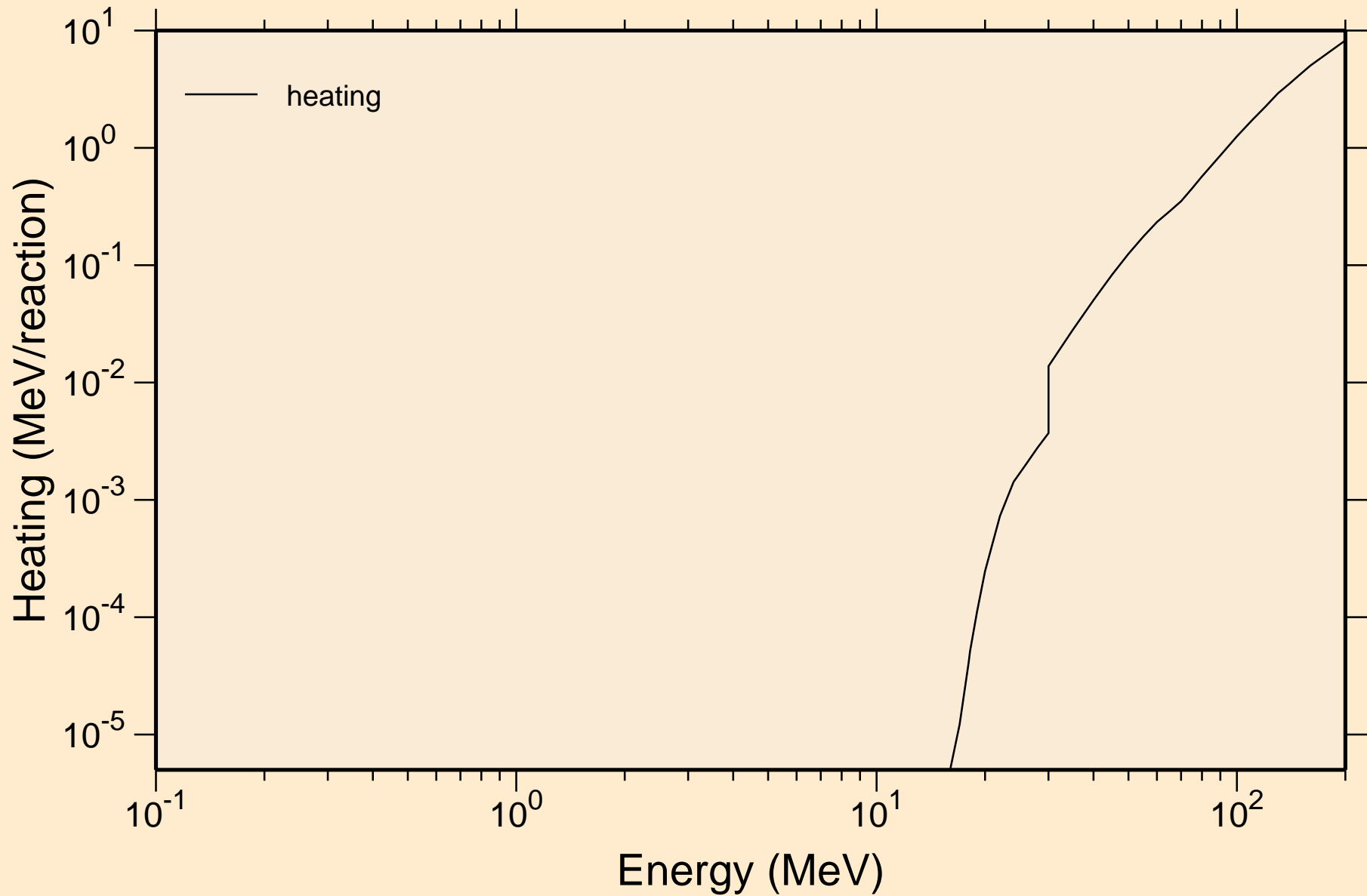

# BH269 PROTON ACER TENDL-2021 LIBRARY; T=0.K

## Principal cross sections

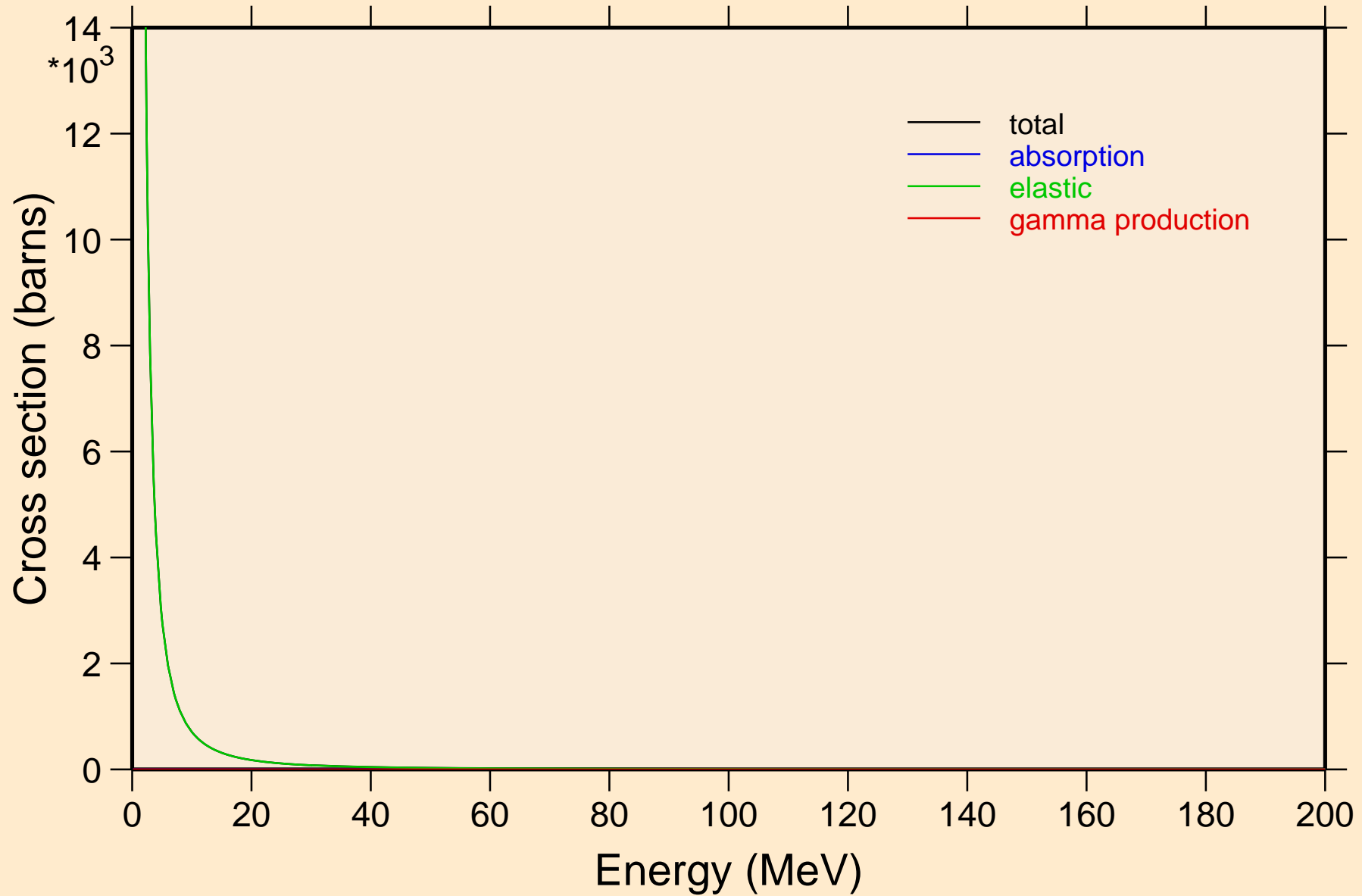

BH269 PROTON ACER TENDL-2021 LIBRARY; T=0.K

Heating

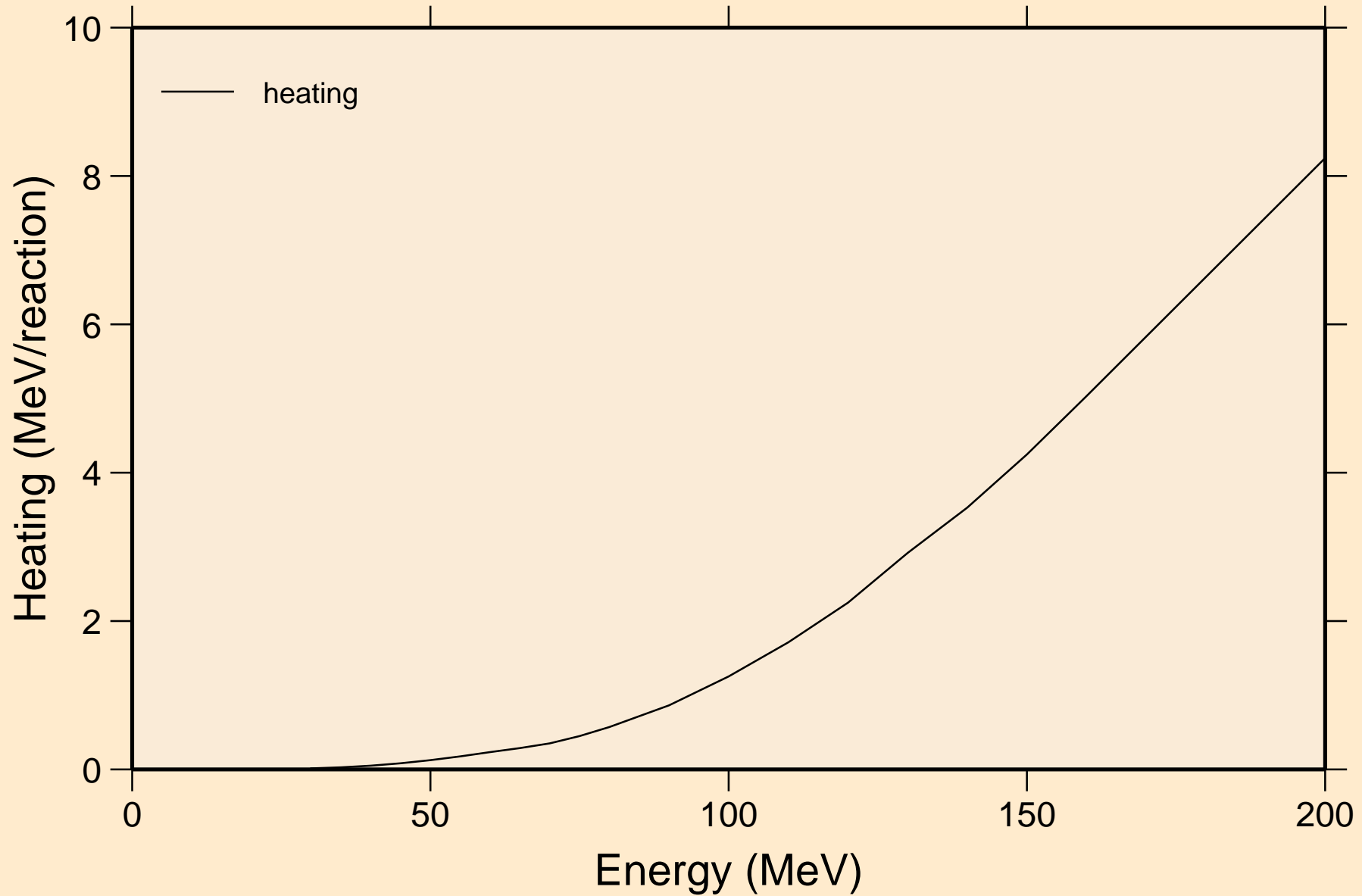

BH269 PROTON ACER TENDL-2021 LIBRARY; T=0.K  
Threshold reactions

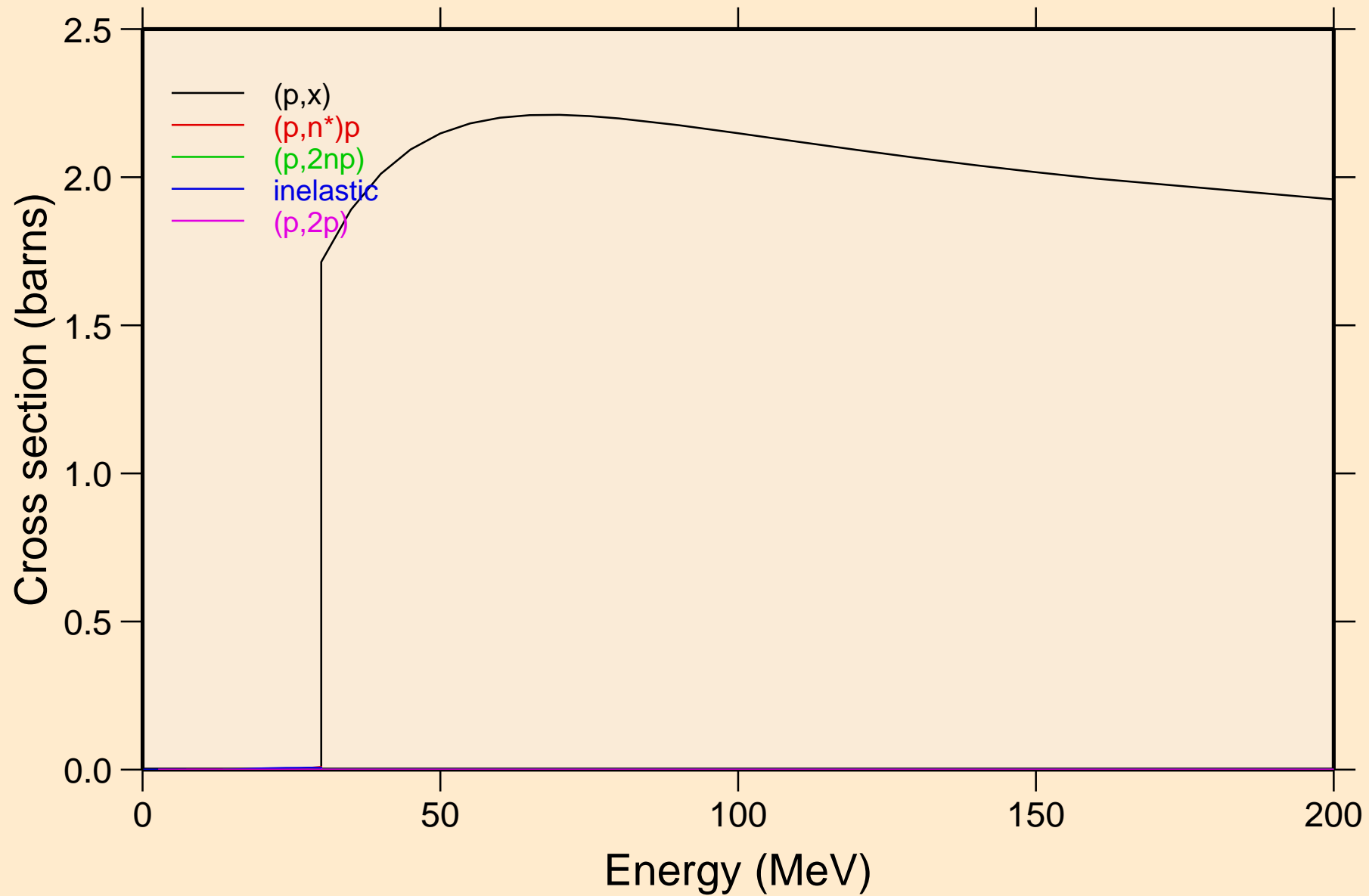

BH269 PROTON ACER TENDL-2021 LIBRARY; T=0.K  
Threshold reactions

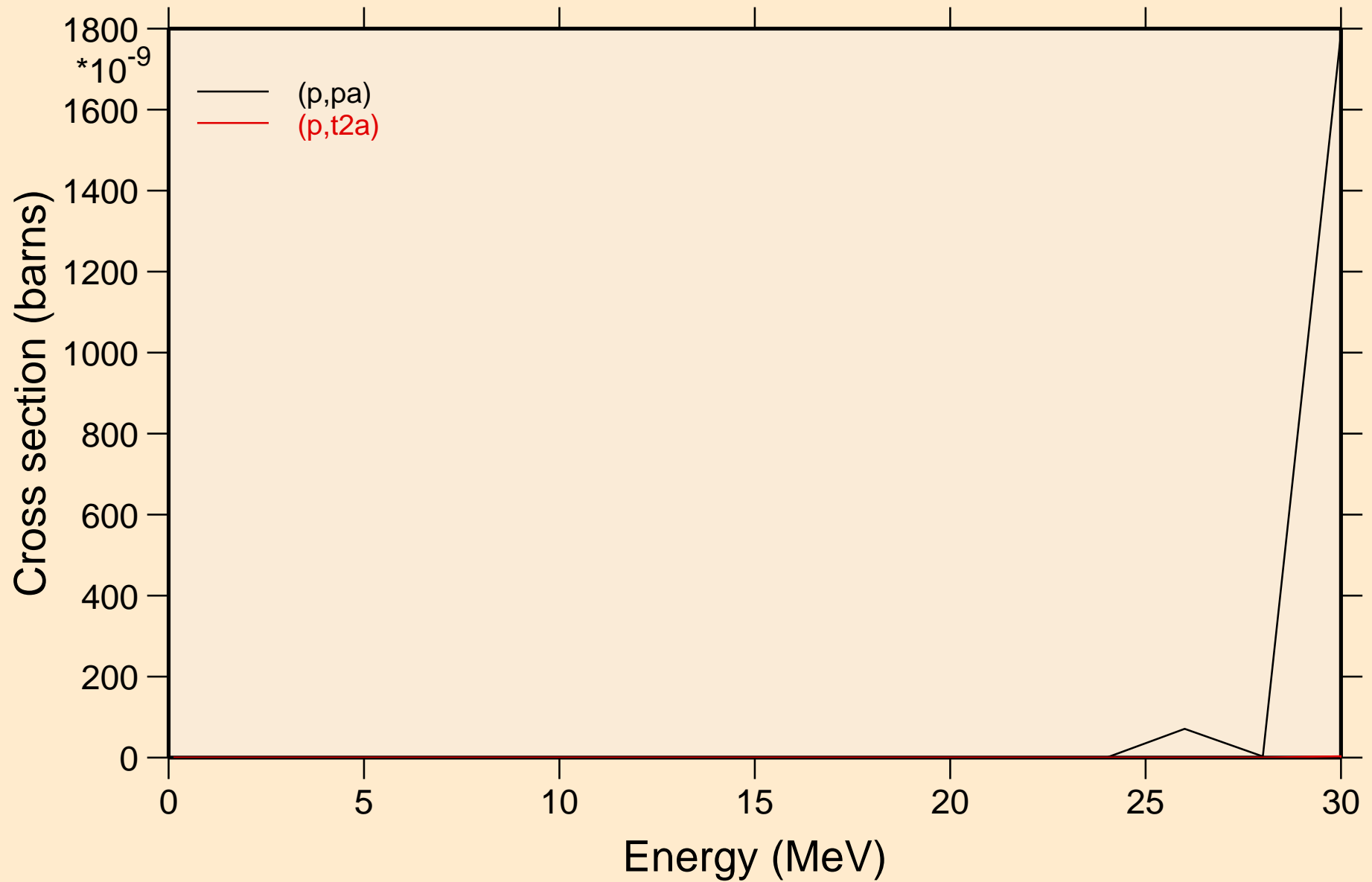

BH269 PROTON ACER TENDL-2021 LIBRARY; T=0.K  
angular distribution for elastic

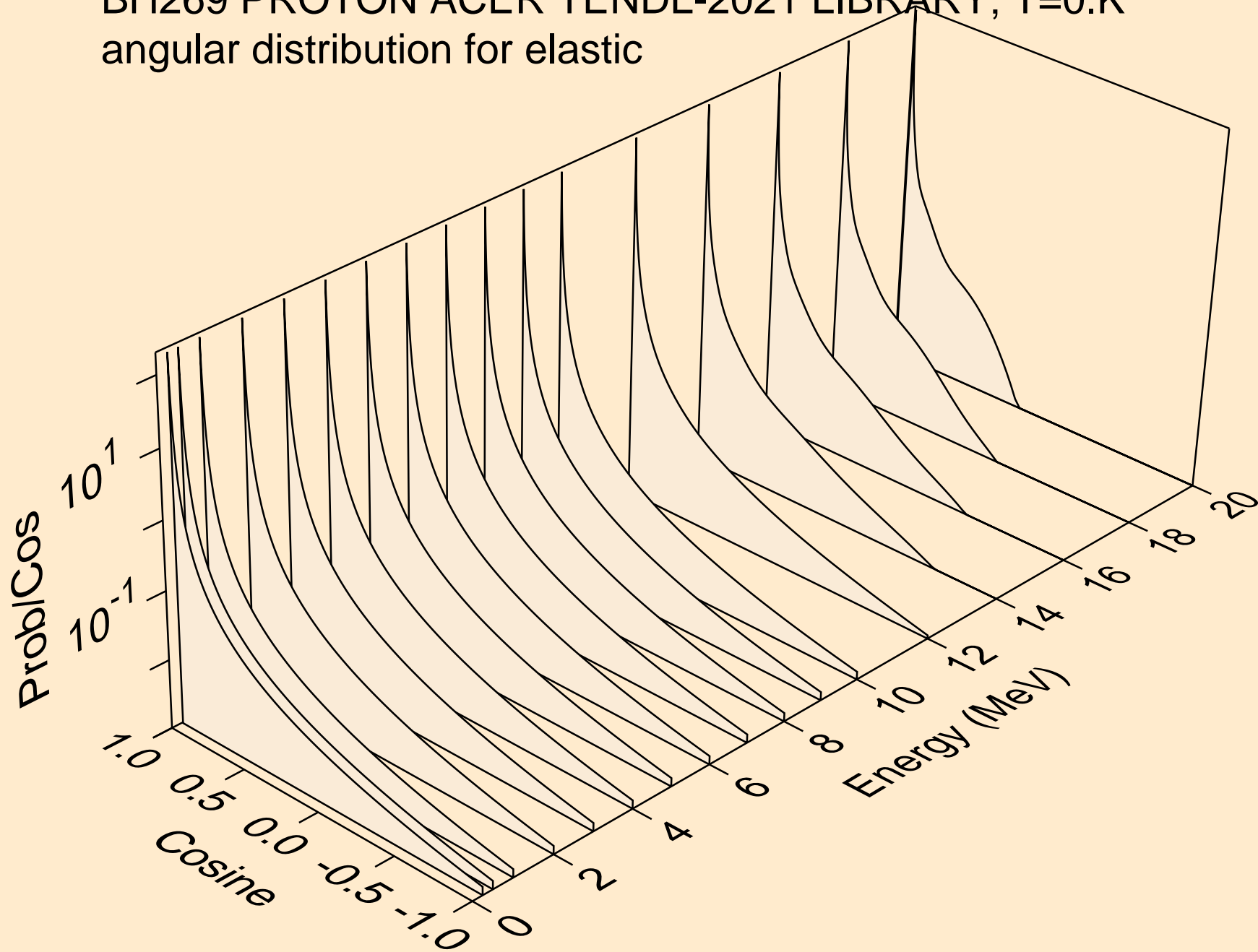

BH269 PROTON ACER TENDL-2021 LIBRARY; T=0.K  
angular distribution for elastic

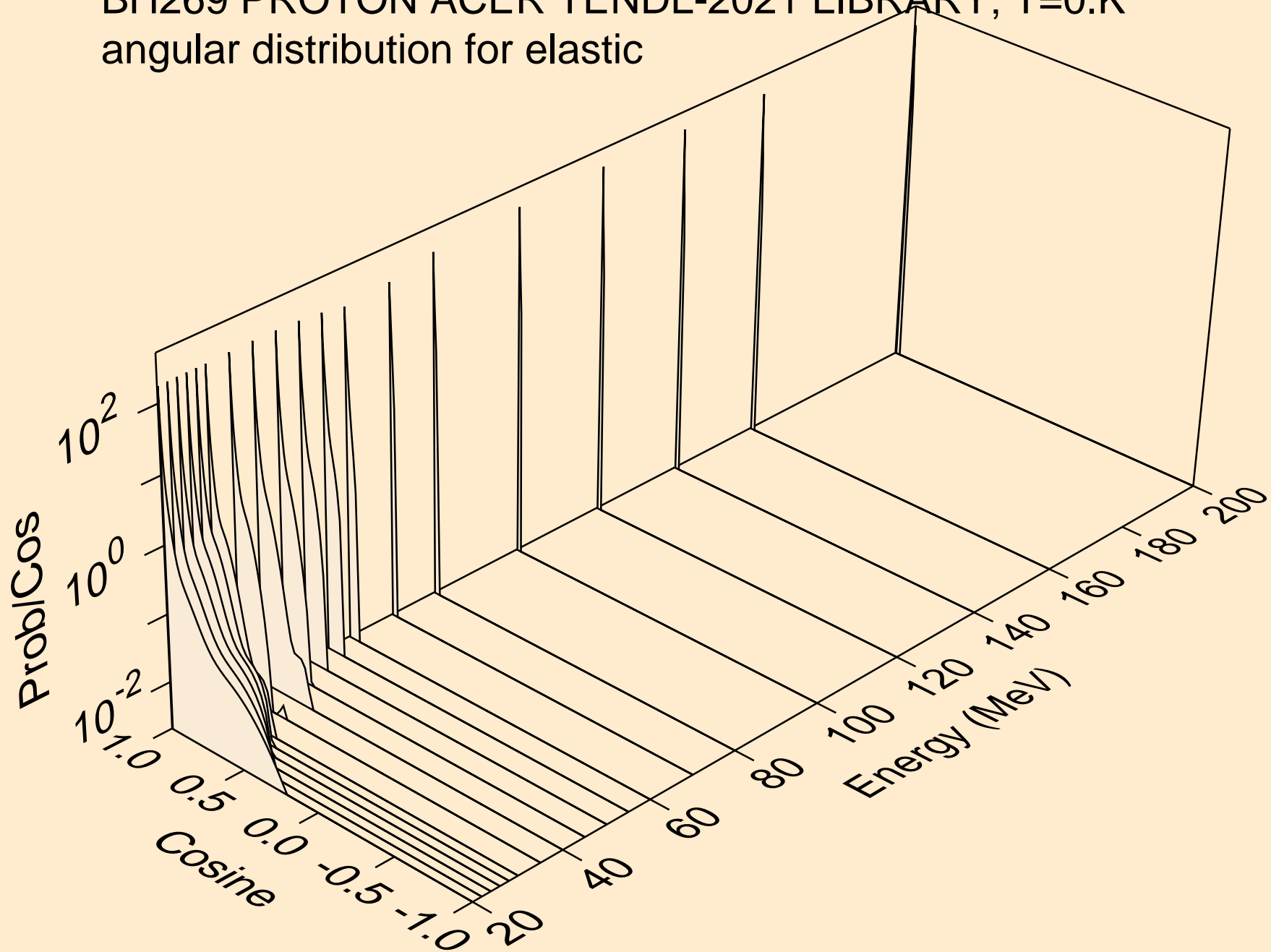



BH269 PROTON ACER TENDL-2021 LIBRARY; T=0.K  
Proton emission for (p,x)

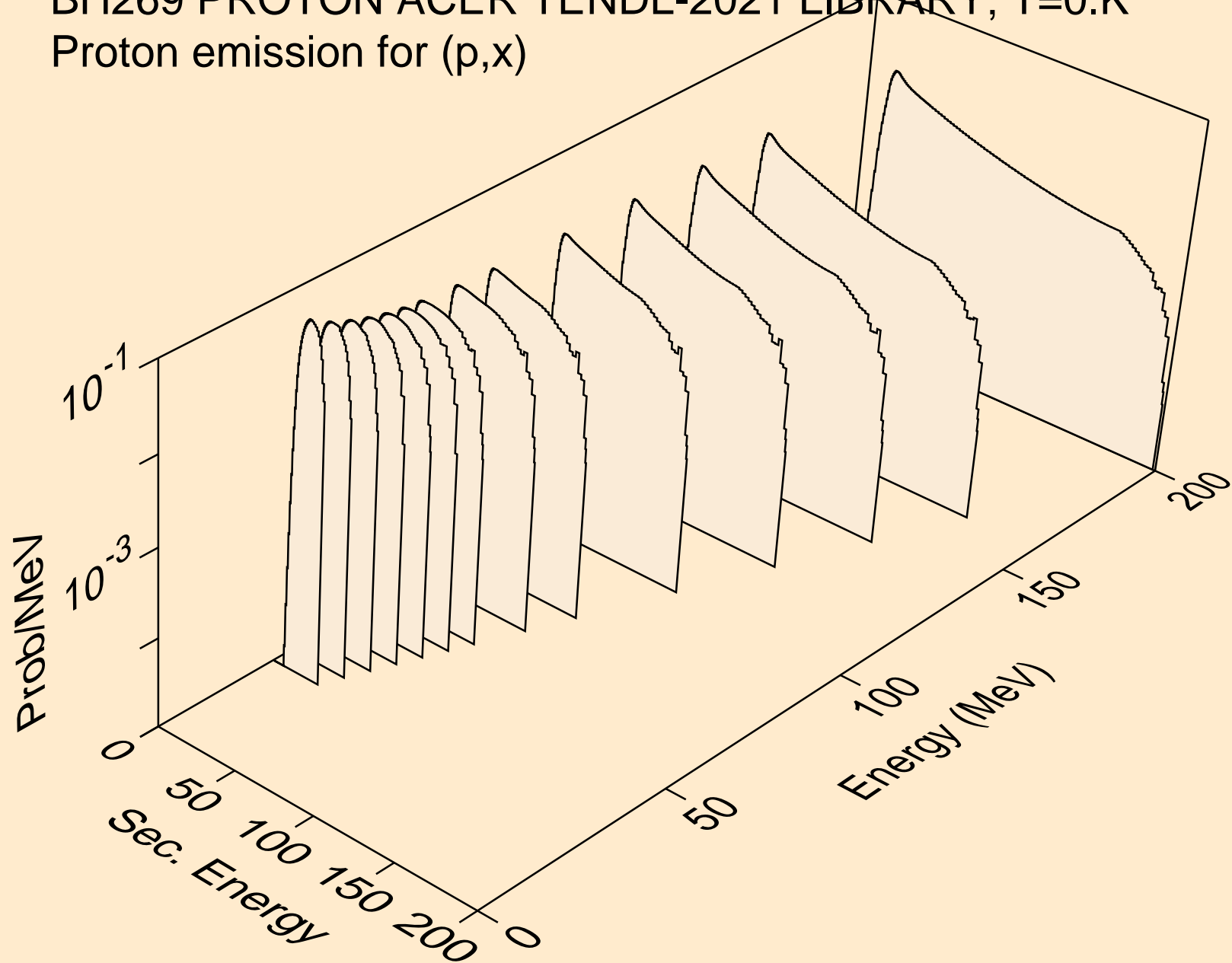

BH269 PROTON ACER TENDL-2021 LIBRARY; T=0.K  
Proton emission for (p,n\*)p

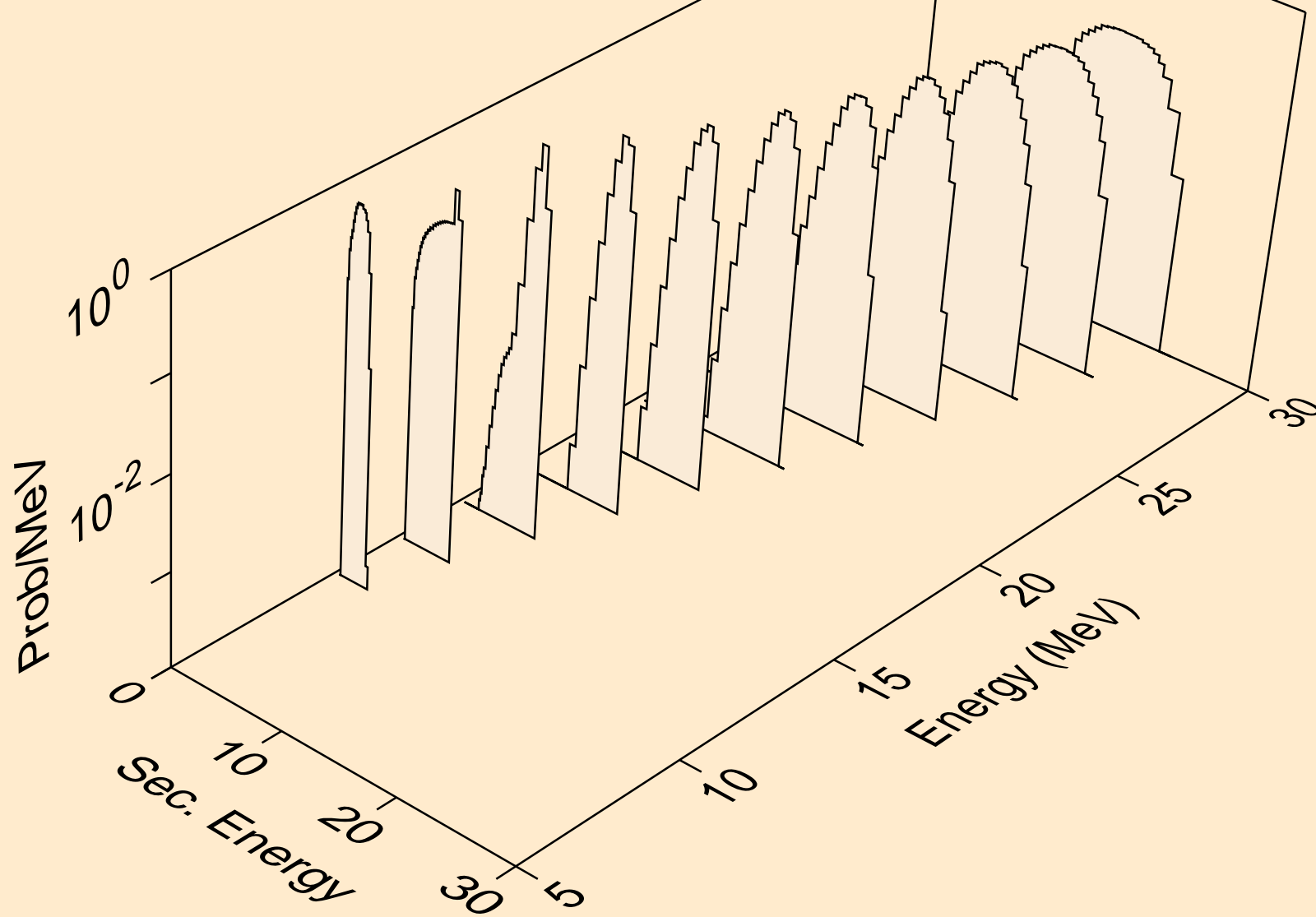

BH269 PROTON ACER TENDL-2021 LIBRARY; T=0.K  
Proton emission for (p,2np)

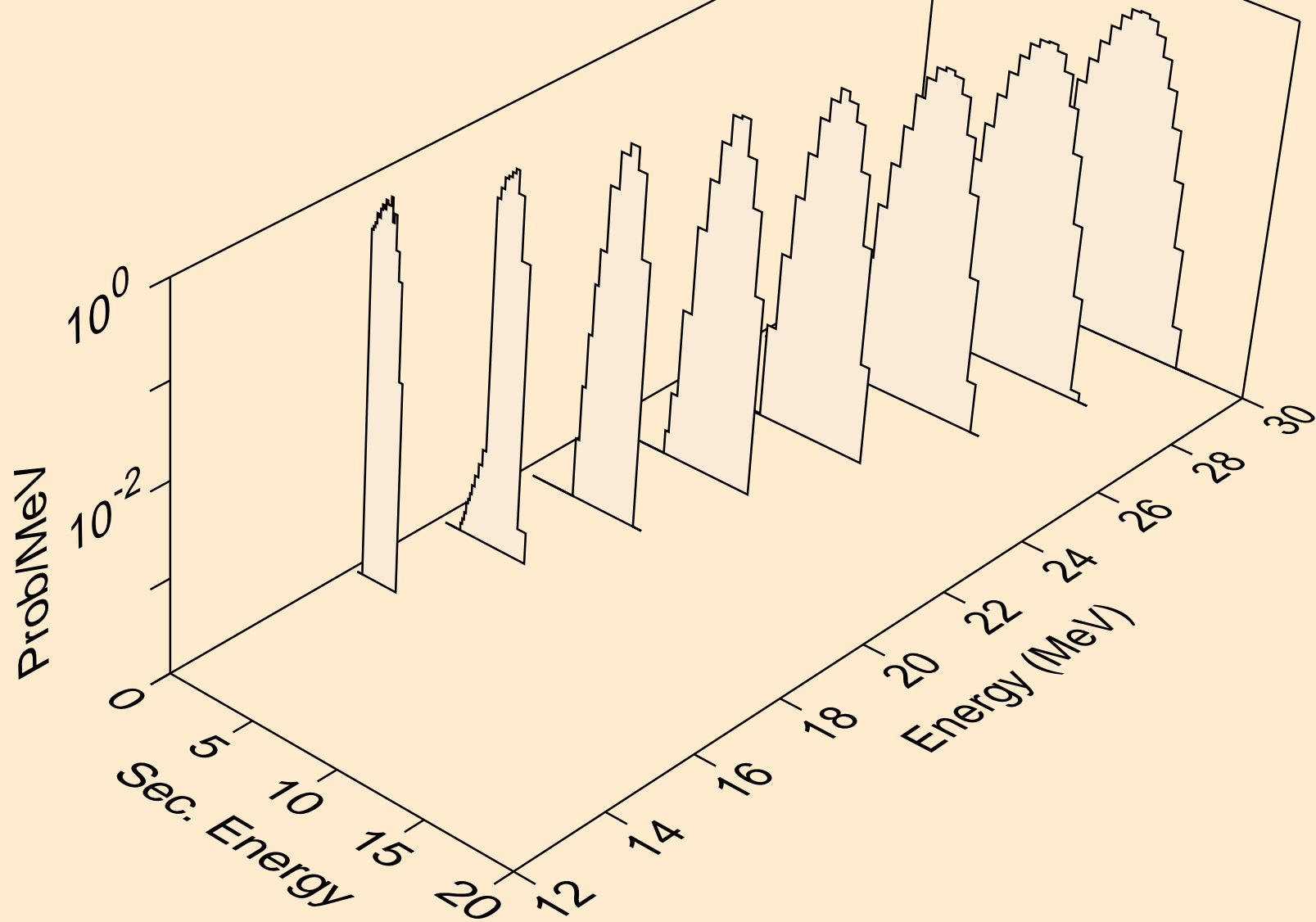

BH269 PROTON ACER TENDL-2021 LIBRARY; T=0.K  
Proton emission for inelastic

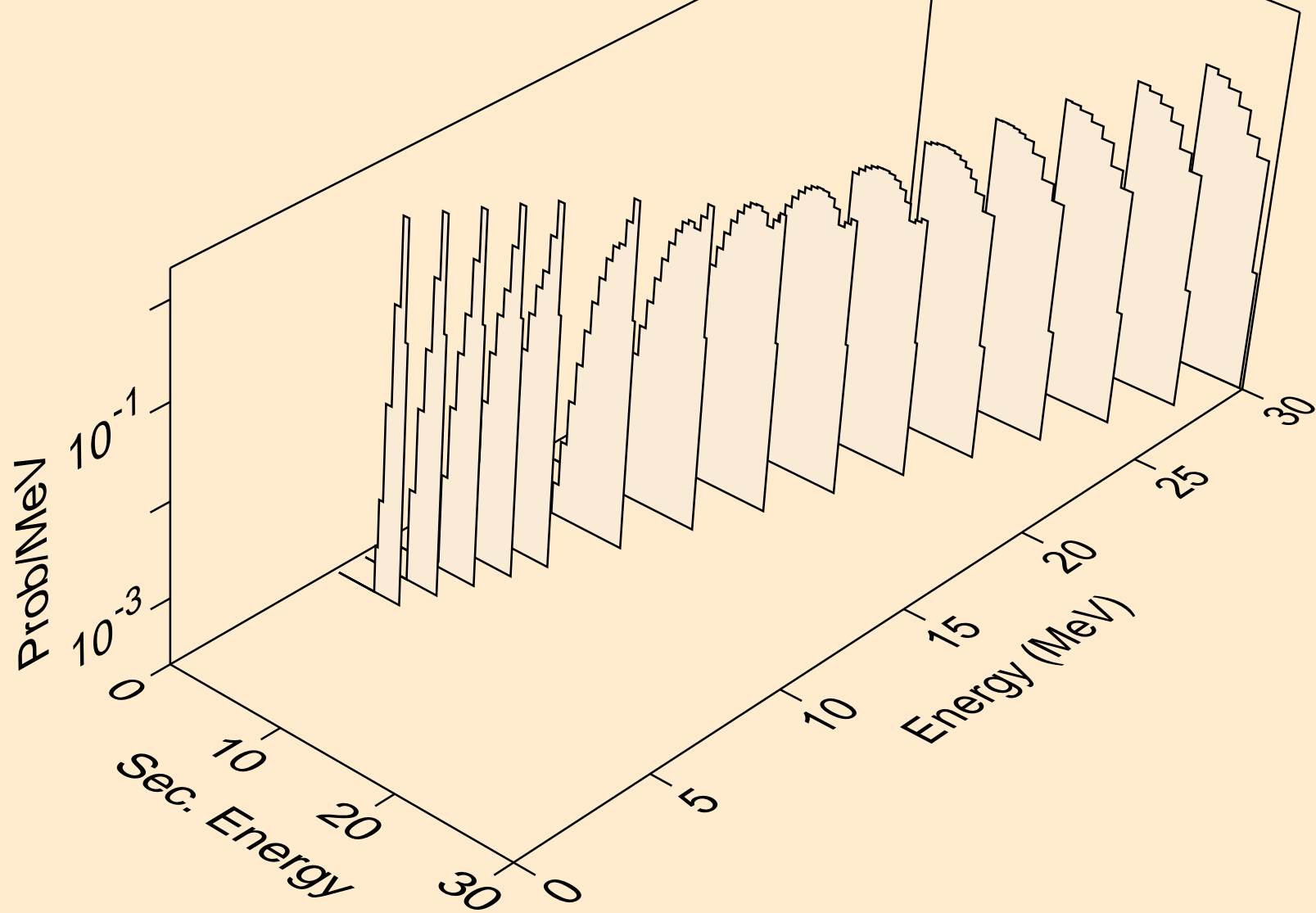

BH269 PROTON ACER TENDL-2021 LIBRARY; T=0.K  
Proton emission for (p,2p)

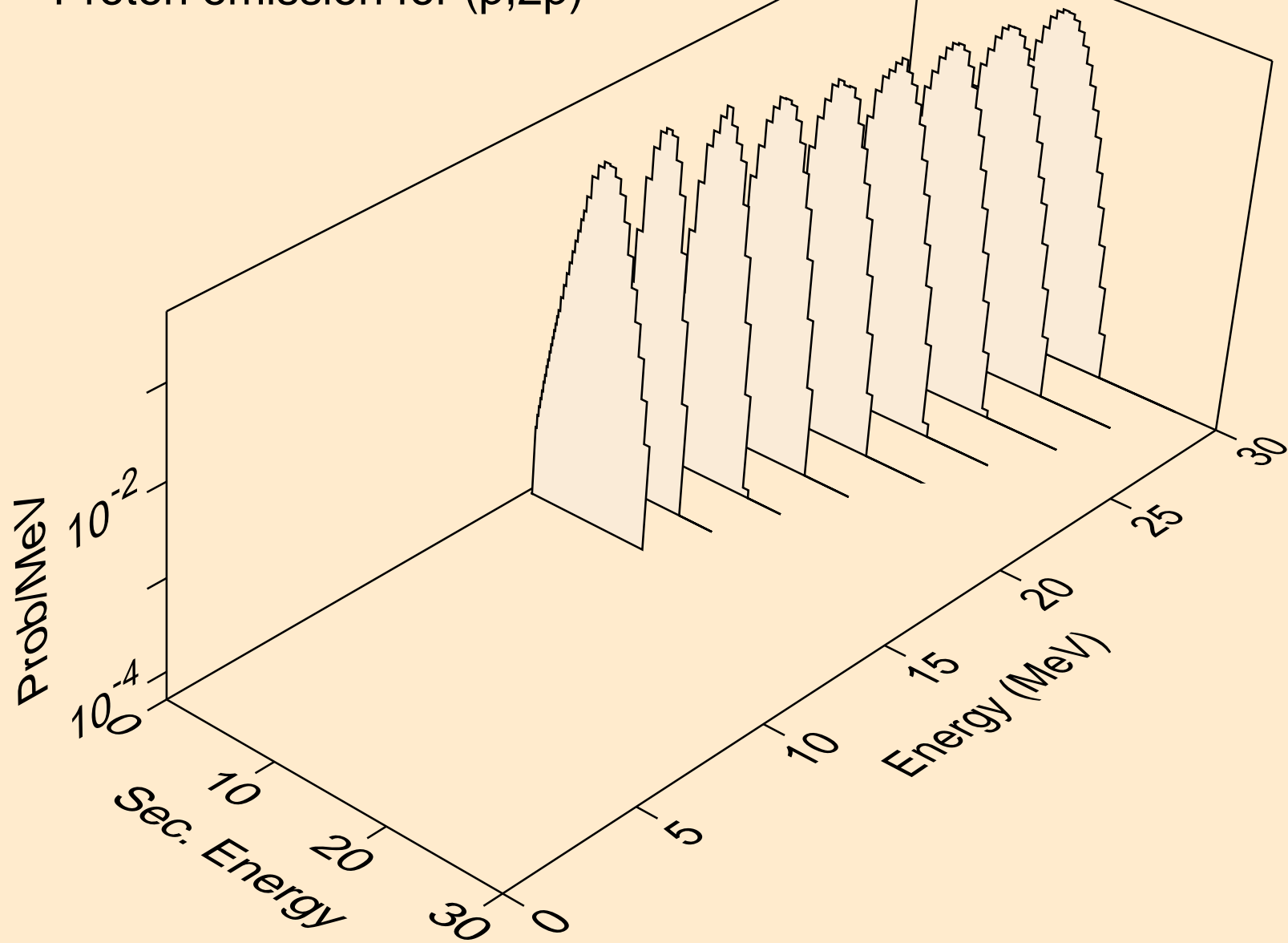

BH269 PROTON ACER TENDL-2021 LIBRARY; T=0.K  
Proton emission for (p,pa)

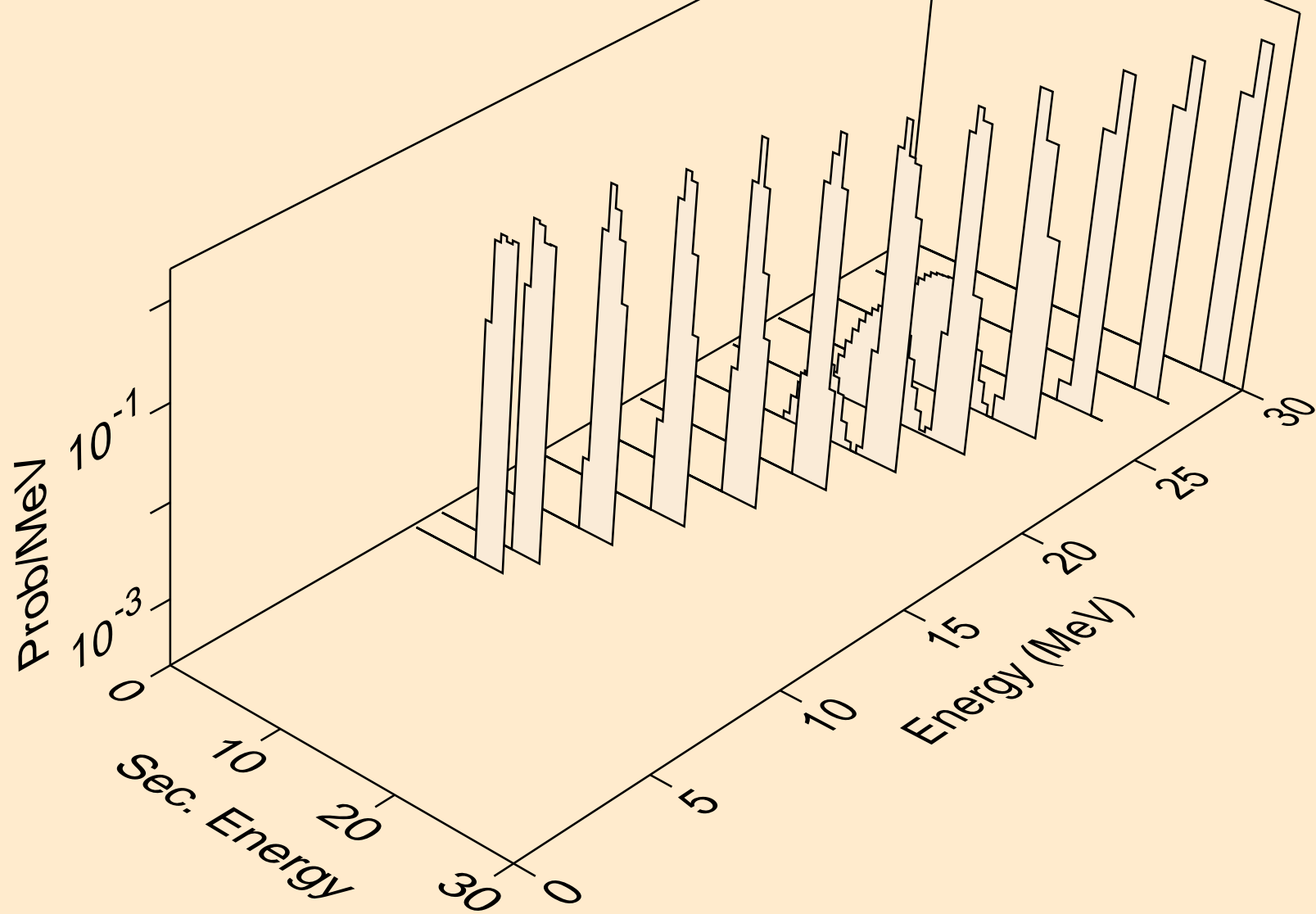

BH269 PROTON ACER TENDL-2021 LIBRARY; T=0.K  
Photon emission for (z,n)

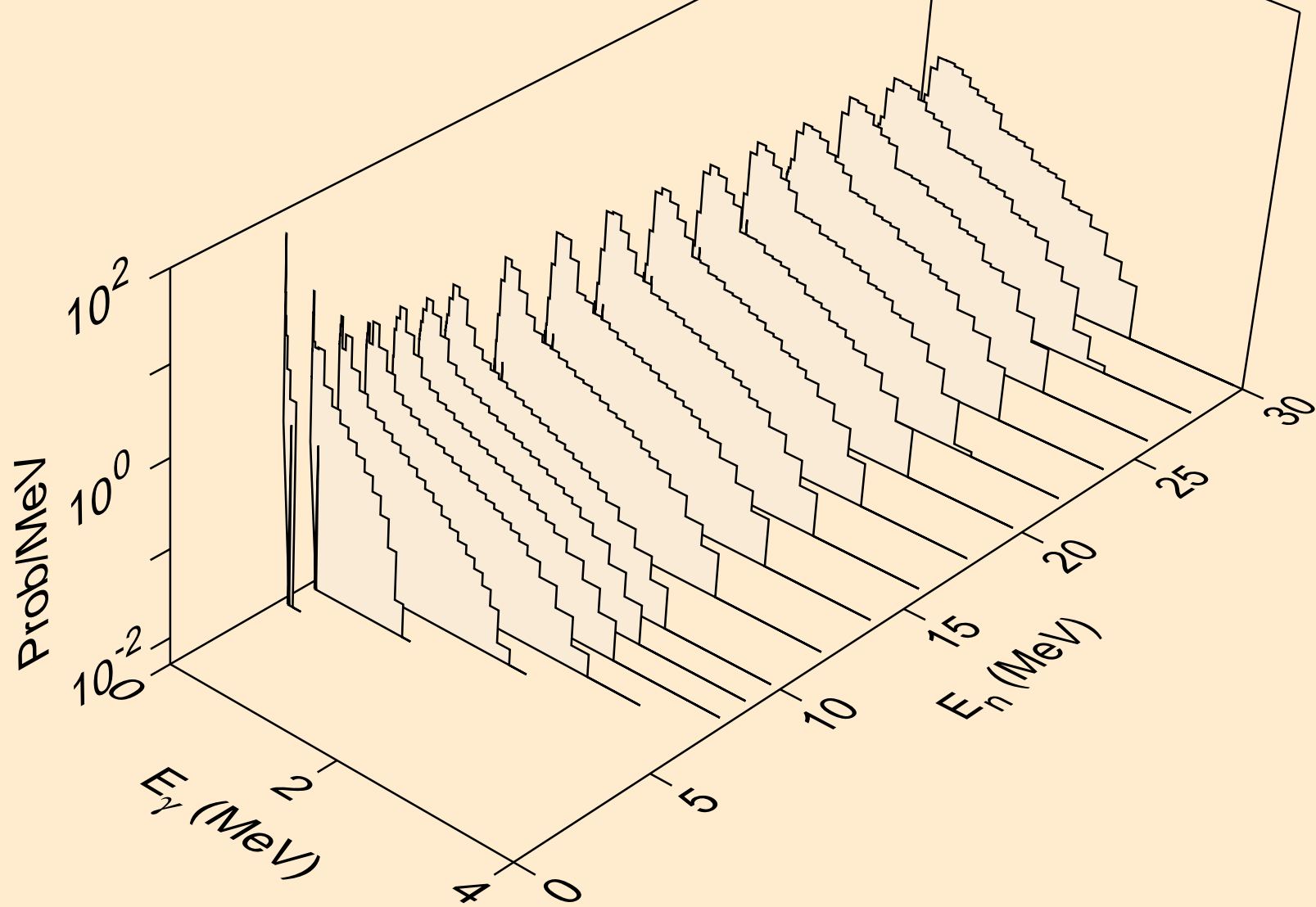

BH269 PROTON ACER TENDL-2021 LIBRARY; T=0.K  
Photon emission for (n,x)

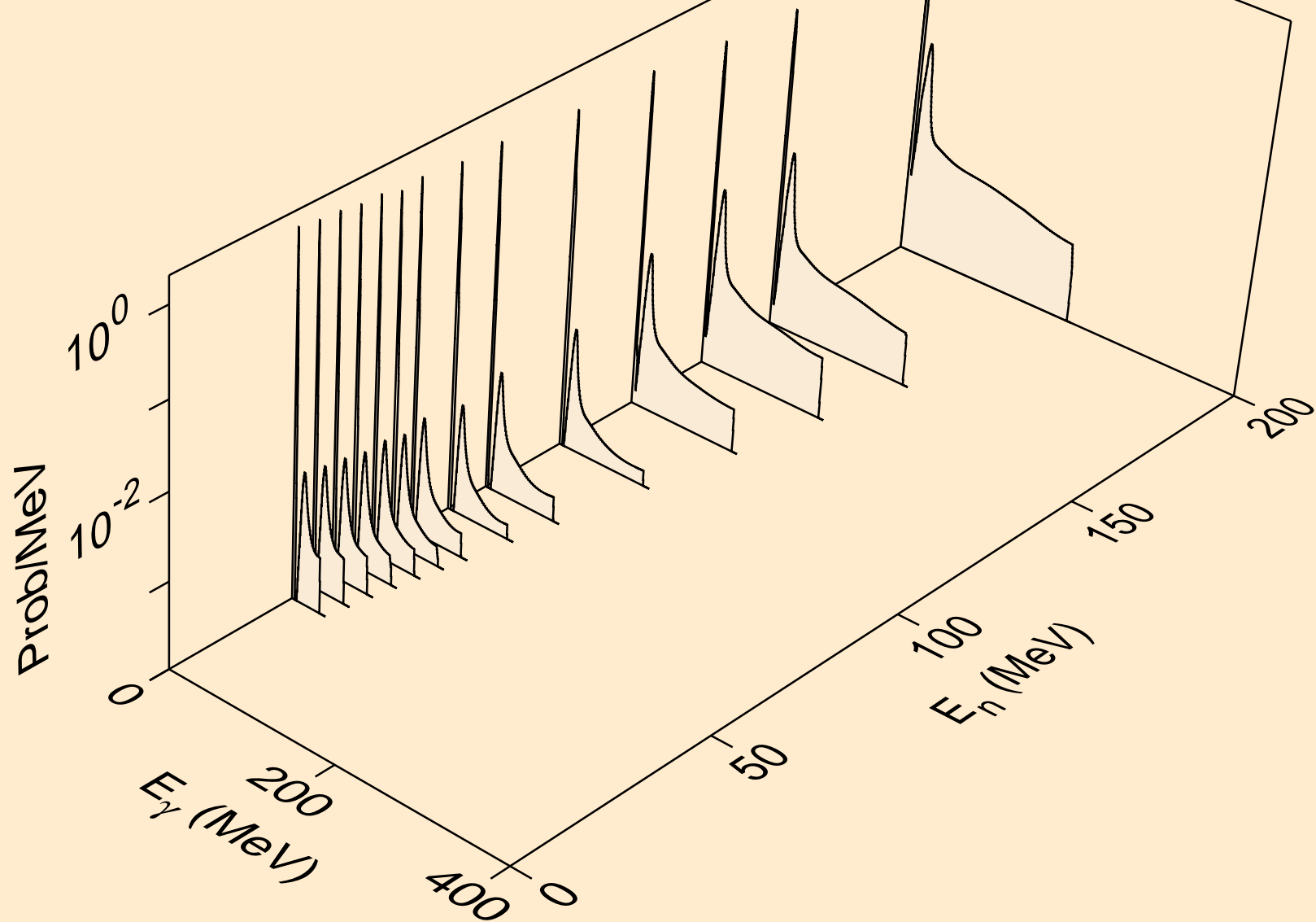



BH269 PROTON ACER TENDL-2021 LIBRARY; T=0.K  
Photon emission for (n,2n)

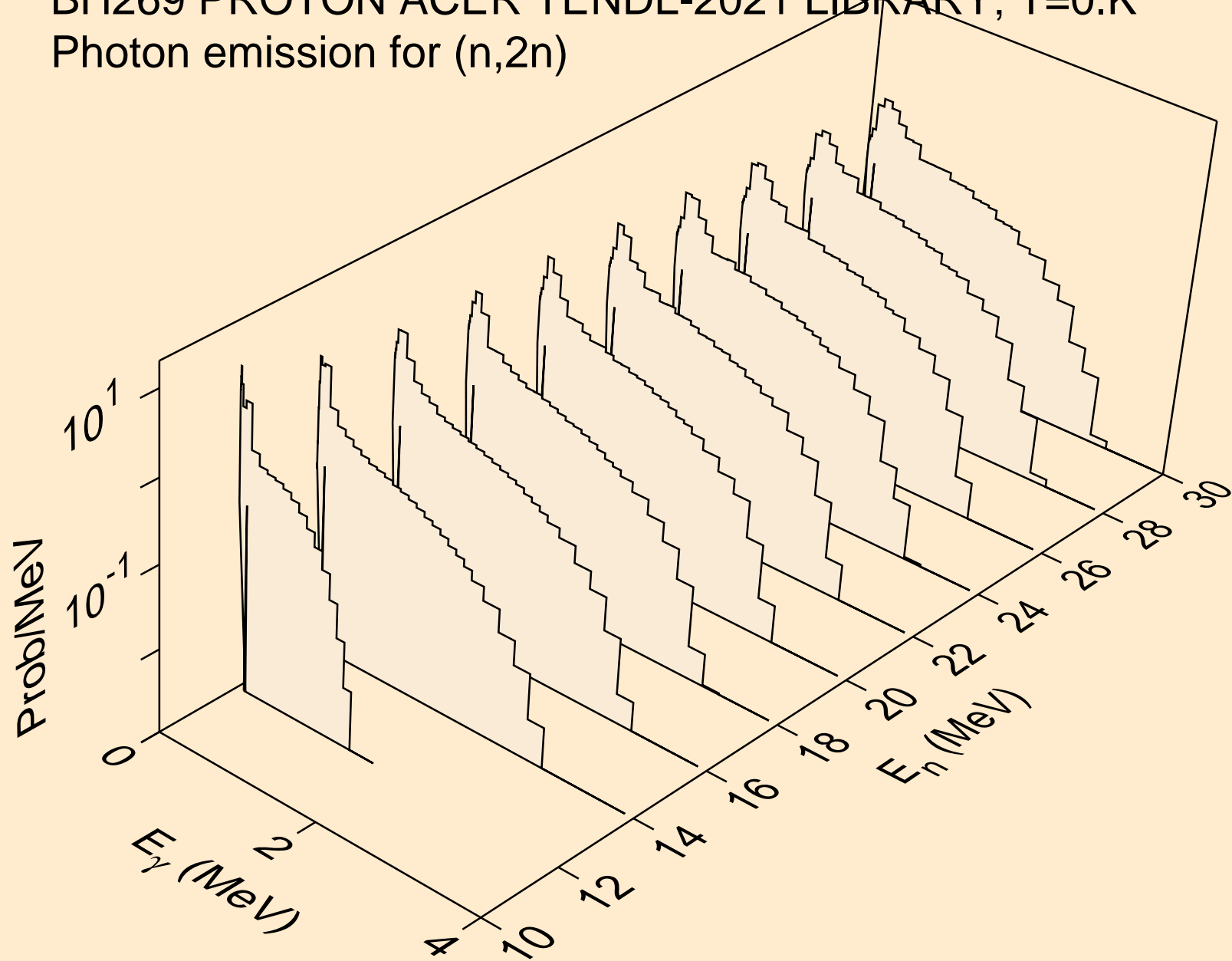

BH269 PROTON ACER TENDL-2021 LIBRARY; T=0.K  
Photon emission for (n,3n)

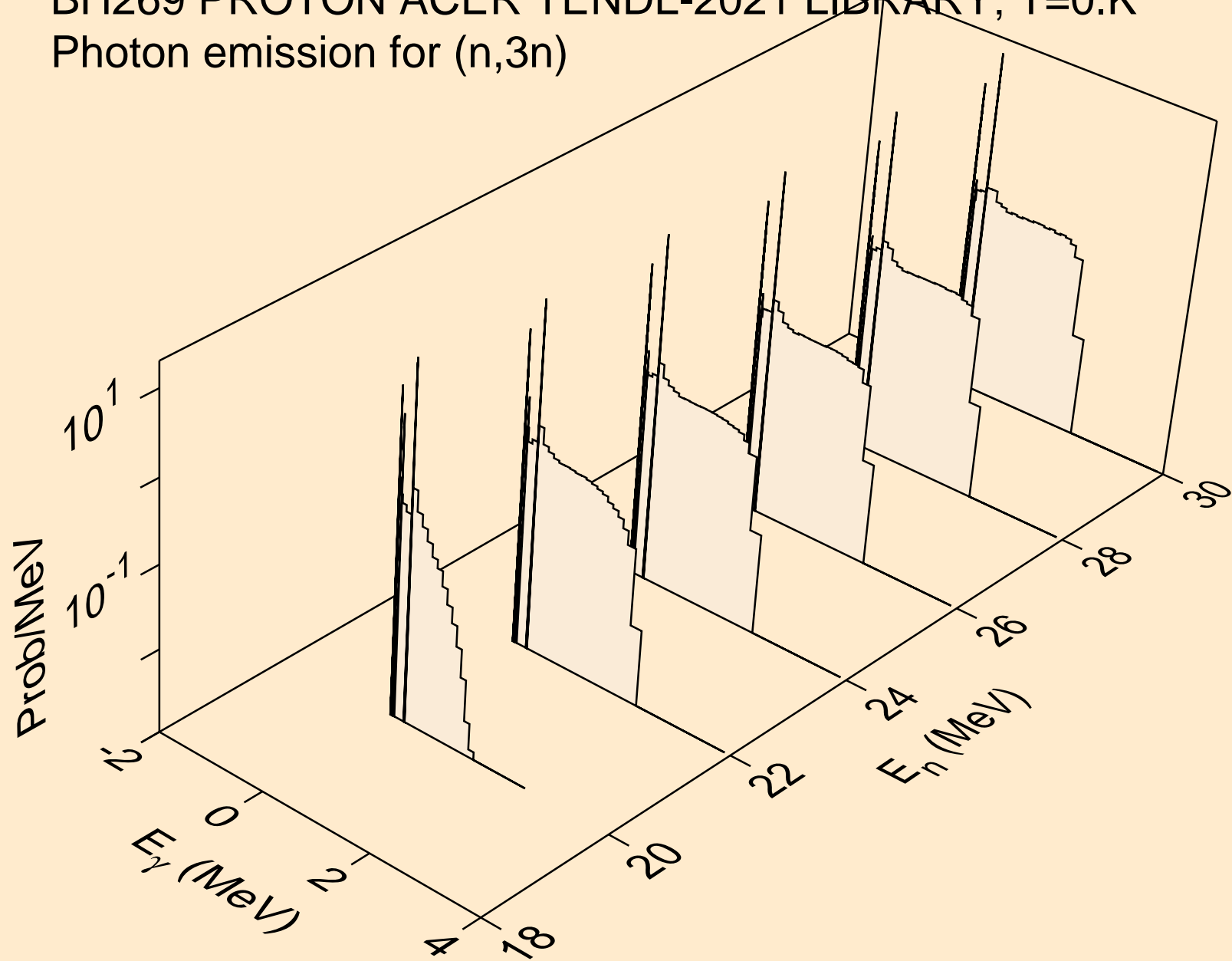

BH269 PROTON ACER TENDL-2021 LIBRARY; T=0.K  
Photon emission for (n,n\*)a

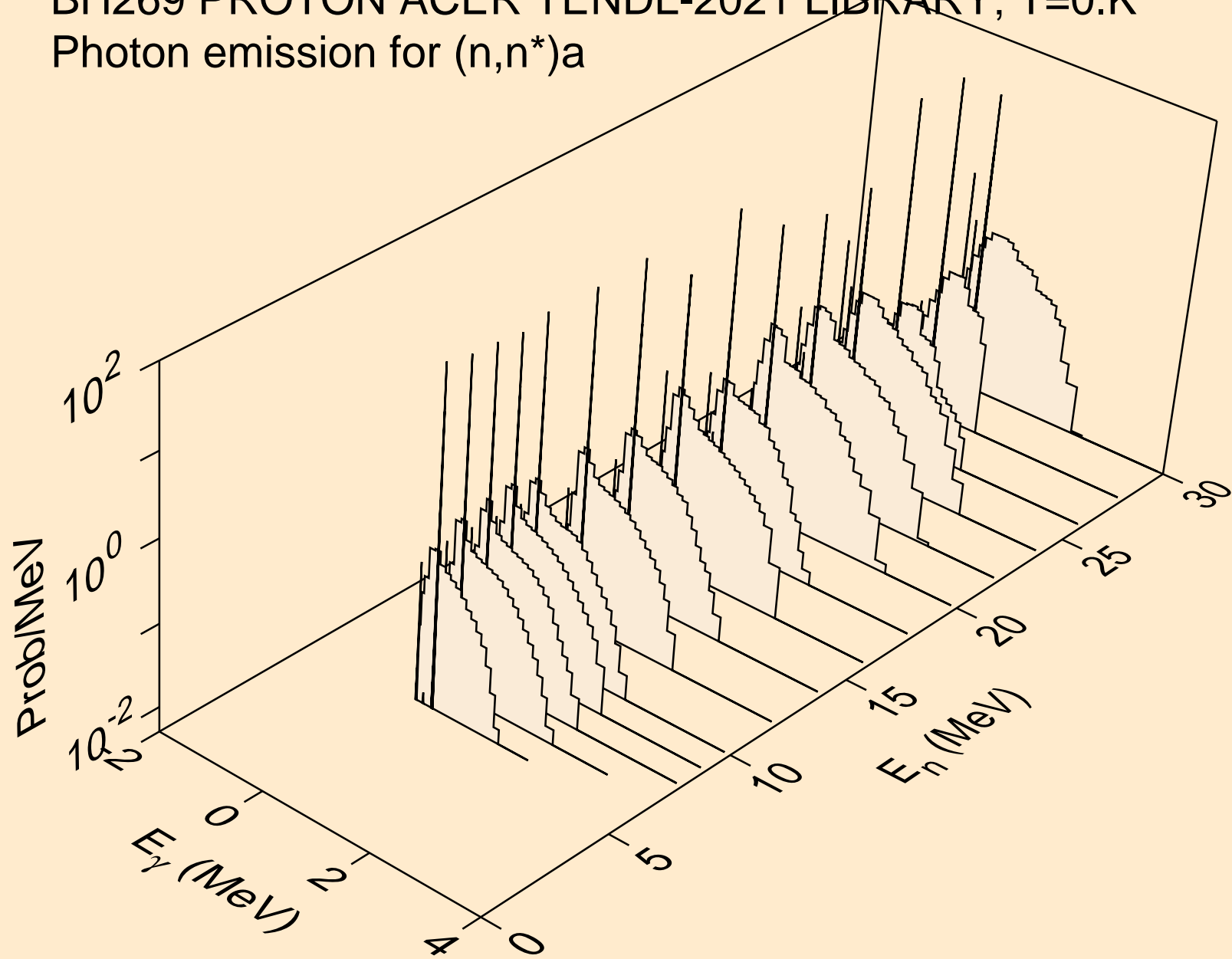

BH269 PROTON ACER TENDL-2021 LIBRARY; T=0.K  
Photon emission for (n,2n)a

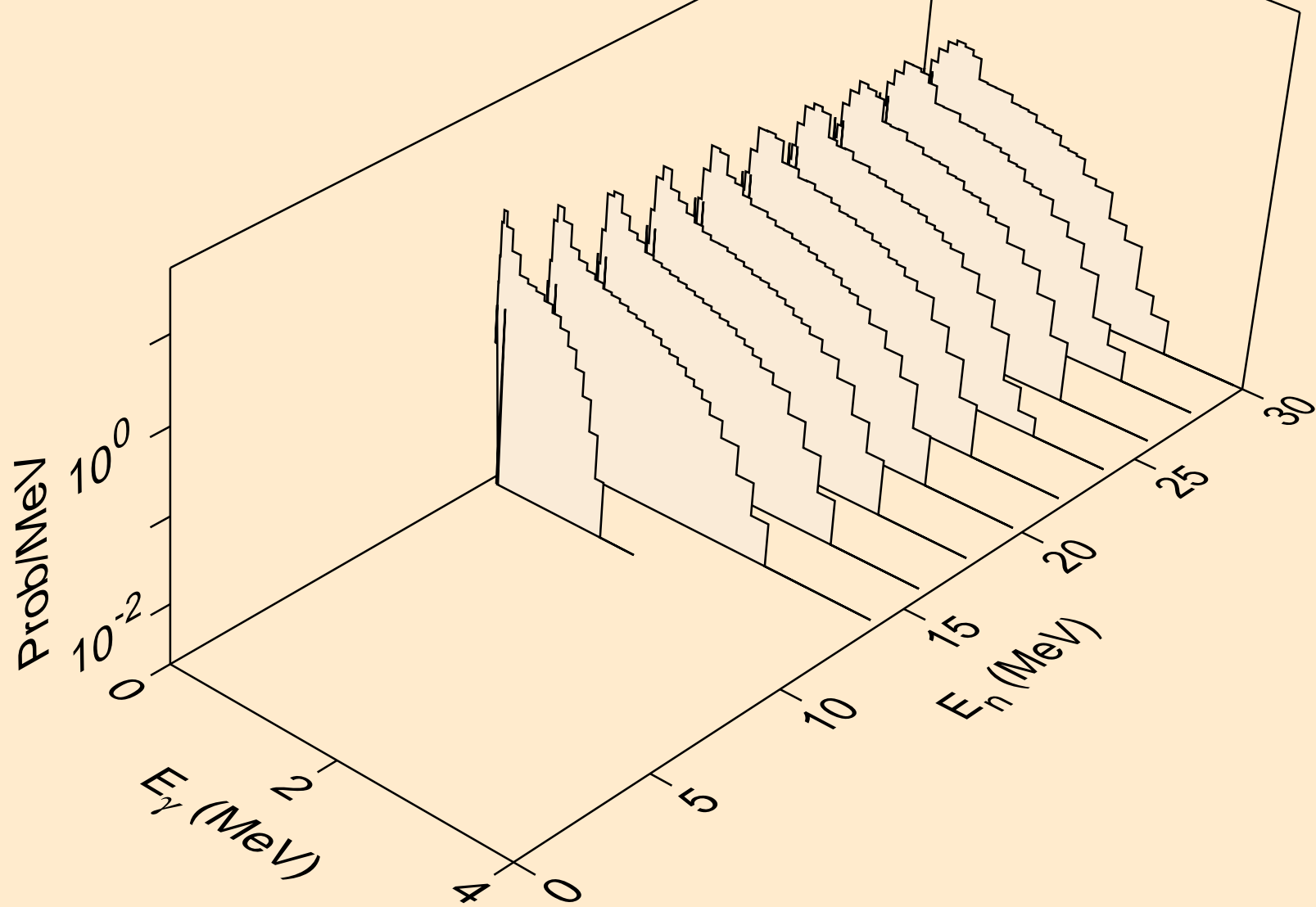

BH269 PROTON ACER TENDL-2021 LIBRARY; T=0.K  
Photon emission for (n,n\*)p

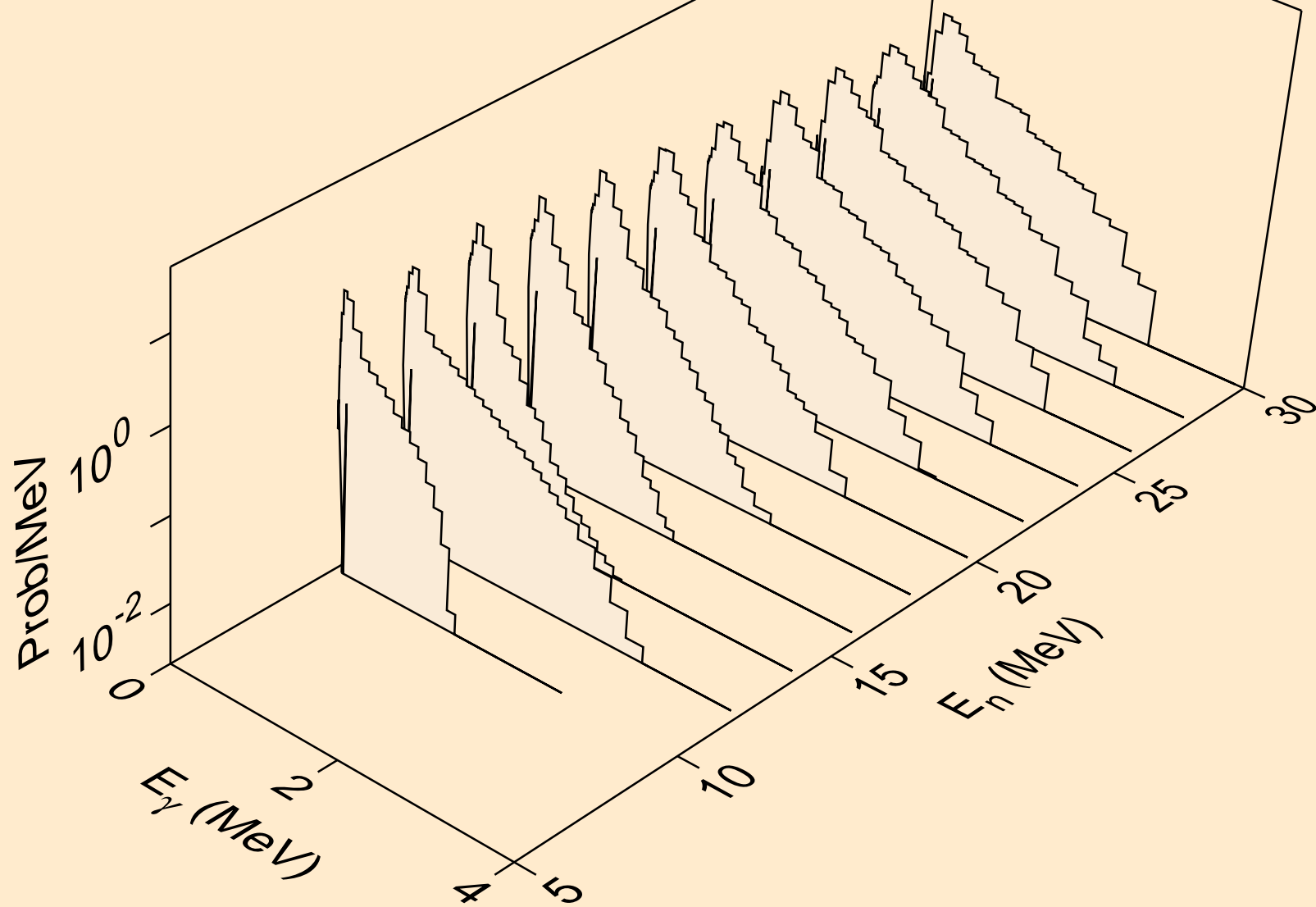

BH269 PROTON ACER TENDL-2021 LIBRARY; T=0.K  
Photon emission for (n,n\*)d

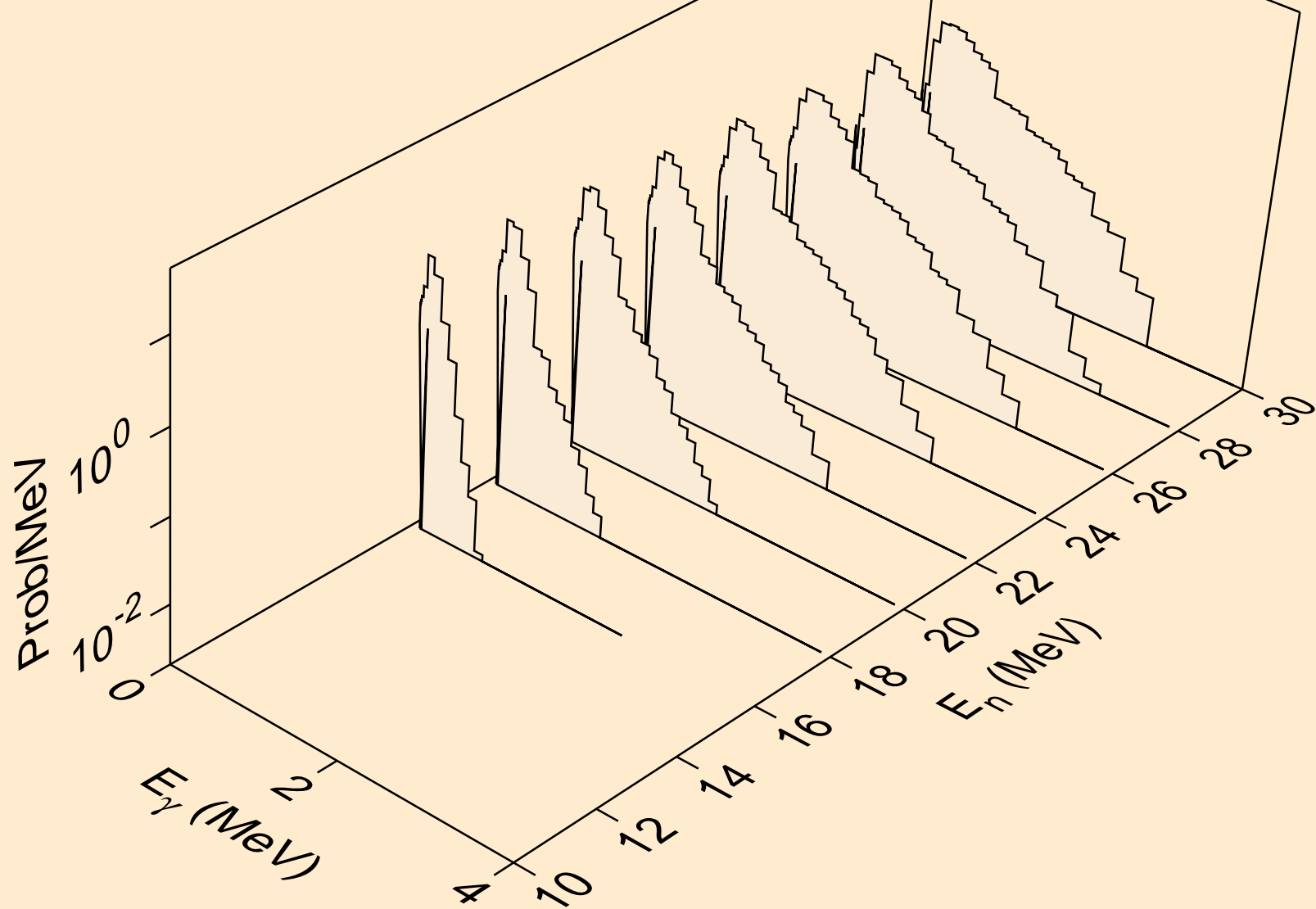

BH269 PROTON ACER TENDL-2021 LIBRARY; T=0.K  
Photon emission for (n,n\*)t

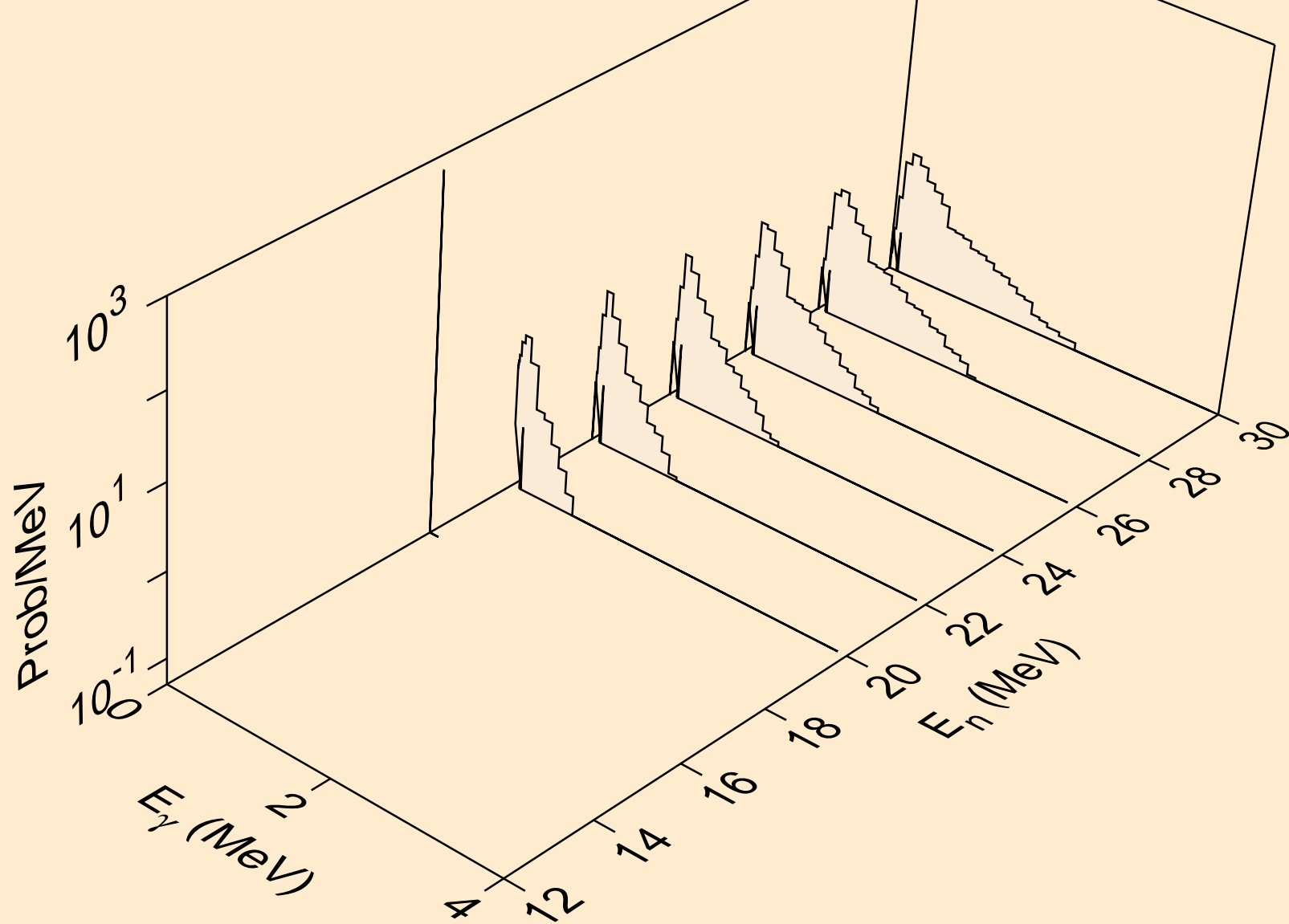

BH269 PROTON ACER TENDL-2021 LIBRARY; T=0.K  
Photon emission for (n,2np)

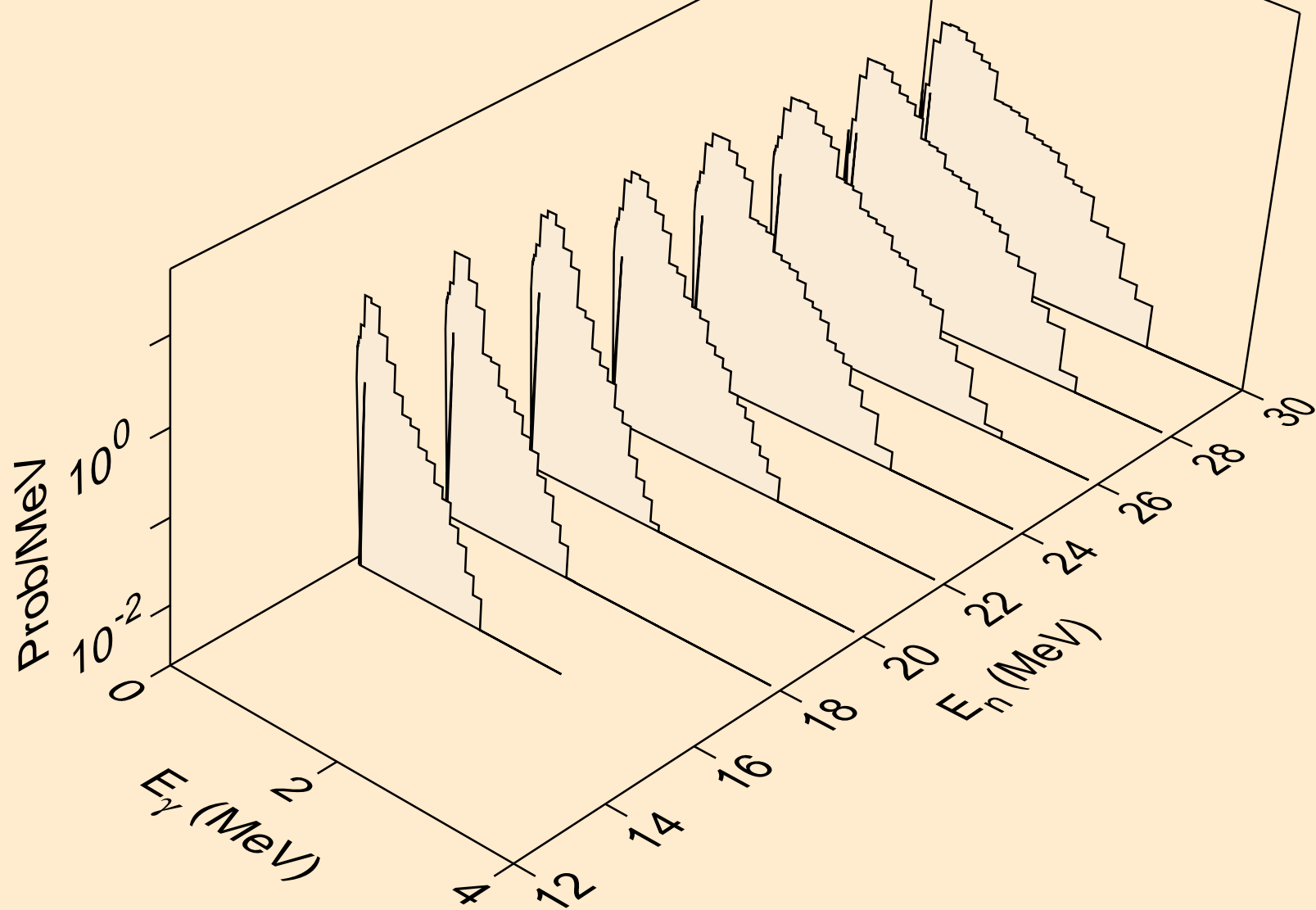



BH269 PROTON ACER TENDL-2021 LIBRARY; T=0.K  
Photon emission for (n,gma)

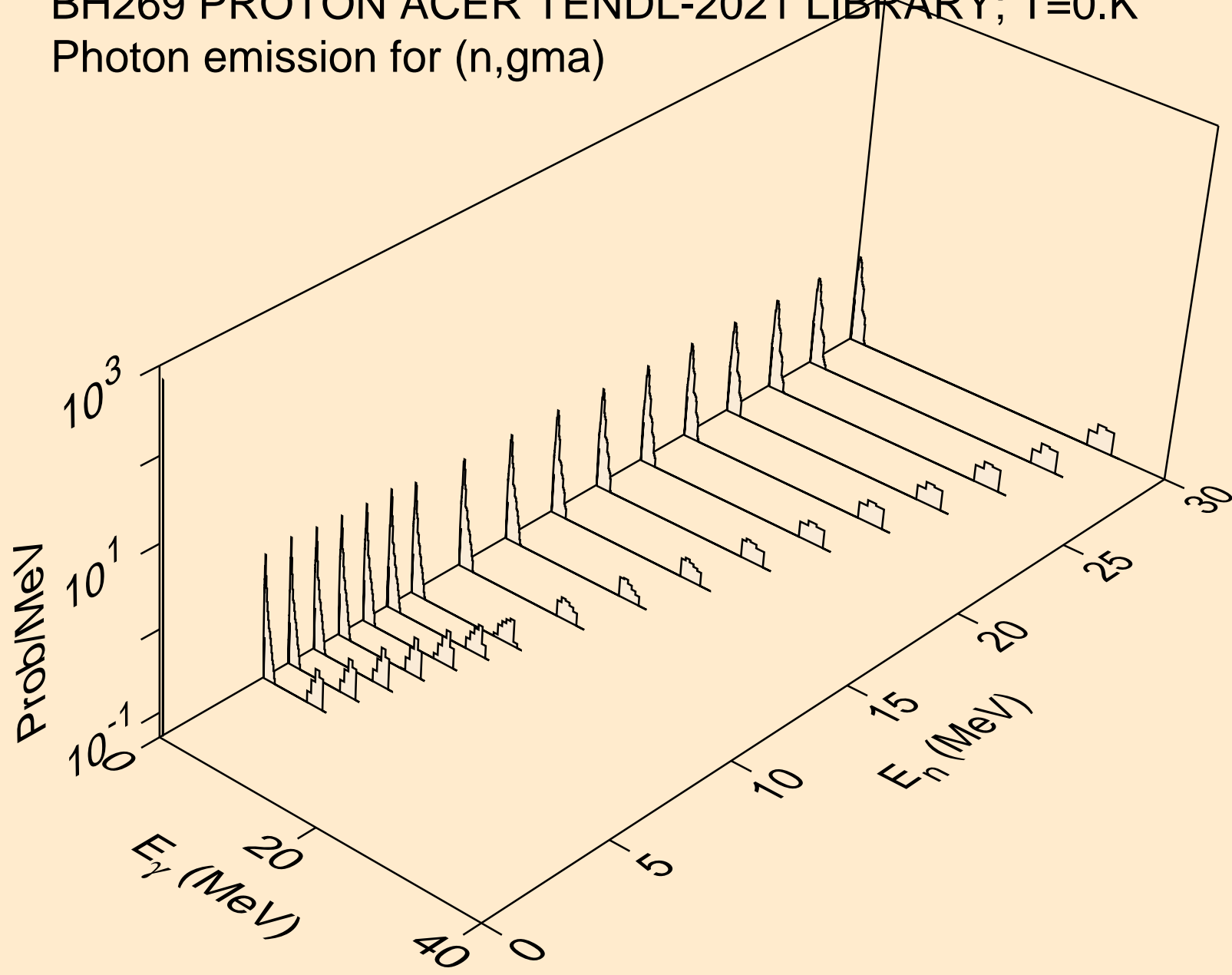

BH269 PROTON ACER TENDL-2021 LIBRARY; T=0.K  
Photon emission for inelastic

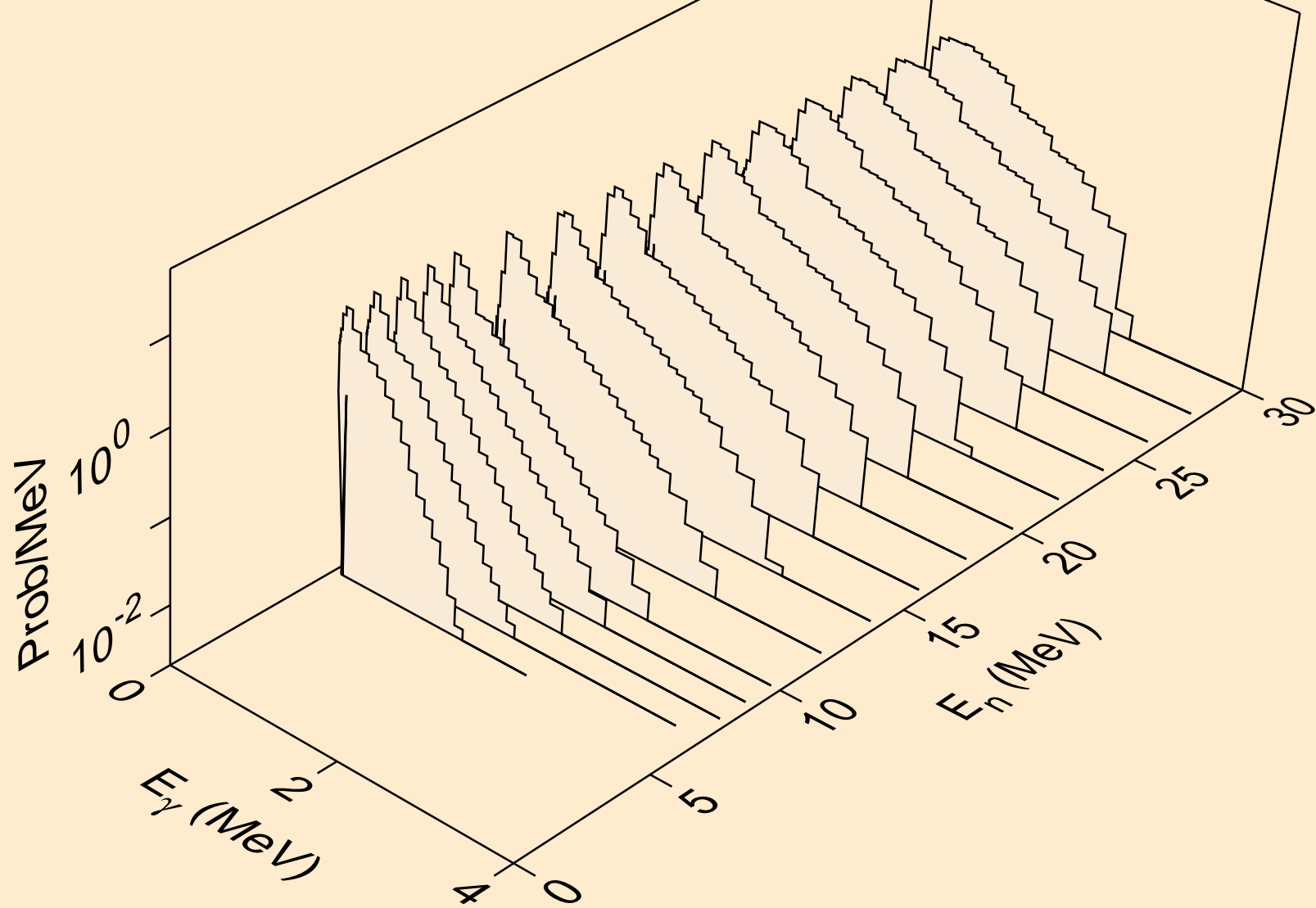

BH269 PROTON ACER TENDL-2021 LIBRARY; T=0.K  
Photon emission for (n,d)

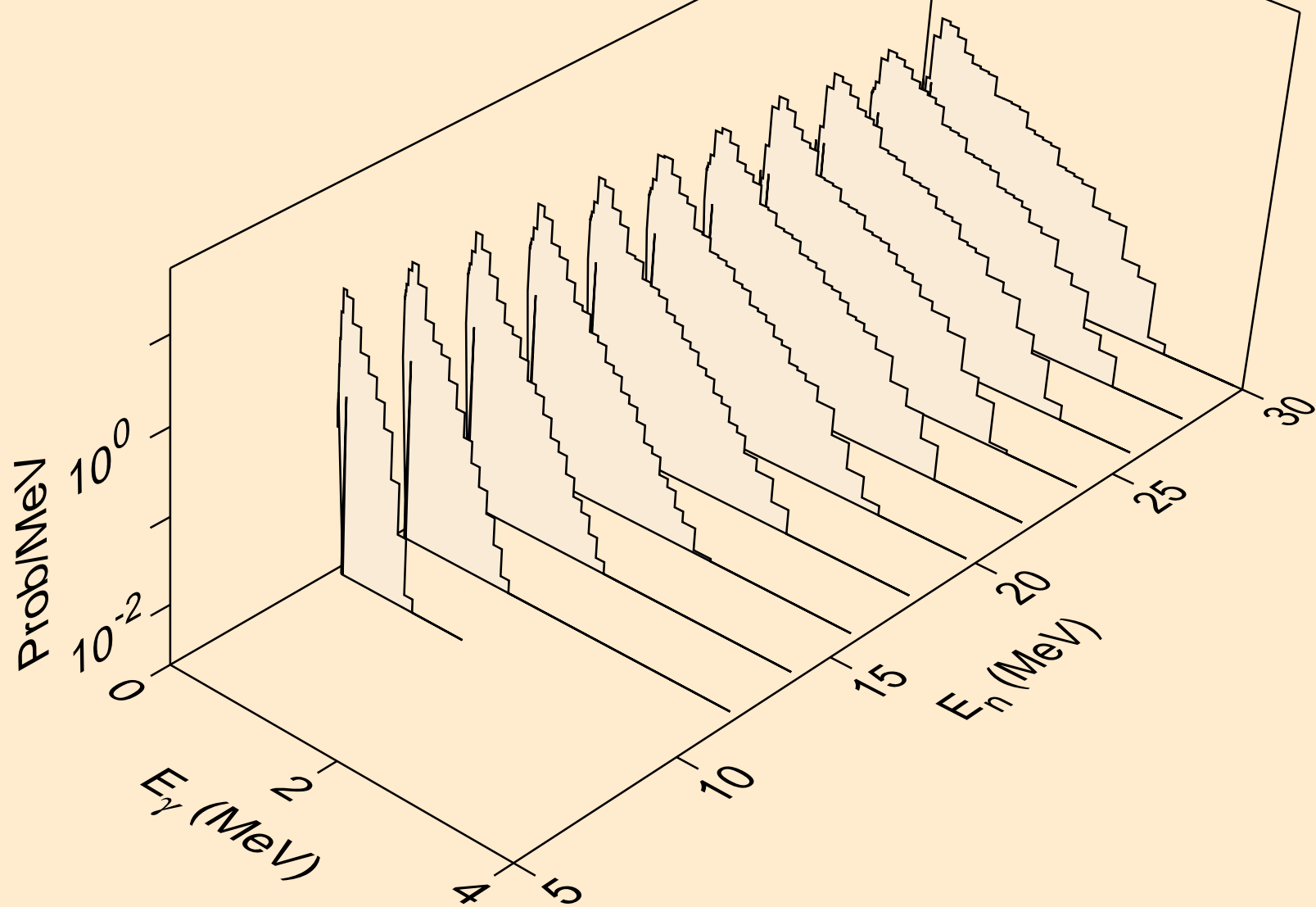

BH269 PROTON ACER TENDL-2021 LIBRARY; T=0.K  
Photon emission for (n,t)

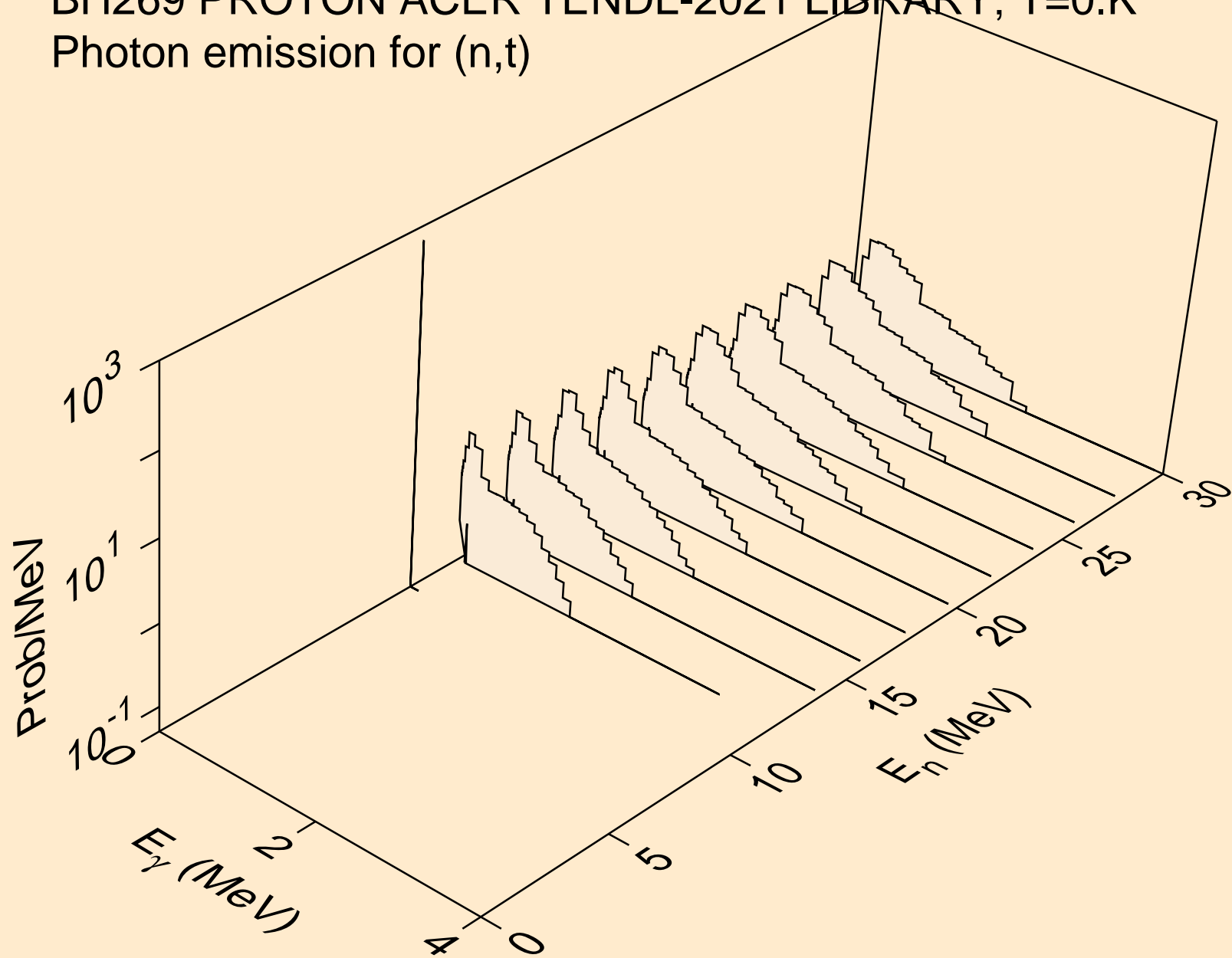

BH269 PROTON ACER TENDL-2021 LIBRARY; T=0.K  
Photon emission for (n,he3)

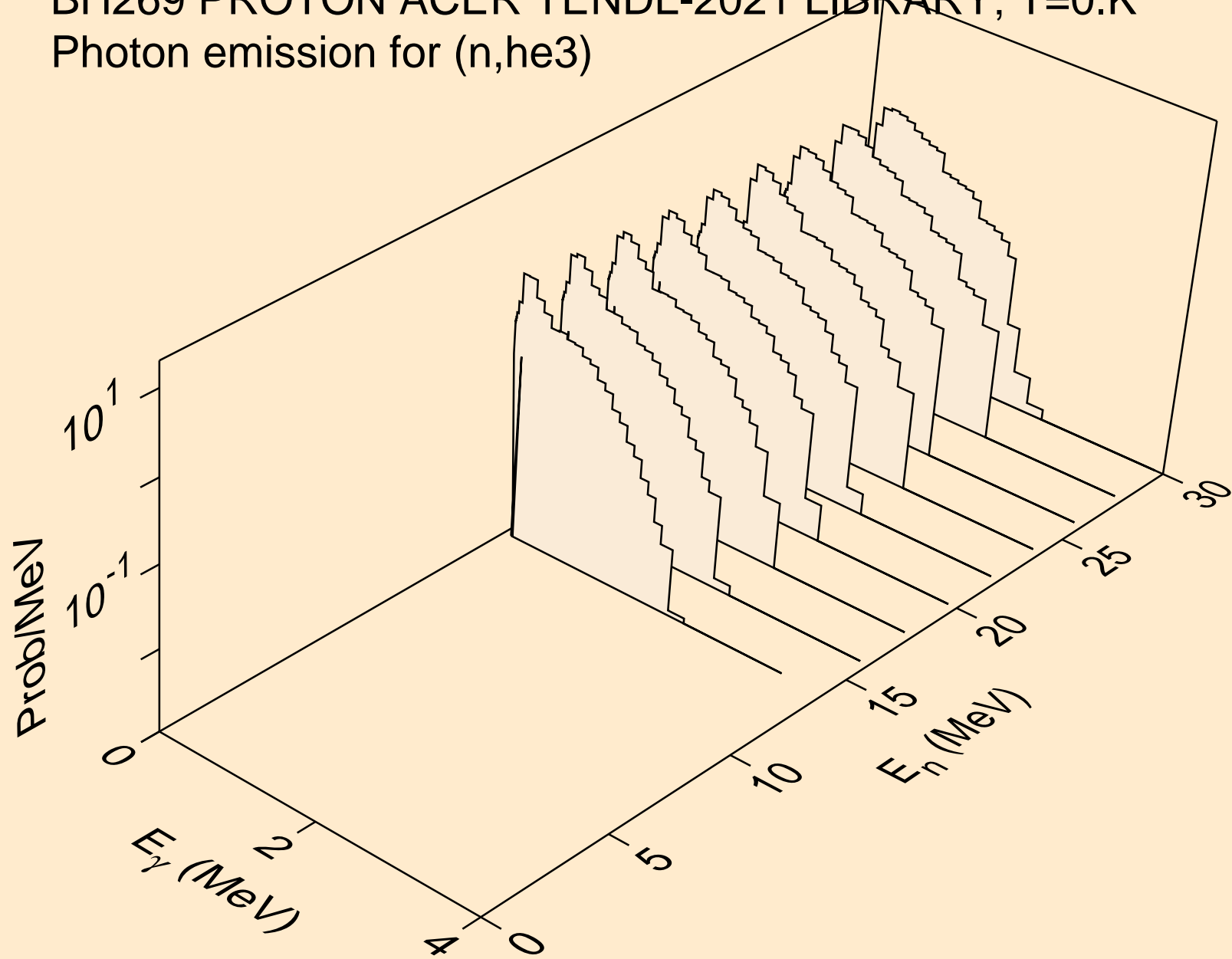

BH269 PROTON ACER TENDL-2021 LIBRARY; T=0.K  
Photon emission for (n,a)

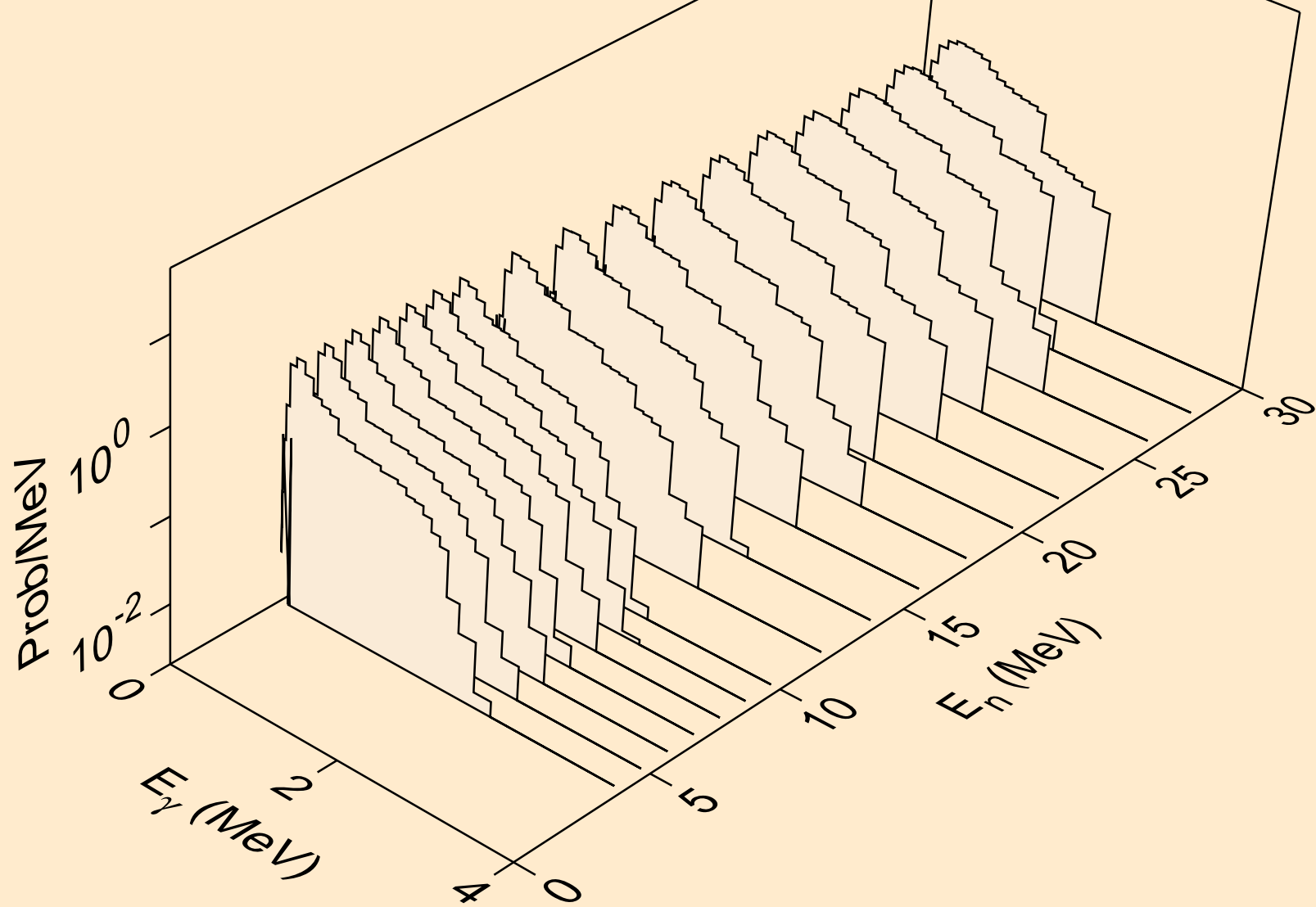

BH269 PROTON ACER TENDL-2021 LIBRARY; T=0.K  
Photon emission for (n,2p)

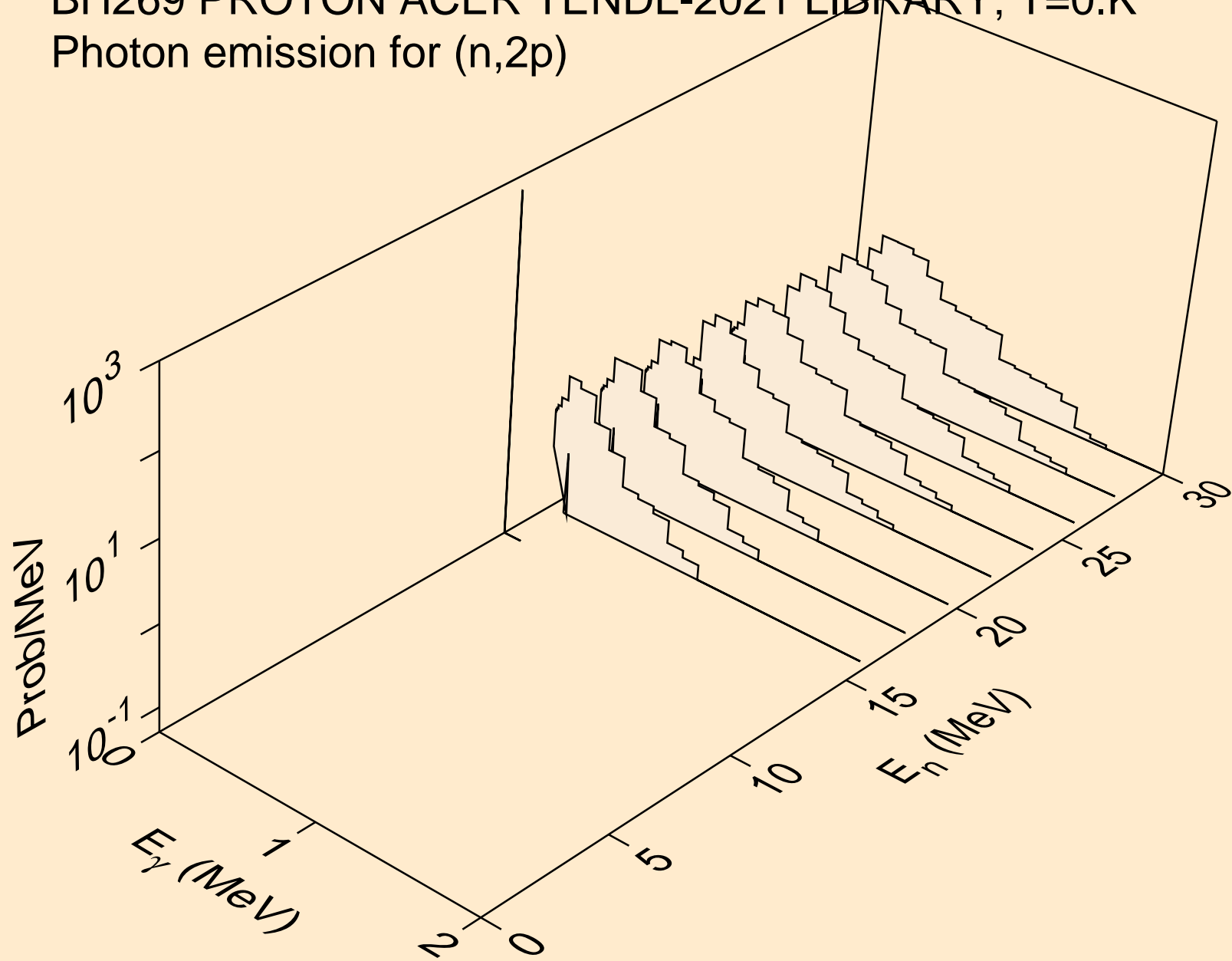

BH269 PROTON ACER TENDL-2021 LIBRARY; T=0.K  
Photon emission for (n,pa)

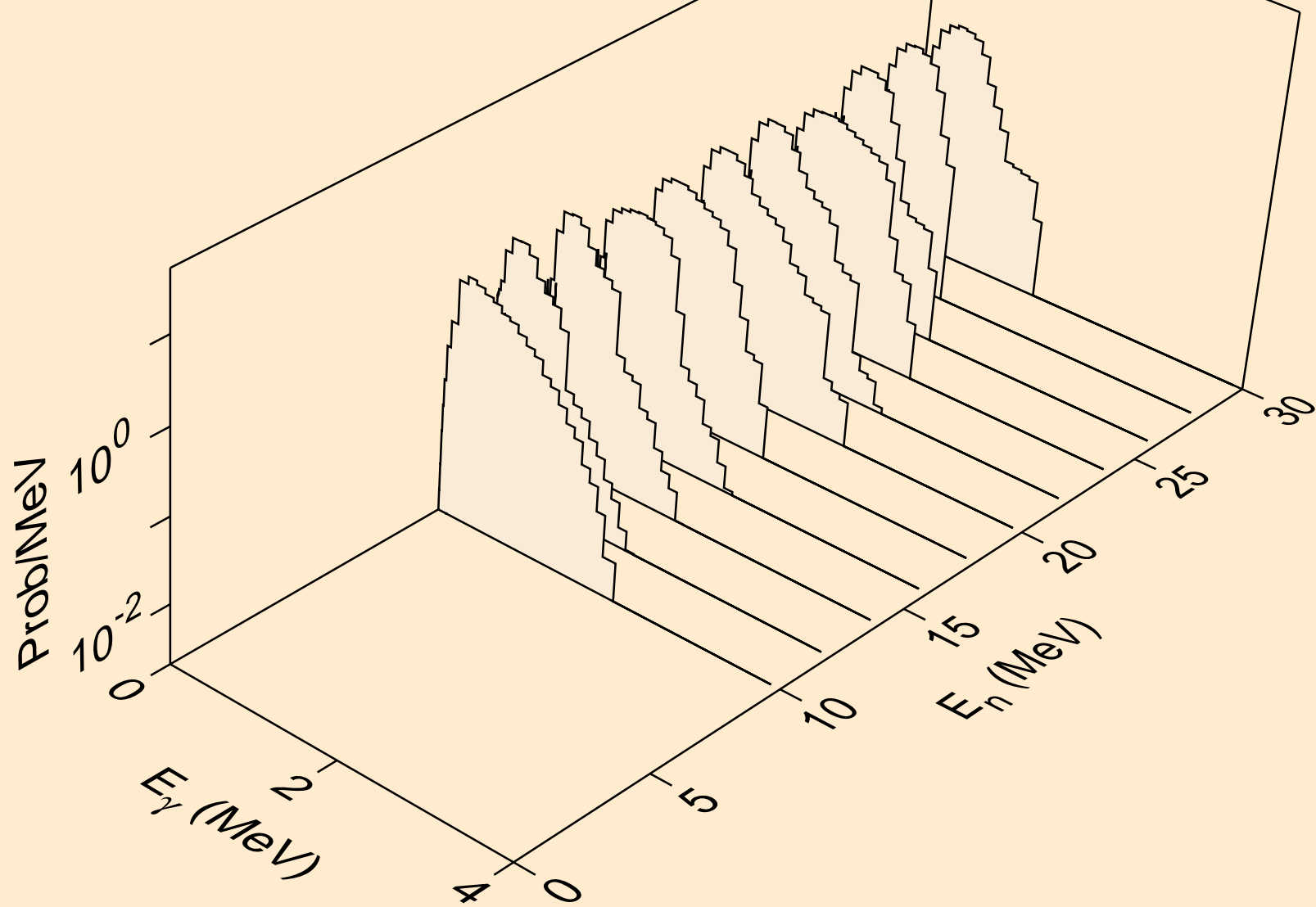



BH269 PROTON ACER TENDL-2021 LIBRARY; T=0.K  
Photon emission for (n,t2a)

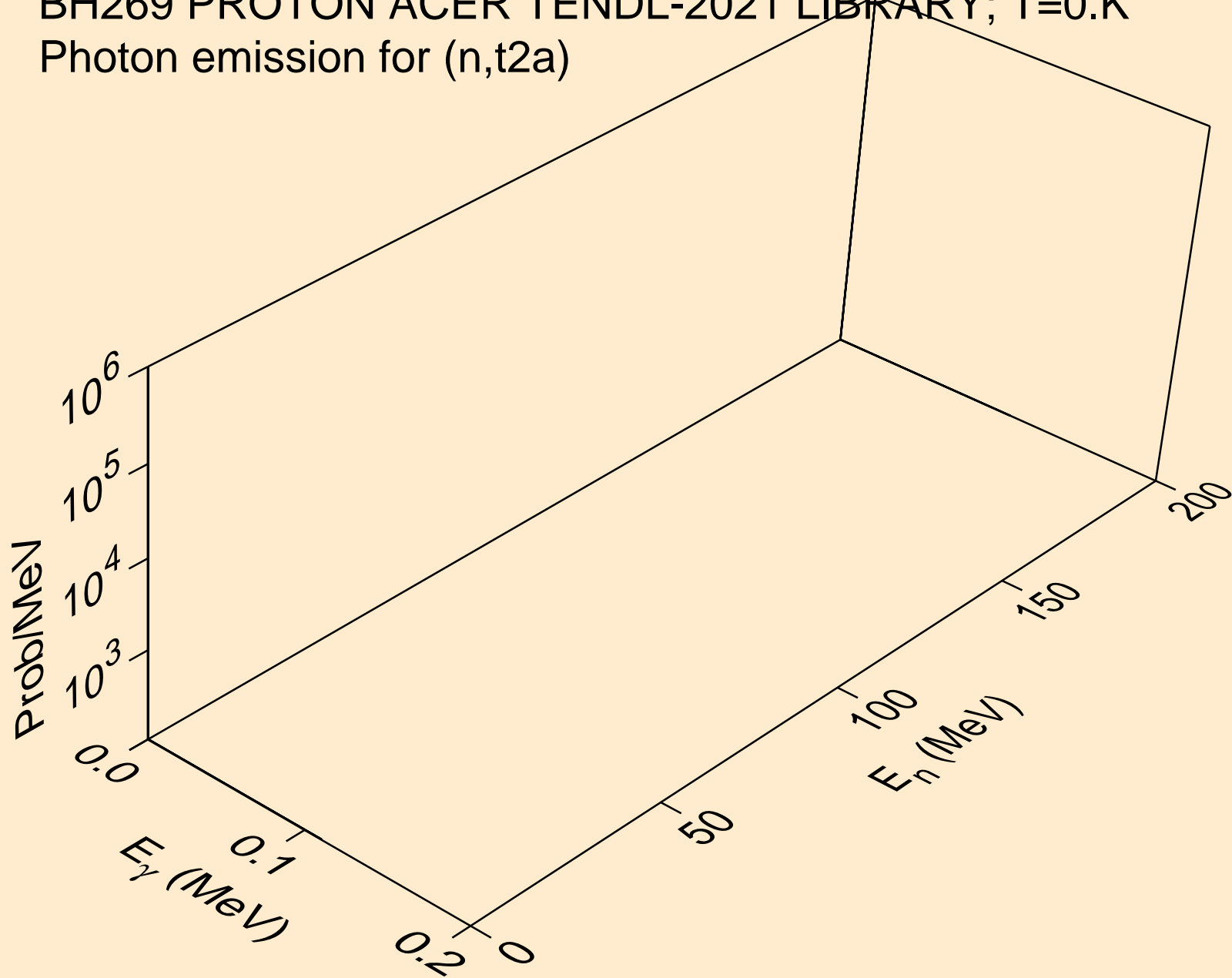

BH269 PROTON ACER TENDL-2021 LIBRARY; T=0.K  
Particle heating contributions

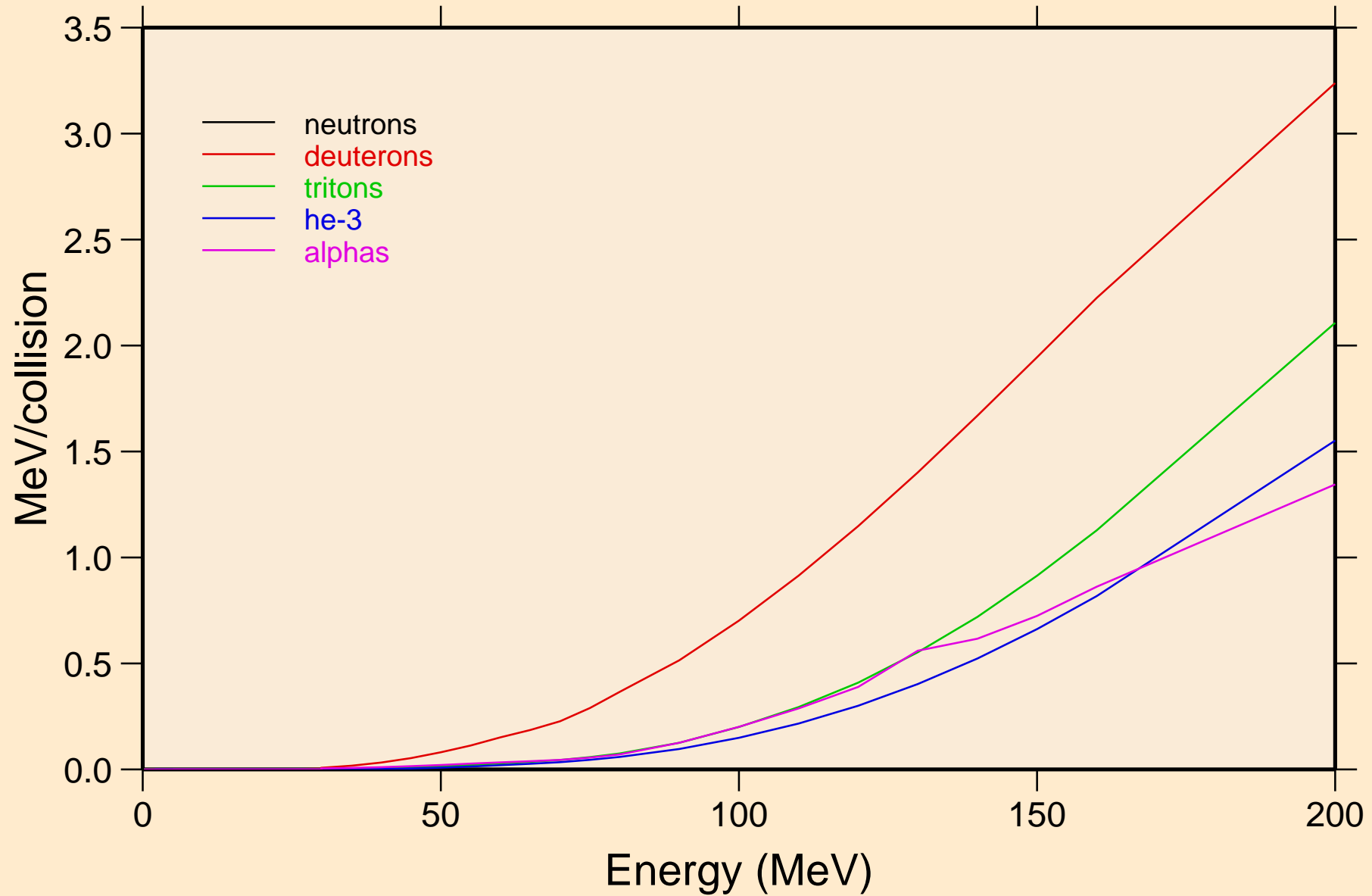

BH269 PROTON ACER TENDL-2021 LIBRARY; T=0.K  
Recoil Heating

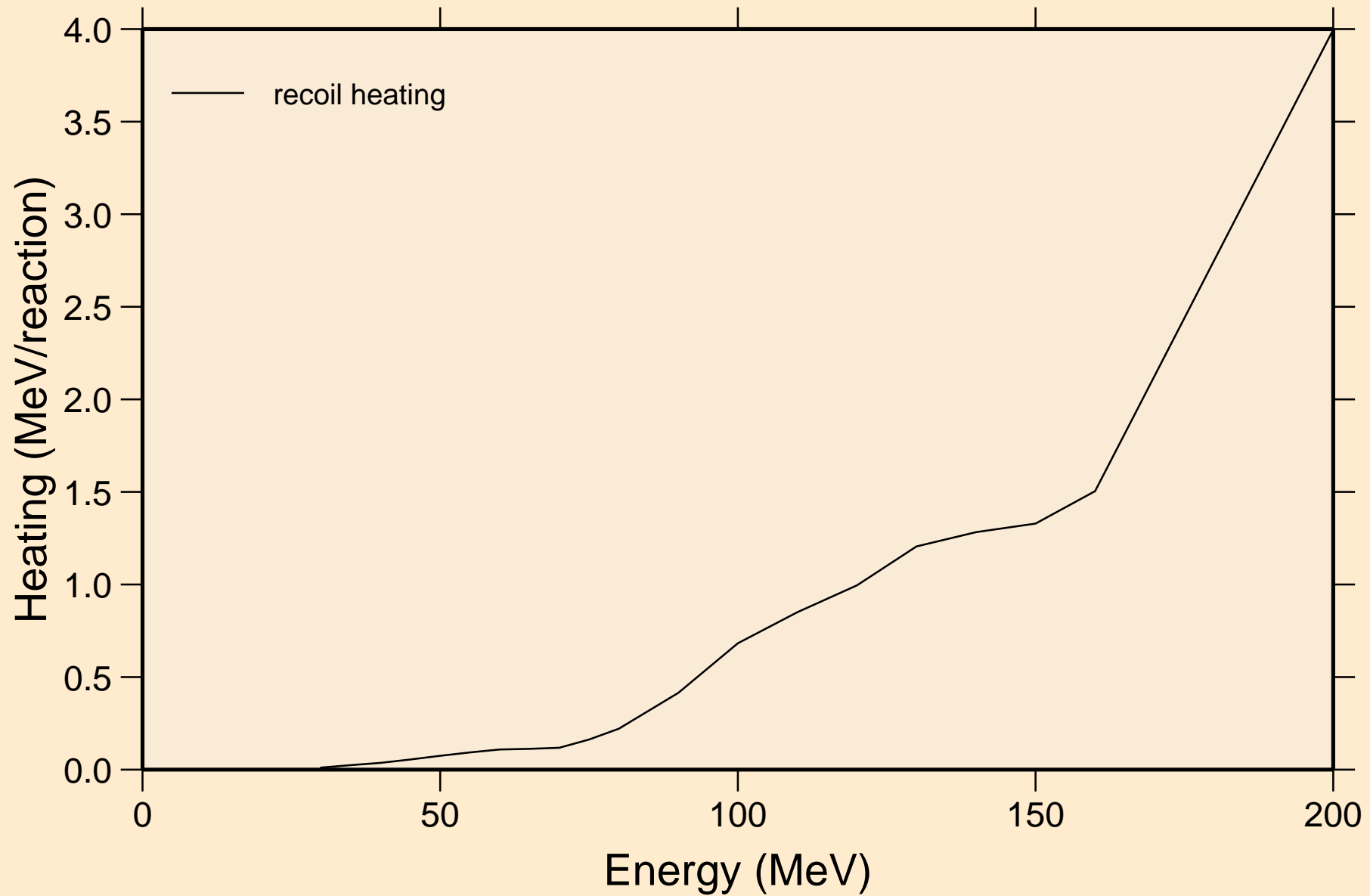

BH269 PROTON ACER TENDL-2021 LIBRARY; T=0.K  
Particle production cross sections

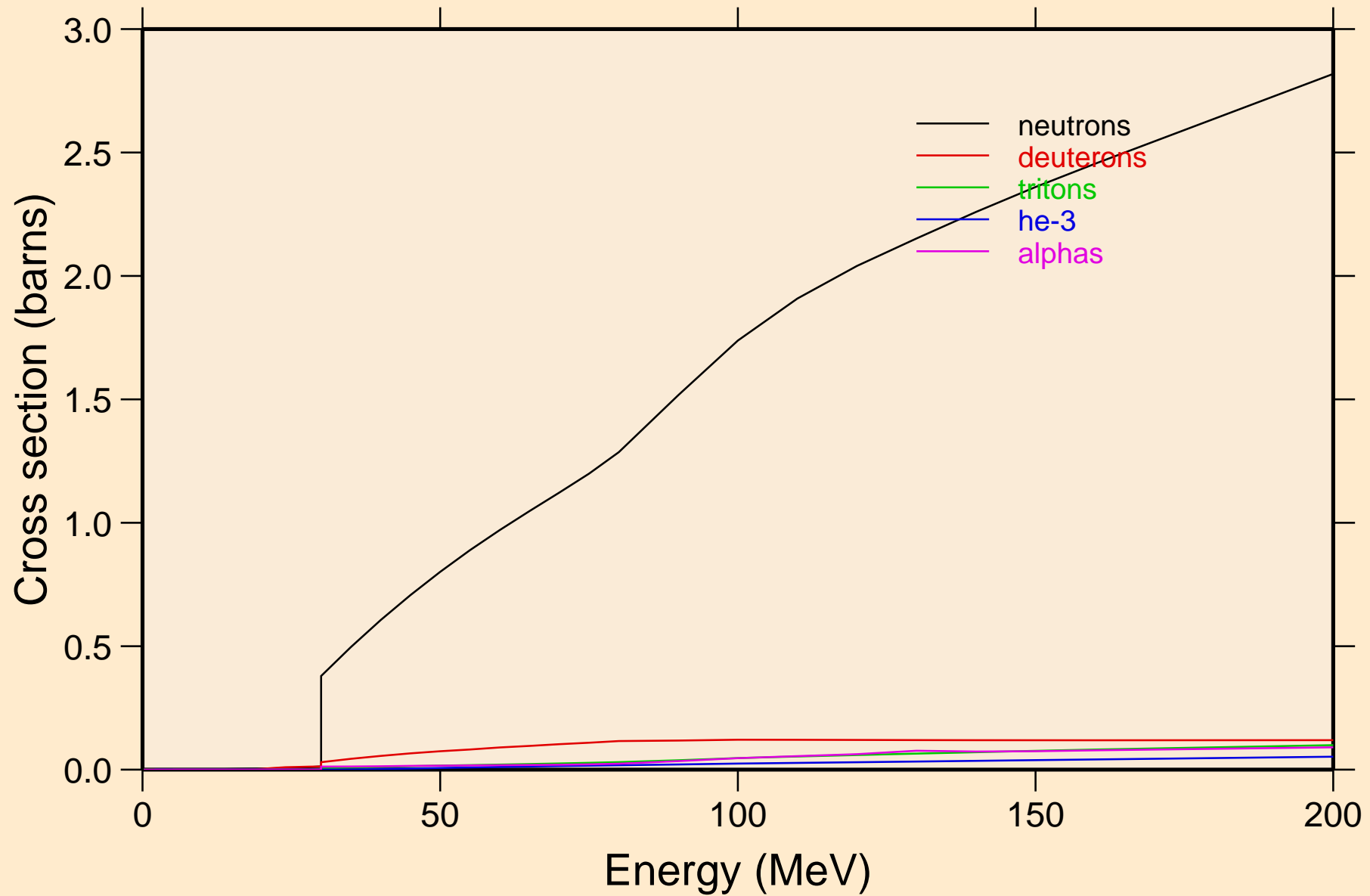

BH269 PROTON ACER TENDL-2021 LIBRARY; T=0.K  
neutrons from (p,n)

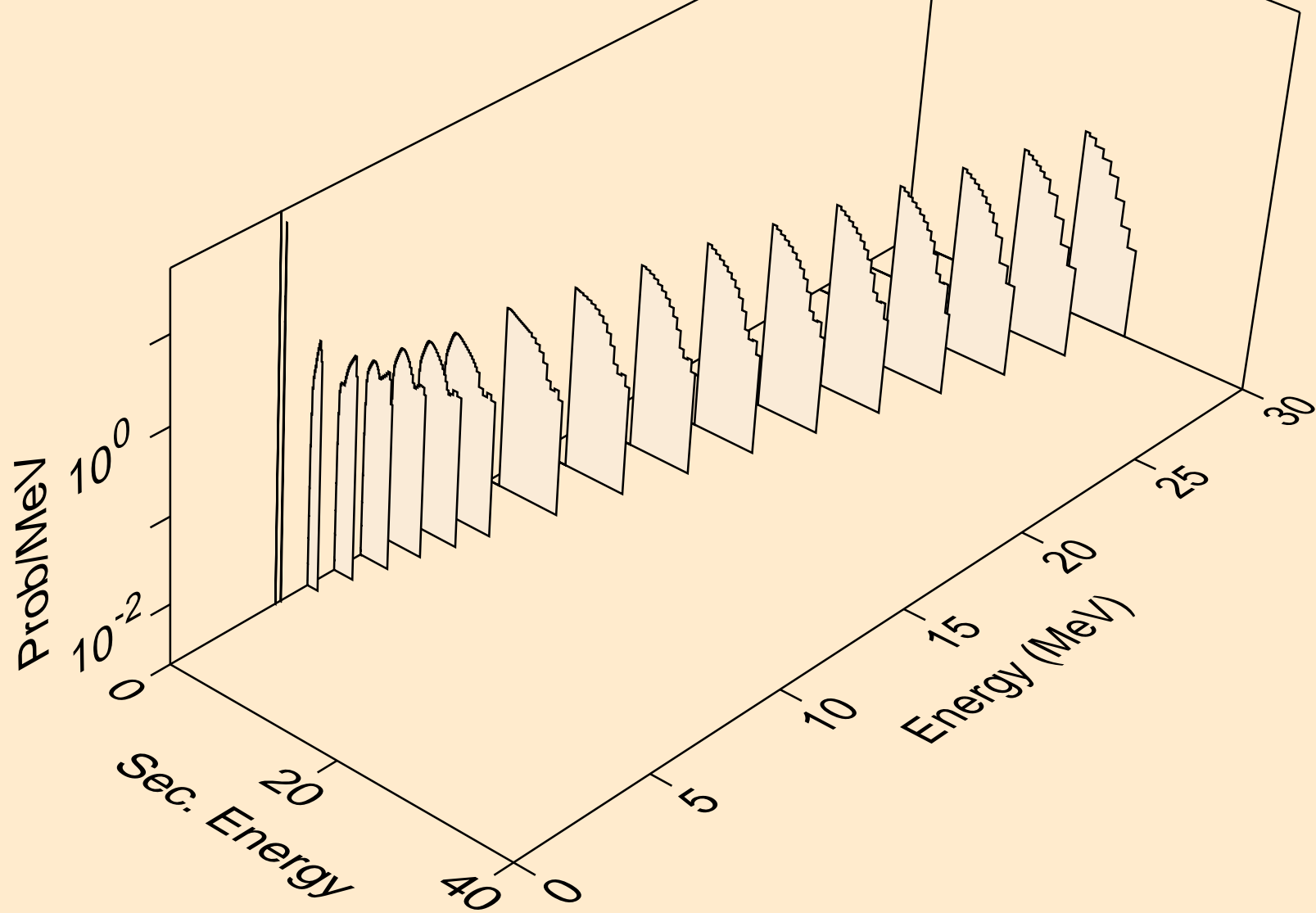

BH269 PROTON ACER TENDL-2021 LIBRARY; T=0.K  
neutrons from (p,x)

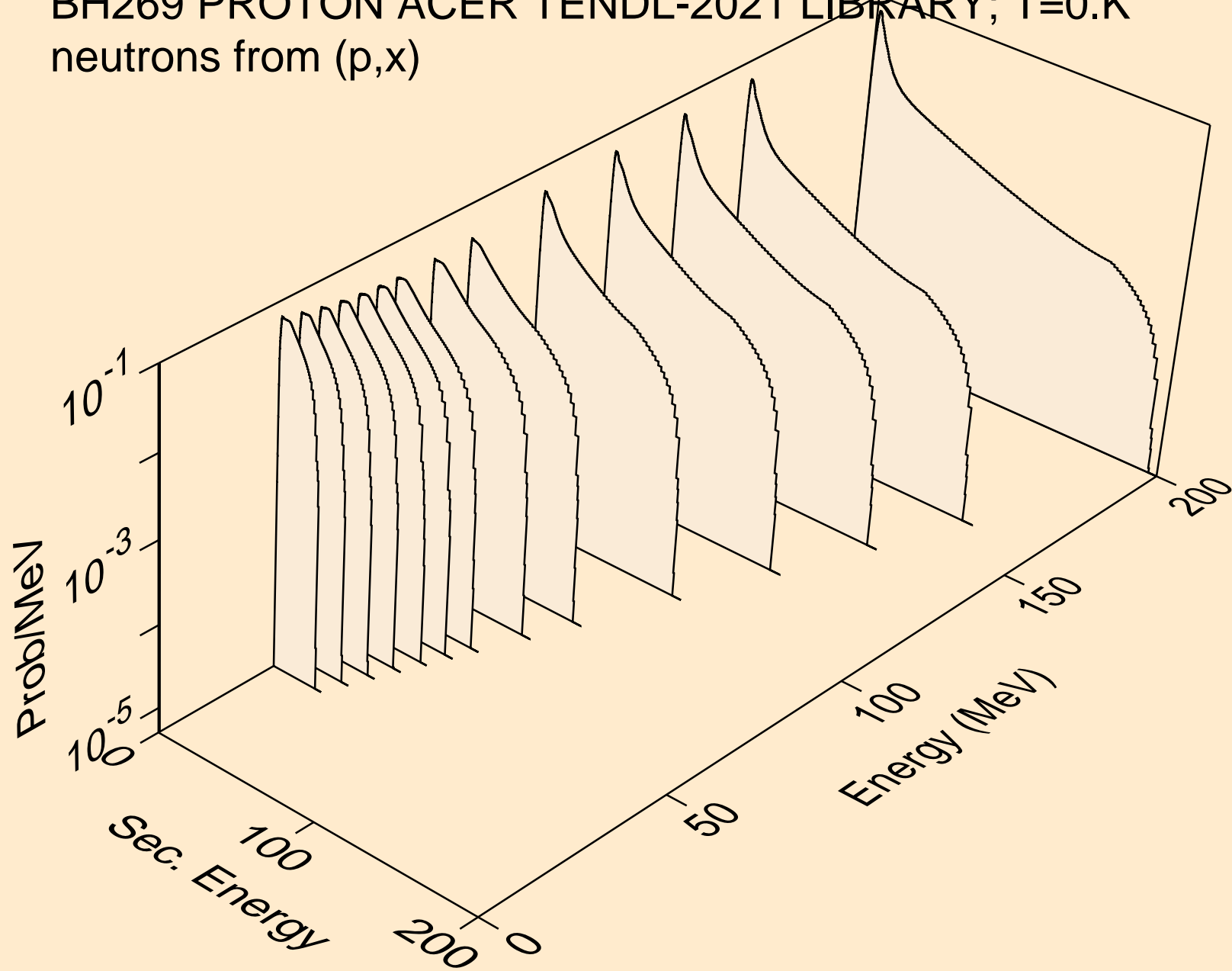

BH269 PROTON ACER TENDL-2021 LIBRARY; T=0.K  
neutrons from (p,2n)

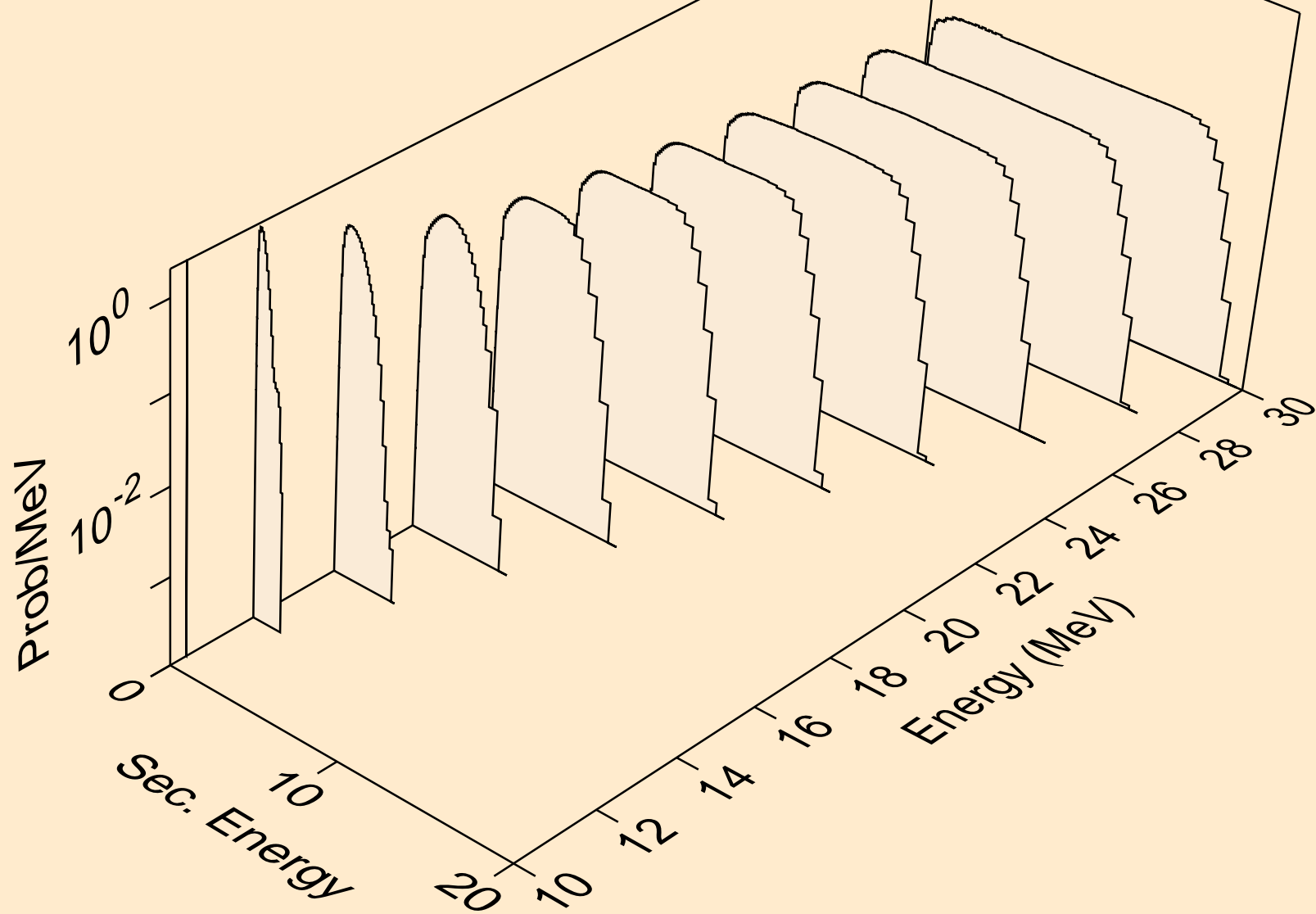

BH269 PROTON ACER TENDL-2021 LIBRARY; T=0.K  
neutrons from (p,3n)

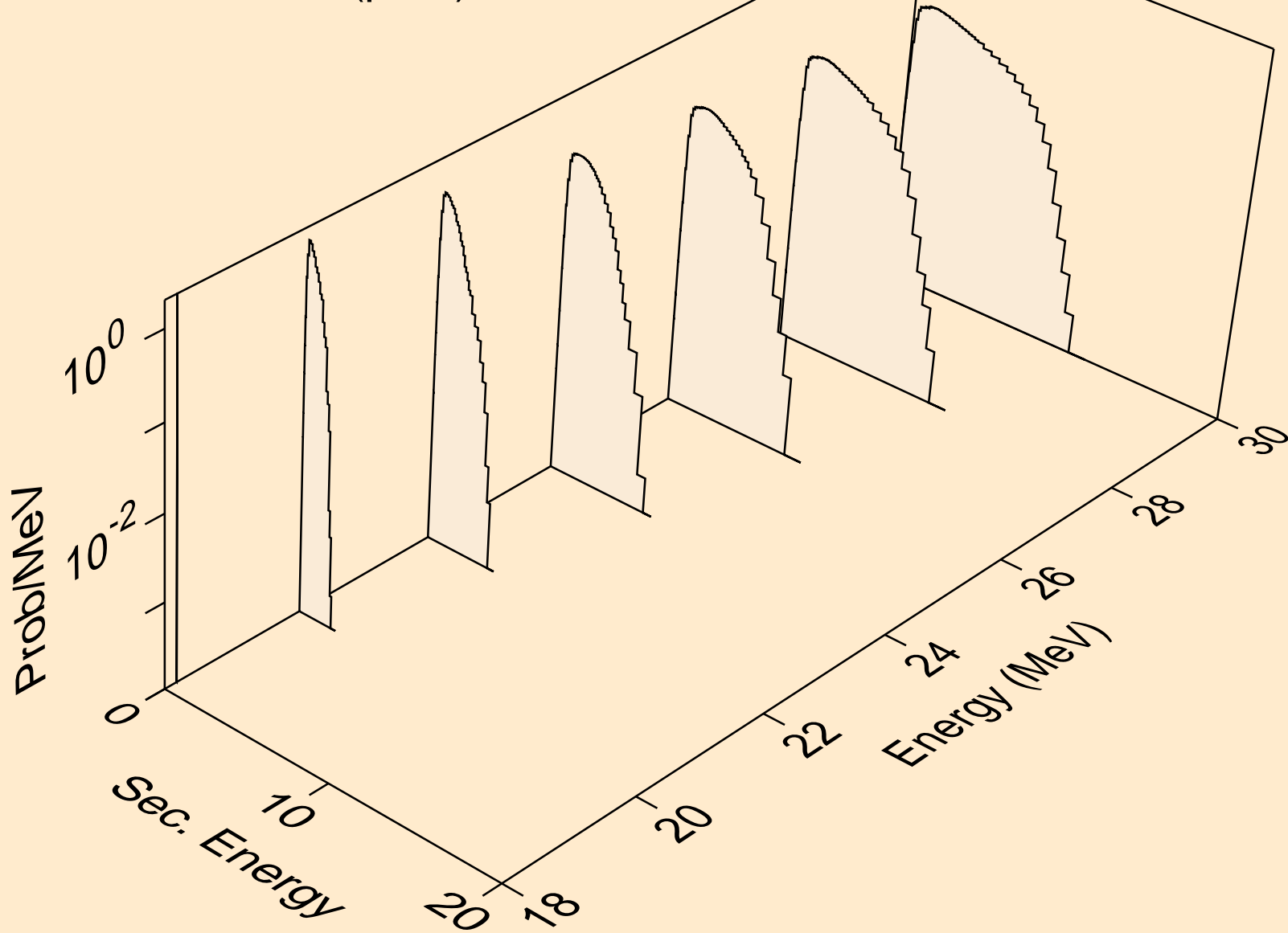



BH269 PROTON ACER TENDL-2021 LIBRARY; T=0.K  
neutrons from (p,n\*)a

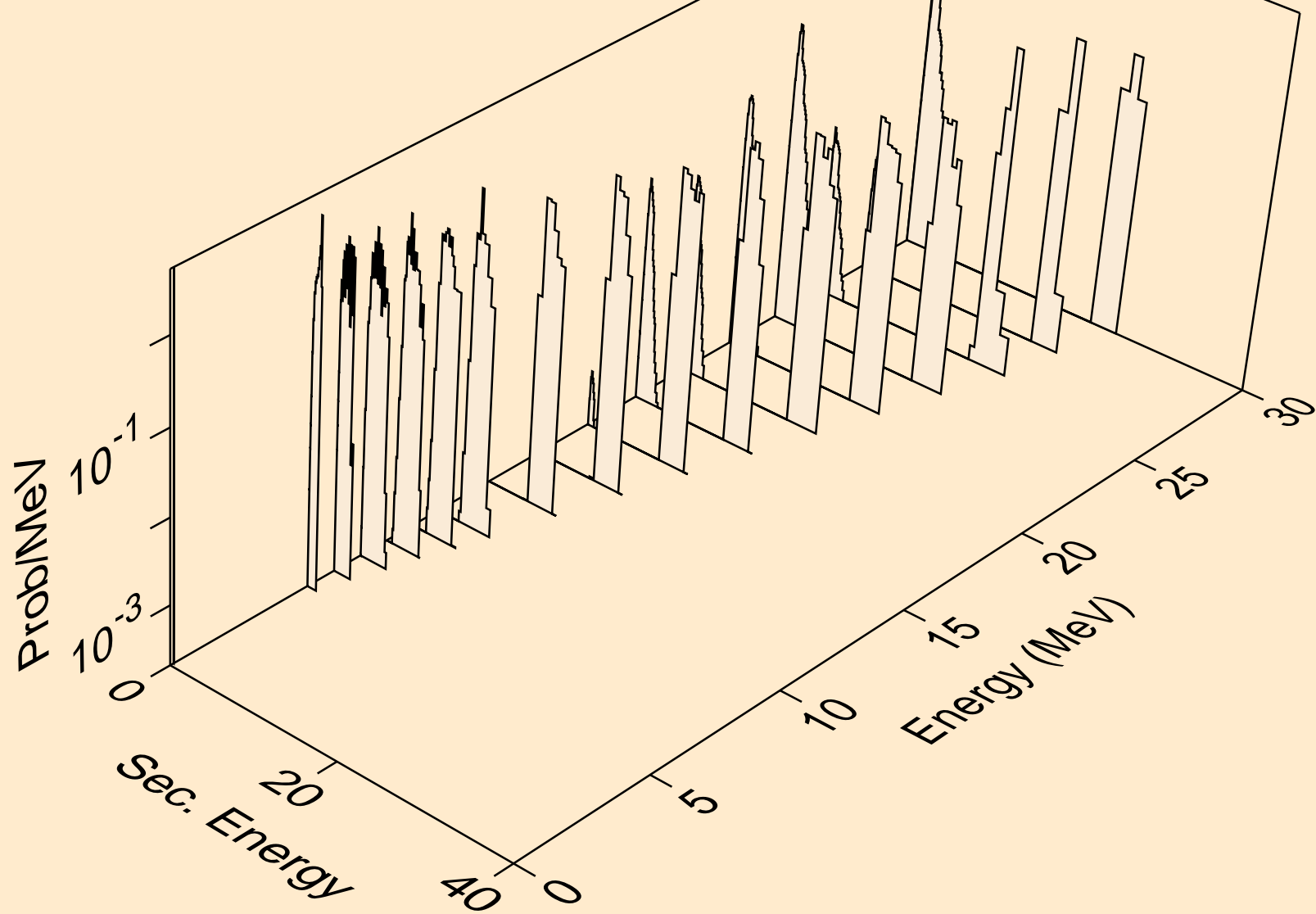

BH269 PROTON ACER TENDL-2021 LIBRARY; T=0.K  
neutrons from (p,2n)a

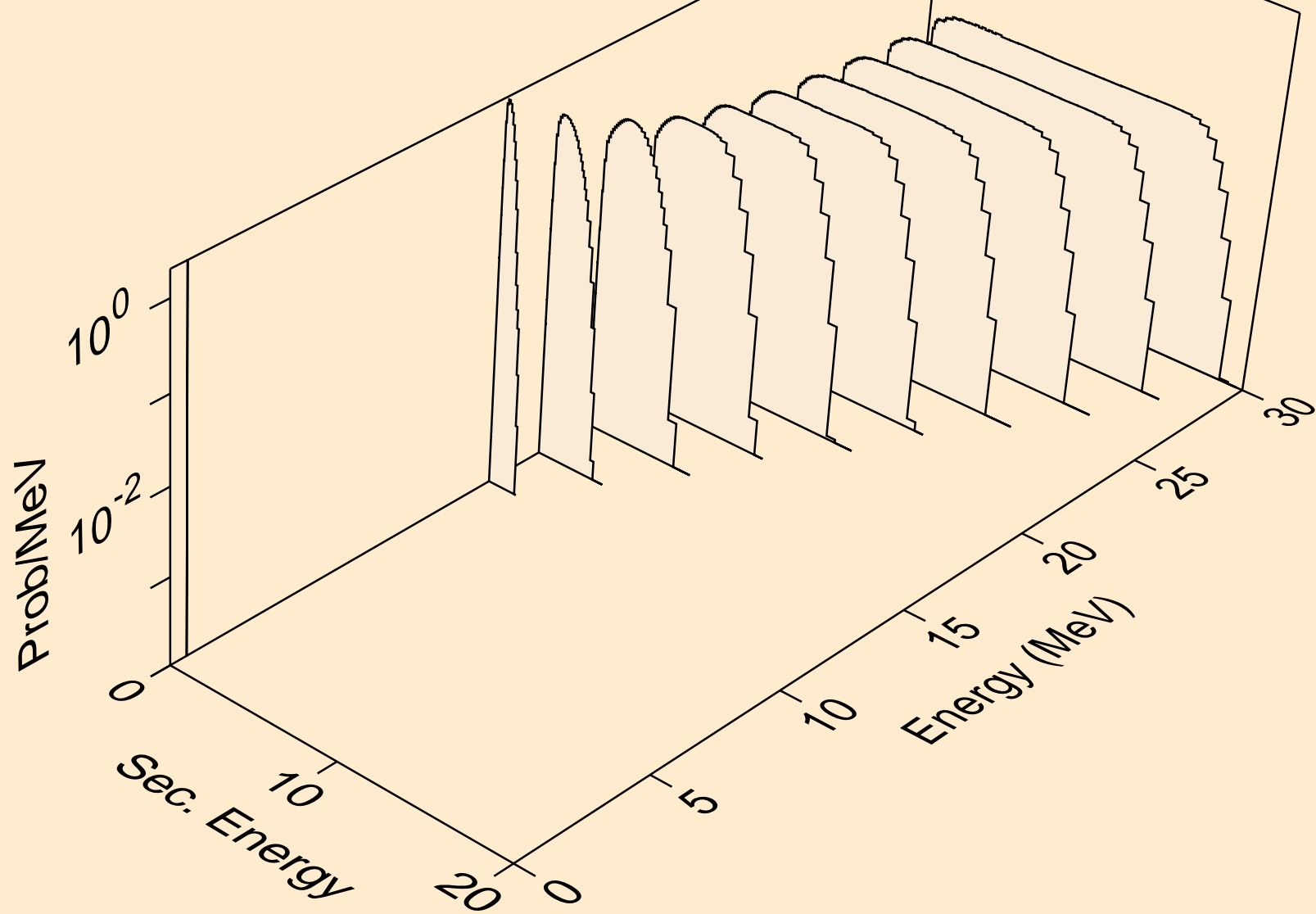

BH269 PROTON ACER TENDL-2021 LIBRARY; T=0.K  
neutrons from (p,n\*)p

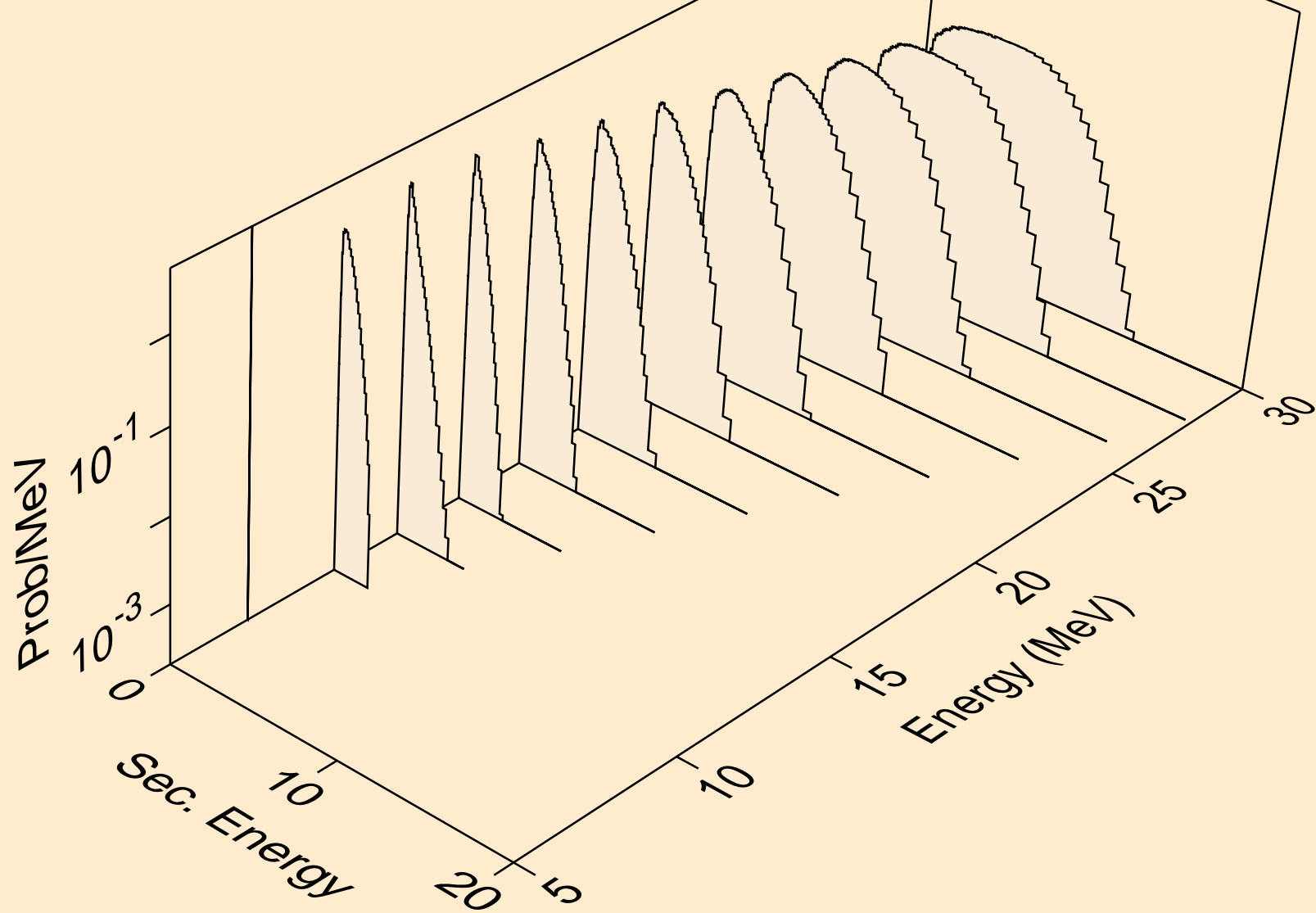

BH269 PROTON ACER TENDL-2021 LIBRARY; T=0.K  
neutrons from (p,n\*)d

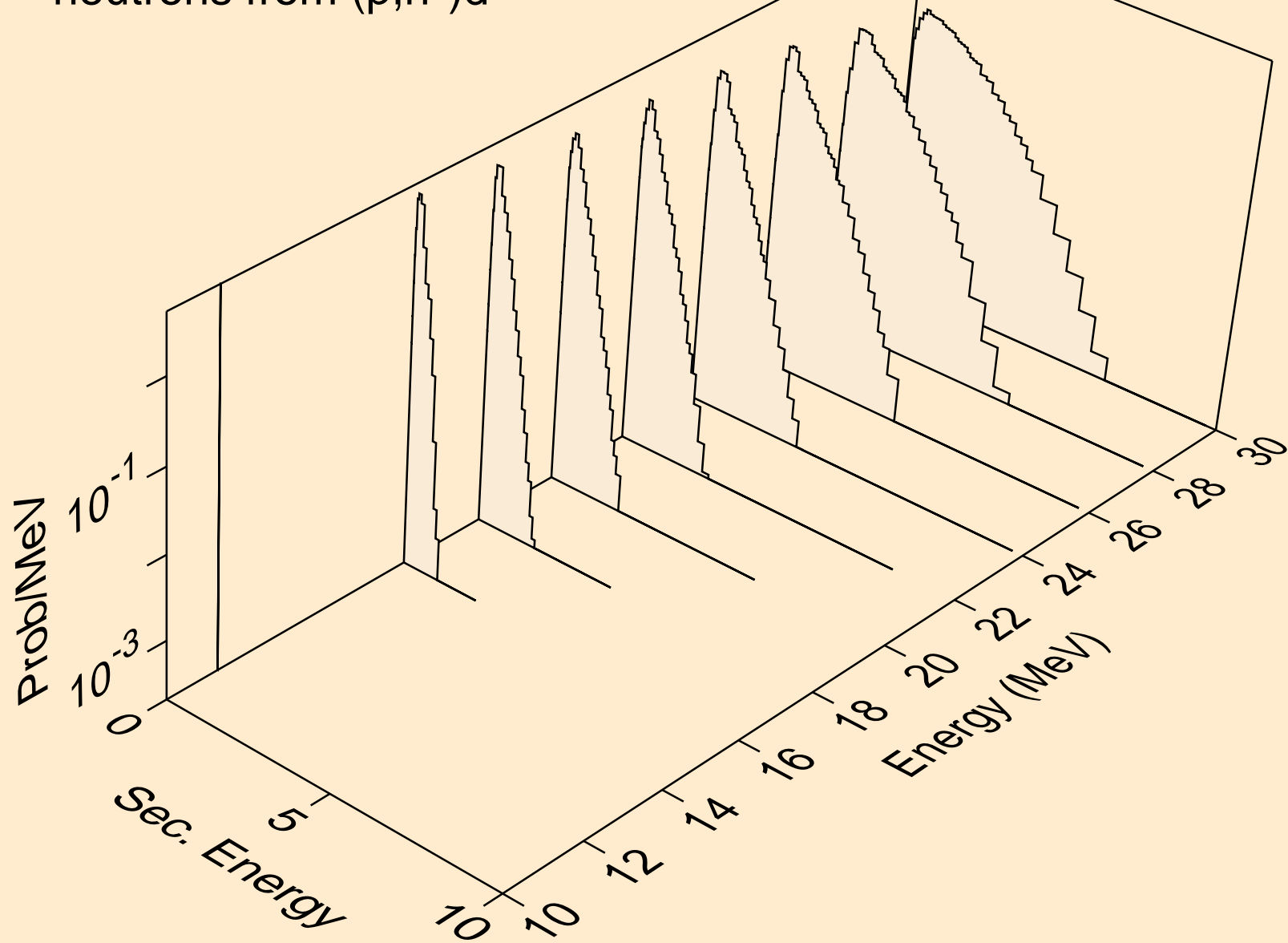

BH269 PROTON ACER TENDL-2021 LIBRARY; T=0.K  
neutrons from (p,n\*)t

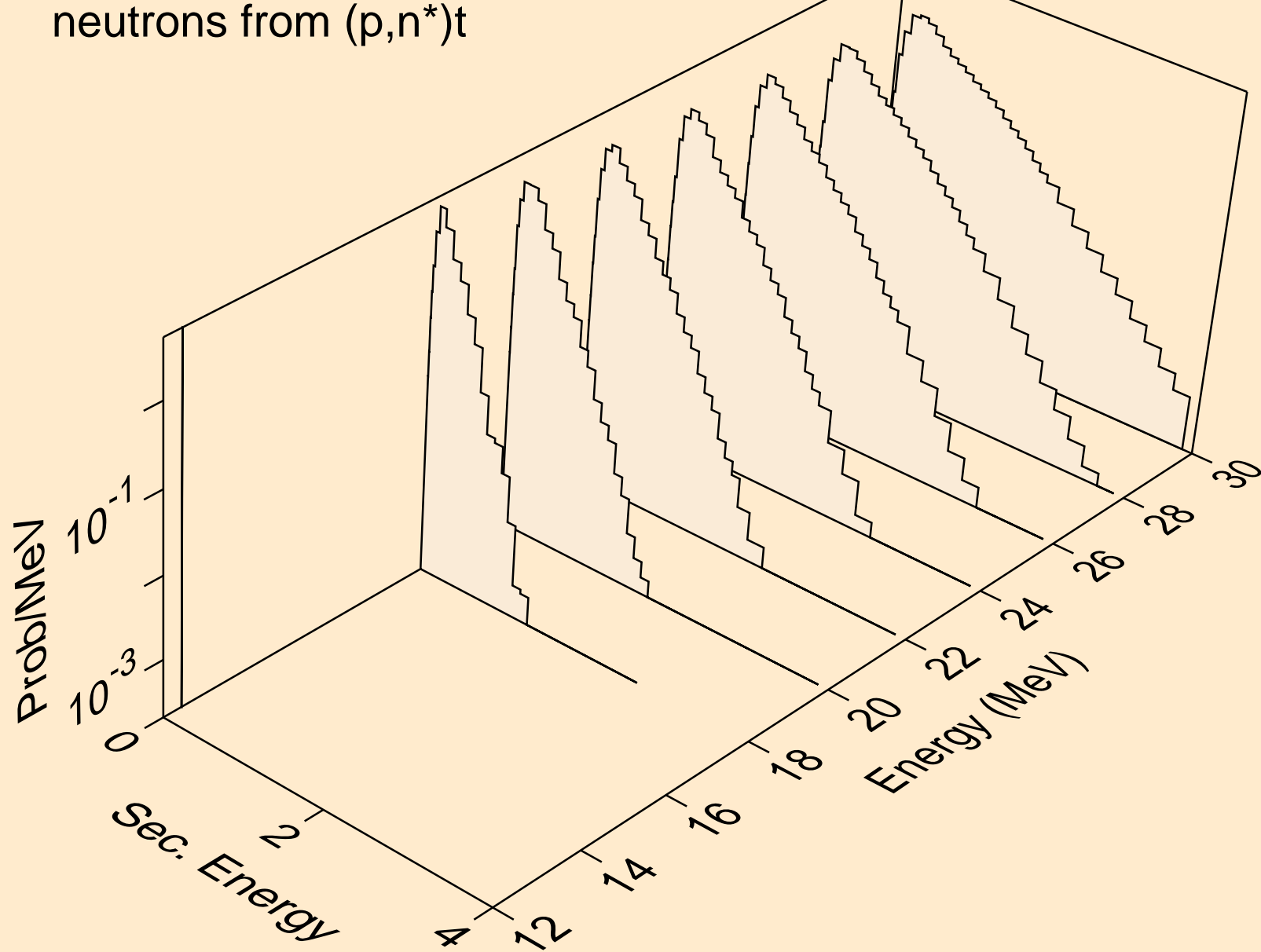

BH269 PROTON ACER TENDL-2021 LIBRARY; T=0.K  
neutrons from (p,2np)

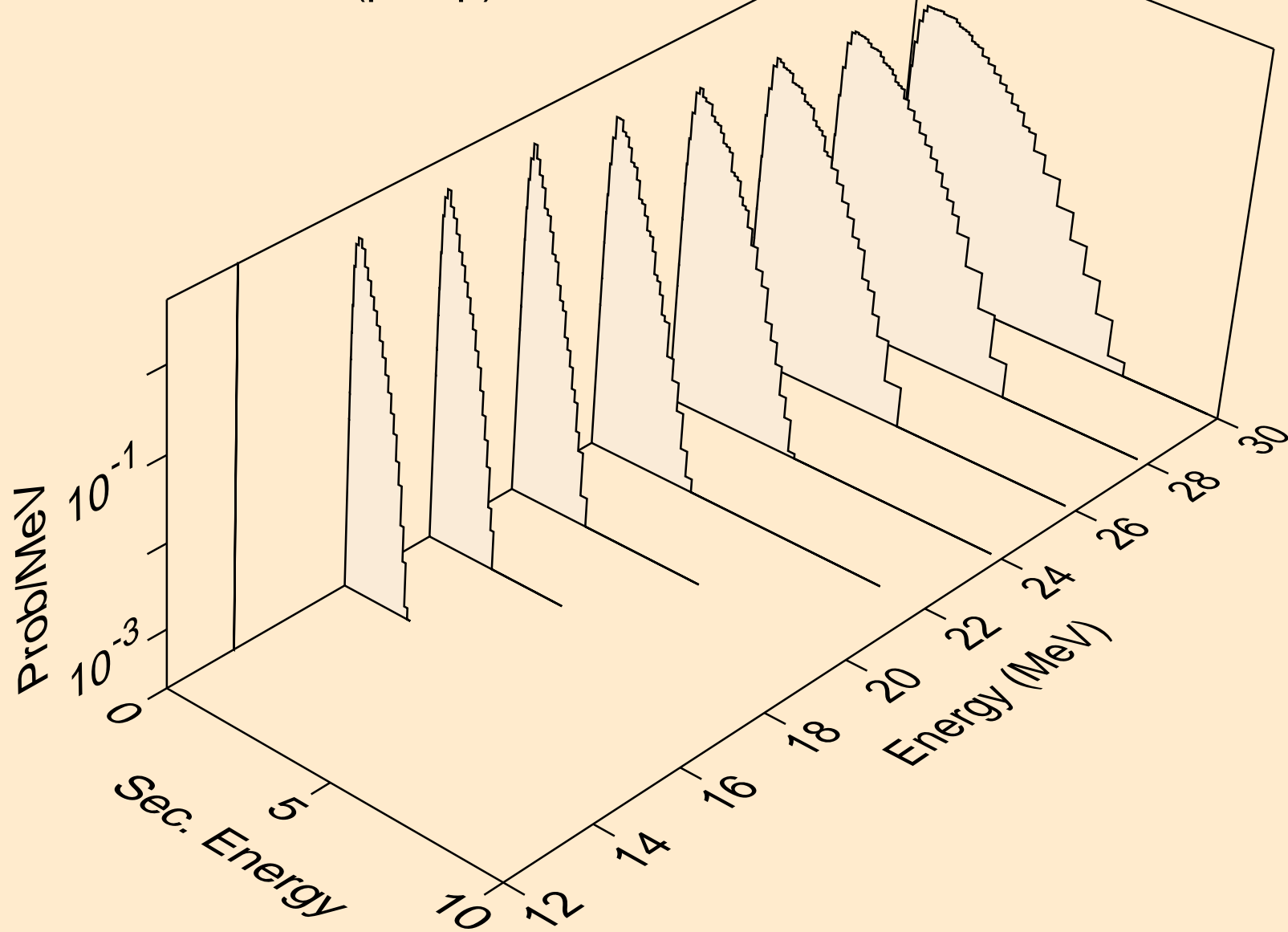

BH269 PROTON ACER TENDL-2021 LIBRARY; T=0.K  
deuterons from (p,x)

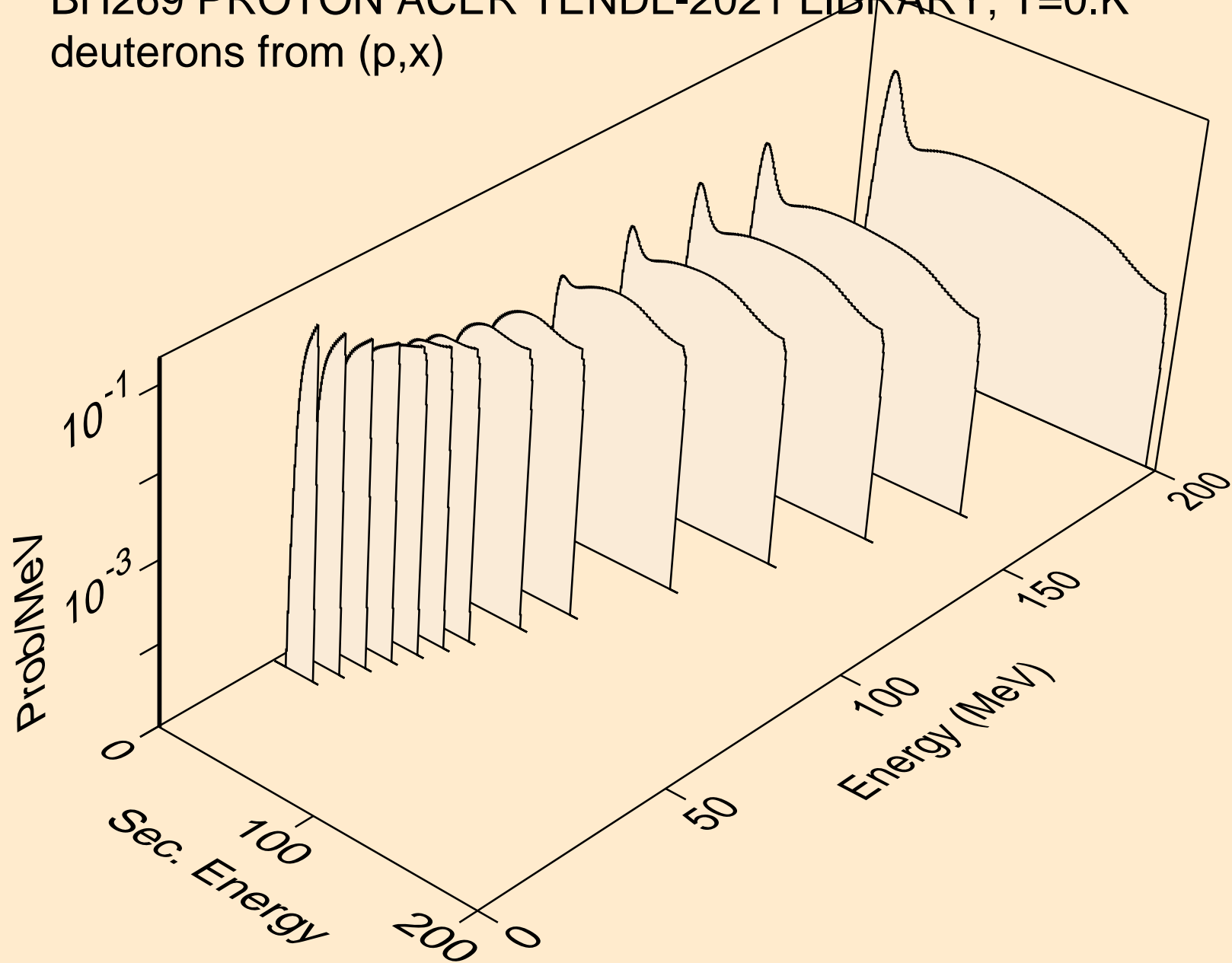

BH269 PROTON ACER TENDL-2021 LIBRARY; T=0.K  
deuterons from (p,n\*)d

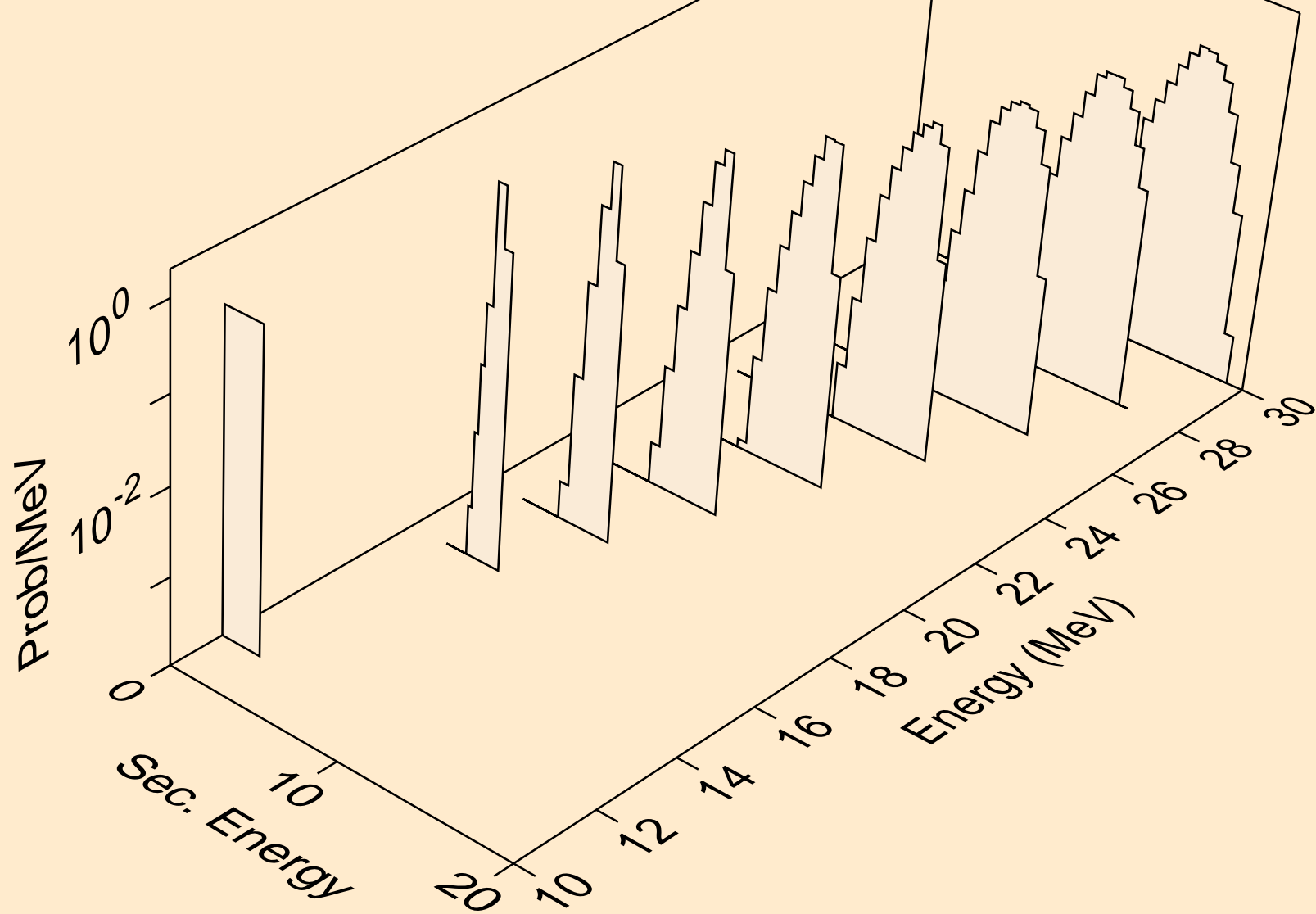



BH269 PROTON ACER TENDL-2021 LIBRARY; T=0.K  
deuterons from (p,d)

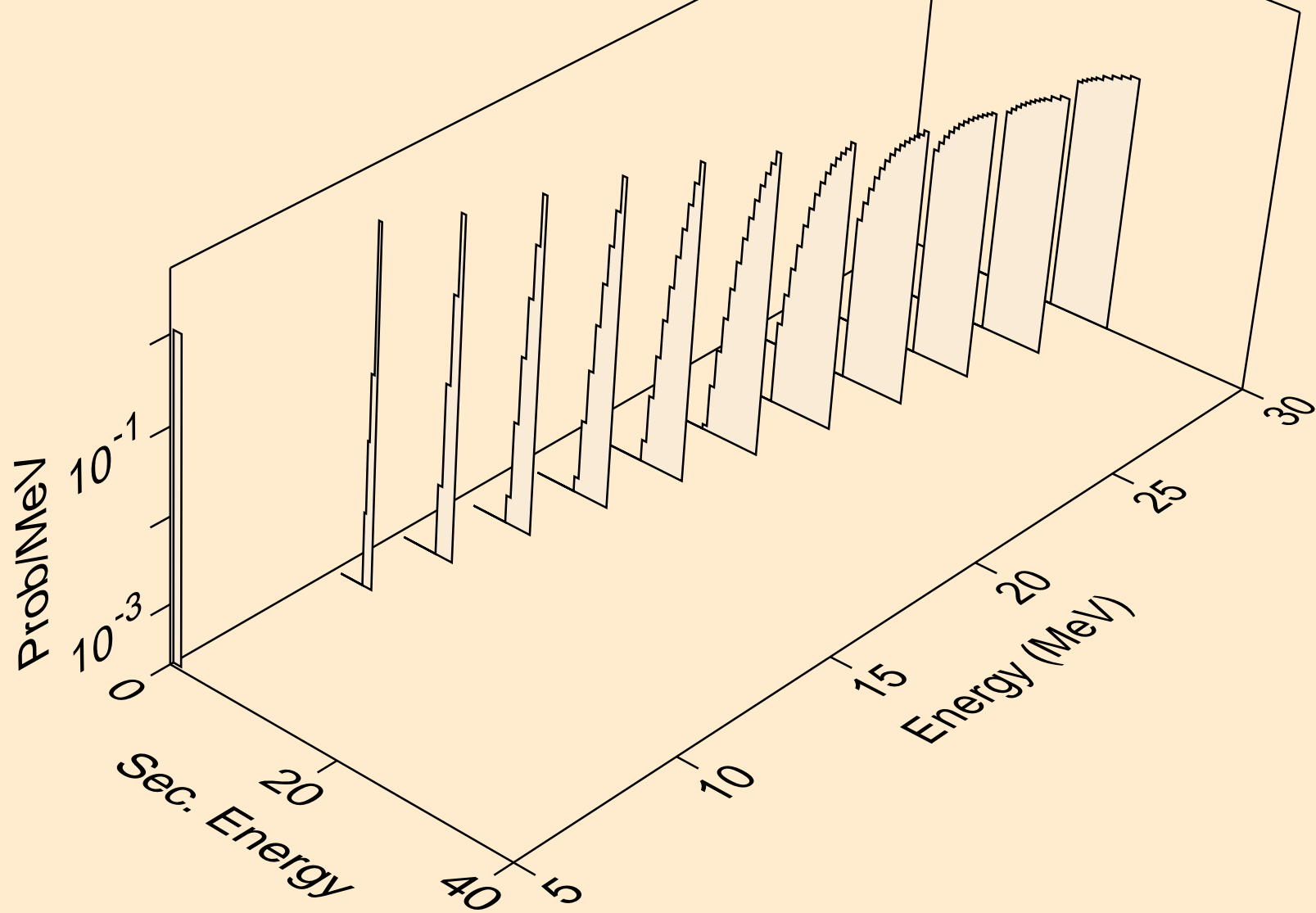

BH269 PROTON ACER TENDL-2021 LIBRARY; T=0.K  
tritons from (p,x)

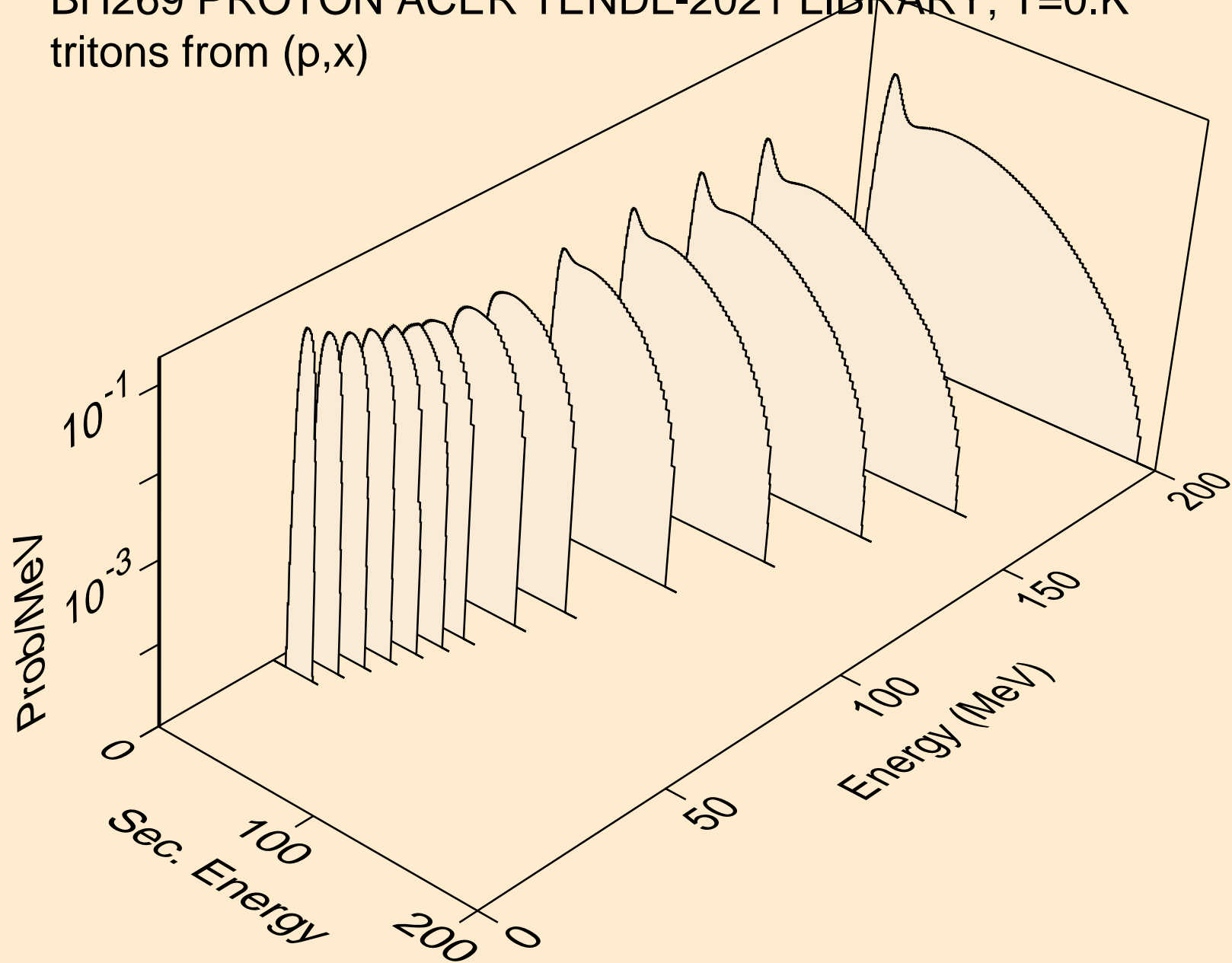

# BH269 PROTON ACER TENDL-2021 LIBRARY; T=0.K

tritons from (p,n\*)t

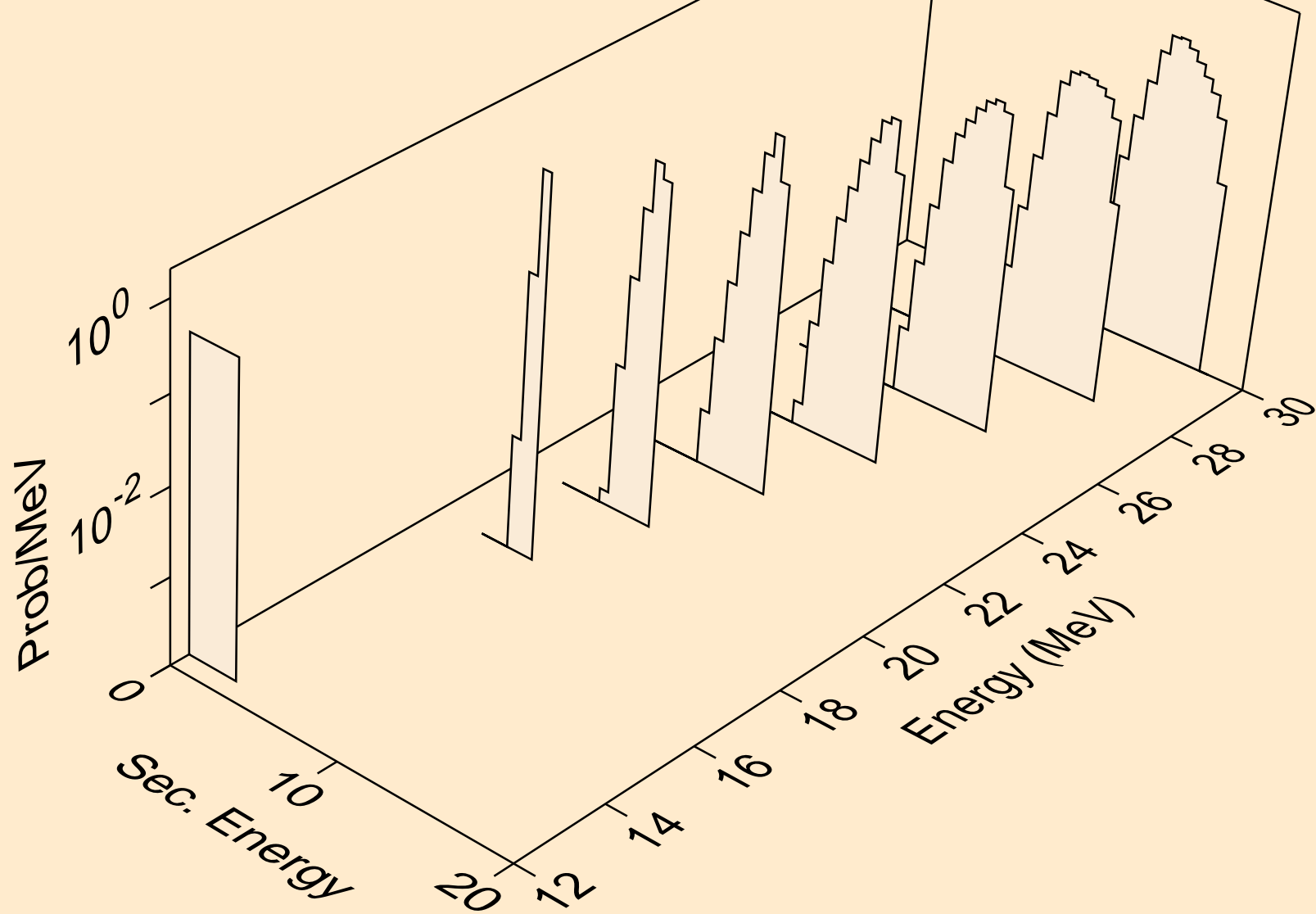

BH269 PROTON ACER TENDL-2021 LIBRARY; T=0.K  
tritons from (p,t)

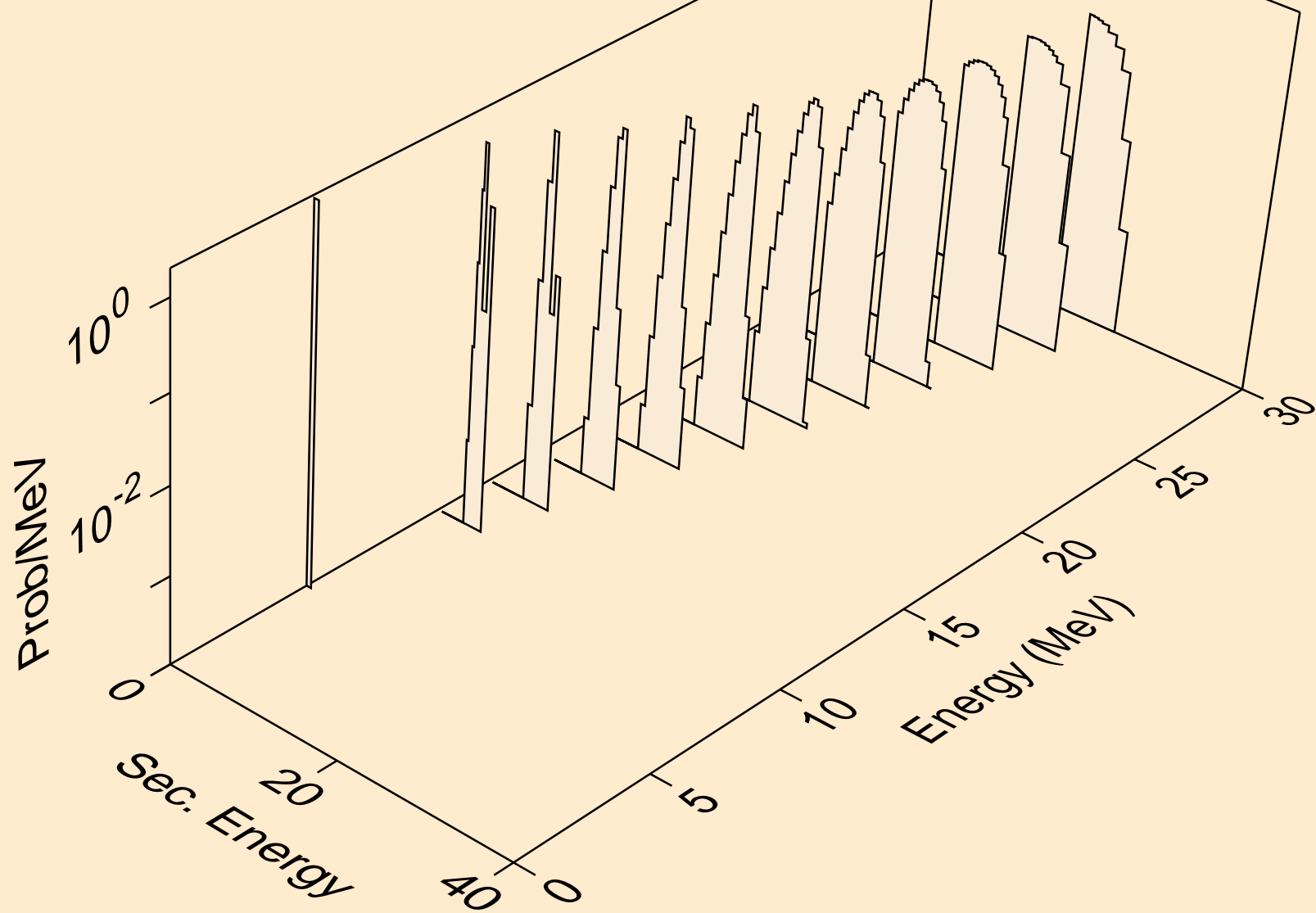

BH269 PROTON ACER TENDL-2021 LIBRARY; T=0.K  
tritons from (p,t2a)

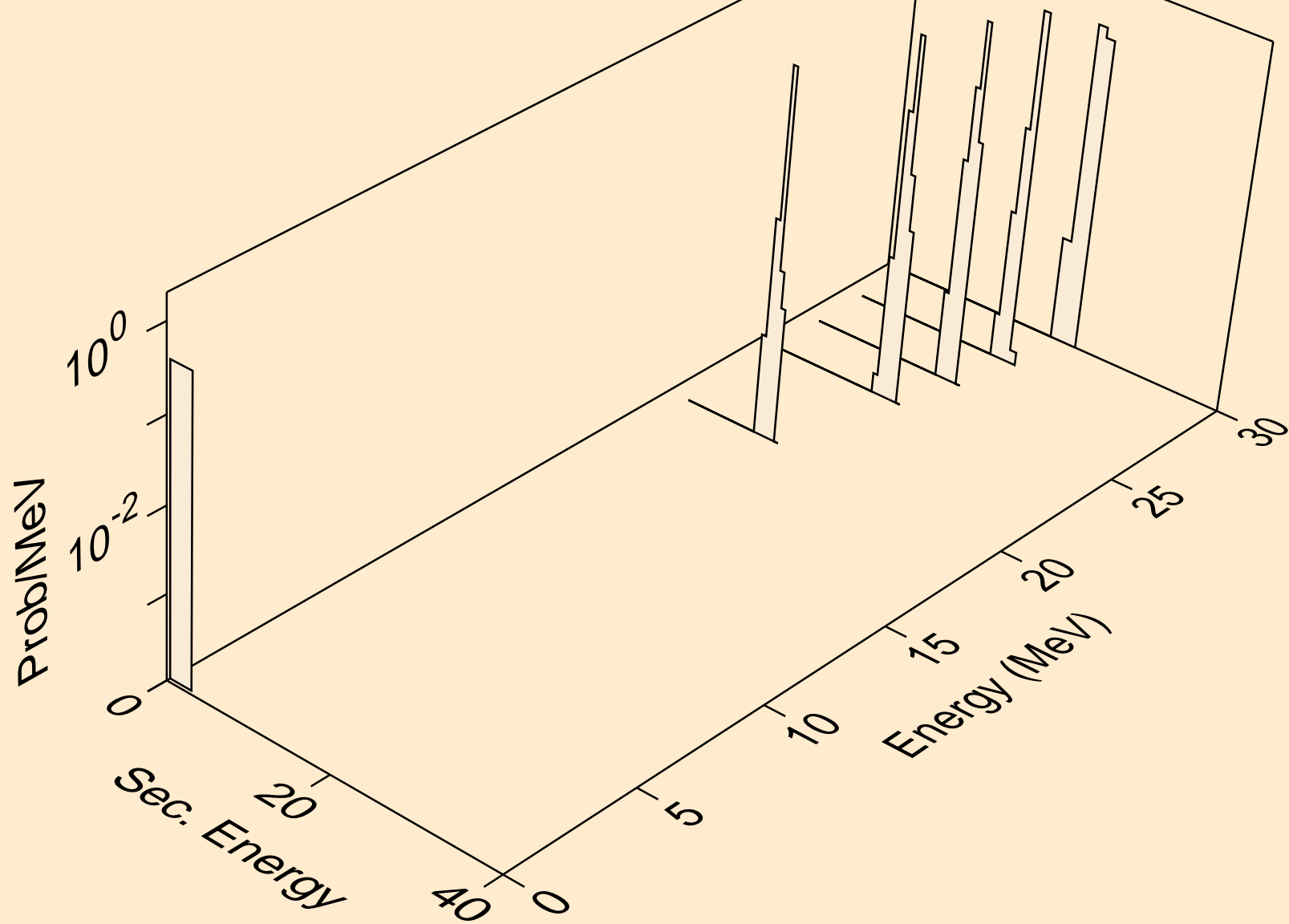

BH269 PROTON ACER TENDL-2021 LIBRARY; T=0.K  
he3s from (p,x)

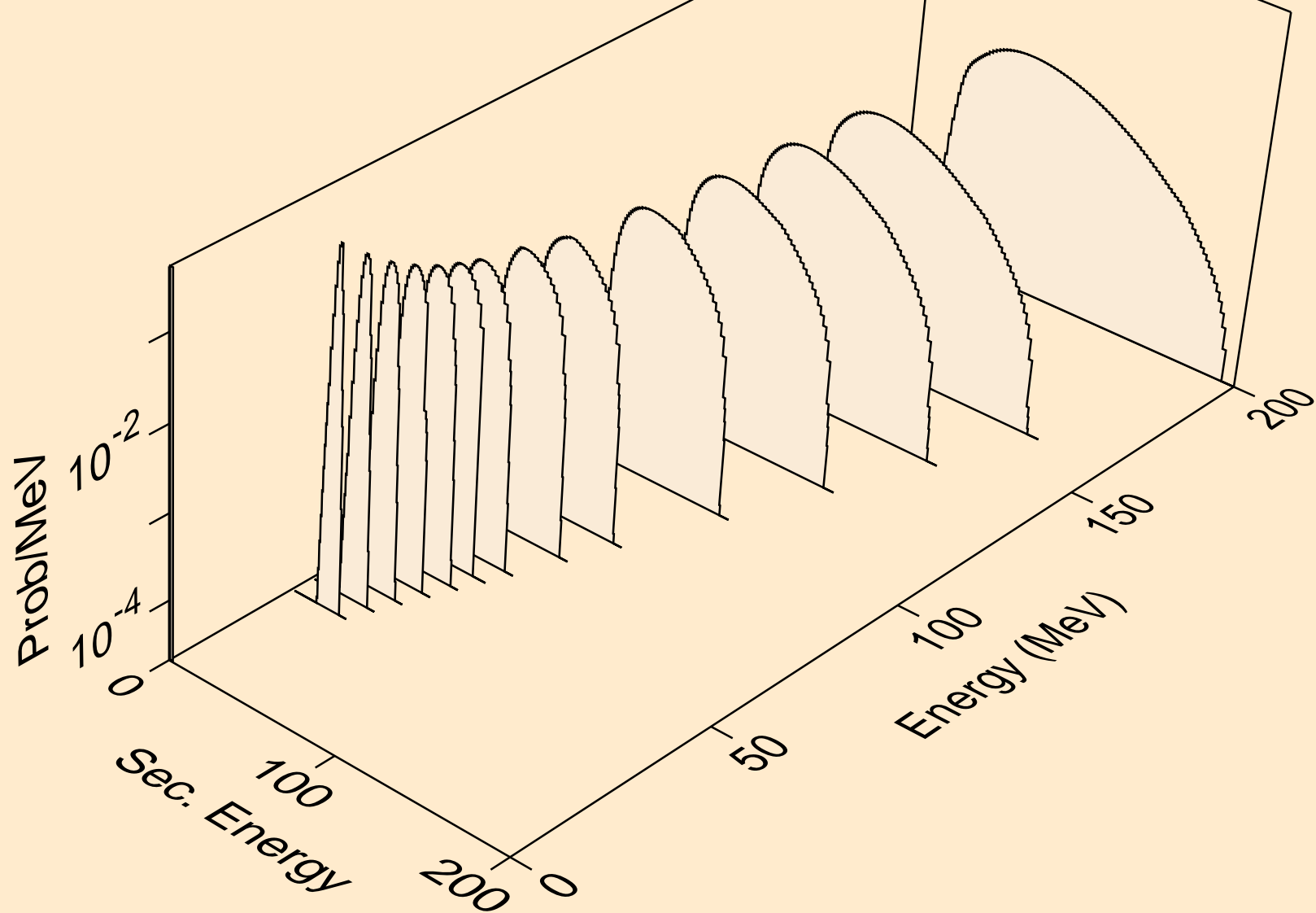

BH269 PROTON ACER TENDL-2021 LIBRARY; T=0.K  
he3s from (p,he3)

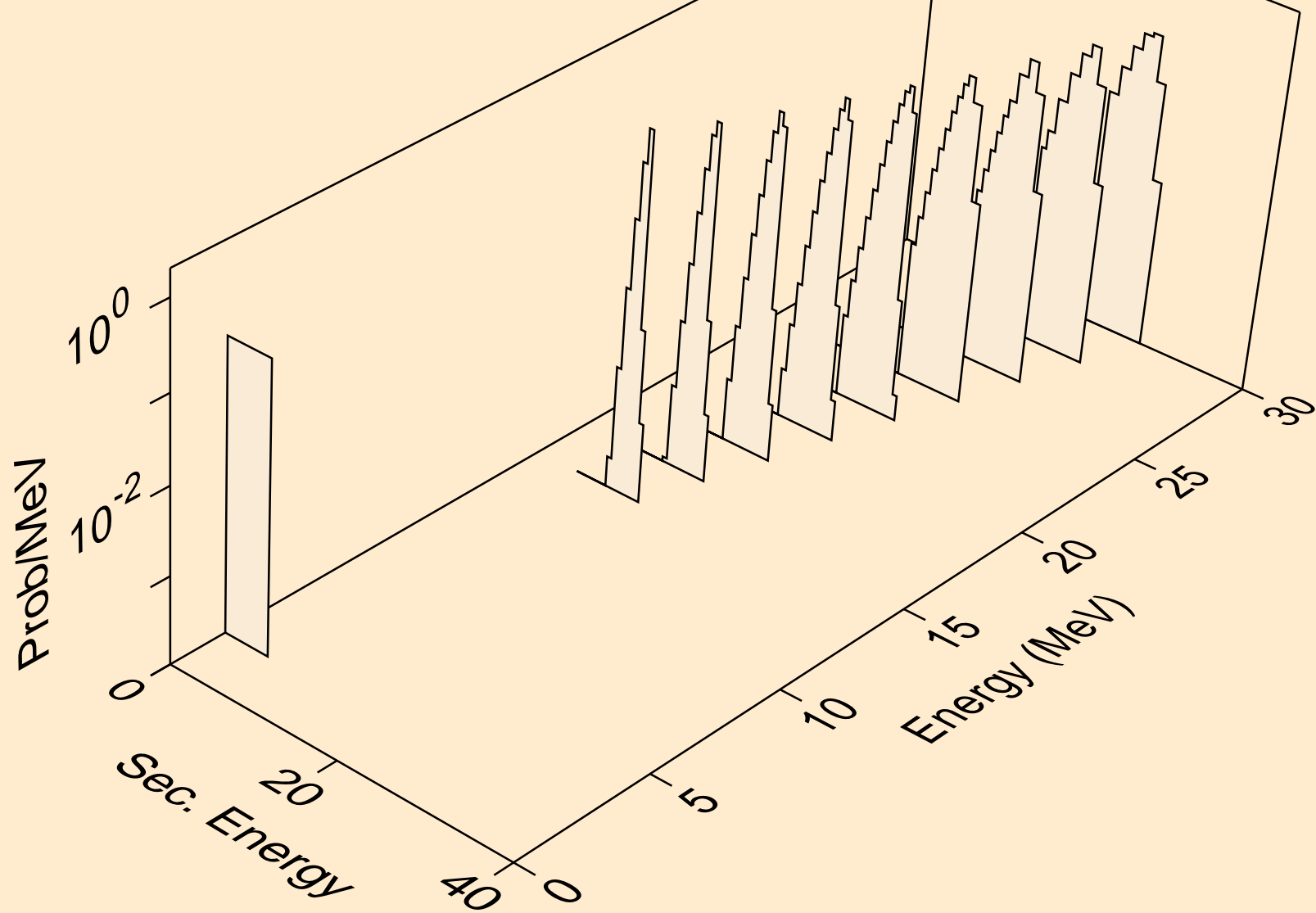

BH269 PROTON ACER TENDL-2021 LIBRARY; T=0.K  
alphas from (p,x)

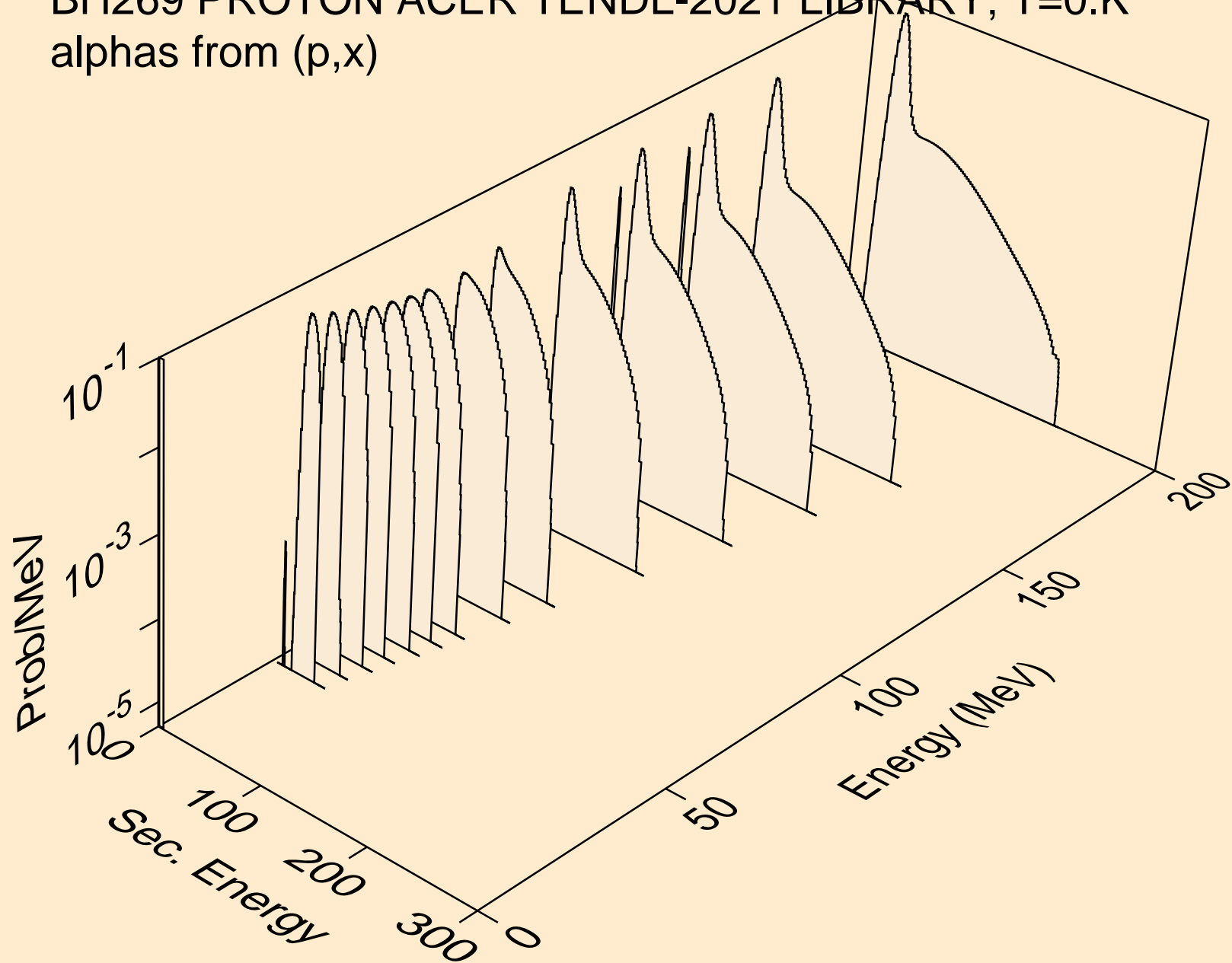



BH269 PROTON ACER TENDL-2021 LIBRARY; T=0.K  
alphas from (p,n\*)a

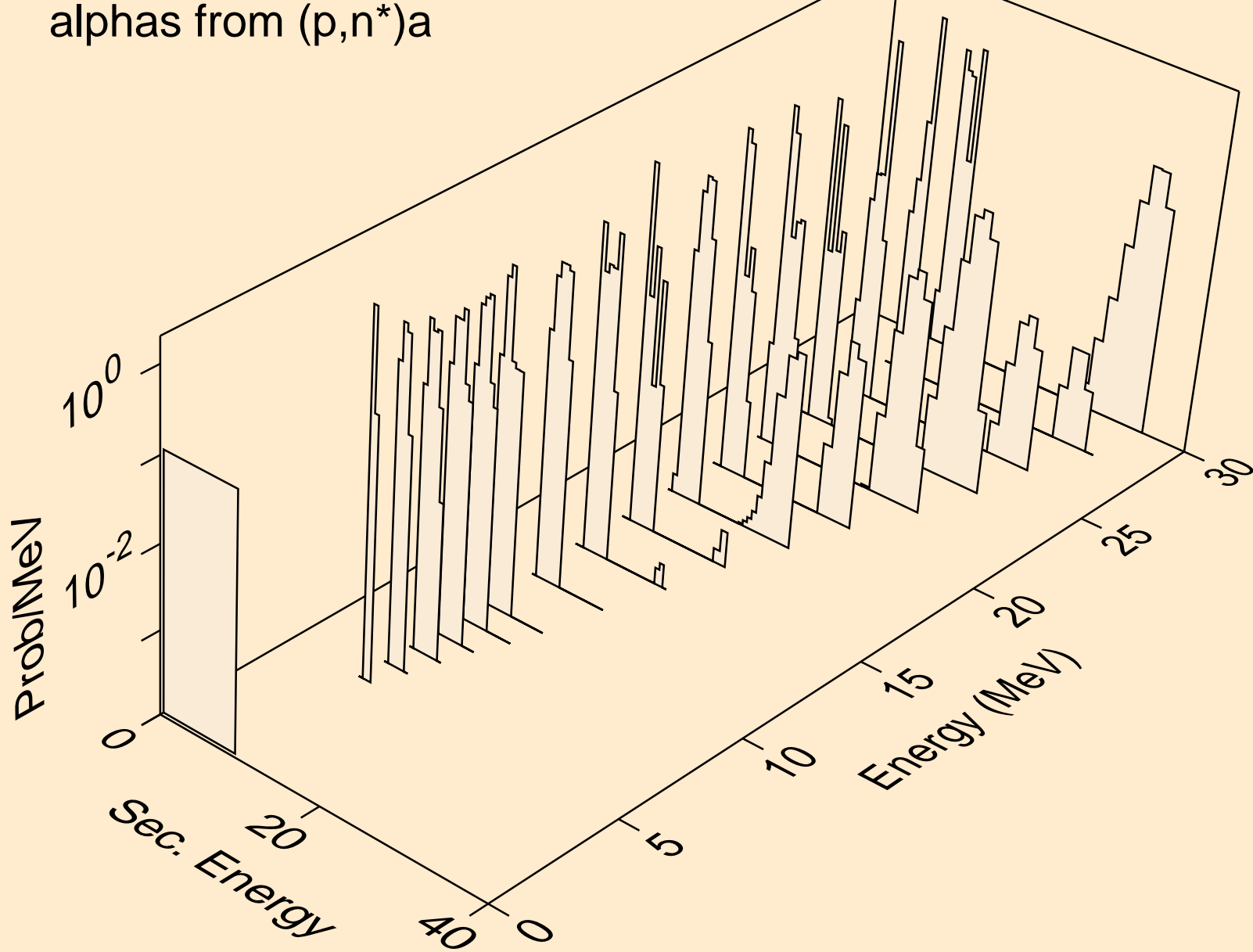

BH269 PROTON ACER TENDL-2021 LIBRARY; T=0.K  
alphas from (p,2n)a

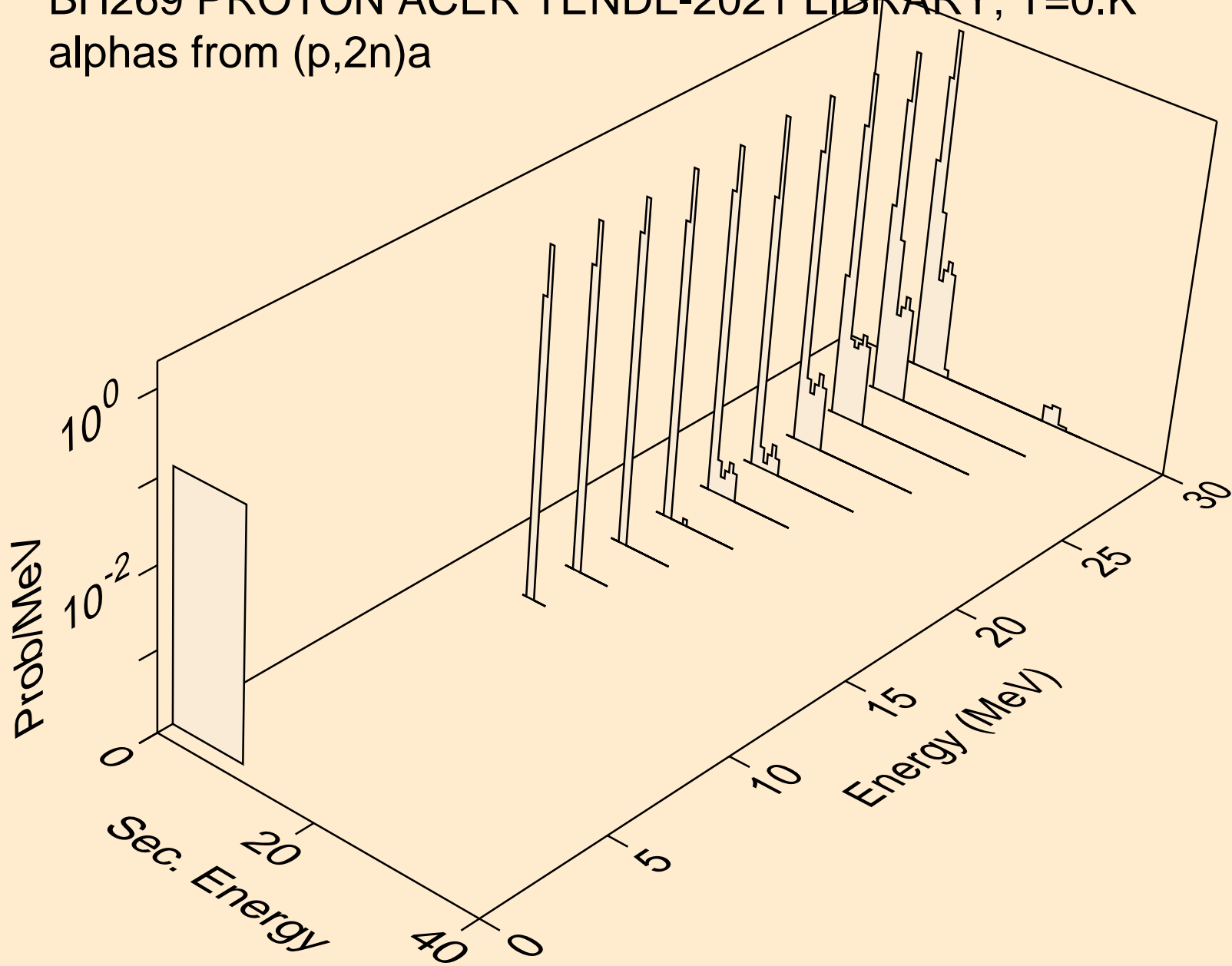

BH269 PROTON ACER TENDL-2021 LIBRARY; T=0.K  
alphas from (p,a)

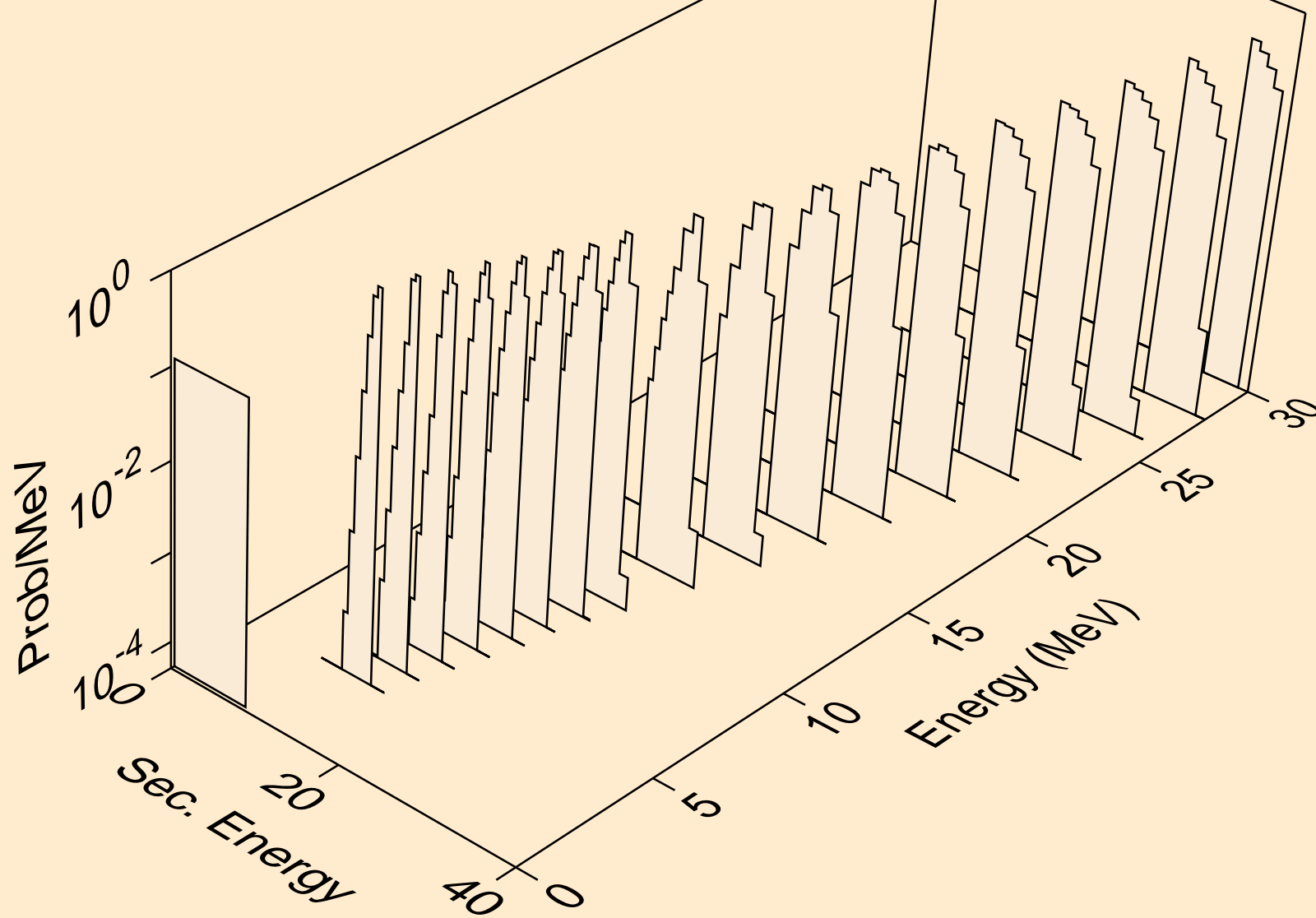

BH269 PROTON ACER TENDL-2021 LIBRARY; T=0.K  
alphas from (p,pa)

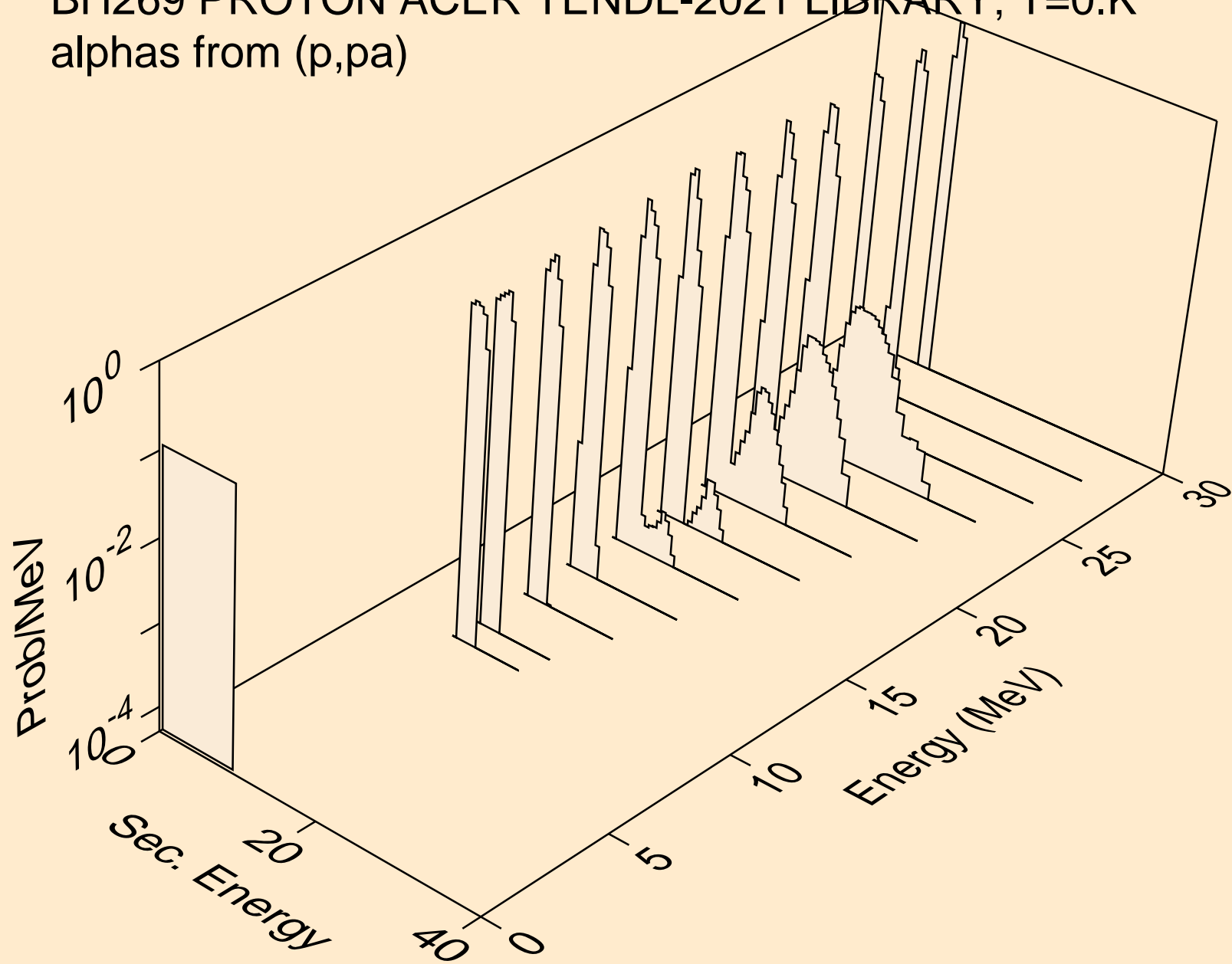

BH269 PROTON ACER TENDL-2021 LIBRARY; T=0.K  
alphas from (p,t2a)

