

BI214 PROTON ACER TENDL-2021 LIBRARY; T=0.K  
Principal cross sections

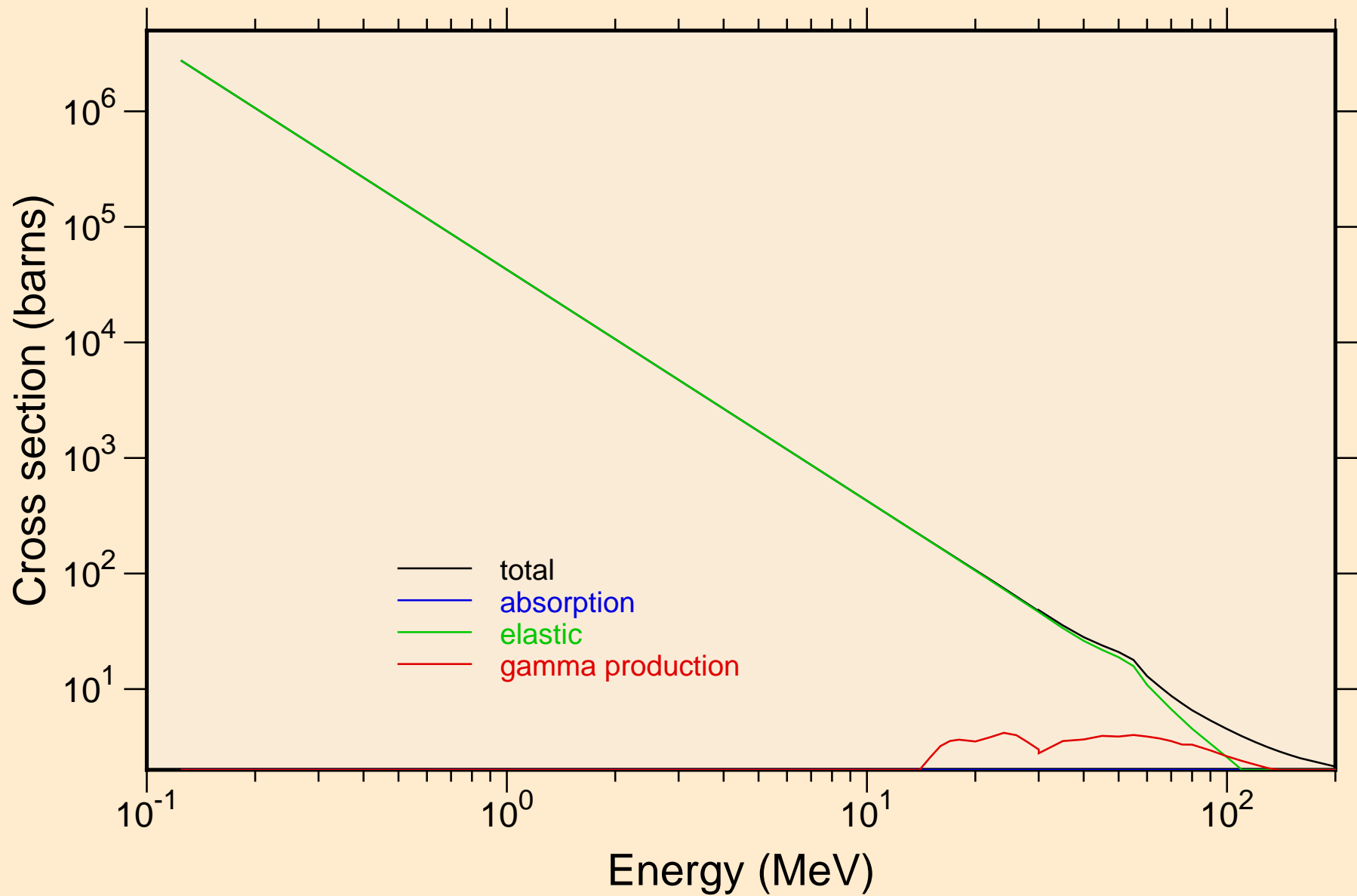

BI214 PROTON ACER TENDL-2021 LIBRARY; T=0.K  
Heating

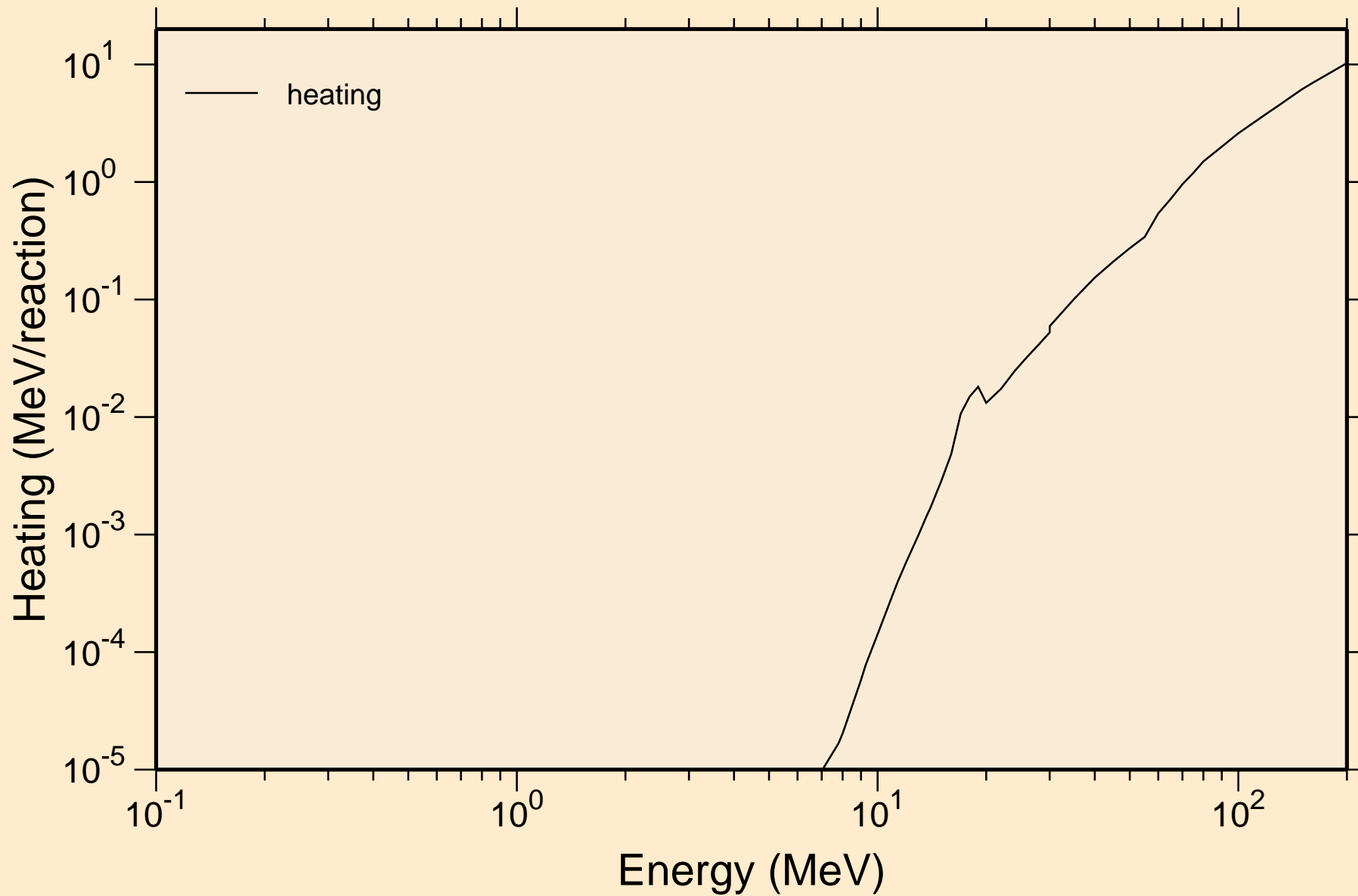

# BI214 PROTON ACER TENDL-2021 LIBRARY; T=0.K

## Principal cross sections

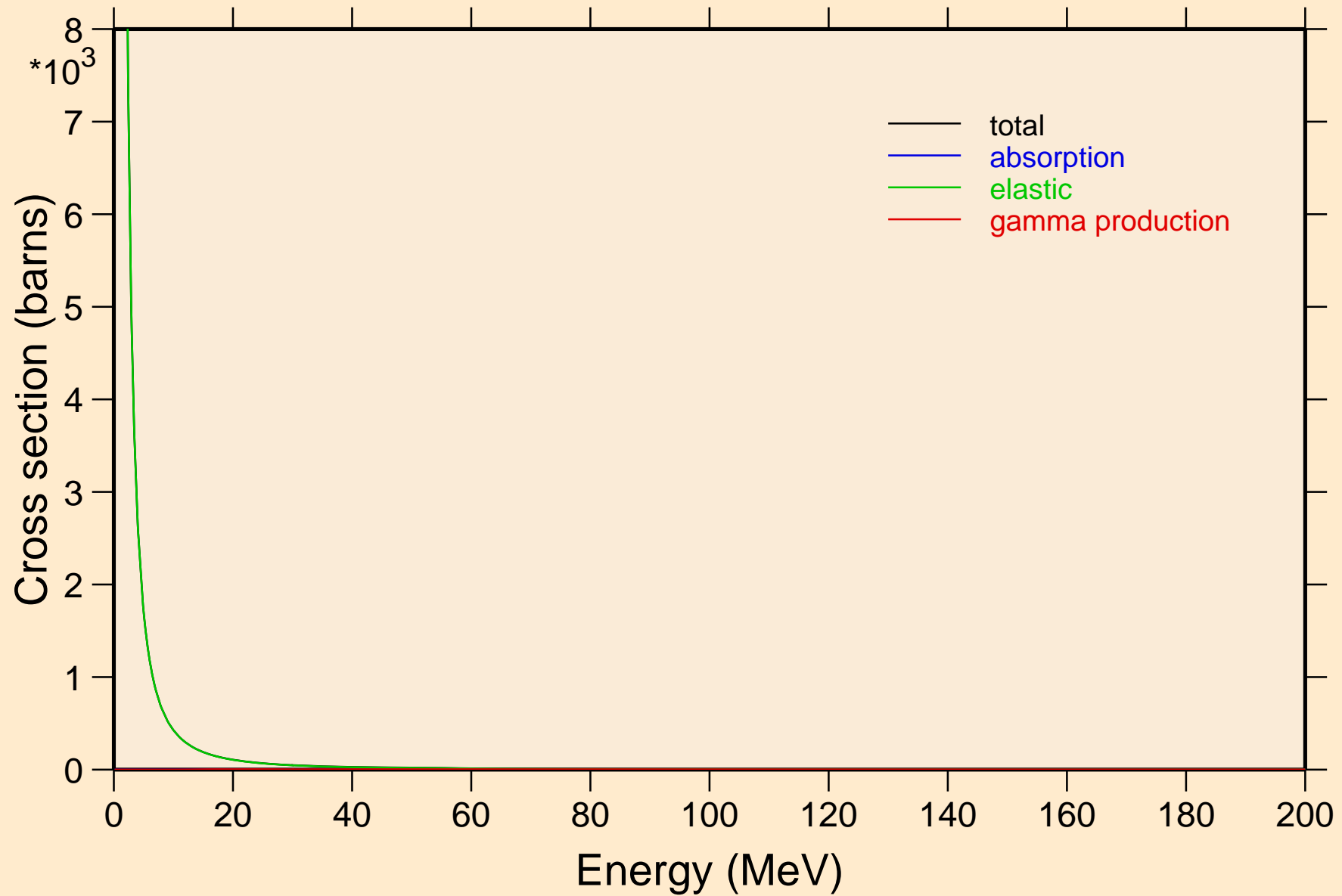

# BI214 PROTON ACER TENDL-2021 LIBRARY; T=0.K

## Heating

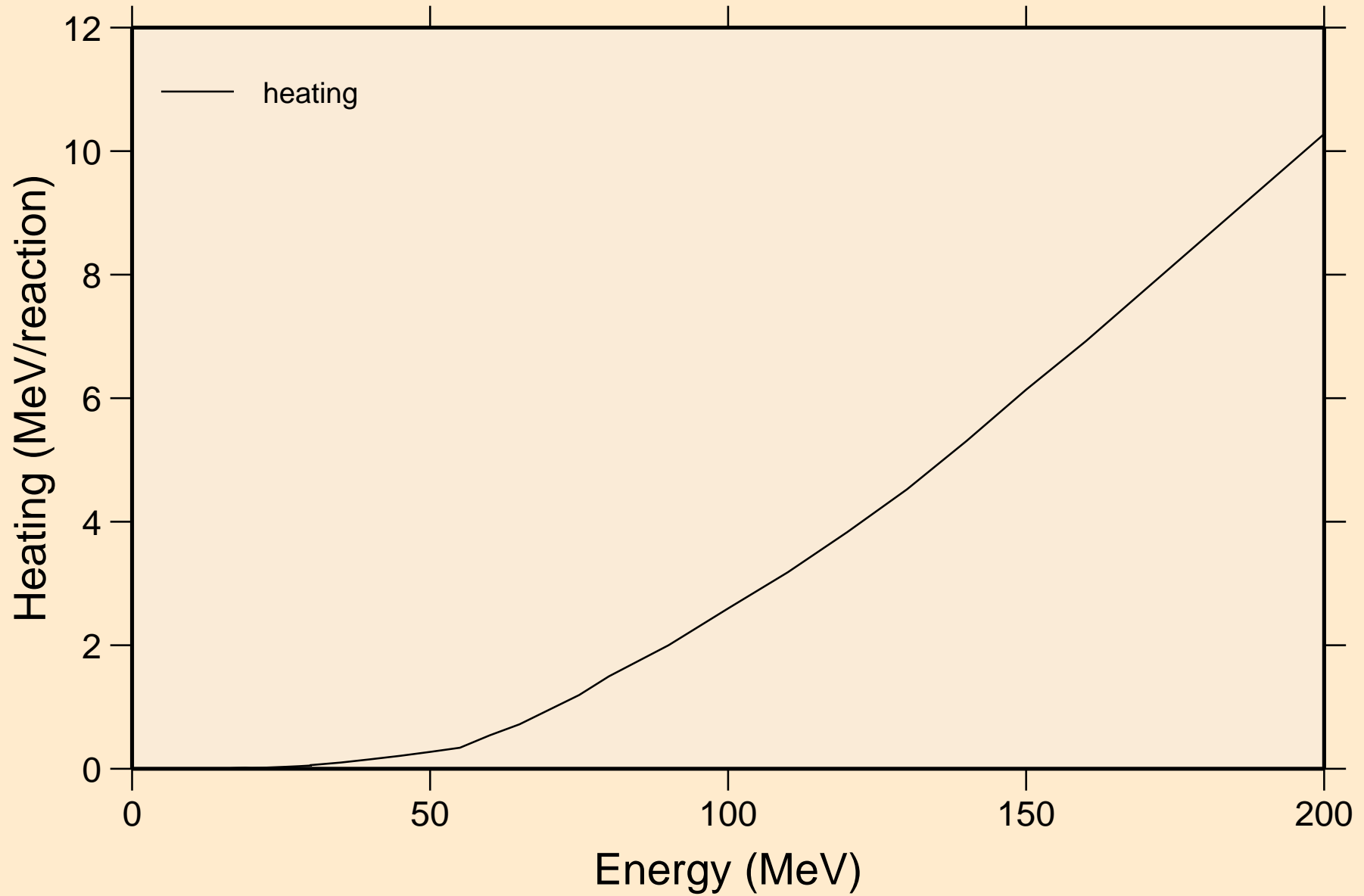

BI214 PROTON ACER TENDL-2021 LIBRARY; T=0.K  
Threshold reactions

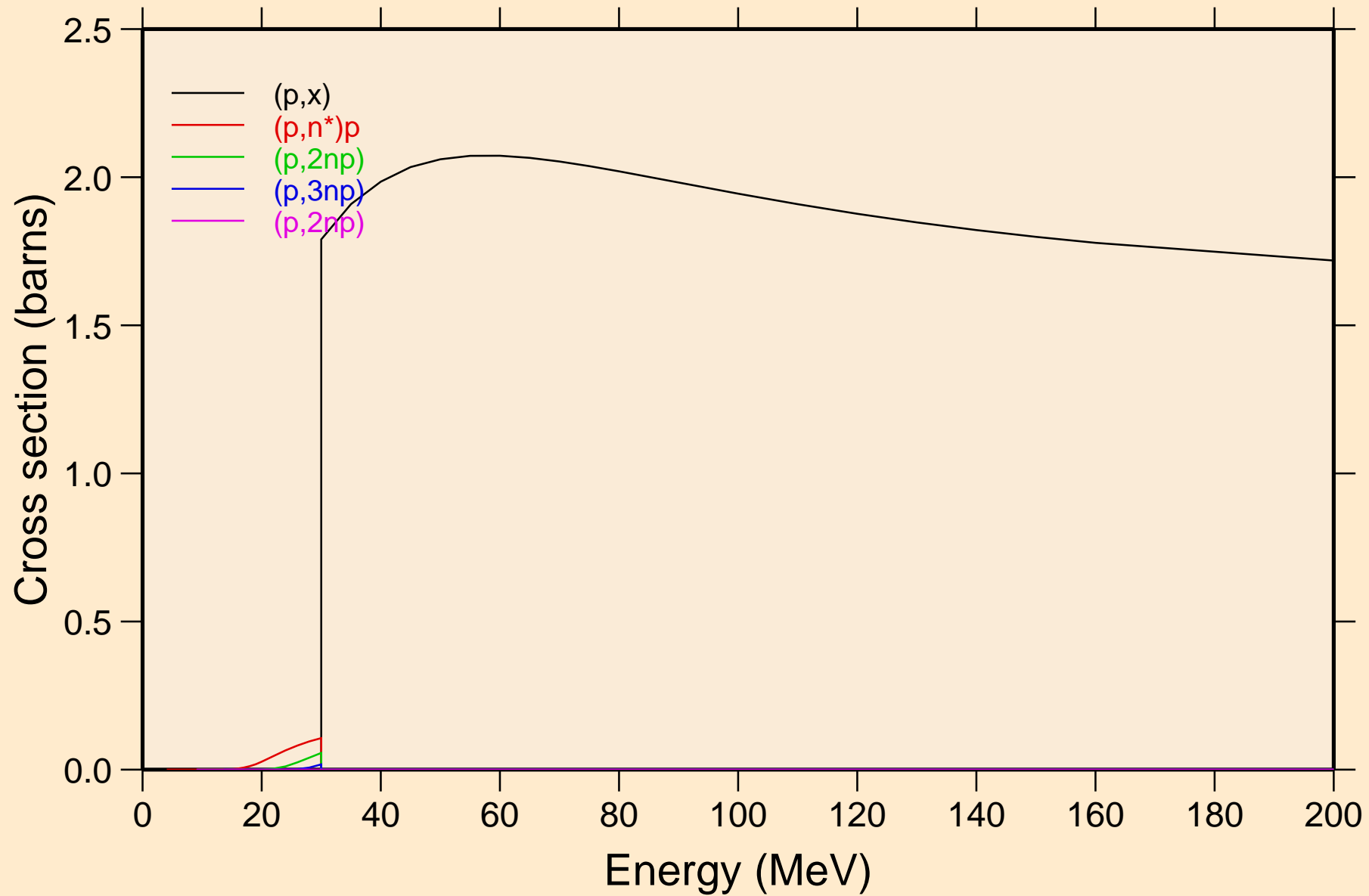

BI214 PROTON ACER TENDL-2021 LIBRARY; T=0.K  
Threshold reactions

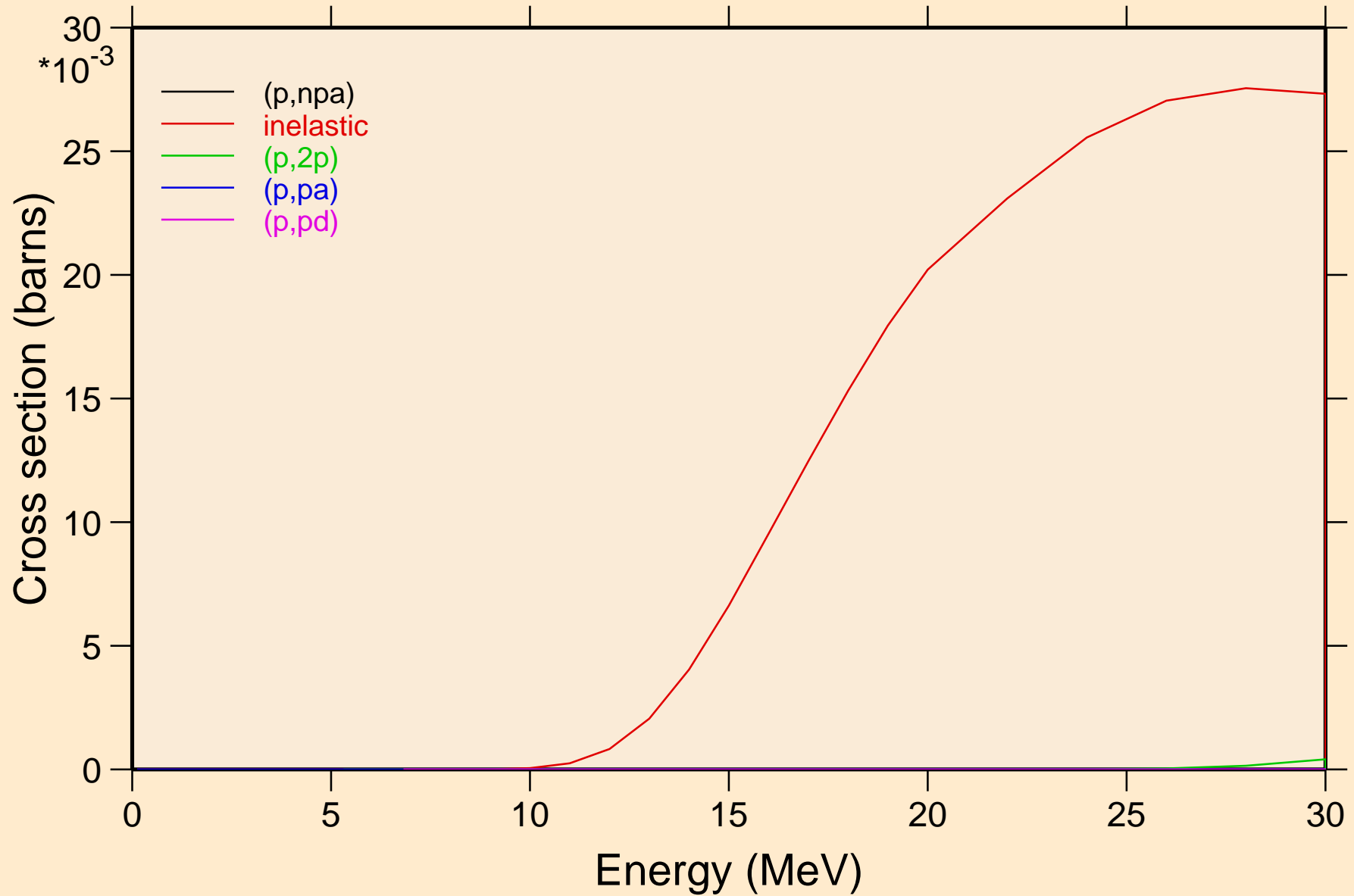

BI214 PROTON ACER TENDL-2021 LIBRARY; T=0.K  
Threshold reactions

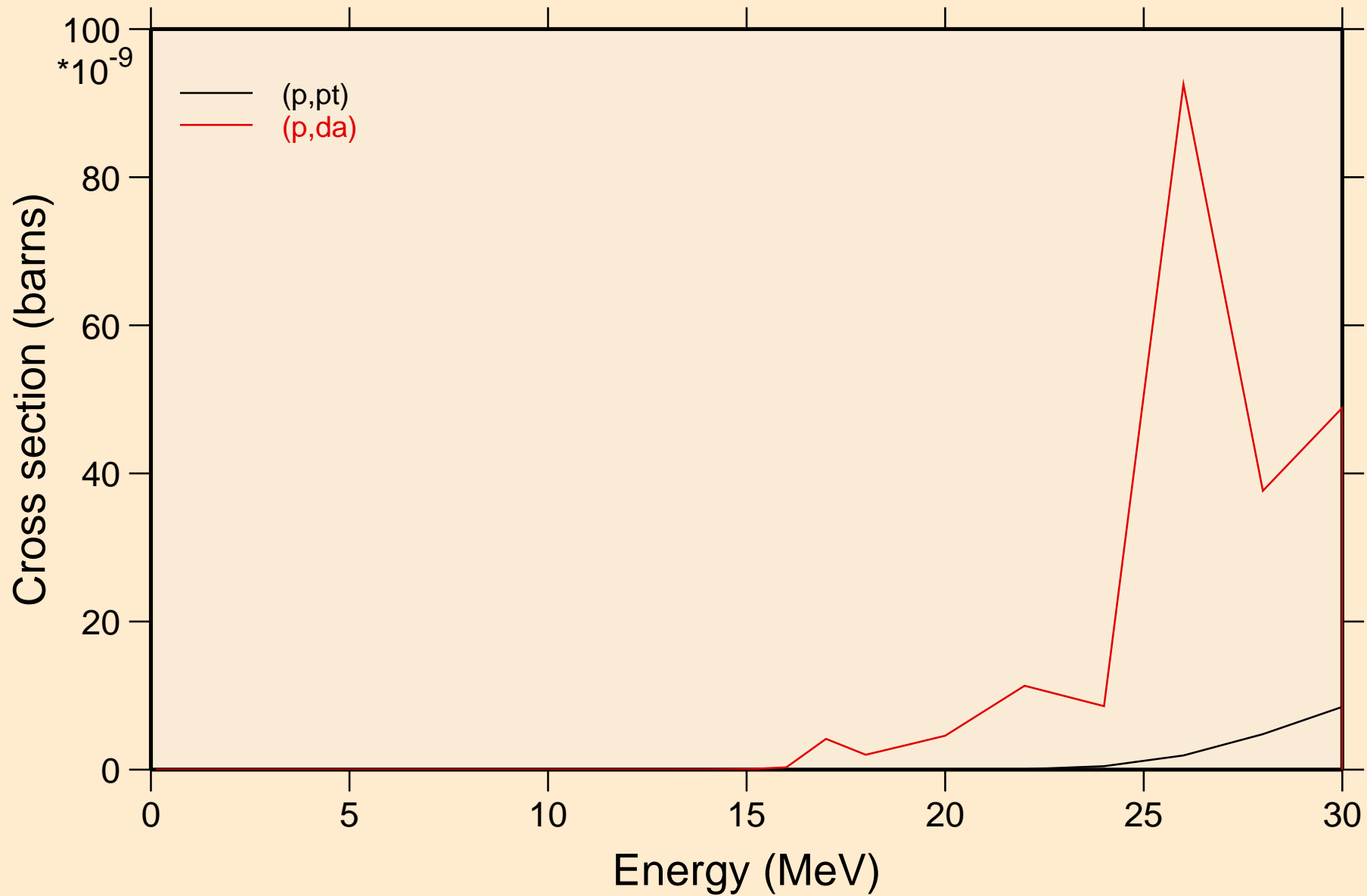

BI214 PROTON ACER TENDL-2021 LIBRARY; T=0.K  
angular distribution for elastic

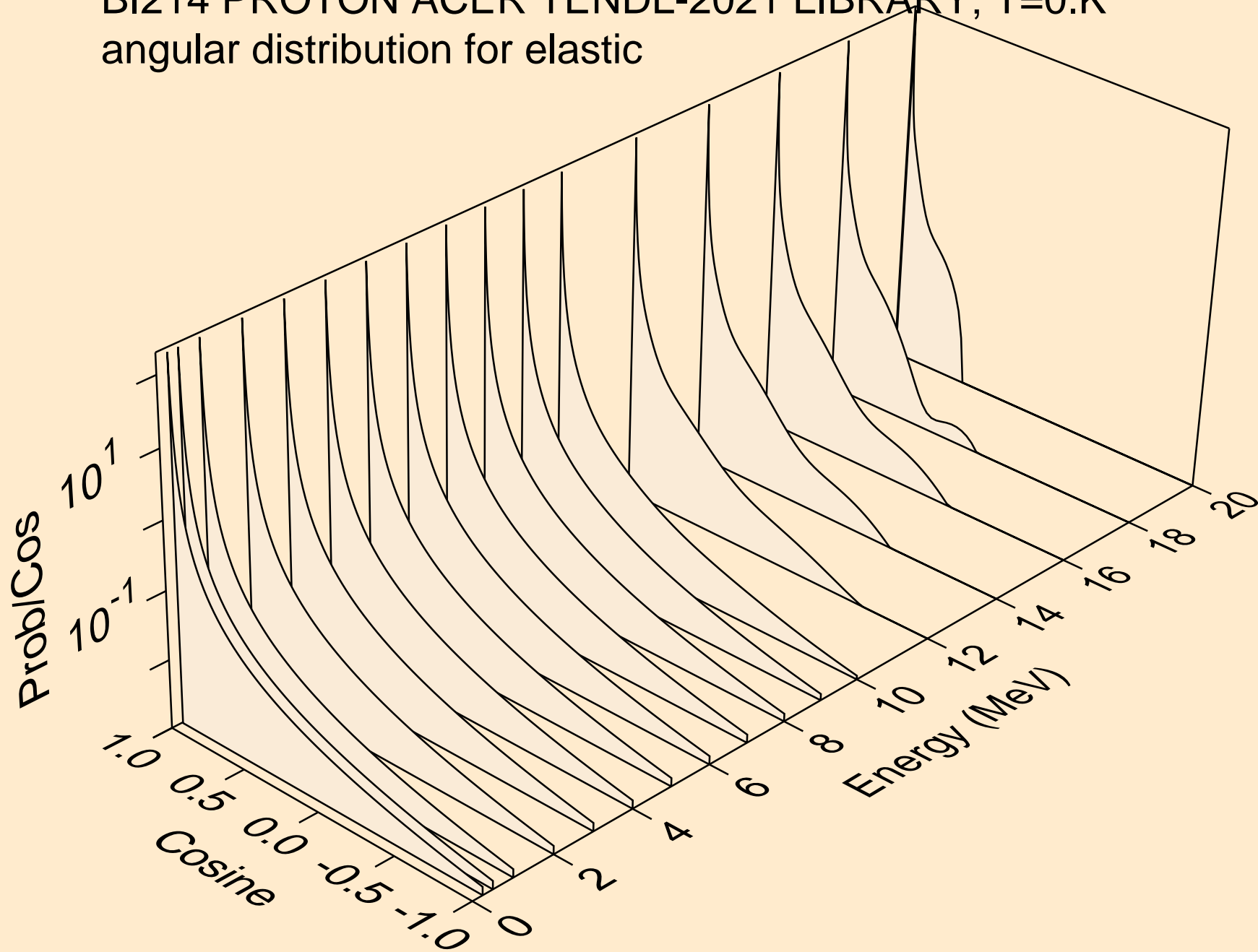



BI214 PROTON ACER TENDL-2021 LIBRARY; T=0.K  
angular distribution for elastic

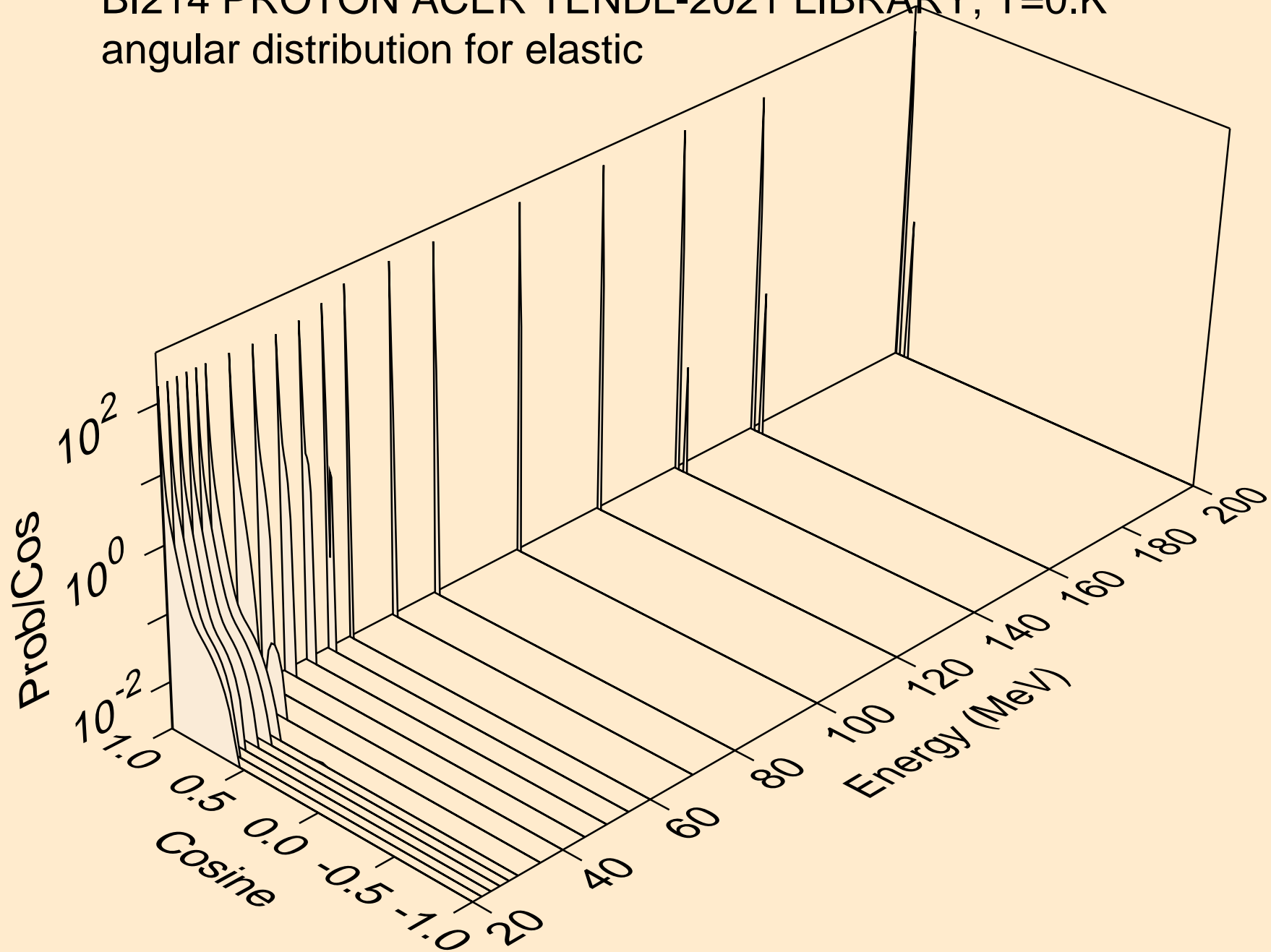

BI214 PROTON ACER TENDL-2021 LIBRARY; T=0.K  
Proton emission for (p,x)

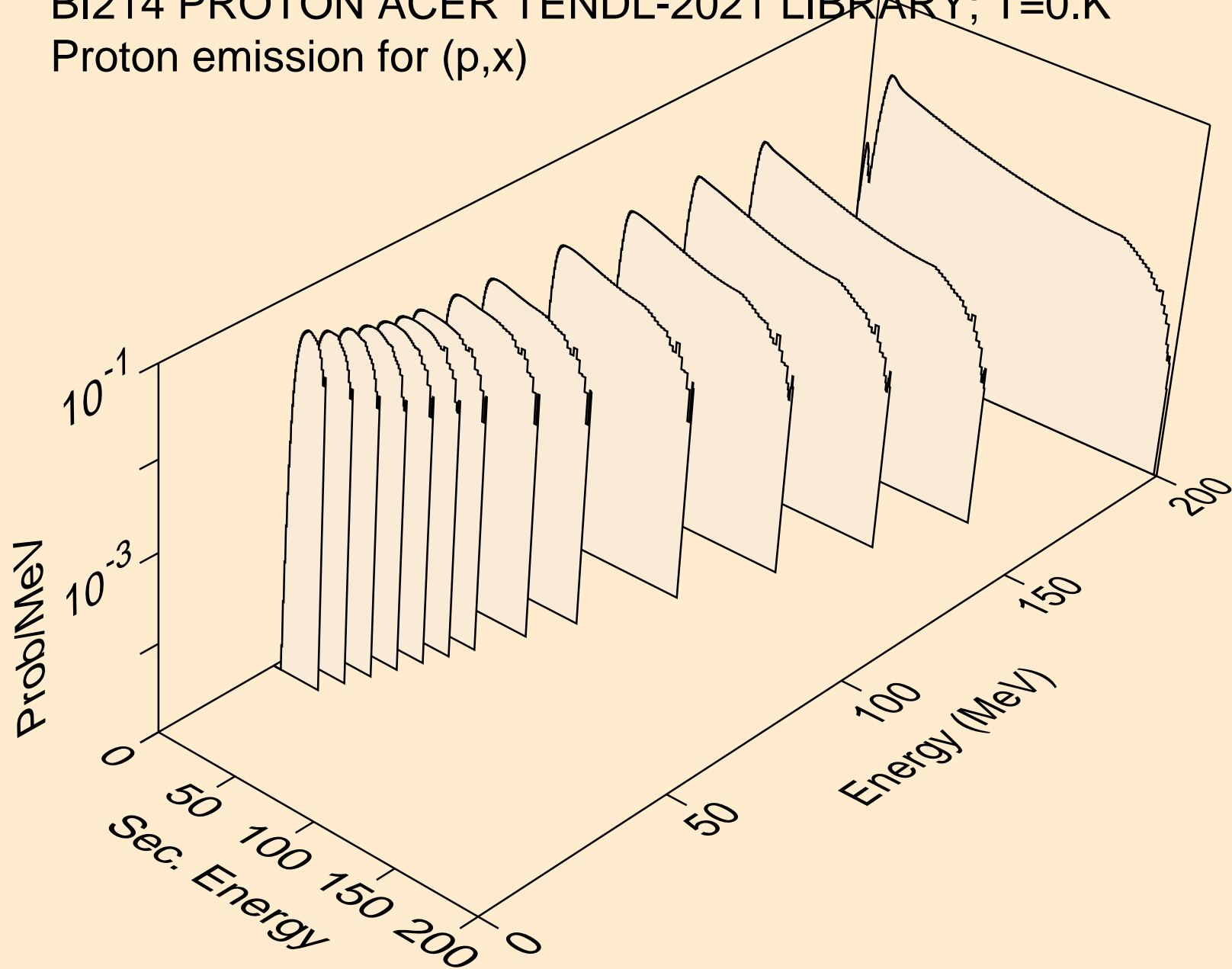

BI214 PROTON ACER TENDL-2021 LIBRARY; T=0.K  
Proton emission for (p,n\*)p

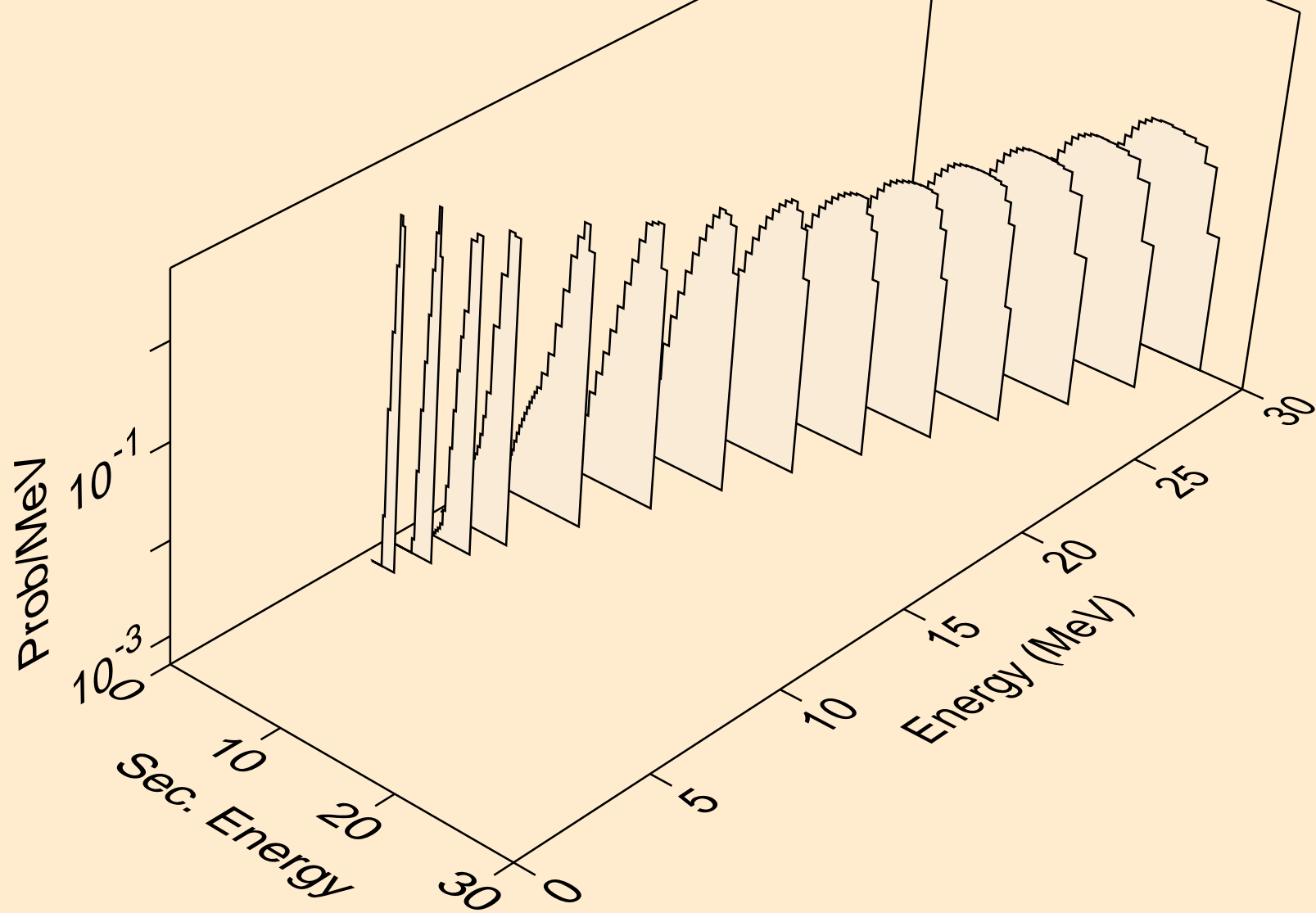

BI214 PROTON ACER TENDL-2021 LIBRARY; T=0.K  
Proton emission for (p,2np)

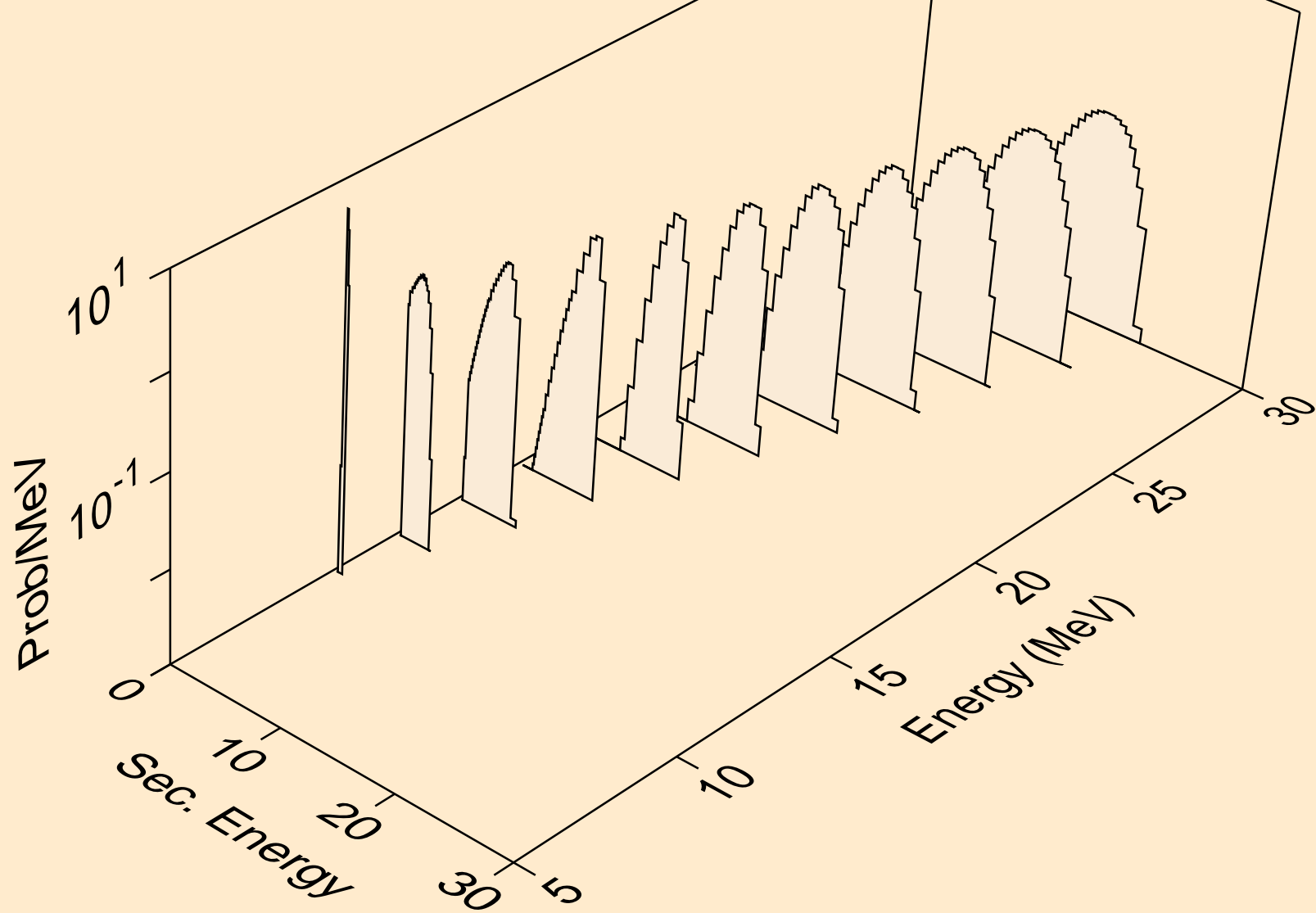

BI214 PROTON ACER TENDL-2021 LIBRARY; T=0.K  
Proton emission for (p,3np)

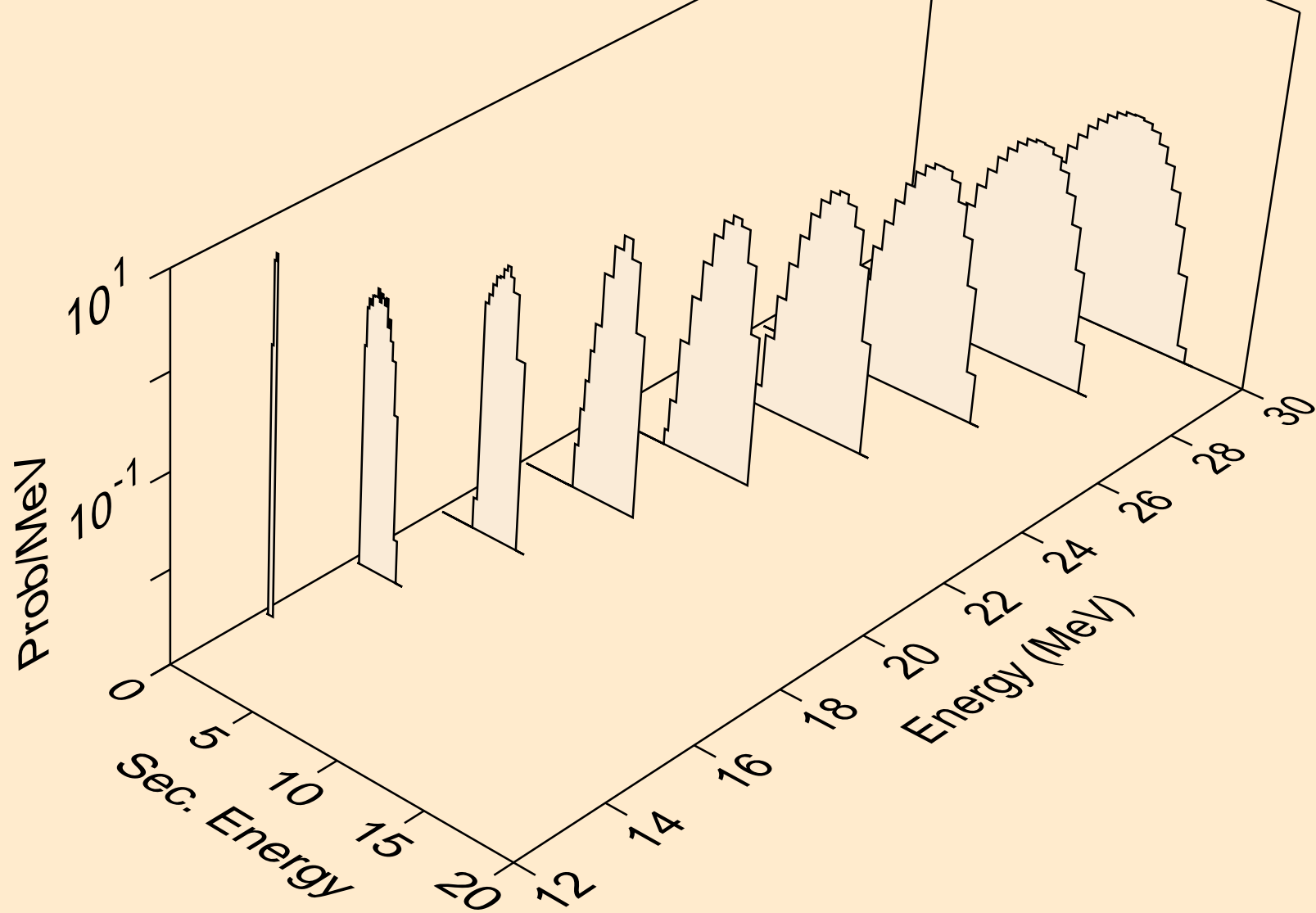

BI214 PROTON ACER TENDL-2021 LIBRARY; T=0.K  
Proton emission for (p,2np)

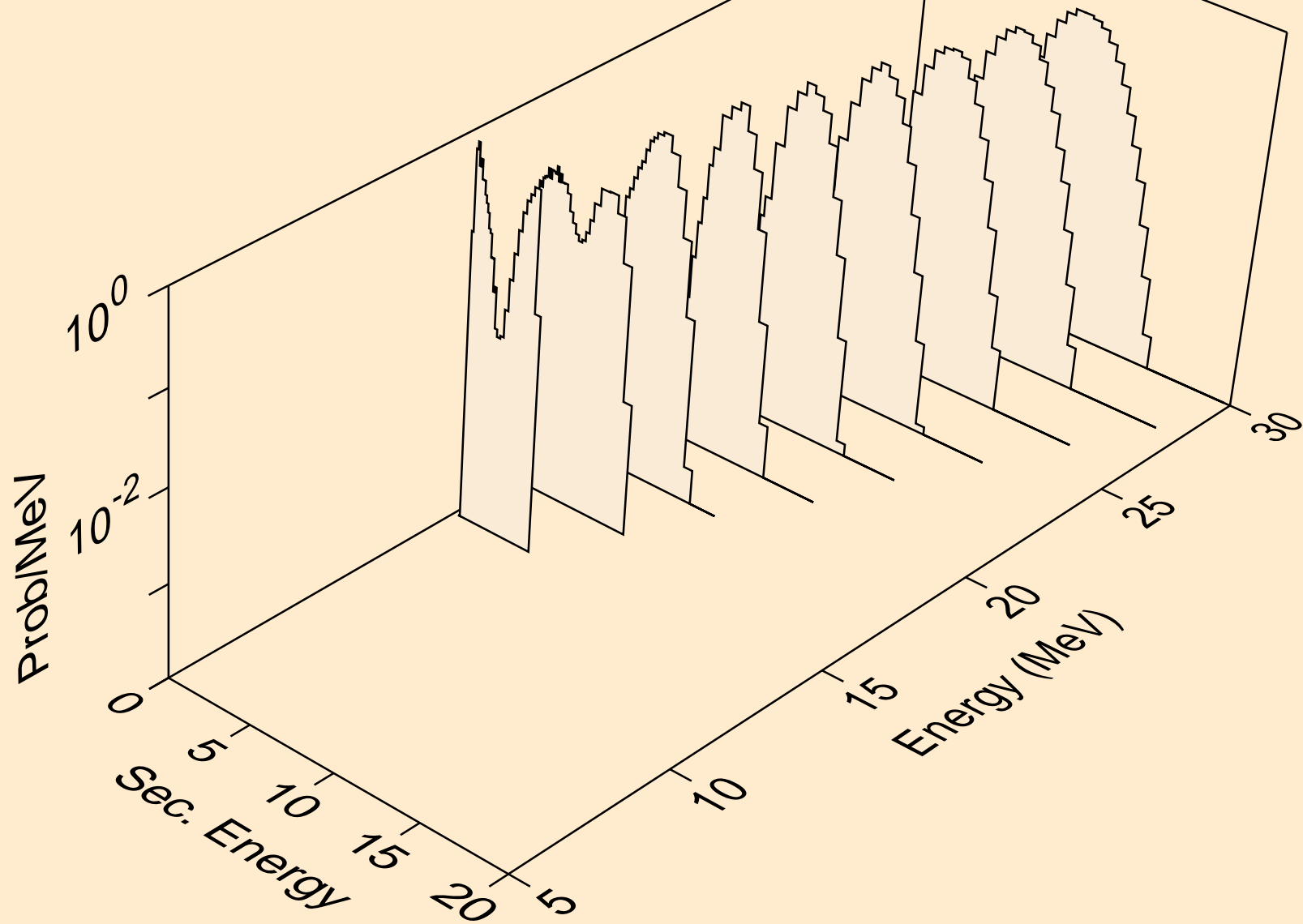

BI214 PROTON ACER TENDL-2021 LIBRARY; T=0.K  
Proton emission for (p,npa)

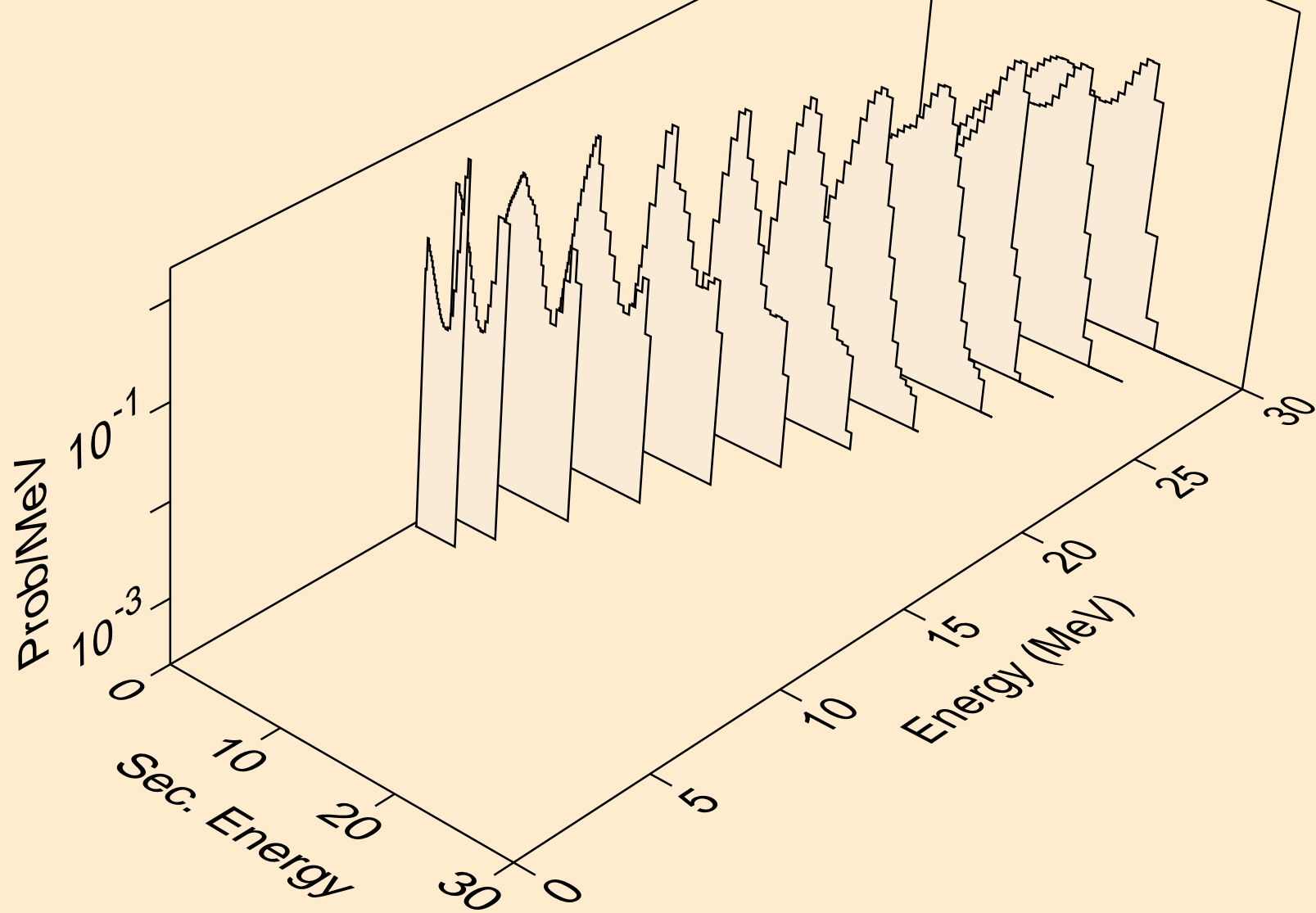

BI214 PROTON ACER TENDL-2021 LIBRARY; T=0.K  
Proton emission for inelastic

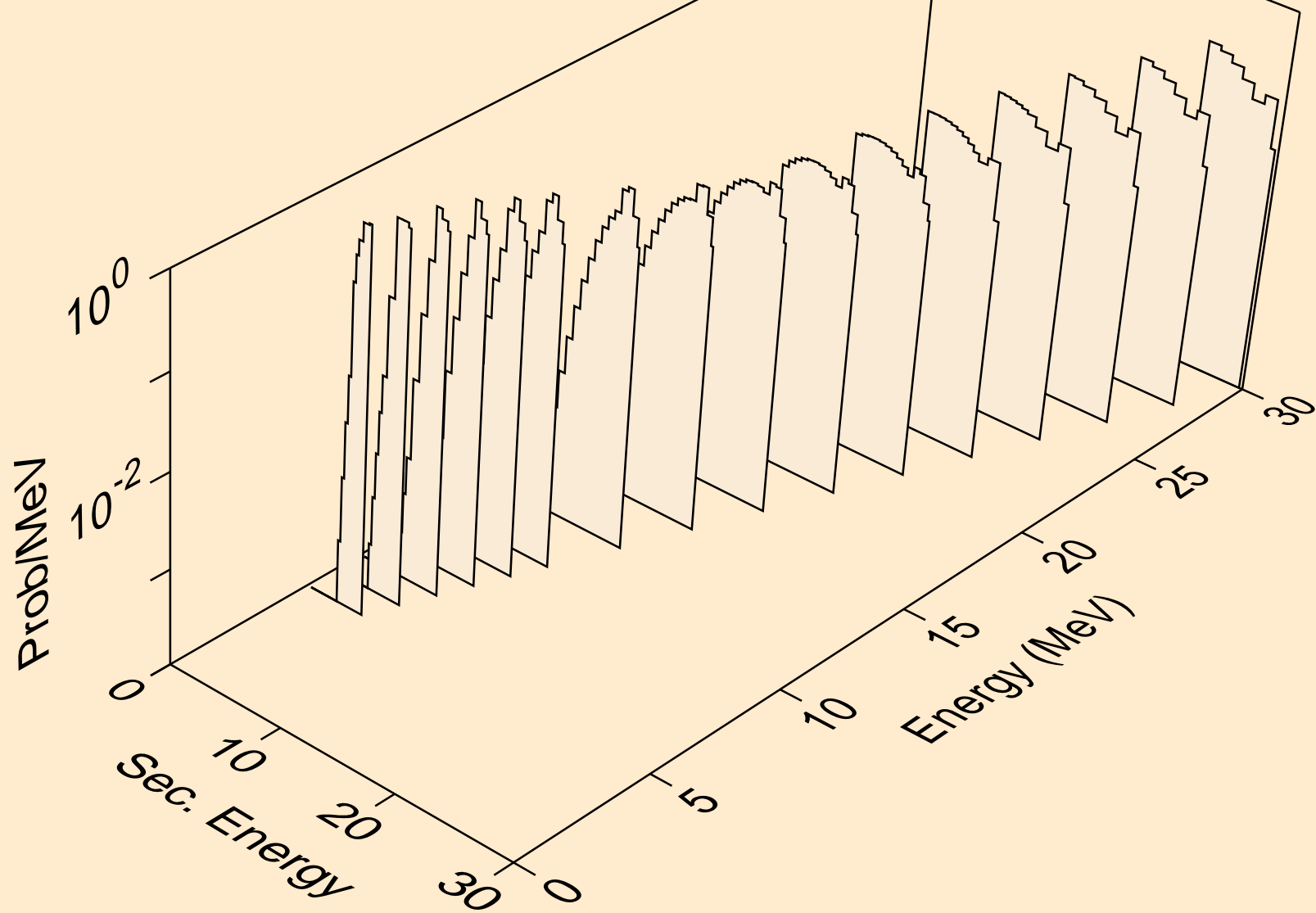



BI214 PROTON ACER TENDL-2021 LIBRARY; T=0.K  
Proton emission for (p,2p)

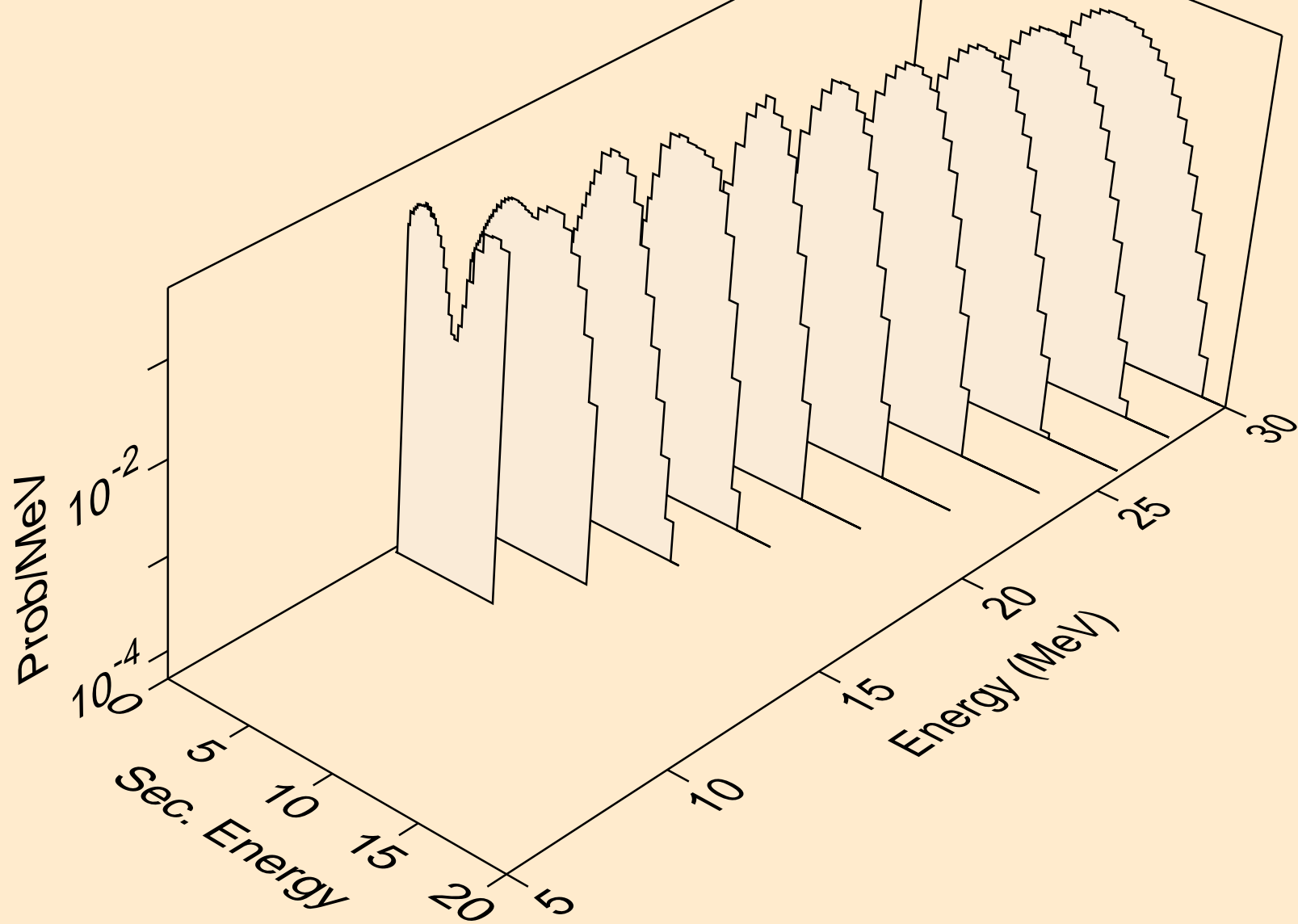

BI214 PROTON ACER TENDL-2021 LIBRARY; T=0.K  
Proton emission for (p,pa)

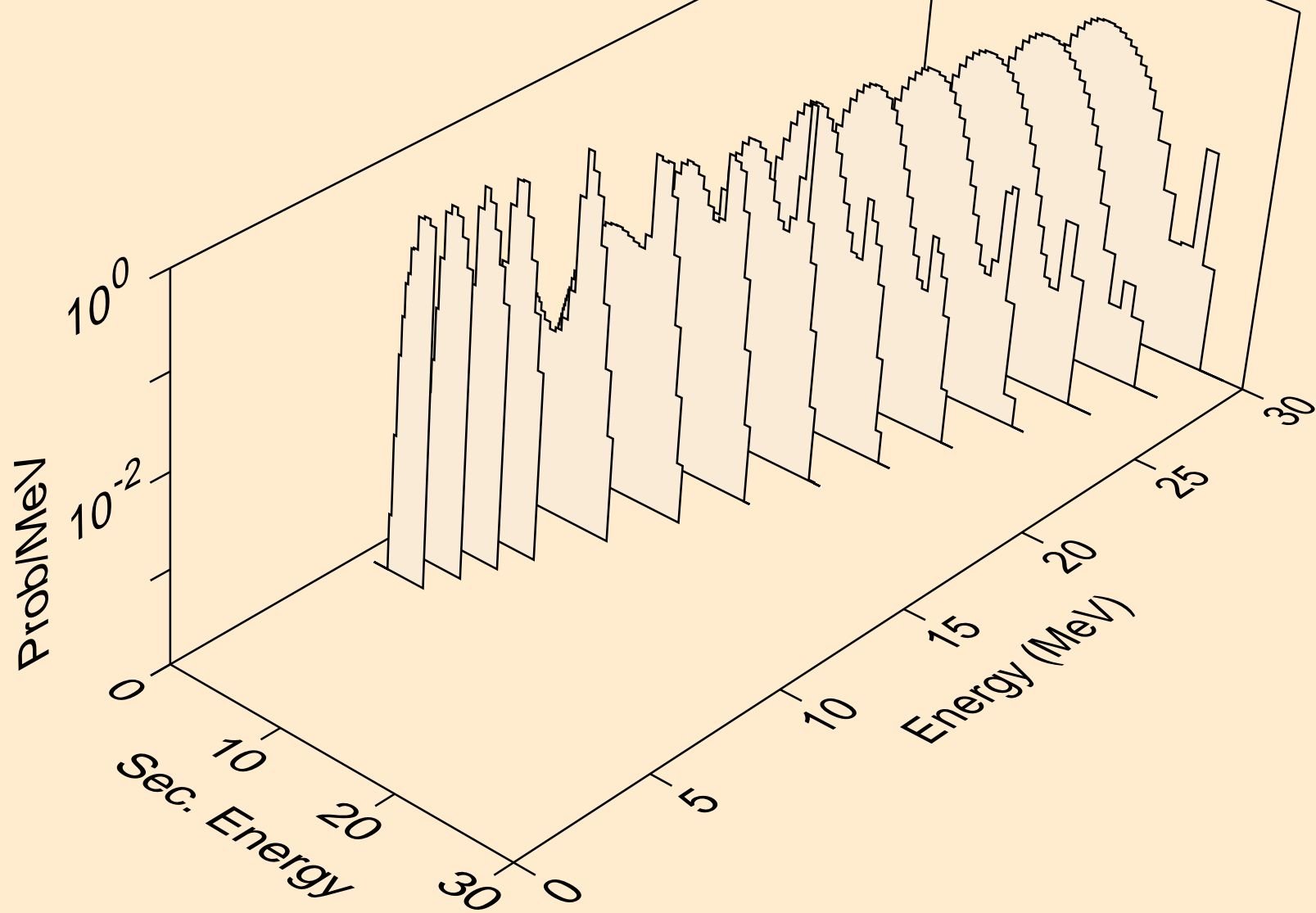

BI214 PROTON ACER TENDL-2021 LIBRARY; T=0.K  
Proton emission for (p,pd)

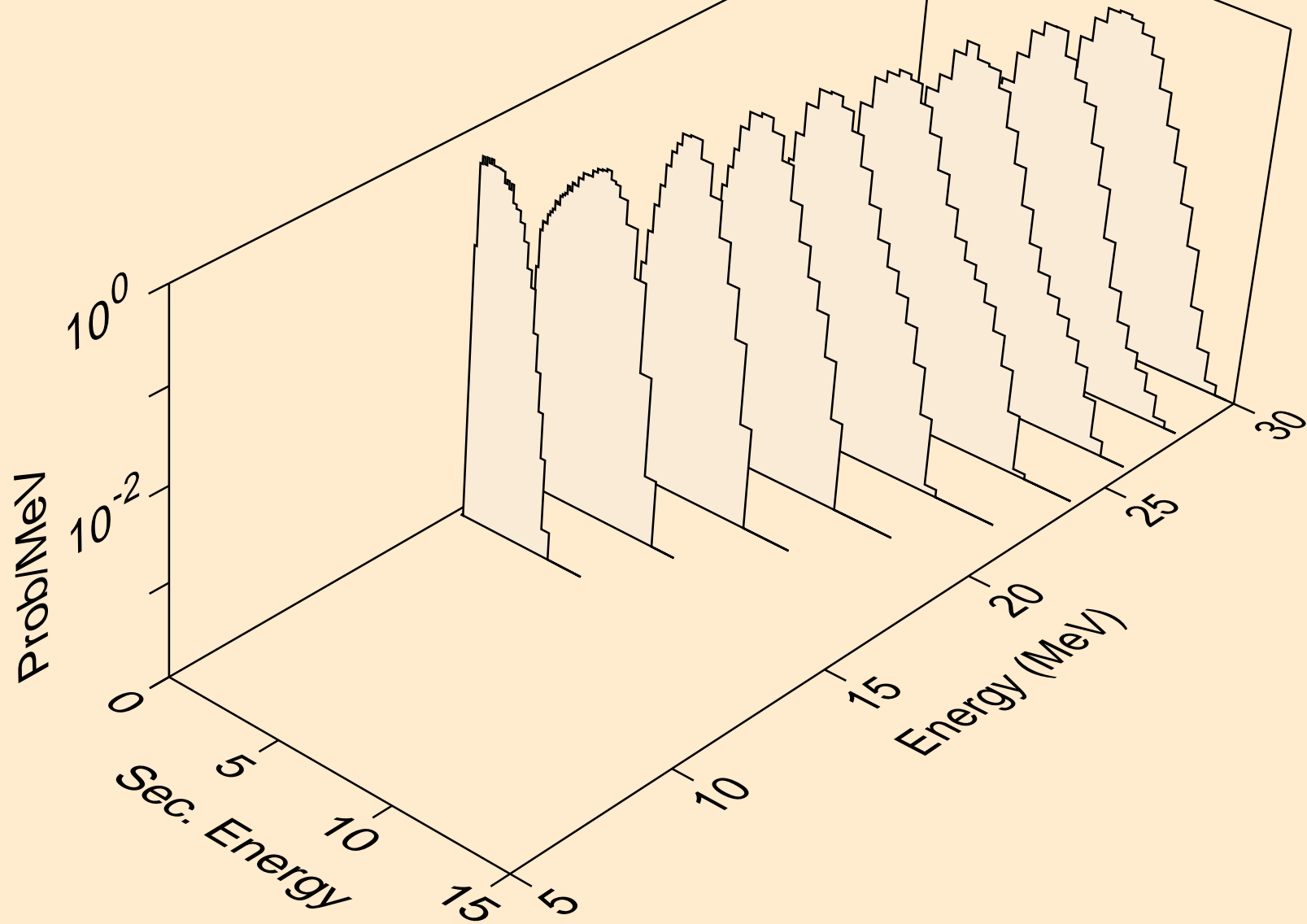

BI214 PROTON ACER TENDL-2021 LIBRARY; T=0.K  
Proton emission for (p,pt)

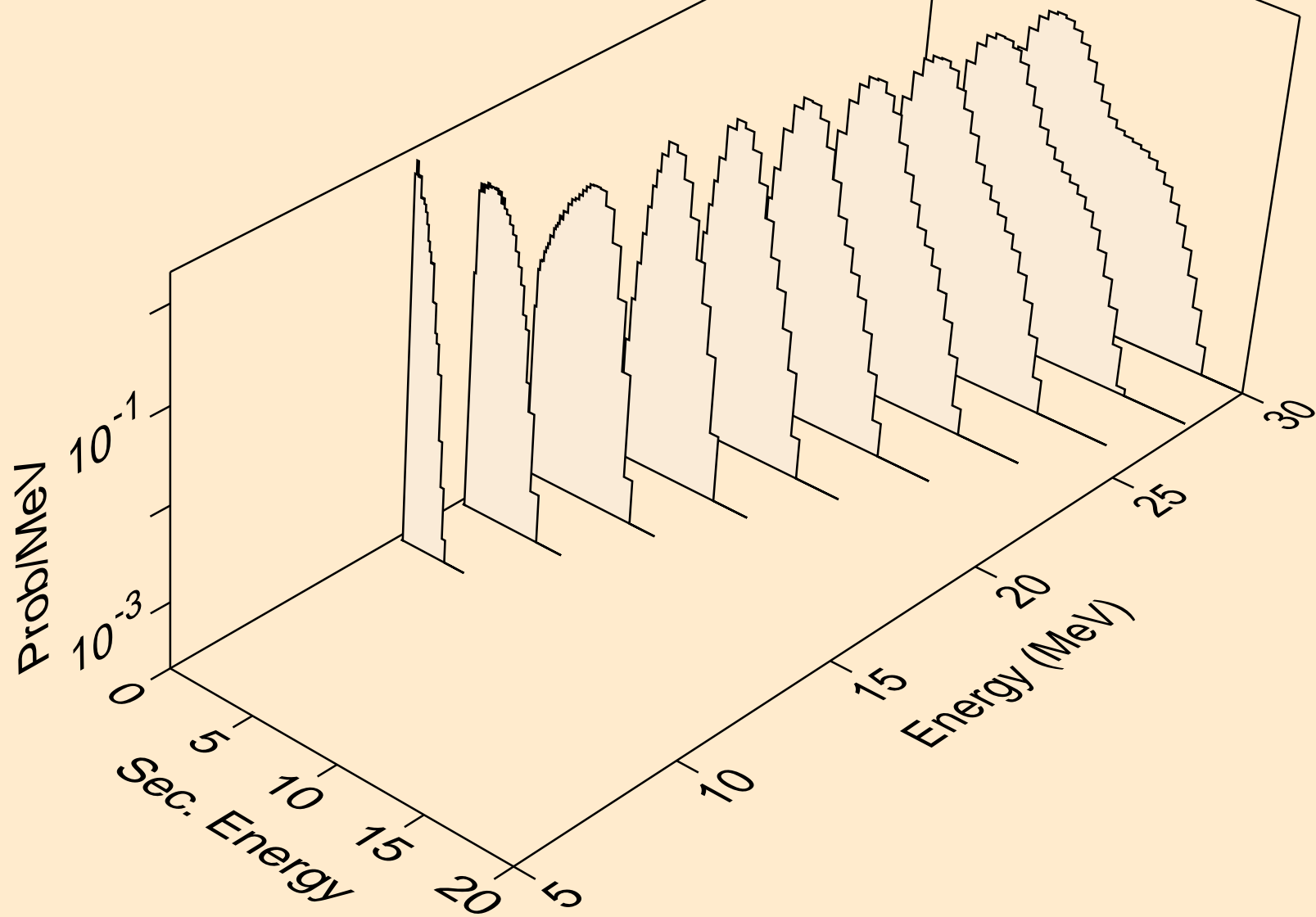

BI214 PROTON ACER TENDL-2021 LIBRARY; T=0.K  
Photon emission for (z,n)

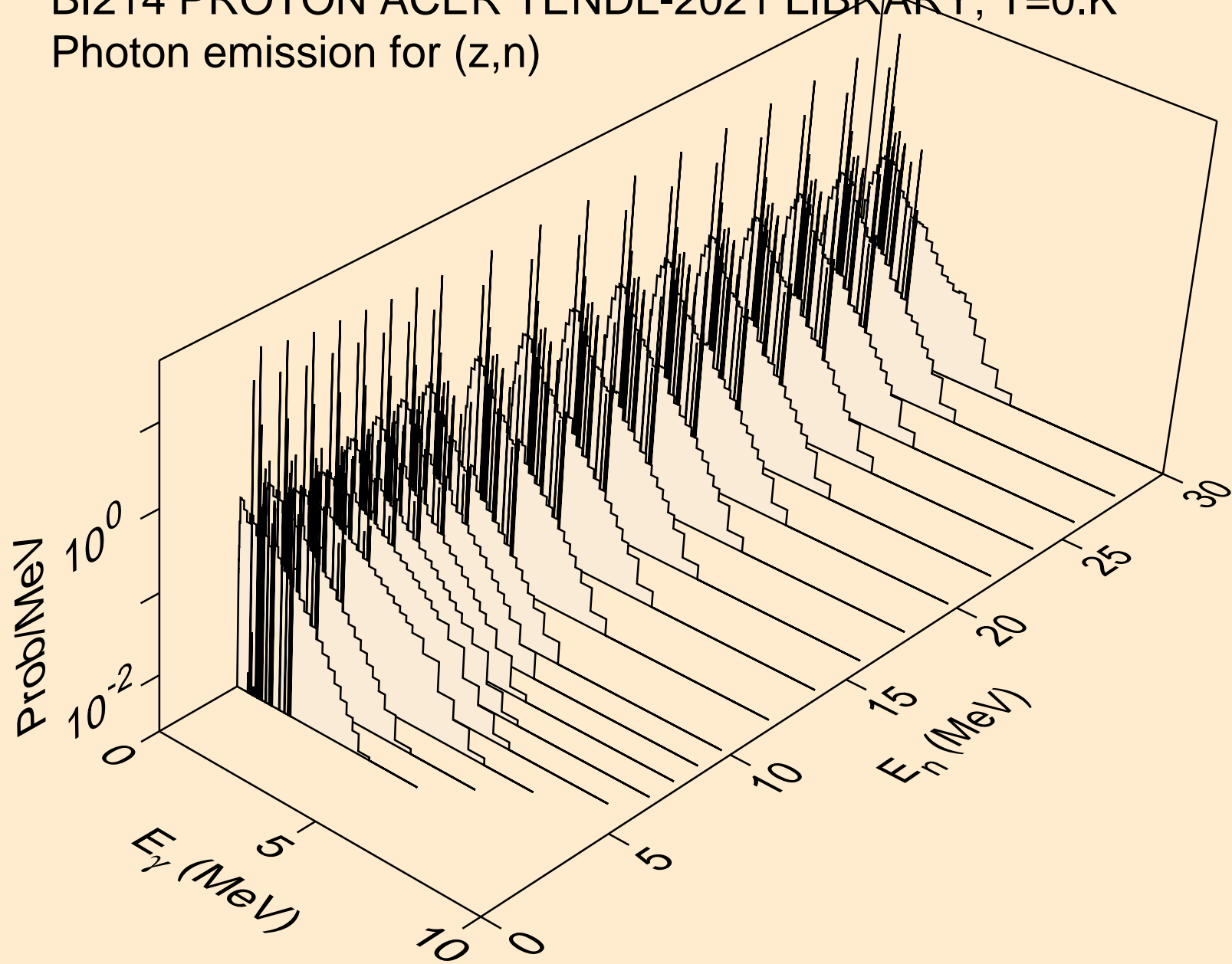

BI214 PROTON ACER TENDL-2021 LIBRARY; T=0.K  
Photon emission for (n,x)

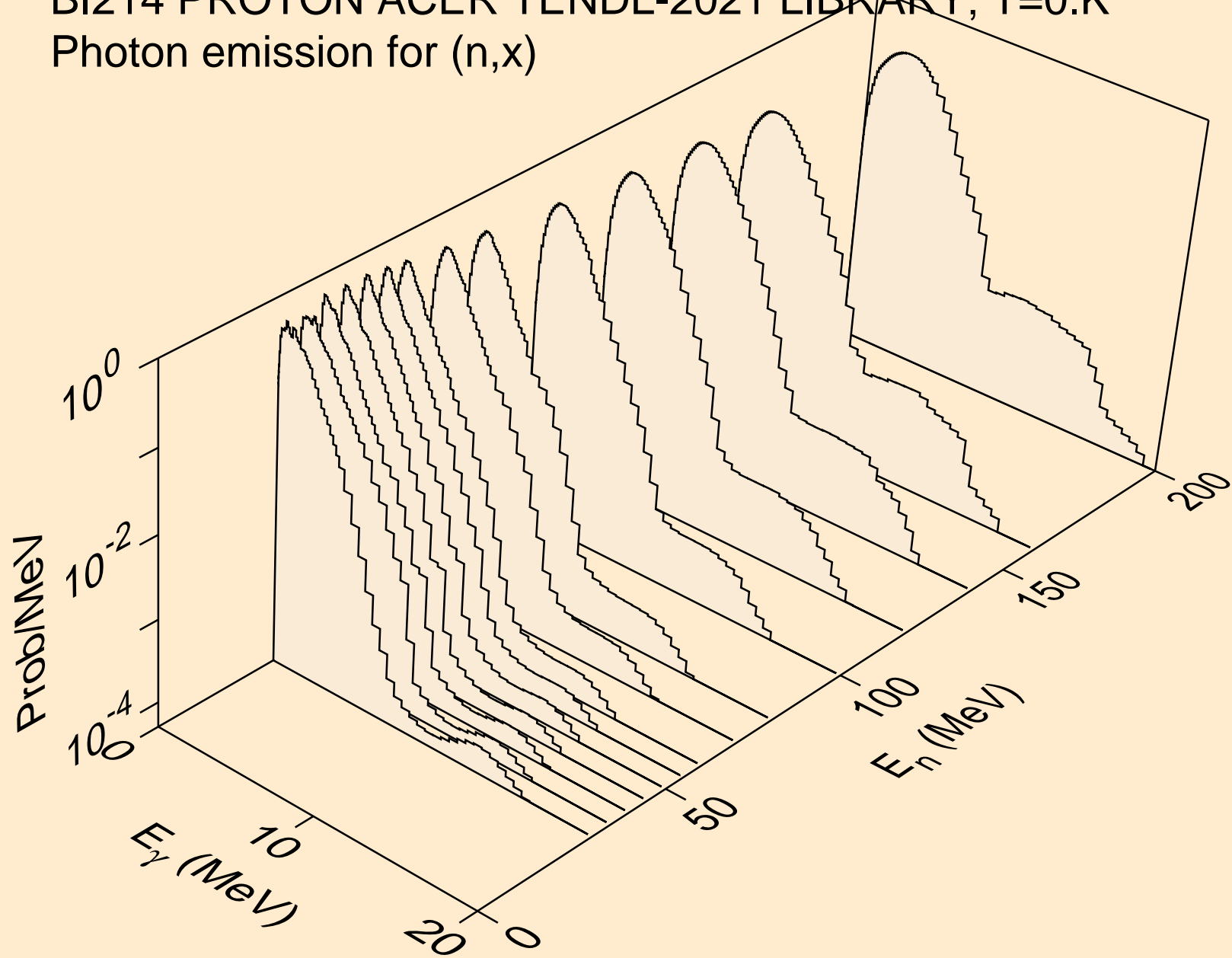

BI214 PROTON ACER TENDL-2021 LIBRARY; T=0.K  
Photon emission for (n,2nd)

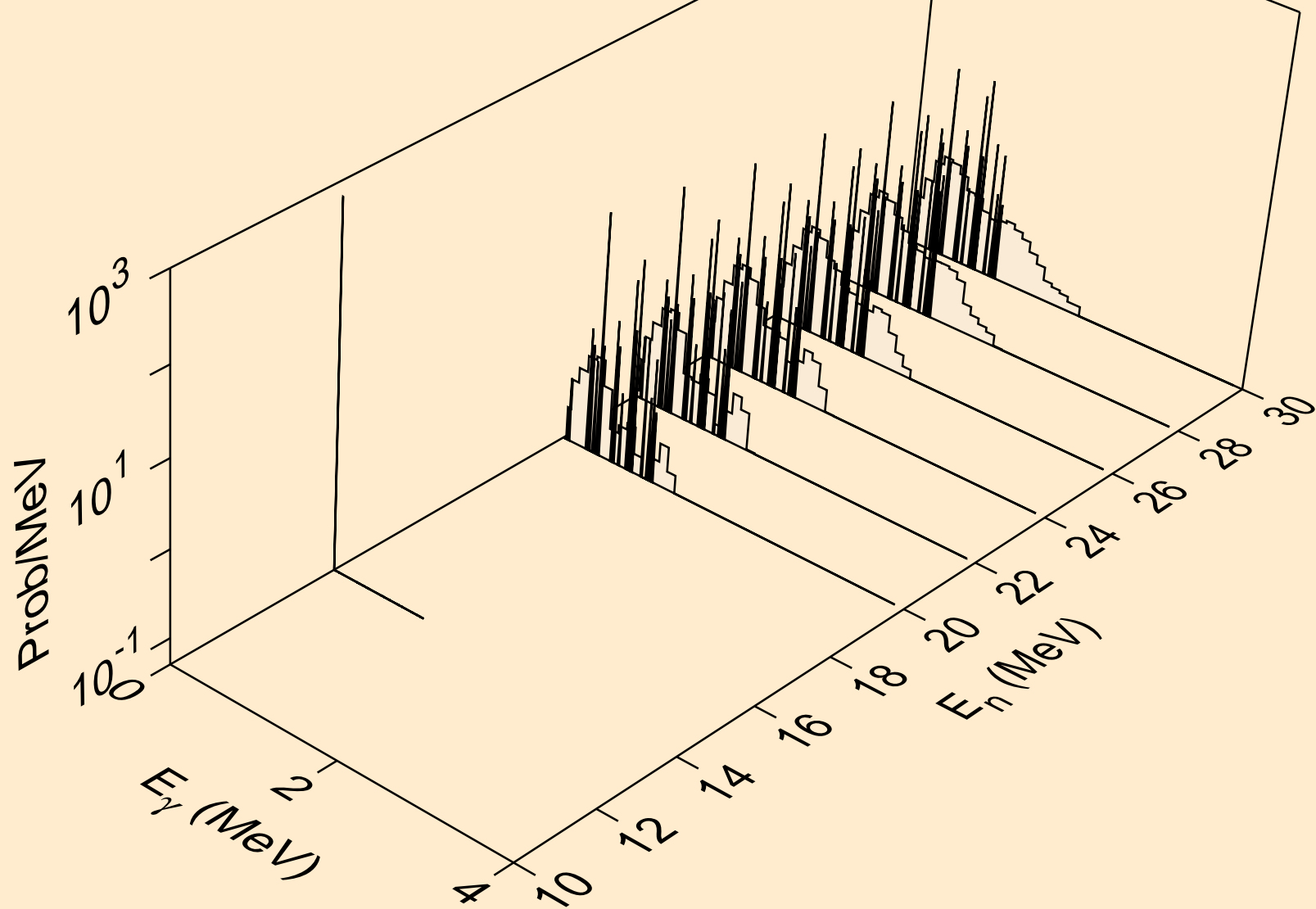

BI214 PROTON ACER TENDL-2021 LIBRARY; T=0.K  
Photon emission for (n,2n)

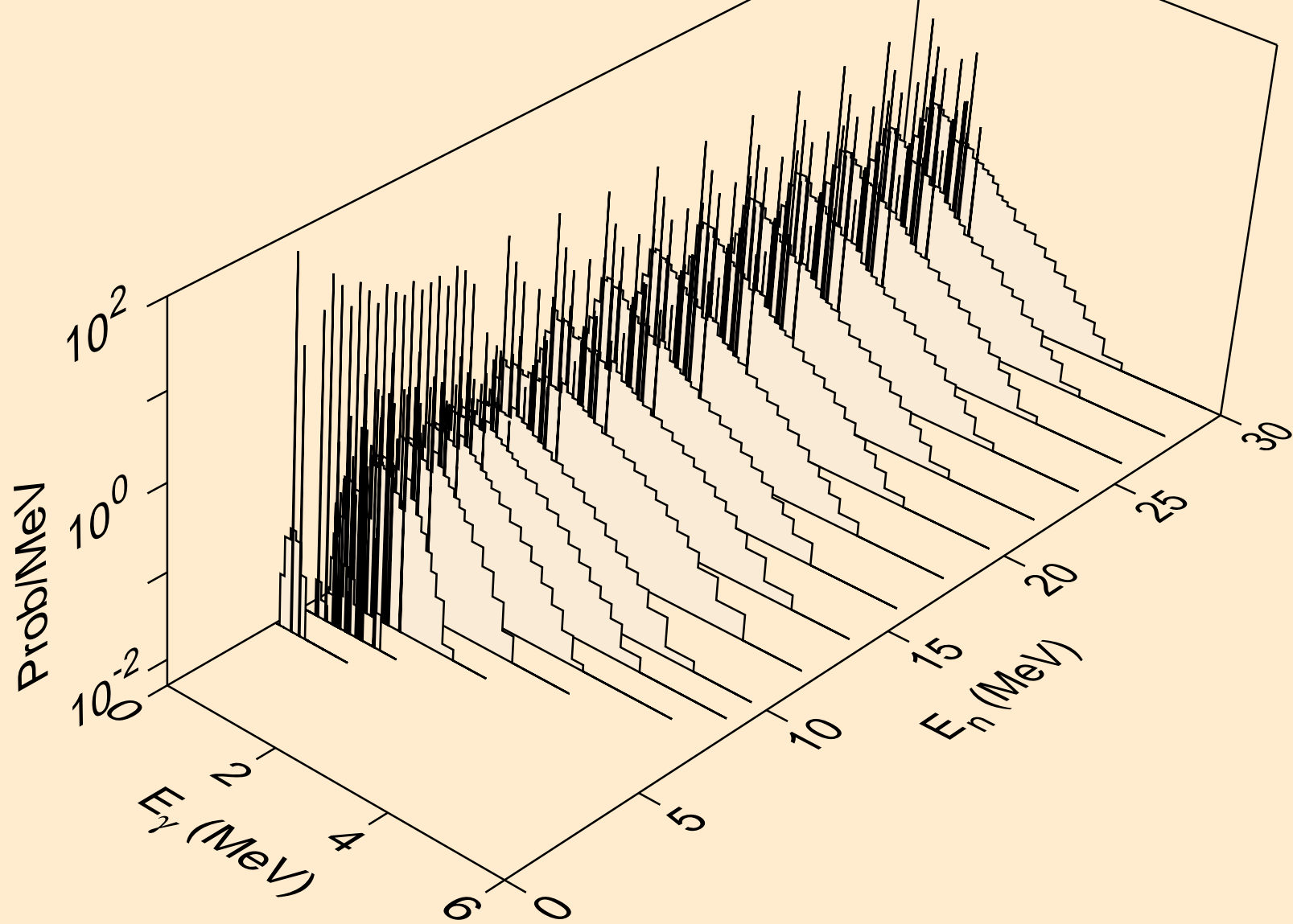



BI214 PROTON ACER TENDL-2021 LIBRARY; T=0.K  
Photon emission for (n,3n)

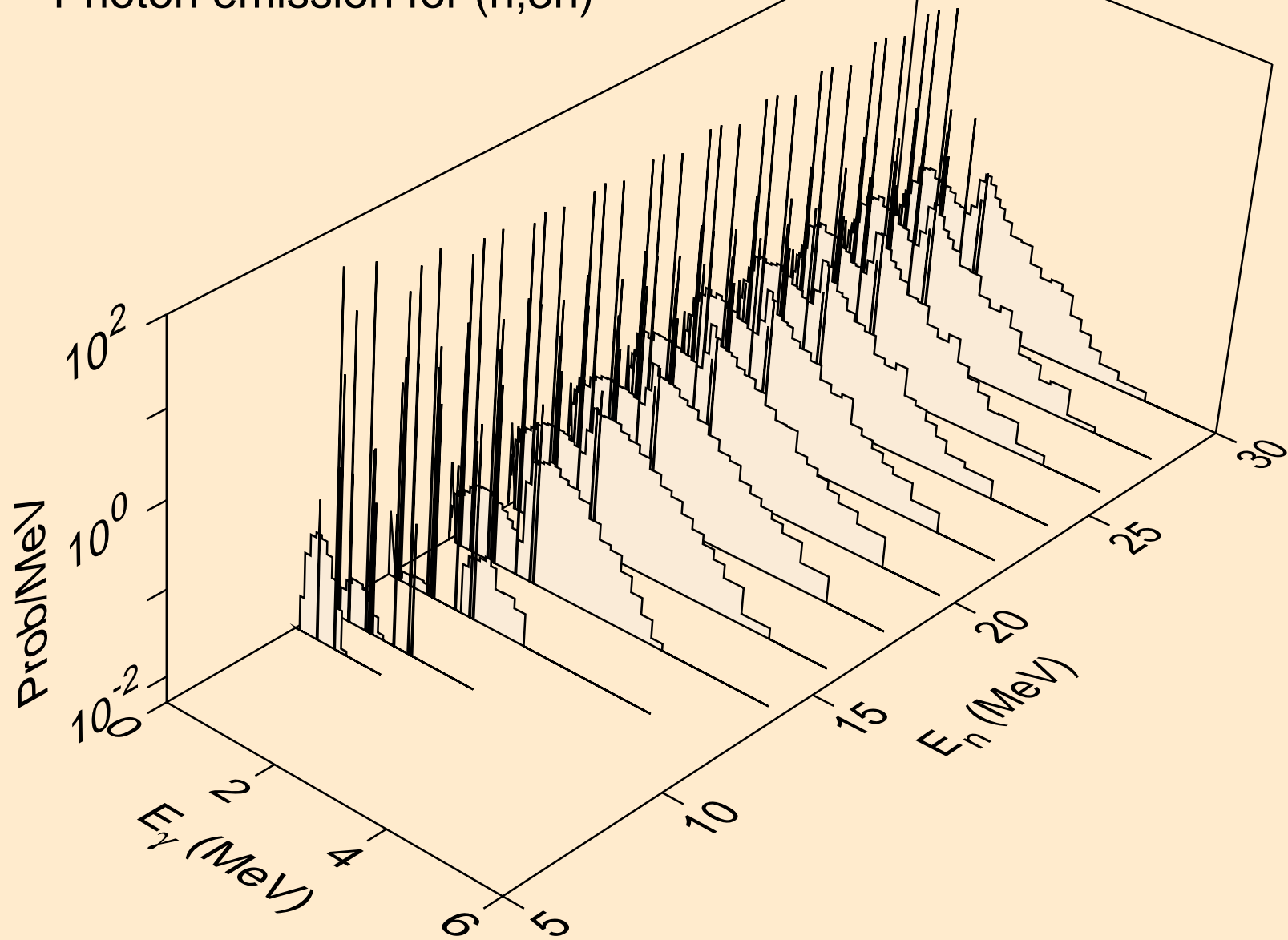

BI214 PROTON ACER TENDL-2021 LIBRARY; T=0.K  
Photon emission for (n,n\*)a

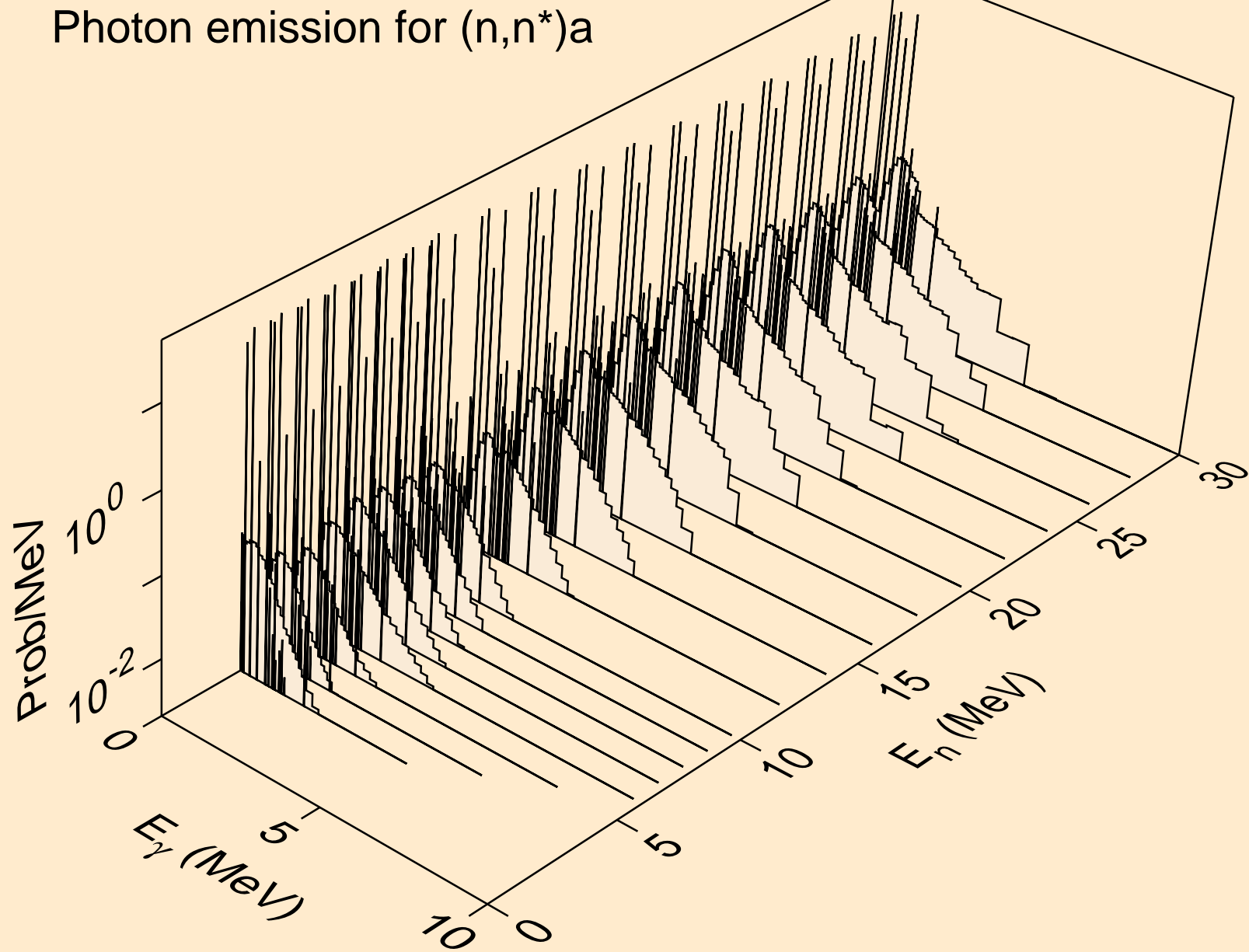

BI214 PROTON ACER TENDL-2021 LIBRARY; T=0.K  
Photon emission for (n,2n)a

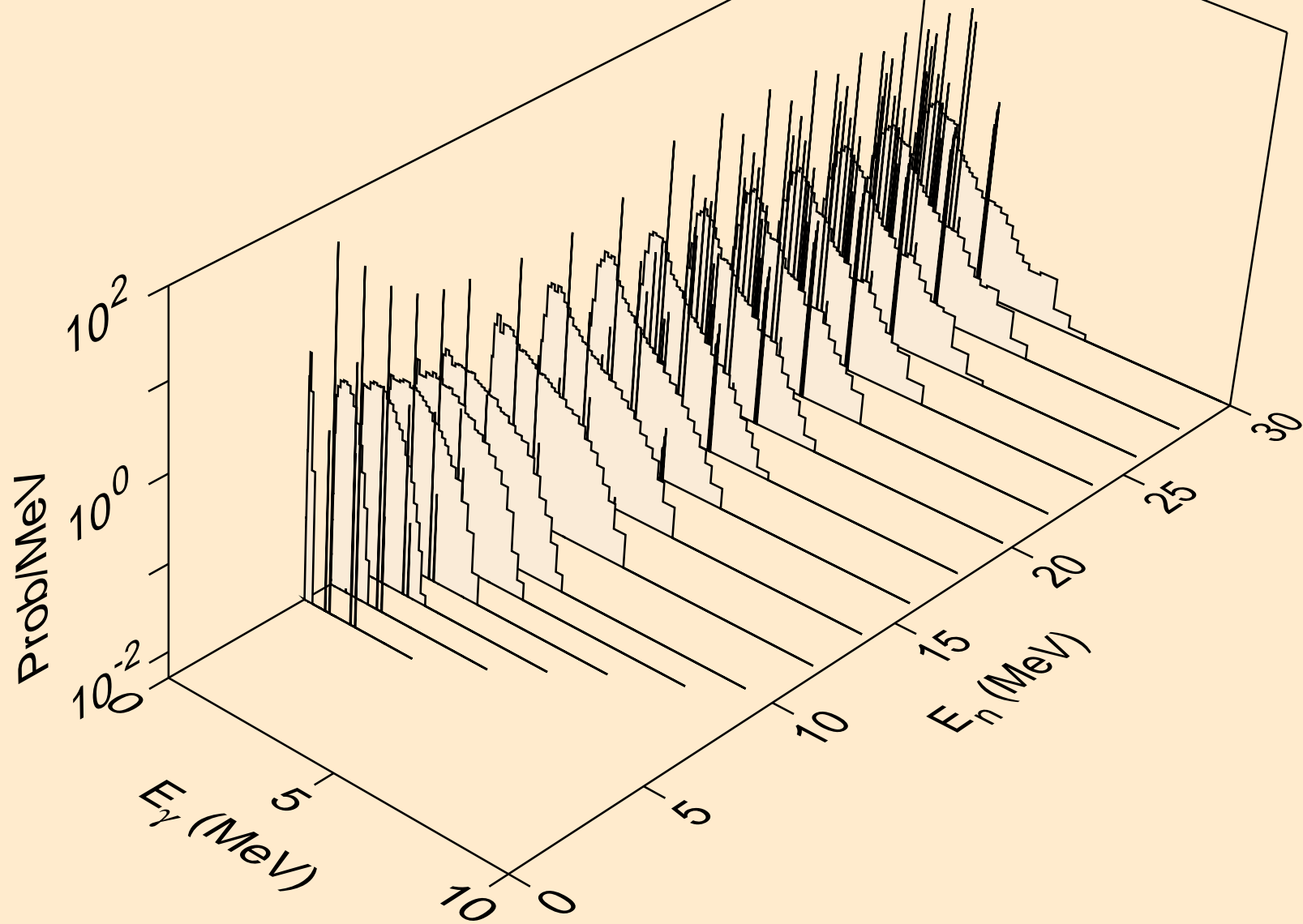

BI214 PROTON ACER TENDL-2021 LIBRARY; T=0.K  
Photon emission for (n,3n)a

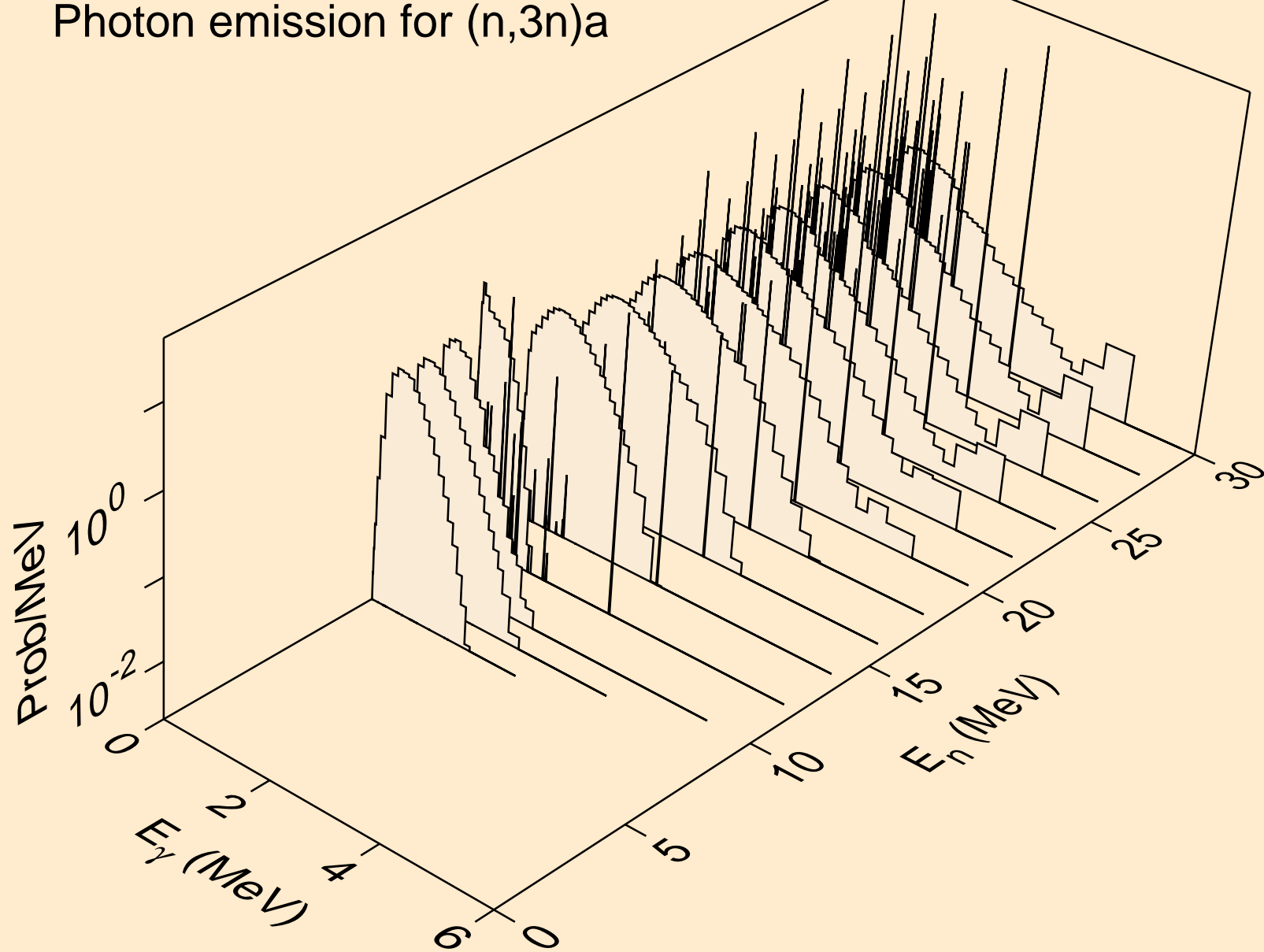

BI214 PROTON ACER TENDL-2021 LIBRARY; T=0.K  
Photon emission for (n,n\*)p

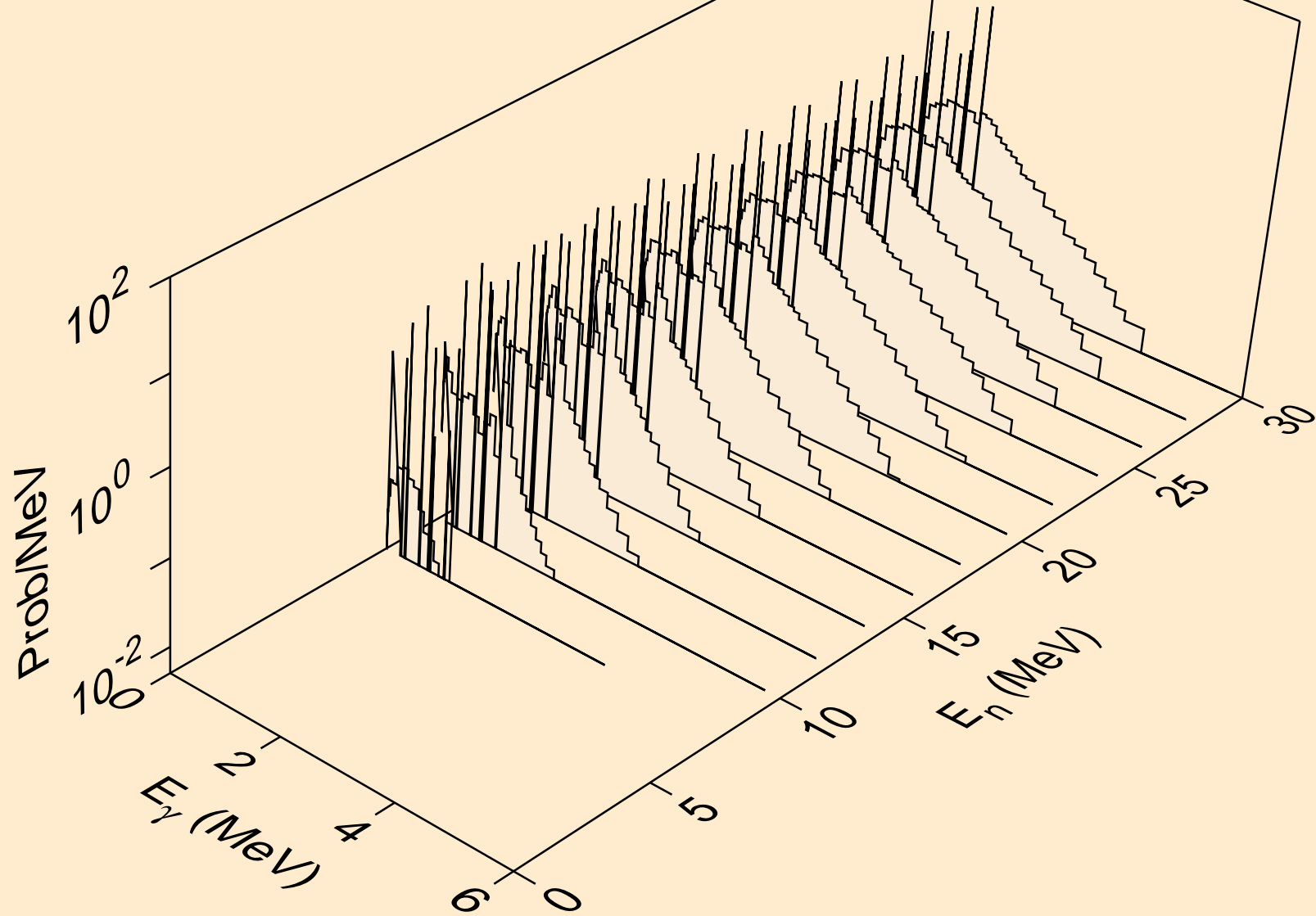

BI214 PROTON ACER TENDL-2021 LIBRARY; T=0.K  
Photon emission for (n,n\*)2a

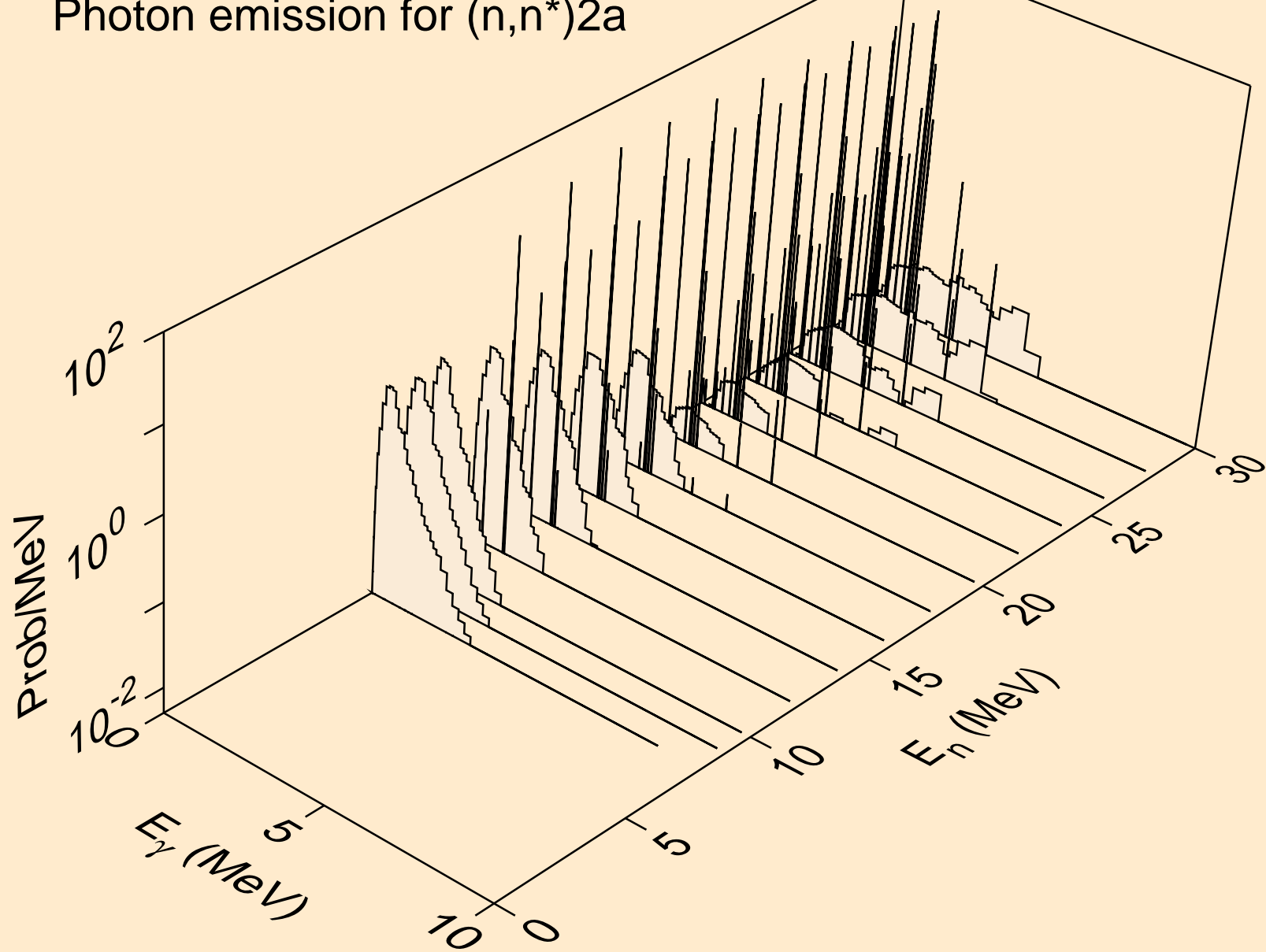

BI214 PROTON ACER TENDL-2021 LIBRARY; T=0.K  
Photon emission for (n,2n)2a

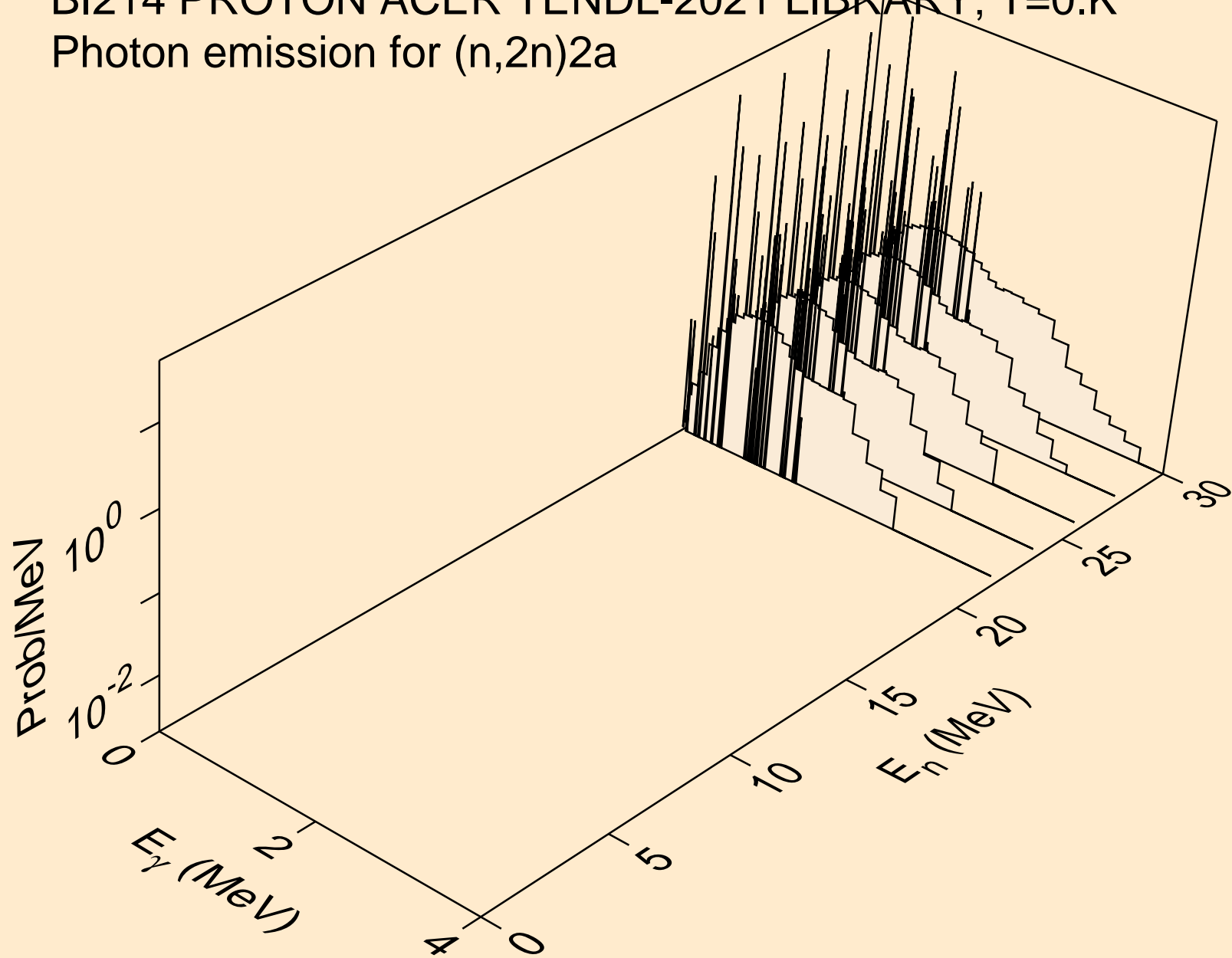

BI214 PROTON ACER TENDL-2021 LIBRARY; T=0.K  
Photon emission for (n,n\*)d

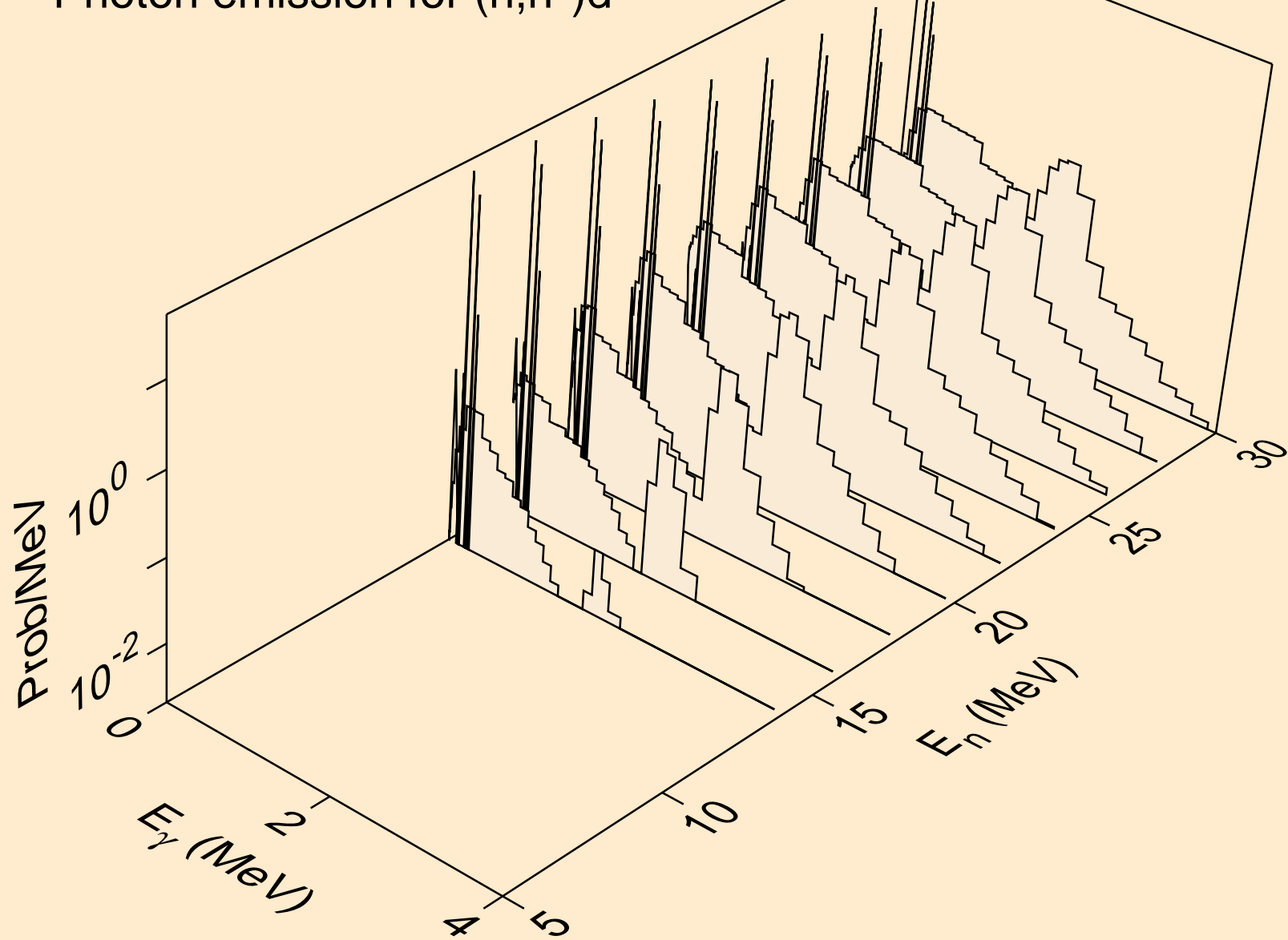



BI214 PROTON ACER TENDL-2021 LIBRARY; T=0.K  
Photon emission for (n,n\*)t

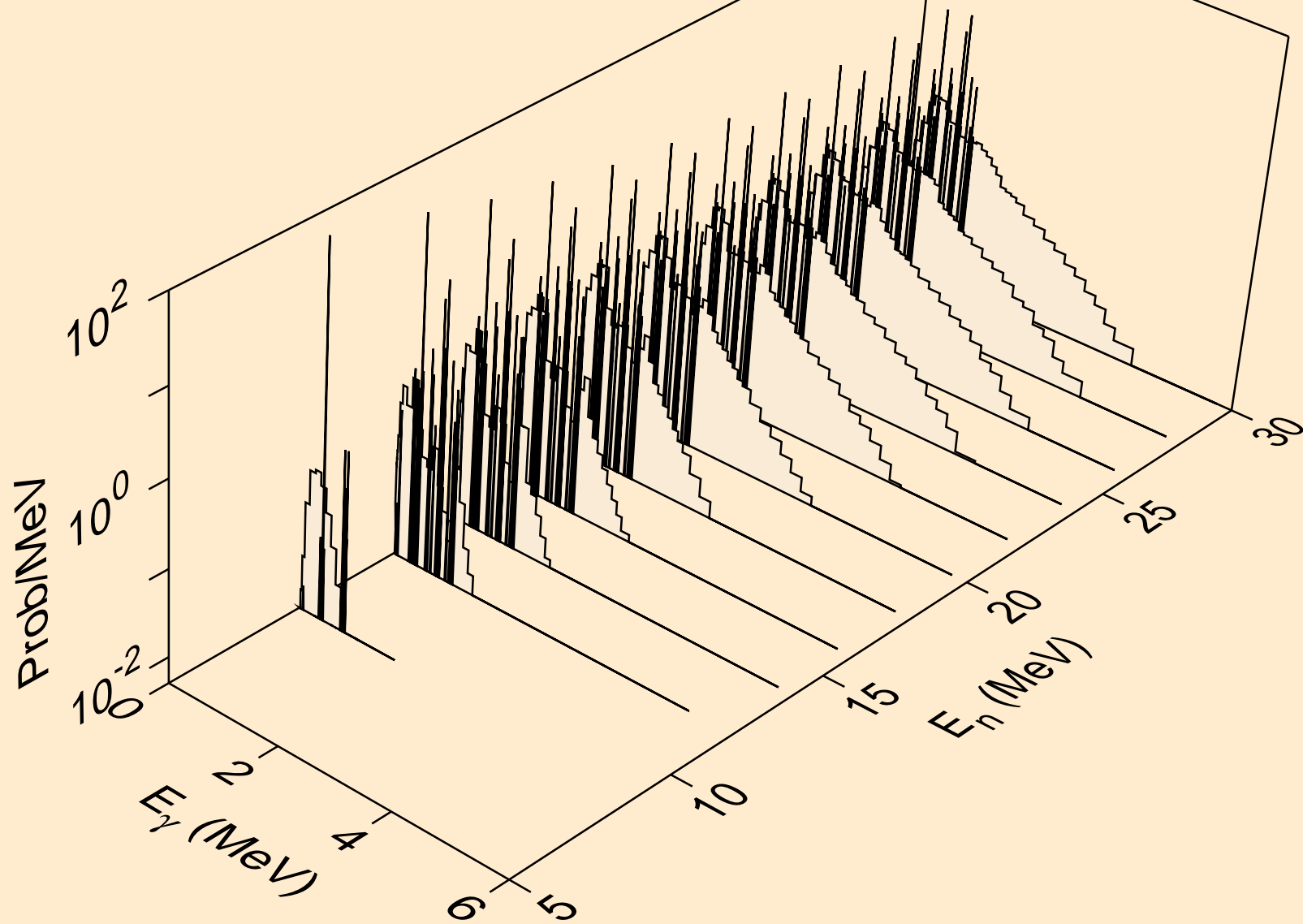

BI214 PROTON ACER TENDL-2021 LIBRARY; T=0.K  
Photon emission for (n,n\*)he3

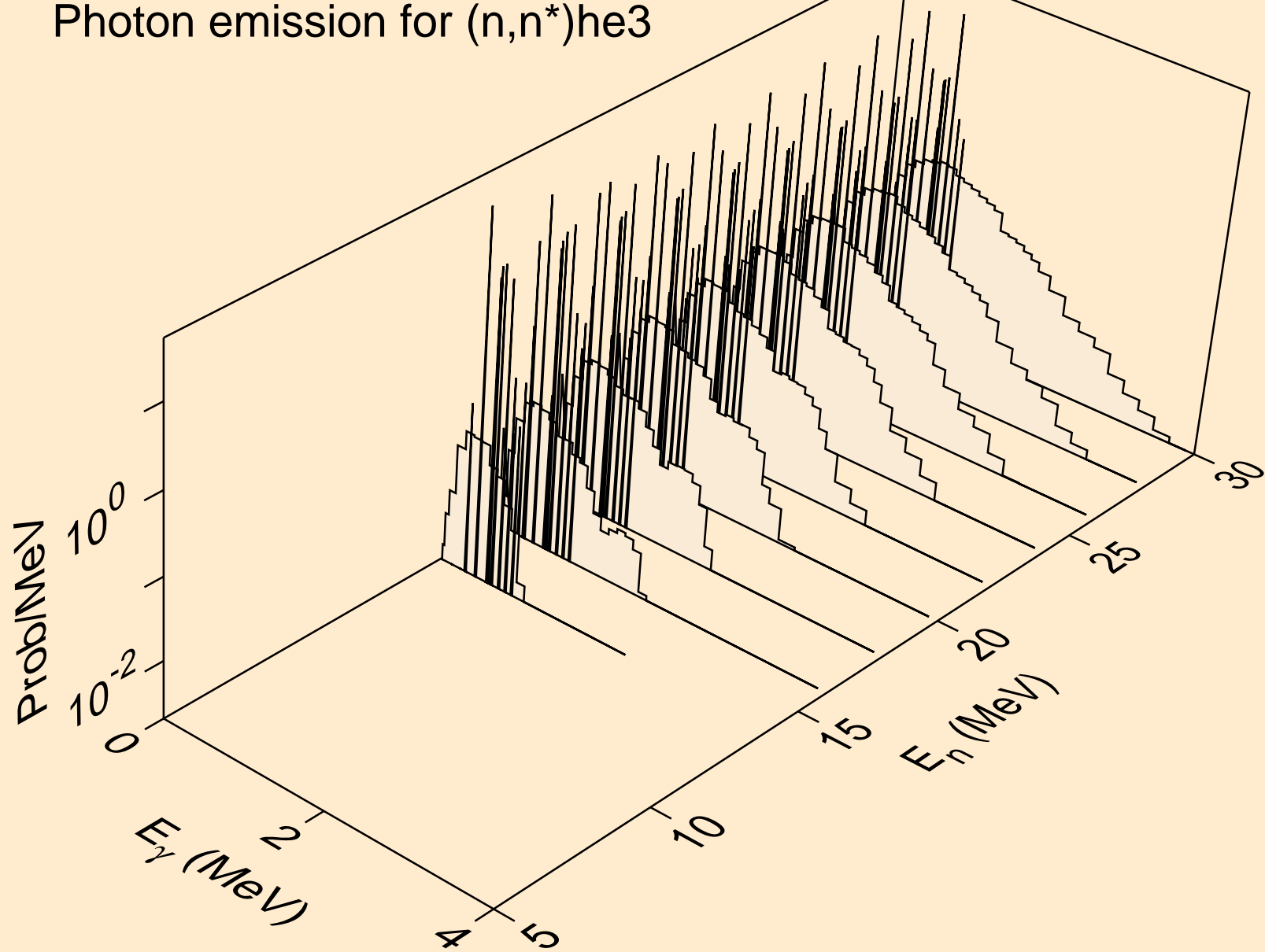

BI214 PROTON ACER TENDL-2021 LIBRARY; T=0.K  
Photon emission for (n,4n)

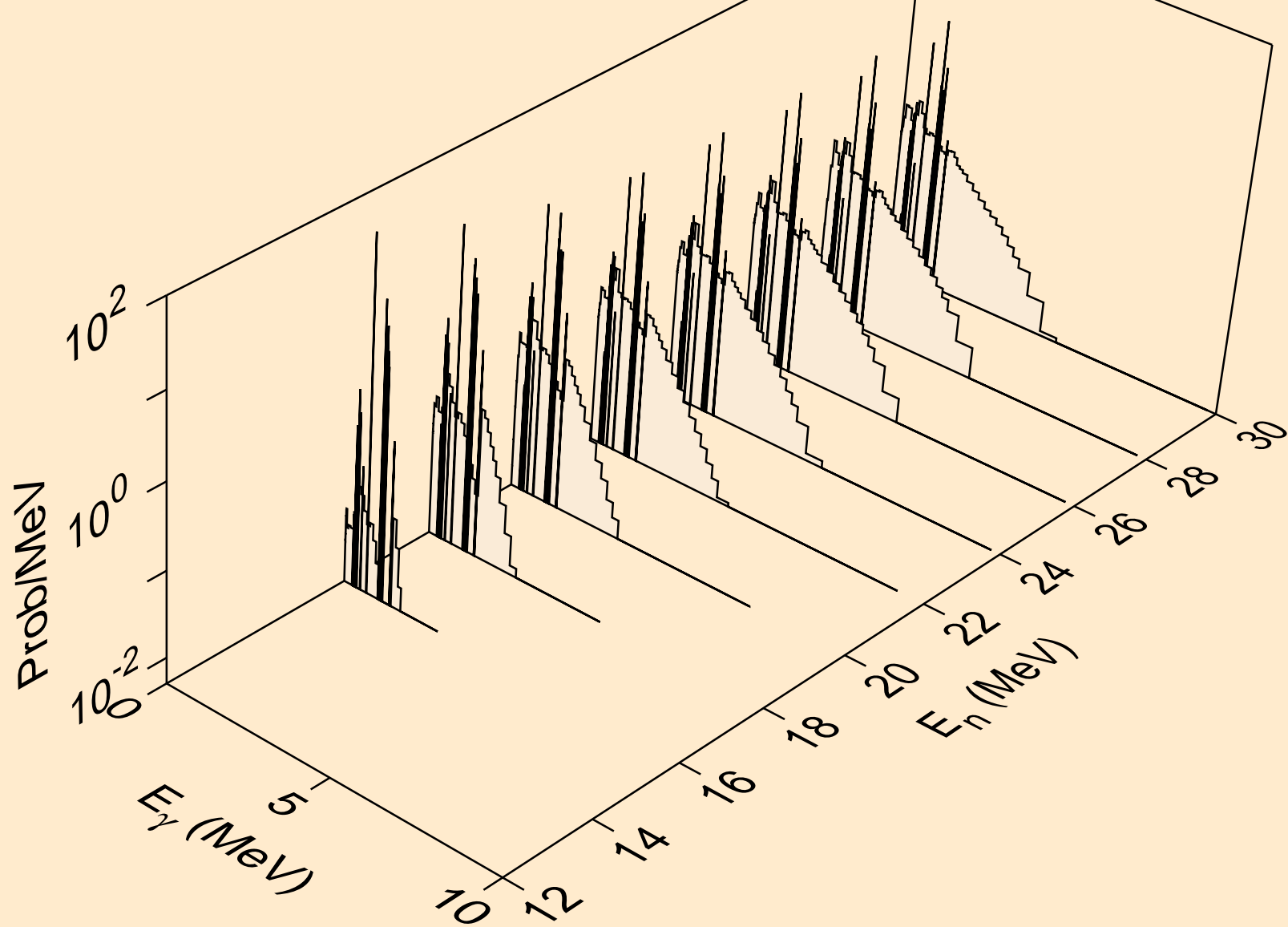

BI214 PROTON ACER TENDL-2021 LIBRARY; T=0.K  
Photon emission for (n,2np)

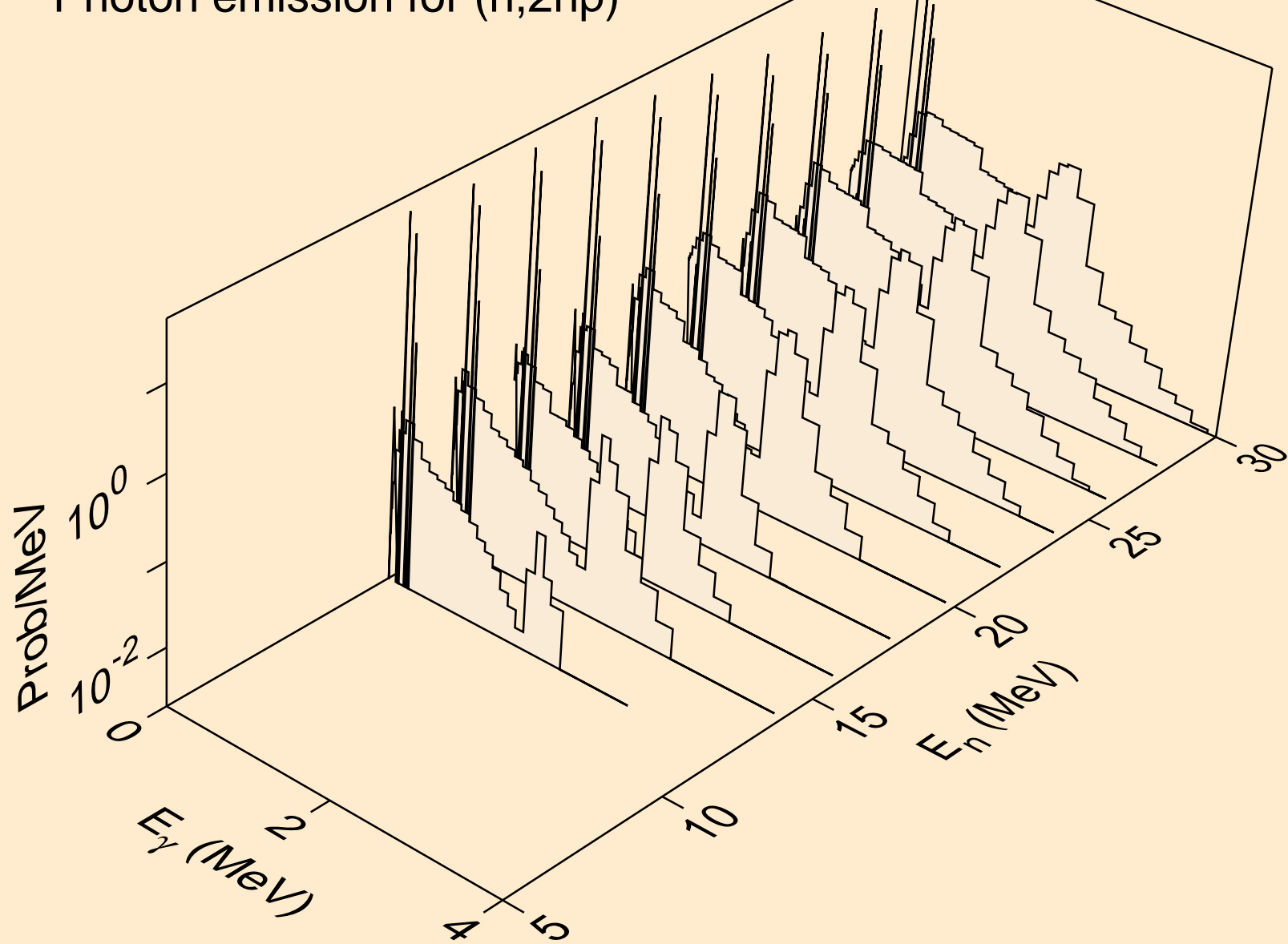

BI214 PROTON ACER TENDL-2021 LIBRARY; T=0.K  
Photon emission for (n,3np)

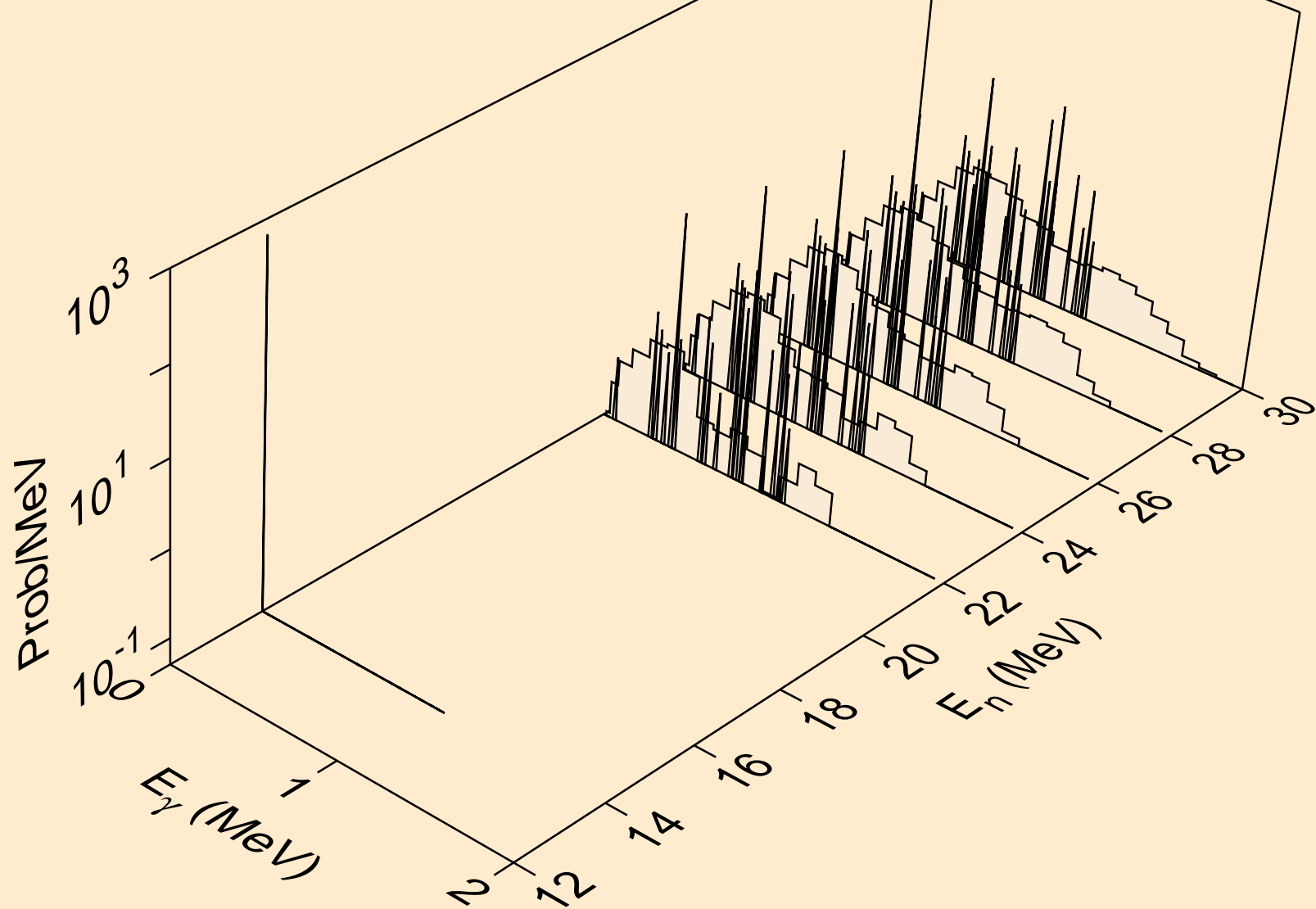

BI214 PROTON ACER TENDL-2021 LIBRARY; T=0.K  
Photon emission for (n,2np)

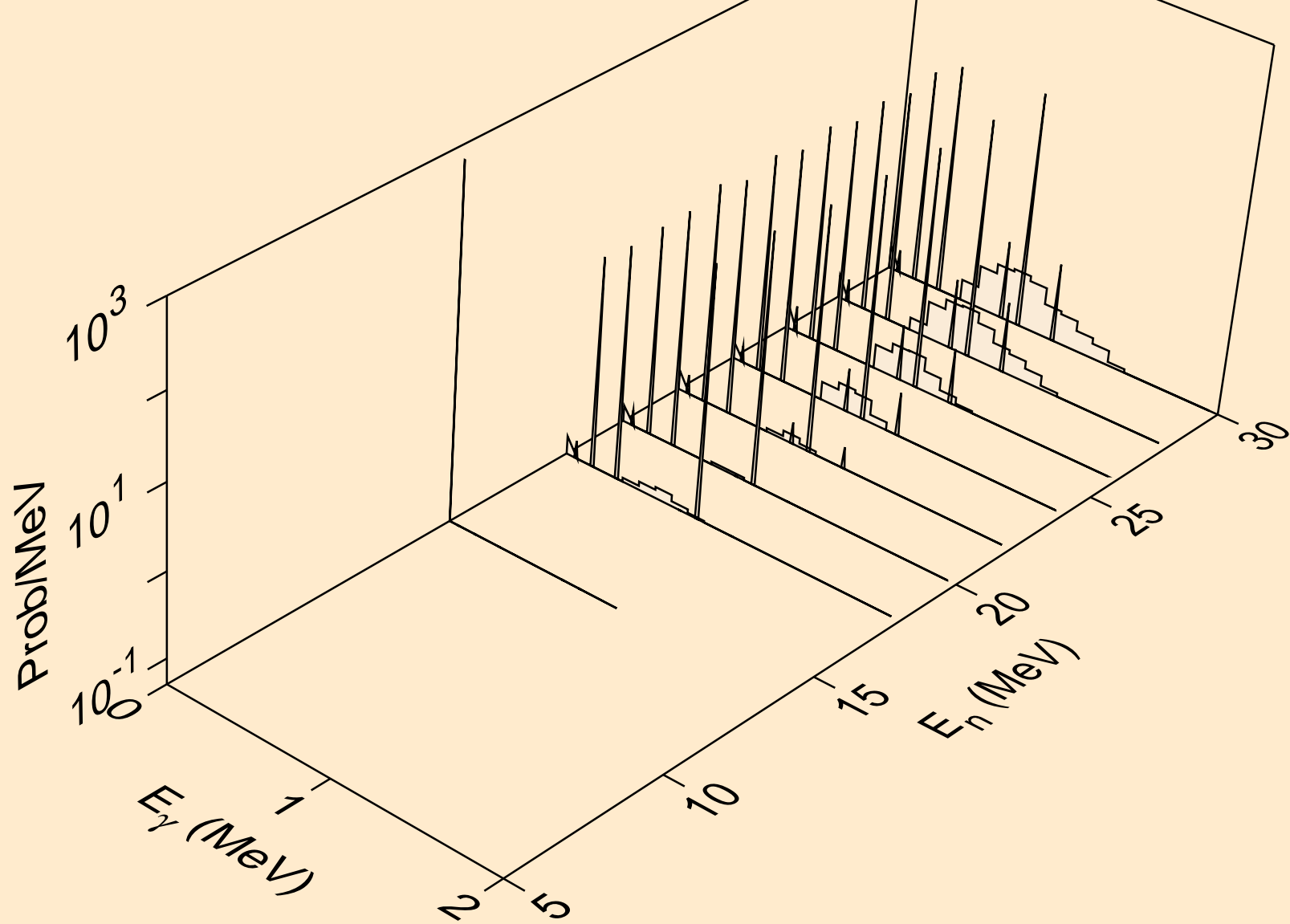

BI214 PROTON ACER TENDL-2021 LIBRARY; T=0.K  
Photon emission for (n,npa)

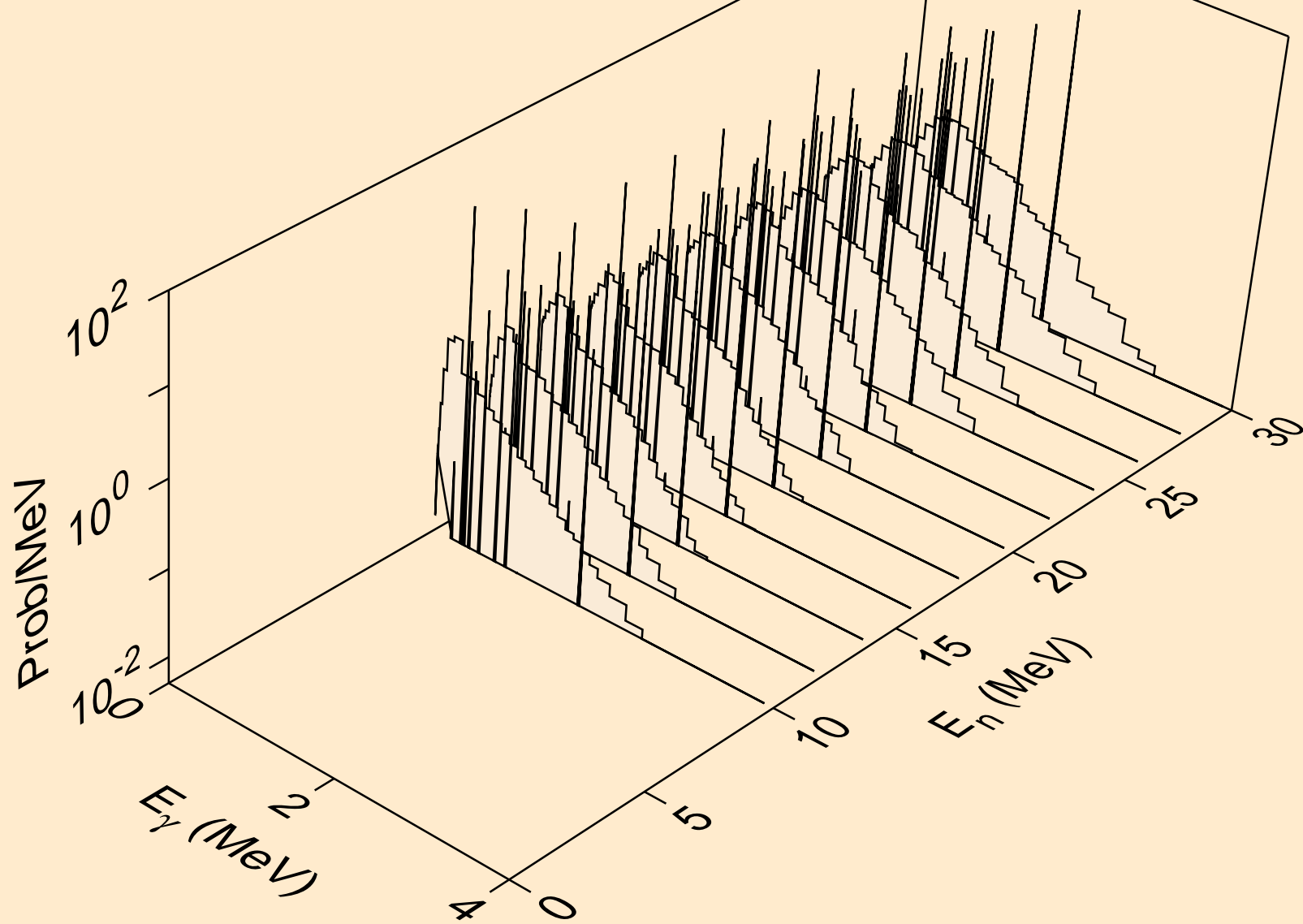

BI214 PROTON ACER TENDL-2021 LIBRARY; T=0.K  
Photon emission for (n,gma)

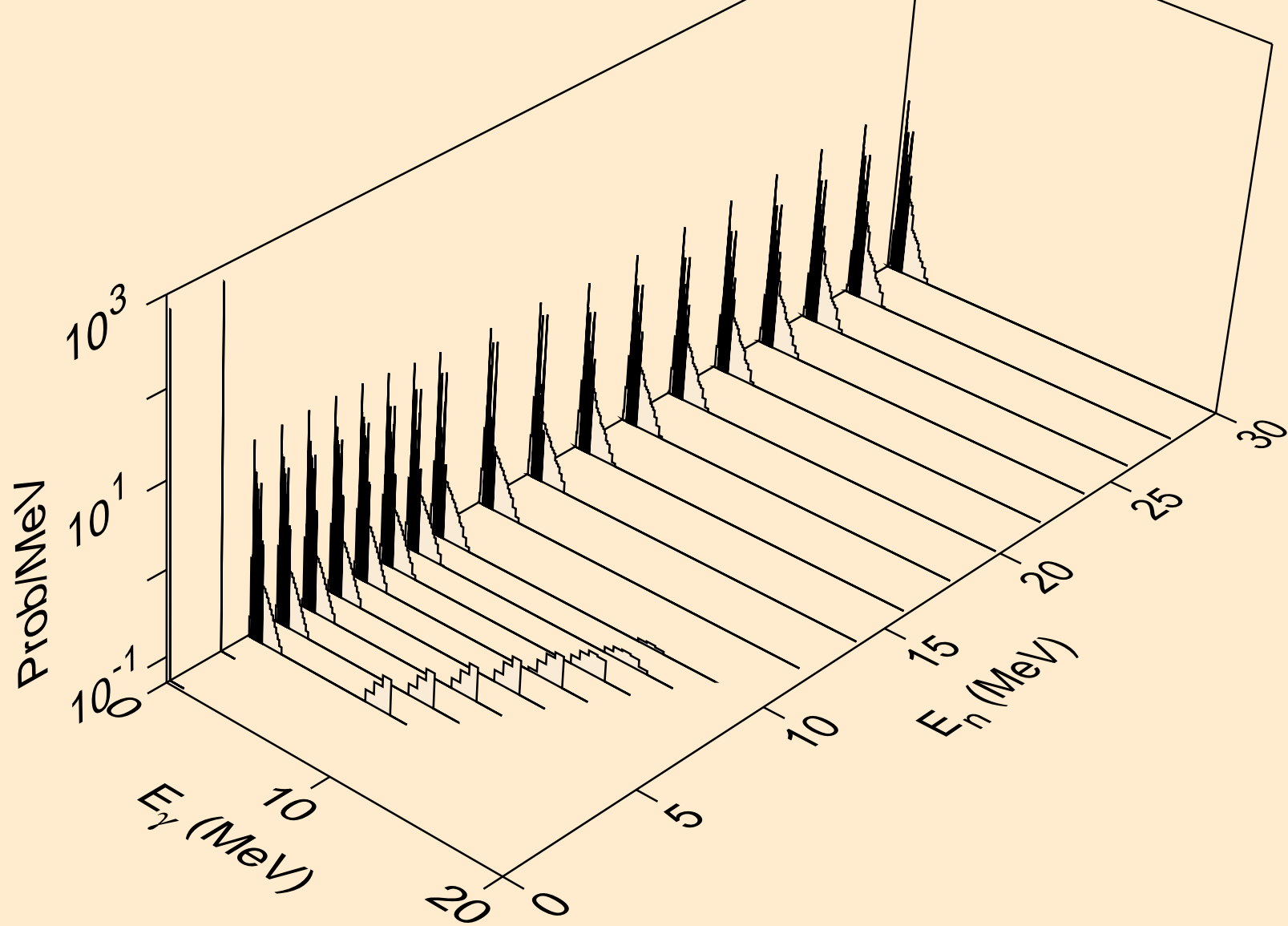



BI214 PROTON ACER TENDL-2021 LIBRARY; T=0.K  
Photon emission for inelastic

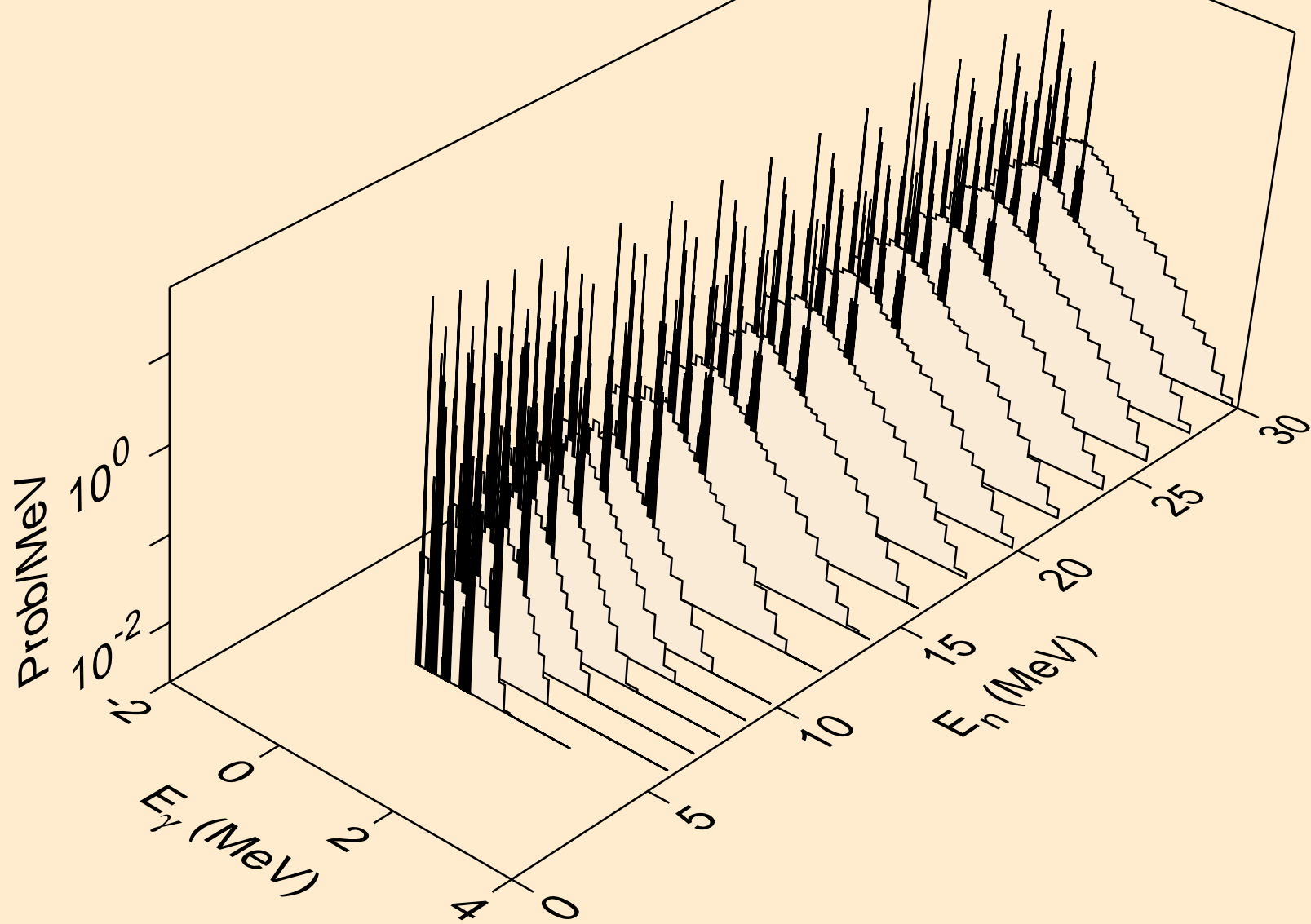

BI214 PROTON ACER TENDL-2021 LIBRARY; T=0.K  
Photon emission for (n,d)

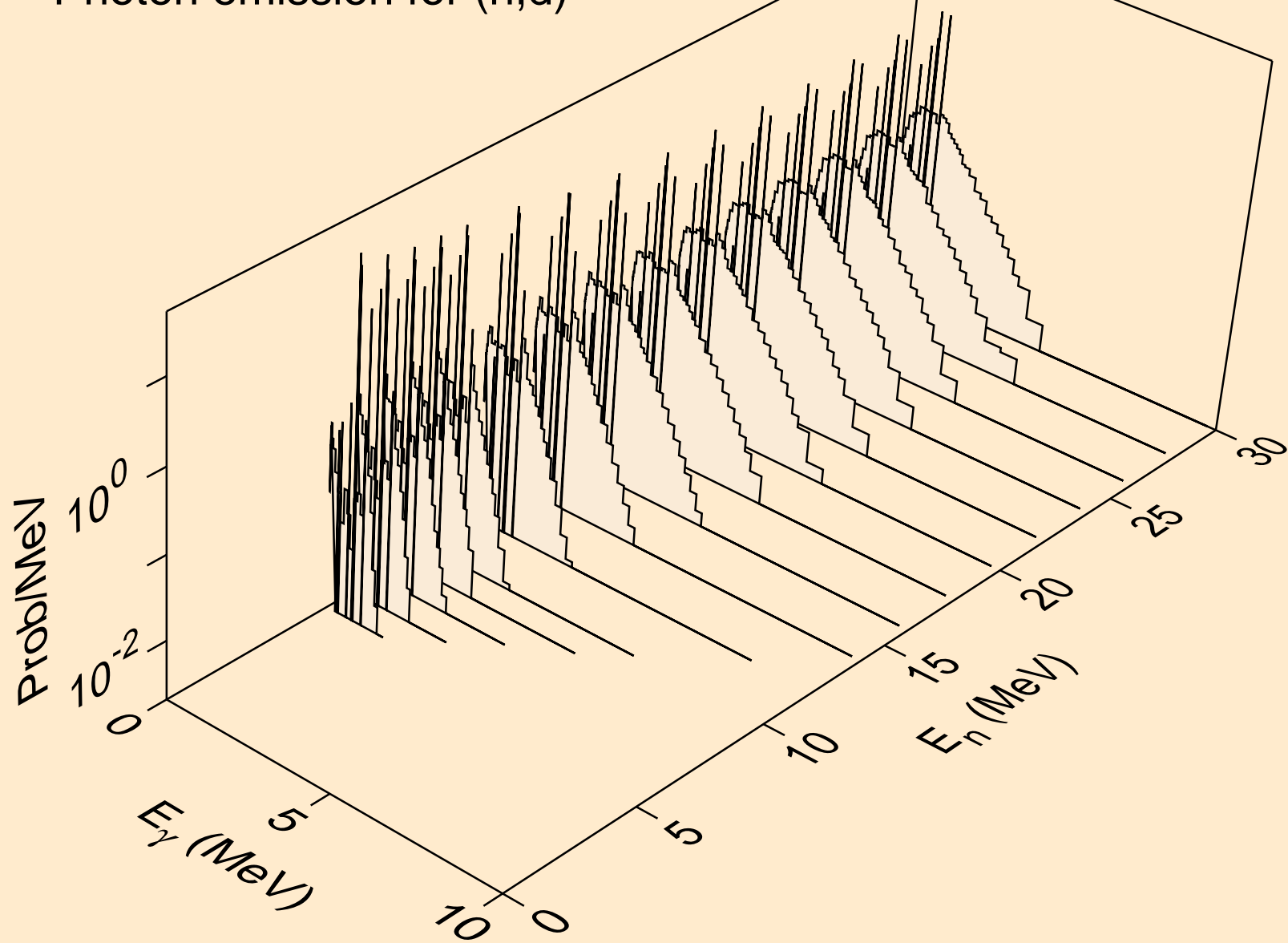

BI214 PROTON ACER TENDL-2021 LIBRARY; T=0.K  
Photon emission for (n,t)

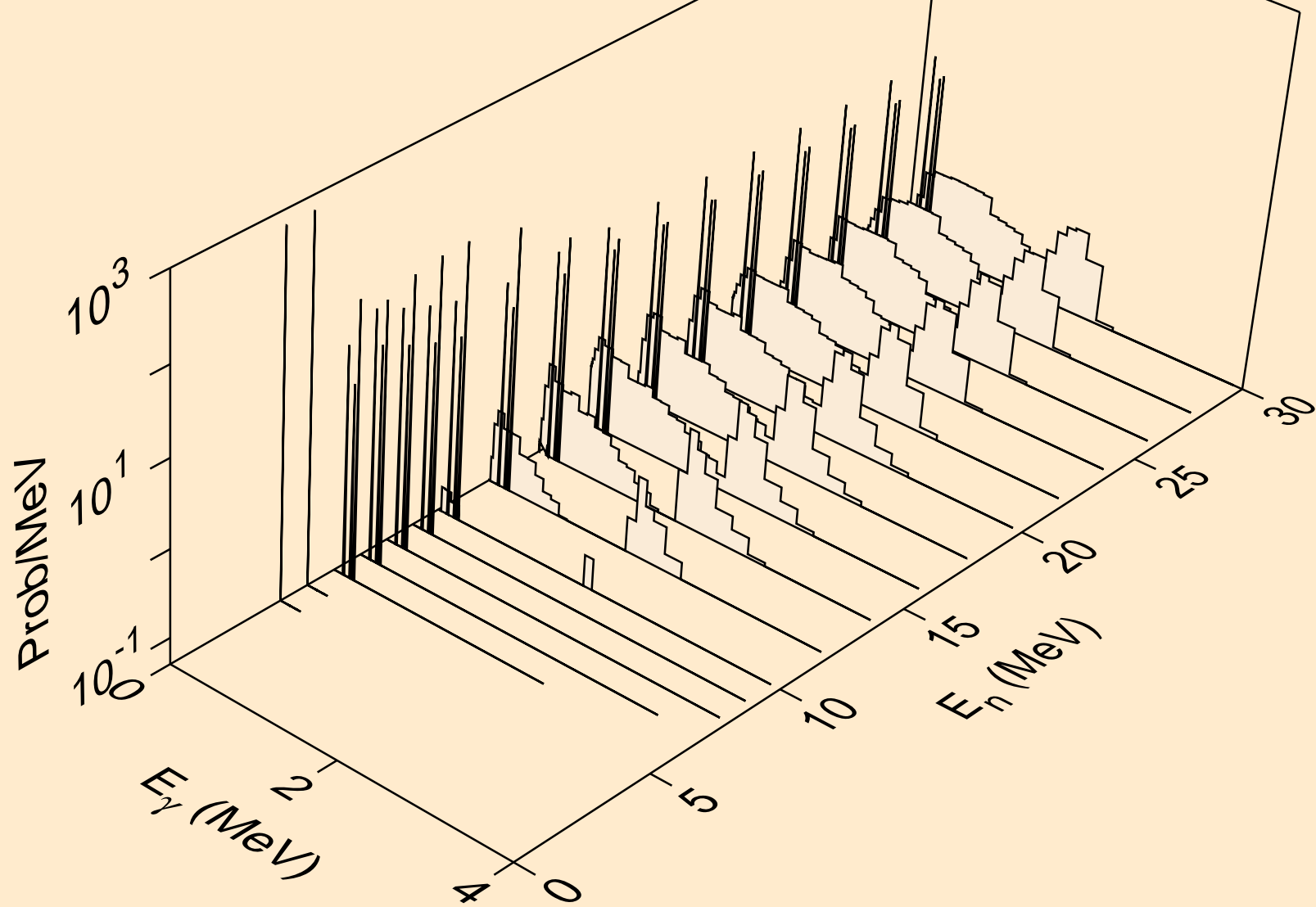

BI214 PROTON ACER TENDL-2021 LIBRARY; T=0.K  
Photon emission for (n,he3)

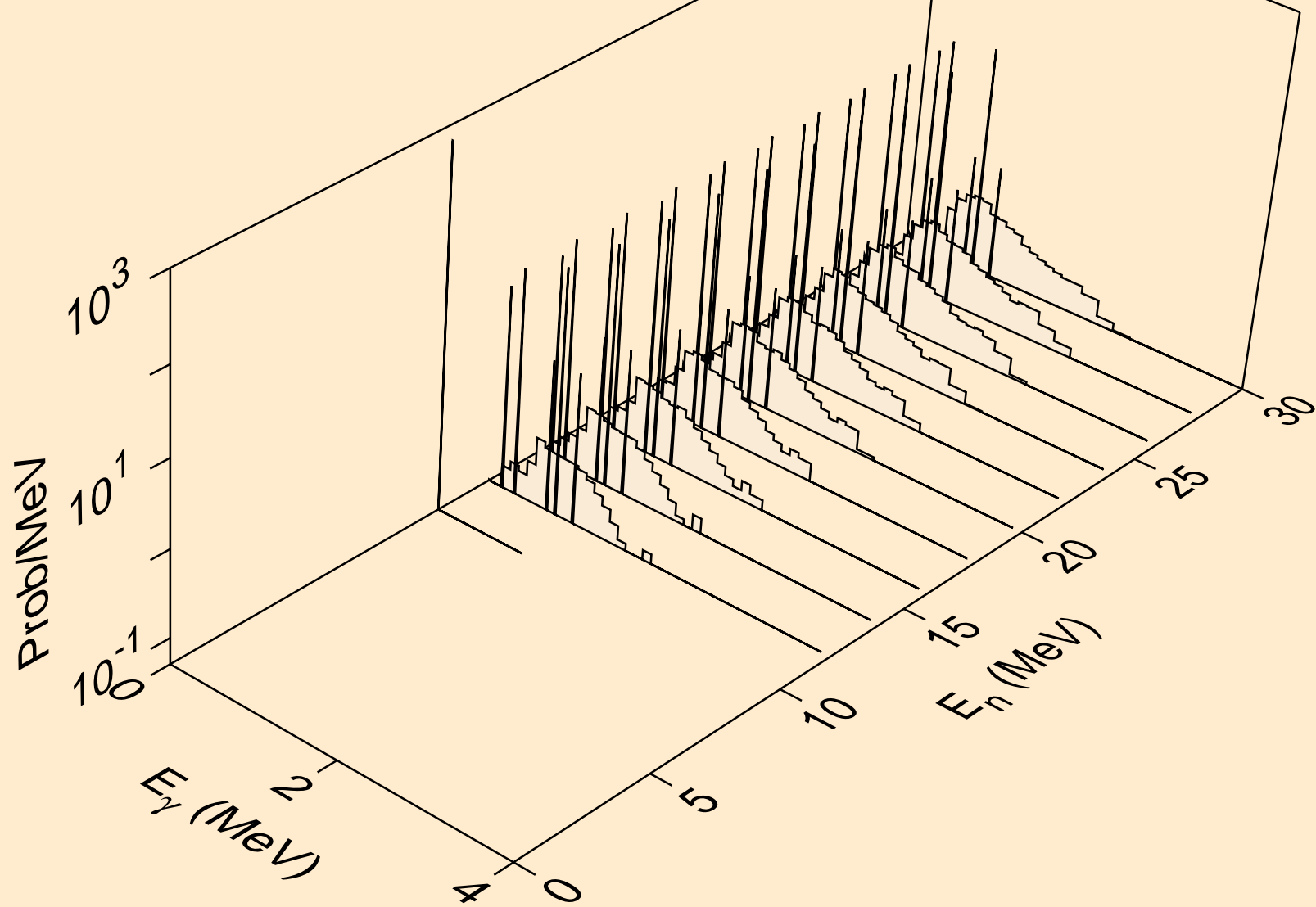

BI214 PROTON ACER TENDL-2021 LIBRARY; T=0.K  
Photon emission for (n,a)

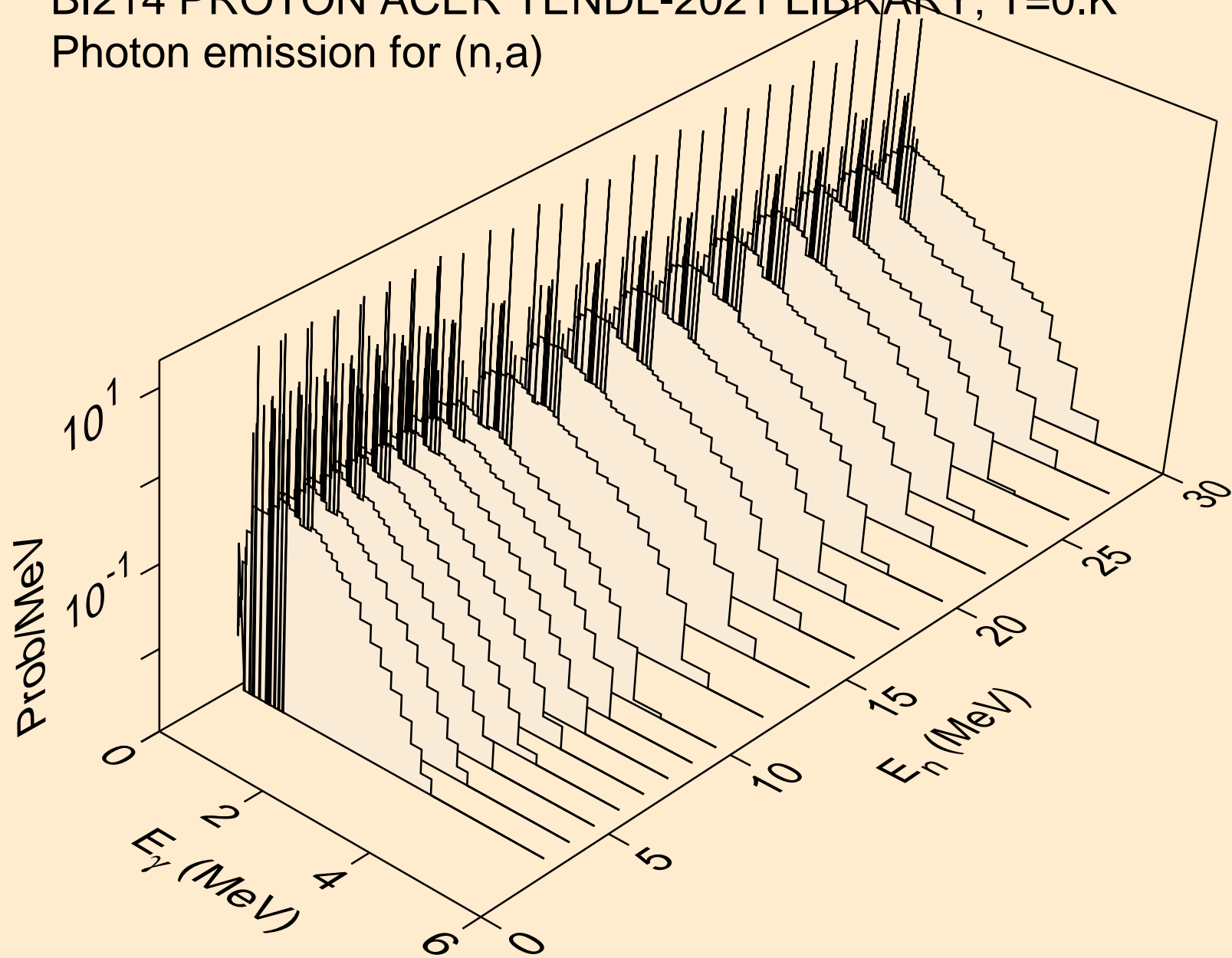

BI214 PROTON ACER TENDL-2021 LIBRARY; T=0.K  
Photon emission for (n,2a)

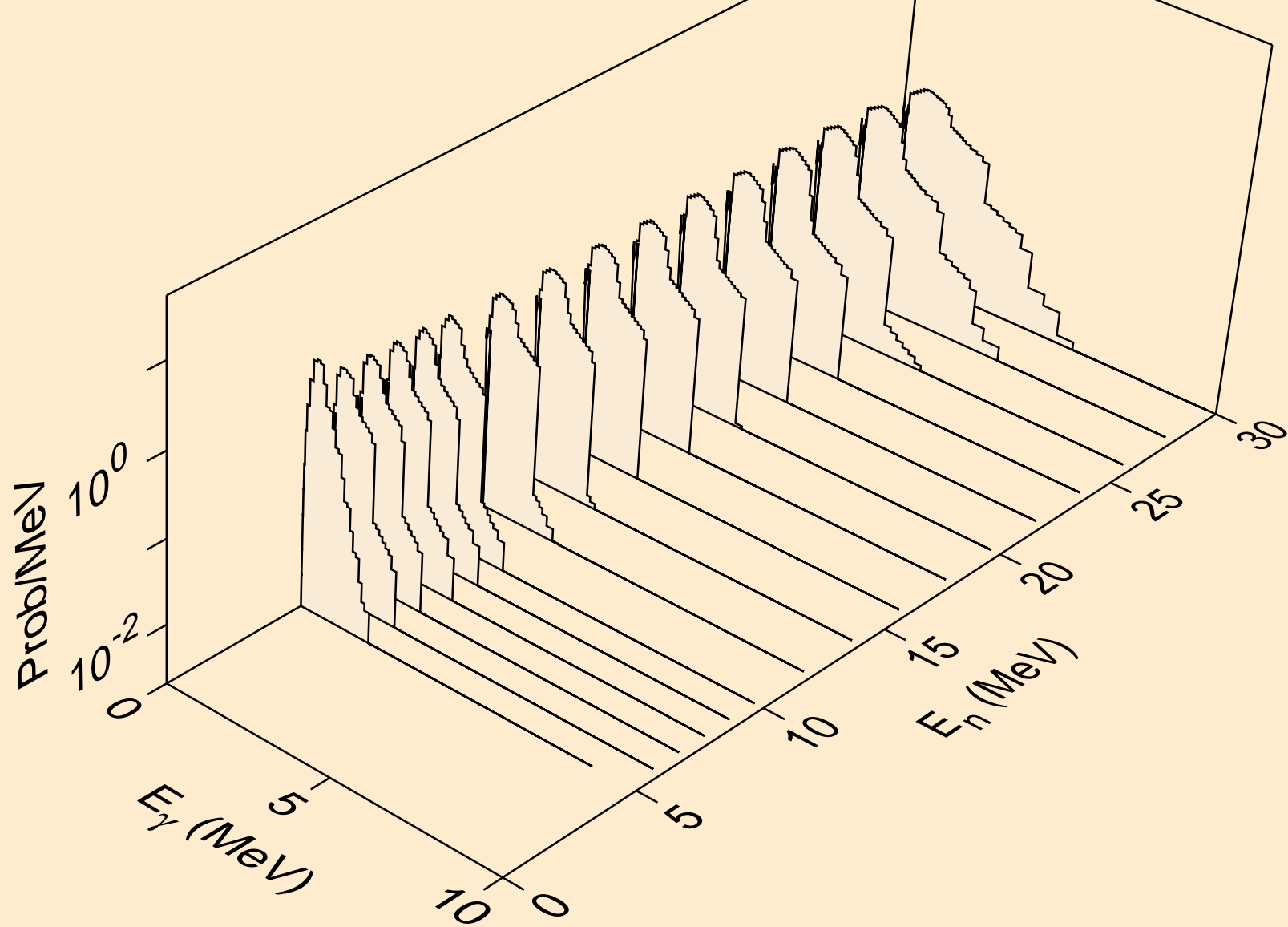

BI214 PROTON ACER TENDL-2021 LIBRARY; T=0.K  
Photon emission for (n,2p)

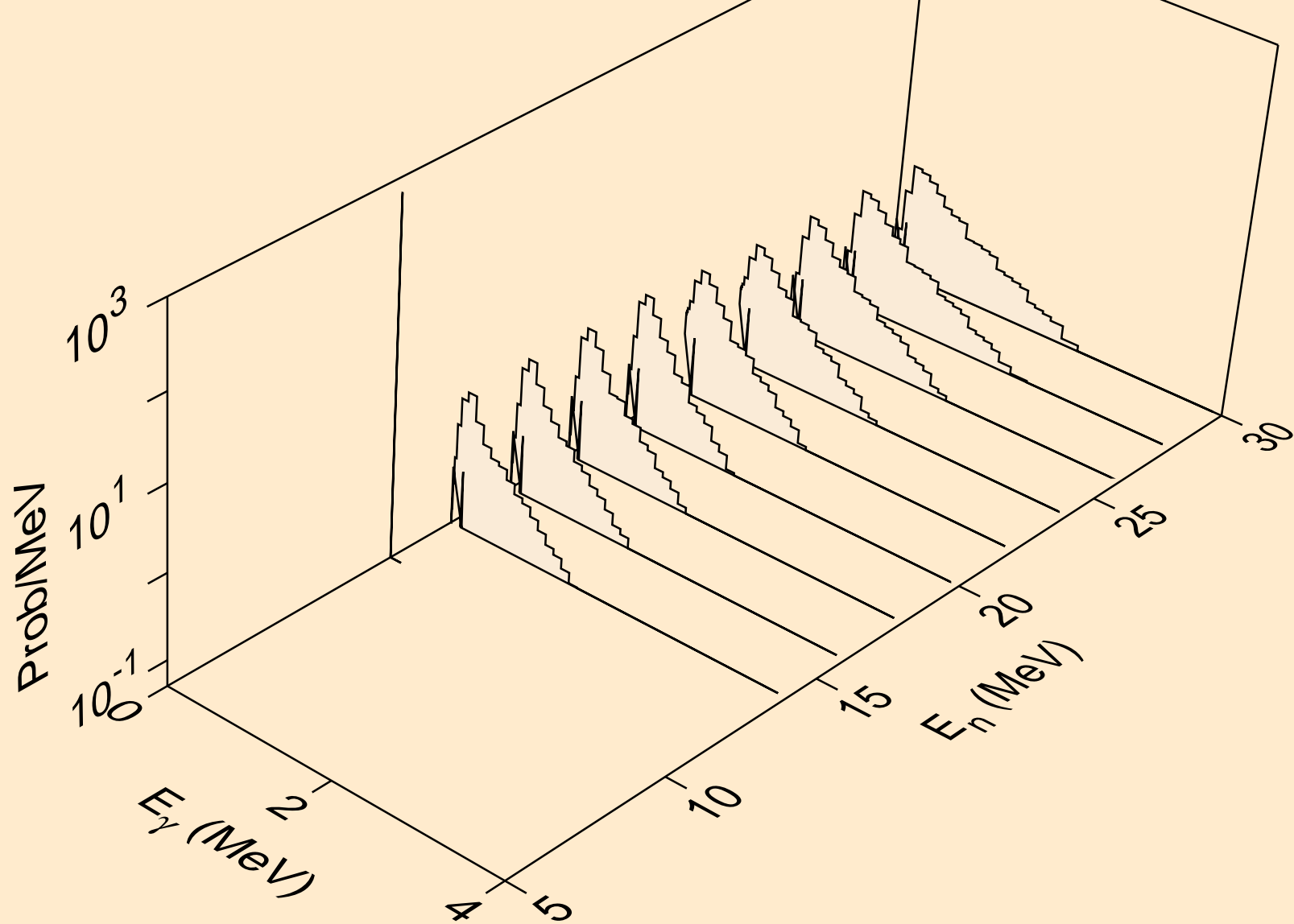

BI214 PROTON ACER TENDL-2021 LIBRARY; T=0.K  
Photon emission for (n,pa)

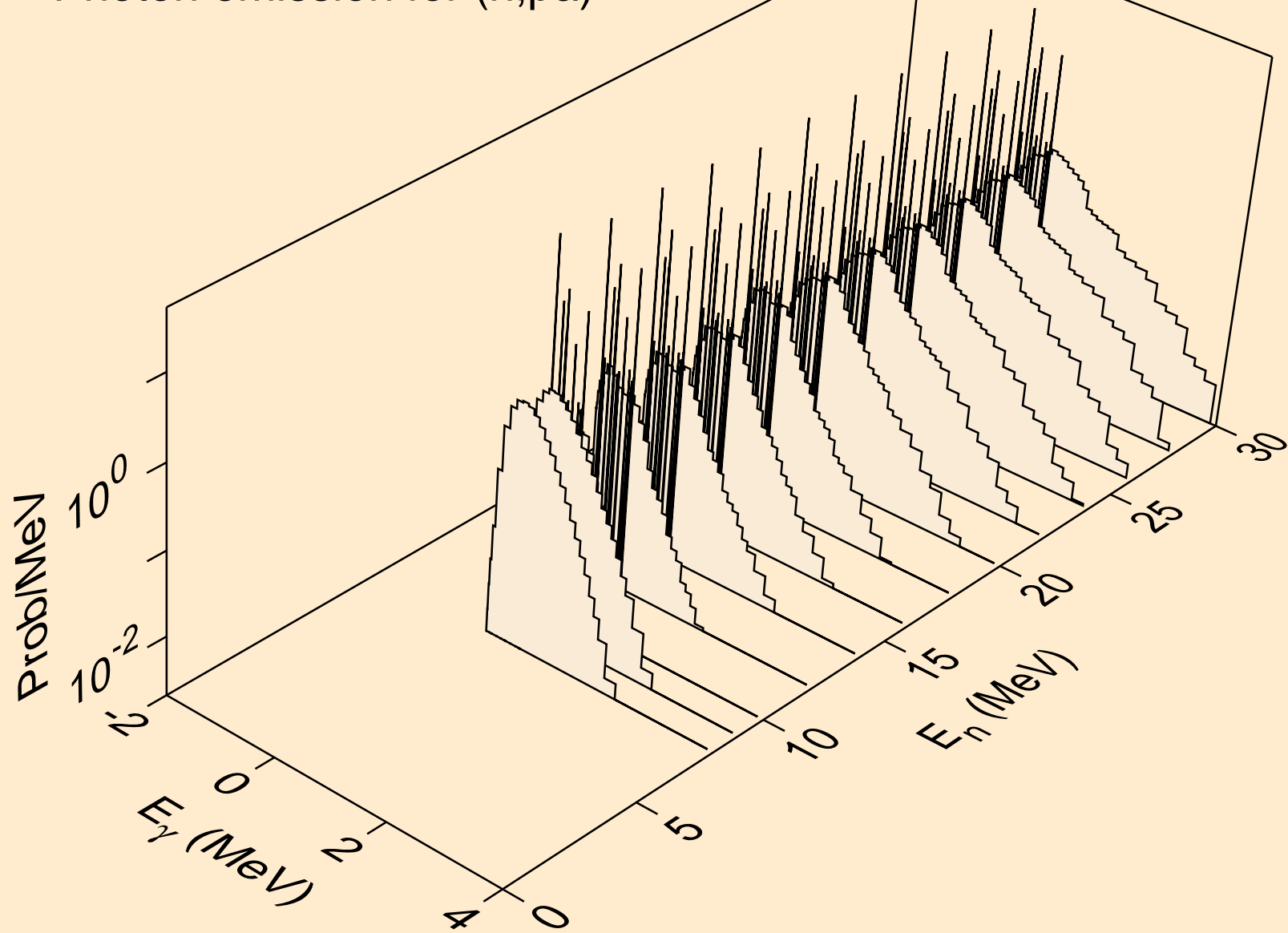



BI214 PROTON ACER TENDL-2021 LIBRARY; T=0.K  
Photon emission for (n,pd)

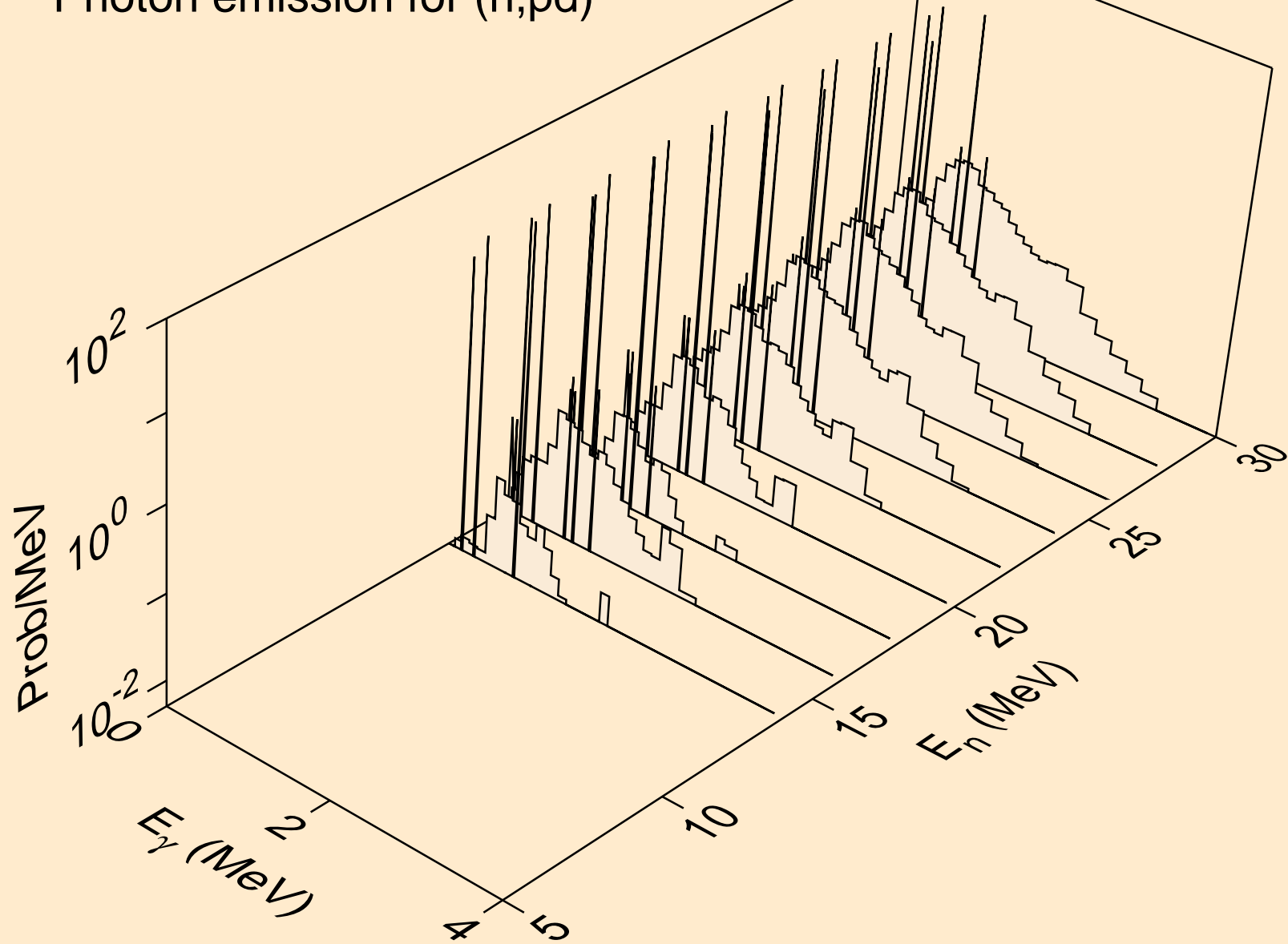

BI214 PROTON ACER TENDL-2021 LIBRARY; T=0.K  
Photon emission for (n,pt)

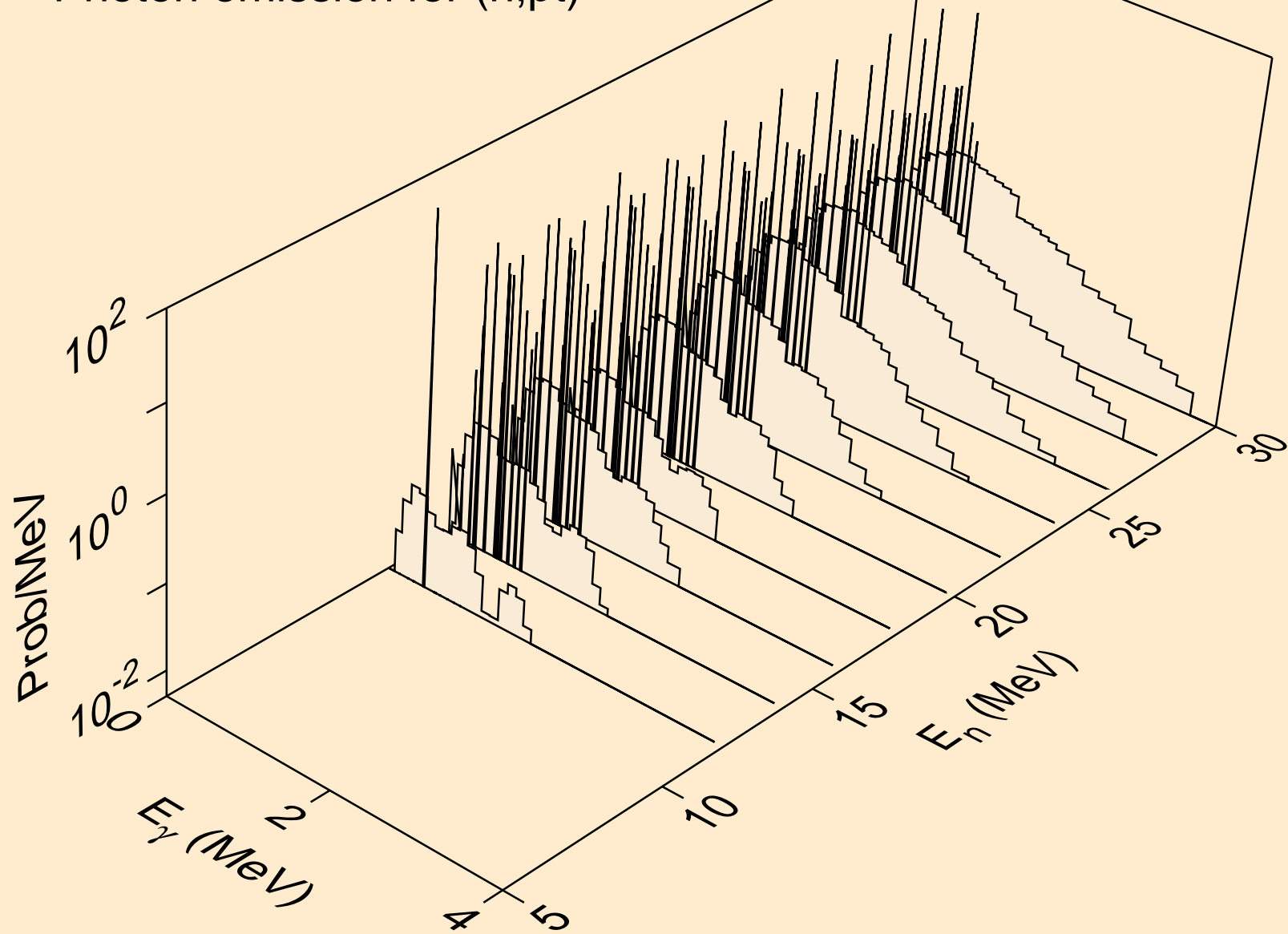

BI214 PROTON ACER TENDL-2021 LIBRARY; T=0.K  
Photon emission for (n,da)

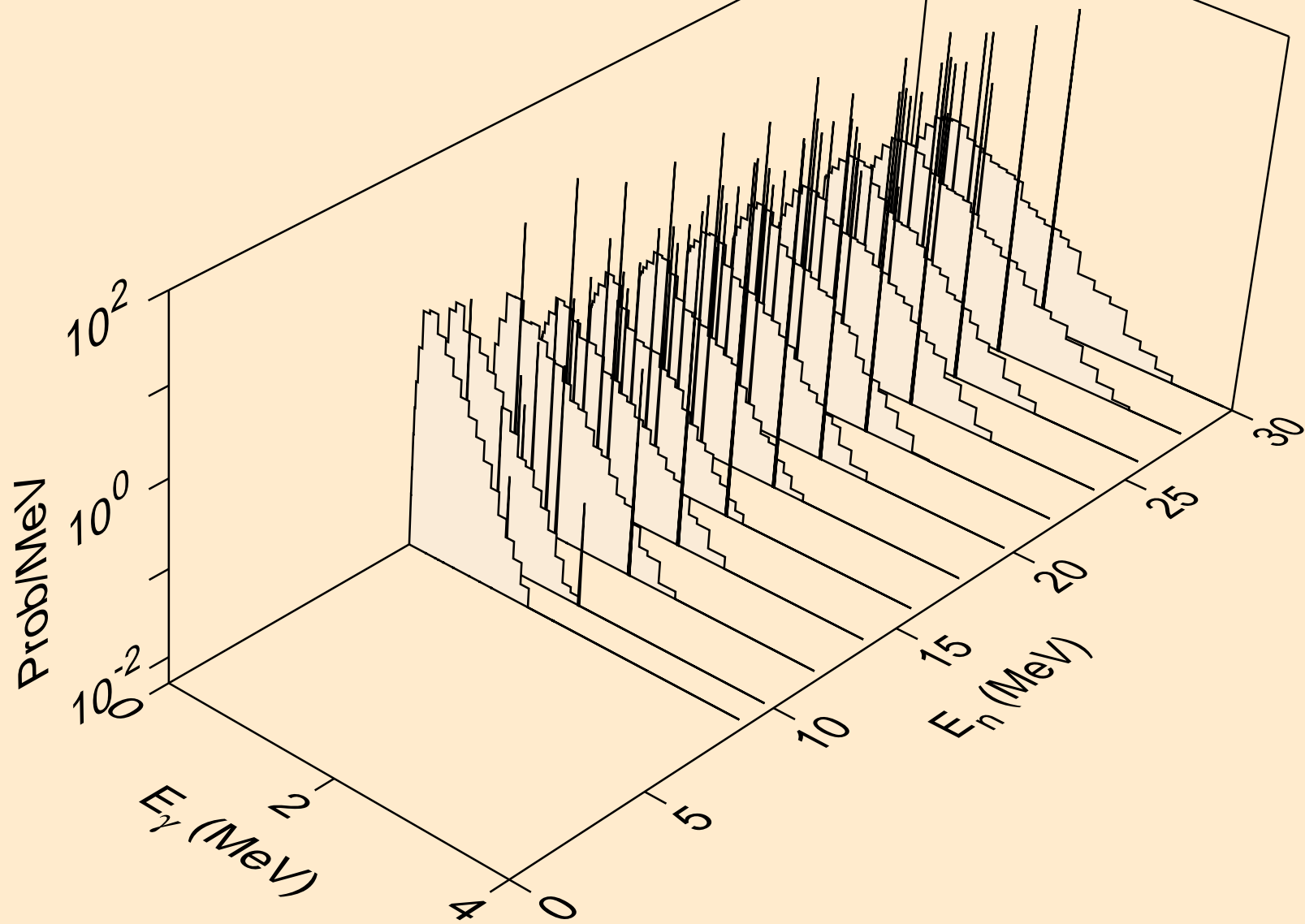

# BI214 PROTON ACER TENDL-2021 LIBRARY; T=0.K

## Particle heating contributions

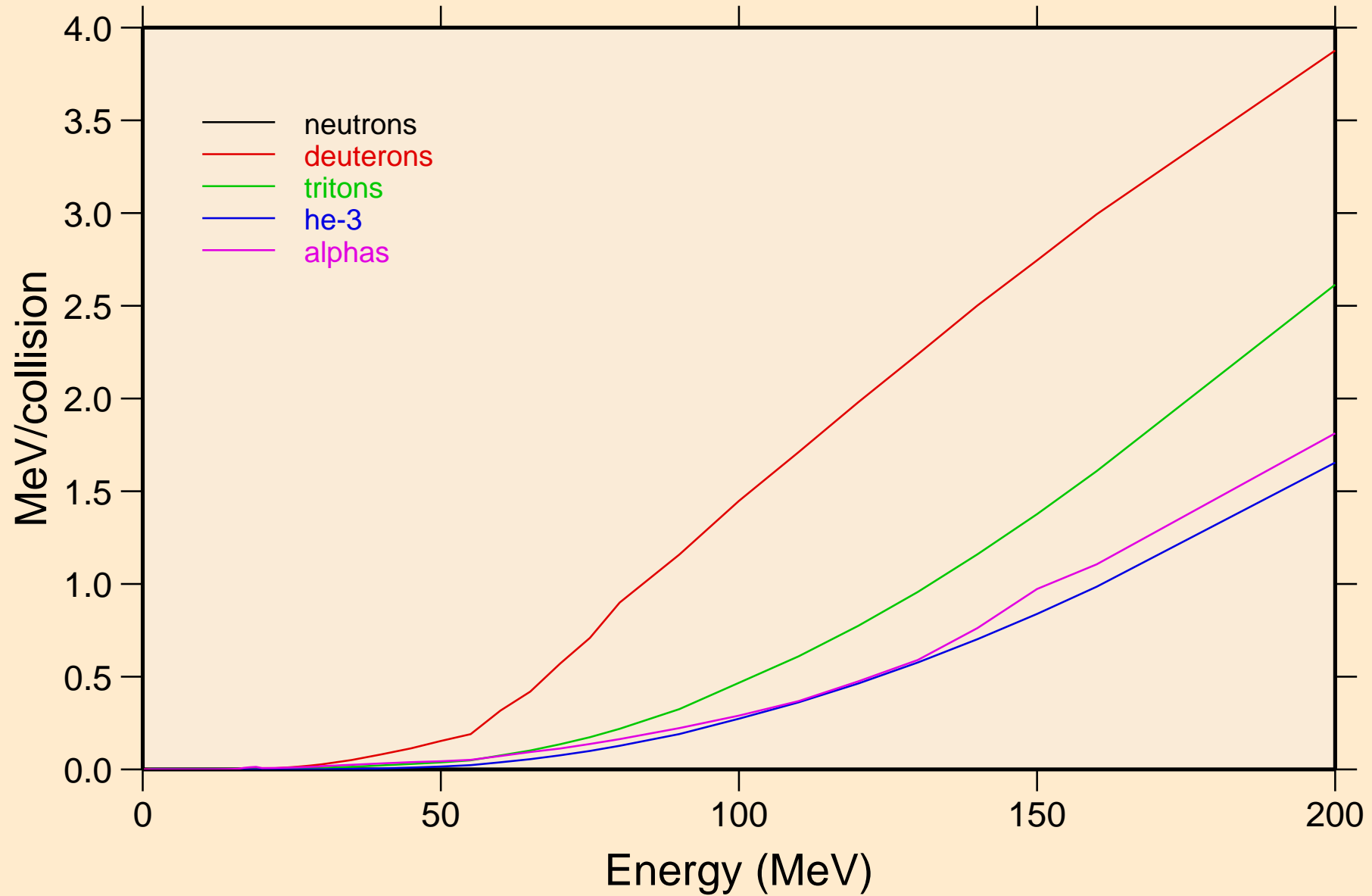

BI214 PROTON ACER TENDL-2021 LIBRARY; T=0.K  
Recoil Heating

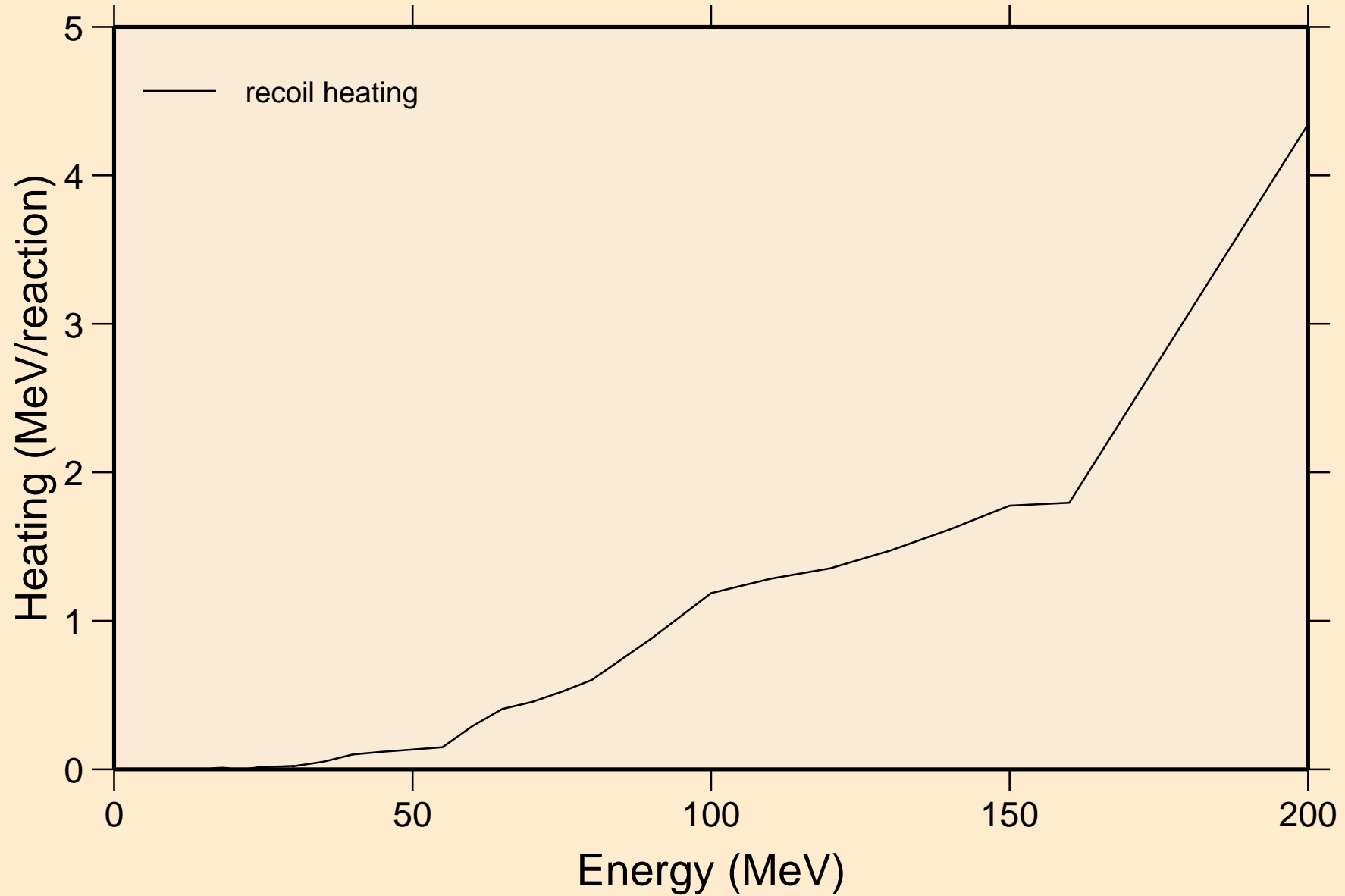

BI214 PROTON ACER TENDL-2021 LIBRARY; T=0.K  
Particle production cross sections

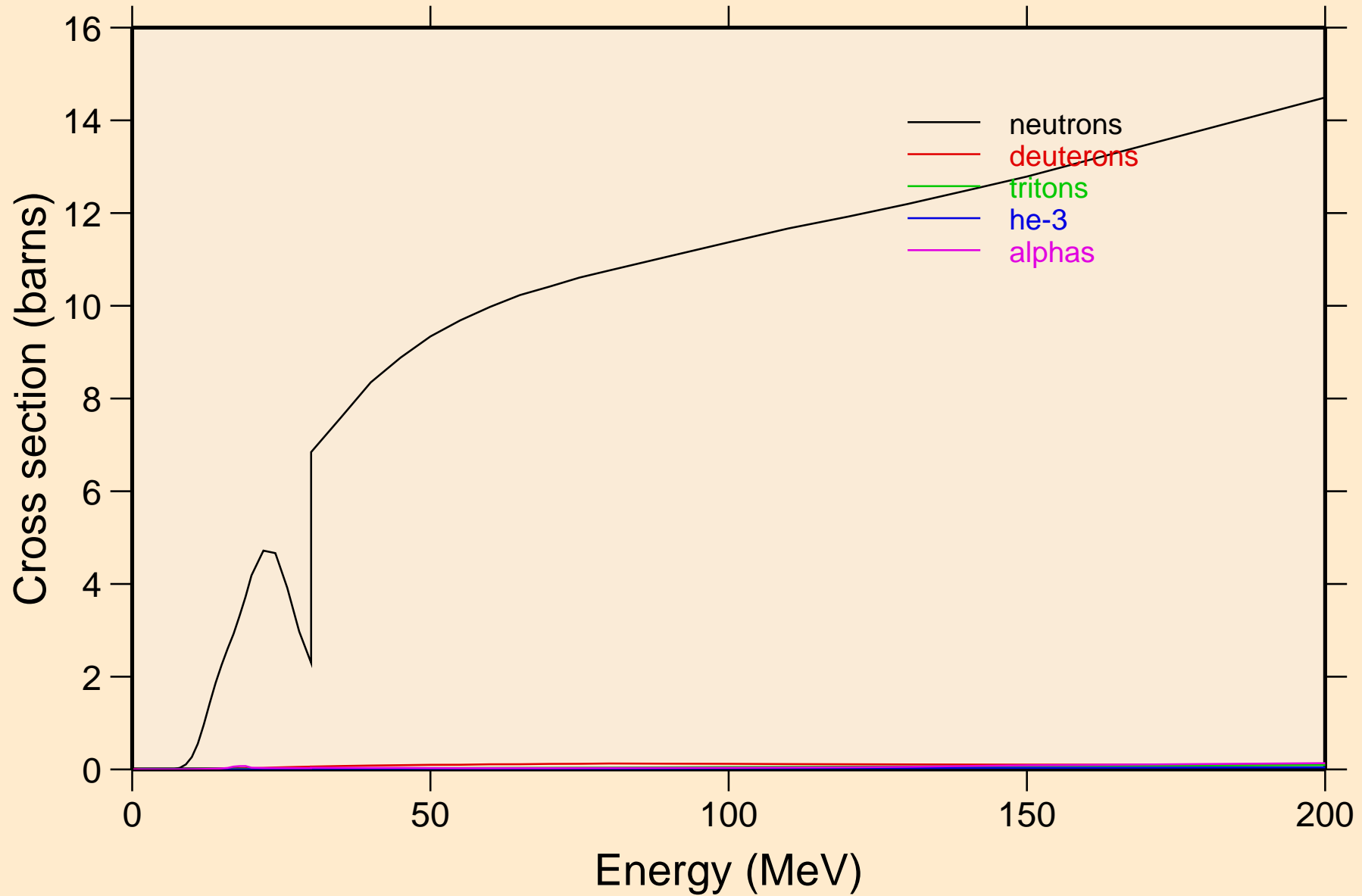

BI214 PROTON ACER TENDL-2021 LIBRARY; T=0.K  
neutrons from (p,n)

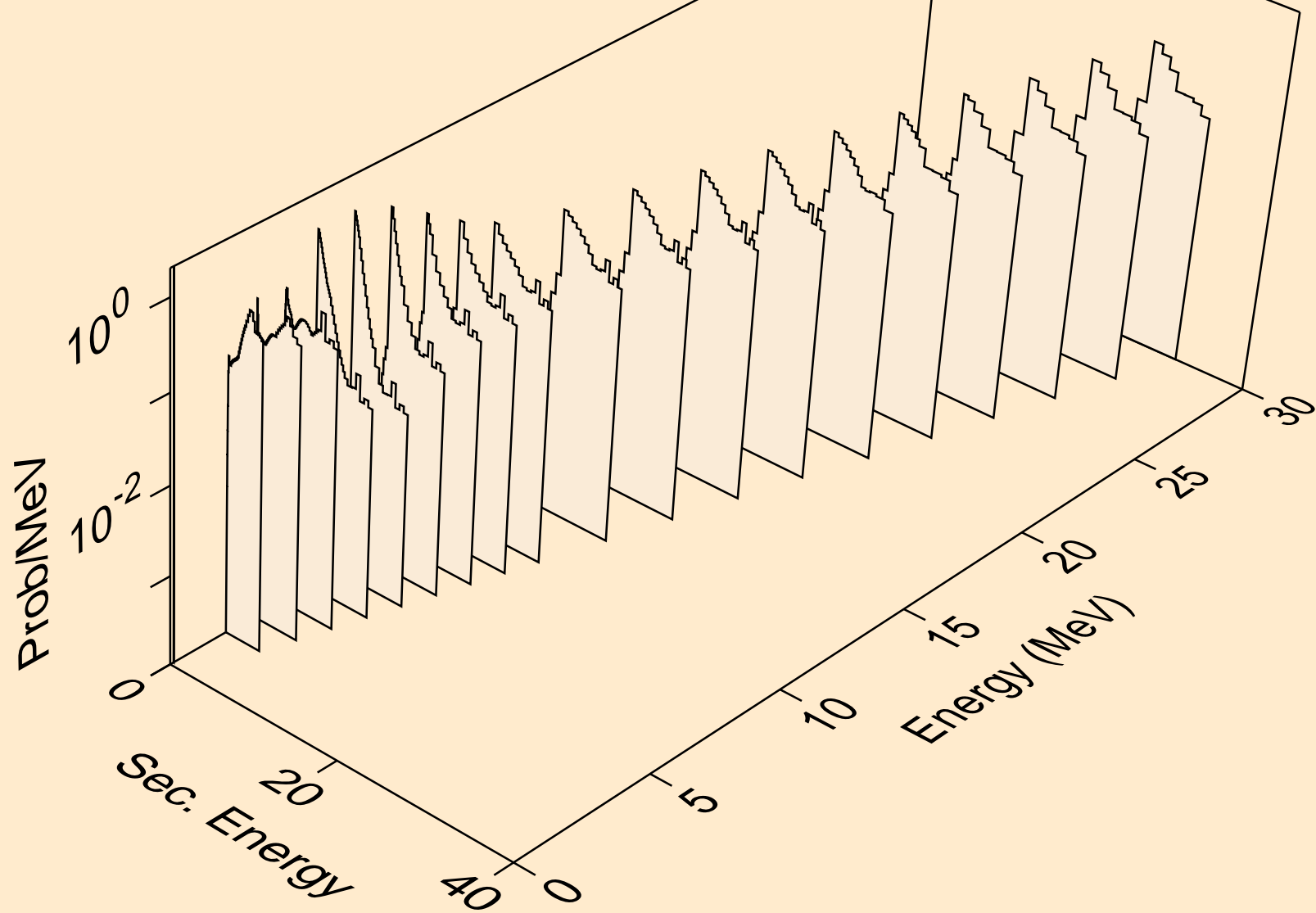

BI214 PROTON ACER TENDL-2021 LIBRARY; T=0.K  
neutrons from (p,x)

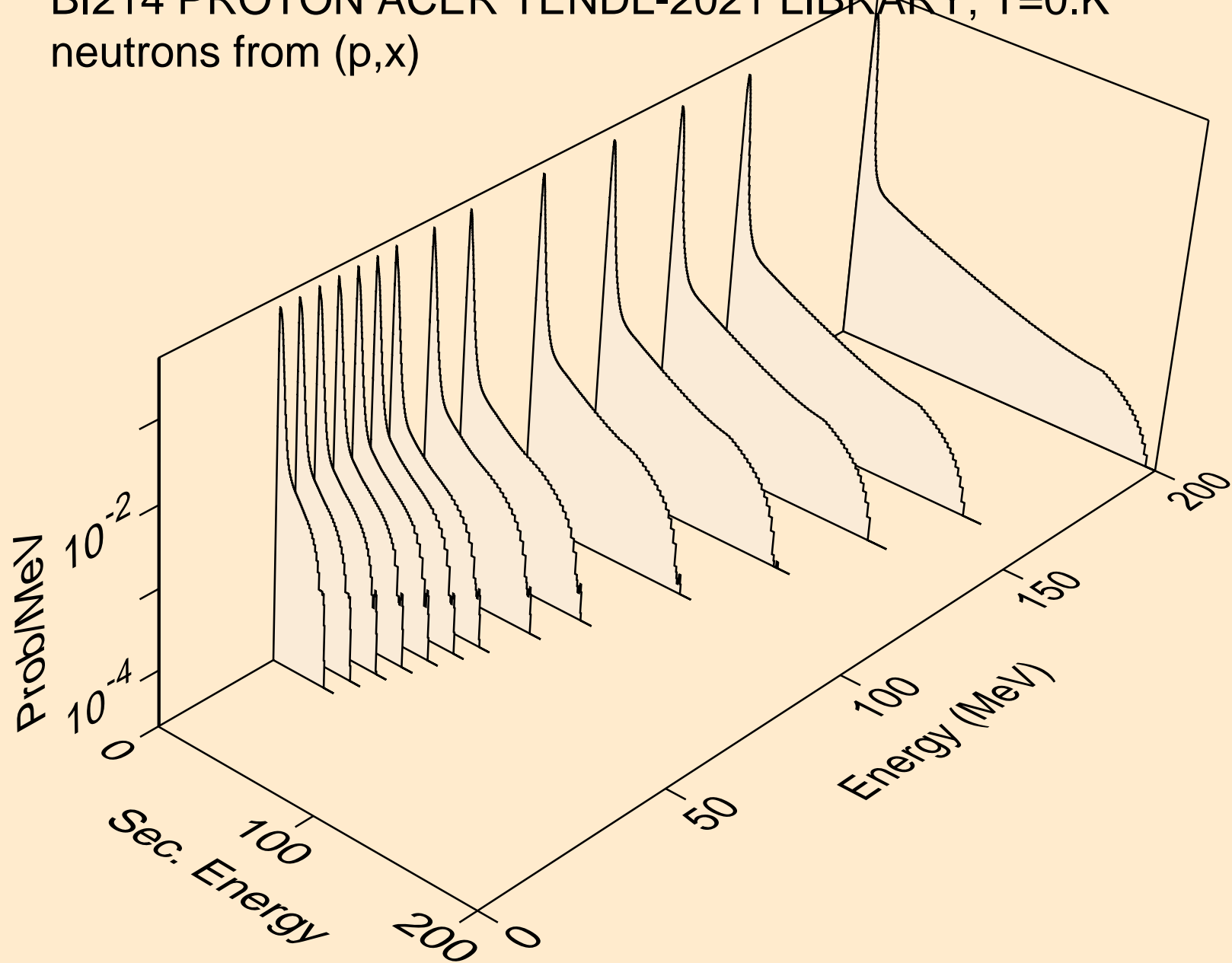



BI214 PROTON ACER TENDL-2021 LIBRARY; T=0.K  
neutrons from (p,2nd)

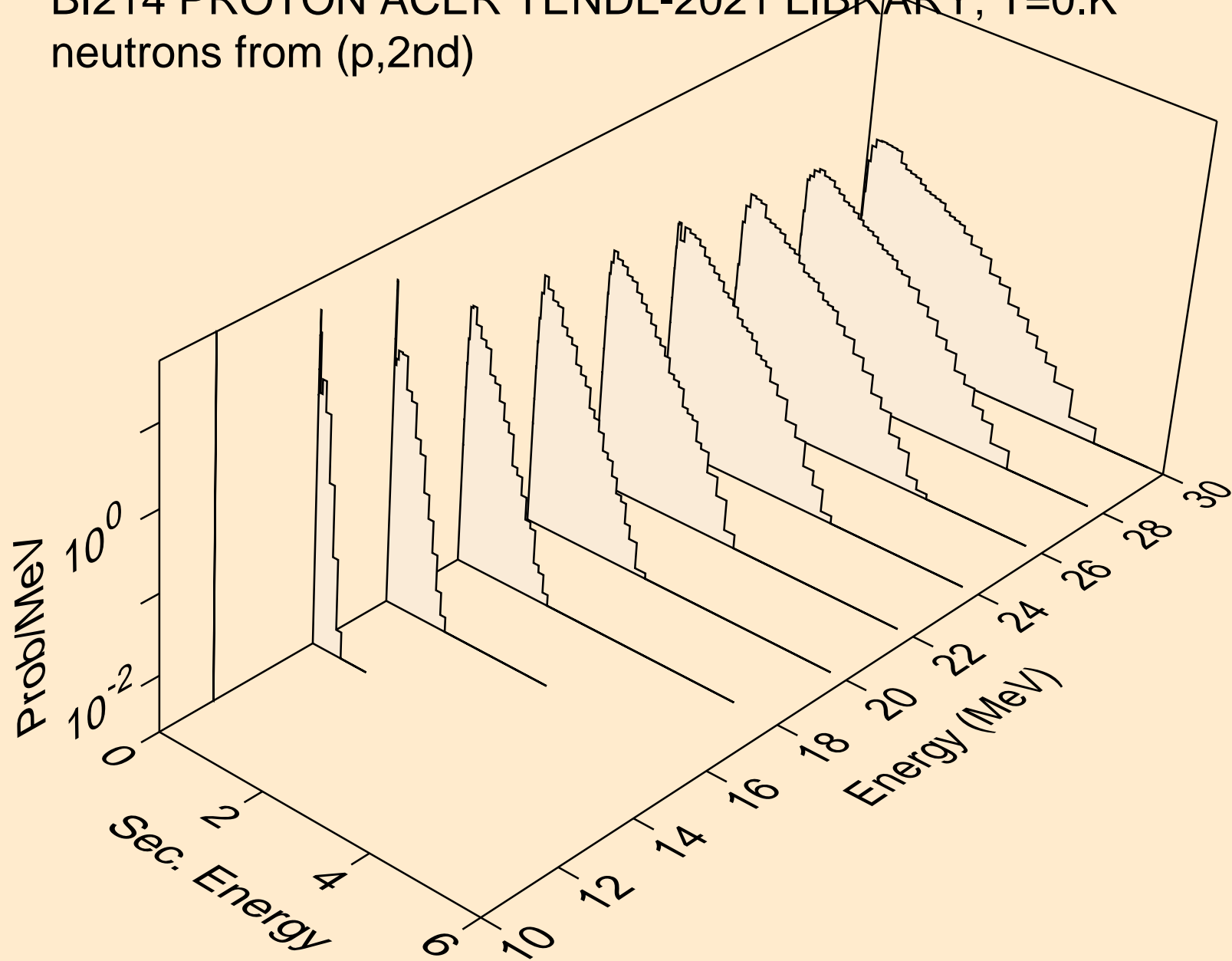

BI214 PROTON ACER TENDL-2021 LIBRARY; T=0.K  
neutrons from (p,2n)

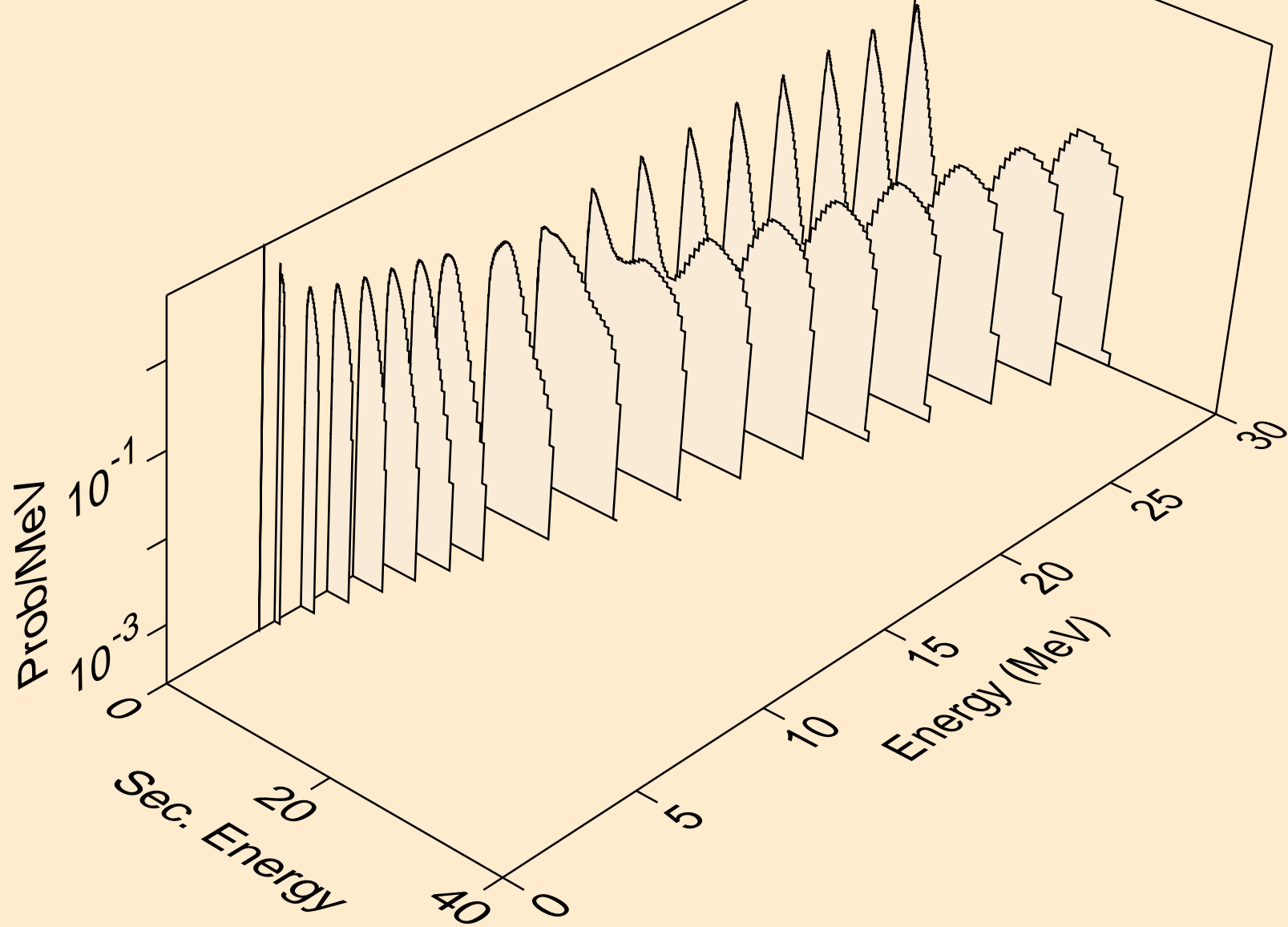

BI214 PROTON ACER TENDL-2021 LIBRARY; T=0.K  
neutrons from (p,3n)

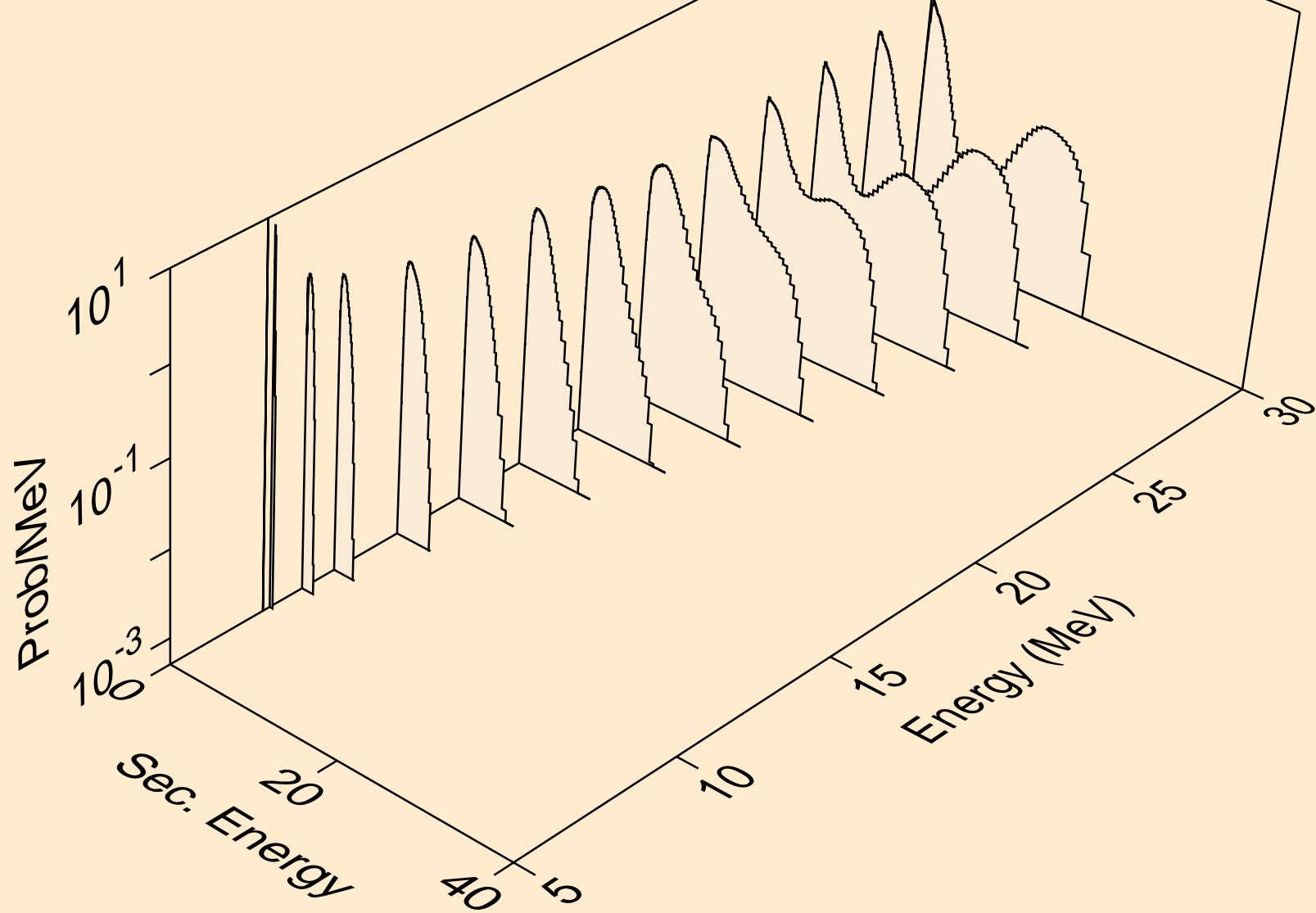

BI214 PROTON ACER TENDL-2021 LIBRARY; T=0.K  
neutrons from (p,n\*)a

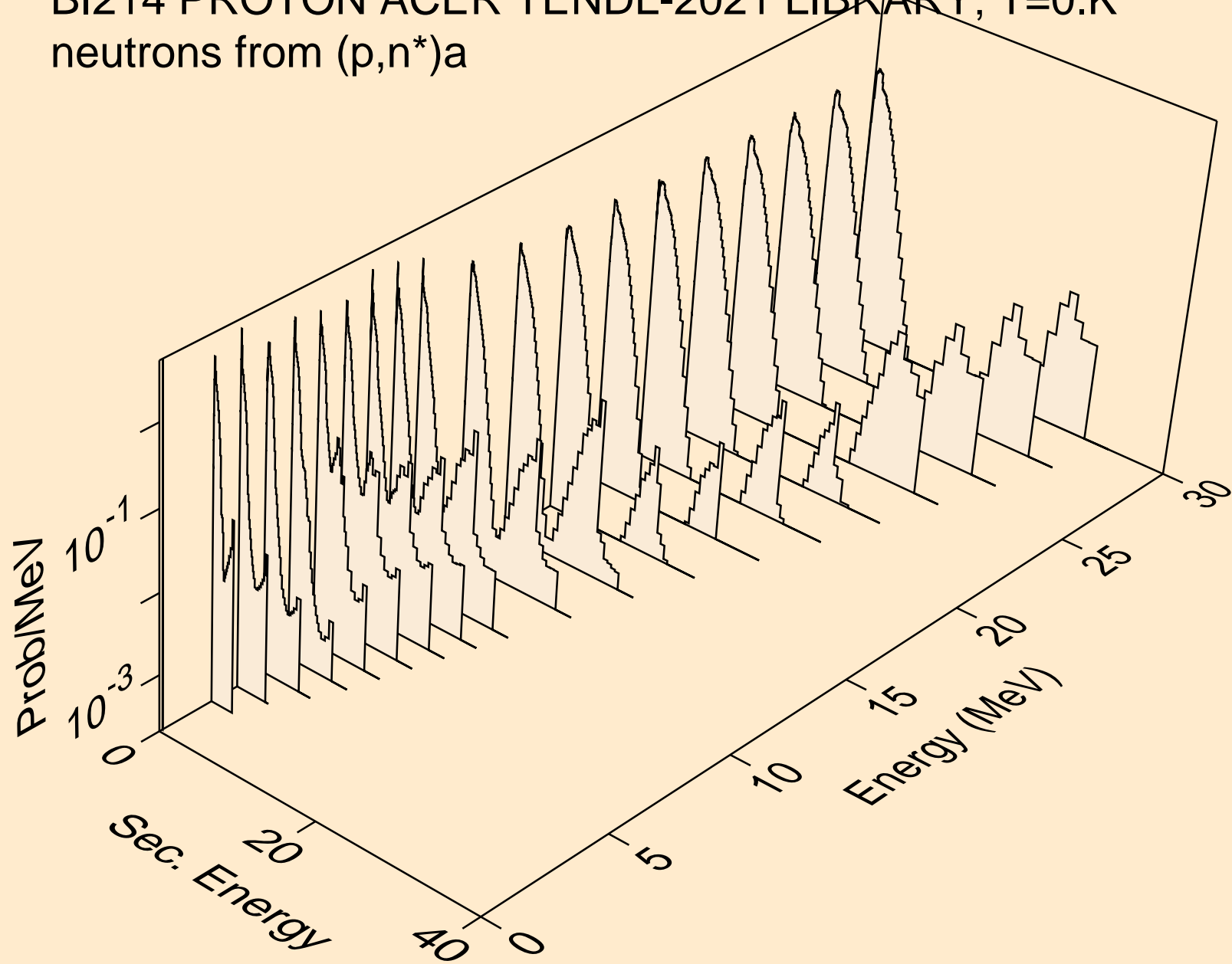

BI214 PROTON ACER TENDL-2021 LIBRARY; T=0.K  
neutrons from (p,2n)a

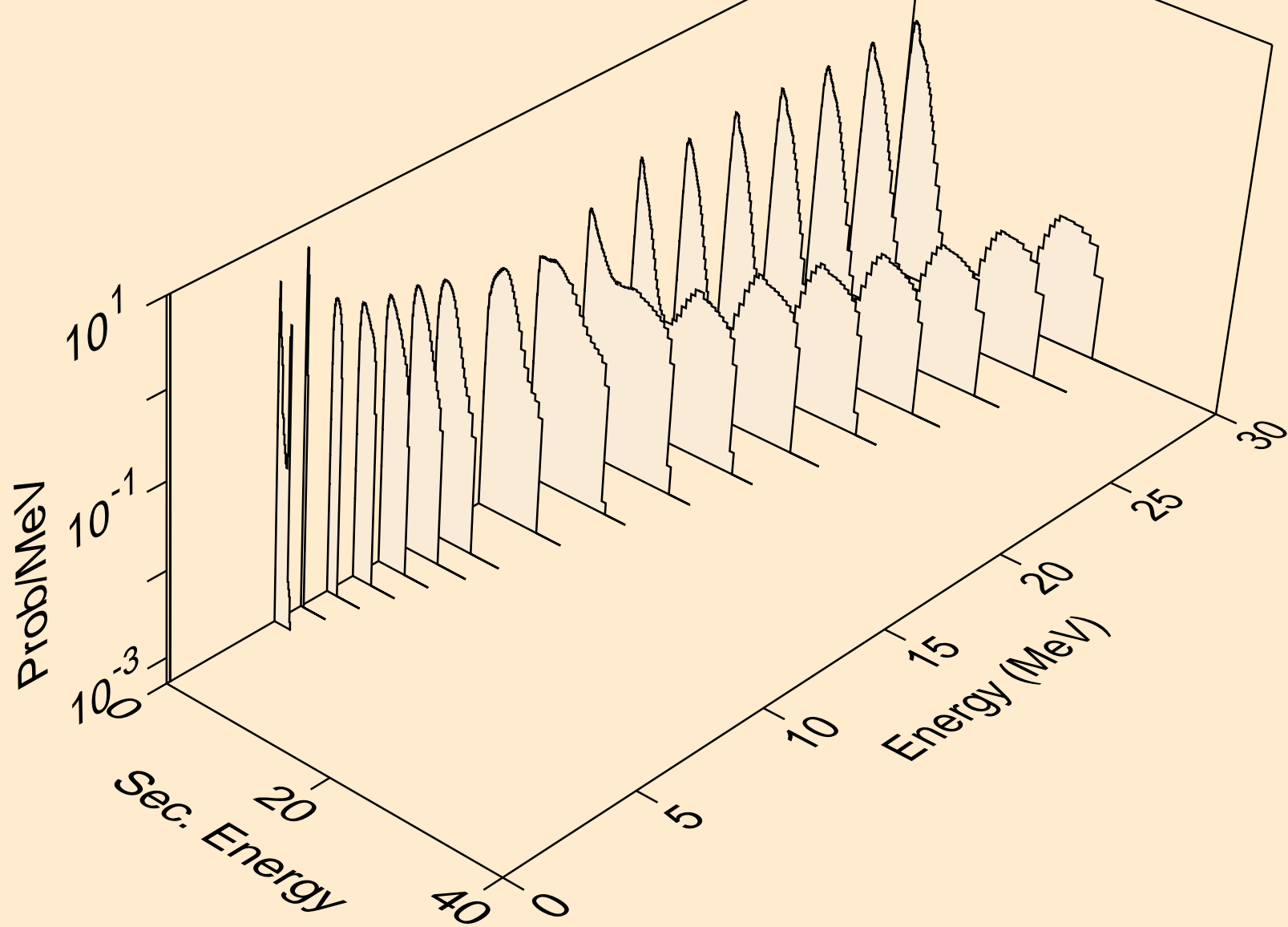

BI214 PROTON ACER TENDL-2021 LIBRARY; T=0.K  
neutrons from (p,3n)a

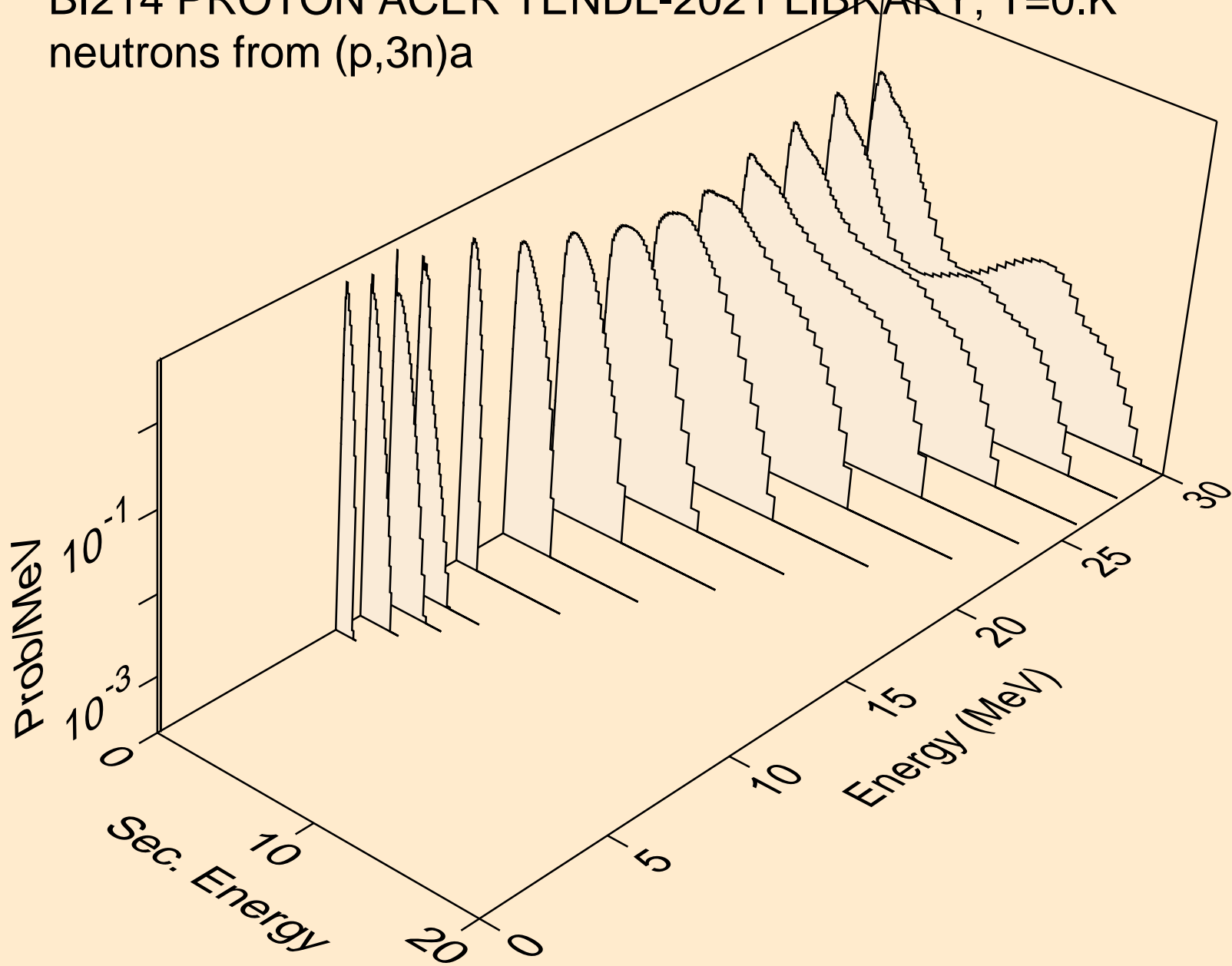

BI214 PROTON ACER TENDL-2021 LIBRARY; T=0.K  
neutrons from (p,n\*)p

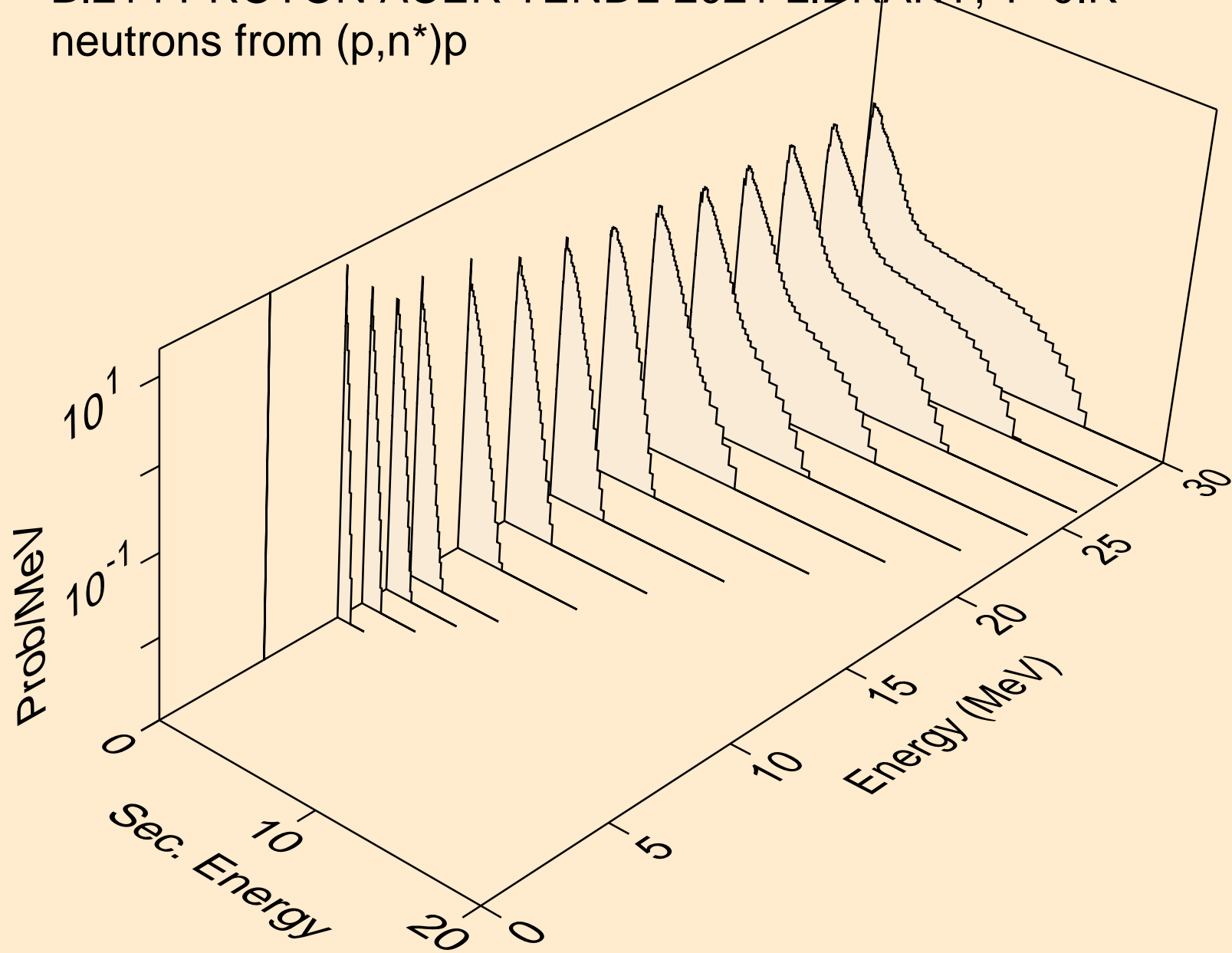

BI214 PROTON ACER TENDL-2021 LIBRARY; T=0.K  
neutrons from (p,n\*)2a

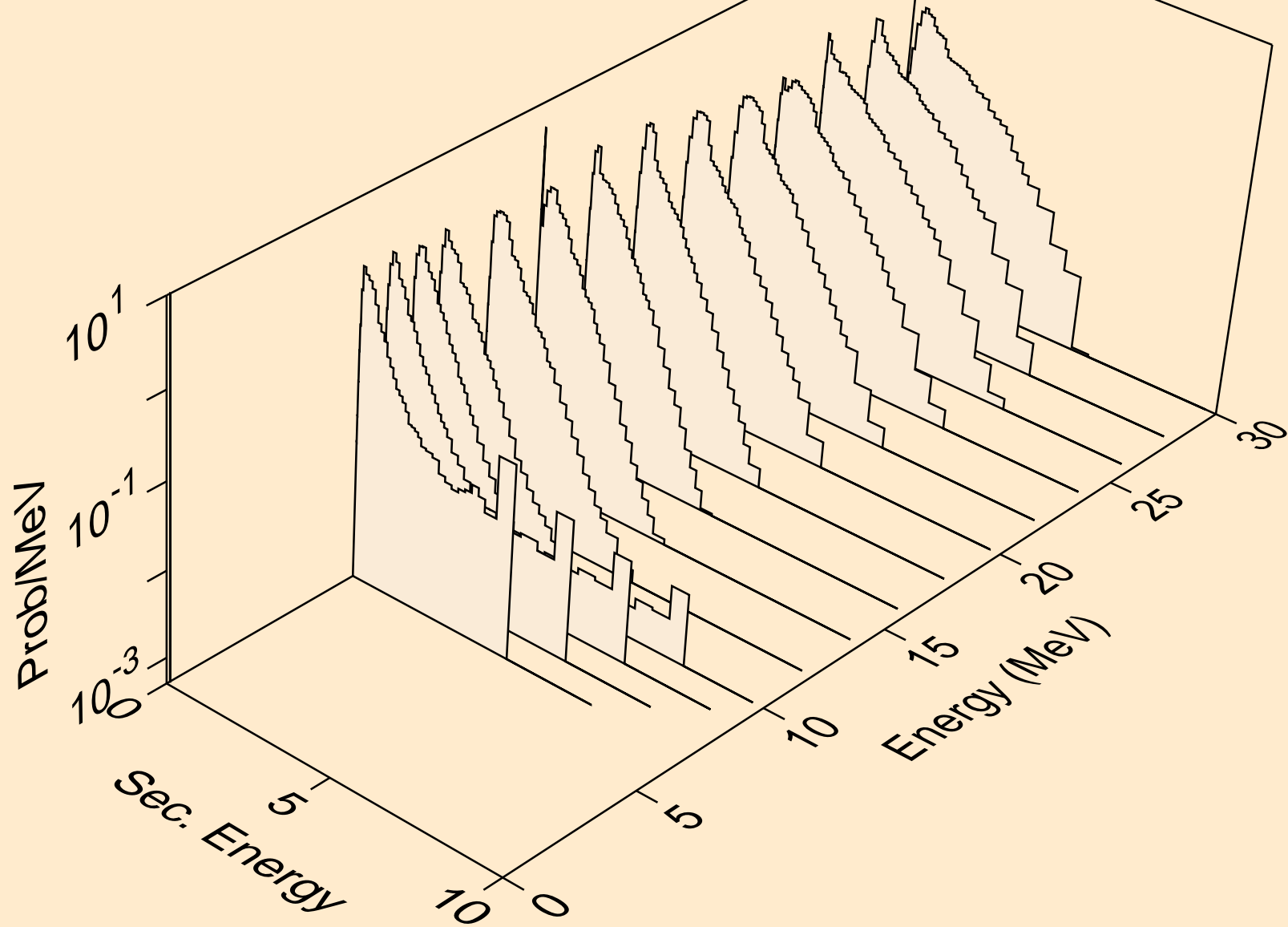



BI214 PROTON ACER TENDL-2021 LIBRARY; T=0.K  
neutrons from (p,2n)2a

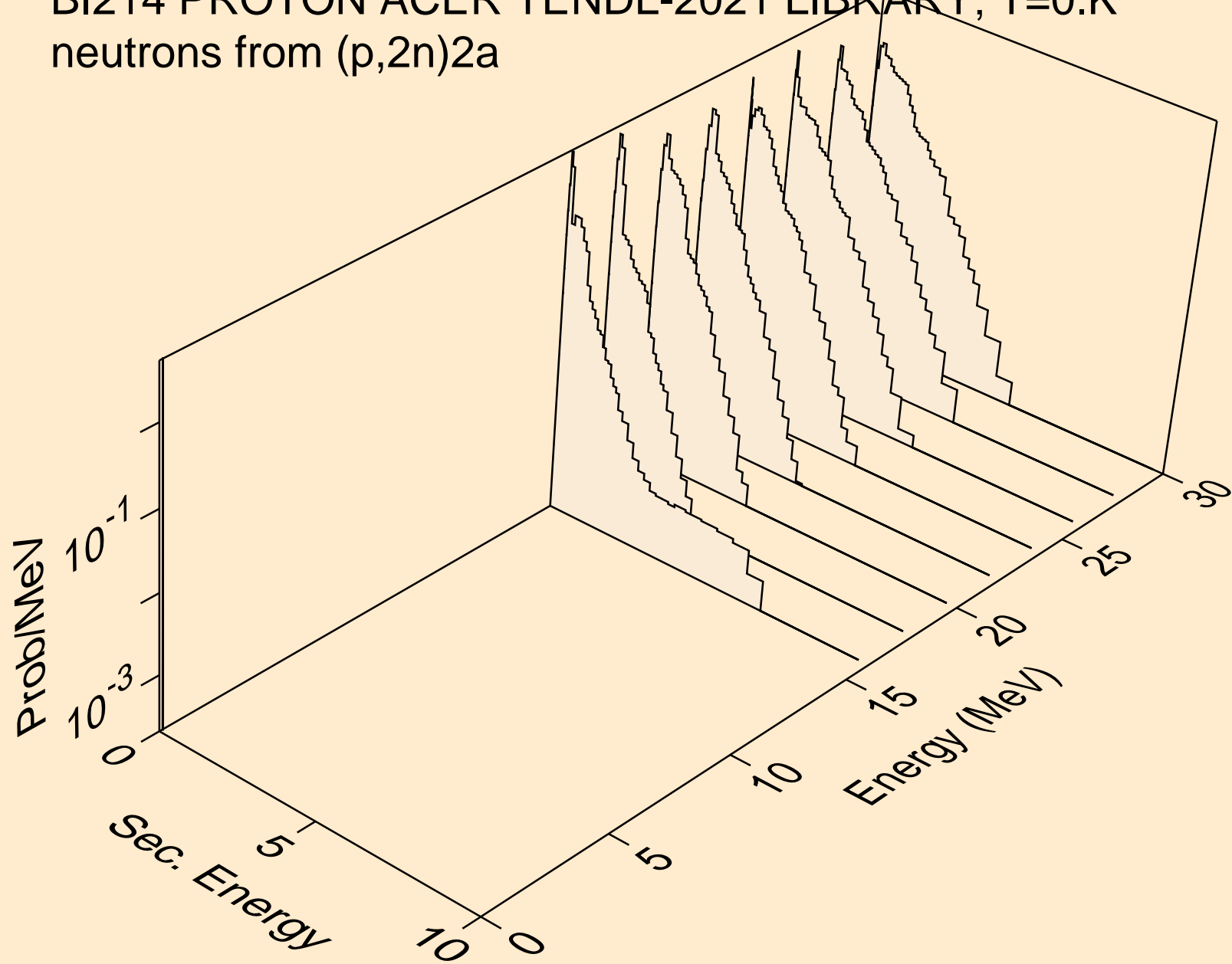

BI214 PROTON ACER TENDL-2021 LIBRARY; T=0.K  
neutrons from (p,n\*)d

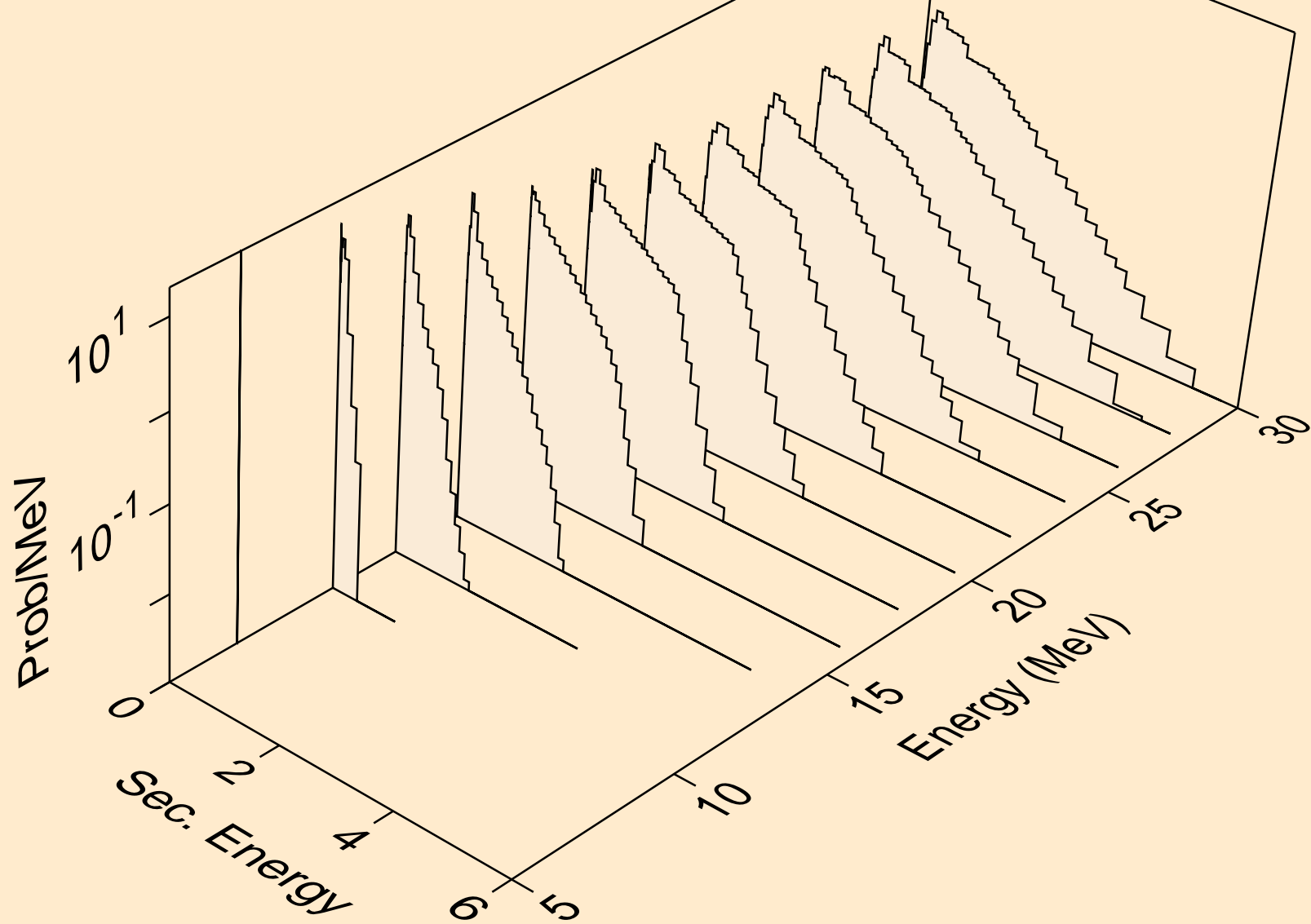

BI214 PROTON ACER TENDL-2021 LIBRARY; T=0.K  
neutrons from (p,n\*)t

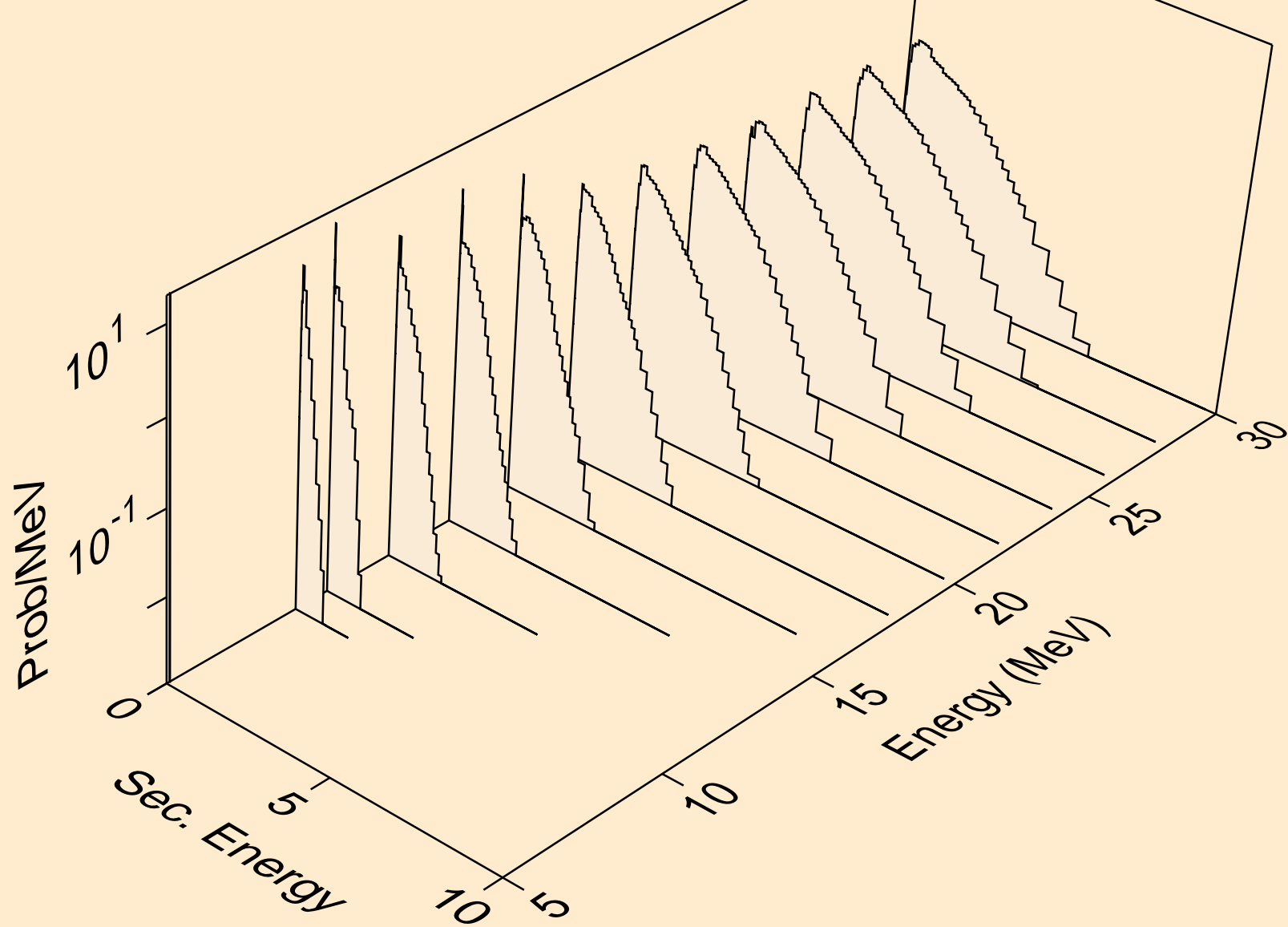

BI214 PROTON ACER TENDL-2021 LIBRARY; T=0.K  
neutrons from (p,n\*)he3

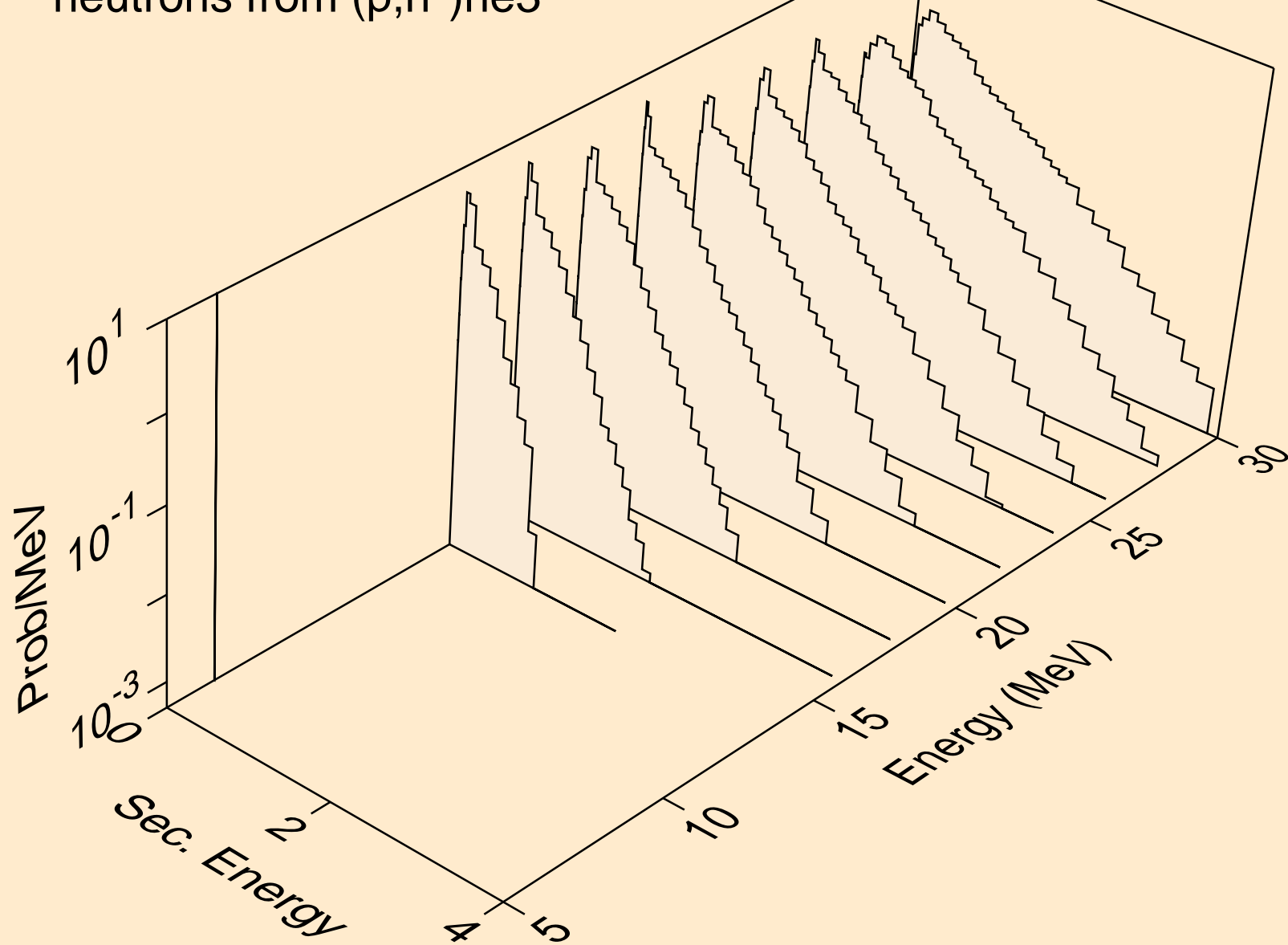

BI214 PROTON ACER TENDL-2021 LIBRARY; T=0.K  
neutrons from (p,4n)

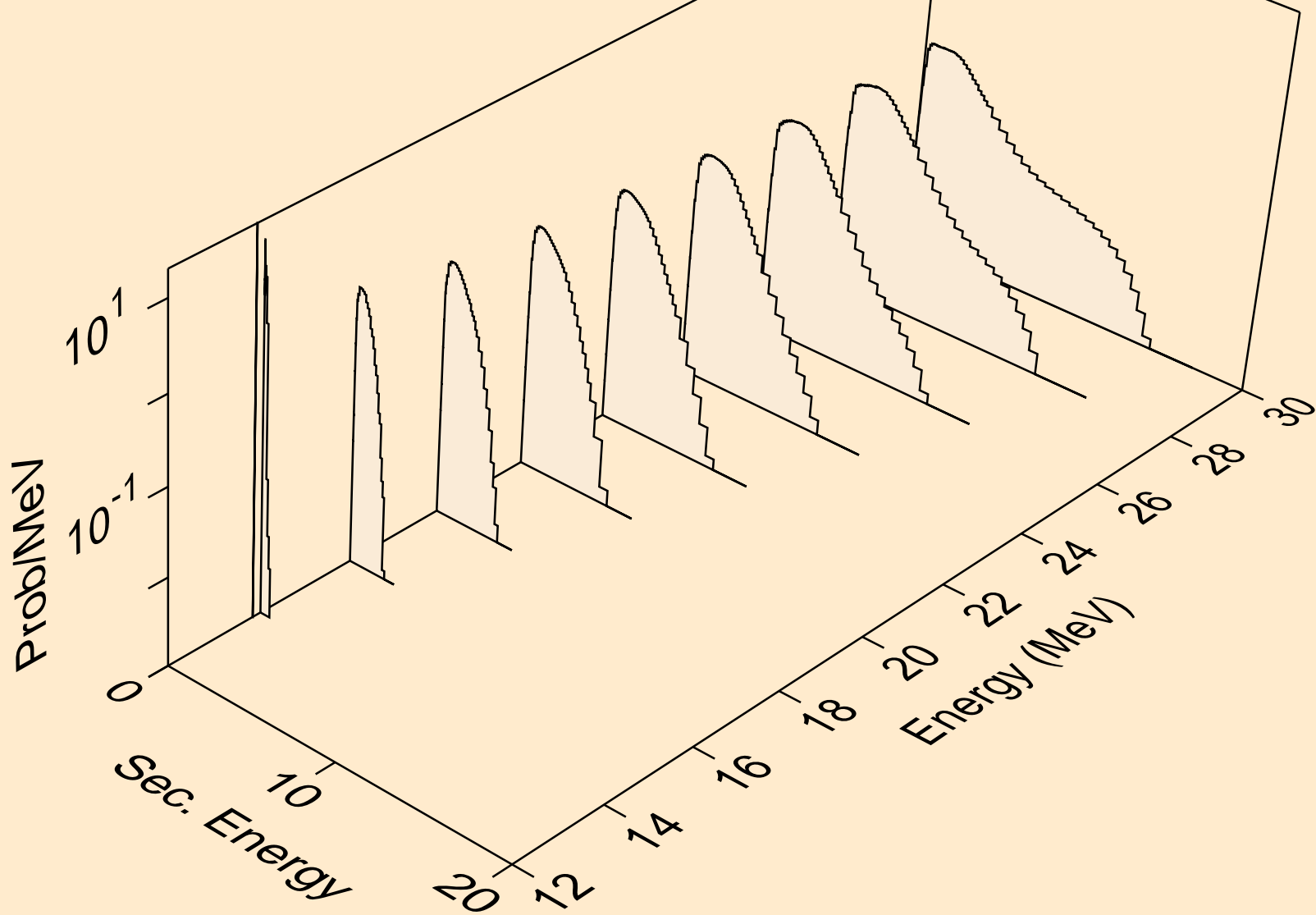

BI214 PROTON ACER TENDL-2021 LIBRARY; T=0.K  
neutrons from (p,2np)

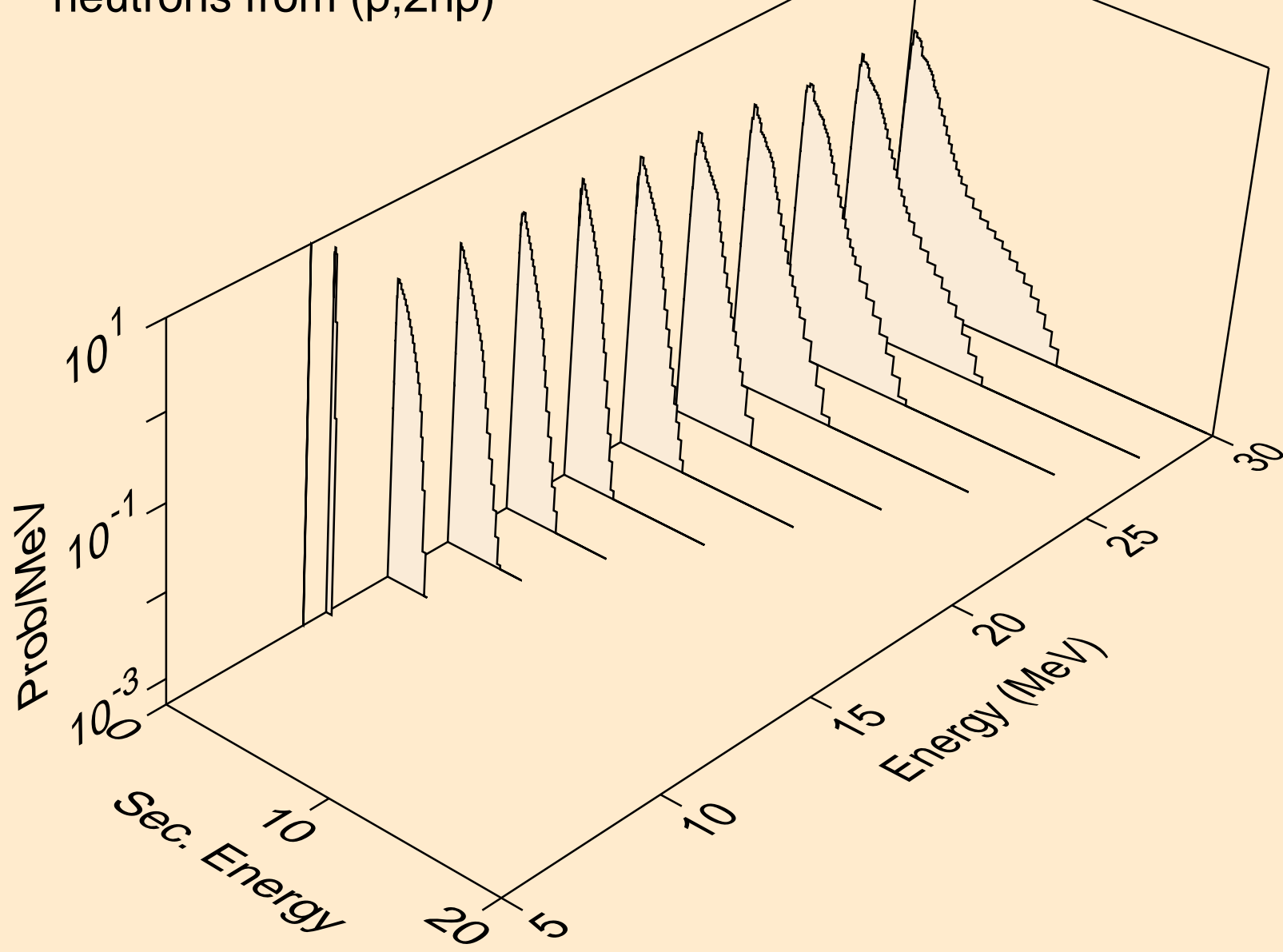

BI214 PROTON ACER TENDL-2021 LIBRARY; T=0.K  
neutrons from (p,3np)

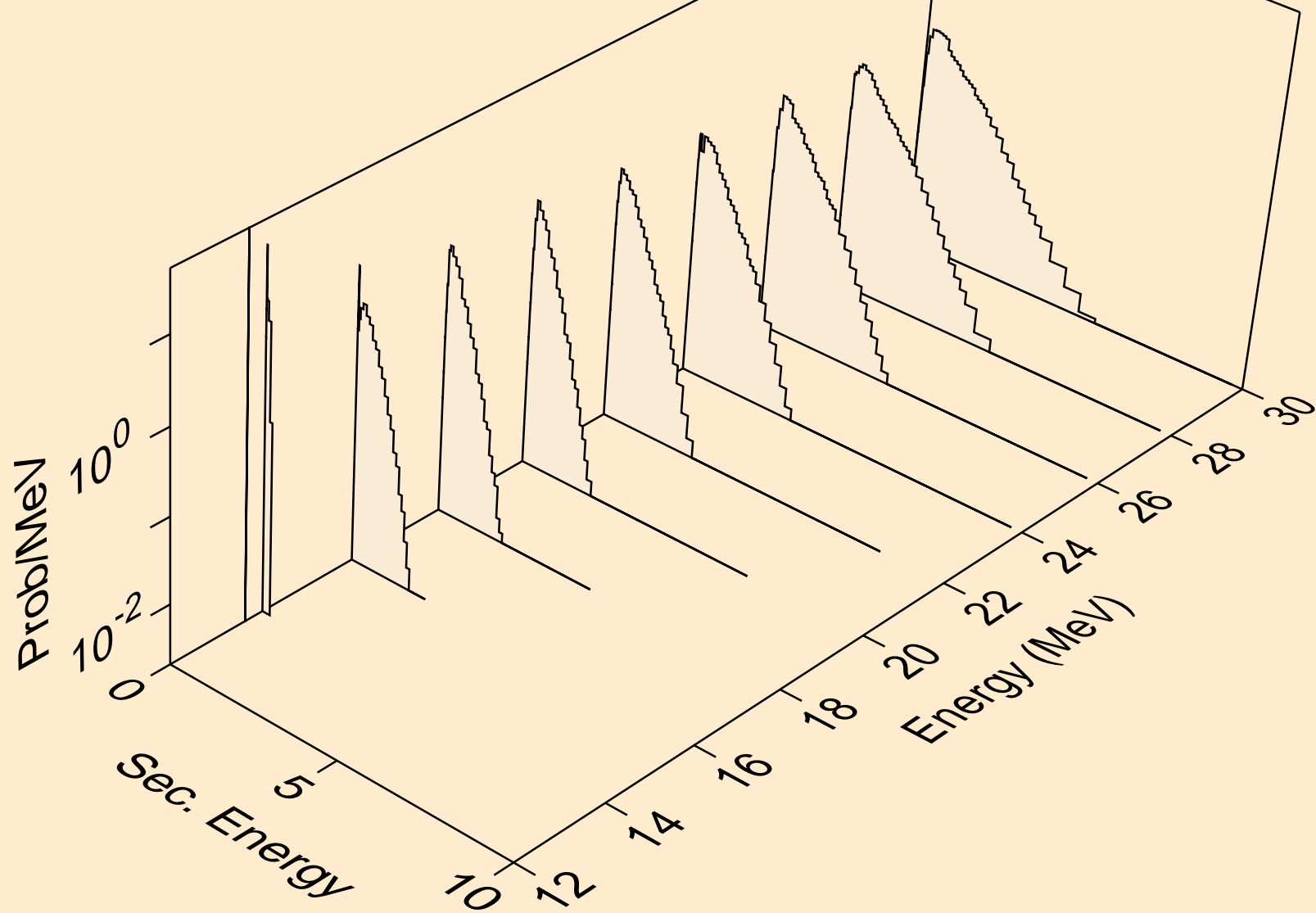

BI214 PROTON ACER TENDL-2021 LIBRARY; T=0.K  
neutrons from (p,2np)

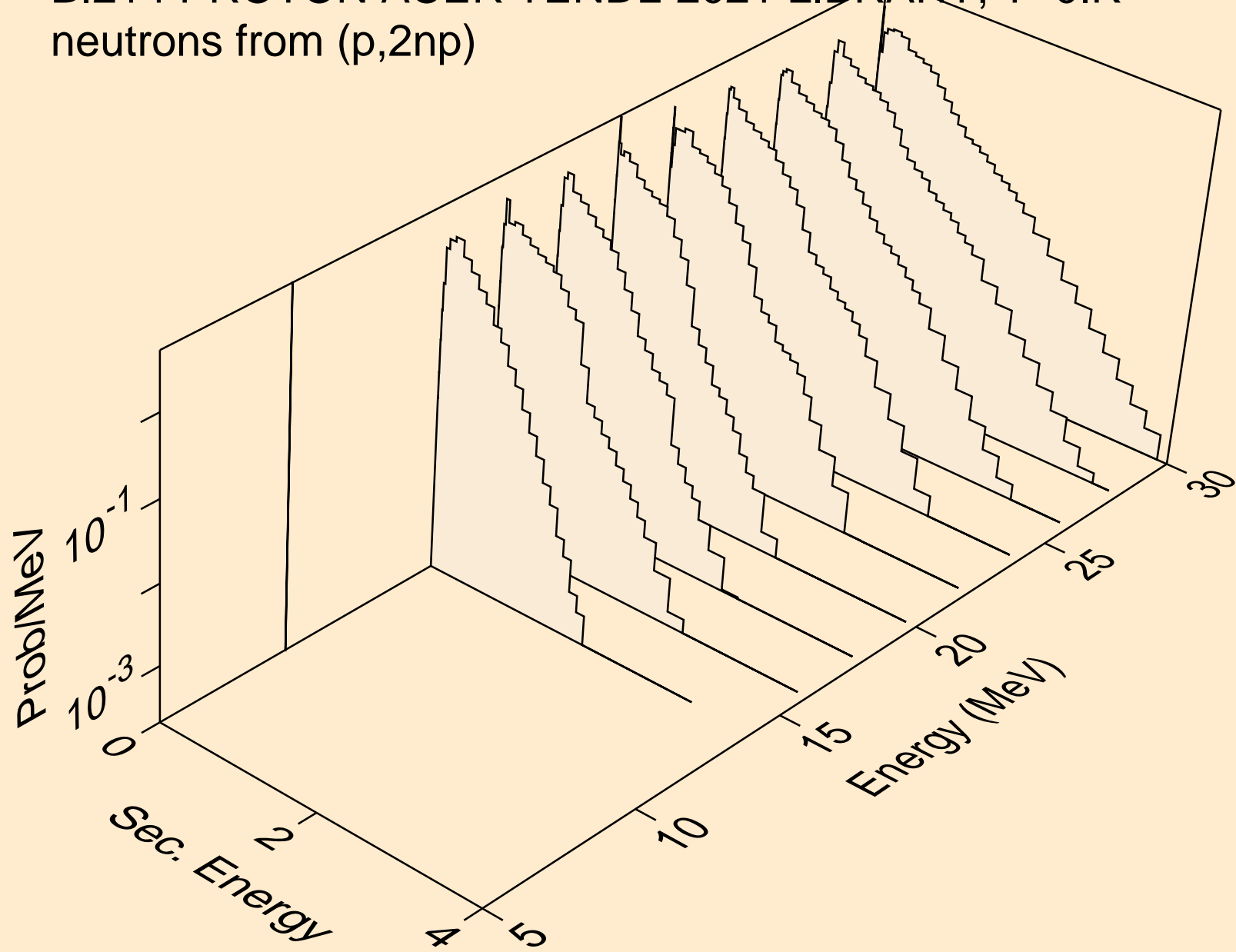



BI214 PROTON ACER TENDL-2021 LIBRARY; T=0.K  
neutrons from (p,npa)

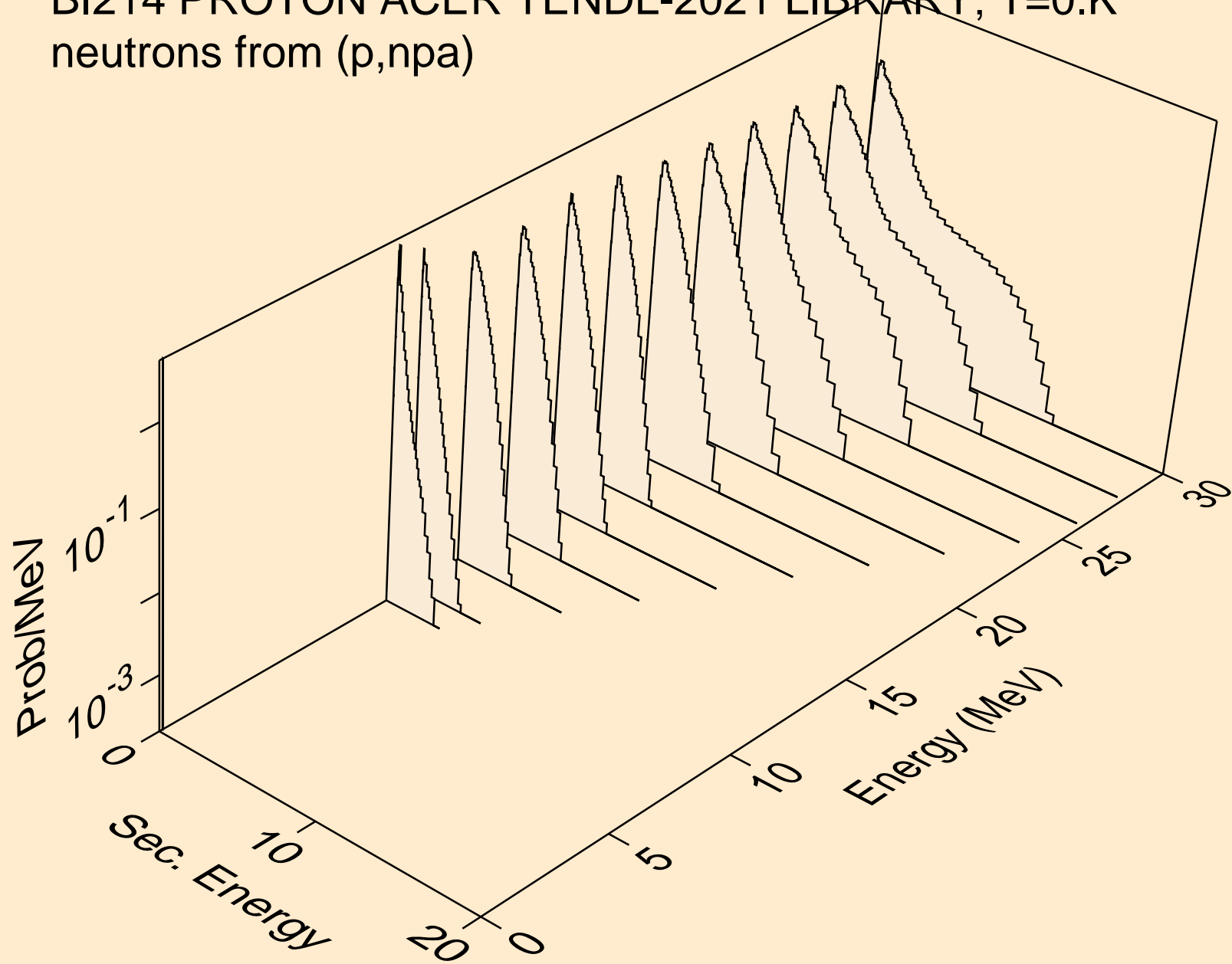

BI214 PROTON ACER TENDL-2021 LIBRARY; T=0.K  
deuterons from (p,x)

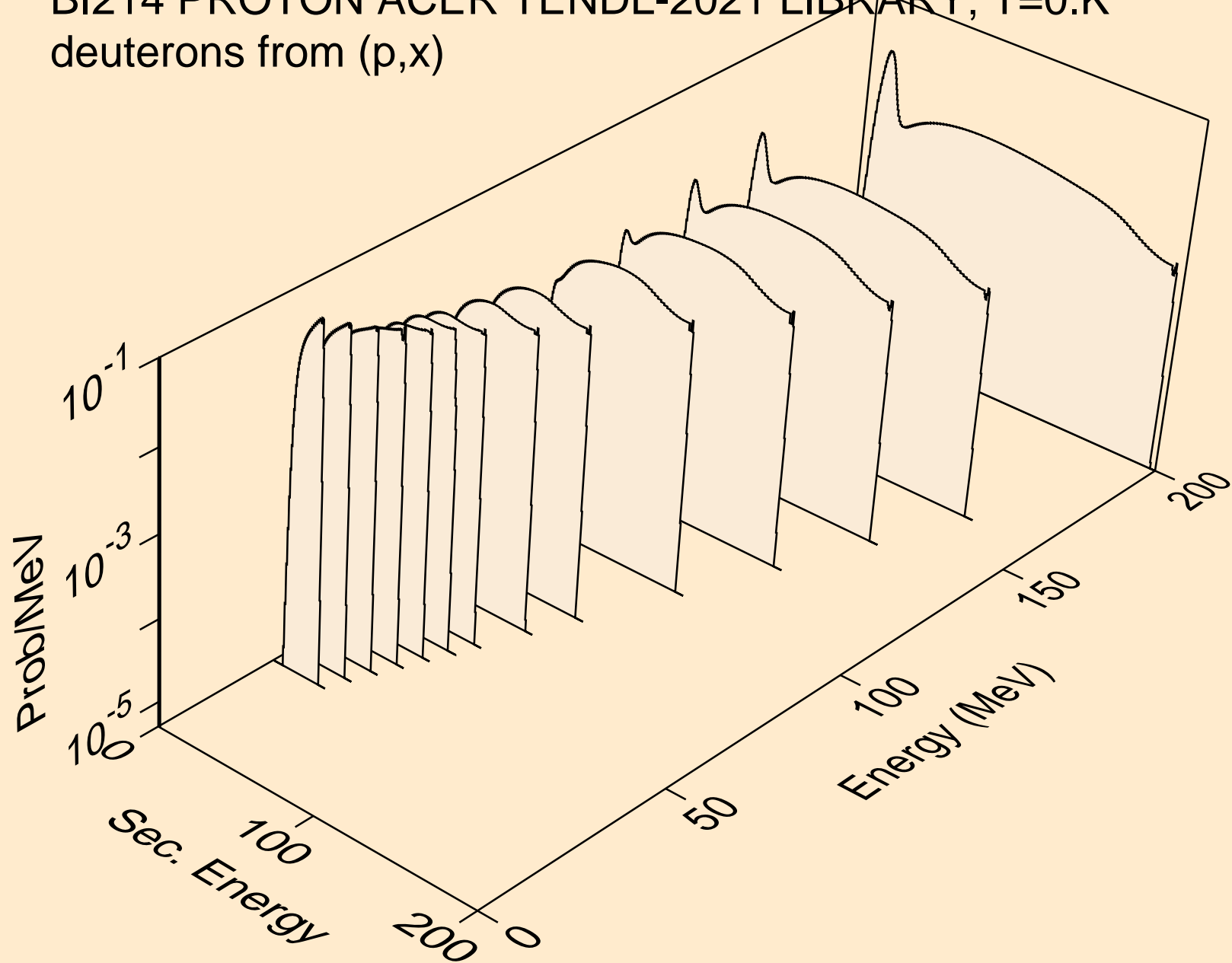

BI214 PROTON ACER TENDL-2021 LIBRARY; T=0.K  
deuterons from (p,2nd)

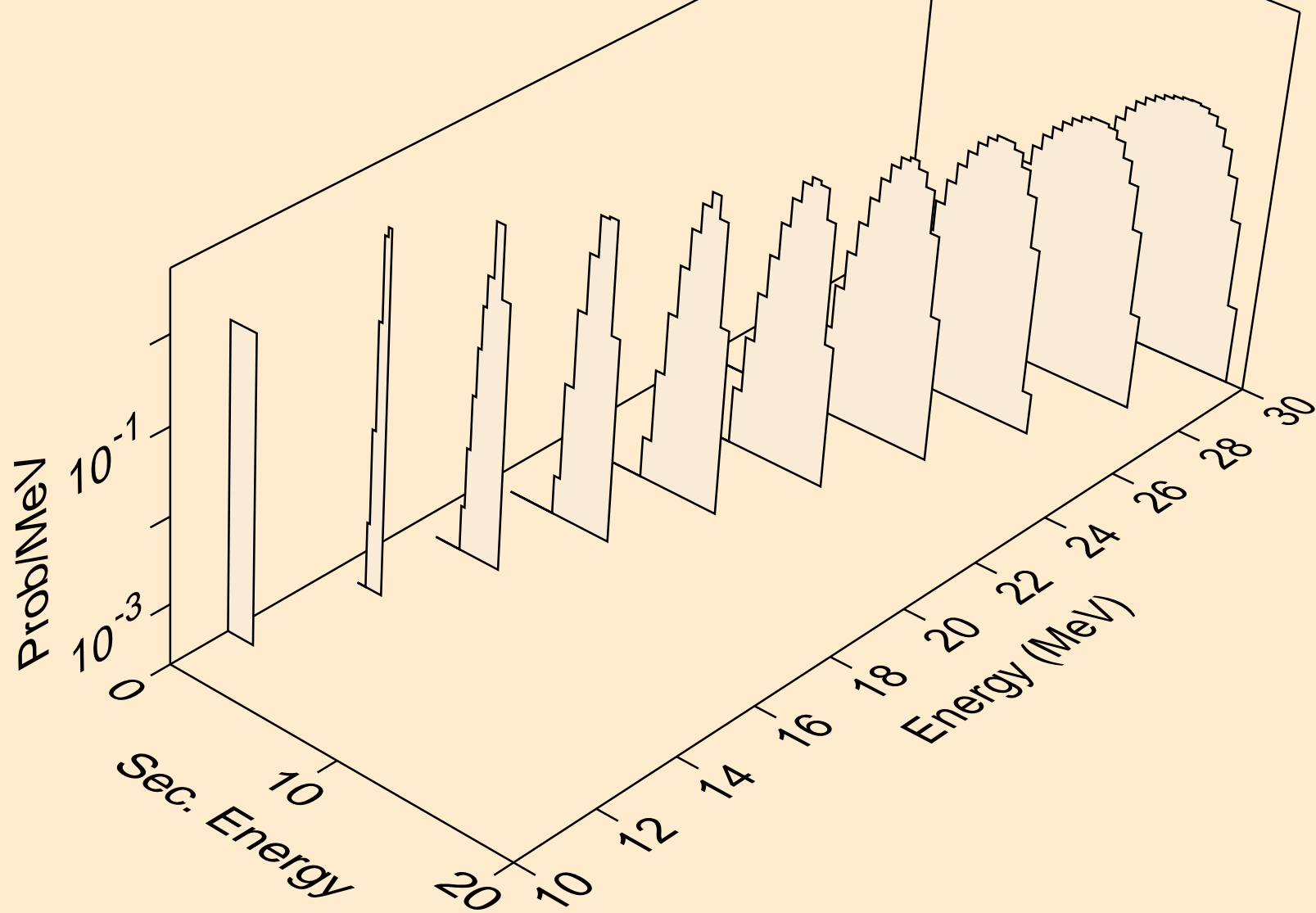

BI214 PROTON ACER TENDL-2021 LIBRARY; T=0.K  
deuterons from (p,n\*)d

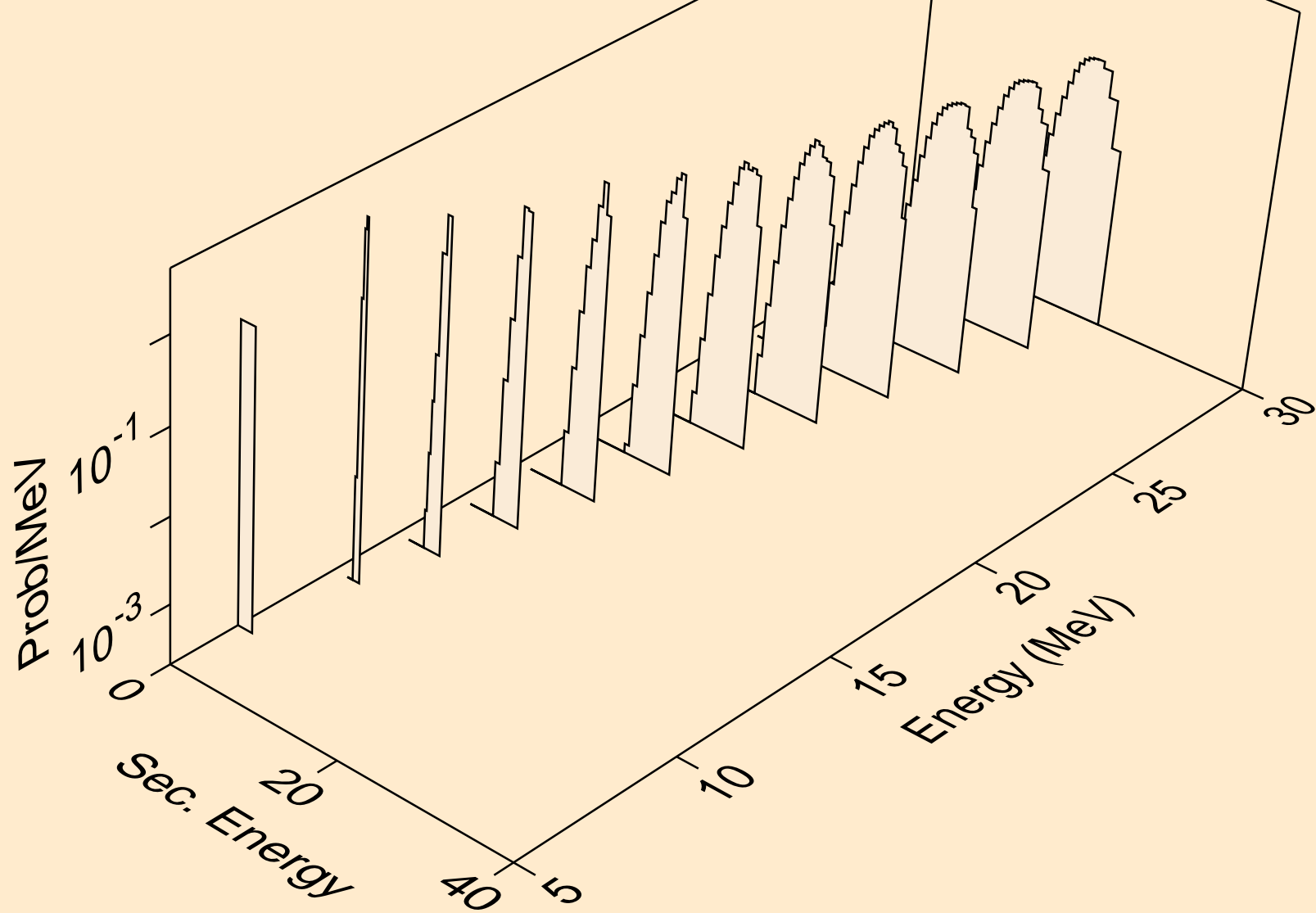

BI214 PROTON ACER TENDL-2021 LIBRARY; T=0.K  
deuterons from (p,d)

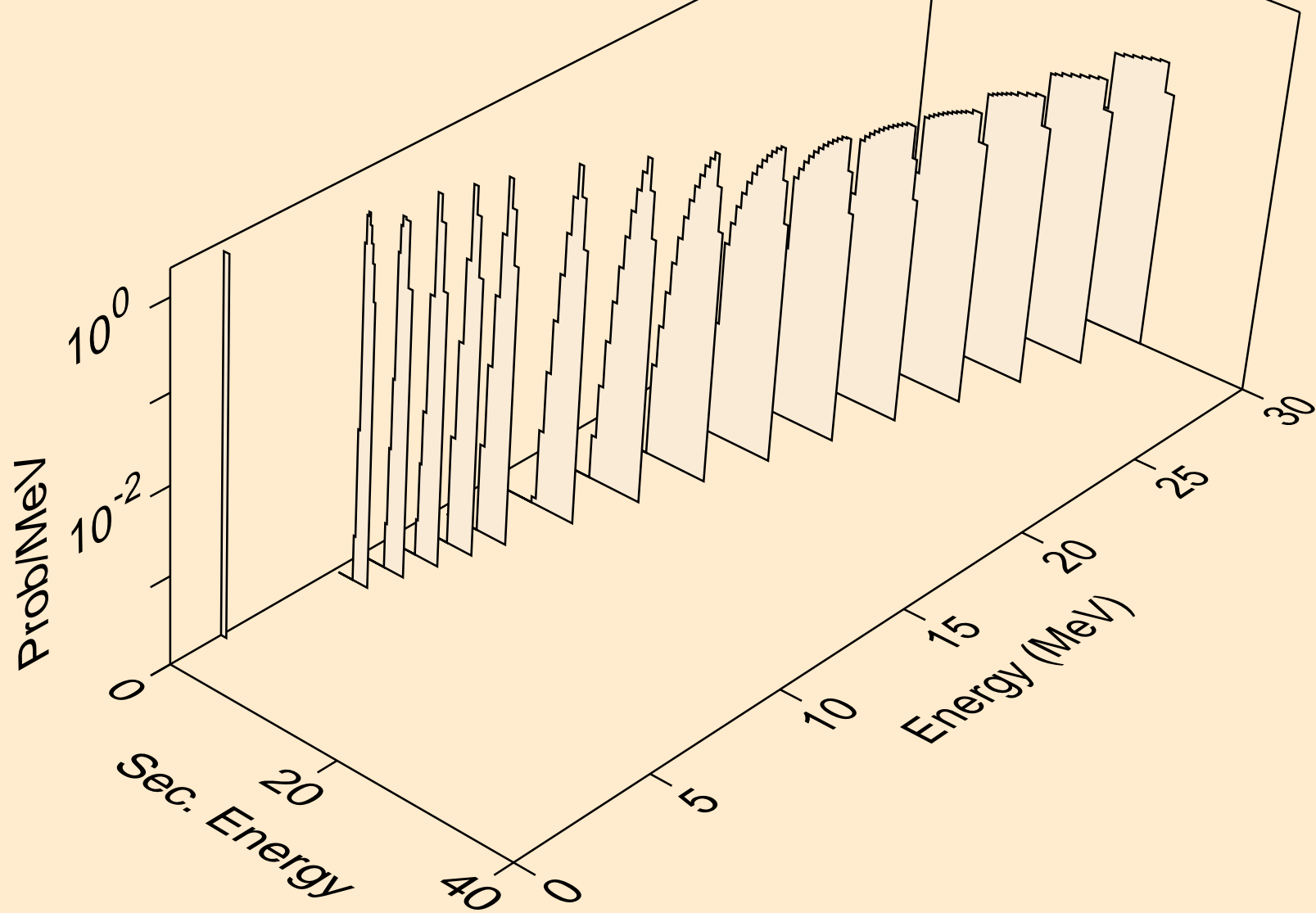

BI214 PROTON ACER TENDL-2021 LIBRARY; T=0.K  
deuterons from (p,pd)

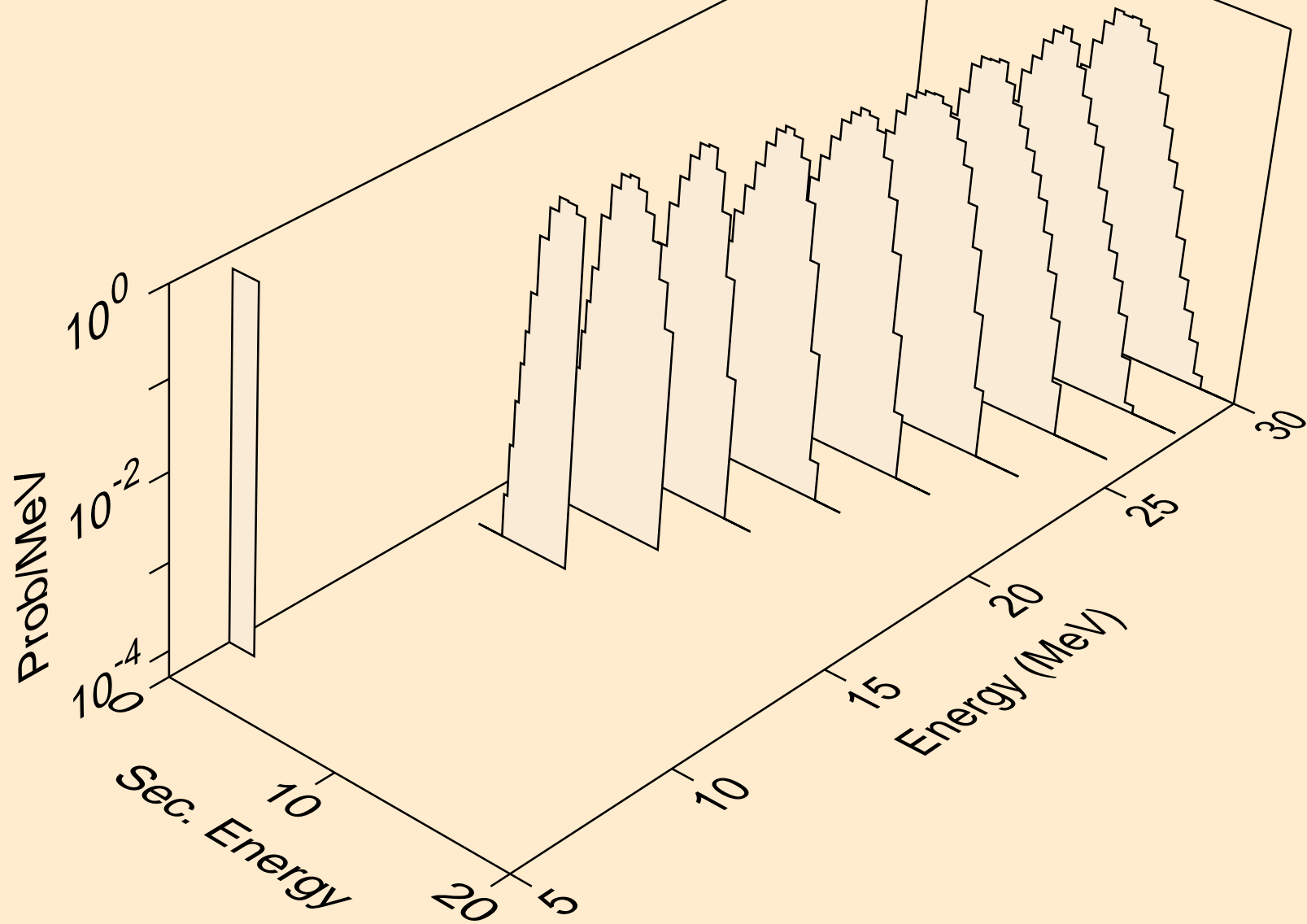

BI214 PROTON ACER TENDL-2021 LIBRARY; T=0.K  
deuterons from (p,da)

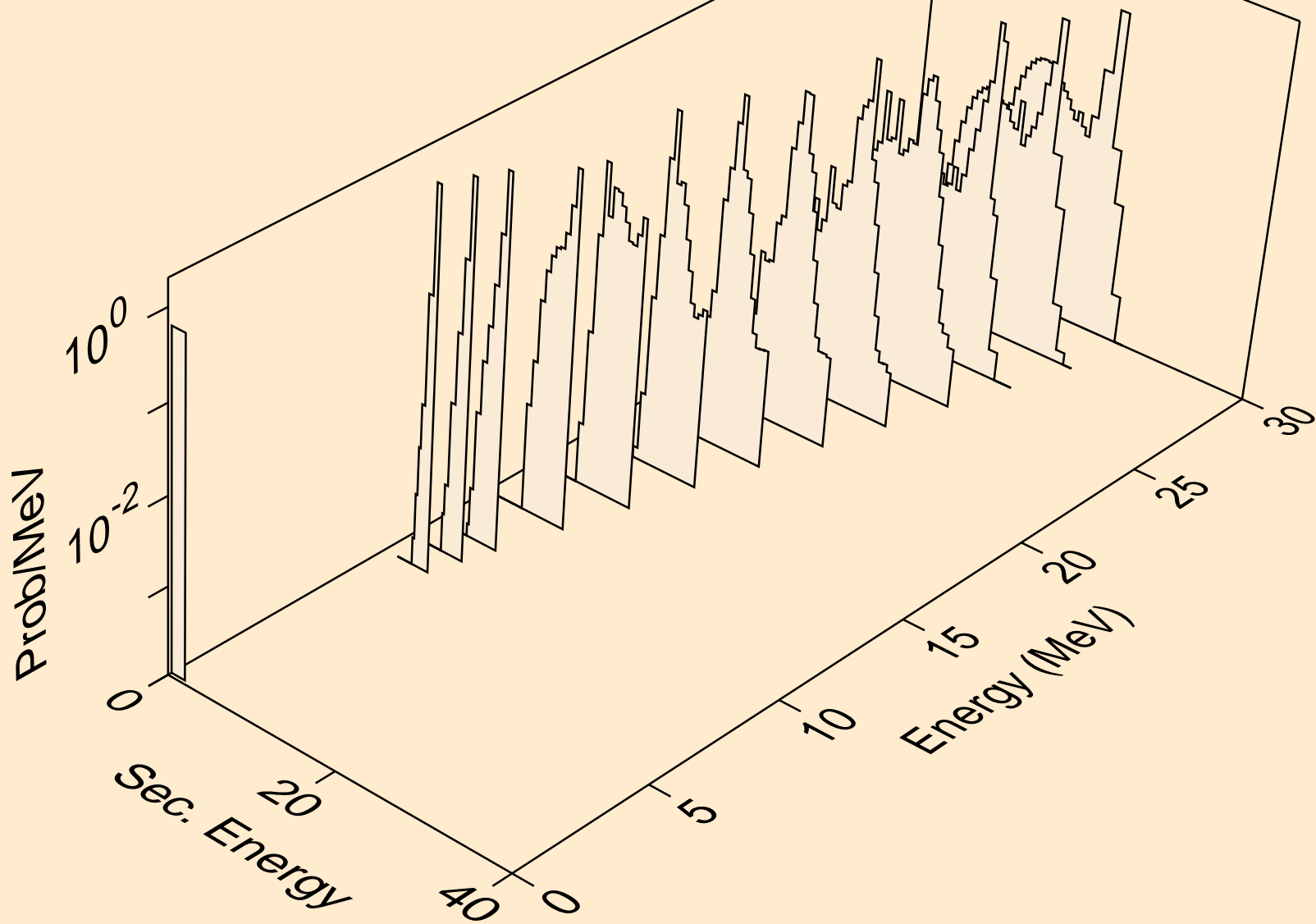

BI214 PROTON ACER TENDL-2021 LIBRARY; T=0.K  
tritons from (p,x)

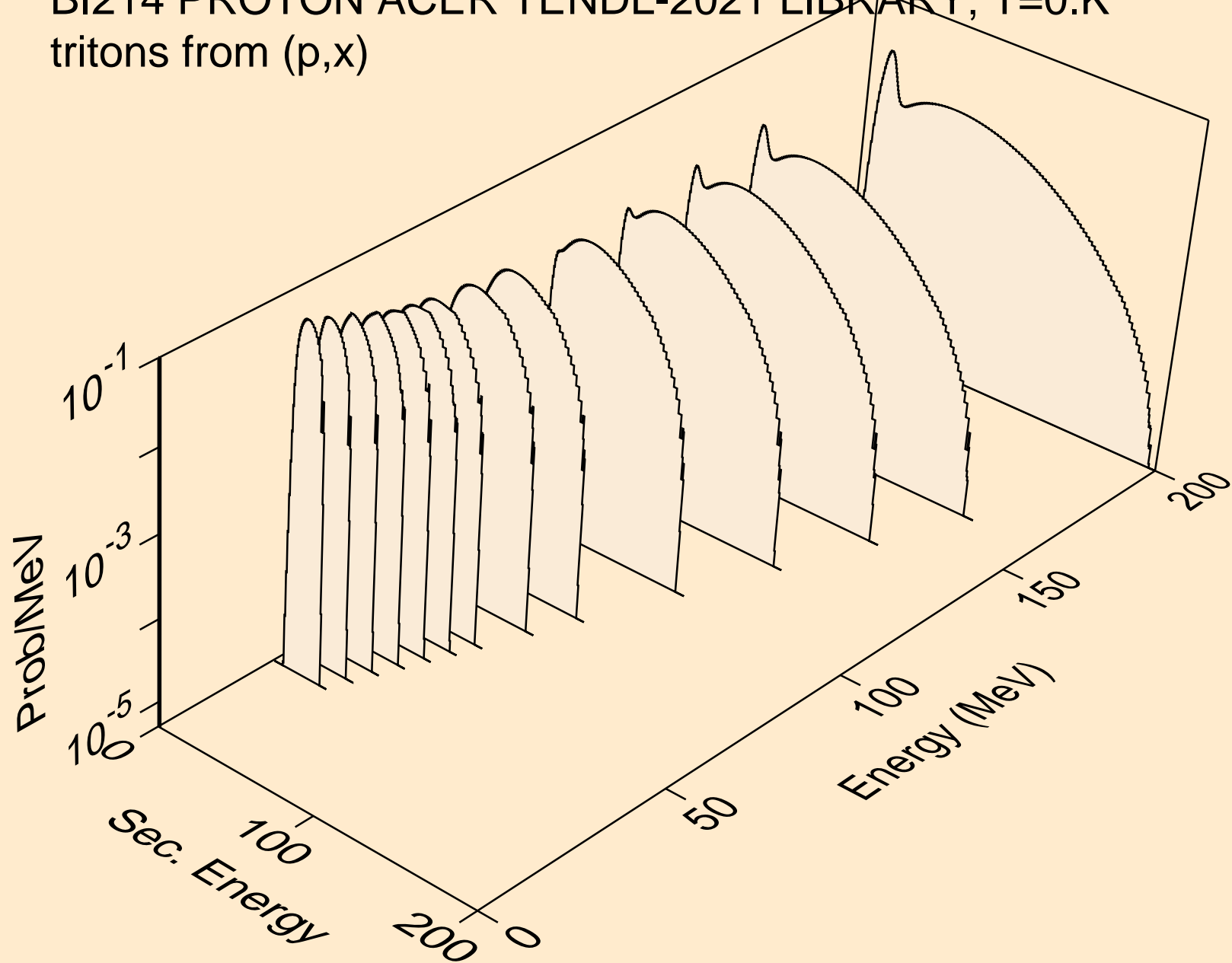



BI214 PROTON ACER TENDL-2021 LIBRARY; T=0.K  
tritons from (p,n\*)t

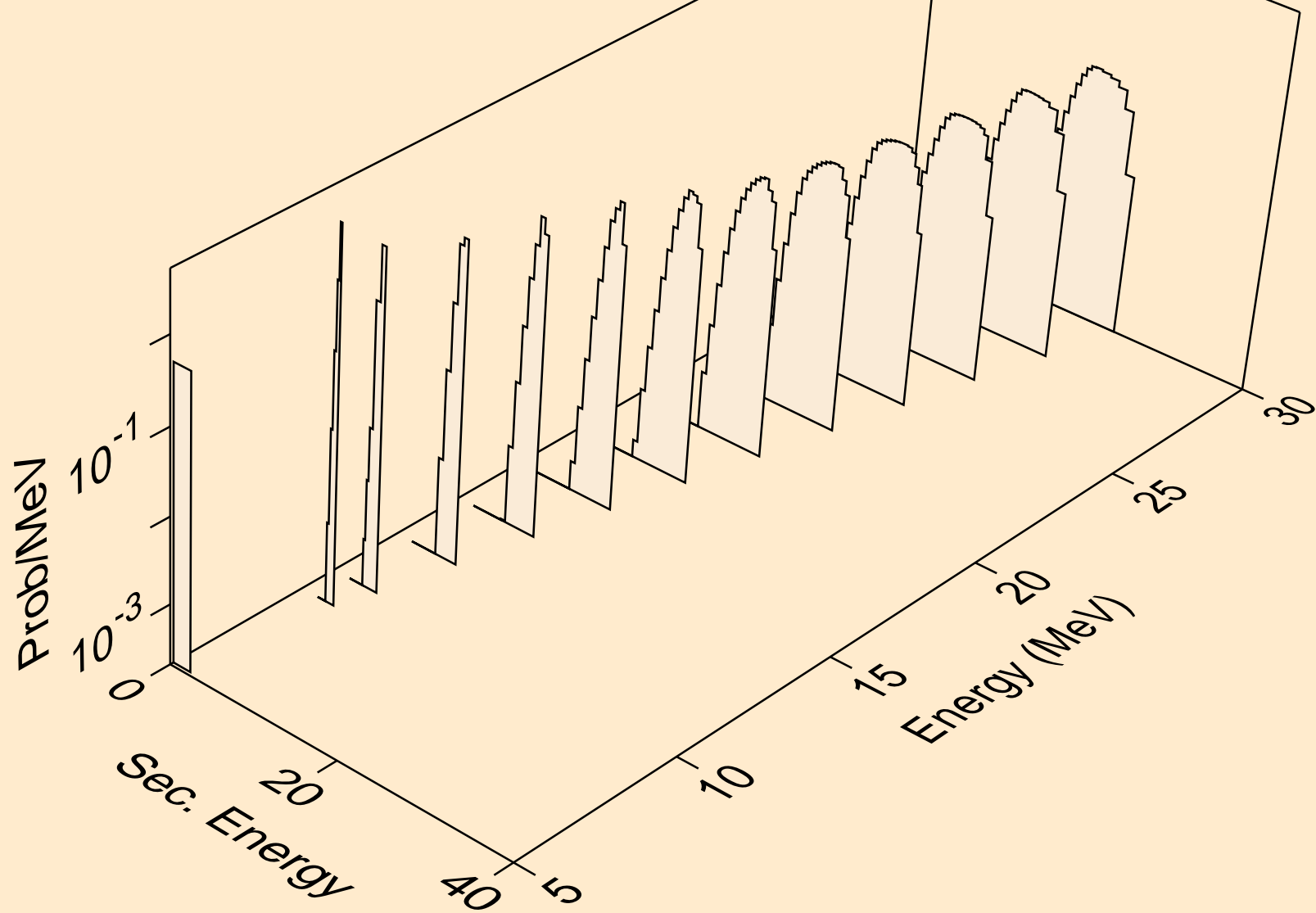

BI214 PROTON ACER TENDL-2021 LIBRARY; T=0.K  
tritons from (p,t)

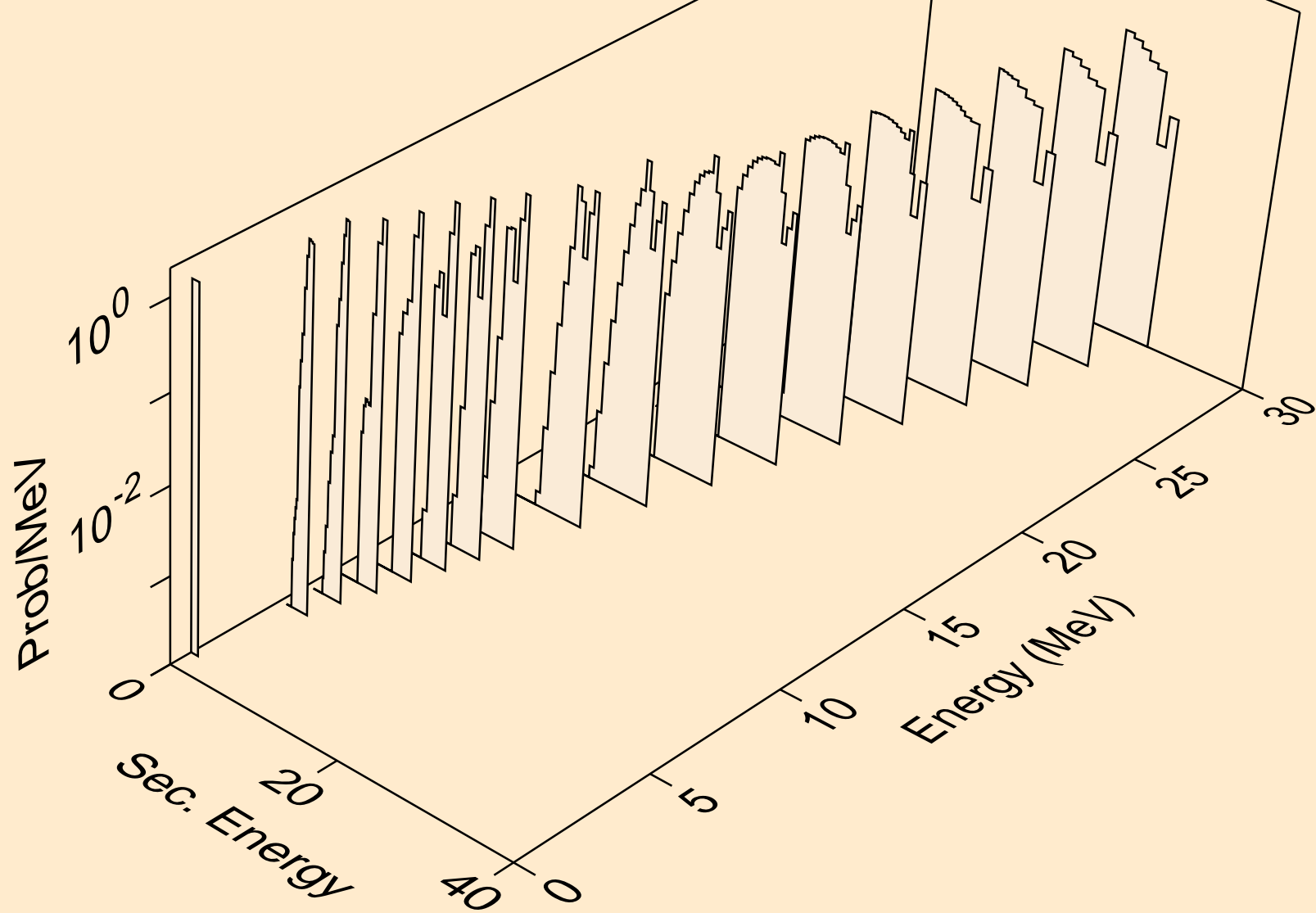

BI214 PROTON ACER TENDL-2021 LIBRARY; T=0.K  
tritons from (p,pt)

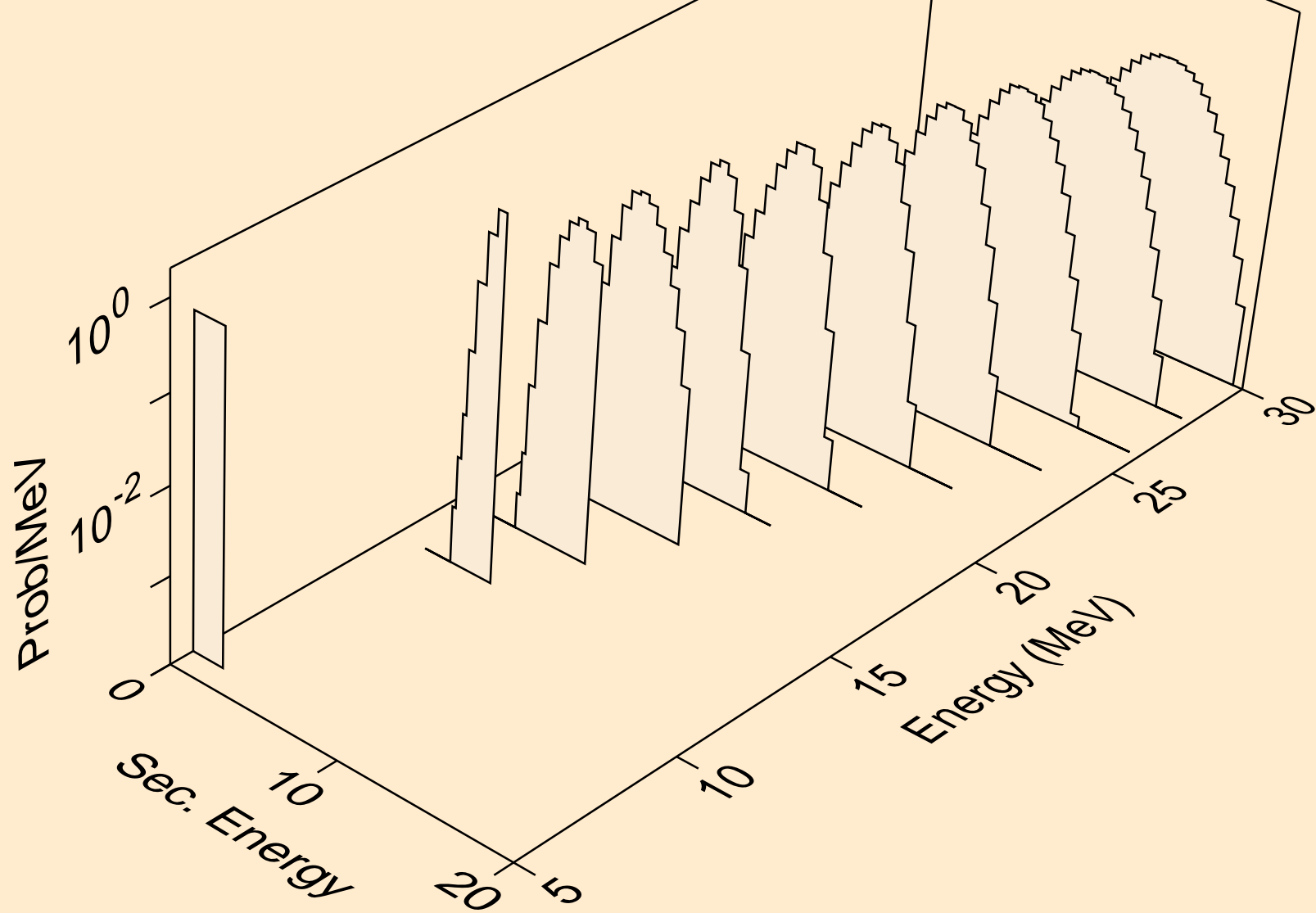

BI214 PROTON ACER TENDL-2021 LIBRARY; T=0.K  
he3s from (p,x)

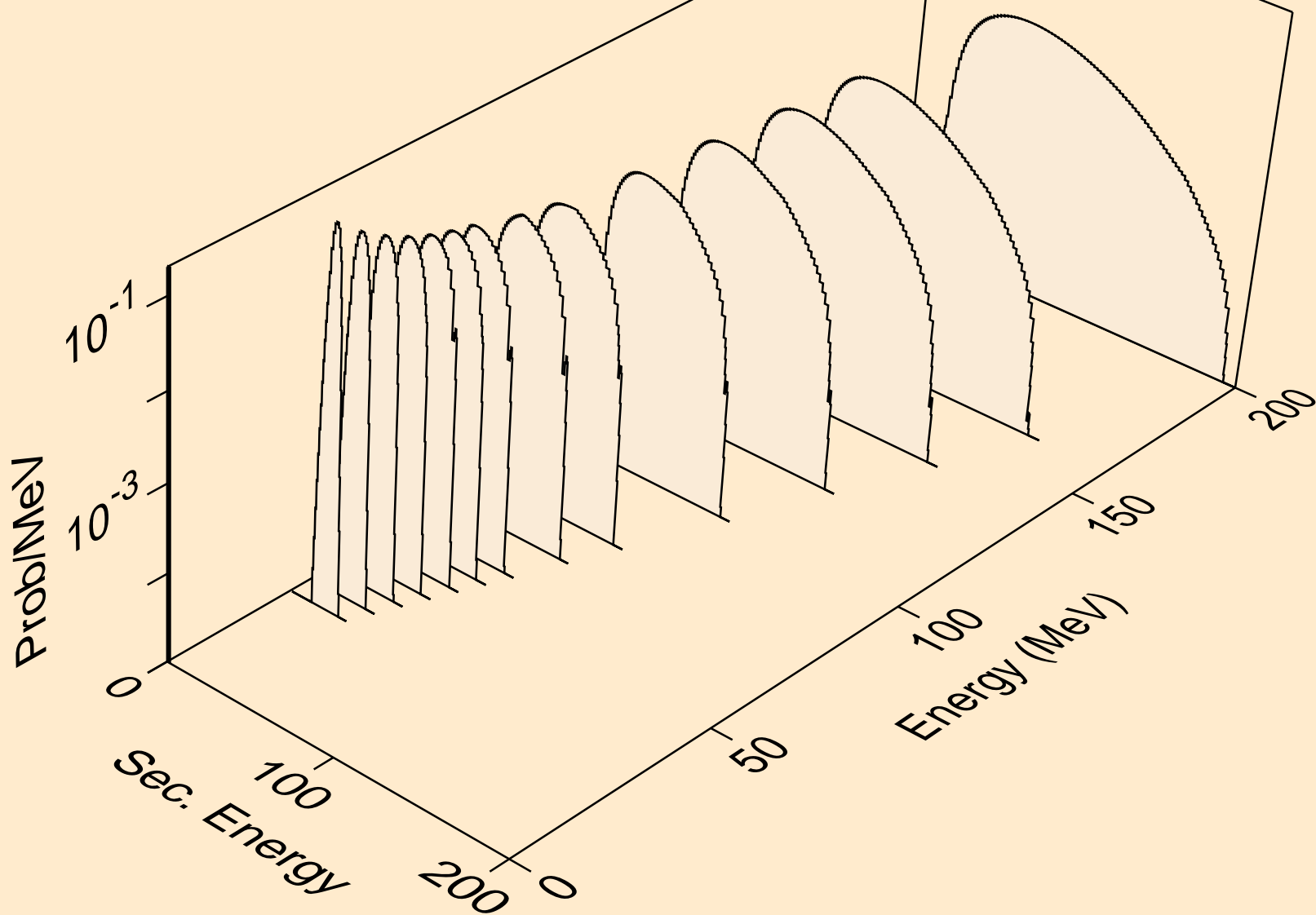

BI214 PROTON ACER TENDL-2021 LIBRARY; T=0.K  
he3s from (p,n\*)he3

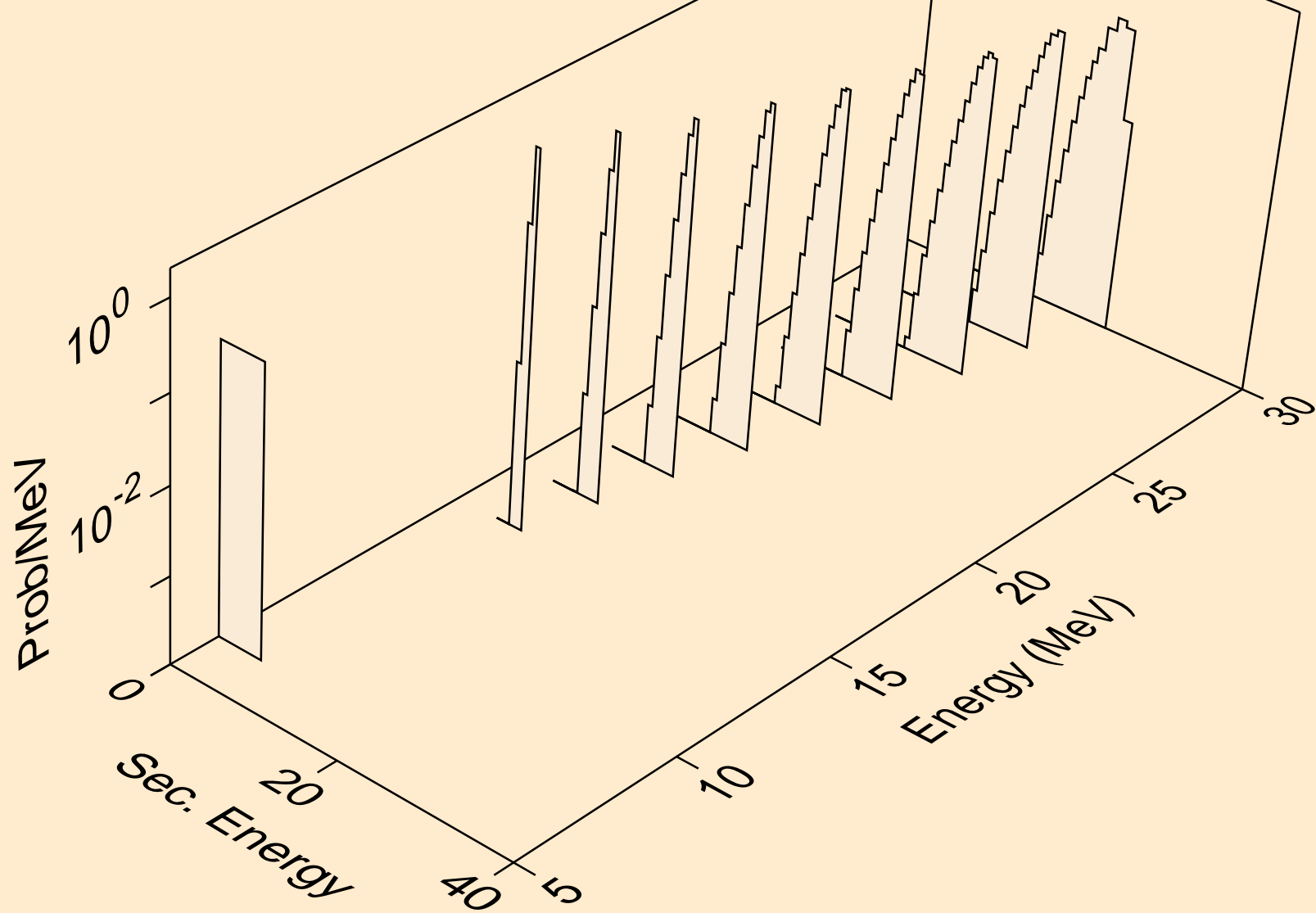

BI214 PROTON ACER TENDL-2021 LIBRARY; T=0.K  
he3s from (p,he3)

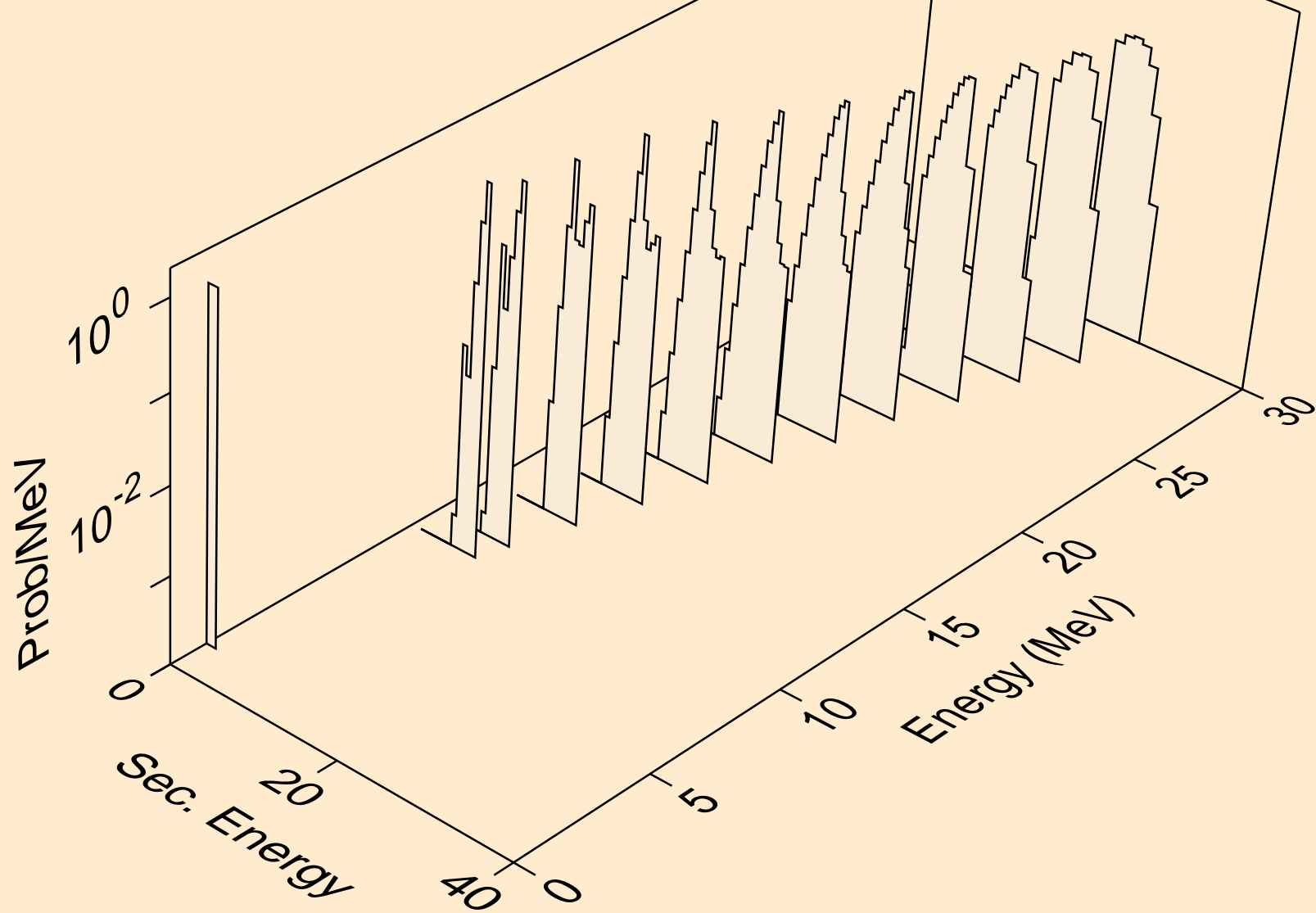

BI214 PROTON ACER TENDL-2021 LIBRARY; T=0.K  
alphas from (p,x)

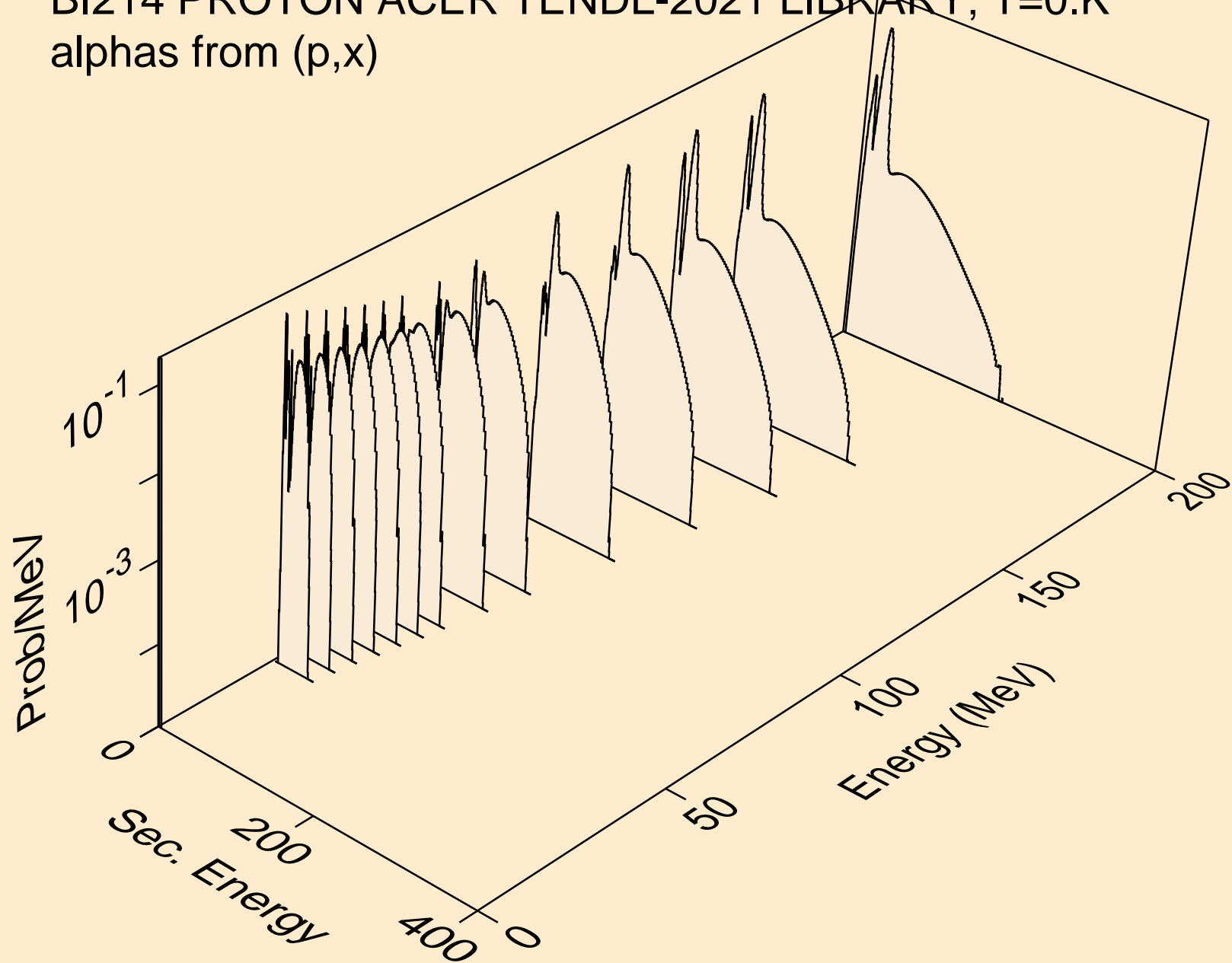

BI214 PROTON ACER TENDL-2021 LIBRARY; T=0.K  
alphas from (p,n\*)a

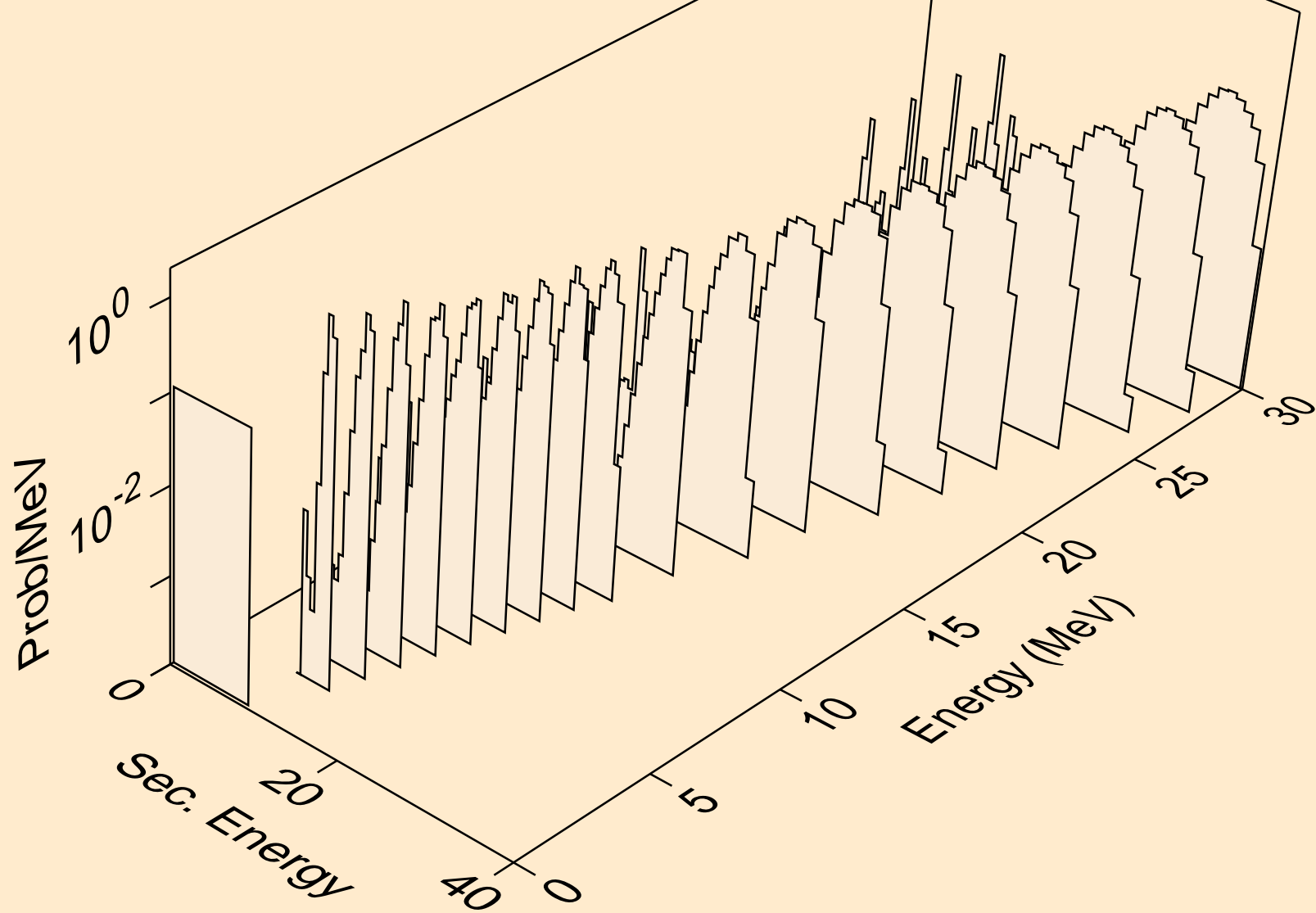



BI214 PROTON ACER TENDL-2021 LIBRARY; T=0.K  
alphas from (p,2n)a

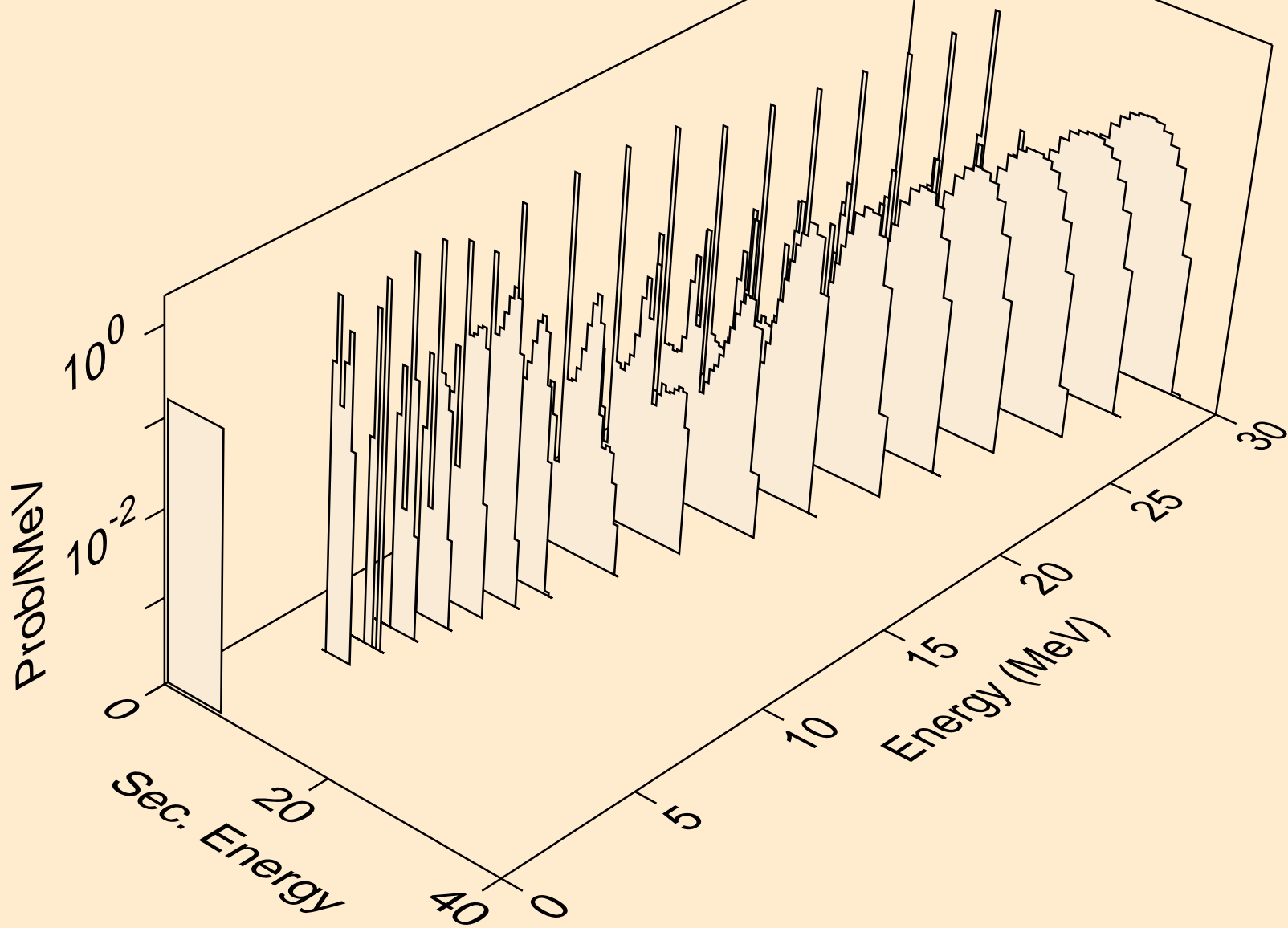

BI214 PROTON ACER TENDL-2021 LIBRARY; T=0.K  
alphas from (p,3n)a

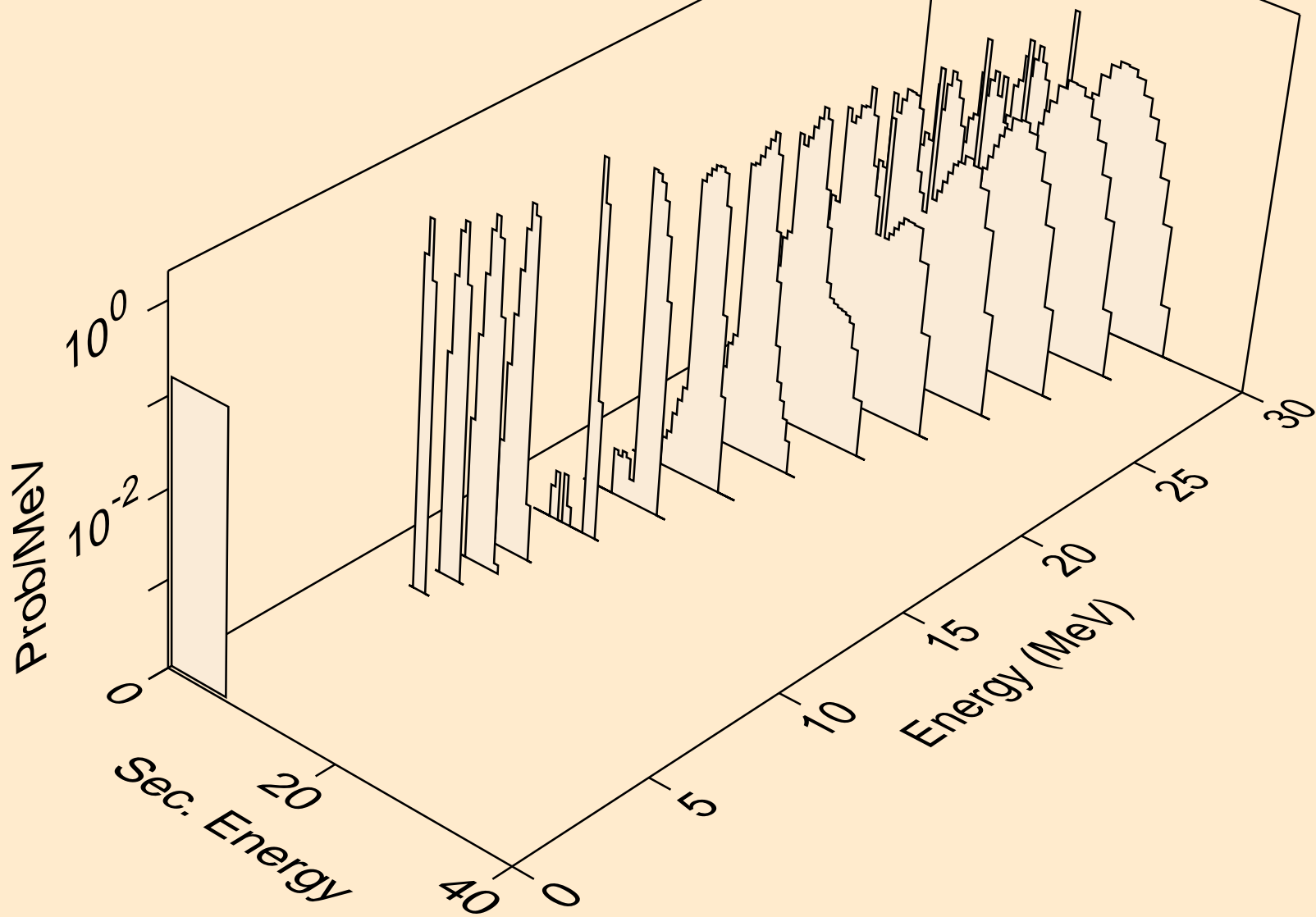

BI214 PROTON ACER TENDL-2021 LIBRARY; T=0.K  
alphas from (p,n\*)2a

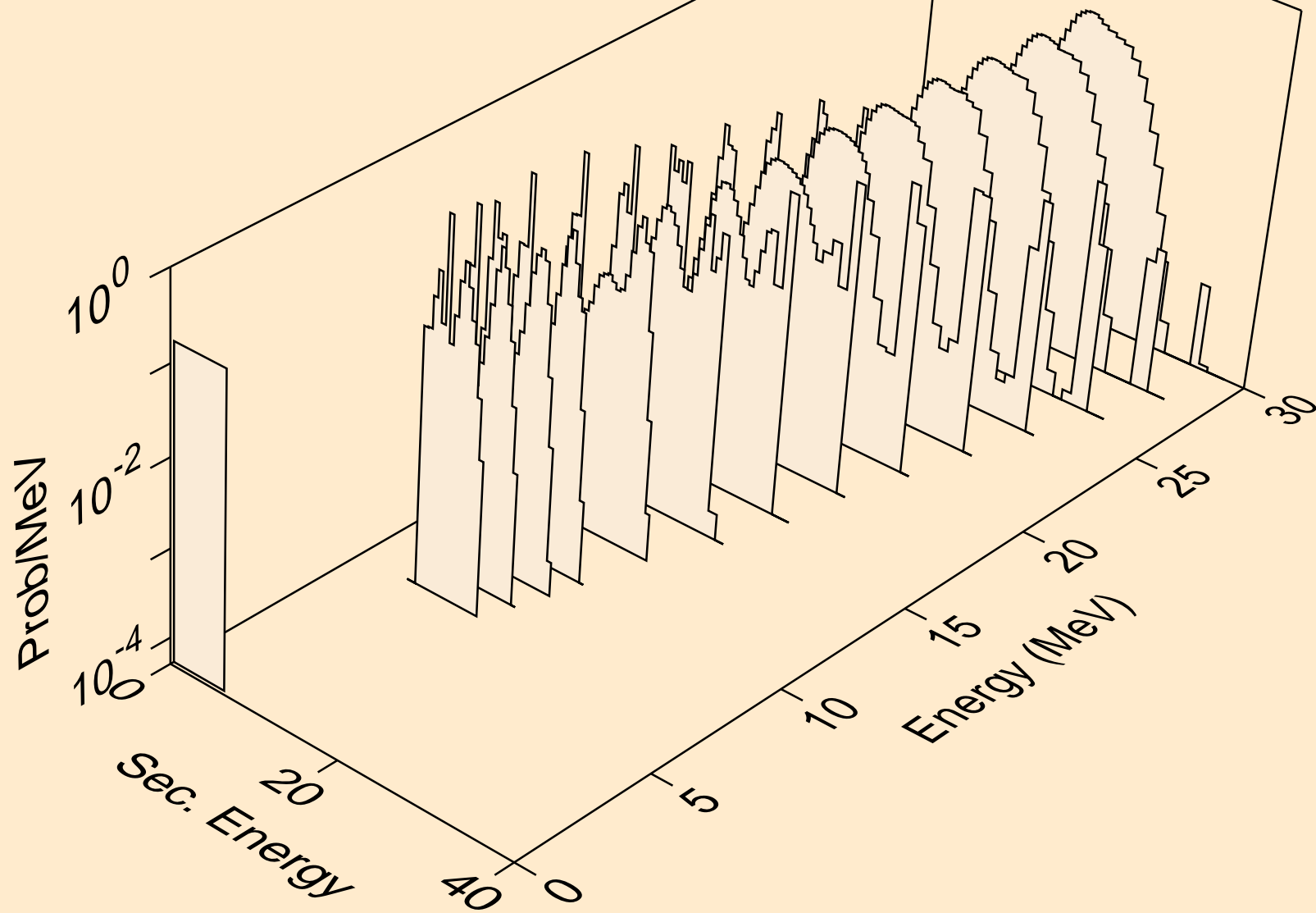

BI214 PROTON ACER TENDL-2021 LIBRARY; T=0.K  
alphas from (p,2n)2a

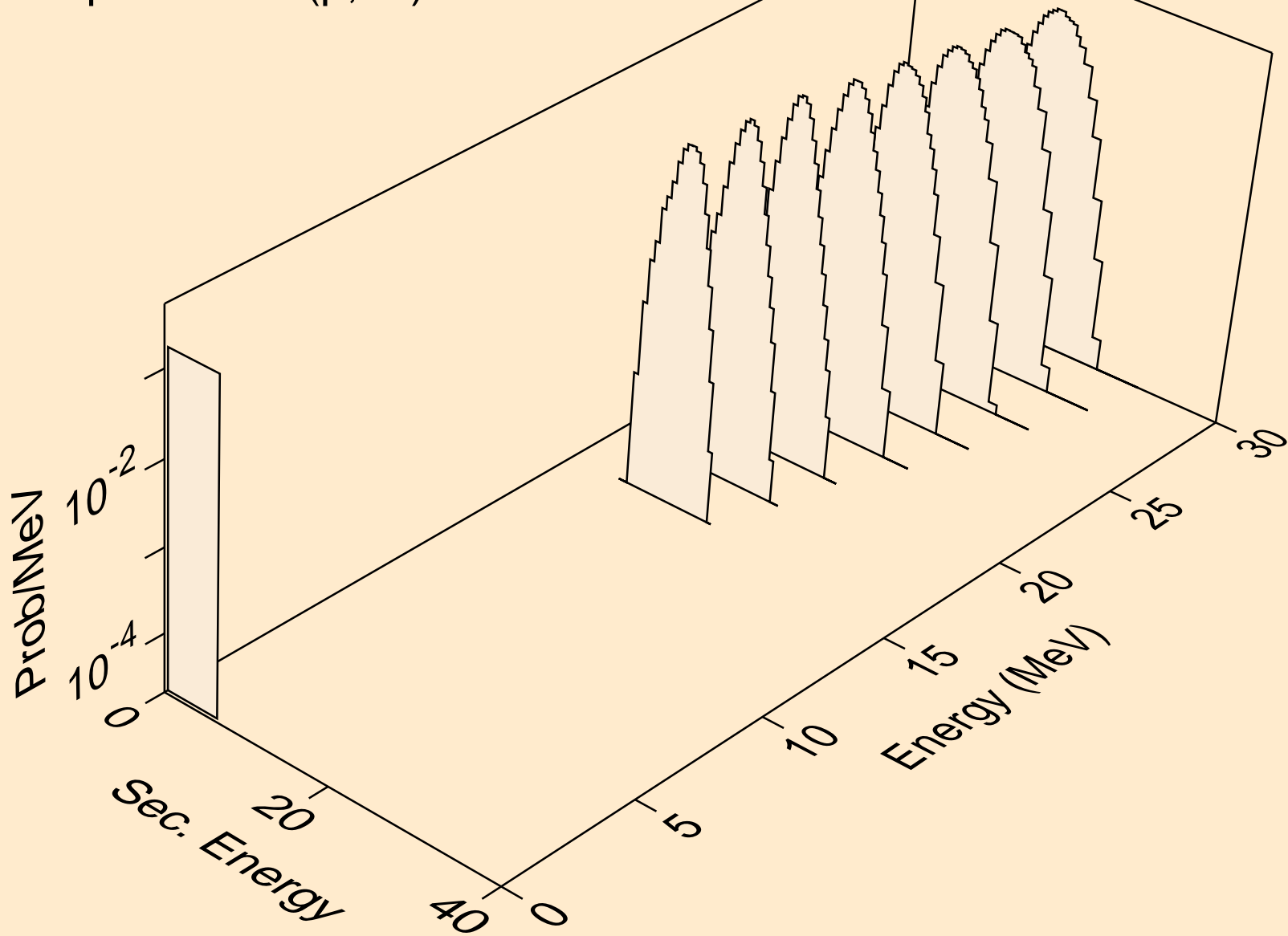

BI214 PROTON ACER TENDL-2021 LIBRARY; T=0.K  
alphas from (p,npa)

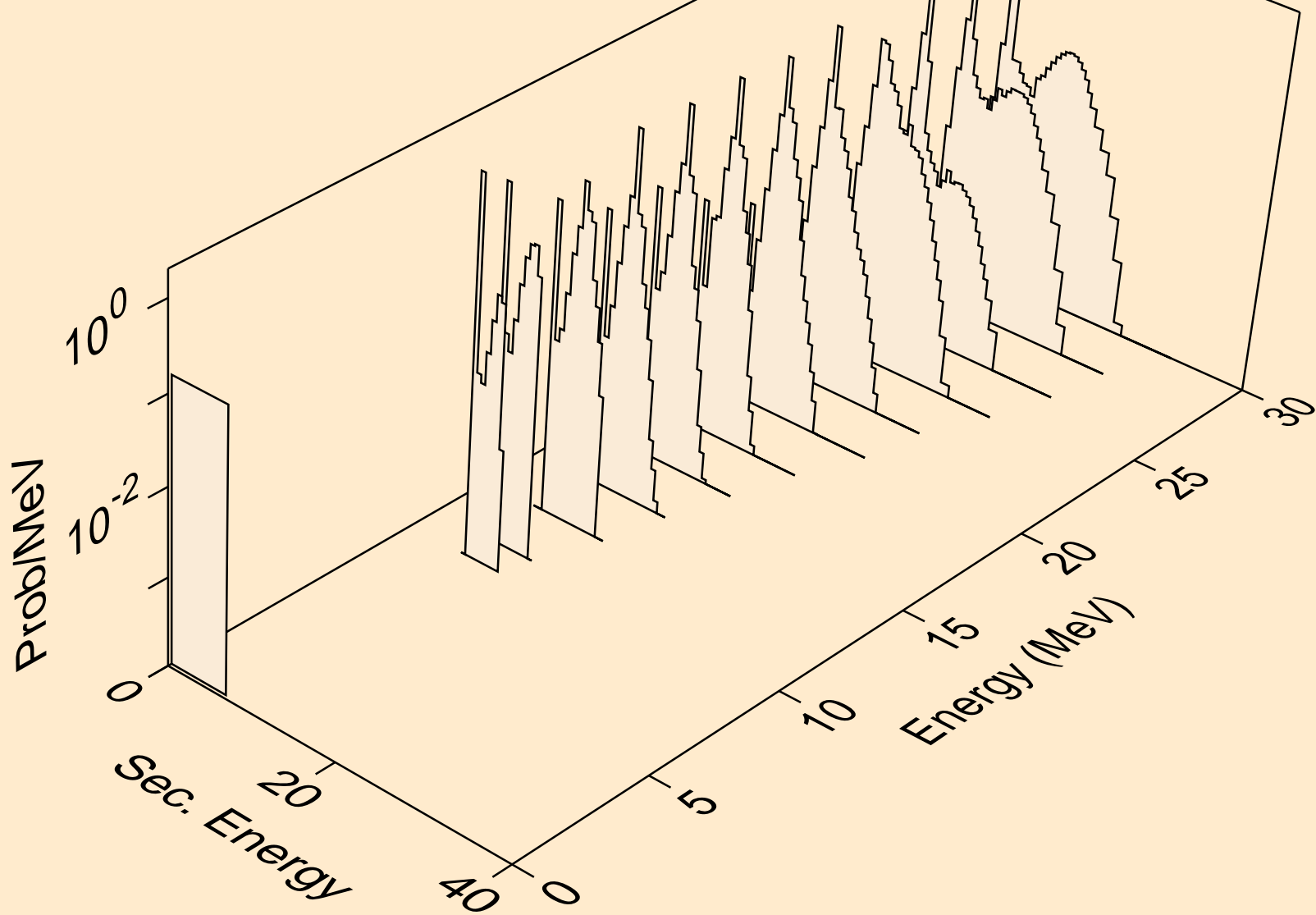

BI214 PROTON ACER TENDL-2021 LIBRARY; T=0.K  
alphas from (p,a)

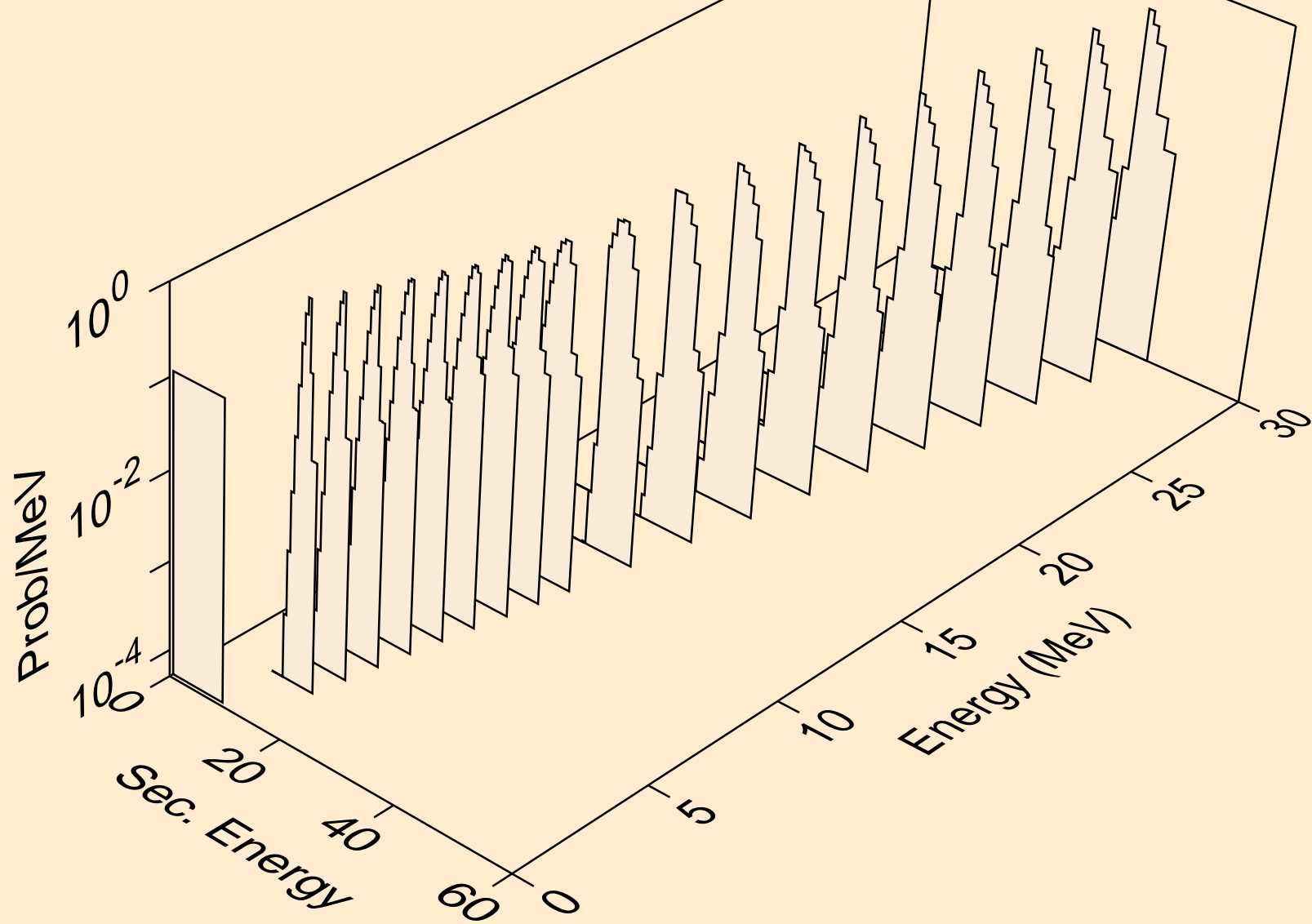

BI214 PROTON ACER TENDL-2021 LIBRARY; T=0.K  
alphas from (p,2a)

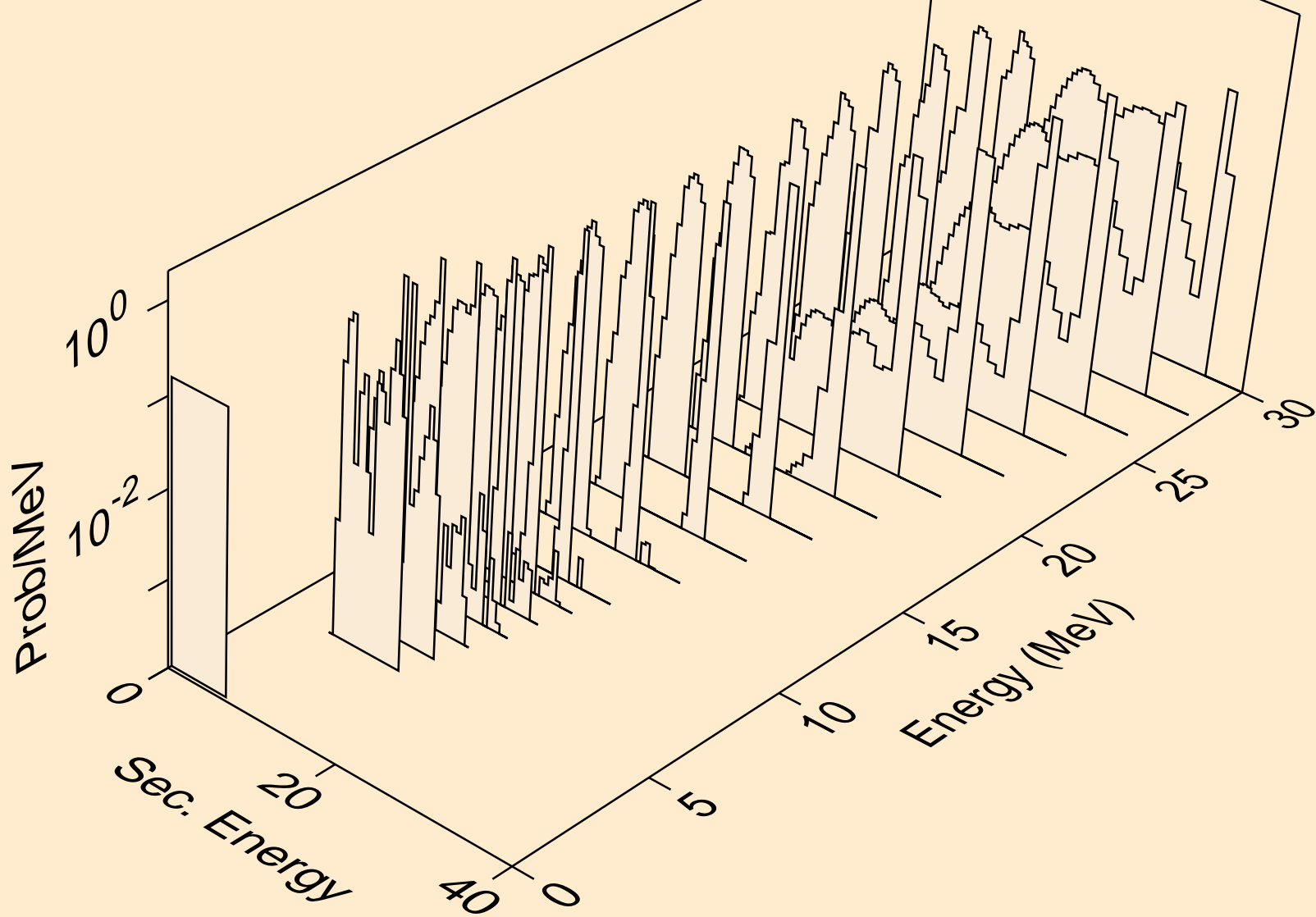

BI214 PROTON ACER TENDL-2021 LIBRARY; T=0.K  
alphas from (p,pa)

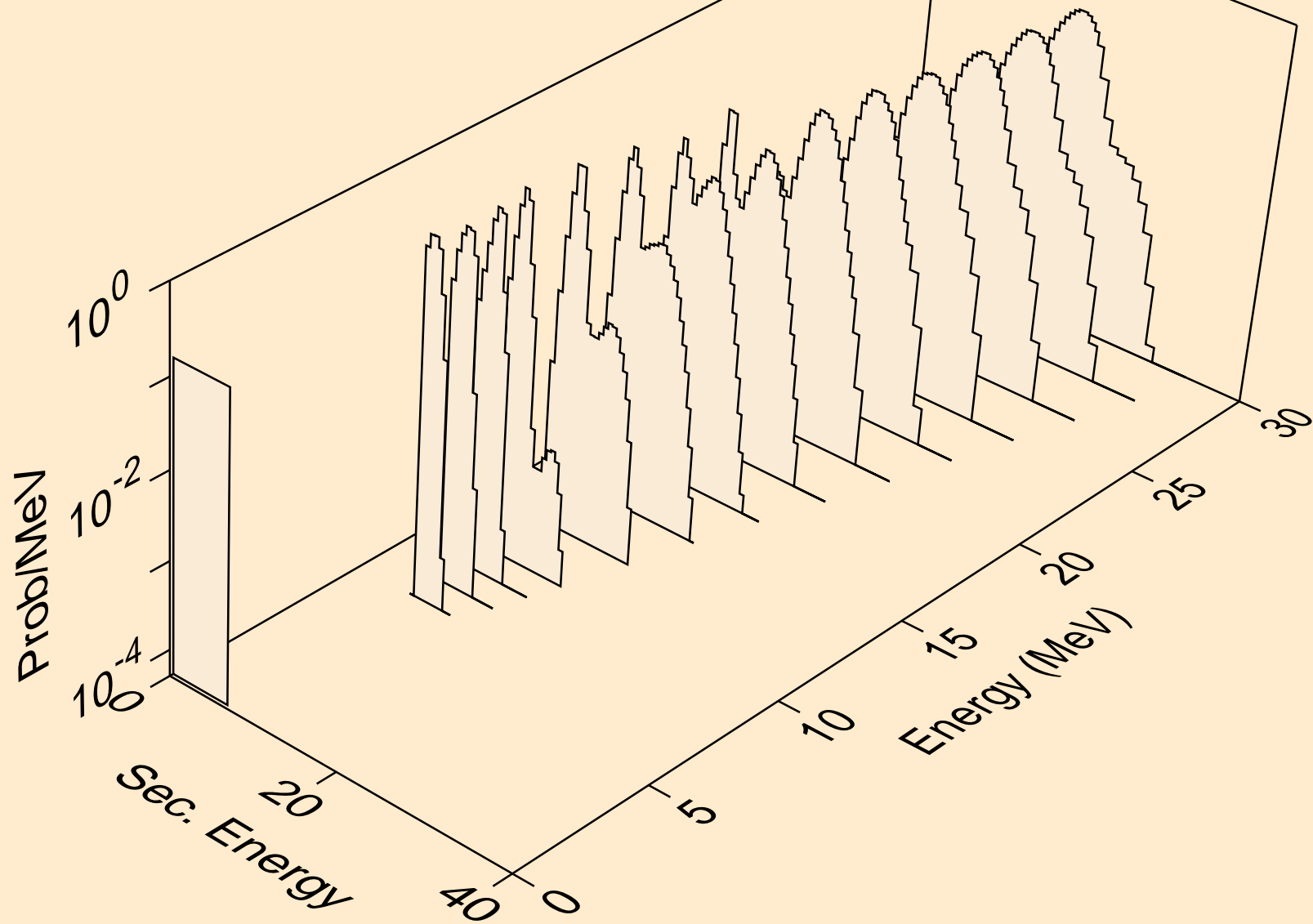



BI214 PROTON ACER TENDL-2021 LIBRARY; T=0.K  
alphas from (p,da)

