

CD121M PROTON ACER TENDL-2021 LIBRARY; T=0.K

Principal cross sections

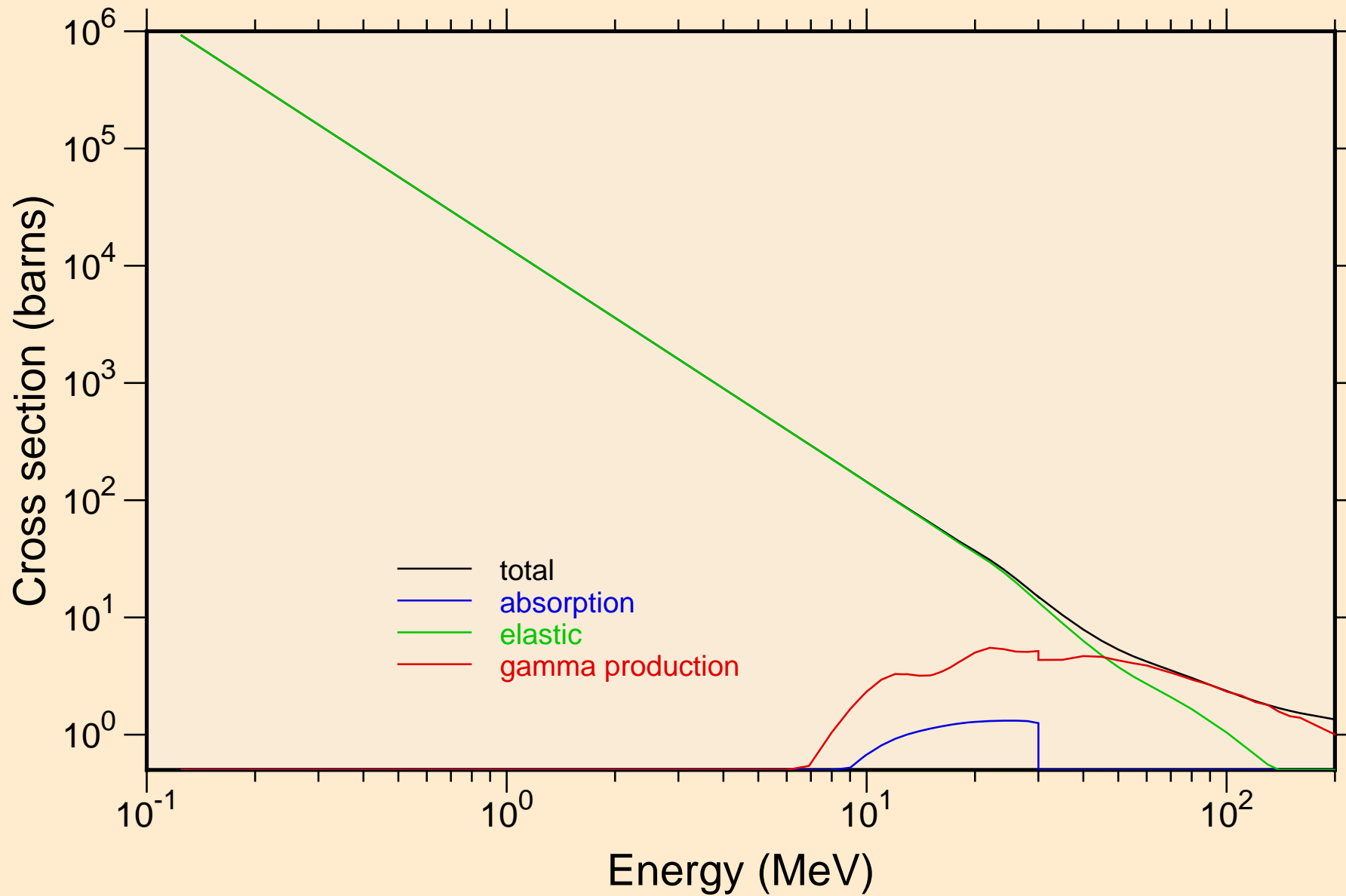

CD121M PROTON ACER TENDL-2021 LIBRARY; T=0.K
Heating

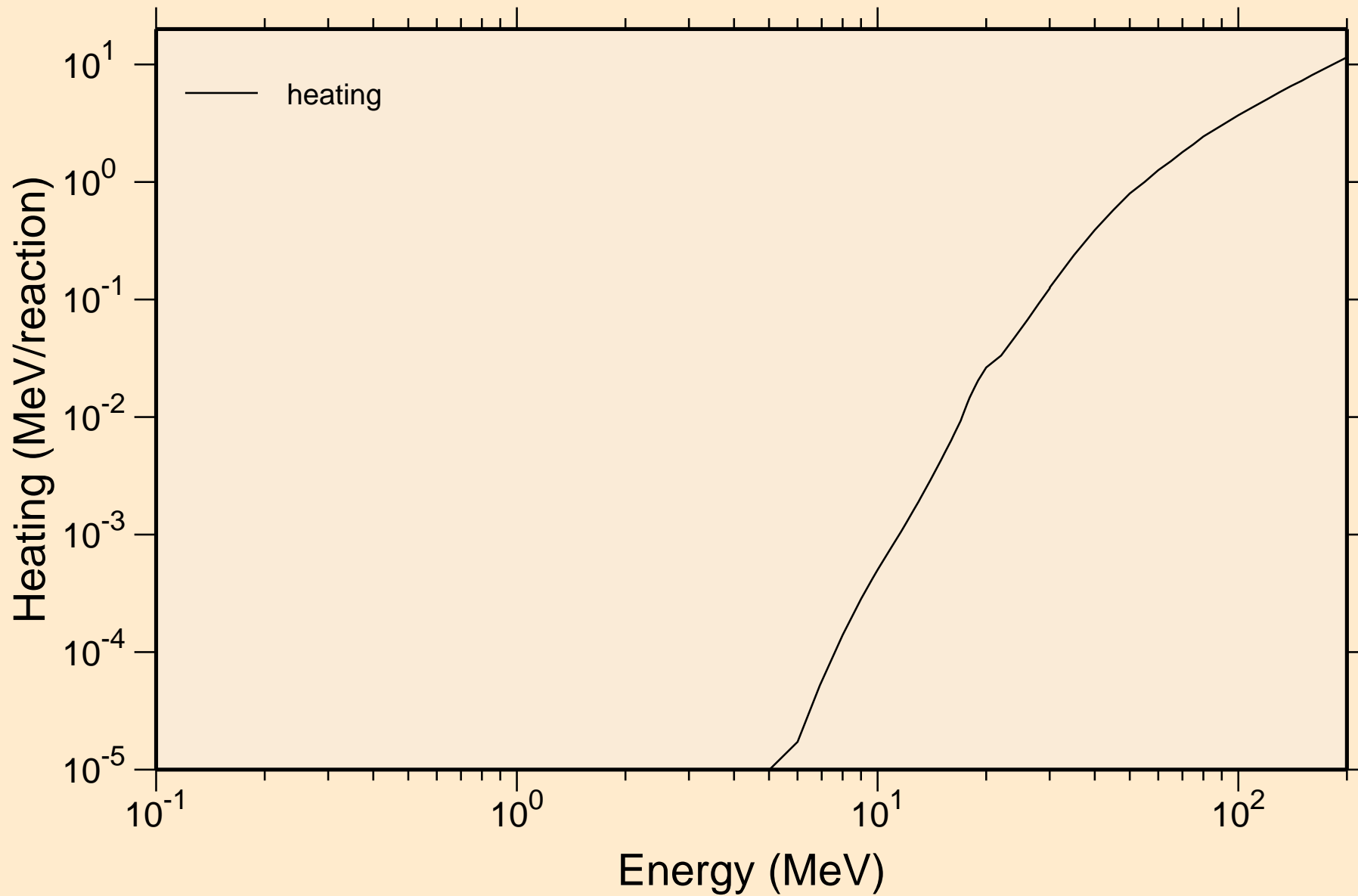

CD121M PROTON ACER TENDL-2021 LIBRARY; T=0.K

Principal cross sections

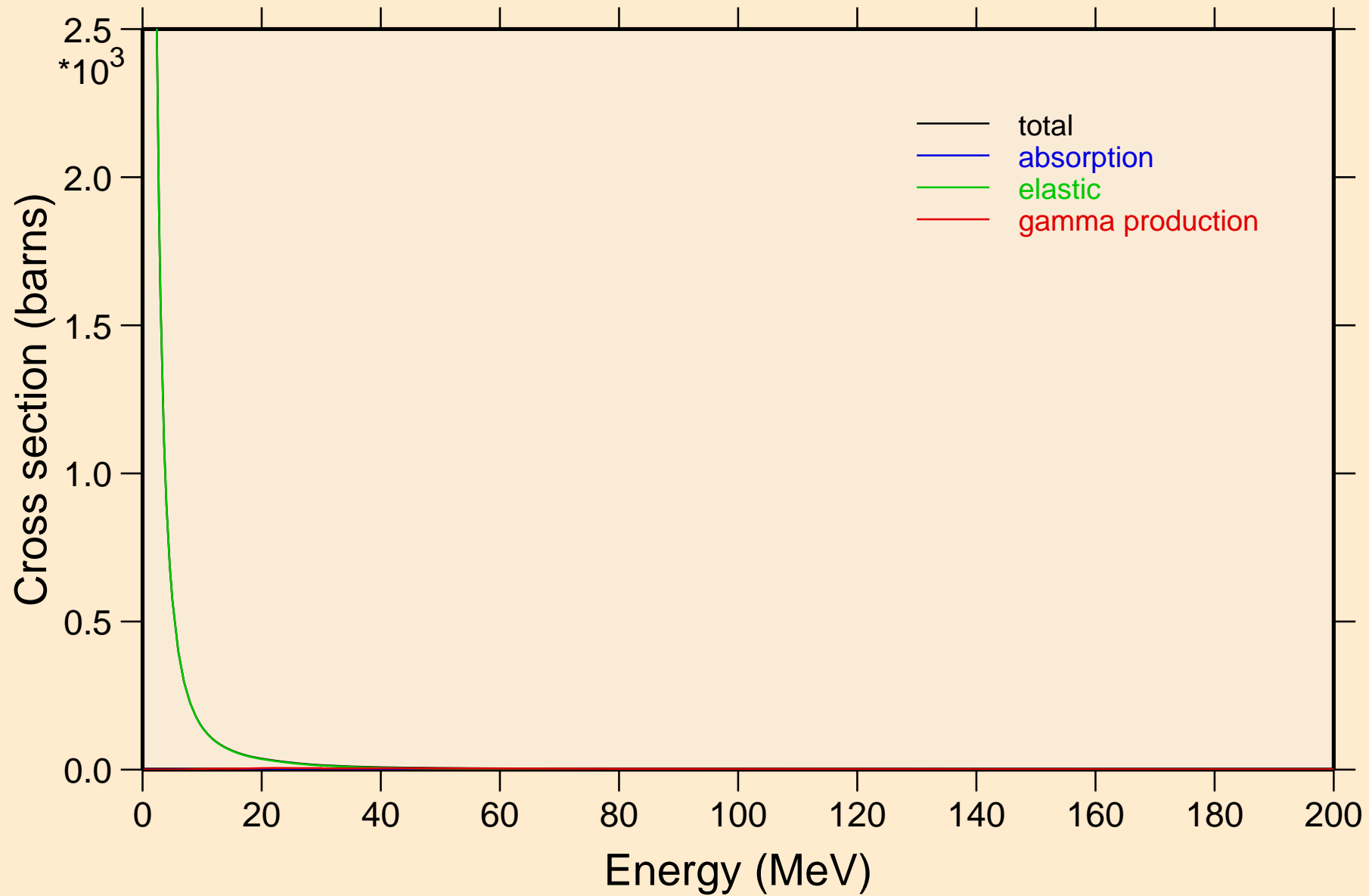

CD121M PROTON ACER TENDL-2021 LIBRARY; T=0.K

Heating

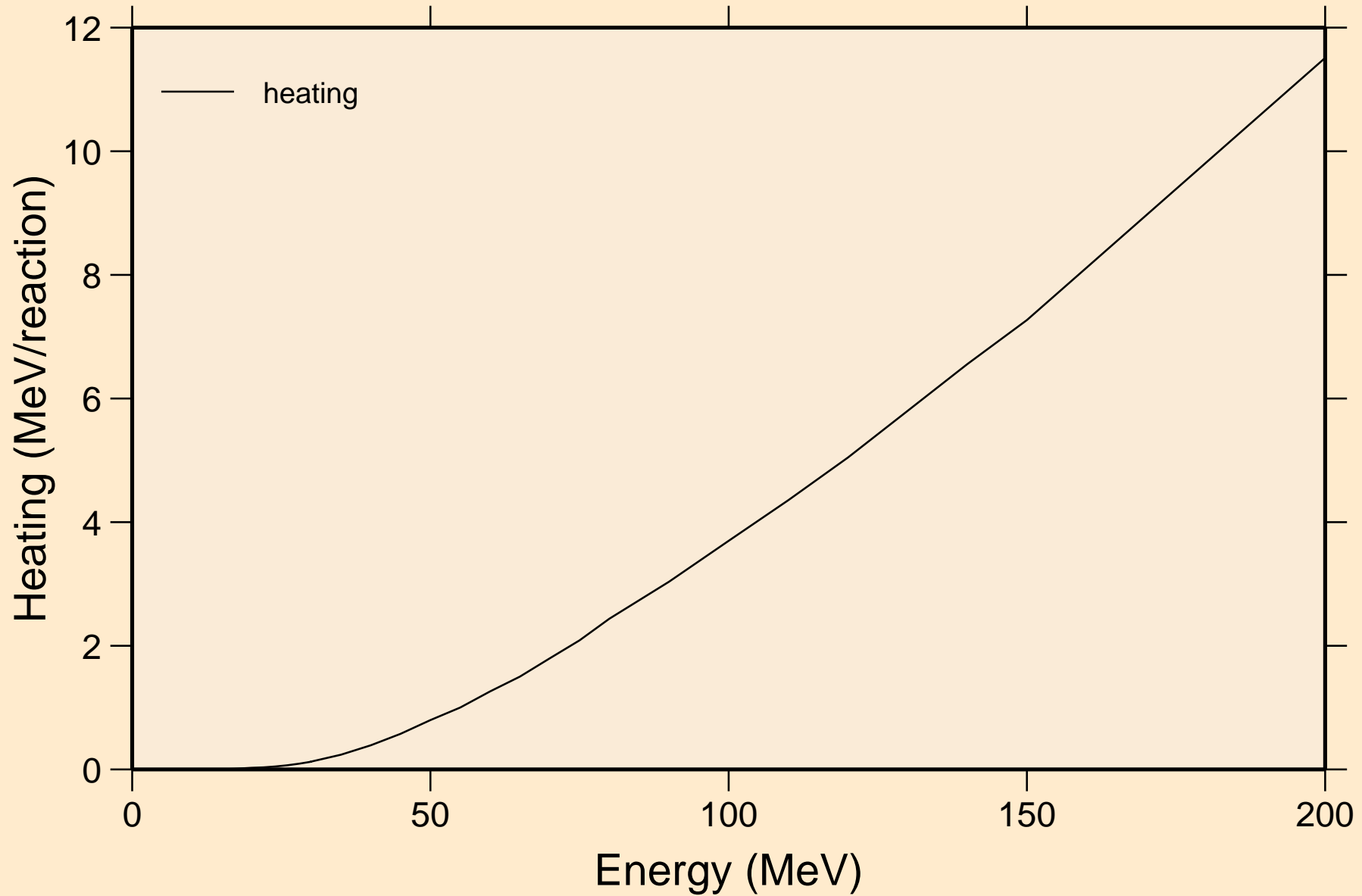

CD121M PROTON ACER TENDL-2021 LIBRARY; T=0.K

Threshold reactions

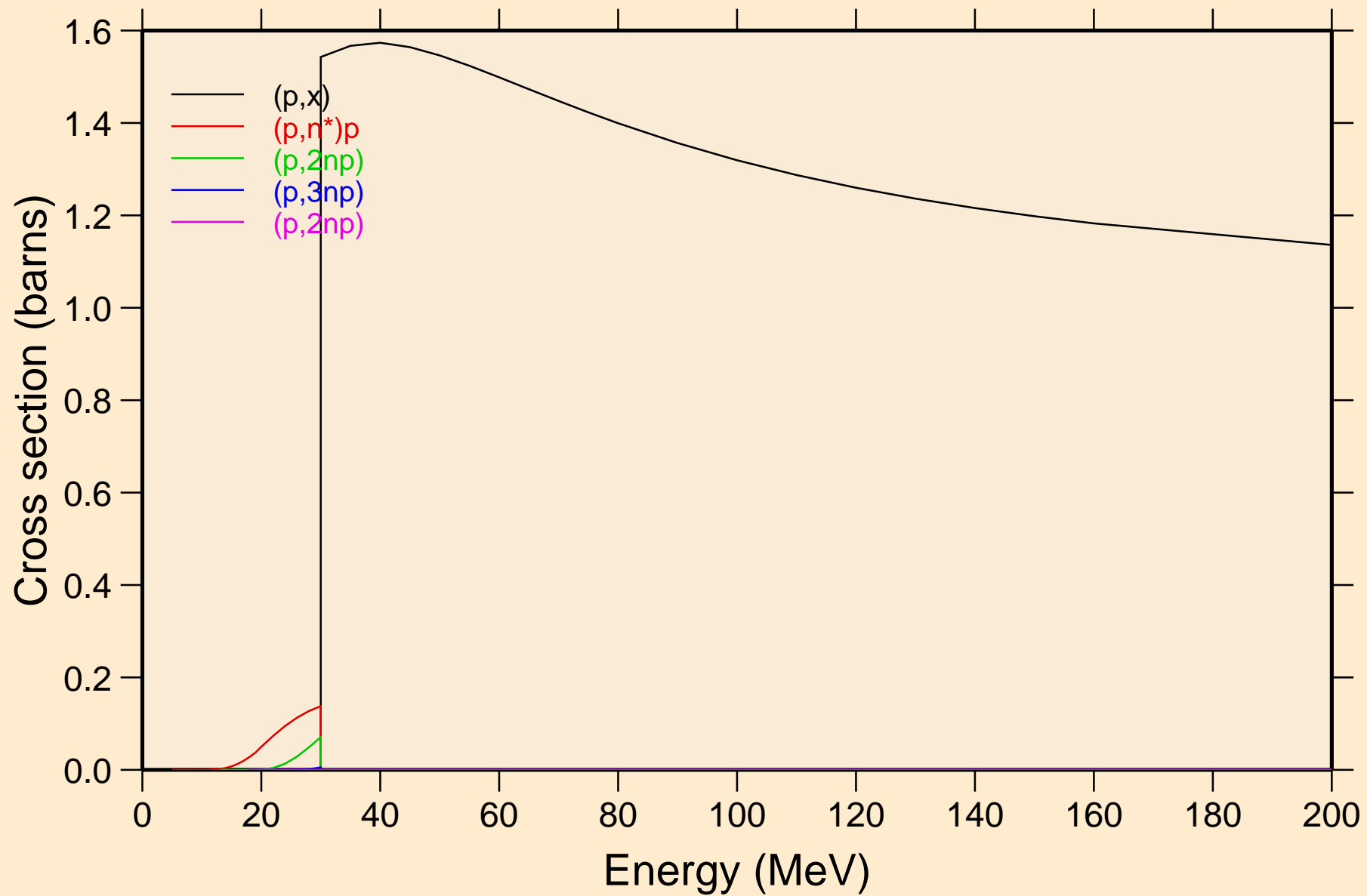

CD121M PROTON ACER TENDL-2021 LIBRARY; T=0.K

Threshold reactions

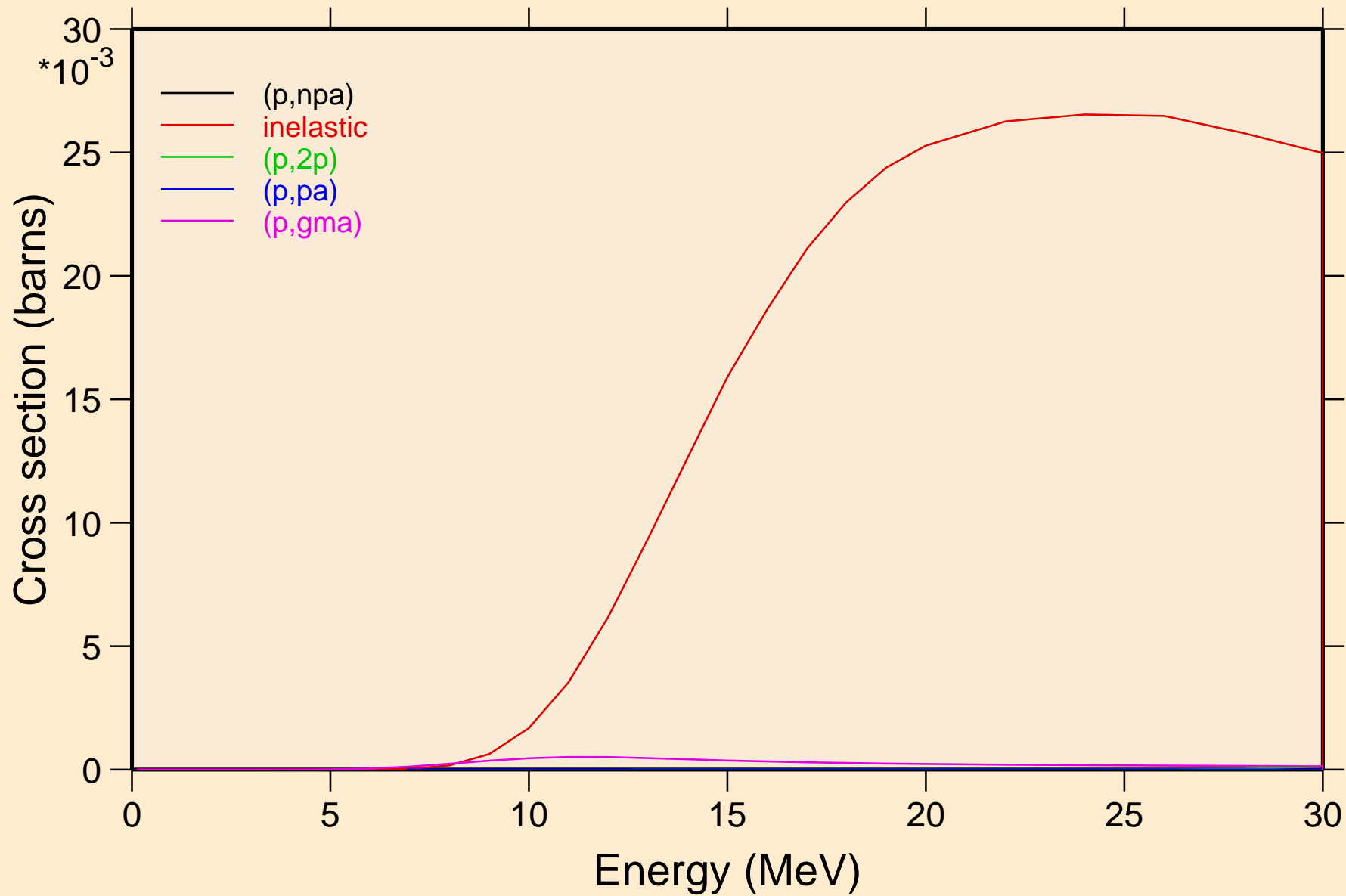

CD121M PROTON ACER TENDL-2021 LIBRARY; T=0.K

Threshold reactions

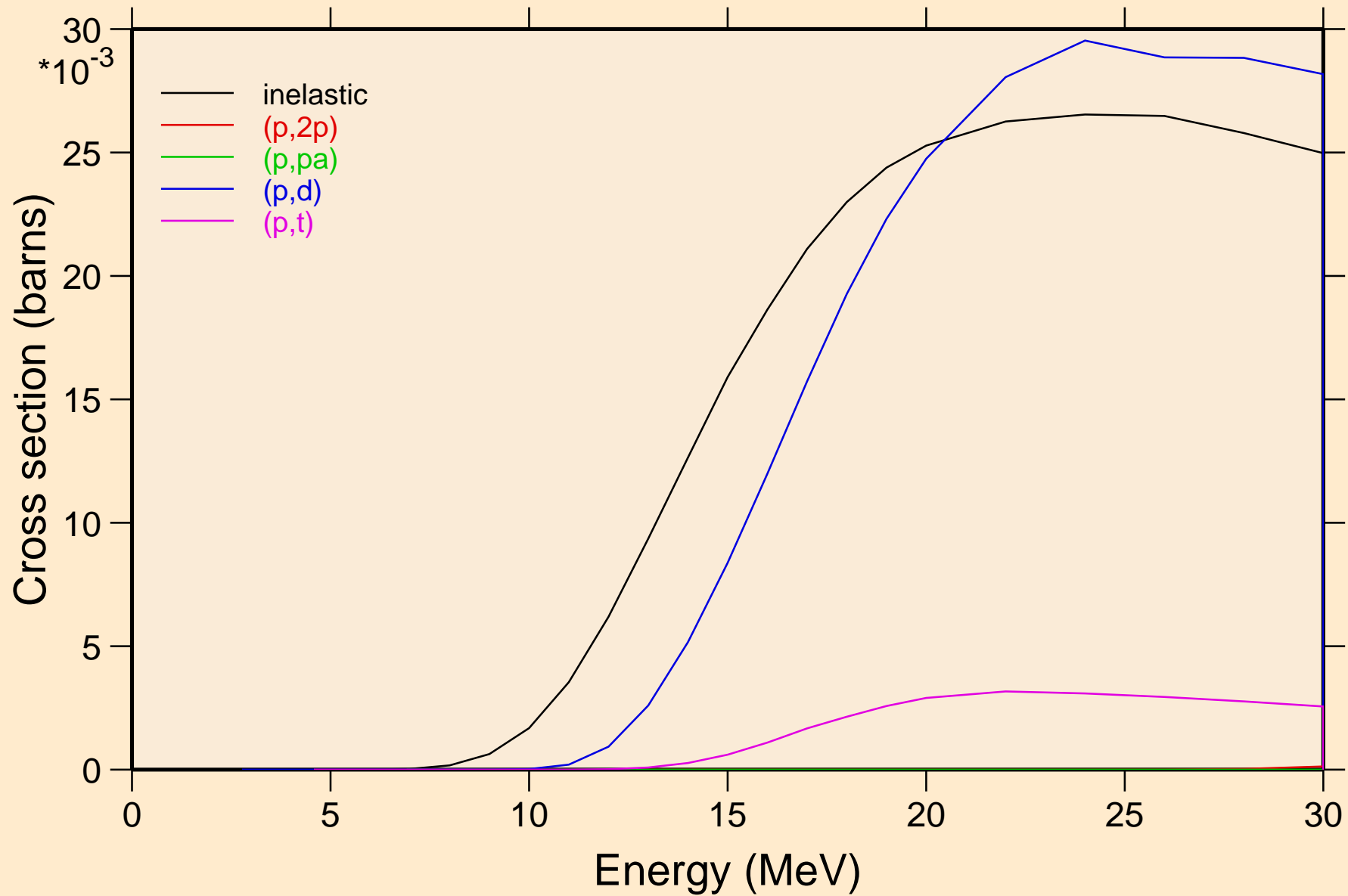

CD121M PROTON ACER TENDL-2021 LIBRARY; T=0.K
Threshold reactions

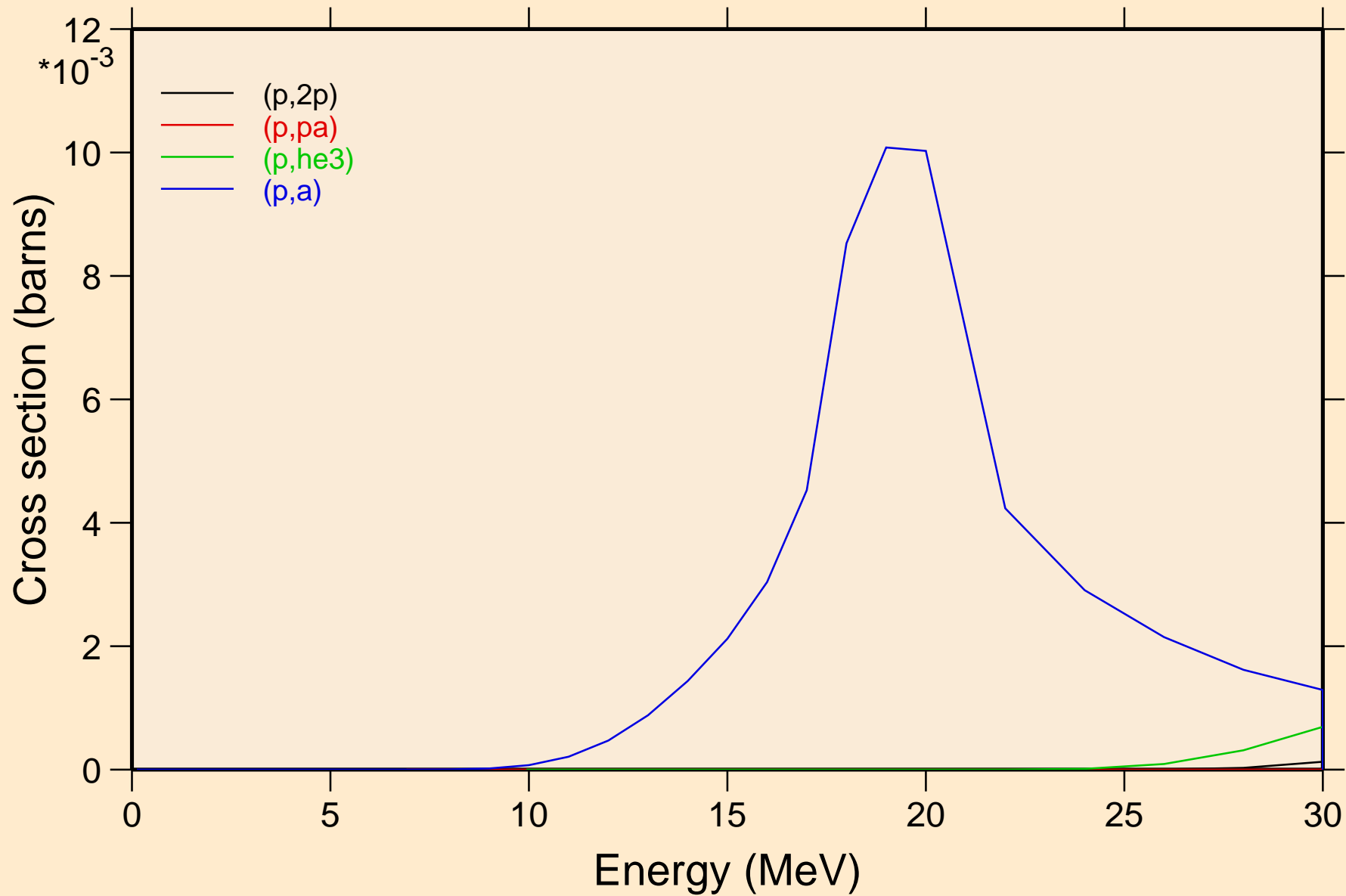

CD121M PROTON ACER TENDL-2021 LIBRARY; T=0.K

Threshold reactions

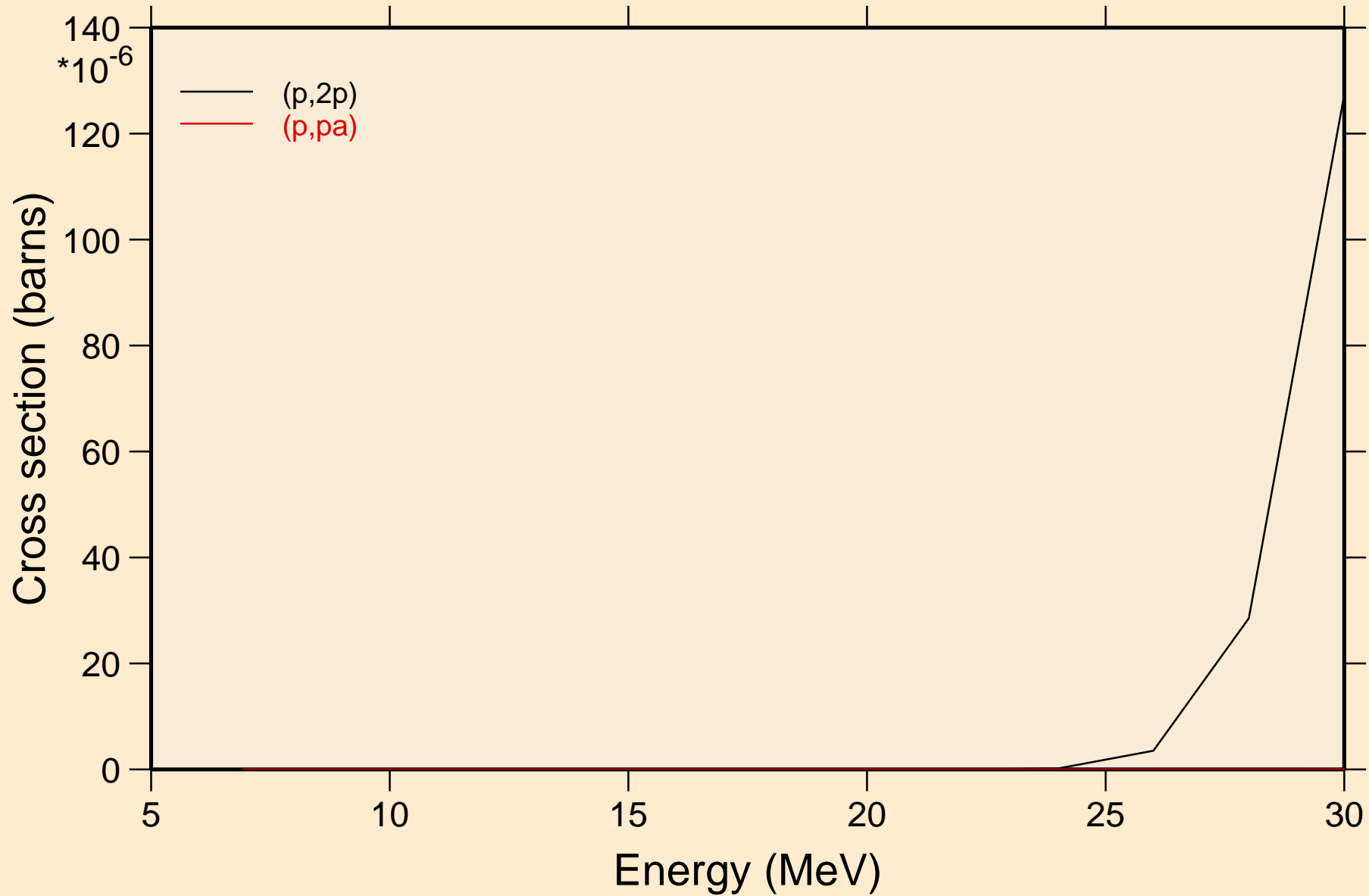

CD121M PROTON ACER TENDL-2021 LIBRARY; T=0.K
angular distribution for elastic

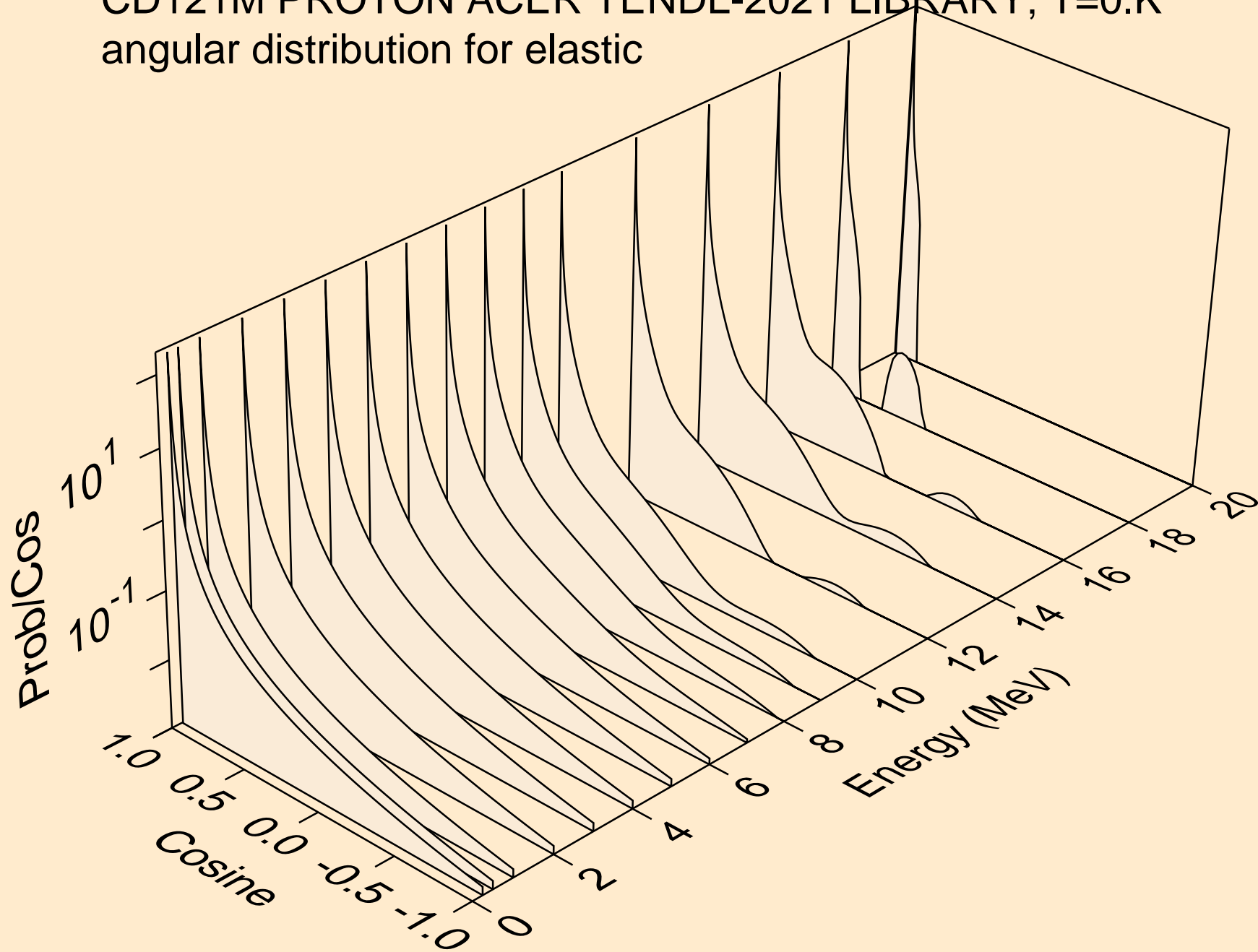

CD121M PROTON ACER TENDL-2021 LIBRARY; T=0.K
angular distribution for elastic

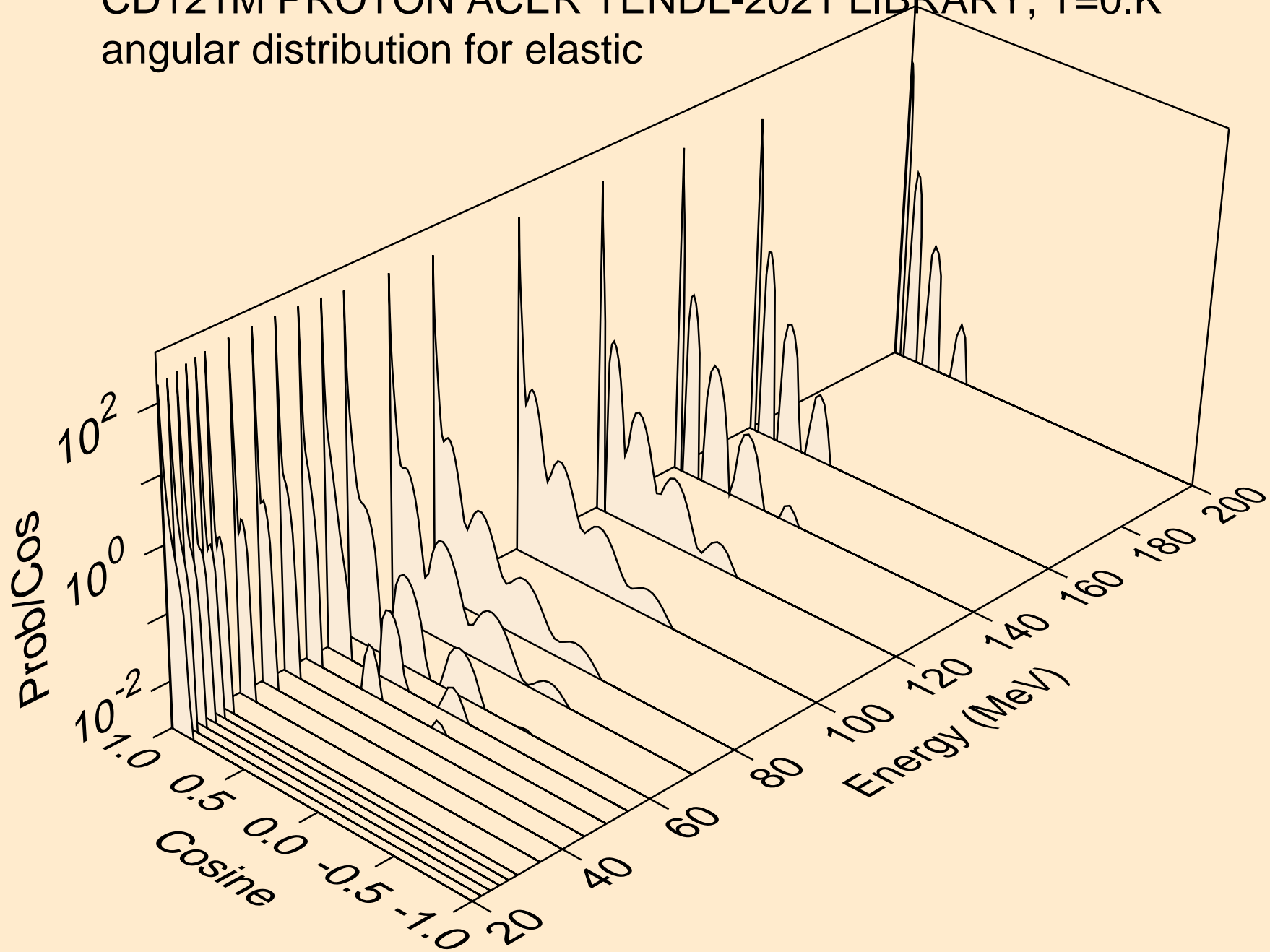

CD121M PROTON ACER TENDL-2021 LIBRARY; T=0.K
Proton emission for (p,x)

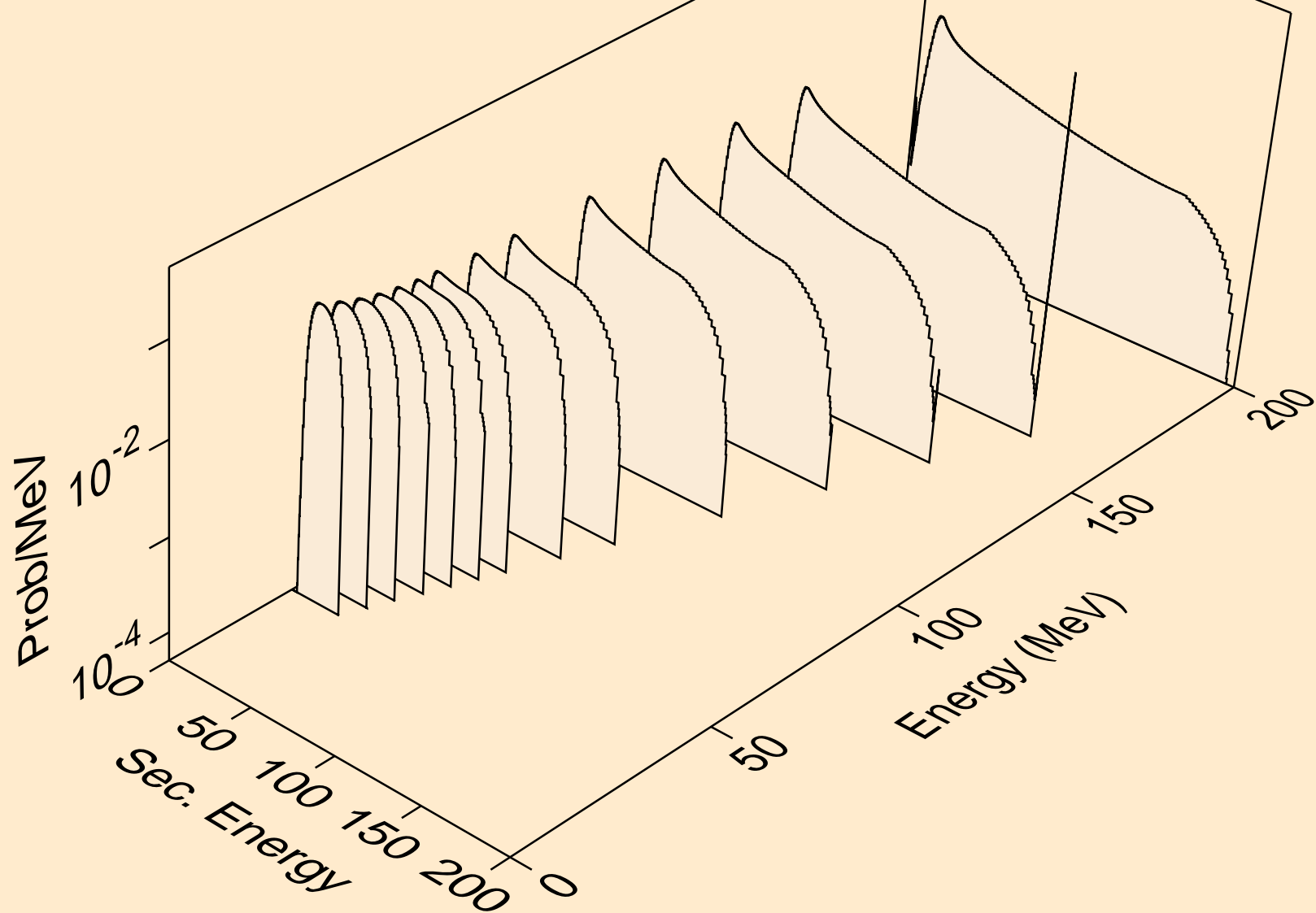

CD121M PROTON ACER TENDL-2021 LIBRARY; T=0.K
Proton emission for (p,n*)p

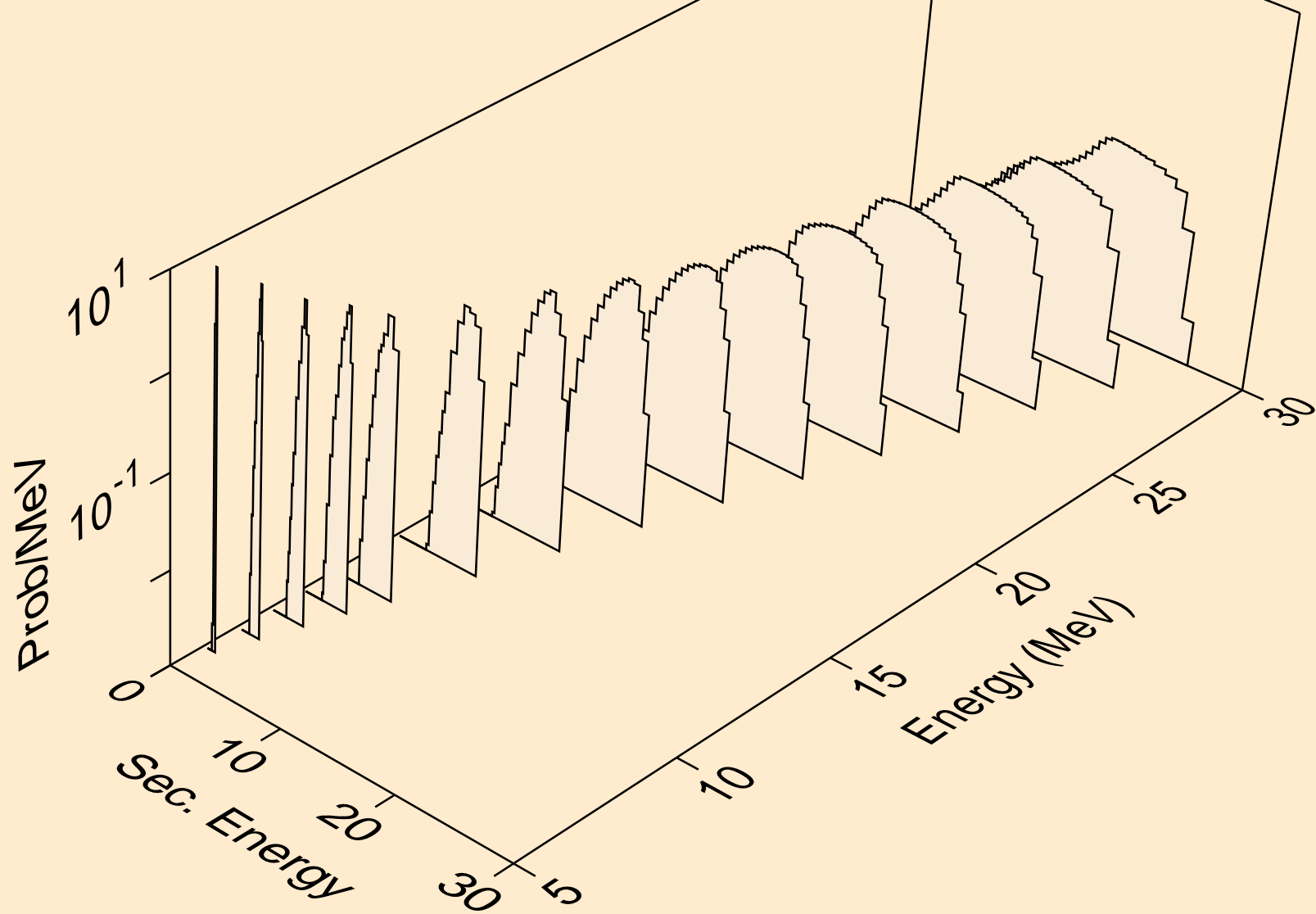

CD121M PROTON ACER TENDL-2021 LIBRARY; T=0.K
Proton emission for (p,2np)

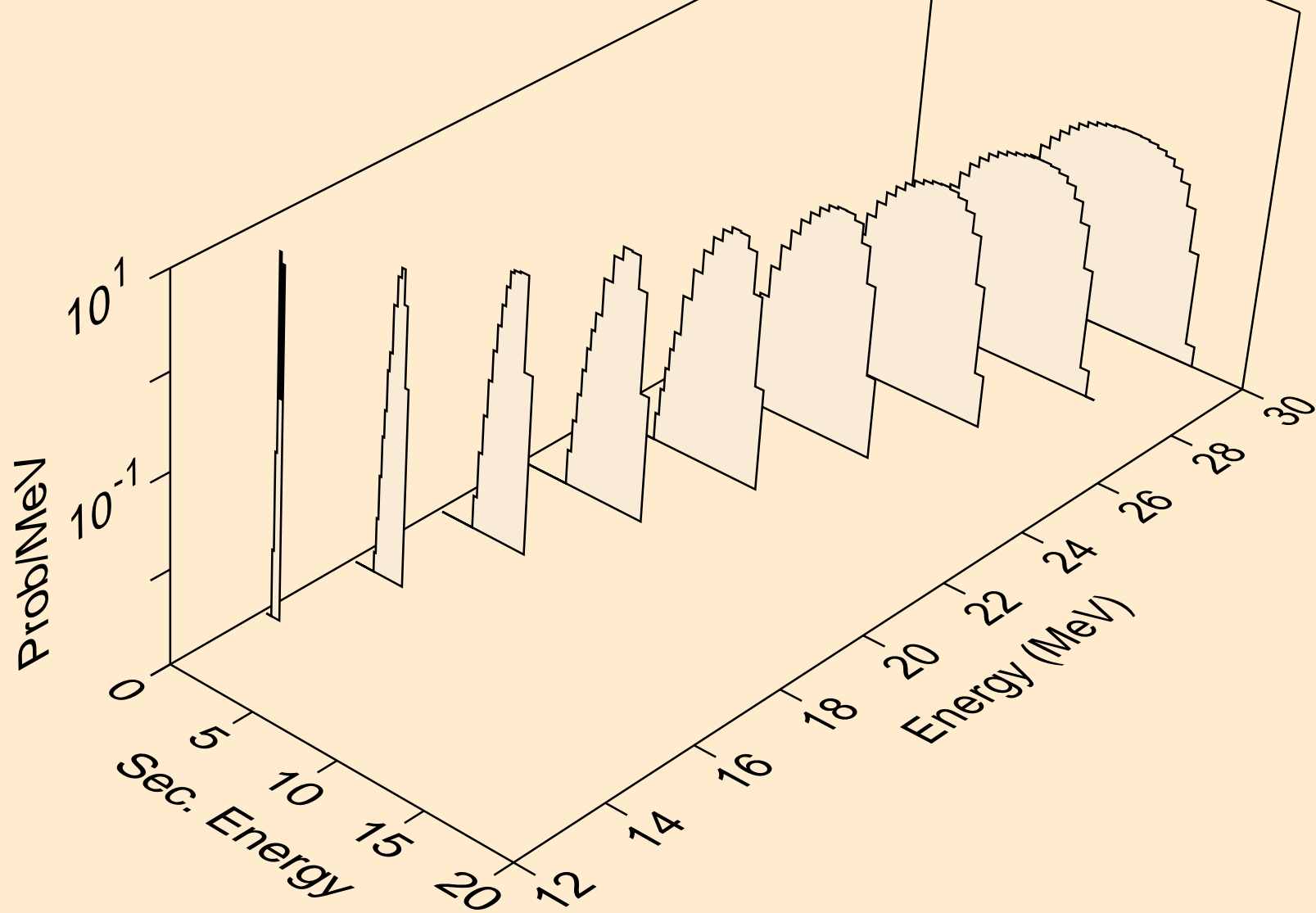

CD121M PROTON ACER TENDL-2021 LIBRARY; T=0.K
Proton emission for (p,3np)

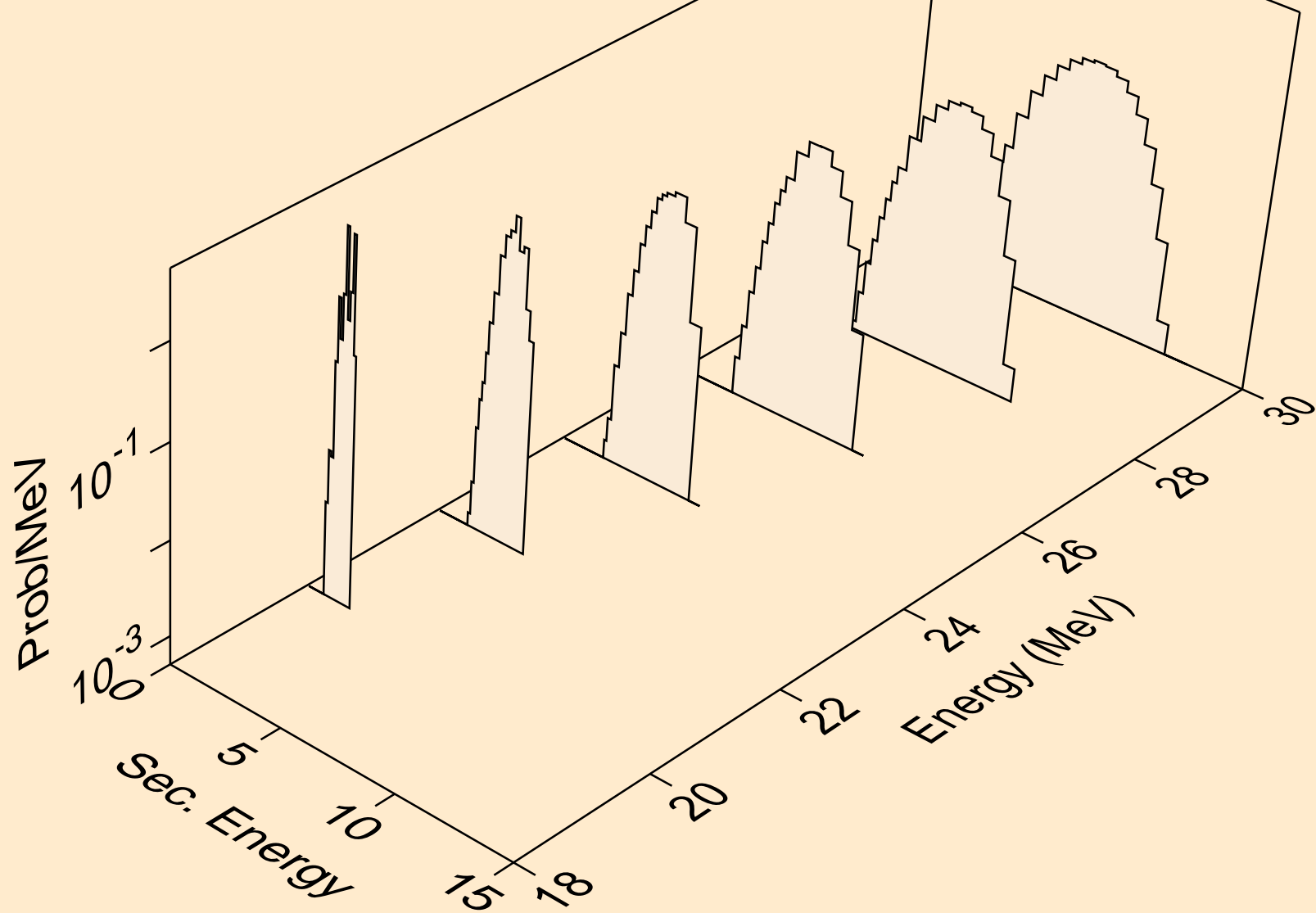

CD121M PROTON ACER TENDL-2021 LIBRARY; T=0.K
Proton emission for (p,2np)

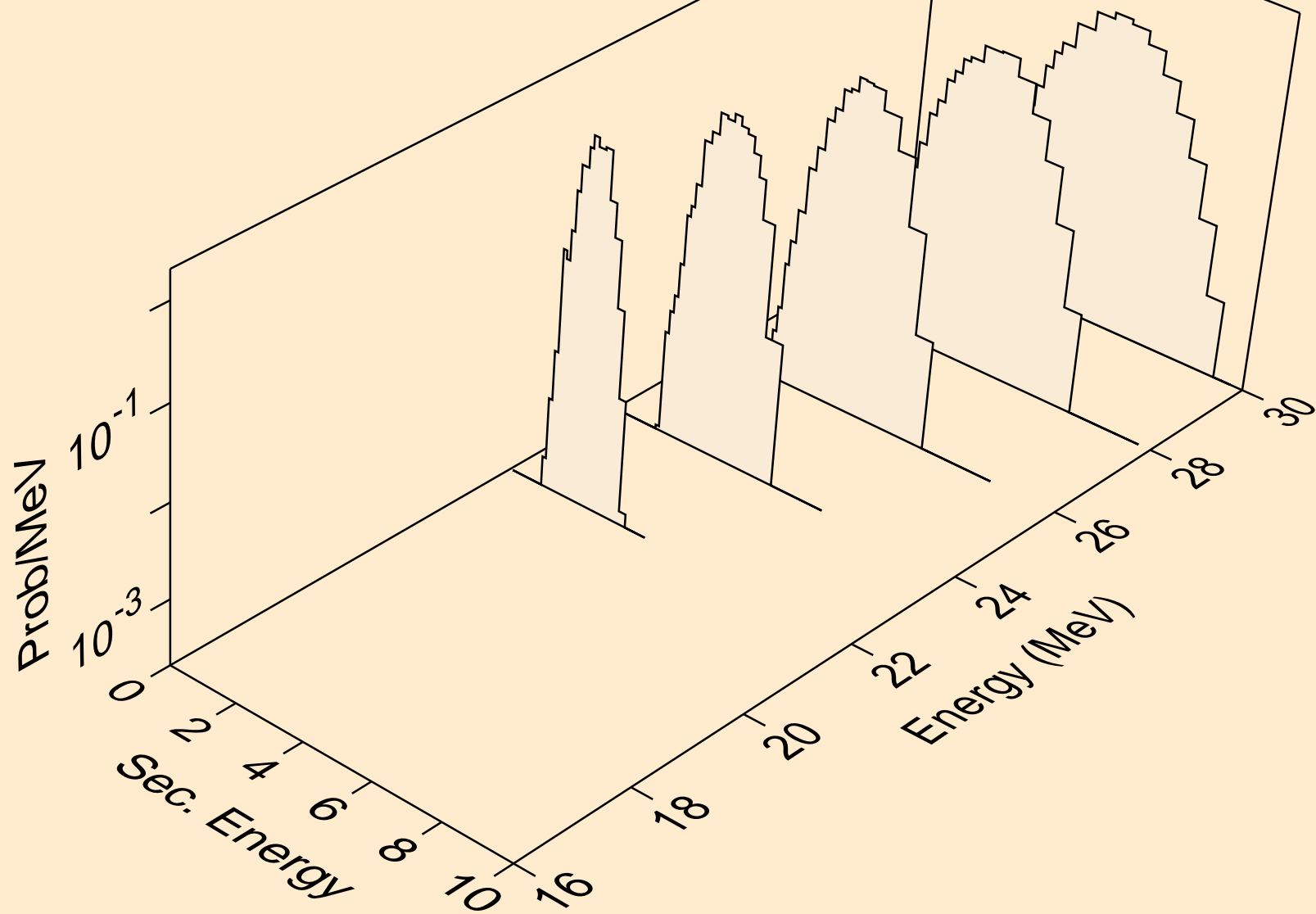

CD121M PROTON ACER TENDL-2021 LIBRARY; T=0.K
Proton emission for (p,npa)

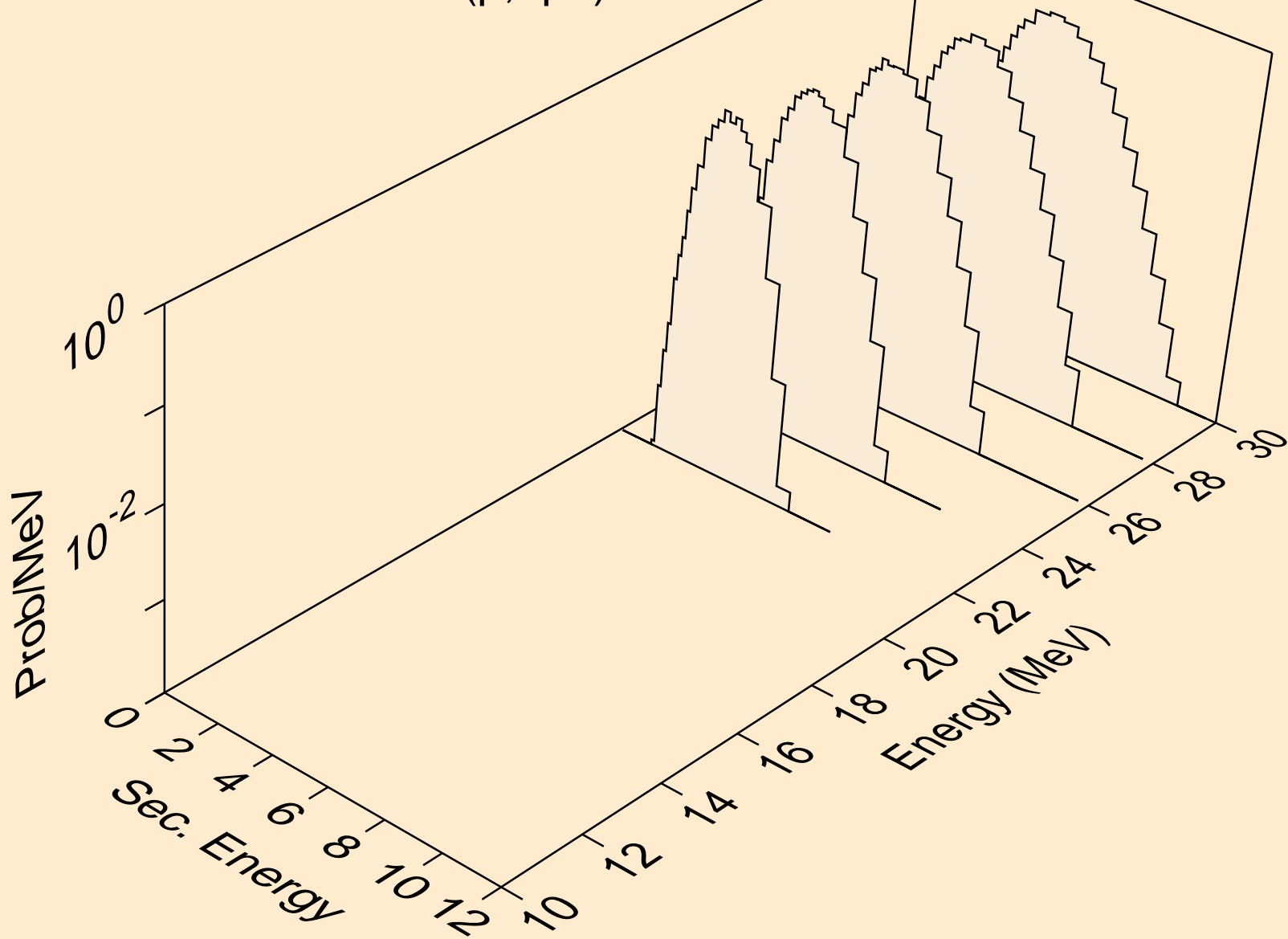

CD121M PROTON ACER TENDL-2021 LIBRARY; T=0.K
Proton emission for inelastic

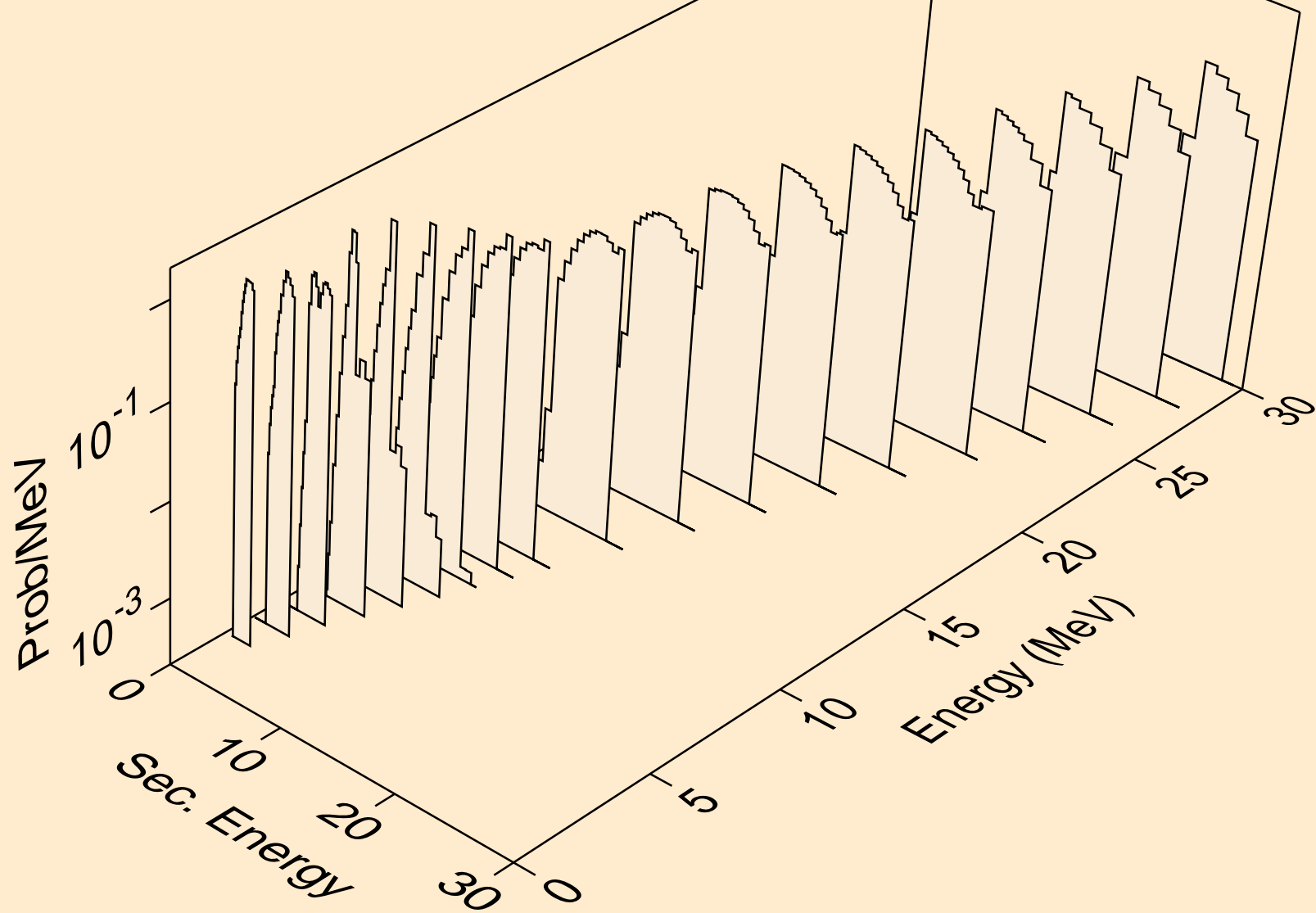

CD121M PROTON ACER TENDL-2021 LIBRARY; T=0.K
Proton emission for (p,2p)

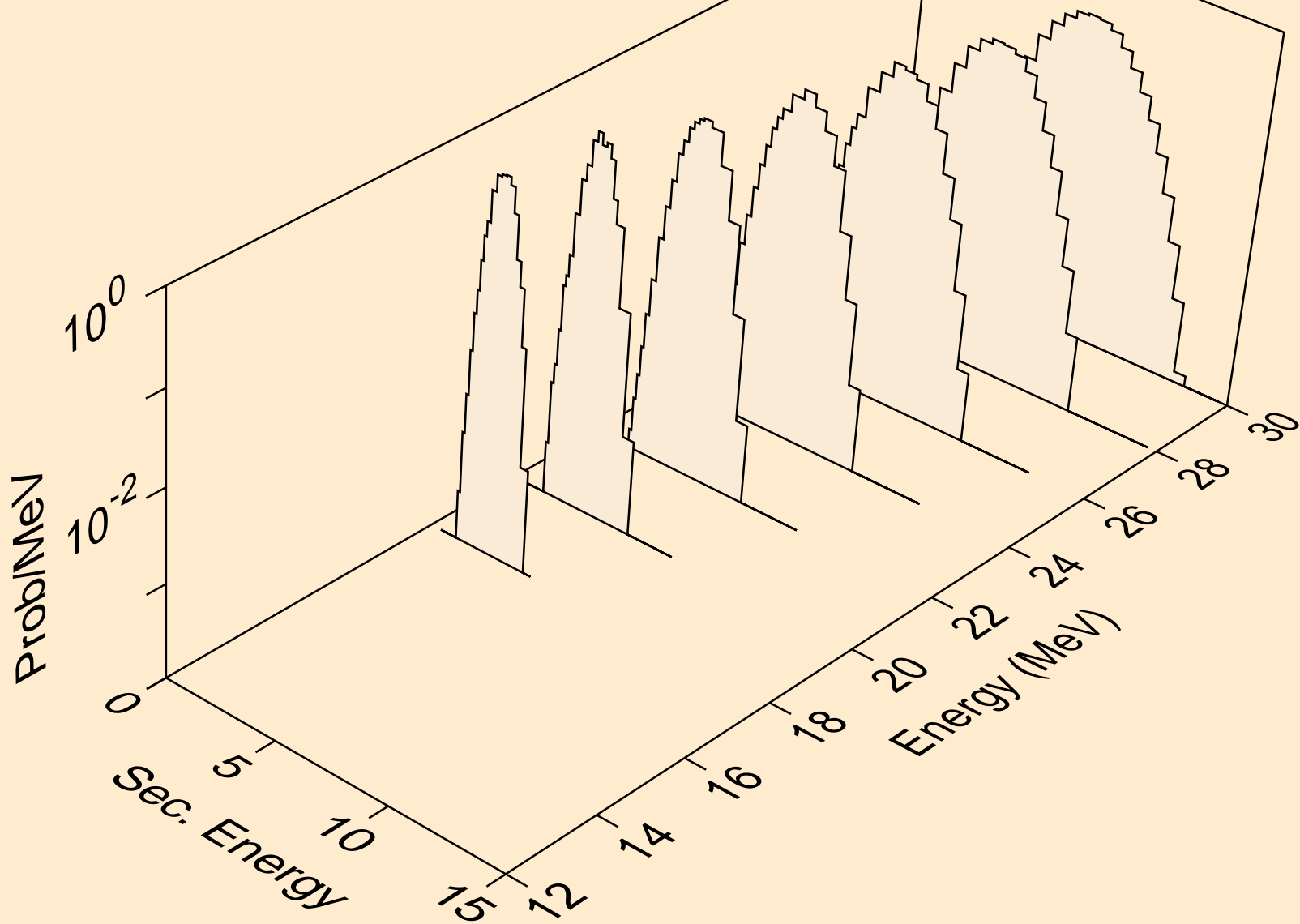

CD121M PROTON ACER TENDL-2021 LIBRARY; T=0.K
Proton emission for (p,pa)

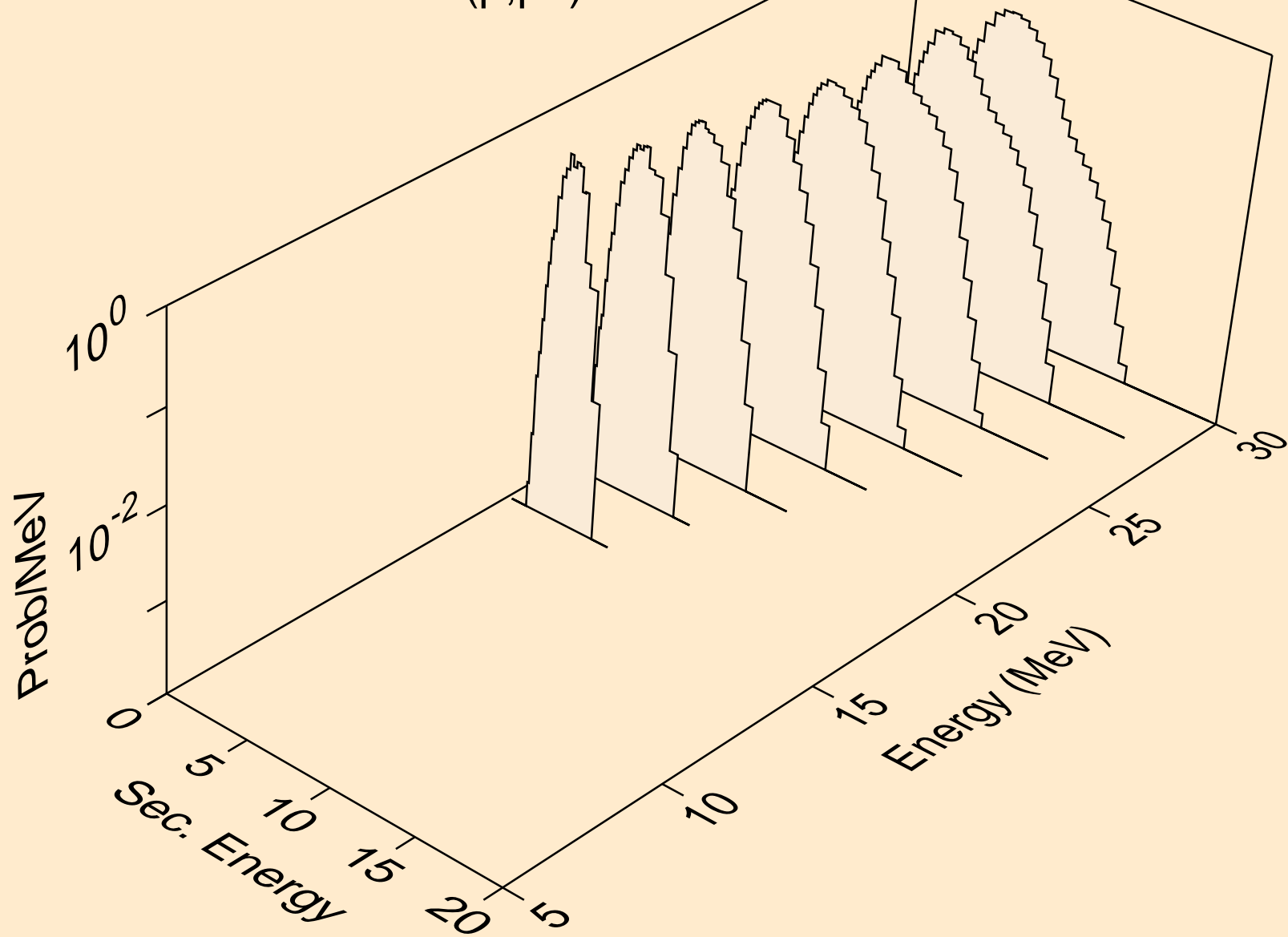

CD121M PROTON ACER TENDL-2021 LIBRARY; T=0.K
Photon emission for (z,n)

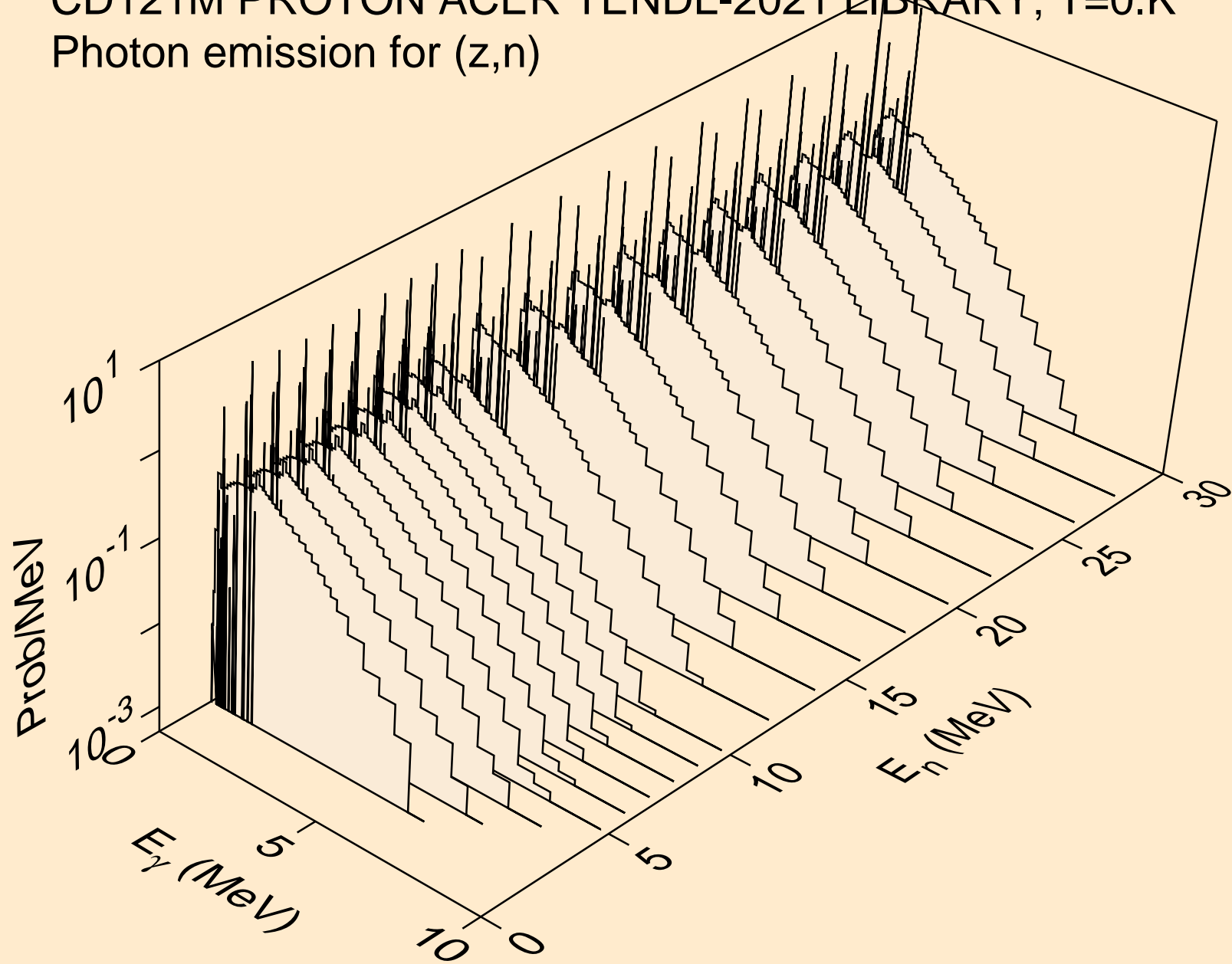

CD121M PROTON ACER TENDL-2021 LIBRARY; T=0.K
Photon emission for (n,x)

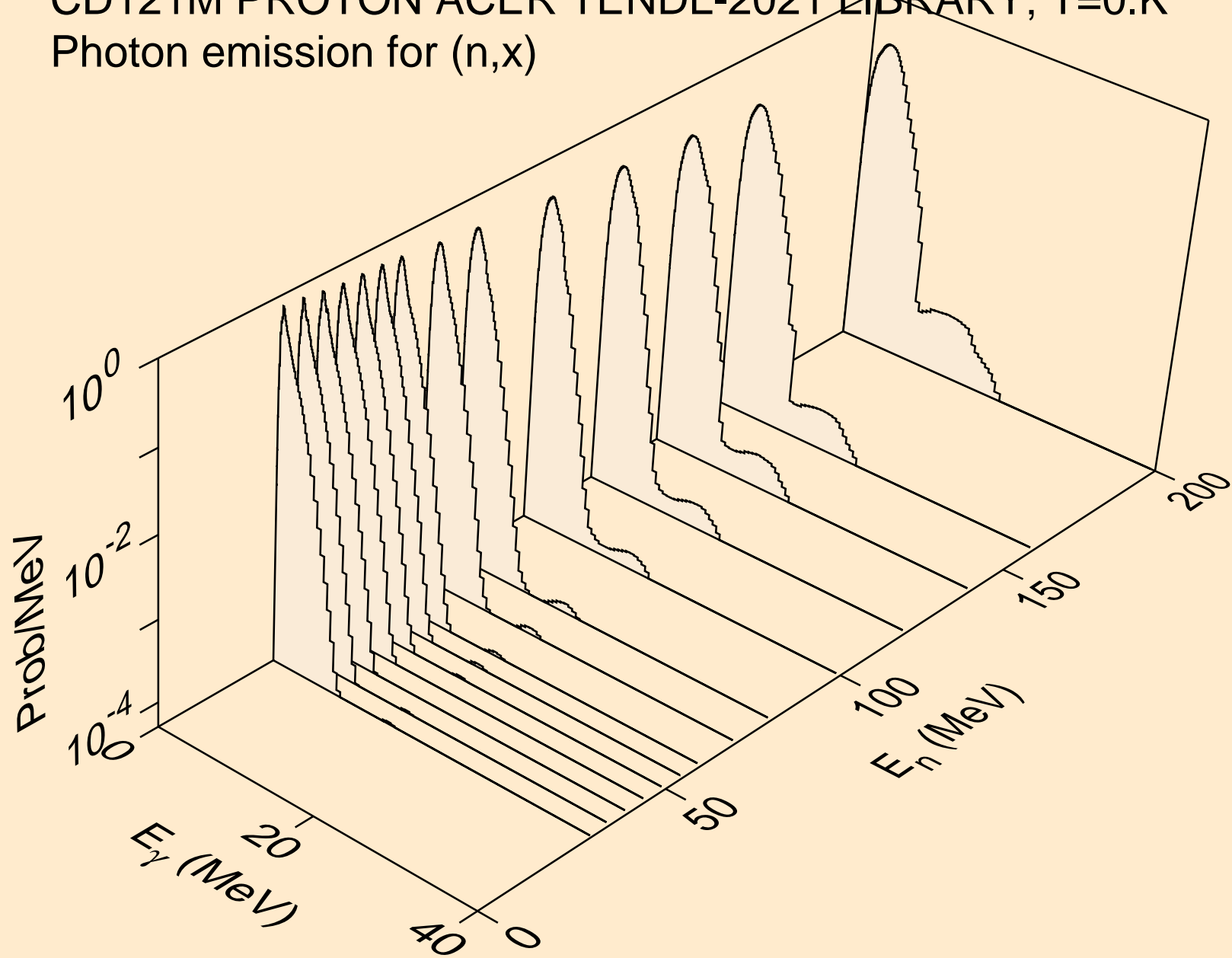

CD121M PROTON ACER TENDL-2021 LIBRARY; T=0.K
Photon emission for (n,2nd)

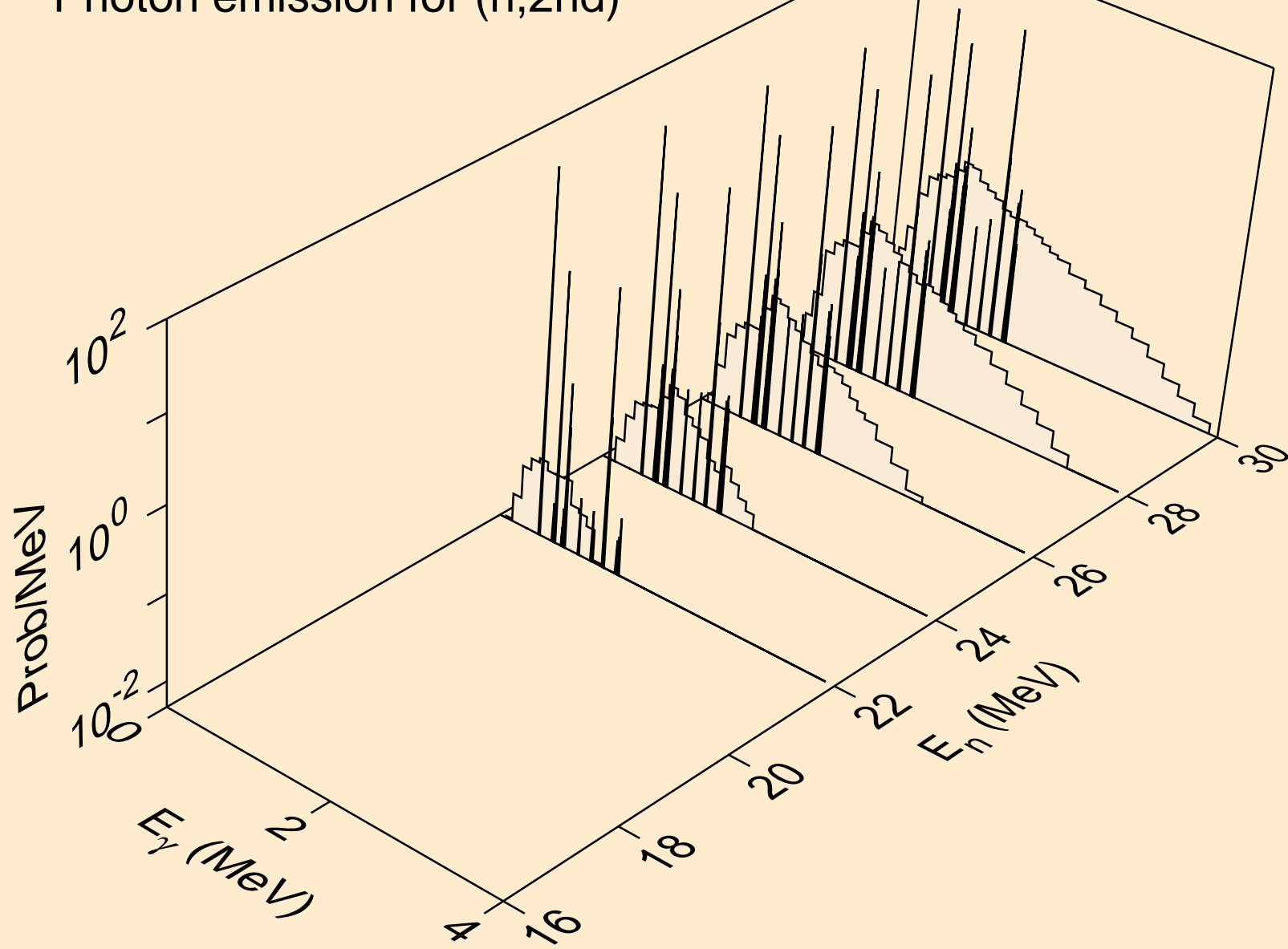

CD121M PROTON ACER TENDL-2021 LIBRARY; T=0.K
Photon emission for (n,2n)

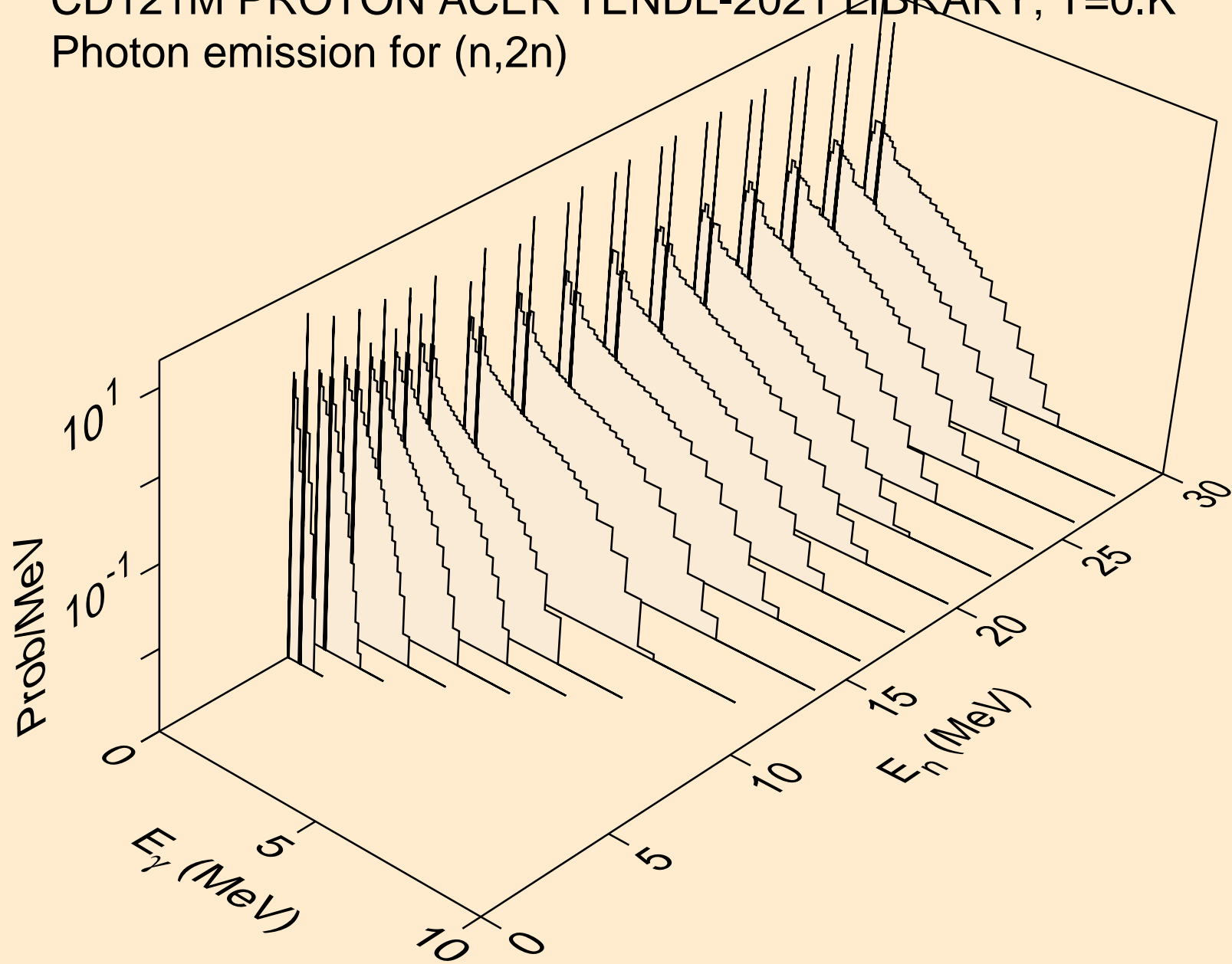

CD121M PROTON ACER TENDL-2021 LIBRARY; T=0.K
Photon emission for (n,3n)

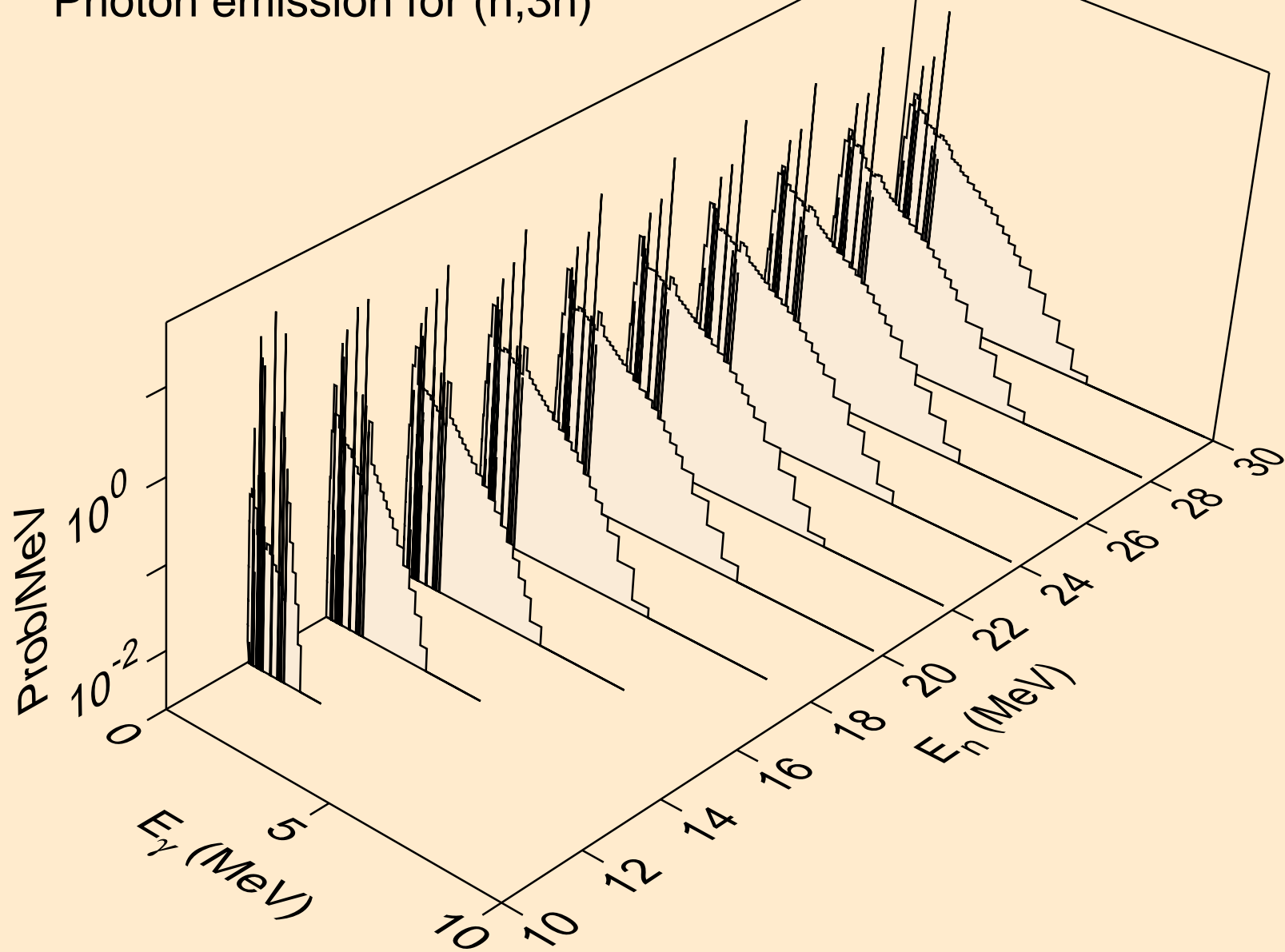

CD121M PROTON ACER TENDL-2021 LIBRARY; T=0.K
Photon emission for (n,n*)a

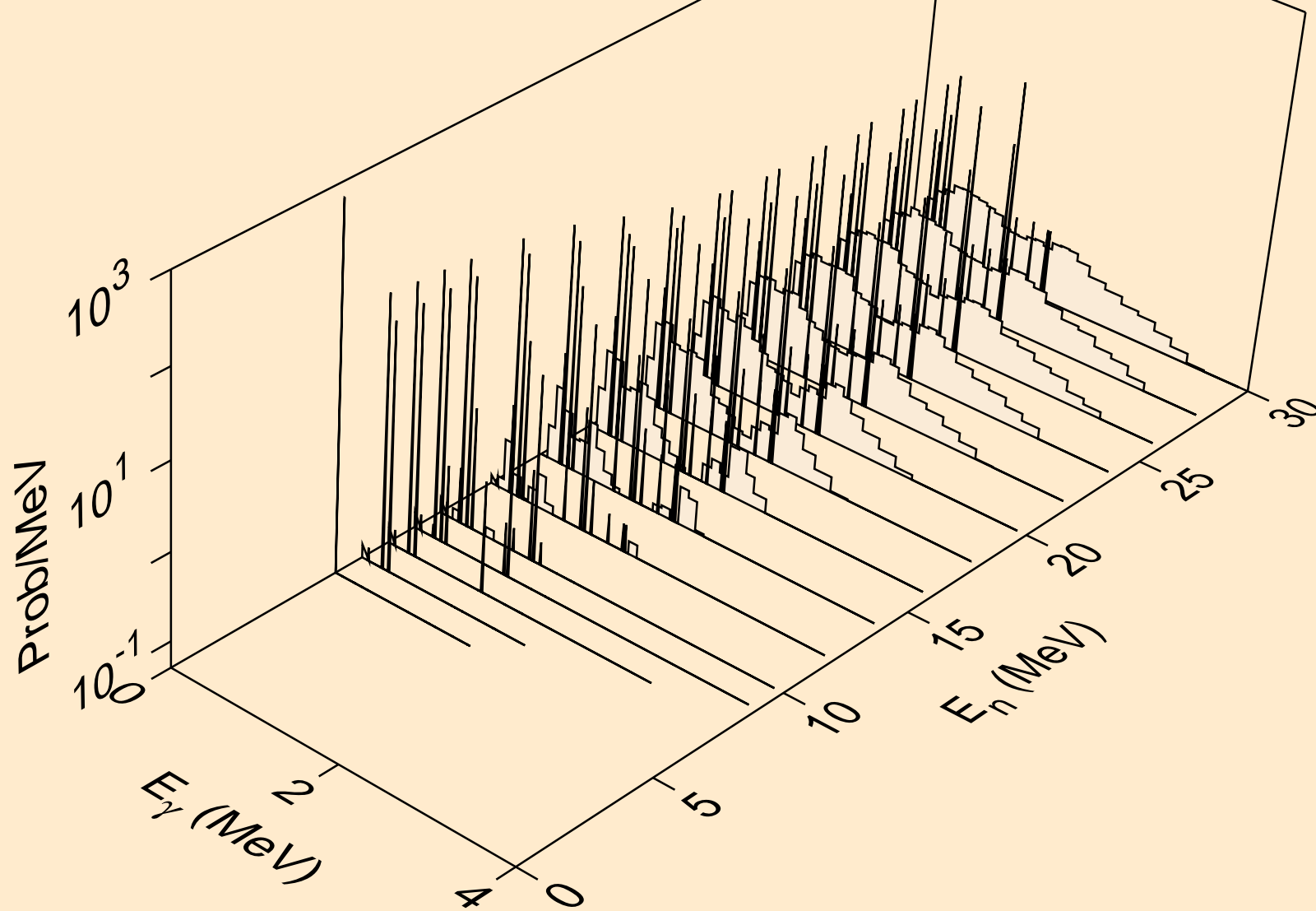

CD121M PROTON ACER TENDL-2021 LIBRARY; T=0.K
Photon emission for (n,2n)a

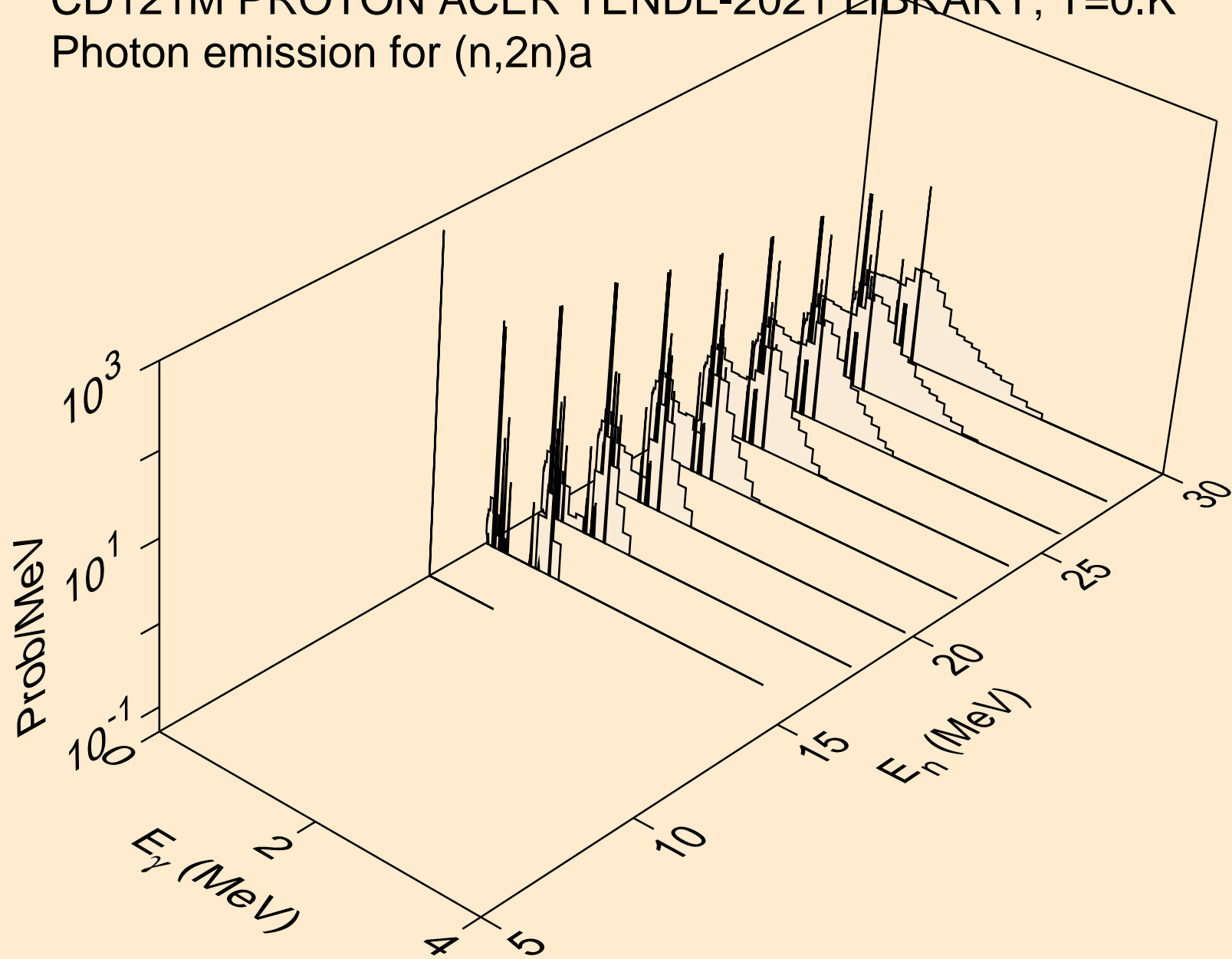

CD121M PROTON ACER TENDL-2021 LIBRARY; T=0.K
Photon emission for (n,3n)a

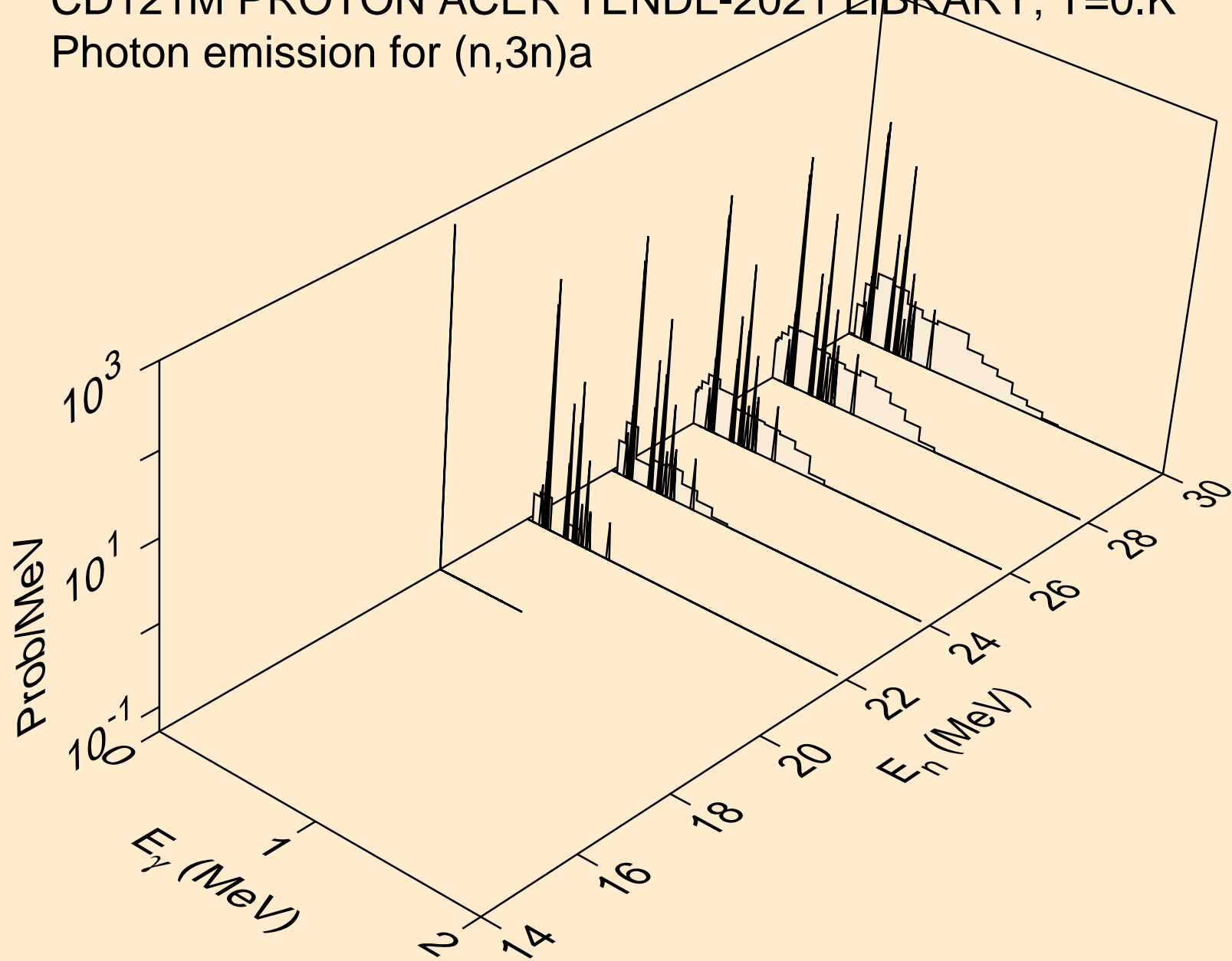

CD121M PROTON ACER TENDL-2021 LIBRARY; T=0.K
Photon emission for (n,n*)p

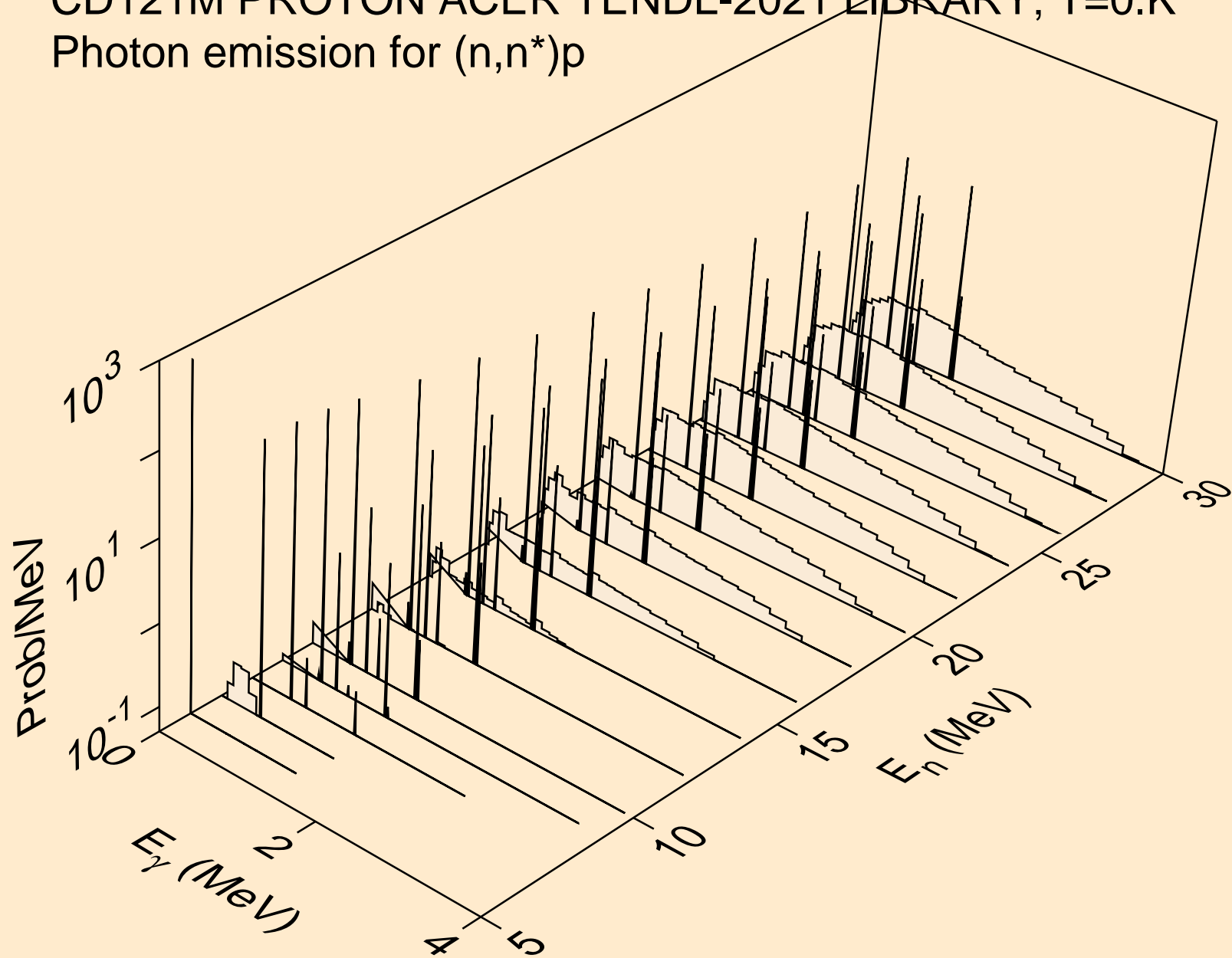

CD121M PROTON ACER TENDL-2021 LIBRARY; T=0.K
Photon emission for (n,n*)d

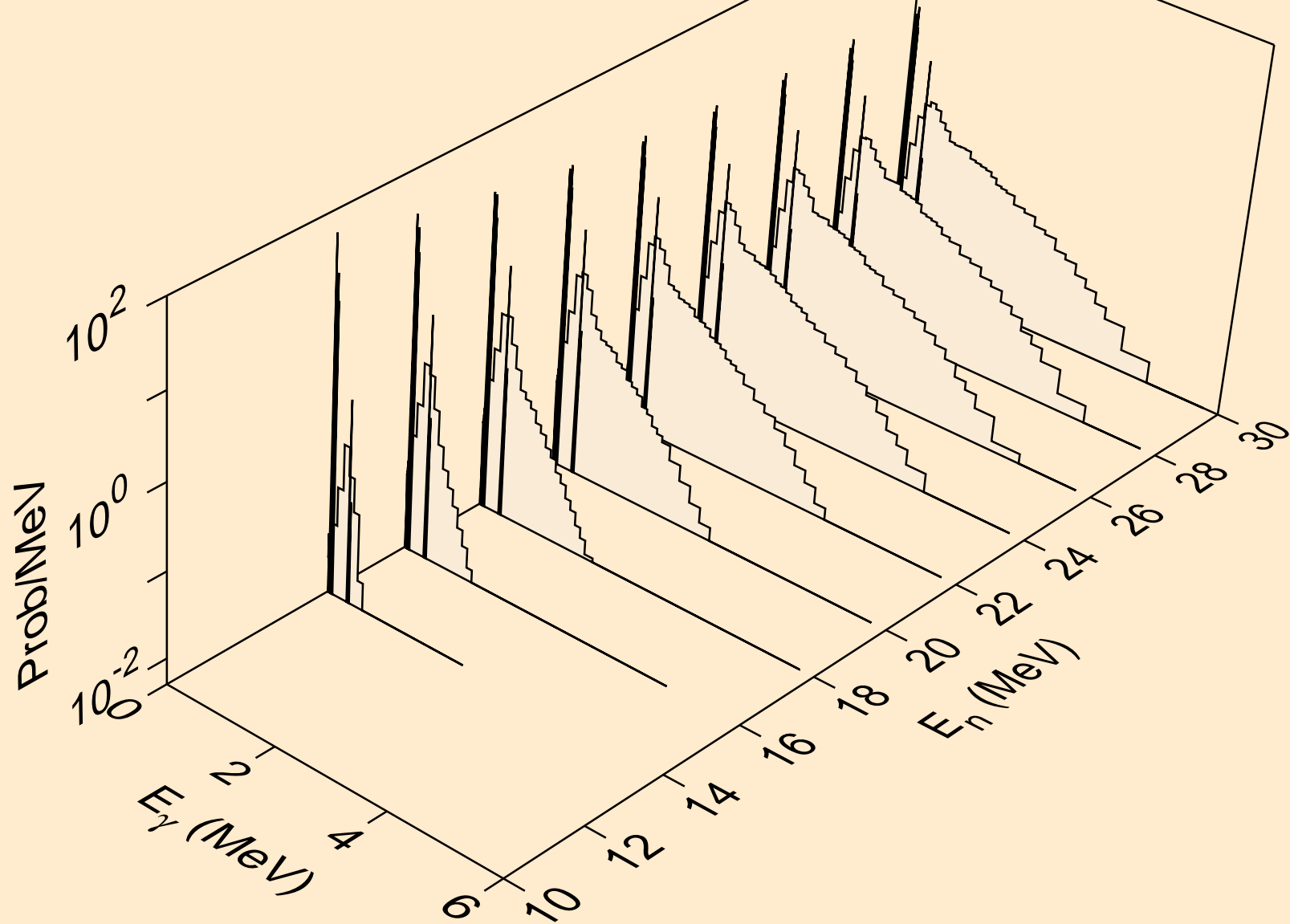

CD121M PROTON ACER TENDL-2021 LIBRARY; T=0.K
Photon emission for (n,n*)t

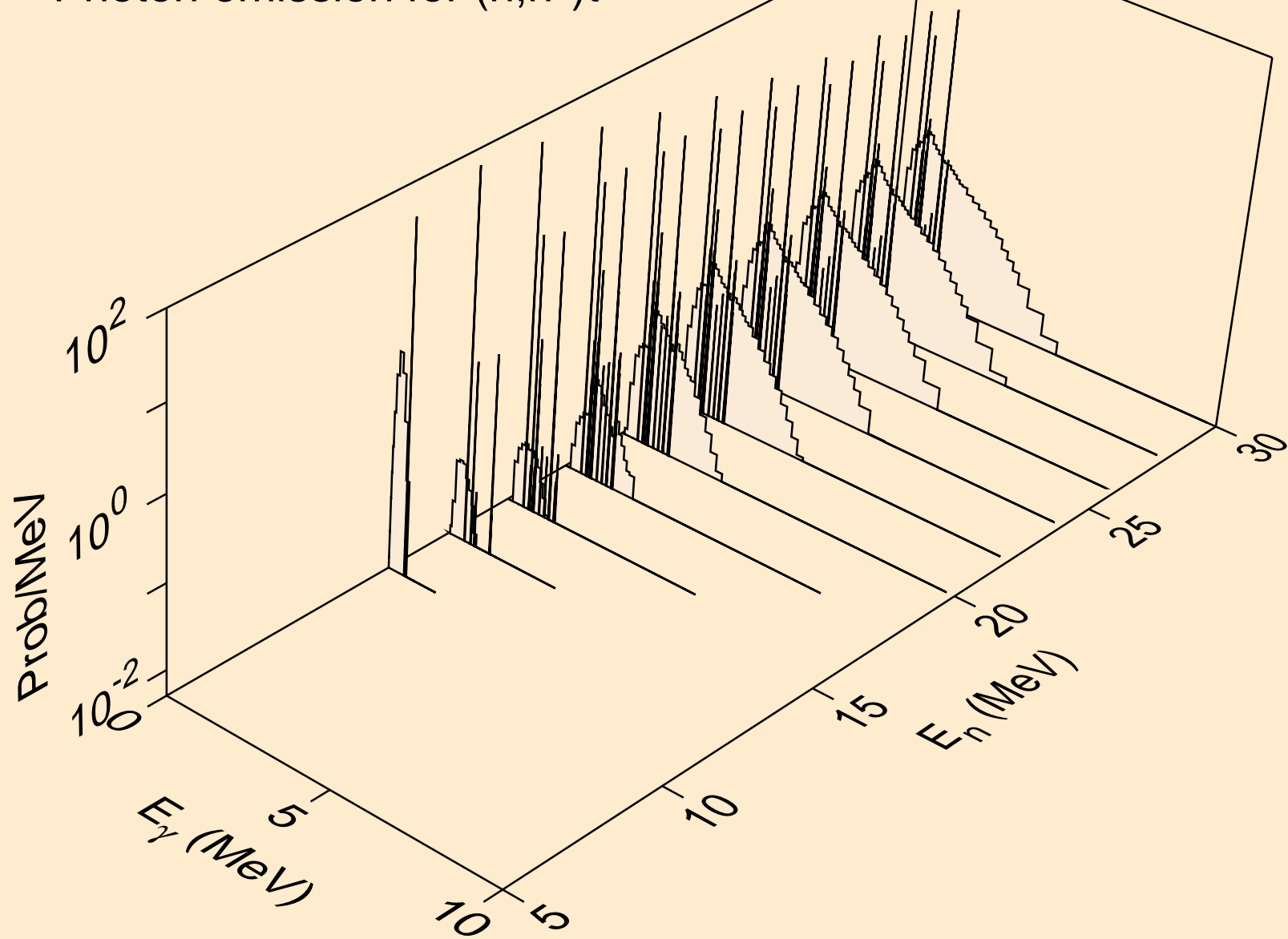

CD121M PROTON ACER TENDL-2021 LIBRARY; T=0.K
Photon emission for (n,n*)he3

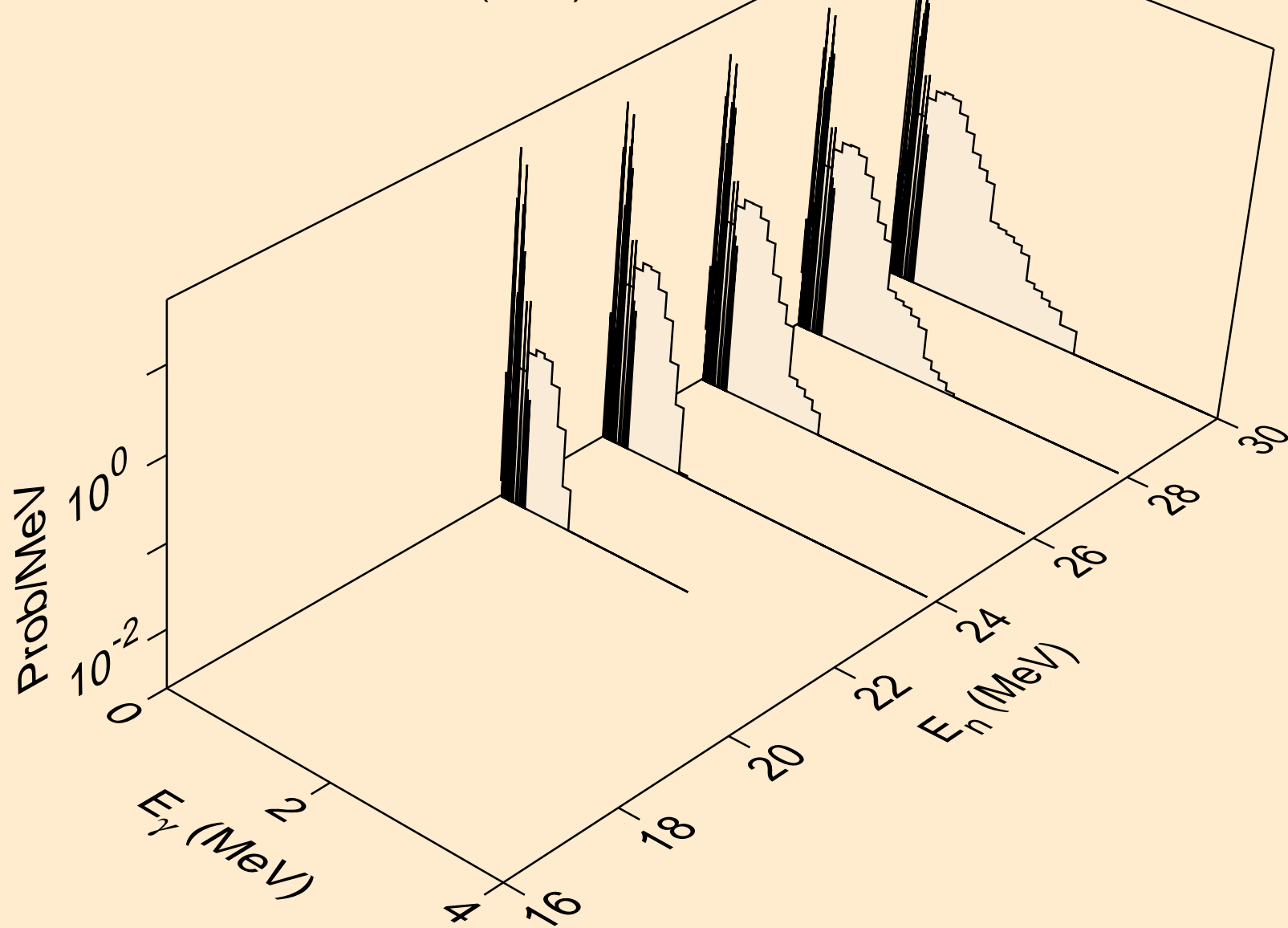

CD121M PROTON ACER TENDL-2021 LIBRARY; T=0.K
Photon emission for (n,4n)

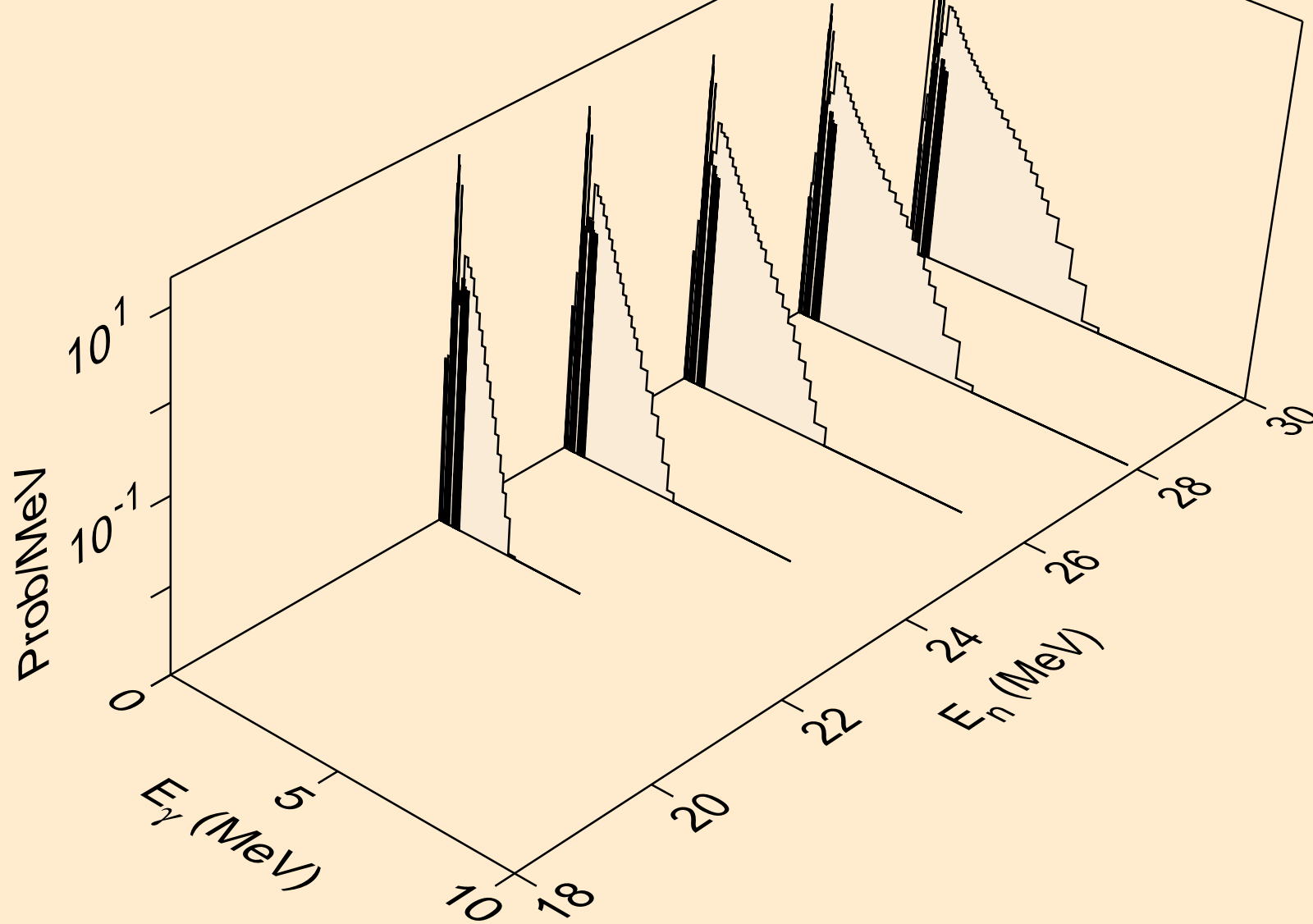

CD121M PROTON ACER TENDL-2021 LIBRARY; T=0.K
Photon emission for (n,2np)

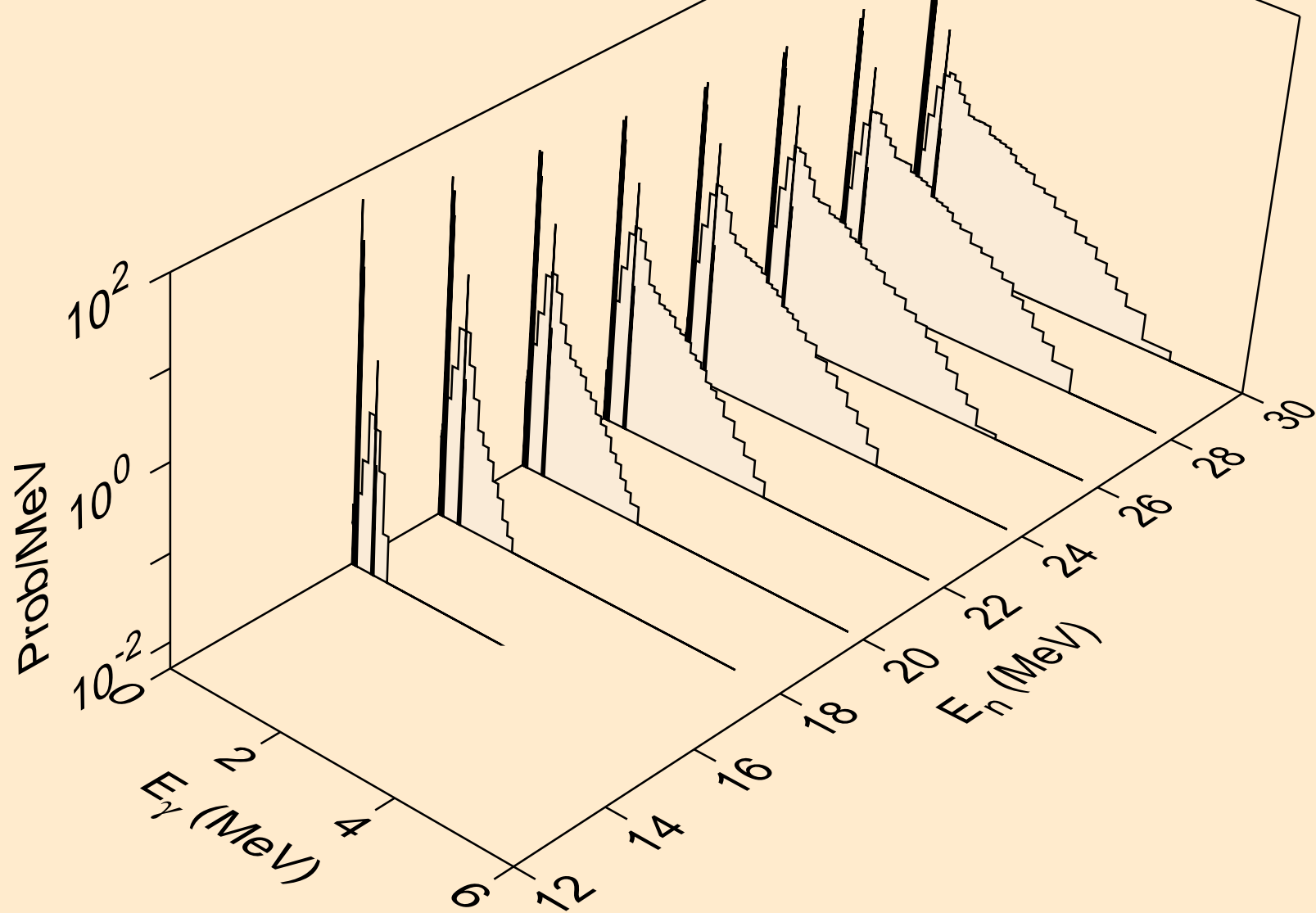

CD121M PROTON ACER TENDL-2021 LIBRARY; T=0.K
Photon emission for (n,3np)

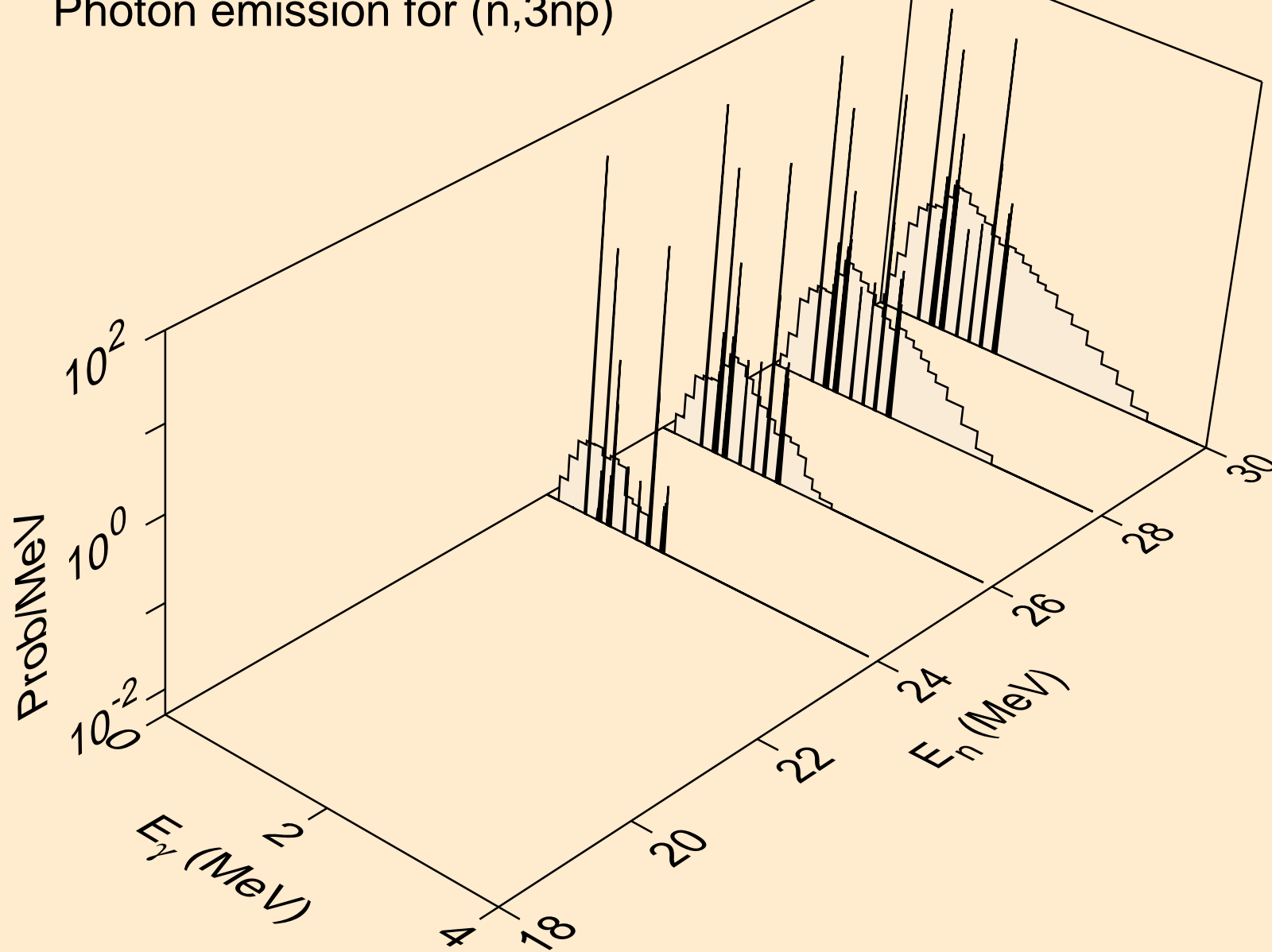

CD121M PROTON ACER TENDL-2021 LIBRARY; T=0.K
Photon emission for (n,2np)

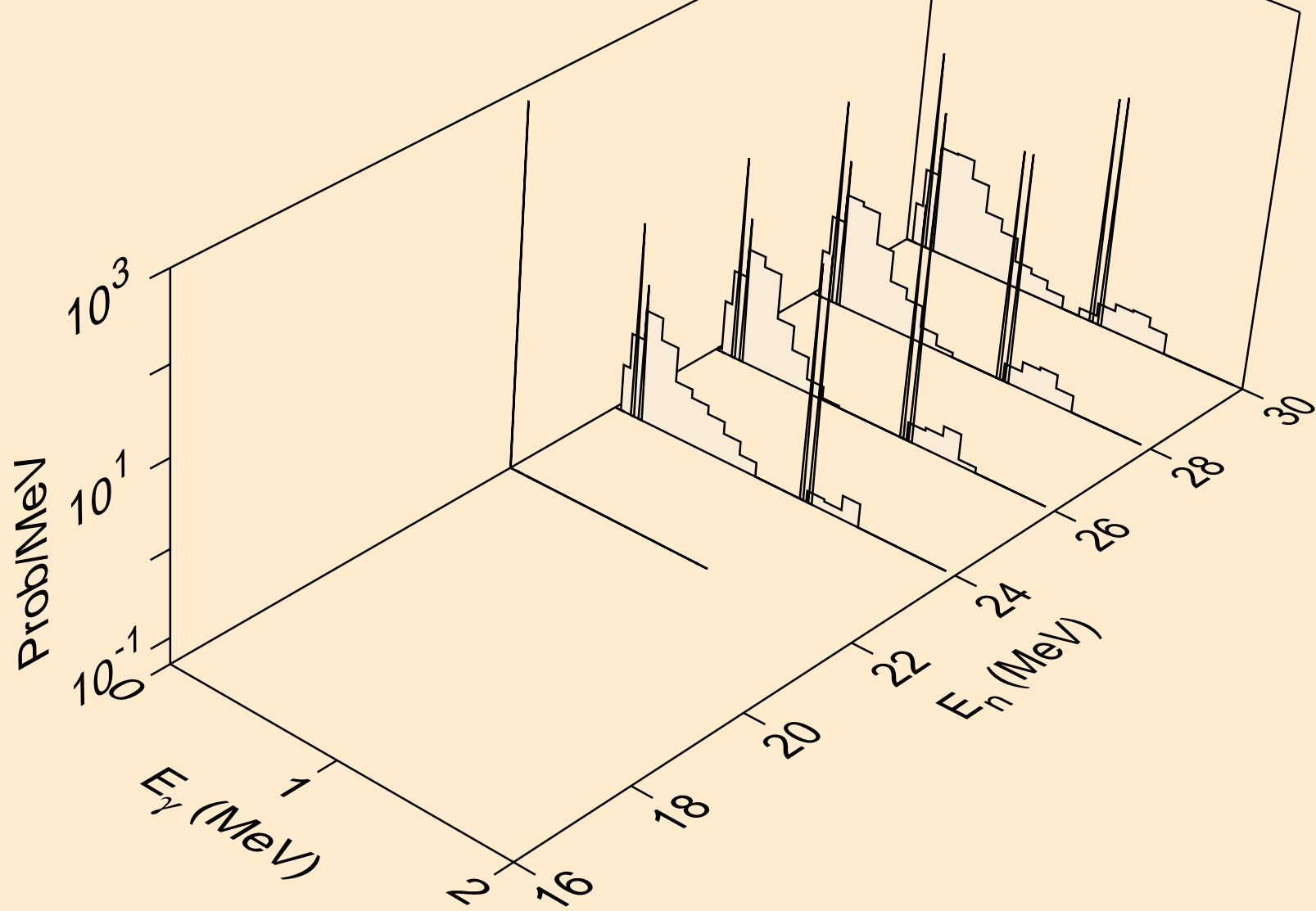

CD121M PROTON ACER TENDL-2021 LIBRARY; T=0.K
Photon emission for (n,npa)

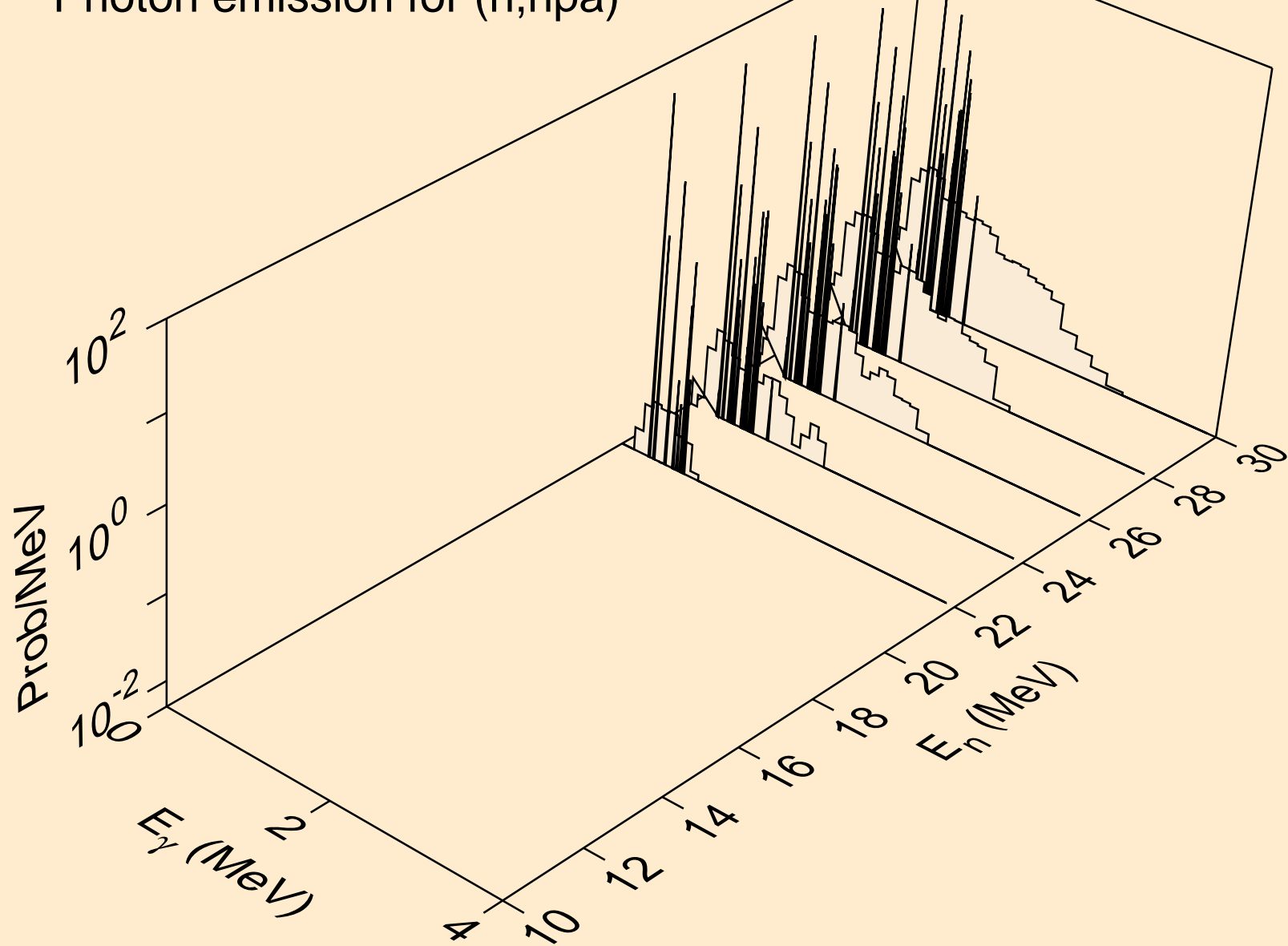

CD121M PROTON ACER TENDL-2021 LIBRARY; T=0.K
Photon emission for (n,gma)

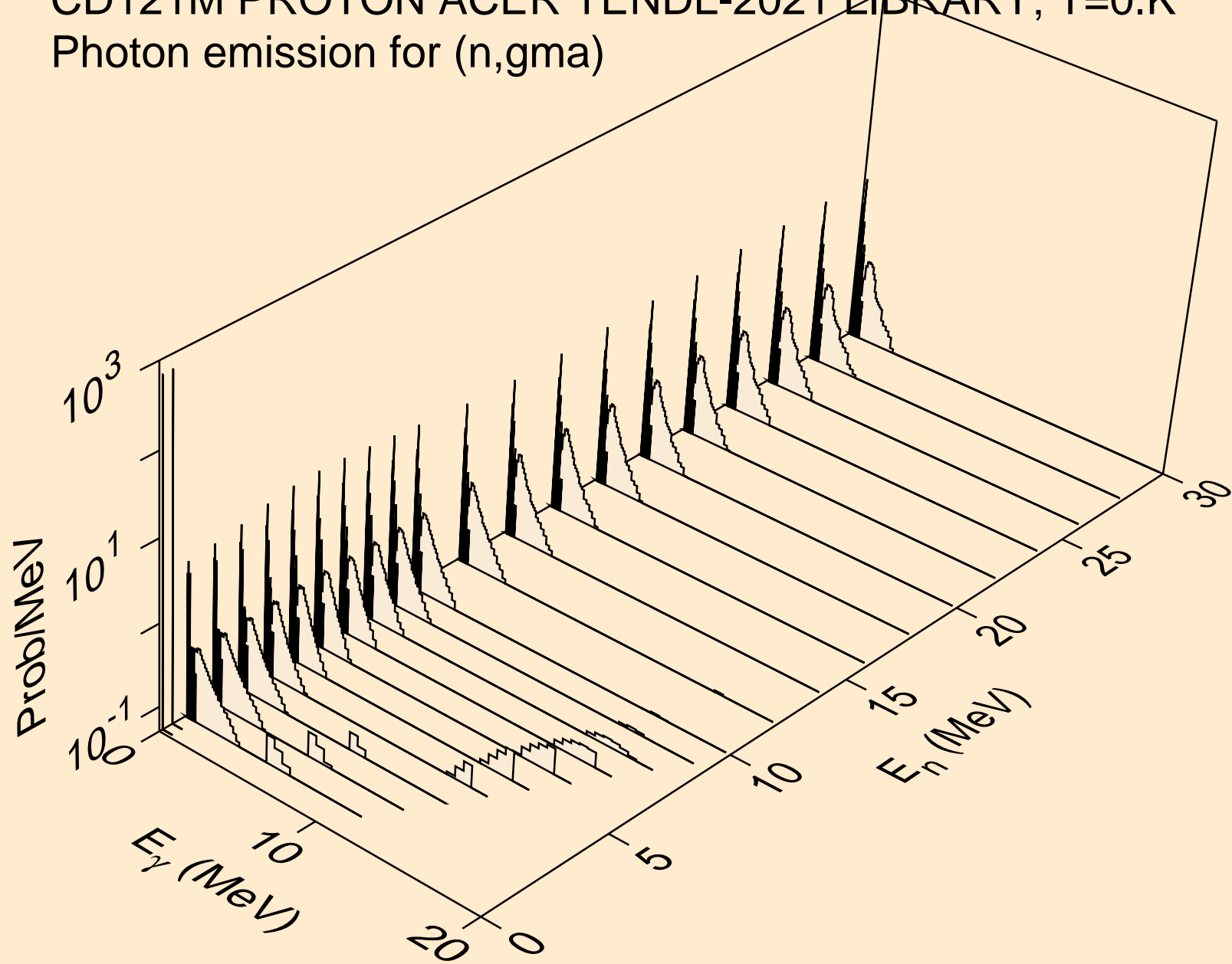

CD121M PROTON ACER TENDL-2021 LIBRARY; T=0.K
Photon emission for inelastic

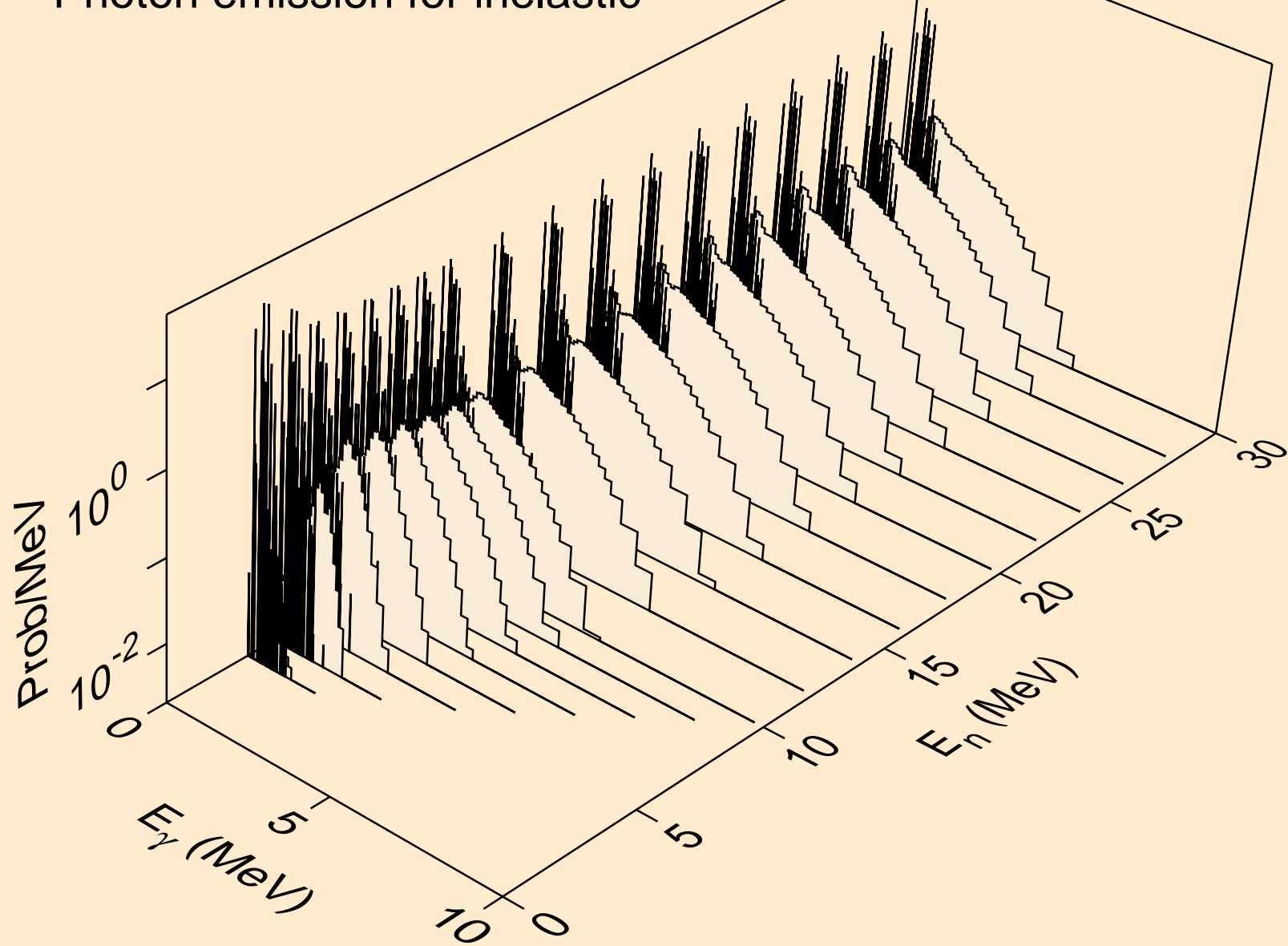

CD121M PROTON ACER TENDL-2021 LIBRARY; T=0.K
Photon emission for (n,d)

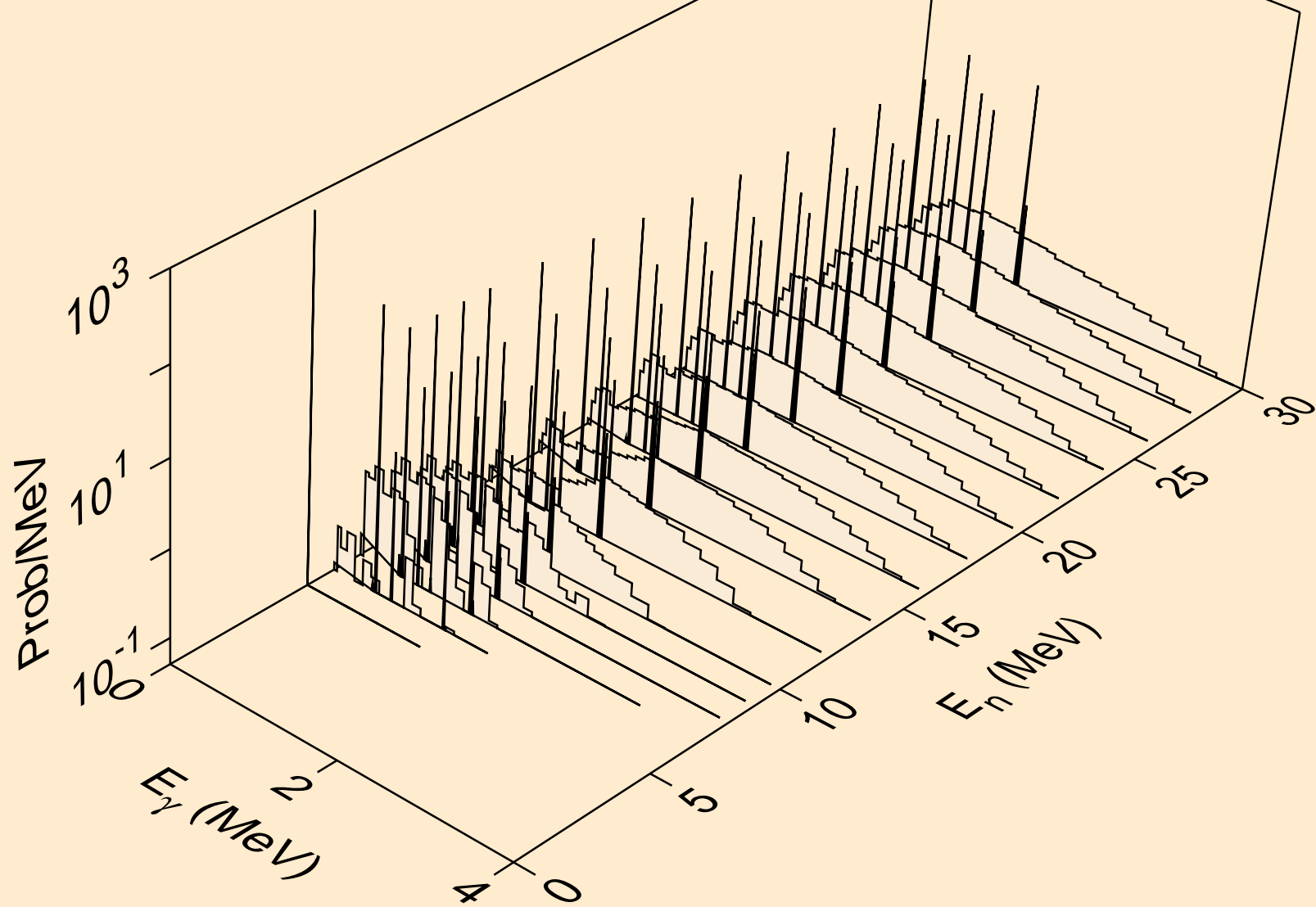

CD121M PROTON ACER TENDL-2021 LIBRARY; T=0.K
Photon emission for (n,t)

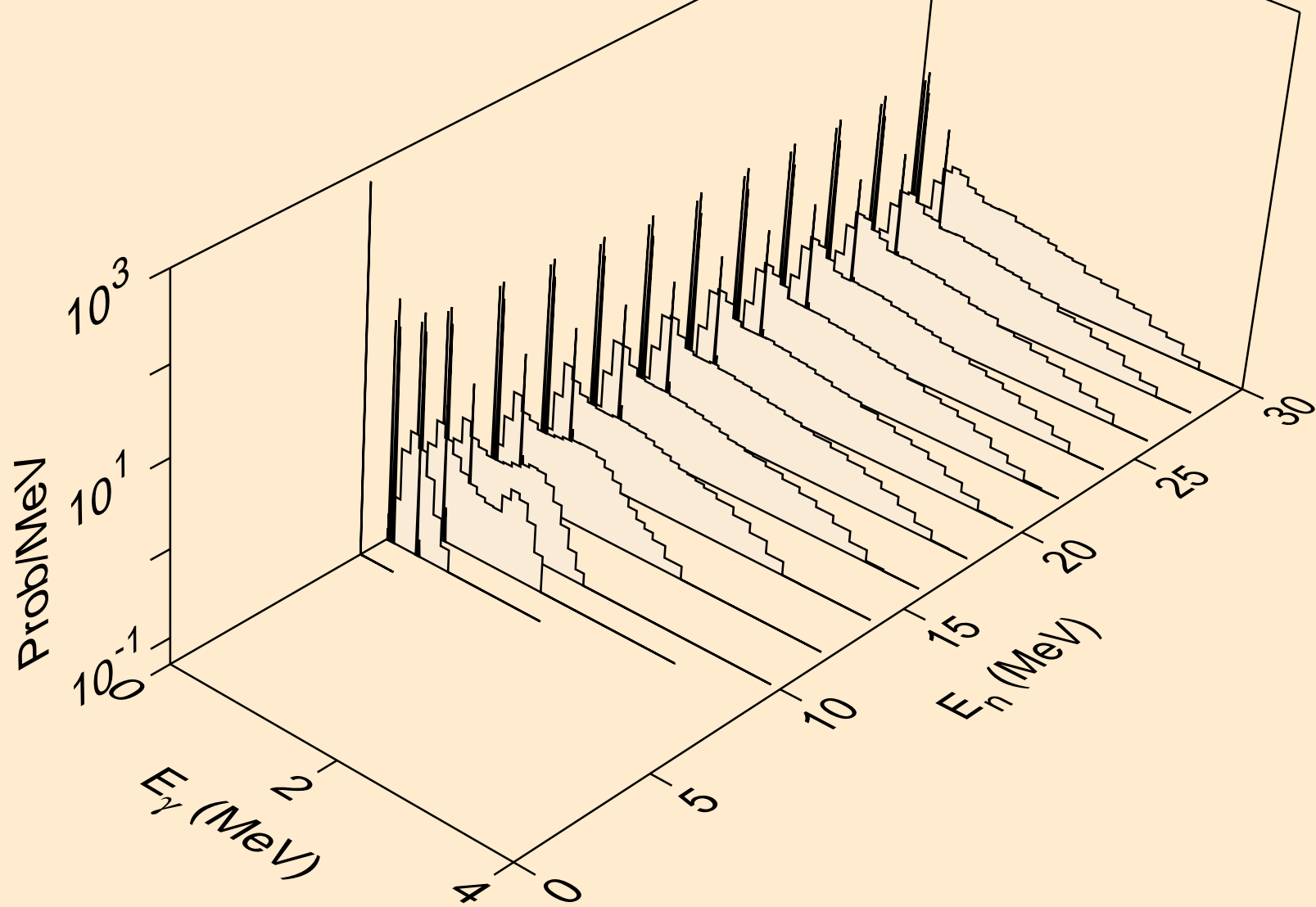

CD121M PROTON ACER TENDL-2021 LIBRARY; T=0.K
Photon emission for (n,he3)

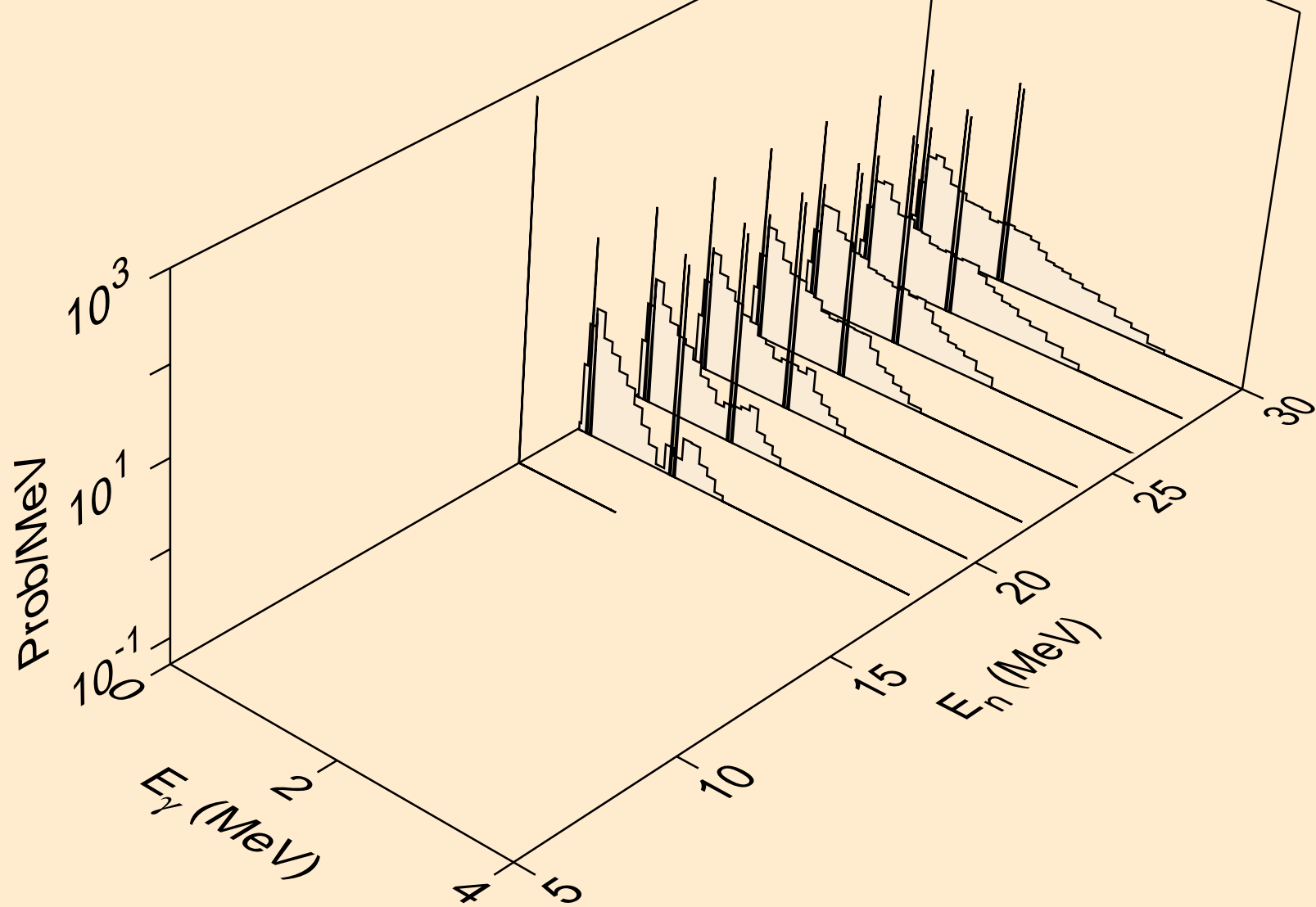

CD121M PROTON ACER TENDL-2021 LIBRARY; T=0.K
Photon emission for (n,a)

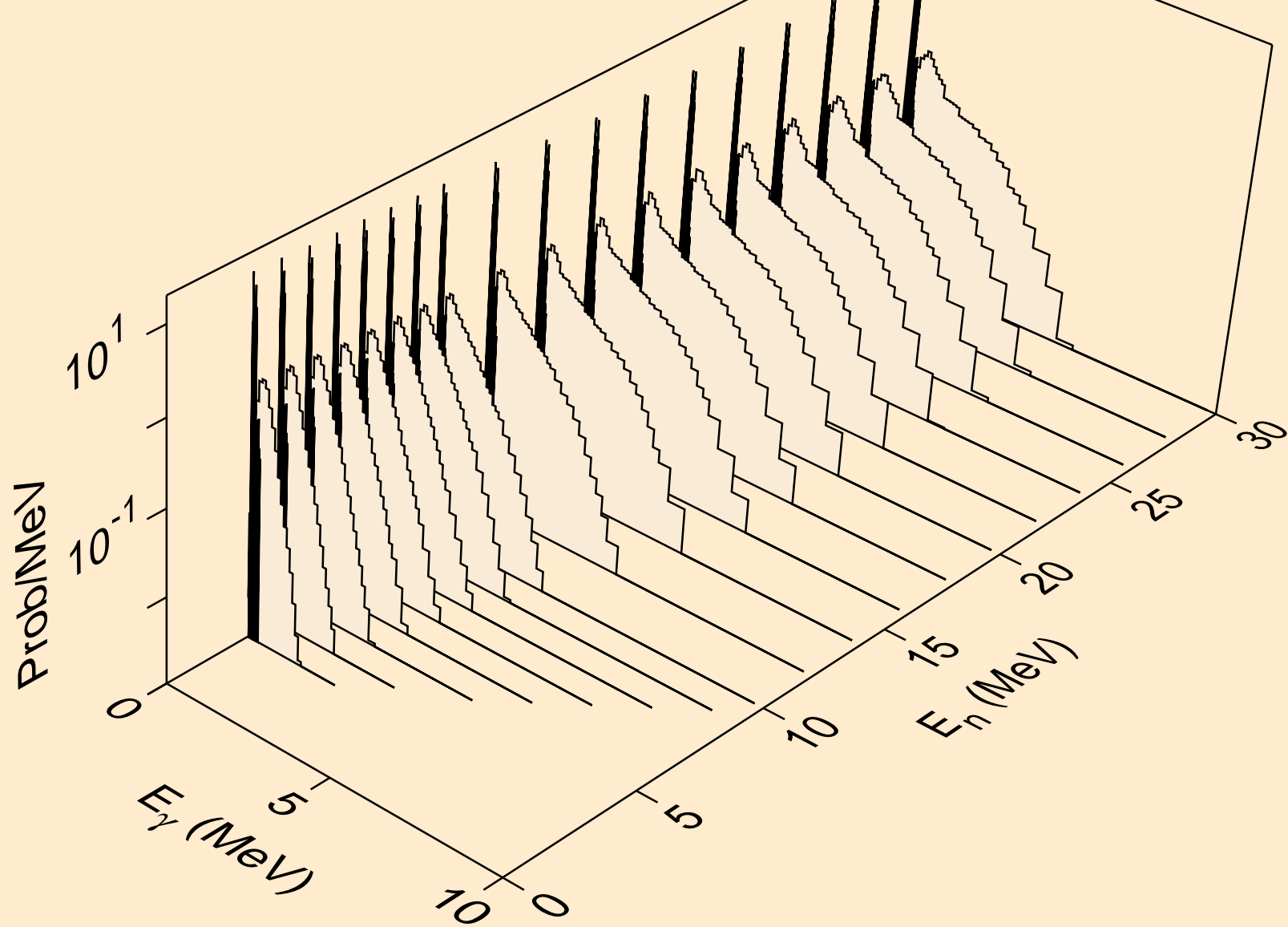

CD121M PROTON ACER TENDL-2021 LIBRARY; T=0.K
Photon emission for (n,2p)

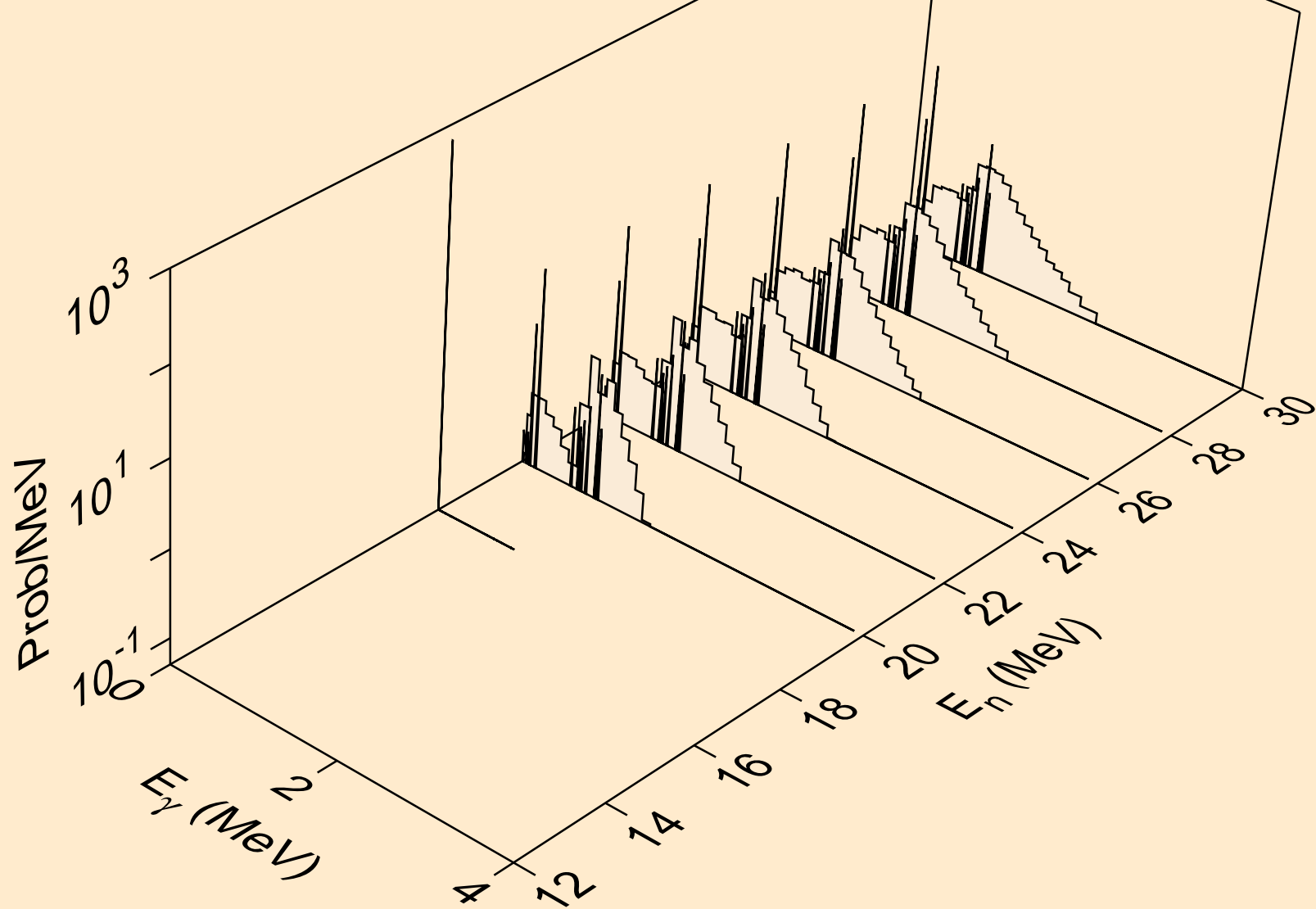

CD121M PROTON ACER TENDL-2021 LIBRARY; T=0.K
Photon emission for (n,pa)

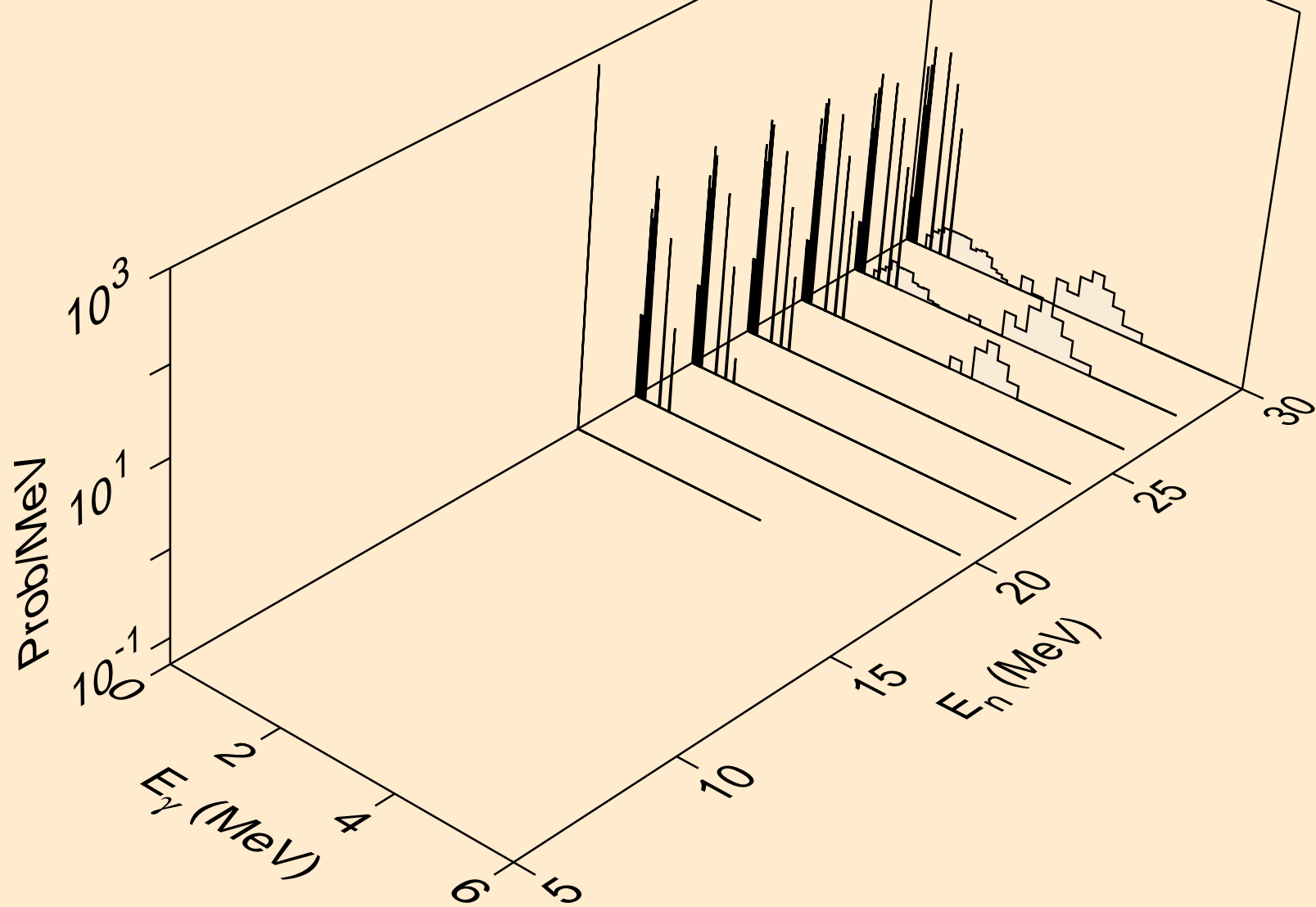

CD121M PROTON ACER TENDL-2021 LIBRARY; T=0.K

Particle heating contributions

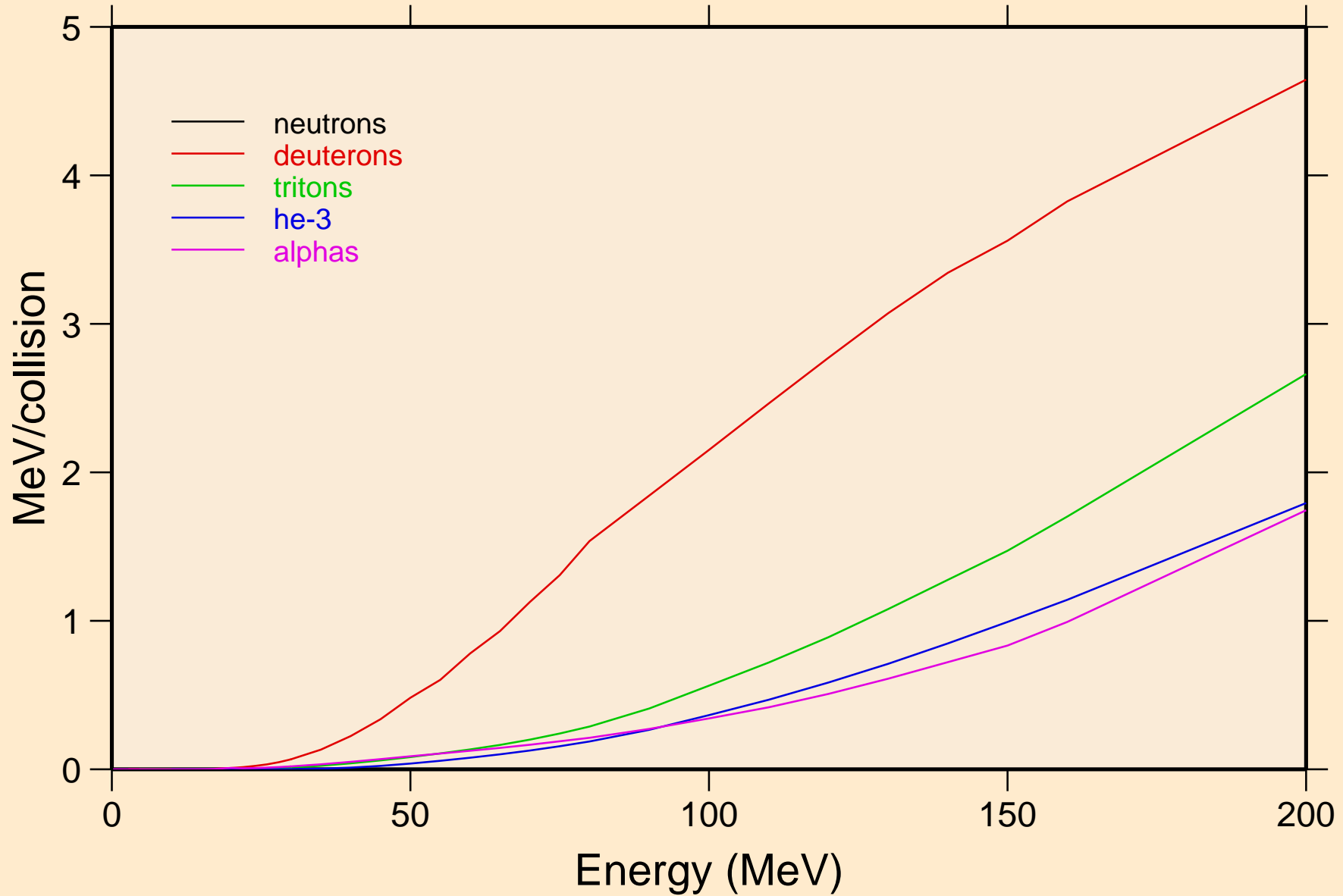

CD121M PROTON ACER TENDL-2021 LIBRARY; T=0.K
Recoil Heating

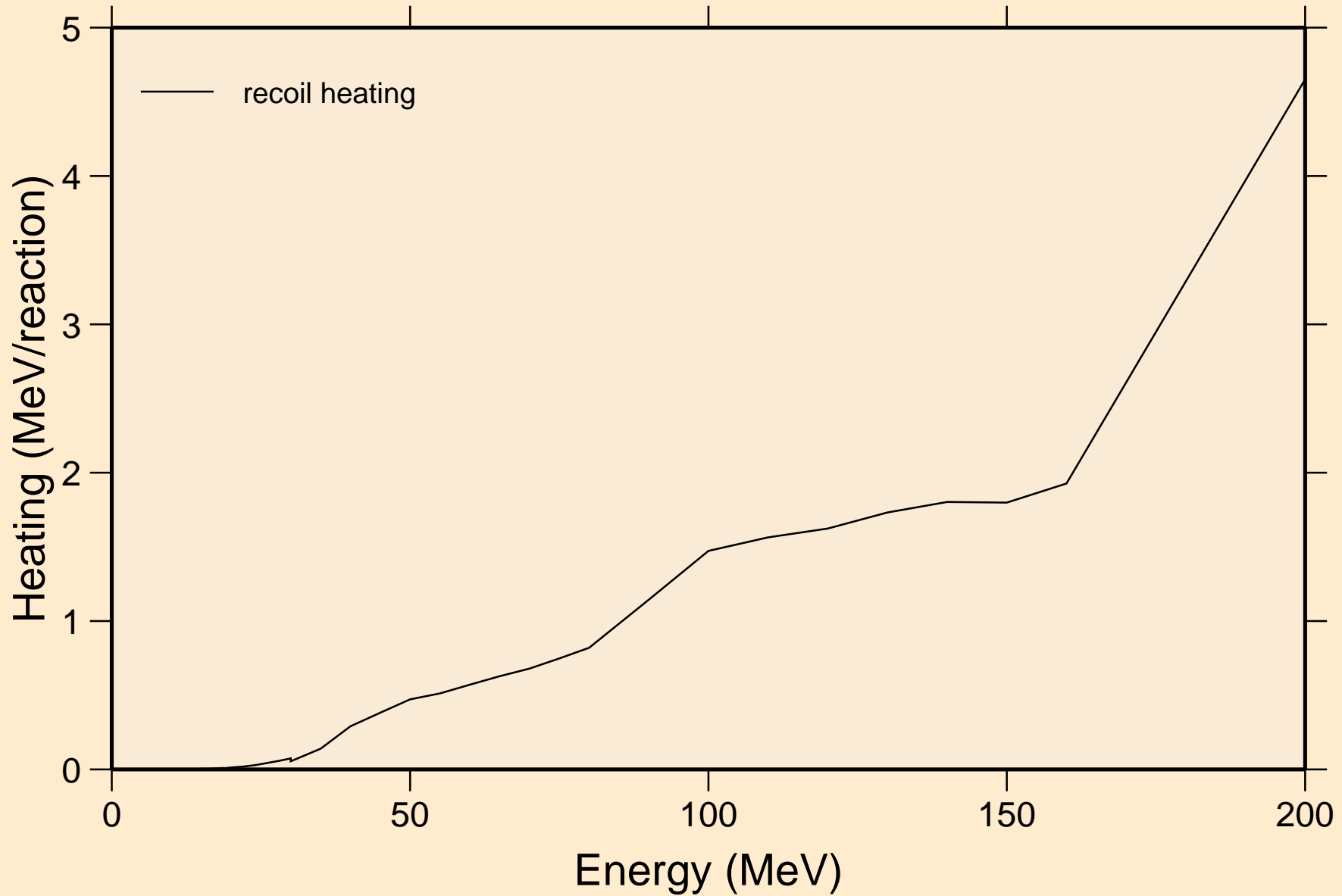

CD121M PROTON ACER TENDL-2021 LIBRARY; T=0.K

Particle production cross sections

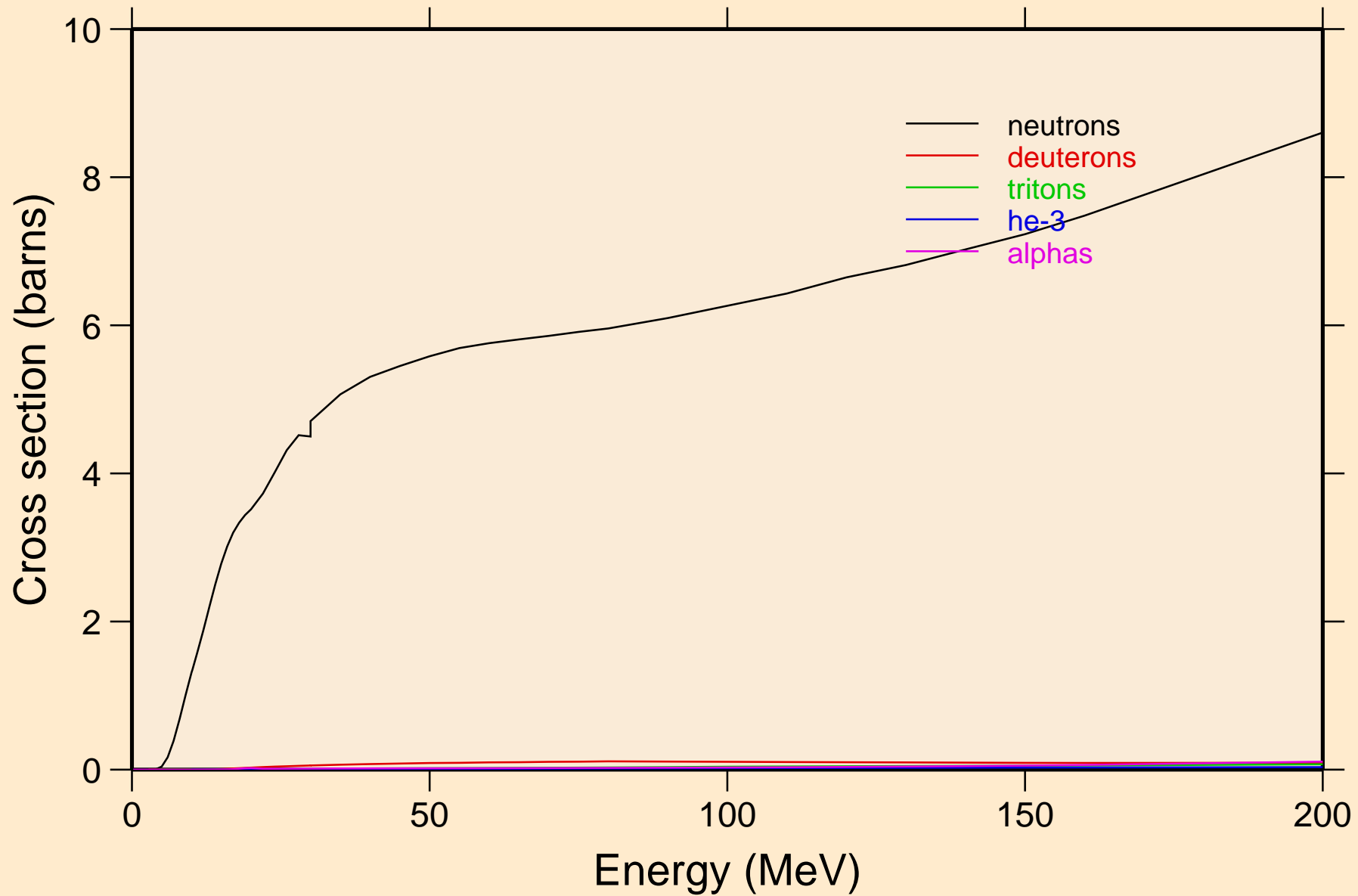

CD121M PROTON ACER TENDL-2021 LIBRARY; T=0.K
neutrons from (p,n)

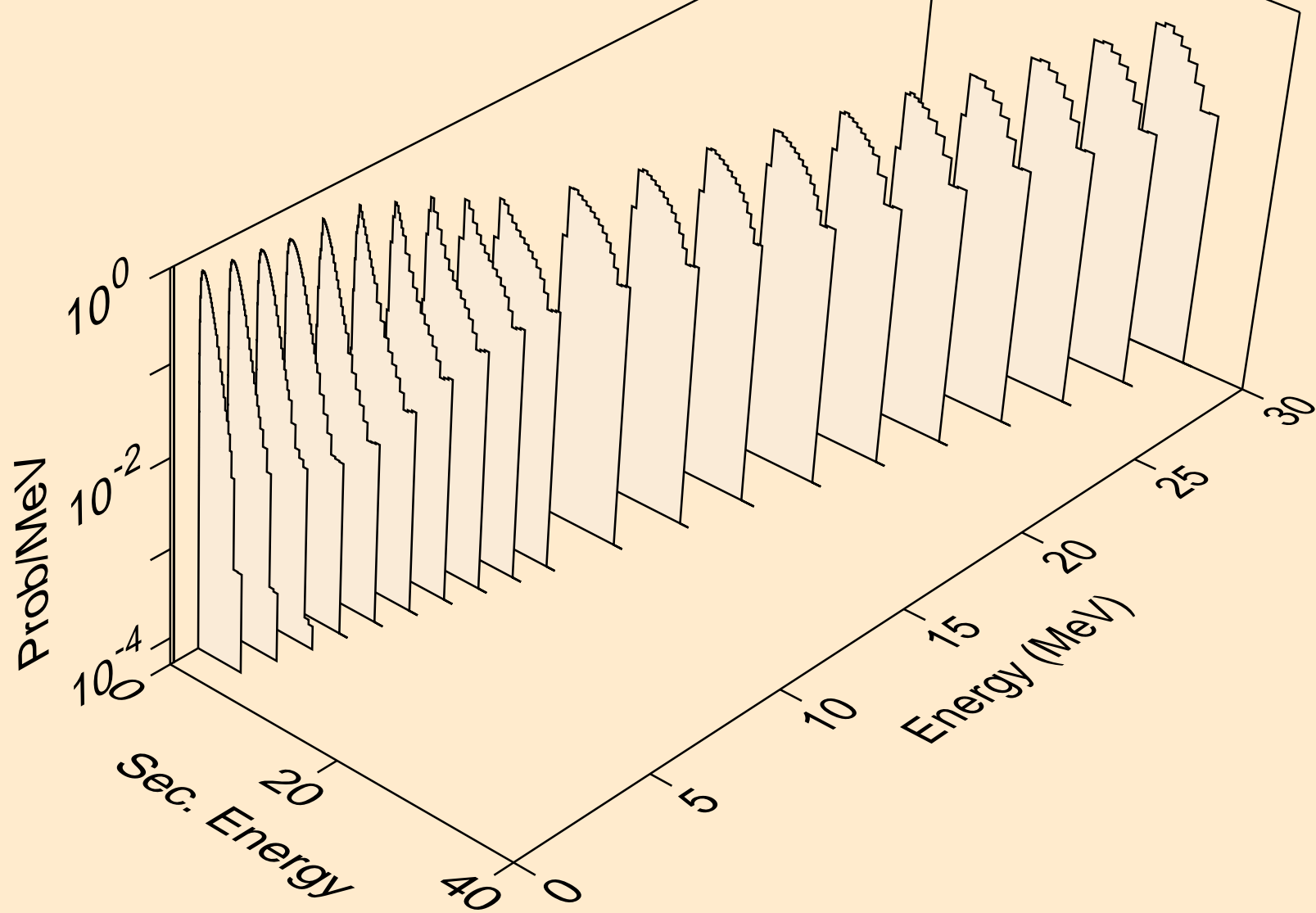

CD121M PROTON ACER TENDL-2021 LIBRARY; T=0.K
neutrons from (p,x)

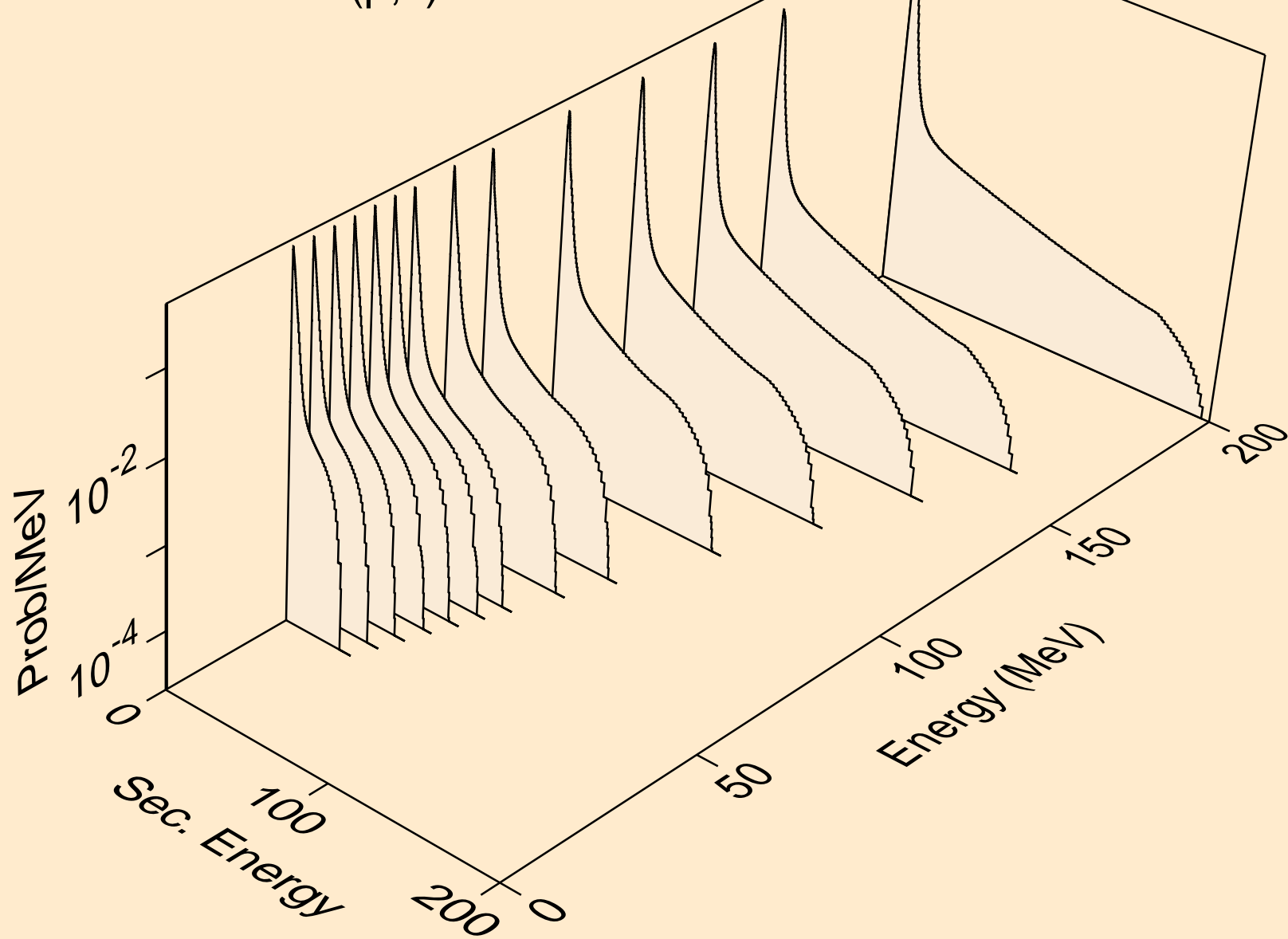

CD121M PROTON ACER TENDL-2021 LIBRARY; T=0.K
neutrons from (p,2nd)

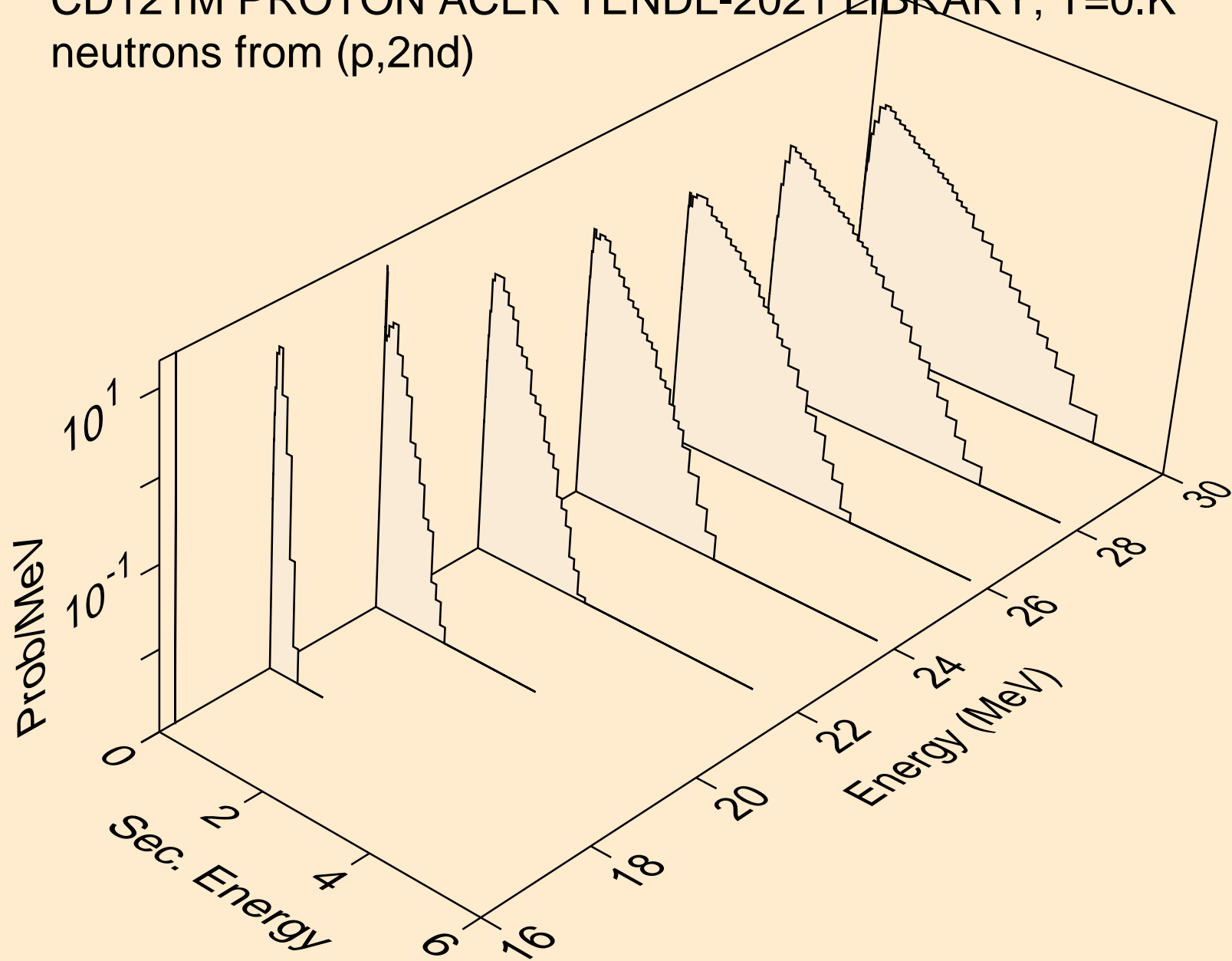

CD121M PROTON ACER TENDL-2021 LIBRARY; T=0.K
neutrons from (p,2n)

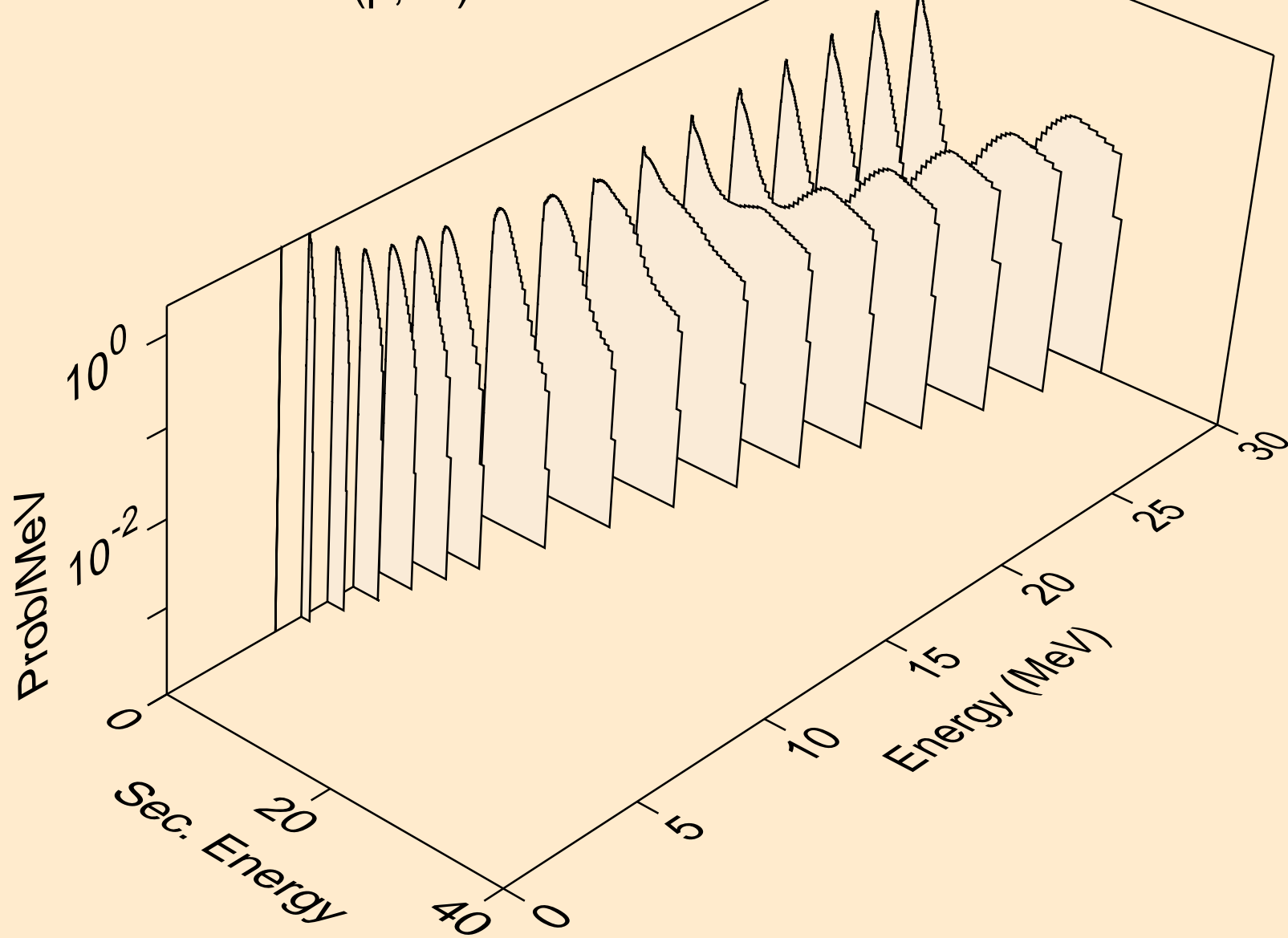

CD121M PROTON ACER TENDL-2021 LIBRARY; T=0.K
neutrons from (p,3n)

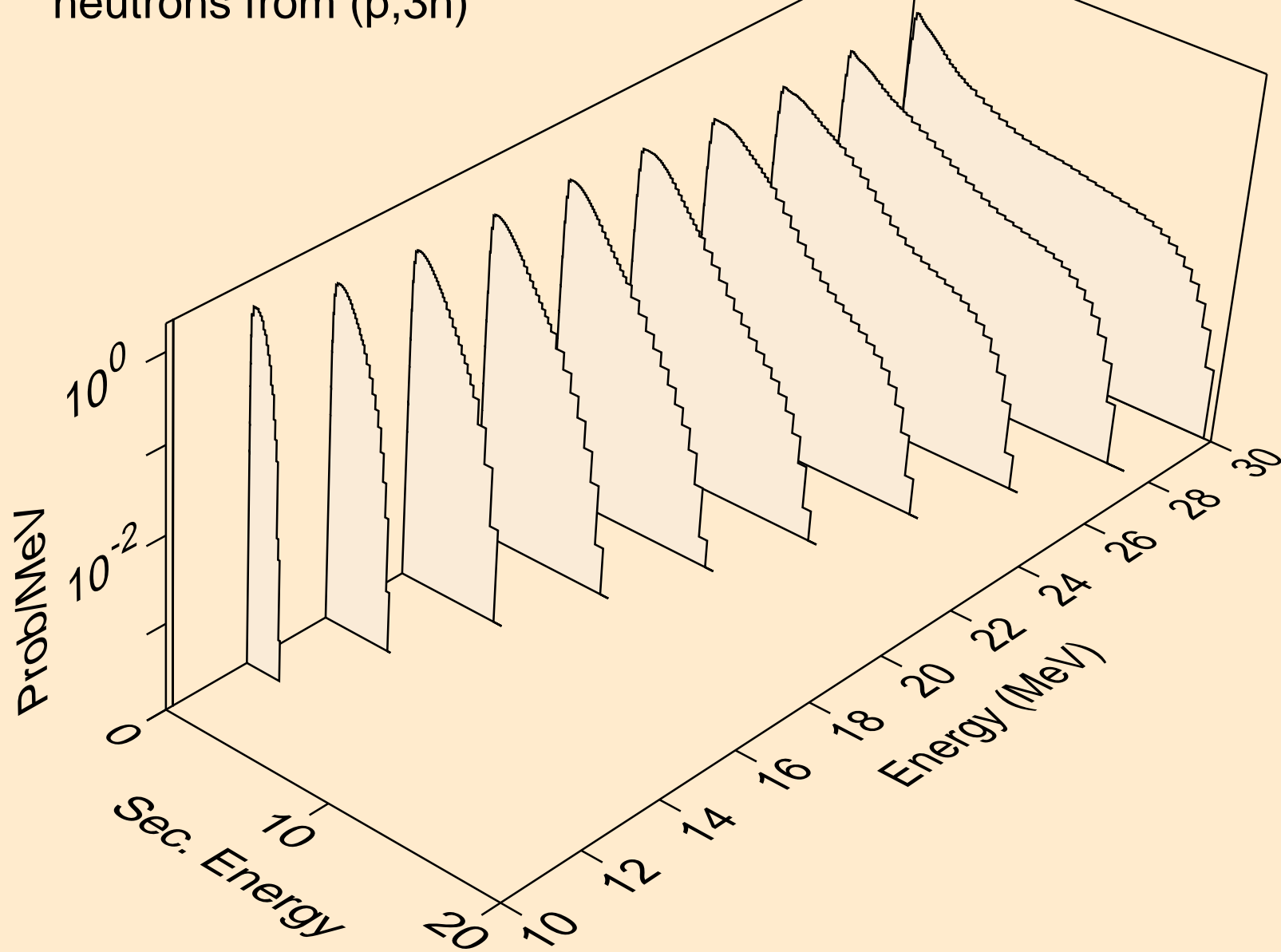

CD121M PROTON ACER TENDL-2021 LIBRARY; T=0.K
neutrons from (p,n*)a

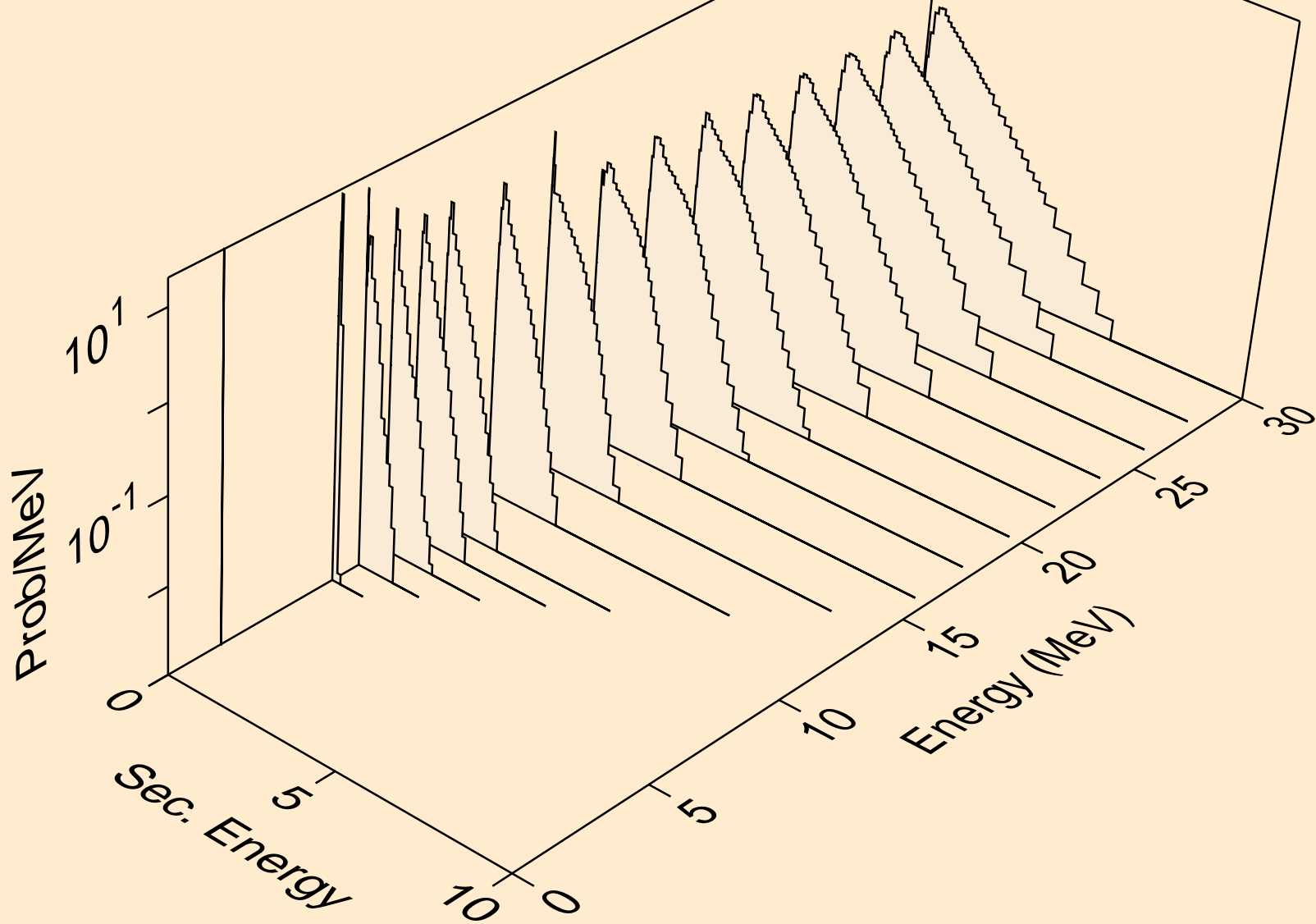

CD121M PROTON ACER TENDL-2021 LIBRARY; T=0.K
neutrons from (p,2n)a

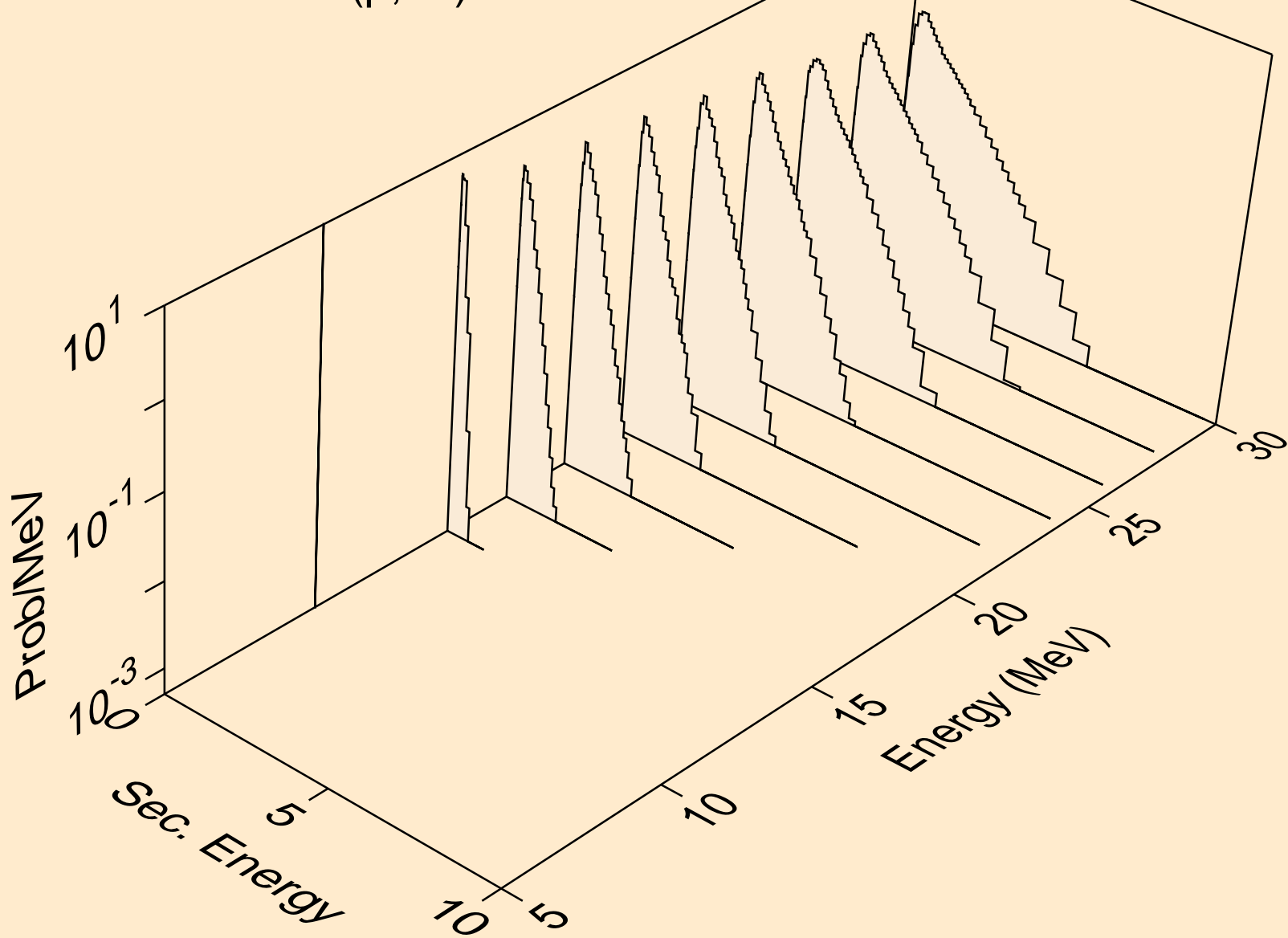

CD121M PROTON ACER TENDL-2021 LIBRARY; T=0.K
neutrons from (p,3n)a

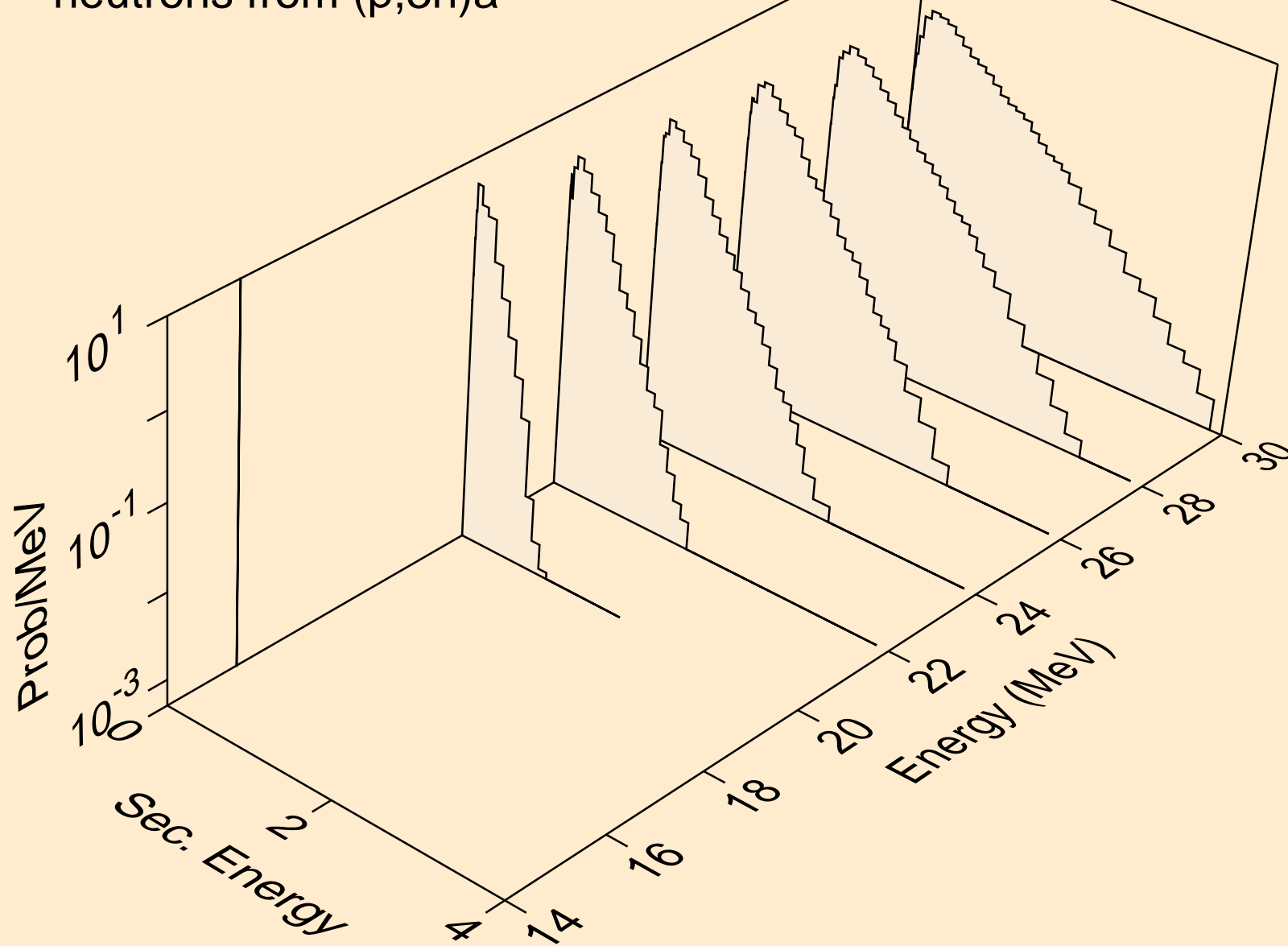

CD121M PROTON ACER TENDL-2021 LIBRARY; T=0.K
neutrons from (p,n*)p

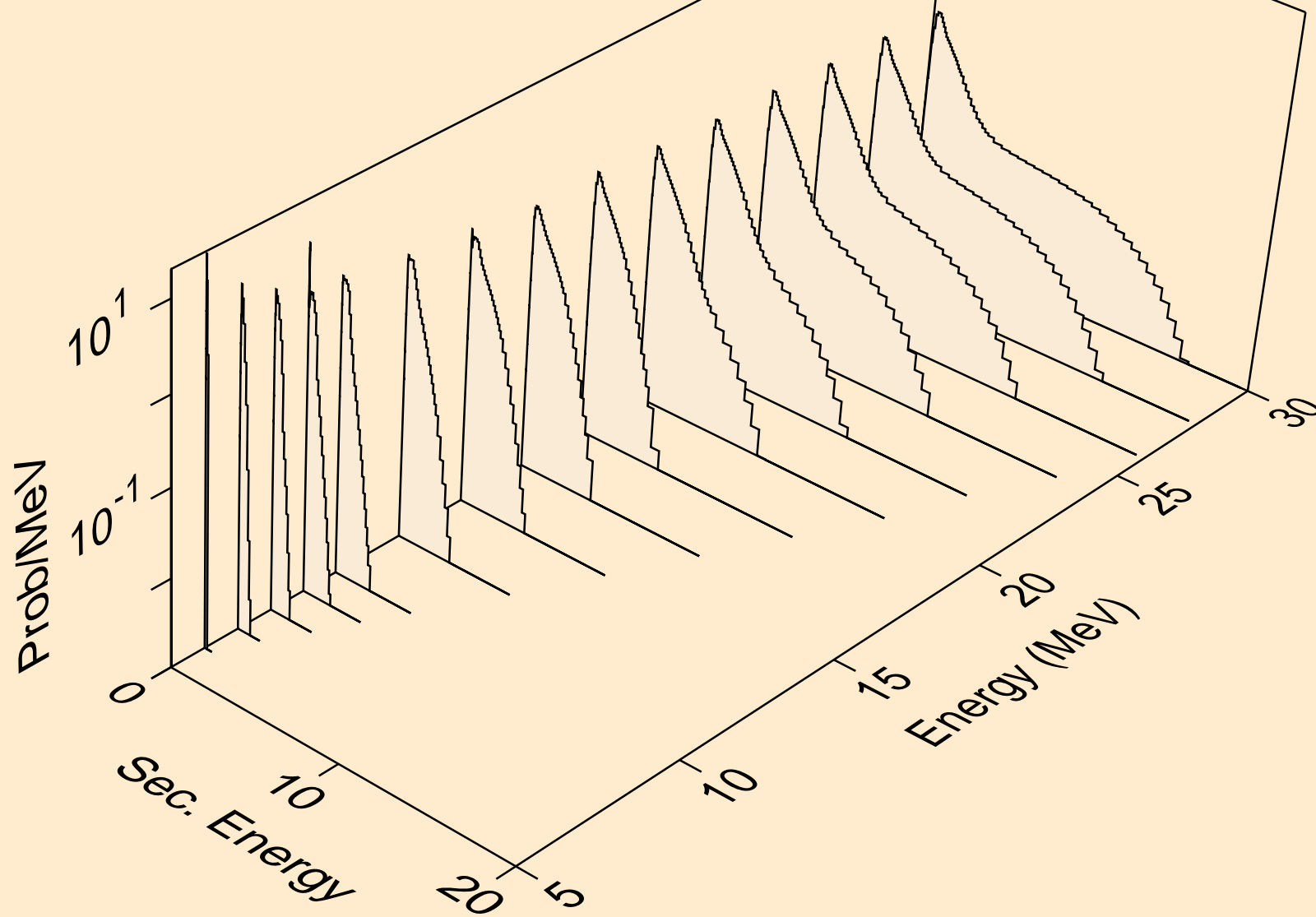

CD121M PROTON ACER TENDL-2021 LIBRARY; T=0.K
neutrons from (p,n*)d

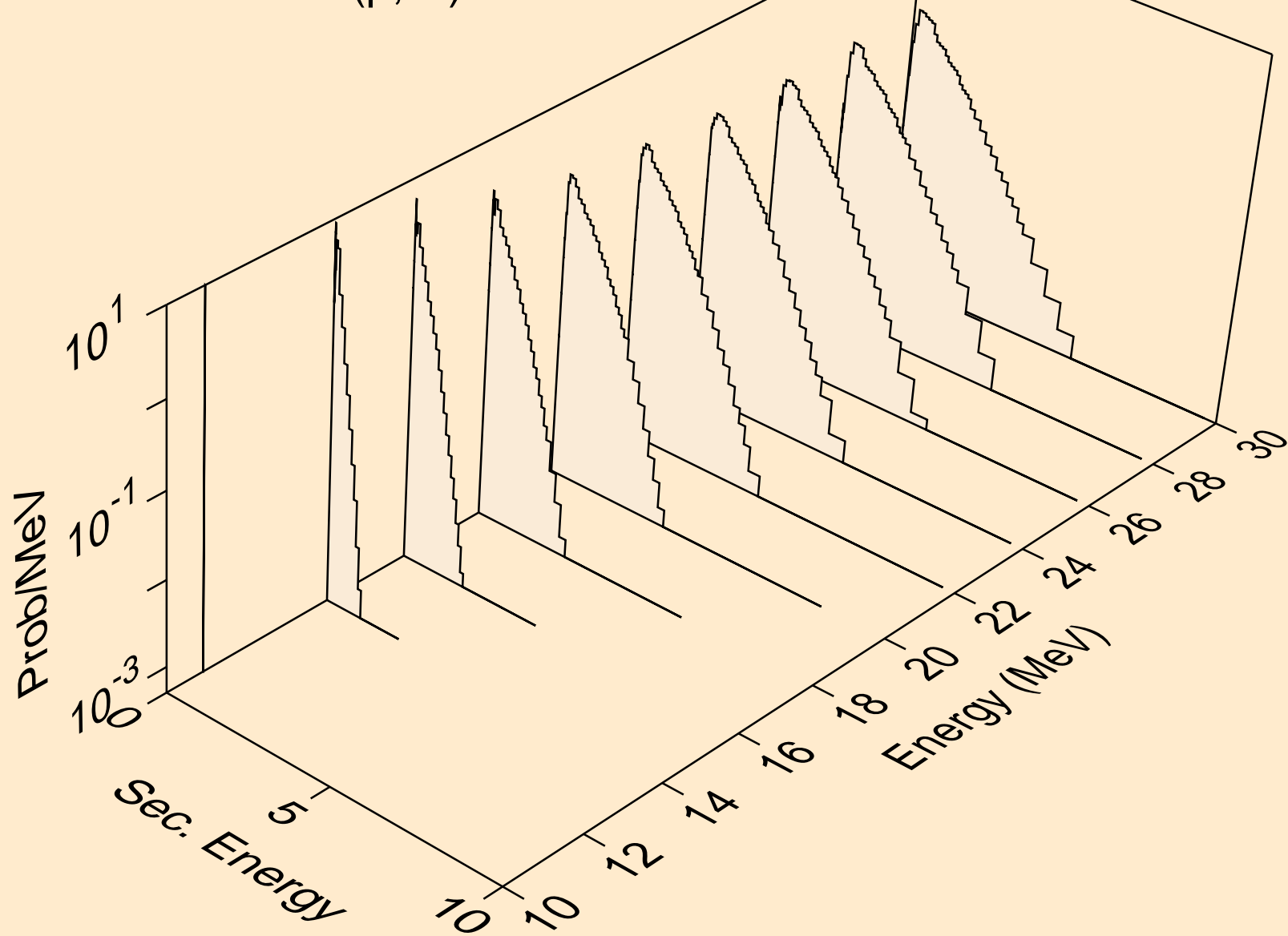

CD121M PROTON ACER TENDL-2021 LIBRARY; T=0.K
neutrons from (p,n*)t

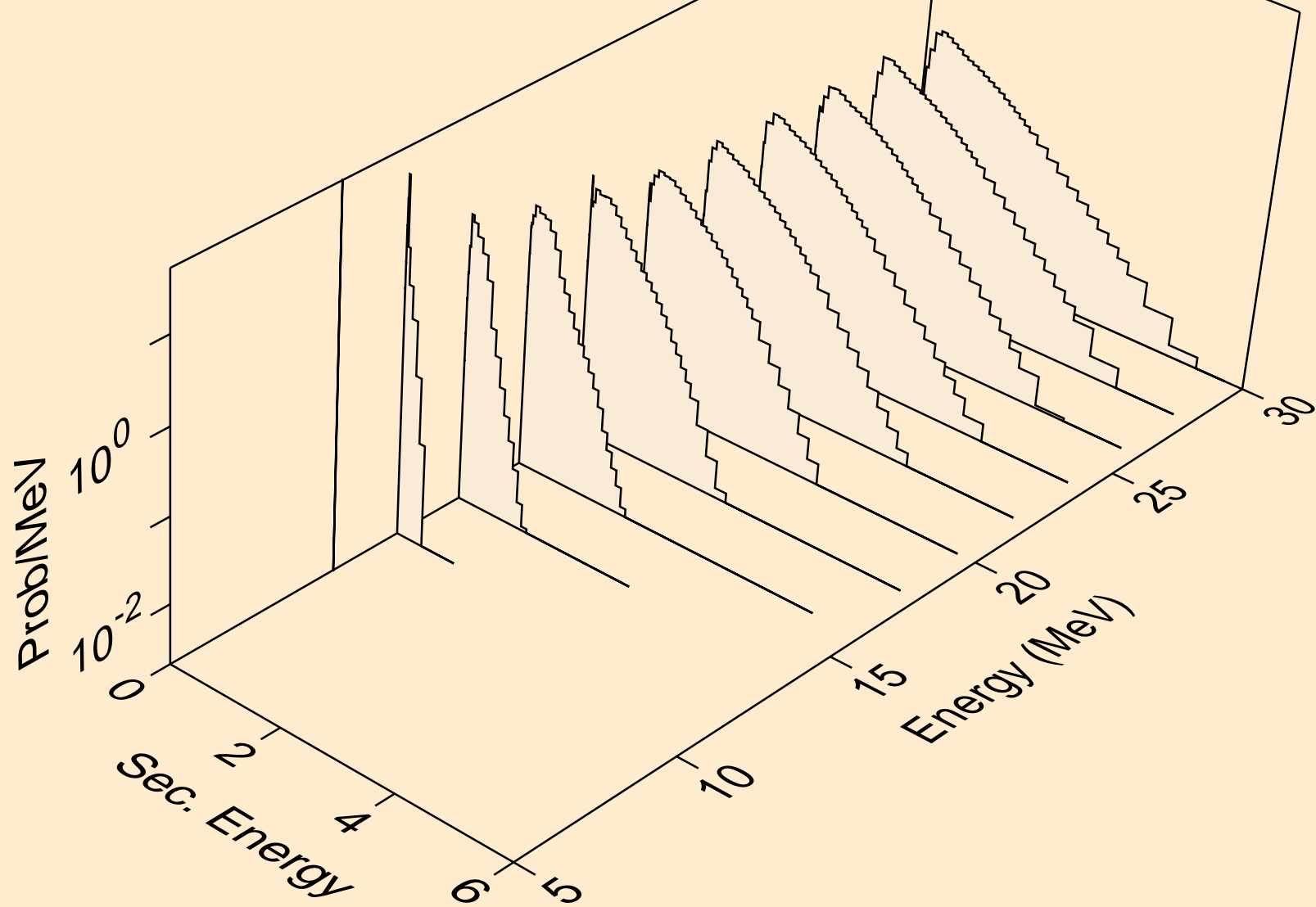

CD121M PROTON ACER TENDL-2021 LIBRARY; T=0.K
neutrons from (p,n*)he3

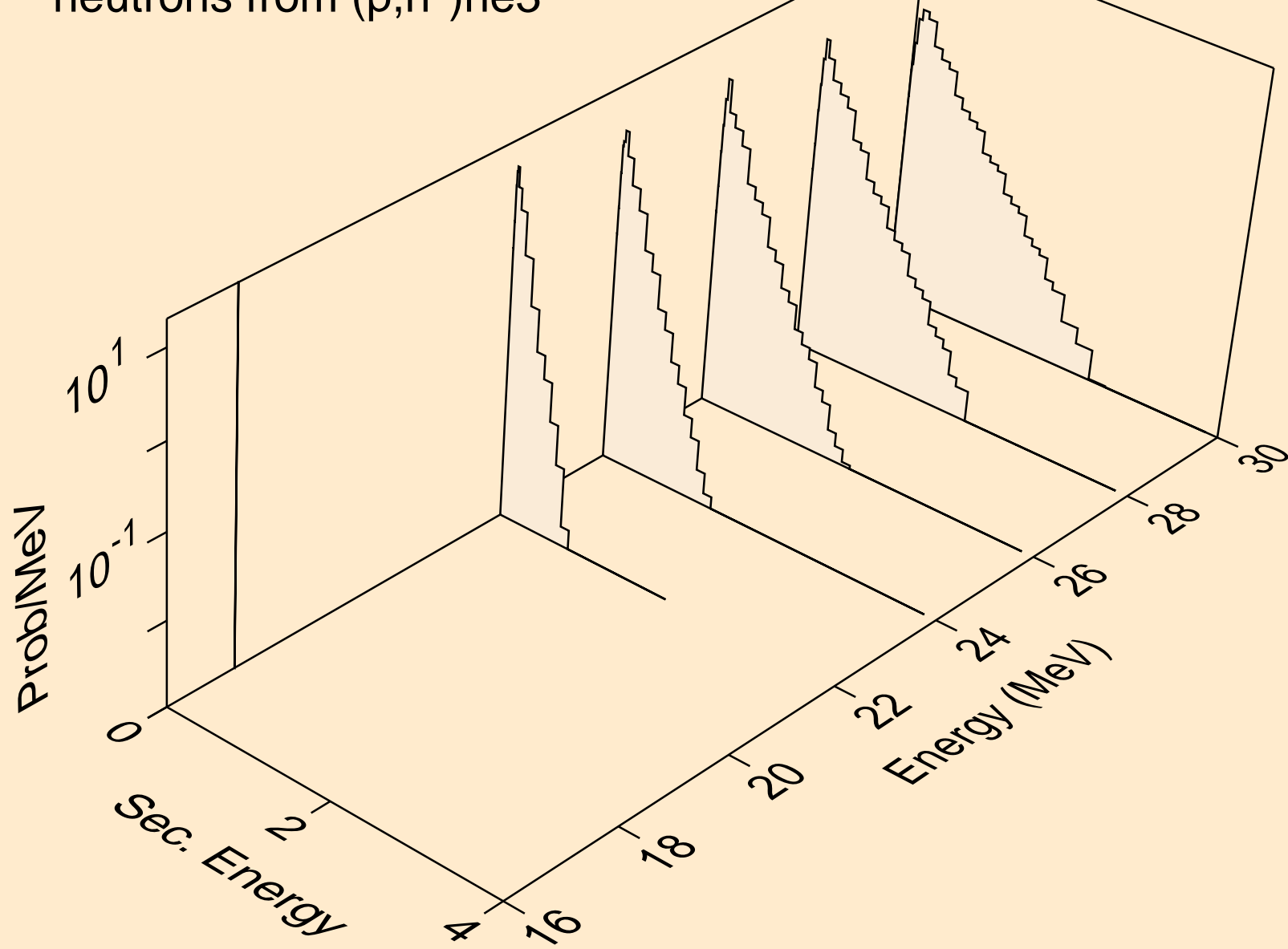

CD121M PROTON ACER TENDL-2021 LIBRARY; T=0.K
neutrons from (p,4n)

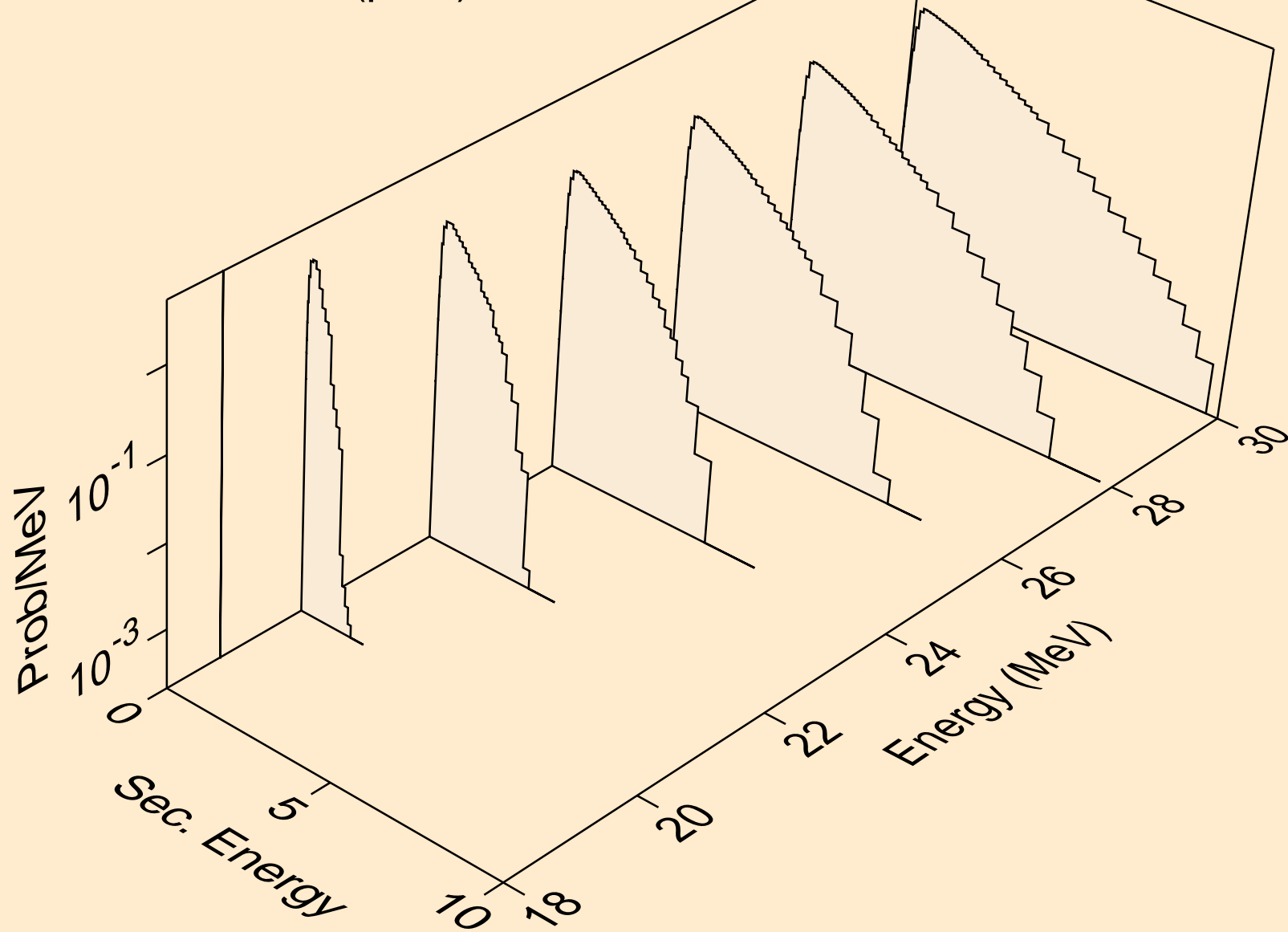

CD121M PROTON ACER TENDL-2021 LIBRARY; T=0.K
neutrons from (p,2np)

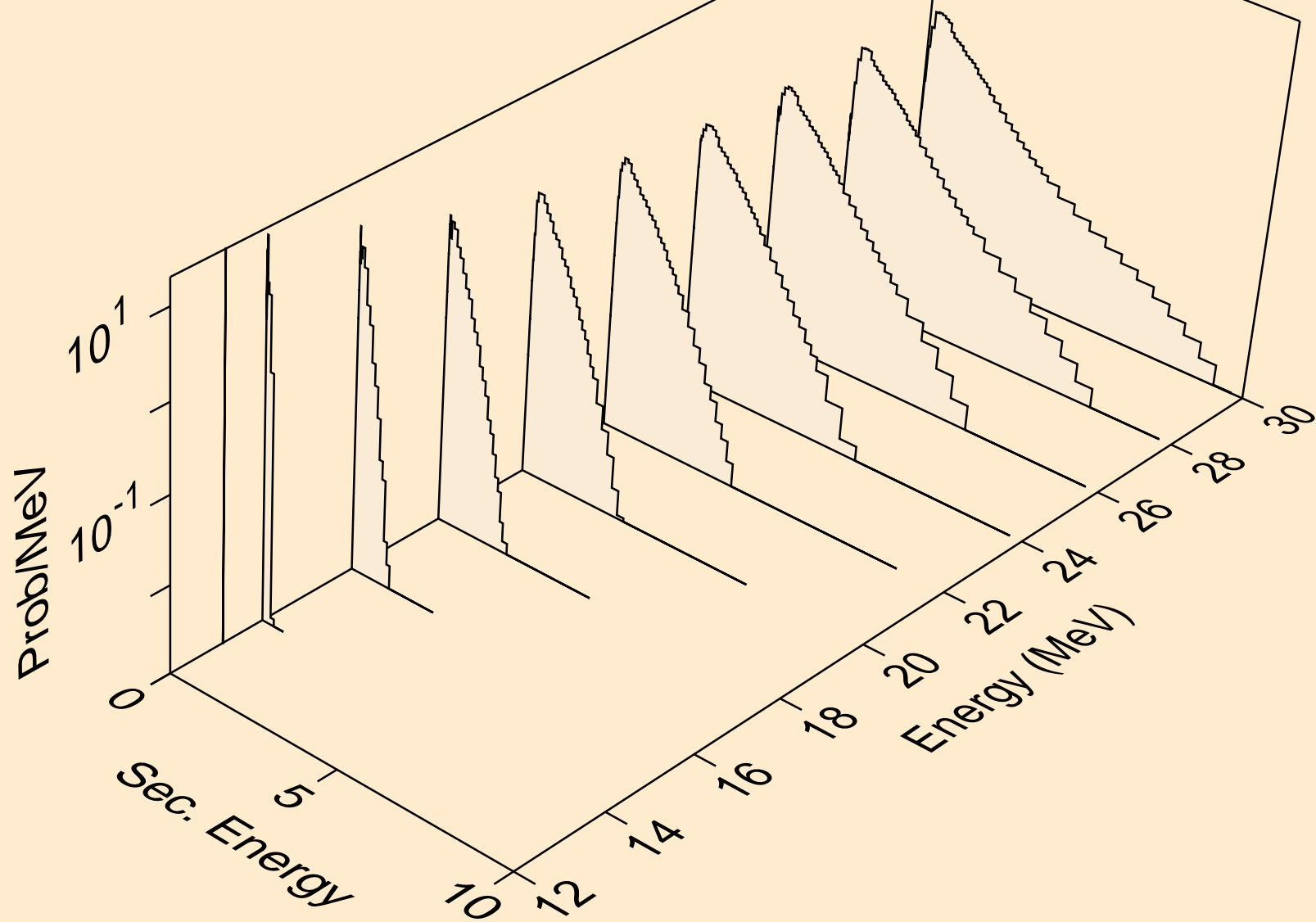

CD121M PROTON ACER TENDL-2021 LIBRARY; T=0.K
neutrons from (p,3np)

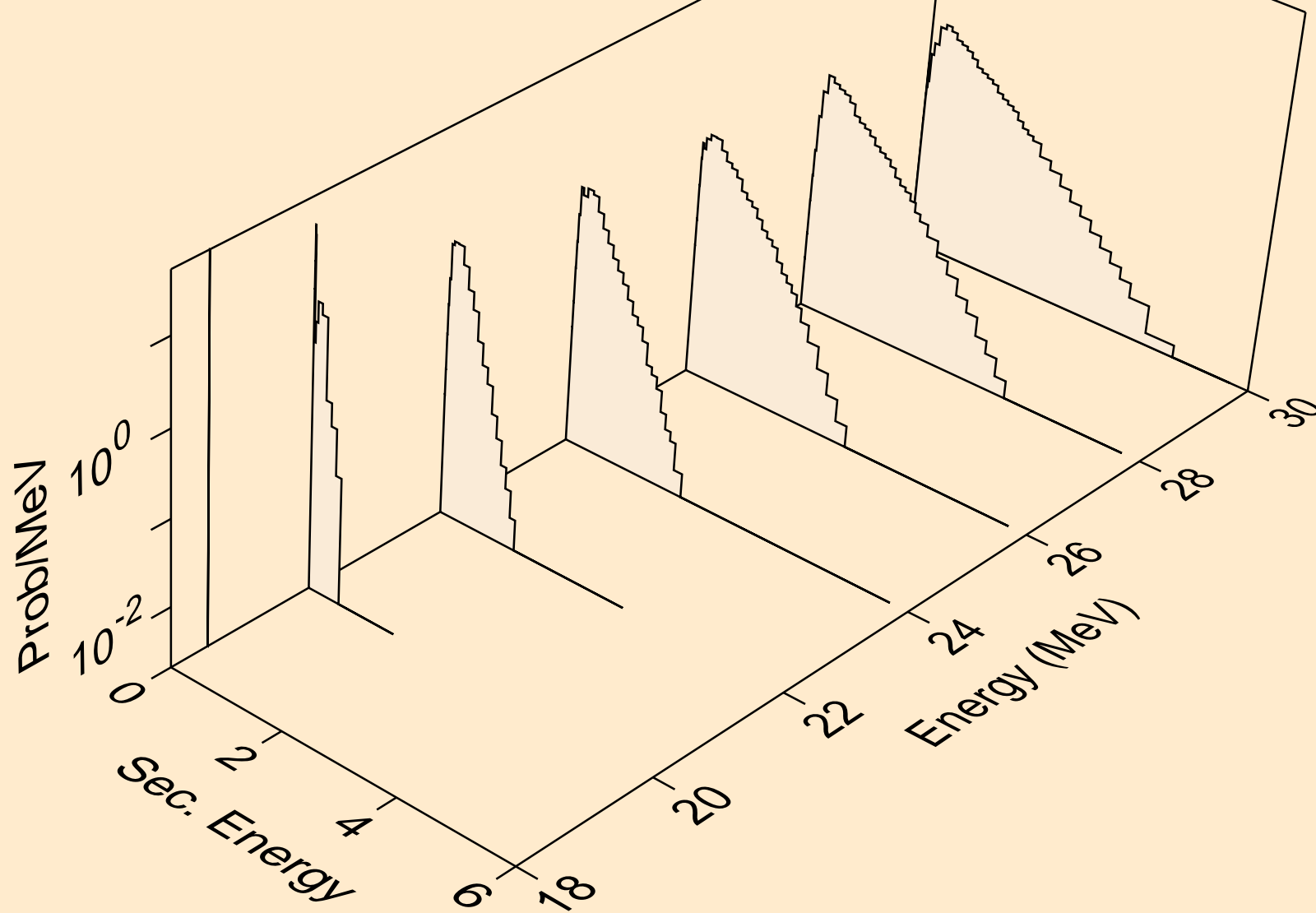

CD121M PROTON ACER TENDL-2021 LIBRARY; T=0.K
neutrons from (p,2np)

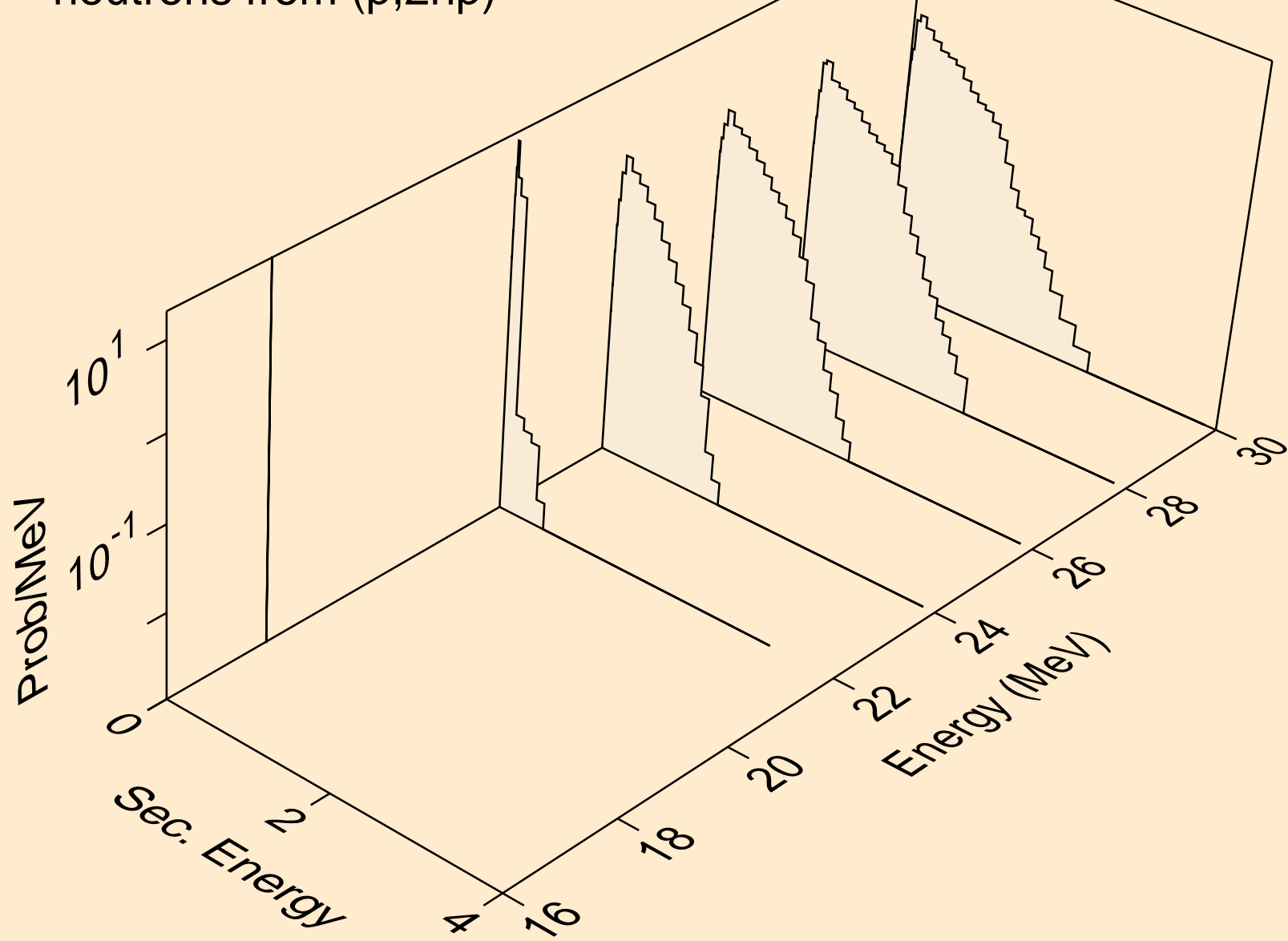

CD121M PROTON ACER TENDL-2021 LIBRARY; T=0.K
neutrons from (p,npa)

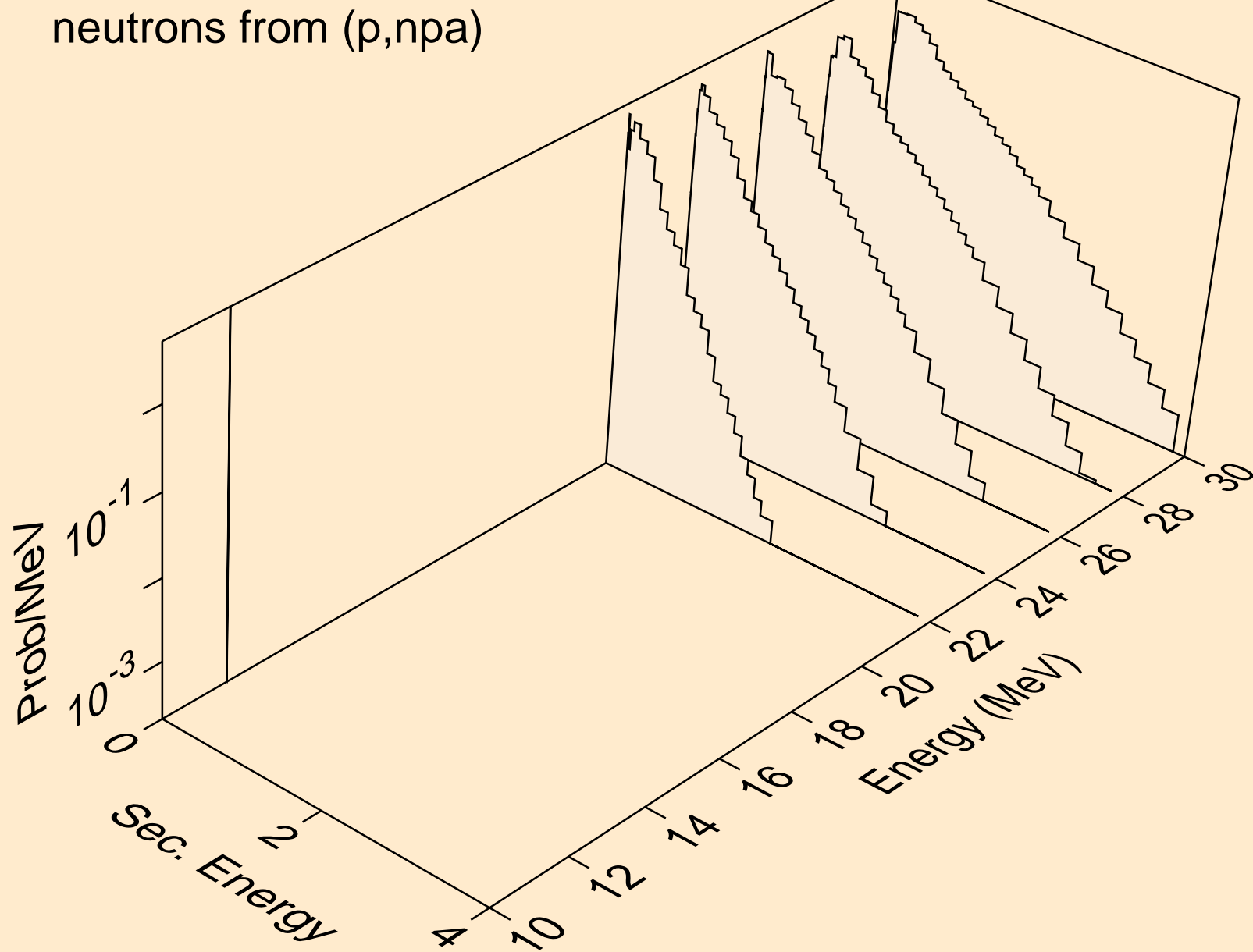

CD121M PROTON ACER TENDL-2021 LIBRARY; T=0.K
deuterons from (p,x)

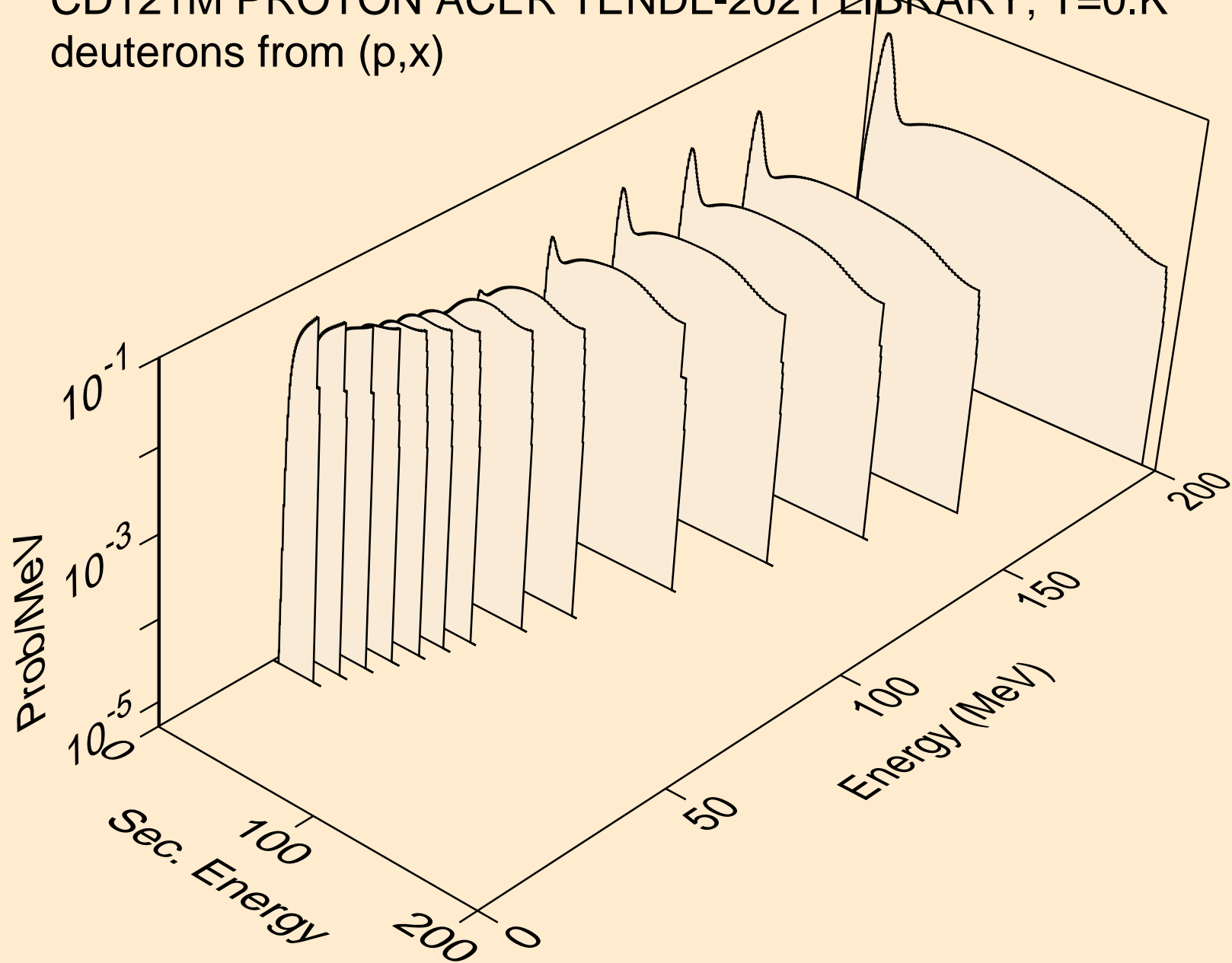

CD121M PROTON ACER TENDL-2021 LIBRARY; T=0.K
deuterons from (p,2nd)

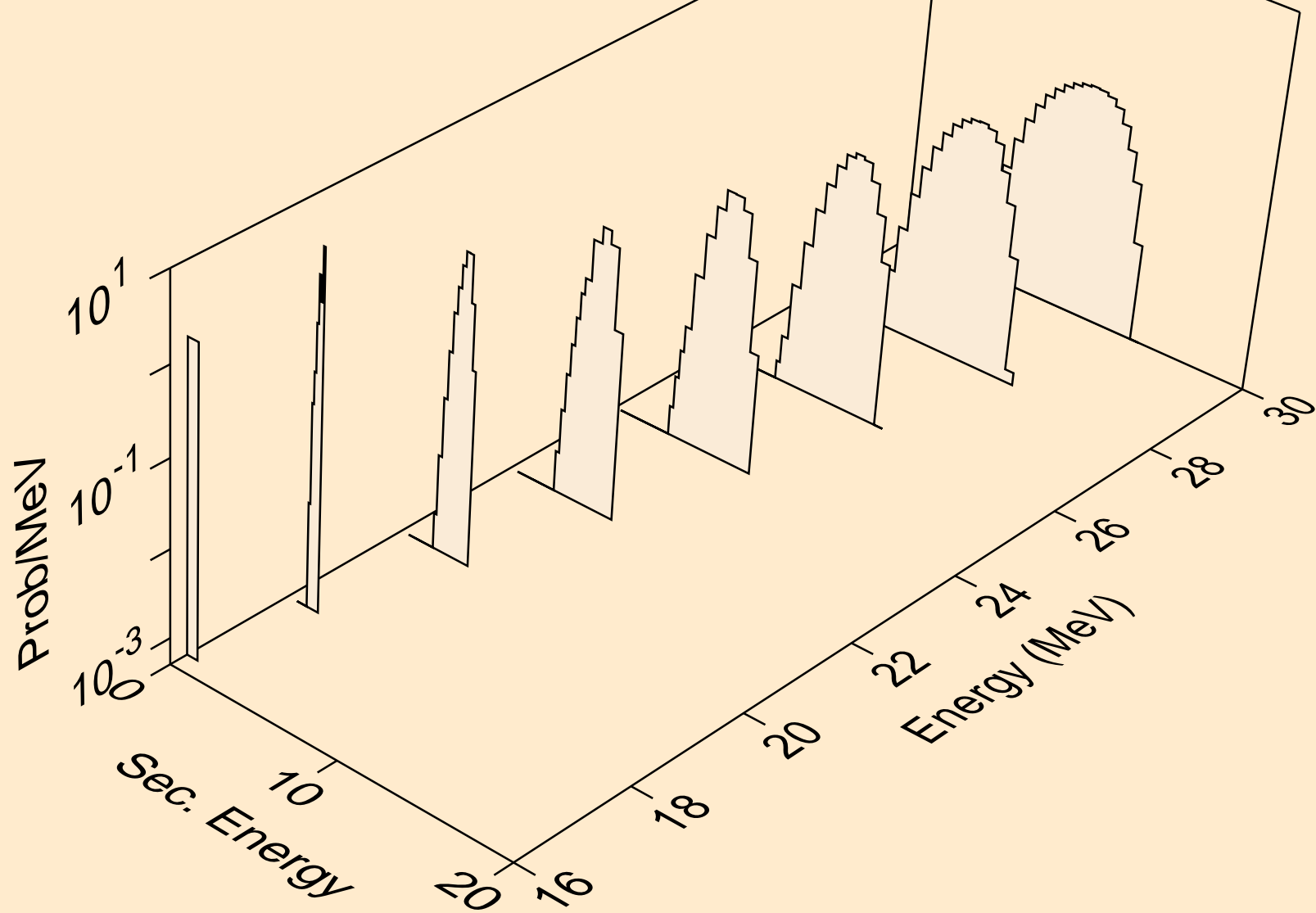

CD121M PROTON ACER TENDL-2021 LIBRARY; T=0.K
deuterons from (p,n*)d

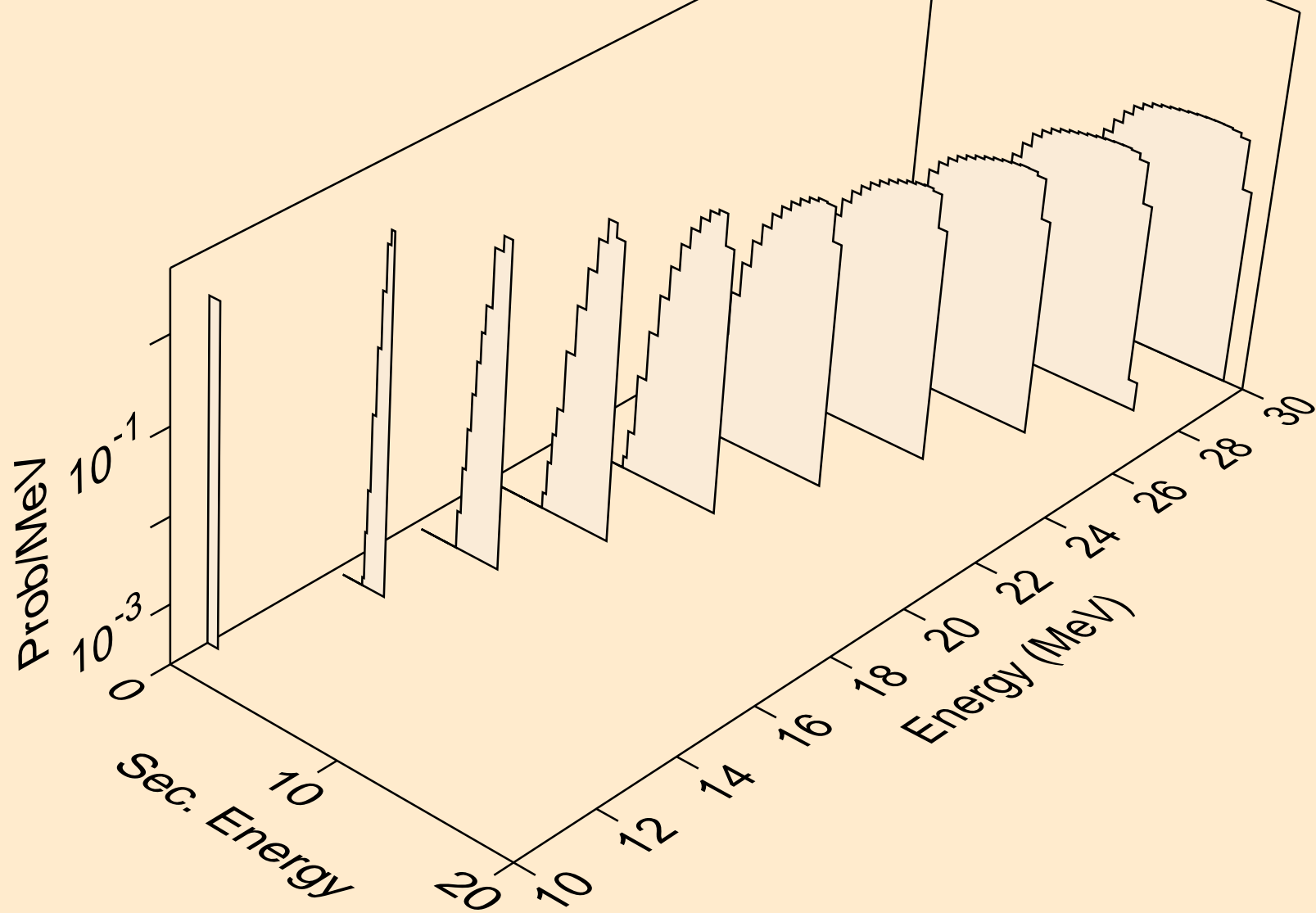

CD121M PROTON ACER TENDL-2021 LIBRARY; T=0.K
deuterons from (p,d)

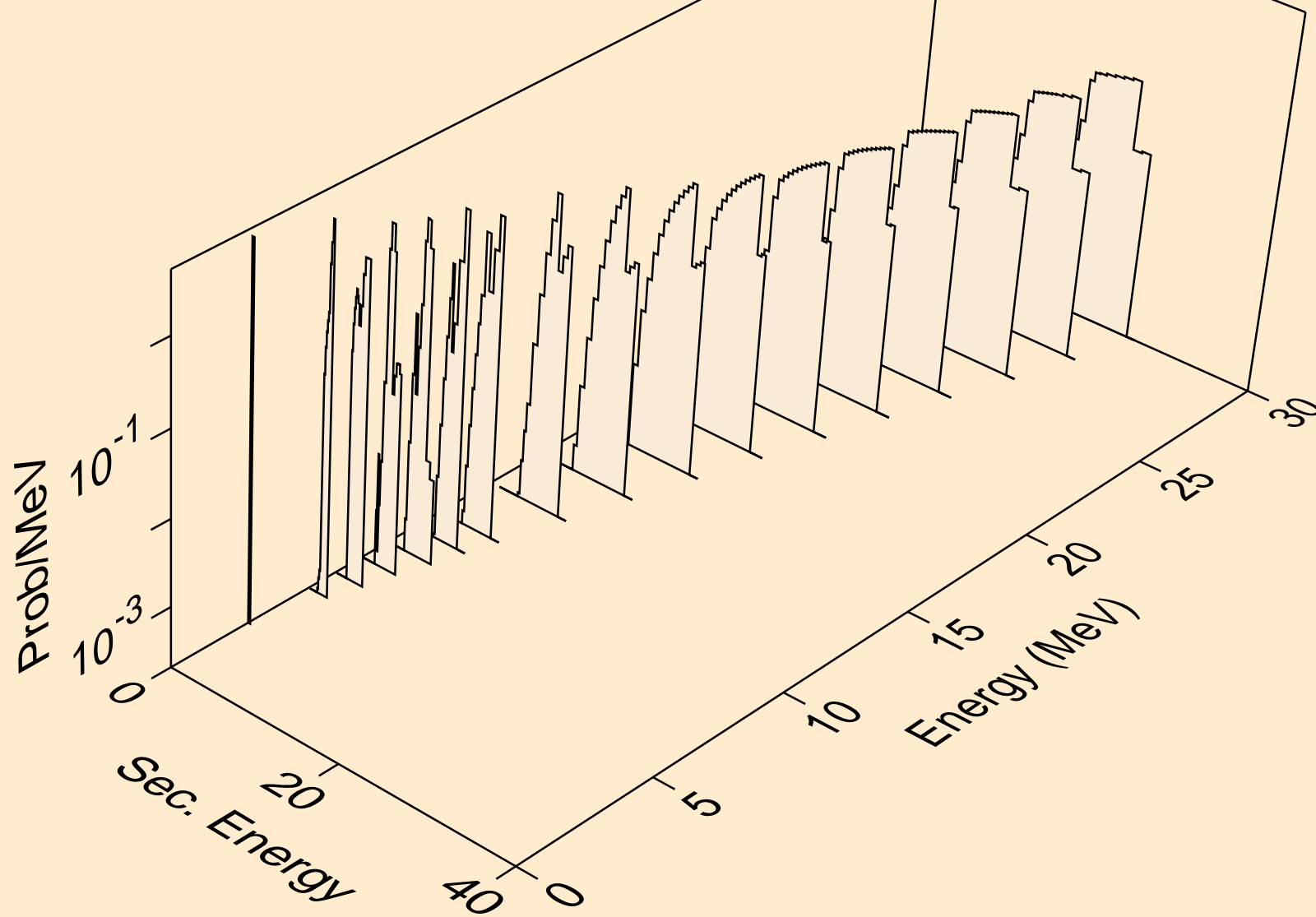

CD121M PROTON ACER TENDL-2021 LIBRARY; T=0.K
tritons from (p,x)

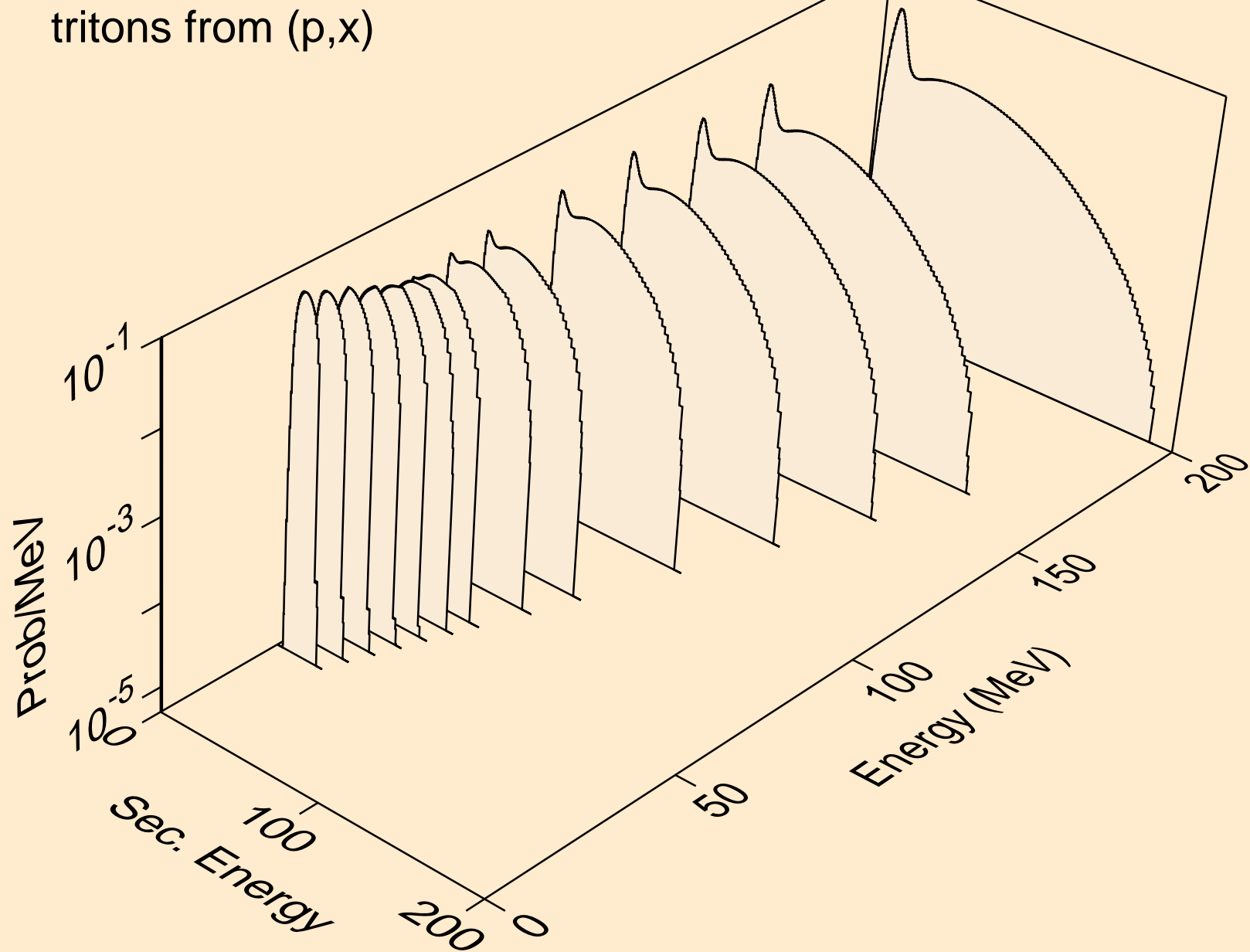

CD121M PROTON ACER TENDL-2021 LIBRARY; T=0.K
tritons from (p,n*)t

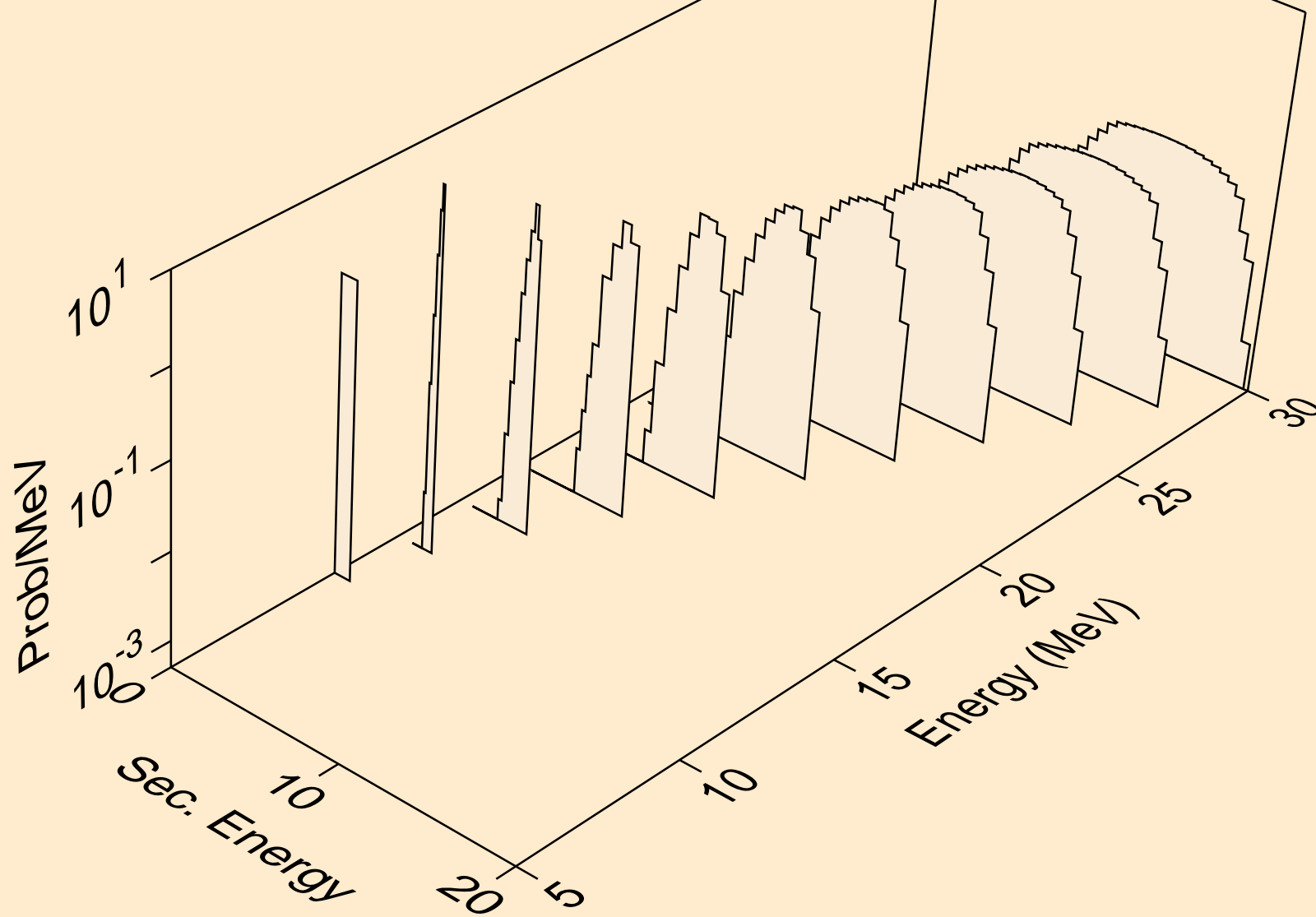

CD121M PROTON ACER TENDL-2021 LIBRARY; T=0.K
tritons from (p,t)

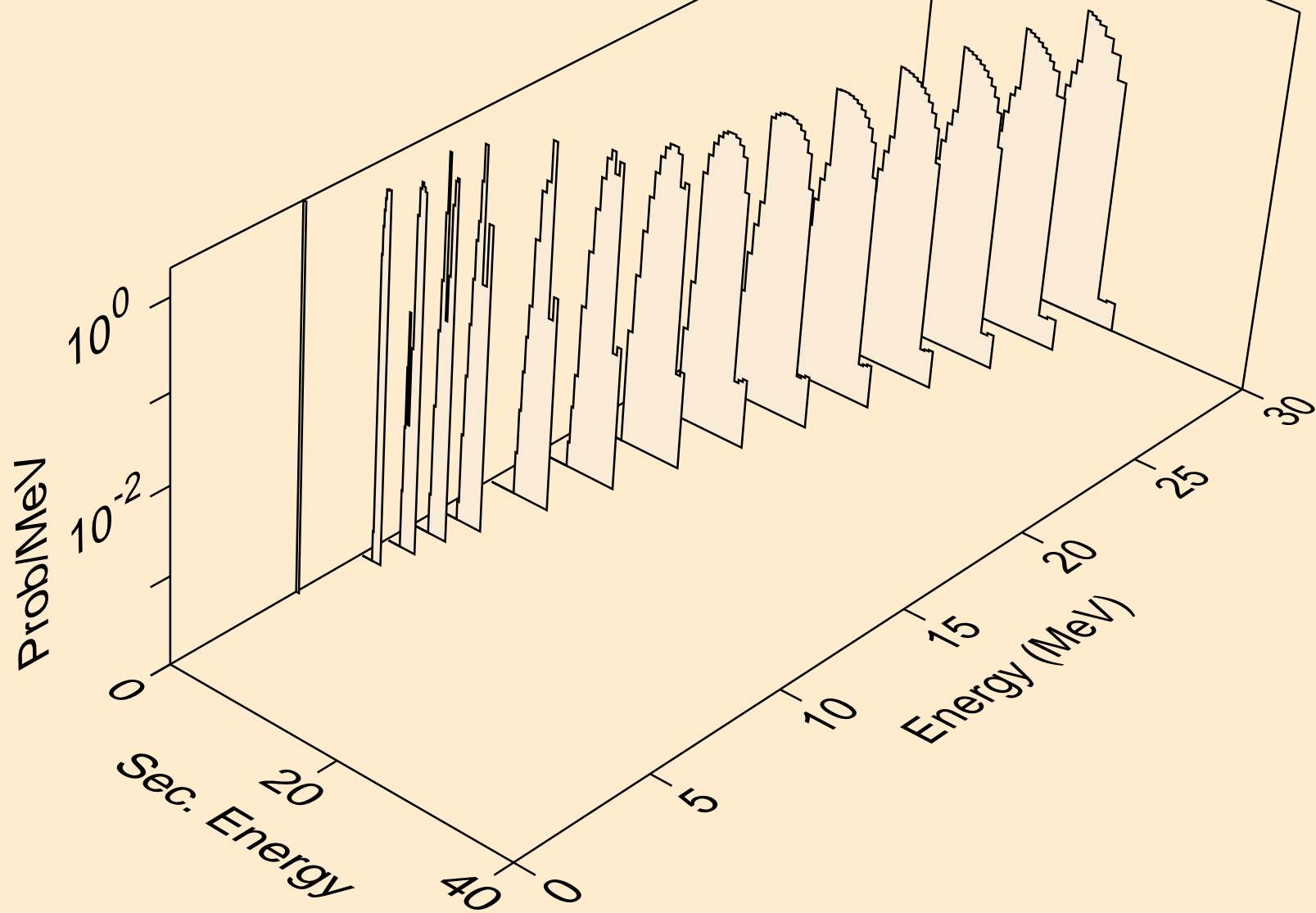

CD121M PROTON ACER TENDL-2021 LIBRARY; T=0.K
he3s from (p,x)

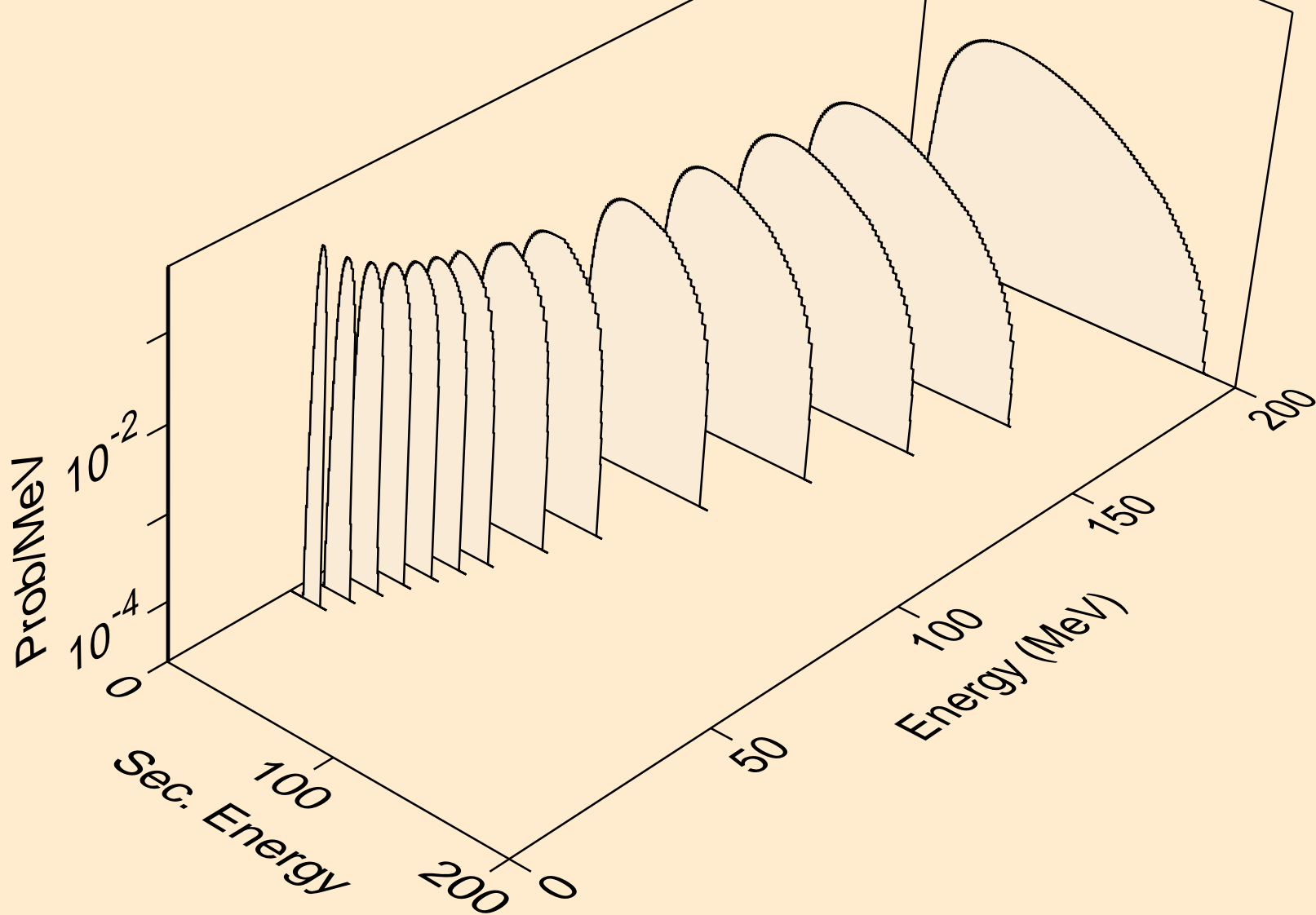

CD121M PROTON ACER TENDL-2021 LIBRARY; T=0.K
he3s from (p,n*)he3

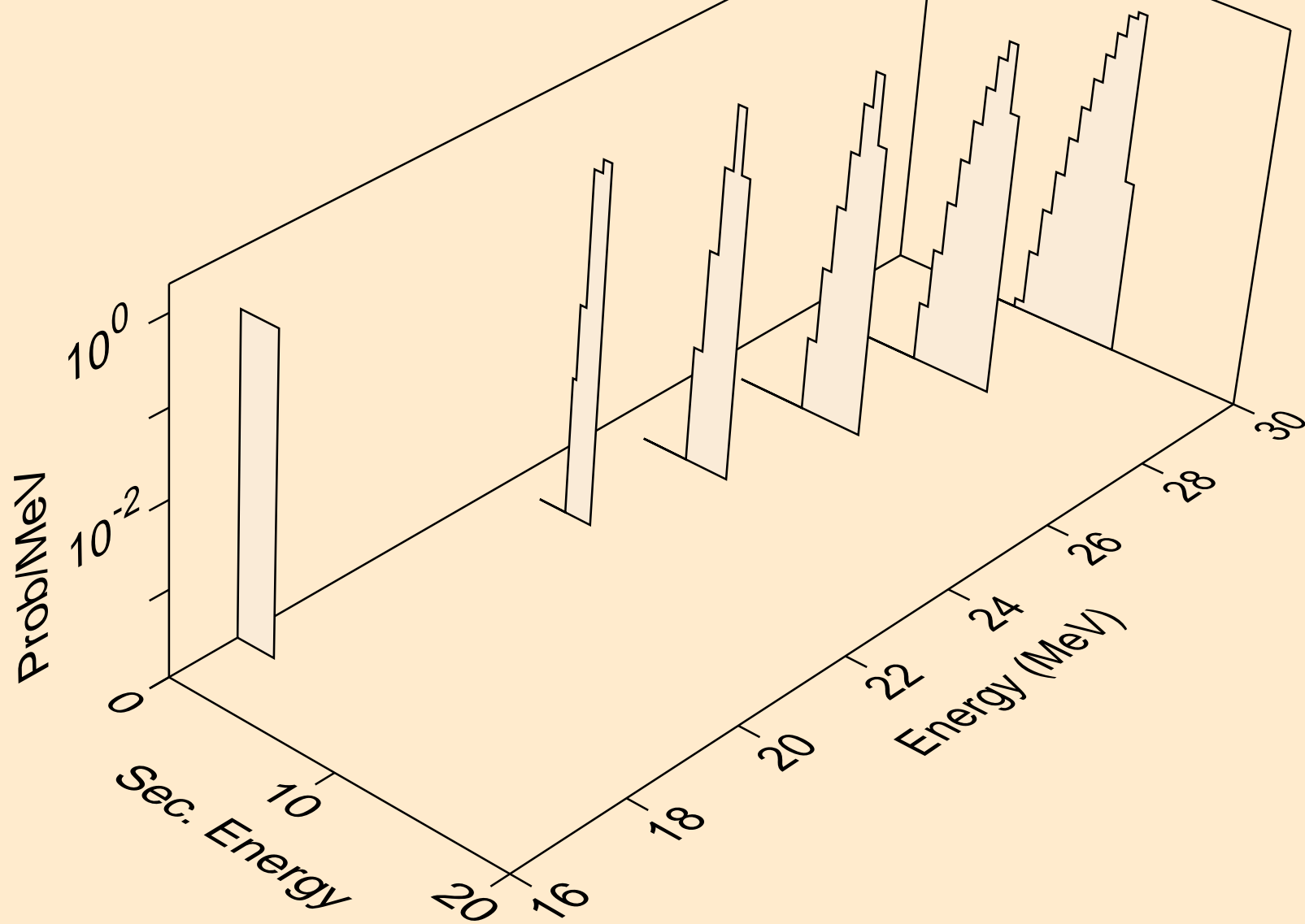

CD121M PROTON ACER TENDL-2021 LIBRARY; T=0.K
he3s from (p,he3)

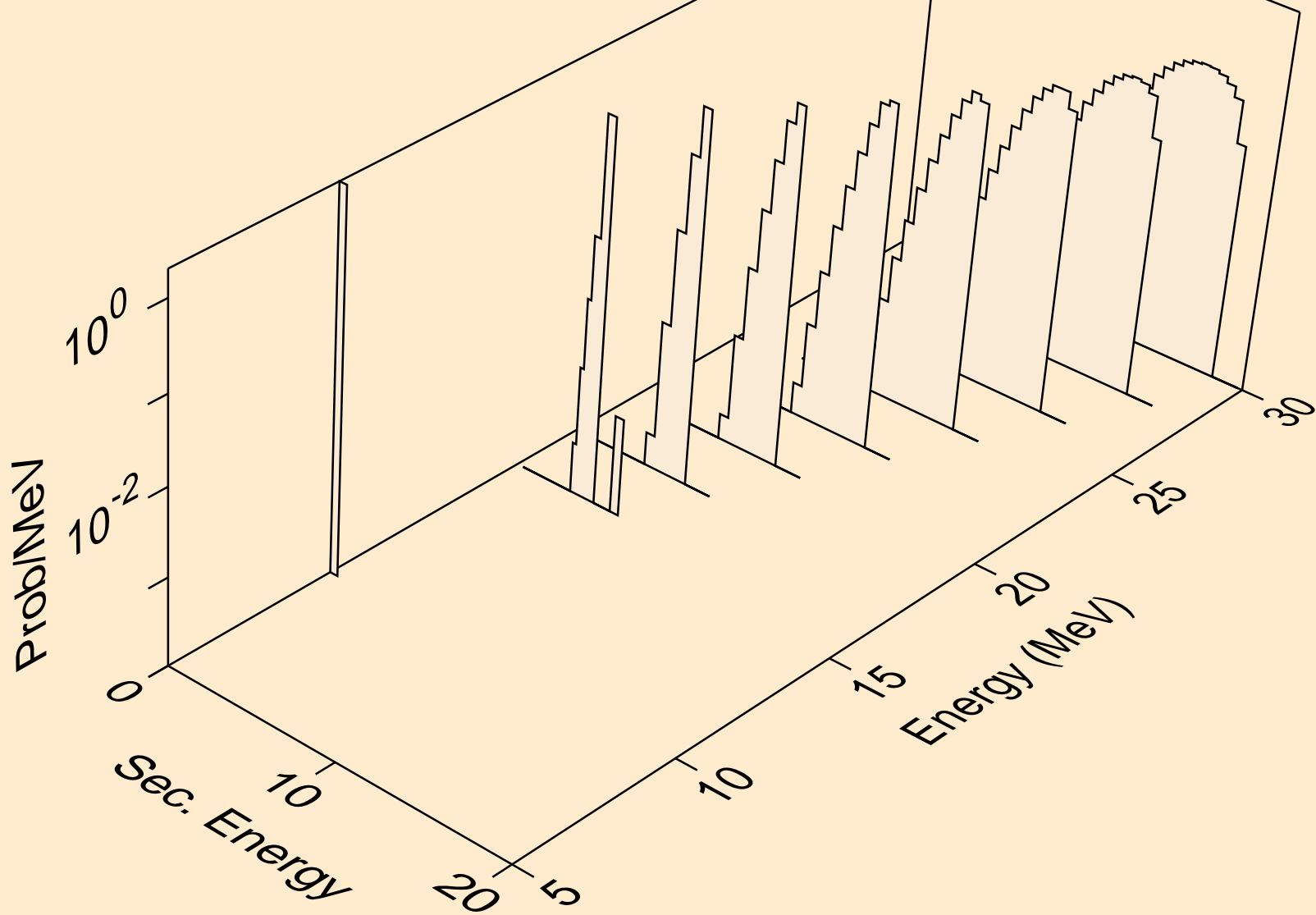

CD121M PROTON ACER TENDL-2021 LIBRARY; T=0.K
alphas from (p,x)

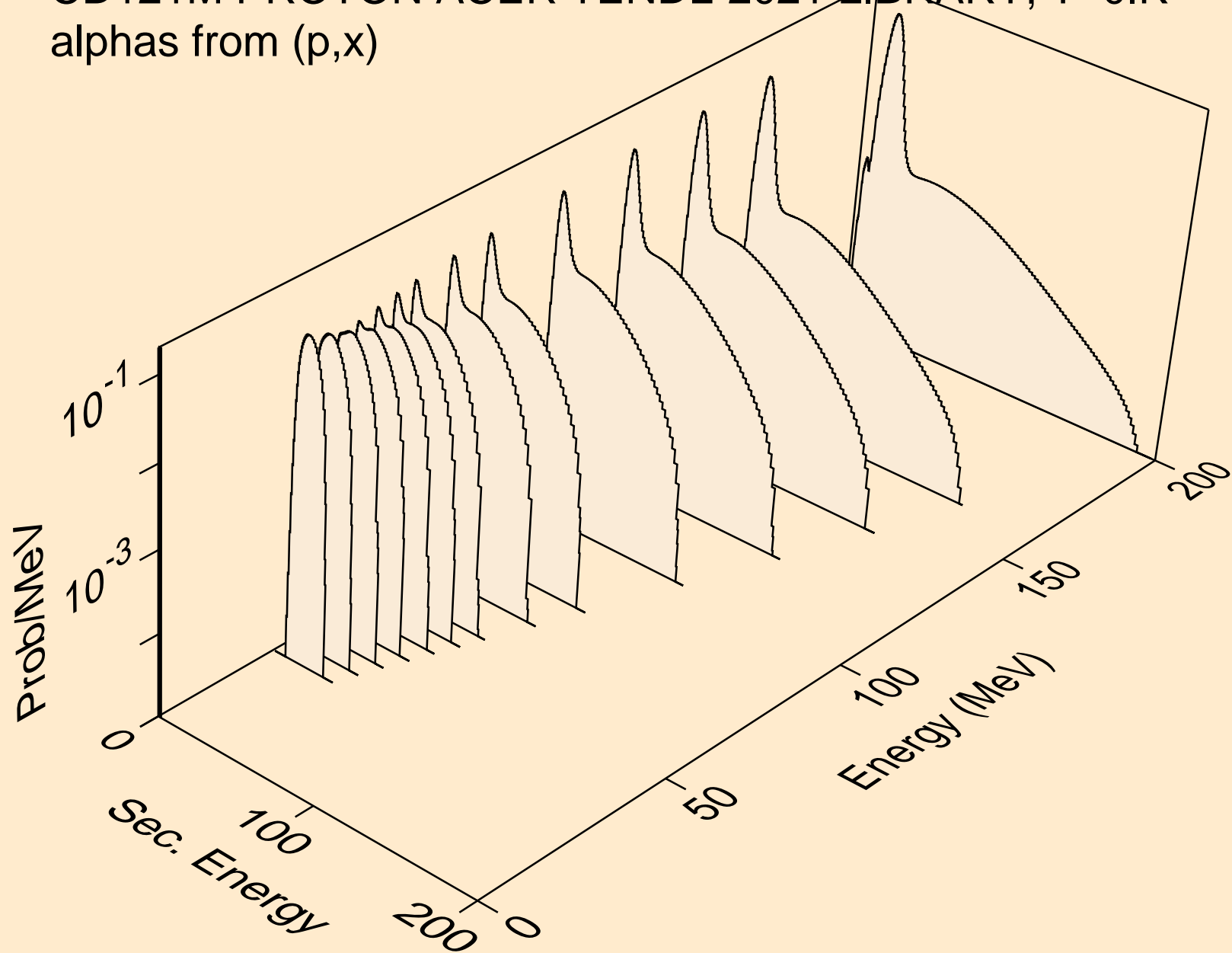

CD121M PROTON ACER TENDL-2021 LIBRARY; T=0.K
alphas from (p,n*)a

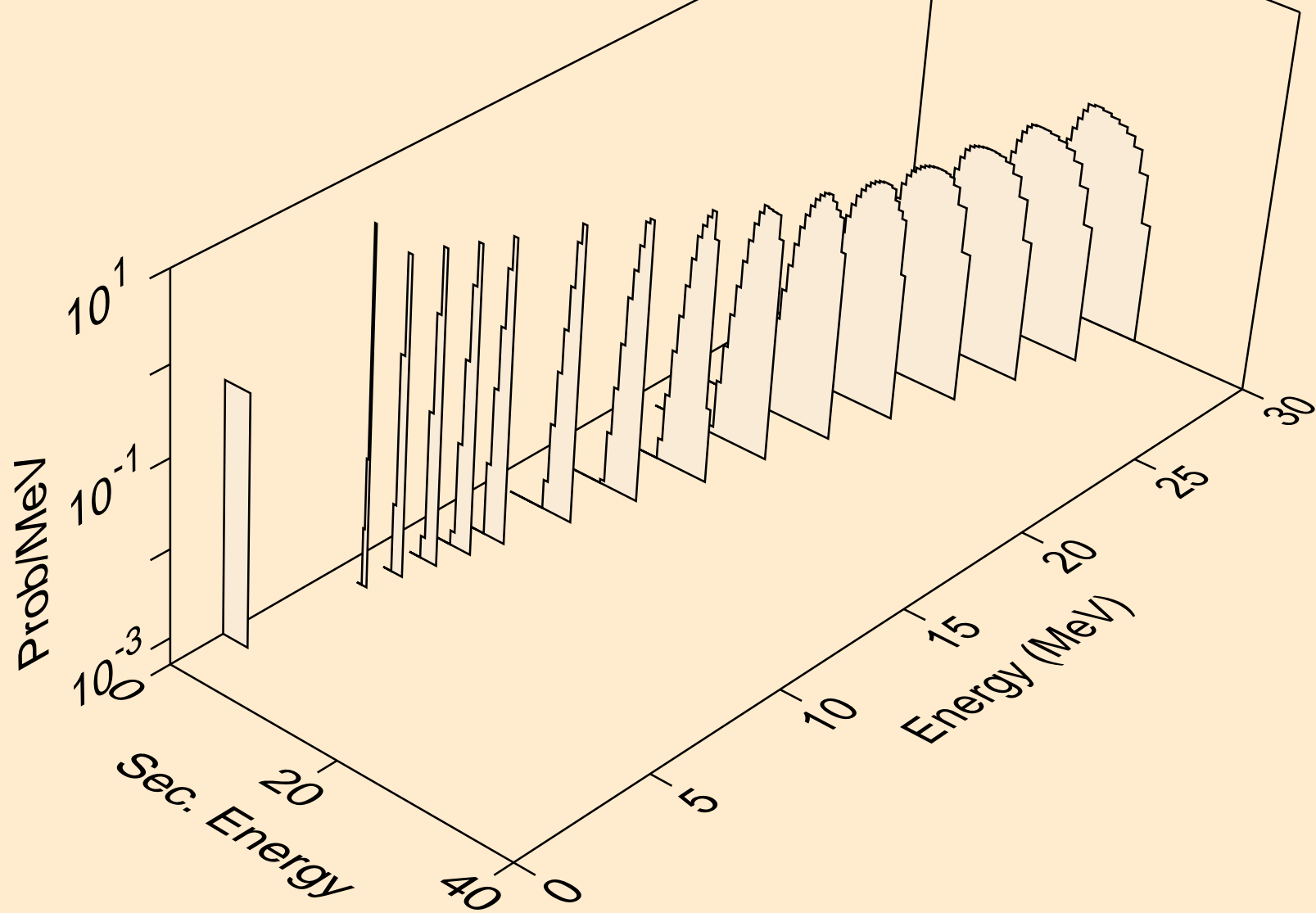

CD121M PROTON ACER TENDL-2021 LIBRARY; T=0.K
alphas from (p,2n)a

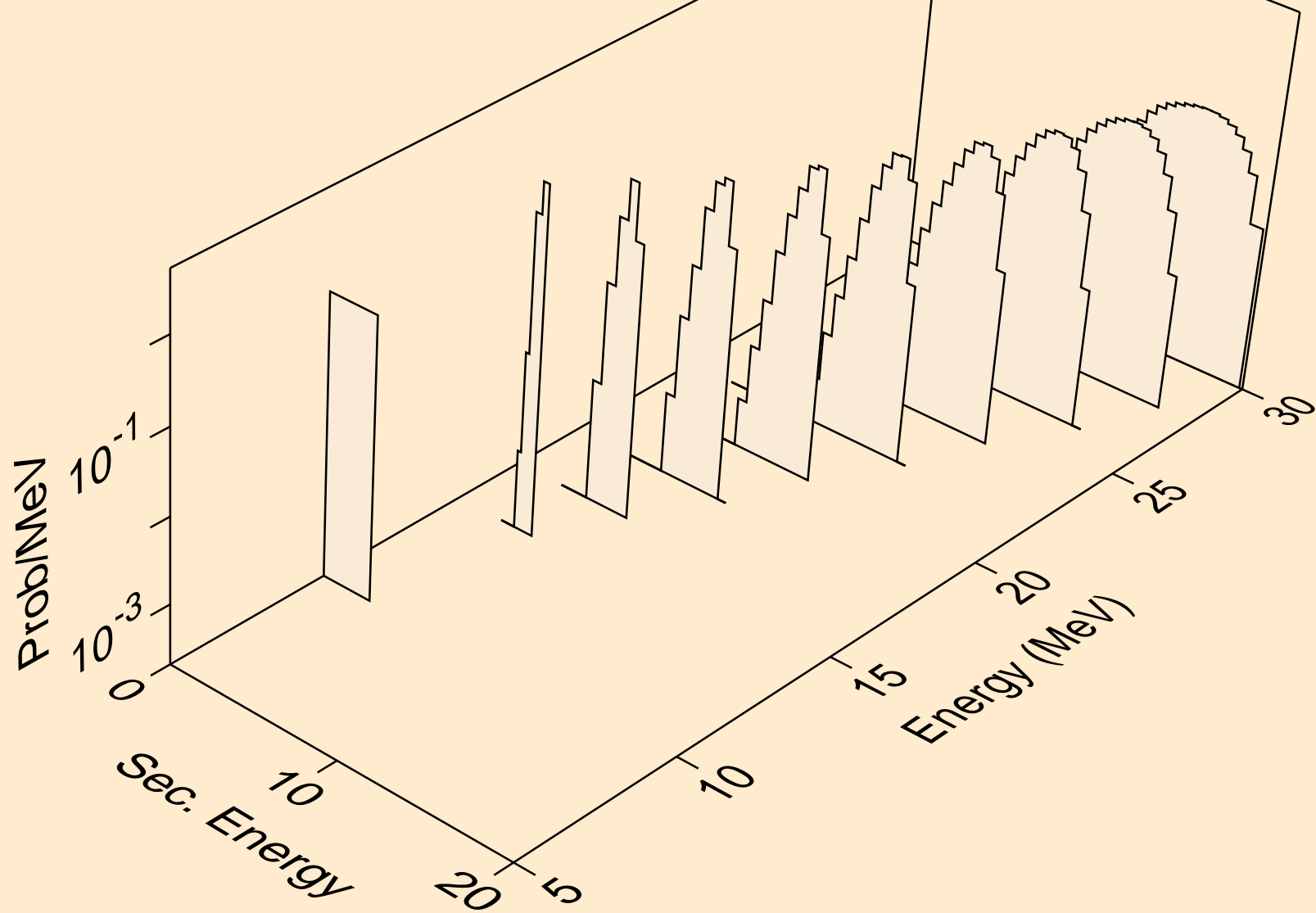

CD121M PROTON ACER TENDL-2021 LIBRARY; T=0.K
alphas from (p,3n)a

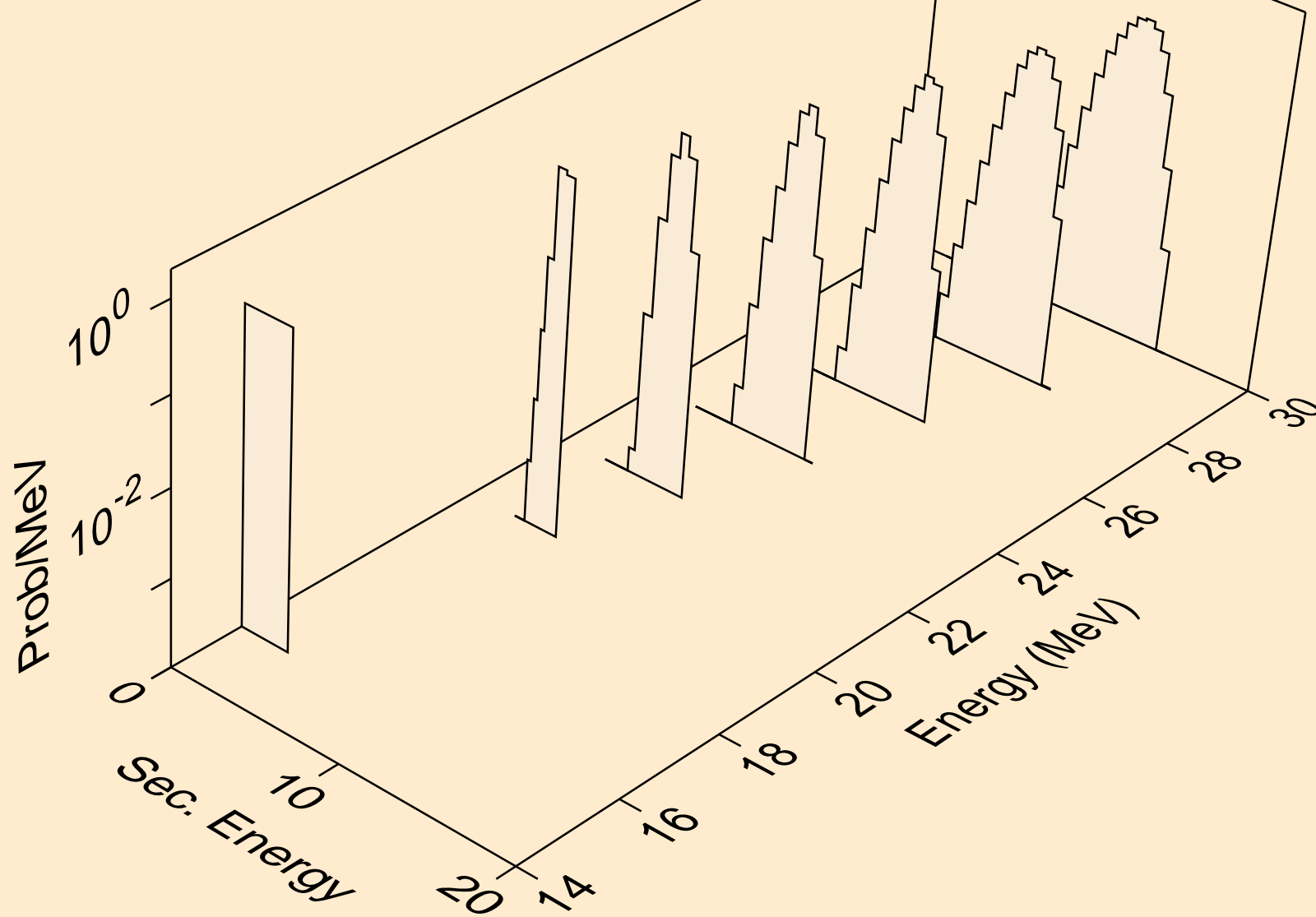

CD121M PROTON ACER TENDL-2021 LIBRARY; T=0.K
alphas from (p,npa)

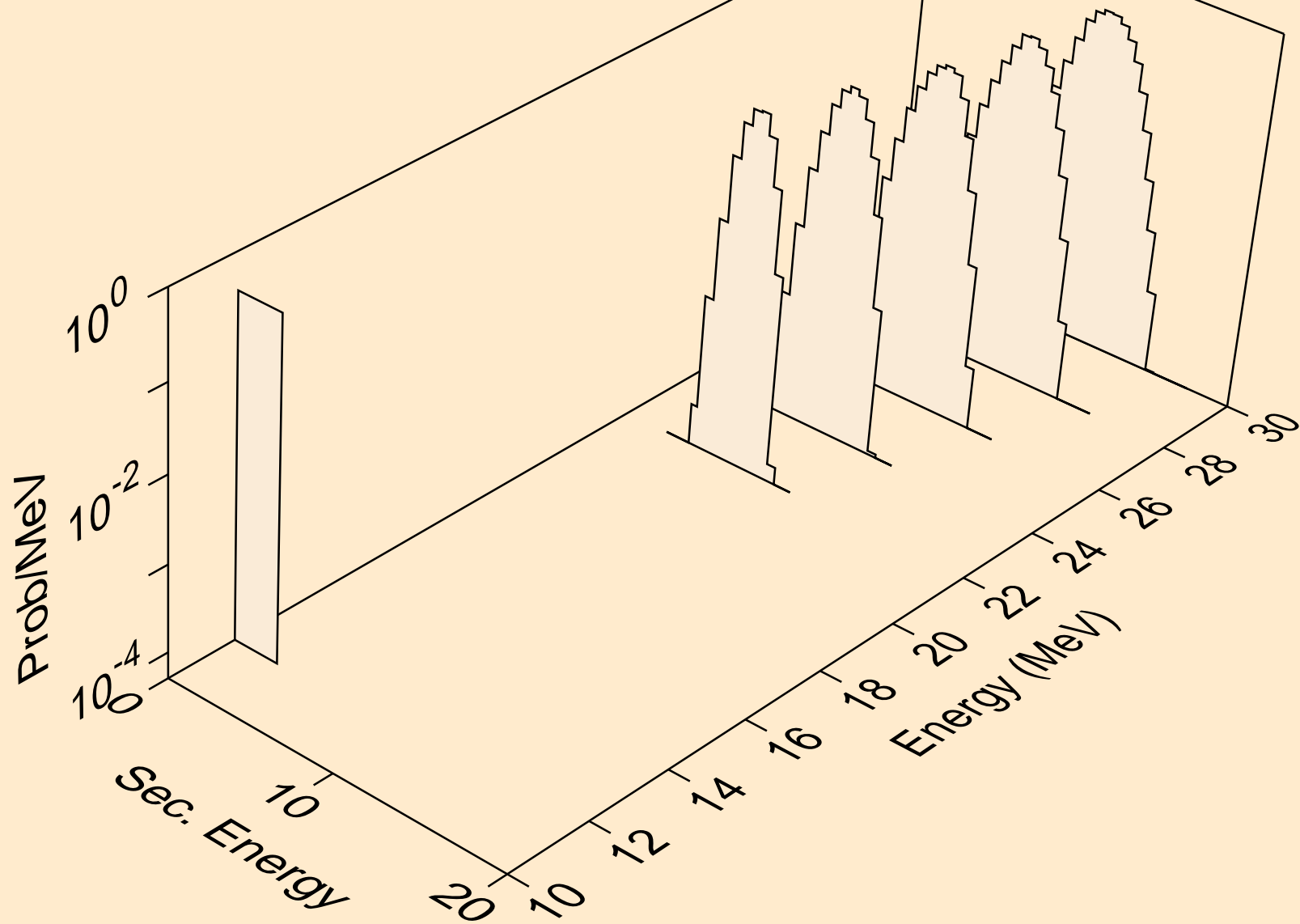

CD121M PROTON ACER TENDL-2021 LIBRARY; T=0.K
alphas from (p,a)

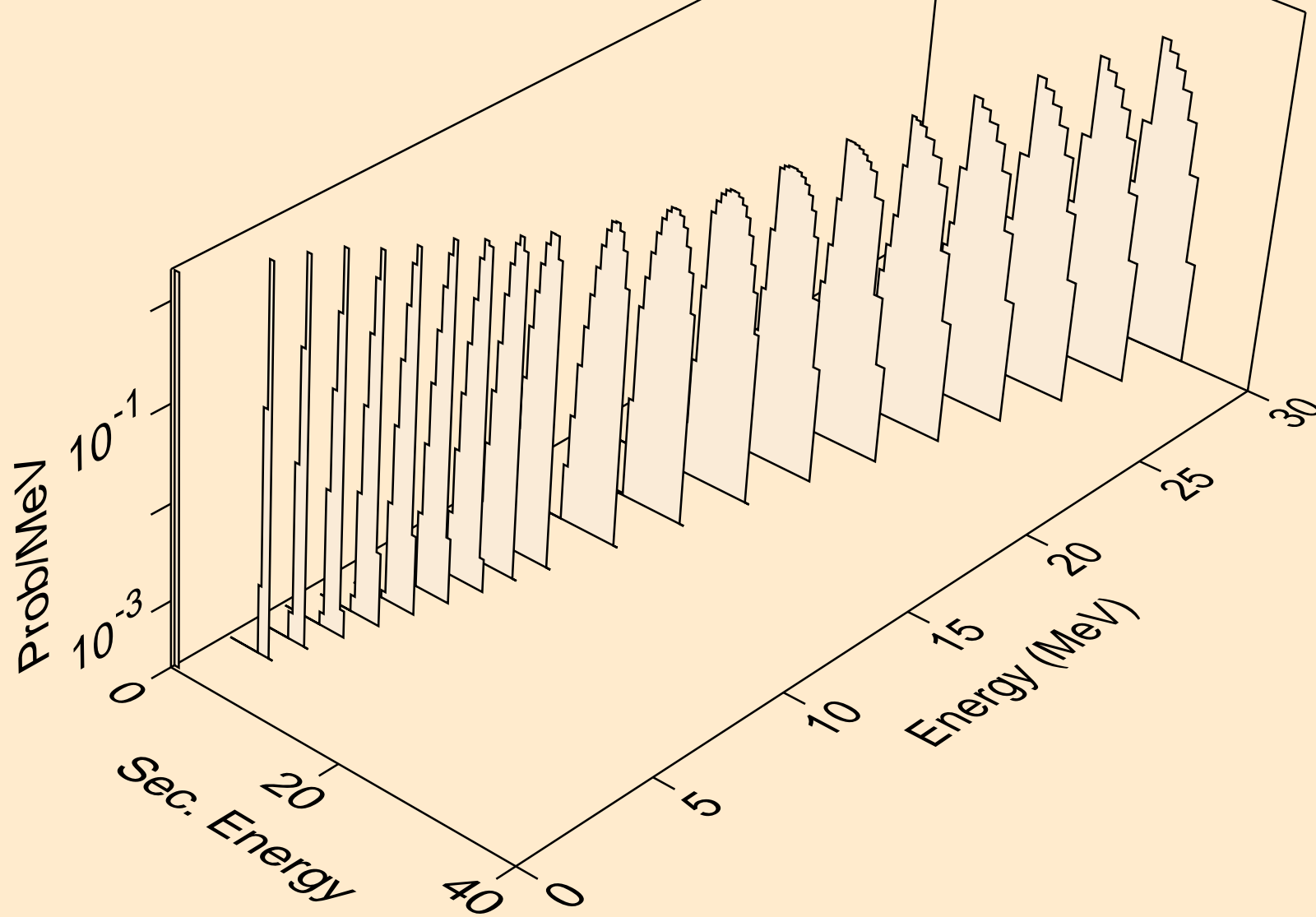

CD121M PROTON ACER TENDL-2021 LIBRARY; T=0.K
alphas from (p,pa)

