

# CO055 PROTON ACER TENDL-2021 LIBRARY; T=0.K

## Principal cross sections

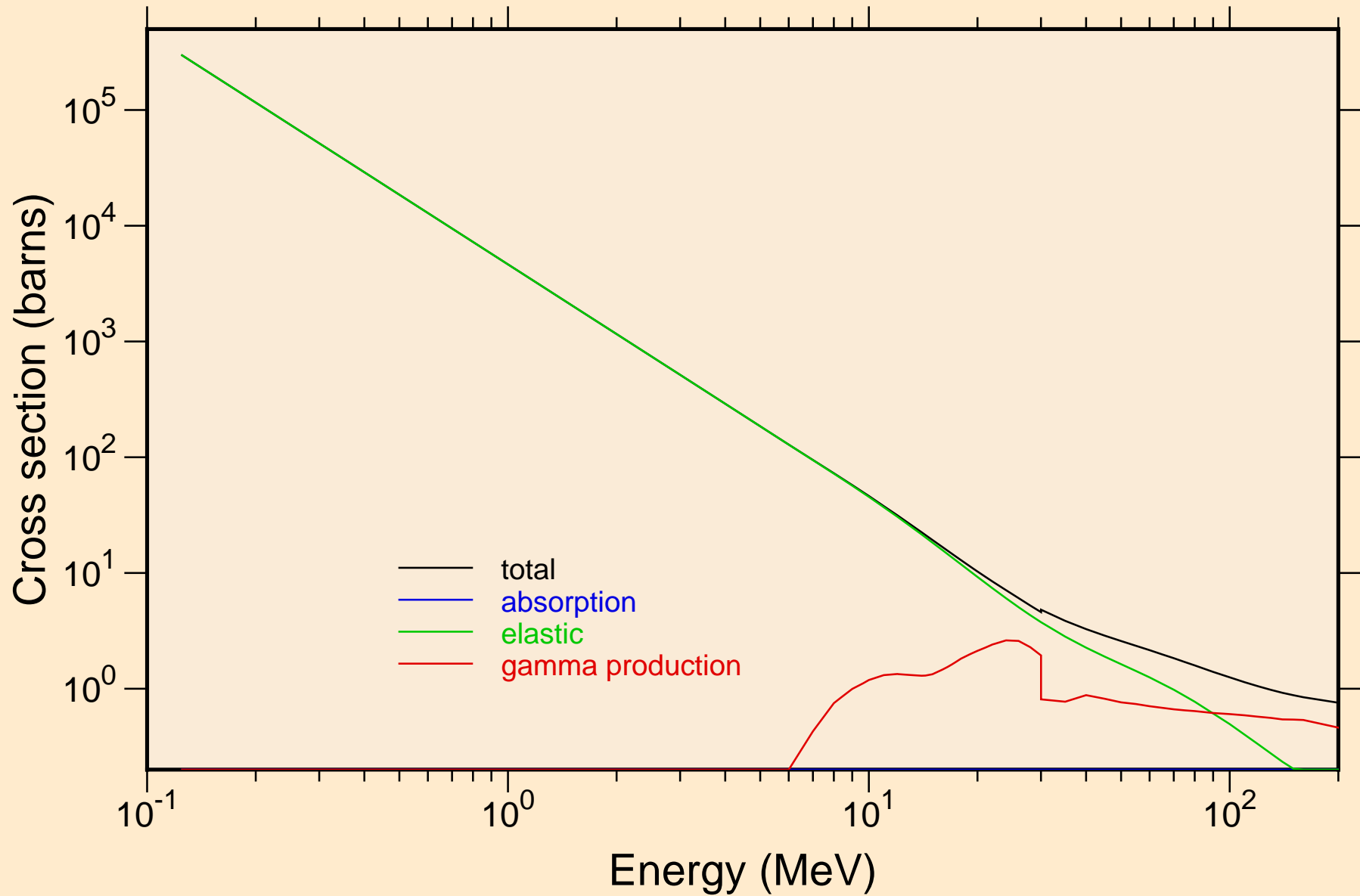

# CO055 PROTON ACER TENDL-2021 LIBRARY; T=0.K

## Heating

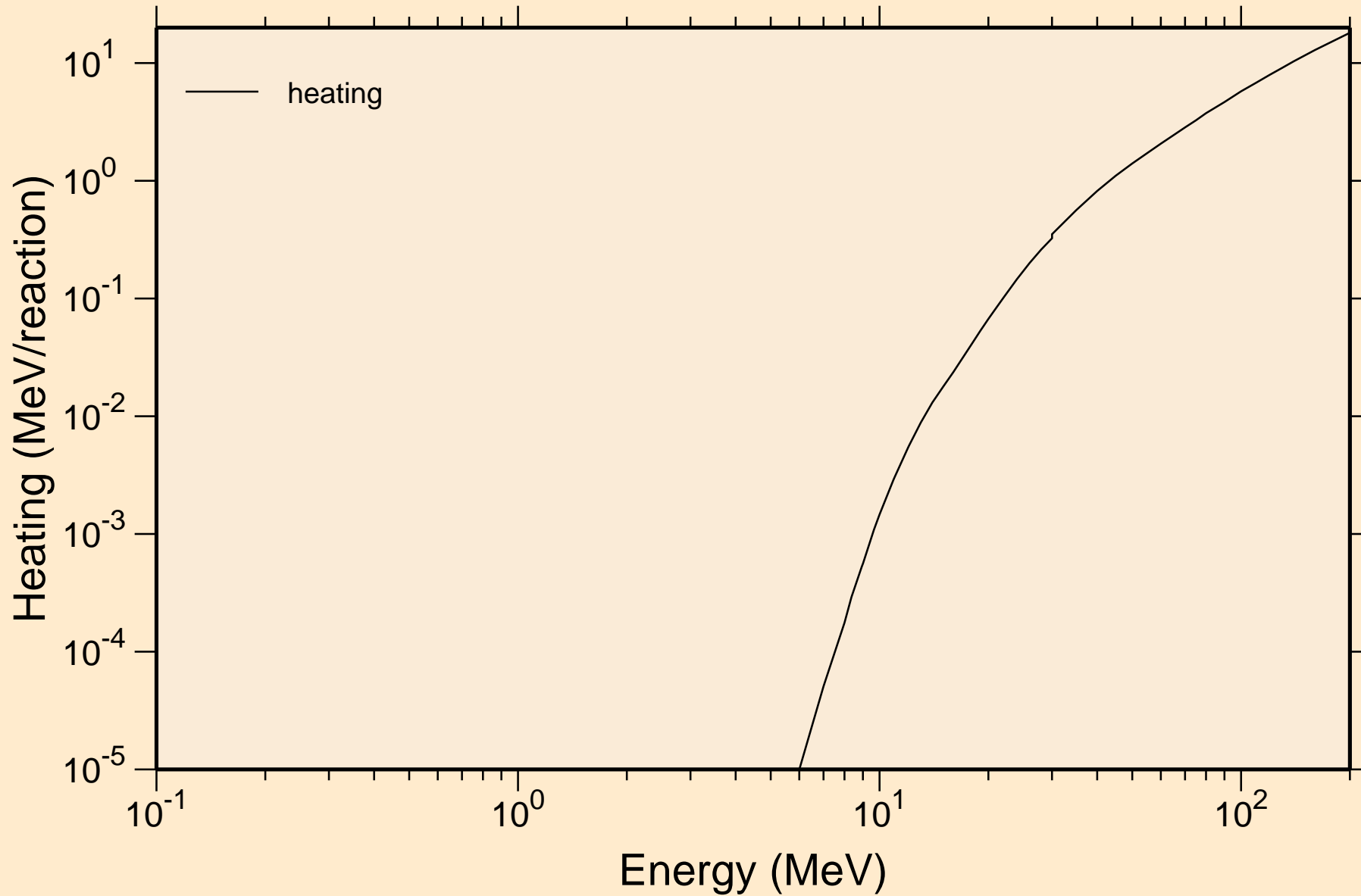

# CO055 PROTON ACER TENDL-2021 LIBRARY; T=0.K

## Principal cross sections

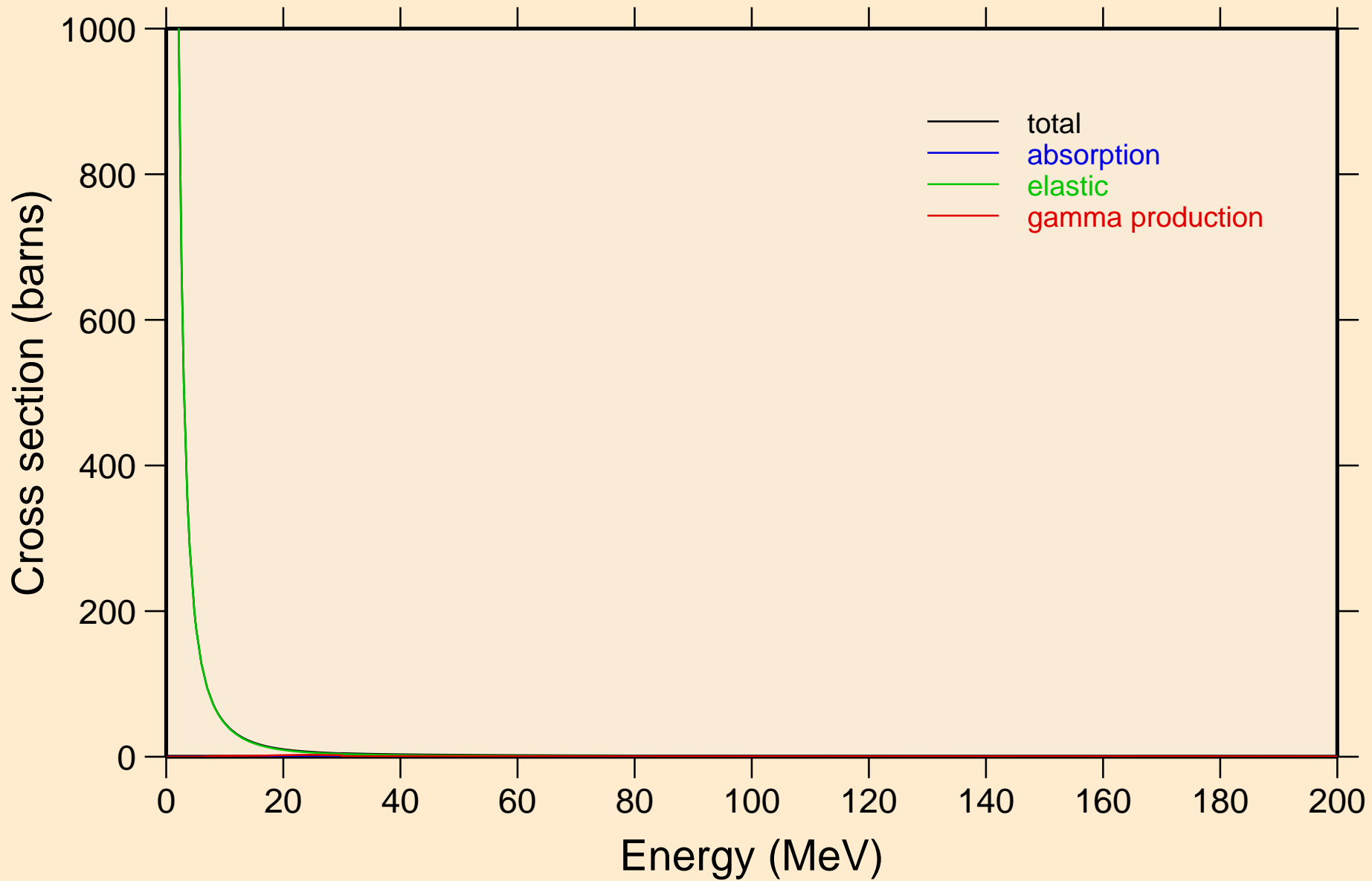

# CO055 PROTON ACER TENDL-2021 LIBRARY; T=0.K

## Heating

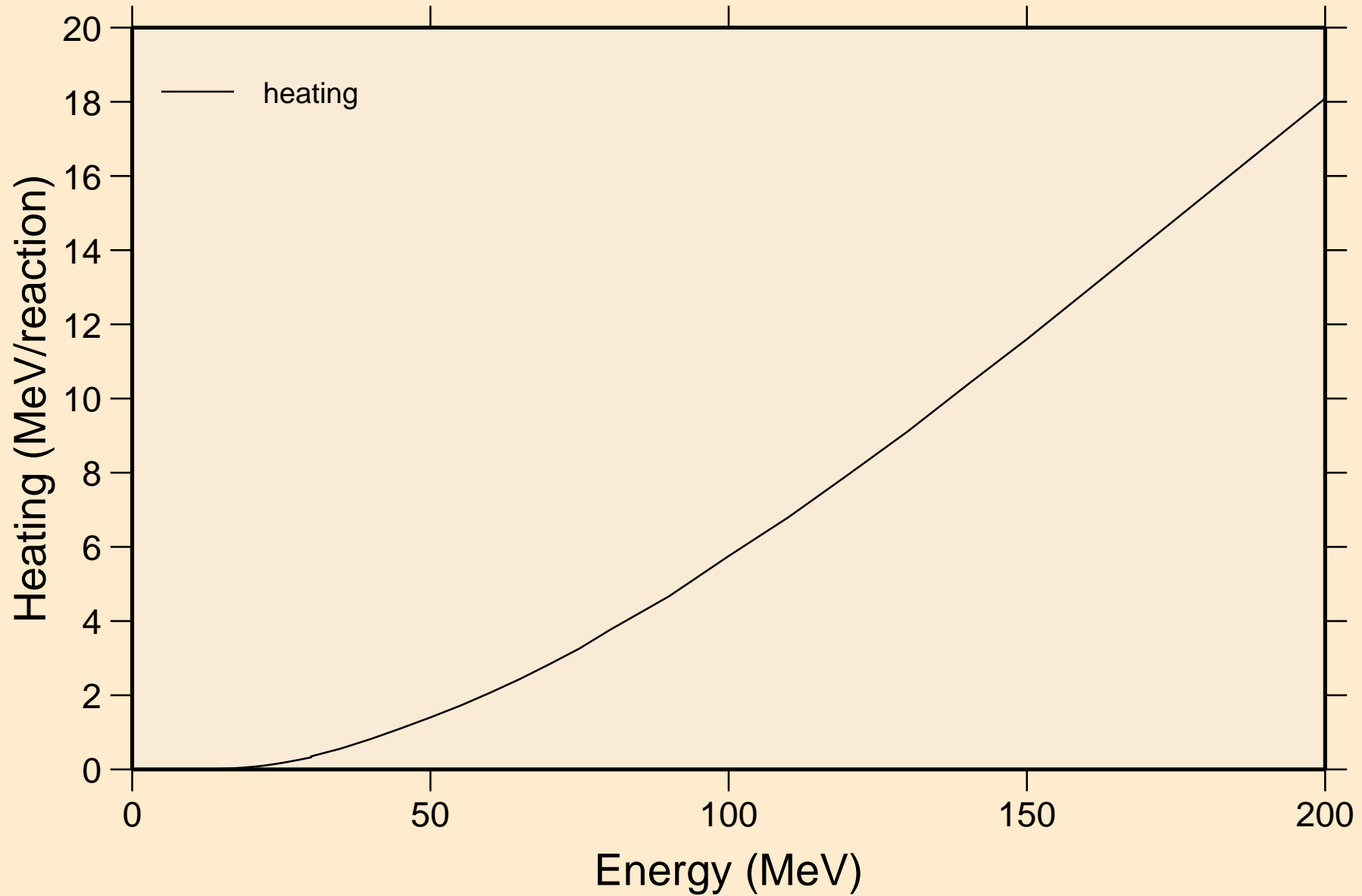

CO055 PROTON ACER TENDL-2021 LIBRARY; T=0.K  
Threshold reactions

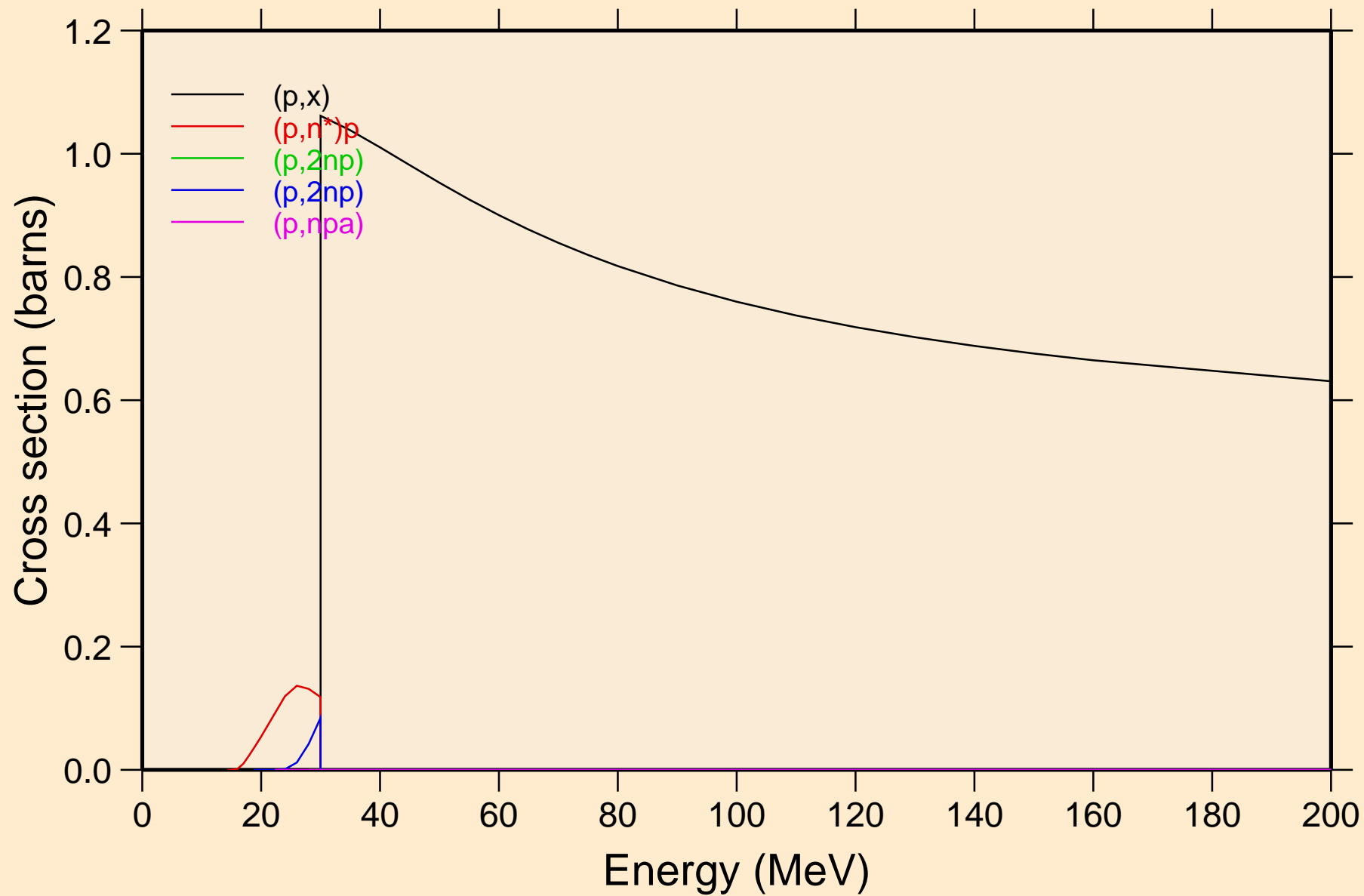

CO055 PROTON ACER TENDL-2021 LIBRARY; T=0.K  
Threshold reactions

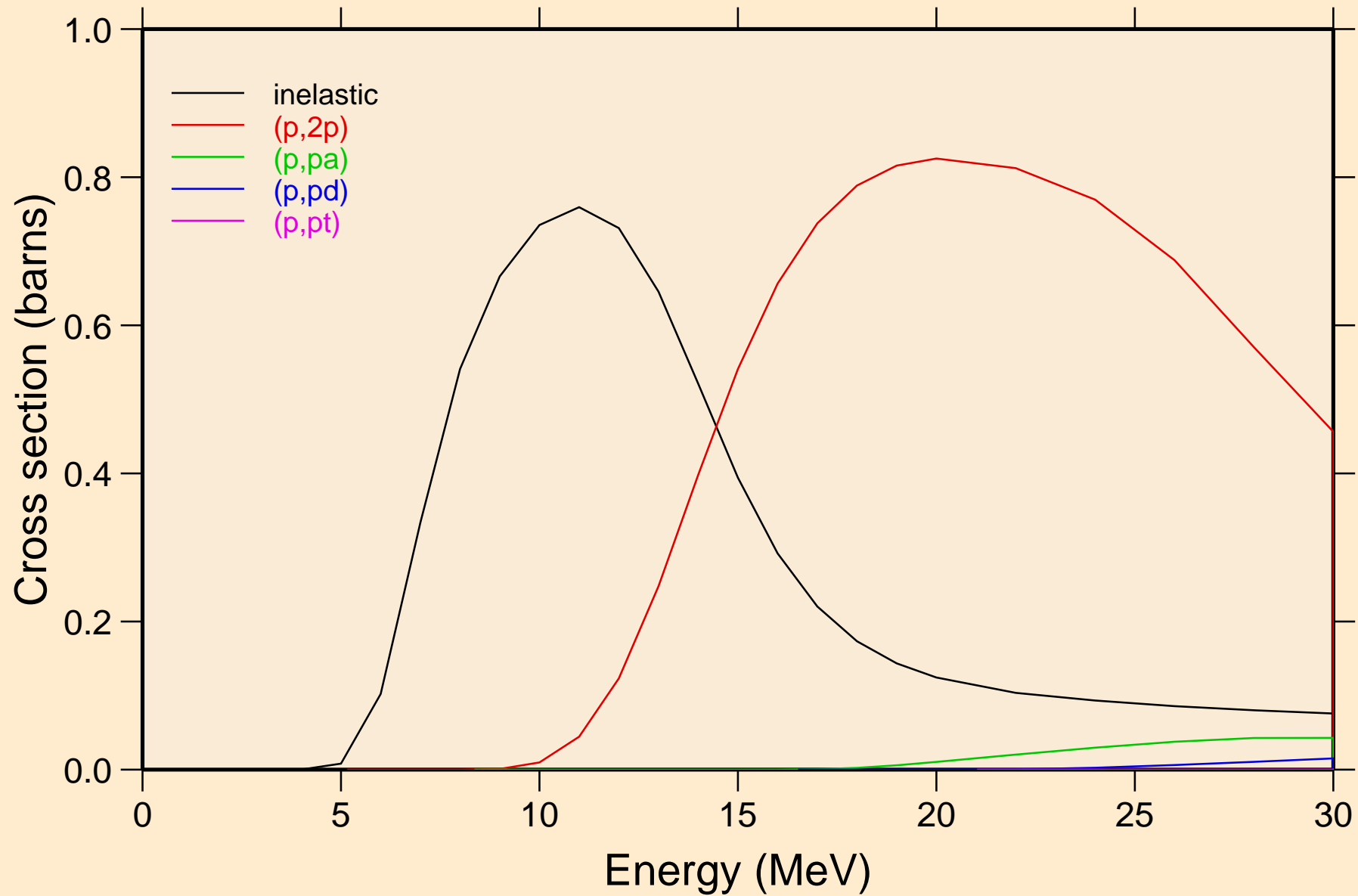

CO055 PROTON ACER TENDL-2021 LIBRARY; T=0.K  
Threshold reactions

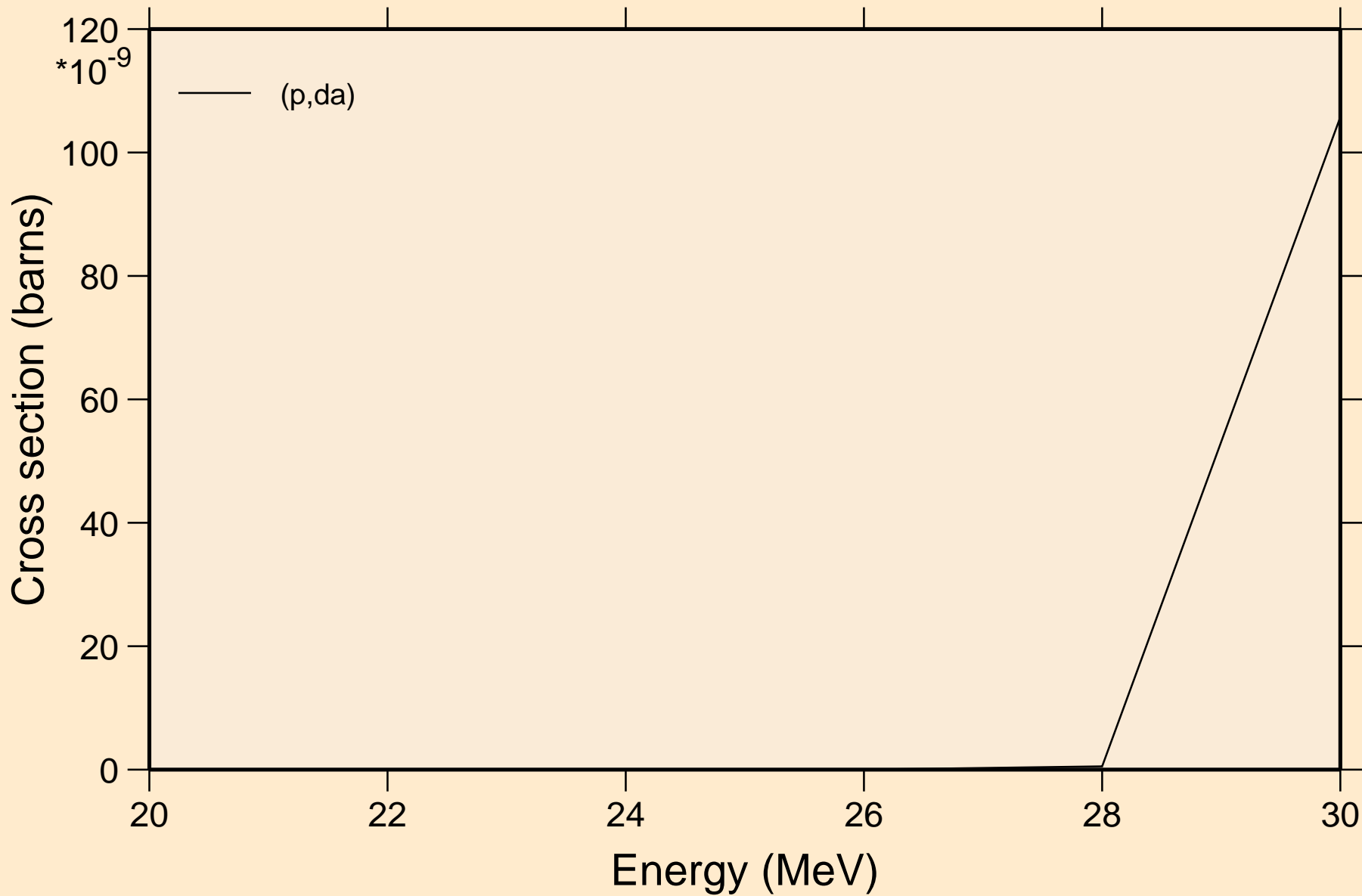

CO055 PROTON ACER TENDL-2021 LIBRARY; T=0.K  
angular distribution for elastic

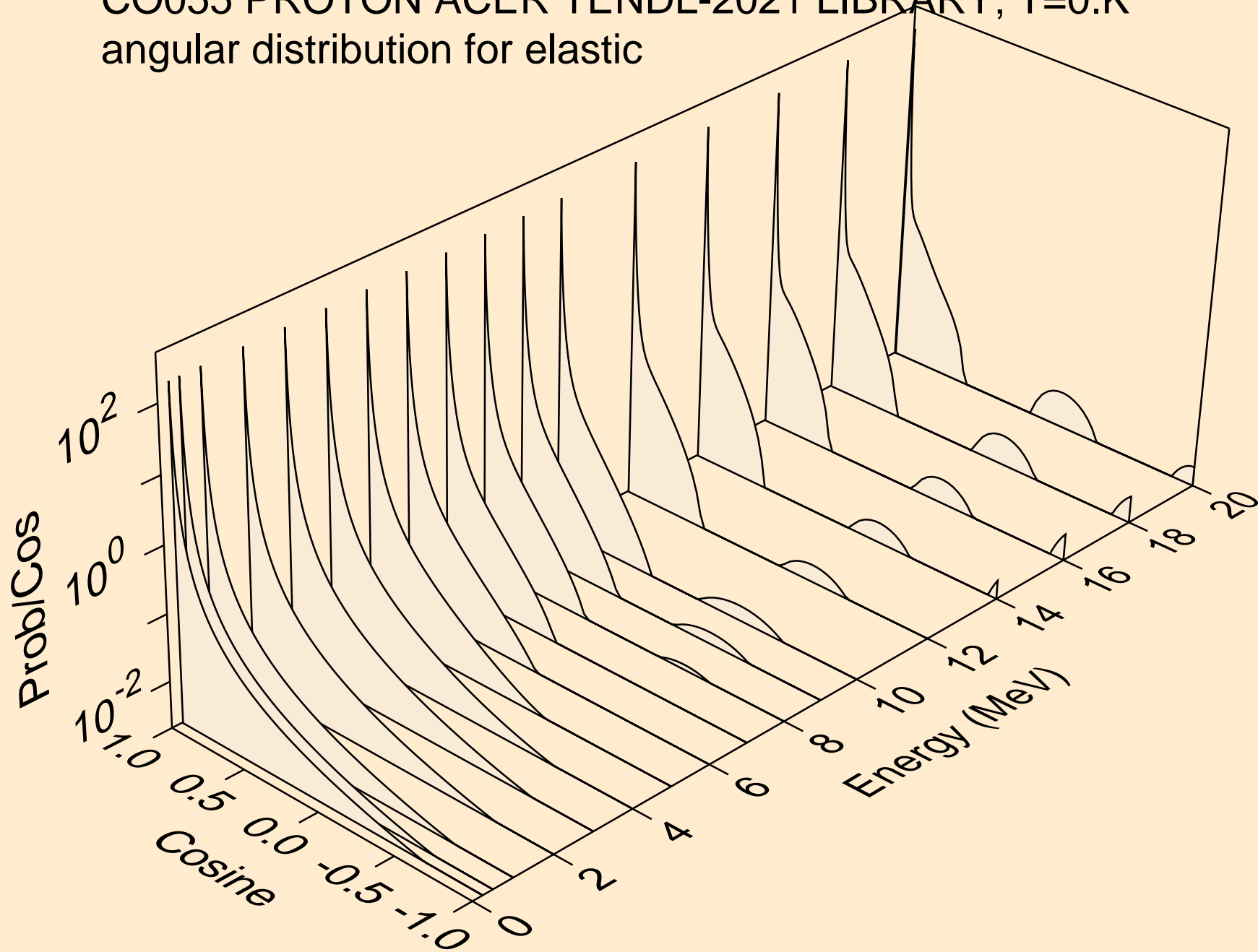



CO055 PROTON ACER TENDL-2021 LIBRARY; T=0.K  
angular distribution for elastic

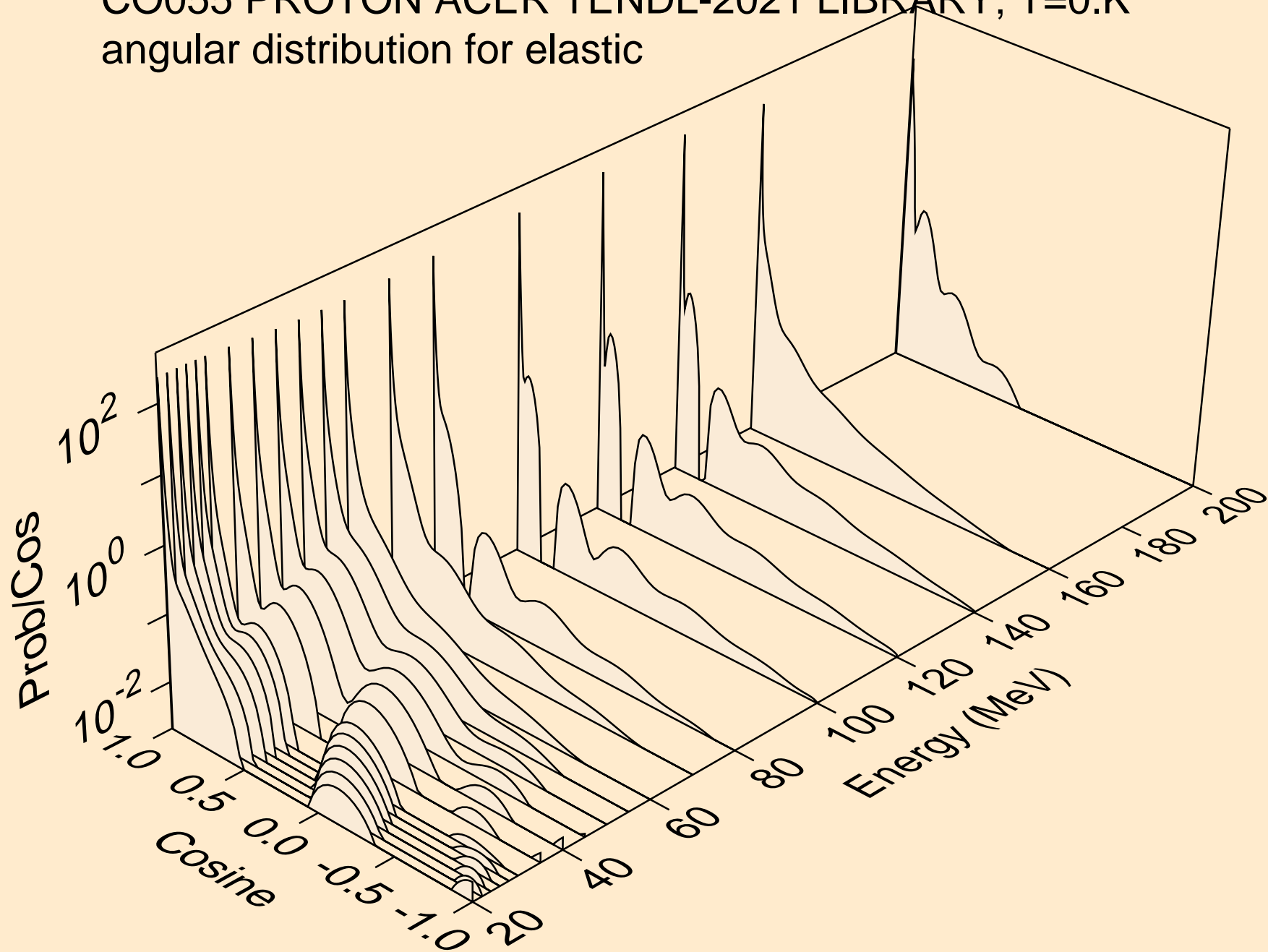

CO055 PROTON ACER TENDL-2021 LIBRARY; T=0.K  
Proton emission for (p,x)

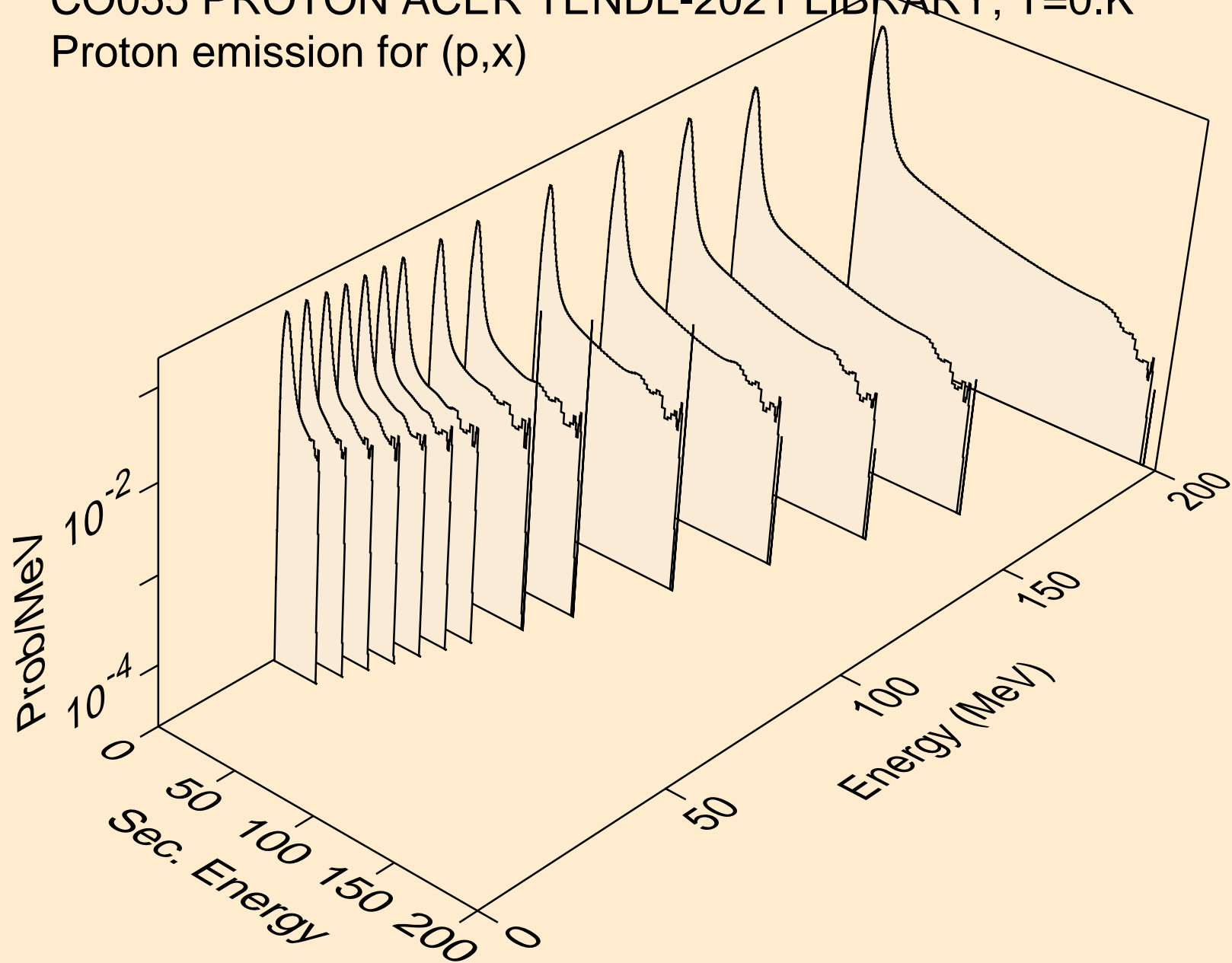

CO055 PROTON ACER TENDL-2021 LIBRARY; T=0.K  
Proton emission for (p,n\*)p

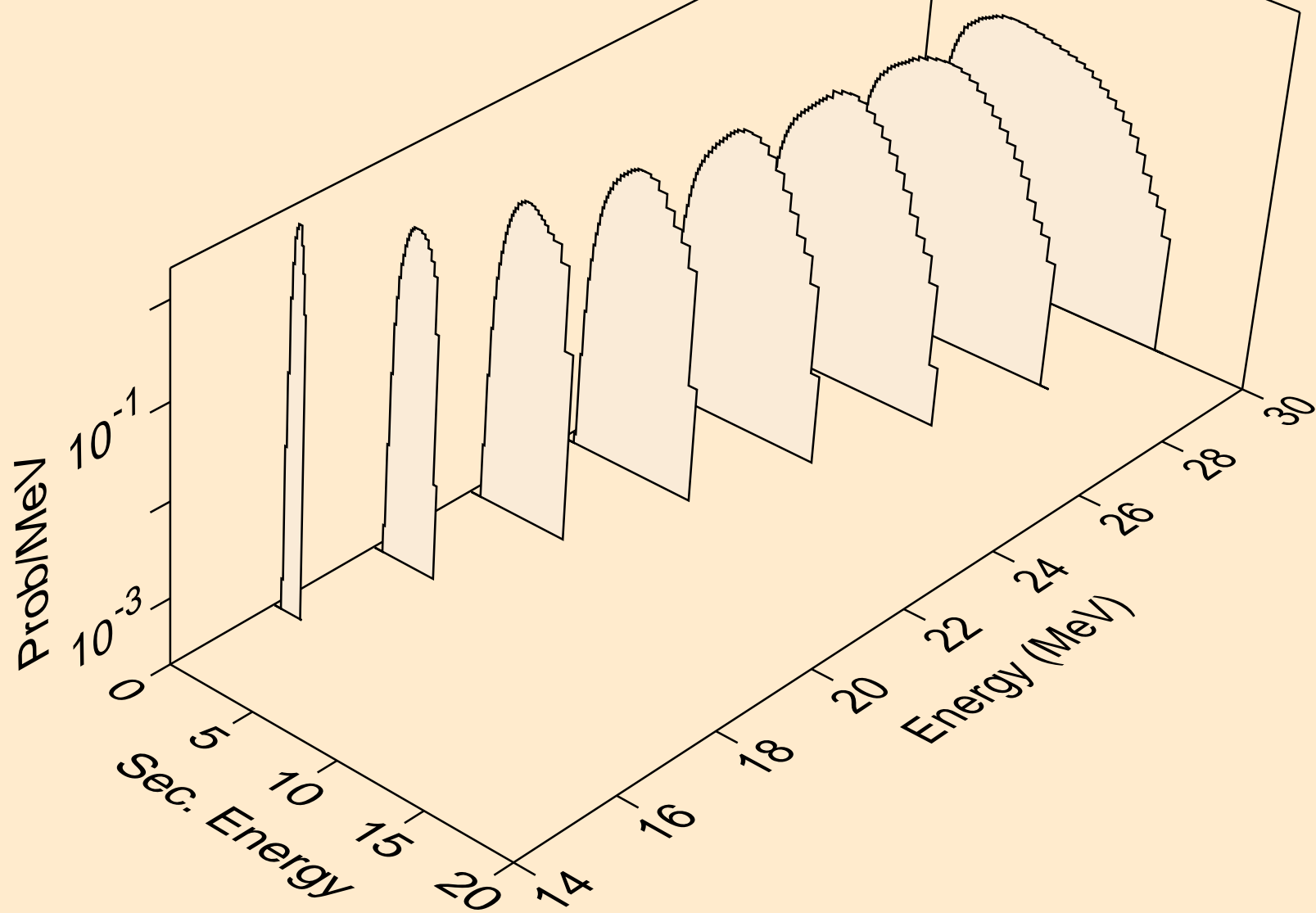

CO055 PROTON ACER TENDL-2021 LIBRARY; T=0.K  
Proton emission for (p,2np)

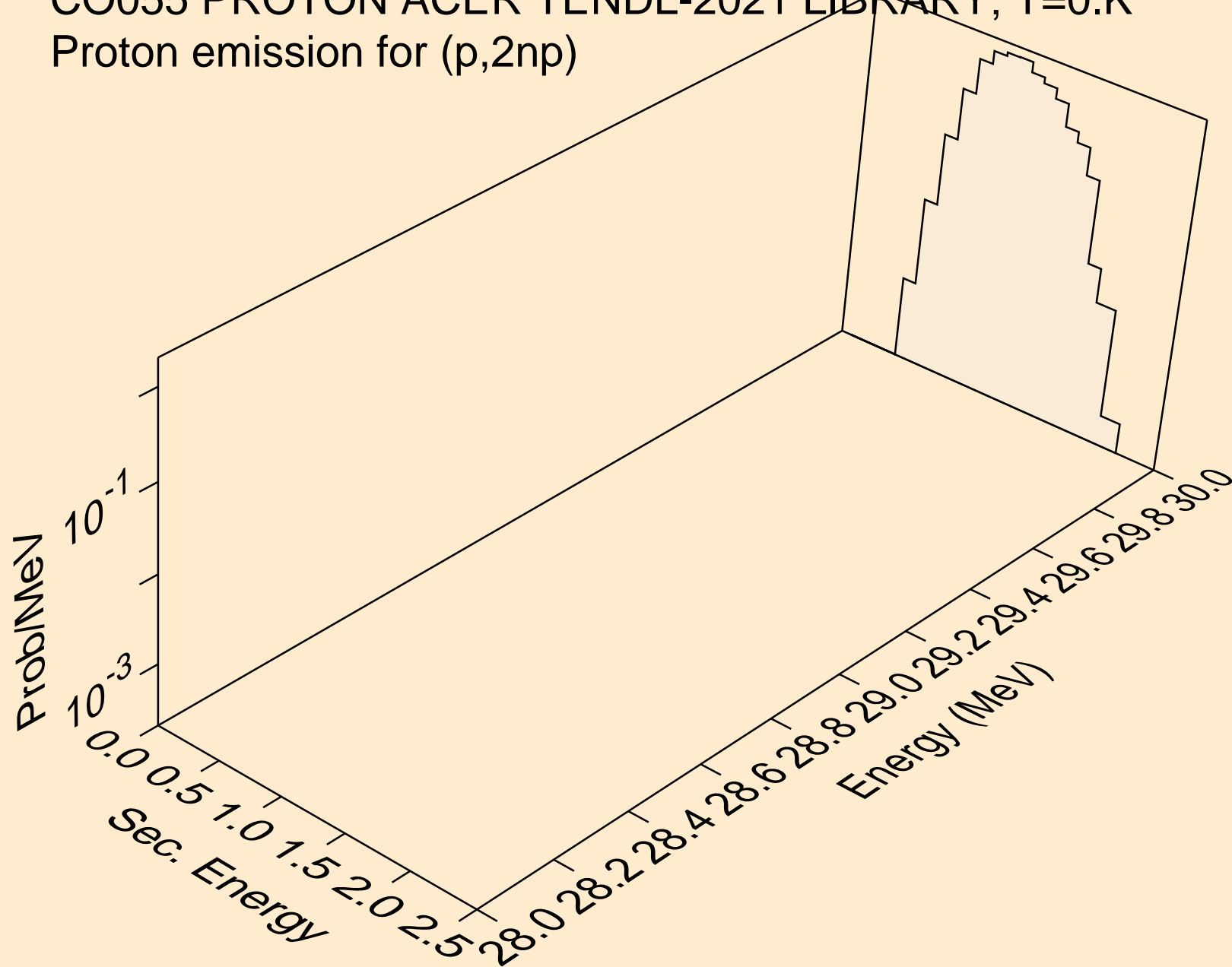

CO055 PROTON ACER TENDL-2021 LIBRARY; T=0.K  
Proton emission for (p,2np)

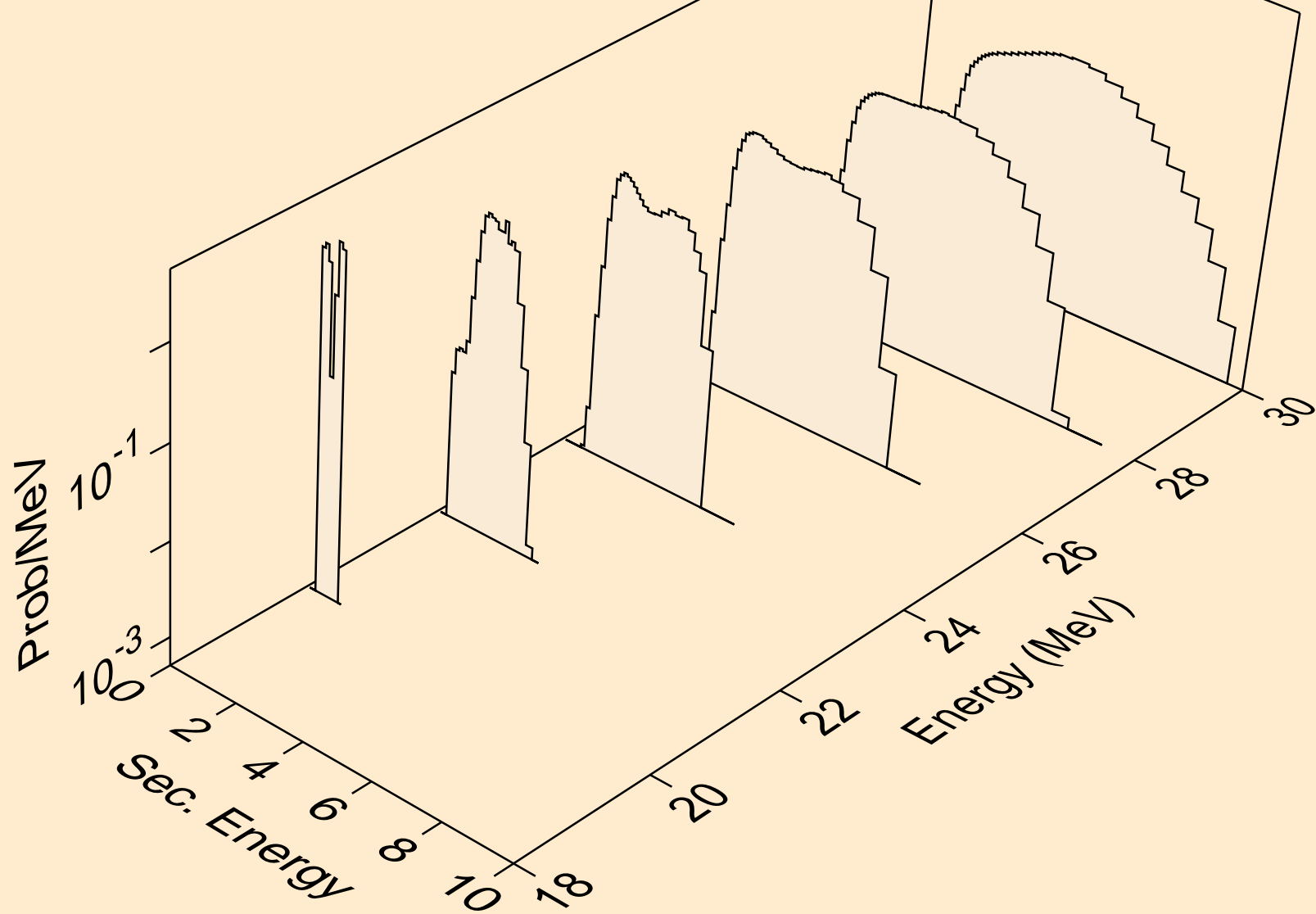

CO055 PROTON ACER TENDL-2021 LIBRARY; T=0.K  
Proton emission for (p,npa)

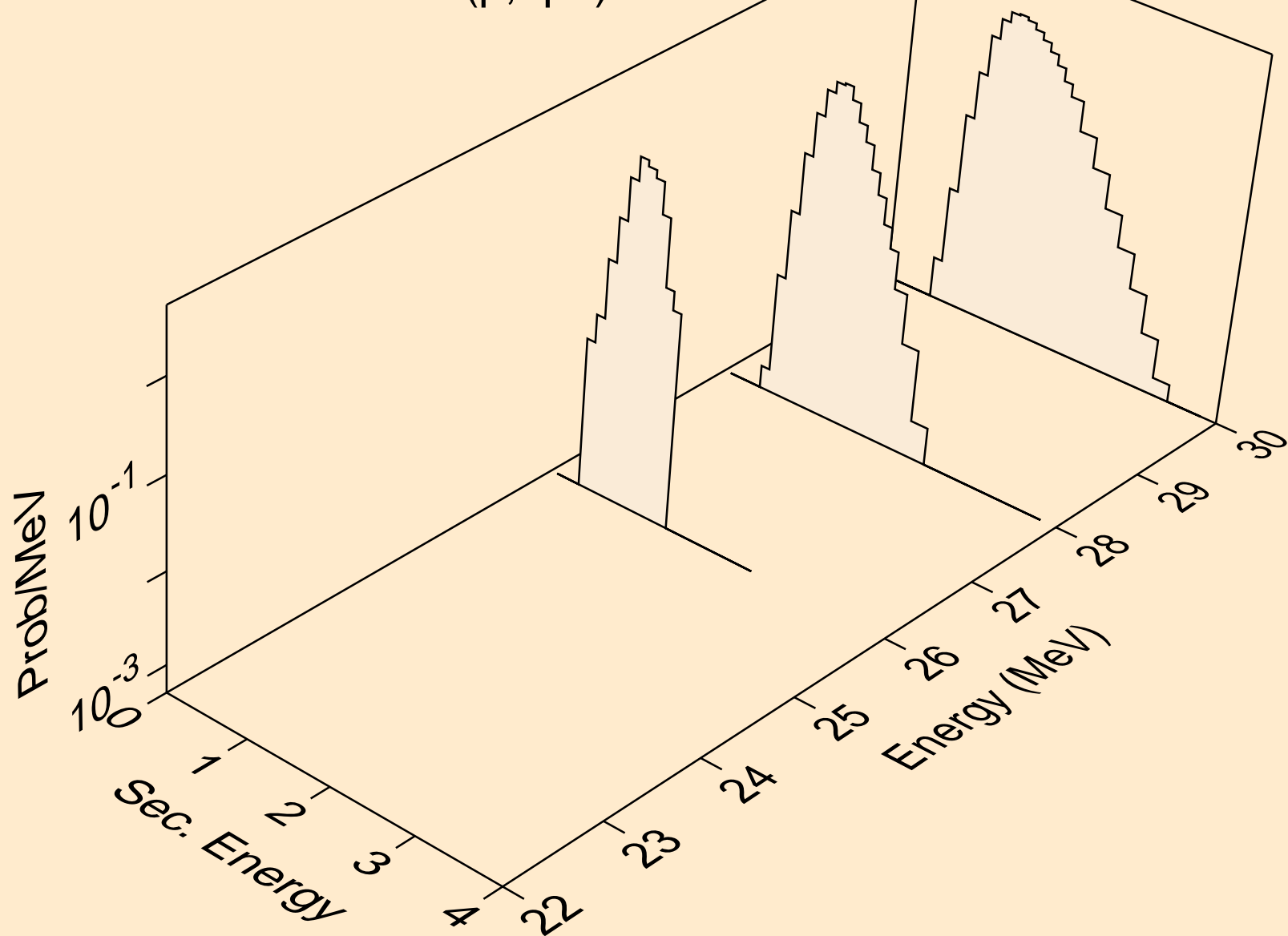

CO055 PROTON ACER TENDL-2021 LIBRARY; T=0.K  
Proton emission for inelastic

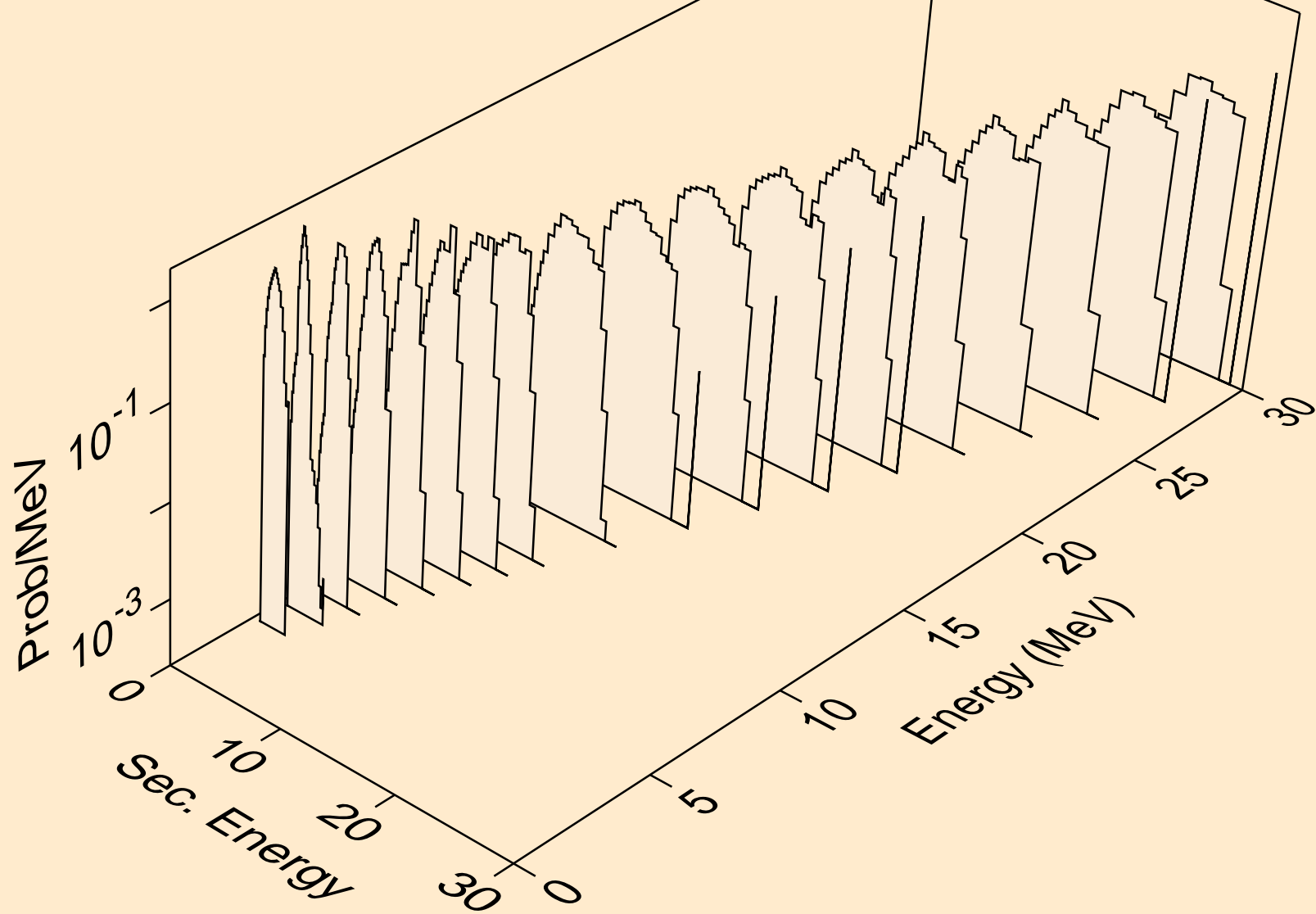

CO055 PROTON ACER TENDL-2021 LIBRARY; T=0.K  
Proton emission for (p,2p)

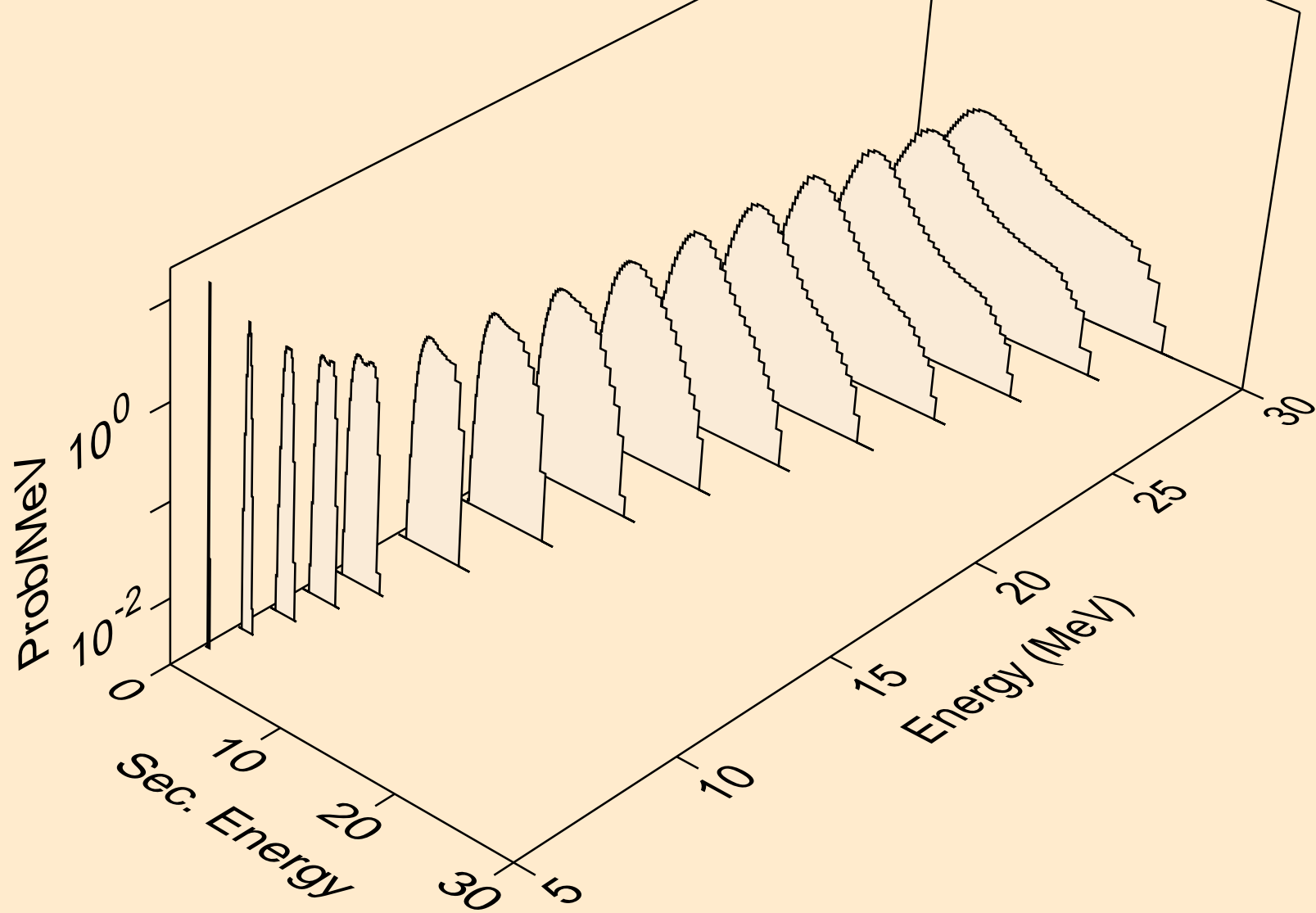



CO055 PROTON ACER TENDL-2021 LIBRARY; T=0.K  
Proton emission for (p,pa)

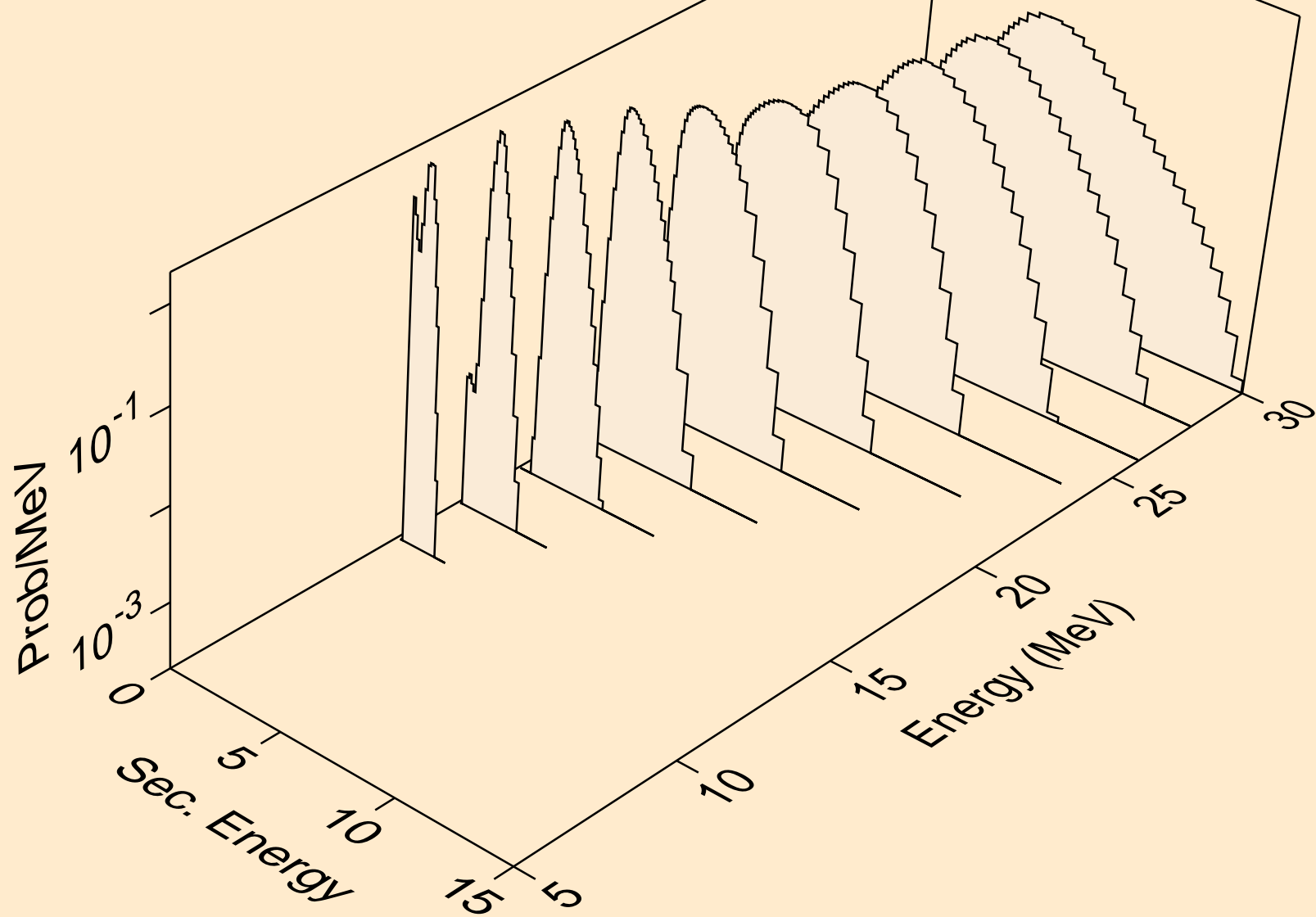

CO055 PROTON ACER TENDL-2021 LIBRARY; T=0.K  
Proton emission for (p,pd)

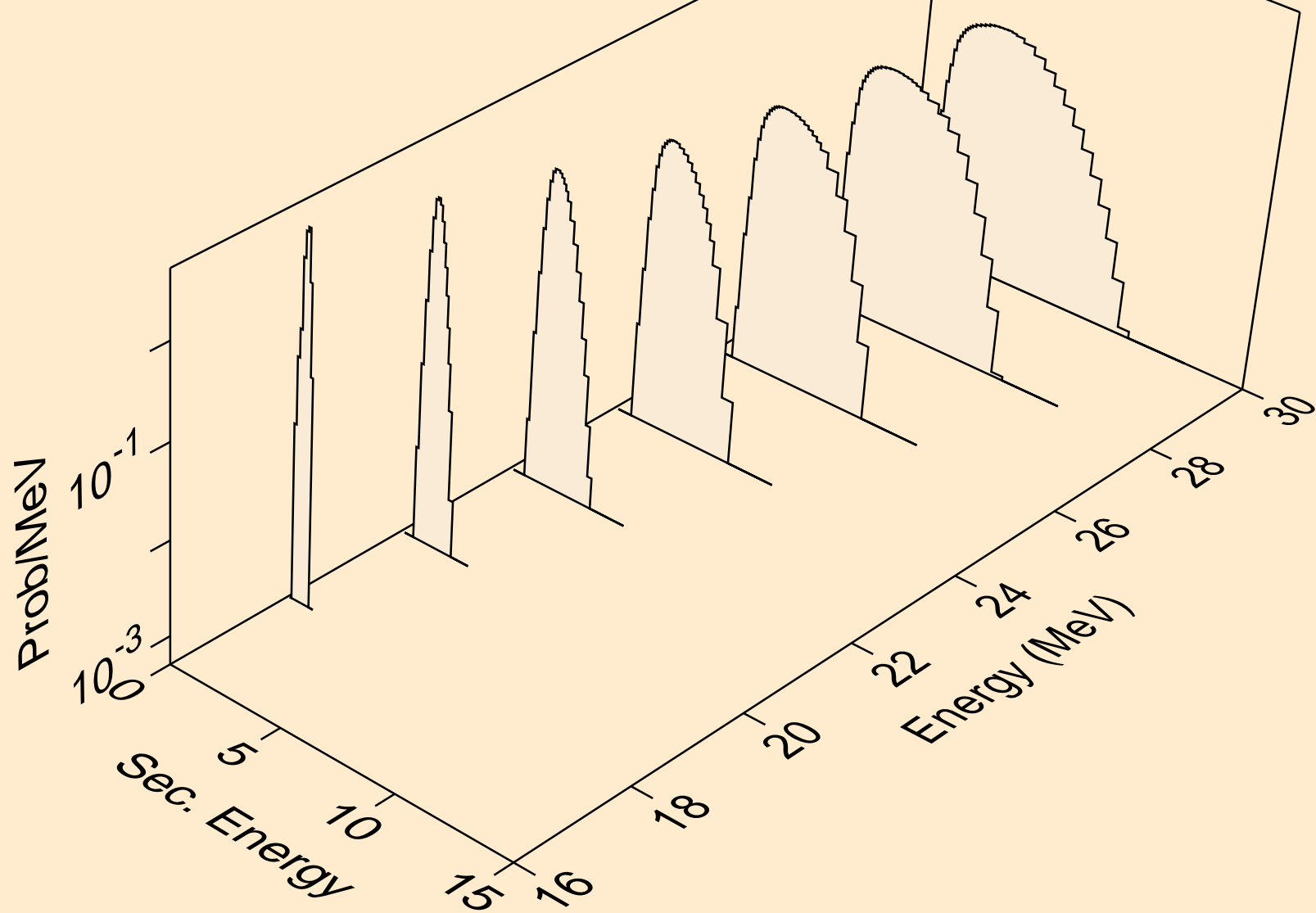

CO055 PROTON ACER TENDL-2021 LIBRARY; T=0.K  
Proton emission for (p,pt)

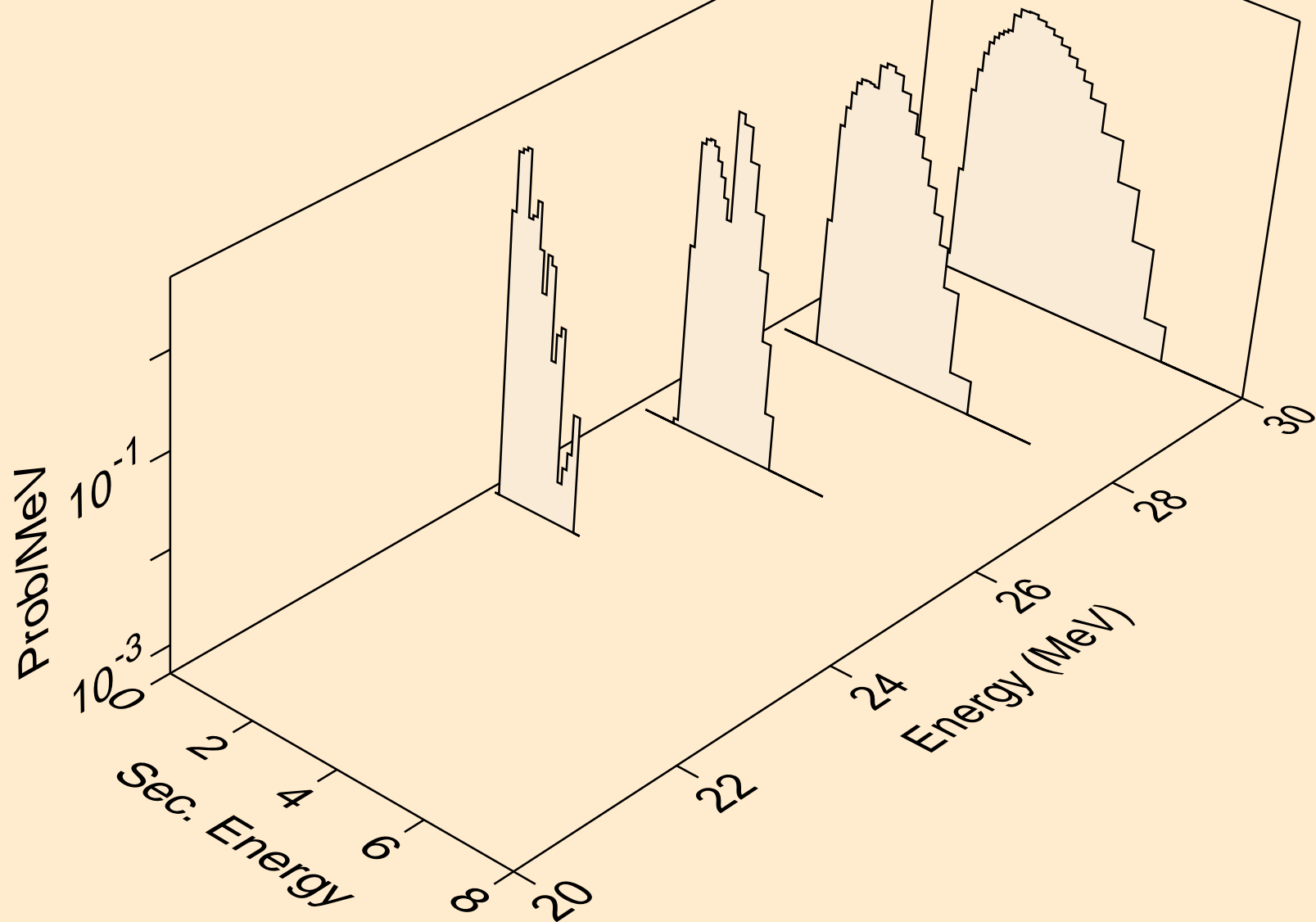

CO055 PROTON ACER TENDL-2021 LIBRARY; T=0.K  
Photon emission for (z,n)

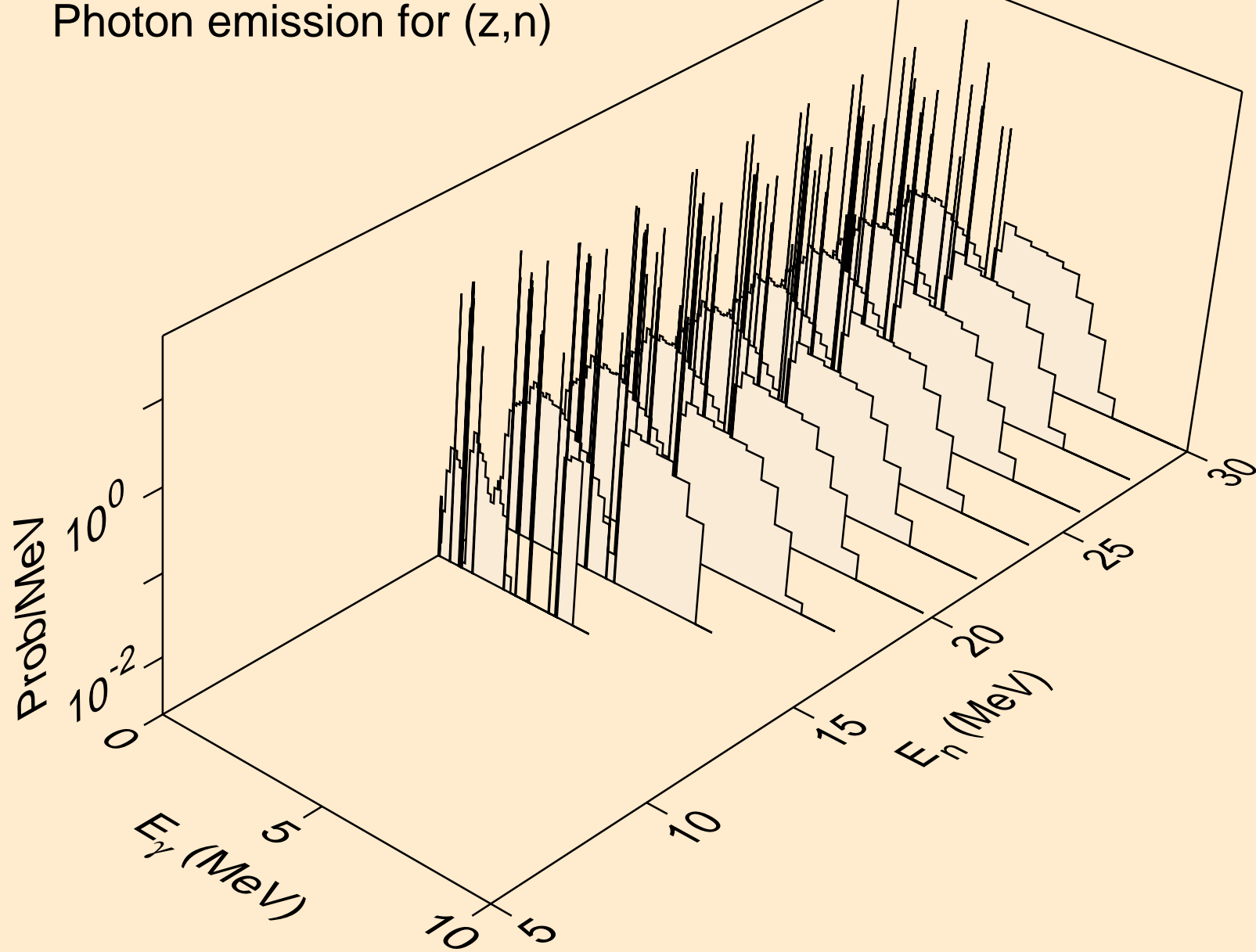

CO055 PROTON ACER TENDL-2021 LIBRARY; T=0.K  
Photon emission for (n,x)

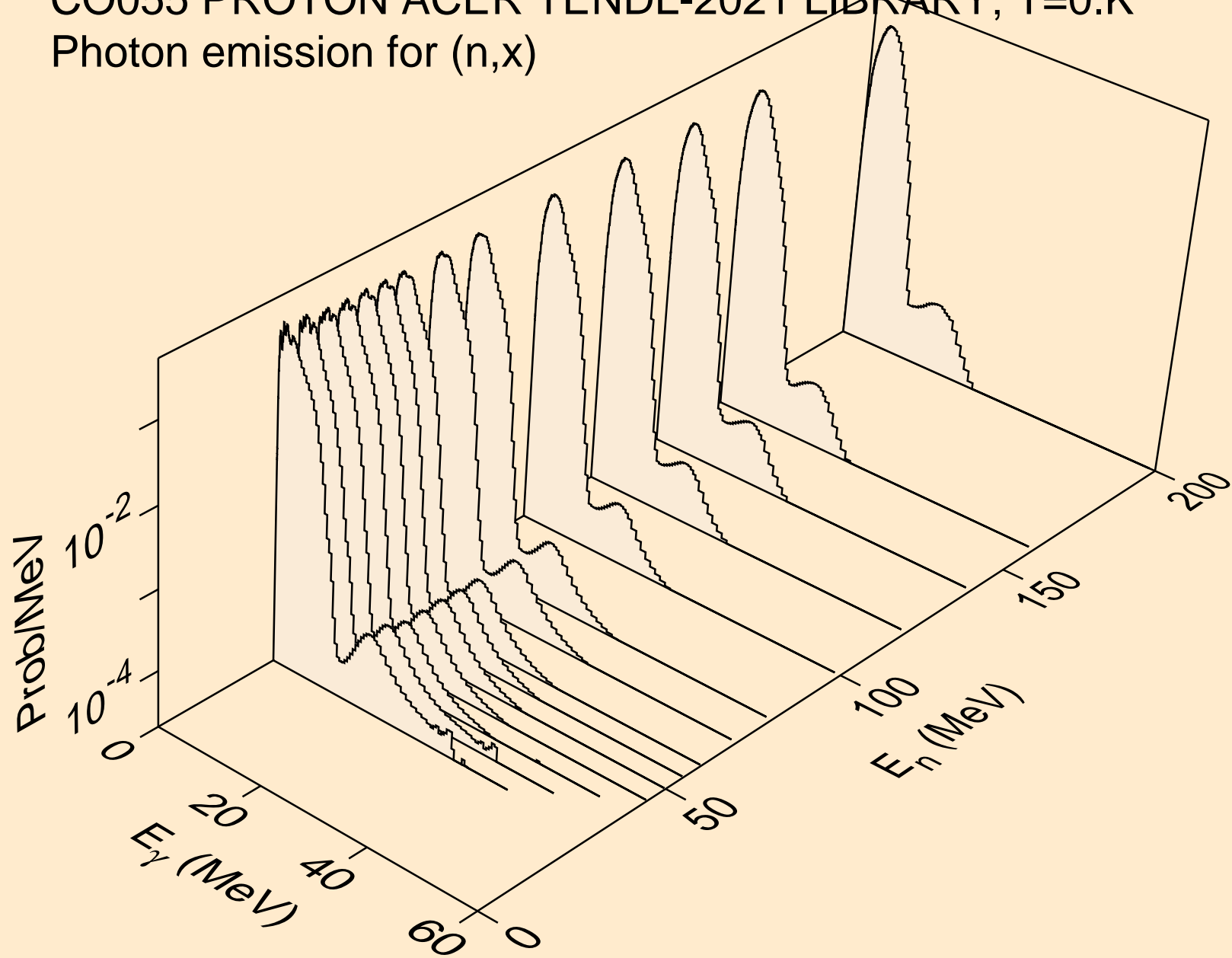

CO055 PROTON ACER TENDL-2021 LIBRARY; T=0.K  
Photon emission for (n,2n)

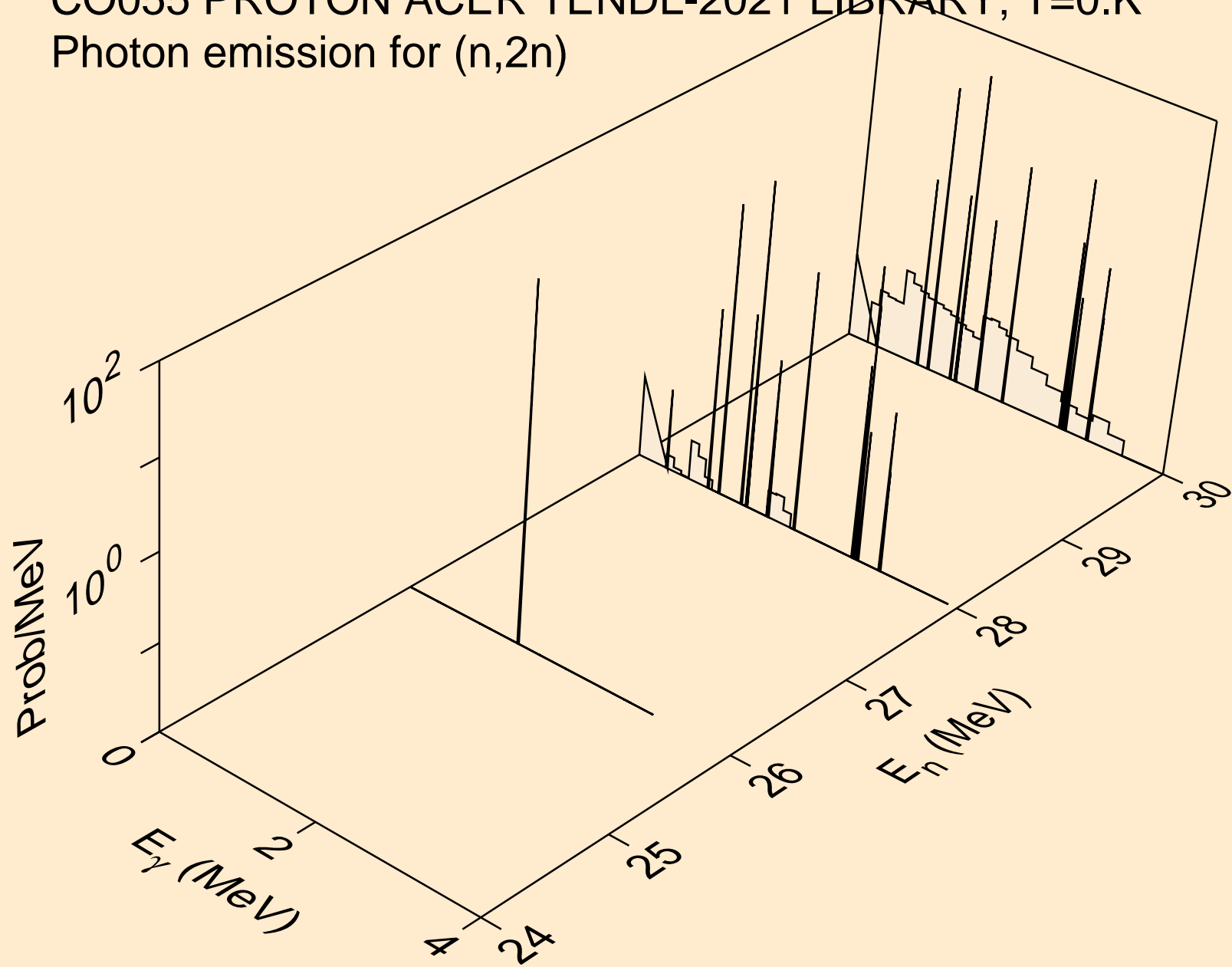

CO055 PROTON ACER TENDL-2021 LIBRARY; T=0.K  
Photon emission for (n,n\*)a

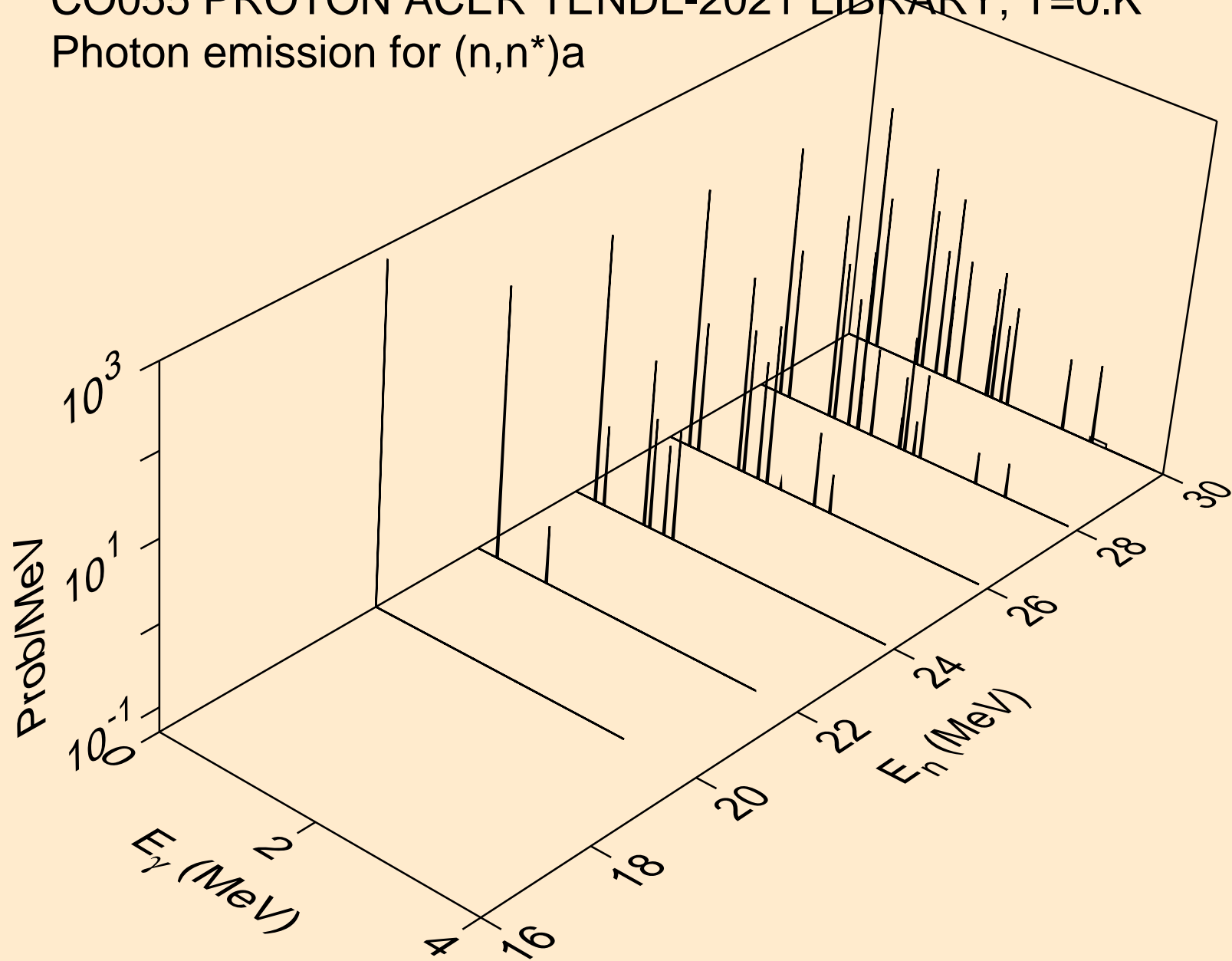

CO055 PROTON ACER TENDL-2021 LIBRARY; T=0.K  
Photon emission for (n,n\*)p

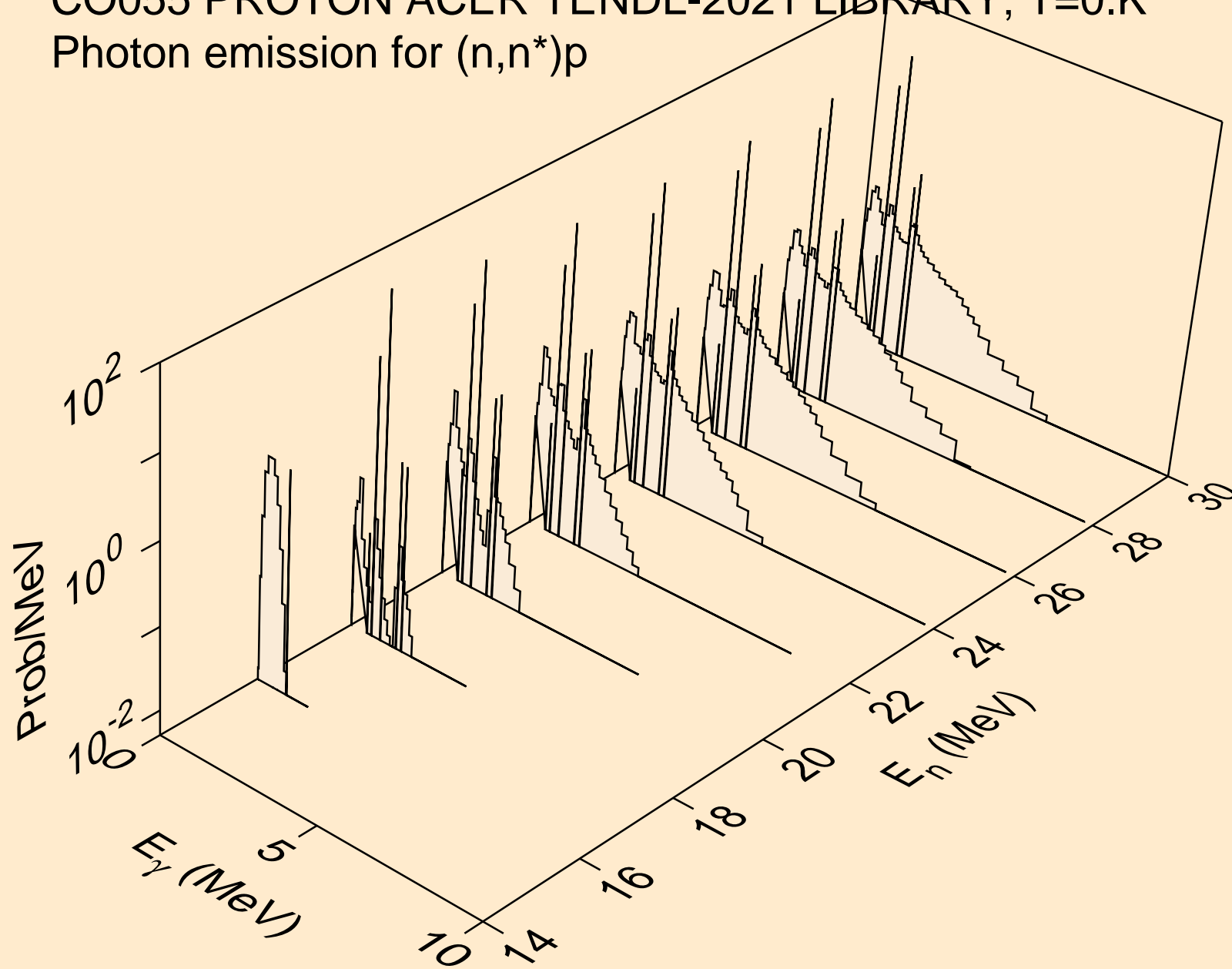



CO055 PROTON ACER TENDL-2021 LIBRARY; T=0.K  
Photon emission for (n,n\*)d

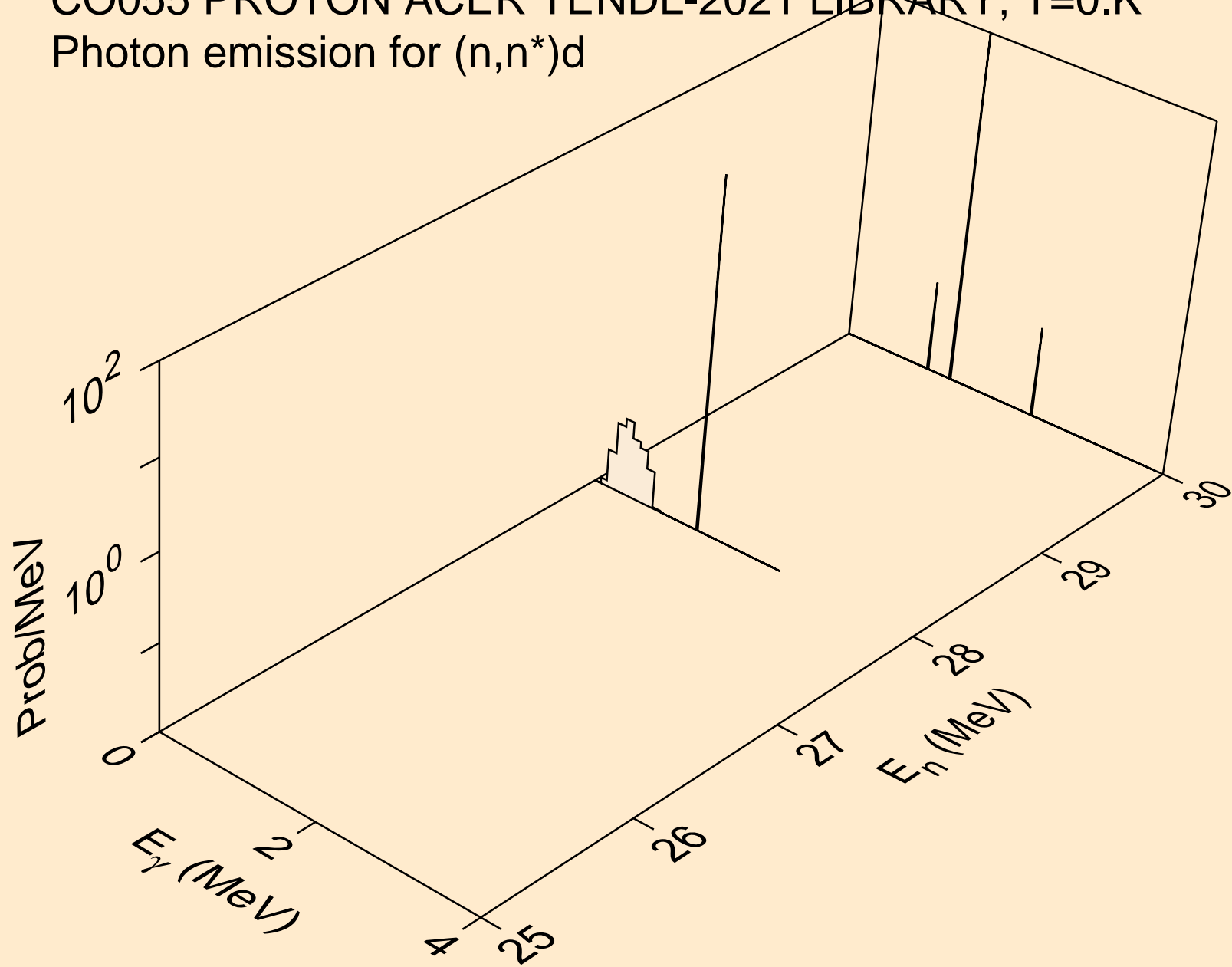

CO055 PROTON ACER TENDL-2021 LIBRARY; T=0.K  
Photon emission for (n,n\*)he3

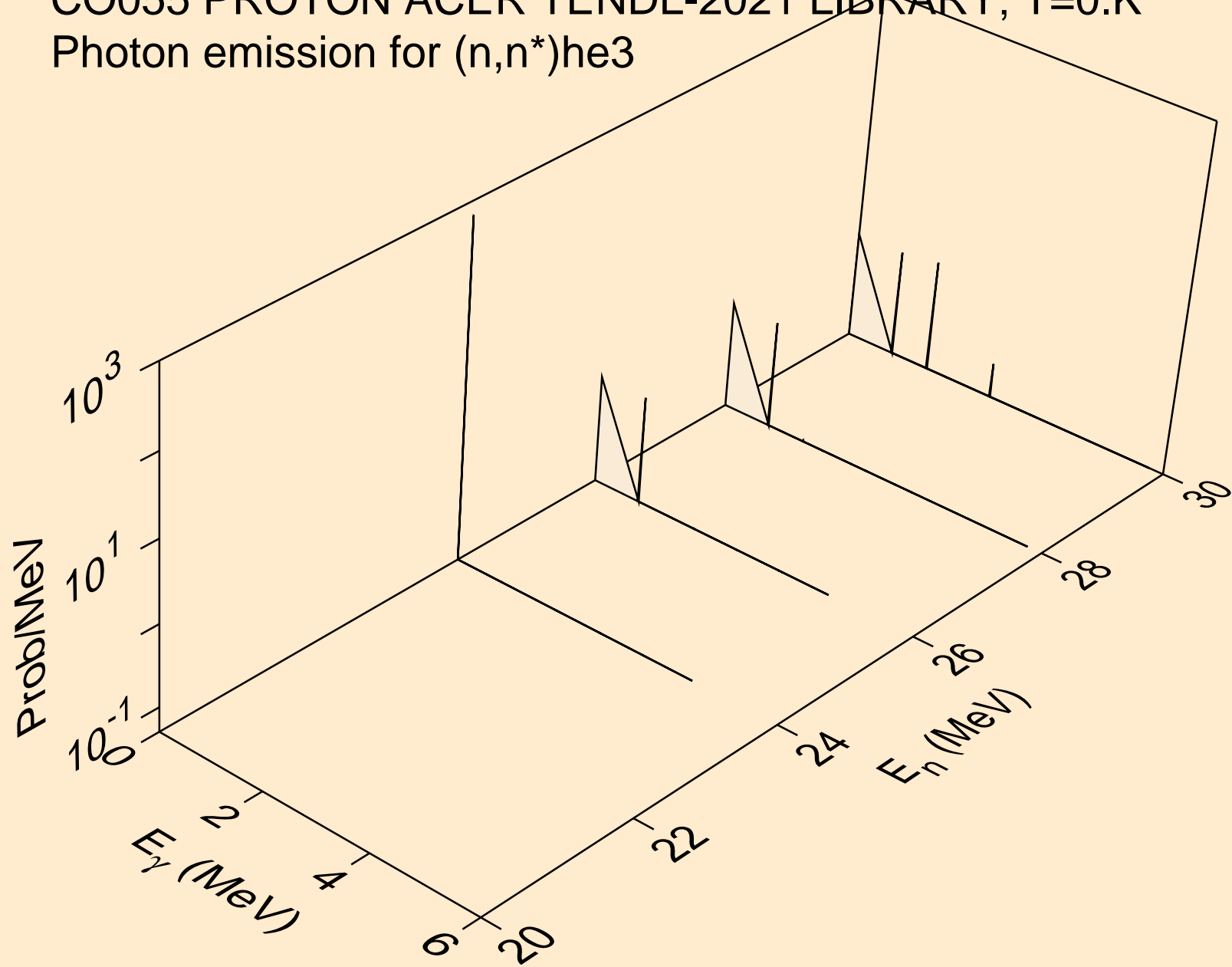

CO055 PROTON ACER TENDL-2021 LIBRARY; T=0.K  
Photon emission for (n,2np)

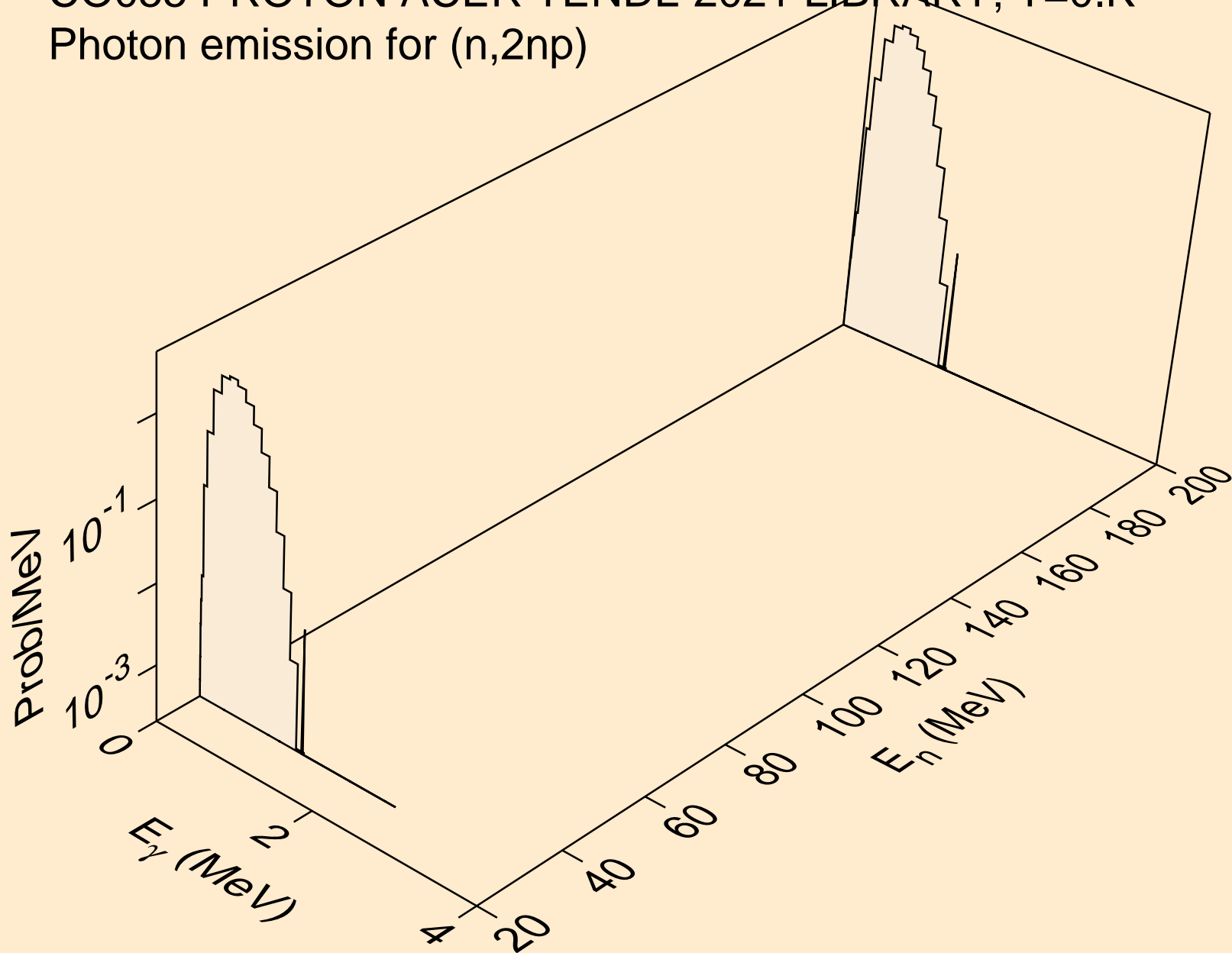

CO055 PROTON ACER TENDL-2021 LIBRARY; T=0.K  
Photon emission for (n,2np)

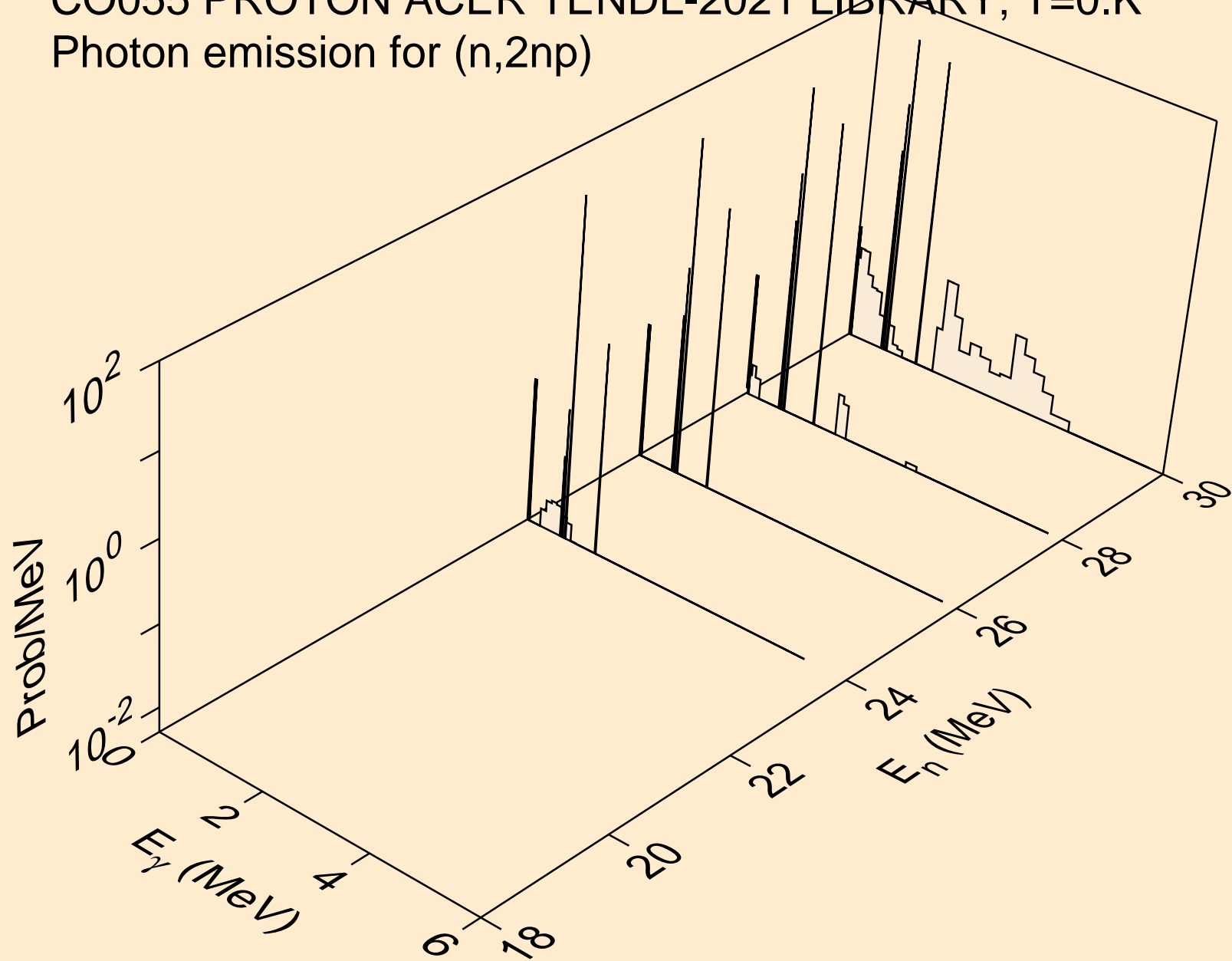

CO055 PROTON ACER TENDL-2021 LIBRARY; T=0.K  
Photon emission for (n,npa)

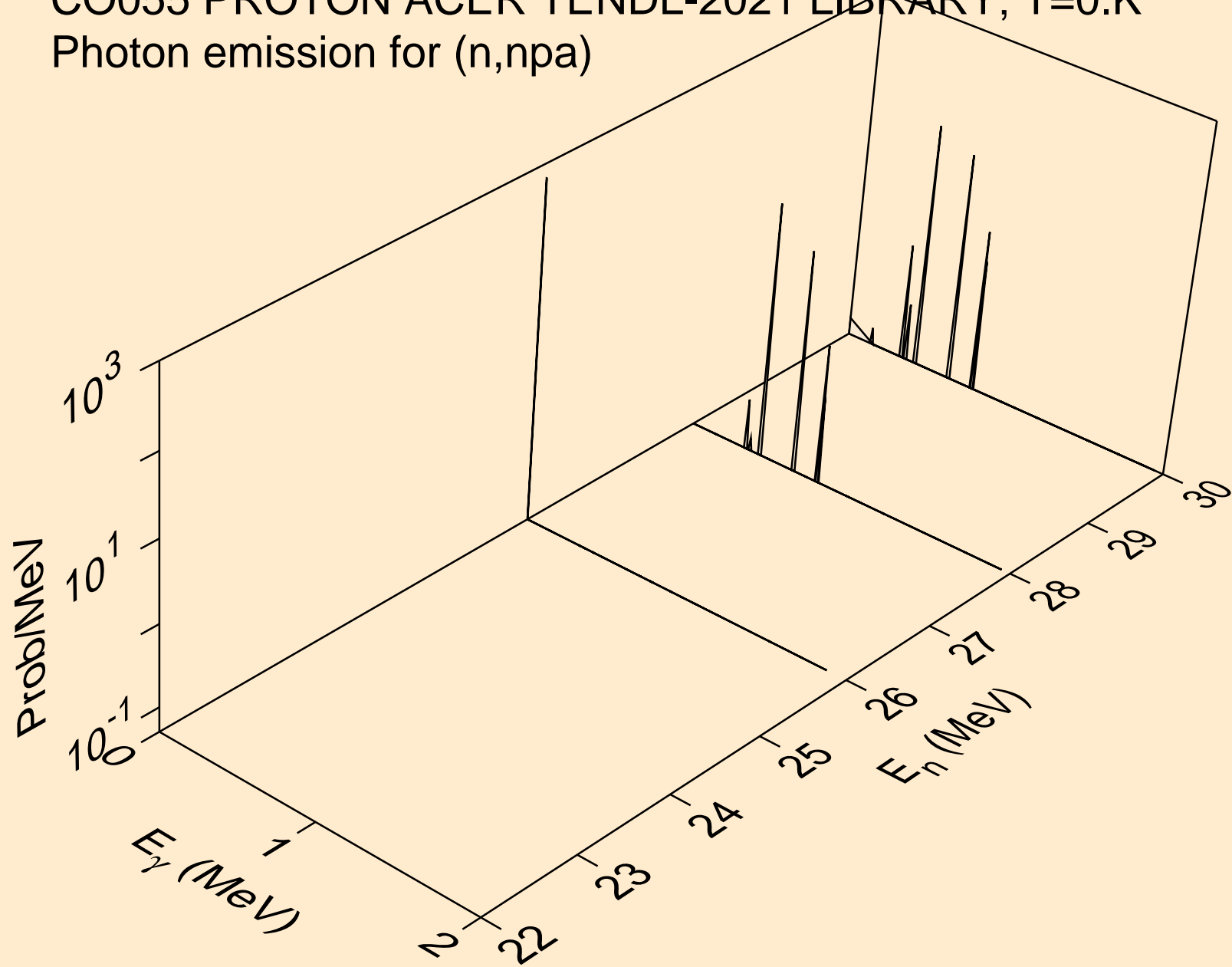

CO055 PROTON ACER TENDL-2021 LIBRARY; T=0.K  
Photon emission for (n,gma)

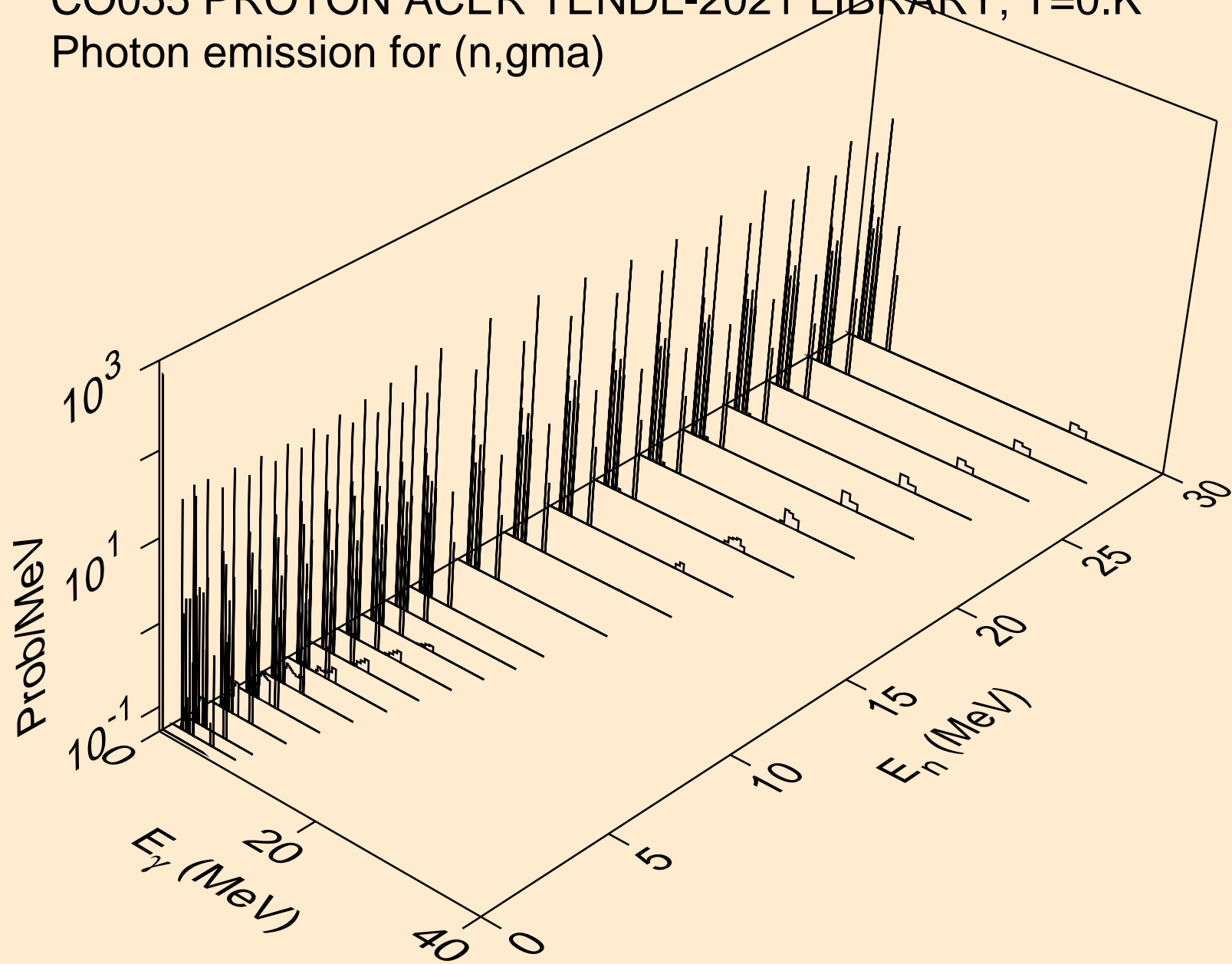

CO055 PROTON ACER TENDL-2021 LIBRARY; T=0.K  
Photon emission for inelastic

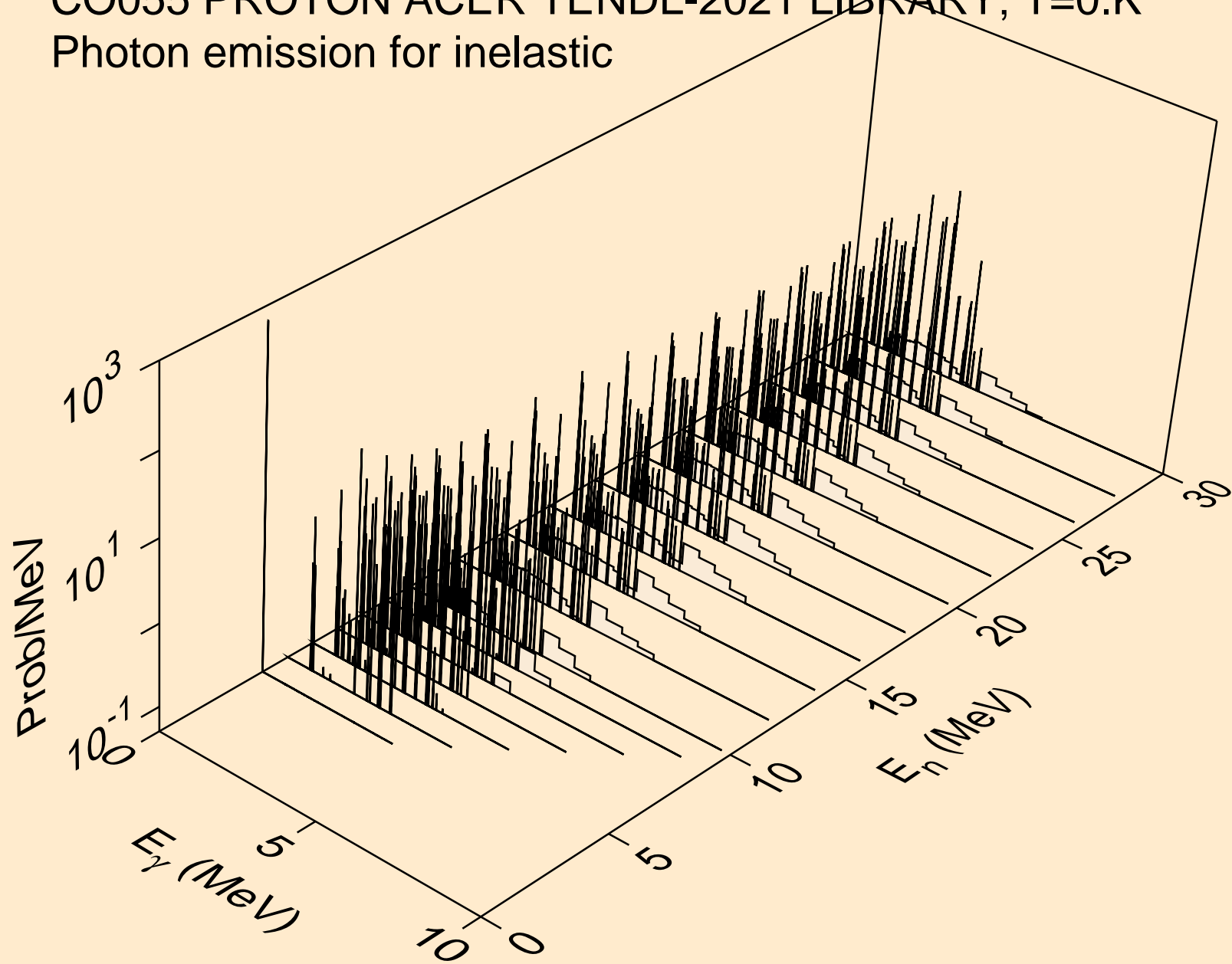

CO055 PROTON ACER TENDL-2021 LIBRARY; T=0.K  
Photon emission for (n,d)

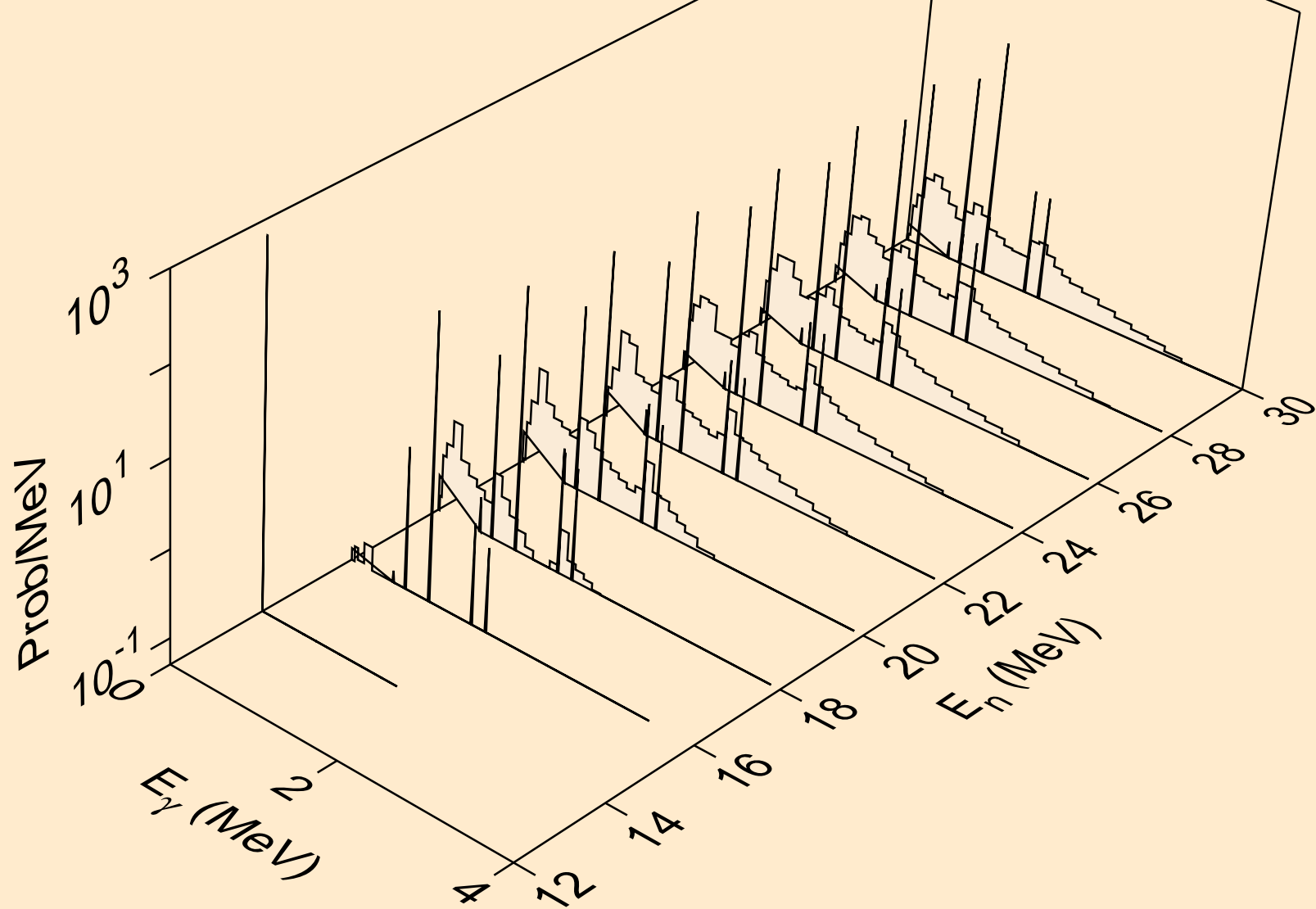



CO055 PROTON ACER TENDL-2021 LIBRARY; T=0.K  
Photon emission for (n,t)

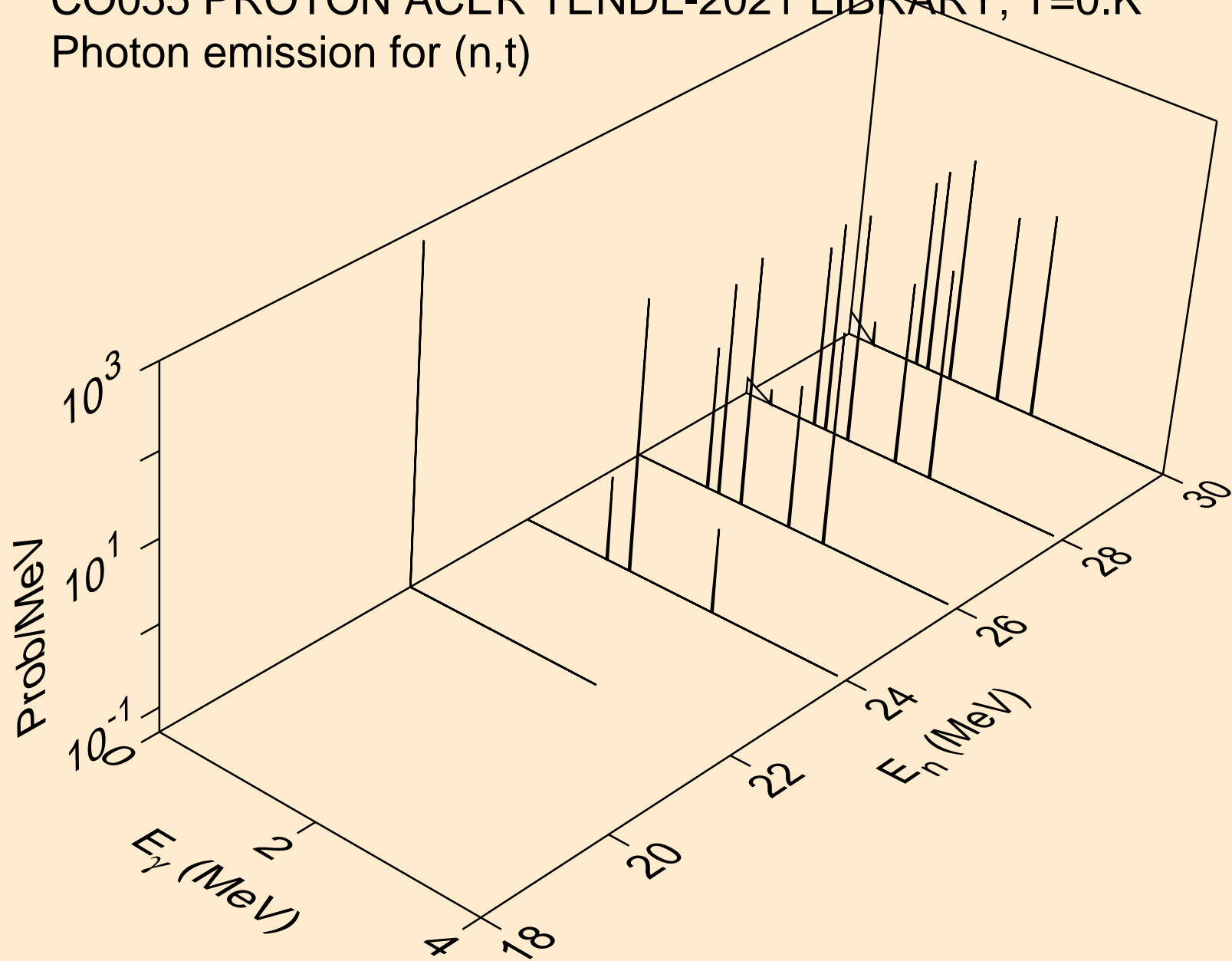

CO055 PROTON ACER TENDL-2021 LIBRARY; T=0.K  
Photon emission for (n,he3)

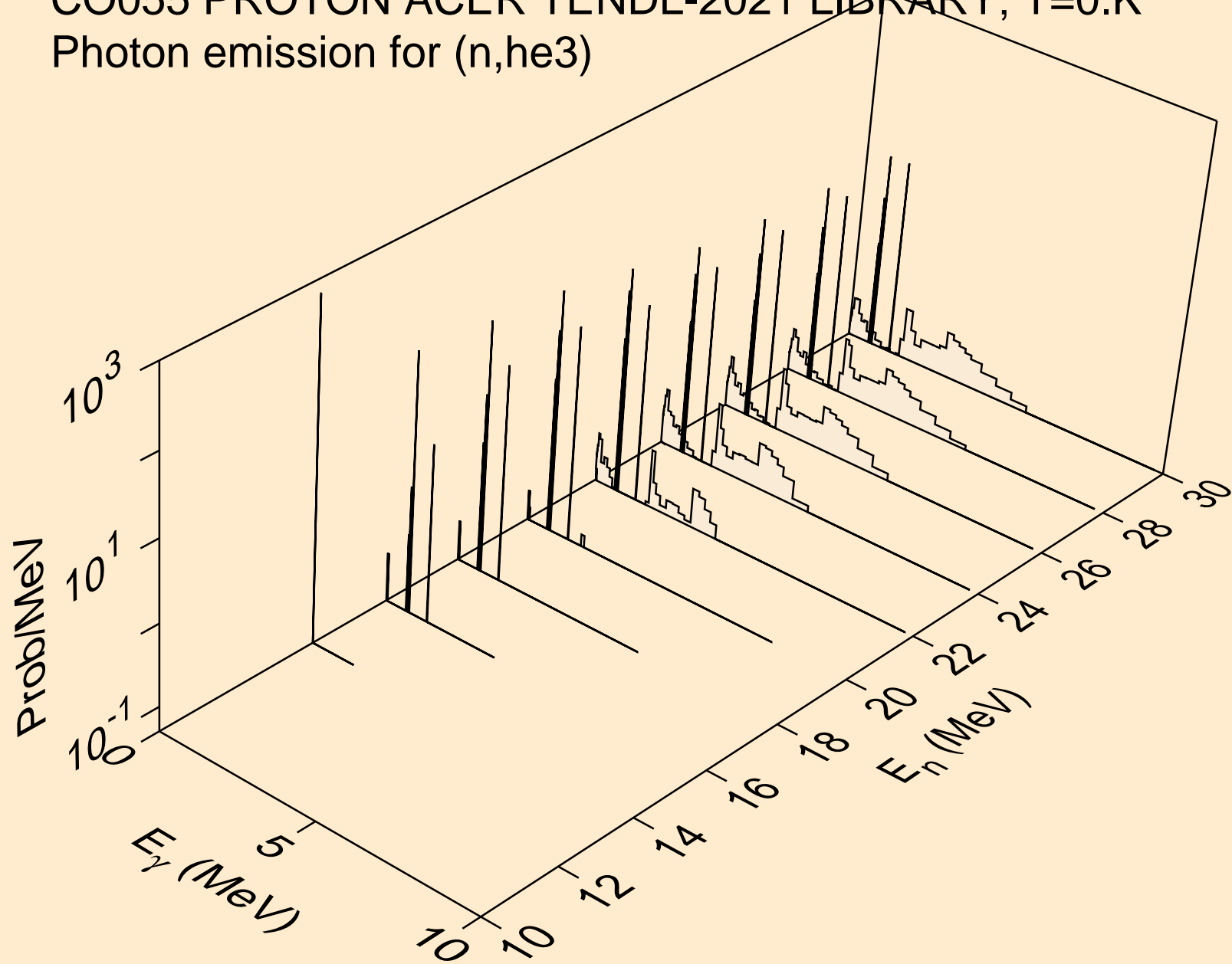

CO055 PROTON ACER TENDL-2021 LIBRARY; T=0.K  
Photon emission for (n,a)

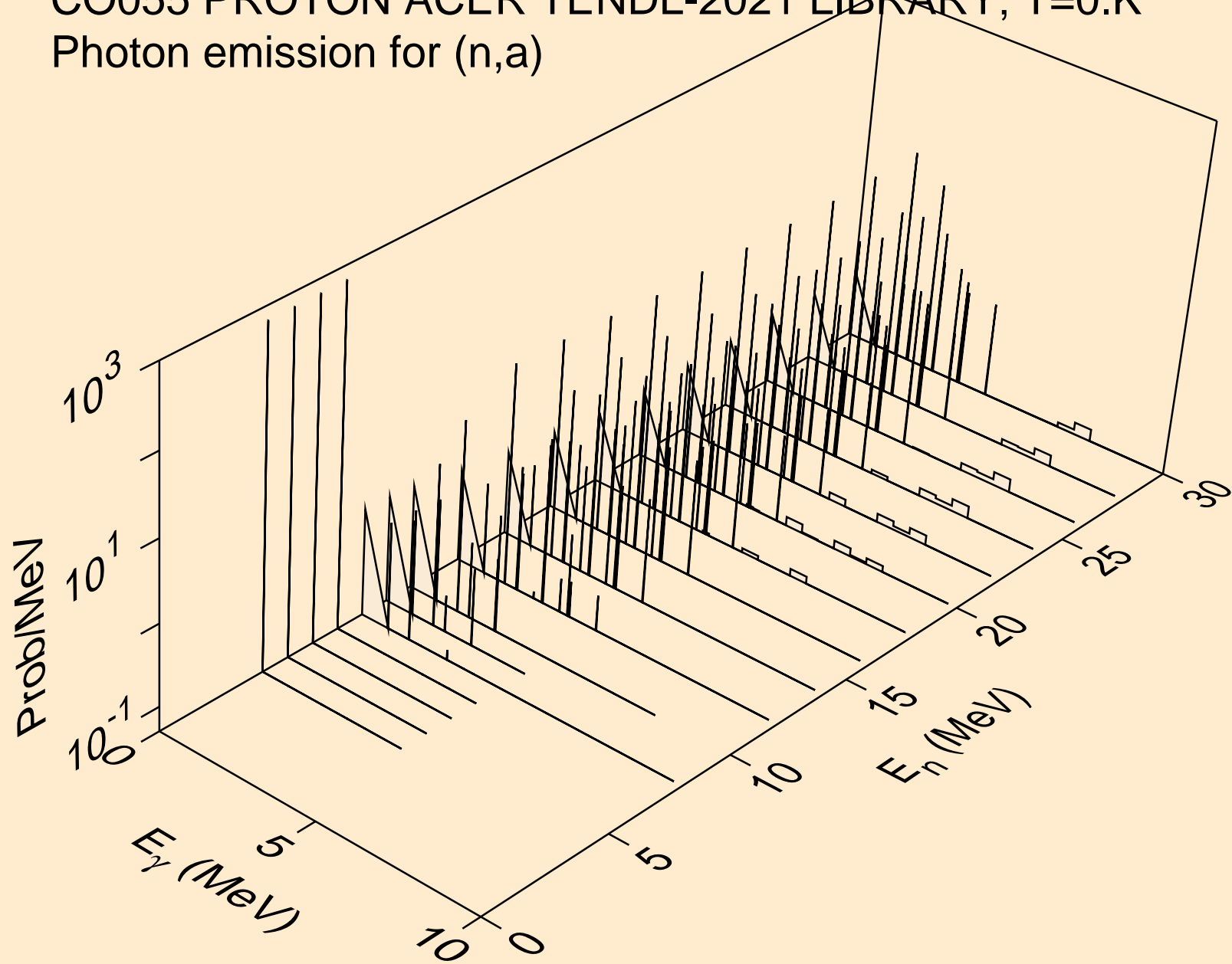

CO055 PROTON ACER TENDL-2021 LIBRARY; T=0.K  
Photon emission for (n,2a)

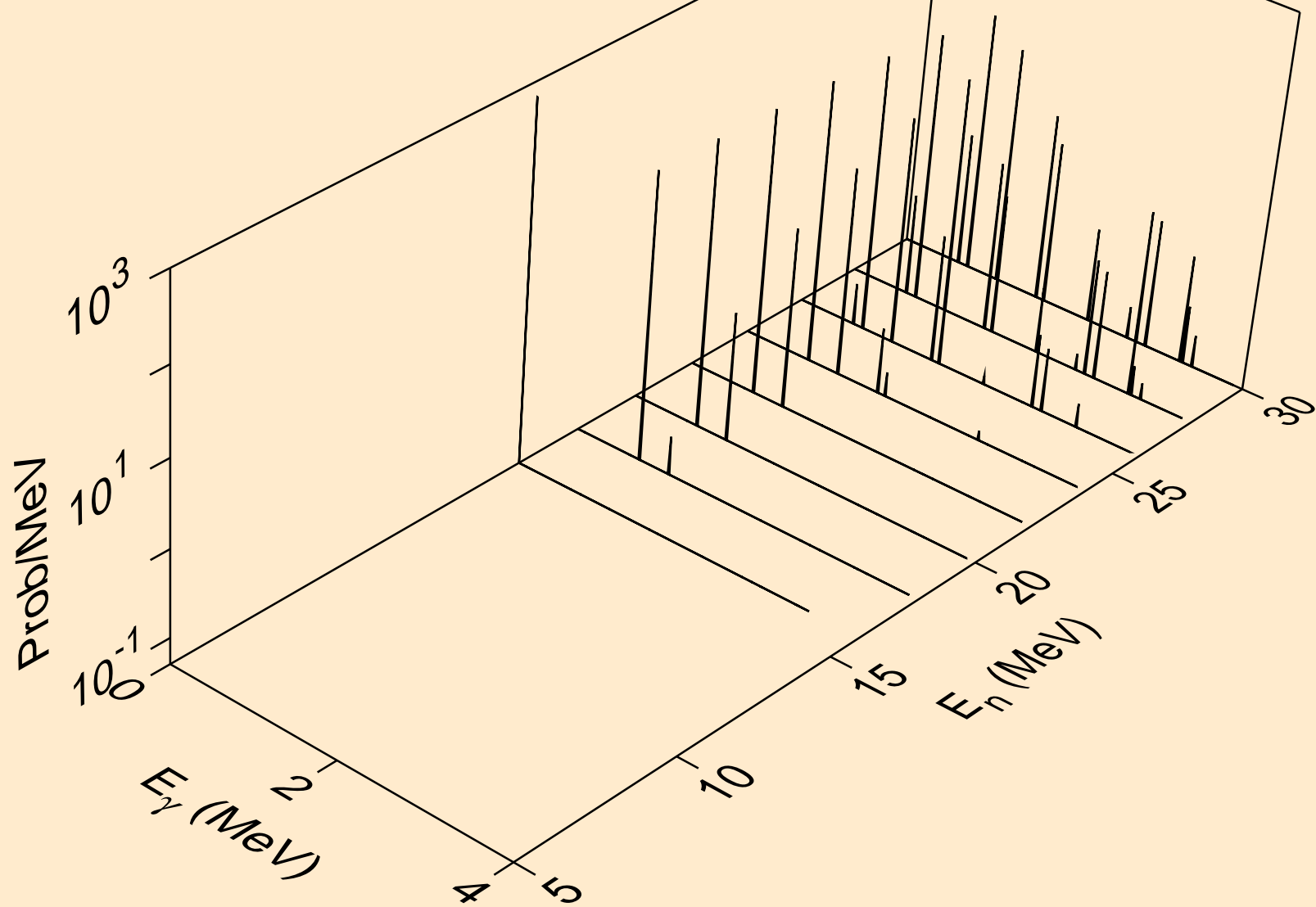

CO055 PROTON ACER TENDL-2021 LIBRARY; T=0.K  
Photon emission for (n,2p)

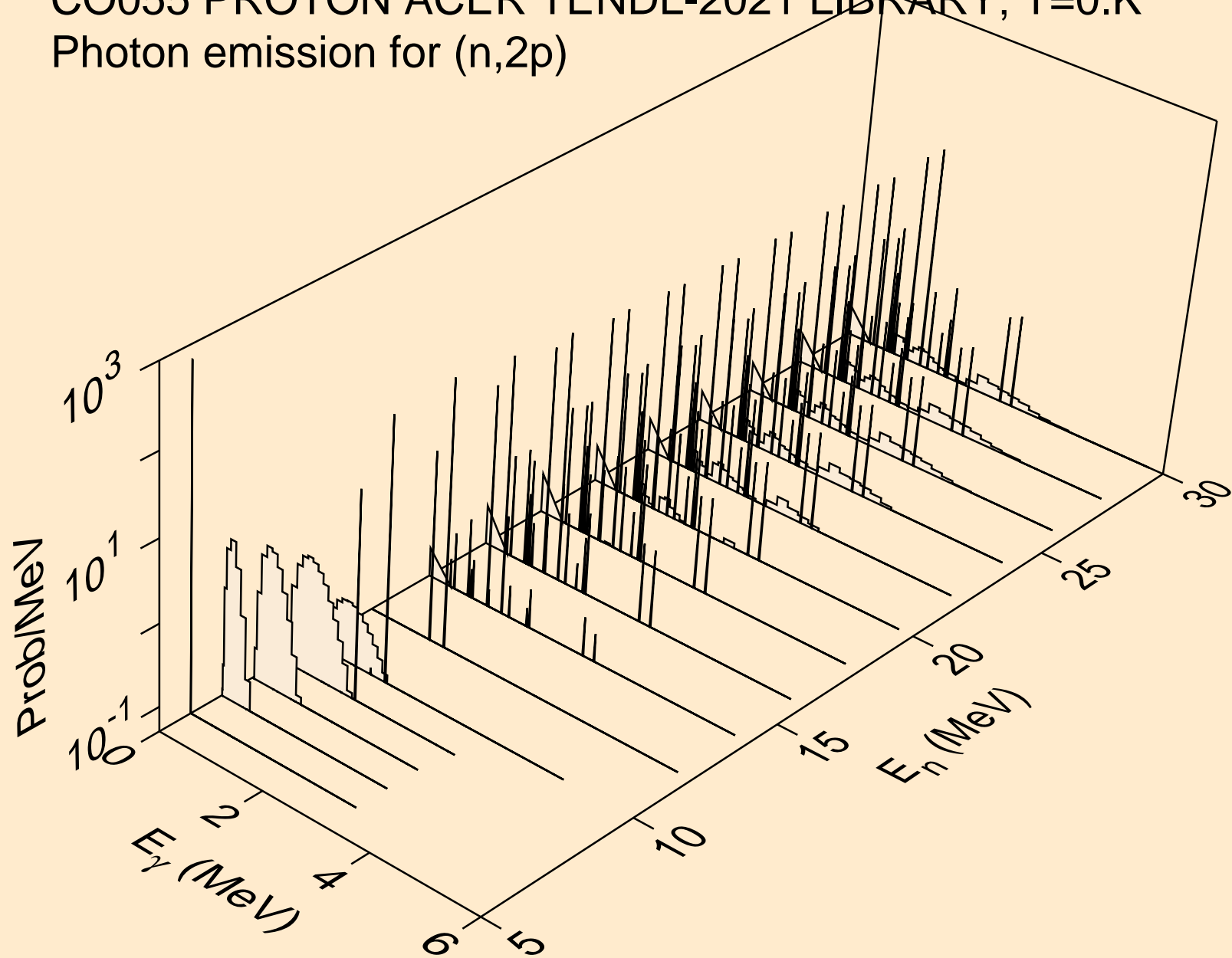

CO055 PROTON ACER TENDL-2021 LIBRARY; T=0.K  
Photon emission for (n,pa)

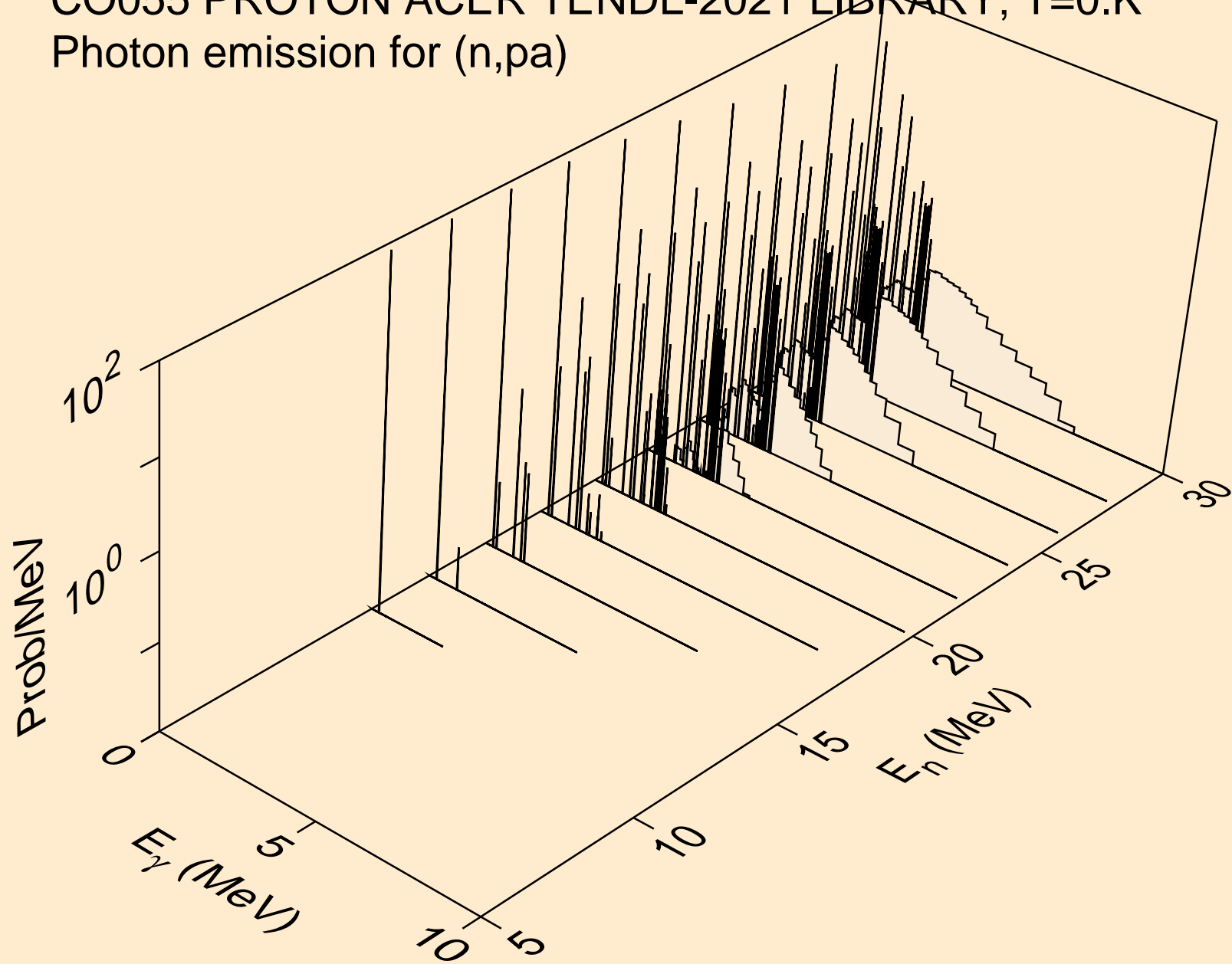

CO055 PROTON ACER TENDL-2021 LIBRARY; T=0.K  
Photon emission for (n,pd)

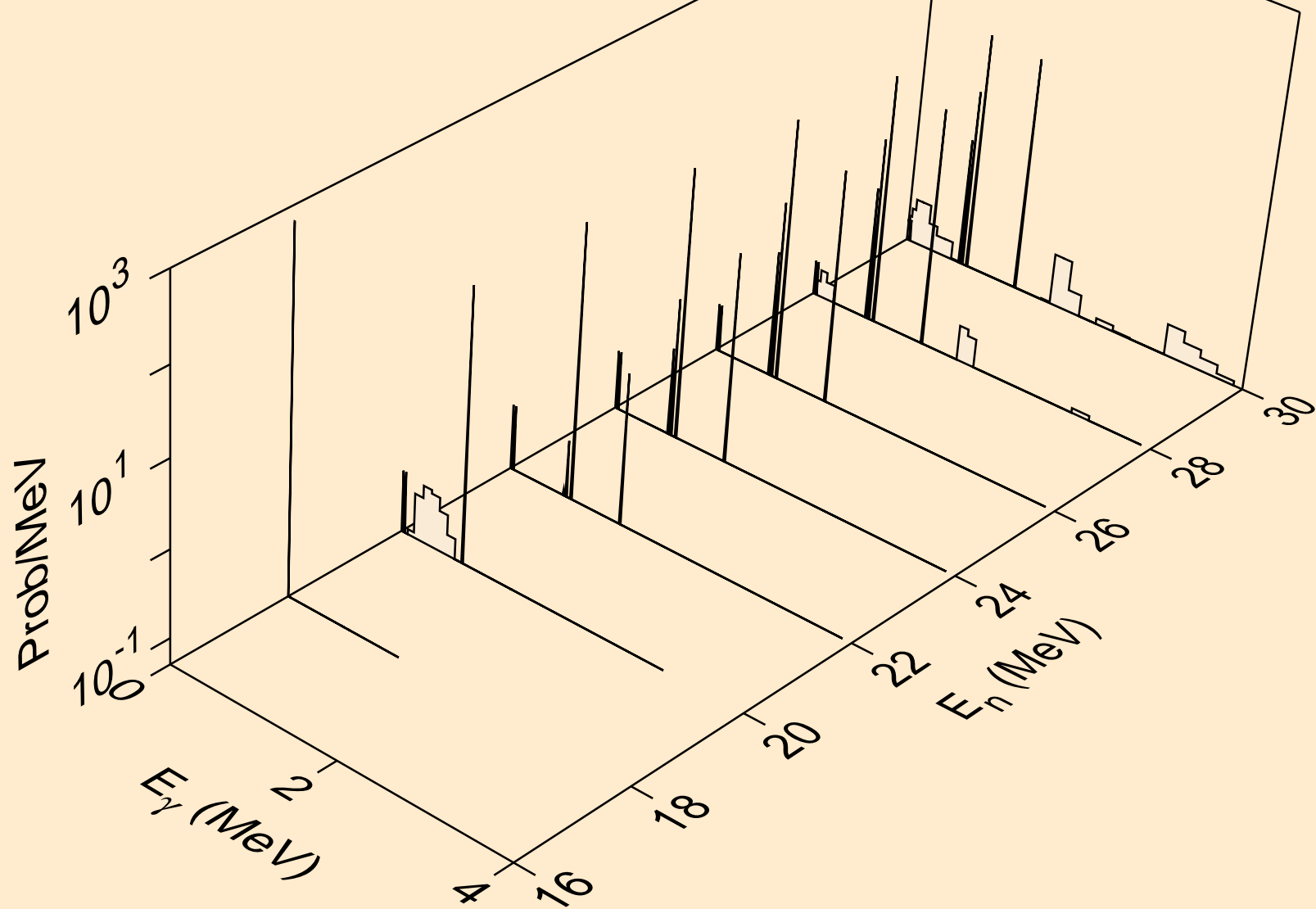

CO055 PROTON ACER TENDL-2021 LIBRARY; T=0.K  
Photon emission for (n,pt)

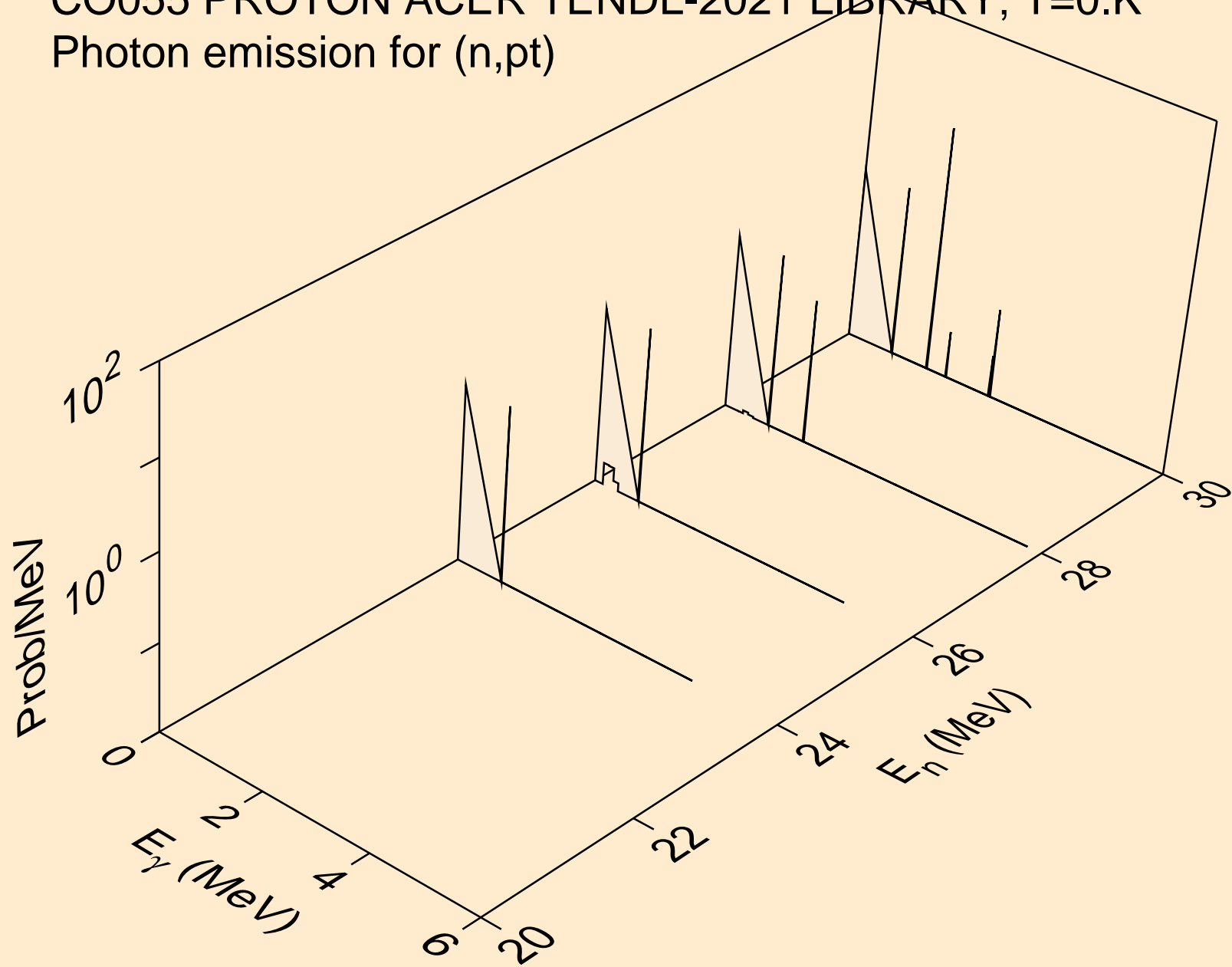



CO055 PROTON ACER TENDL-2021 LIBRARY; T=0.K  
Photon emission for (n,da)

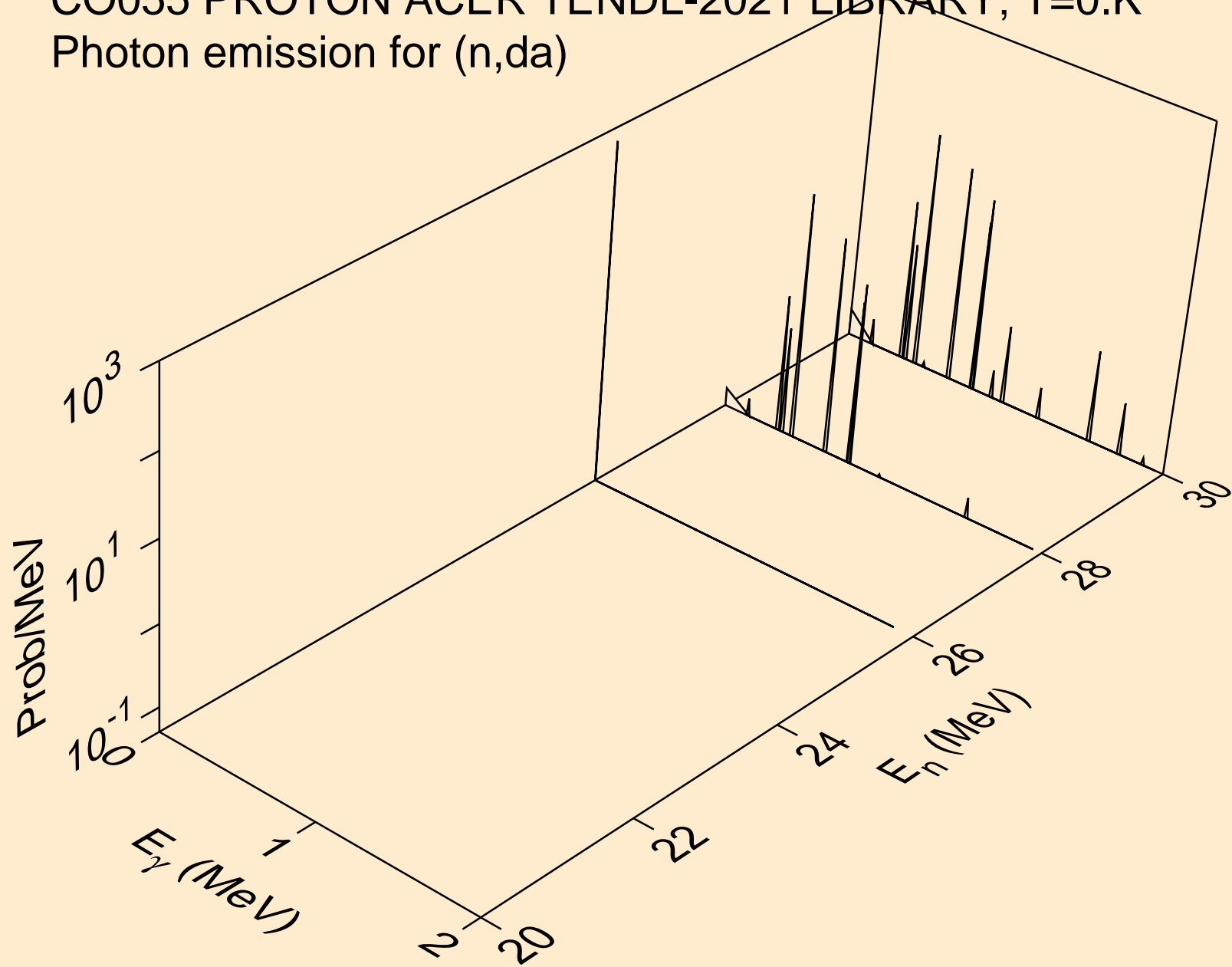

CO055 PROTON ACER TENDL-2021 LIBRARY; T=0.K  
Particle heating contributions

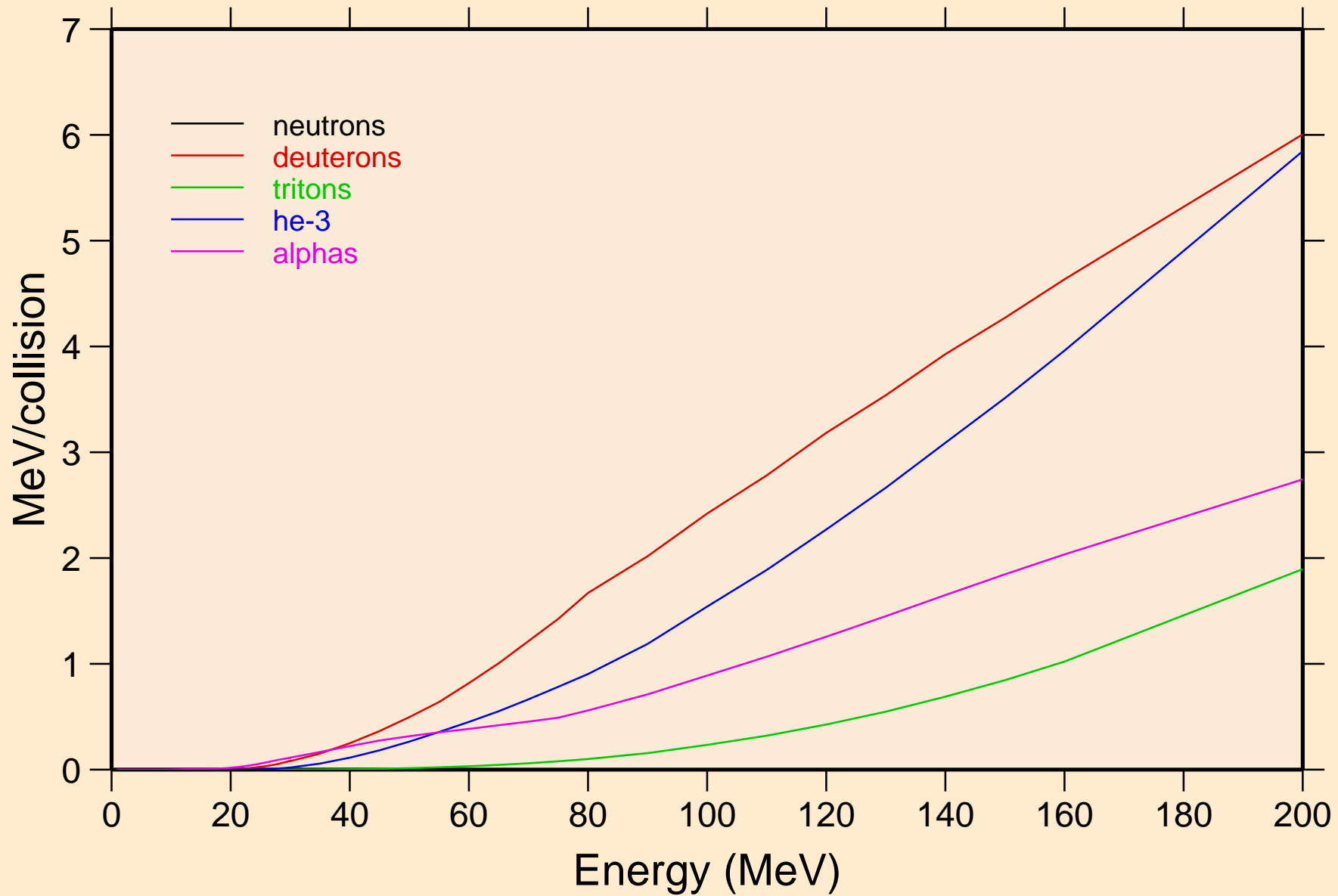

CO055 PROTON ACER TENDL-2021 LIBRARY; T=0.K  
Recoil Heating

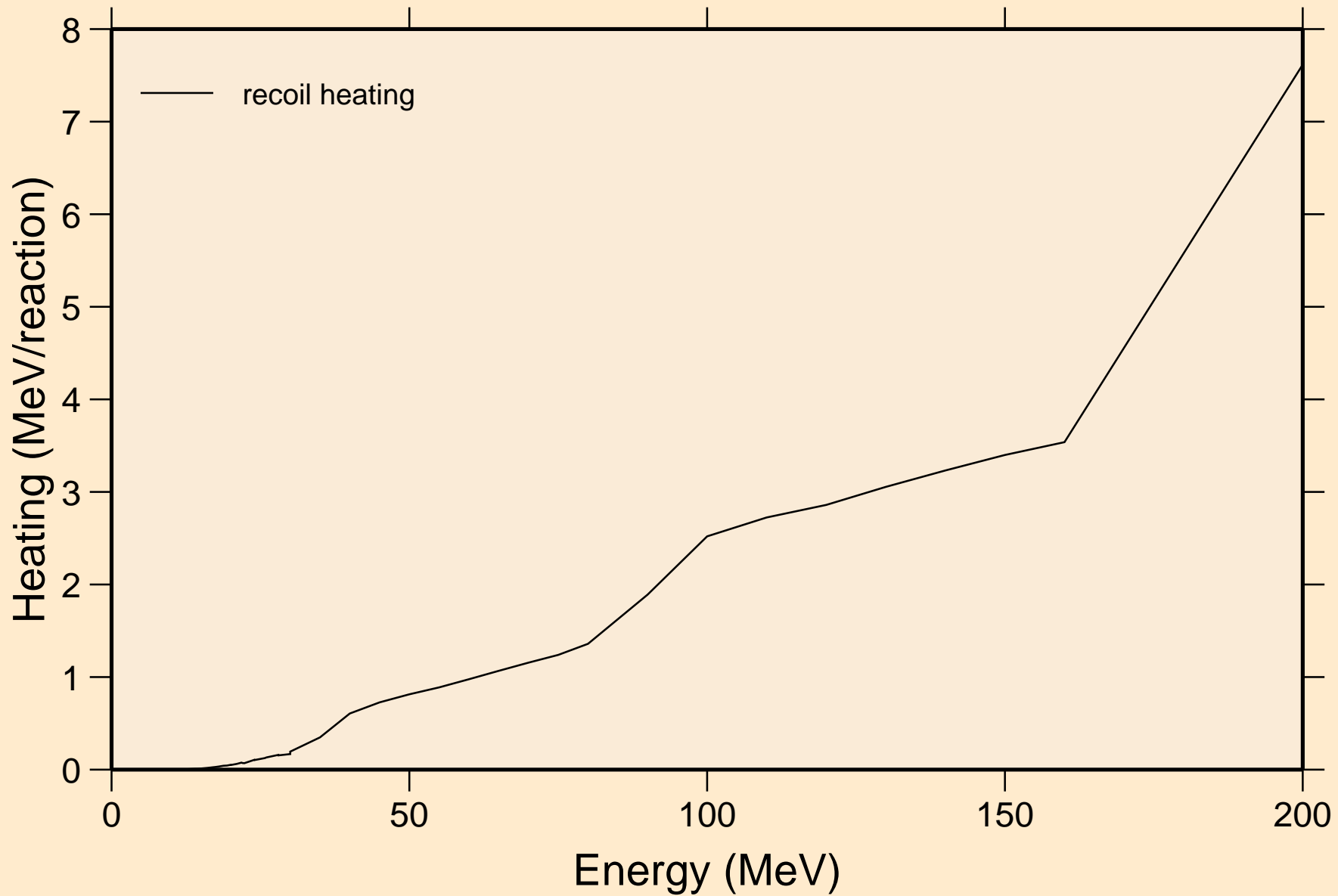

CO055 PROTON ACER TENDL-2021 LIBRARY; T=0.K  
Particle production cross sections

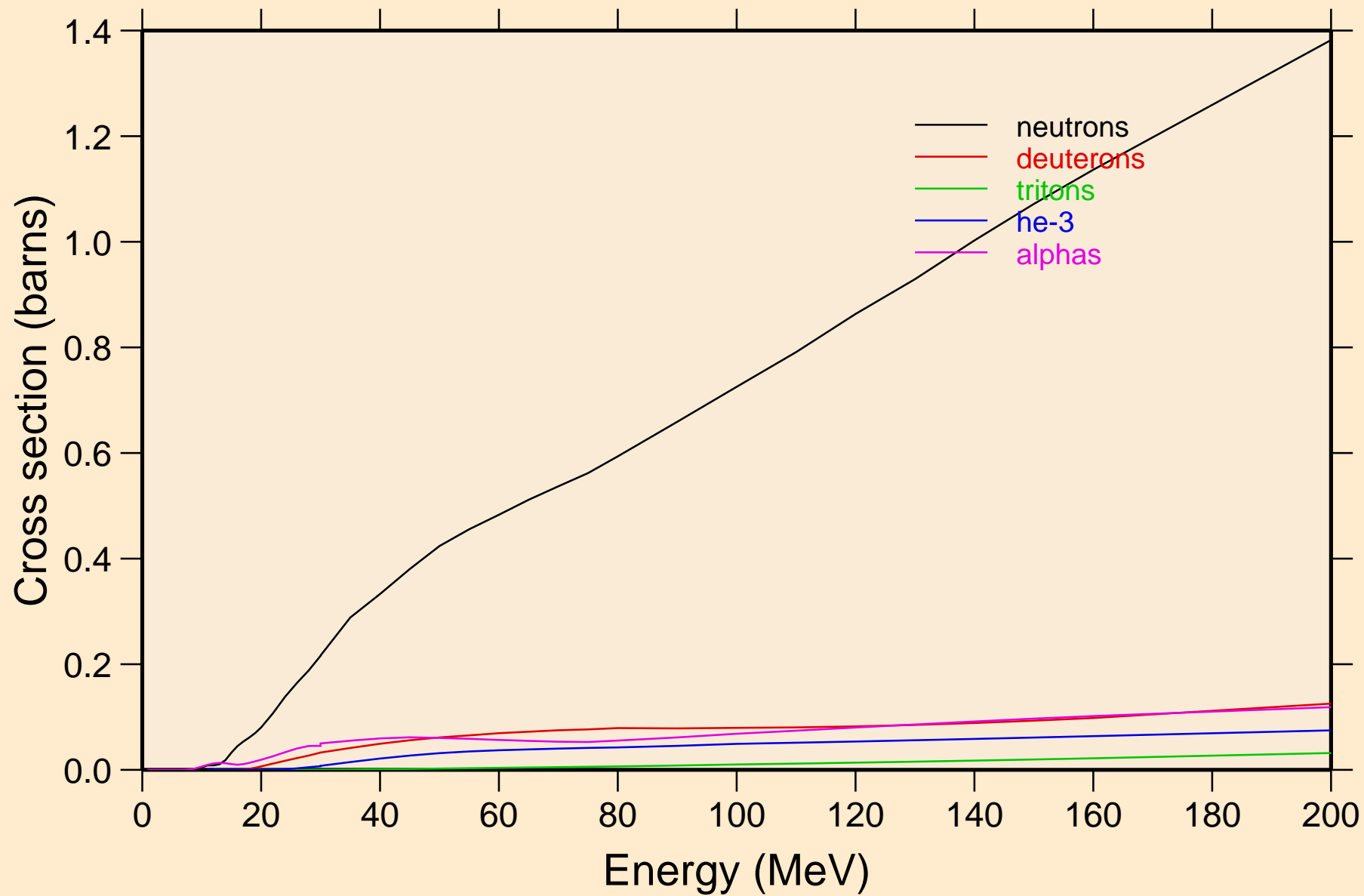

CO055 PROTON ACER TENDL-2021 LIBRARY; T=0.K  
neutrons from (p,n)

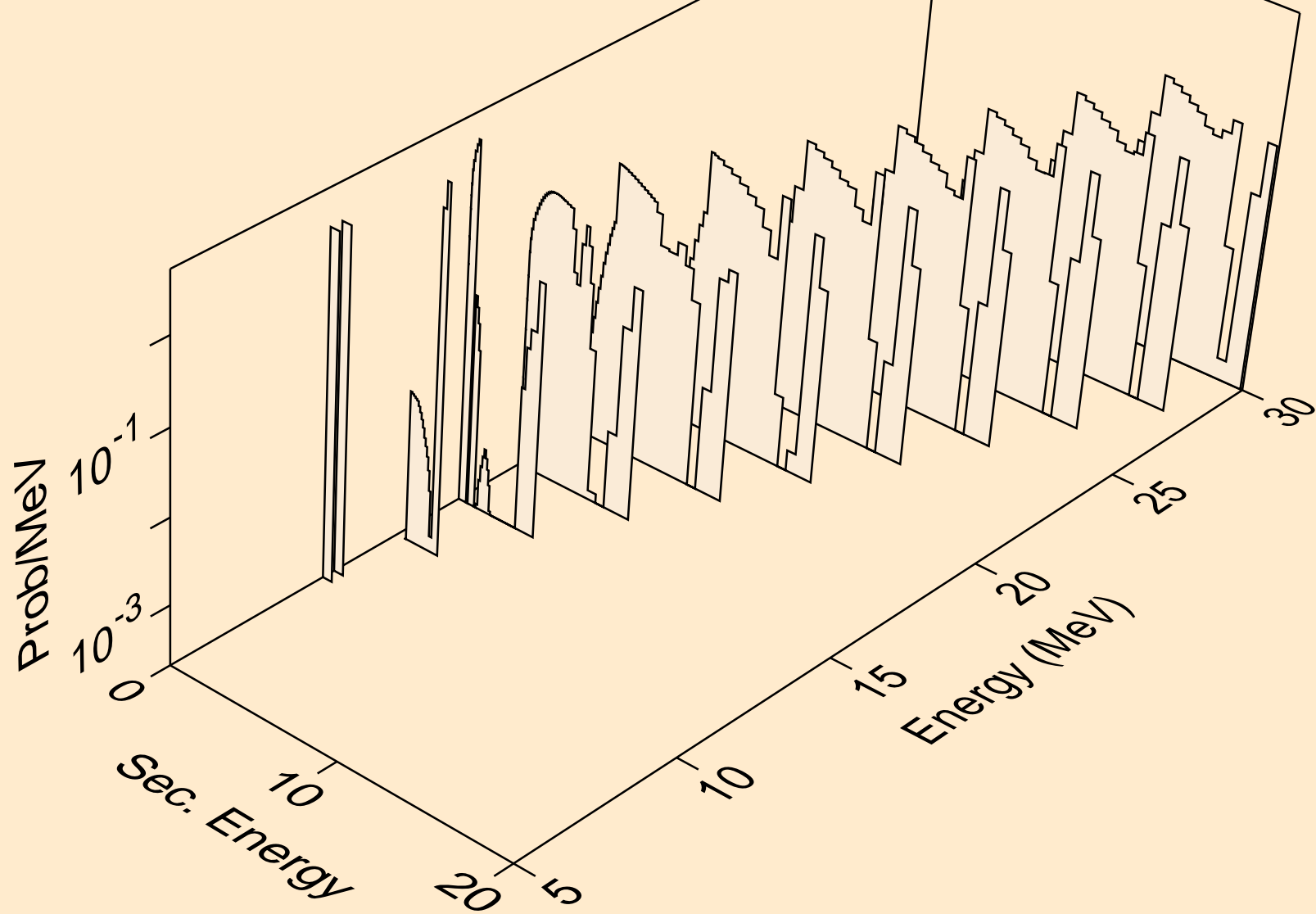

CO055 PROTON ACER TENDL-2021 LIBRARY; T=0.K  
neutrons from (p,x)

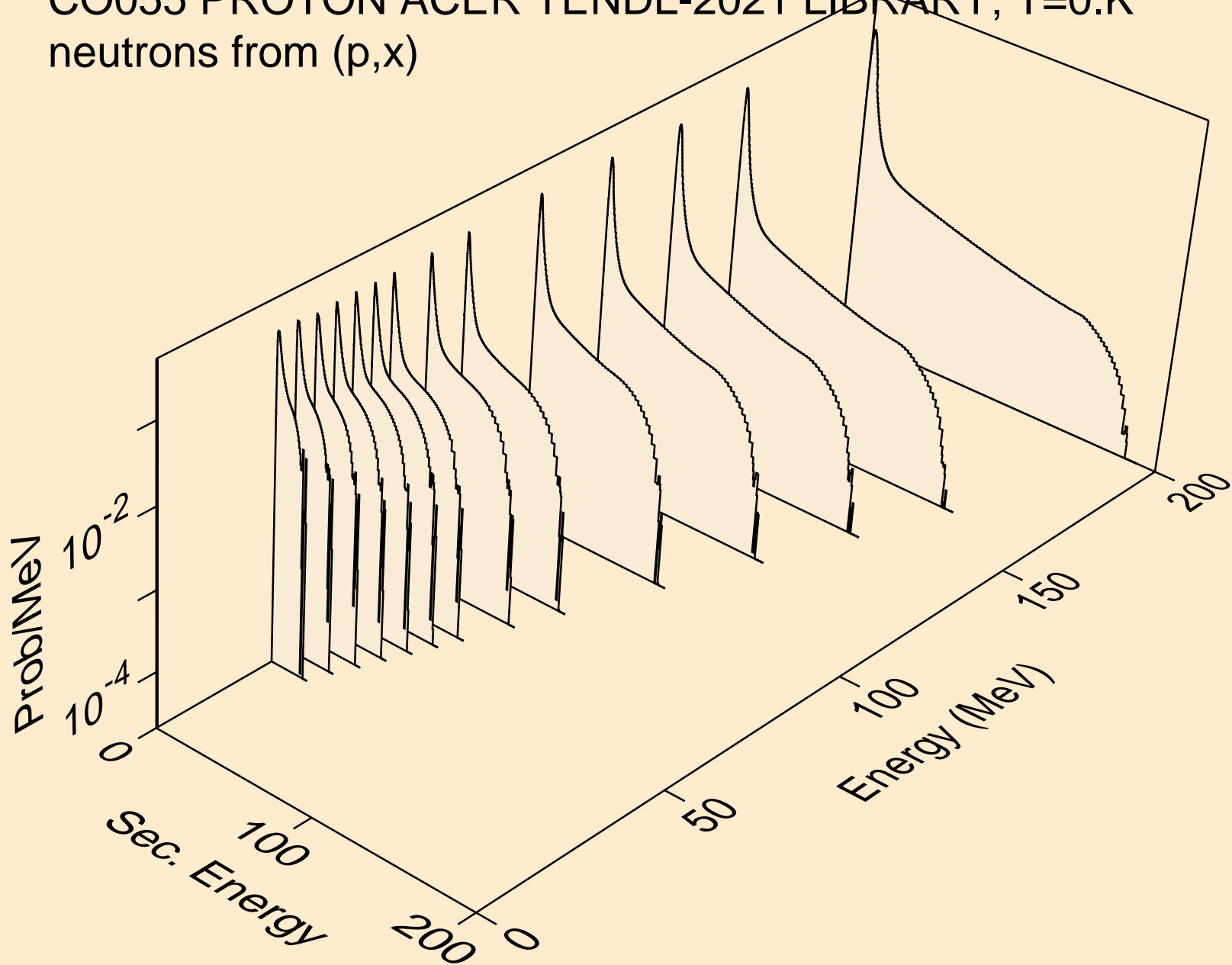

CO055 PROTON ACER TENDL-2021 LIBRARY; T=0.K  
neutrons from (p,2n)

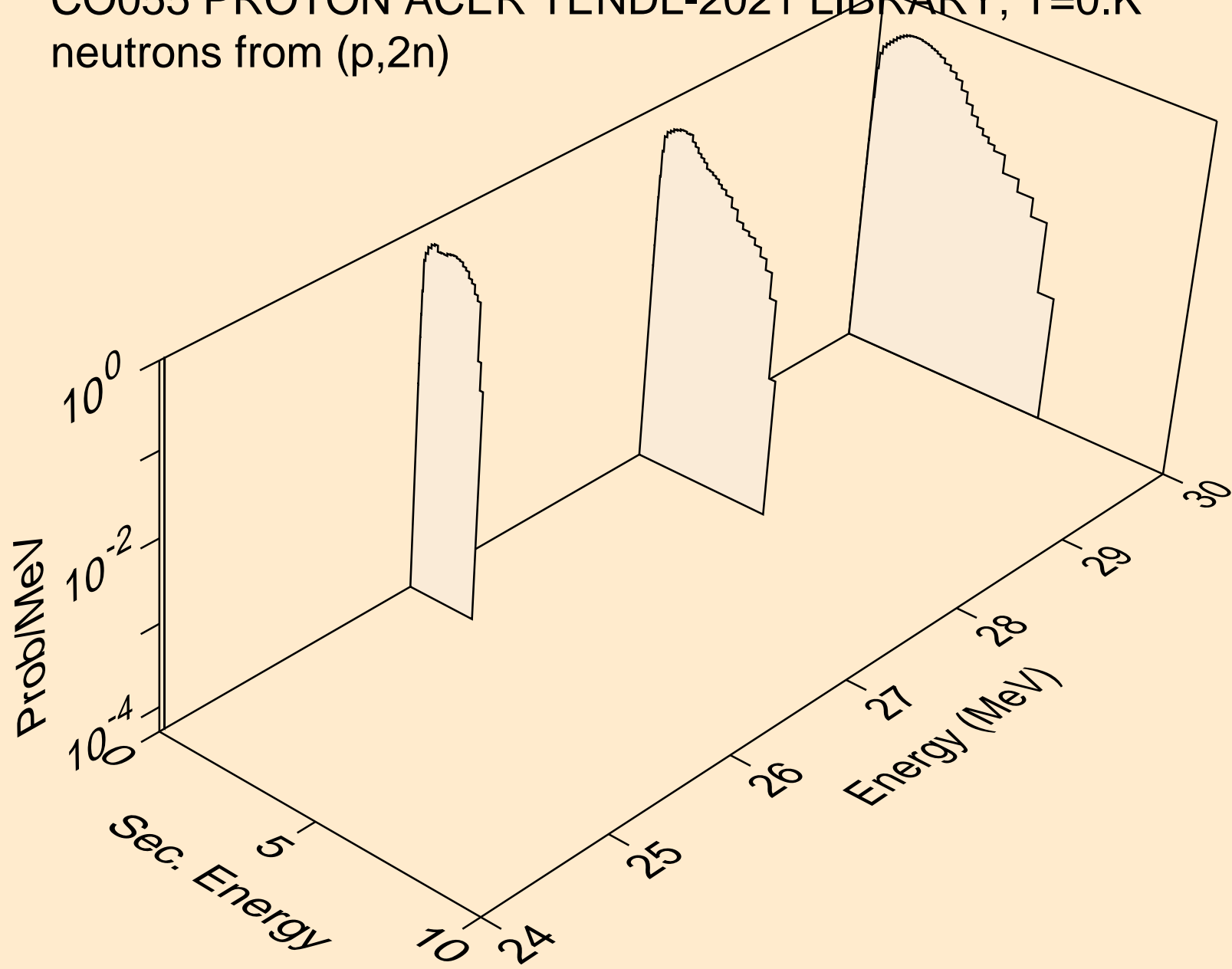

CO055 PROTON ACER TENDL-2021 LIBRARY; T=0.K  
neutrons from (p,n\*)a

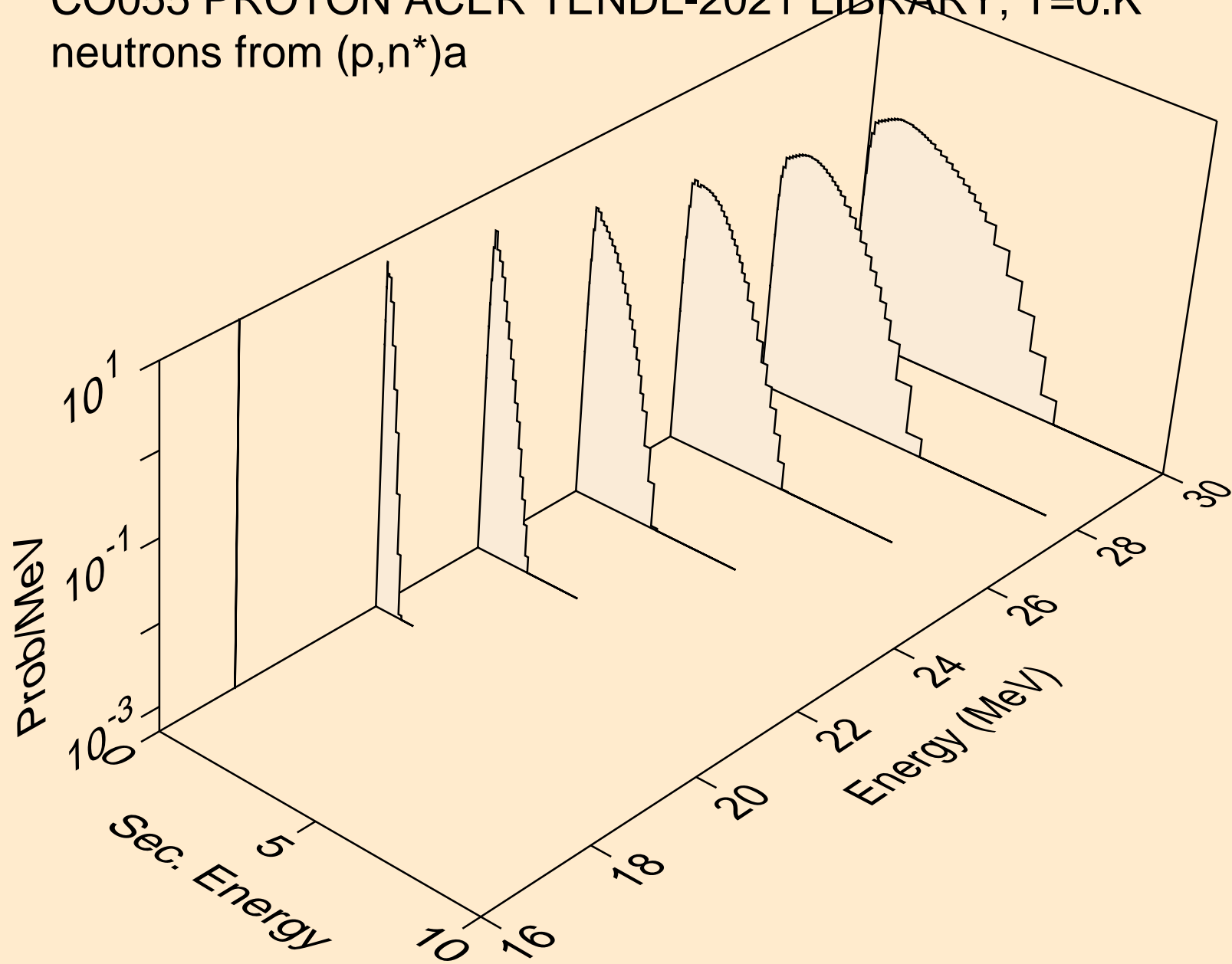



CO055 PROTON ACER TENDL-2021 LIBRARY; T=0.K  
neutrons from (p,n\*)p

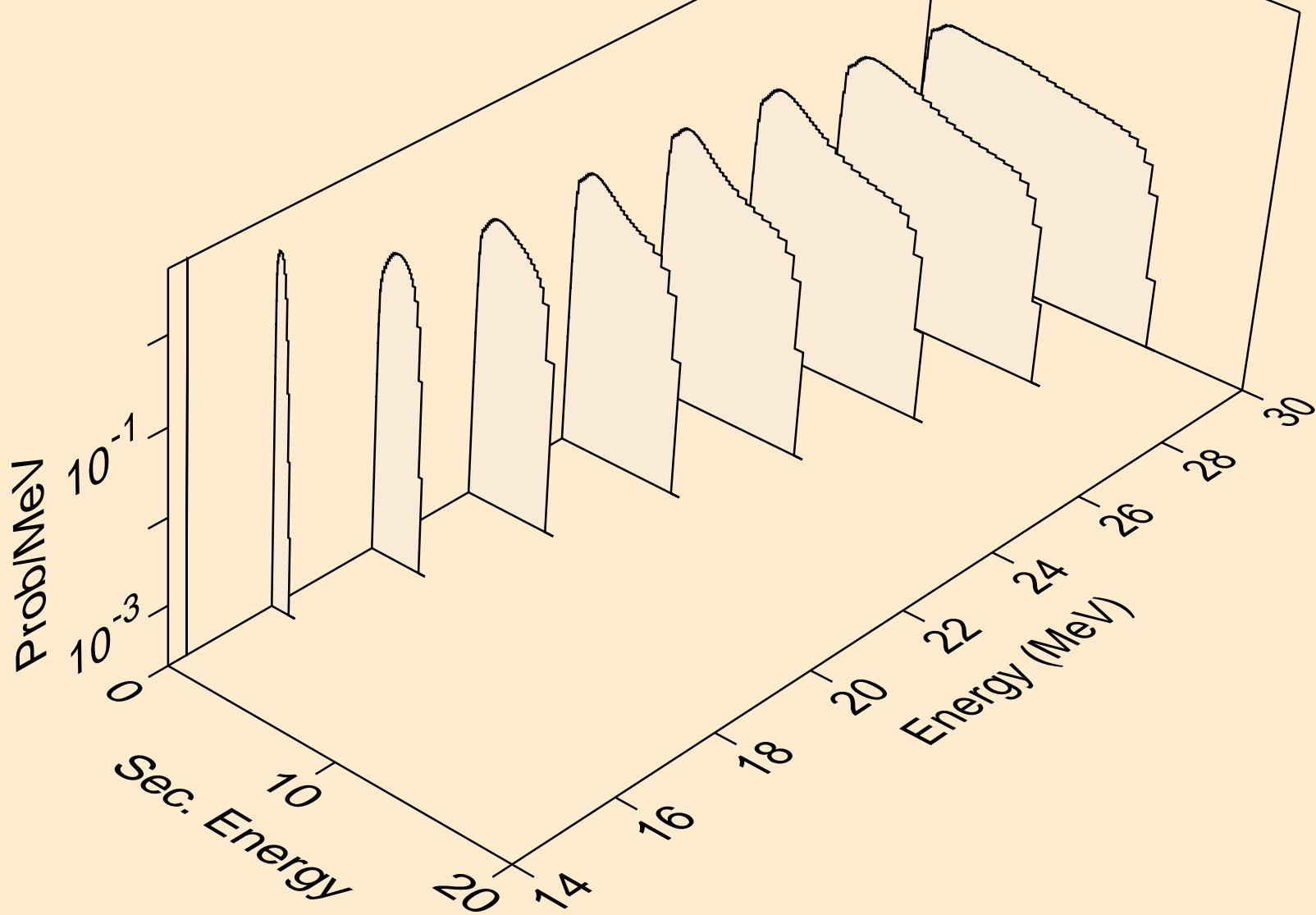

CO055 PROTON ACER TENDL-2021 LIBRARY; T=0.K  
neutrons from (p,n\*)d

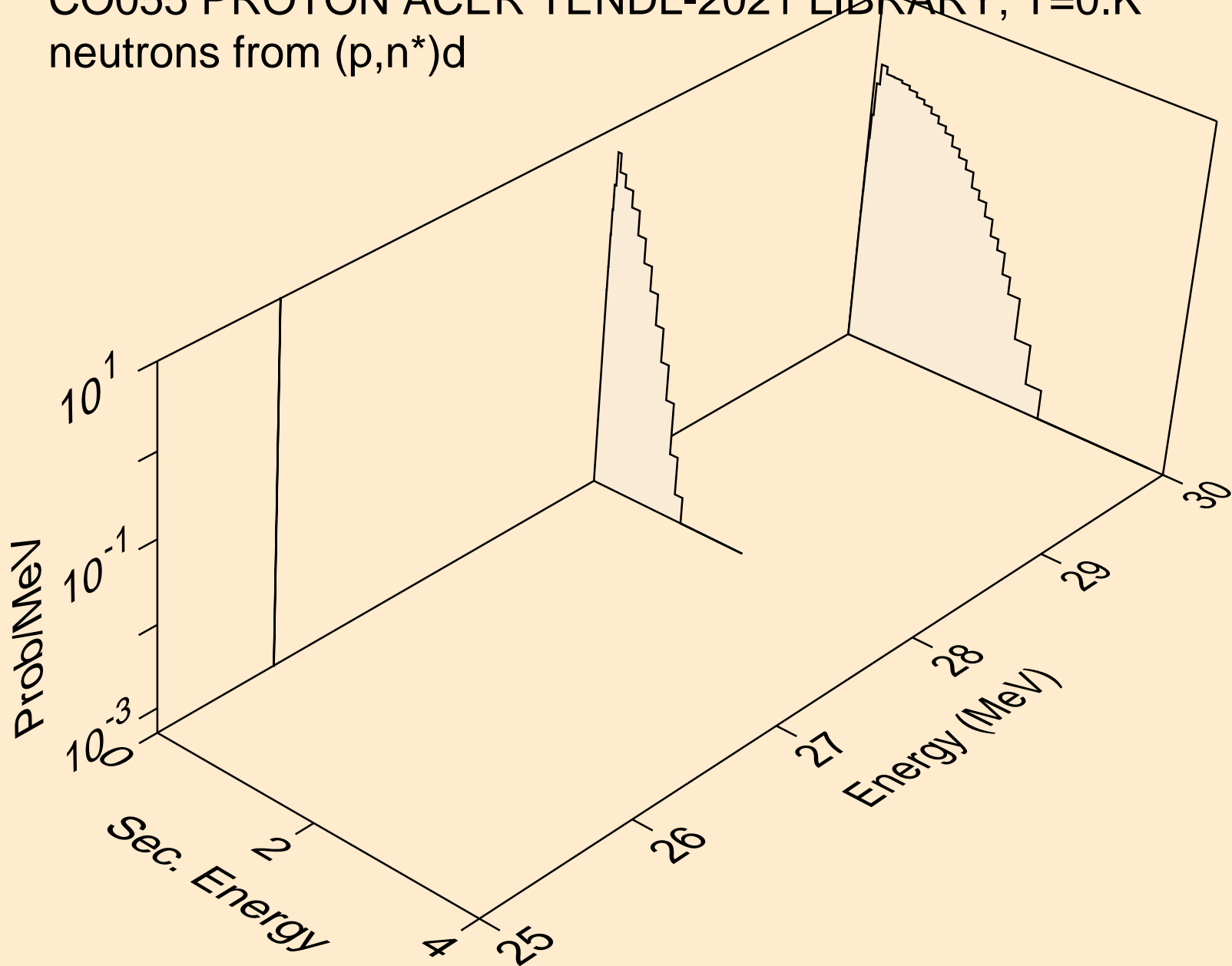

CO055 PROTON ACER TENDL-2021 LIBRARY; T=0.K  
neutrons from (p,n\*)he3

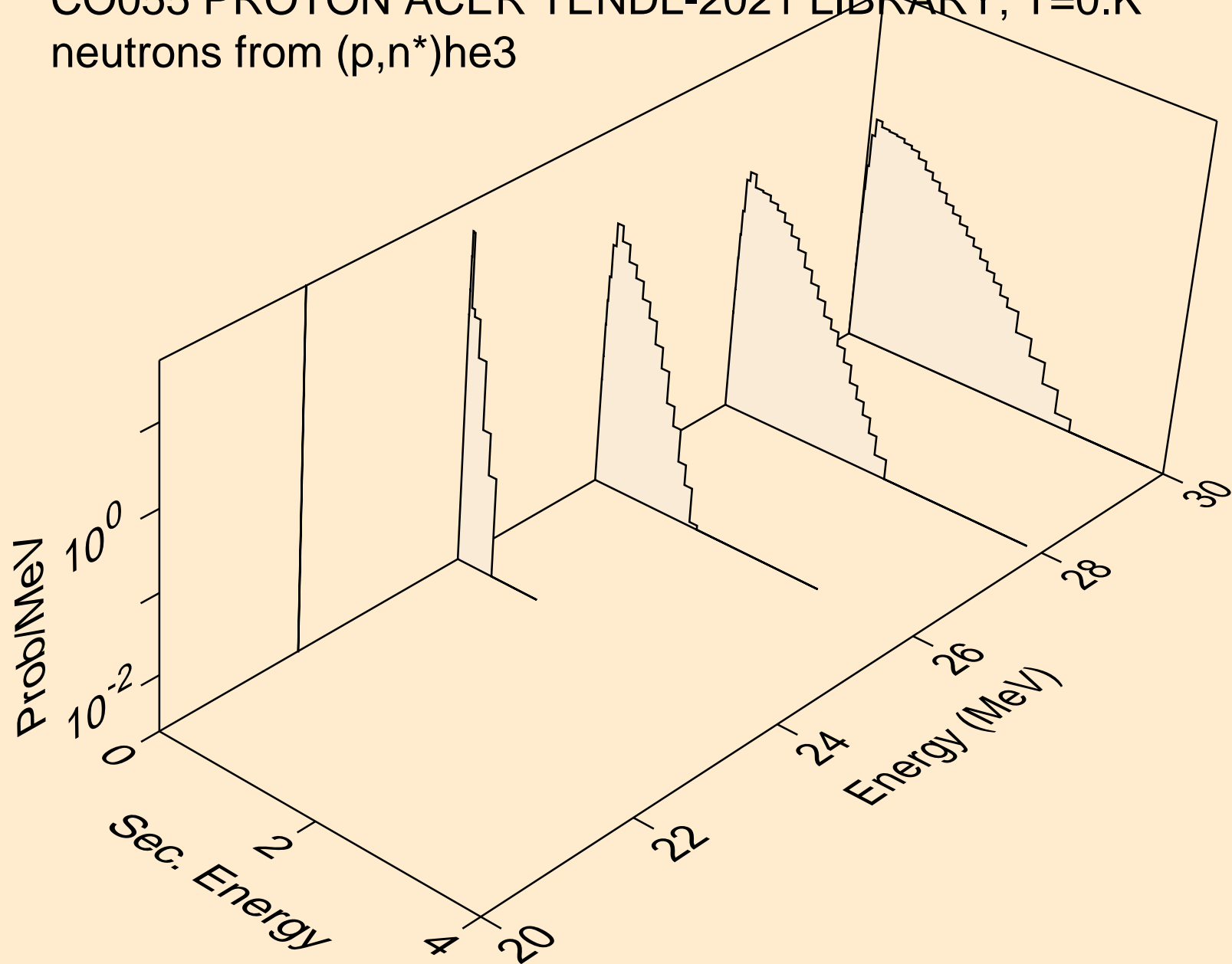

CO055 PROTON ACER TENDL-2021 LIBRARY; T=0.K  
neutrons from (p,2np)

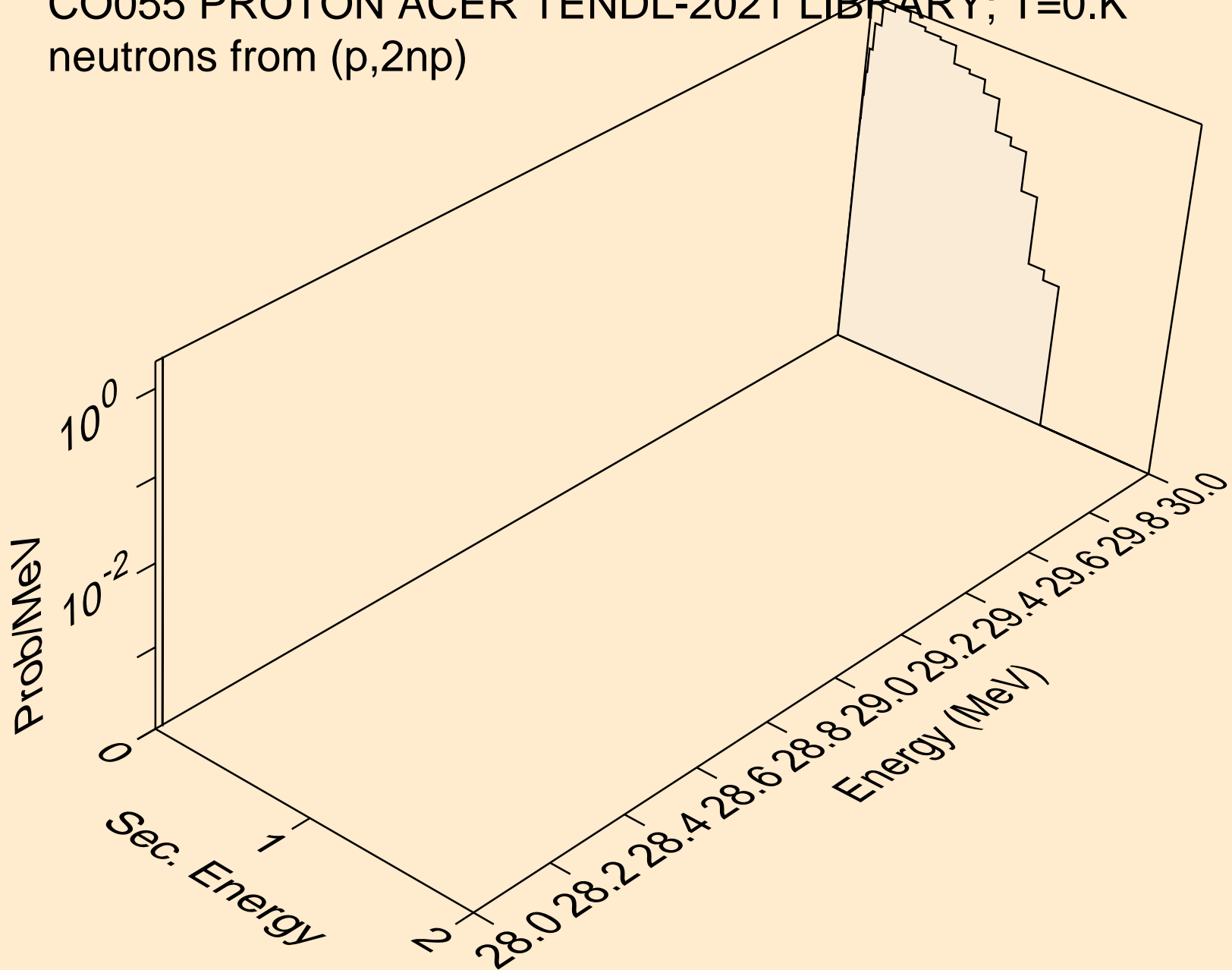

CO055 PROTON ACER TENDL-2021 LIBRARY; T=0.K  
neutrons from (p,2np)

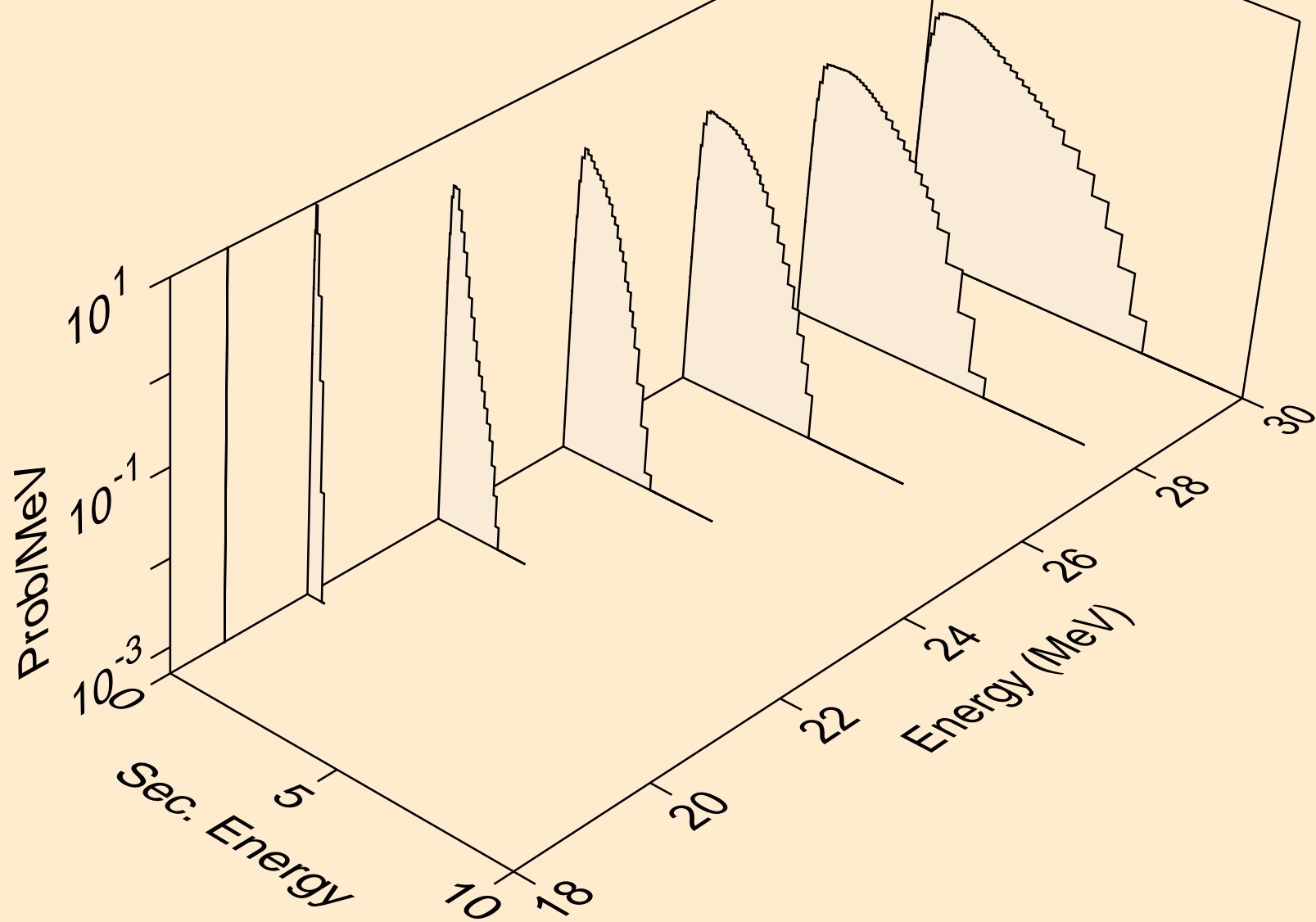

CO055 PROTON ACER TENDL-2021 LIBRARY; T=0.K  
neutrons from (p,npa)

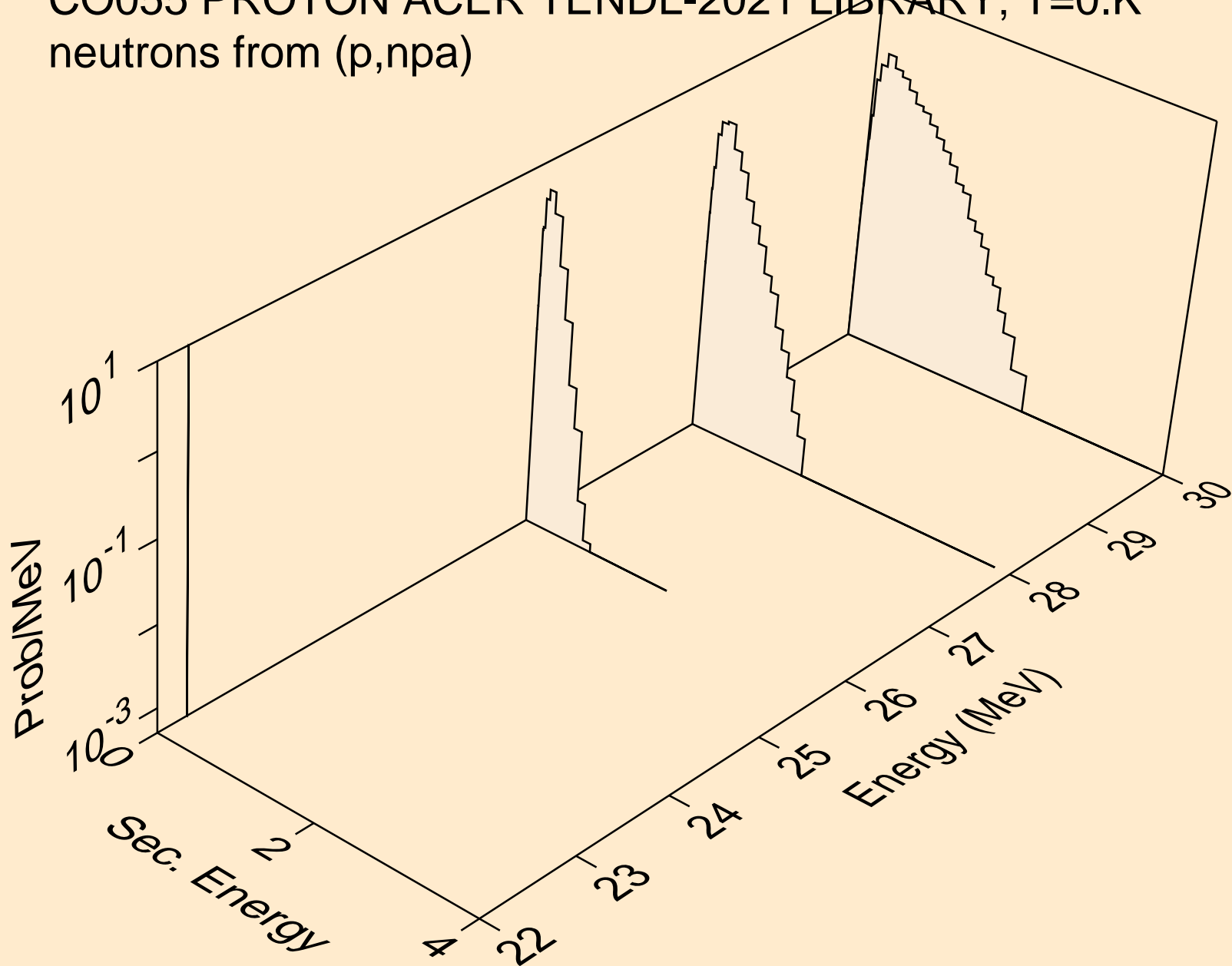

CO055 PROTON ACER TENDL-2021 LIBRARY; T=0.K  
deuterons from (p,x)

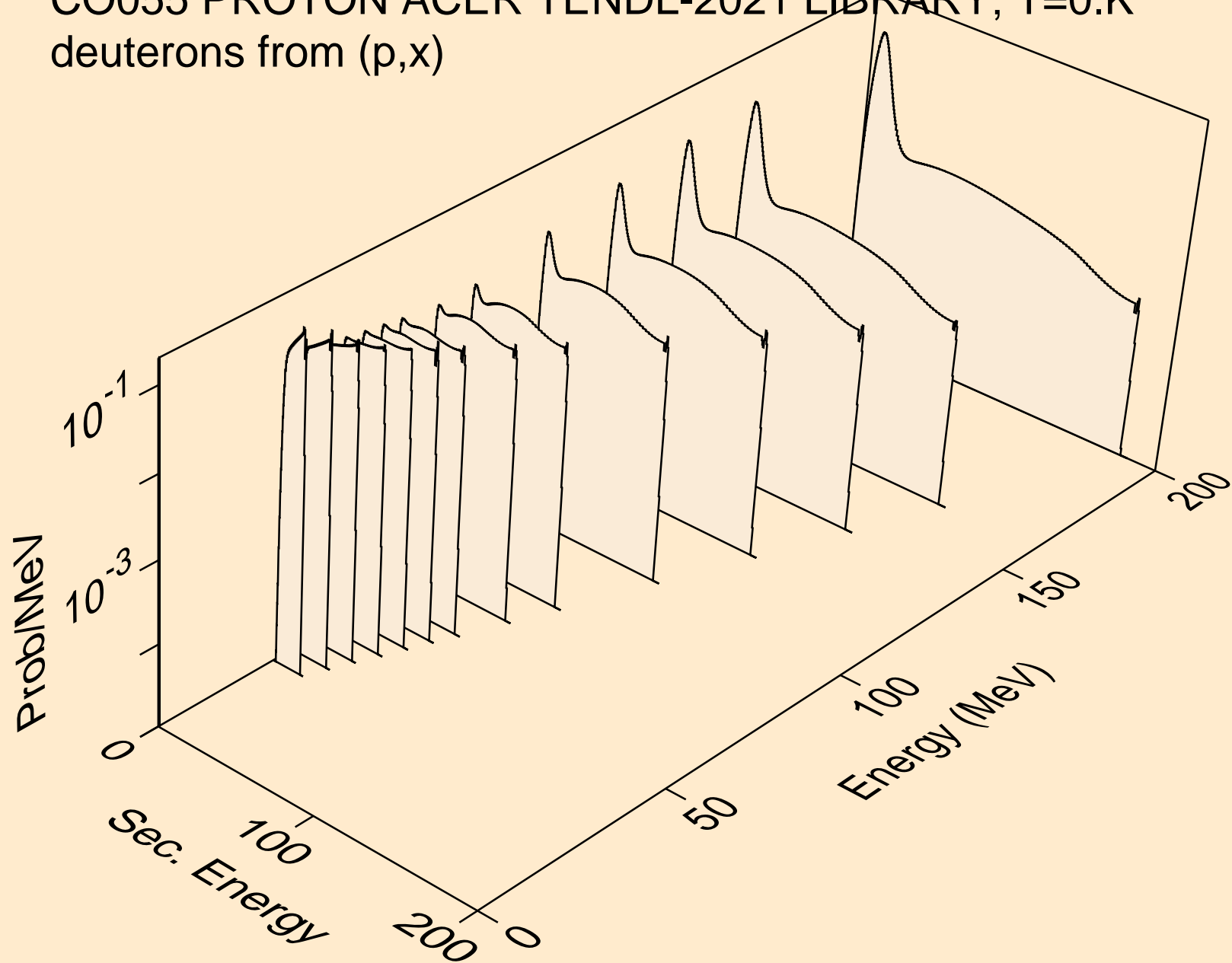

CO055 PROTON ACER TENDL-2021 LIBRARY; T=0.K  
deuterons from (p,n\*)d

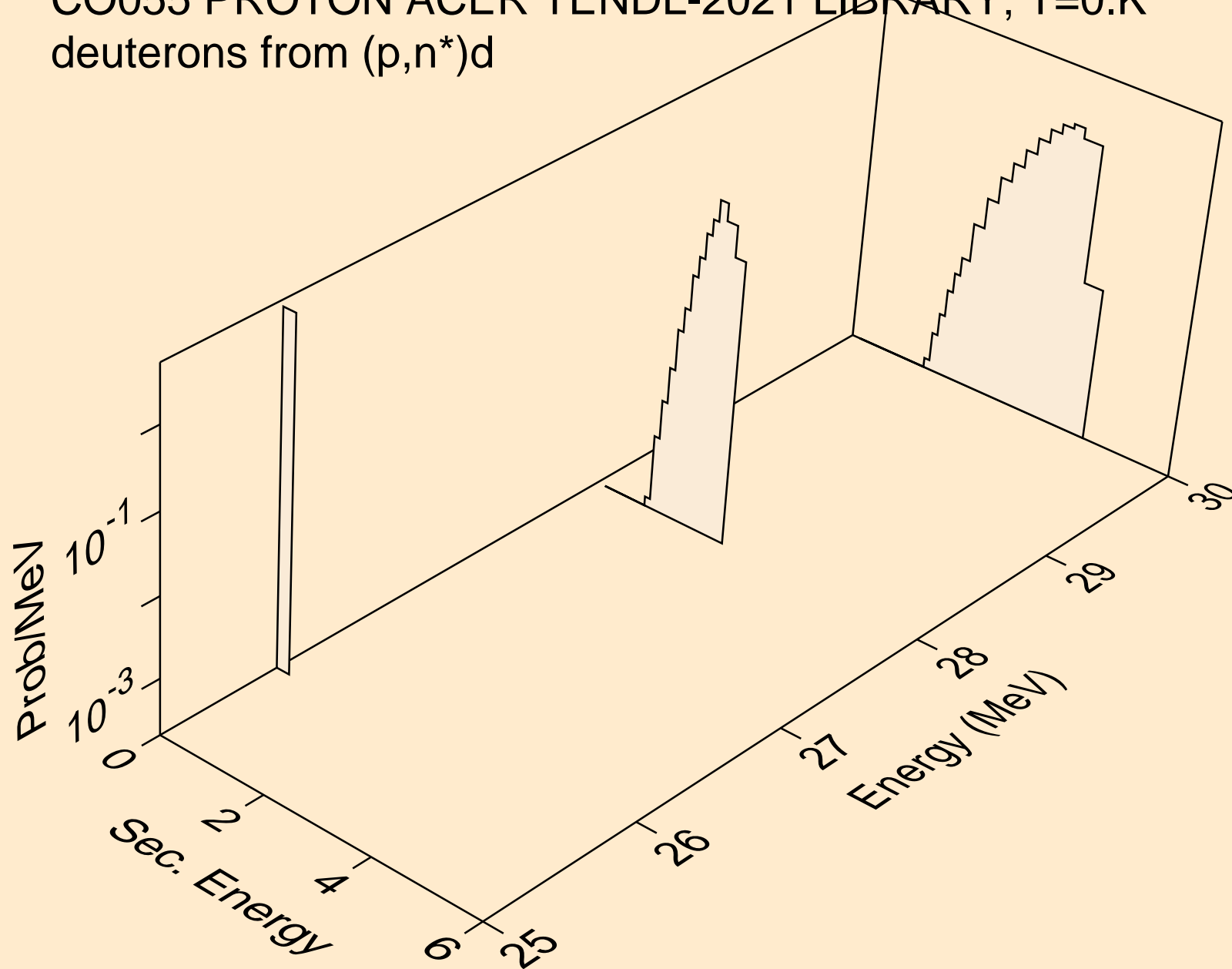



CO055 PROTON ACER TENDL-2021 LIBRARY; T=0.K  
deuterons from (p,d)

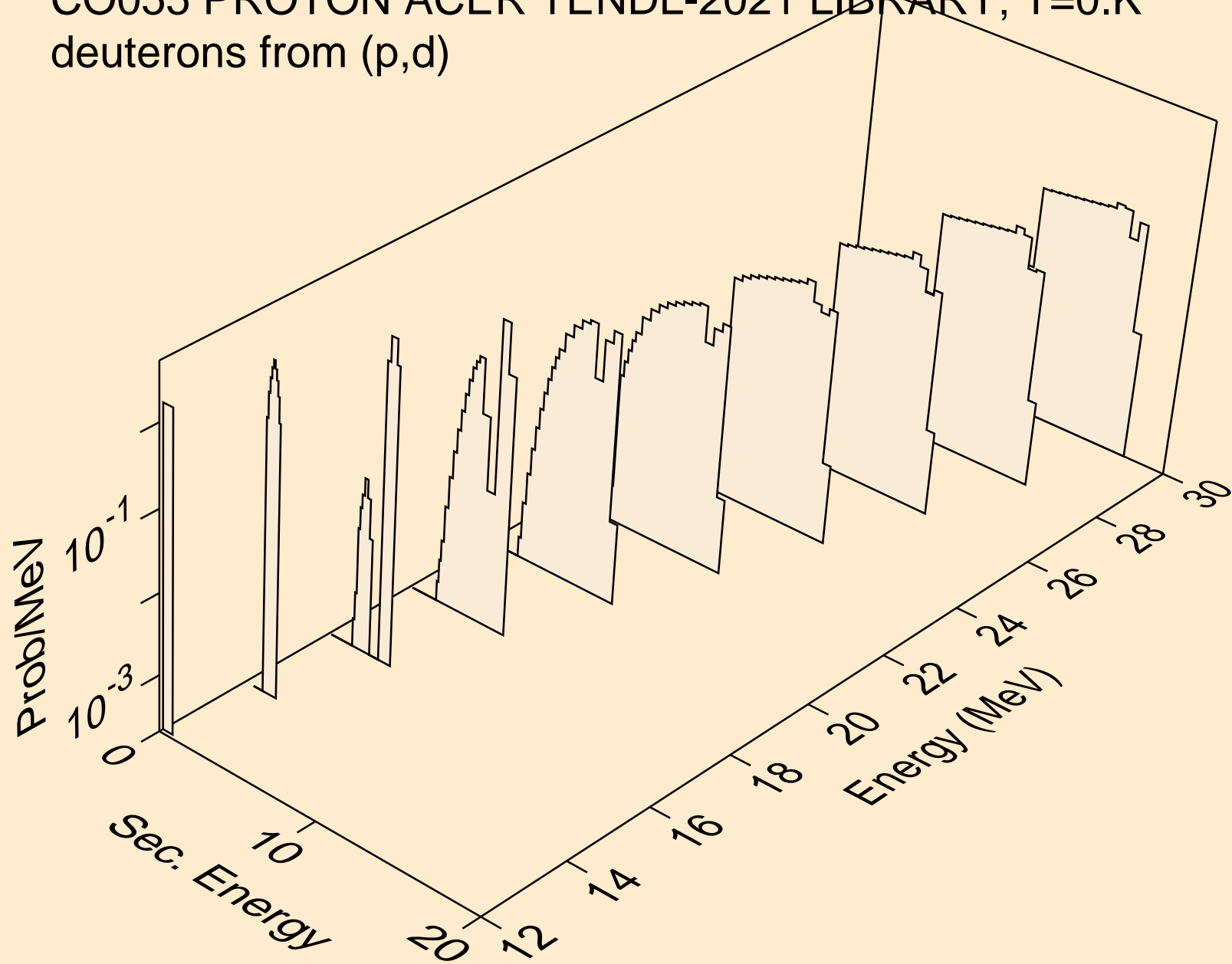

CO055 PROTON ACER TENDL-2021 LIBRARY; T=0.K  
deuterons from (p,pd)

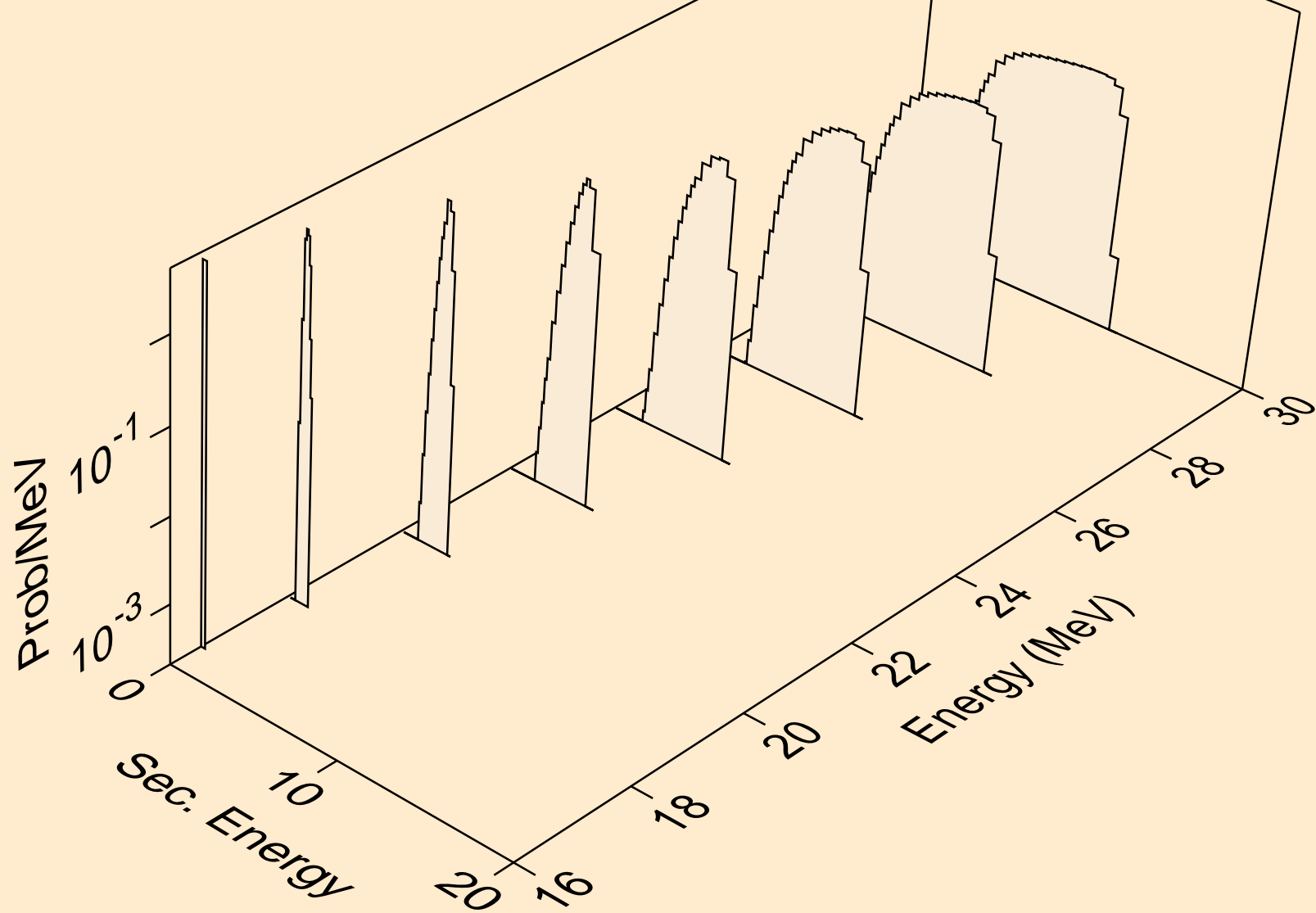

CO055 PROTON ACER TENDL-2021 LIBRARY; T=0.K  
deuterons from (p,da)

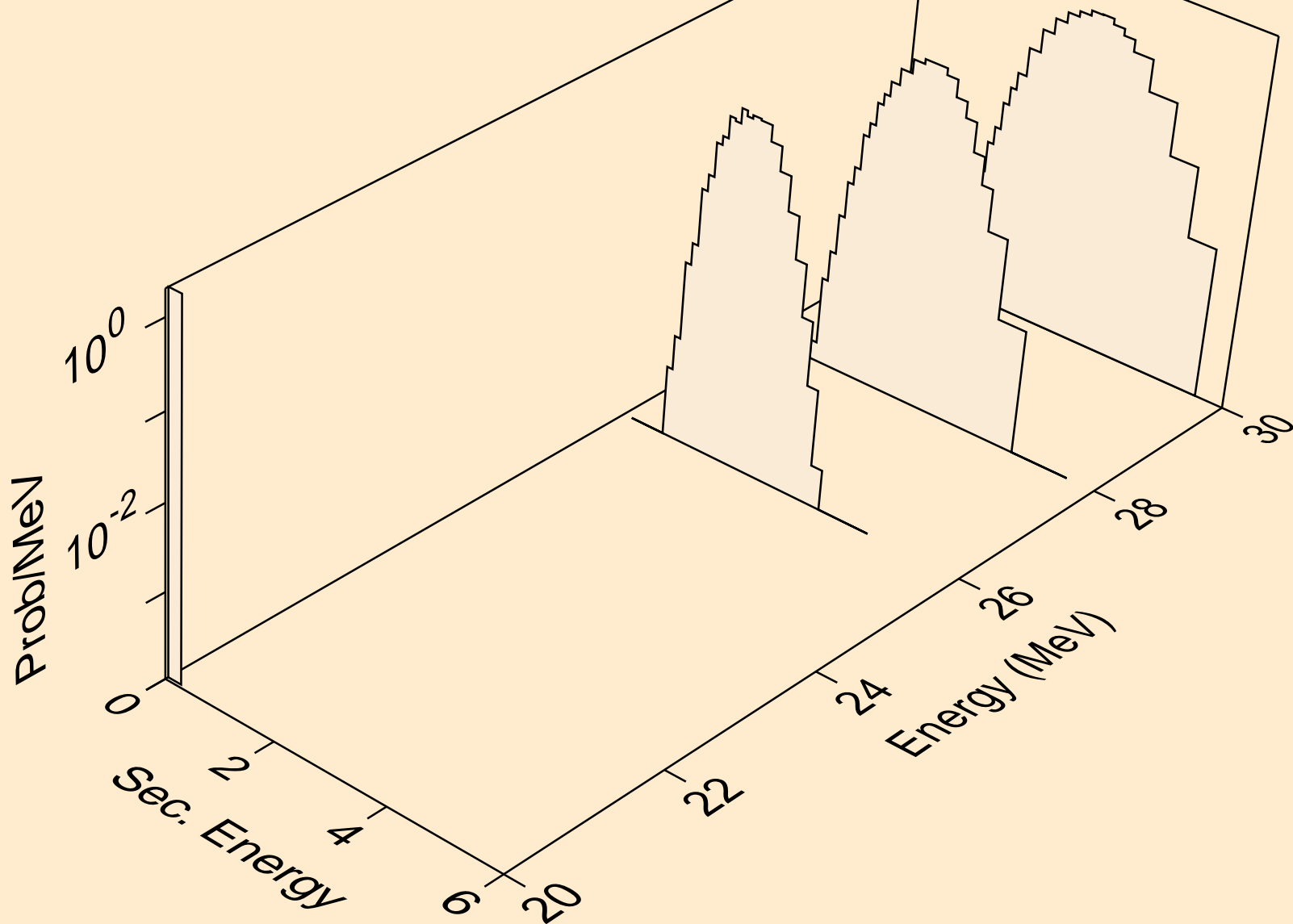

CO055 PROTON ACER TENDL-2021 LIBRARY; T=0.K  
tritons from (p,x)

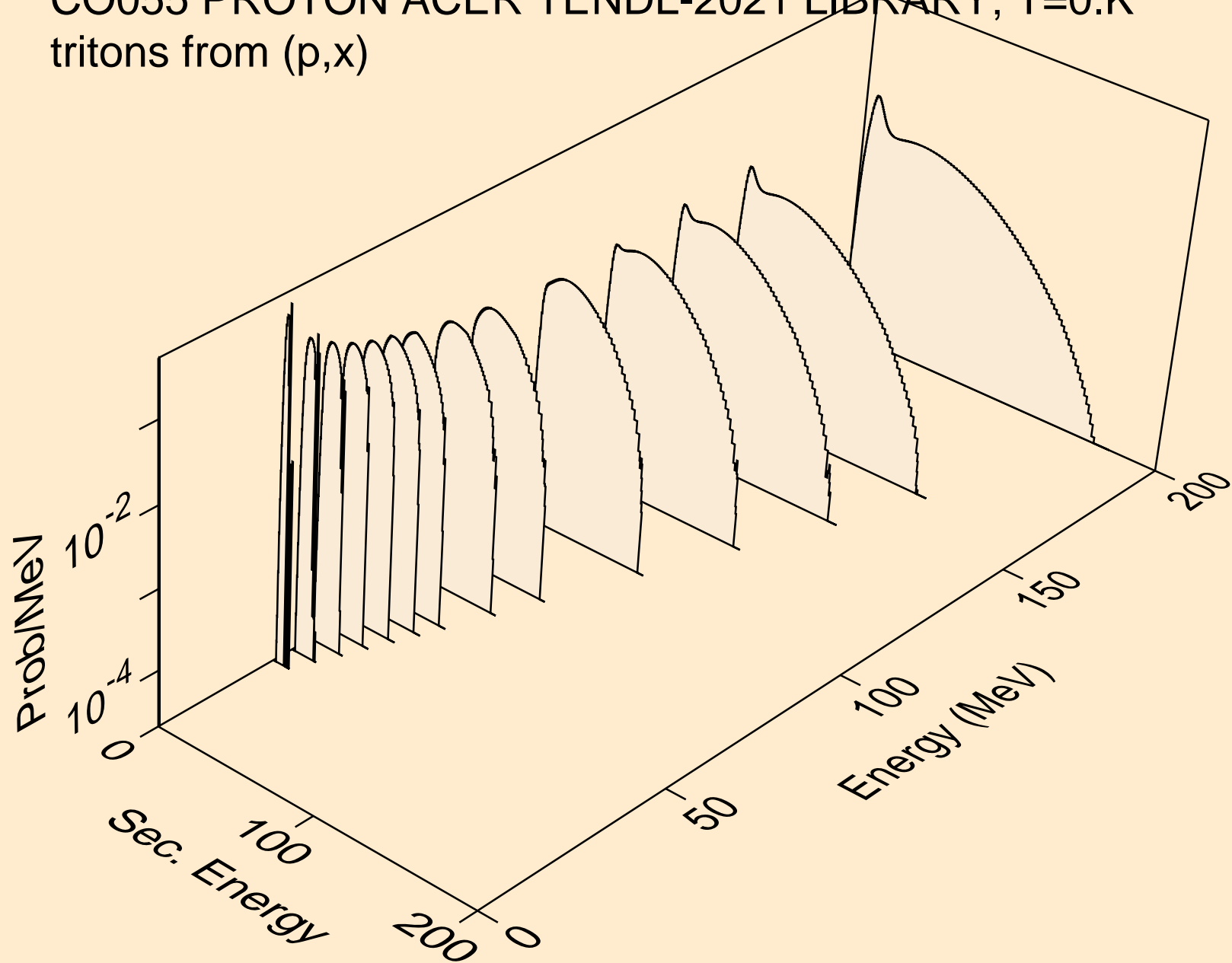

CO055 PROTON ACER TENDL-2021 LIBRARY; T=0.K  
tritons from (p,t)

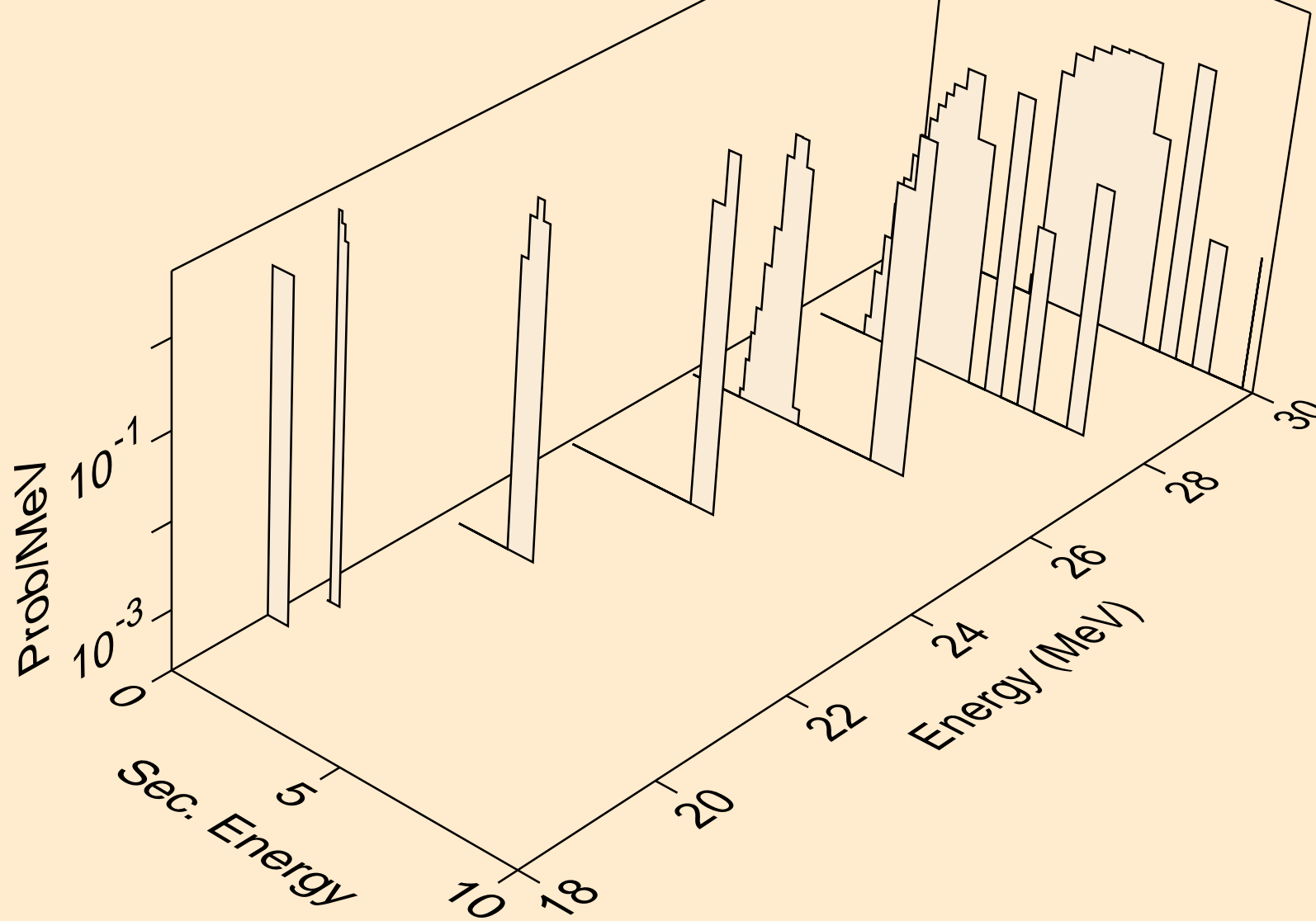

CO055 PROTON ACER TENDL-2021 LIBRARY; T=0.K  
tritons from (p,pt)

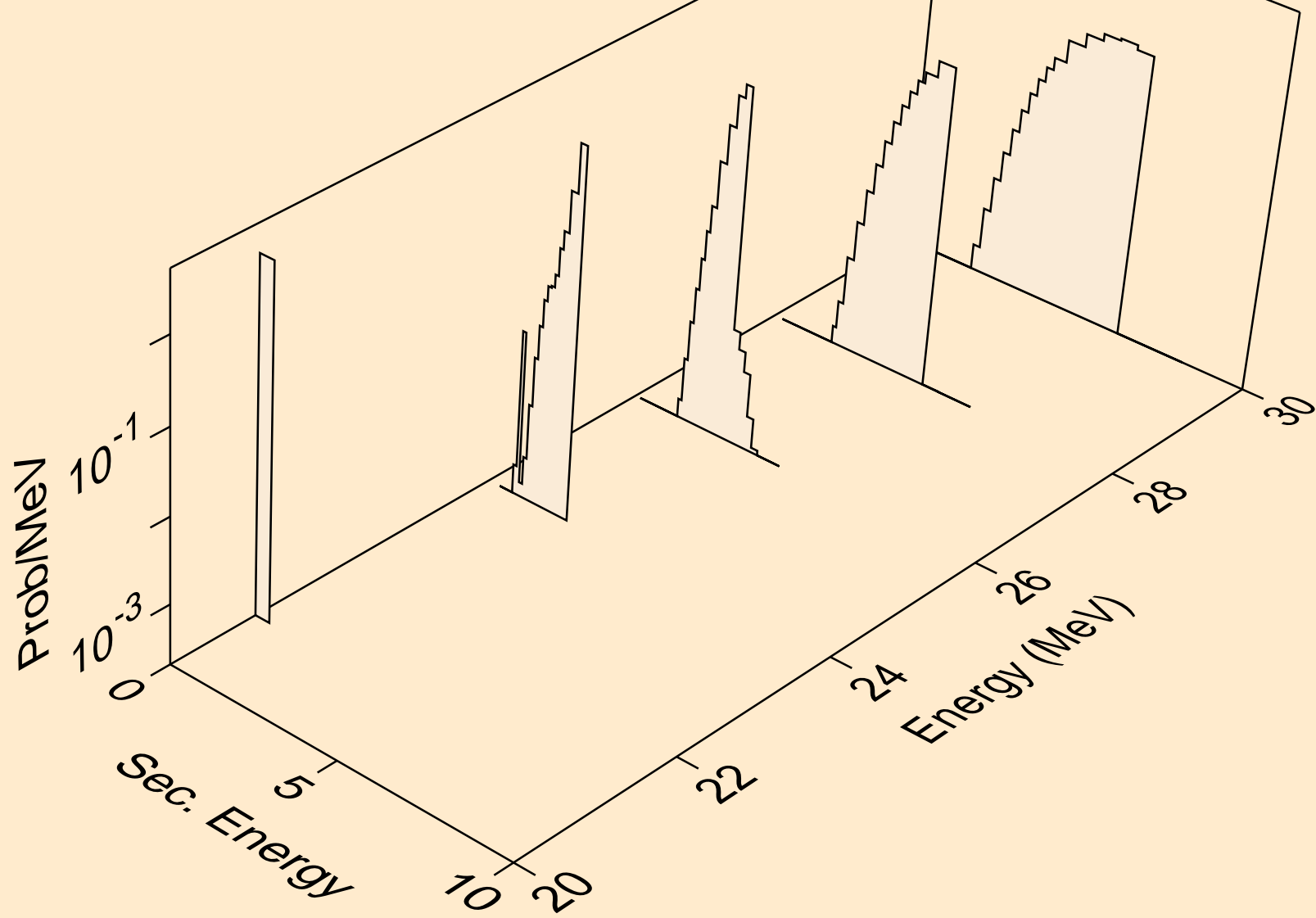

CO055 PROTON ACER TENDL-2021 LIBRARY; T=0.K  
he3s from (p,x)

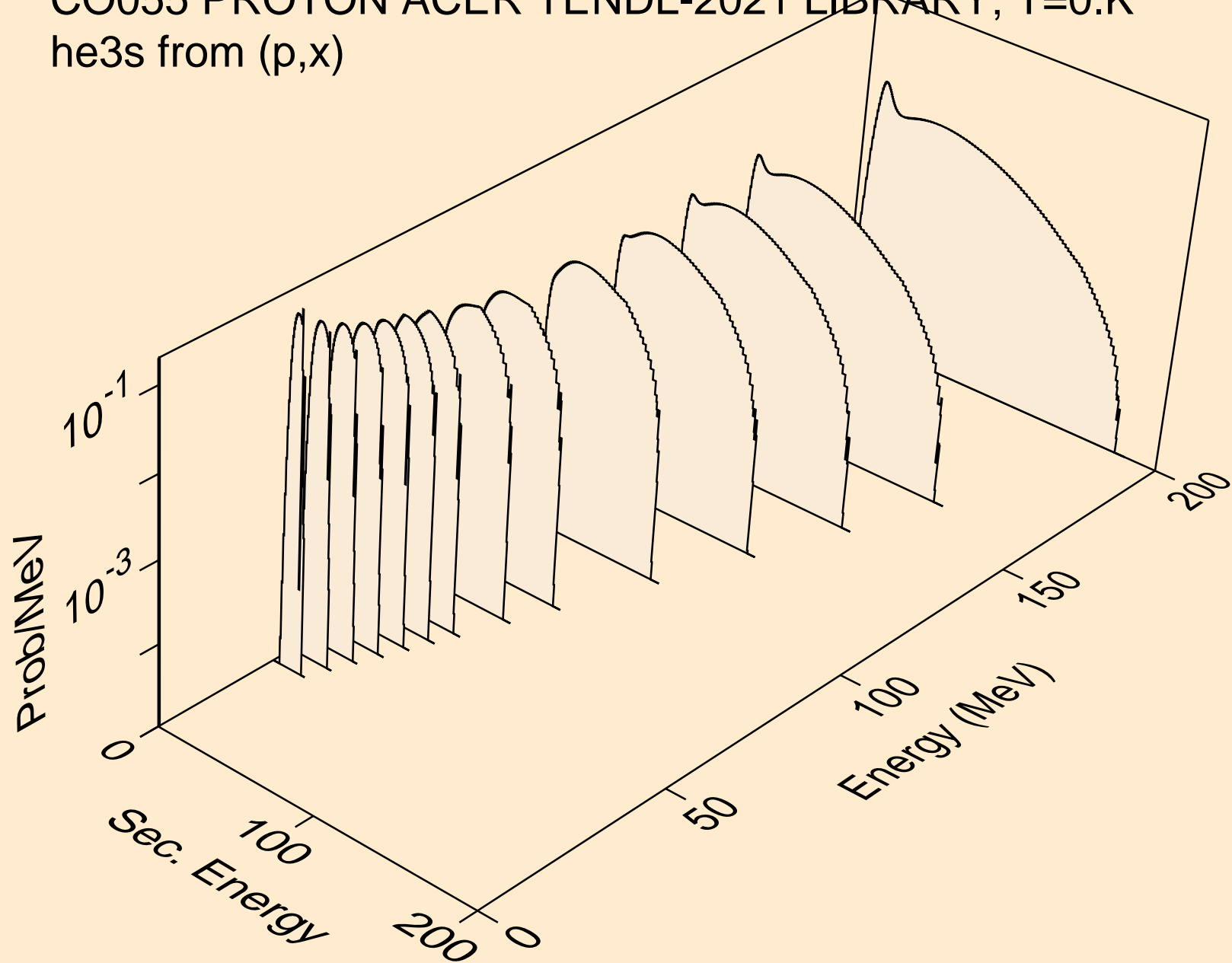

CO055 PROTON ACER TENDL-2021 LIBRARY; T=0.K  
he3s from (p,n\*)he3

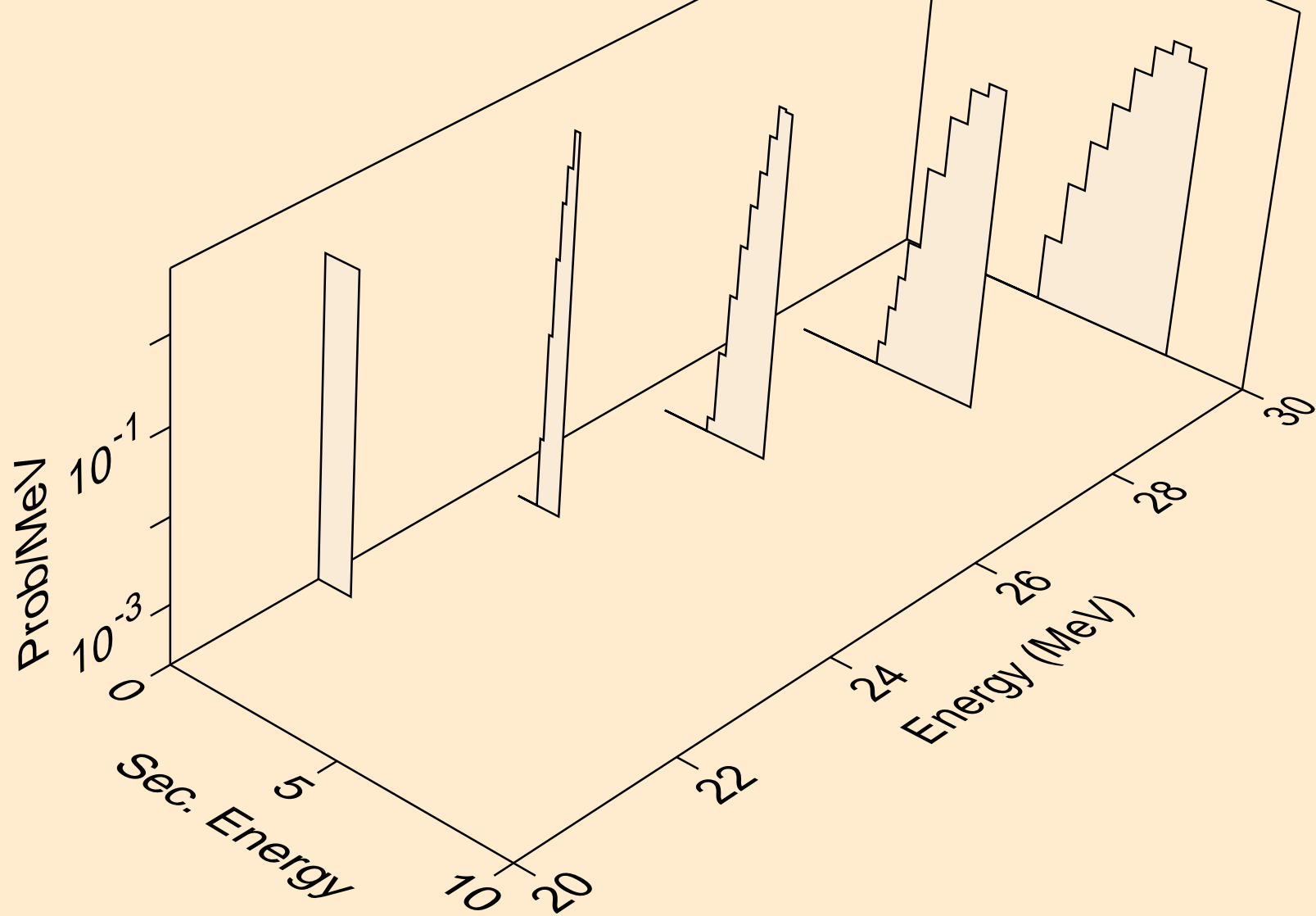



CO055 PROTON ACER TENDL-2021 LIBRARY; T=0.K  
he3s from (p,he3)

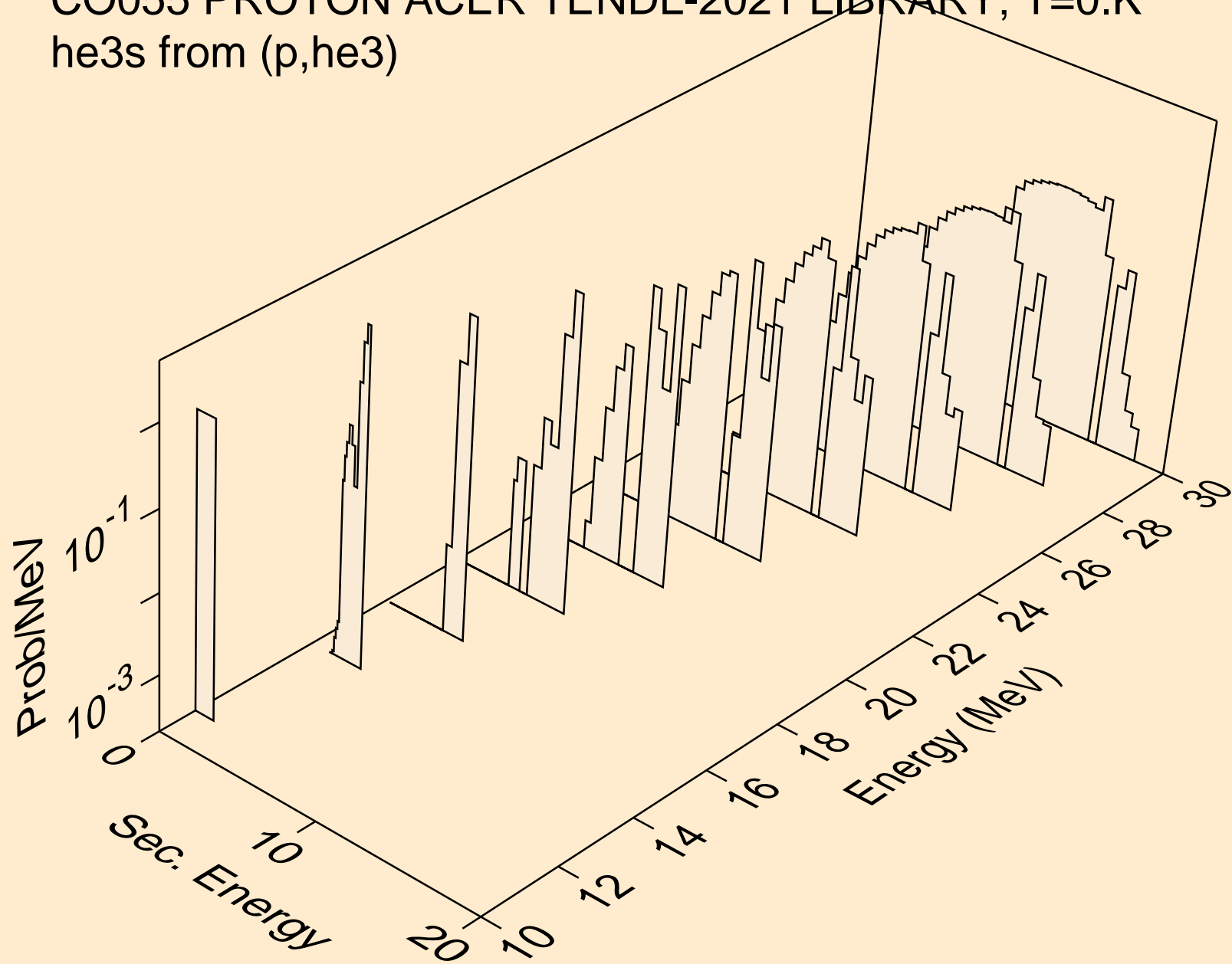

CO055 PROTON ACER TENDL-2021 LIBRARY; T=0.K  
alphas from (p,x)

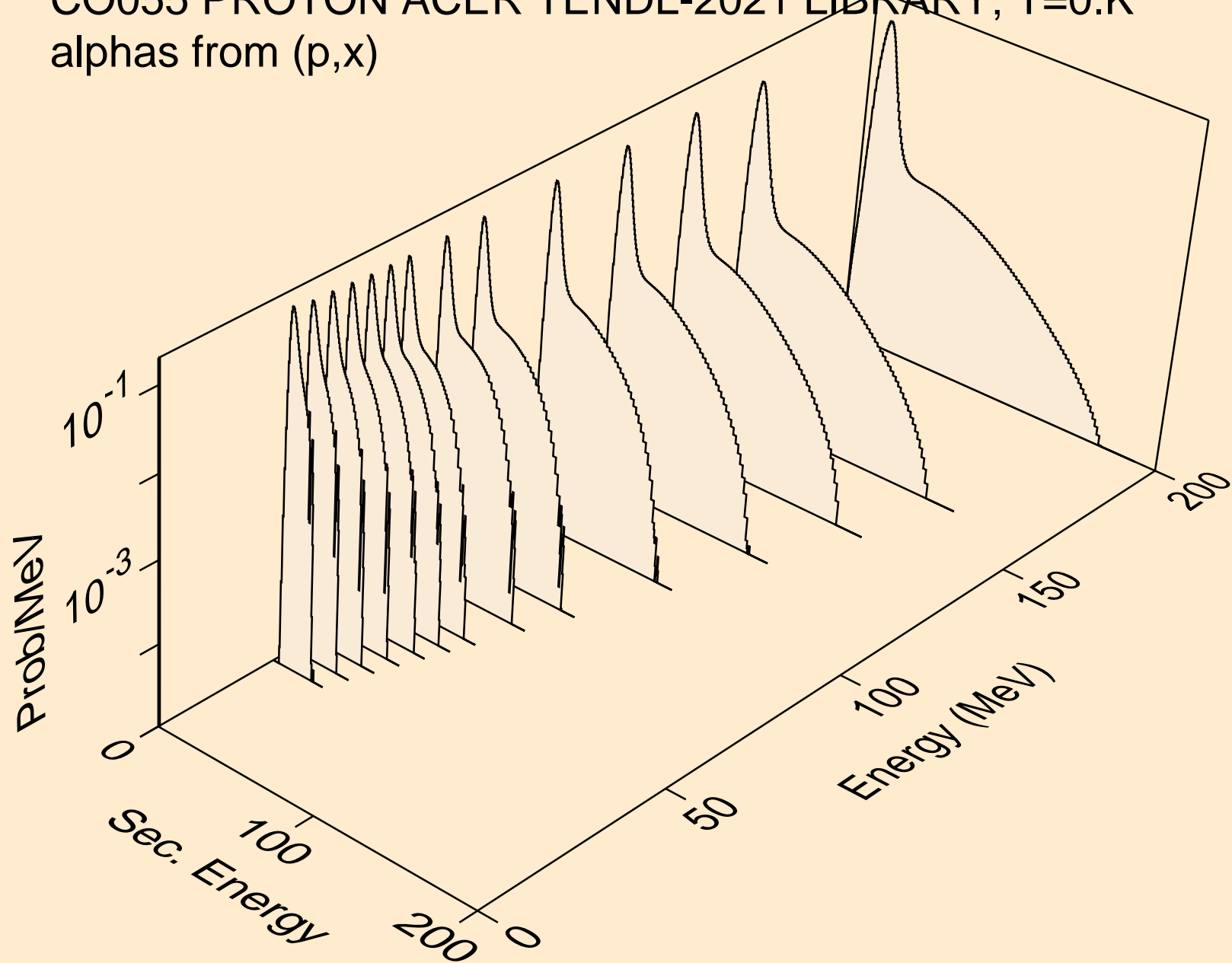

CO055 PROTON ACER TENDL-2021 LIBRARY; T=0.K  
alphas from (p,n\*)a

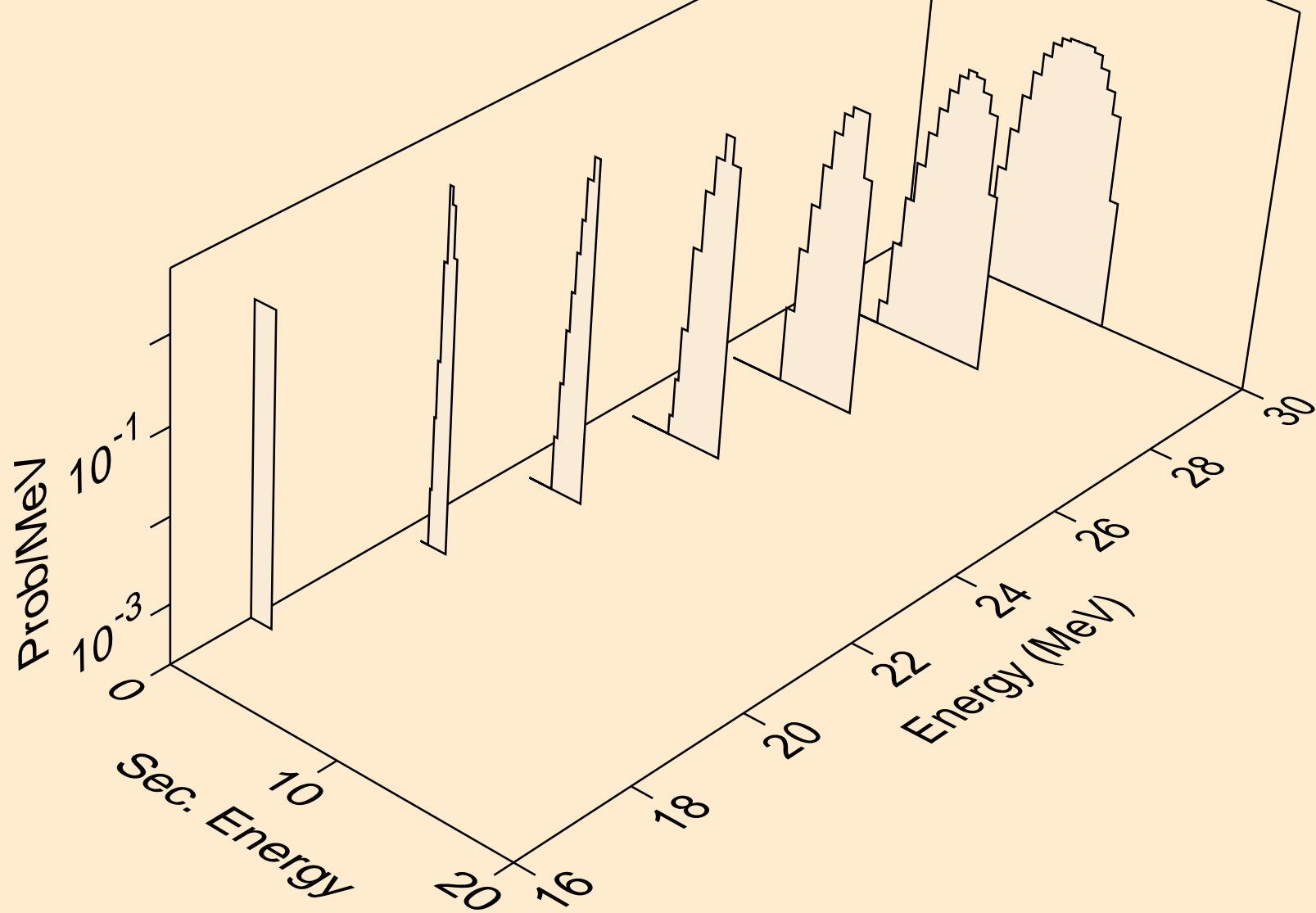

CO055 PROTON ACER TENDL-2021 LIBRARY; T=0.K  
alphas from (p,npa)

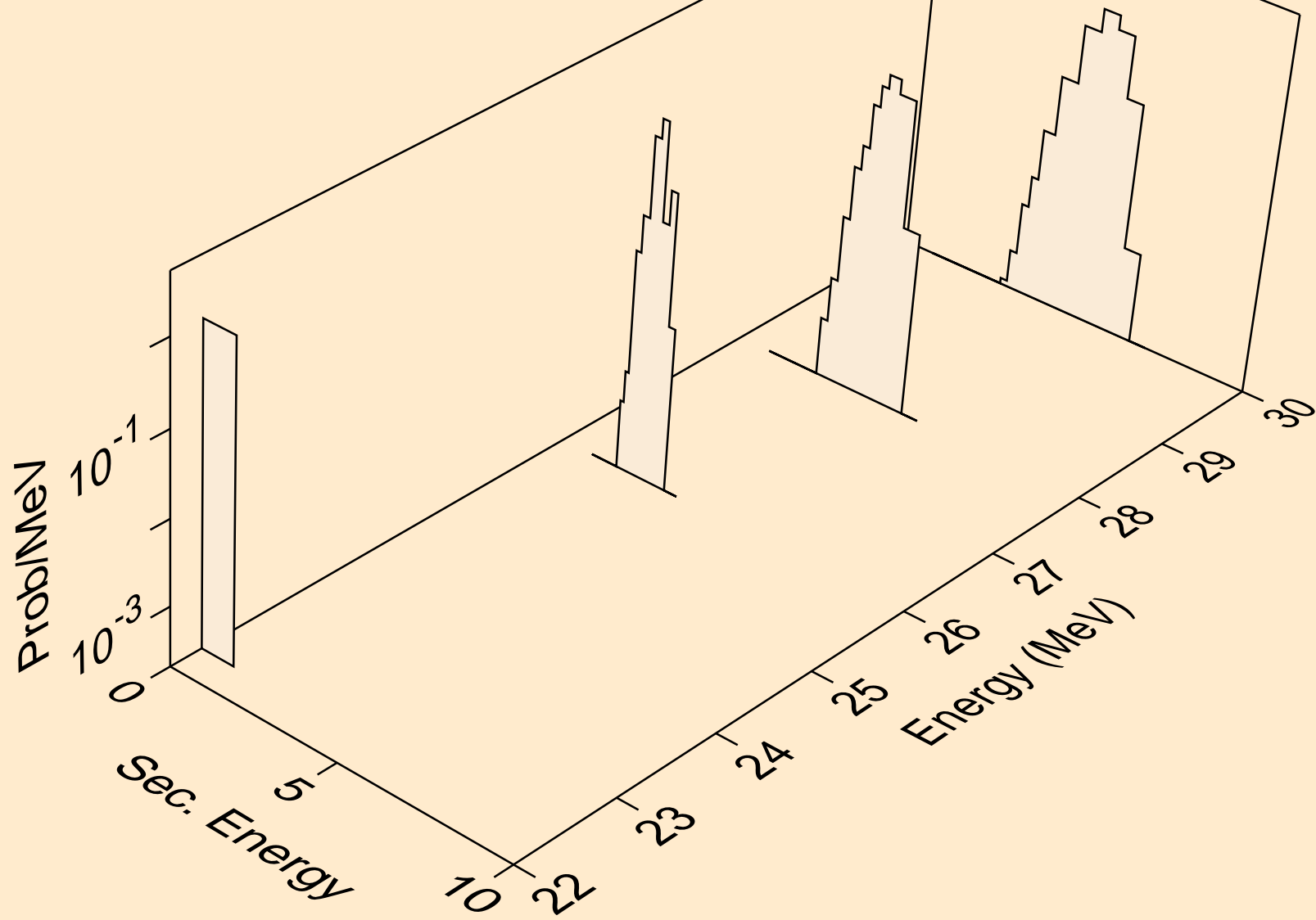

CO055 PROTON ACER TENDL-2021 LIBRARY; T=0.K  
alphas from (p,a)

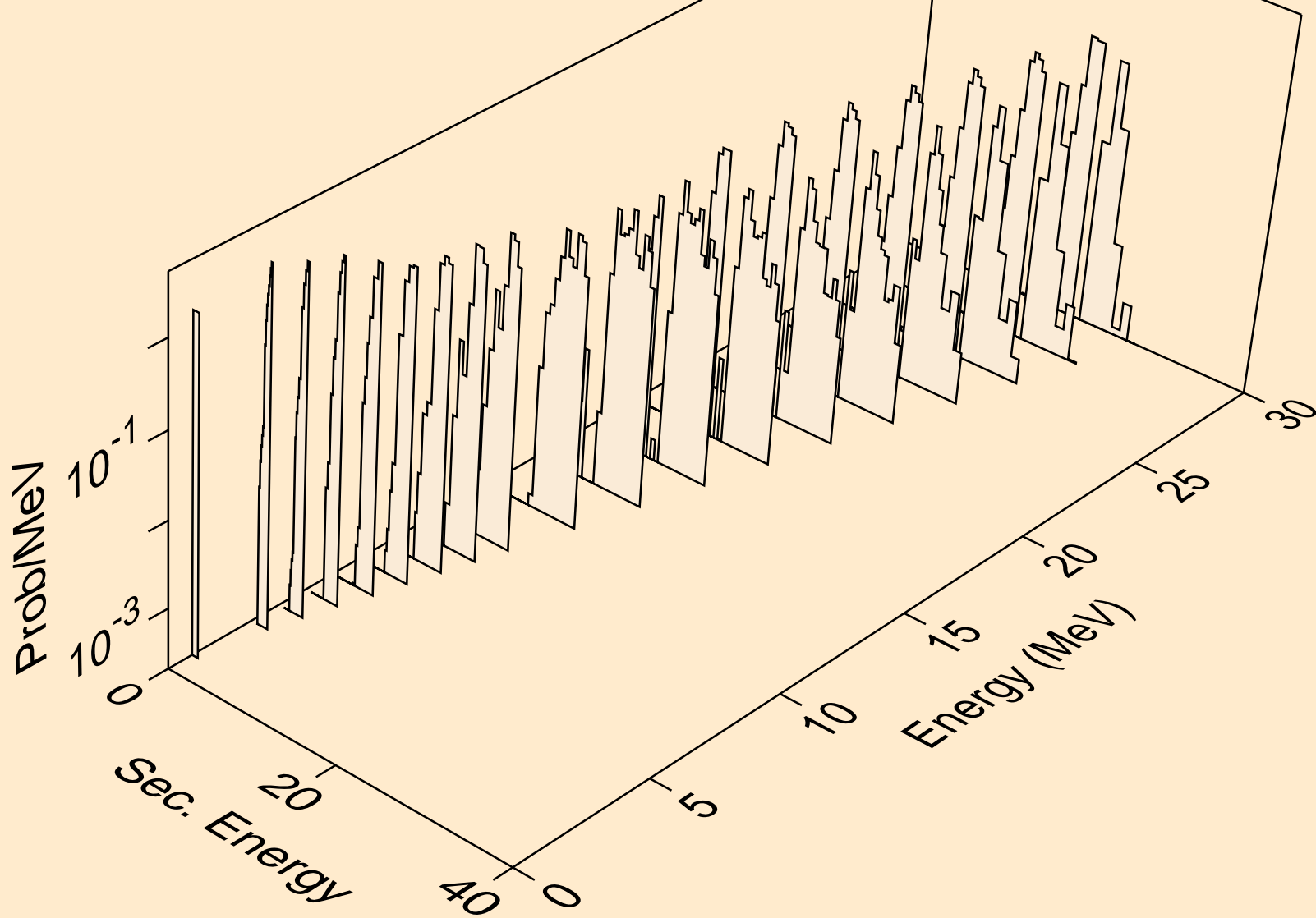

CO055 PROTON ACER TENDL-2021 LIBRARY; T=0.K  
alphas from (p,2a)

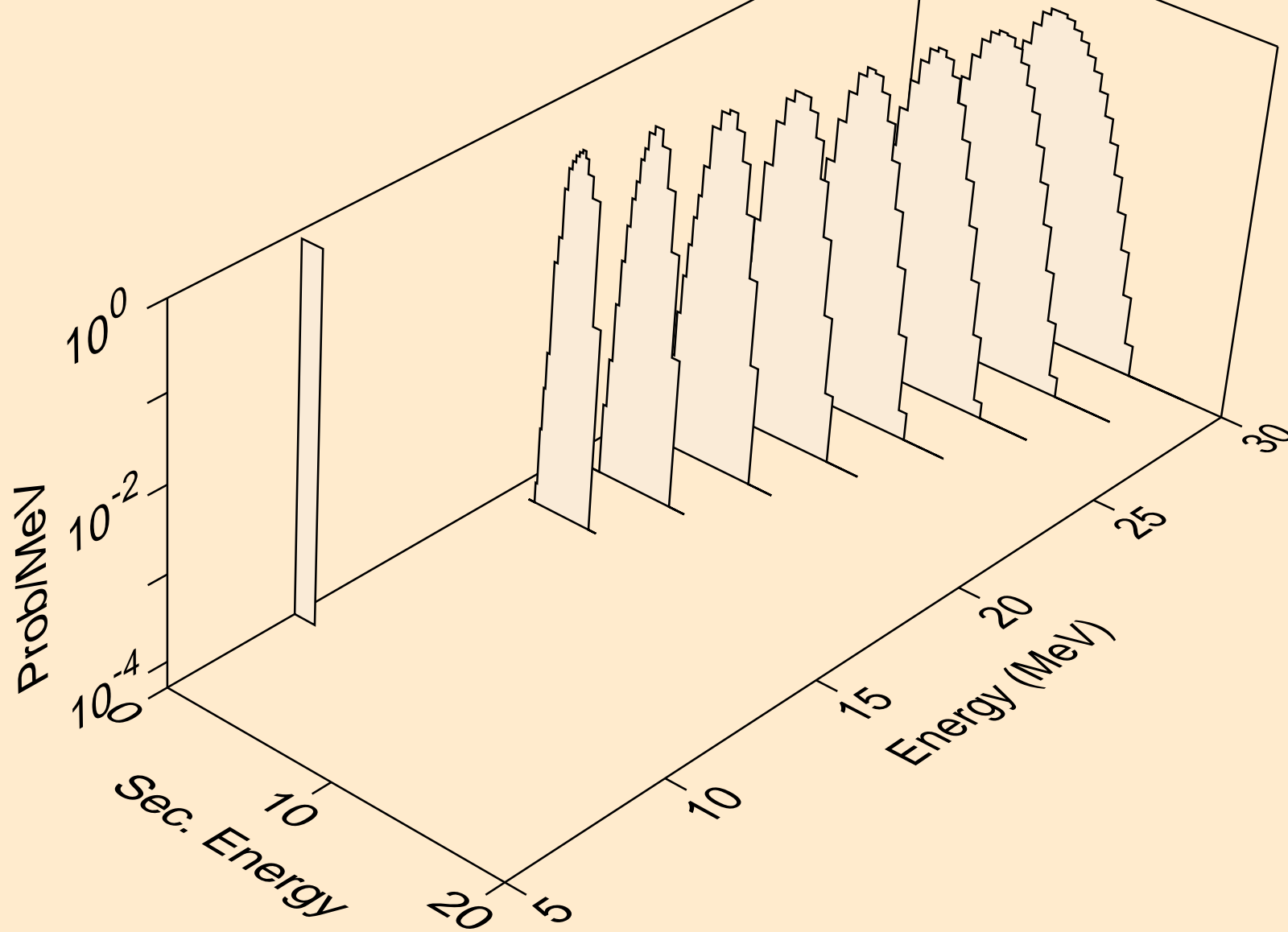

CO055 PROTON ACER TENDL-2021 LIBRARY; T=0.K  
alphas from (p,pa)

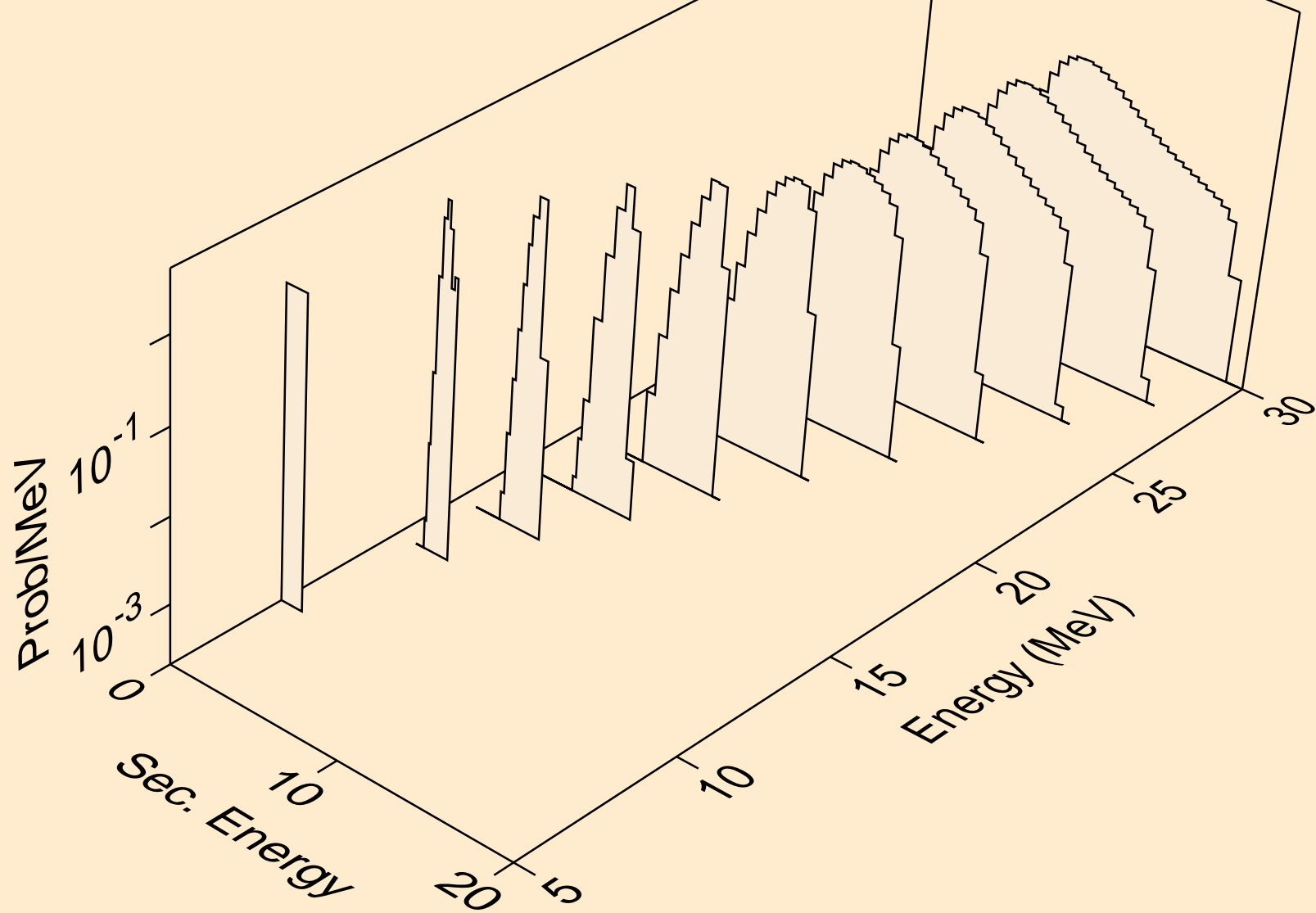

CO055 PROTON ACER TENDL-2021 LIBRARY; T=0.K  
alphas from (p,da)

