

IR174M PROTON ACER TENDL-2021 LIBRARY; T=0.K  
Principal cross sections

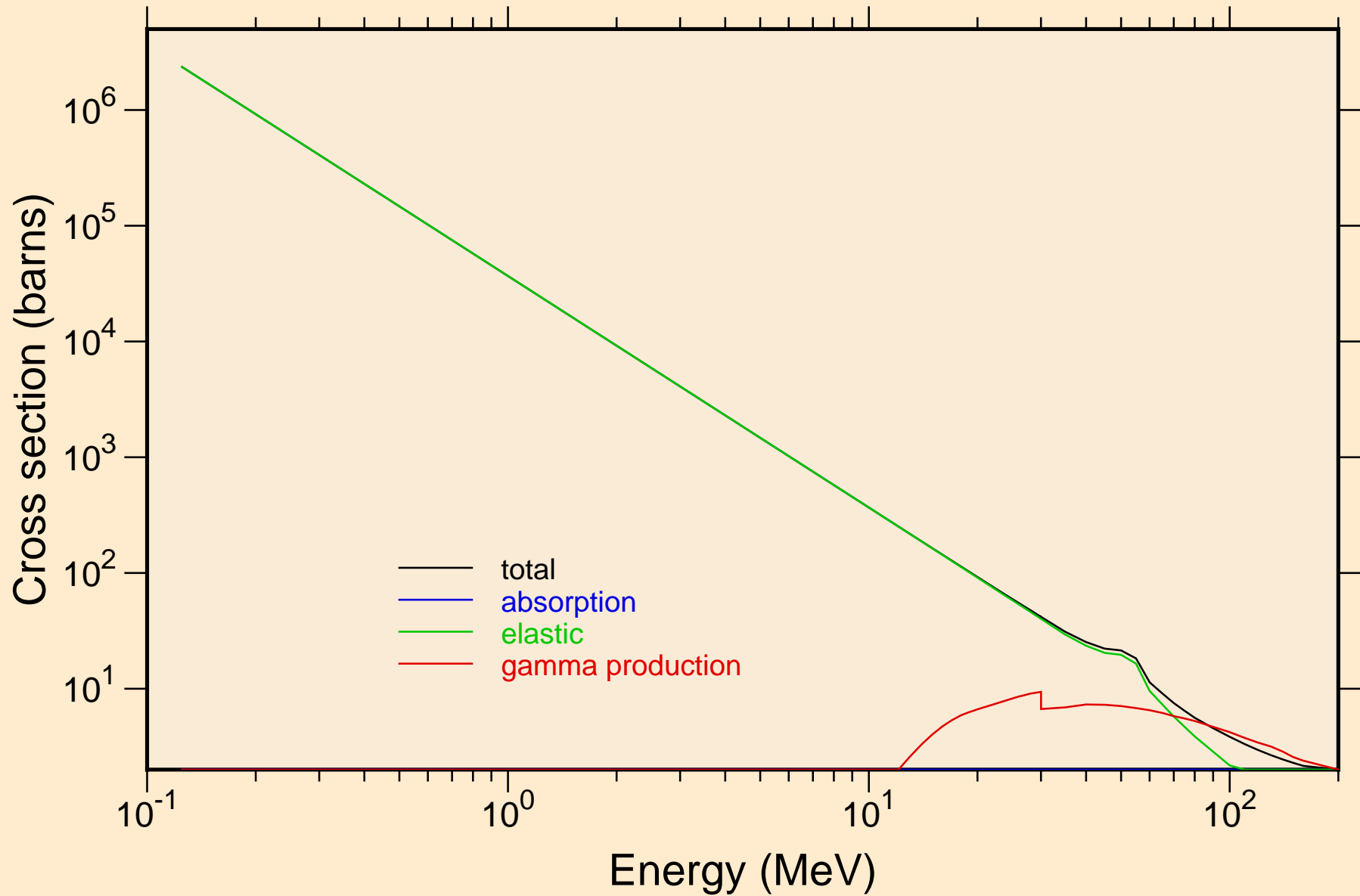

IR174M PROTON ACER TENDL-2021 LIBRARY; T=0.K  
Heating

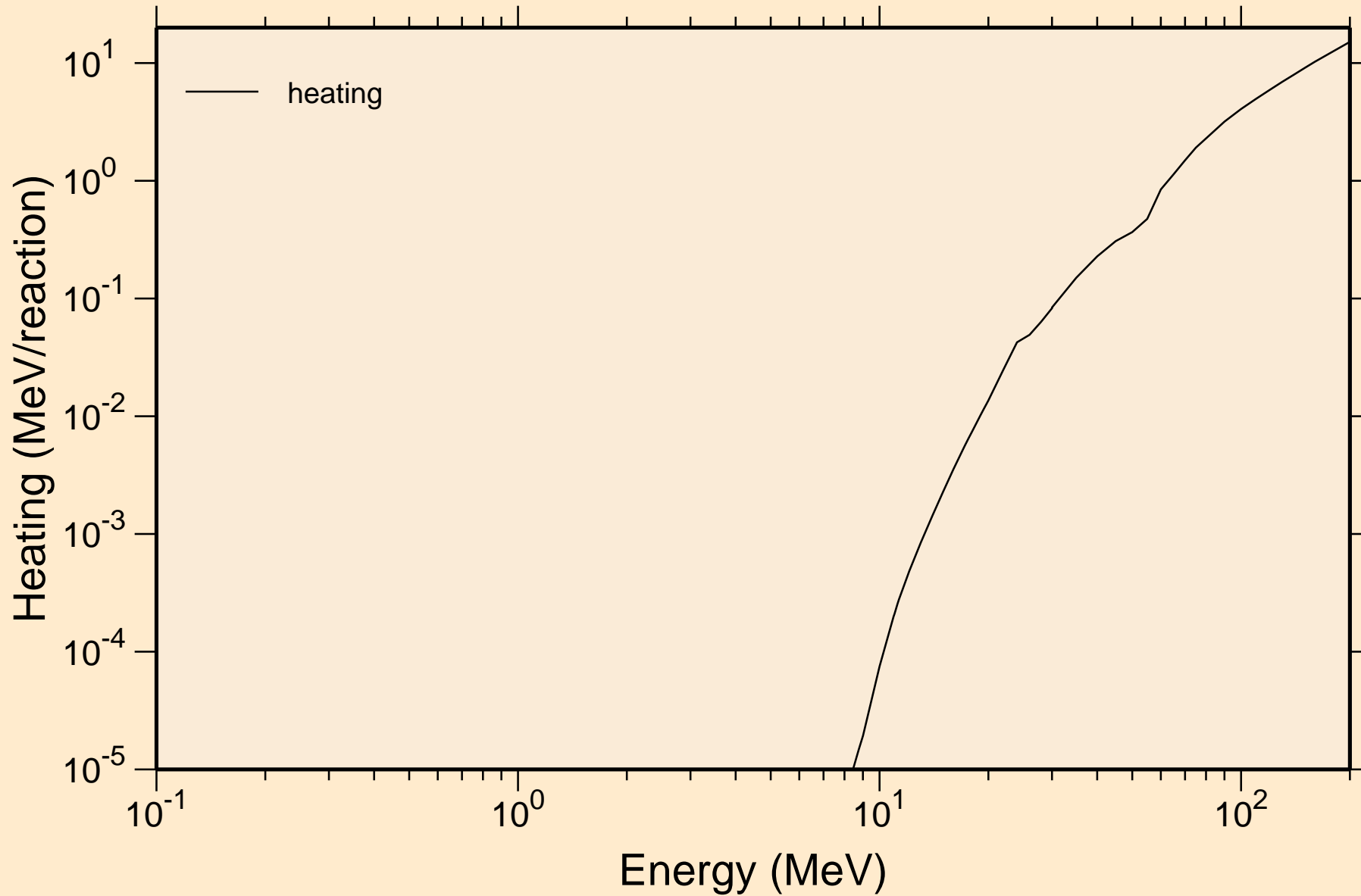

# IR174M PROTON ACER TENDL-2021 LIBRARY; T=0.K

## Principal cross sections

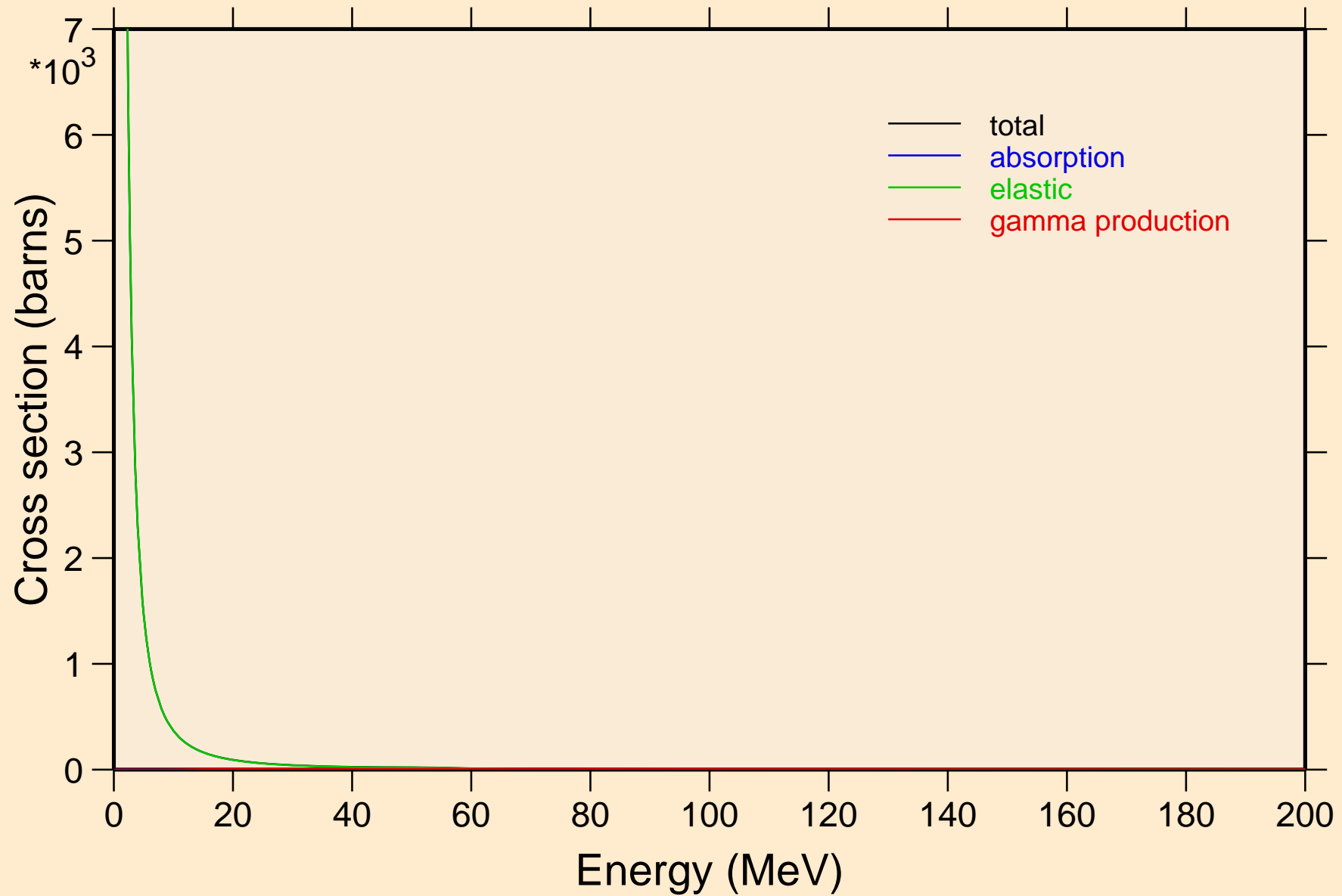

IR174M PROTON ACER TENDL-2021 LIBRARY; T=0.K

Heating

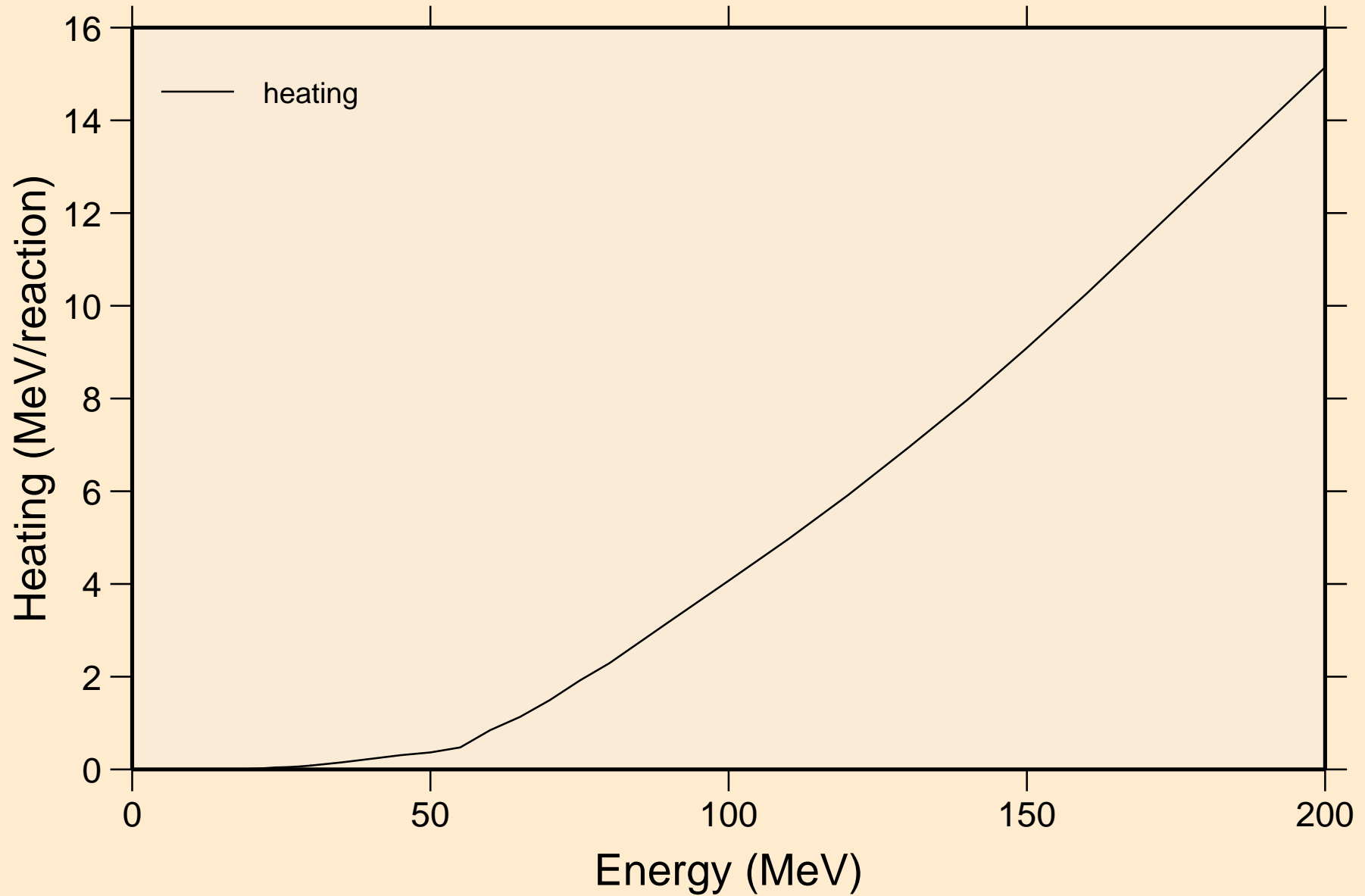

IR174M PROTON ACER TENDL-2021 LIBRARY; T=0.K  
Threshold reactions

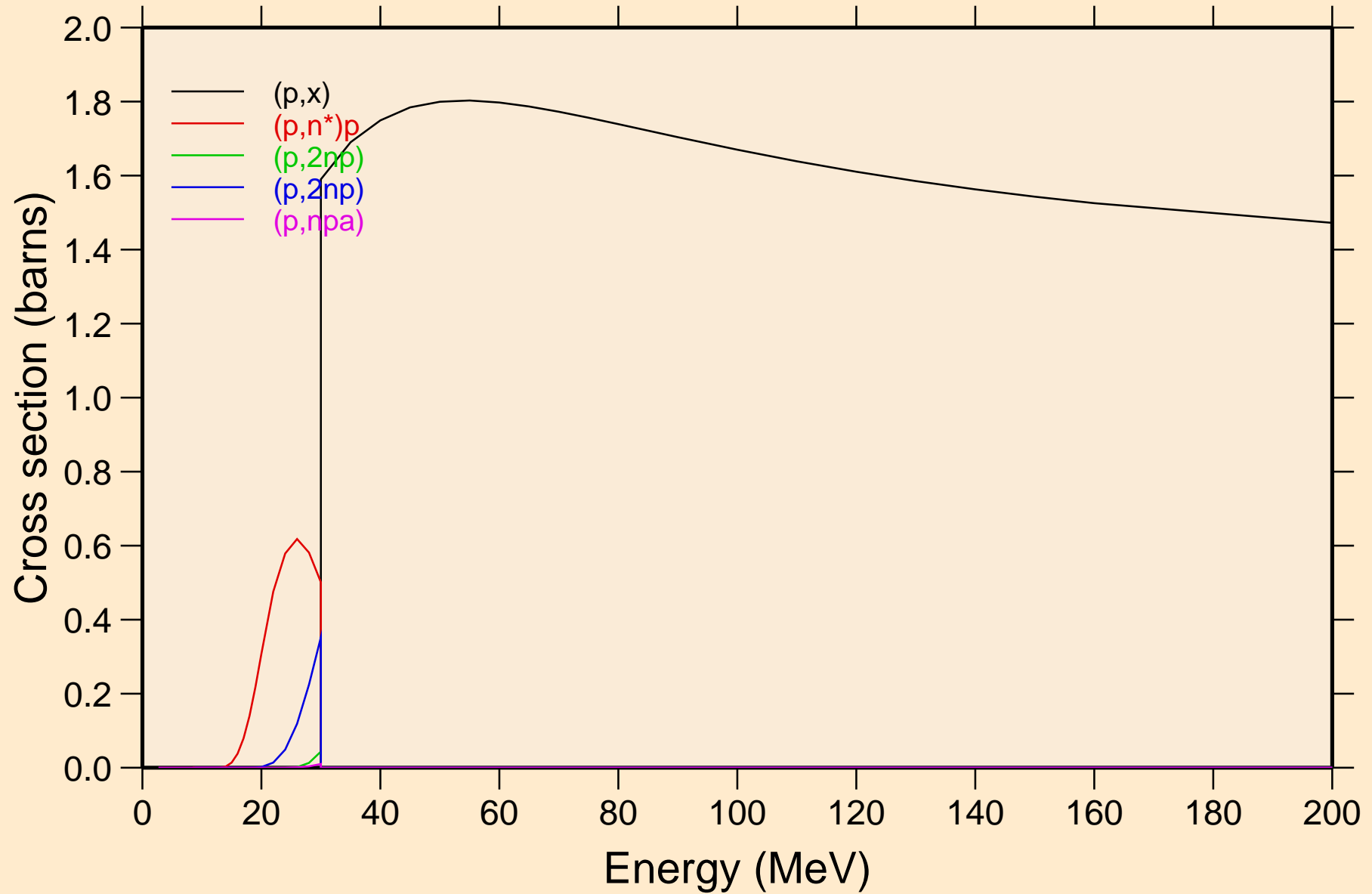

IR174M PROTON ACER TENDL-2021 LIBRARY; T=0.K  
Threshold reactions

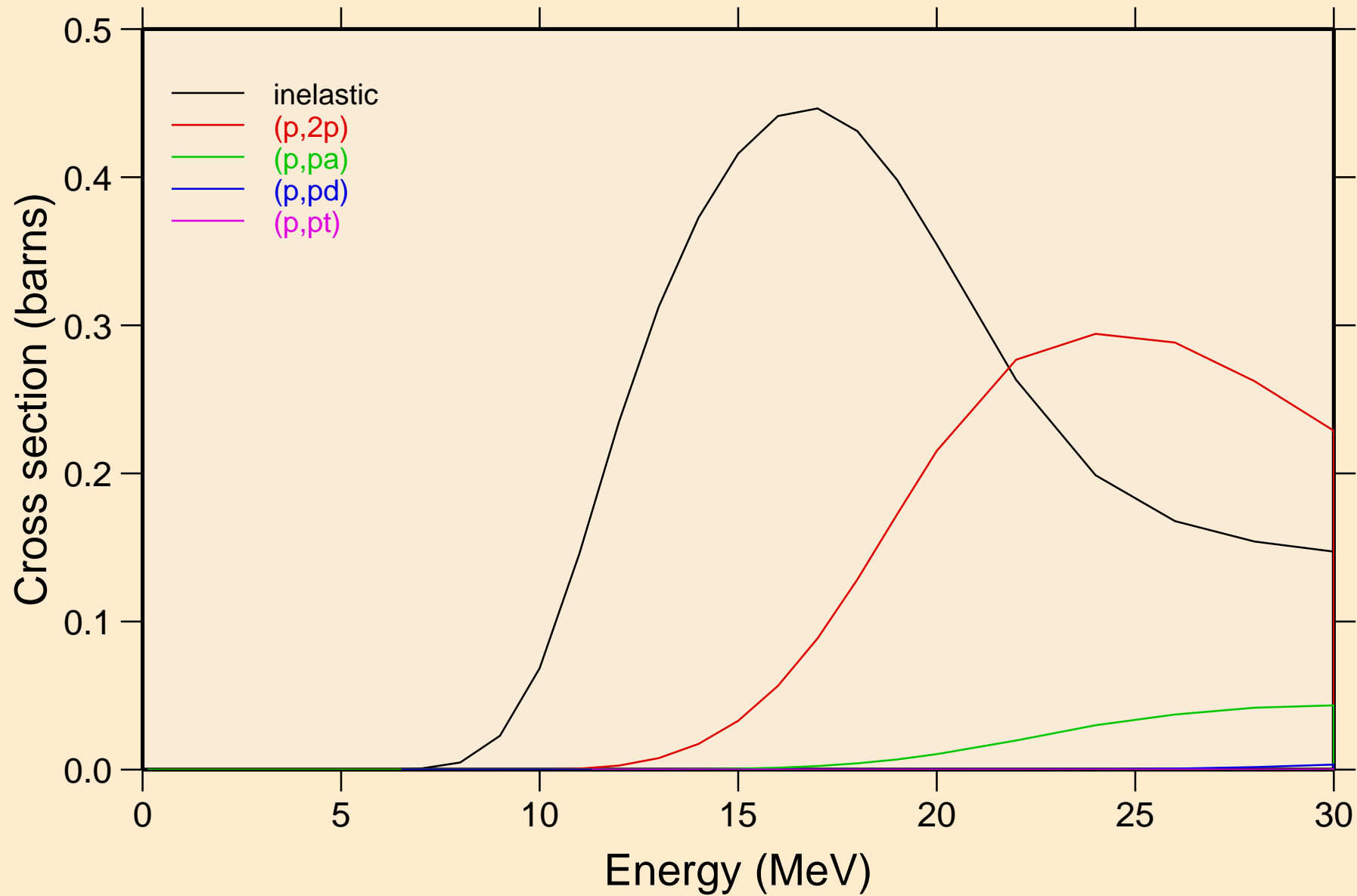

IR174M PROTON ACER TENDL-2021 LIBRARY; T=0.K  
Threshold reactions

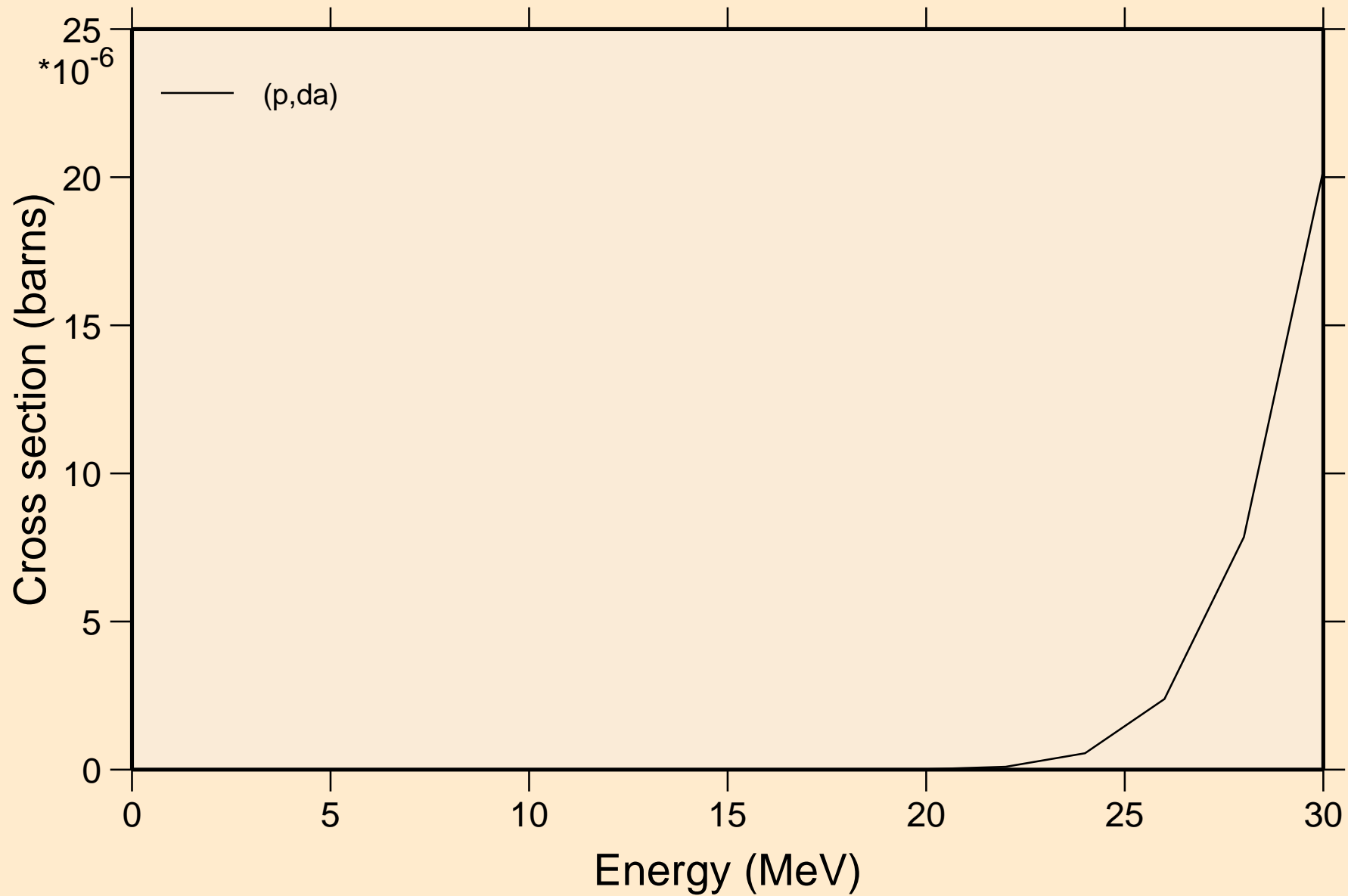

IR174M PROTON ACER TENDL-2021 LIBRARY; T=0.K  
angular distribution for elastic

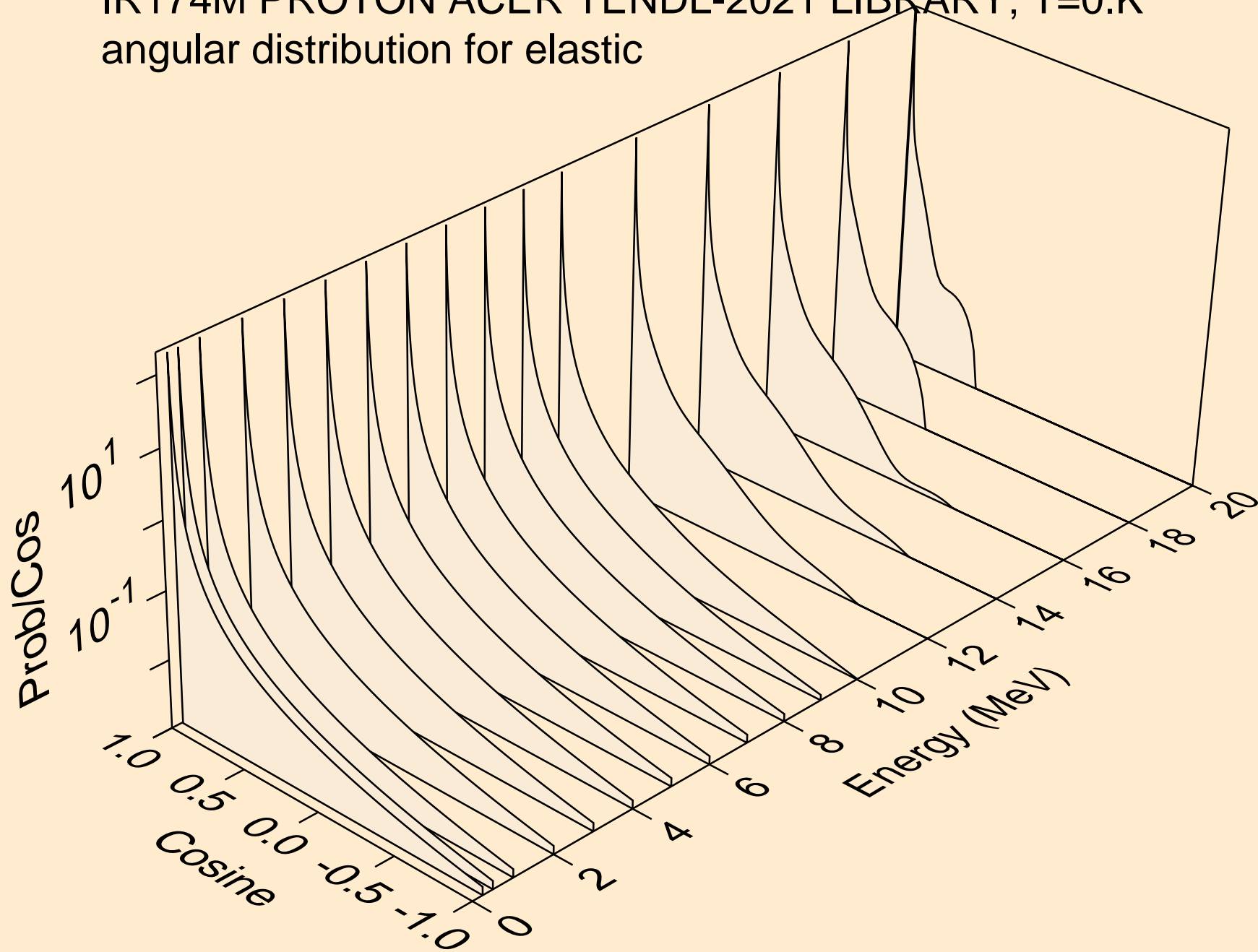



IR174M PROTON ACER TENDL-2021 LIBRARY; T=0.K  
angular distribution for elastic

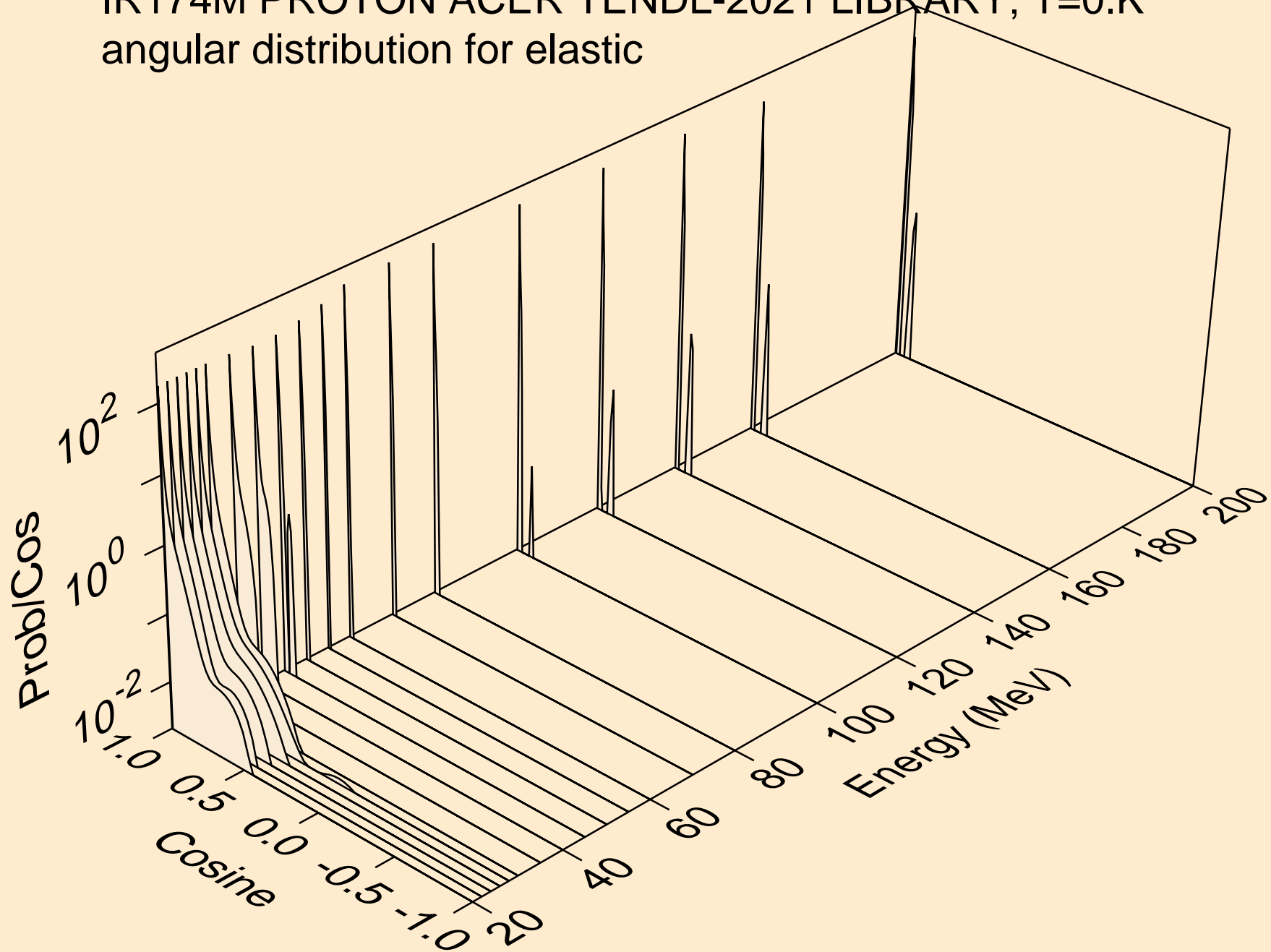

IR174M PROTON ACER TENDL-2021 LIBRARY; T=0.K  
Proton emission for (p,x)

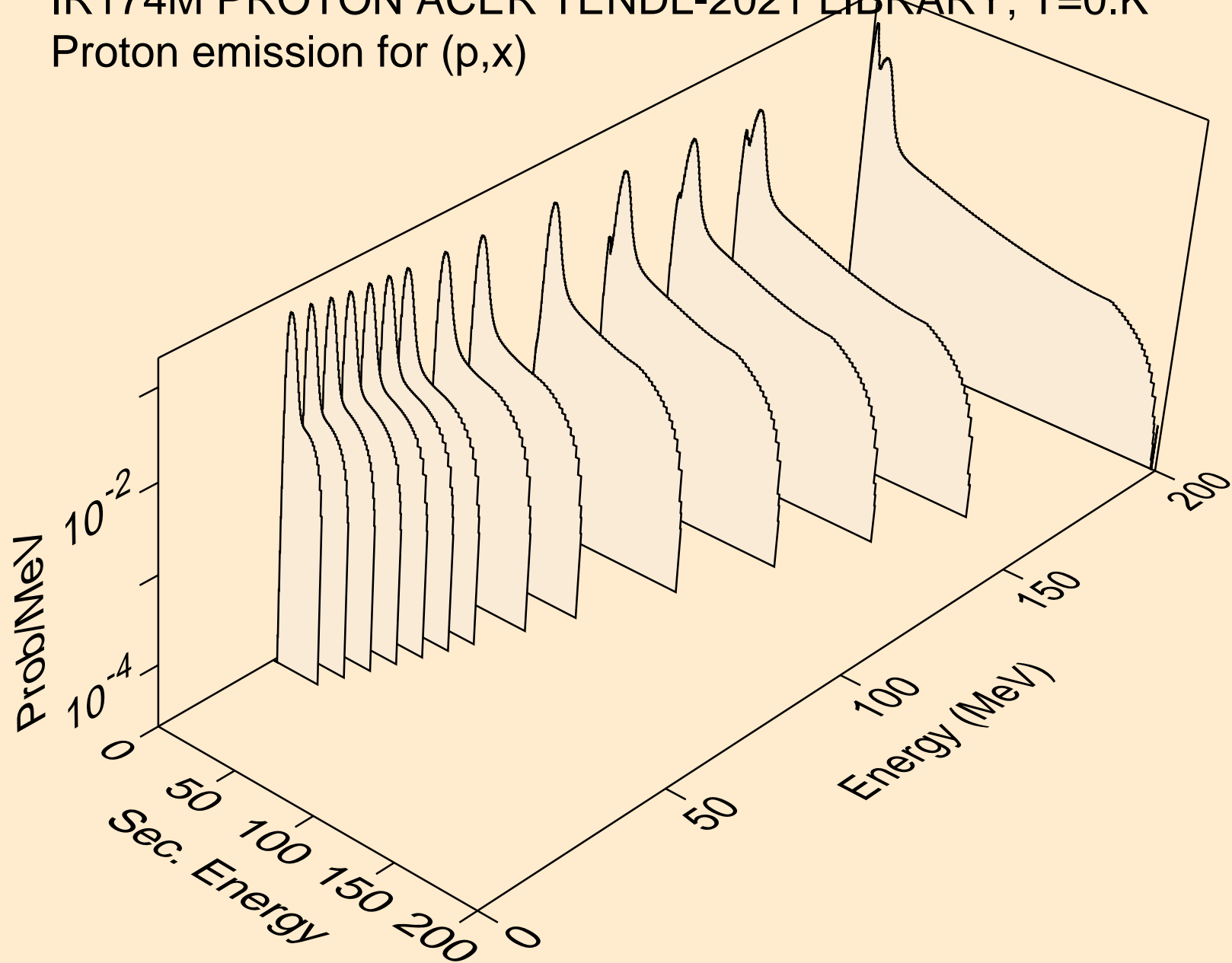

IR174M PROTON ACER TENDL-2021 LIBRARY; T=0.K  
Proton emission for (p,n\*)p

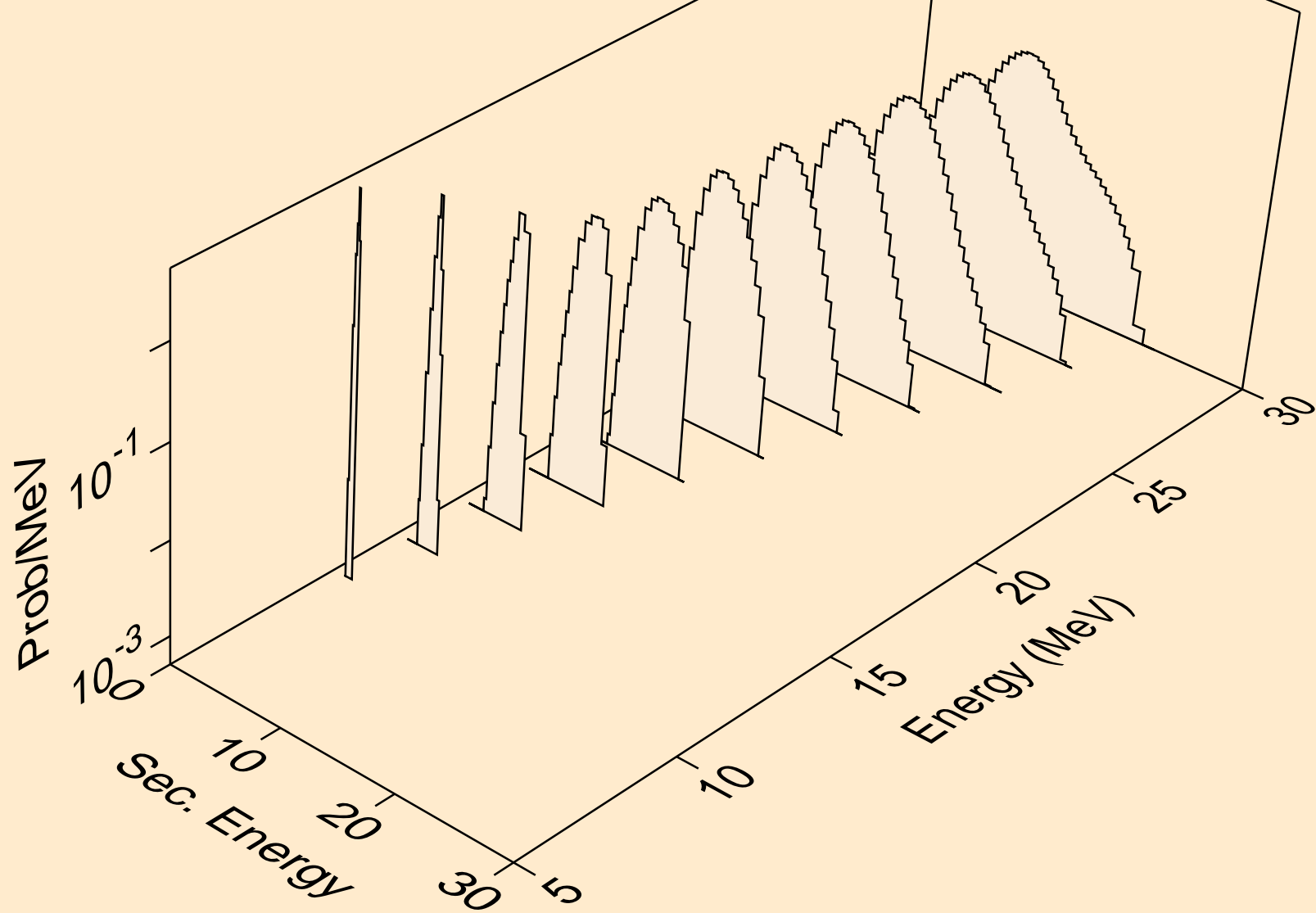

IR174M PROTON ACER TENDL-2021 LIBRARY; T=0.K  
Proton emission for (p,2np)

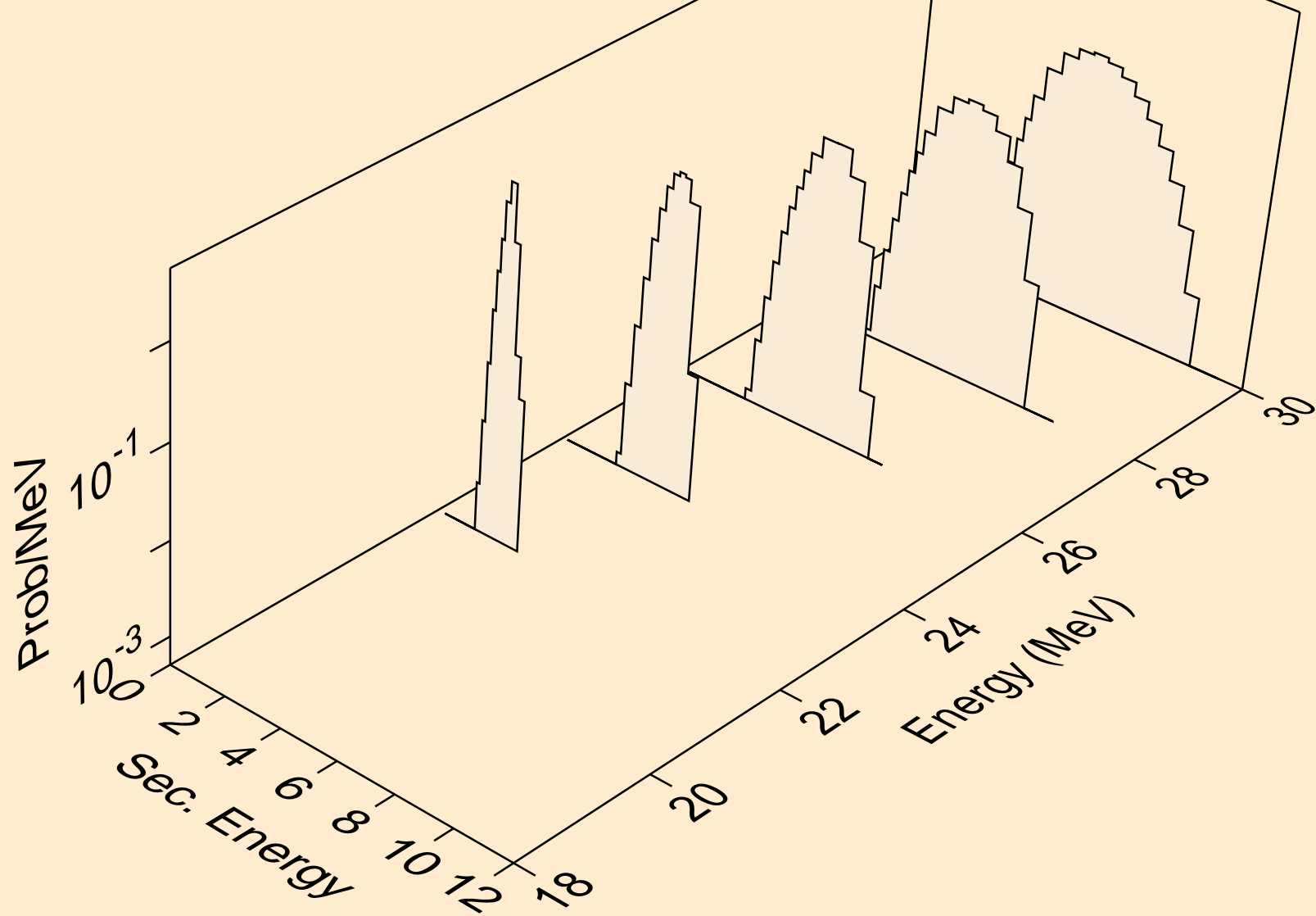

IR174M PROTON ACER TENDL-2021 LIBRARY; T=0.K  
Proton emission for (p,2np)

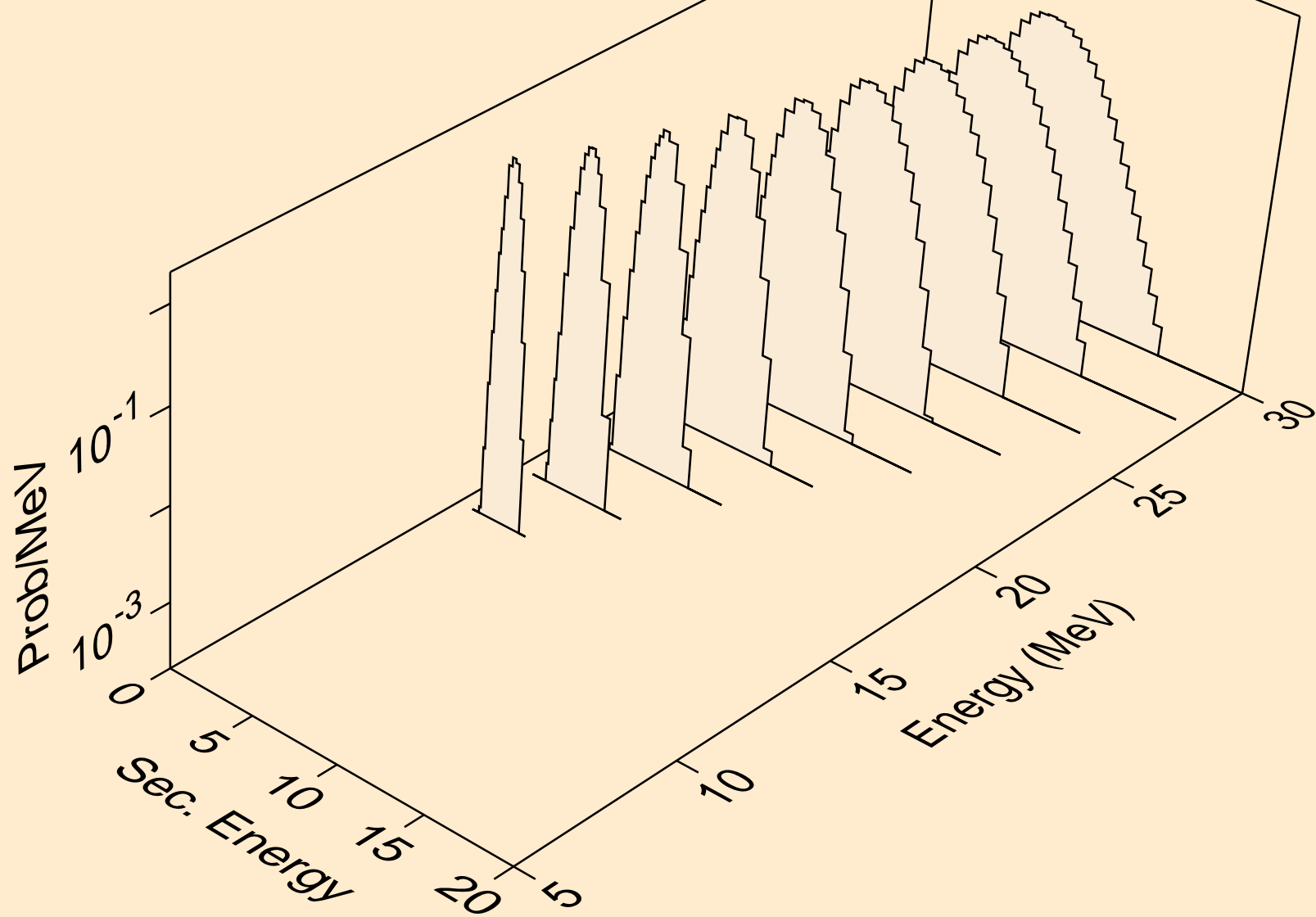

IR174M PROTON ACER TENDL-2021 LIBRARY; T=0.K  
Proton emission for (p,npa)

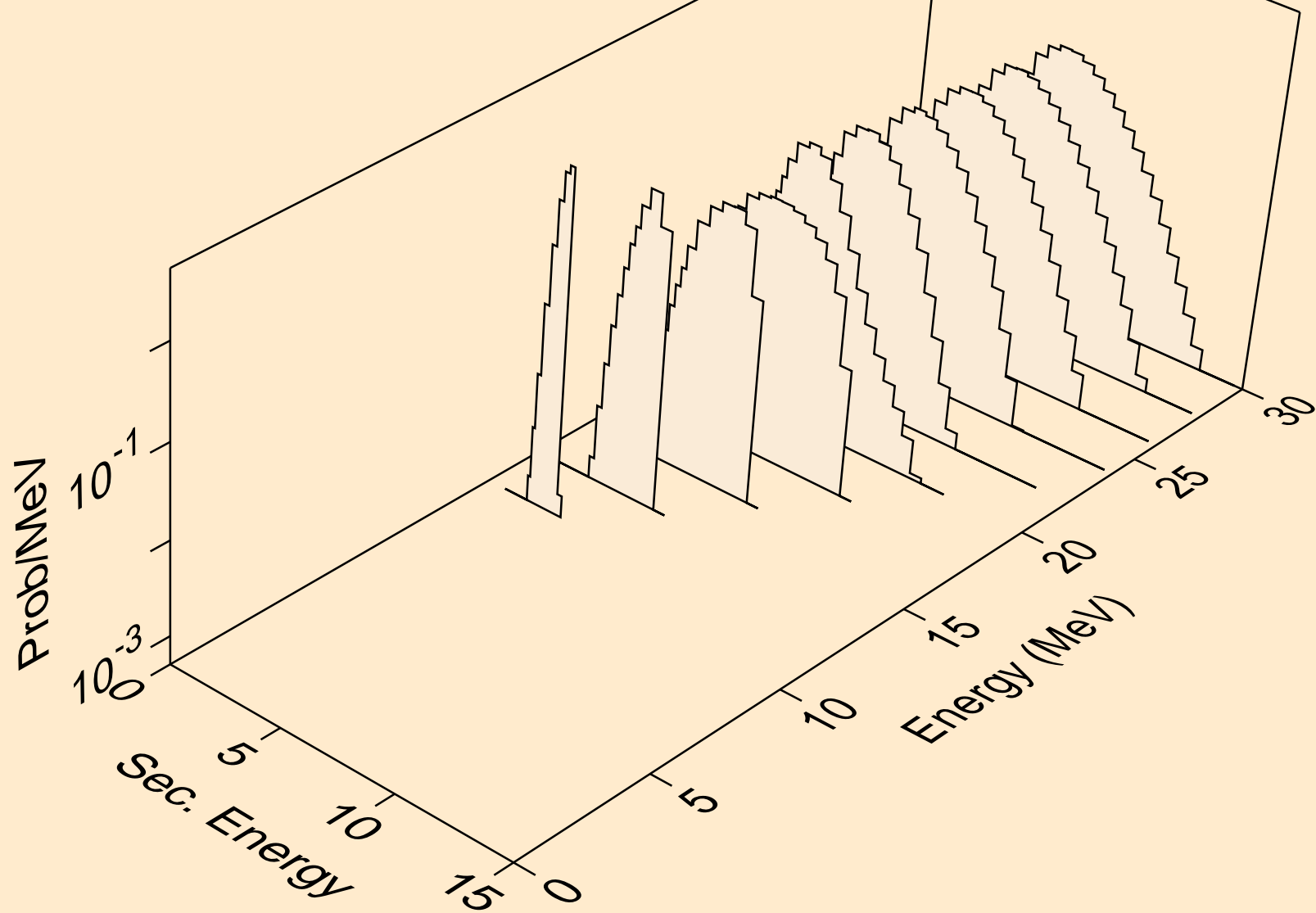

IR174M PROTON ACER TENDL-2021 LIBRARY; T=0.K  
Proton emission for inelastic

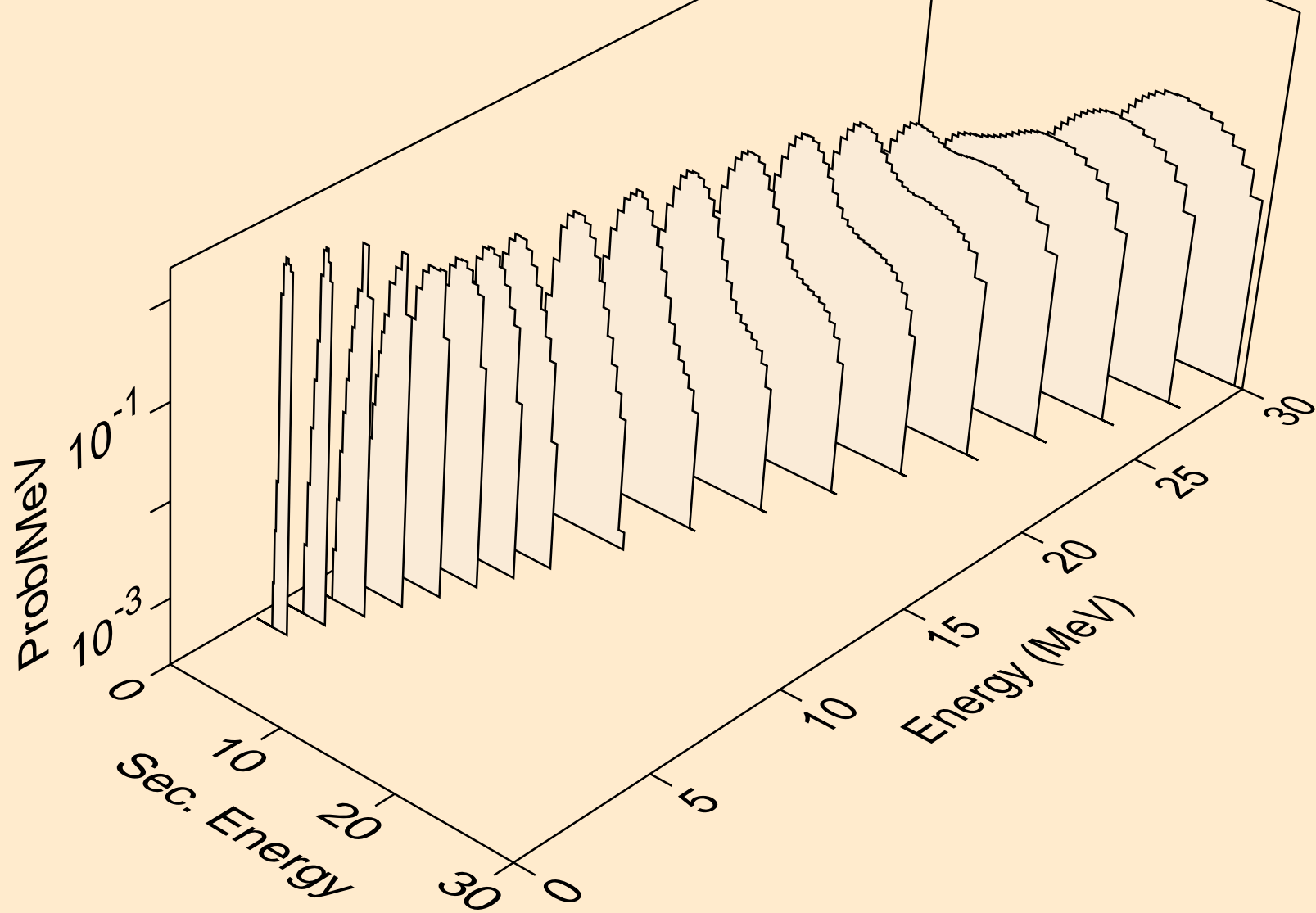

IR174M PROTON ACER TENDL-2021 LIBRARY; T=0.K  
Proton emission for (p,2p)

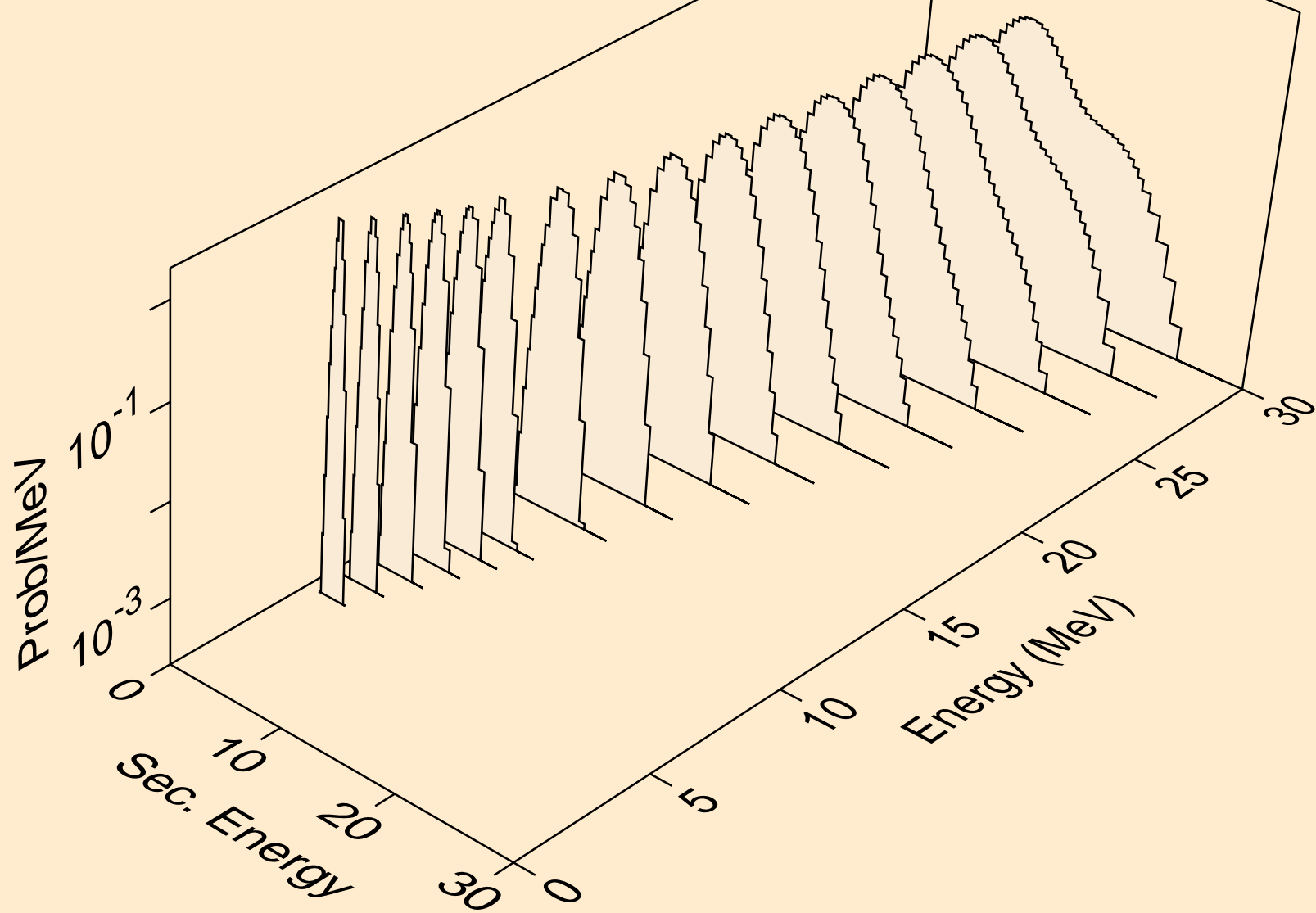



IR174M PROTON ACER TENDL-2021 LIBRARY; T=0.K  
Proton emission for (p,pa)

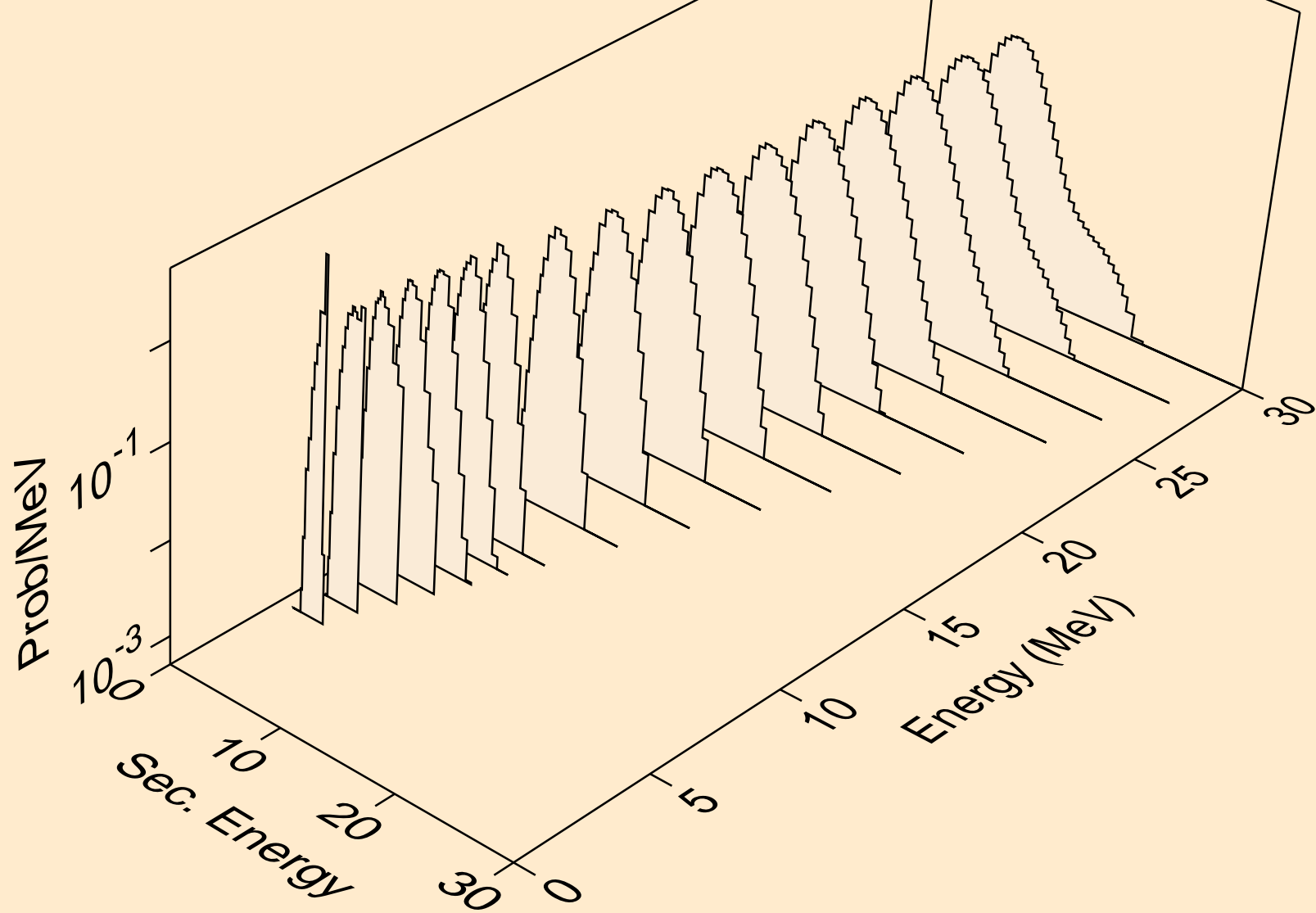

IR174M PROTON ACER TENDL-2021 LIBRARY; T=0.K  
Proton emission for (p,pd)

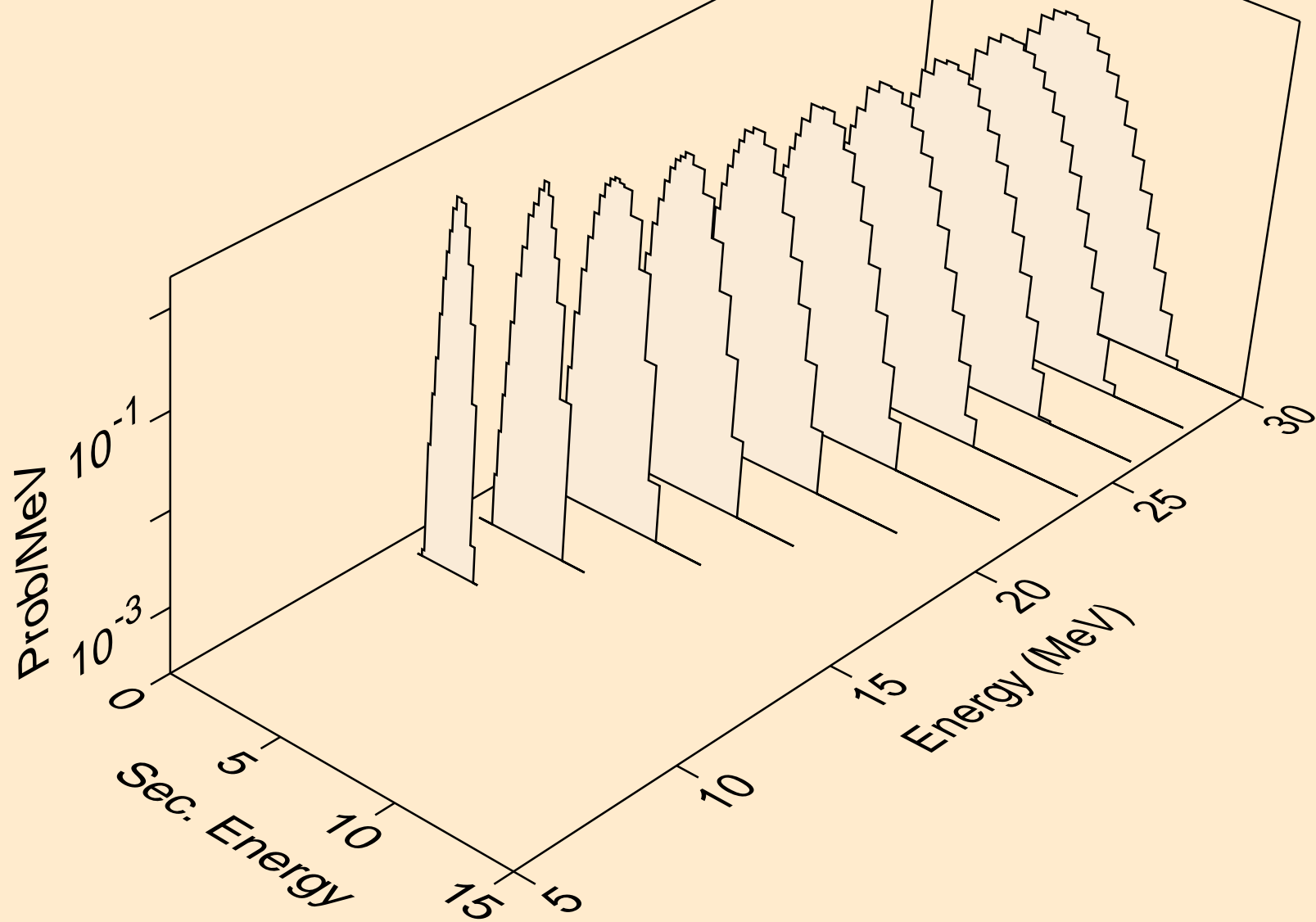

IR174M PROTON ACER TENDL-2021 LIBRARY; T=0.K  
Proton emission for (p,pt)

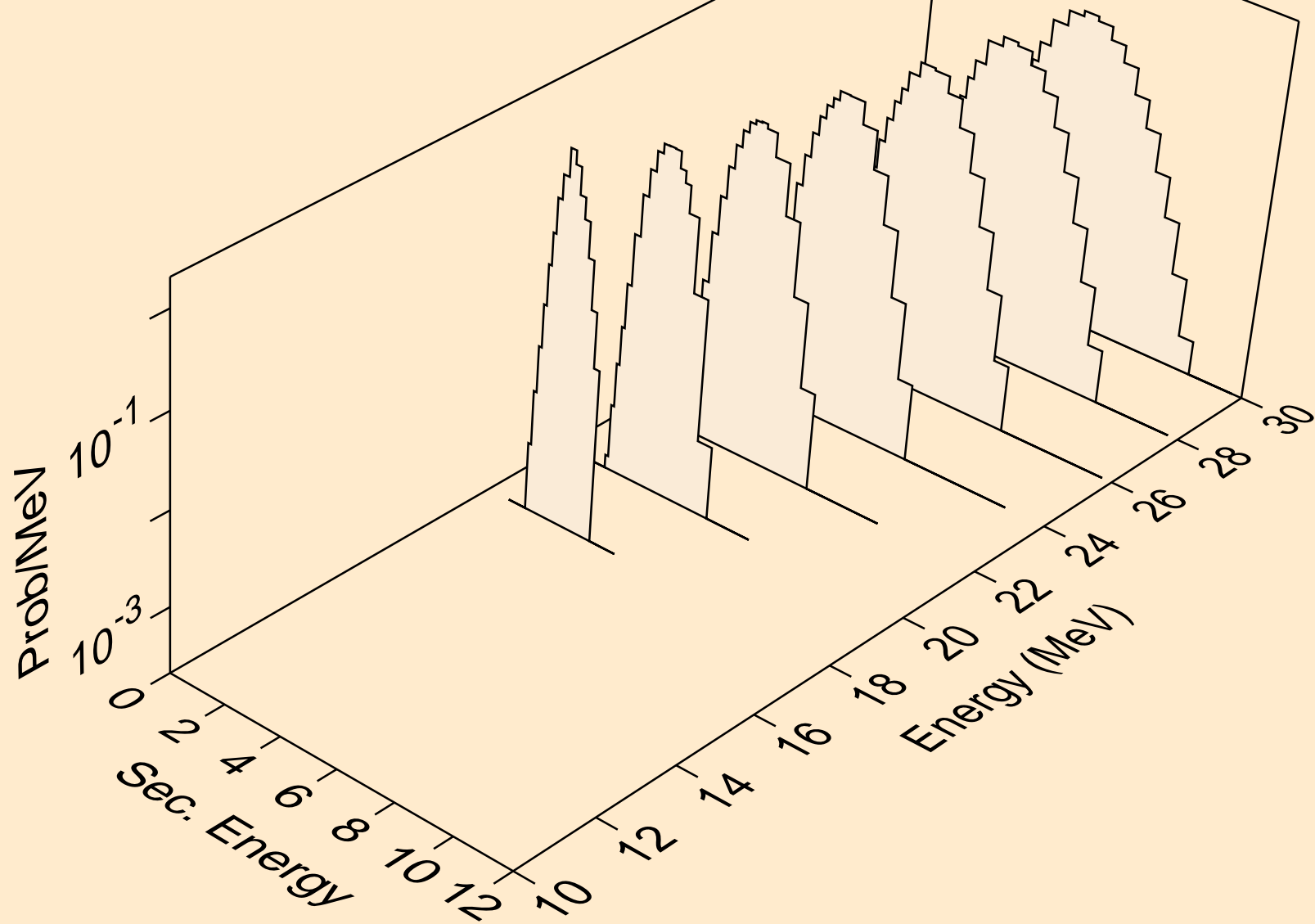

IR174M PROTON ACER TENDL-2021 LIBRARY; T=0.K  
Photon emission for (z,n)

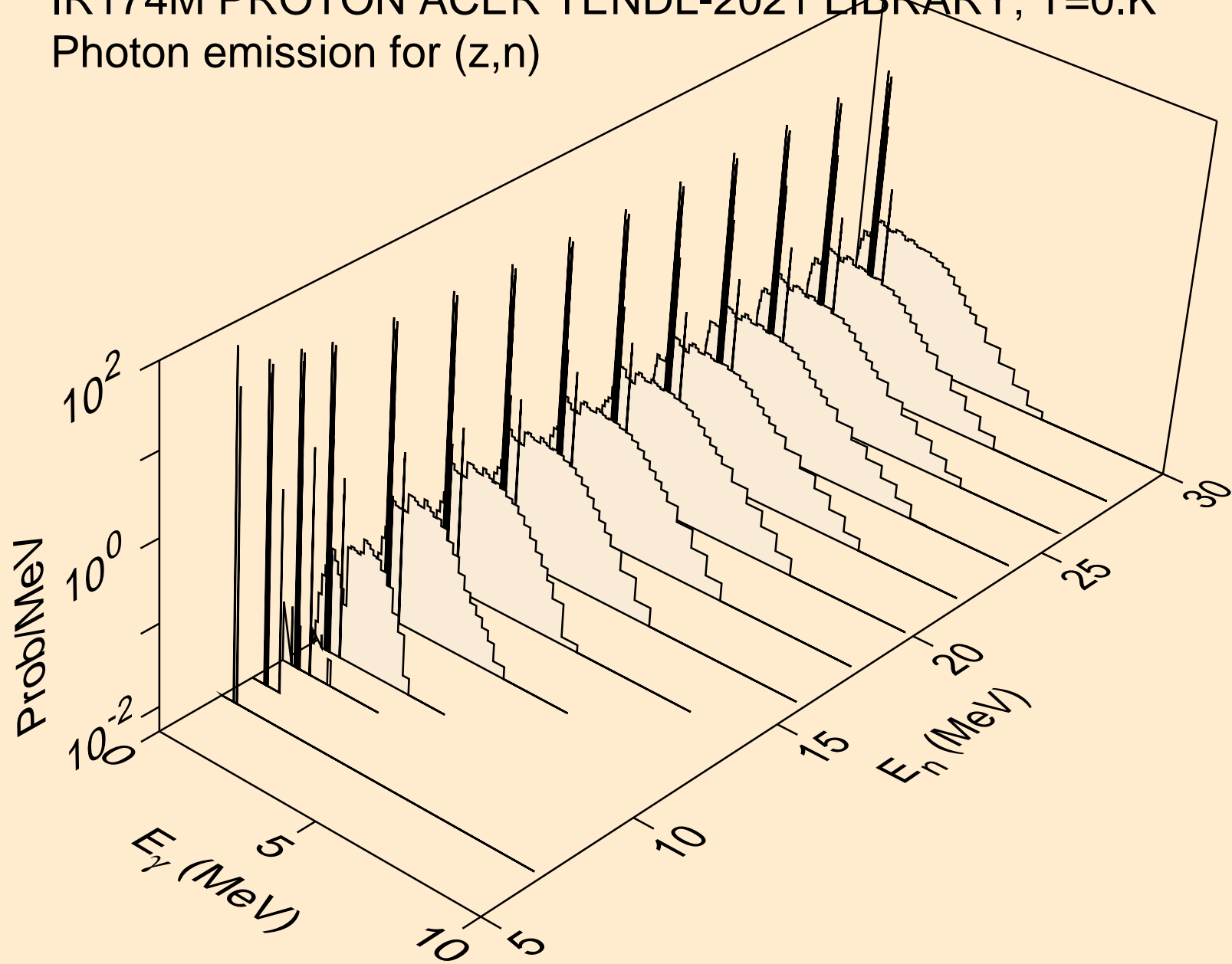

IR174M PROTON ACER TENDL-2021 LIBRARY; T=0.K  
Photon emission for (n,x)

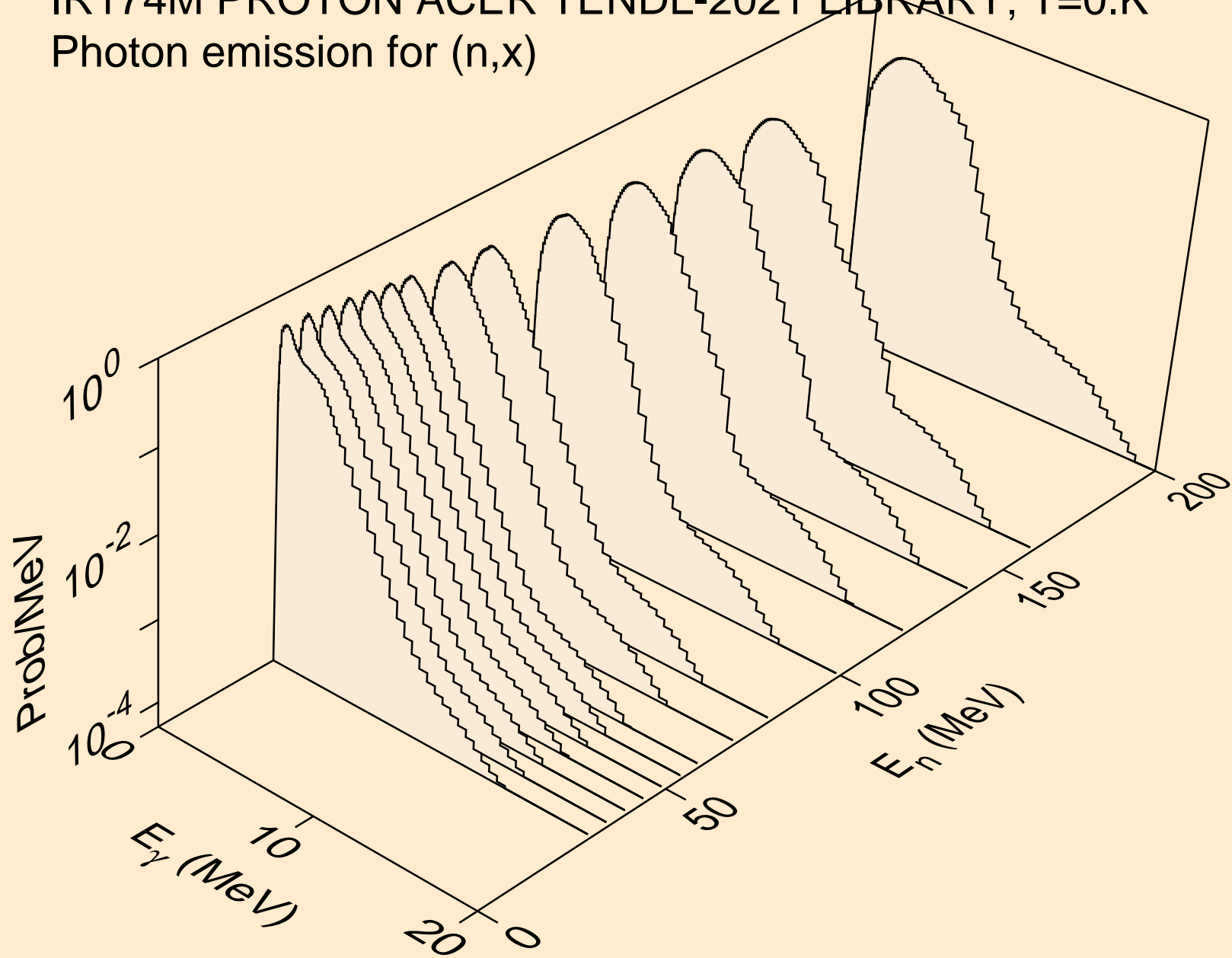

IR174M PROTON ACER TENDL-2021 LIBRARY; T=0.K  
Photon emission for (n,2n)

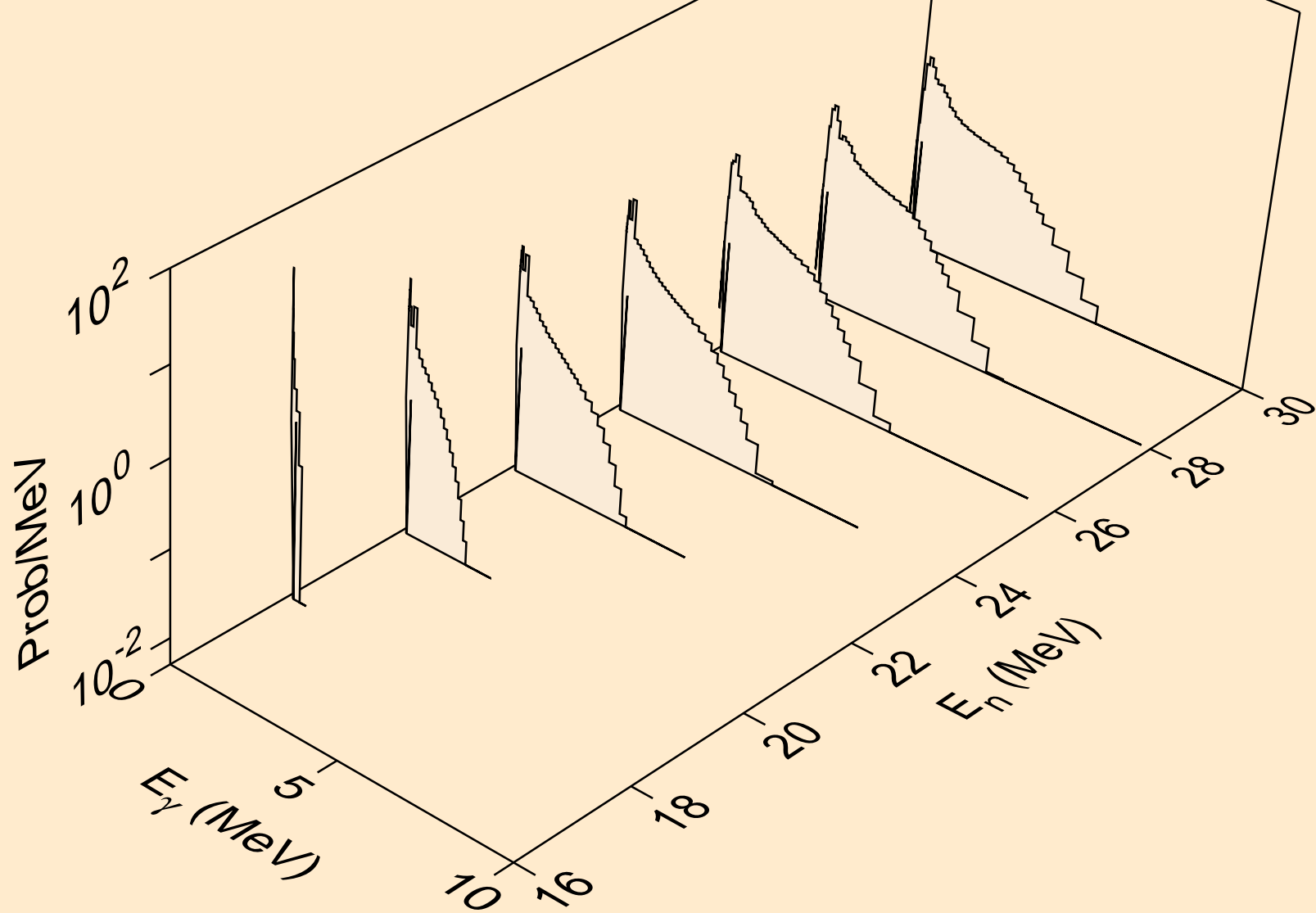

IR174M PROTON ACER TENDL-2021 LIBRARY; T=0.K  
Photon emission for (n,3n)

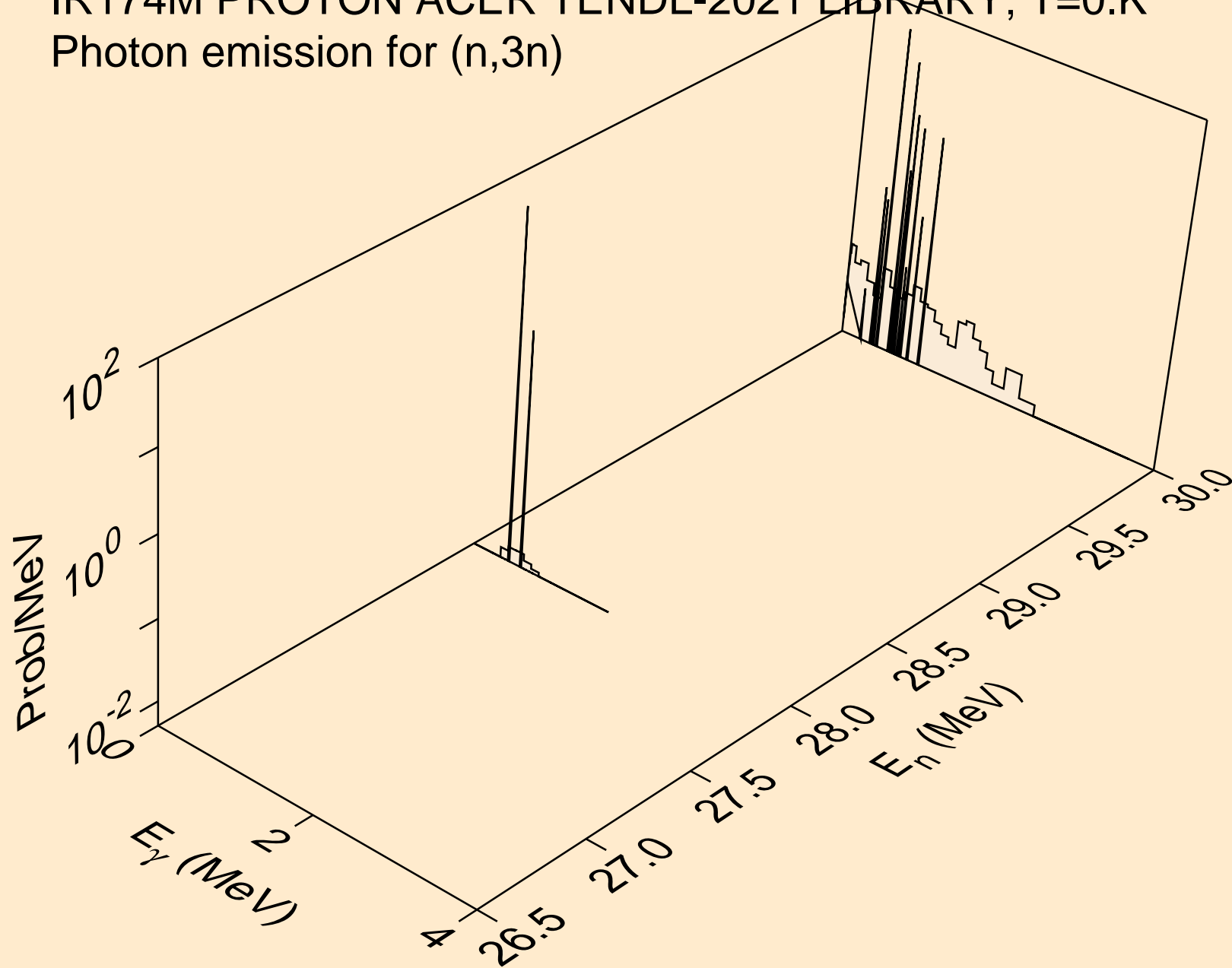

IR174M PROTON ACER TENDL-2021 LIBRARY; T=0.K  
Photon emission for (n,n\*)a

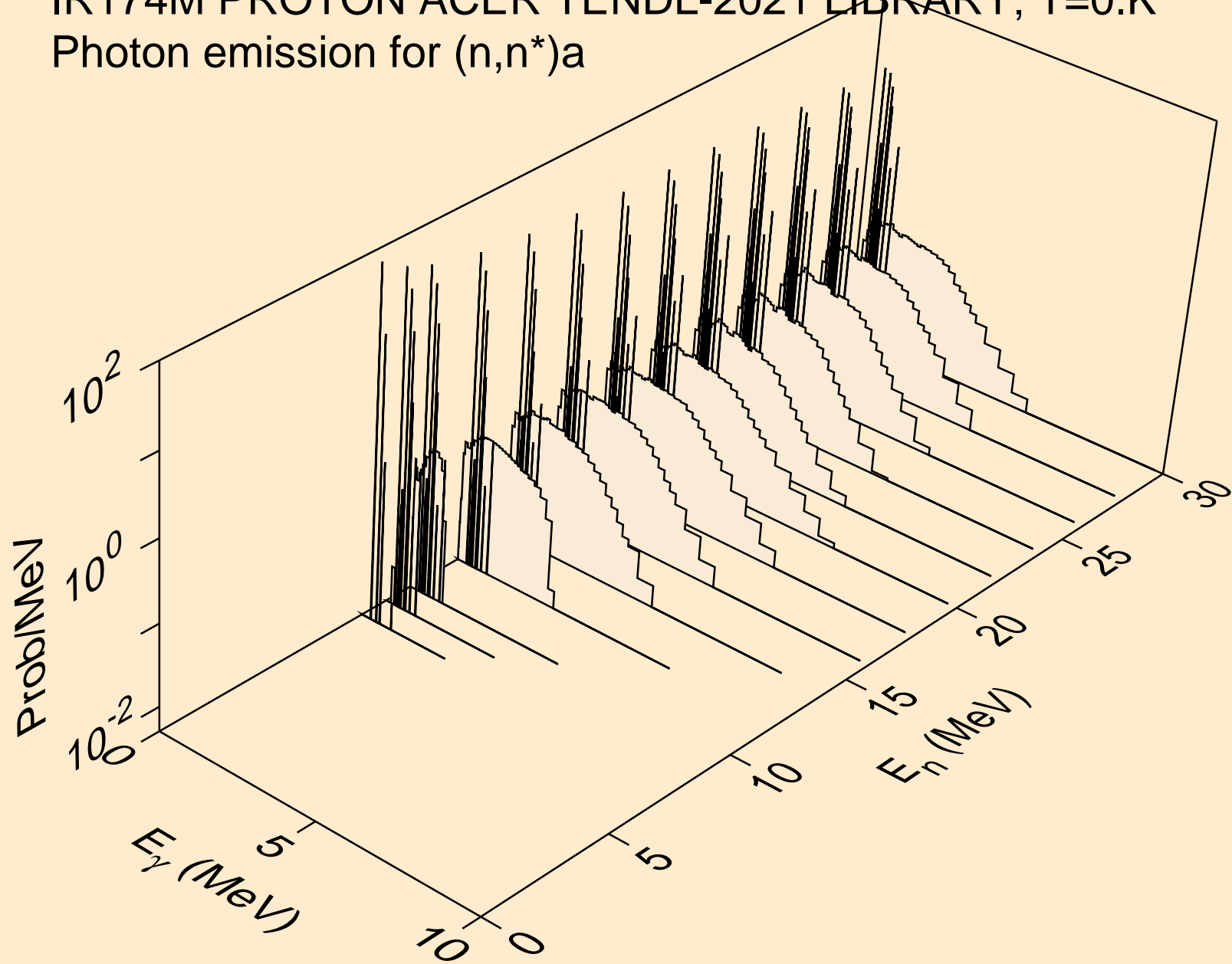



IR174M PROTON ACER TENDL-2021 LIBRARY; T=0.K  
Photon emission for (n,2n)a

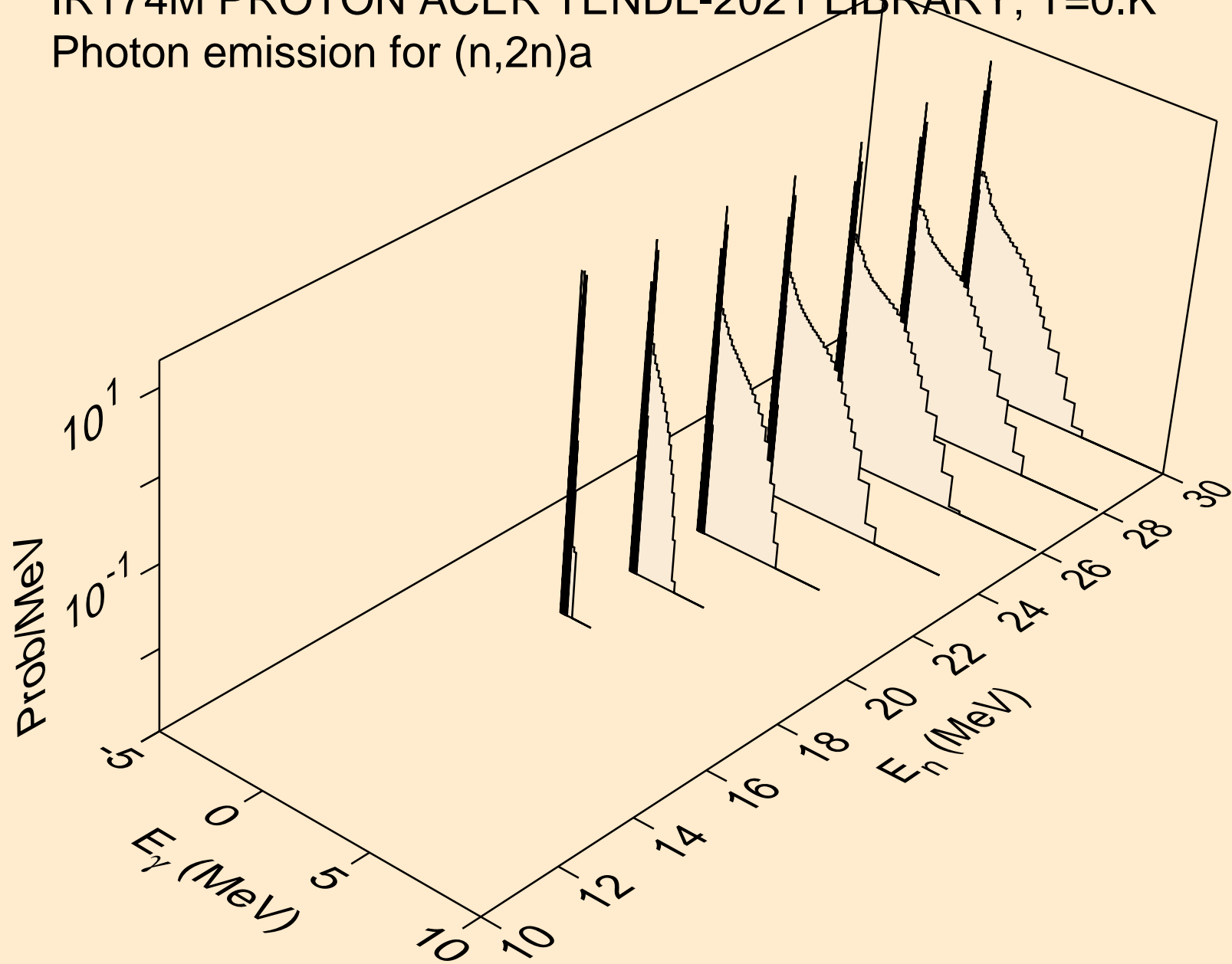

IR174M PROTON ACER TENDL-2021 LIBRARY; T=0.K  
Photon emission for (n,3n)a

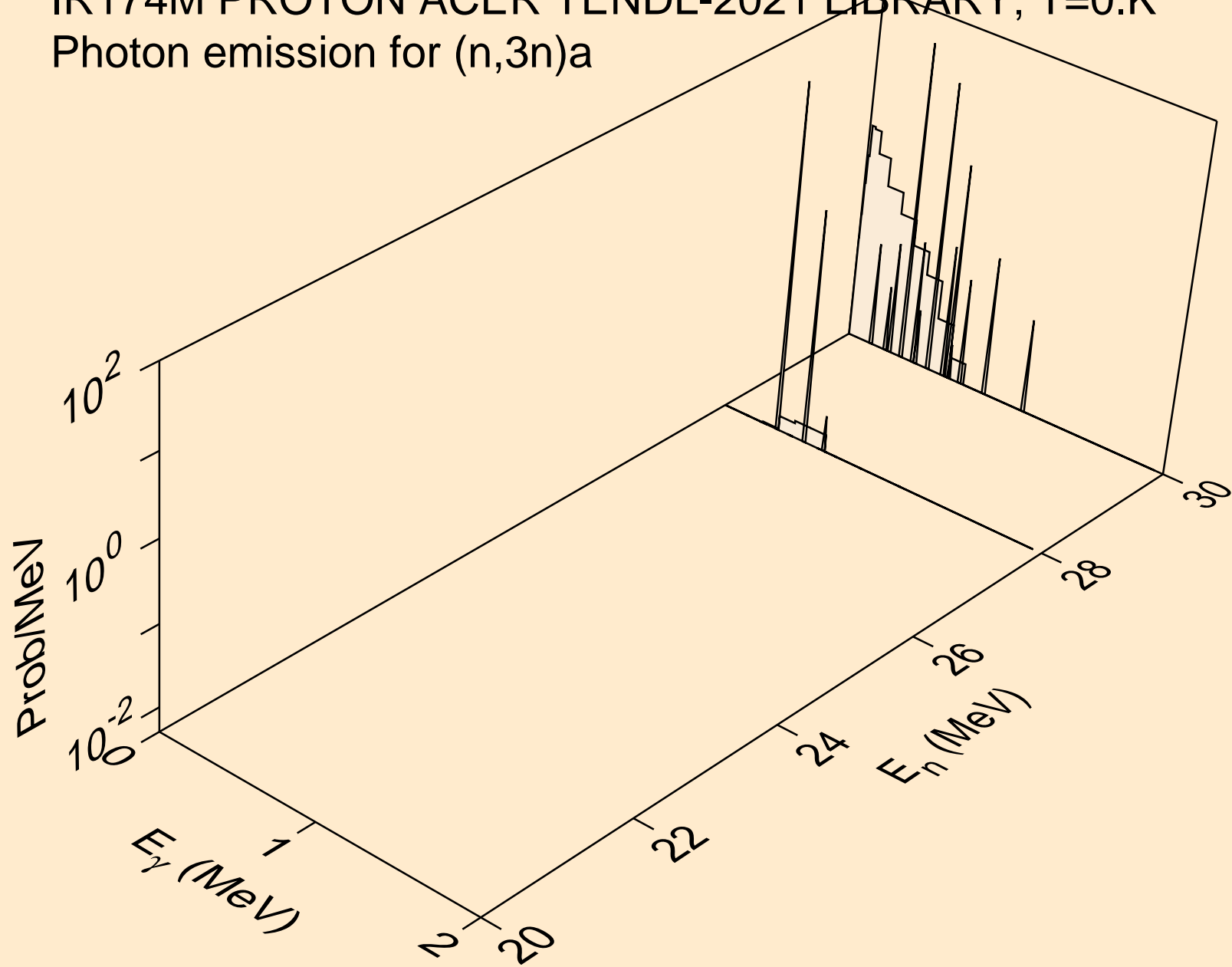

IR174M PROTON ACER TENDL-2021 LIBRARY; T=0.K  
Photon emission for (n,n\*)p

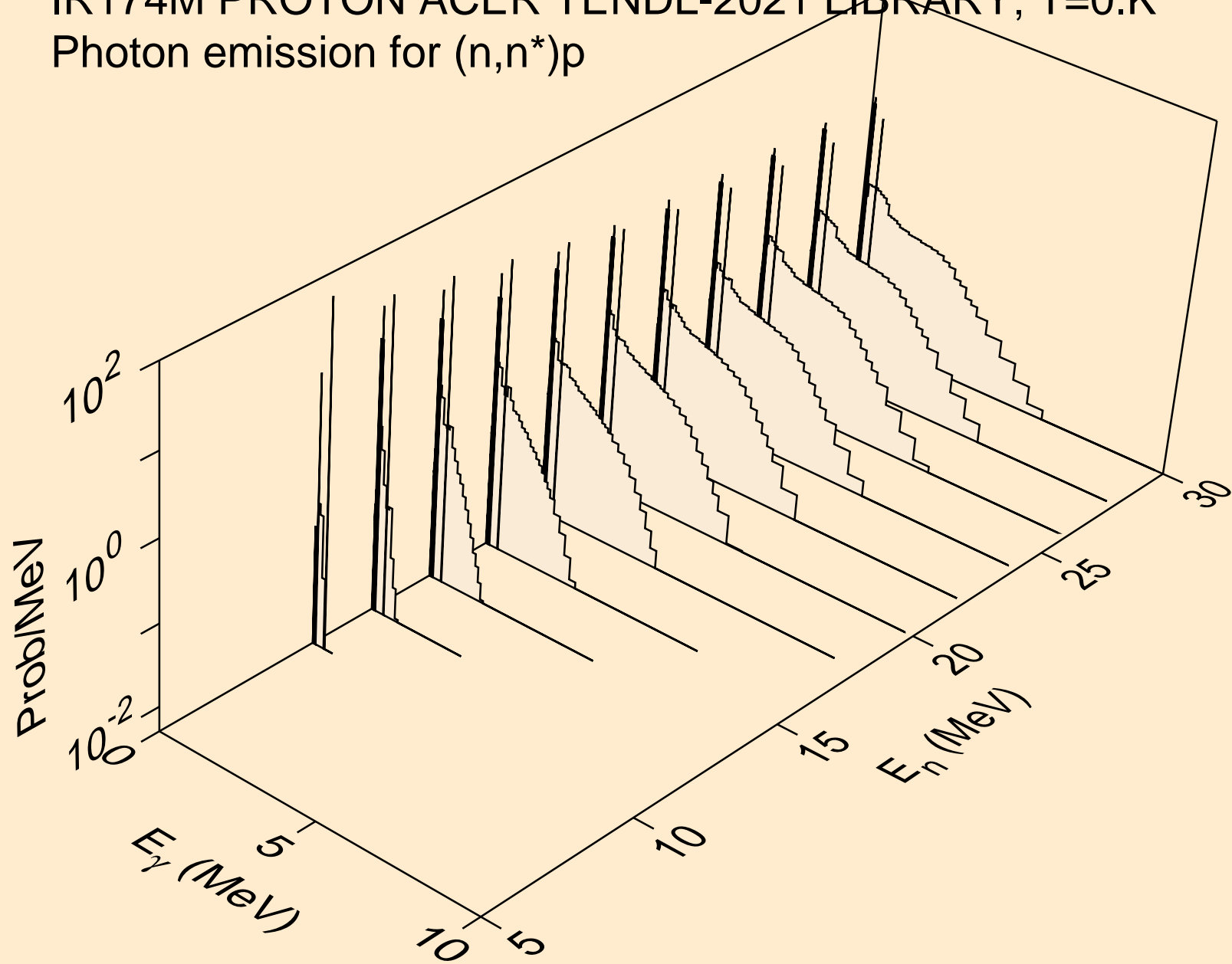

IR174M PROTON ACER TENDL-2021 LIBRARY; T=0.K  
Photon emission for (n,n\*)2a

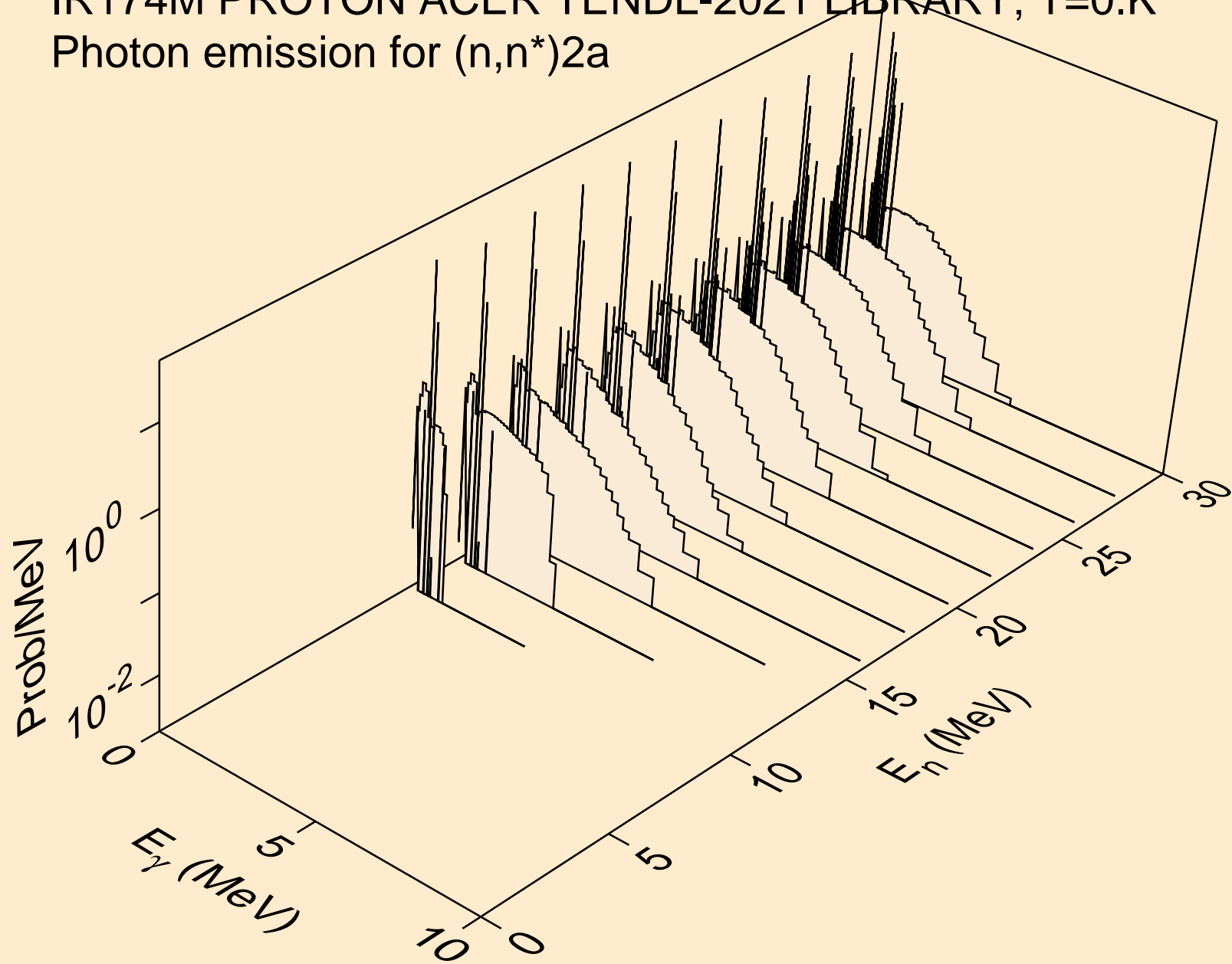

IR174M PROTON ACER TENDL-2021 LIBRARY; T=0.K  
Photon emission for (n,2n)2a

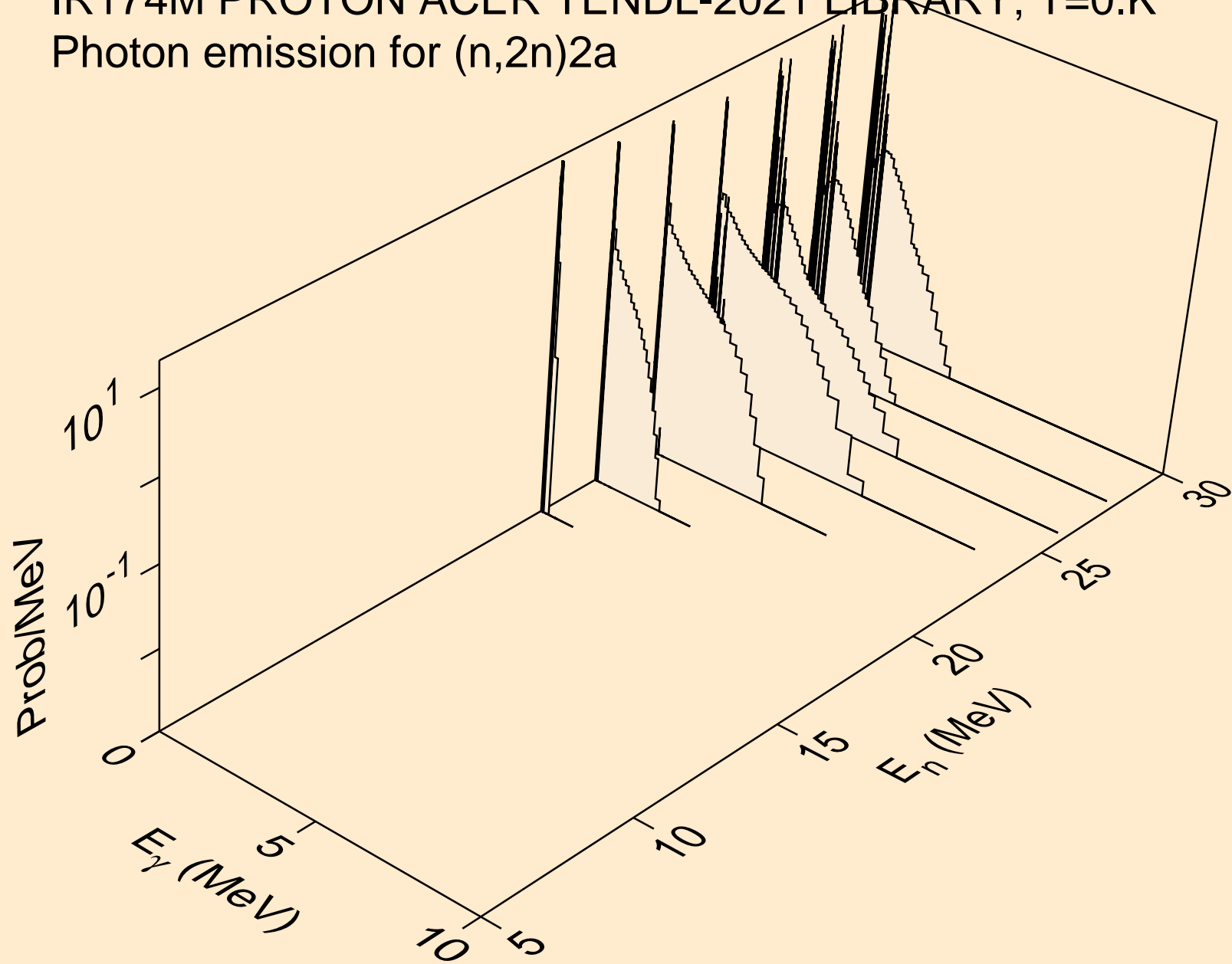

IR174M PROTON ACER TENDL-2021 LIBRARY; T=0.K  
Photon emission for (n,n\*)d

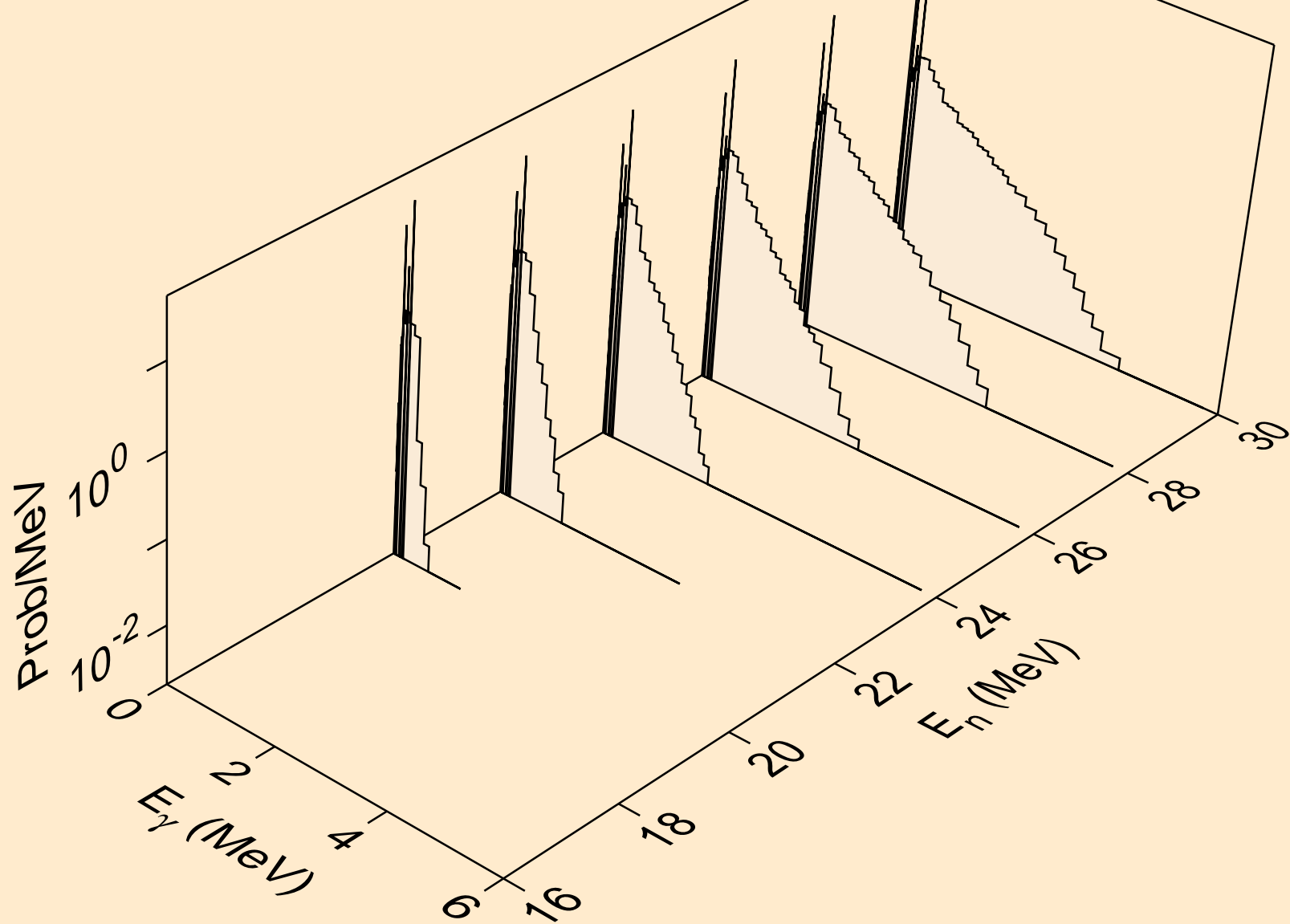

IR174M PROTON ACER TENDL-2021 LIBRARY; T=0.K  
Photon emission for (n,n\*)t

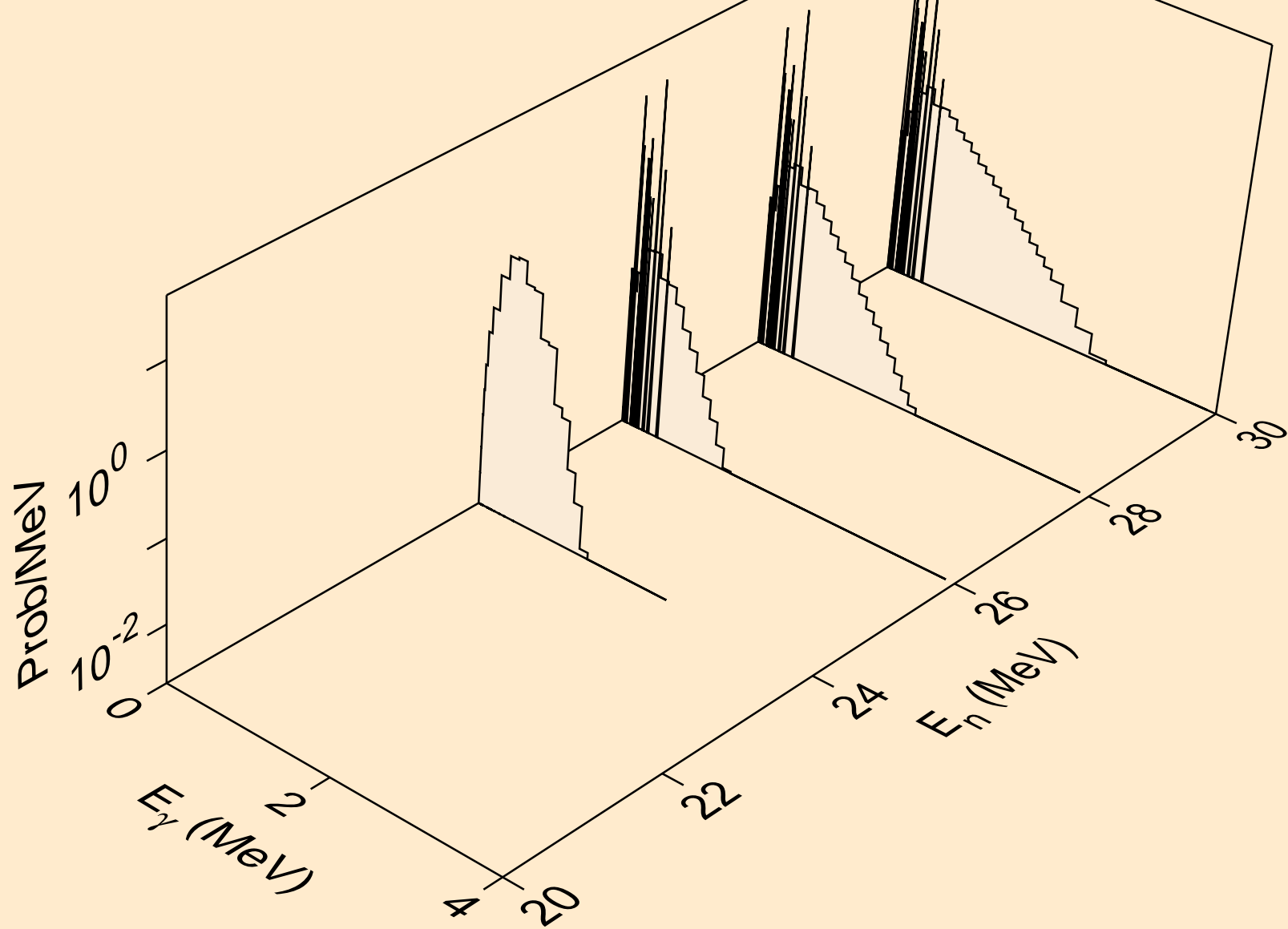

IR174M PROTON ACER TENDL-2021 LIBRARY; T=0.K  
Photon emission for (n,n\*)he3

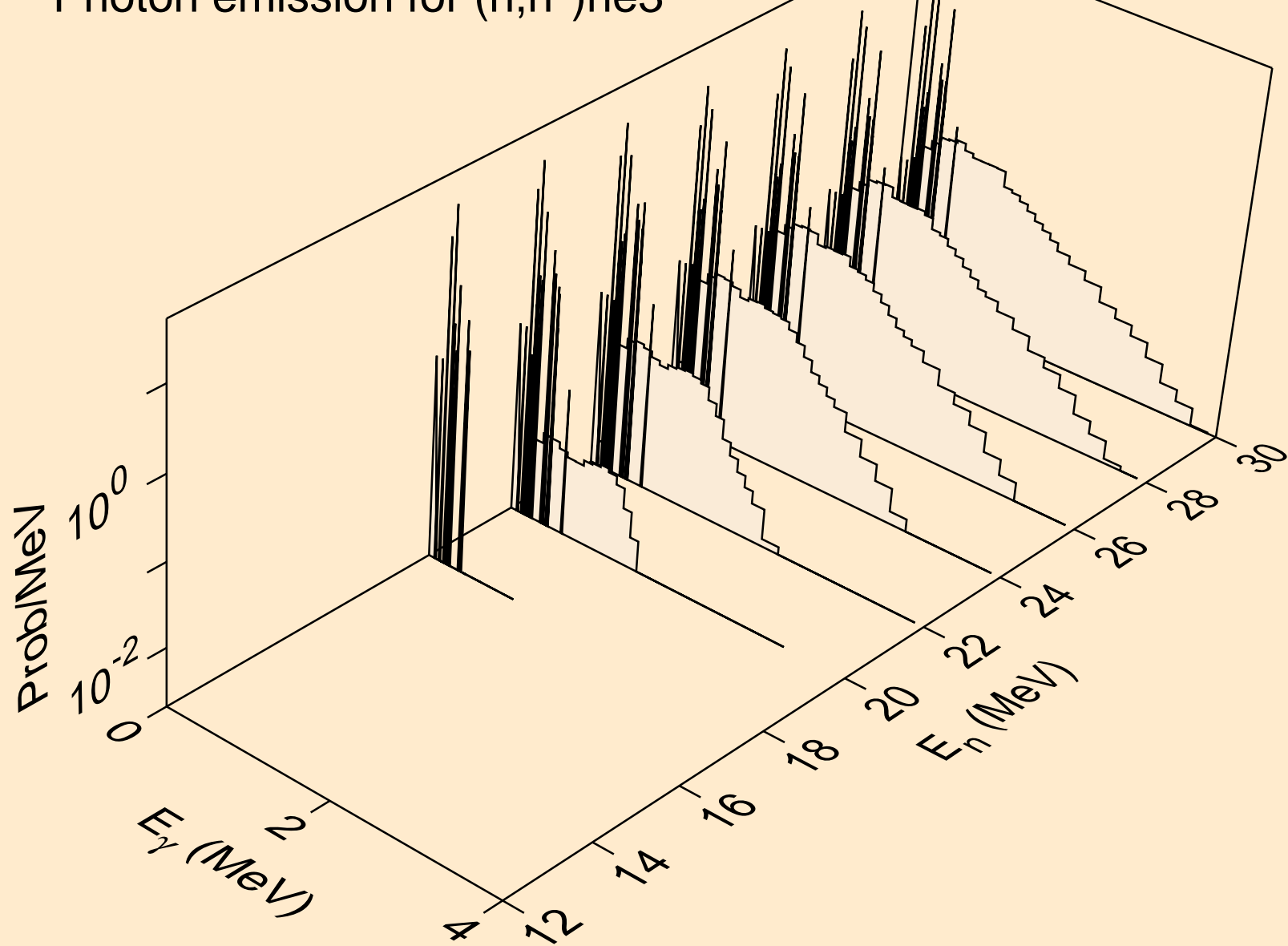



IR174M PROTON ACER TENDL-2021 LIBRARY; T=0.K  
Photon emission for (n,2np)

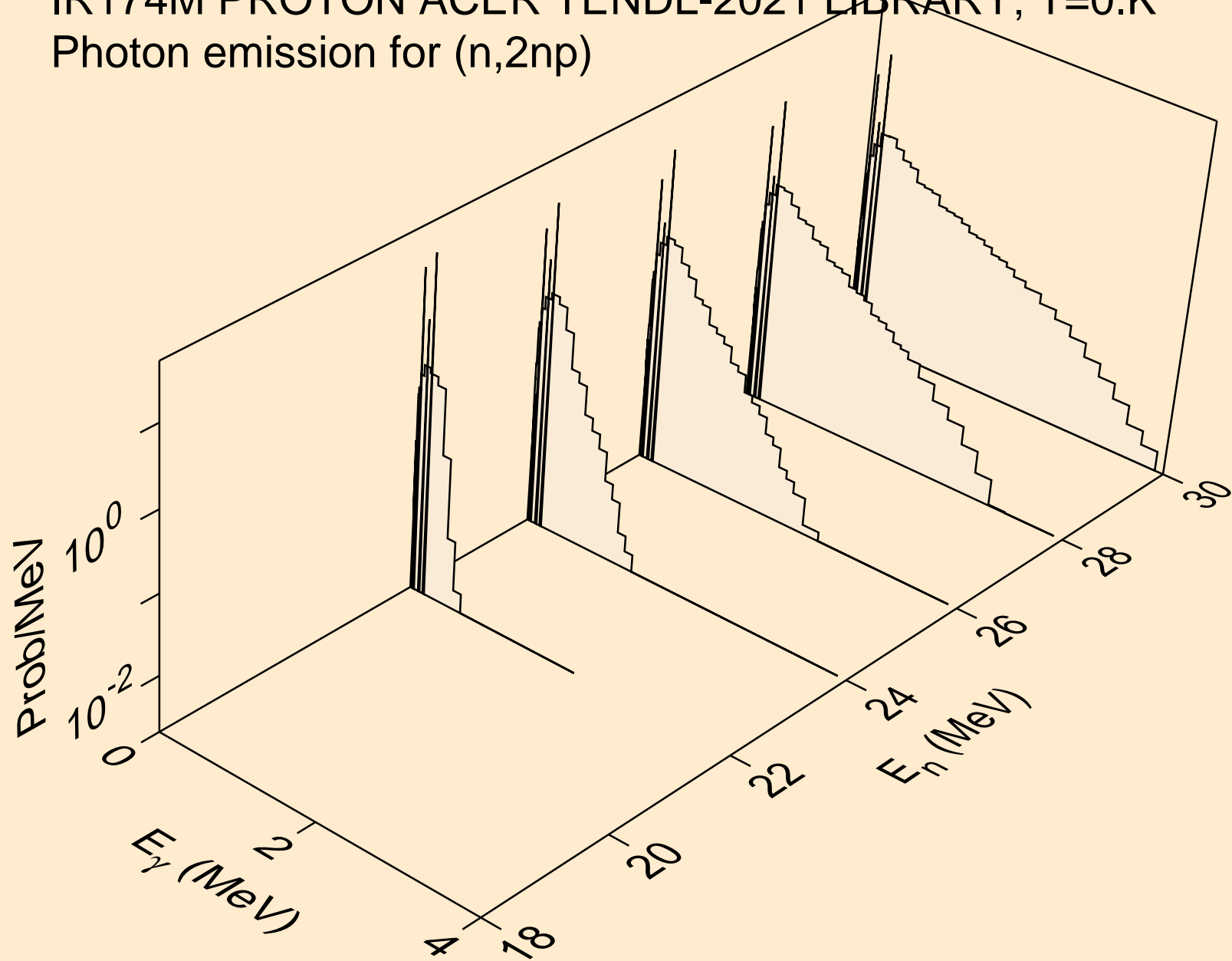

IR174M PROTON ACER TENDL-2021 LIBRARY; T=0.K  
Photon emission for (n,2np)

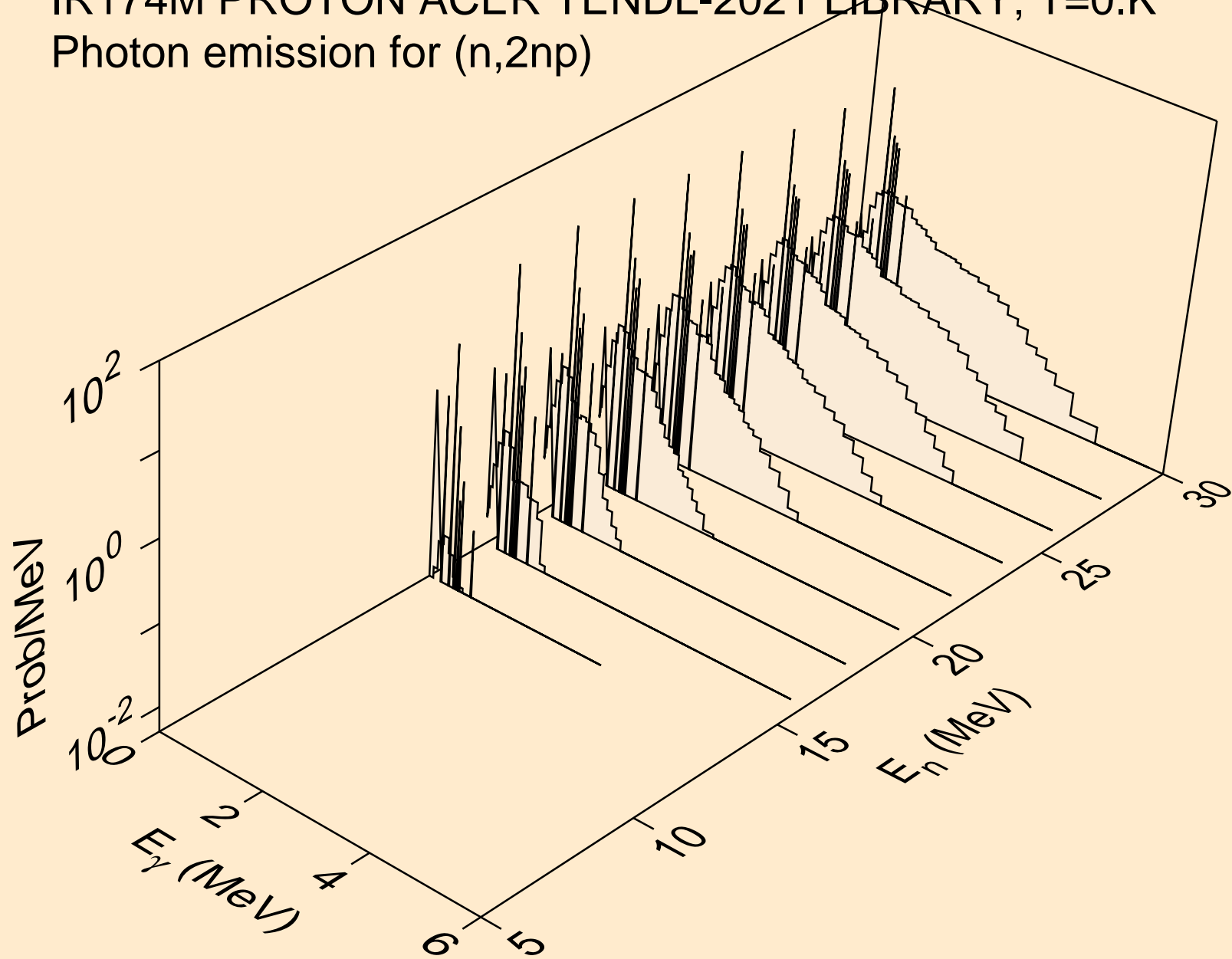

IR174M PROTON ACER TENDL-2021 LIBRARY; T=0.K  
Photon emission for (n,npa)

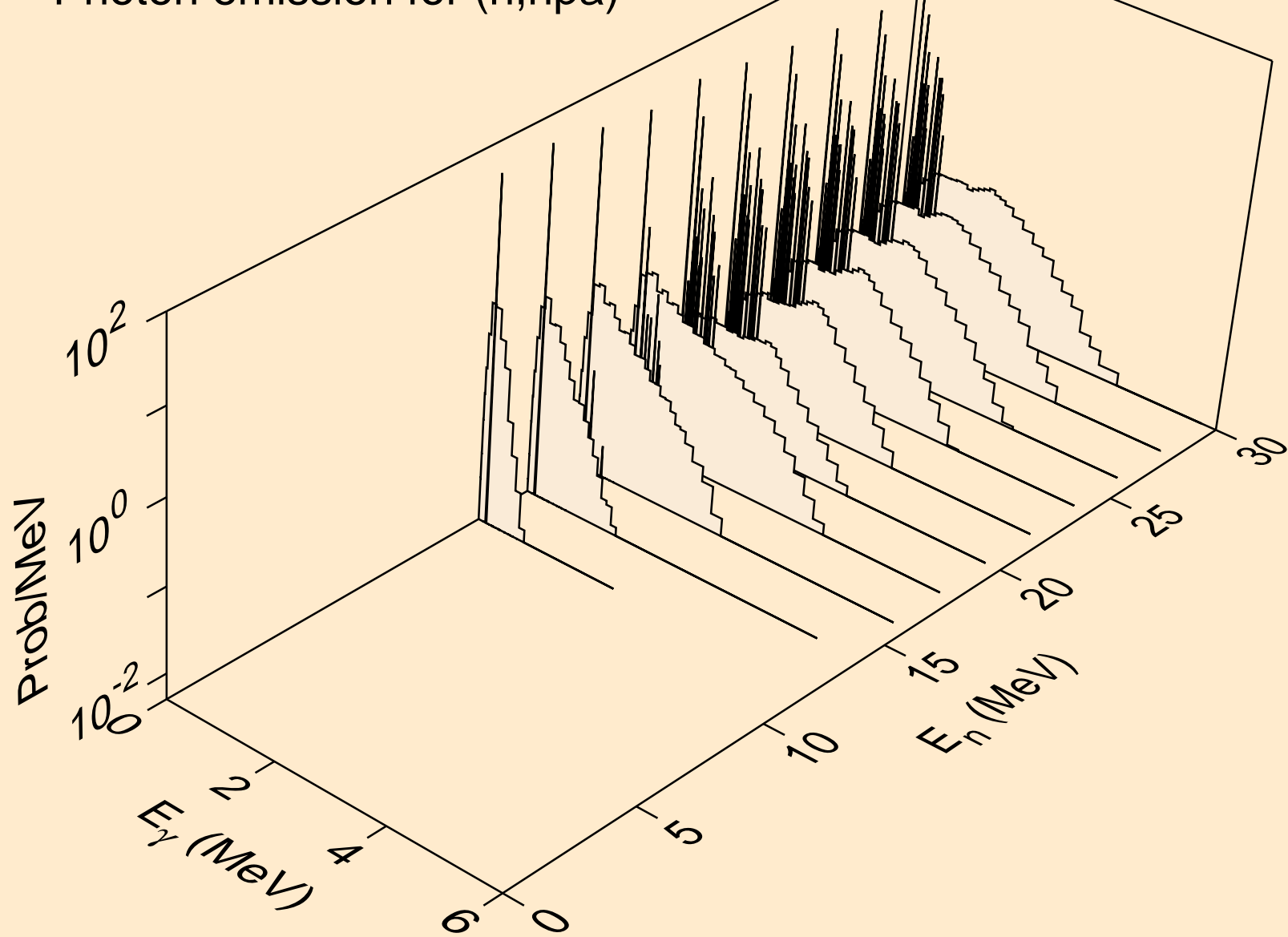

IR174M PROTON ACER TENDL-2021 LIBRARY; T=0.K  
Photon emission for (n,gma)

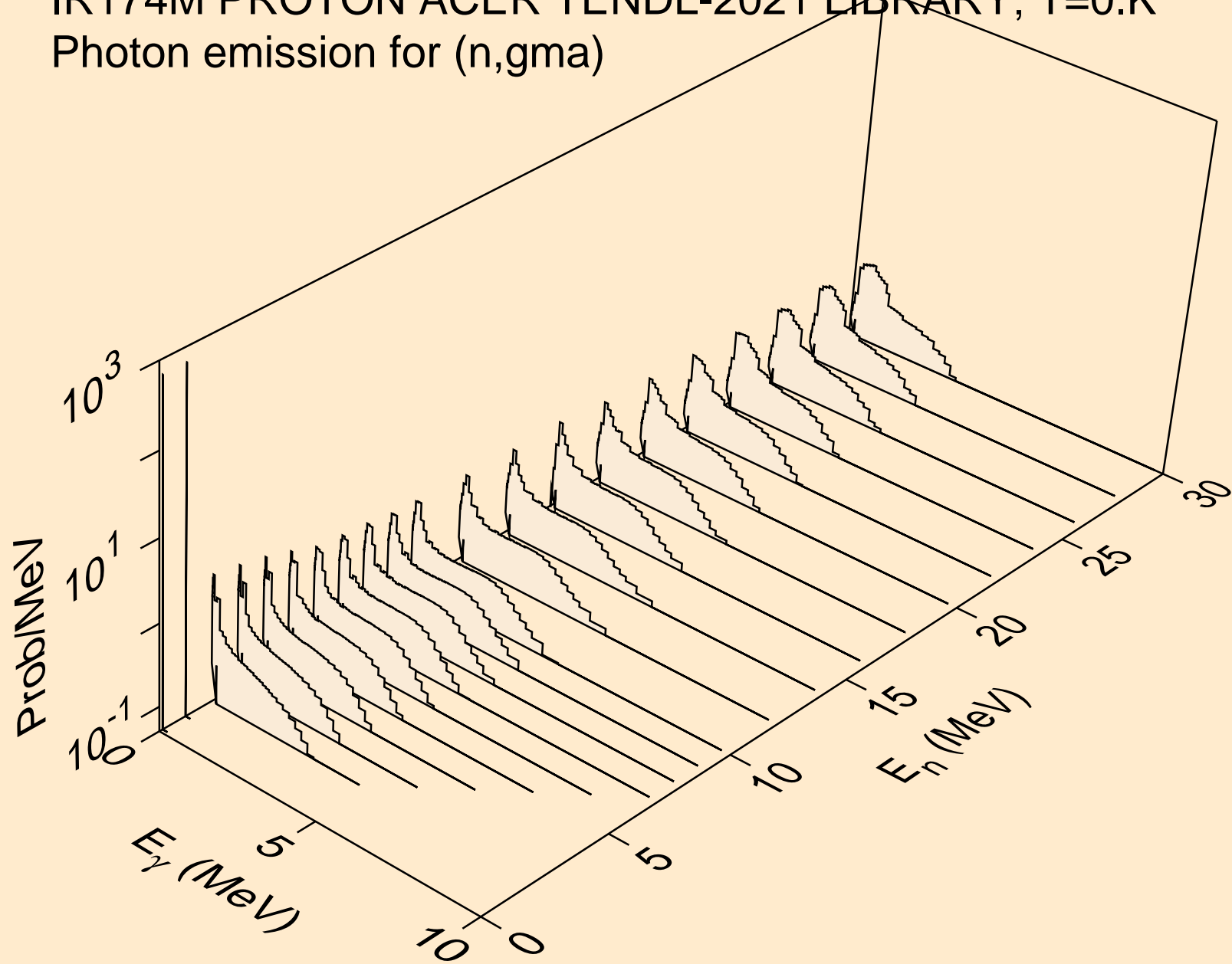

IR174M PROTON ACER TENDL-2021 LIBRARY; T=0.K  
Photon emission for inelastic

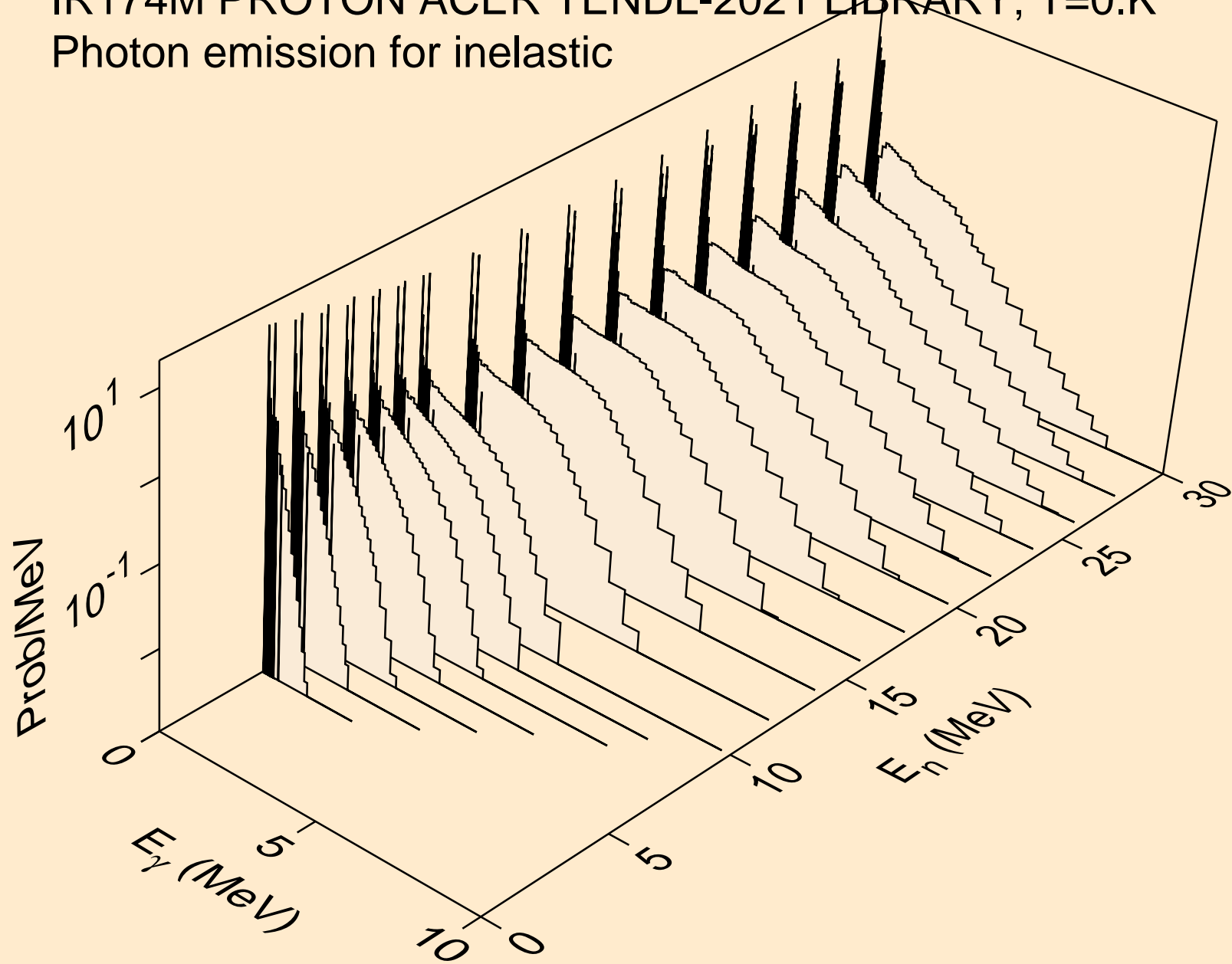

IR174M PROTON ACER TENDL-2021 LIBRARY; T=0.K  
Photon emission for (n,d)

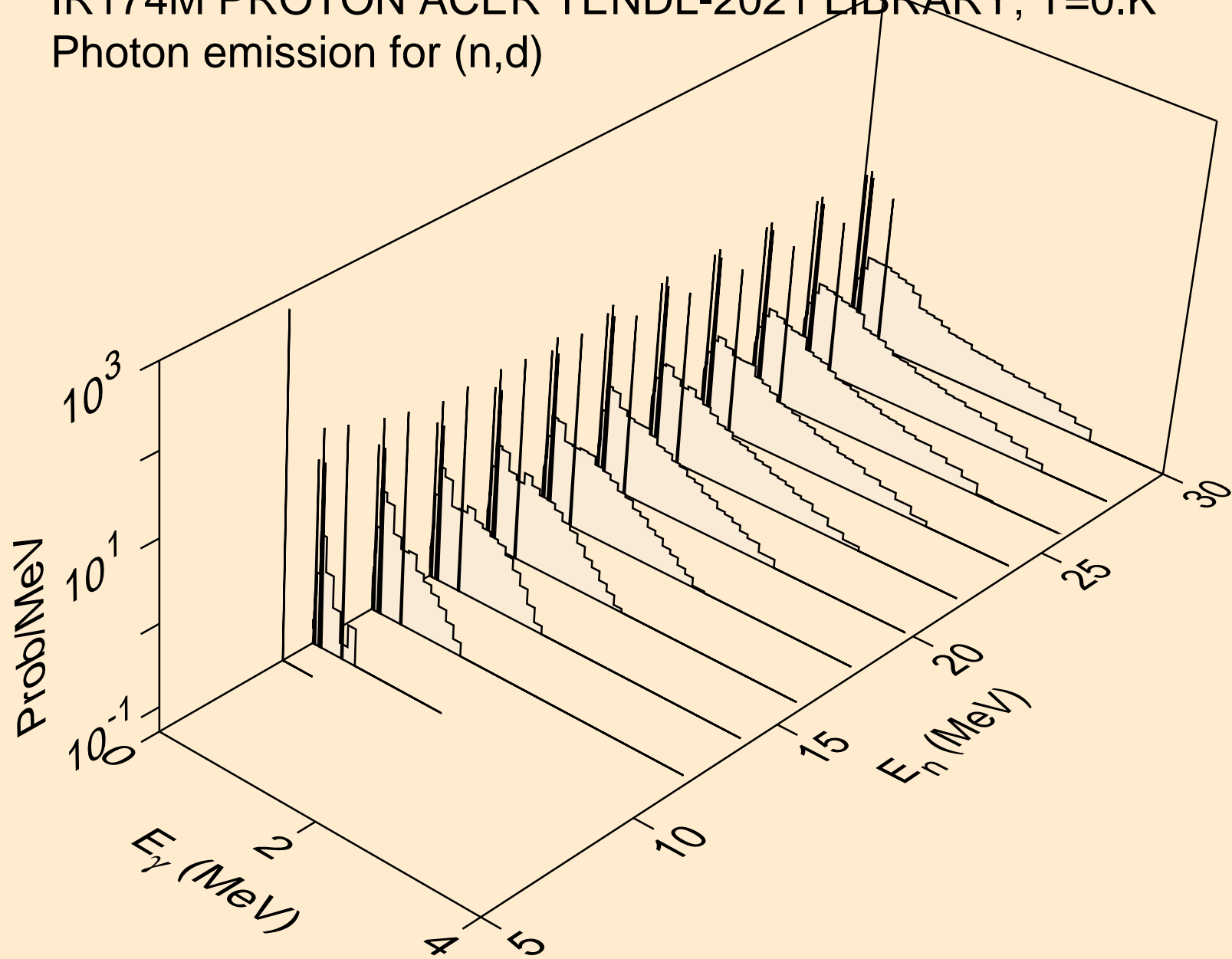

IR174M PROTON ACER TENDL-2021 LIBRARY; T=0.K  
Photon emission for (n,t)

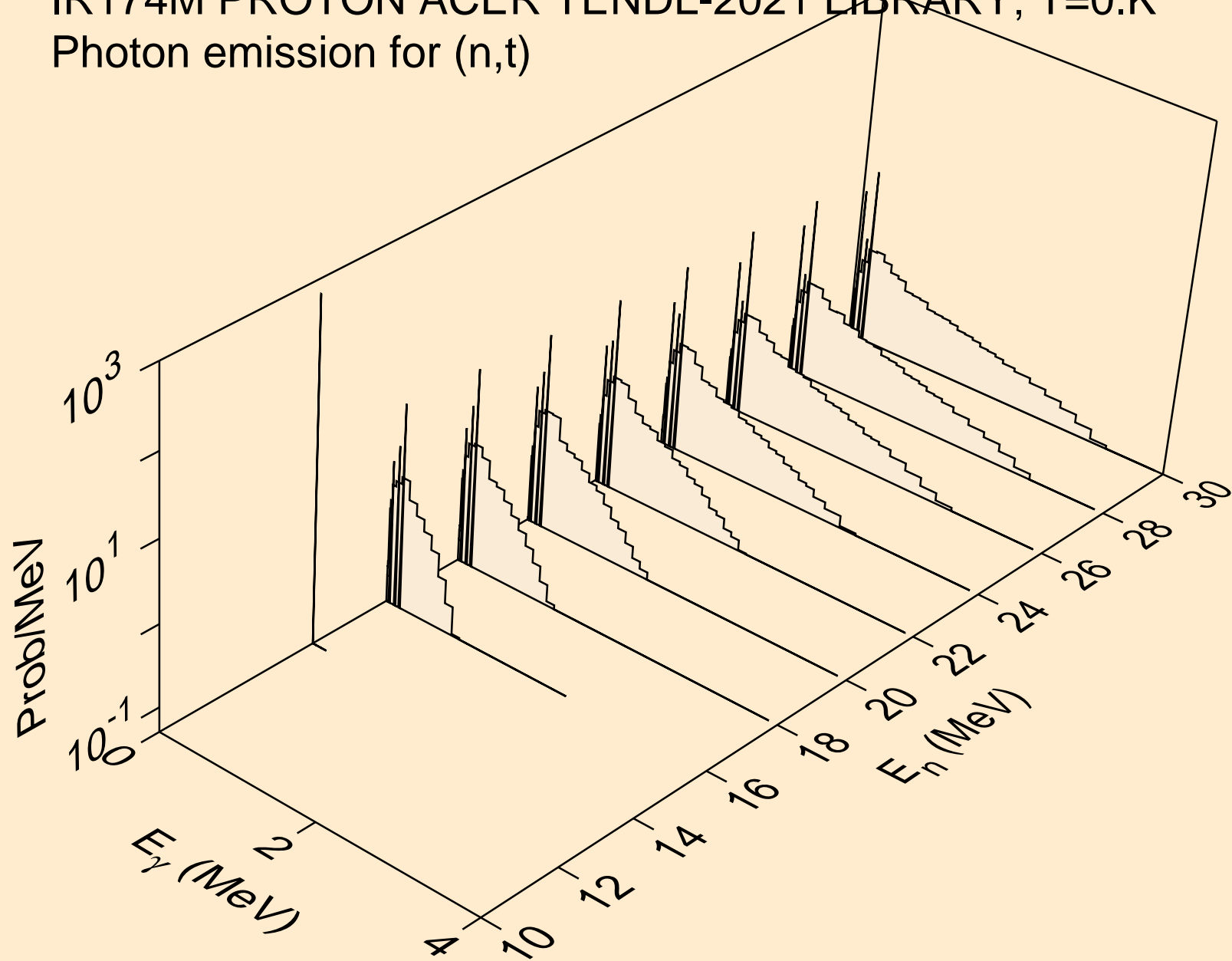

IR174M PROTON ACER TENDL-2021 LIBRARY; T=0.K  
Photon emission for (n,he3)

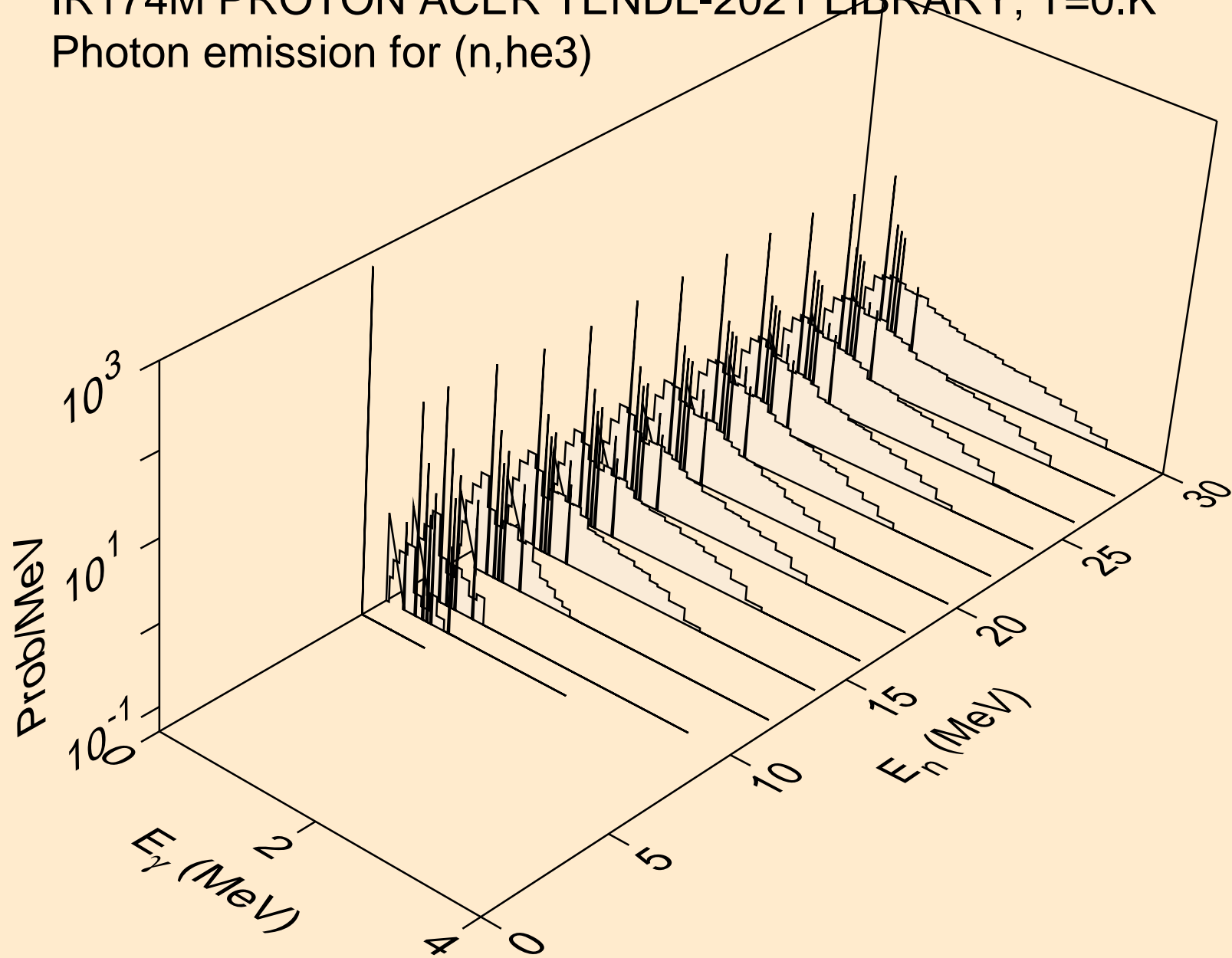



IR174M PROTON ACER TENDL-2021 LIBRARY; T=0.K  
Photon emission for (n,a)

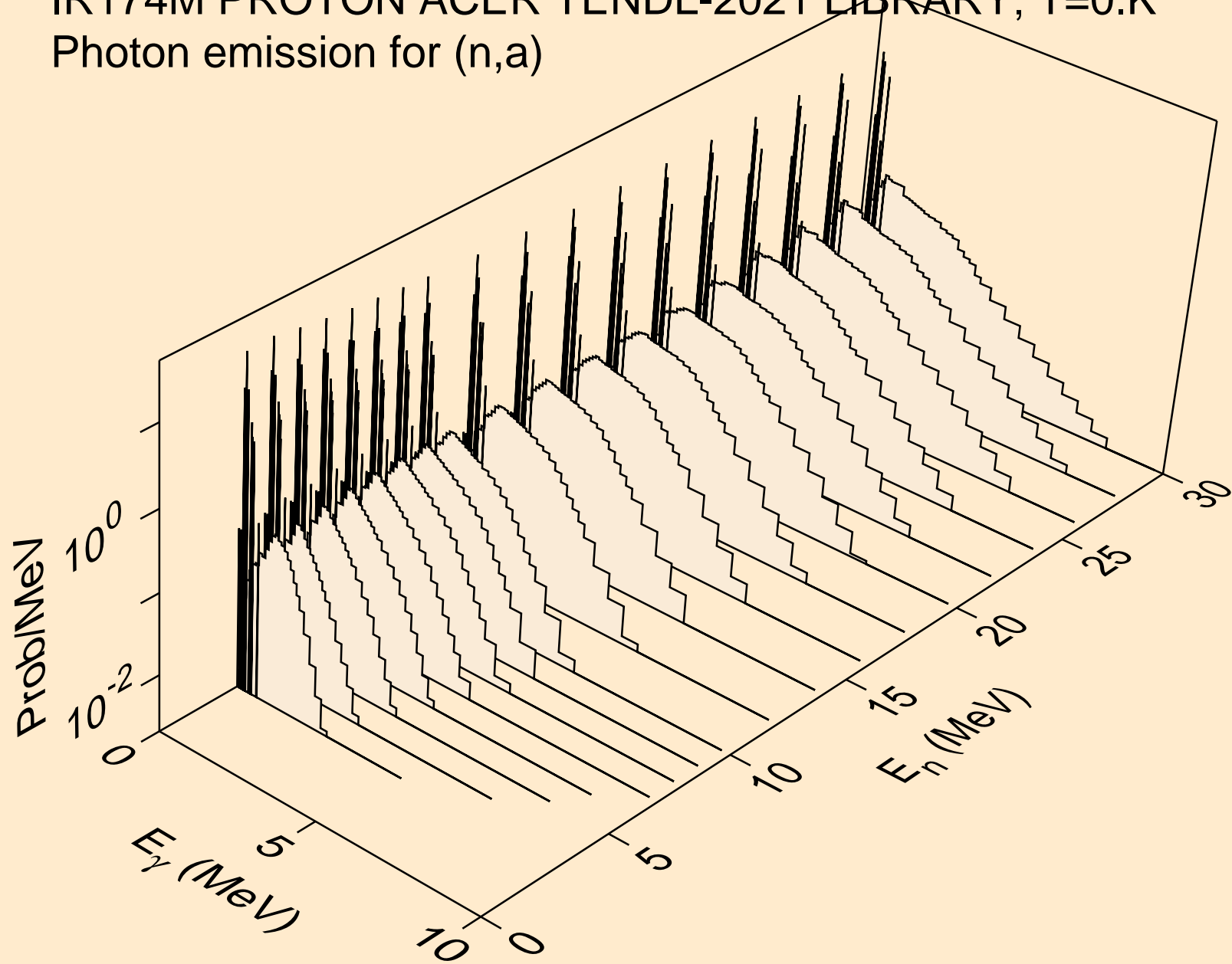

IR174M PROTON ACER TENDL-2021 LIBRARY; T=0.K  
Photon emission for (n,2a)

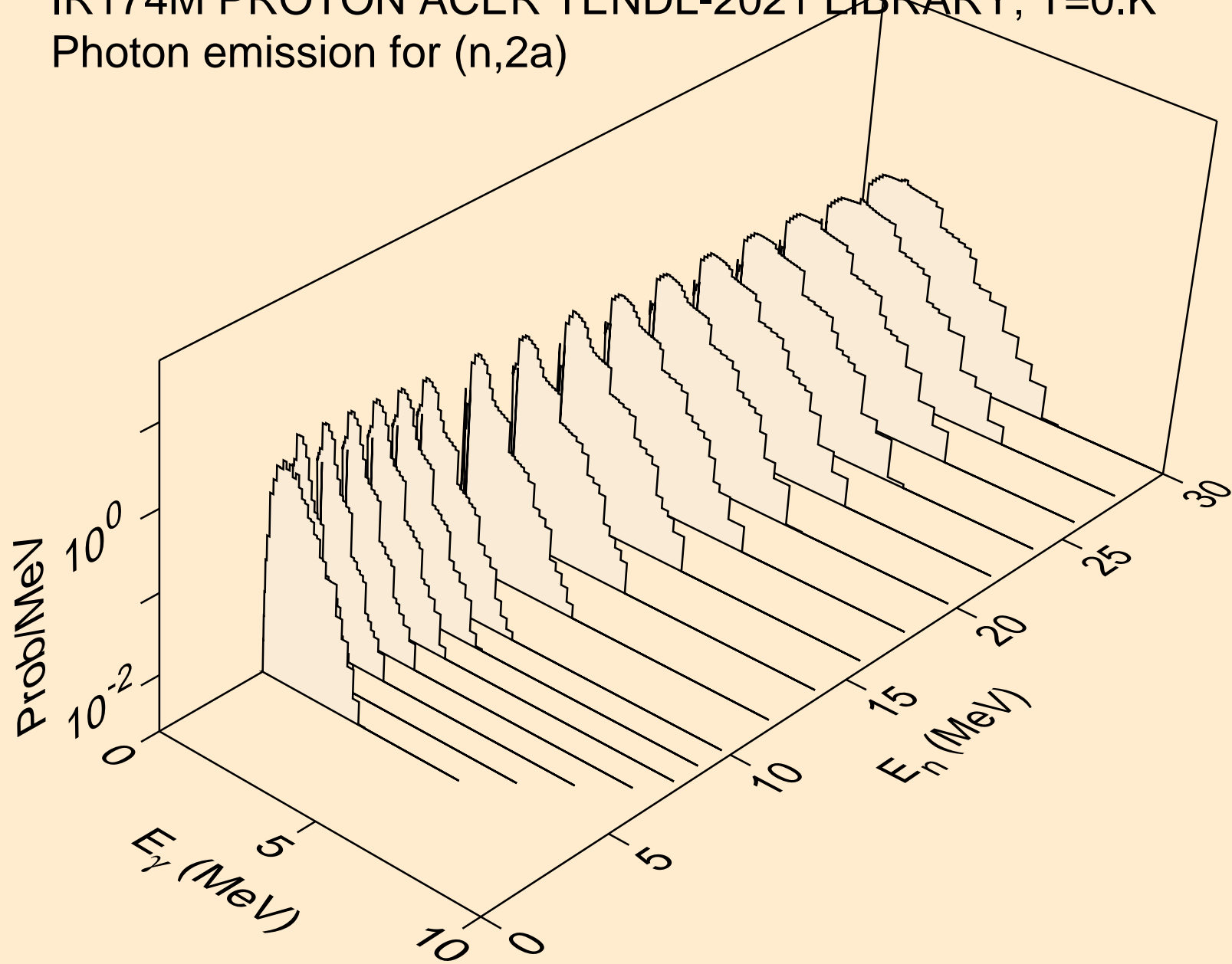

IR174M PROTON ACER TENDL-2021 LIBRARY; T=0.K  
Photon emission for (n,3a)

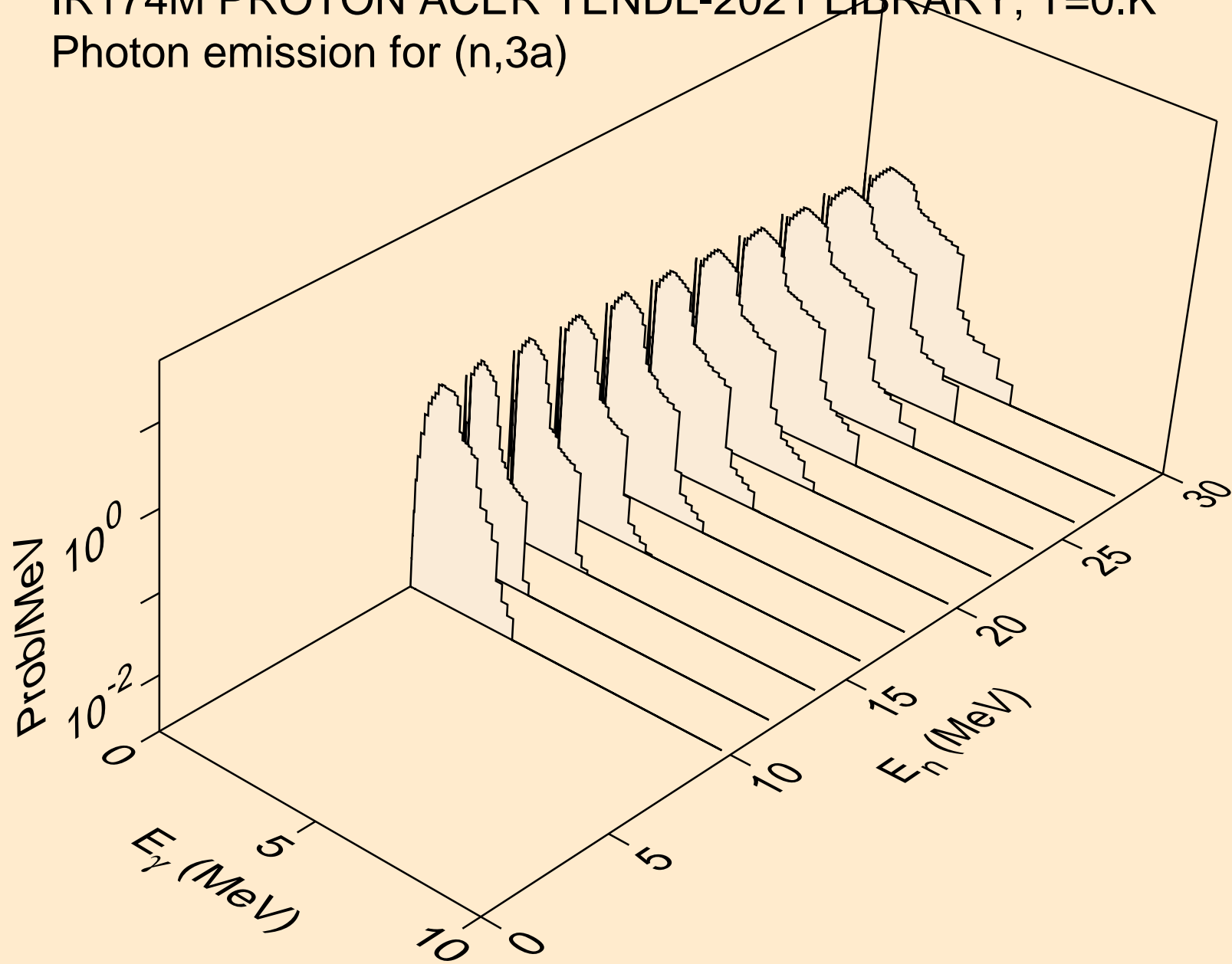

IR174M PROTON ACER TENDL-2021 LIBRARY; T=0.K  
Photon emission for (n,2p)

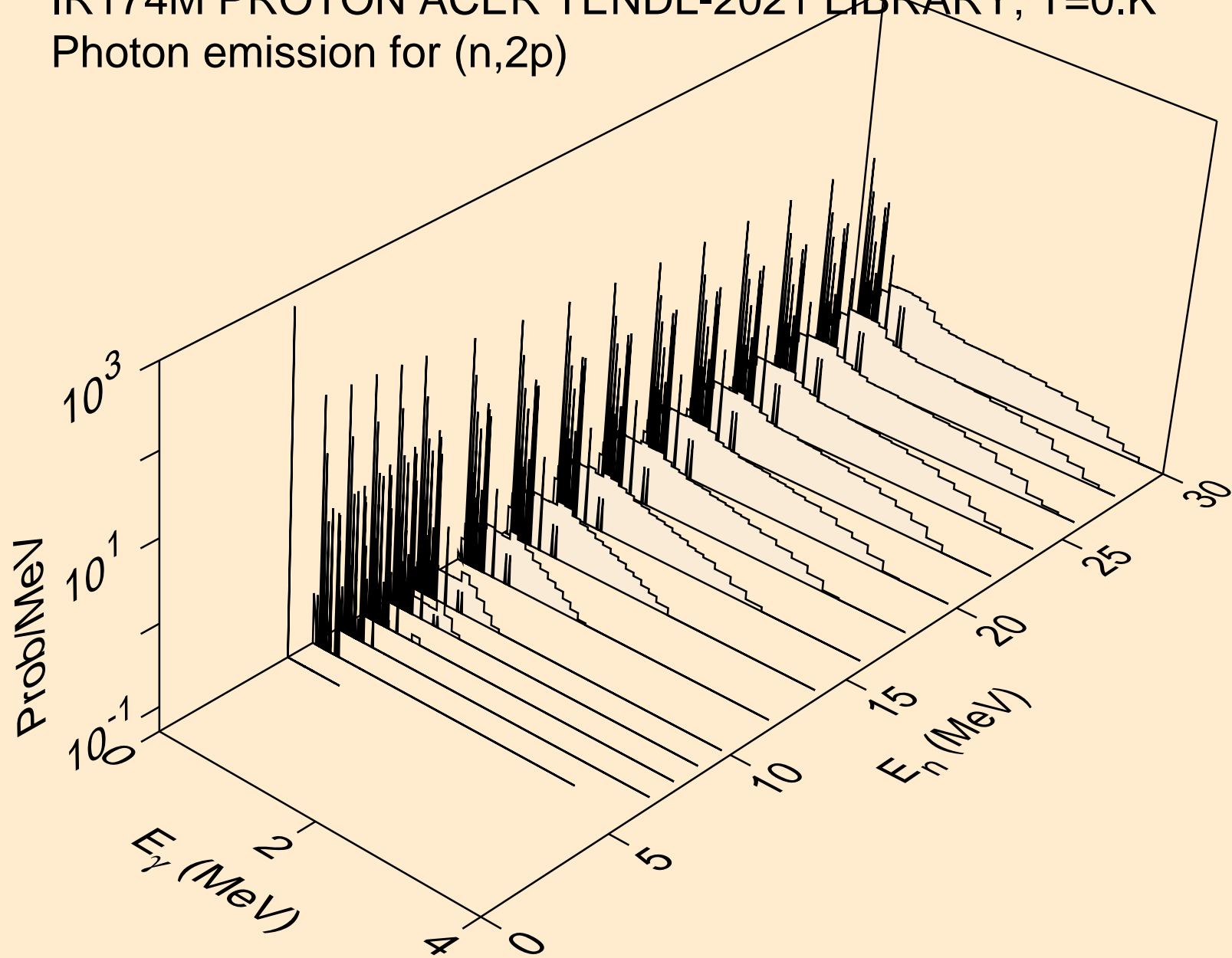

IR174M PROTON ACER TENDL-2021 LIBRARY; T=0.K  
Photon emission for (n,pa)

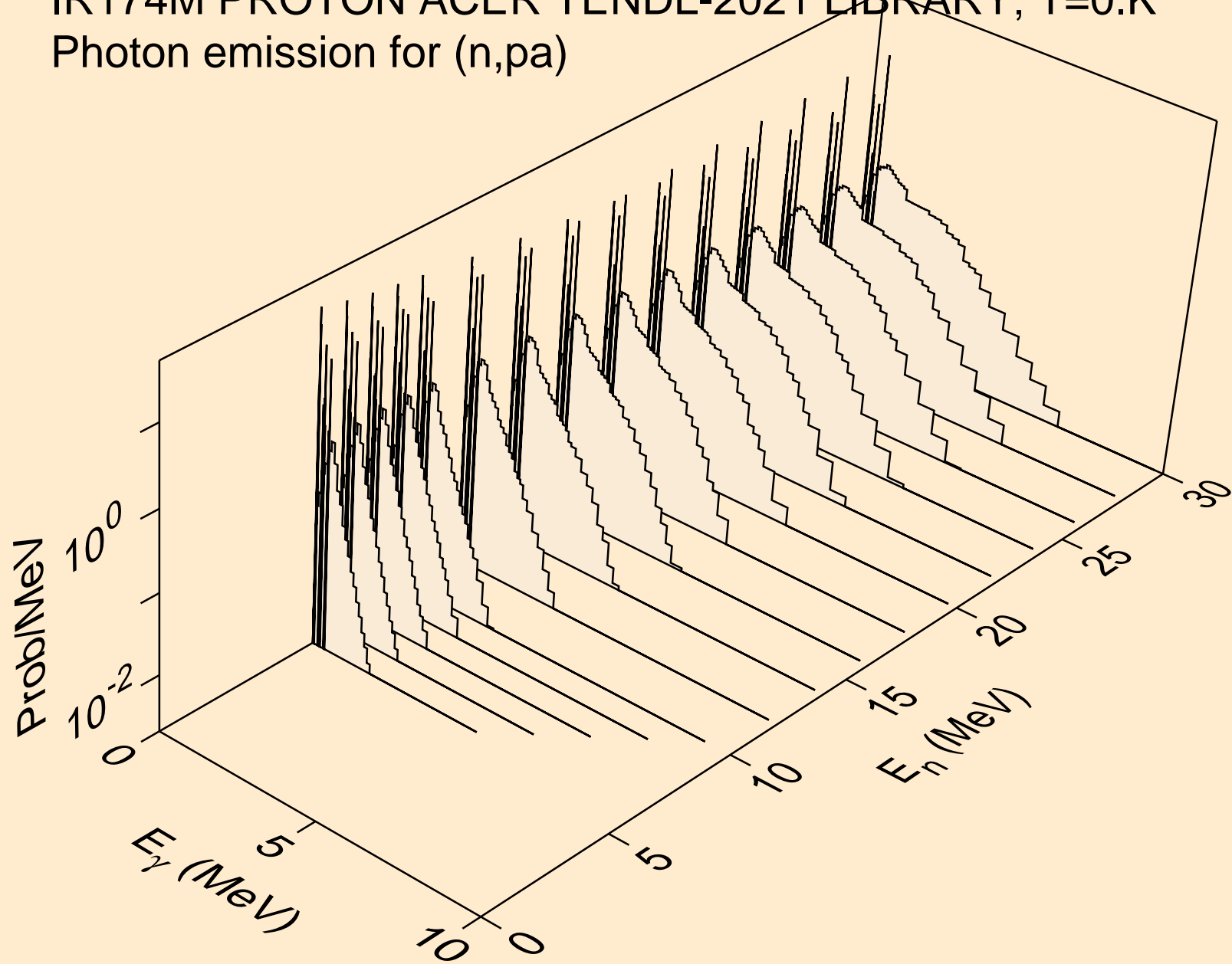

IR174M PROTON ACER TENDL-2021 LIBRARY; T=0.K  
Photon emission for (n,pd)

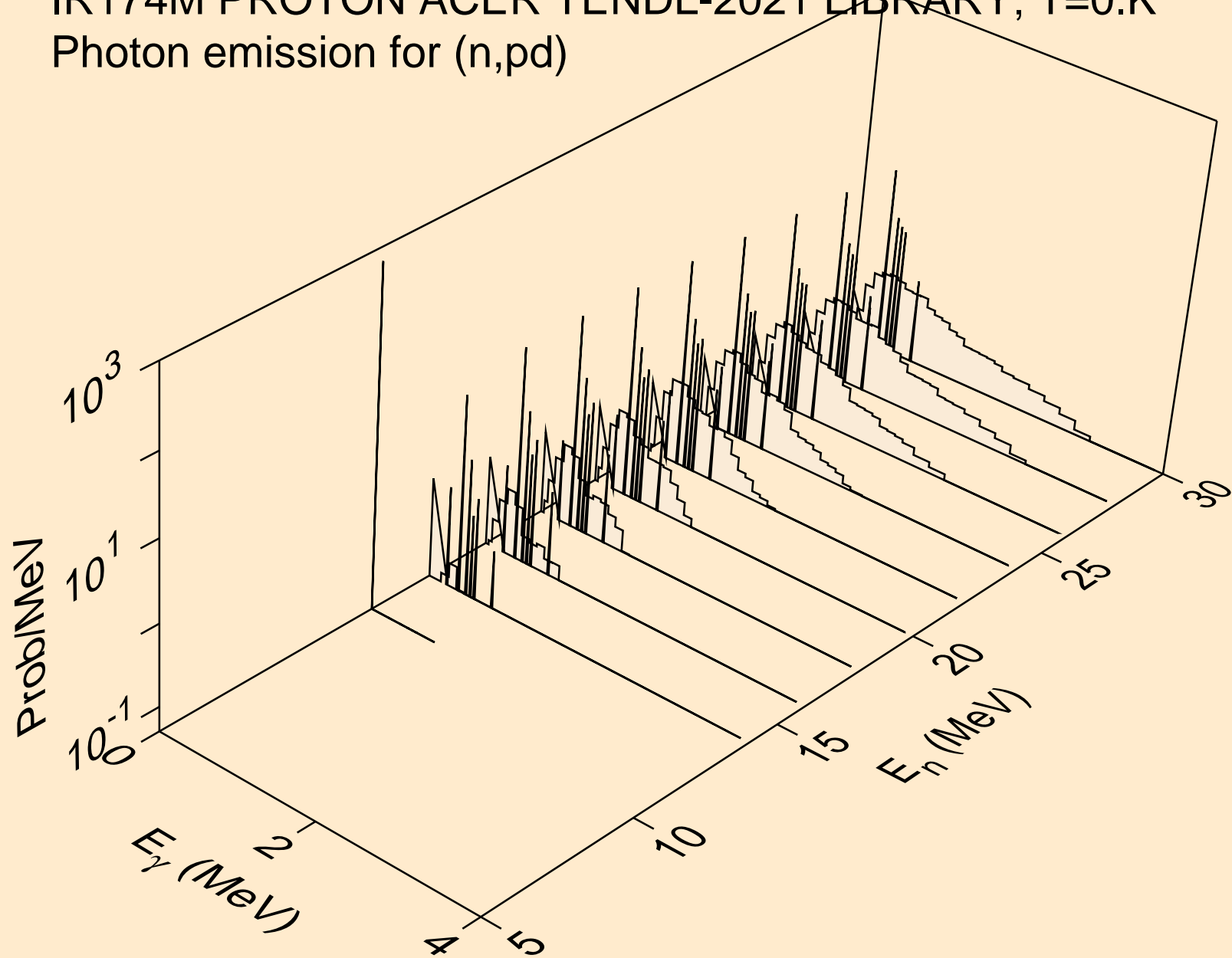

IR174M PROTON ACER TENDL-2021 LIBRARY; T=0.K  
Photon emission for (n,pt)

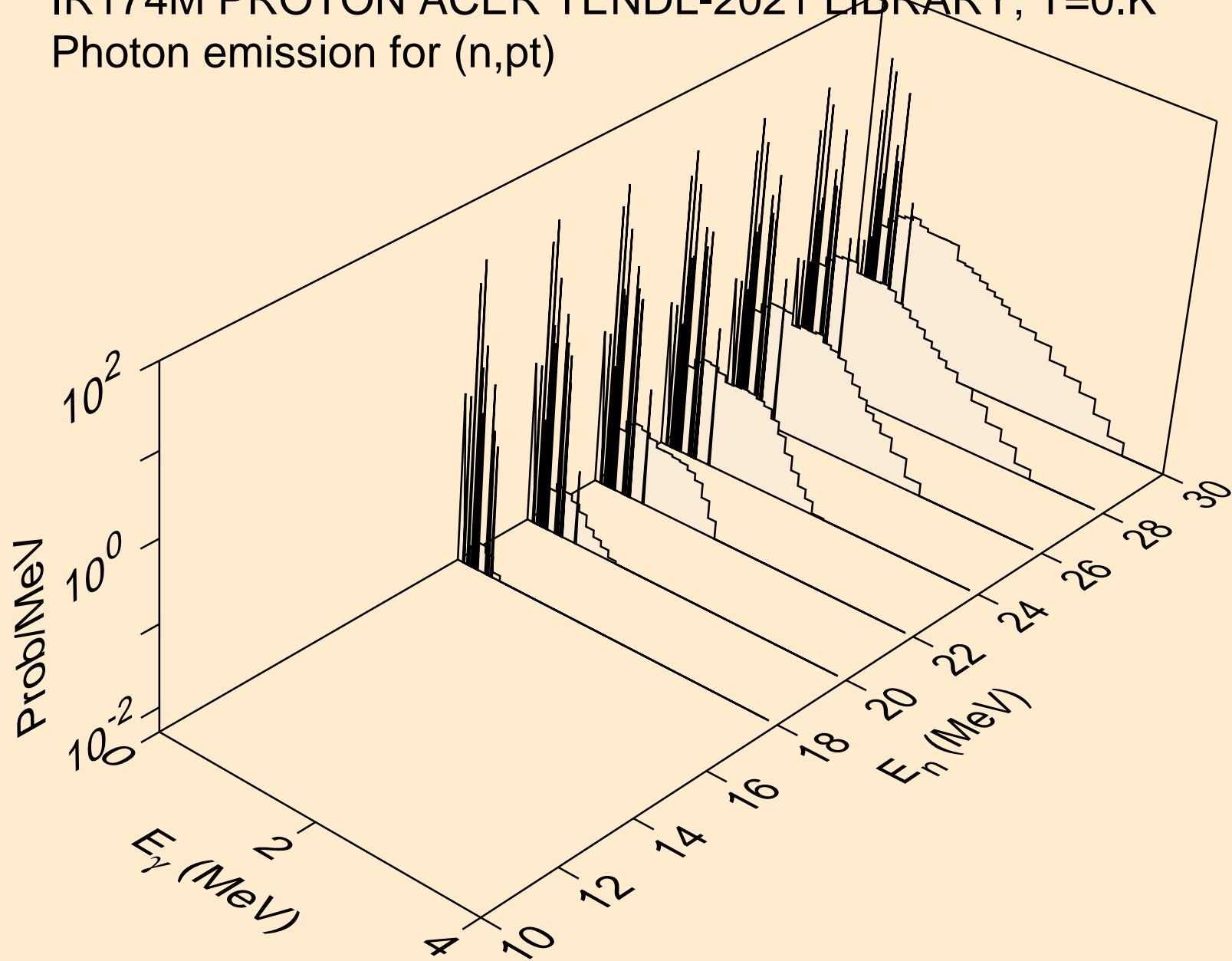

IR174M PROTON ACER TENDL-2021 LIBRARY; T=0.K  
Photon emission for (n,da)

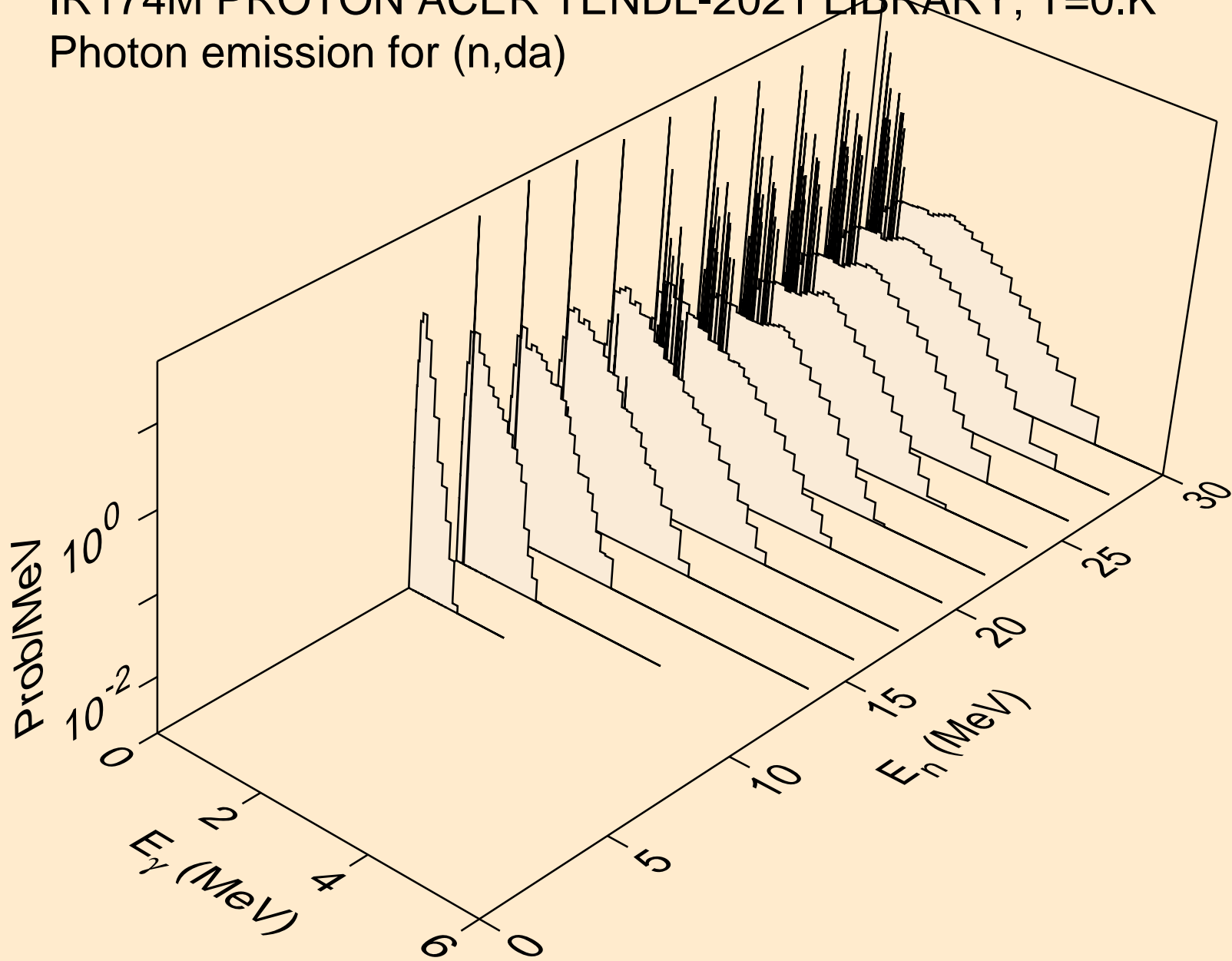



IR174M PROTON ACER TENDL-2021 LIBRARY; T=0.K  
Particle heating contributions

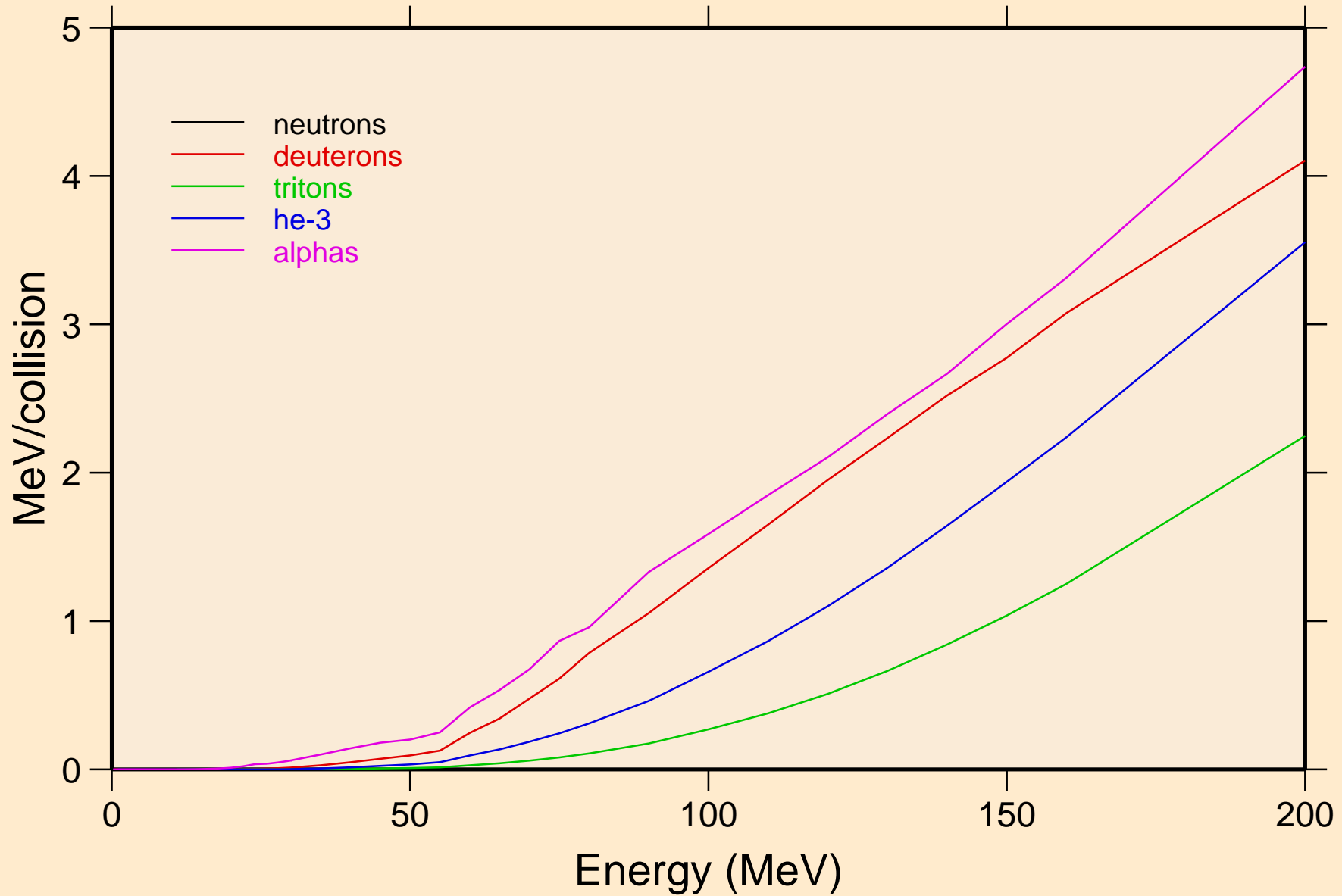

IR174M PROTON ACER TENDL-2021 LIBRARY; T=0.K  
Recoil Heating

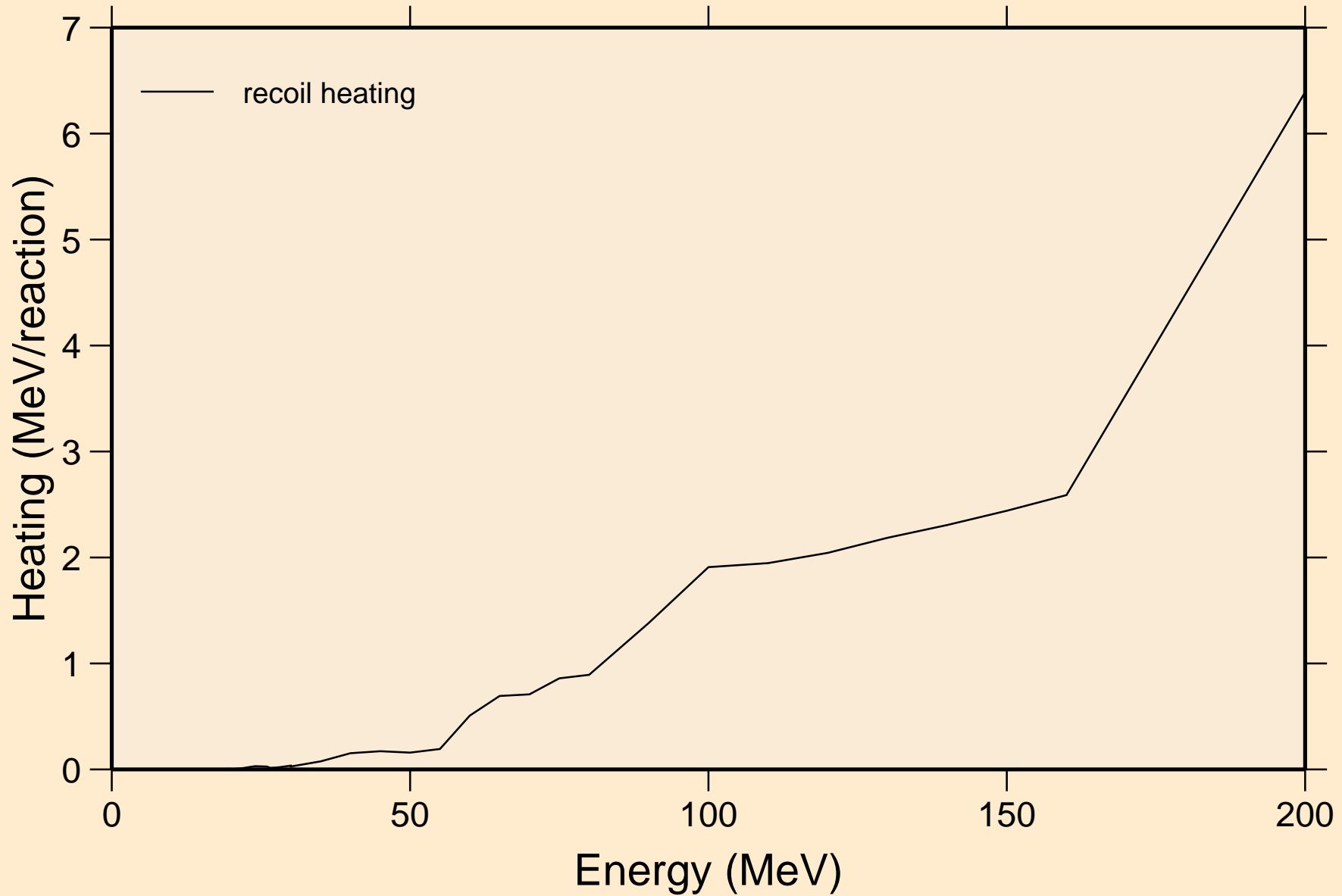

IR174M PROTON ACER TENDL-2021 LIBRARY; T=0.K  
Particle production cross sections

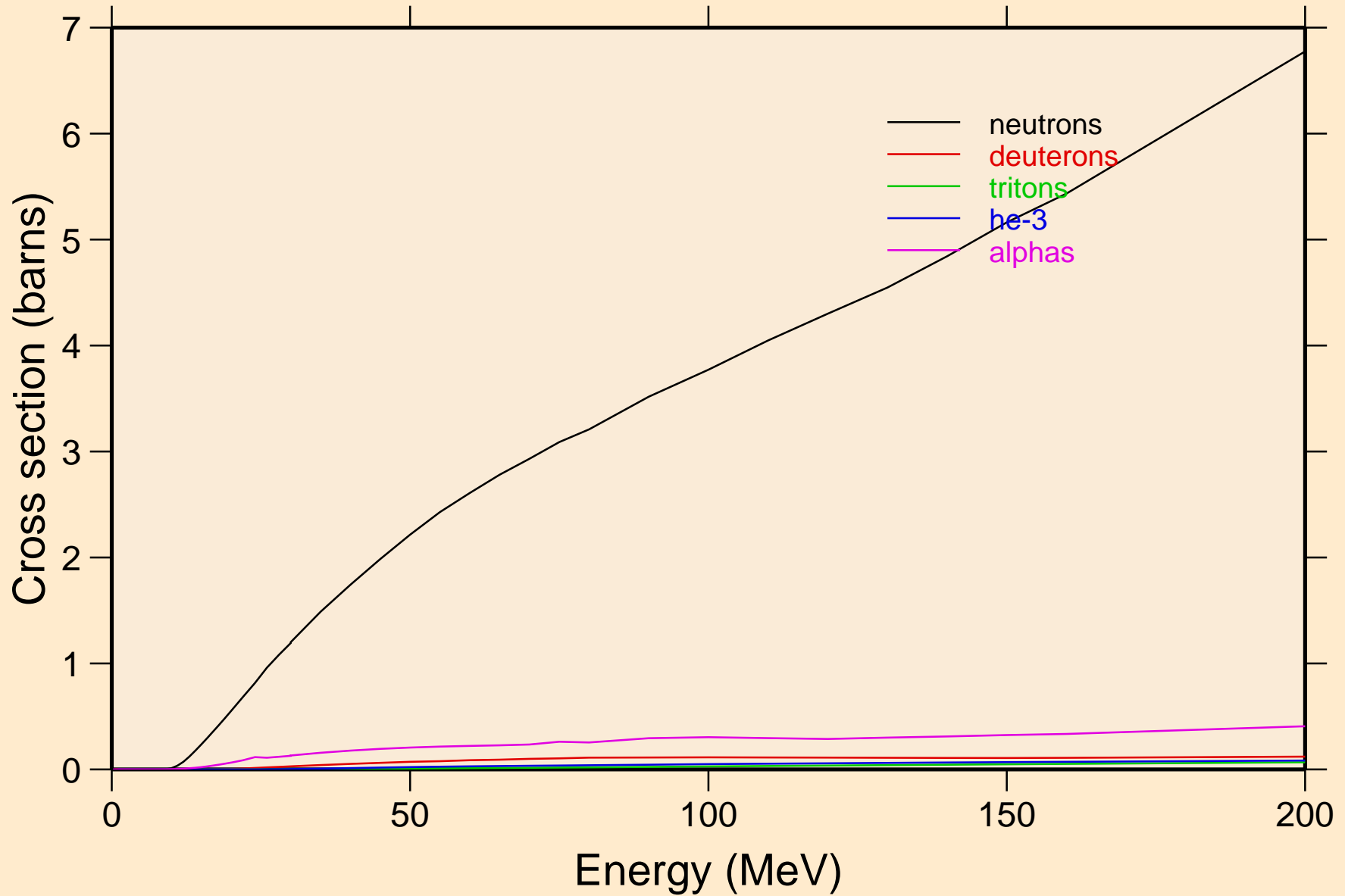

IR174M PROTON ACER TENDL-2021 LIBRARY; T=0.K  
neutrons from (p,n)

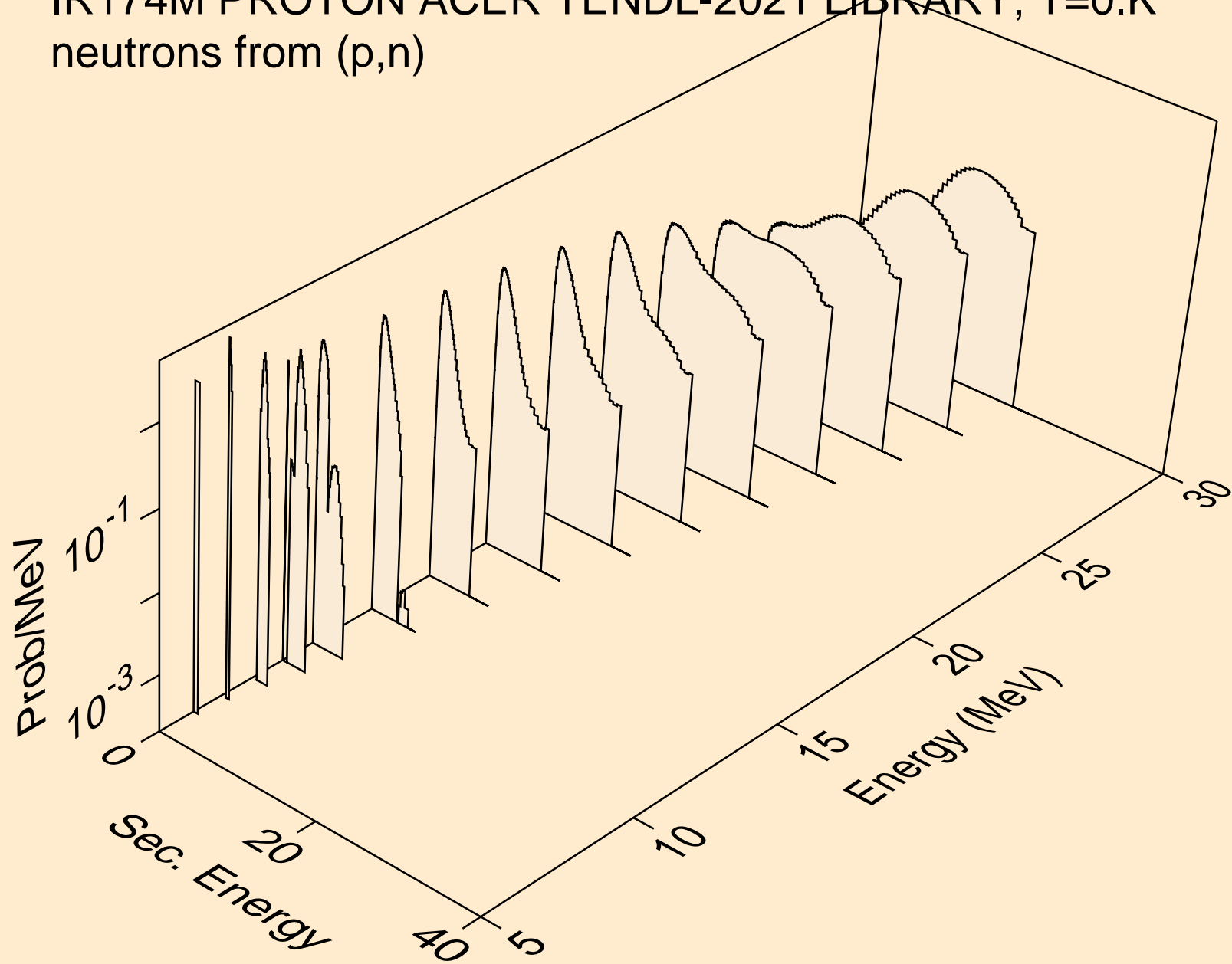

IR174M PROTON ACER TENDL-2021 LIBRARY; T=0.K  
neutrons from (p,x)

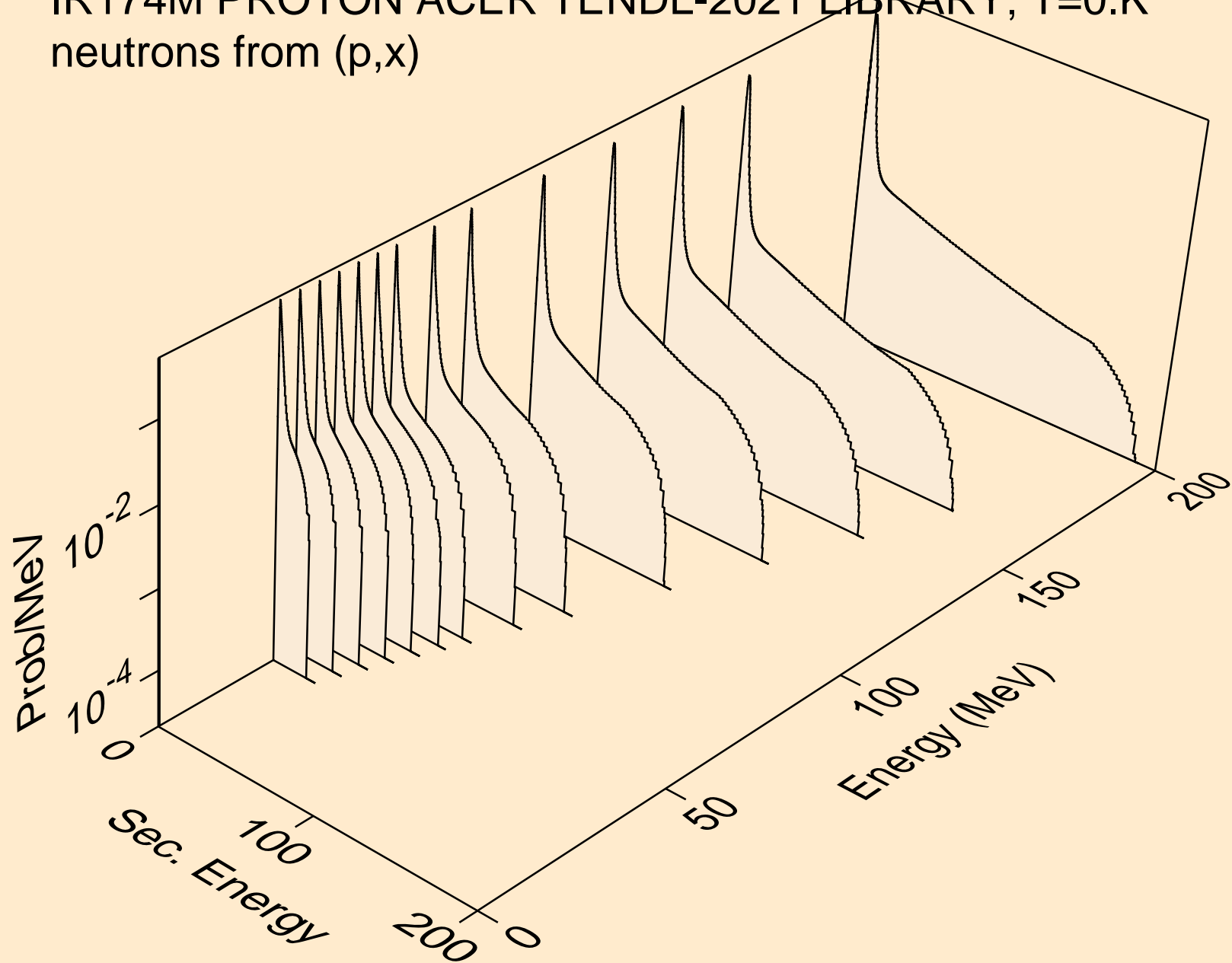

IR174M PROTON ACER TENDL-2021 LIBRARY; T=0.K  
neutrons from (p,2n)

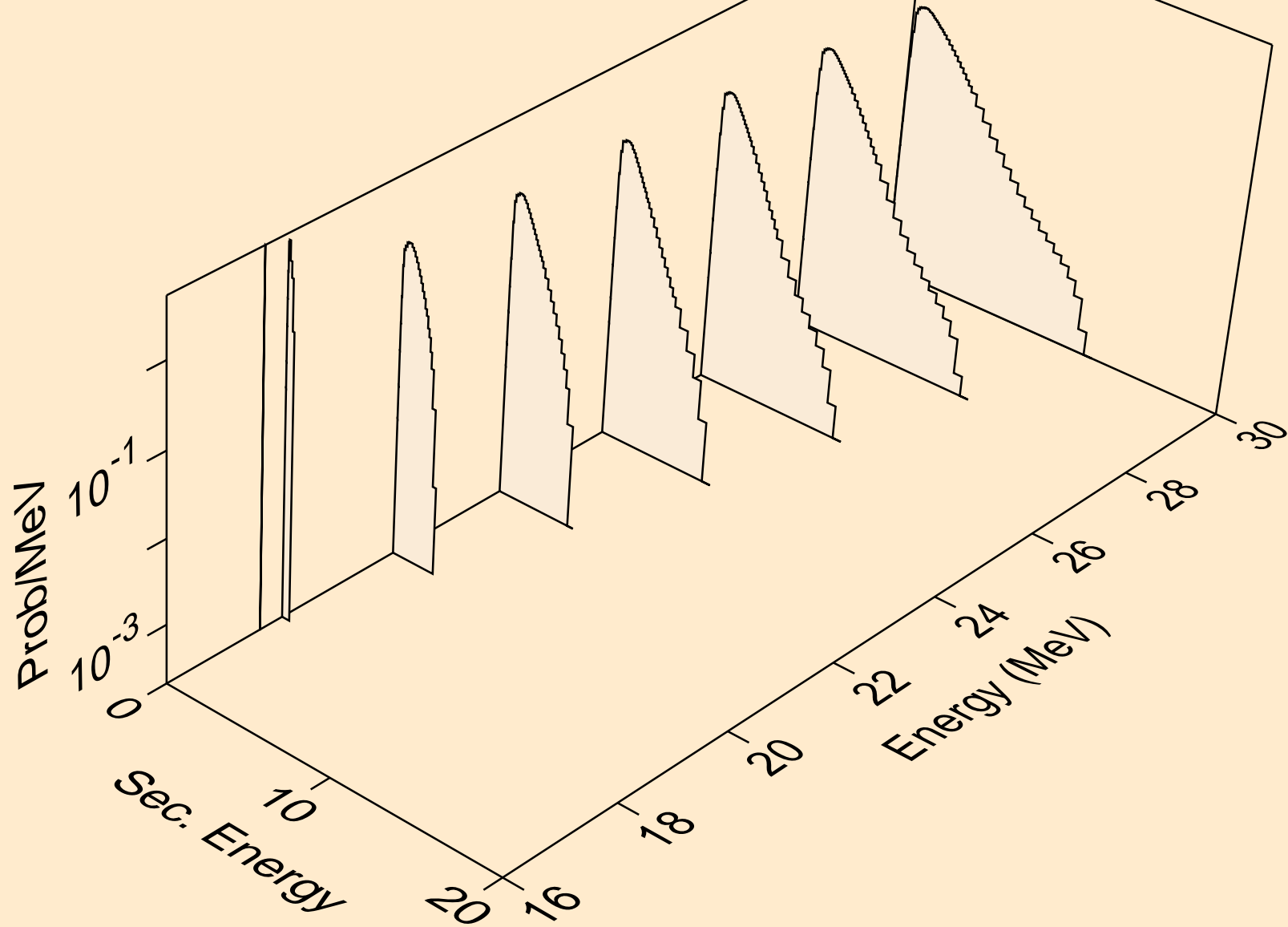

IR174M PROTON ACER TENDL-2021 LIBRARY; T=0.K  
neutrons from (p,3n)

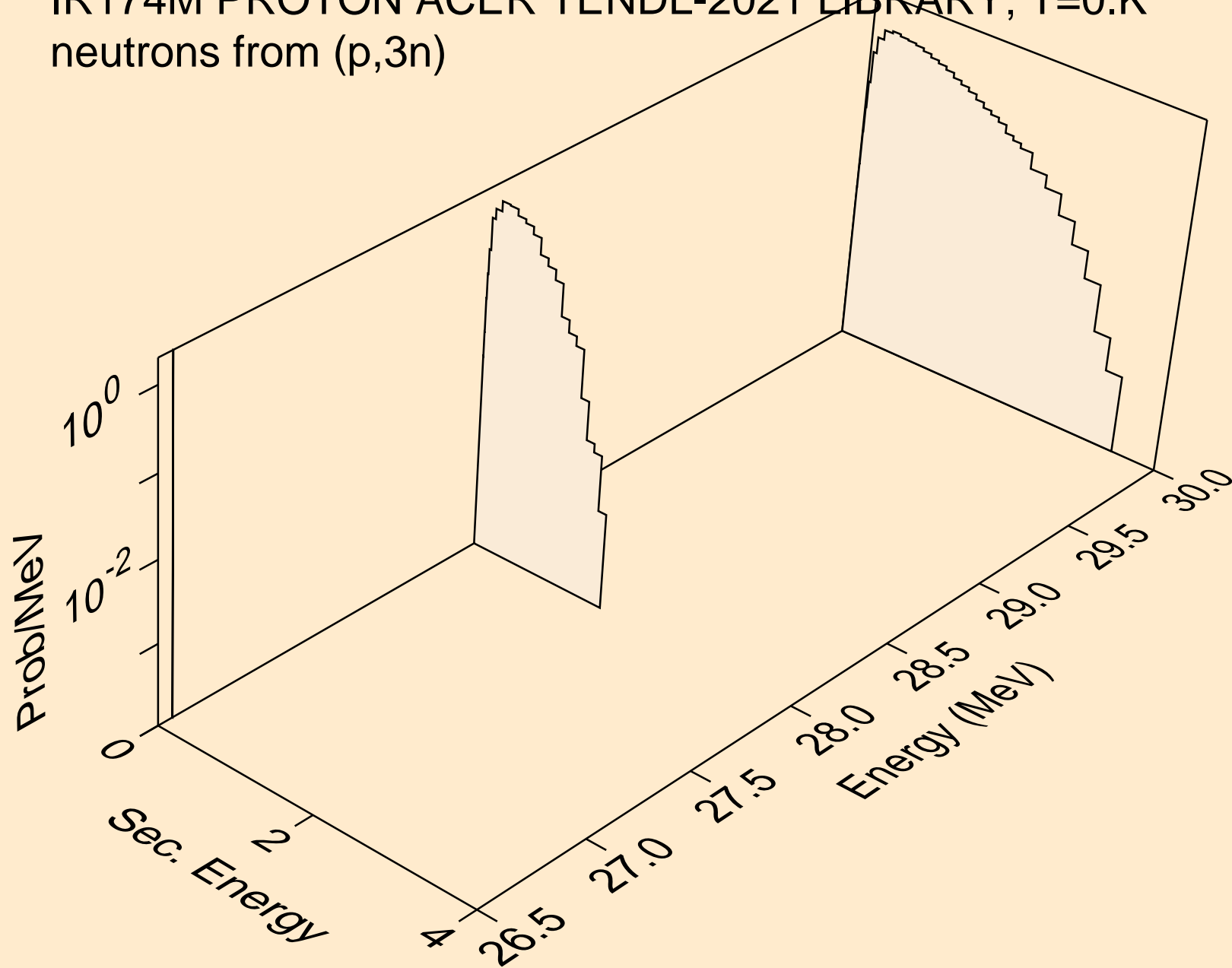

IR174M PROTON ACER TENDL-2021 LIBRARY; T=0.K  
neutrons from (p,n\*)a

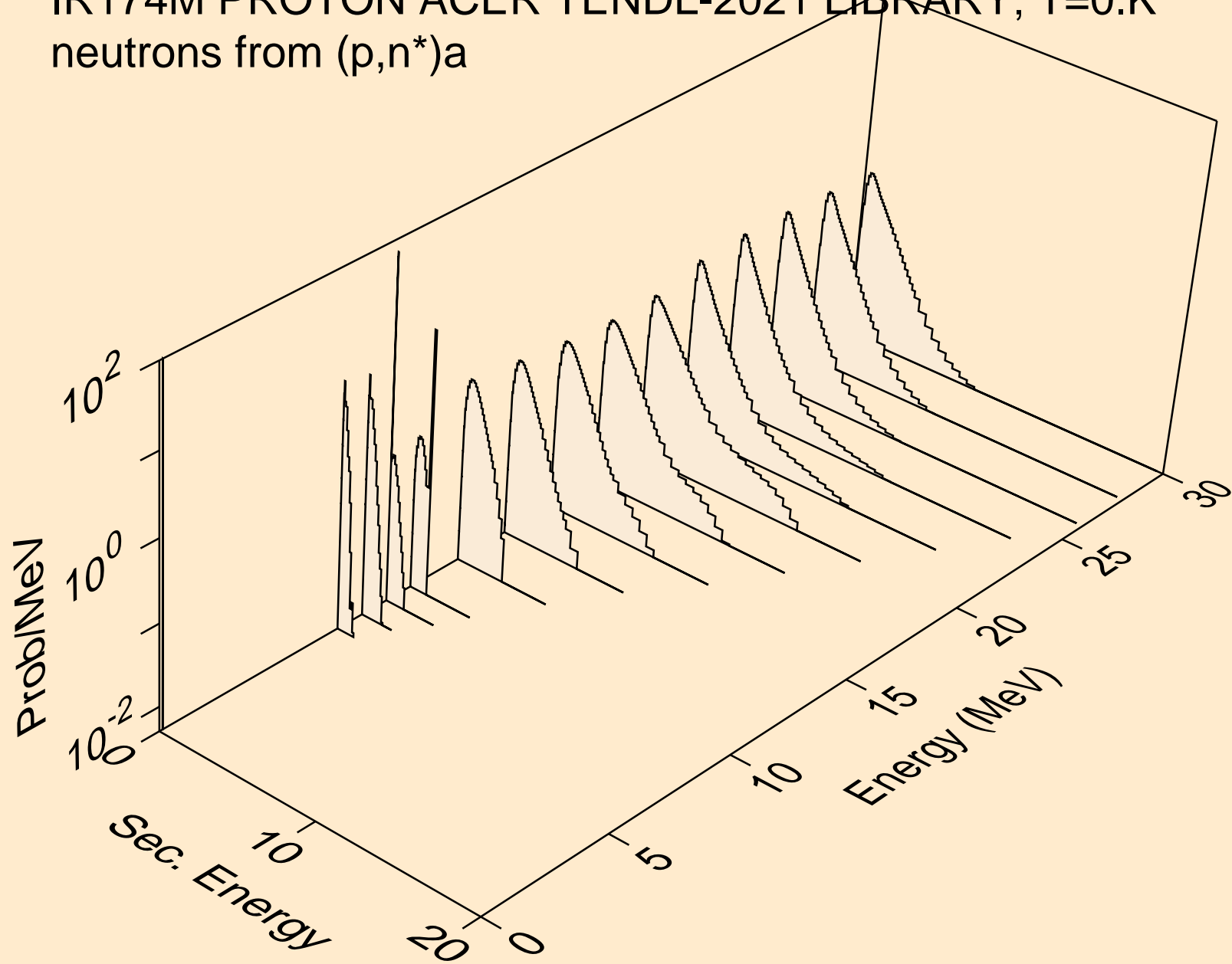



IR174M PROTON ACER TENDL-2021 LIBRARY; T=0.K  
neutrons from (p,2n)a

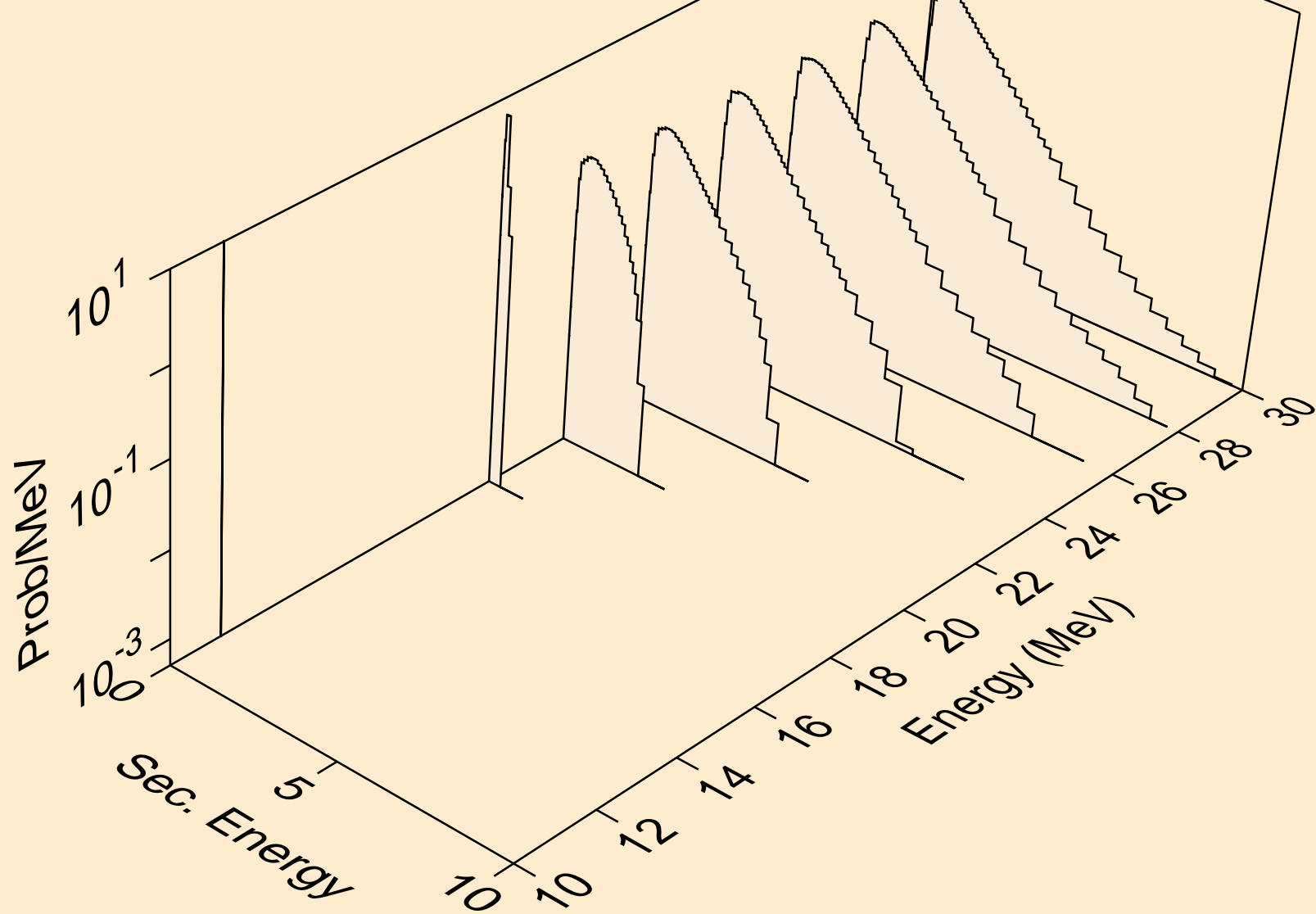

IR174M PROTON ACER TENDL-2021 LIBRARY; T=0.K  
neutrons from (p,3n)a

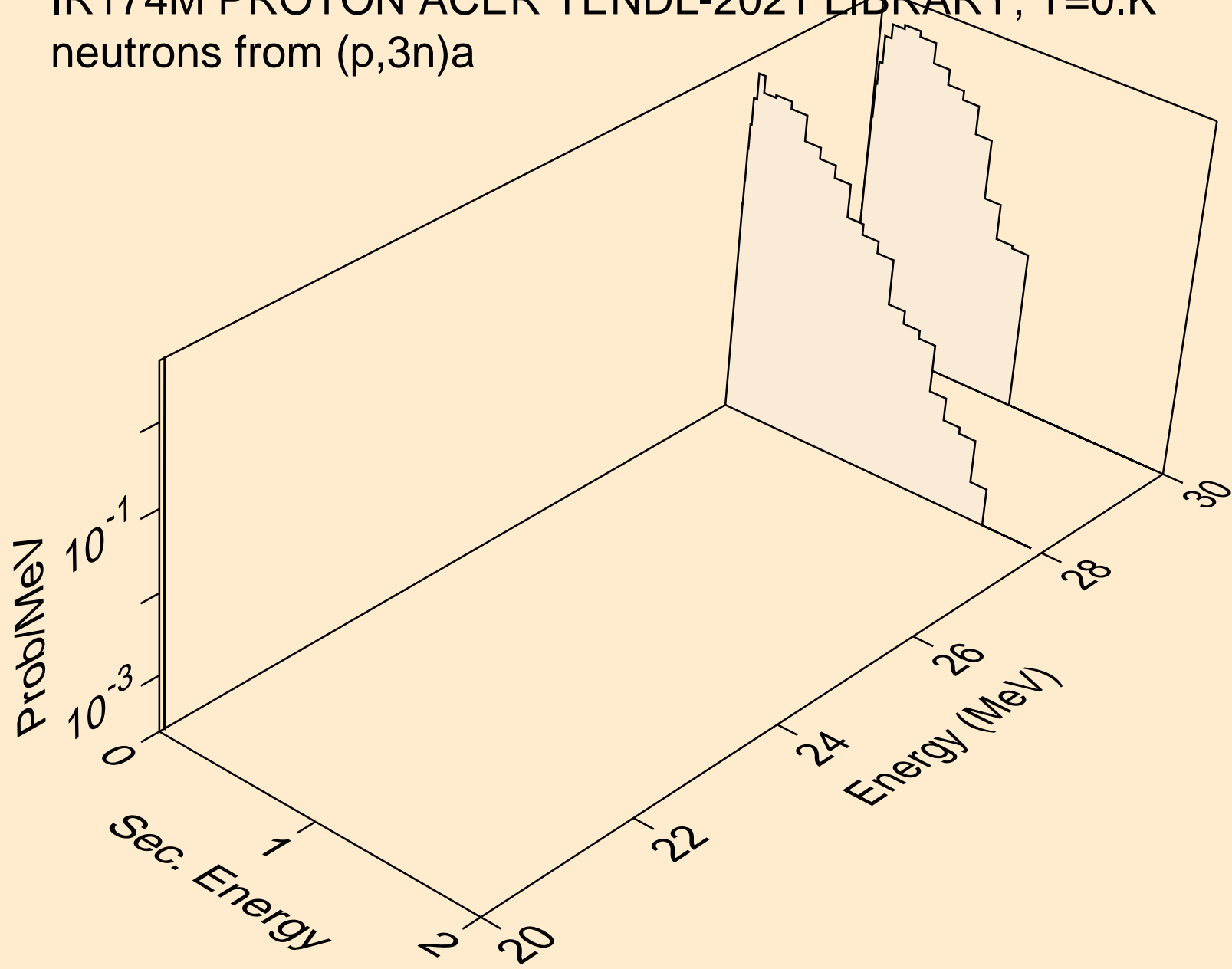

IR174M PROTON ACER TENDL-2021 LIBRARY; T=0.K  
neutrons from (p,n\*)p

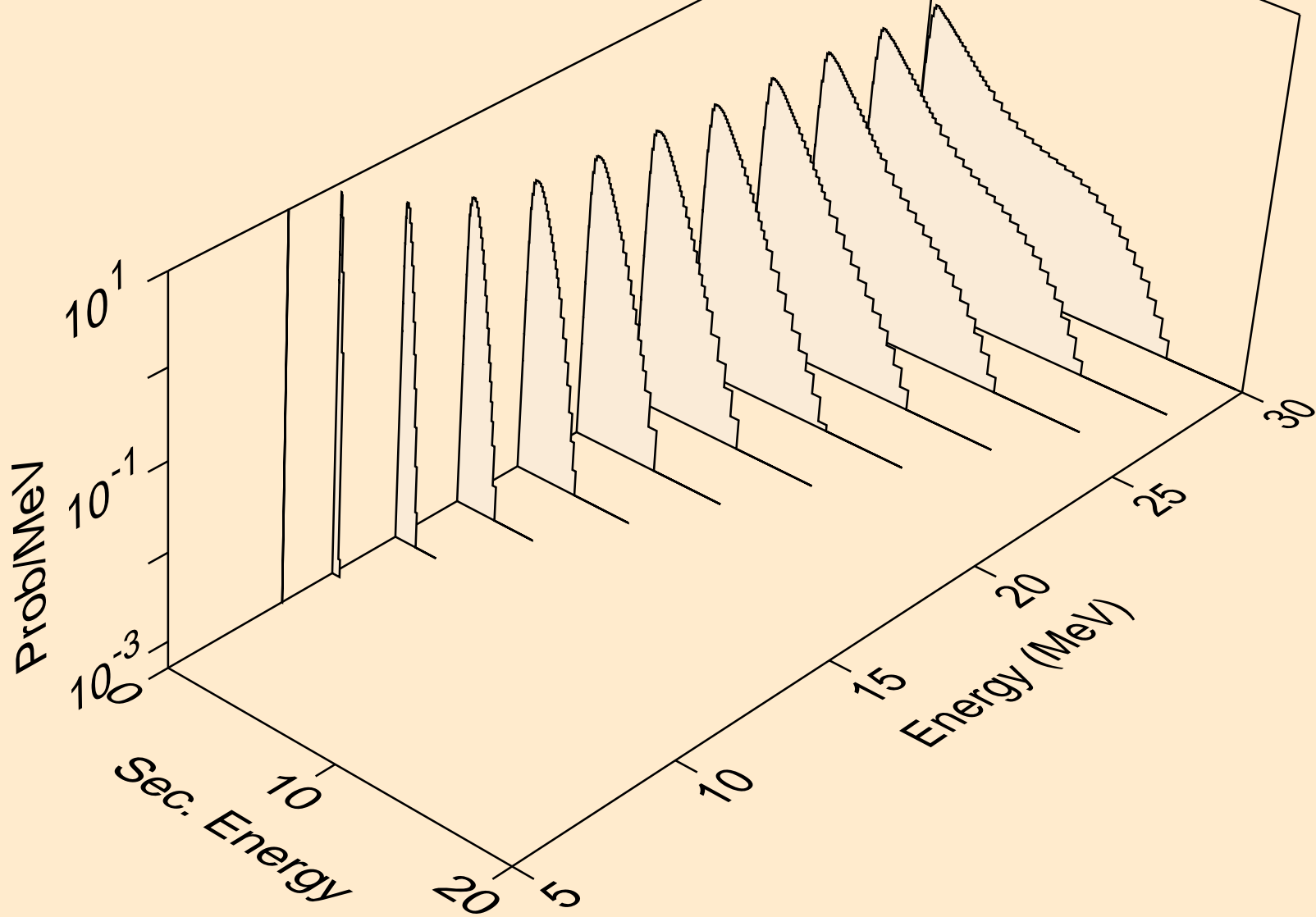

IR174M PROTON ACER TENDL-2021 LIBRARY; T=0.K  
neutrons from (p,n\*)2a

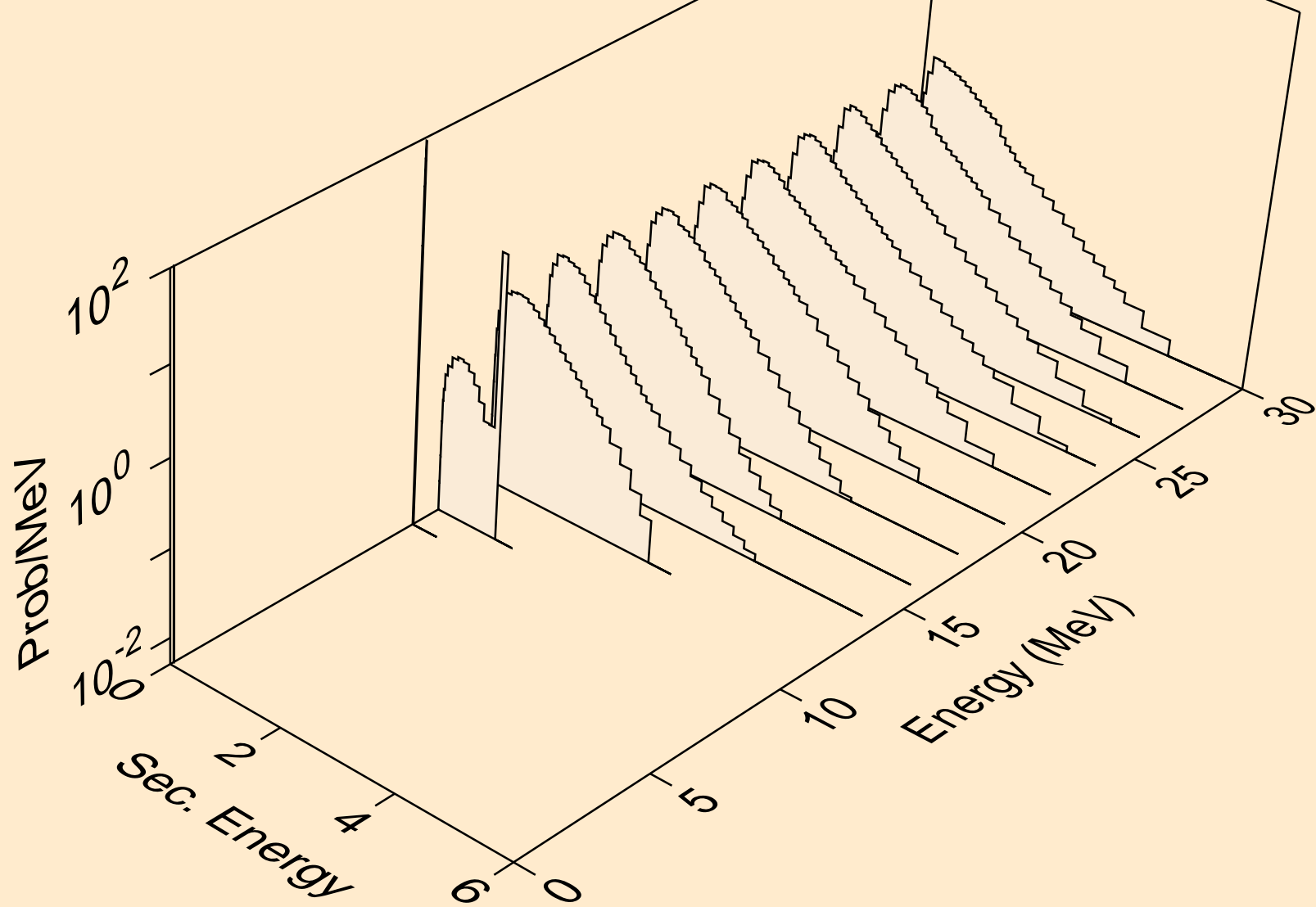

IR174M PROTON ACER TENDL-2021 LIBRARY; T=0.K  
neutrons from (p,2n)2a

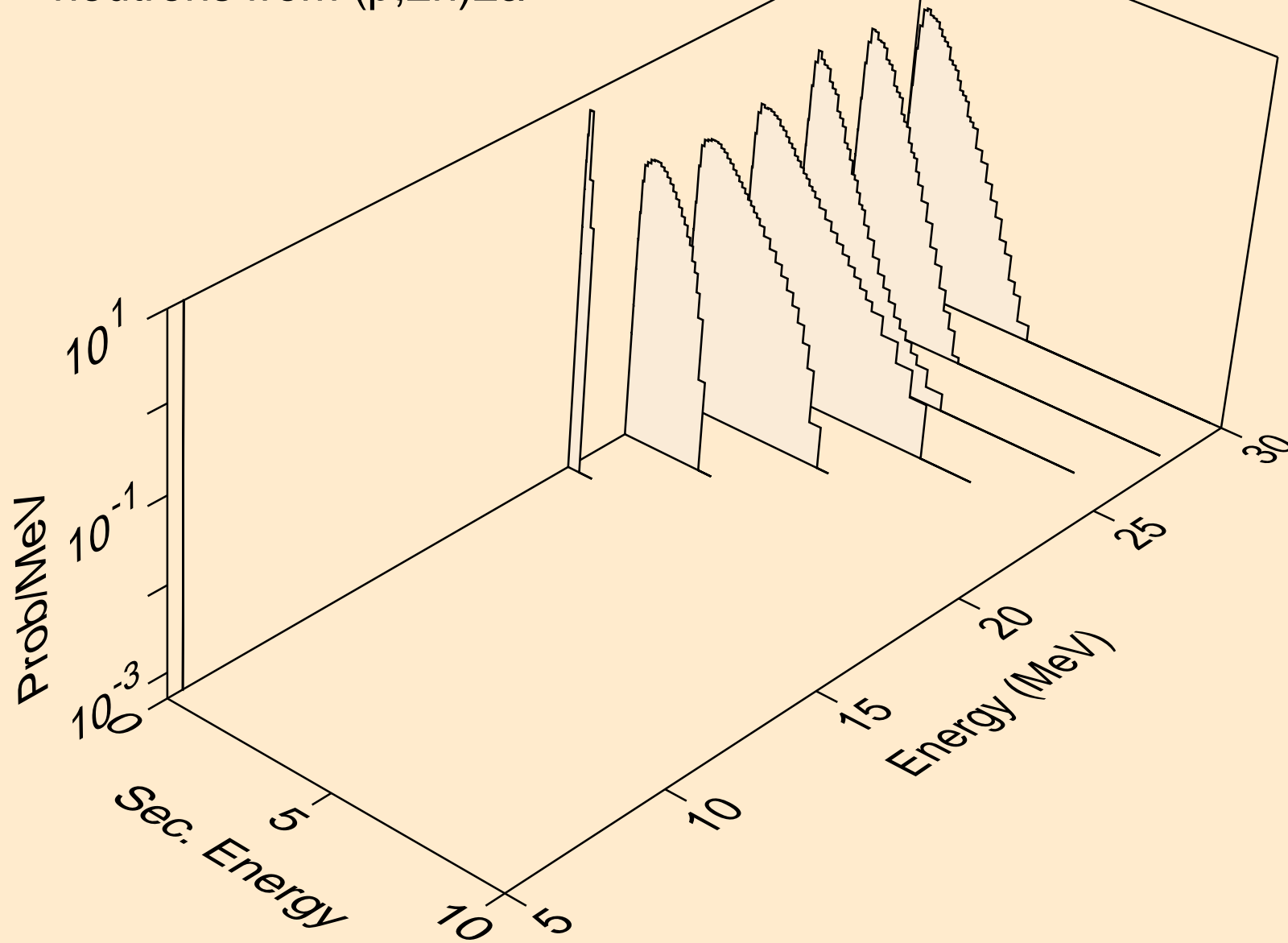

IR174M PROTON ACER TENDL-2021 LIBRARY; T=0.K  
neutrons from (p,n\*)d

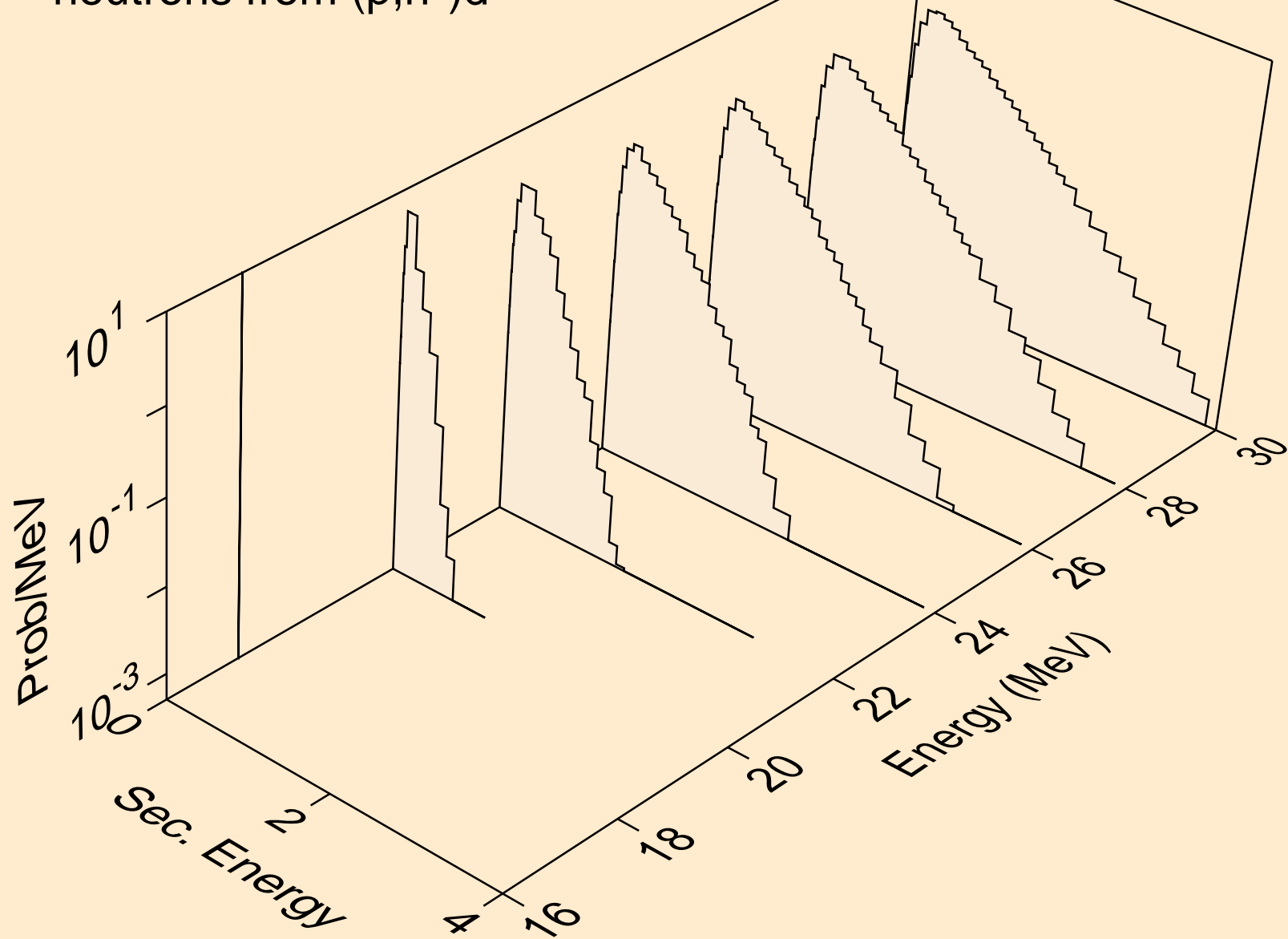

IR174M PROTON ACER TENDL-2021 LIBRARY; T=0.K  
neutrons from (p,n\*)t

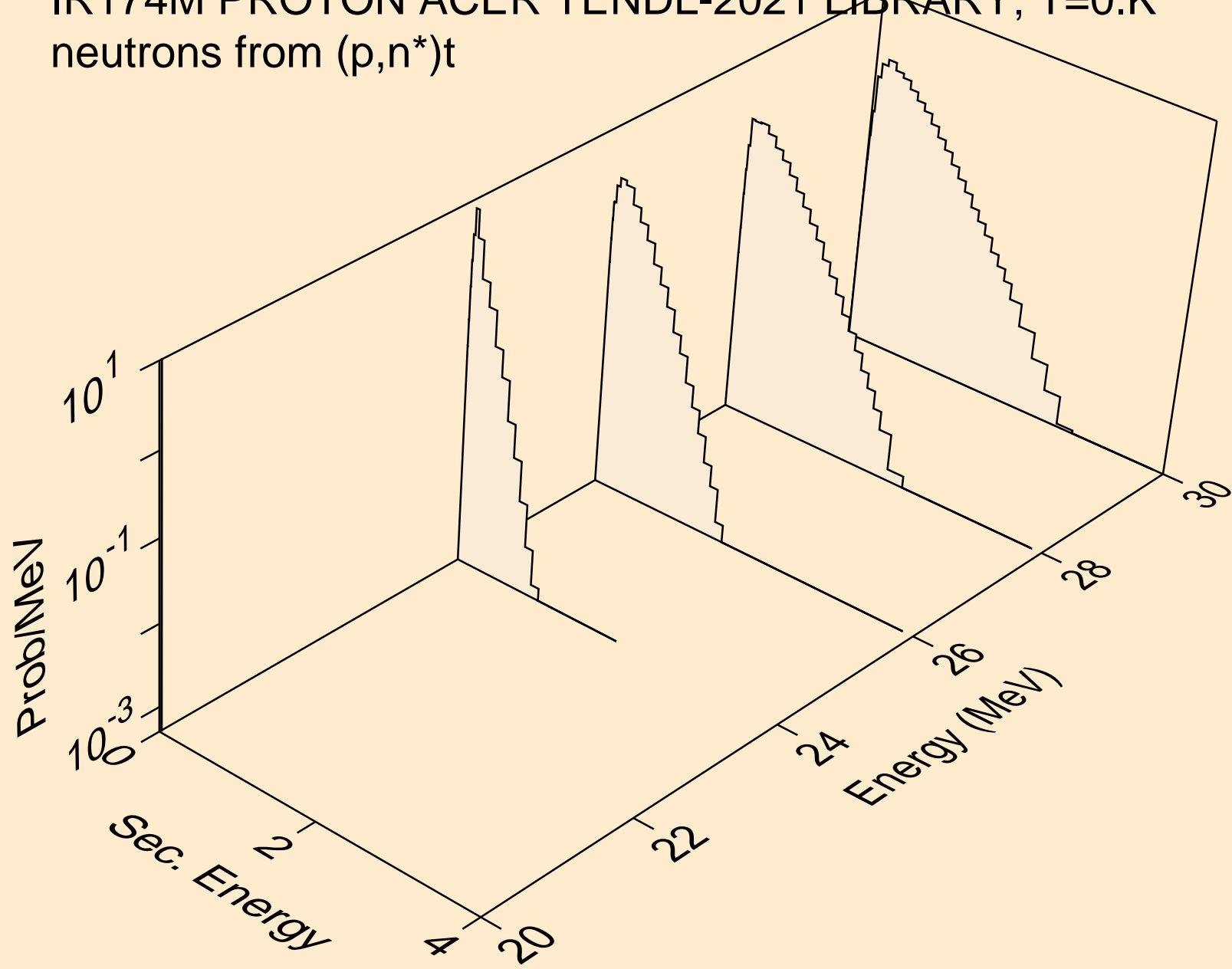

IR174M PROTON ACER TENDL-2021 LIBRARY; T=0.K  
neutrons from (p,n\*)he3

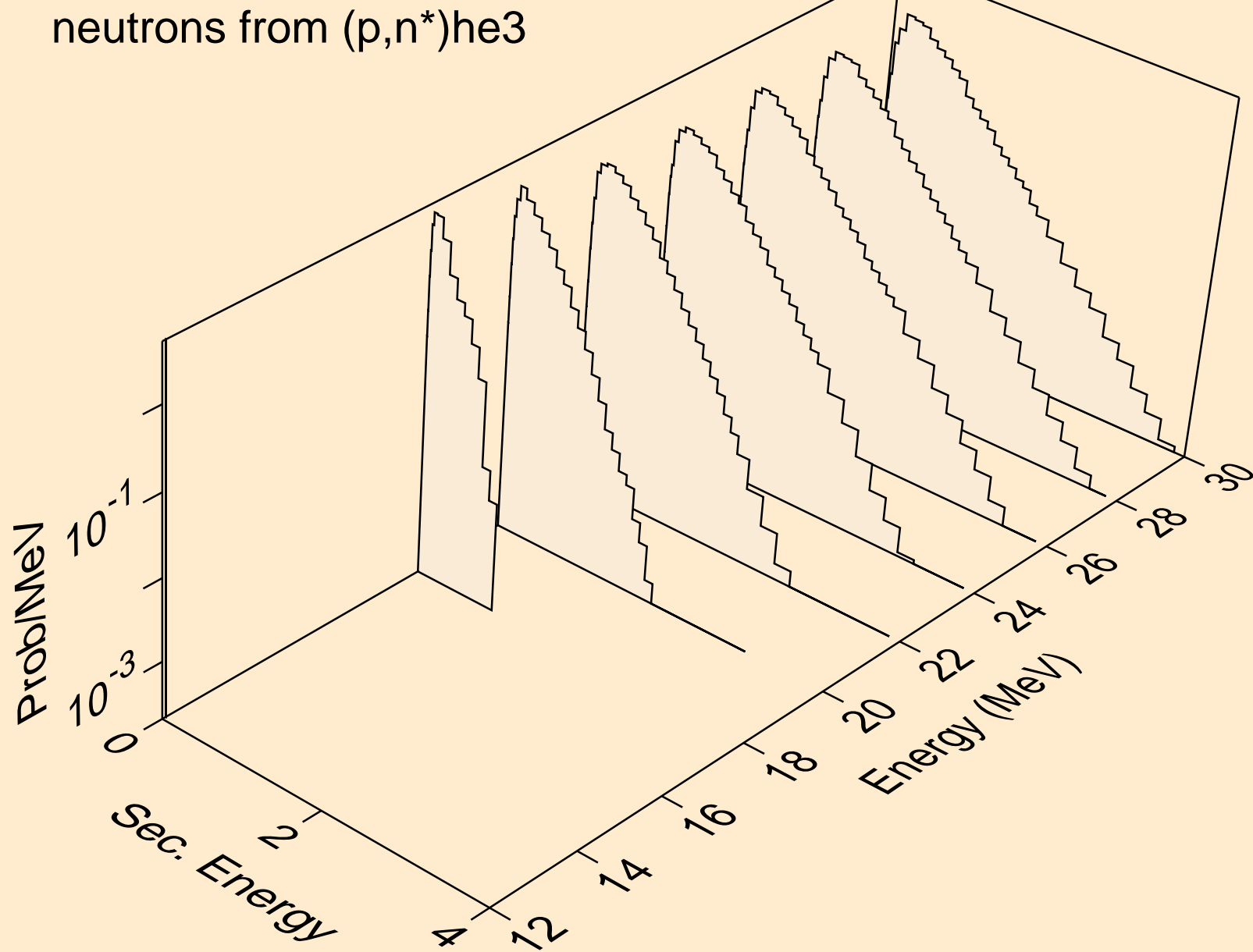



IR174M PROTON ACER TENDL-2021 LIBRARY; T=0.K  
neutrons from (p,2np)

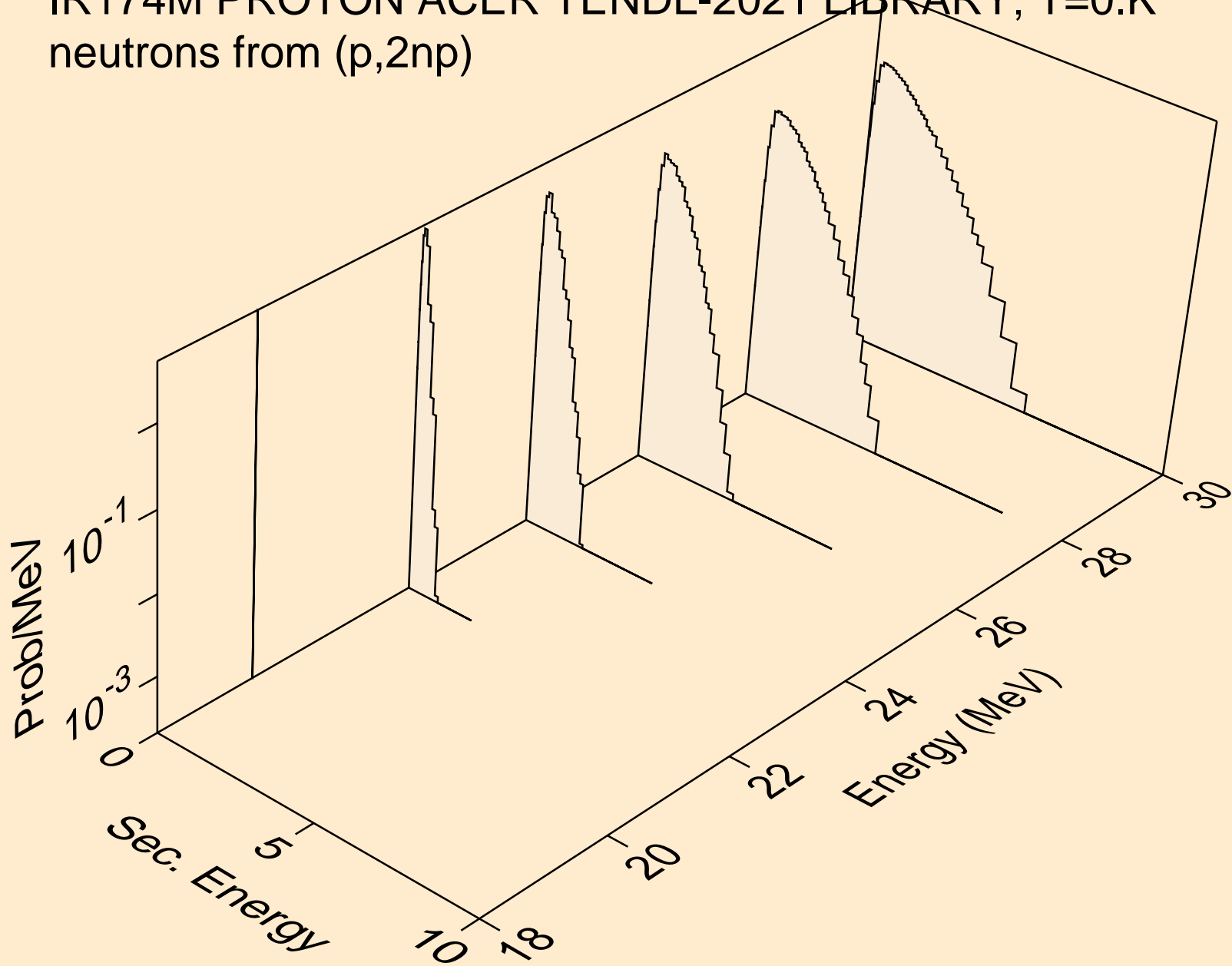

IR174M PROTON ACER TENDL-2021 LIBRARY; T=0.K  
neutrons from (p,2np)

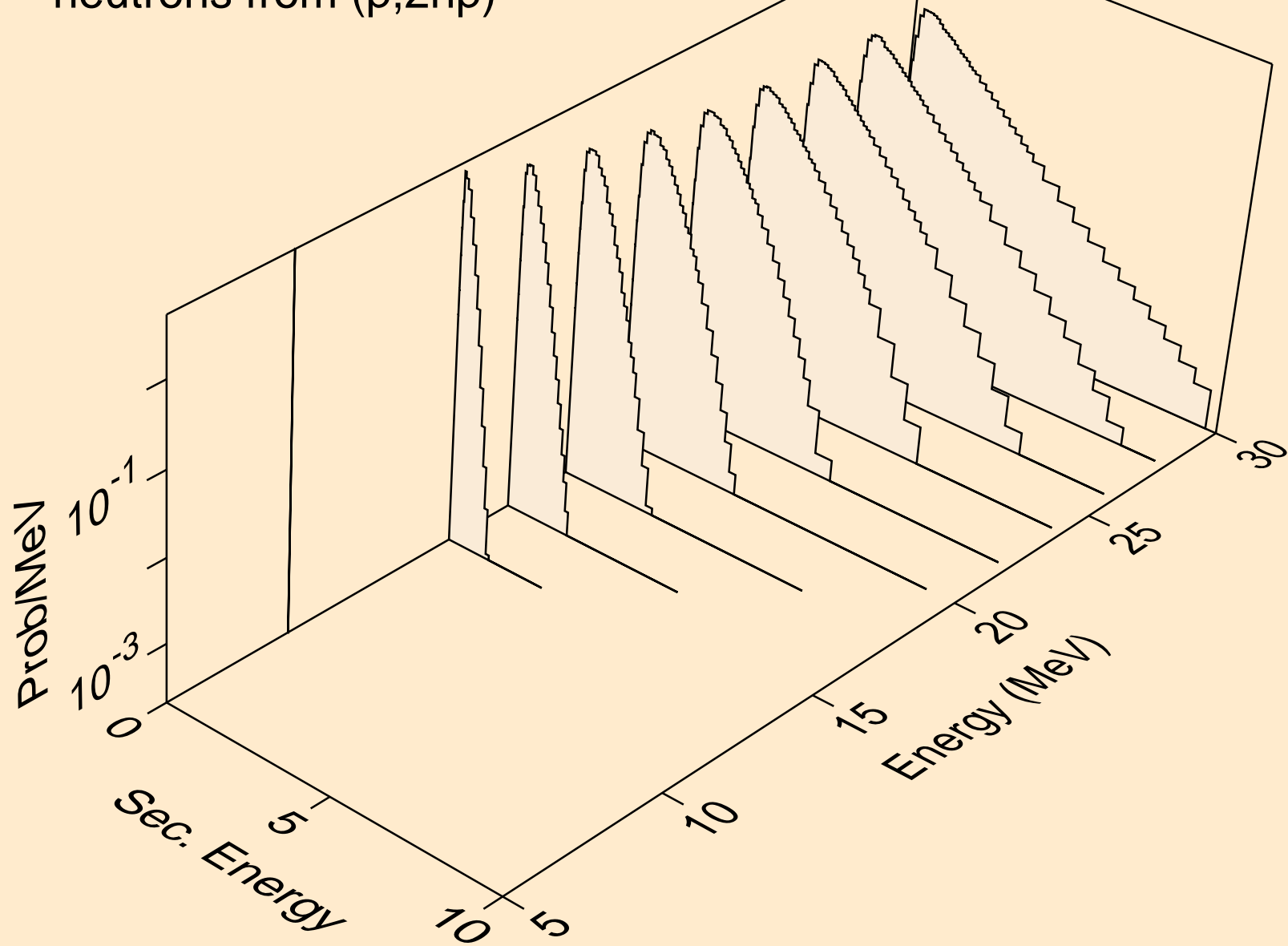

IR174M PROTON ACER TENDL-2021 LIBRARY; T=0.K  
neutrons from (p,npa)

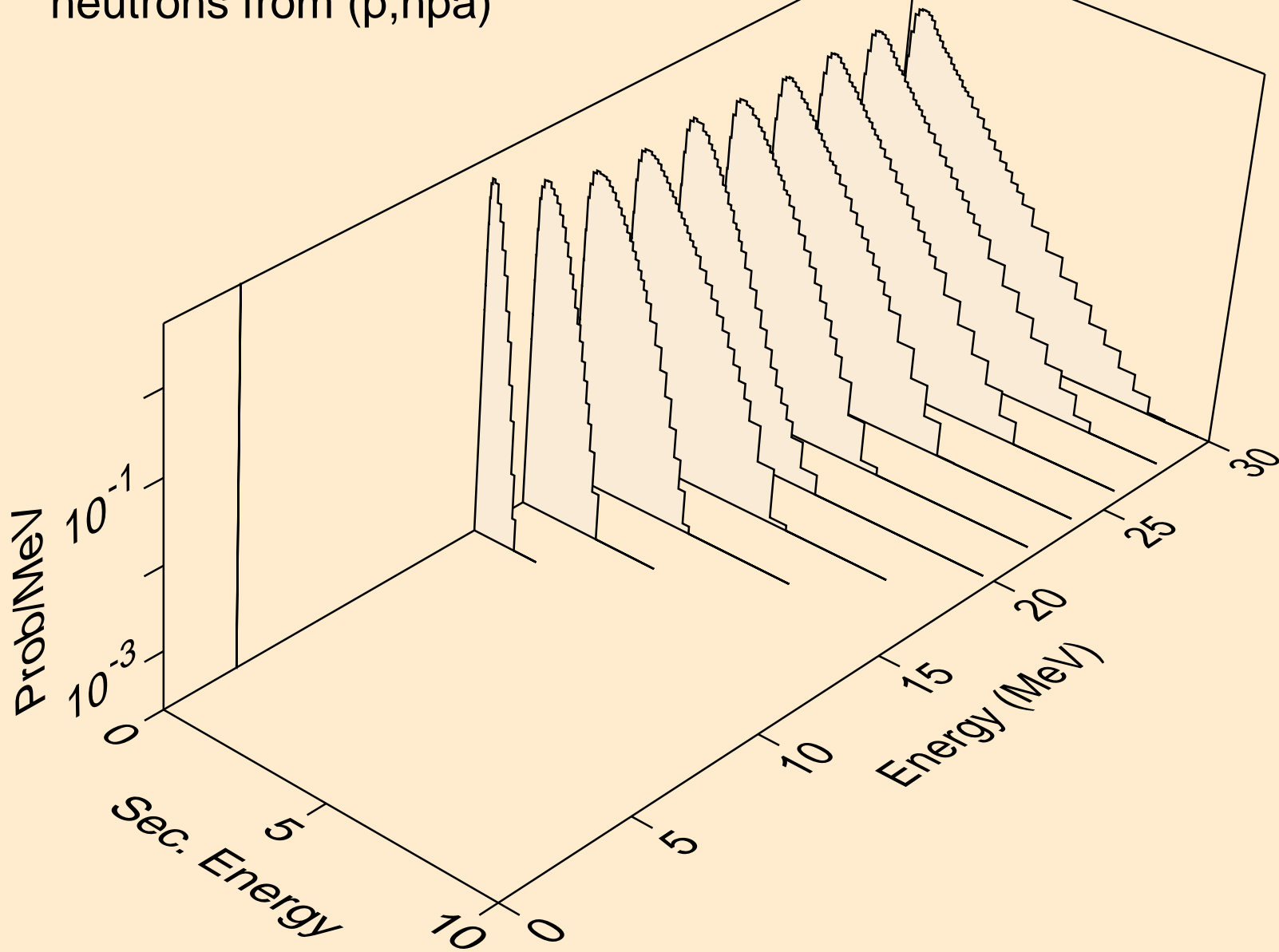

IR174M PROTON ACER TENDL-2021 LIBRARY; T=0.K  
deuterons from (p,x)

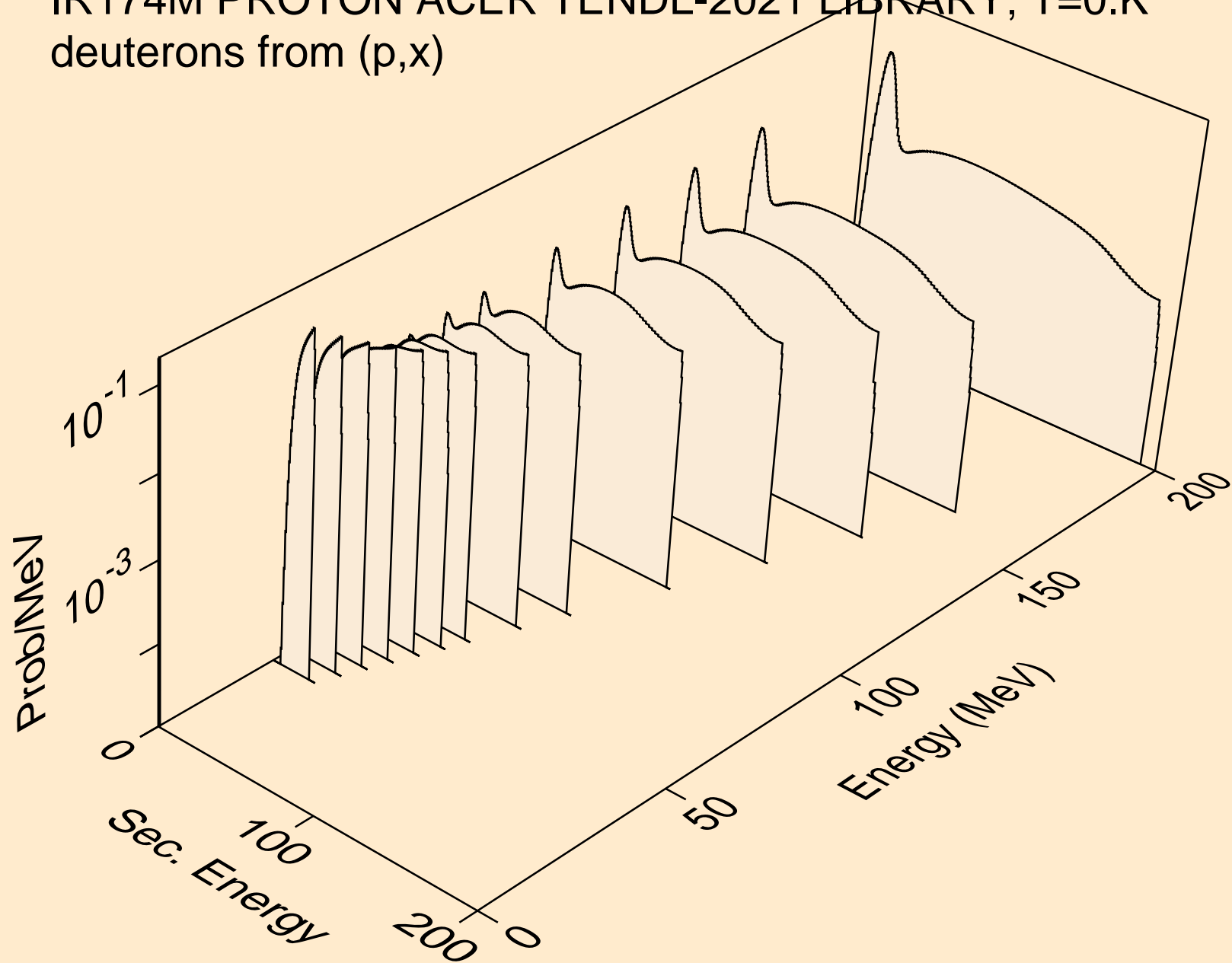

IR174M PROTON ACER TENDL-2021 LIBRARY; T=0.K  
deuterons from (p,n\*)d

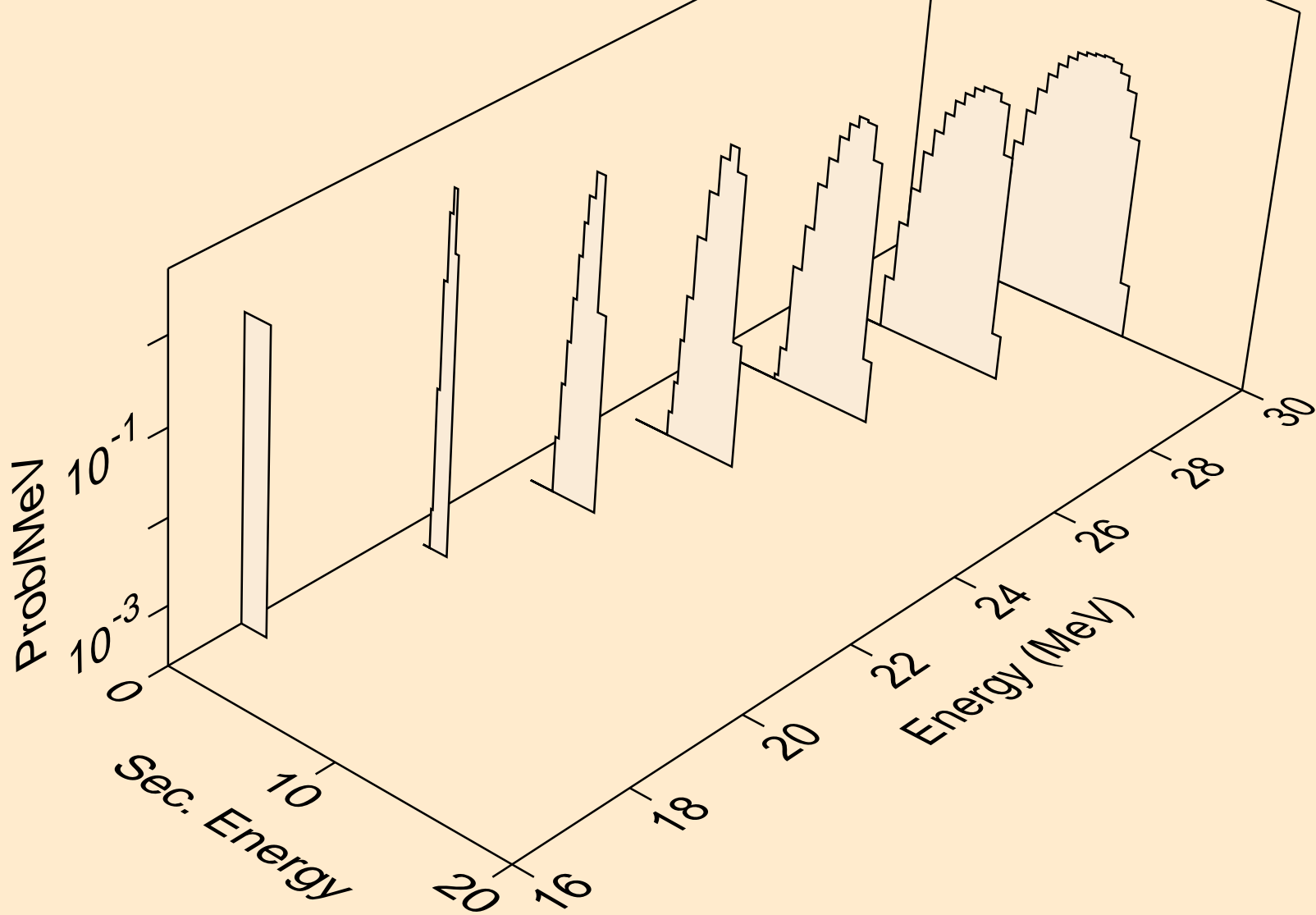

IR174M PROTON ACER TENDL-2021 LIBRARY; T=0.K  
deuterons from (p,d)

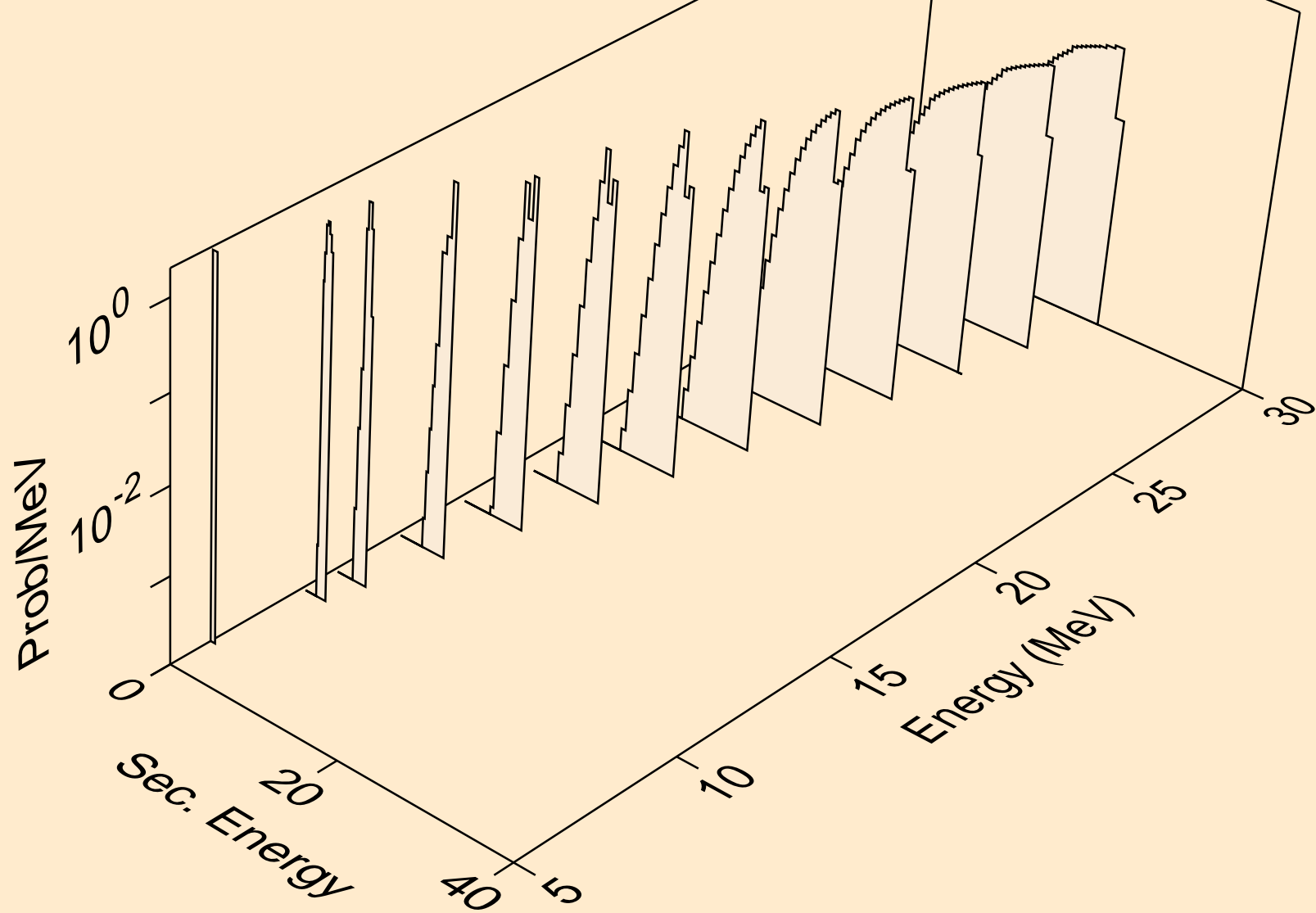

IR174M PROTON ACER TENDL-2021 LIBRARY; T=0.K  
deuterons from (p,pd)

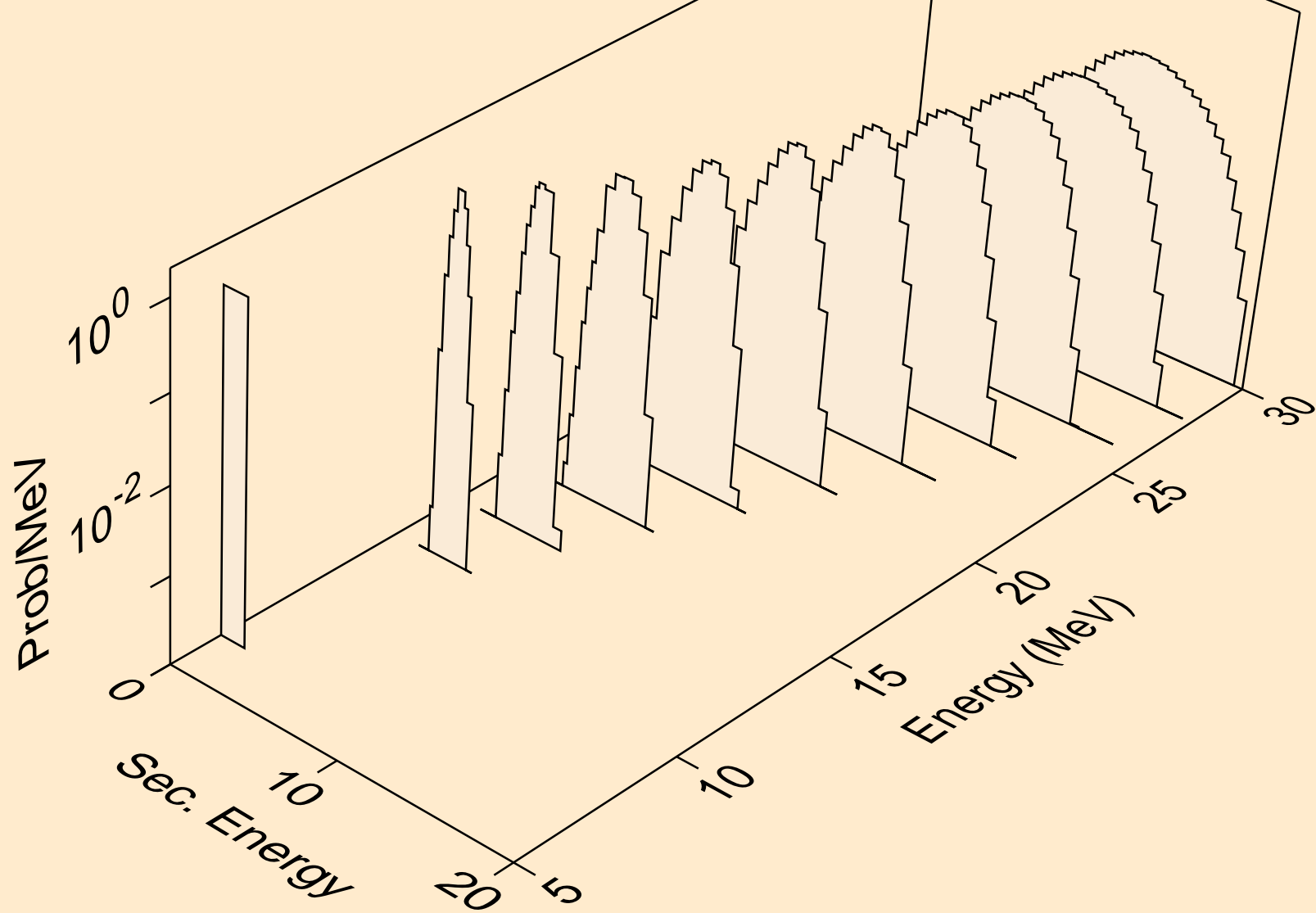

IR174M PROTON ACER TENDL-2021 LIBRARY; T=0.K  
deuterons from (p,da)

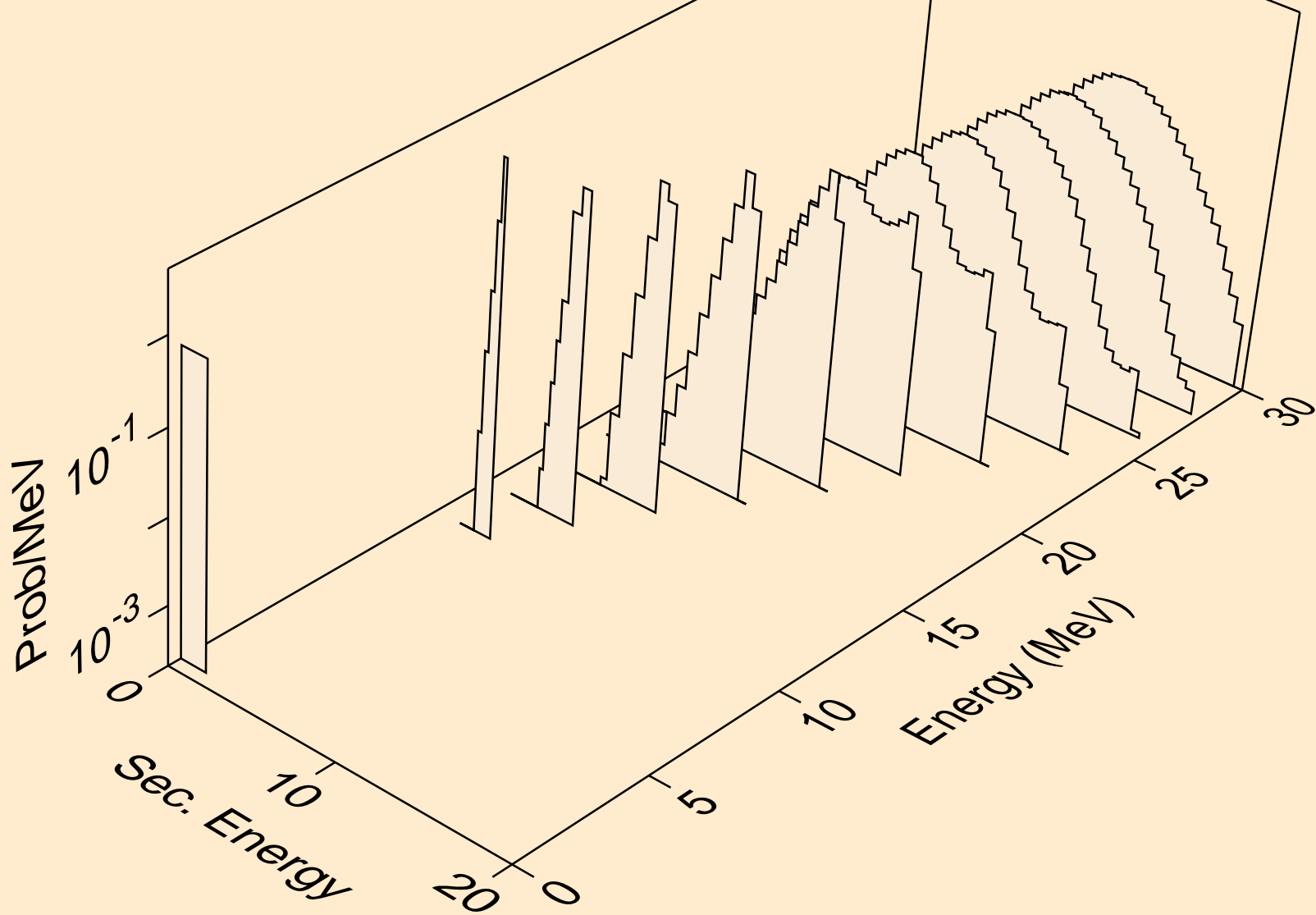



IR174M PROTON ACER TENDL-2021 LIBRARY; T=0.K  
tritons from (p,x)

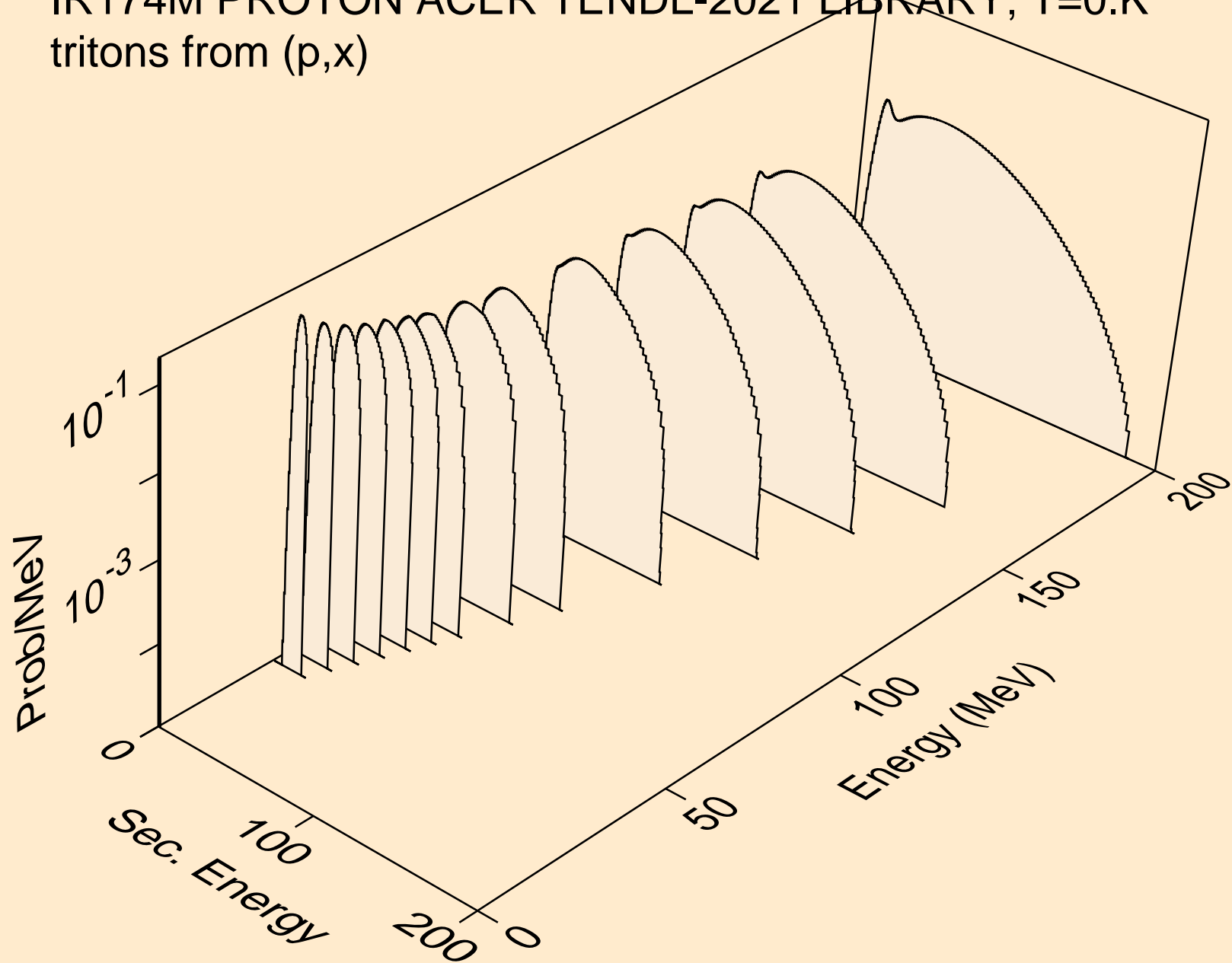

IR174M PROTON ACER TENDL-2021 LIBRARY; T=0.K  
tritons from (p,n\*)t

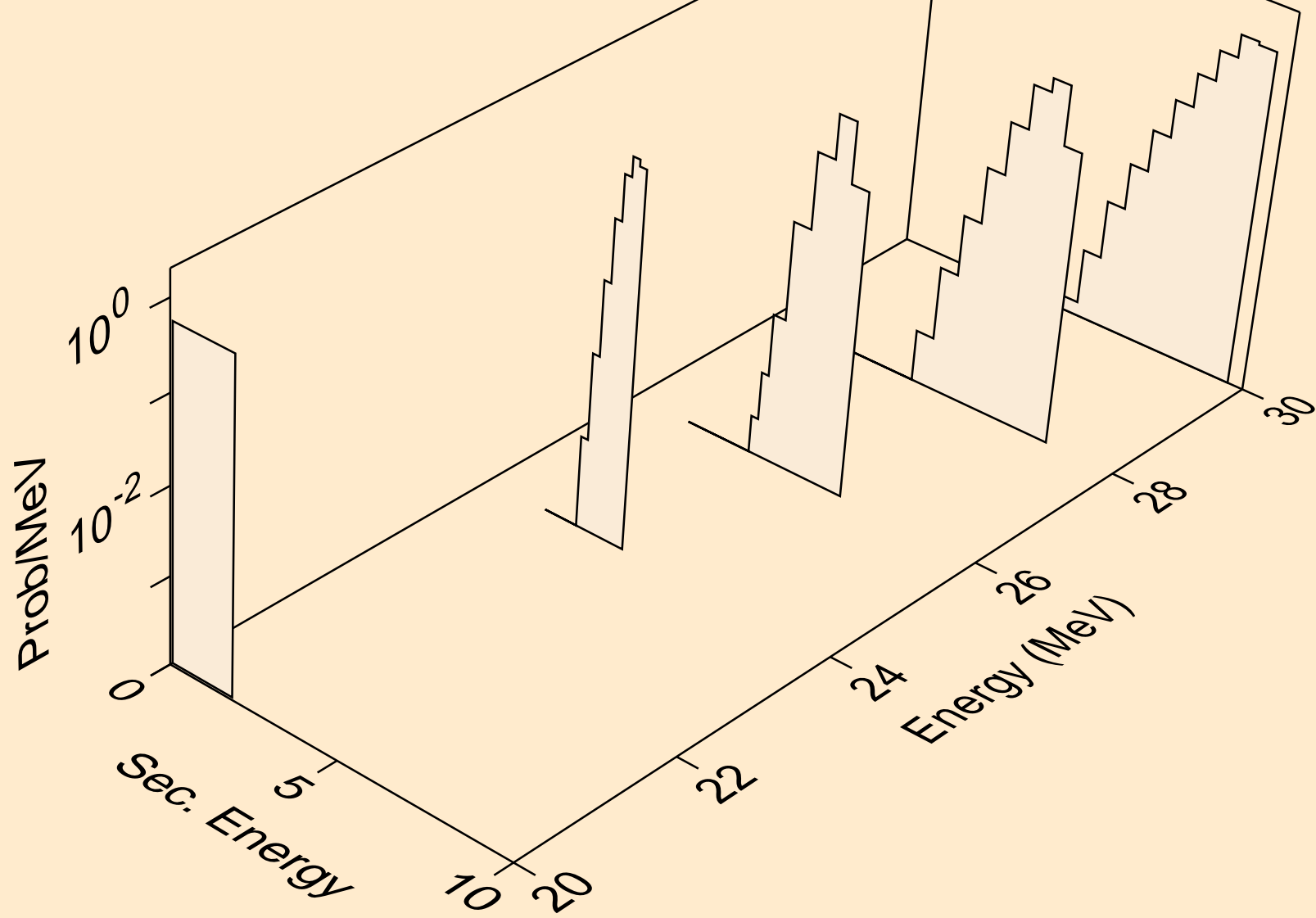

IR174M PROTON ACER TENDL-2021 LIBRARY; T=0.K  
tritons from (p,t)

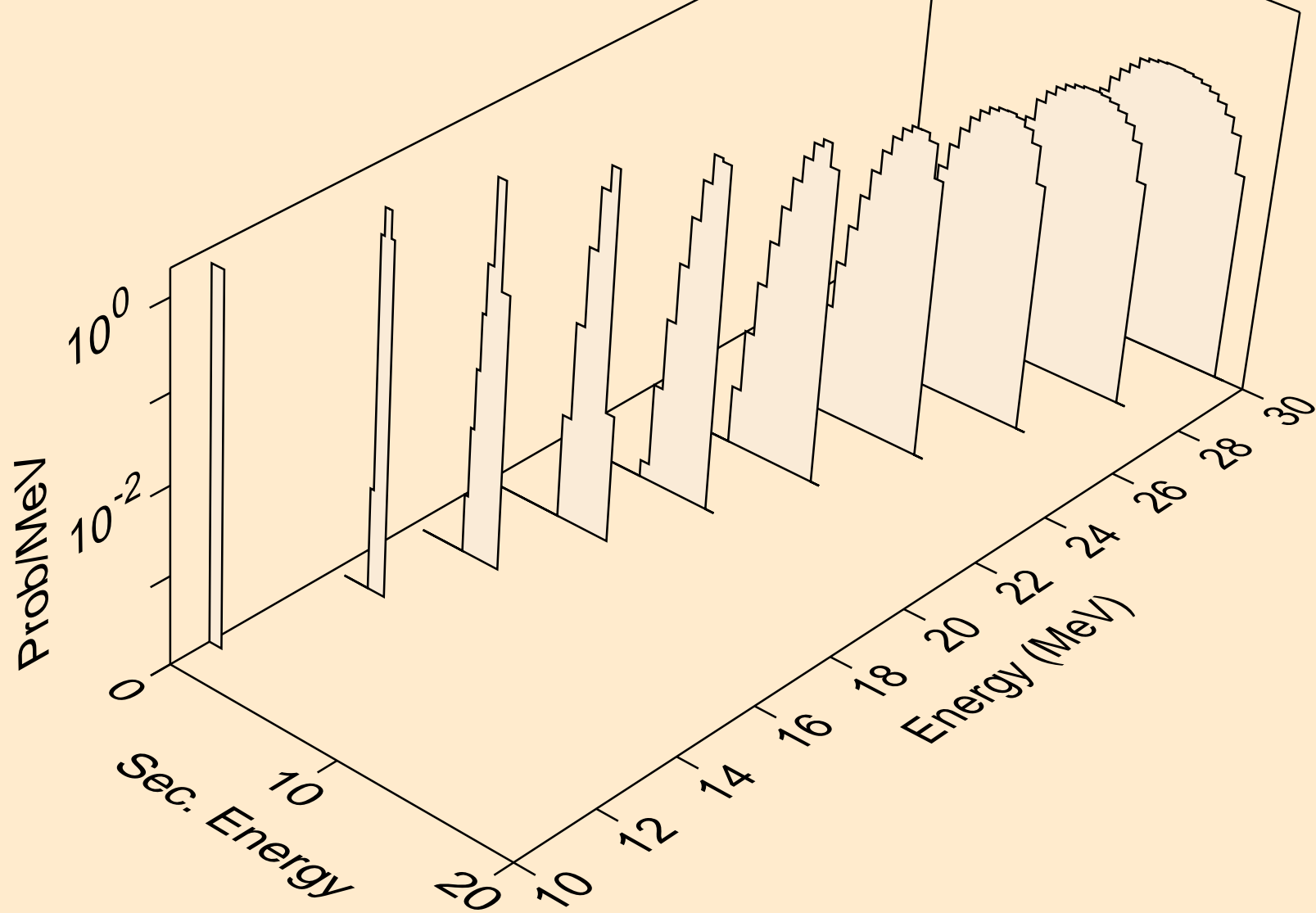

IR174M PROTON ACER TENDL-2021 LIBRARY; T=0.K  
tritons from (p,pt)

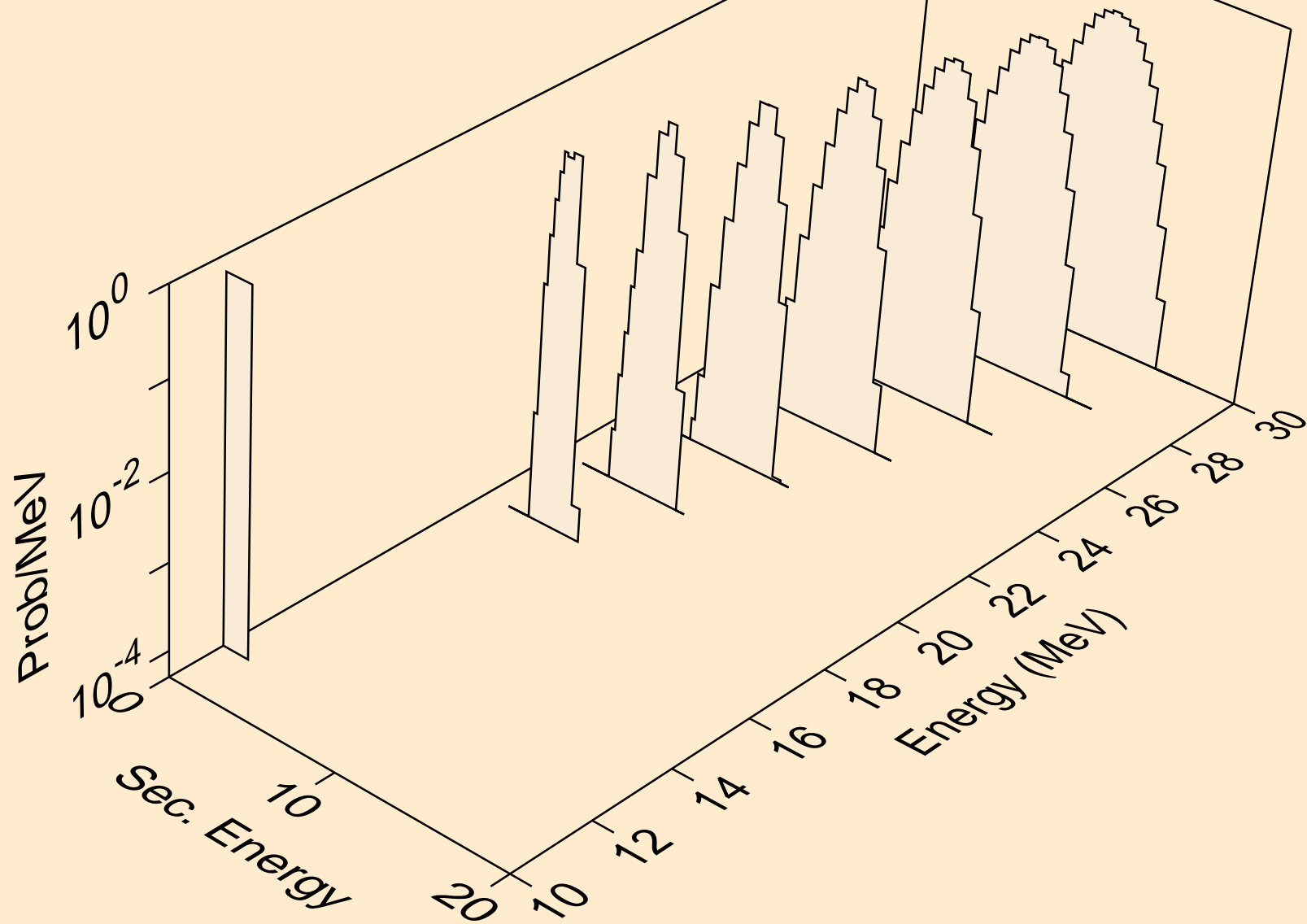

IR174M PROTON ACER TENDL-2021 LIBRARY; T=0.K  
he3s from (p,x)

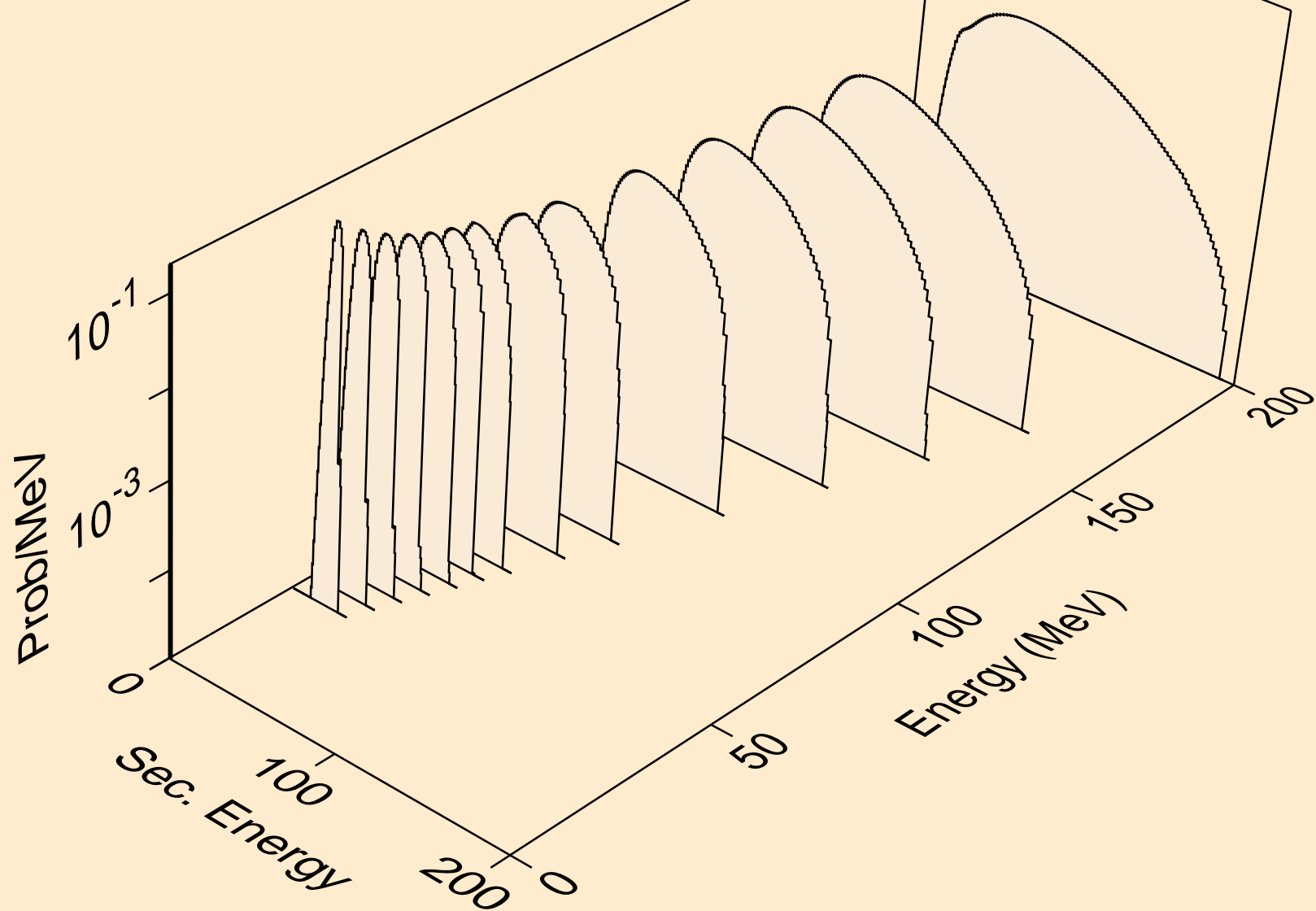

IR174M PROTON ACER TENDL-2021 LIBRARY; T=0.K  
he3s from (p,n\*)he3

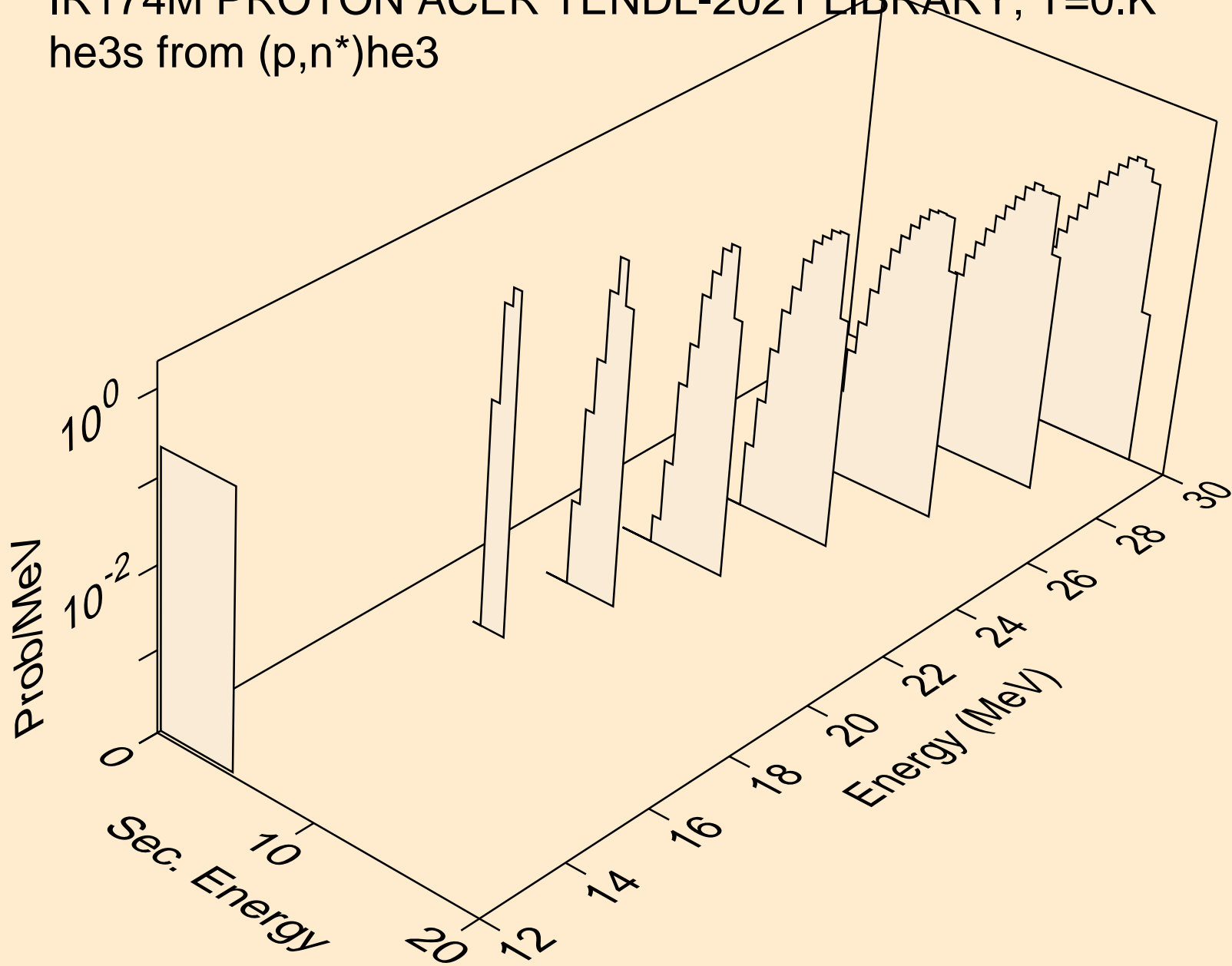

IR174M PROTON ACER TENDL-2021 LIBRARY; T=0.K  
he3s from (p,he3)

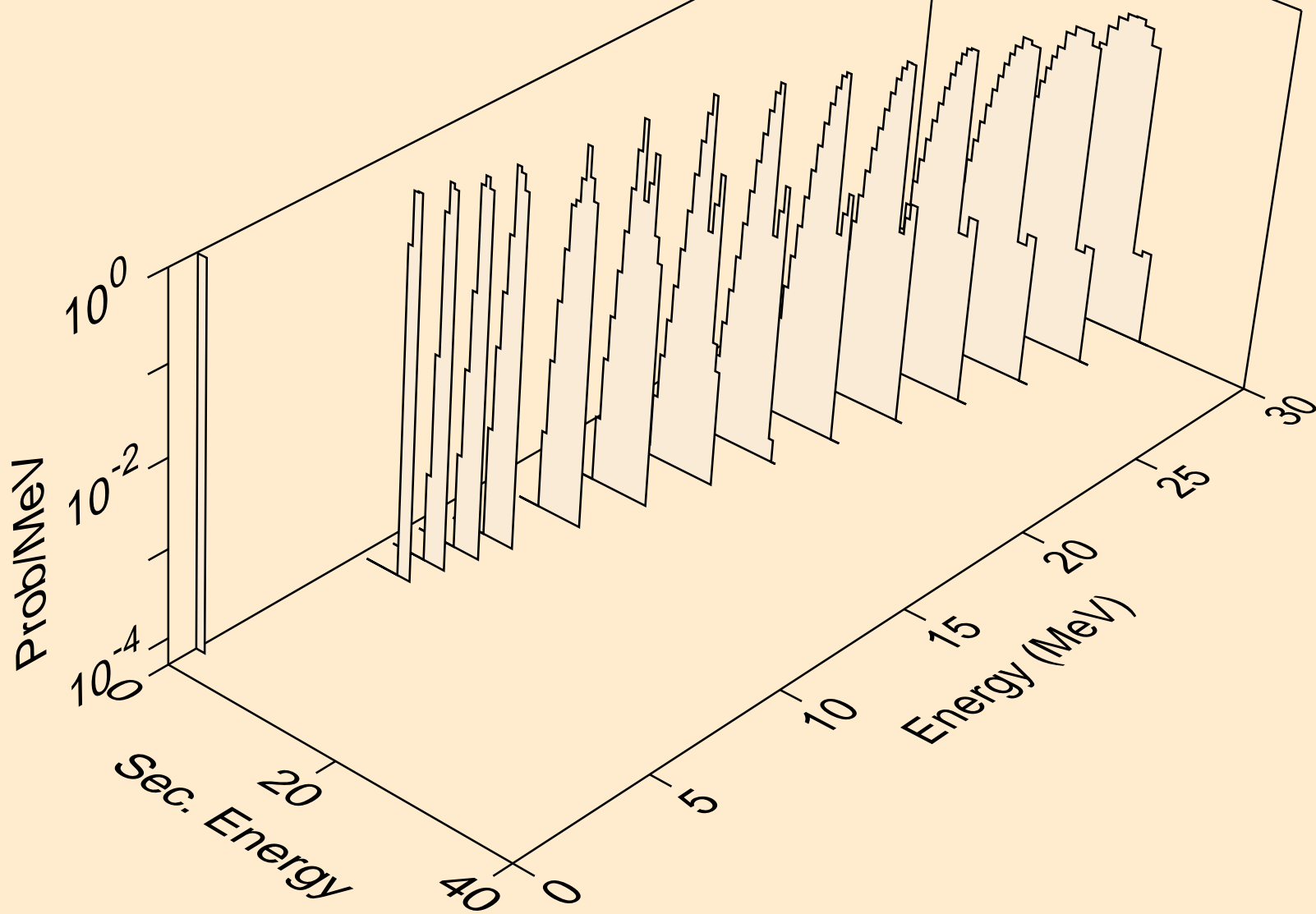

IR174M PROTON ACER TENDL-2021 LIBRARY; T=0.K  
alphas from (p,x)

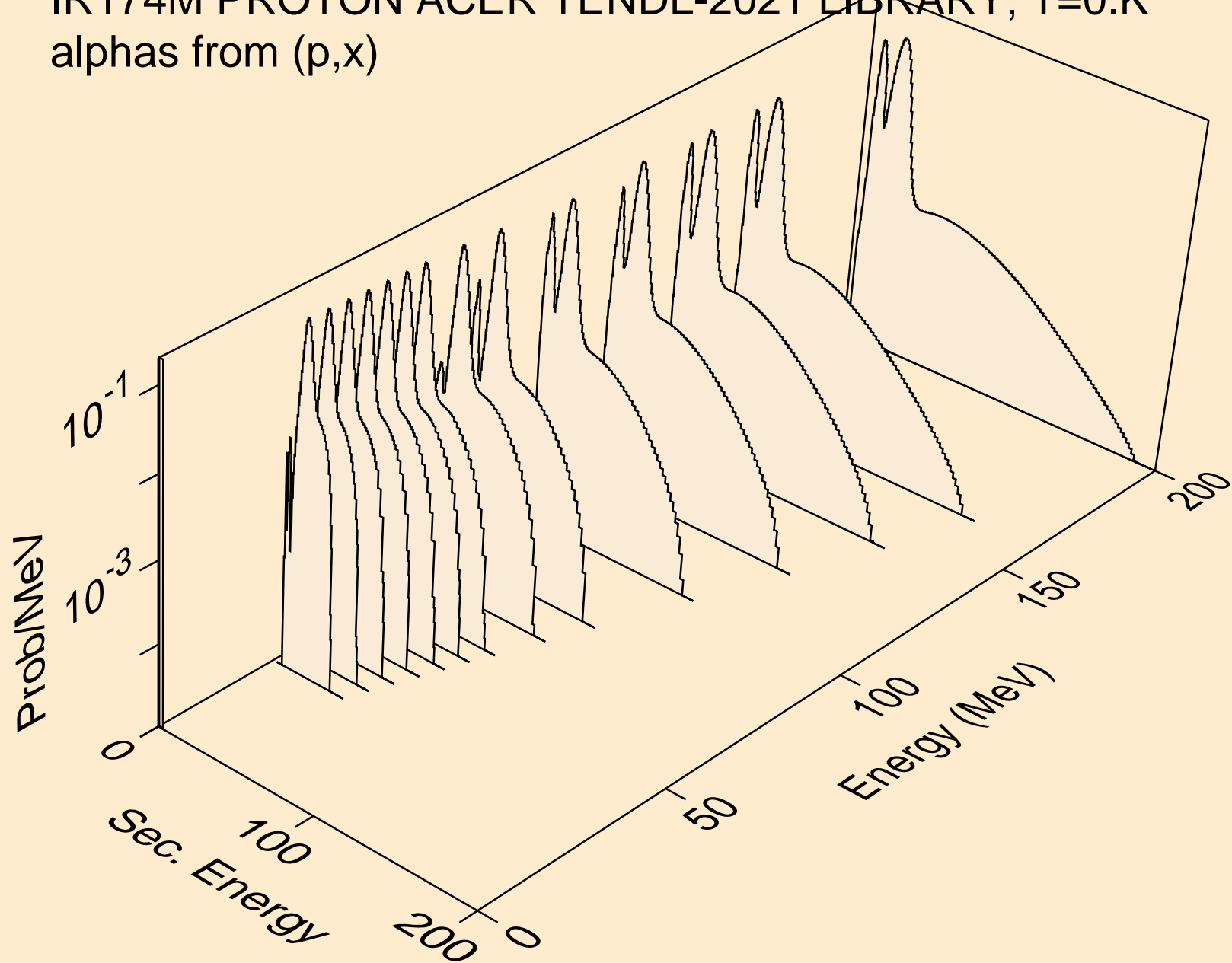



IR174M PROTON ACER TENDL-2021 LIBRARY; T=0.K  
alphas from (p,n\*)a

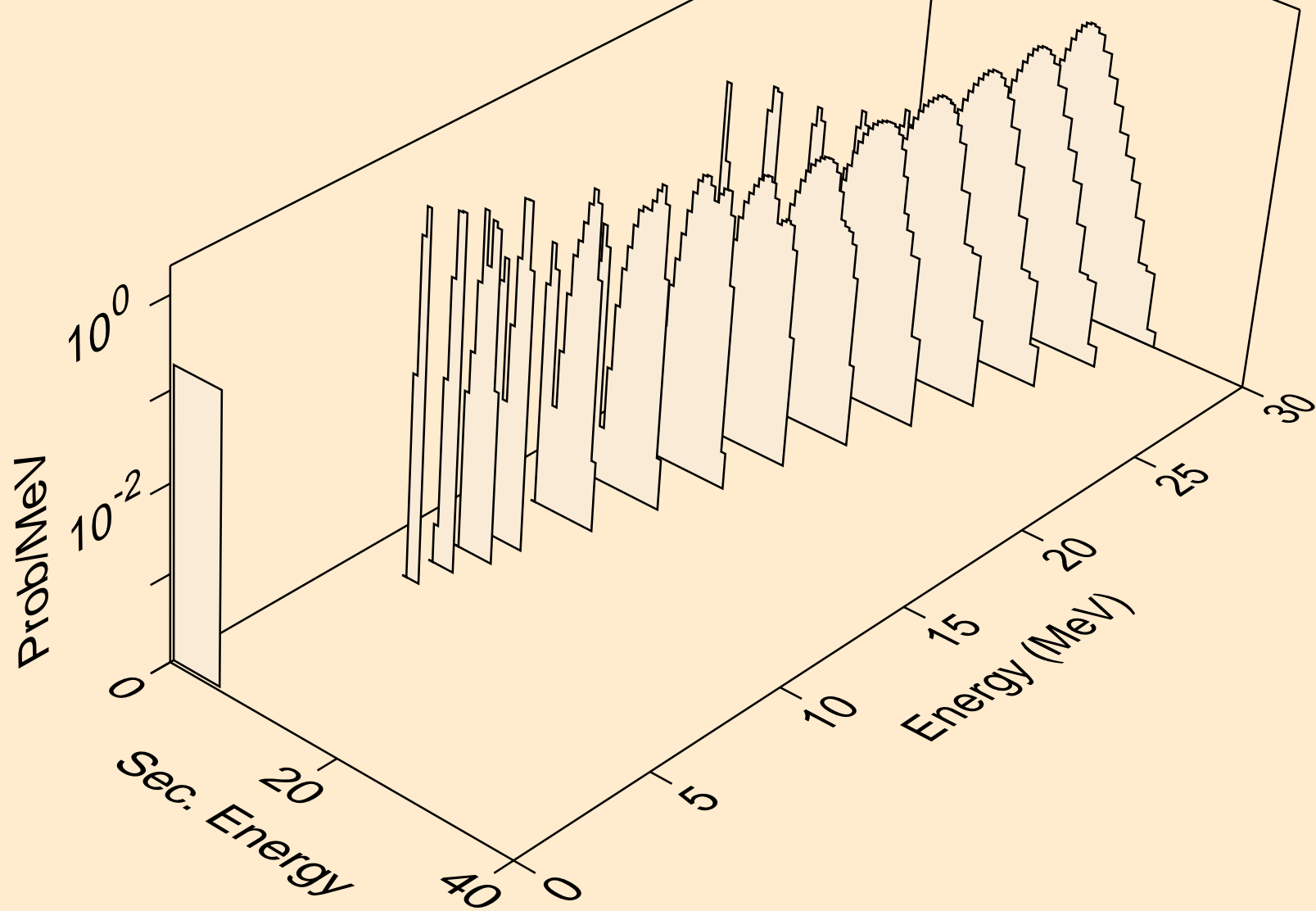

IR174M PROTON ACER TENDL-2021 LIBRARY; T=0.K  
alphas from (p,2n)a

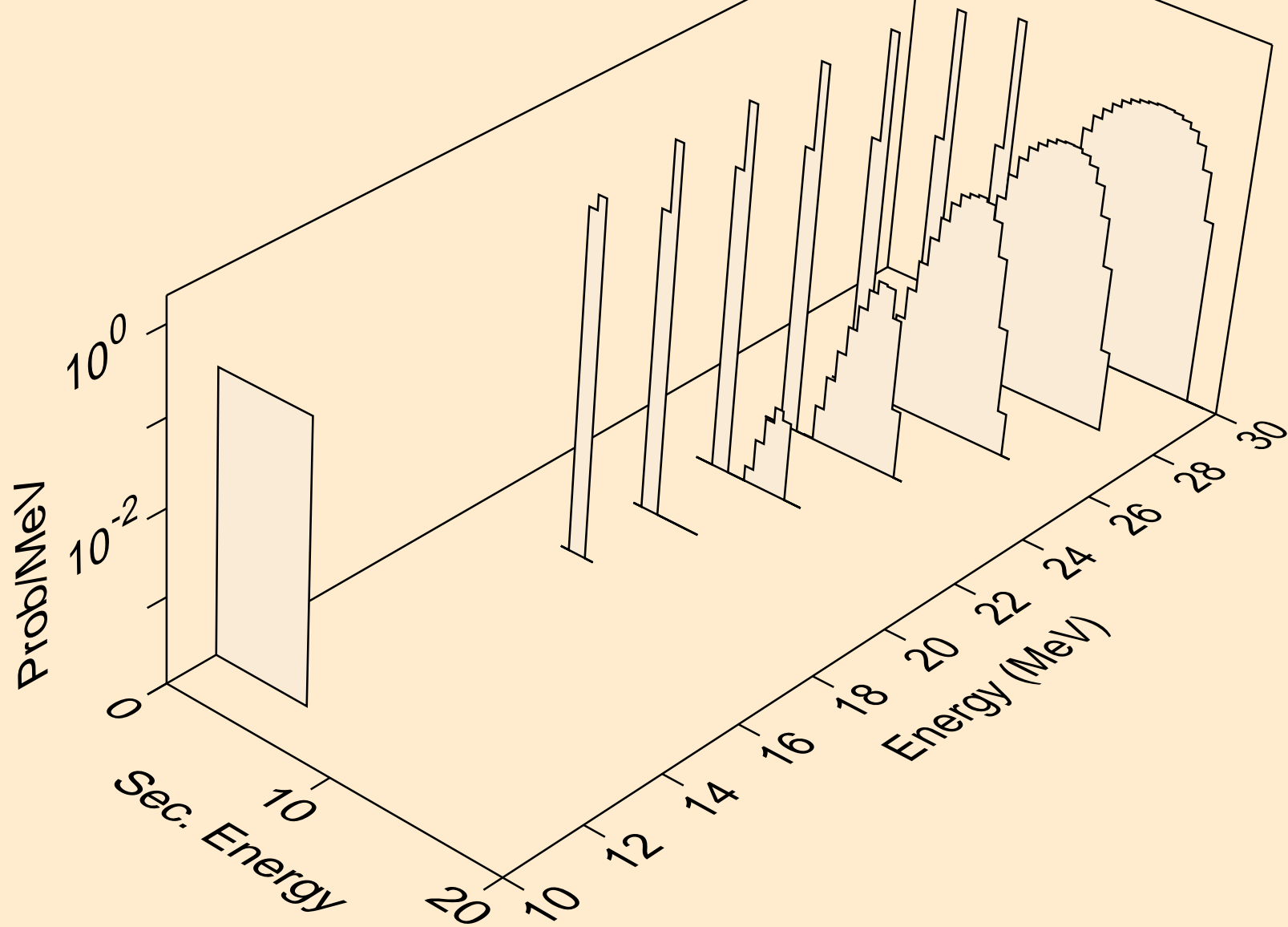

IR174M PROTON ACER TENDL-2021 LIBRARY; T=0.K  
alphas from (p,3n)a

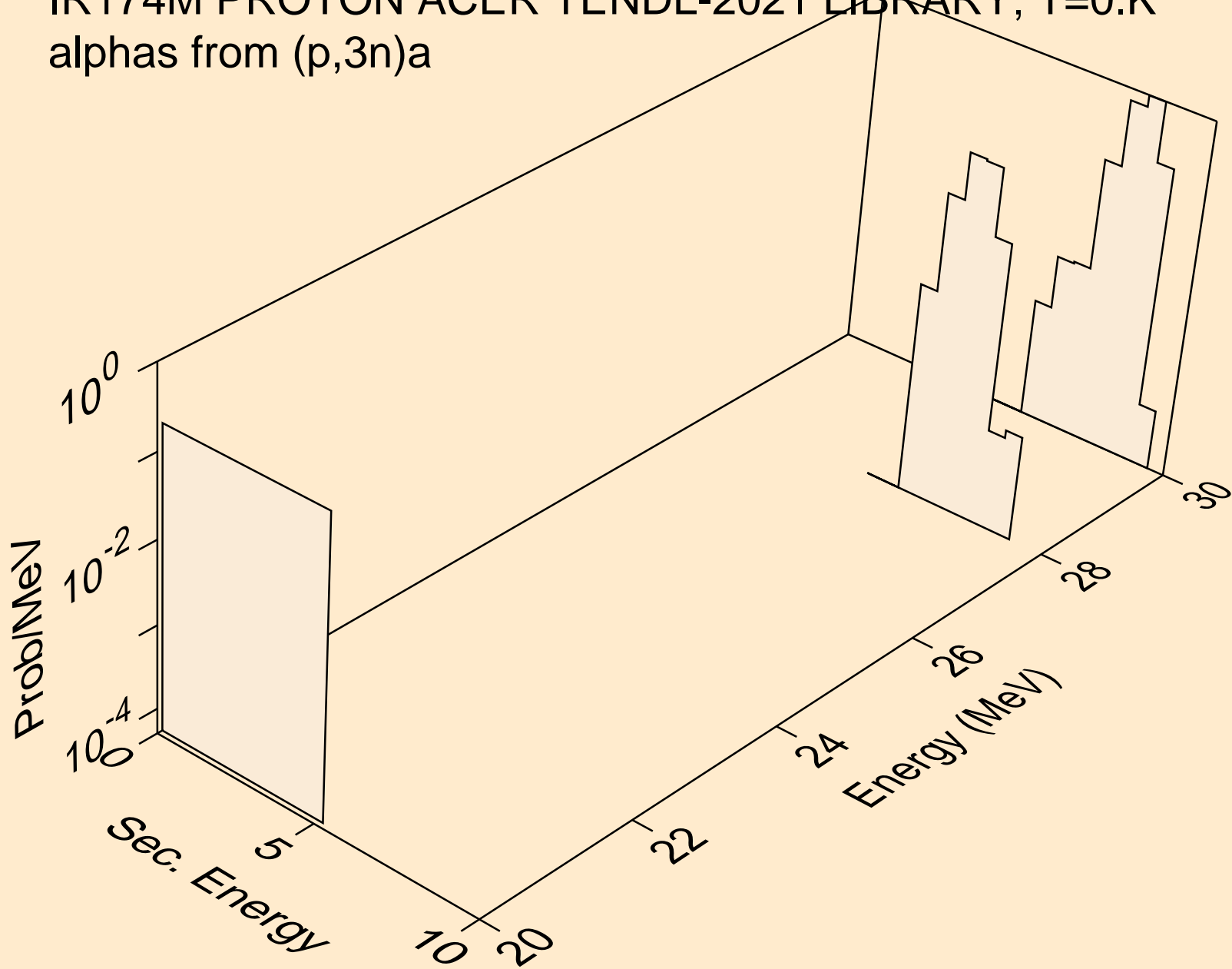

IR174M PROTON ACER TENDL-2021 LIBRARY; T=0.K  
alphas from (p,n\*)2a

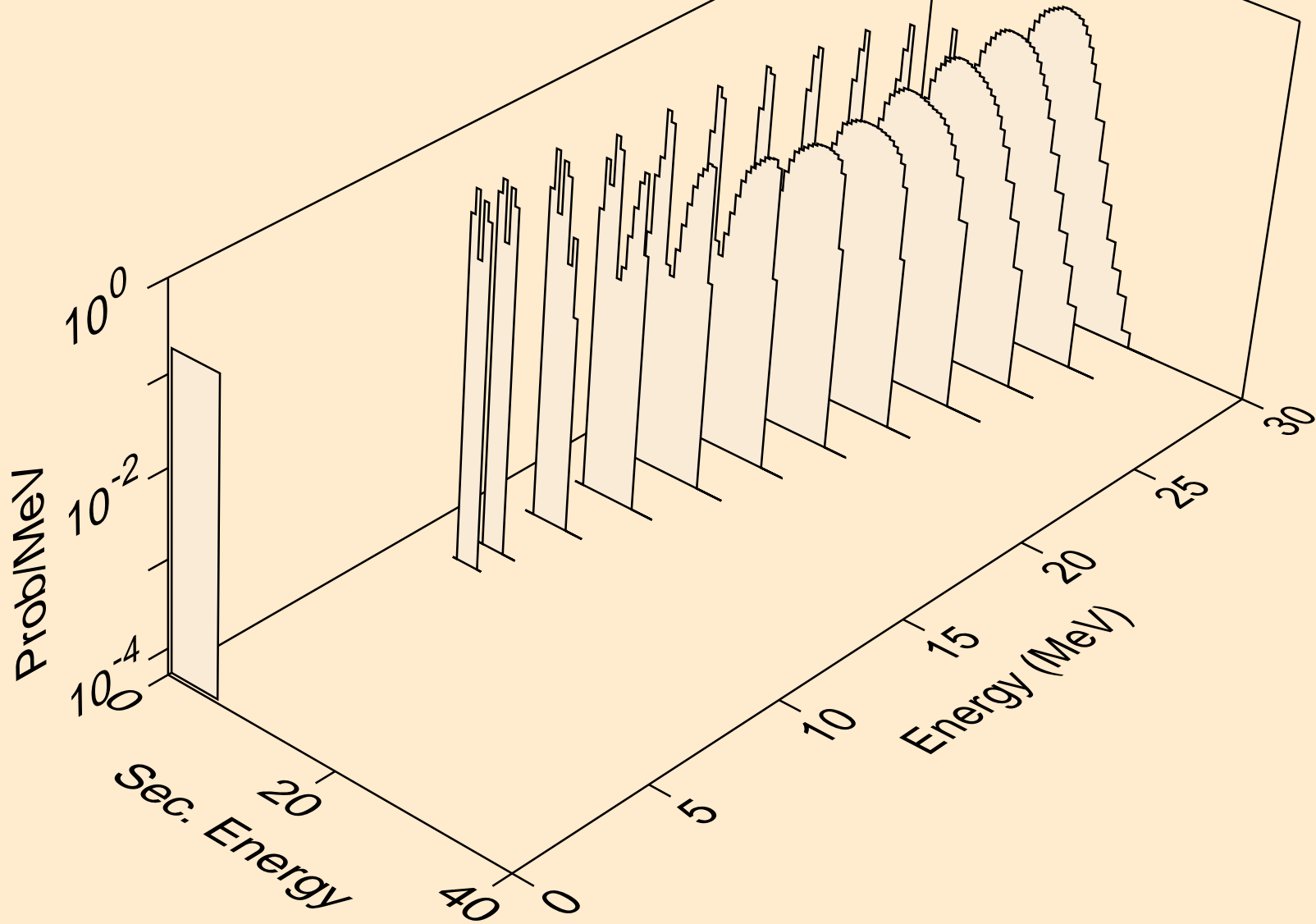

IR174M PROTON ACER TENDL-2021 LIBRARY; T=0.K  
alphas from (p,2n)2a

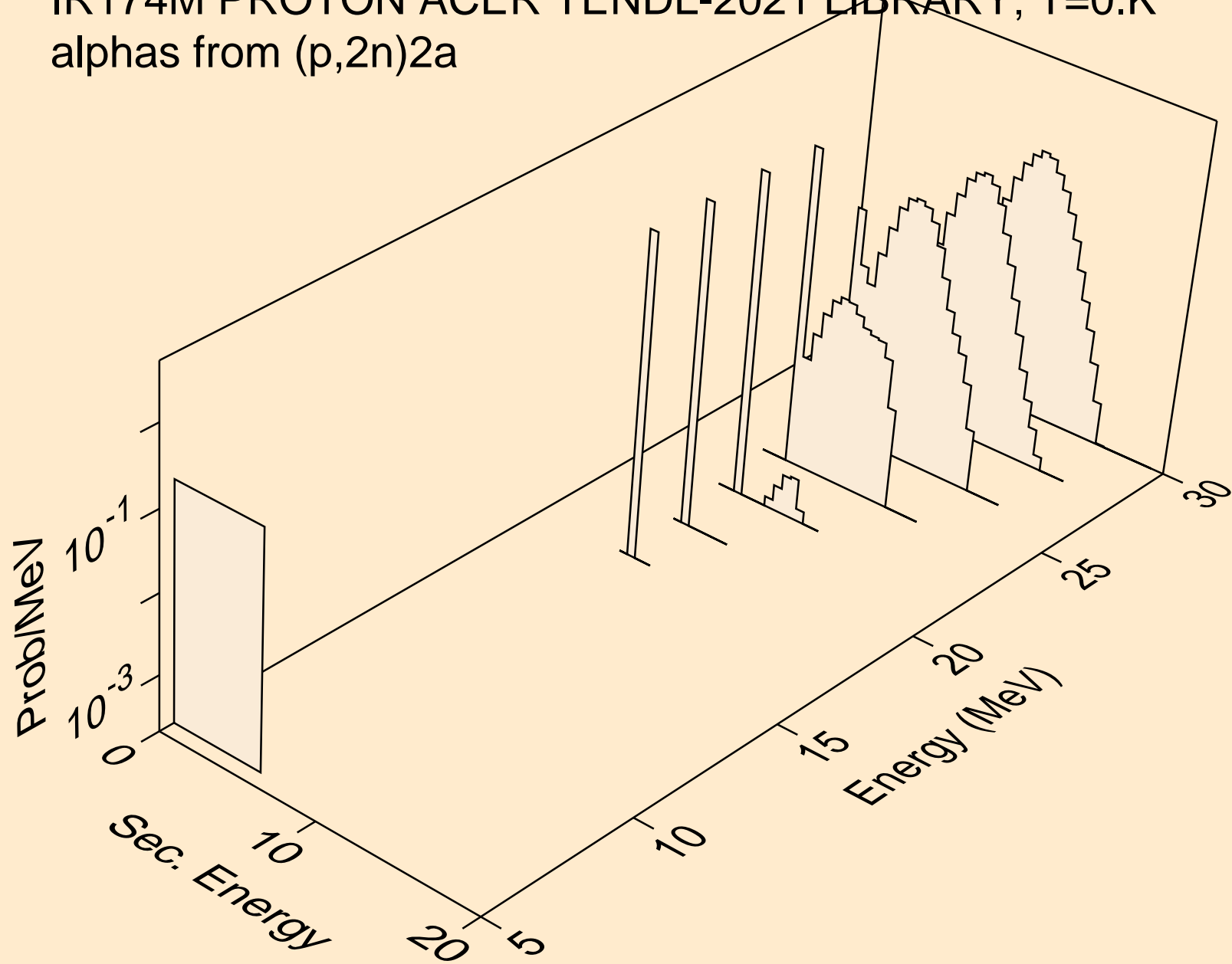

IR174M PROTON ACER TENDL-2021 LIBRARY; T=0.K  
alphas from (p,npa)

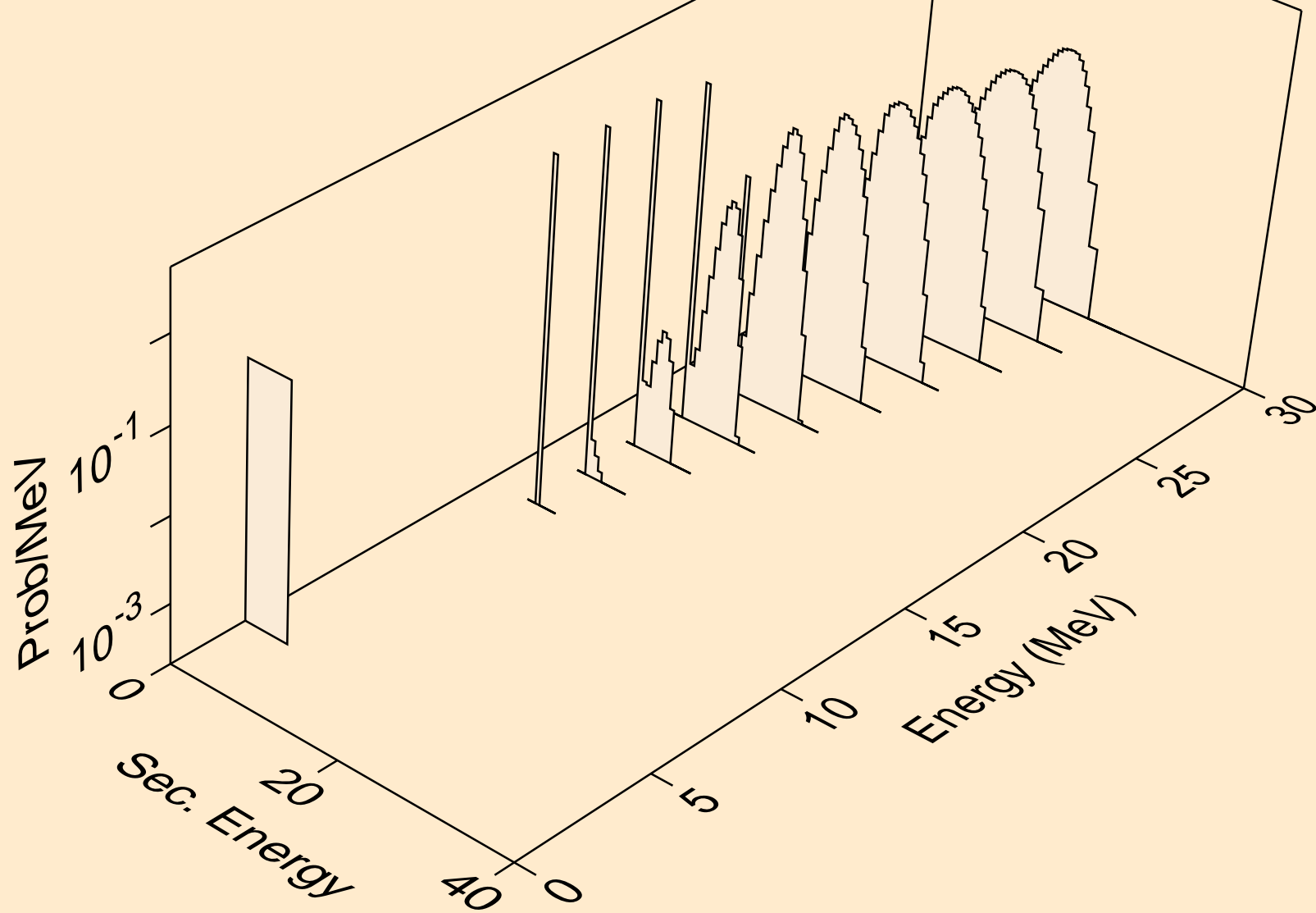

IR174M PROTON ACER TENDL-2021 LIBRARY; T=0.K  
alphas from (p,a)

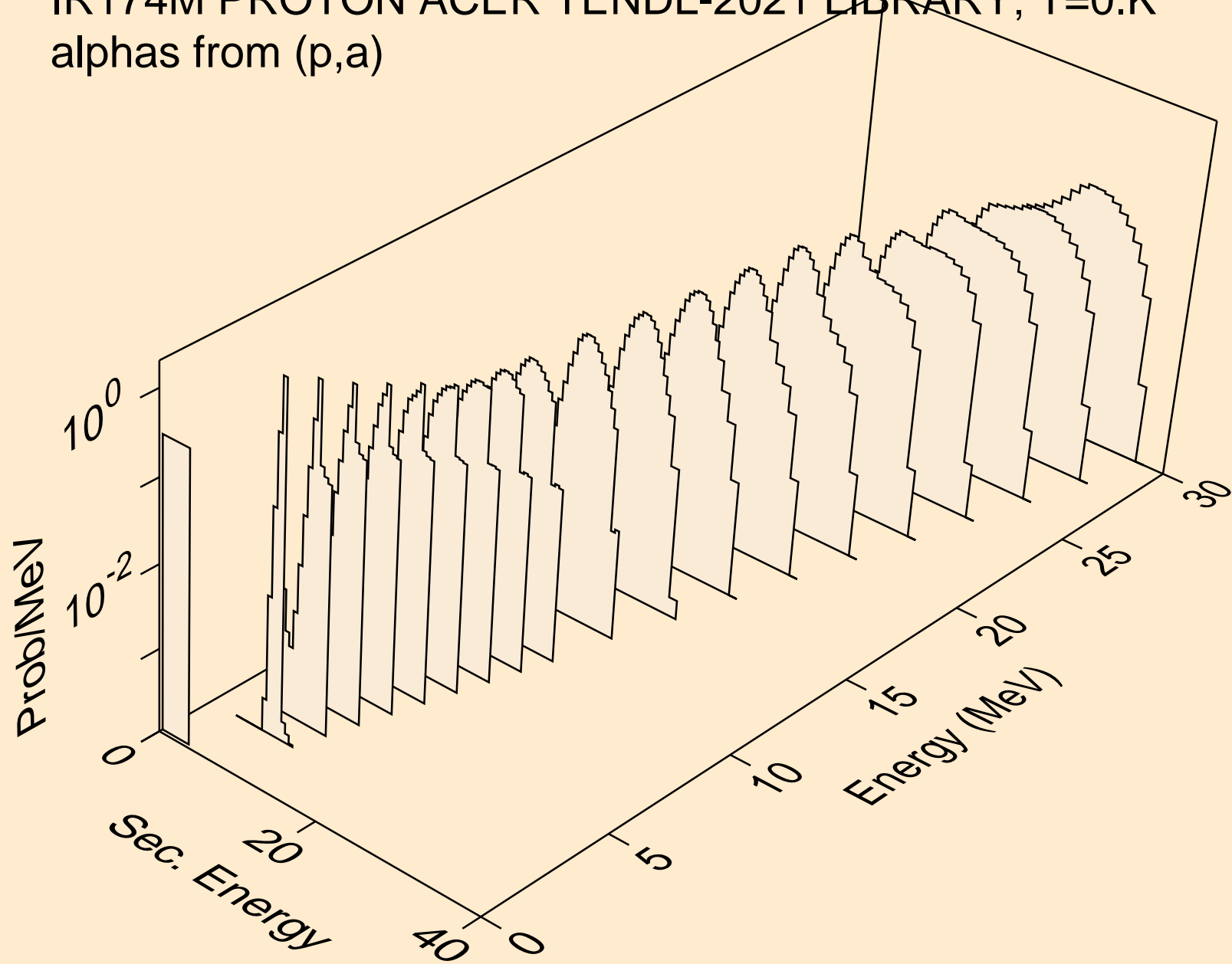

IR174M PROTON ACER TENDL-2021 LIBRARY; T=0.K  
alphas from (p,2a)

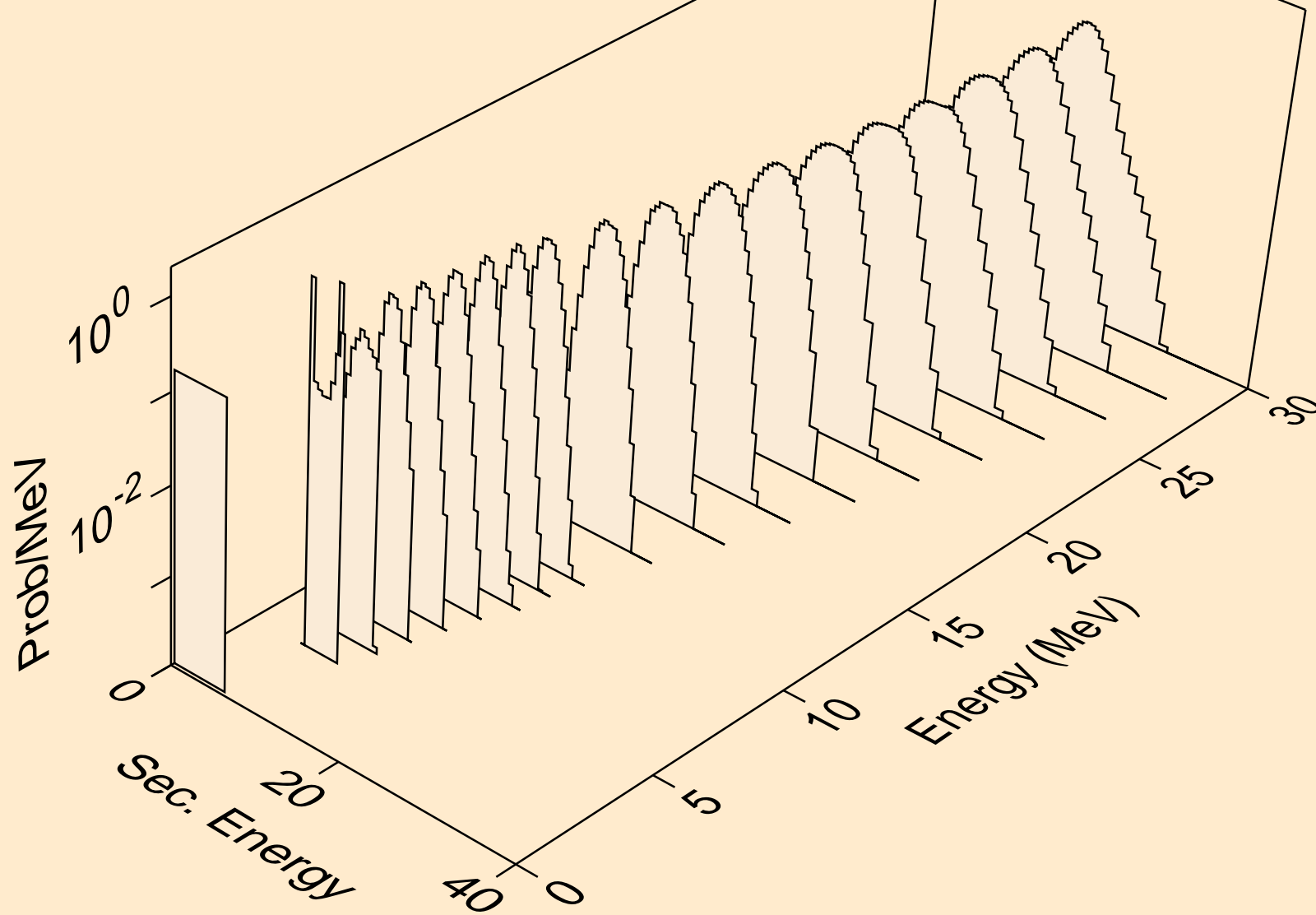



IR174M PROTON ACER TENDL-2021 LIBRARY; T=0.K  
alphas from (p,3a)

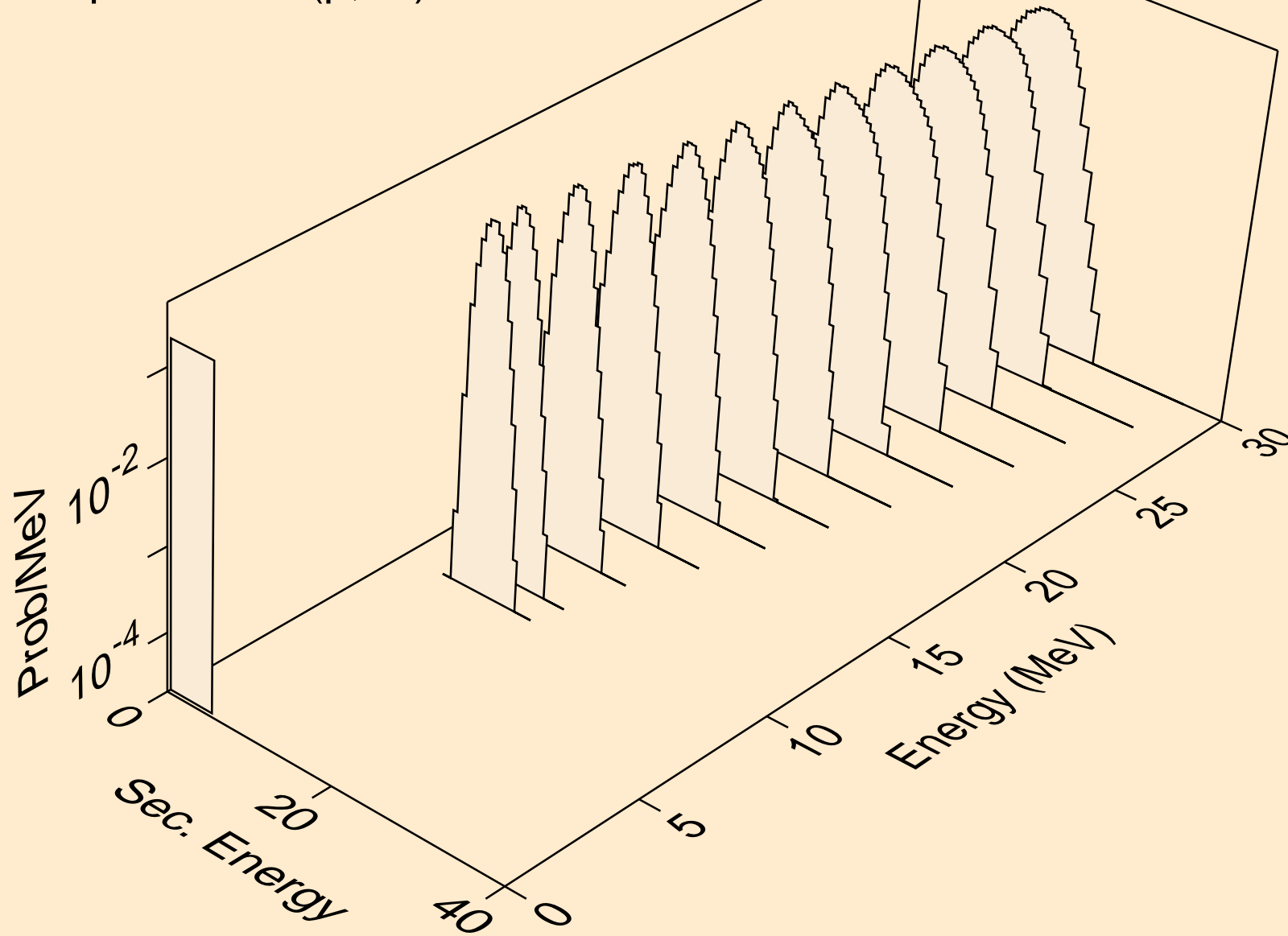

IR174M PROTON ACER TENDL-2021 LIBRARY; T=0.K  
alphas from (p,pa)

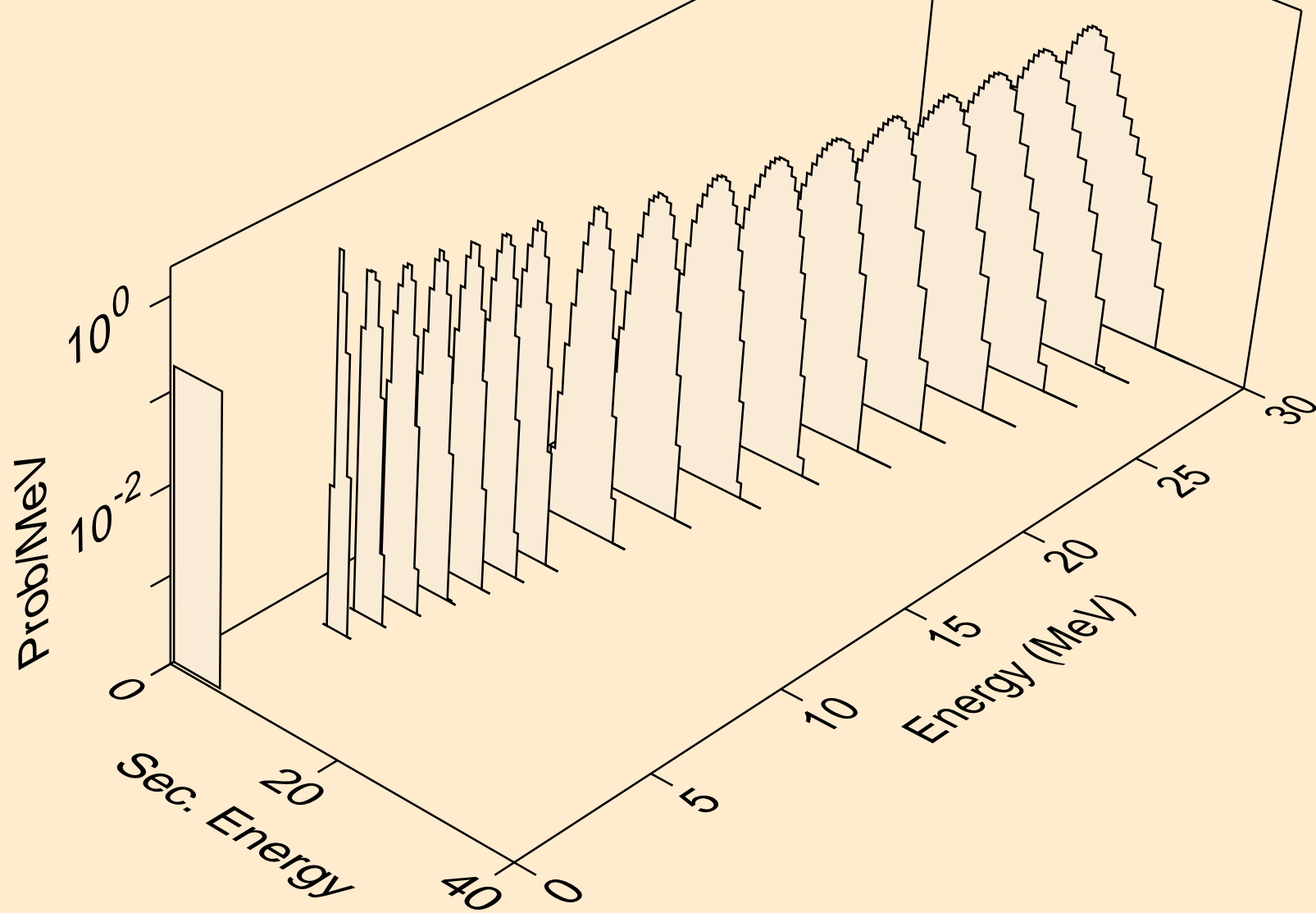

IR174M PROTON ACER TENDL-2021 LIBRARY; T=0.K  
alphas from (p,da)

