

# K046 PROTON ACER TENDL-2021 LIBRARY; T=0.K

## Principal cross sections

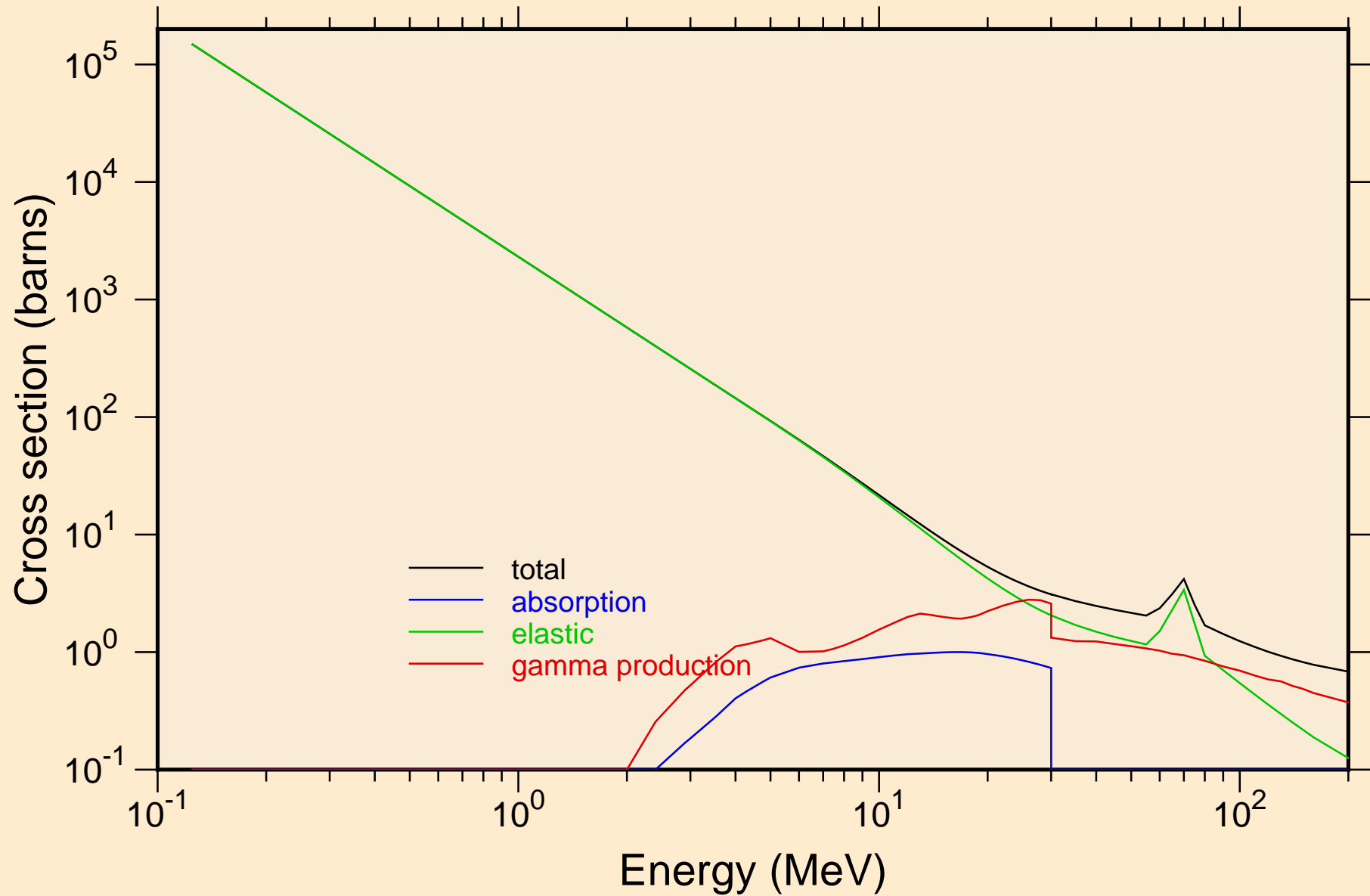

K046 PROTON ACER TENDL-2021 LIBRARY; T=0.K  
Heating

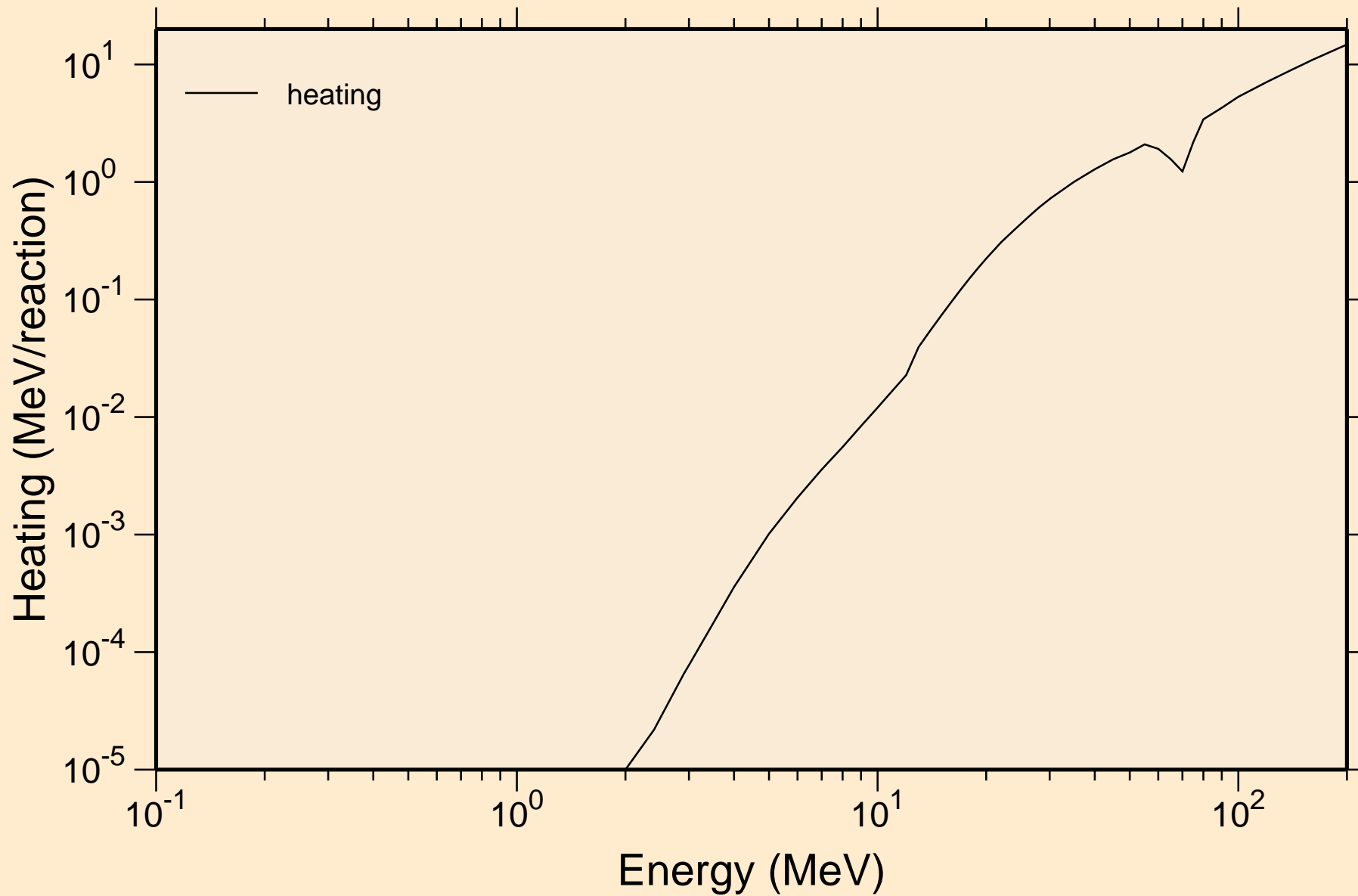

# K046 PROTON ACER TENDL-2021 LIBRARY; T=0.K

## Principal cross sections

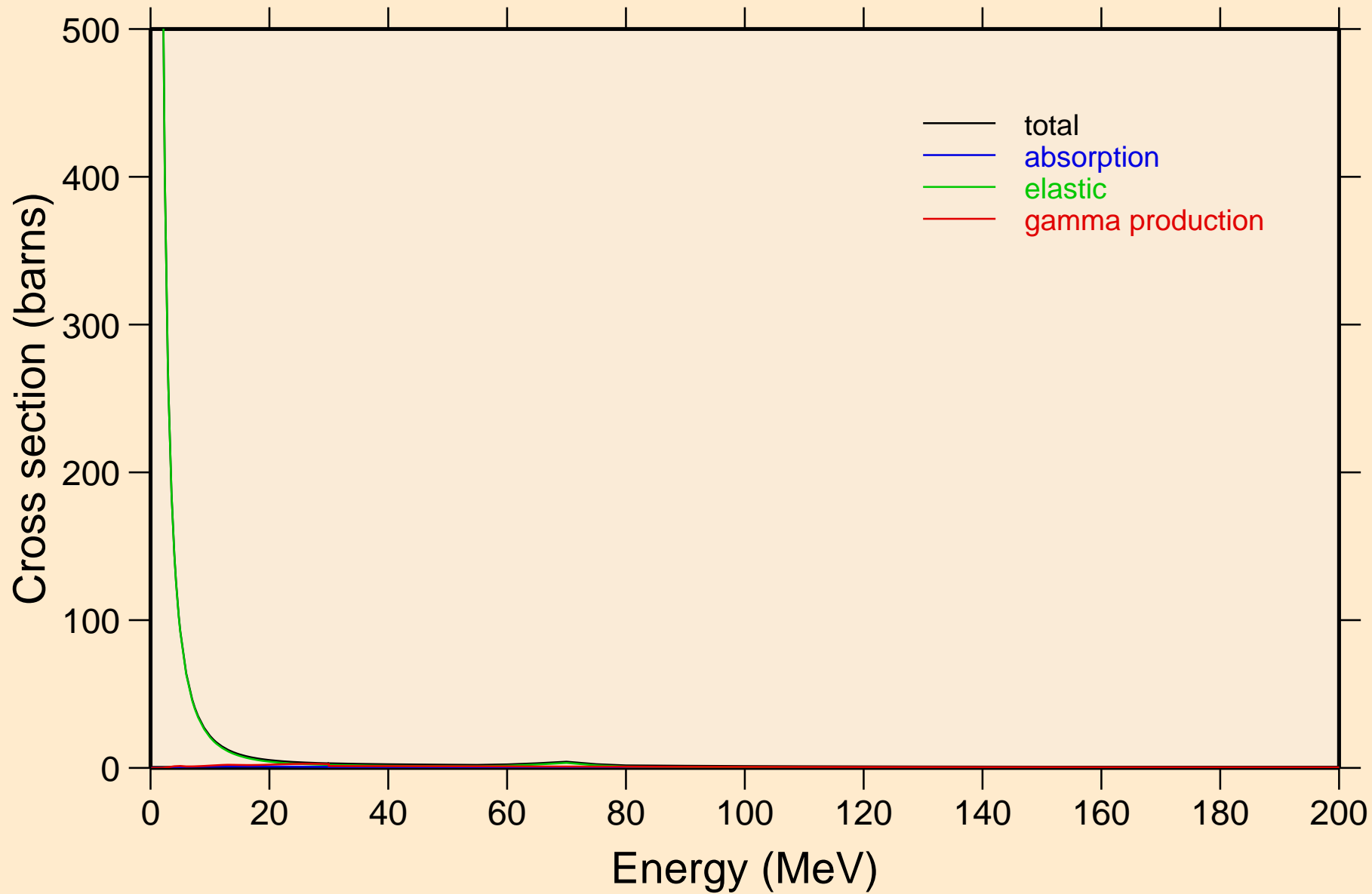

# K046 PROTON ACER TENDL-2021 LIBRARY; T=0.K

## Heating

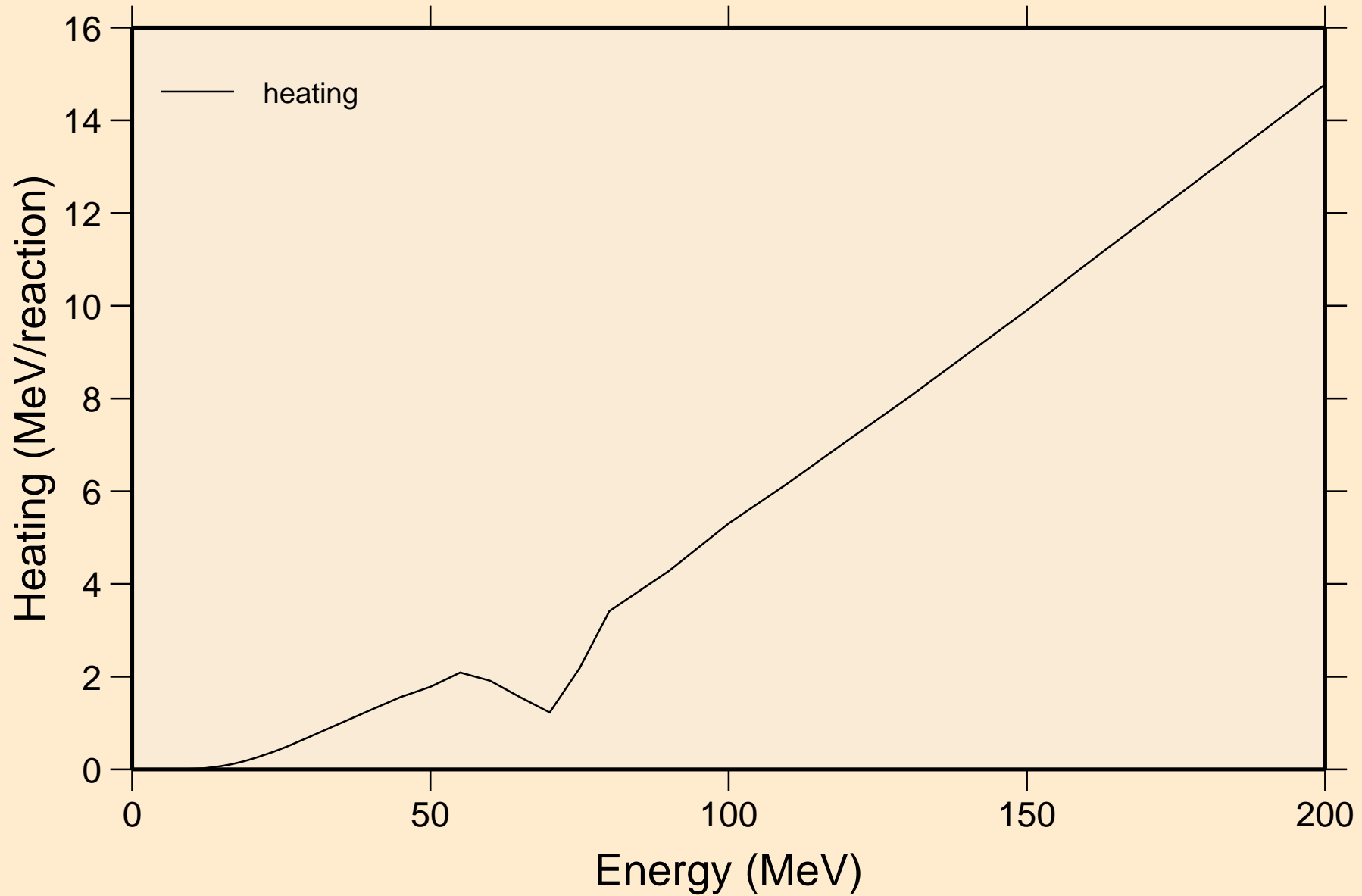

# K046 PROTON ACER TENDL-2021 LIBRARY; T=0.K

## Threshold reactions

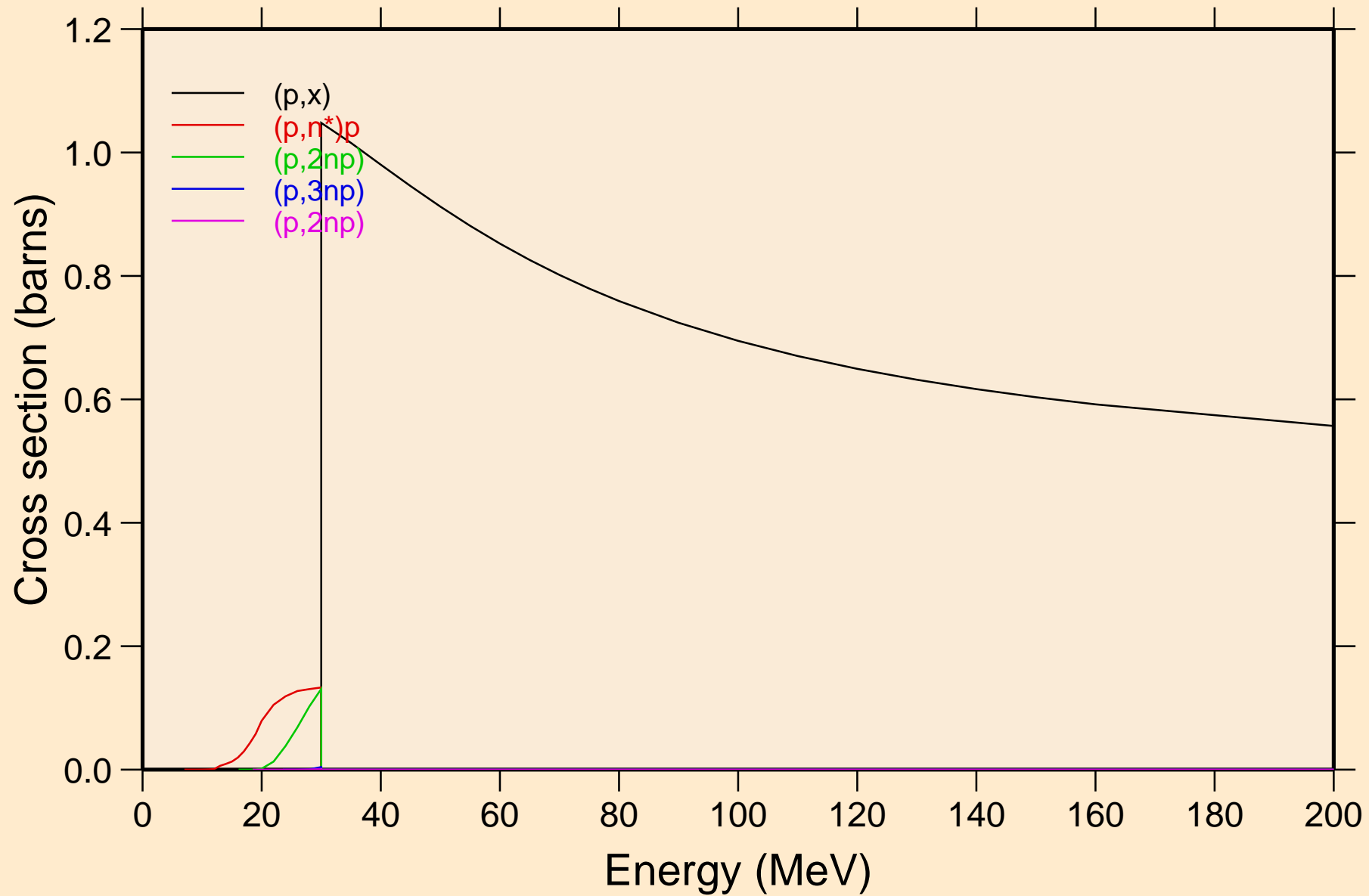

K046 PROTON ACER TENDL-2021 LIBRARY; T=0.K  
Threshold reactions

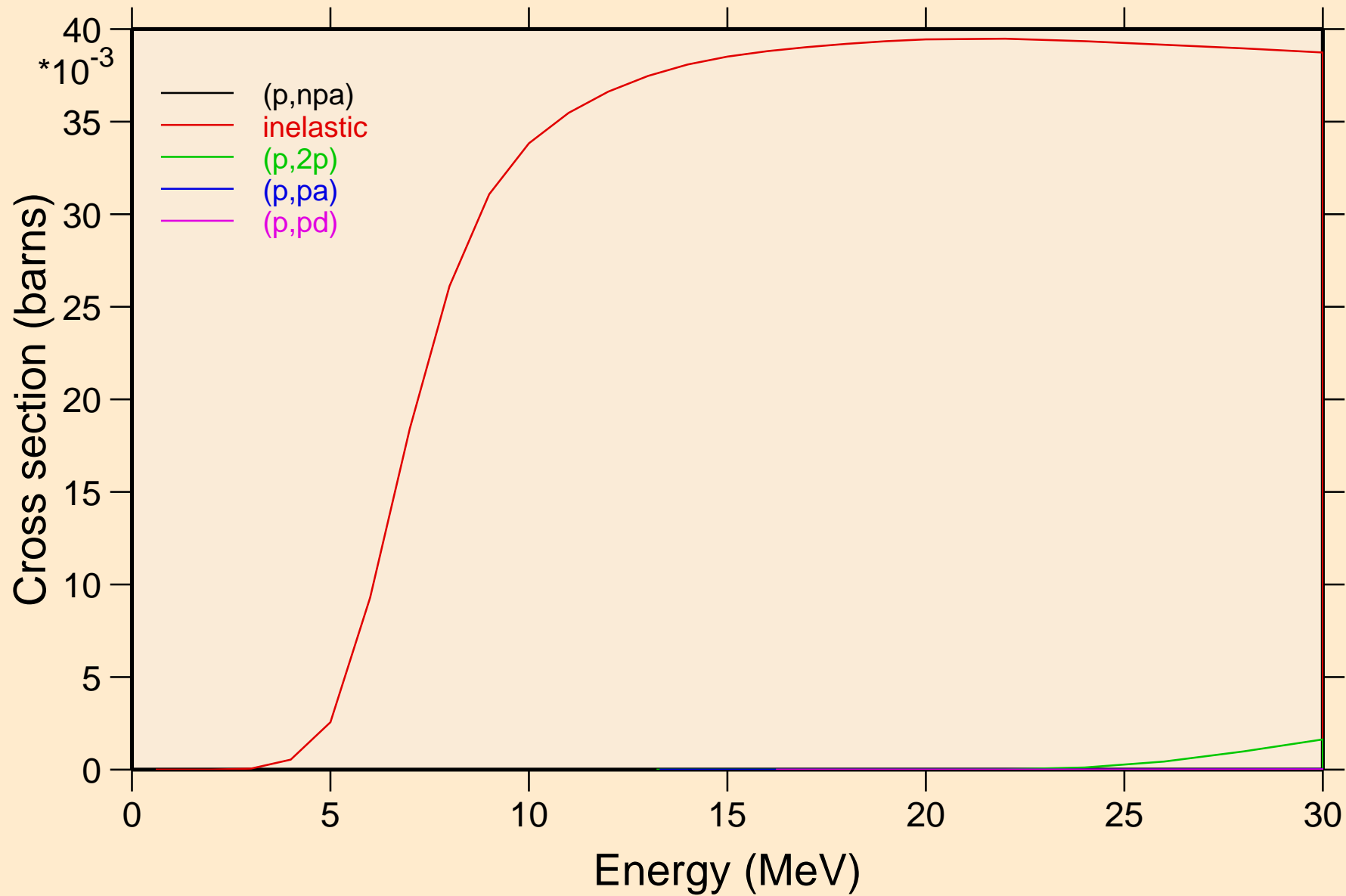

K046 PROTON ACER TENDL-2021 LIBRARY; T=0.K  
Threshold reactions

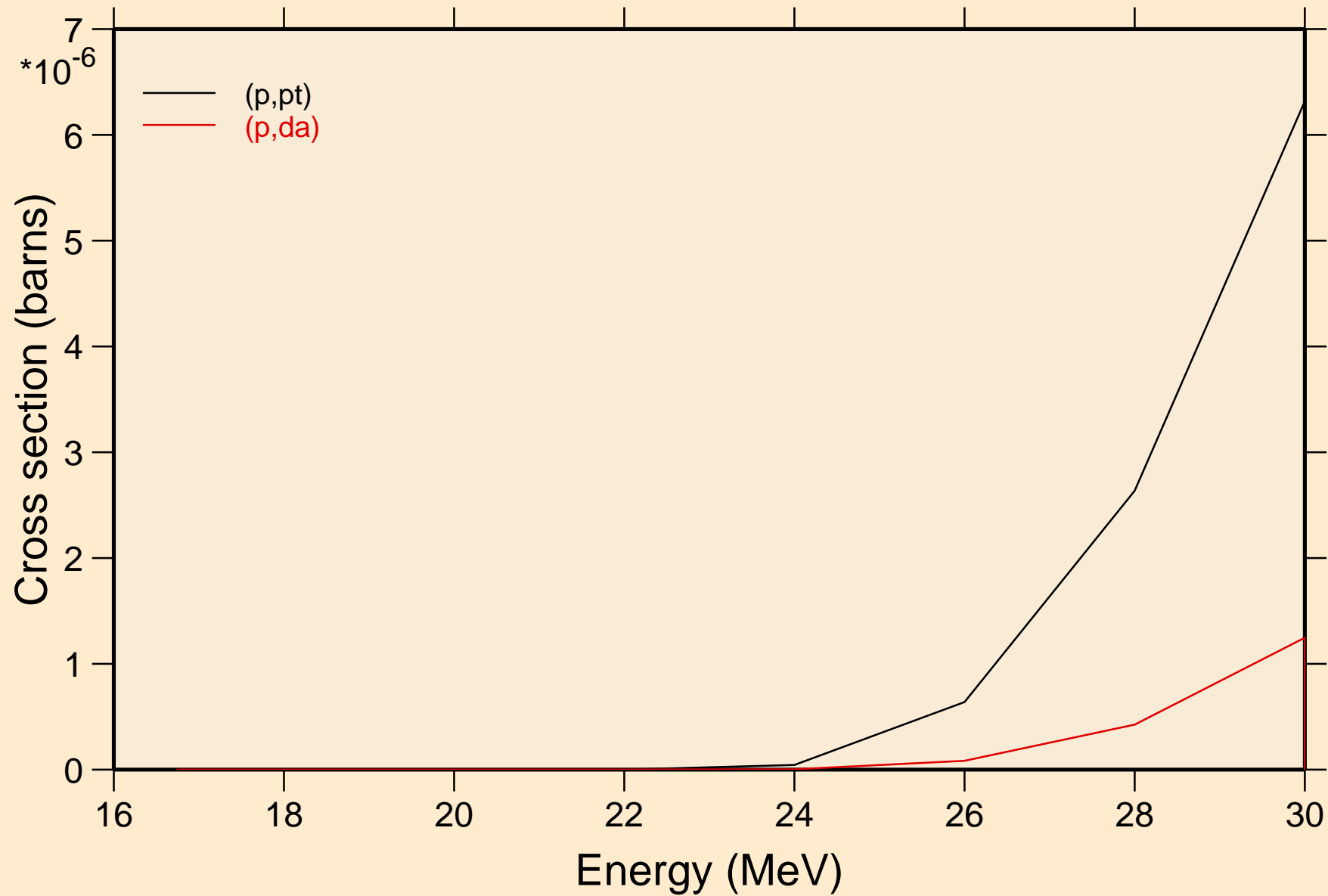

K046 PROTON ACER TENDL-2021 LIBRARY; T=0.K  
angular distribution for elastic

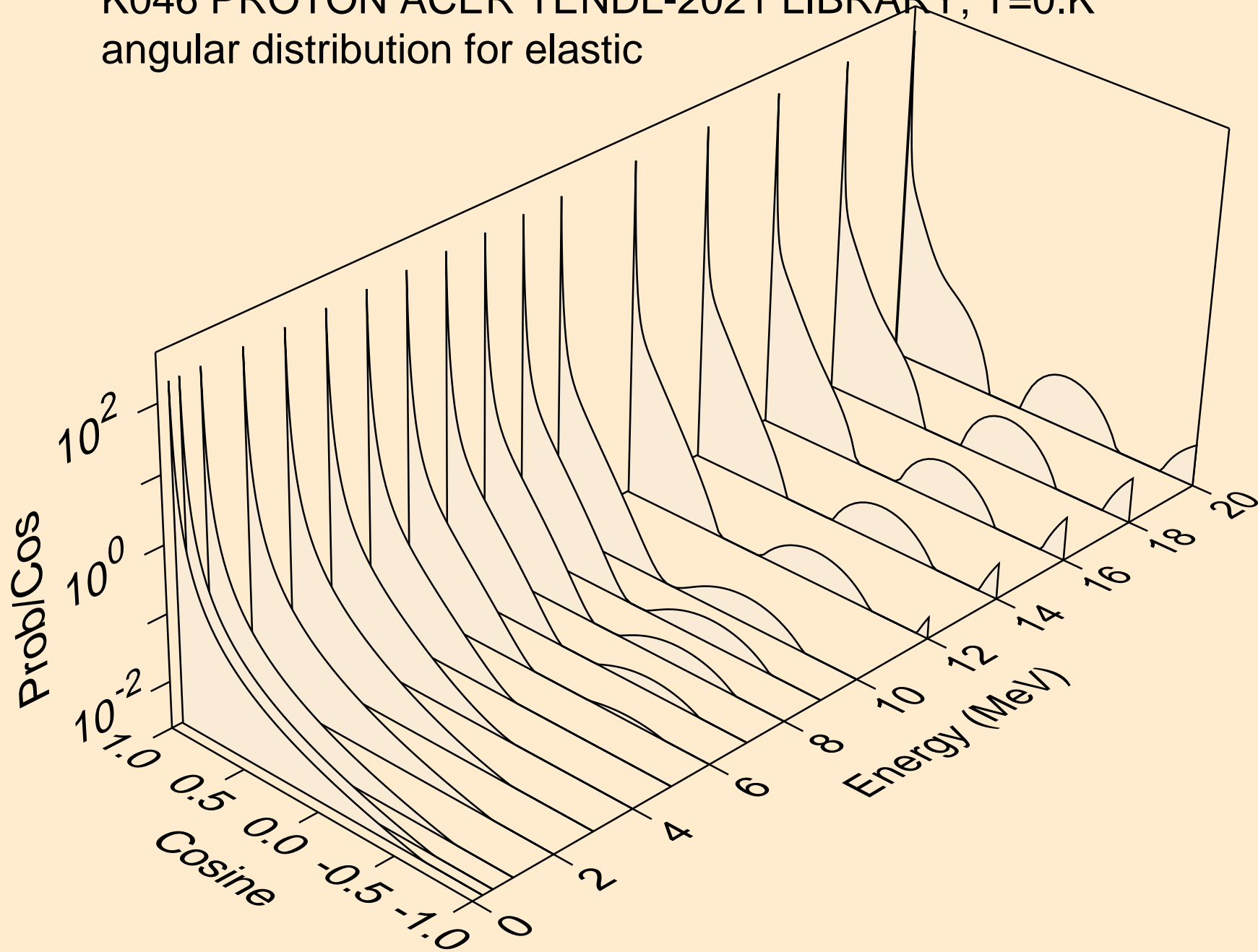



K046 PROTON ACER TENDL-2021 LIBRARY; T=0.K  
angular distribution for elastic

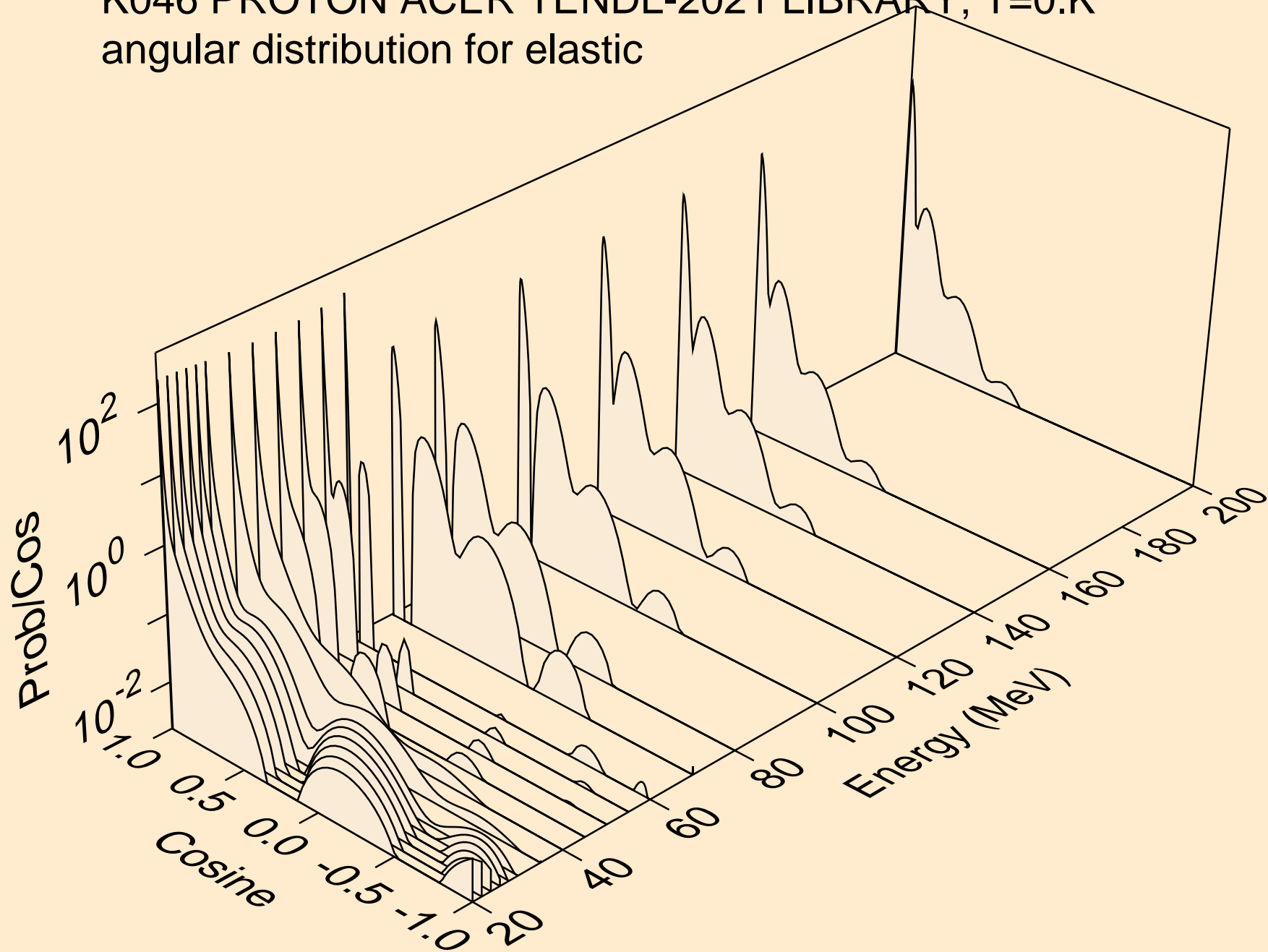

K046 PROTON ACER TENDL-2021 LIBRARY; T=0.K  
Proton emission for (p,x)

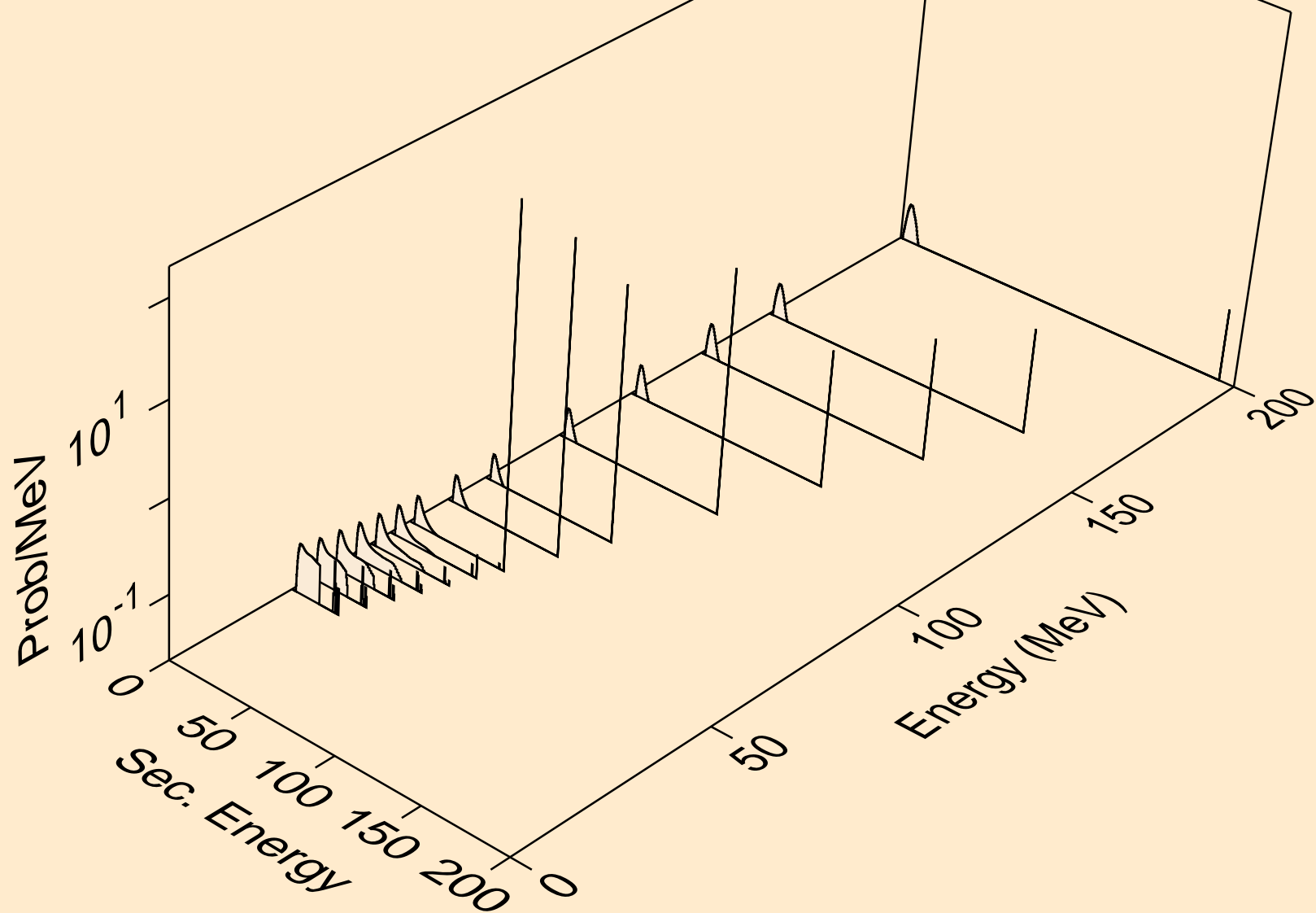

K046 PROTON ACER TENDL-2021 LIBRARY; T=0.K  
Proton emission for (p,n\*)p

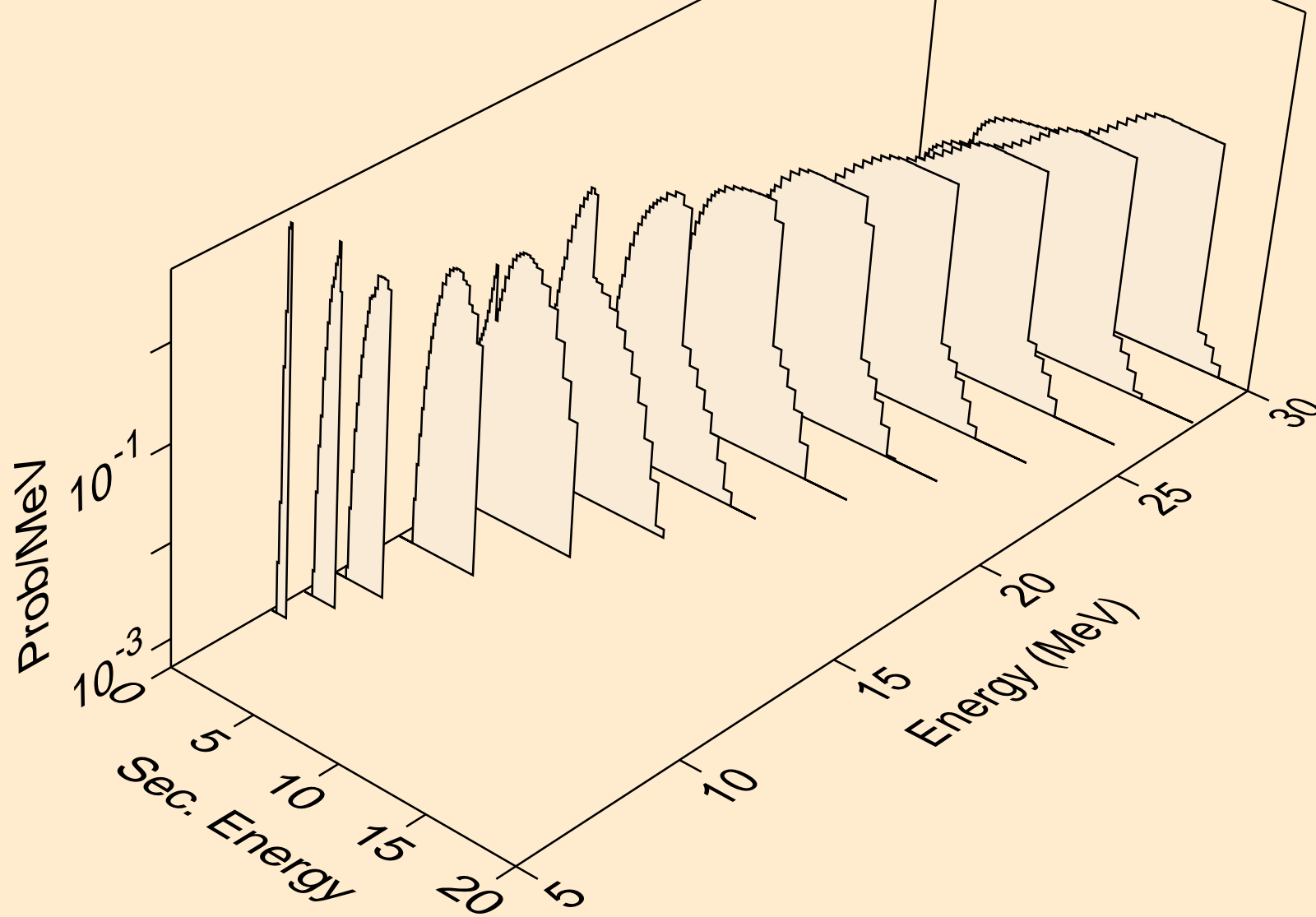

K046 PROTON ACER TENDL-2021 LIBRARY; T=0.K  
Proton emission for (p,2np)

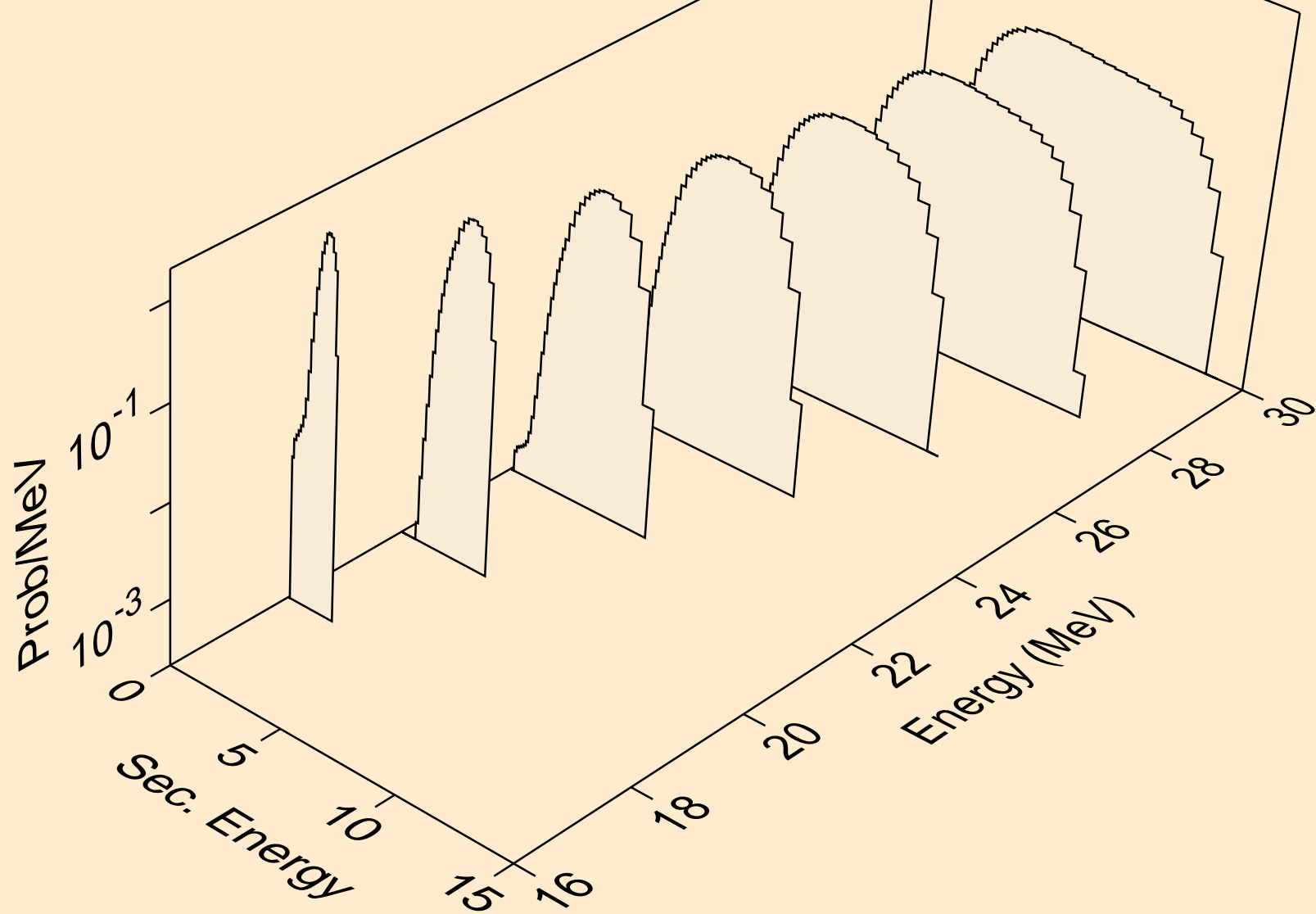

K046 PROTON ACER TENDL-2021 LIBRARY; T=0.K  
Proton emission for (p,3np)

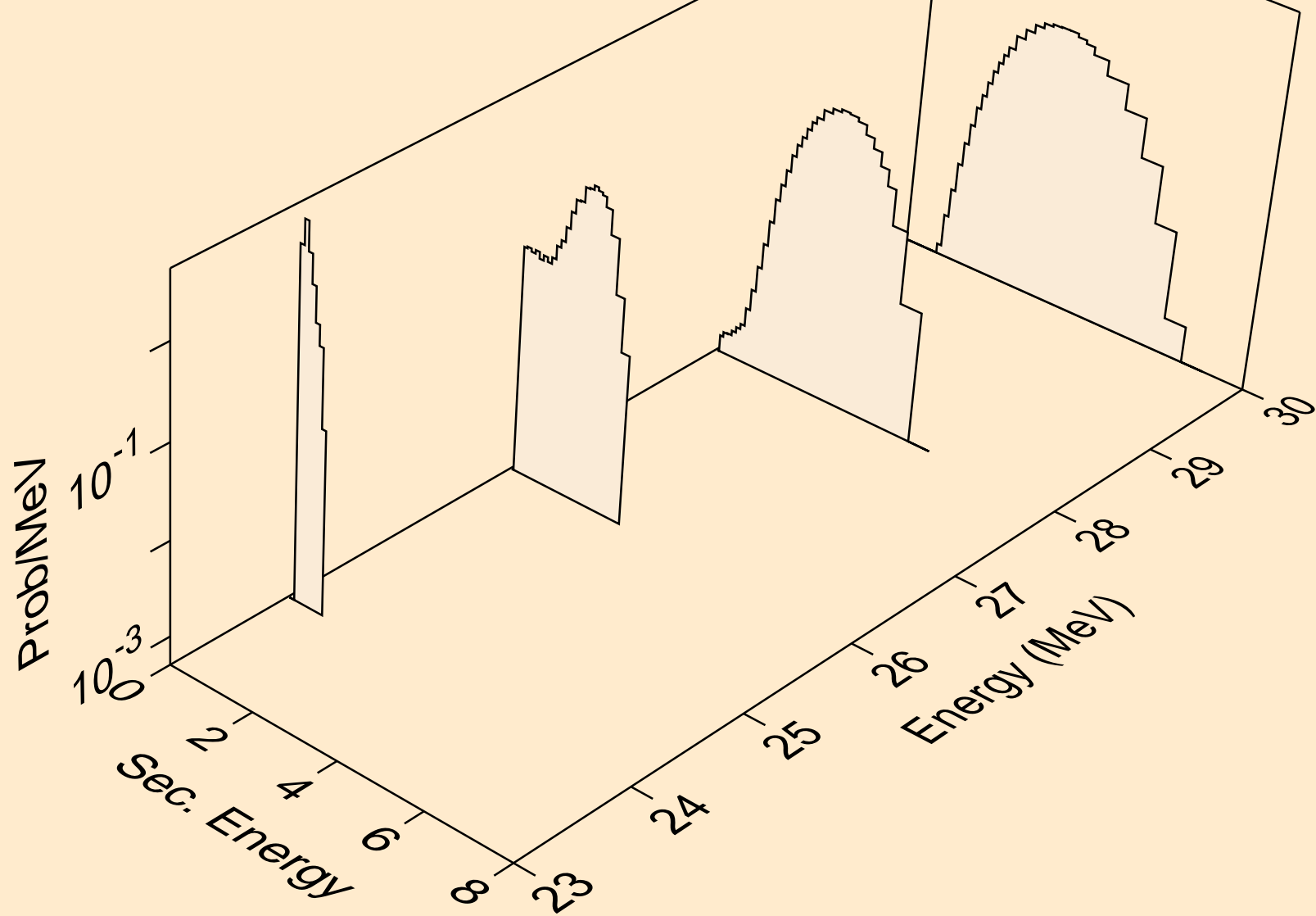

K046 PROTON ACER TENDL-2021 LIBRARY; T=0.K  
Proton emission for (p,2np)

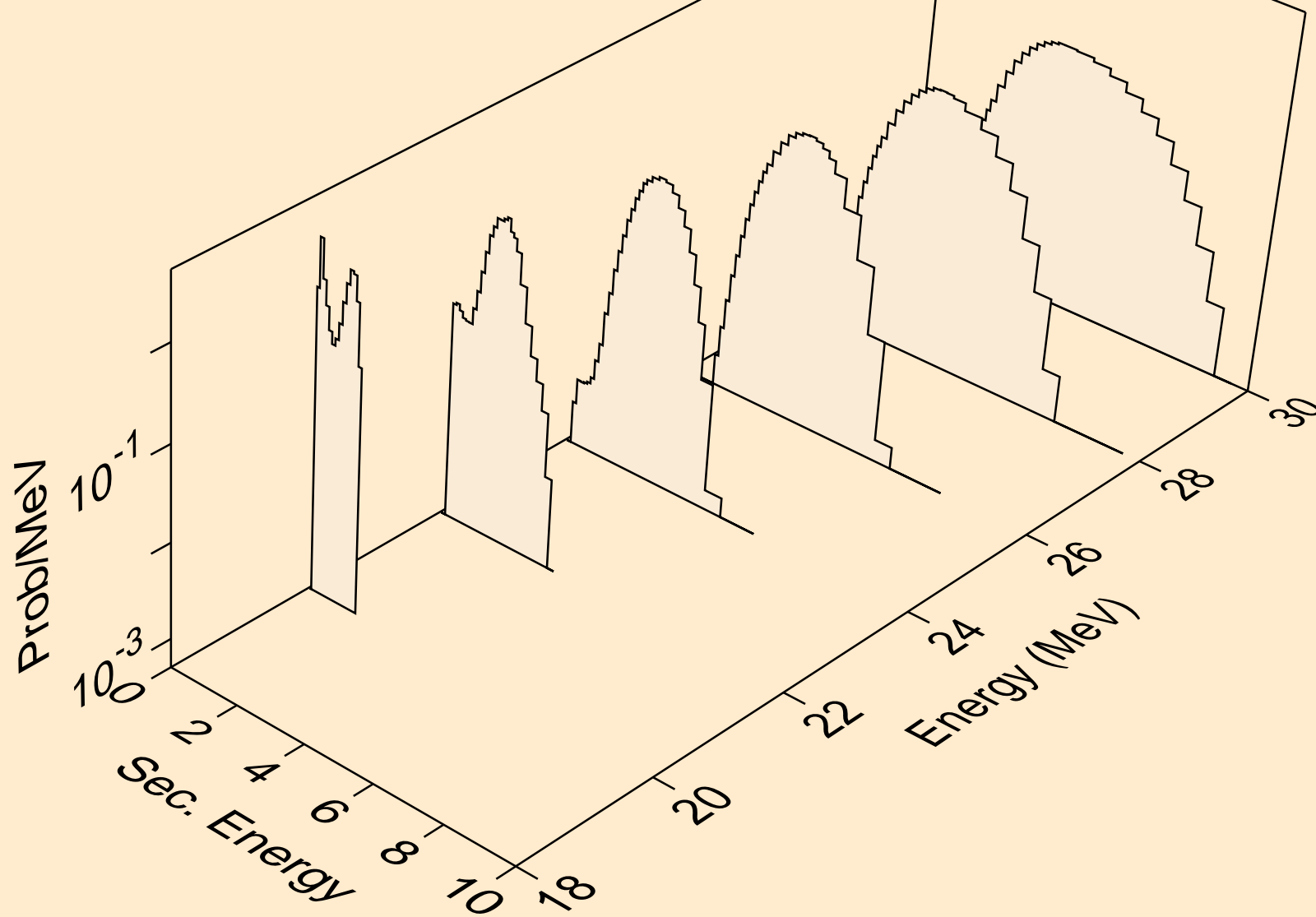

K046 PROTON ACER TENDL-2021 LIBRARY; T=0.K  
Proton emission for (p,npa)

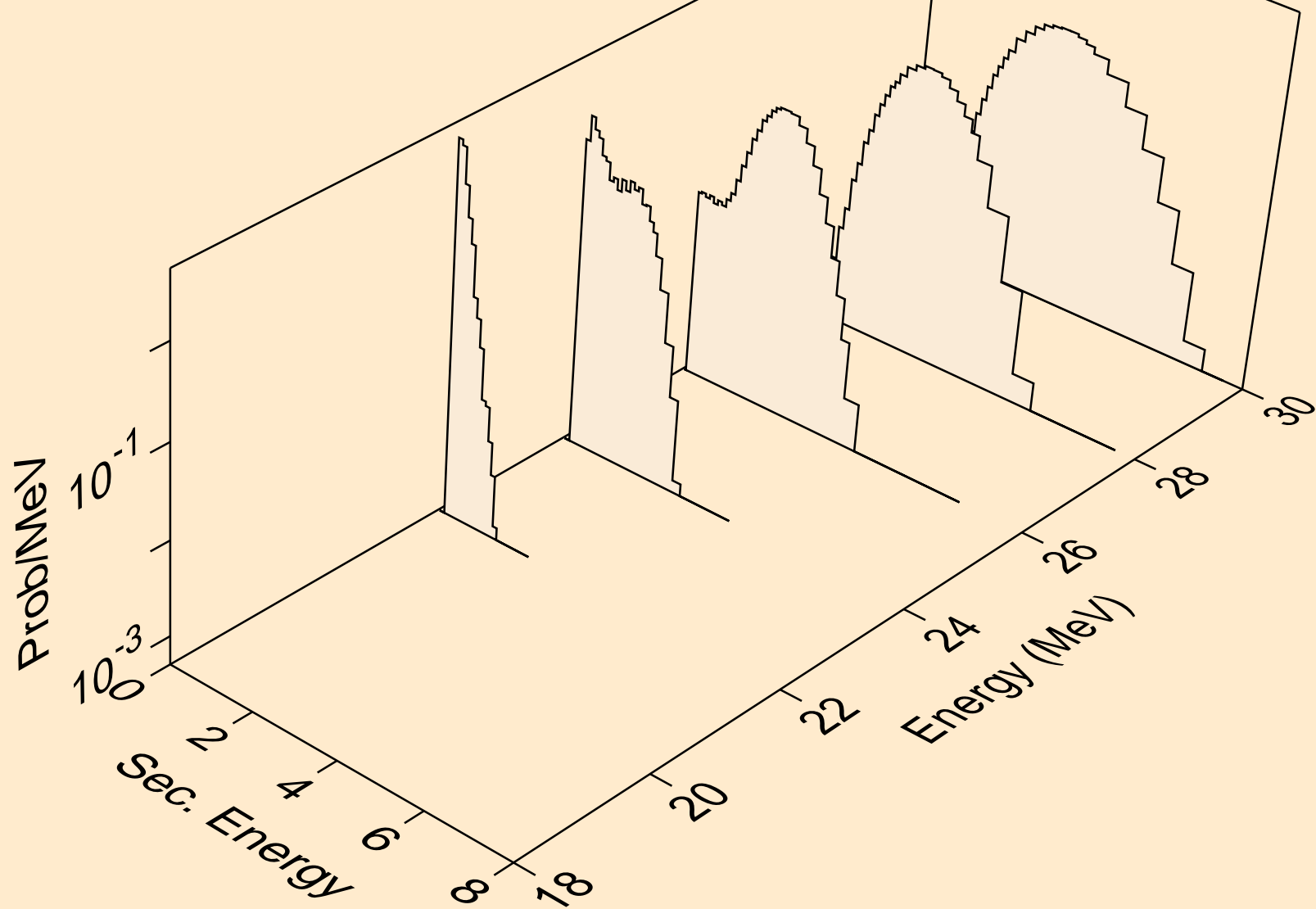

K046 PROTON ACER TENDL-2021 LIBRARY; T=0.K  
Proton emission for inelastic

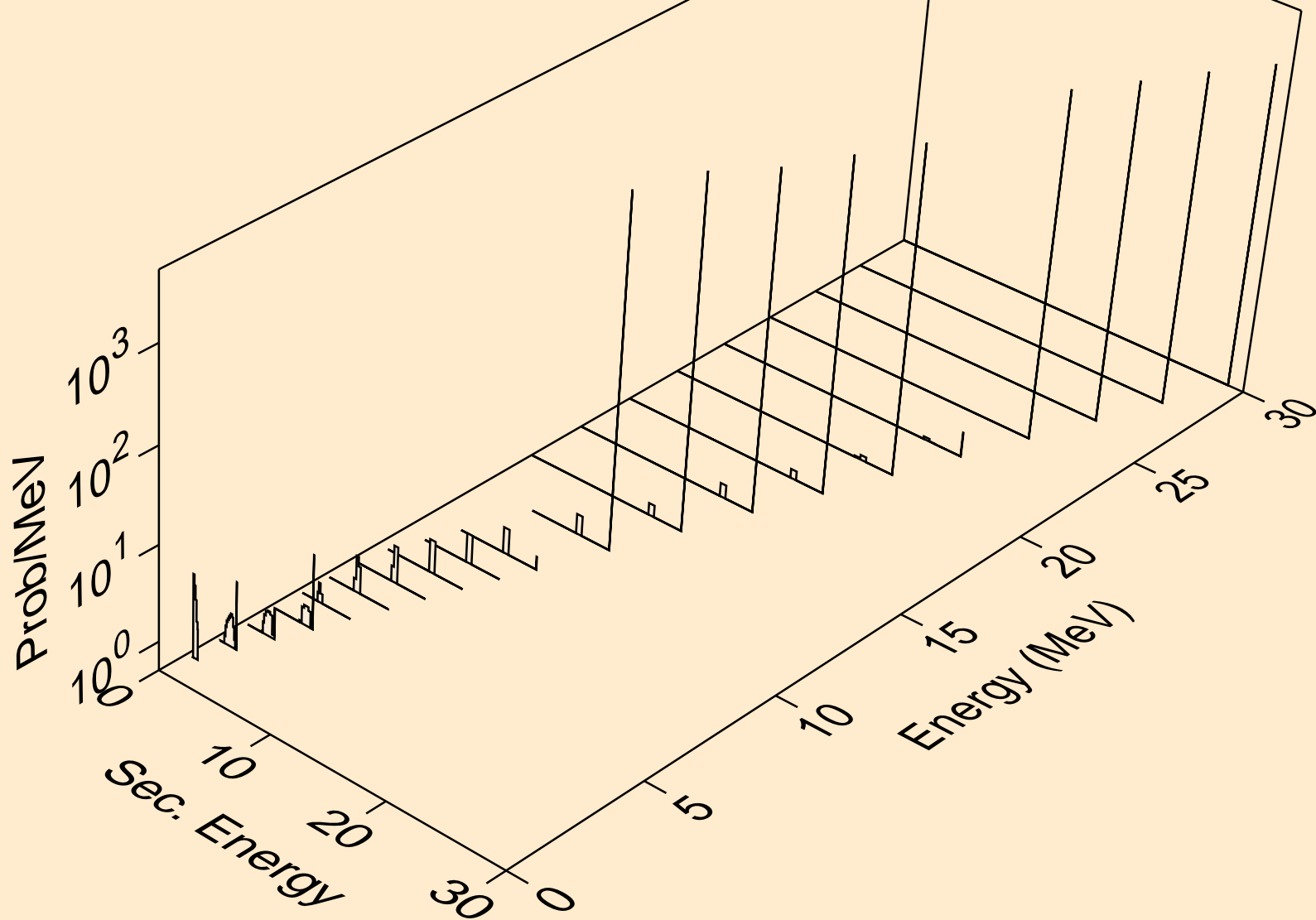



K046 PROTON ACER TENDL-2021 LIBRARY; T=0.K  
Proton emission for (p,2p)

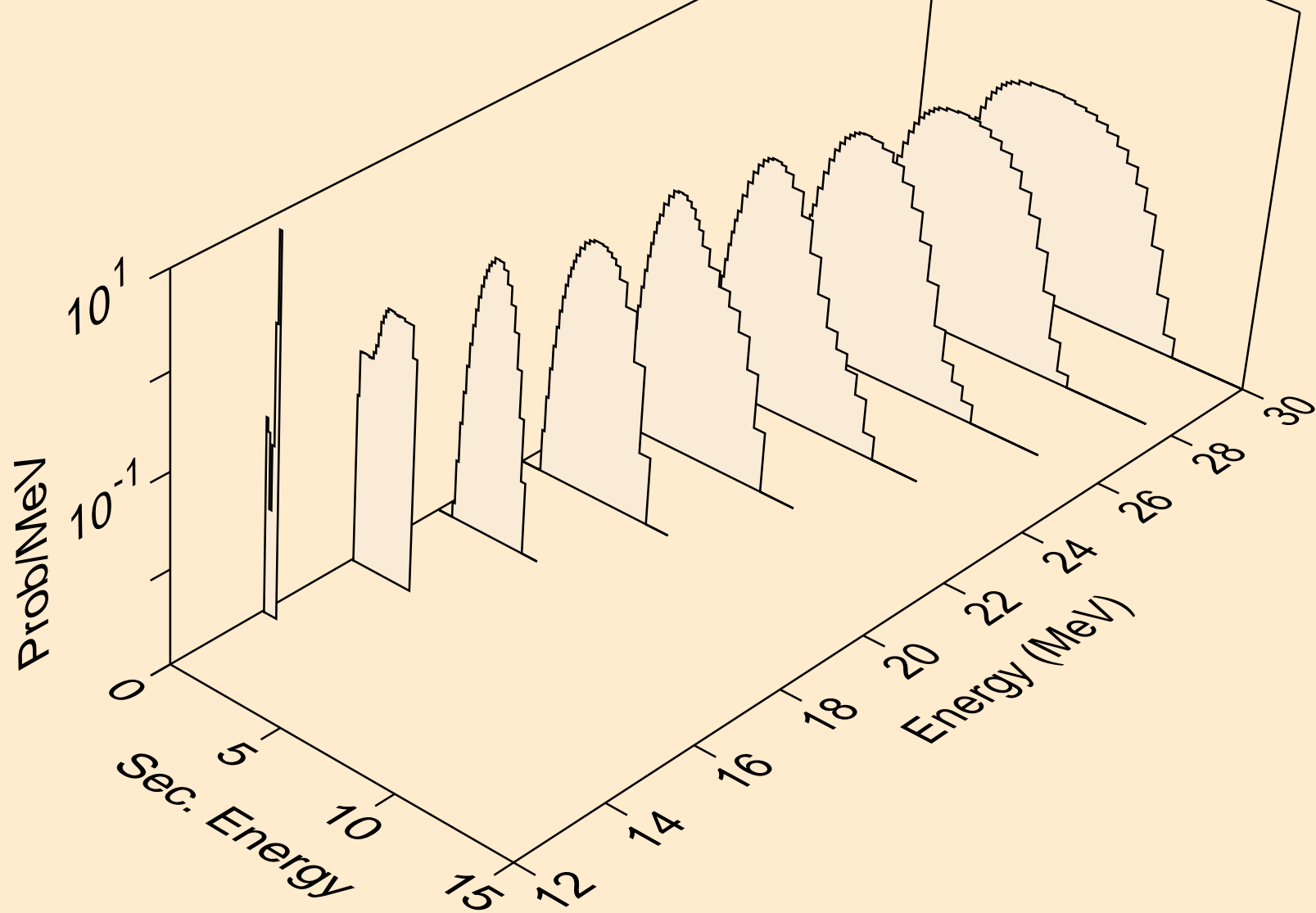

K046 PROTON ACER TENDL-2021 LIBRARY; T=0.K  
Proton emission for (p,pa)

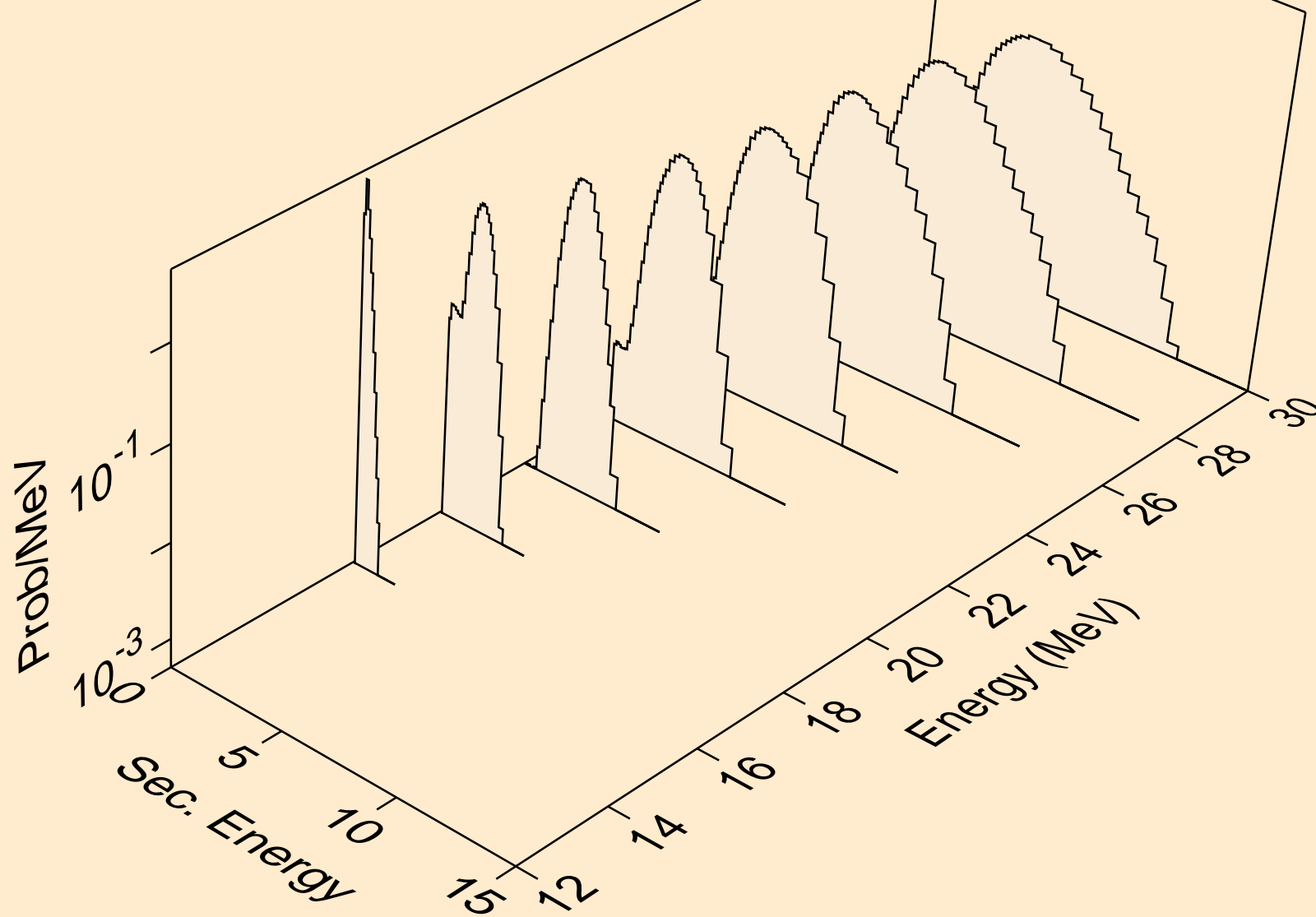

K046 PROTON ACER TENDL-2021 LIBRARY; T=0.K  
Proton emission for (p,pd)

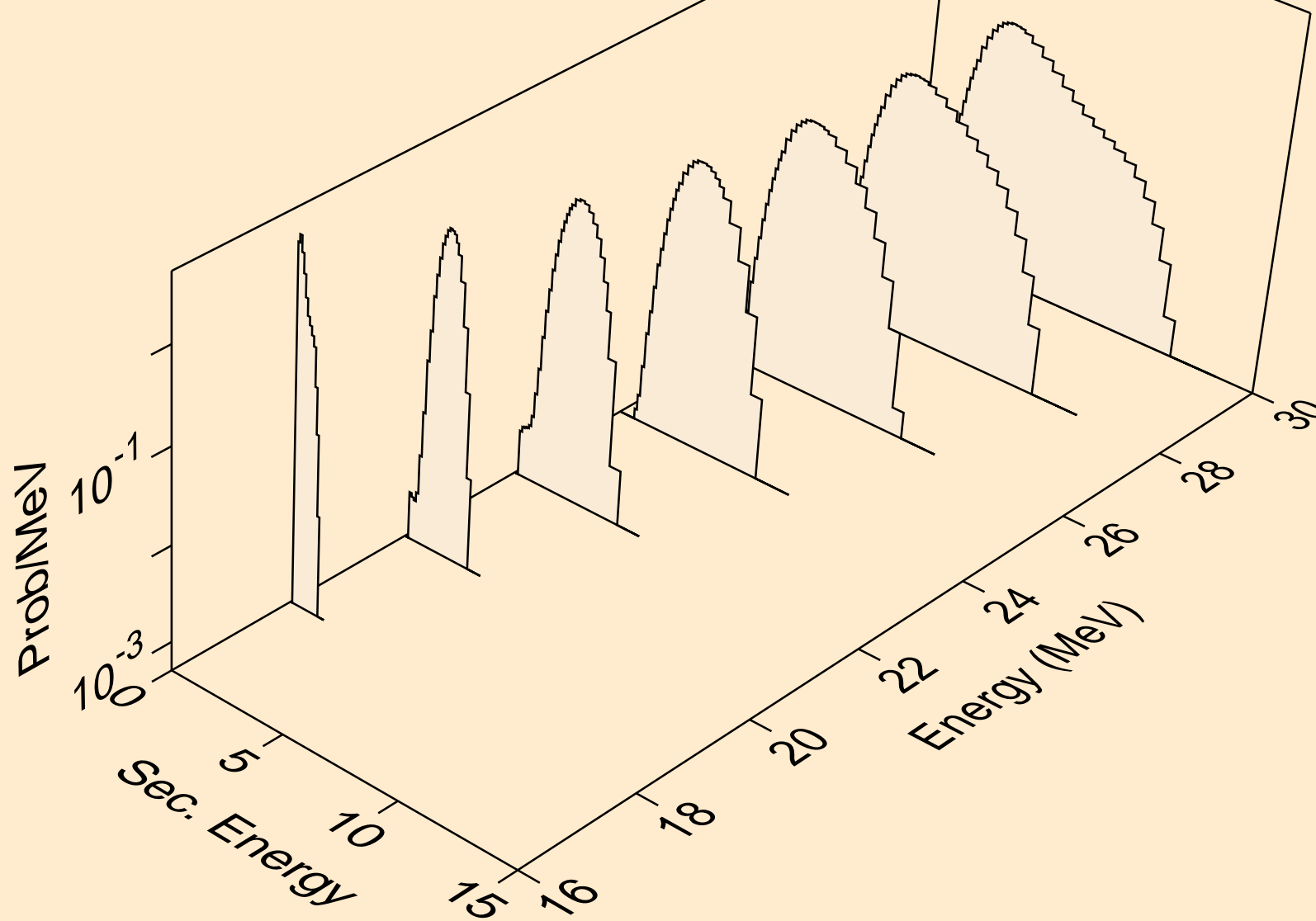

K046 PROTON ACER TENDL-2021 LIBRARY; T=0.K  
Proton emission for (p,pt)

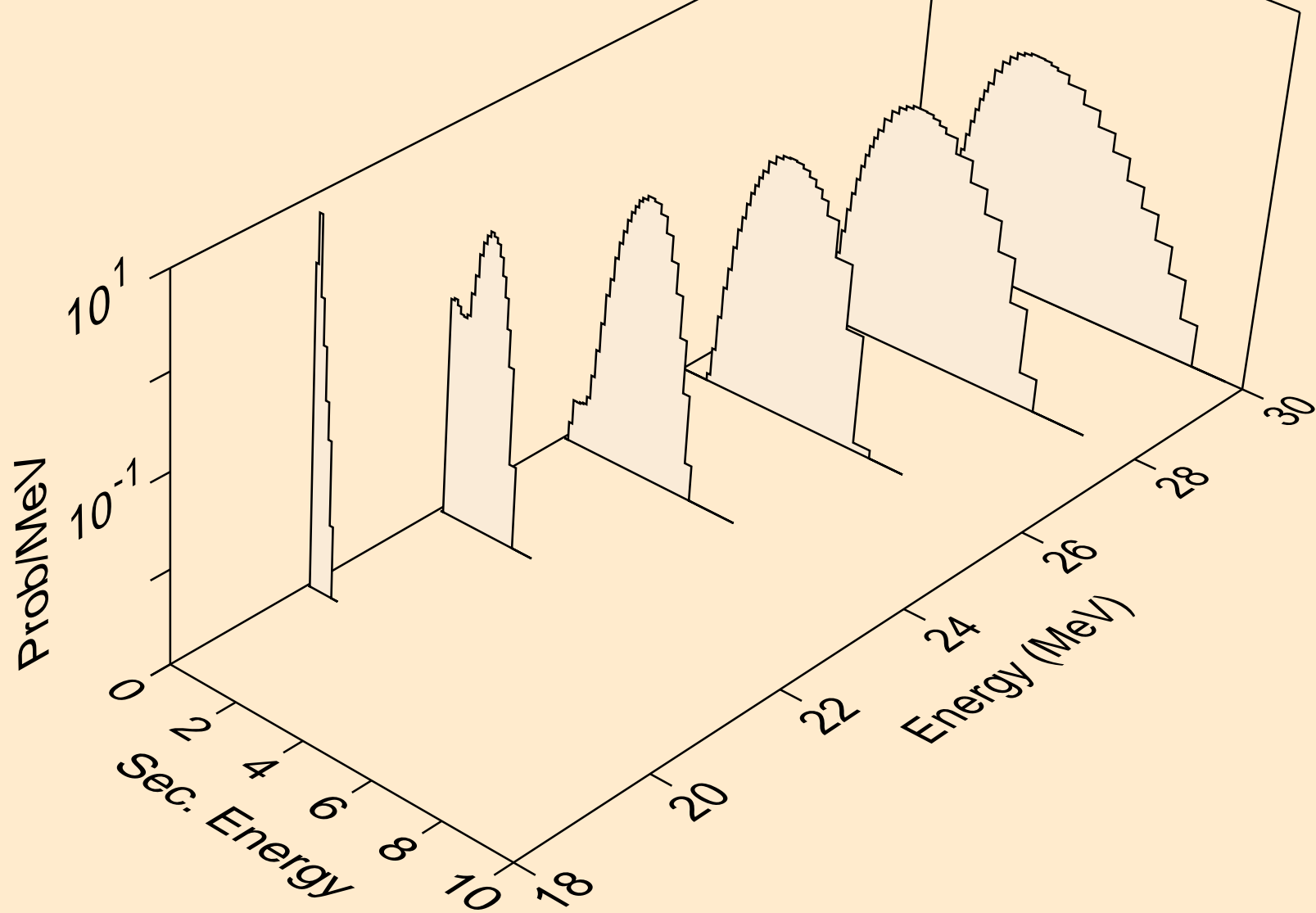

K046 PROTON ACER TENDL-2021 LIBRARY; T=0.K  
Photon emission for (z,n)

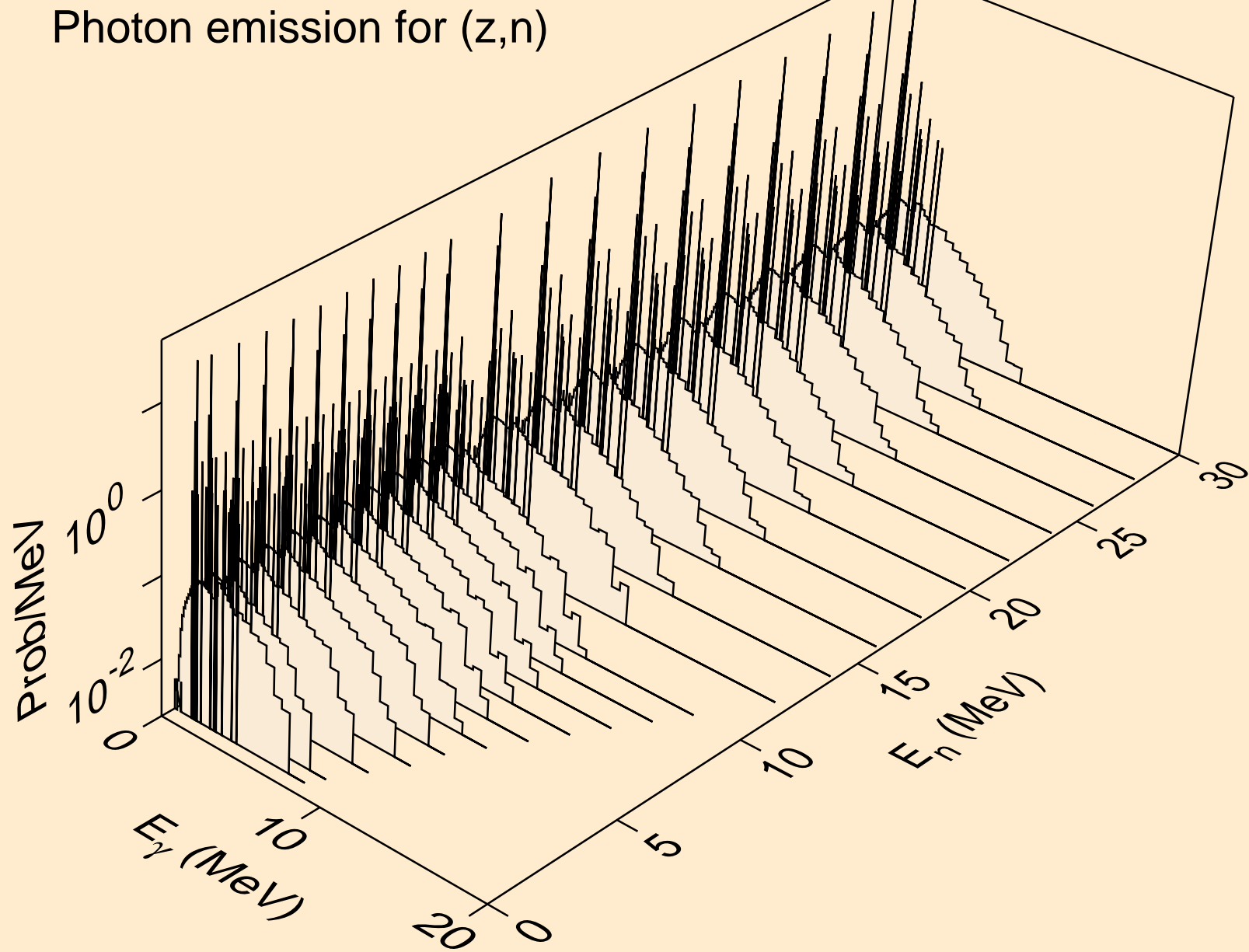

K046 PROTON ACER TENDL-2021 LIBRARY; T=0.K  
Photon emission for (n,x)

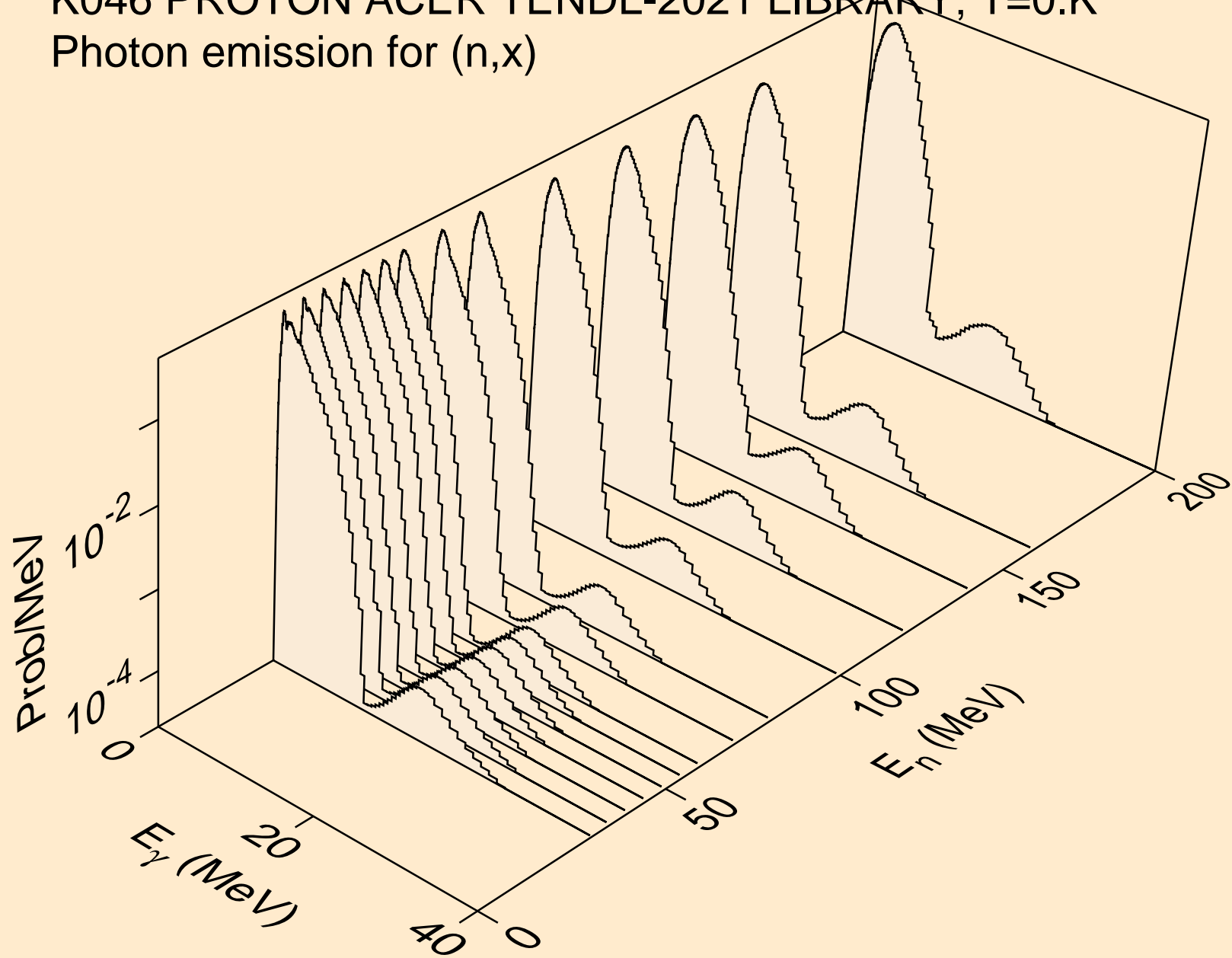

K046 PROTON ACER TENDL-2021 LIBRARY; T=0.K  
Photon emission for (n,2nd)

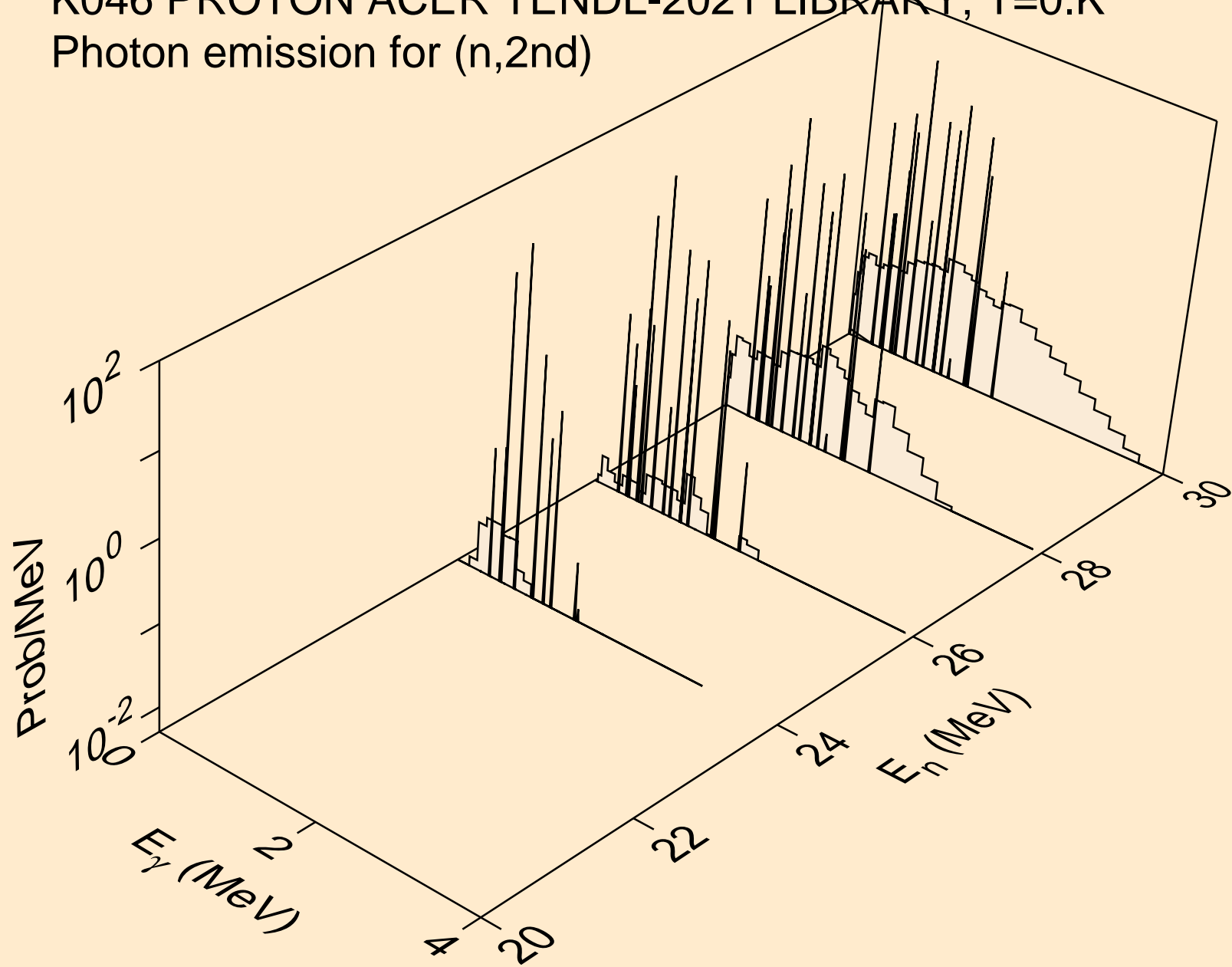

K046 PROTON ACER TENDL-2021 LIBRARY; T=0.K  
Photon emission for (n,2n)

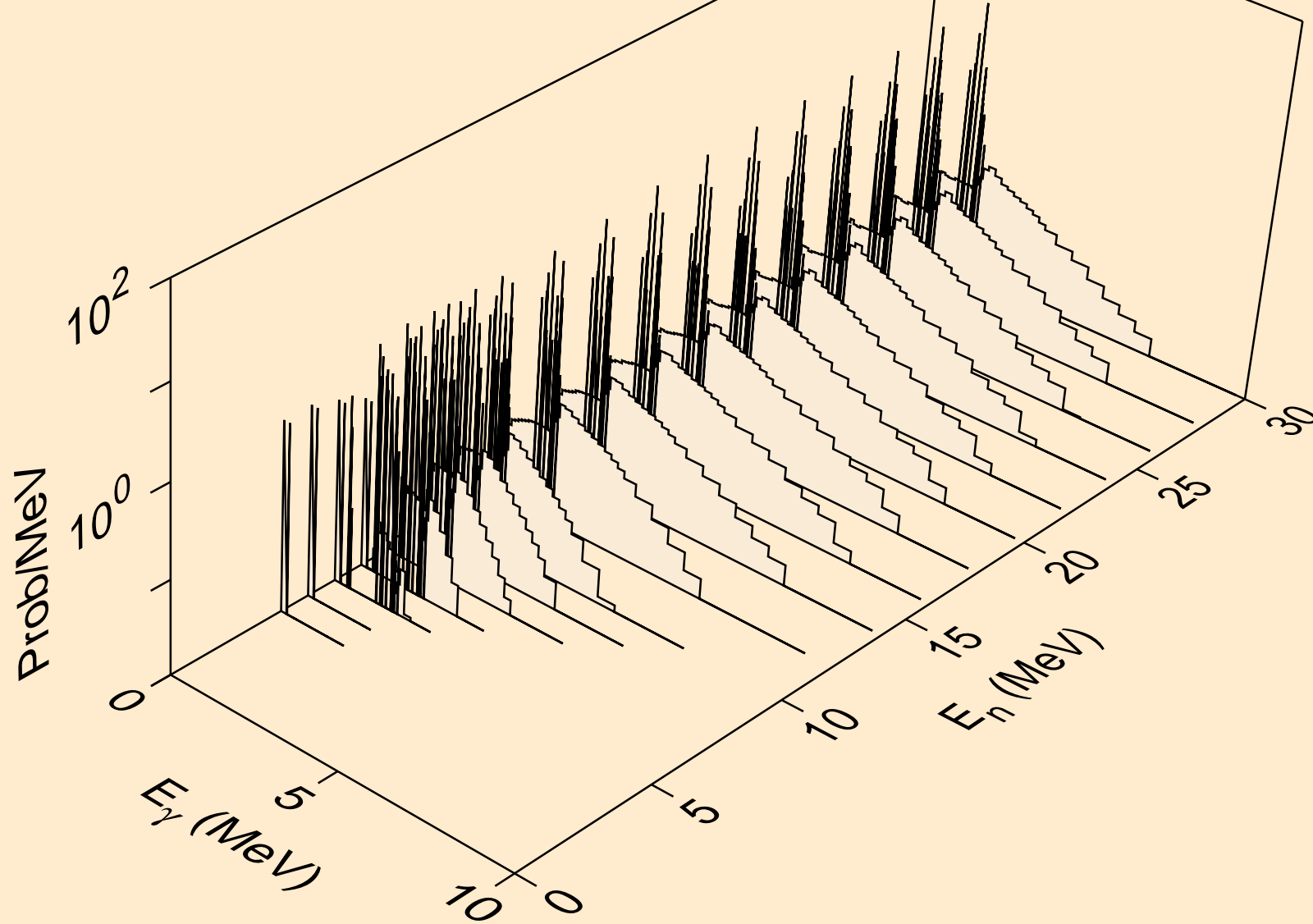



K046 PROTON ACER TENDL-2021 LIBRARY; T=0.K  
Photon emission for (n,3n)

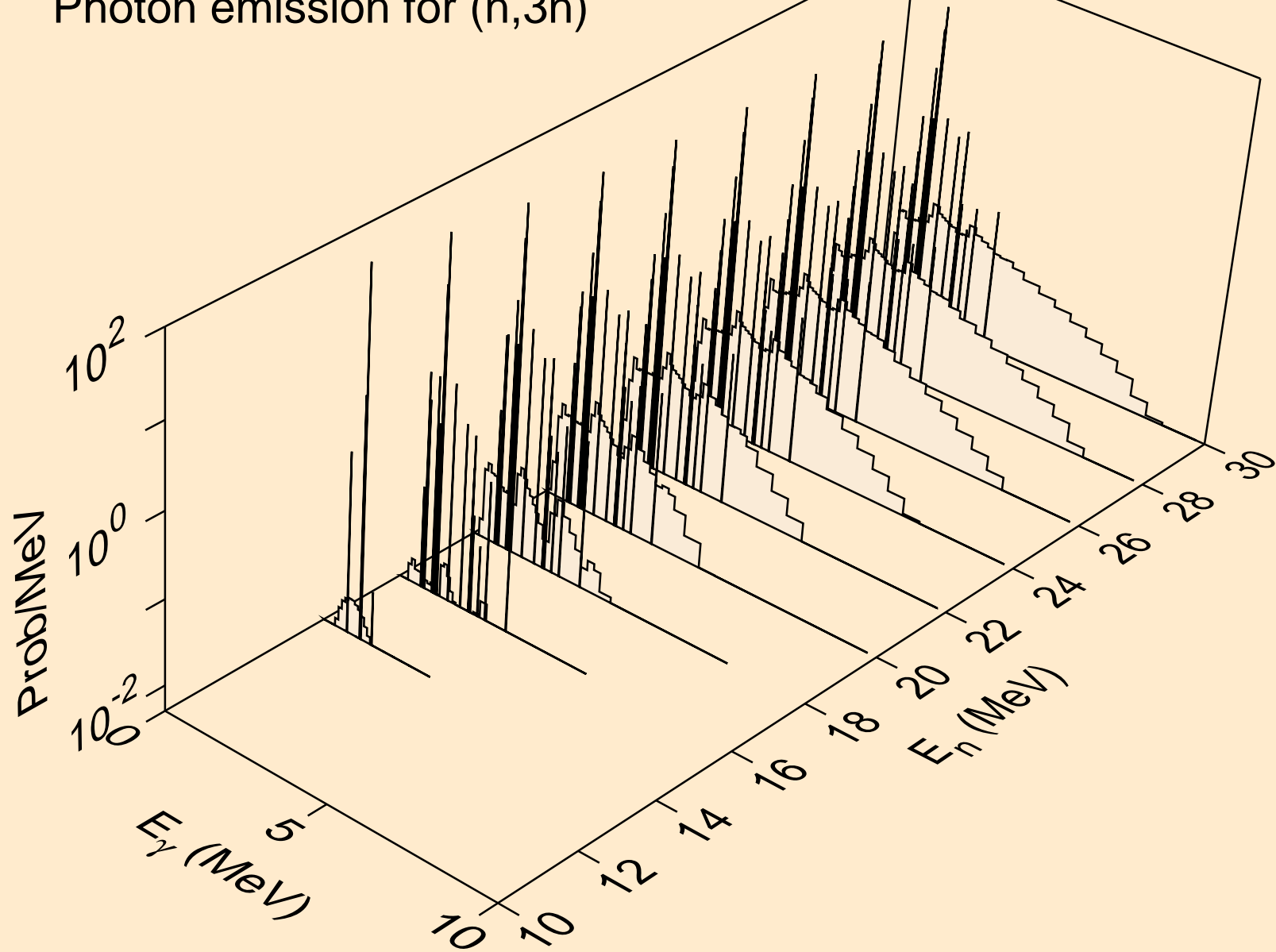

K046 PROTON ACER TENDL-2021 LIBRARY; T=0.K  
Photon emission for (n,n\*)a

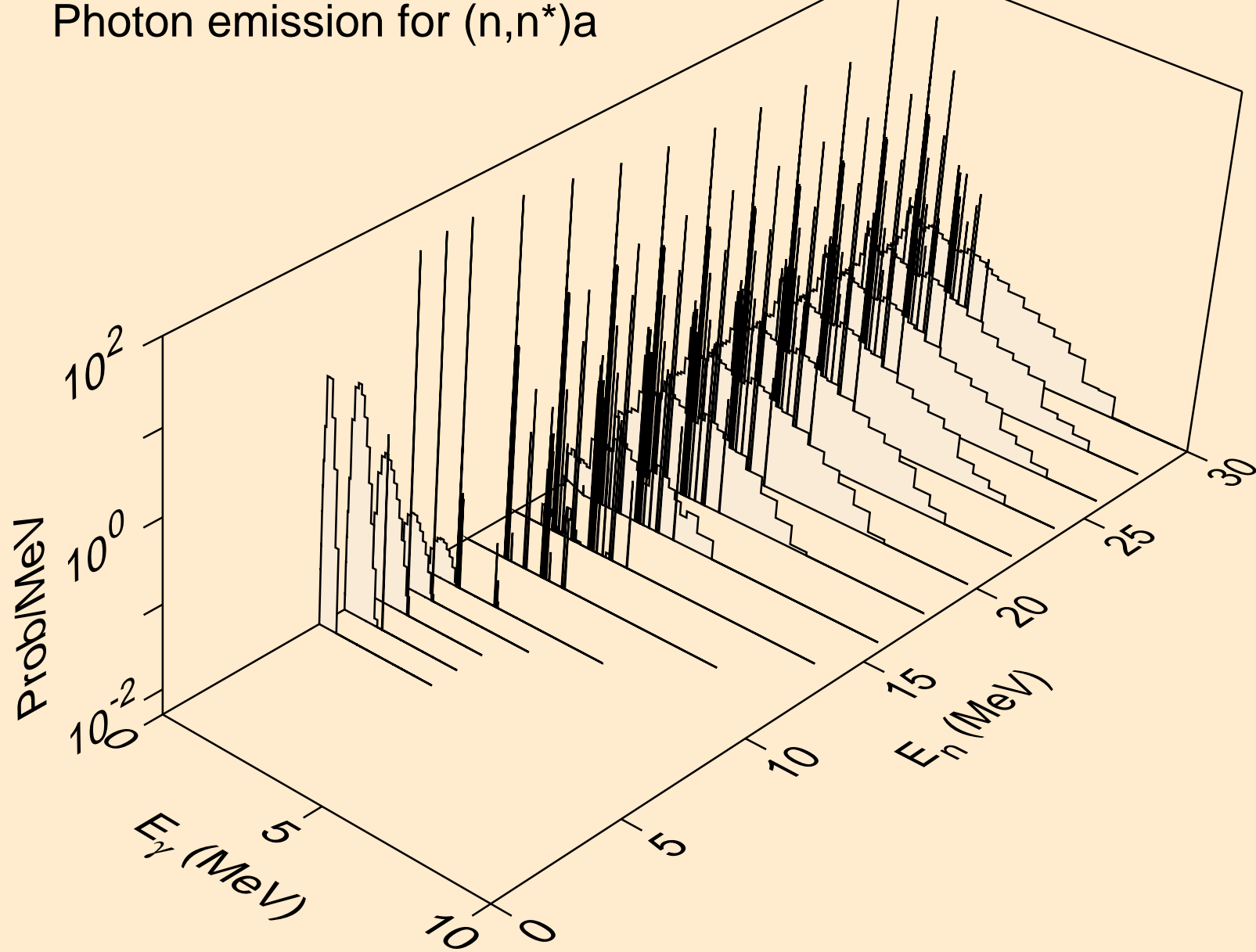

K046 PROTON ACER TENDL-2021 LIBRARY; T=0.K  
Photon emission for (n,2n)a

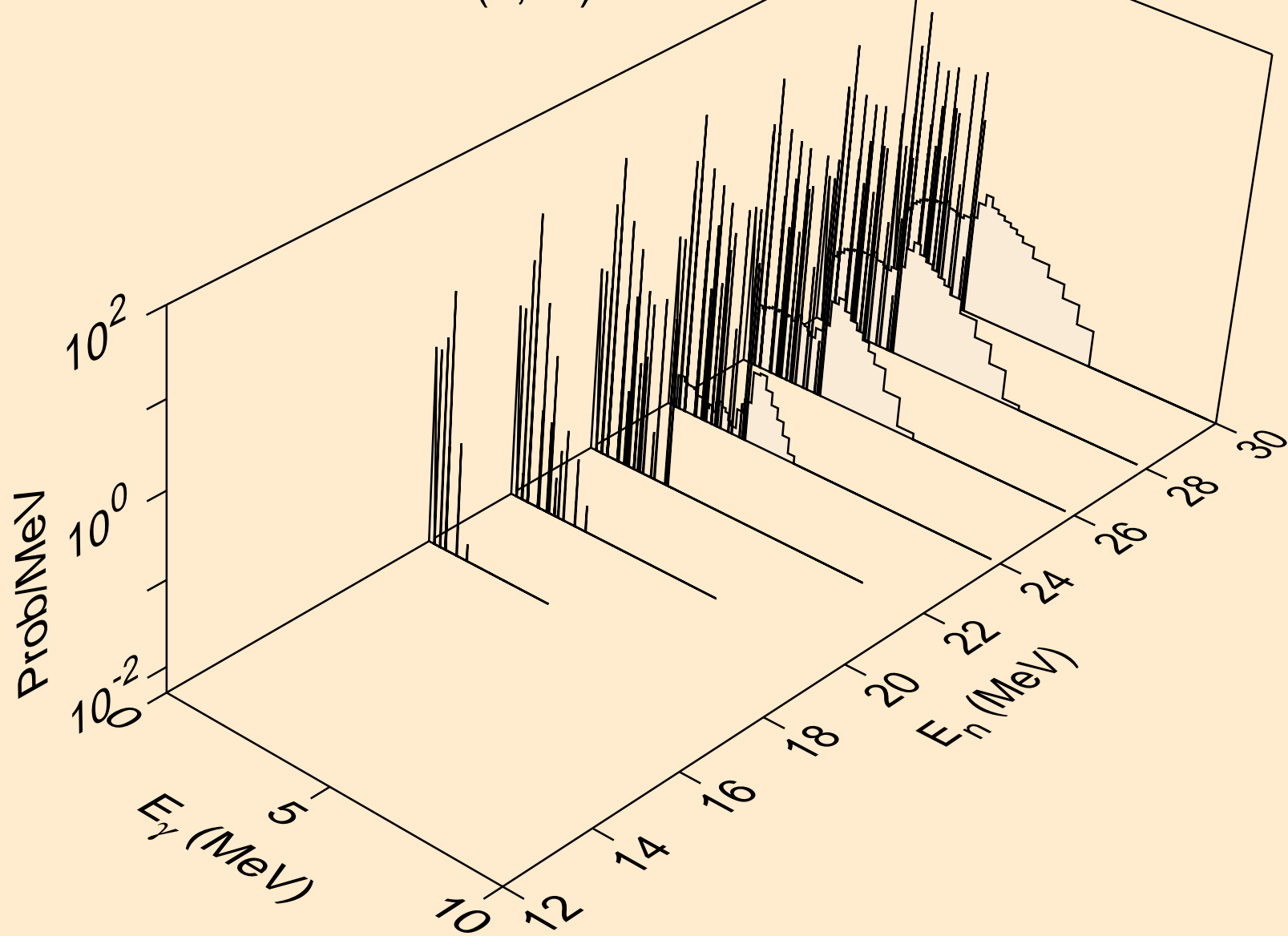

K046 PROTON ACER TENDL-2021 LIBRARY; T=0.K  
Photon emission for (n,3n)a

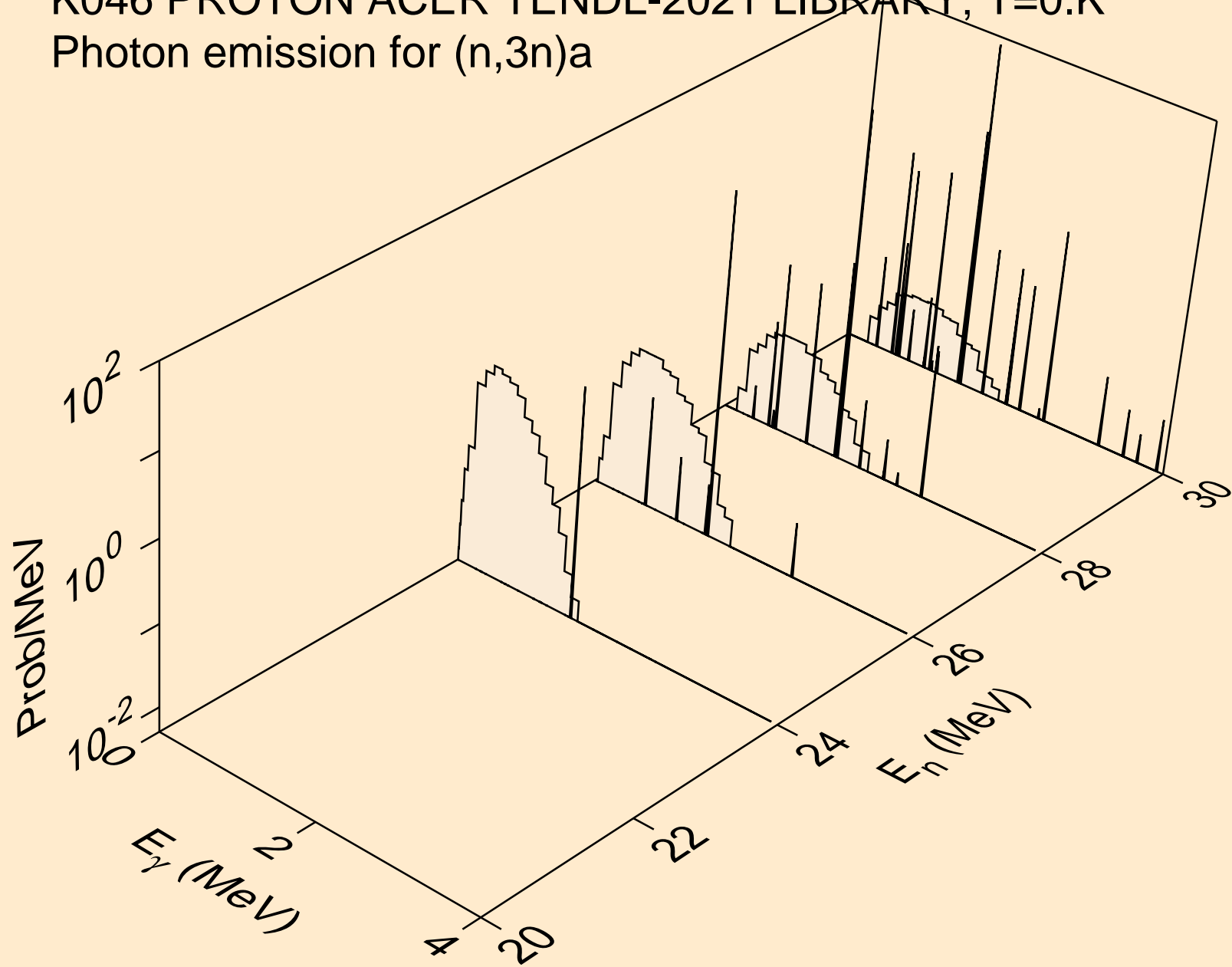

K046 PROTON ACER TENDL-2021 LIBRARY; T=0.K  
Photon emission for (n,n\*)p

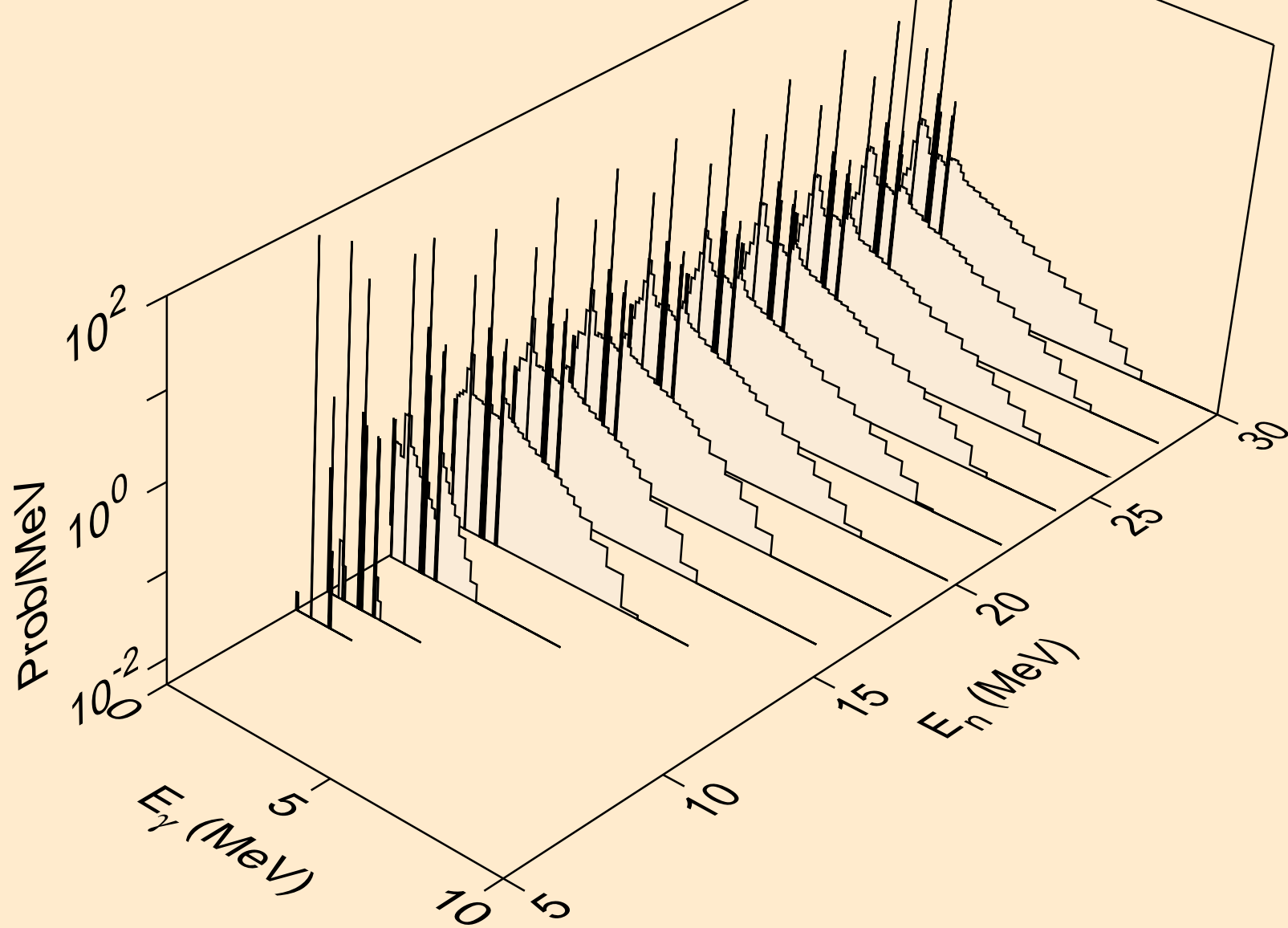

K046 PROTON ACER TENDL-2021 LIBRARY; T=0.K  
Photon emission for (n,n\*)2a

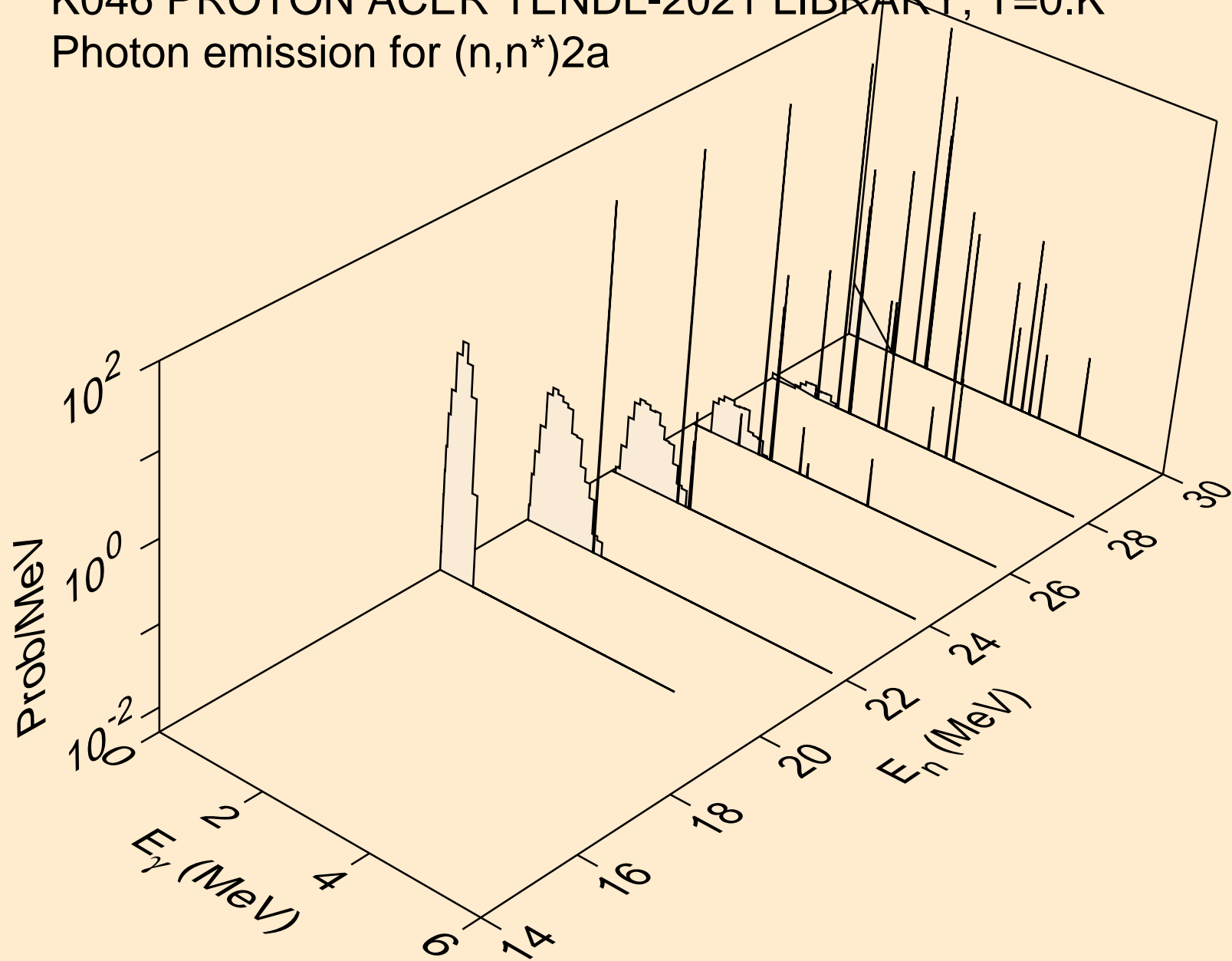

K046 PROTON ACER TENDL-2021 LIBRARY; T=0.K  
Photon emission for (n,n\*)d

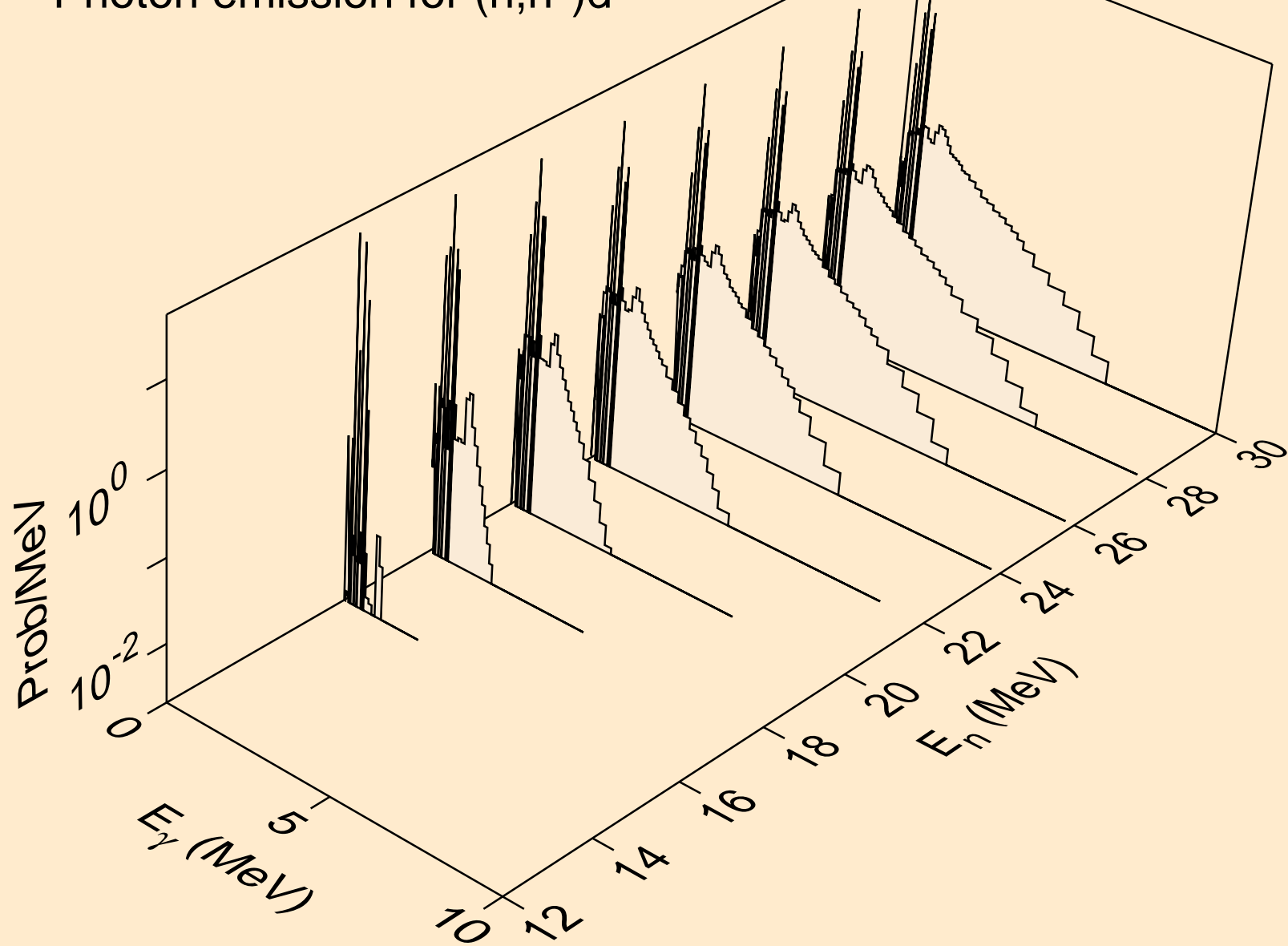

K046 PROTON ACER TENDL-2021 LIBRARY; T=0.K  
Photon emission for (n,n\*)t

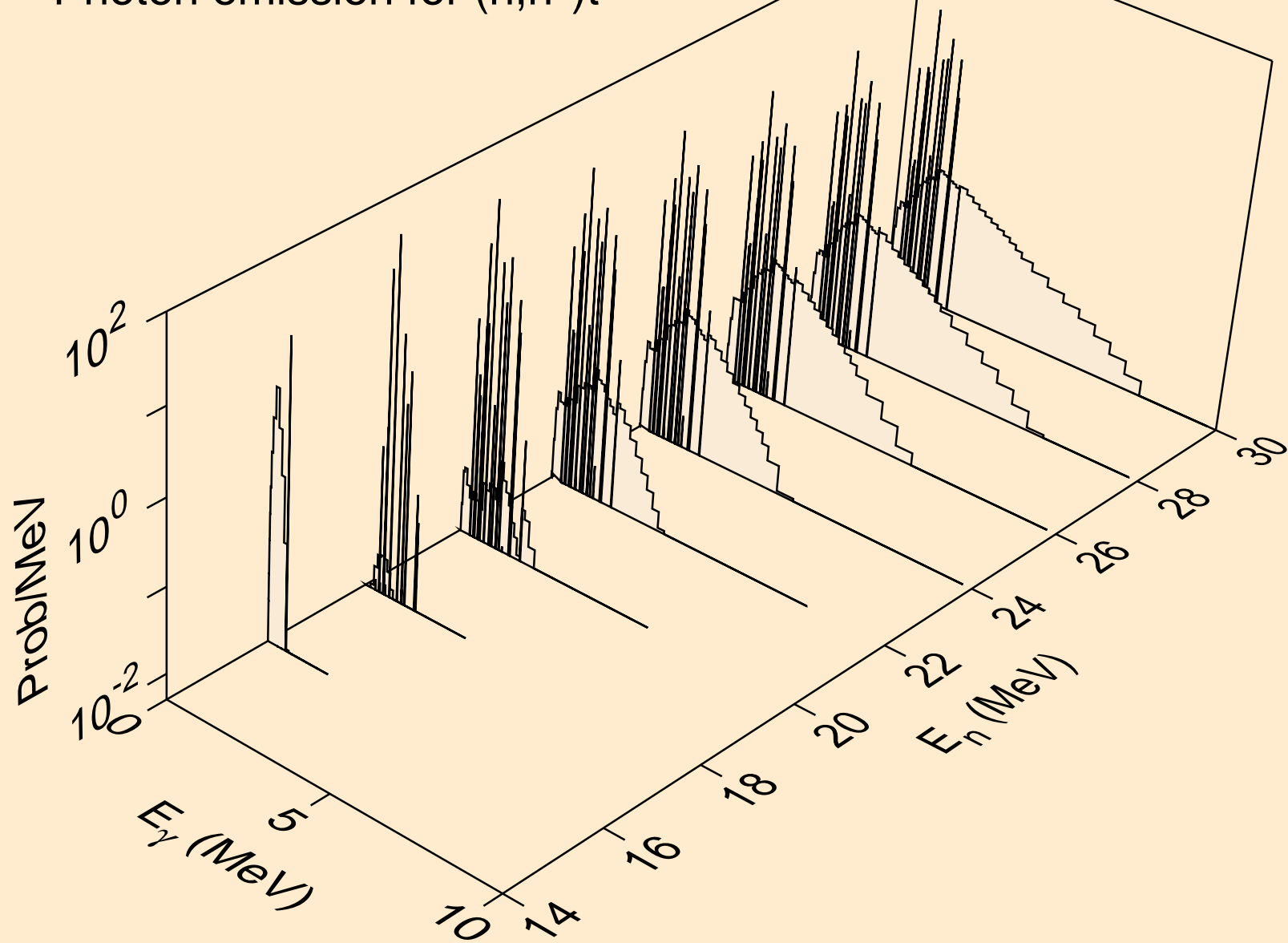



K046 PROTON ACER TENDL-2021 LIBRARY; T=0.K  
Photon emission for (n,n\*)he3

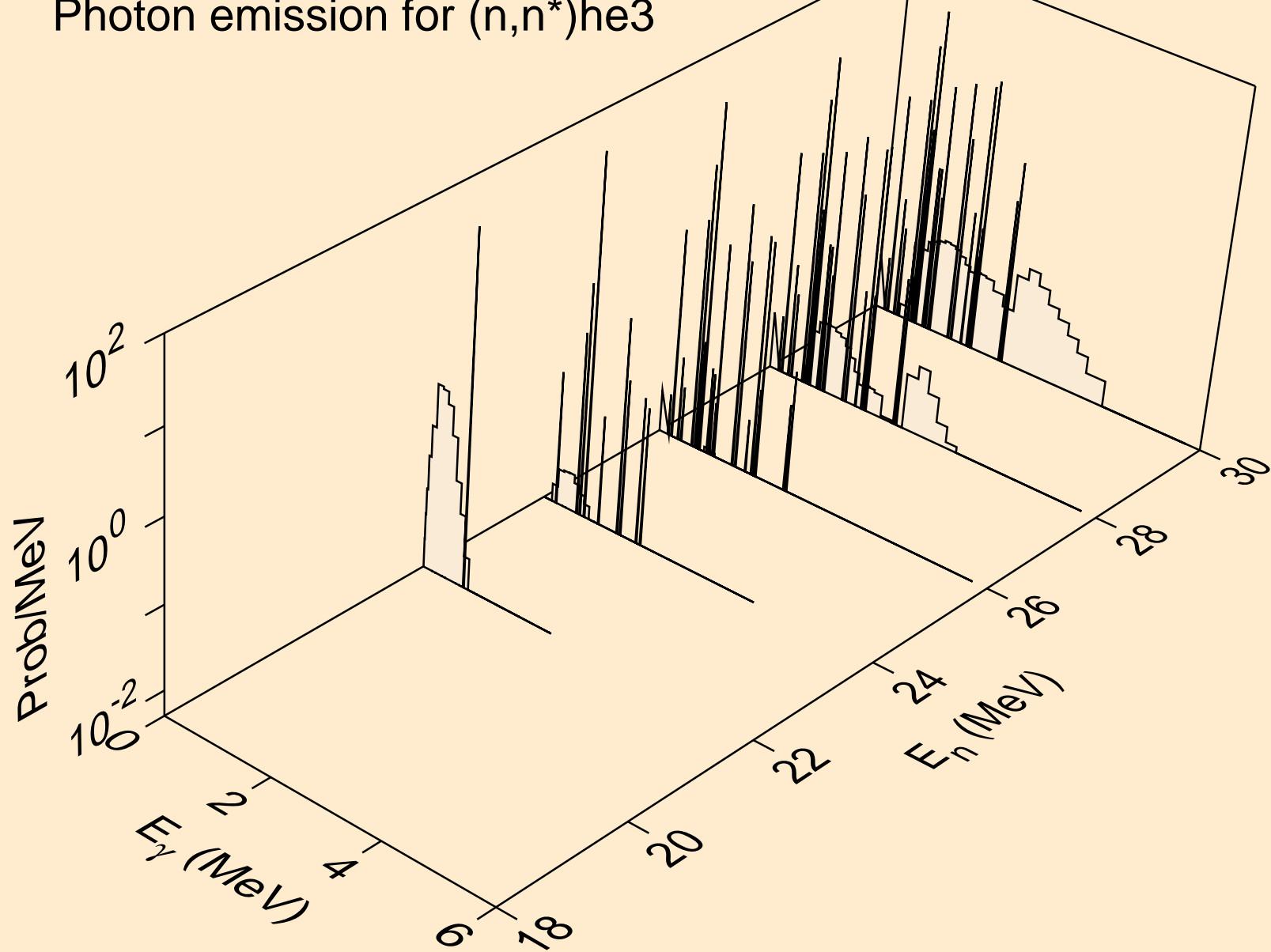

K046 PROTON ACER TENDL-2021 LIBRARY; T=0.K  
Photon emission for (n,4n)

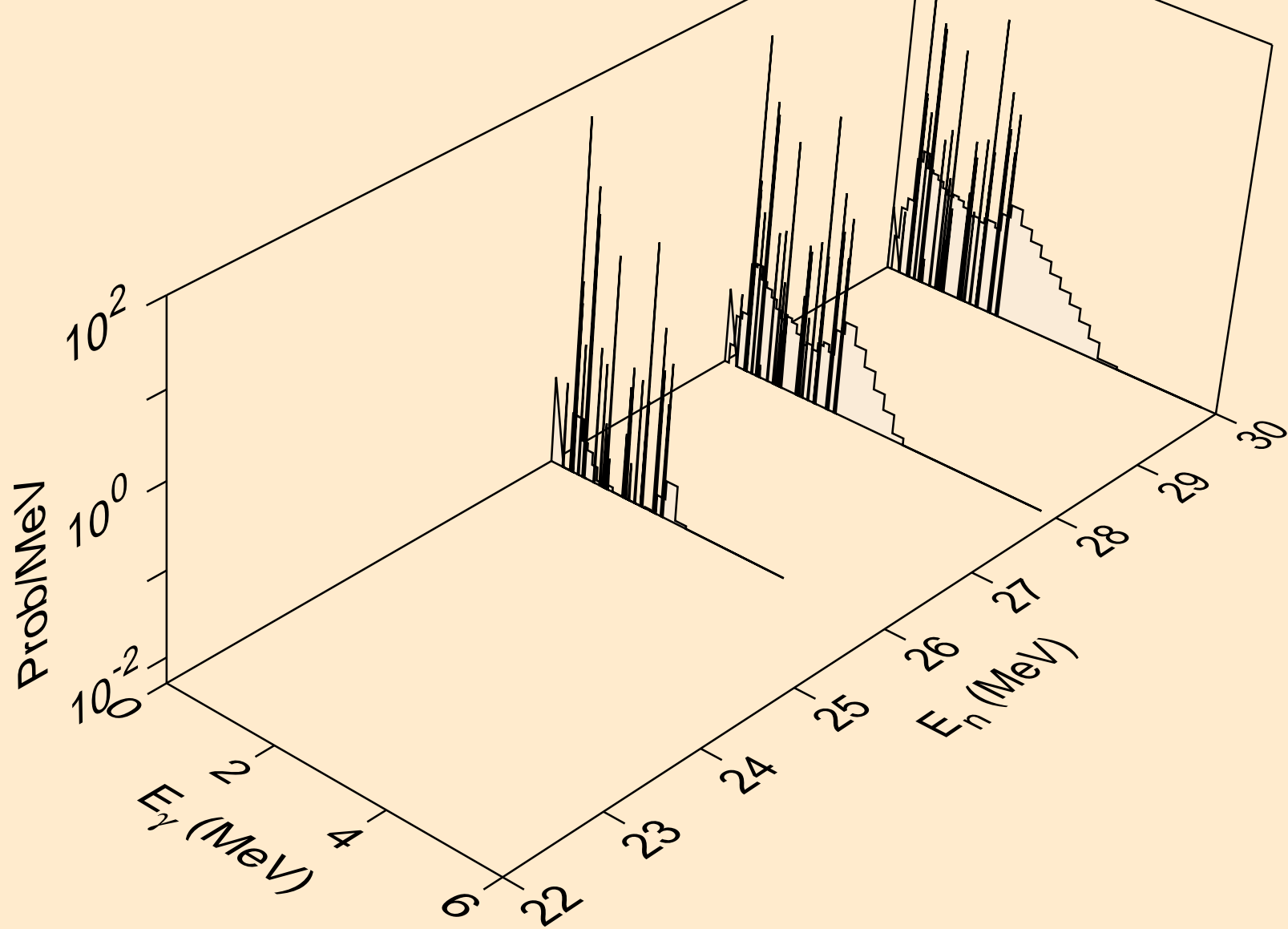

K046 PROTON ACER TENDL-2021 LIBRARY; T=0.K  
Photon emission for (n,2np)

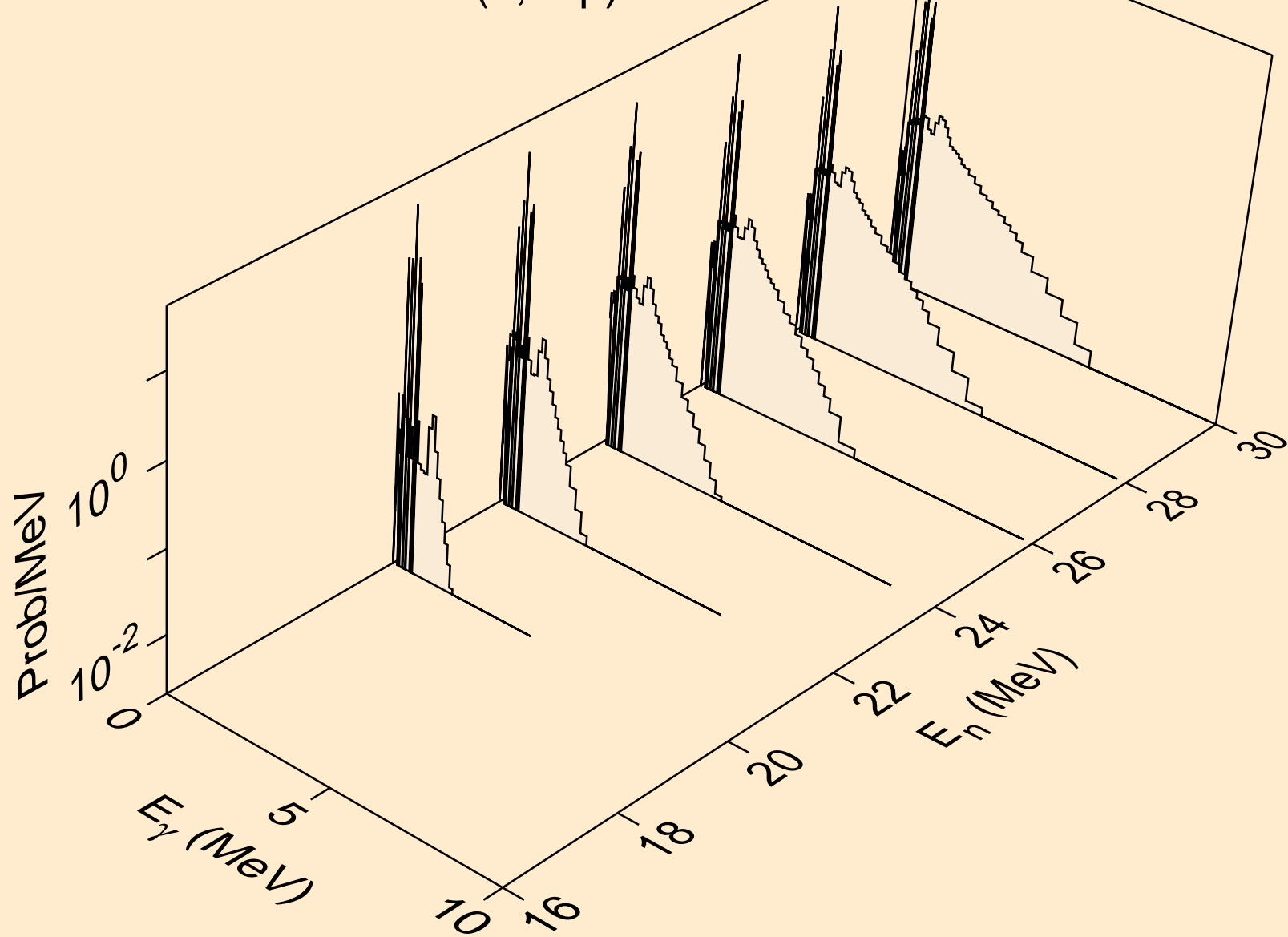

K046 PROTON ACER TENDL-2021 LIBRARY; T=0.K  
Photon emission for (n,3np)

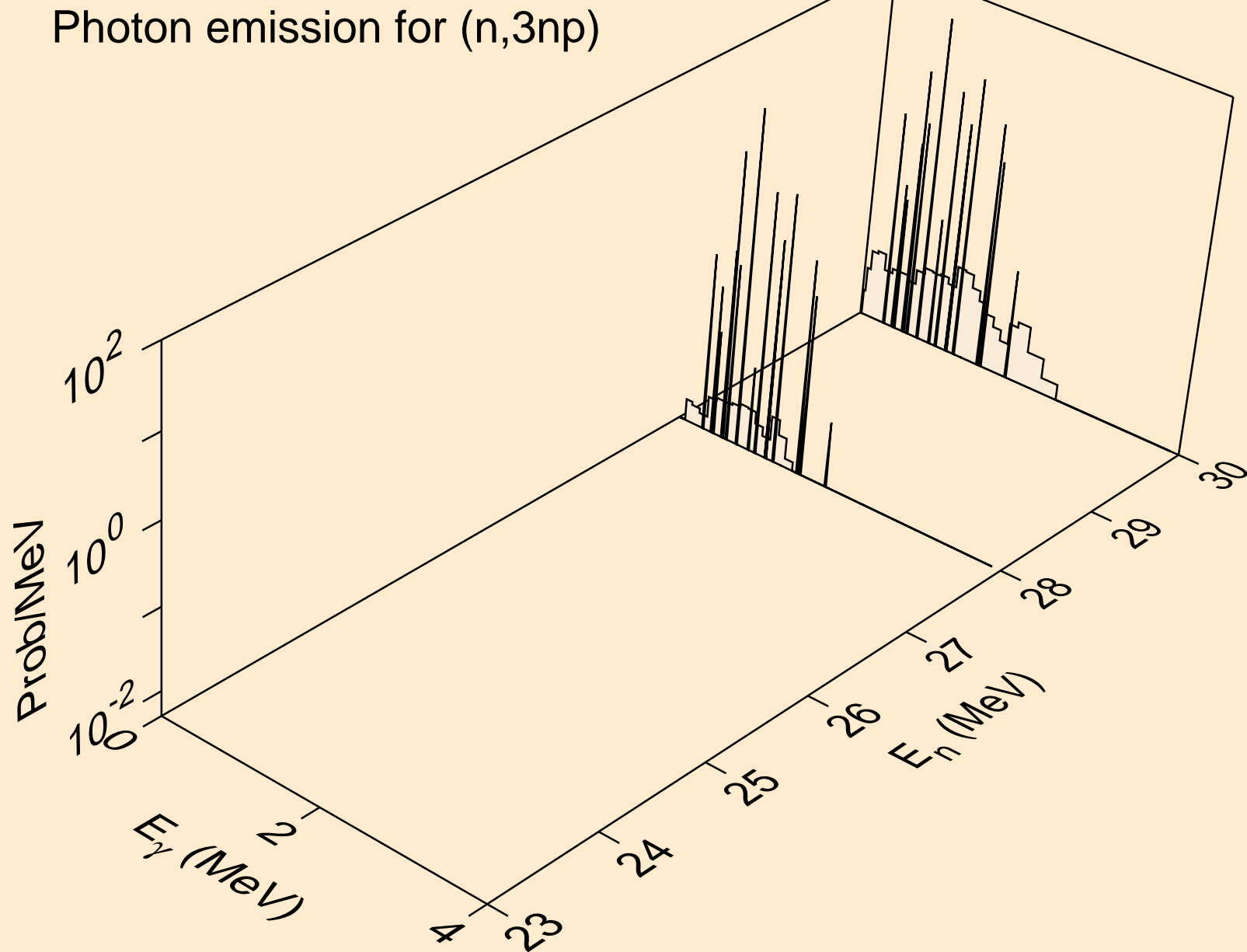

K046 PROTON ACER TENDL-2021 LIBRARY; T=0.K  
Photon emission for (n,2np)

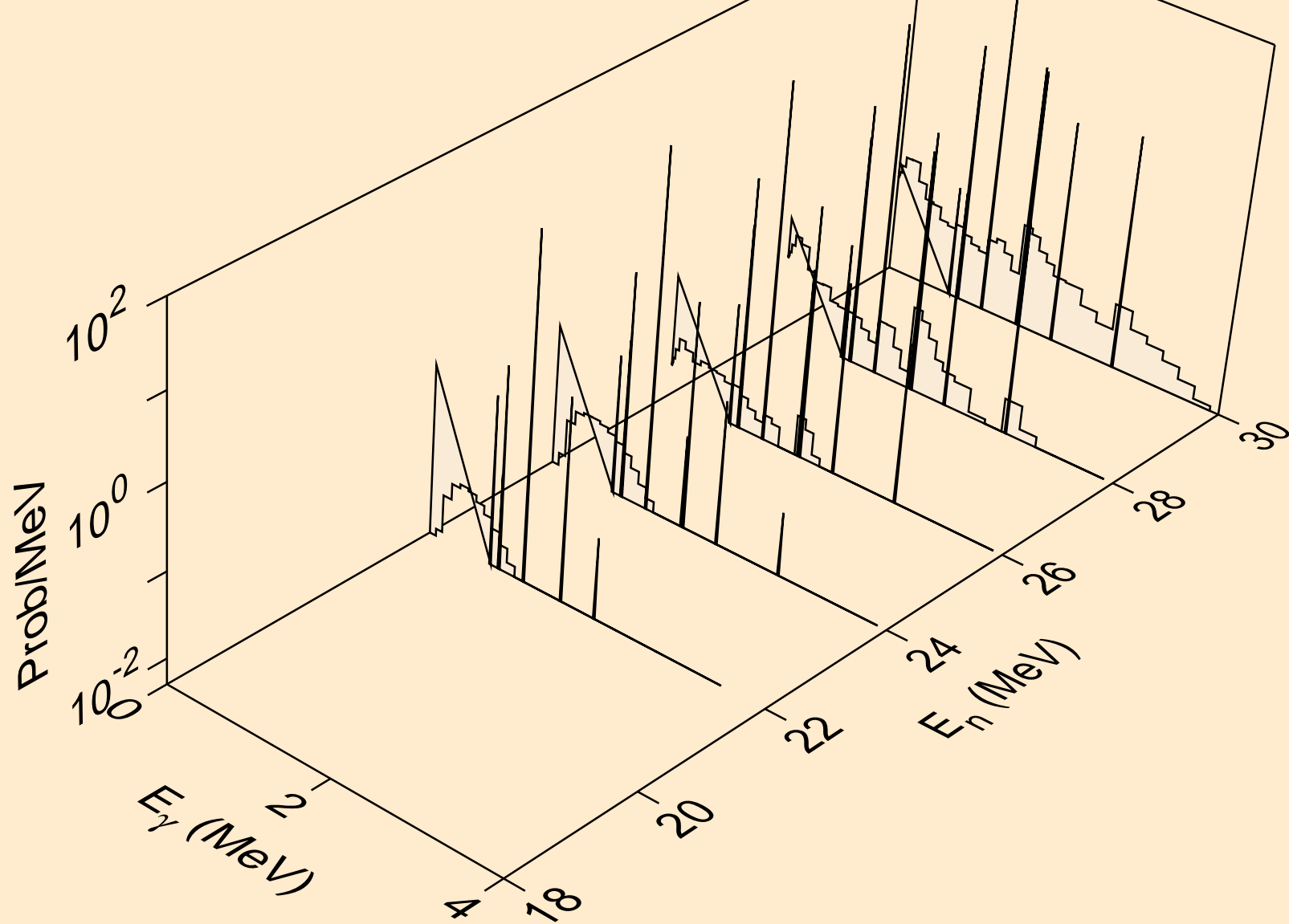

K046 PROTON ACER TENDL-2021 LIBRARY; T=0.K  
Photon emission for (n,npa)

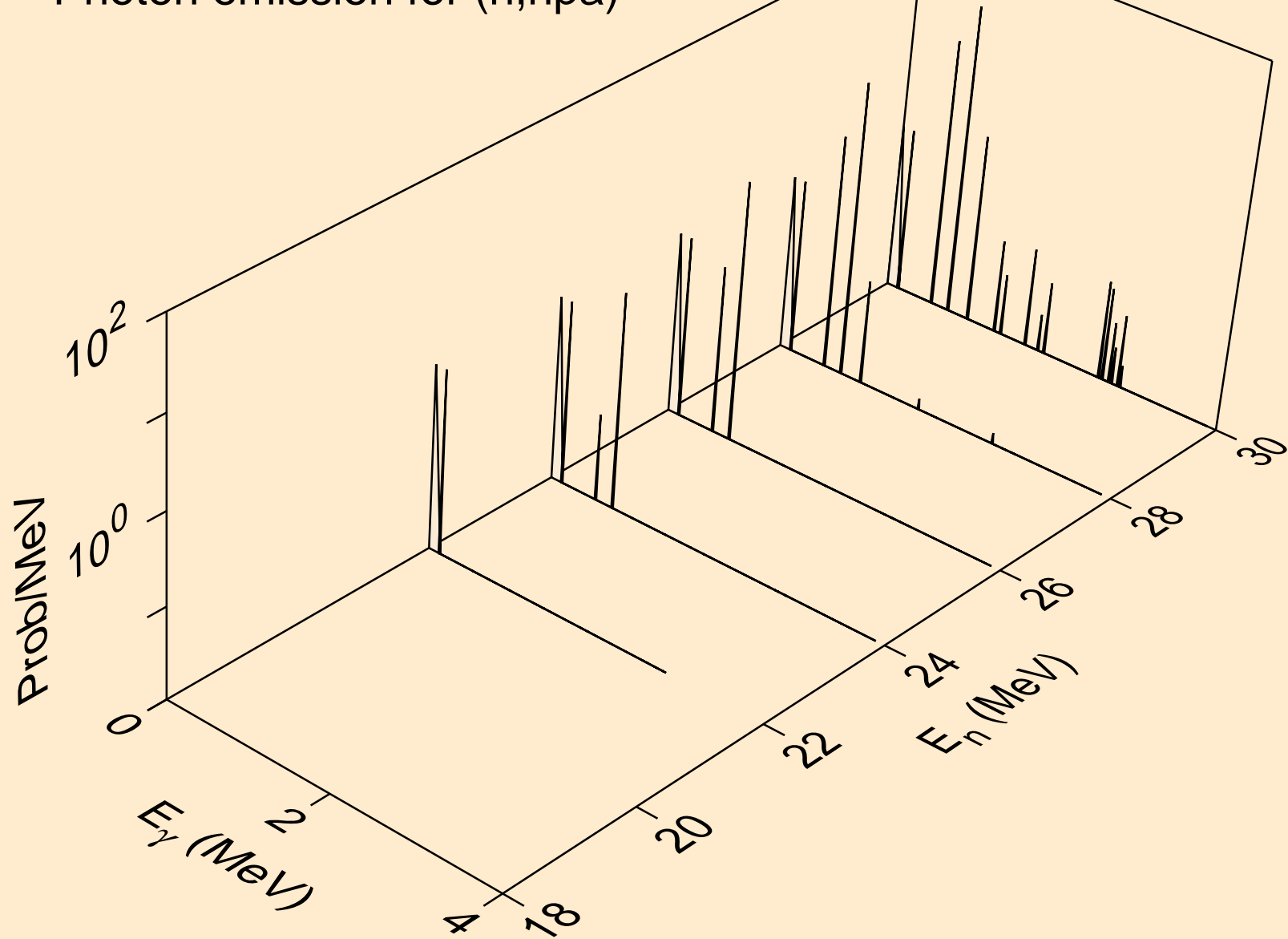

K046 PROTON ACER TENDL-2021 LIBRARY; T=0.K  
Photon emission for (n,gma)

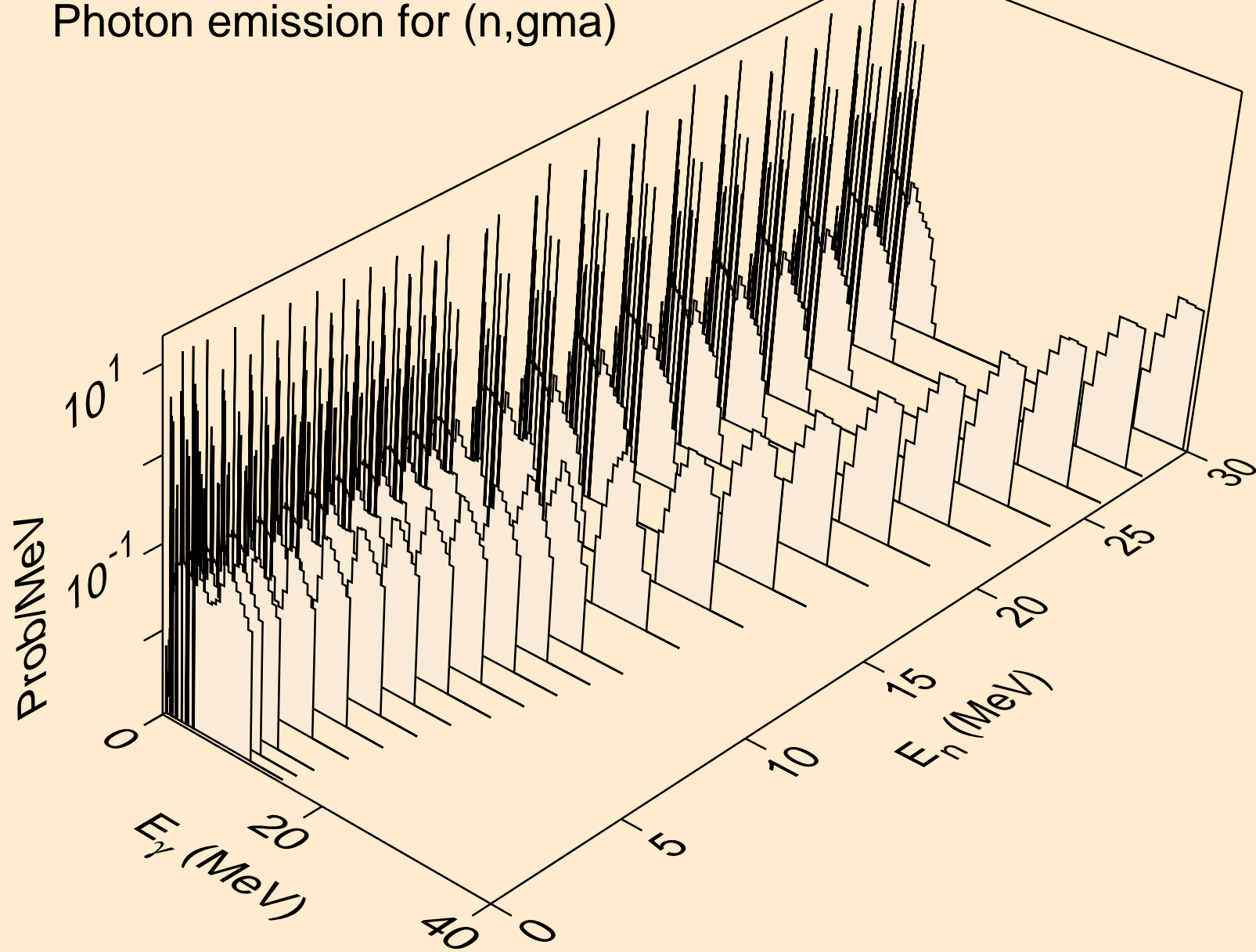

K046 PROTON ACER TENDL-2021 LIBRARY; T=0.K  
Photon emission for inelastic

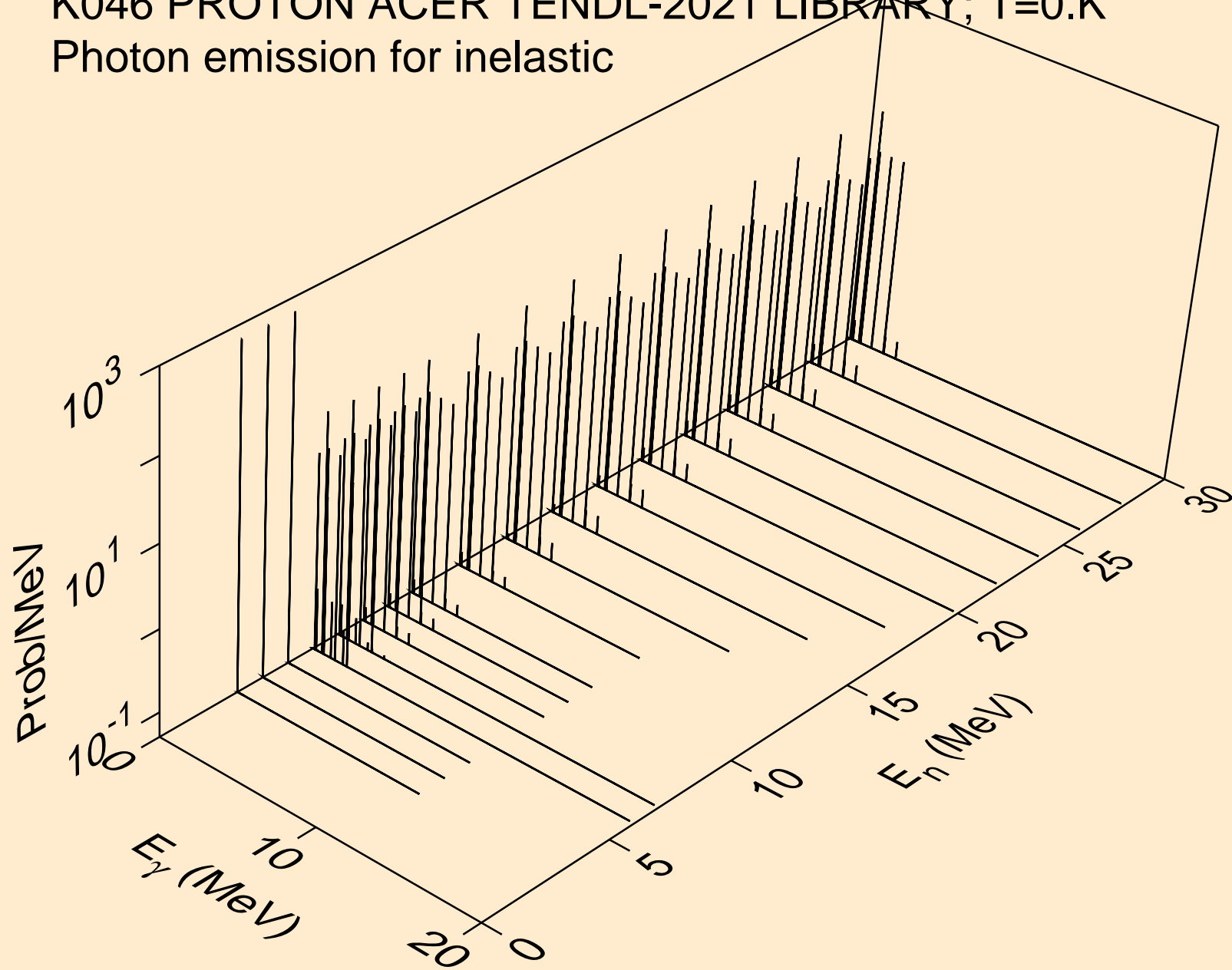



K046 PROTON ACER TENDL-2021 LIBRARY; T=0.K  
Photon emission for (n,d)

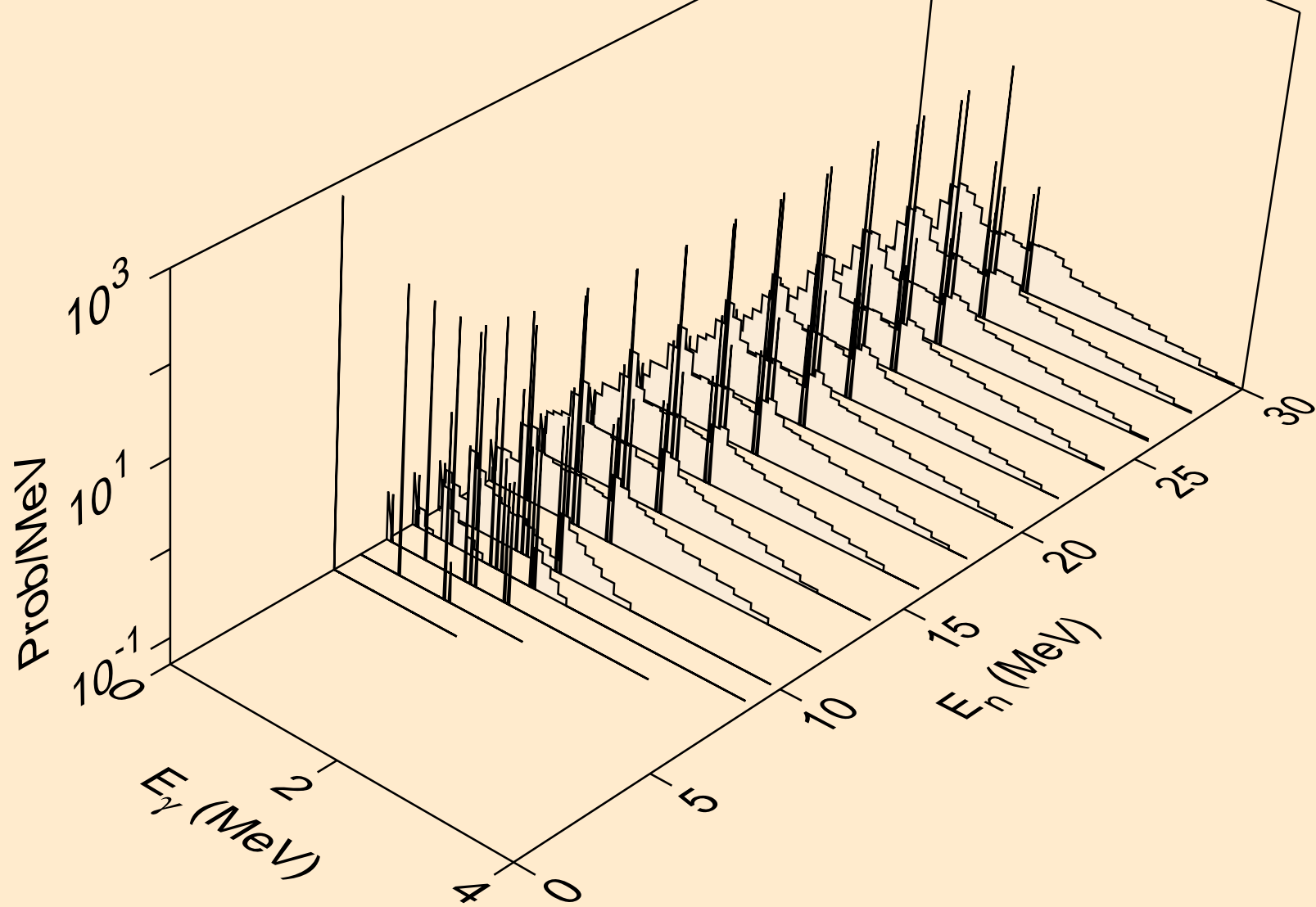

K046 PROTON ACER TENDL-2021 LIBRARY; T=0.K  
Photon emission for (n,t)

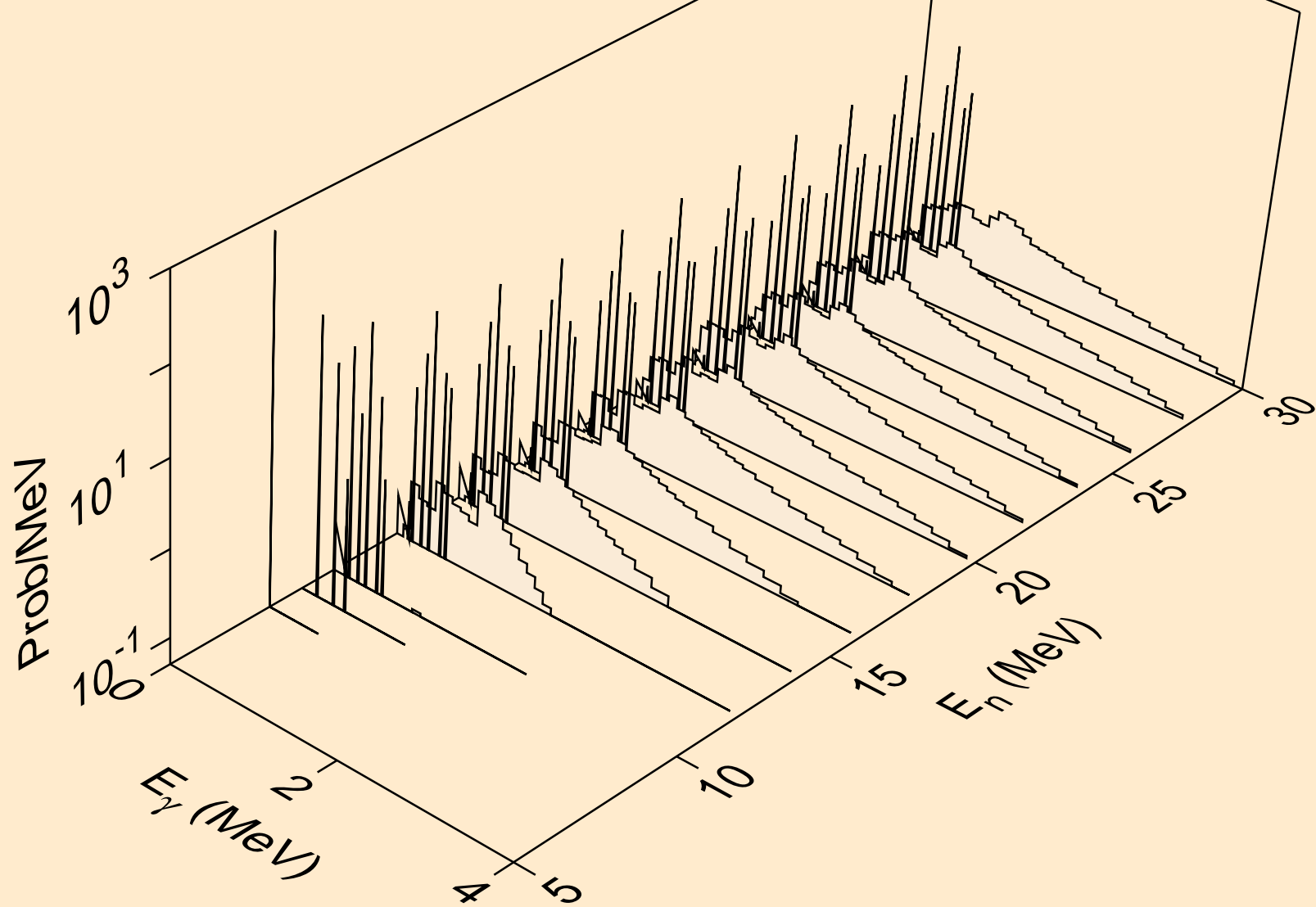

K046 PROTON ACER TENDL-2021 LIBRARY; T=0.K  
Photon emission for (n,he3)

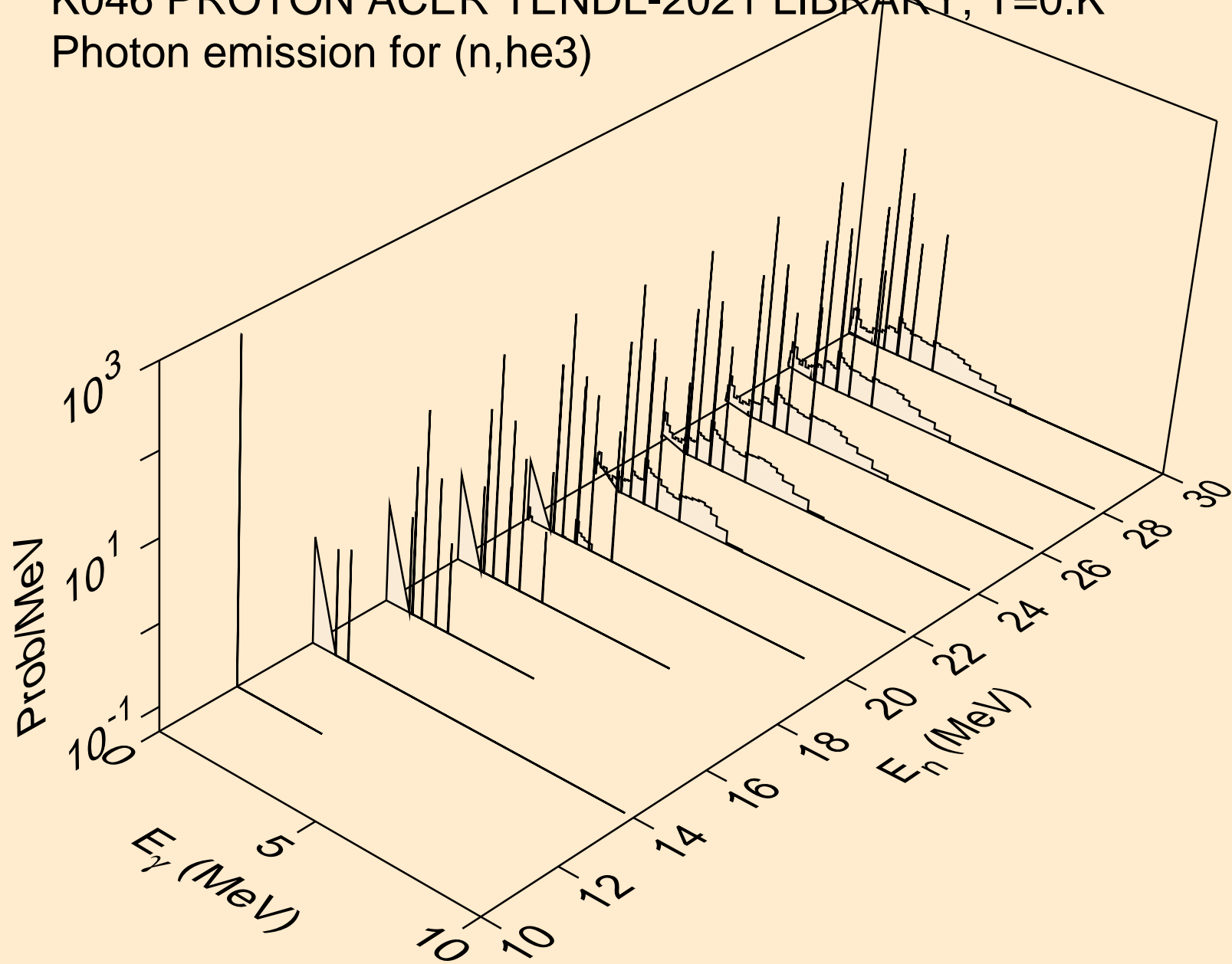

K046 PROTON ACER TENDL-2021 LIBRARY; T=0.K  
Photon emission for (n,a)

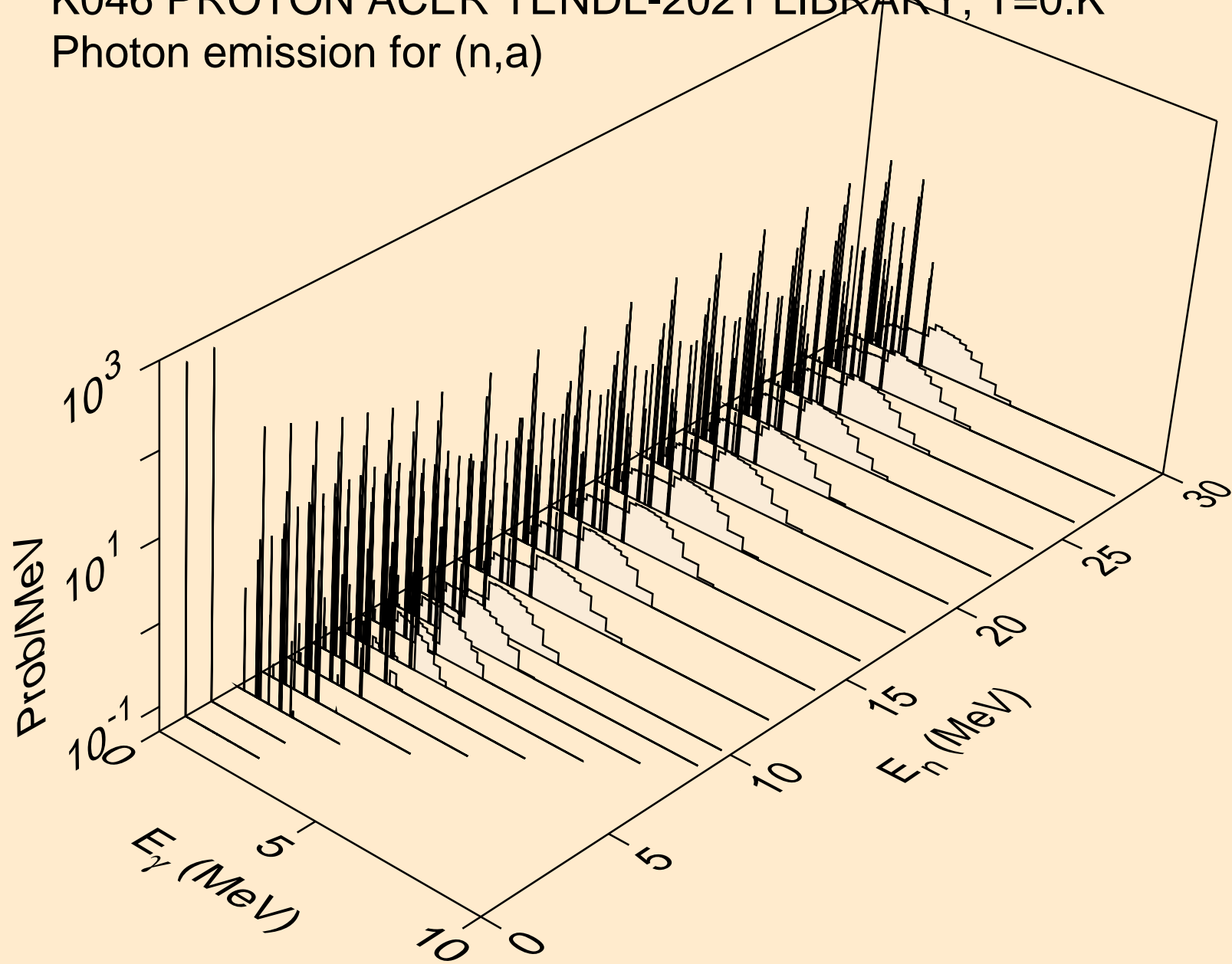

K046 PROTON ACER TENDL-2021 LIBRARY; T=0.K  
Photon emission for (n,2a)

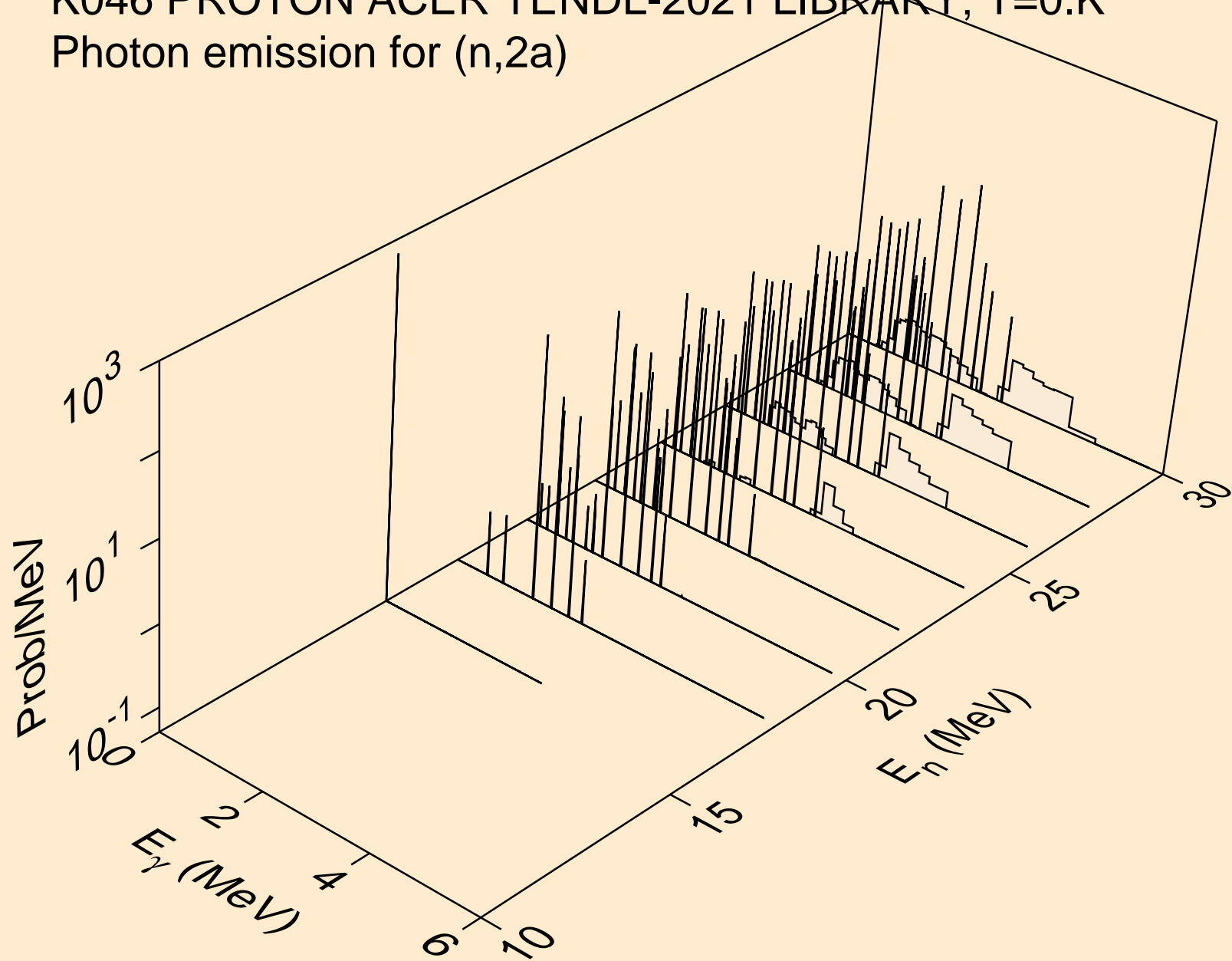

K046 PROTON ACER TENDL-2021 LIBRARY; T=0.K  
Photon emission for (n,2p)

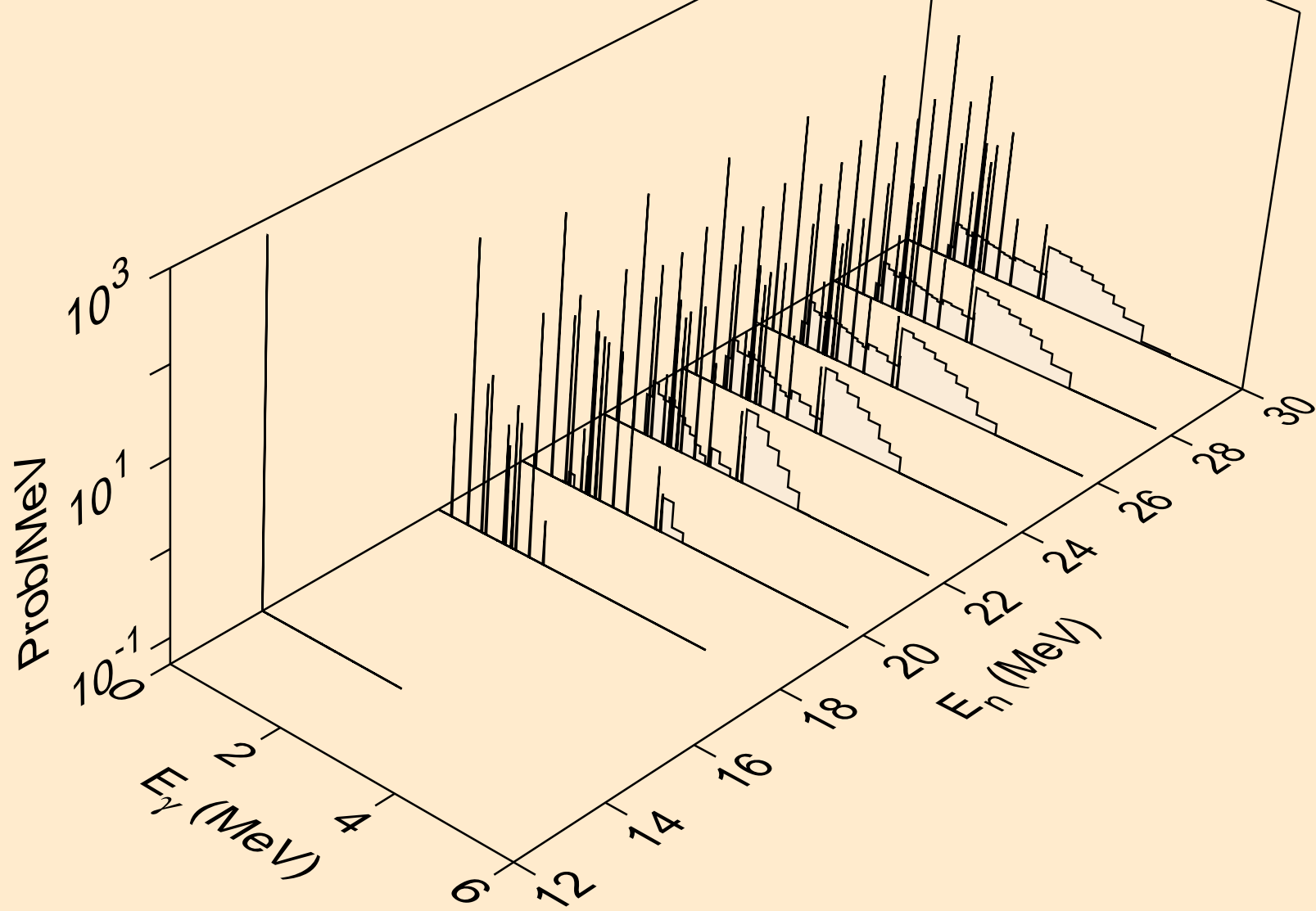

K046 PROTON ACER TENDL-2021 LIBRARY; T=0.K  
Photon emission for (n,pa)

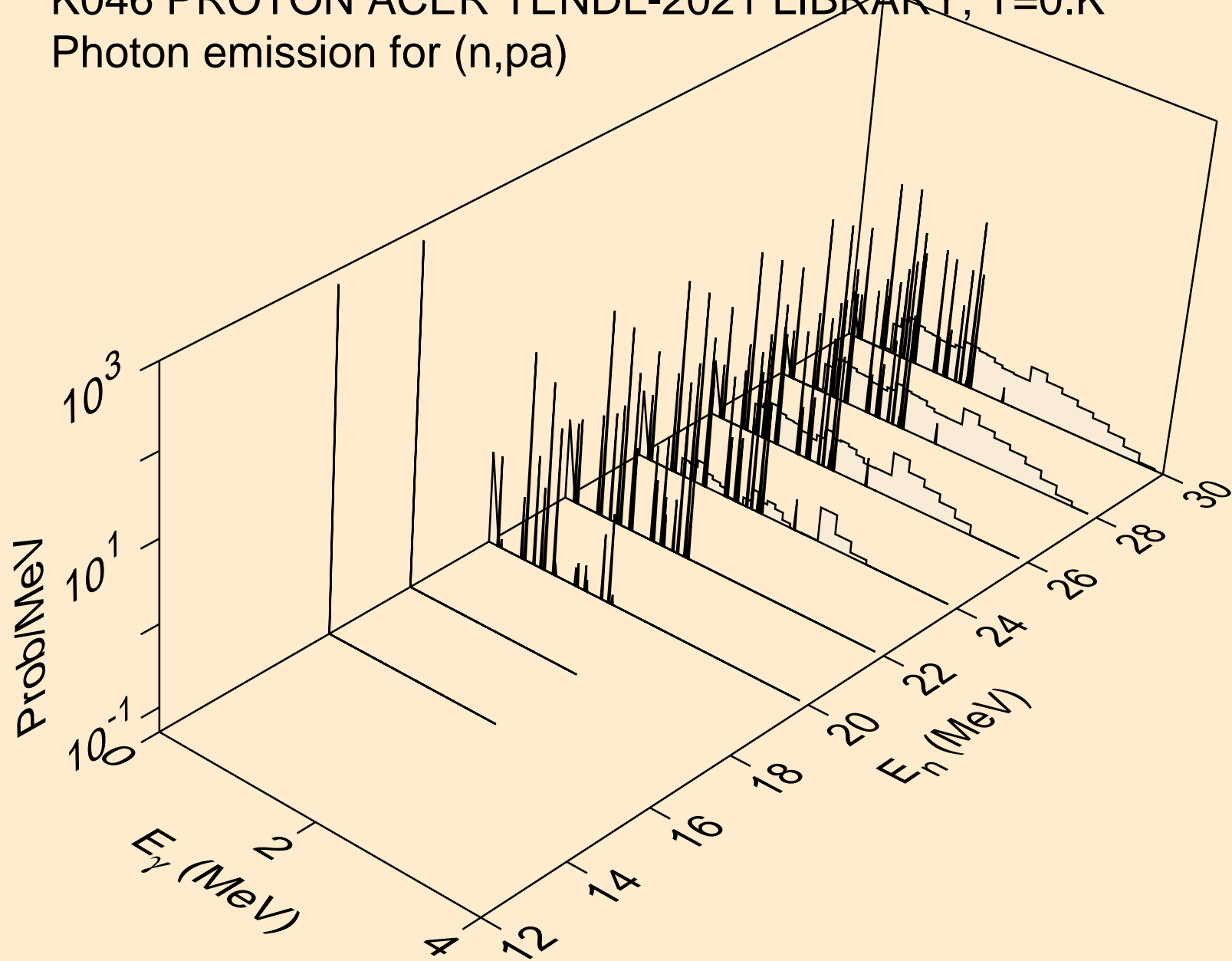

K046 PROTON ACER TENDL-2021 LIBRARY; T=0.K  
Photon emission for (n,pd)

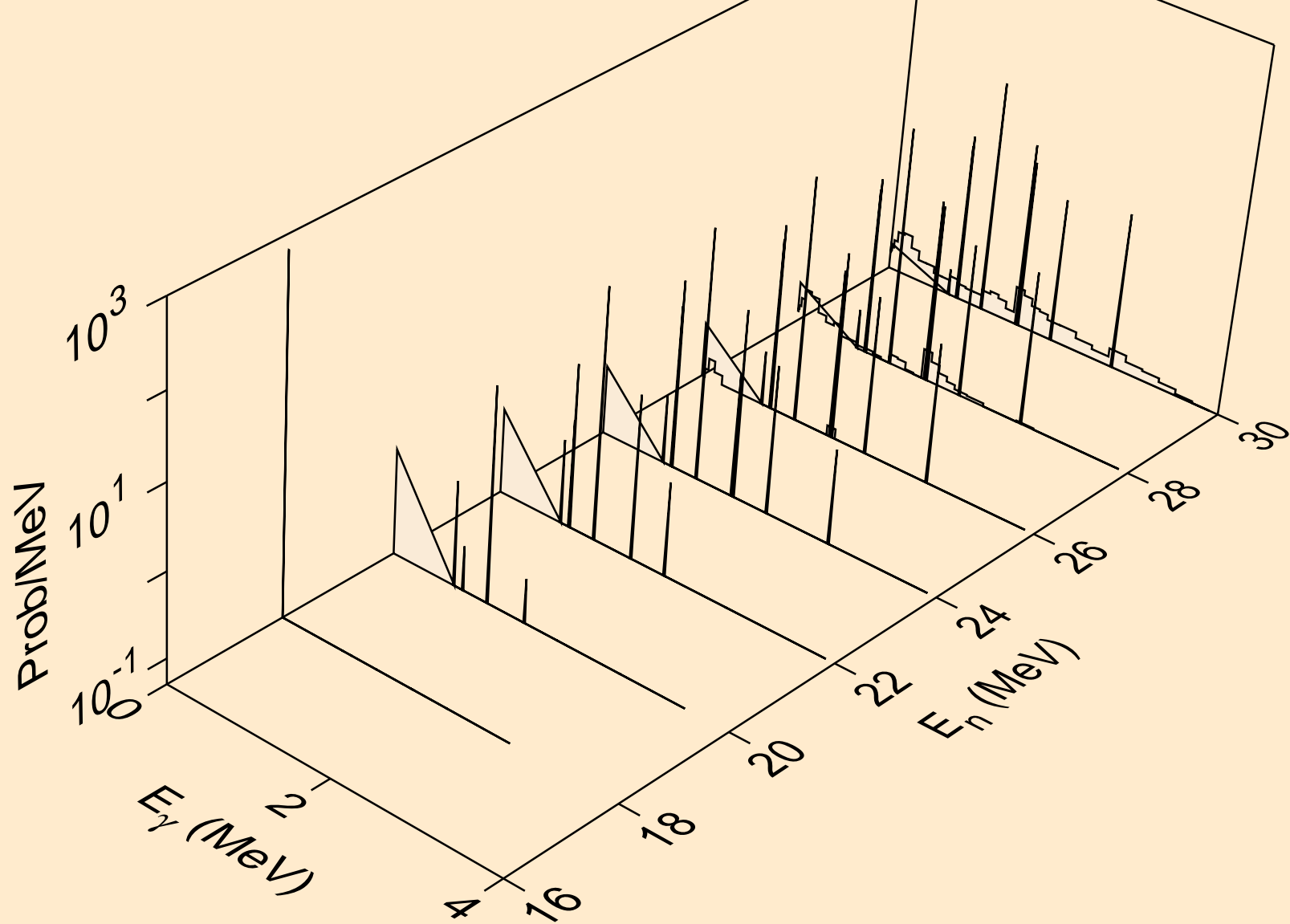



K046 PROTON ACER TENDL-2021 LIBRARY; T=0.K  
Photon emission for (n,pt)

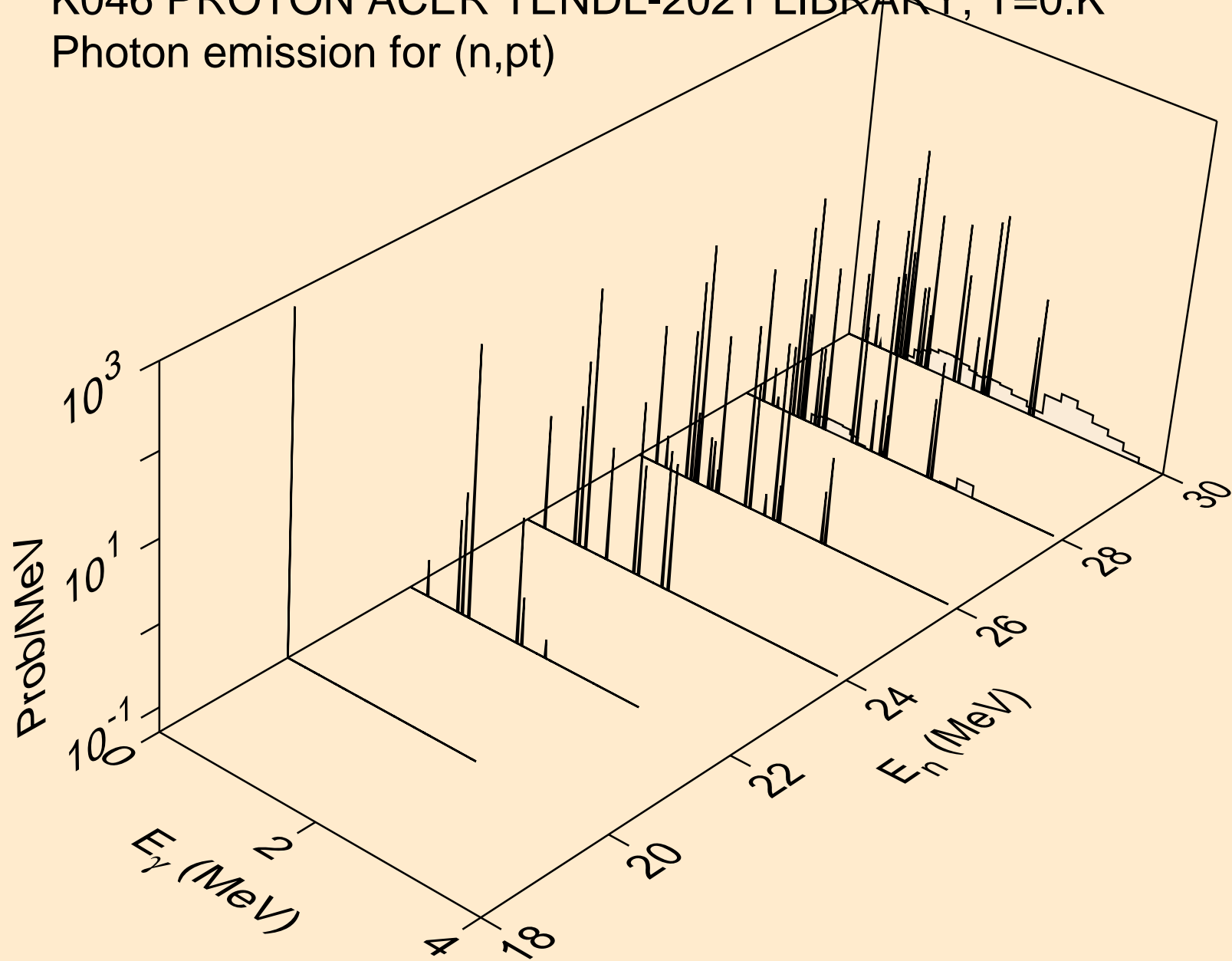

K046 PROTON ACER TENDL-2021 LIBRARY; T=0.K  
Photon emission for (n,da)

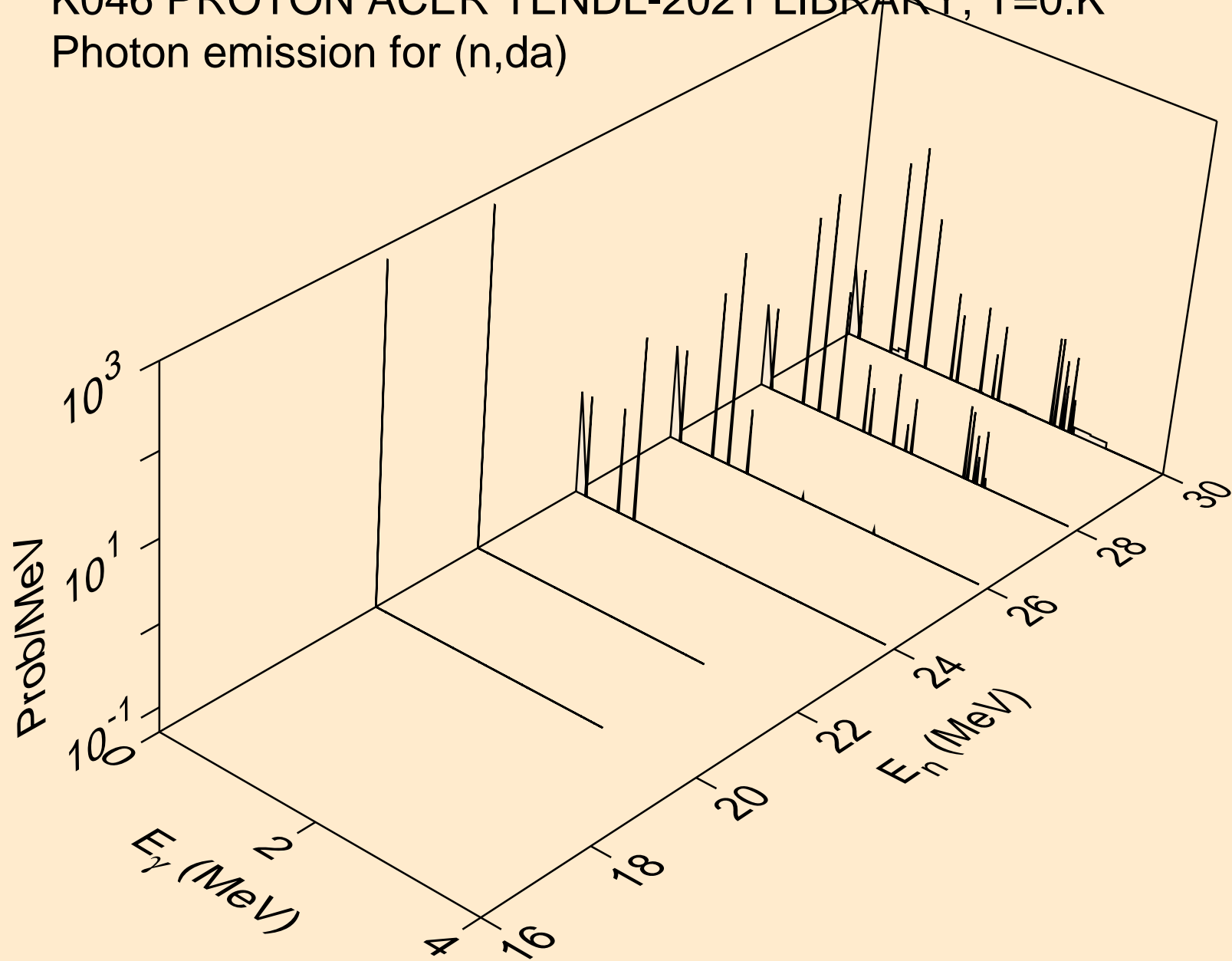

# K046 PROTON ACER TENDL-2021 LIBRARY; T=0.K

## Particle heating contributions

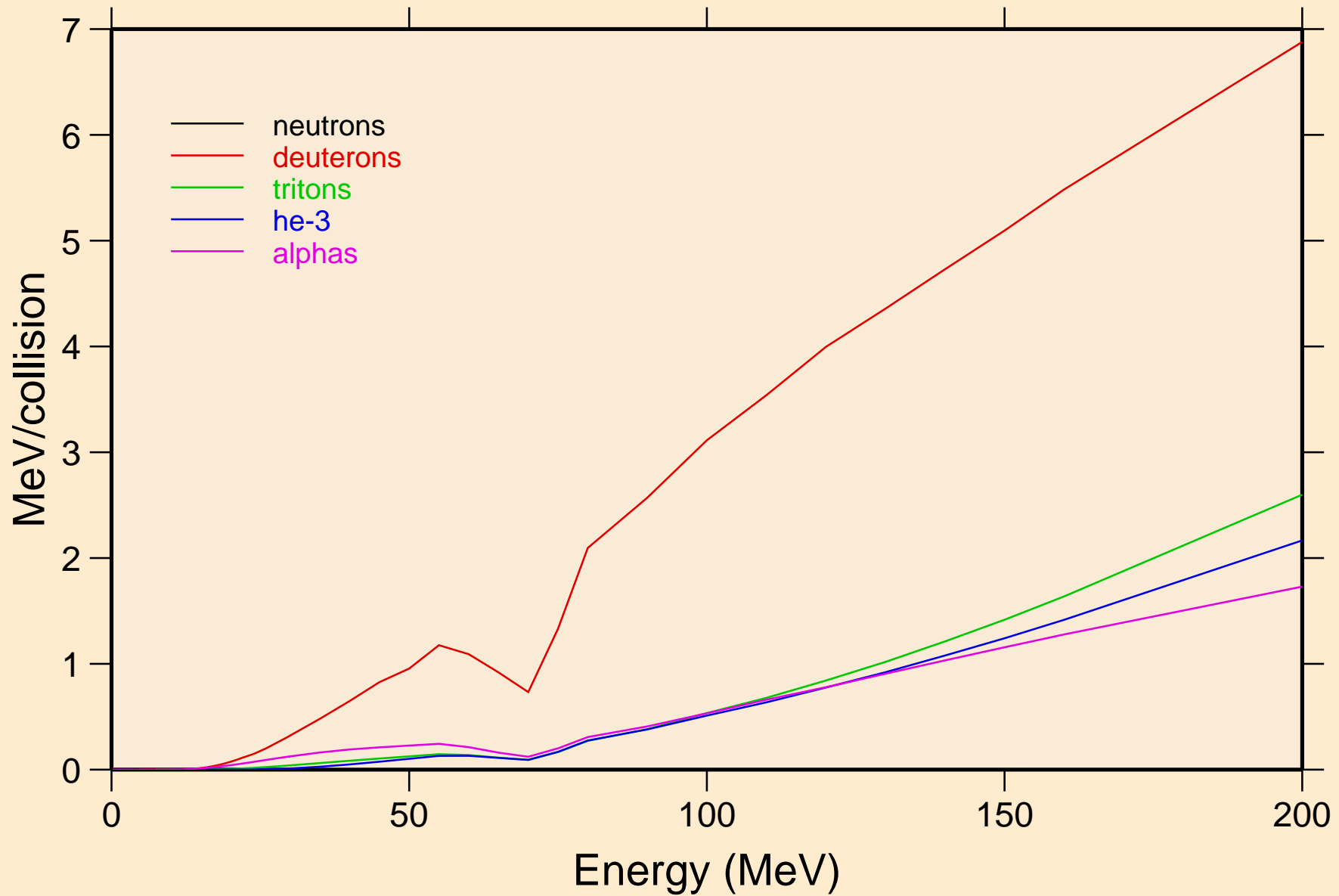

K046 PROTON ACER TENDL-2021 LIBRARY; T=0.K  
Recoil Heating

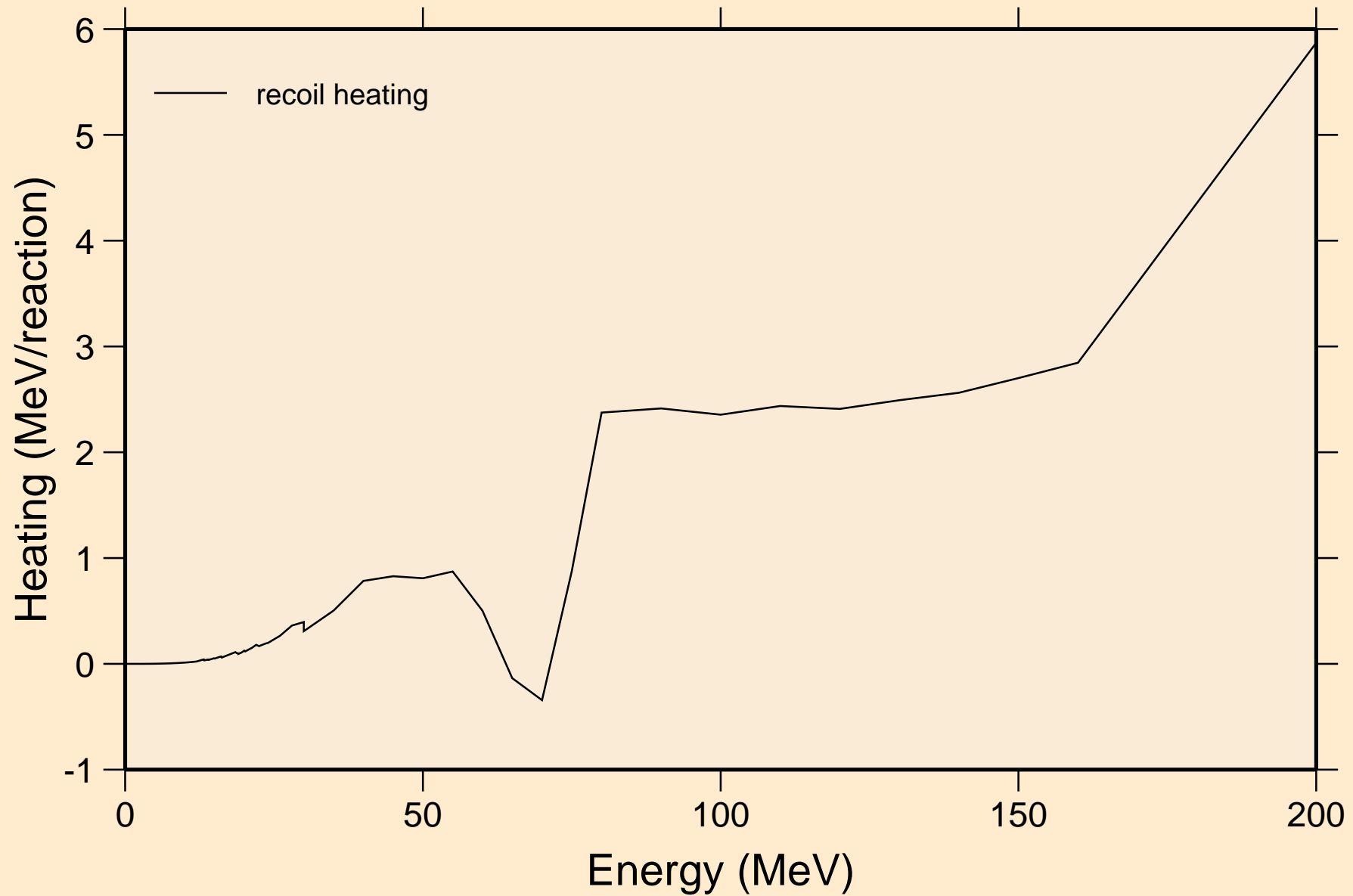

K046 PROTON ACER TENDL-2021 LIBRARY; T=0.K  
Particle production cross sections

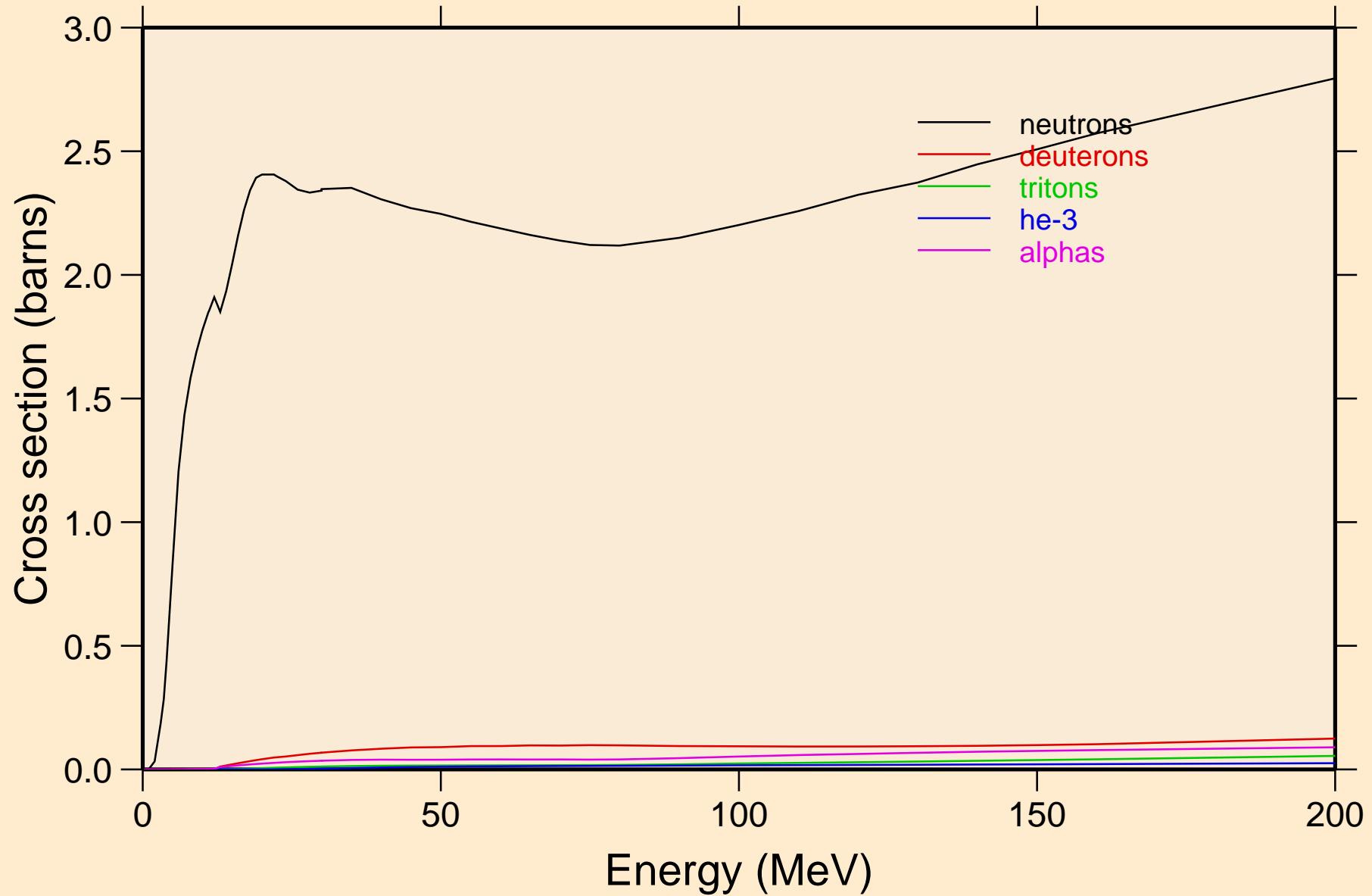

K046 PROTON ACER TENDL-2021 LIBRARY; T=0.K  
neutrons from (p,n)

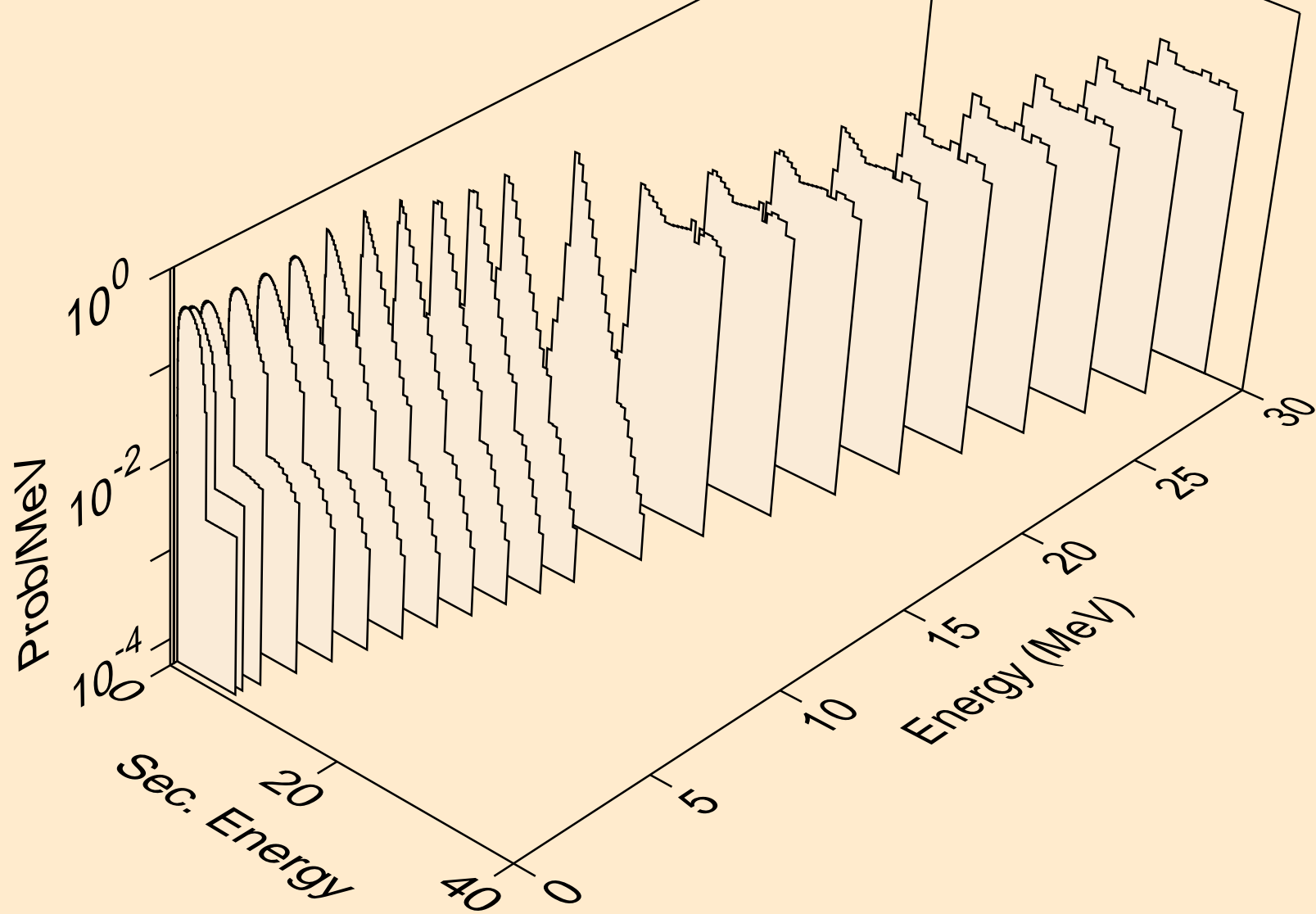

K046 PROTON ACER TENDL-2021 LIBRARY; T=0.K  
neutrons from (p,x)

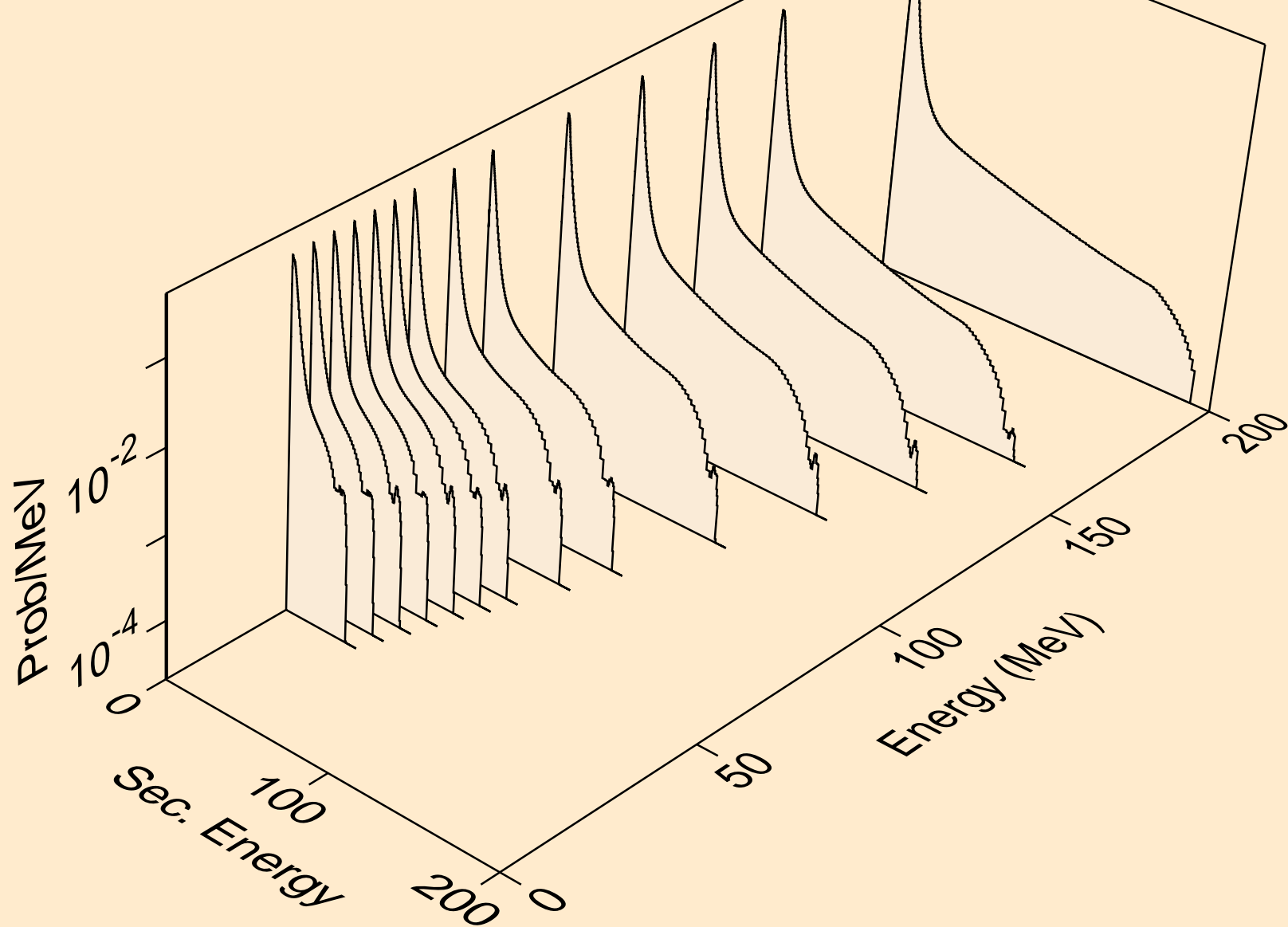

K046 PROTON ACER TENDL-2021 LIBRARY; T=0.K  
neutrons from (p,2nd)

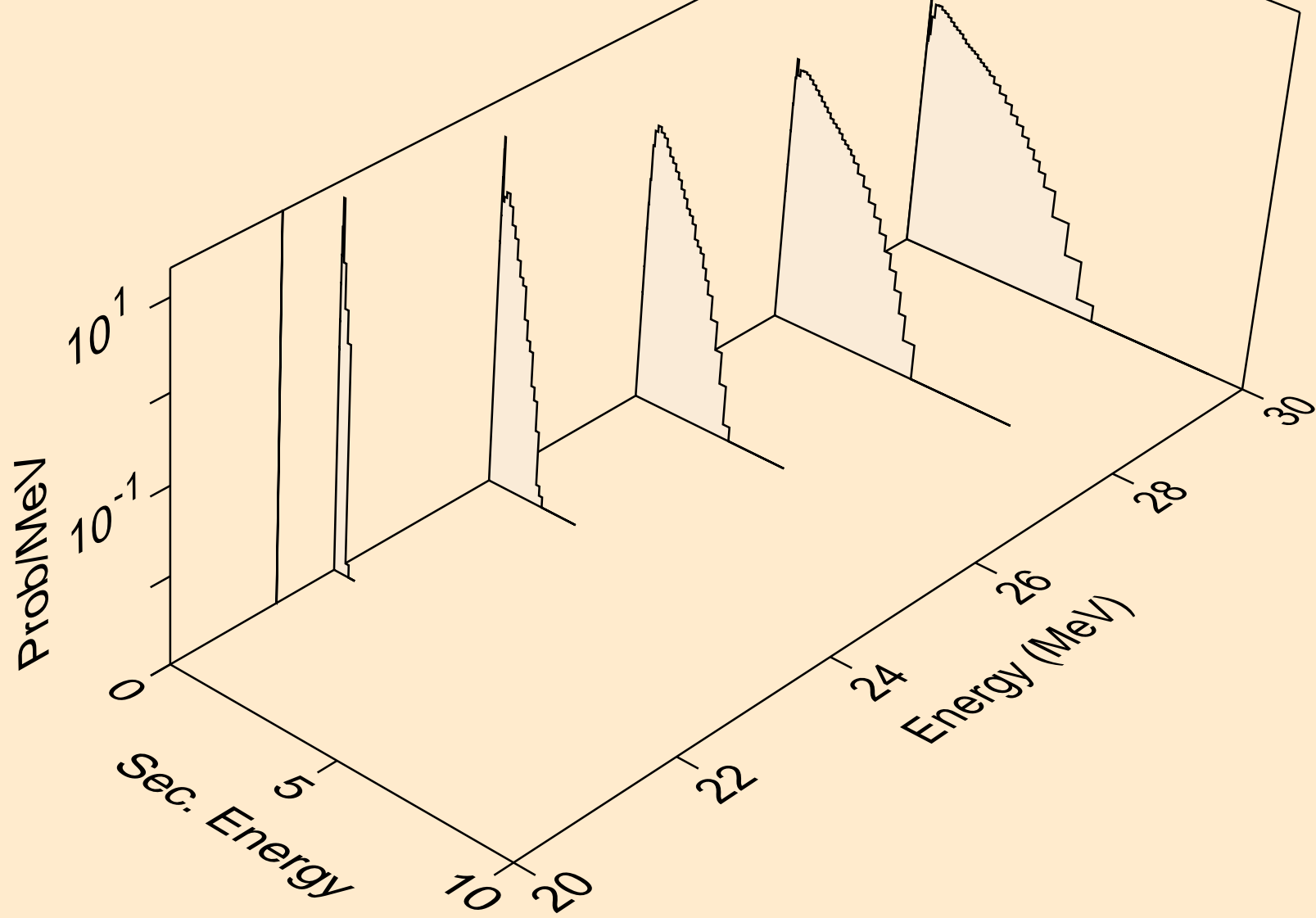



K046 PROTON ACER TENDL-2021 LIBRARY; T=0.K  
neutrons from (p,2n)

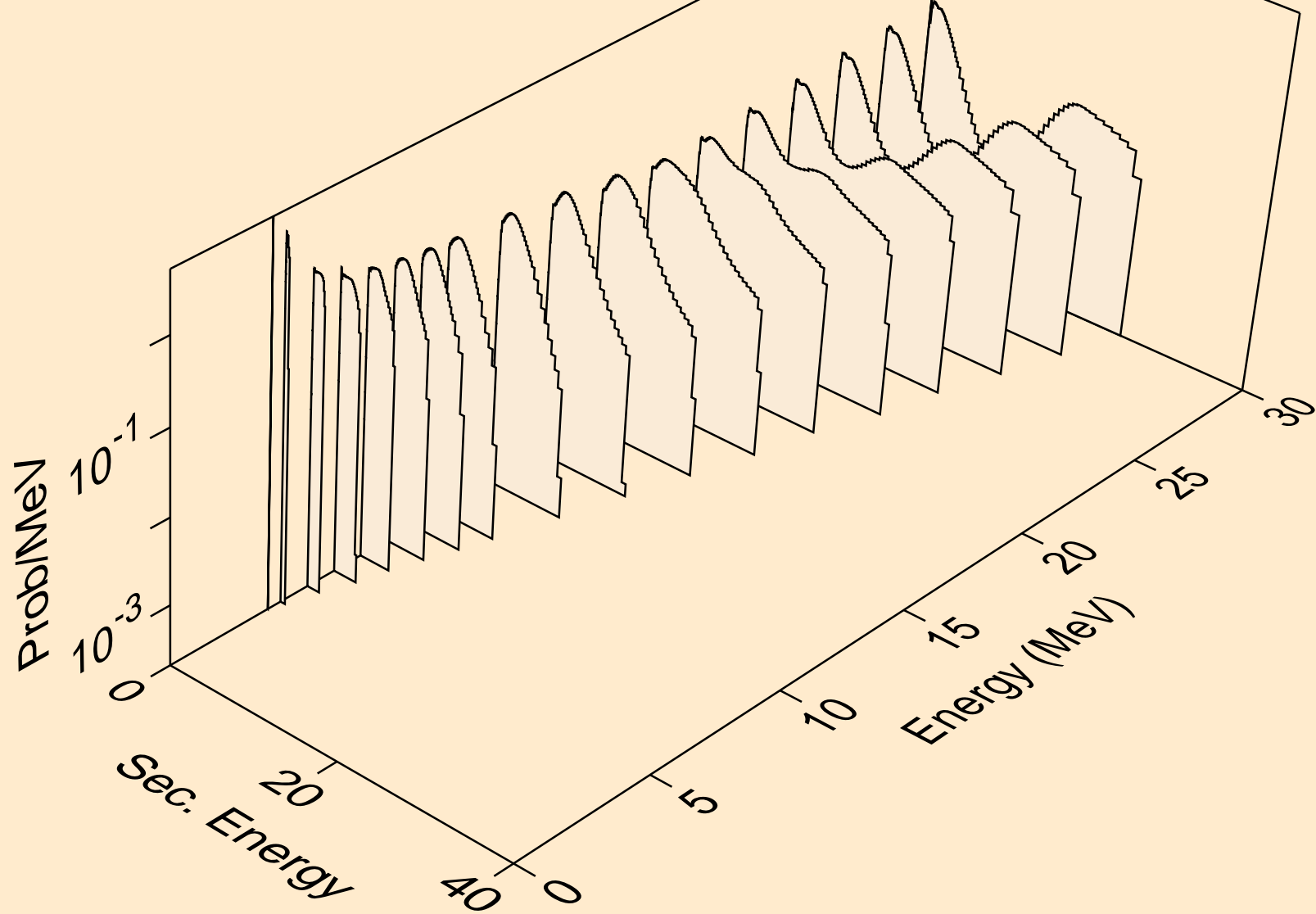

K046 PROTON ACER TENDL-2021 LIBRARY; T=0.K  
neutrons from (p,3n)

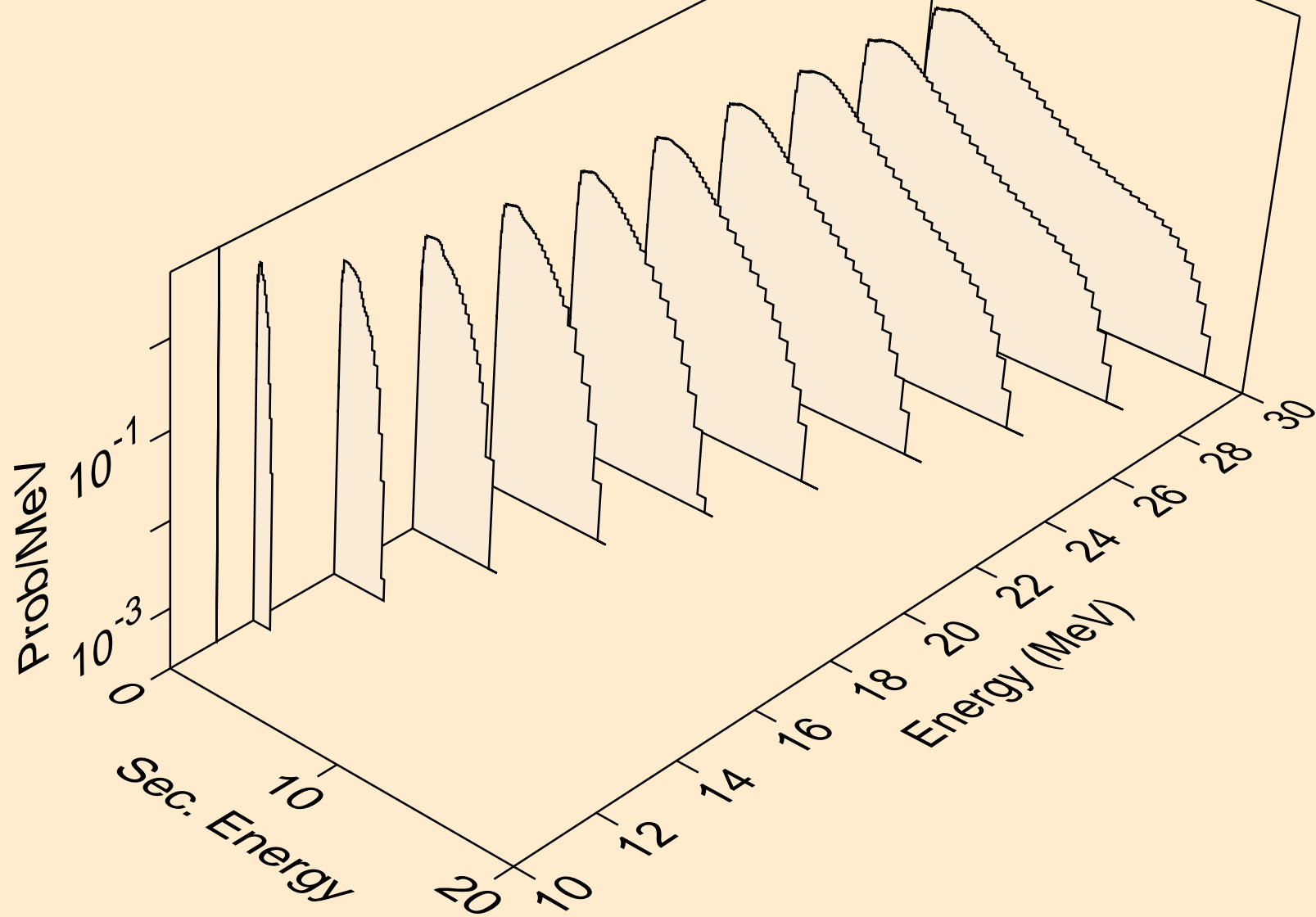

K046 PROTON ACER TENDL-2021 LIBRARY; T=0.K  
neutrons from (p,n\*)a

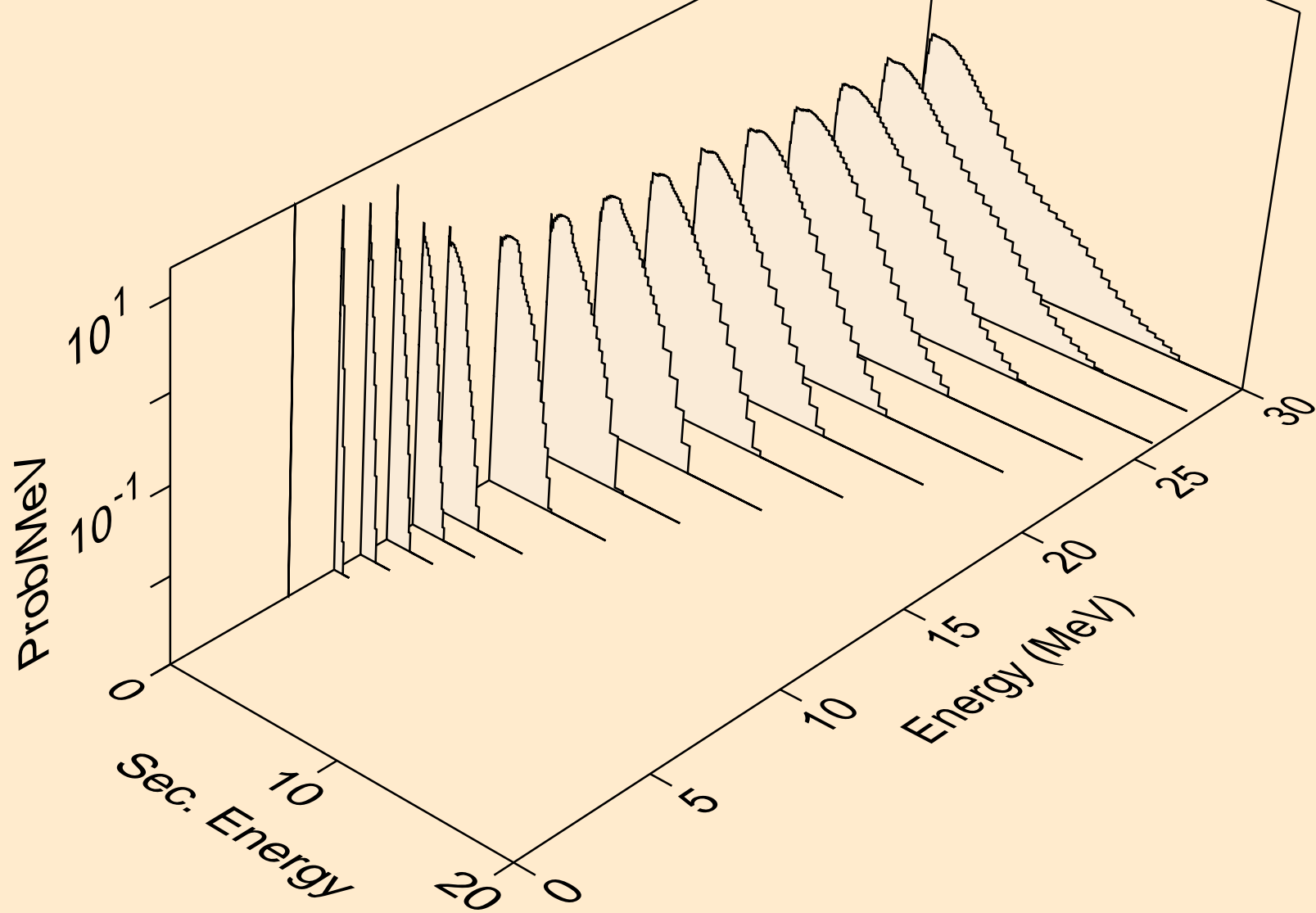

K046 PROTON ACER TENDL-2021 LIBRARY; T=0.K  
neutrons from (p,2n)a

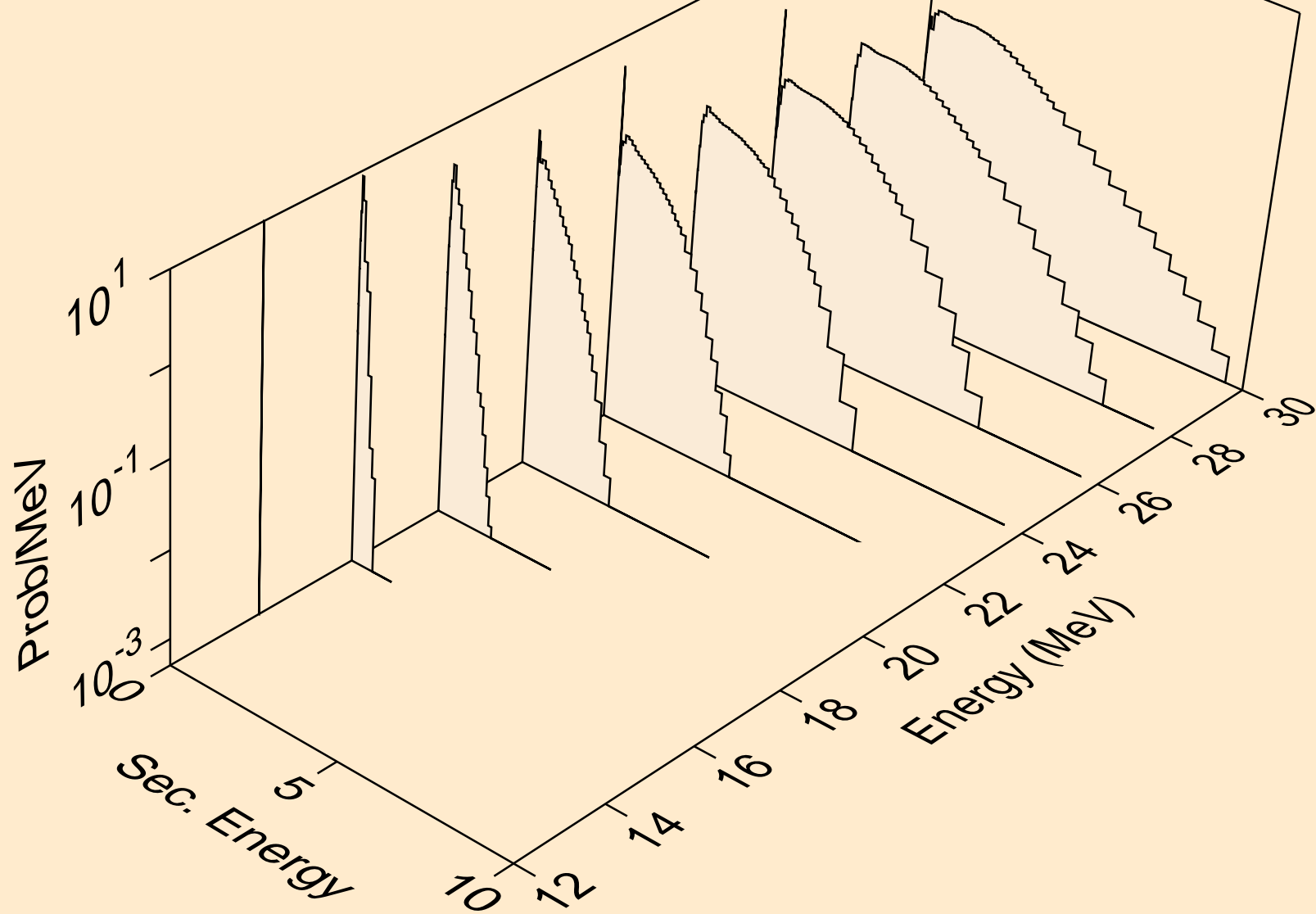

K046 PROTON ACER TENDL-2021 LIBRARY; T=0.K  
neutrons from (p,3n)a

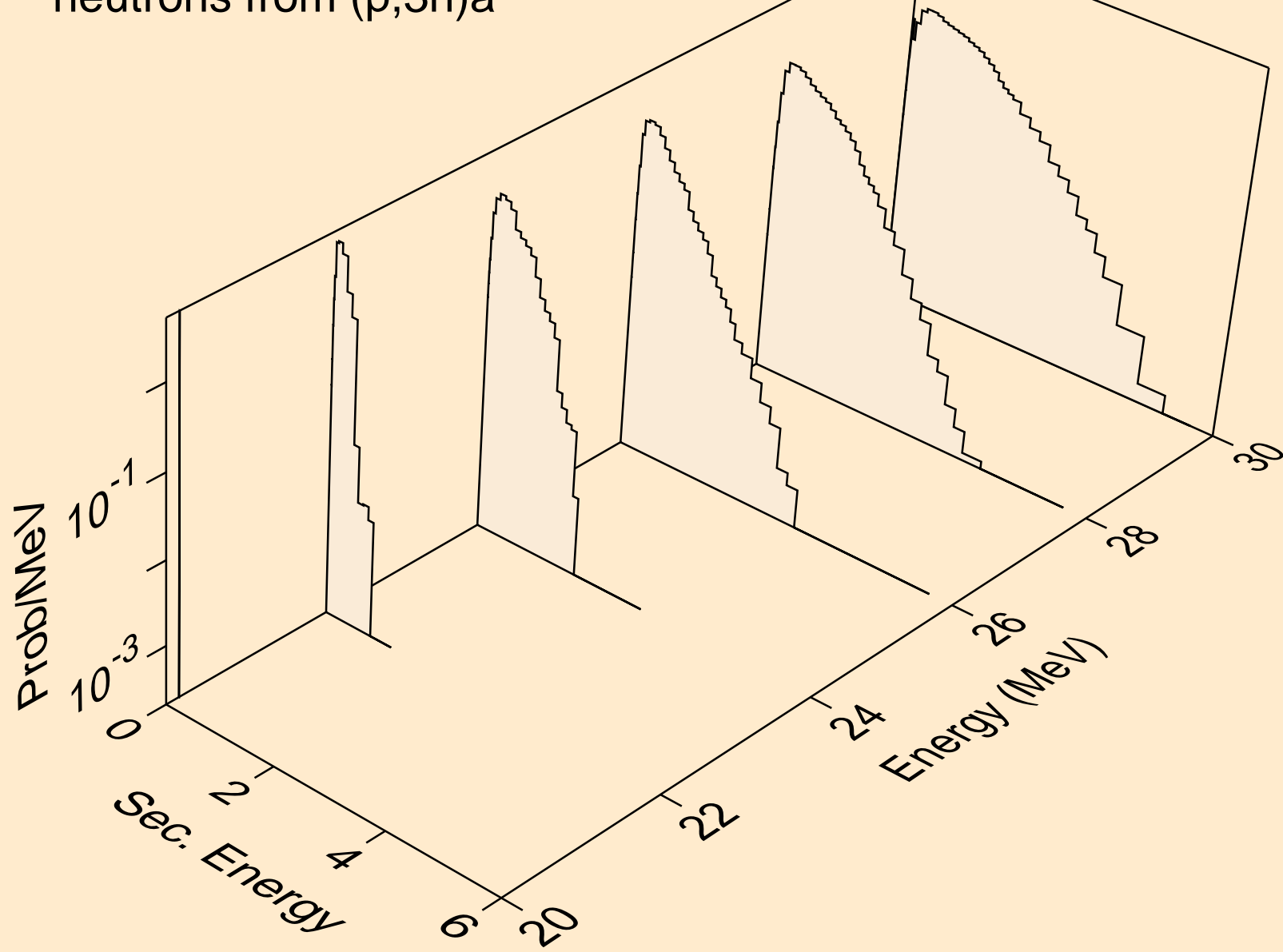

K046 PROTON ACER TENDL-2021 LIBRARY; T=0.K  
neutrons from (p,n\*)p

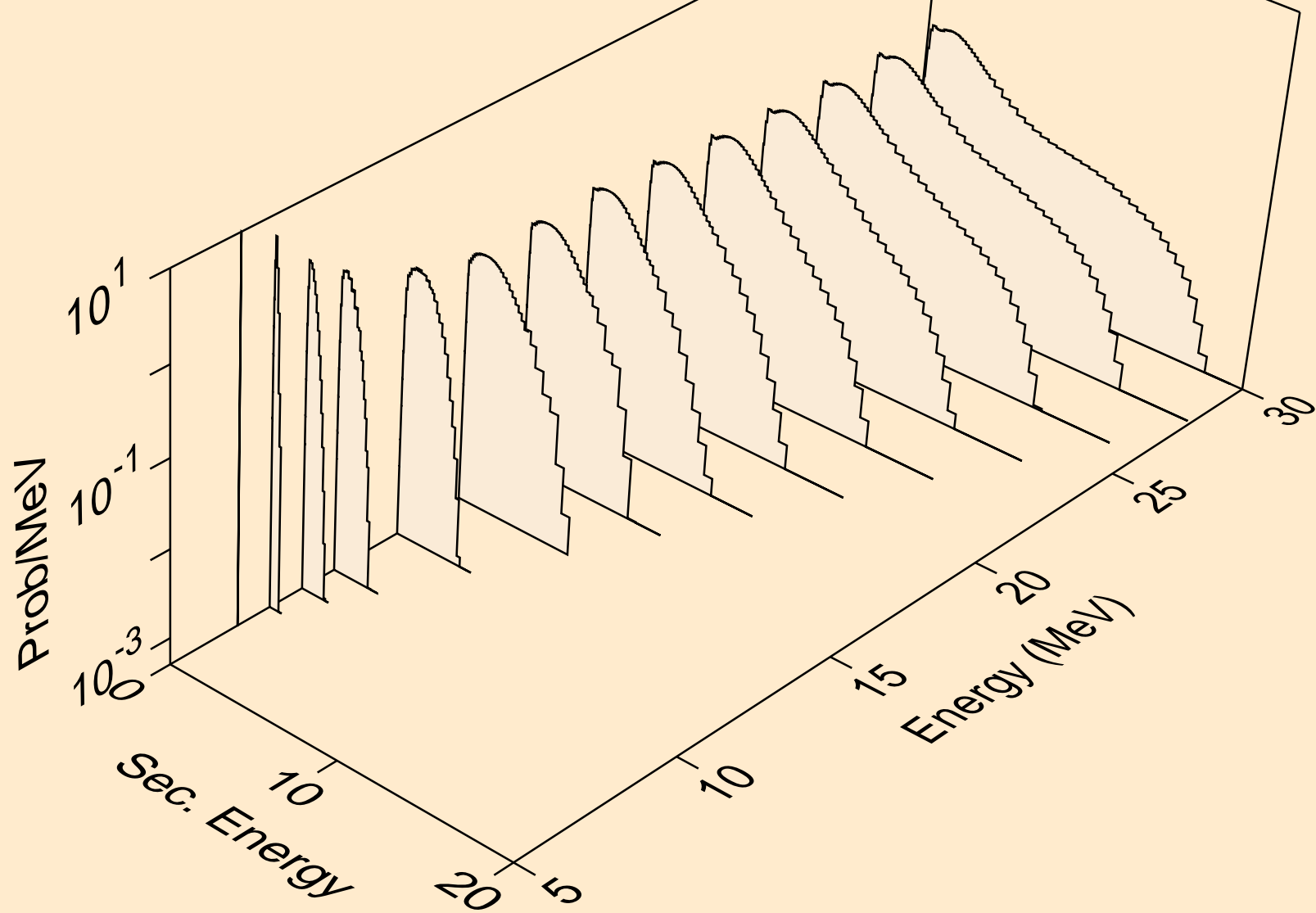

K046 PROTON ACER TENDL-2021 LIBRARY; T=0.K  
neutrons from (p,n\*)2a

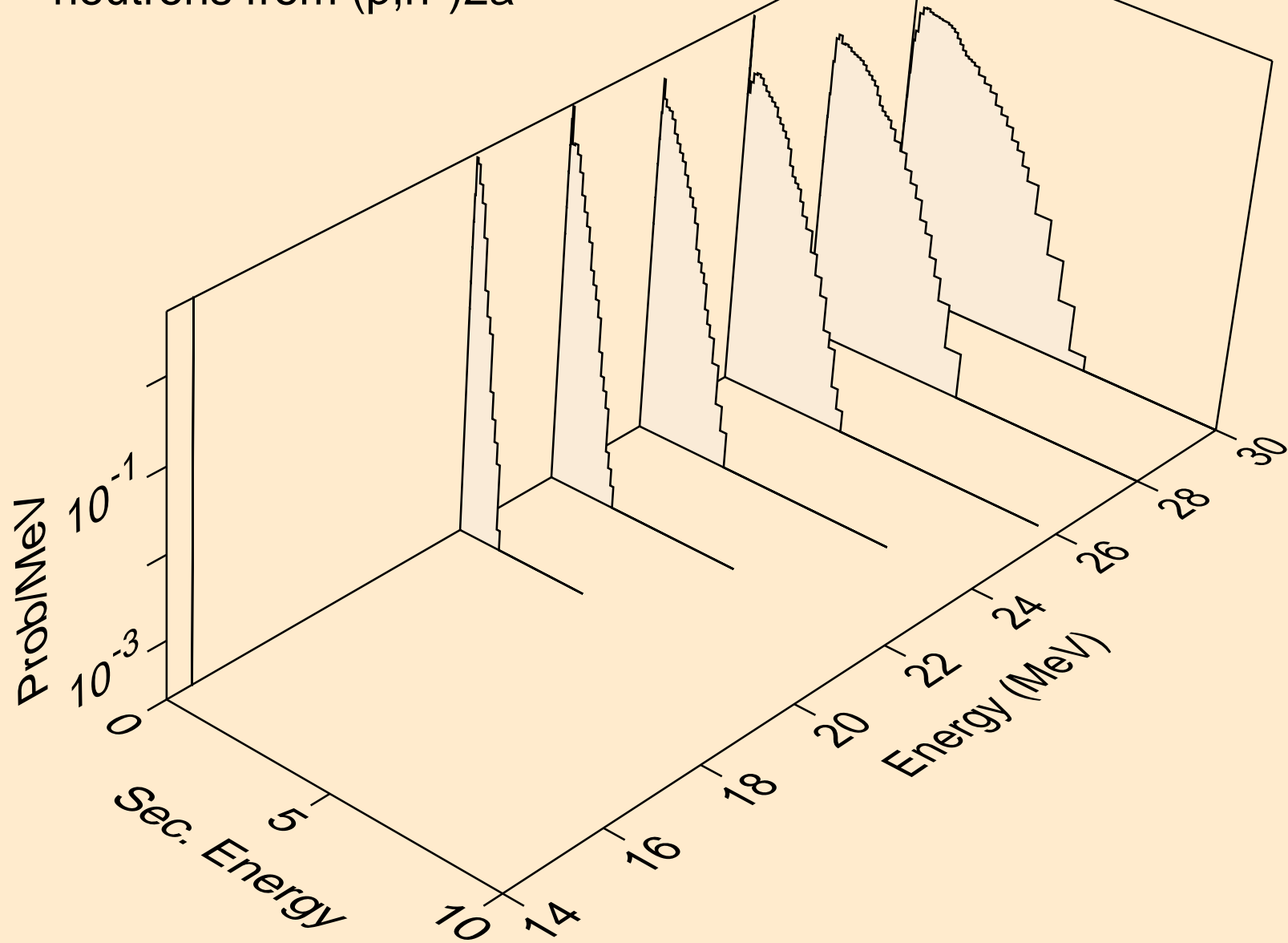

K046 PROTON ACER TENDL-2021 LIBRARY; T=0.K  
neutrons from (p,n\*)d

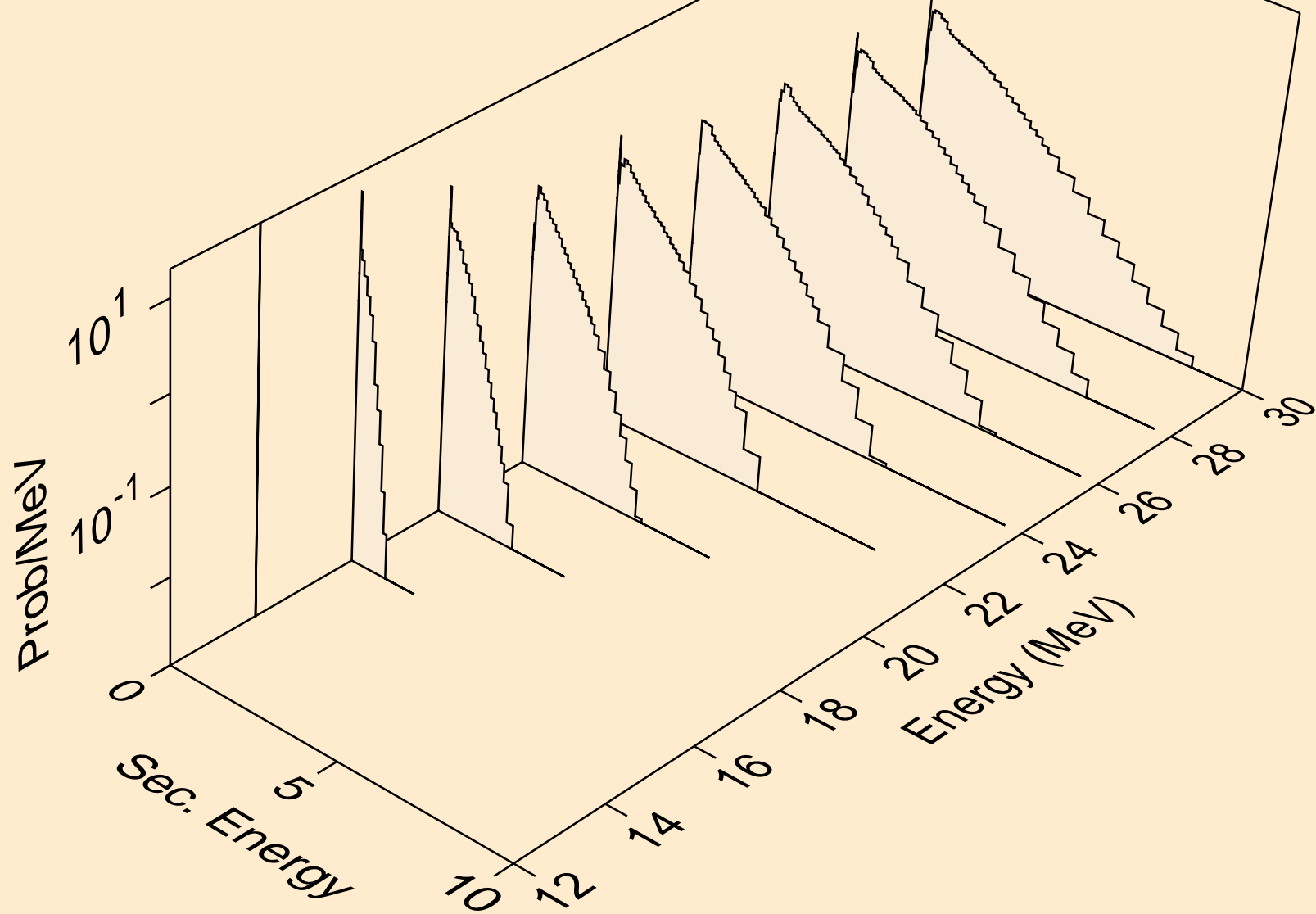



K046 PROTON ACER TENDL-2021 LIBRARY; T=0.K  
neutrons from (p,n\*)t

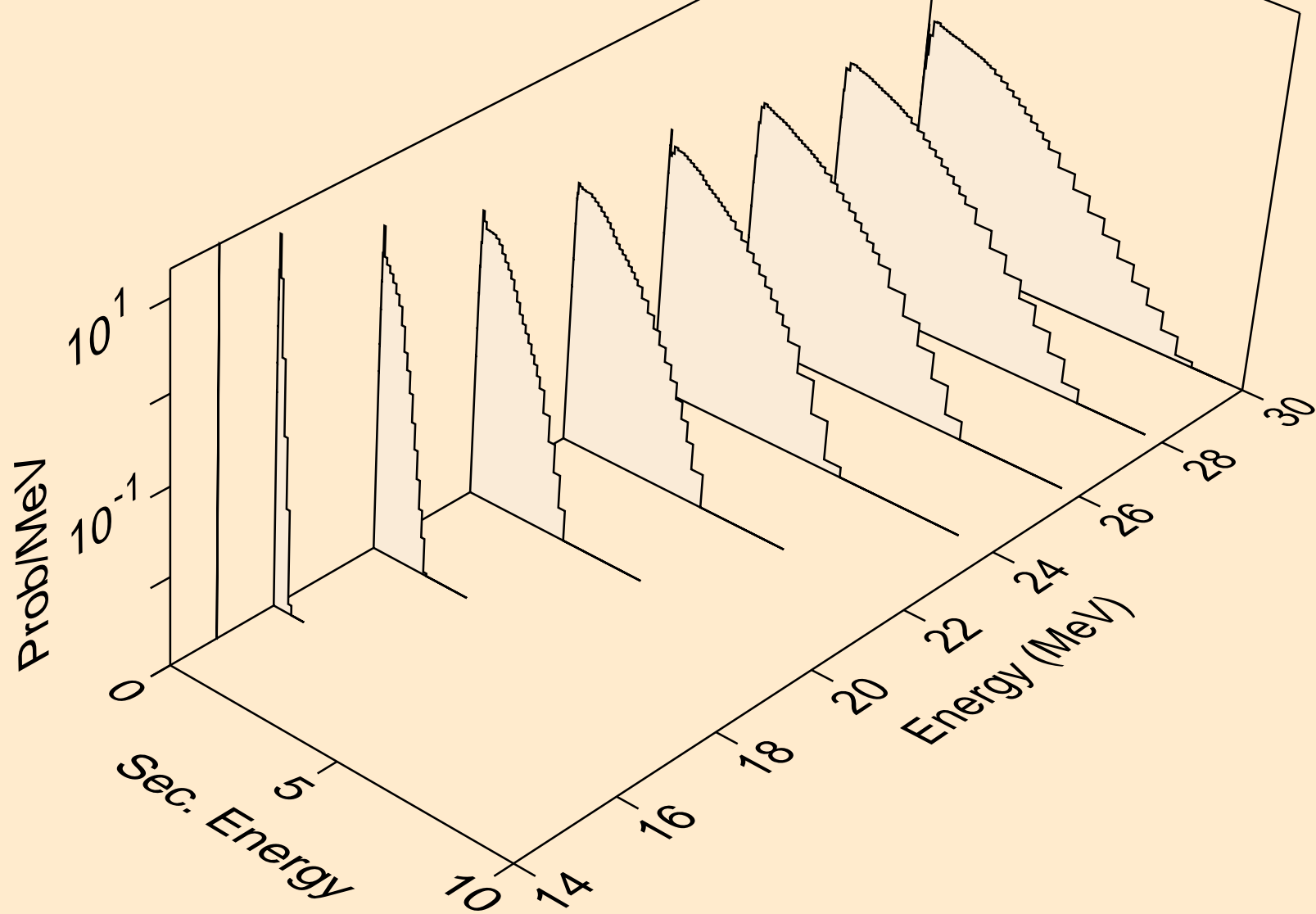

K046 PROTON ACER TENDL-2021 LIBRARY; T=0.K  
neutrons from (p,n\*)he3

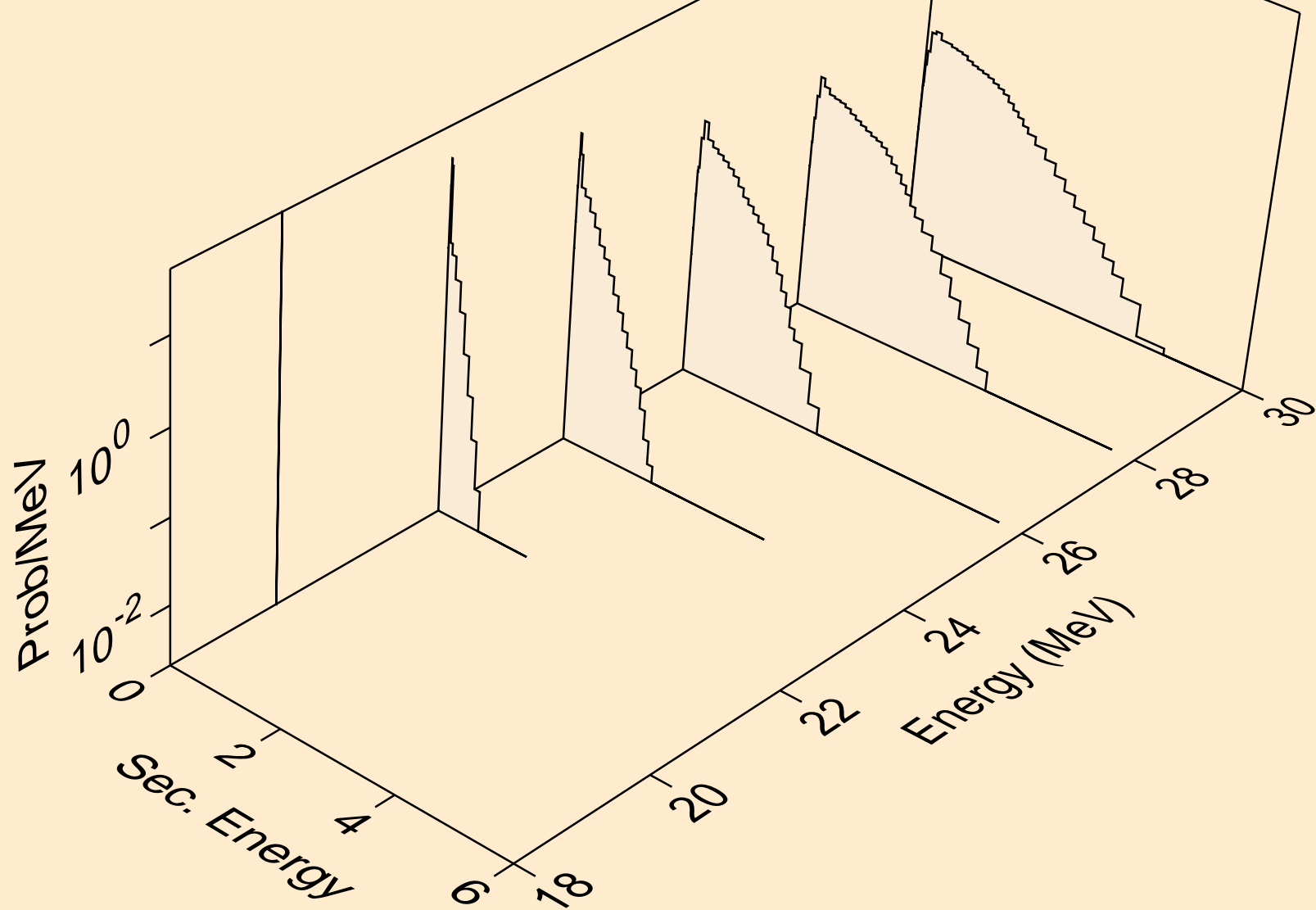

K046 PROTON ACER TENDL-2021 LIBRARY; T=0.K  
neutrons from (p,4n)

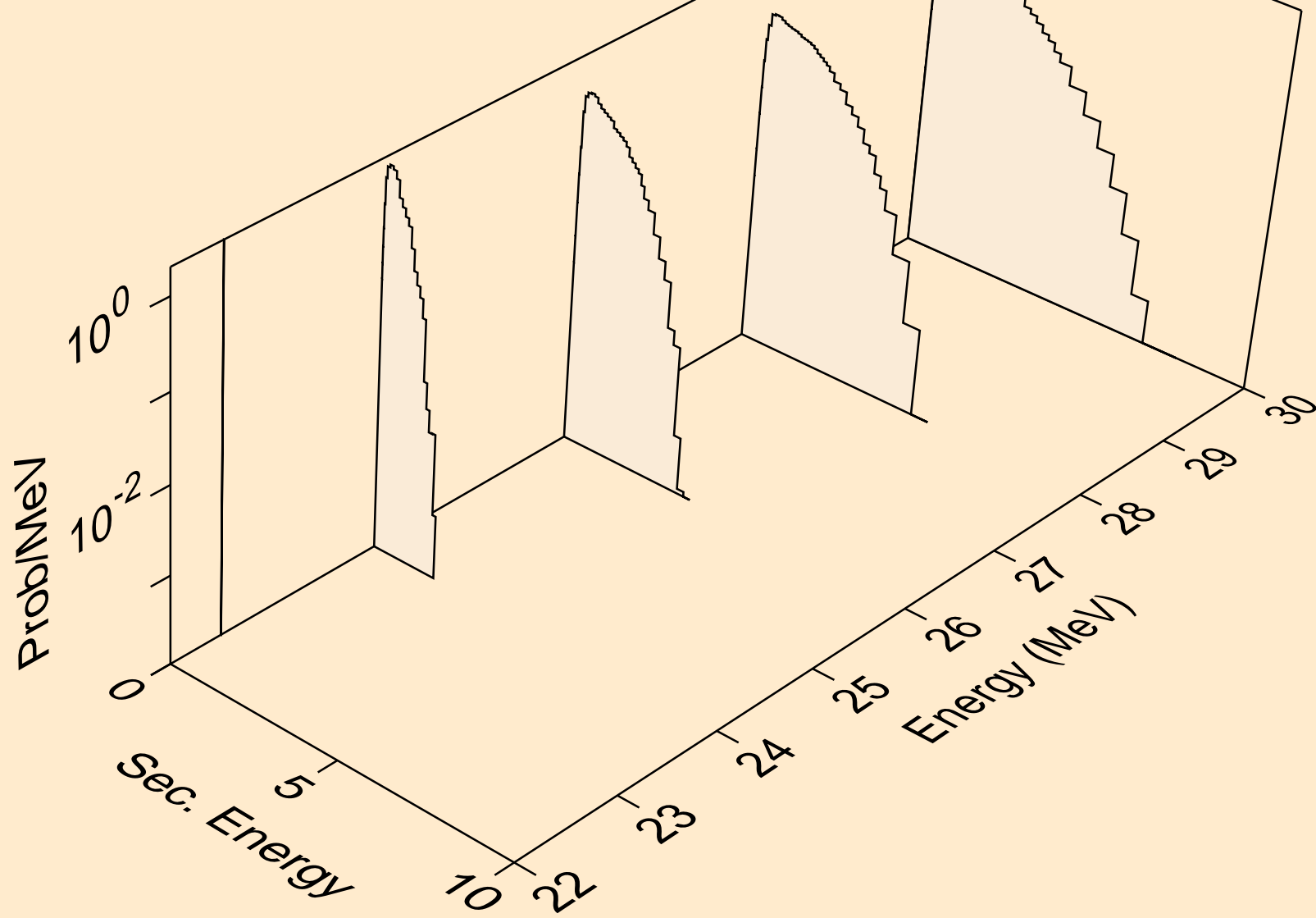

K046 PROTON ACER TENDL-2021 LIBRARY; T=0.K  
neutrons from (p,2np)

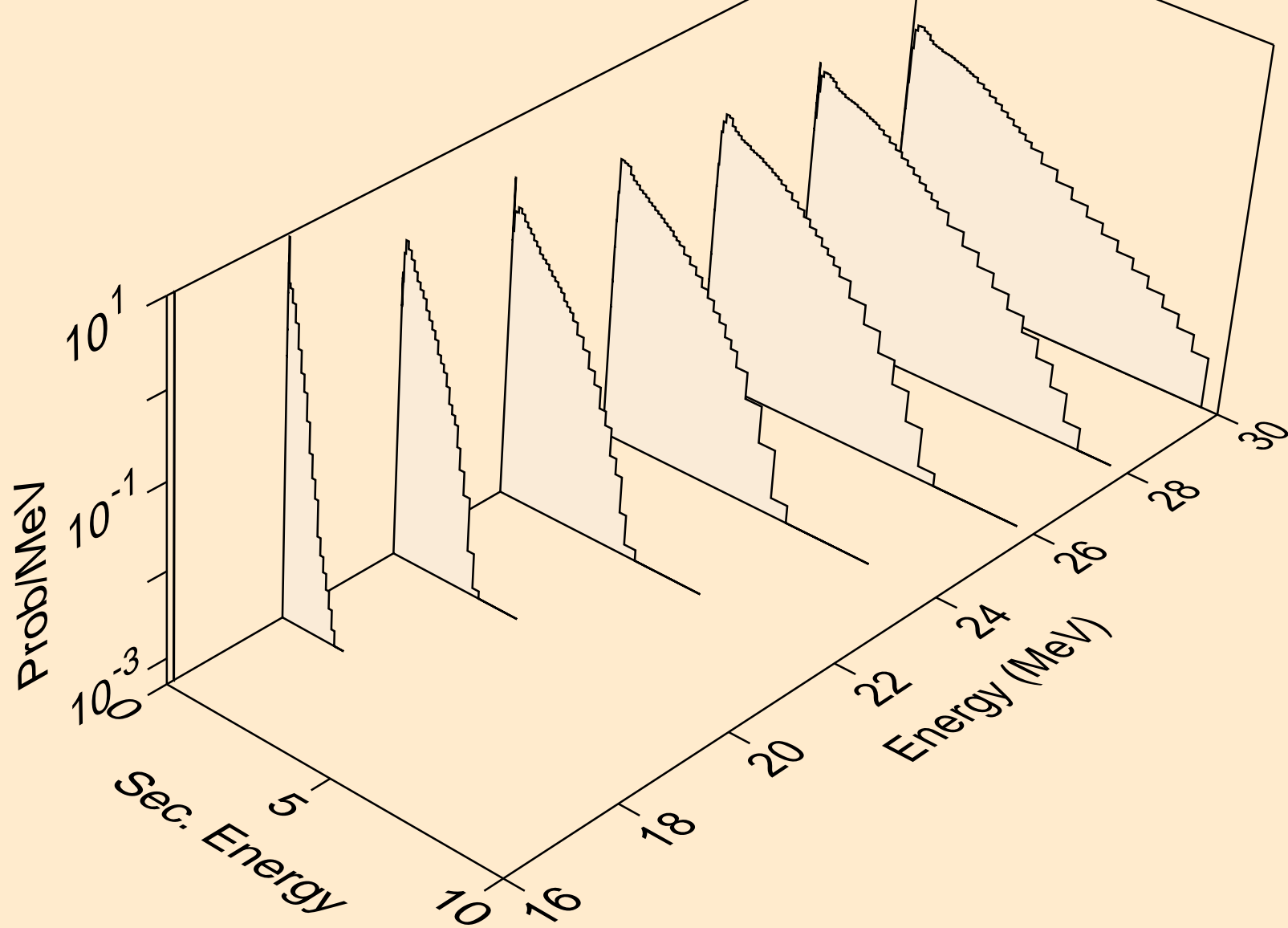

K046 PROTON ACER TENDL-2021 LIBRARY; T=0.K  
neutrons from (p,3np)

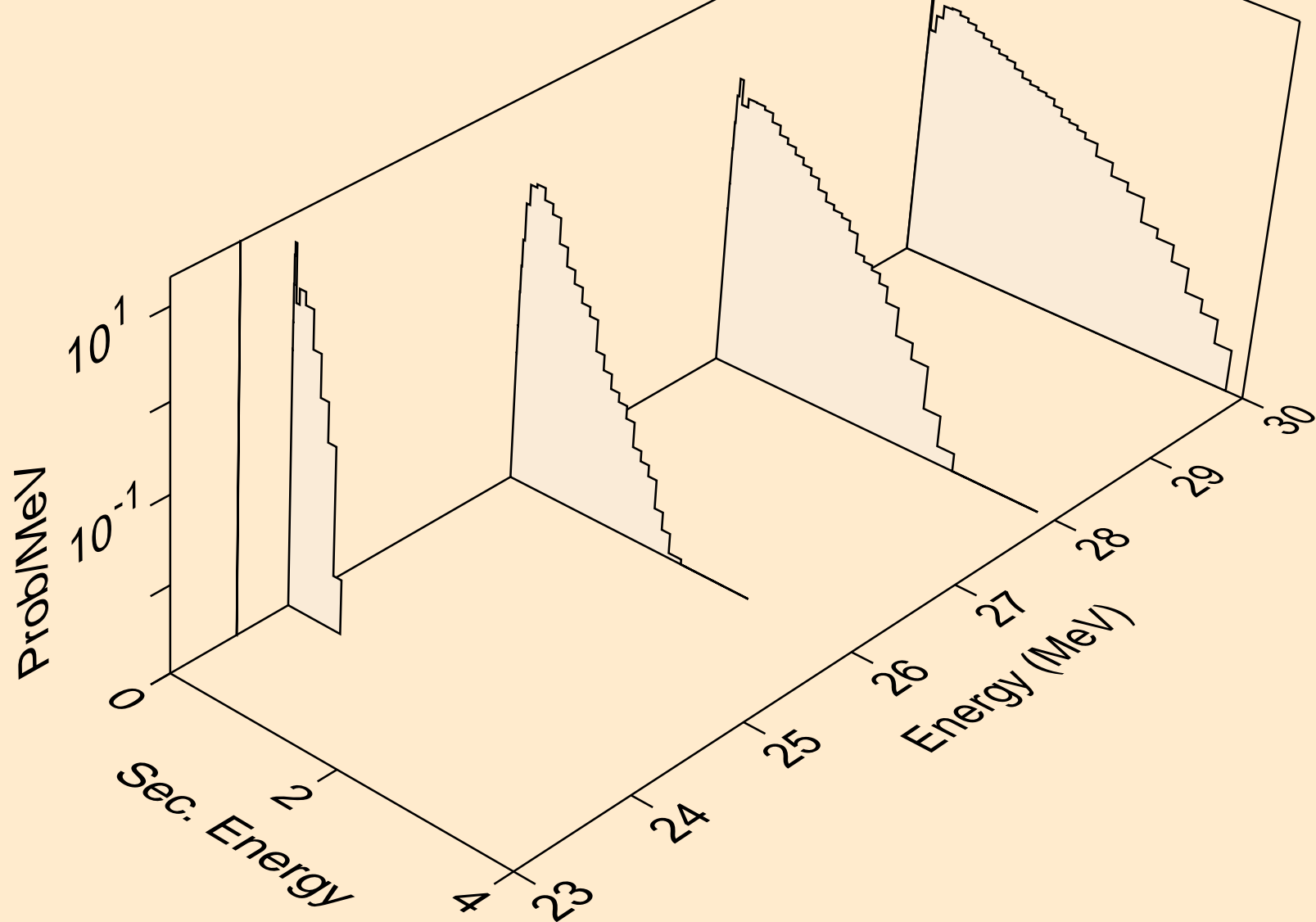

K046 PROTON ACER TENDL-2021 LIBRARY; T=0.K  
neutrons from (p,2np)

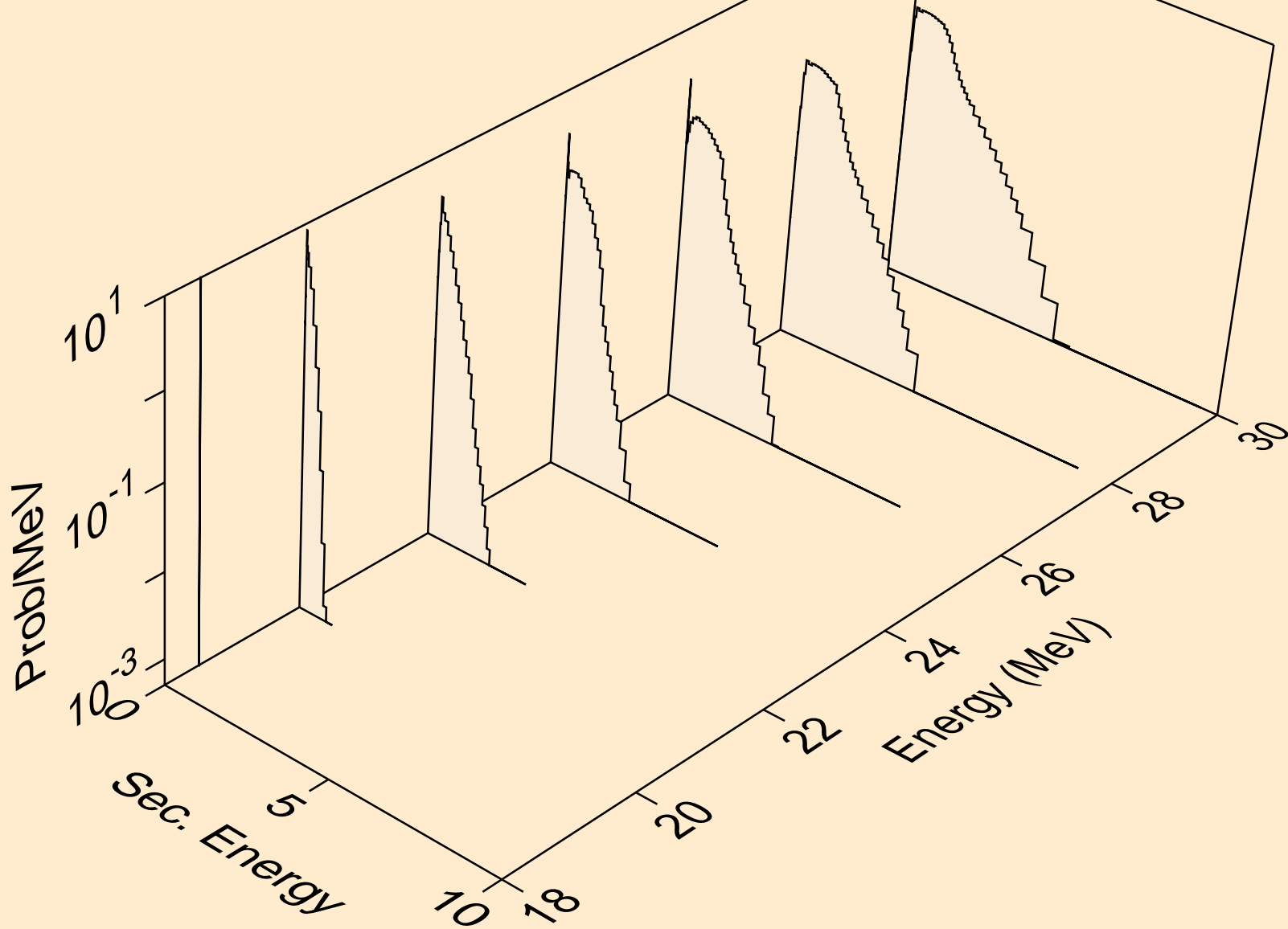

K046 PROTON ACER TENDL-2021 LIBRARY; T=0.K  
neutrons from (p,npa)

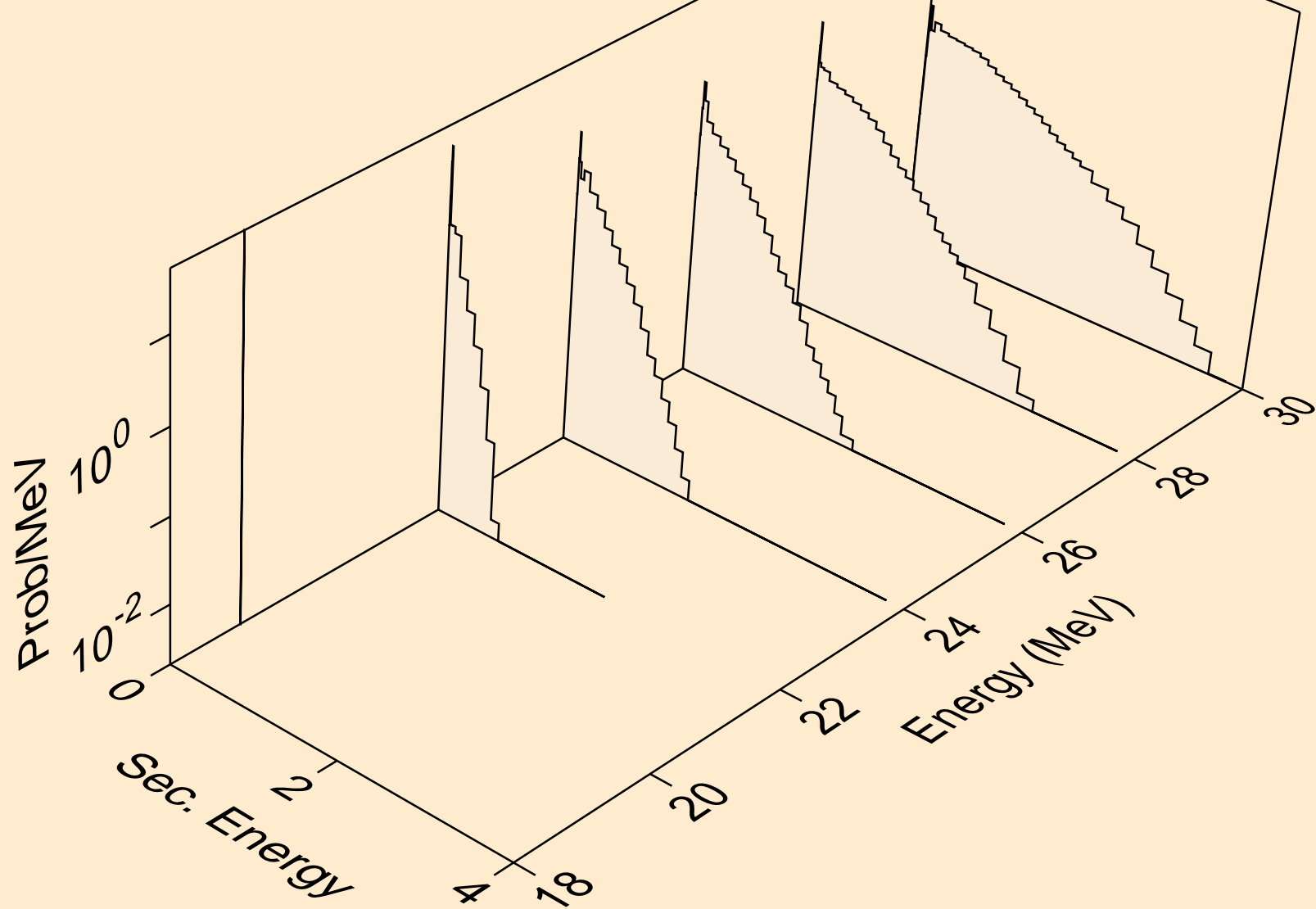

K046 PROTON ACER TENDL-2021 LIBRARY; T=0.K  
deuterons from (p,x)

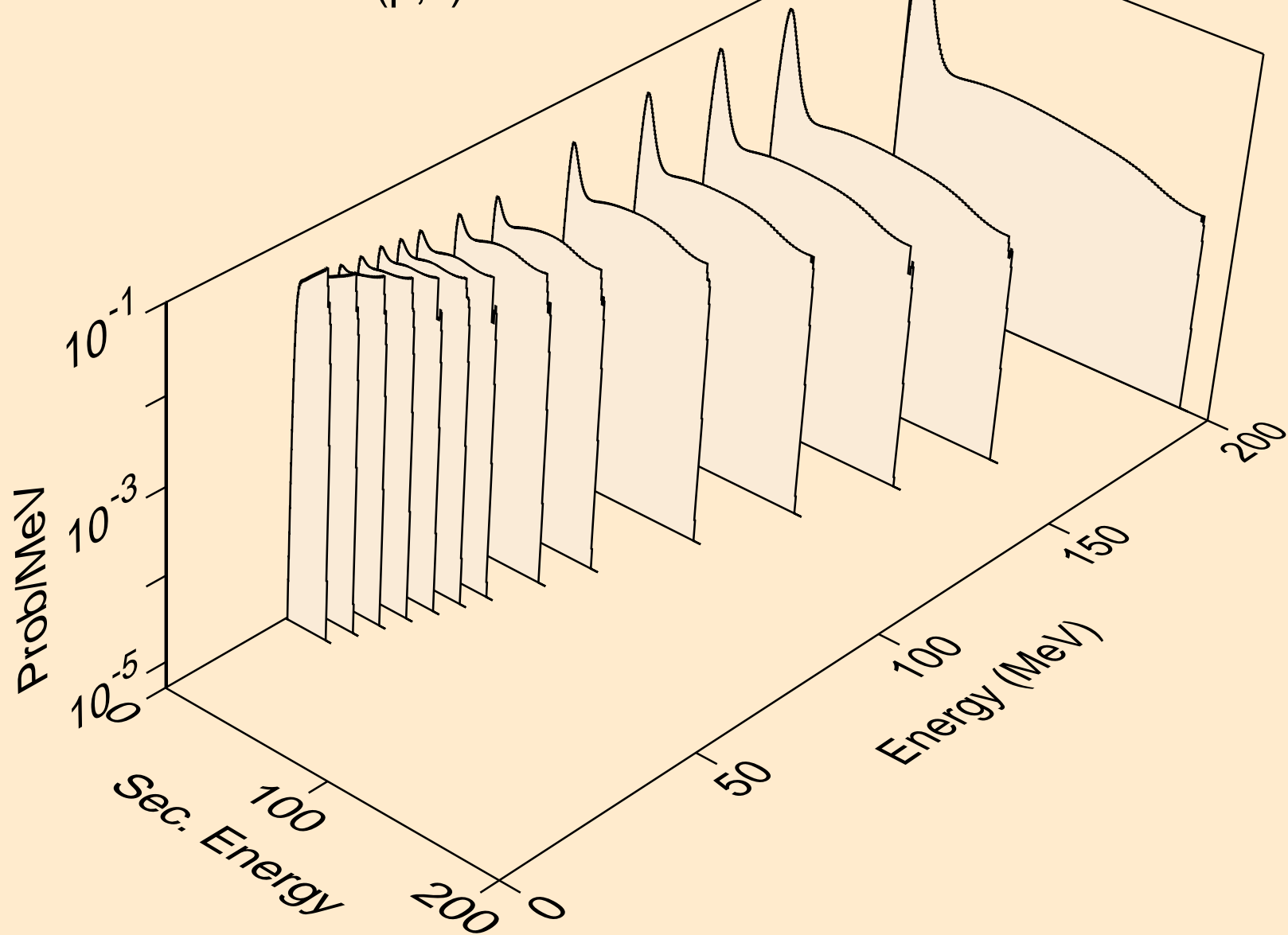



K046 PROTON ACER TENDL-2021 LIBRARY; T=0.K  
deuterons from (p,2nd)

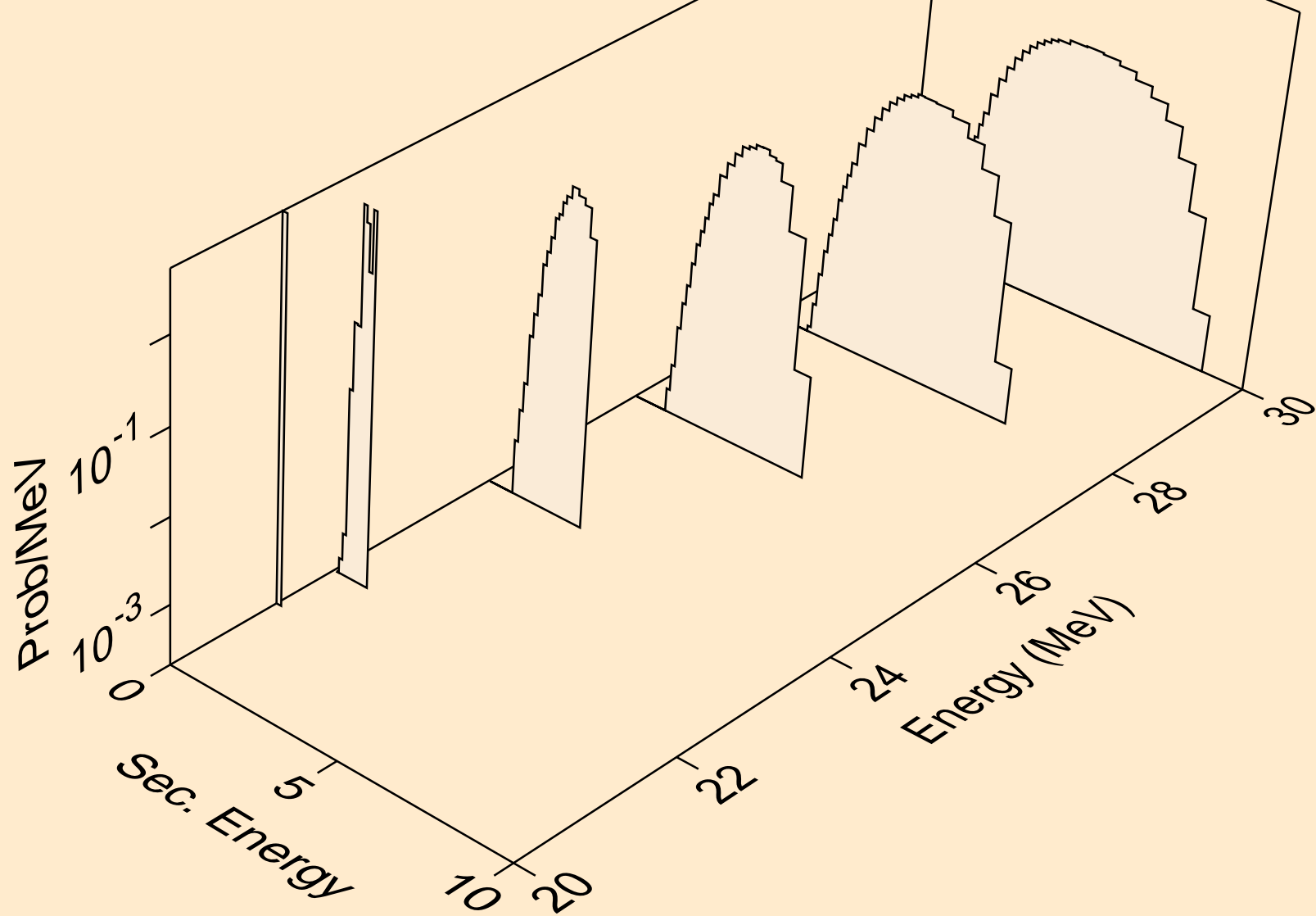

K046 PROTON ACER TENDL-2021 LIBRARY; T=0.K  
deuterons from (p,n\*)d

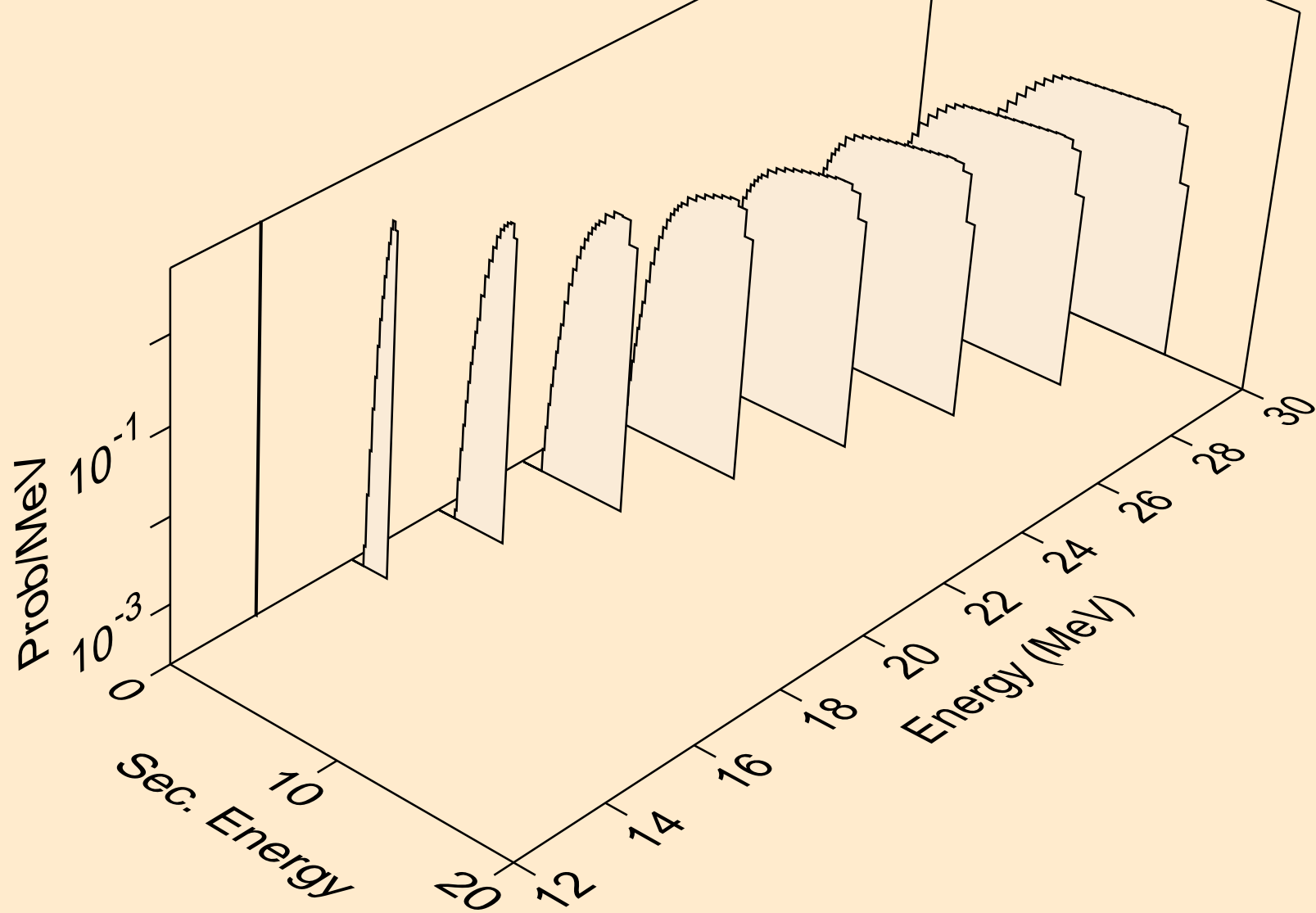

K046 PROTON ACER TENDL-2021 LIBRARY; T=0.K  
deuterons from (p,d)

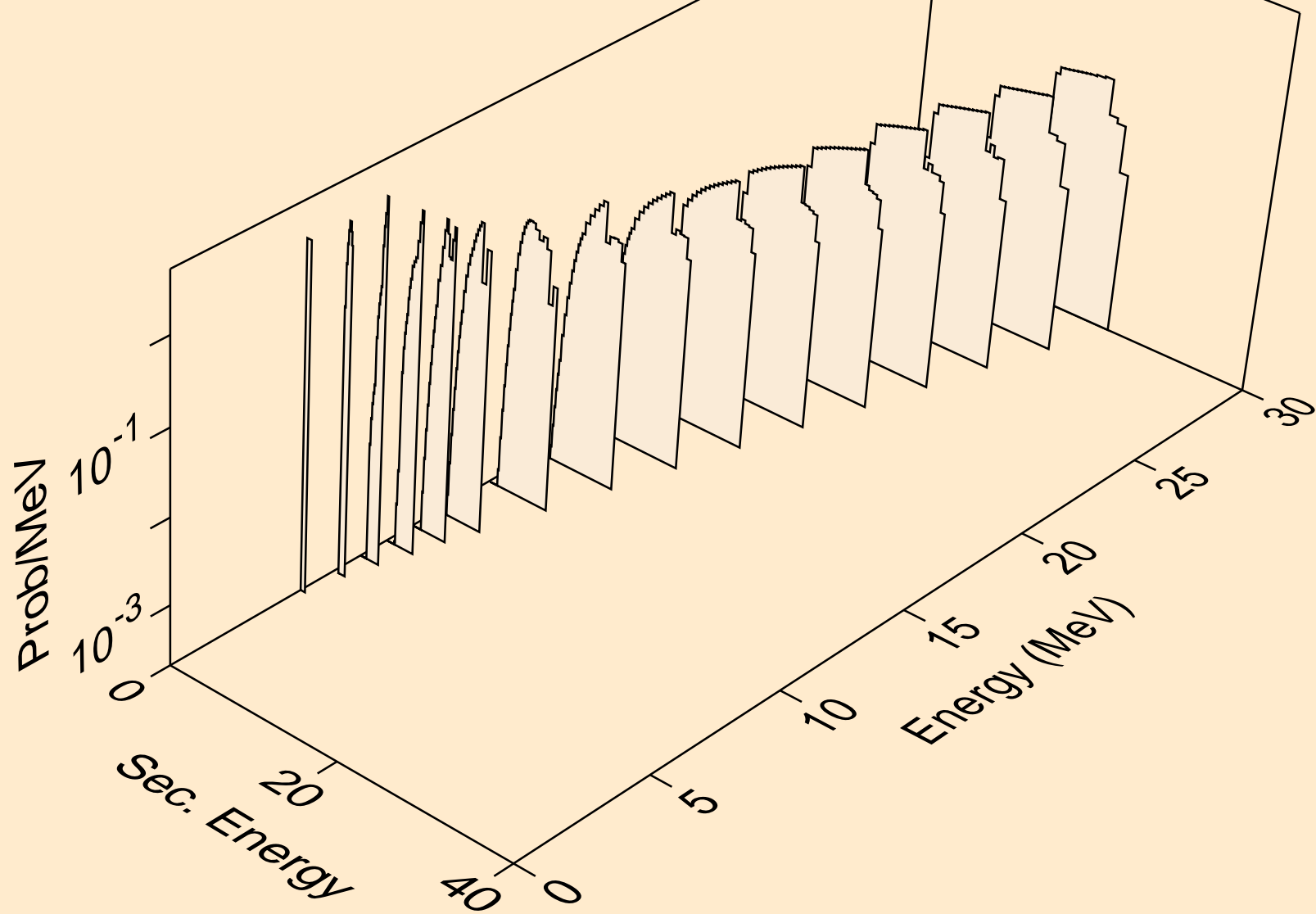

K046 PROTON ACER TENDL-2021 LIBRARY; T=0.K  
deuterons from (p,pd)

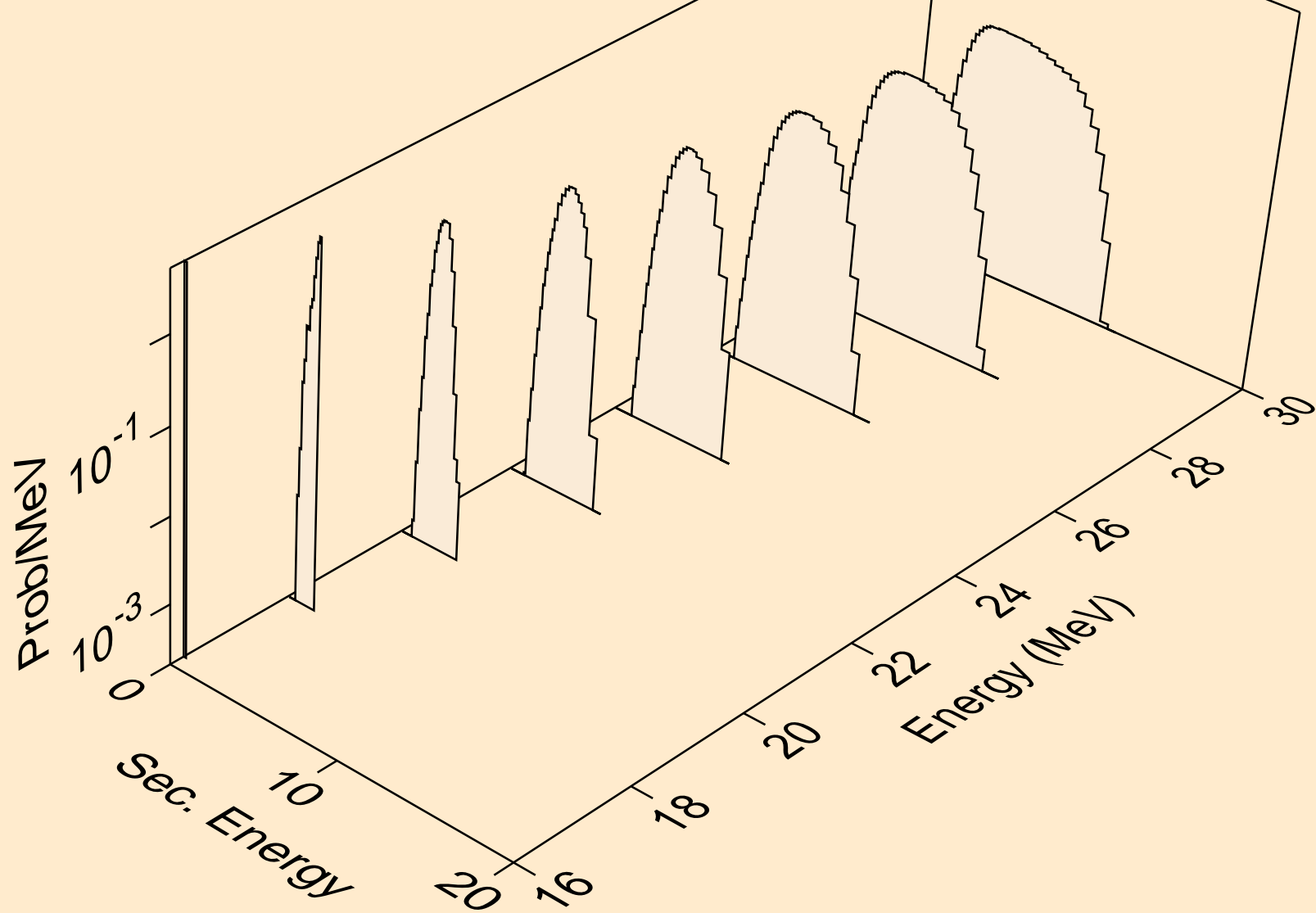

K046 PROTON ACER TENDL-2021 LIBRARY; T=0.K  
deuterons from (p,da)

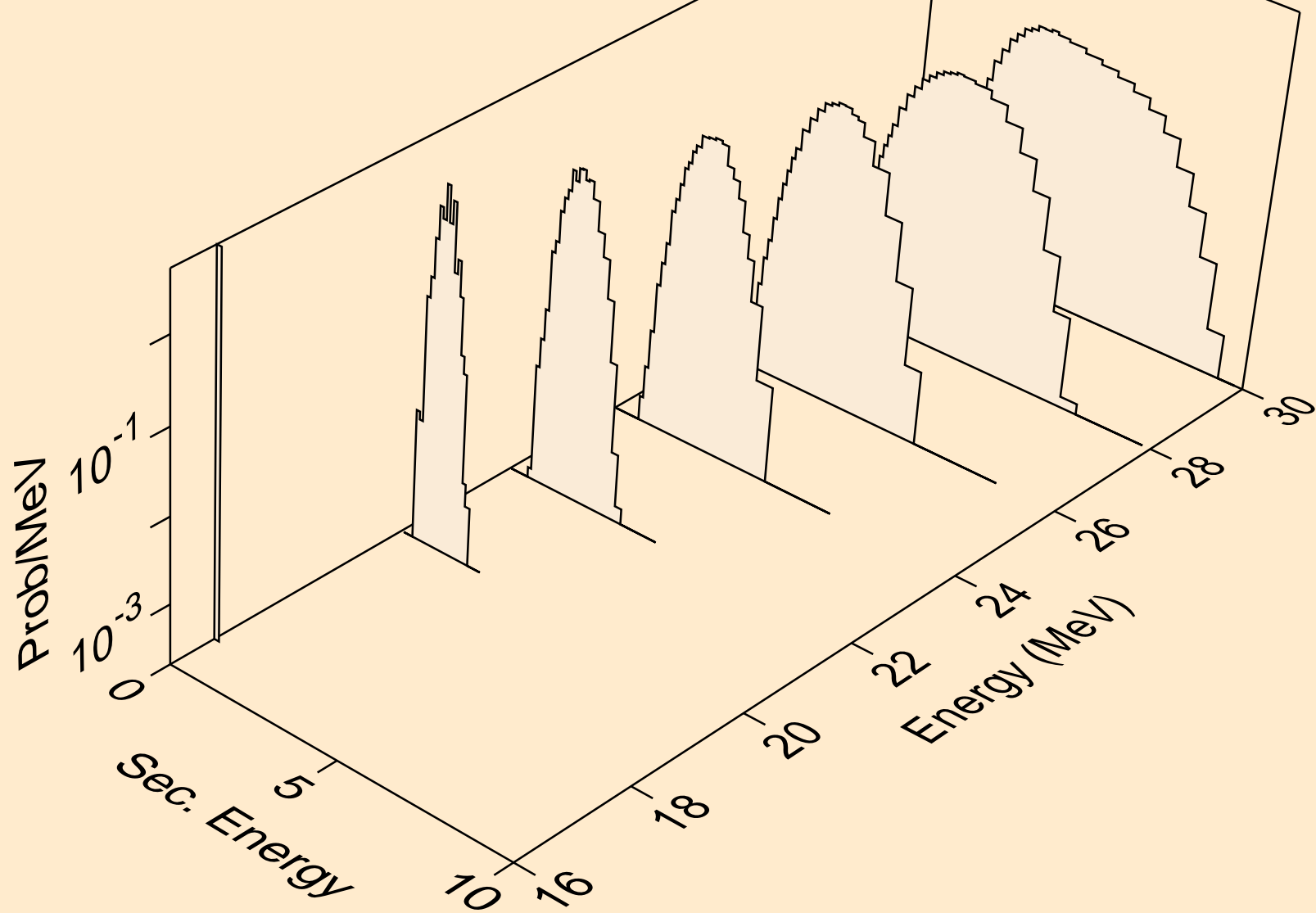

K046 PROTON ACER TENDL-2021 LIBRARY; T=0.K  
tritons from (p,x)

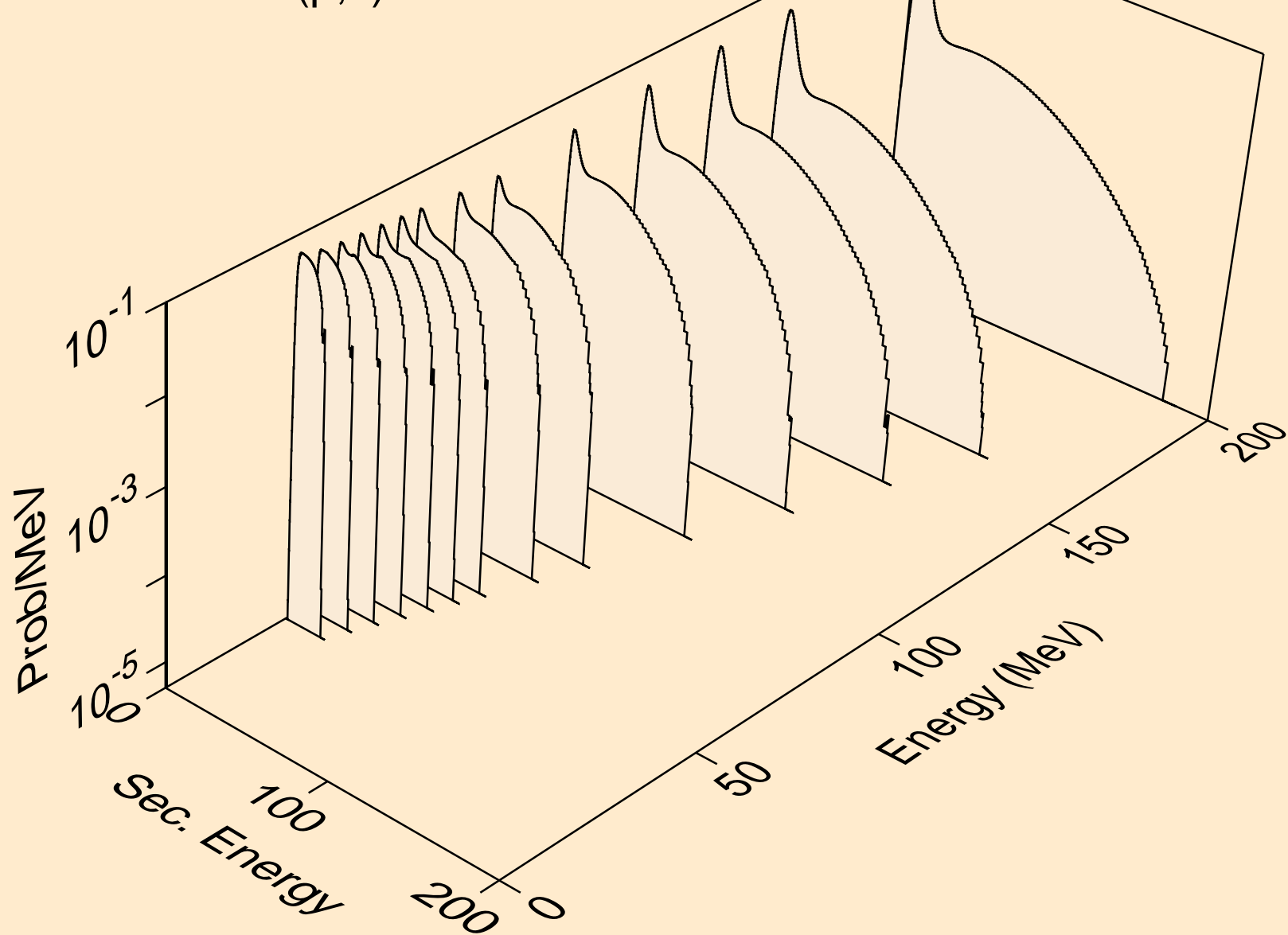

K046 PROTON ACER TENDL-2021 LIBRARY; T=0.K  
tritons from (p,n\*)t

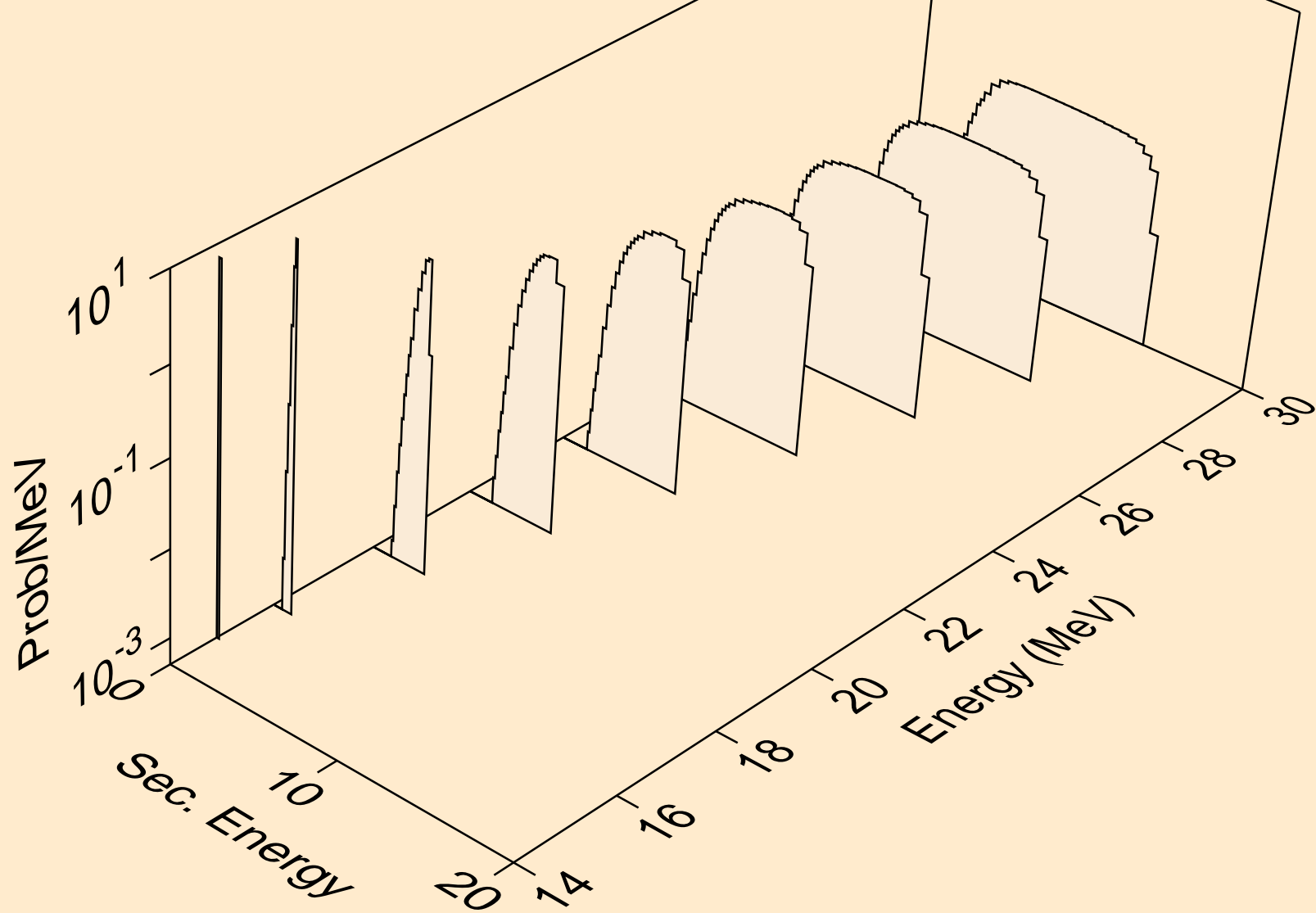

K046 PROTON ACER TENDL-2021 LIBRARY; T=0.K  
tritons from (p,t)

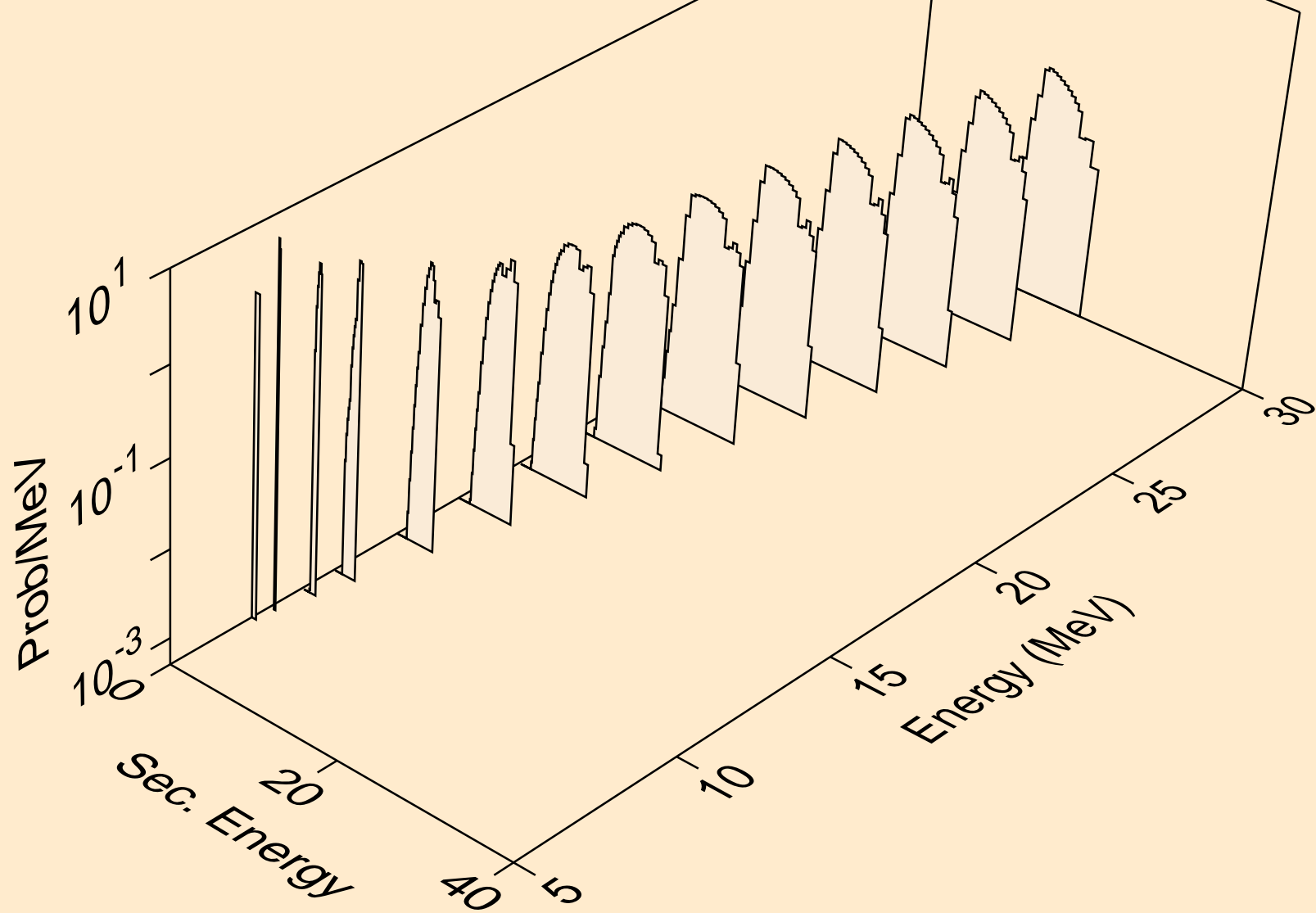



K046 PROTON ACER TENDL-2021 LIBRARY; T=0.K  
tritons from (p,pt)

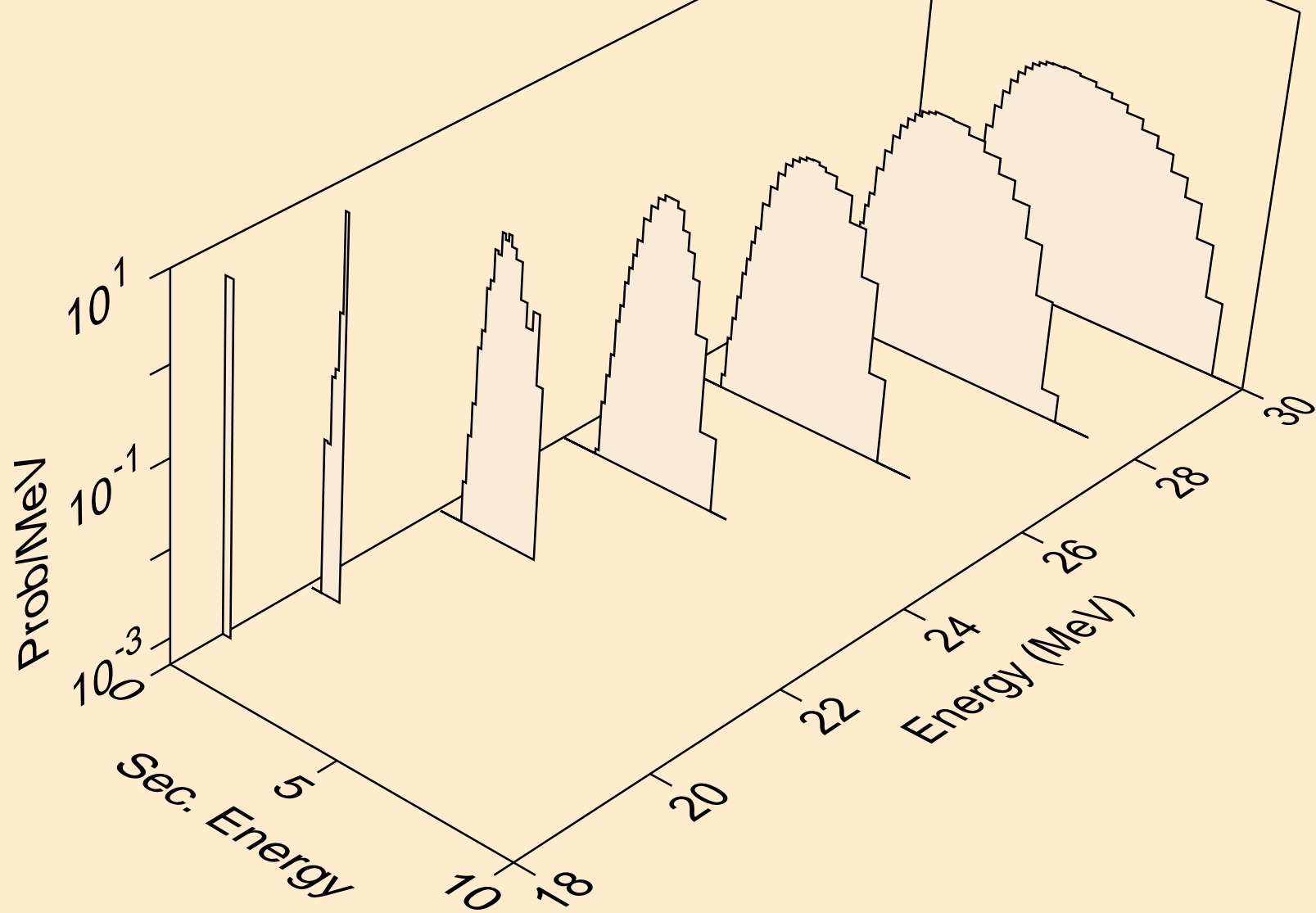

K046 PROTON ACER TENDL-2021 LIBRARY; T=0.K  
he3s from (p,x)

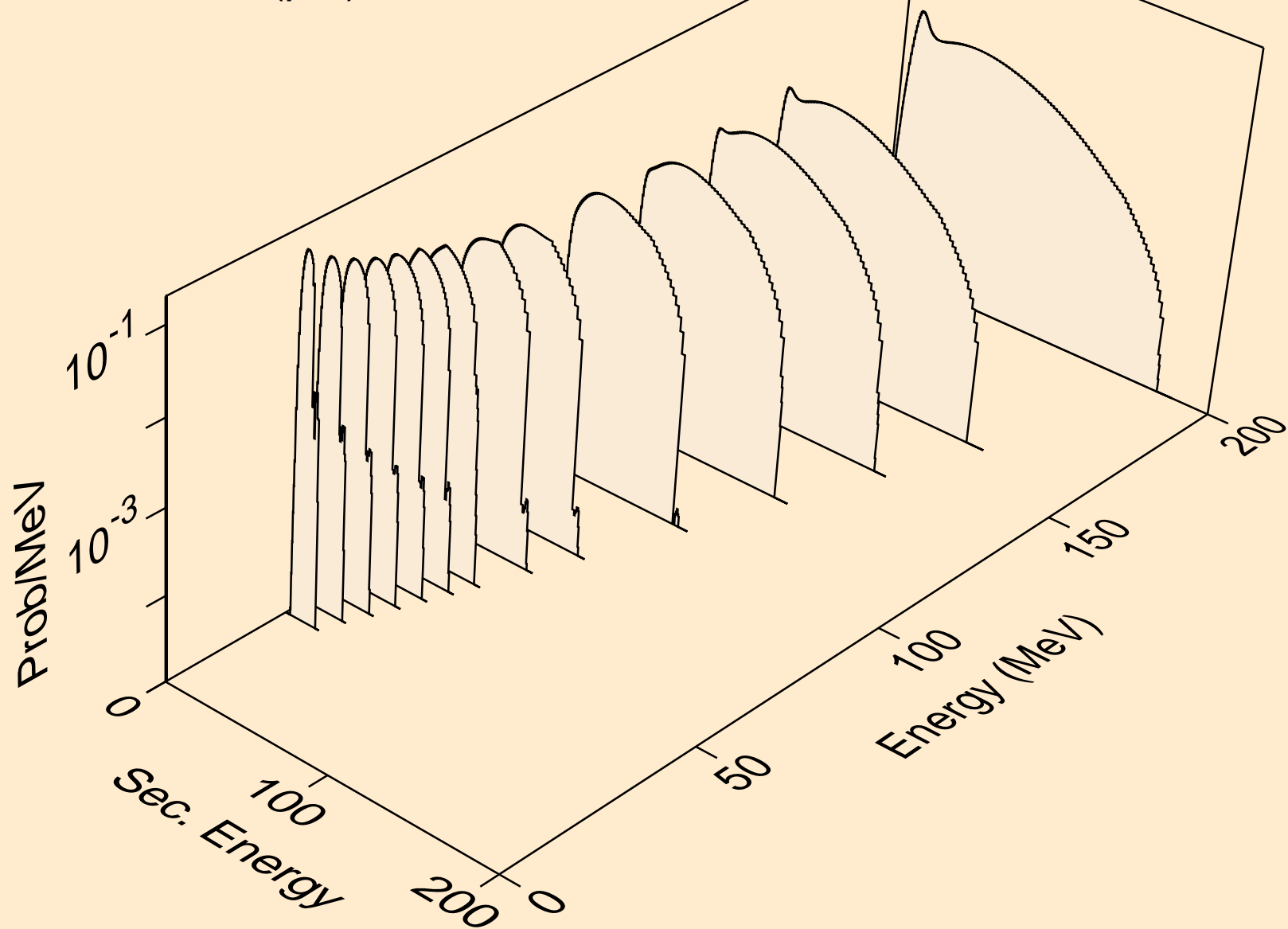

K046 PROTON ACER TENDL-2021 LIBRARY; T=0.K  
he3s from (p,n\*)he3

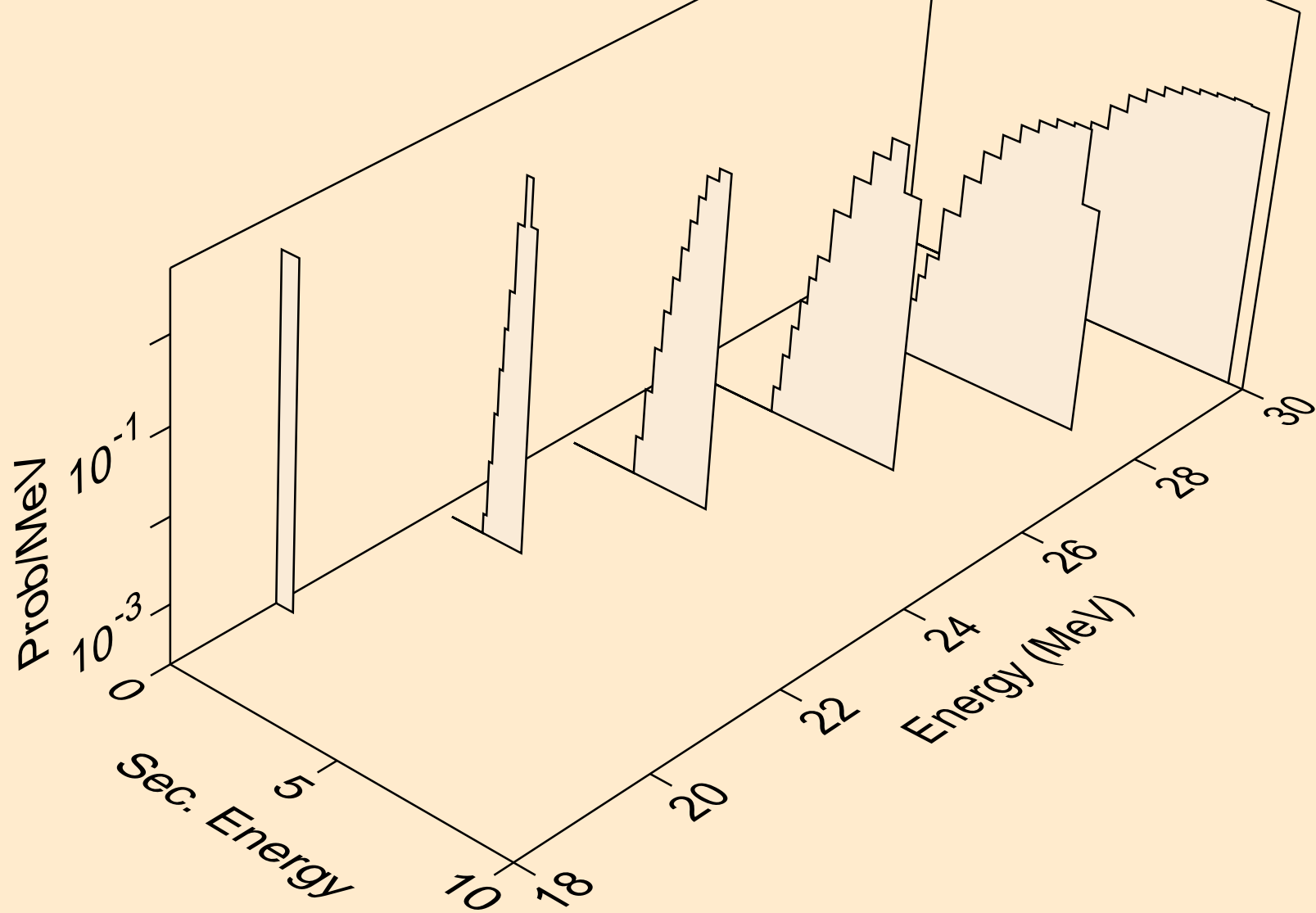

K046 PROTON ACER TENDL-2021 LIBRARY; T=0.K  
he3s from (p,he3)

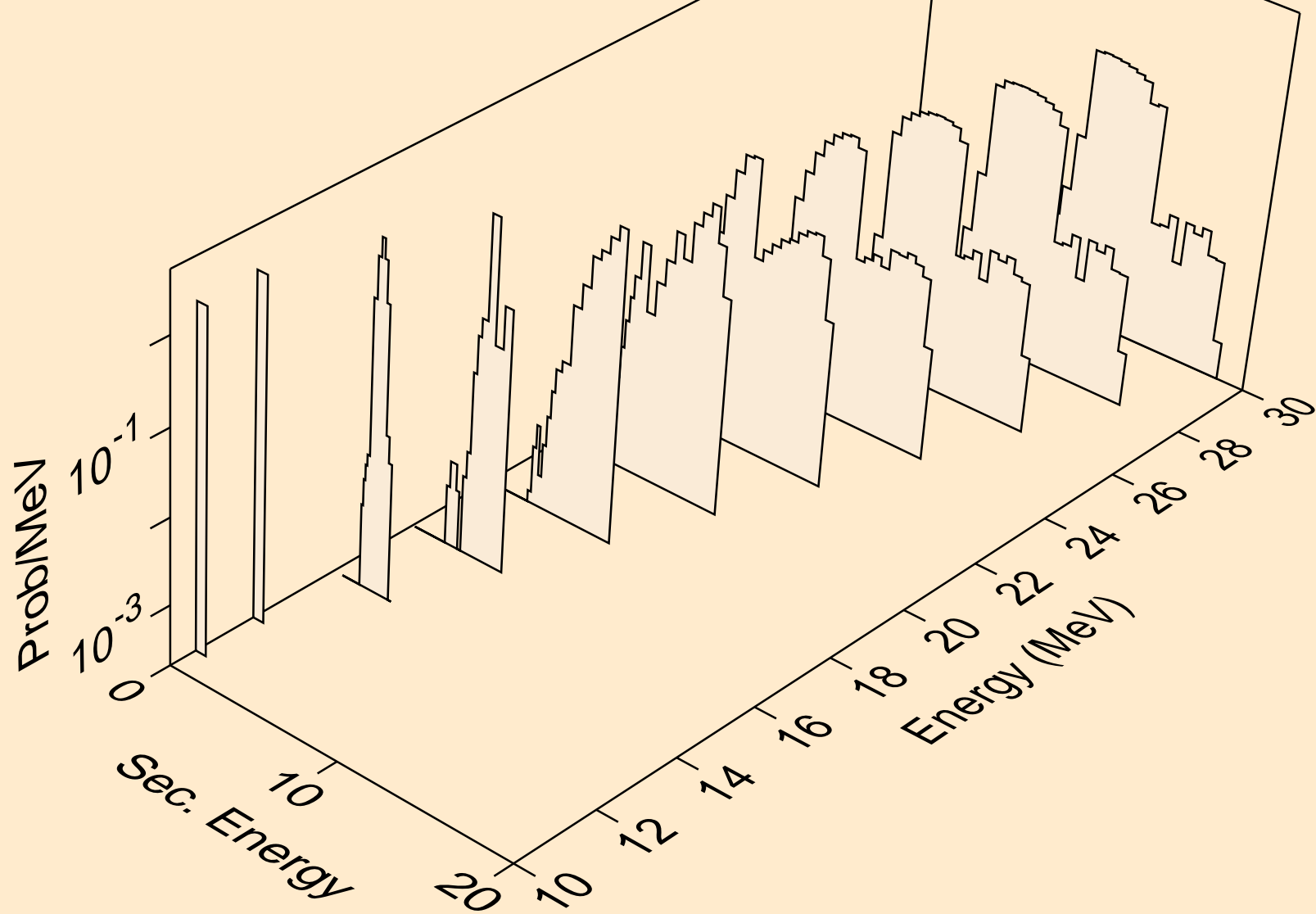

K046 PROTON ACER TENDL-2021 LIBRARY; T=0.K  
alphas from (p,x)

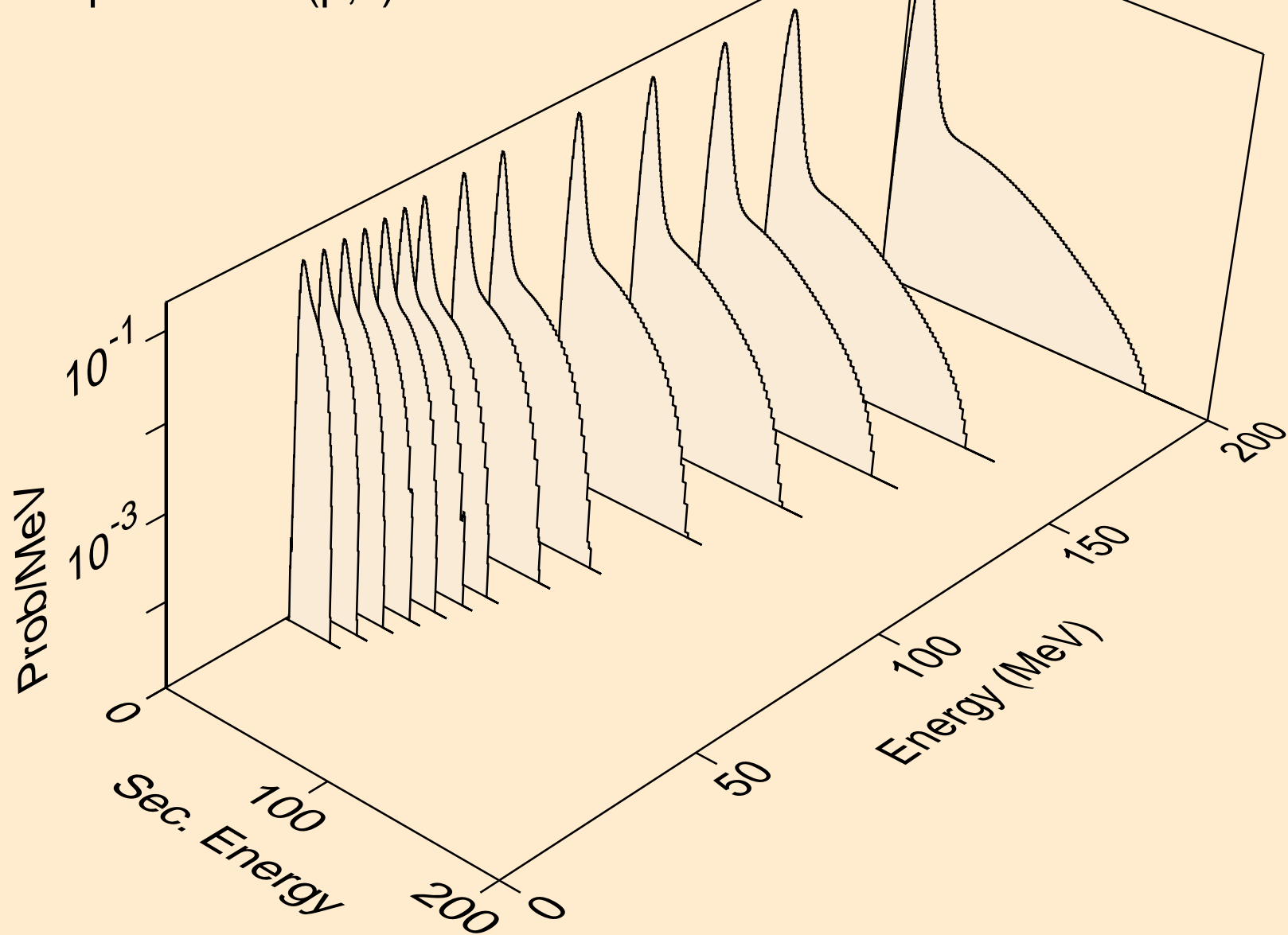

K046 PROTON ACER TENDL-2021 LIBRARY; T=0.K  
alphas from (p,n\*)a

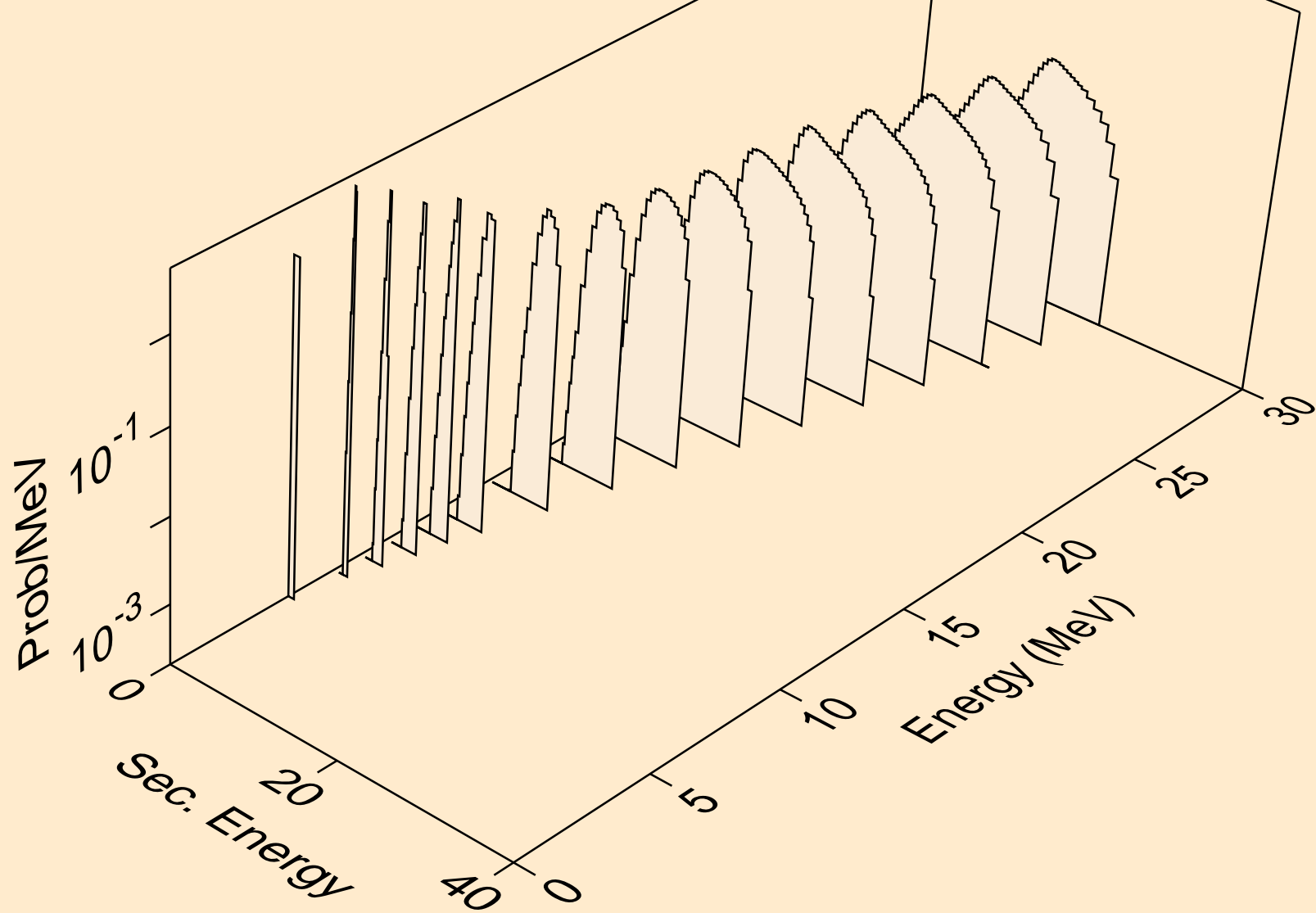

K046 PROTON ACER TENDL-2021 LIBRARY; T=0.K  
alphas from (p,2n)a

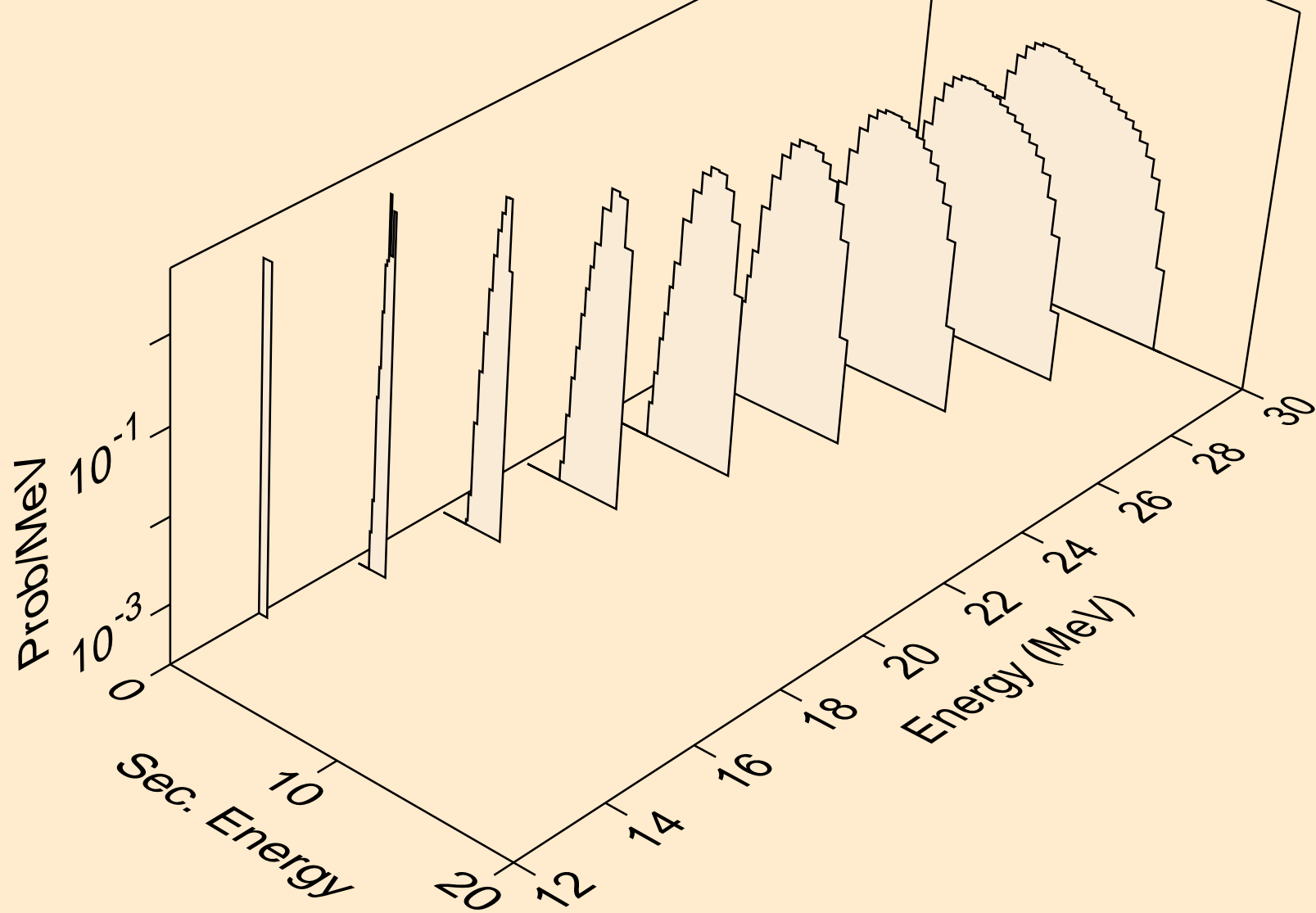

K046 PROTON ACER TENDL-2021 LIBRARY; T=0.K  
alphas from (p,3n)a

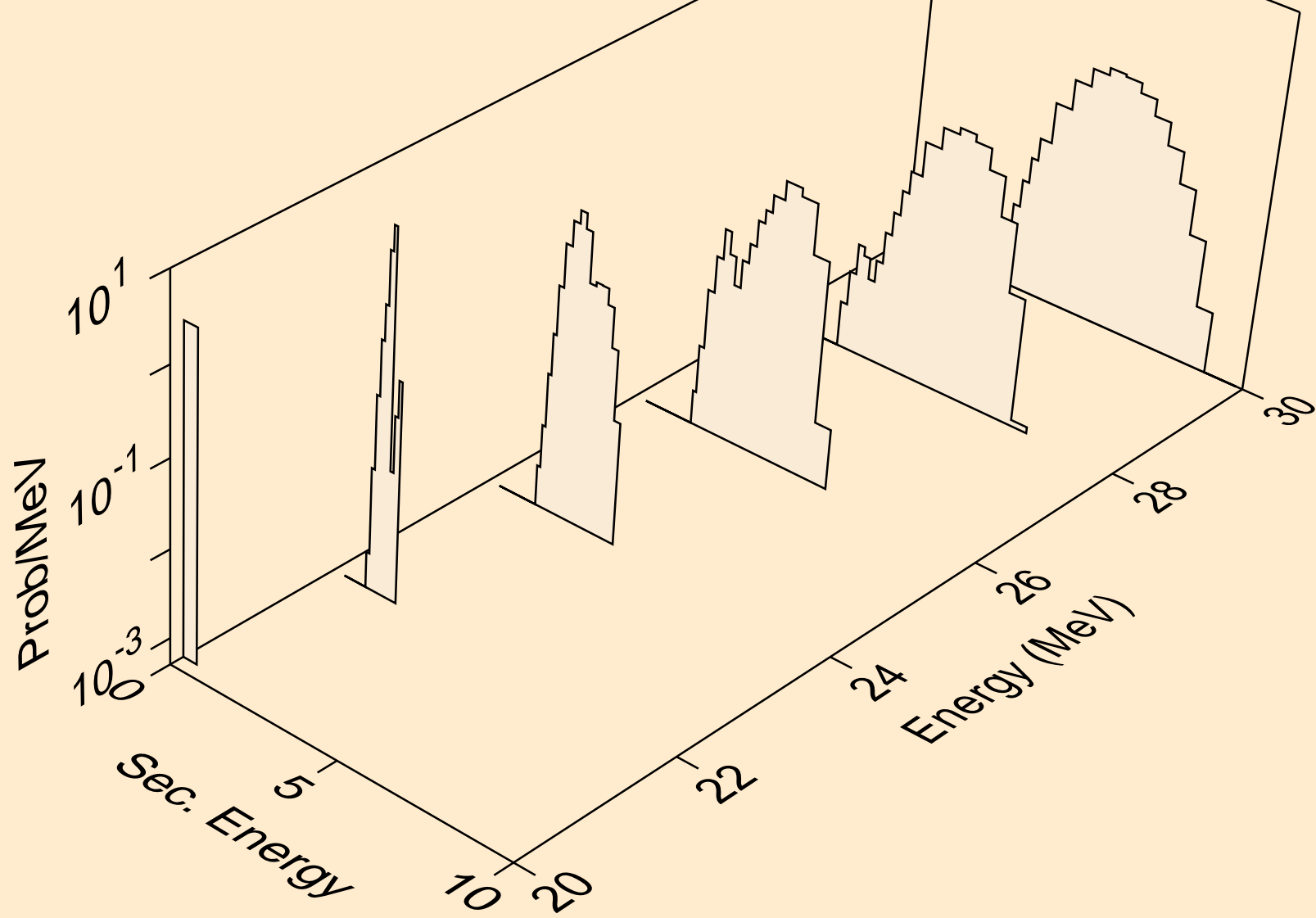



K046 PROTON ACER TENDL-2021 LIBRARY; T=0.K  
alphas from (p,n\*)2a

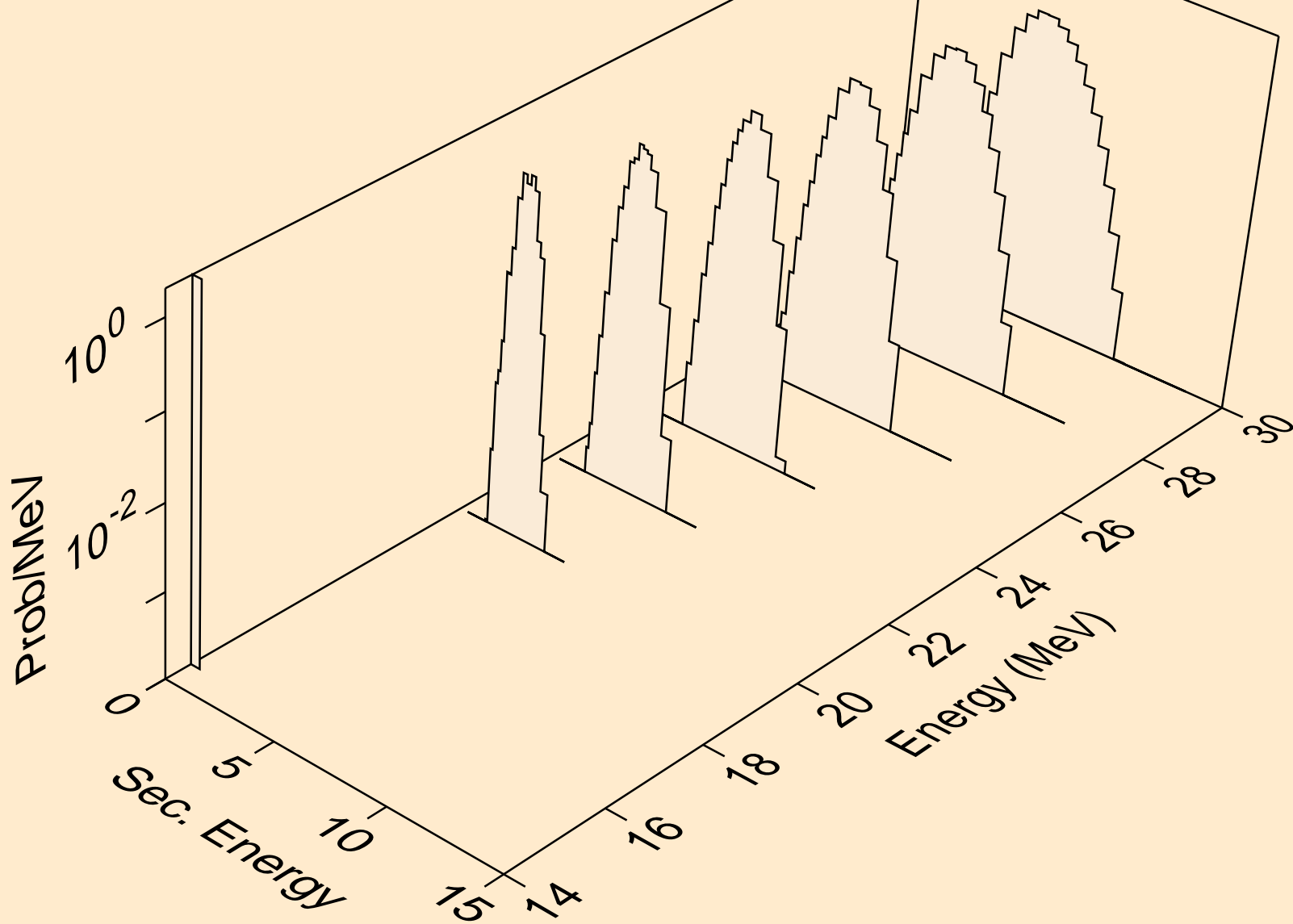

K046 PROTON ACER TENDL-2021 LIBRARY; T=0.K  
alphas from (p,npa)

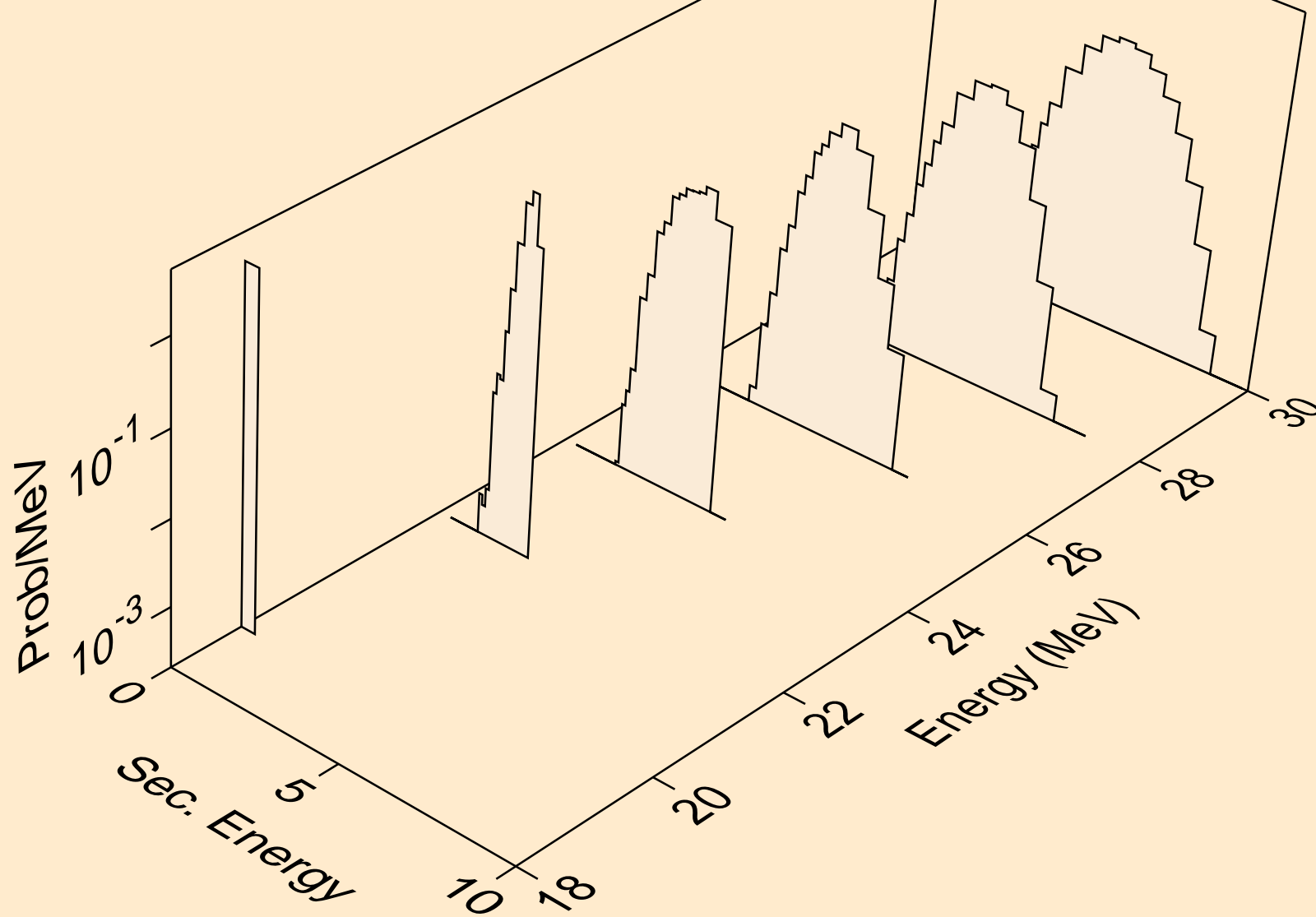

K046 PROTON ACER TENDL-2021 LIBRARY; T=0.K  
alphas from (p,a)

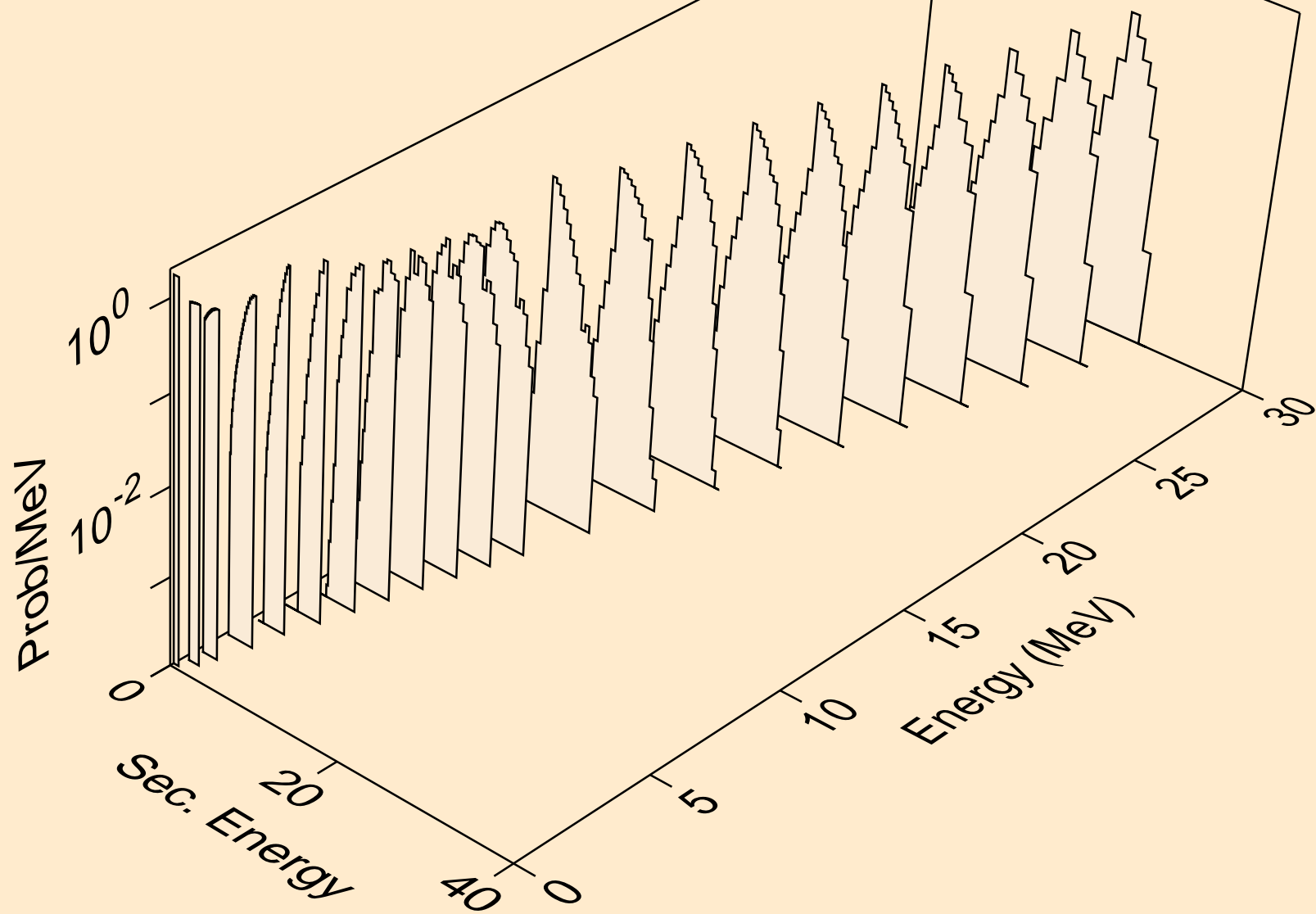

K046 PROTON ACER TENDL-2021 LIBRARY; T=0.K  
alphas from (p,2a)

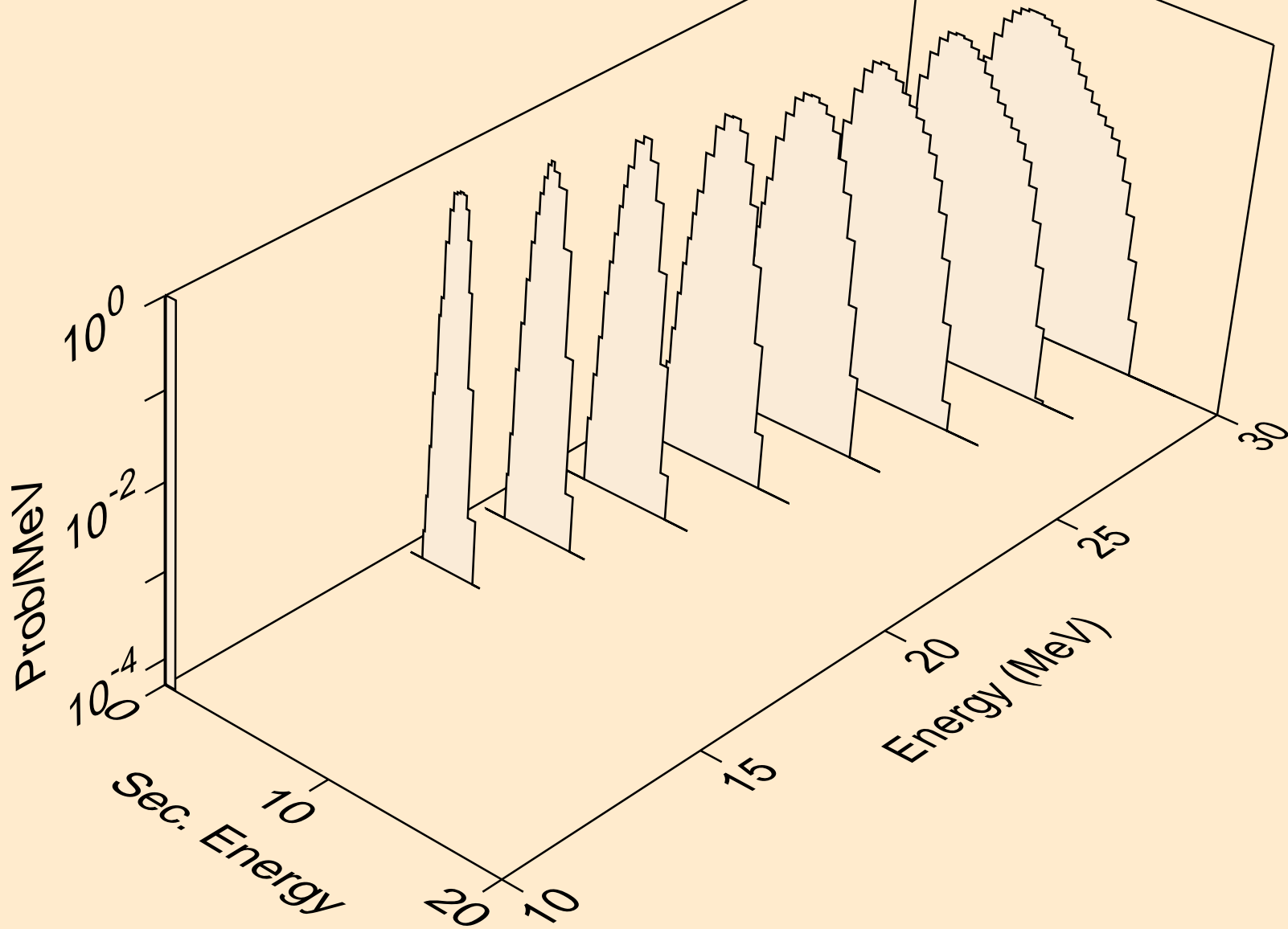

K046 PROTON ACER TENDL-2021 LIBRARY; T=0.K  
alphas from (p,pa)

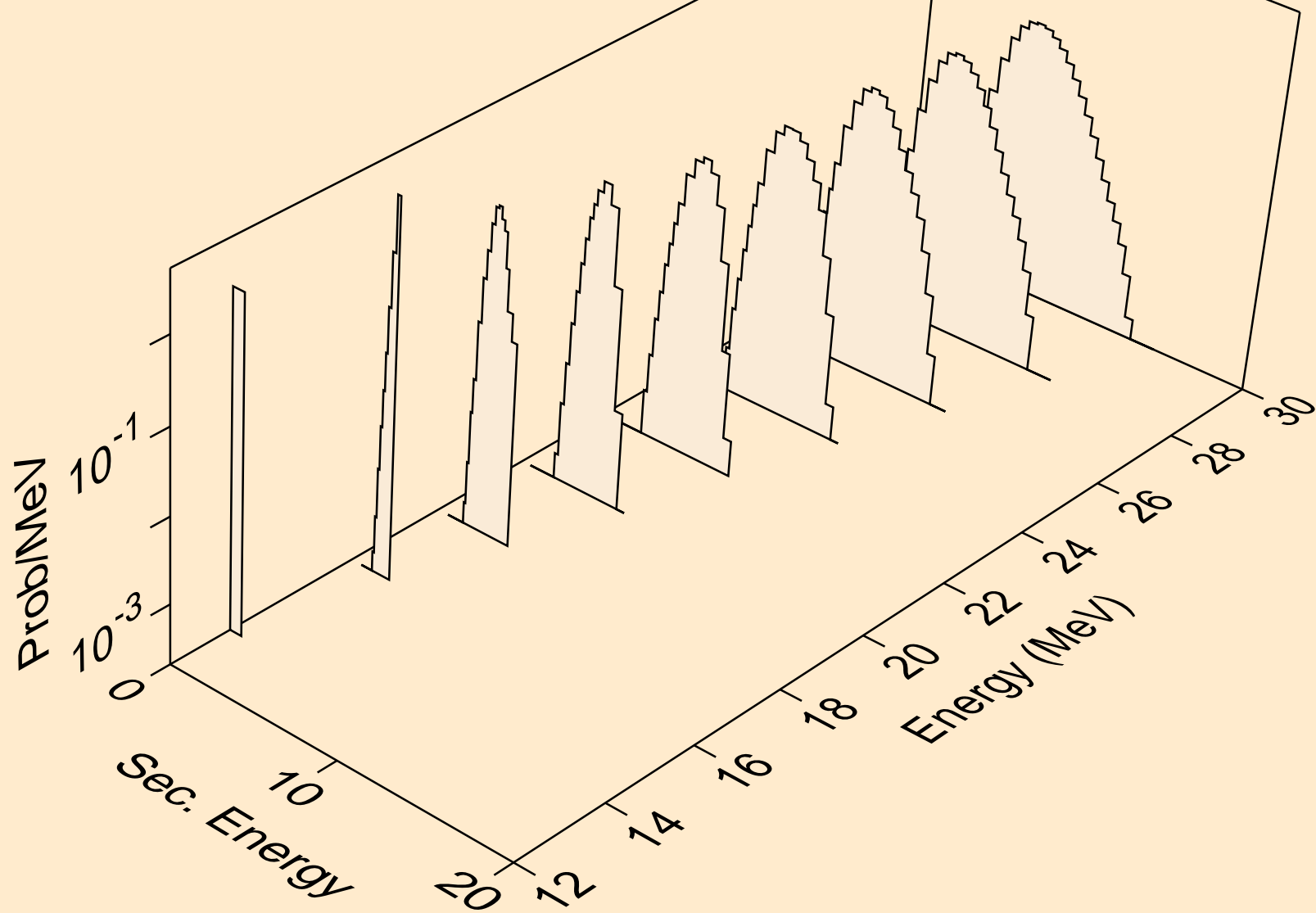

K046 PROTON ACER TENDL-2021 LIBRARY; T=0.K  
alphas from (p,da)

