

ND157 PROTON ACER TENDL-2021 LIBRARY; T=0.K

Principal cross sections

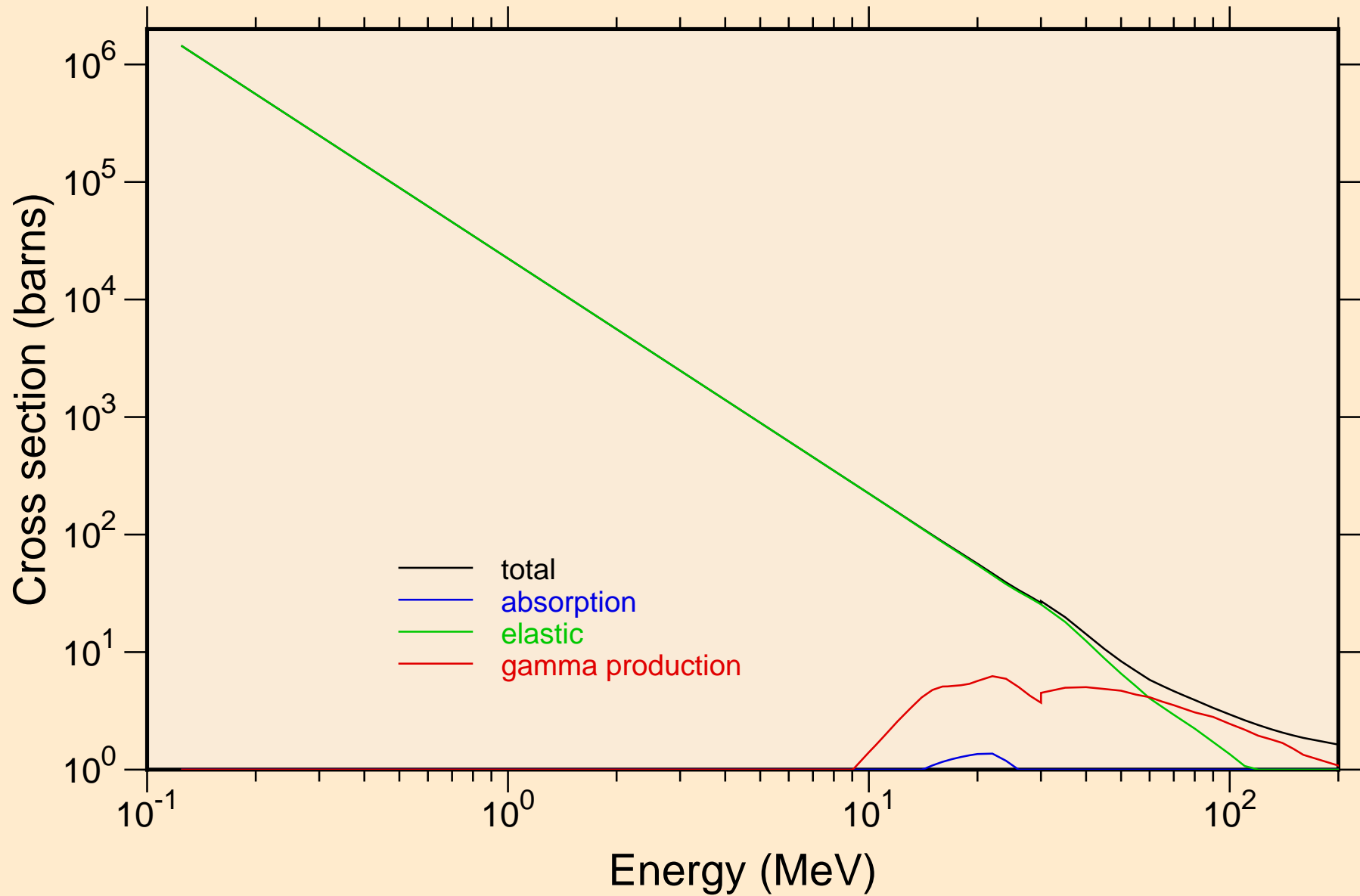

ND157 PROTON ACER TENDL-2021 LIBRARY; T=0.K
Heating

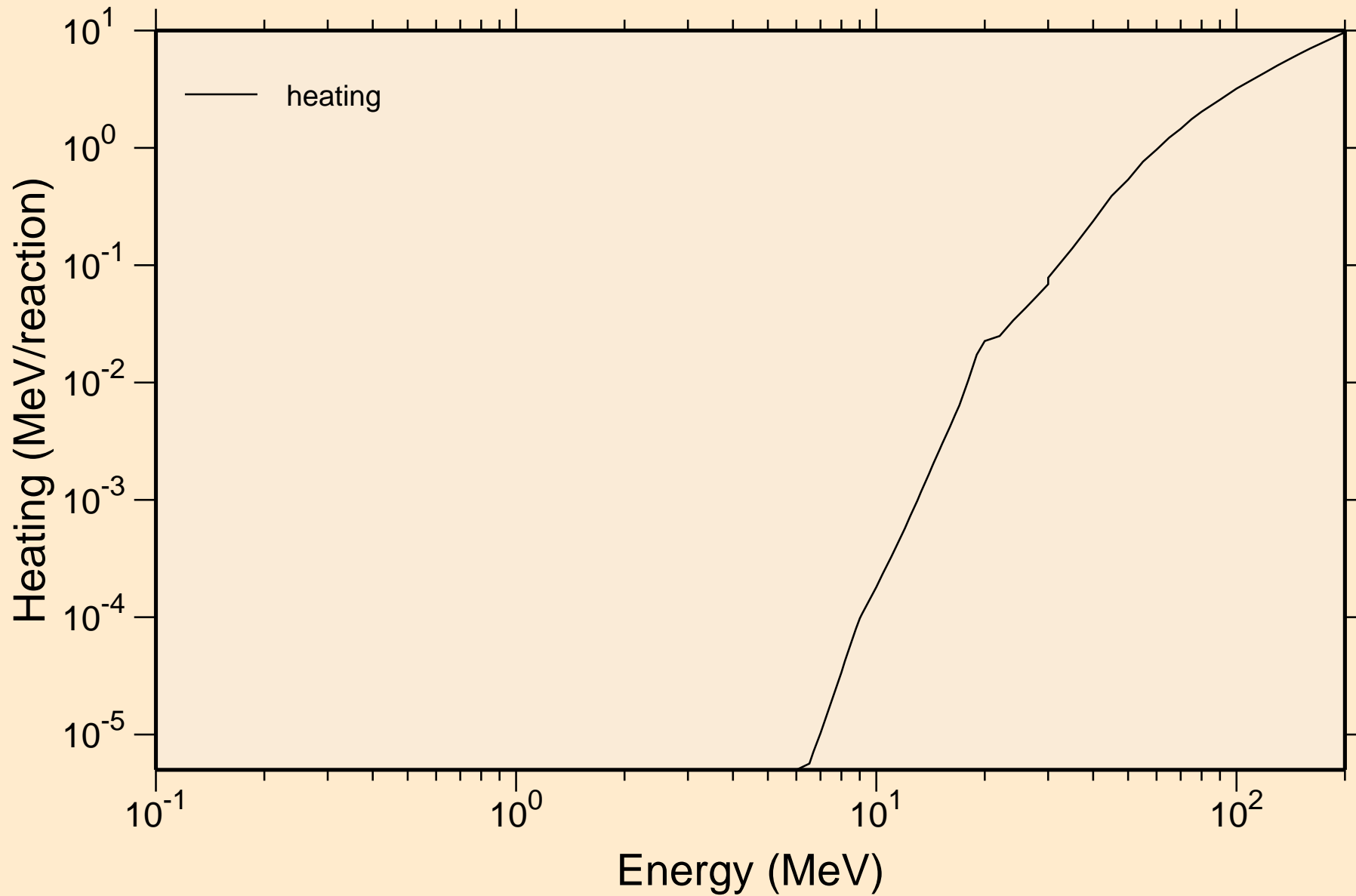

ND157 PROTON ACER TENDL-2021 LIBRARY; T=0.K

Principal cross sections

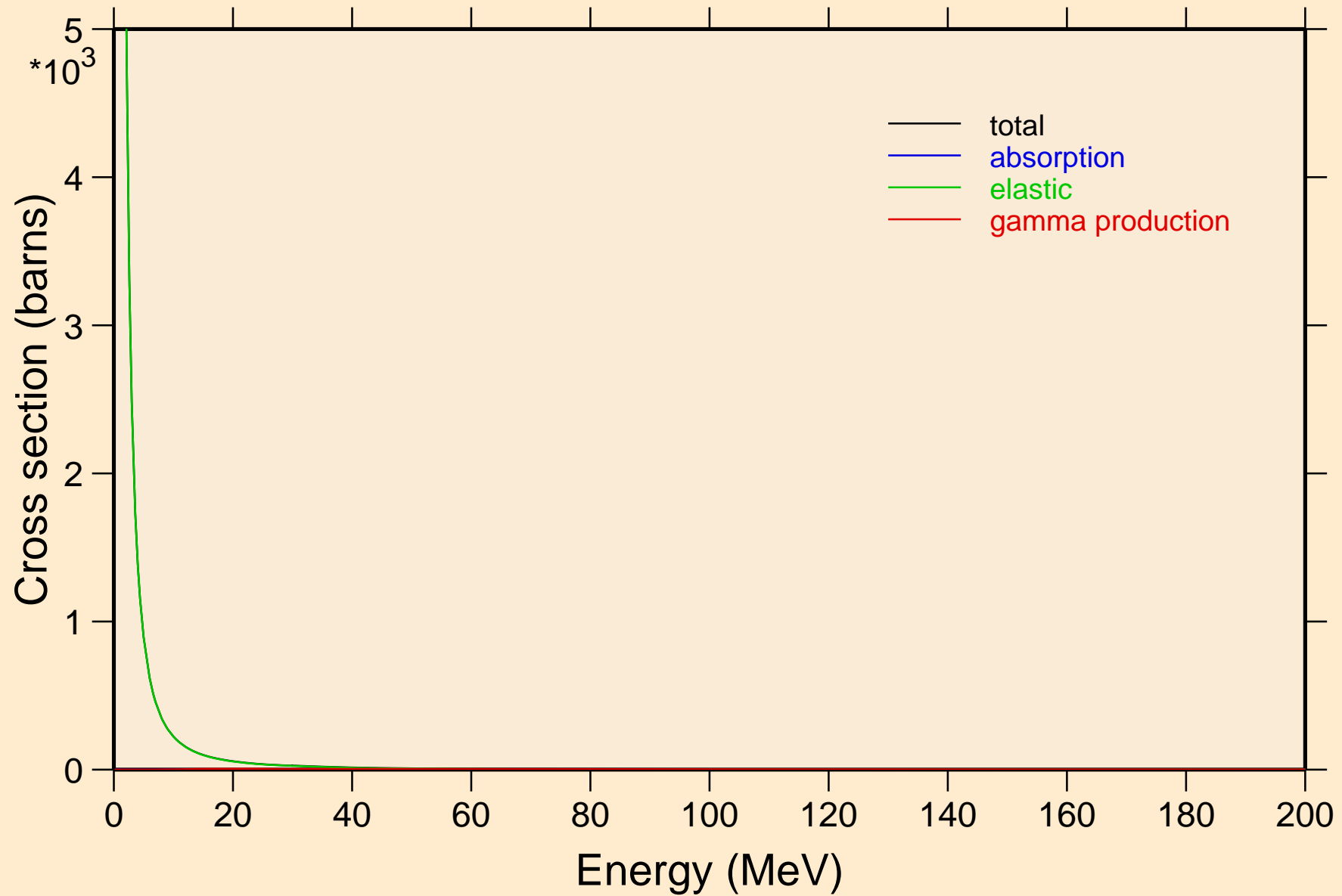

ND157 PROTON ACER TENDL-2021 LIBRARY; T=0.K

Heating

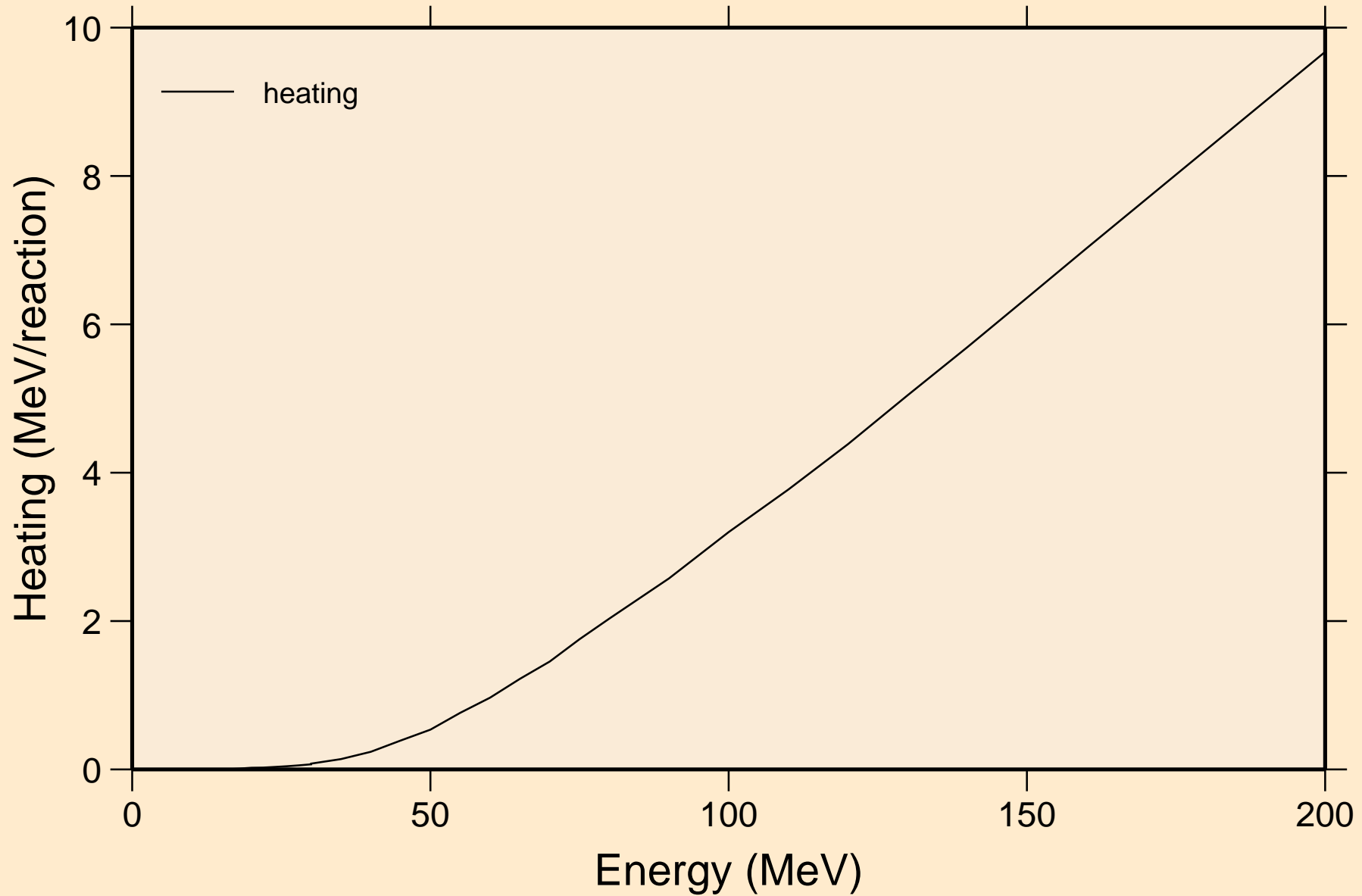

ND157 PROTON ACER TENDL-2021 LIBRARY; T=0.K

Threshold reactions

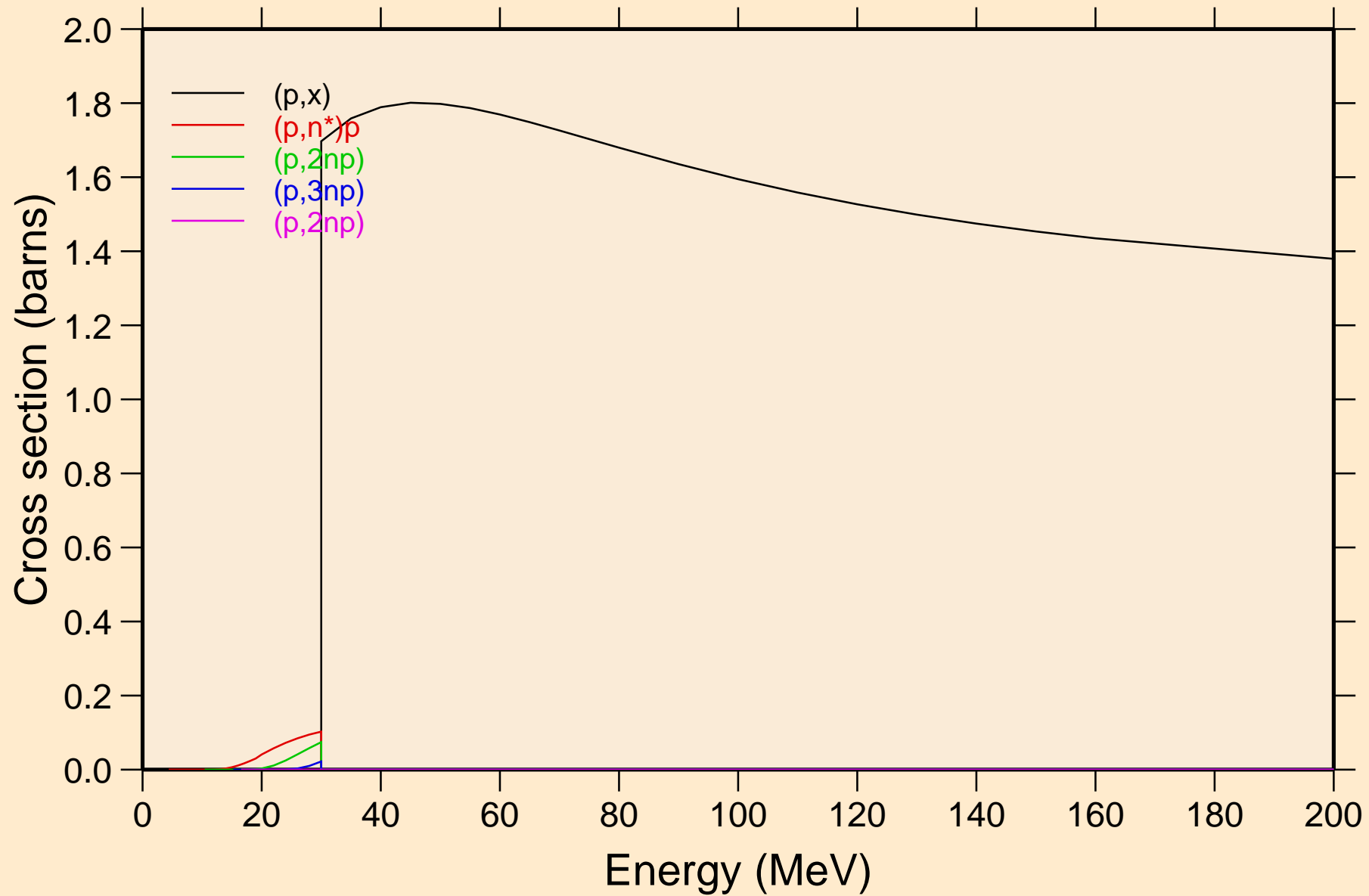

ND157 PROTON ACER TENDL-2021 LIBRARY; T=0.K

Threshold reactions

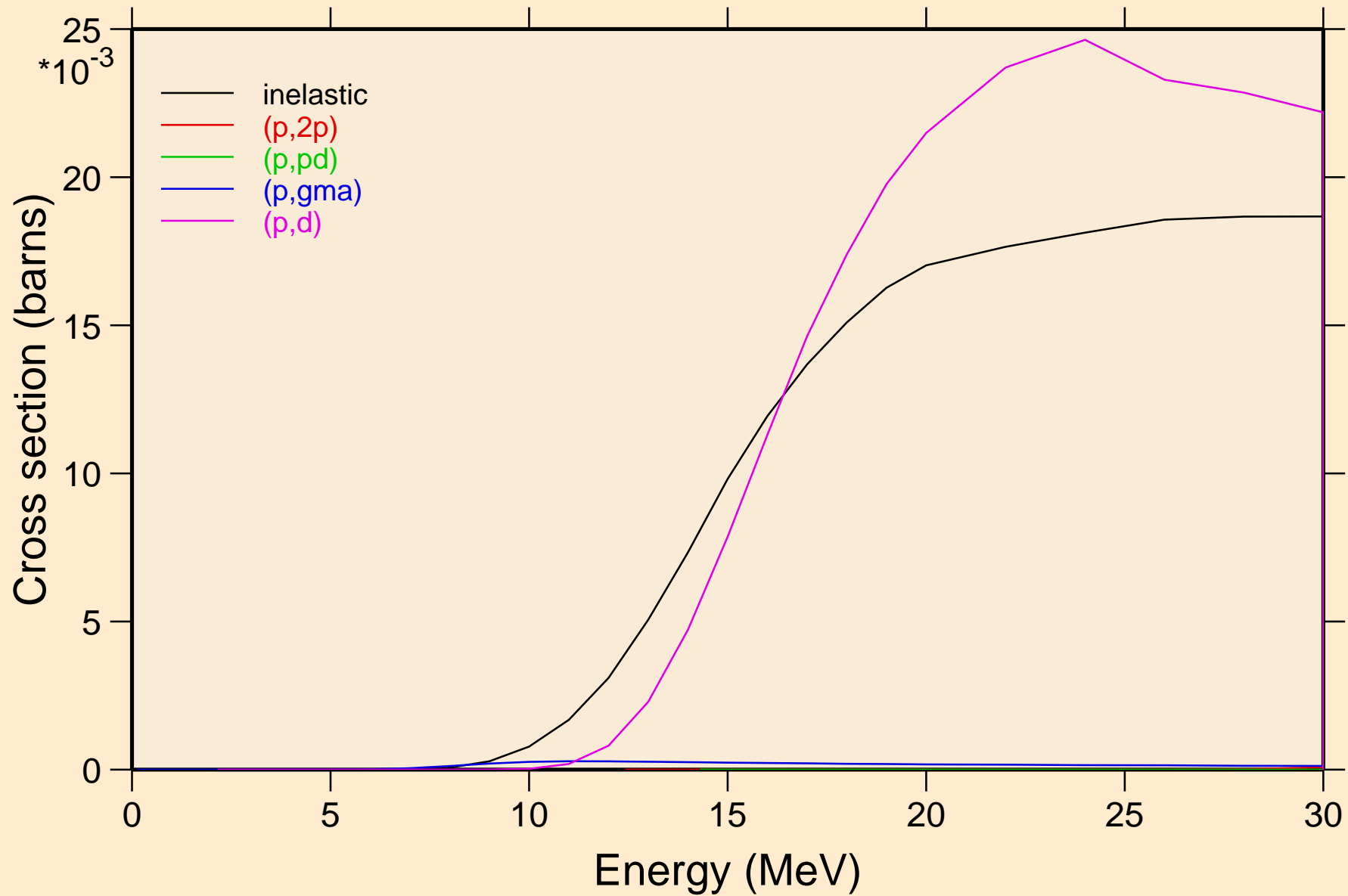

ND157 PROTON ACER TENDL-2021 LIBRARY; T=0.K
Threshold reactions

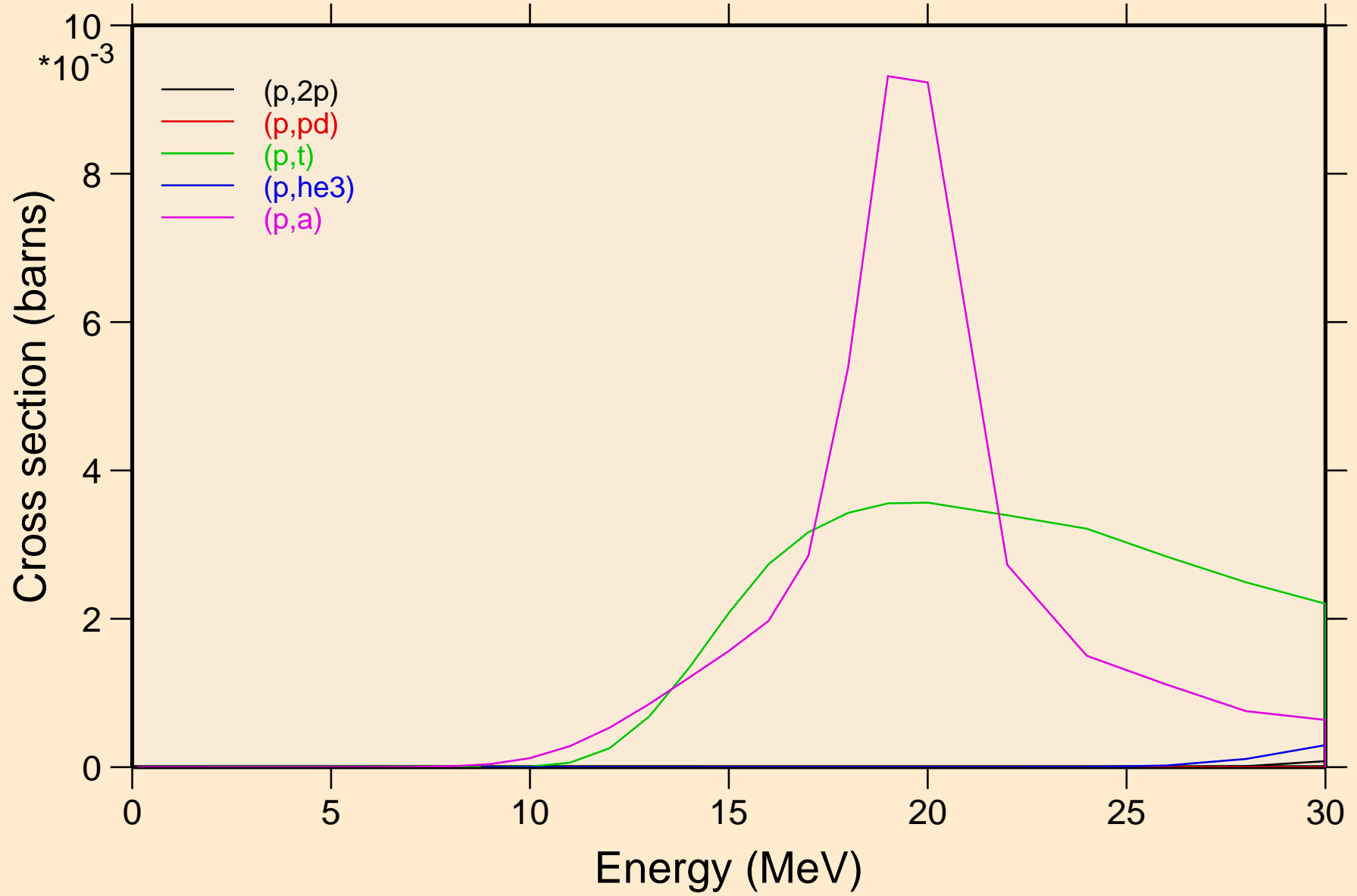

ND157 PROTON ACER TENDL-2021 LIBRARY; T=0.K
Threshold reactions

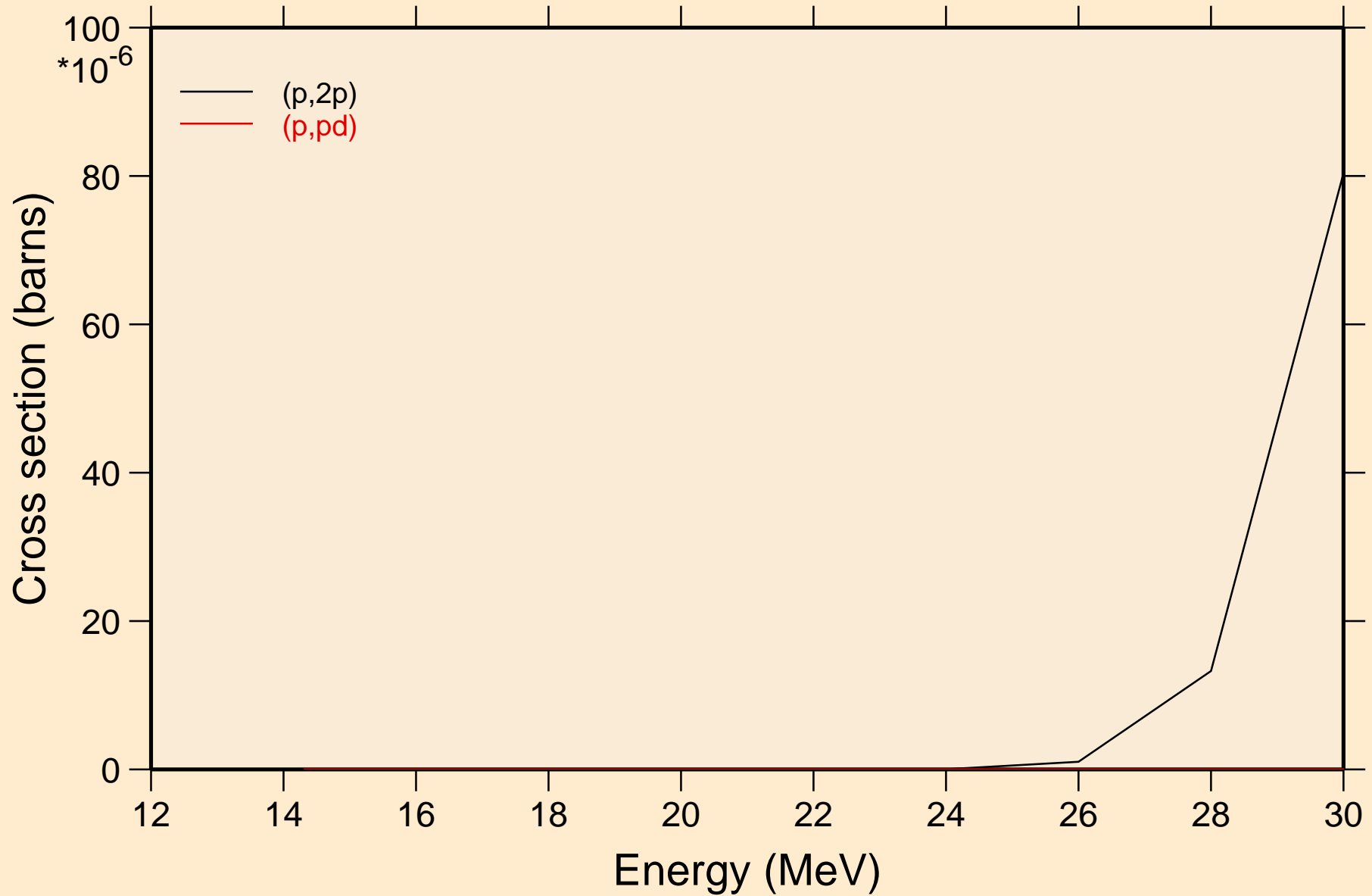

ND157 PROTON ACER TENDL-2021 LIBRARY; T=0.K
angular distribution for elastic

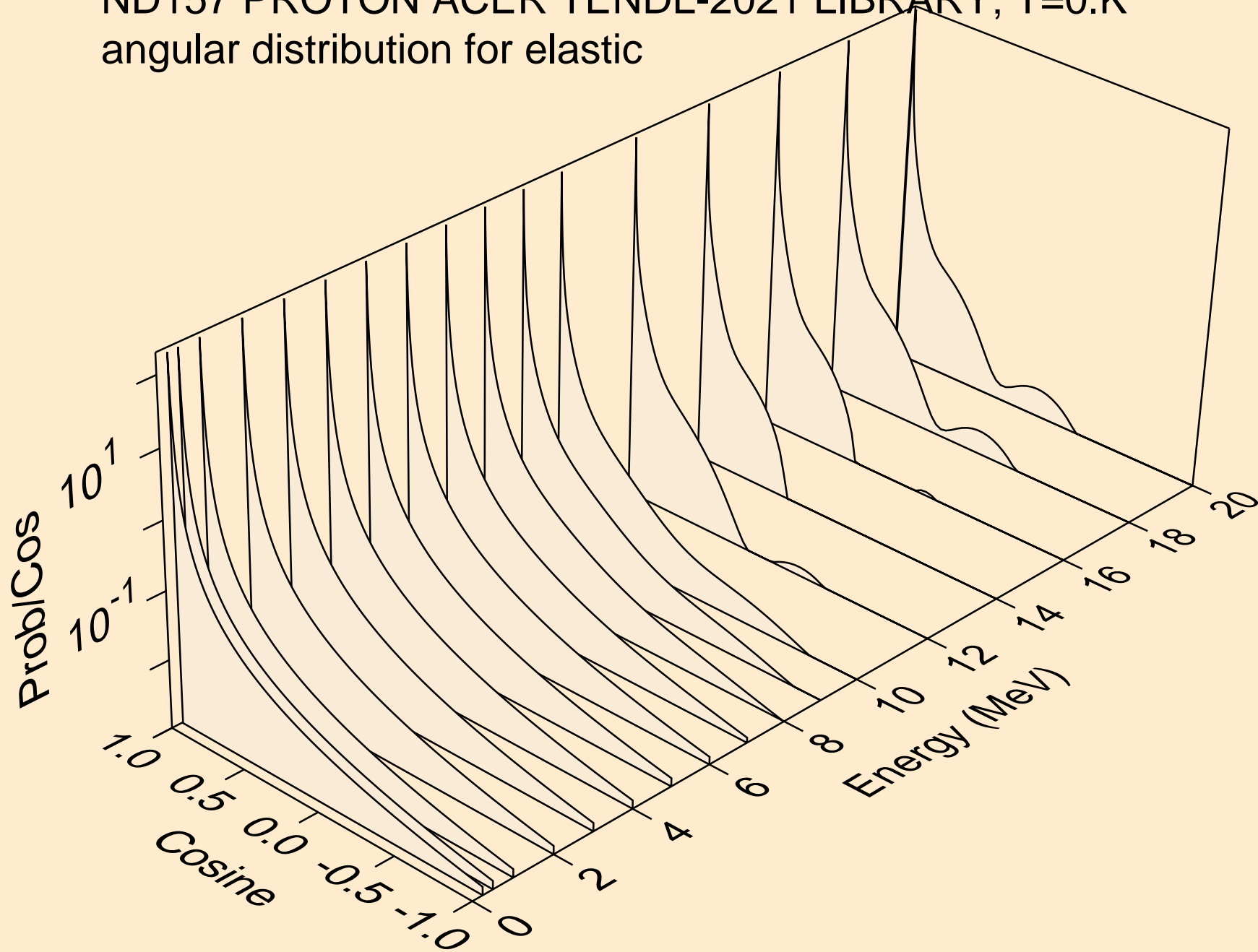

ND157 PROTON ACER TENDL-2021 LIBRARY; T=0.K
angular distribution for elastic

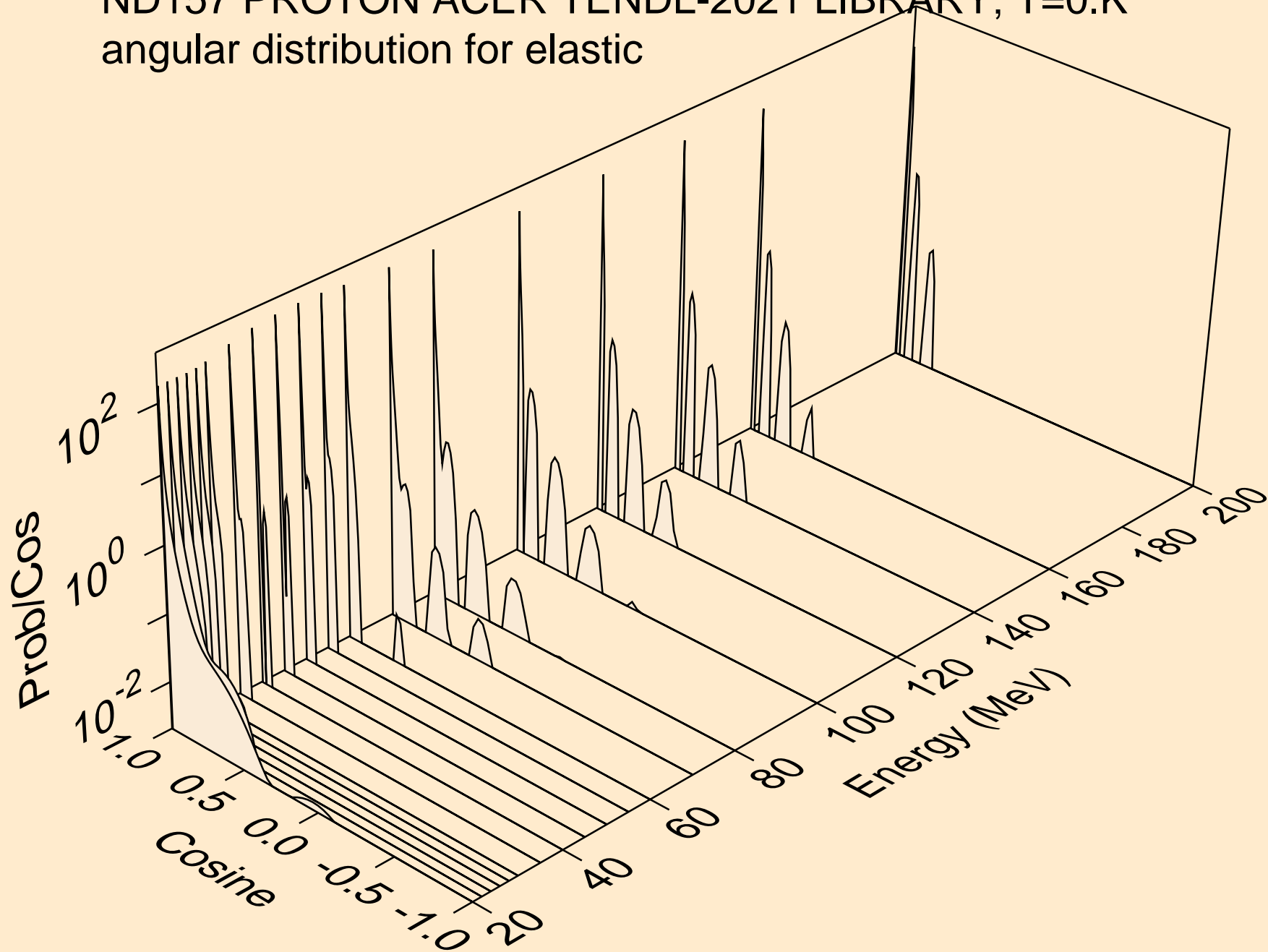

ND157 PROTON ACER TENDL-2021 LIBRARY; T=0.K
Proton emission for (p,x)

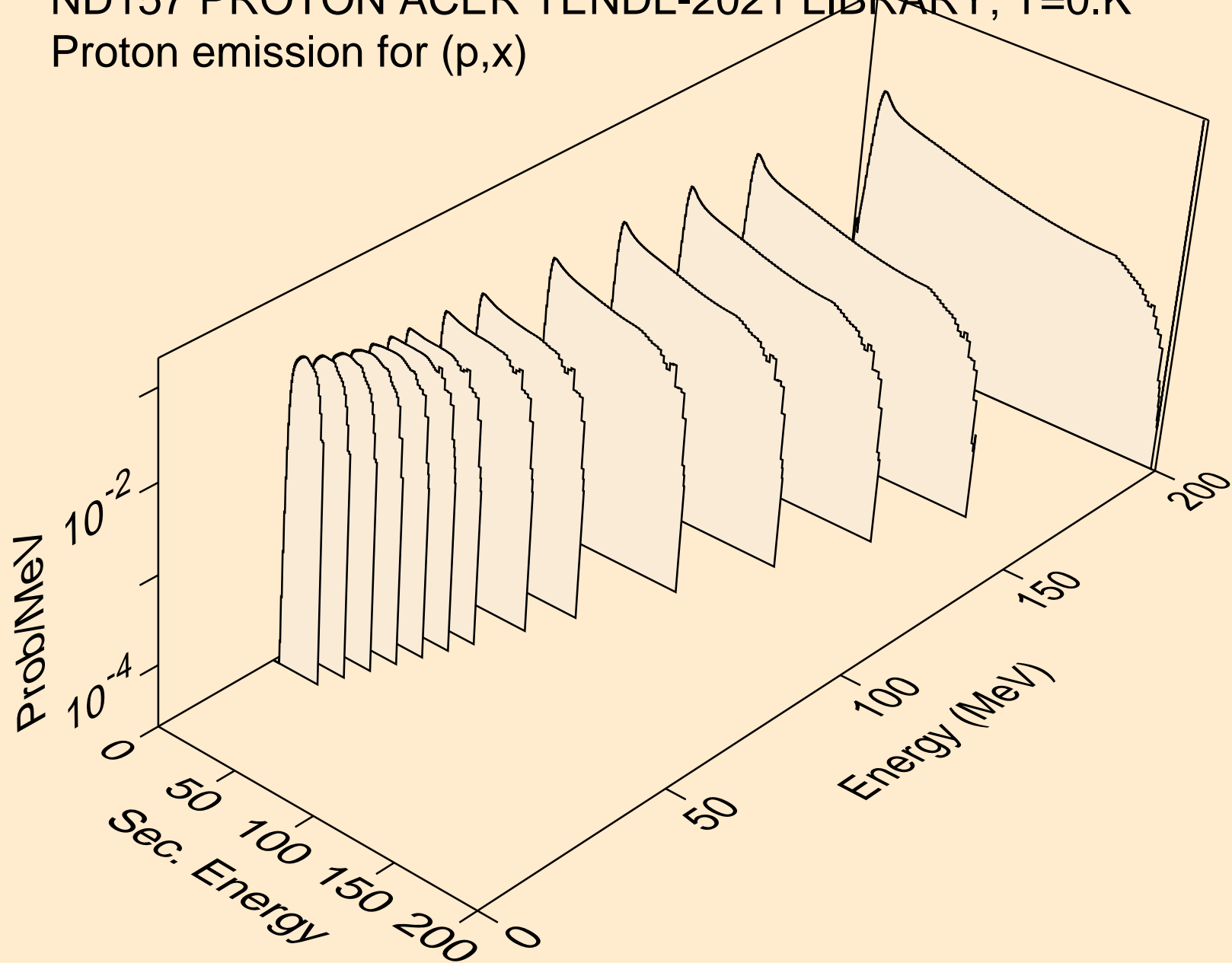

ND157 PROTON ACER TENDL-2021 LIBRARY; T=0.K
Proton emission for (p,n*)p

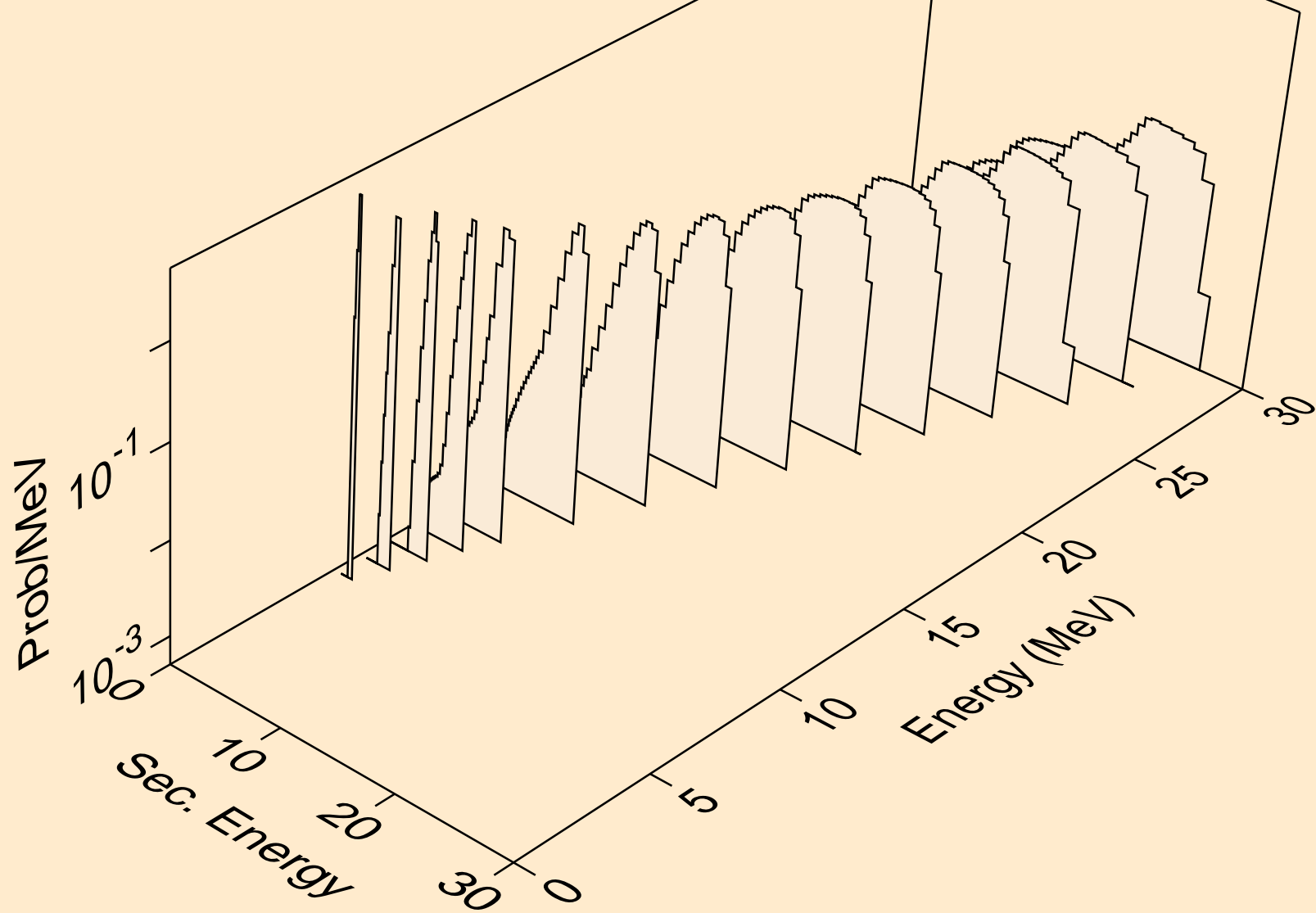

ND157 PROTON ACER TENDL-2021 LIBRARY; T=0.K
Proton emission for (p,2np)

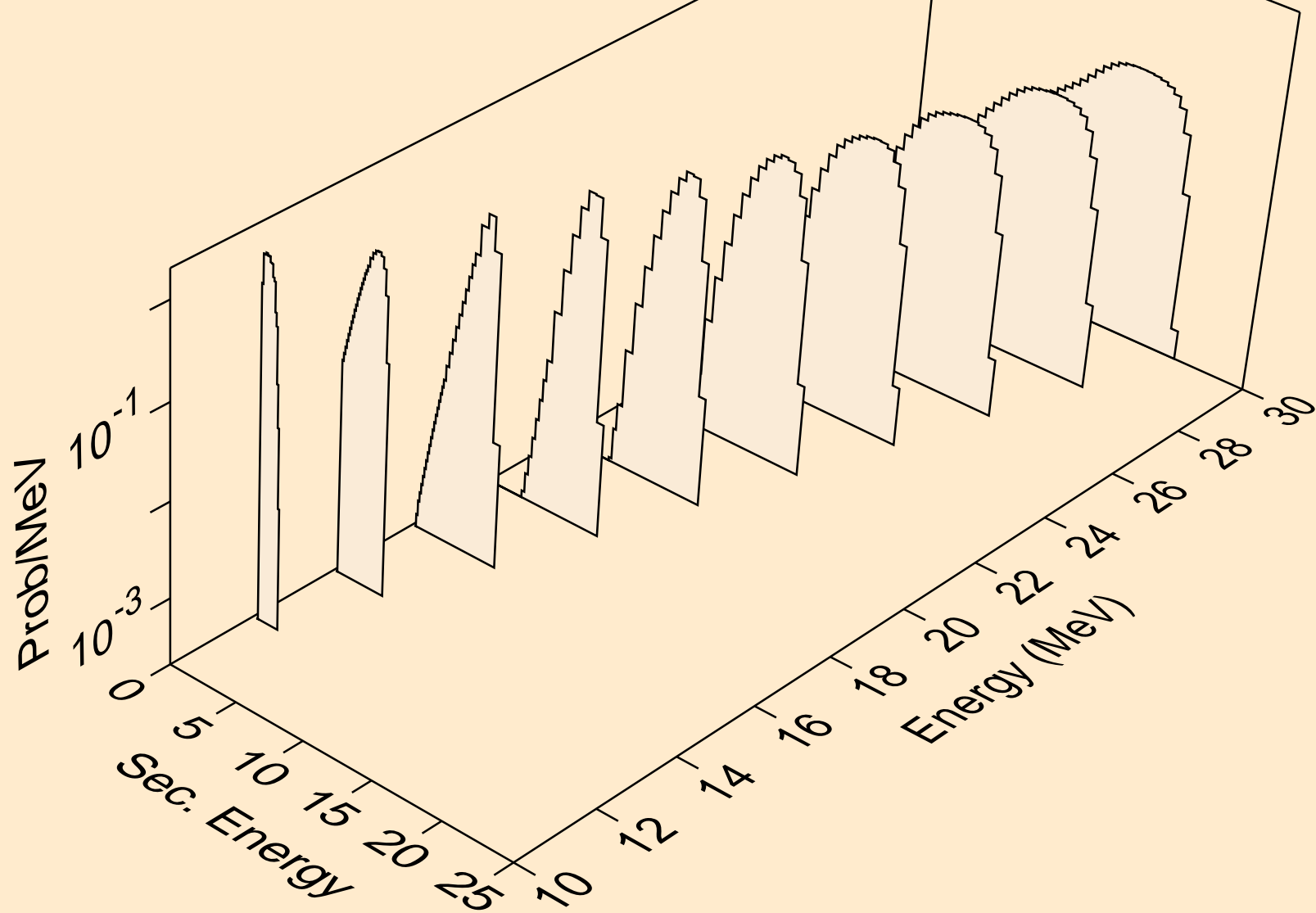

ND157 PROTON ACER TENDL-2021 LIBRARY; T=0.K
Proton emission for (p,3np)

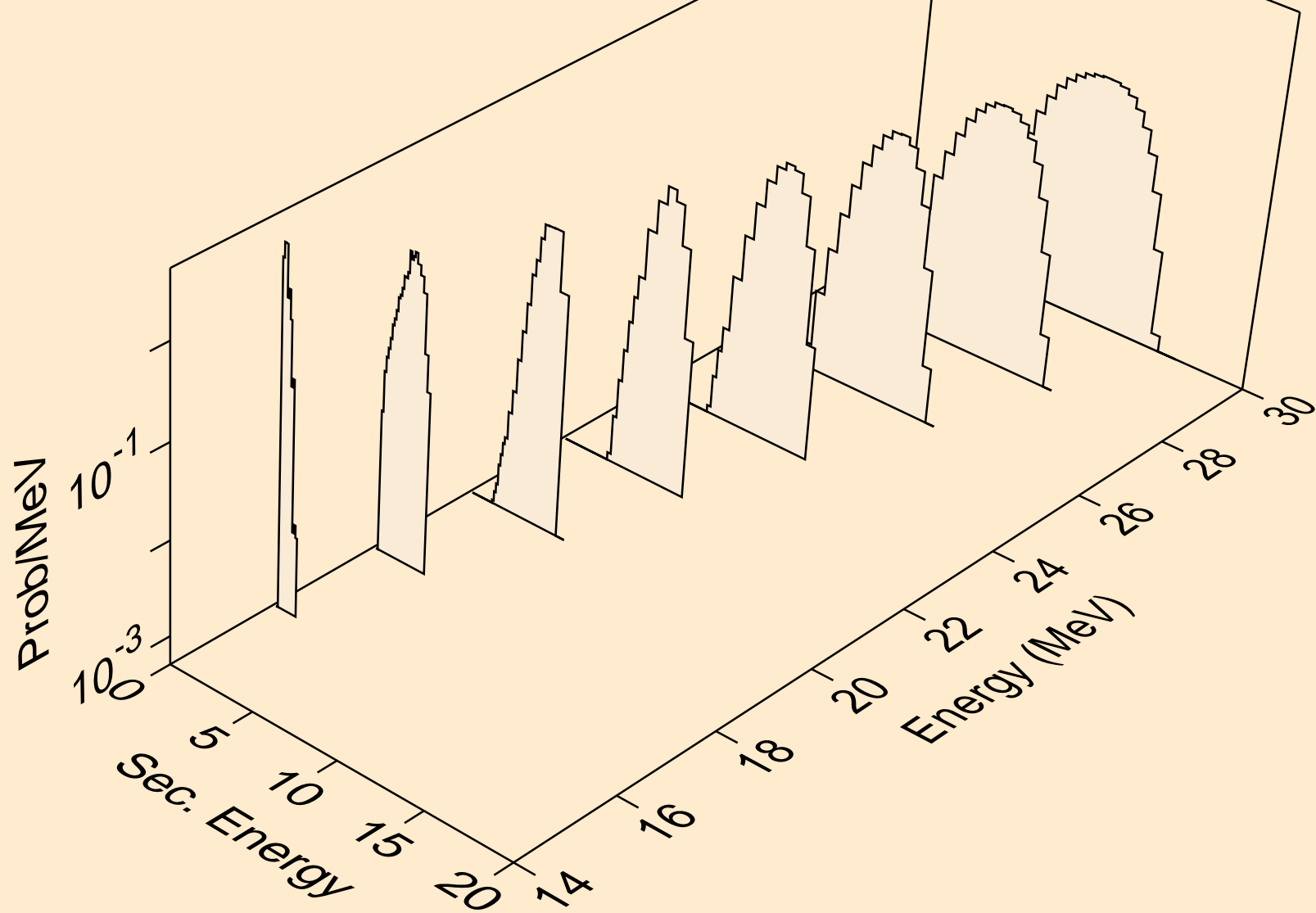

ND157 PROTON ACER TENDL-2021 LIBRARY; T=0.K
Proton emission for (p,2np)

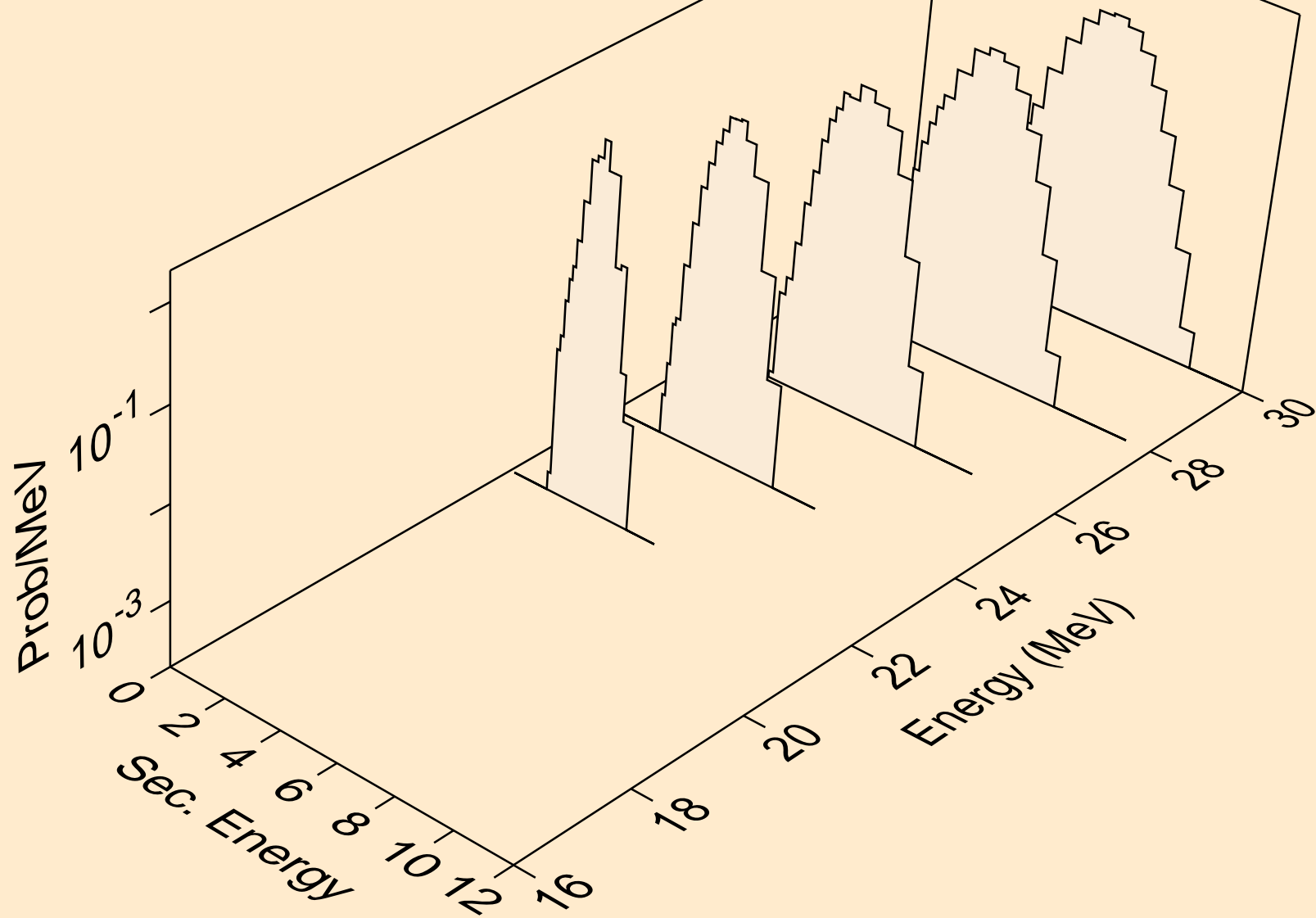

ND157 PROTON ACER TENDL-2021 LIBRARY; T=0.K
Proton emission for inelastic

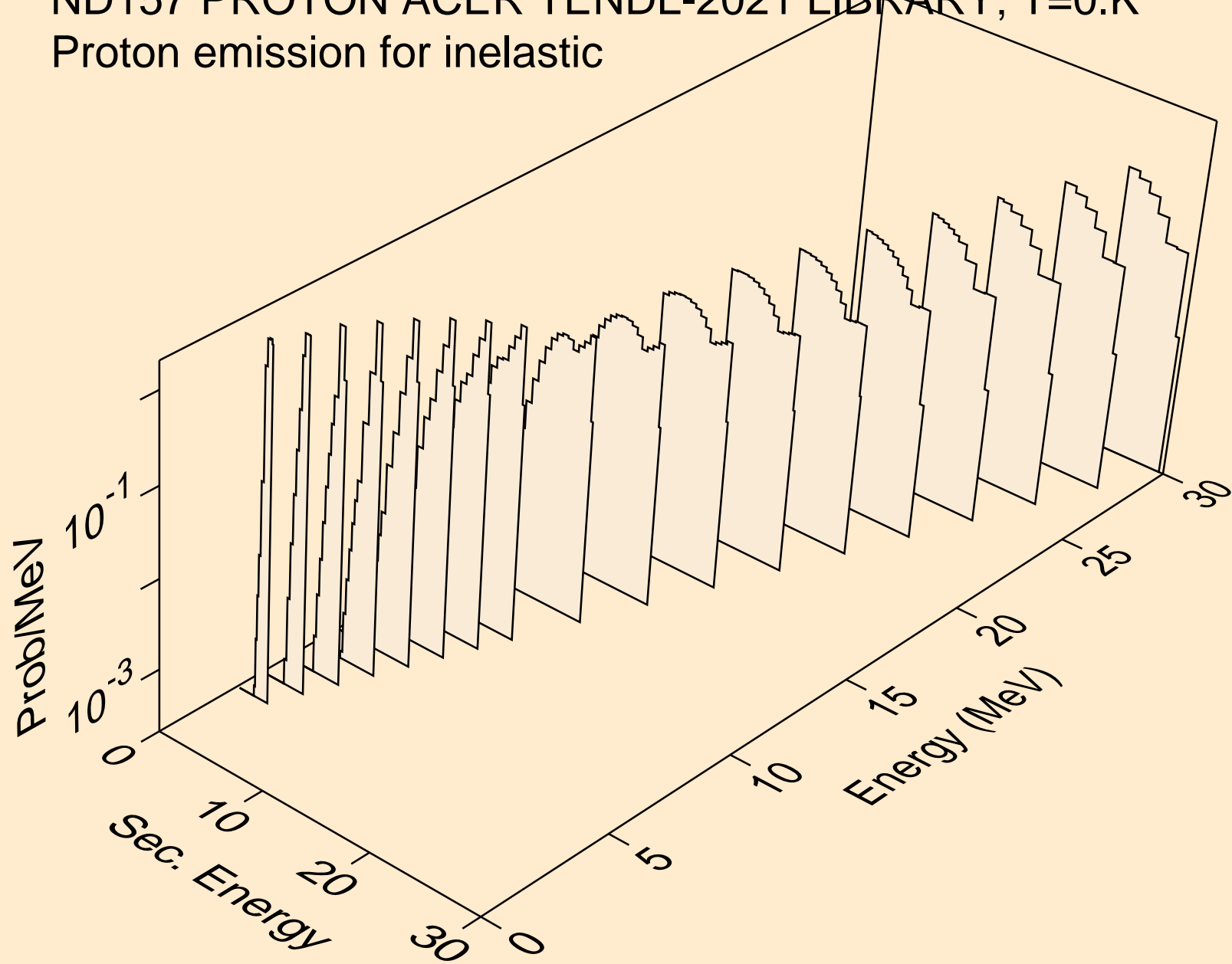

ND157 PROTON ACER TENDL-2021 LIBRARY; T=0.K
Proton emission for (p,2p)

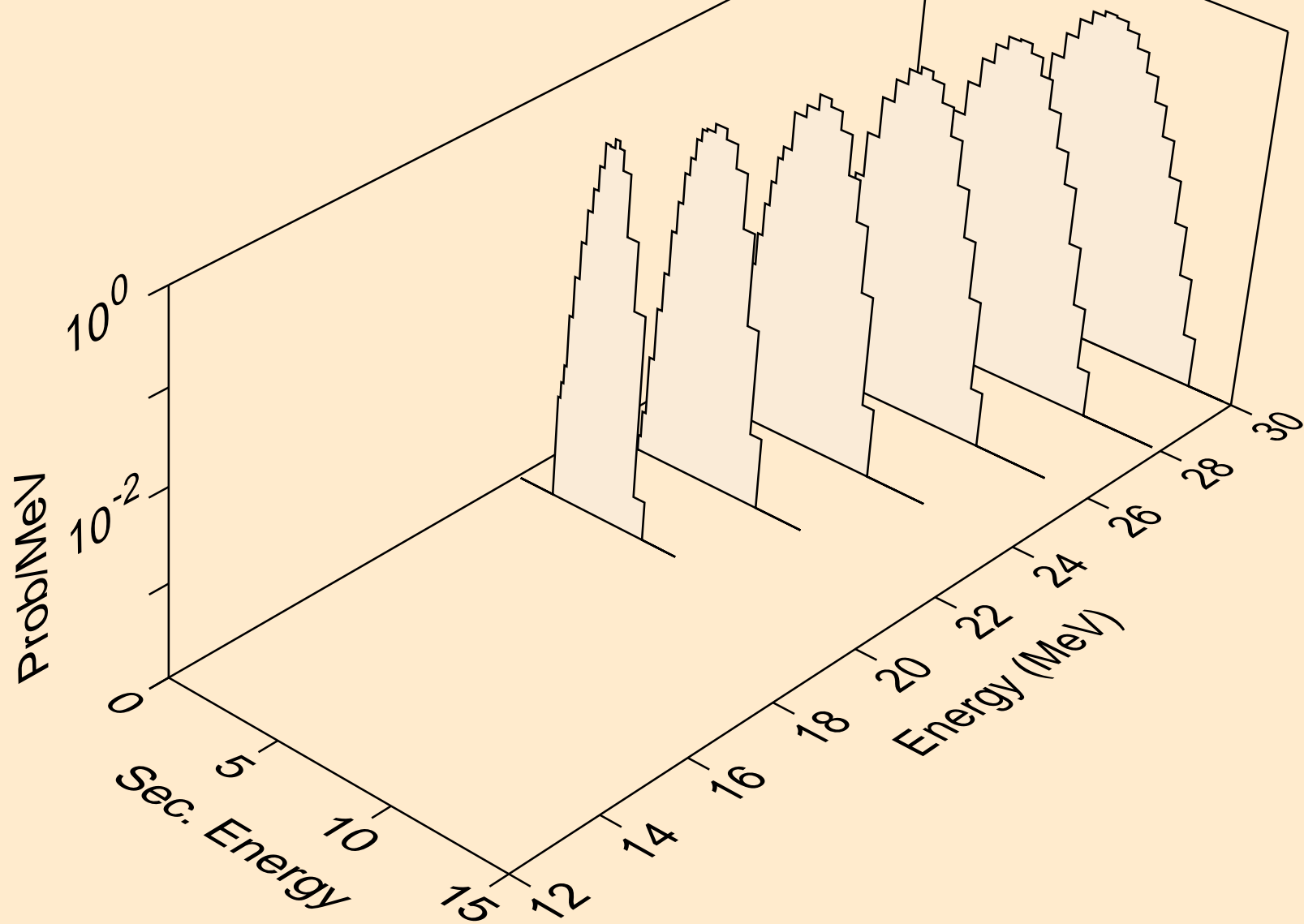

ND157 PROTON ACER TENDL-2021 LIBRARY; T=0.K
Proton emission for (p,pd)

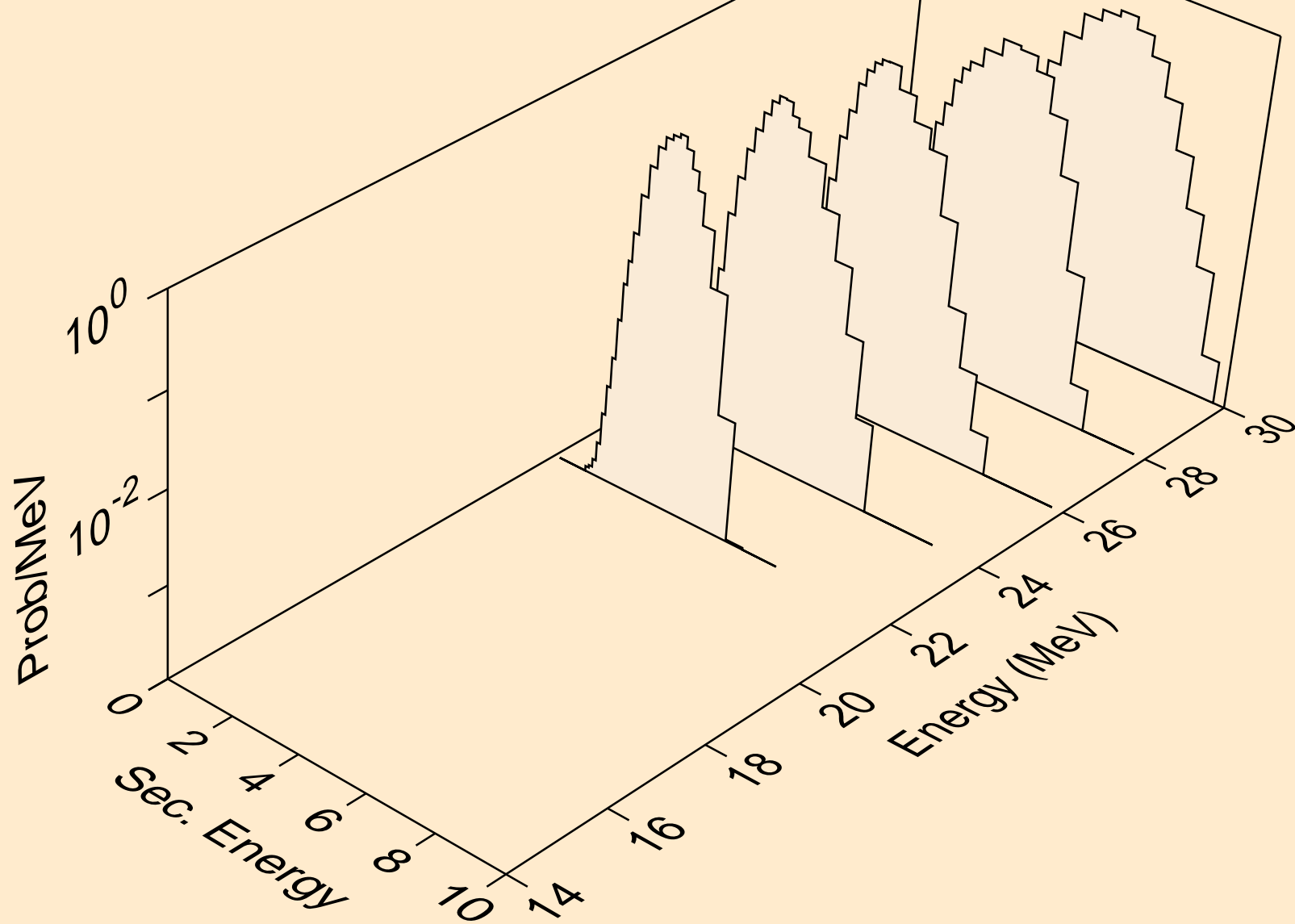

ND157 PROTON ACER TENDL-2021 LIBRARY; T=0.K
Photon emission for (z,n)

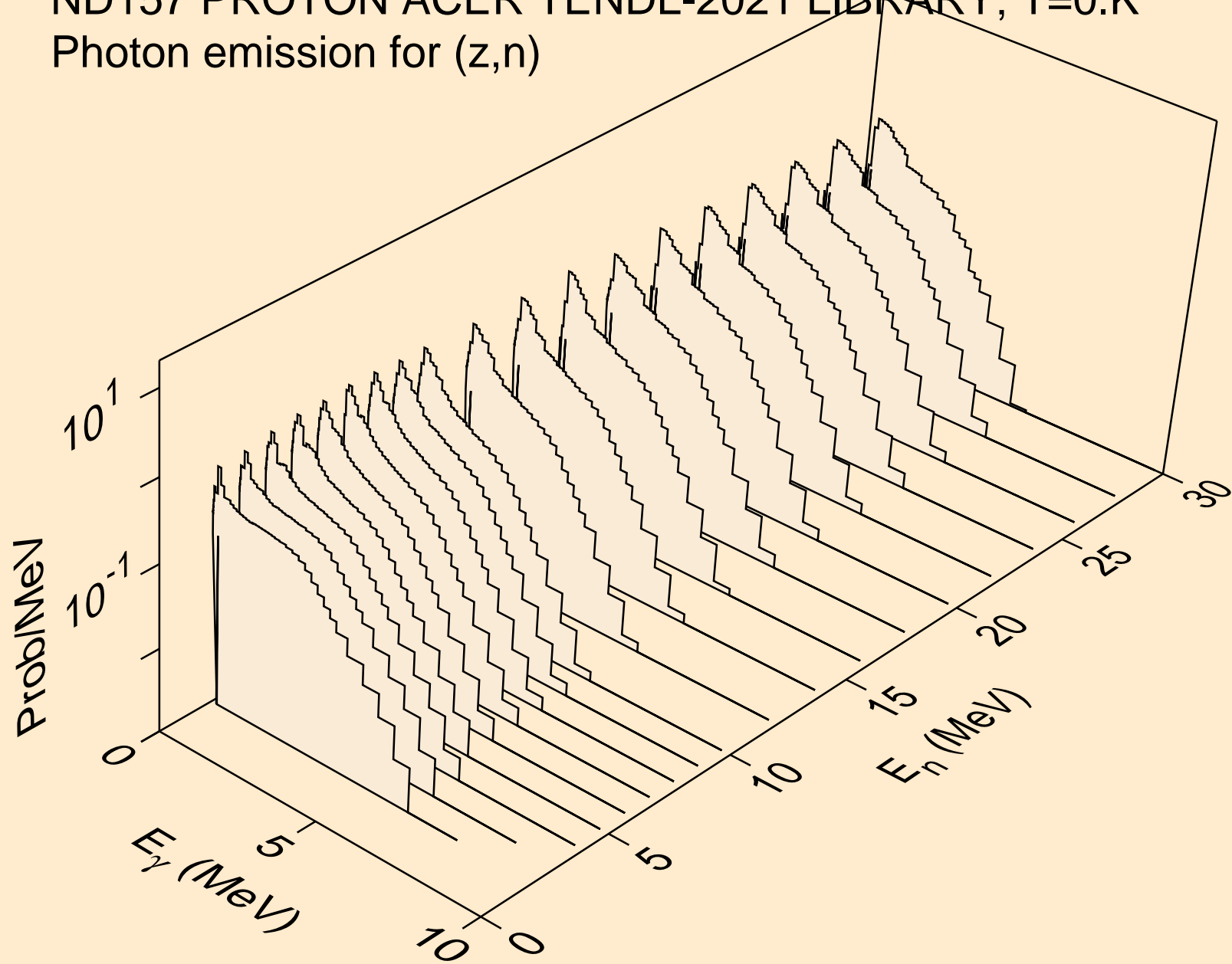

ND157 PROTON ACER TENDL-2021 LIBRARY; T=0.K
Photon emission for (n,x)

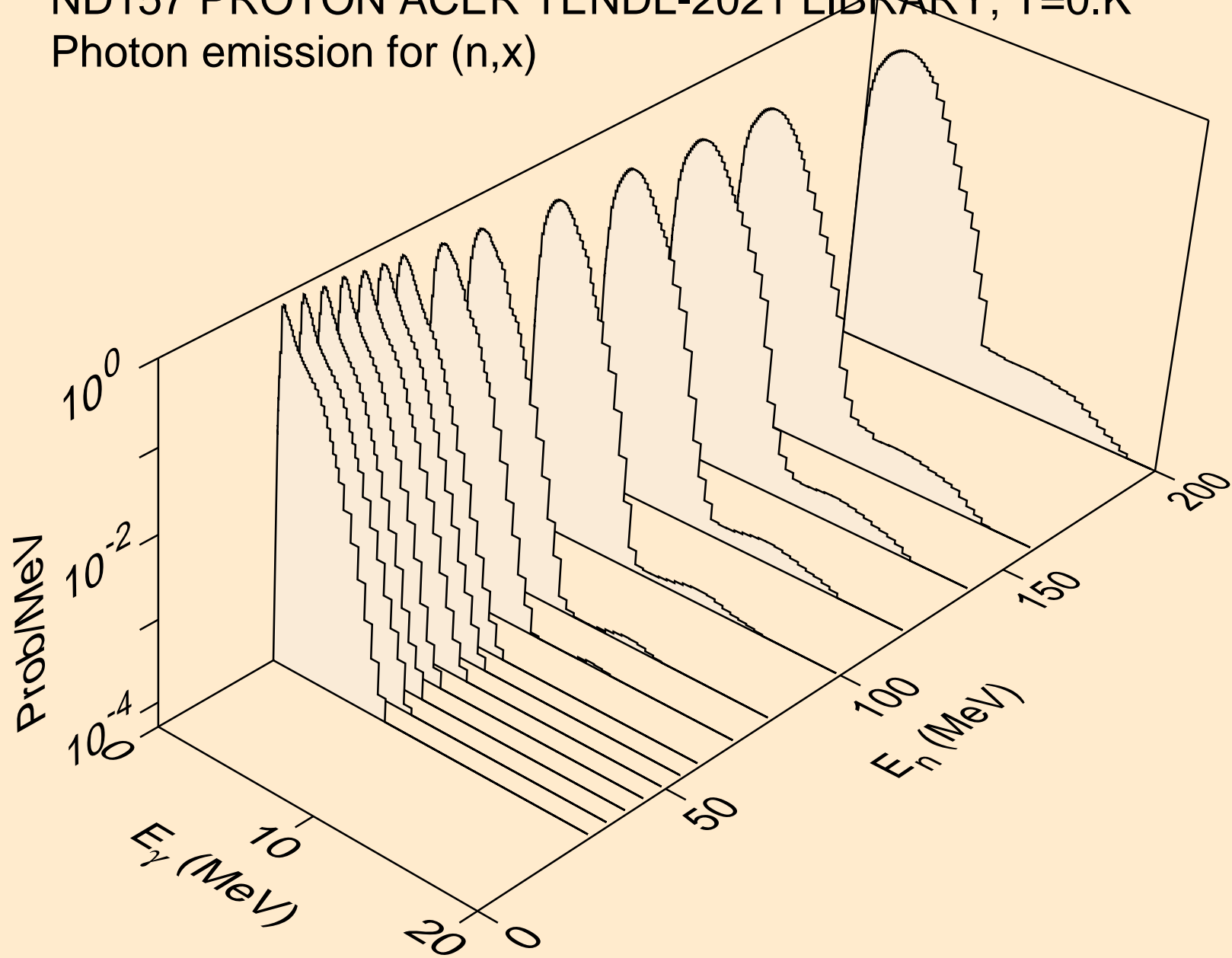

ND157 PROTON ACER TENDL-2021 LIBRARY; T=0.K
Photon emission for (n,2nd)

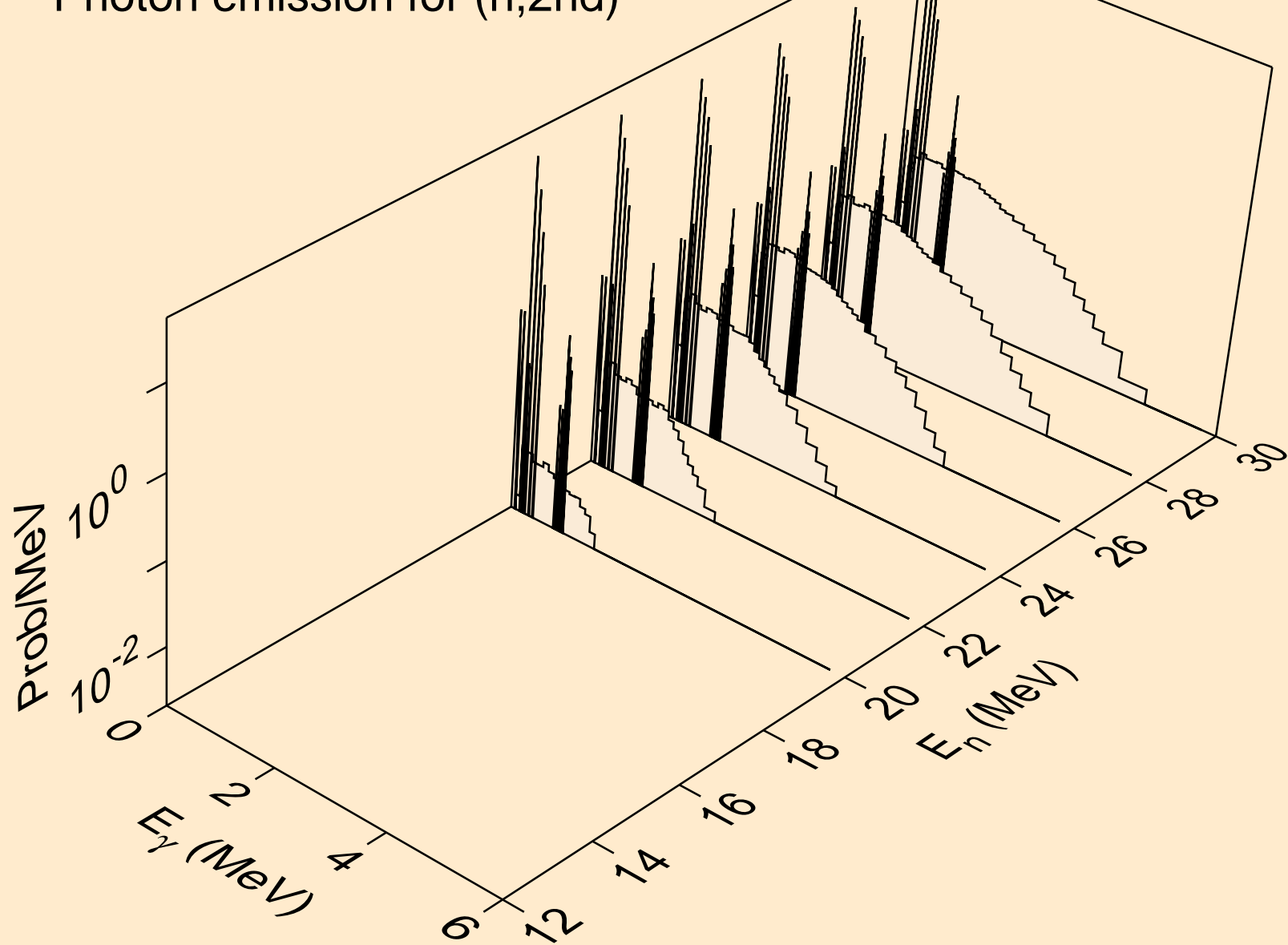

ND157 PROTON ACER TENDL-2021 LIBRARY; T=0.K
Photon emission for (n,2n)

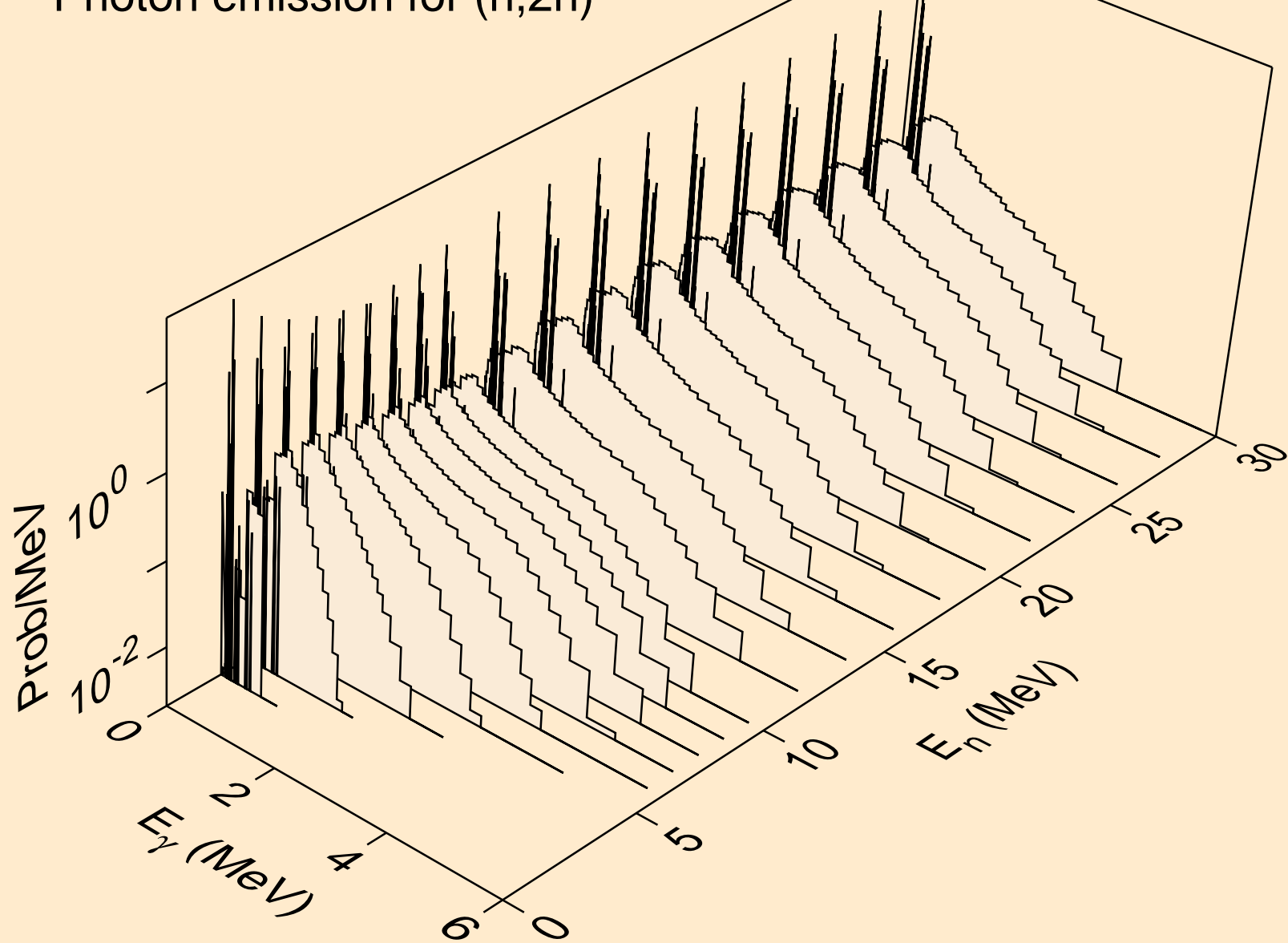

ND157 PROTON ACER TENDL-2021 LIBRARY; T=0.K
Photon emission for (n,3n)

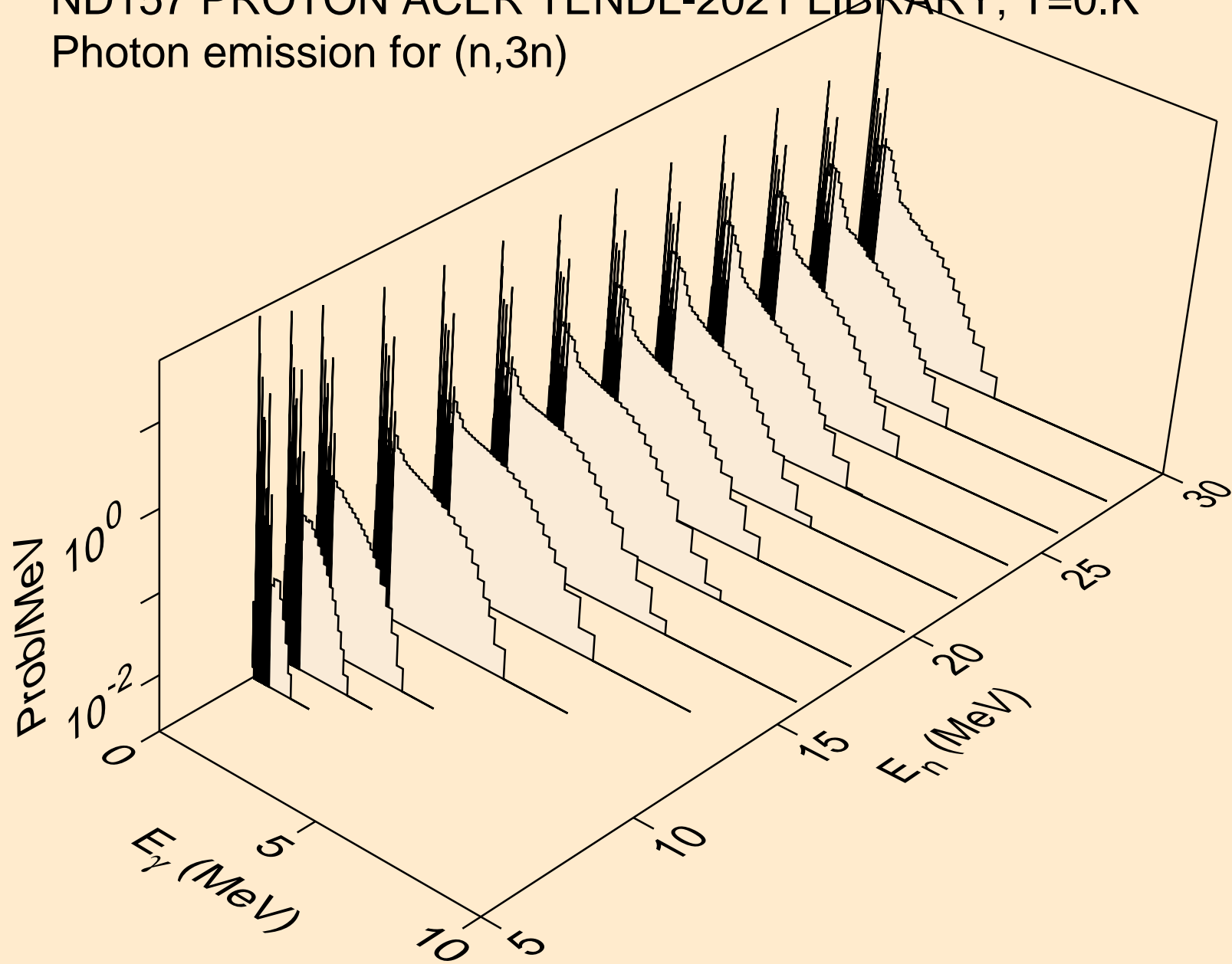

ND157 PROTON ACER TENDL-2021 LIBRARY; T=0.K
Photon emission for (n,n*)a

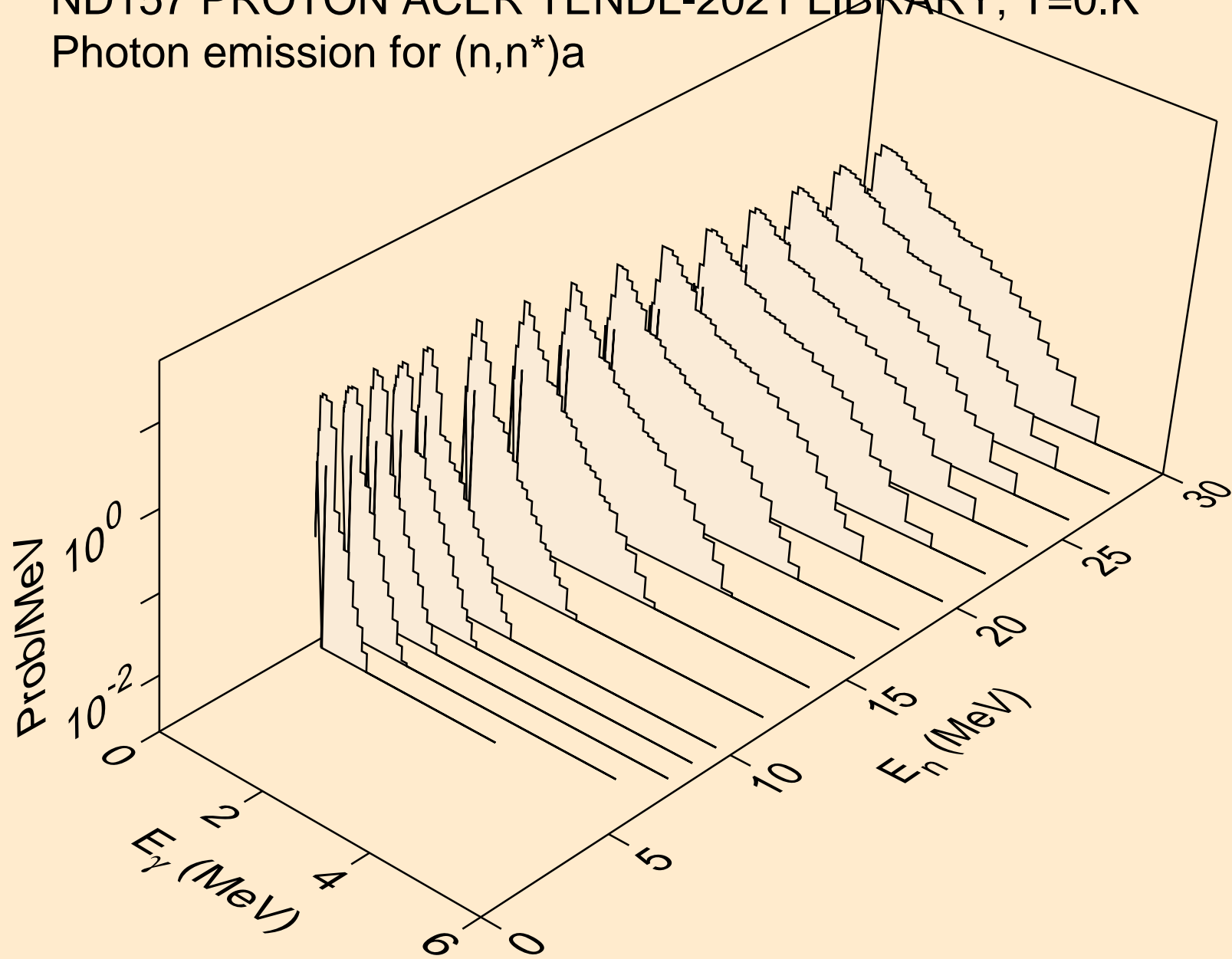

ND157 PROTON ACER TENDL-2021 LIBRARY; T=0.K
Photon emission for (n,2n)a

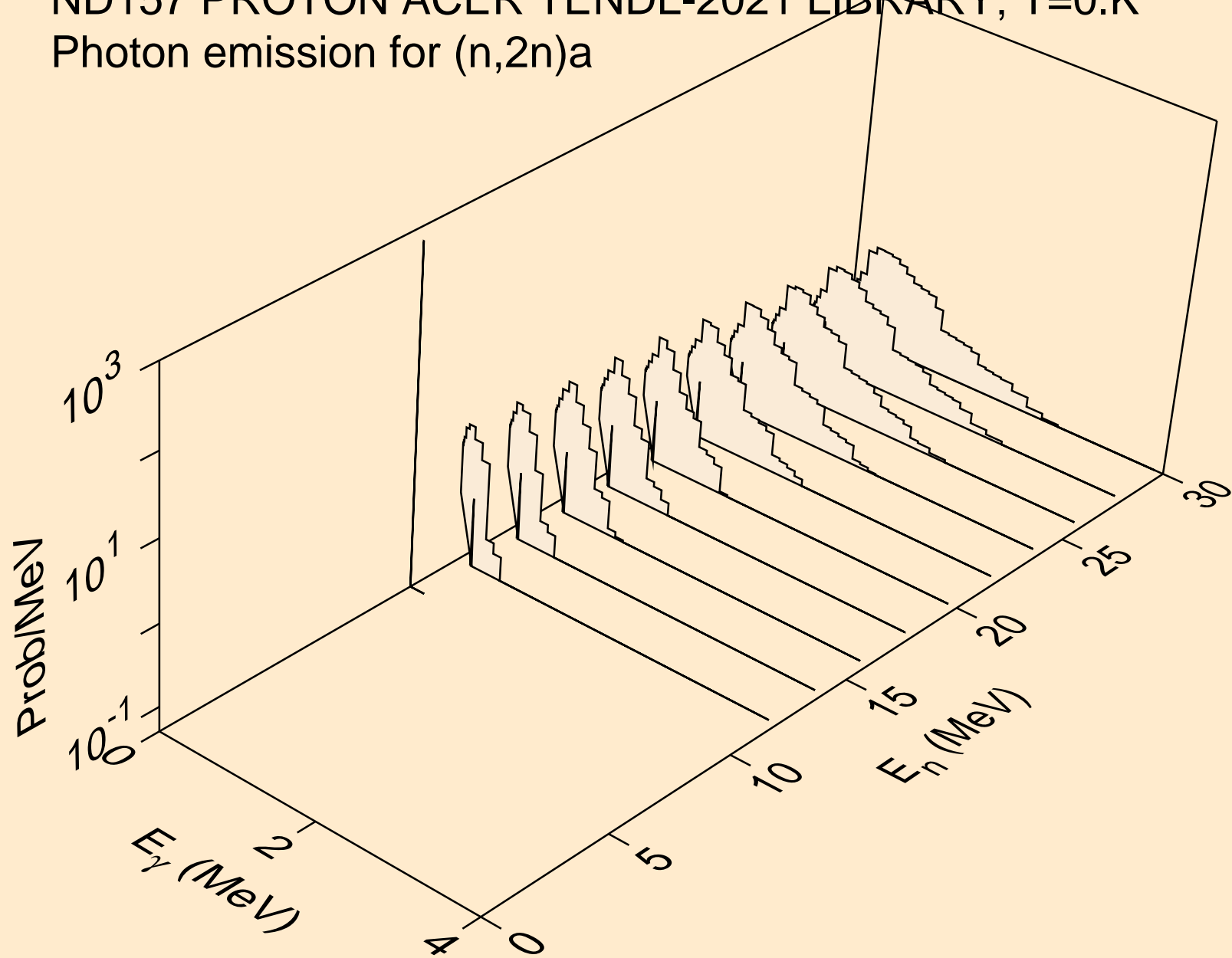

ND157 PROTON ACER TENDL-2021 LIBRARY; T=0.K
Photon emission for (n,3n)a

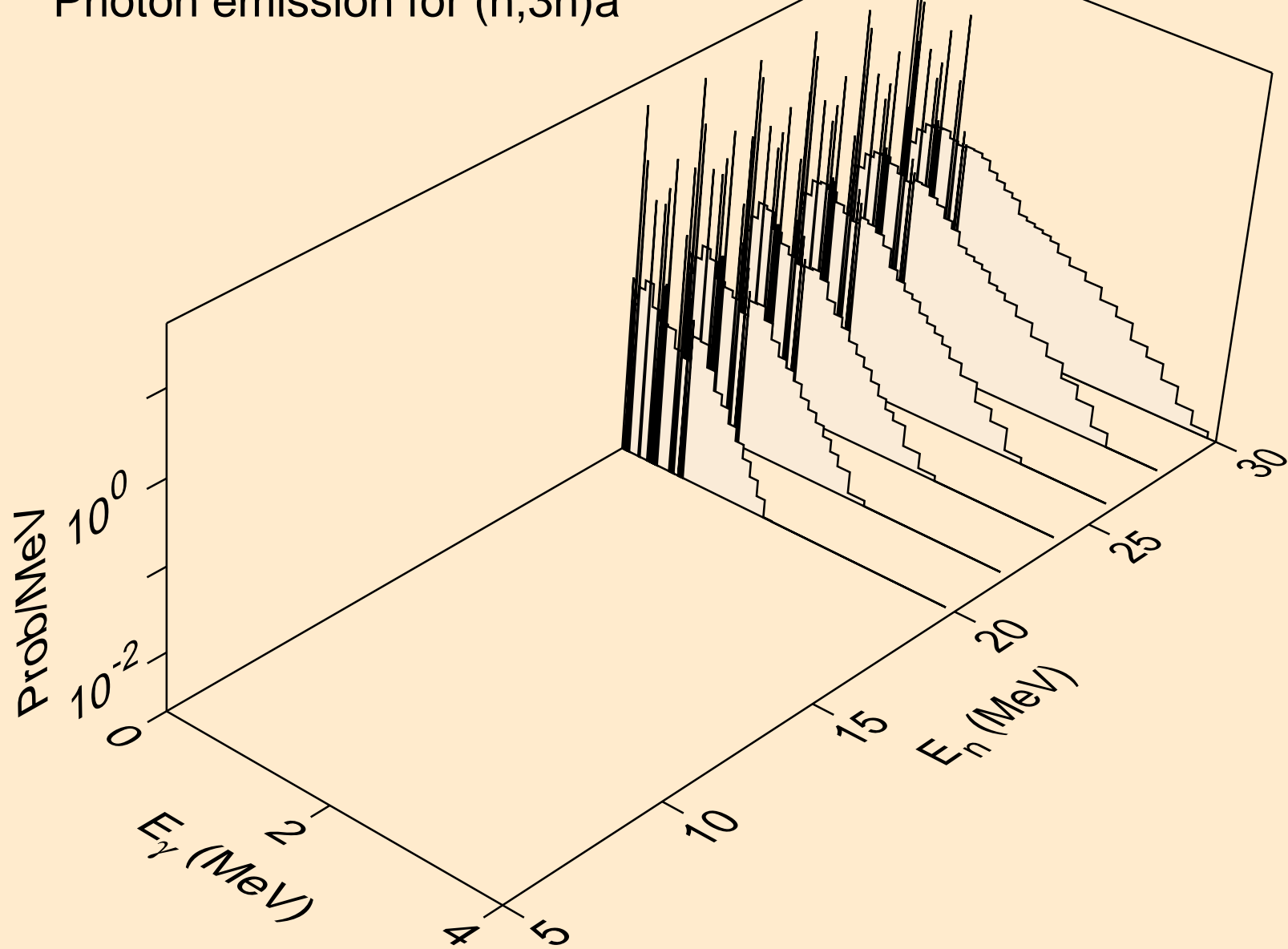

ND157 PROTON ACER TENDL-2021 LIBRARY; T=0.K
Photon emission for (n,n*)p

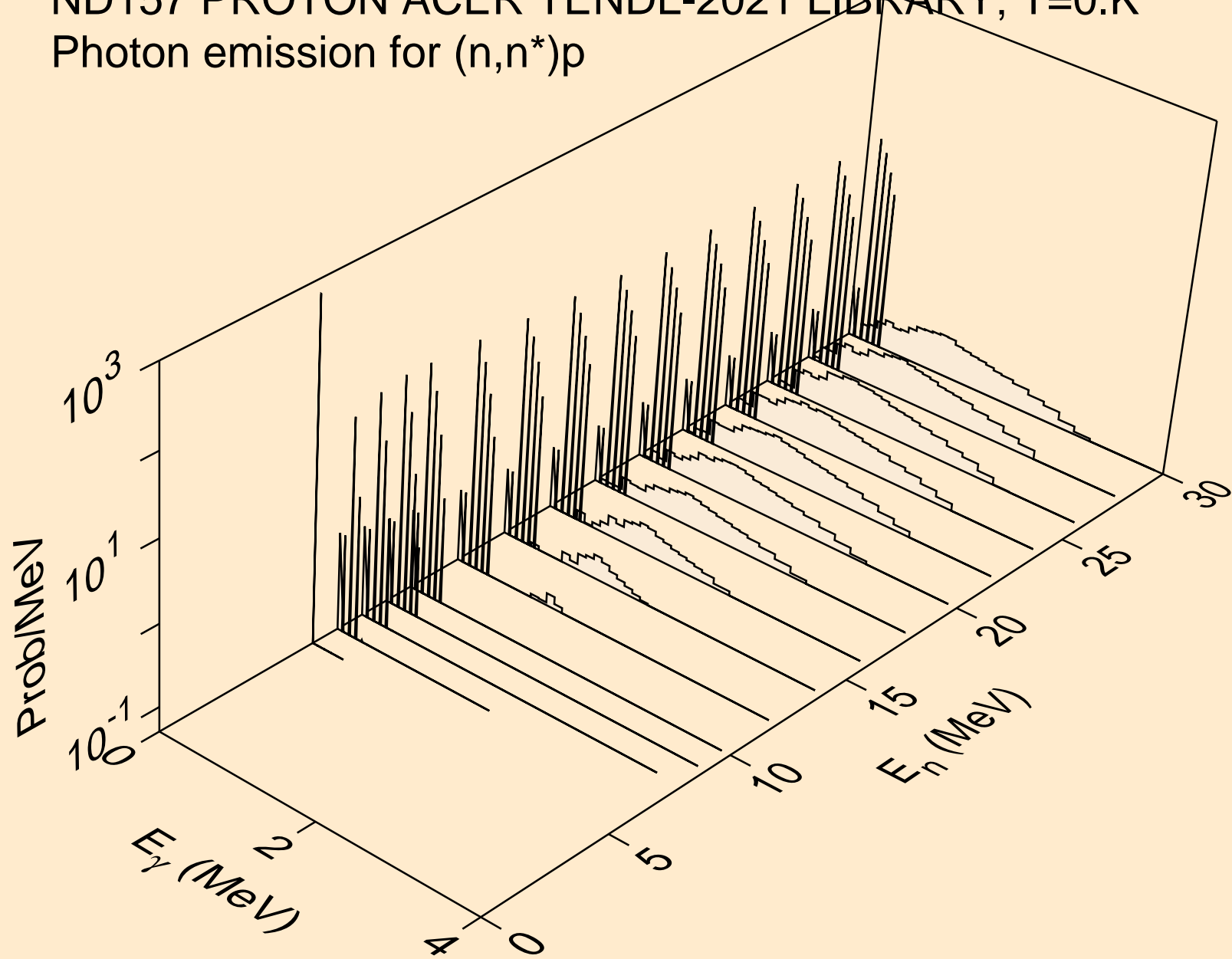

ND157 PROTON ACER TENDL-2021 LIBRARY; T=0.K
Photon emission for (n,n*)d

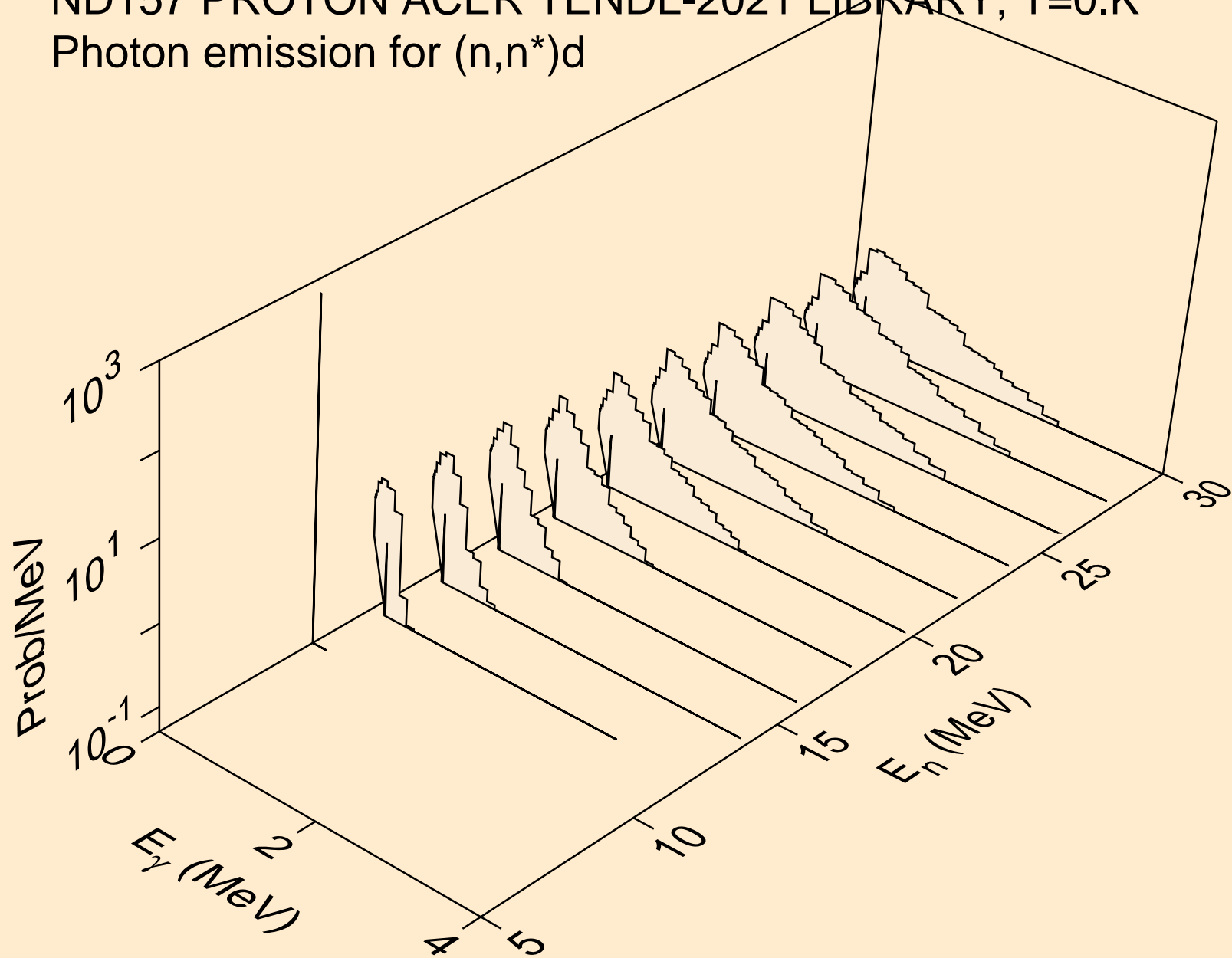

ND157 PROTON ACER TENDL-2021 LIBRARY; T=0.K
Photon emission for (n,n*)t

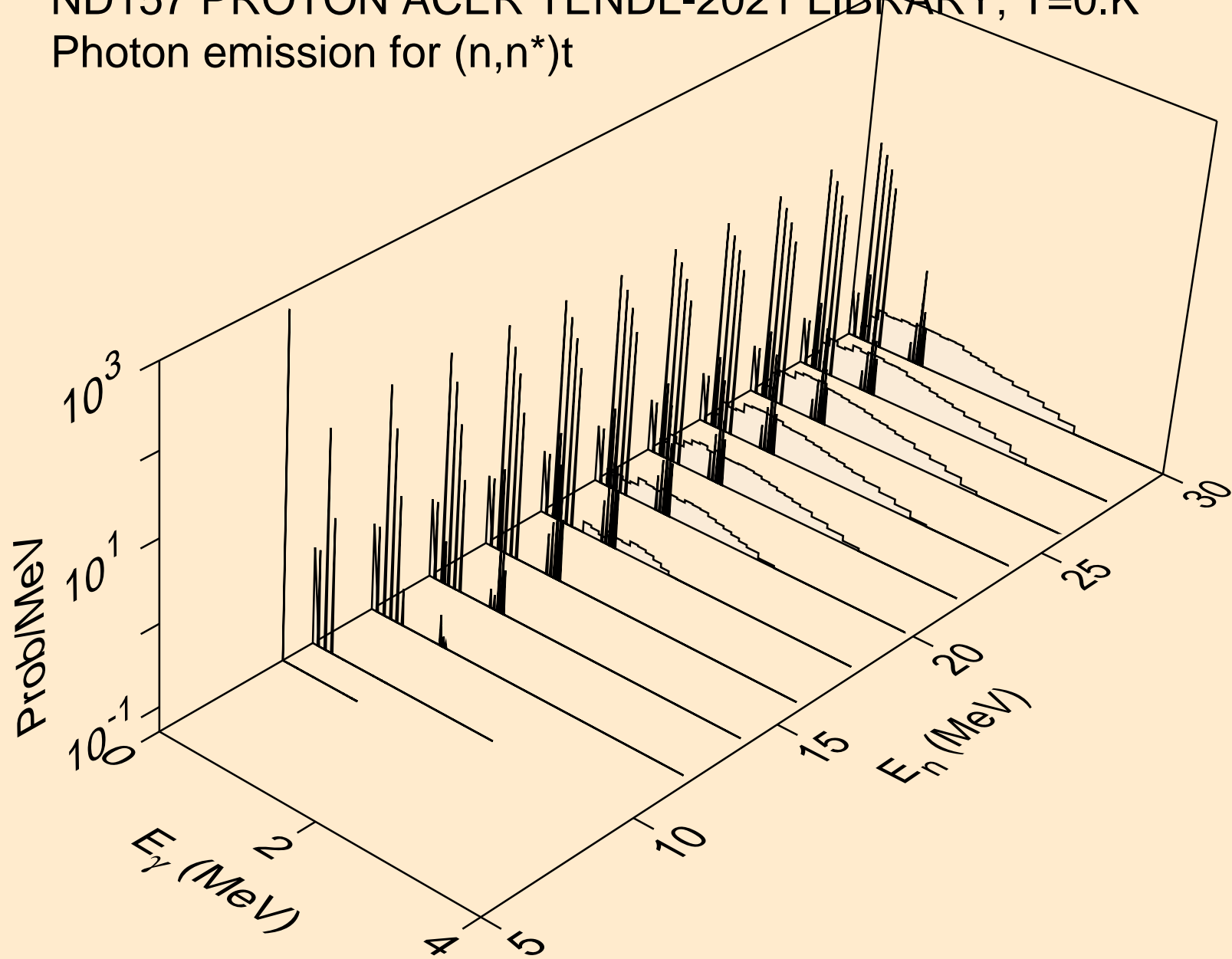

ND157 PROTON ACER TENDL-2021 LIBRARY; T=0.K
Photon emission for (n,n*)he3

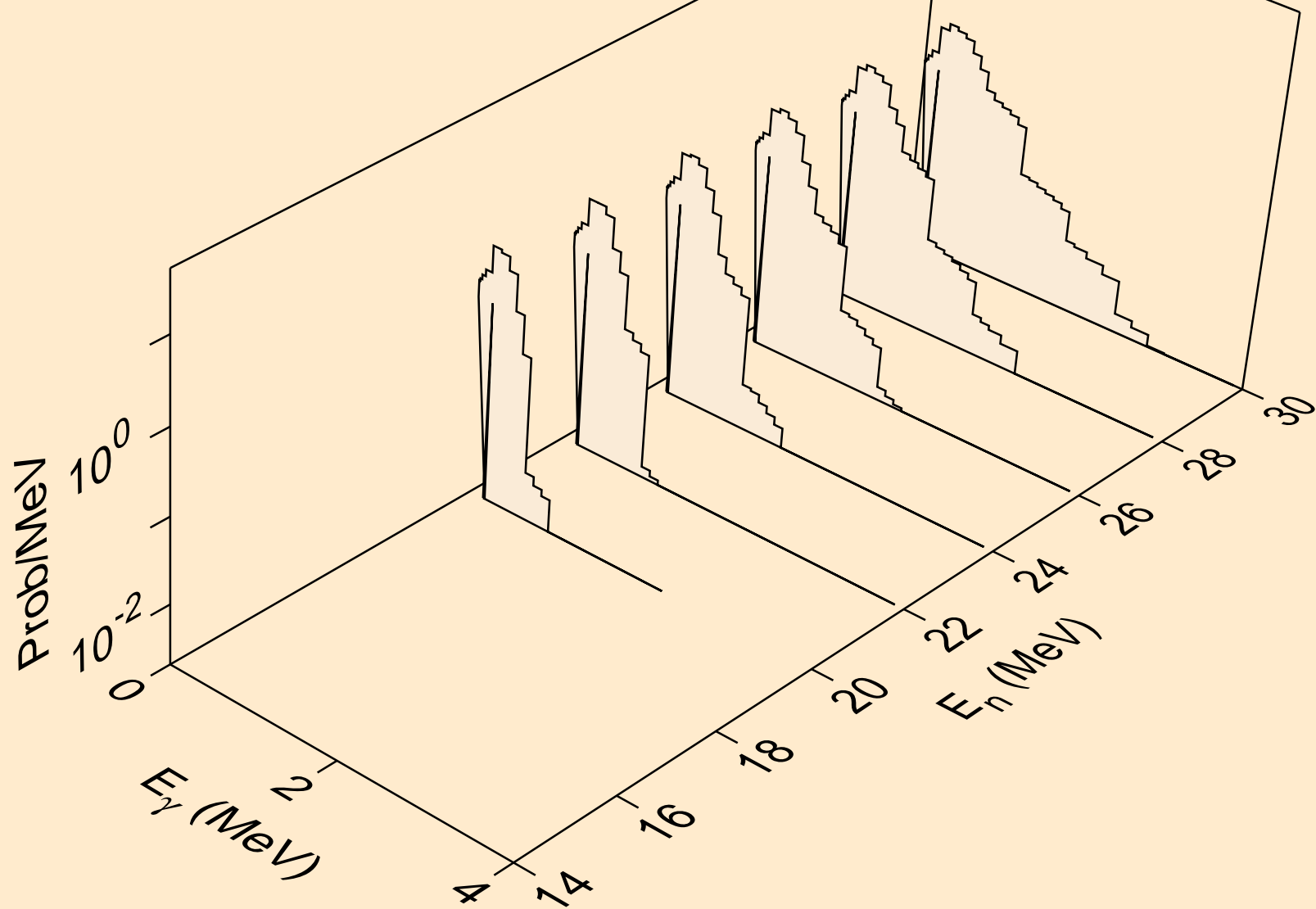

ND157 PROTON ACER TENDL-2021 LIBRARY; T=0.K
Photon emission for (n,4n)

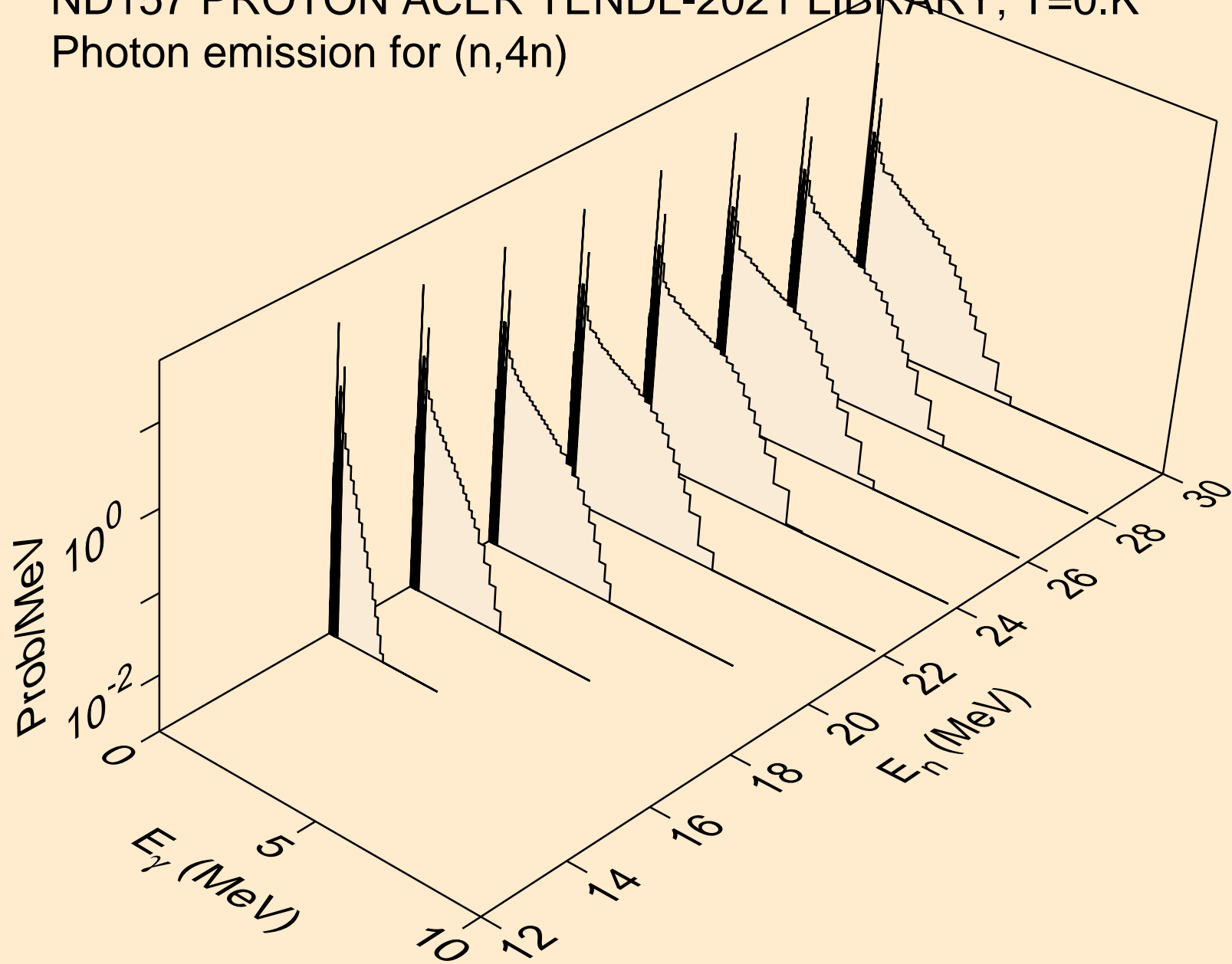

ND157 PROTON ACER TENDL-2021 LIBRARY; T=0.K
Photon emission for (n,2np)

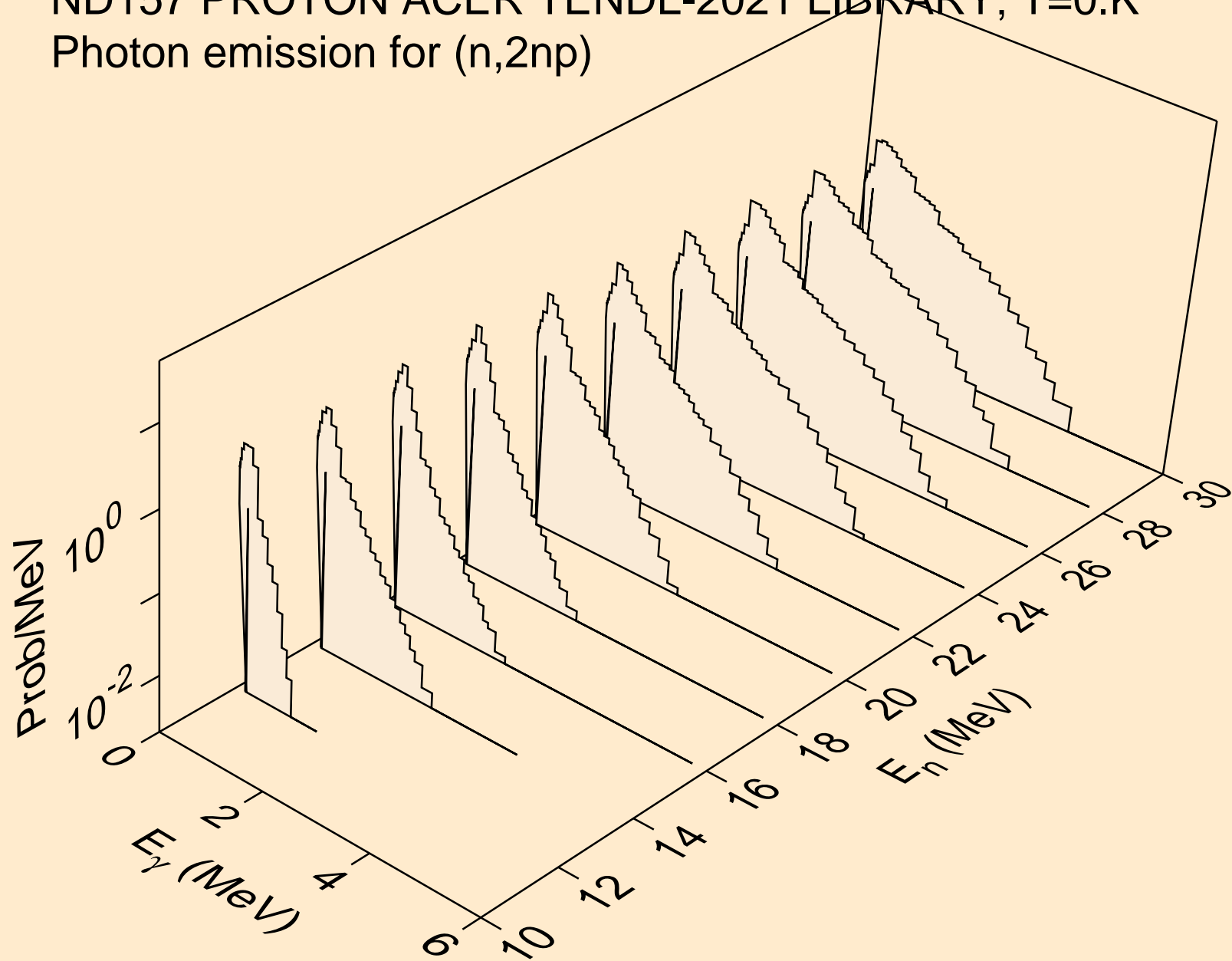

ND157 PROTON ACER TENDL-2021 LIBRARY; T=0.K
Photon emission for (n,3np)

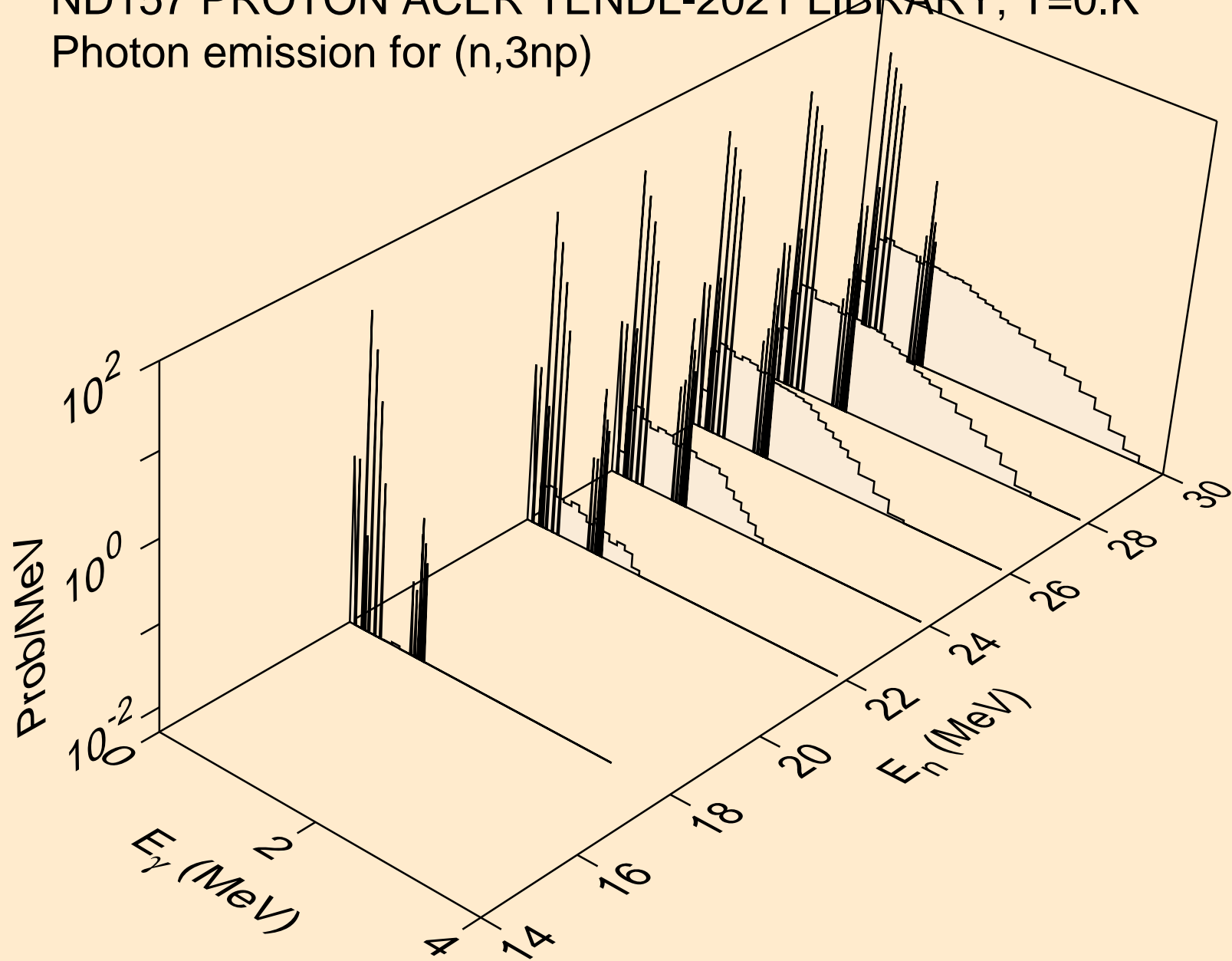

ND157 PROTON ACER TENDL-2021 LIBRARY; T=0.K
Photon emission for (n,2np)

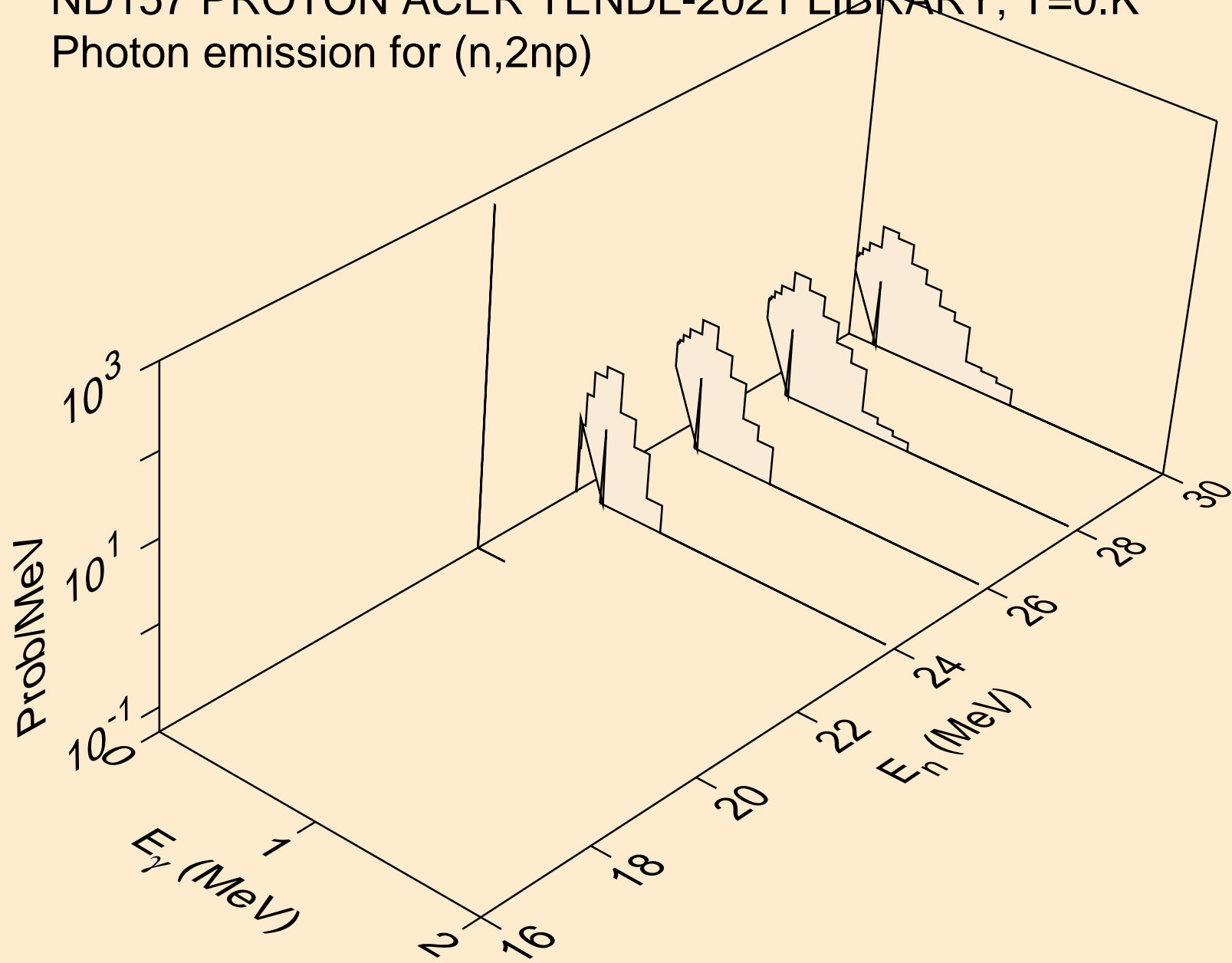

ND157 PROTON ACER TENDL-2021 LIBRARY; T=0.K
Photon emission for (n,gma)

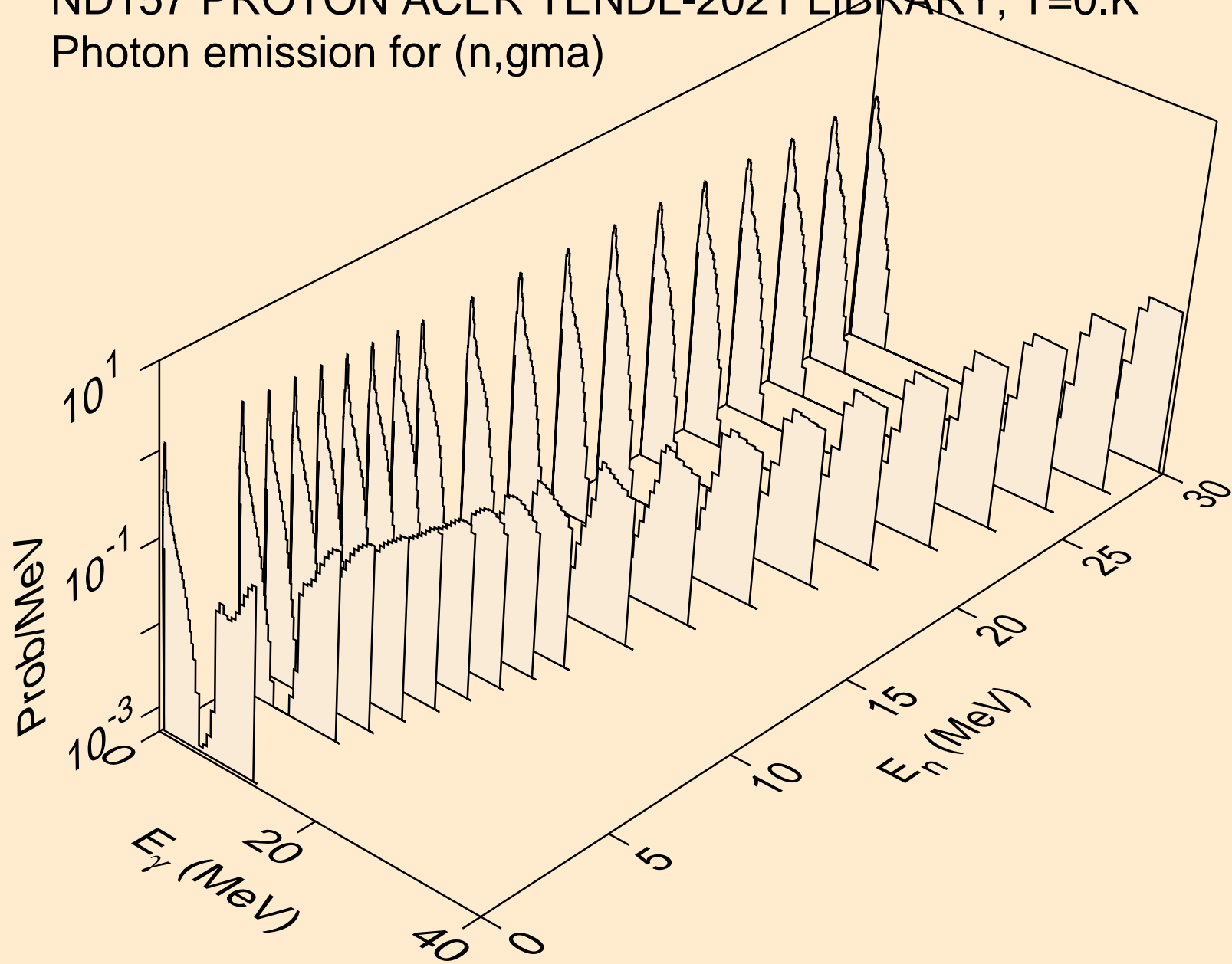

ND157 PROTON ACER TENDL-2021 LIBRARY; T=0.K
Photon emission for inelastic

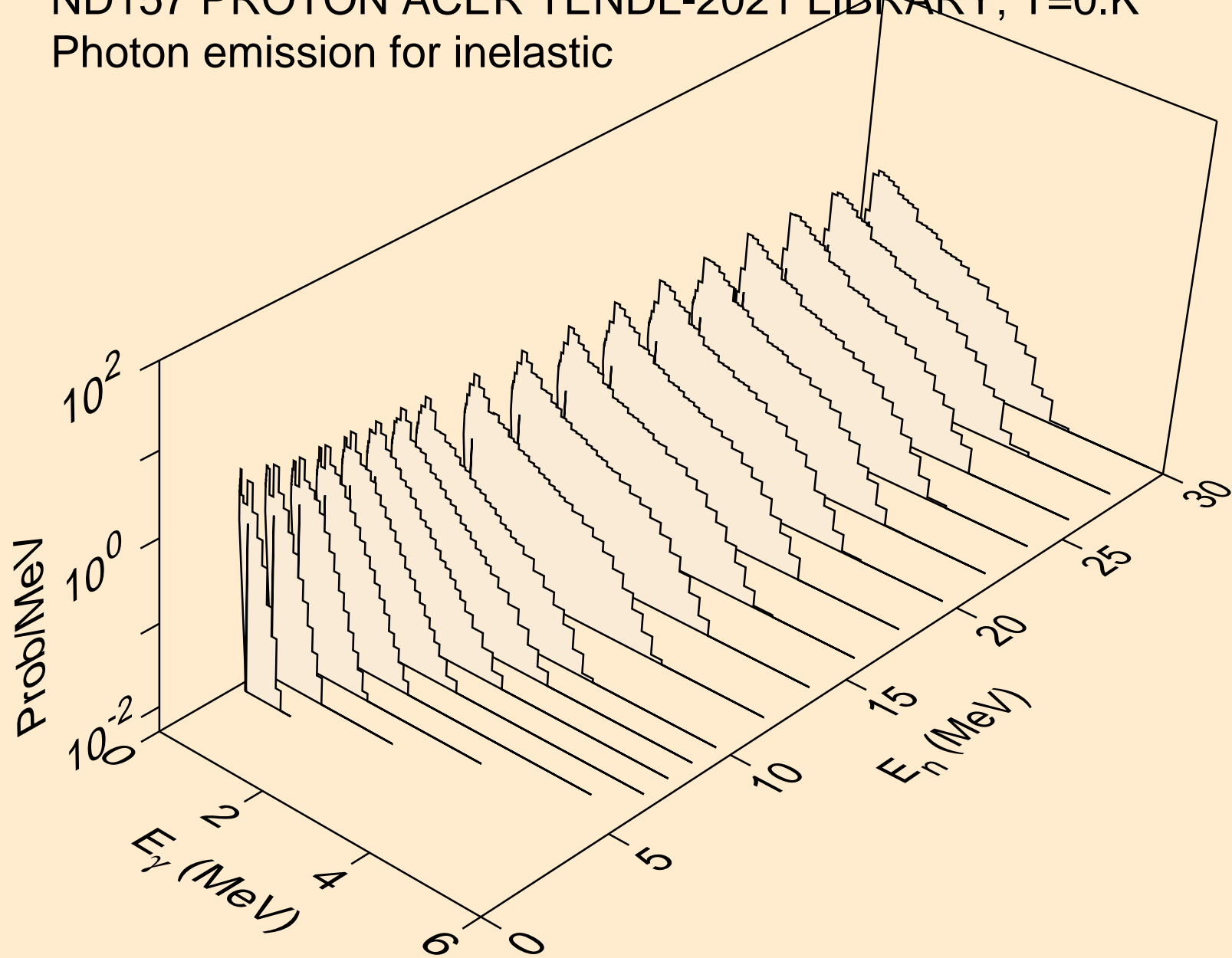

ND157 PROTON ACER TENDL-2021 LIBRARY; T=0.K
Photon emission for (n,d)

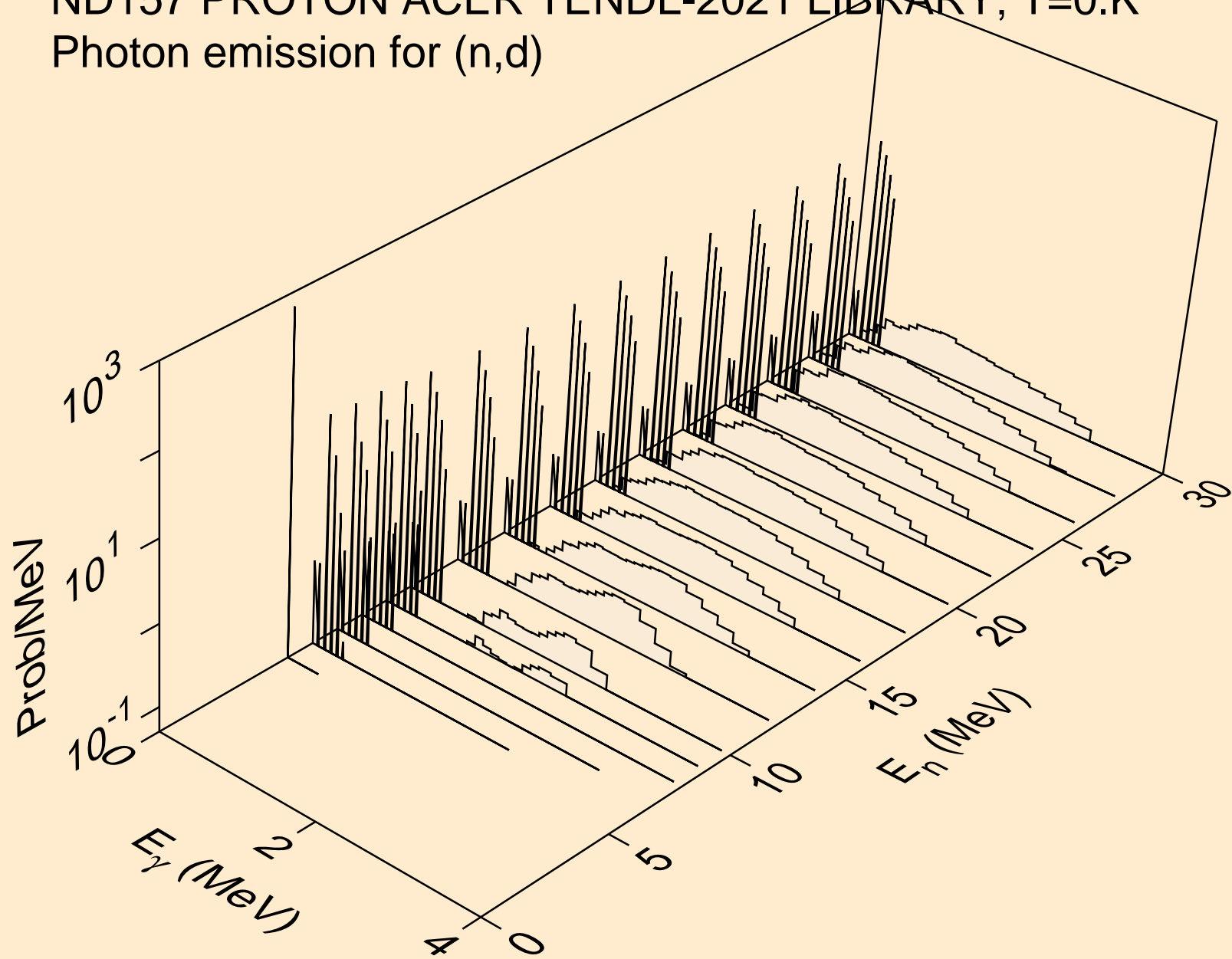

ND157 PROTON ACER TENDL-2021 LIBRARY; T=0.K
Photon emission for (n,t)

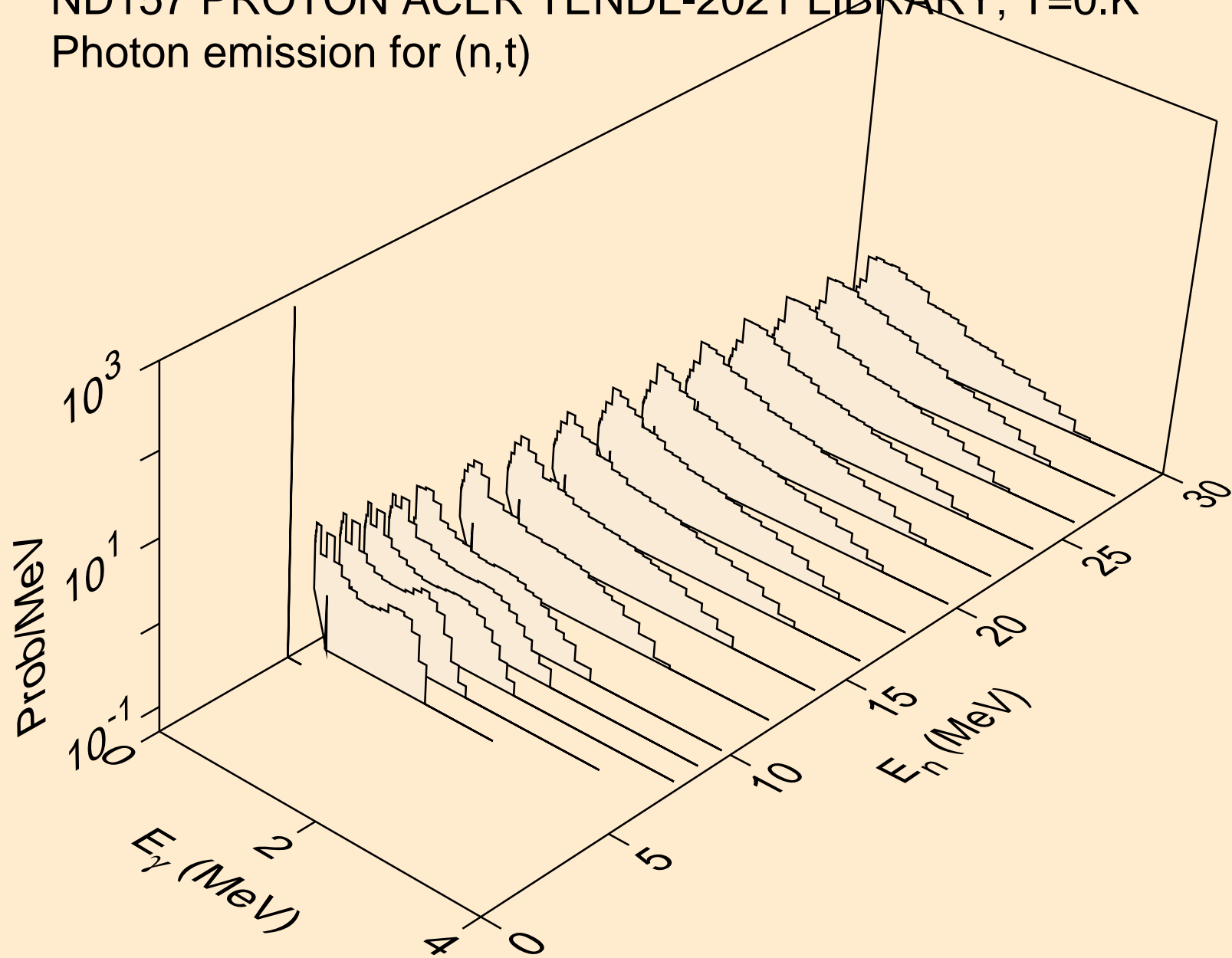

ND157 PROTON ACER TENDL-2021 LIBRARY; T=0.K
Photon emission for (n,he3)

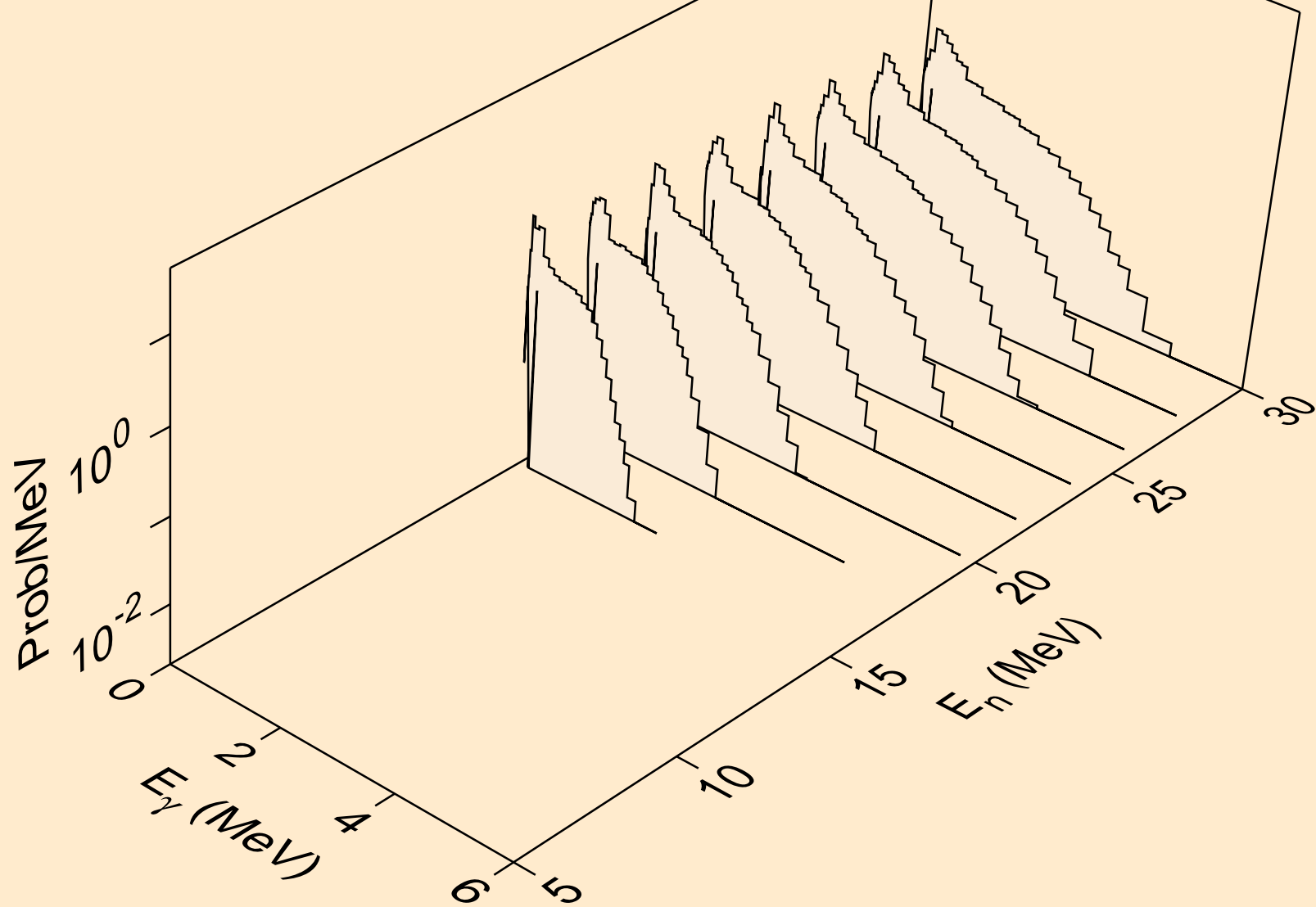

ND157 PROTON ACER TENDL-2021 LIBRARY; T=0.K
Photon emission for (n,a)

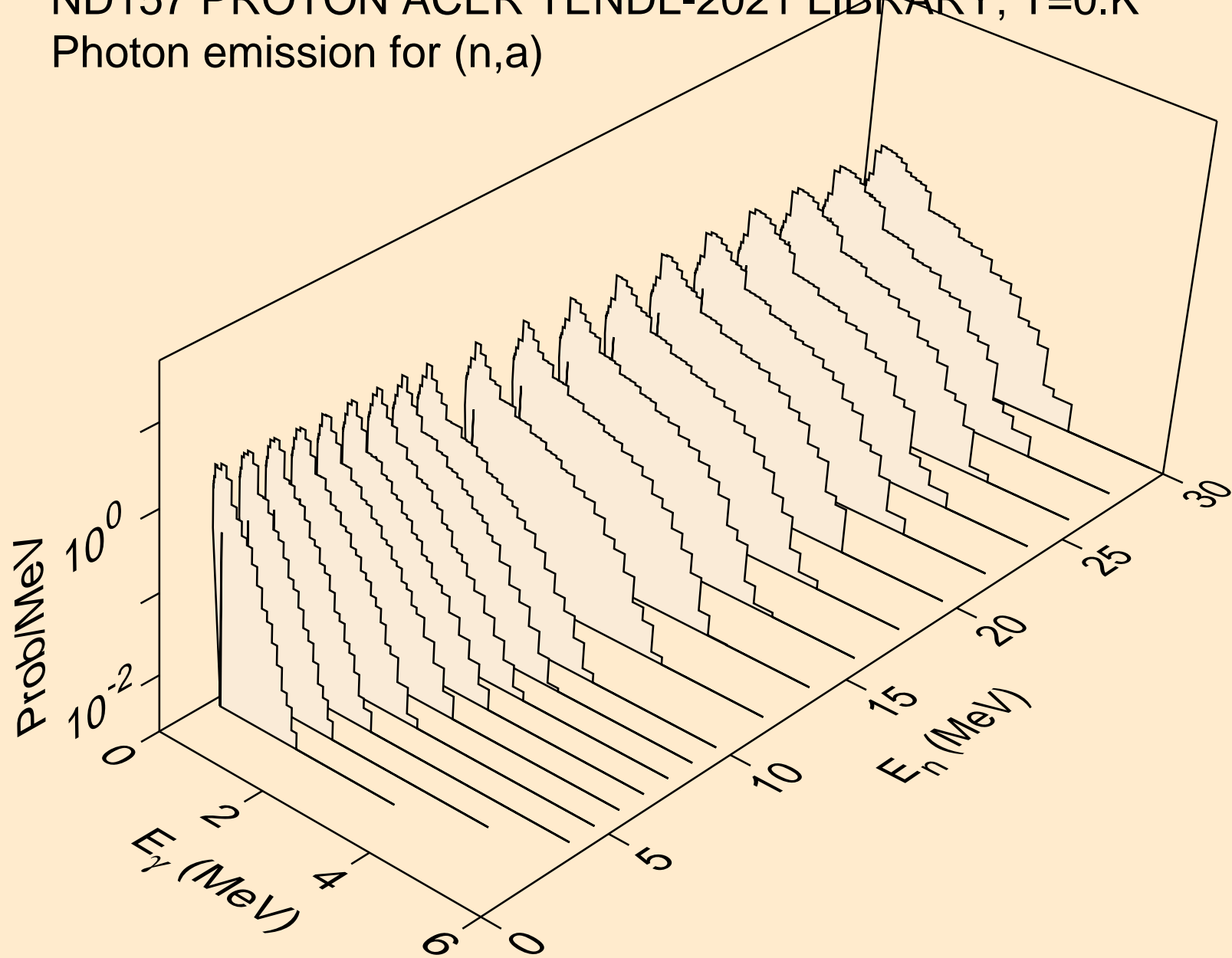

ND157 PROTON ACER TENDL-2021 LIBRARY; T=0.K
Photon emission for (n,2p)

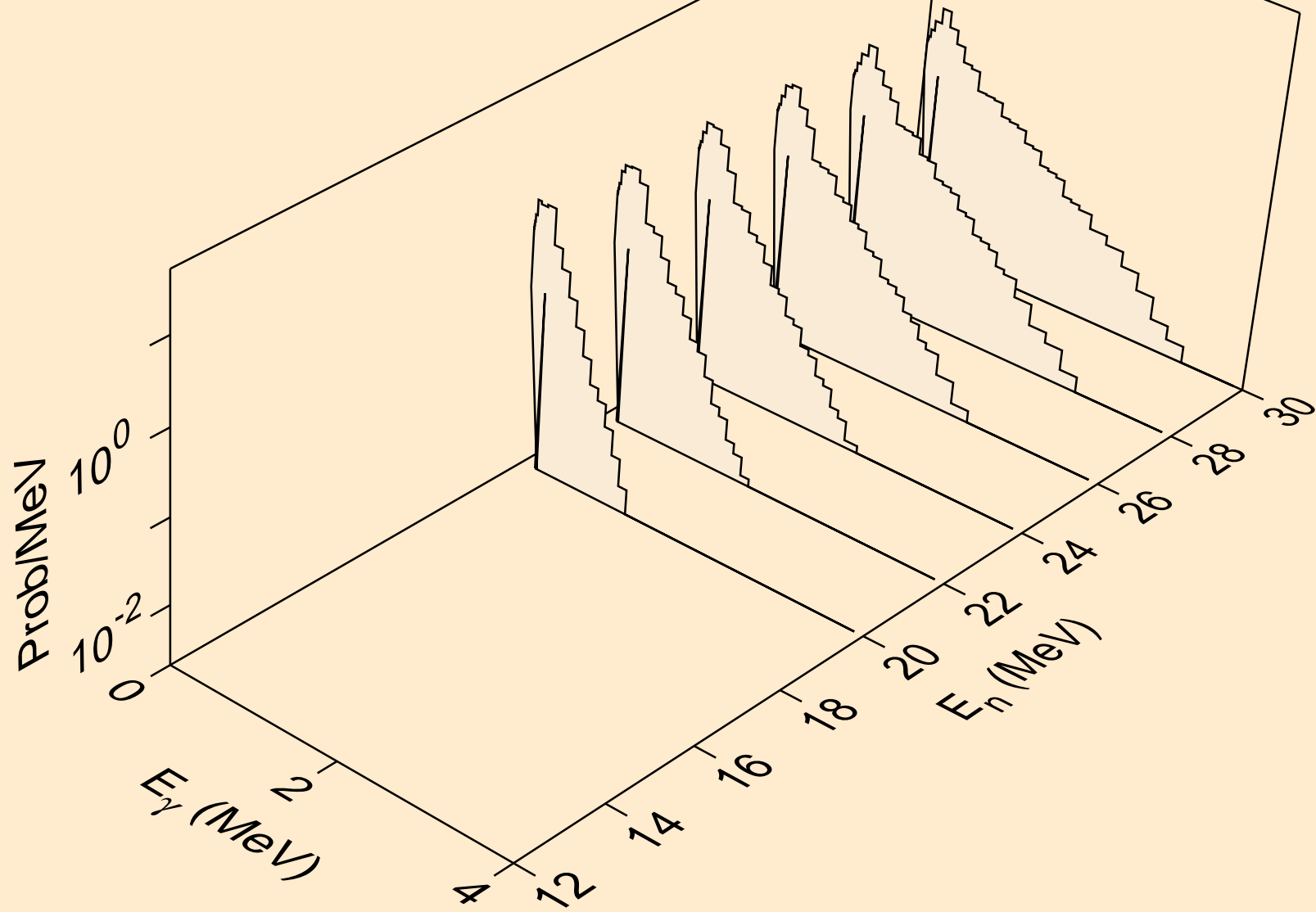

ND157 PROTON ACER TENDL-2021 LIBRARY; T=0.K
Photon emission for (n,pd)

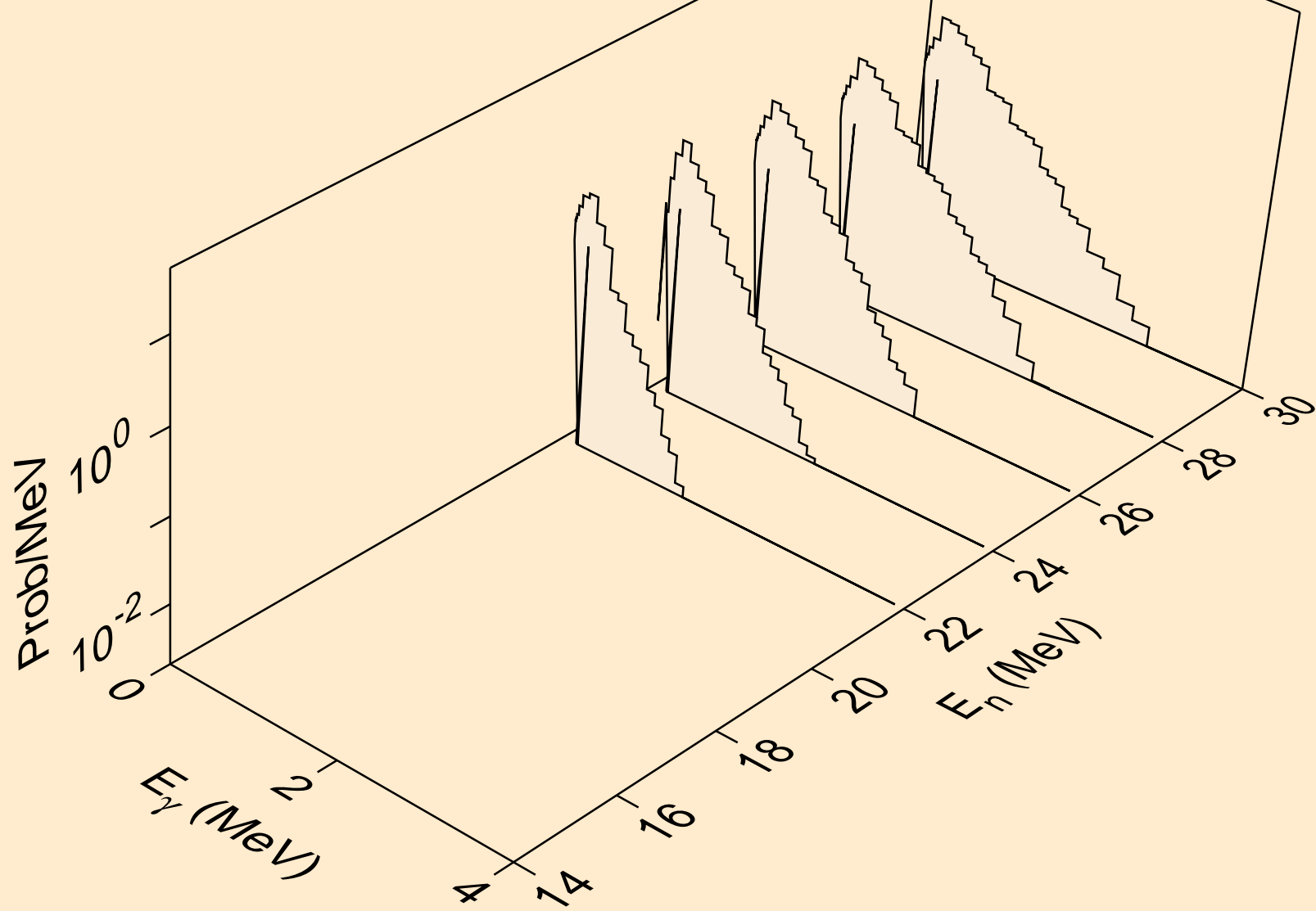

ND157 PROTON ACER TENDL-2021 LIBRARY; T=0.K
Particle heating contributions

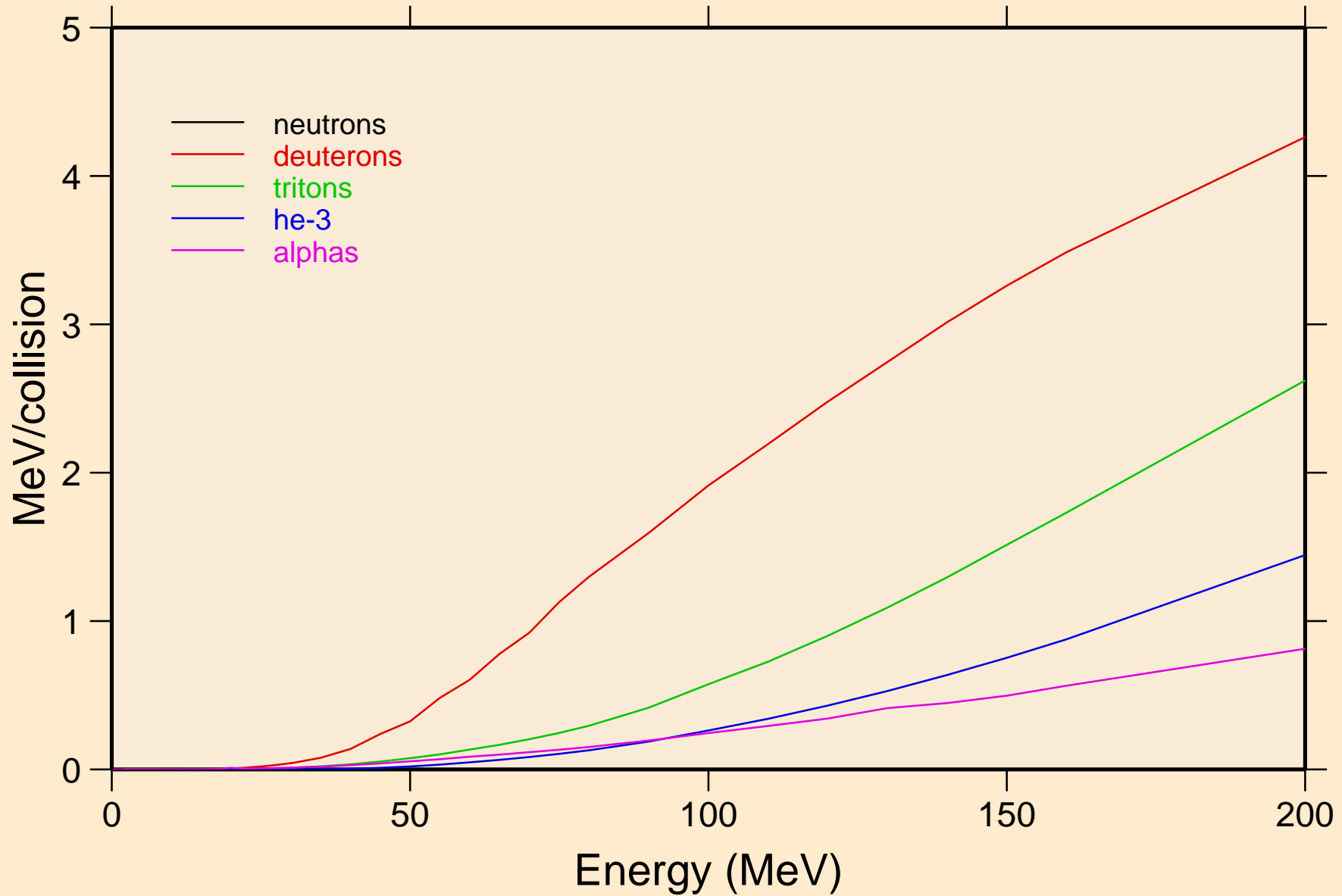

ND157 PROTON ACER TENDL-2021 LIBRARY; T=0.K
Recoil Heating

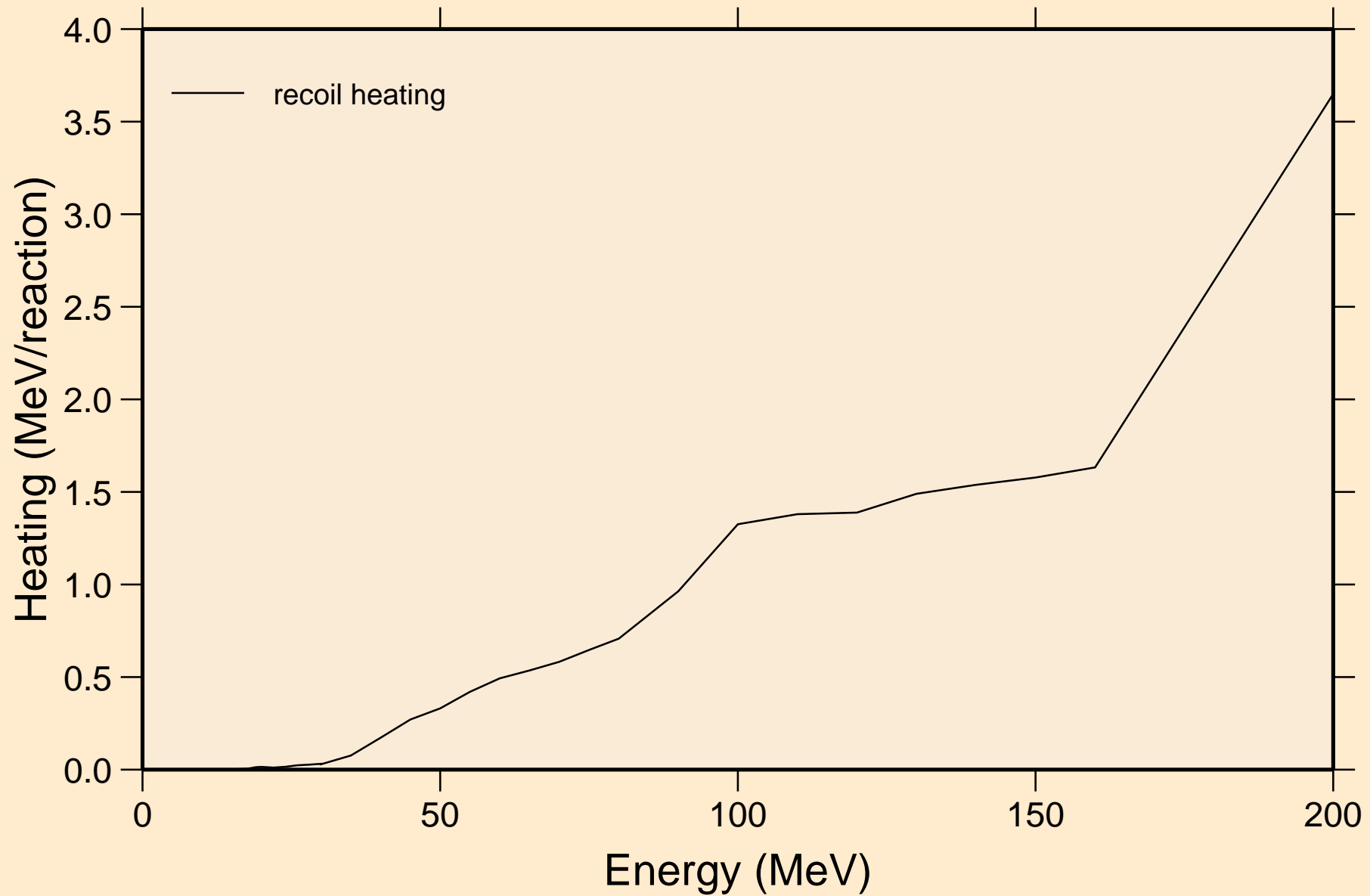

ND157 PROTON ACER TENDL-2021 LIBRARY; T=0.K

Particle production cross sections

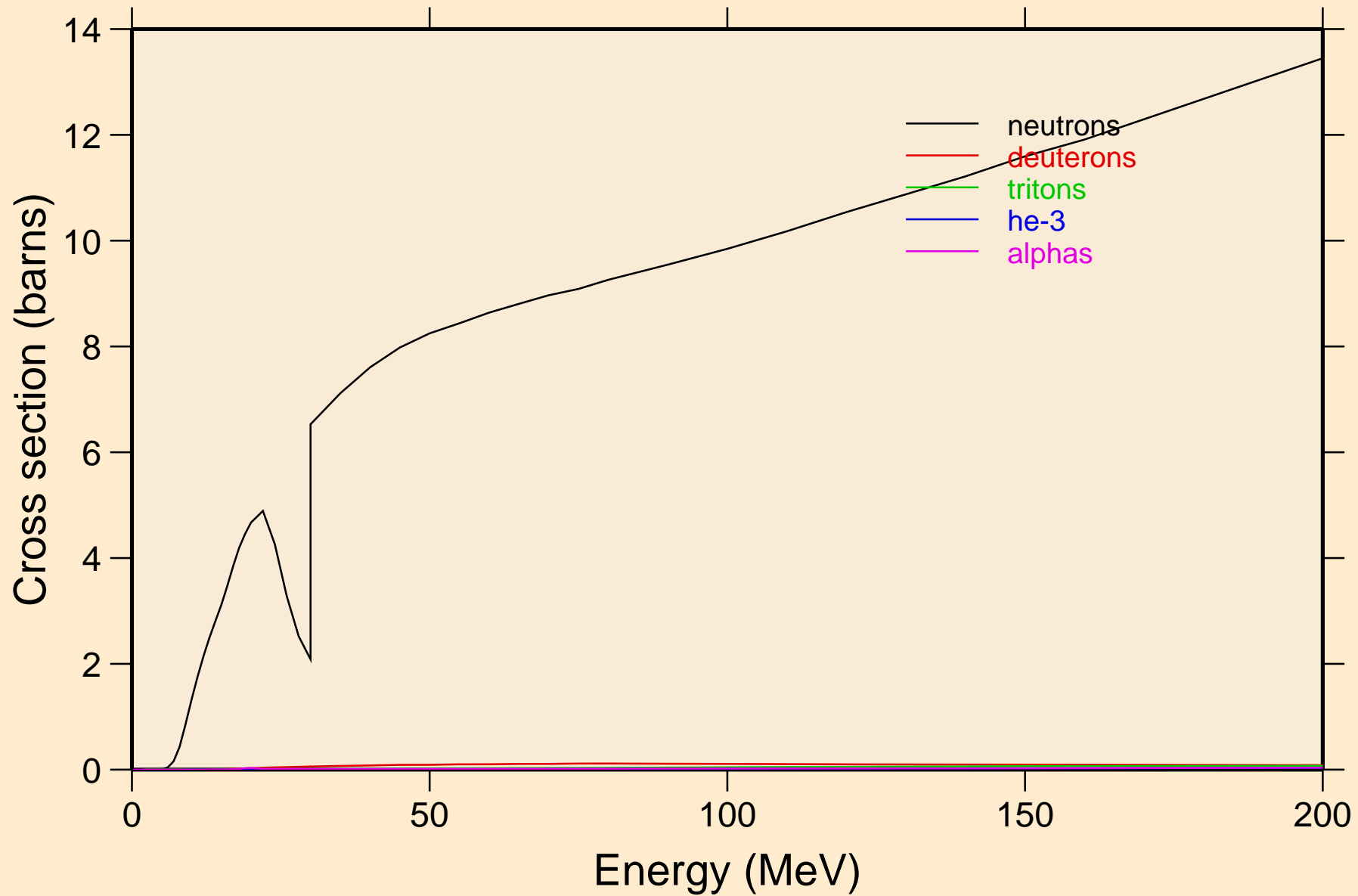

ND157 PROTON ACER TENDL-2021 LIBRARY; T=0.K
neutrons from (p,n)

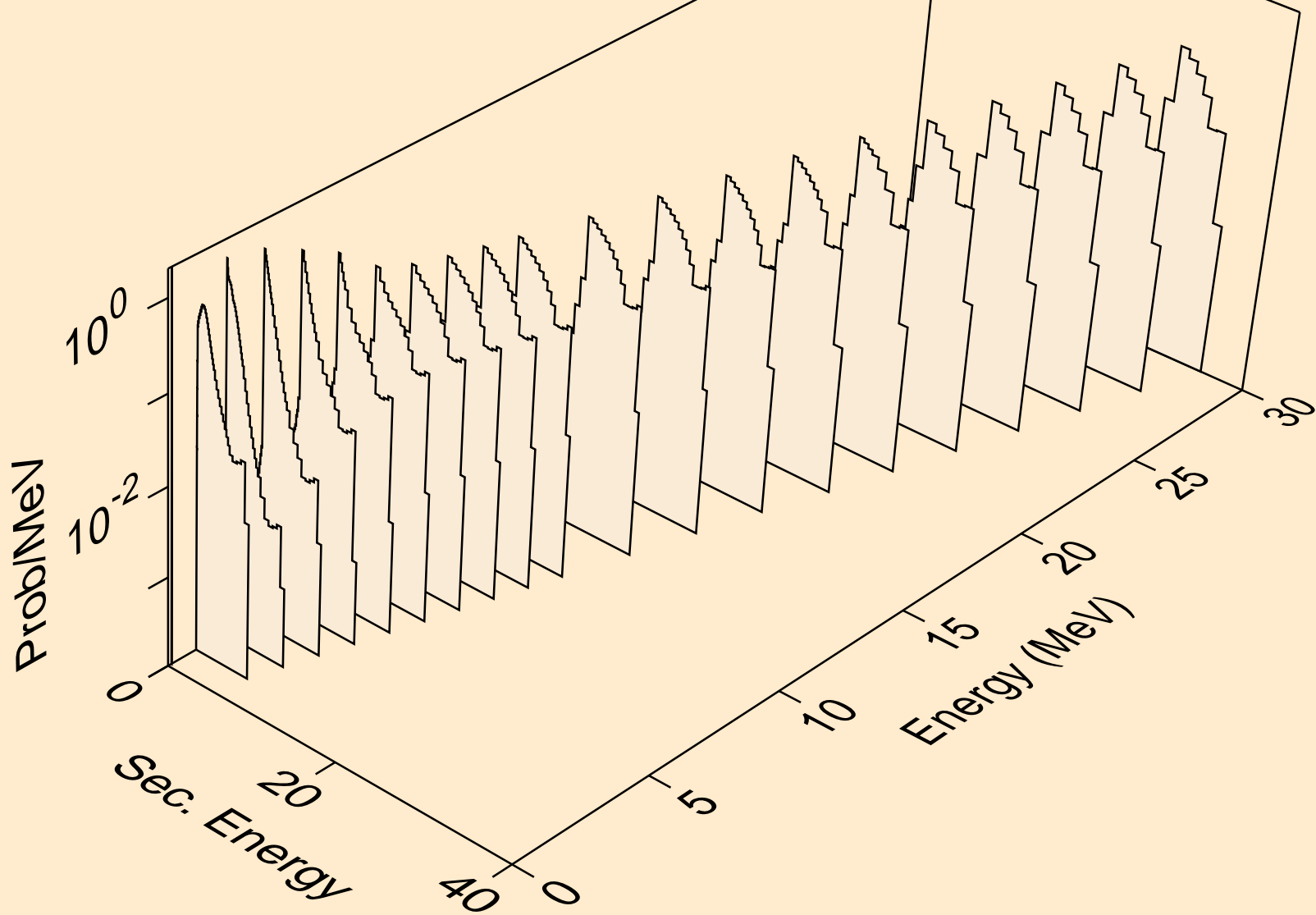

ND157 PROTON ACER TENDL-2021 LIBRARY; T=0.K
neutrons from (p,x)

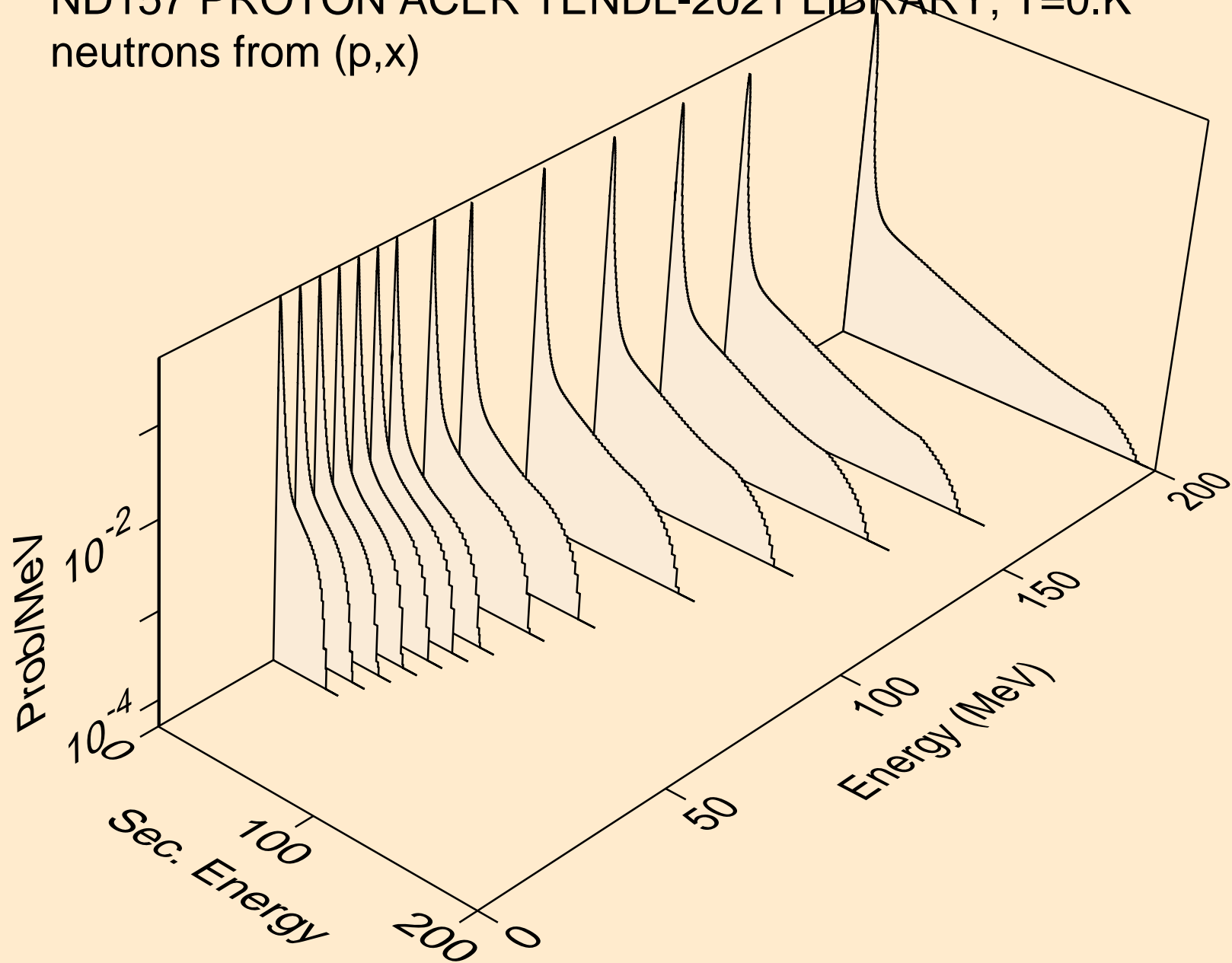

ND157 PROTON ACER TENDL-2021 LIBRARY; T=0.K
neutrons from (p,2nd)

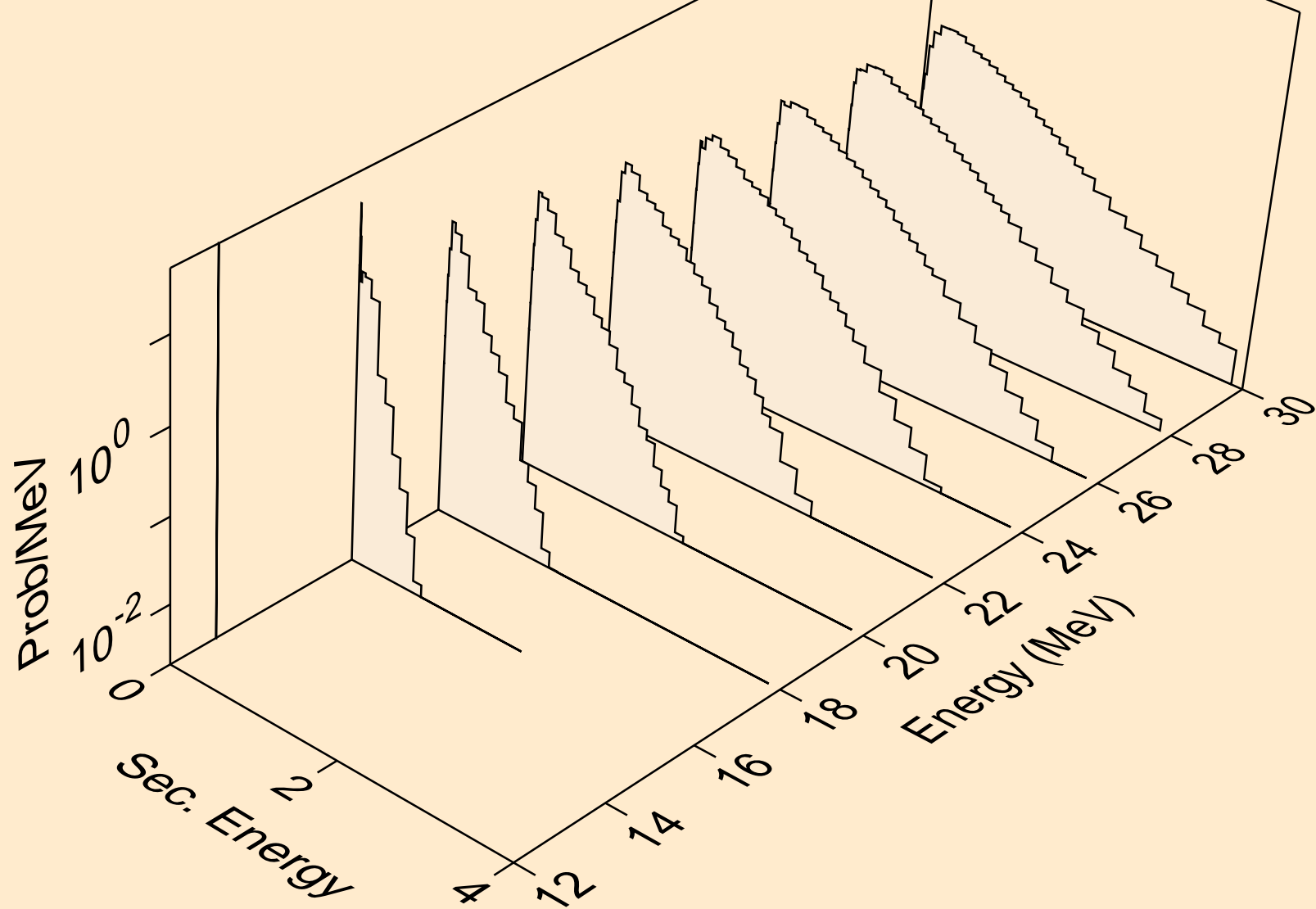

ND157 PROTON ACER TENDL-2021 LIBRARY; T=0.K
neutrons from (p,2n)

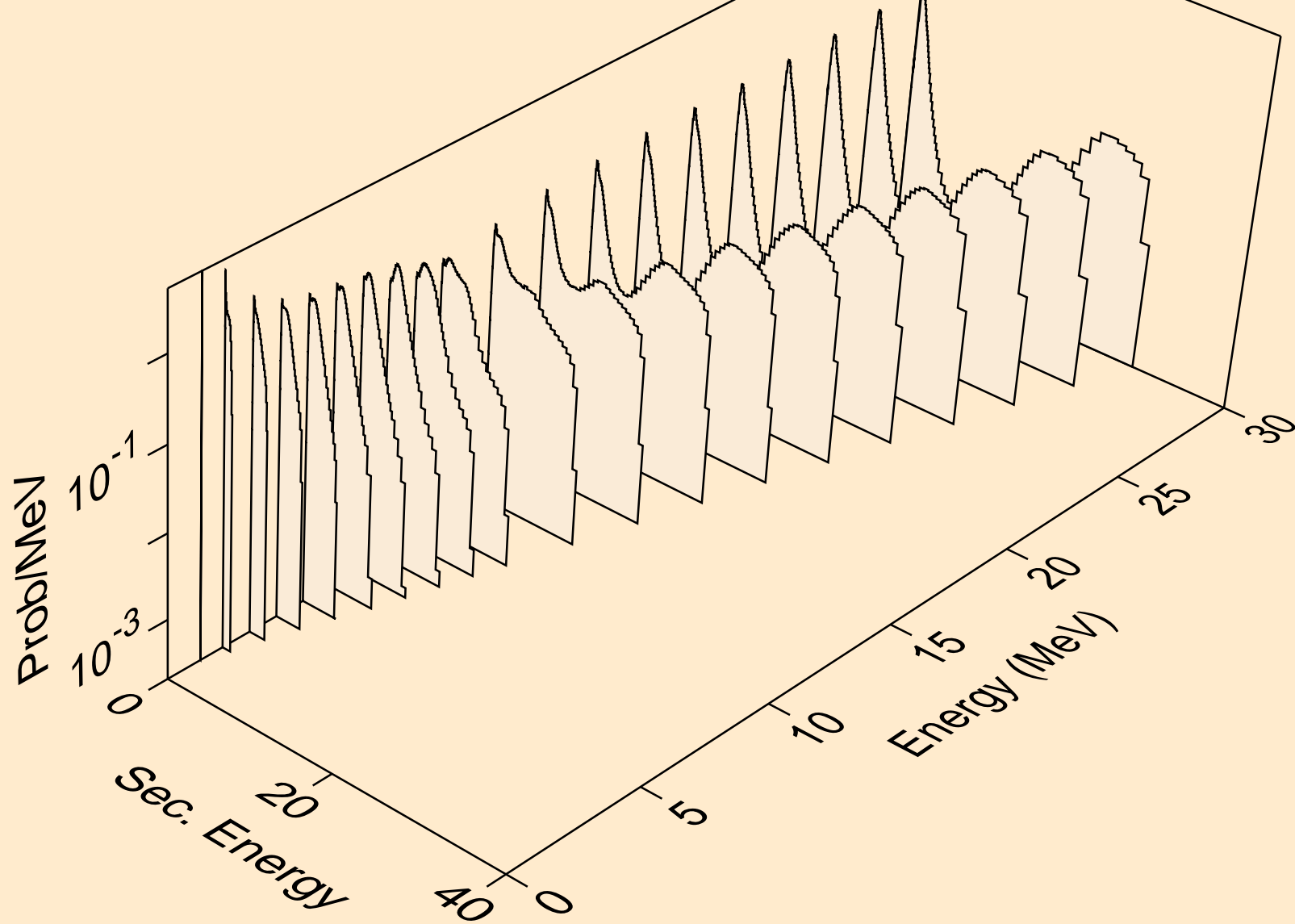

ND157 PROTON ACER TENDL-2021 LIBRARY; T=0.K
neutrons from (p,3n)

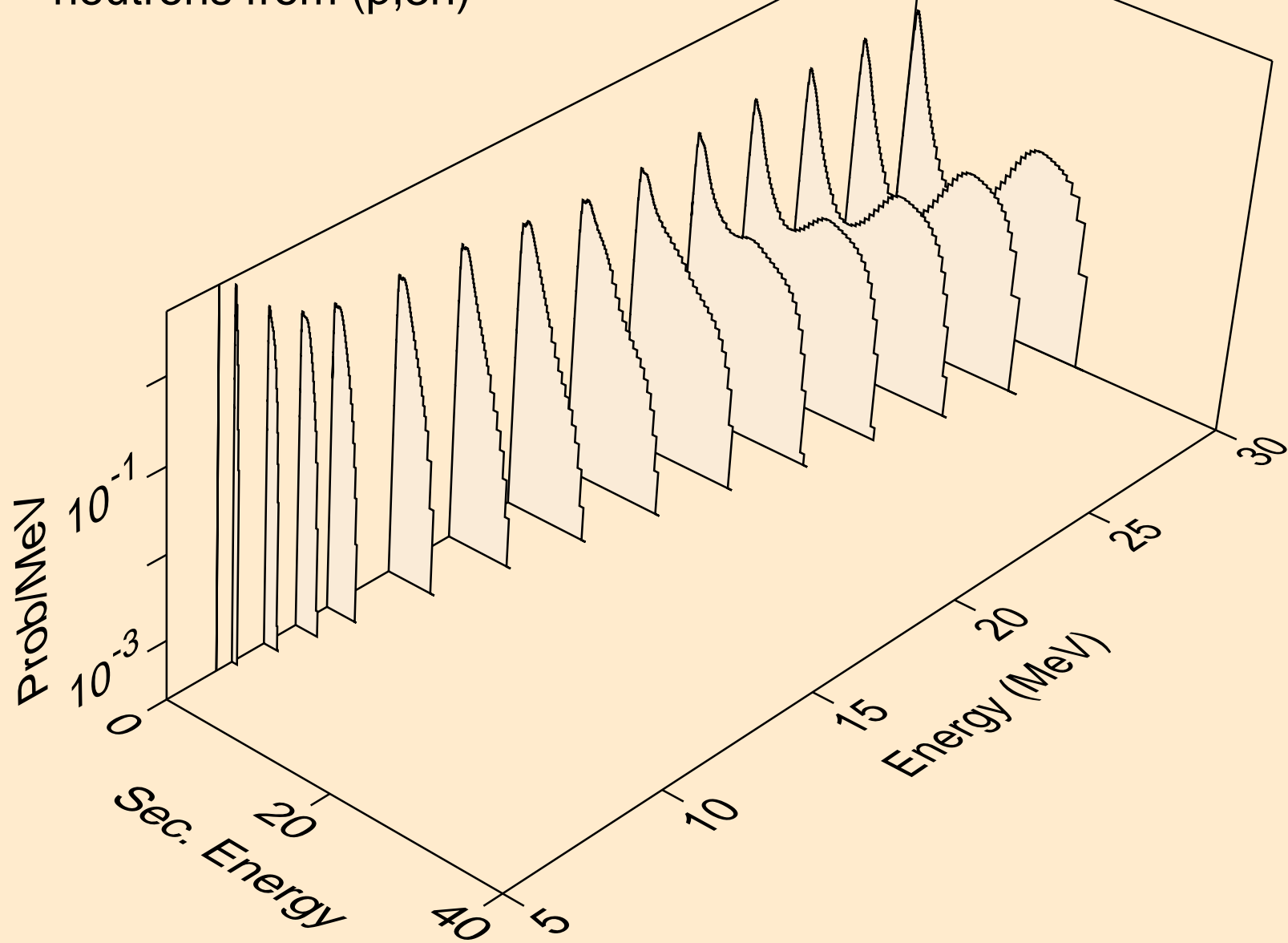

ND157 PROTON ACER TENDL-2021 LIBRARY; T=0.K
neutrons from (p,n*)a

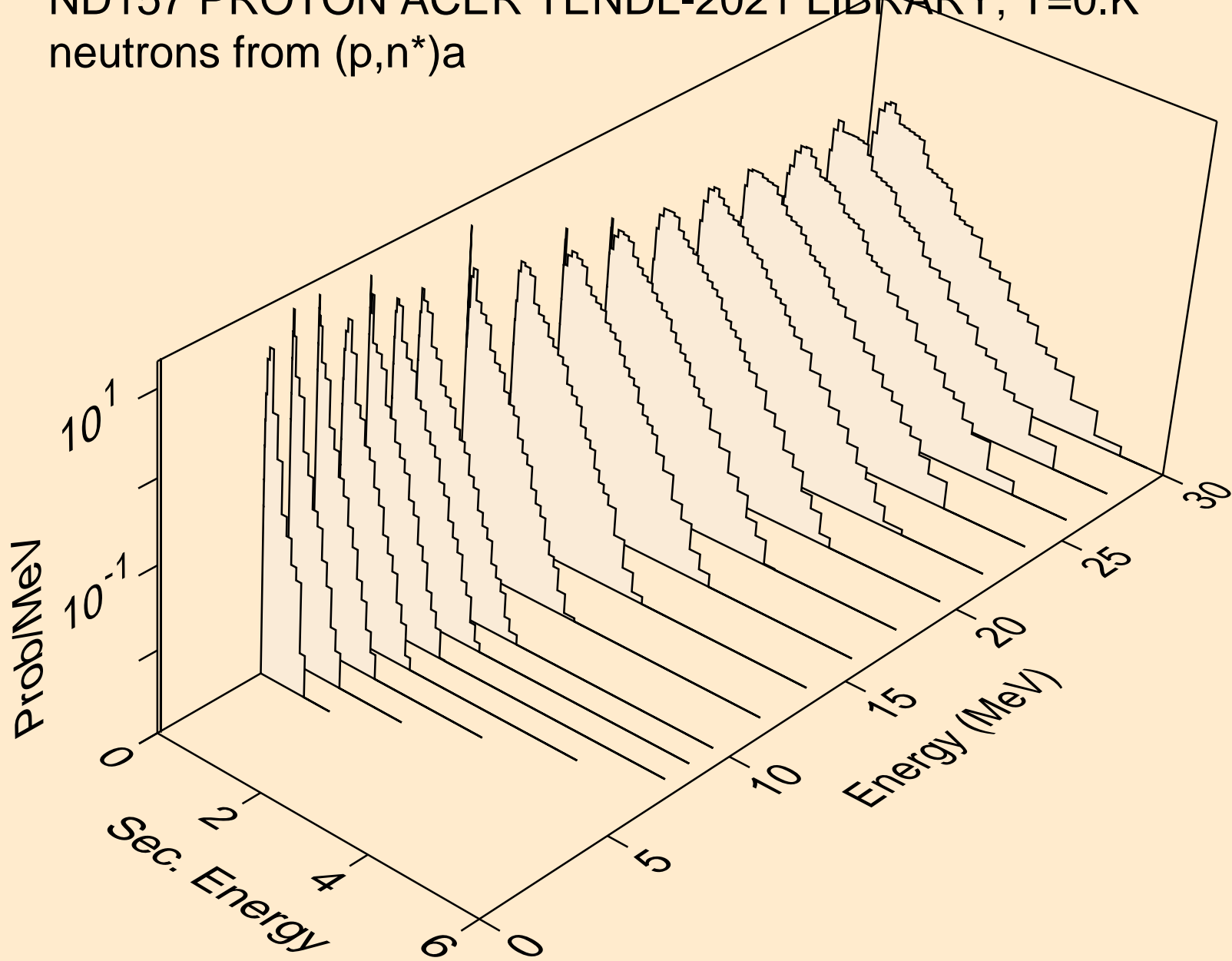

ND157 PROTON ACER TENDL-2021 LIBRARY; T=0.K
neutrons from (p,2n)a

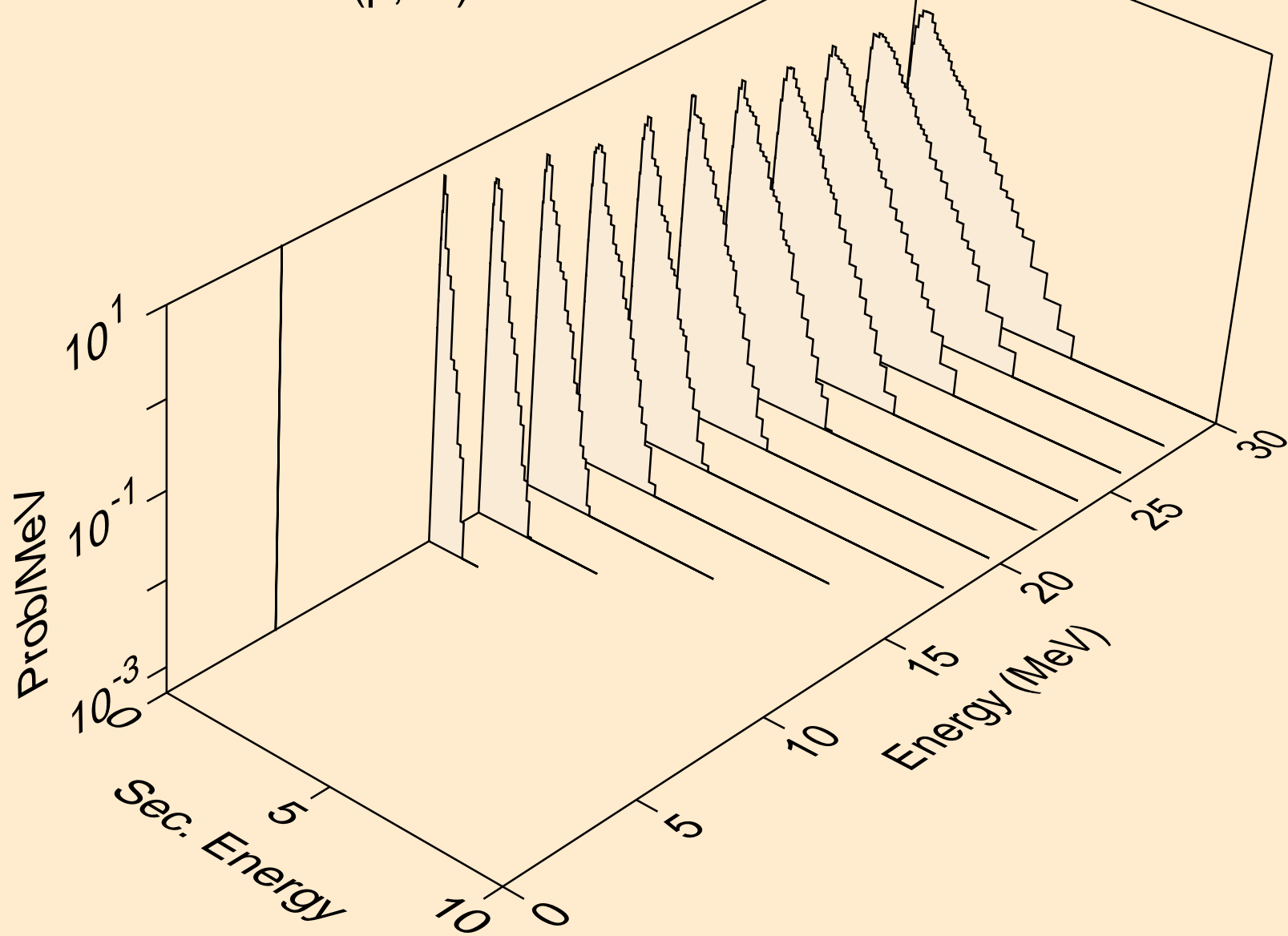

ND157 PROTON ACER TENDL-2021 LIBRARY; T=0.K
neutrons from (p,3n)a

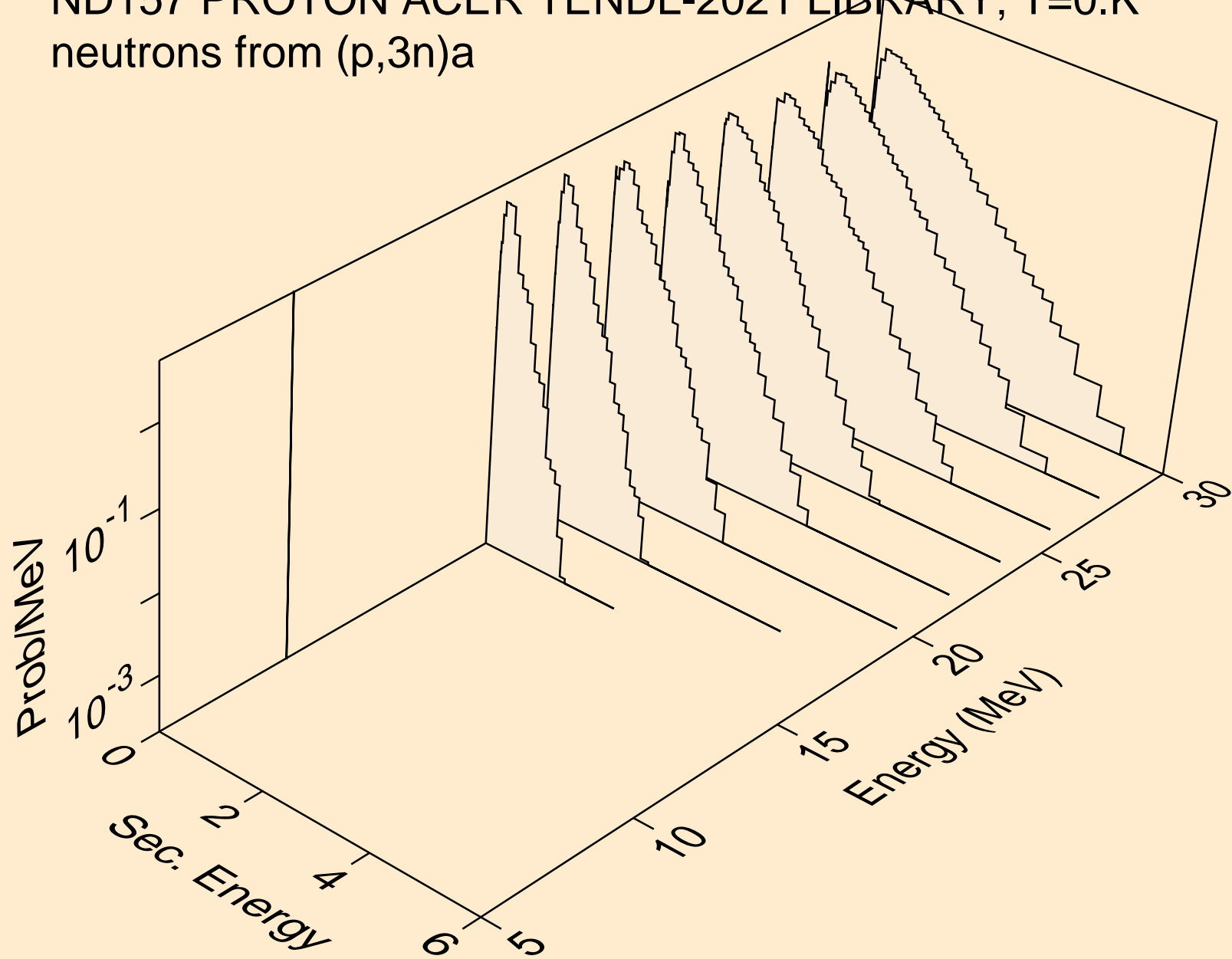

ND157 PROTON ACER TENDL-2021 LIBRARY; T=0.K
neutrons from (p,n*)p

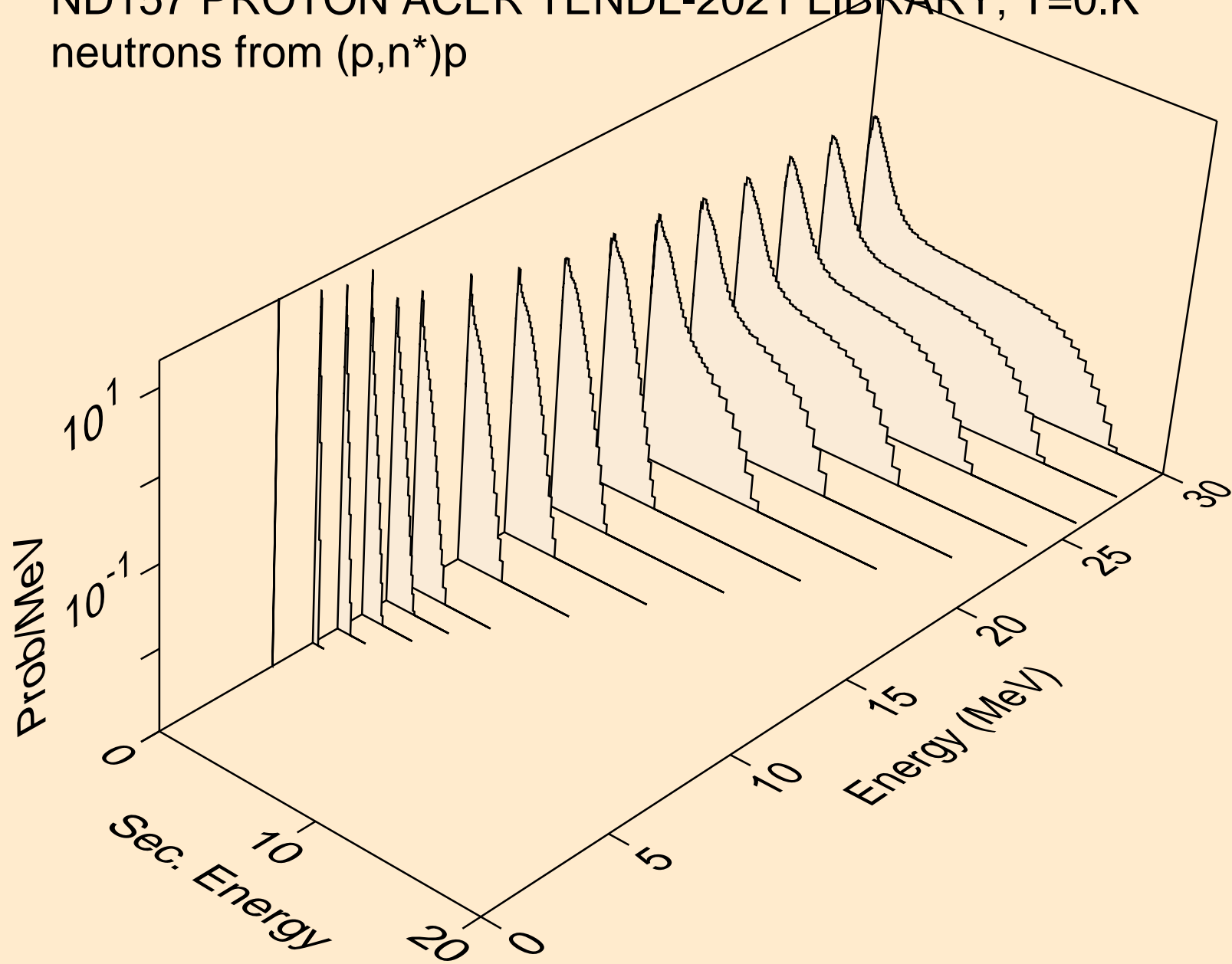

ND157 PROTON ACER TENDL-2021 LIBRARY; T=0.K
neutrons from (p,n*)d

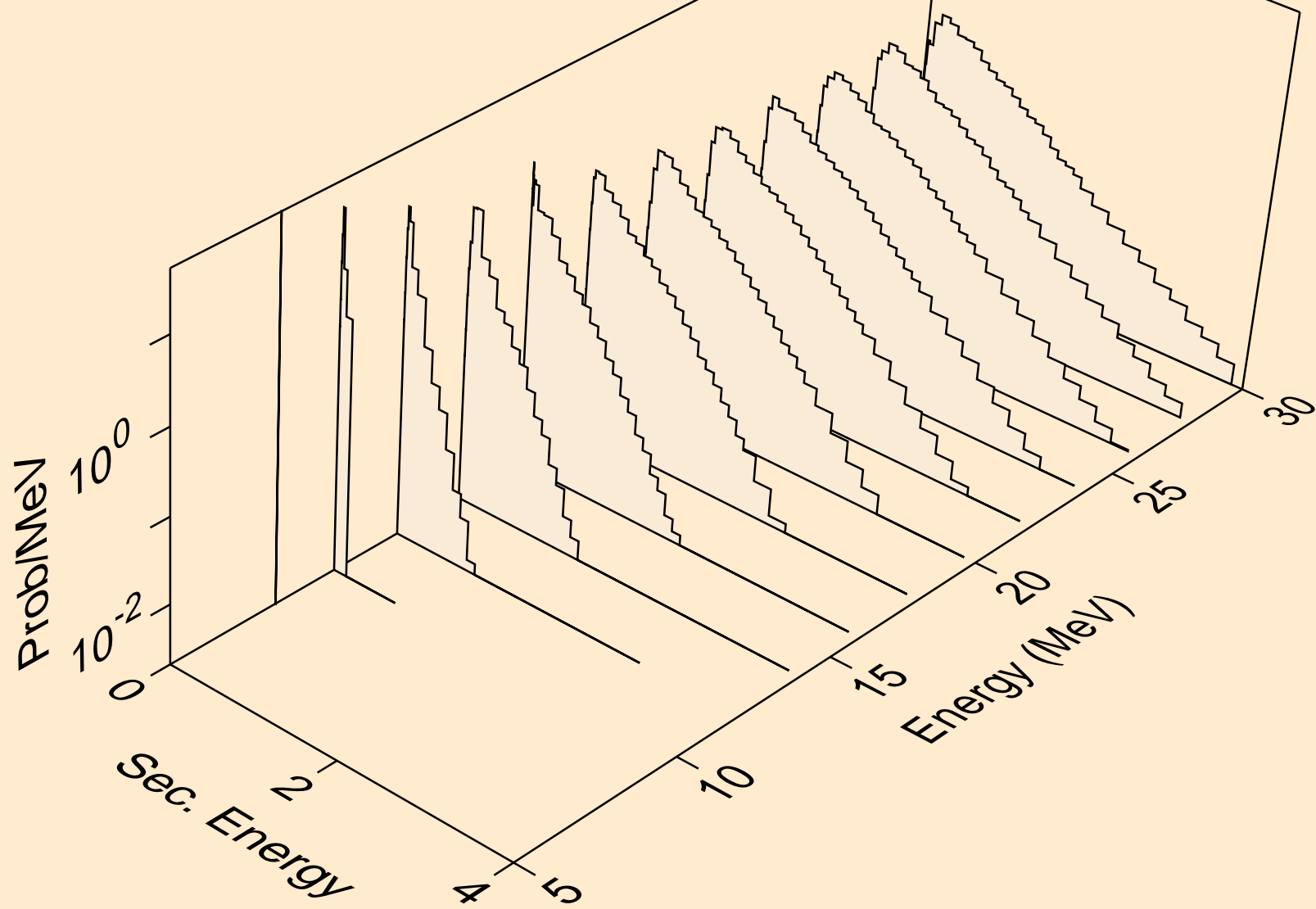

ND157 PROTON ACER TENDL-2021 LIBRARY; T=0.K
neutrons from (p,n*)t

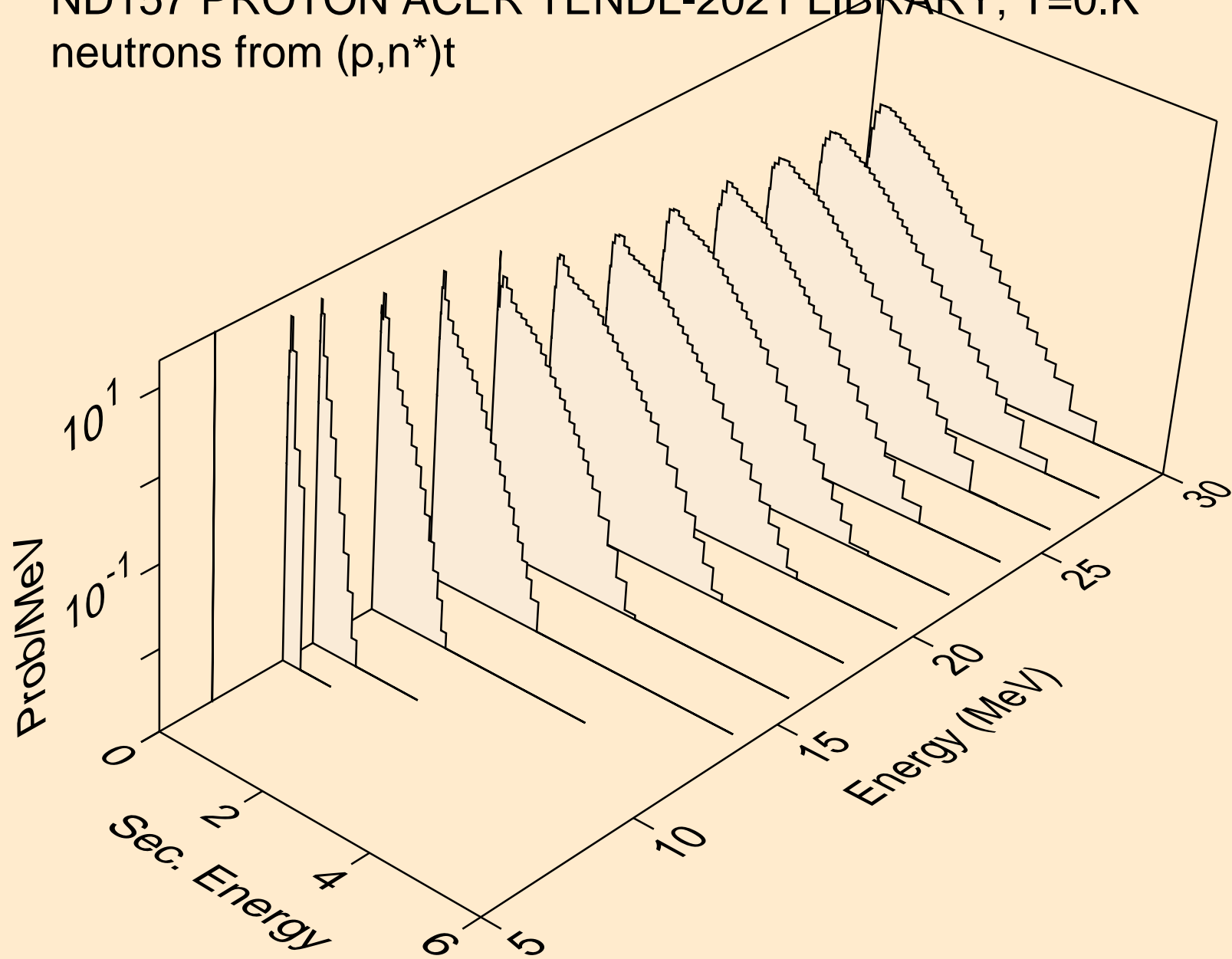

ND157 PROTON ACER TENDL-2021 LIBRARY; T=0.K
neutrons from (p,n*)he3

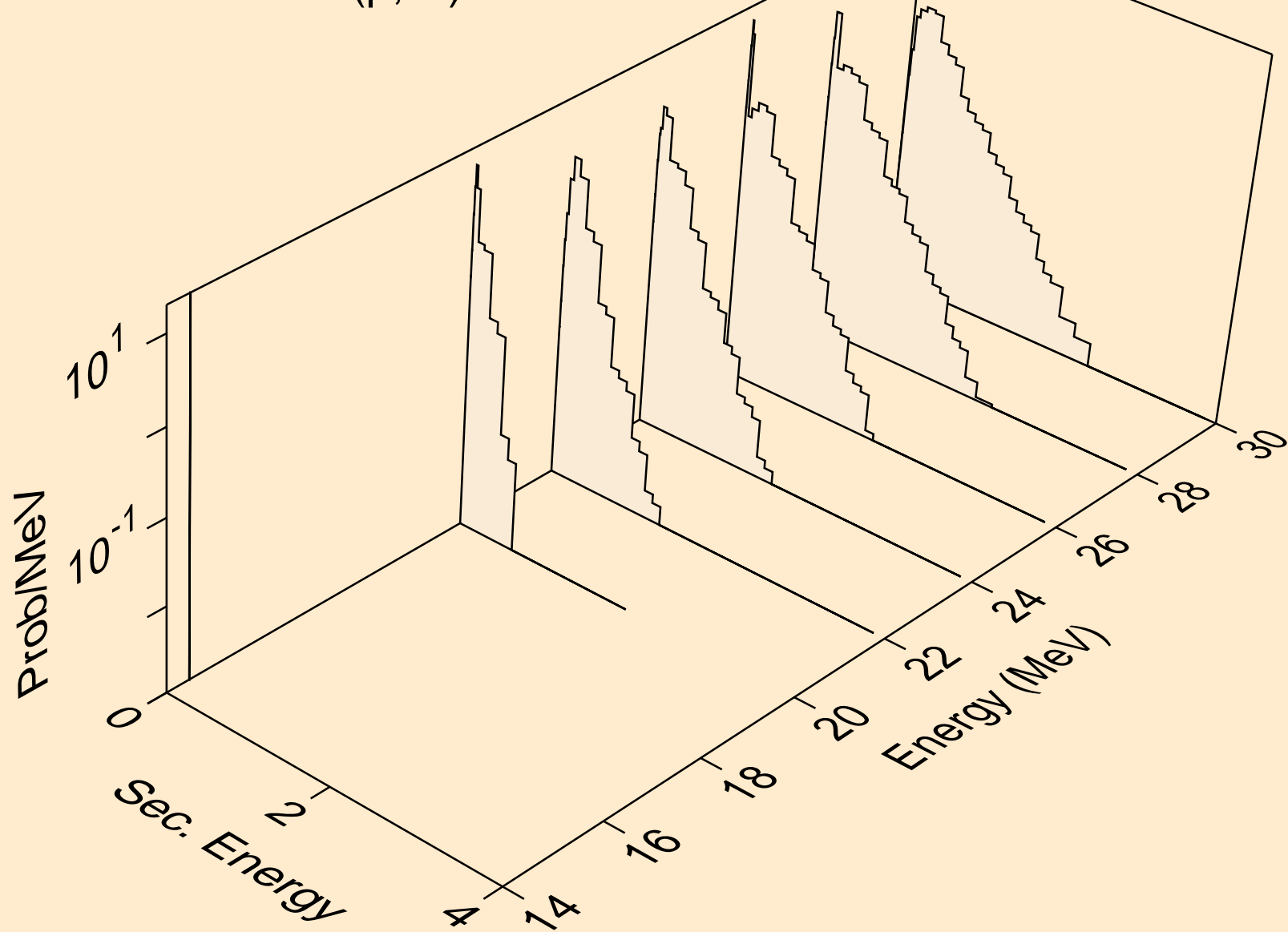

ND157 PROTON ACER TENDL-2021 LIBRARY; T=0.K
neutrons from (p,4n)

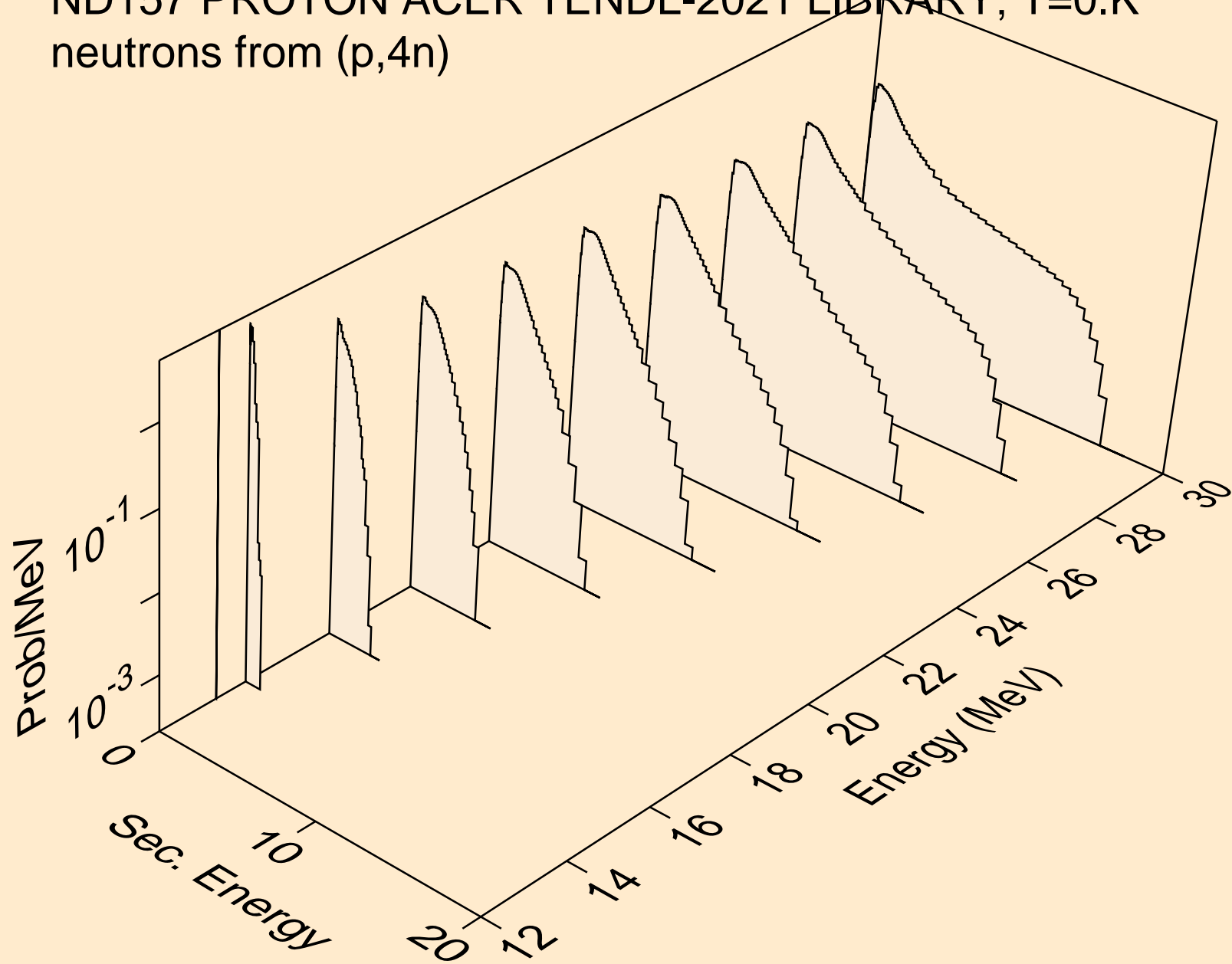

ND157 PROTON ACER TENDL-2021 LIBRARY; T=0.K
neutrons from (p,2np)

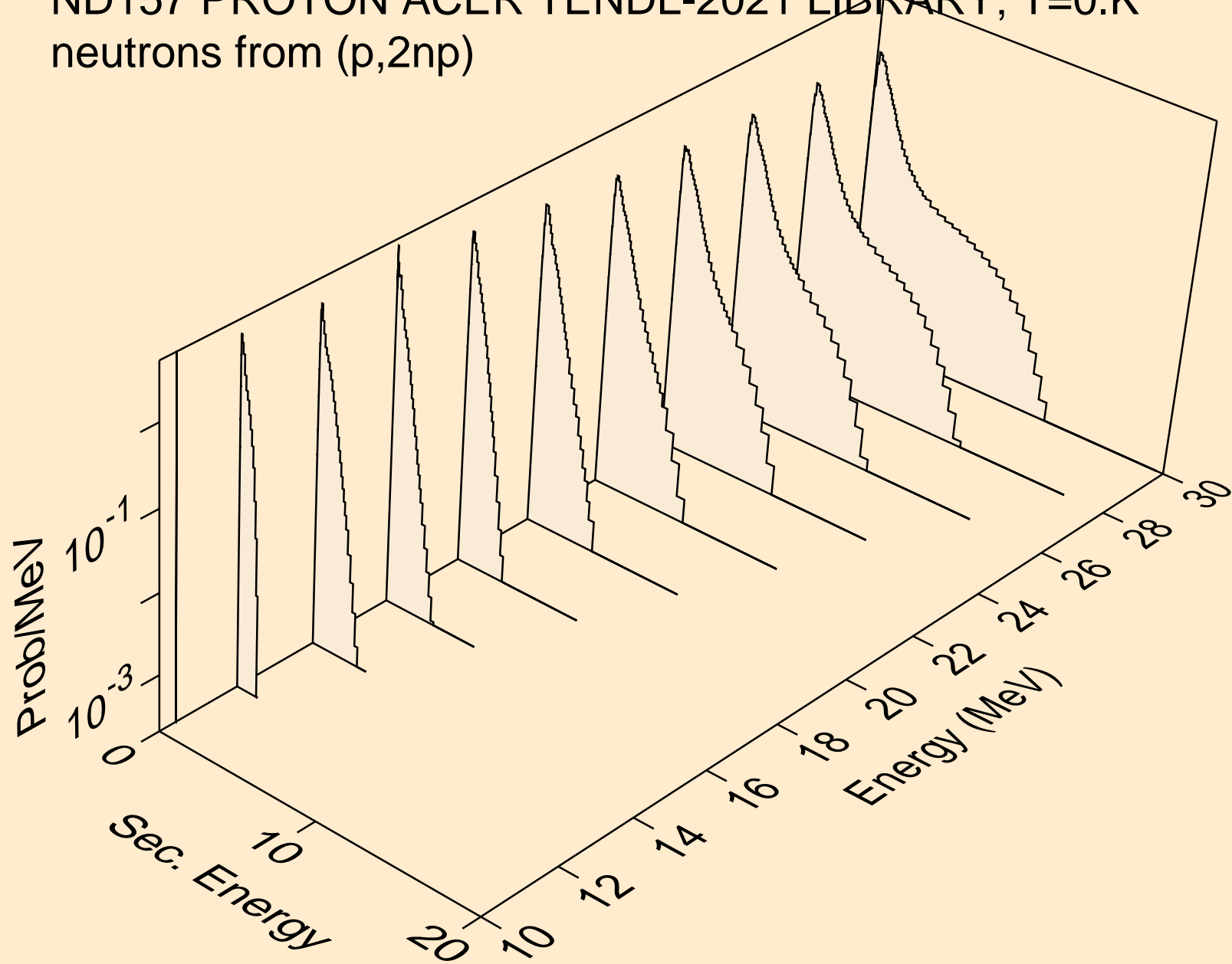

ND157 PROTON ACER TENDL-2021 LIBRARY; T=0.K
neutrons from (p,3np)

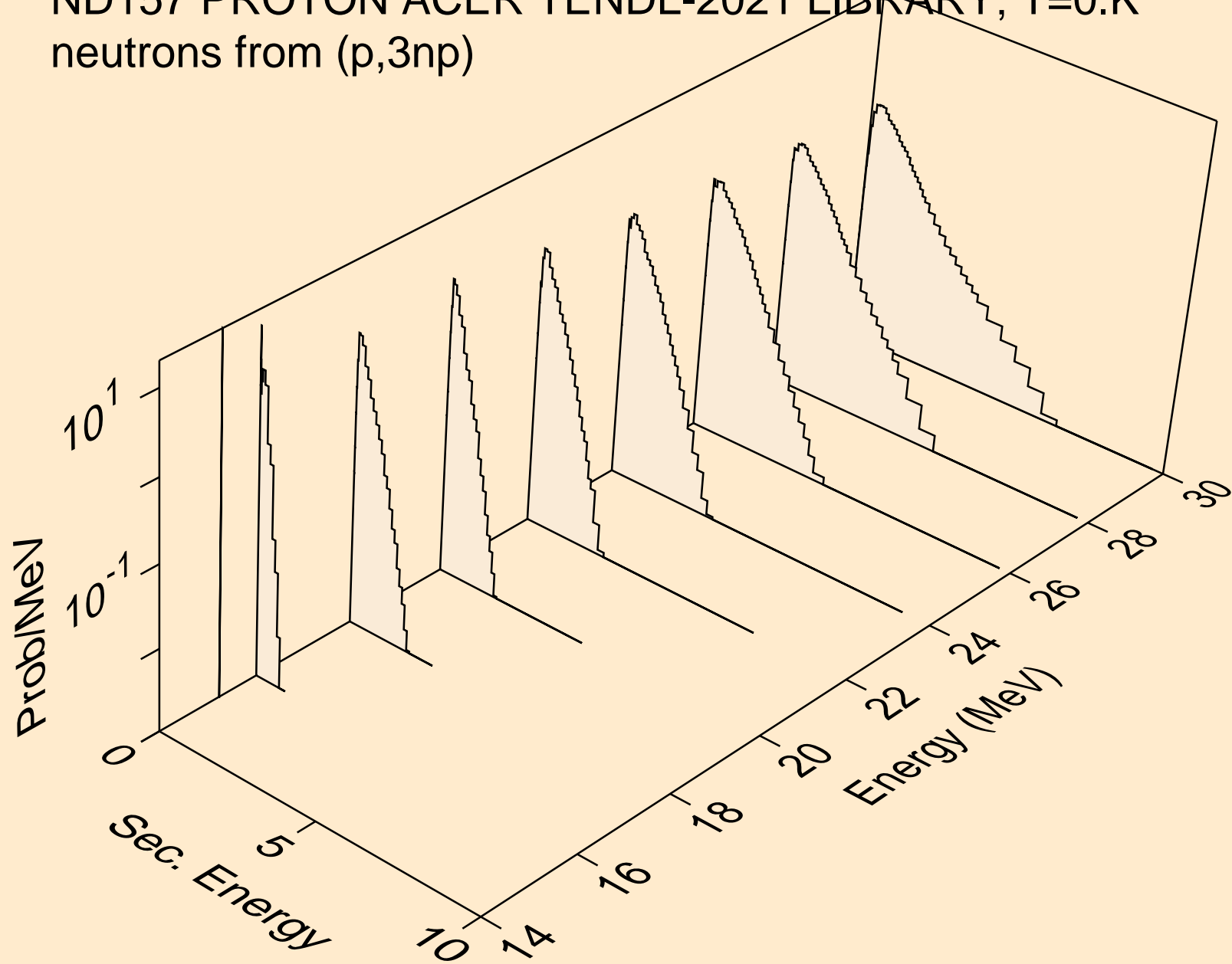

ND157 PROTON ACER TENDL-2021 LIBRARY; T=0.K
neutrons from (p,2np)

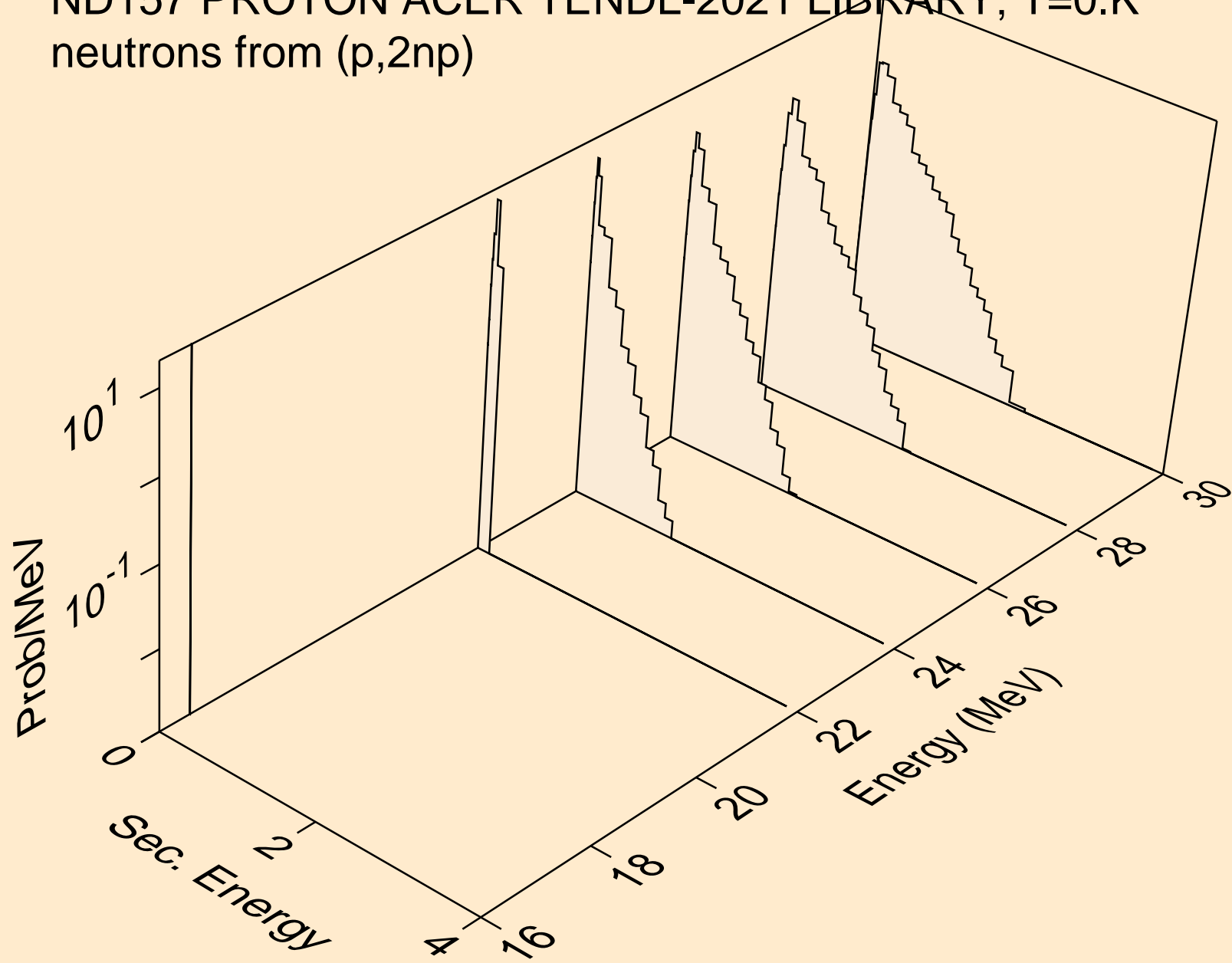

ND157 PROTON ACER TENDL-2021 LIBRARY; T=0.K
deuterons from (p,x)

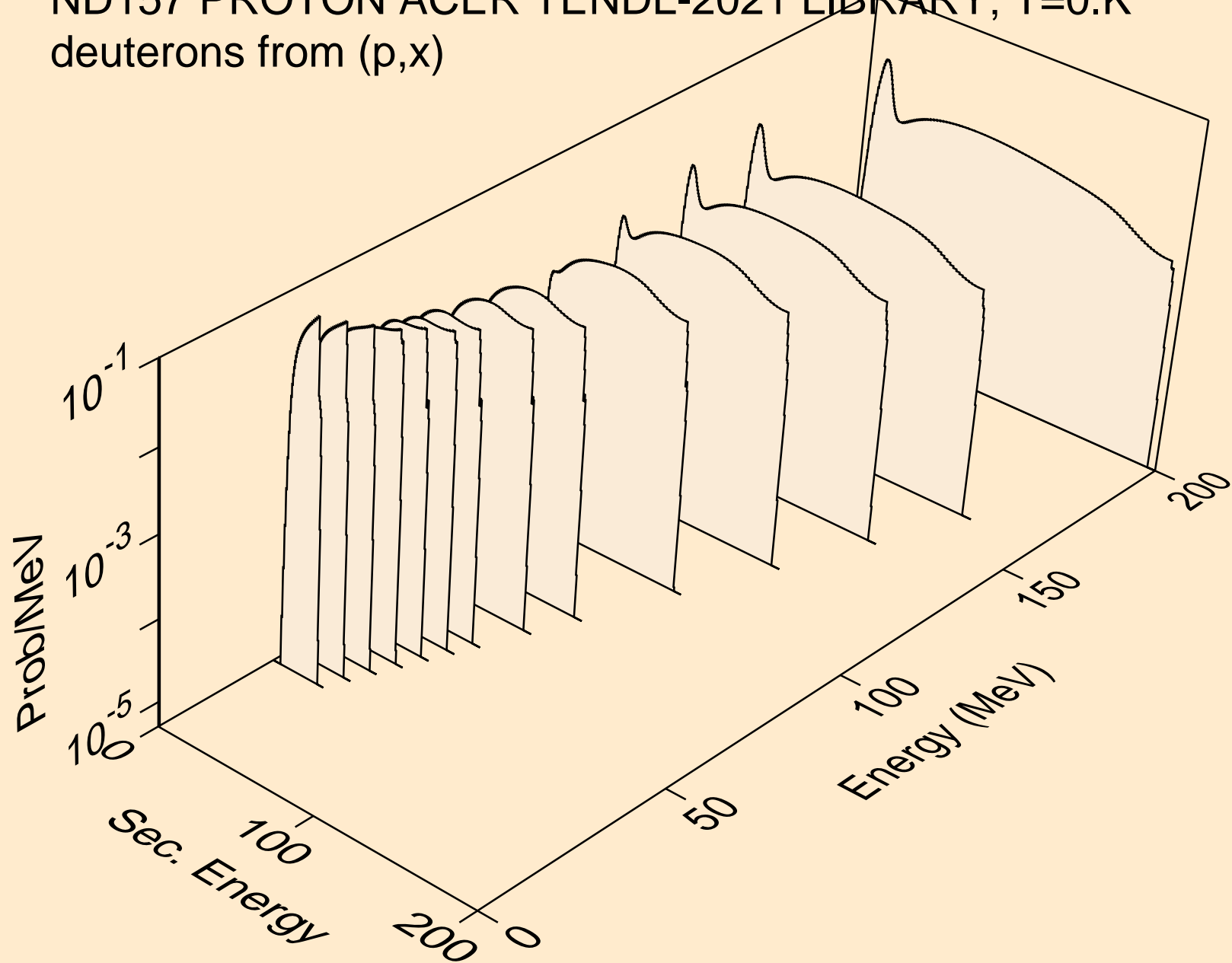

ND157 PROTON ACER TENDL-2021 LIBRARY; T=0.K
deuterons from (p,2nd)

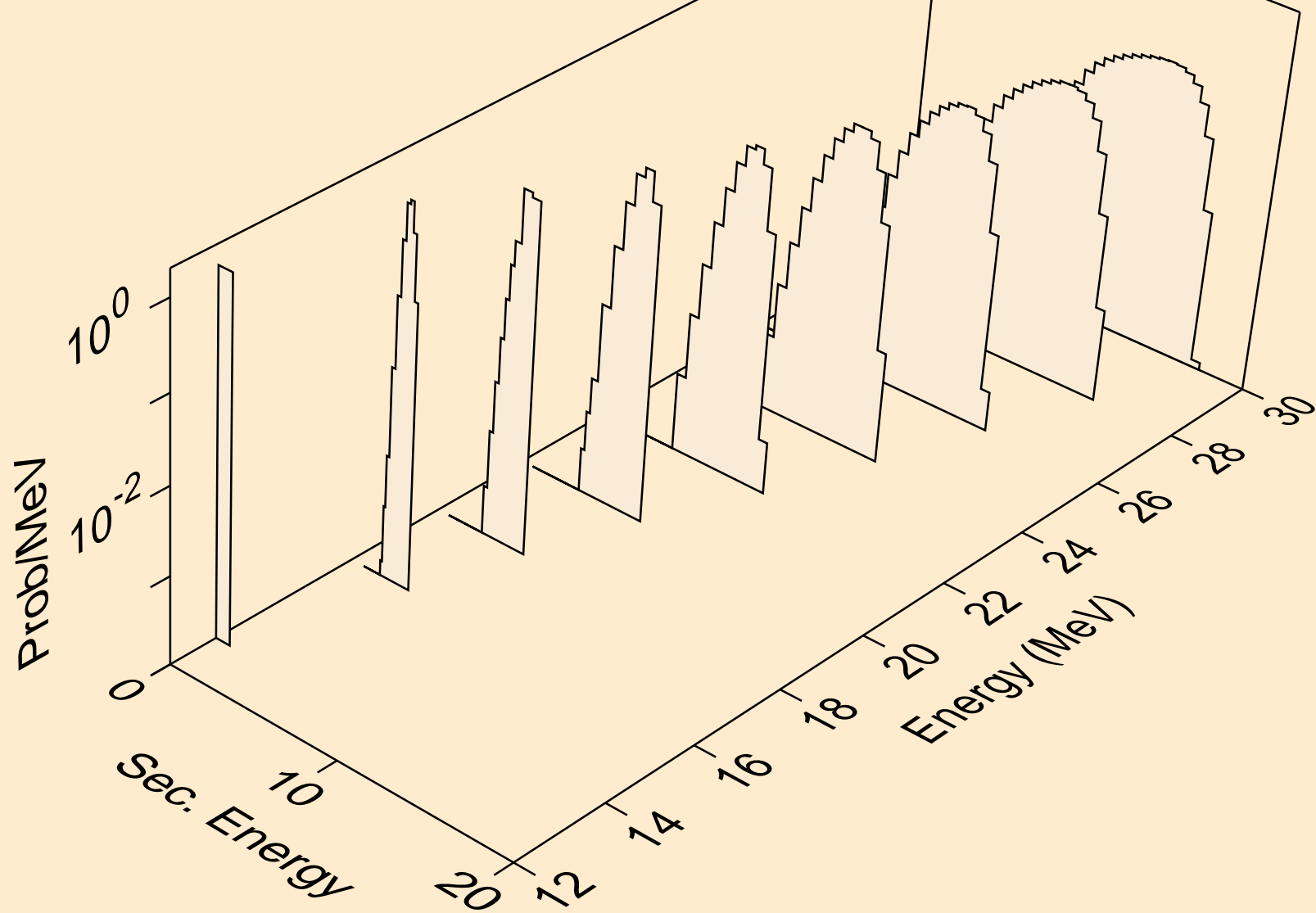

ND157 PROTON ACER TENDL-2021 LIBRARY; T=0.K
deuterons from (p,n*)d

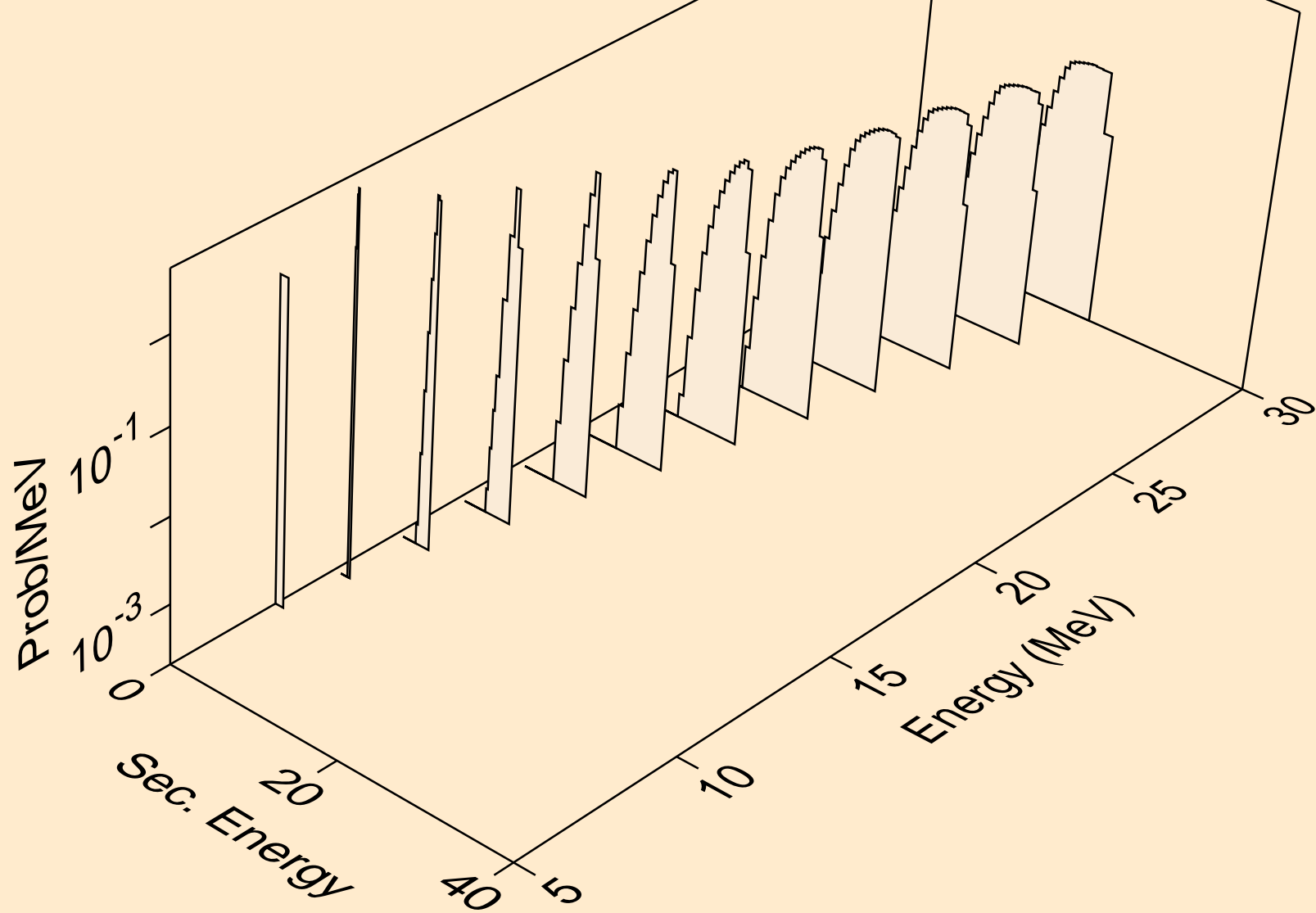

ND157 PROTON ACER TENDL-2021 LIBRARY; T=0.K
deuterons from (p,d)

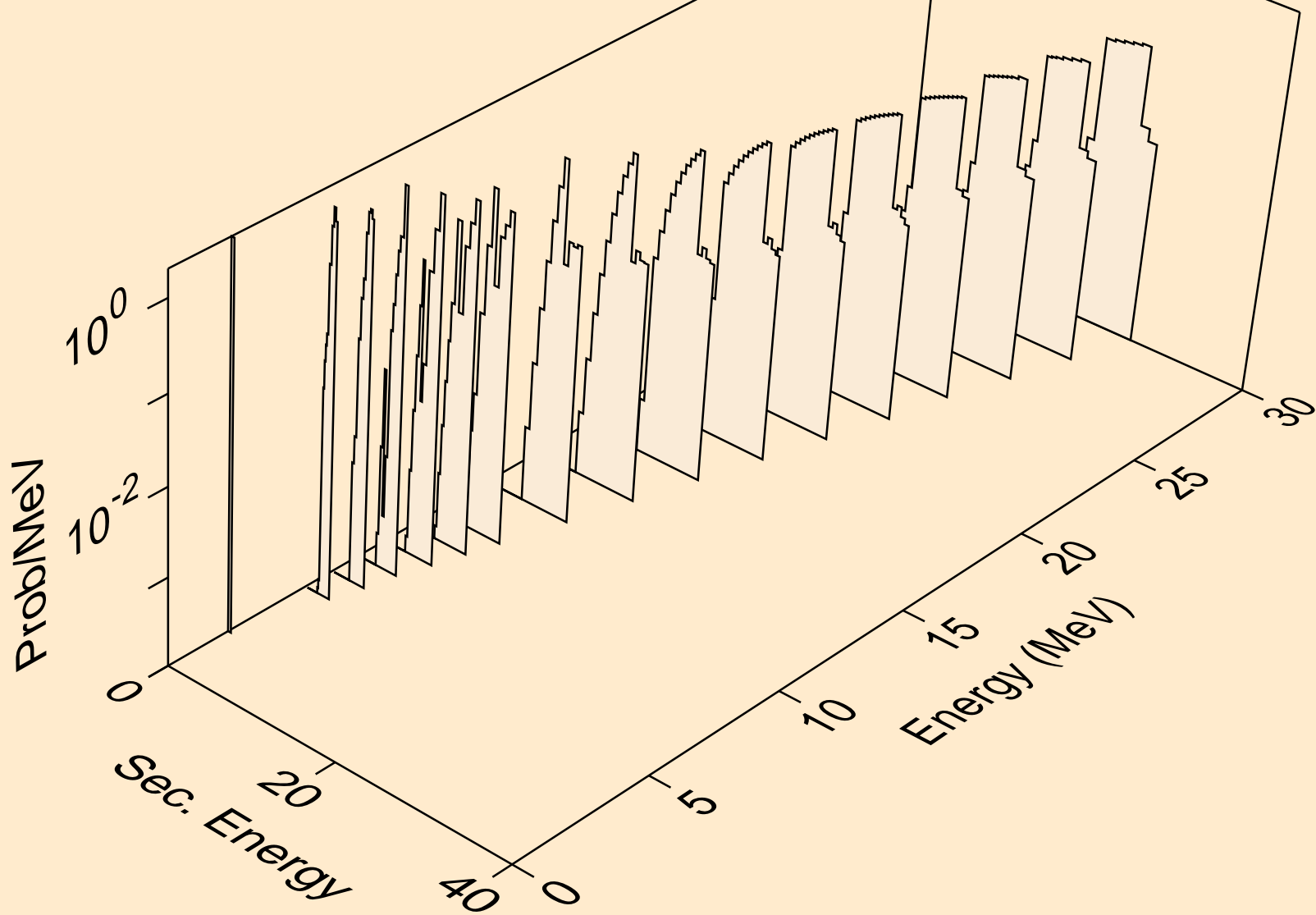

ND157 PROTON ACER TENDL-2021 LIBRARY; T=0.K
deuterons from (p,pd)

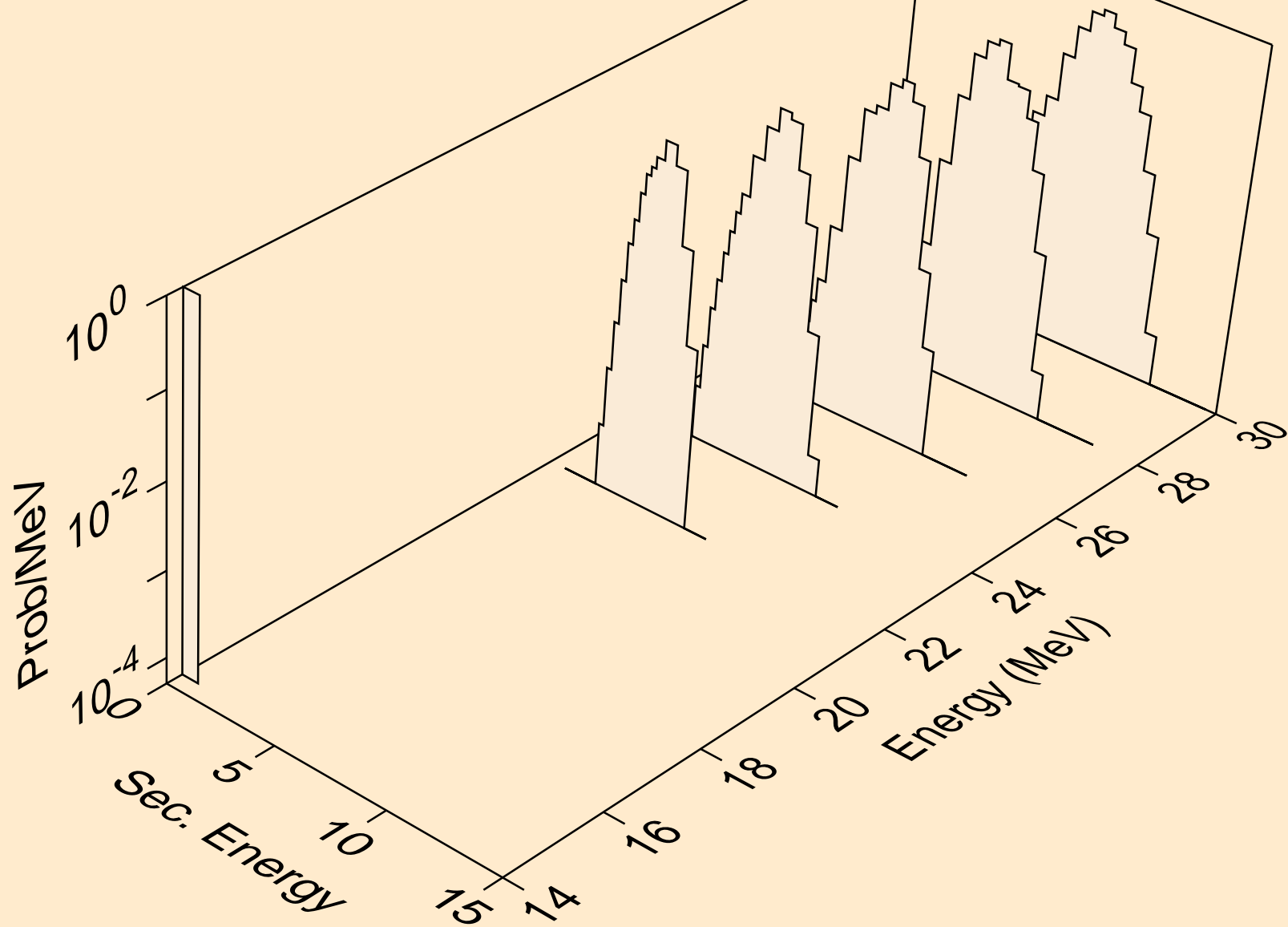

ND157 PROTON ACER TENDL-2021 LIBRARY; T=0.K
tritons from (p,x)

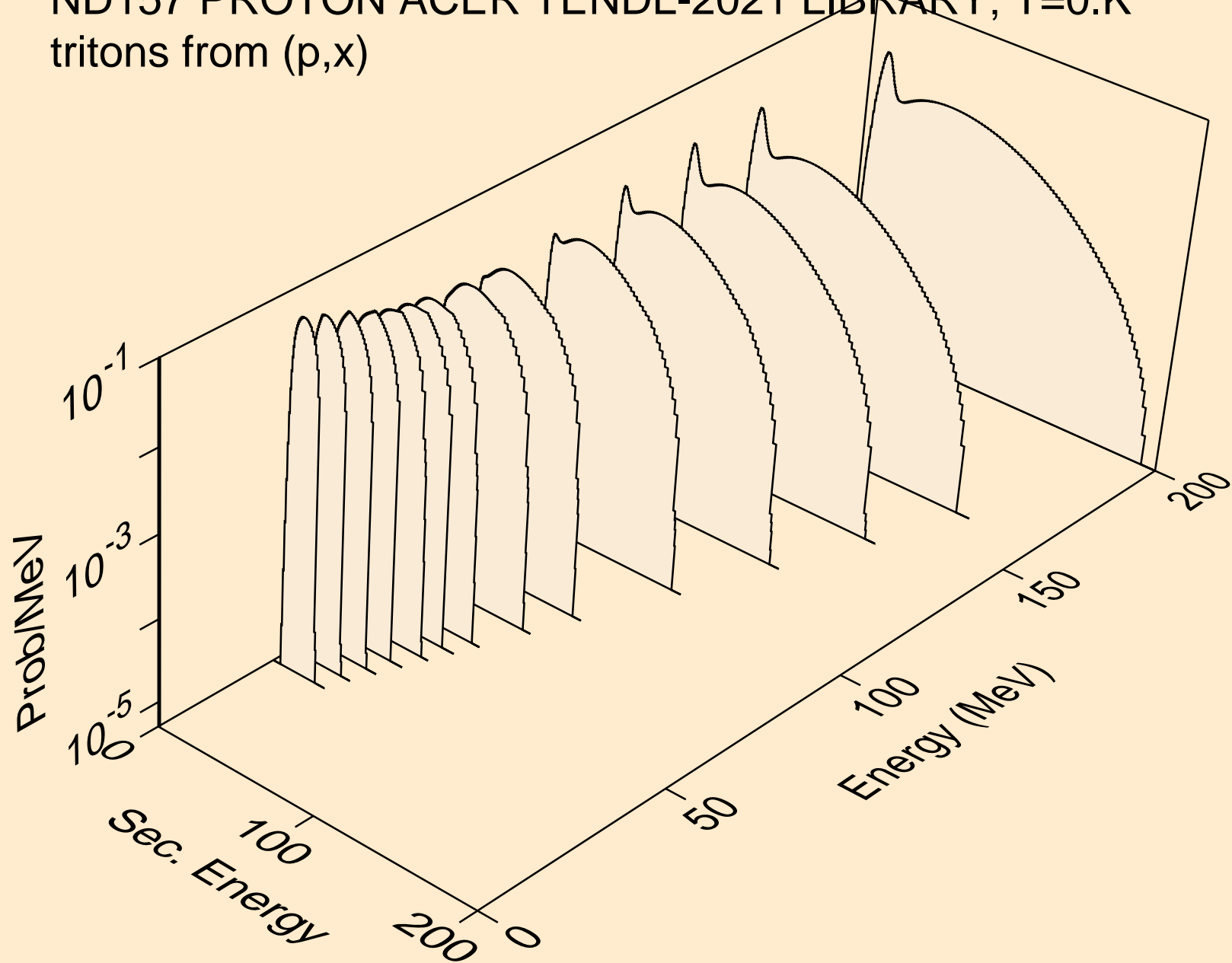

ND157 PROTON ACER TENDL-2021 LIBRARY; T=0.K
tritons from (p,n*)t

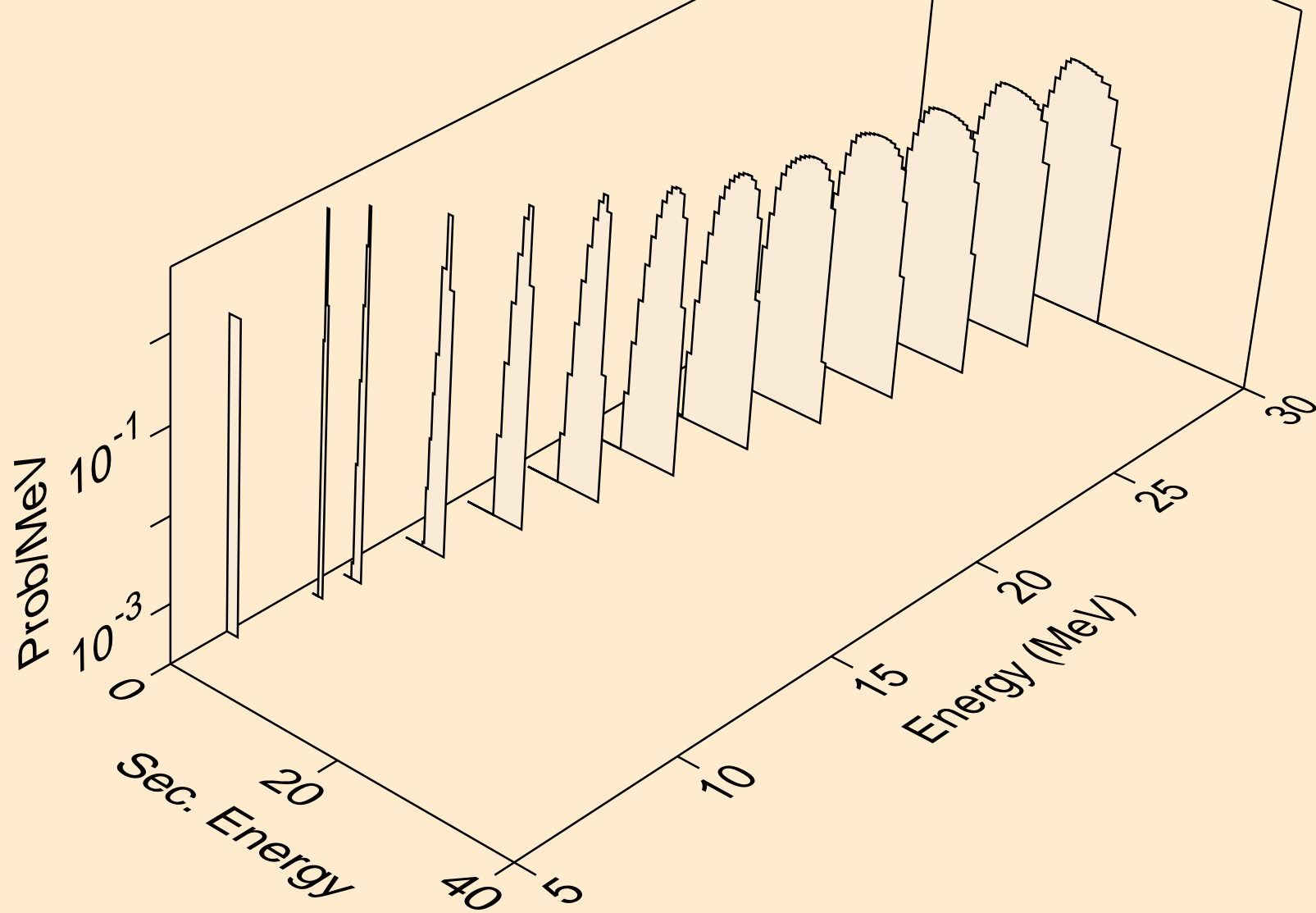

ND157 PROTON ACER TENDL-2021 LIBRARY; T=0.K
tritons from (p,t)

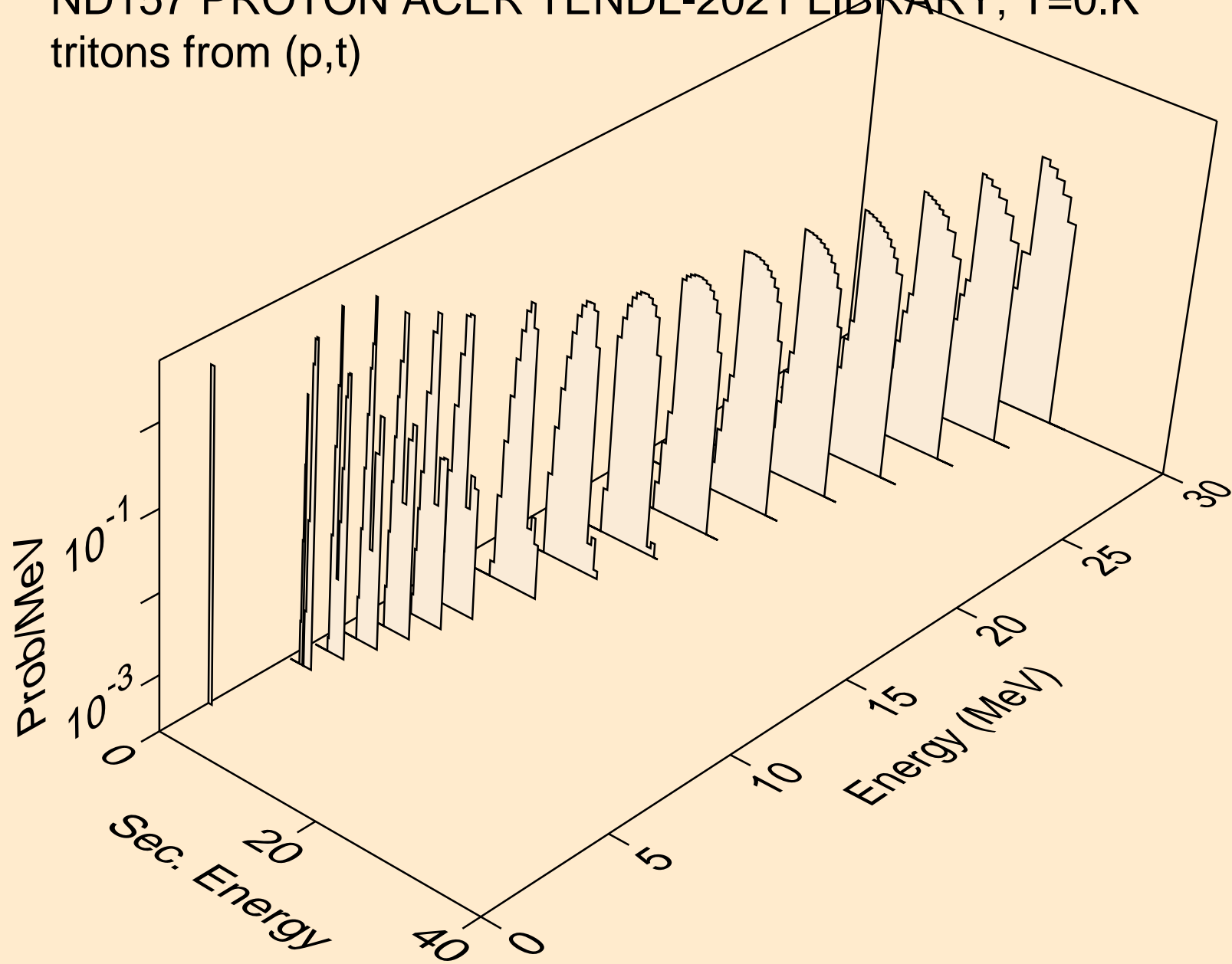

ND157 PROTON ACER TENDL-2021 LIBRARY; T=0.K
he3s from (p,x)

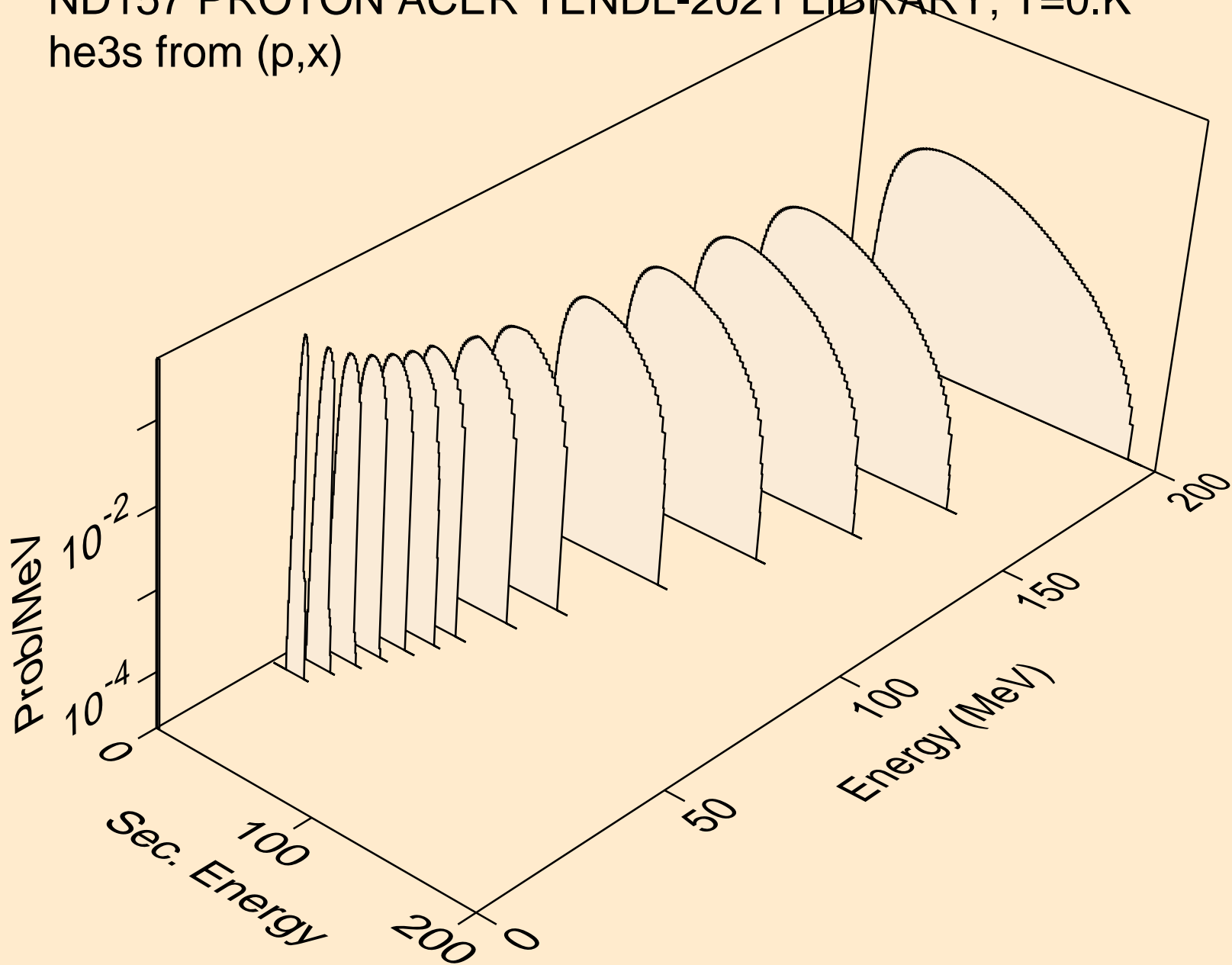

ND157 PROTON ACER TENDL-2021 LIBRARY; T=0.K
he3s from (p,n*)he3

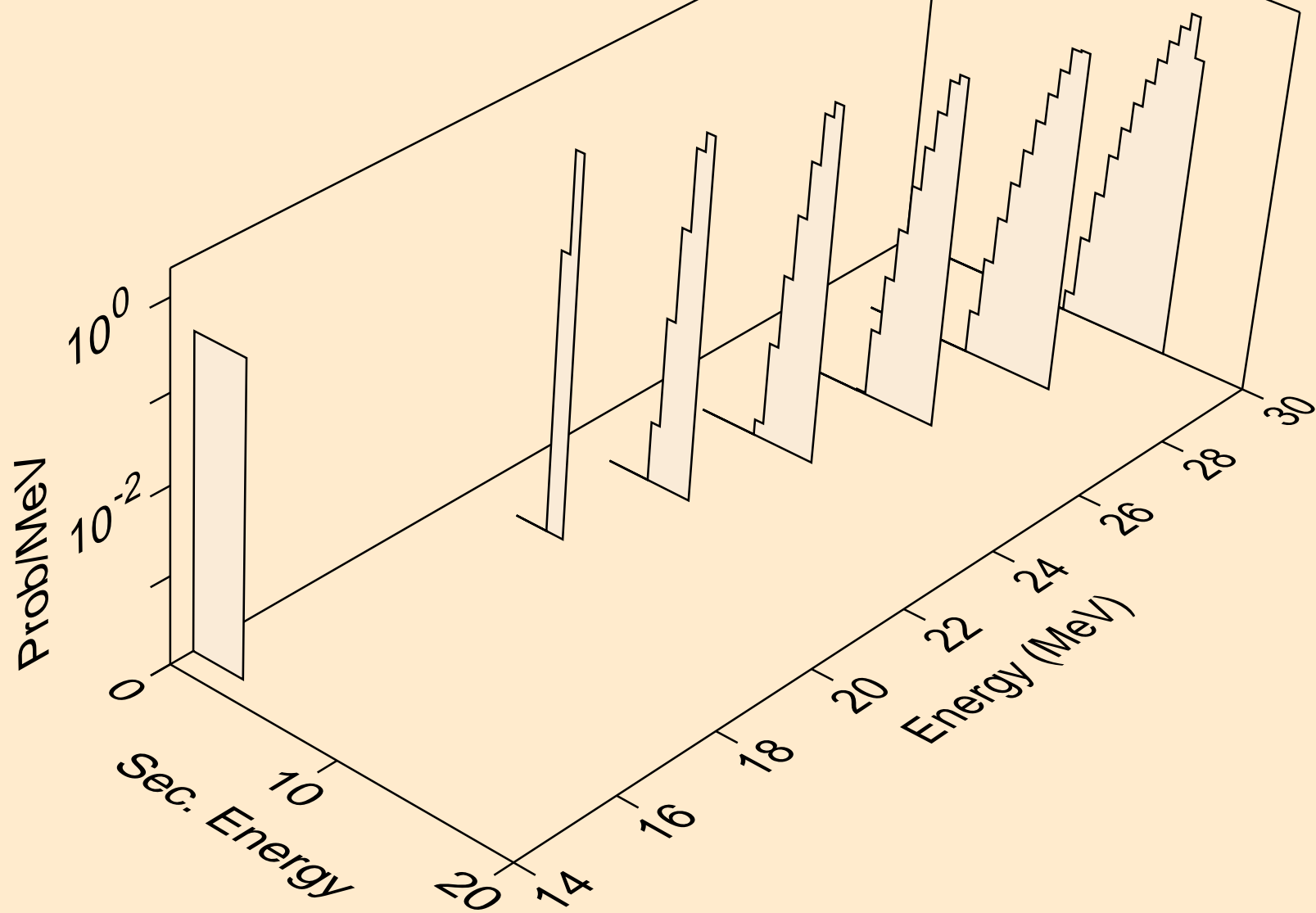

ND157 PROTON ACER TENDL-2021 LIBRARY; T=0.K
he3s from (p,he3)

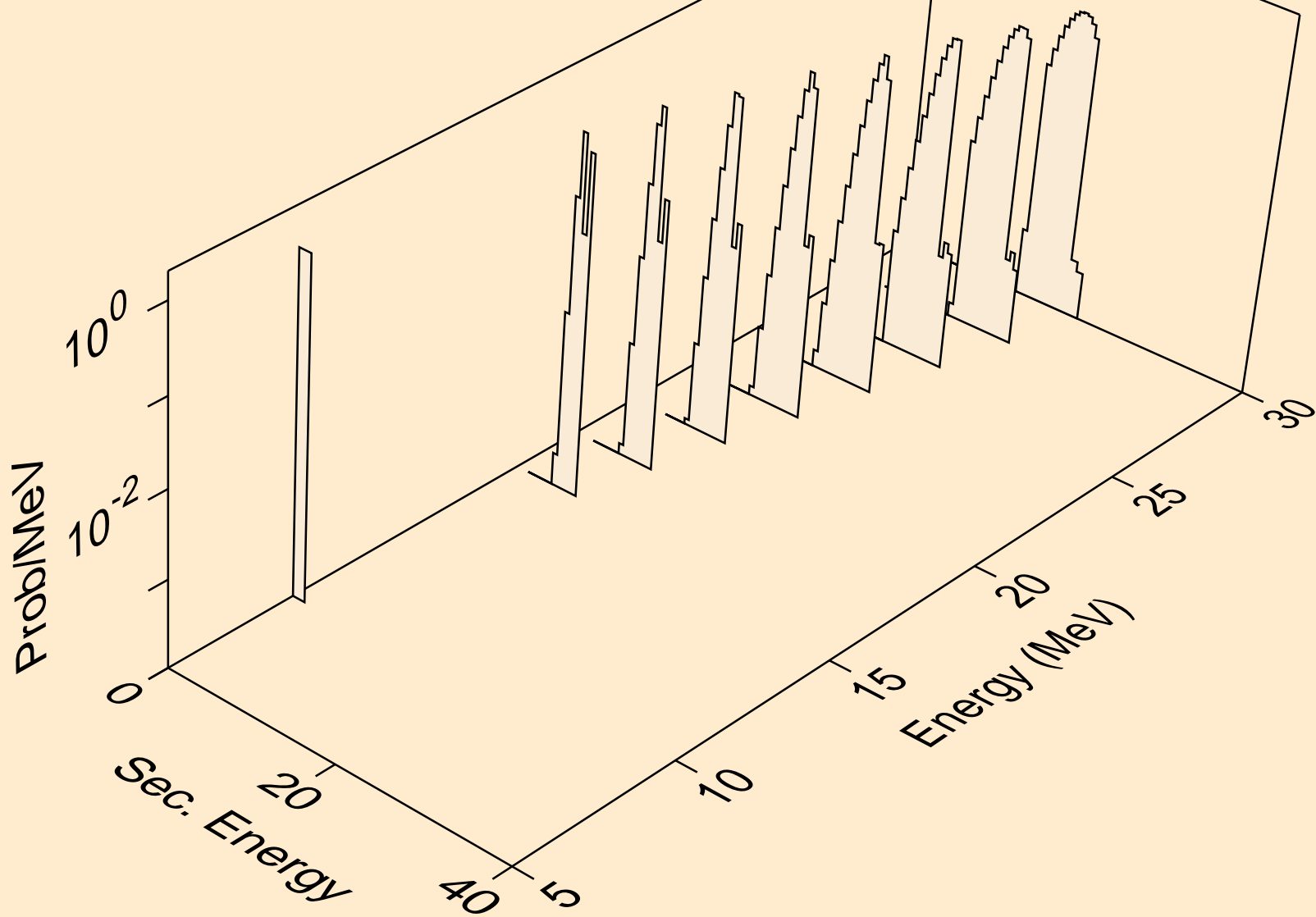

ND157 PROTON ACER TENDL-2021 LIBRARY; T=0.K
alphas from (p,x)

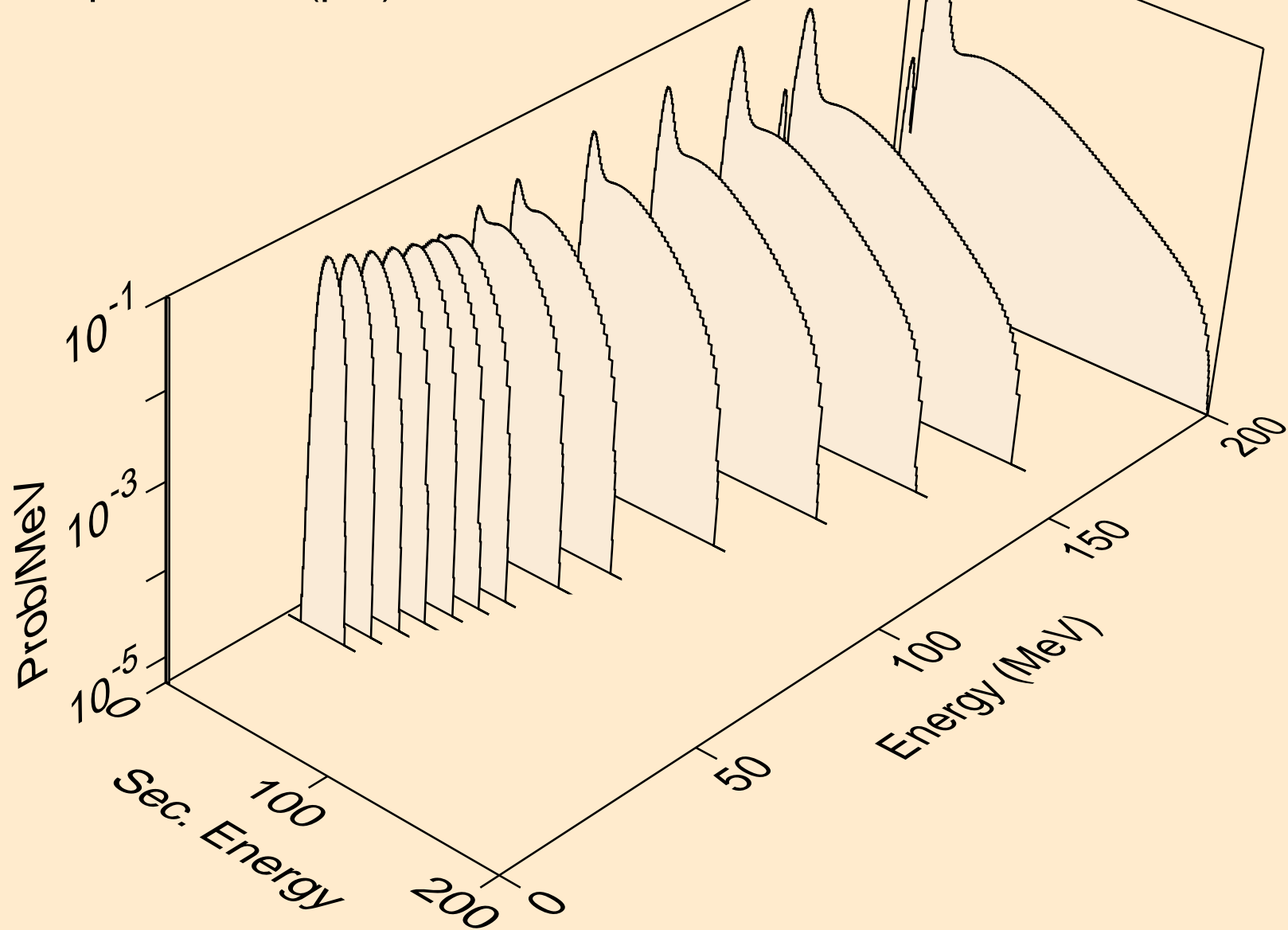

ND157 PROTON ACER TENDL-2021 LIBRARY; T=0.K
alphas from (p,n*)a

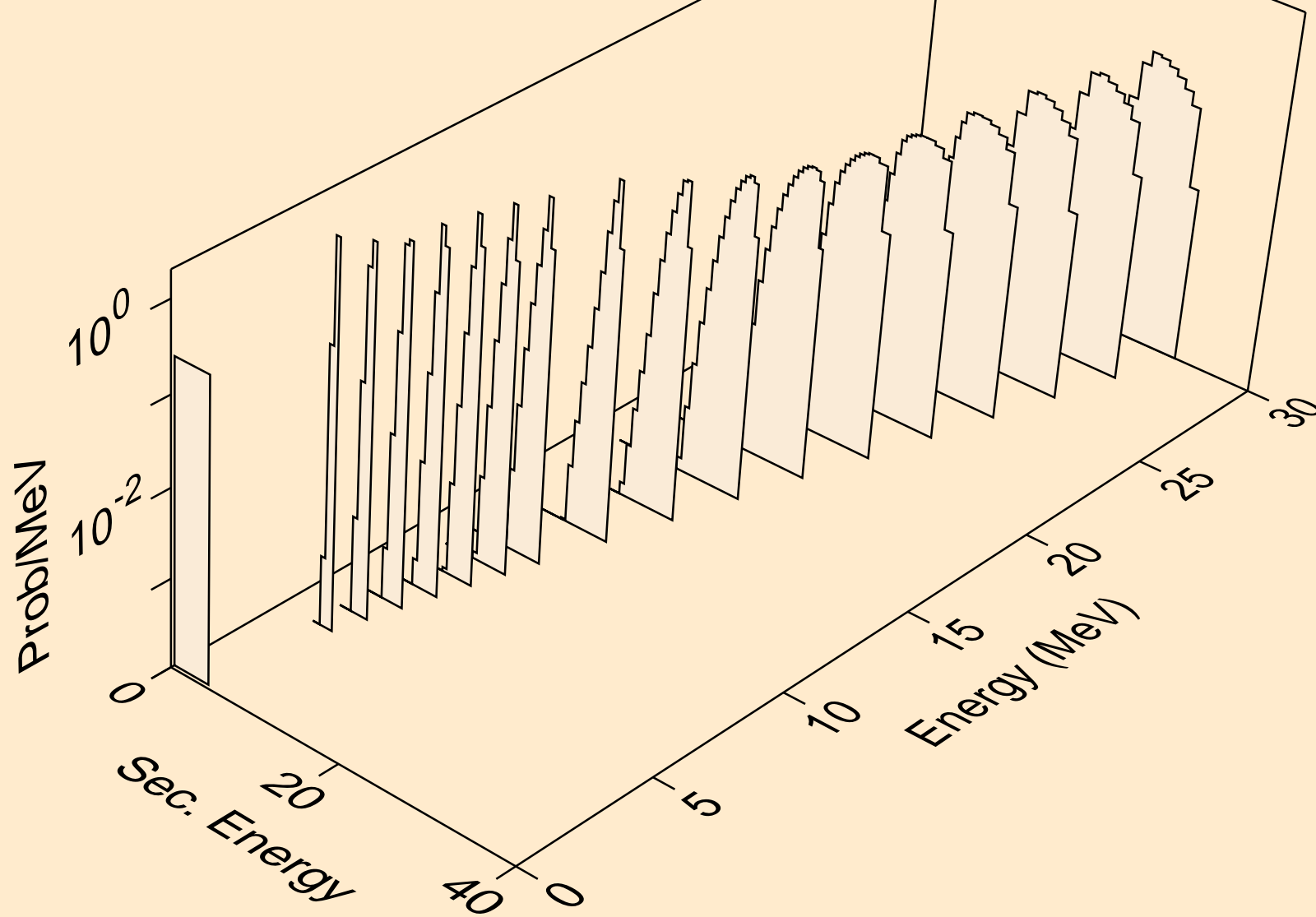

ND157 PROTON ACER TENDL-2021 LIBRARY; T=0.K
alphas from (p,2n)a

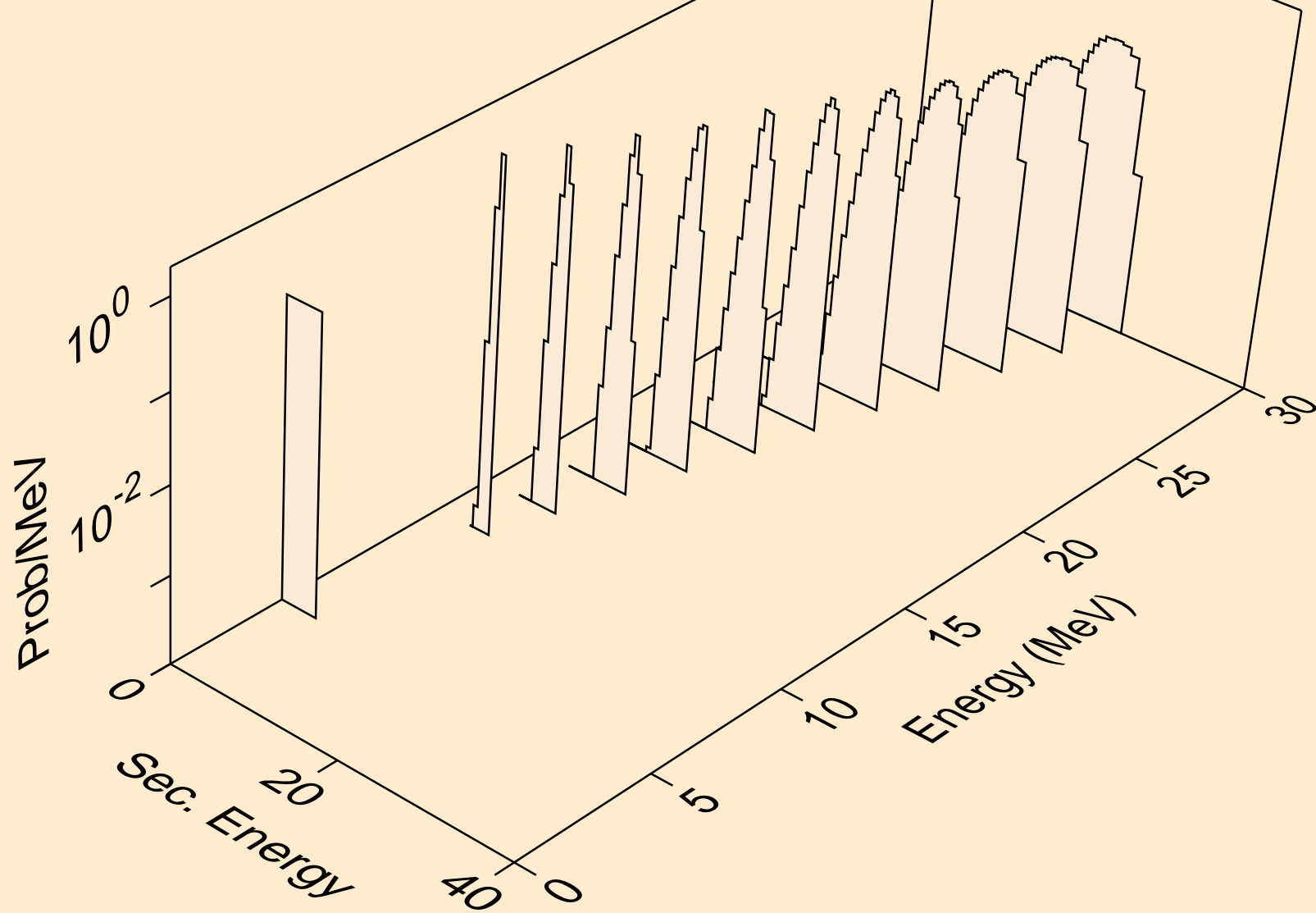

ND157 PROTON ACER TENDL-2021 LIBRARY; T=0.K
alphas from (p,3n)a

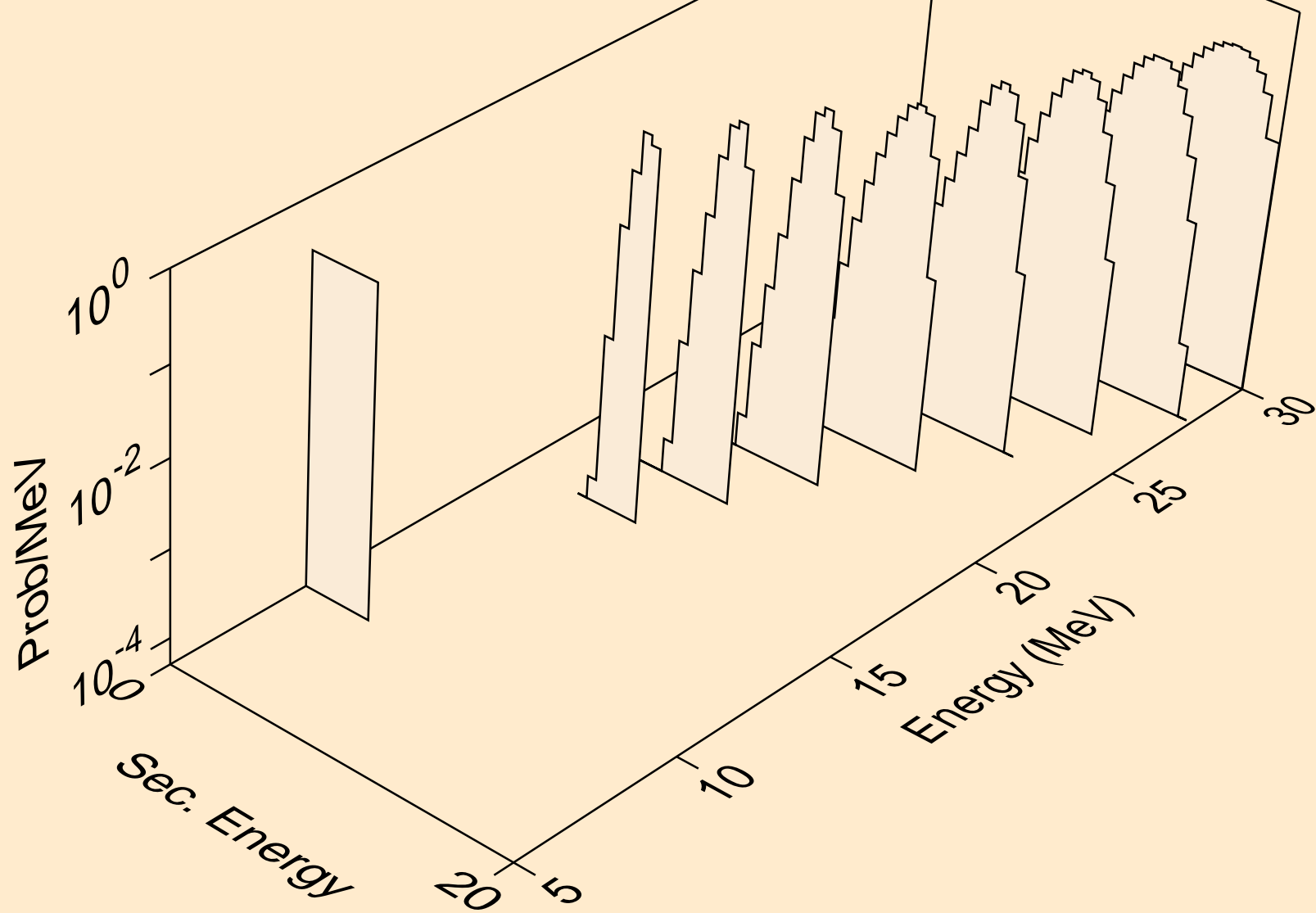

ND157 PROTON ACER TENDL-2021 LIBRARY; T=0.K
alphas from (p,a)

