

SG273 PROTON ACER TENDL-2021 LIBRARY; T=0.K

Principal cross sections

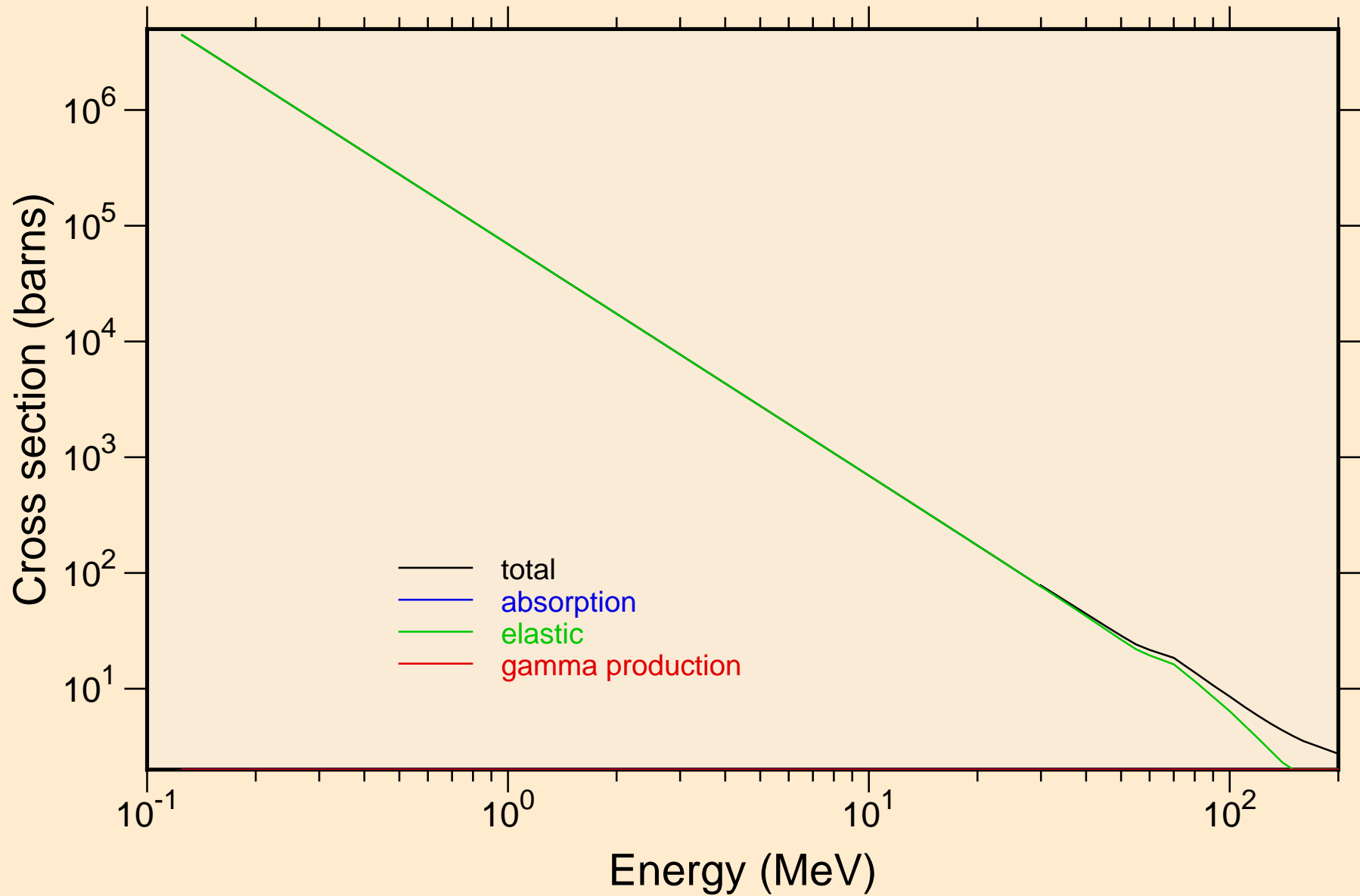

SG273 PROTON ACER TENDL-2021 LIBRARY; T=0.K

Heating

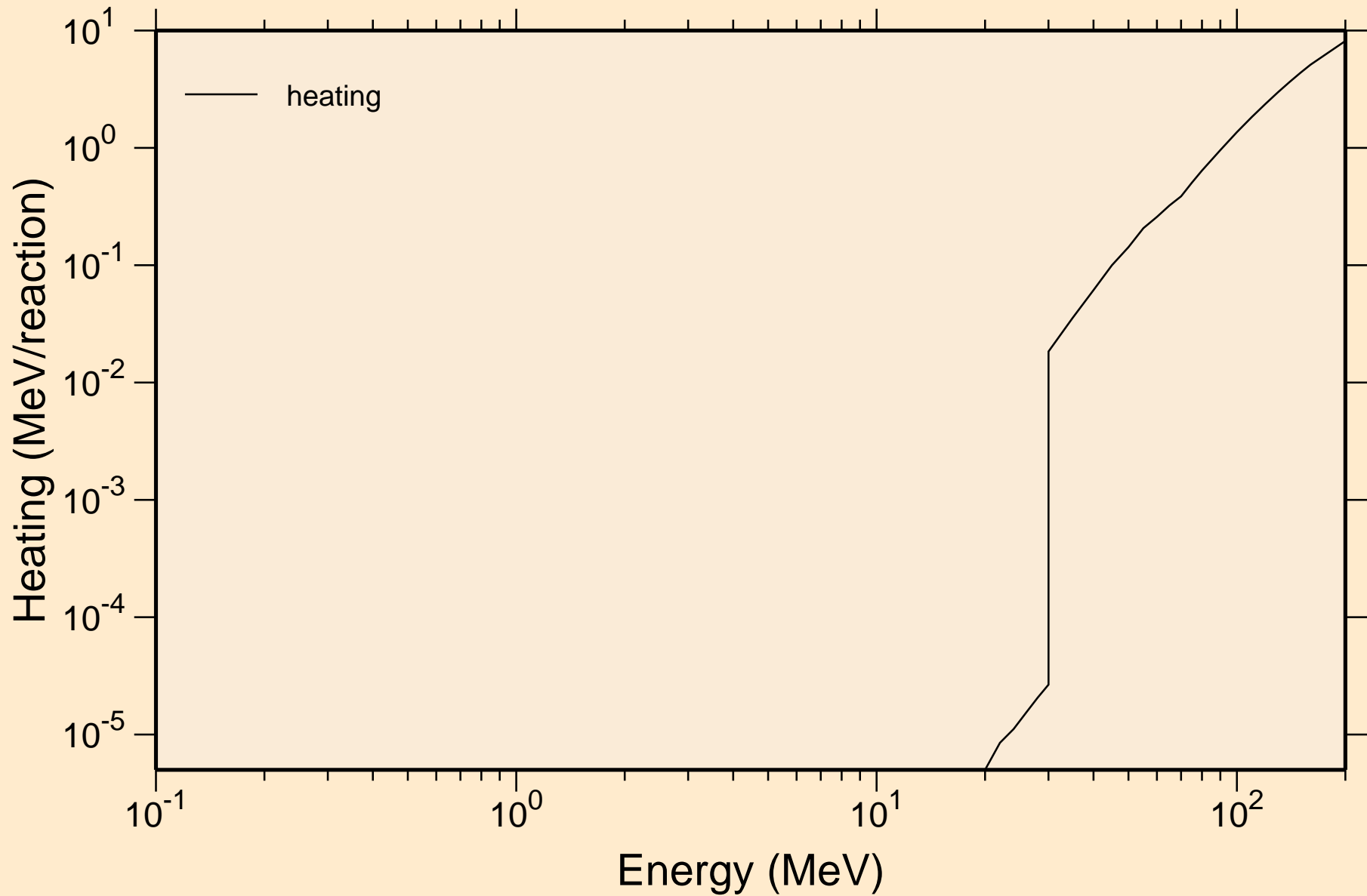

SG273 PROTON ACER TENDL-2021 LIBRARY; T=0.K

Principal cross sections

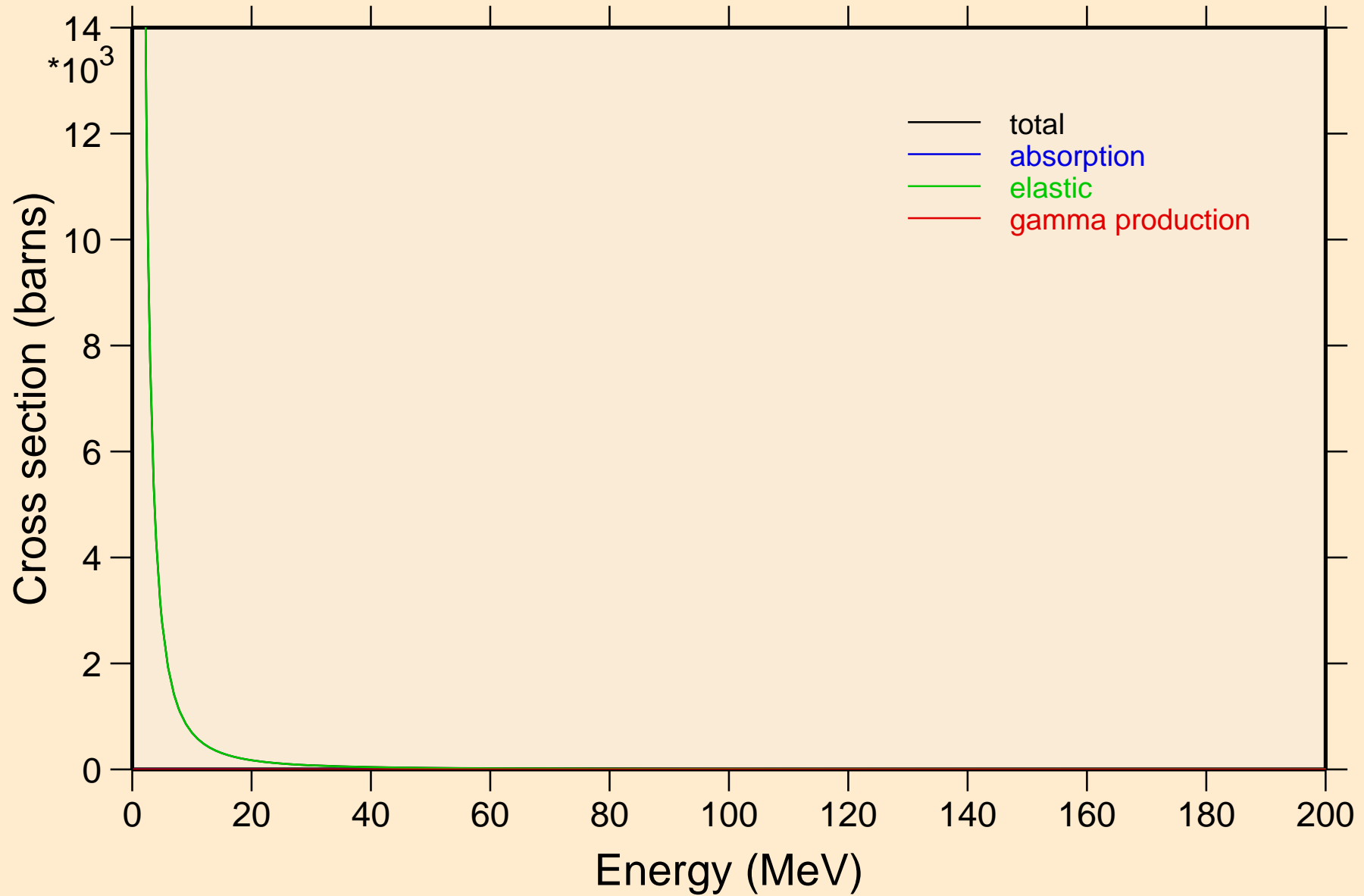

SG273 PROTON ACER TENDL-2021 LIBRARY; T=0.K

Heating

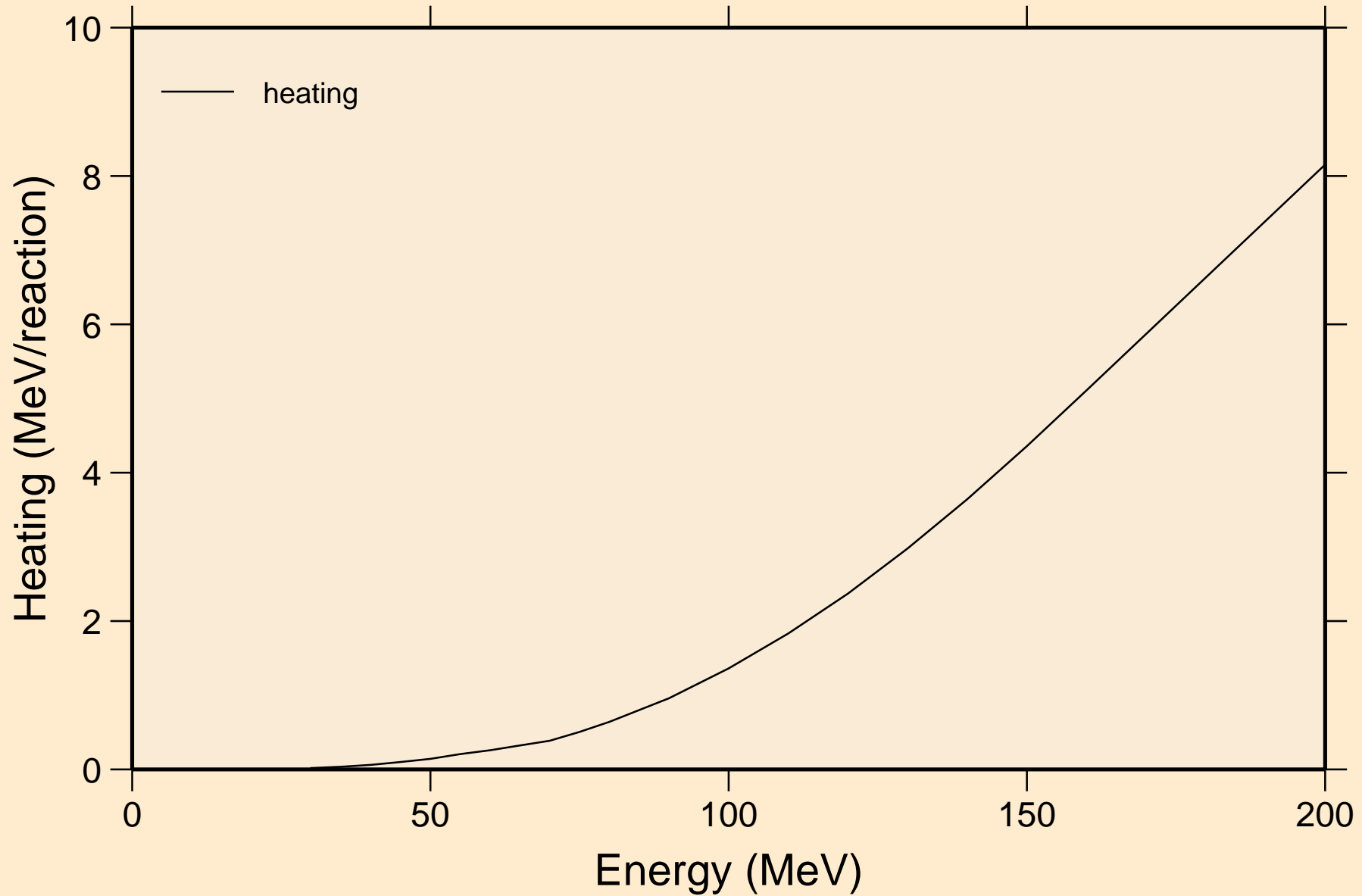

SG273 PROTON ACER TENDL-2021 LIBRARY; T=0.K

Threshold reactions

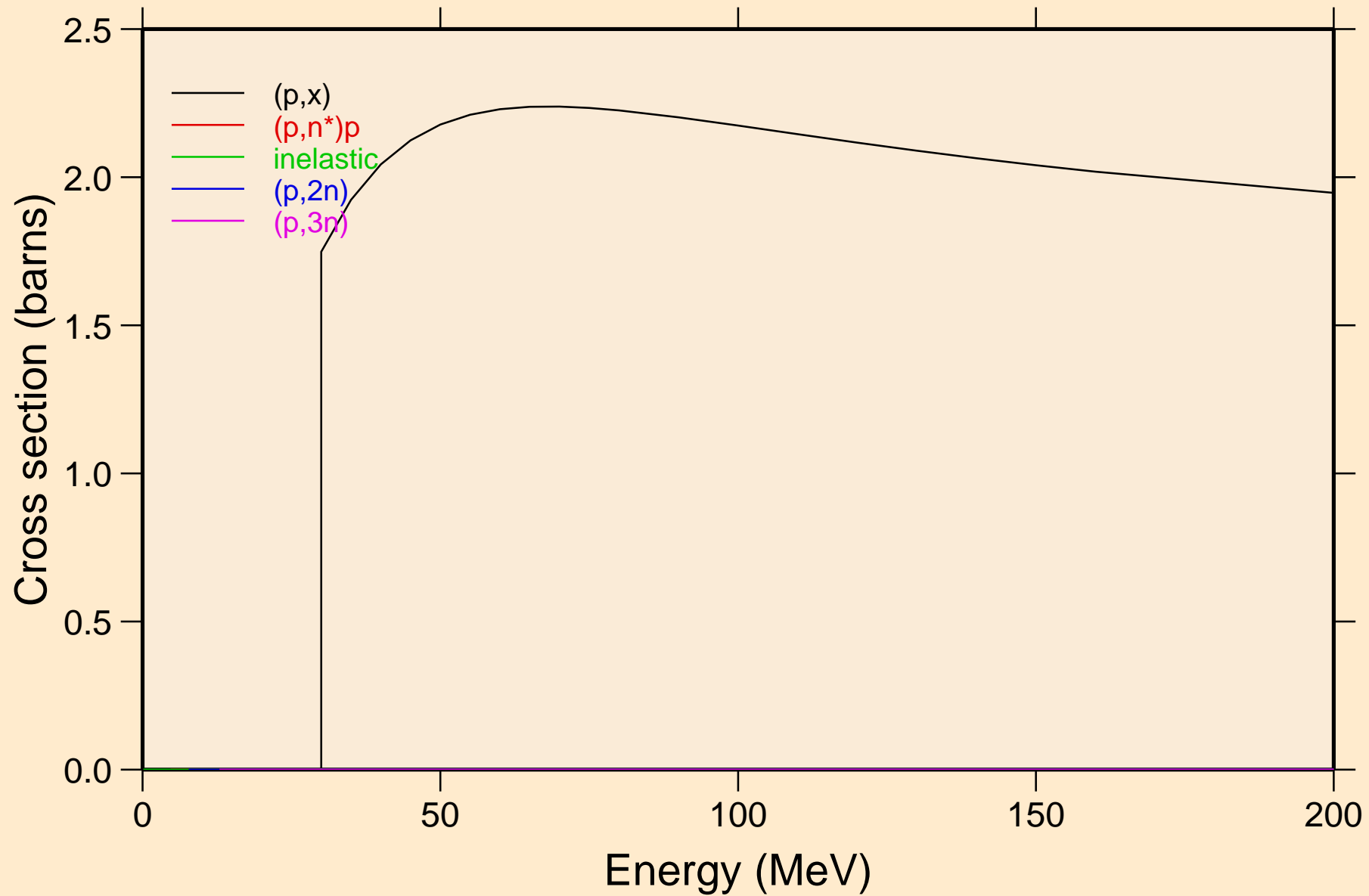

SG273 PROTON ACER TENDL-2021 LIBRARY; T=0.K

Threshold reactions

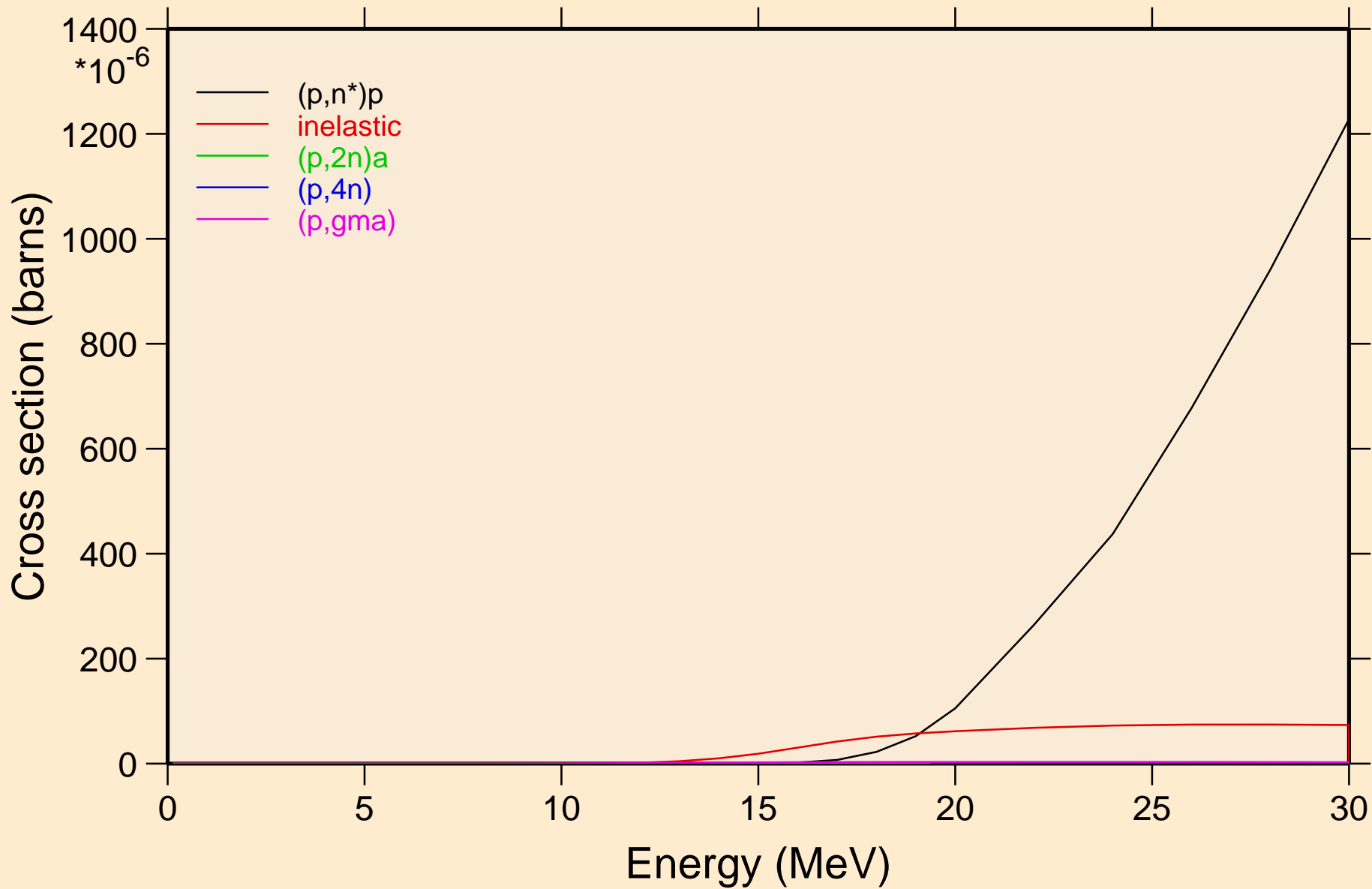

SG273 PROTON ACER TENDL-2021 LIBRARY; T=0.K

Threshold reactions

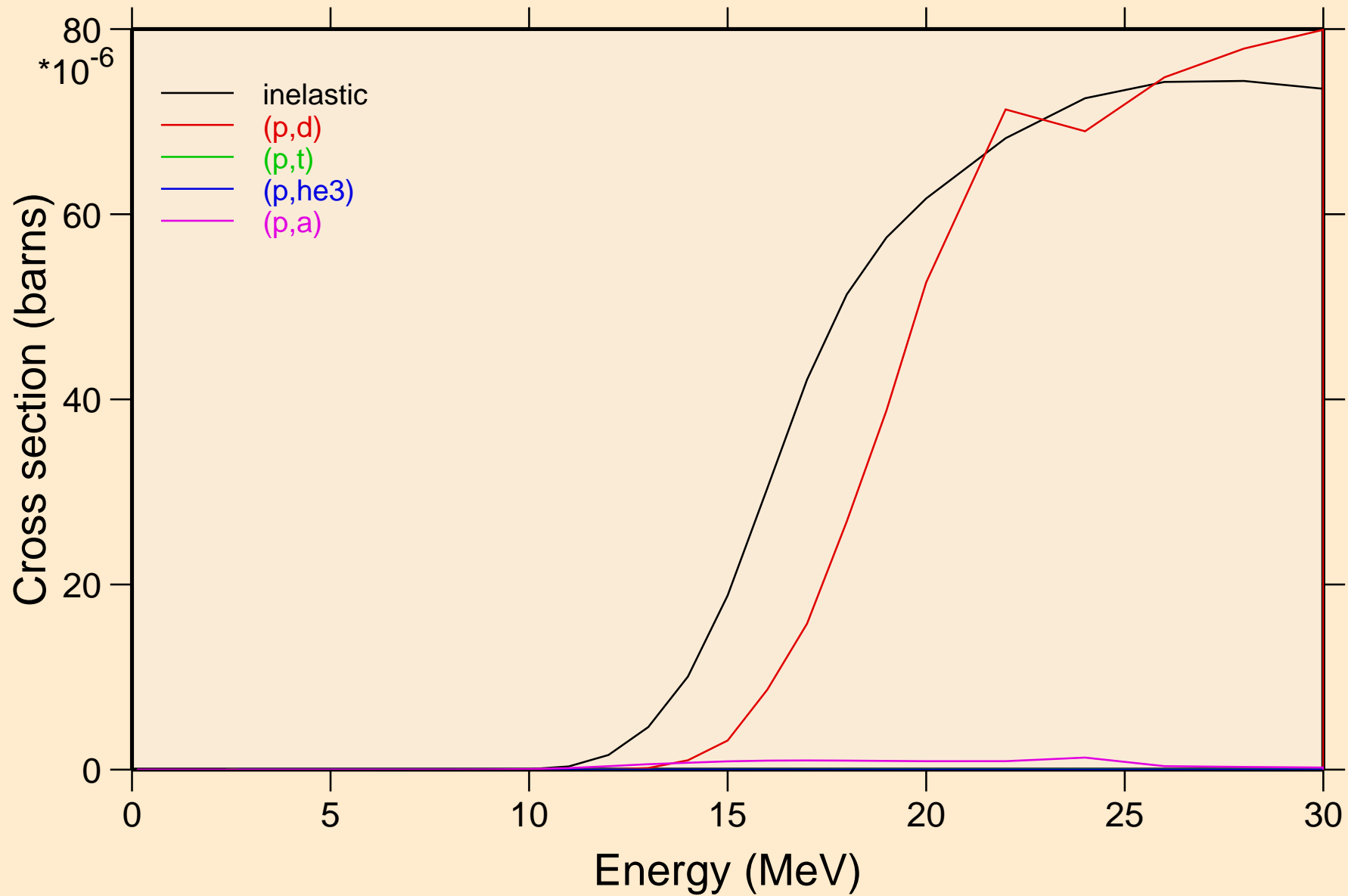

SG273 PROTON ACER TENDL-2021 LIBRARY; T=0.K
angular distribution for elastic

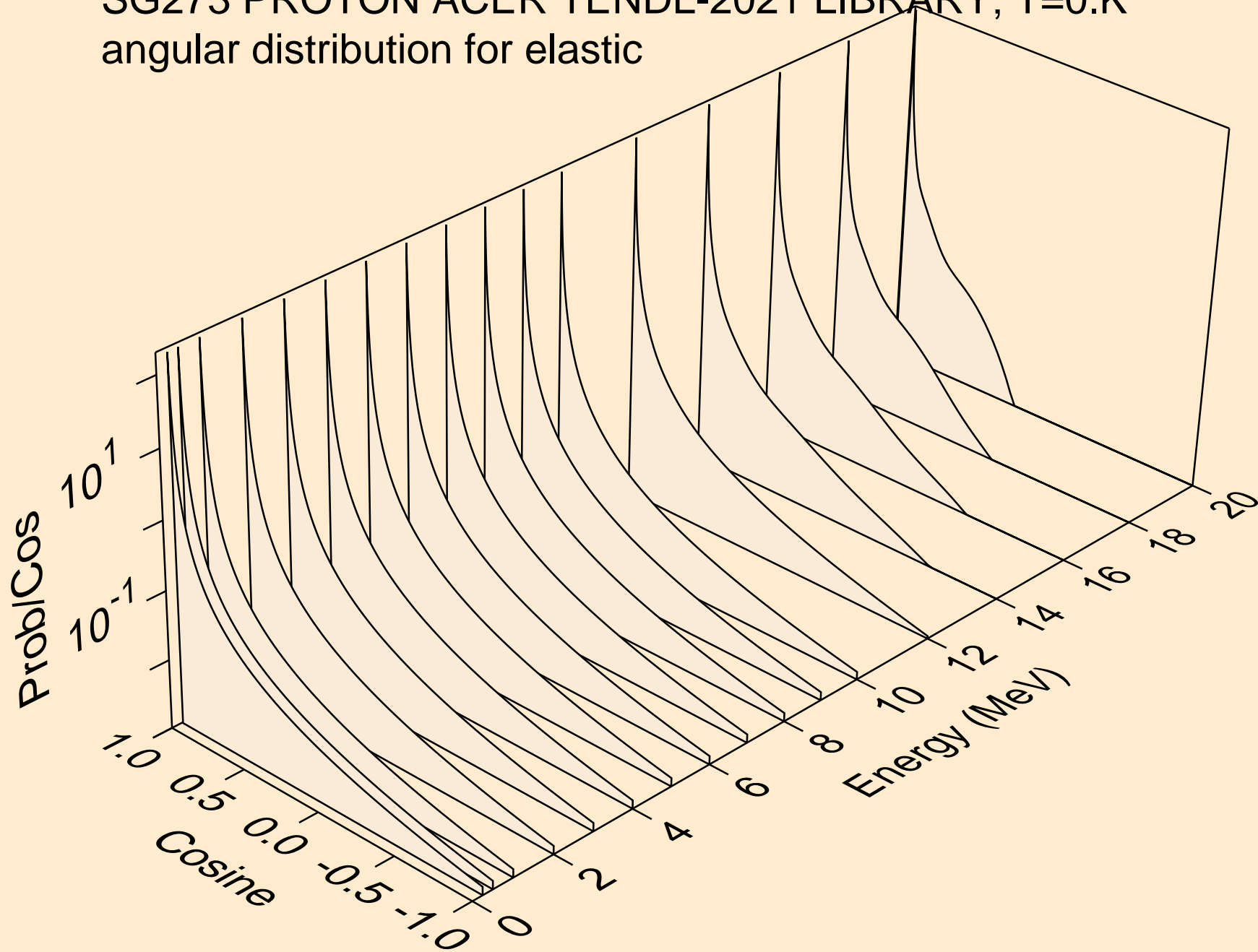

SG273 PROTON ACER TENDL-2021 LIBRARY; T=0.K
angular distribution for elastic

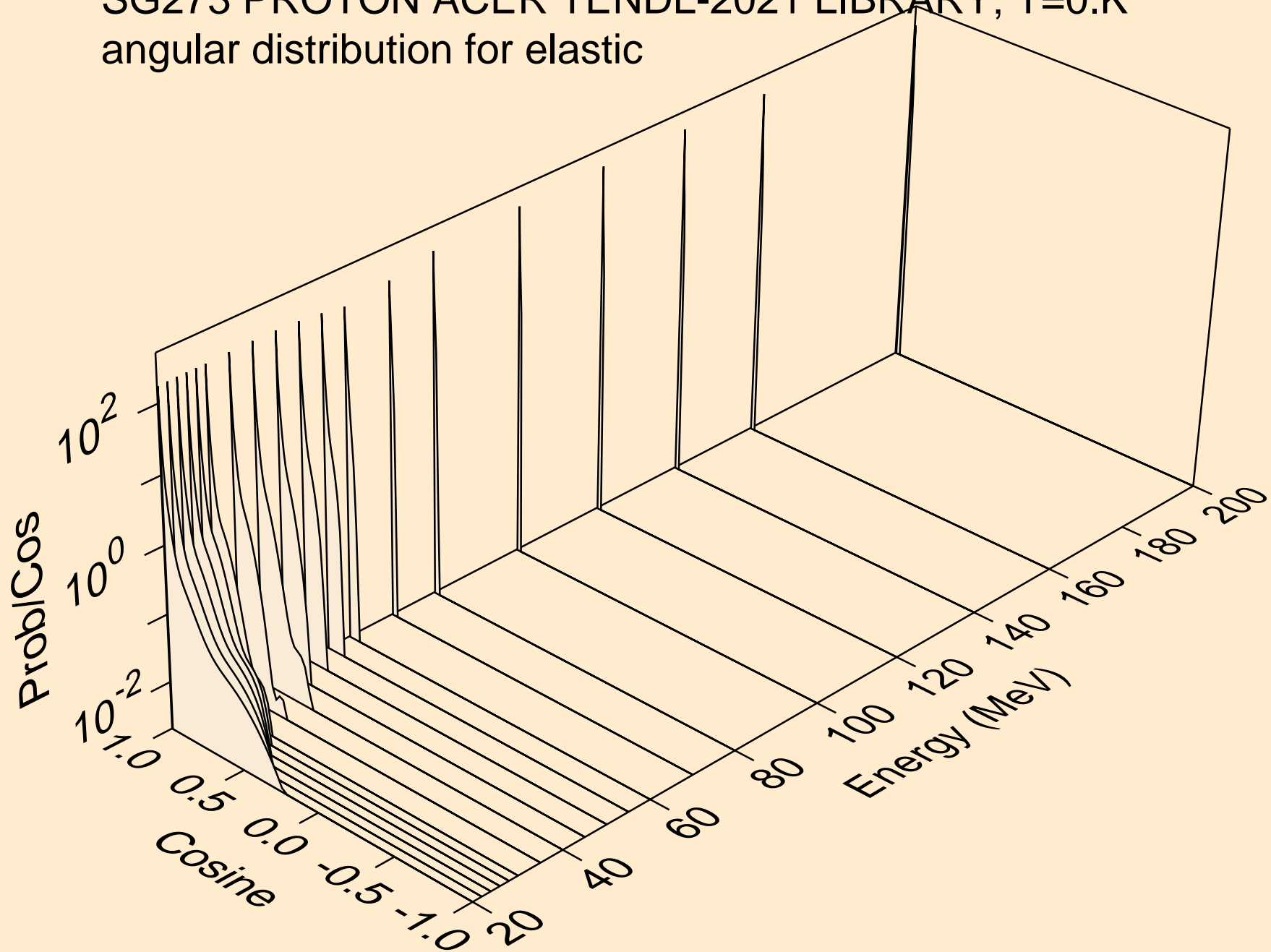

SG273 PROTON ACER TENDL-2021 LIBRARY; T=0.K
Proton emission for (p,x)

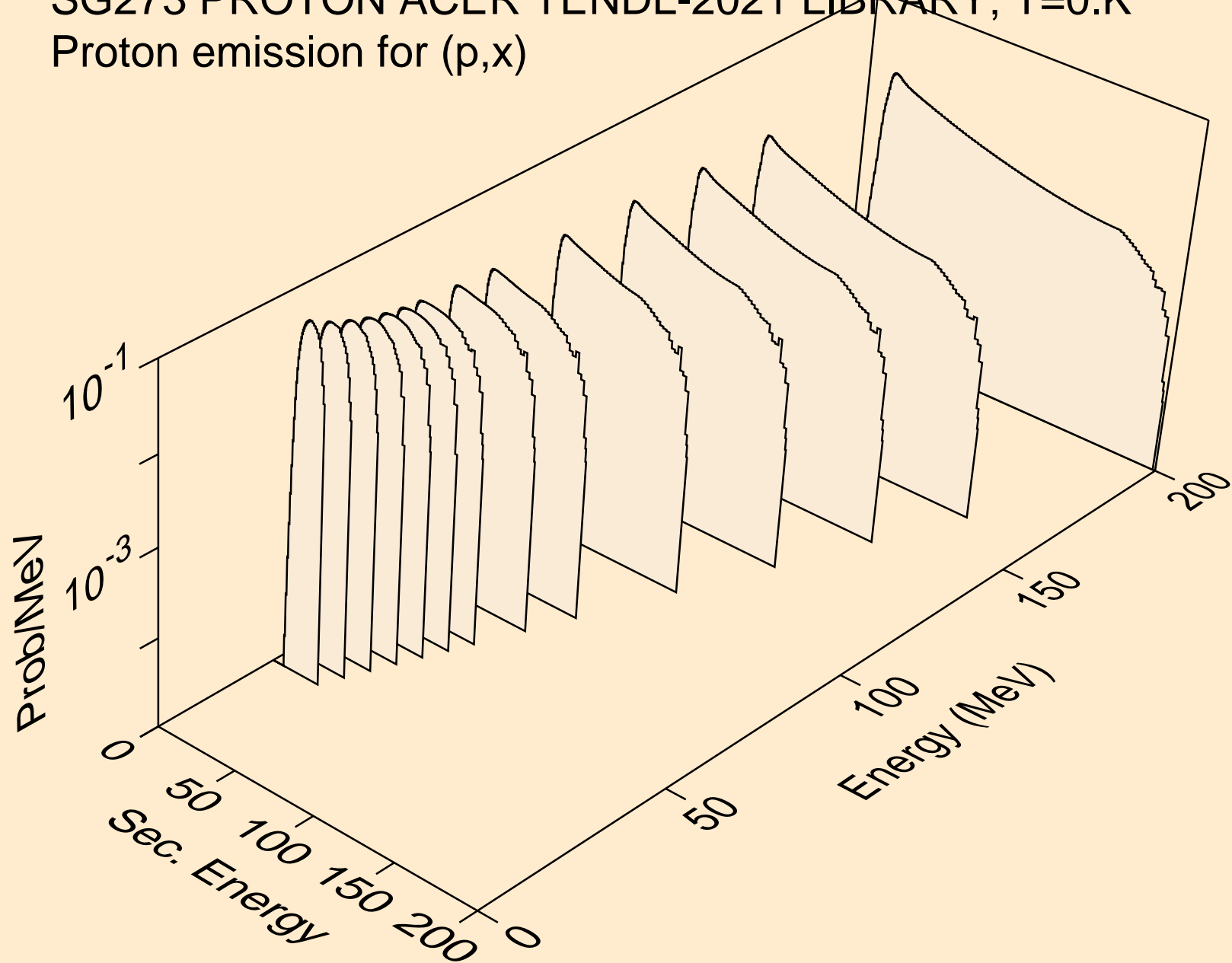

SG273 PROTON ACER TENDL-2021 LIBRARY; T=0.K
Proton emission for (p,n*)p

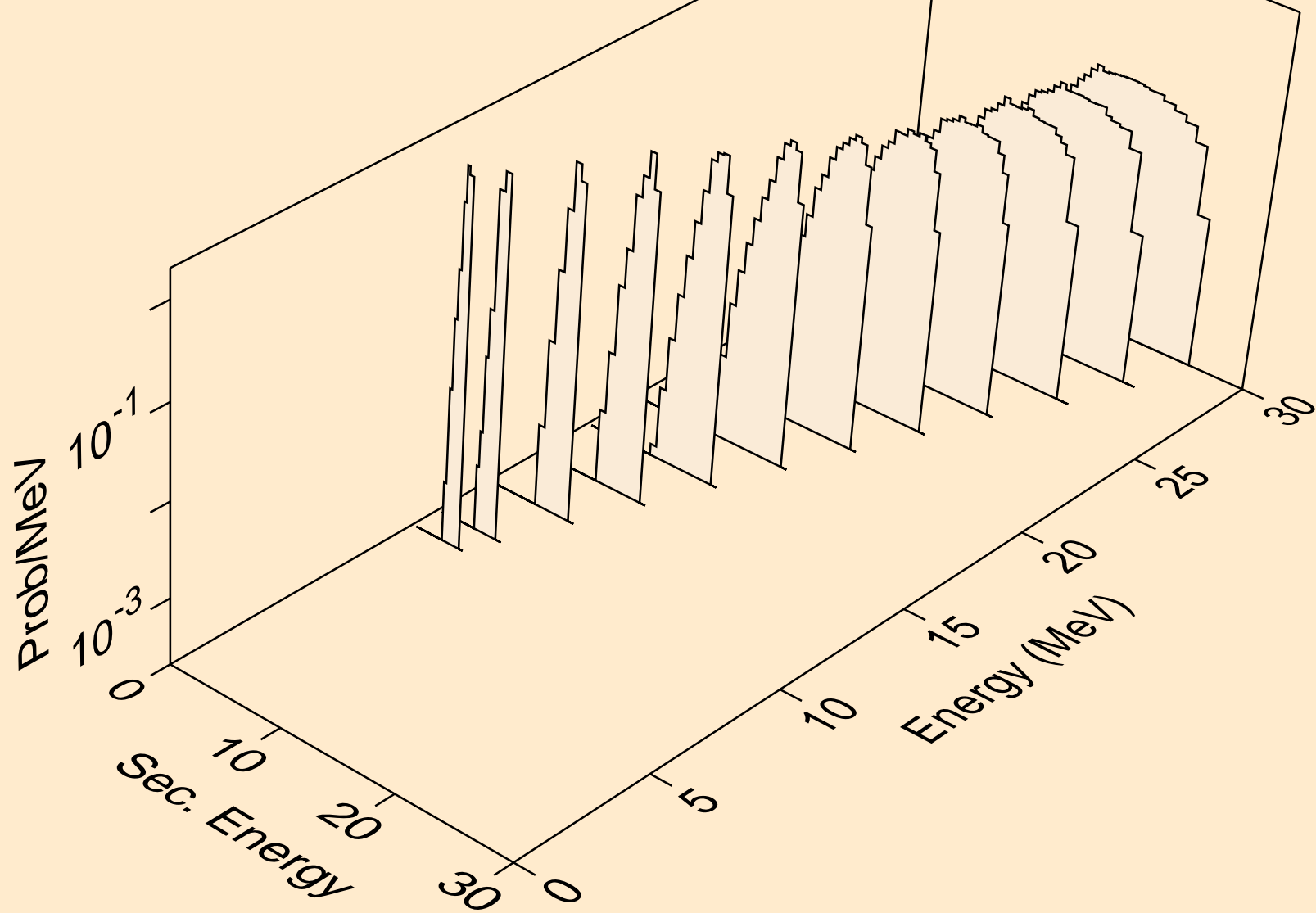

SG273 PROTON ACER TENDL-2021 LIBRARY; T=0.K
Proton emission for inelastic

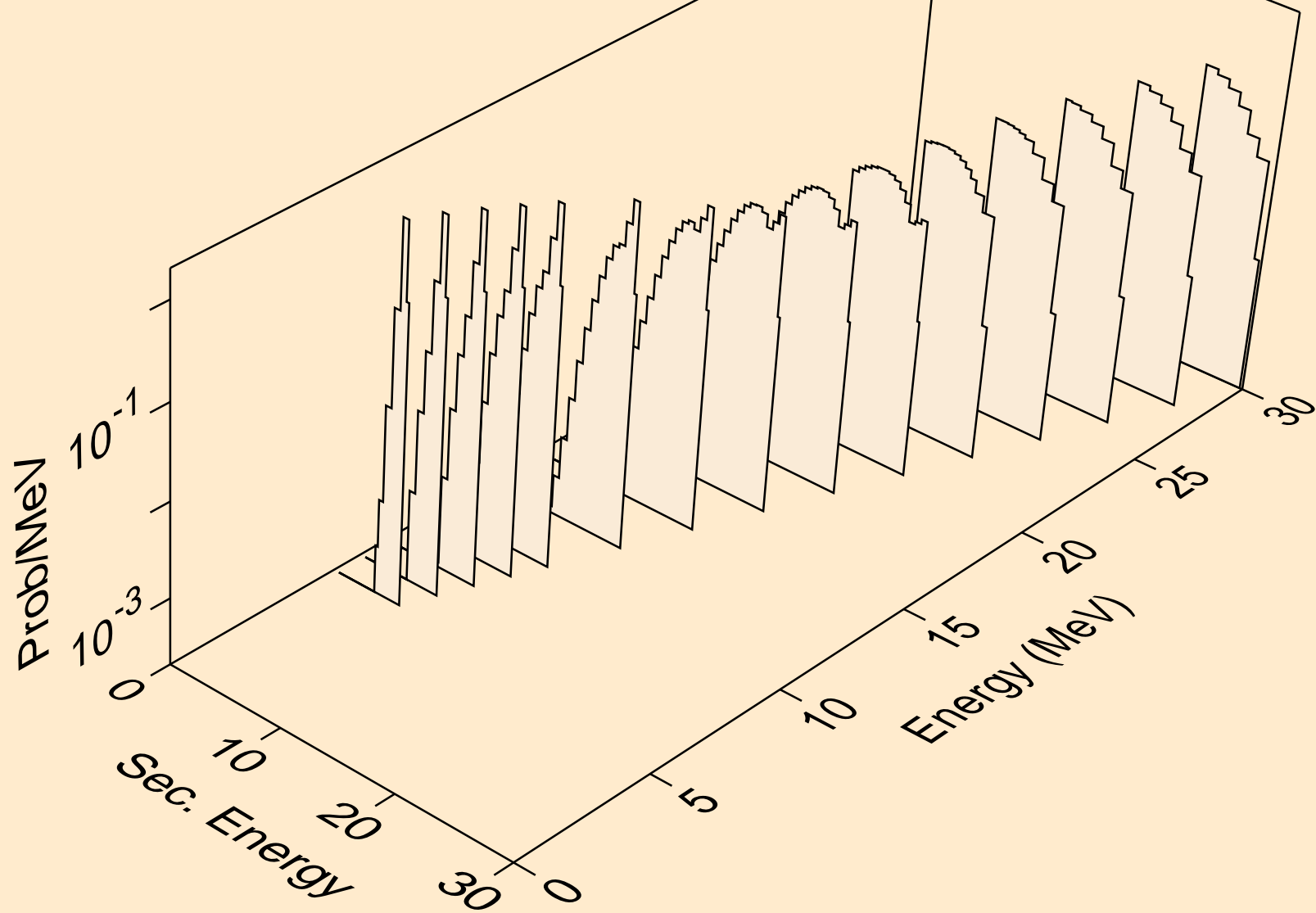

SG273 PROTON ACER TENDL-2021 LIBRARY; T=0.K
Photon emission for (z,n)

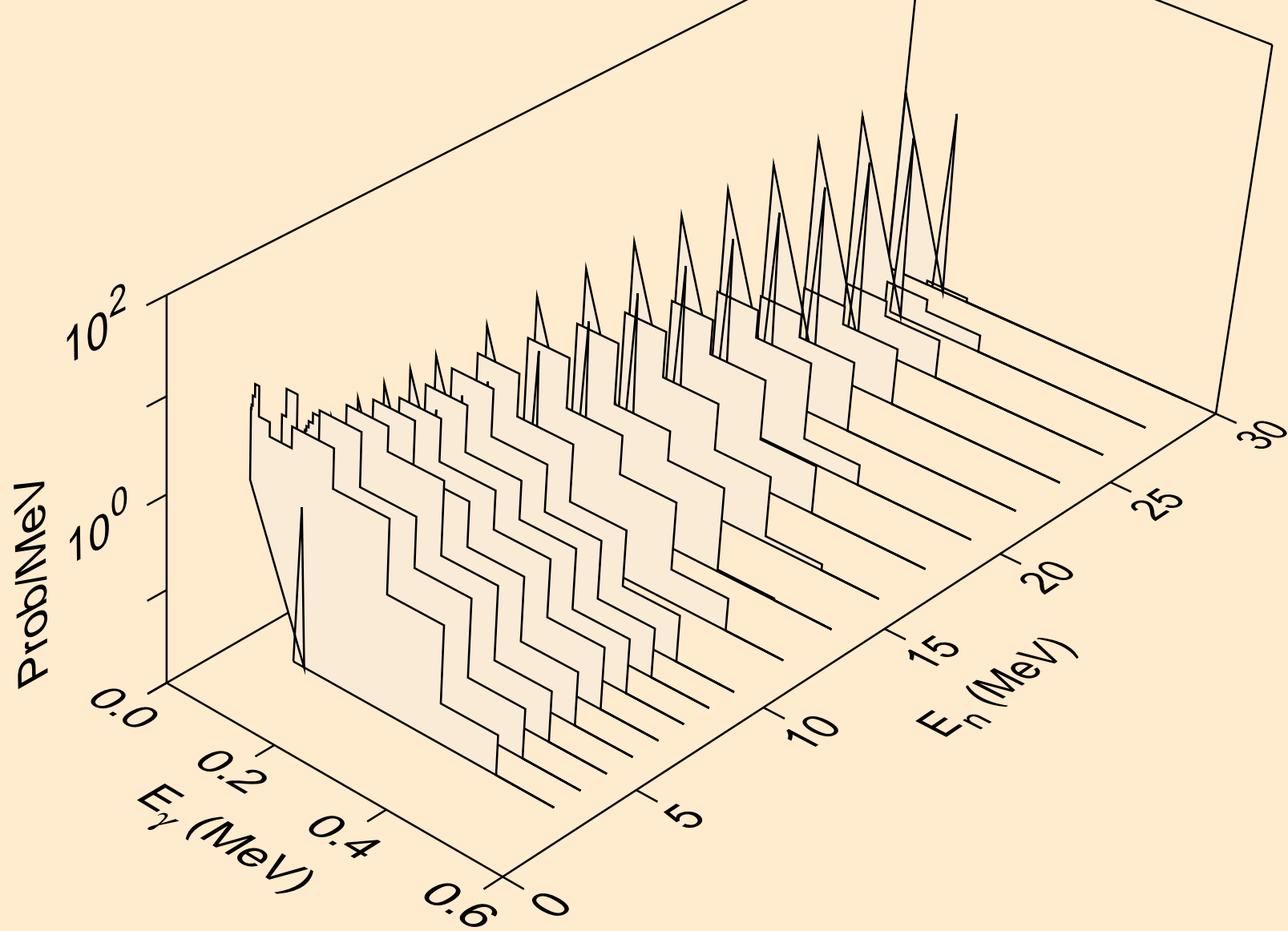

SG273 PROTON ACER TENDL-2021 LIBRARY; T=0.K
Photon emission for (n,x)

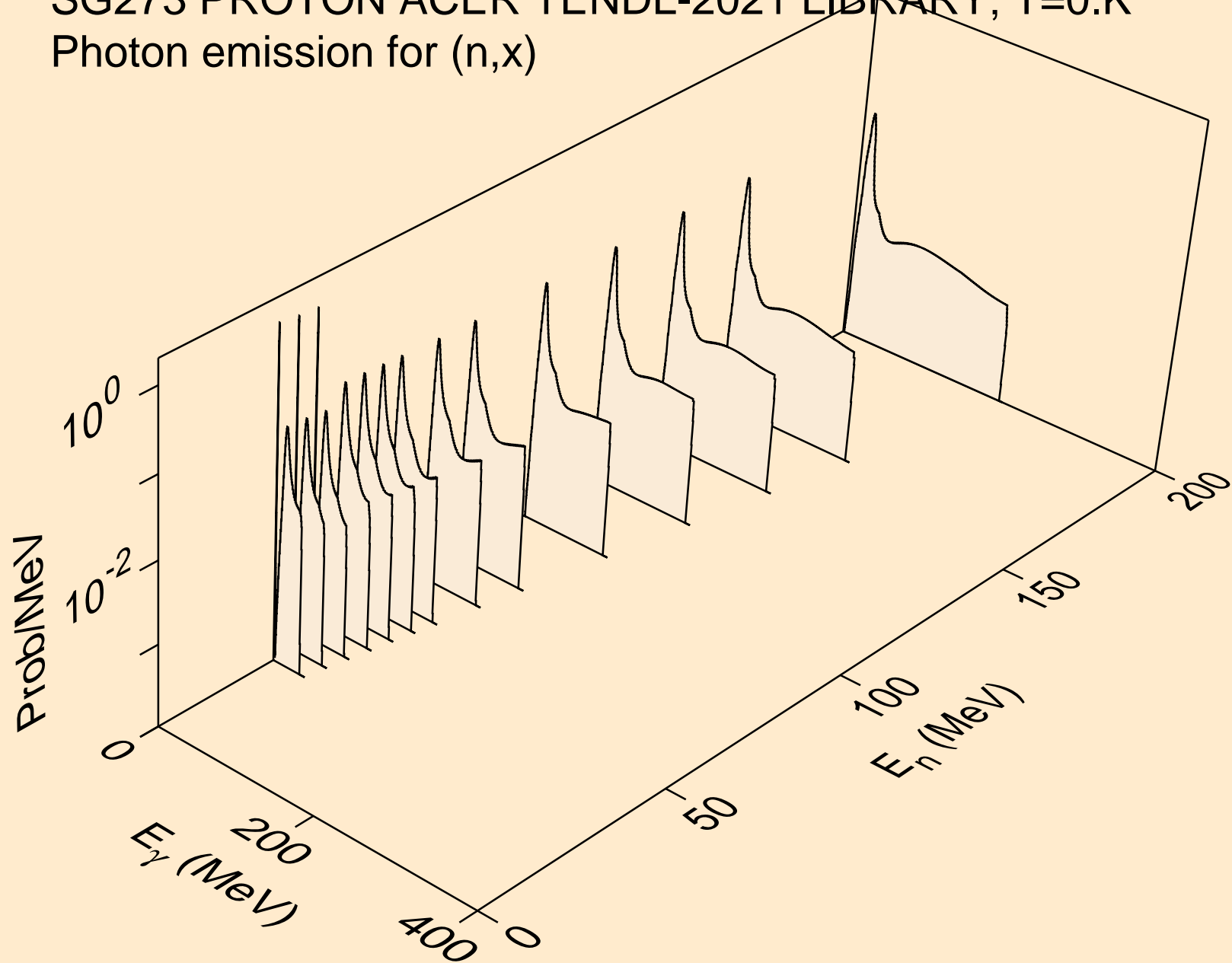

SG273 PROTON ACER TENDL-2021 LIBRARY; T=0.K
Photon emission for (n,2n)

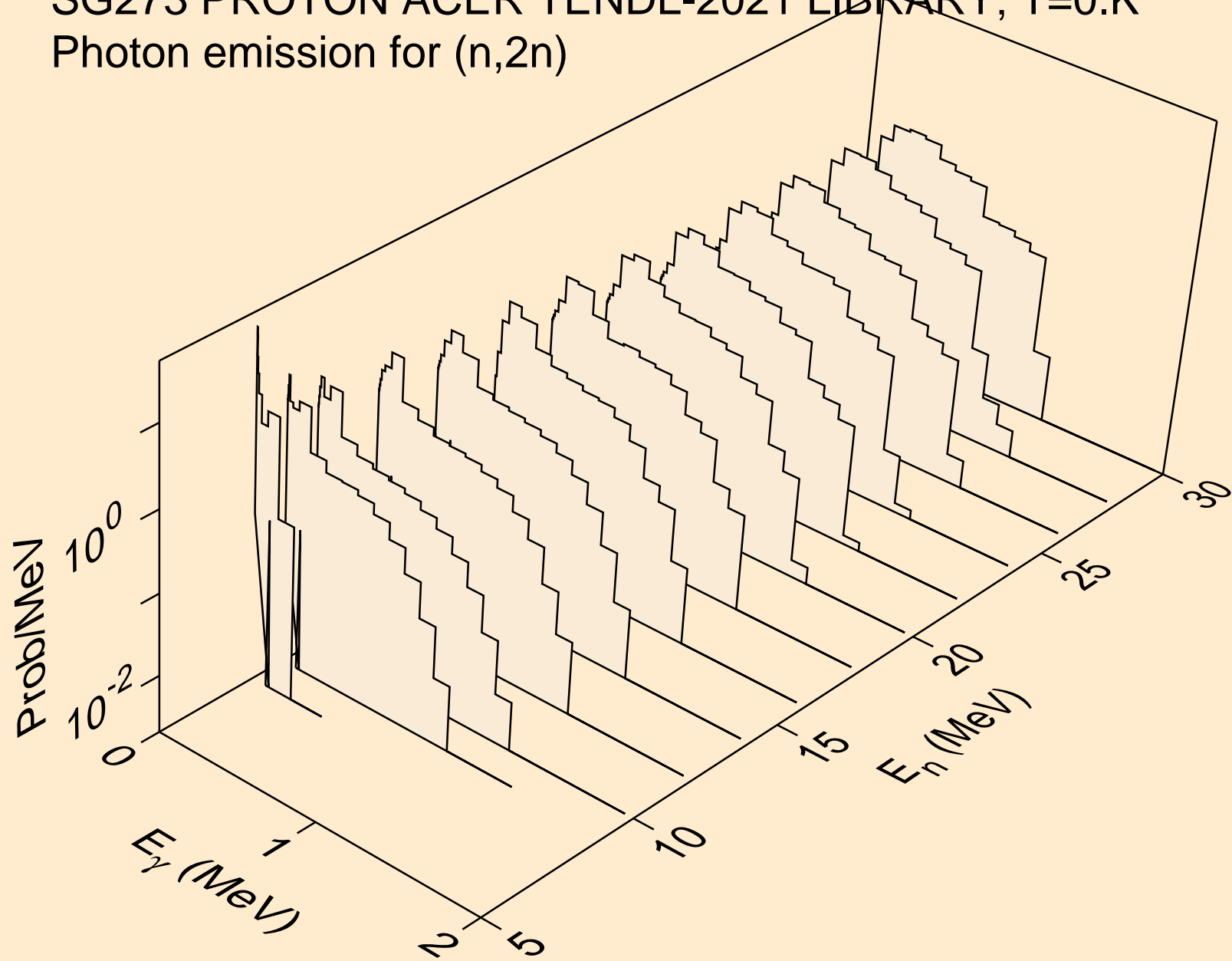

SG273 PROTON ACER TENDL-2021 LIBRARY; T=0.K
Photon emission for (n,3n)

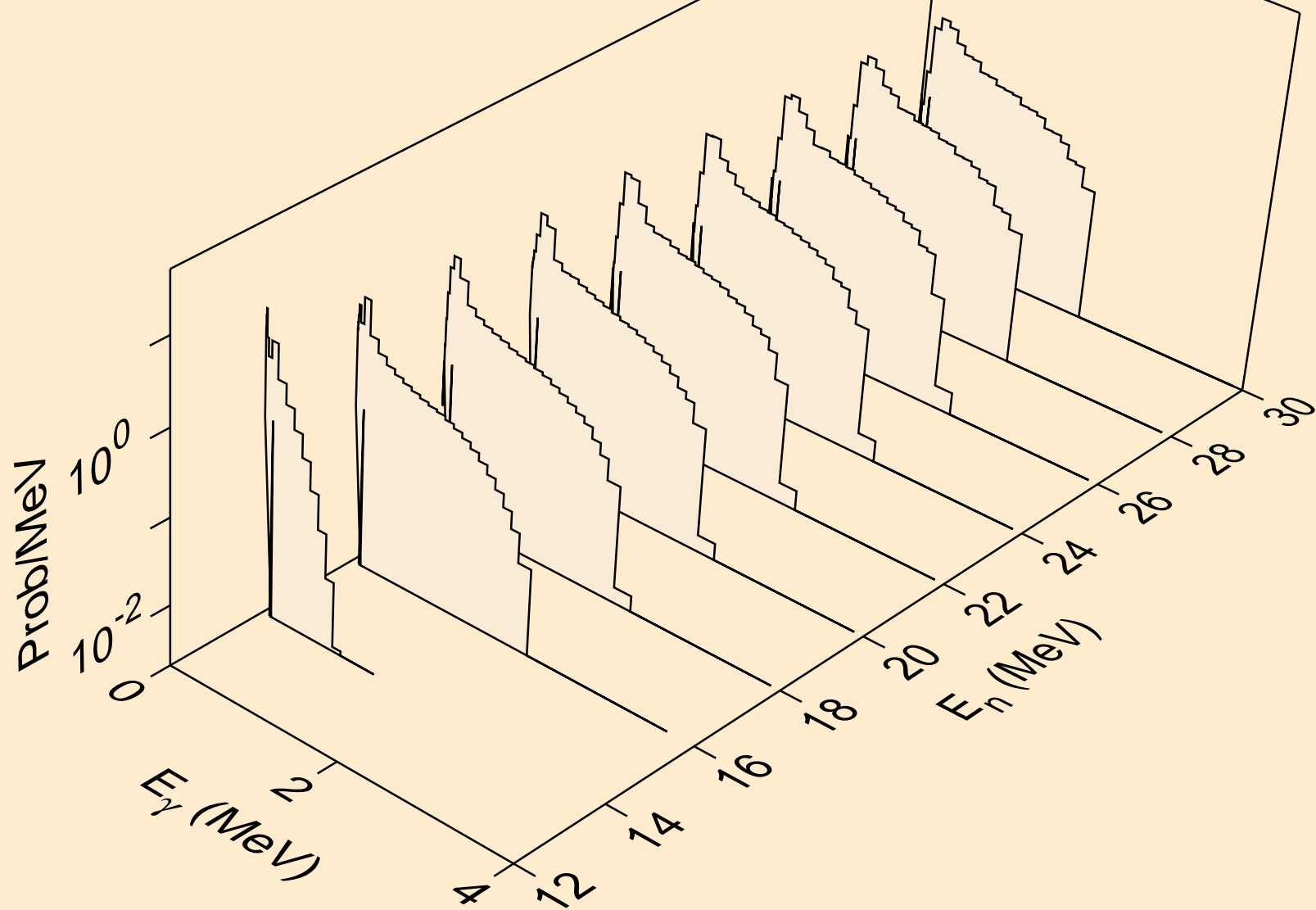

SG273 PROTON ACER TENDL-2021 LIBRARY; T=0.K
Photon emission for (n,2n)a

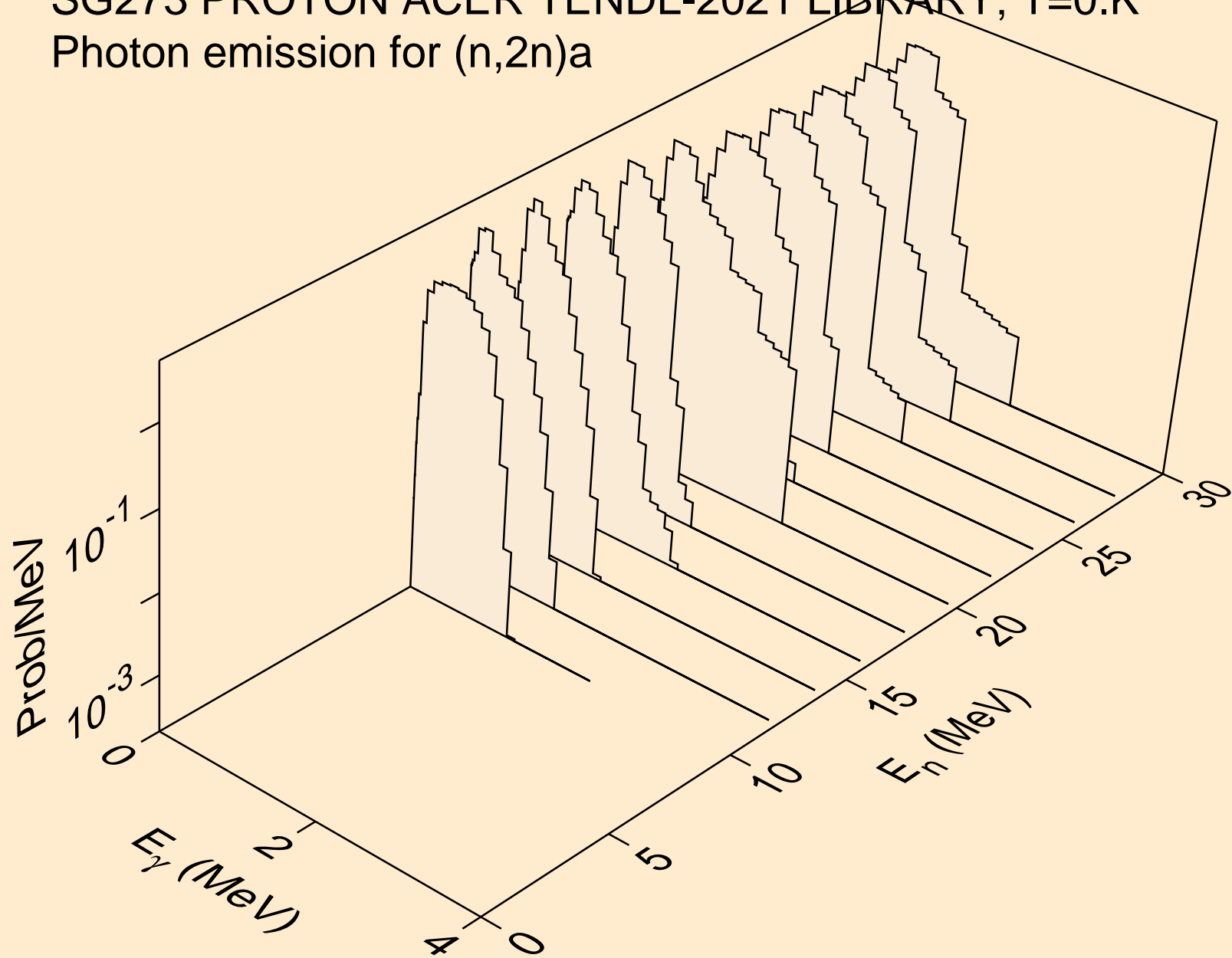

SG273 PROTON ACER TENDL-2021 LIBRARY; T=0.K
Photon emission for (n,n*)p

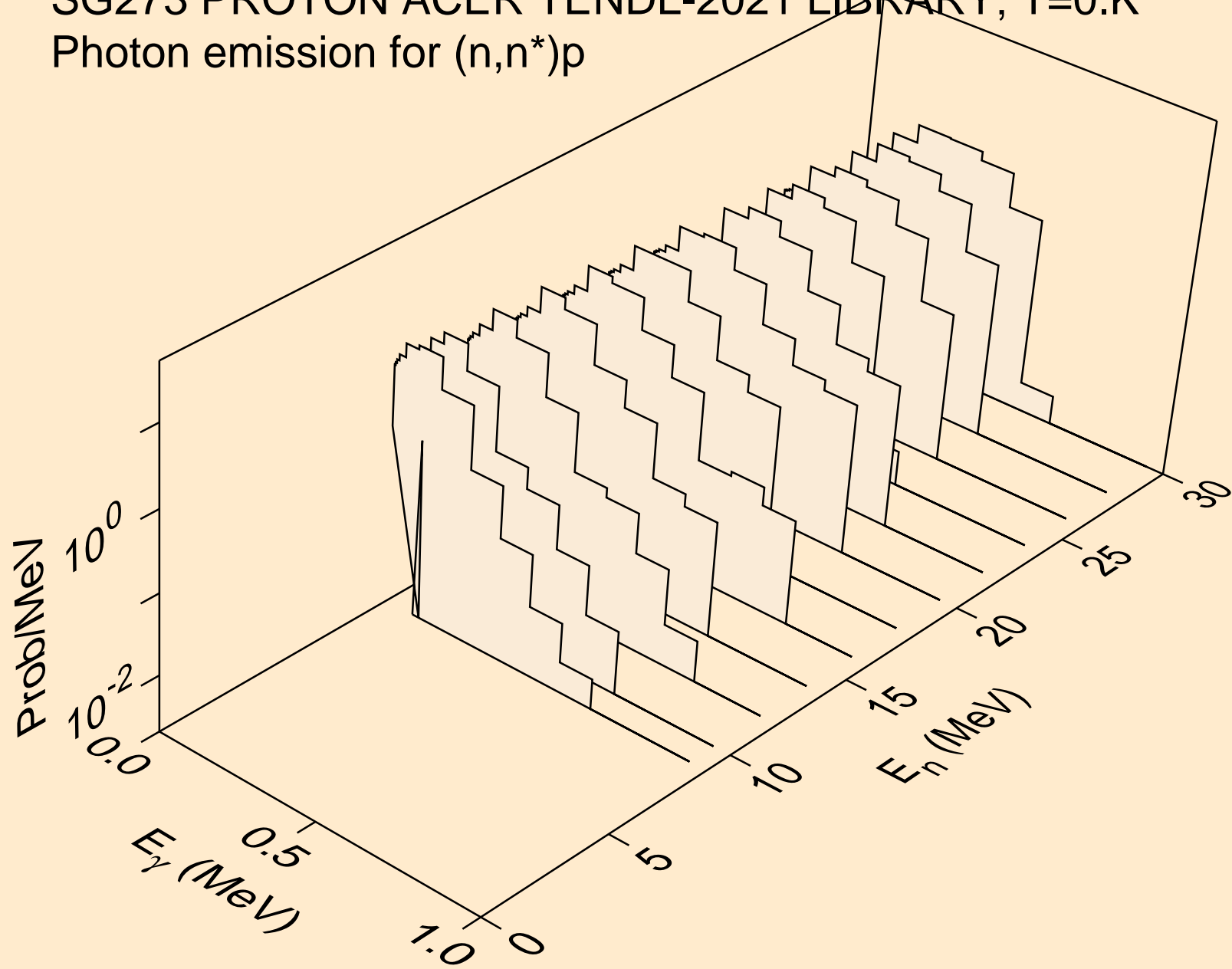

SG273 PROTON ACER TENDL-2021 LIBRARY; T=0.K
Photon emission for (n,4n)

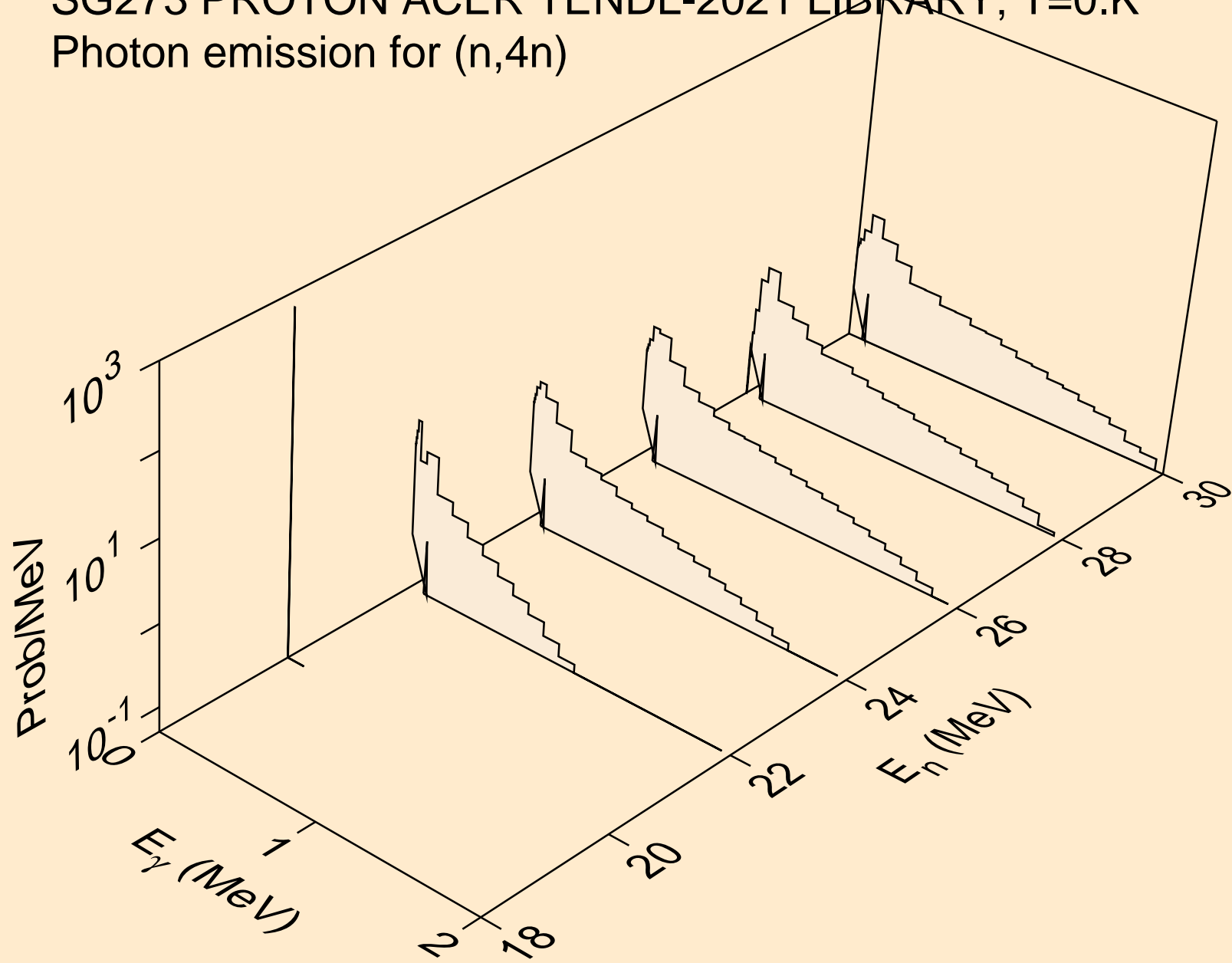

SG273 PROTON ACER TENDL-2021 LIBRARY; T=0.K
Photon emission for (n,gma)

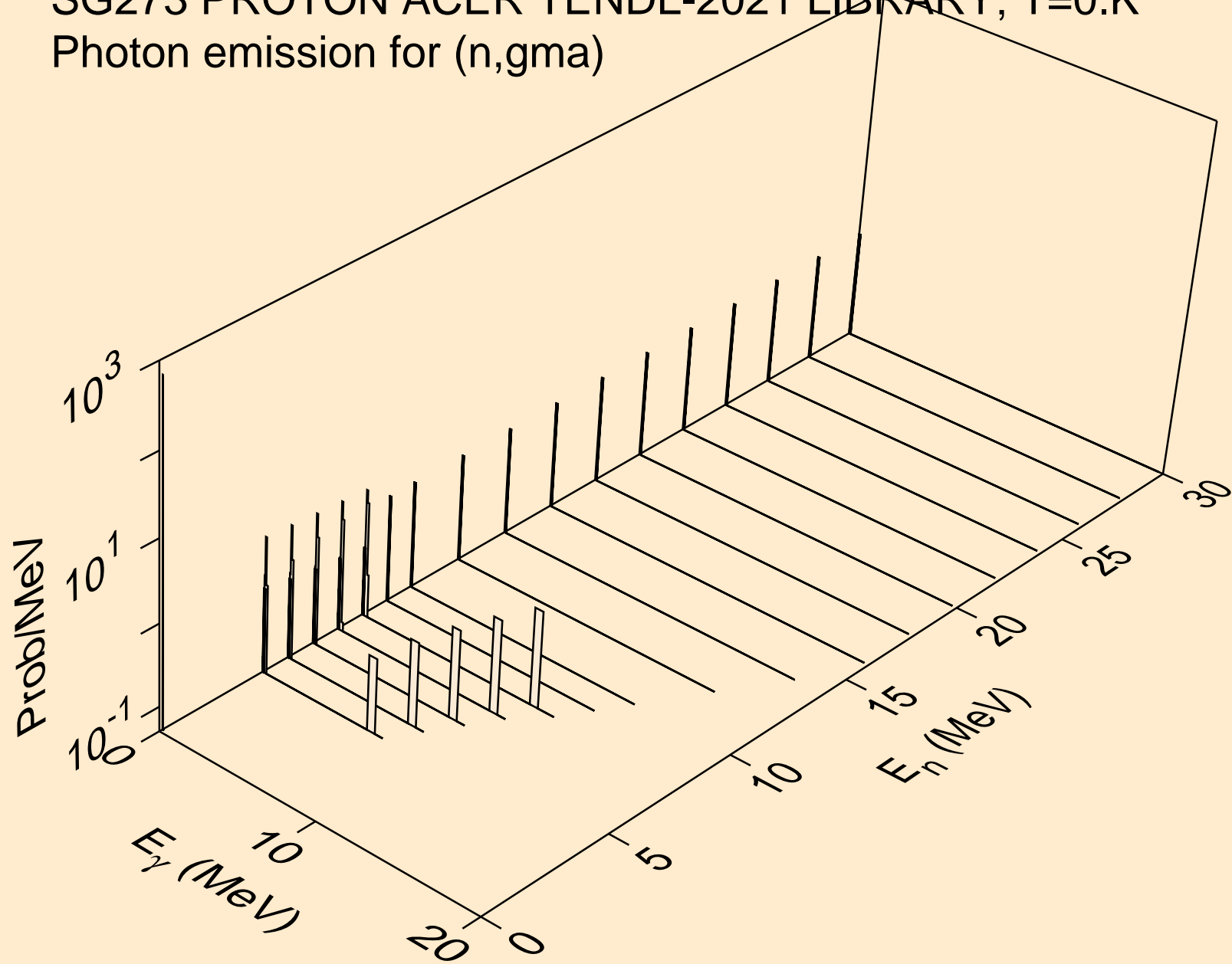

SG273 PROTON ACER TENDL-2021 LIBRARY; T=0.K
Photon emission for inelastic

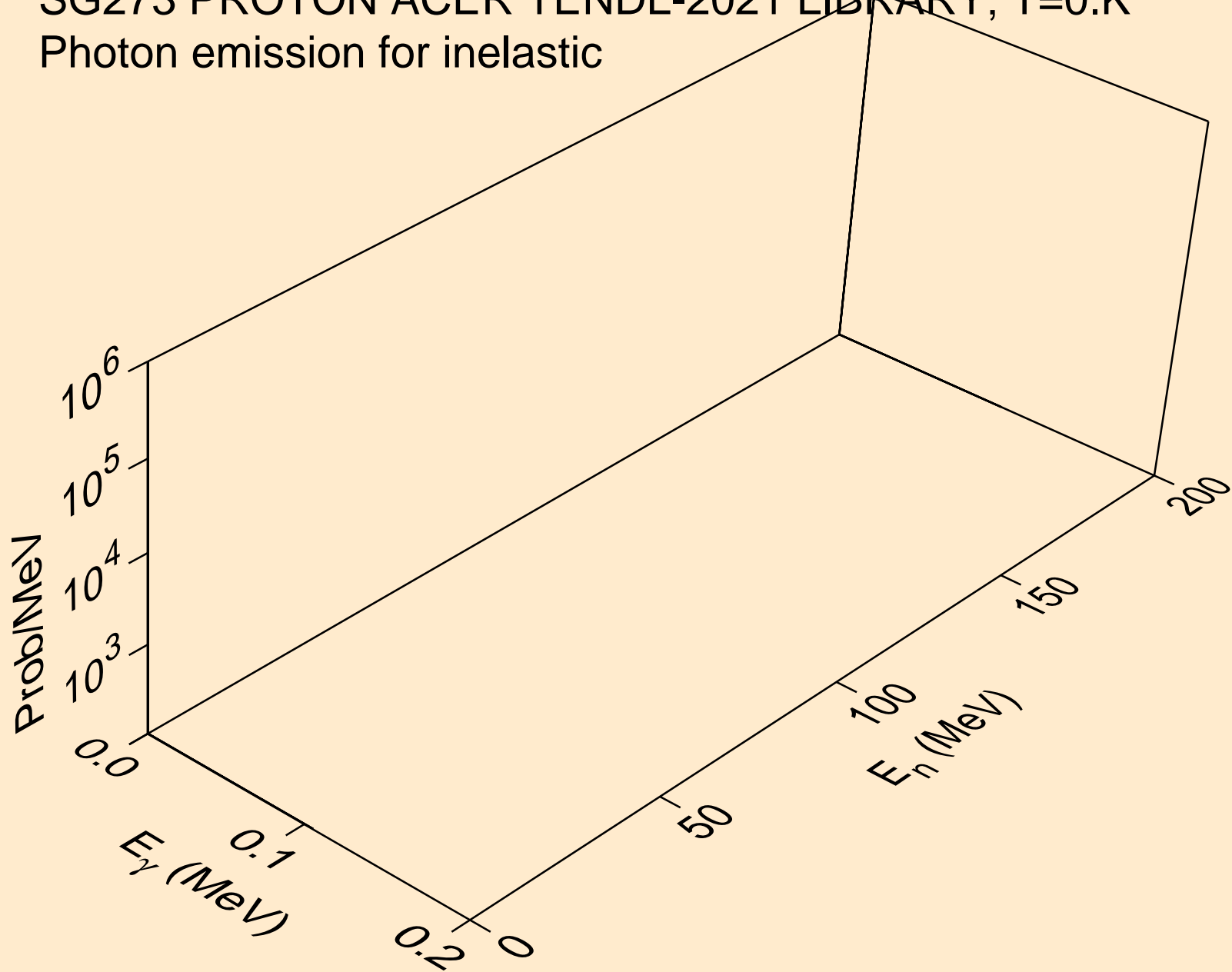

SG273 PROTON ACER TENDL-2021 LIBRARY; T=0.K
Photon emission for (n,d)

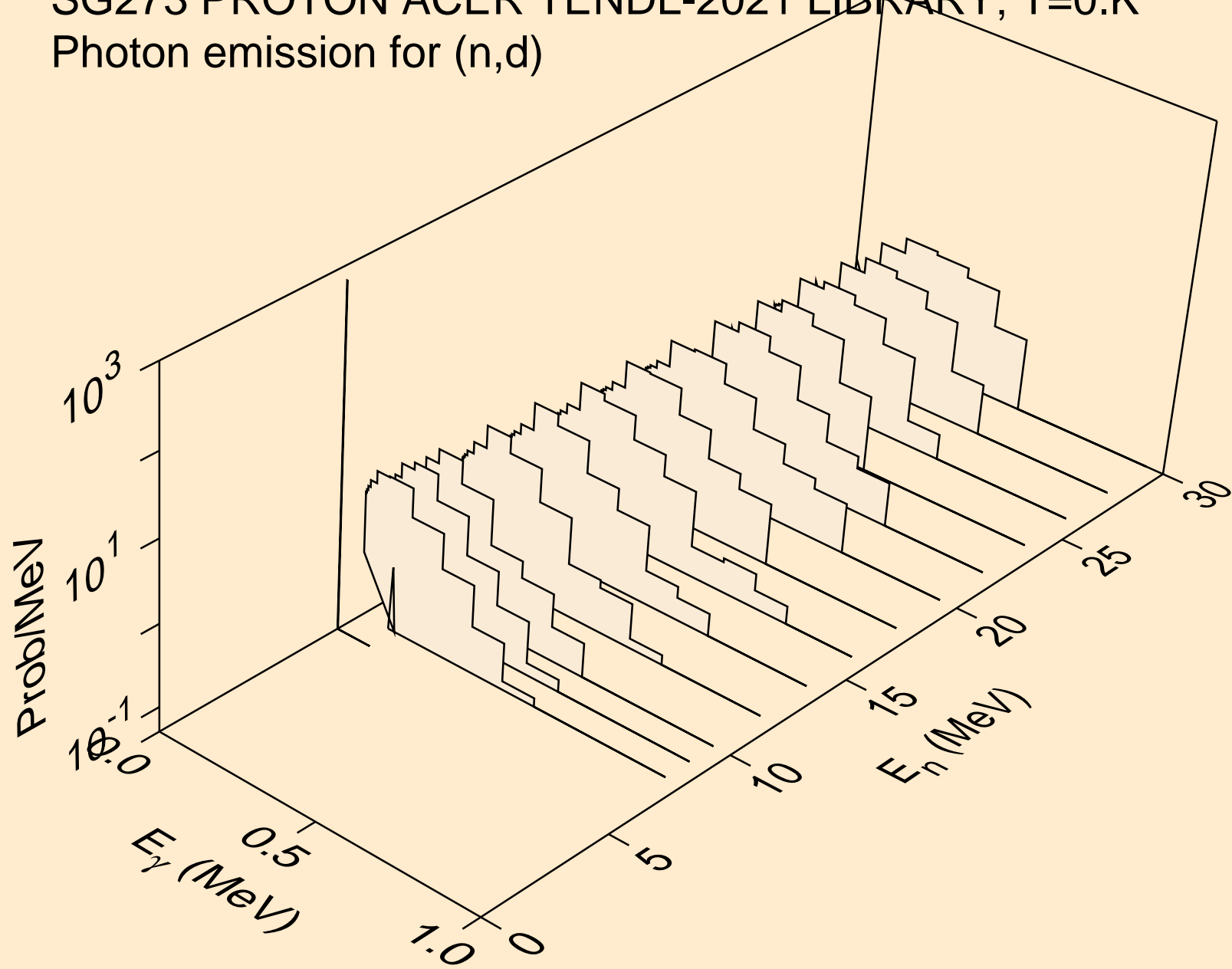

SG273 PROTON ACER TENDL-2021 LIBRARY; T=0.K
Photon emission for (n,t)

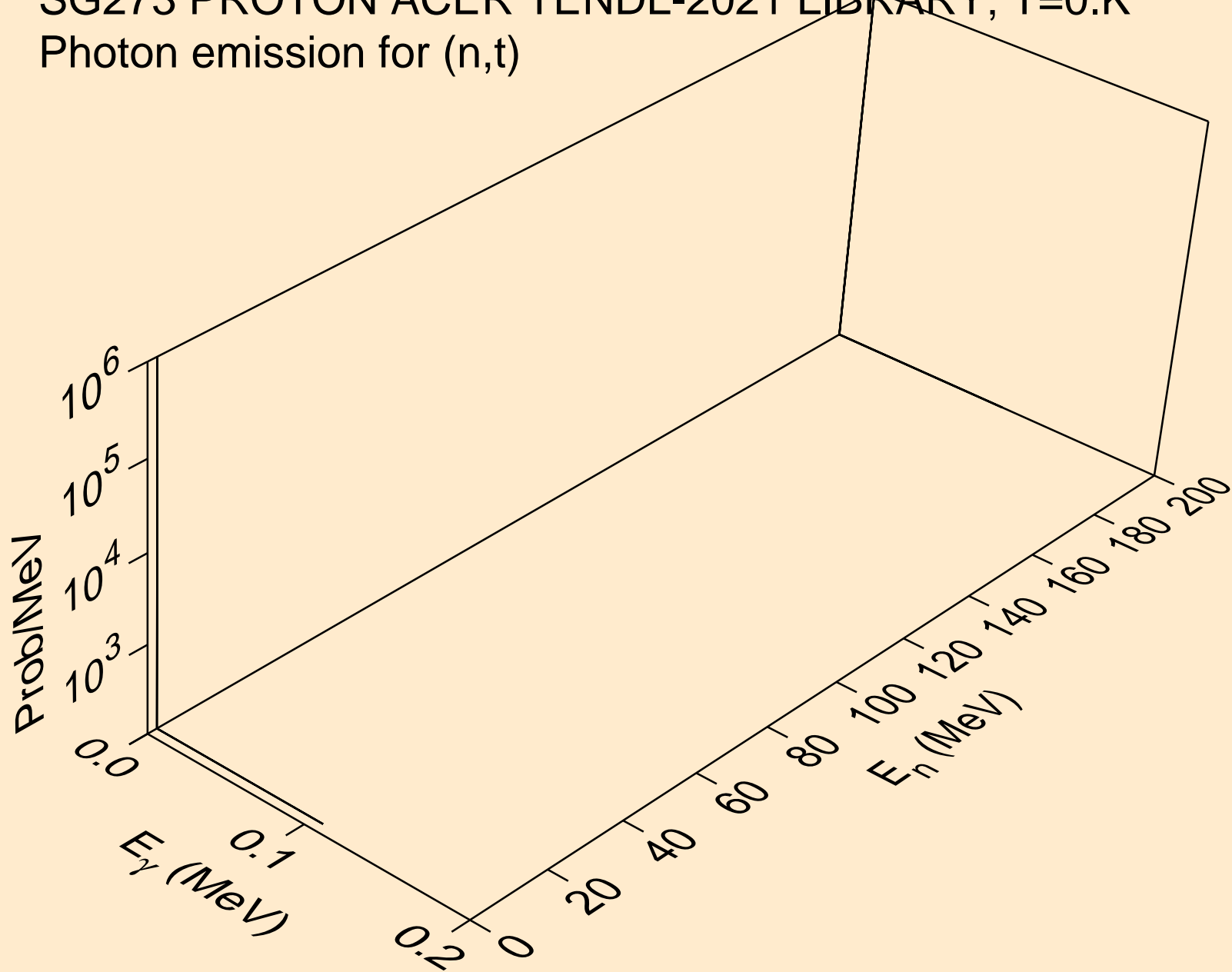

SG273 PROTON ACER TENDL-2021 LIBRARY; T=0.K
Photon emission for (n,he3)

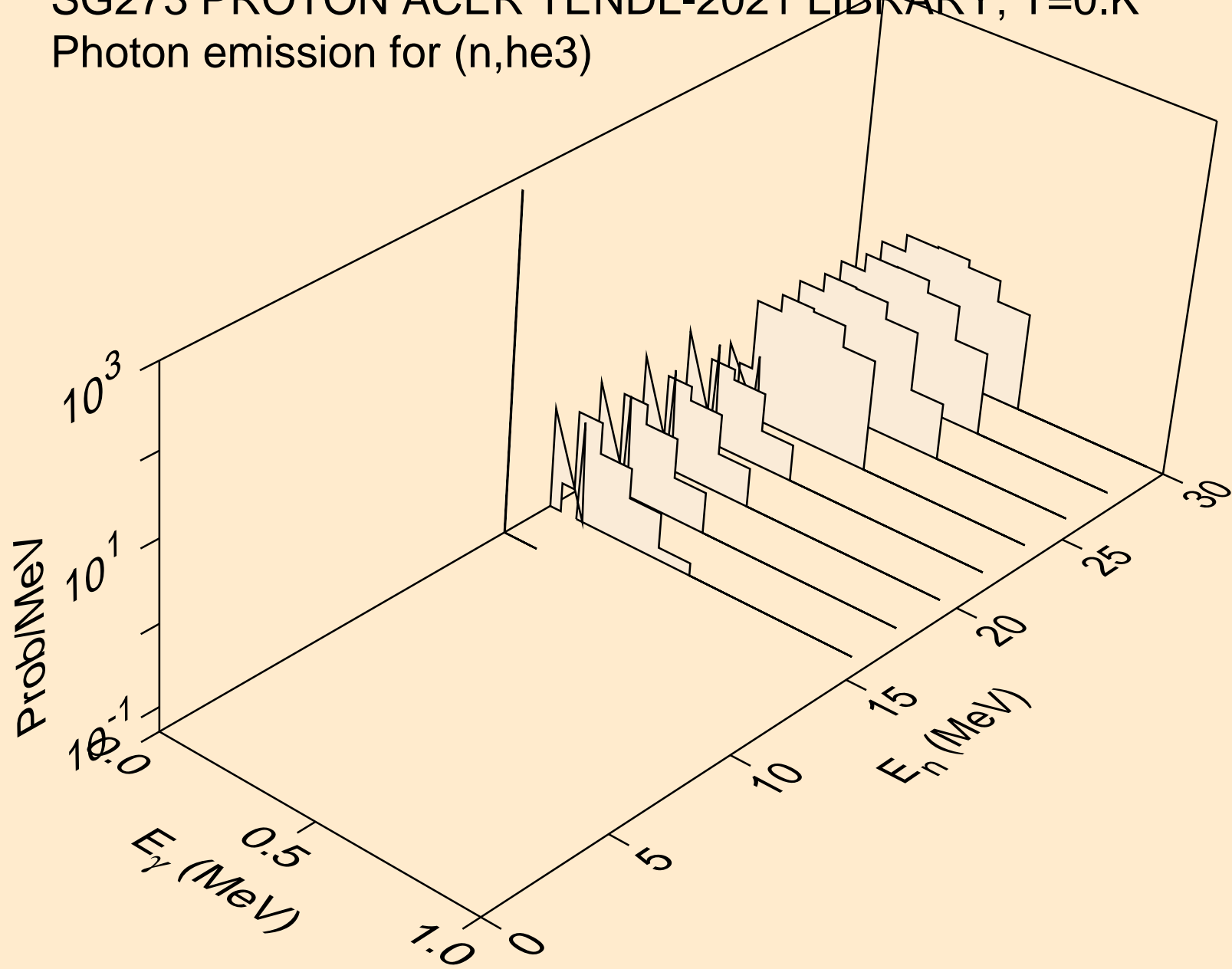

SG273 PROTON ACER TENDL-2021 LIBRARY; T=0.K
Photon emission for (n,a)

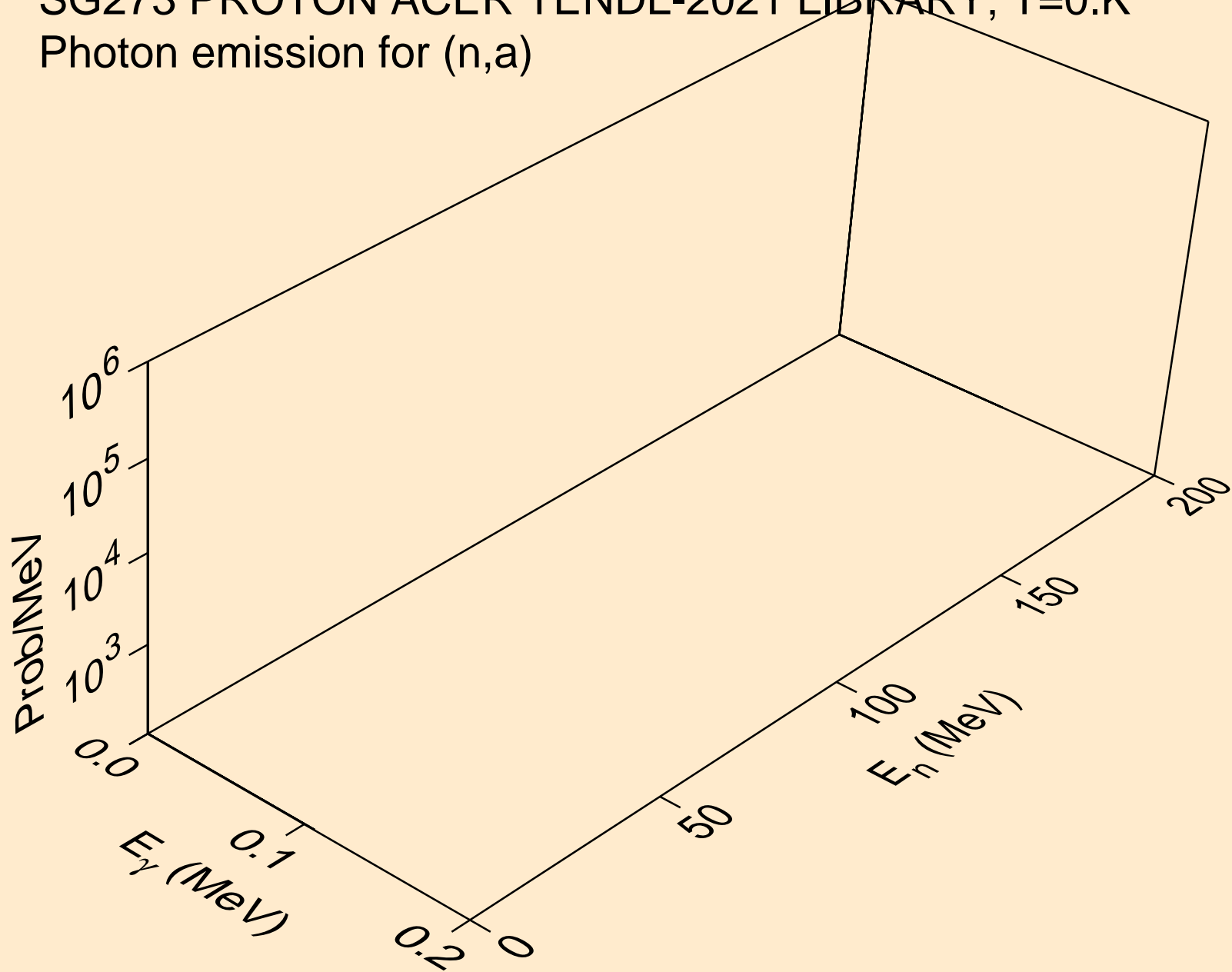

SG273 PROTON ACER TENDL-2021 LIBRARY; T=0.K

Particle heating contributions

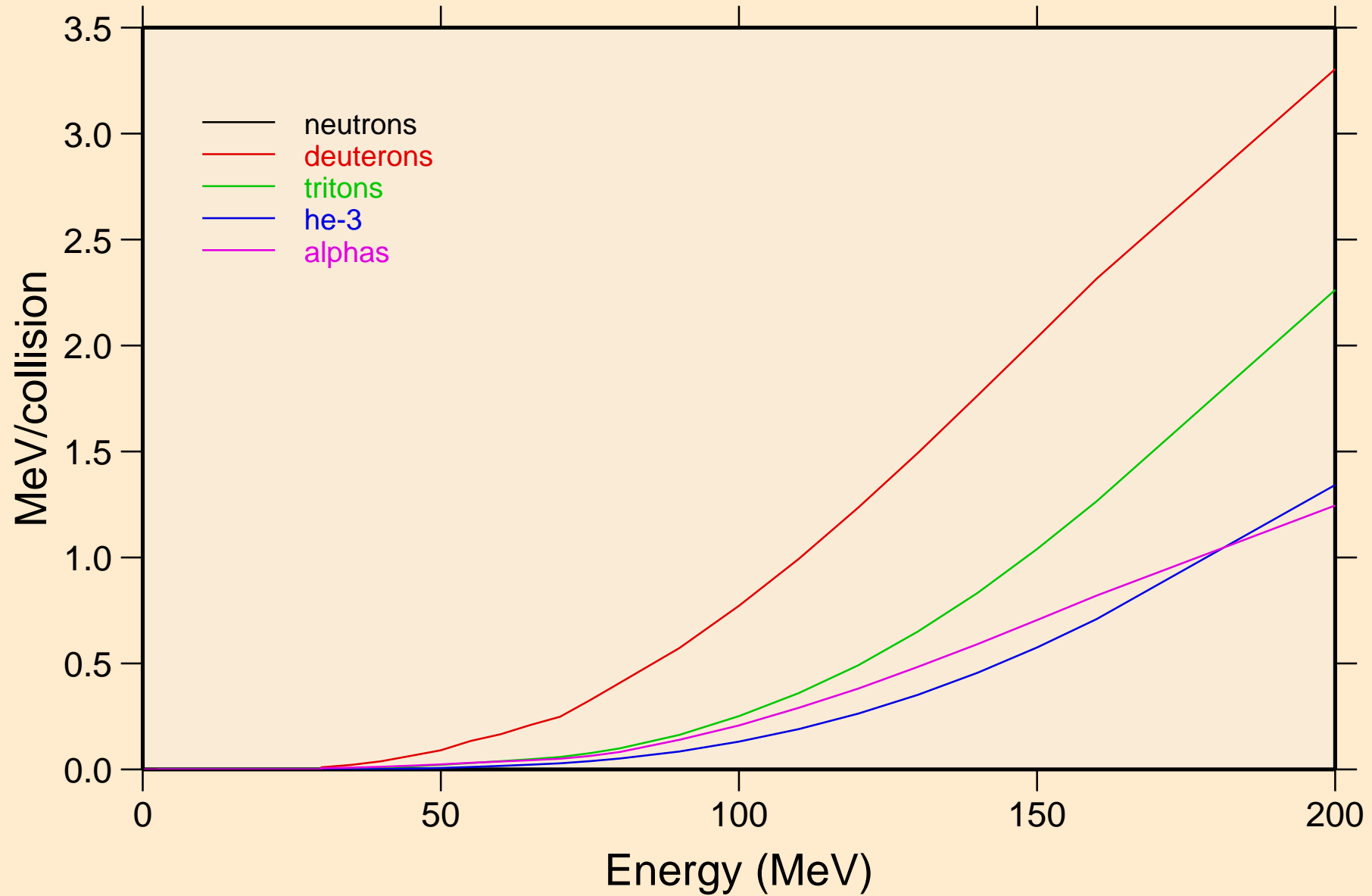

SG273 PROTON ACER TENDL-2021 LIBRARY; T=0.K

Recoil Heating

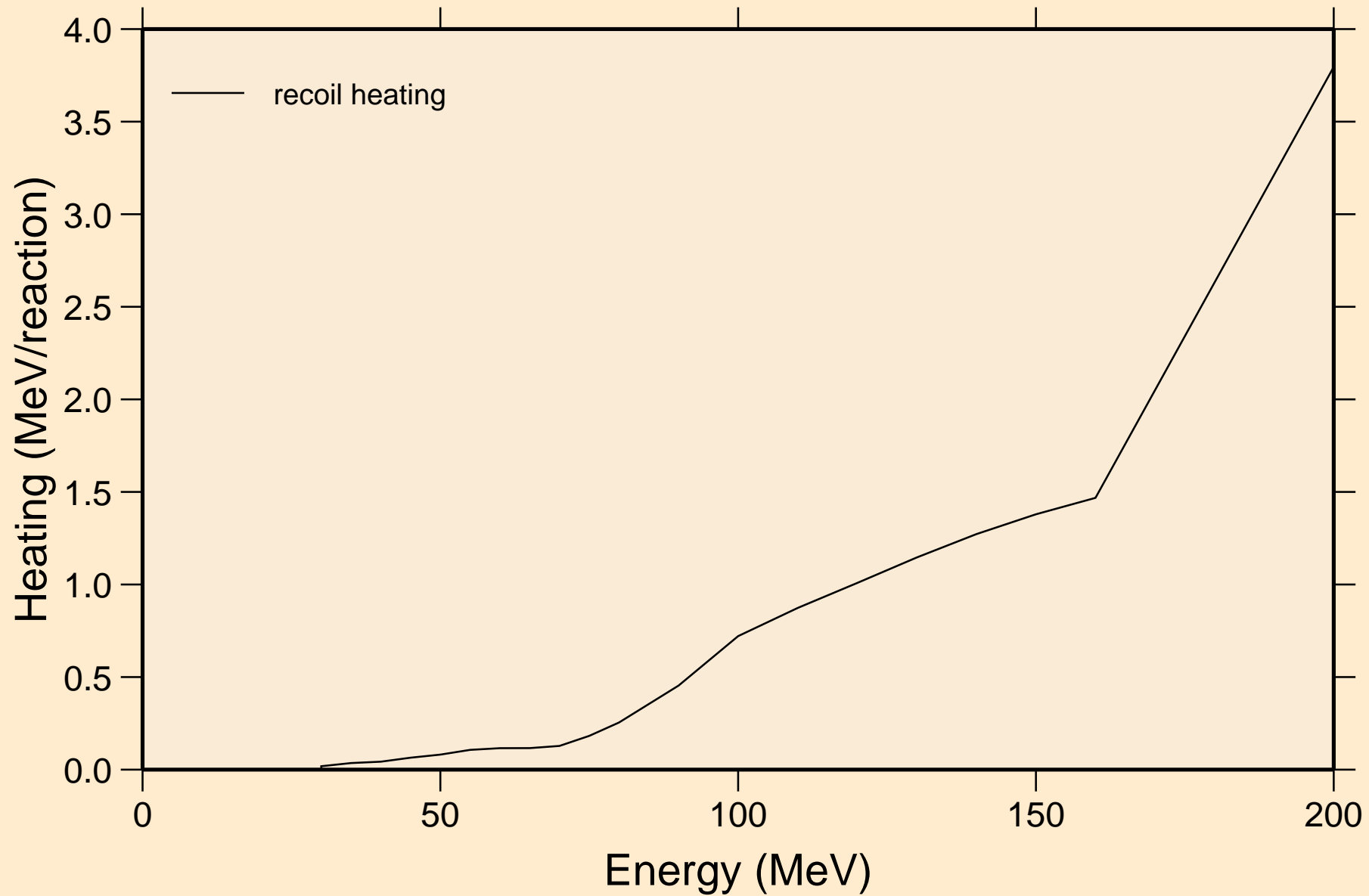

SG273 PROTON ACER TENDL-2021 LIBRARY; T=0.K

Particle production cross sections

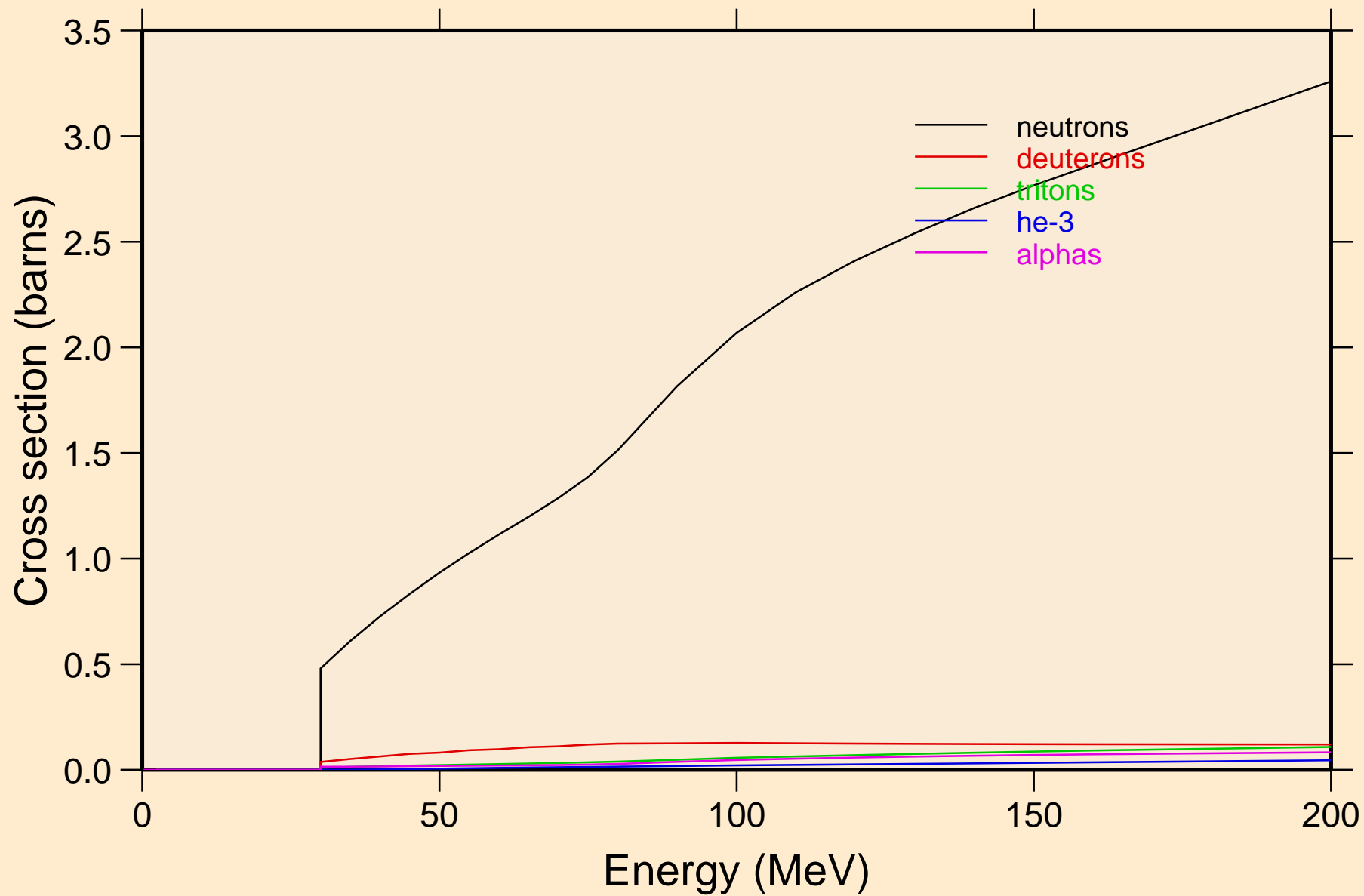

SG273 PROTON ACER TENDL-2021 LIBRARY; T=0.K
neutrons from (p,n)

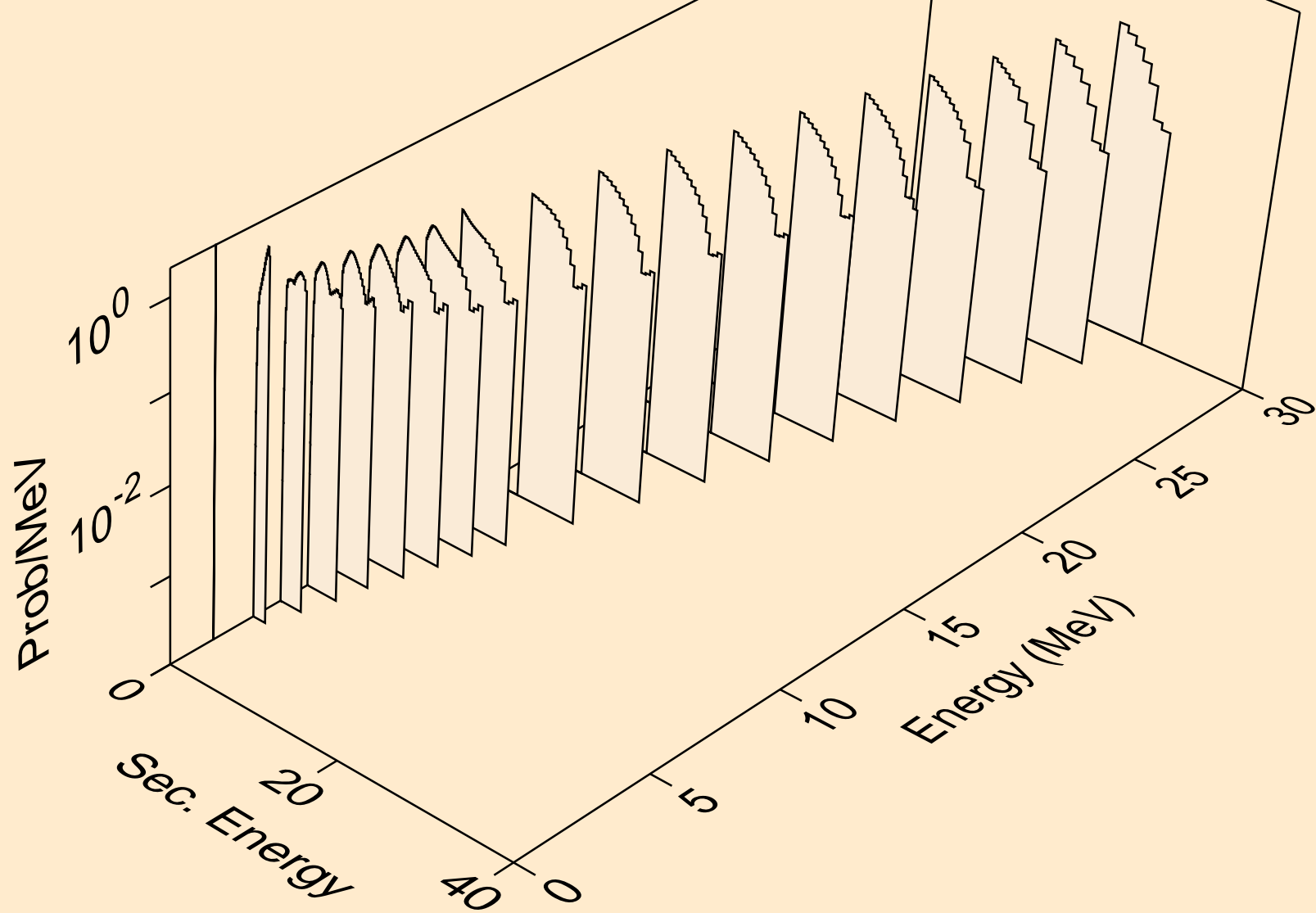

SG273 PROTON ACER TENDL-2021 LIBRARY; T=0.K
neutrons from (p,x)

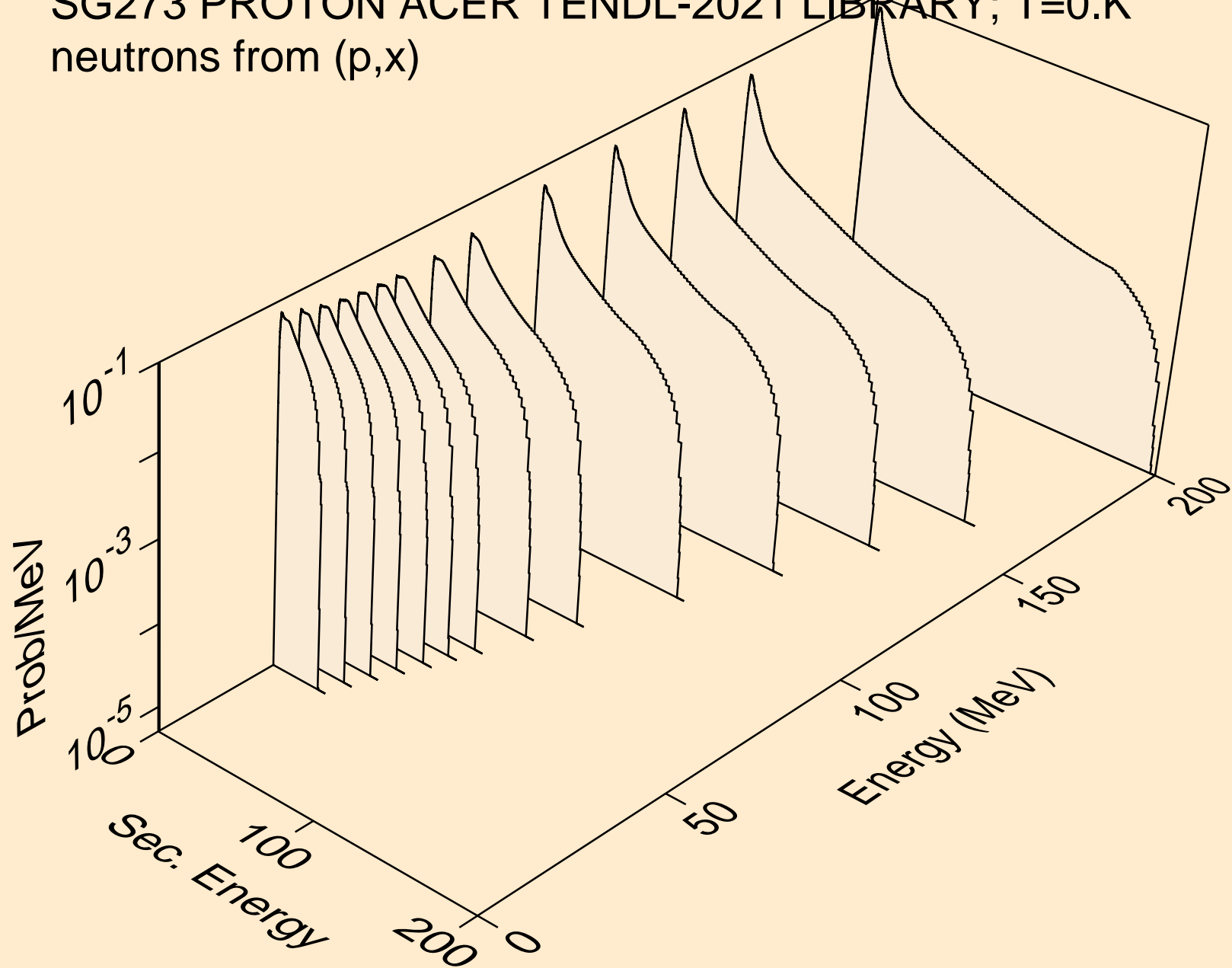

SG273 PROTON ACER TENDL-2021 LIBRARY; T=0.K
neutrons from (p,2n)

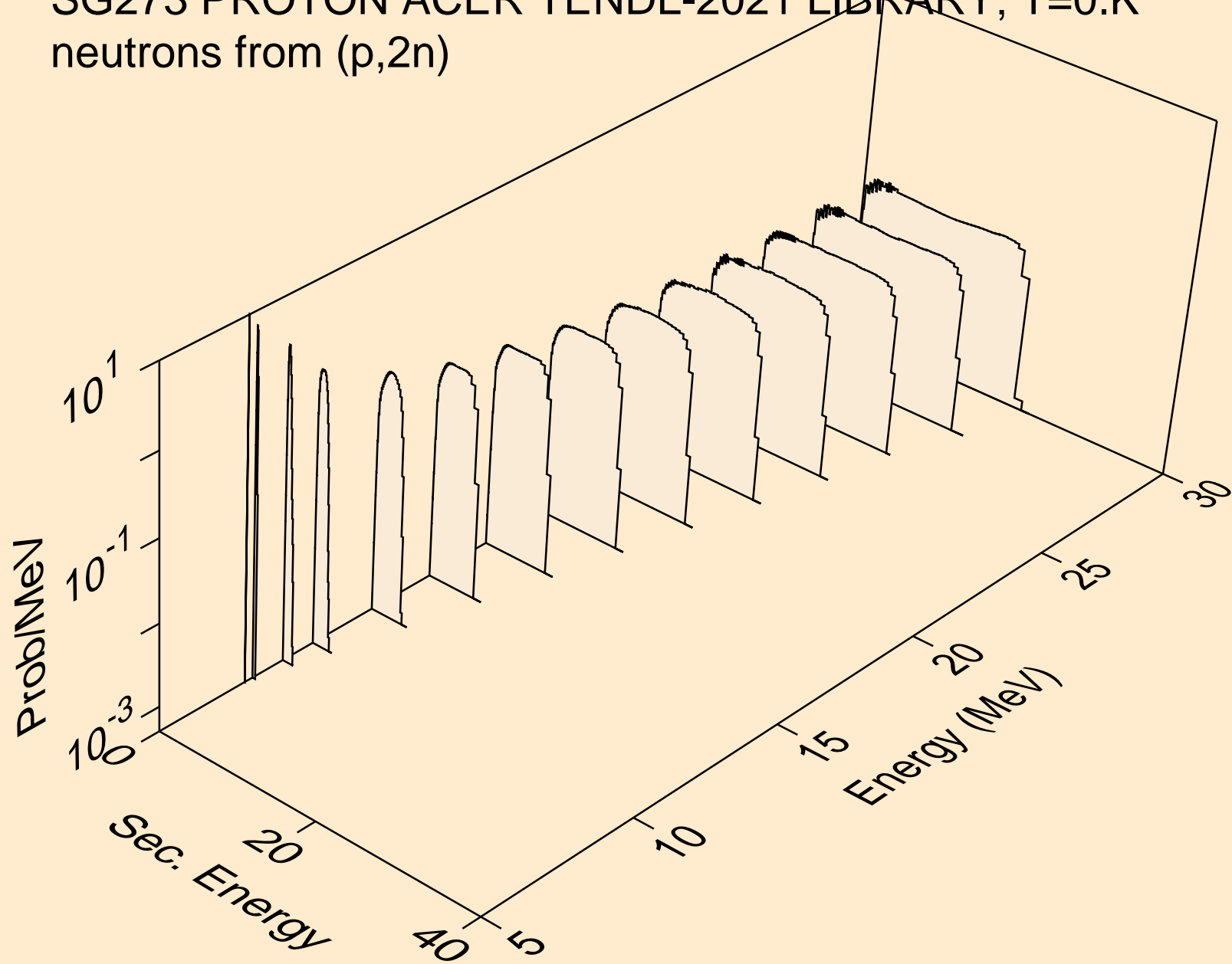

SG273 PROTON ACER TENDL-2021 LIBRARY; T=0.K
neutrons from (p,3n)

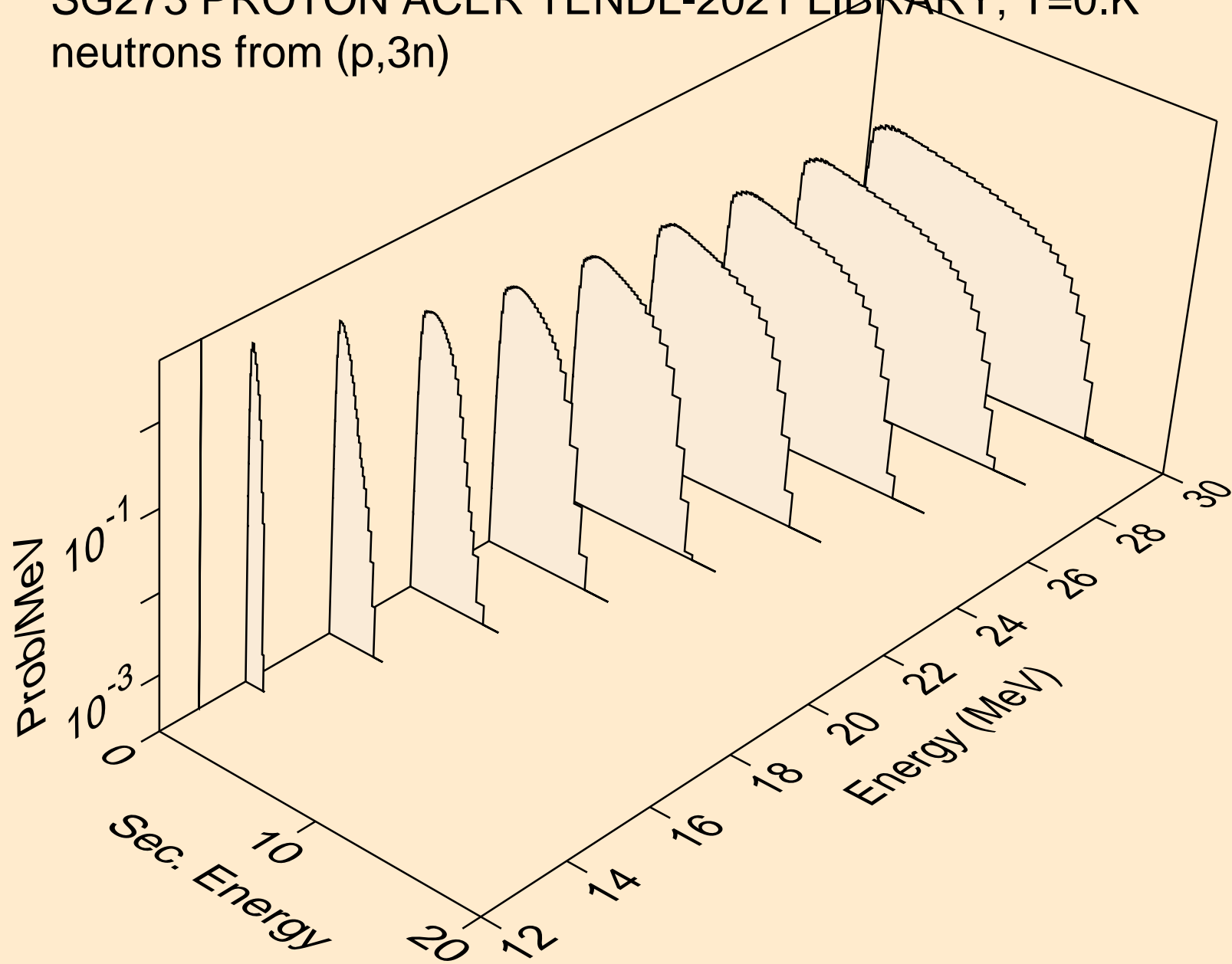

SG273 PROTON ACER TENDL-2021 LIBRARY; T=0.K
neutrons from (p,2n)a

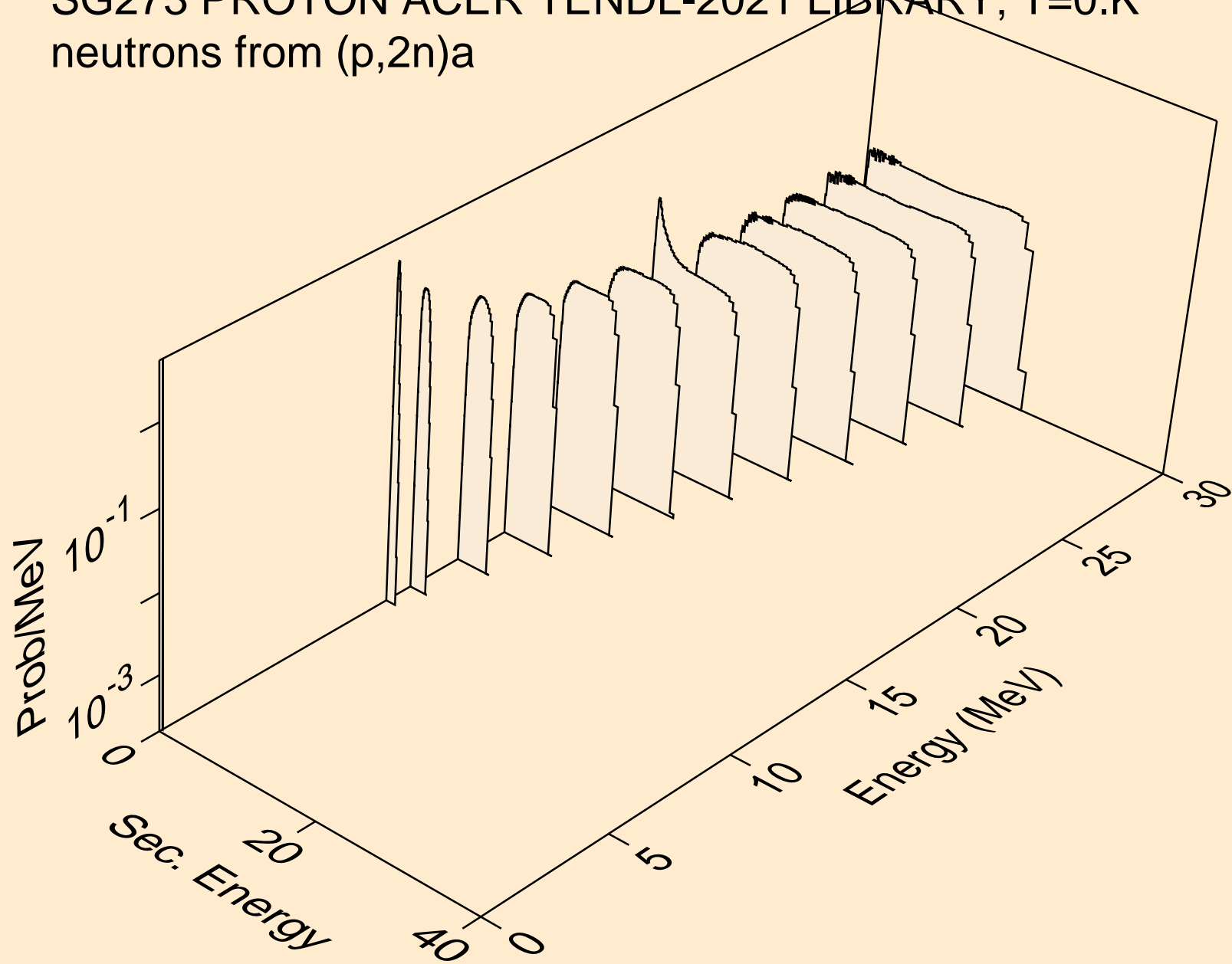

SG273 PROTON ACER TENDL-2021 LIBRARY; T=0.K
neutrons from (p,n*)p

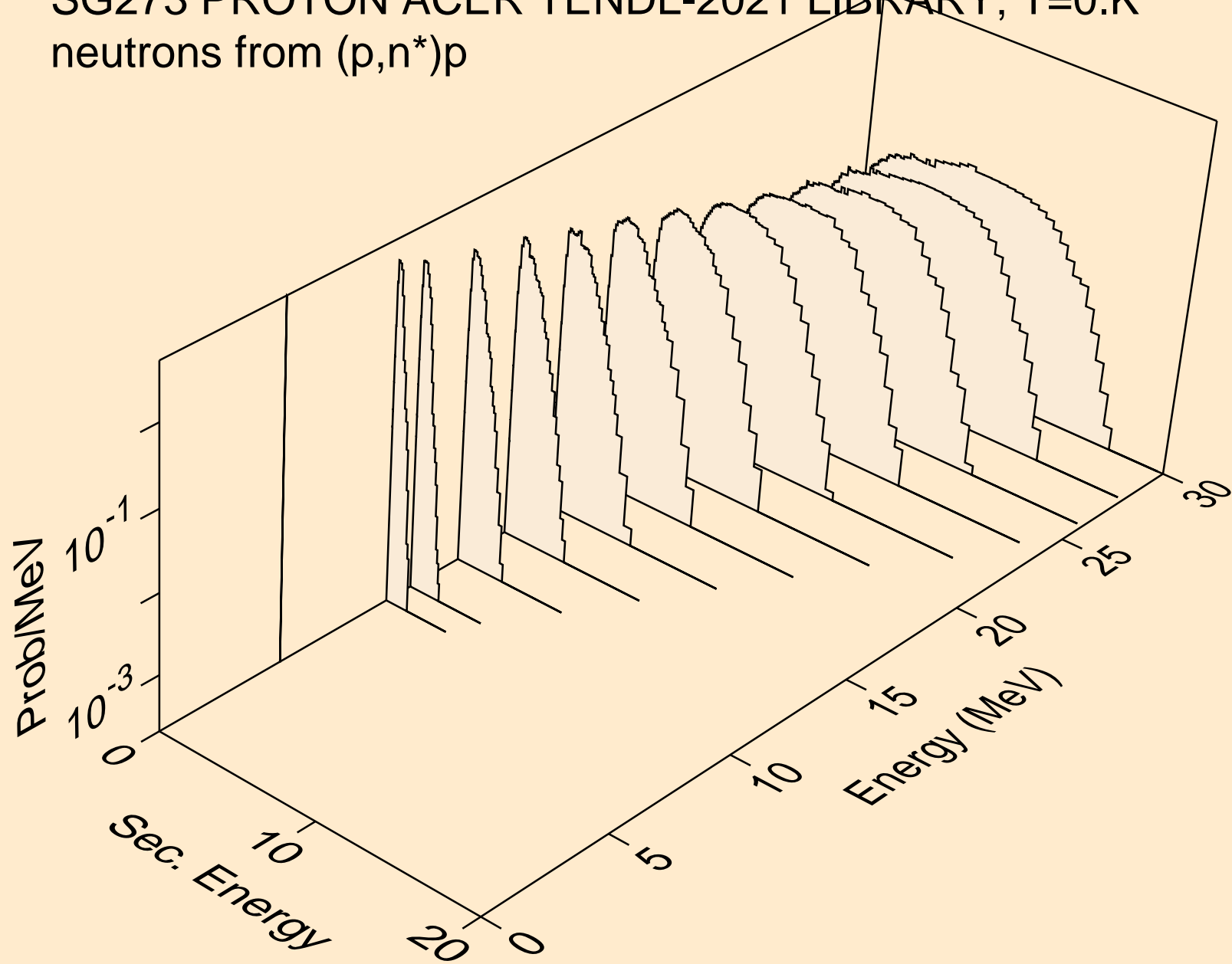

SG273 PROTON ACER TENDL-2021 LIBRARY; T=0.K
neutrons from (p,4n)

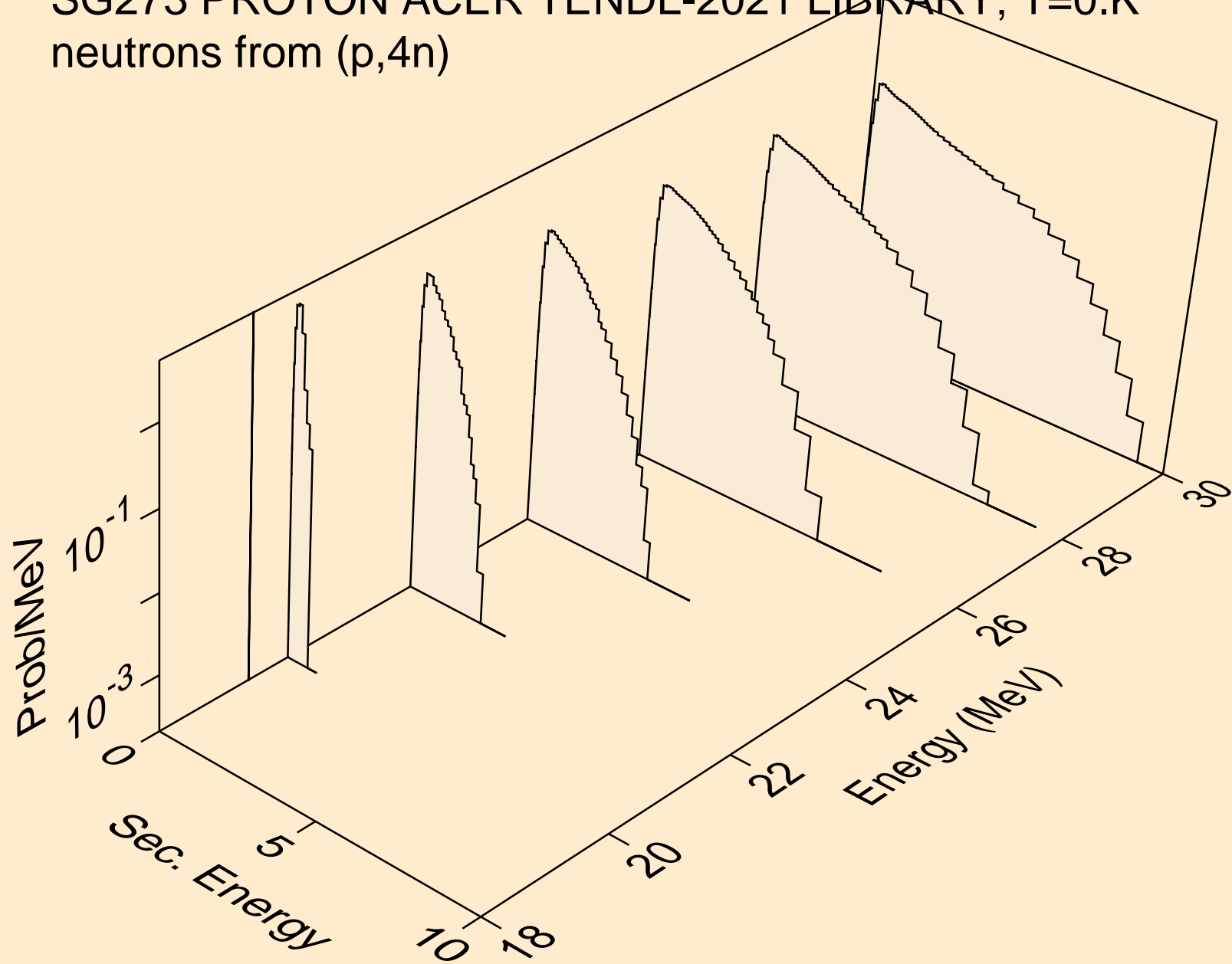

SG273 PROTON ACER TENDL-2021 LIBRARY; T=0.K
deuterons from (p,x)

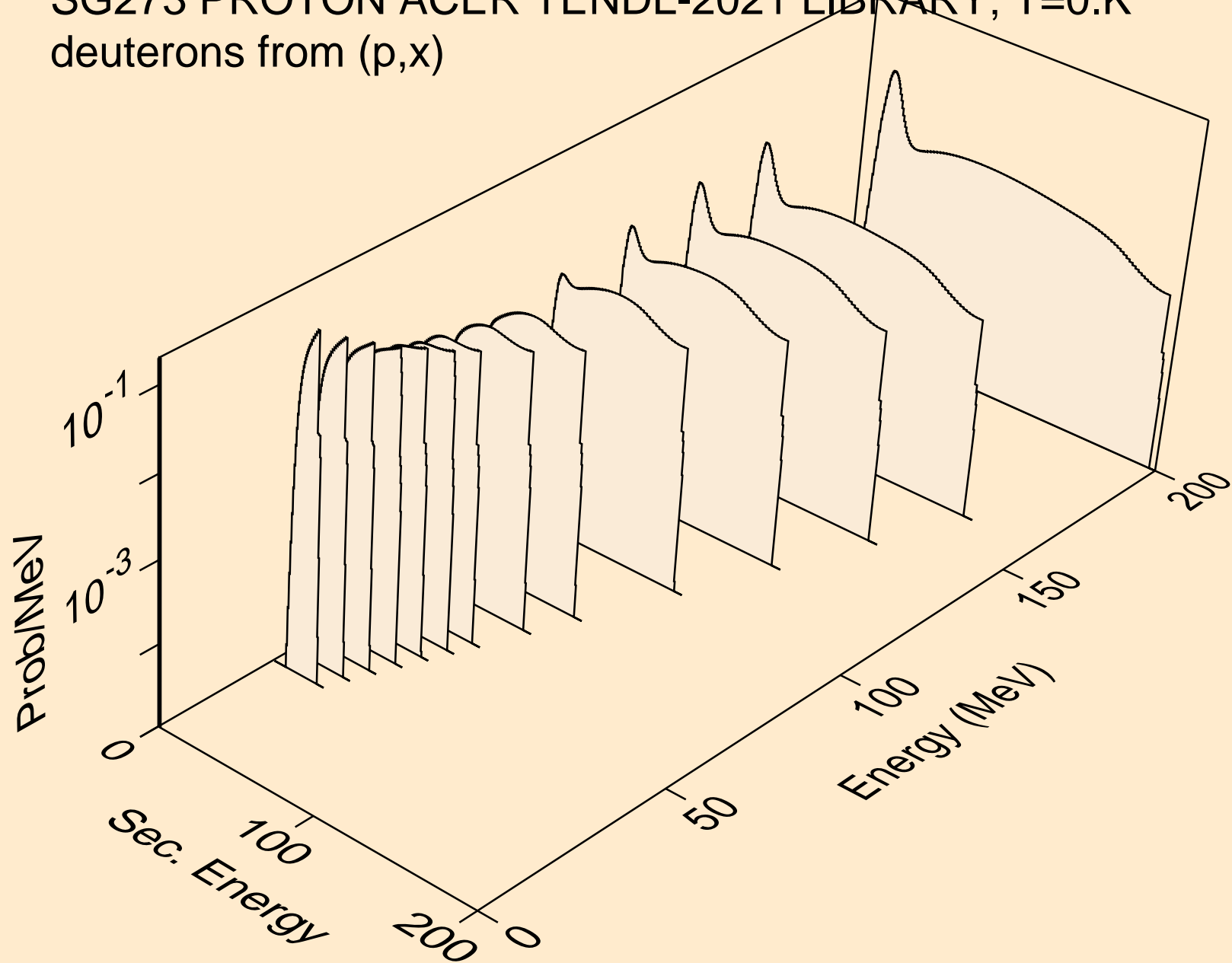

SG273 PROTON ACER TENDL-2021 LIBRARY; T=0.K
deuterons from (p,d)

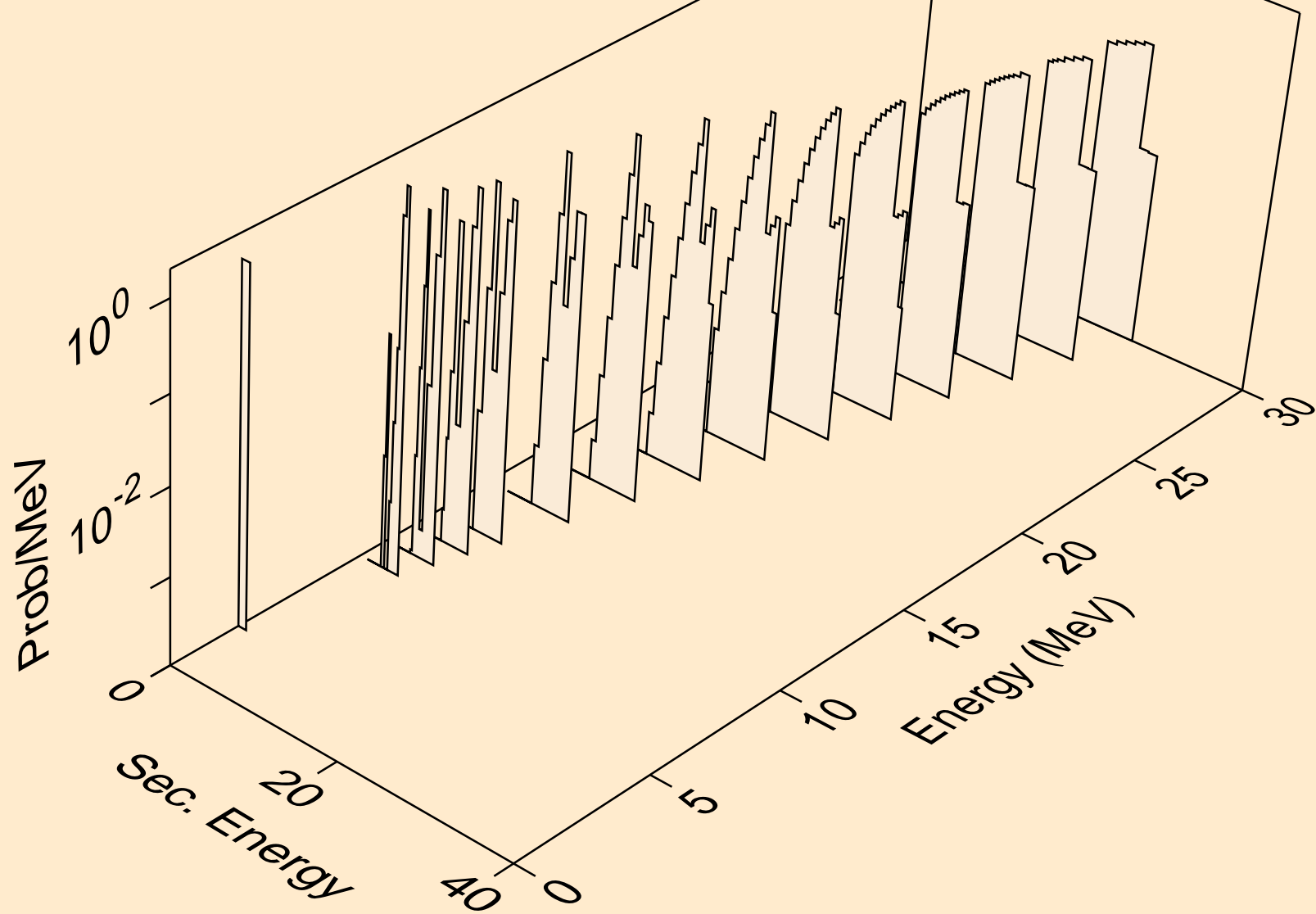

SG273 PROTON ACER TENDL-2021 LIBRARY; T=0.K
tritons from (p,x)

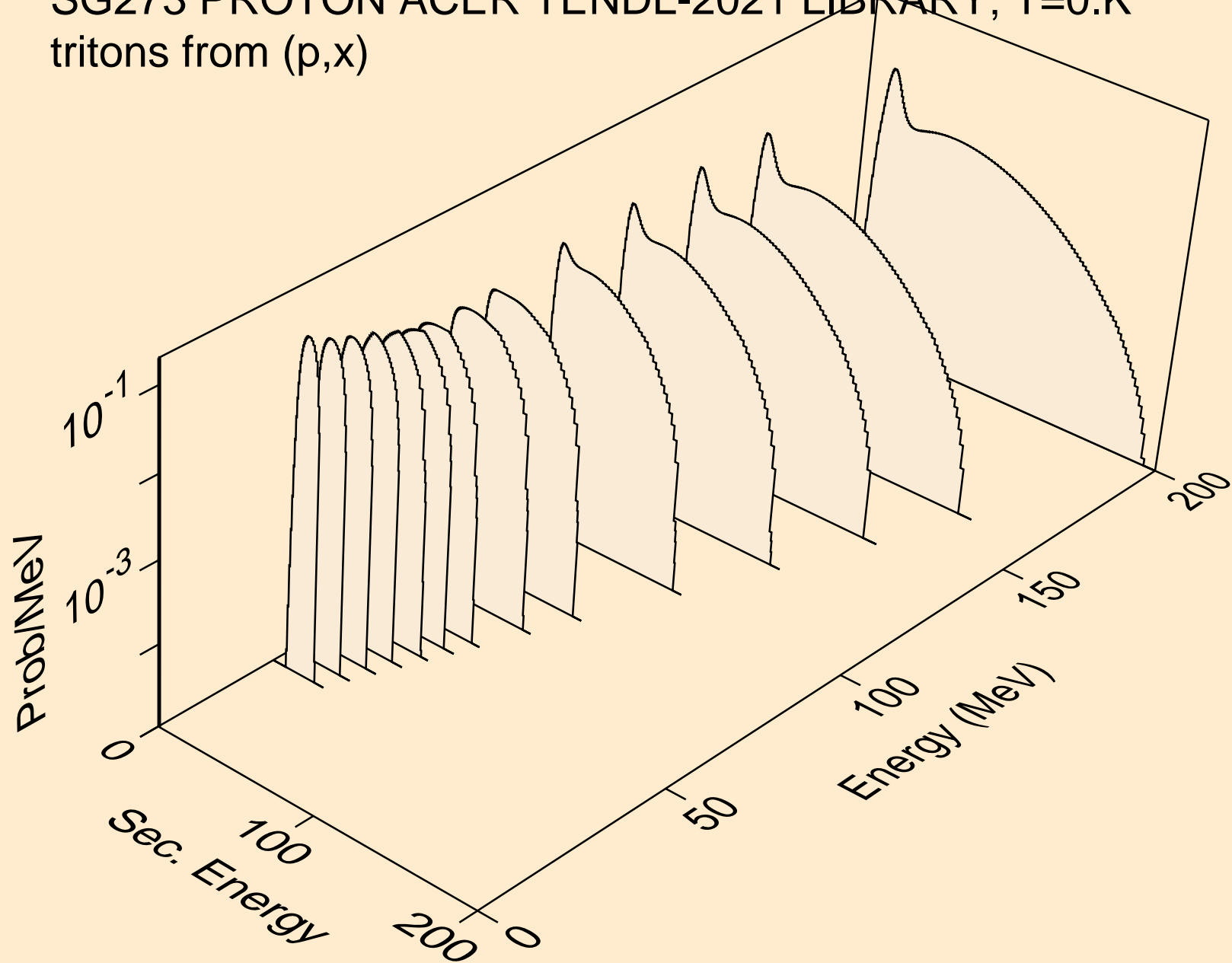

SG273 PROTON ACER TENDL-2021 LIBRARY; T=0.K
tritons from (p,t)

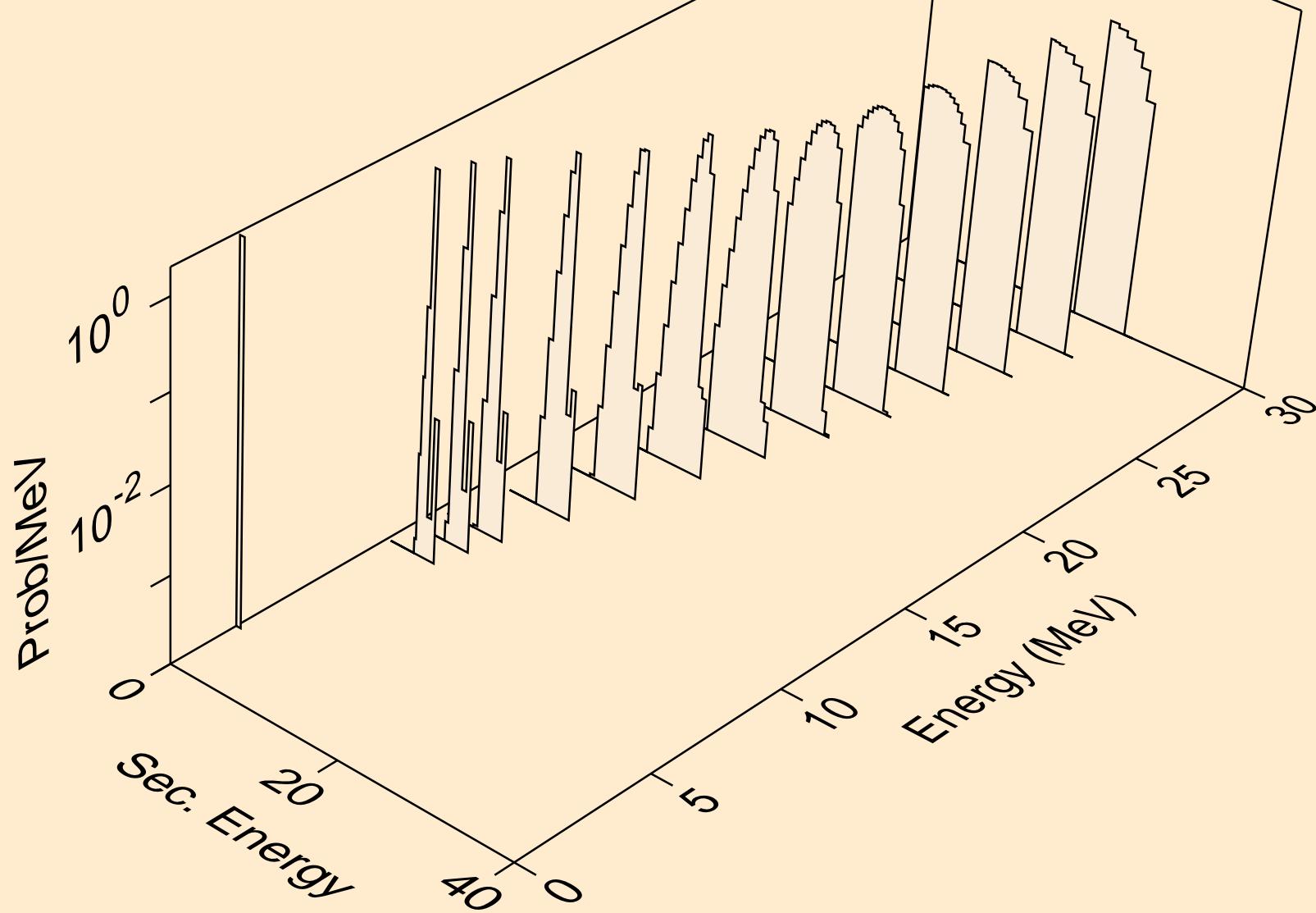

SG273 PROTON ACER TENDL-2021 LIBRARY; T=0.K
he3s from (p,x)

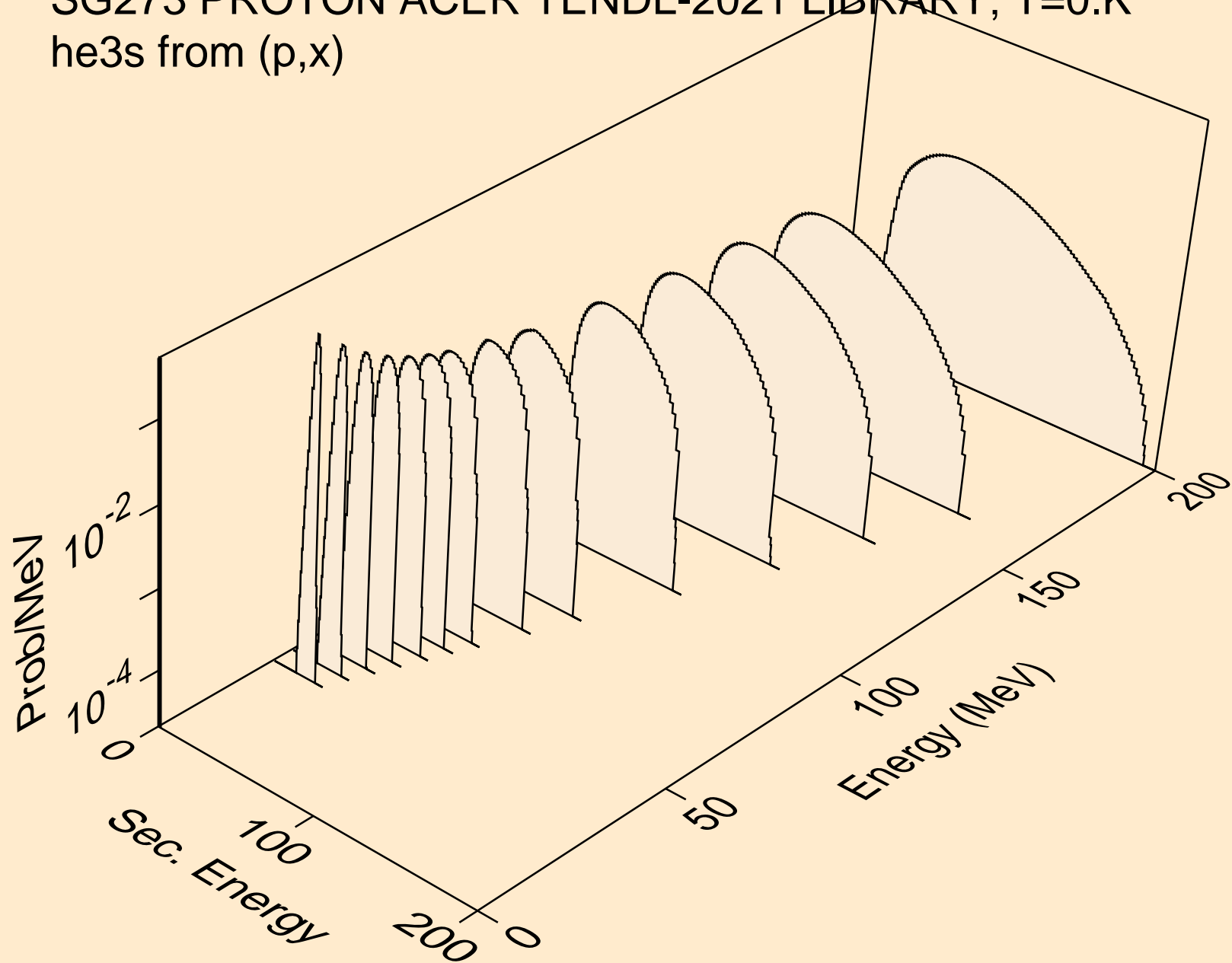

SG273 PROTON ACER TENDL-2021 LIBRARY; T=0.K
he3s from (p,he3)

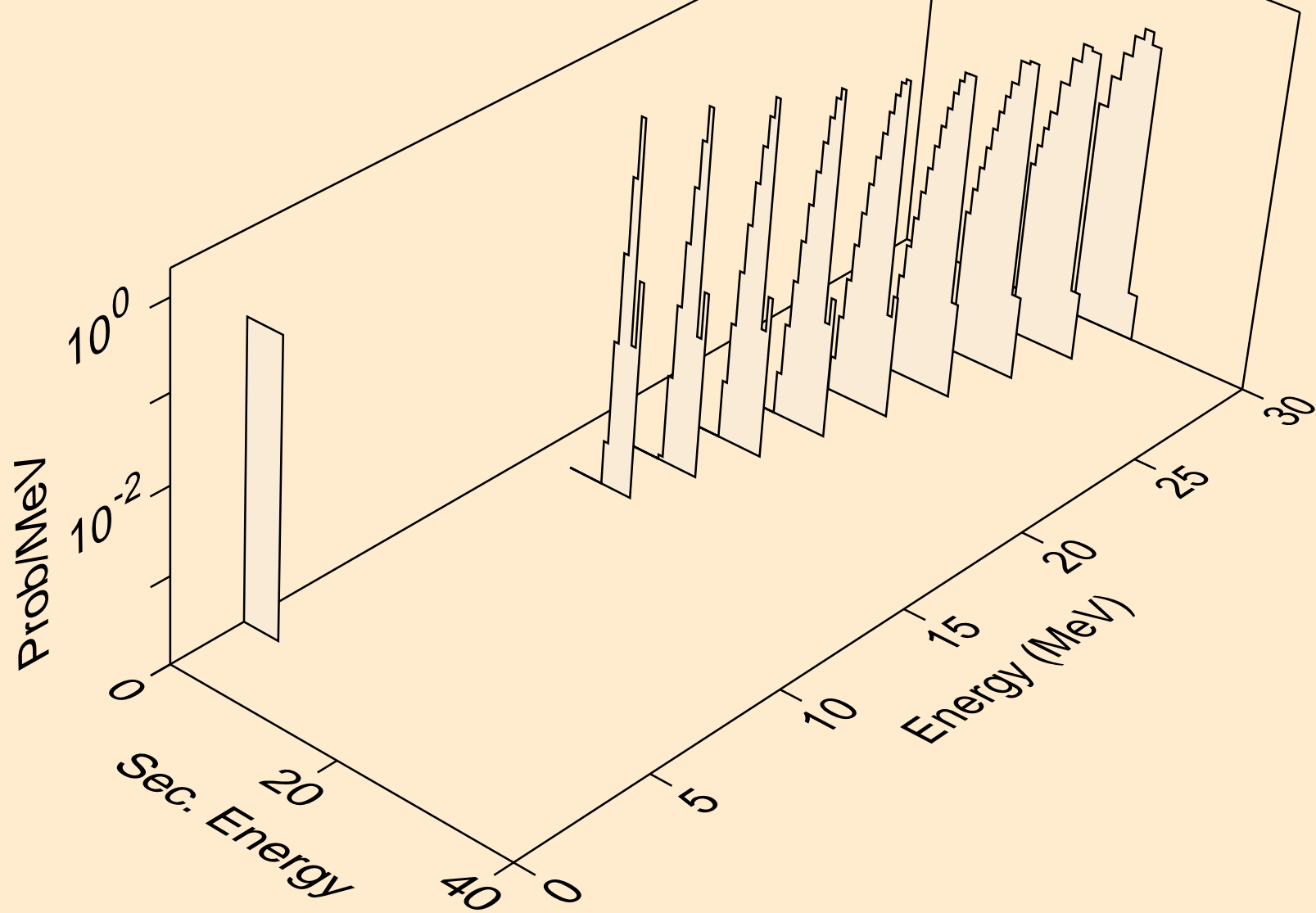

SG273 PROTON ACER TENDL-2021 LIBRARY; T=0.K
alphas from (p,x)

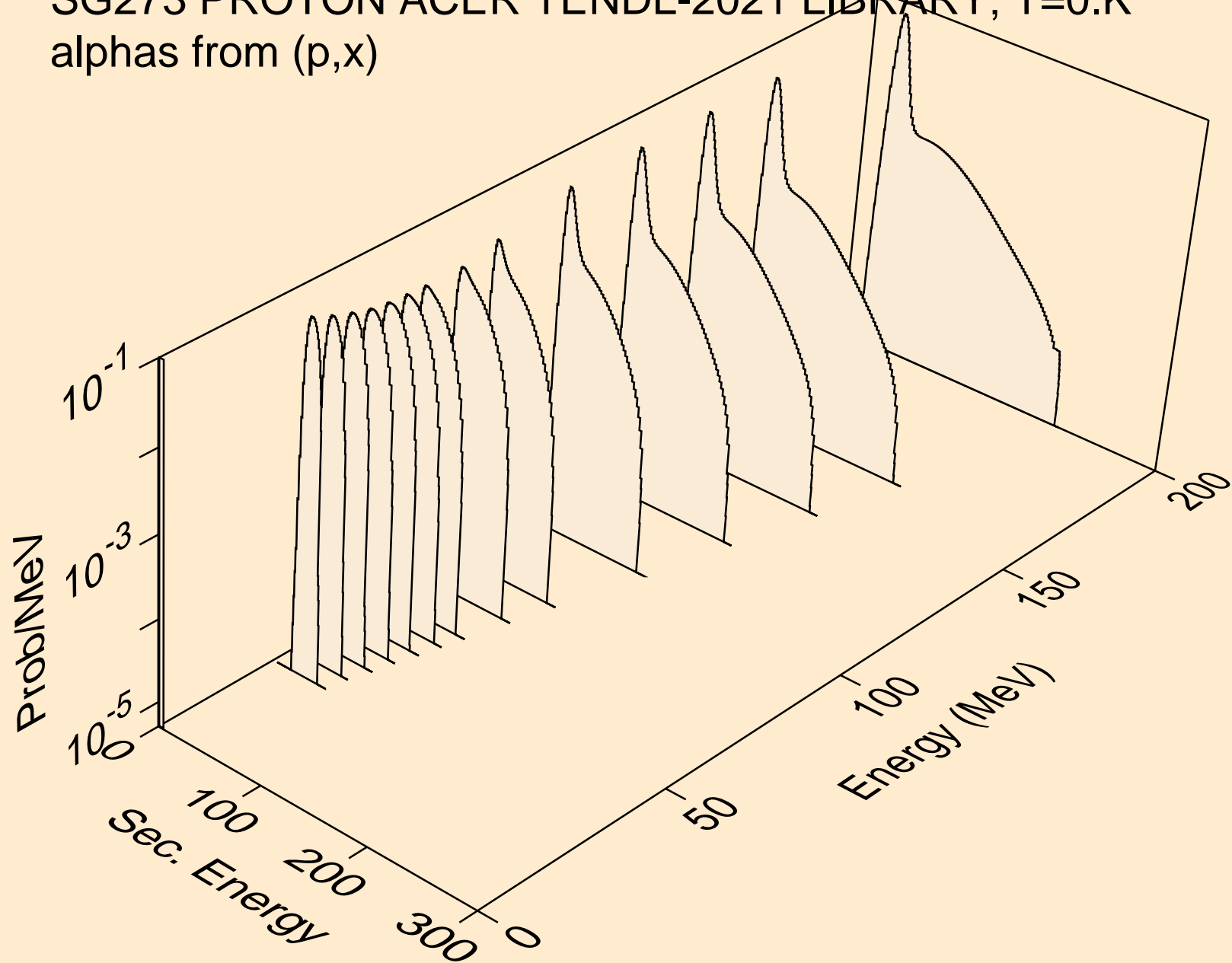

SG273 PROTON ACER TENDL-2021 LIBRARY; T=0.K
alphas from (p,2n)a

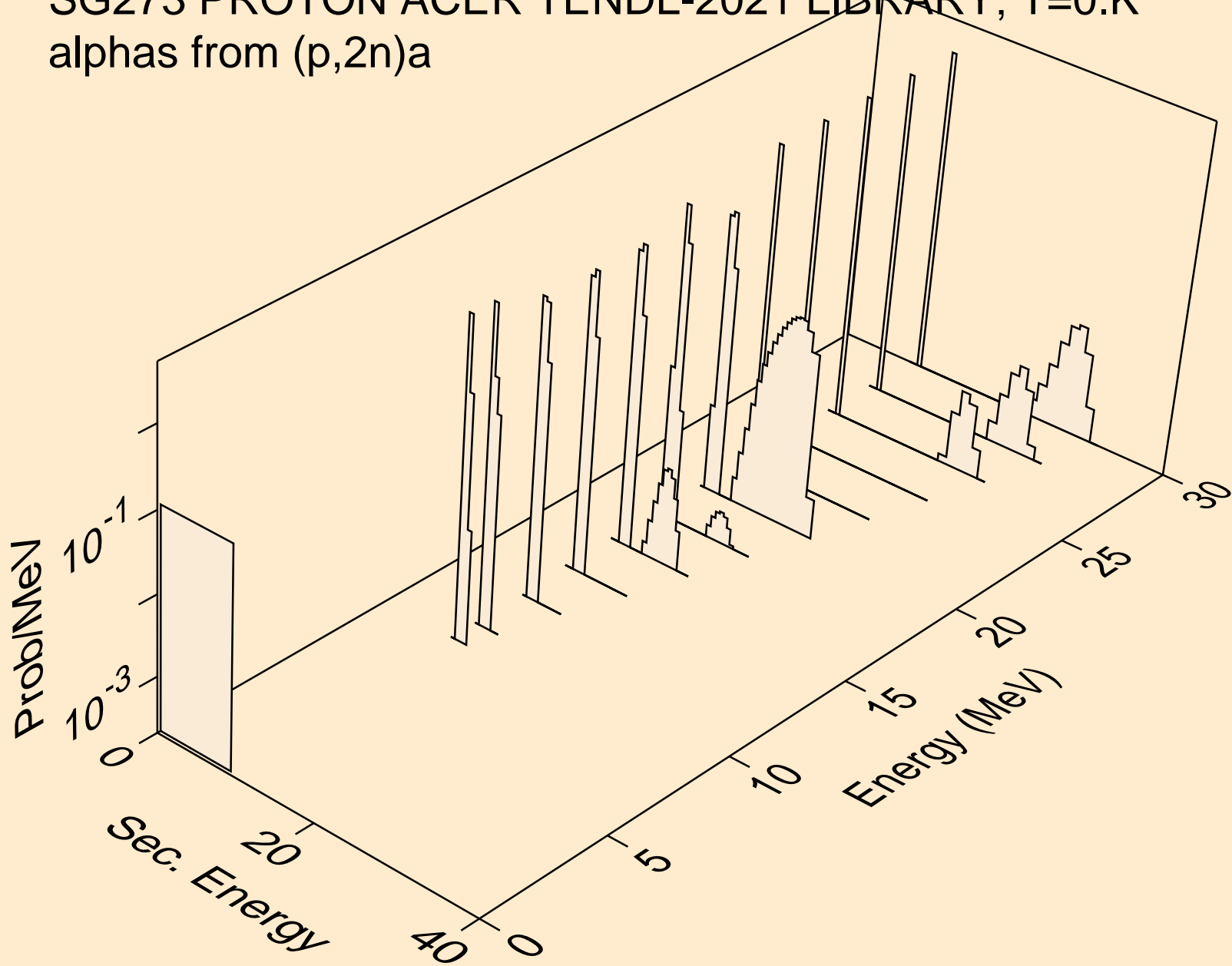

SG273 PROTON ACER TENDL-2021 LIBRARY; T=0.K
alphas from (p,a)

