

# SN113M PROTON ACER TENDL-2021 LIBRARY; T=0.K

## Principal cross sections

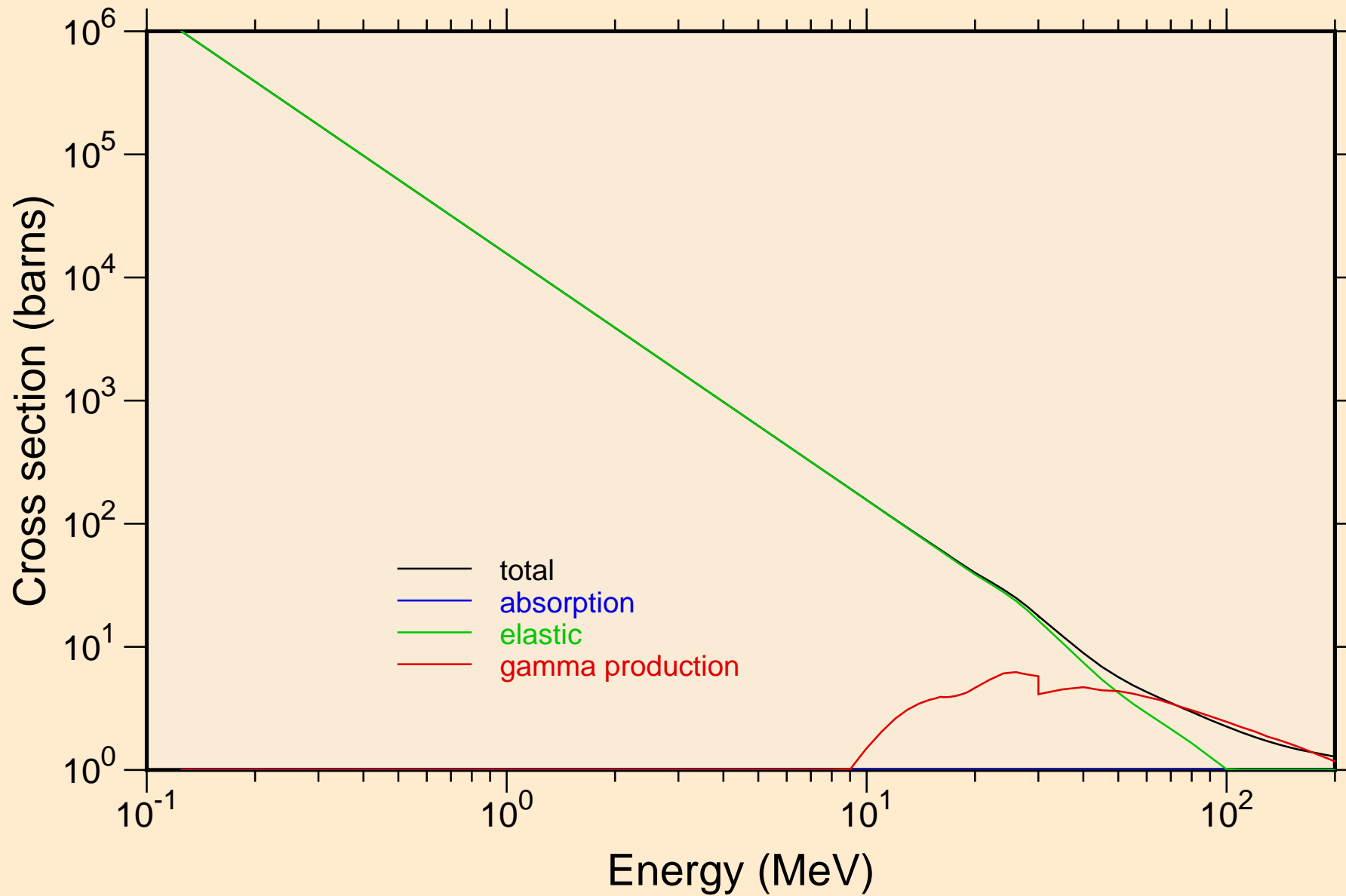

SN113M PROTON ACER TENDL-2021 LIBRARY; T=0.K  
Heating

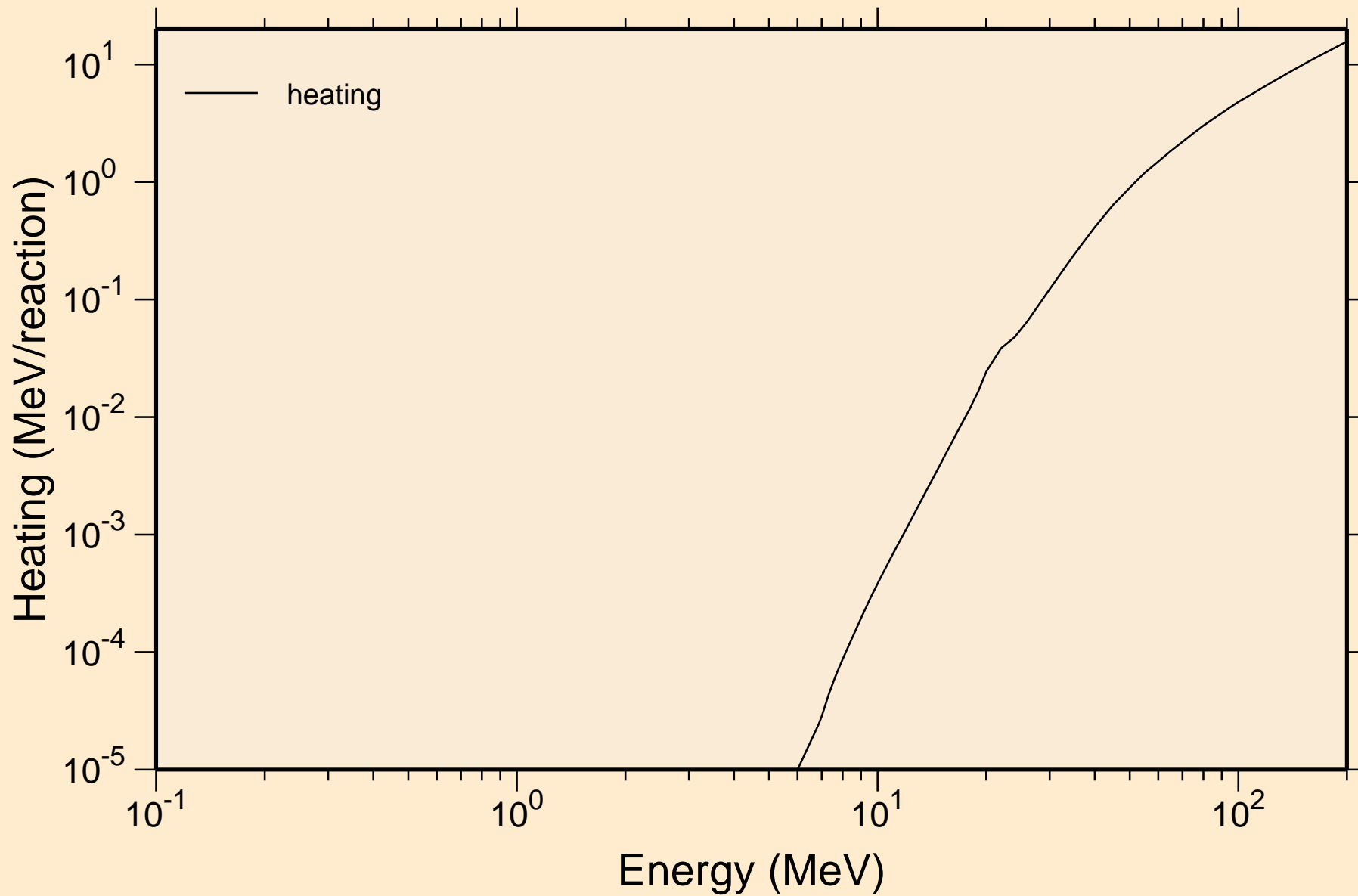

# SN113M PROTON ACER TENDL-2021 LIBRARY; T=0.K

## Principal cross sections

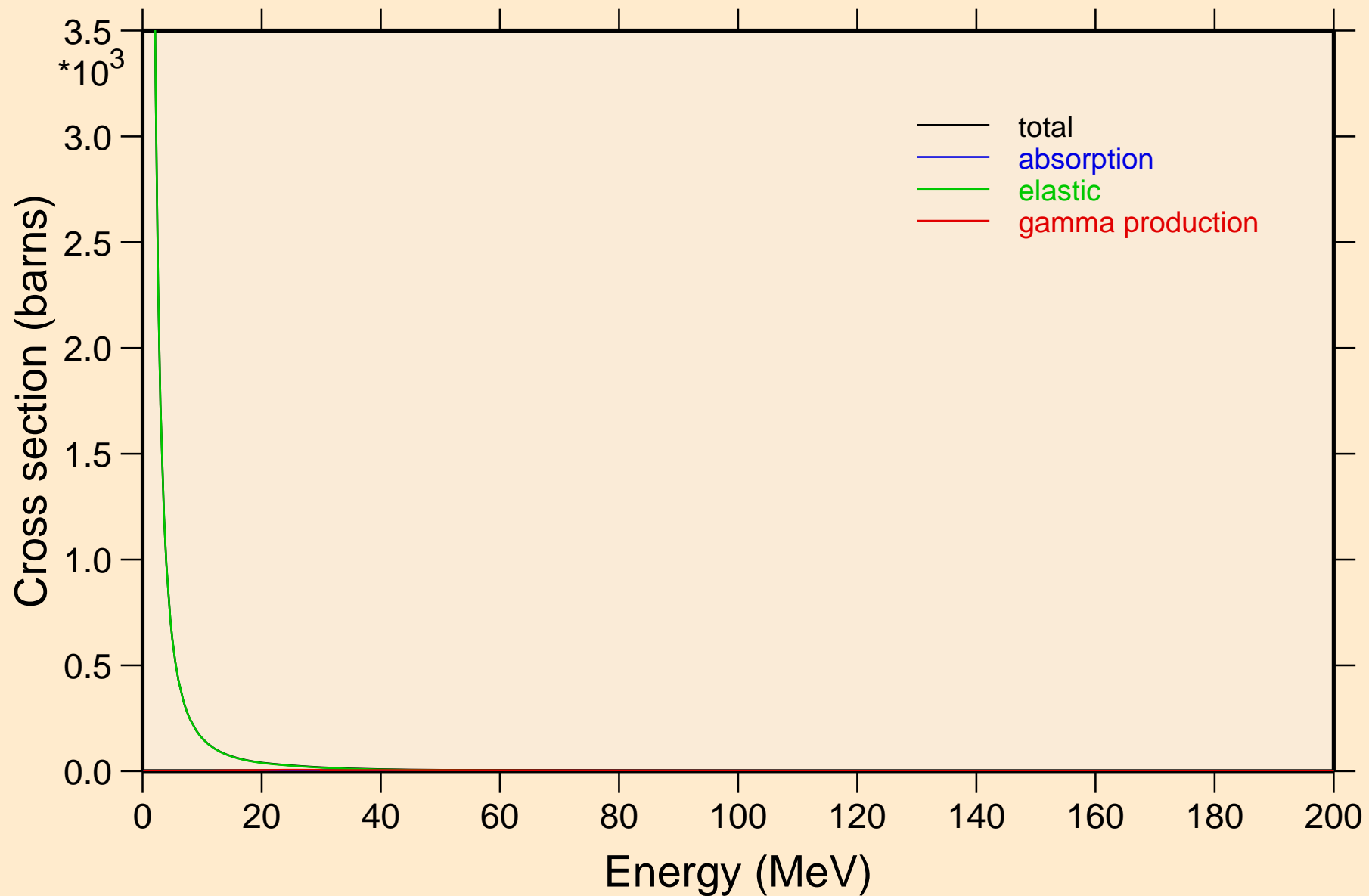

# SN113M PROTON ACER TENDL-2021 LIBRARY; T=0.K

## Heating

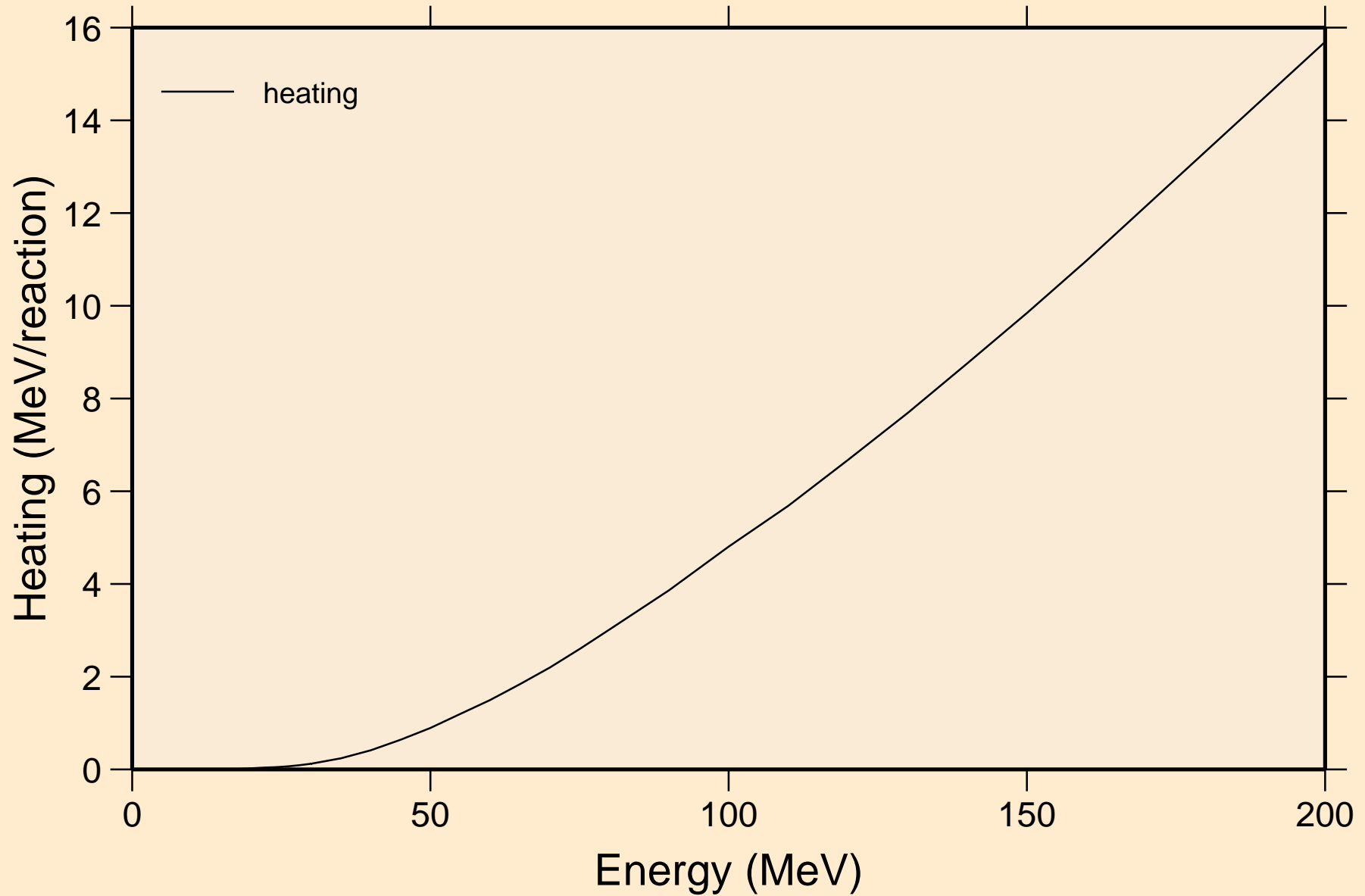

# SN113M PROTON ACER TENDL-2021 LIBRARY; T=0.K

## Threshold reactions

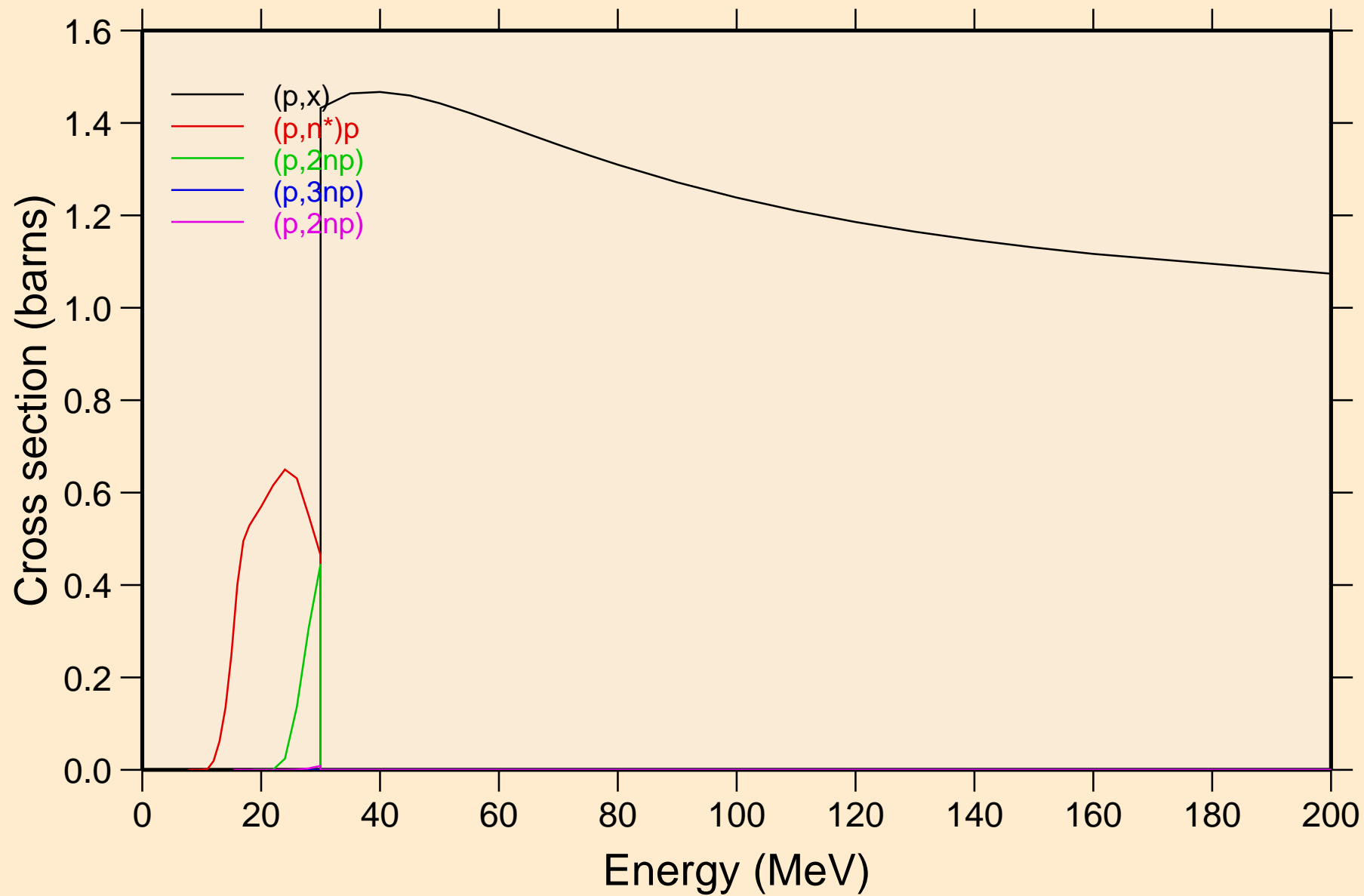

# SN113M PROTON ACER TENDL-2021 LIBRARY; T=0.K

## Threshold reactions

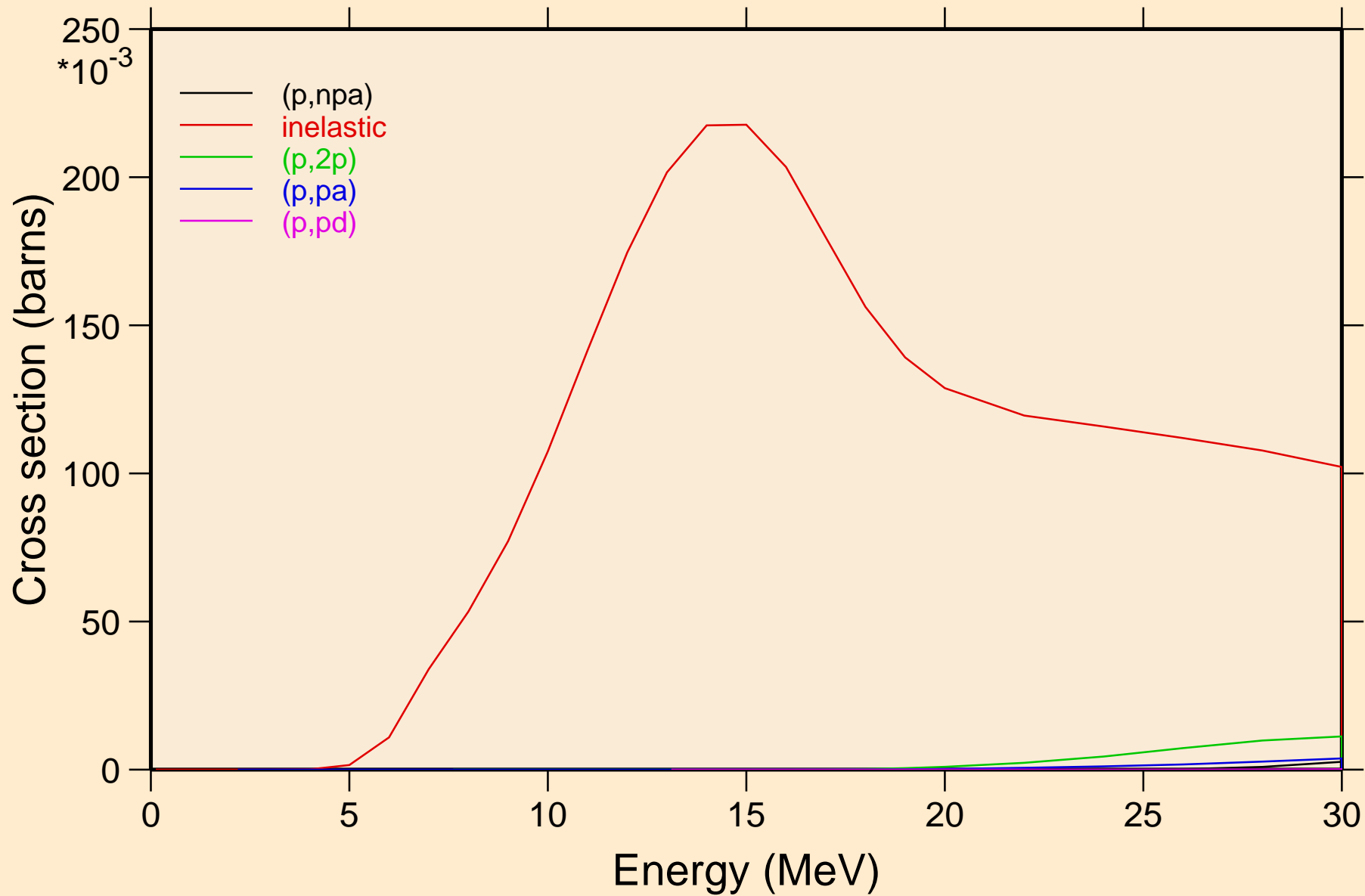

# SN113M PROTON ACER TENDL-2021 LIBRARY; T=0.K

## Threshold reactions

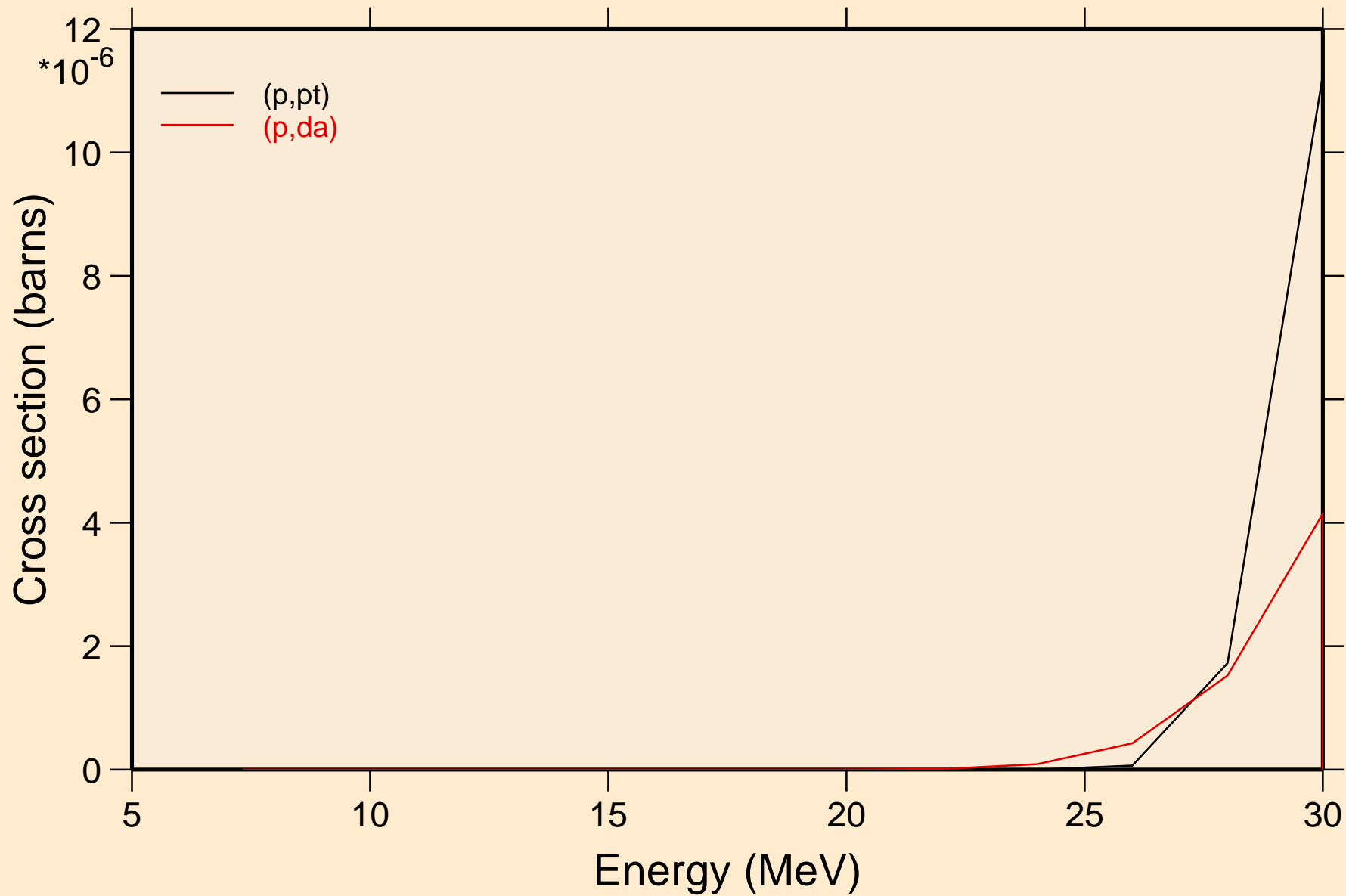

SN113M PROTON ACER TENDL-2021 LIBRARY; T=0.K  
angular distribution for elastic

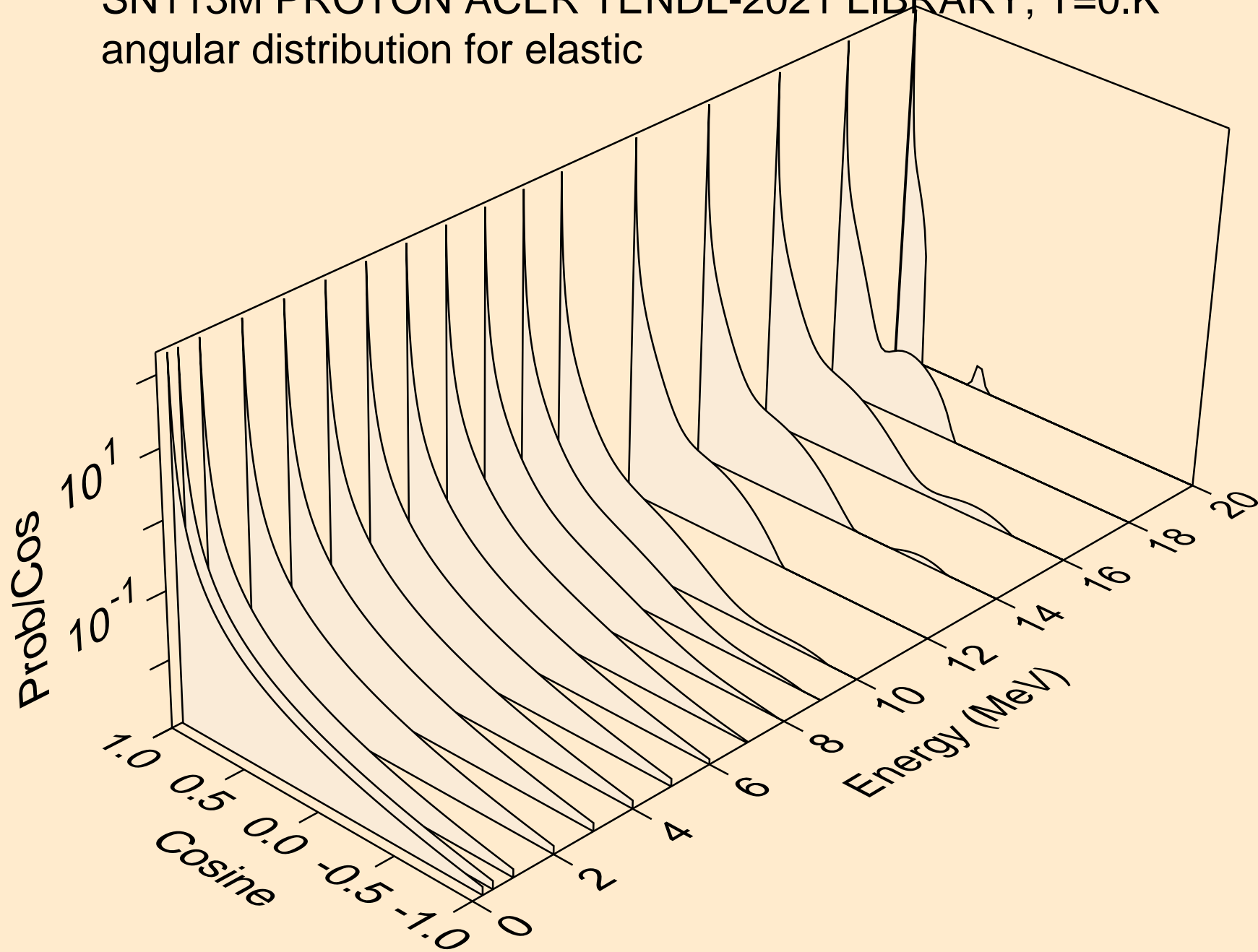



SN113M PROTON ACER TENDL-2021 LIBRARY; T=0.K  
angular distribution for elastic

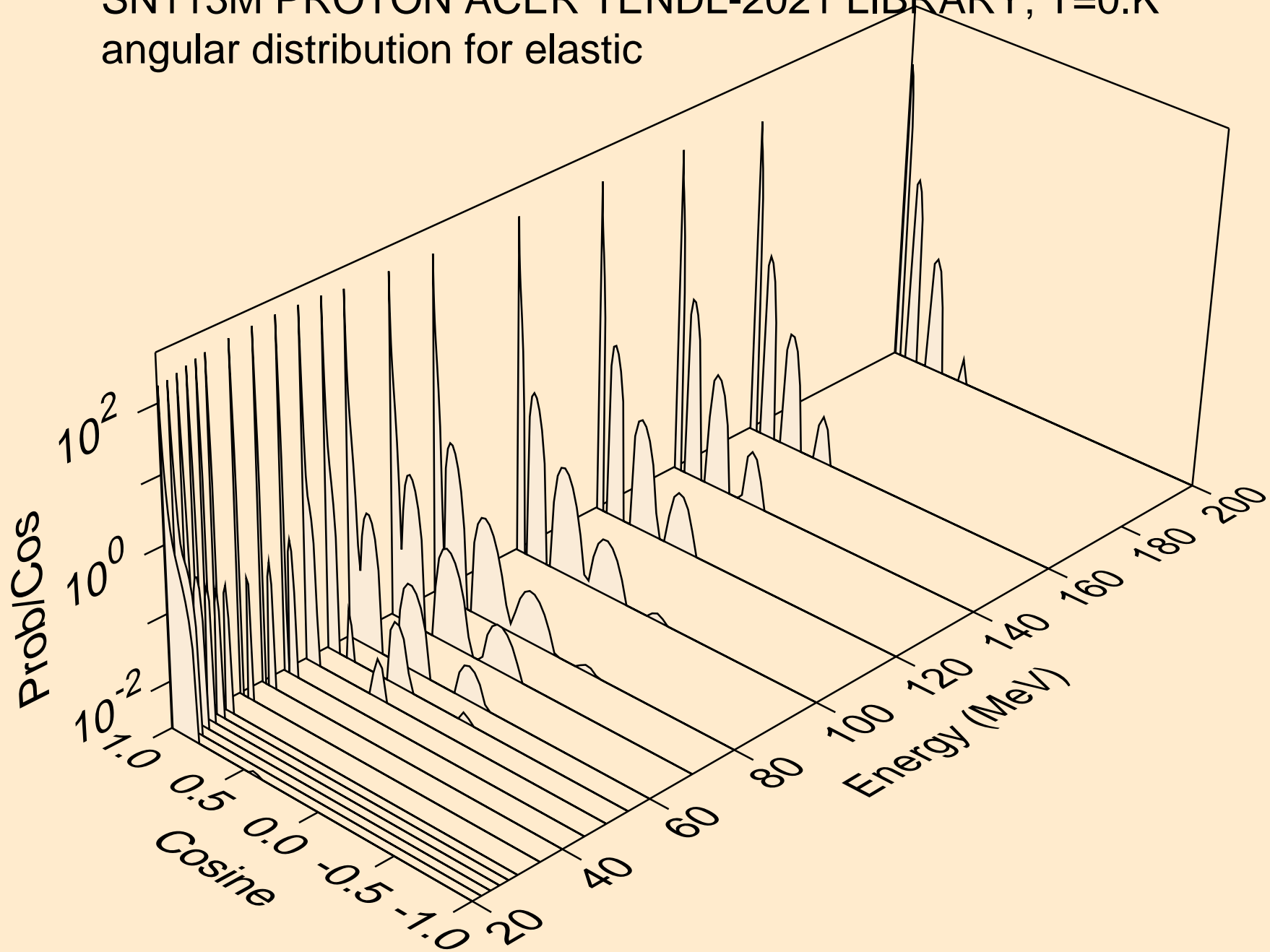

SN113M PROTON ACER TENDL-2021 LIBRARY; T=0.K  
Proton emission for (p,x)

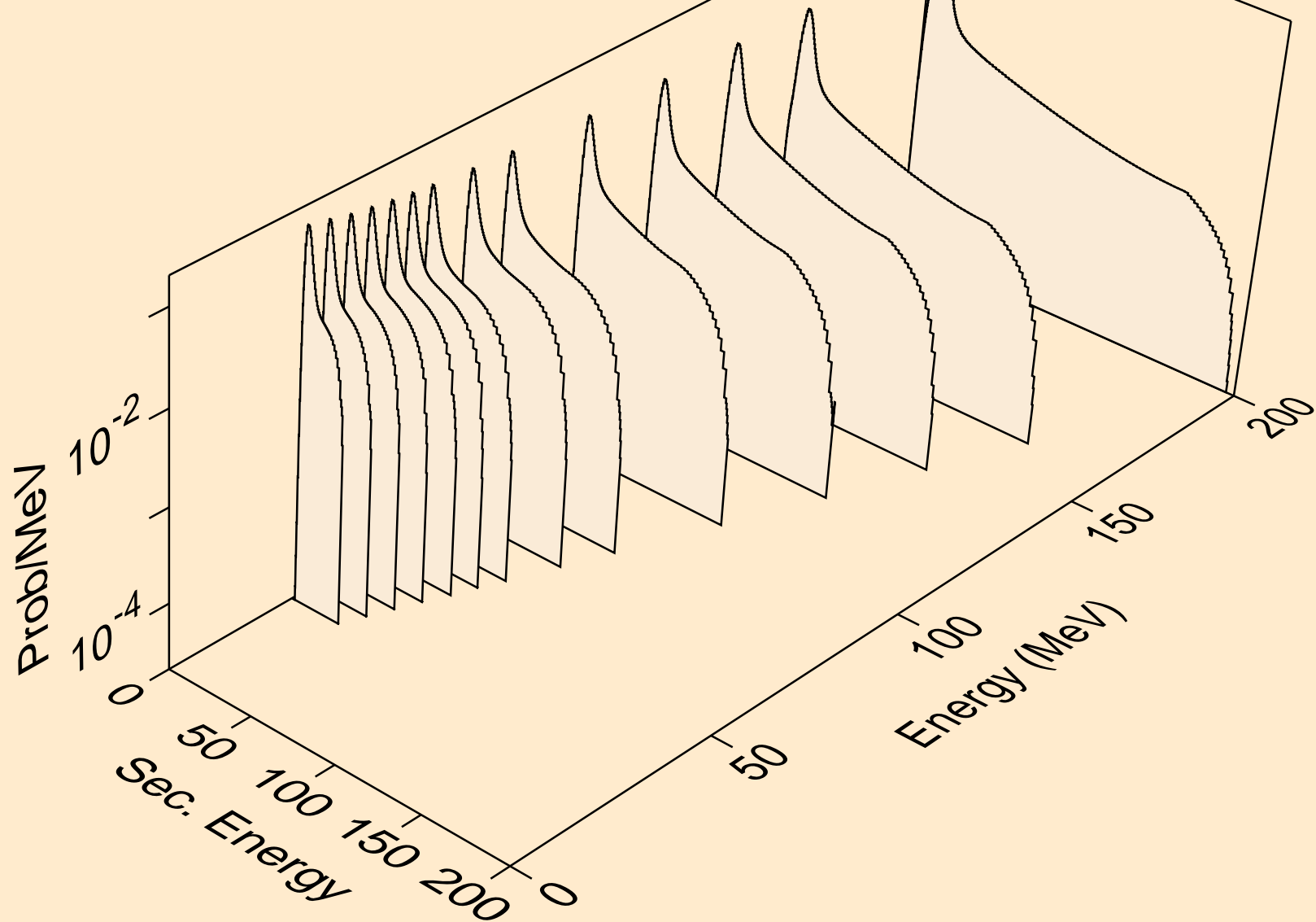

SN113M PROTON ACER TENDL-2021 LIBRARY; T=0.K  
Proton emission for (p,n\*)p

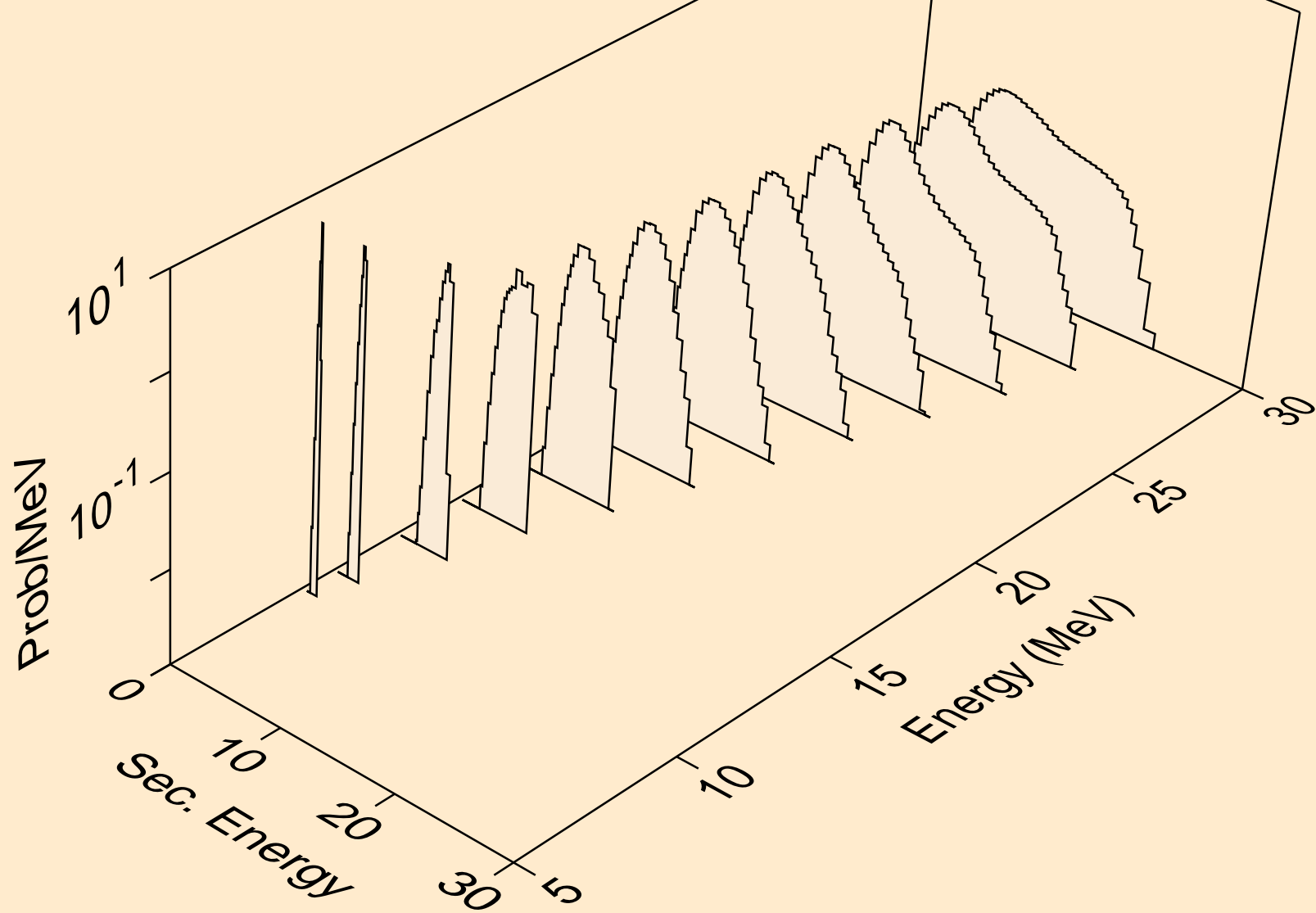

SN113M PROTON ACER TENDL-2021 LIBRARY; T=0.K  
Proton emission for (p,2np)

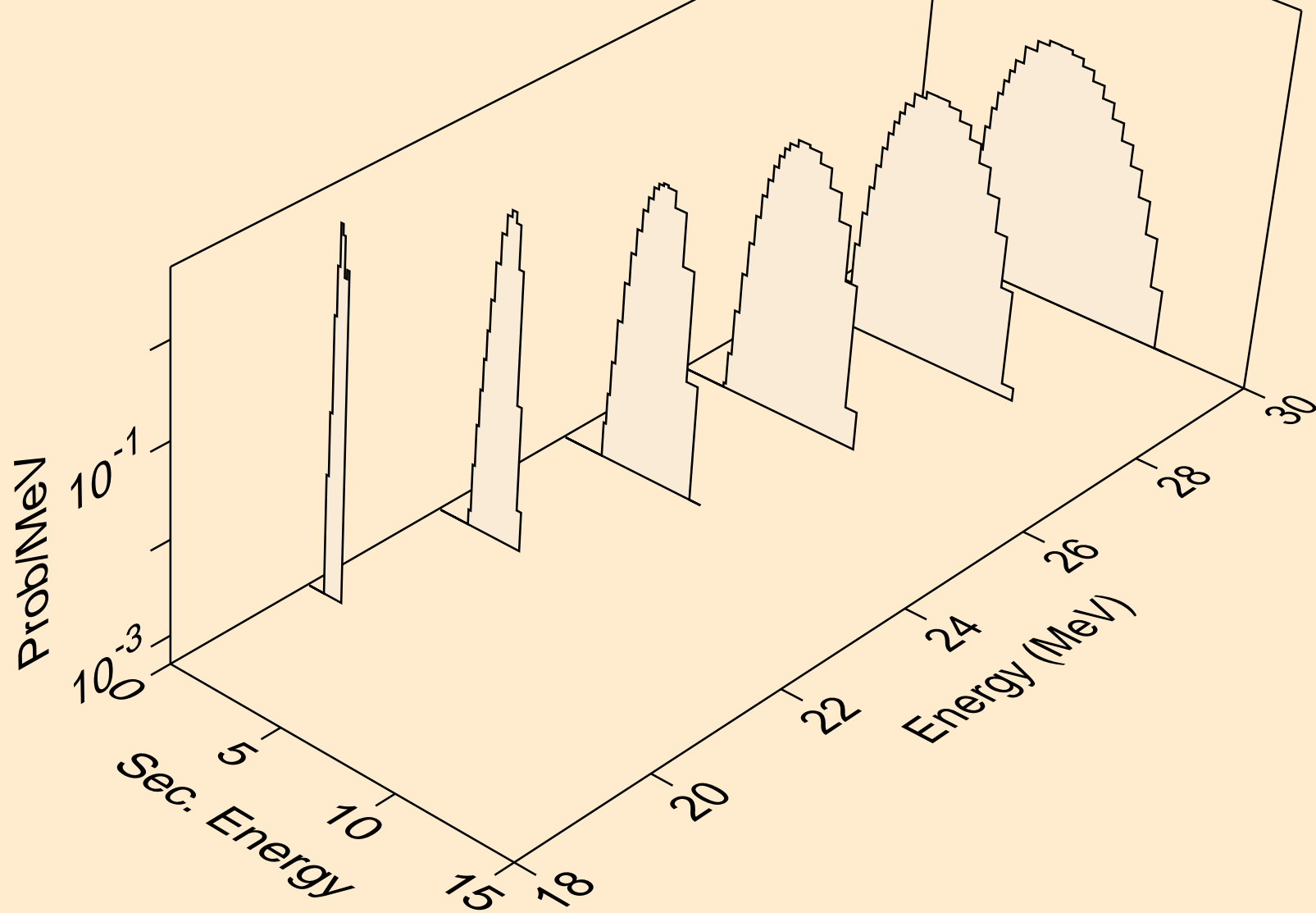

SN113M PROTON ACER TENDL-2021 LIBRARY; T=0.K  
Proton emission for (p,3np)

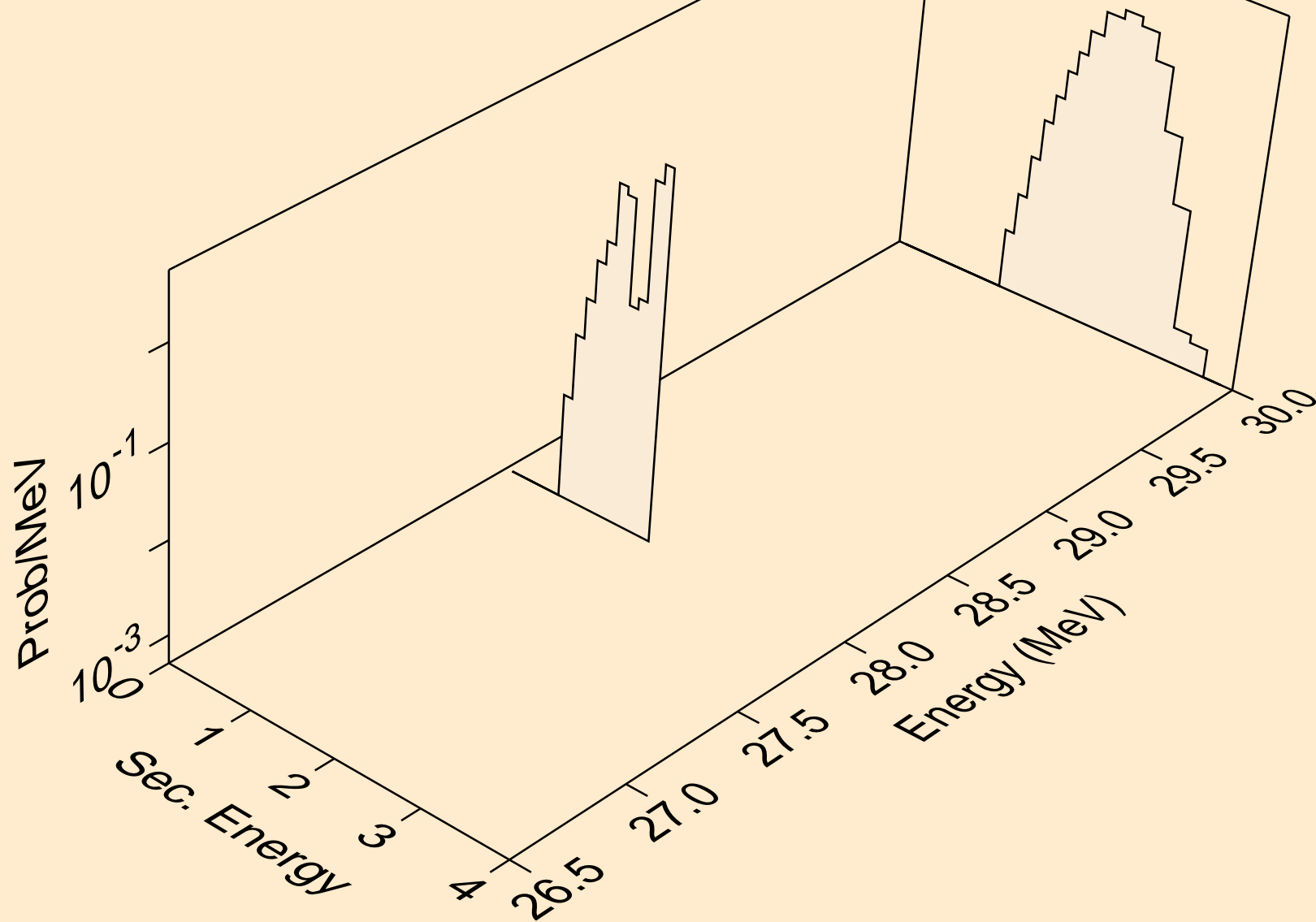

SN113M PROTON ACER TENDL-2021 LIBRARY; T=0.K  
Proton emission for (p,2np)

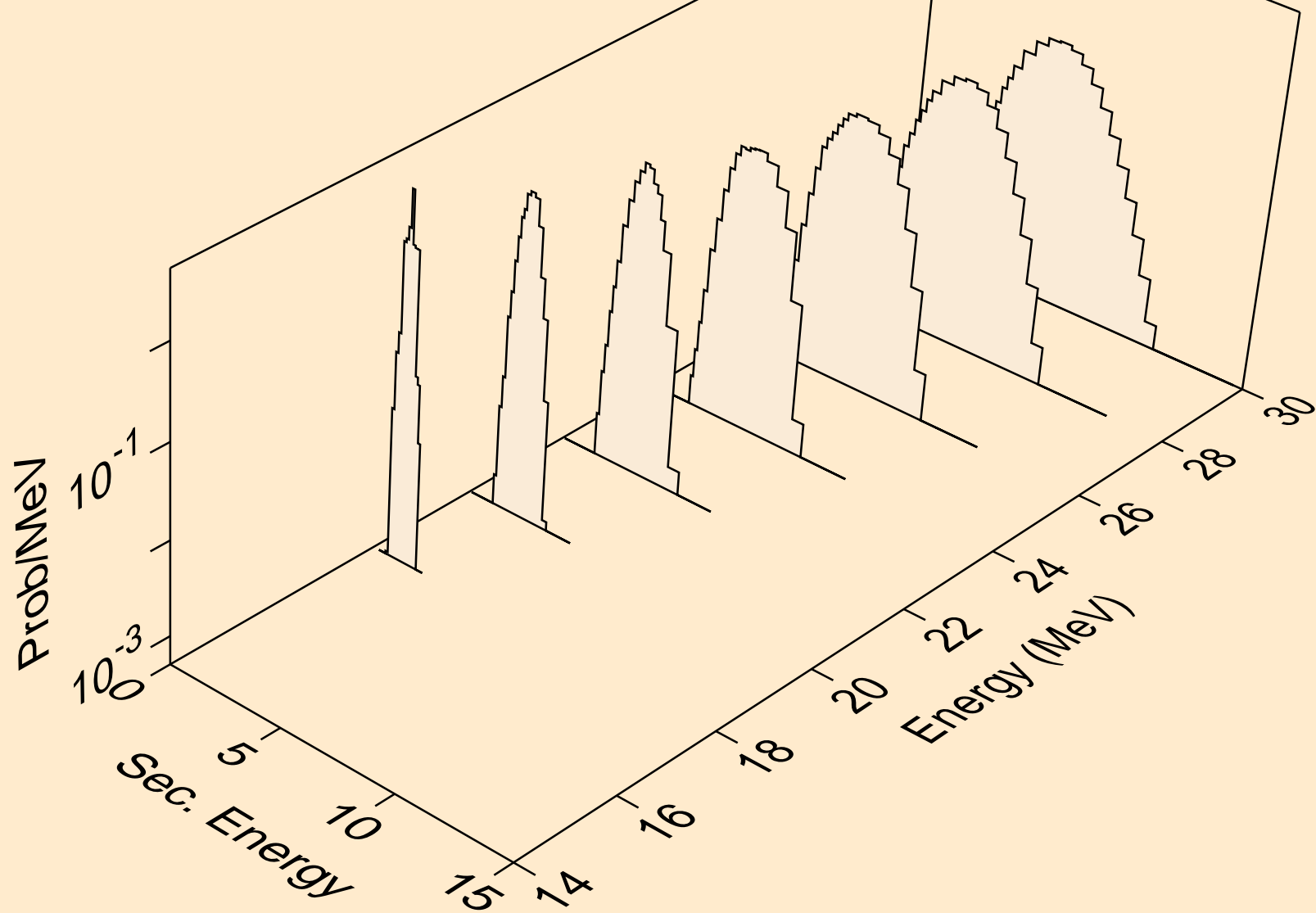

SN113M PROTON ACER TENDL-2021 LIBRARY; T=0.K  
Proton emission for (p,npa)

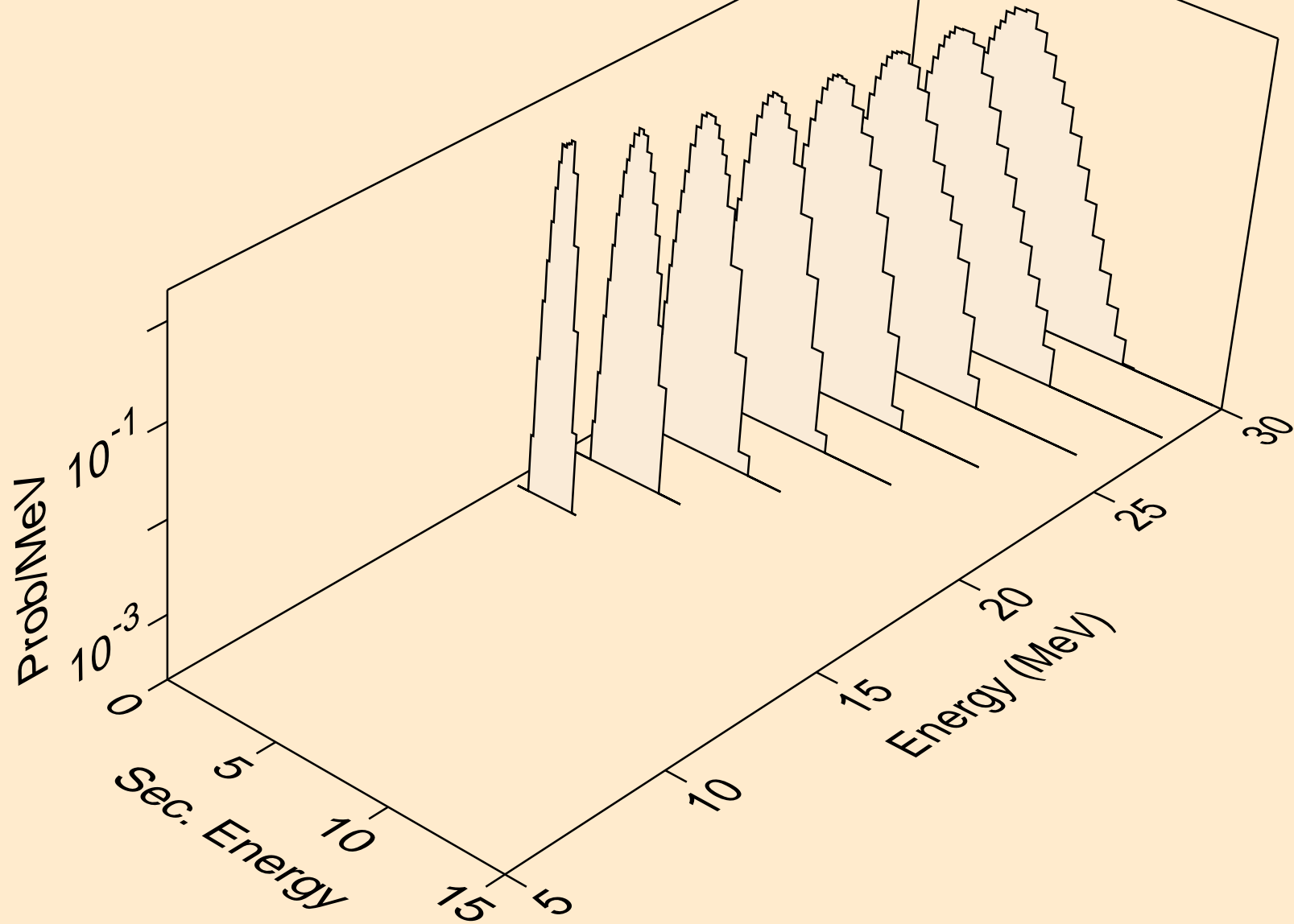

SN113M PROTON ACER TENDL-2021 LIBRARY; T=0.K  
Proton emission for inelastic

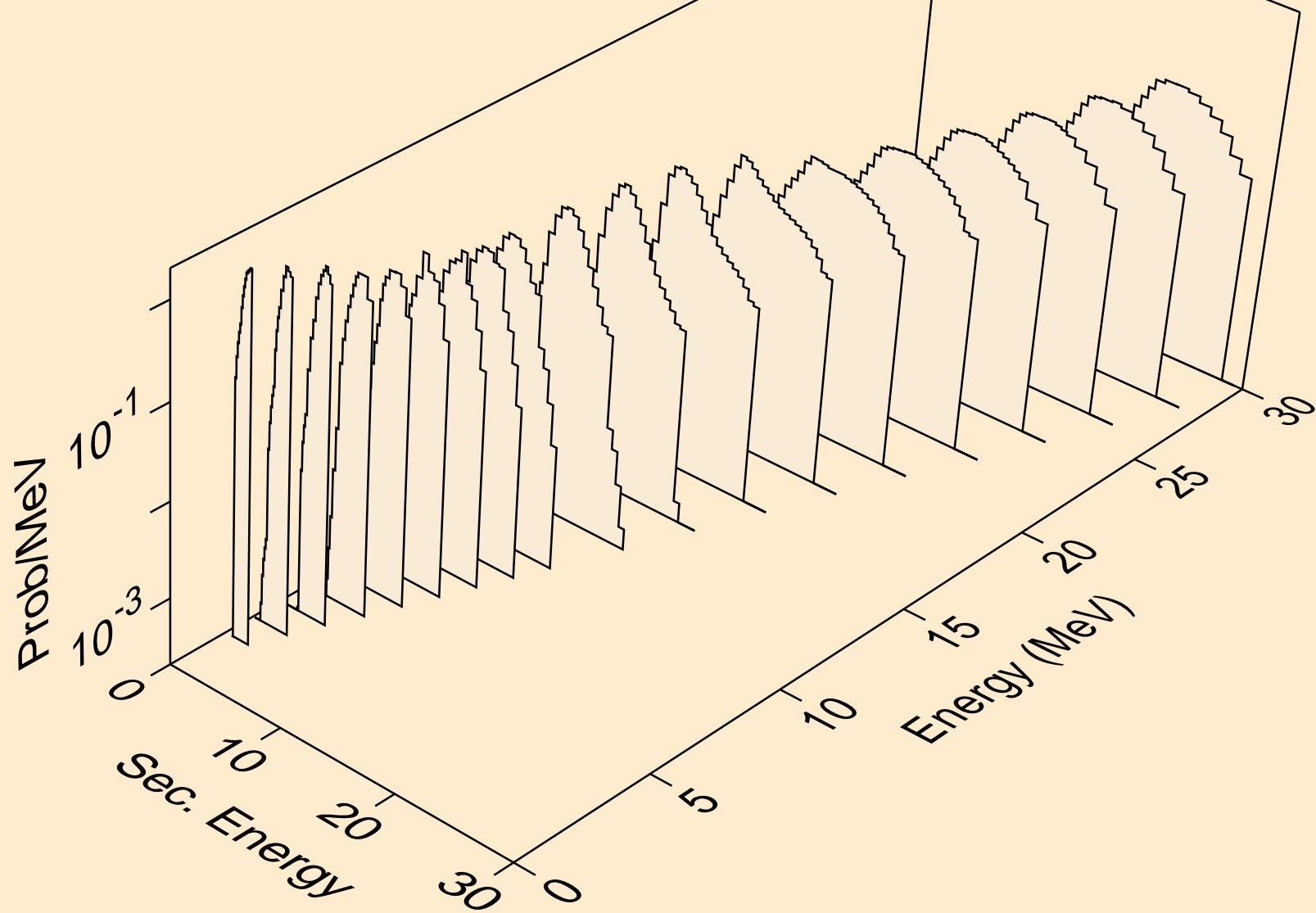



SN113M PROTON ACER TENDL-2021 LIBRARY; T=0.K  
Proton emission for (p,2p)

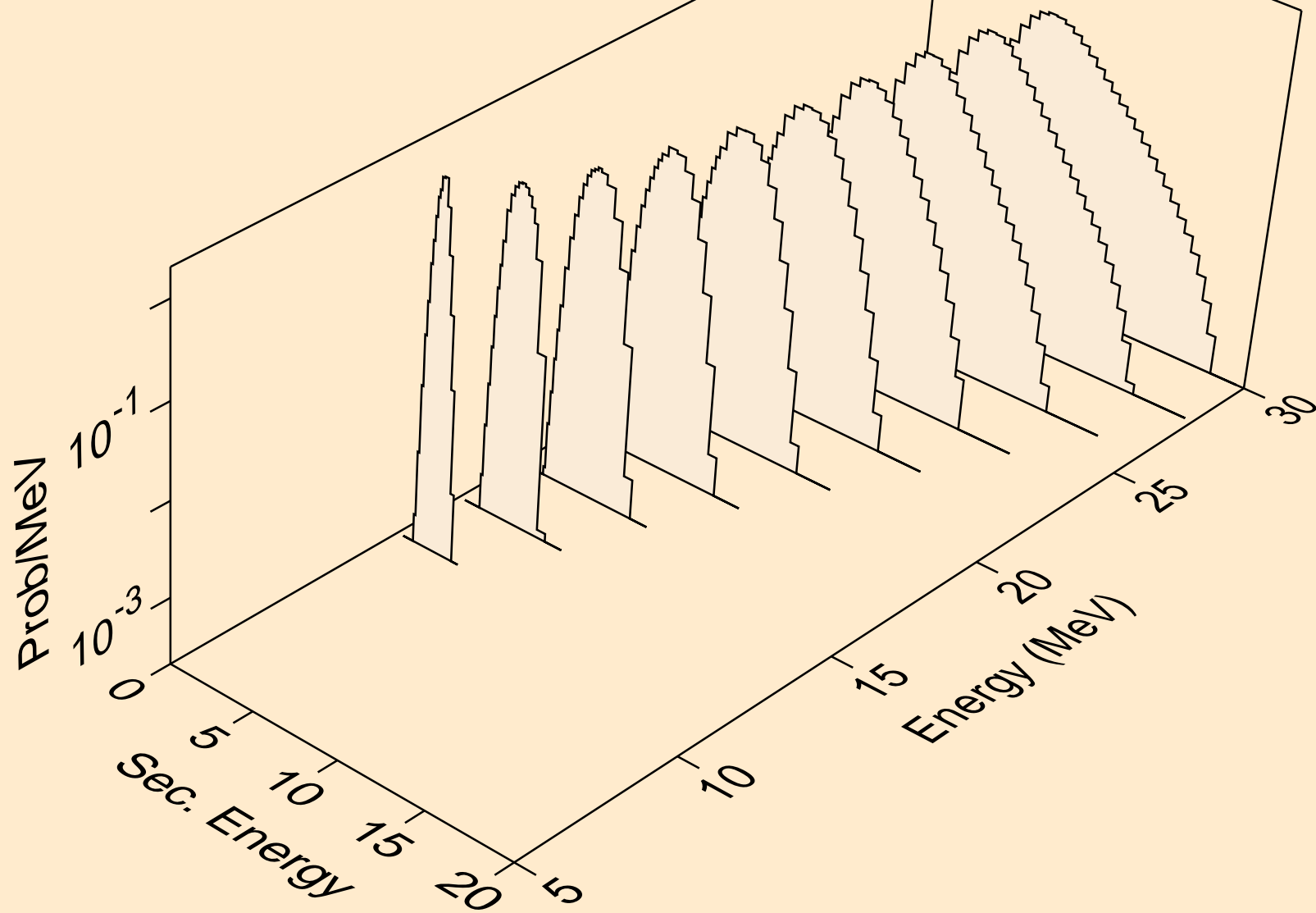

SN113M PROTON ACER TENDL-2021 LIBRARY; T=0.K  
Proton emission for (p,pa)

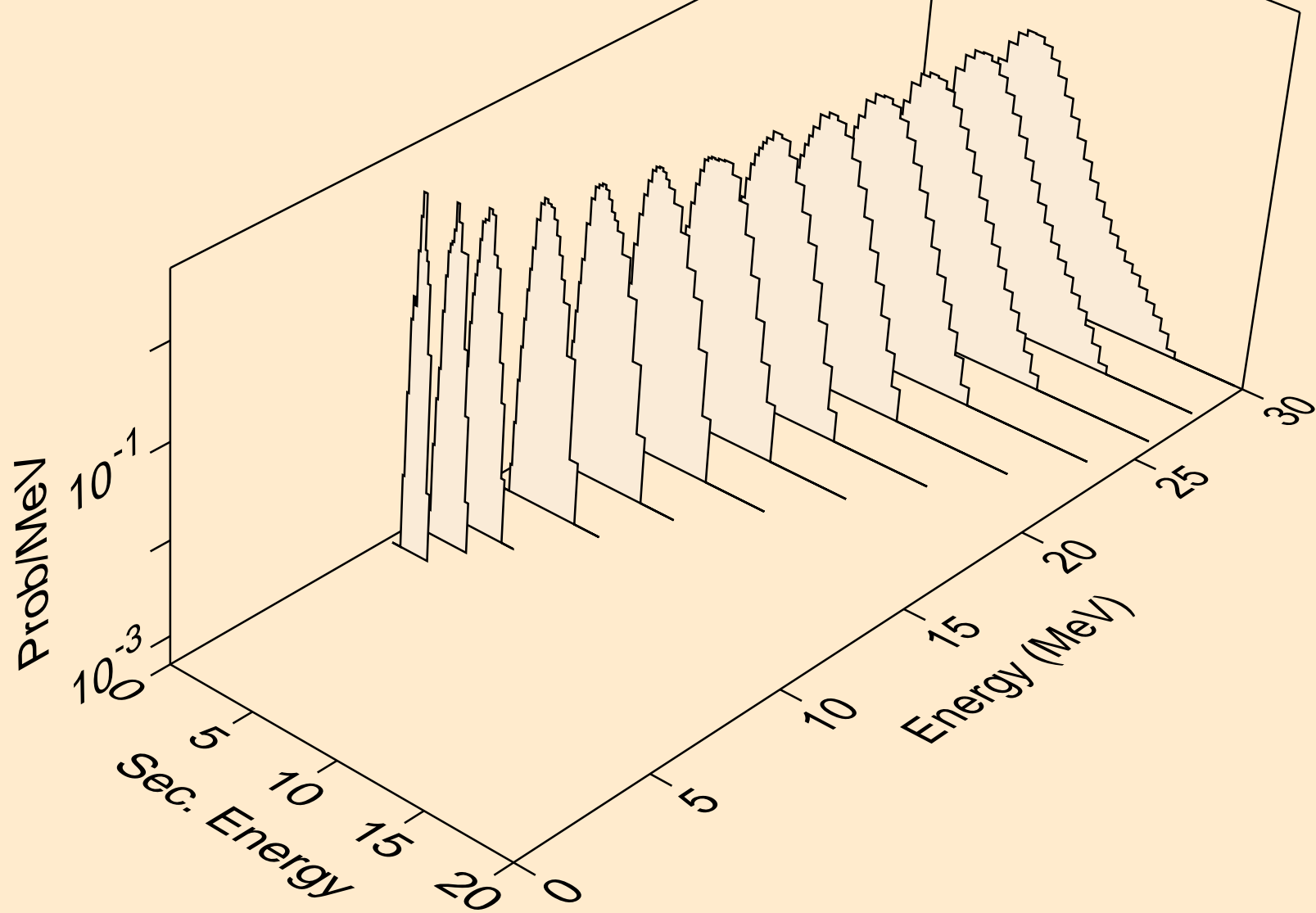

SN113M PROTON ACER TENDL-2021 LIBRARY; T=0.K  
Proton emission for (p,pd)

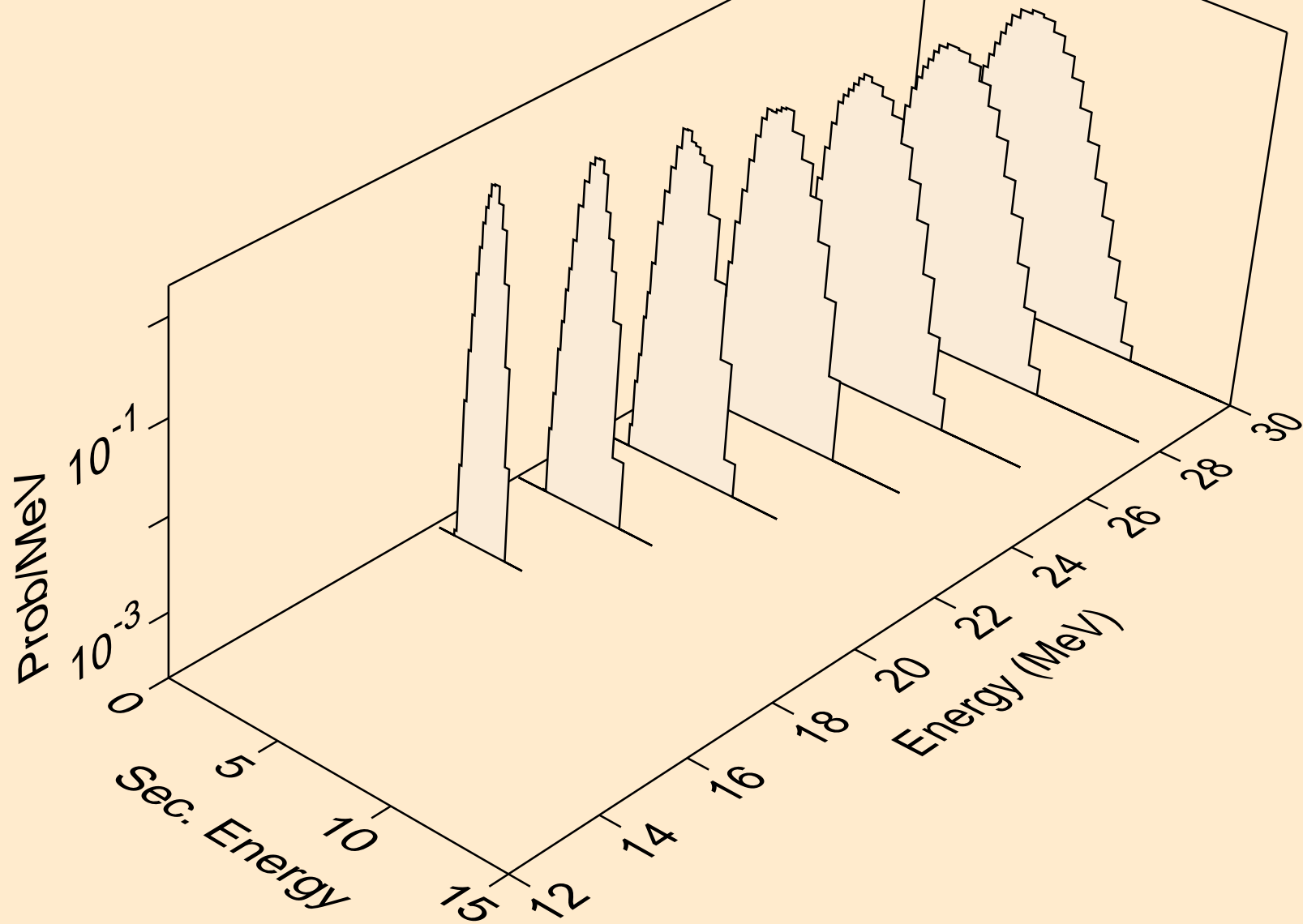

SN113M PROTON ACER TENDL-2021 LIBRARY; T=0.K  
Proton emission for (p,pt)

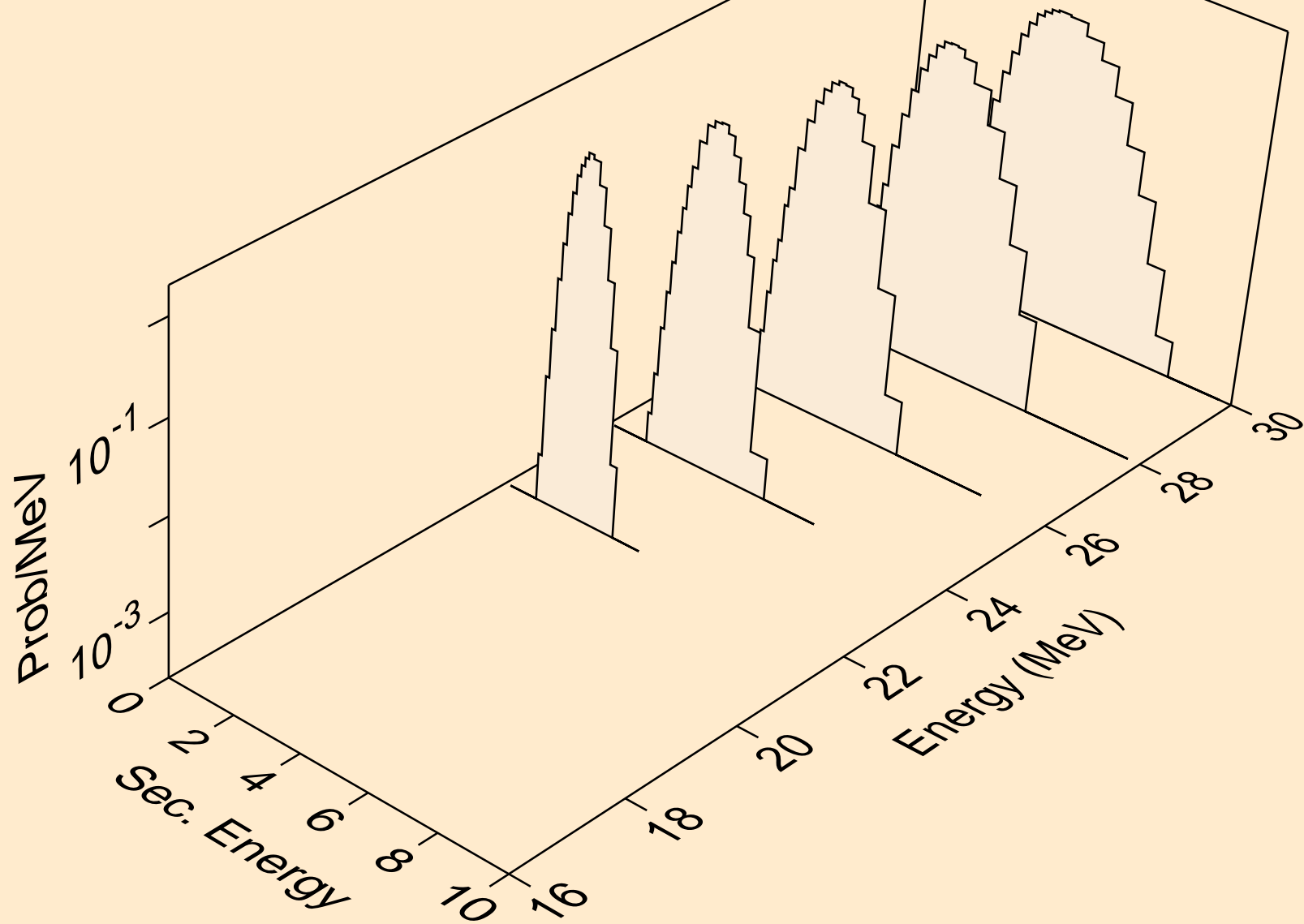

SN113M PROTON ACER TENDL-2021 LIBRARY; T=0.K  
Photon emission for (z,n)

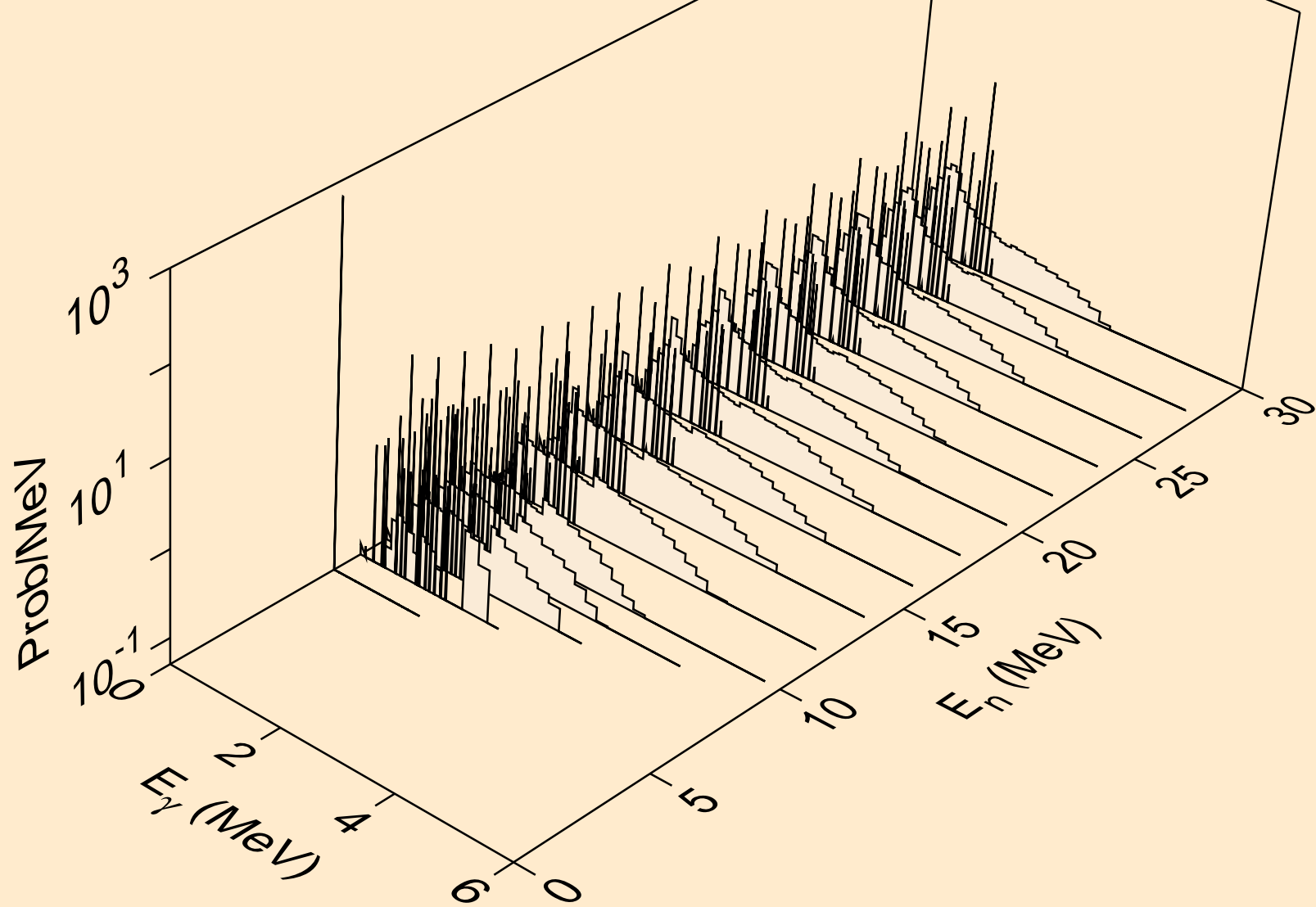

SN113M PROTON ACER TENDL-2021 LIBRARY; T=0.K  
Photon emission for (n,x)

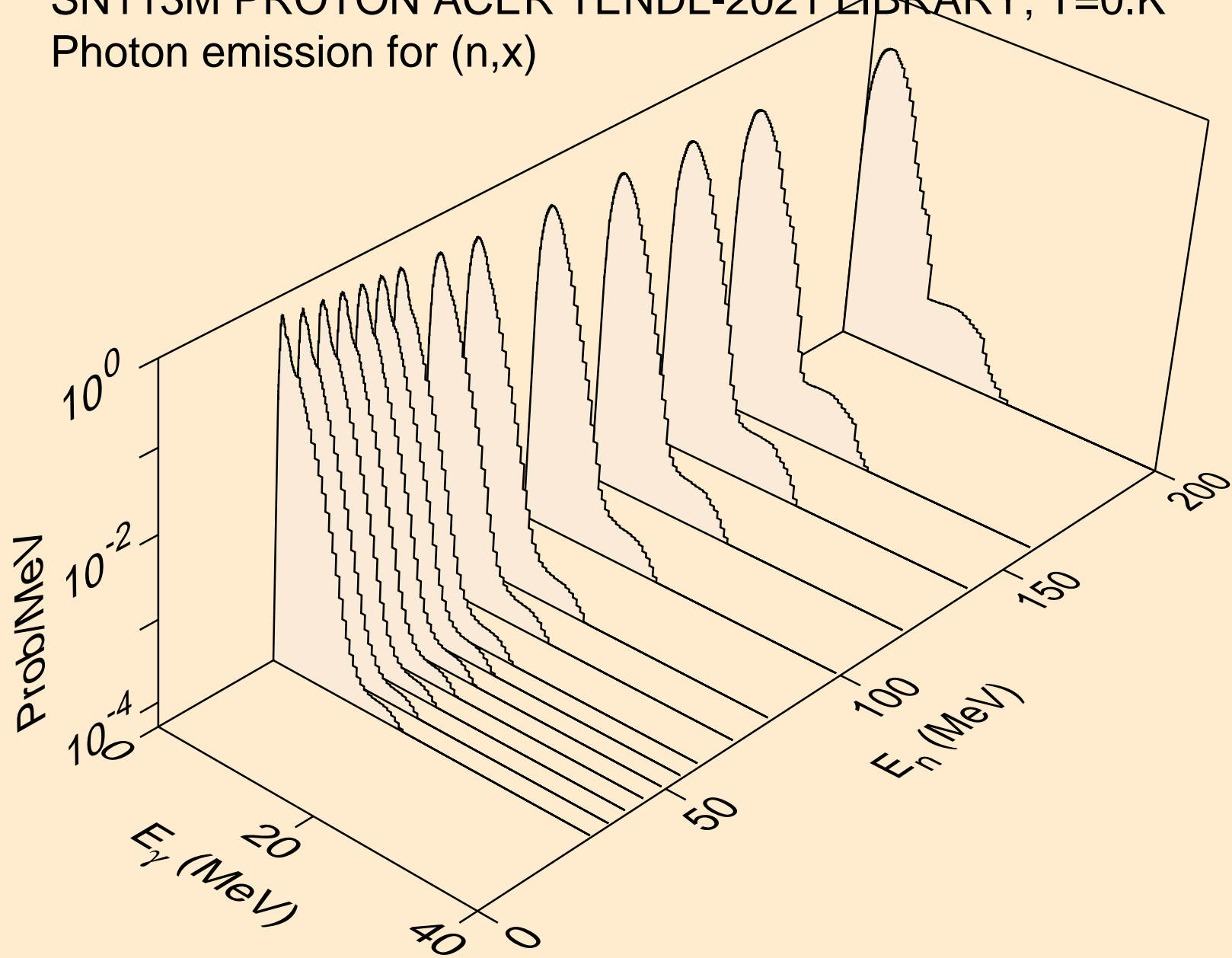

SN113M PROTON ACER TENDL-2021 LIBRARY; T=0.K  
Photon emission for (n,2nd)

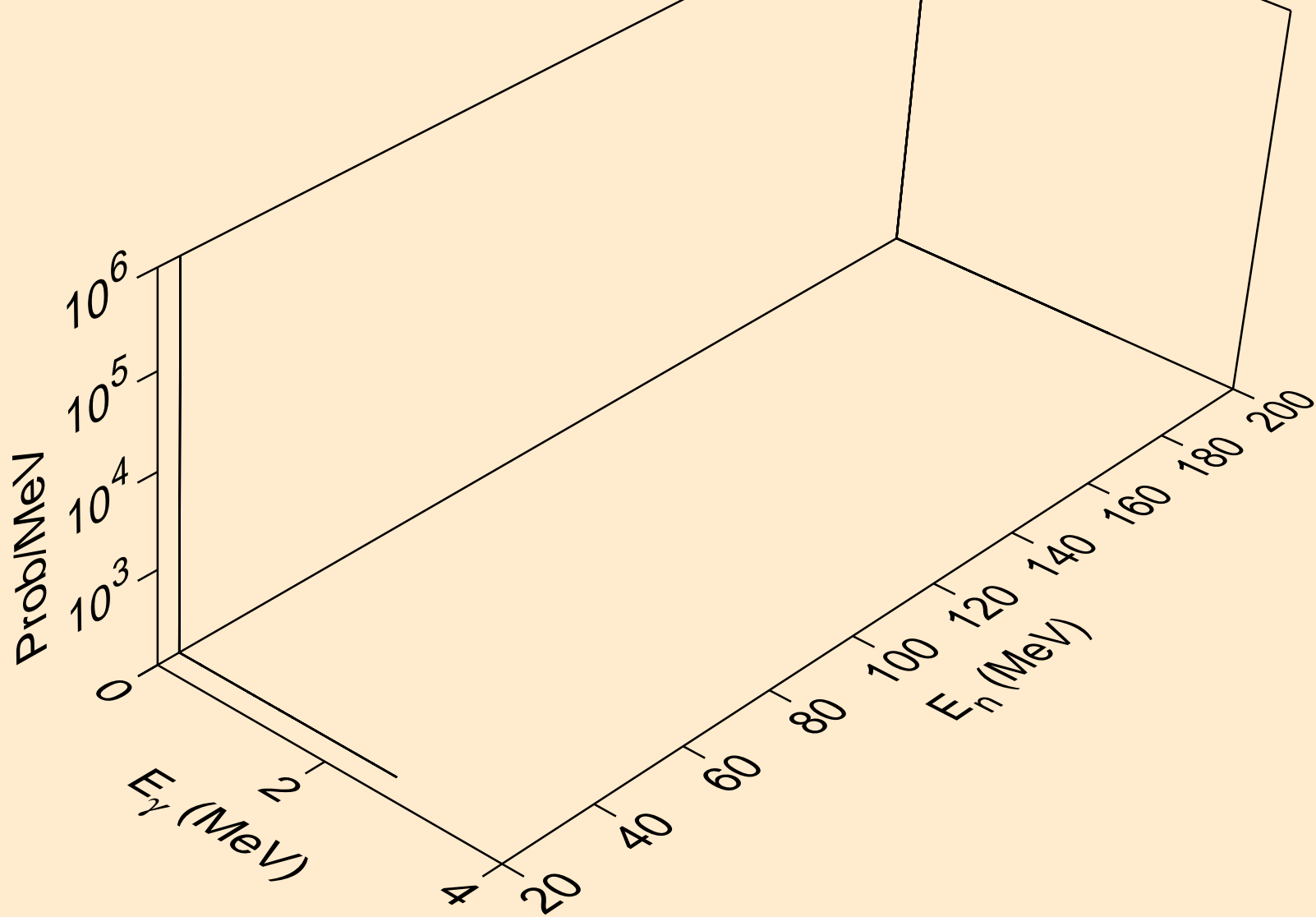

SN113M PROTON ACER TENDL-2021 LIBRARY; T=0.K  
Photon emission for (n,2n)

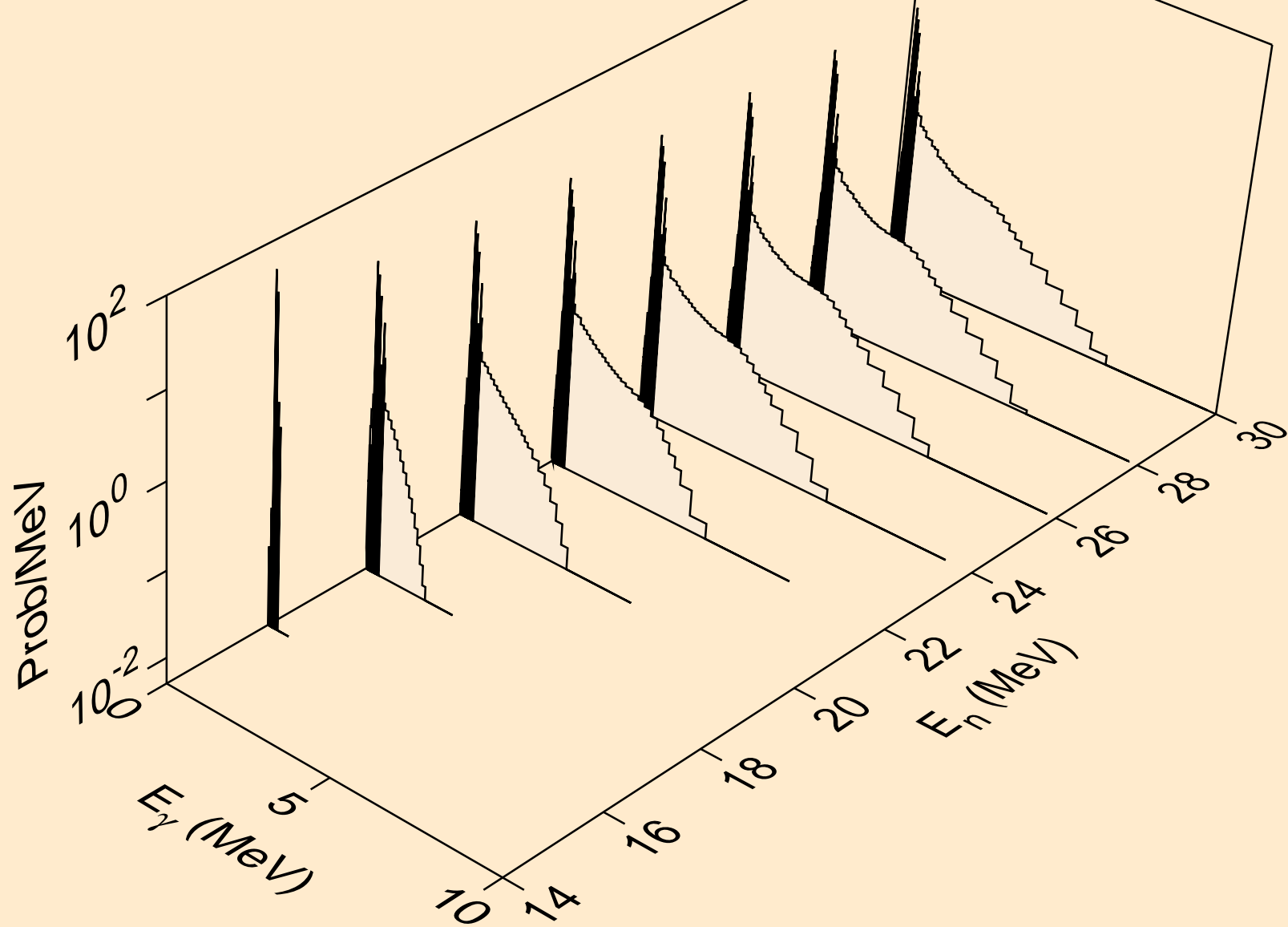



SN113M PROTON ACER TENDL-2021 LIBRARY; T=0.K  
Photon emission for (n,3n)

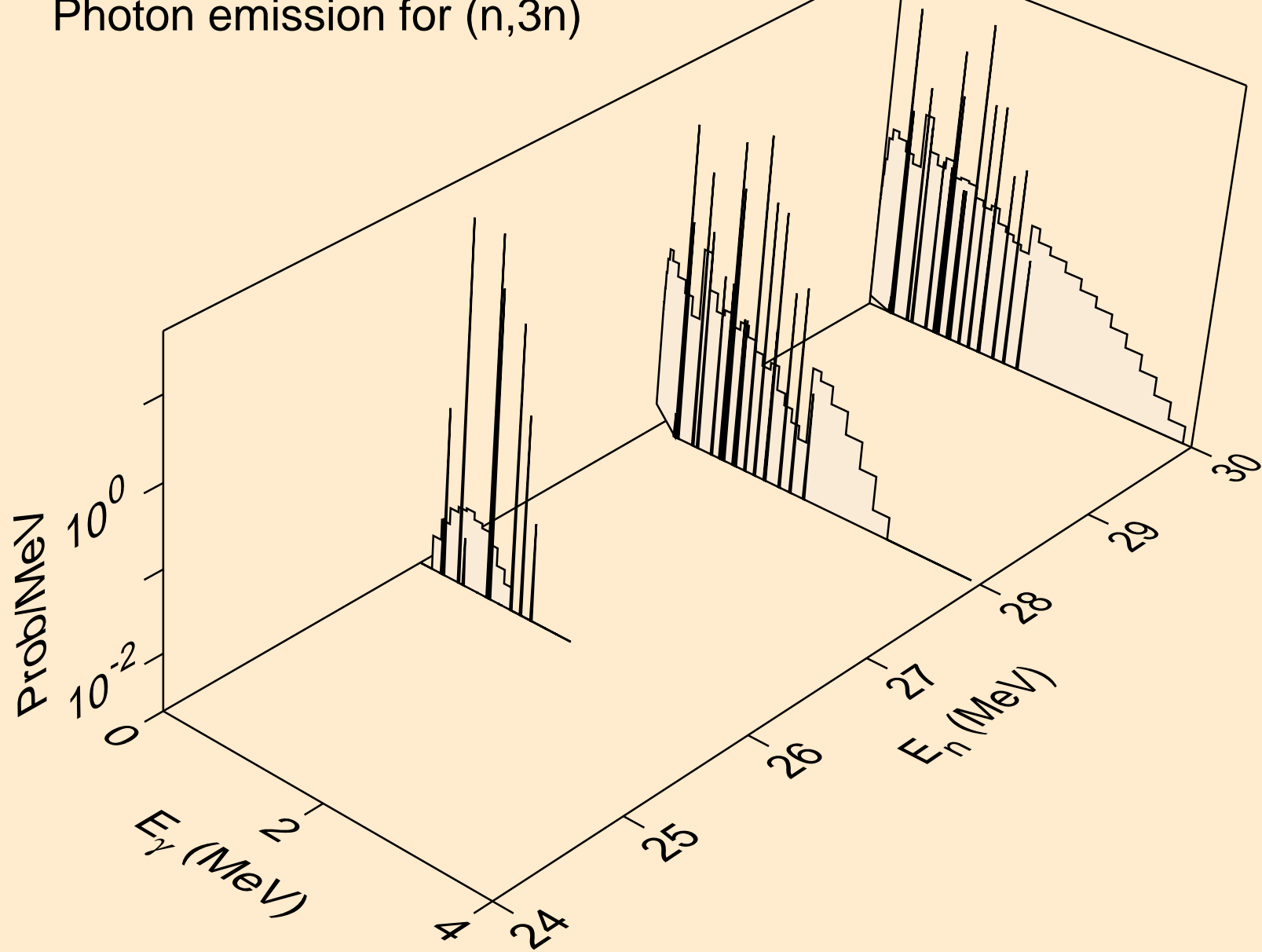

SN113M PROTON ACER TENDL-2021 LIBRARY; T=0.K  
Photon emission for (n,n\*)a

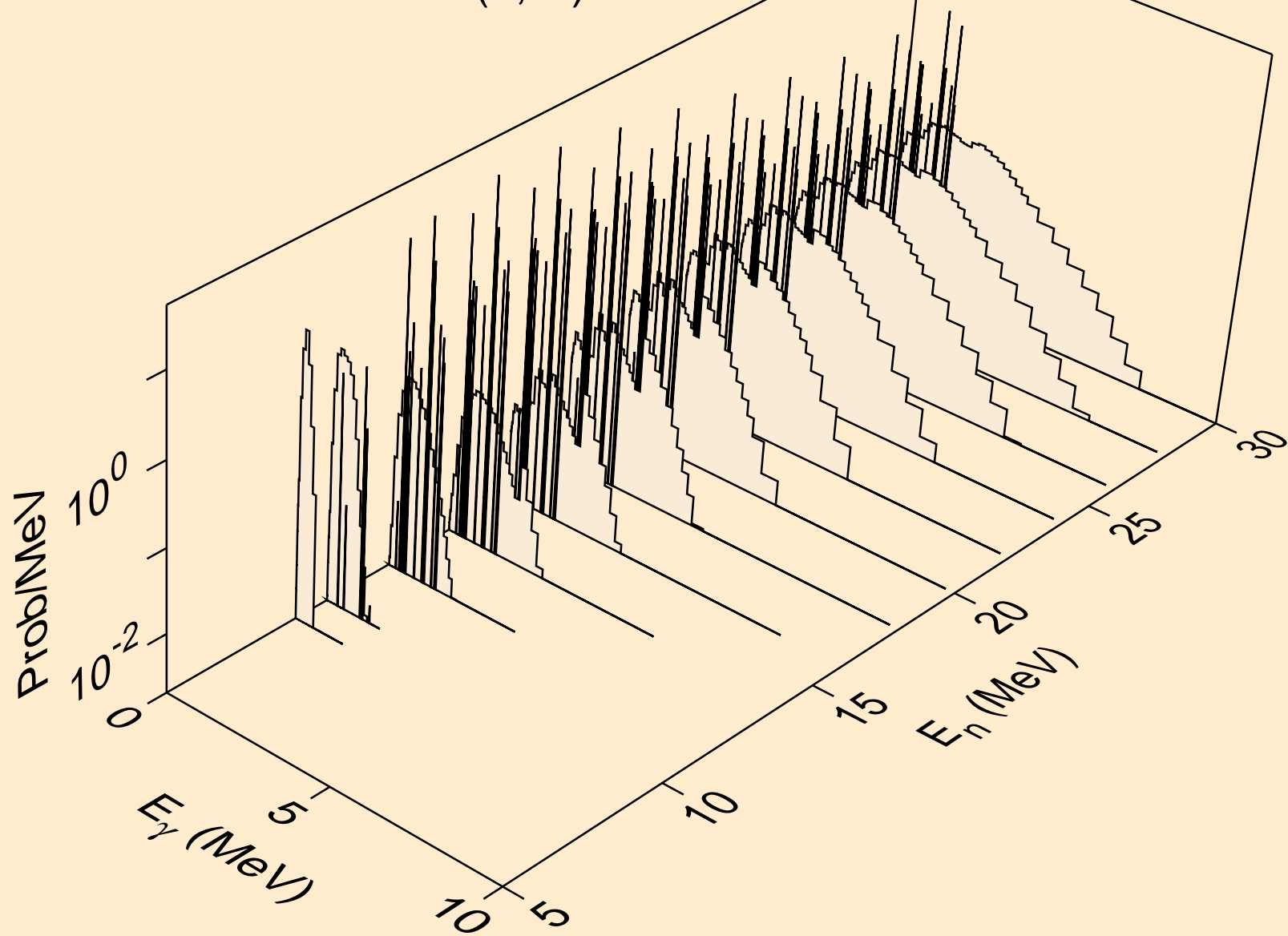

SN113M PROTON ACER TENDL-2021 LIBRARY; T=0.K  
Photon emission for (n,2n)a

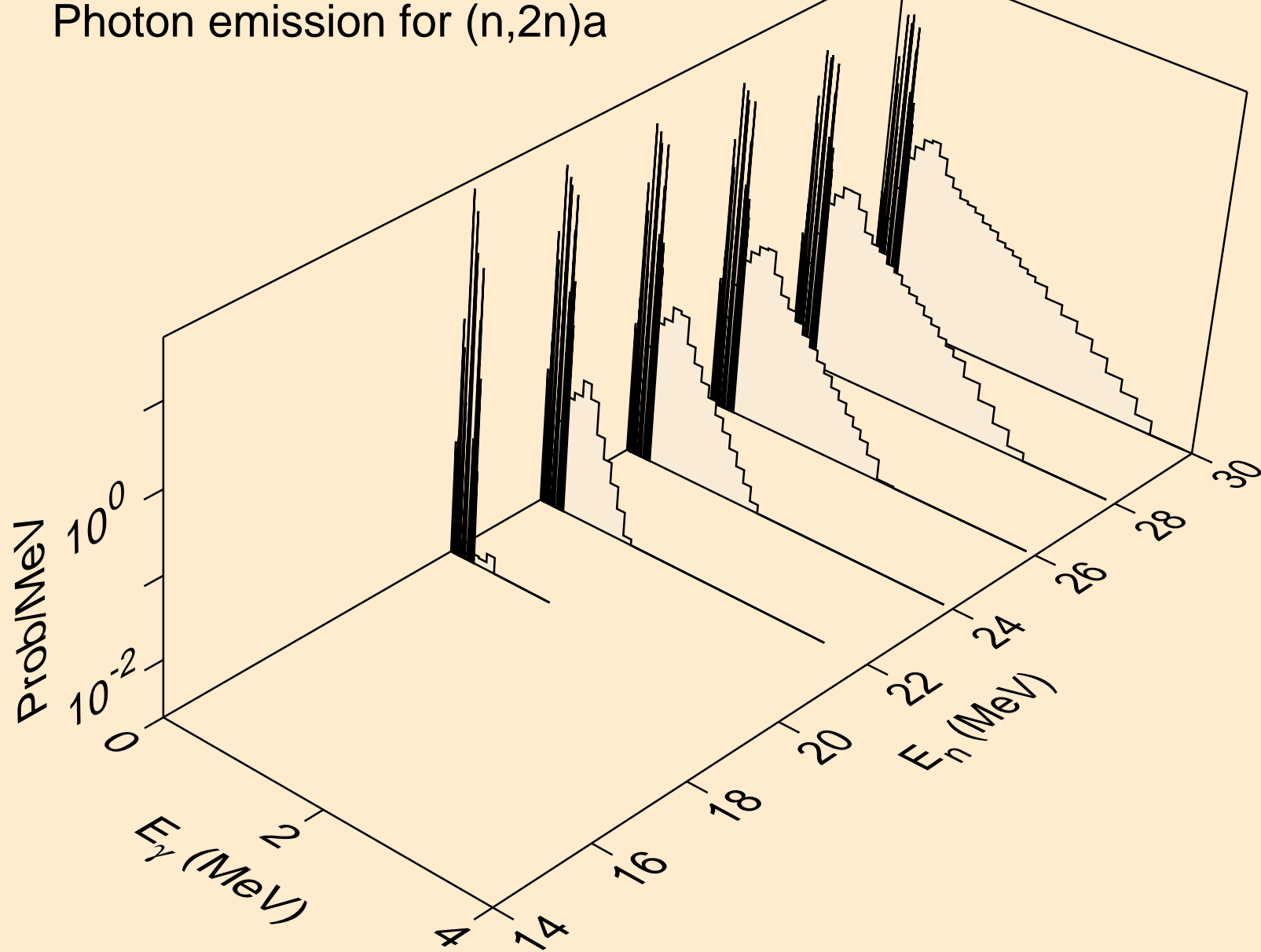

SN113M PROTON ACER TENDL-2021 LIBRARY; T=0.K  
Photon emission for (n,n\*)p

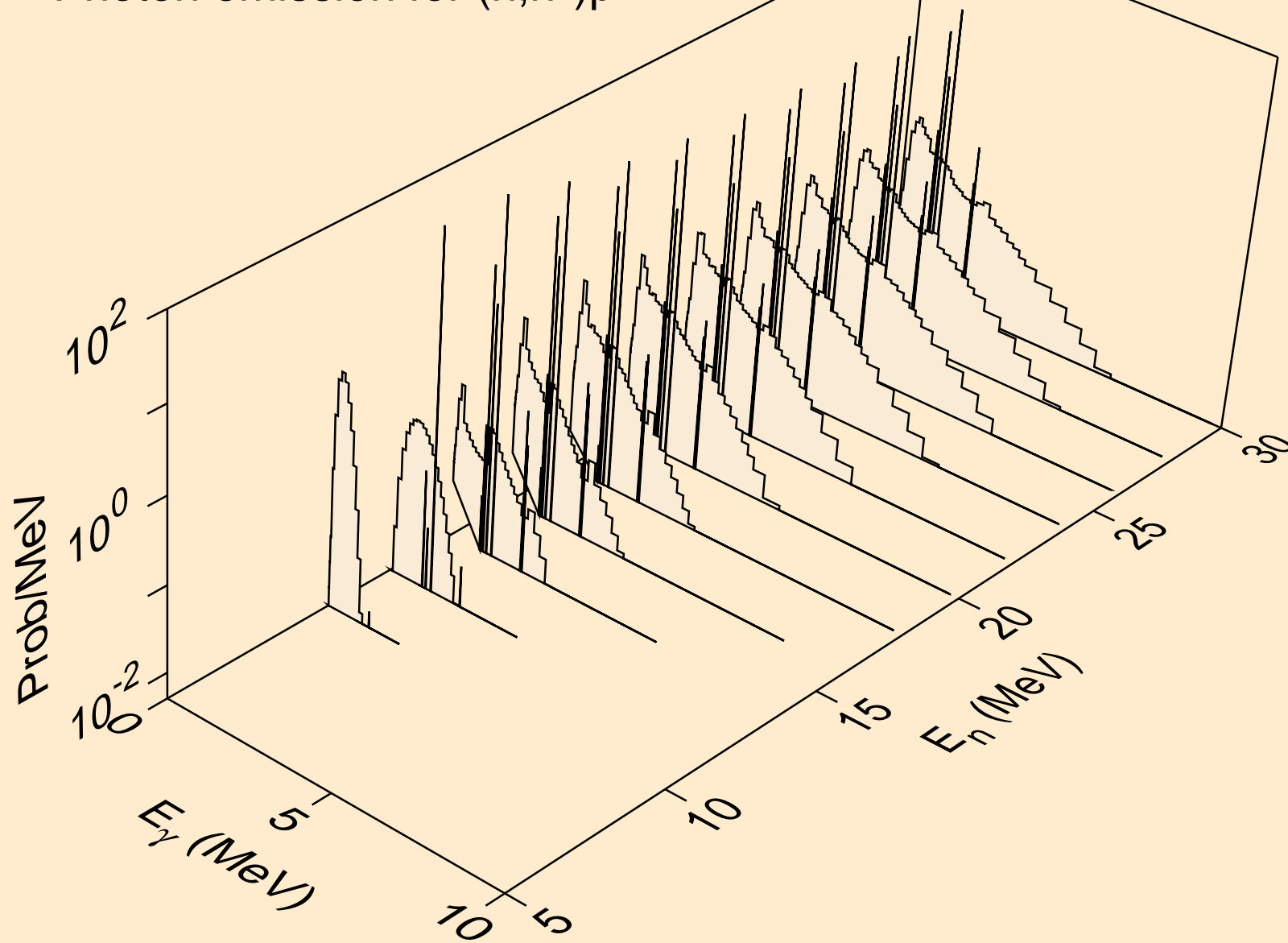

SN113M PROTON ACER TENDL-2021 LIBRARY; T=0.K  
Photon emission for (n,n\*)2a

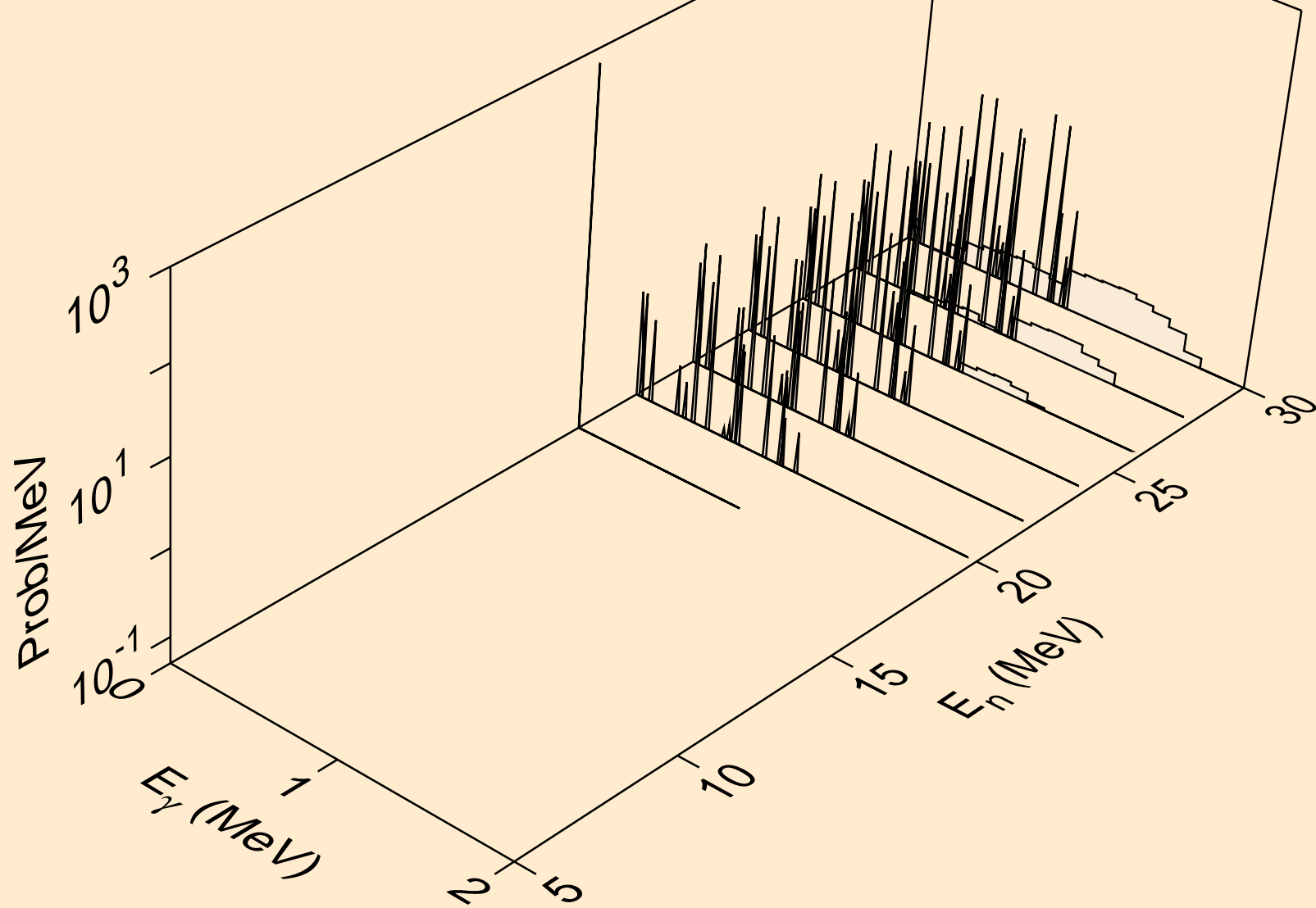

SN113M PROTON ACER TENDL-2021 LIBRARY; T=0.K  
Photon emission for (n,n\*)d

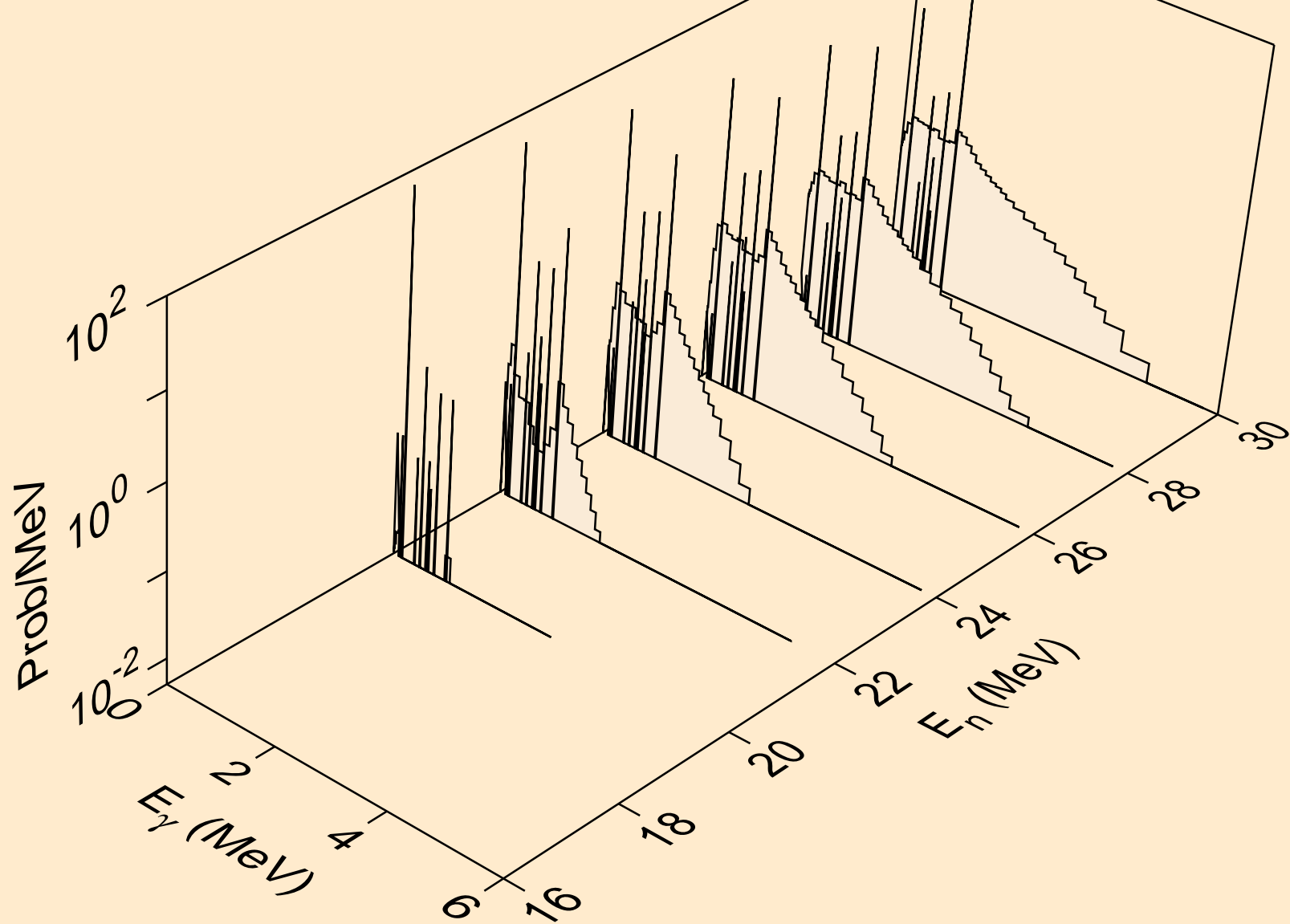

SN113M PROTON ACER TENDL-2021 LIBRARY; T=0.K  
Photon emission for (n,n\*)t

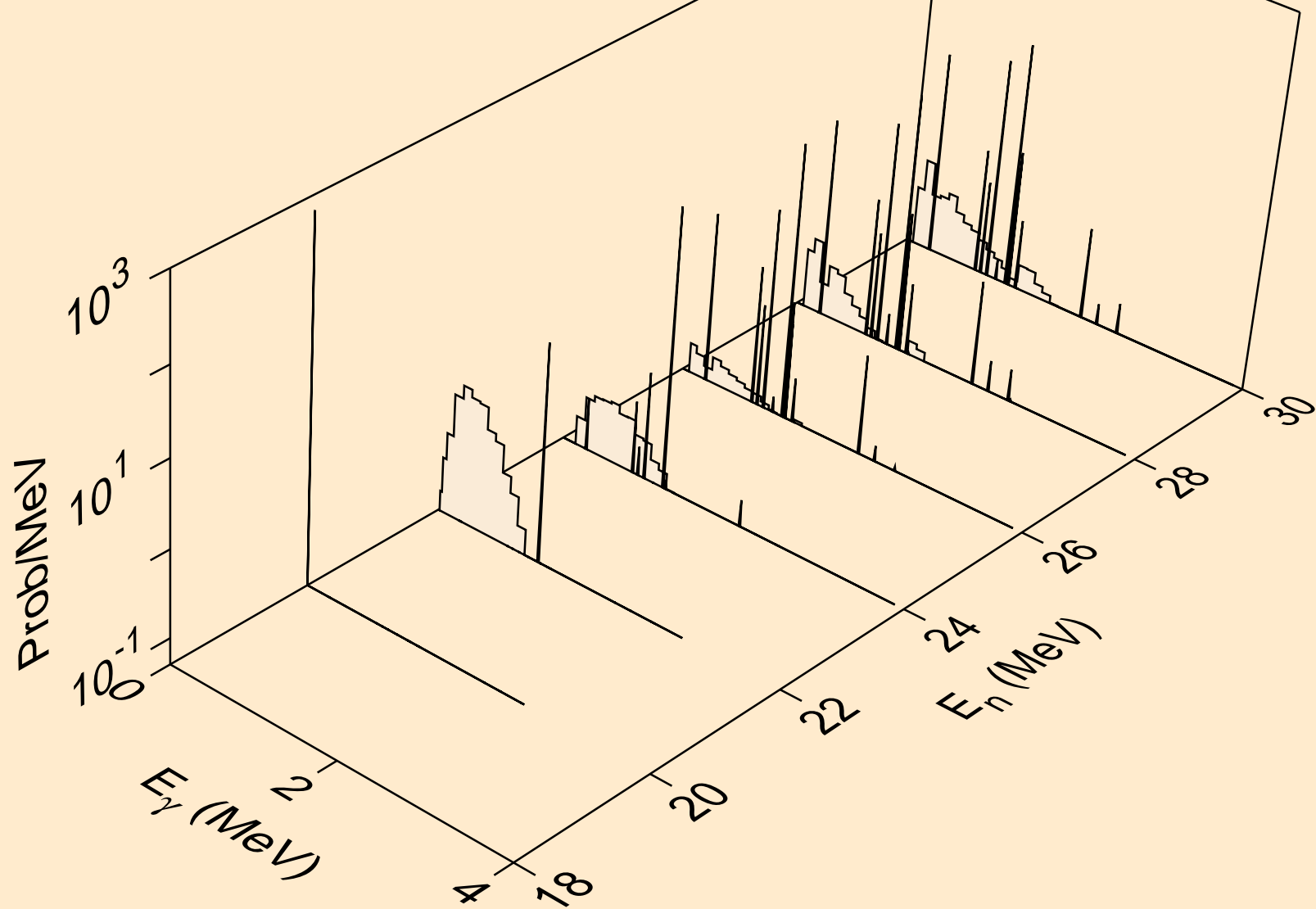

SN113M PROTON ACER TENDL-2021 LIBRARY; T=0.K  
Photon emission for (n,n\*)he3

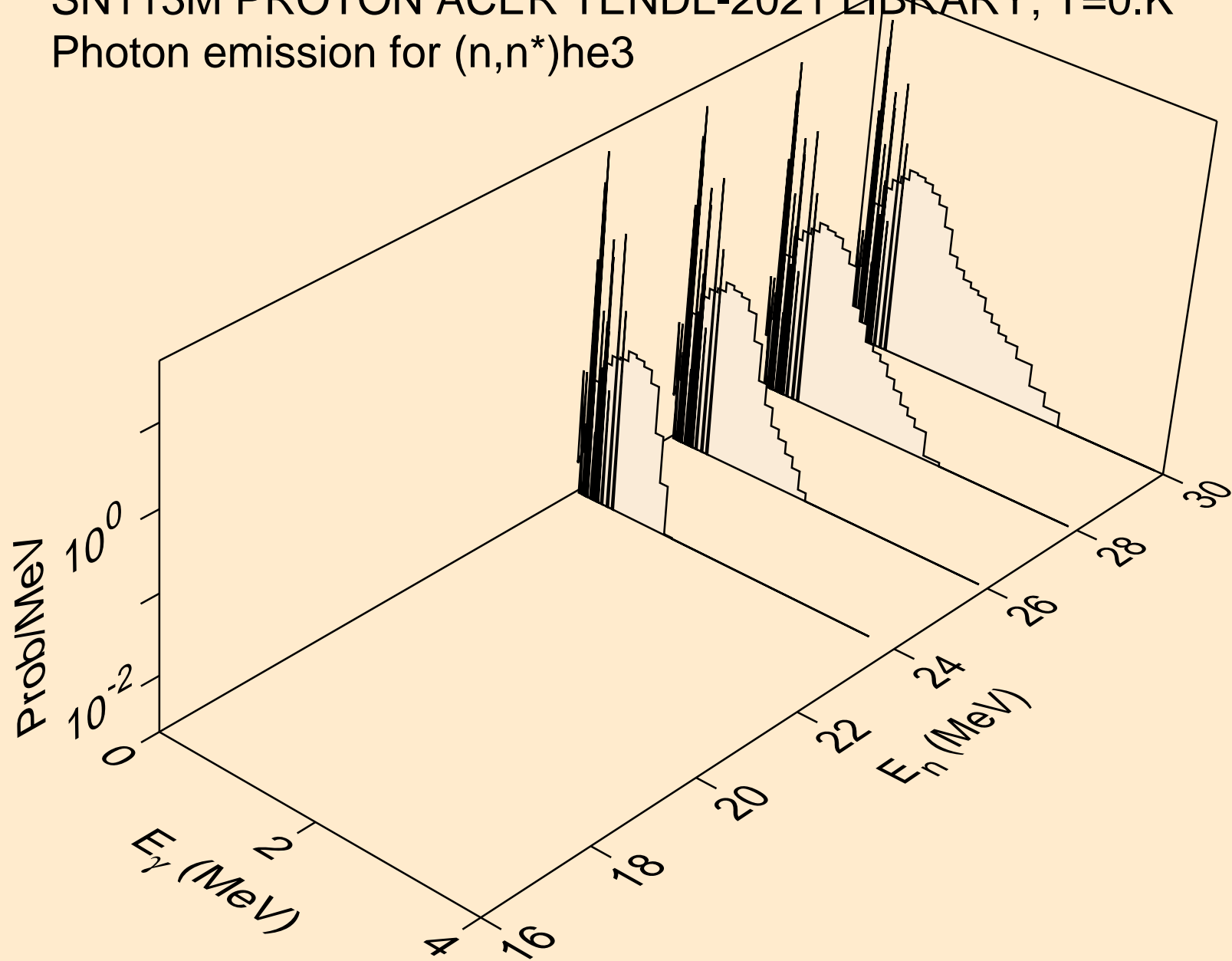



SN113M PROTON ACER TENDL-2021 LIBRARY; T=0.K  
Photon emission for (n,2np)

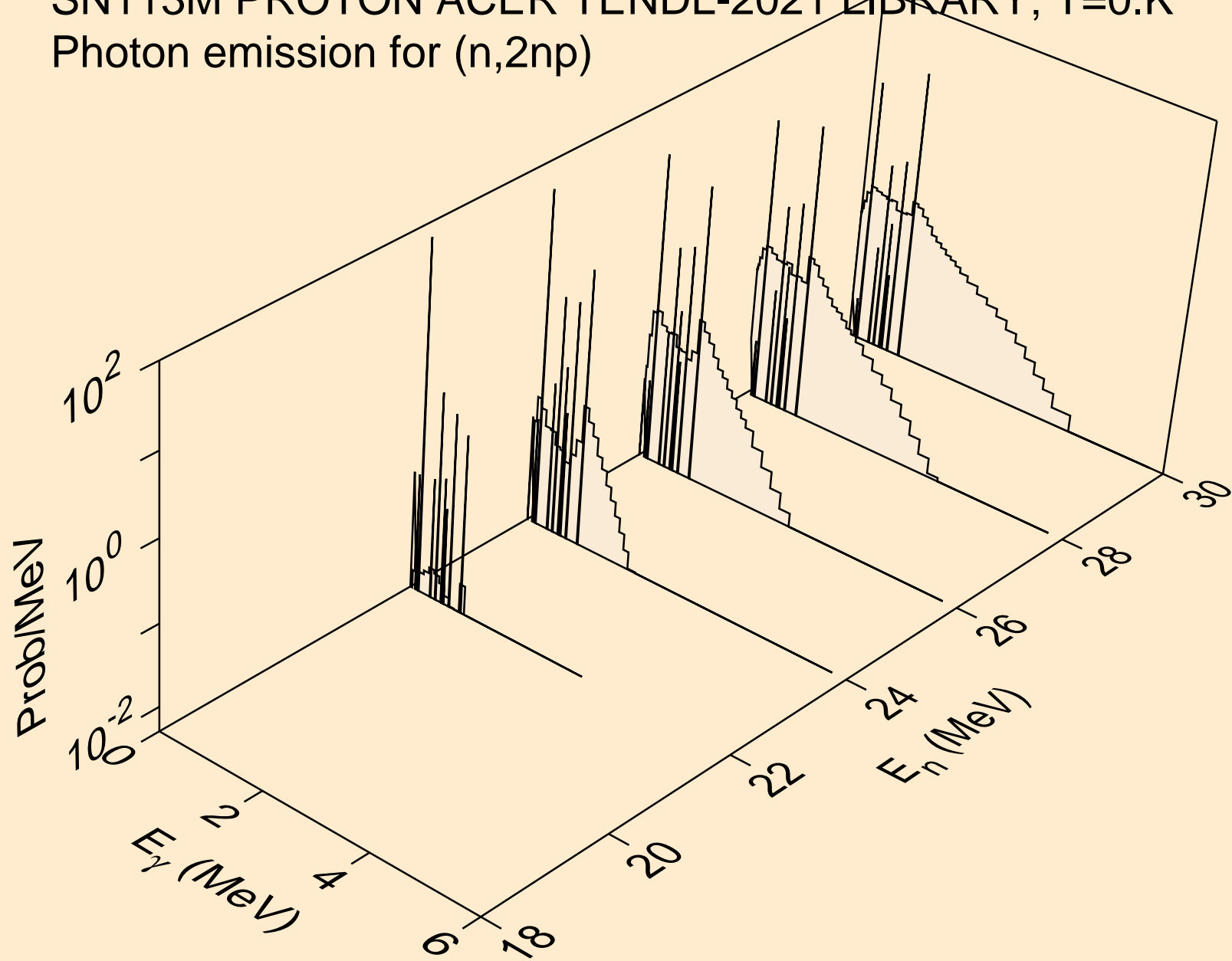

SN113M PROTON ACER TENDL-2021 LIBRARY; T=0.K  
Photon emission for (n,3np)

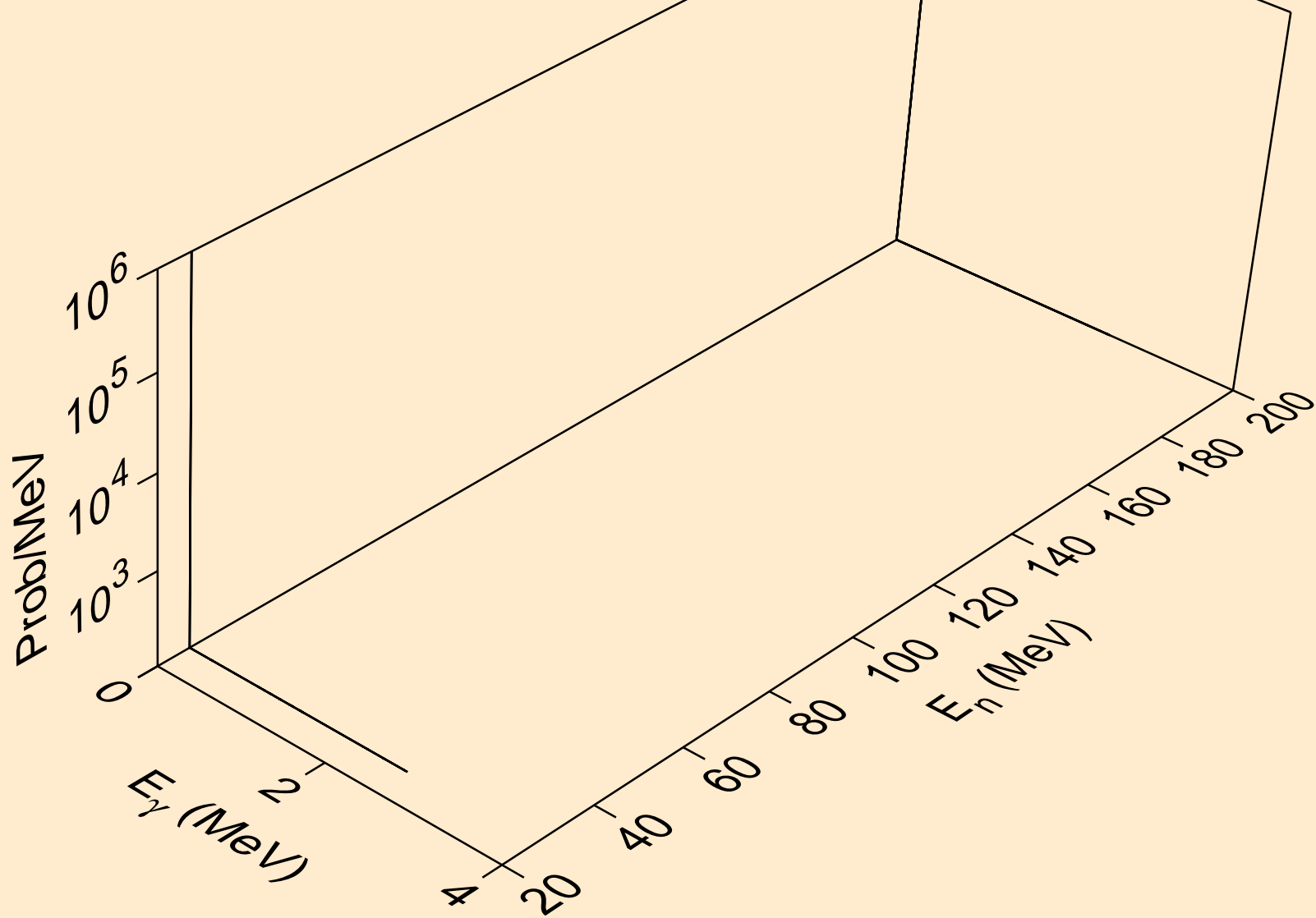

SN113M PROTON ACER TENDL-2021 LIBRARY; T=0.K  
Photon emission for (n,2np)

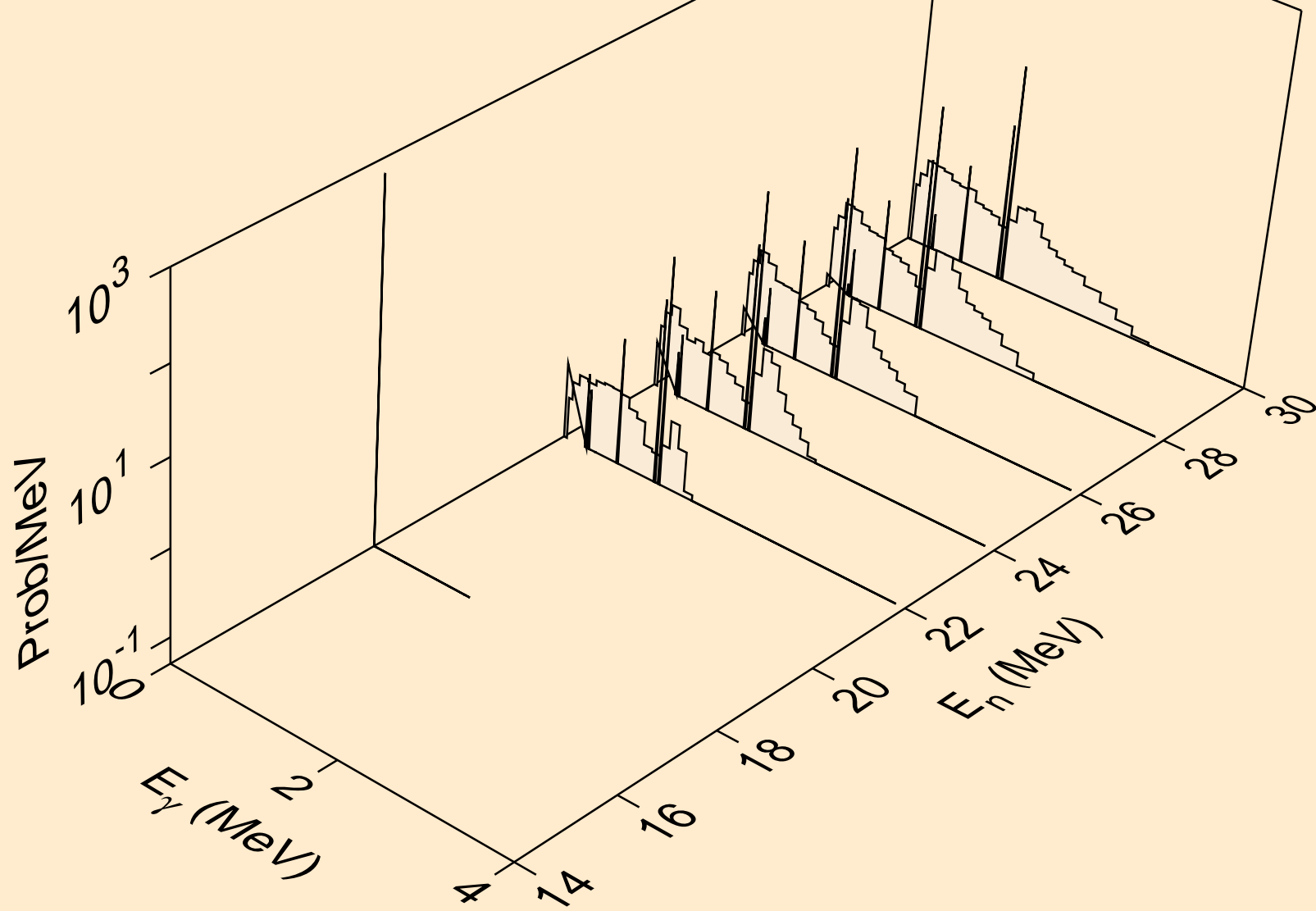

SN113M PROTON ACER TENDL-2021 LIBRARY; T=0.K  
Photon emission for (n,npa)

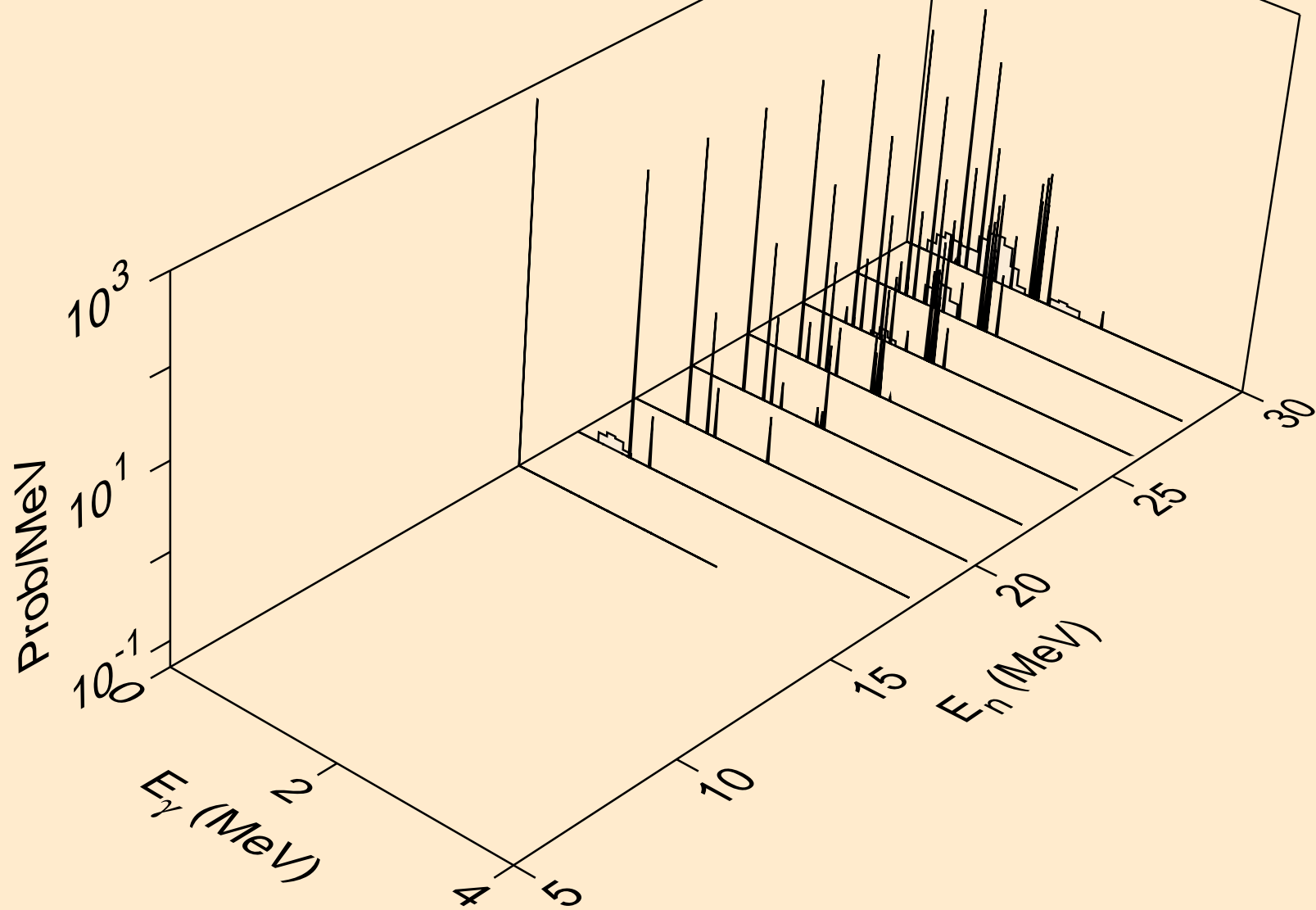

SN113M PROTON ACER TENDL-2021 LIBRARY; T=0.K  
Photon emission for (n,gma)

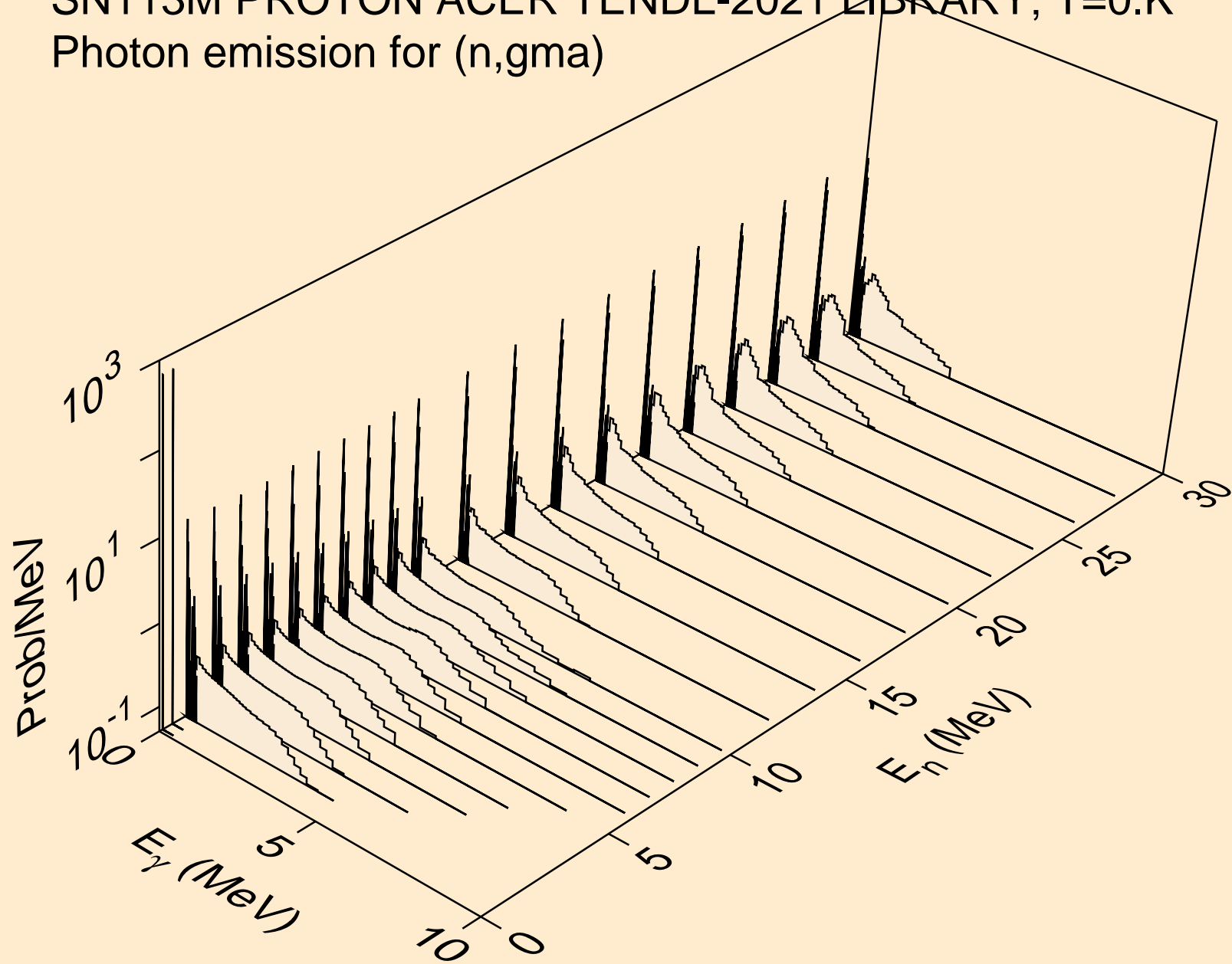

SN113M PROTON ACER TENDL-2021 LIBRARY; T=0.K  
Photon emission for inelastic

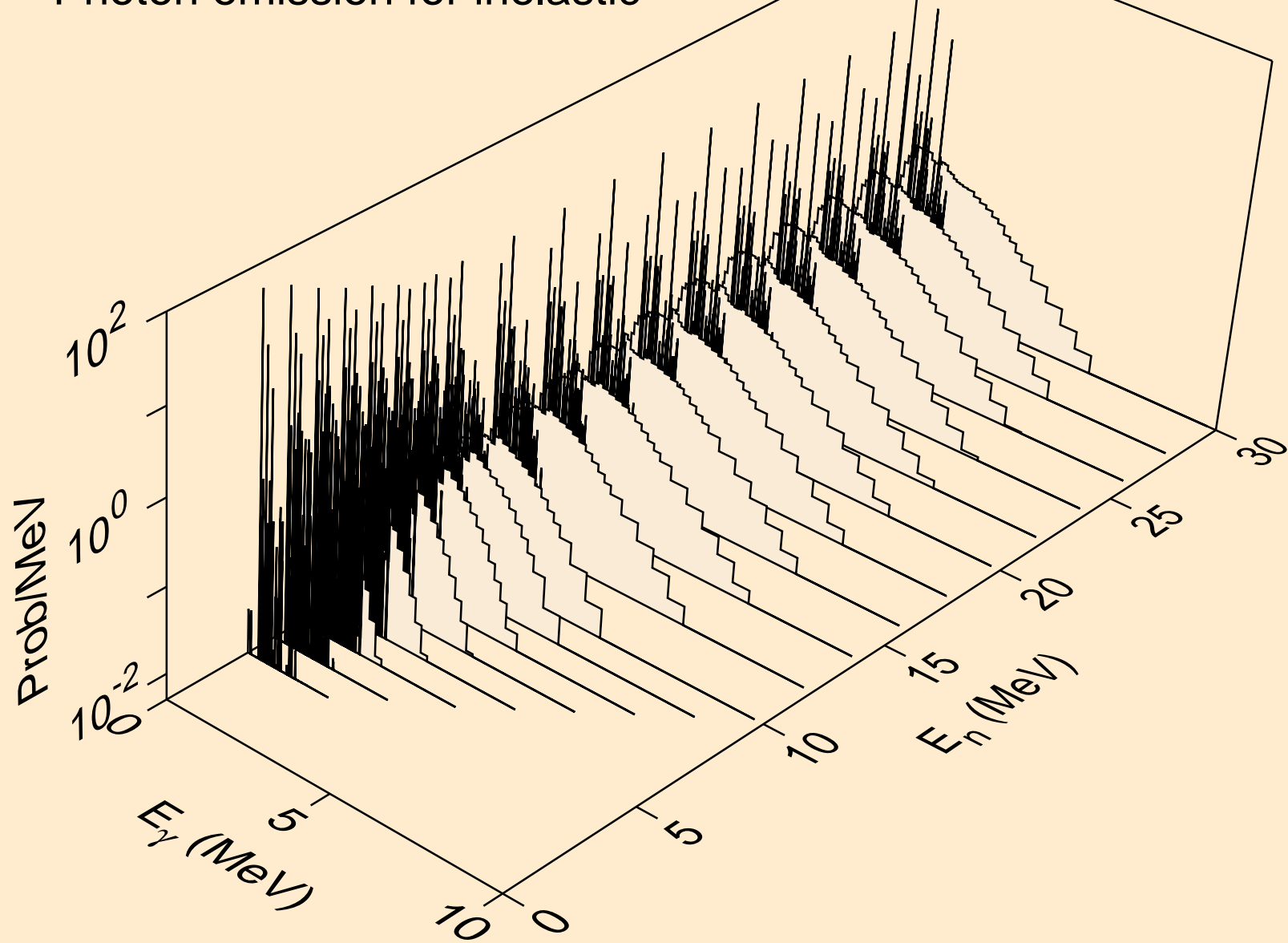

SN113M PROTON ACER TENDL-2021 LIBRARY; T=0.K  
Photon emission for (n,d)

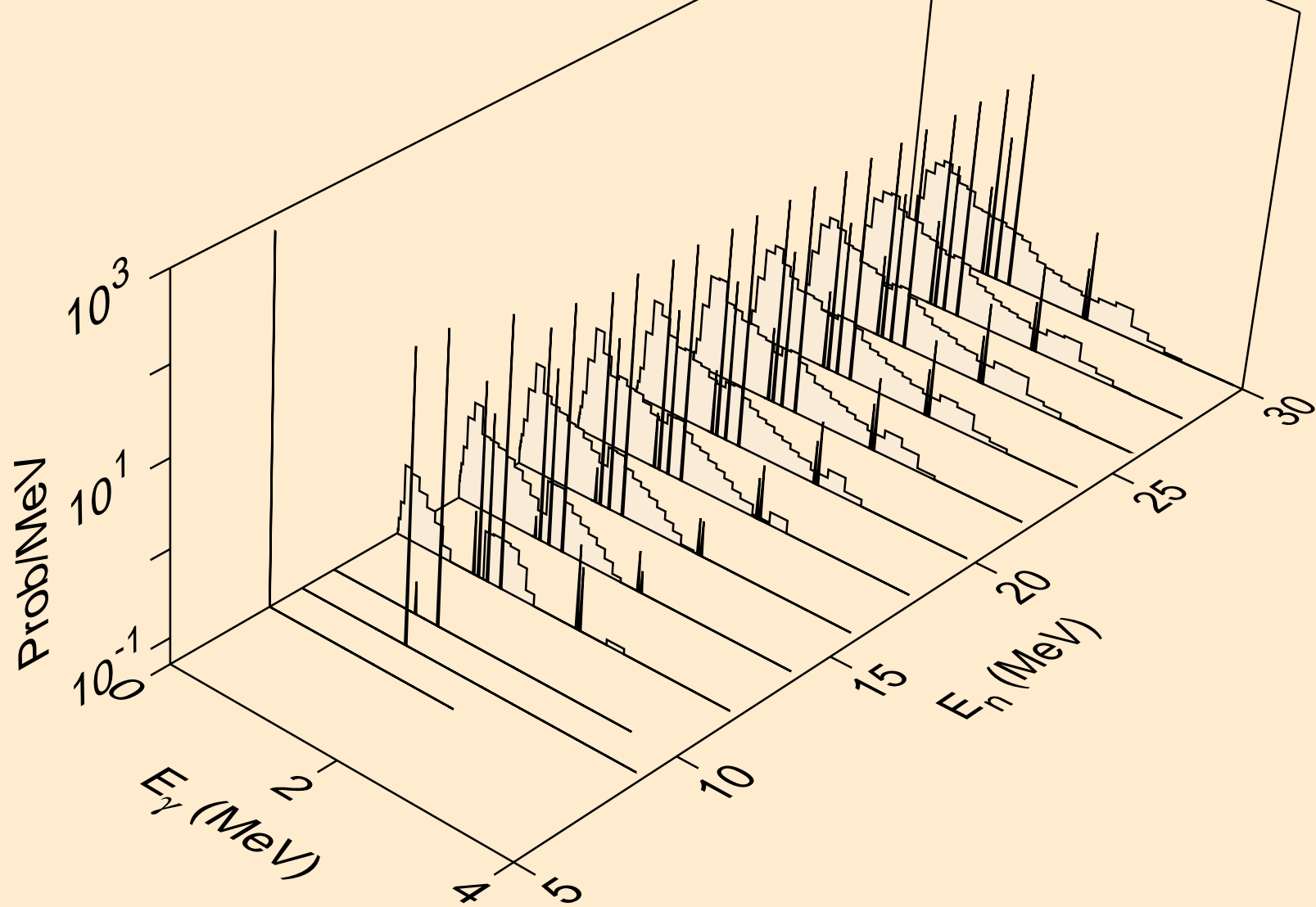

SN113M PROTON ACER TENDL-2021 LIBRARY; T=0.K  
Photon emission for (n,t)

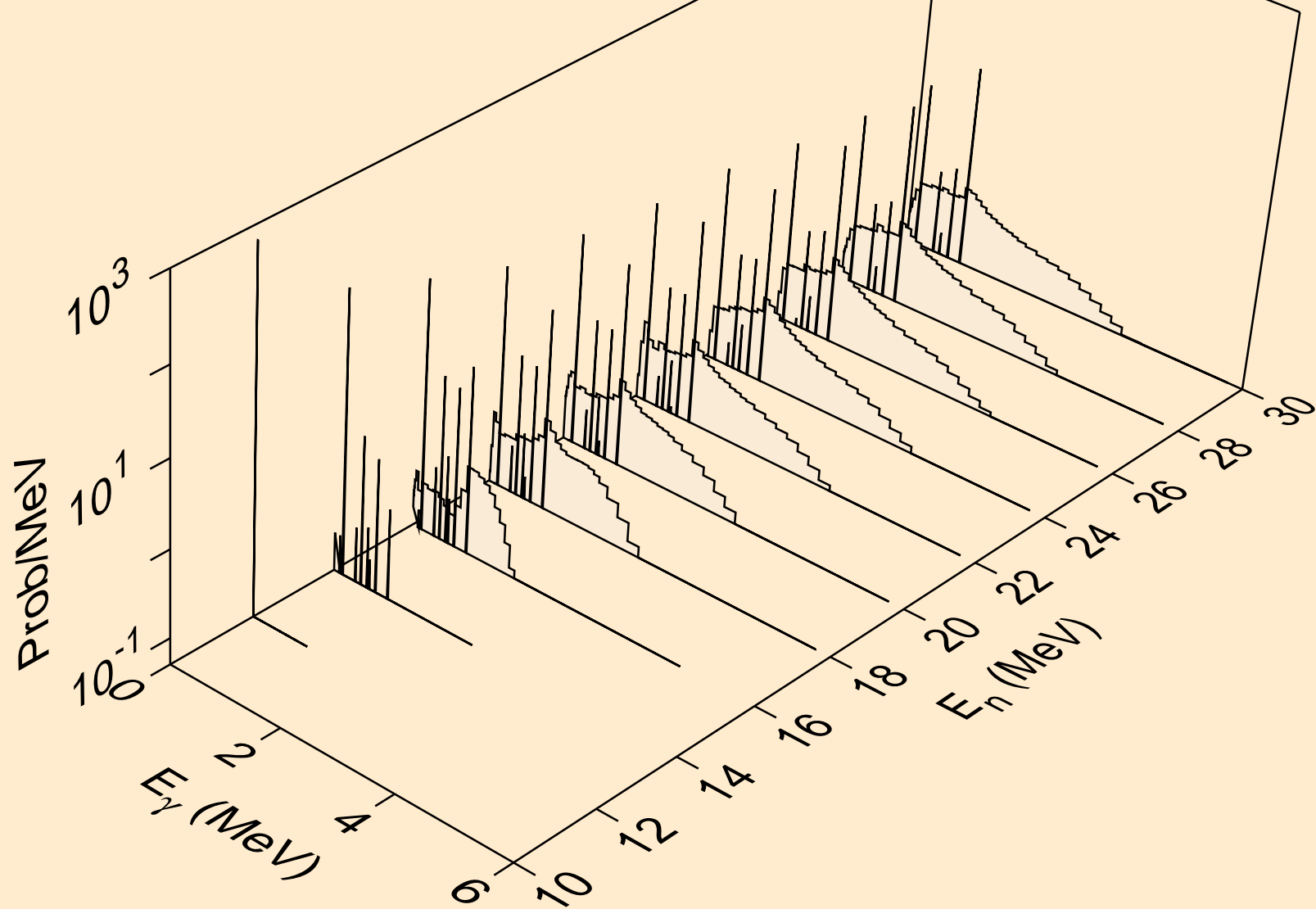



SN113M PROTON ACER TENDL-2021 LIBRARY; T=0.K  
Photon emission for (n,he3)

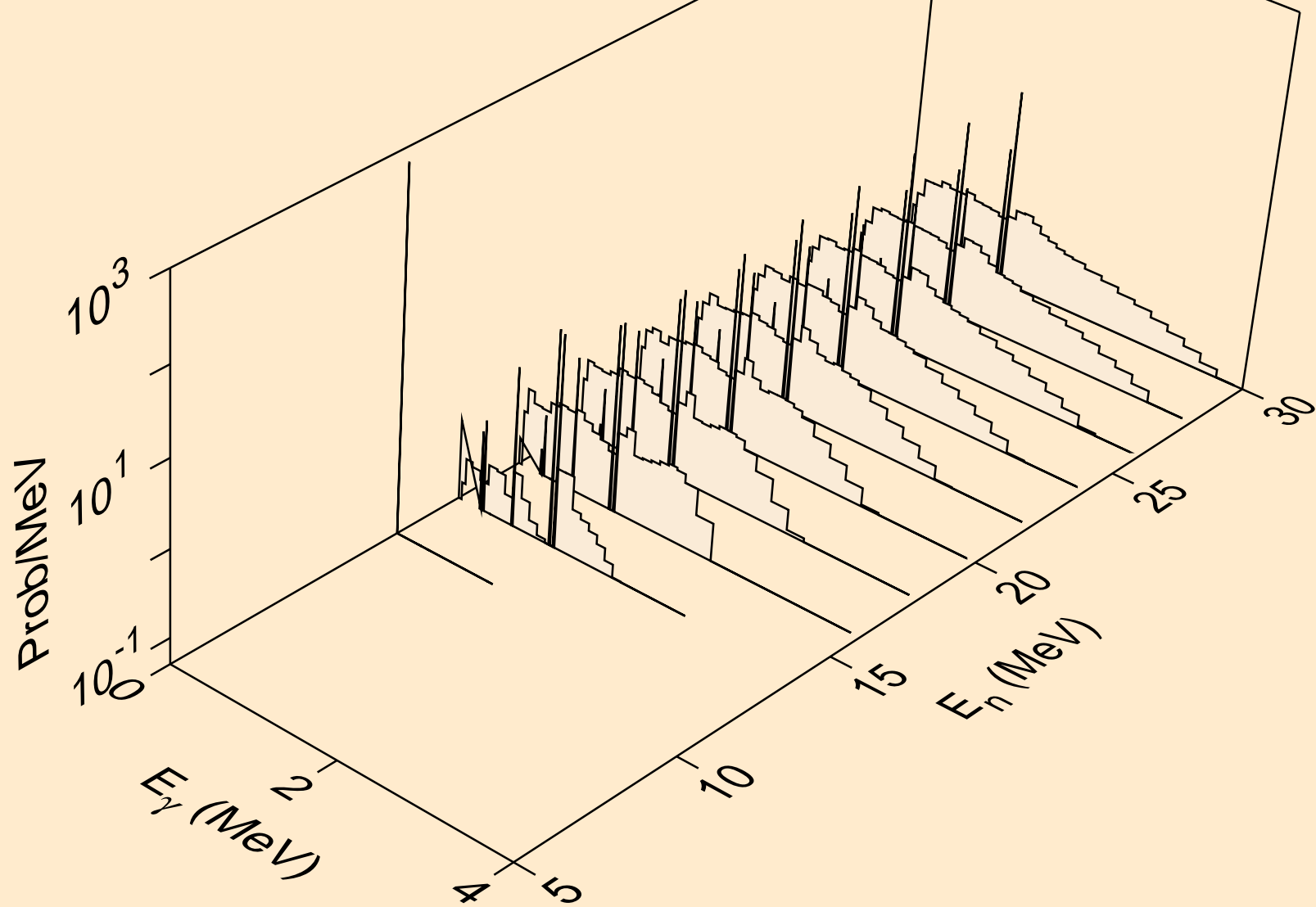

SN113M PROTON ACER TENDL-2021 LIBRARY; T=0.K  
Photon emission for (n,a)

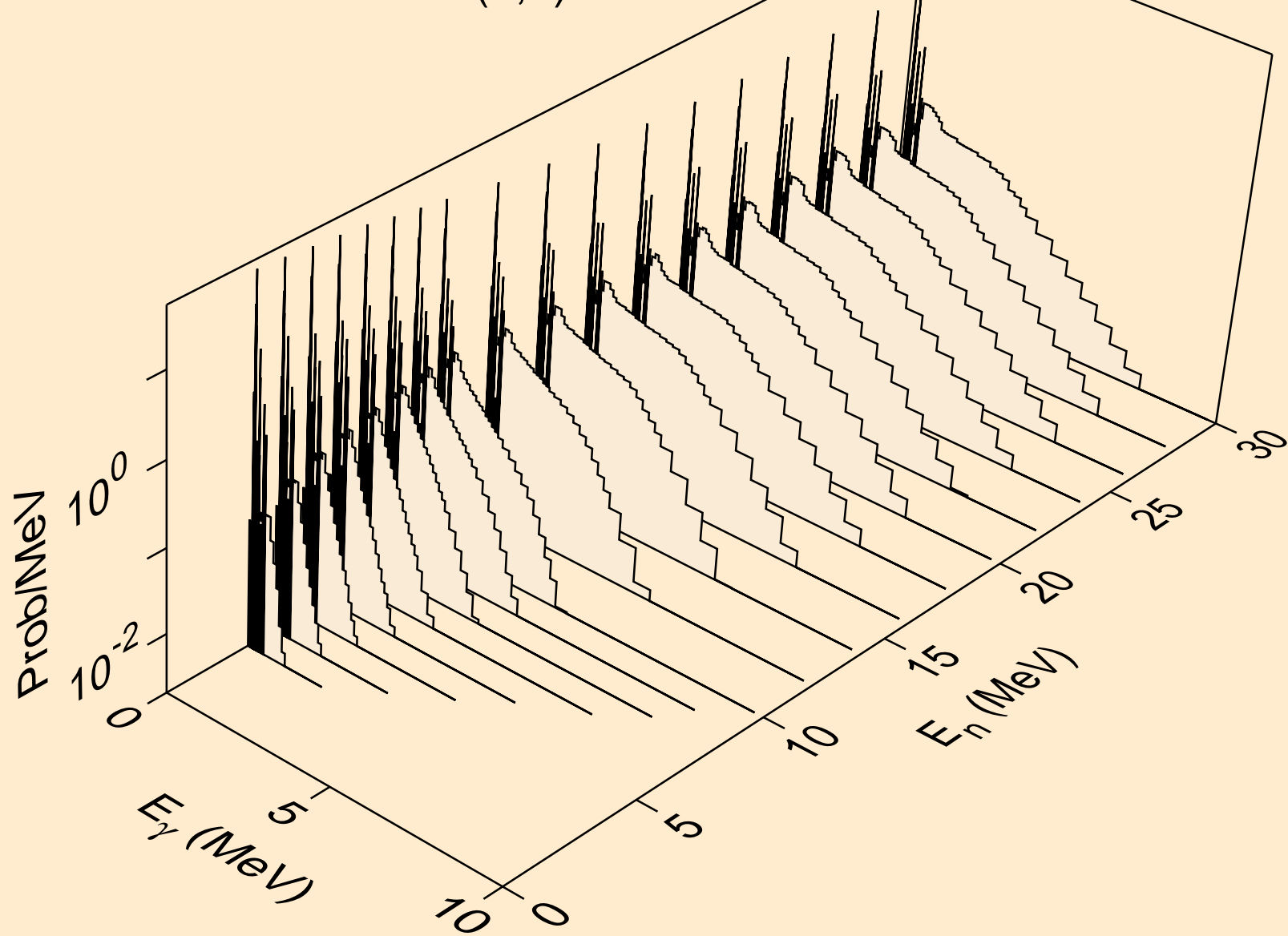

SN113M PROTON ACER TENDL-2021 LIBRARY; T=0.K  
Photon emission for (n,2a)

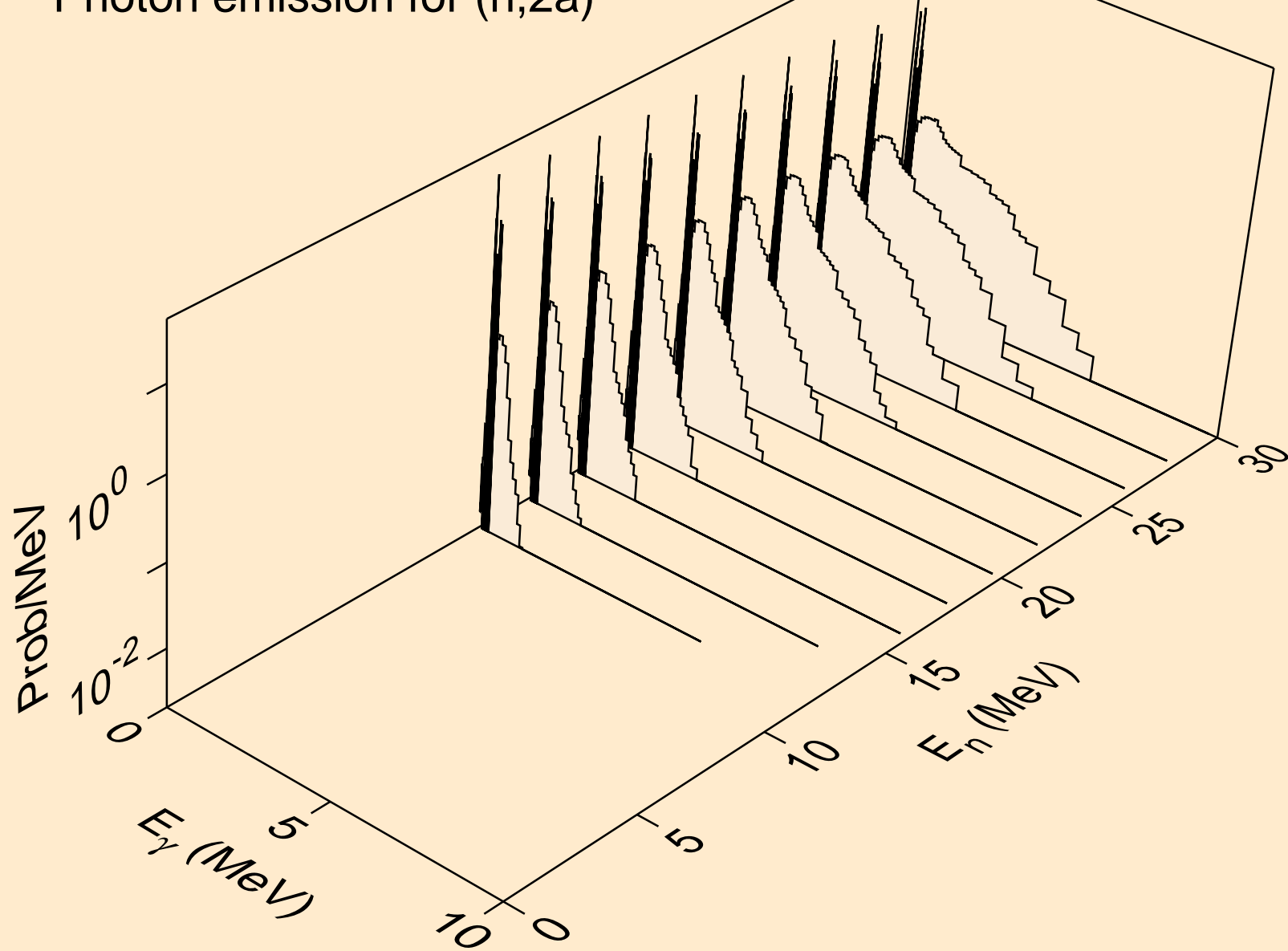

SN113M PROTON ACER TENDL-2021 LIBRARY; T=0.K  
Photon emission for (n,2p)

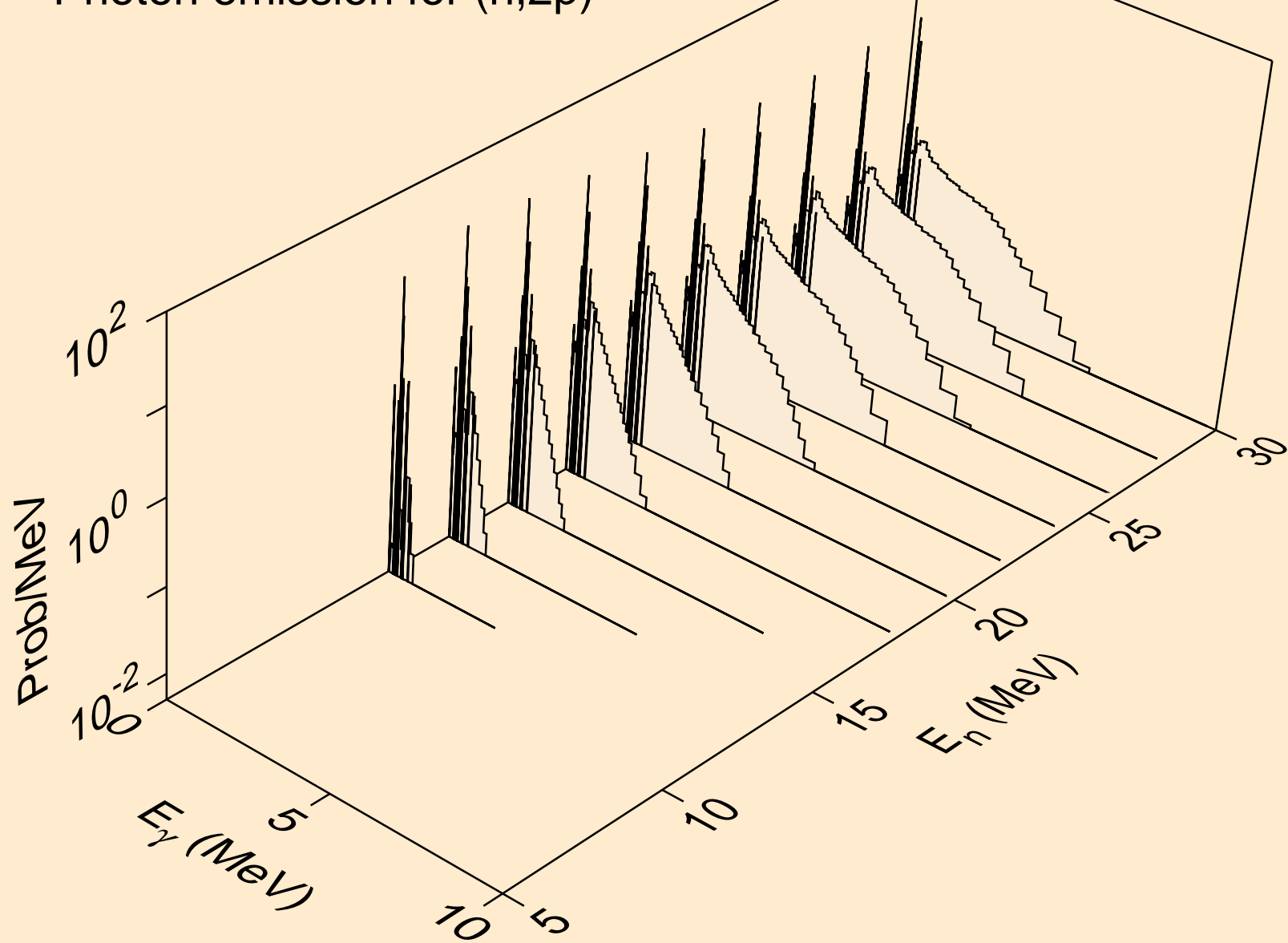

SN113M PROTON ACER TENDL-2021 LIBRARY; T=0.K  
Photon emission for (n,p)

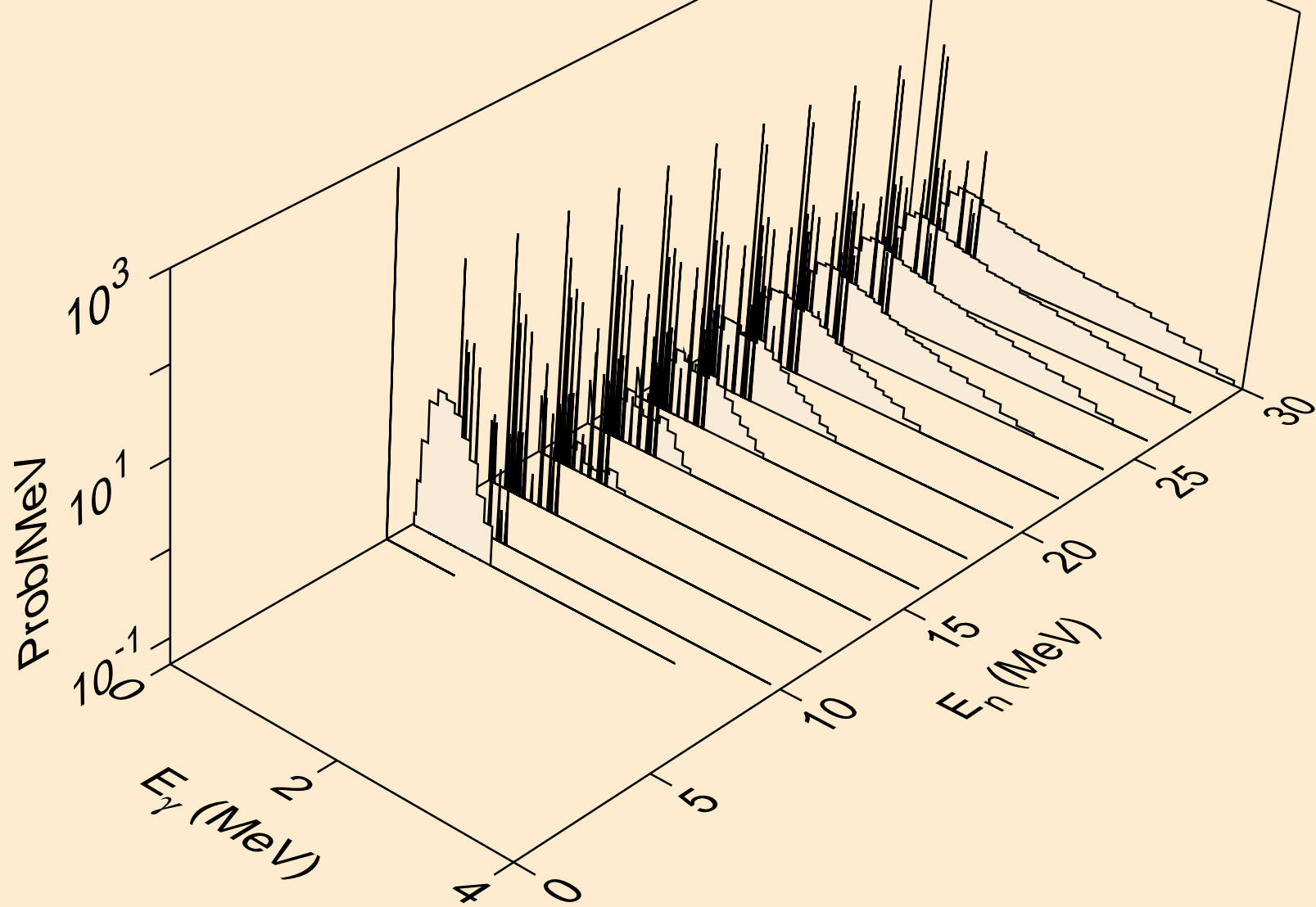

SN113M PROTON ACER TENDL-2021 LIBRARY; T=0.K  
Photon emission for (n,pd)

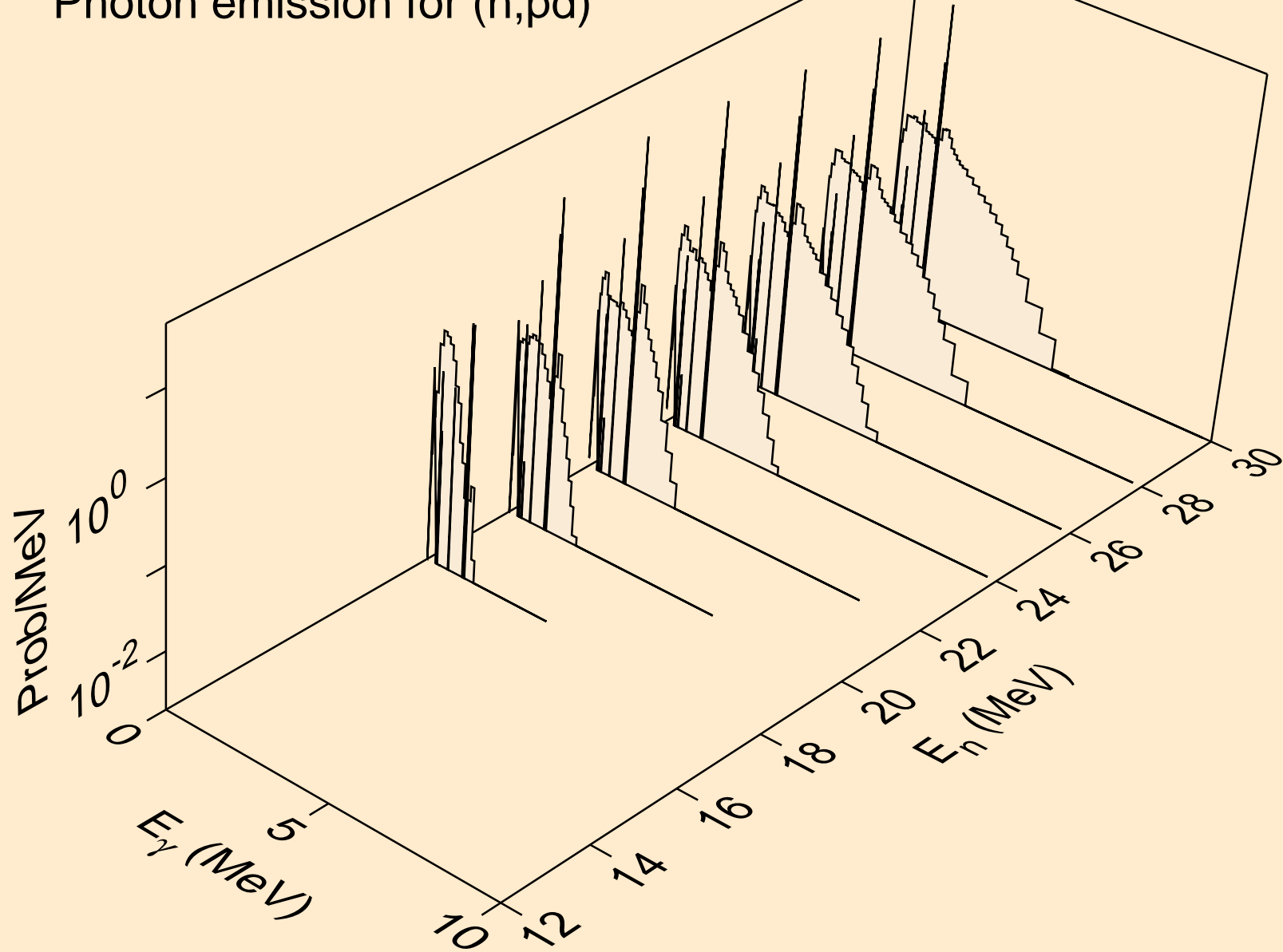

SN113M PROTON ACER TENDL-2021 LIBRARY; T=0.K  
Photon emission for (n,pt)

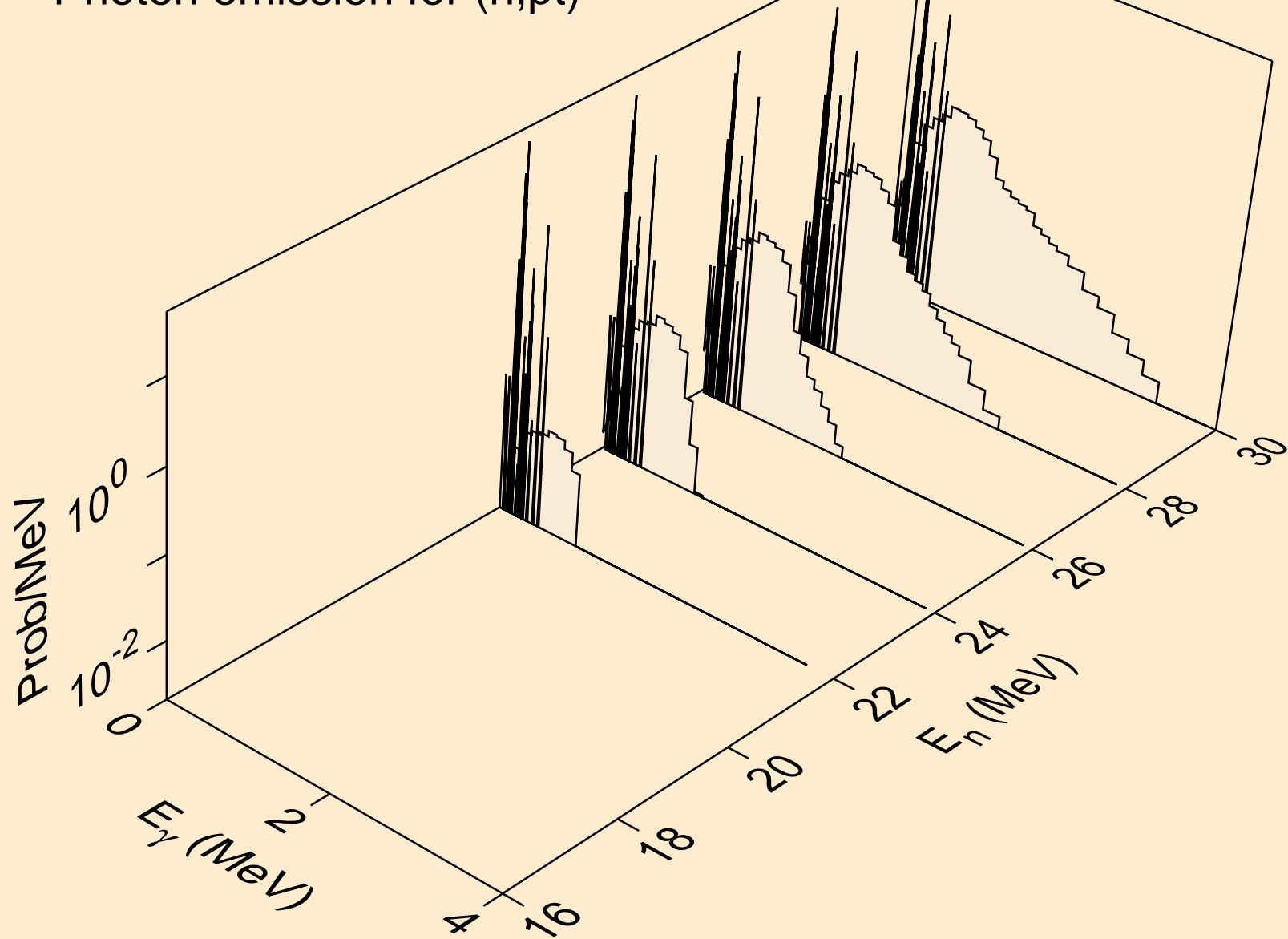

SN113M PROTON ACER TENDL-2021 LIBRARY; T=0.K  
Photon emission for (n,da)

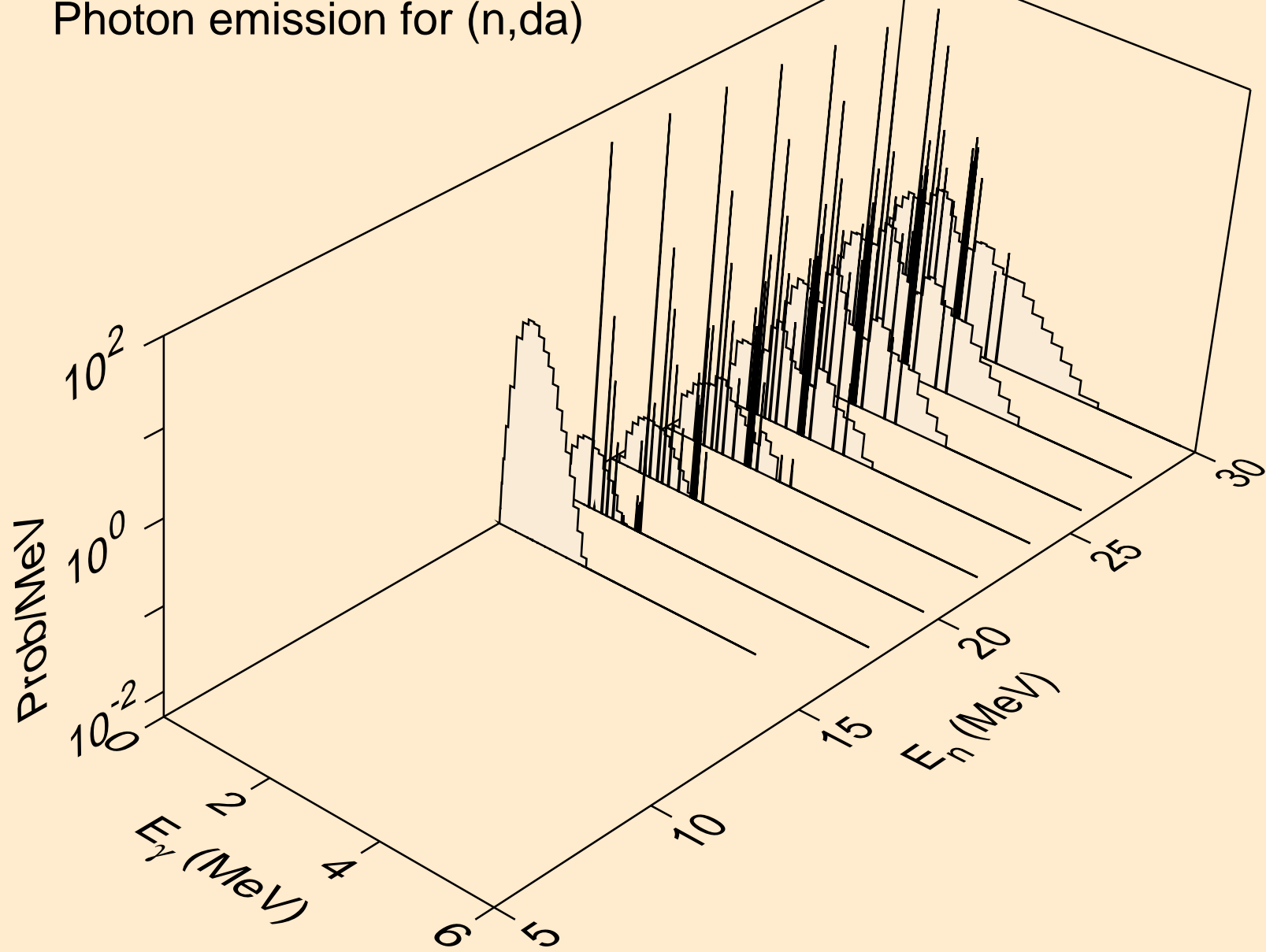



# SN113M PROTON ACER TENDL-2021 LIBRARY; T=0.K

## Particle heating contributions

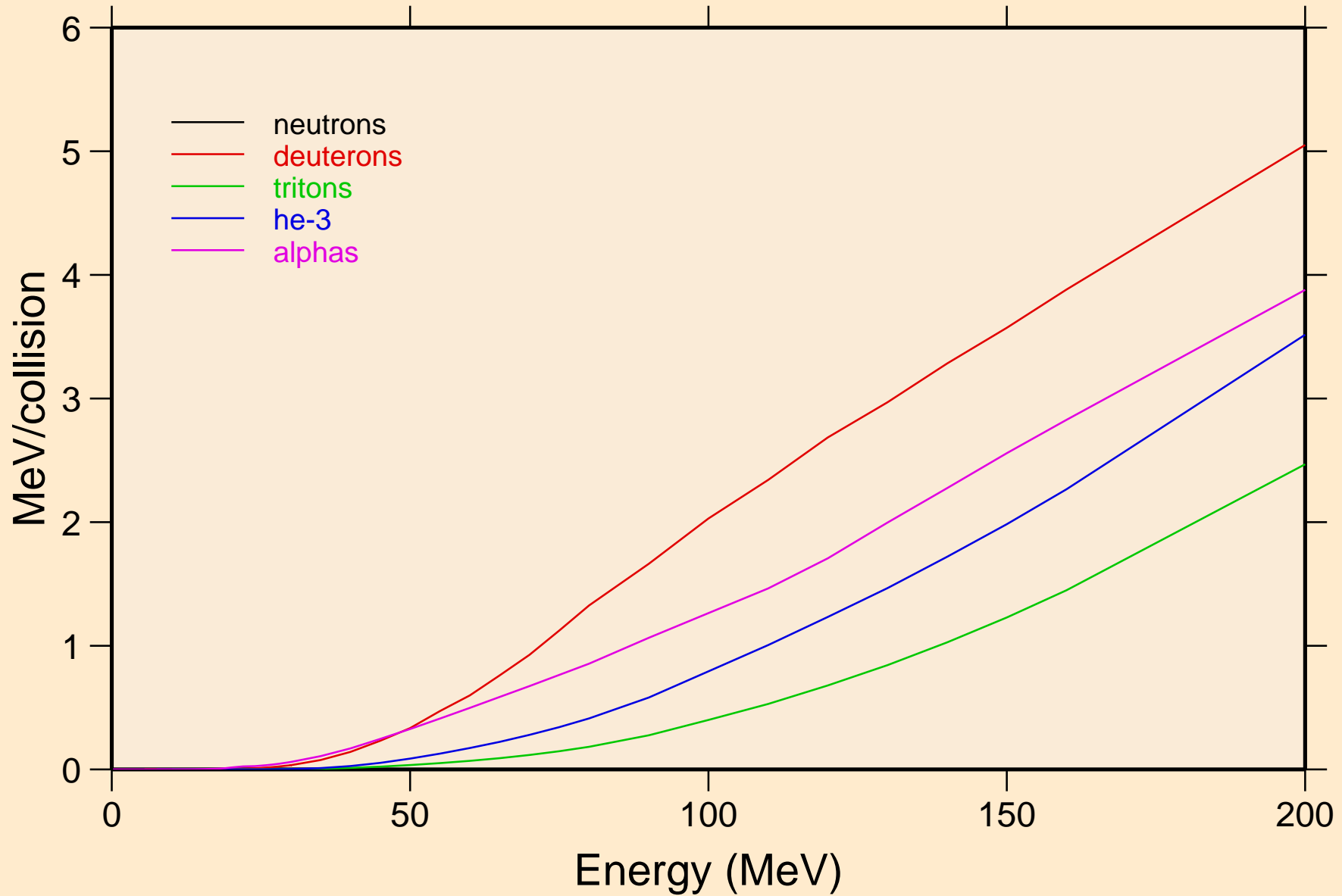

SN113M PROTON ACER TENDL-2021 LIBRARY; T=0.K  
Recoil Heating

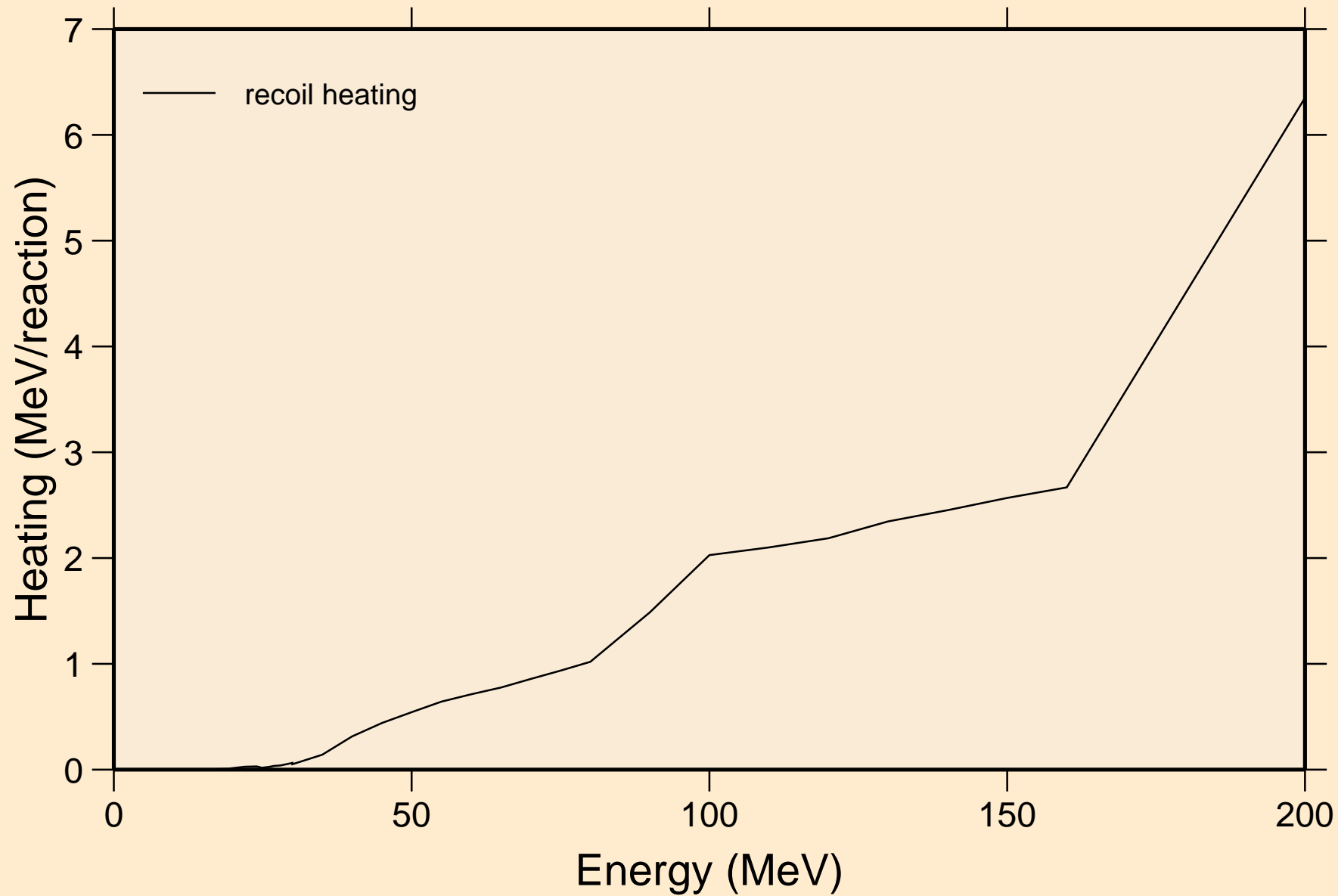

SN113M PROTON ACER TENDL-2021 LIBRARY; T=0.K  
Particle production cross sections

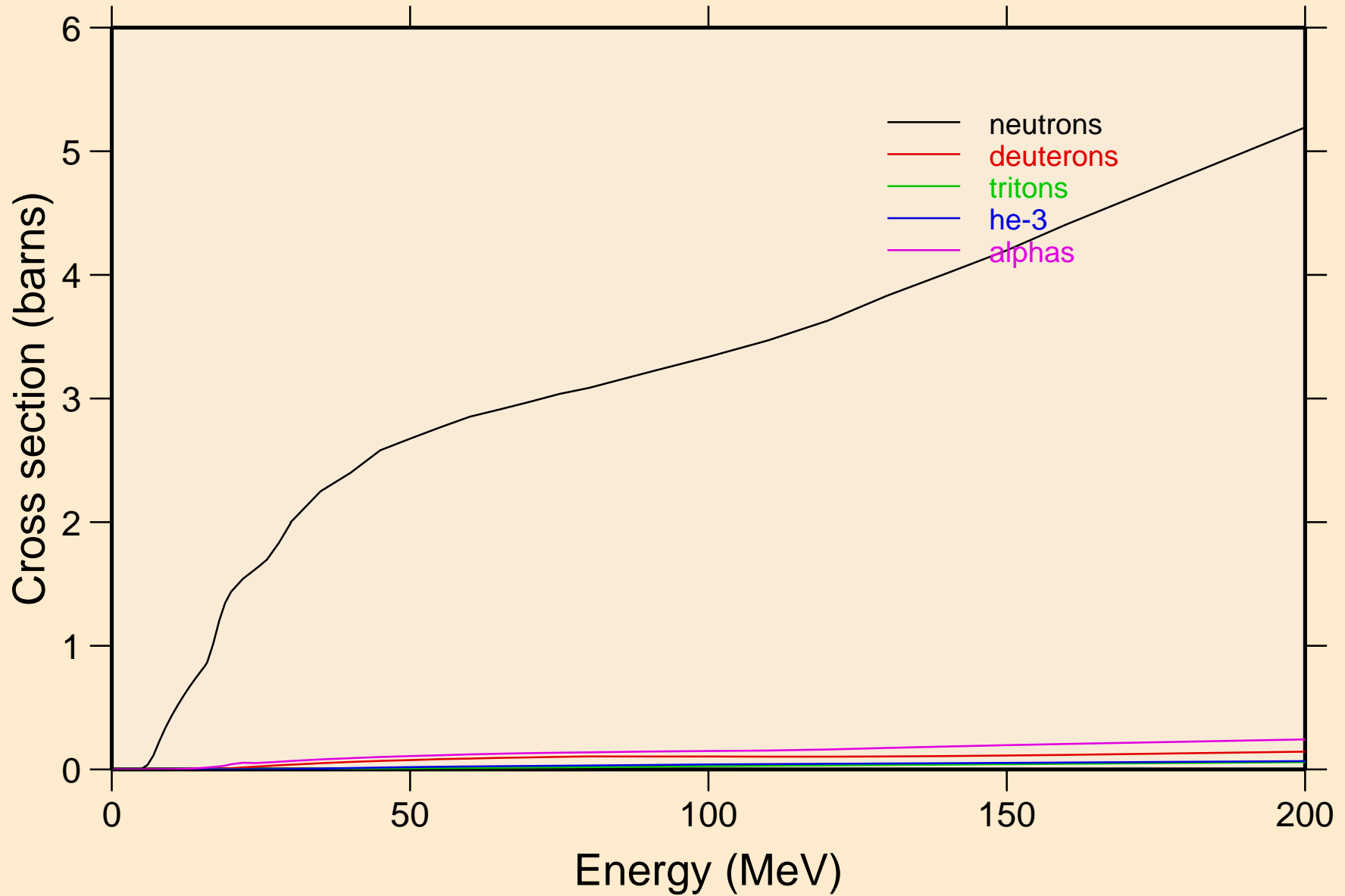

SN113M PROTON ACER TENDL-2021 LIBRARY; T=0.K  
neutrons from (p,n)

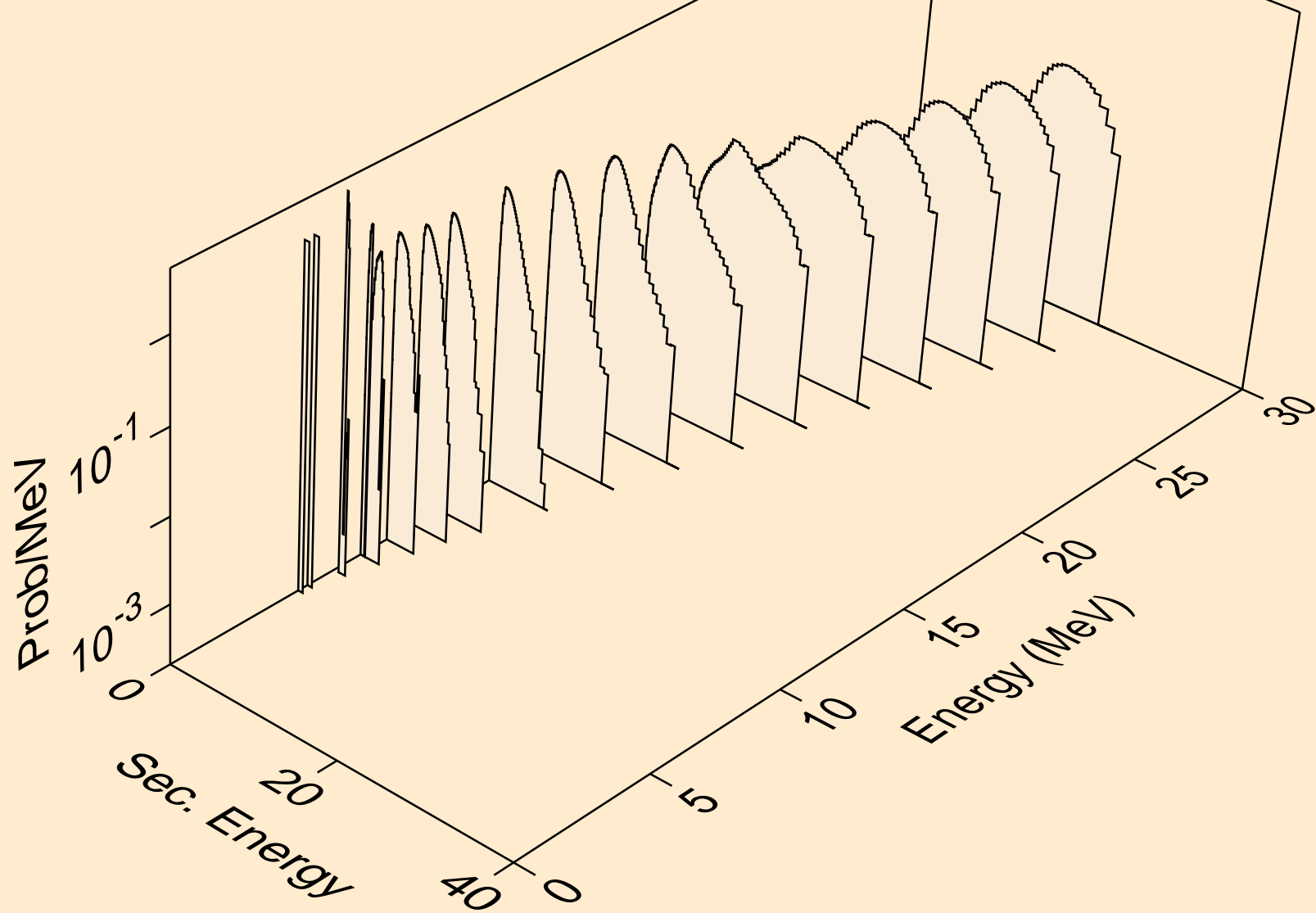

SN113M PROTON ACER TENDL-2021 LIBRARY; T=0.K  
neutrons from (p,x)

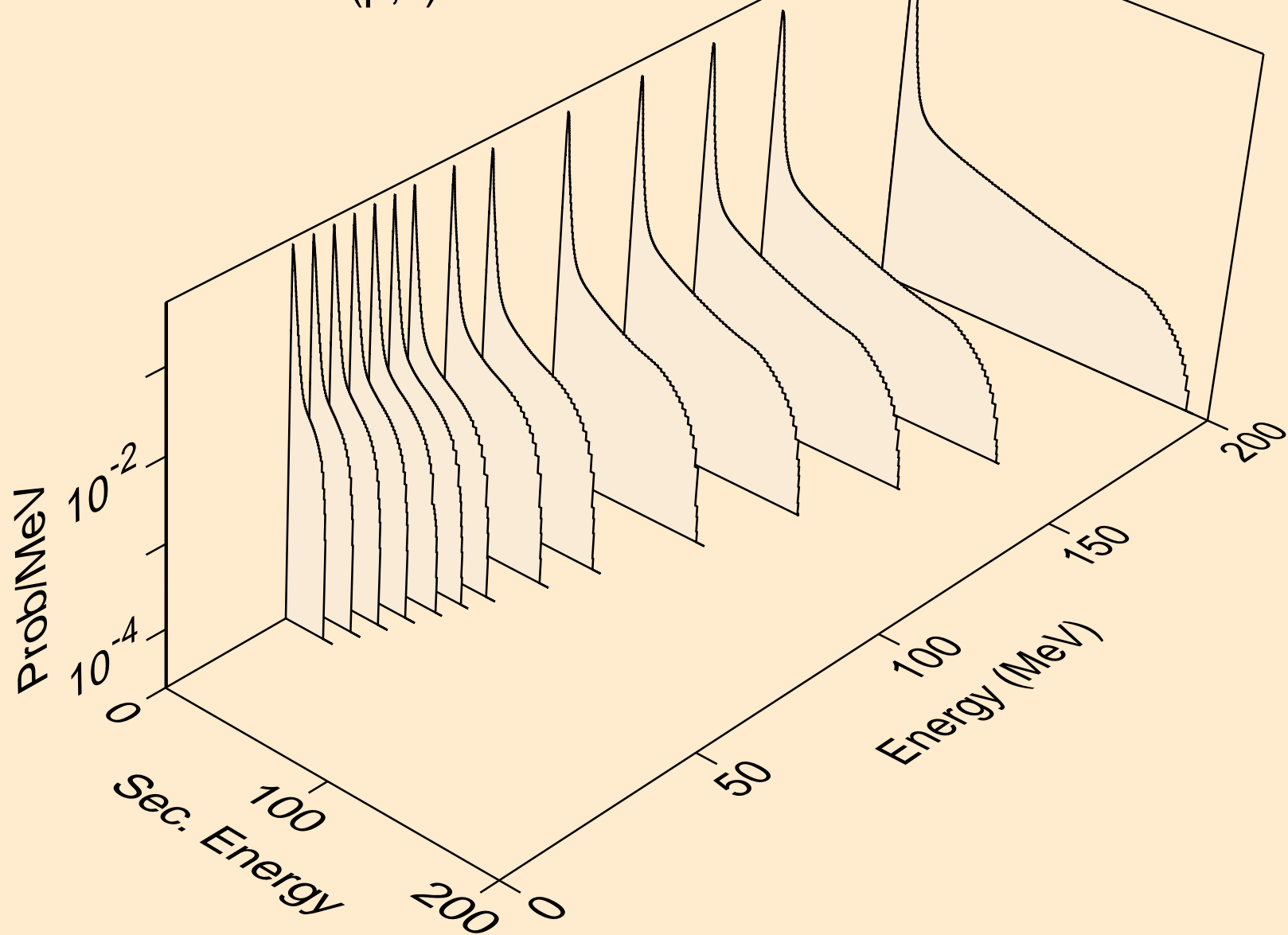

SN113M PROTON ACER TENDL-2021 LIBRARY; T=0.K  
neutrons from (p,2nd)

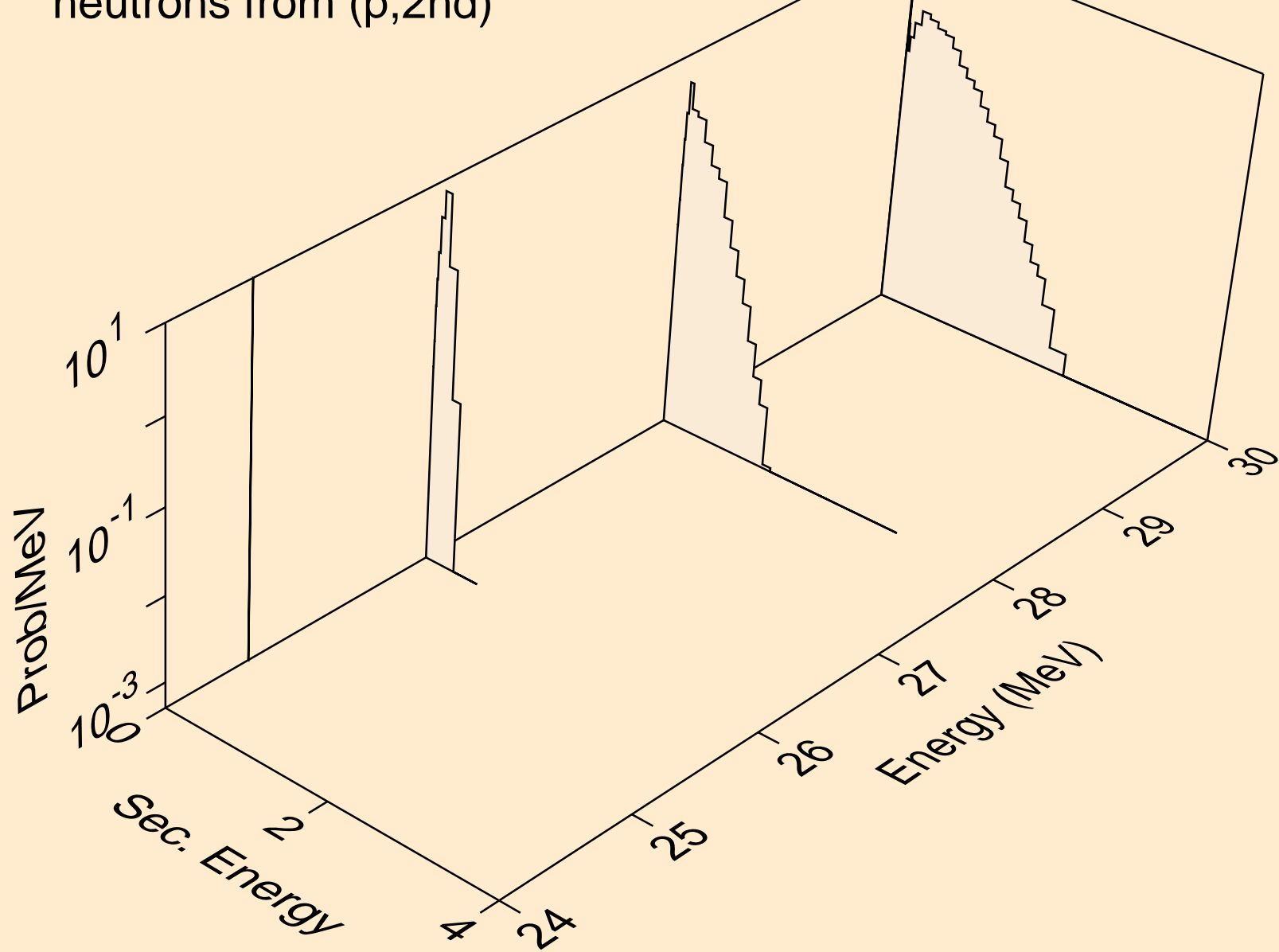

SN113M PROTON ACER TENDL-2021 LIBRARY; T=0.K  
neutrons from (p,2n)

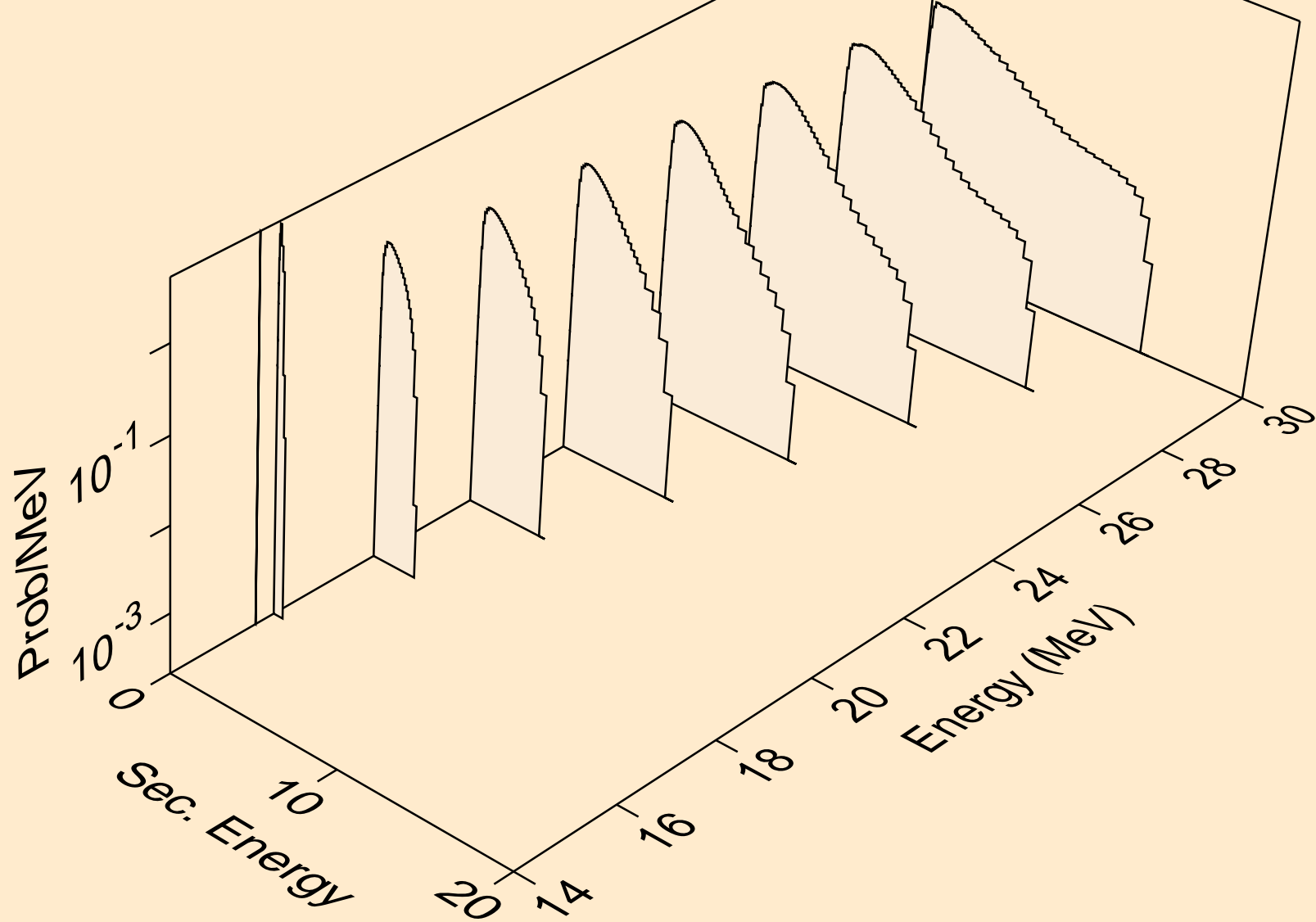

SN113M PROTON ACER TENDL-2021 LIBRARY; T=0.K  
neutrons from (p,3n)

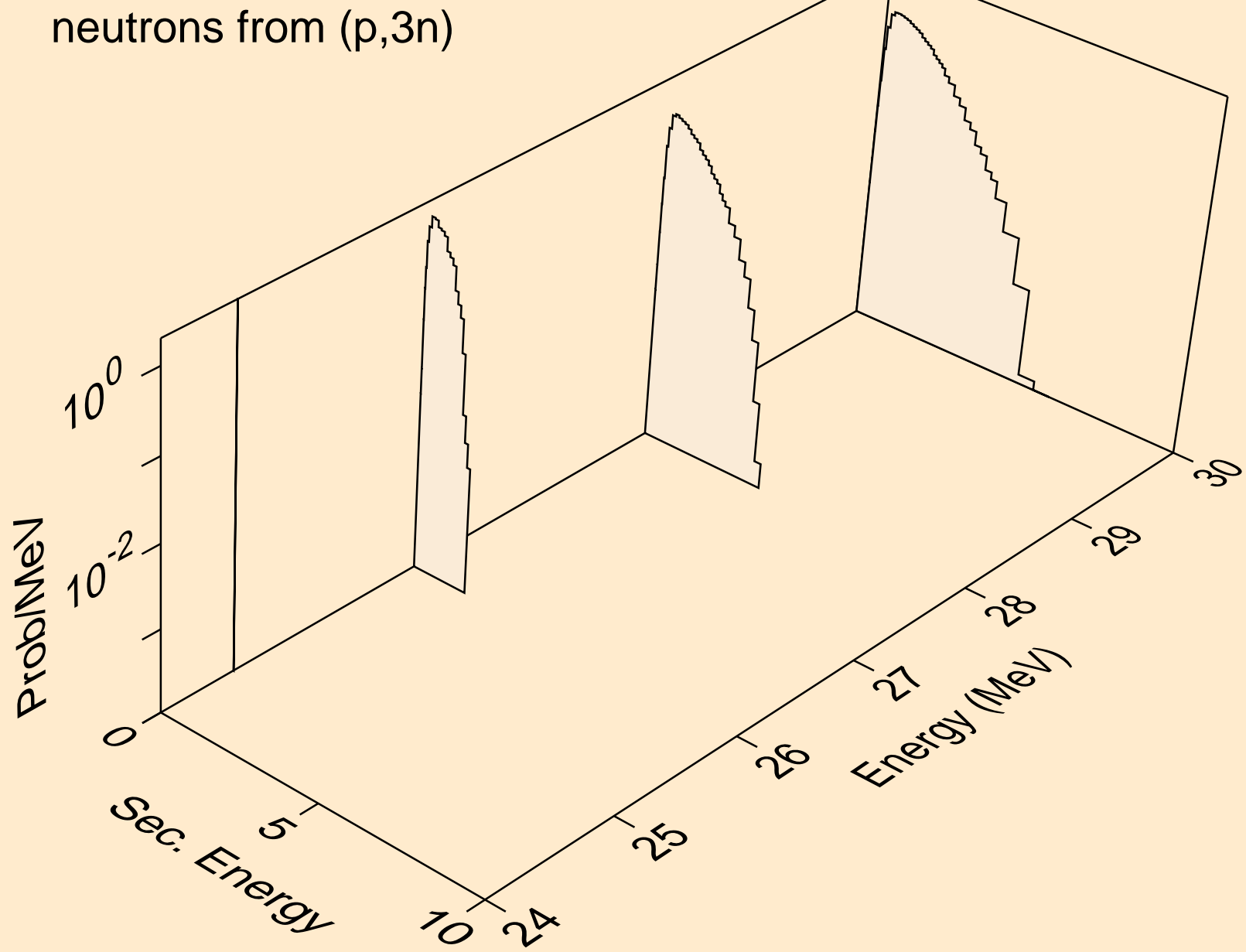



SN113M PROTON ACER TENDL-2021 LIBRARY; T=0.K  
neutrons from (p,n\*)a

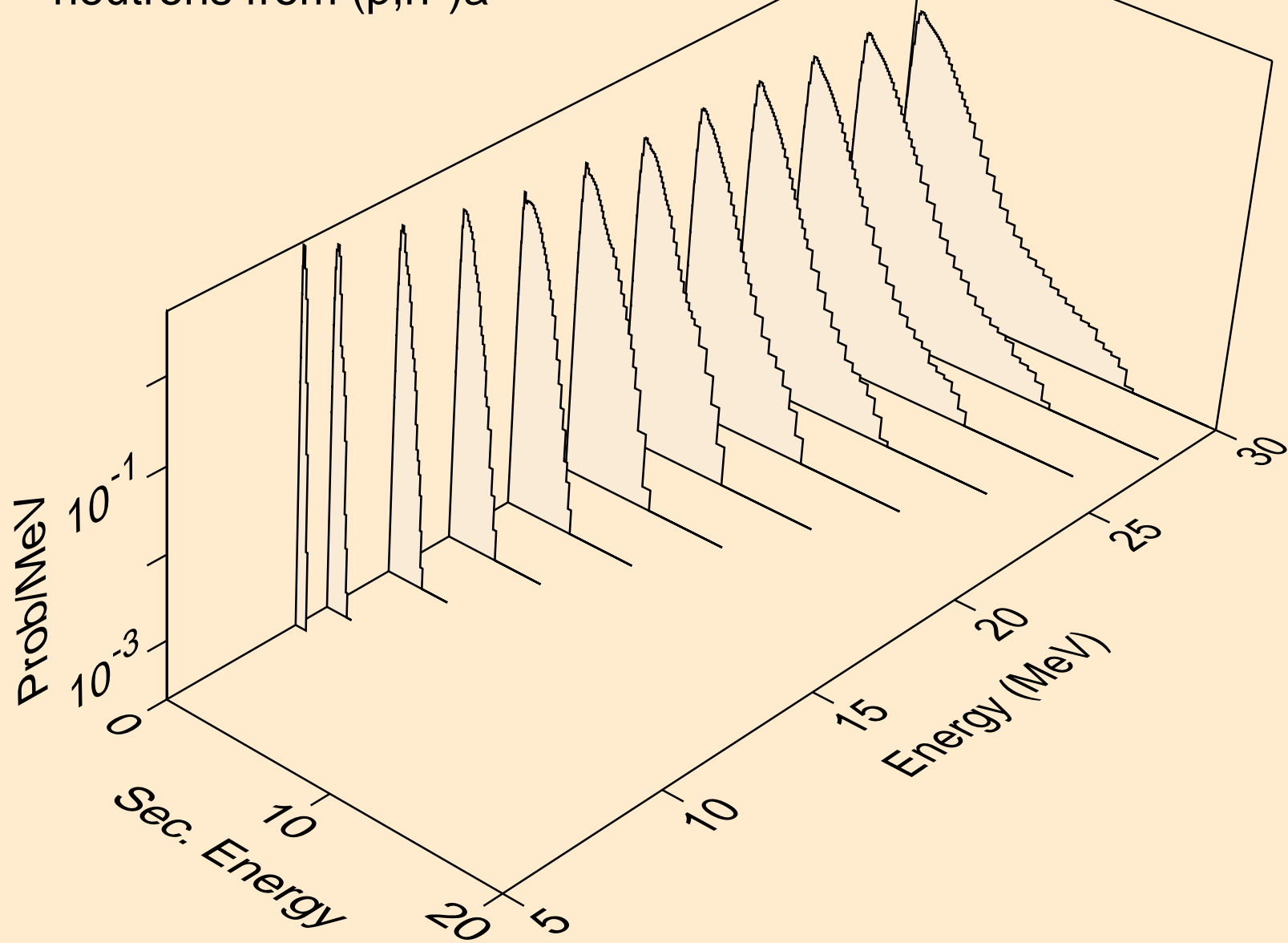

SN113M PROTON ACER TENDL-2021 LIBRARY; T=0.K  
neutrons from (p,2n)a

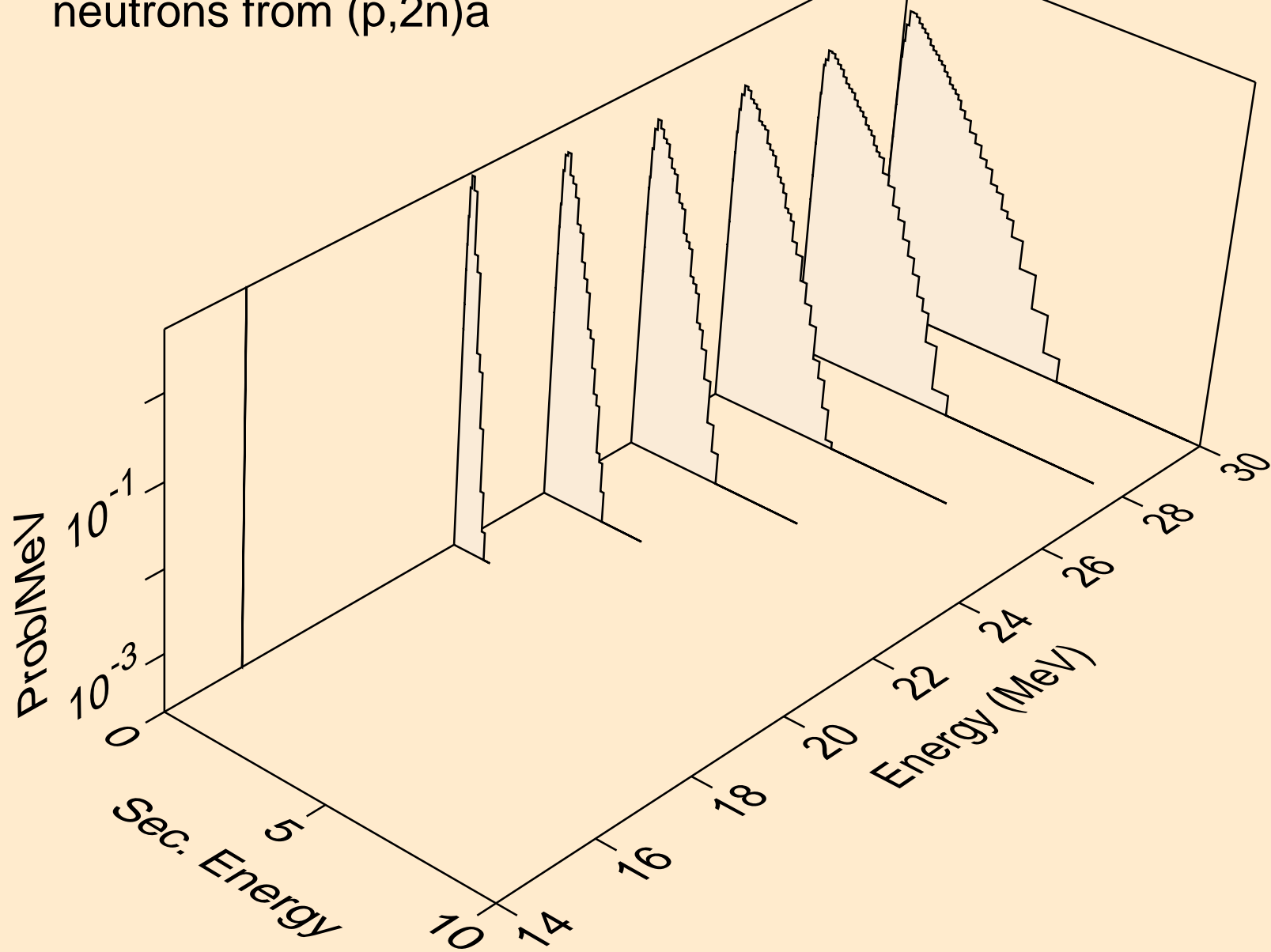

SN113M PROTON ACER TENDL-2021 LIBRARY; T=0.K  
neutrons from (p,n\*)p

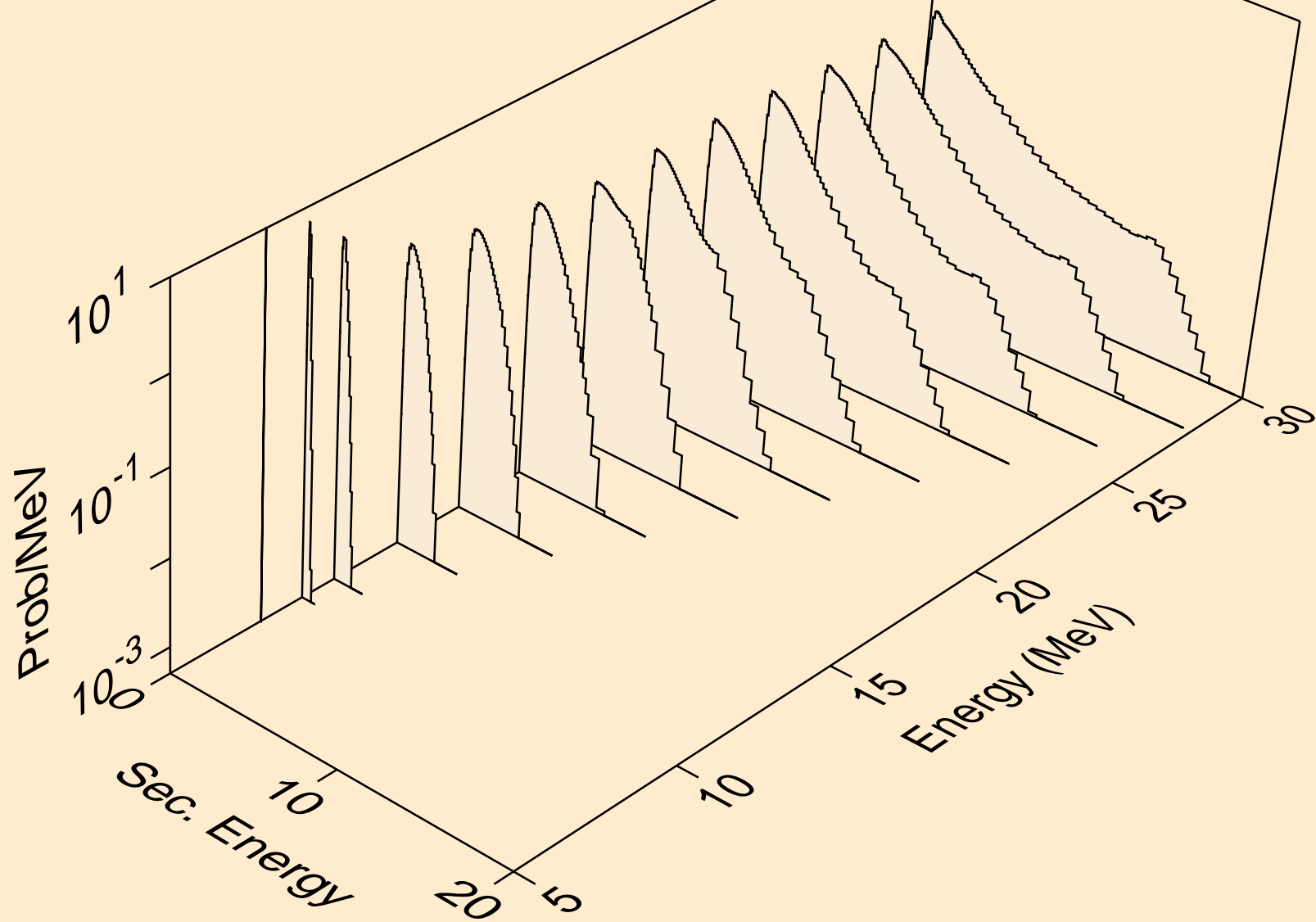

SN113M PROTON ACER TENDL-2021 LIBRARY; T=0.K  
neutrons from (p,n\*)2a

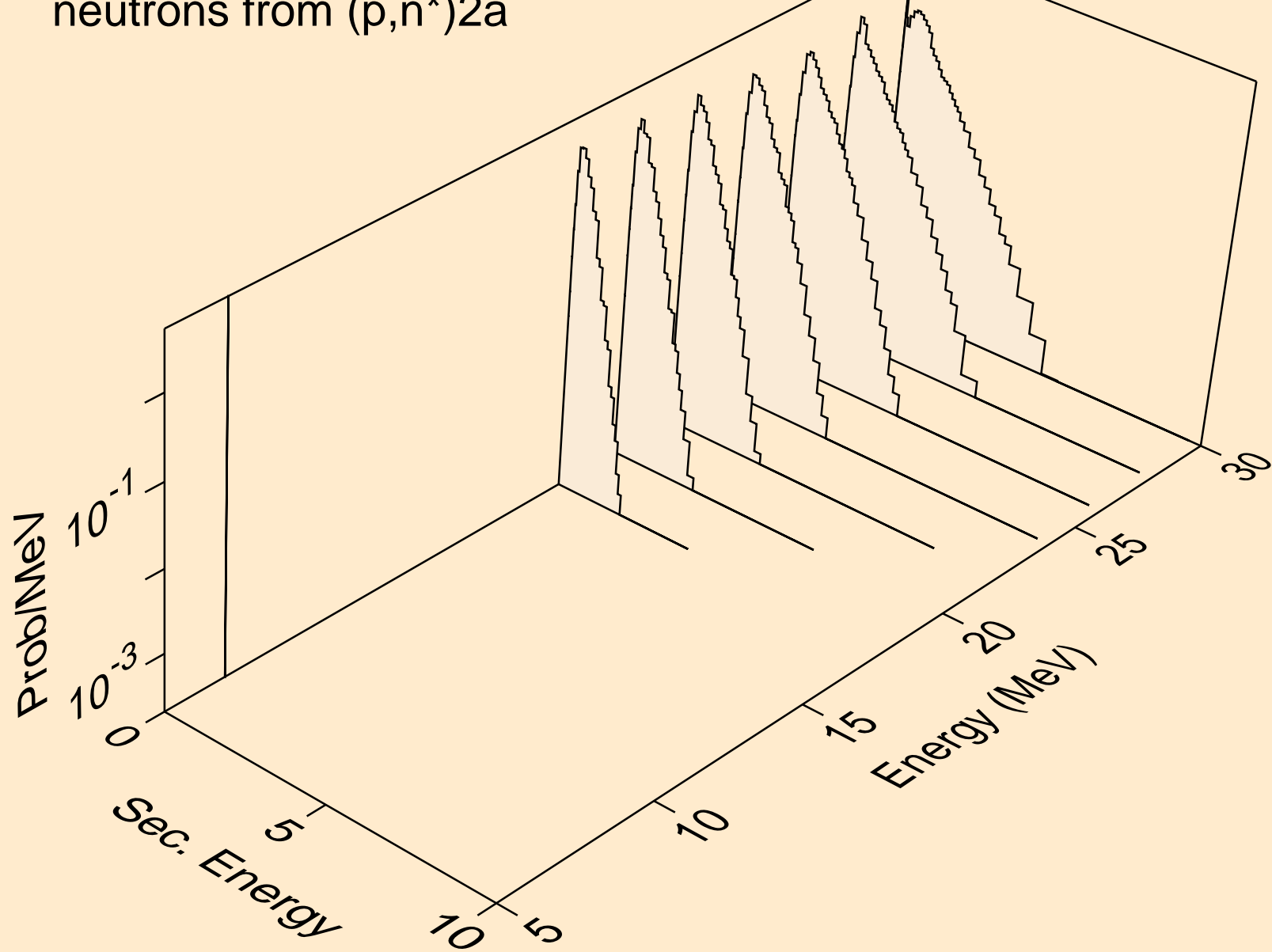

SN113M PROTON ACER TENDL-2021 LIBRARY; T=0.K  
neutrons from (p,n\*)d

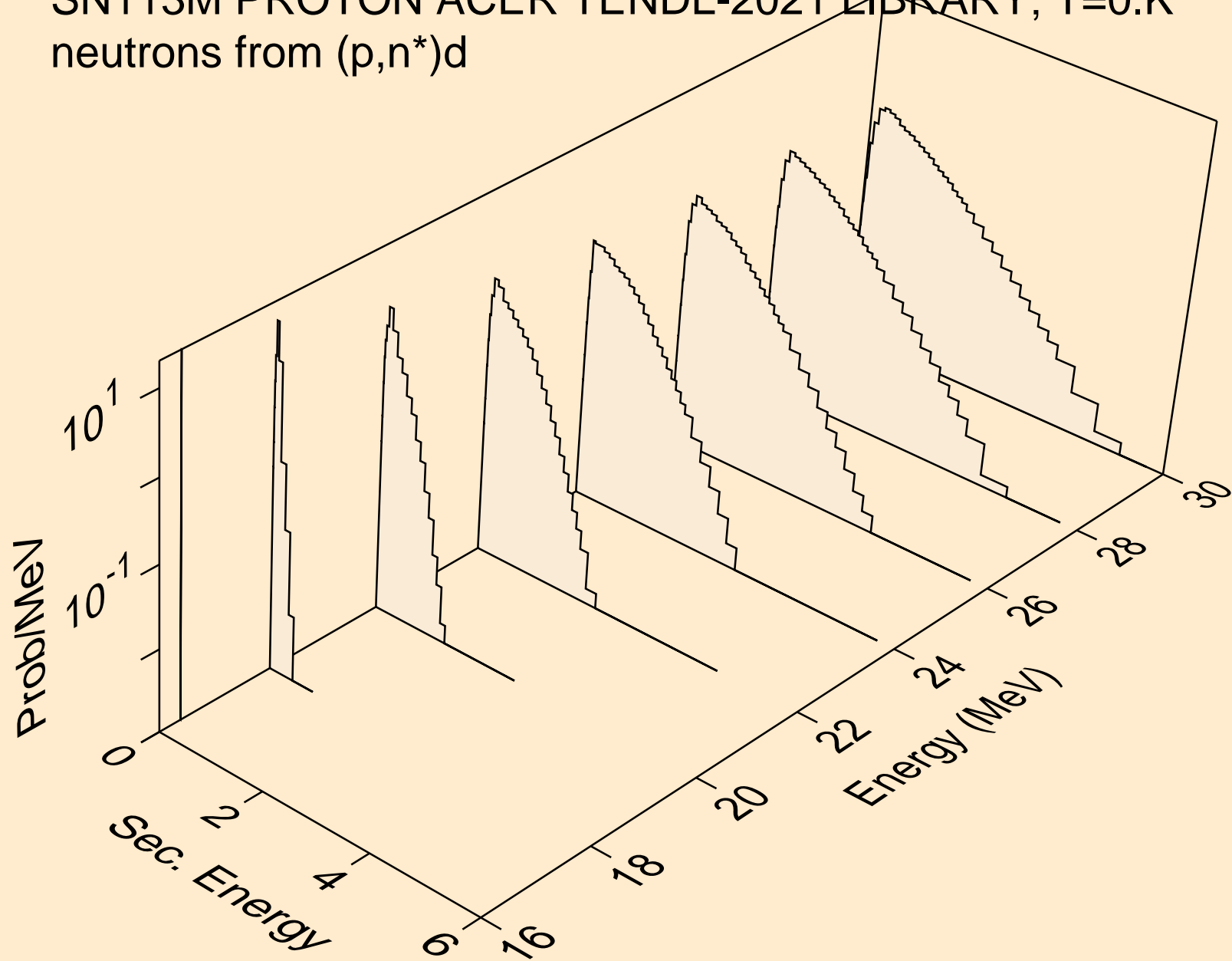

SN113M PROTON ACER TENDL-2021 LIBRARY; T=0.K  
neutrons from (p,n\*)t

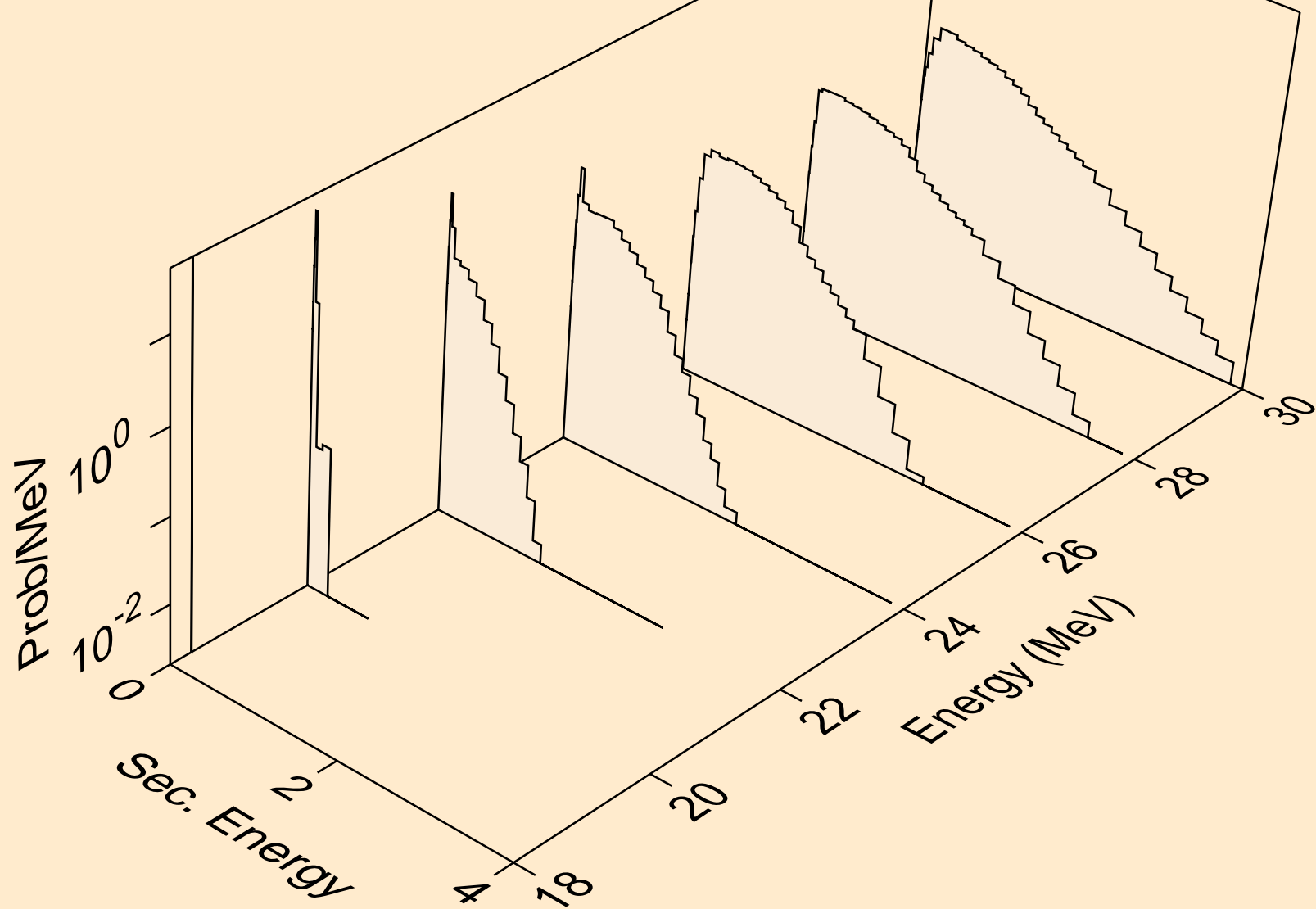

SN113M PROTON ACER TENDL-2021 LIBRARY; T=0.K  
neutrons from (p,n\*)he3

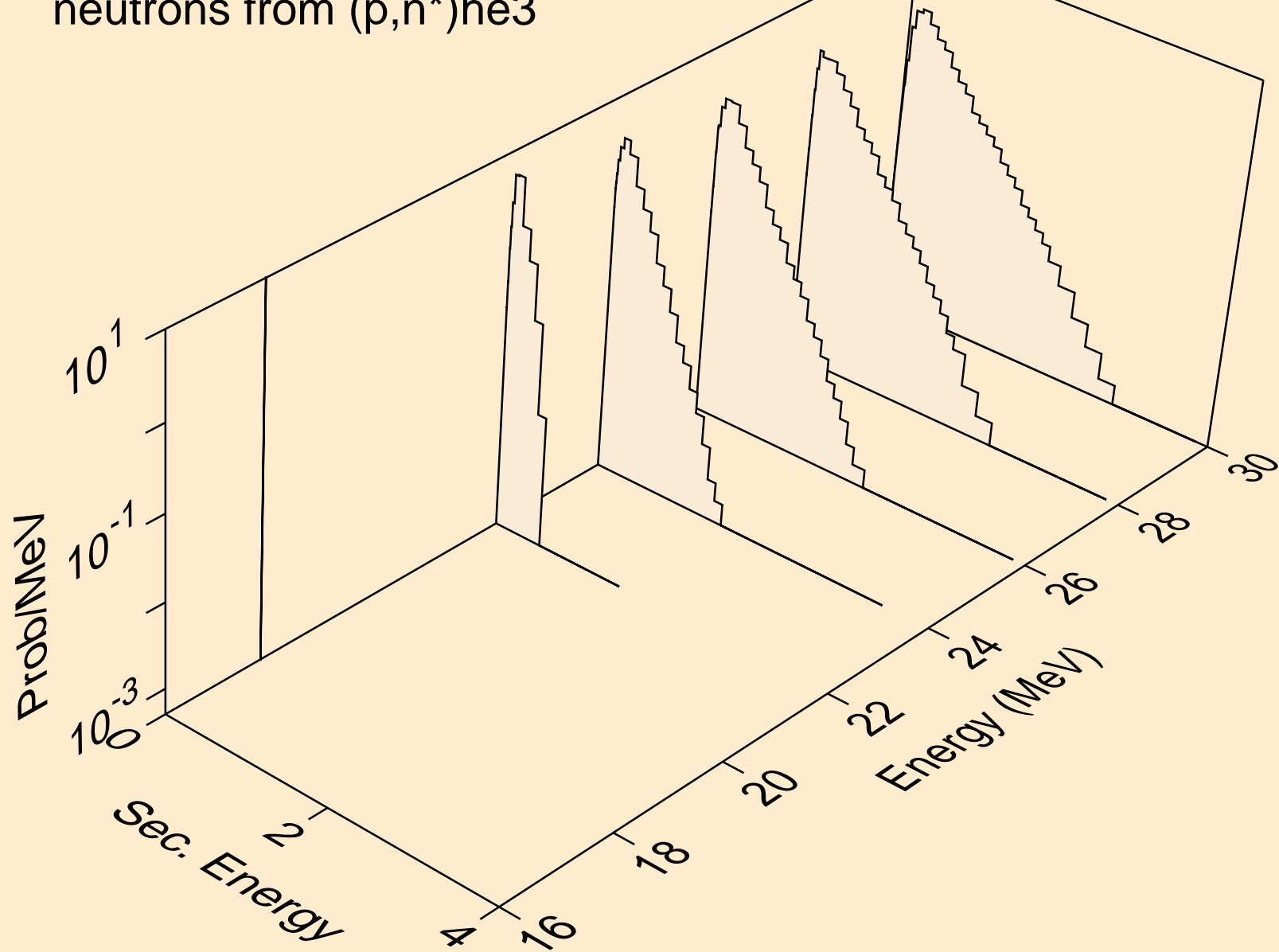

SN113M PROTON ACER TENDL-2021 LIBRARY; T=0.K  
neutrons from (p,2np)

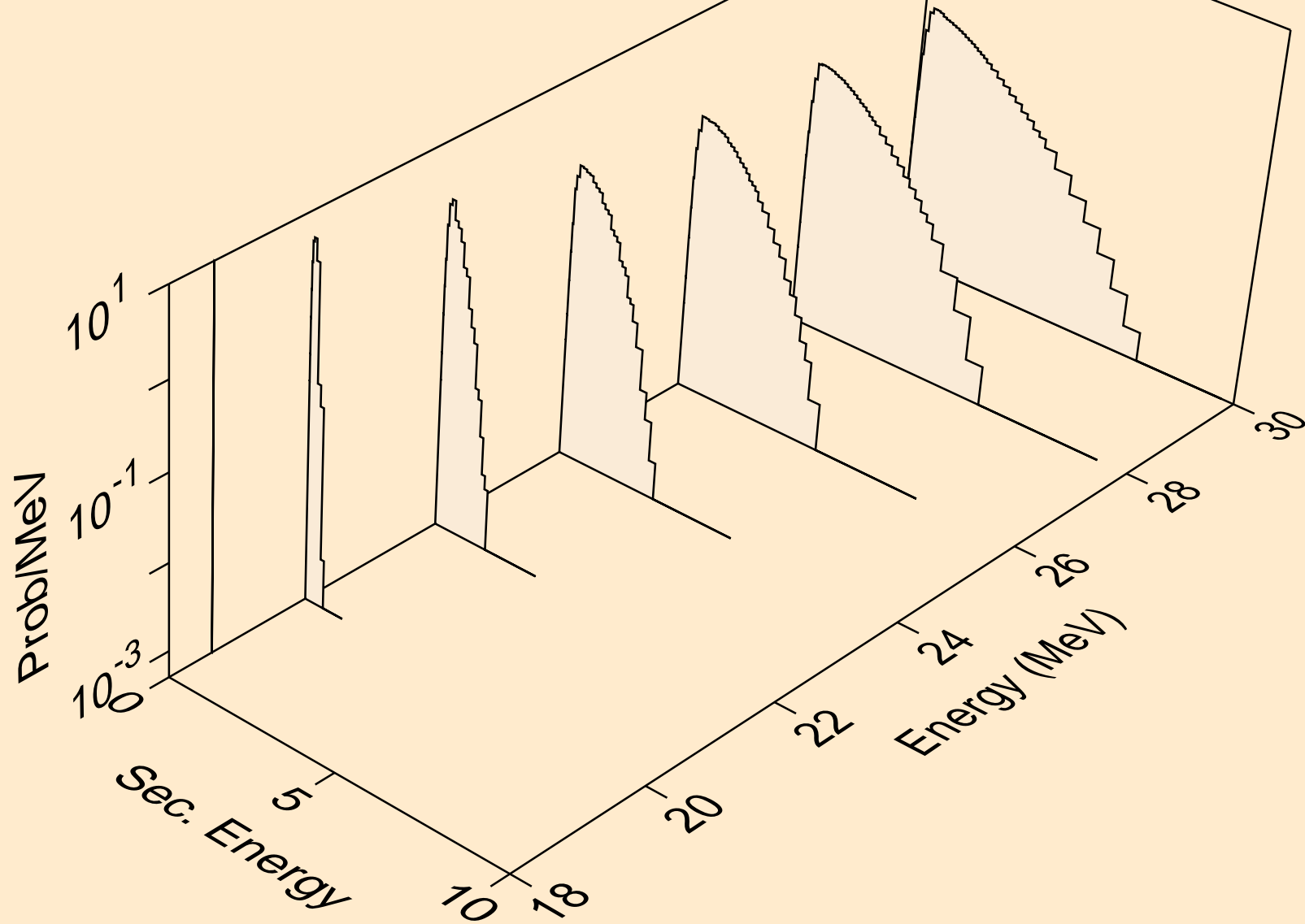



SN113M PROTON ACER TENDL-2021 LIBRARY; T=0.K  
neutrons from (p,3np)

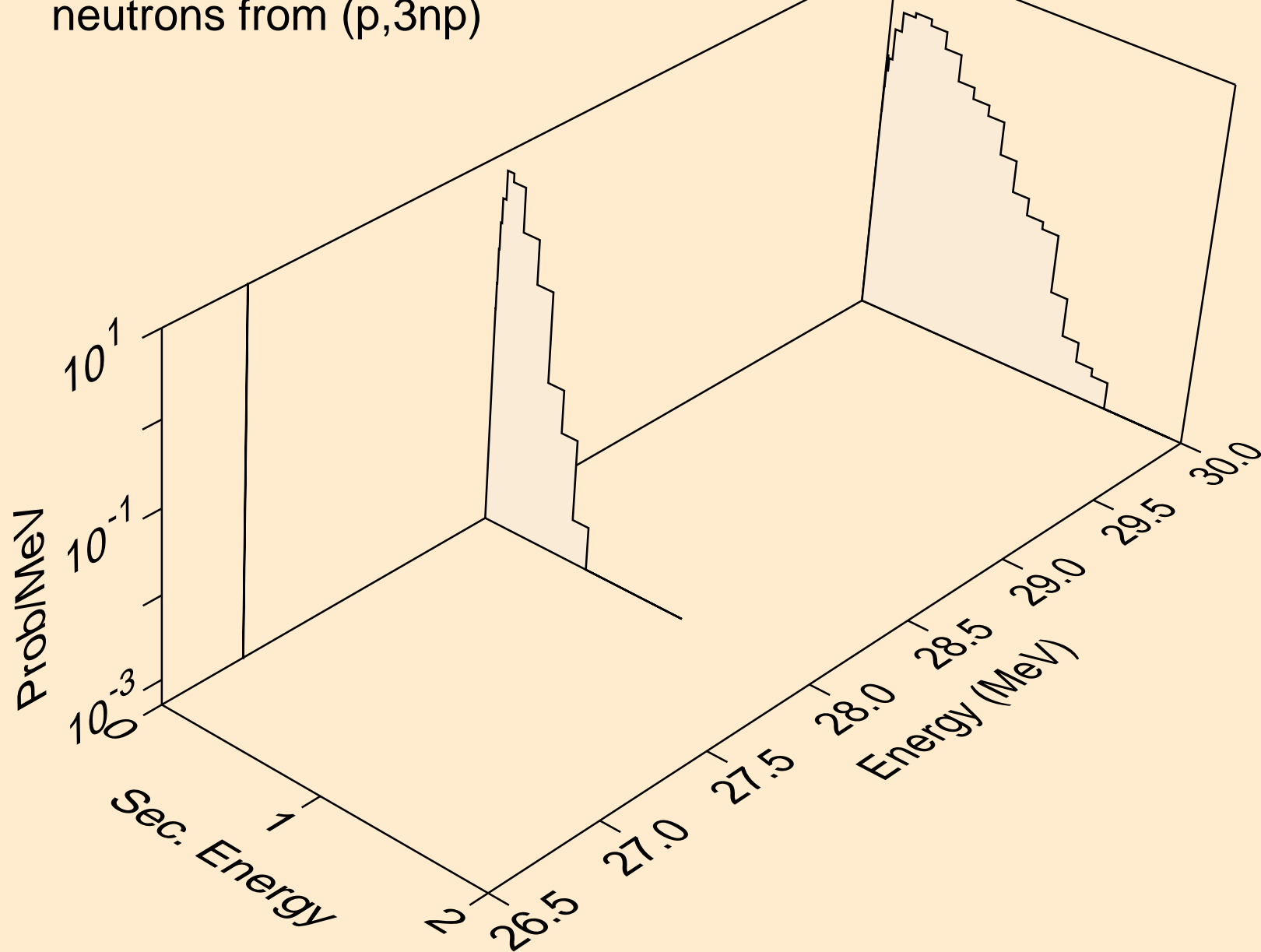

SN113M PROTON ACER TENDL-2021 LIBRARY; T=0.K  
neutrons from (p,2np)

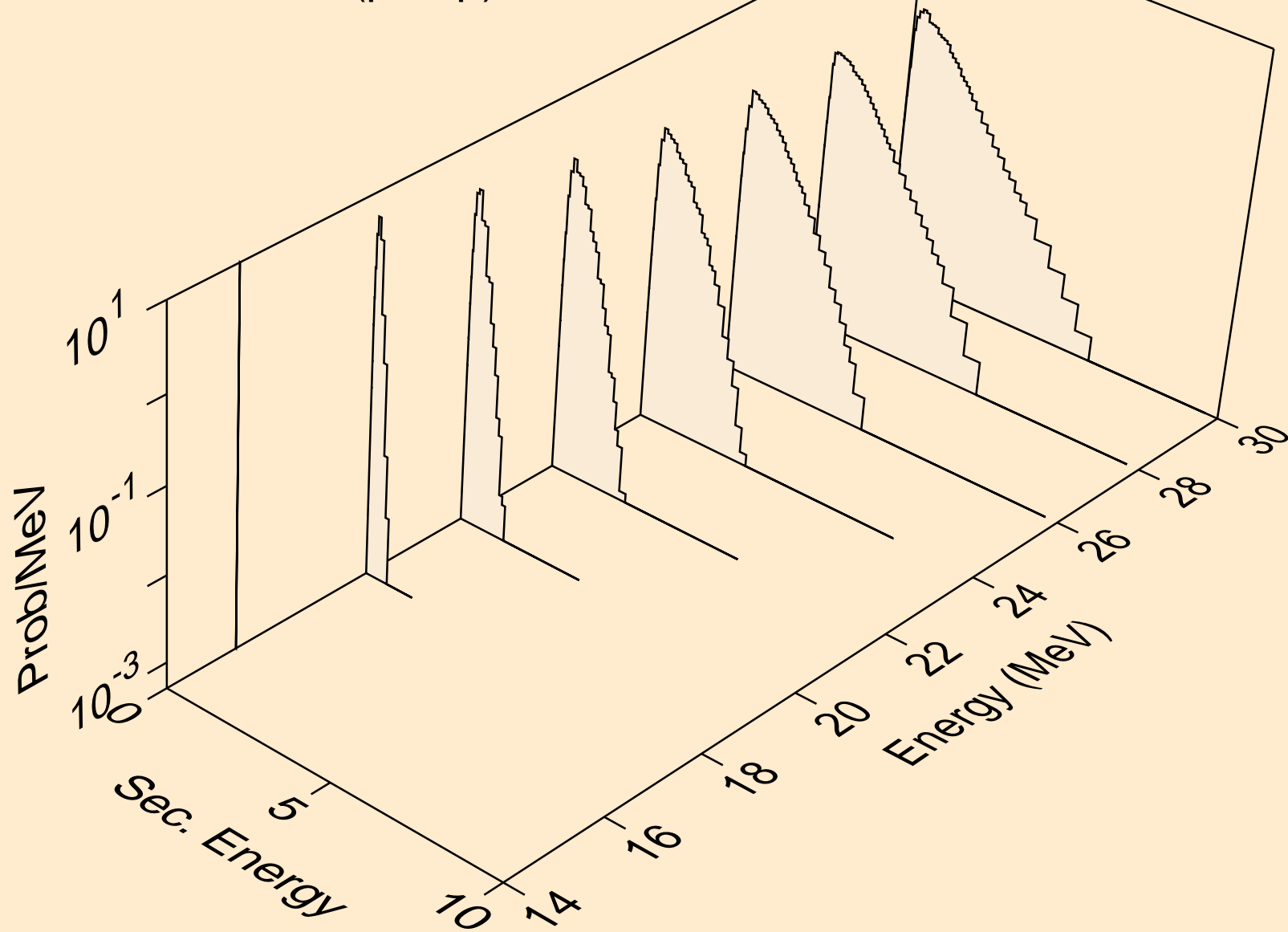

SN113M PROTON ACER TENDL-2021 LIBRARY; T=0.K  
neutrons from (p,npa)

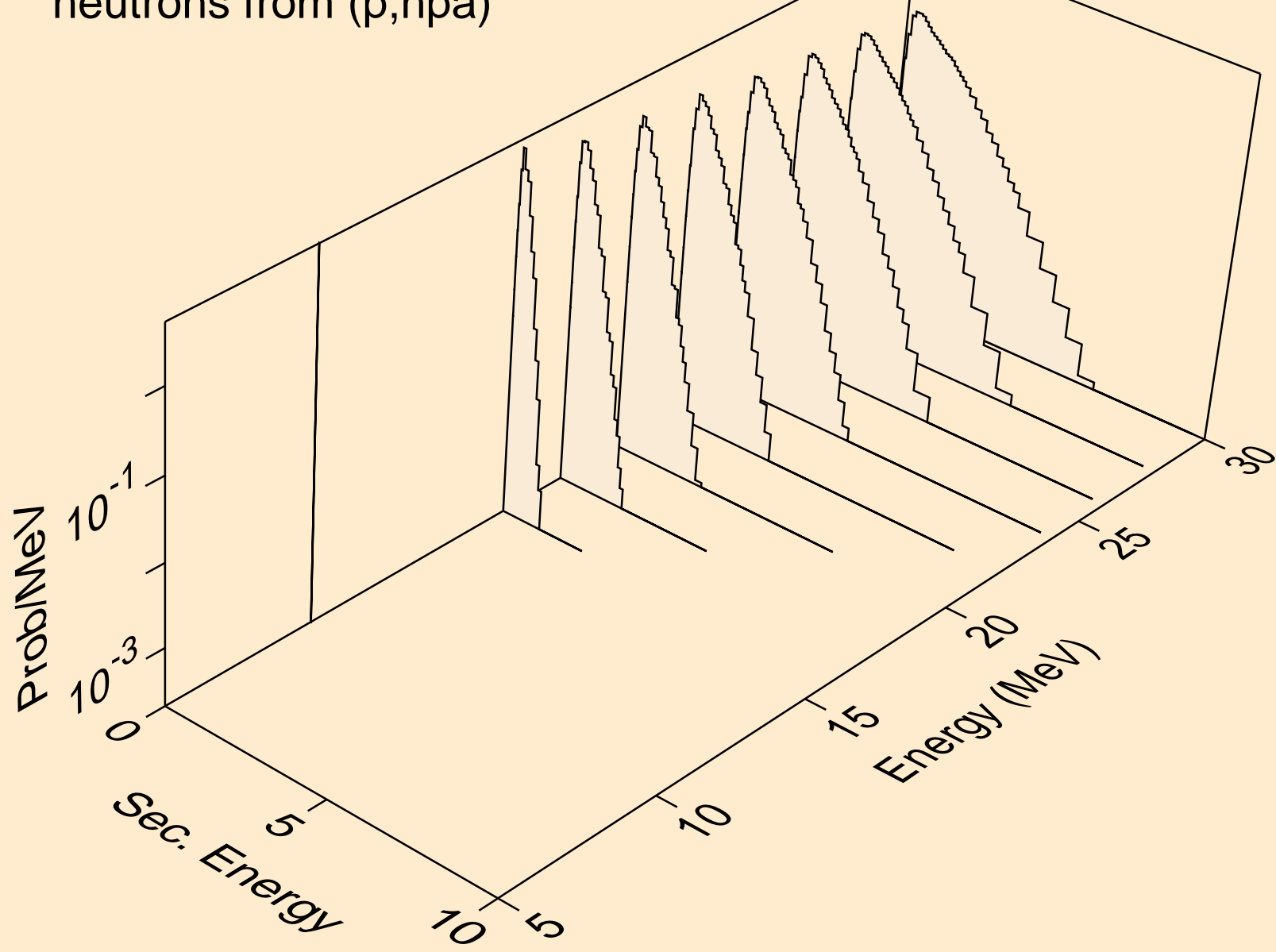

SN113M PROTON ACER TENDL-2021 LIBRARY; T=0.K  
deuterons from (p,x)

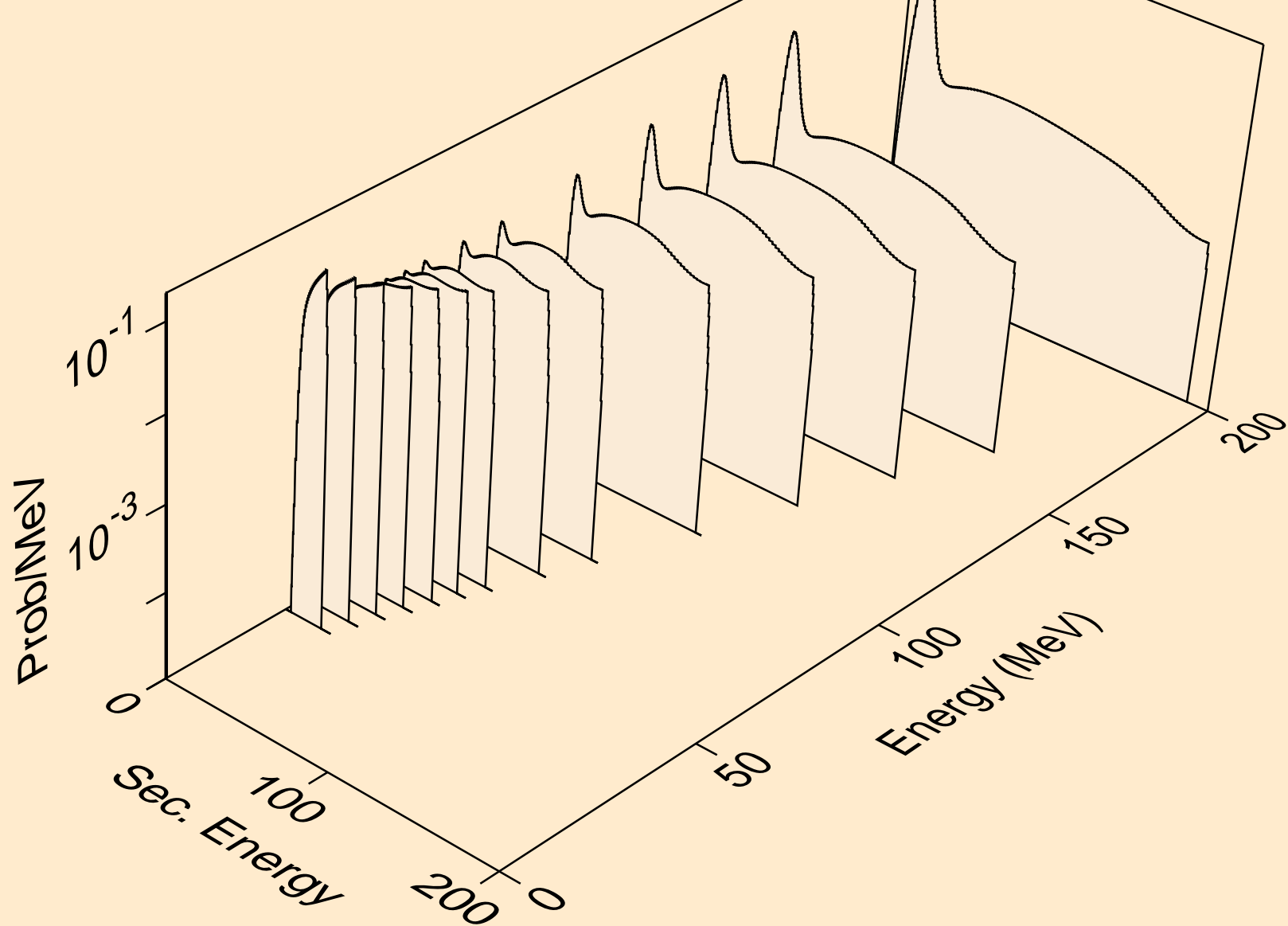

SN113M PROTON ACER TENDL-2021 LIBRARY; T=0.K  
deuterons from (p,2nd)

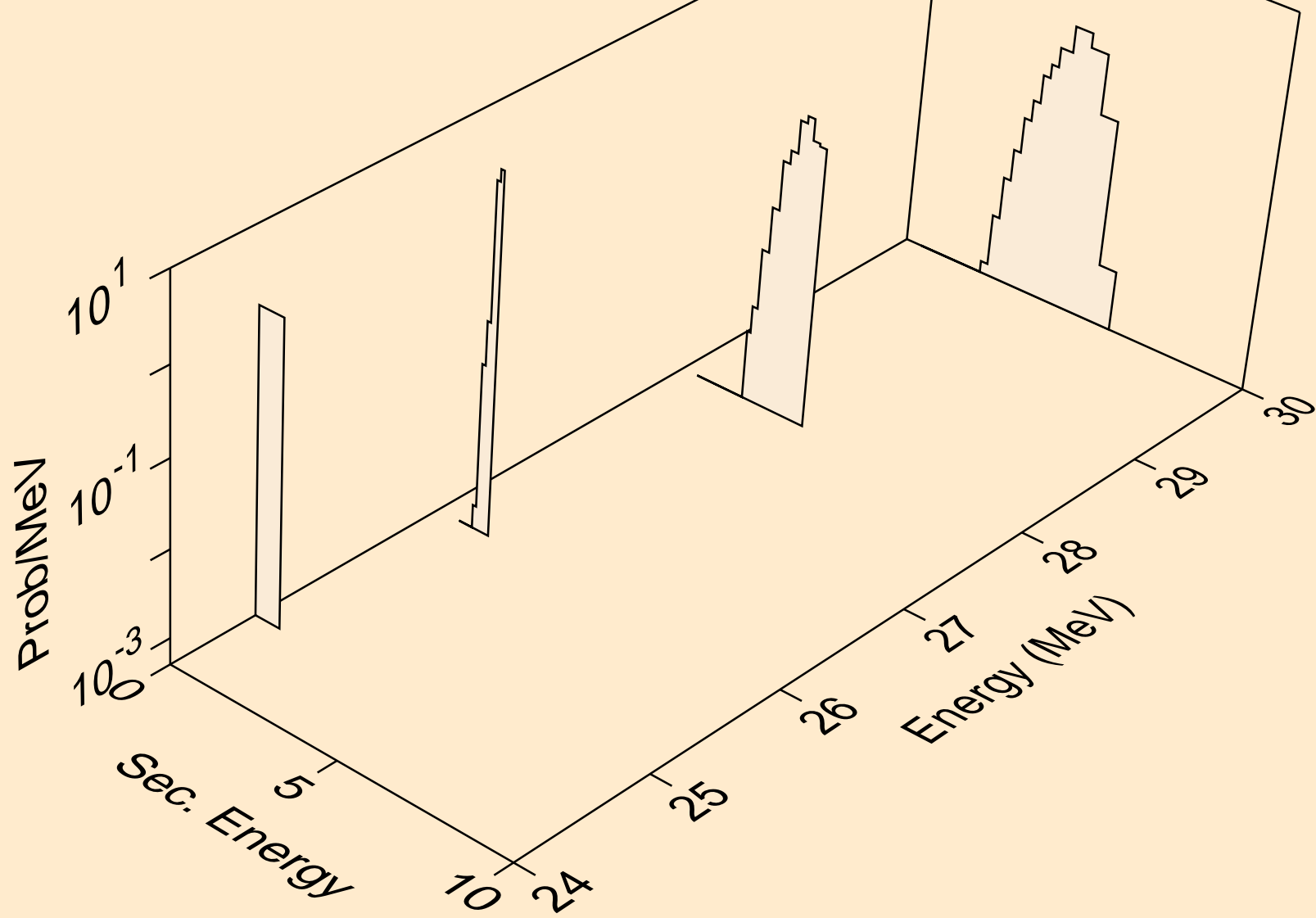

SN113M PROTON ACER TENDL-2021 LIBRARY; T=0.K  
deuterons from (p,n\*)d

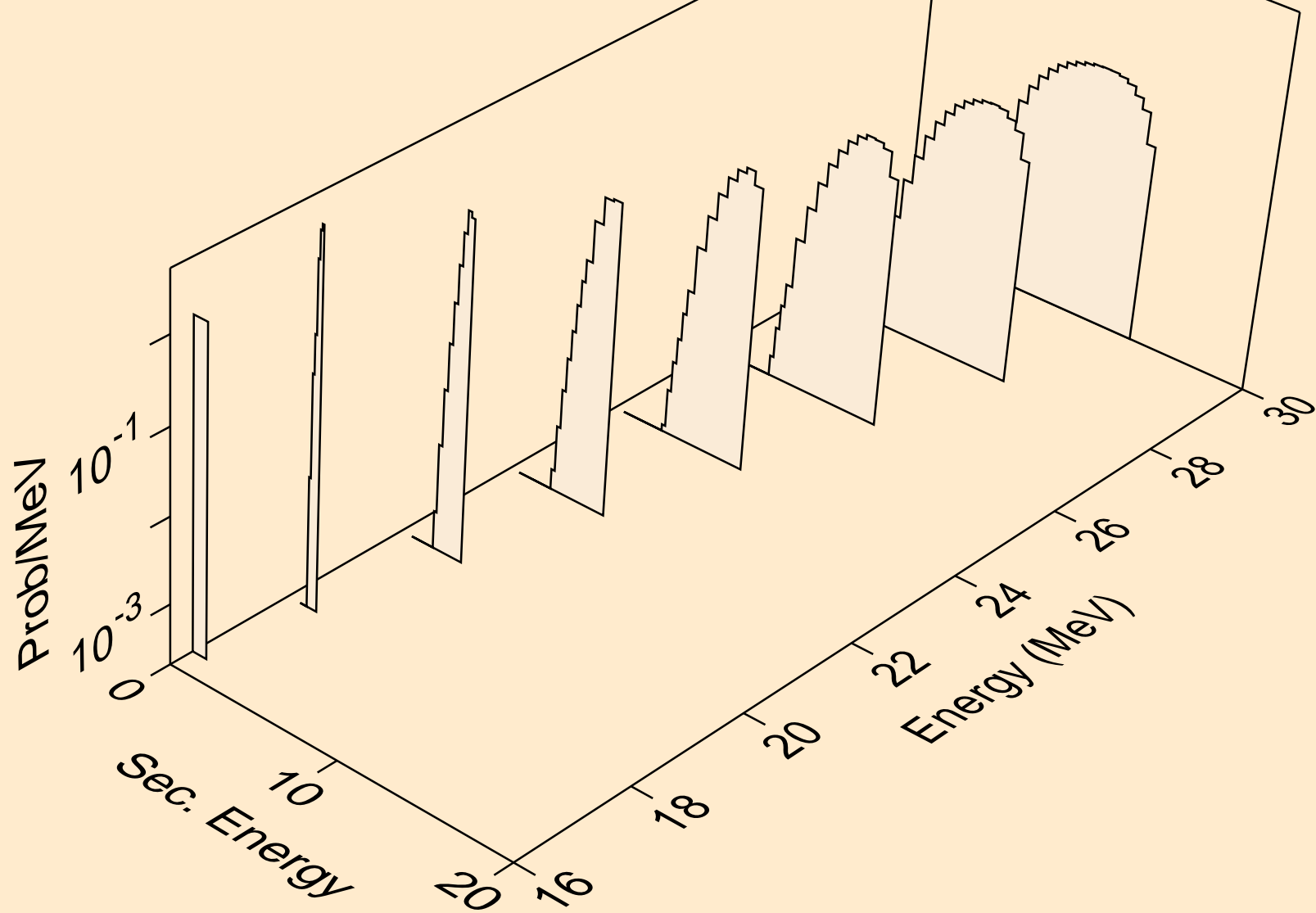

SN113M PROTON ACER TENDL-2021 LIBRARY; T=0.K  
deuterons from (p,d)

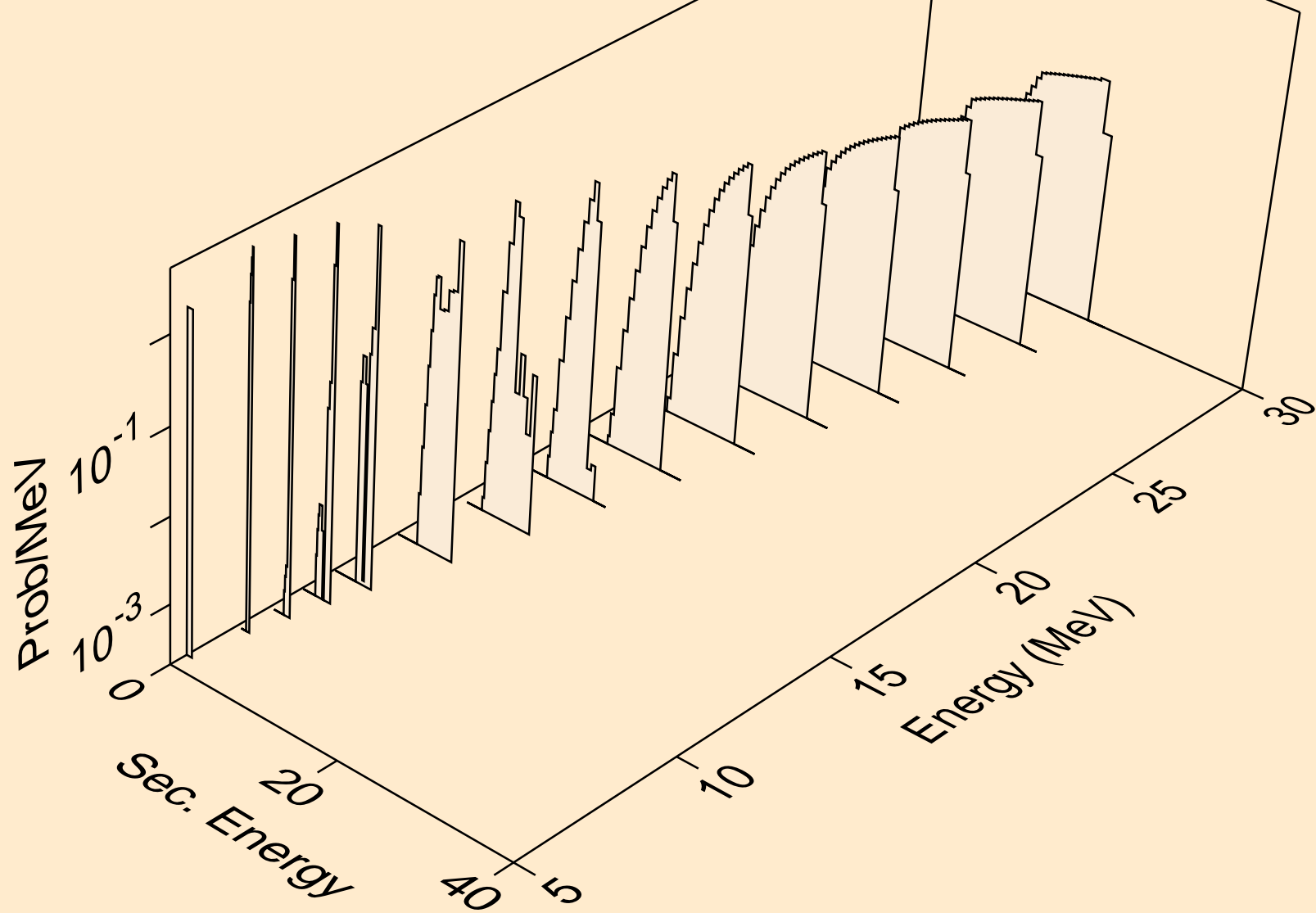

SN113M PROTON ACER TENDL-2021 LIBRARY; T=0.K  
deuterons from (p,pd)

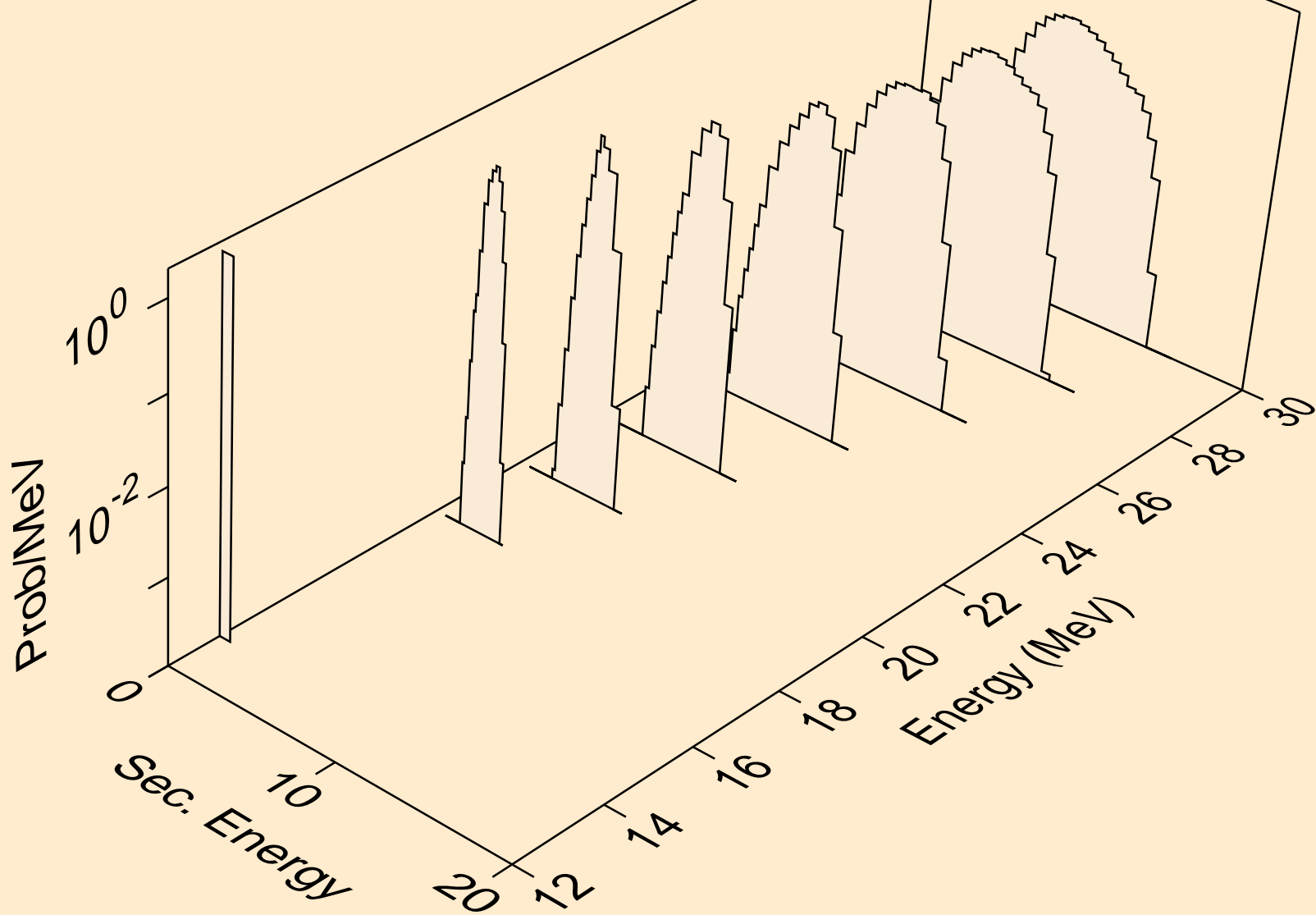



SN113M PROTON ACER TENDL-2021 LIBRARY; T=0.K  
deuterons from (p,da)

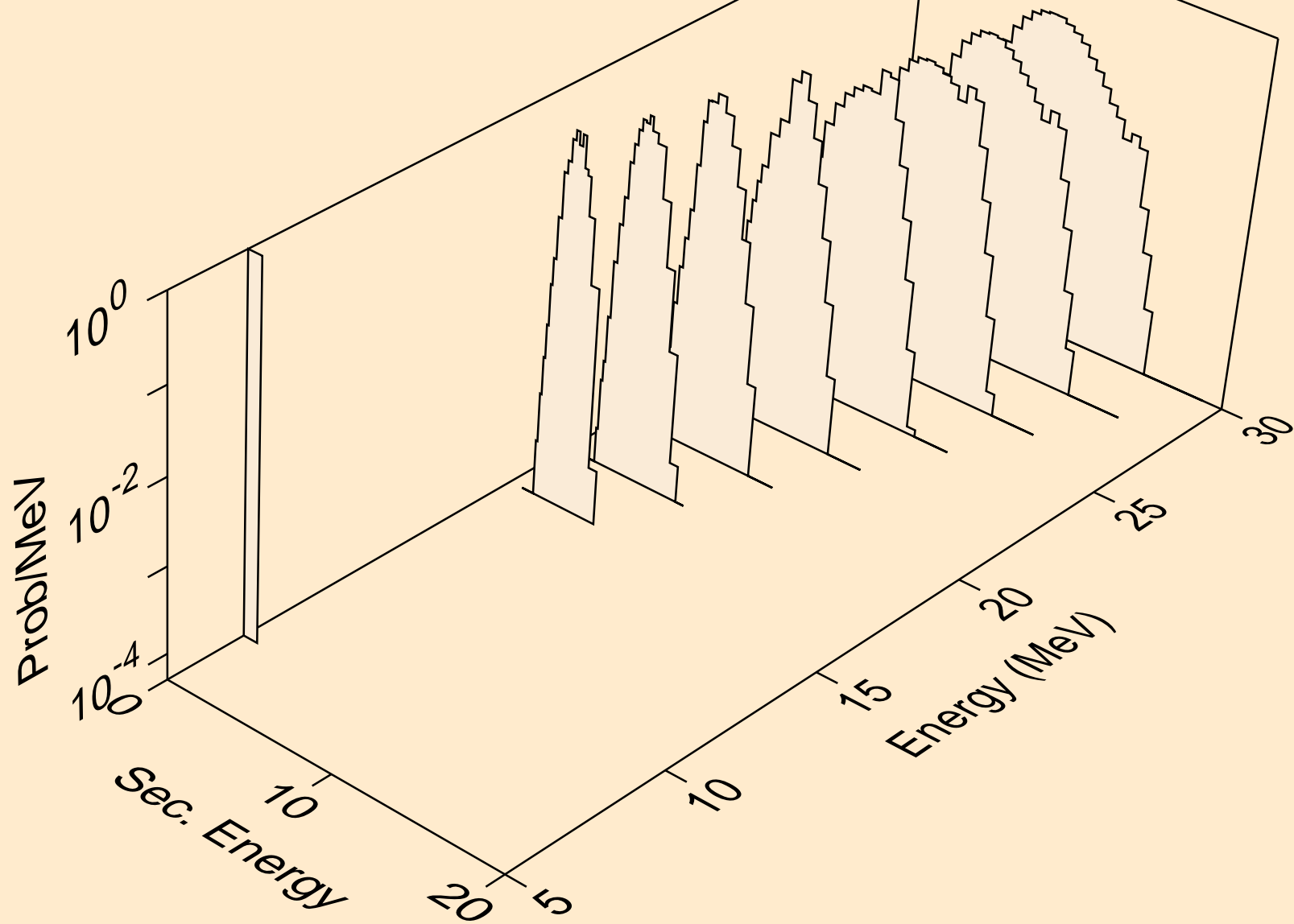

SN113M PROTON ACER TENDL-2021 LIBRARY; T=0.K  
tritons from (p,x)

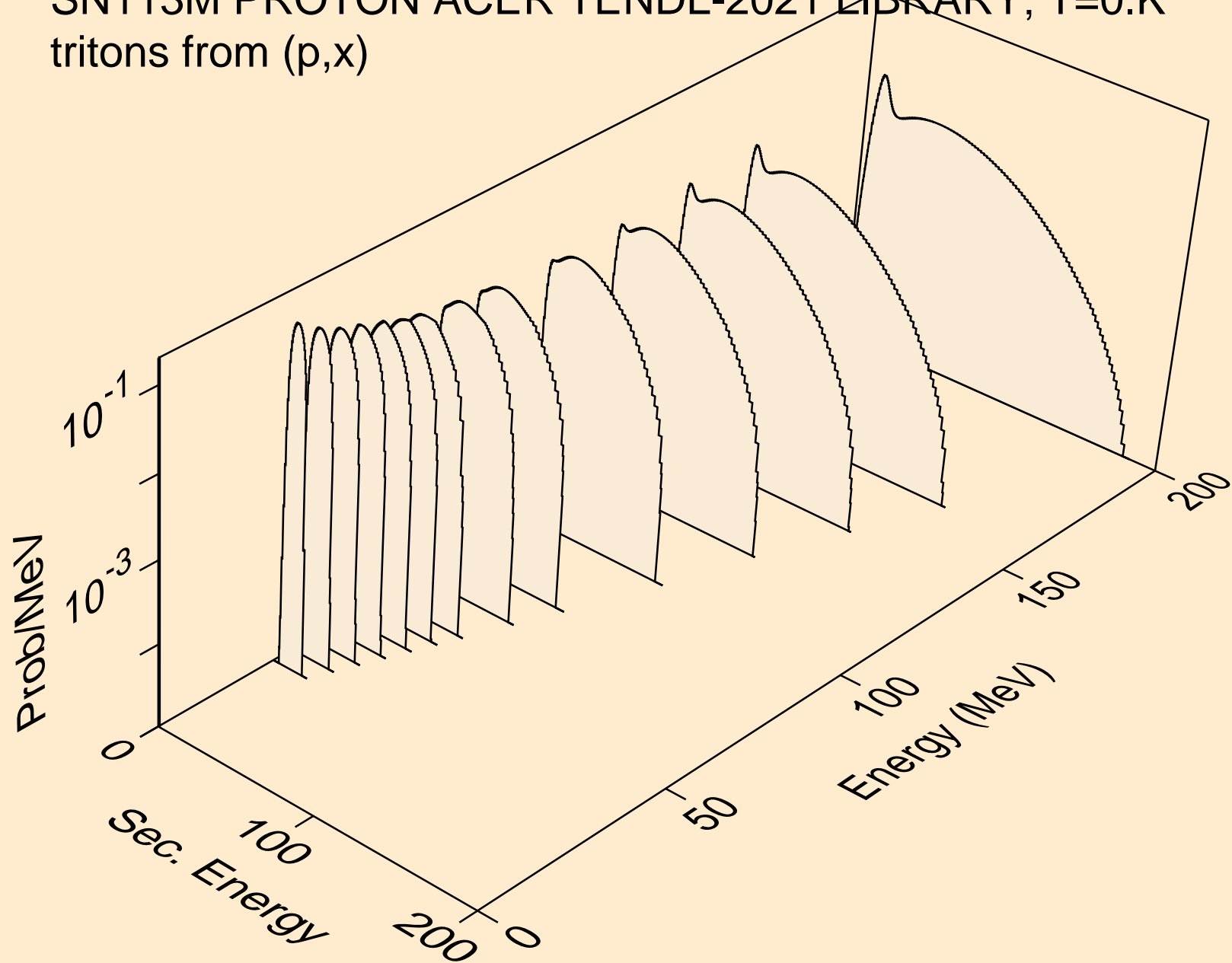

SN113M PROTON ACER TENDL-2021 LIBRARY; T=0.K  
tritons from (p,n\*)t

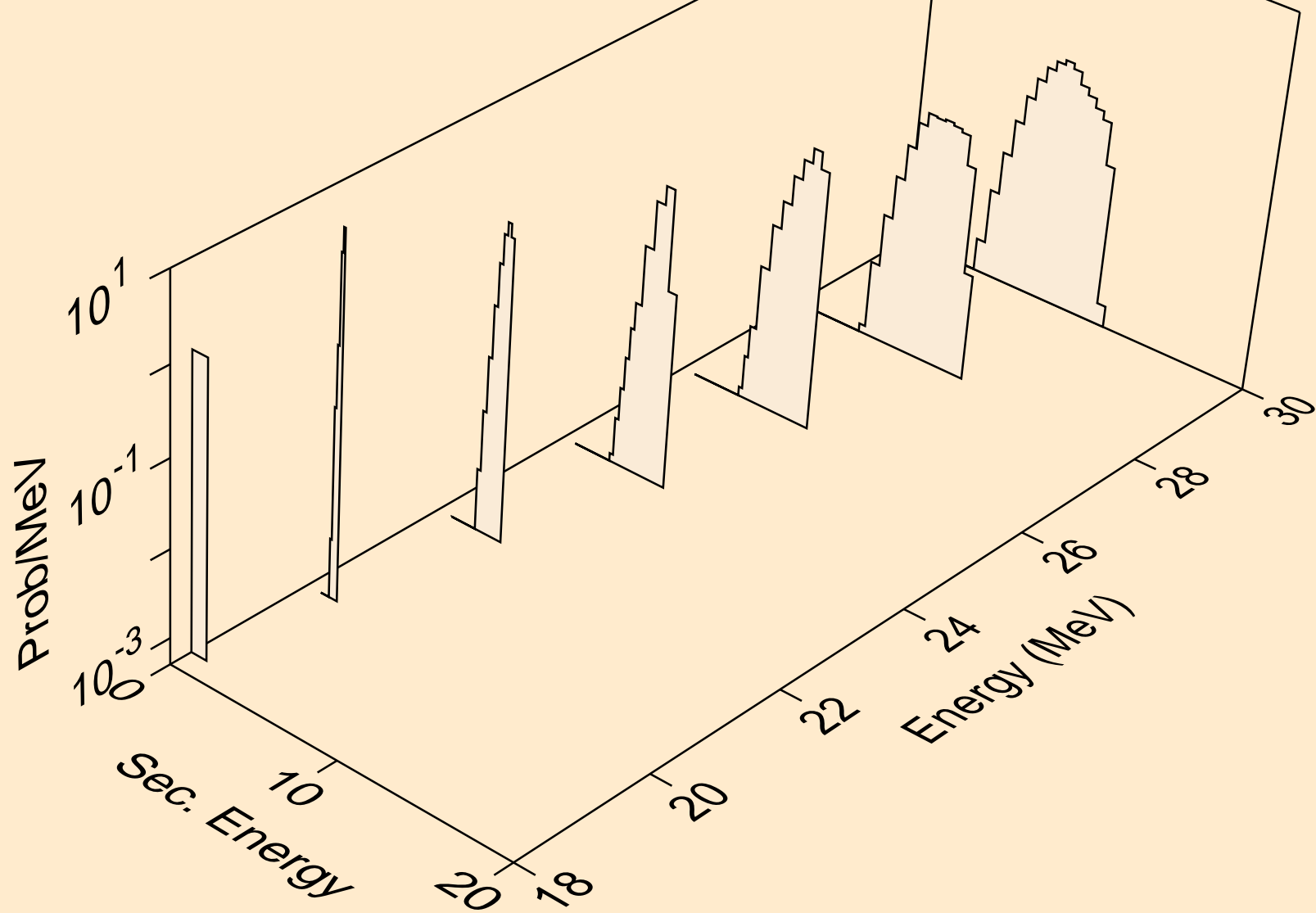

SN113M PROTON ACER TENDL-2021 LIBRARY; T=0.K  
tritons from (p,t)

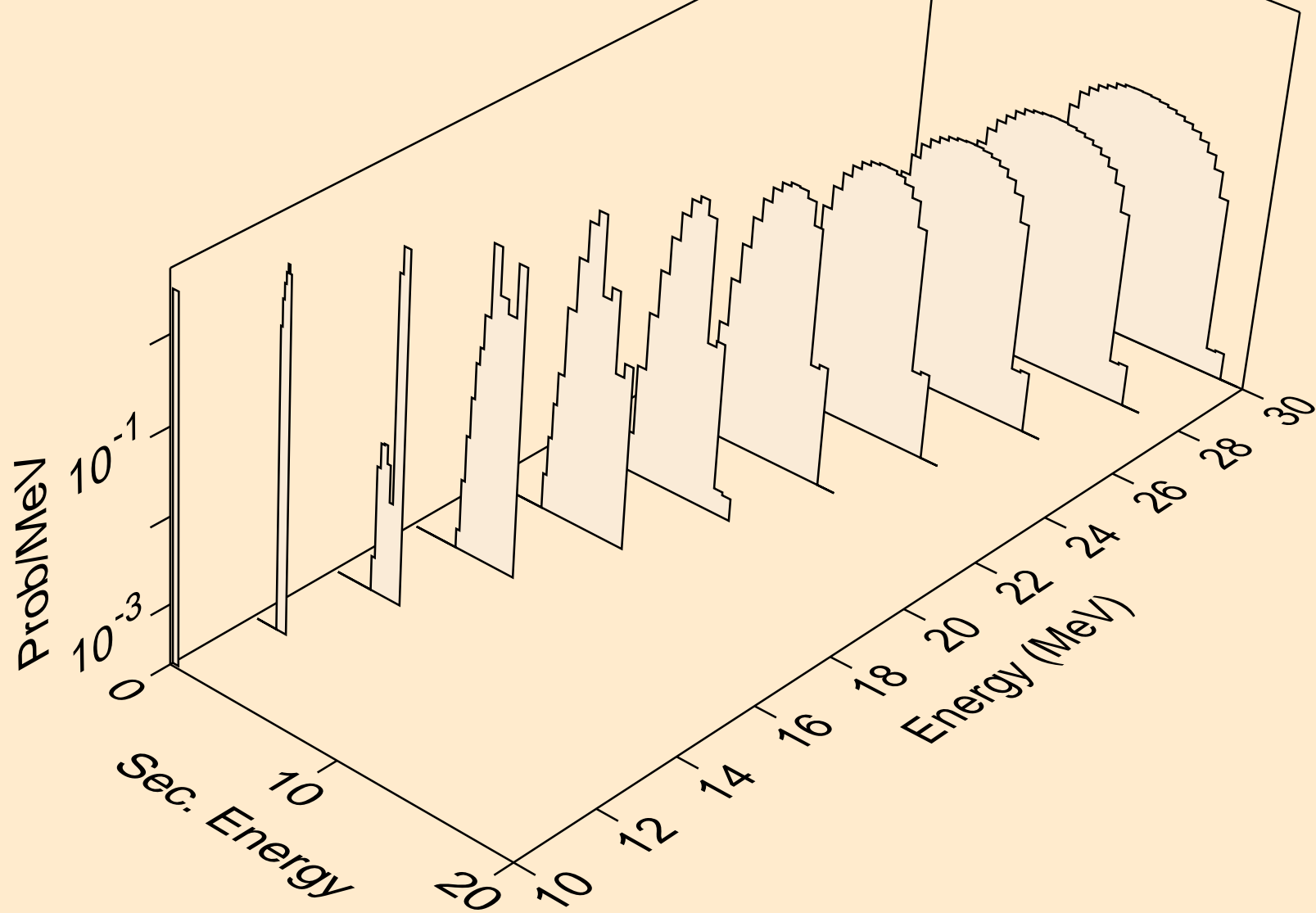

SN113M PROTON ACER TENDL-2021 LIBRARY; T=0.K  
tritons from (p,pt)

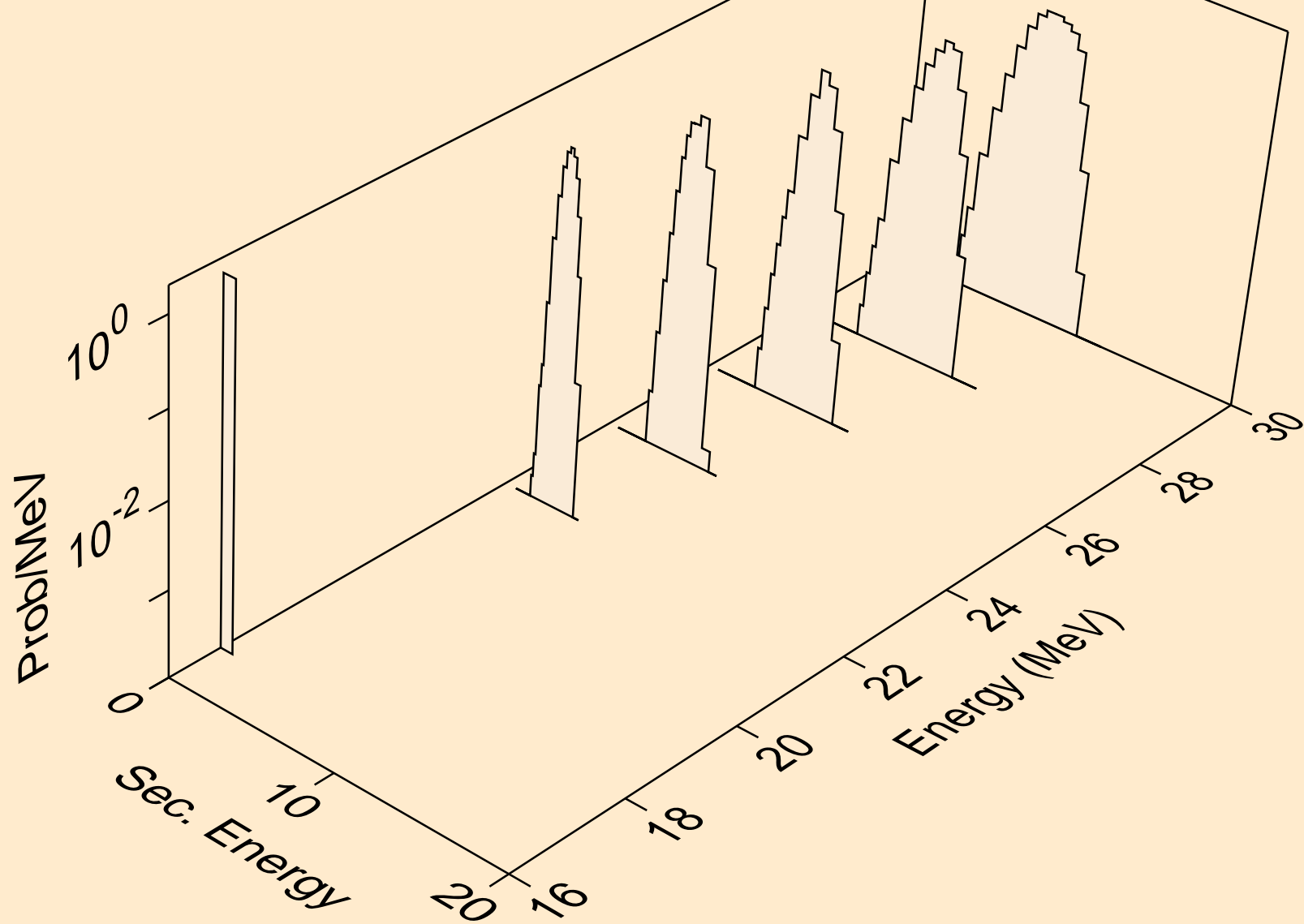

SN113M PROTON ACER TENDL-2021 LIBRARY; T=0.K  
he3s from (p,x)

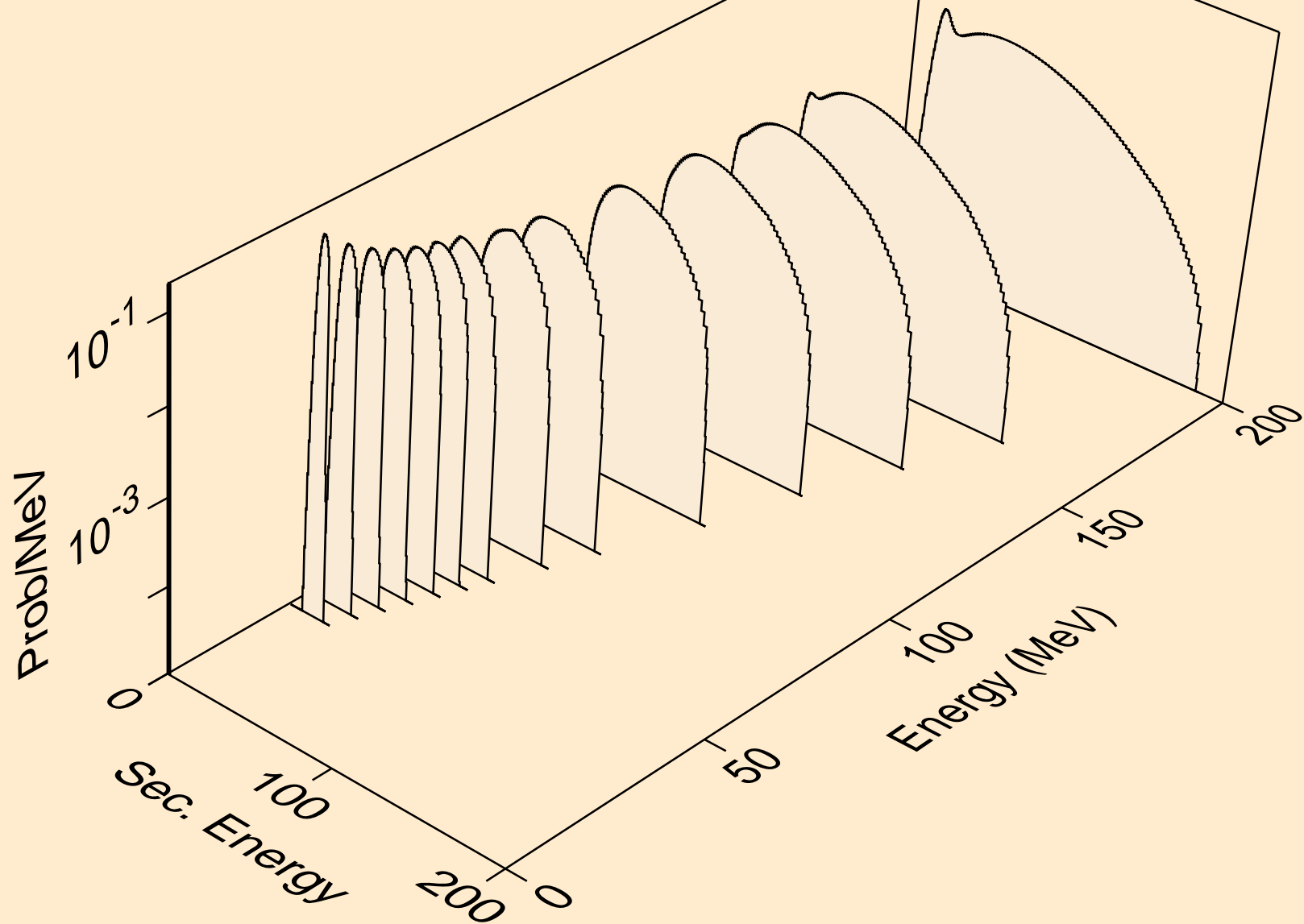

SN113M PROTON ACER TENDL-2021 LIBRARY; T=0.K  
he3s from (p,n\*)he3

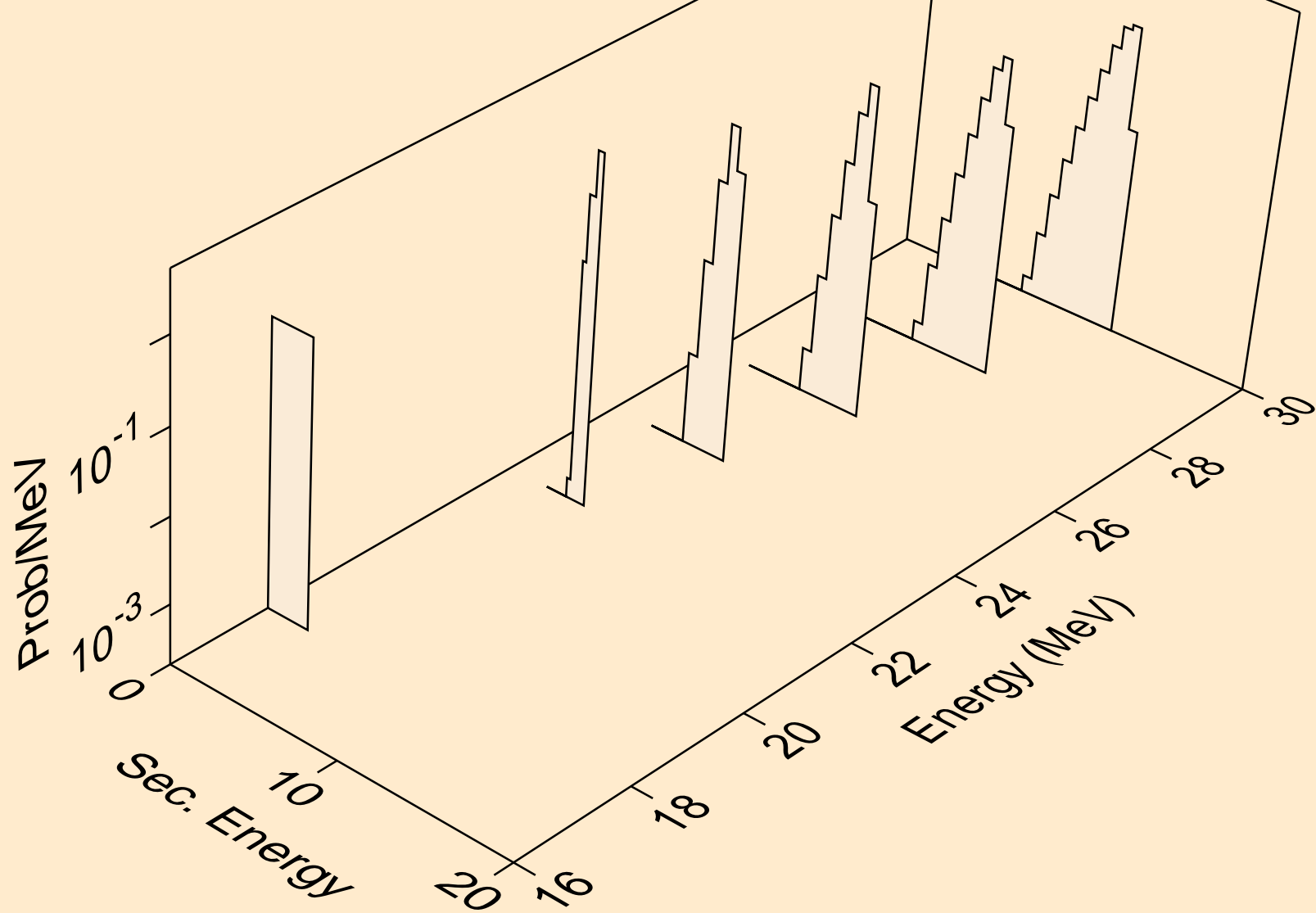

SN113M PROTON ACER TENDL-2021 LIBRARY; T=0.K  
he3s from (p,he3)

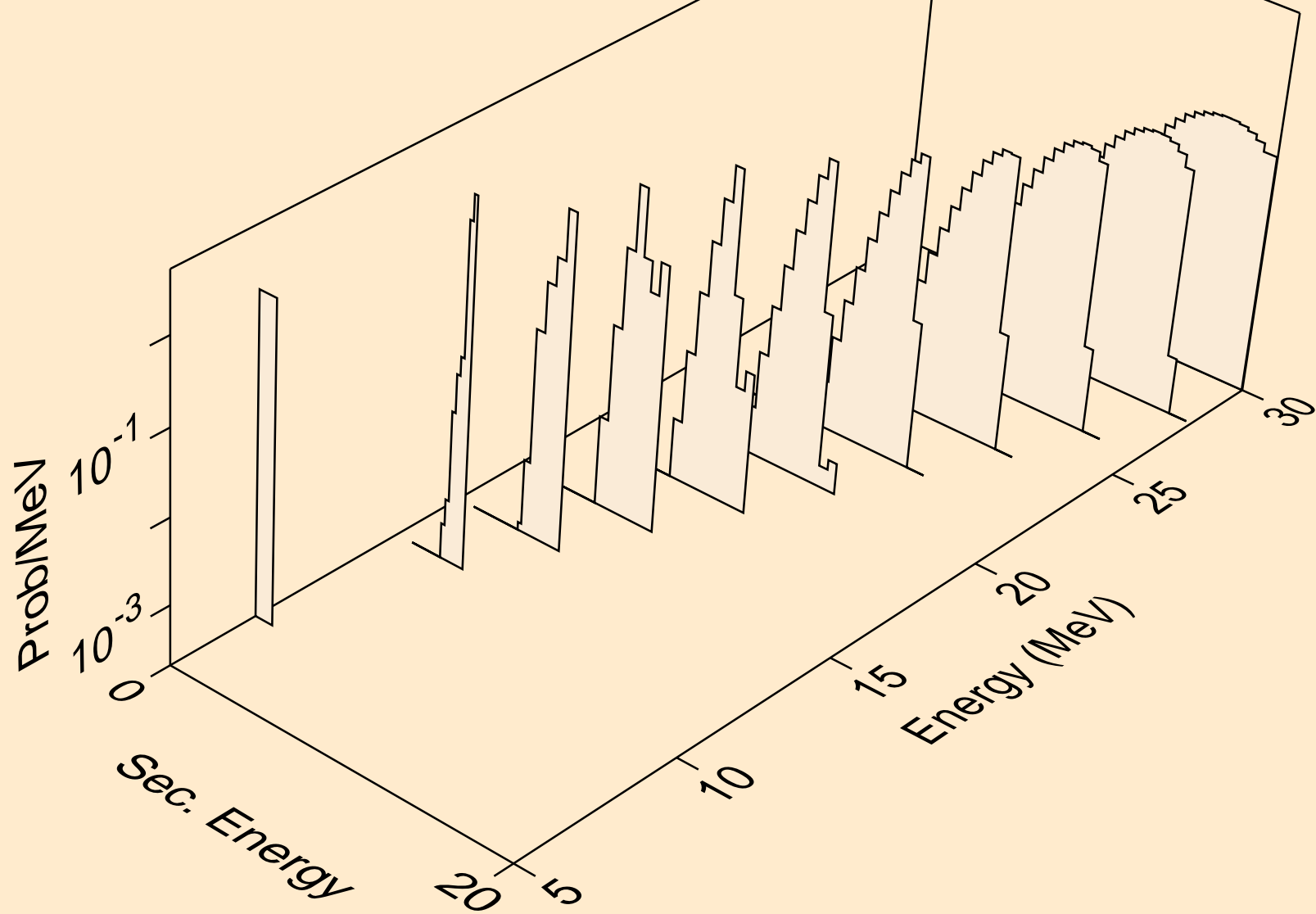



SN113M PROTON ACER TENDL-2021 LIBRARY; T=0.K  
alphas from (p,x)

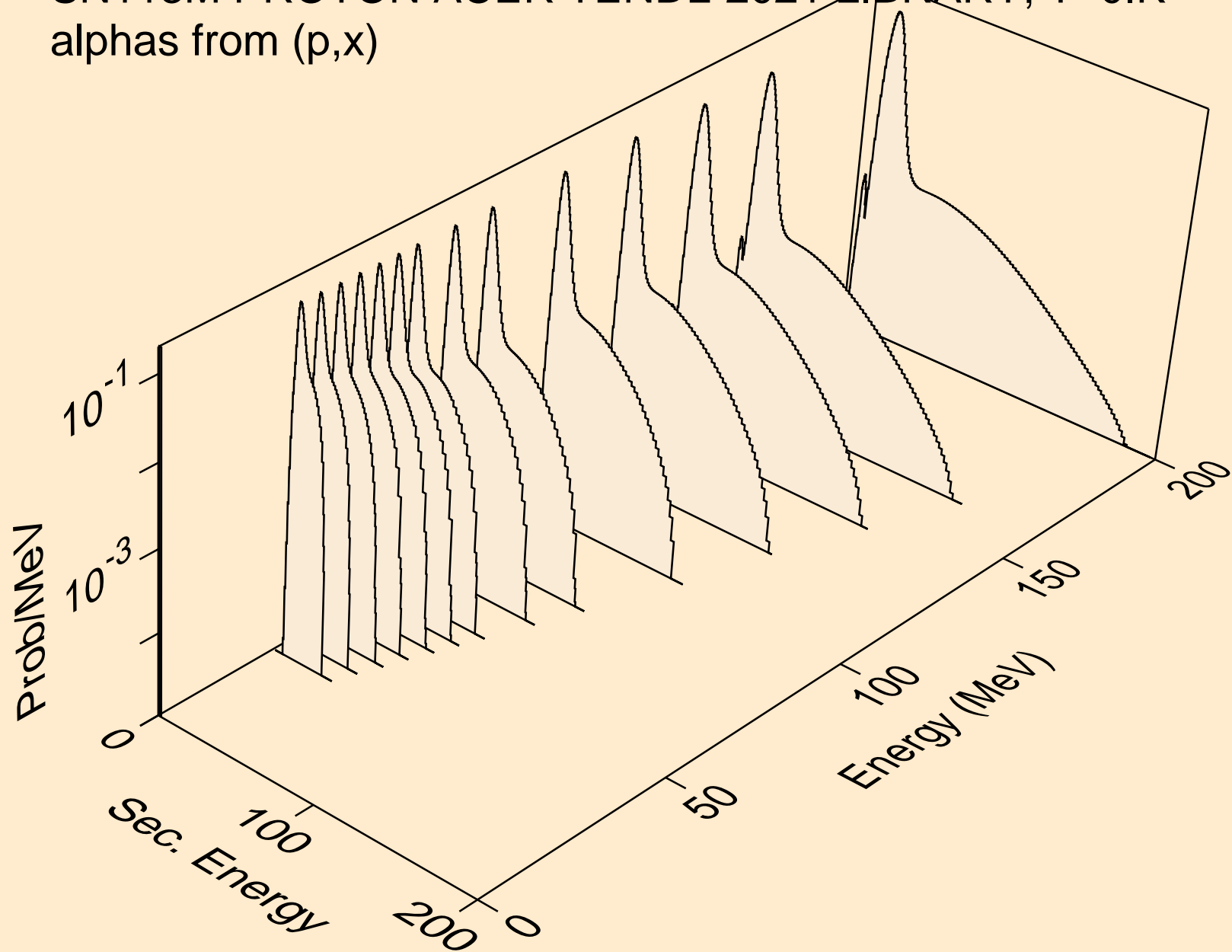

SN113M PROTON ACER TENDL-2021 LIBRARY; T=0.K  
alphas from (p,n\*)a

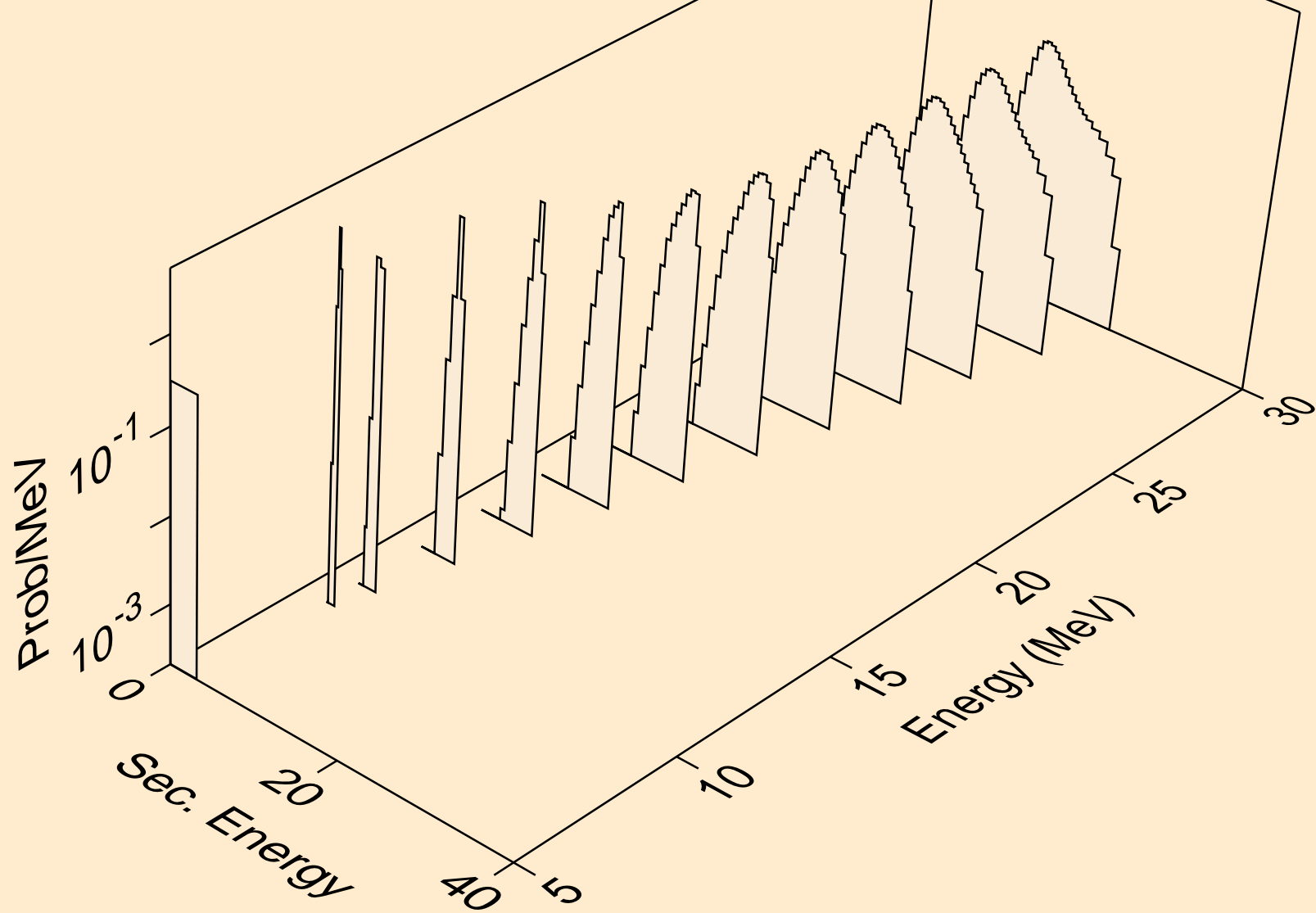

SN113M PROTON ACER TENDL-2021 LIBRARY; T=0.K  
alphas from (p,2n)a

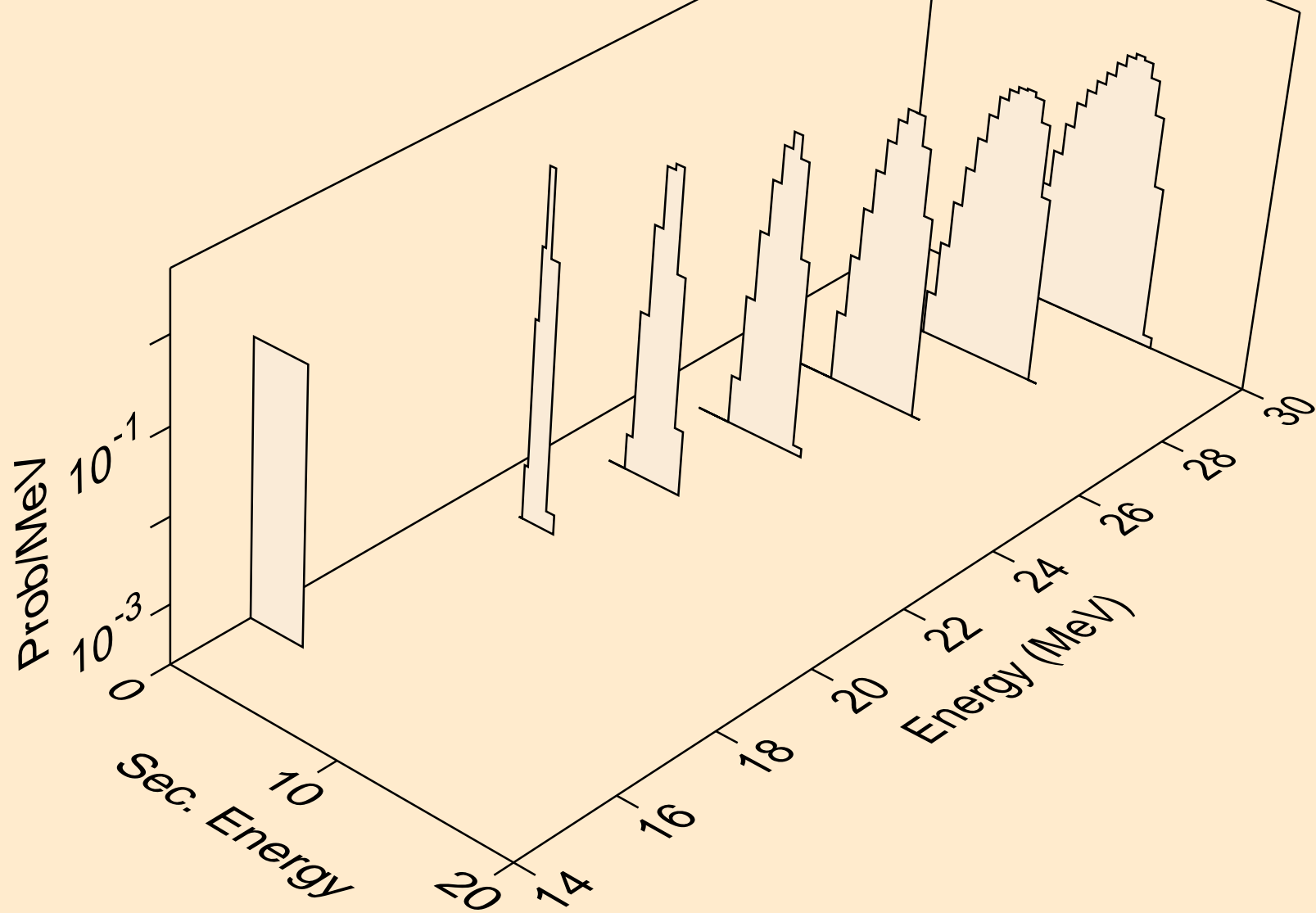

SN113M PROTON ACER TENDL-2021 LIBRARY; T=0.K  
alphas from (p,n\*)2a

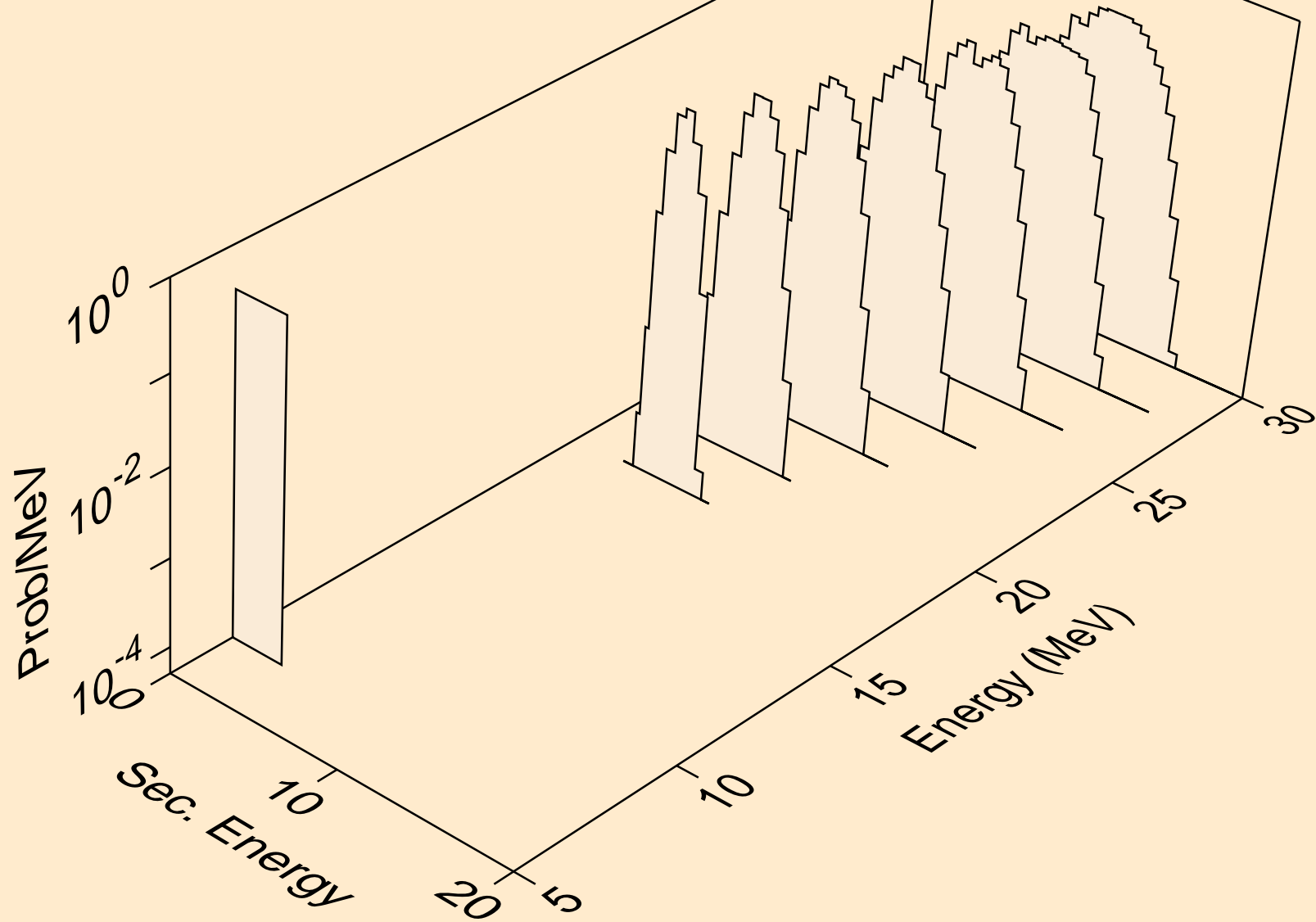

SN113M PROTON ACER TENDL-2021 LIBRARY; T=0.K  
alphas from (p,npa)

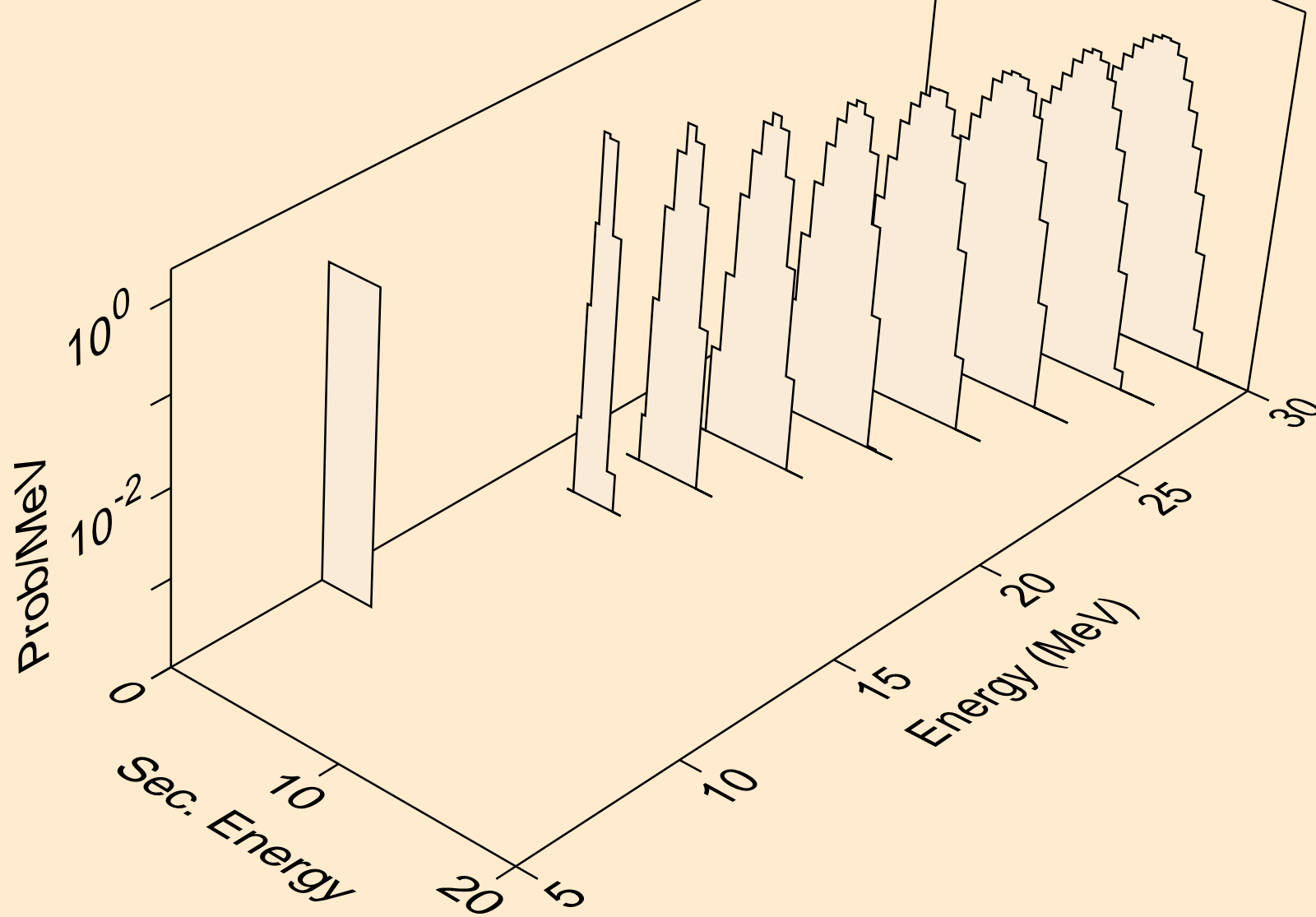

SN113M PROTON ACER TENDL-2021 LIBRARY; T=0.K  
alphas from (p,a)

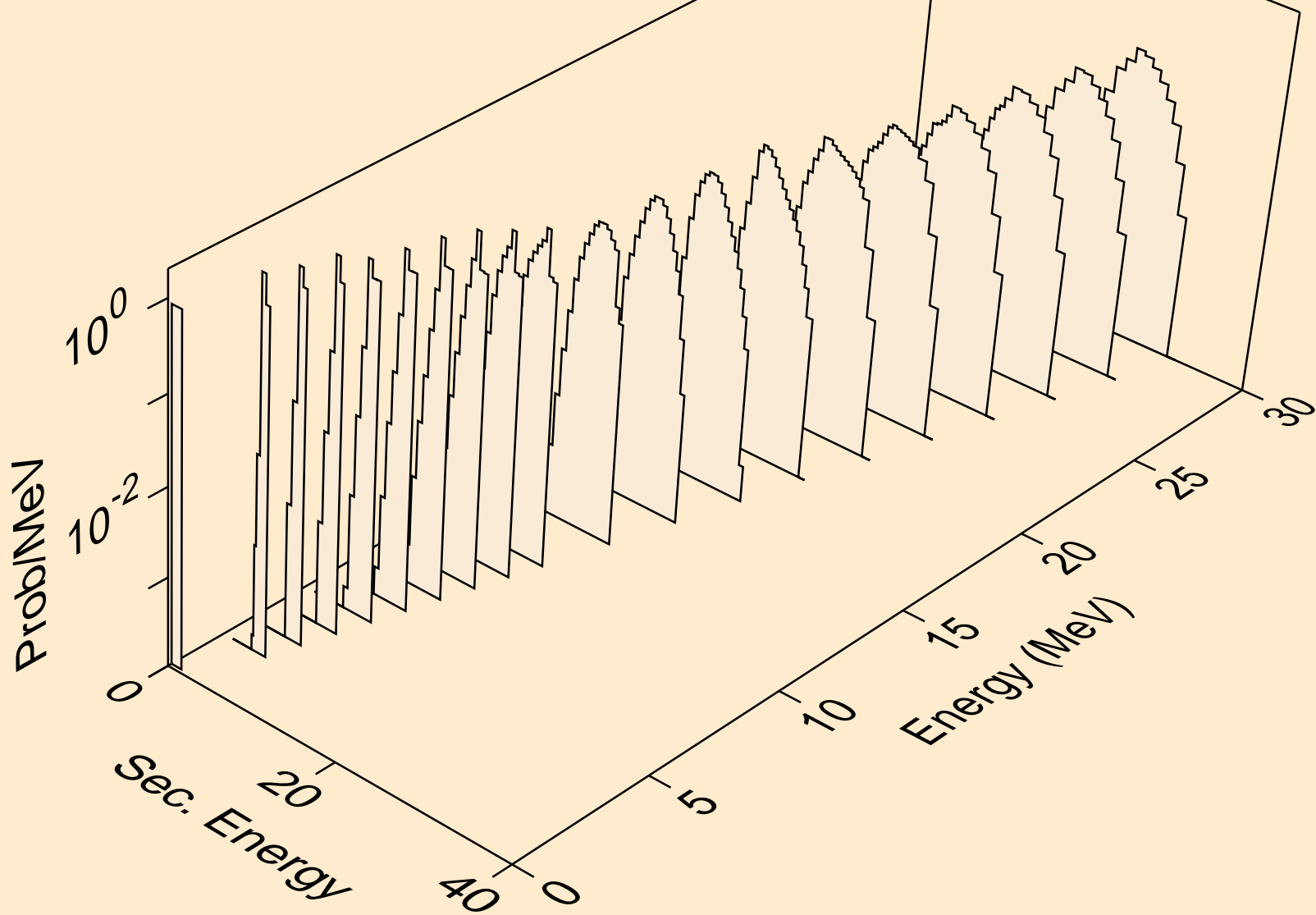

SN113M PROTON ACER TENDL-2021 LIBRARY; T=0.K  
alphas from (p,2a)

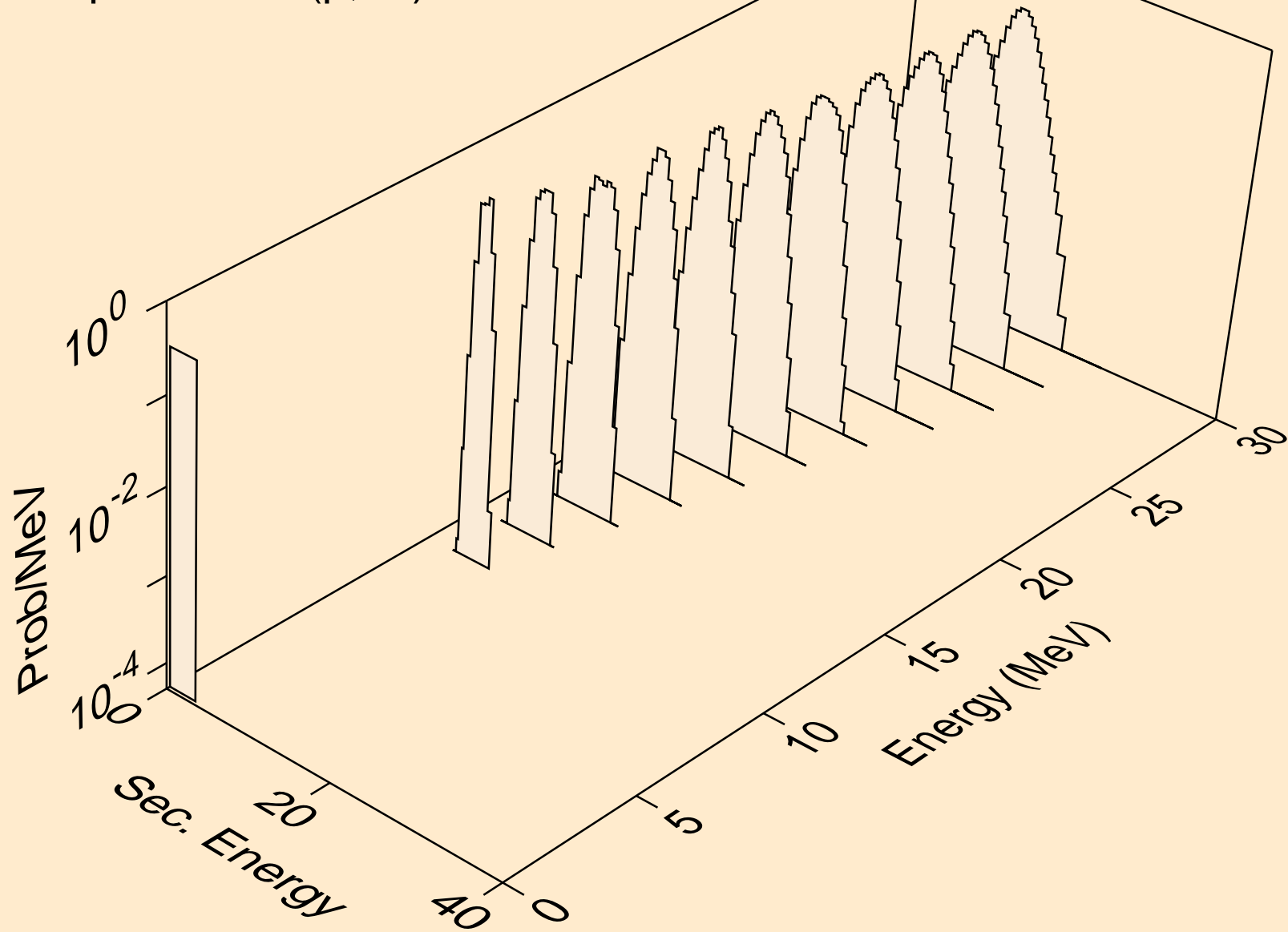

SN113M PROTON ACER TENDL-2021 LIBRARY; T=0.K  
alphas from (p,pa)

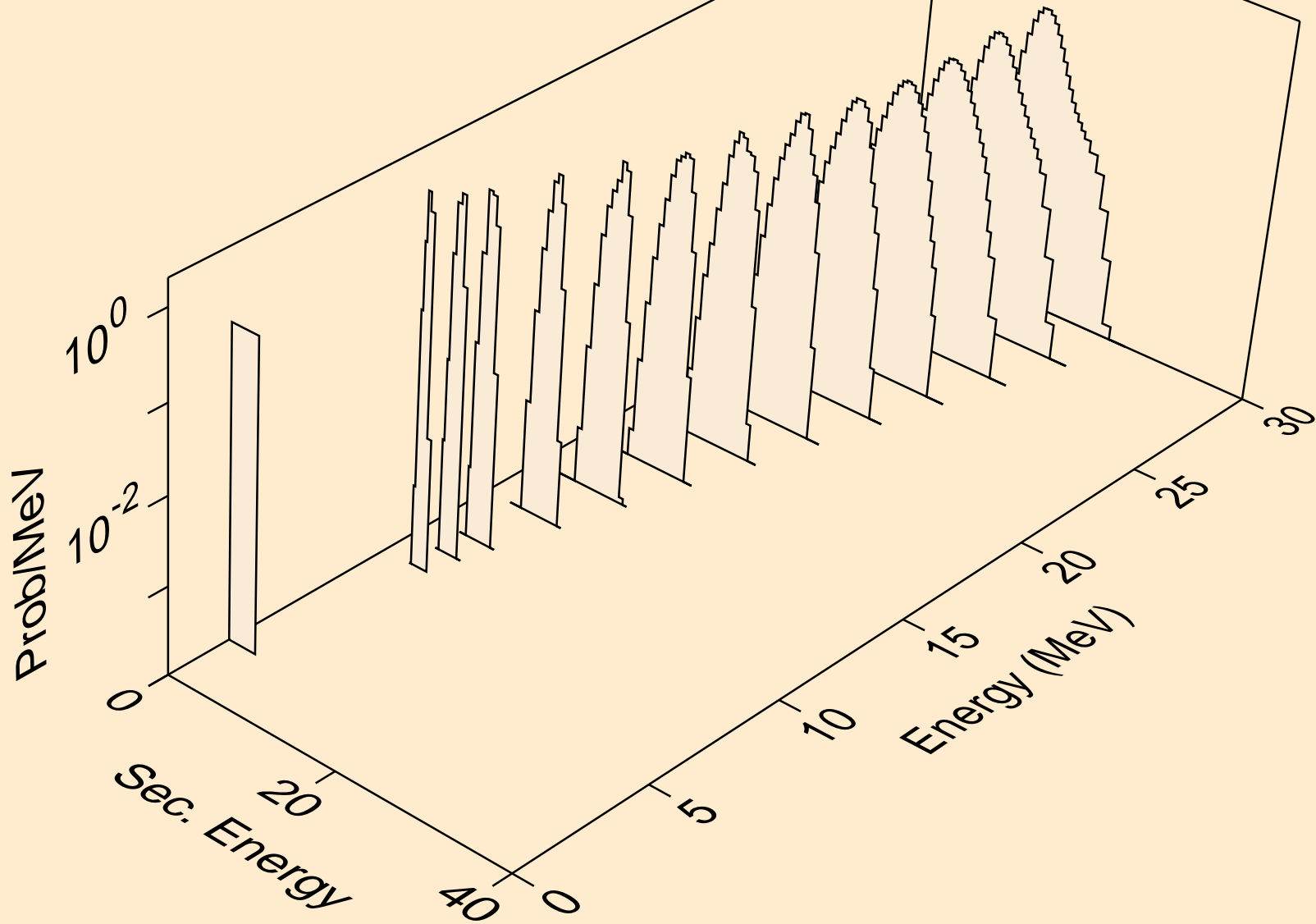



SN113M PROTON ACER TENDL-2021 LIBRARY; T=0.K  
alphas from (p,da)

