

# TC108 PROTON ACER TENDL-2021 LIBRARY; T=0.K

## Principal cross sections

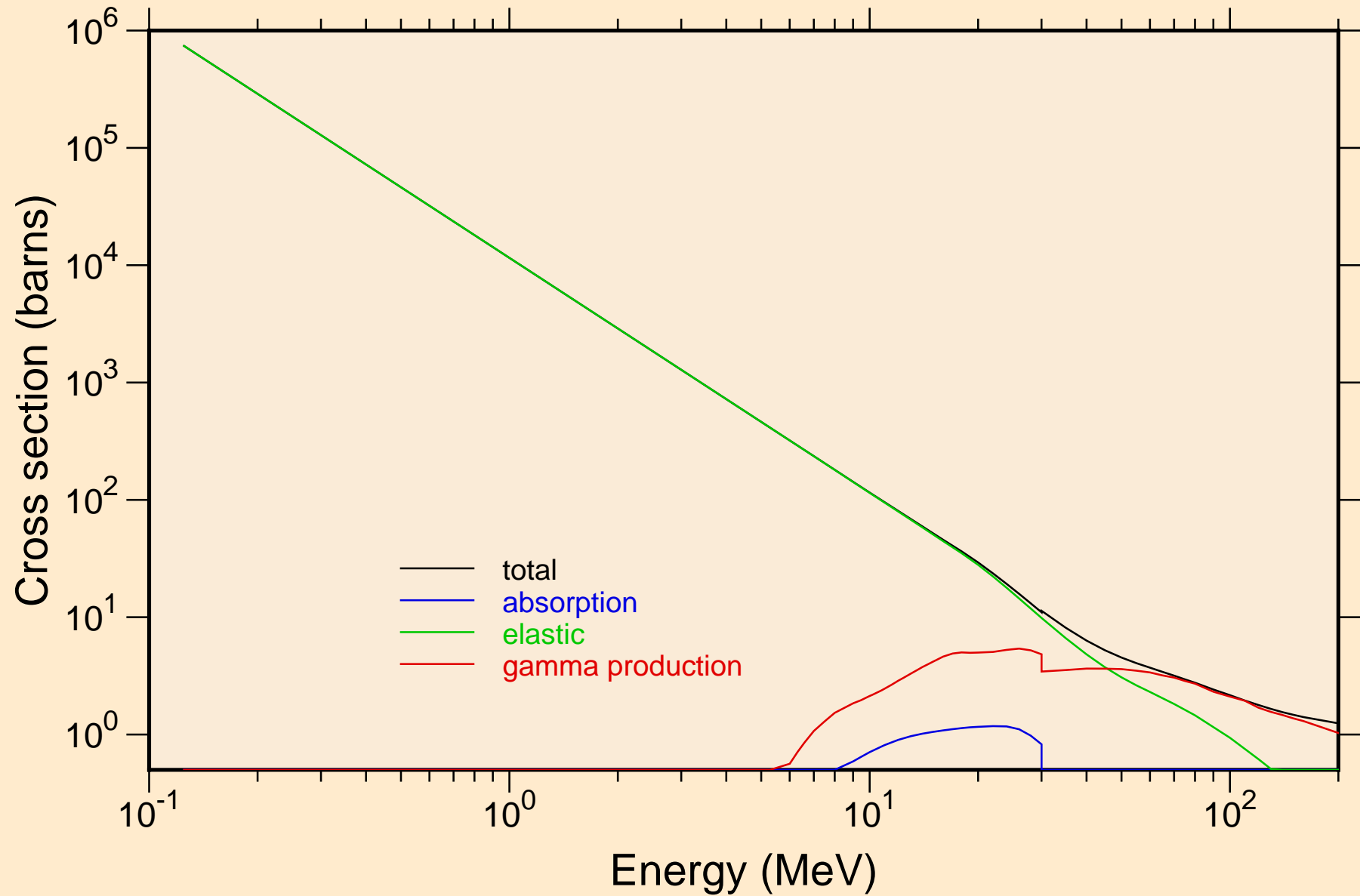

# TC108 PROTON ACER TENDL-2021 LIBRARY; T=0.K

## Heating

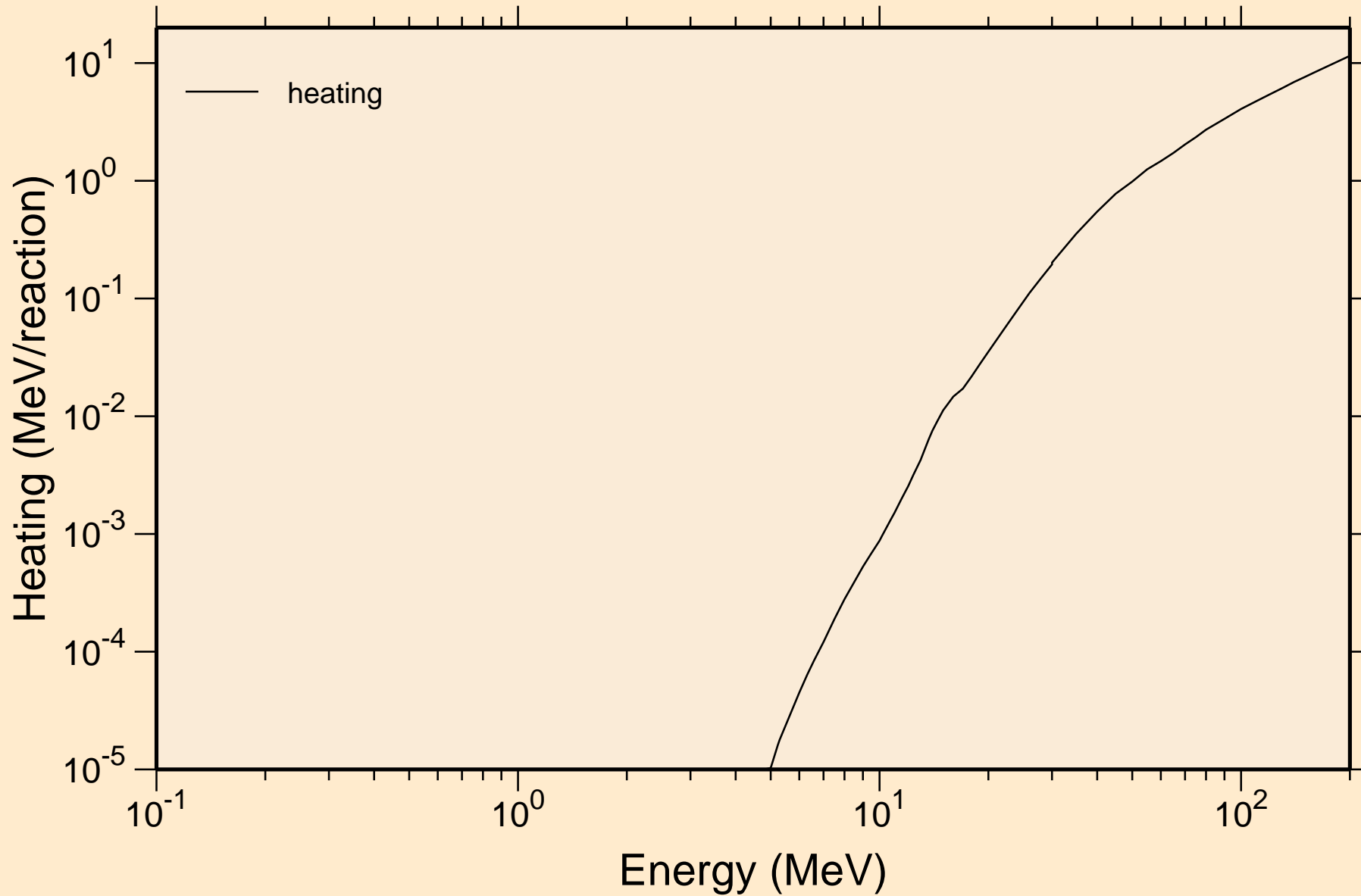

# TC108 PROTON ACER TENDL-2021 LIBRARY; T=0.K

## Principal cross sections

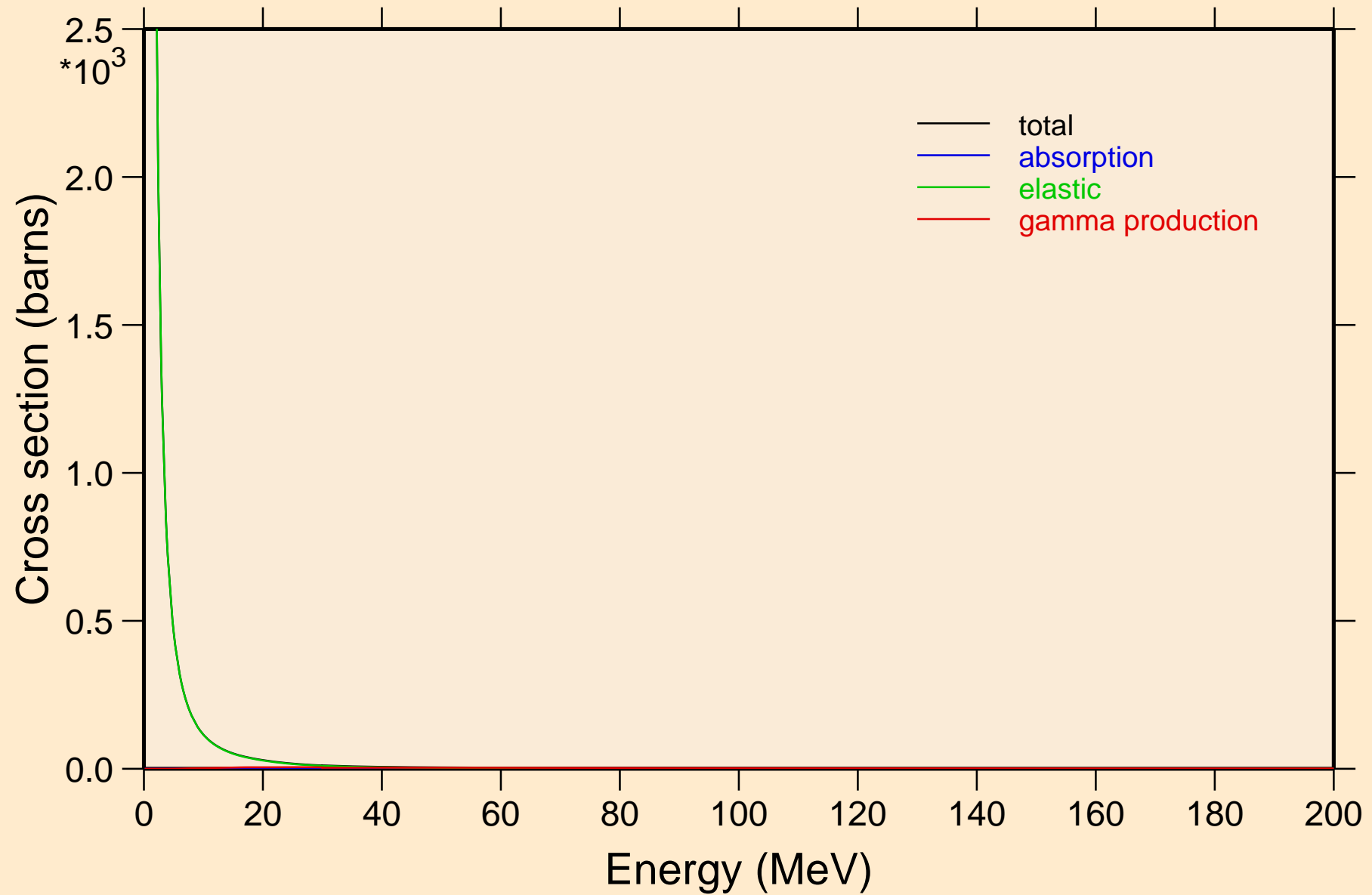

TC108 PROTON ACER TENDL-2021 LIBRARY; T=0.K

Heating

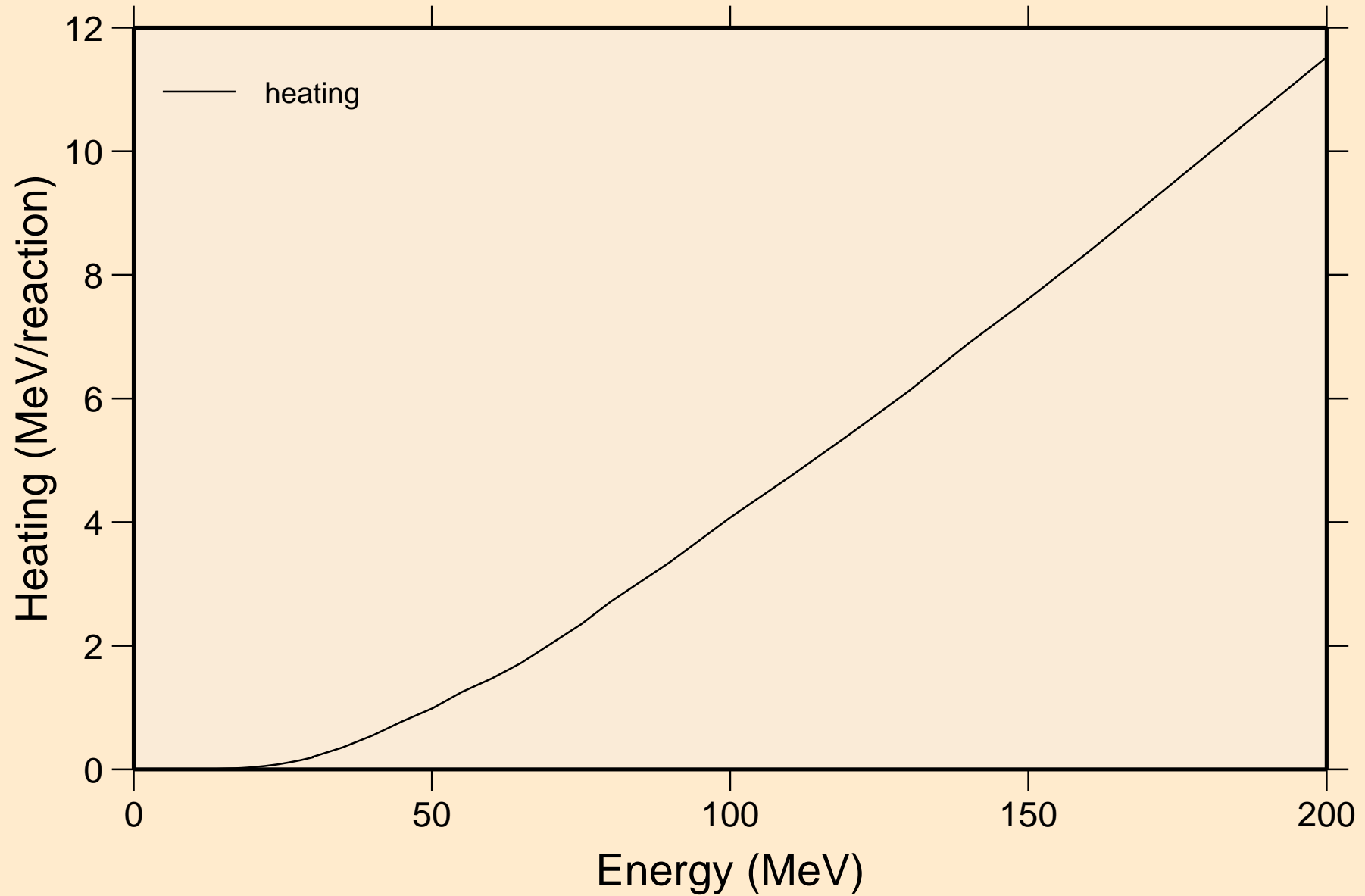

TC108 PROTON ACER TENDL-2021 LIBRARY; T=0.K  
Threshold reactions

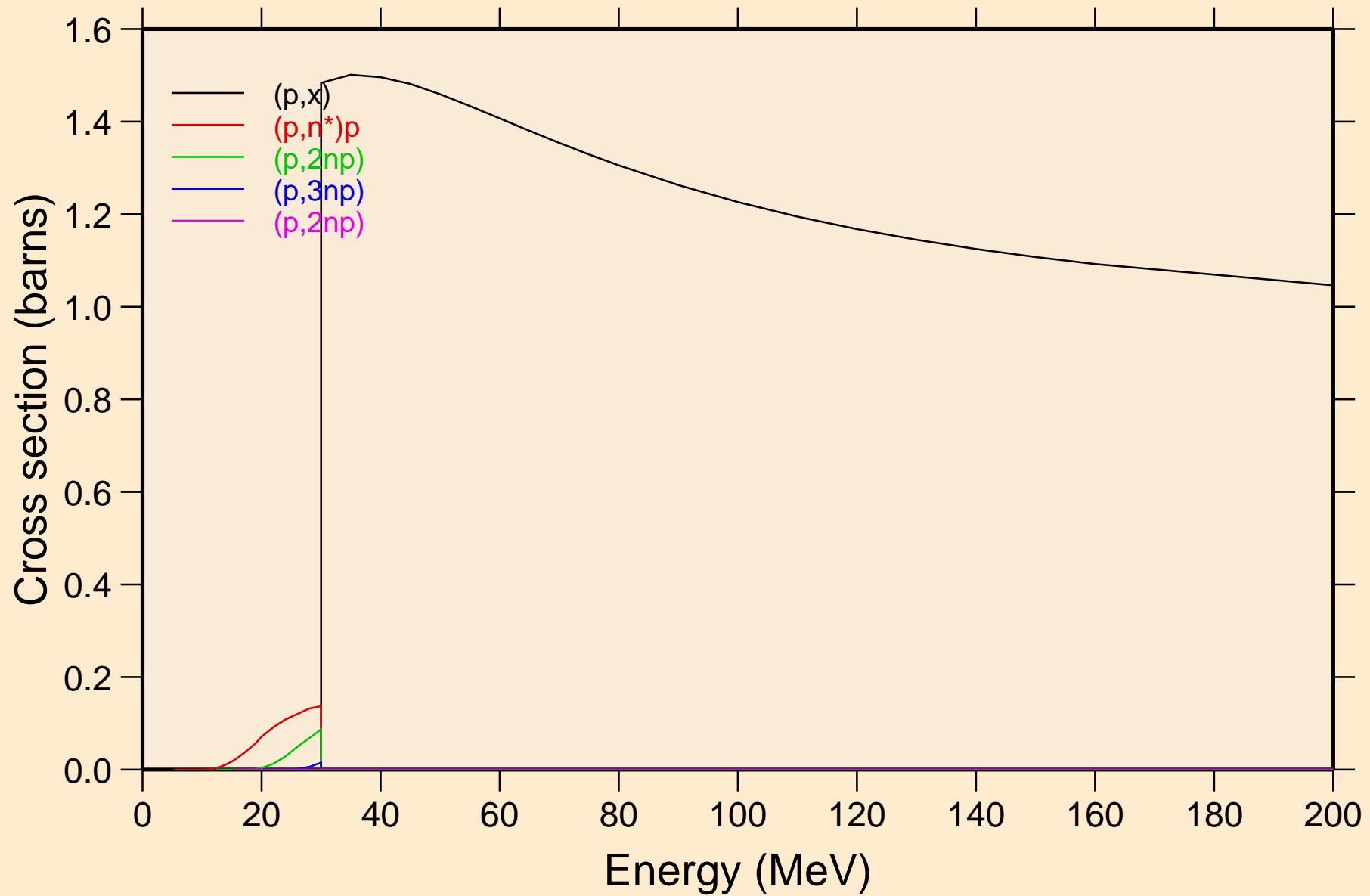

TC108 PROTON ACER TENDL-2021 LIBRARY; T=0.K  
Threshold reactions

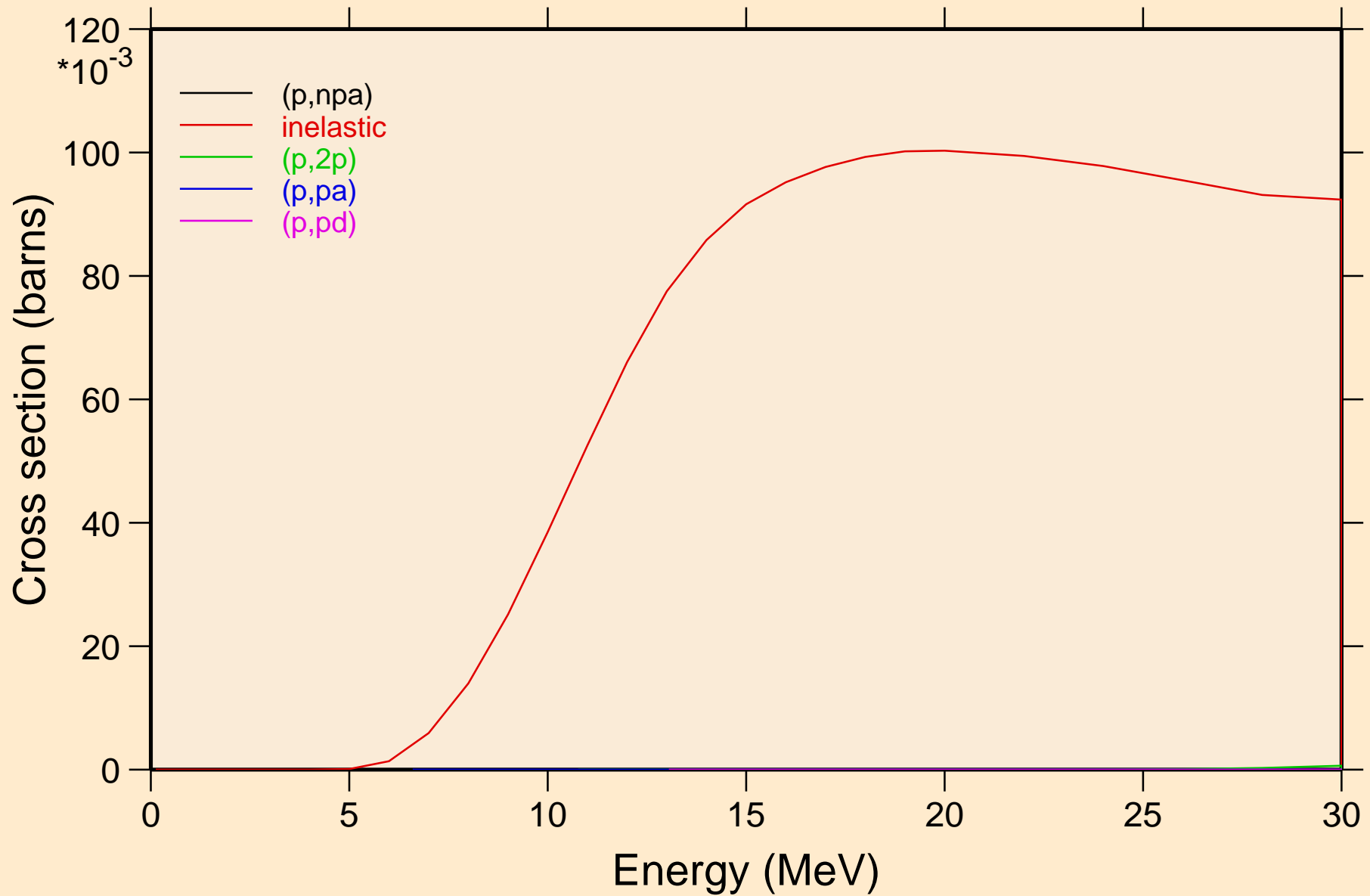

TC108 PROTON ACER TENDL-2021 LIBRARY; T=0.K  
Threshold reactions

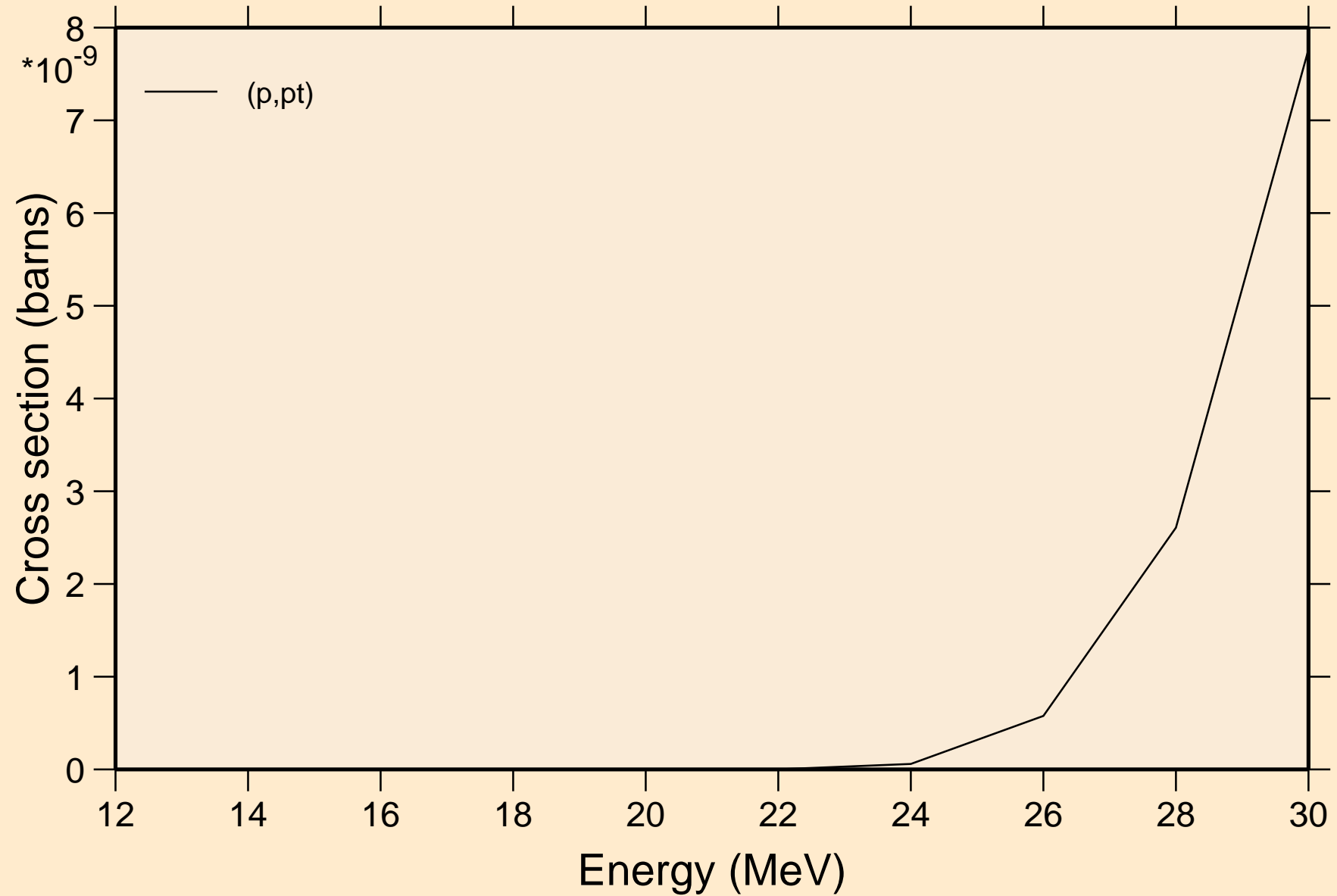

TC108 PROTON ACER TENDL-2021 LIBRARY; T=0.K  
angular distribution for elastic

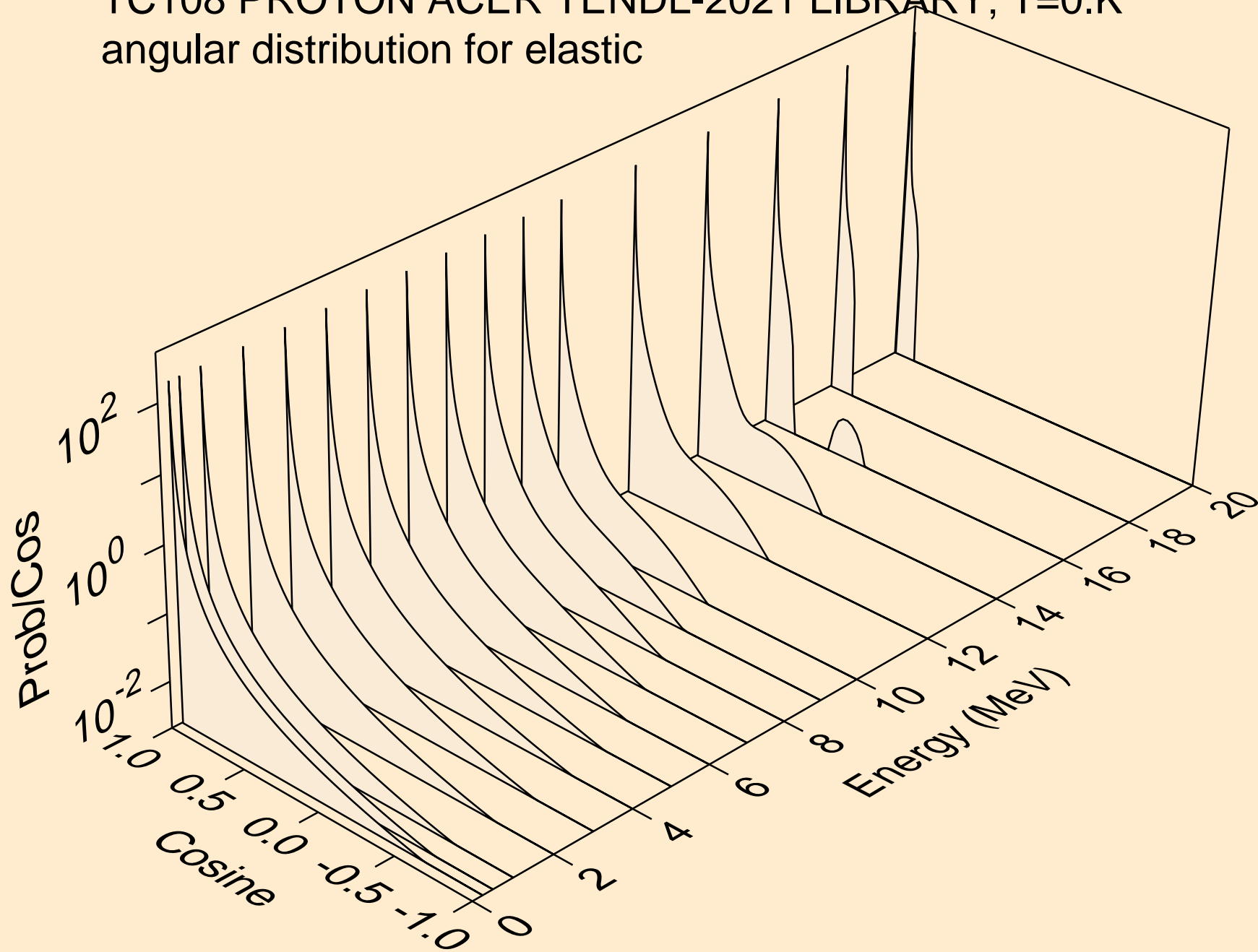



TC108 PROTON ACER TENDL-2021 LIBRARY; T=0.K  
angular distribution for elastic

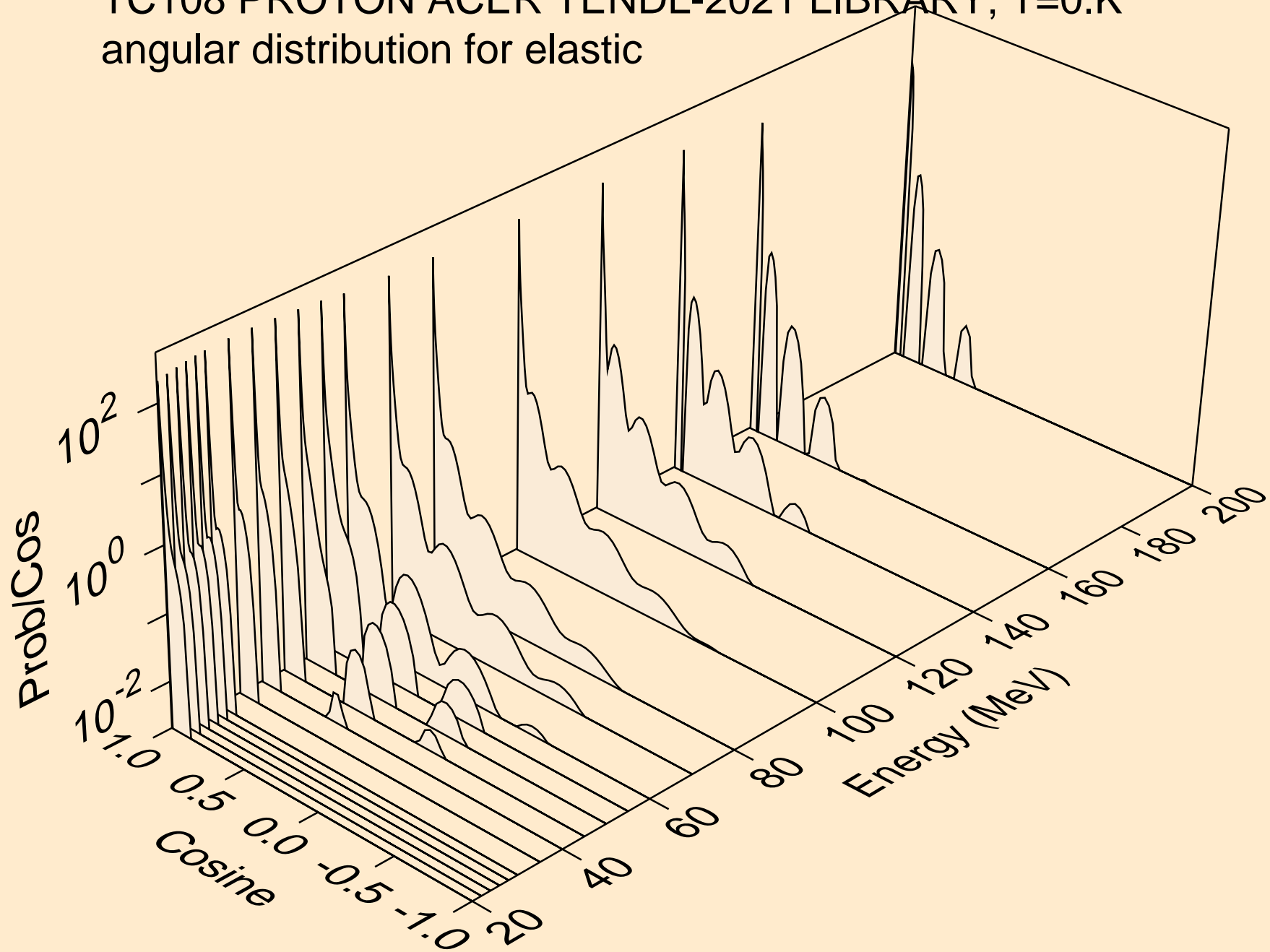

TC108 PROTON ACER TENDL-2021 LIBRARY; T=0.K  
Proton emission for (p,x)

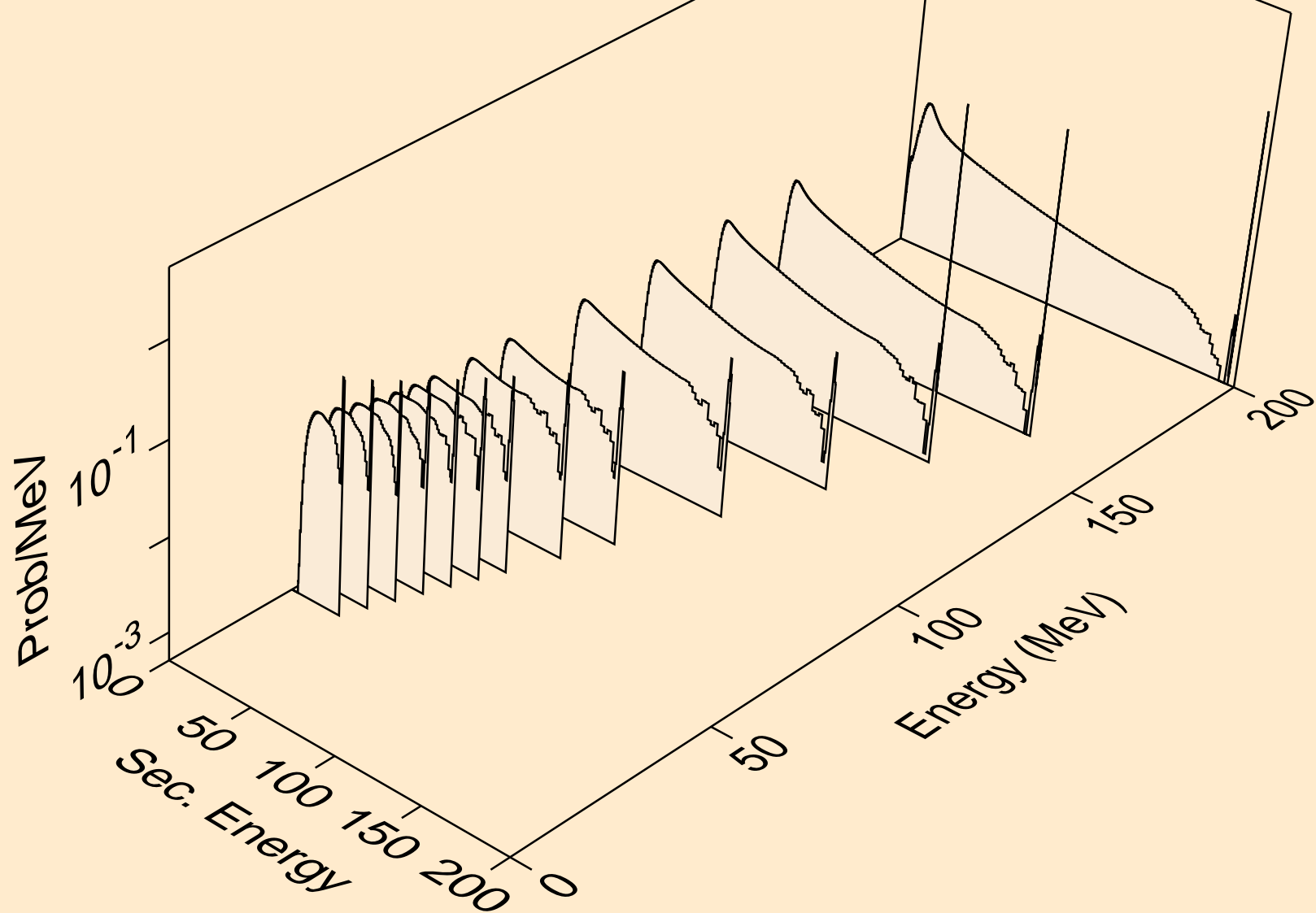

TC108 PROTON ACER TENDL-2021 LIBRARY; T=0.K  
Proton emission for (p,n\*)p

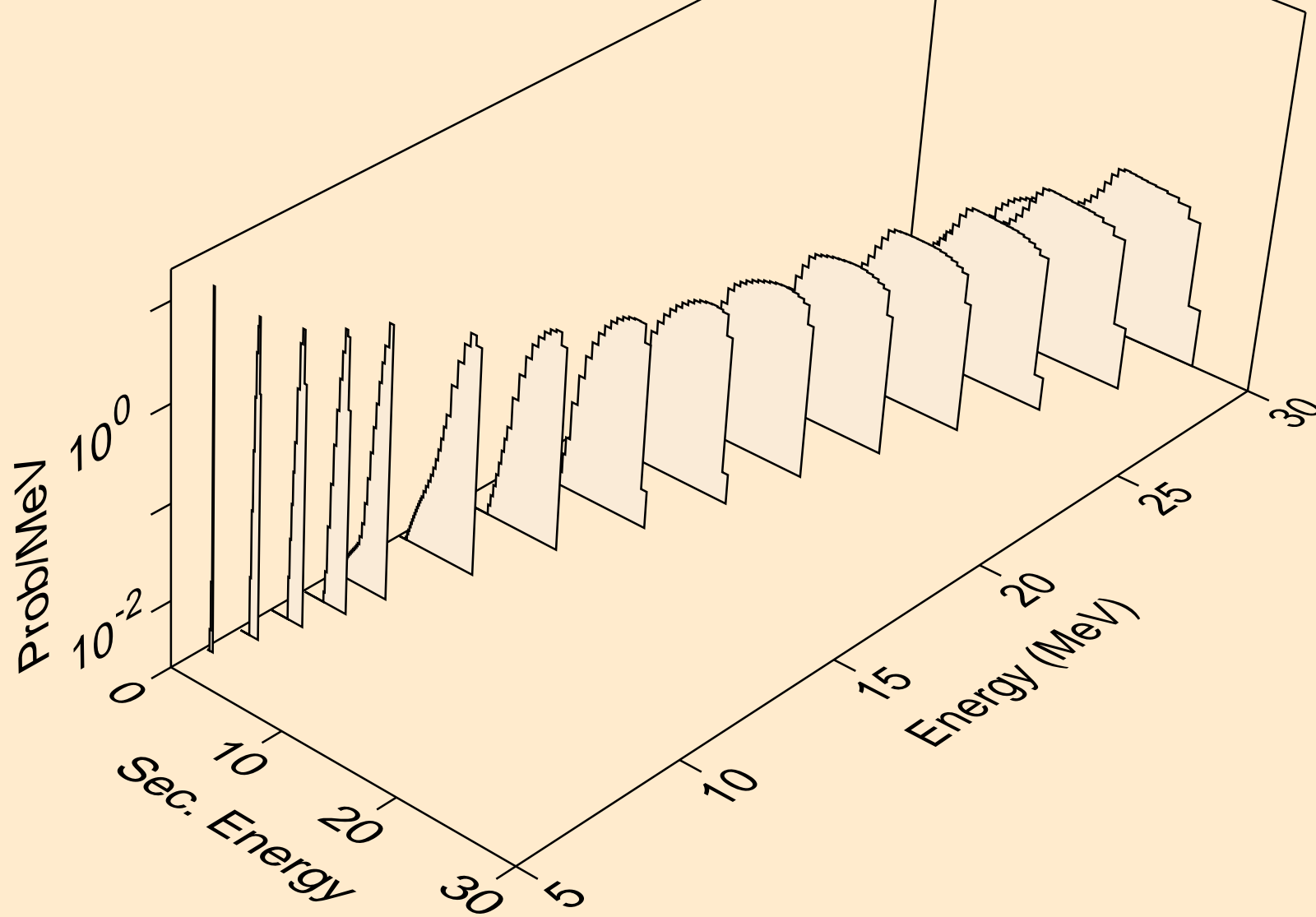

TC108 PROTON ACER TENDL-2021 LIBRARY; T=0.K  
Proton emission for (p,2np)

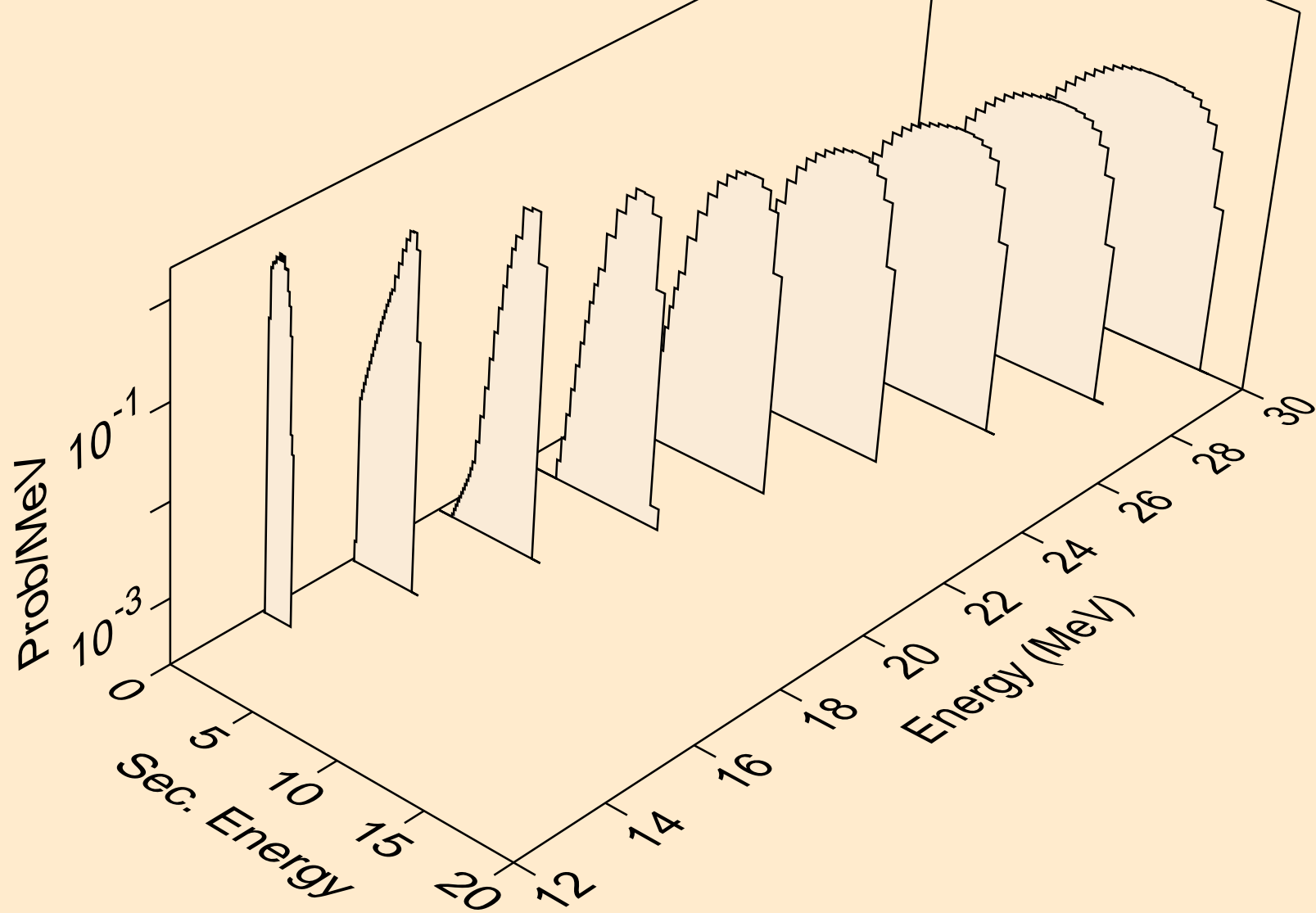

TC108 PROTON ACER TENDL-2021 LIBRARY; T=0.K  
Proton emission for (p,3np)

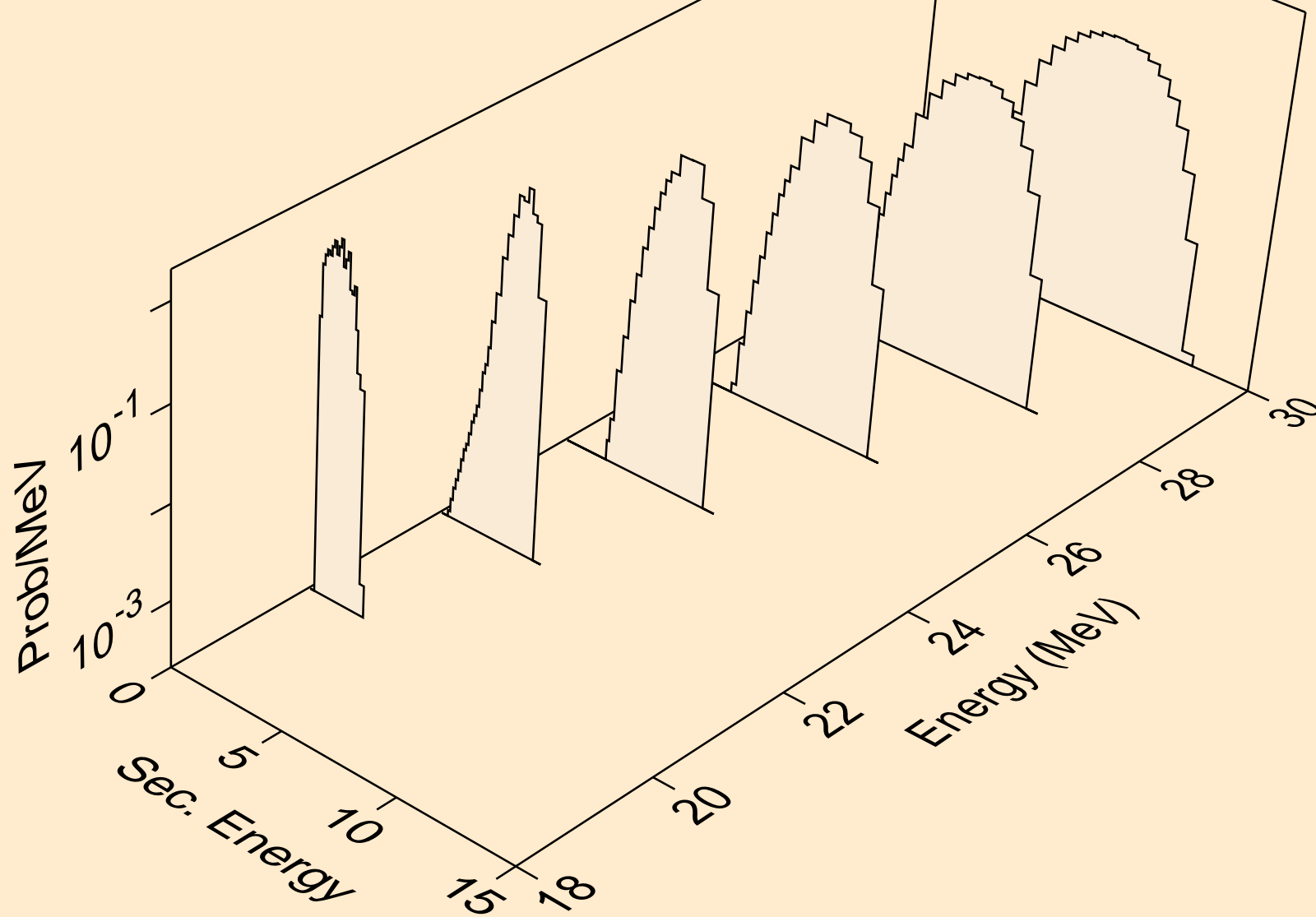

TC108 PROTON ACER TENDL-2021 LIBRARY; T=0.K  
Proton emission for (p,2np)

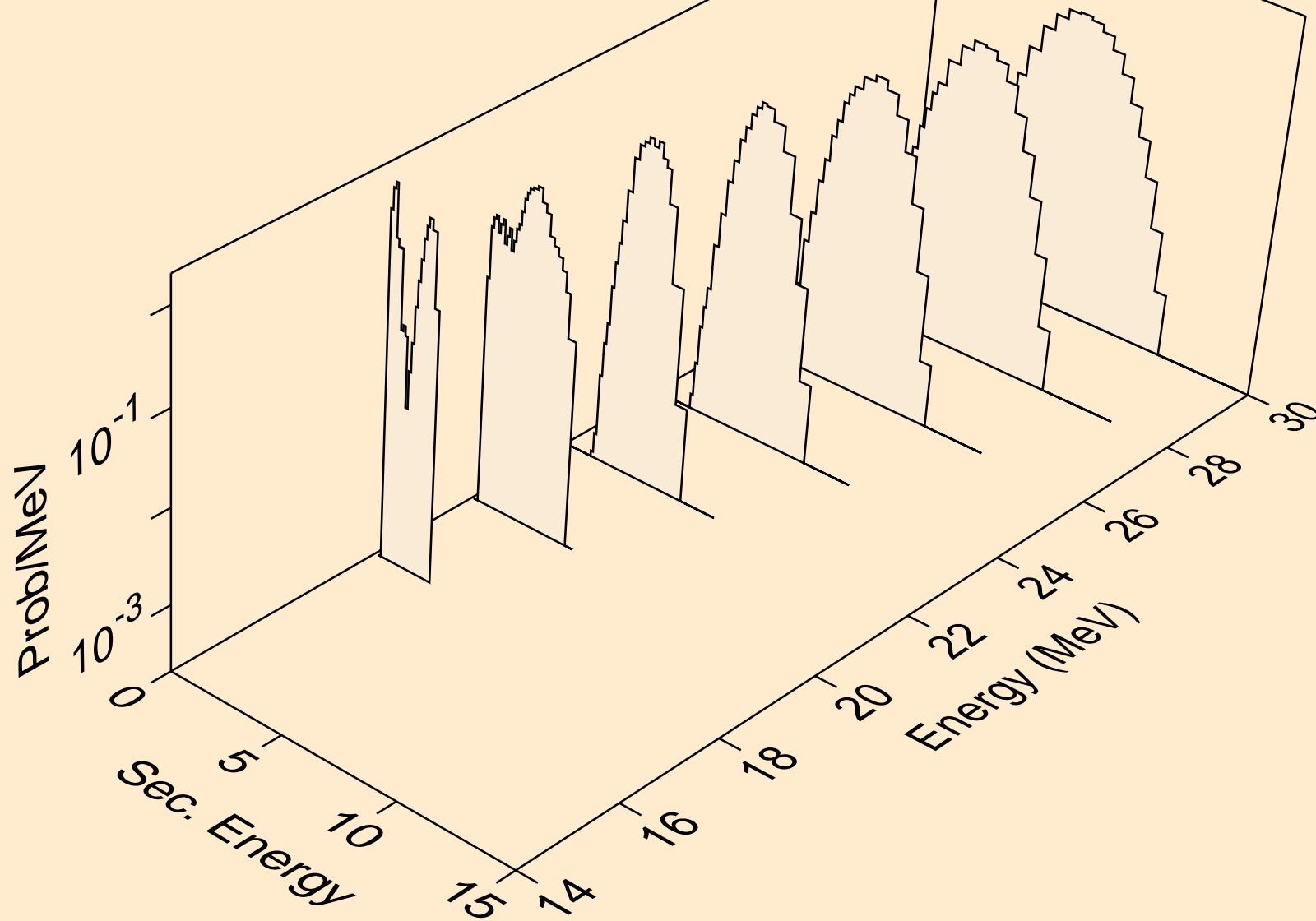

TC108 PROTON ACER TENDL-2021 LIBRARY; T=0.K  
Proton emission for (p,npa)

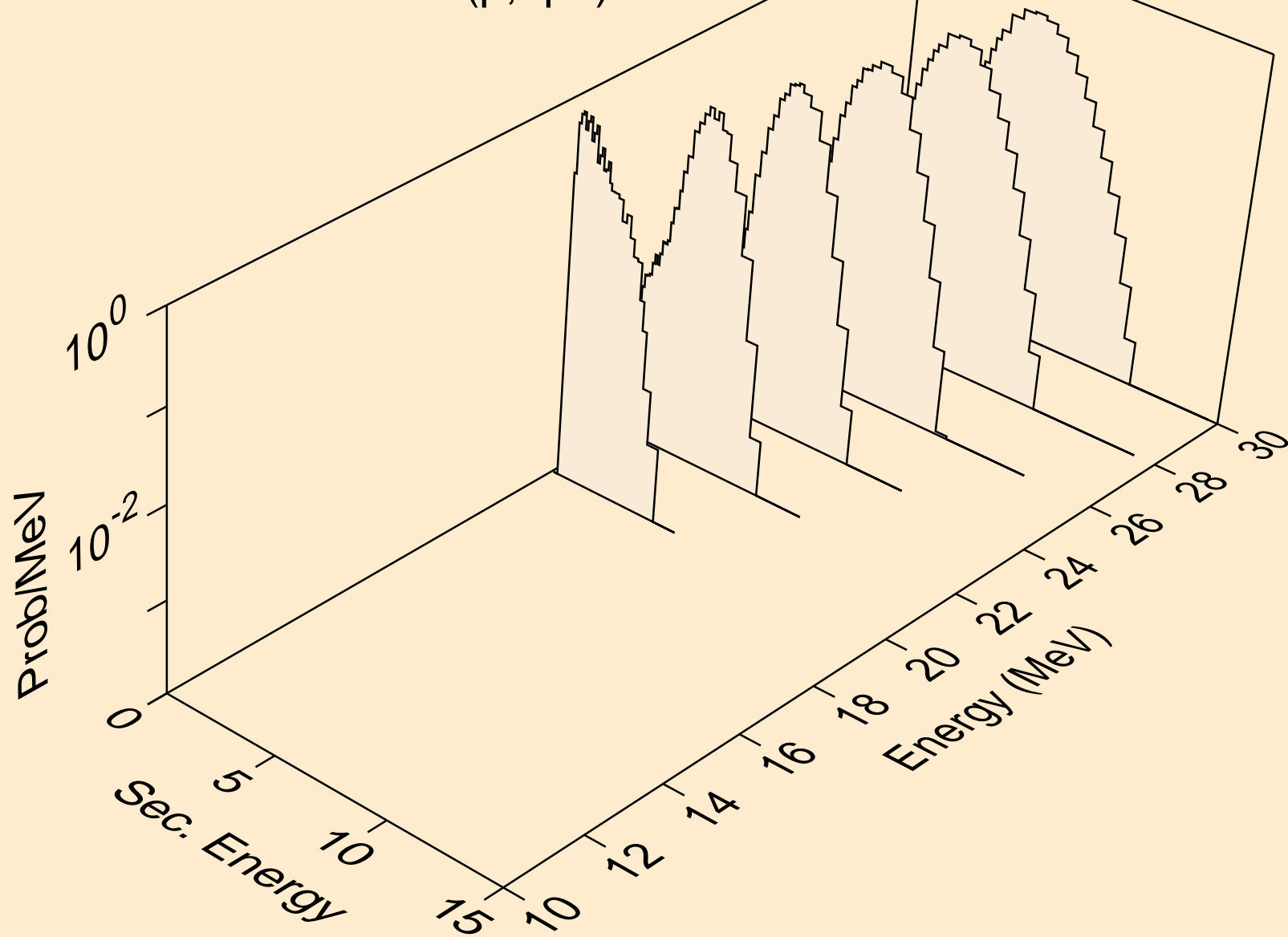

TC108 PROTON ACER TENDL-2021 LIBRARY; T=0.K  
Proton emission for inelastic

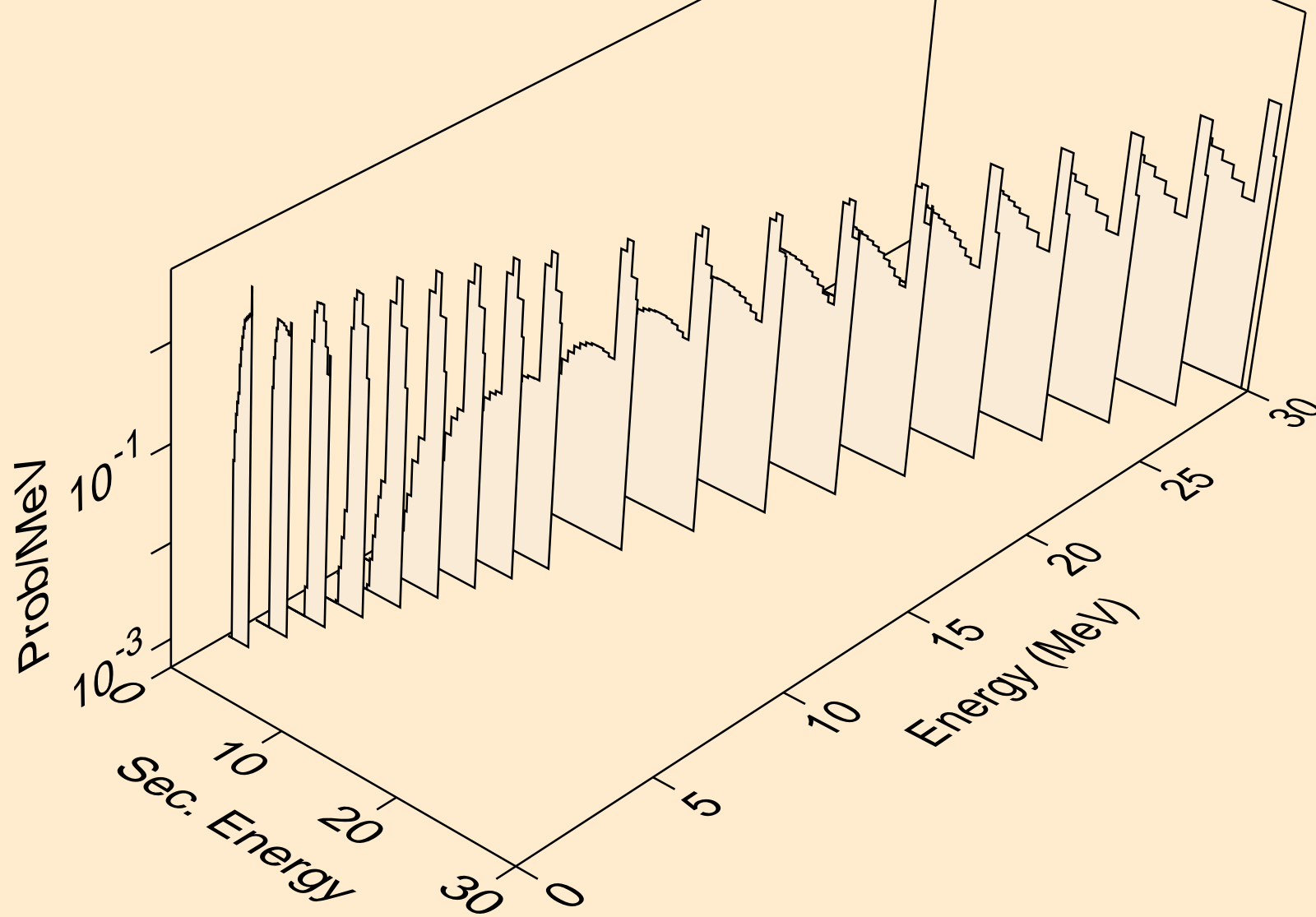



TC108 PROTON ACER TENDL-2021 LIBRARY; T=0.K  
Proton emission for (p,2p)

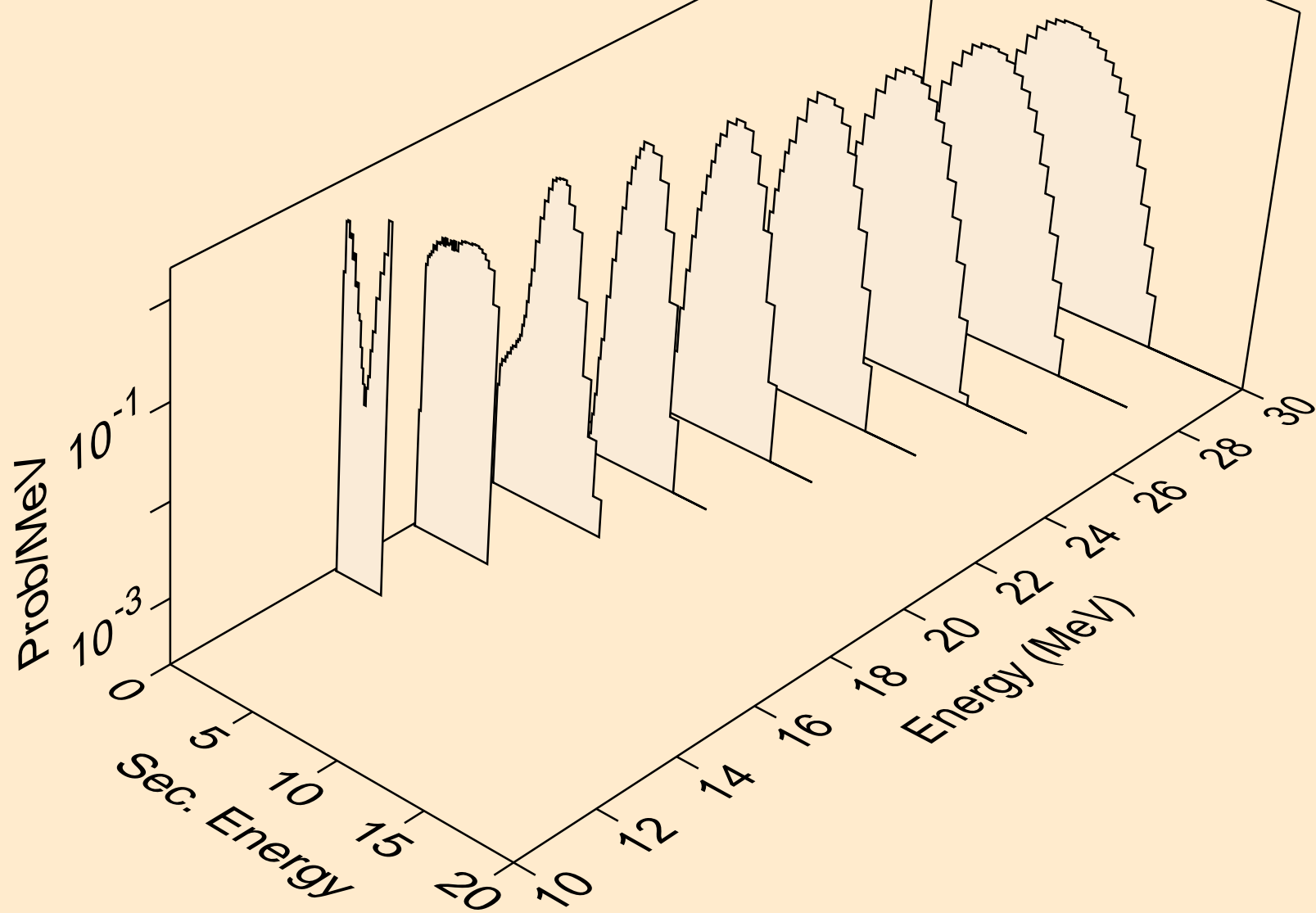

TC108 PROTON ACER TENDL-2021 LIBRARY; T=0.K  
Proton emission for (p,pa)

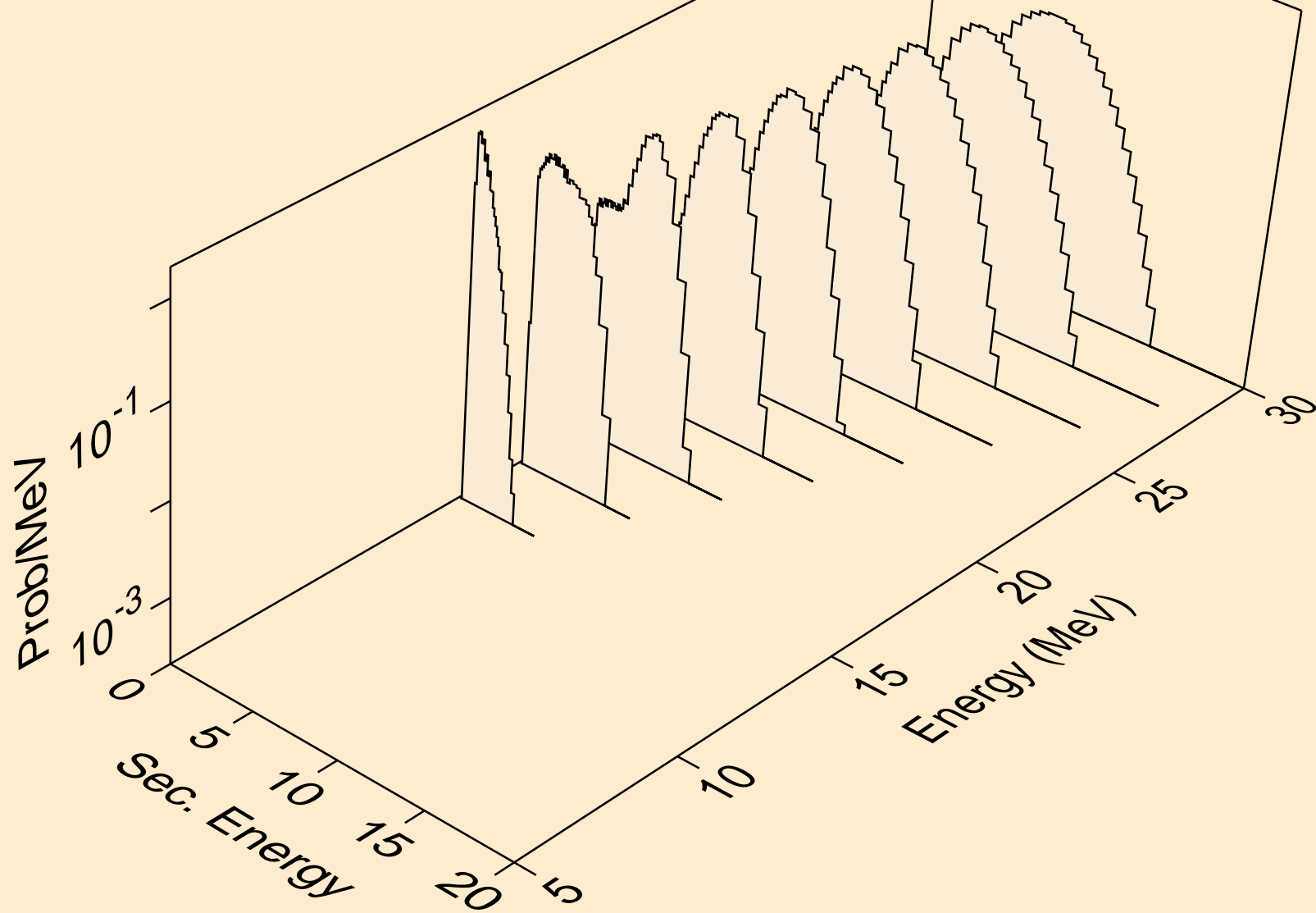

TC108 PROTON ACER TENDL-2021 LIBRARY; T=0.K  
Proton emission for (p,pd)

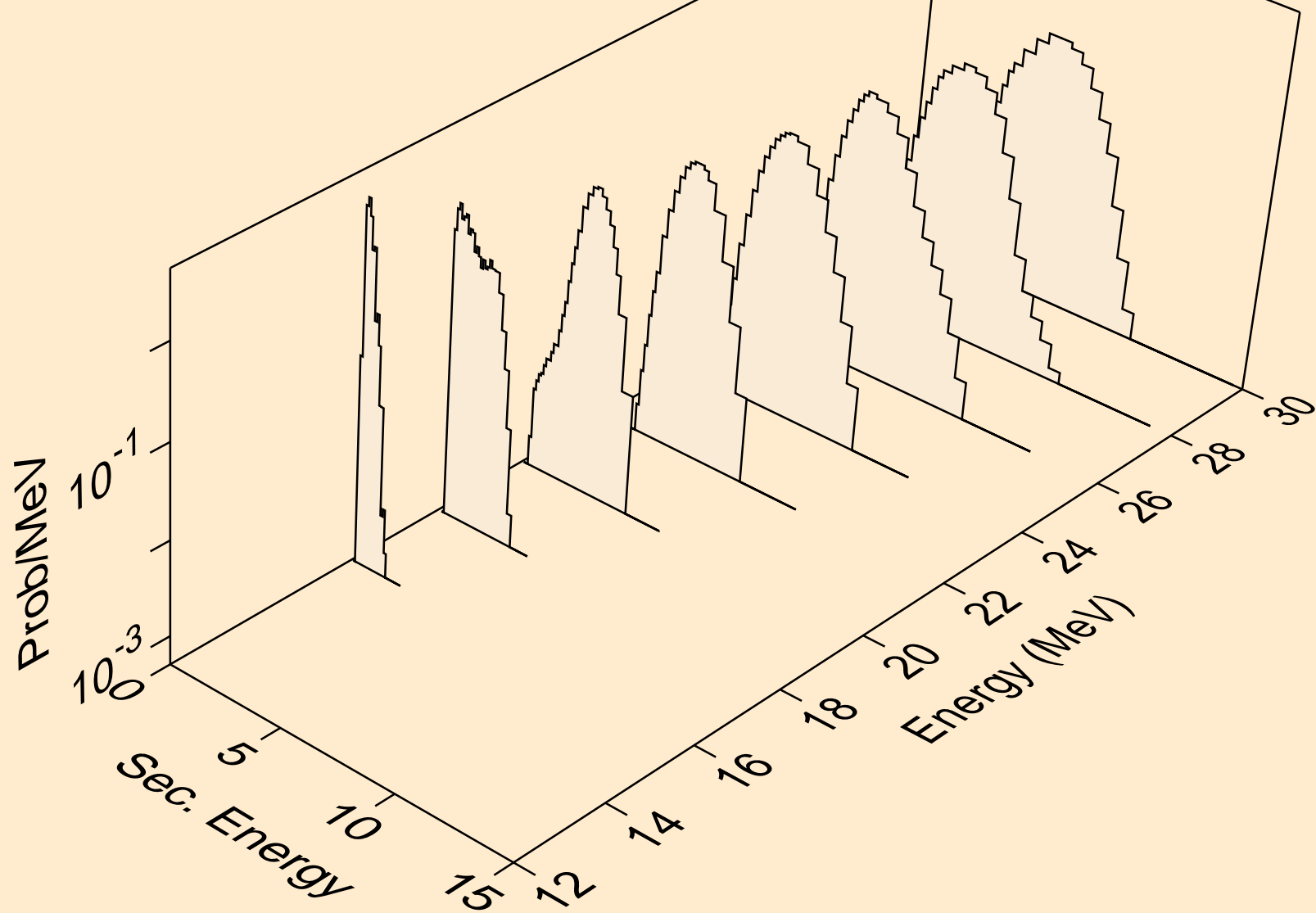

TC108 PROTON ACER TENDL-2021 LIBRARY; T=0.K  
Proton emission for (p,pt)

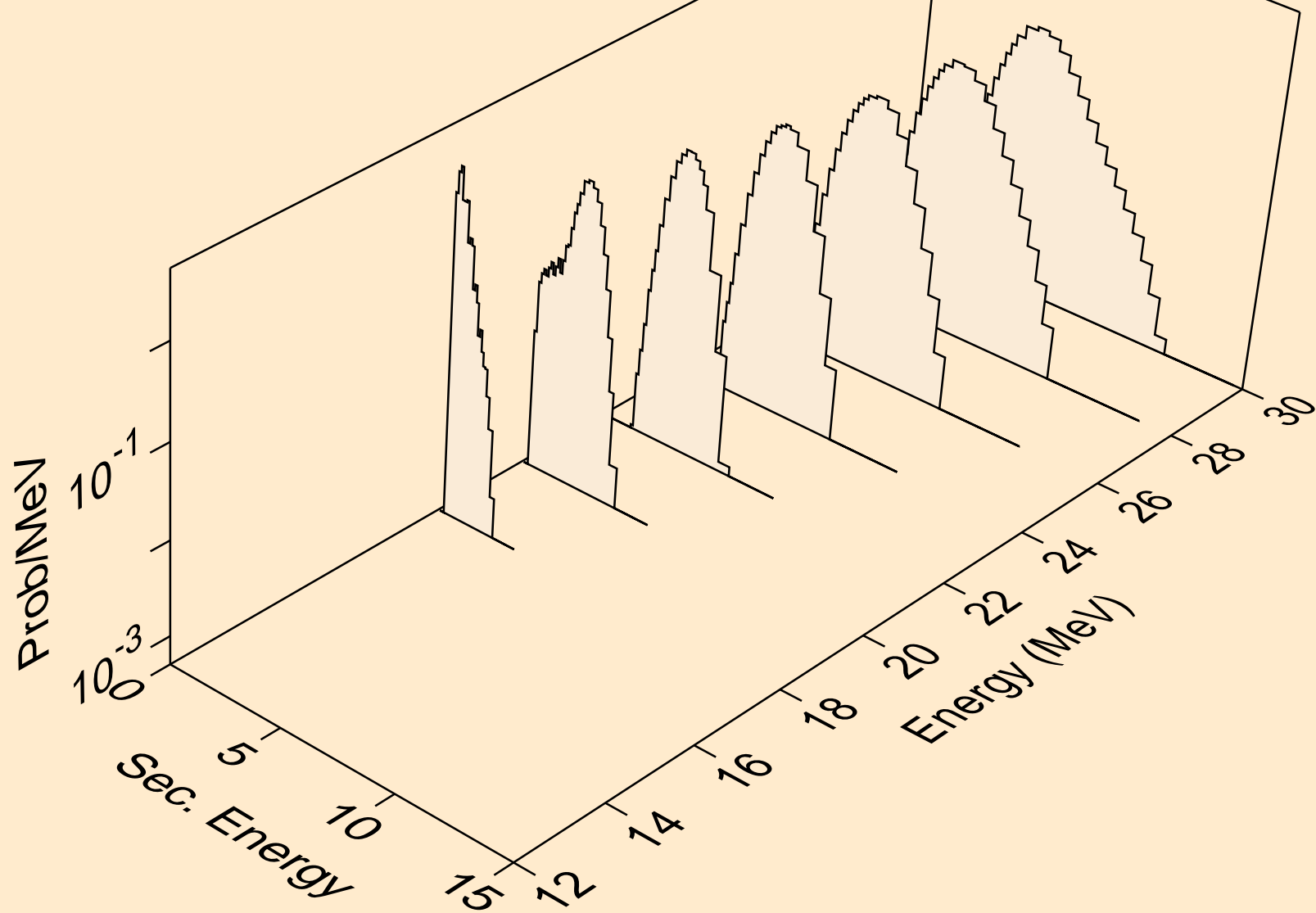

TC108 PROTON ACER TENDL-2021 LIBRARY; T=0.K  
Photon emission for (z,n)

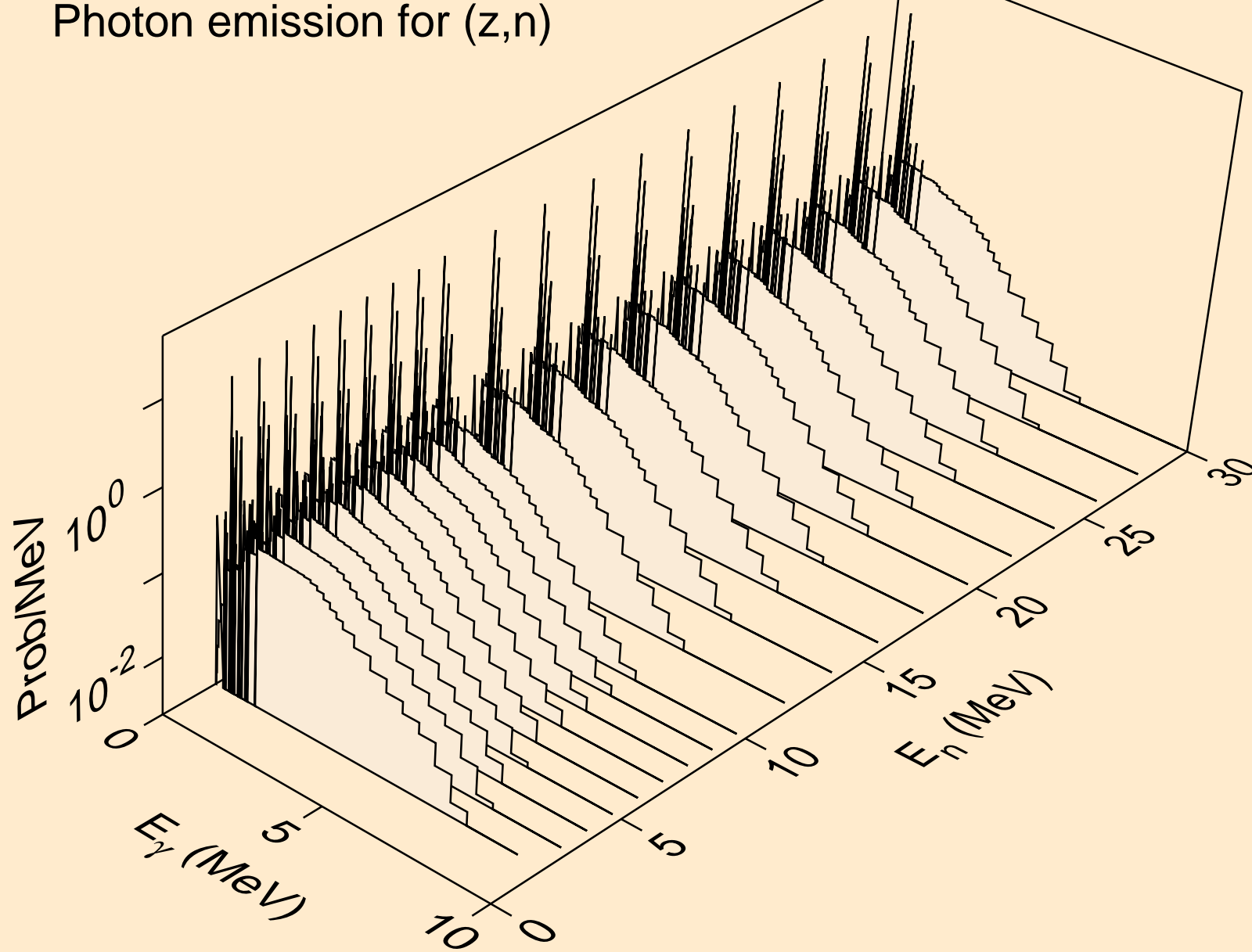

TC108 PROTON ACER TENDL-2021 LIBRARY; T=0.K  
Photon emission for (n,x)

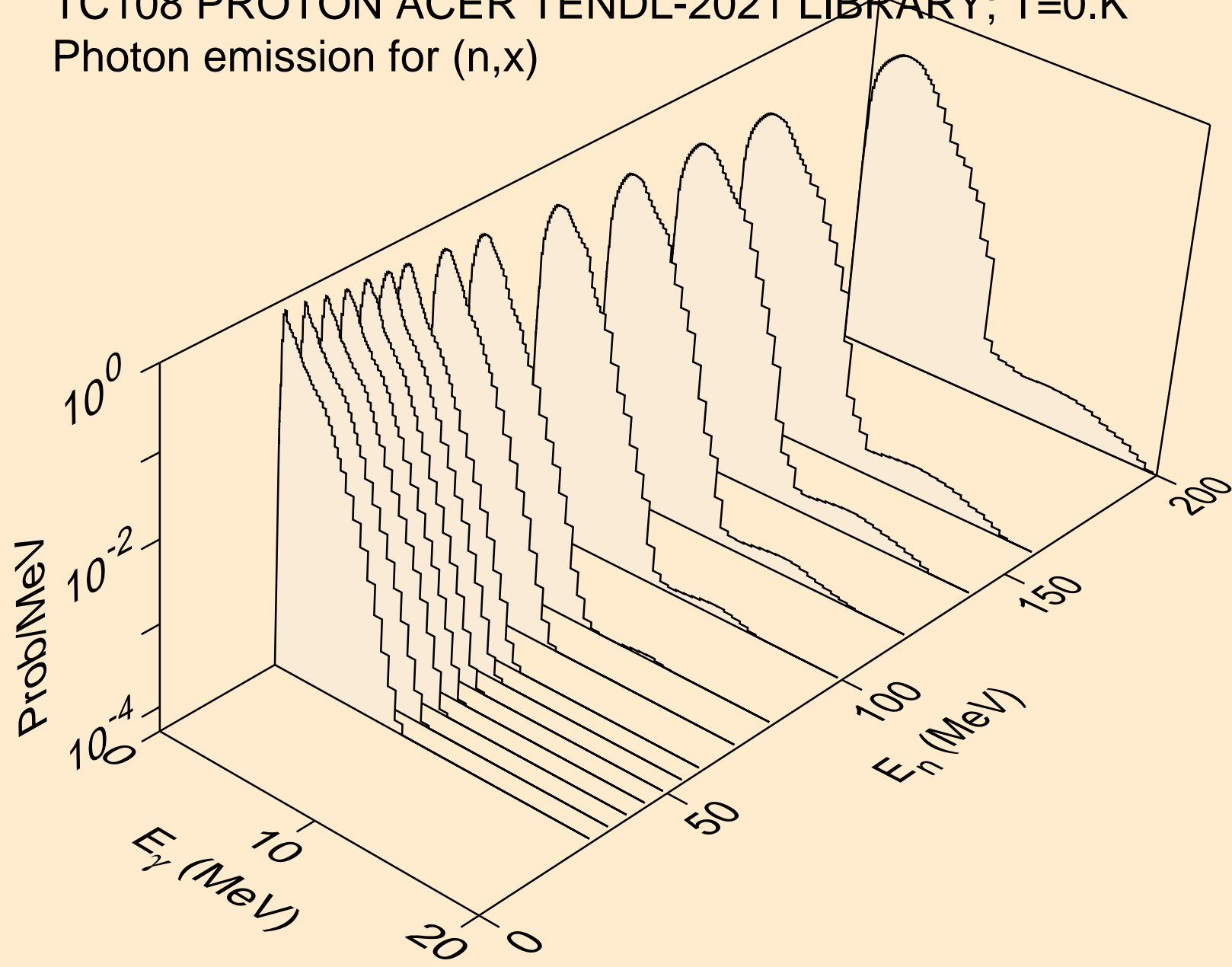

TC108 PROTON ACER TENDL-2021 LIBRARY; T=0.K  
Photon emission for (n,2nd)

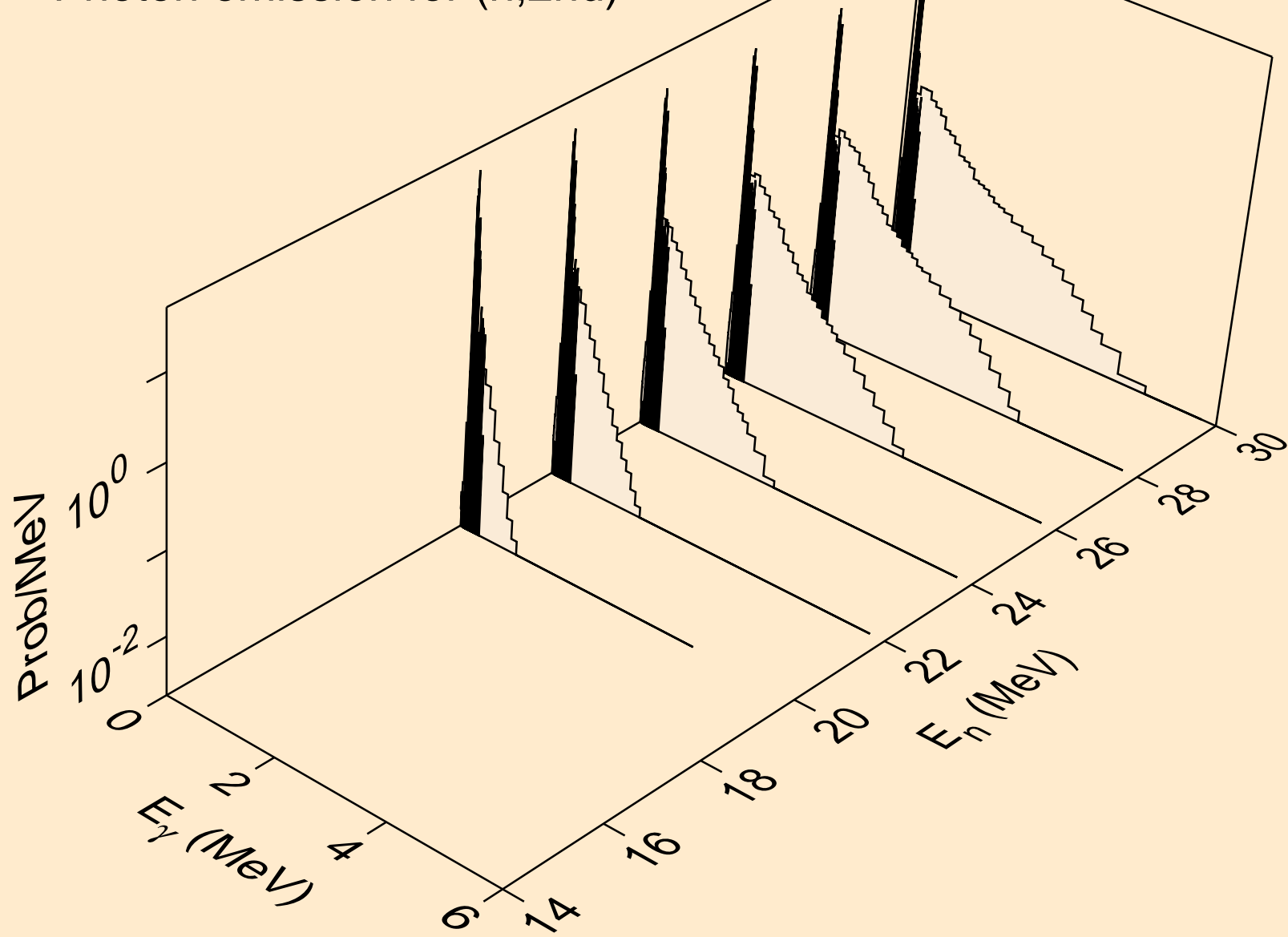

TC108 PROTON ACER TENDL-2021 LIBRARY; T=0.K  
Photon emission for (n,2n)

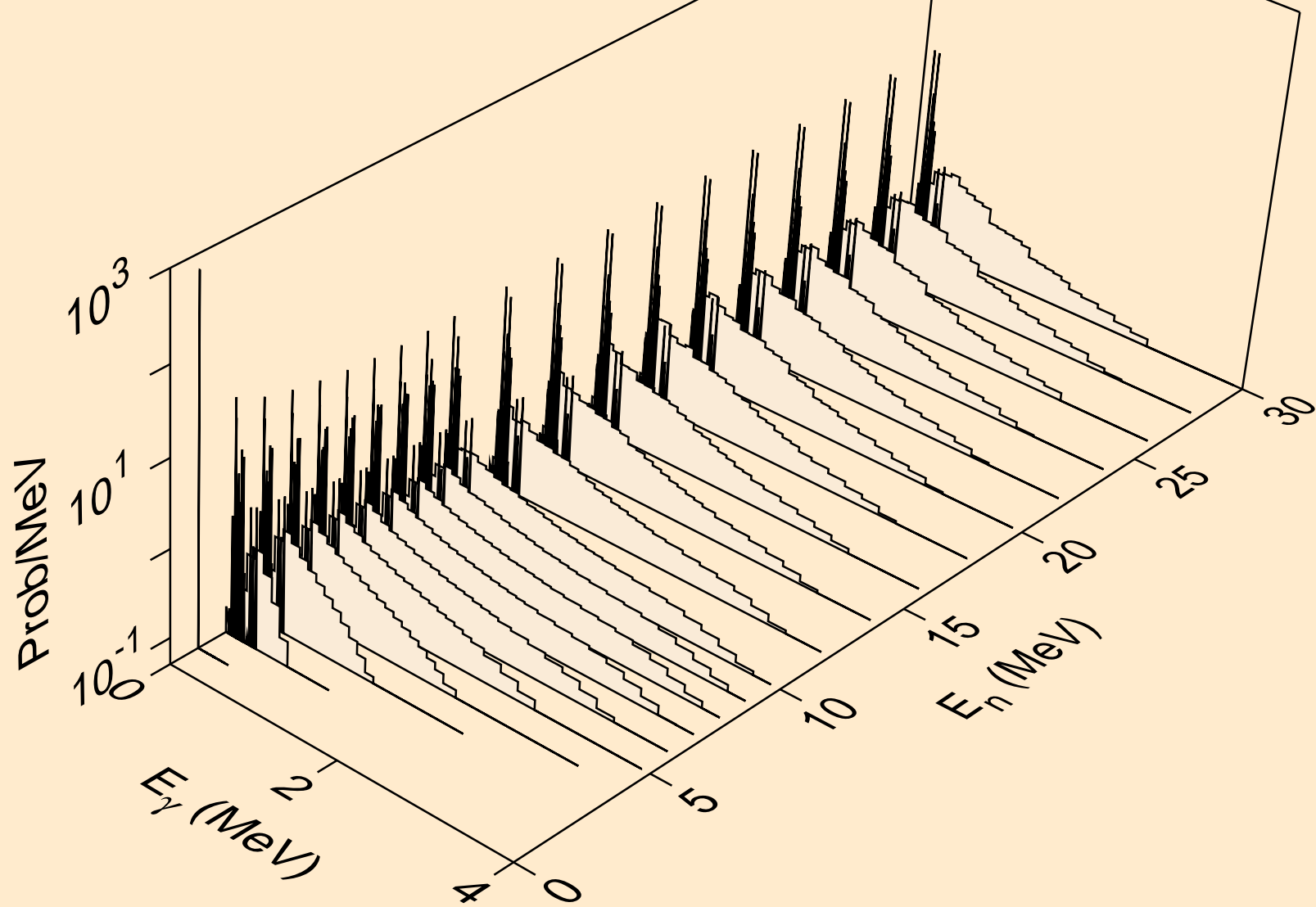



TC108 PROTON ACER TENDL-2021 LIBRARY; T=0.K  
Photon emission for (n,3n)

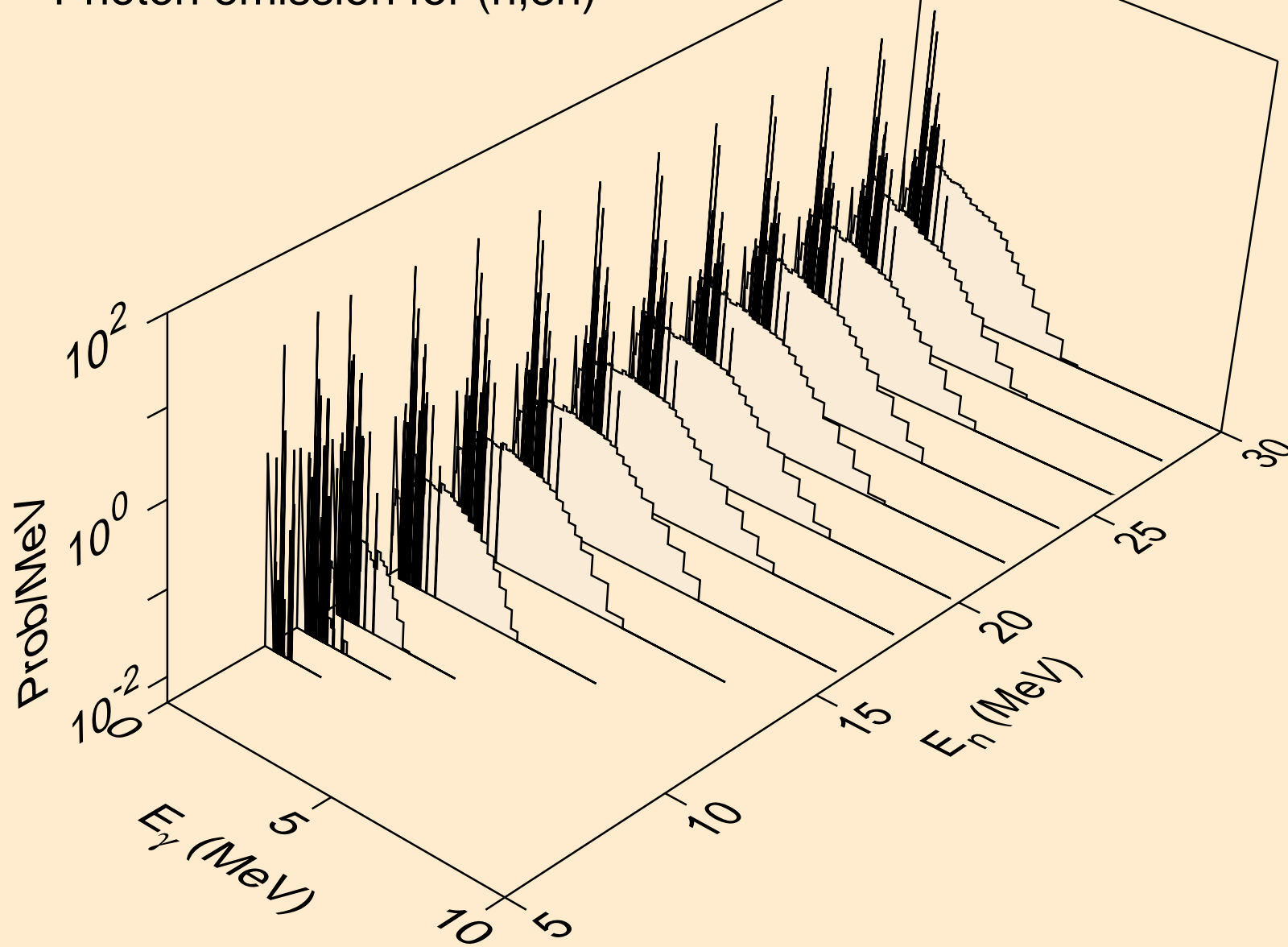

TC108 PROTON ACER TENDL-2021 LIBRARY; T=0.K  
Photon emission for (n,n\*)a

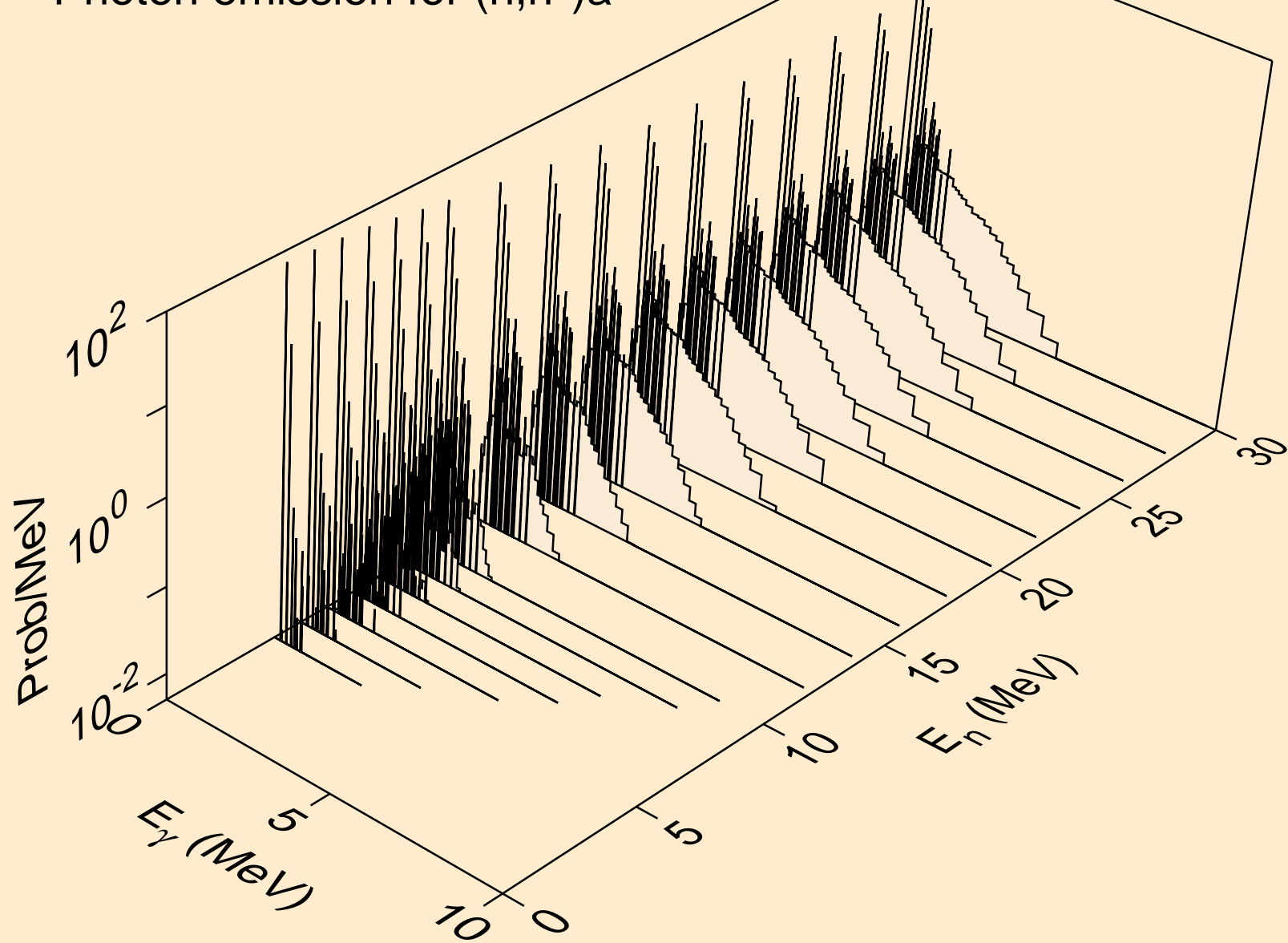

TC108 PROTON ACER TENDL-2021 LIBRARY; T=0.K  
Photon emission for (n,2n)a

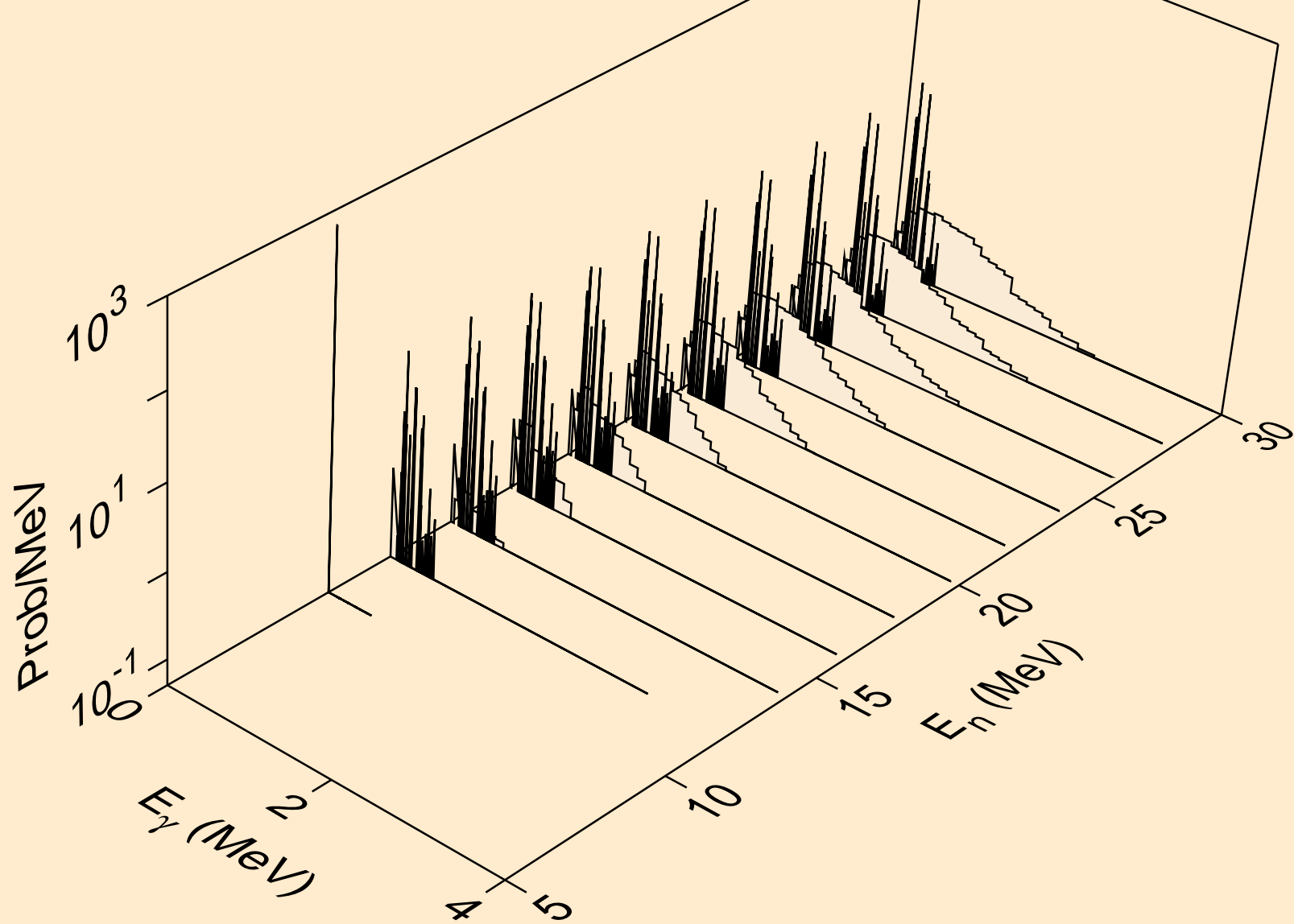

TC108 PROTON ACER TENDL-2021 LIBRARY; T=0.K  
Photon emission for (n,3n)a

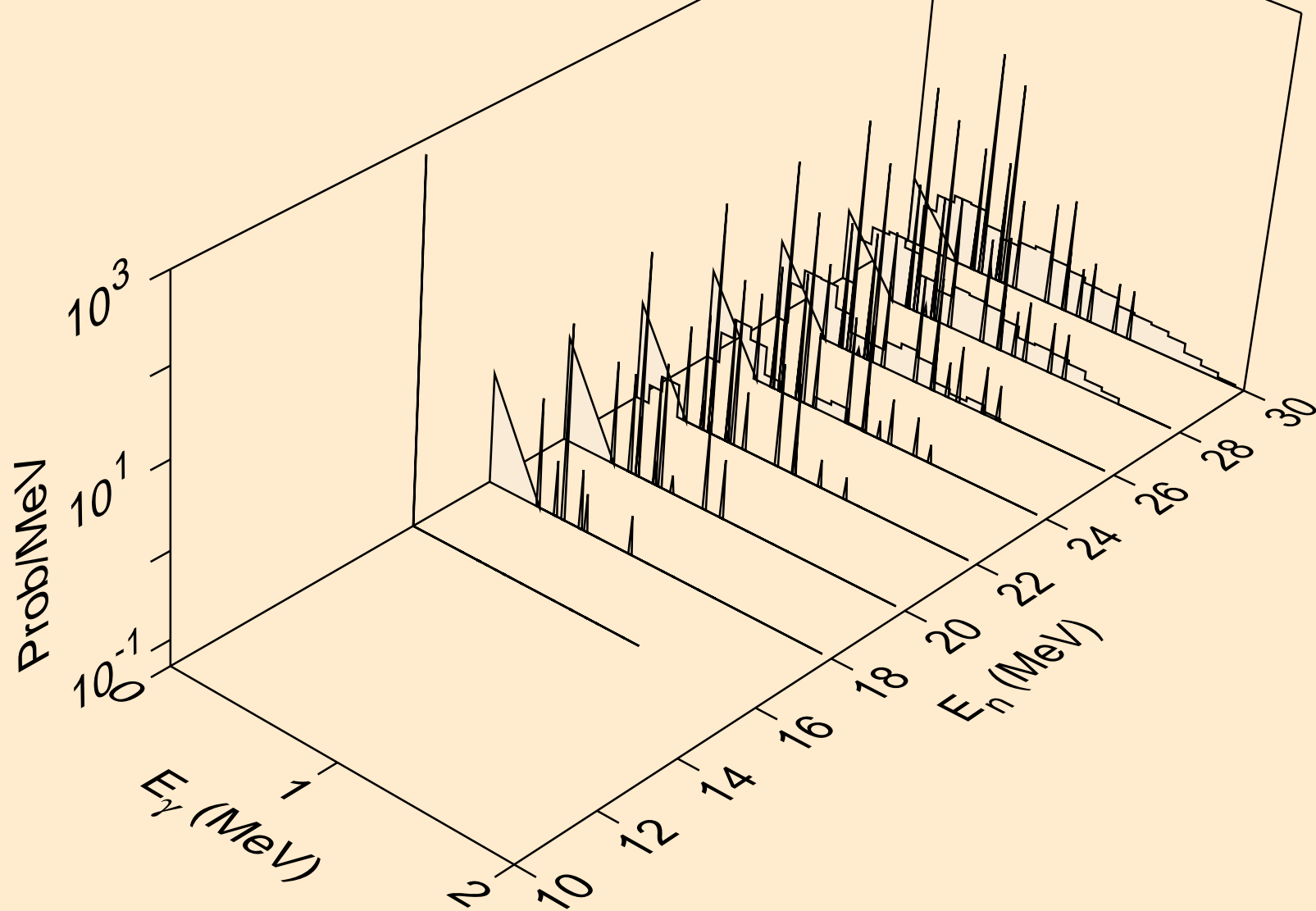

TC108 PROTON ACER TENDL-2021 LIBRARY; T=0.K  
Photon emission for (n,n\*)p

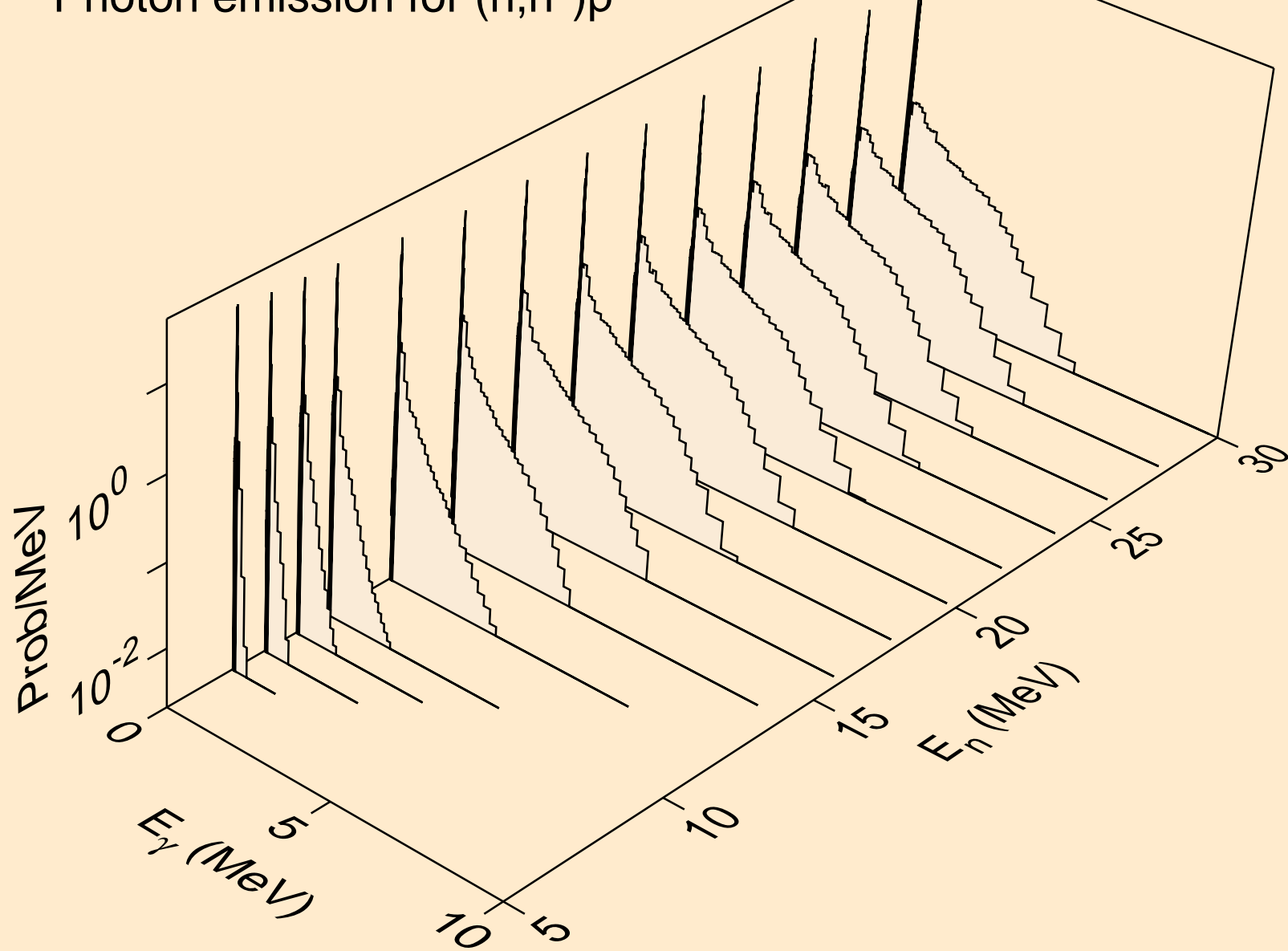

TC108 PROTON ACER TENDL-2021 LIBRARY; T=0.K  
Photon emission for (n,n\*)2a

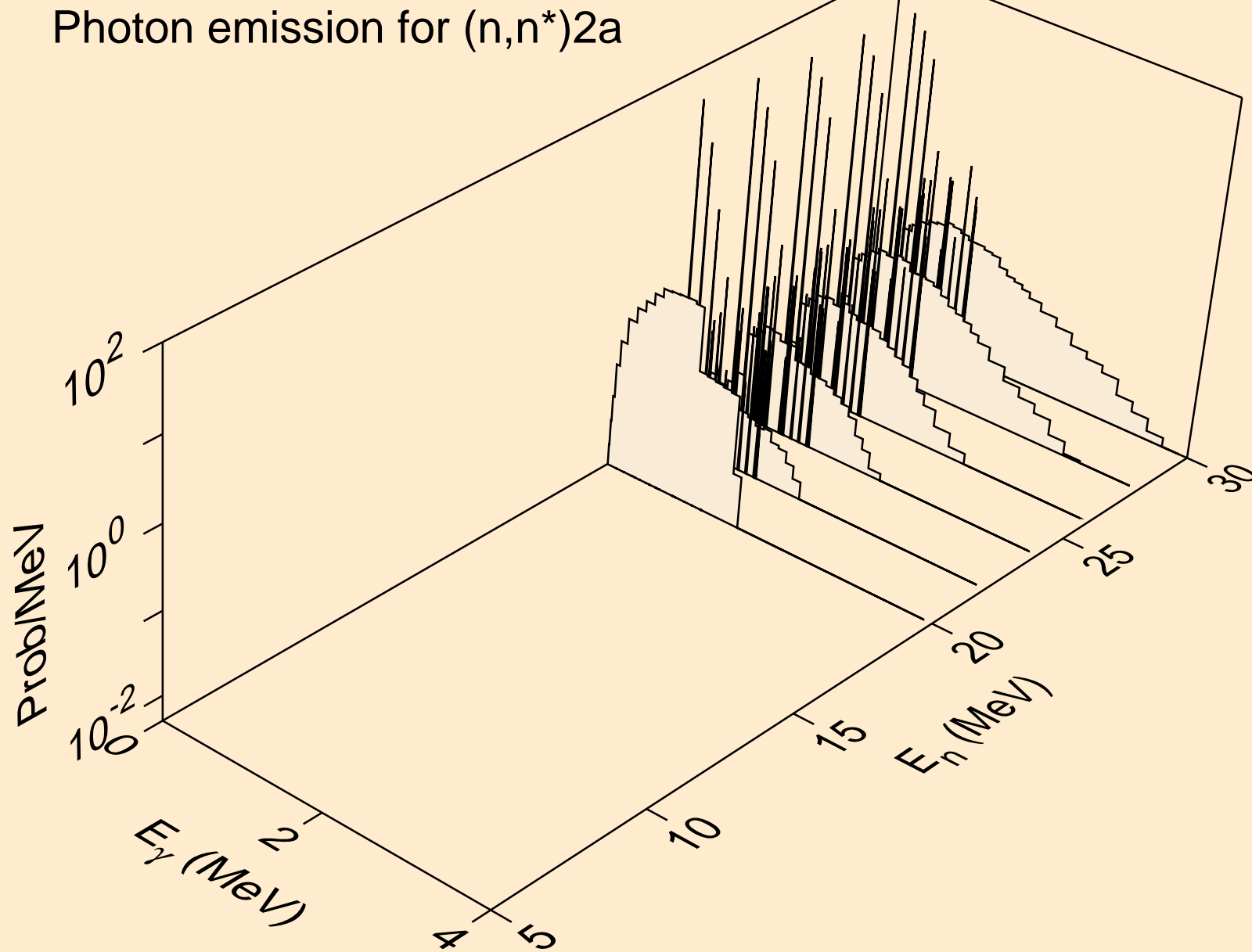

TC108 PROTON ACER TENDL-2021 LIBRARY; T=0.K  
Photon emission for (n,n\*)d

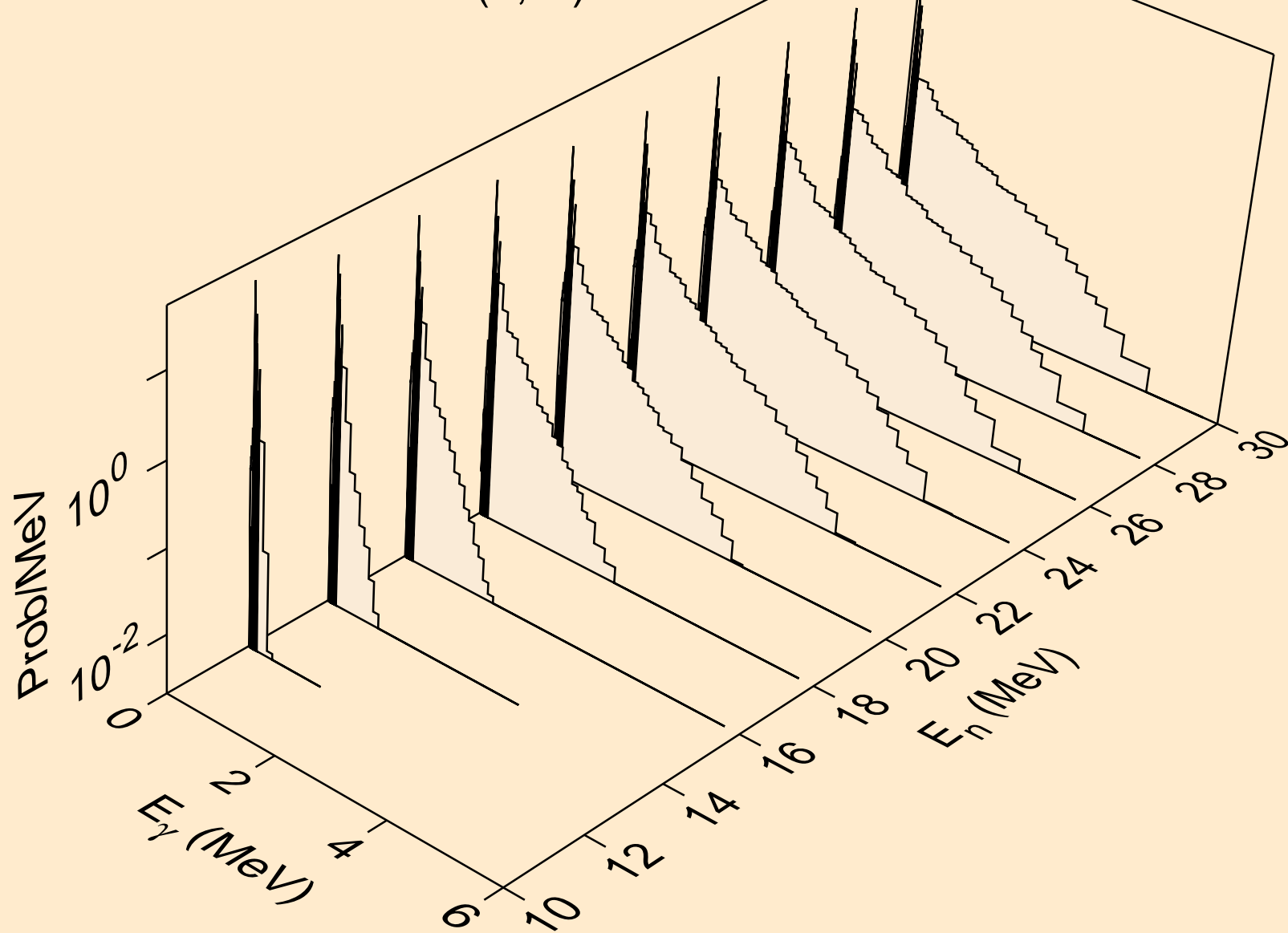

TC108 PROTON ACER TENDL-2021 LIBRARY; T=0.K

Photon emission for (n,n\*)t

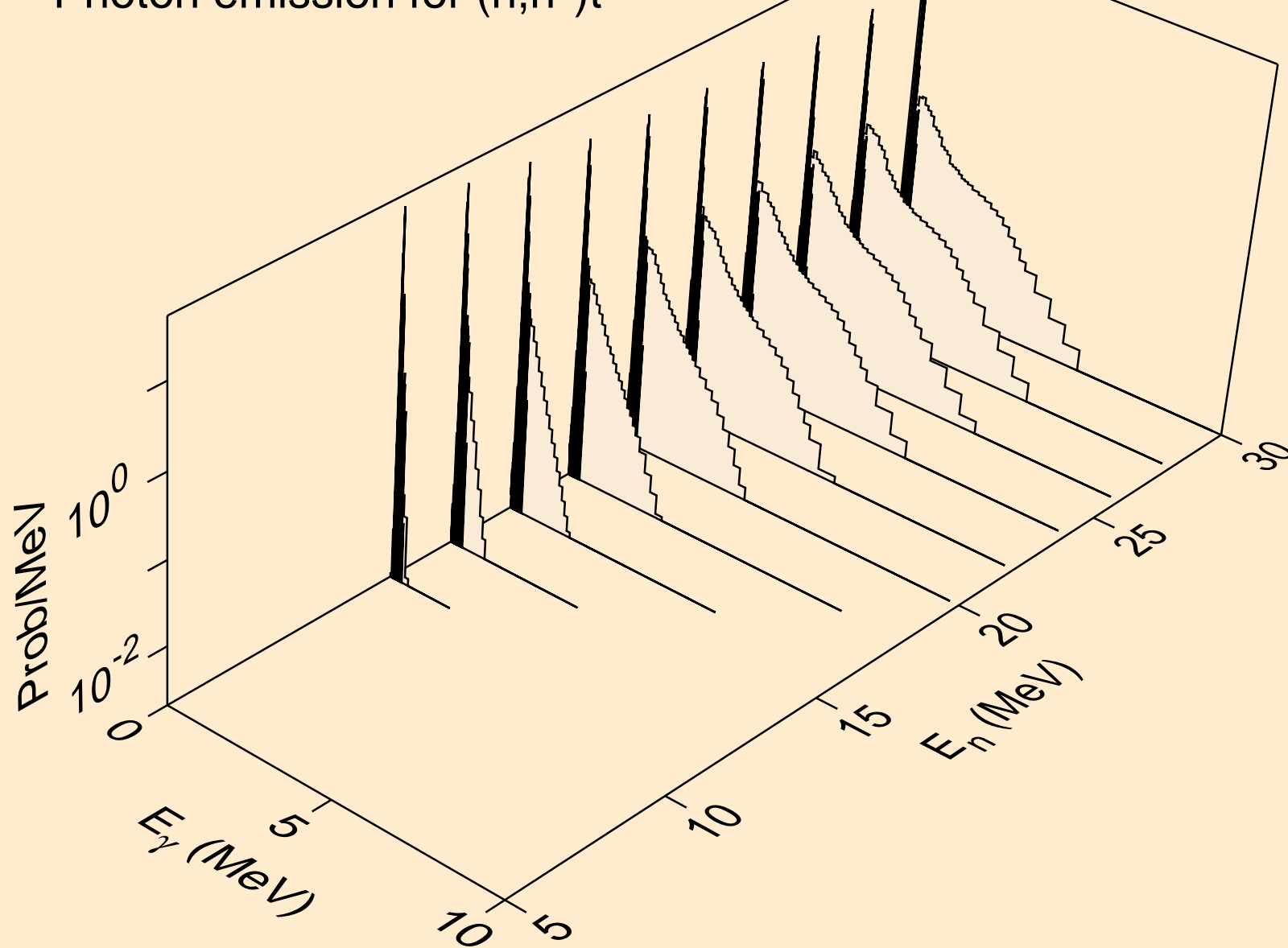



TC108 PROTON ACER TENDL-2021 LIBRARY; T=0.K  
Photon emission for (n,n\*)he3

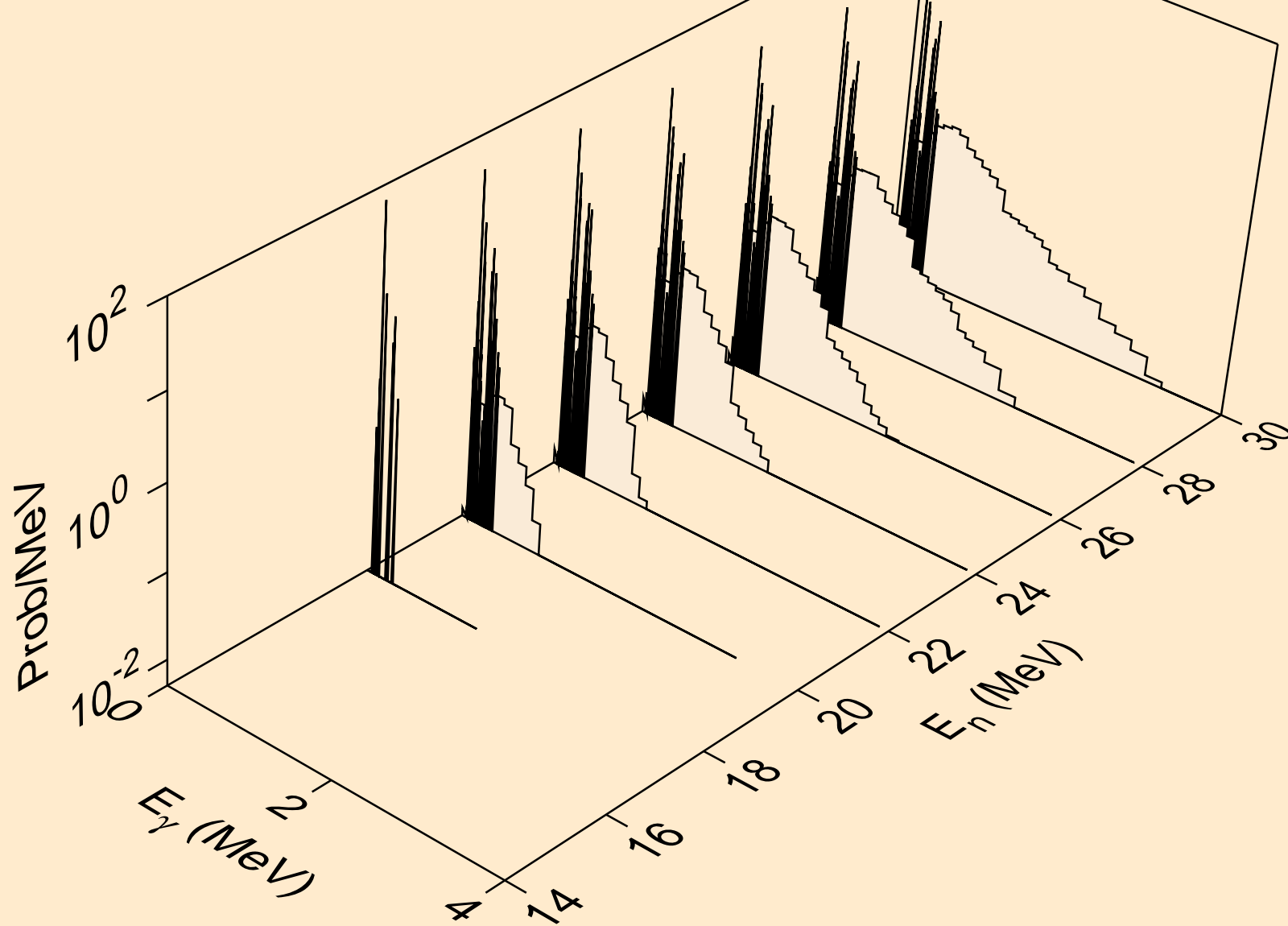

TC108 PROTON ACER TENDL-2021 LIBRARY; T=0.K  
Photon emission for (n,4n)

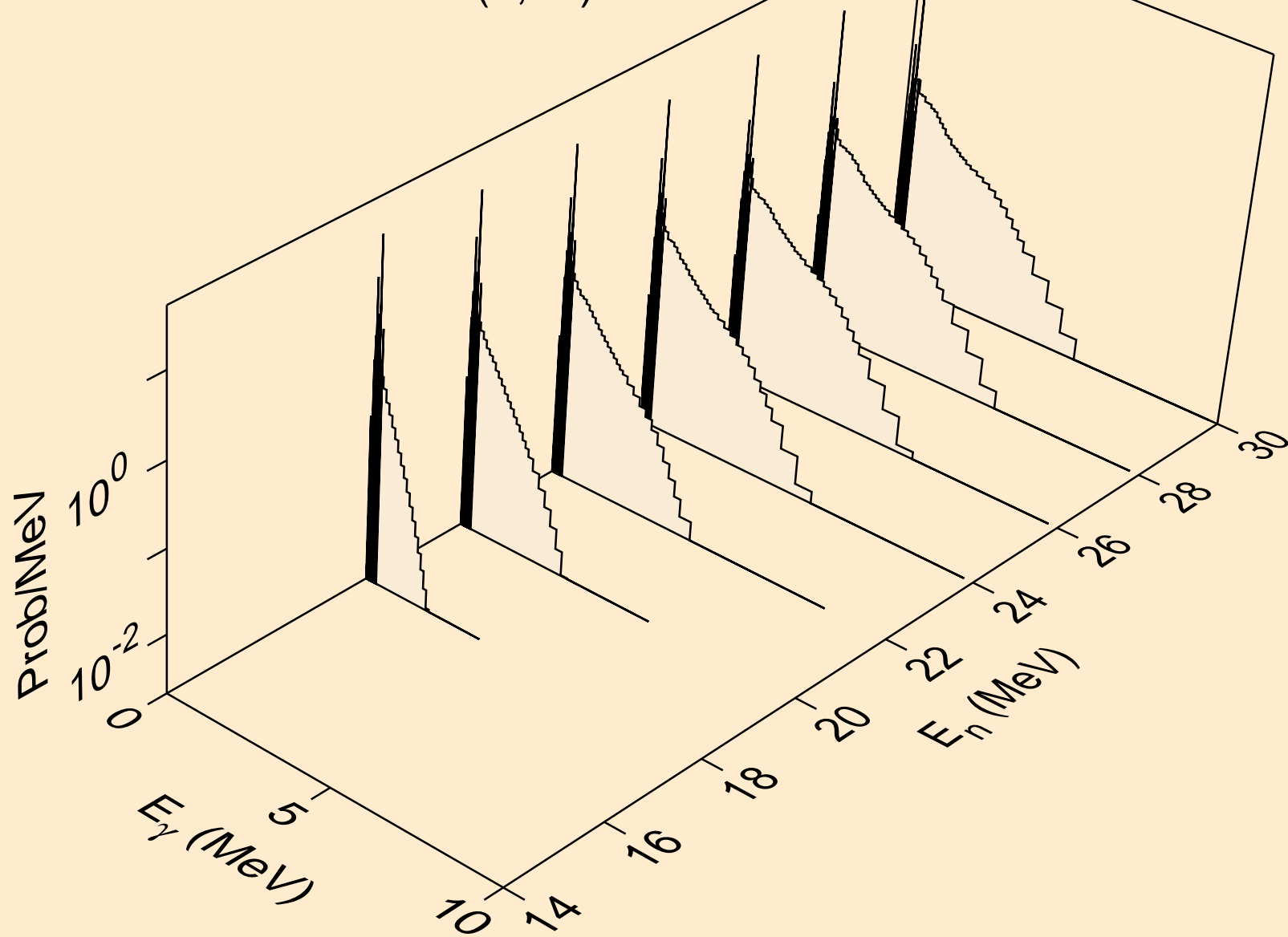

TC108 PROTON ACER TENDL-2021 LIBRARY; T=0.K  
Photon emission for (n,2np)

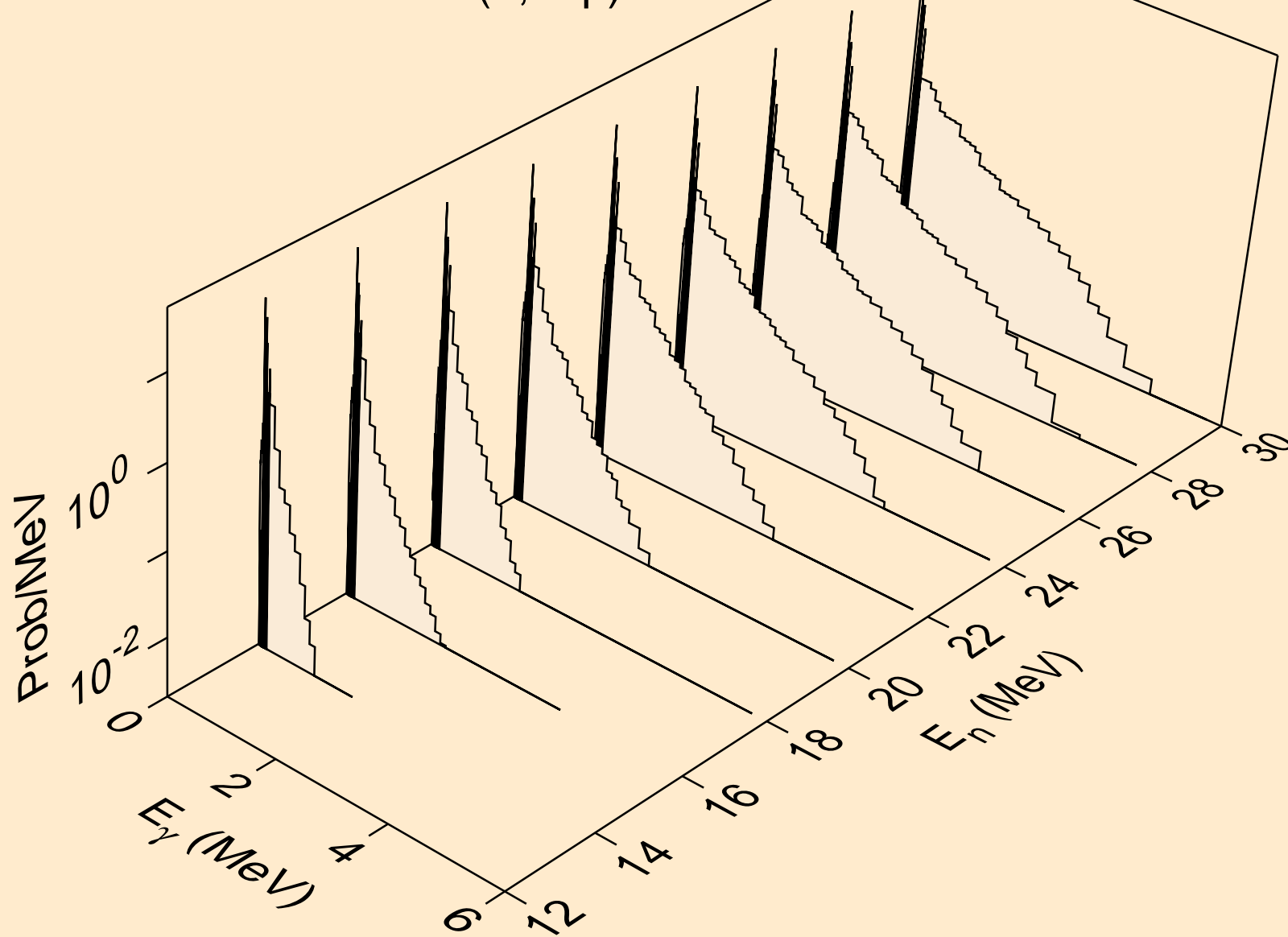

TC108 PROTON ACER TENDL-2021 LIBRARY; T=0.K  
Photon emission for (n,3np)

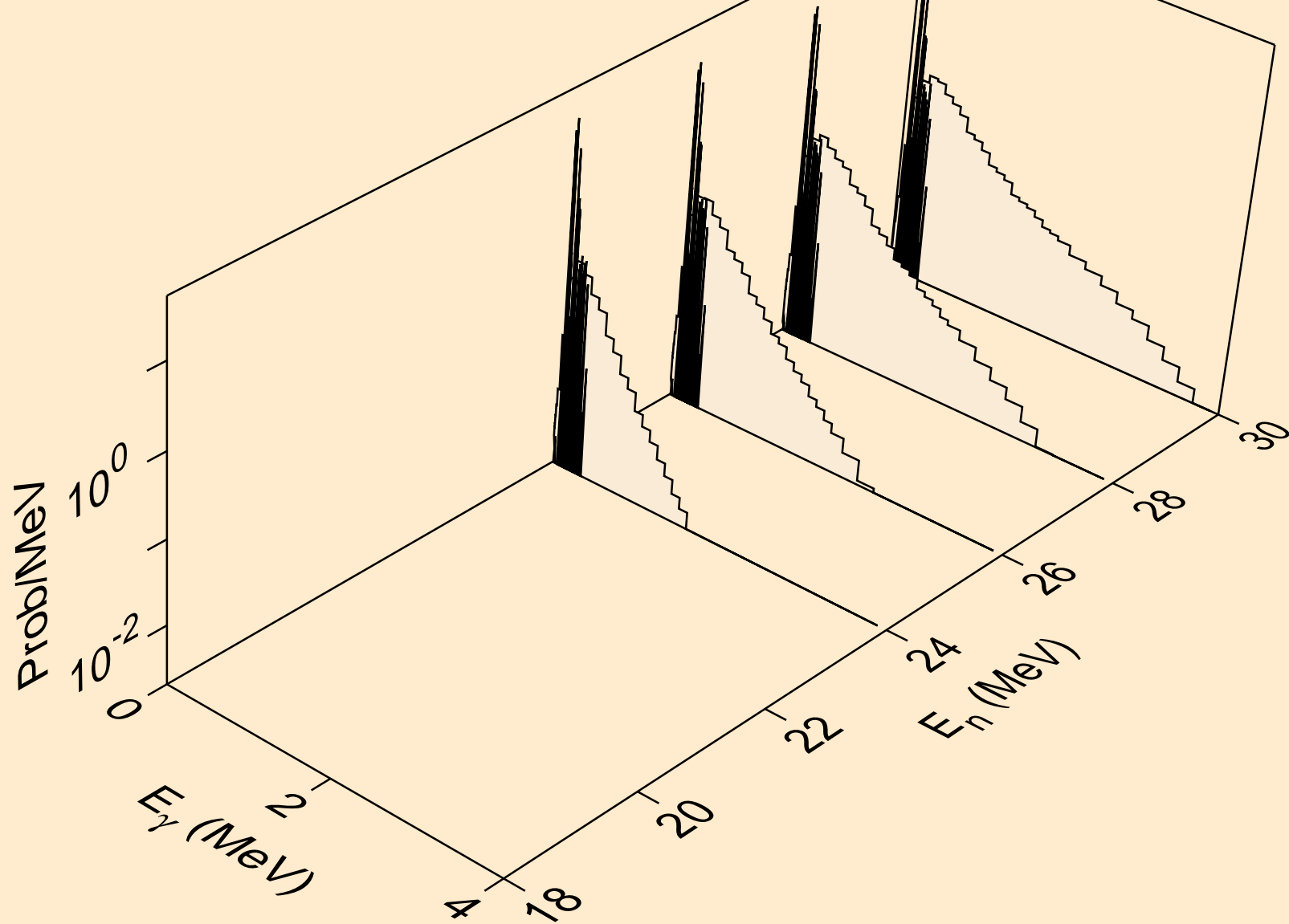

TC108 PROTON ACER TENDL-2021 LIBRARY; T=0.K  
Photon emission for (n,2np)

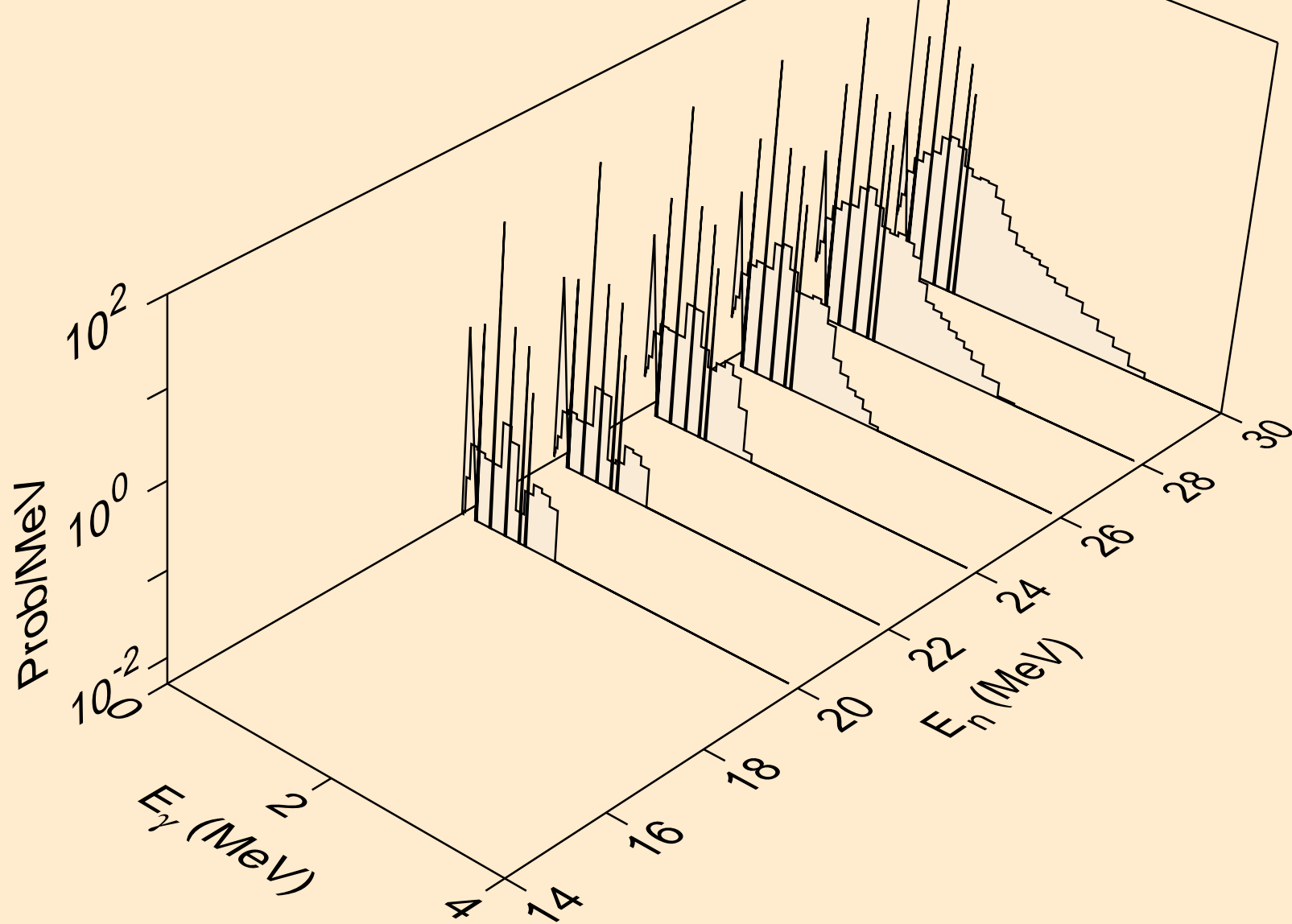

TC108 PROTON ACER TENDL-2021 LIBRARY; T=0.K  
Photon emission for (n,npa)

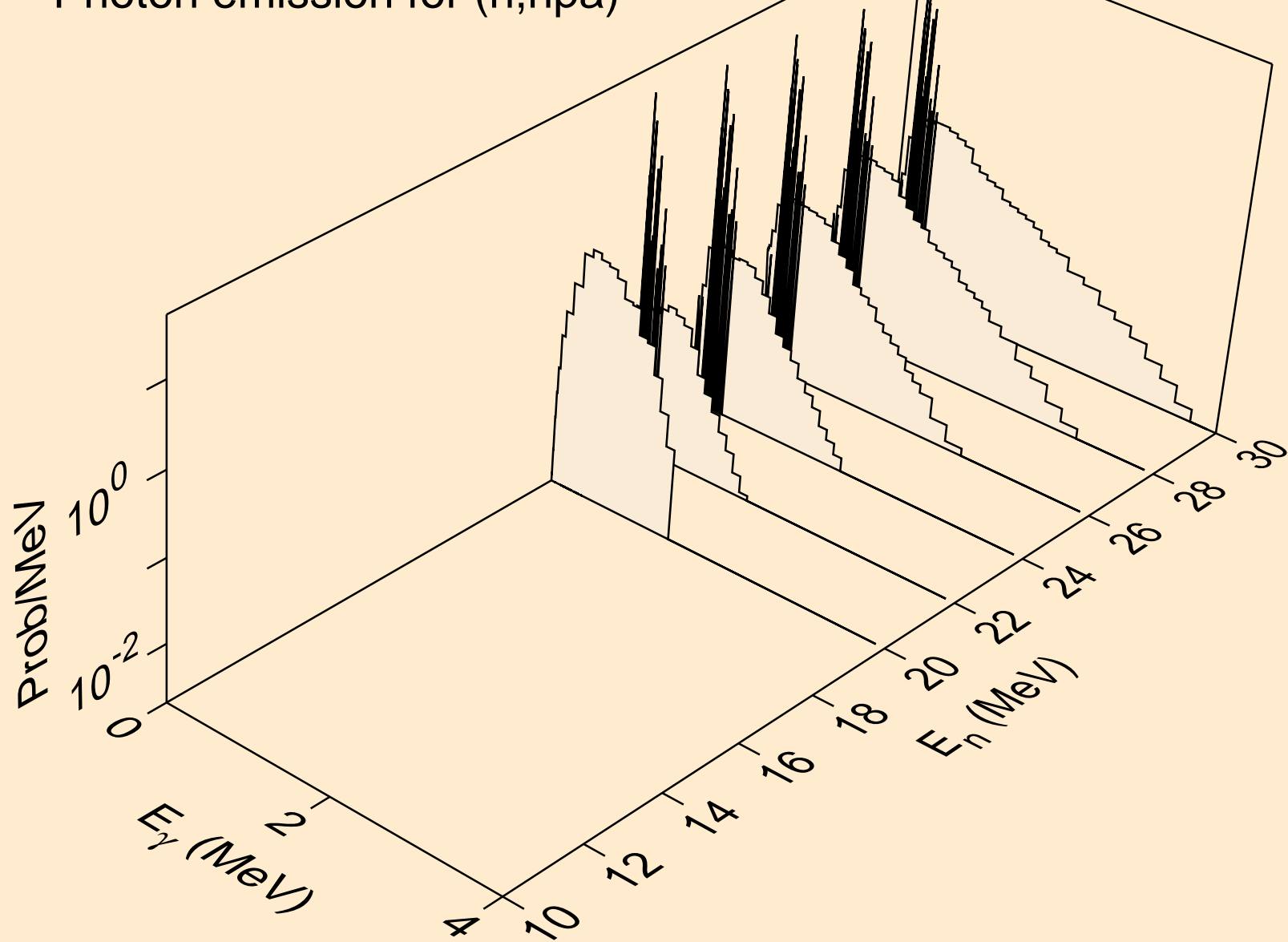

TC108 PROTON ACER TENDL-2021 LIBRARY; T=0.K  
Photon emission for (n,gma)

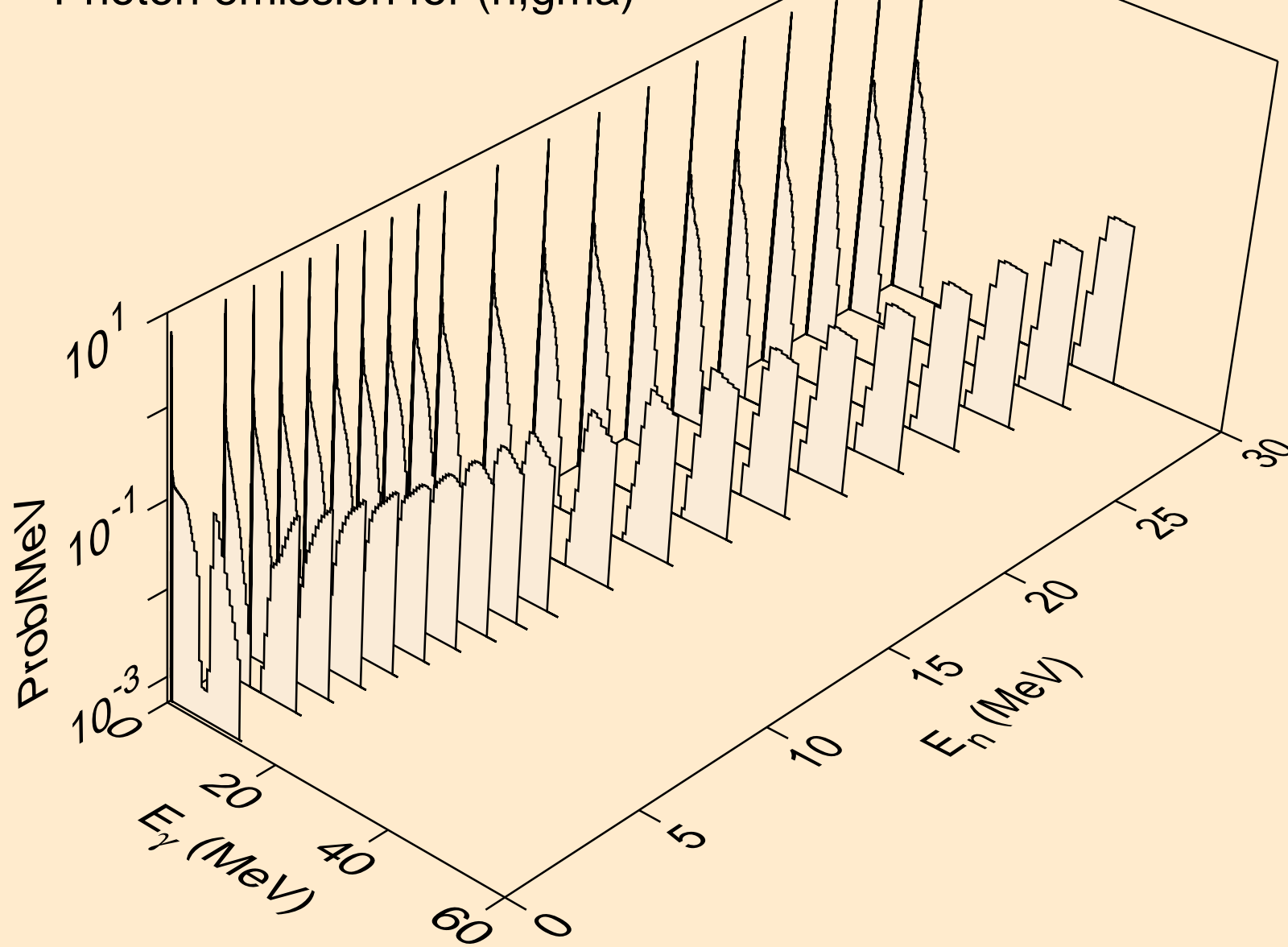

TC108 PROTON ACER TENDL-2021 LIBRARY; T=0.K  
Photon emission for inelastic

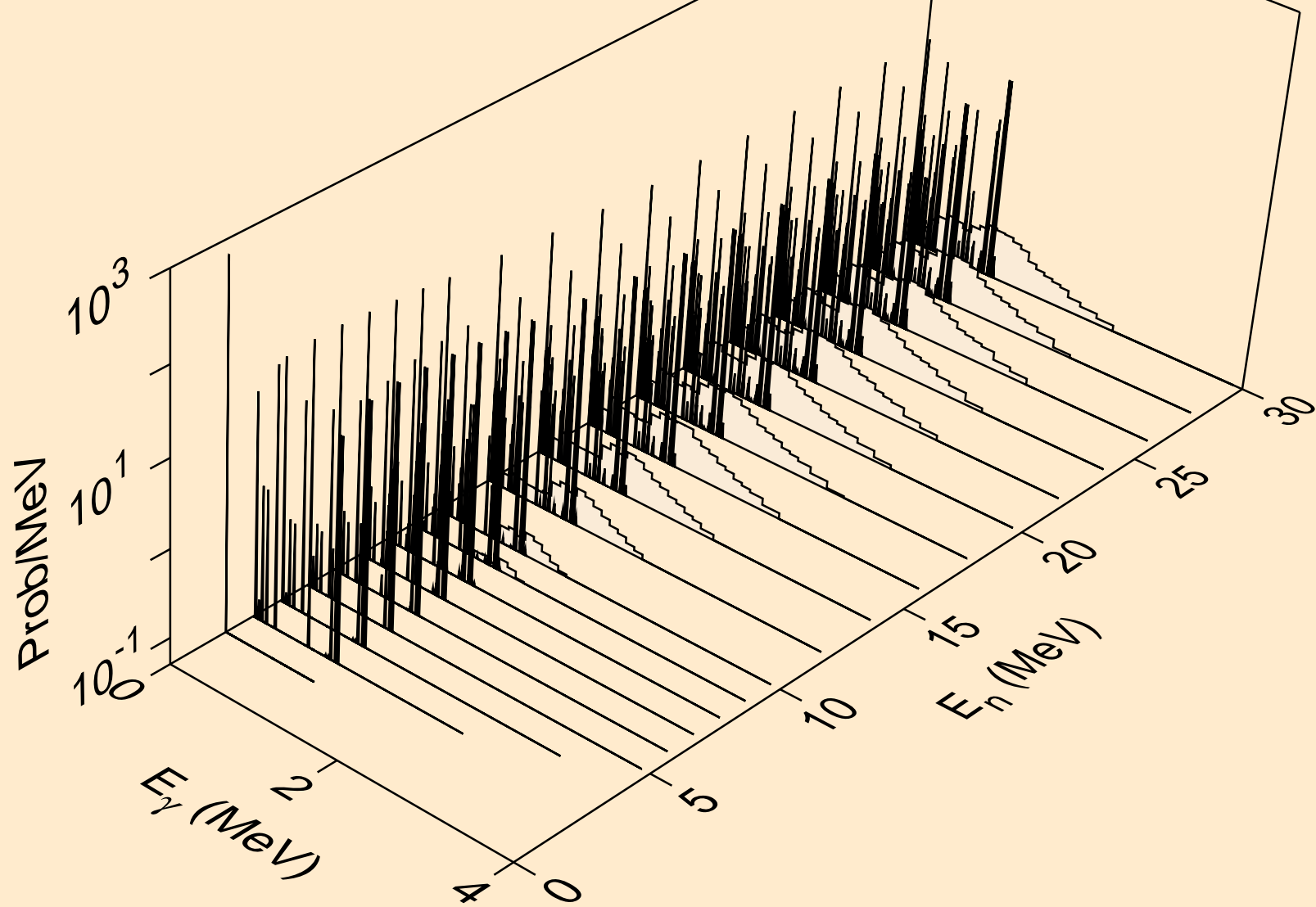



TC108 PROTON ACER TENDL-2021 LIBRARY; T=0.K  
Photon emission for (n,d)

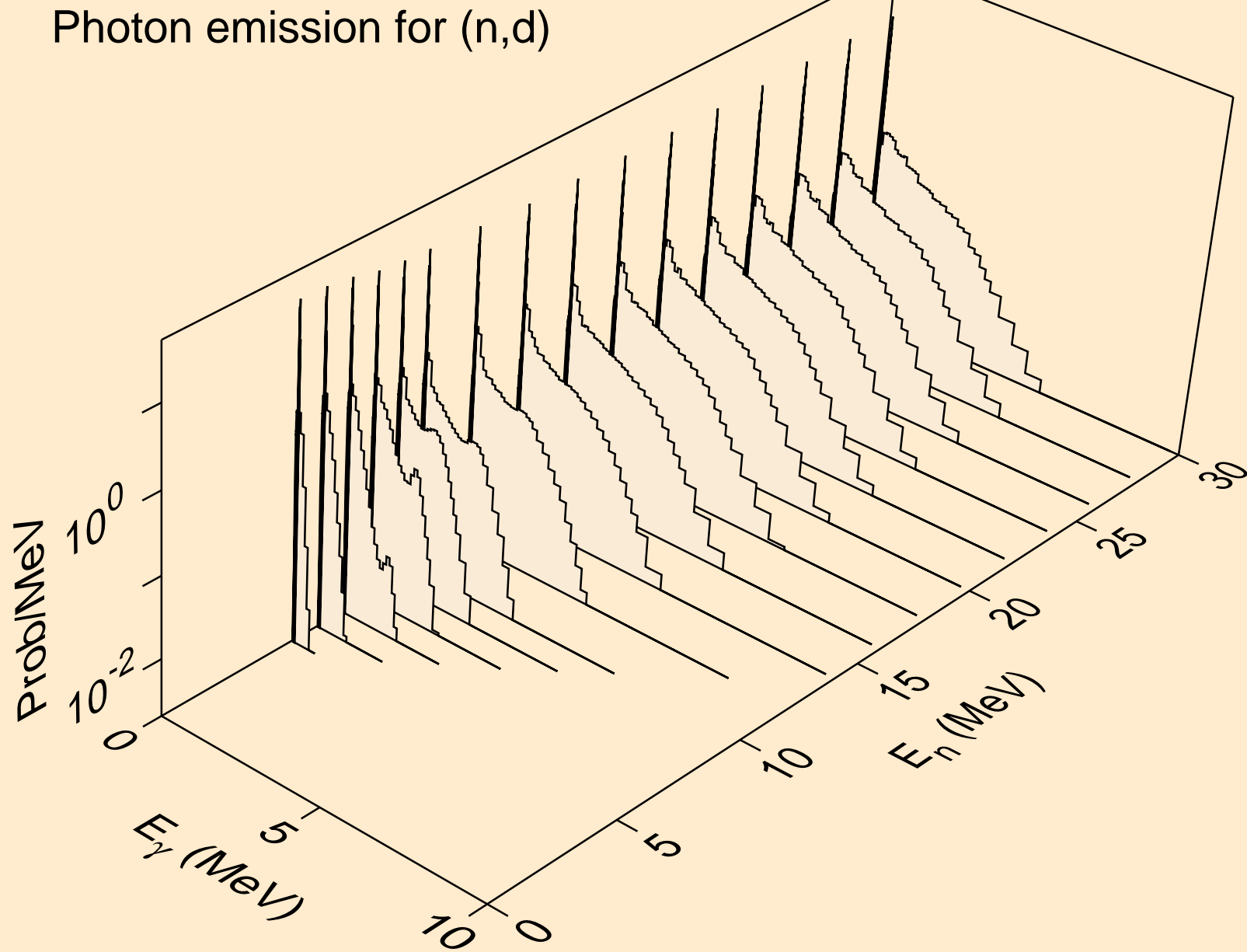

TC108 PROTON ACER TENDL-2021 LIBRARY; T=0.K  
Photon emission for (n,t)

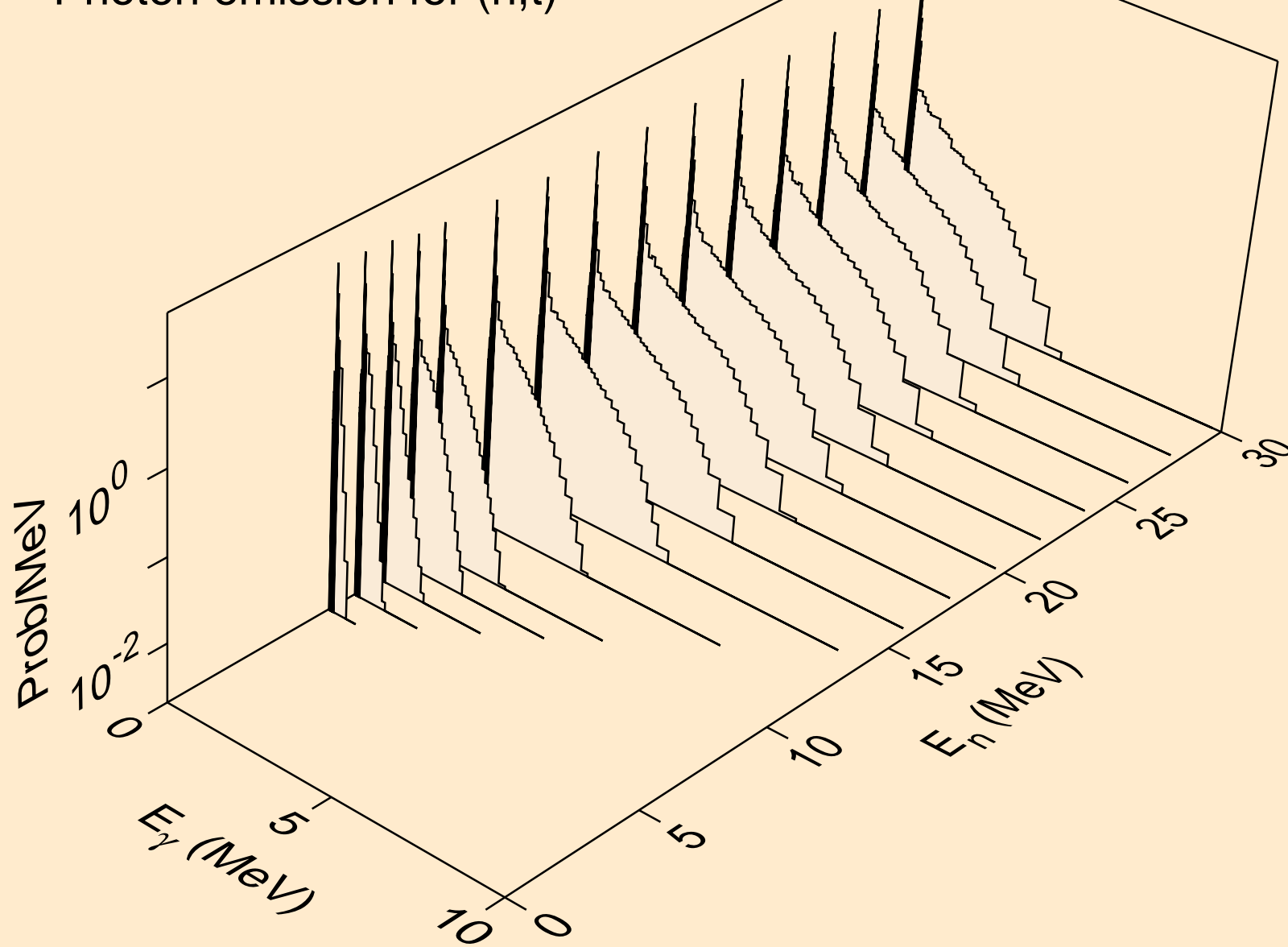

TC108 PROTON ACER TENDL-2021 LIBRARY; T=0.K  
Photon emission for (n,he3)

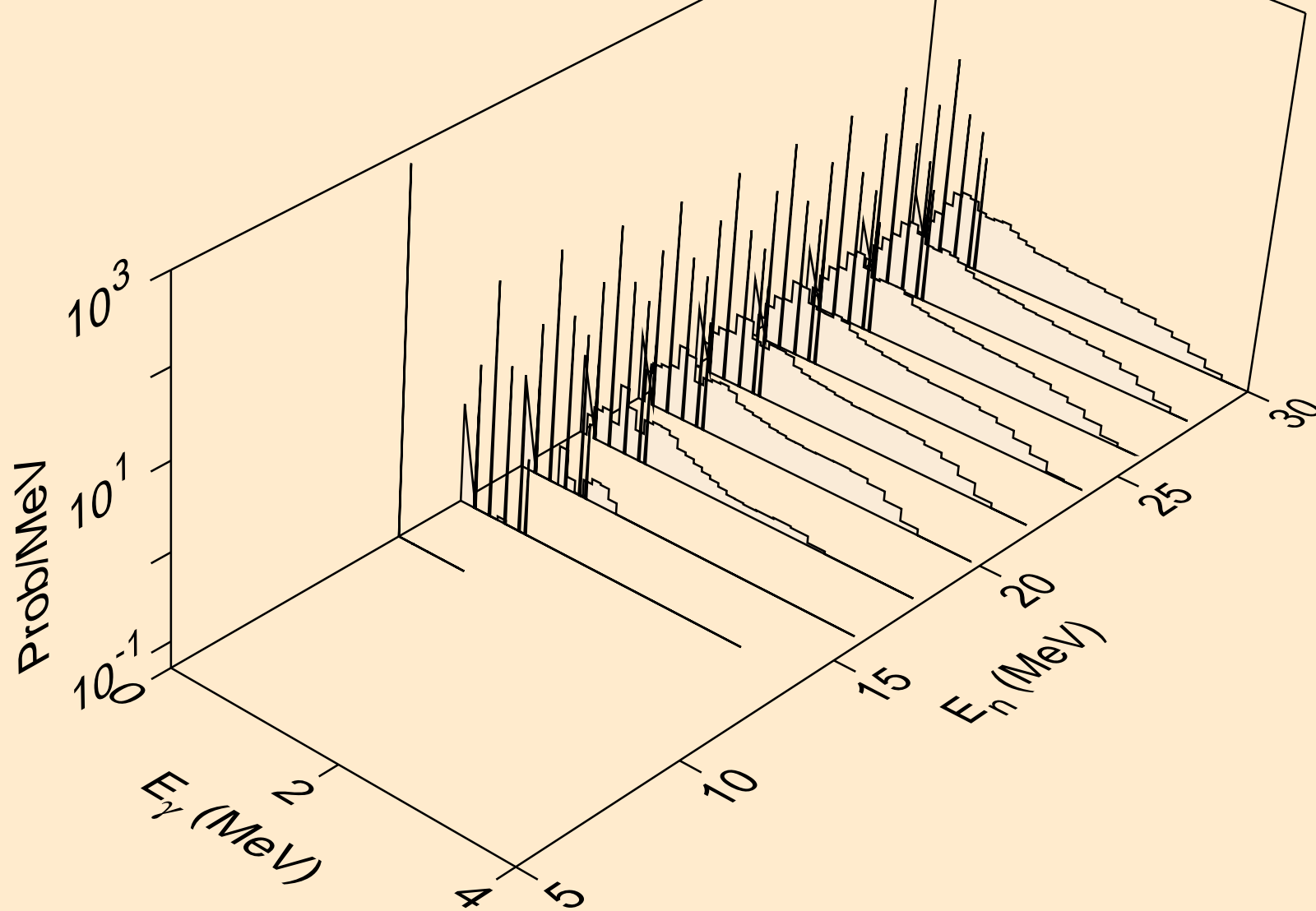

TC108 PROTON ACER TENDL-2021 LIBRARY; T=0.K  
Photon emission for (n,a)

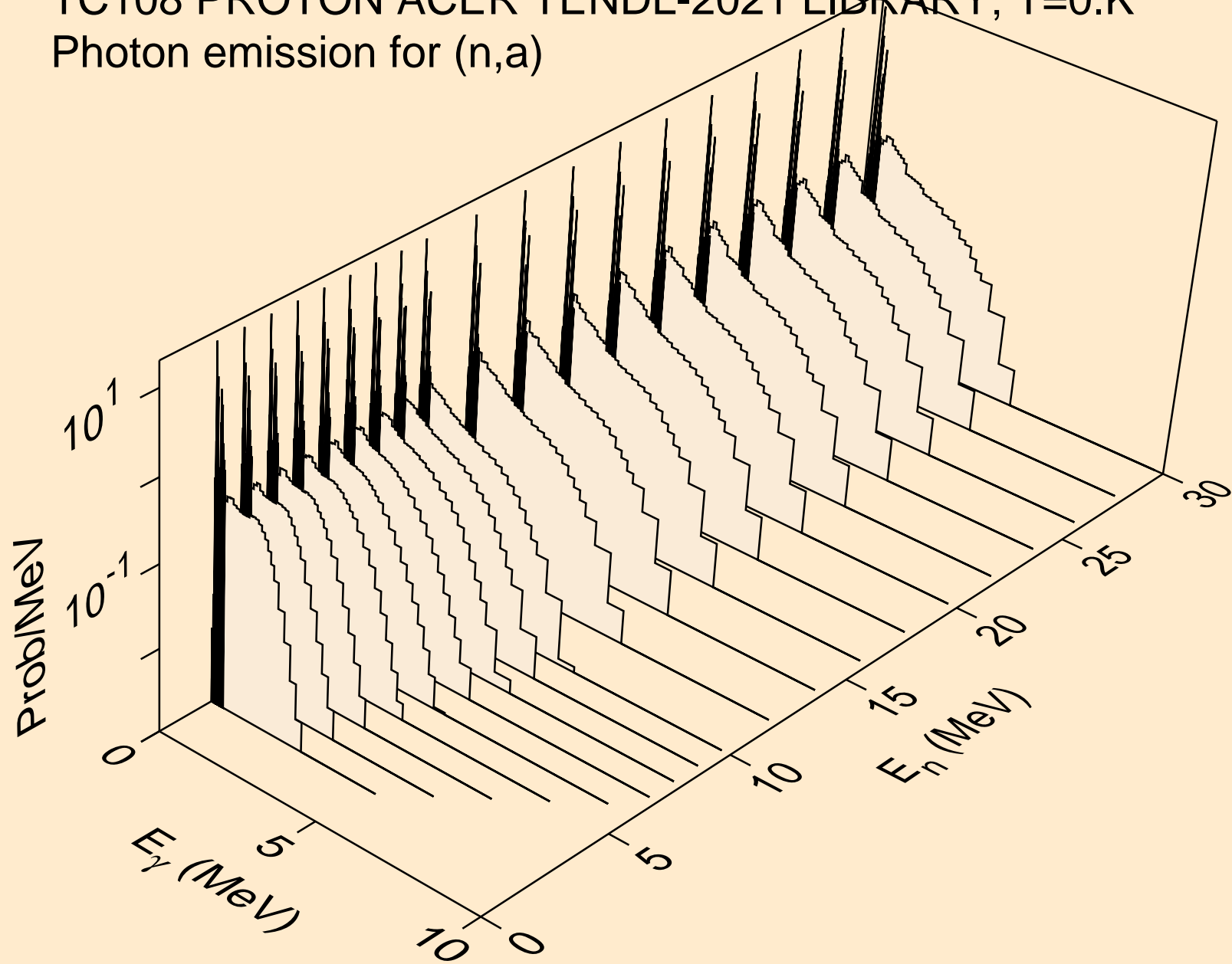

TC108 PROTON ACER TENDL-2021 LIBRARY; T=0.K  
Photon emission for (n,2a)

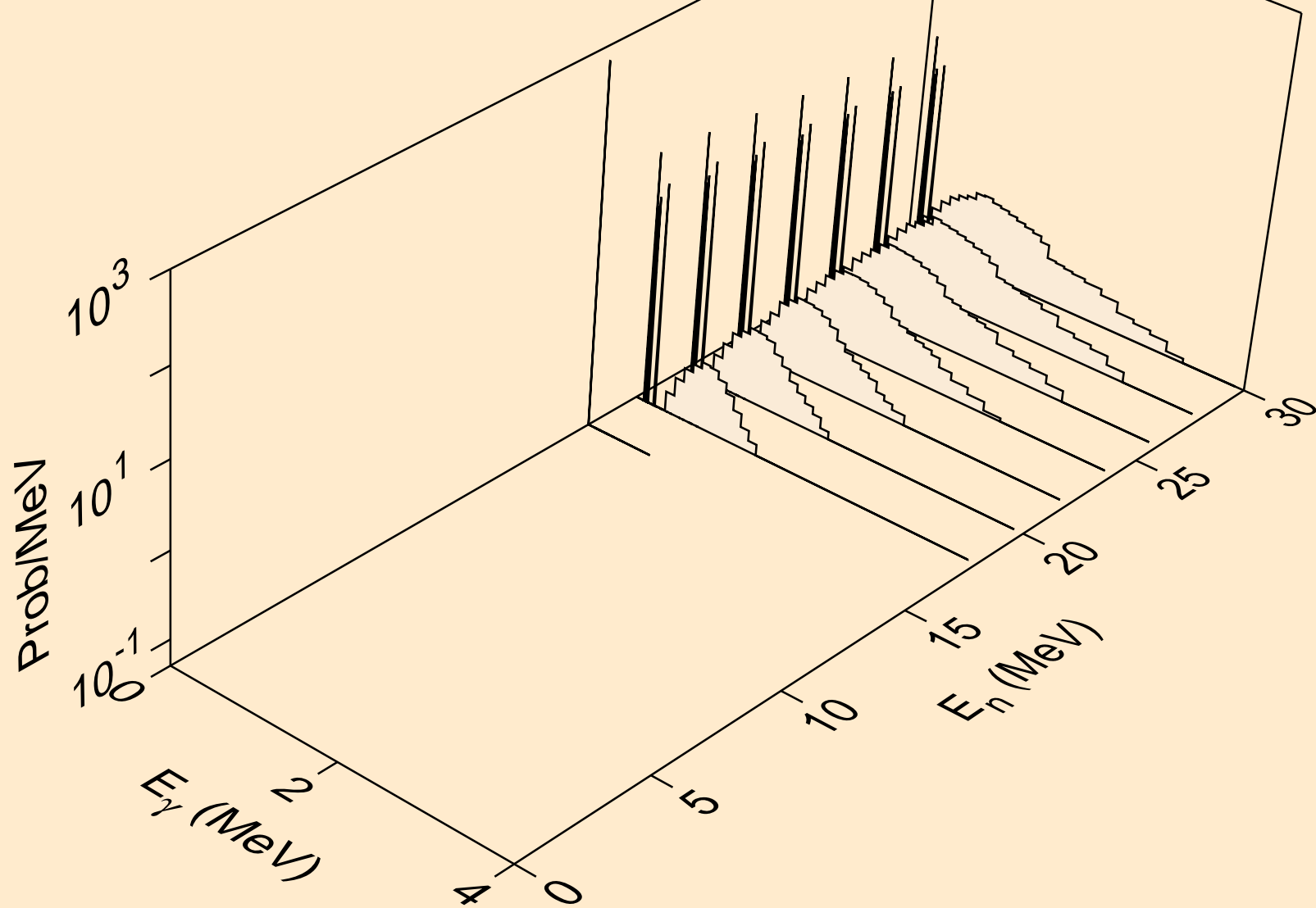

TC108 PROTON ACER TENDL-2021 LIBRARY; T=0.K  
Photon emission for (n,2p)

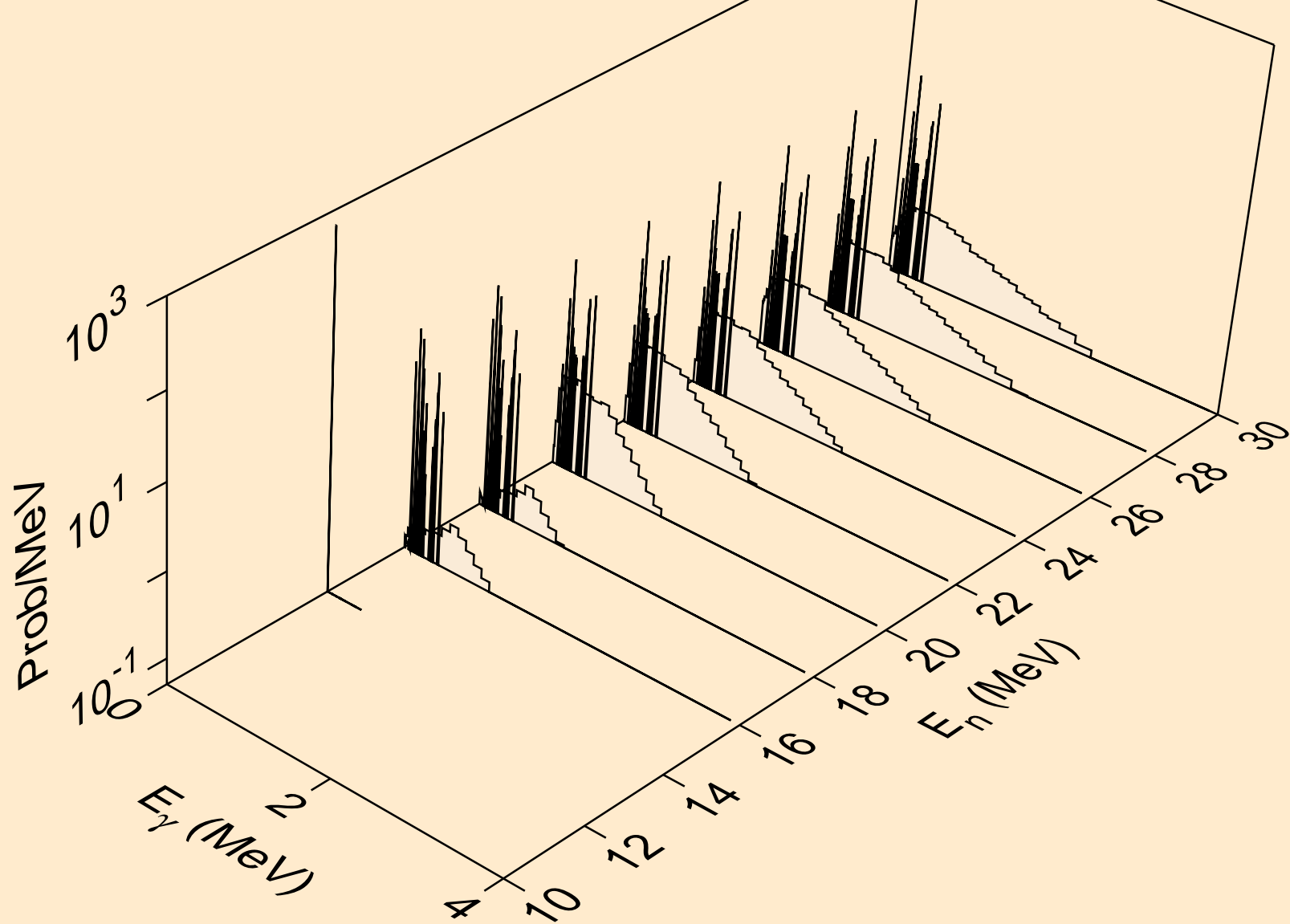

TC108 PROTON ACER TENDL-2021 LIBRARY; T=0.K  
Photon emission for (n,pa)

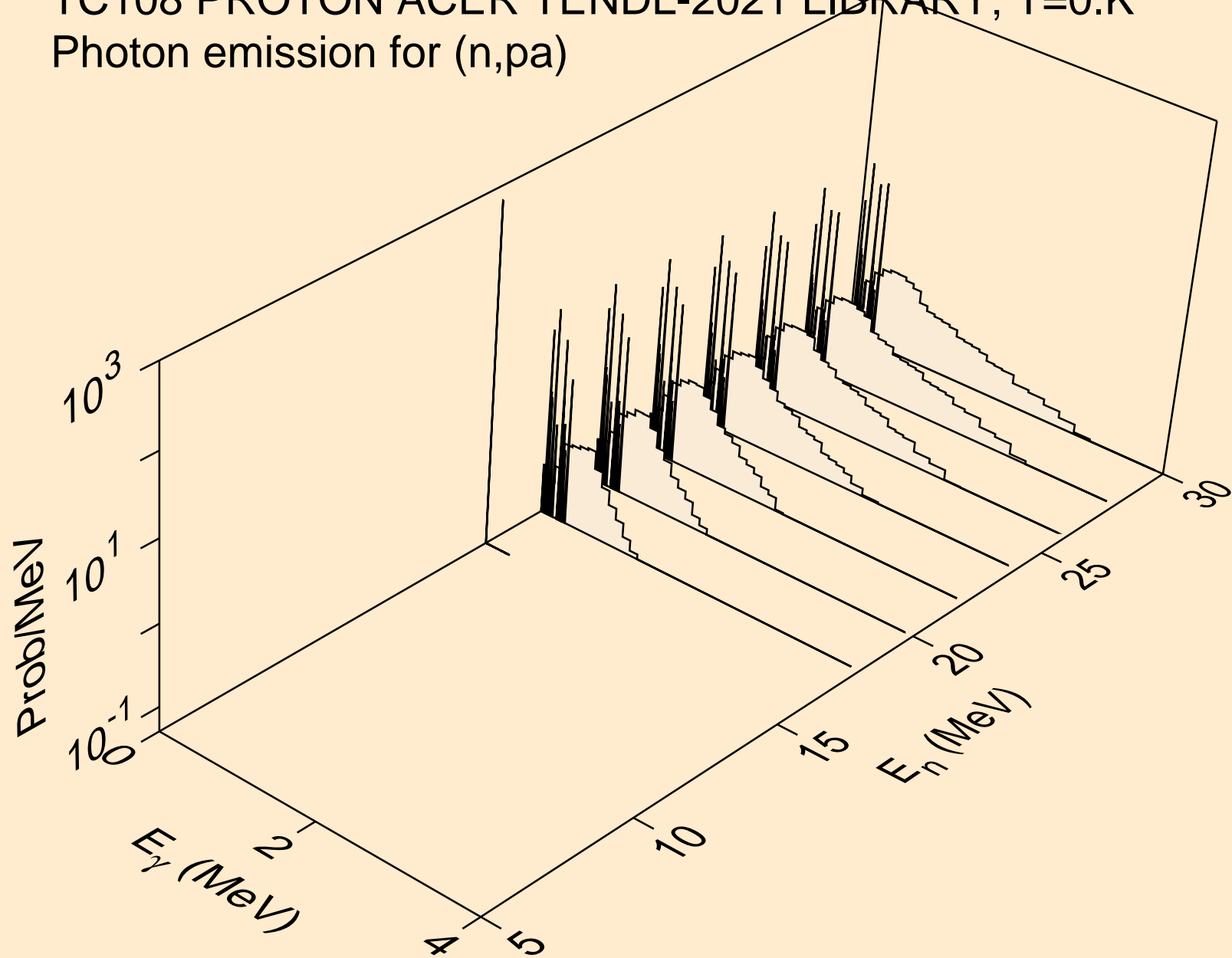

TC108 PROTON ACER TENDL-2021 LIBRARY; T=0.K  
Photon emission for (n,pd)

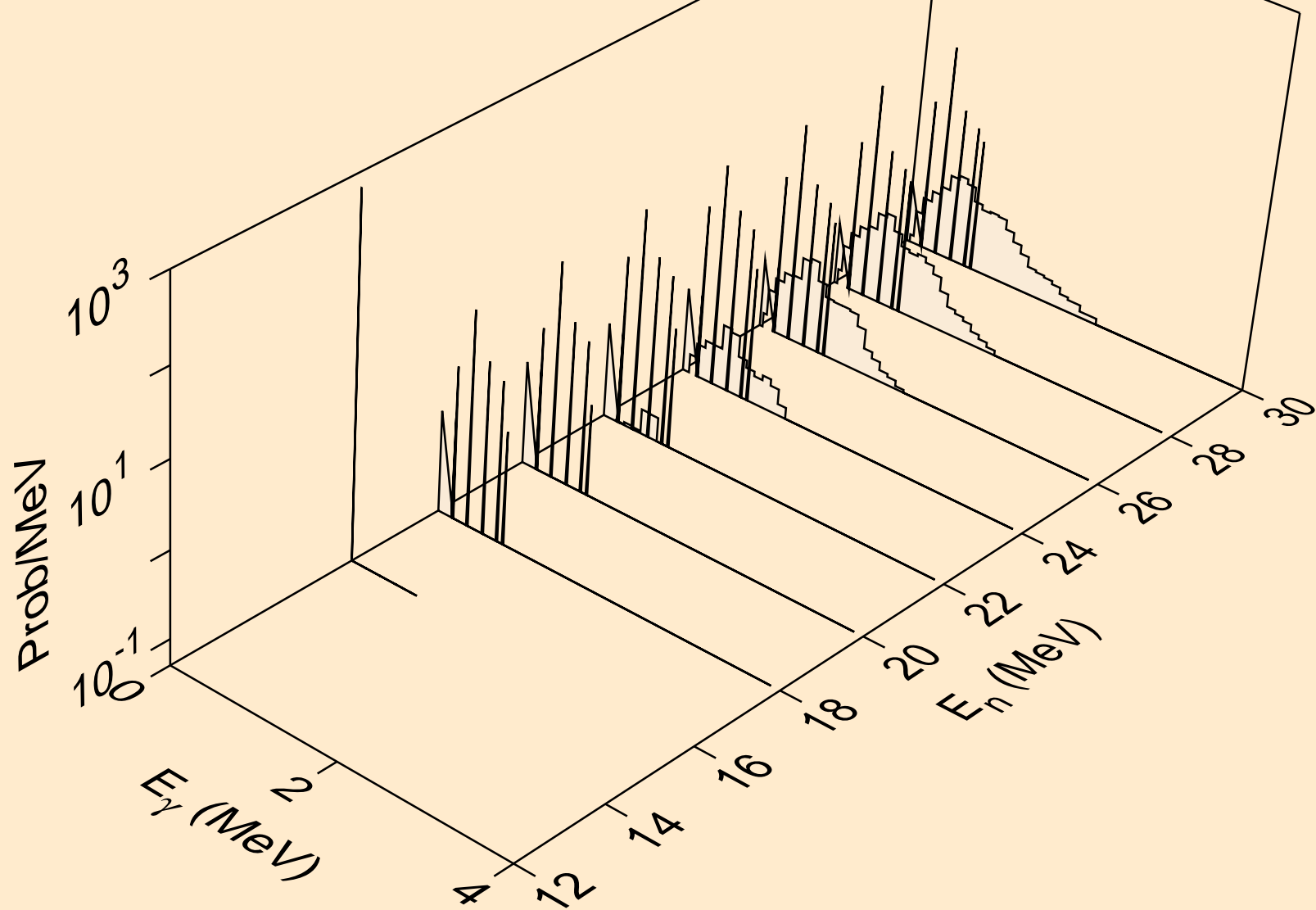



TC108 PROTON ACER TENDL-2021 LIBRARY; T=0.K  
Photon emission for (n,pt)

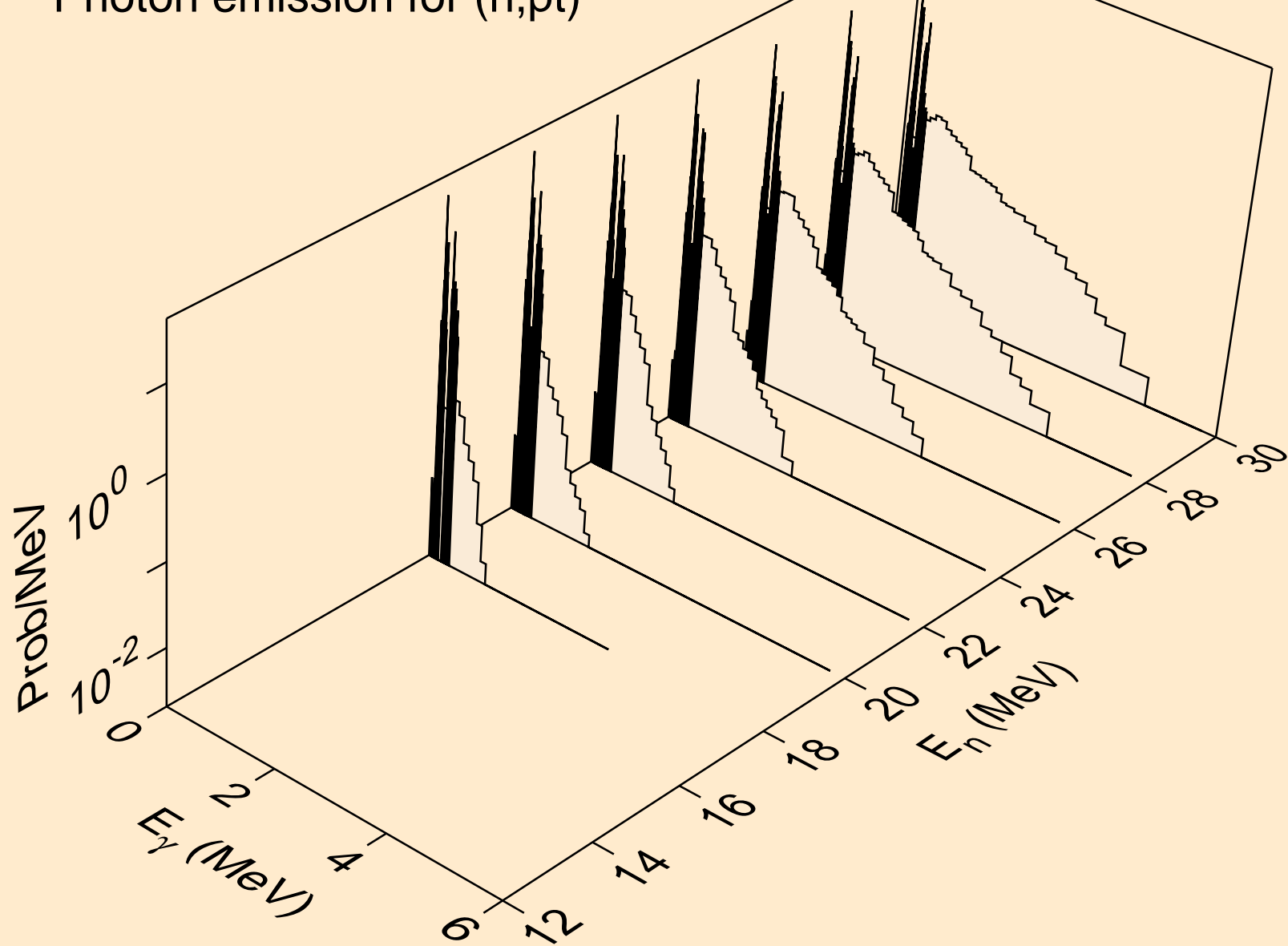

TC108 PROTON ACER TENDL-2021 LIBRARY; T=0.K  
Particle heating contributions

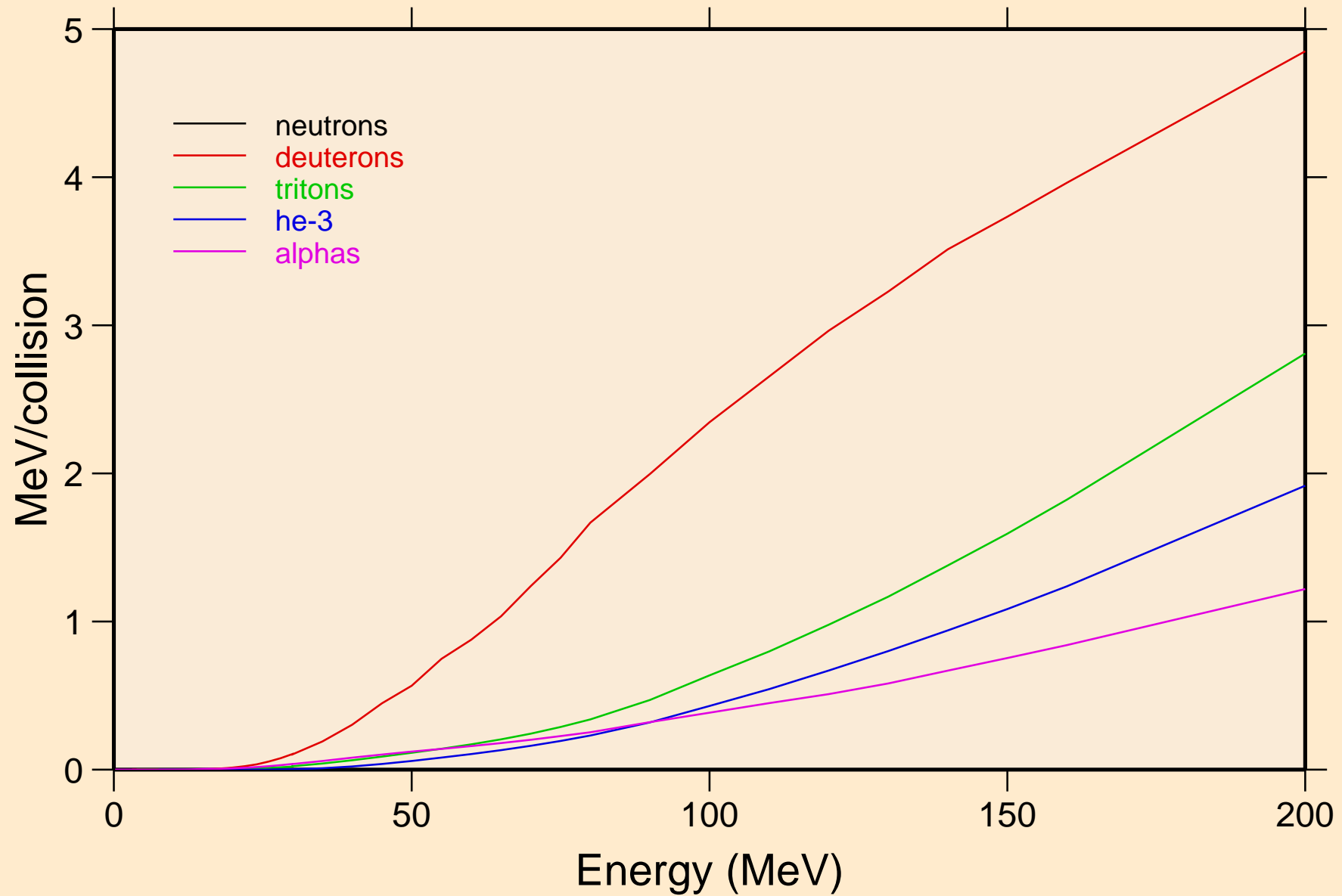

TC108 PROTON ACER TENDL-2021 LIBRARY; T=0.K  
Recoil Heating

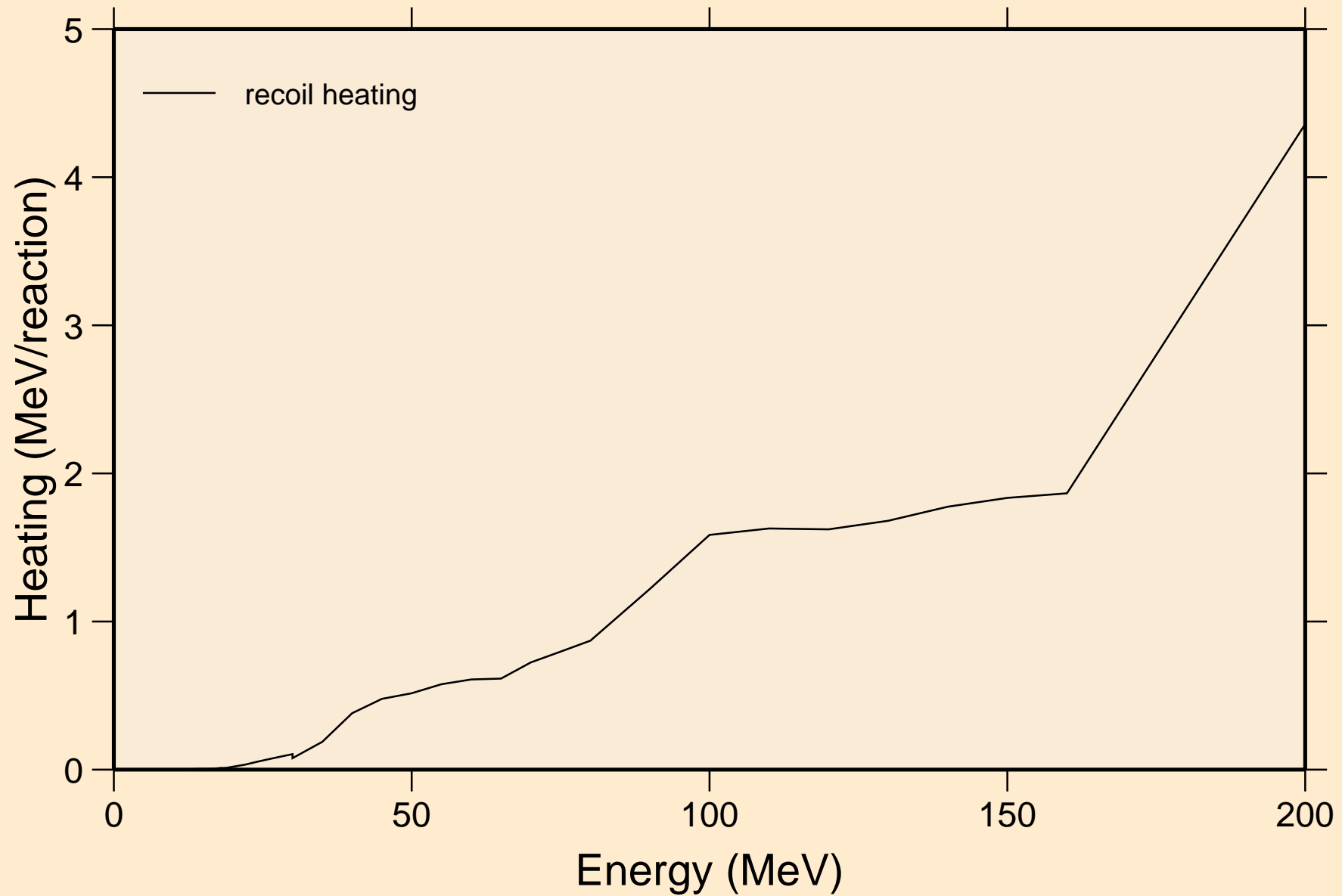

TC108 PROTON ACER TENDL-2021 LIBRARY; T=0.K  
Particle production cross sections

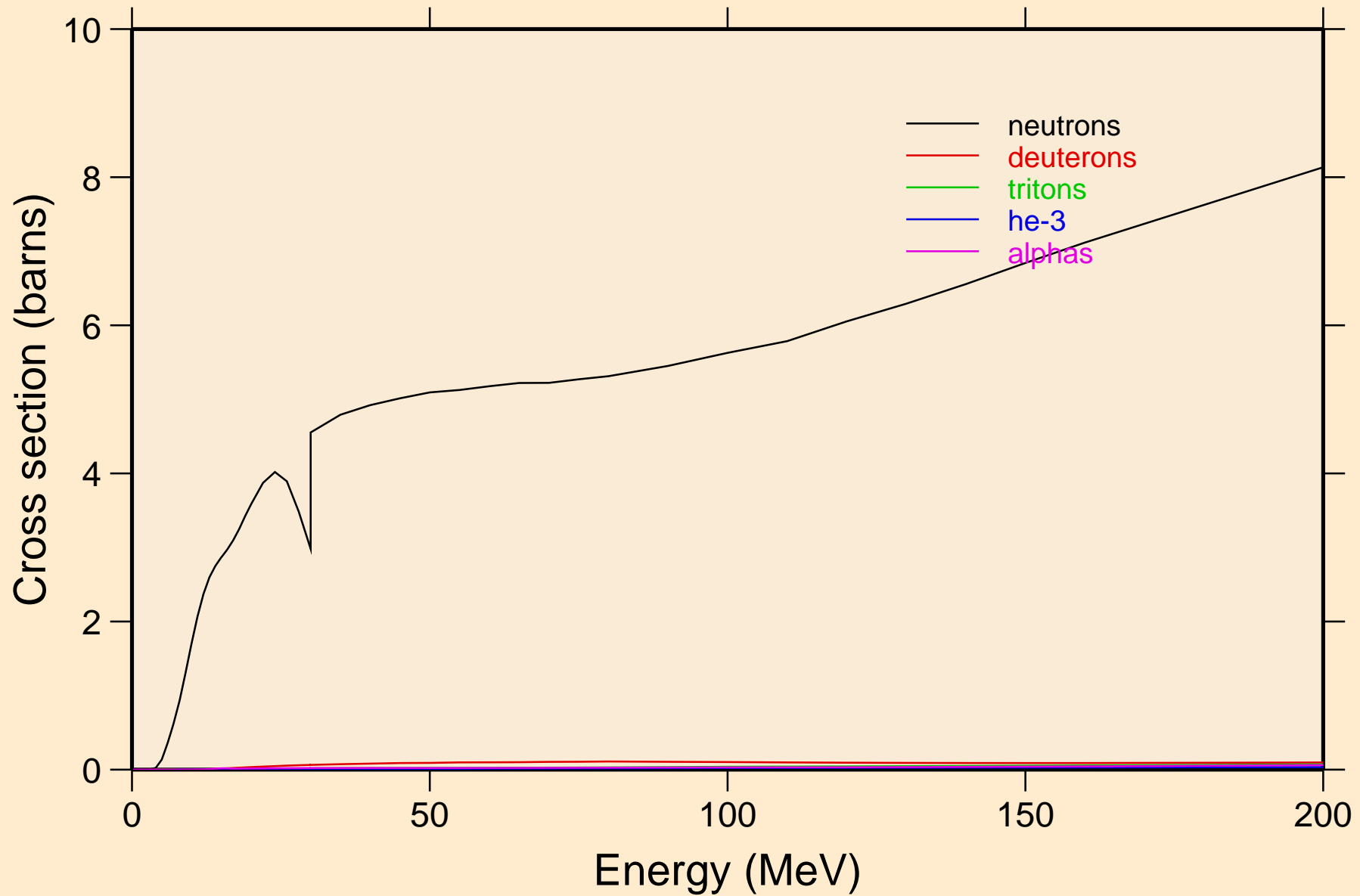

TC108 PROTON ACER TENDL-2021 LIBRARY; T=0.K  
neutrons from (p,n)

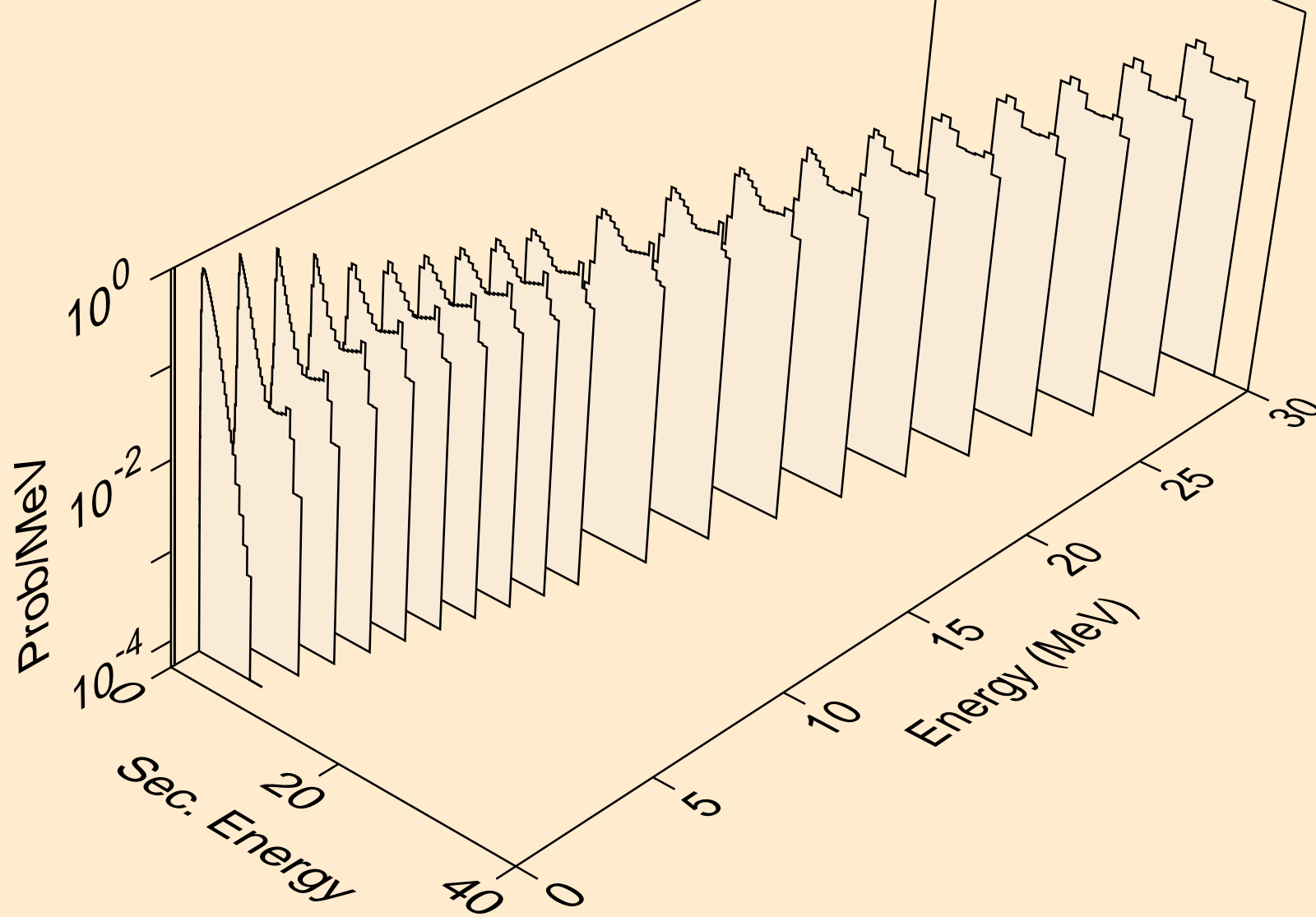

TC108 PROTON ACER TENDL-2021 LIBRARY; T=0.K  
neutrons from (p,x)

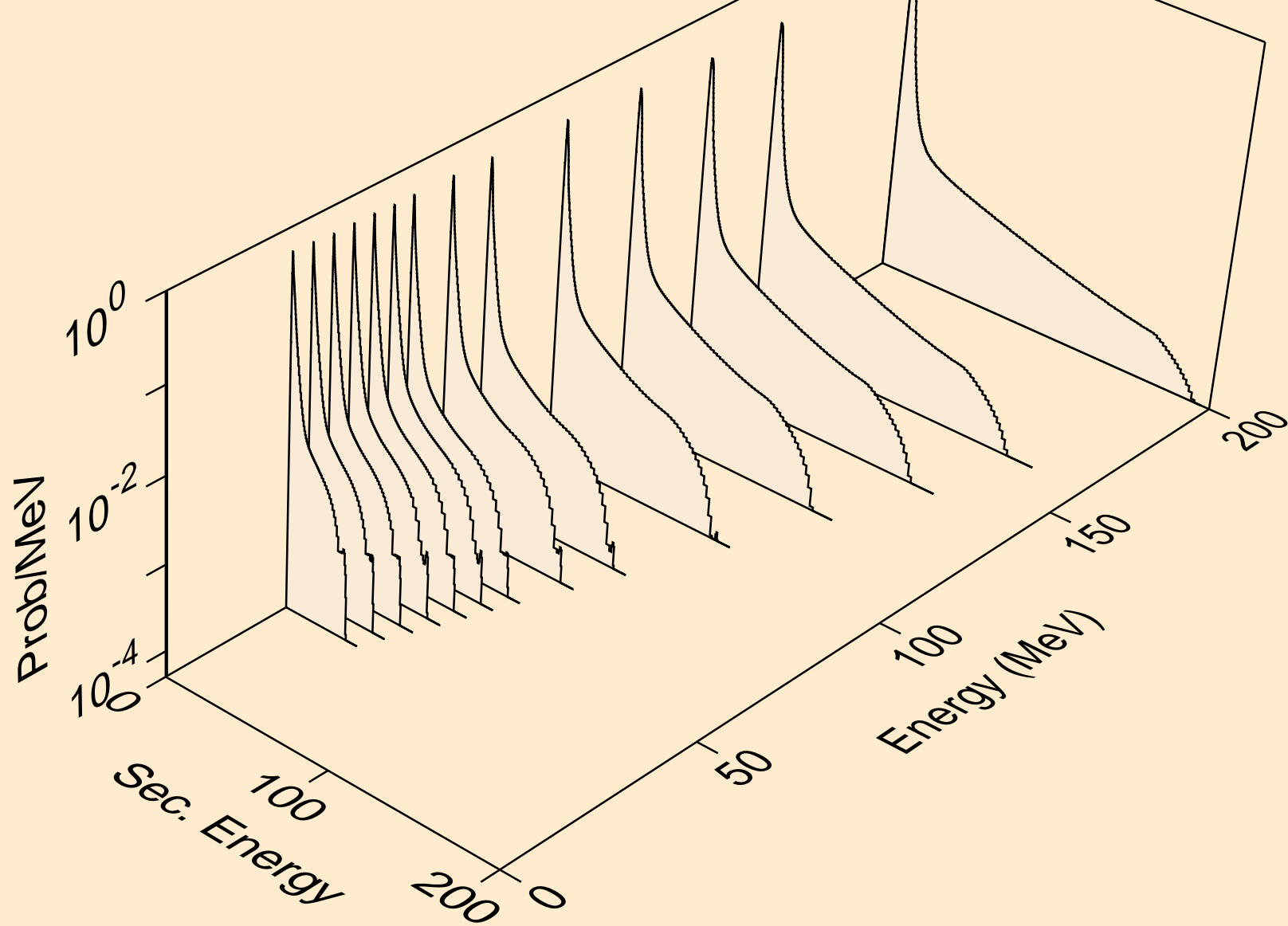

TC108 PROTON ACER TENDL-2021 LIBRARY; T=0.K  
neutrons from (p,2nd)

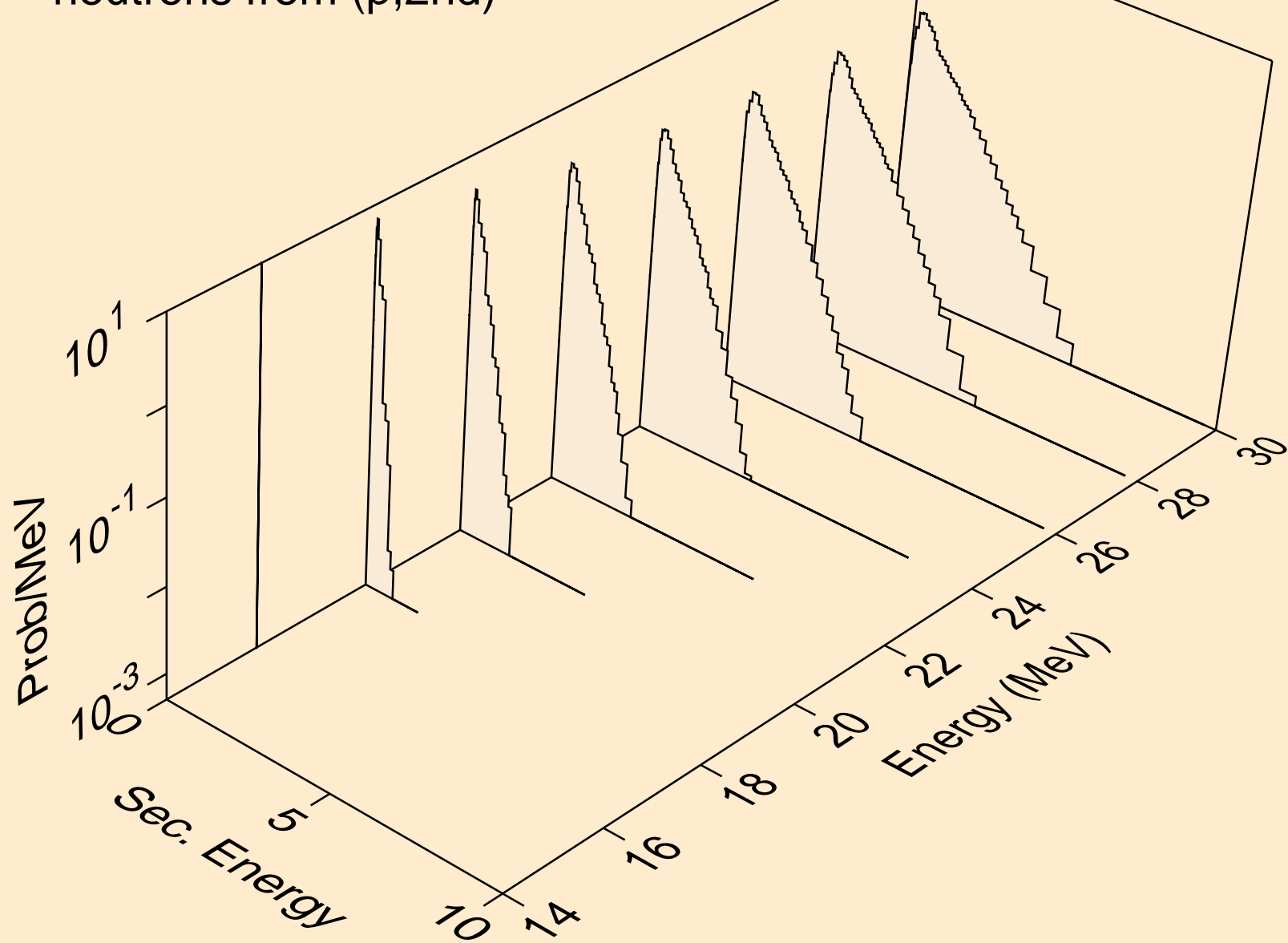

TC108 PROTON ACER TENDL-2021 LIBRARY; T=0.K  
neutrons from (p,2n)

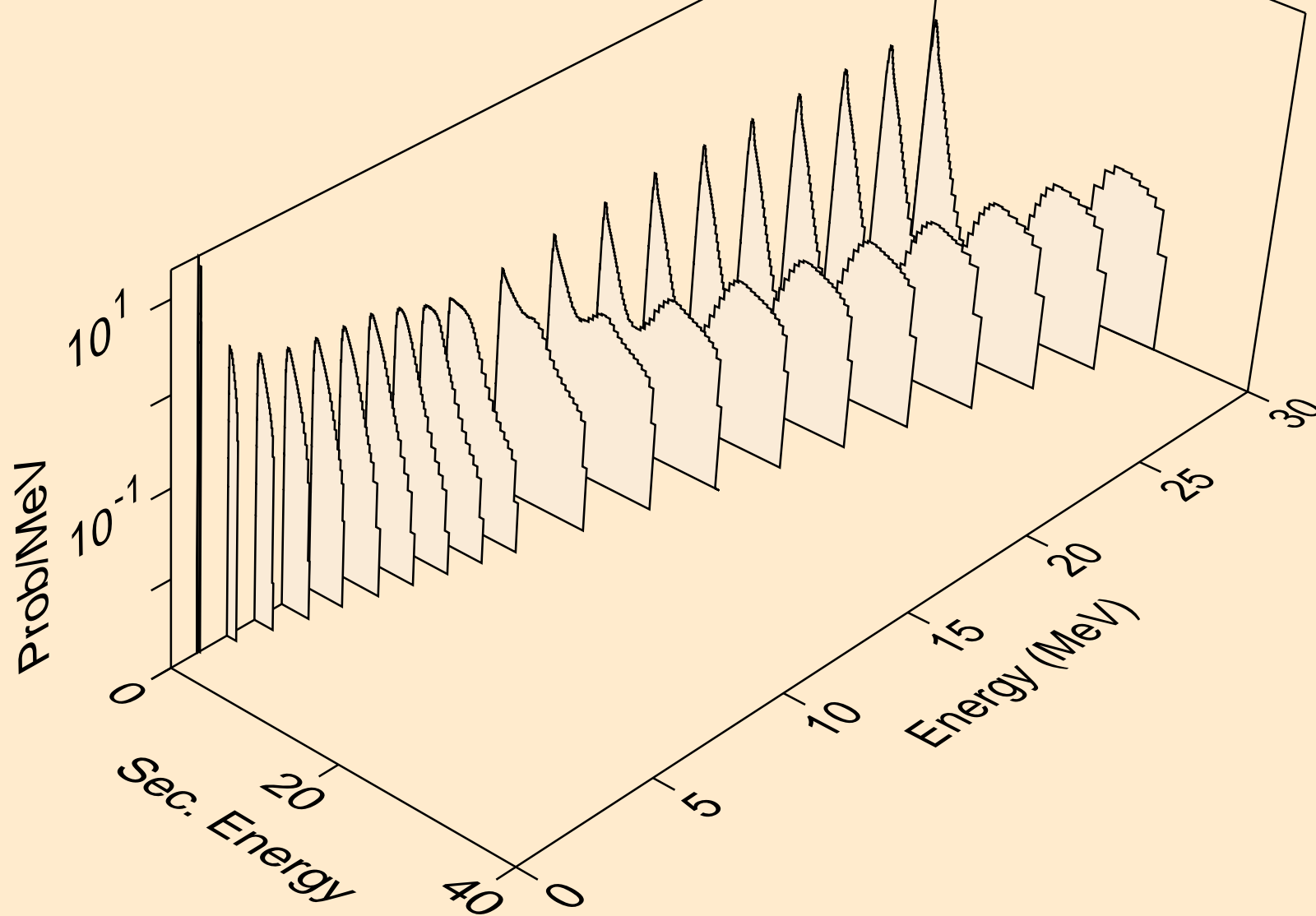



TC108 PROTON ACER TENDL-2021 LIBRARY; T=0.K  
neutrons from (p,3n)

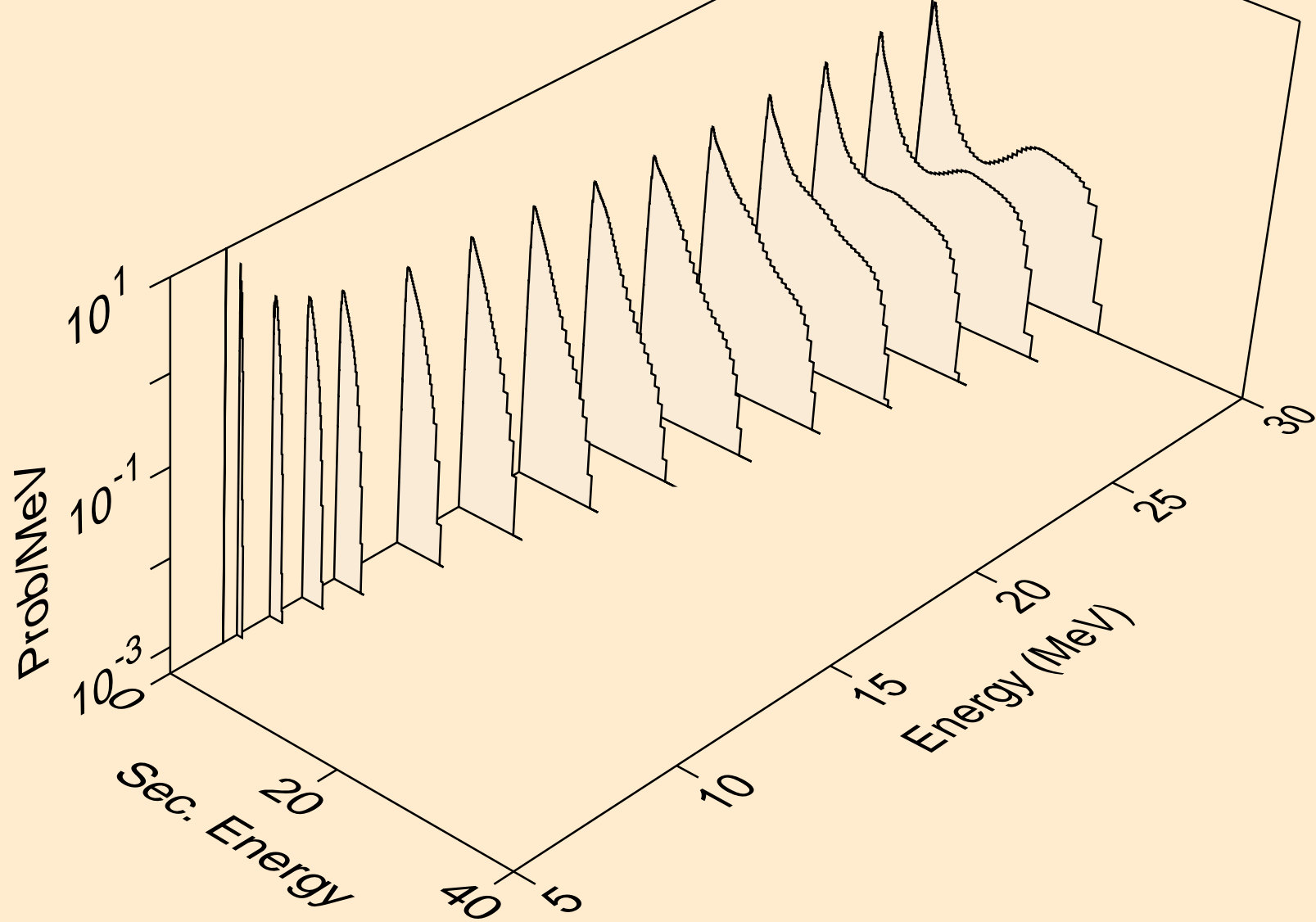

TC108 PROTON ACER TENDL-2021 LIBRARY; T=0.K  
neutrons from (p,n\*)a

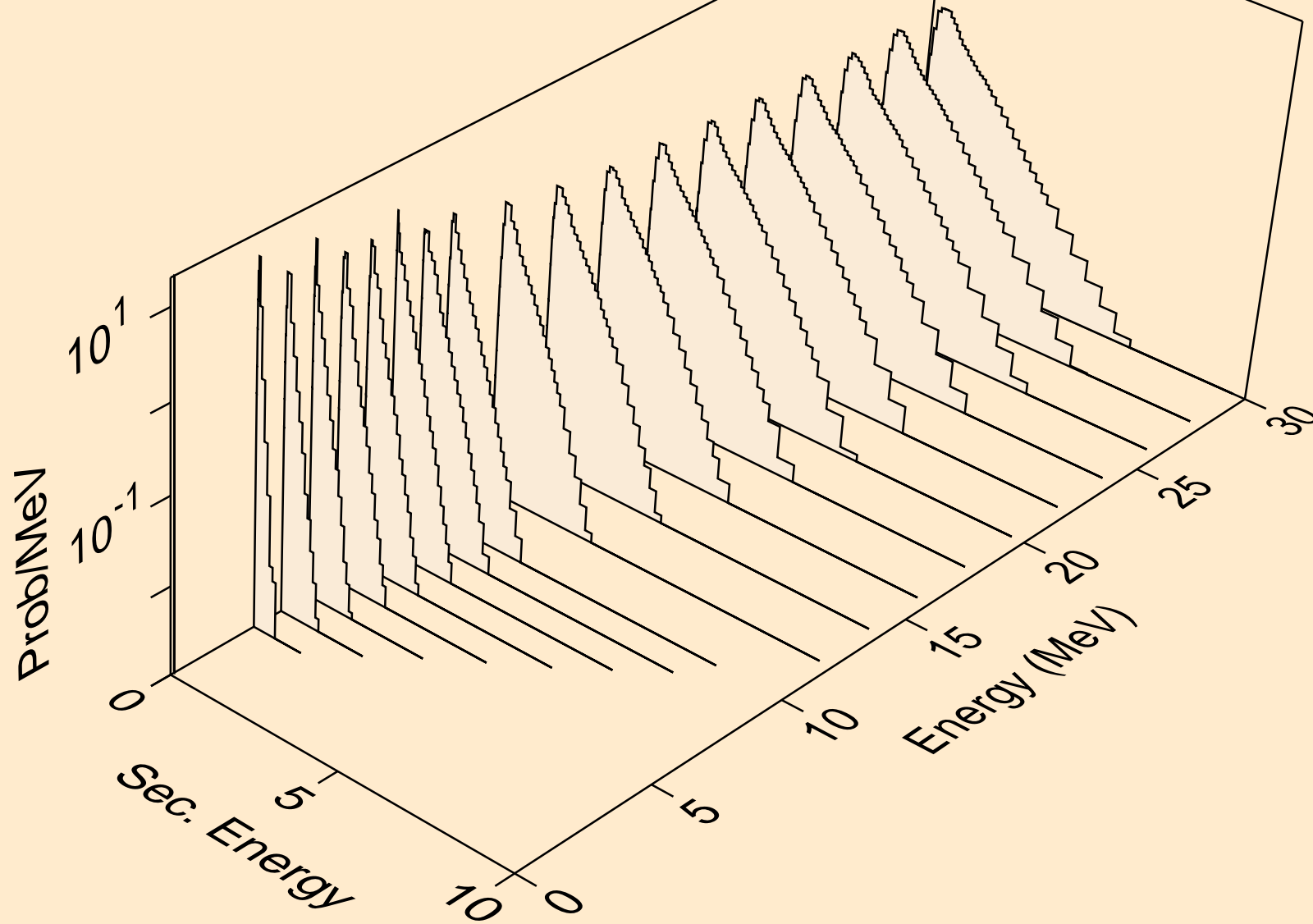

TC108 PROTON ACER TENDL-2021 LIBRARY; T=0.K  
neutrons from (p,2n)a

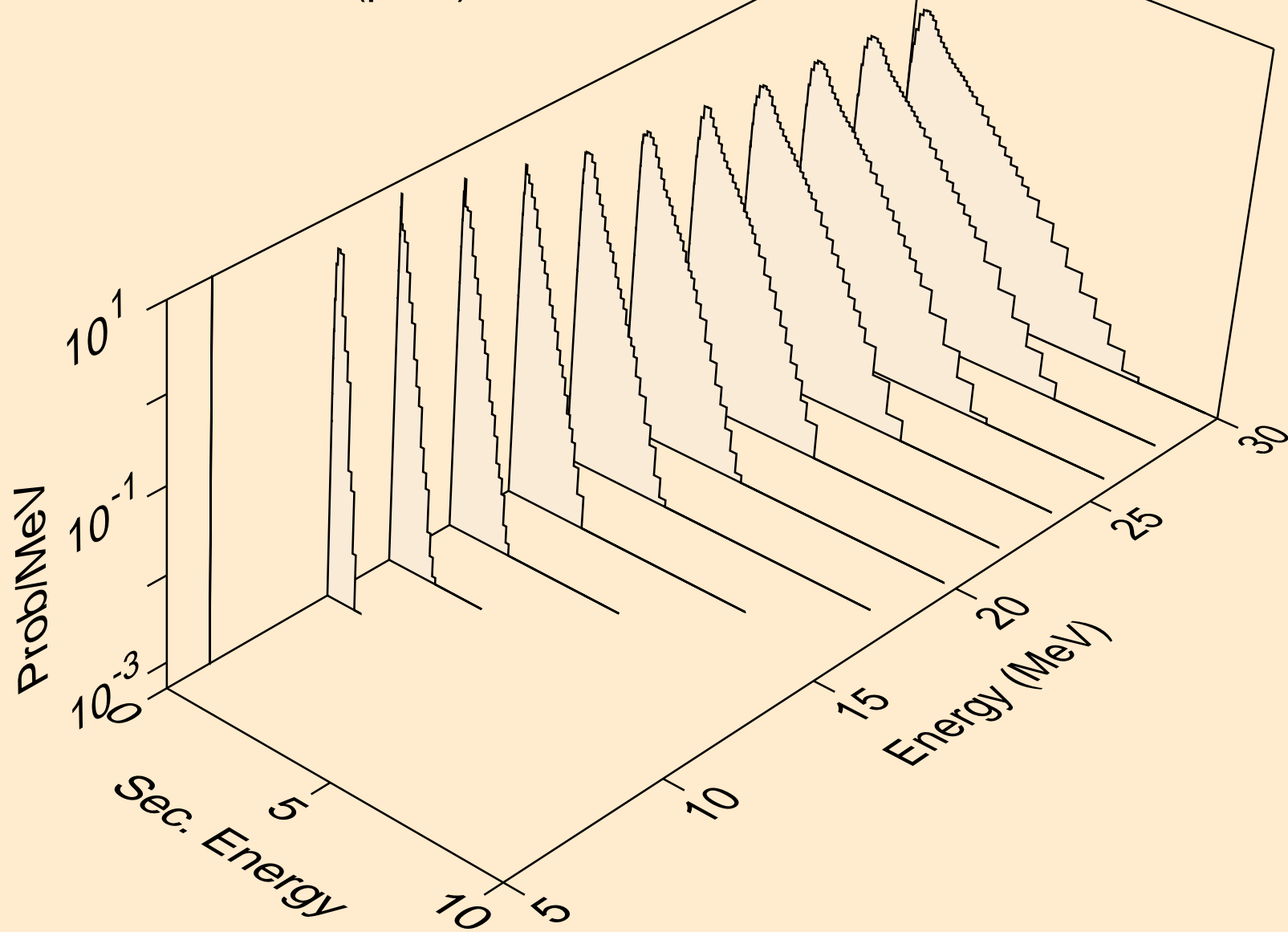

TC108 PROTON ACER TENDL-2021 LIBRARY; T=0.K  
neutrons from (p,3n)a

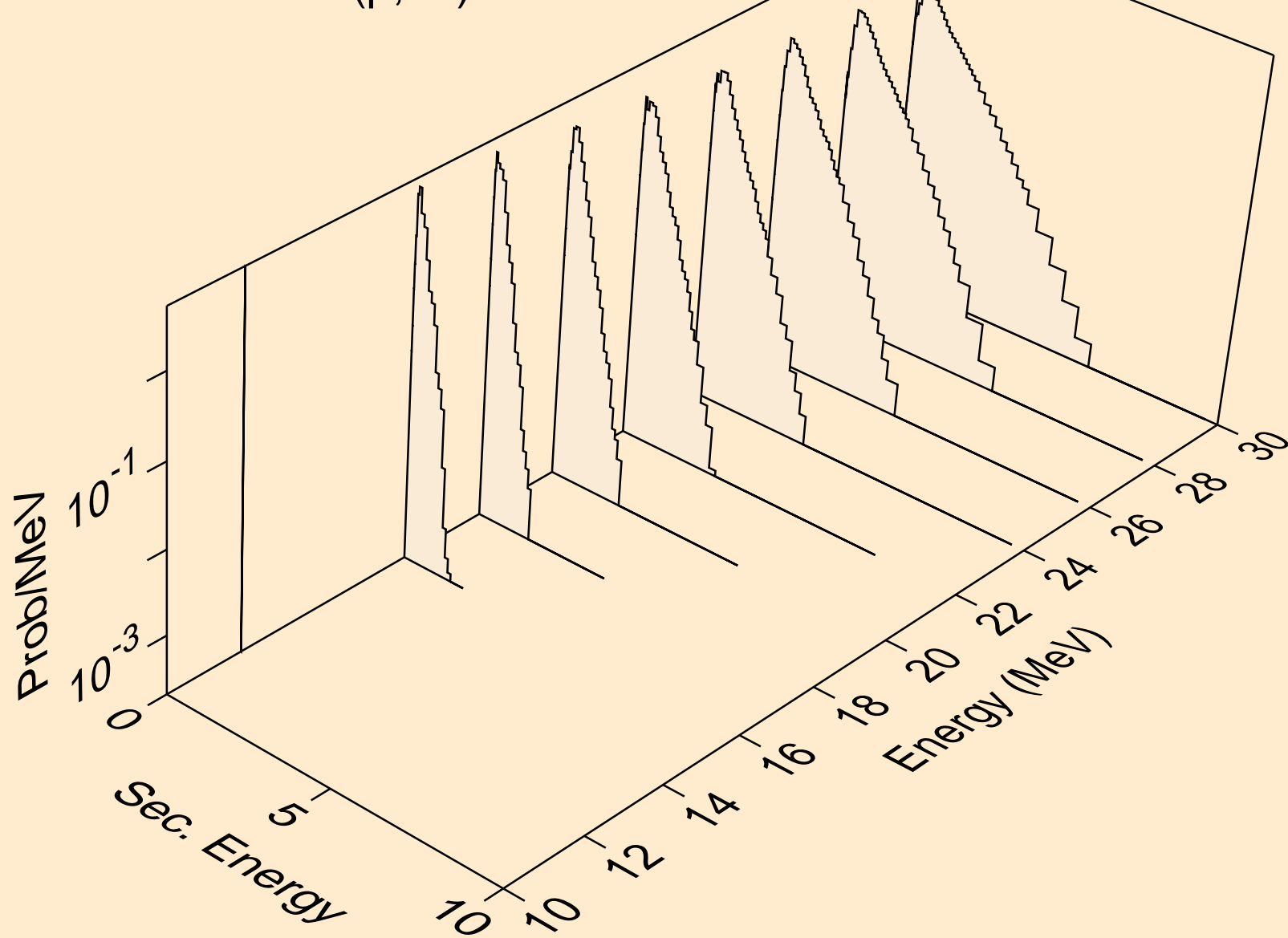

TC108 PROTON ACER TENDL-2021 LIBRARY; T=0.K  
neutrons from (p,n\*)p

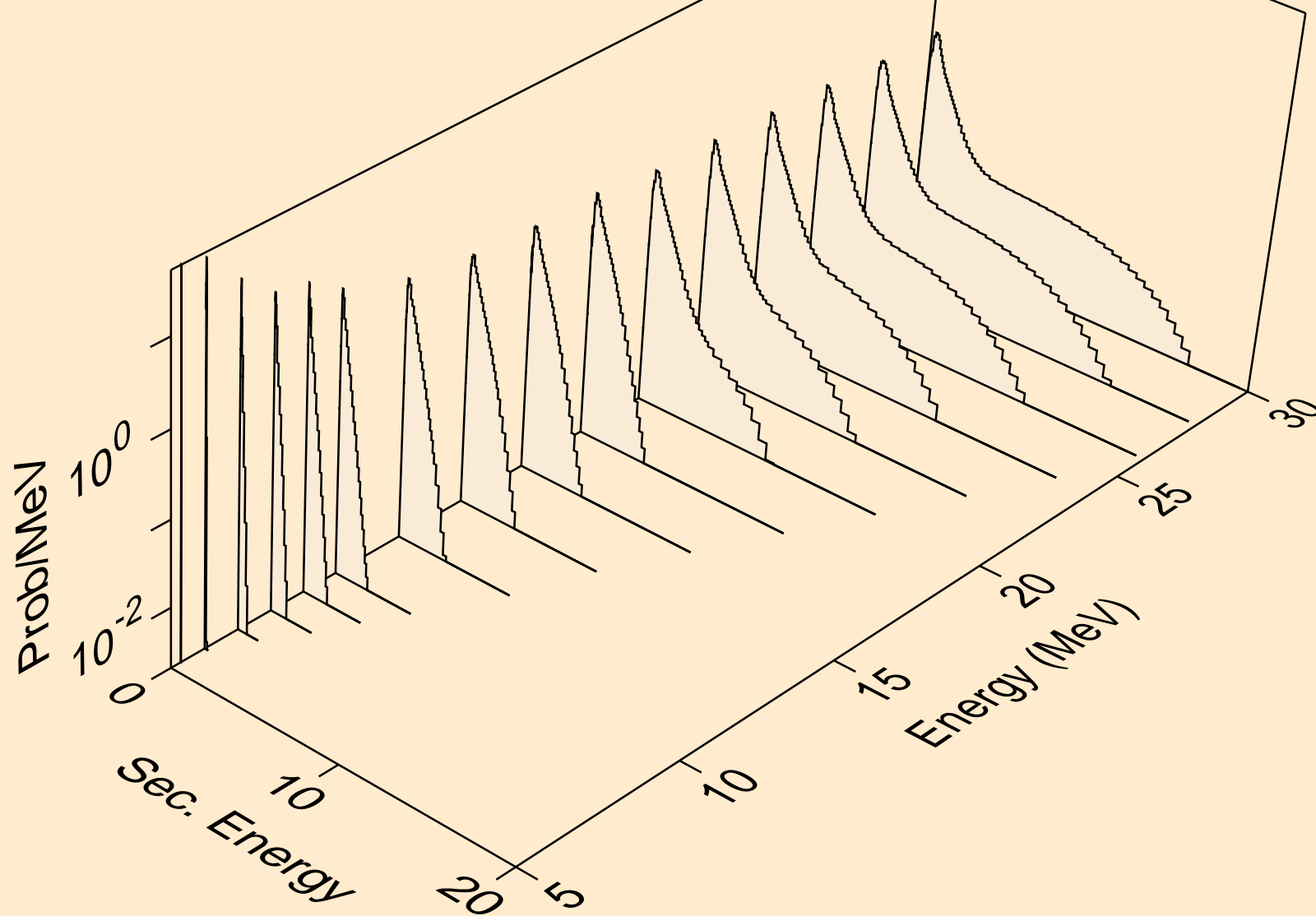

TC108 PROTON ACER TENDL-2021 LIBRARY; T=0.K  
neutrons from (p,n\*)2a

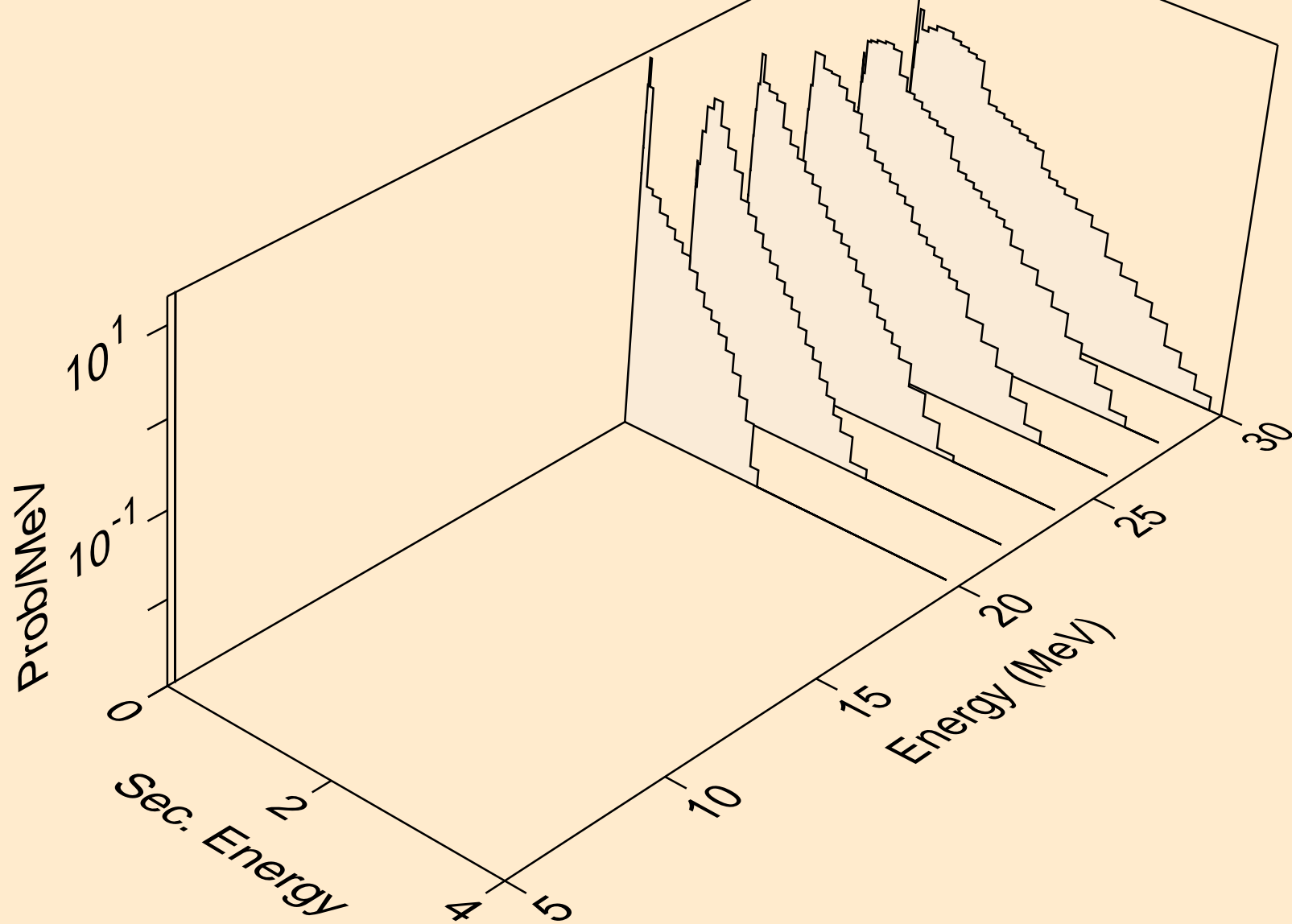

TC108 PROTON ACER TENDL-2021 LIBRARY; T=0.K  
neutrons from (p,n\*)d

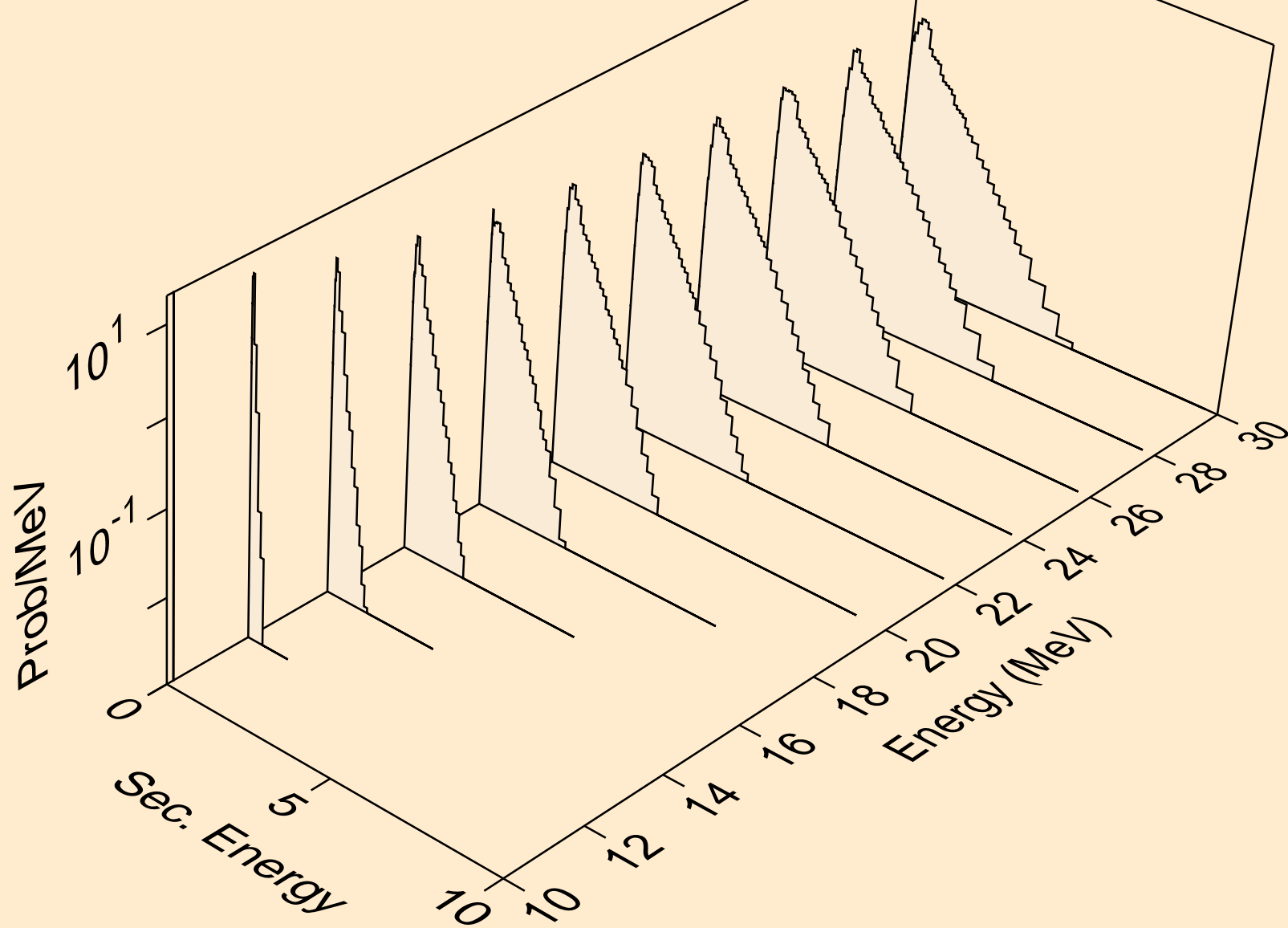

TC108 PROTON ACER TENDL-2021 LIBRARY; T=0.K  
neutrons from (p,n\*)t

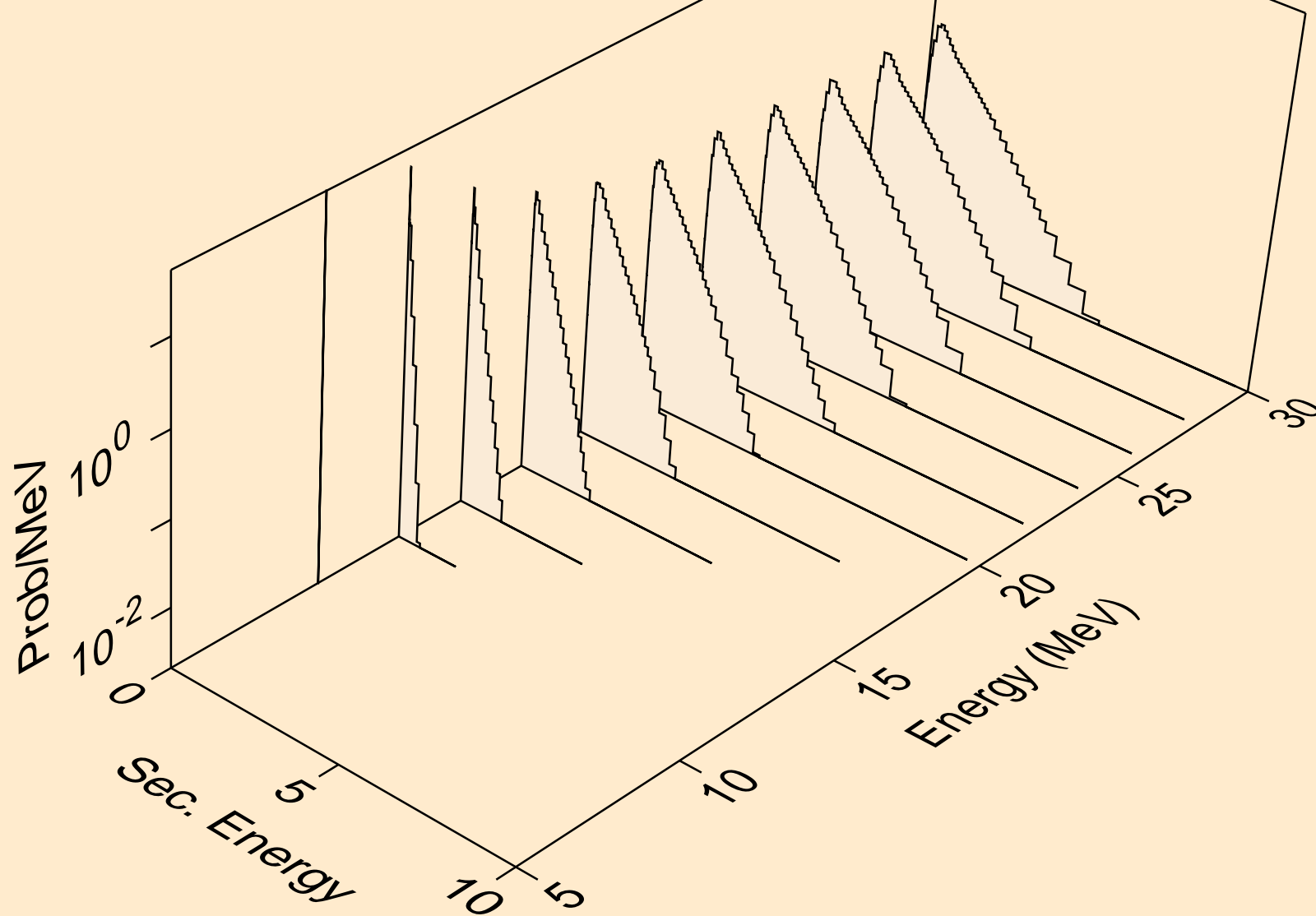



TC108 PROTON ACER TENDL-2021 LIBRARY; T=0.K  
neutrons from (p,n\*)he3

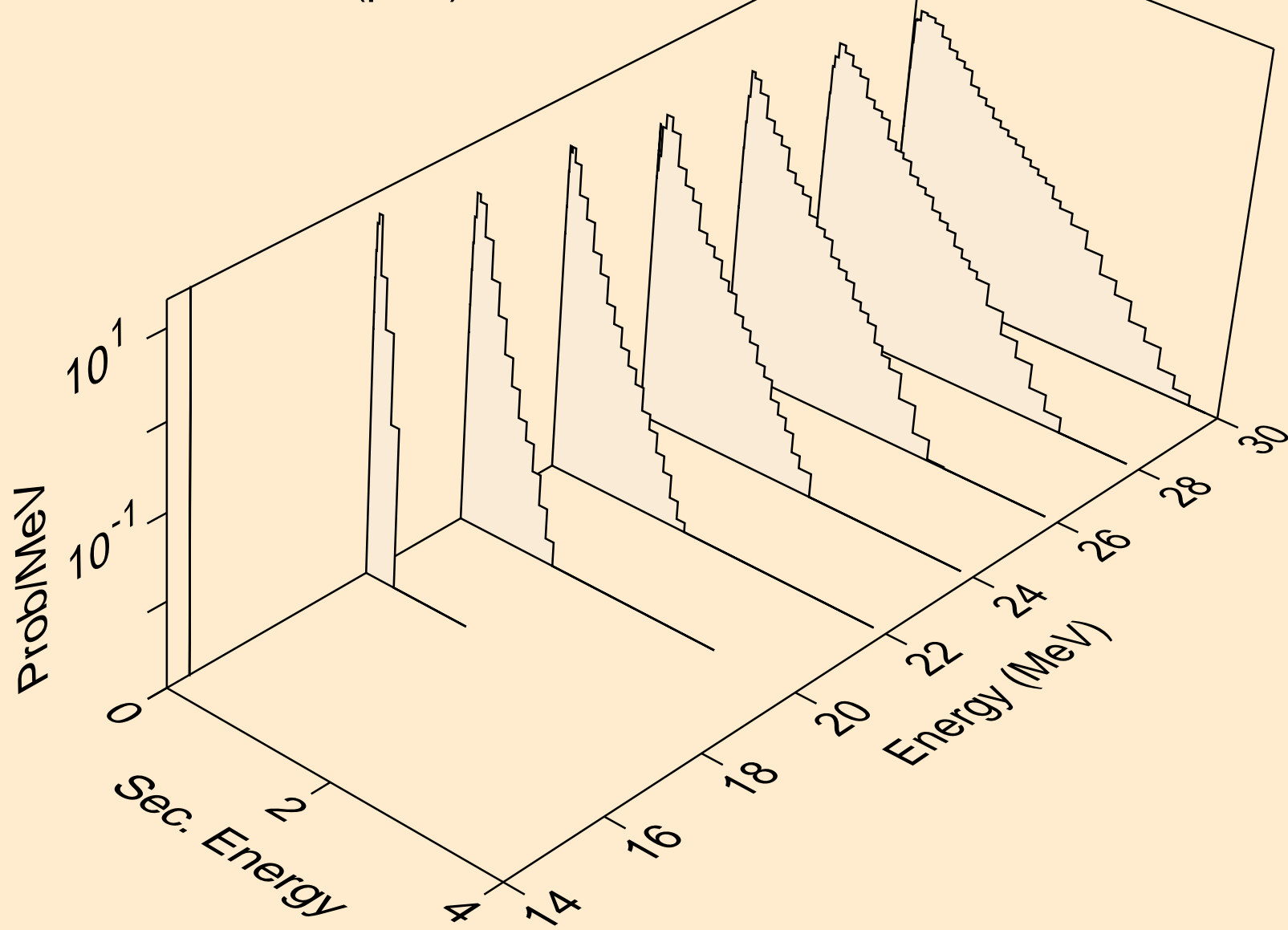

TC108 PROTON ACER TENDL-2021 LIBRARY; T=0.K  
neutrons from (p,4n)

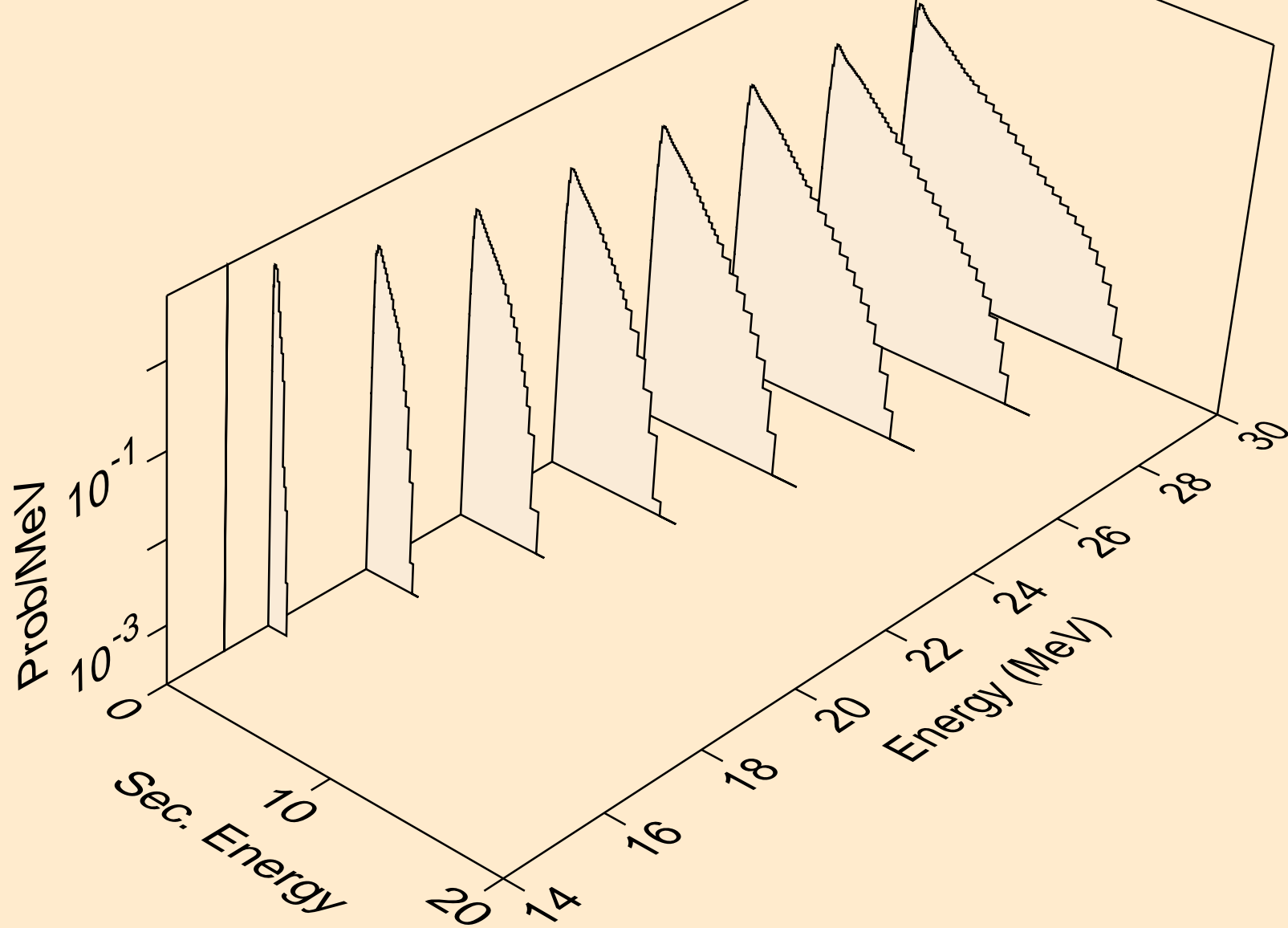

TC108 PROTON ACER TENDL-2021 LIBRARY; T=0.K  
neutrons from (p,2np)

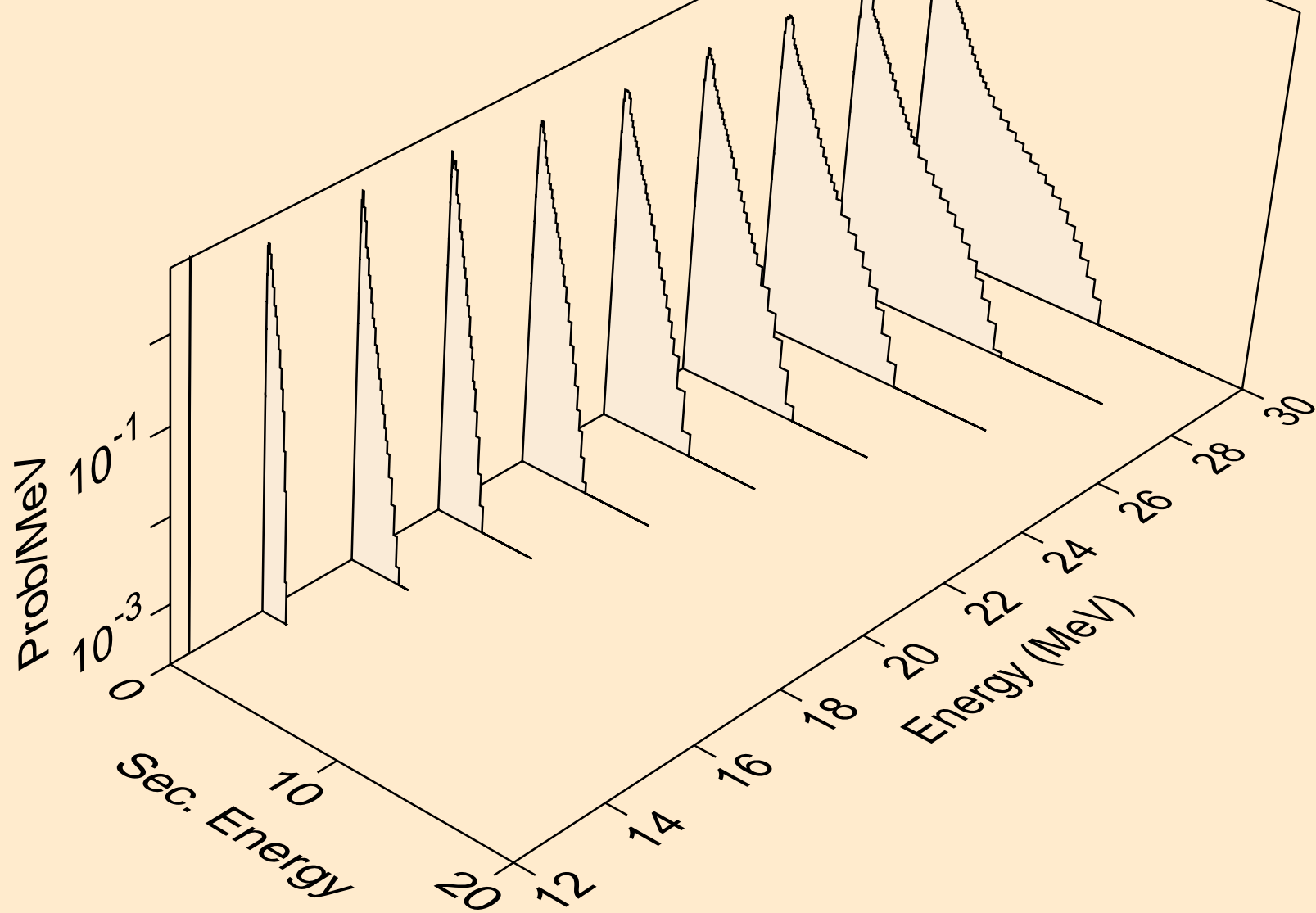

TC108 PROTON ACER TENDL-2021 LIBRARY; T=0.K  
neutrons from (p,3np)

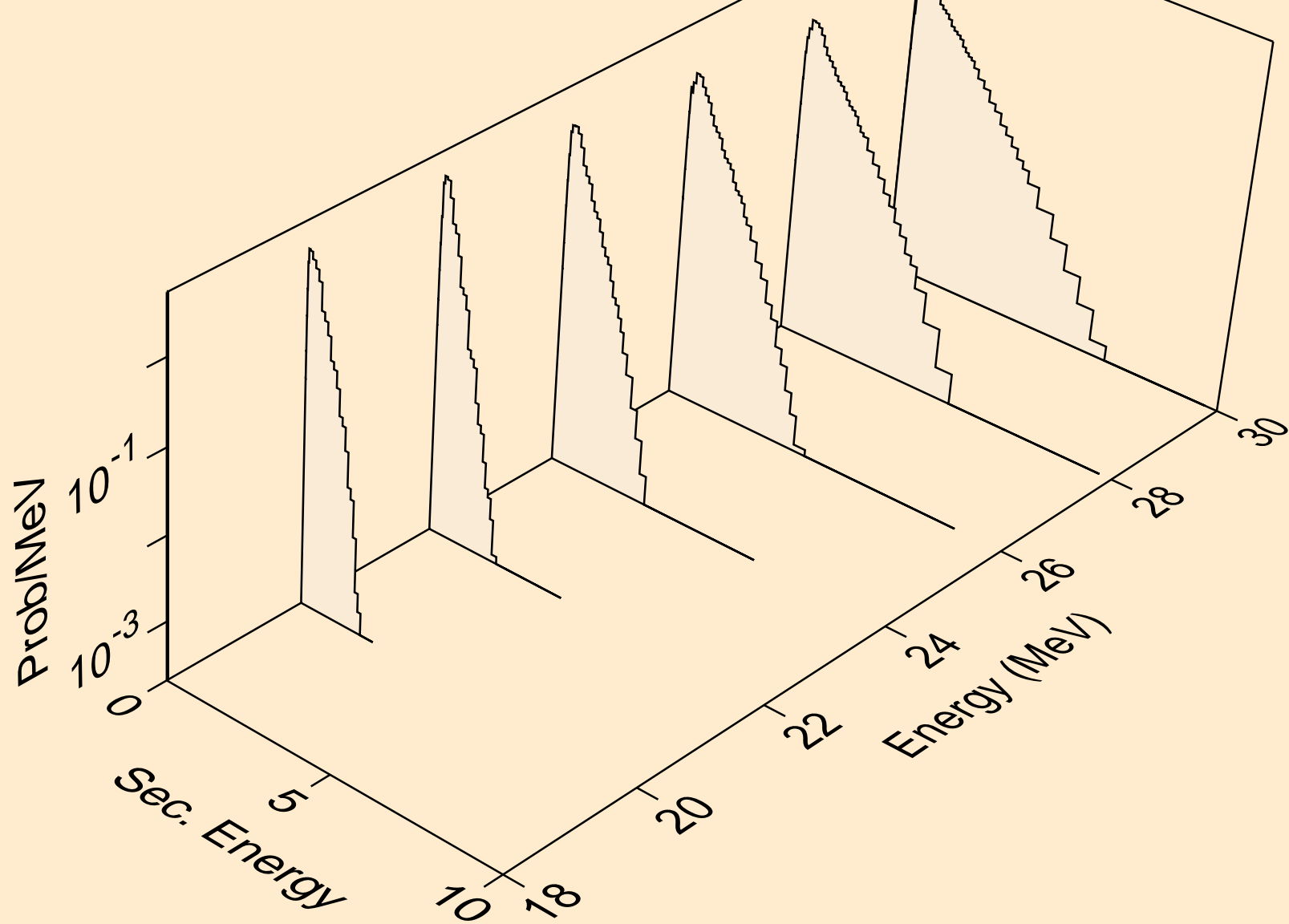

TC108 PROTON ACER TENDL-2021 LIBRARY; T=0.K  
neutrons from (p,2np)

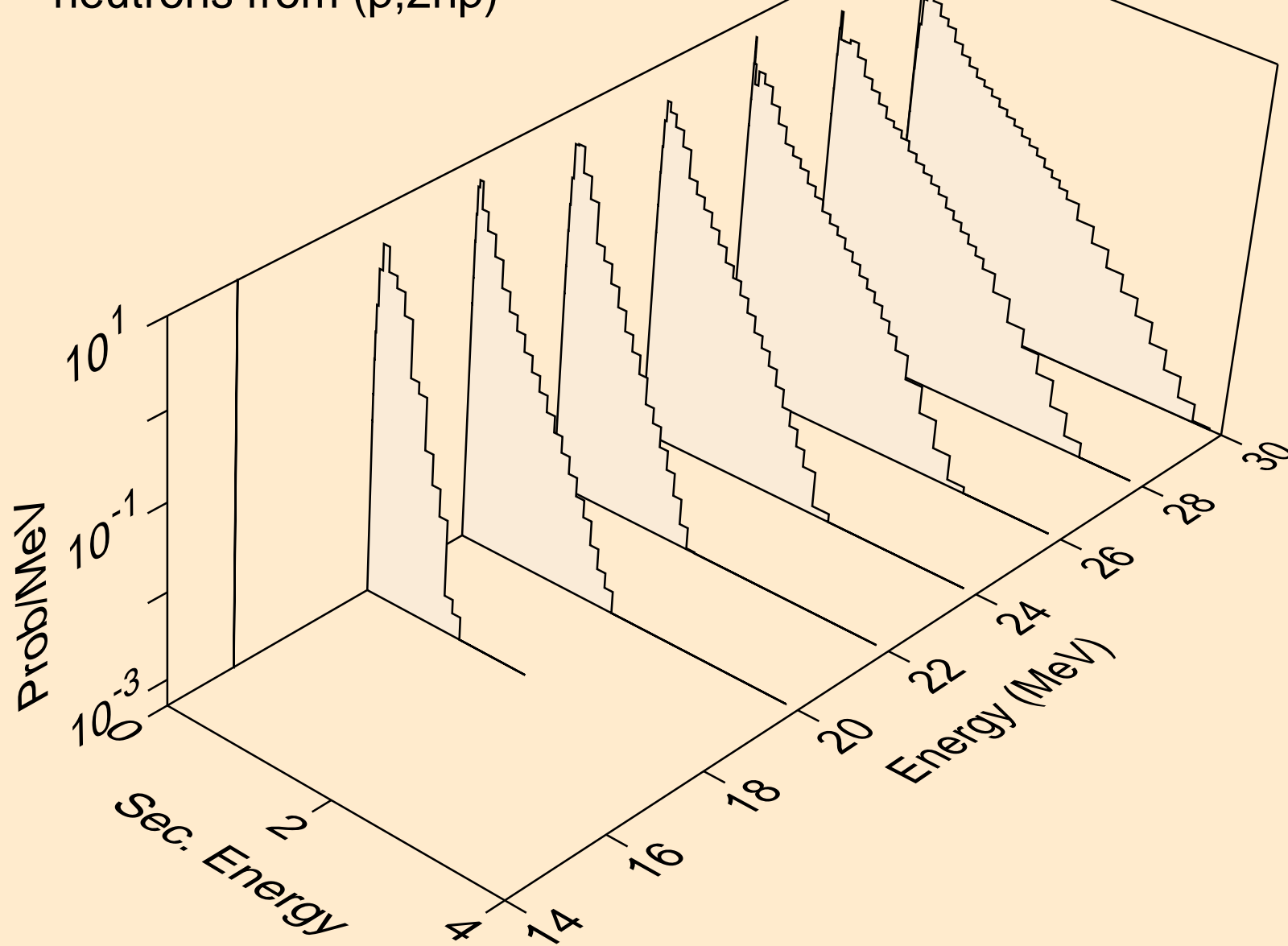

TC108 PROTON ACER TENDL-2021 LIBRARY; T=0.K  
neutrons from (p,npa)

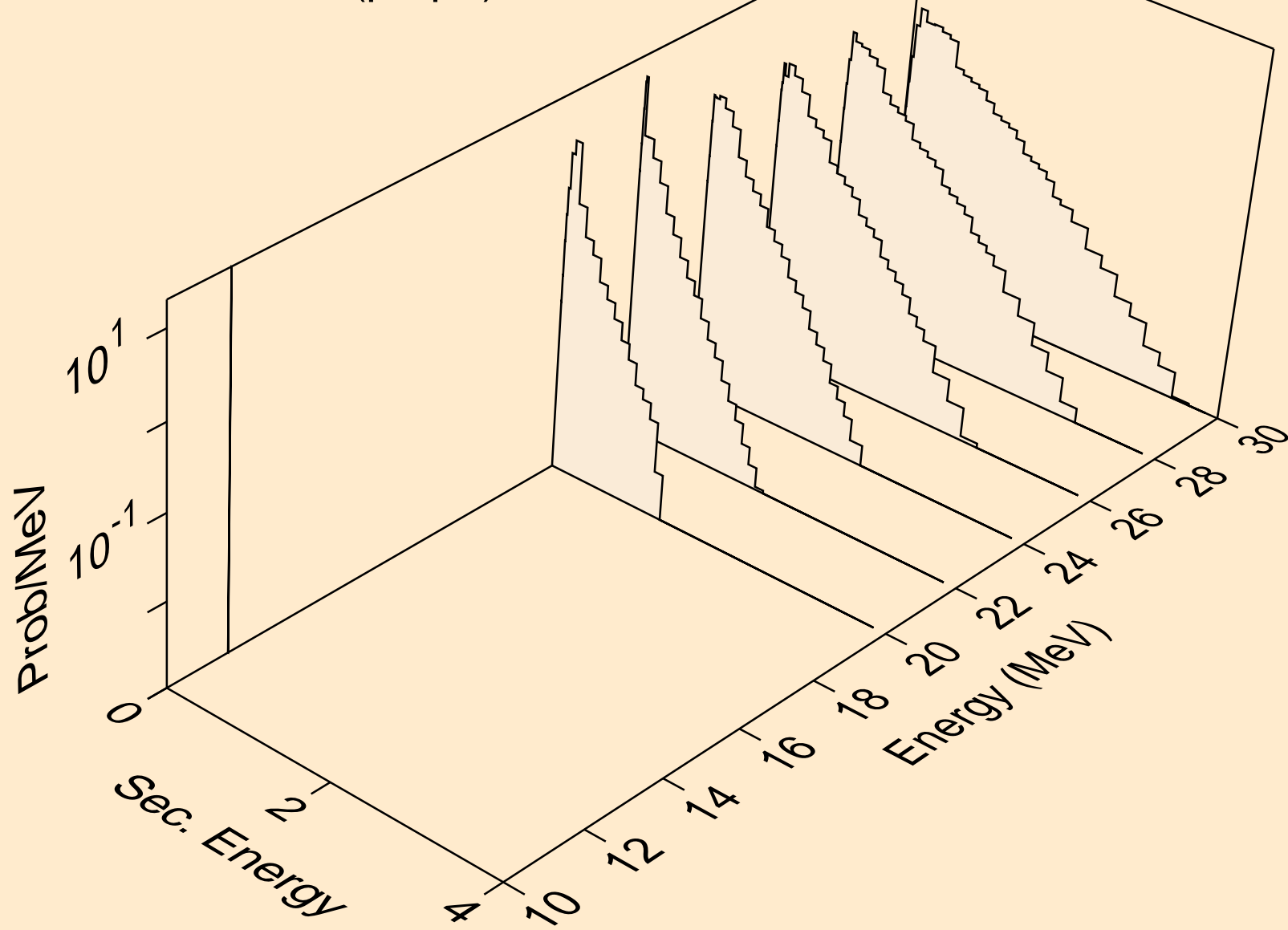

TC108 PROTON ACER TENDL-2021 LIBRARY; T=0.K  
deuterons from (p,x)

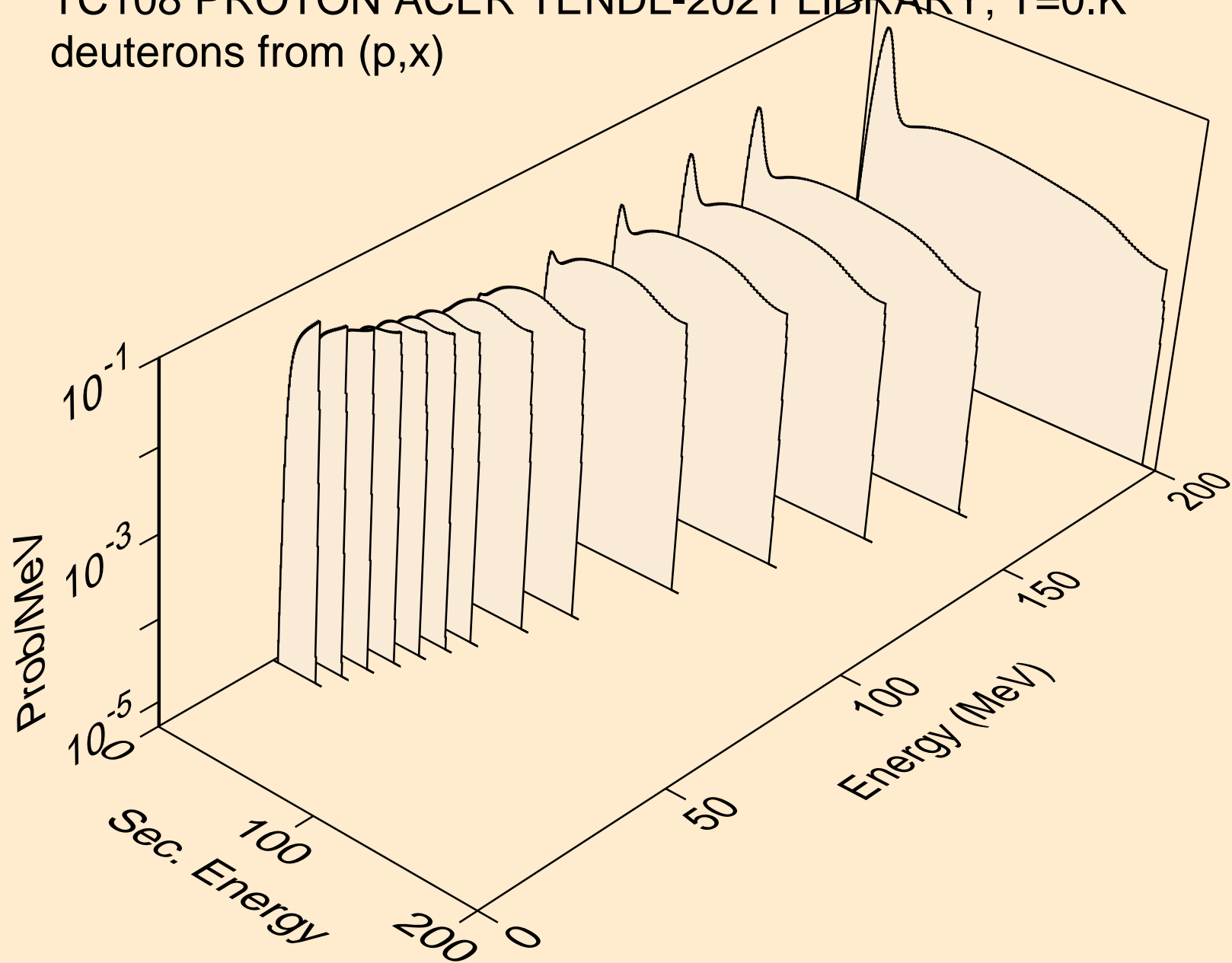

TC108 PROTON ACER TENDL-2021 LIBRARY; T=0.K  
deuterons from (p,2nd)

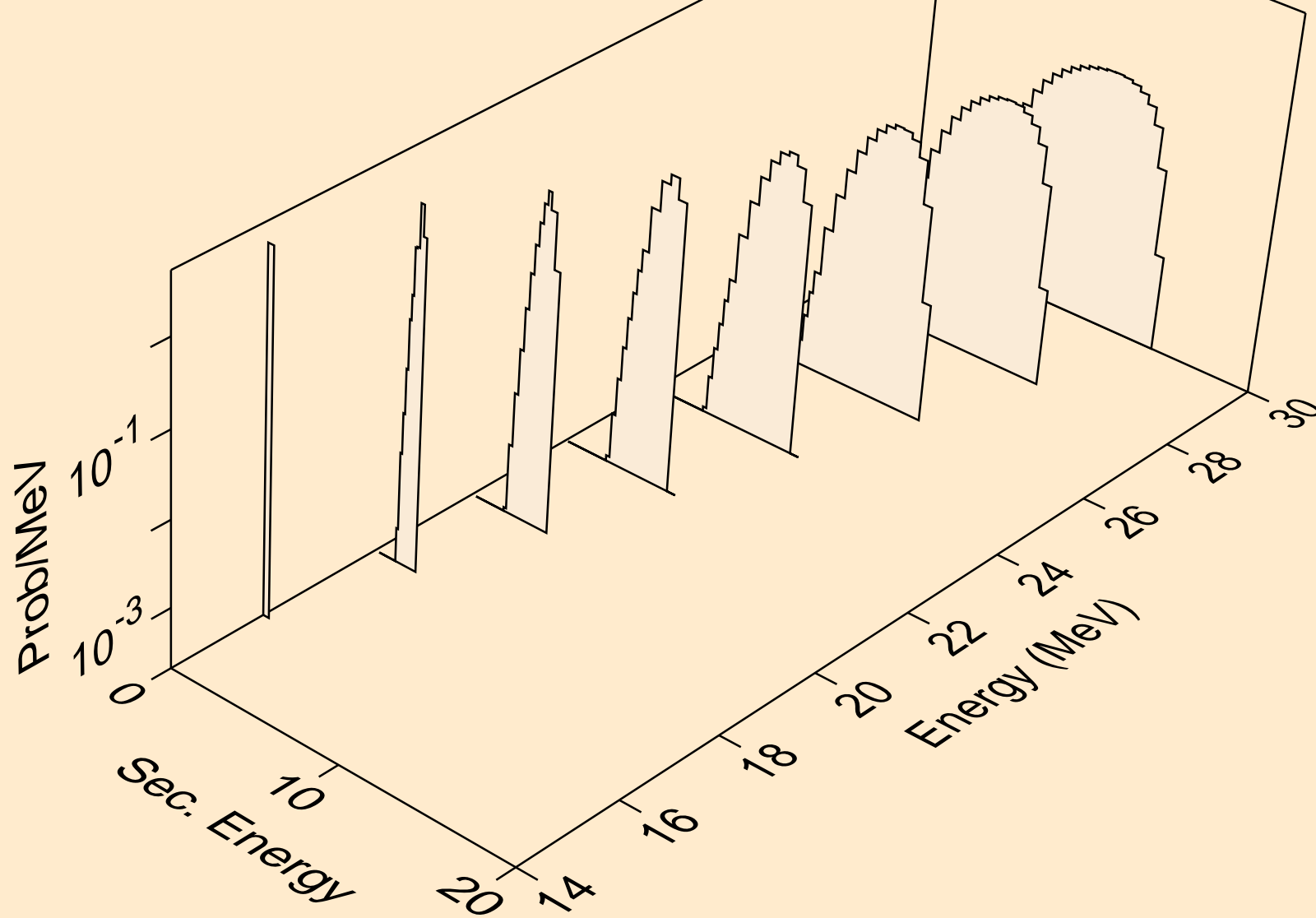



TC108 PROTON ACER TENDL-2021 LIBRARY; T=0.K  
deuterons from (p,n\*)d

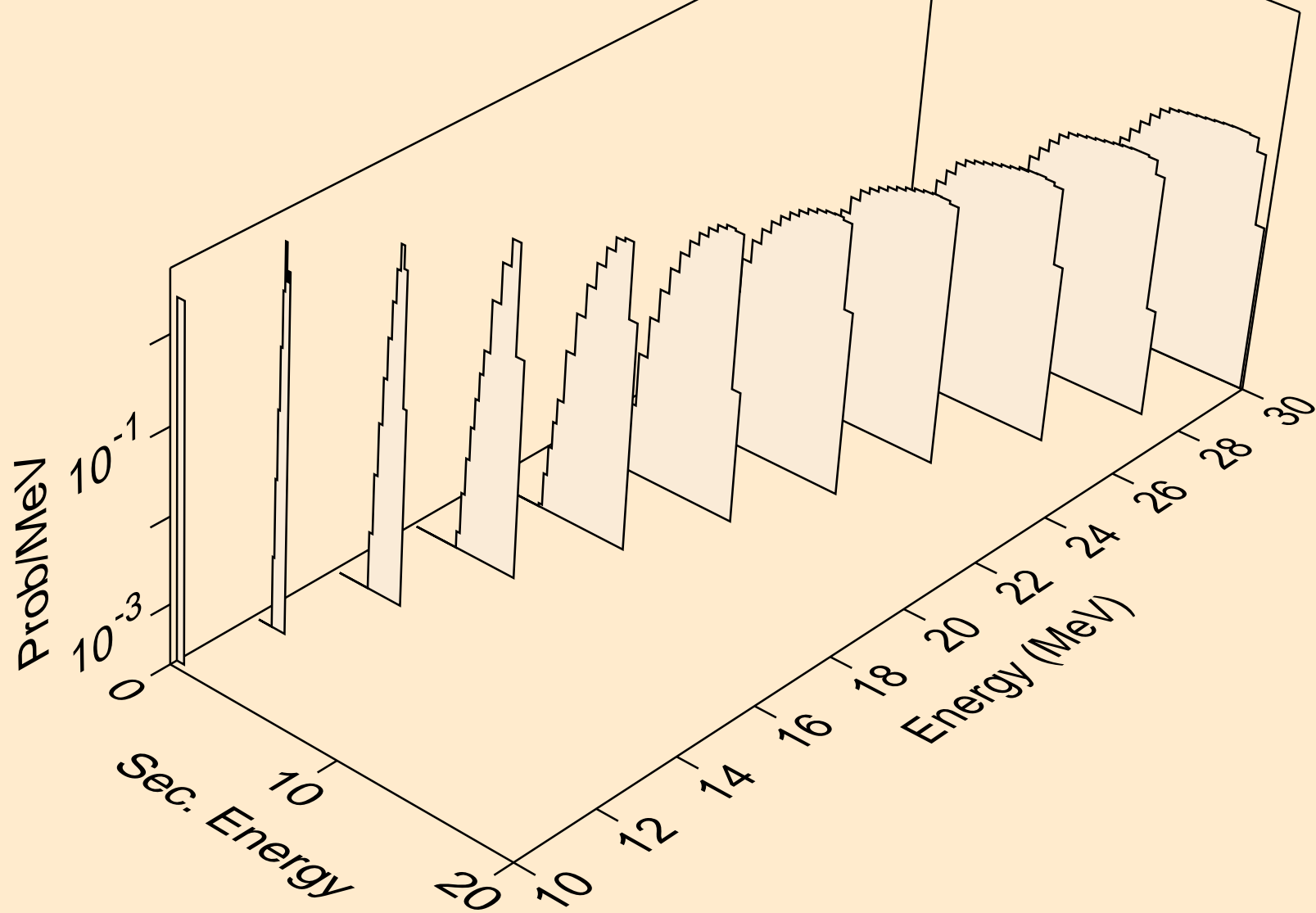

TC108 PROTON ACER TENDL-2021 LIBRARY; T=0.K  
deuterons from (p,d)

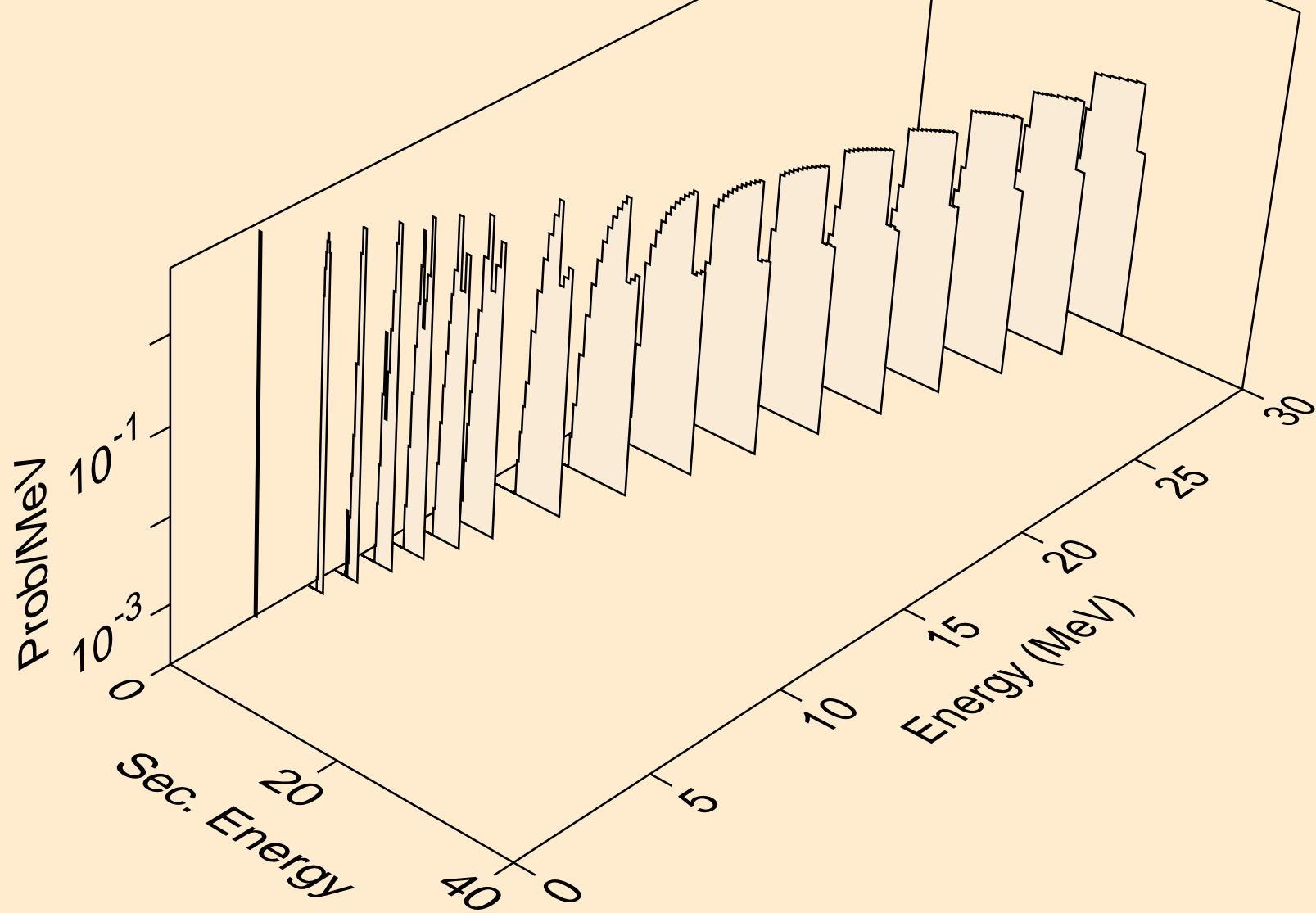

TC108 PROTON ACER TENDL-2021 LIBRARY; T=0.K  
deuterons from (p,pd)

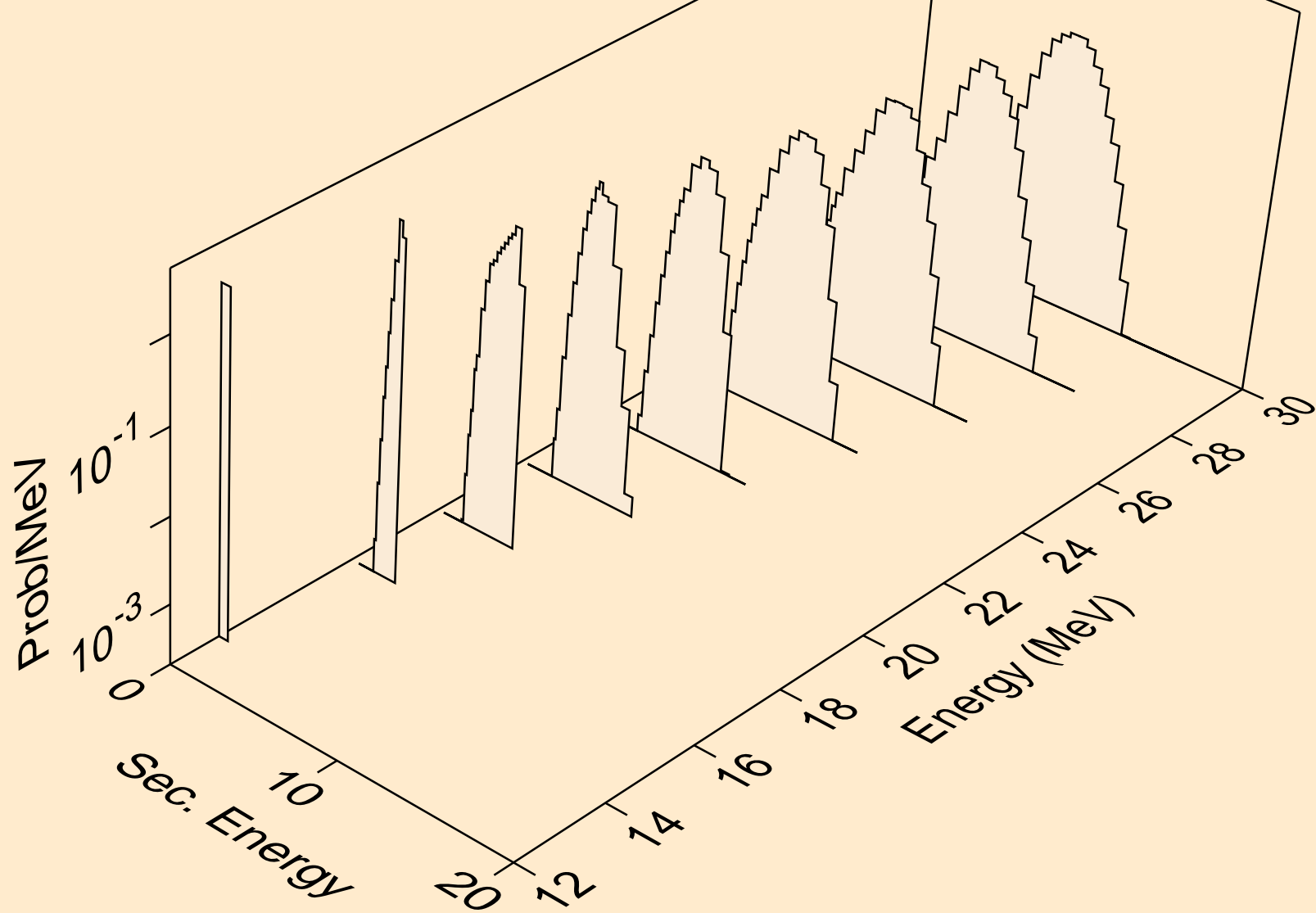

TC108 PROTON ACER TENDL-2021 LIBRARY; T=0.K  
tritons from (p,x)

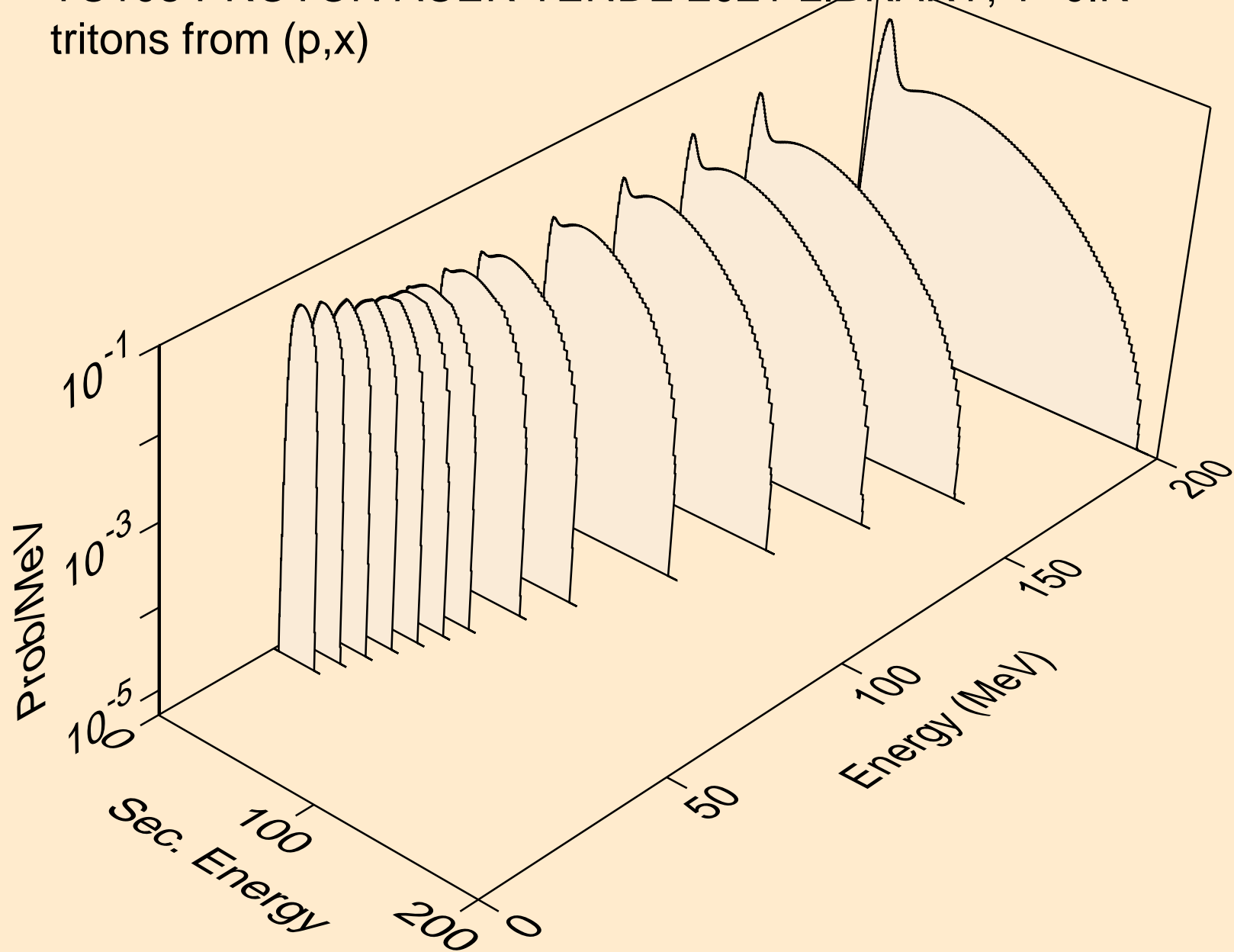

TC108 PROTON ACER TENDL-2021 LIBRARY; T=0.K  
tritons from (p,n\*)t

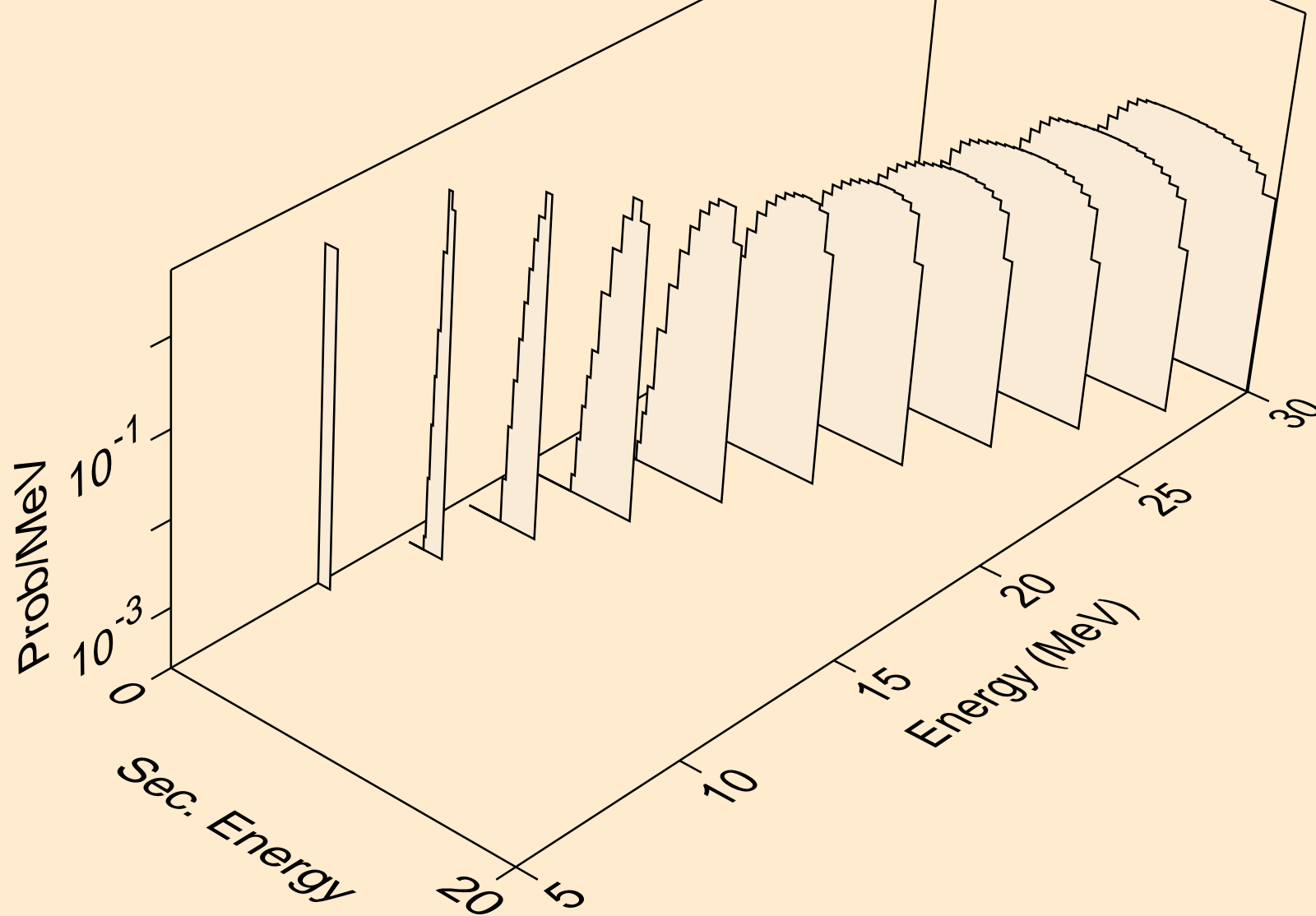

TC108 PROTON ACER TENDL-2021 LIBRARY; T=0.K  
tritons from (p,t)

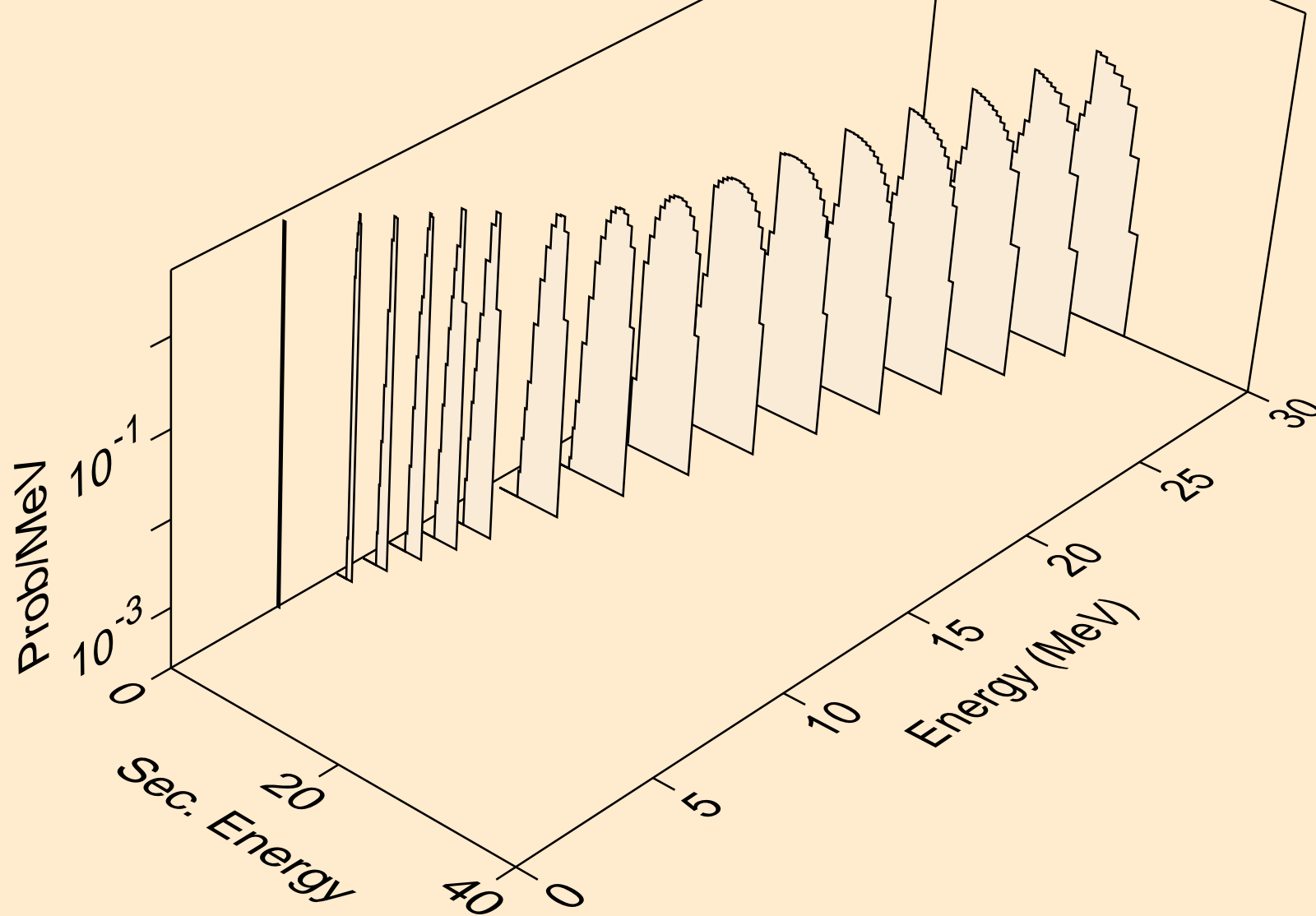

TC108 PROTON ACER TENDL-2021 LIBRARY; T=0.K  
tritons from (p,pt)

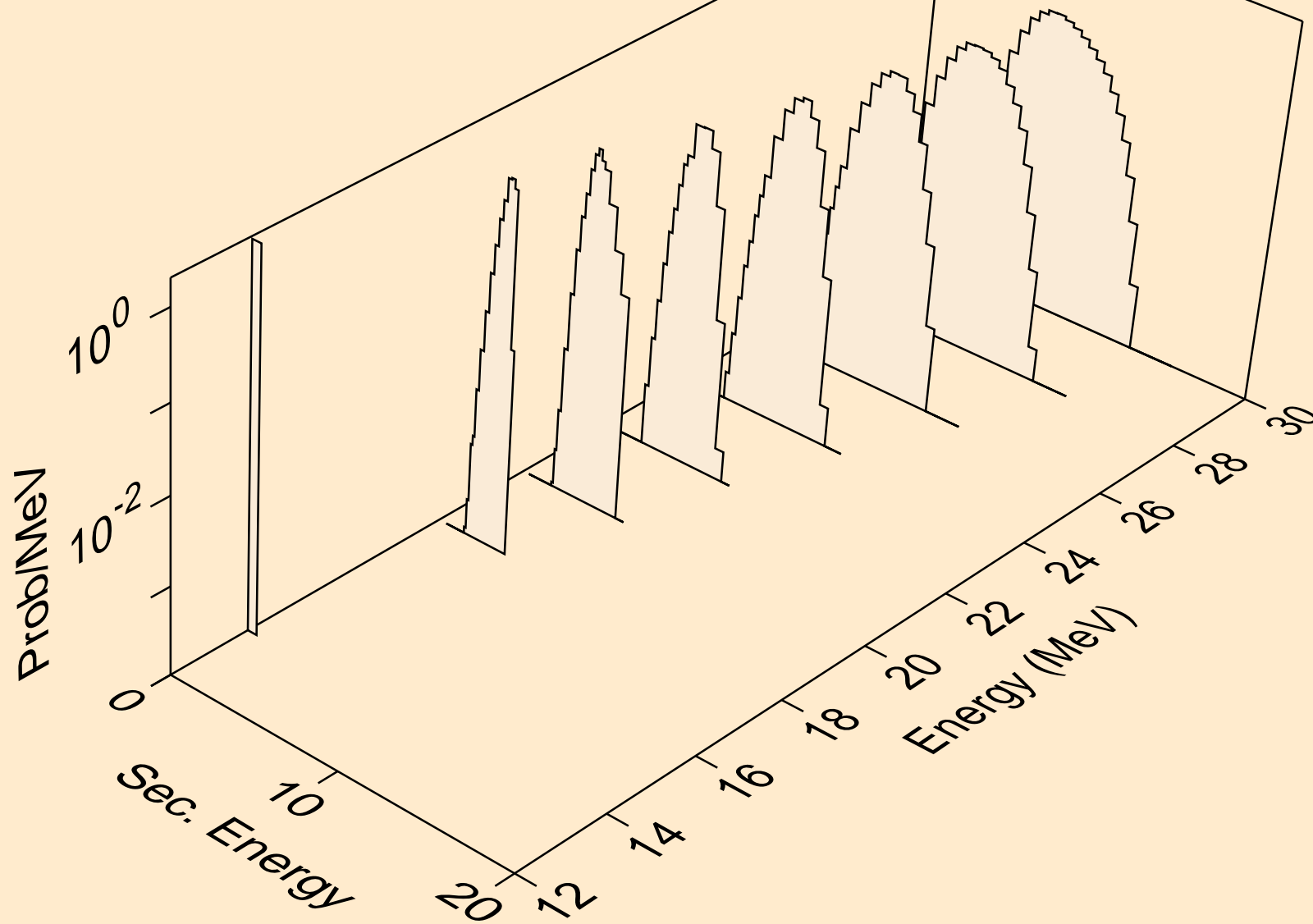

TC108 PROTON ACER TENDL-2021 LIBRARY; T=0.K  
he3s from (p,x)

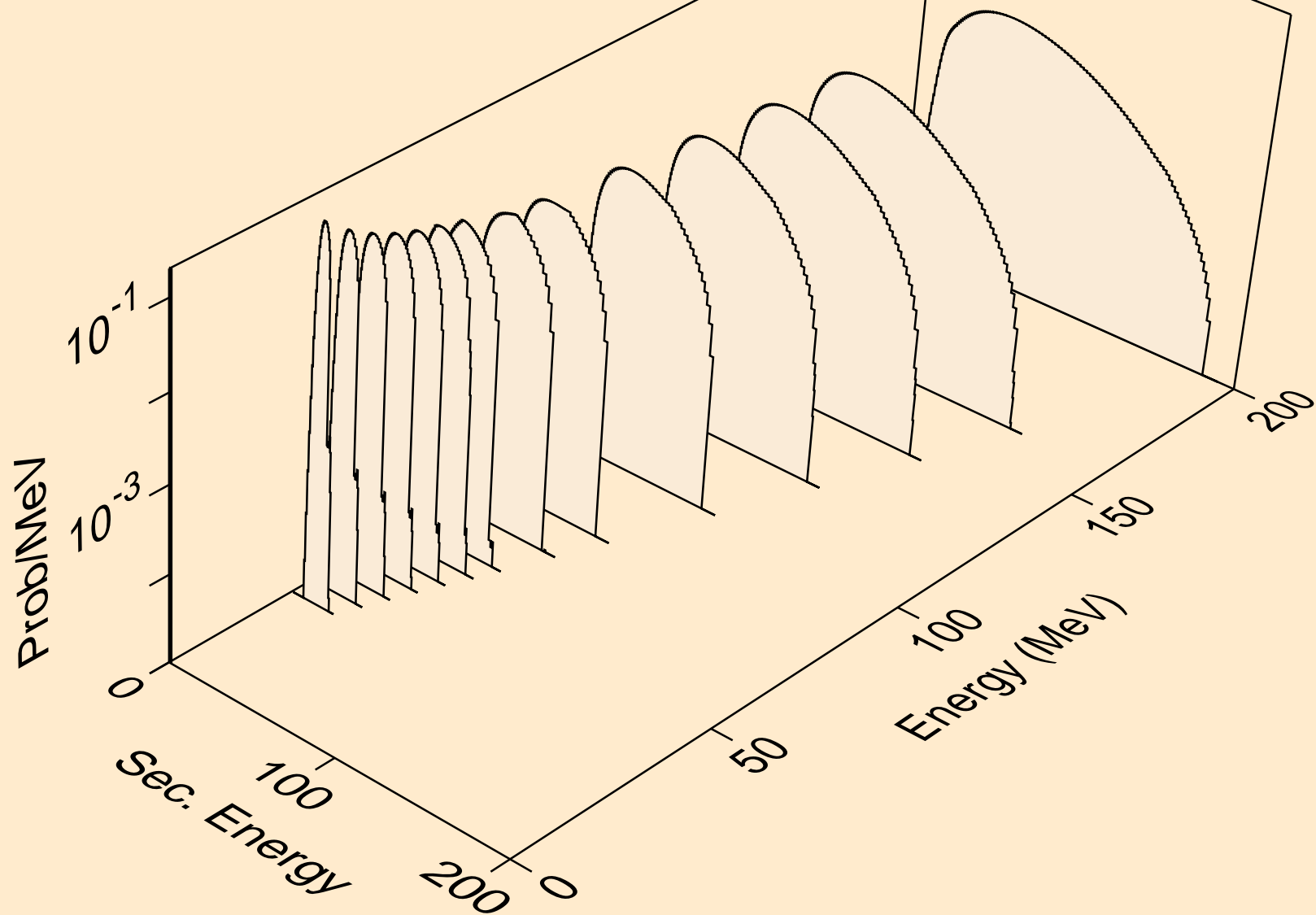



TC108 PROTON ACER TENDL-2021 LIBRARY; T=0.K  
he3s from (p,n\*)he3

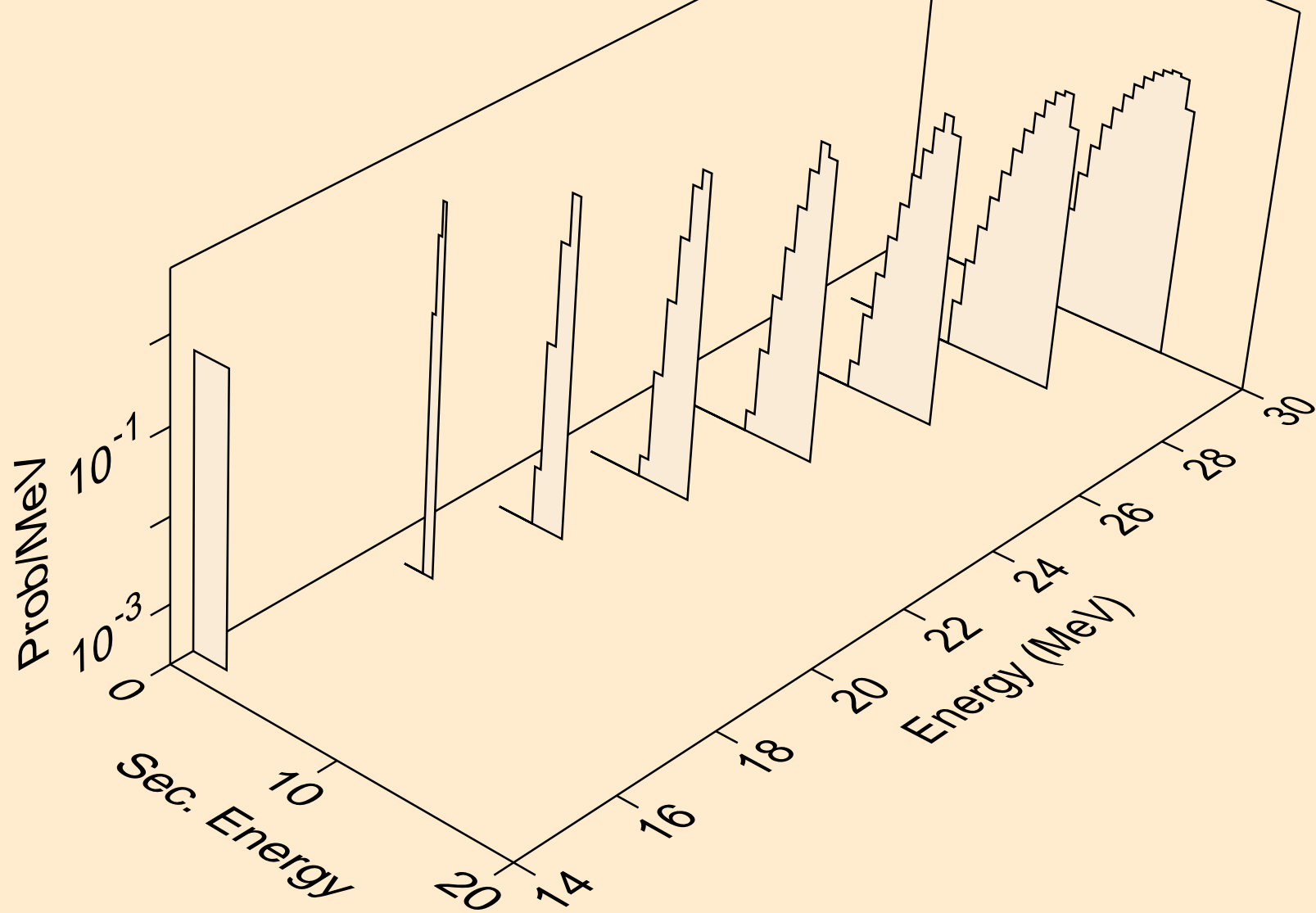

TC108 PROTON ACER TENDL-2021 LIBRARY; T=0.K  
he3s from (p,he3)

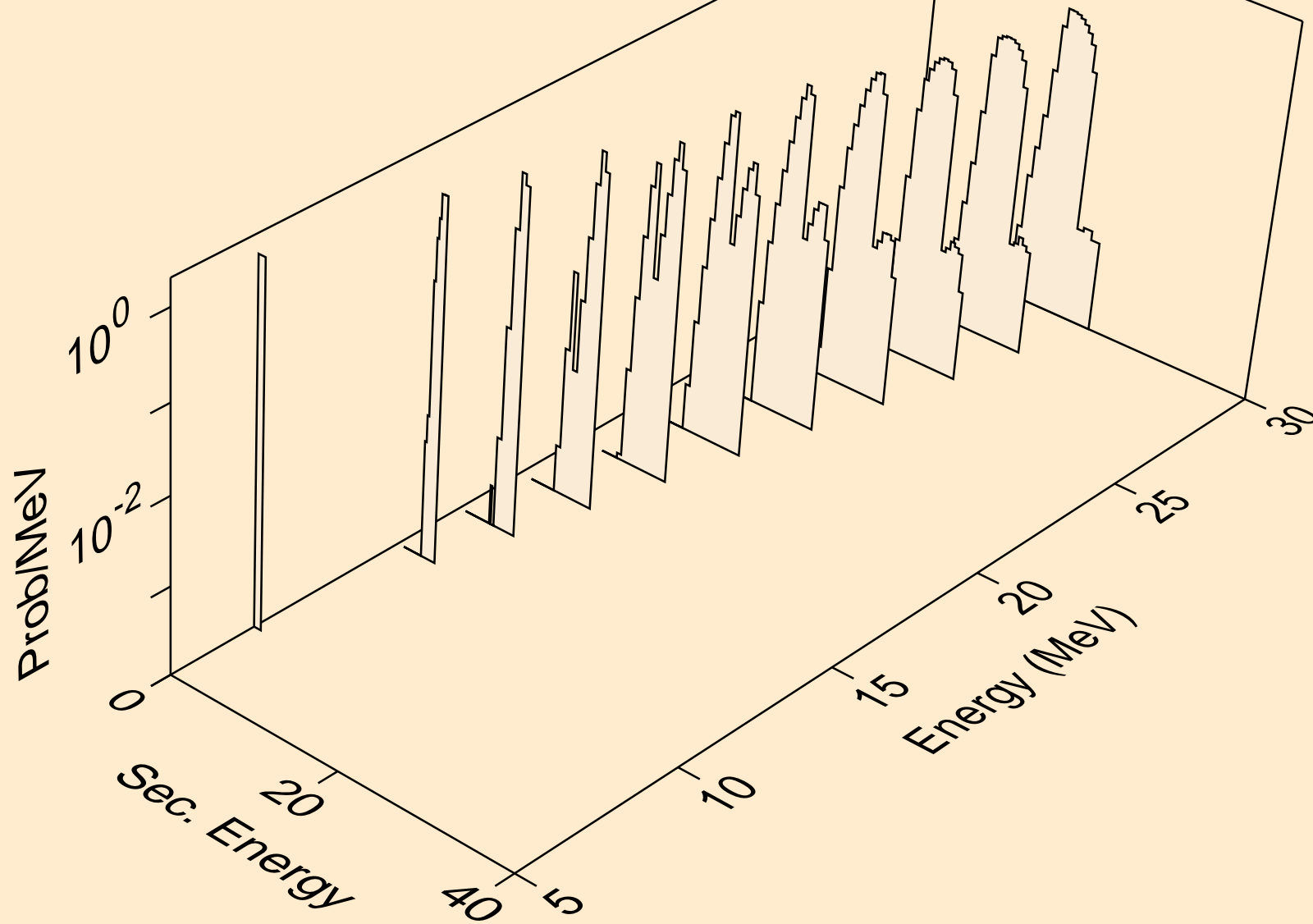

TC108 PROTON ACER TENDL-2021 LIBRARY; T=0.K  
alphas from (p,x)

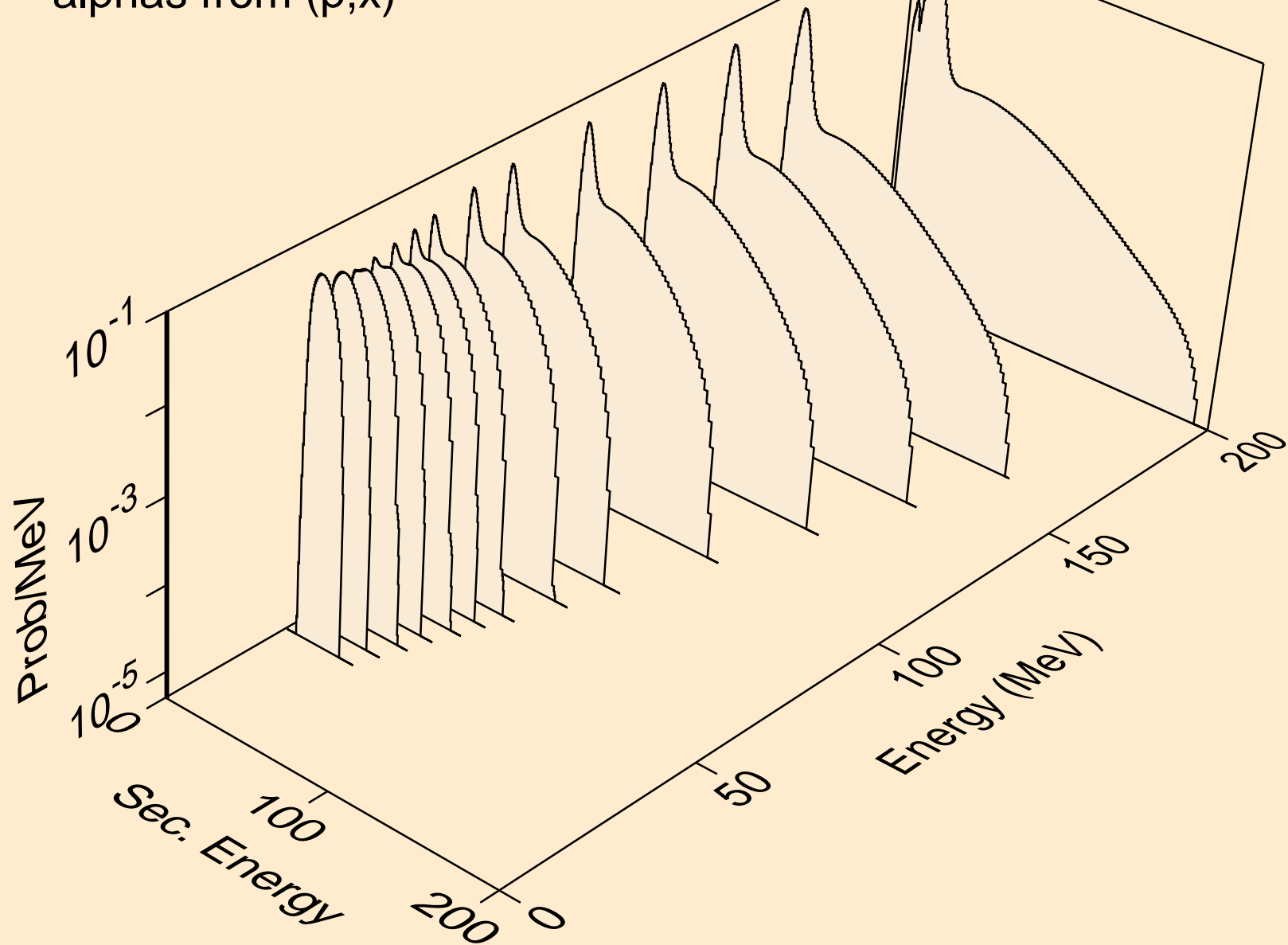

TC108 PROTON ACER TENDL-2021 LIBRARY; T=0.K  
alphas from (p,n\*)a

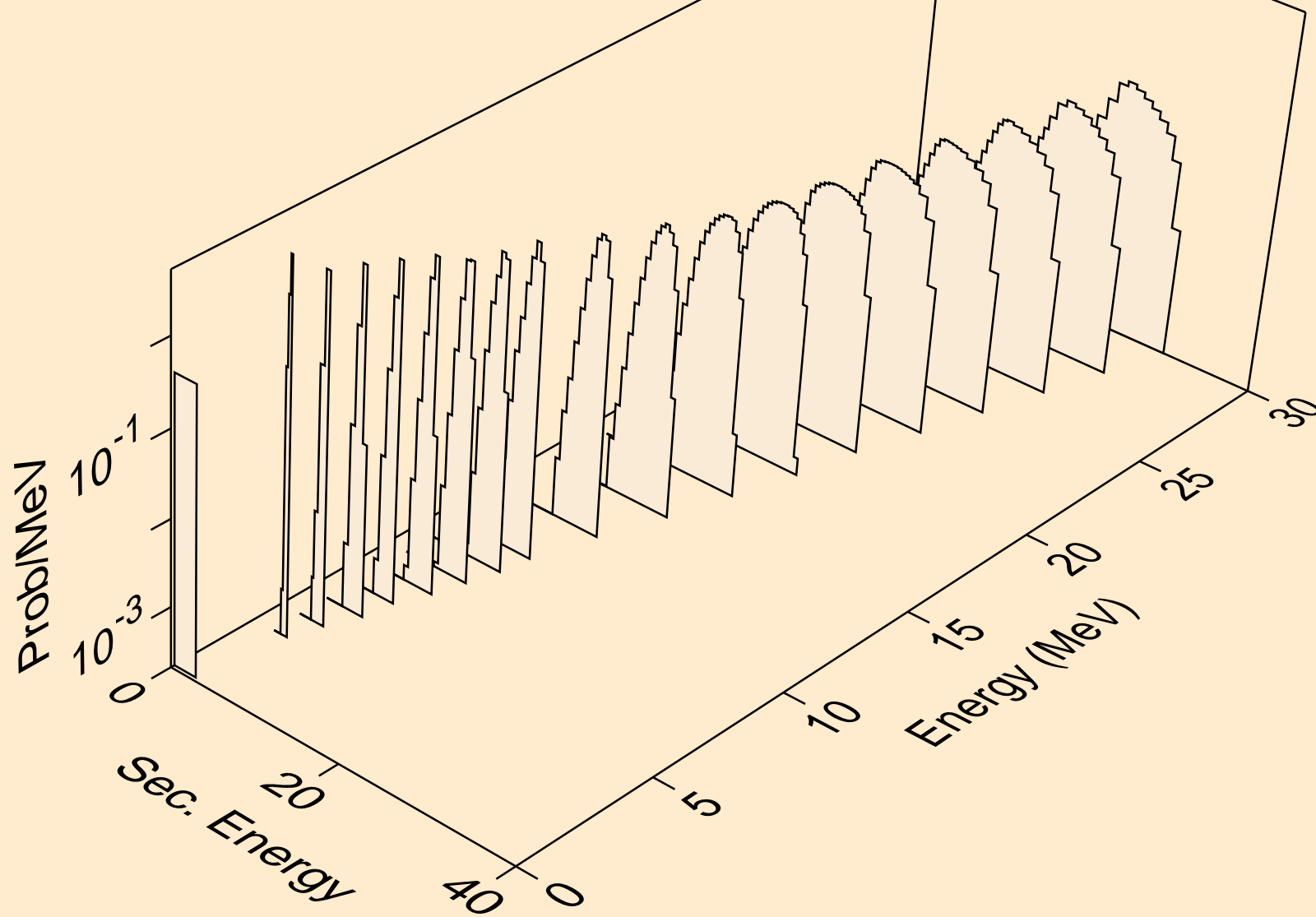

TC108 PROTON ACER TENDL-2021 LIBRARY; T=0.K  
alphas from (p,2n)a

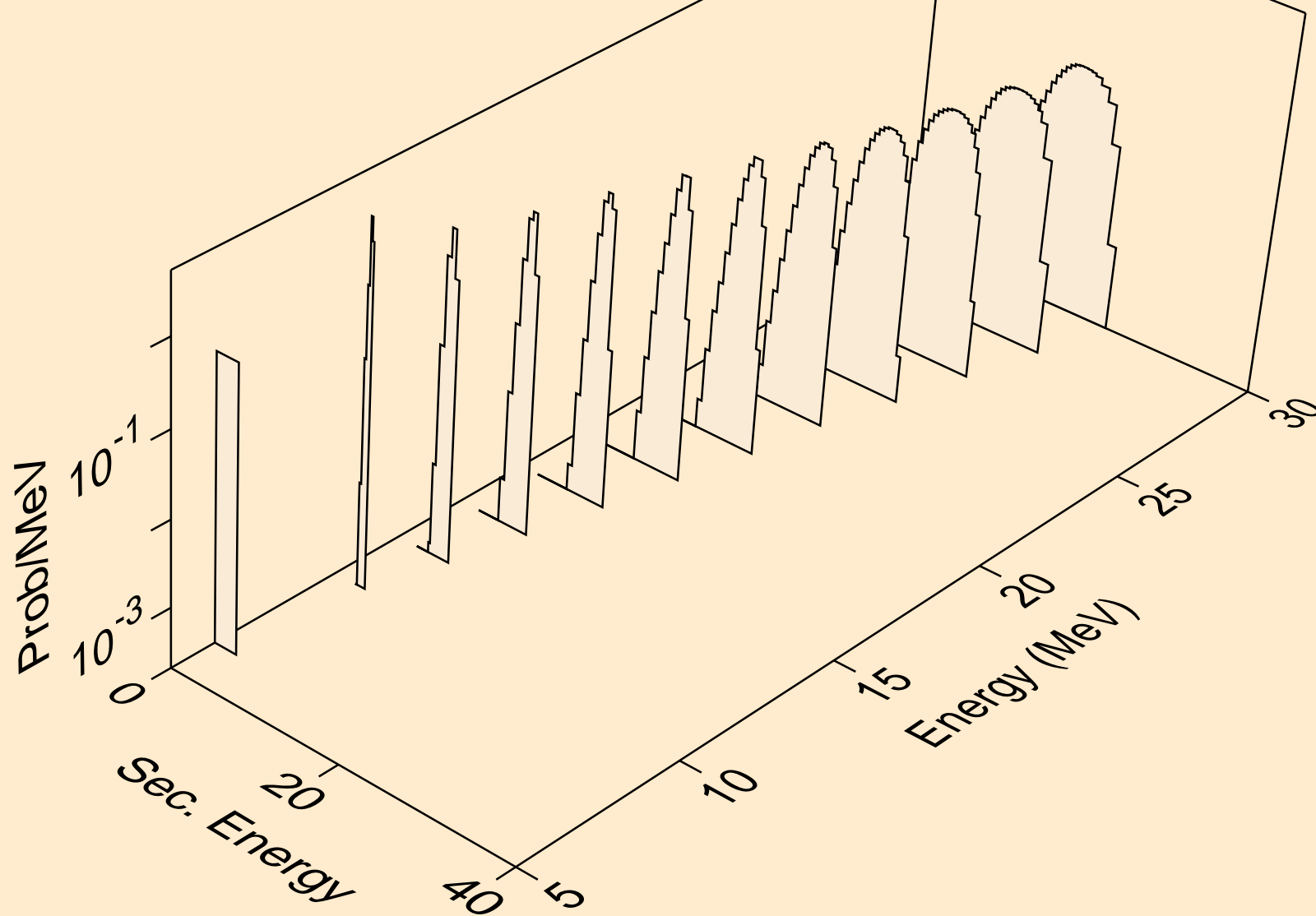

TC108 PROTON ACER TENDL-2021 LIBRARY; T=0.K  
alphas from (p,3n)a

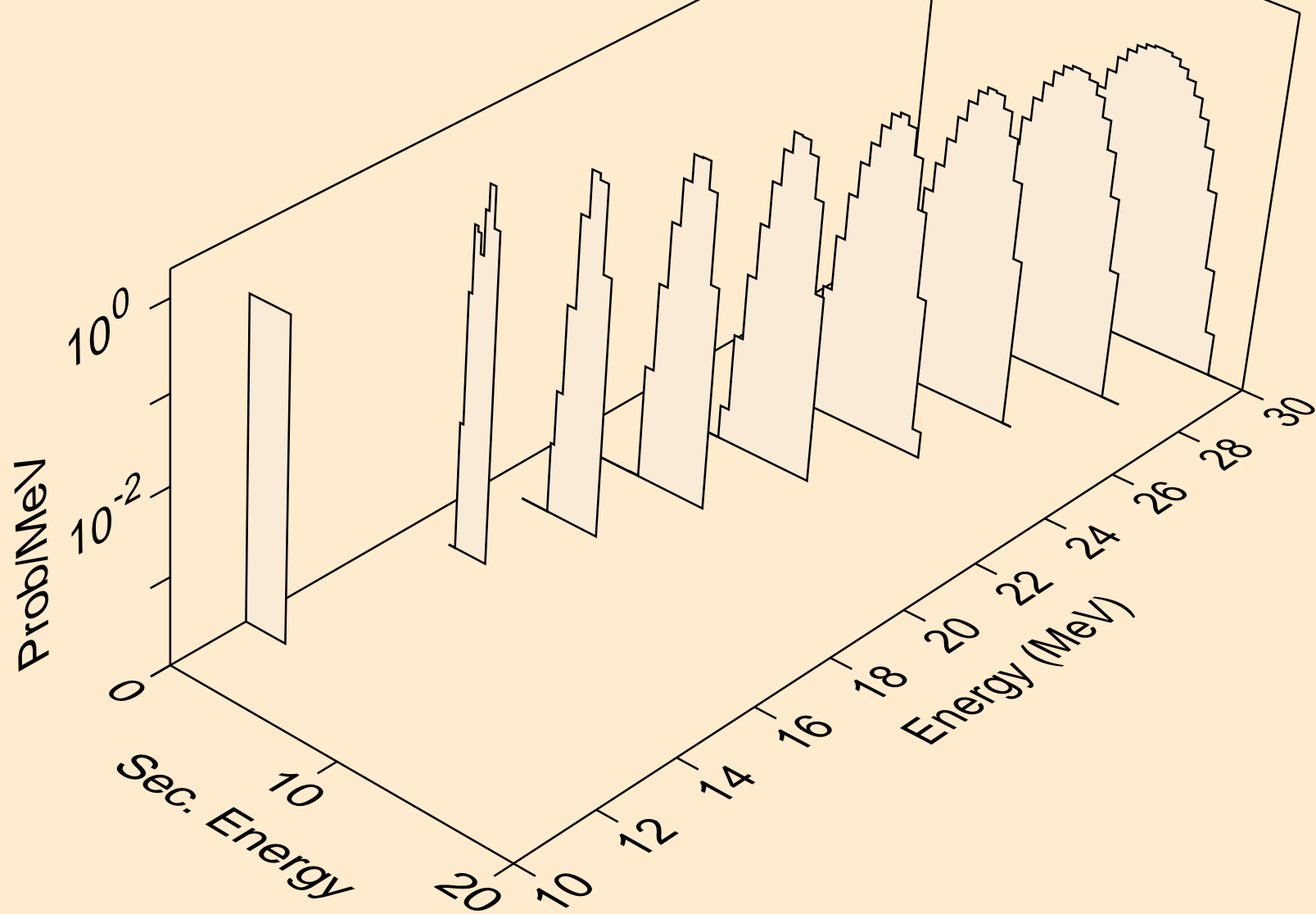

TC108 PROTON ACER TENDL-2021 LIBRARY; T=0.K  
alphas from (p,n\*)2a

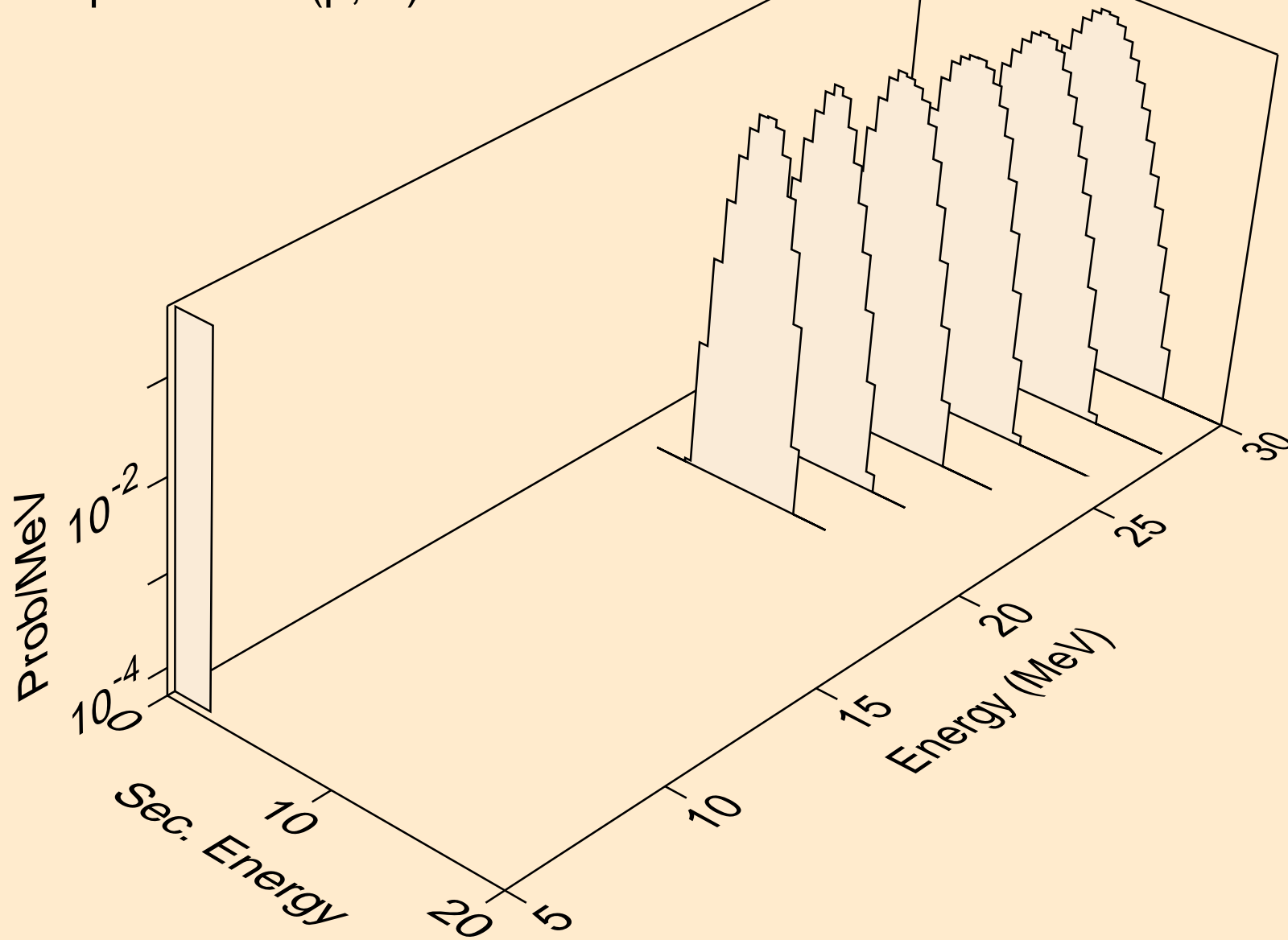

TC108 PROTON ACER TENDL-2021 LIBRARY; T=0.K  
alphas from (p,npa)

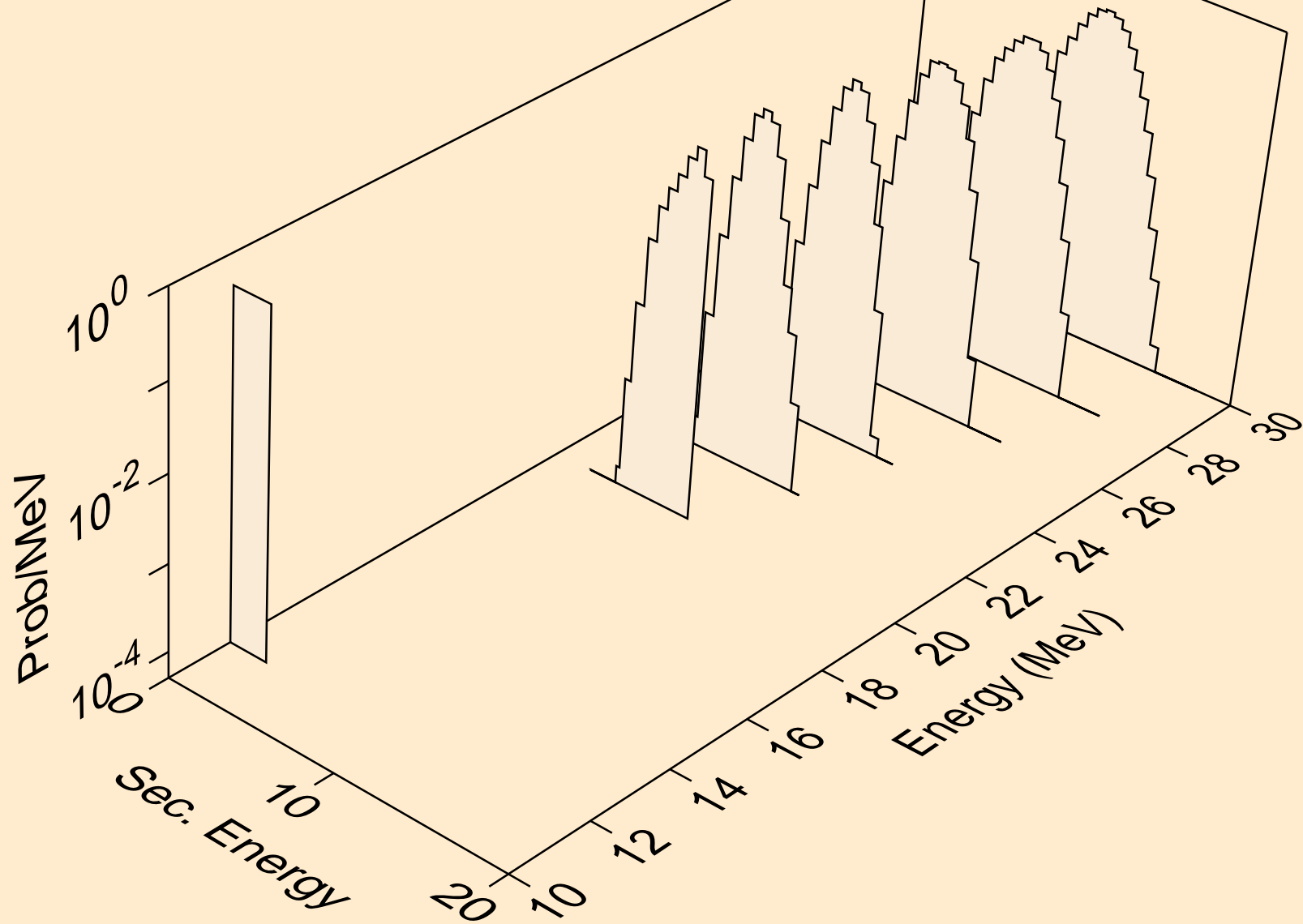



TC108 PROTON ACER TENDL-2021 LIBRARY; T=0.K  
alphas from (p,a)

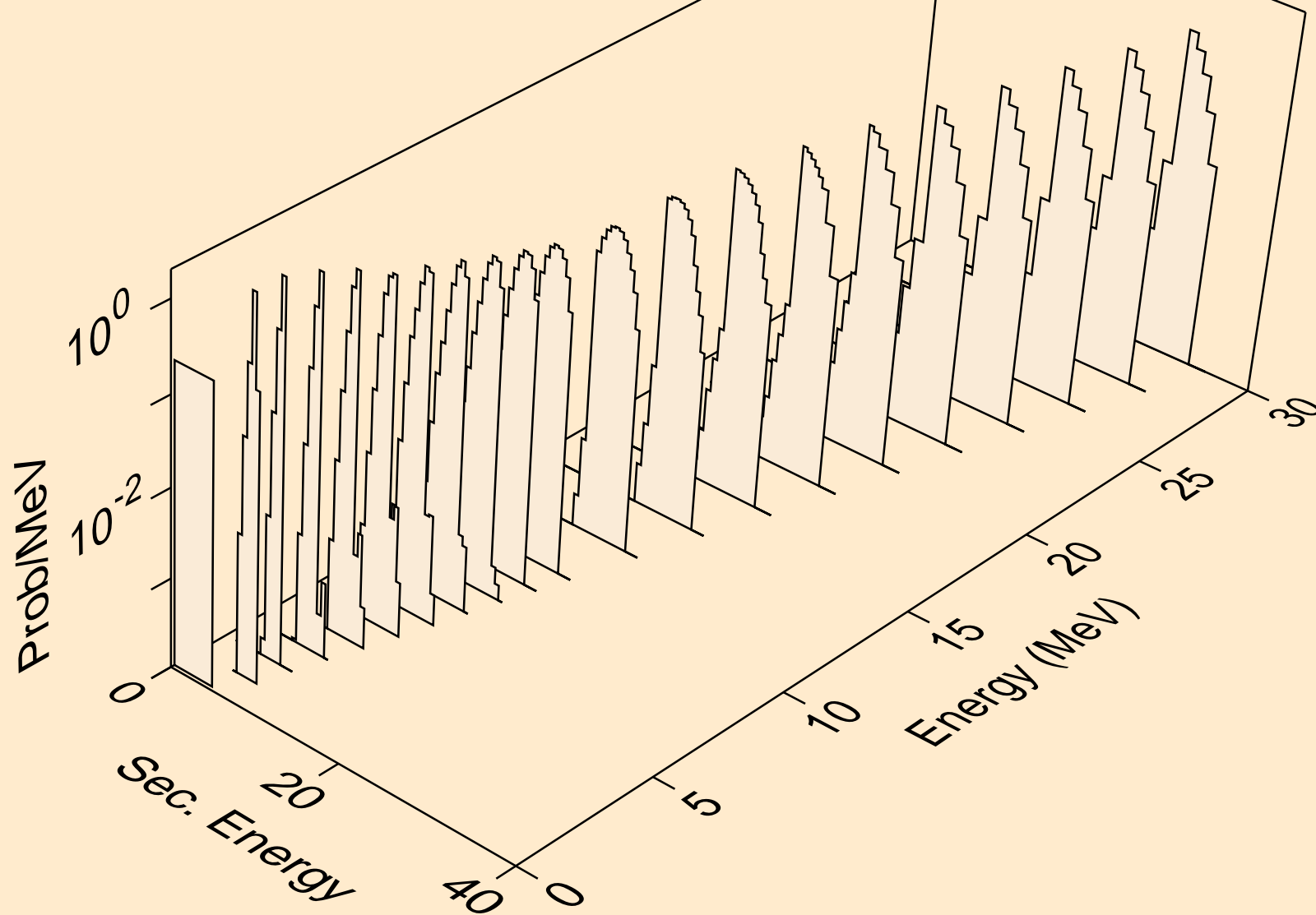

TC108 PROTON ACER TENDL-2021 LIBRARY; T=0.K  
alphas from (p,2a)

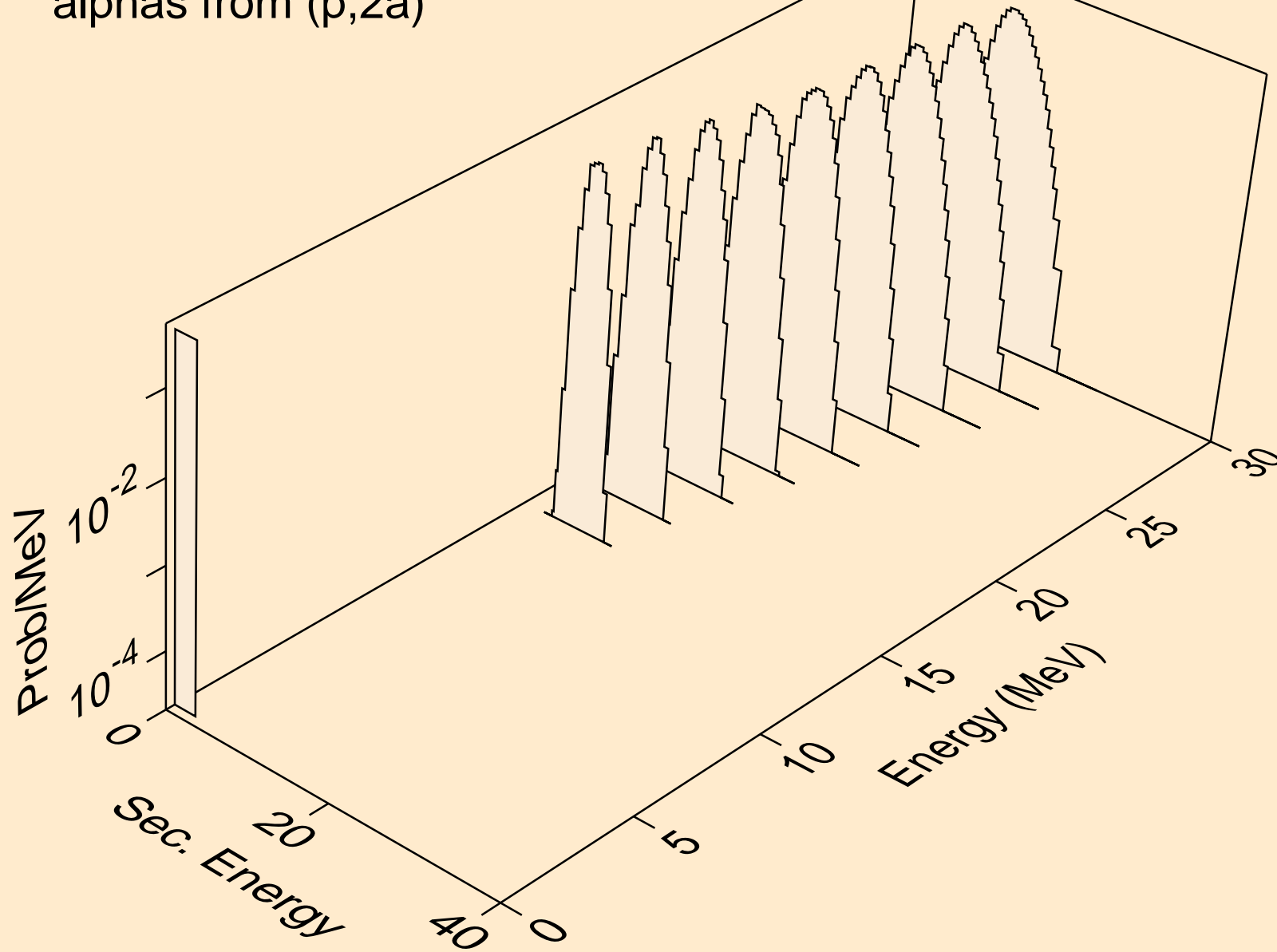

TC108 PROTON ACER TENDL-2021 LIBRARY; T=0.K  
alphas from (p,pa)

