

# SG272 TRITON ACER TENDL-2021 LIBRARY; T=0.K

## Principal cross sections

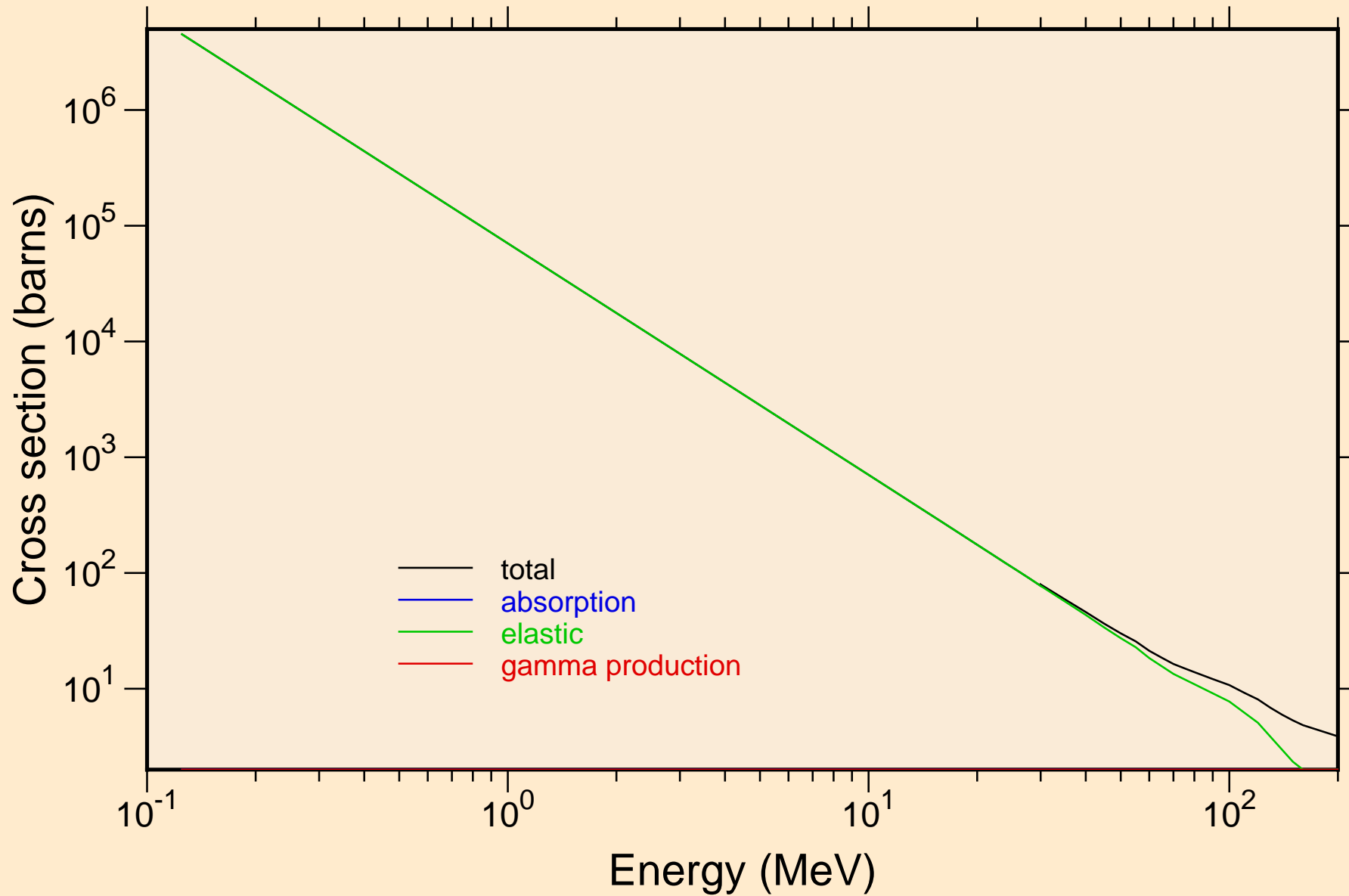

# SG272 TRITON ACER TENDL-2021 LIBRARY; T=0.K

## Heating

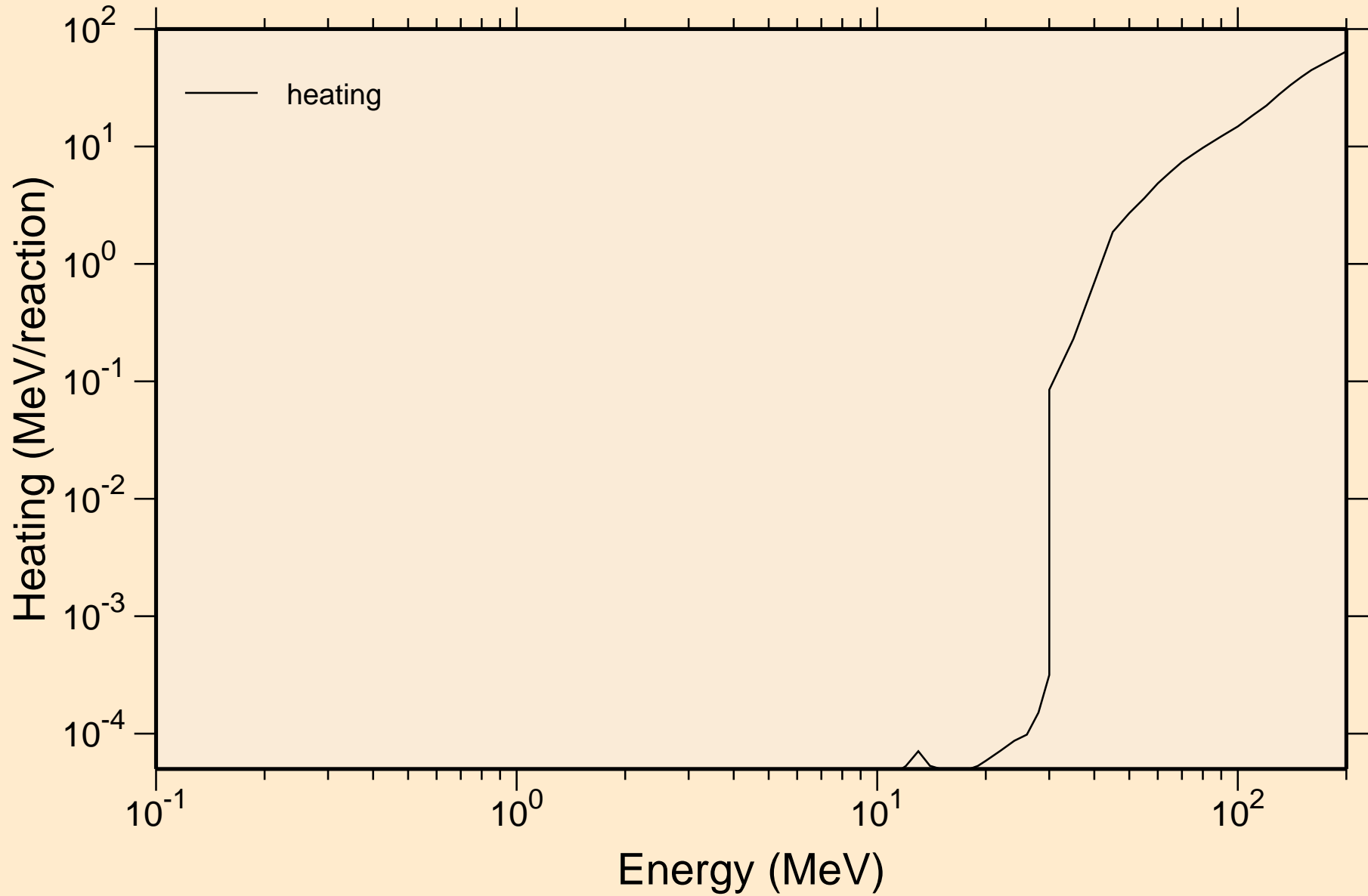

# SG272 TRITON ACER TENDL-2021 LIBRARY; T=0.K

## Principal cross sections

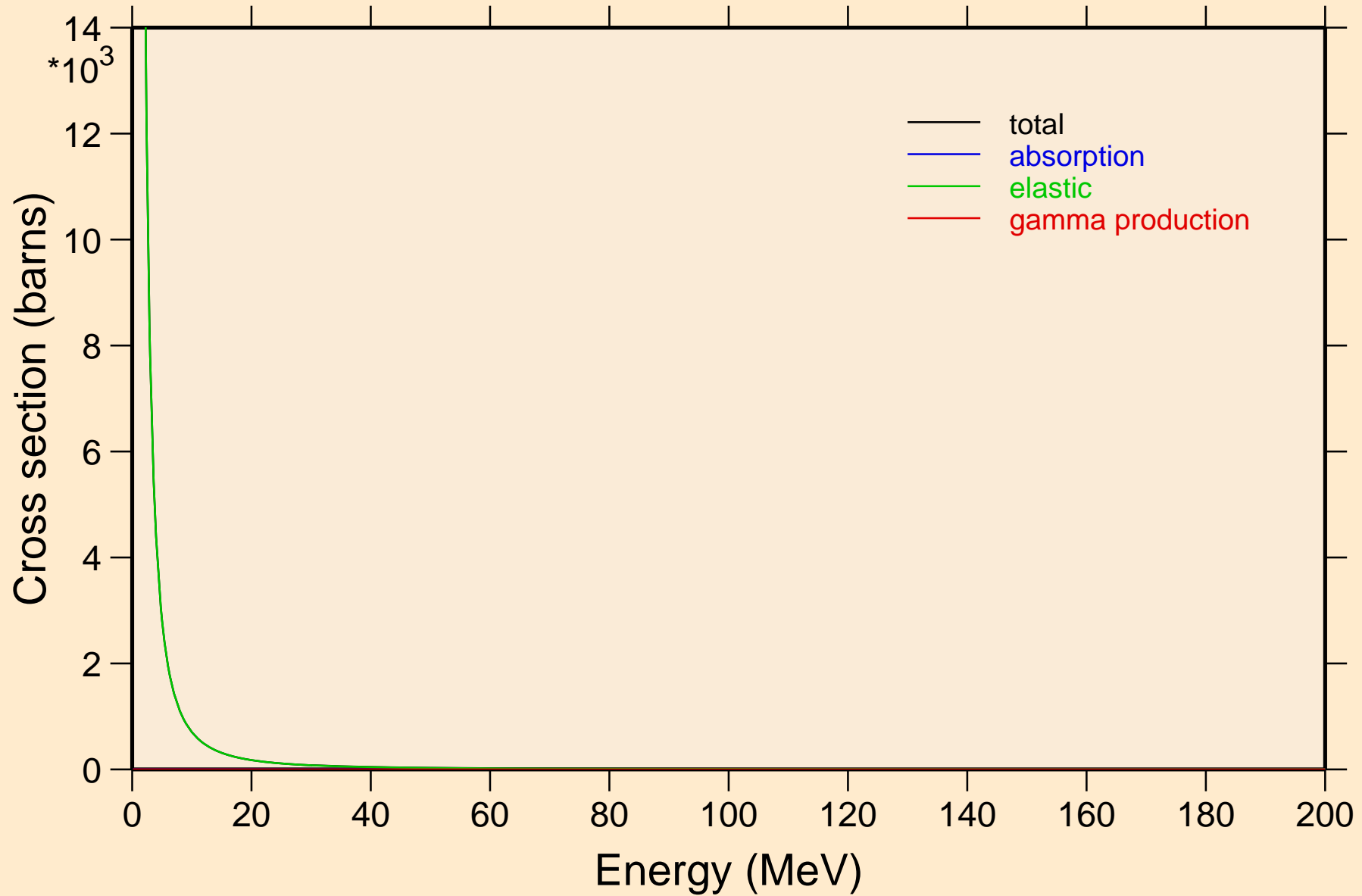

# SG272 TRITON ACER TENDL-2021 LIBRARY; T=0.K

## Heating

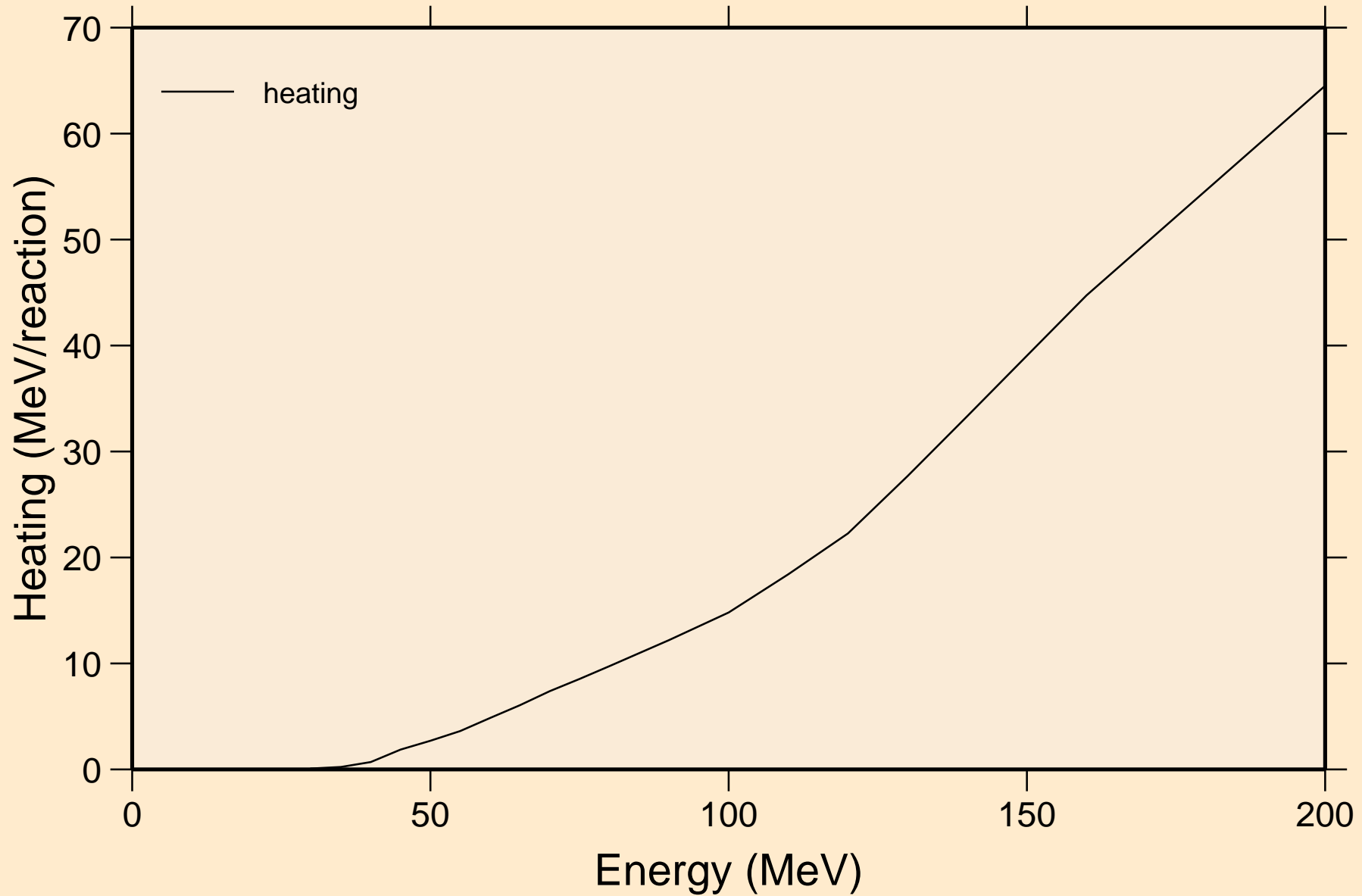

# SG272 TRITON ACER TENDL-2021 LIBRARY; T=0.K

## Threshold reactions

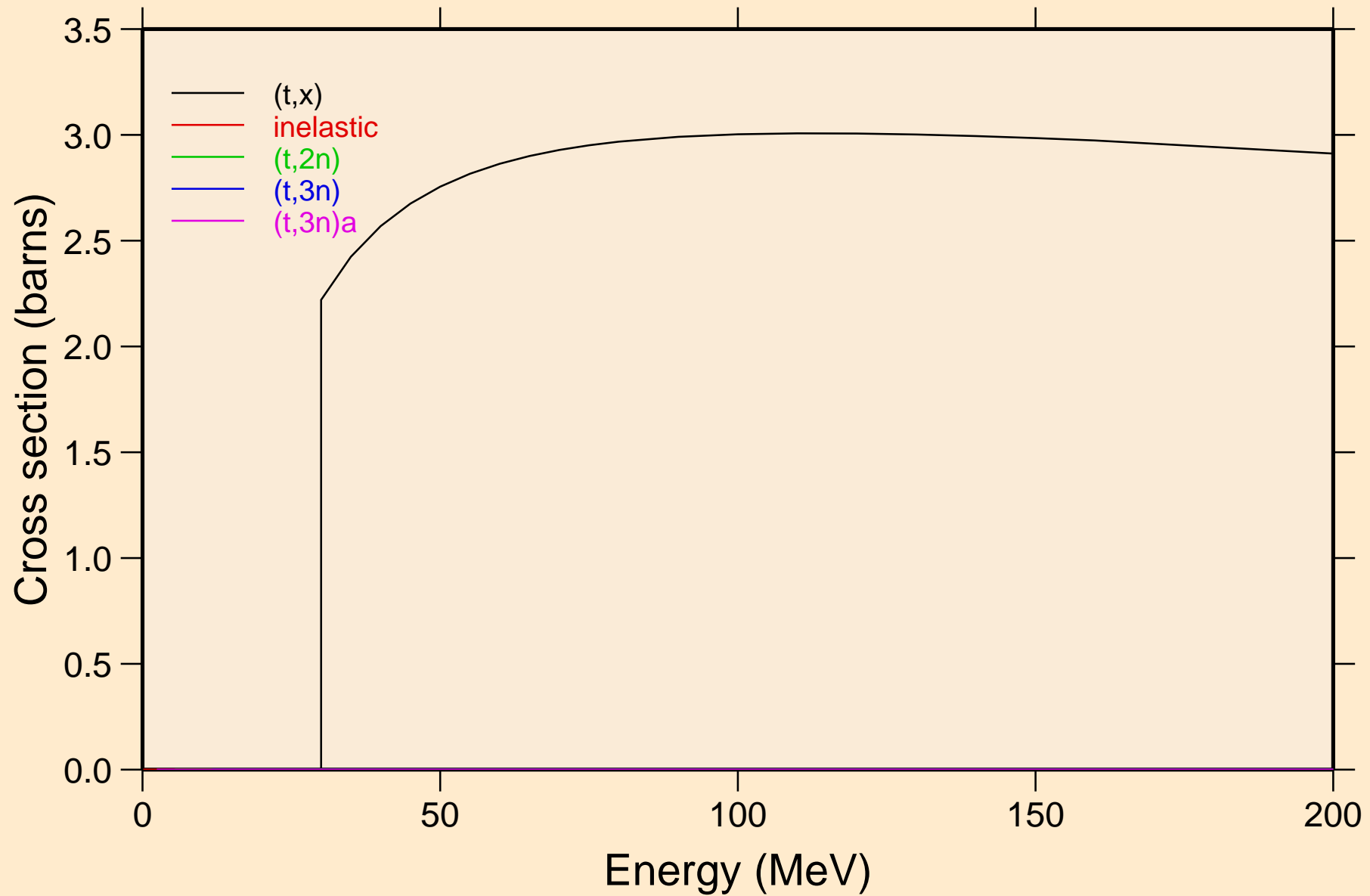

SG272 TRITON ACER TENDL-2021 LIBRARY; T=0.K  
Threshold reactions

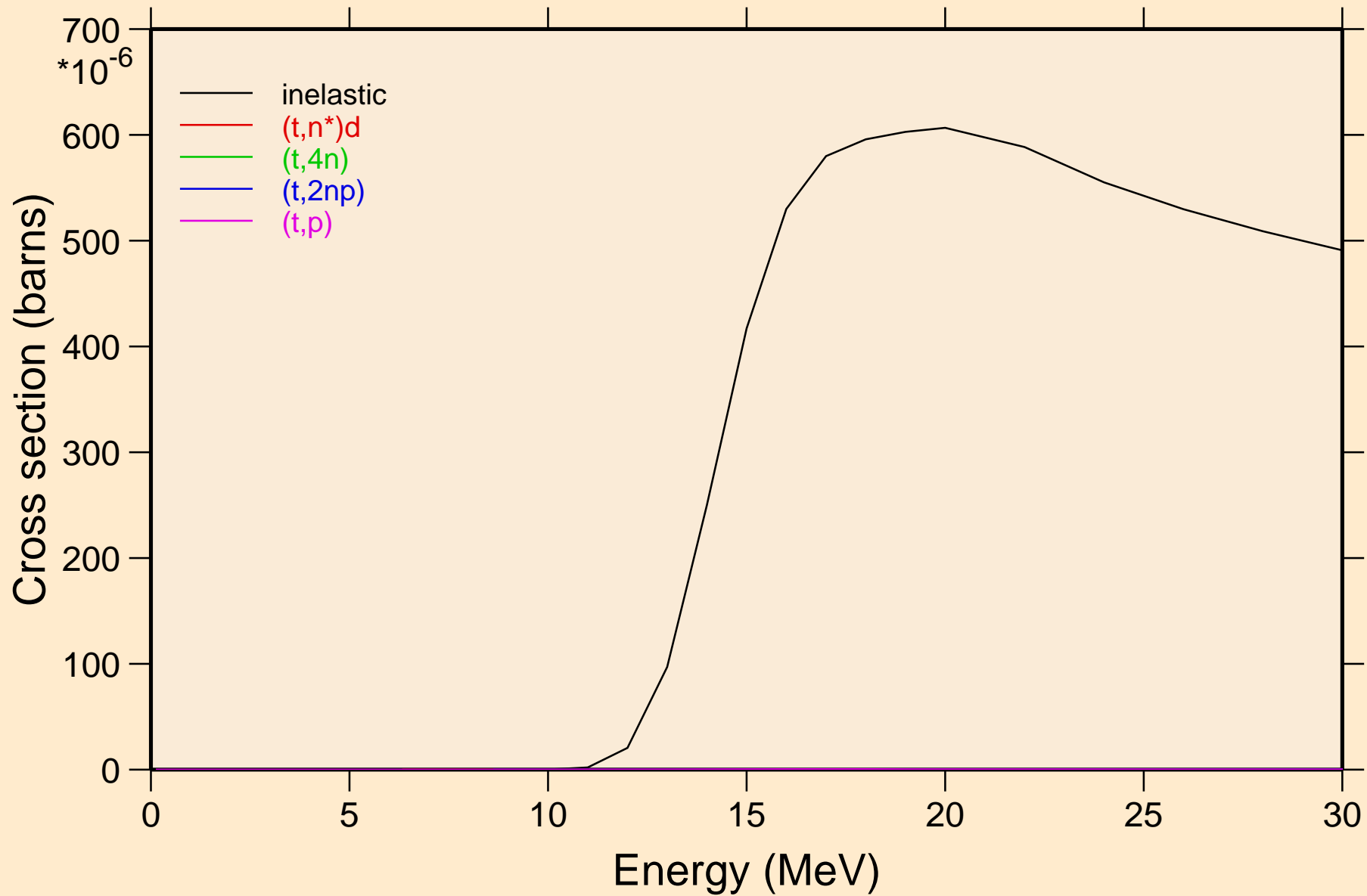

SG272 TRITON ACER TENDL-2021 LIBRARY; T=0.K  
Threshold reactions

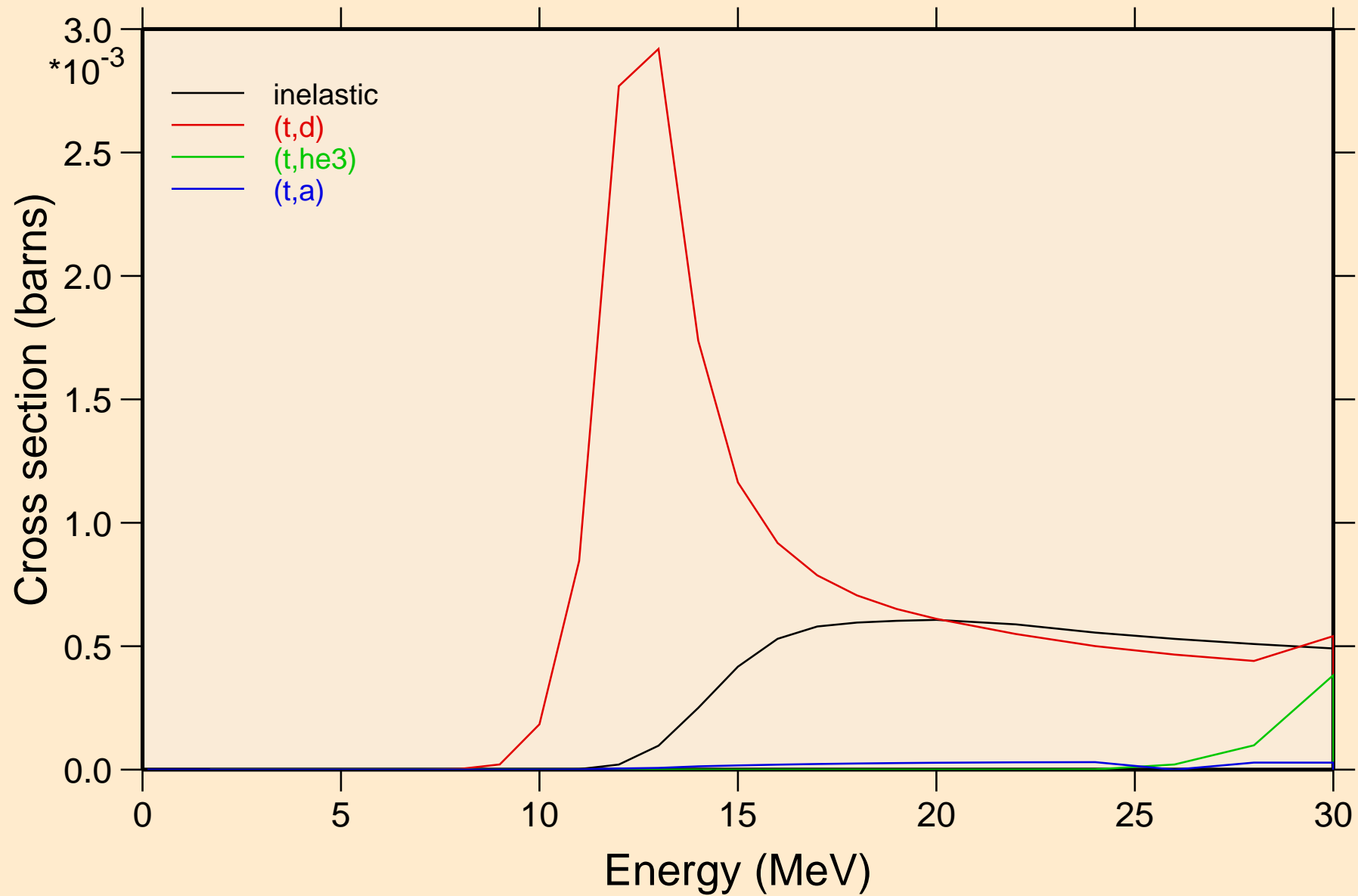

SG272 TRITON ACER TENDL-2021 LIBRARY; T=0.K  
angular distribution for elastic

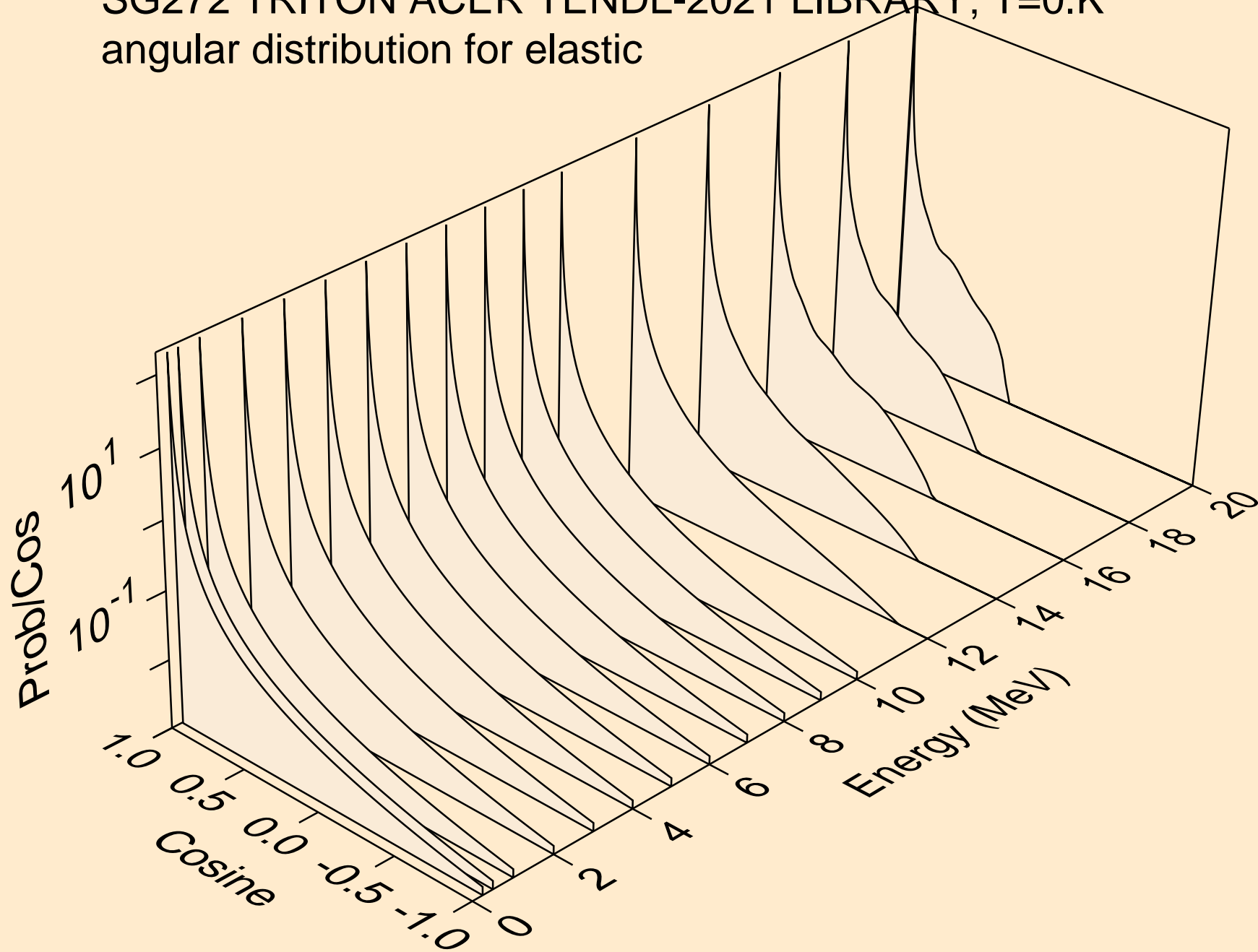



SG272 TRITON ACER TENDL-2021 LIBRARY; T=0.K  
angular distribution for elastic

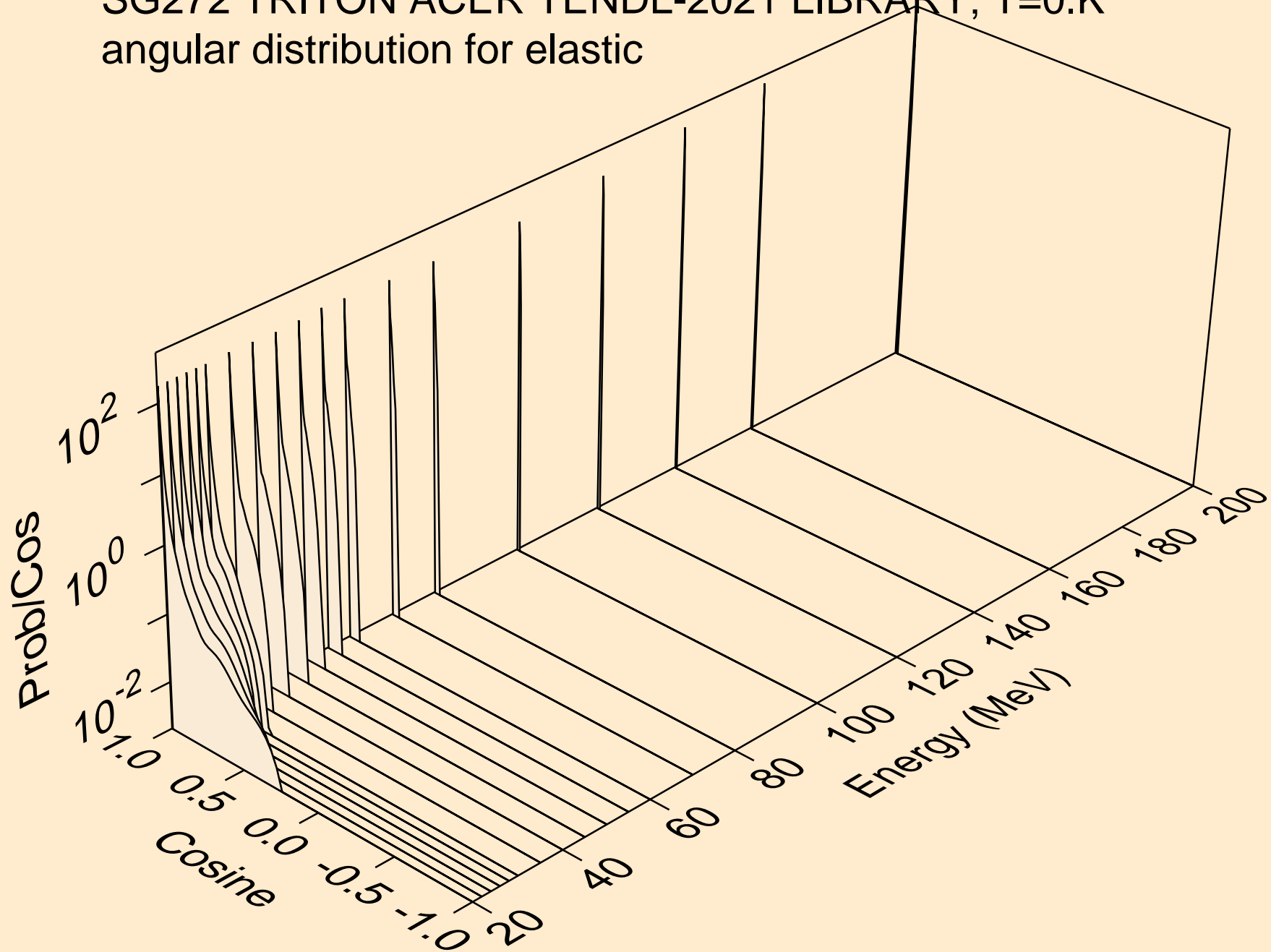

SG272 TRITON ACER TENDL-2021 LIBRARY; T=0.K  
Triton emission for (t,x)

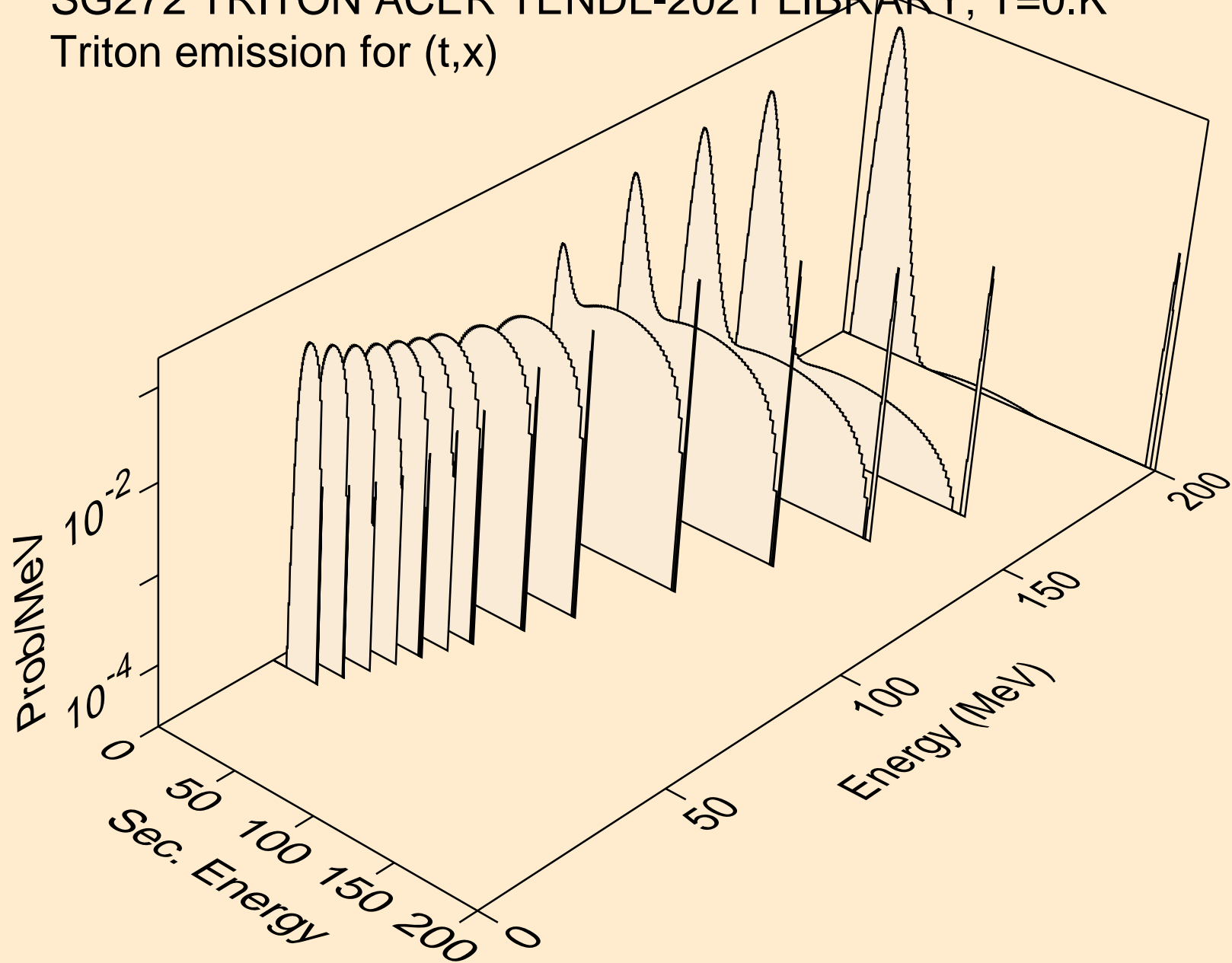

SG272 TRITON ACER TENDL-2021 LIBRARY; T=0.K  
Triton emission for inelastic

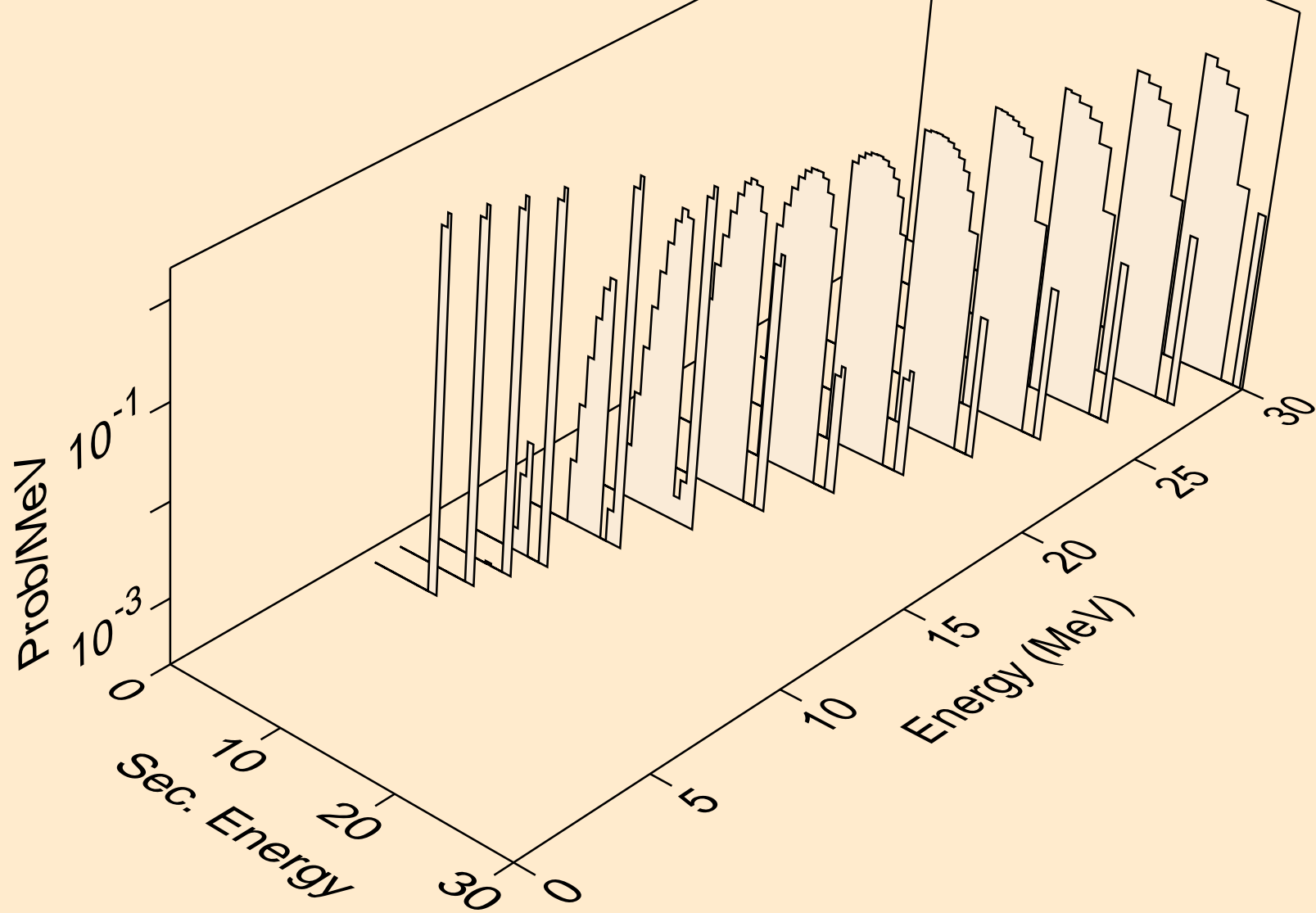

SG272 TRITON ACER TENDL-2021 LIBRARY; T=0.K  
Photon emission for (z,n)

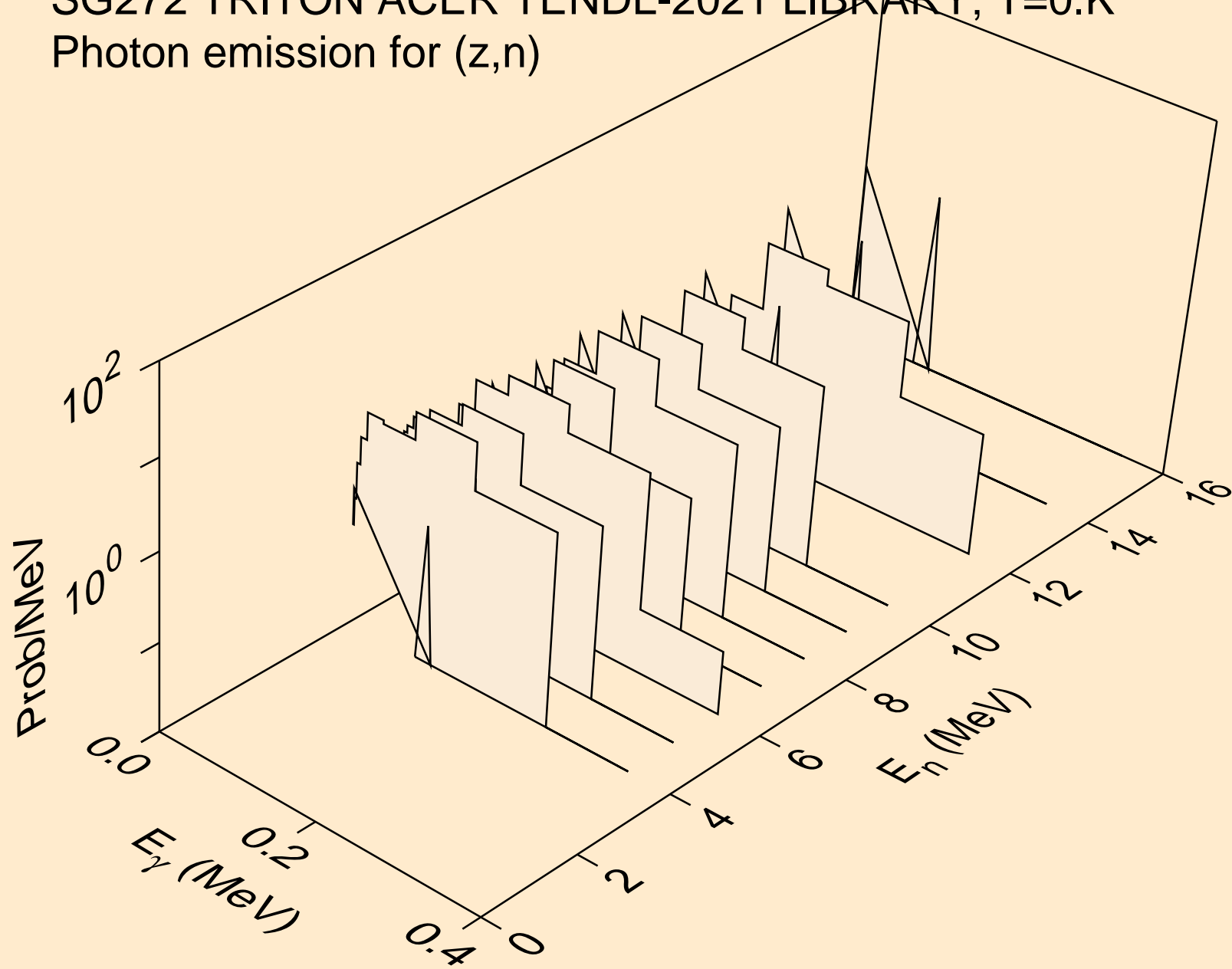

SG272 TRITON ACER TENDL-2021 LIBRARY; T=0.K  
Photon emission for (n,x)

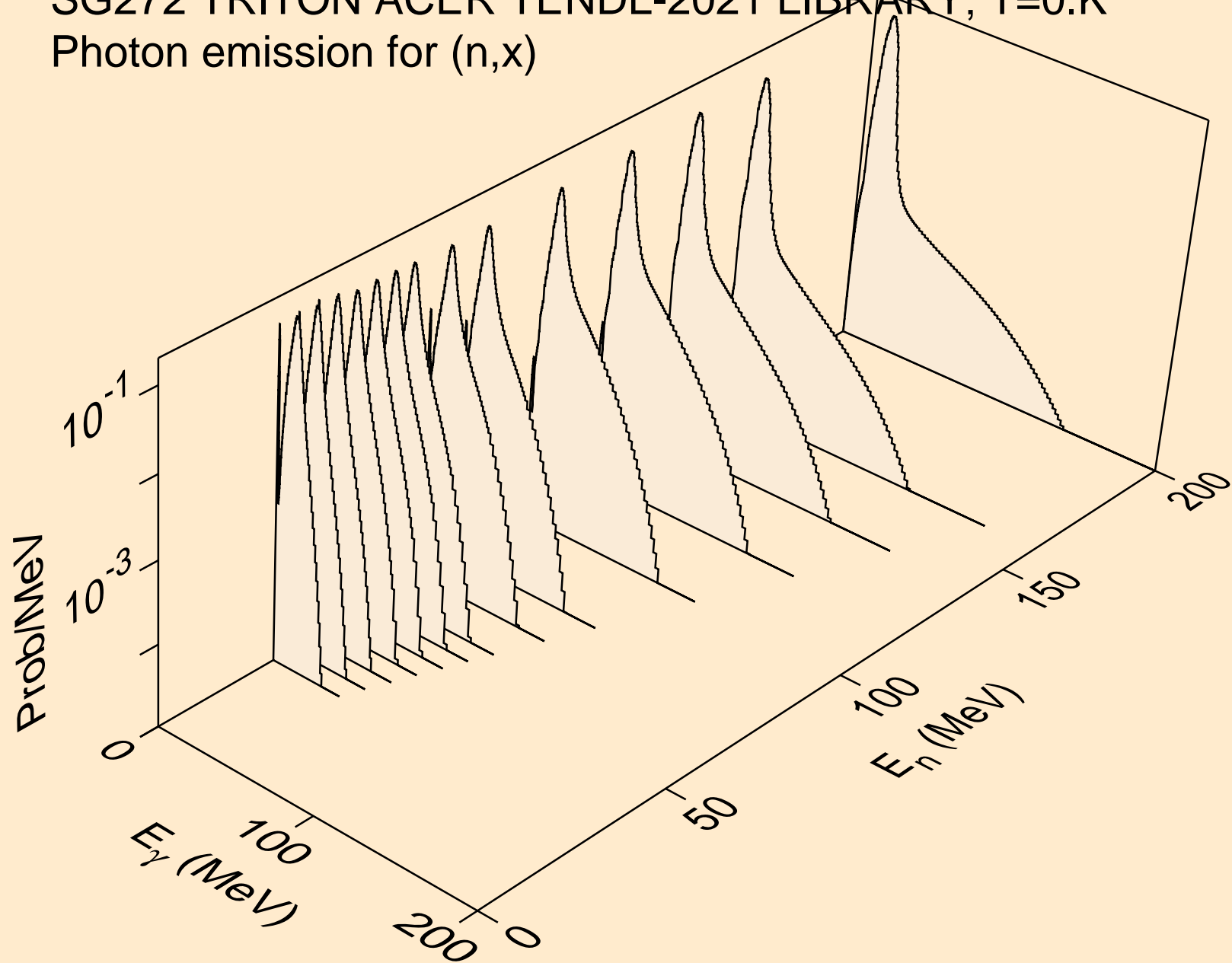

SG272 TRITON ACER TENDL-2021 LIBRARY; T=0.K  
Photon emission for (n,2n)

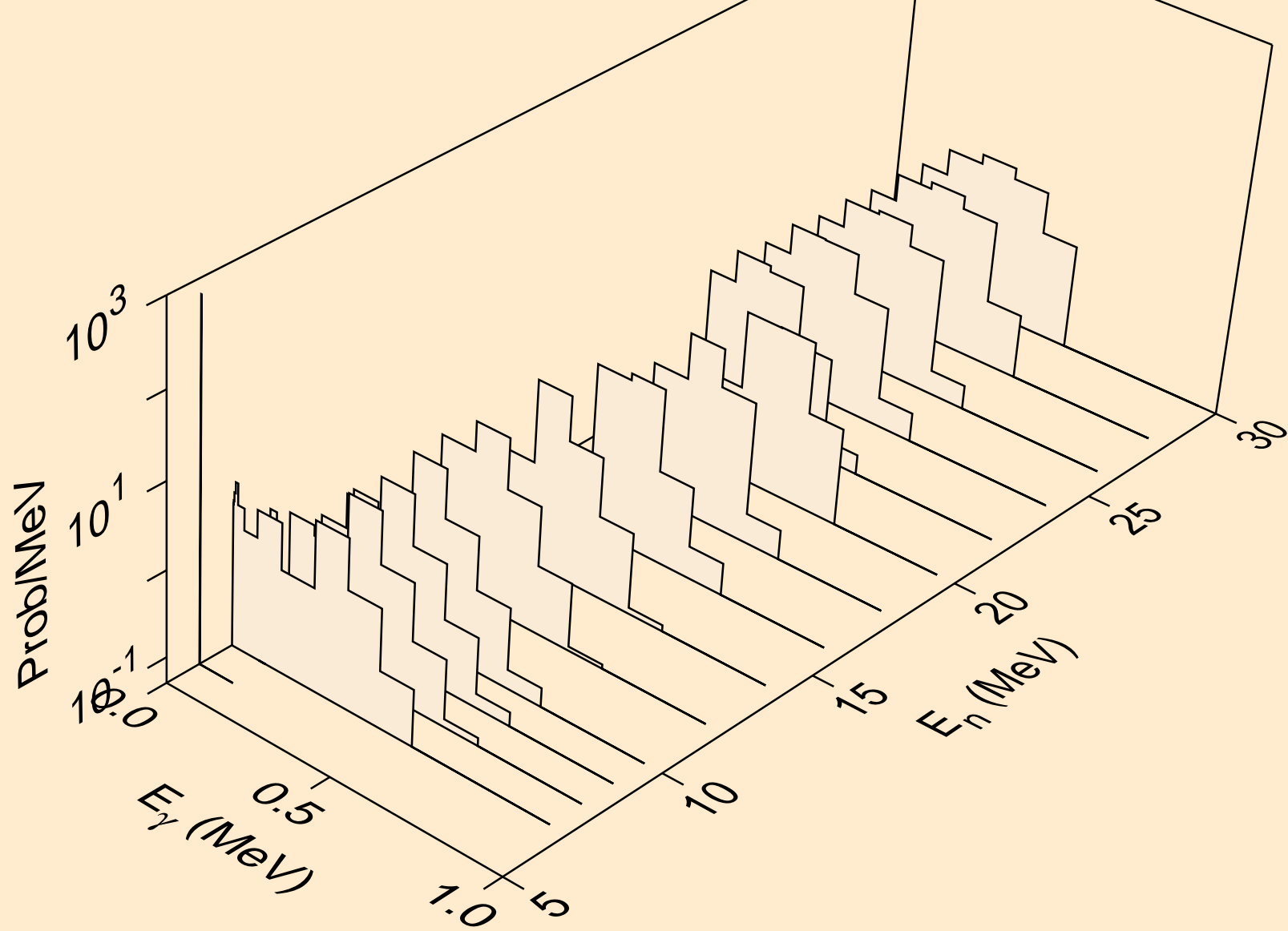

SG272 TRITON ACER TENDL-2021 LIBRARY; T=0.K  
Photon emission for (n,3n)

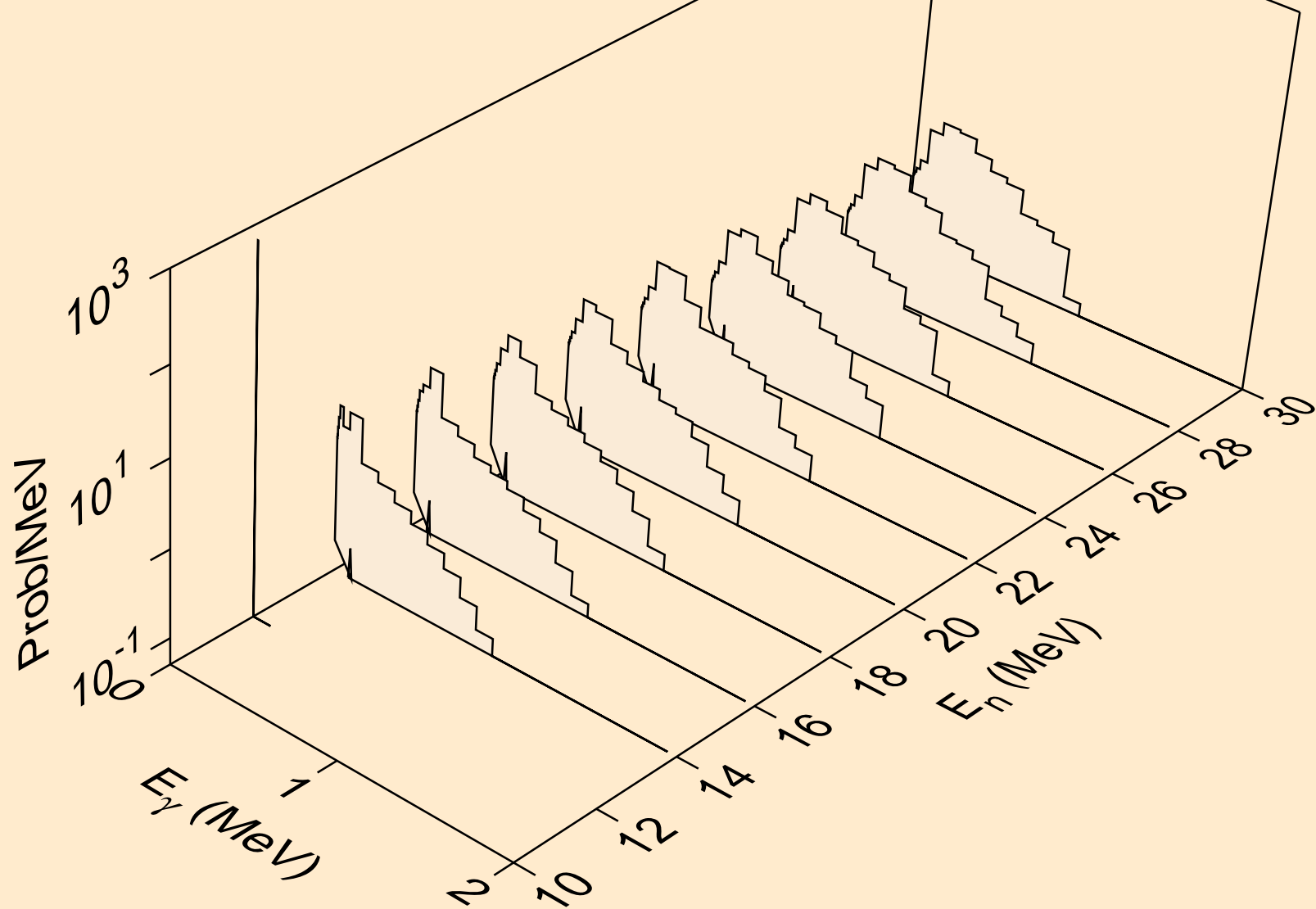

SG272 TRITON ACER TENDL-2021 LIBRARY; T=0.K  
Photon emission for (n,3n)a

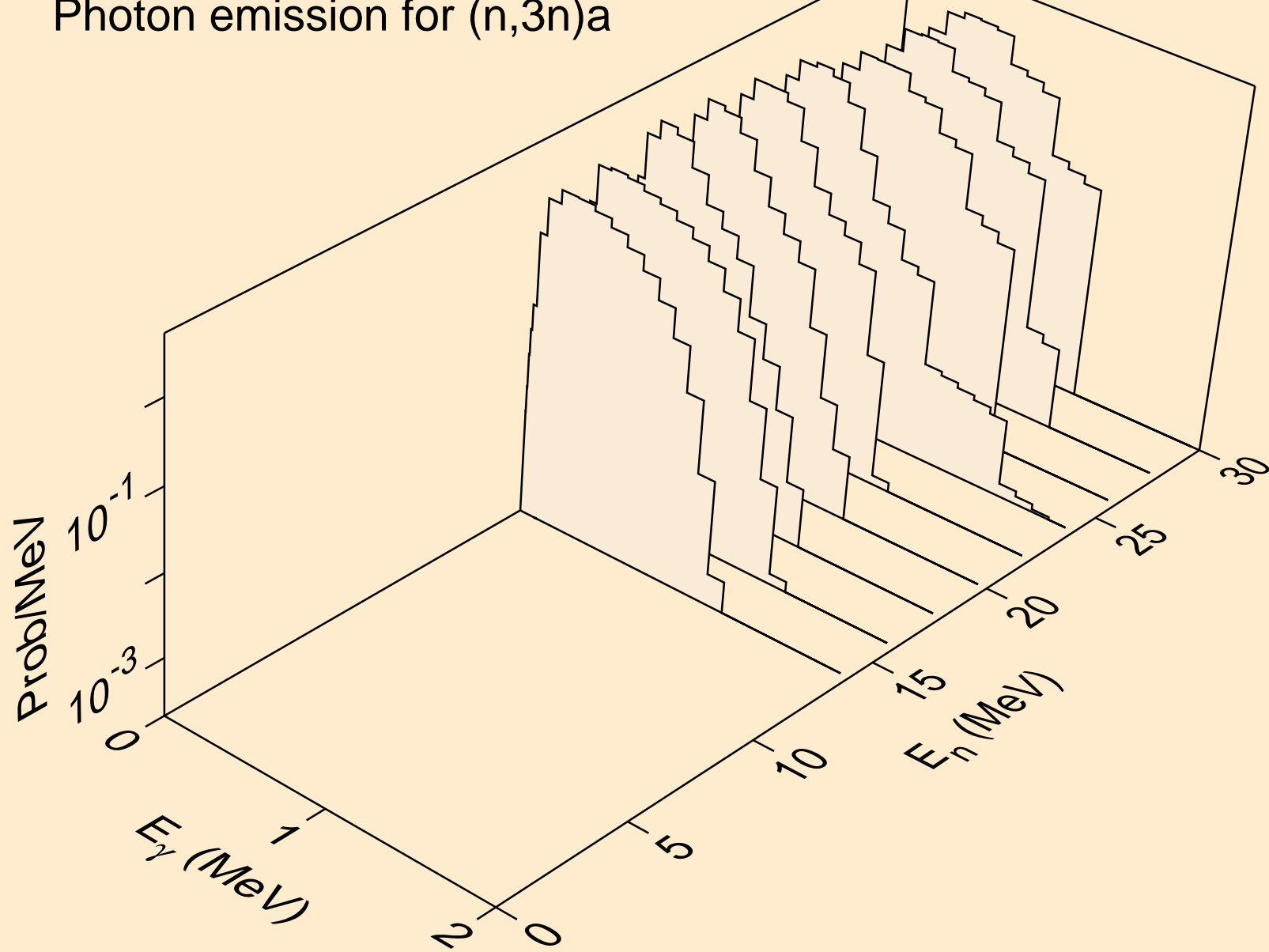



SG272 TRITON ACER TENDL-2021 LIBRARY; T=0.K  
Photon emission for (n,n\*)d

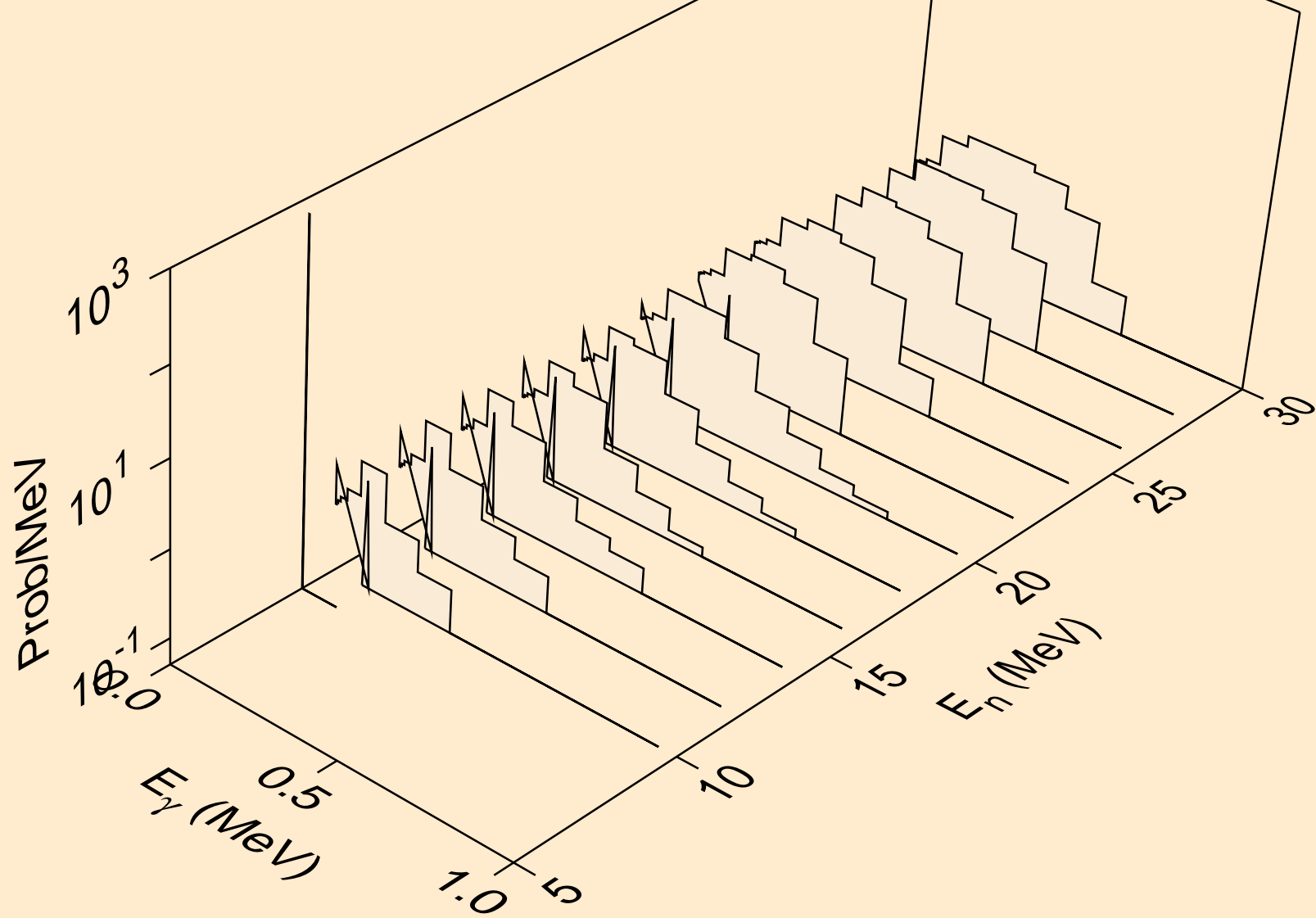

SG272 TRITON ACER TENDL-2021 LIBRARY; T=0.K  
Photon emission for (n,4n)

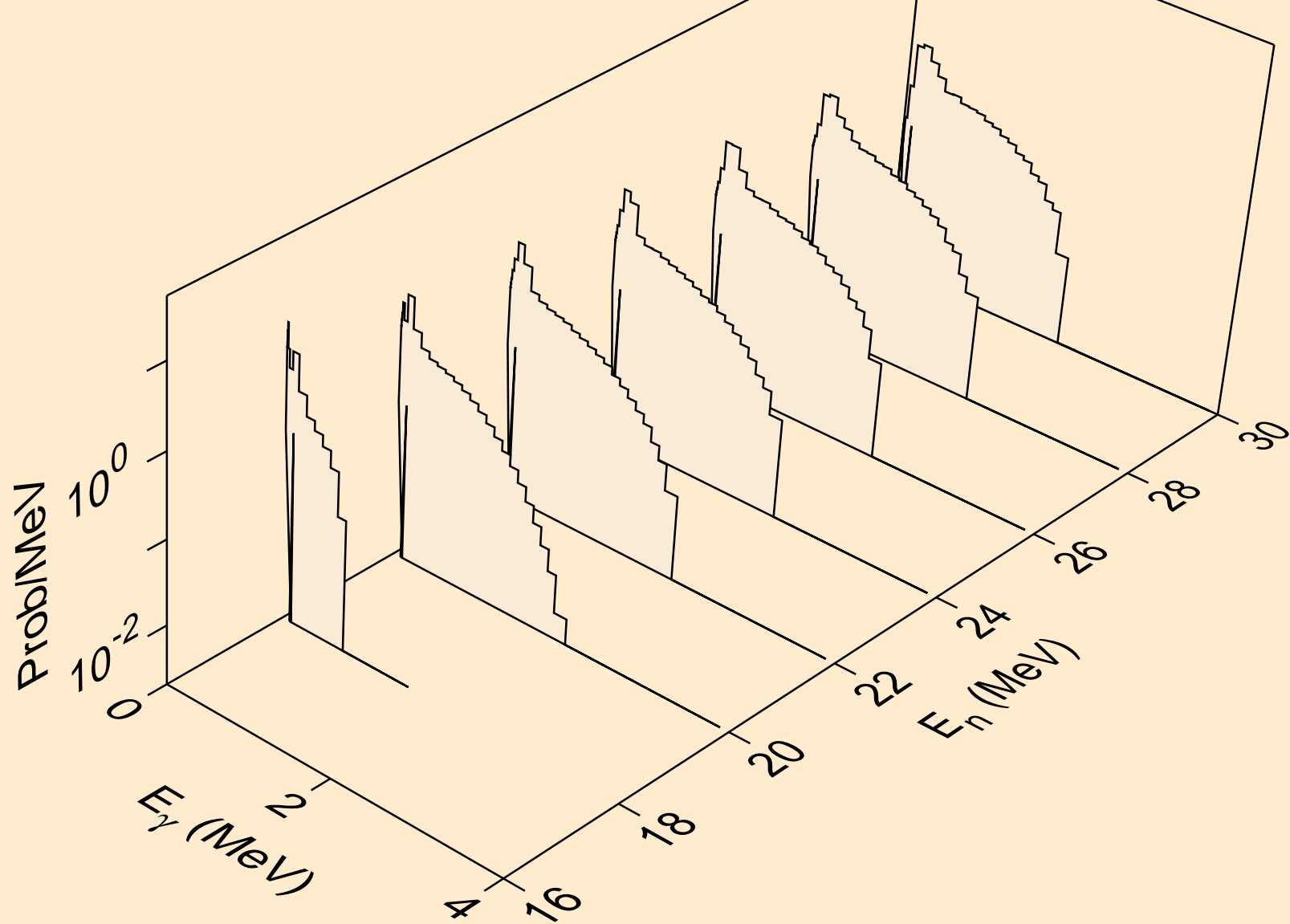

SG272 TRITON ACER TENDL-2021 LIBRARY; T=0.K  
Photon emission for (n,2np)

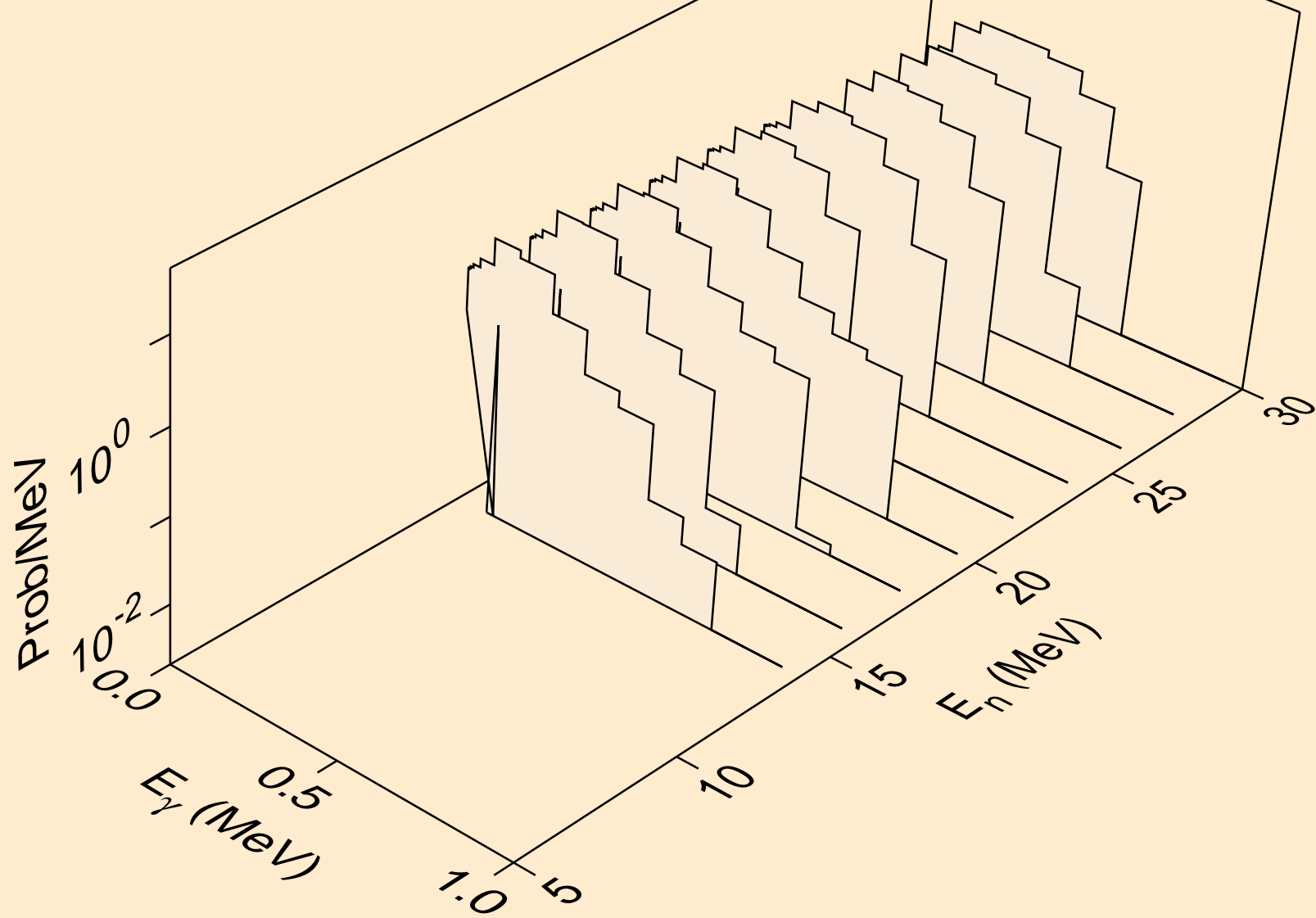

SG272 TRITON ACER TENDL-2021 LIBRARY; T=0.K  
Photon emission for (n,p)

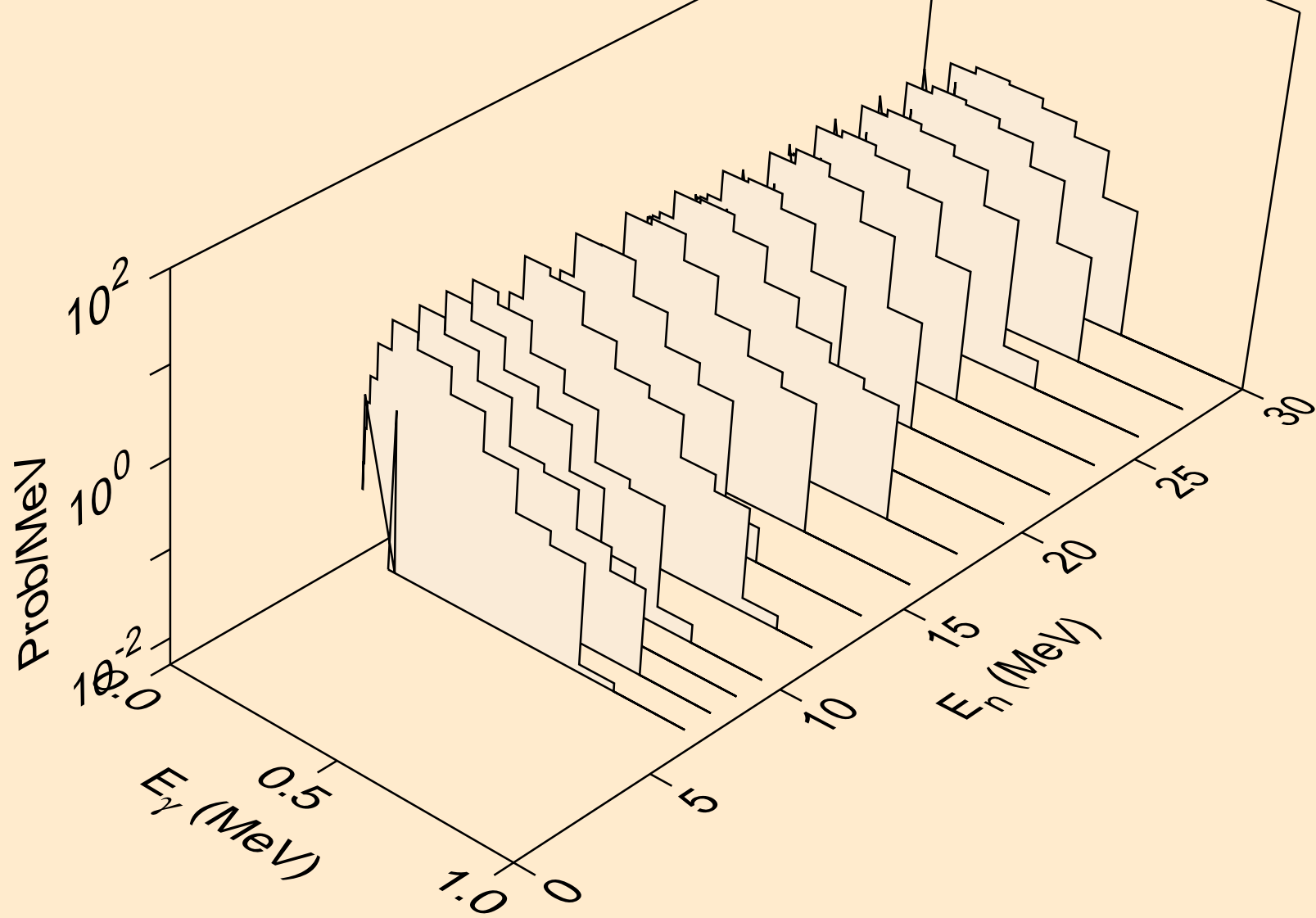

SG272 TRITON ACER TENDL-2021 LIBRARY; T=0.K  
Photon emission for (n,d)

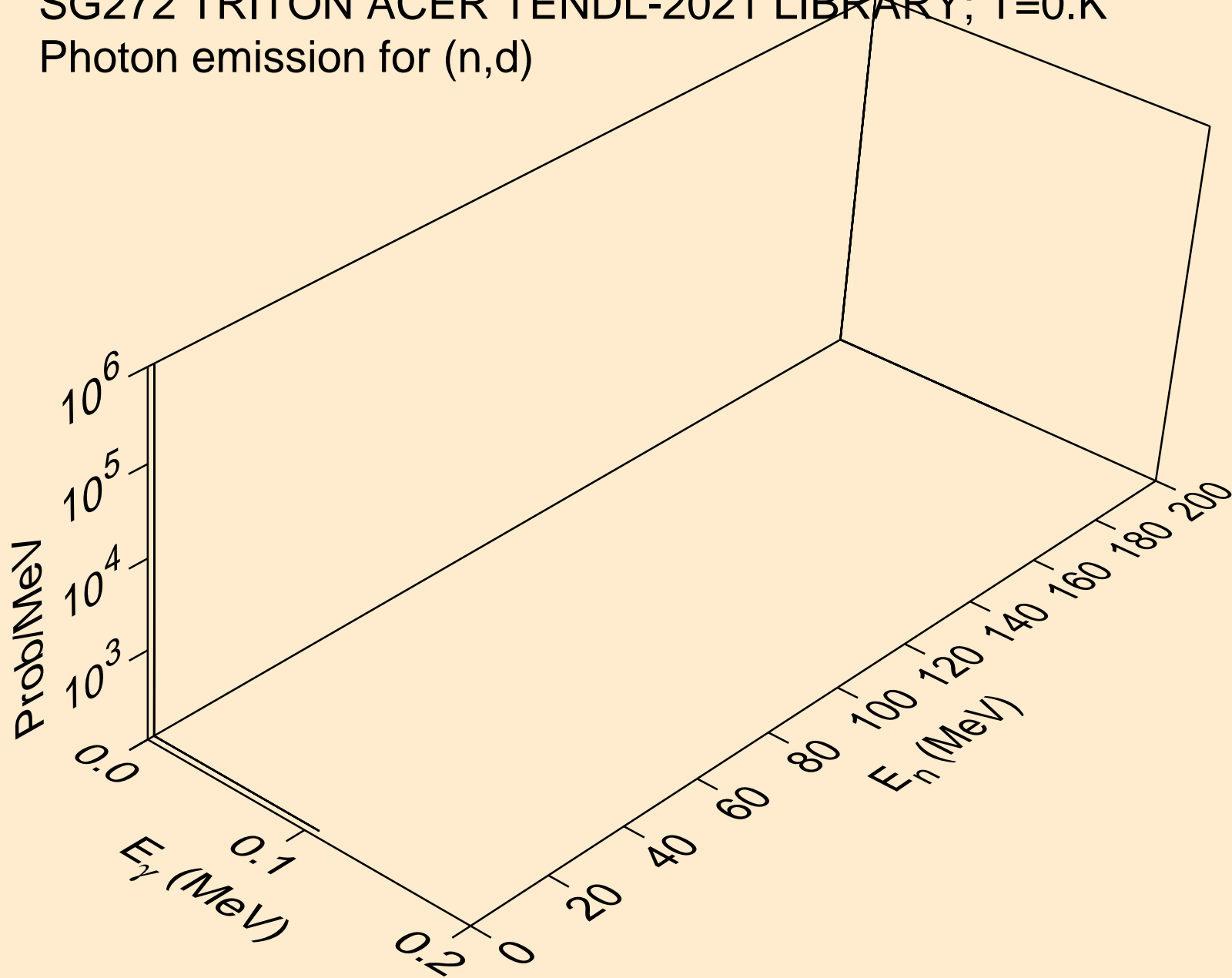

SG272 TRITON ACER TENDL-2021 LIBRARY; T=0.K  
Photon emission for inelastic

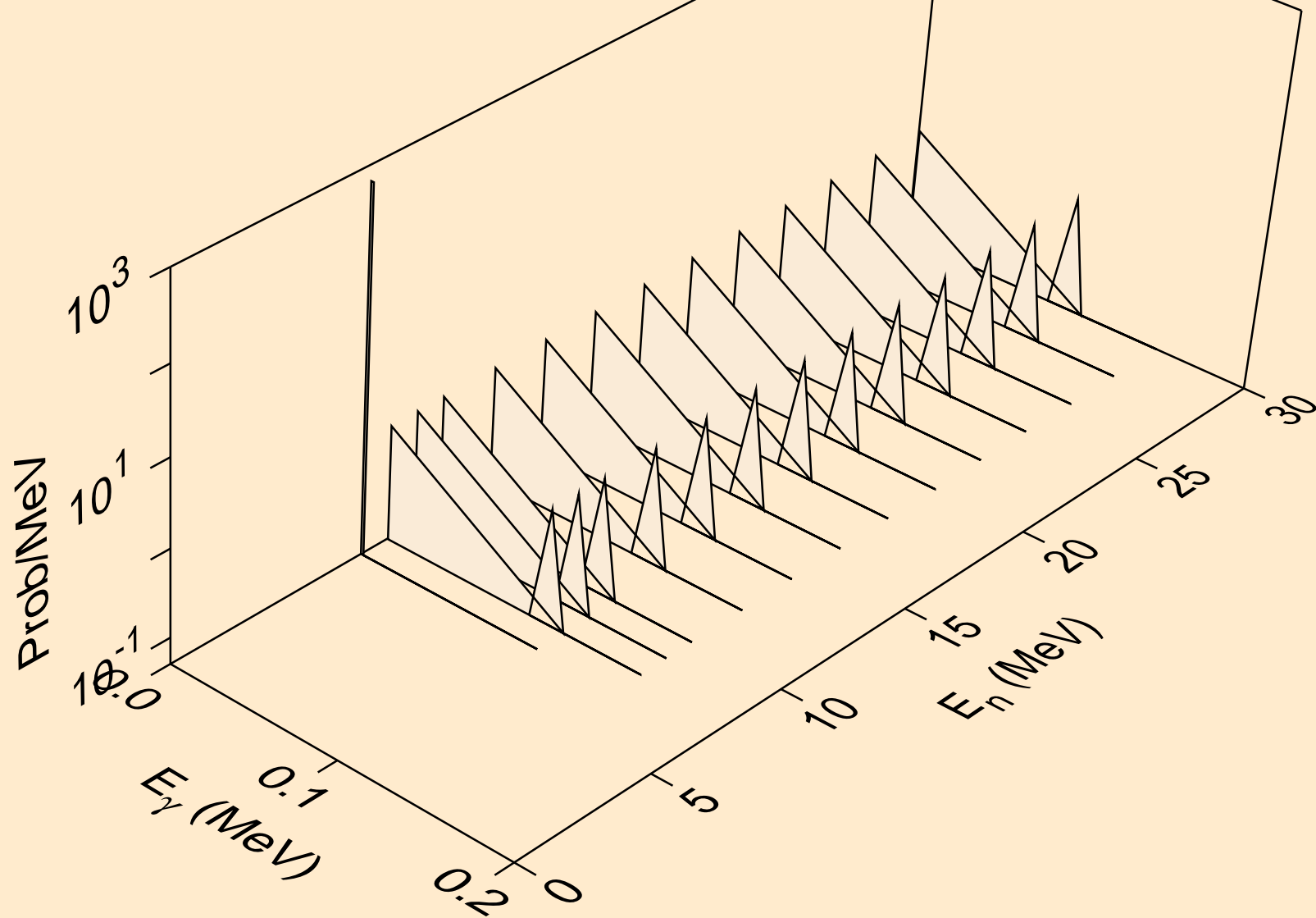

SG272 TRITON ACER TENDL-2021 LIBRARY; T=0.K  
Photon emission for (n,he3)

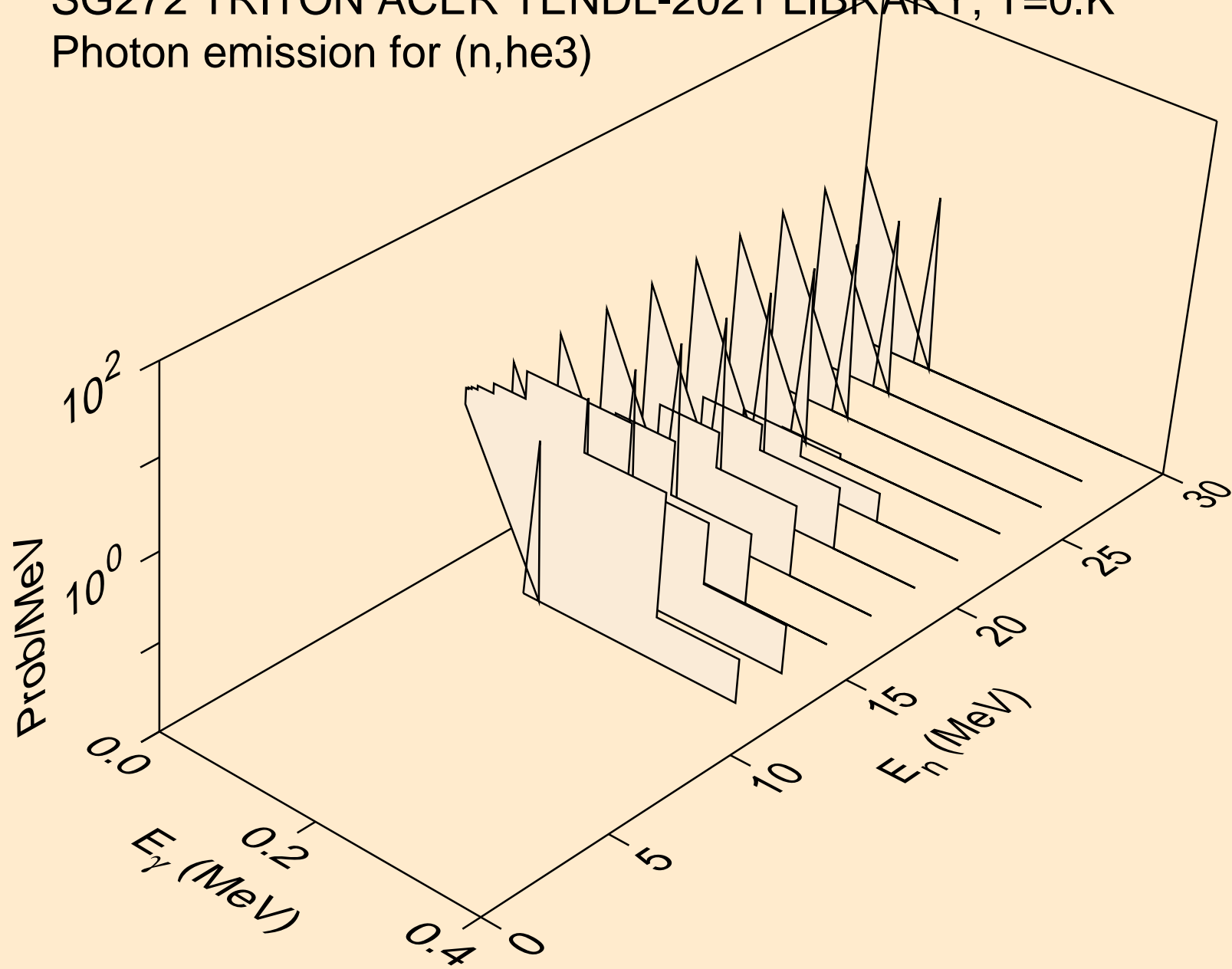

SG272 TRITON ACER TENDL-2021 LIBRARY; T=0.K  
Photon emission for (n,a)

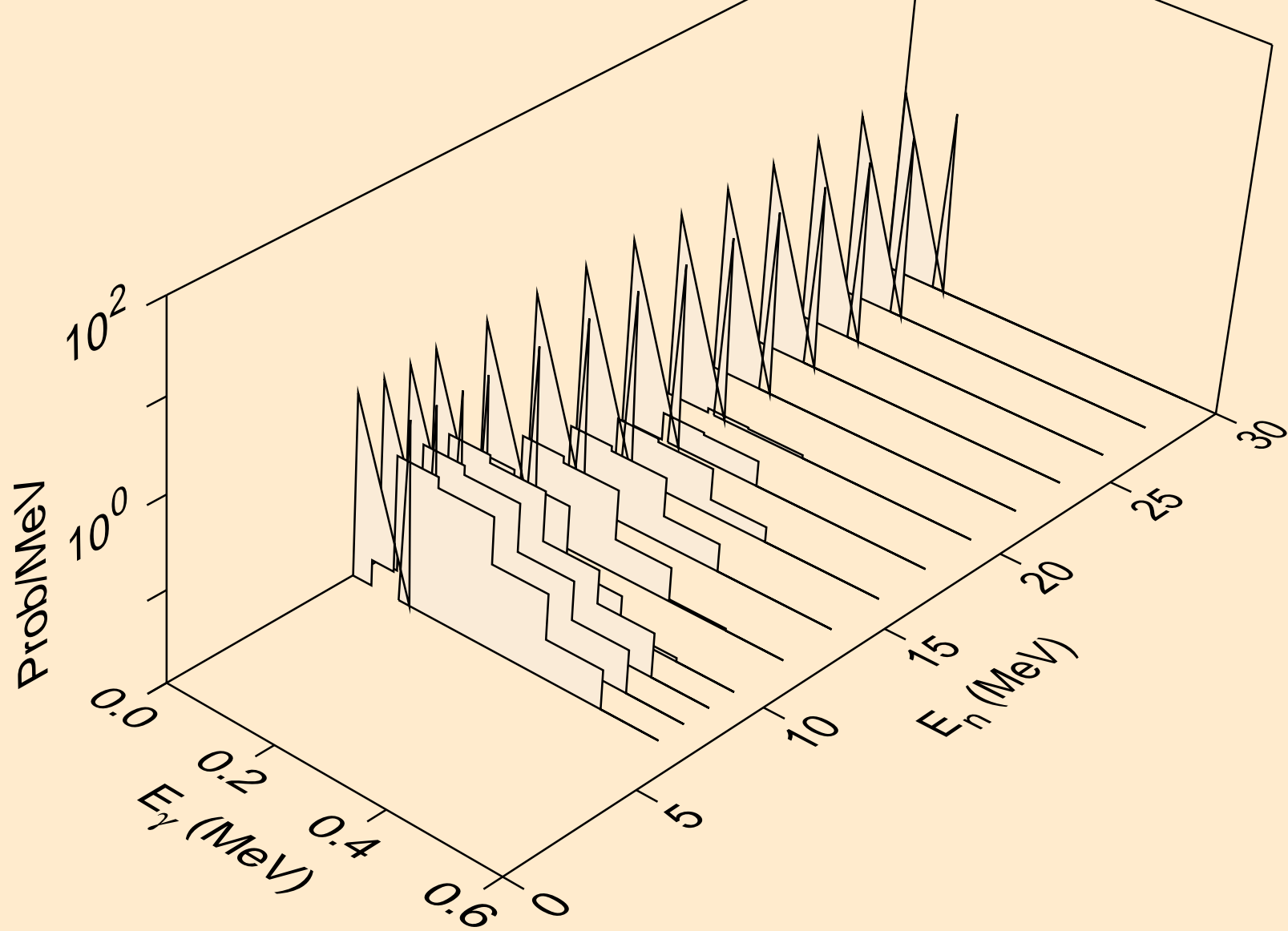



# SG272 TRITON ACER TENDL-2021 LIBRARY; T=0.K

## Particle heating contributions

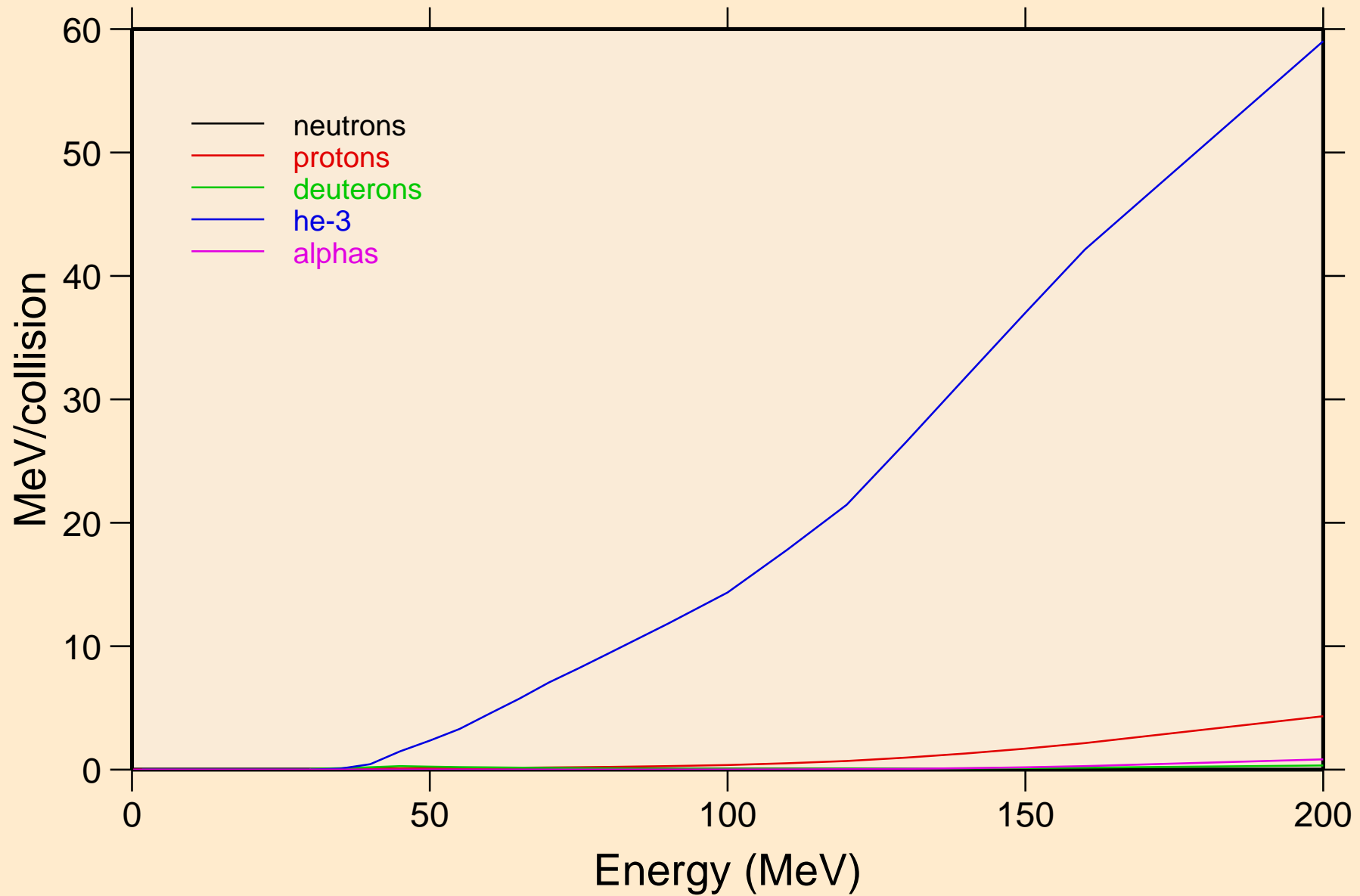

SG272 TRITON ACER TENDL-2021 LIBRARY; T=0.K  
Recoil Heating

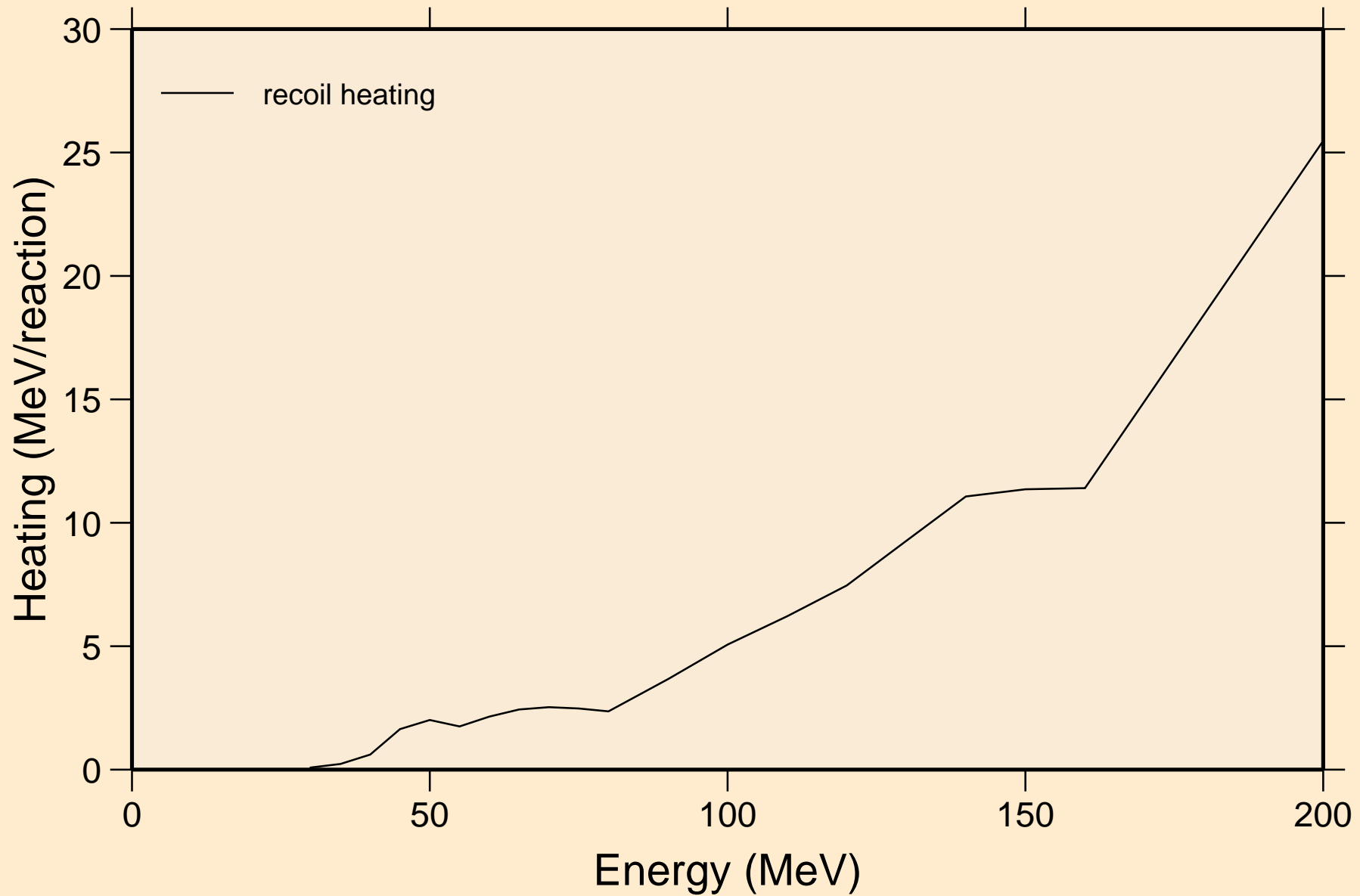

SG272 TRITON ACER TENDL-2021 LIBRARY; T=0.K  
Particle production cross sections

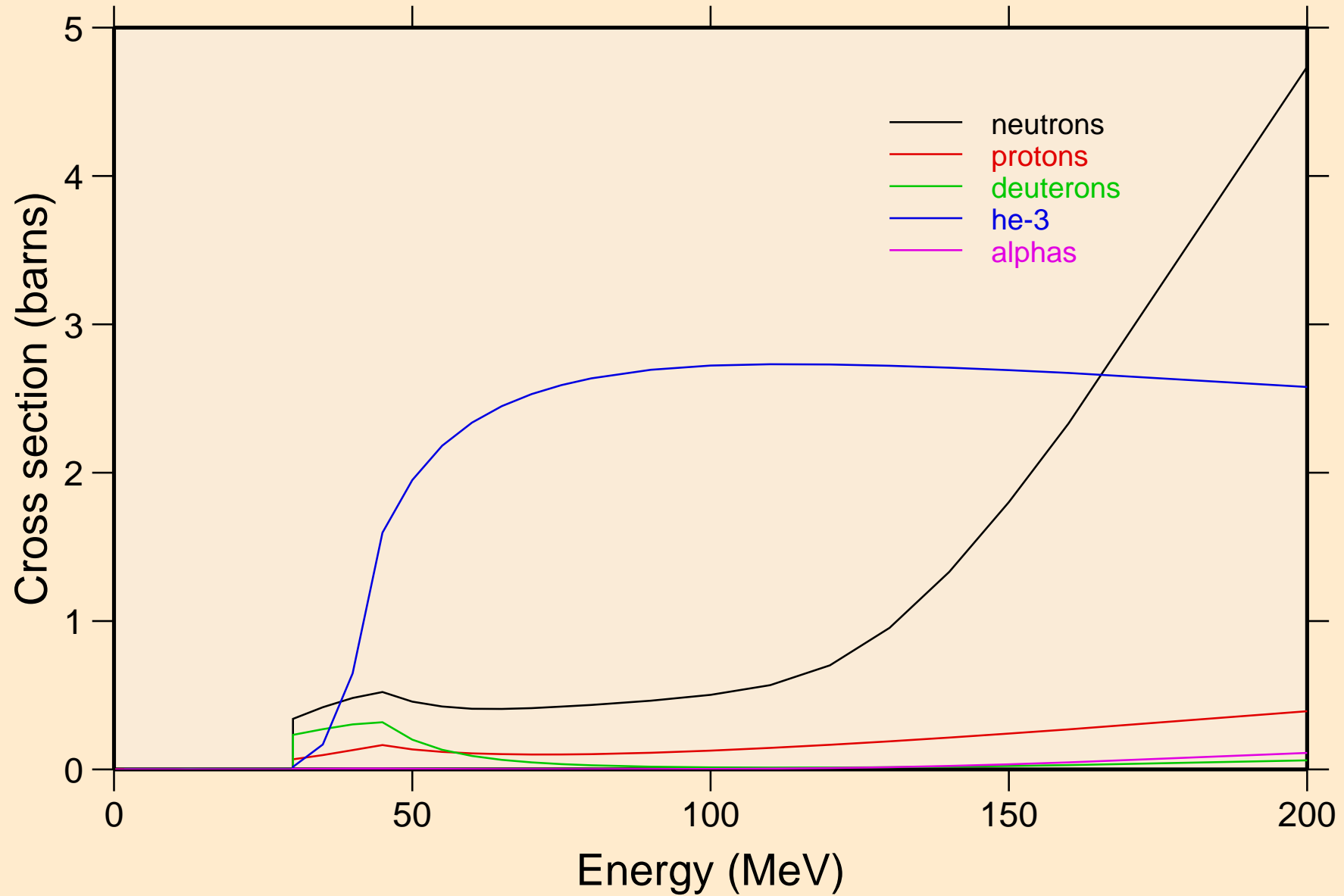

SG272 TRITON ACER TENDL-2021 LIBRARY; T=0.K  
neutrons from (t,n)

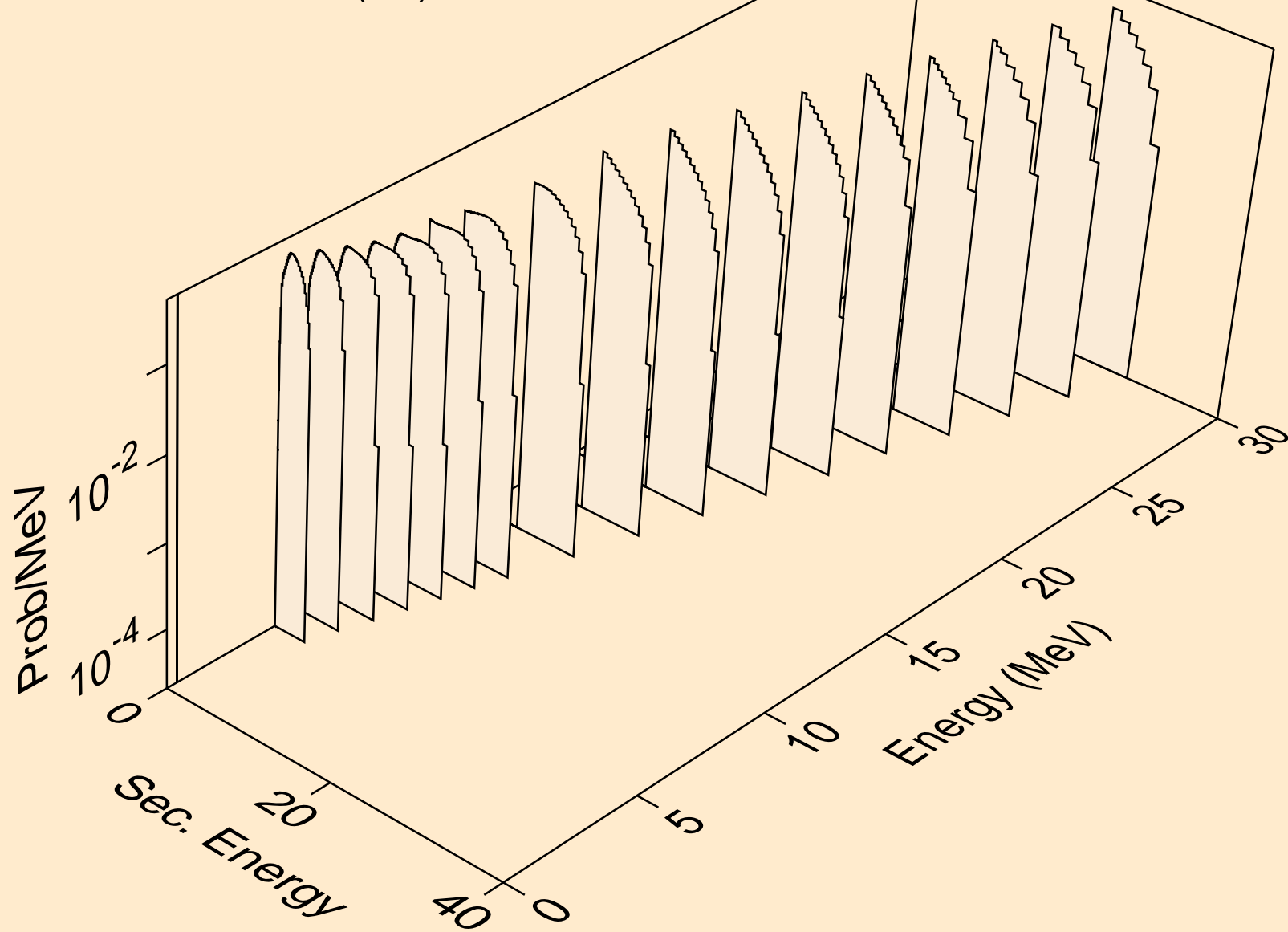

SG272 TRITON ACER TENDL-2021 LIBRARY; T=0.K  
neutrons from (t,x)

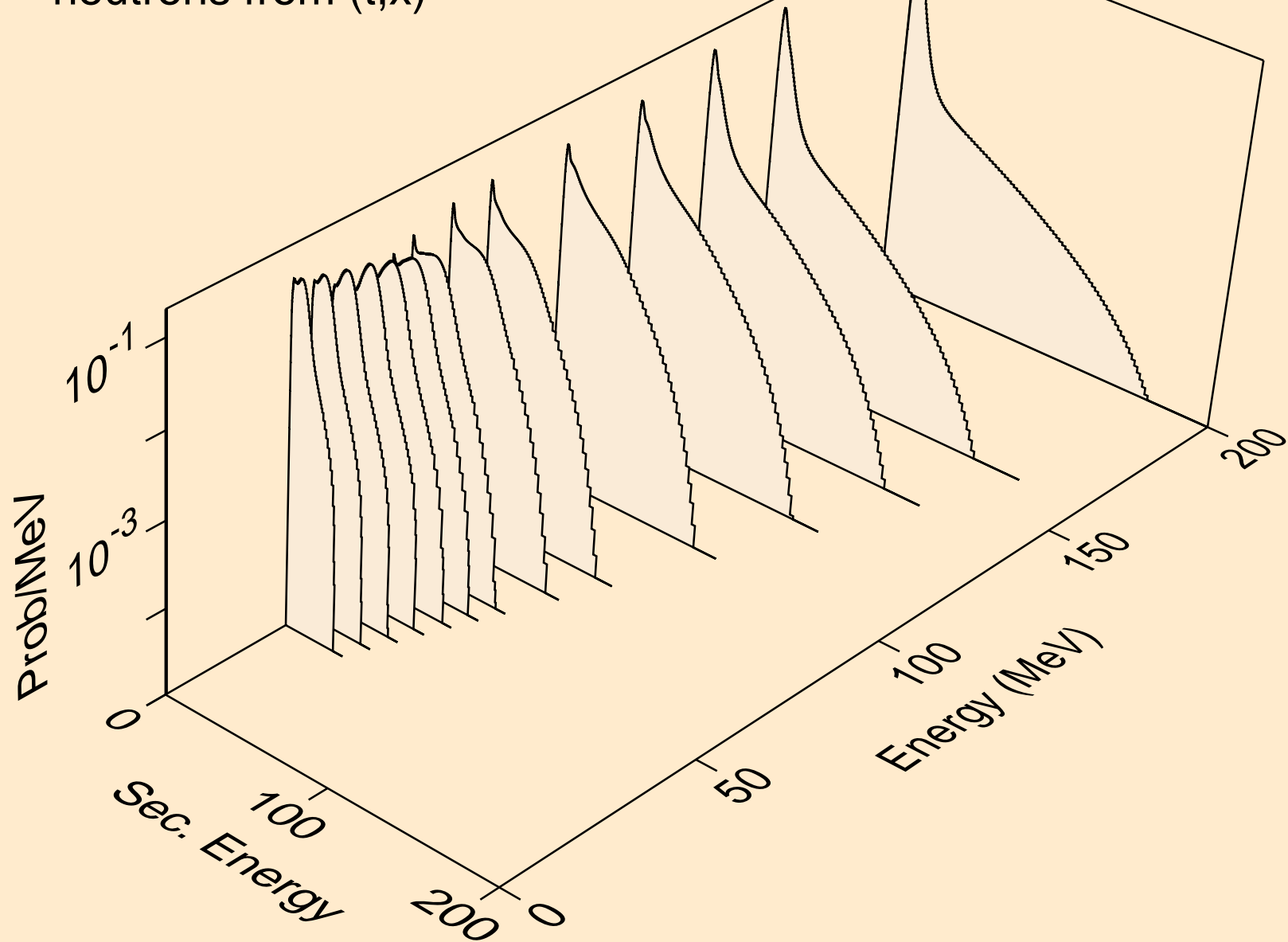

SG272 TRITON ACER TENDL-2021 LIBRARY; T=0.K  
neutrons from (t,2n)

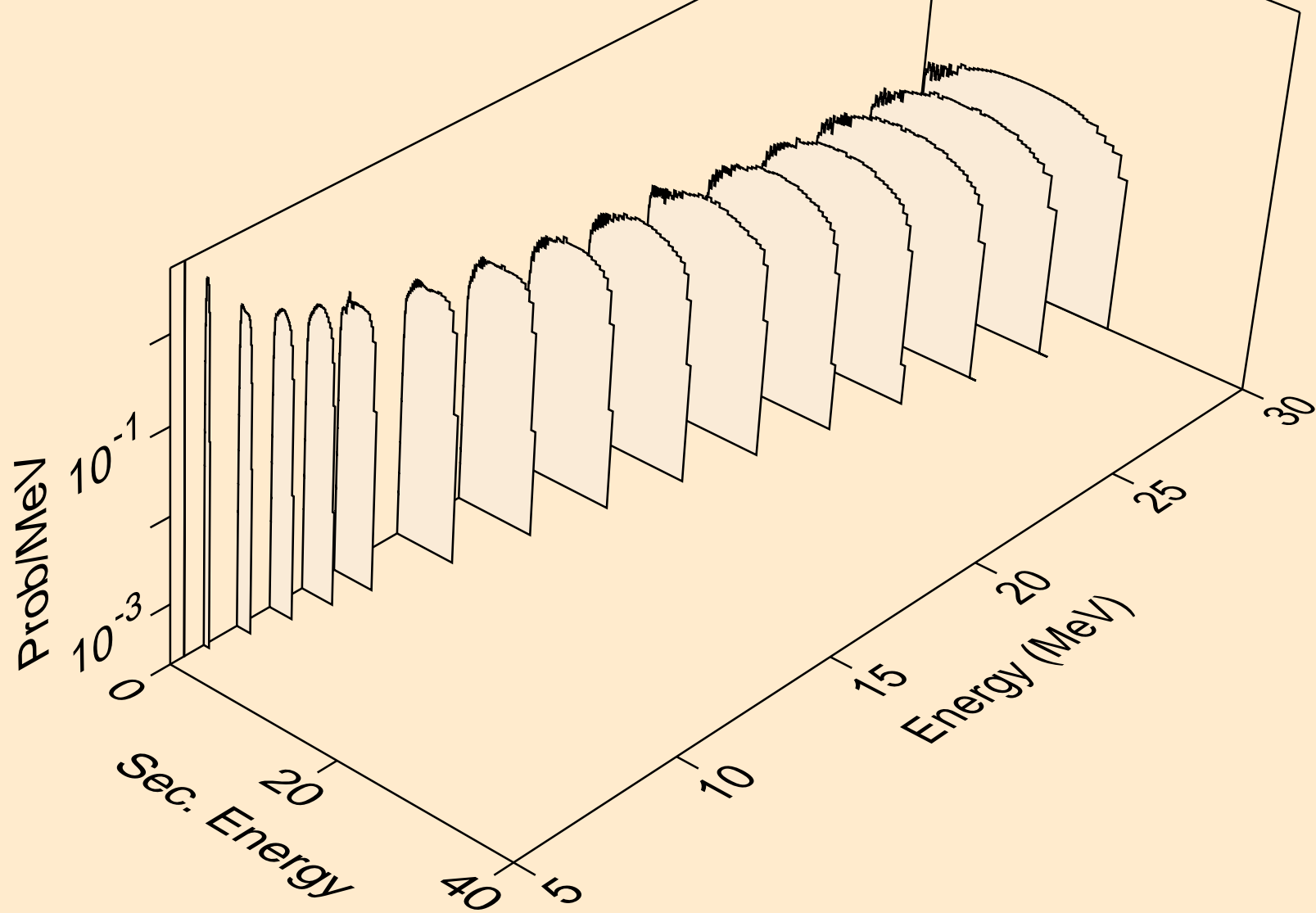

SG272 TRITON ACER TENDL-2021 LIBRARY; T=0.K  
neutrons from (t,3n)

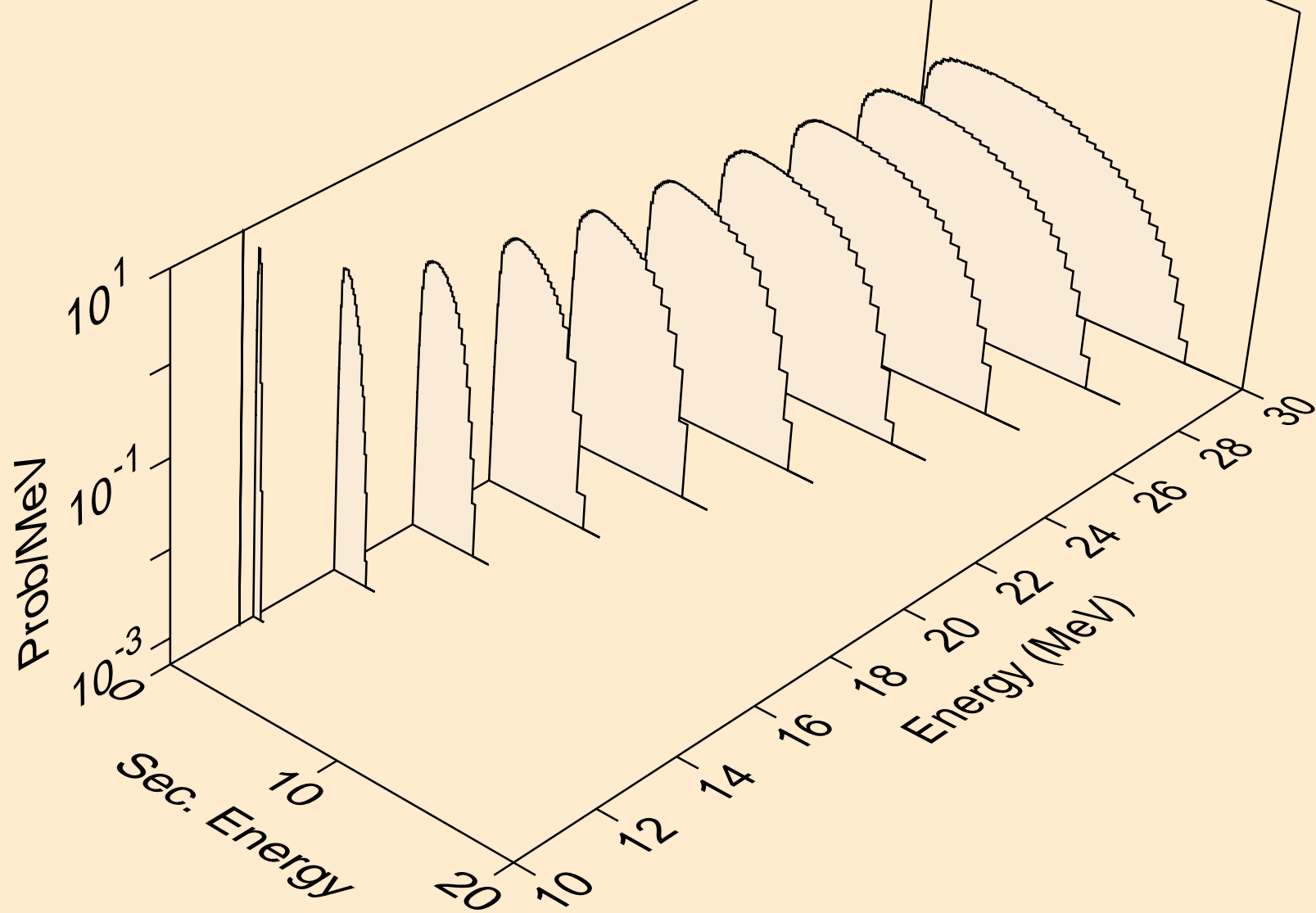

SG272 TRITON ACER TENDL-2021 LIBRARY; T=0.K  
neutrons from (t,3n)a

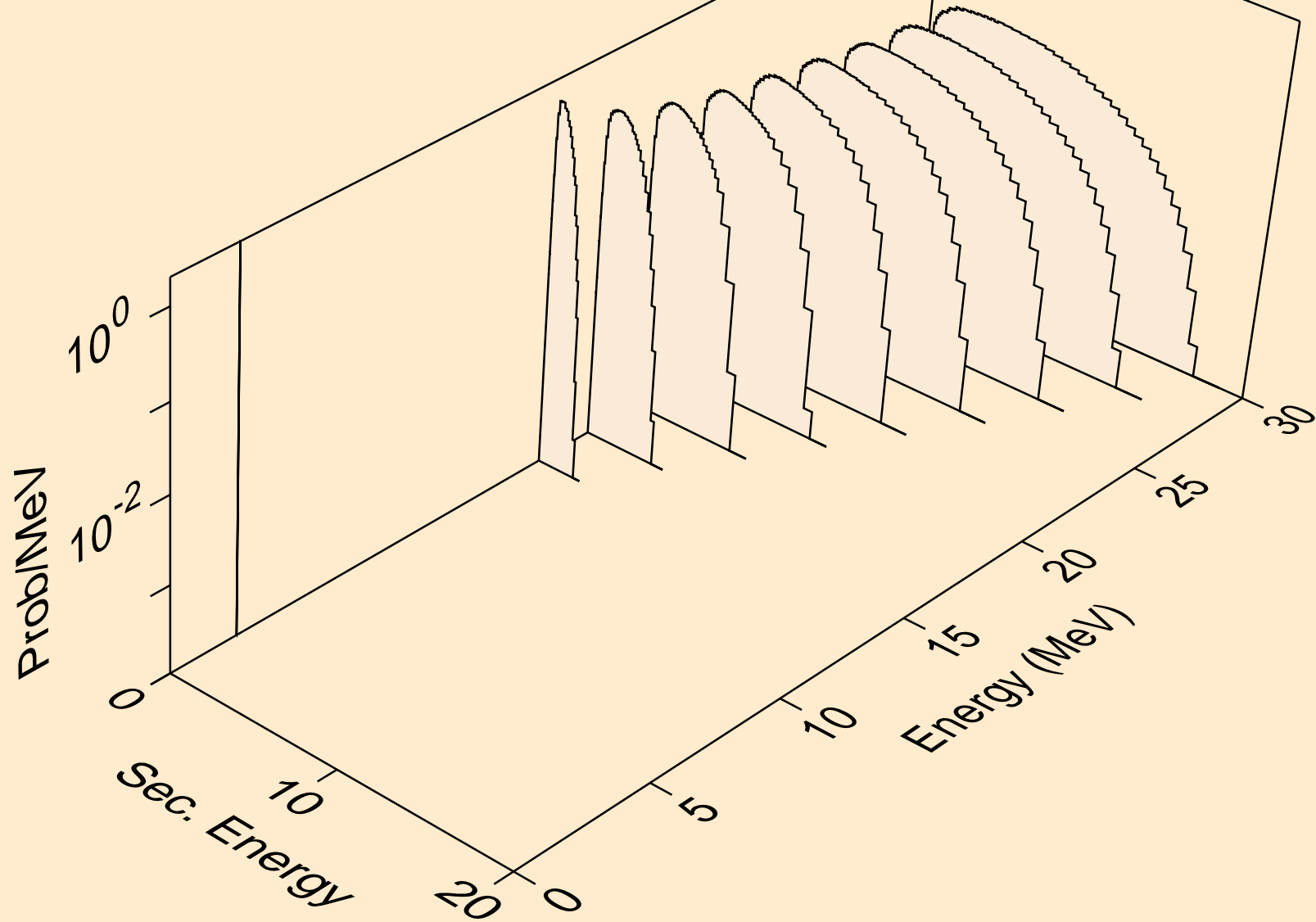



SG272 TRITON ACER TENDL-2021 LIBRARY; T=0.K  
neutrons from (t,n\*)d

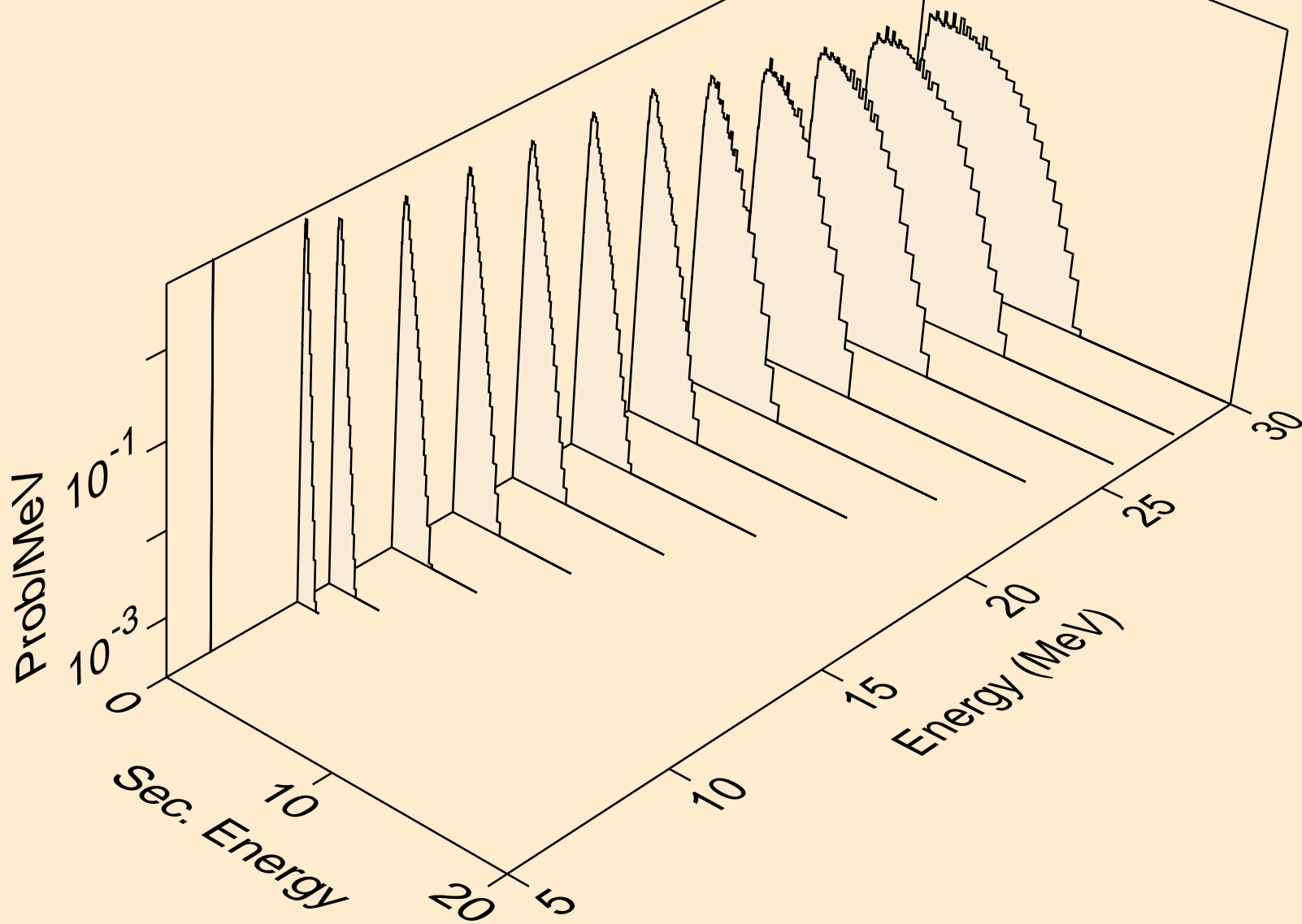

SG272 TRITON ACER TENDL-2021 LIBRARY; T=0.K  
neutrons from (t,4n)

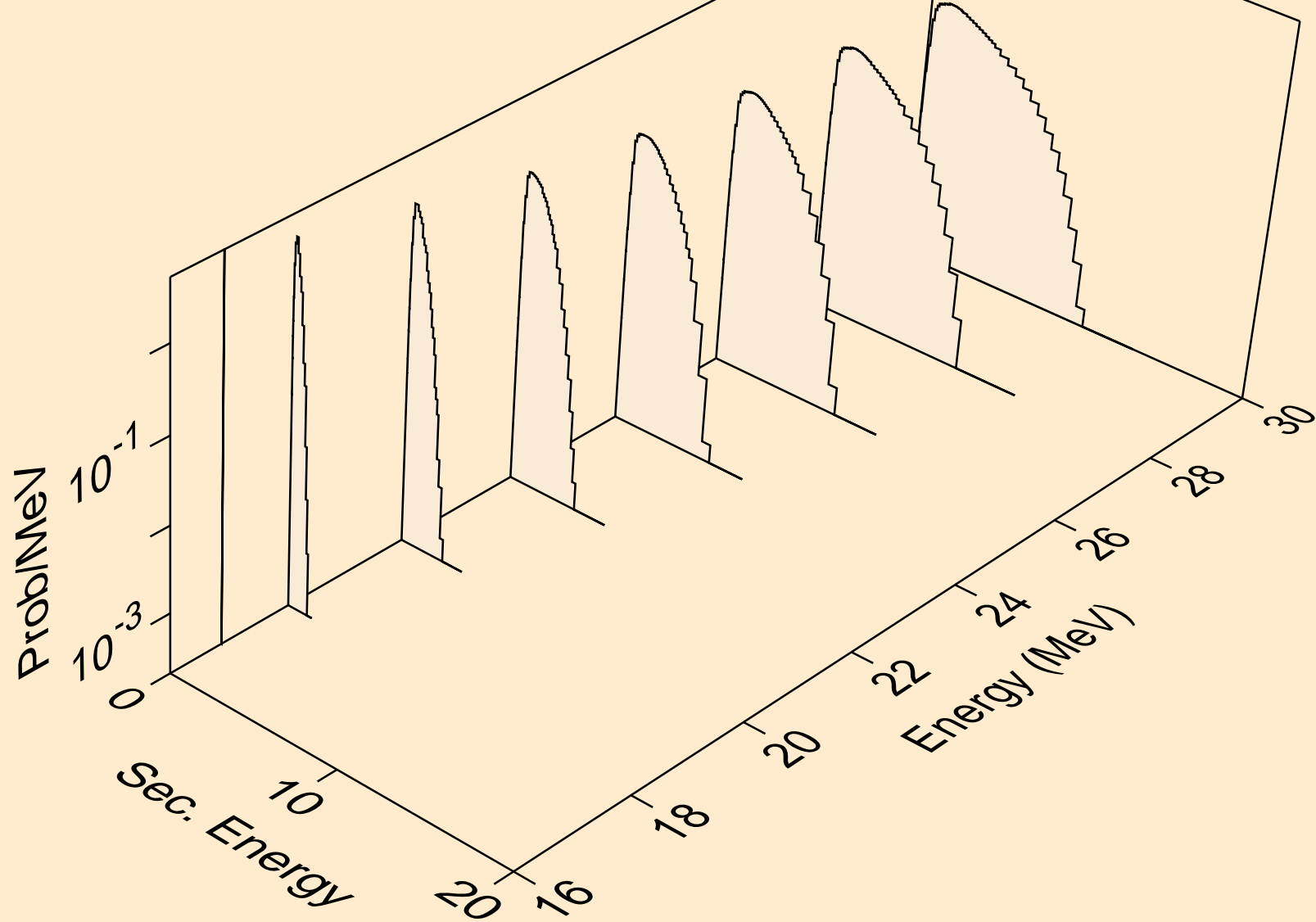

SG272 TRITON ACER TENDL-2021 LIBRARY; T=0.K  
neutrons from (t,2np)

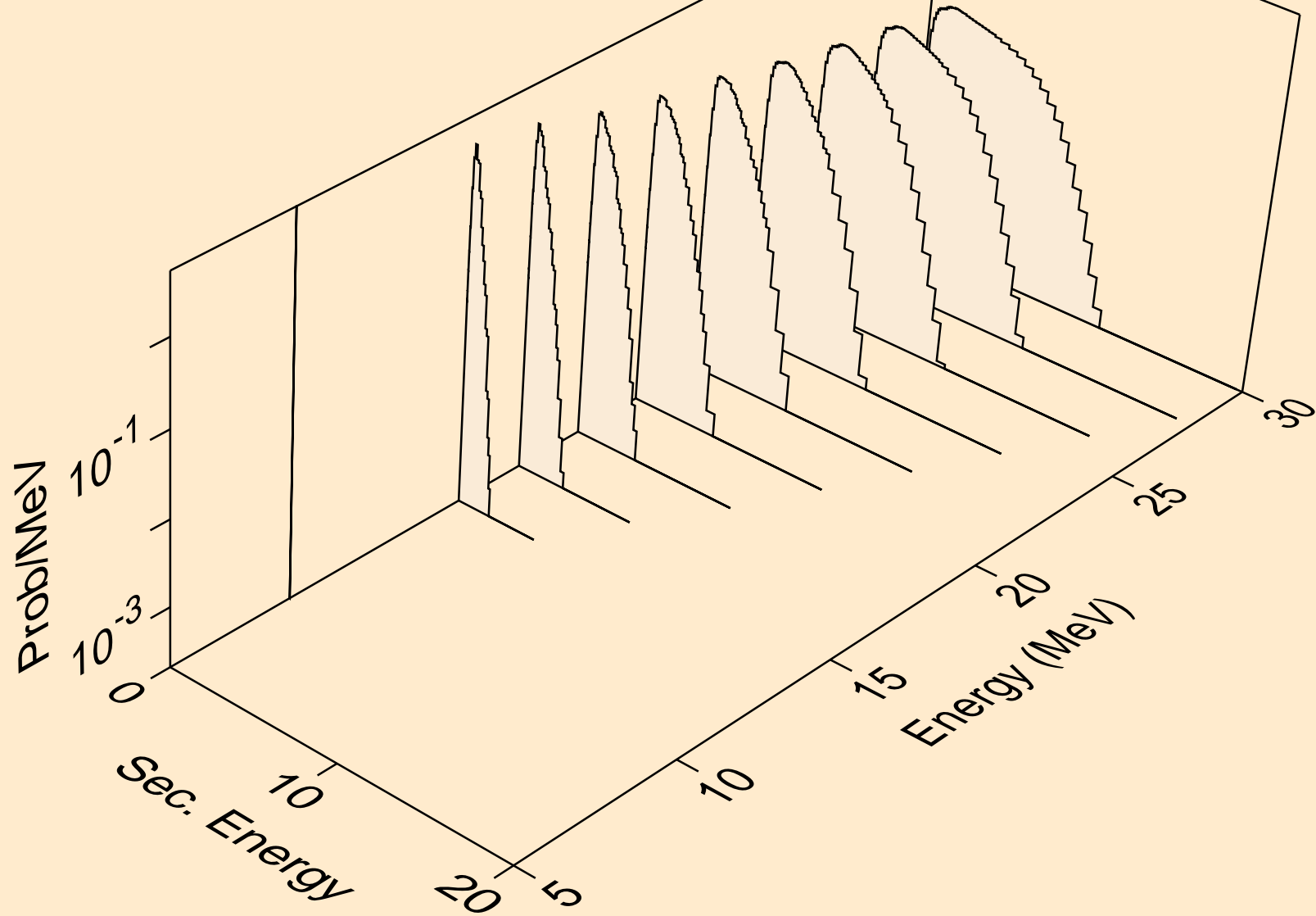

SG272 TRITON ACER TENDL-2021 LIBRARY; T=0.K  
protons from (t,x)

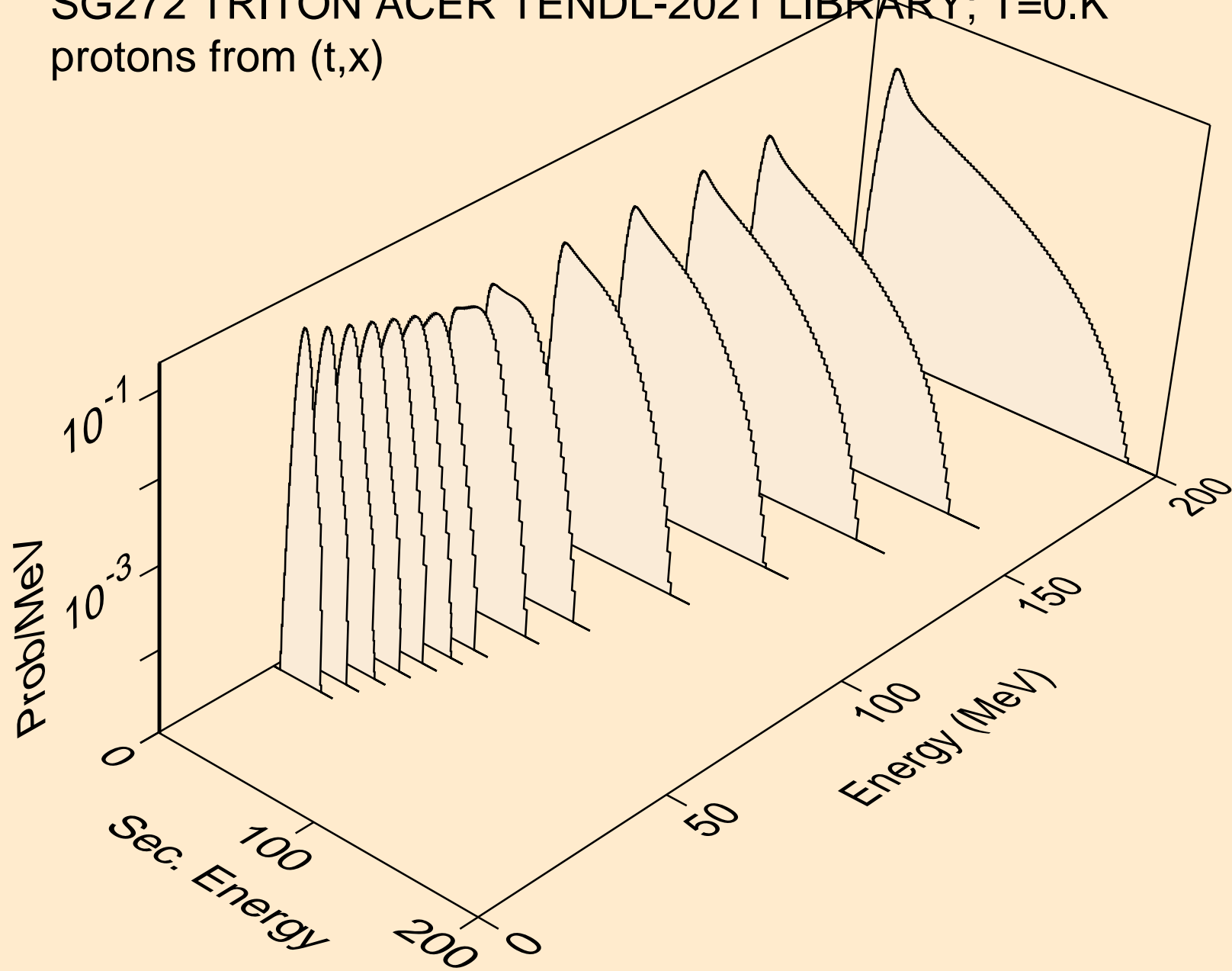

SG272 TRITON ACER TENDL-2021 LIBRARY; T=0.K  
protons from (t,2np)

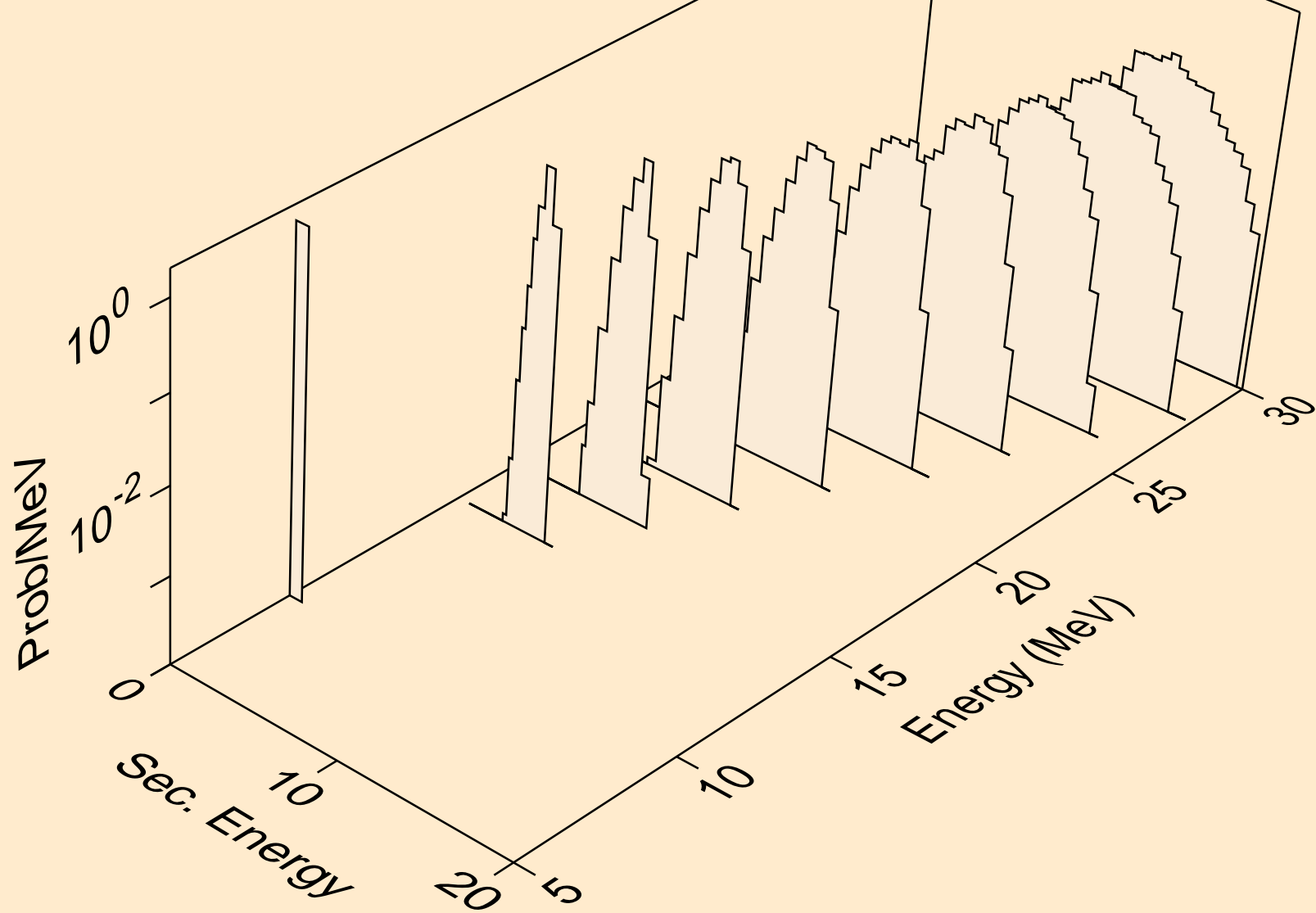

SG272 TRITON ACER TENDL-2021 LIBRARY; T=0.K  
protons from (t,p)

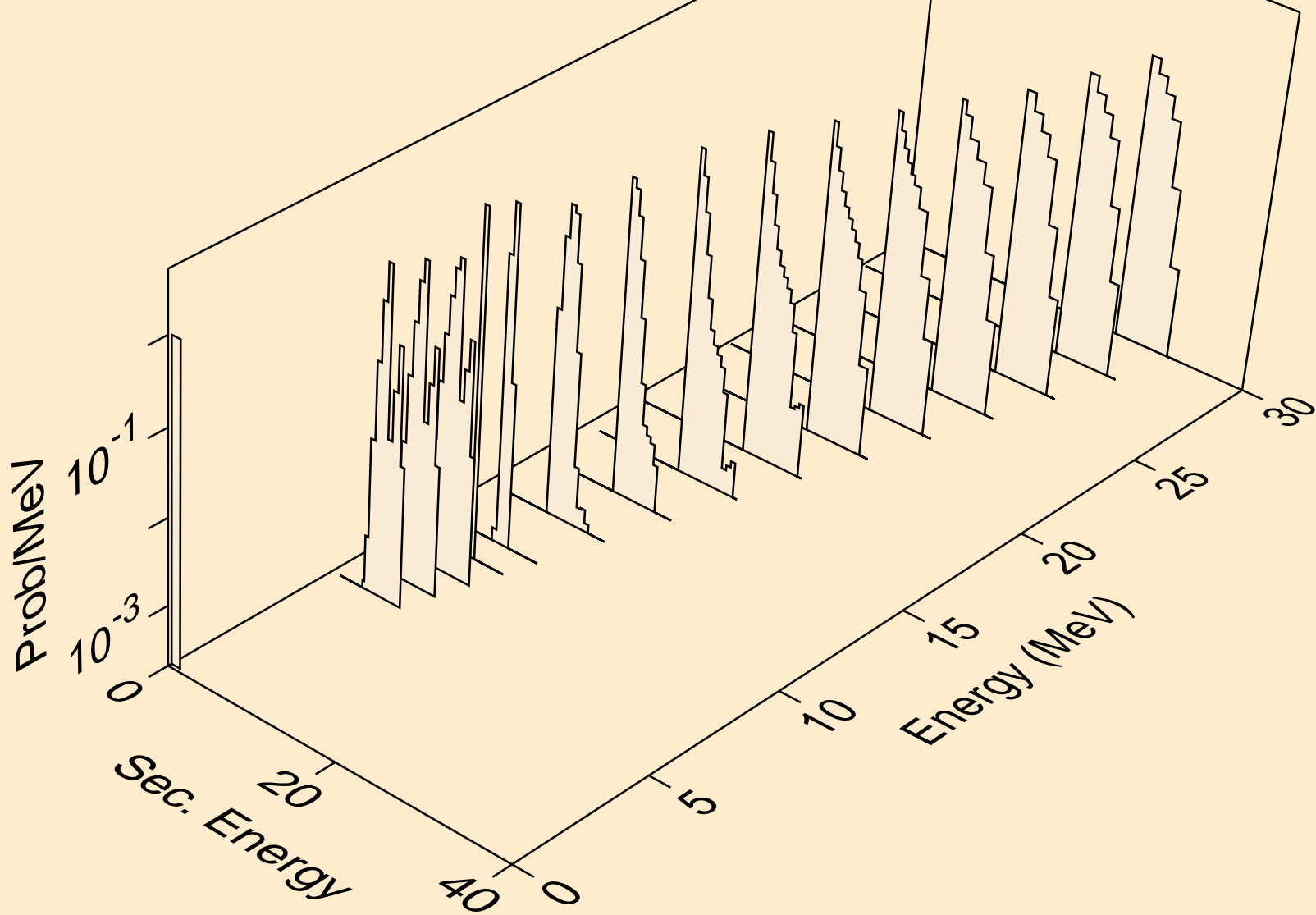

SG272 TRITON ACER TENDL-2021 LIBRARY; T=0.K  
deuterons from (t,x)

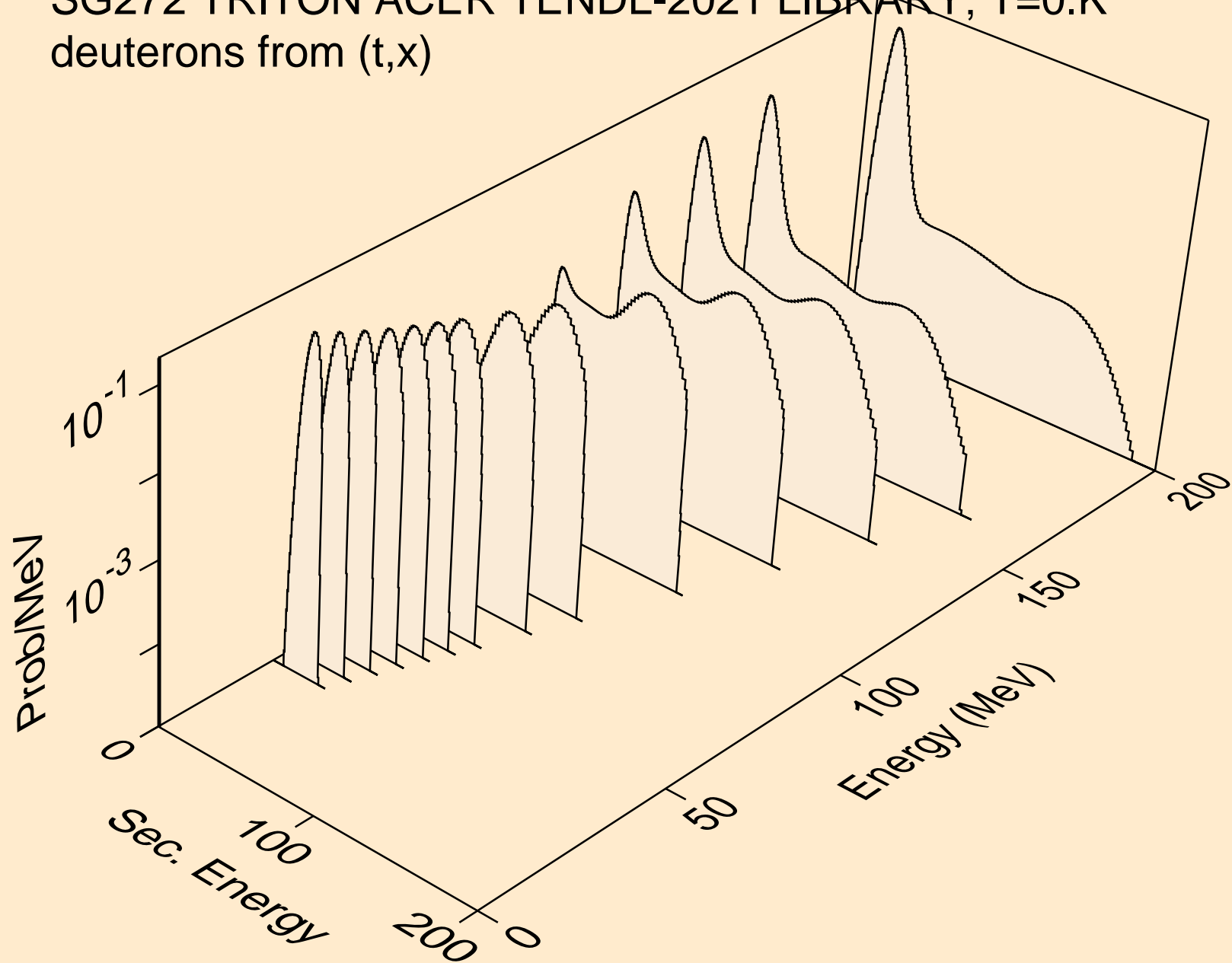

SG272 TRITON ACER TENDL-2021 LIBRARY; T=0.K  
deuterons from (t,n\*)d

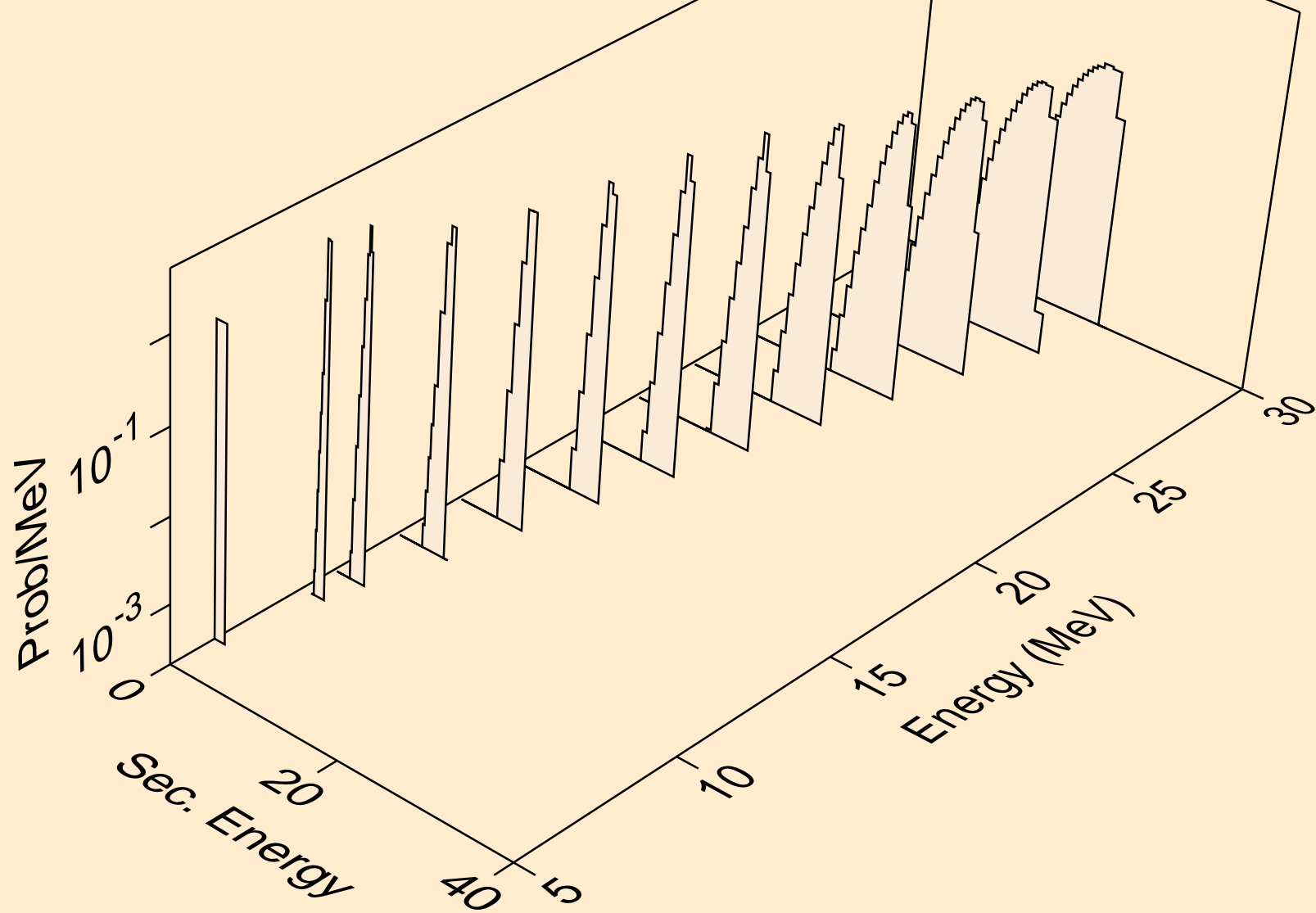



SG272 TRITON ACER TENDL-2021 LIBRARY; T=0.K  
deuterons from (t,d)

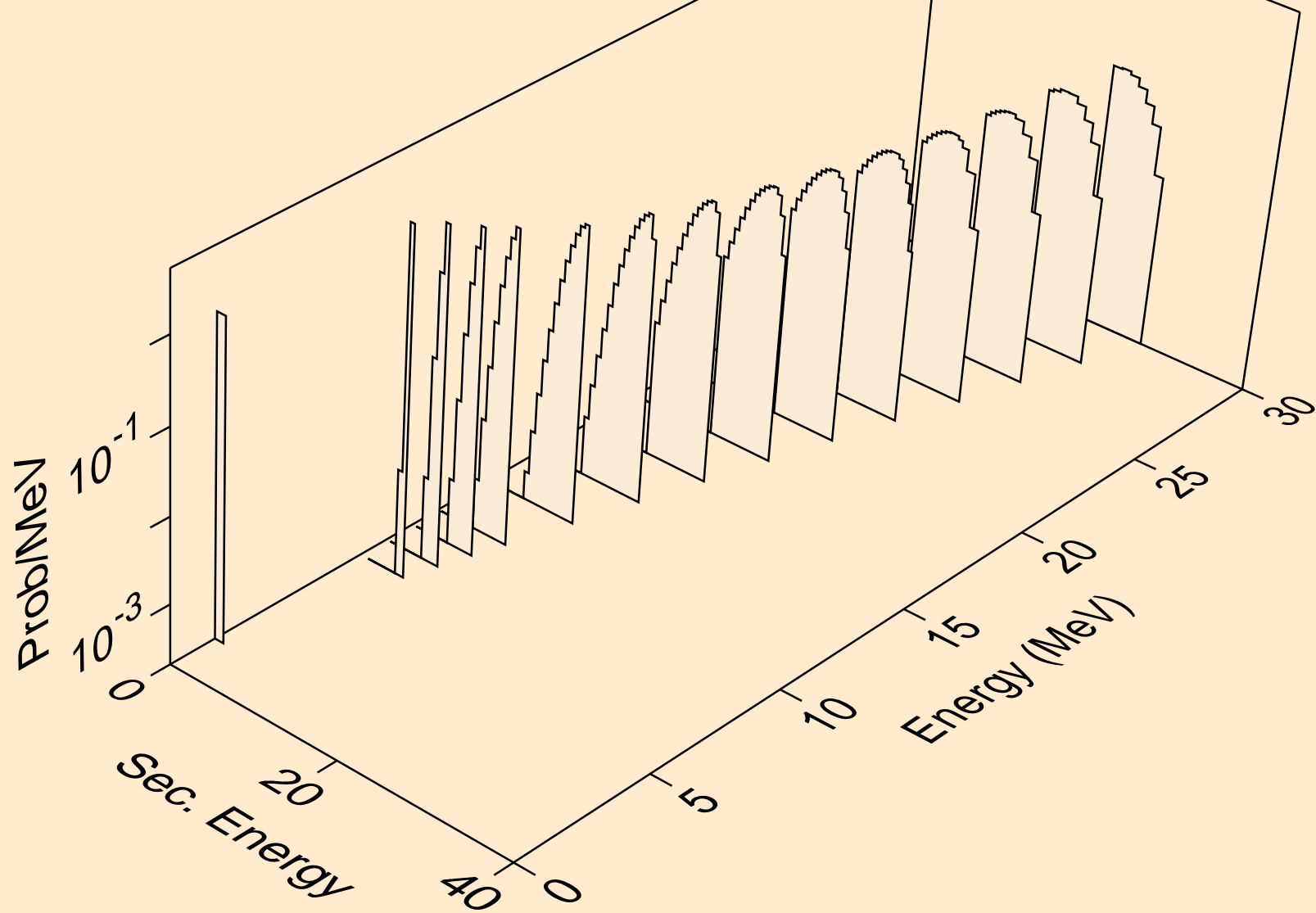

SG272 TRITON ACER TENDL-2021 LIBRARY; T=0.K  
he3s from (t,x)

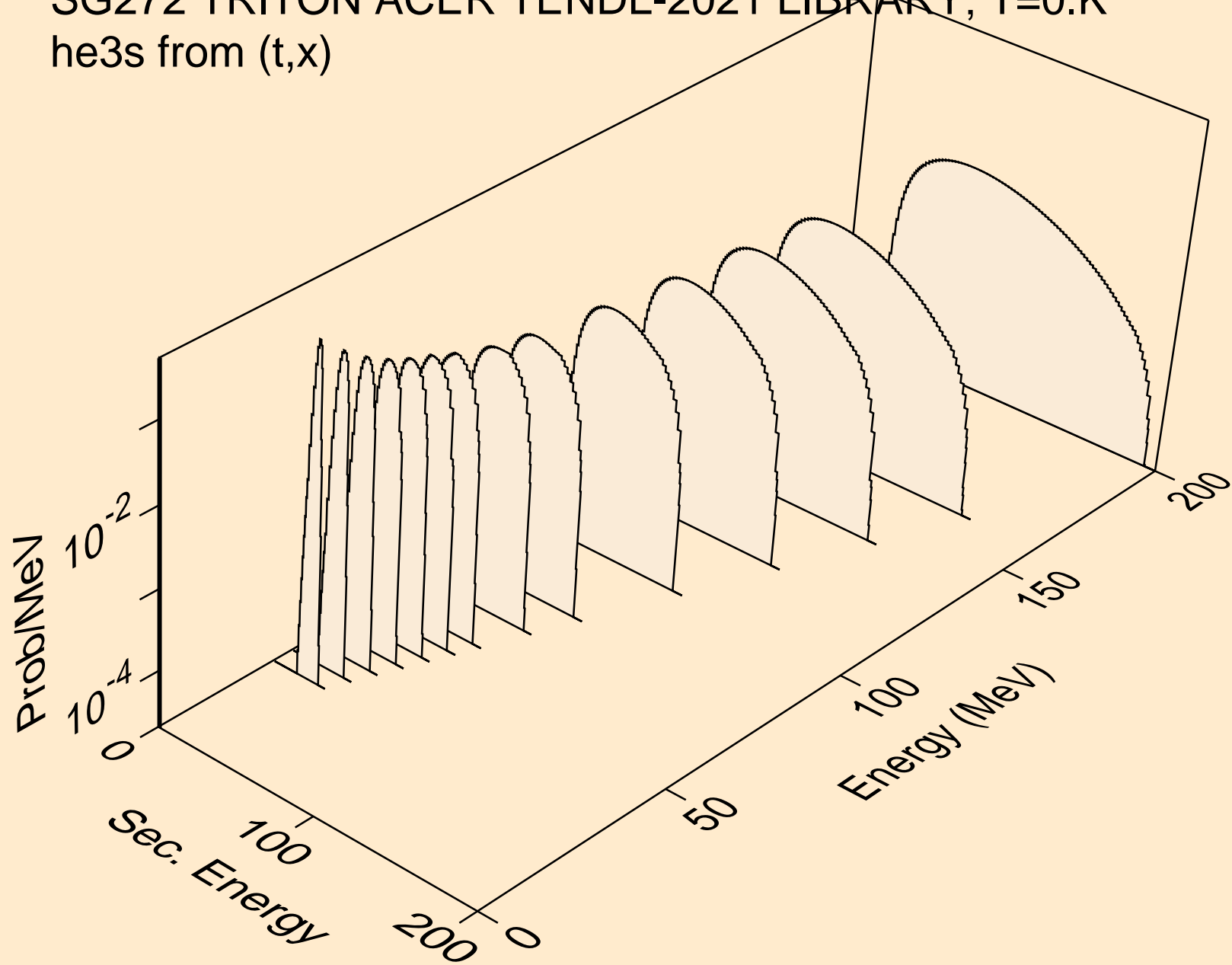

SG272 TRITON ACER TENDL-2021 LIBRARY; T=0.K  
he3s from (t,he3)

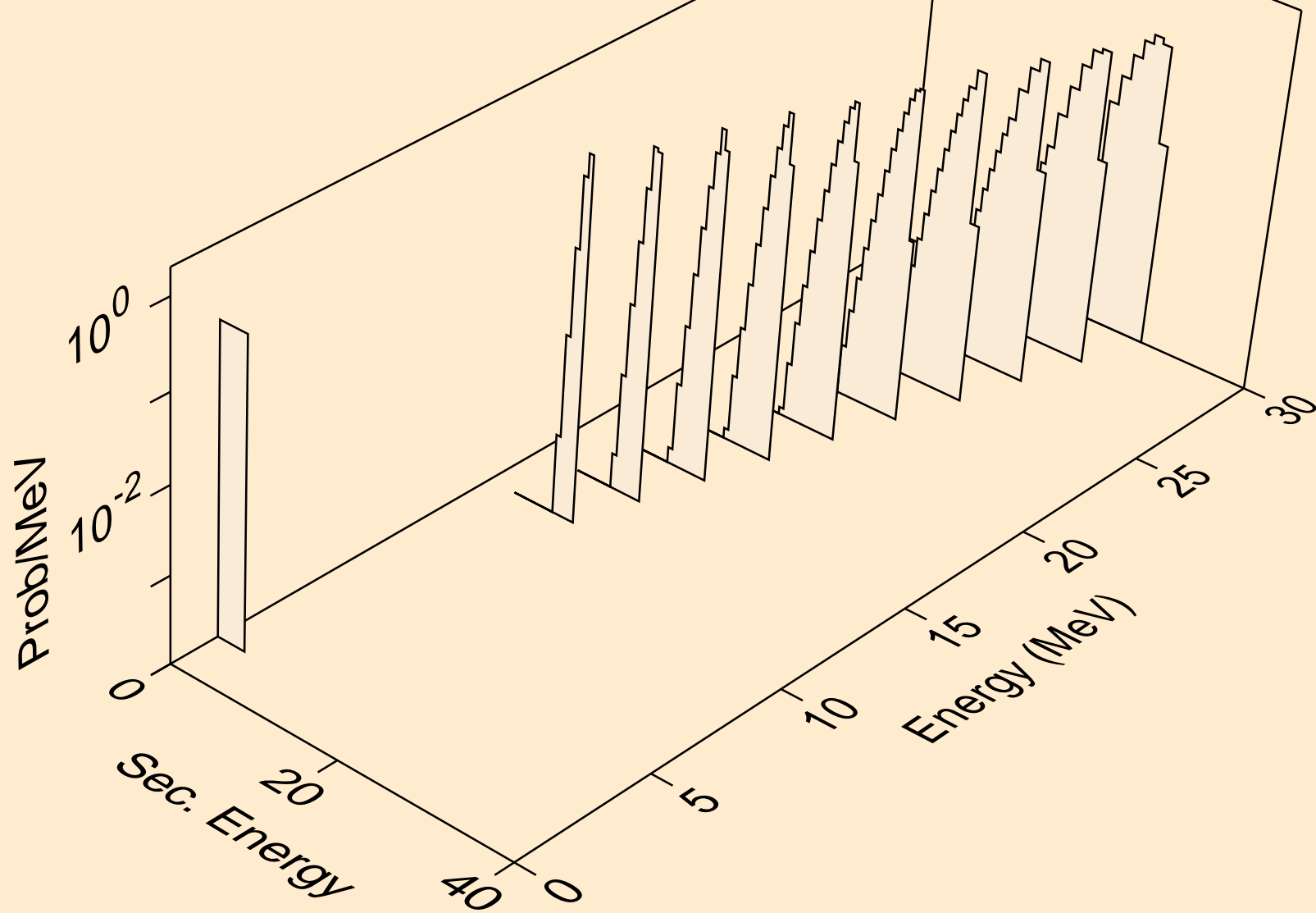

SG272 TRITON ACER TENDL-2021 LIBRARY; T=0.K  
alphas from (t,x)

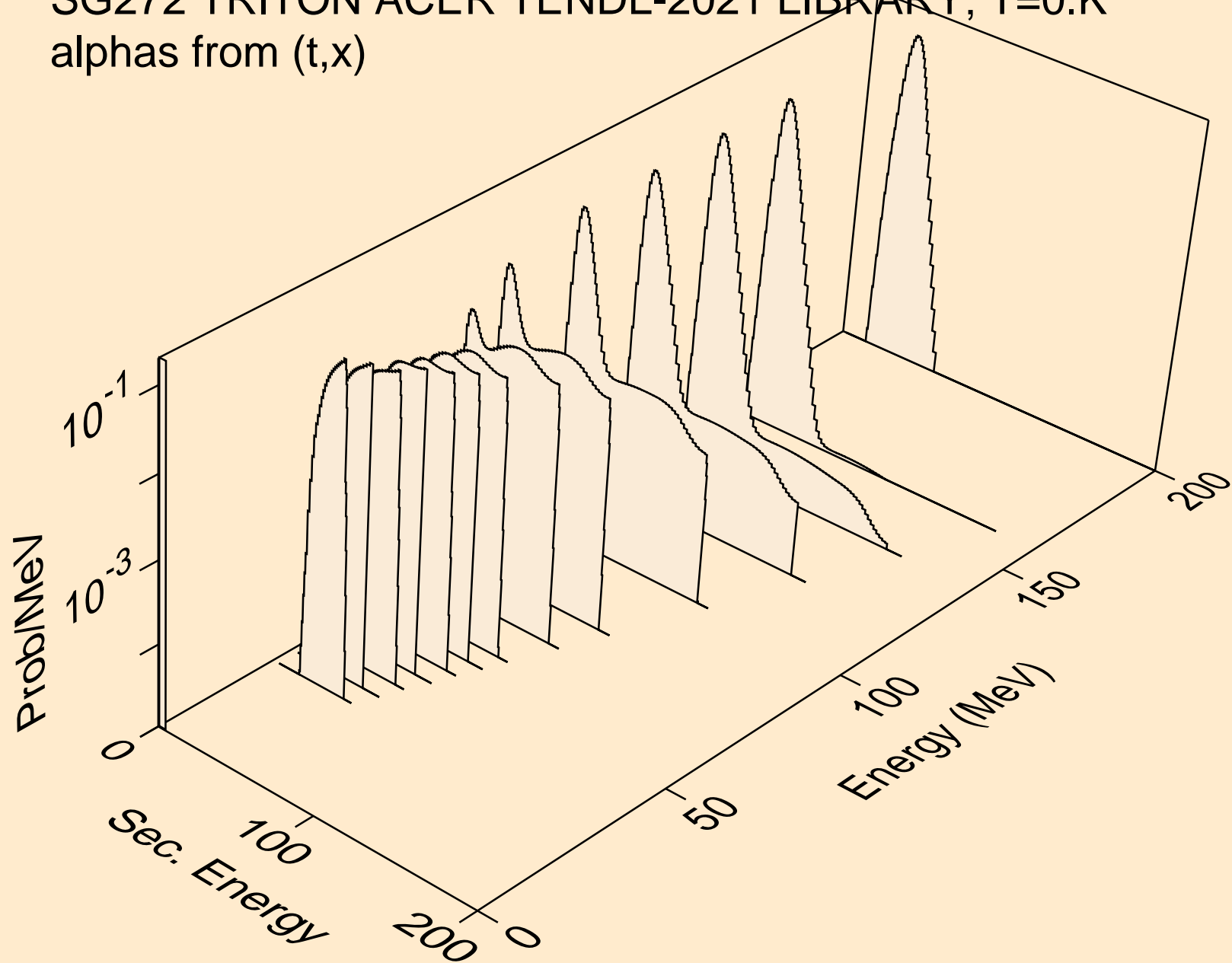

SG272 TRITON ACER TENDL-2021 LIBRARY; T=0.K  
alphas from (t,3n)a

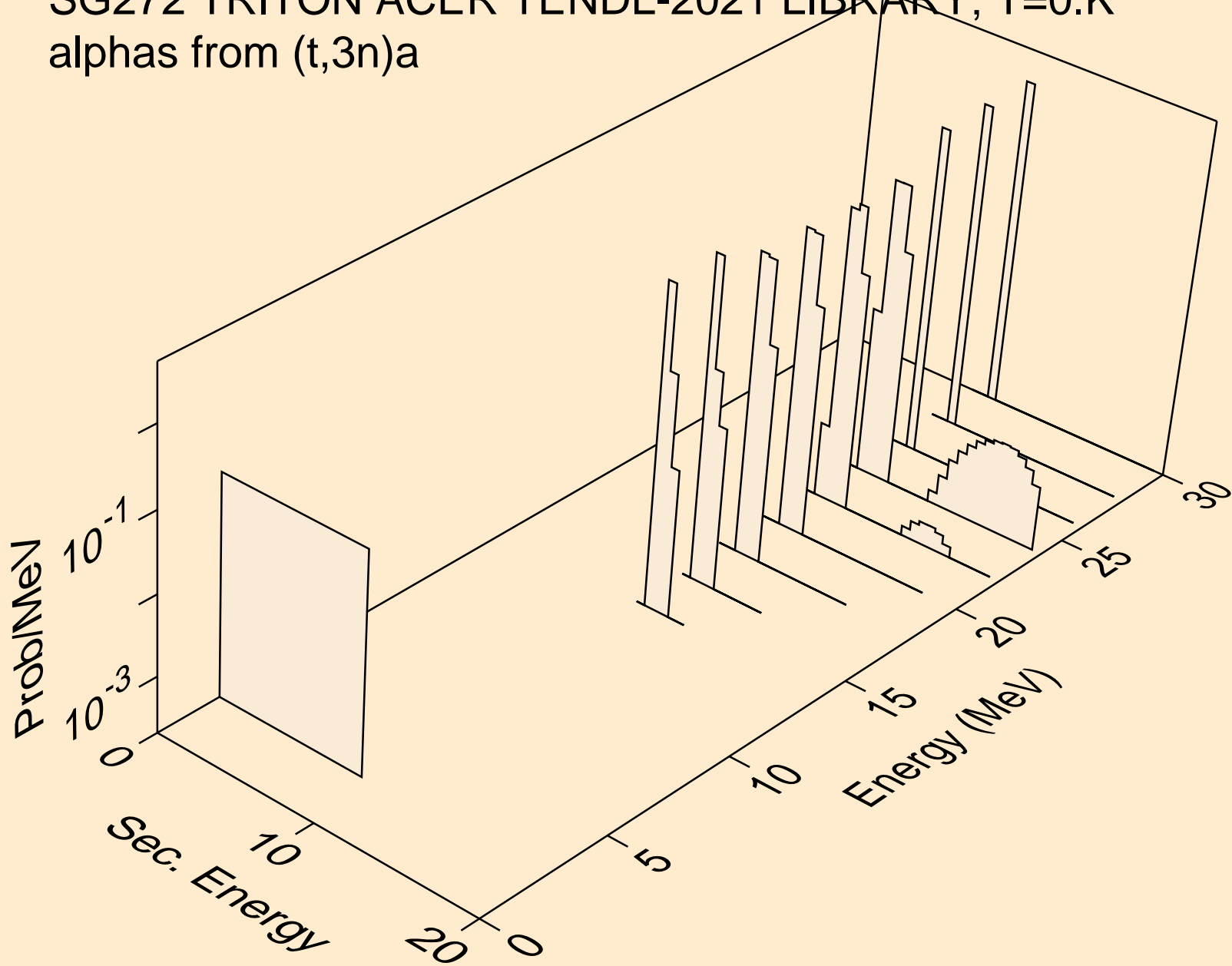

SG272 TRITON ACER TENDL-2021 LIBRARY; T=0.K  
alphas from (t,a)

