

# SN127M TRITON ACER TENDL-2021 LIBRARY; T=0.K

## Principal cross sections

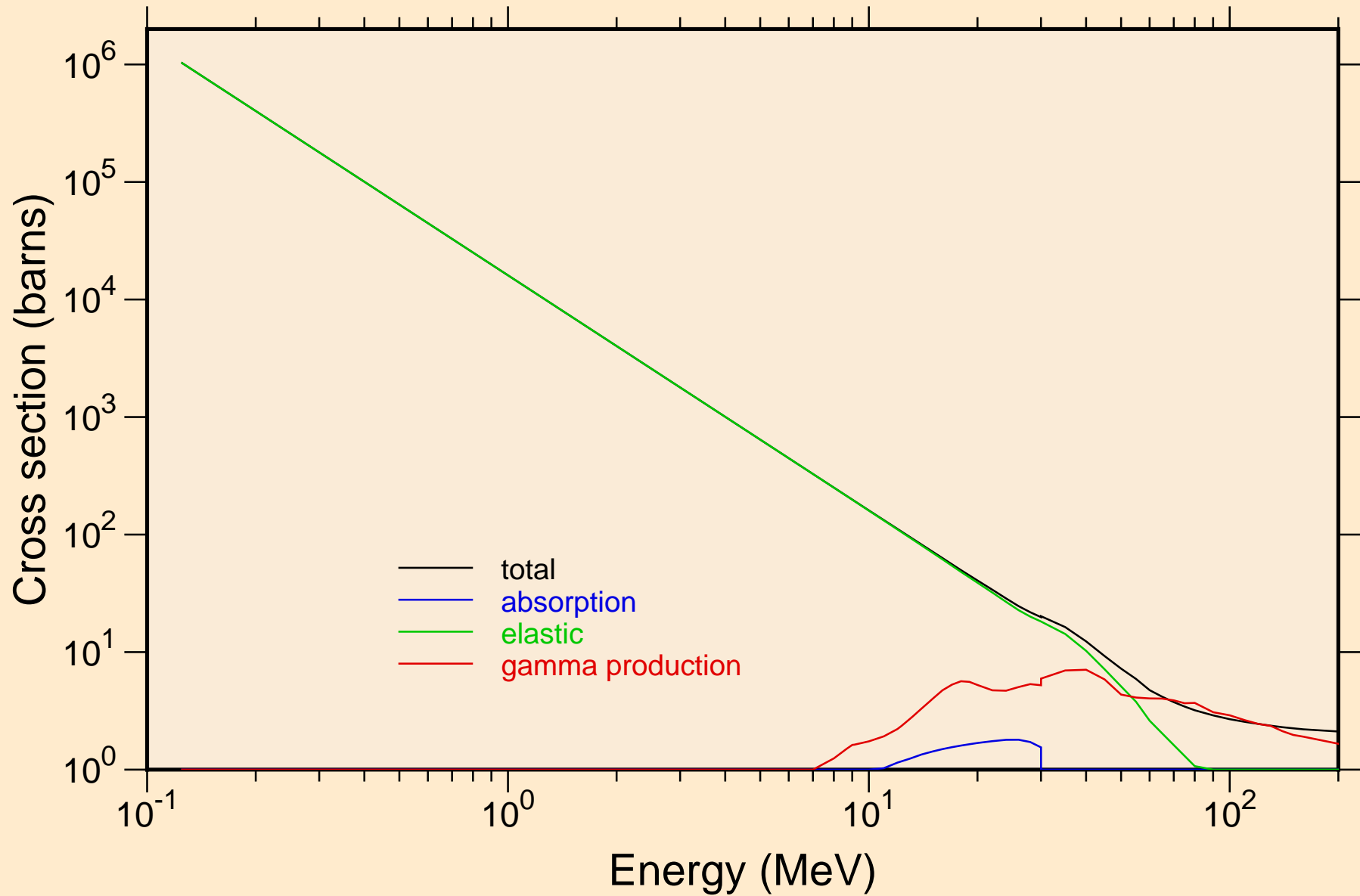

# SN127M TRITON ACER TENDL-2021 LIBRARY; T=0.K

## Heating

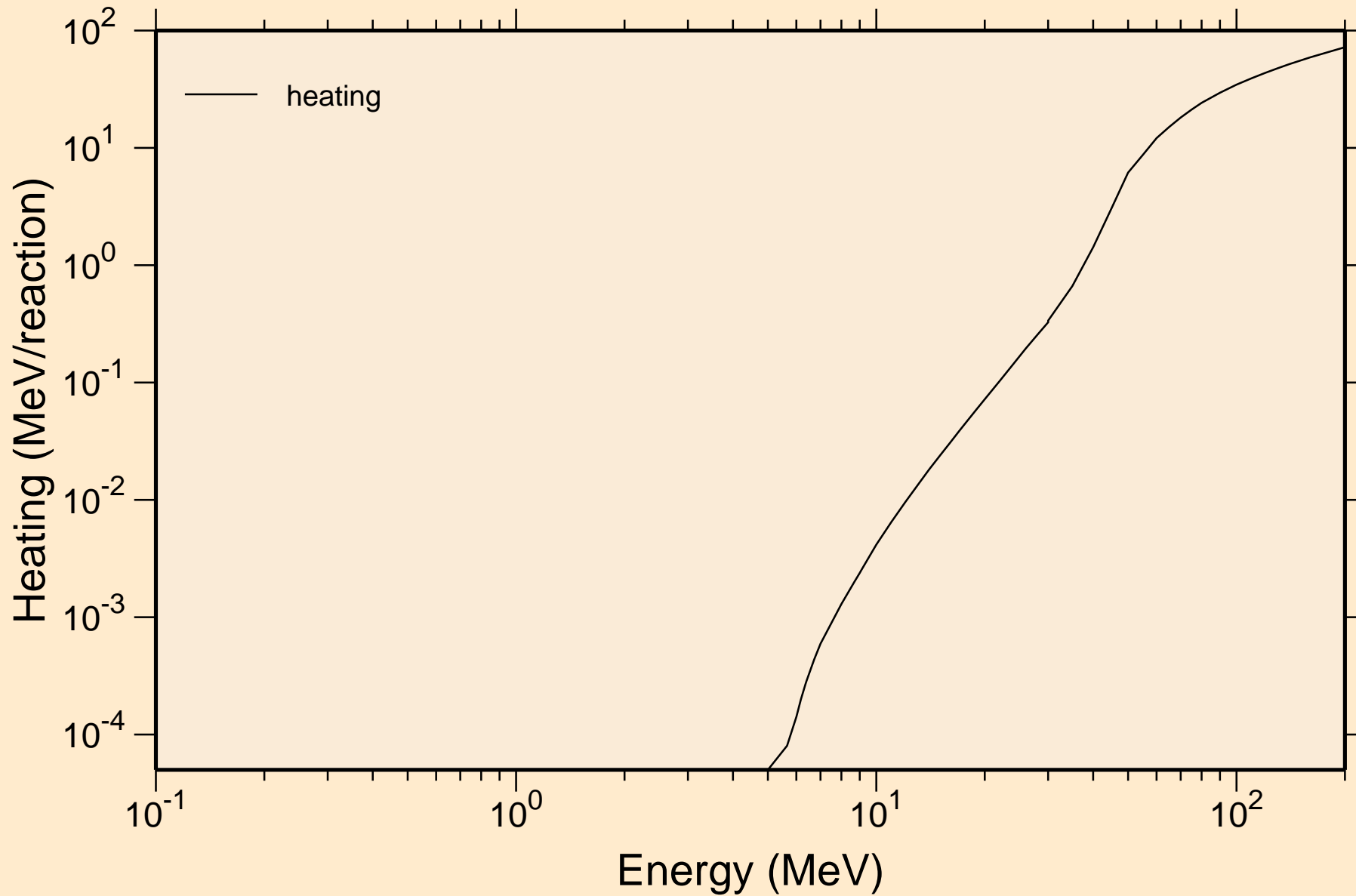

# SN127M TRITON ACER TENDL-2021 LIBRARY; T=0.K

## Principal cross sections

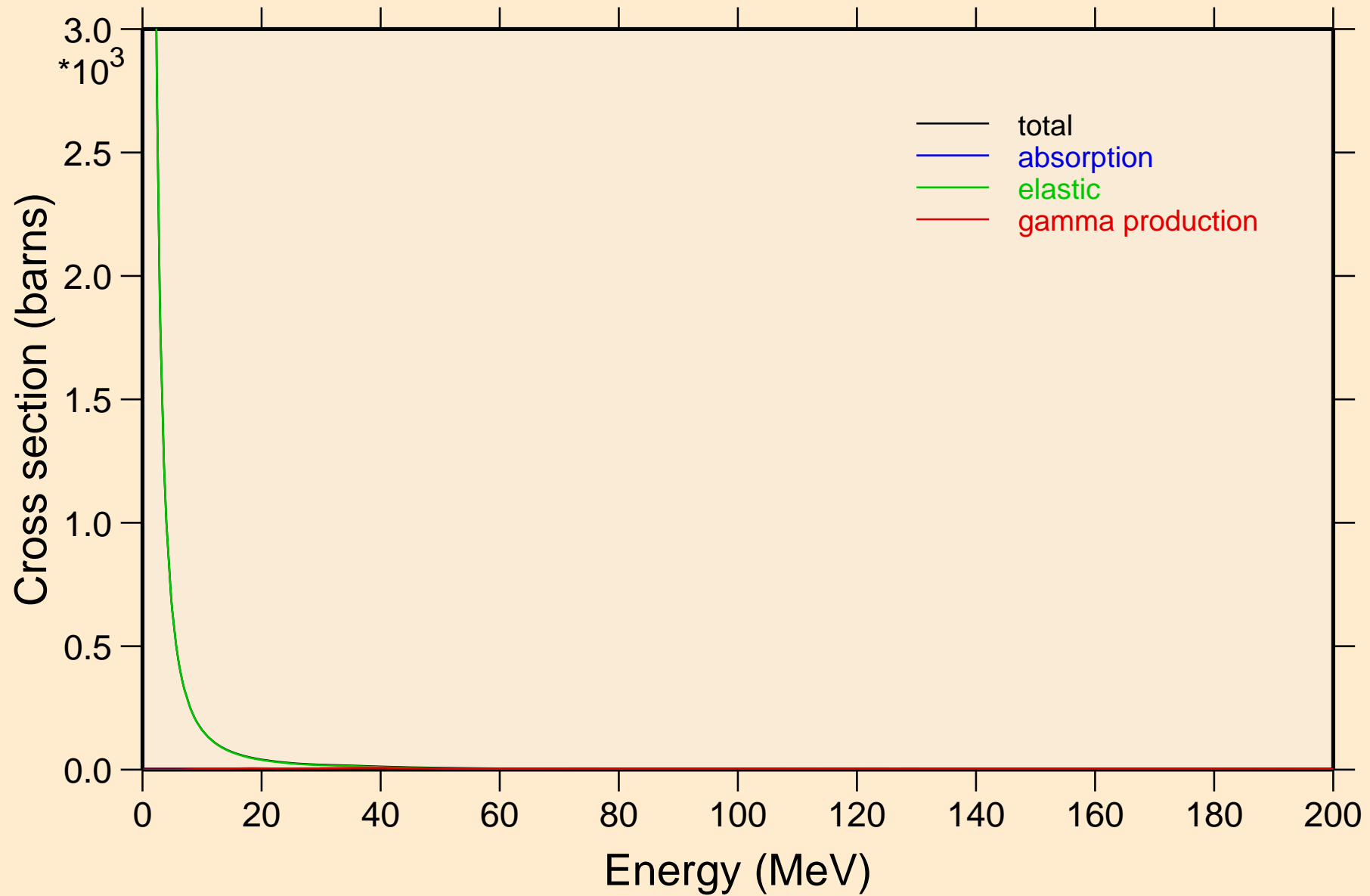

SN127M TRITON ACER TENDL-2021 LIBRARY; T=0.K

Heating

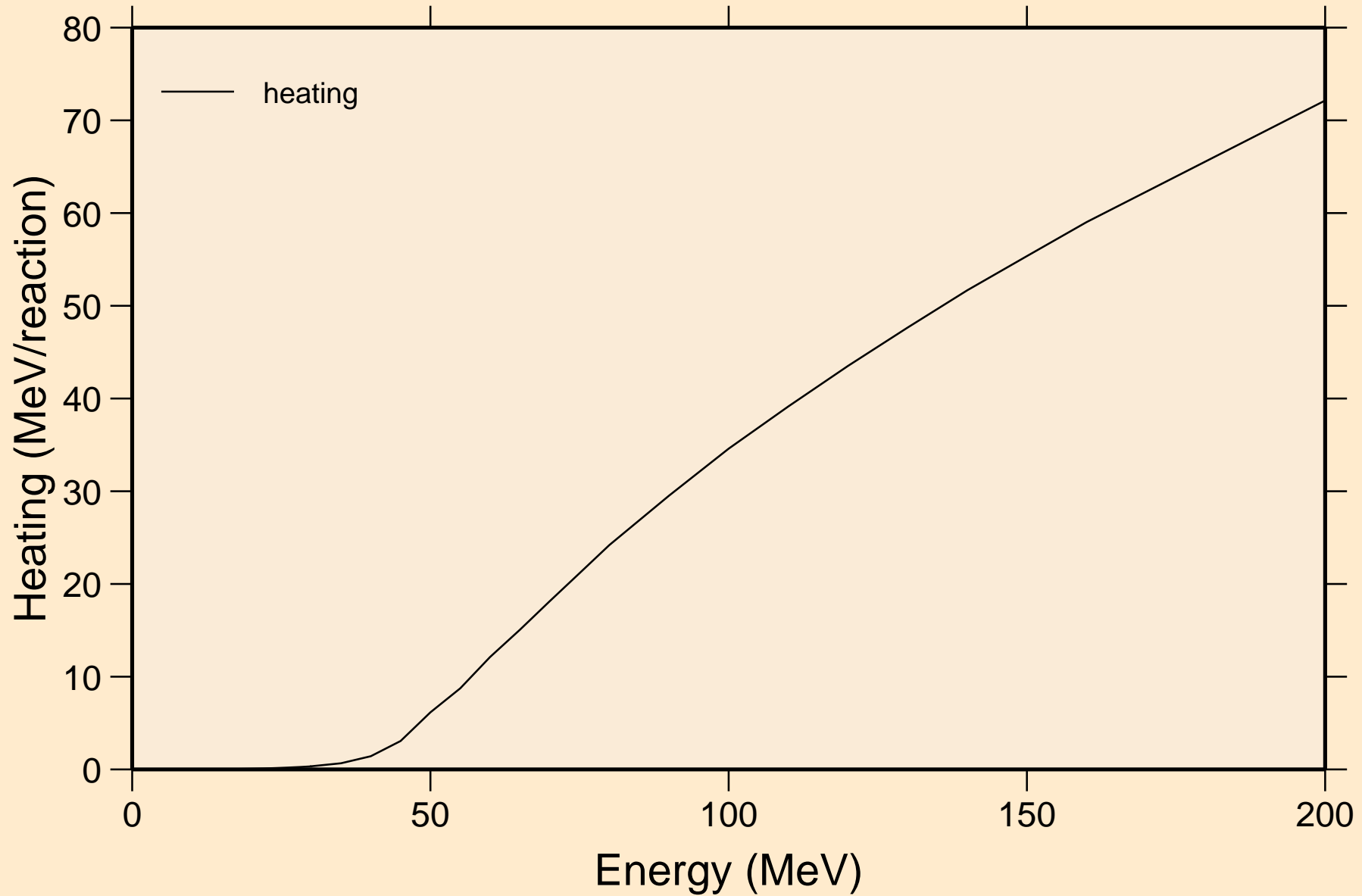

# SN127M TRITON ACER TENDL-2021 LIBRARY; T=0.K

## Threshold reactions

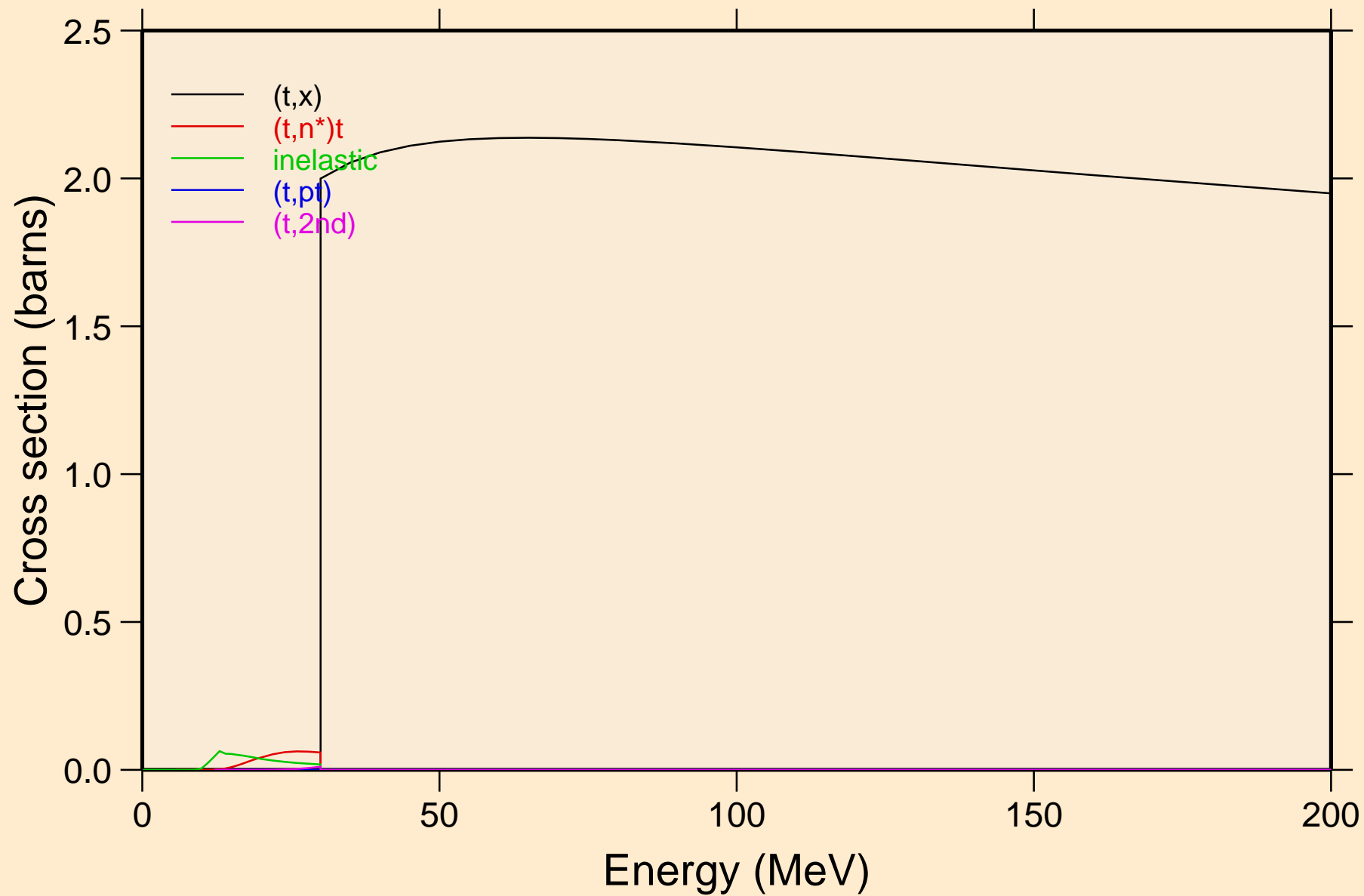

# SN127M TRITON ACER TENDL-2021 LIBRARY; T=0.K

## Threshold reactions

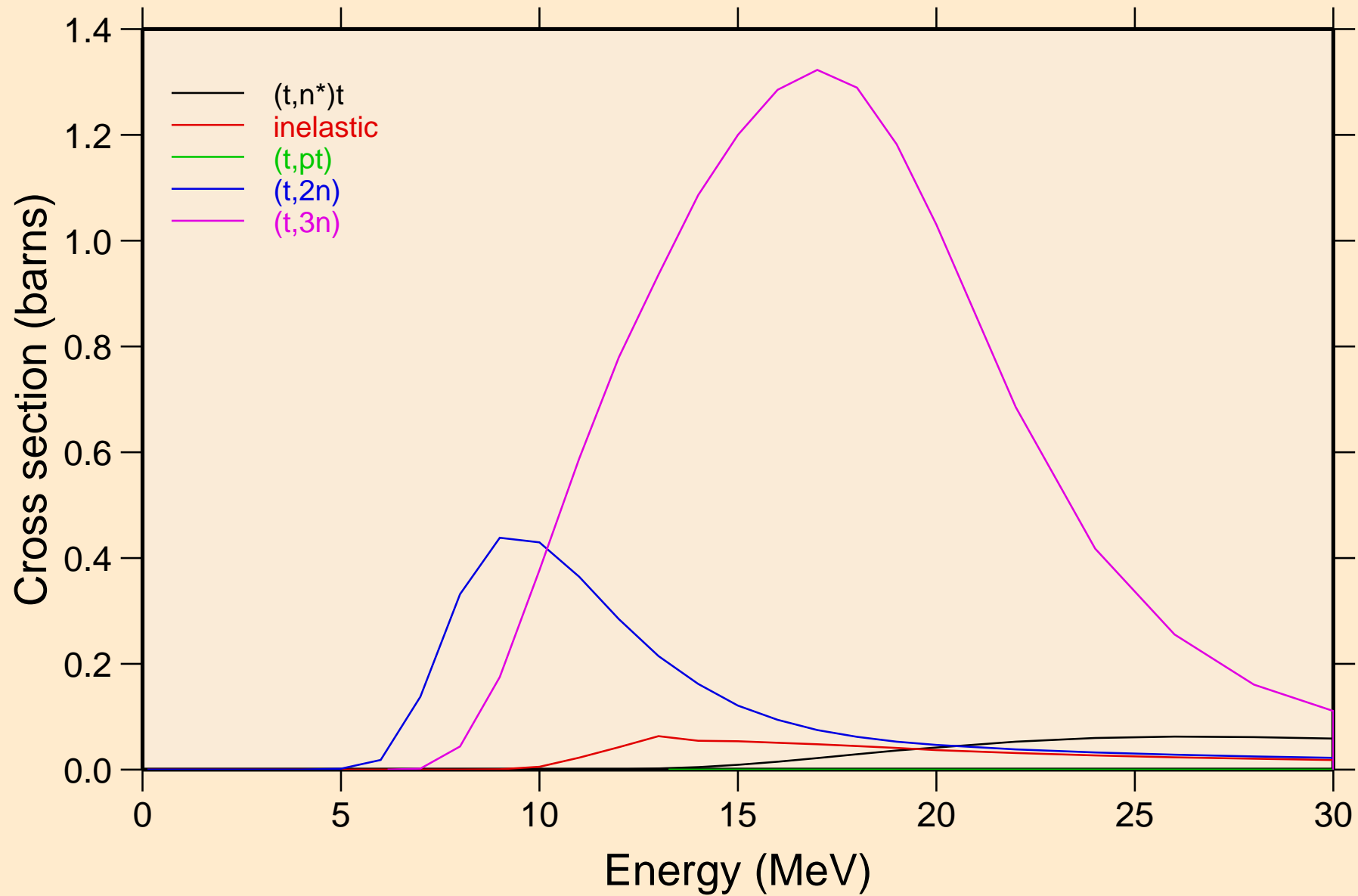

SN127M TRITON ACER TENDL-2021 LIBRARY; T=0.K  
Threshold reactions

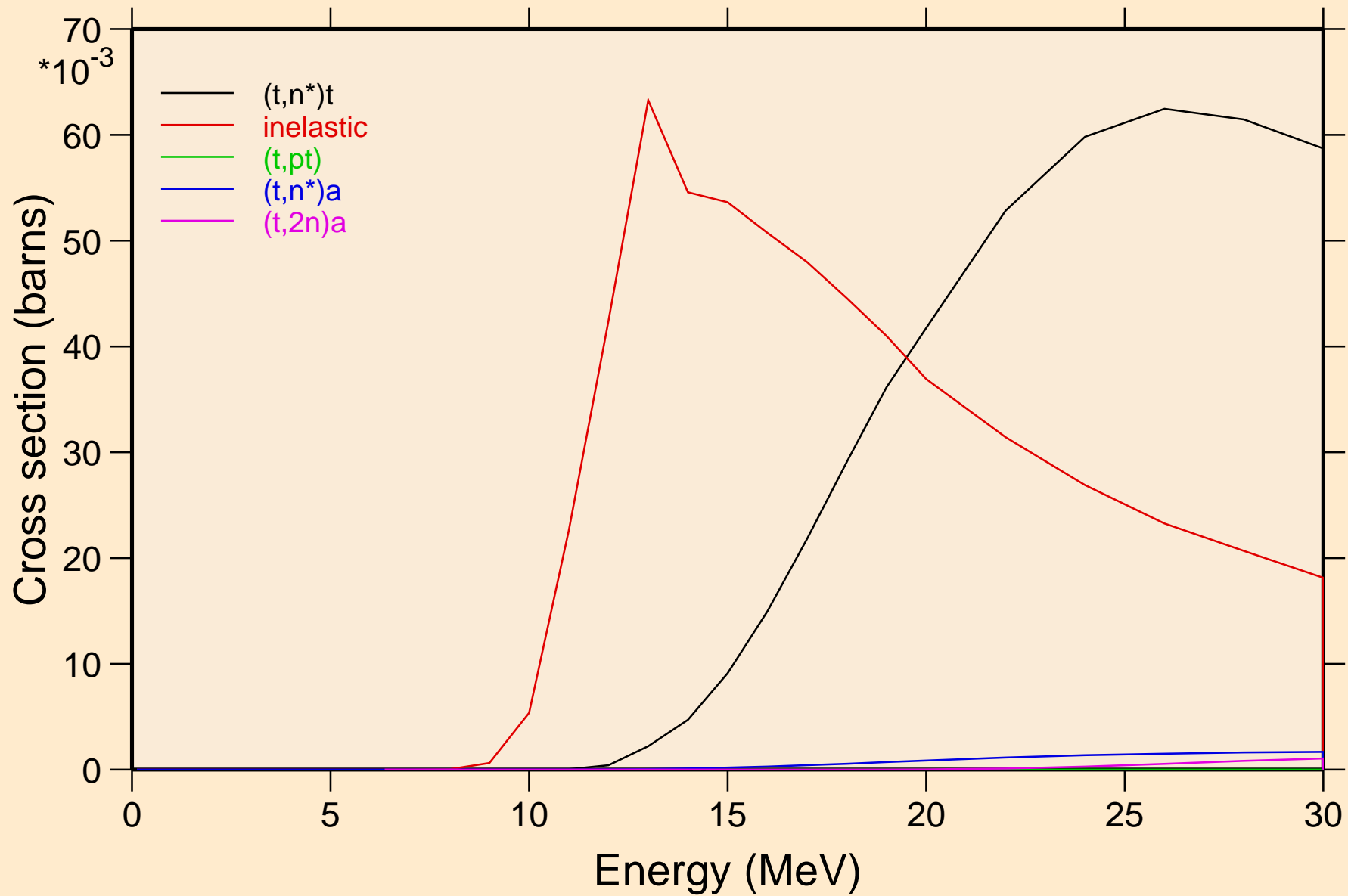

# SN127M TRITON ACER TENDL-2021 LIBRARY; T=0.K

## Threshold reactions

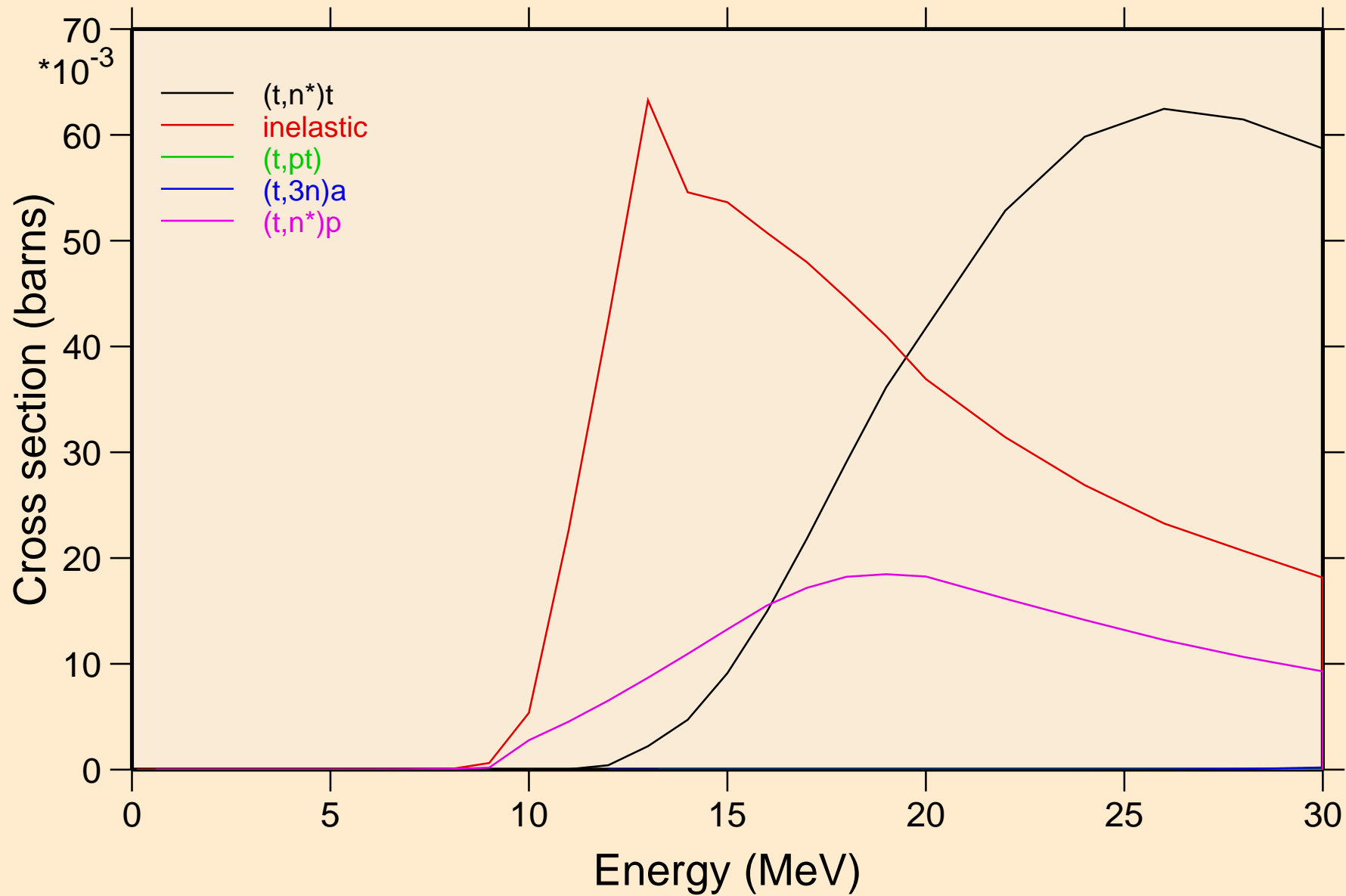



# SN127M TRITON ACER TENDL-2021 LIBRARY; T=0.K

## Threshold reactions

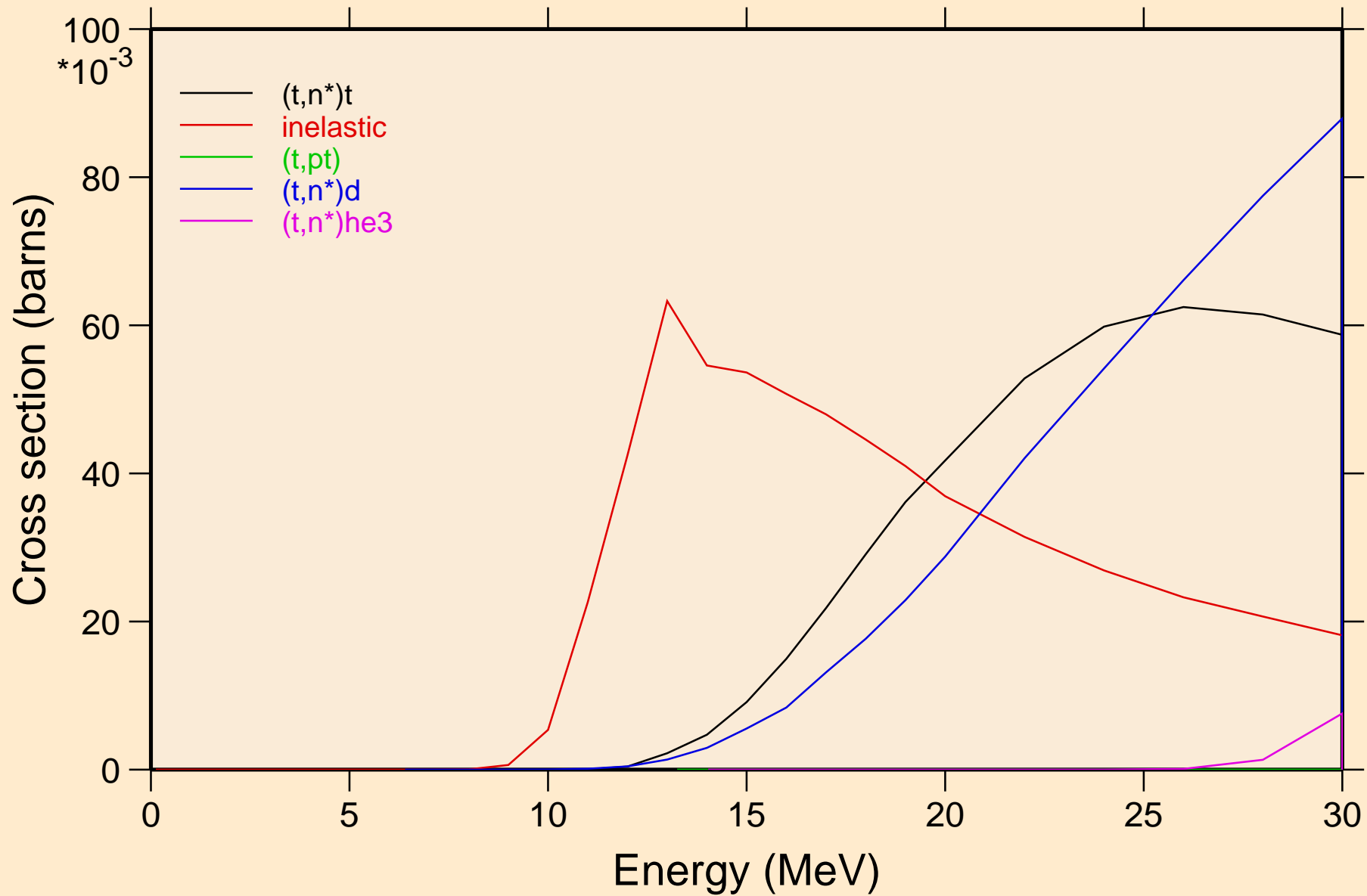

# SN127M TRITON ACER TENDL-2021 LIBRARY; T=0.K

## Threshold reactions

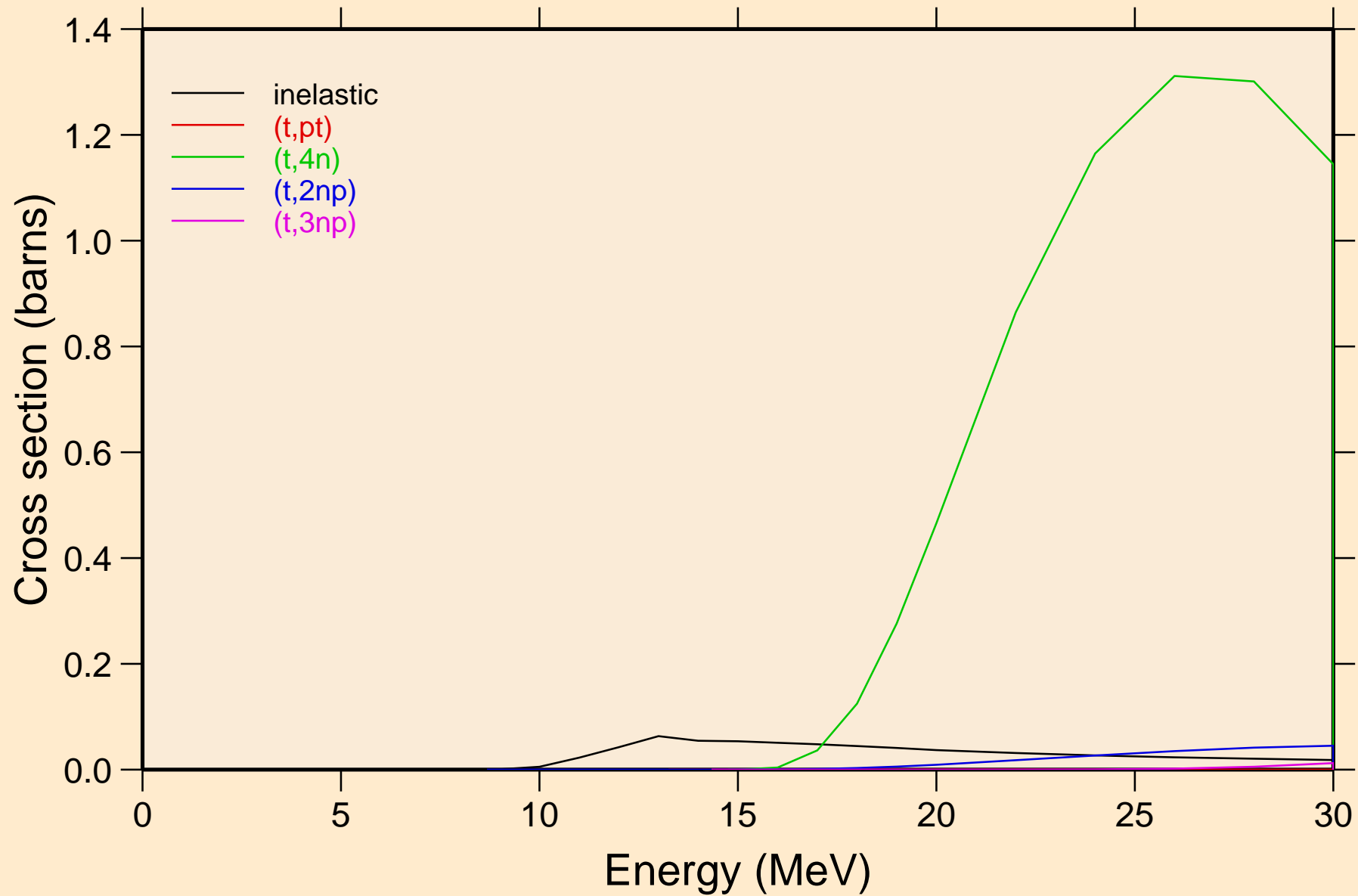

SN127M TRITON ACER TENDL-2021 LIBRARY; T=0.K  
Threshold reactions

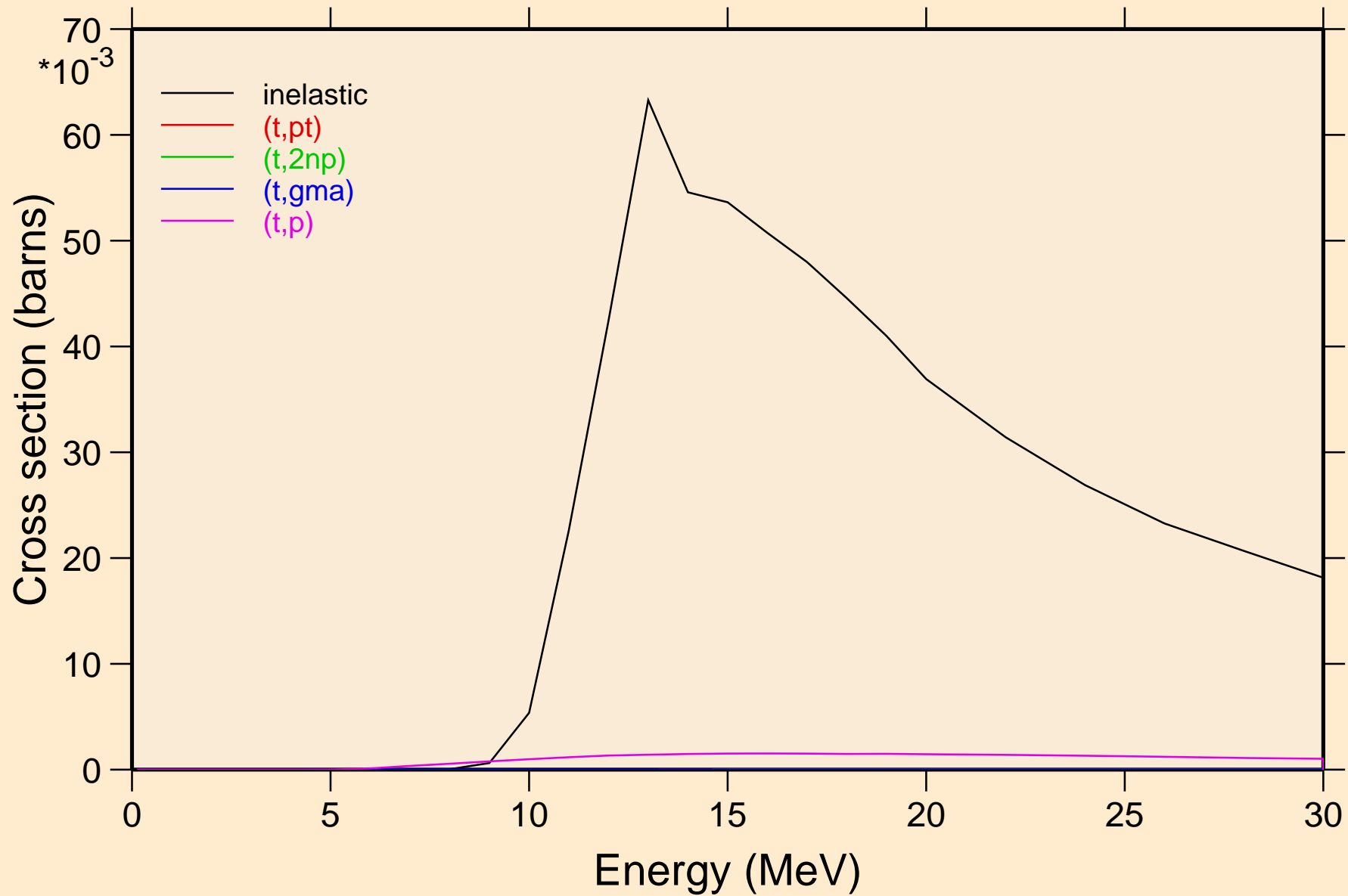

# SN127M TRITON ACER TENDL-2021 LIBRARY; T=0.K

## Threshold reactions

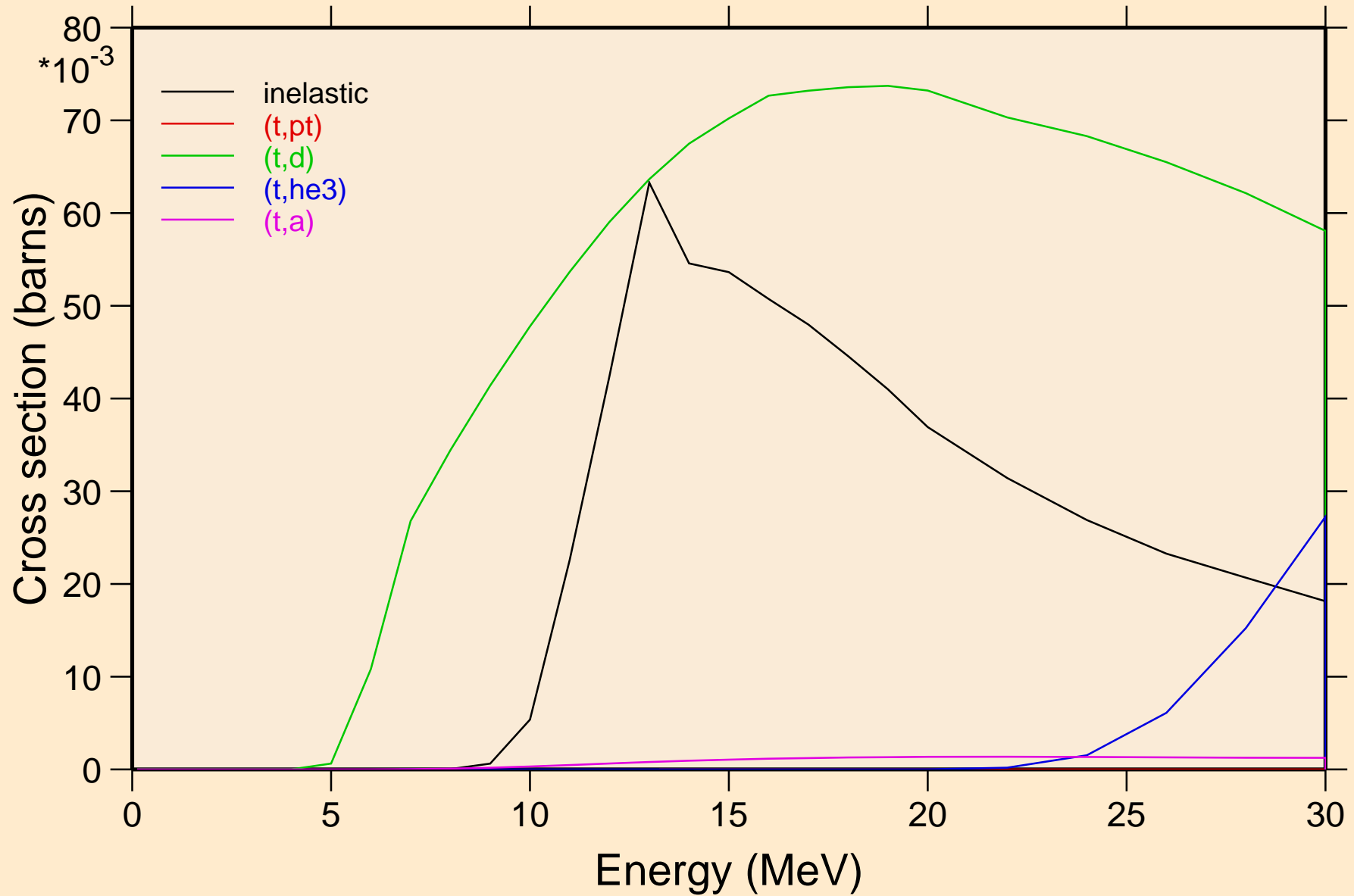

# SN127M TRITON ACER TENDL-2021 LIBRARY; T=0.K

## Threshold reactions

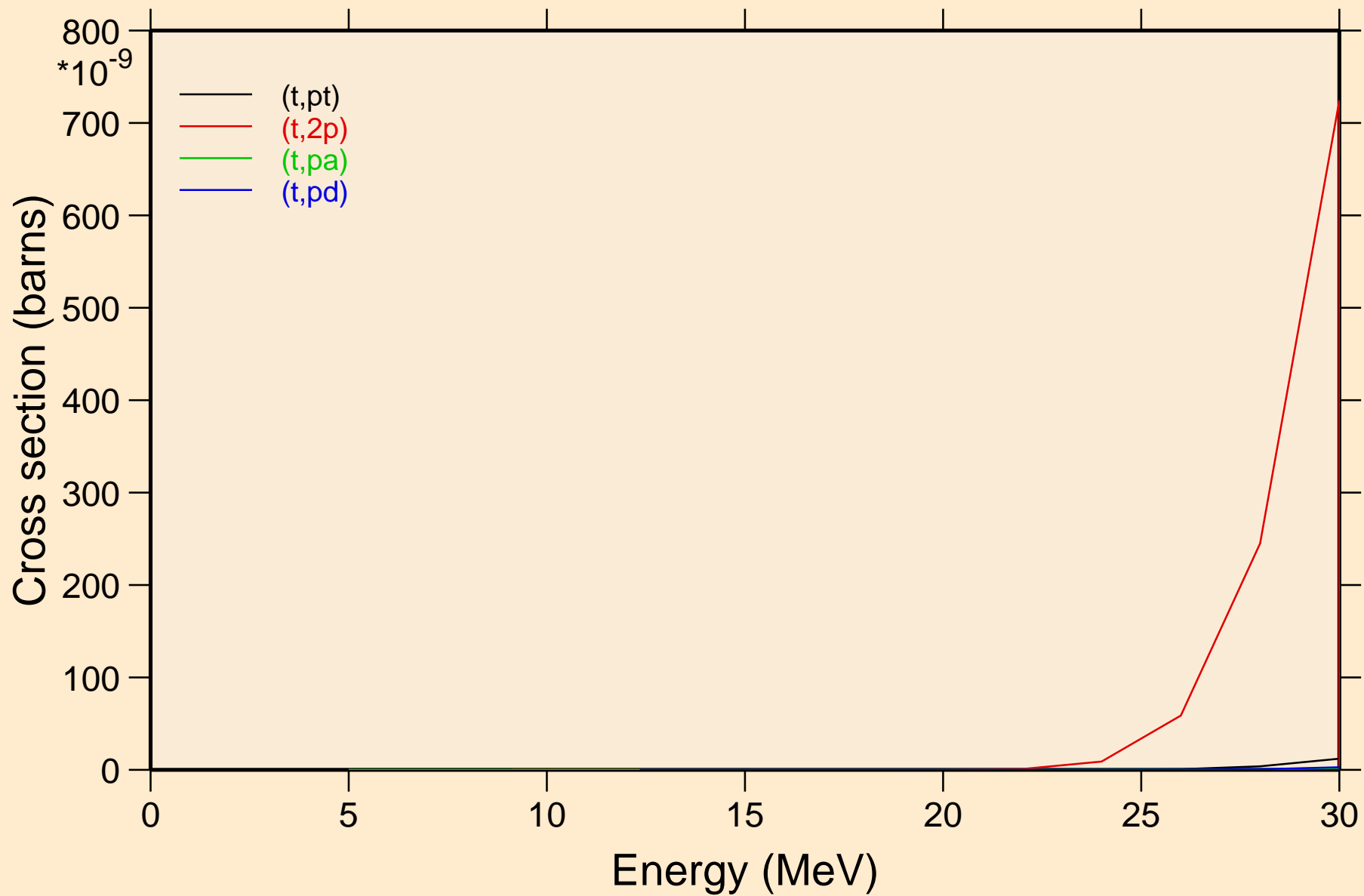

SN127M TRITON ACER TENDL-2021 LIBRARY; T=0.K  
Threshold reactions

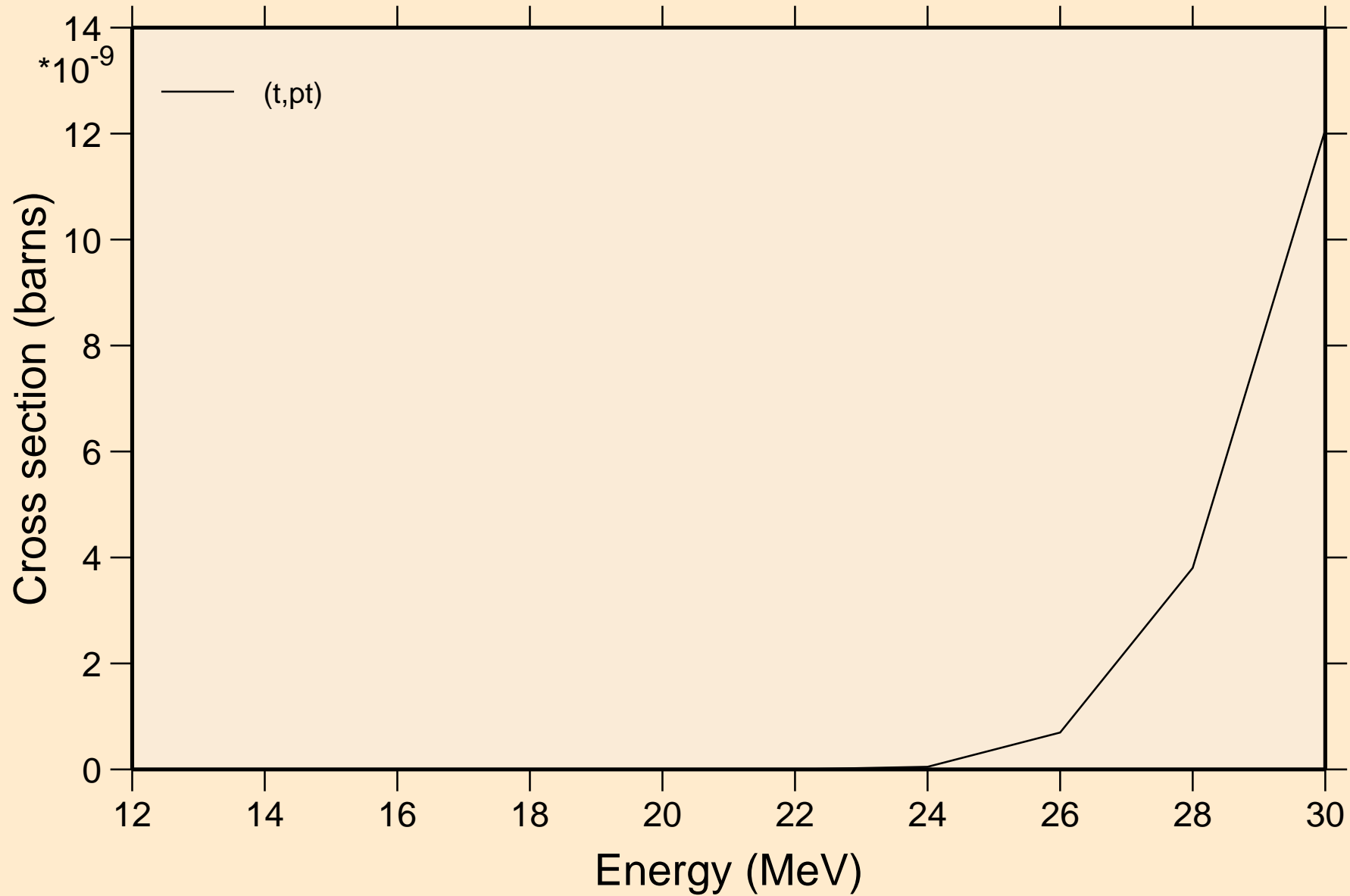

SN127M TRITON ACER TENDL-2021 LIBRARY; T=0.K  
angular distribution for elastic

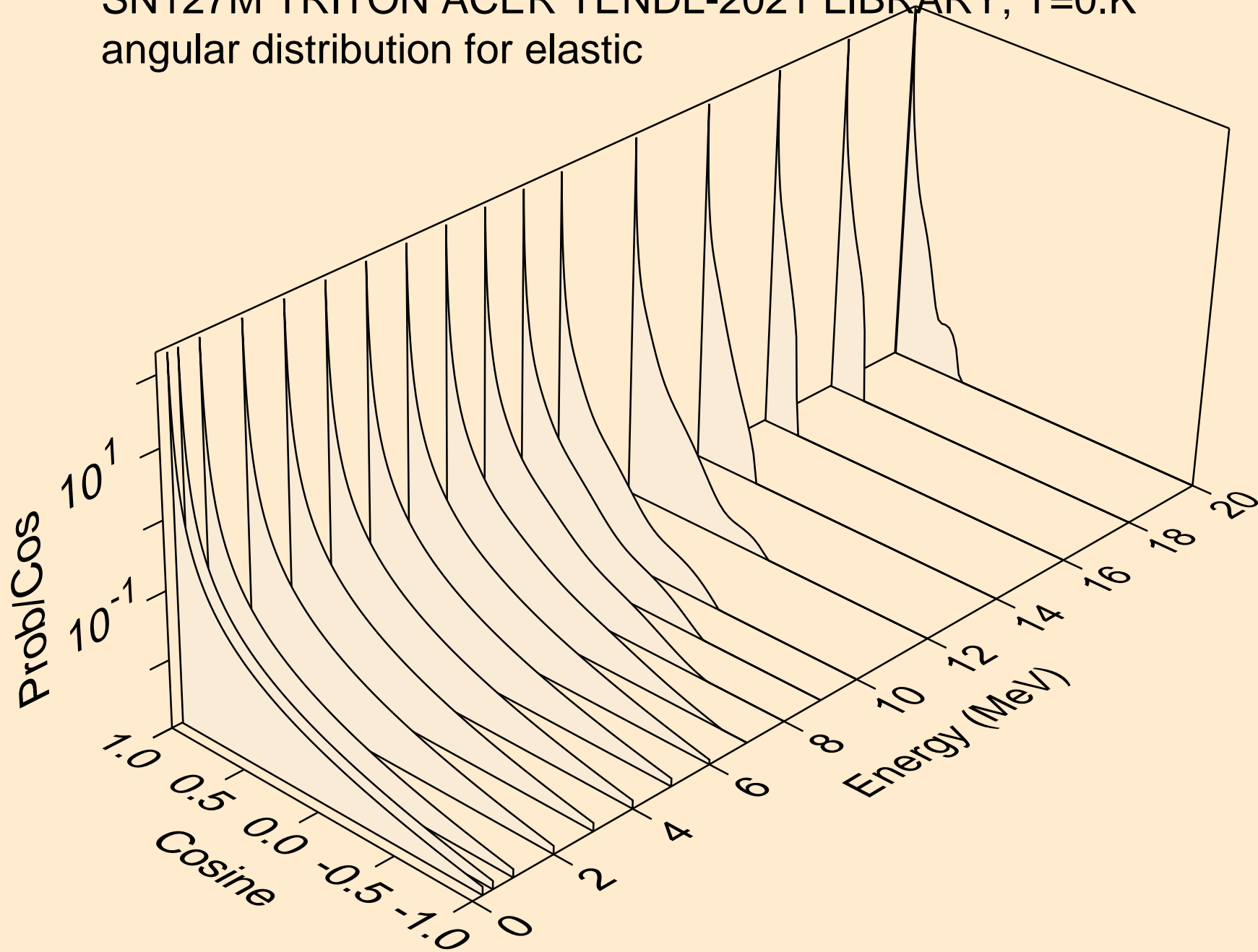

SN127M TRITON ACER TENDL-2021 LIBRARY; T=0.K  
angular distribution for elastic

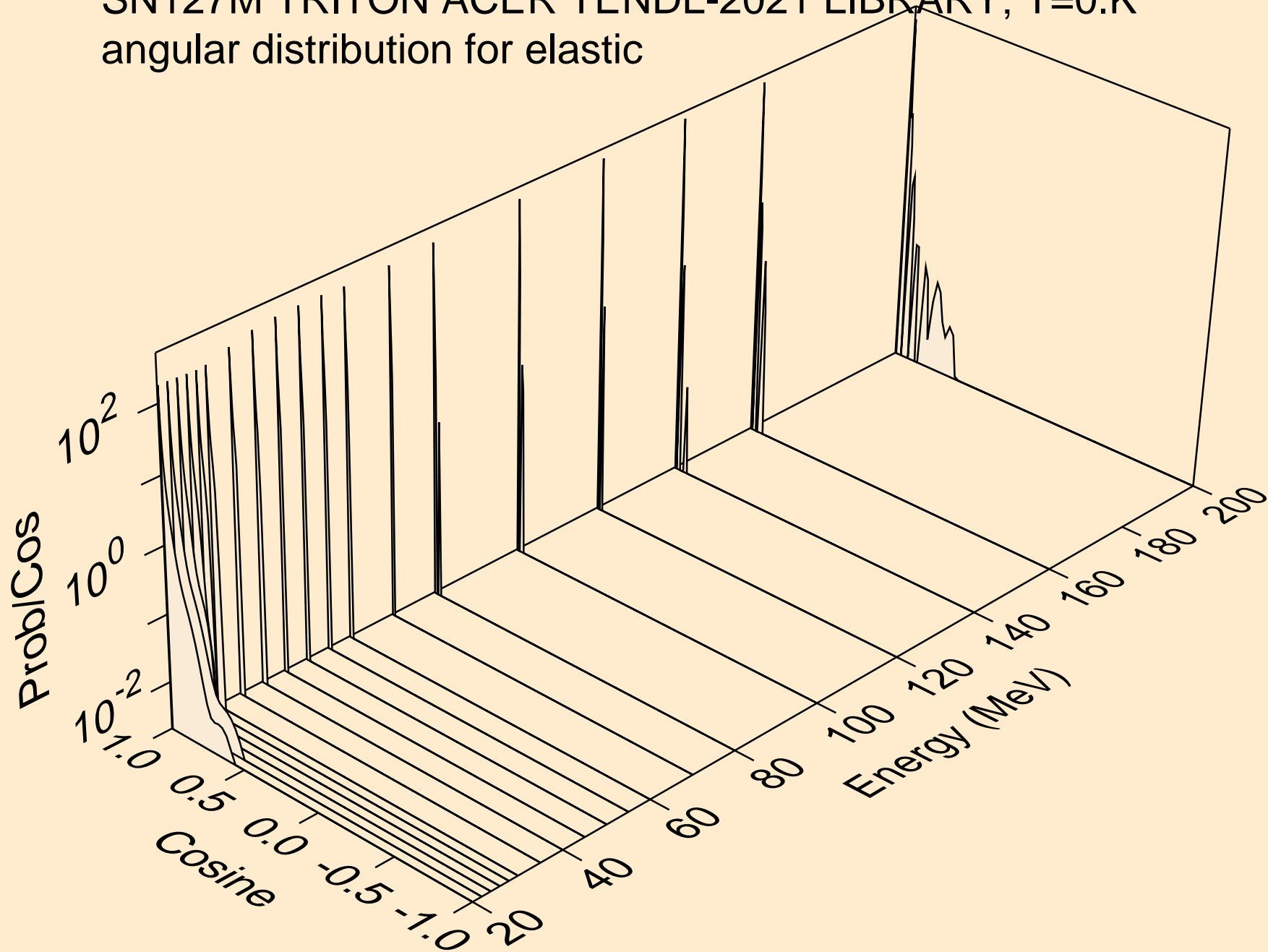



SN127M TRITON ACER TENDL-2021 LIBRARY; T=0.K  
Triton emission for (t,x)

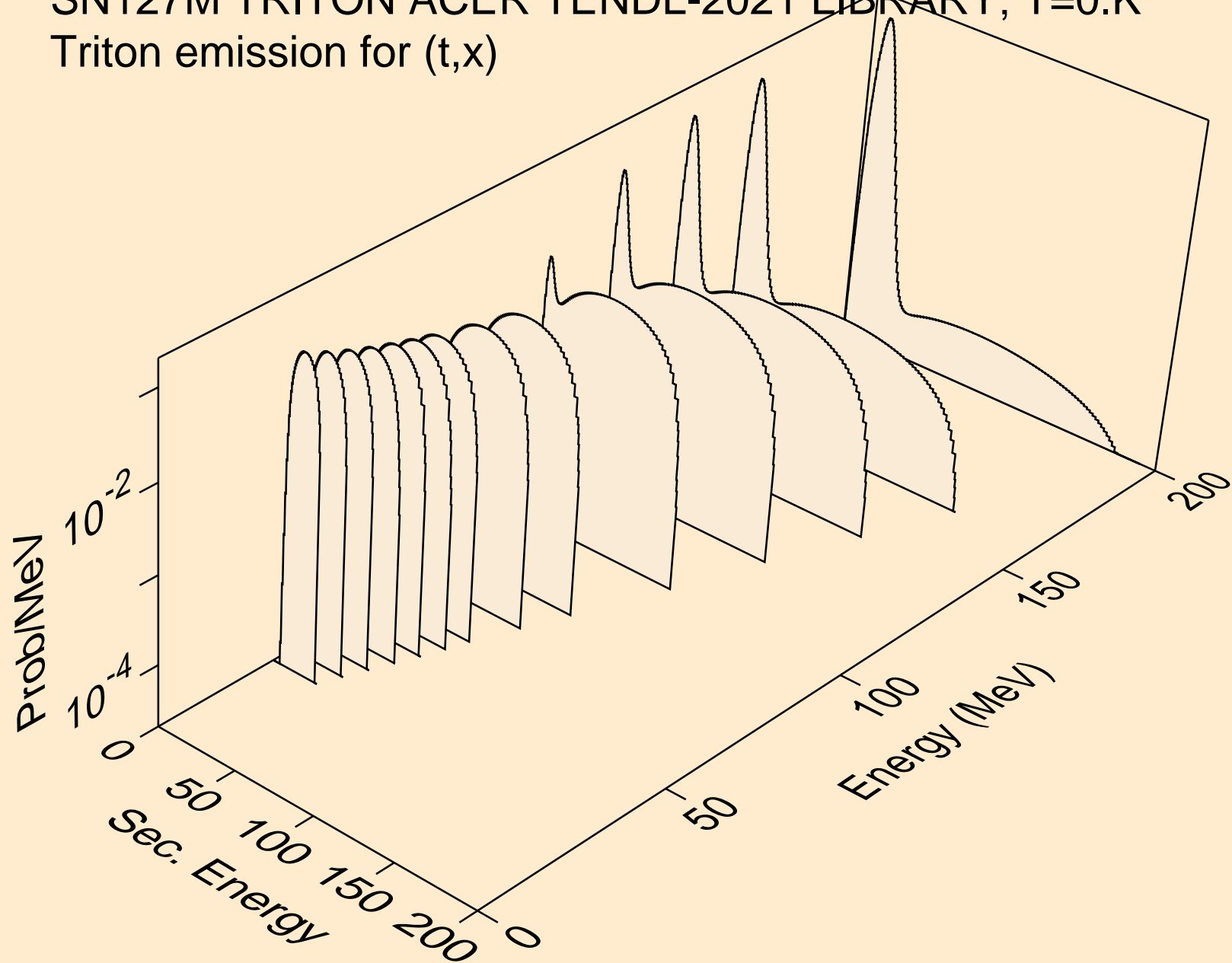

SN127M TRITON ACER TENDL-2021 LIBRARY; T=0.K  
Triton emission for (t,n\*)t

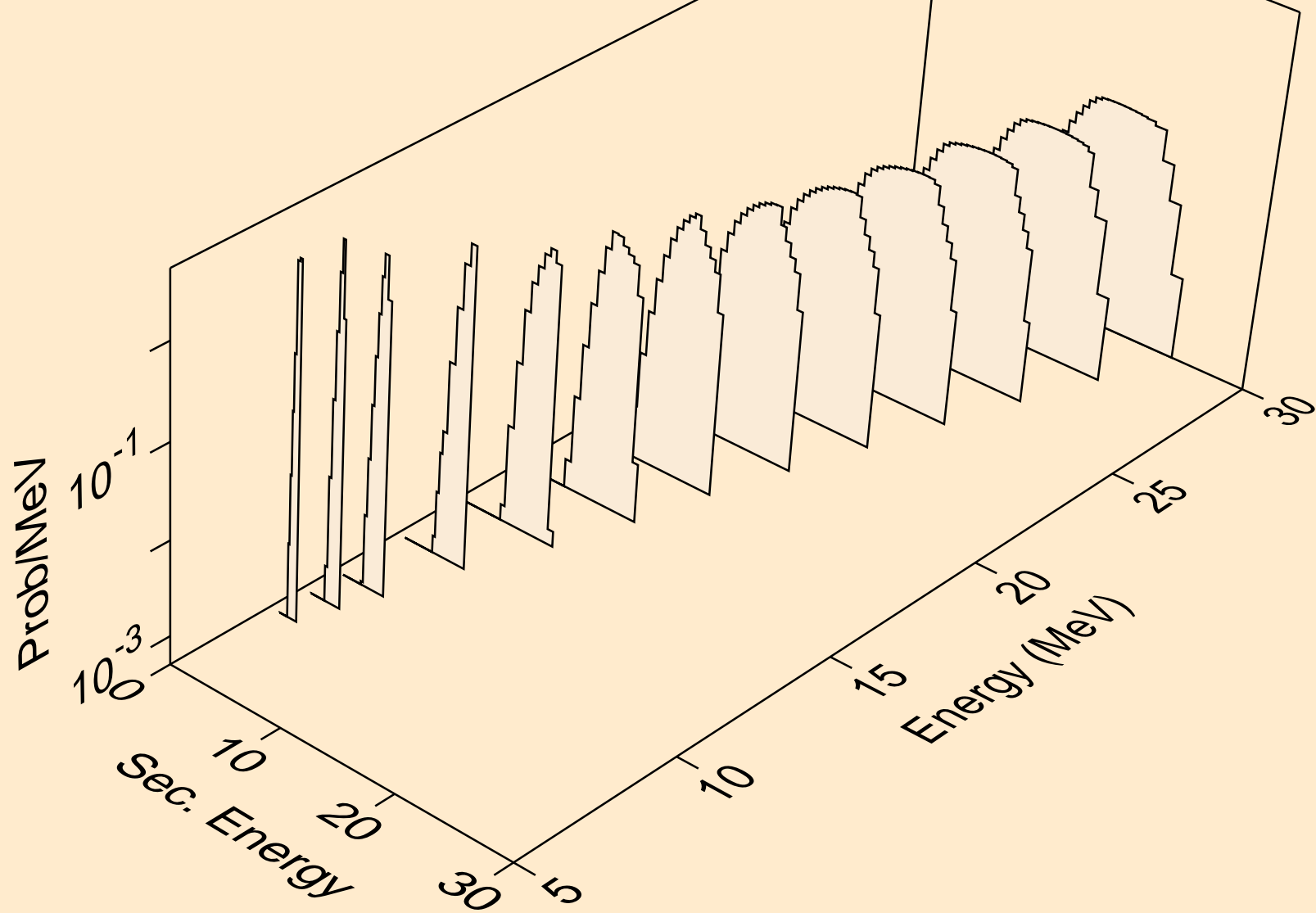

SN127M TRITON ACER TENDL-2021 LIBRARY; T=0.K  
Triton emission for inelastic

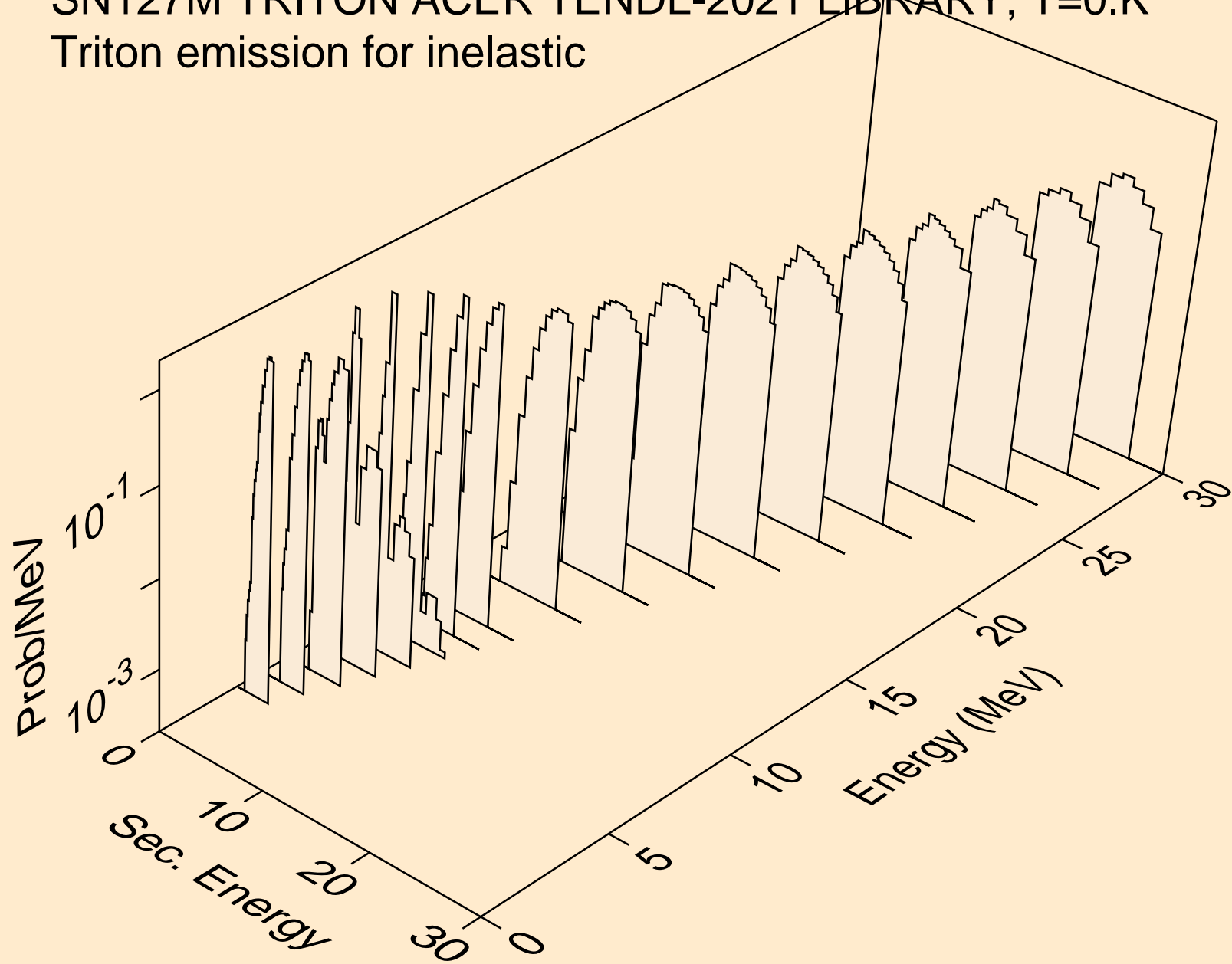

SN127M TRITON ACER TENDL-2021 LIBRARY; T=0.K  
Triton emission for (t,pt)

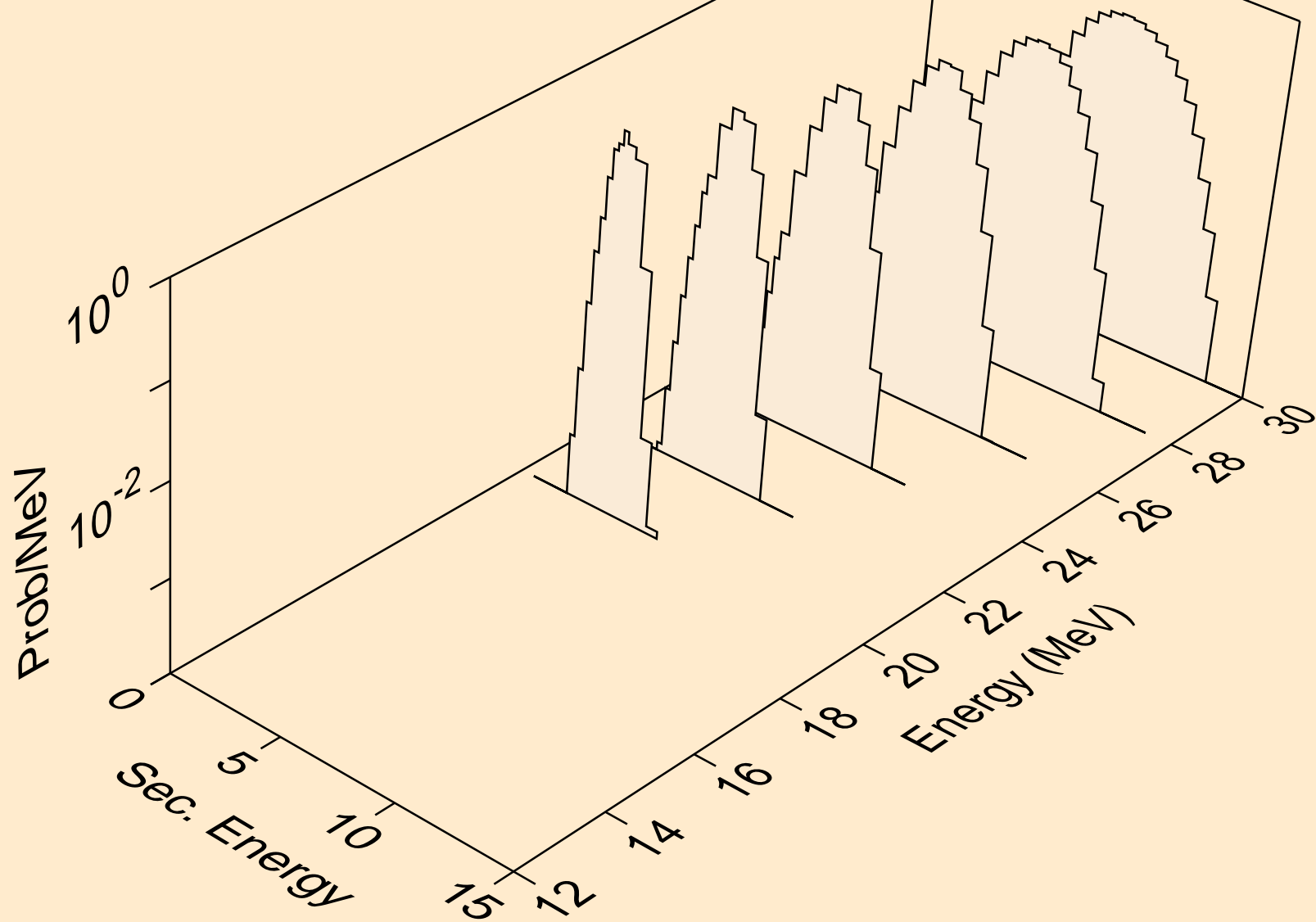

SN127M TRITON ACER TENDL-2021 LIBRARY; T=0.K  
Photon emission for (z,n)

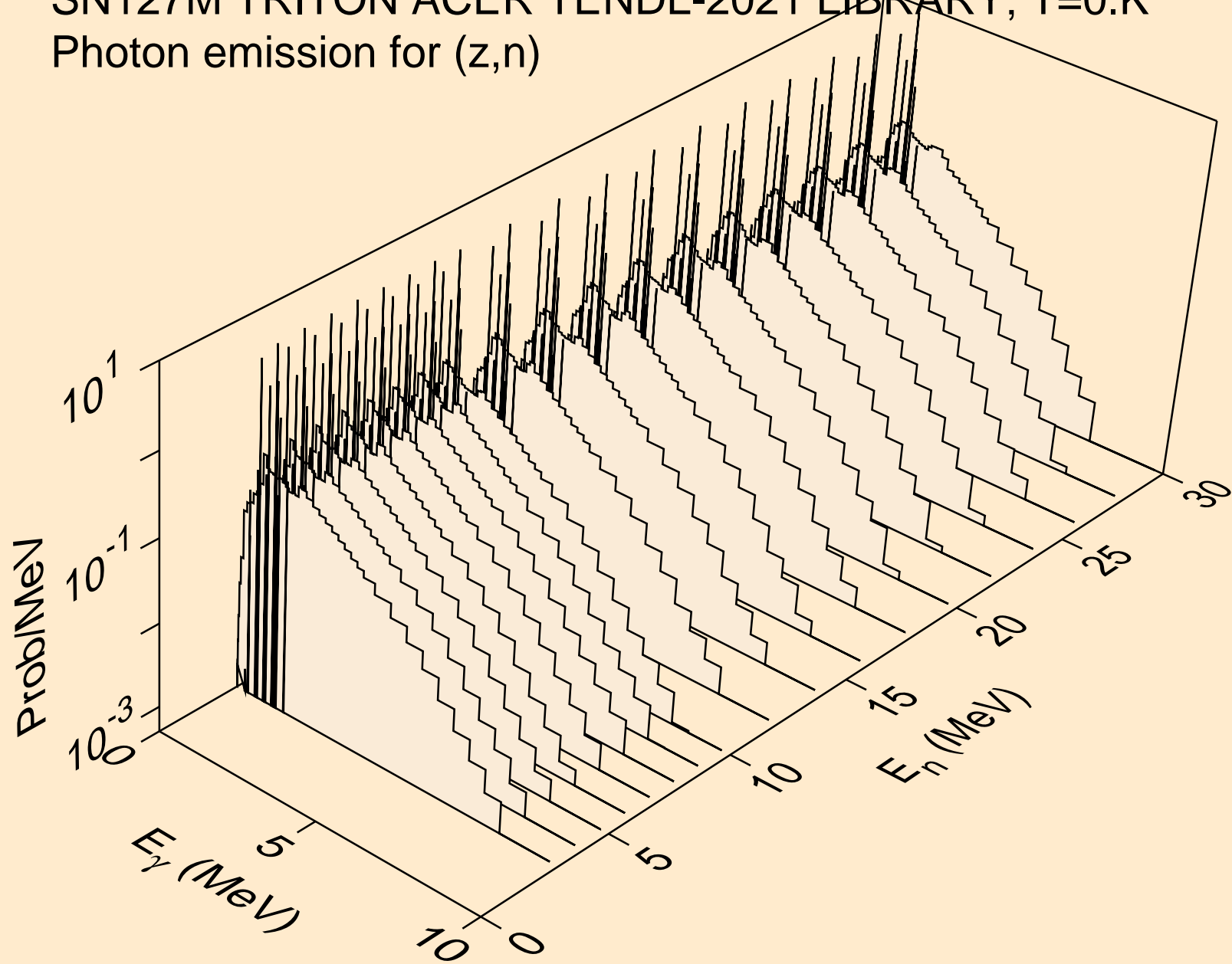

SN127M TRITON ACER TENDL-2021 LIBRARY; T=0.K  
Photon emission for (n,x)

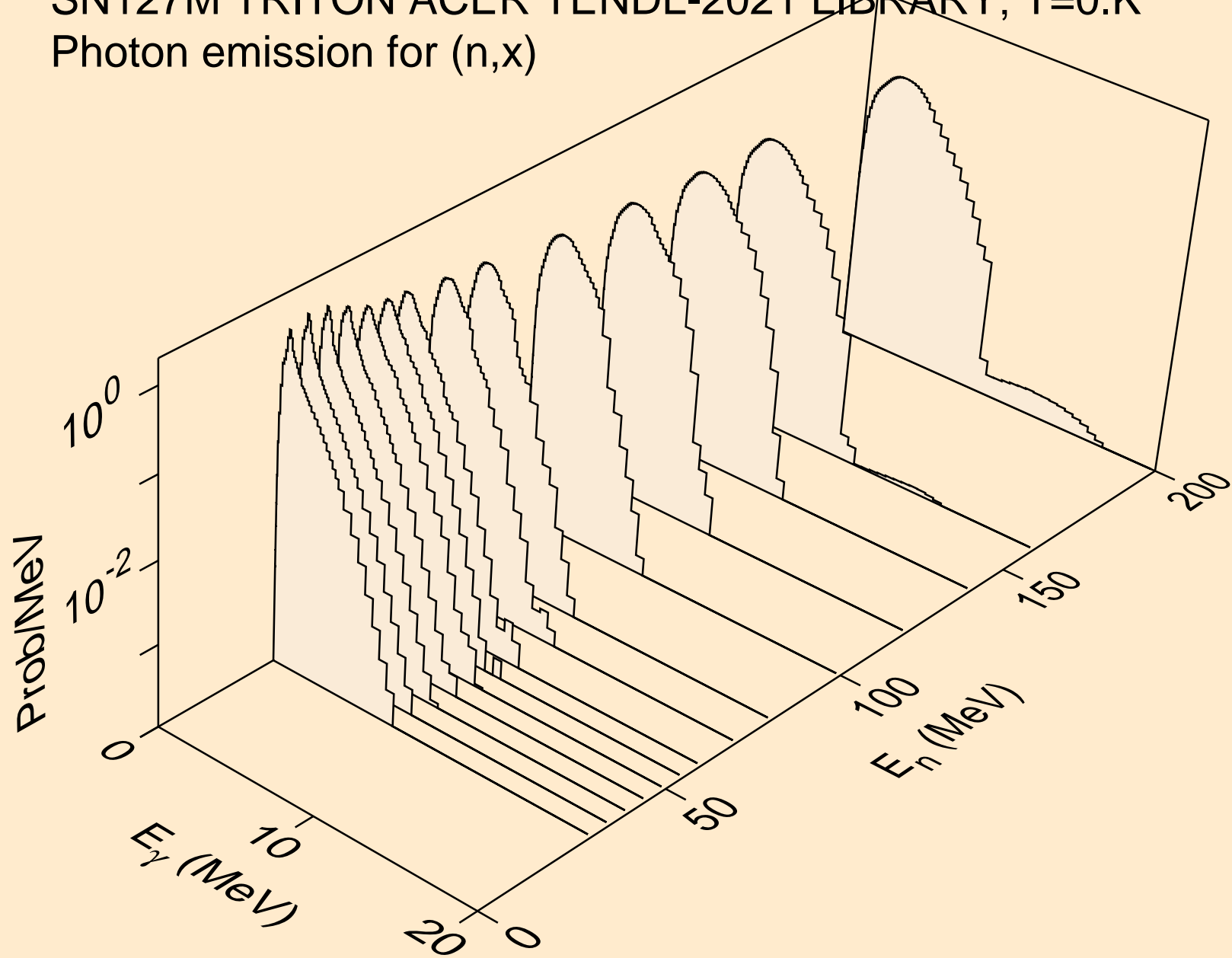

SN127M TRITON ACER TENDL-2021 LIBRARY; T=0.K  
Photon emission for (n,2nd)

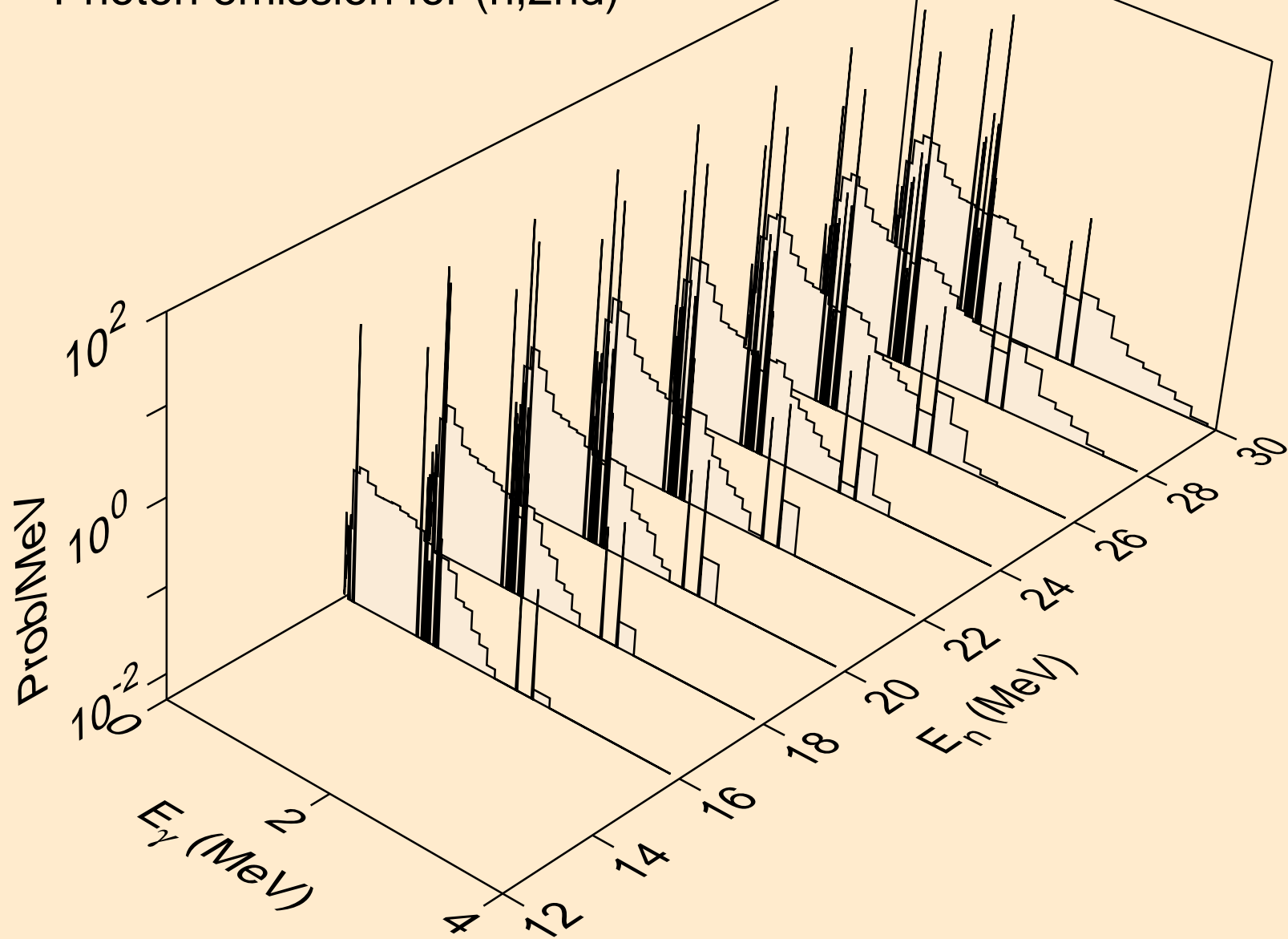

SN127M TRITON ACER TENDL-2021 LIBRARY; T=0.K  
Photon emission for (n,2n)

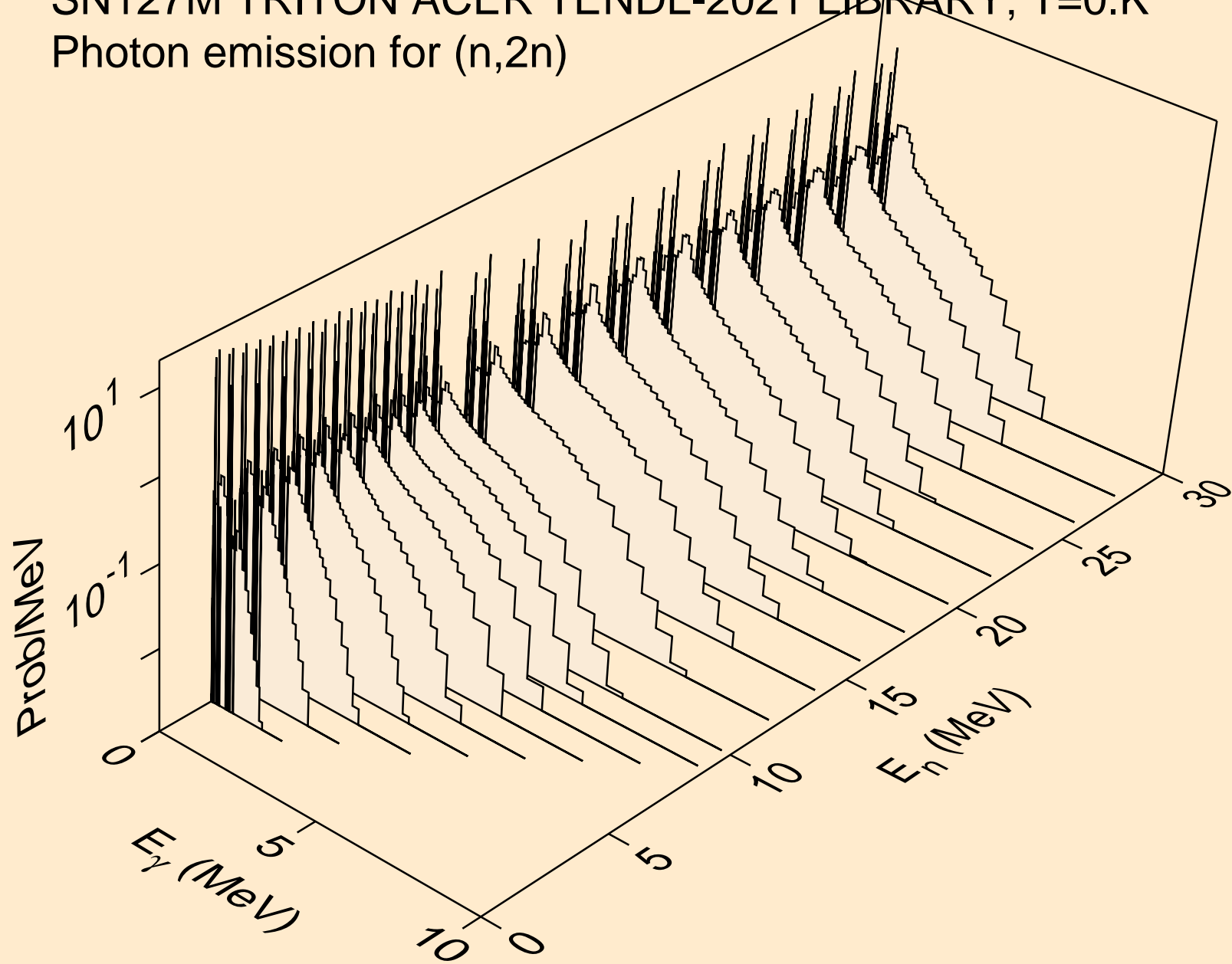



SN127M TRITON ACER TENDL-2021 LIBRARY; T=0.K  
Photon emission for (n,3n)

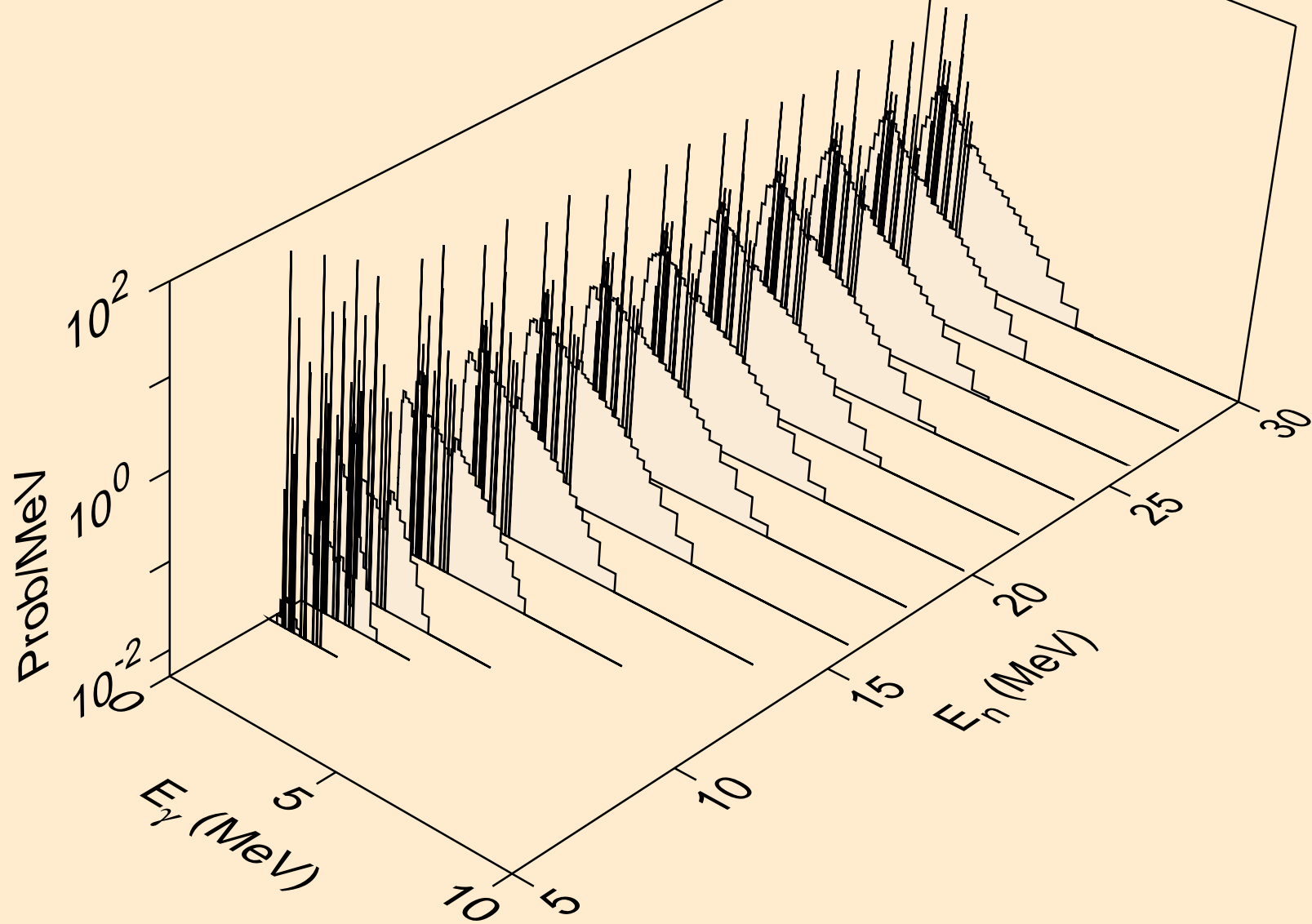

SN127M TRITON ACER TENDL-2021 LIBRARY; T=0.K  
Photon emission for (n,n\*)a

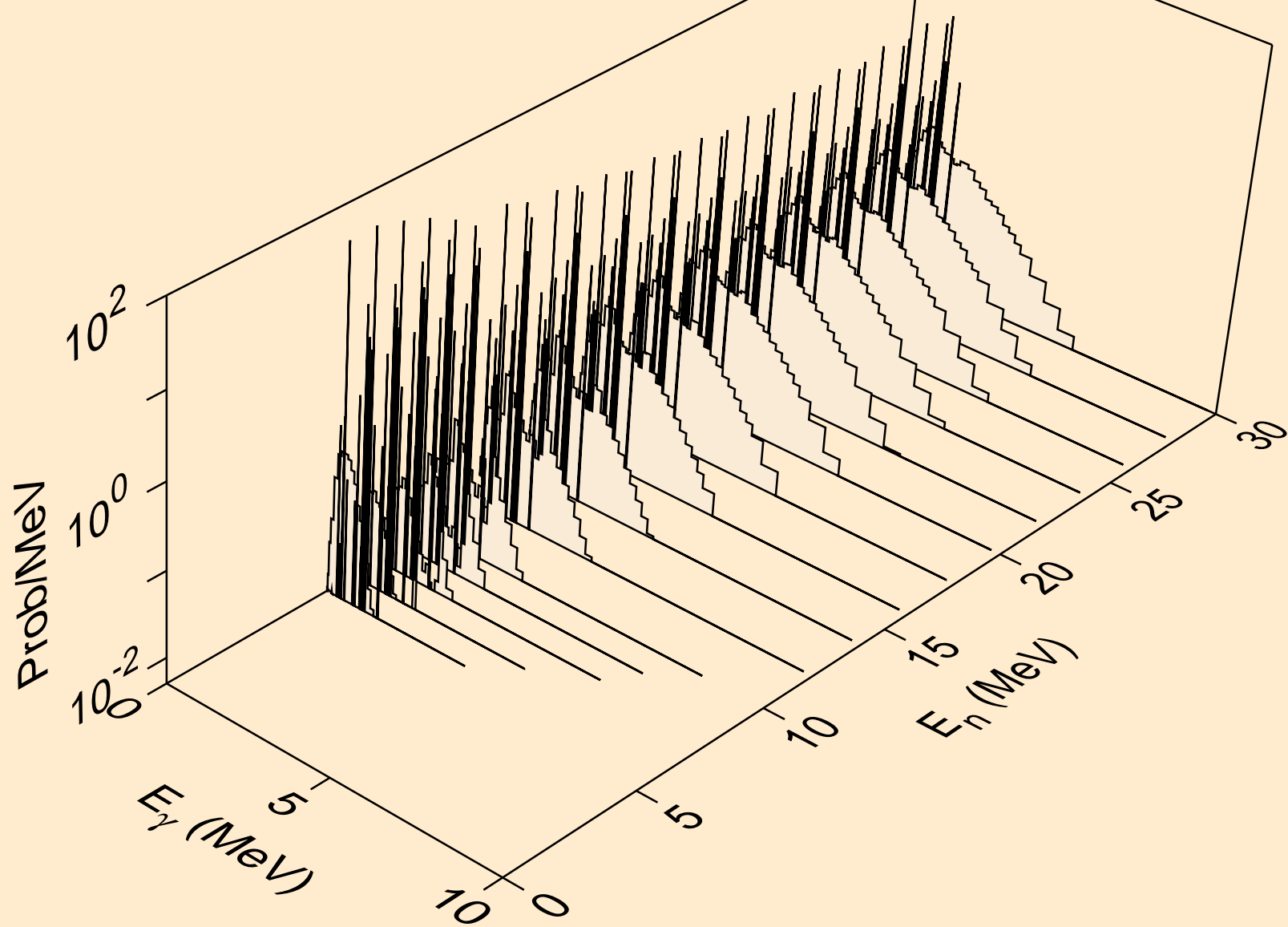

SN127M TRITON ACER TENDL-2021 LIBRARY; T=0.K  
Photon emission for (n,2n)a

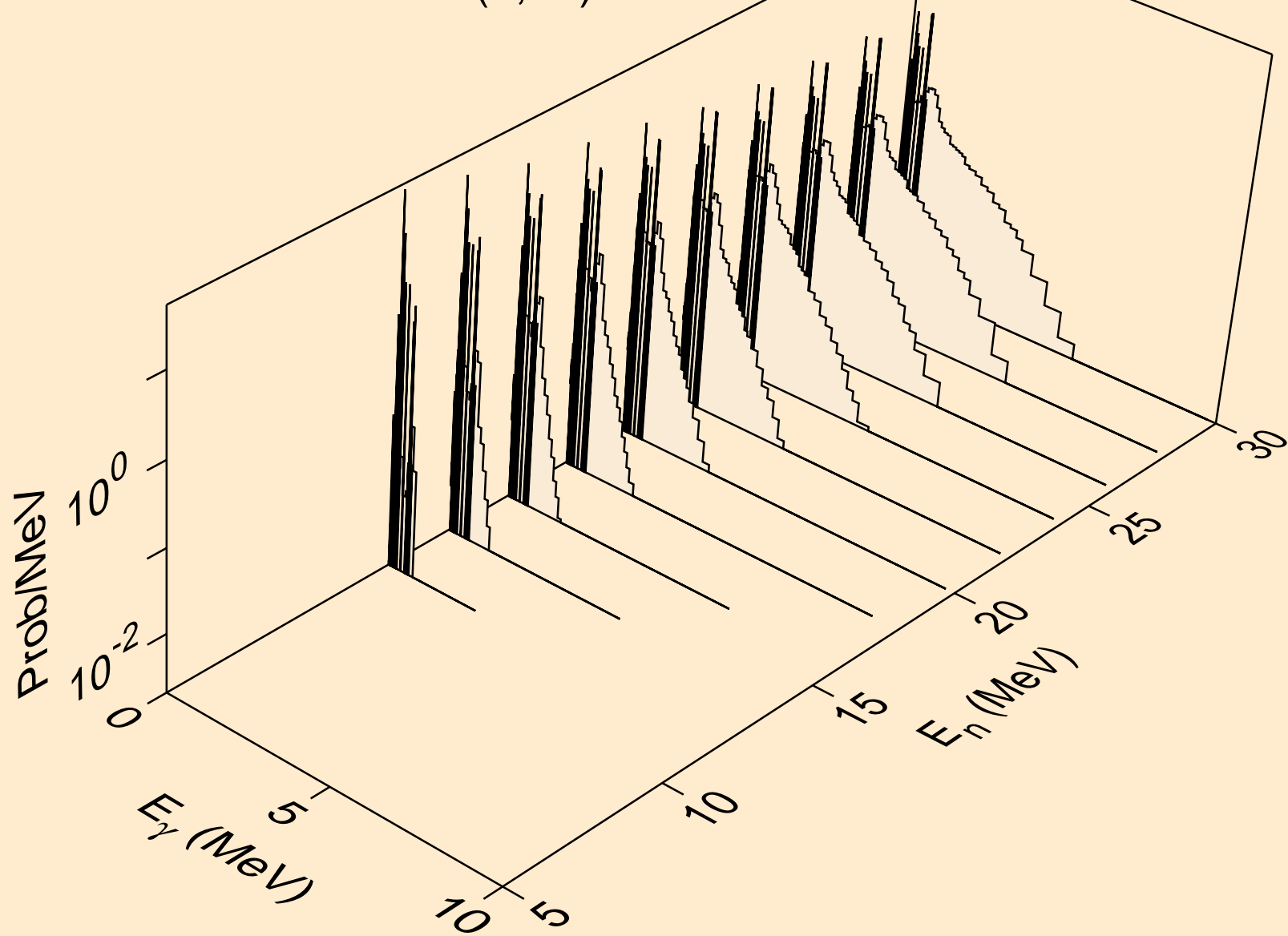

SN127M TRITON ACER TENDL-2021 LIBRARY; T=0.K  
Photon emission for (n,3n)a

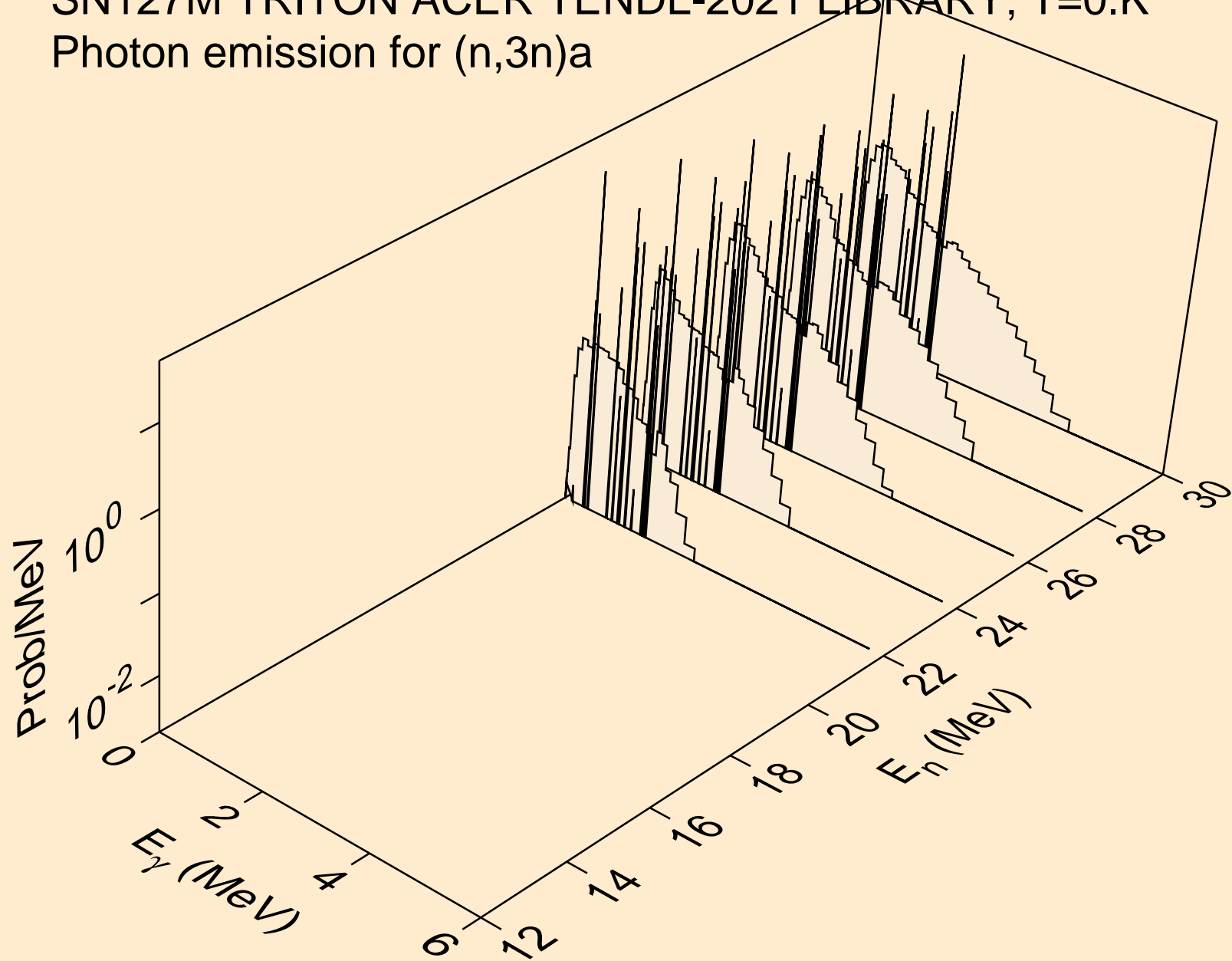

SN127M TRITON ACER TENDL-2021 LIBRARY; T=0.K  
Photon emission for (n,n\*)p

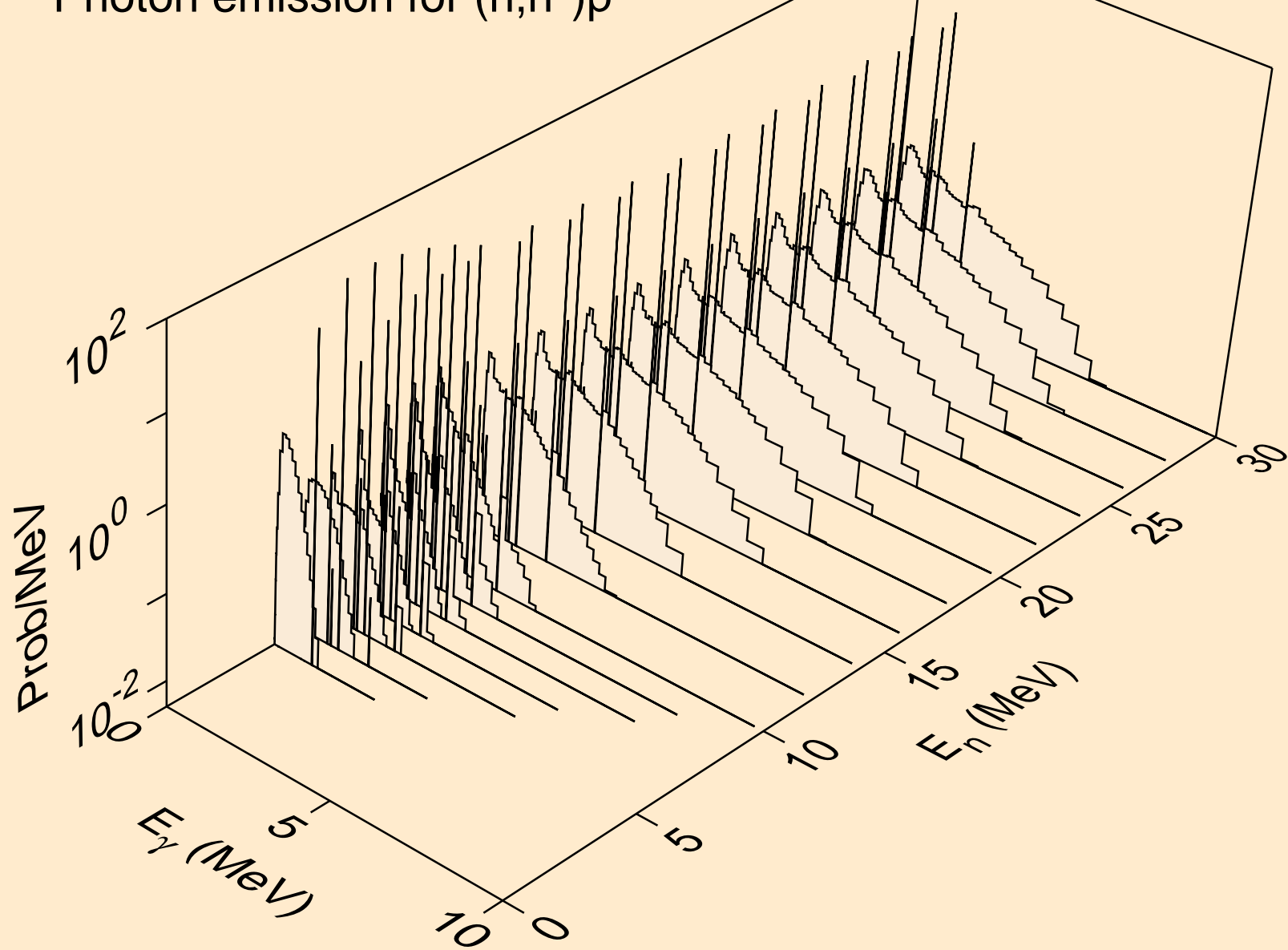

SN127M TRITON ACER TENDL-2021 LIBRARY; T=0.K  
Photon emission for (n,n\*)d

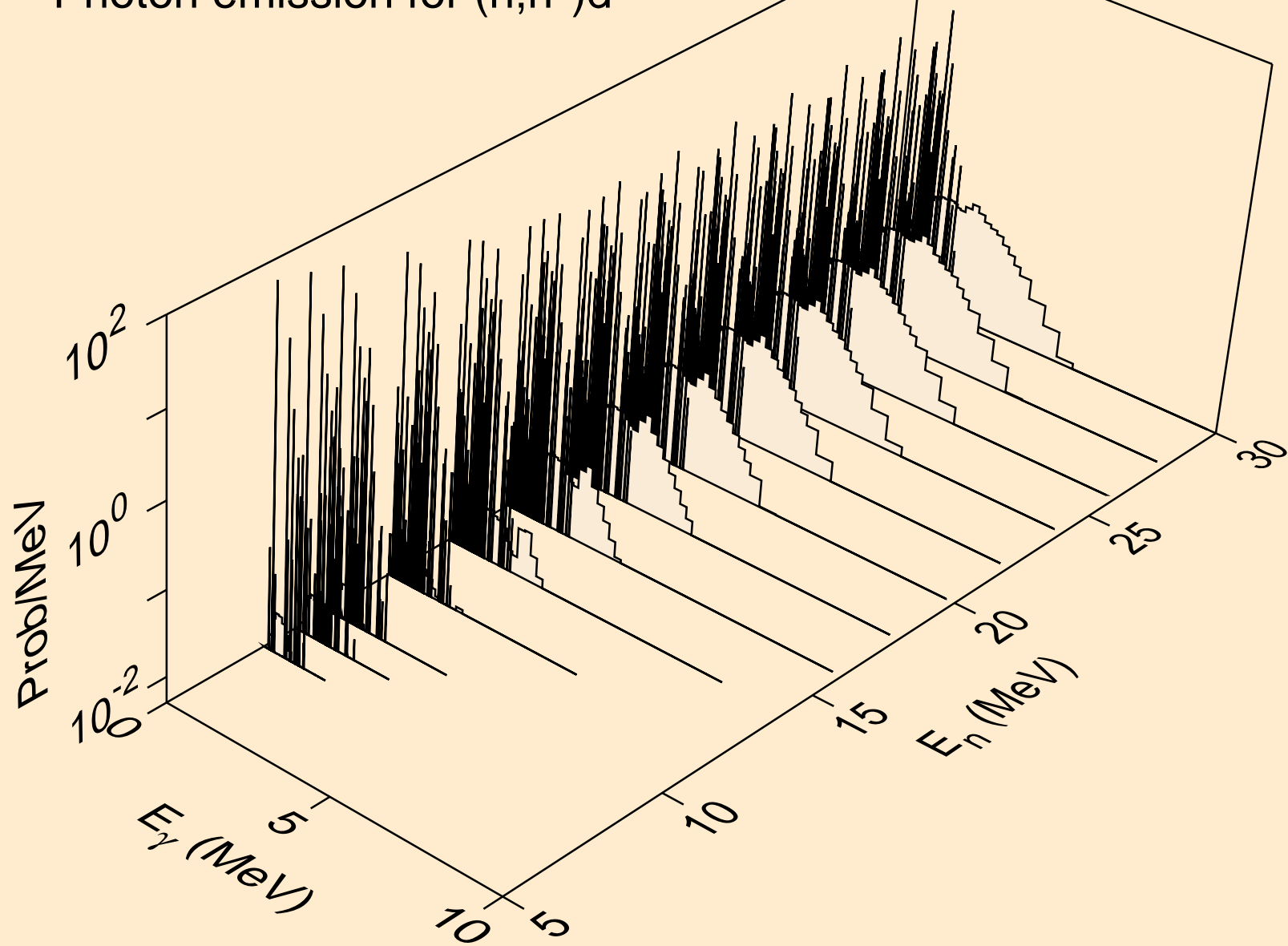

SN127M TRITON ACER TENDL-2021 LIBRARY; T=0.K  
Photon emission for (n,n\*)t

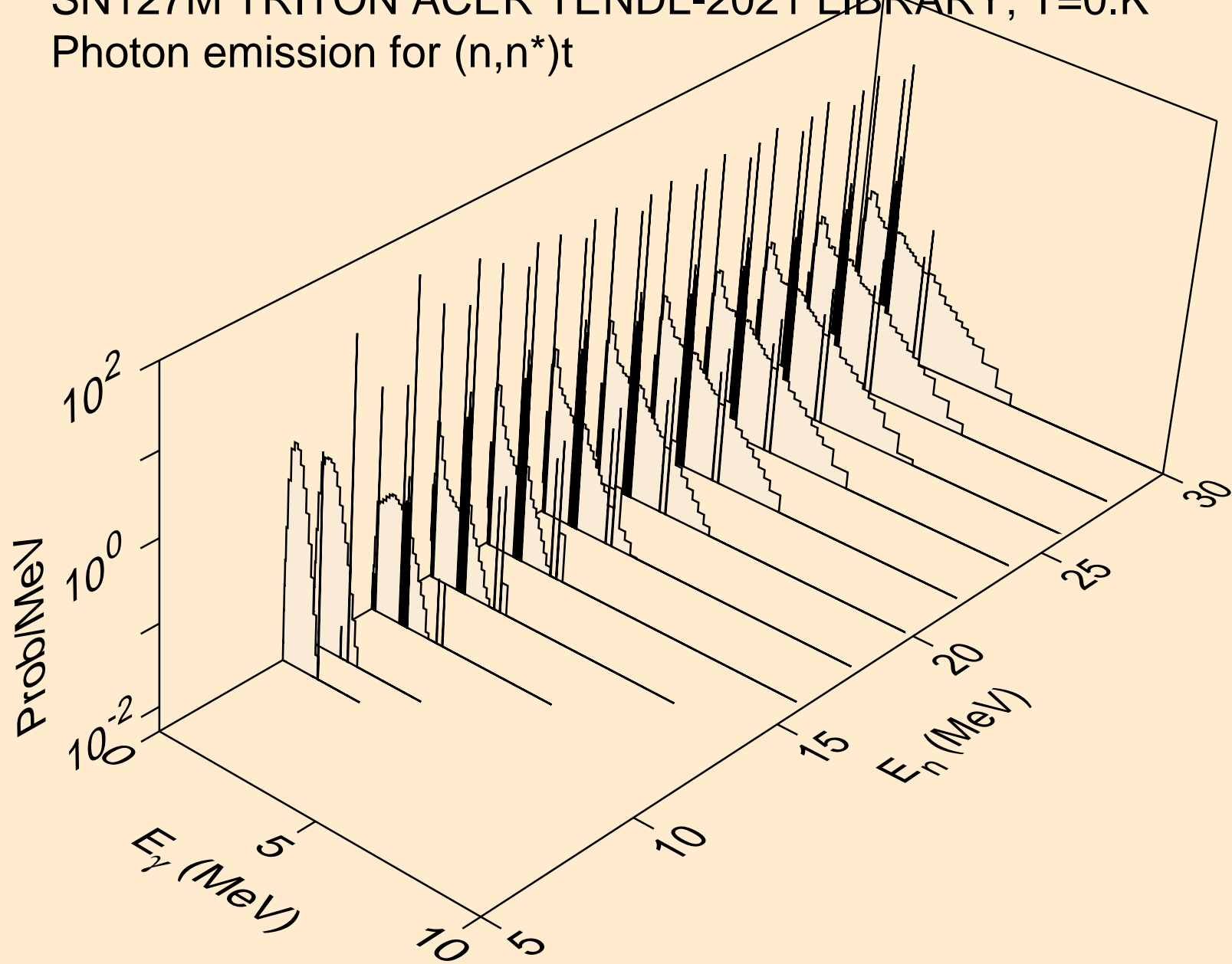

SN127M TRITON ACER TENDL-2021 LIBRARY; T=0.K  
Photon emission for (n,n\*)he3

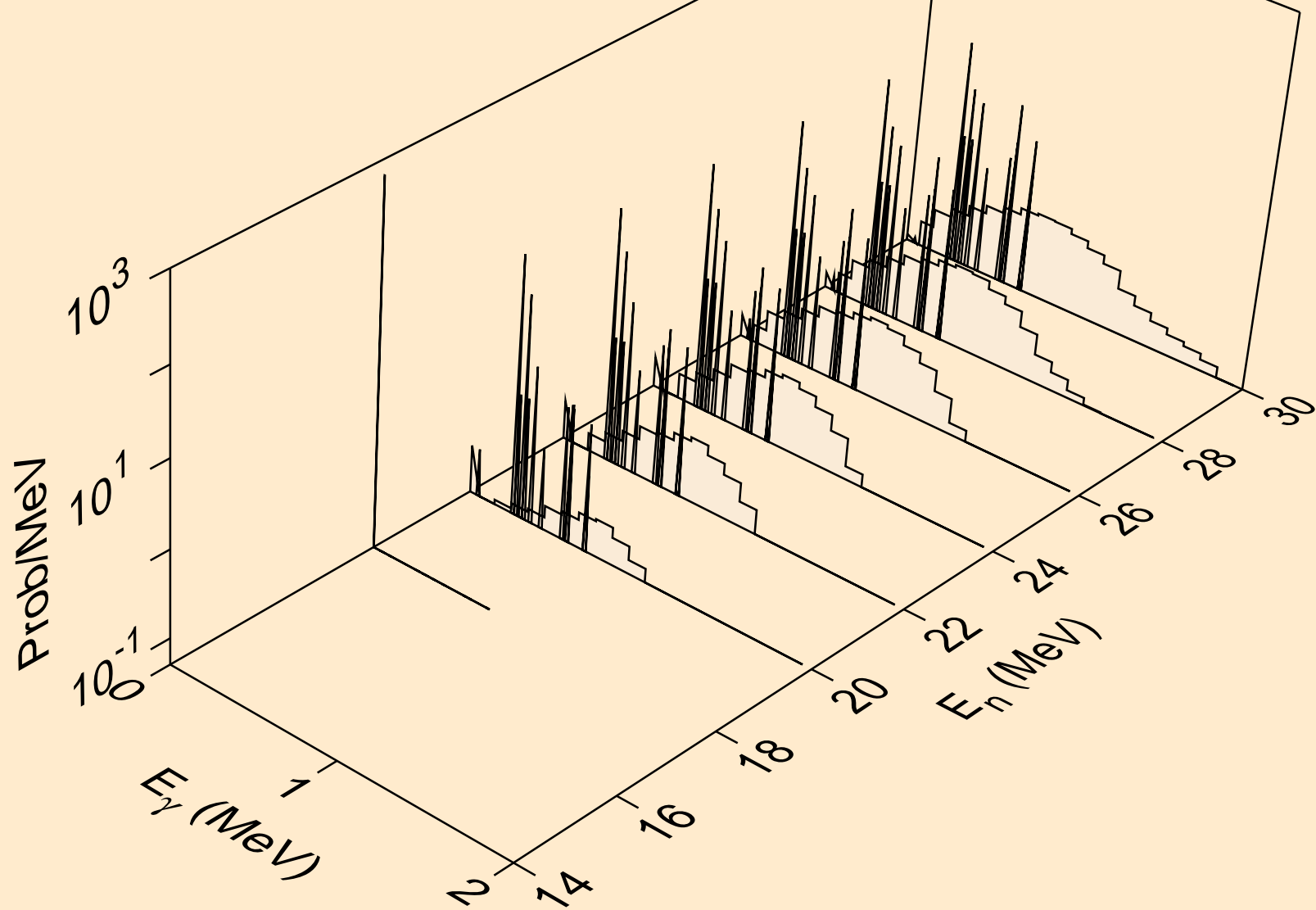



SN127M TRITON ACER TENDL-2021 LIBRARY; T=0.K  
Photon emission for (n,4n)

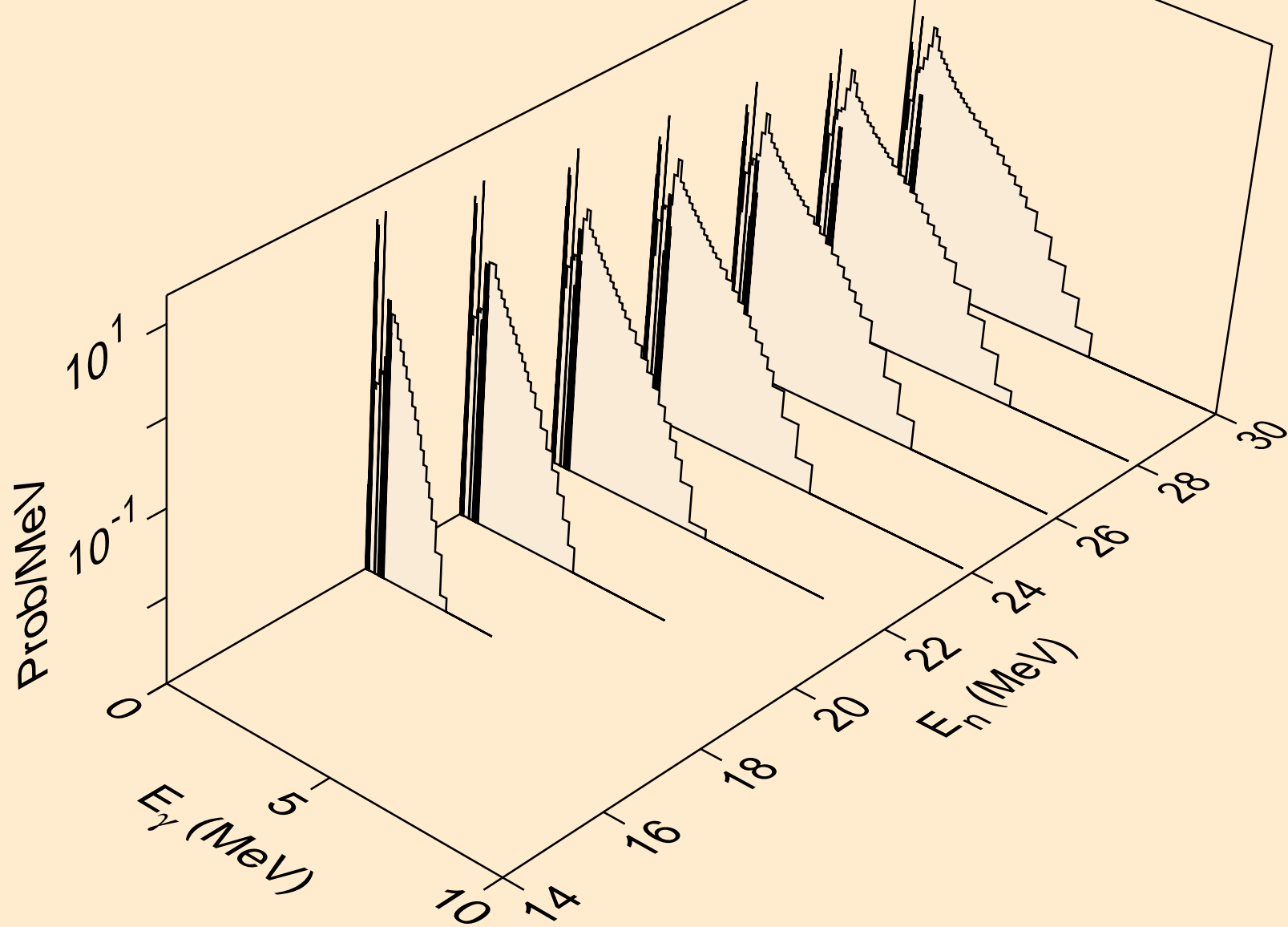

SN127M TRITON ACER TENDL-2021 LIBRARY; T=0.K  
Photon emission for (n,2np)

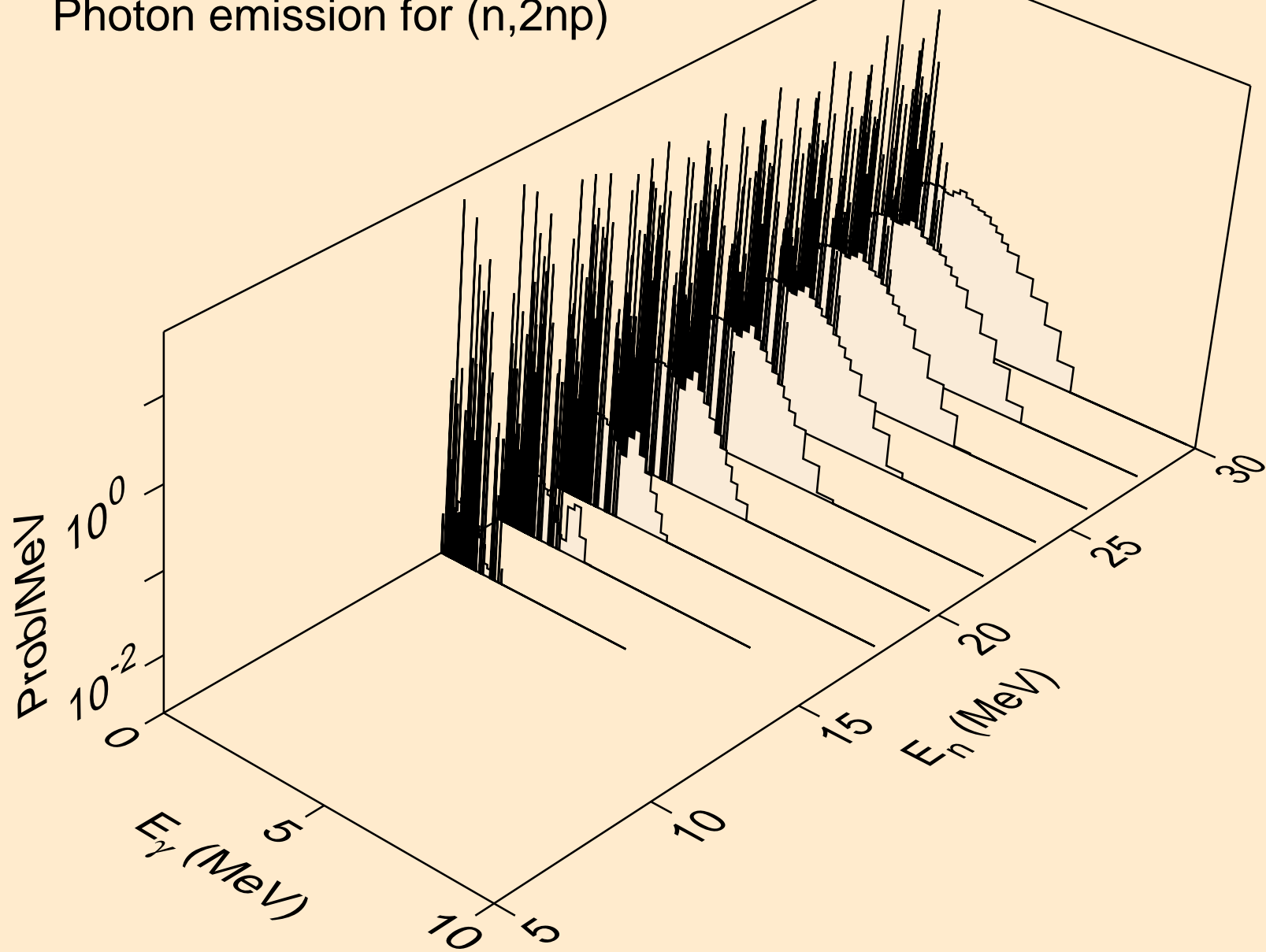

SN127M TRITON ACER TENDL-2021 LIBRARY; T=0.K  
Photon emission for (n,3np)

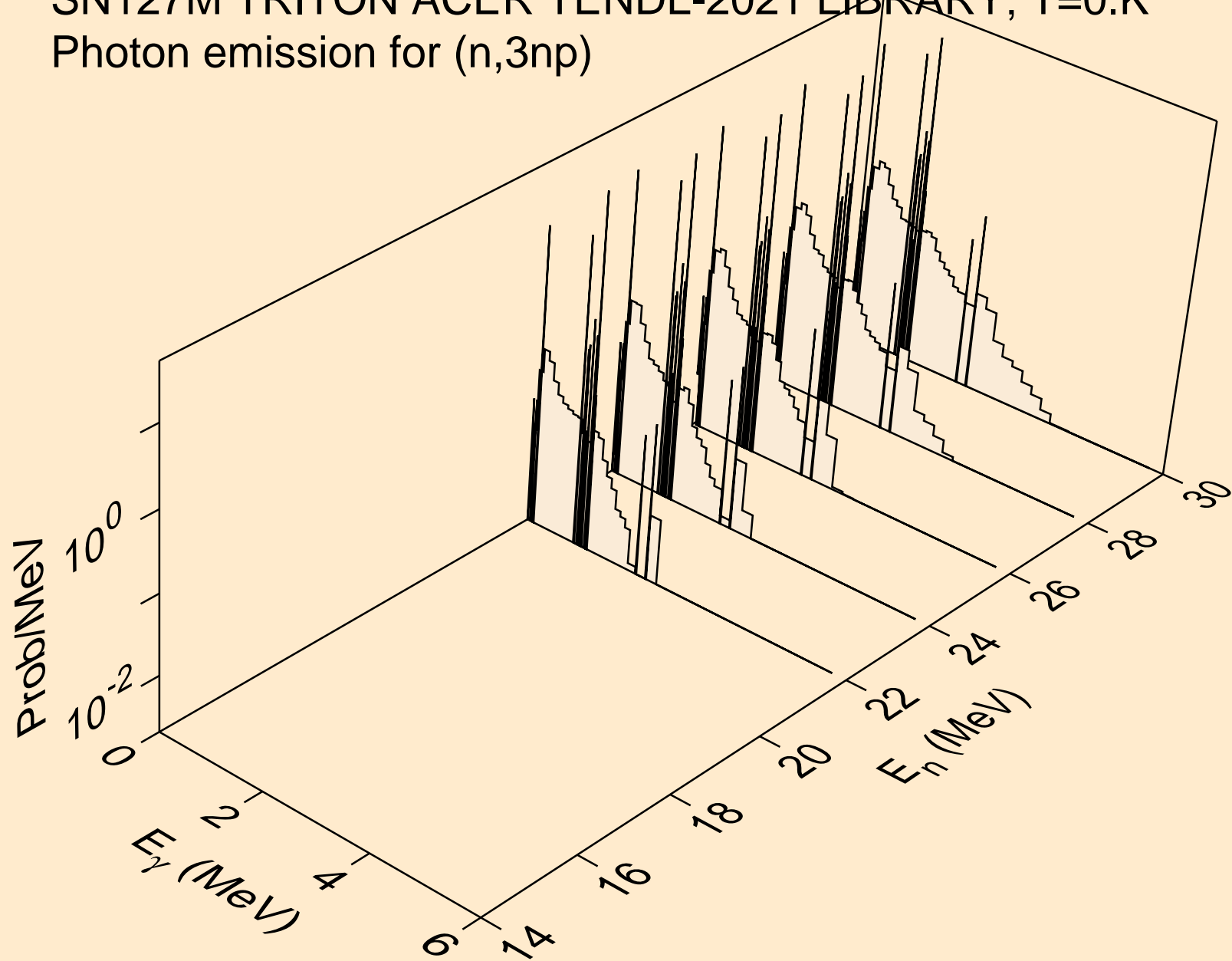

SN127M TRITON ACER TENDL-2021 LIBRARY; T=0.K  
Photon emission for (n,2np)

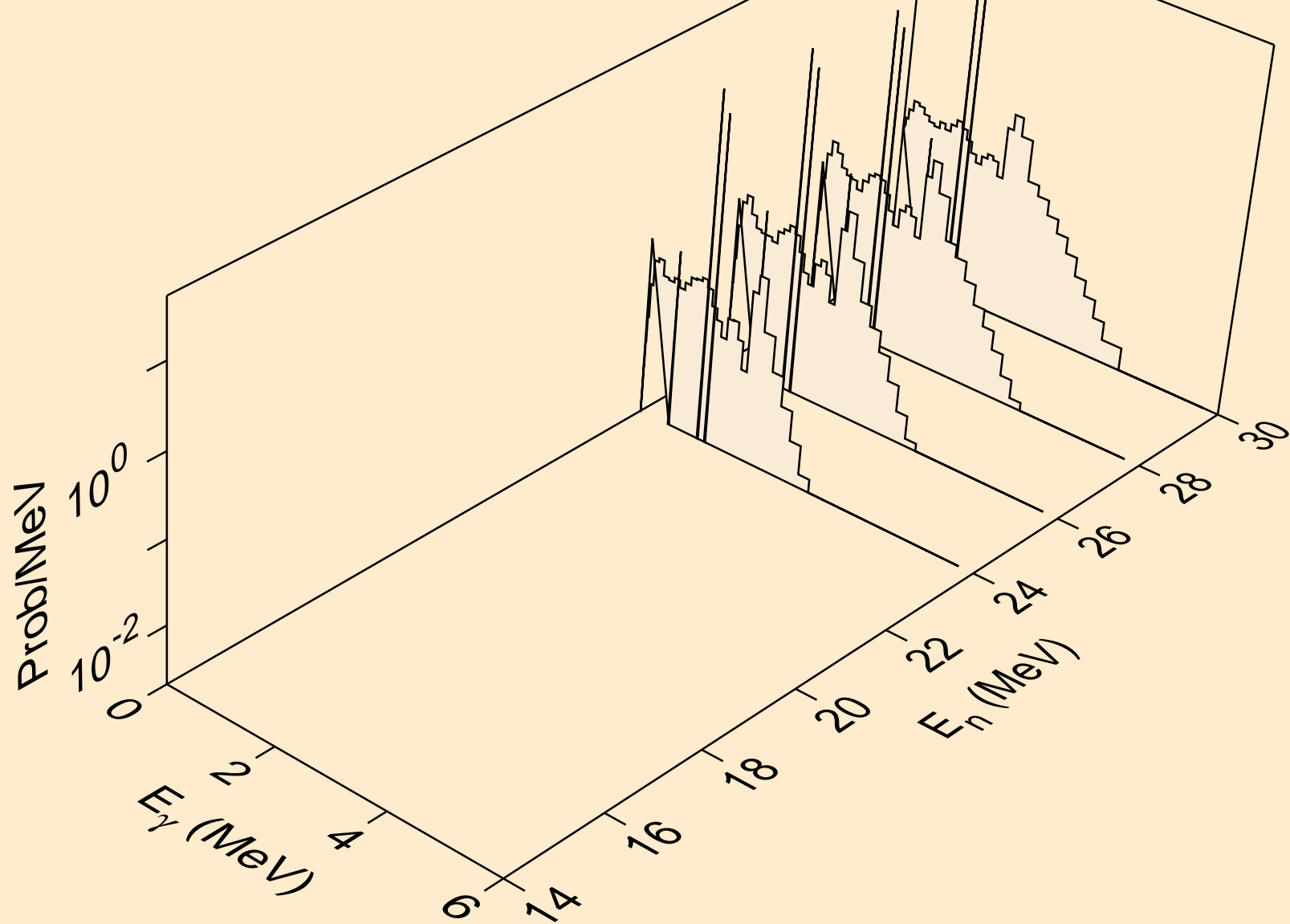

SN127M TRITON ACER TENDL-2021 LIBRARY; T=0.K  
Photon emission for (n,gma)

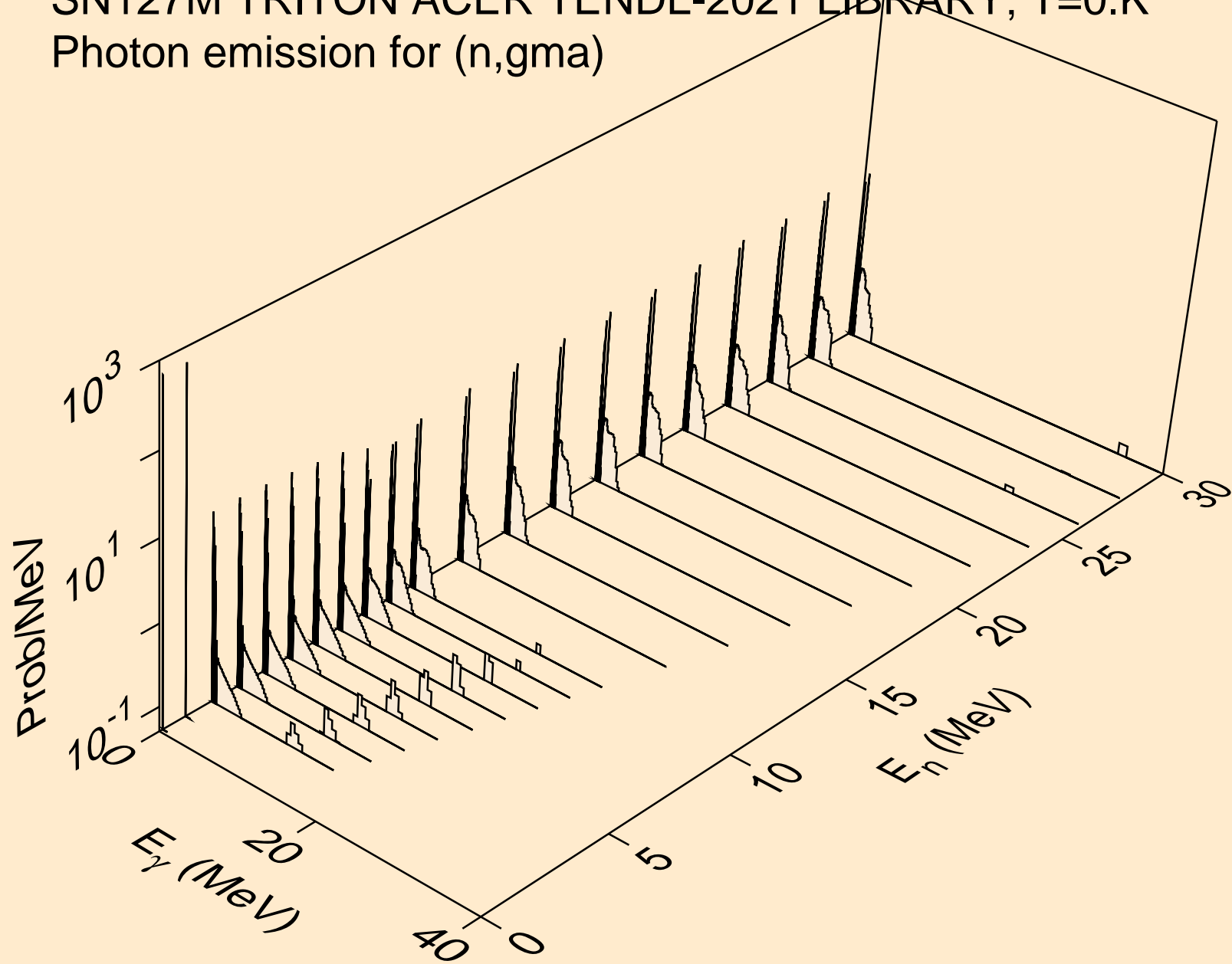

SN127M TRITON ACER TENDL-2021 LIBRARY; T=0.K  
Photon emission for (n,p)

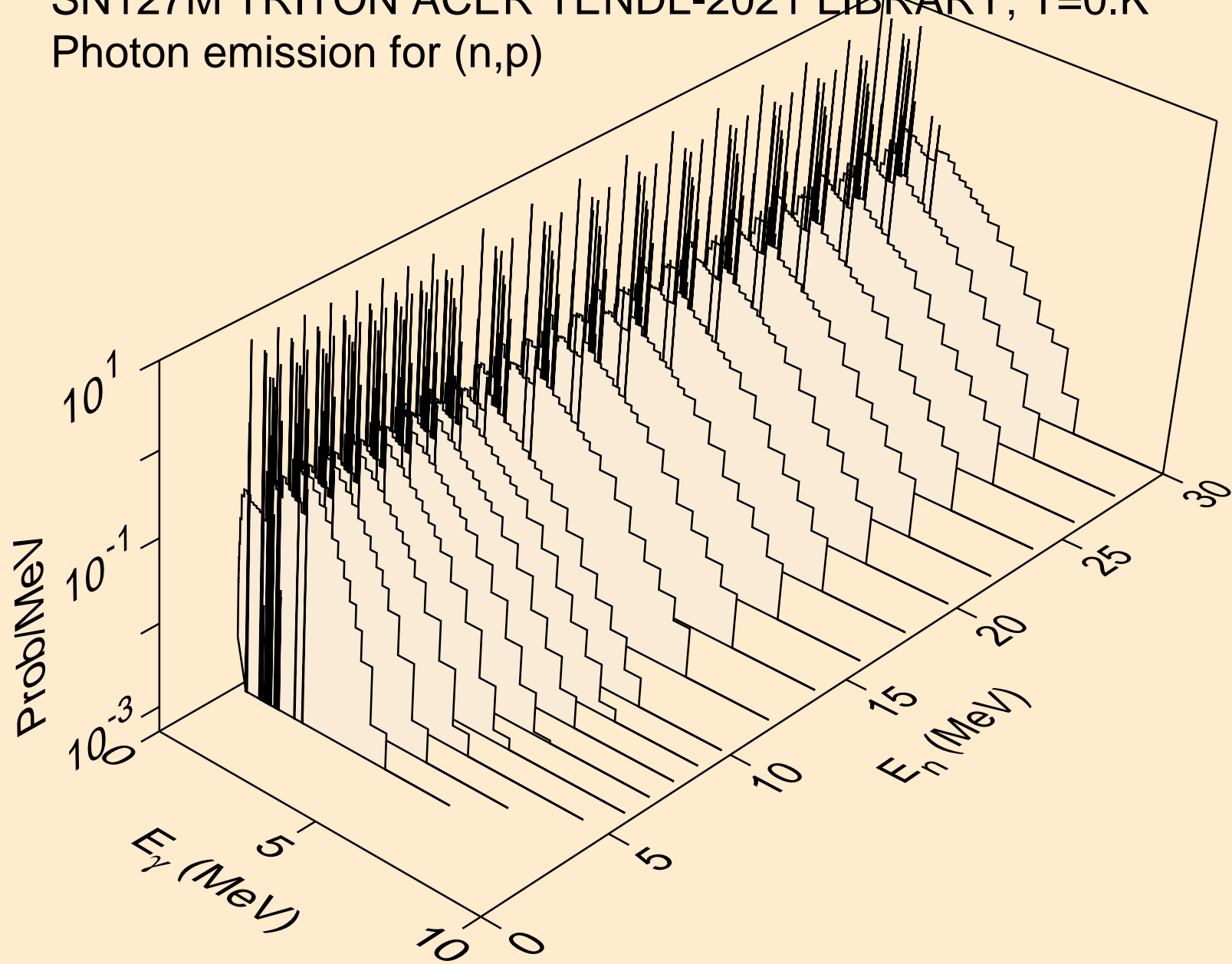

SN127M TRITON ACER TENDL-2021 LIBRARY; T=0.K  
Photon emission for (n,d)

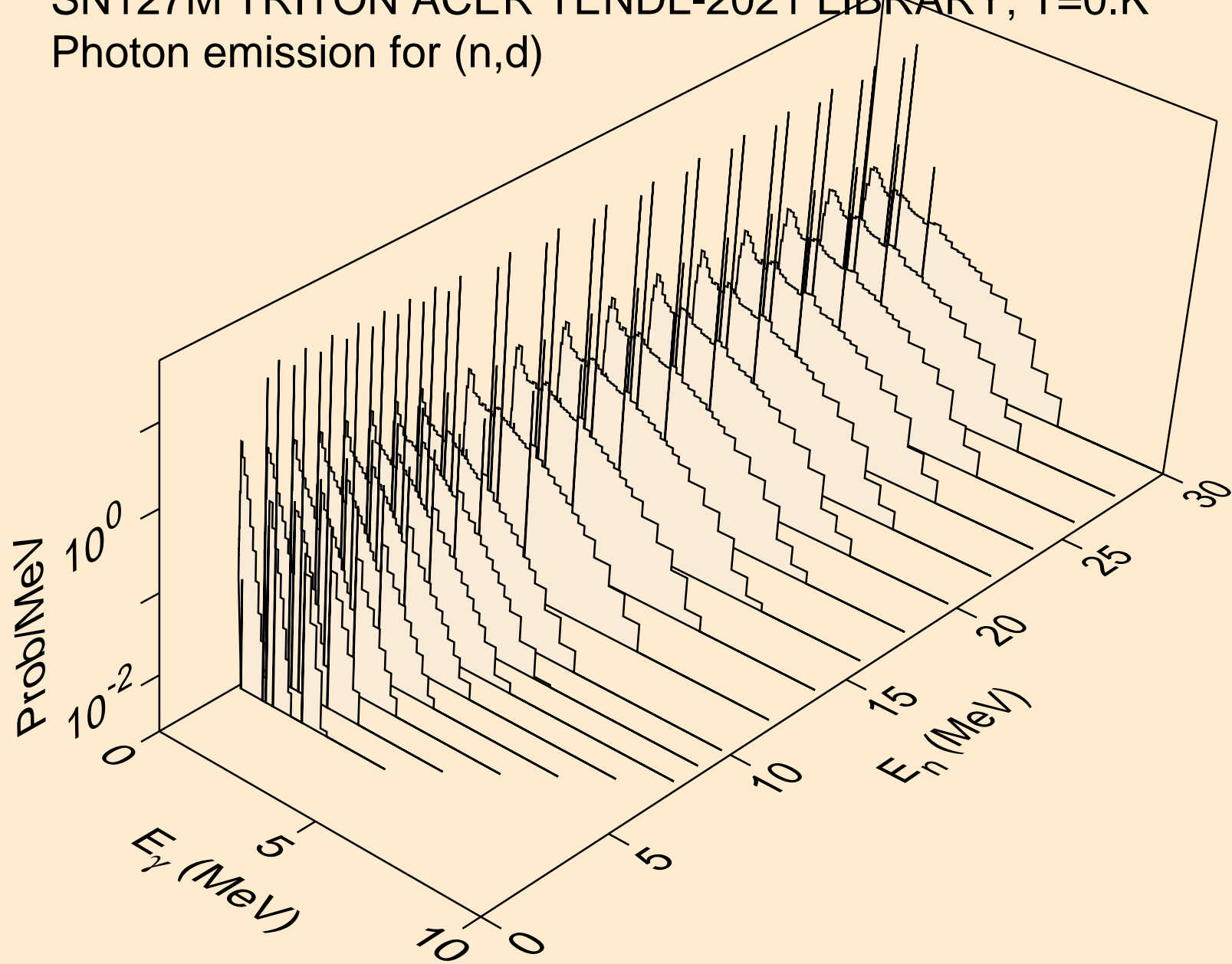

SN127M TRITON ACER TENDL-2021 LIBRARY; T=0.K  
Photon emission for inelastic

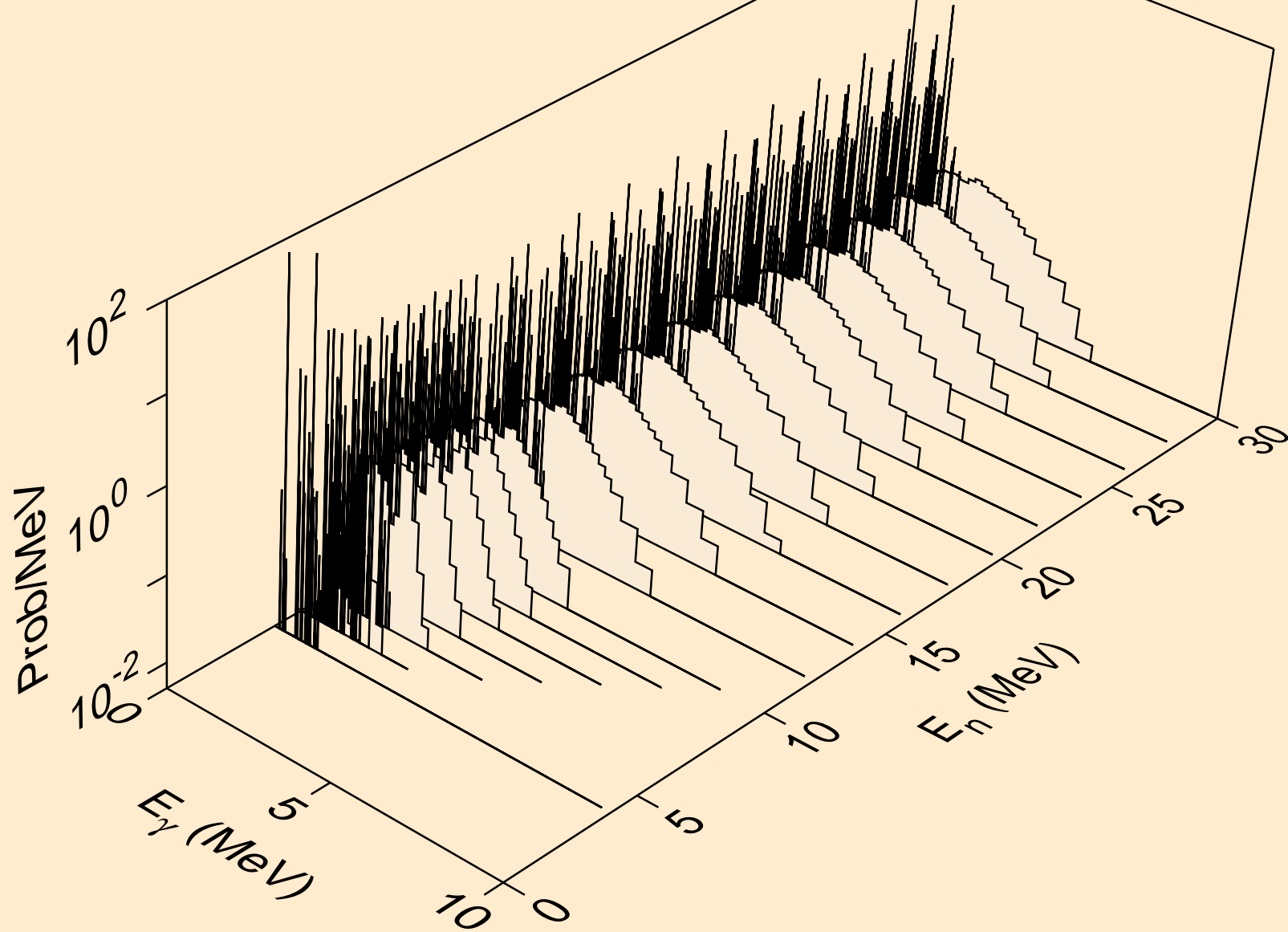



SN127M TRITON ACER TENDL-2021 LIBRARY; T=0.K  
Photon emission for (n,he3)

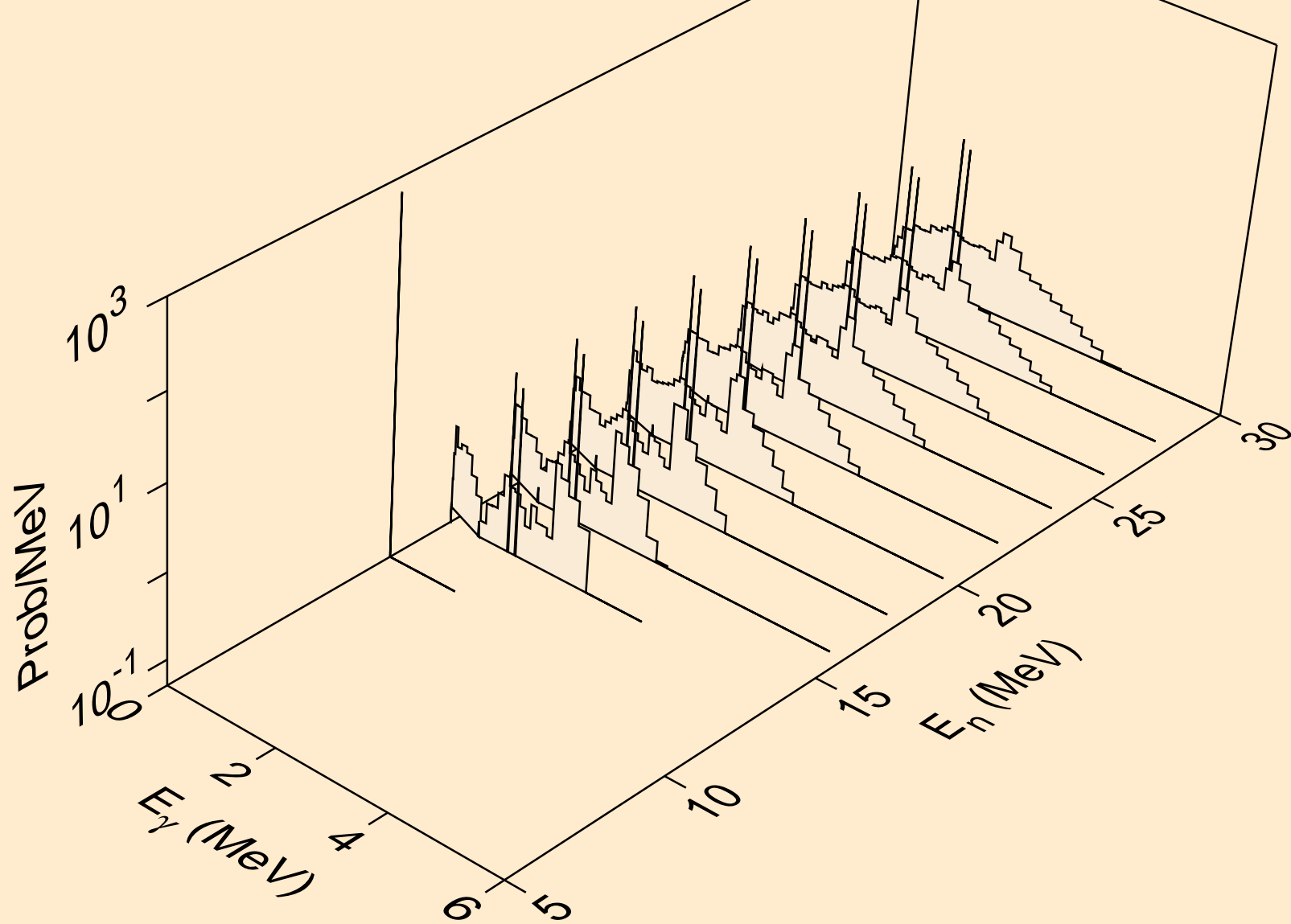

SN127M TRITON ACER TENDL-2021 LIBRARY; T=0.K  
Photon emission for (n,a)

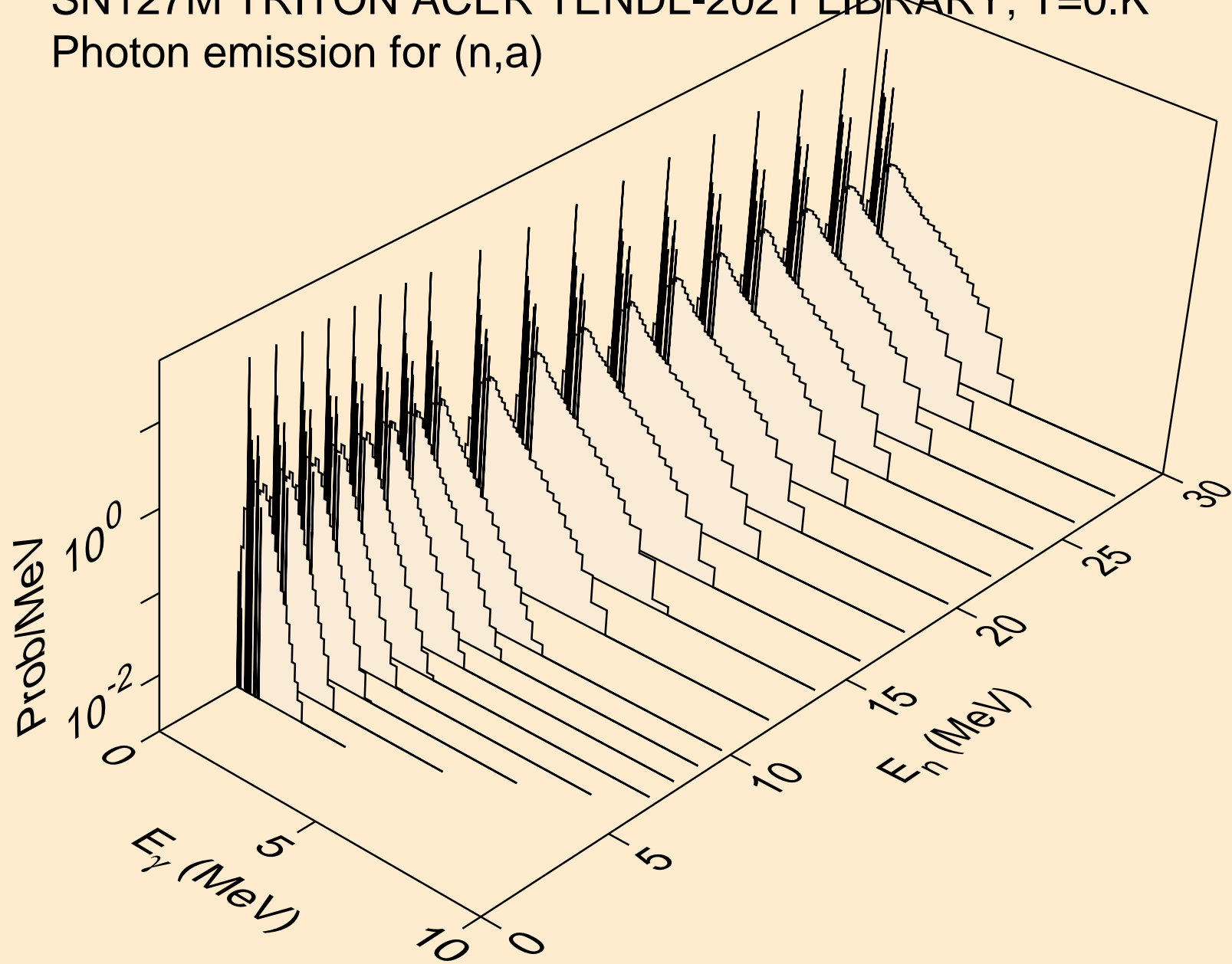

SN127M TRITON ACER TENDL-2021 LIBRARY; T=0.K  
Photon emission for (n,2p)

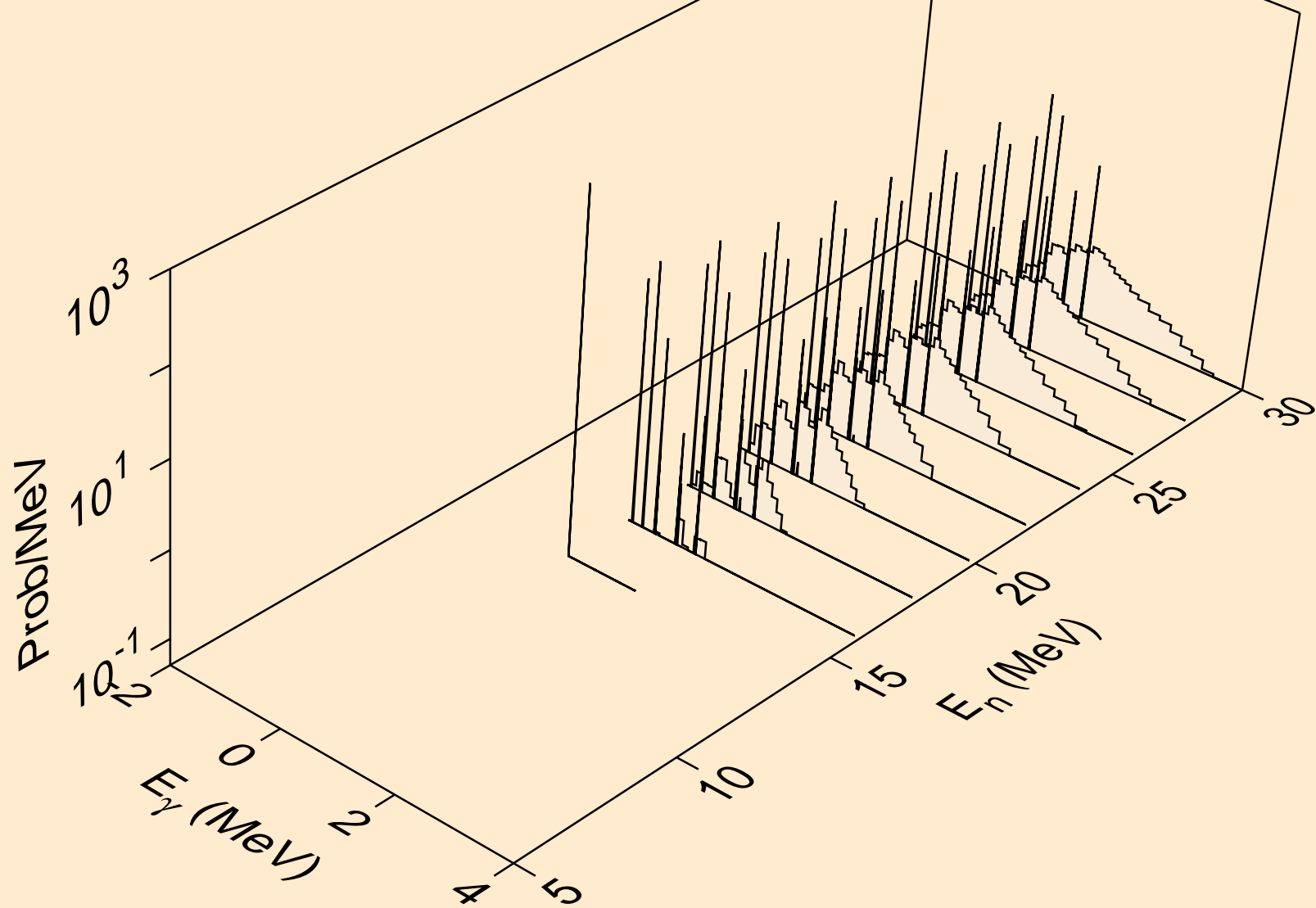

SN127M TRITON ACER TENDL-2021 LIBRARY; T=0.K  
Photon emission for (n,pa)

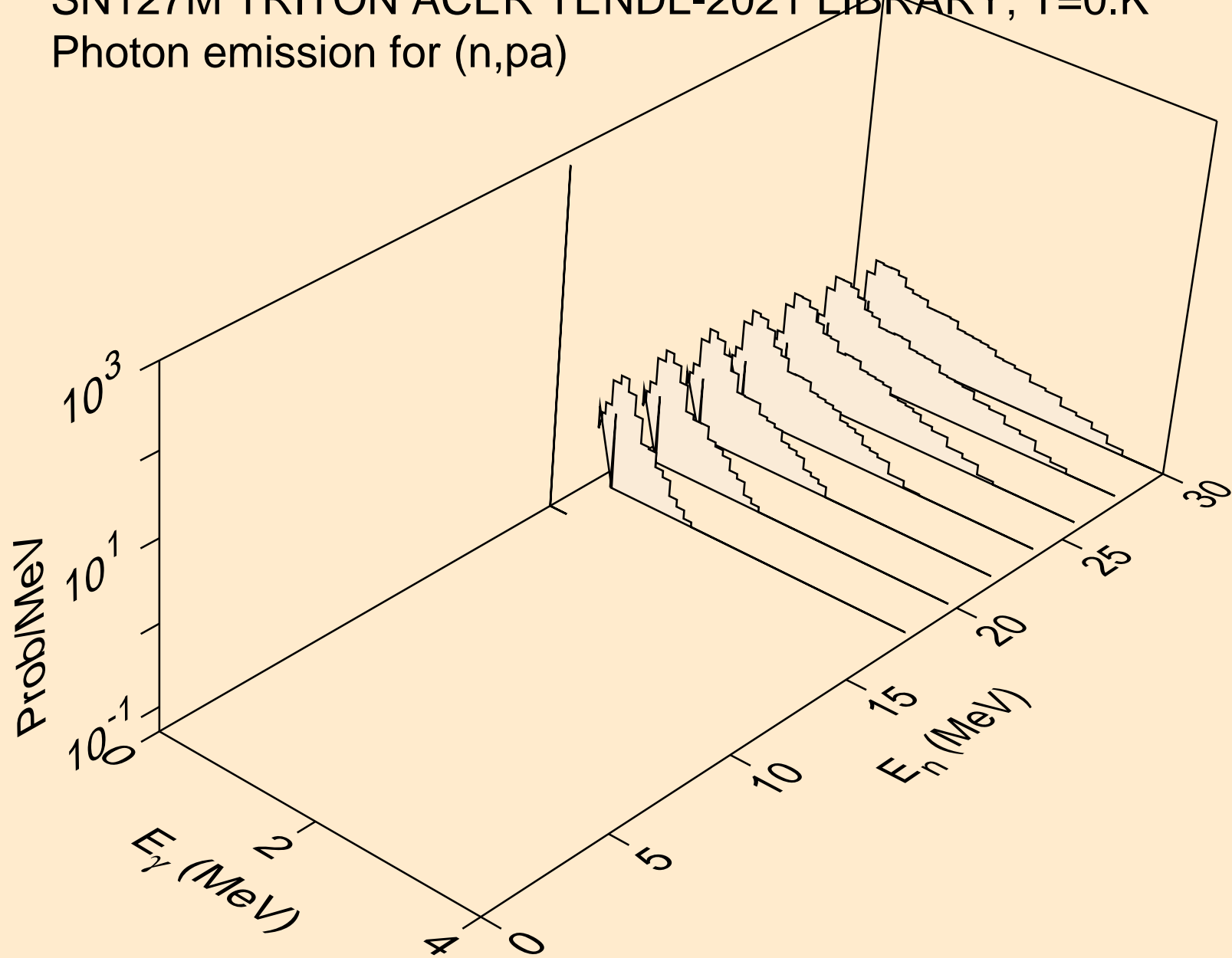

SN127M TRITON ACER TENDL-2021 LIBRARY; T=0.K  
Photon emission for (n,pd)

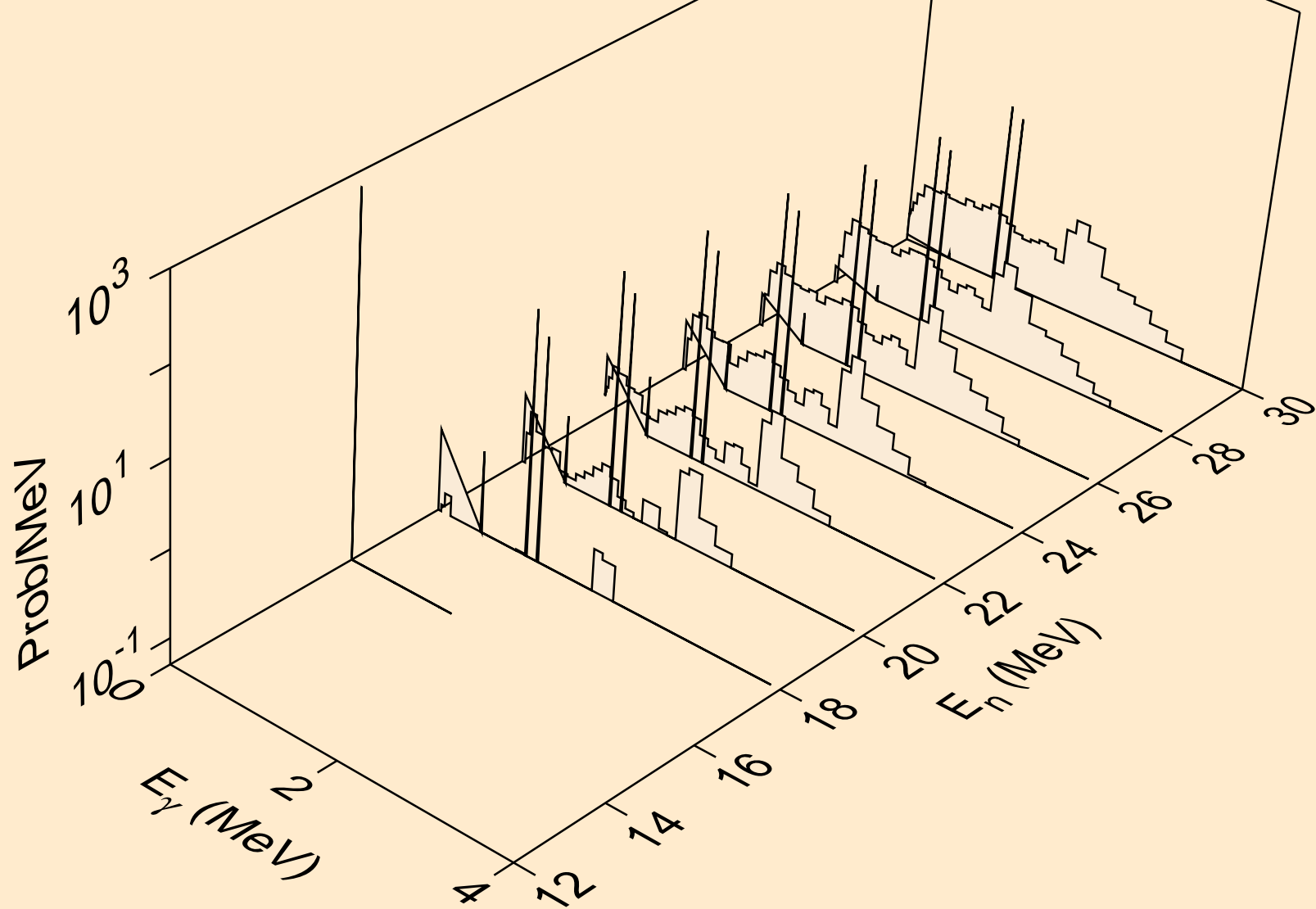

SN127M TRITON ACER TENDL-2021 LIBRARY; T=0.K  
Photon emission for (n,pt)

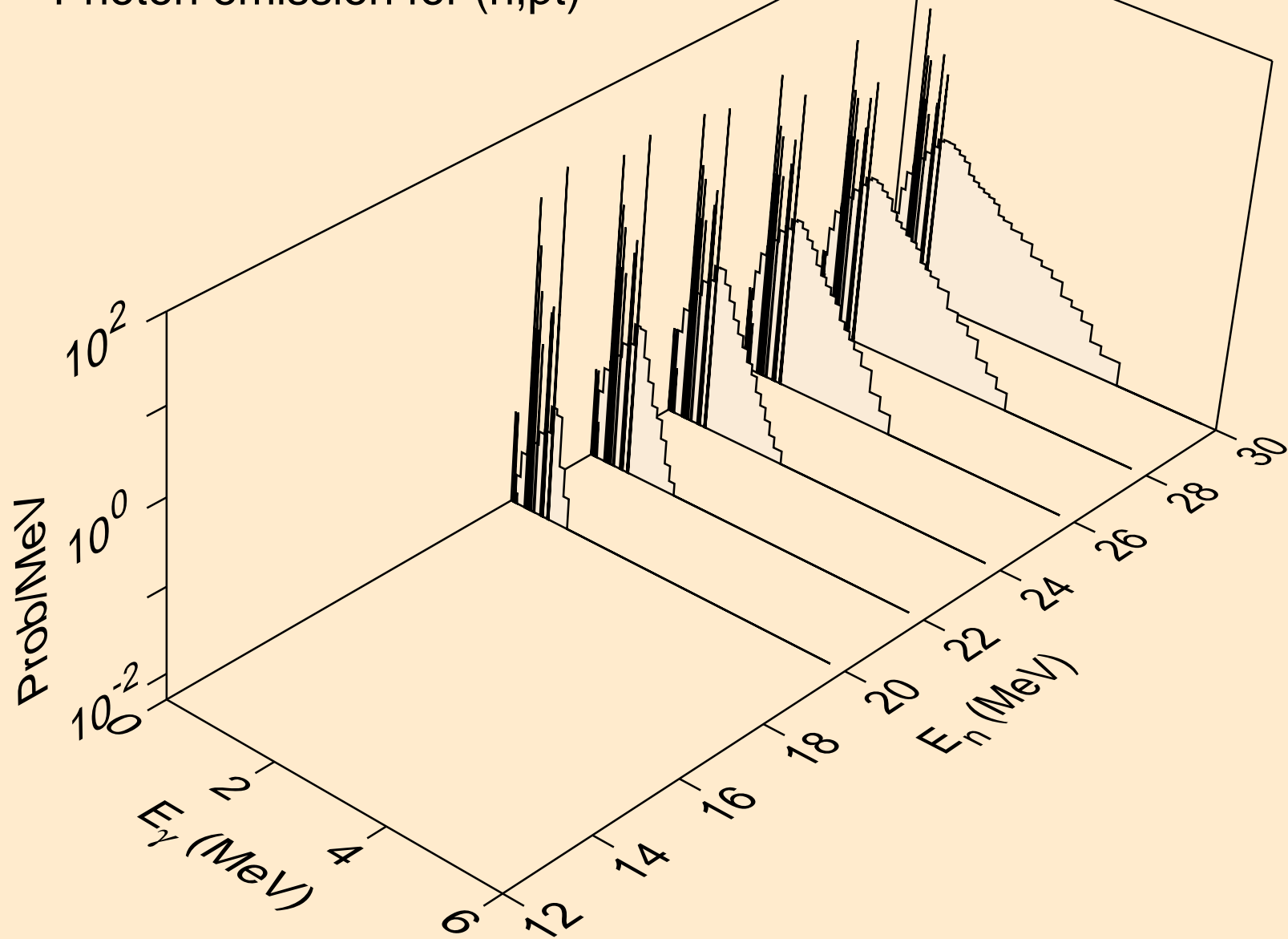

# SN127M TRITON ACER TENDL-2021 LIBRARY; T=0.K

## Particle heating contributions

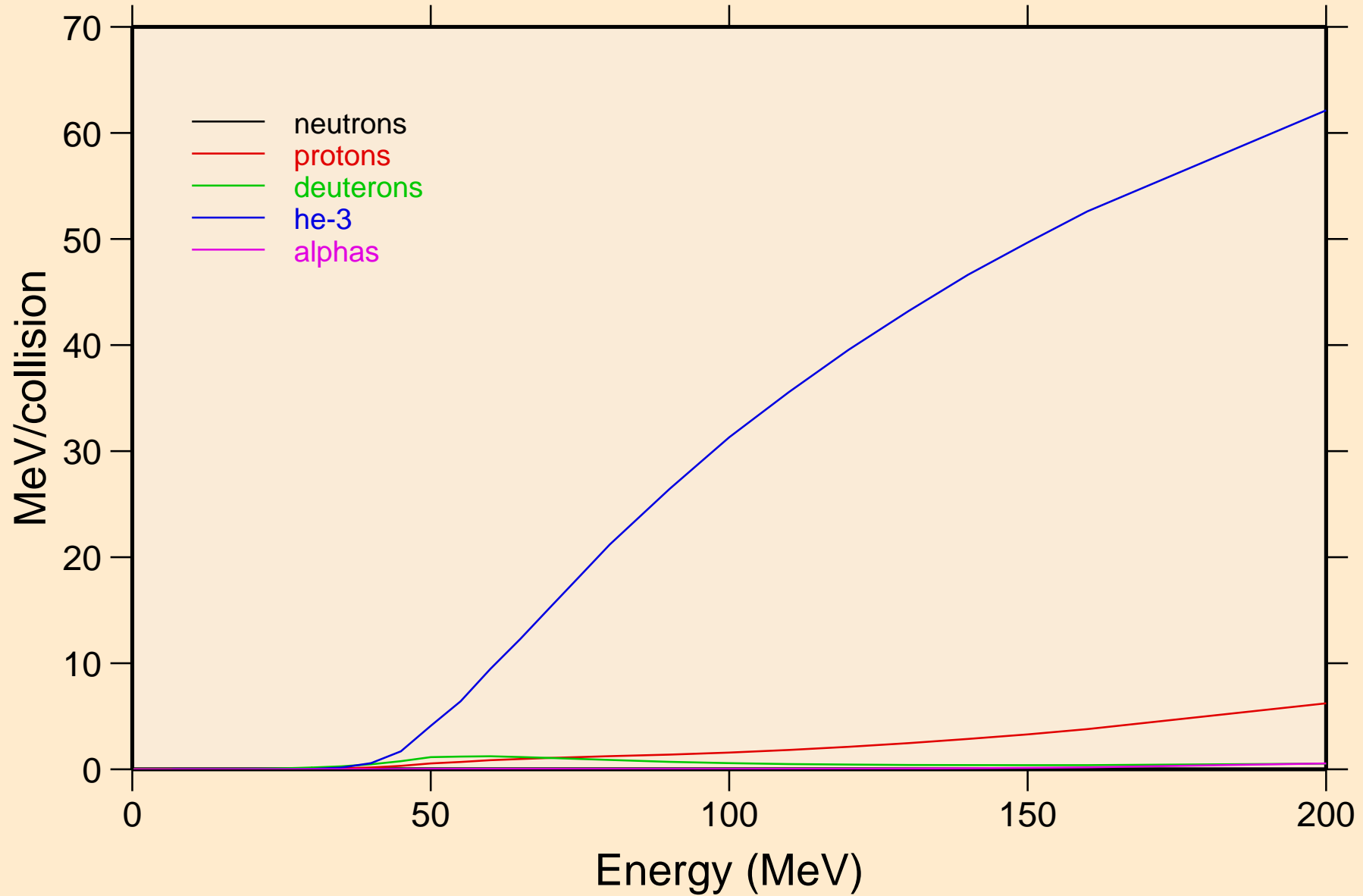

SN127M TRITON ACER TENDL-2021 LIBRARY; T=0.K  
Recoil Heating

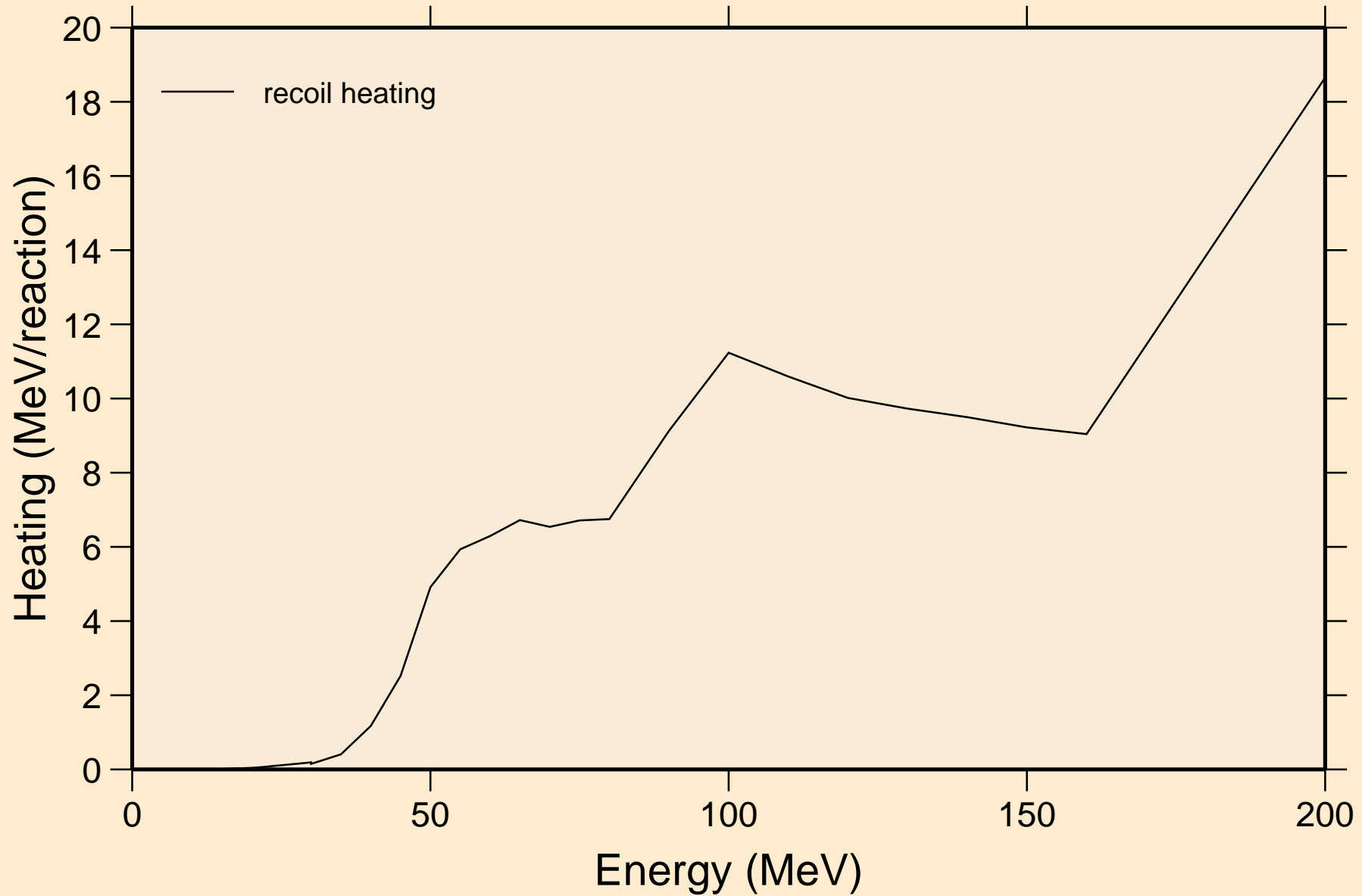



# SN127M TRITON ACER TENDL-2021 LIBRARY; T=0.K

## Particle production cross sections

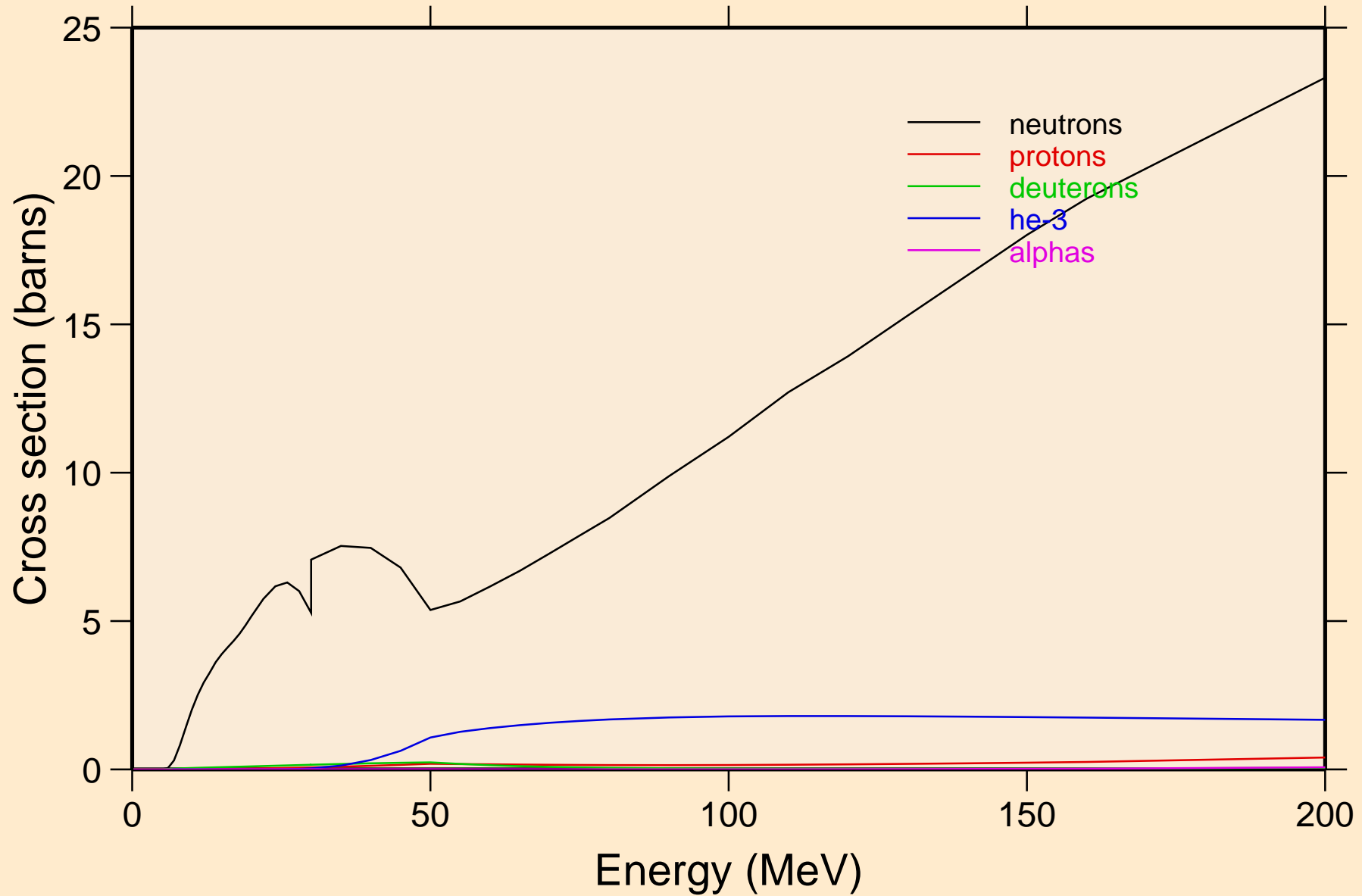

SN127M TRITON ACER TENDL-2021 LIBRARY; T=0.K  
neutrons from (t,n)

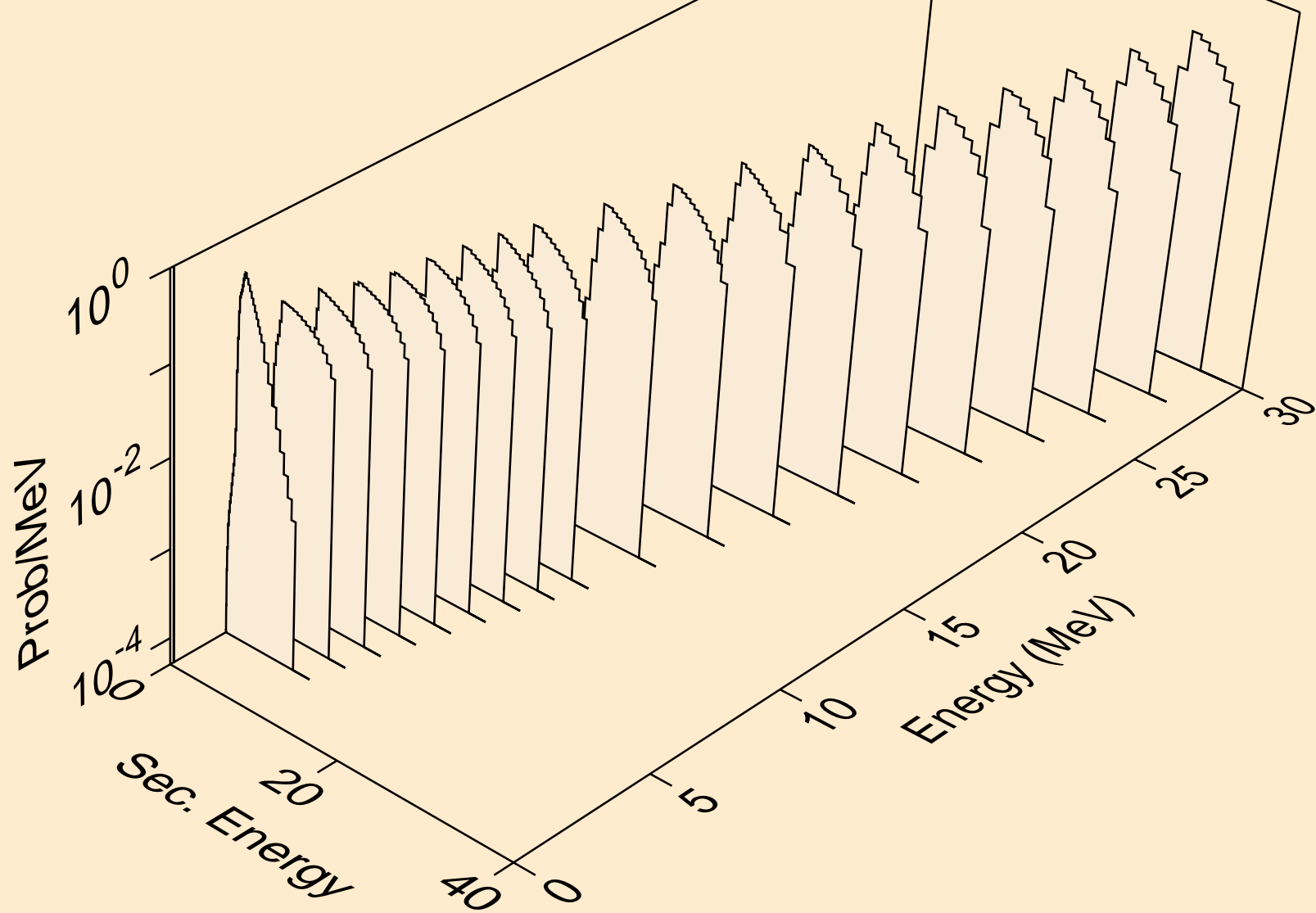

SN127M TRITON ACER TENDL-2021 LIBRARY; T=0.K  
neutrons from (t,x)

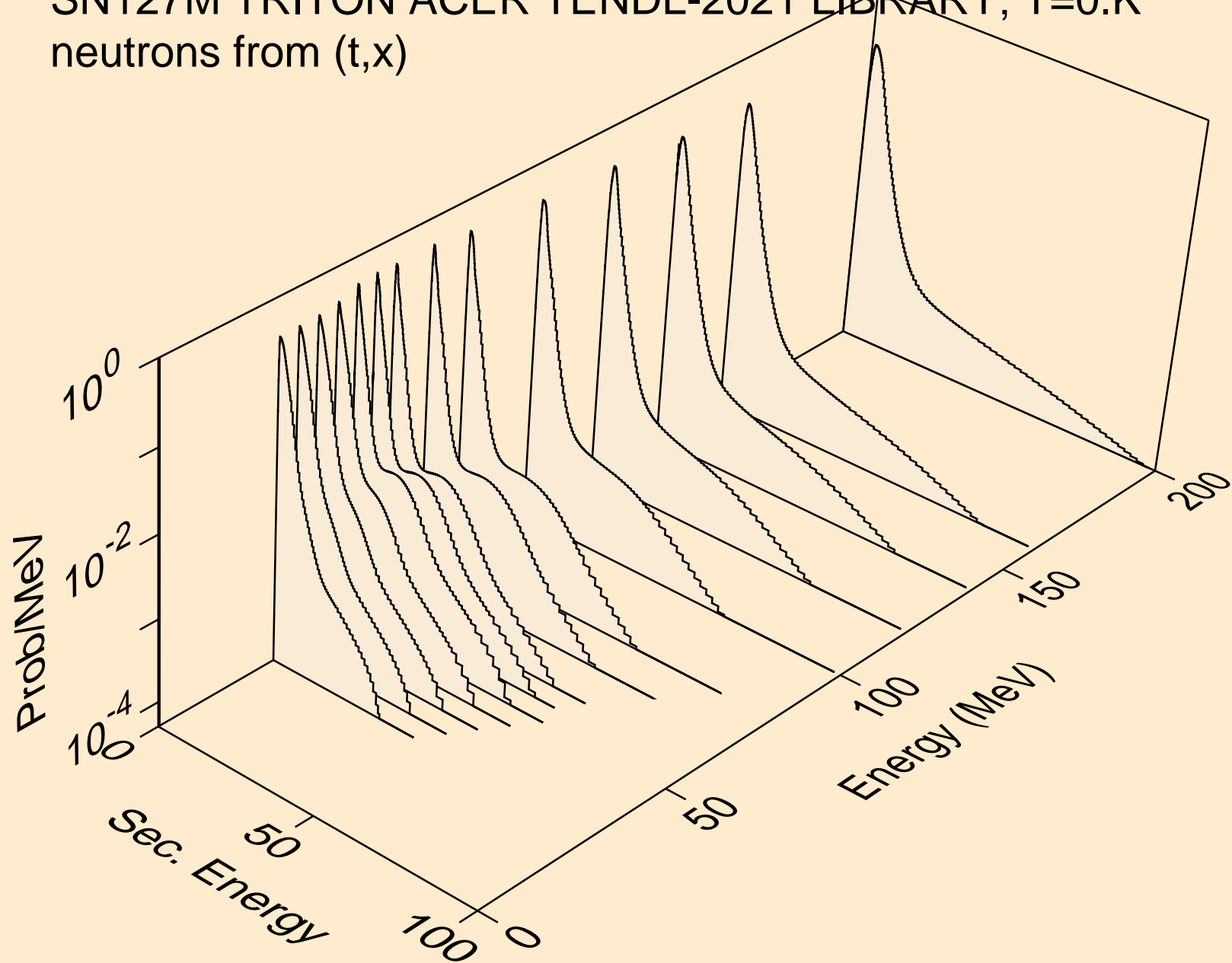

SN127M TRITON ACER TENDL-2021 LIBRARY; T=0.K  
neutrons from (t,2nd)

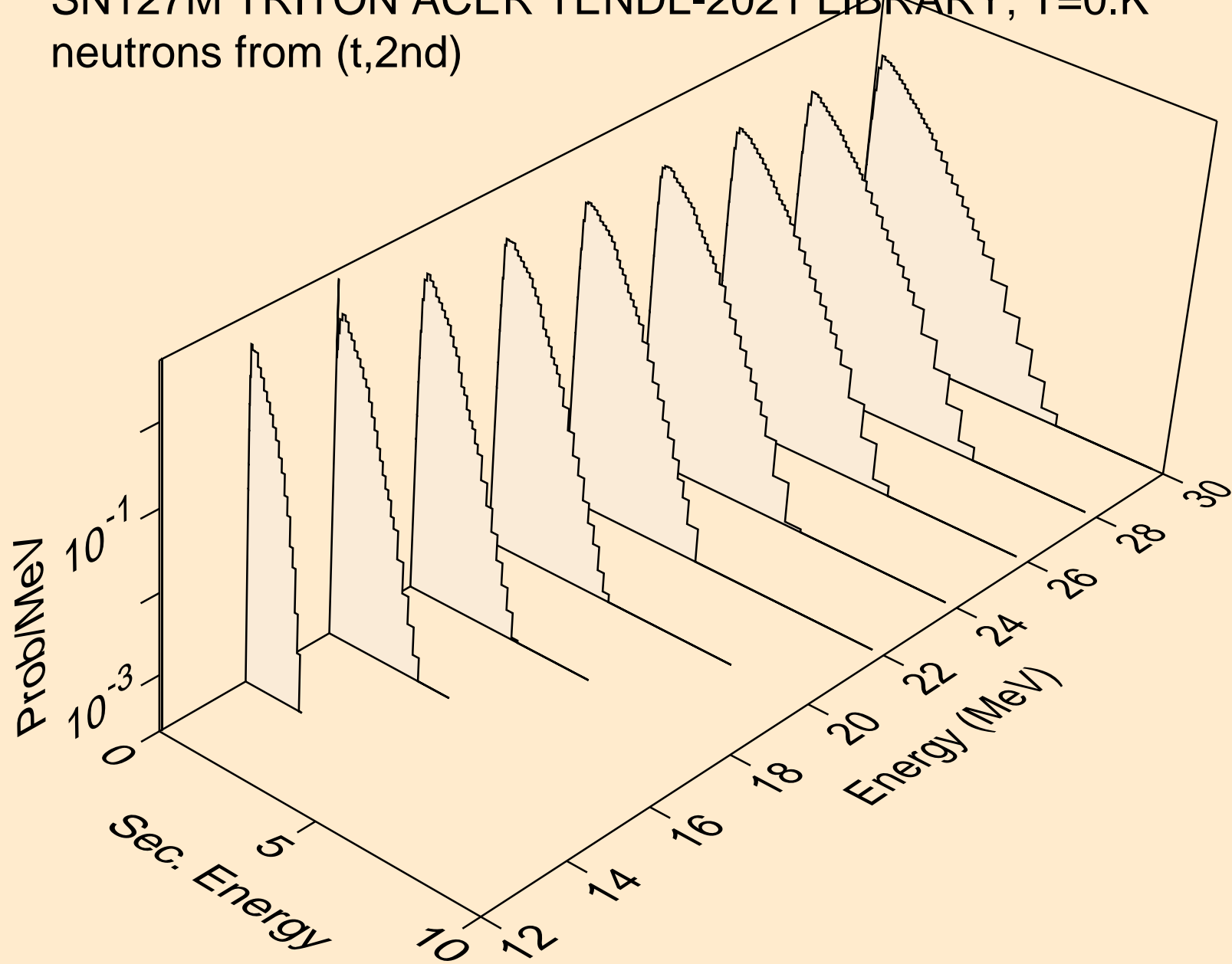

SN127M TRITON ACER TENDL-2021 LIBRARY; T=0.K  
neutrons from (t,2n)

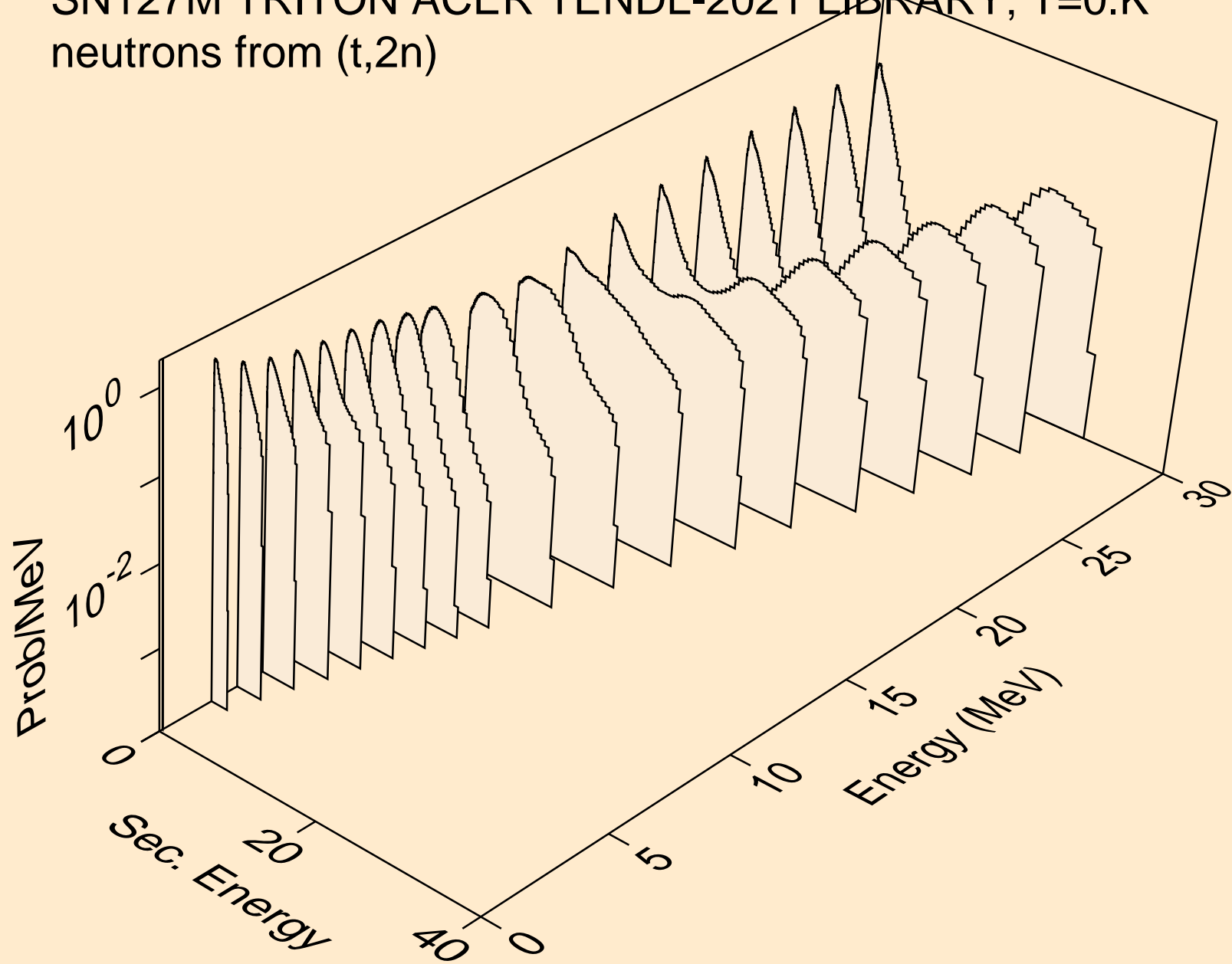

SN127M TRITON ACER TENDL-2021 LIBRARY; T=0.K  
neutrons from (t,3n)

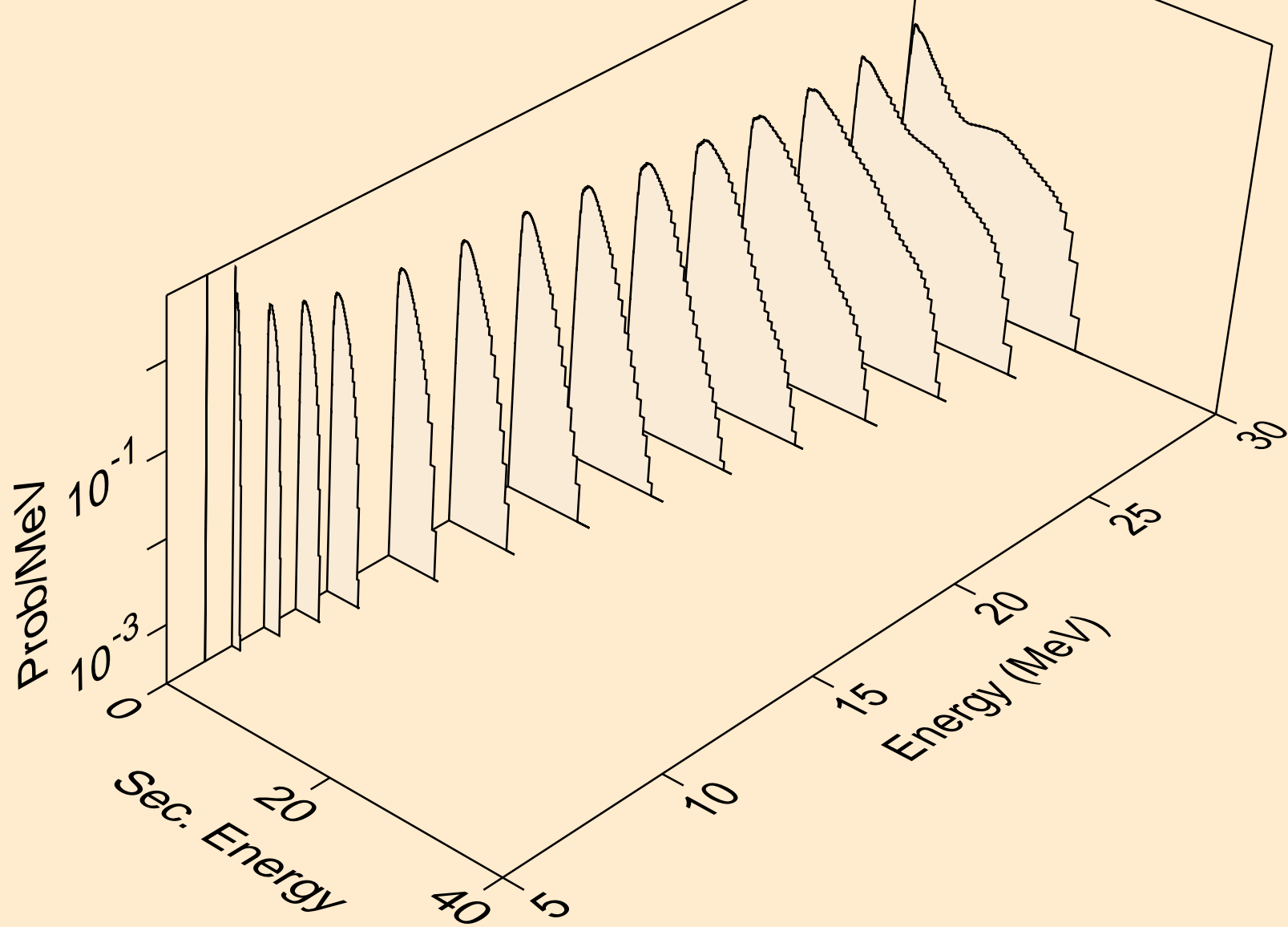

SN127M TRITON ACER TENDL-2021 LIBRARY; T=0.K  
neutrons from (t,n\*)a

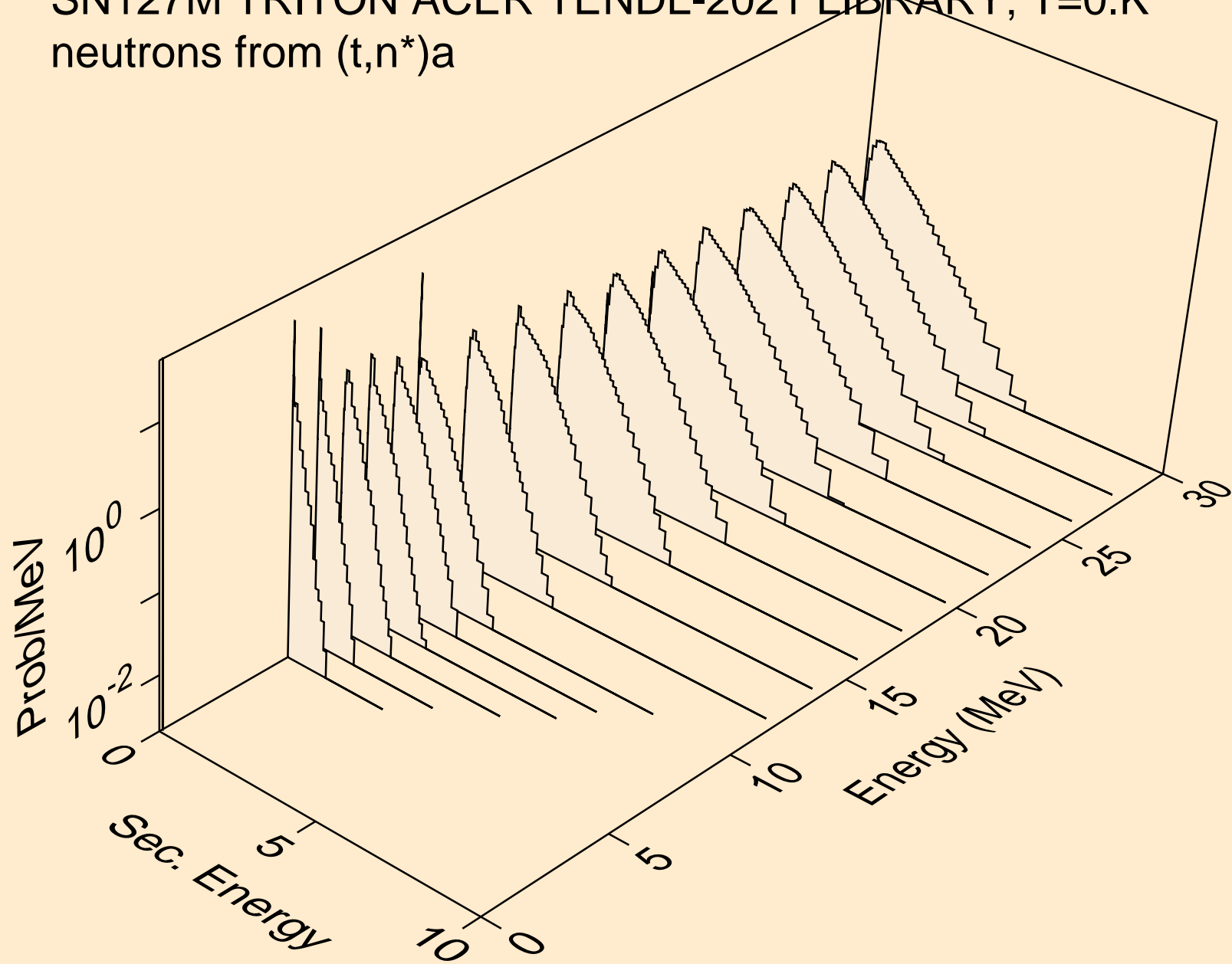

SN127M TRITON ACER TENDL-2021 LIBRARY; T=0.K  
neutrons from (t,2n)a

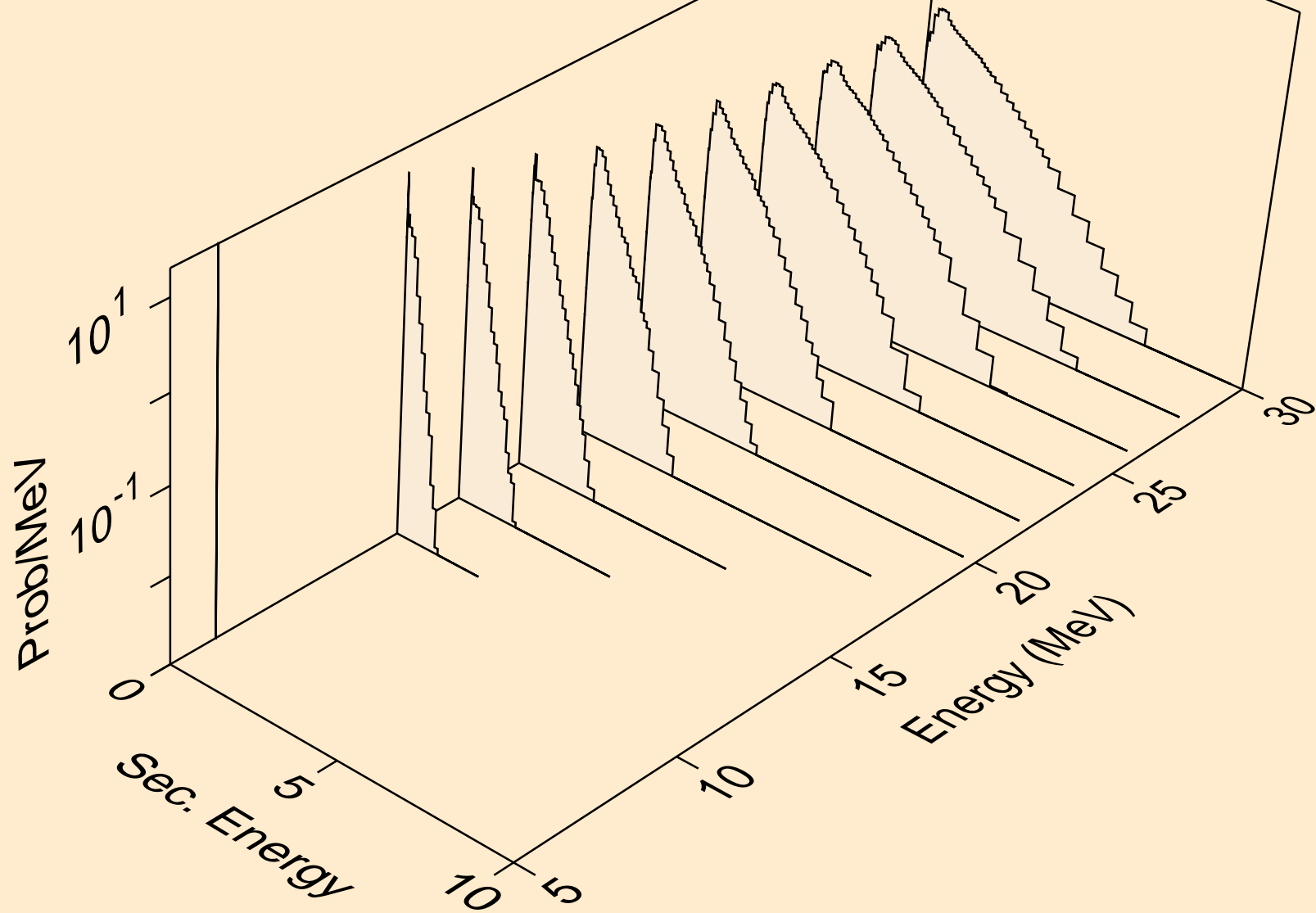



SN127M TRITON ACER TENDL-2021 LIBRARY; T=0.K  
neutrons from (t,3n)a

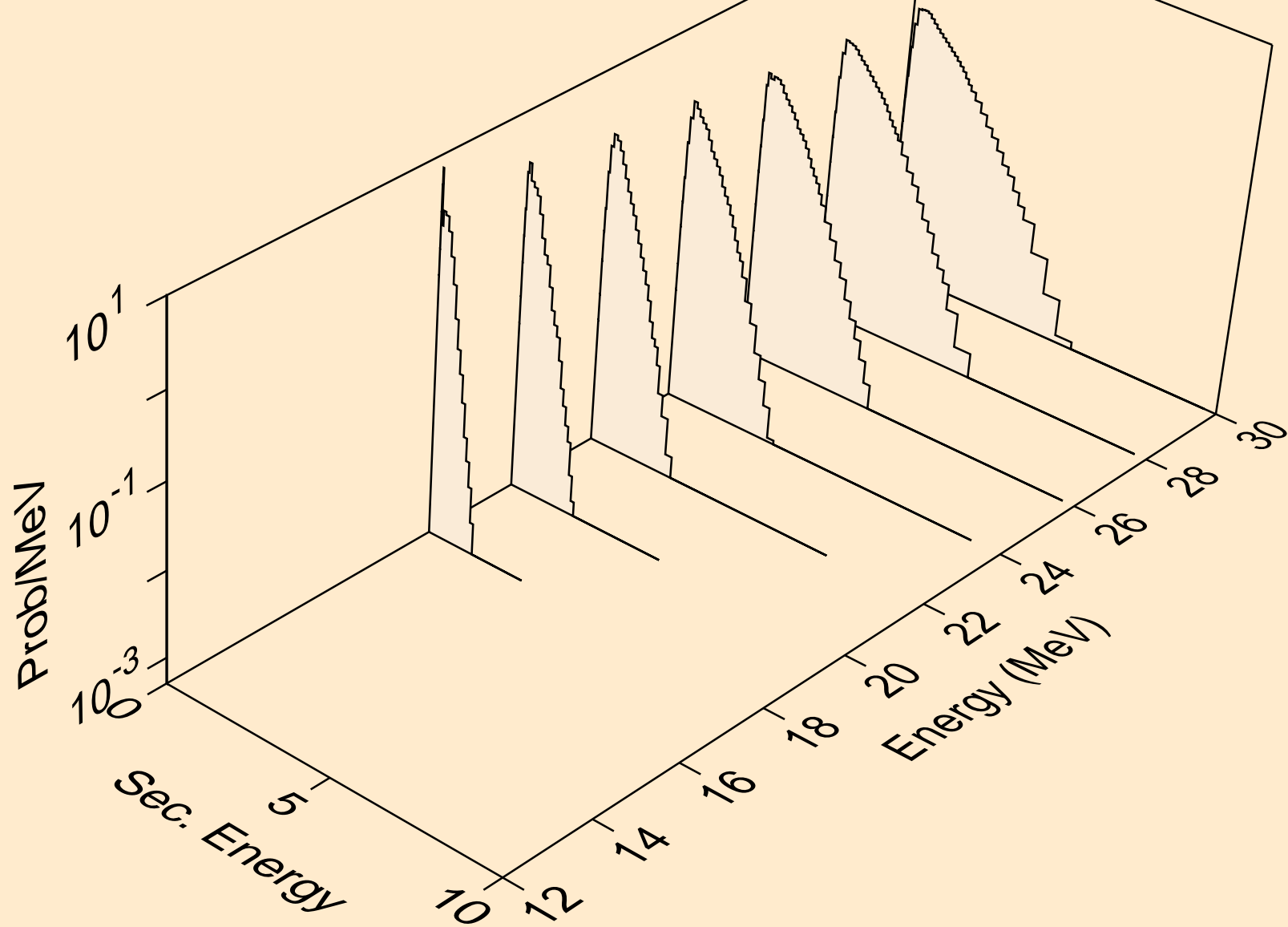

SN127M TRITON ACER TENDL-2021 LIBRARY; T=0.K  
neutrons from (t,n\*)p

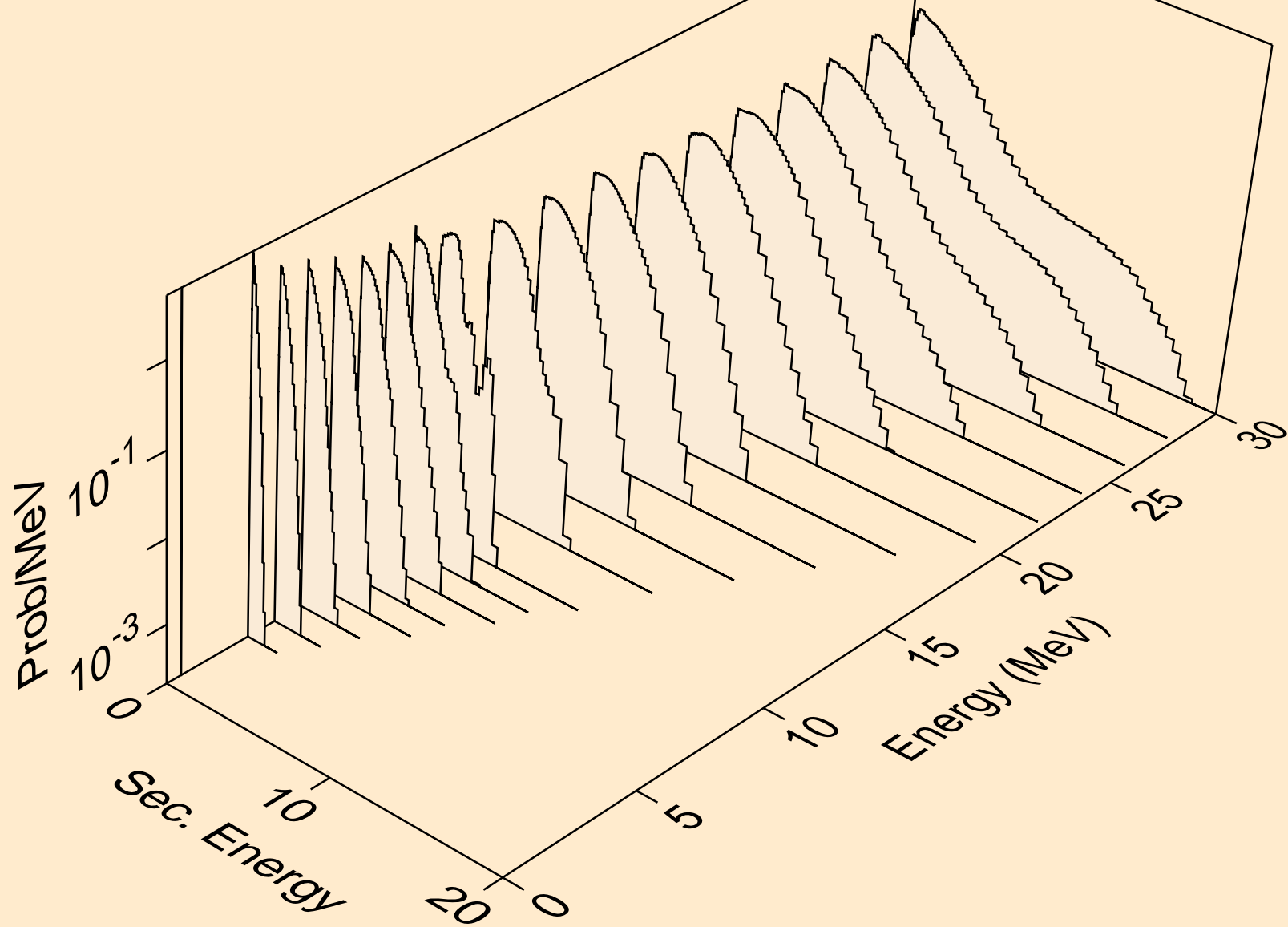

SN127M TRITON ACER TENDL-2021 LIBRARY; T=0.K  
neutrons from (t,n\*)d

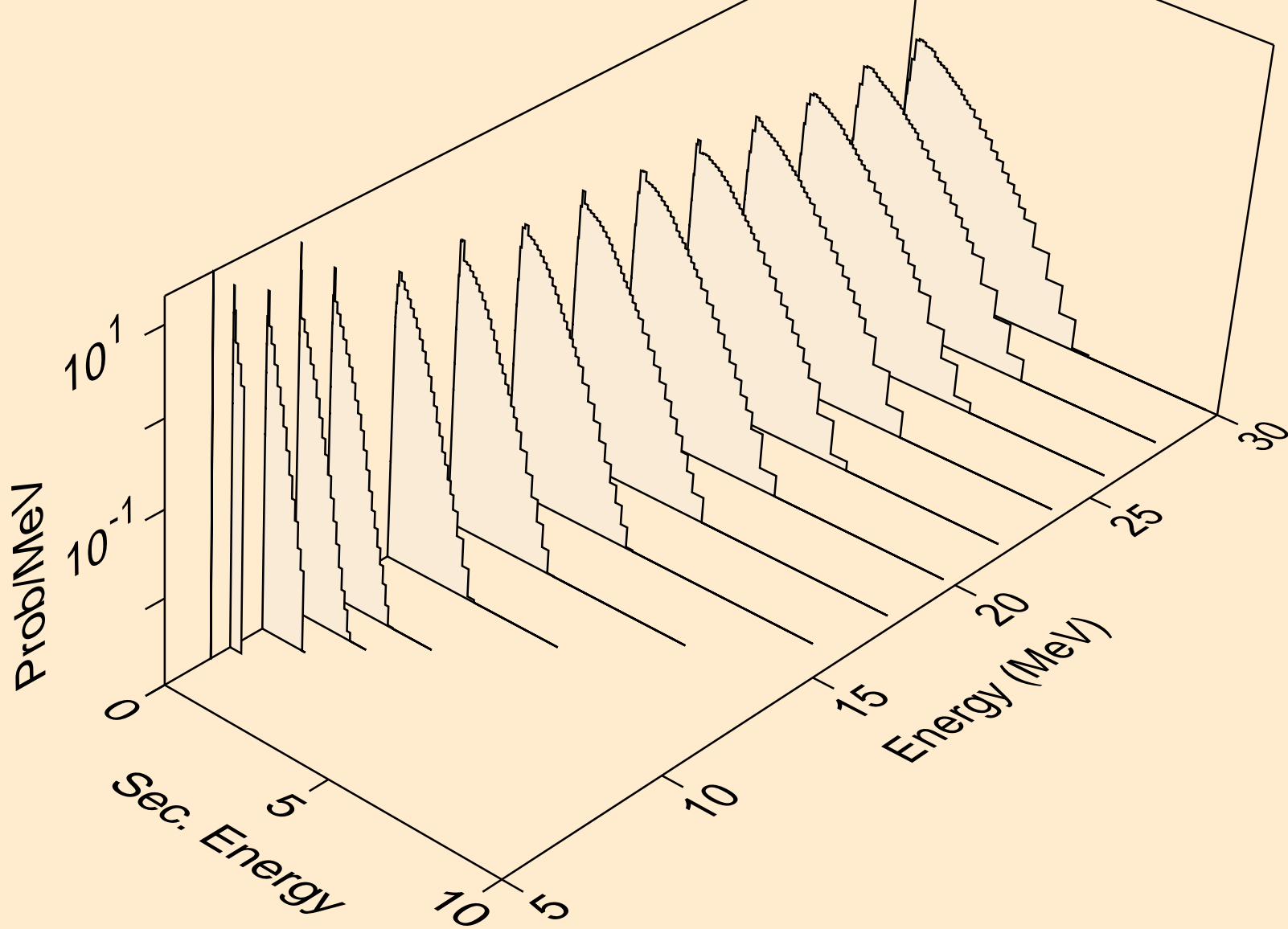

SN127M TRITON ACER TENDL-2021 LIBRARY; T=0.K  
neutrons from (t,n\*)t

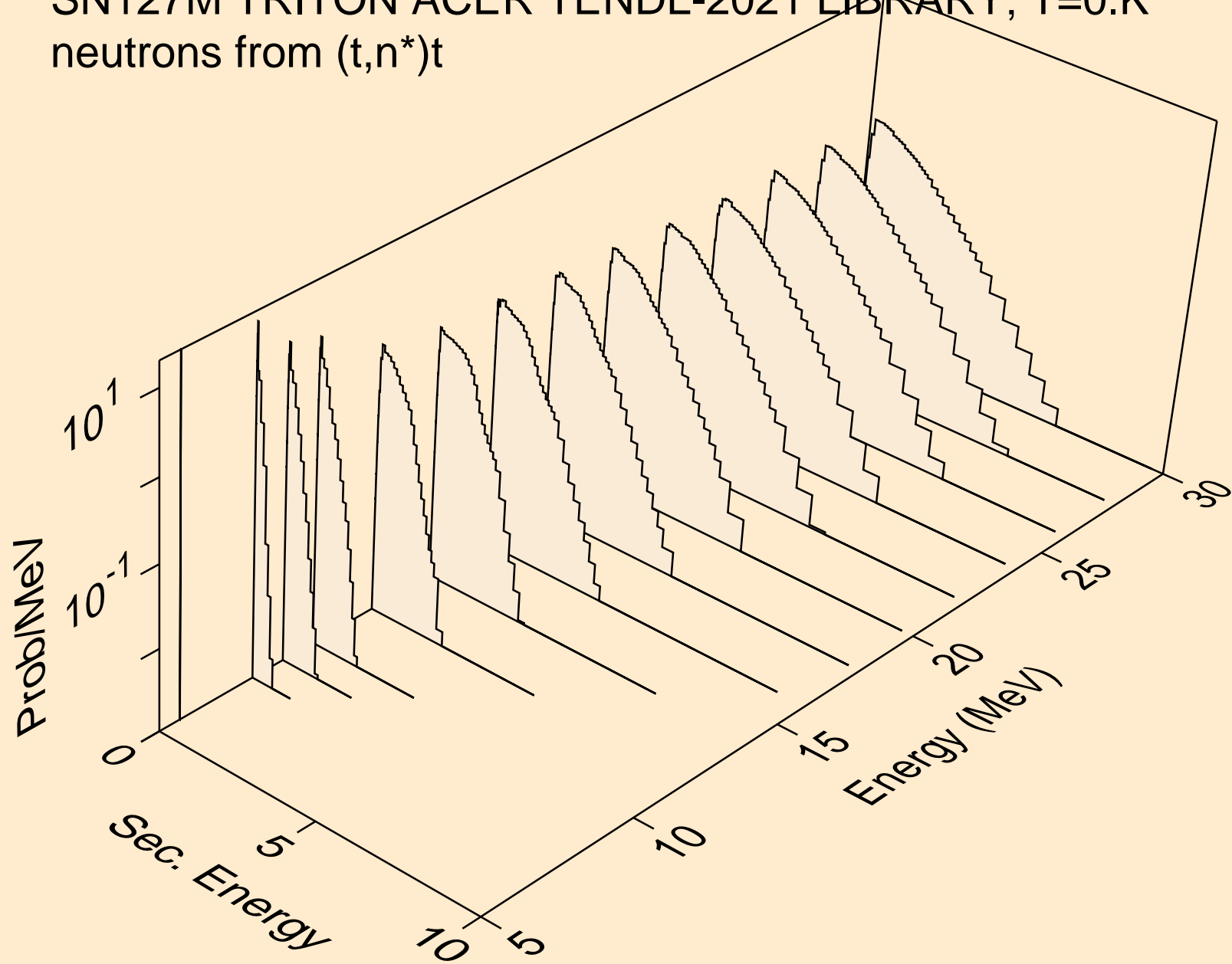

SN127M TRITON ACER TENDL-2021 LIBRARY; T=0.K  
neutrons from (t,n\*)he3

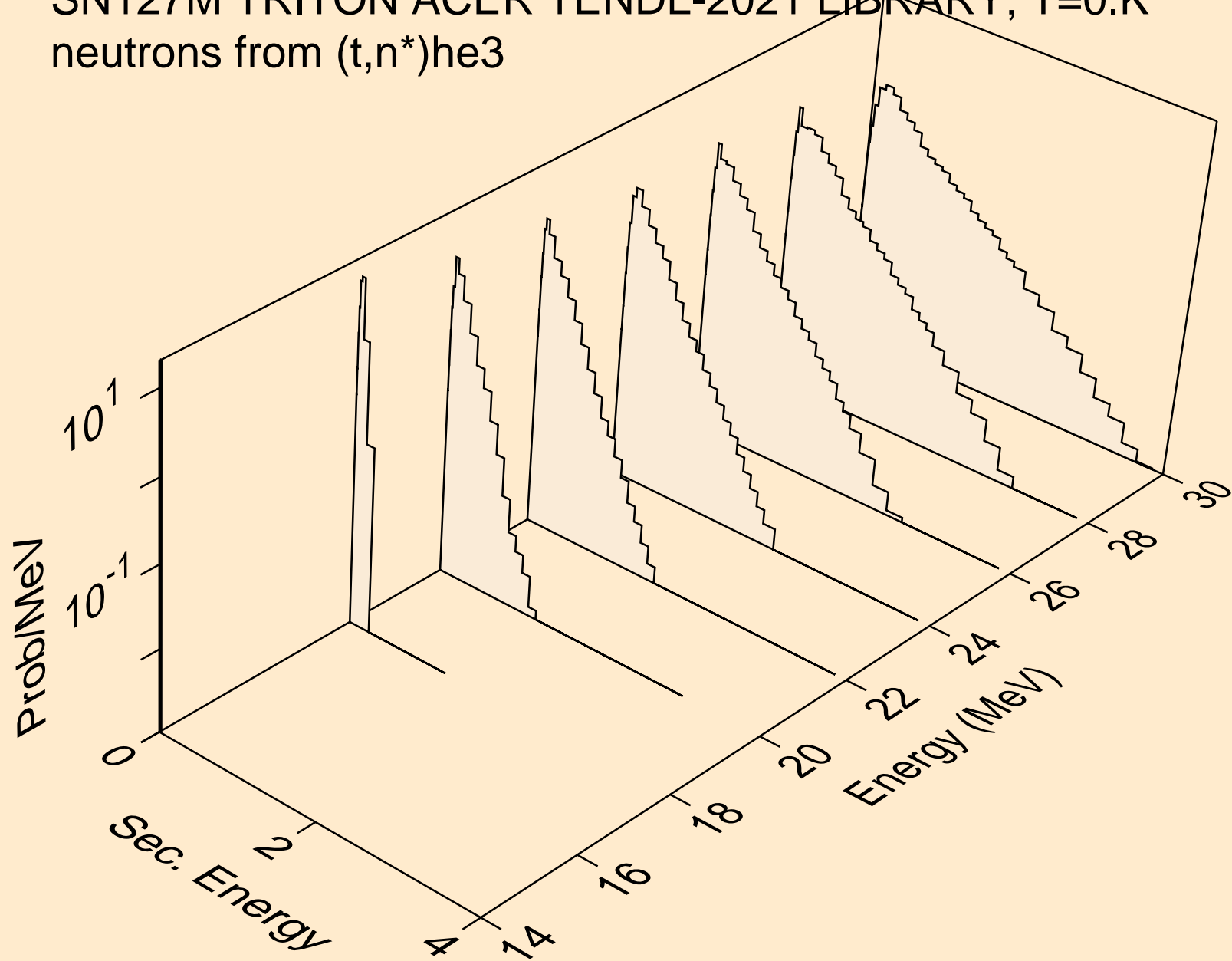

SN127M TRITON ACER TENDL-2021 LIBRARY; T=0.K  
neutrons from (t,4n)

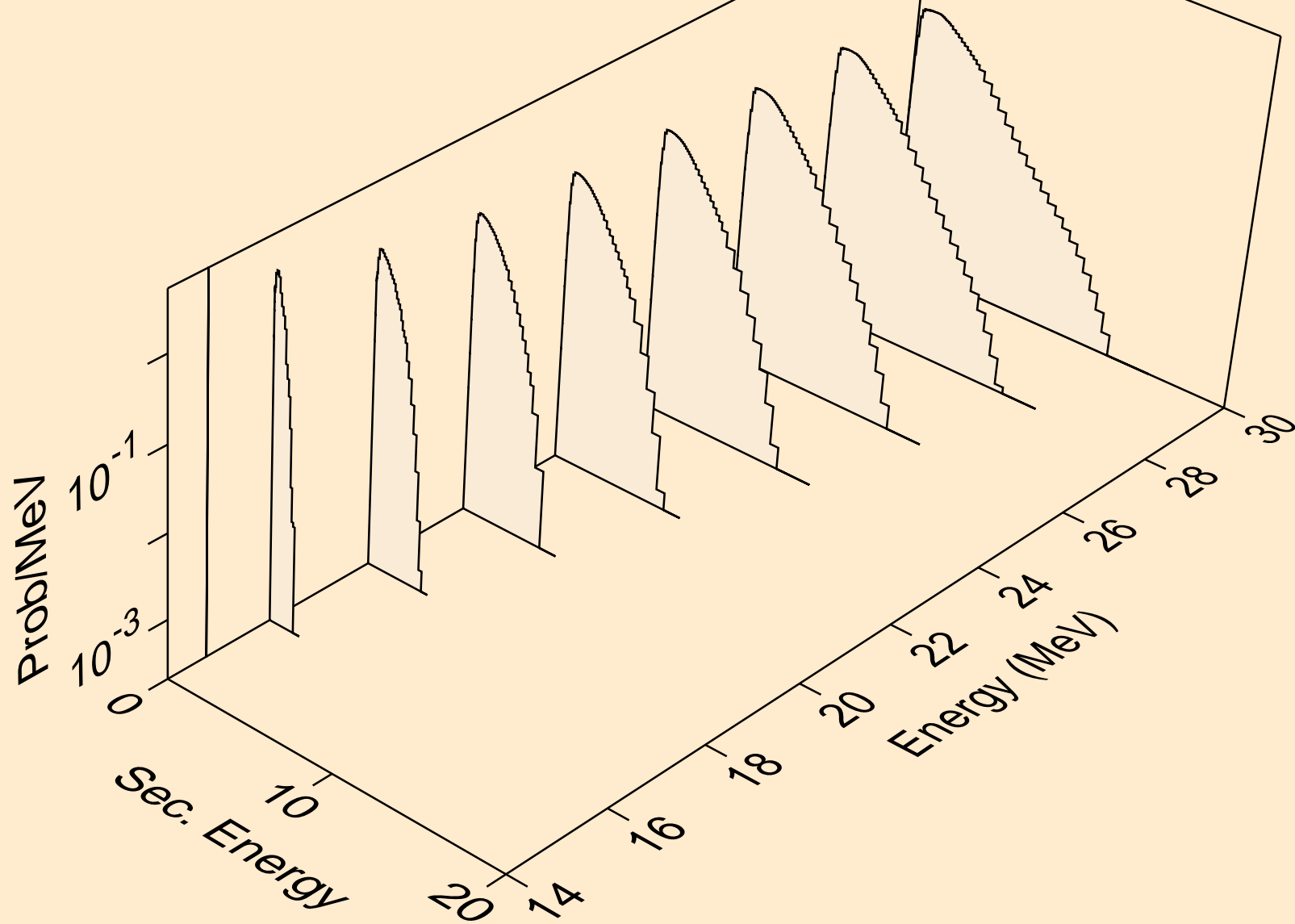

SN127M TRITON ACER TENDL-2021 LIBRARY; T=0.K  
neutrons from (t,2np)

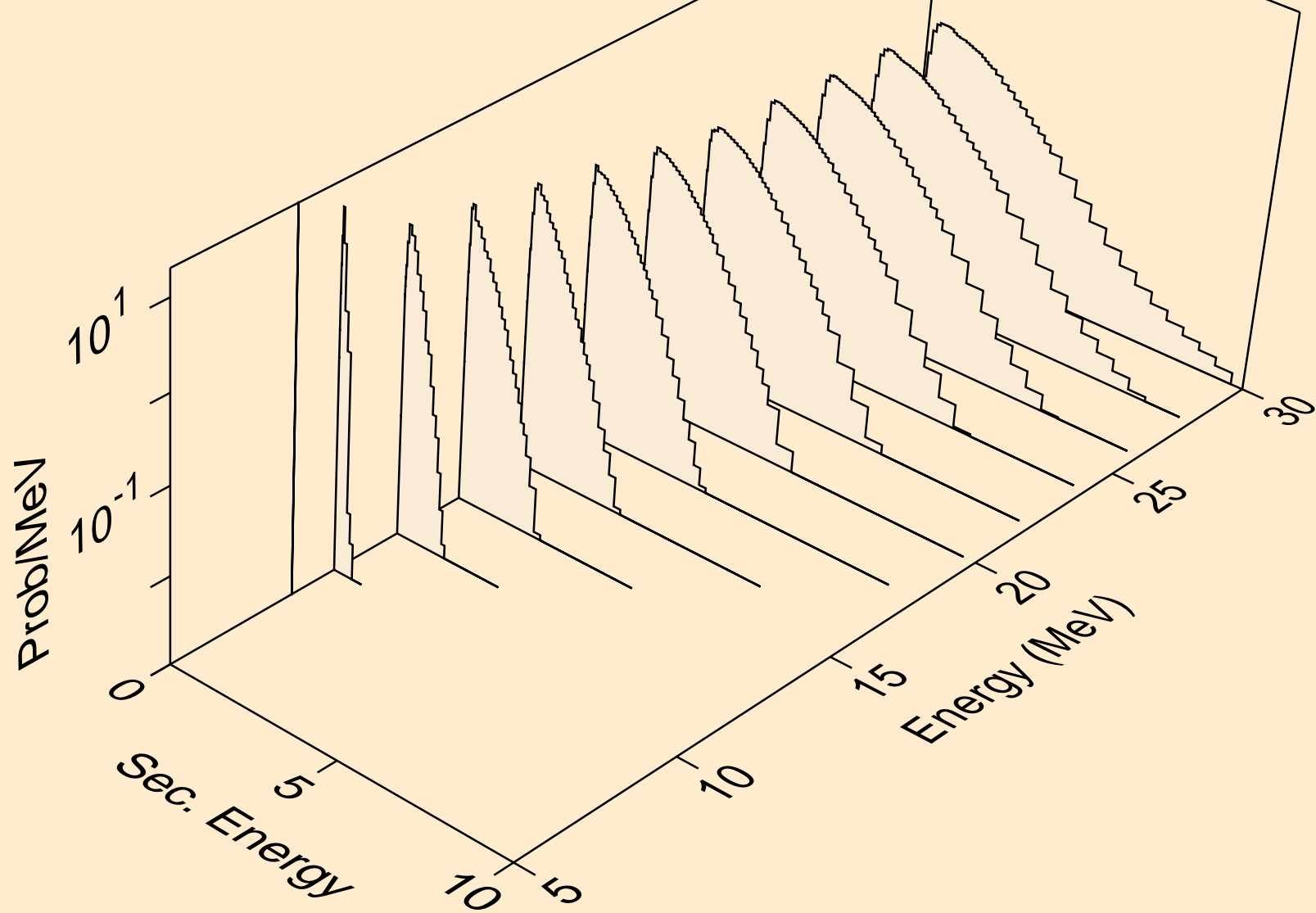

SN127M TRITON ACER TENDL-2021 LIBRARY; T=0.K  
neutrons from (t,3np)

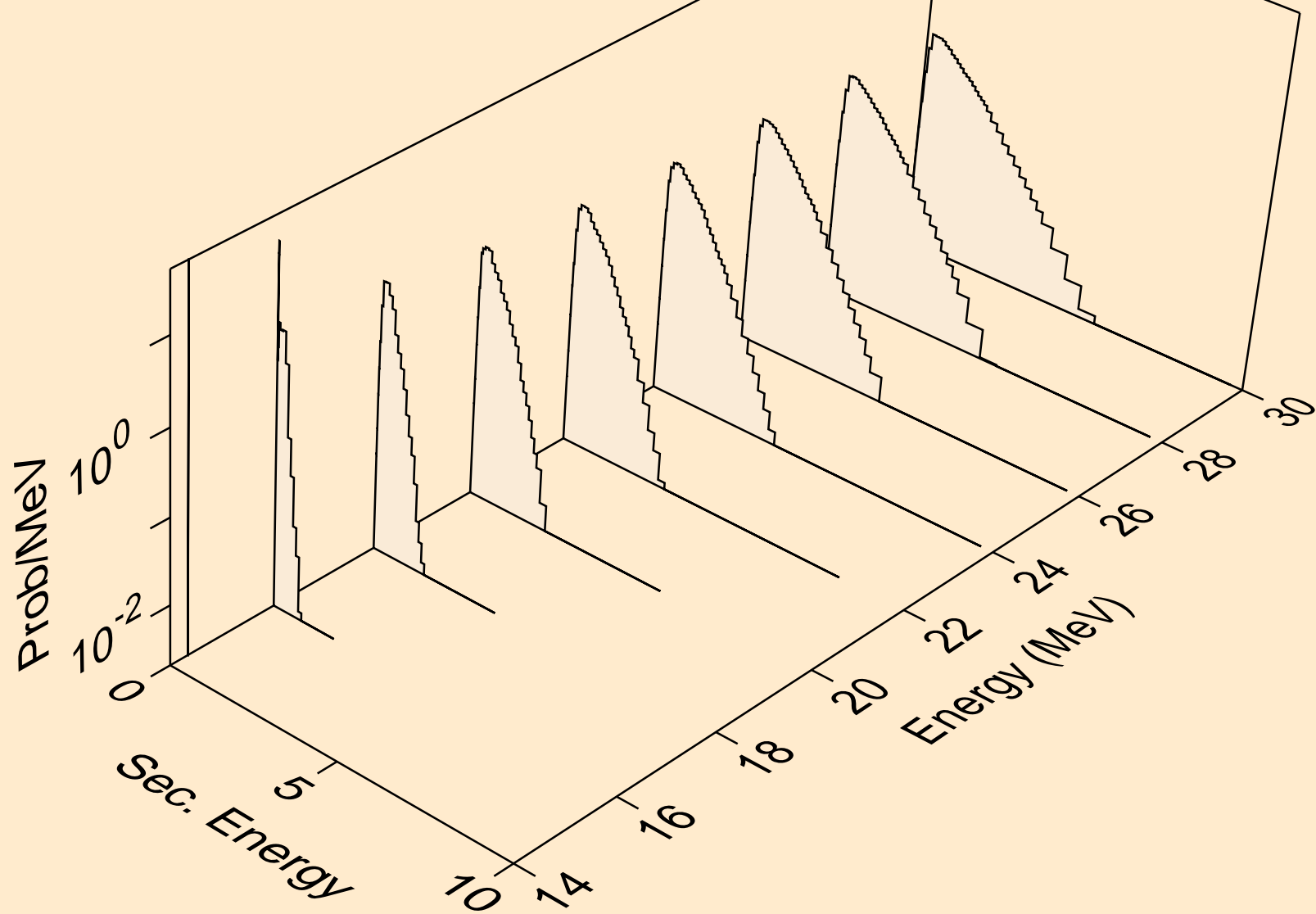



SN127M TRITON ACER TENDL-2021 LIBRARY; T=0.K  
neutrons from (t,2np)

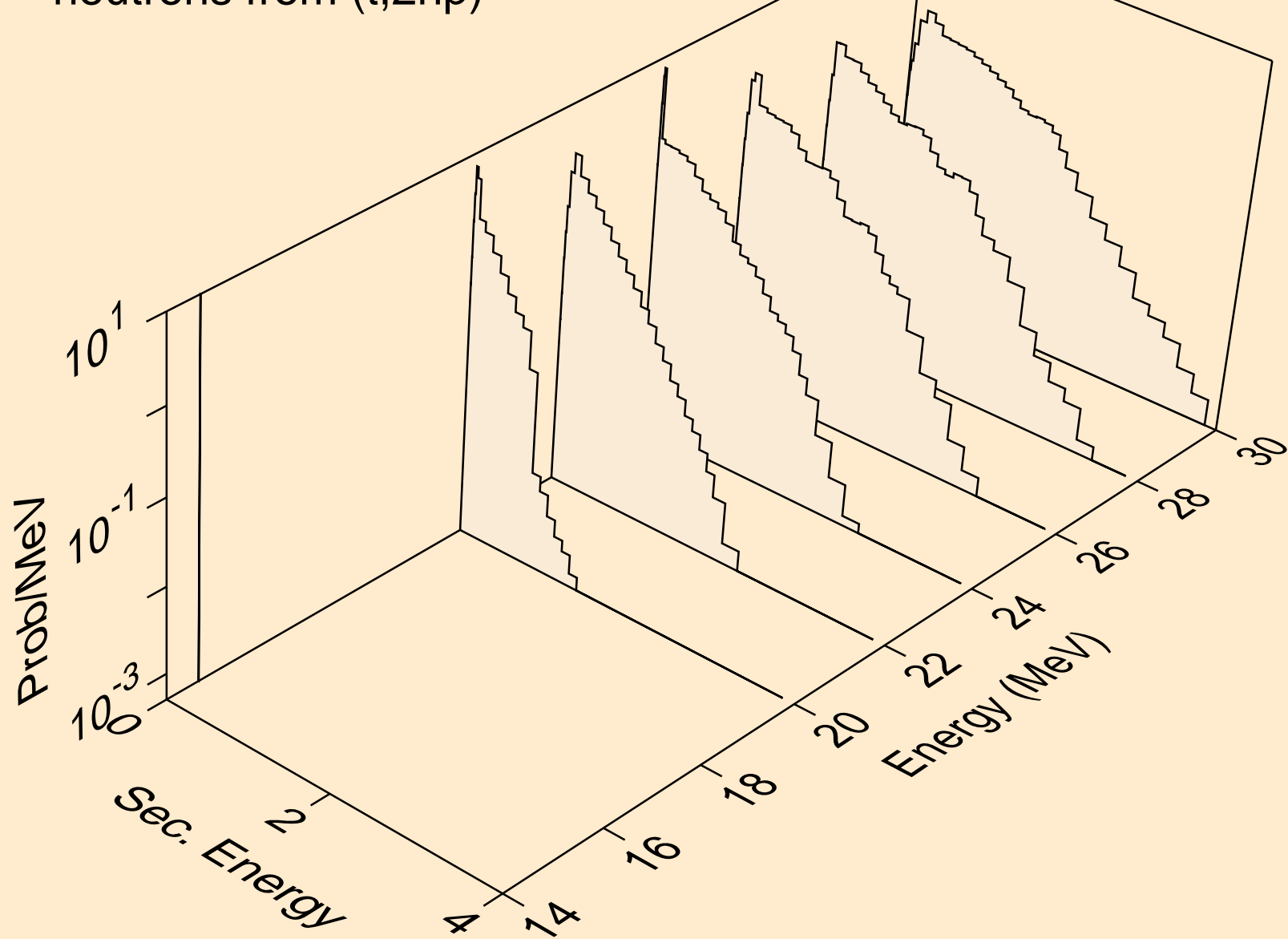

SN127M TRITON ACER TENDL-2021 LIBRARY; T=0.K  
protons from (t,x)

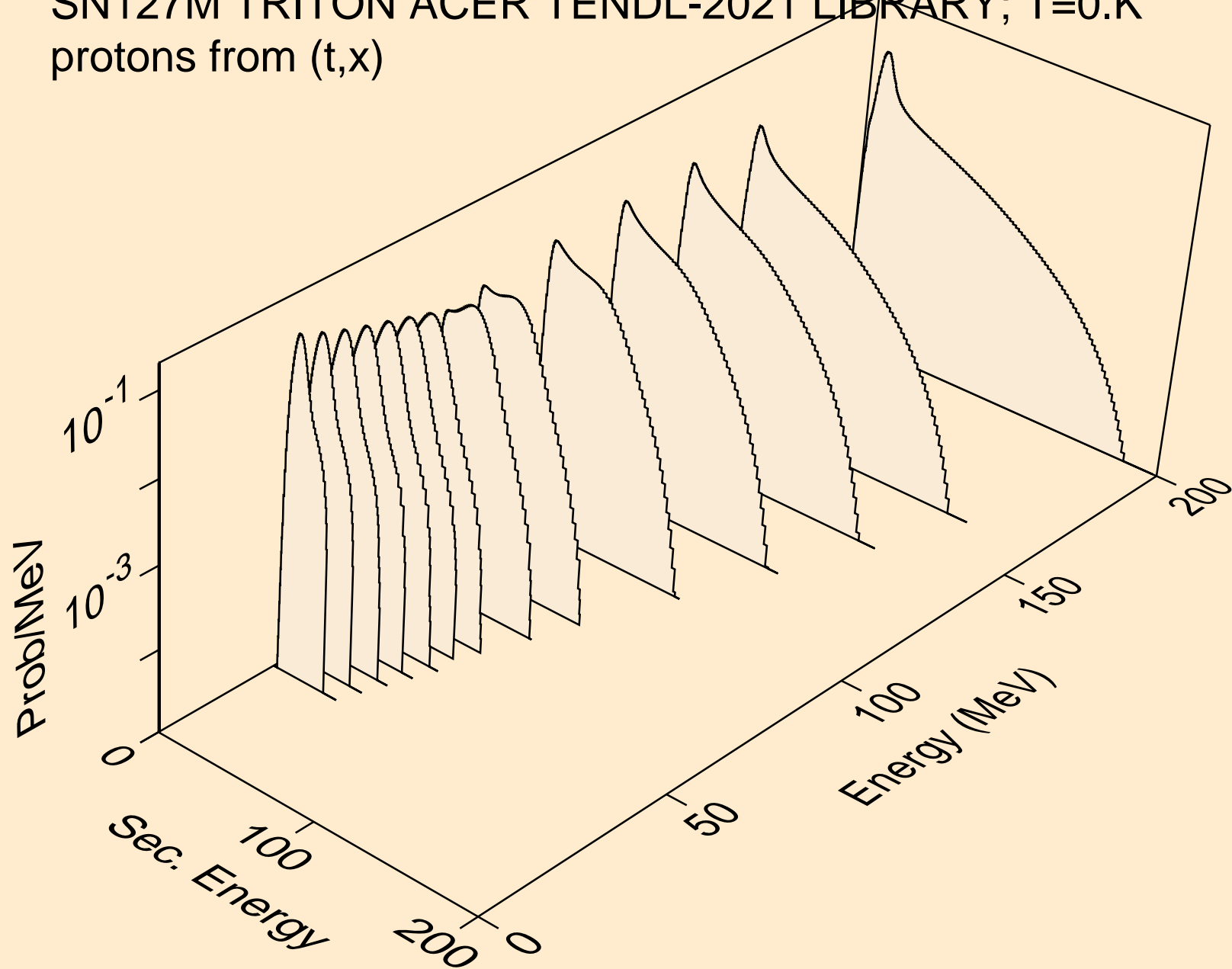

SN127M TRITON ACER TENDL-2021 LIBRARY; T=0.K  
protons from (t,n\*)p

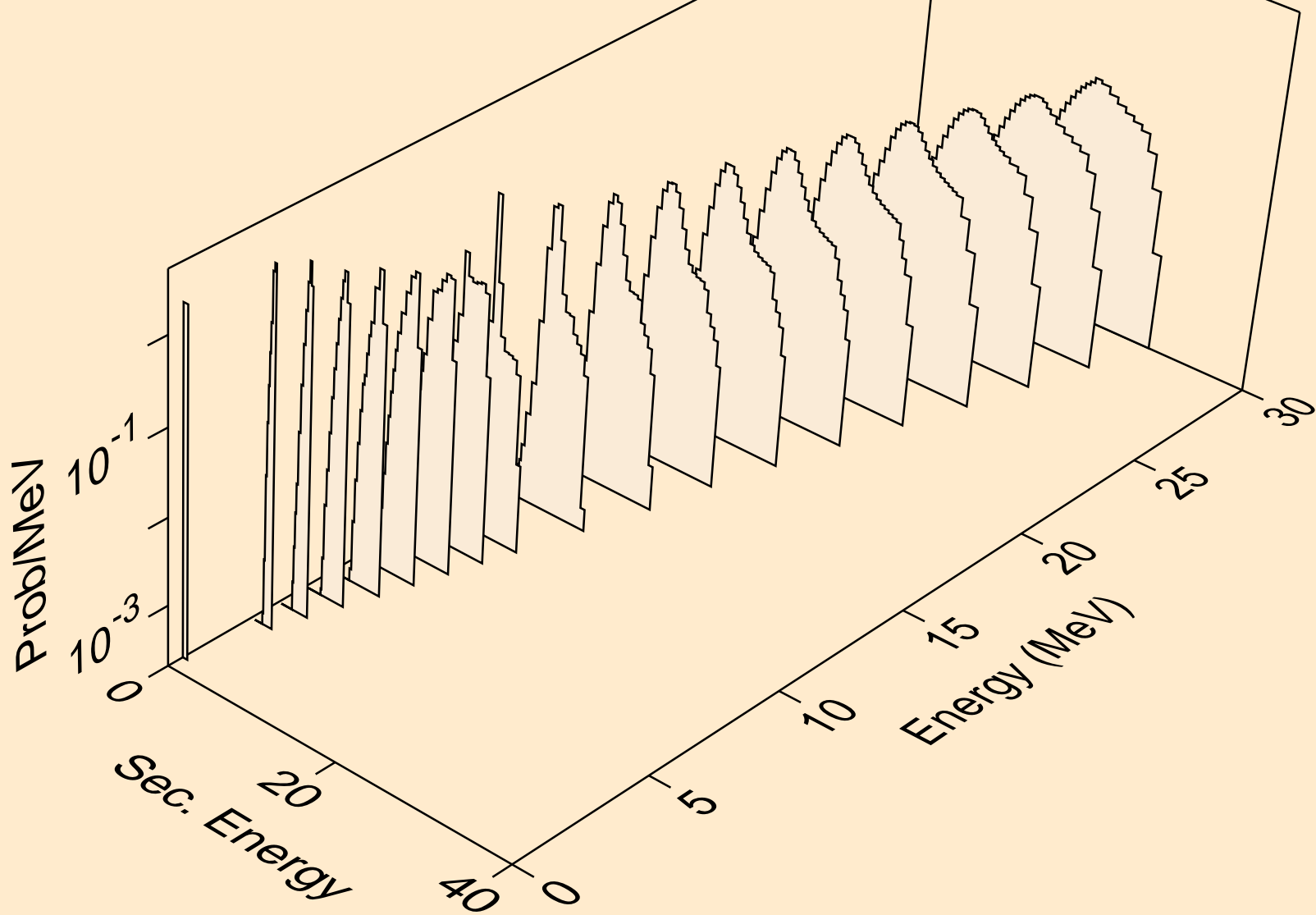

SN127M TRITON ACER TENDL-2021 LIBRARY; T=0.K  
protons from (t,2np)

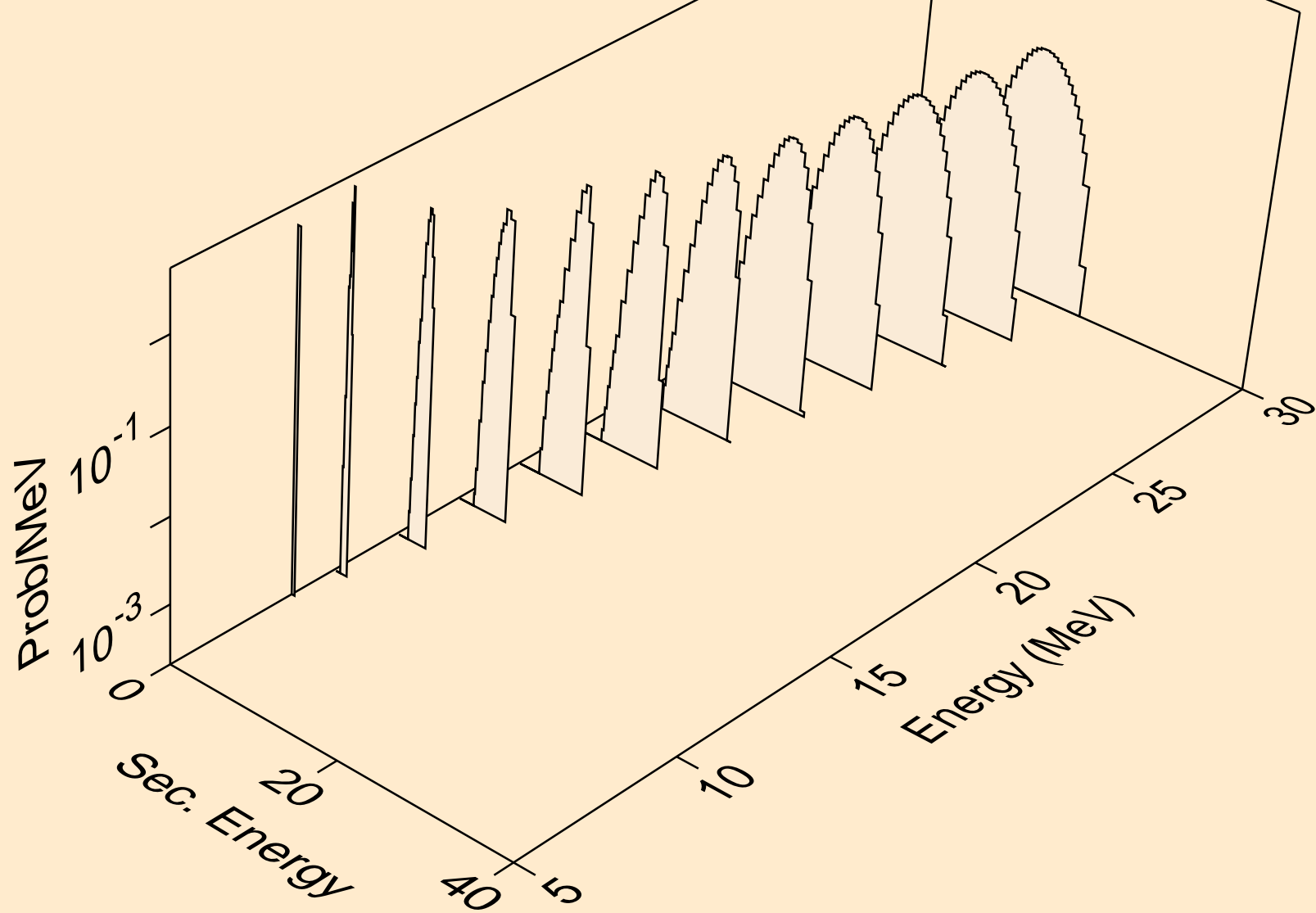

SN127M TRITON ACER TENDL-2021 LIBRARY; T=0.K  
protons from (t,3np)

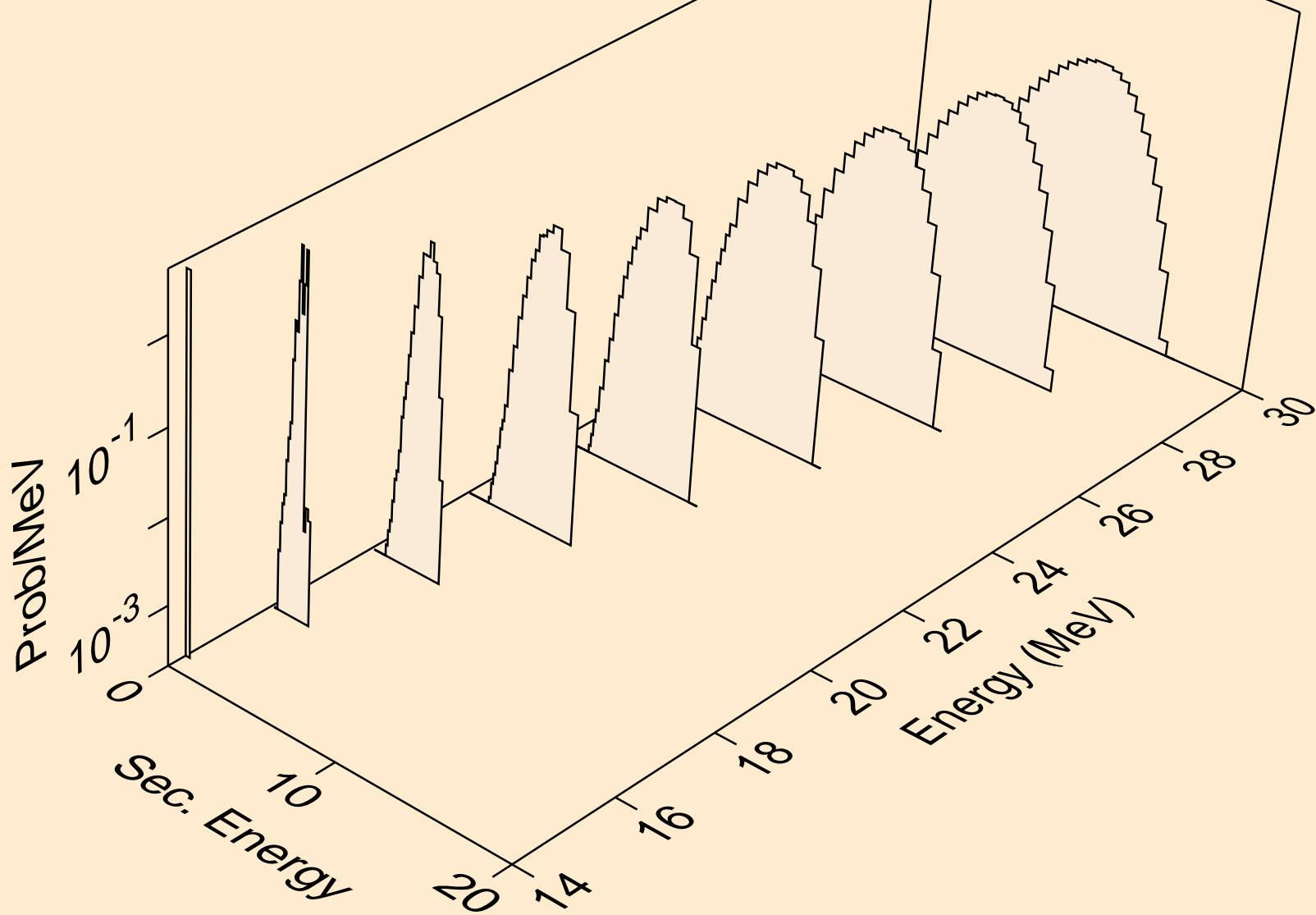

SN127M TRITON ACER TENDL-2021 LIBRARY; T=0.K  
protons from (t,2np)

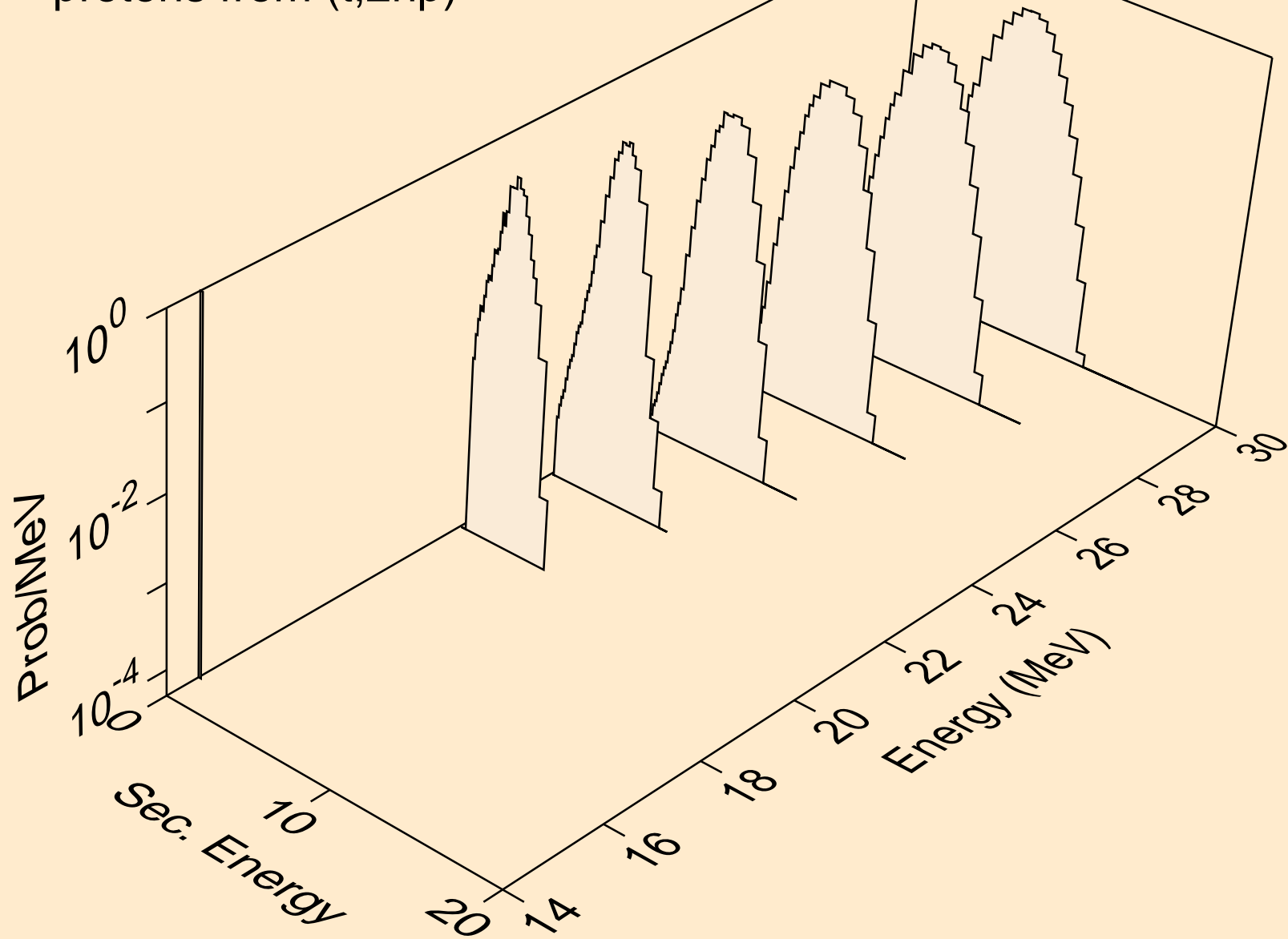

SN127M TRITON ACER TENDL-2021 LIBRARY; T=0.K  
protons from (t,p)

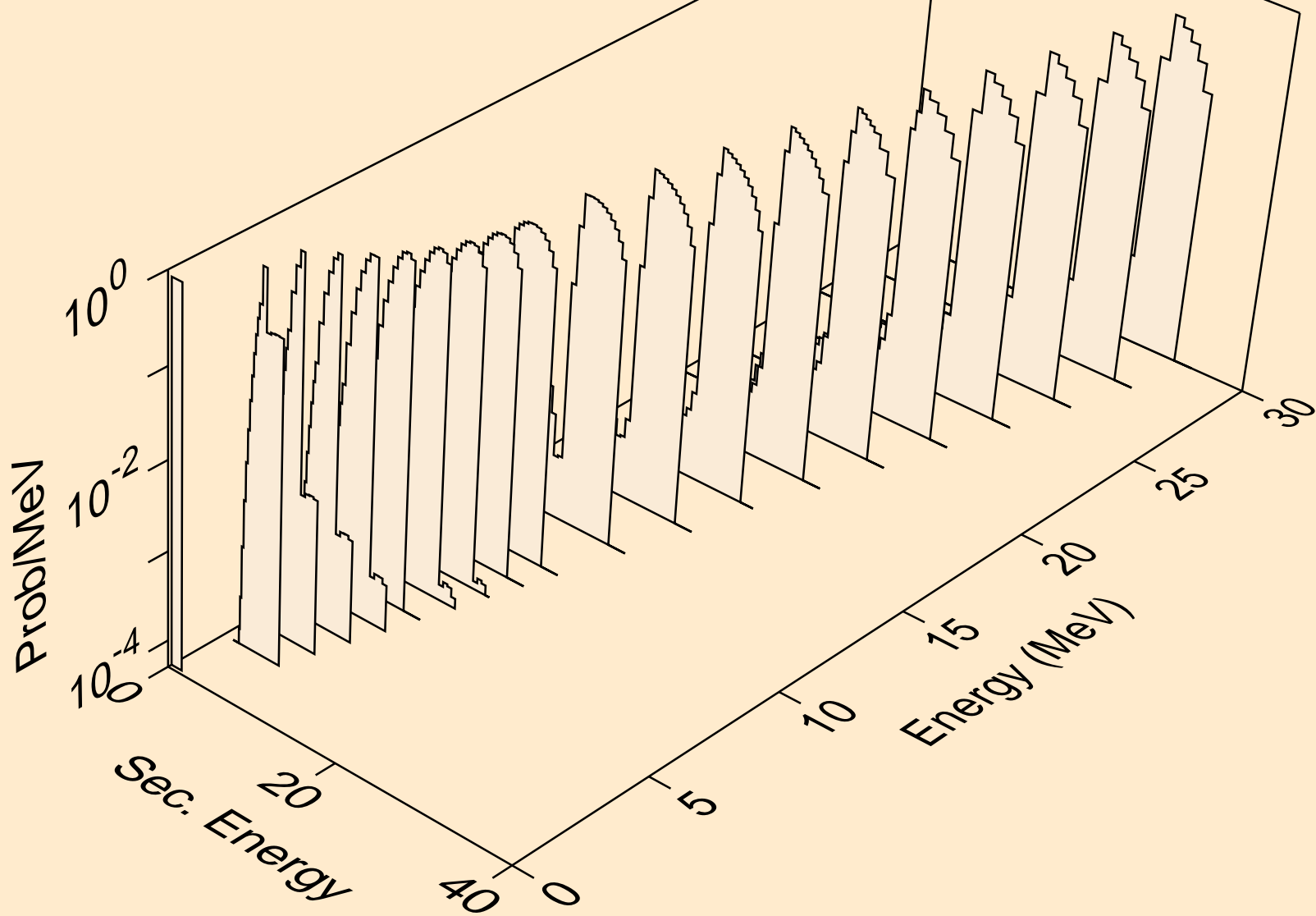

SN127M TRITON ACER TENDL-2021 LIBRARY; T=0.K  
protons from (t,2p)

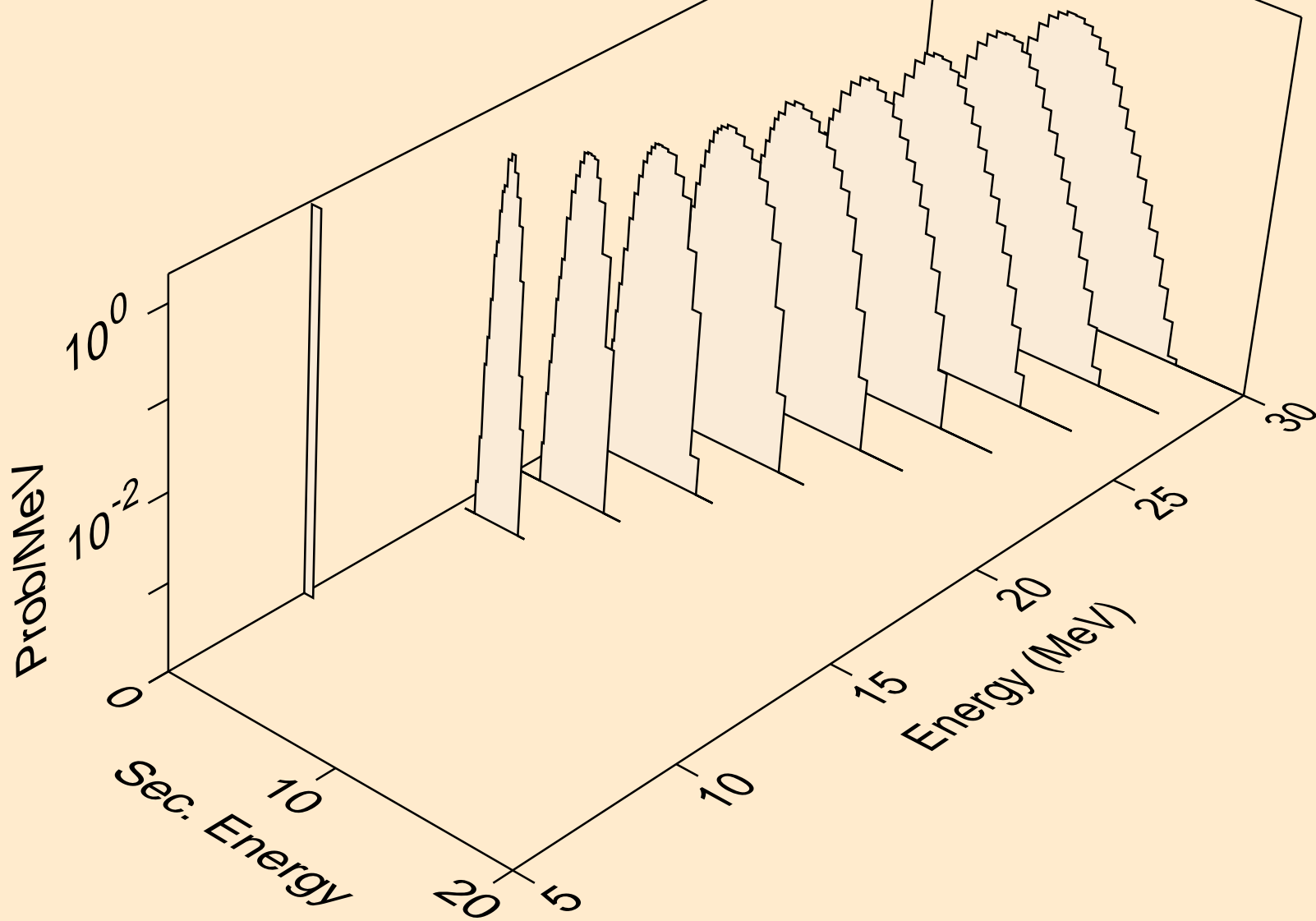



SN127M TRITON ACER TENDL-2021 LIBRARY; T=0.K  
protons from (t,pa)

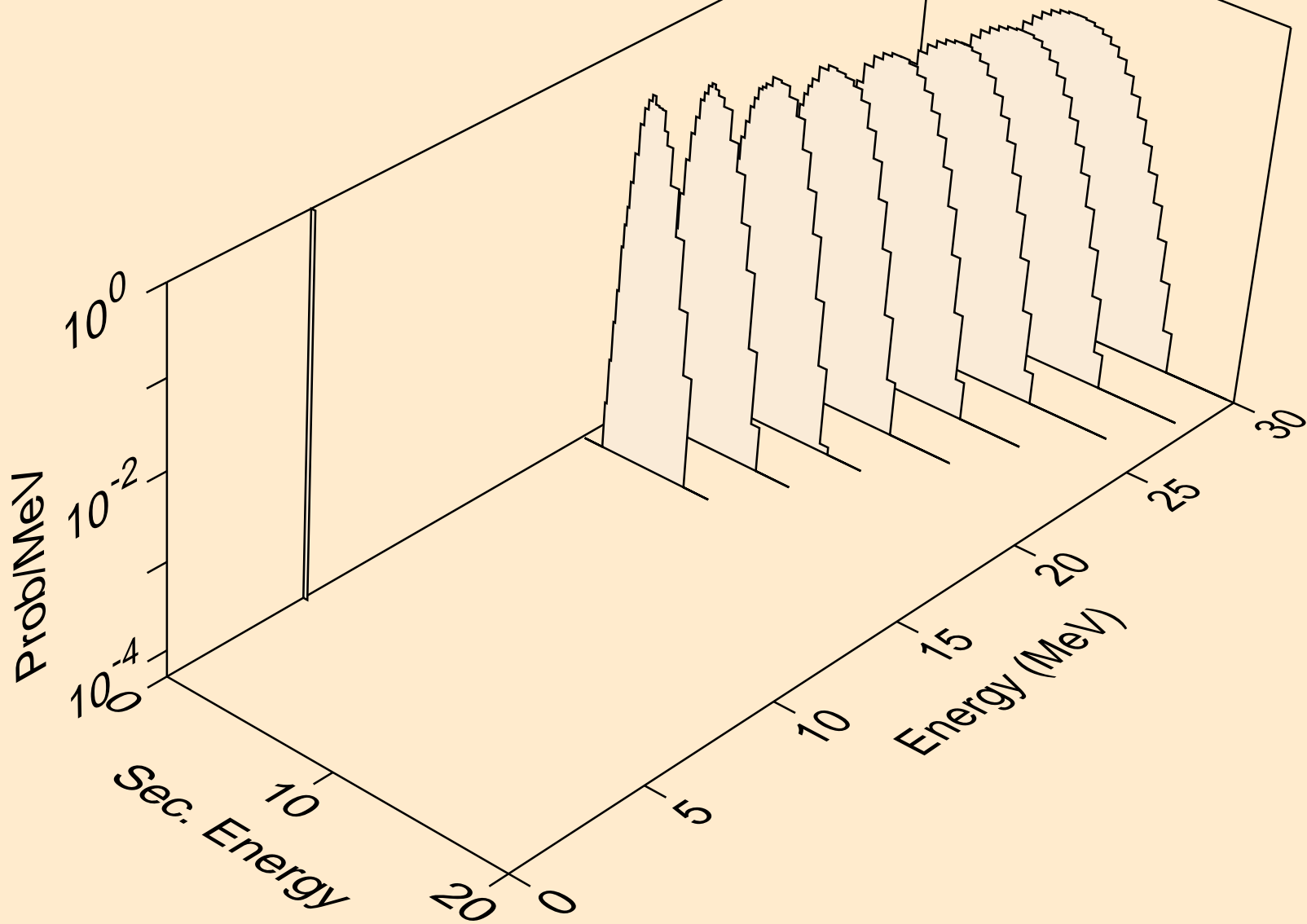

SN127M TRITON ACER TENDL-2021 LIBRARY; T=0.K  
protons from (t,pd)

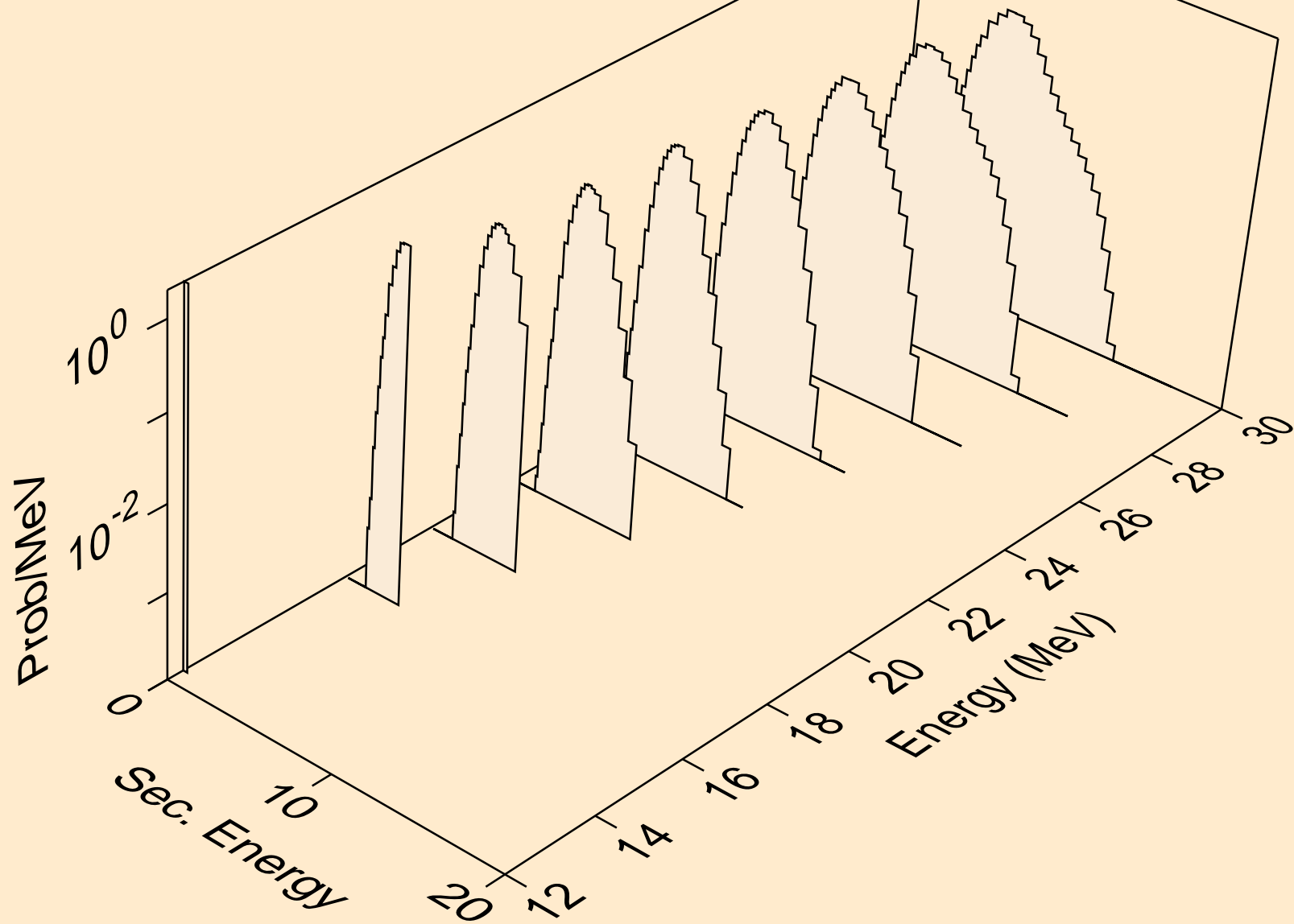

SN127M TRITON ACER TENDL-2021 LIBRARY; T=0.K  
protons from (t,pt)

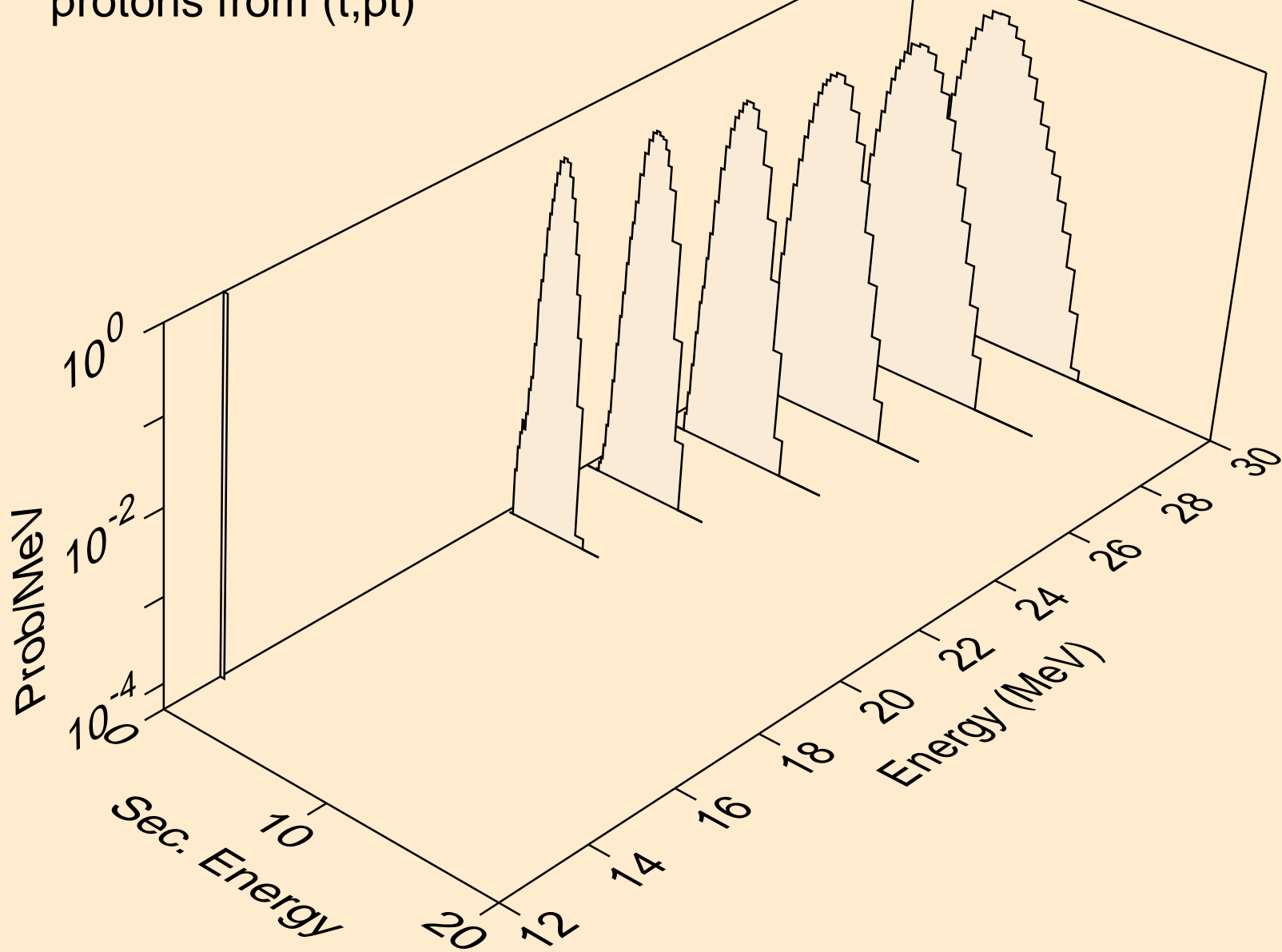

SN127M TRITON ACER TENDL-2021 LIBRARY; T=0.K  
deuterons from (t,x)

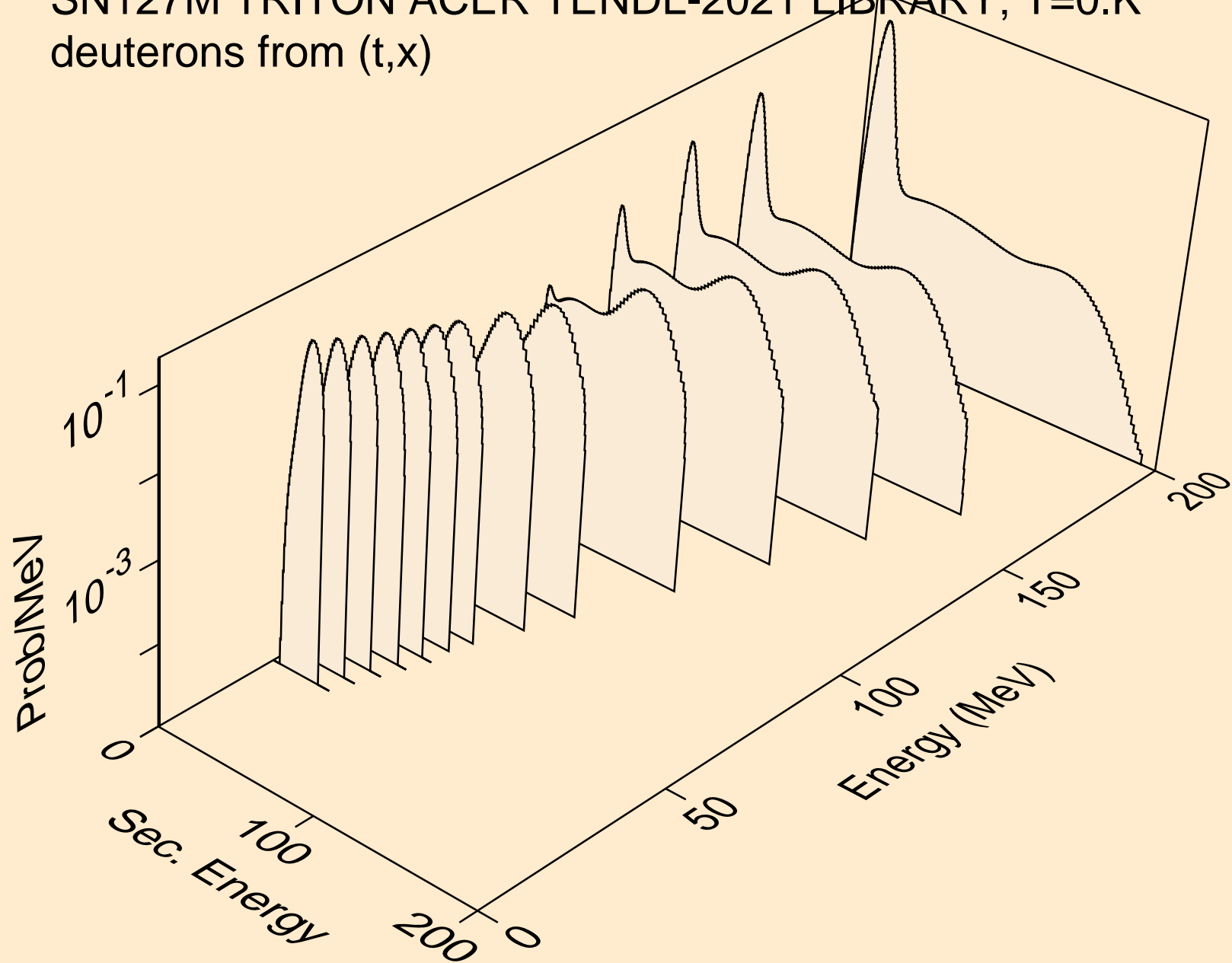

SN127M TRITON ACER TENDL-2021 LIBRARY; T=0.K  
deuterons from (t,2nd)

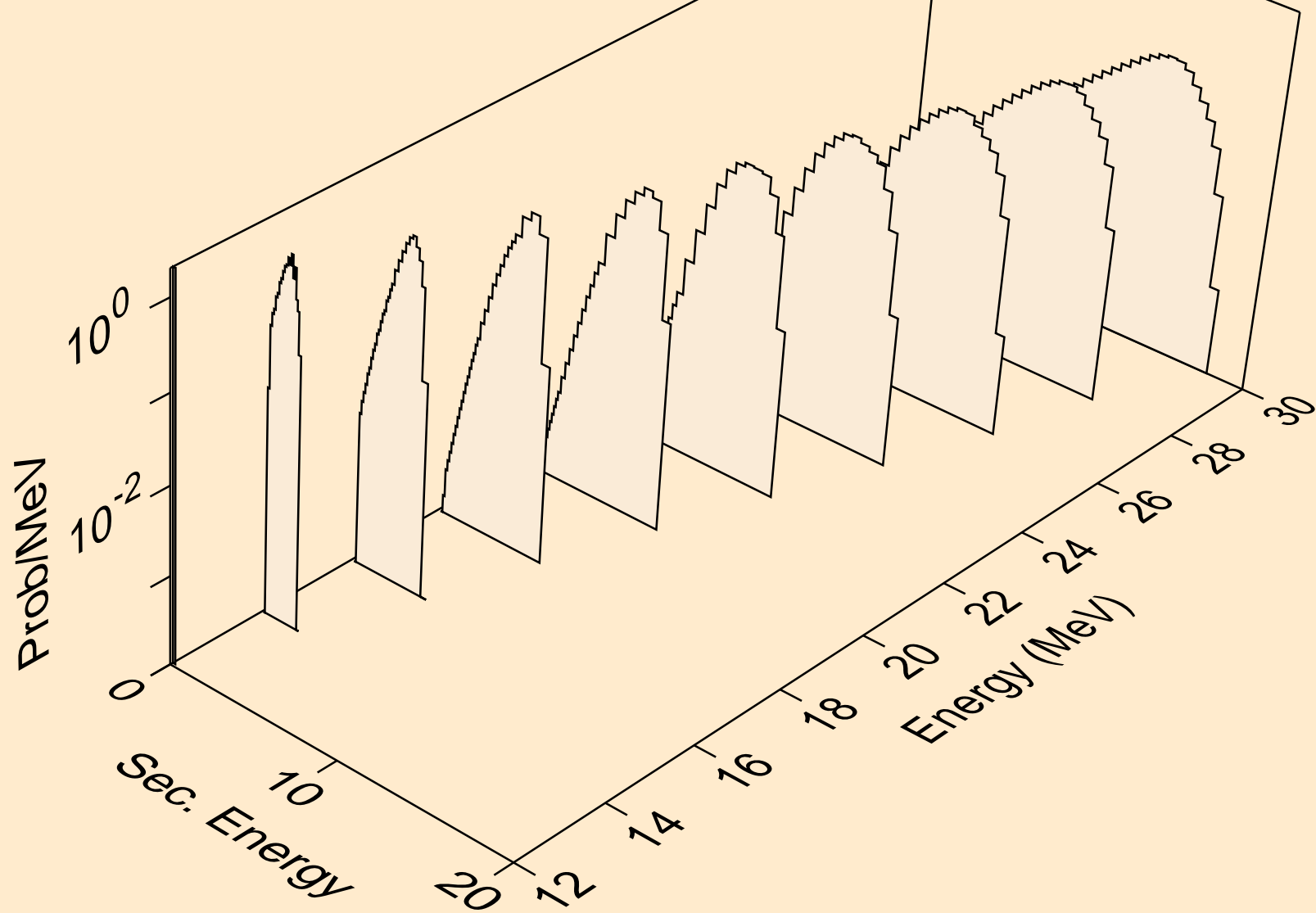

SN127M TRITON ACER TENDL-2021 LIBRARY; T=0.K  
deuterons from (t,n\*)d

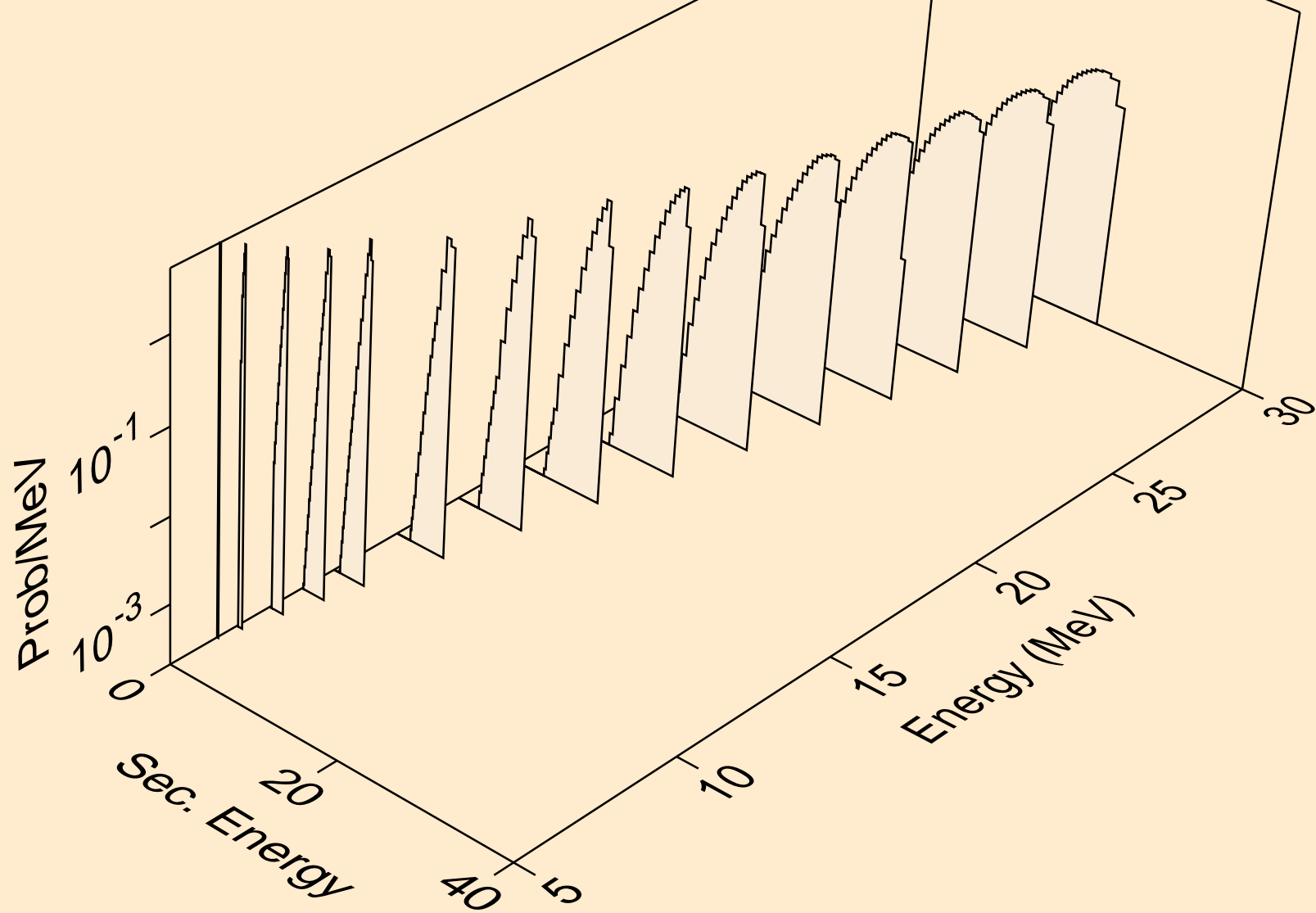

SN127M TRITON ACER TENDL-2021 LIBRARY; T=0.K  
deuterons from (t,d)

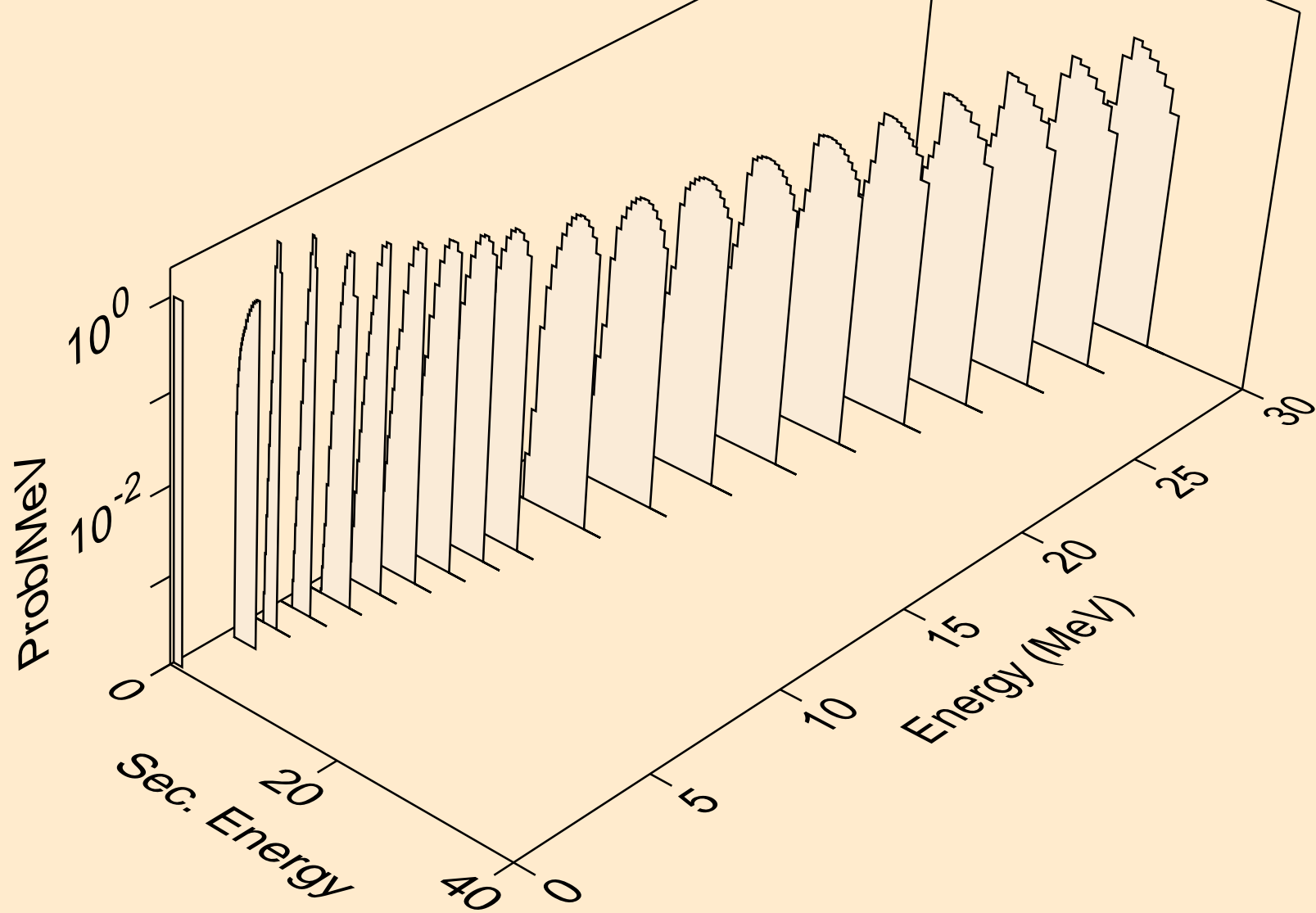

SN127M TRITON ACER TENDL-2021 LIBRARY; T=0.K  
deuterons from (t,pd)

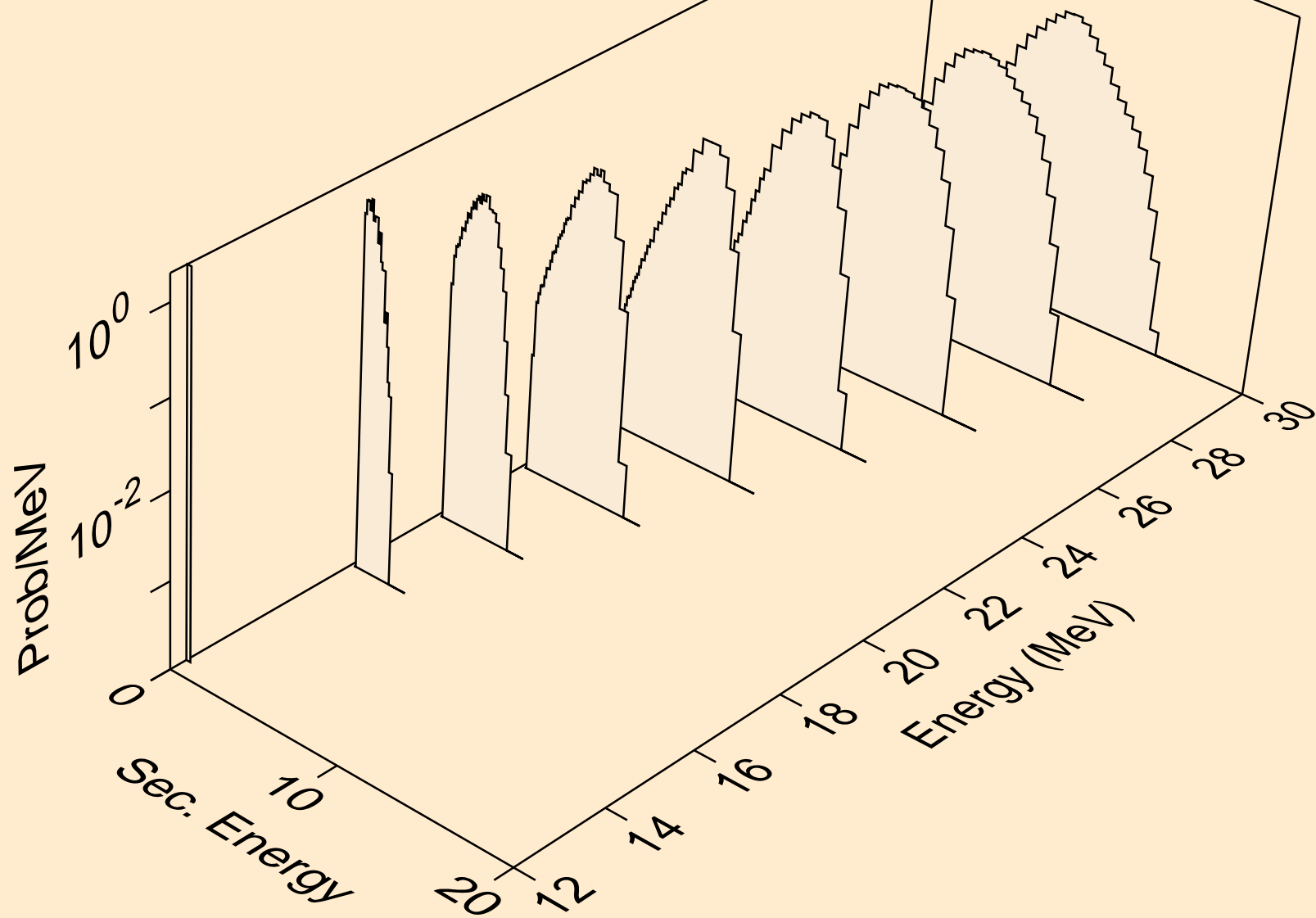



SN127M TRITON ACER TENDL-2021 LIBRARY; T=0.K  
he3s from (t,x)

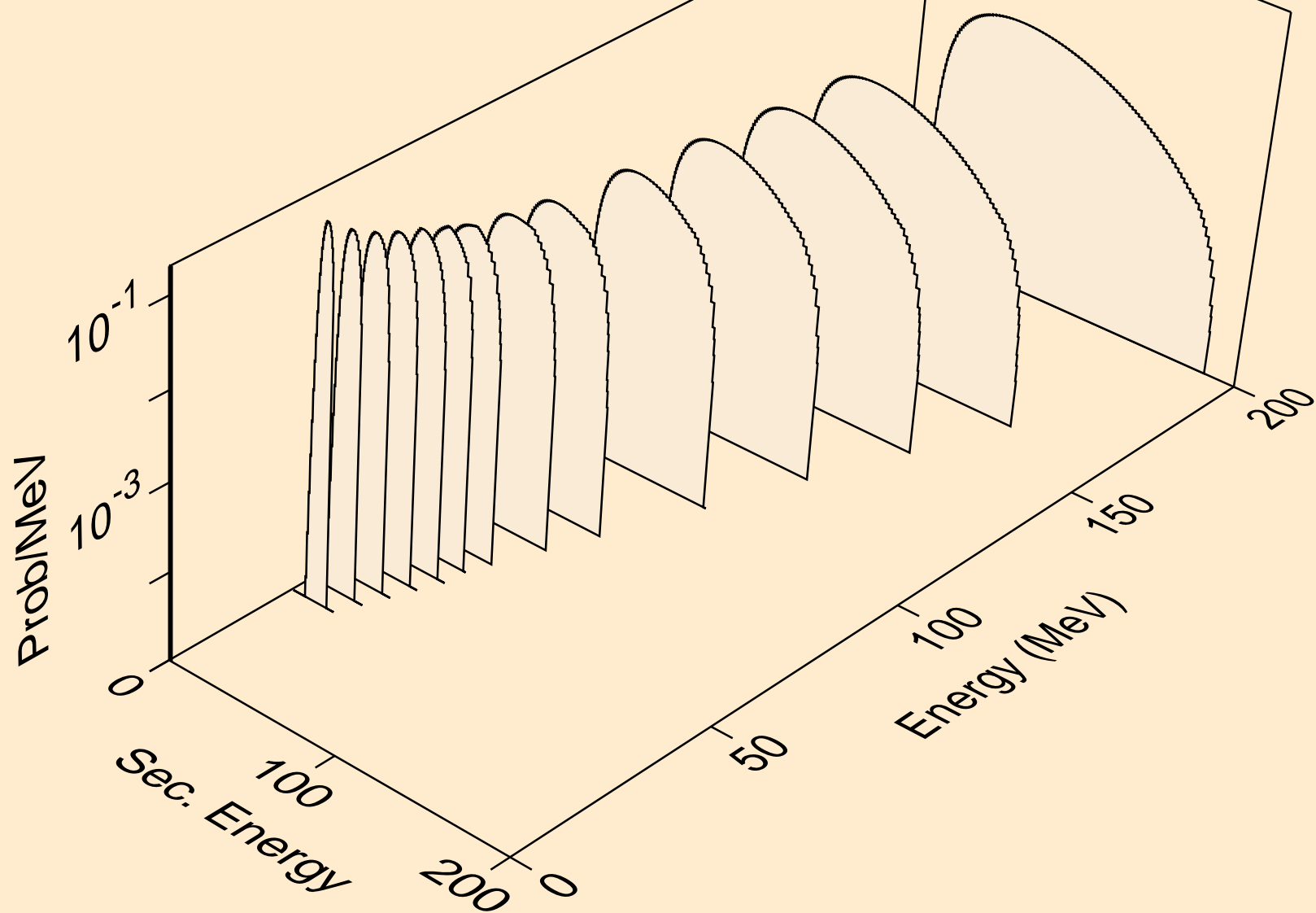

SN127M TRITON ACER TENDL-2021 LIBRARY; T=0.K  
he3s from (t,n\*)he3

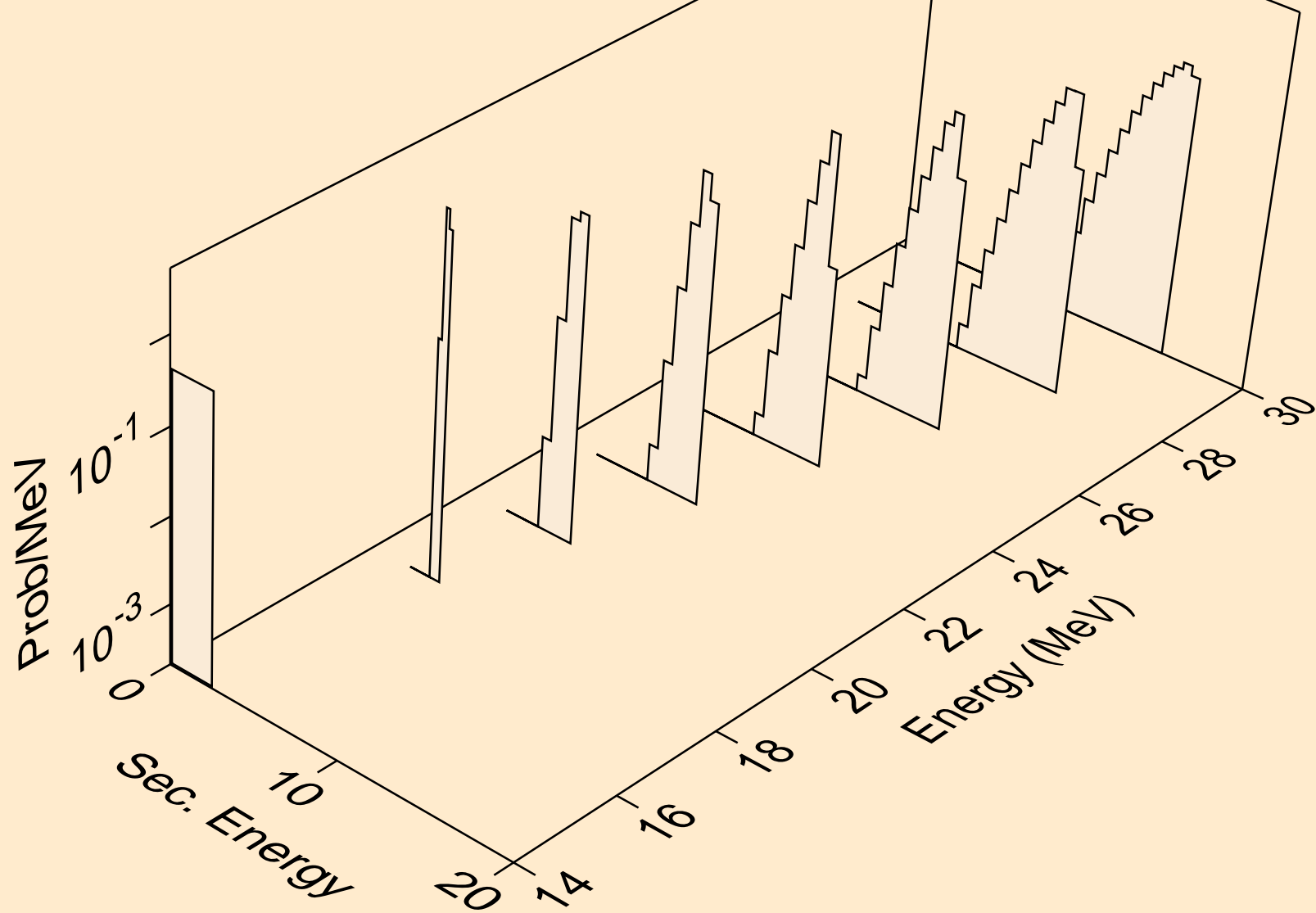

SN127M TRITON ACER TENDL-2021 LIBRARY; T=0.K  
he3s from (t,he3)

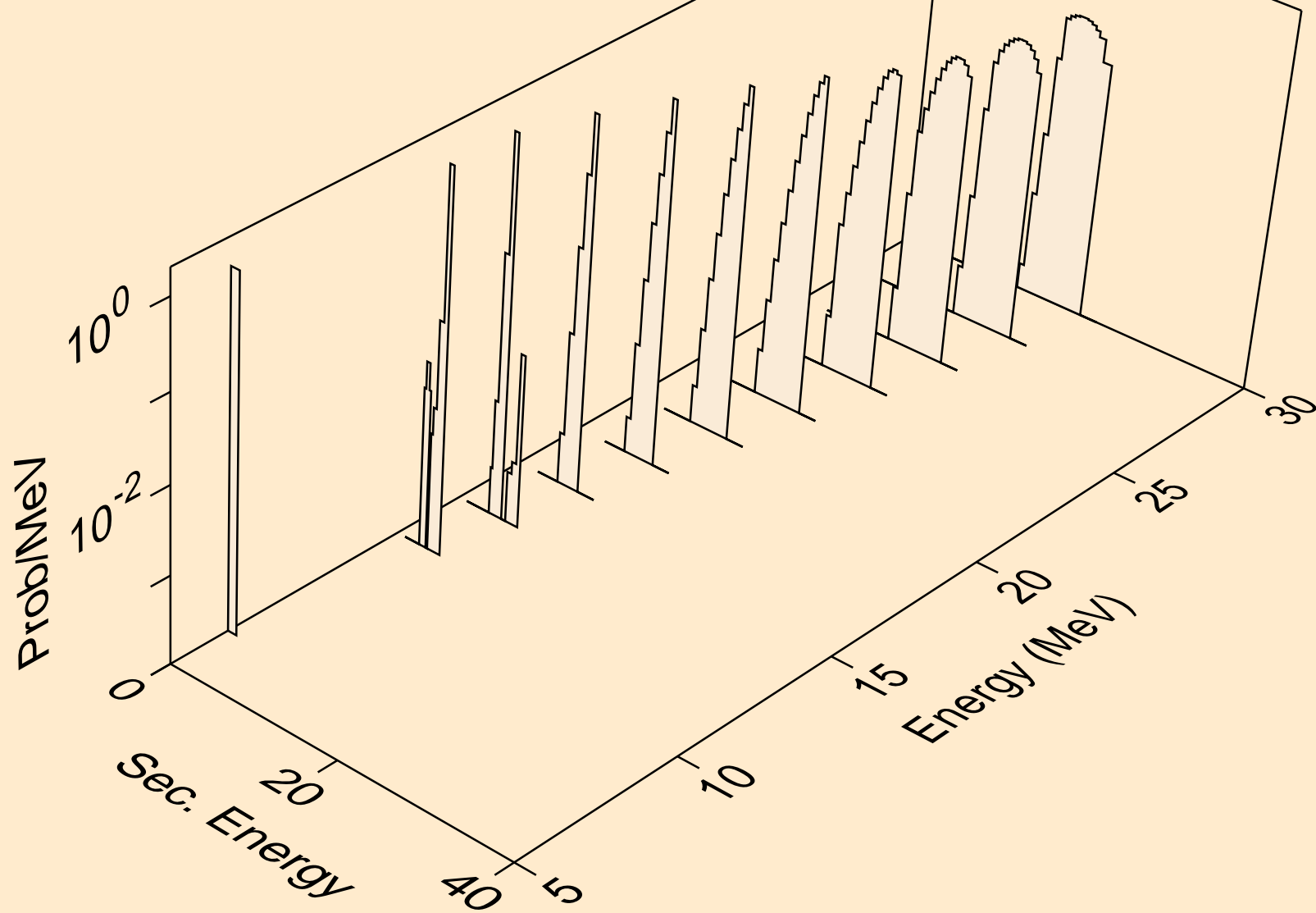

SN127M TRITON ACER TENDL-2021 LIBRARY; T=0.K  
alphas from (t,x)

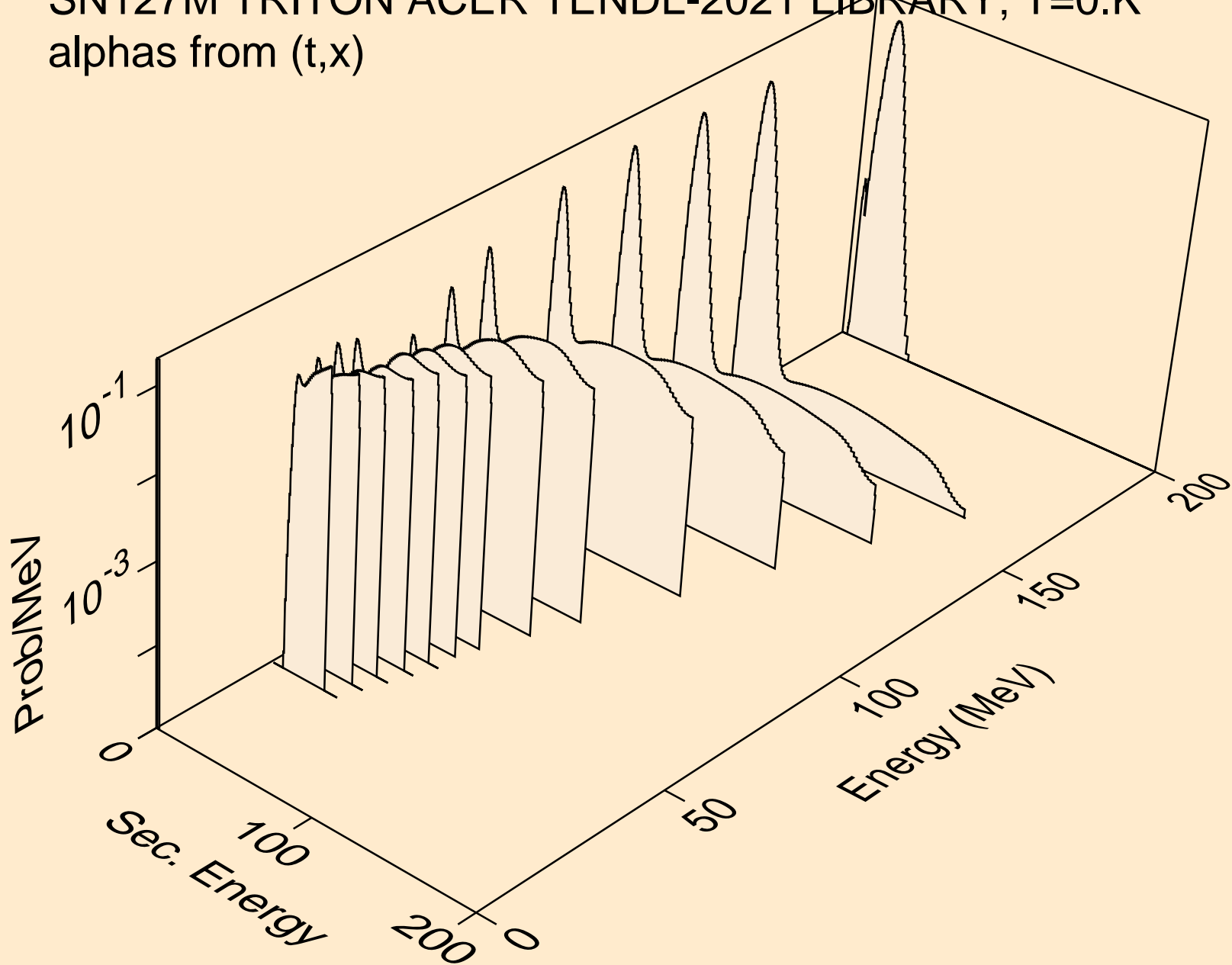

SN127M TRITON ACER TENDL-2021 LIBRARY; T=0.K  
alphas from (t,n\*)a

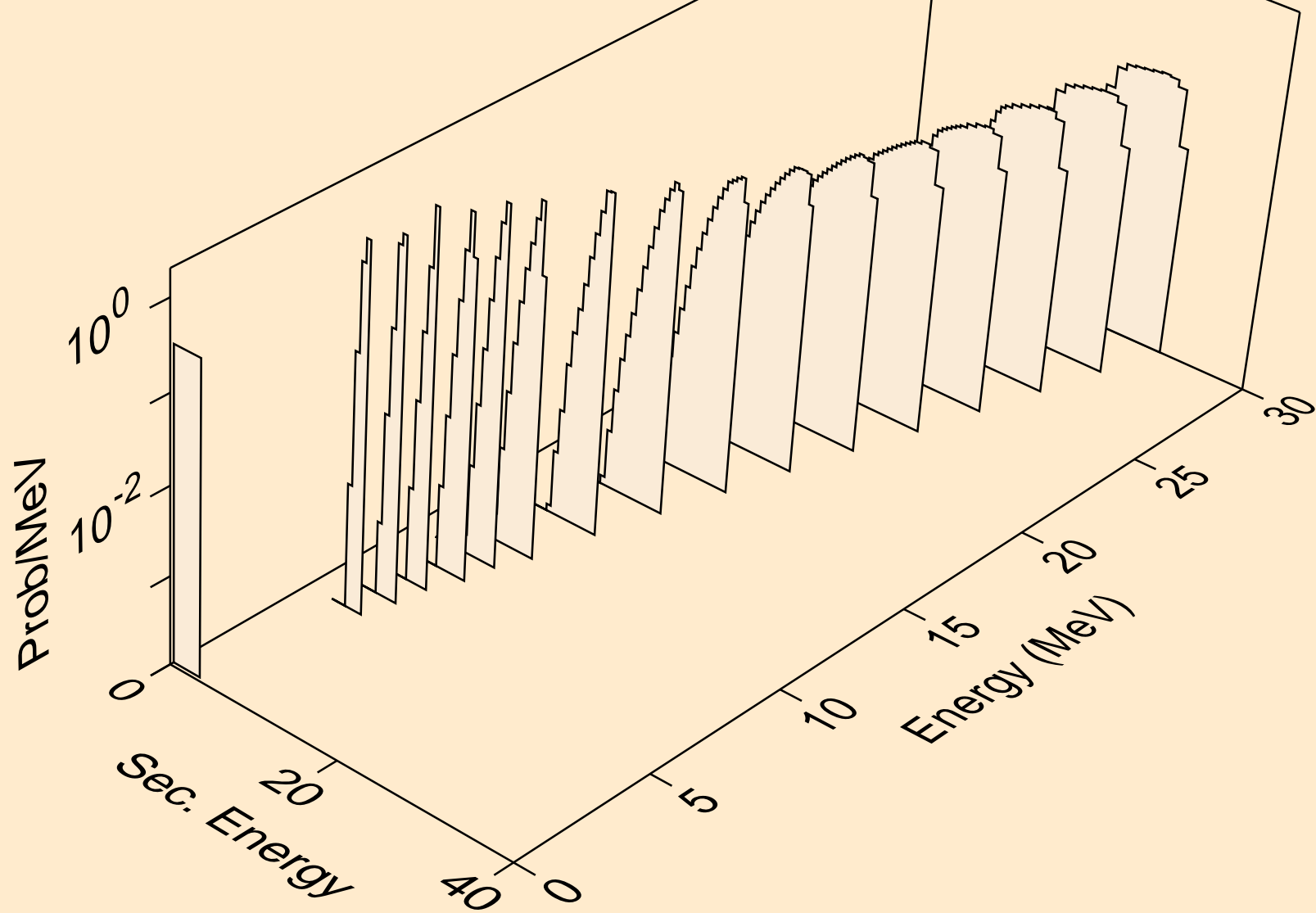

SN127M TRITON ACER TENDL-2021 LIBRARY; T=0.K  
alphas from (t,2n)a

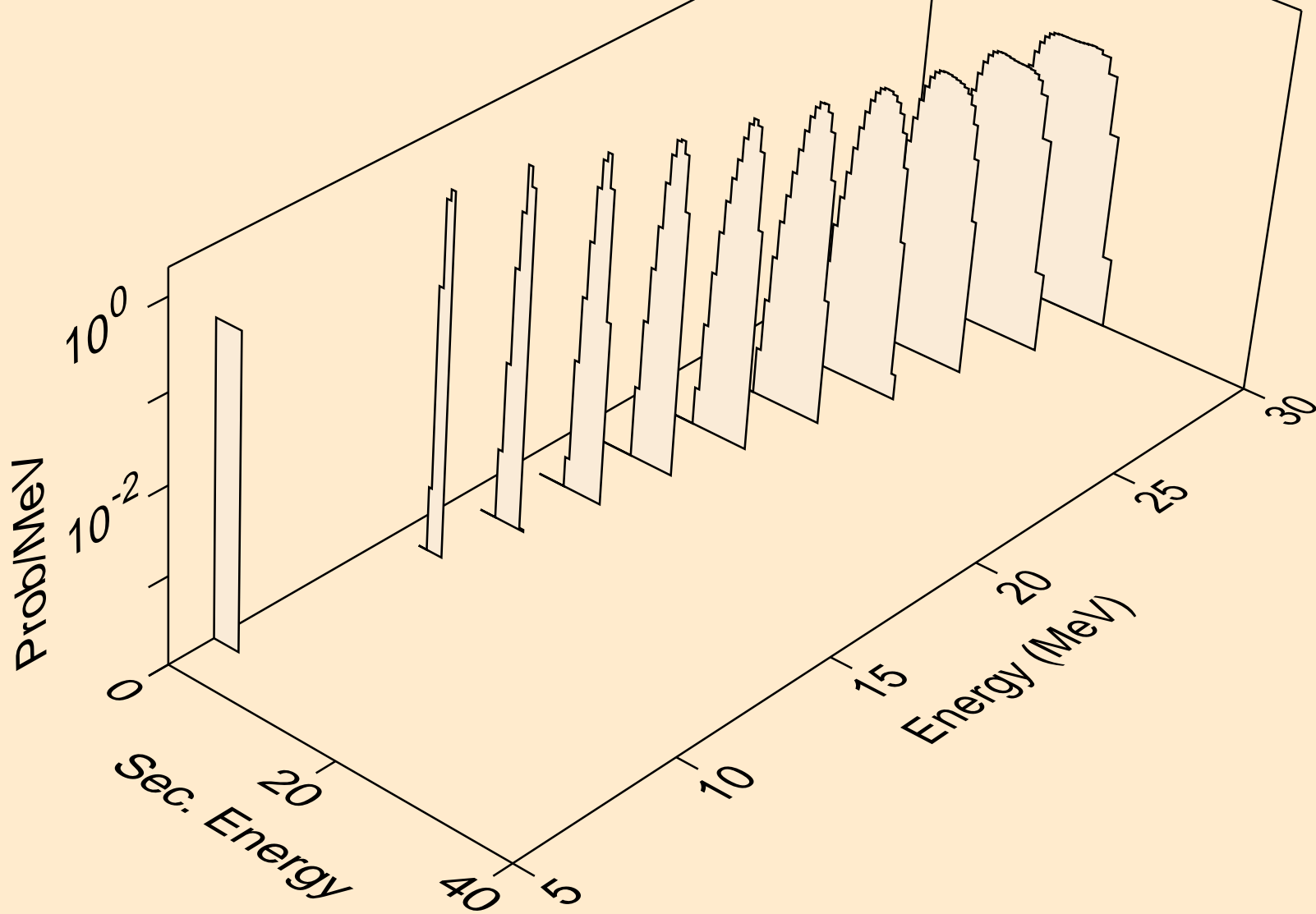

SN127M TRITON ACER TENDL-2021 LIBRARY; T=0.K  
alphas from (t,3n)a

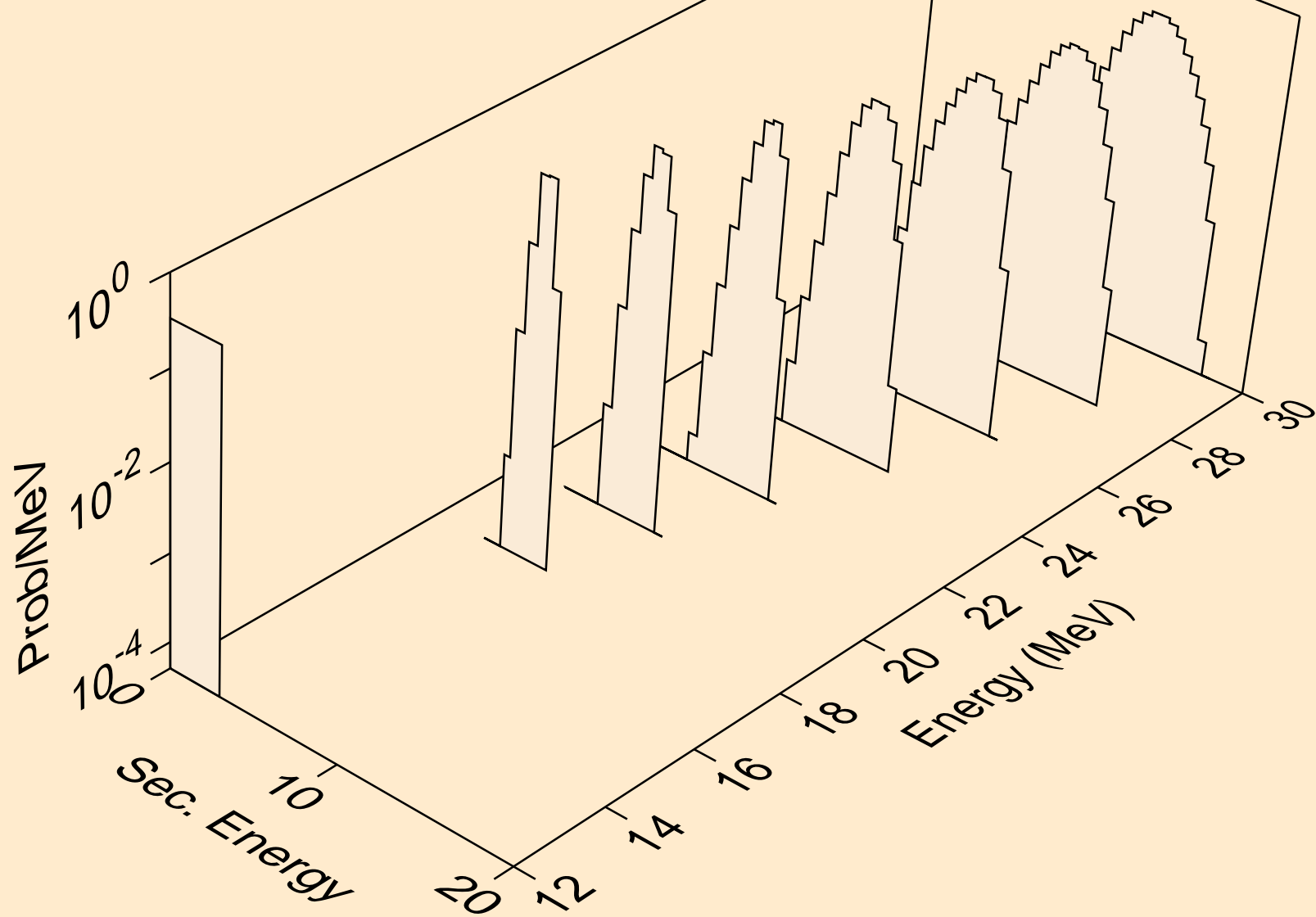

SN127M TRITON ACER TENDL-2021 LIBRARY; T=0.K  
alphas from (t,a)

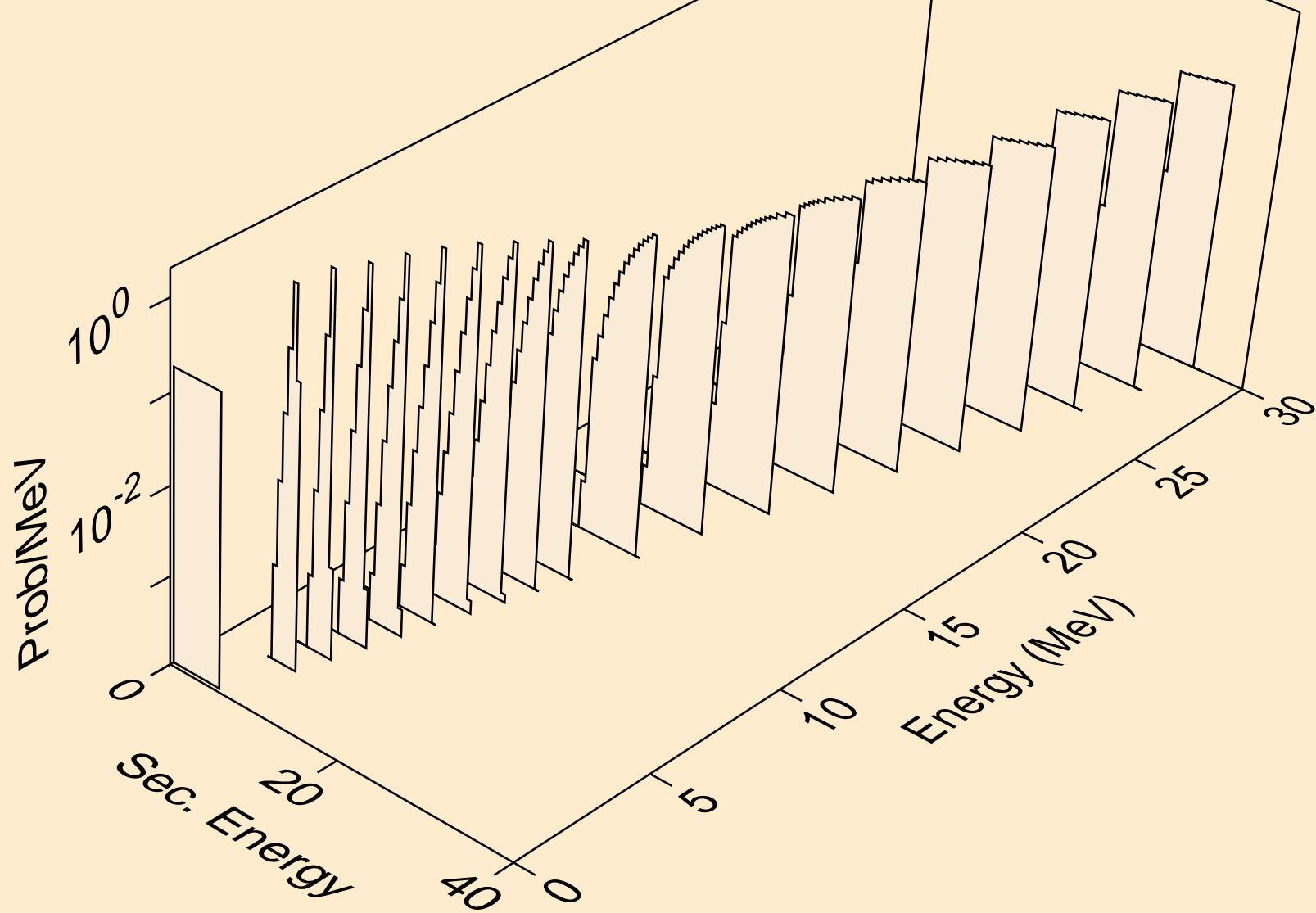



SN127M TRITON ACER TENDL-2021 LIBRARY; T=0.K  
alphas from (t,pa)

