

AL030 ALPHA ACER TENDL-2023 LIBRARY; T=0.K  
Principal cross sections

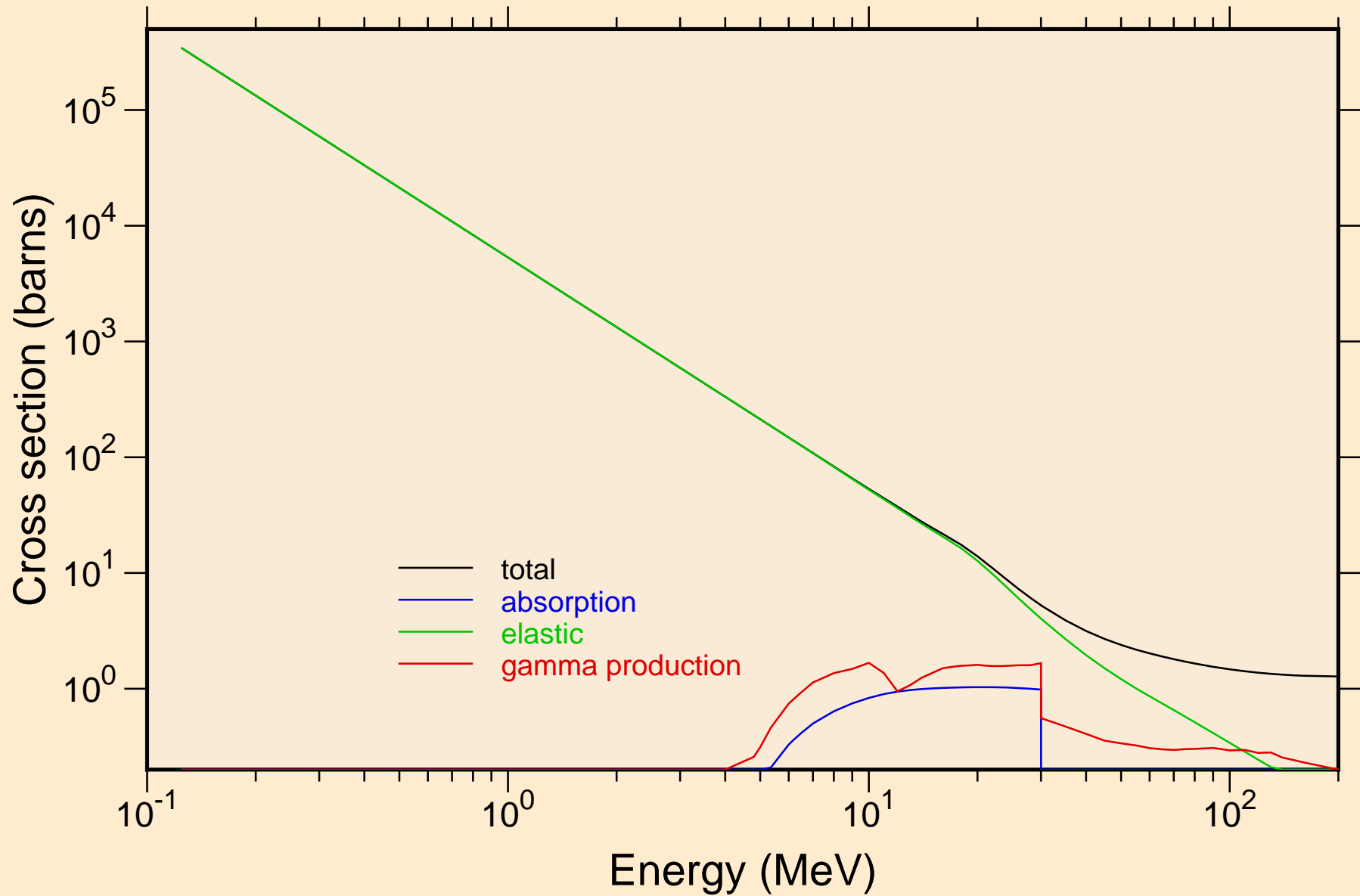

AL030 ALPHA ACER TENDL-2023 LIBRARY; T=0.K

Heating

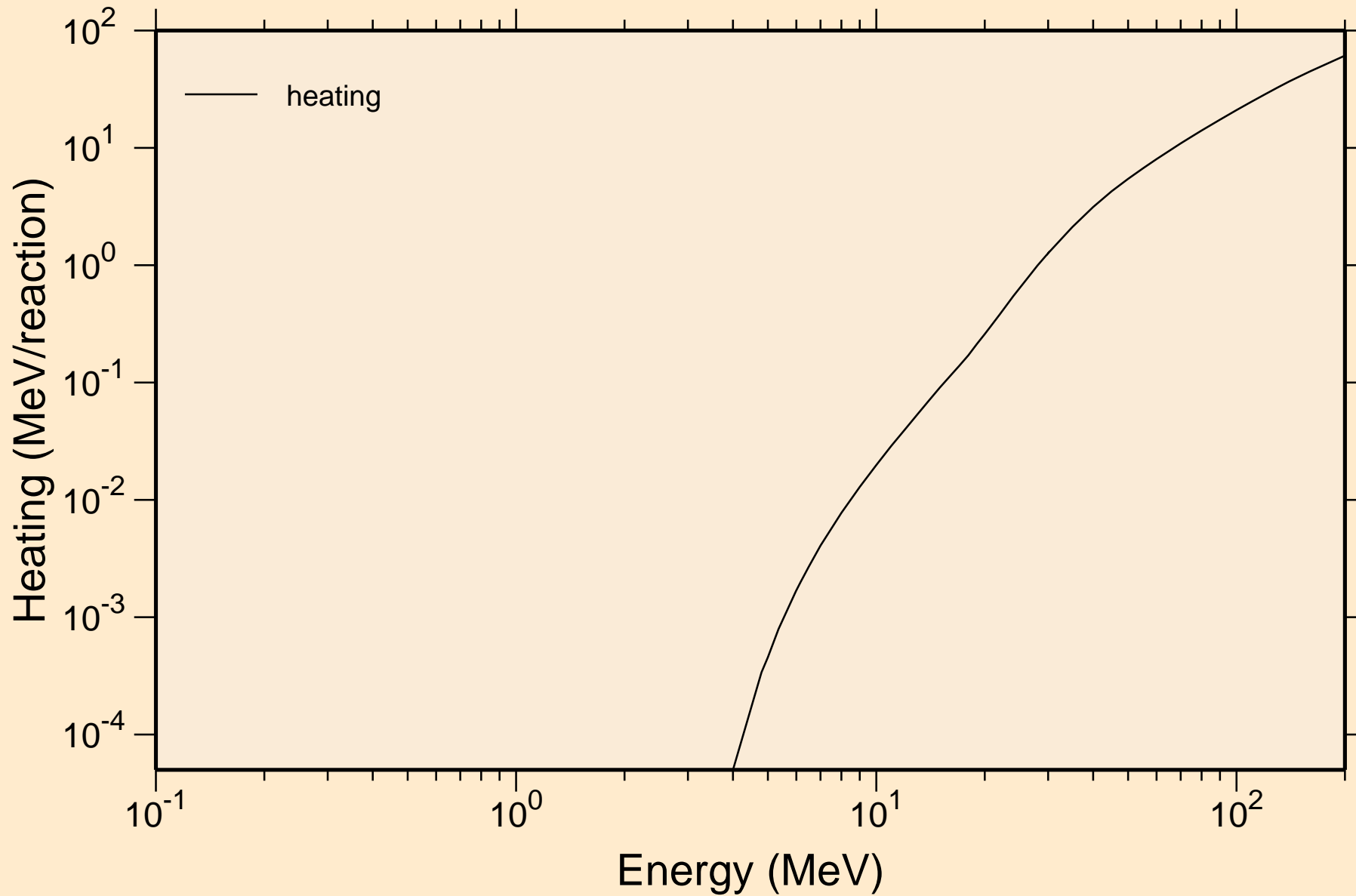

# AL030 ALPHA ACER TENDL-2023 LIBRARY; T=0.K

## Principal cross sections

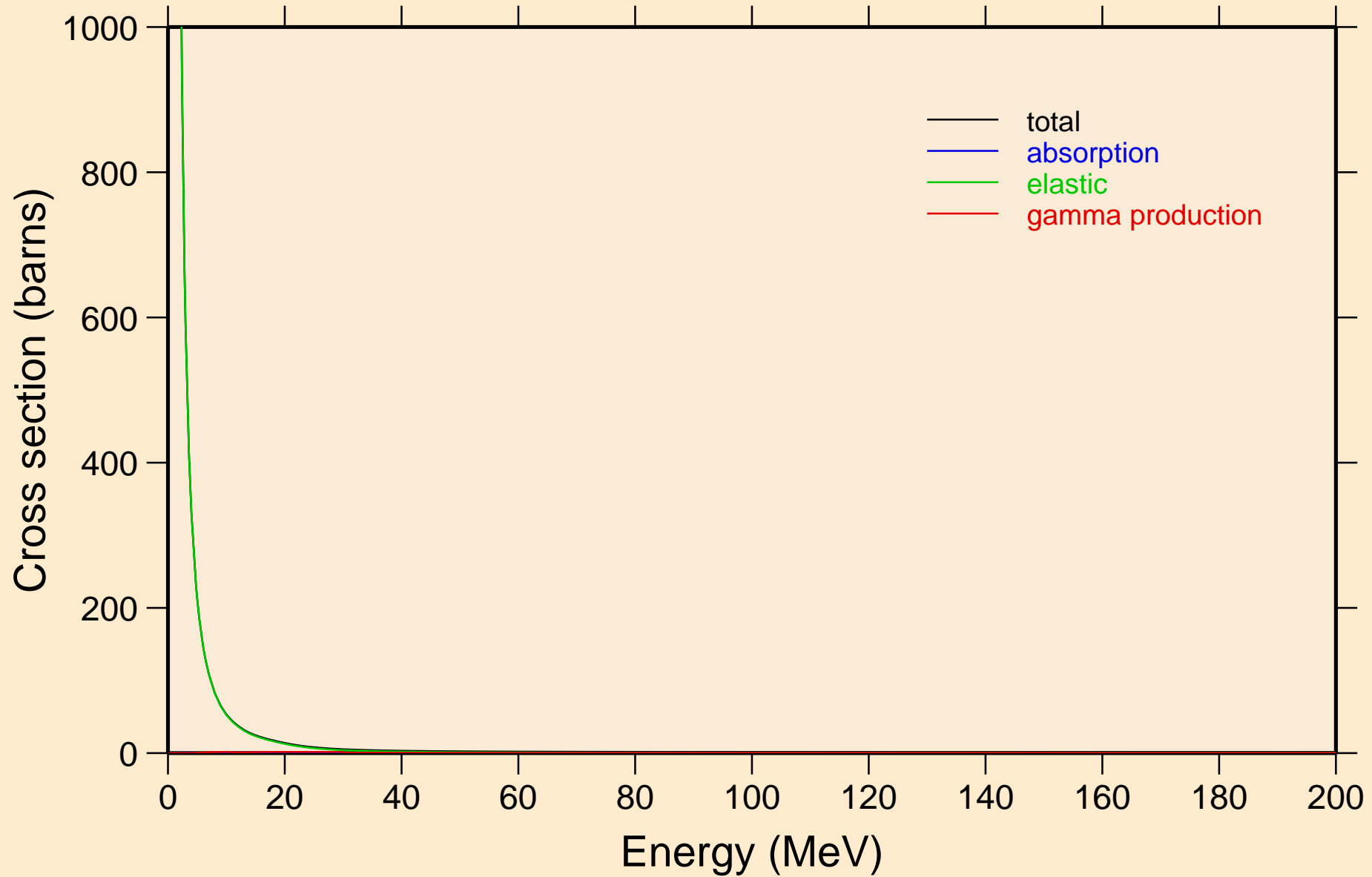

AL030 ALPHA ACER TENDL-2023 LIBRARY; T=0.K

Heating

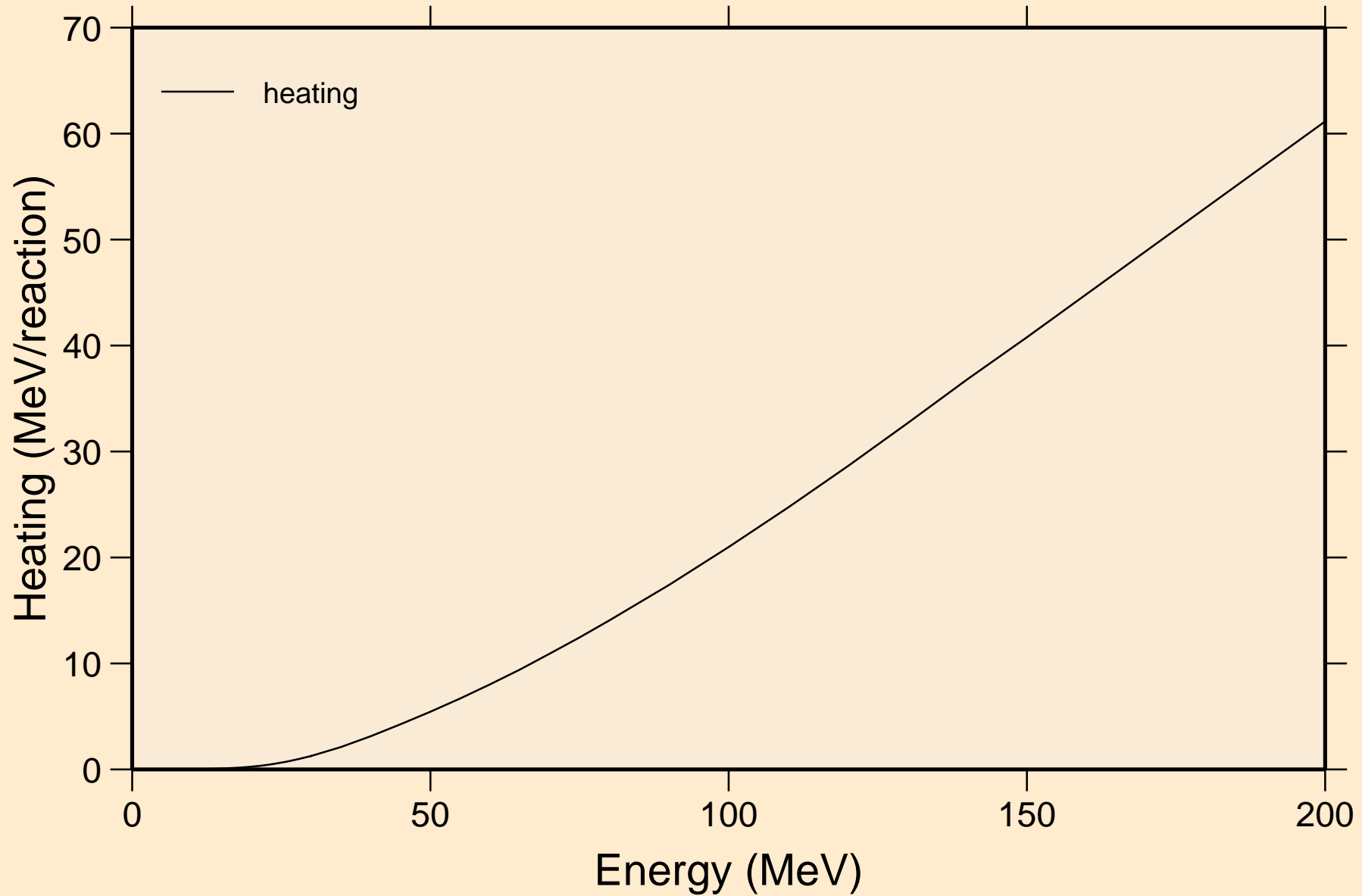

# AL030 ALPHA ACER TENDL-2023 LIBRARY; T=0.K

## Threshold reactions

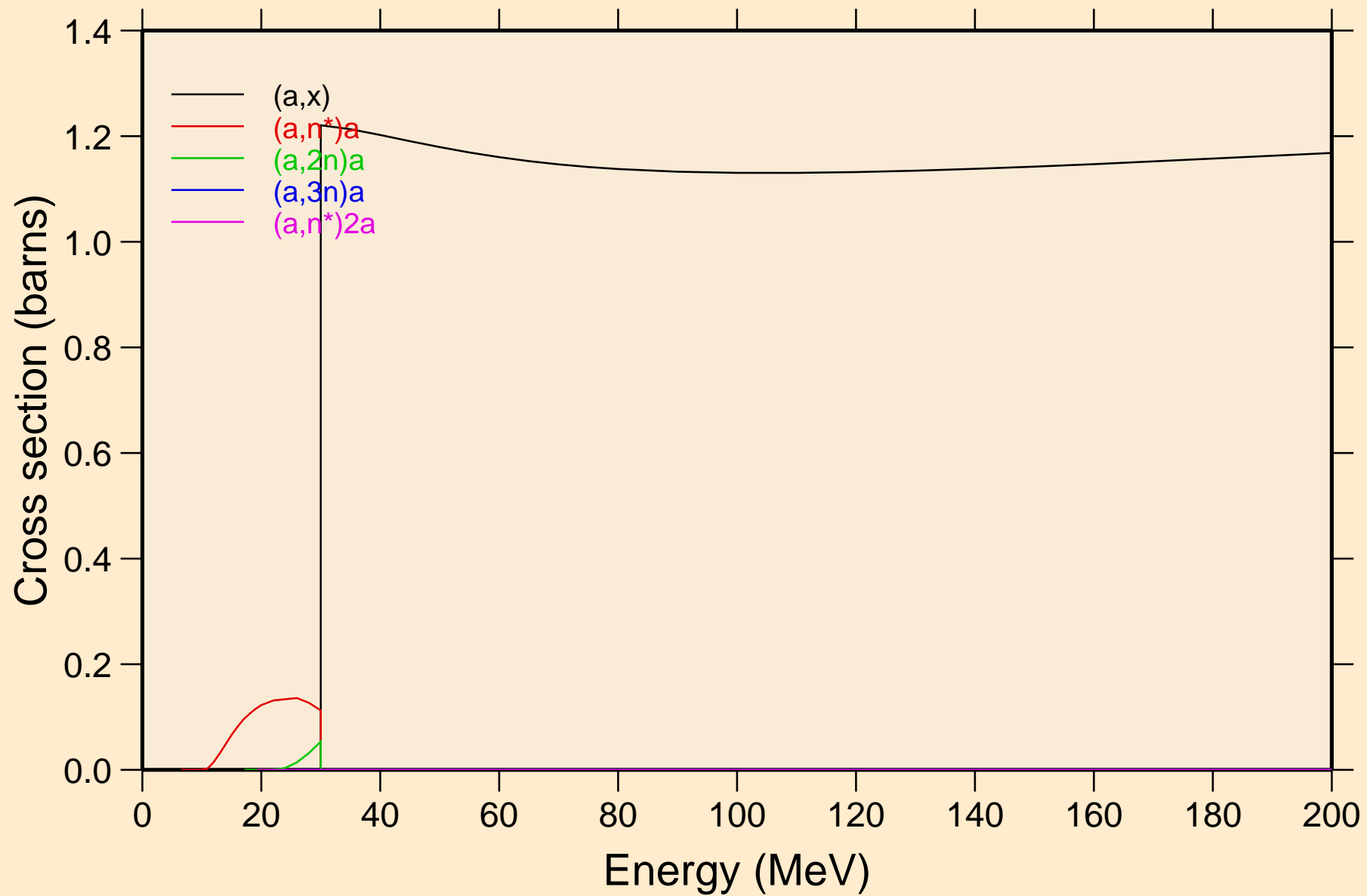

AL030 ALPHA ACER TENDL-2023 LIBRARY; T=0.K  
Threshold reactions

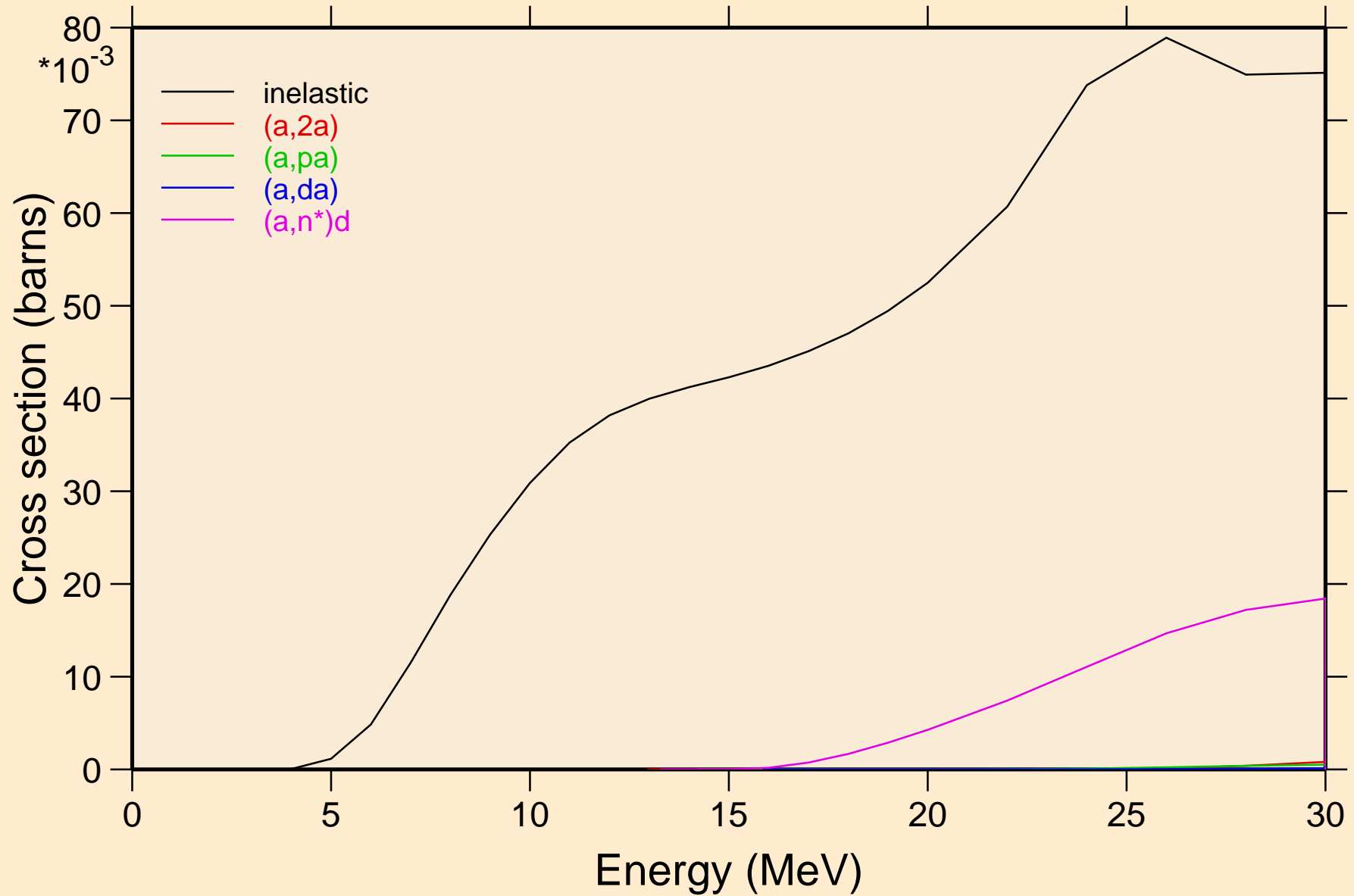

AL030 ALPHA ACER TENDL-2023 LIBRARY; T=0.K  
Threshold reactions

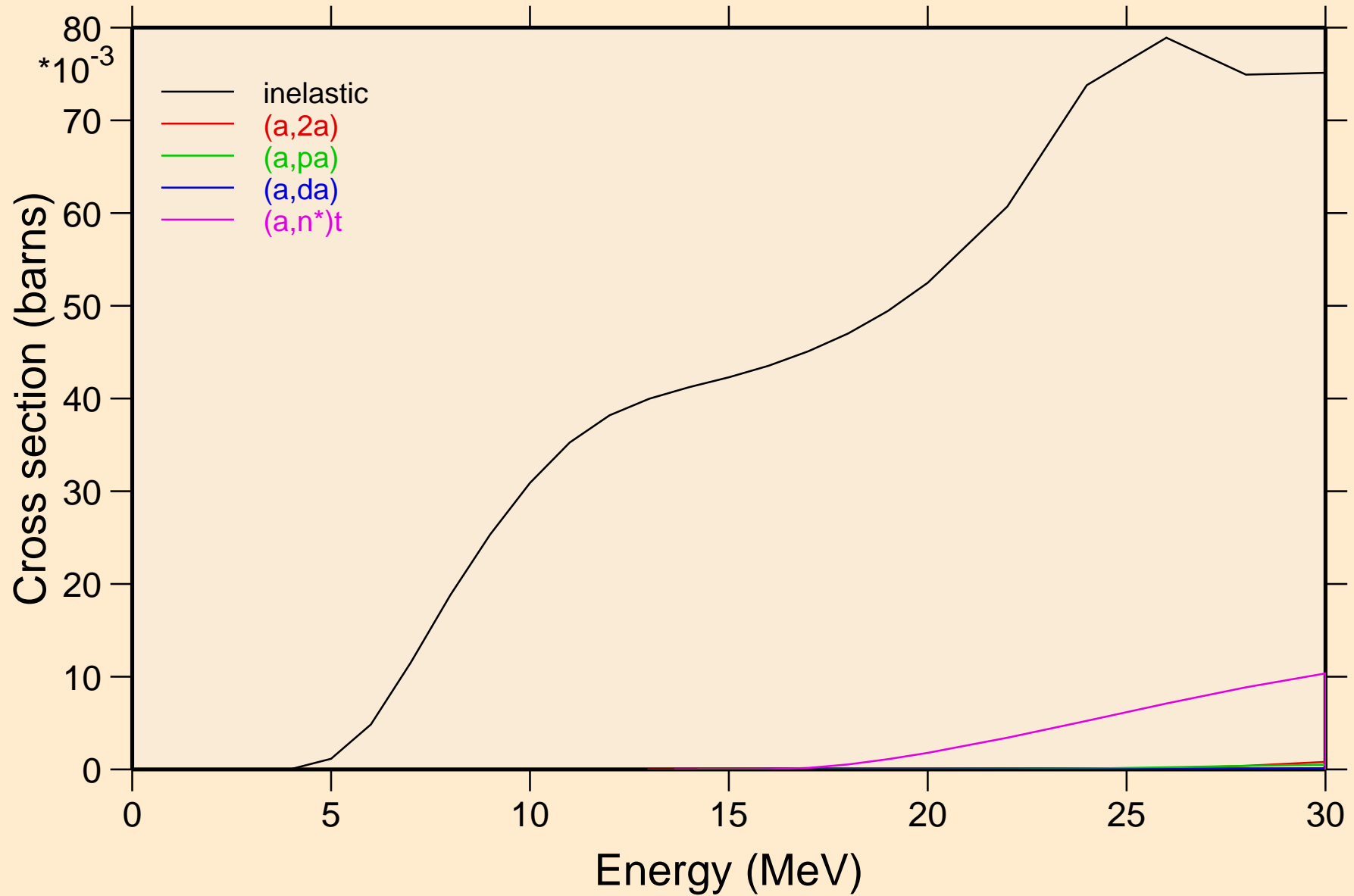

AL030 ALPHA ACER TENDL-2023 LIBRARY; T=0.K  
Threshold reactions

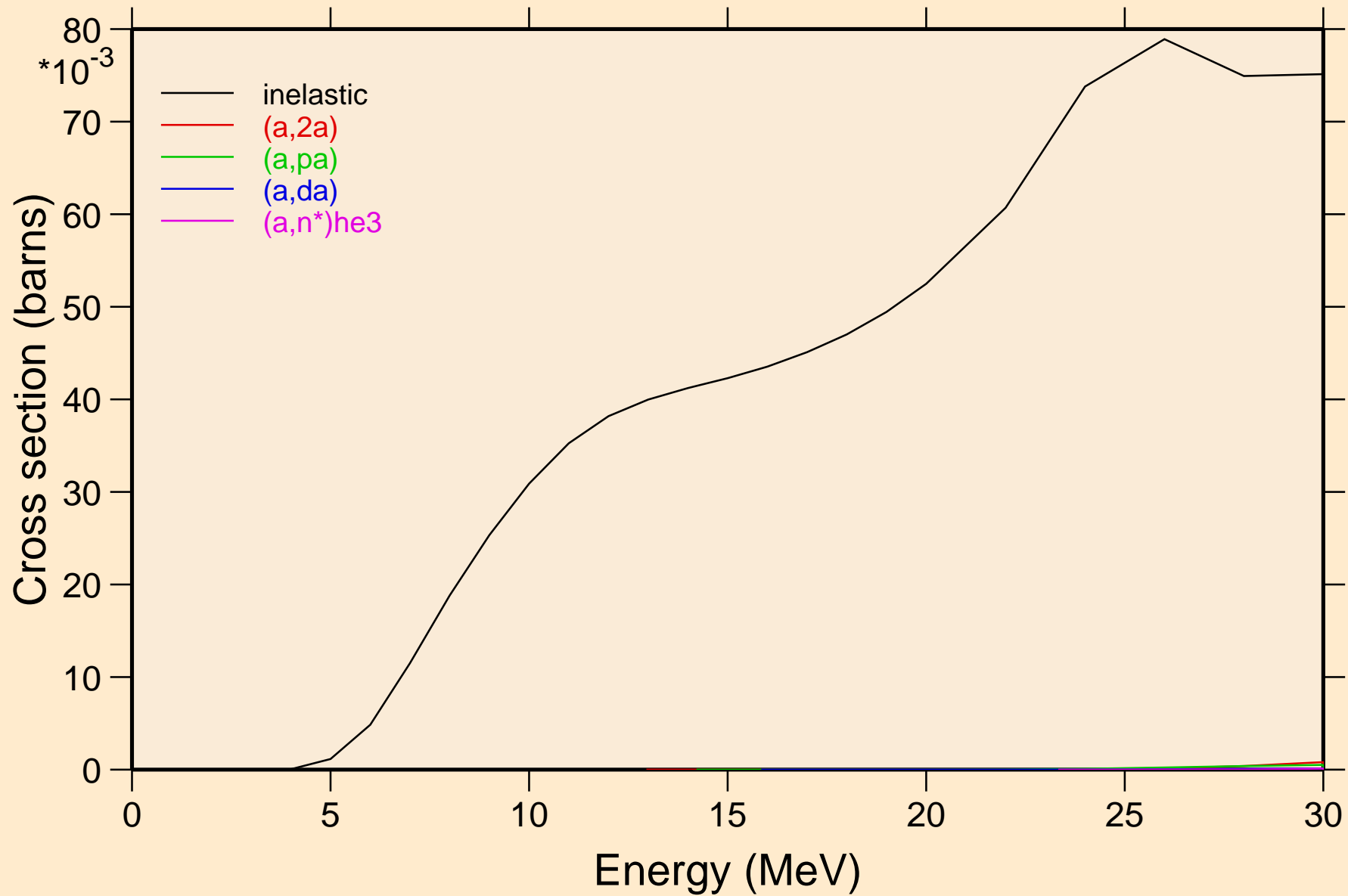



AL030 ALPHA ACER TENDL-2023 LIBRARY; T=0.K  
Threshold reactions

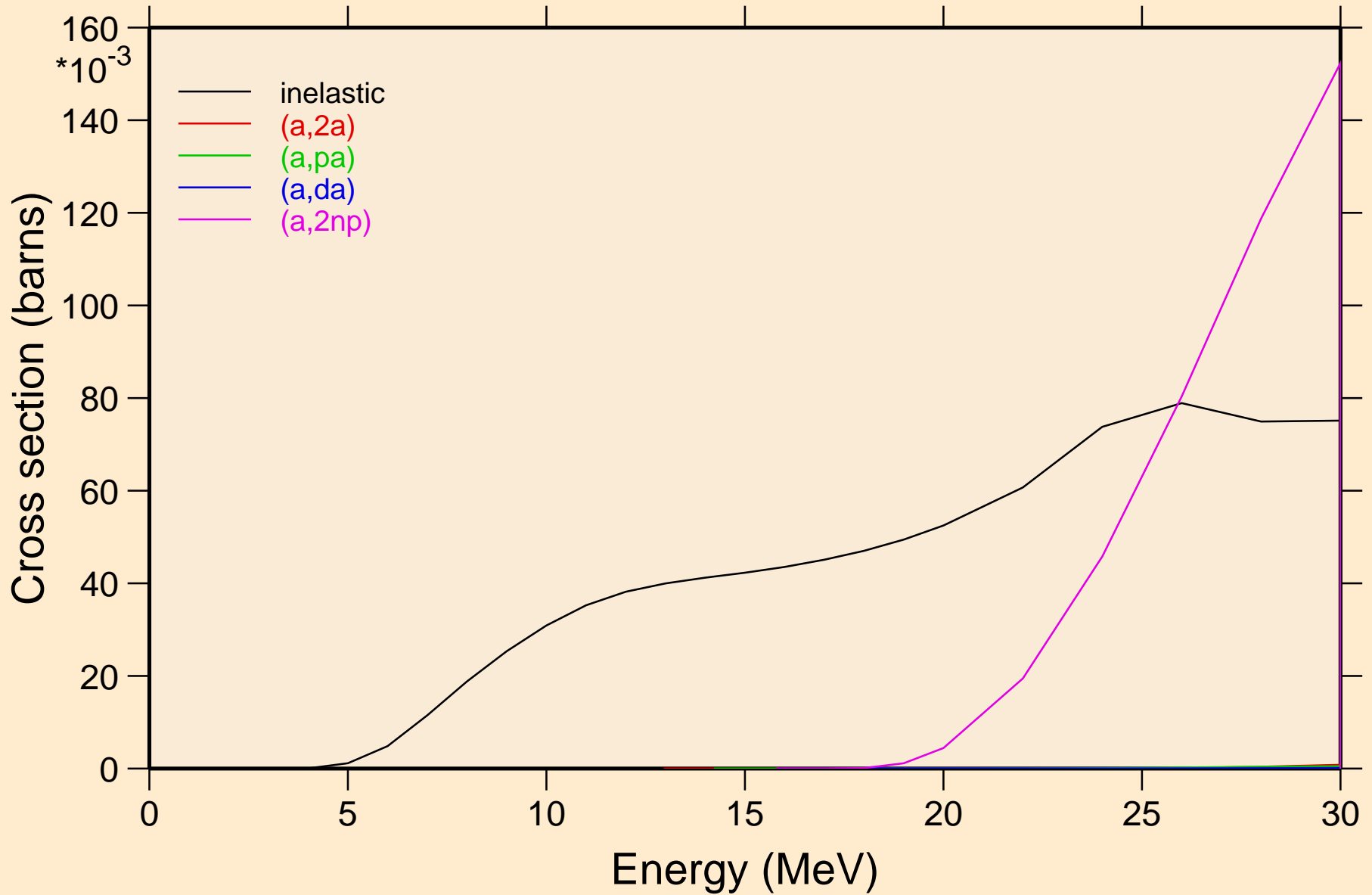

AL030 ALPHA ACER TENDL-2023 LIBRARY; T=0.K  
Threshold reactions

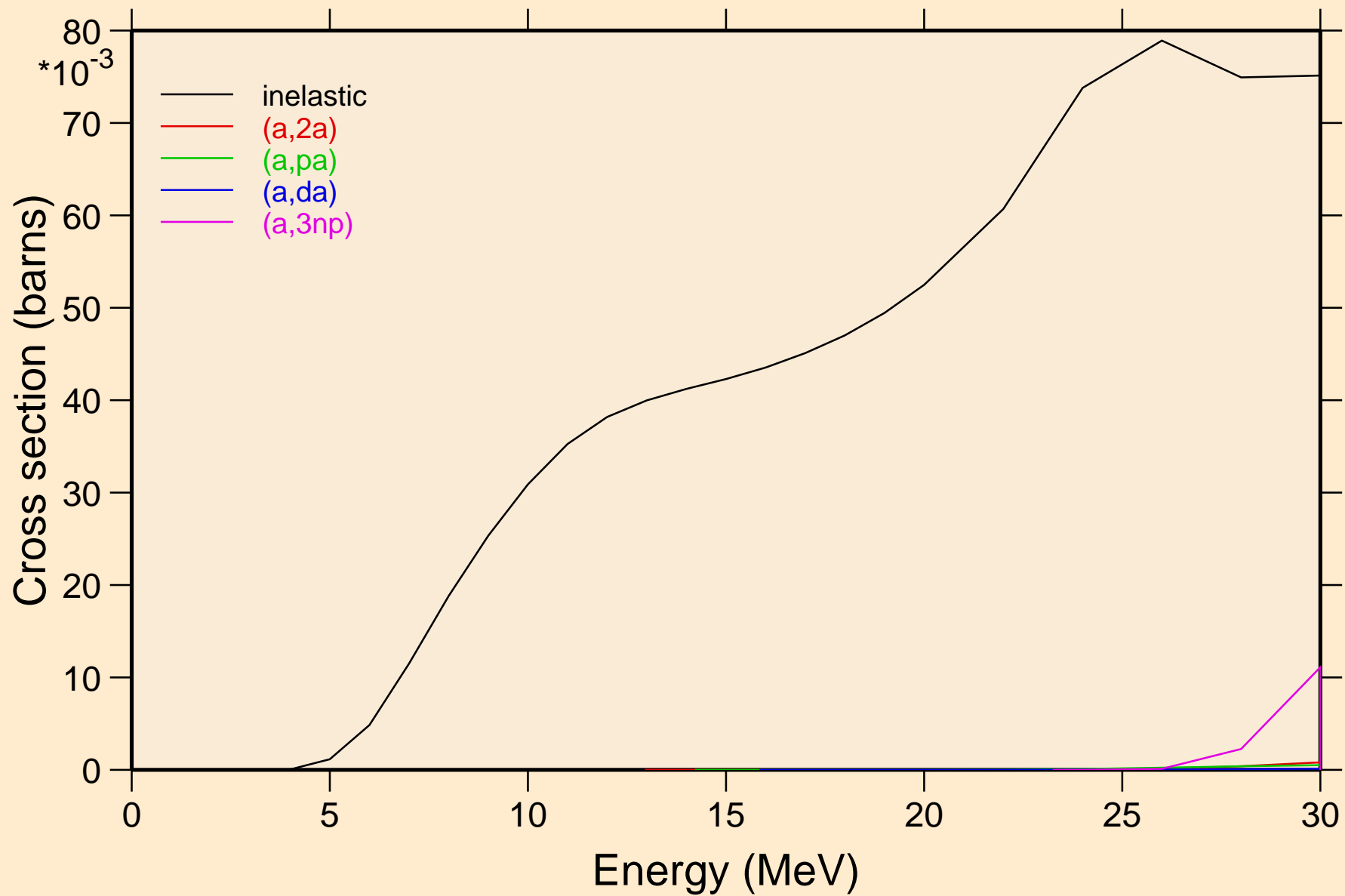

AL030 ALPHA ACER TENDL-2023 LIBRARY; T=0.K  
Threshold reactions

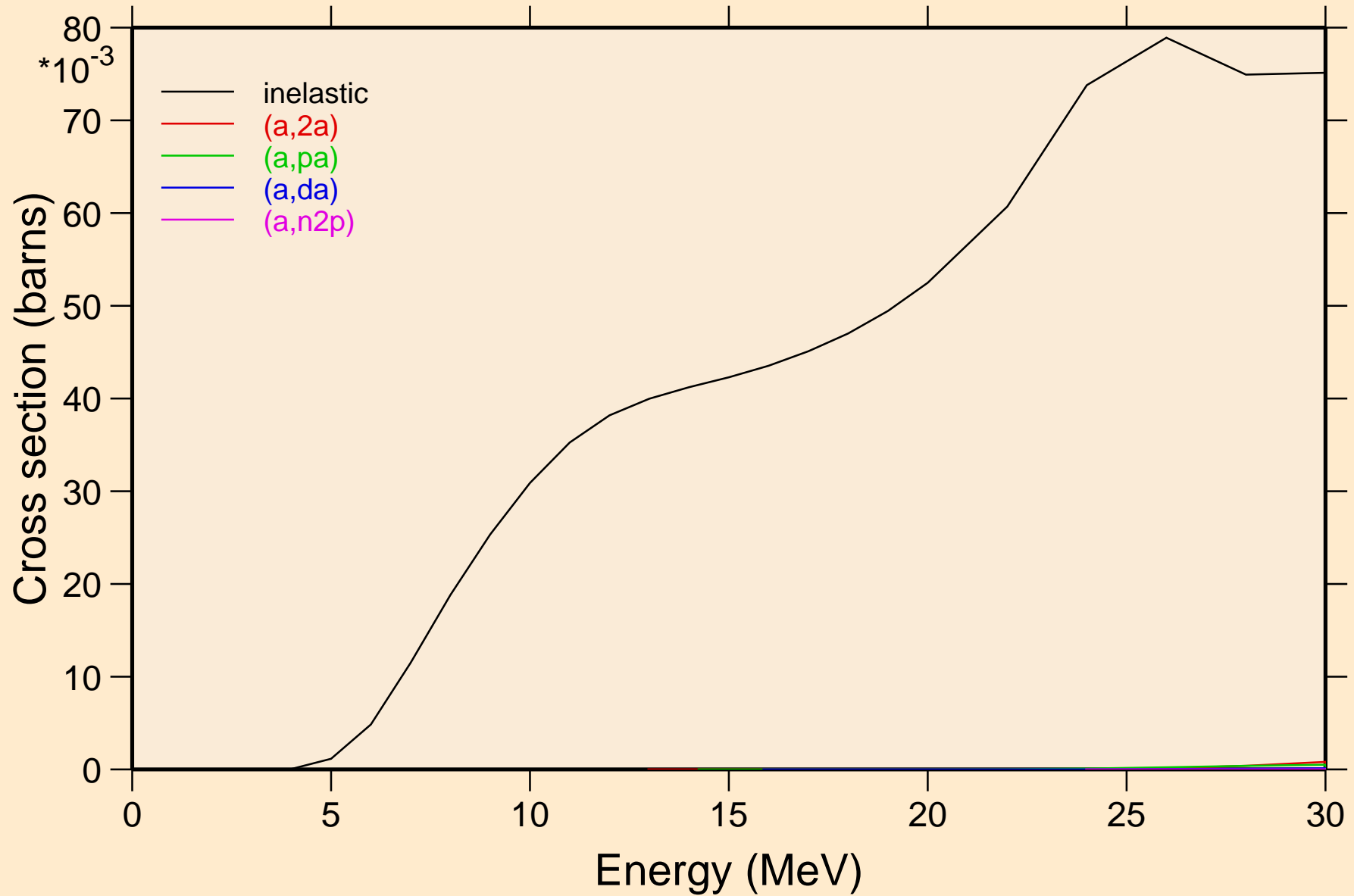

AL030 ALPHA ACER TENDL-2023 LIBRARY; T=0.K  
Threshold reactions

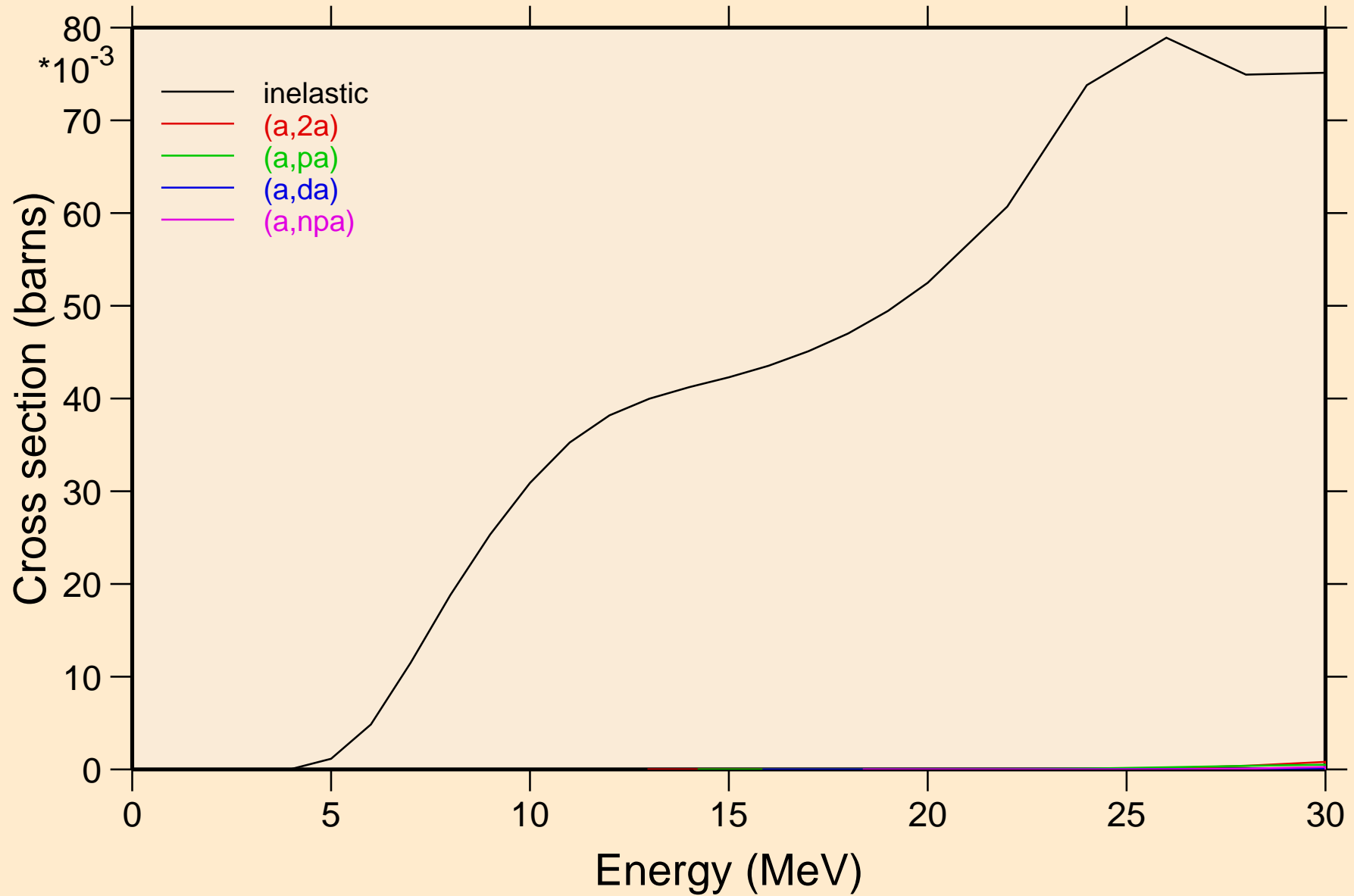

AL030 ALPHA ACER TENDL-2023 LIBRARY; T=0.K  
Threshold reactions

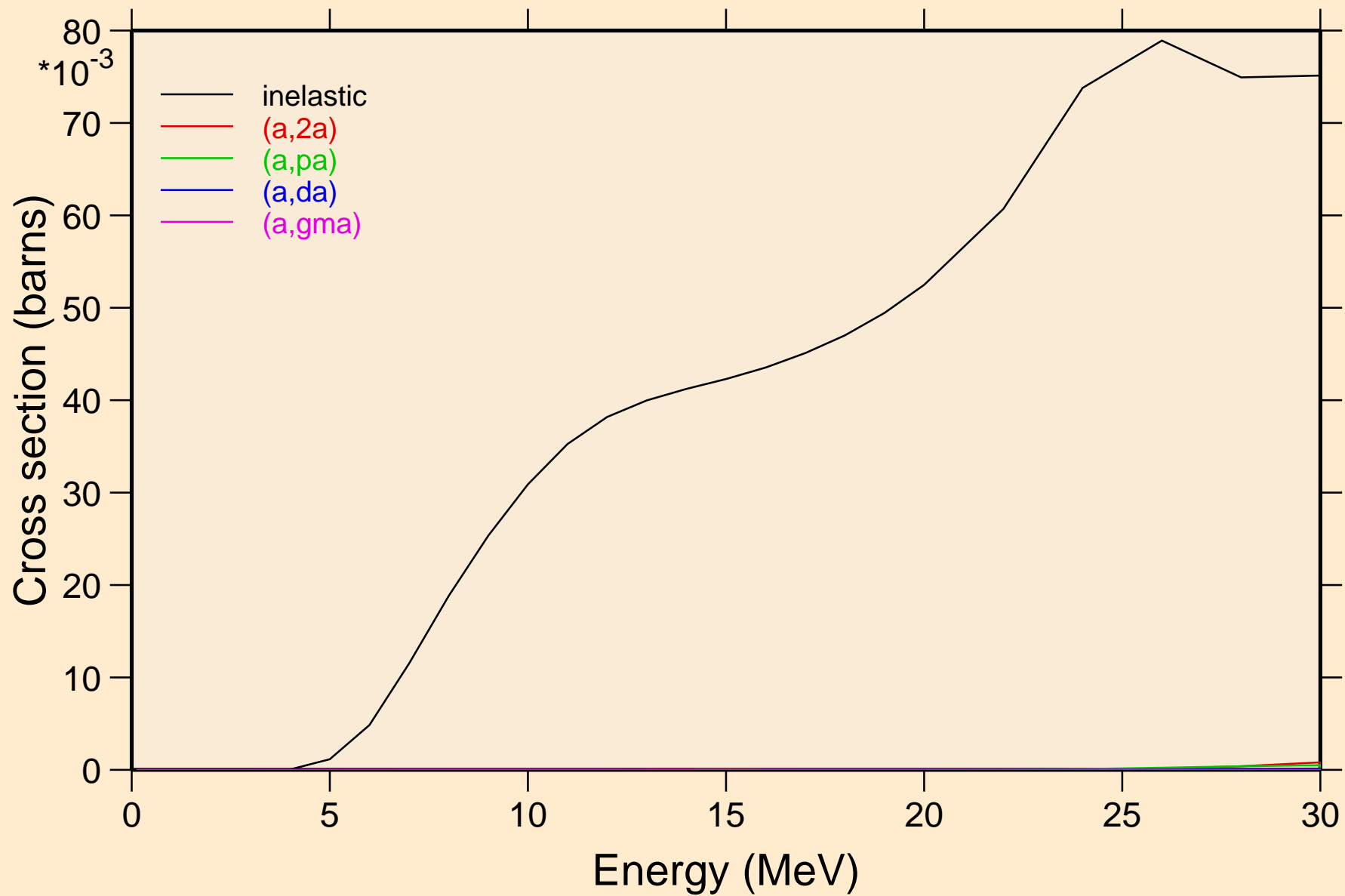

AL030 ALPHA ACER TENDL-2023 LIBRARY; T=0.K  
Threshold reactions

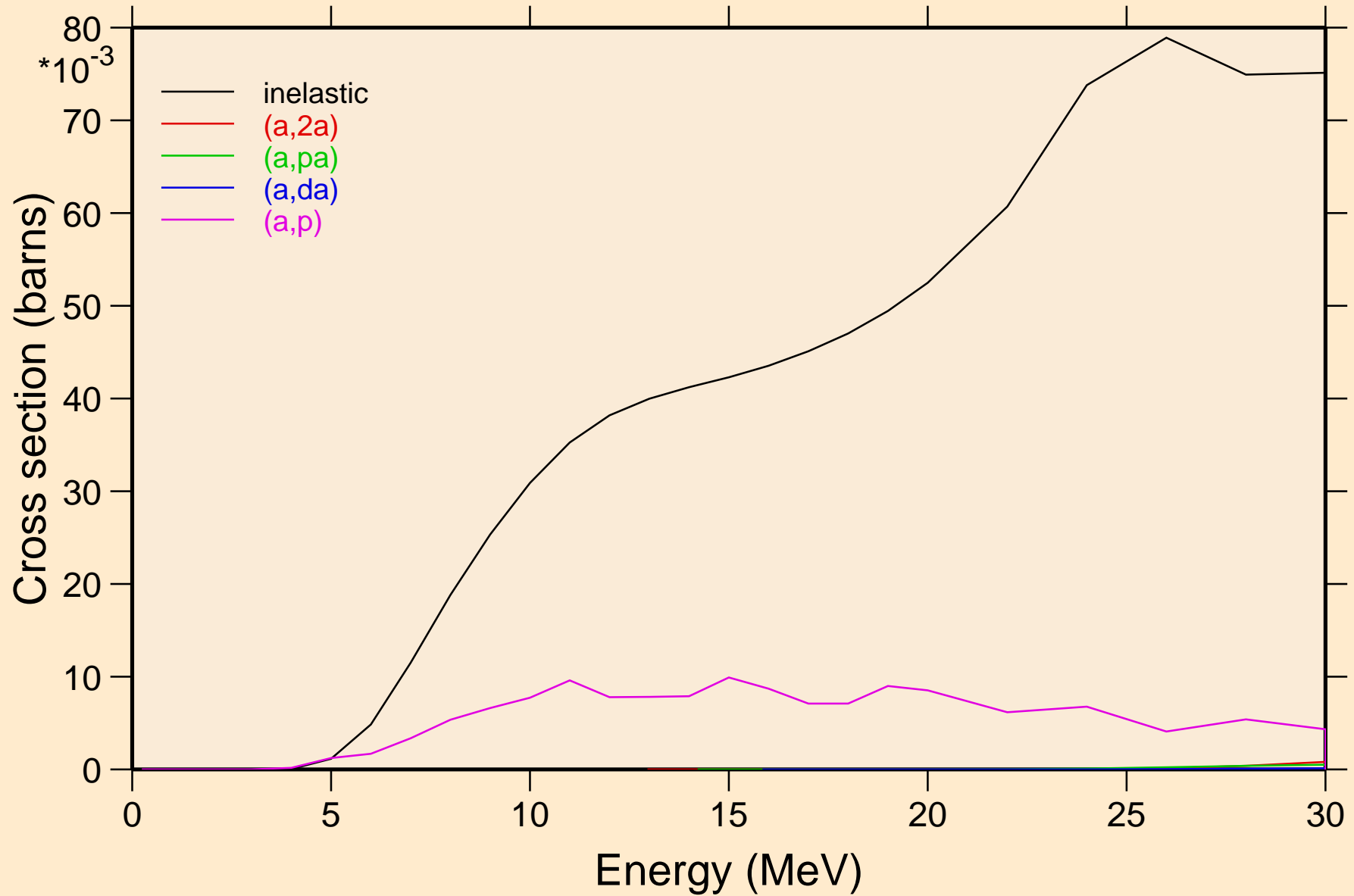

AL030 ALPHA ACER TENDL-2023 LIBRARY; T=0.K  
Threshold reactions

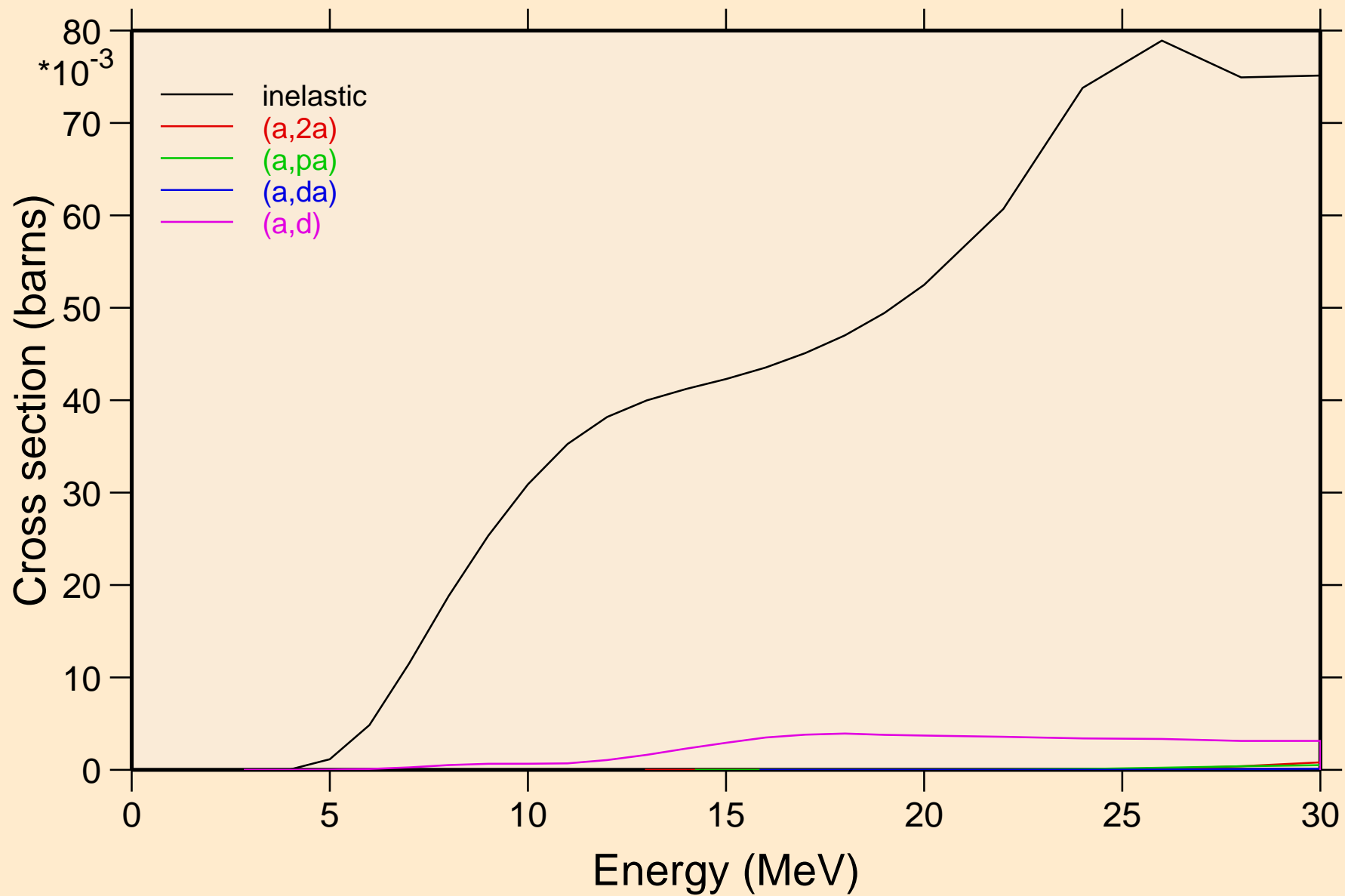

AL030 ALPHA ACER TENDL-2023 LIBRARY; T=0.K  
Threshold reactions

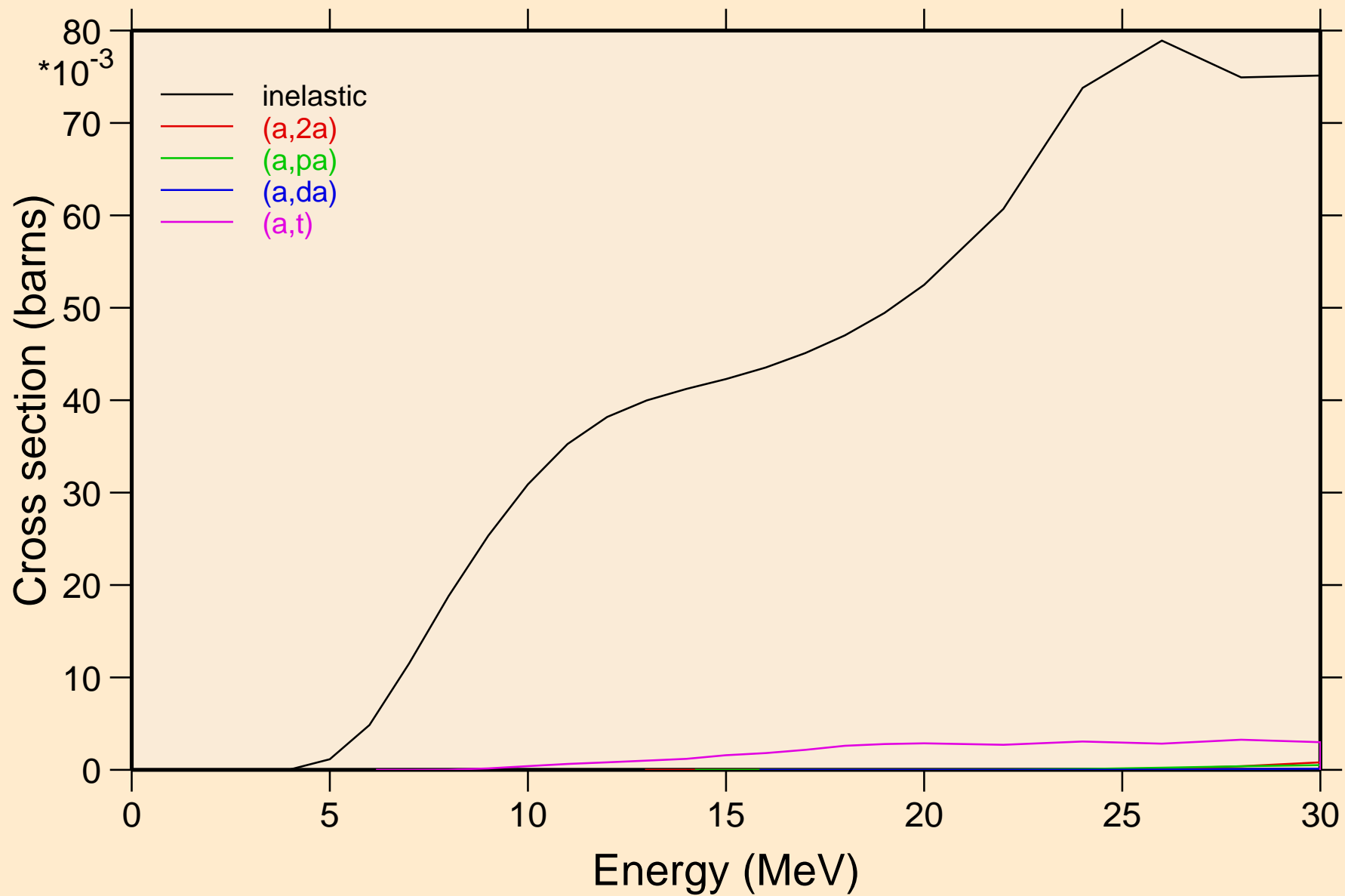



AL030 ALPHA ACER TENDL-2023 LIBRARY; T=0.K  
Threshold reactions

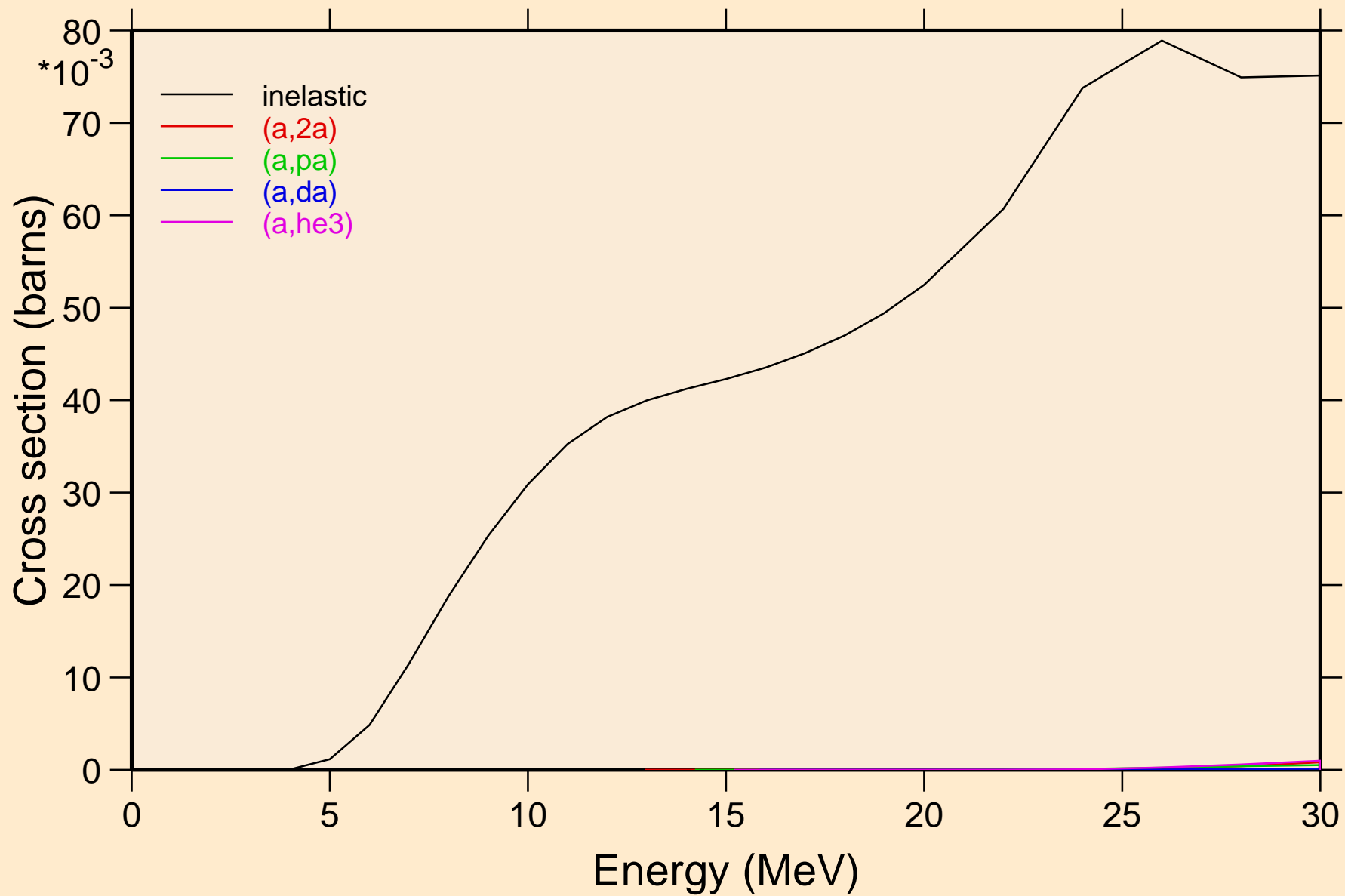

AL030 ALPHA ACER TENDL-2023 LIBRARY; T=0.K  
Threshold reactions

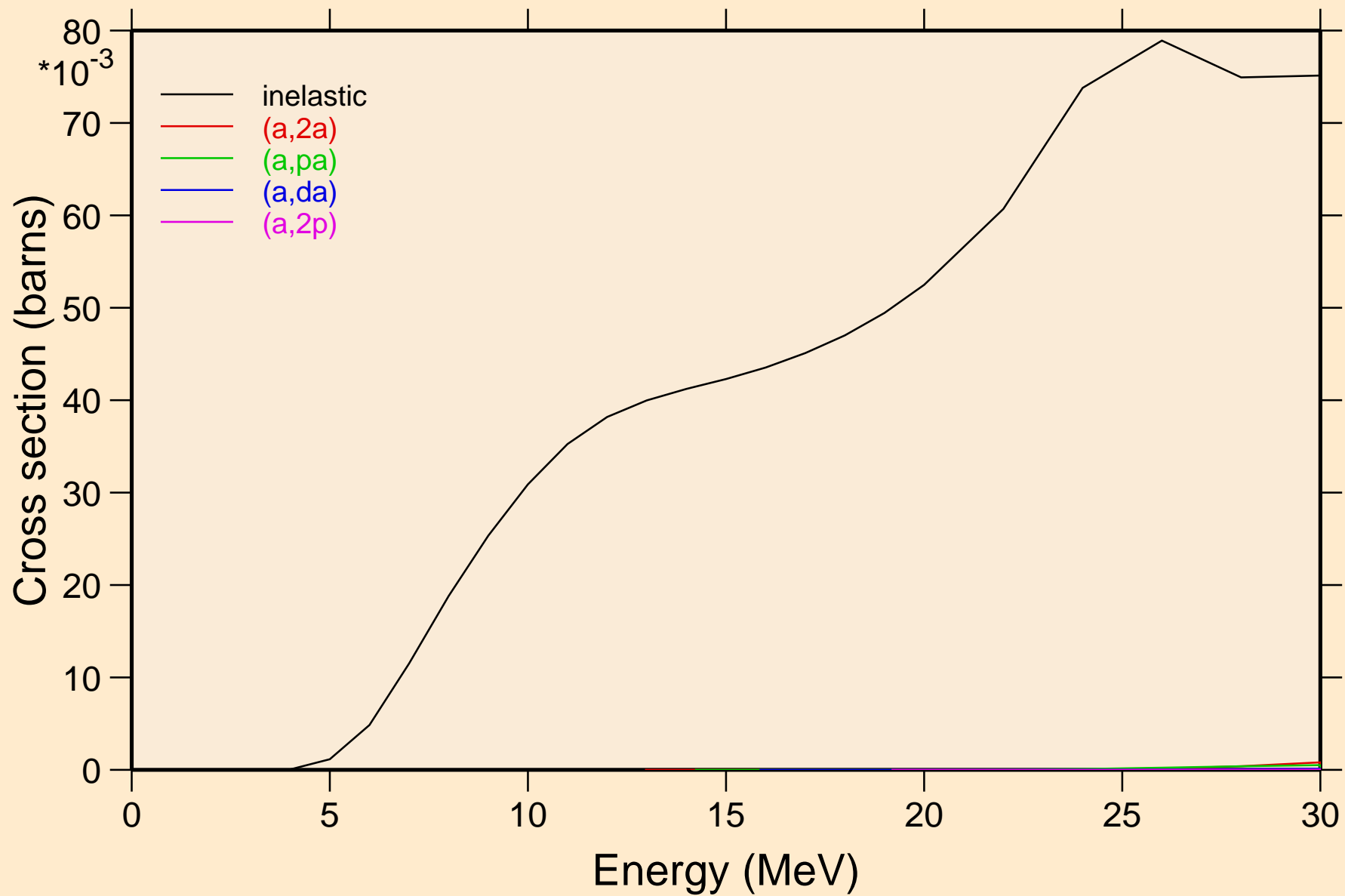

AL030 ALPHA ACER TENDL-2023 LIBRARY; T=0.K  
Threshold reactions

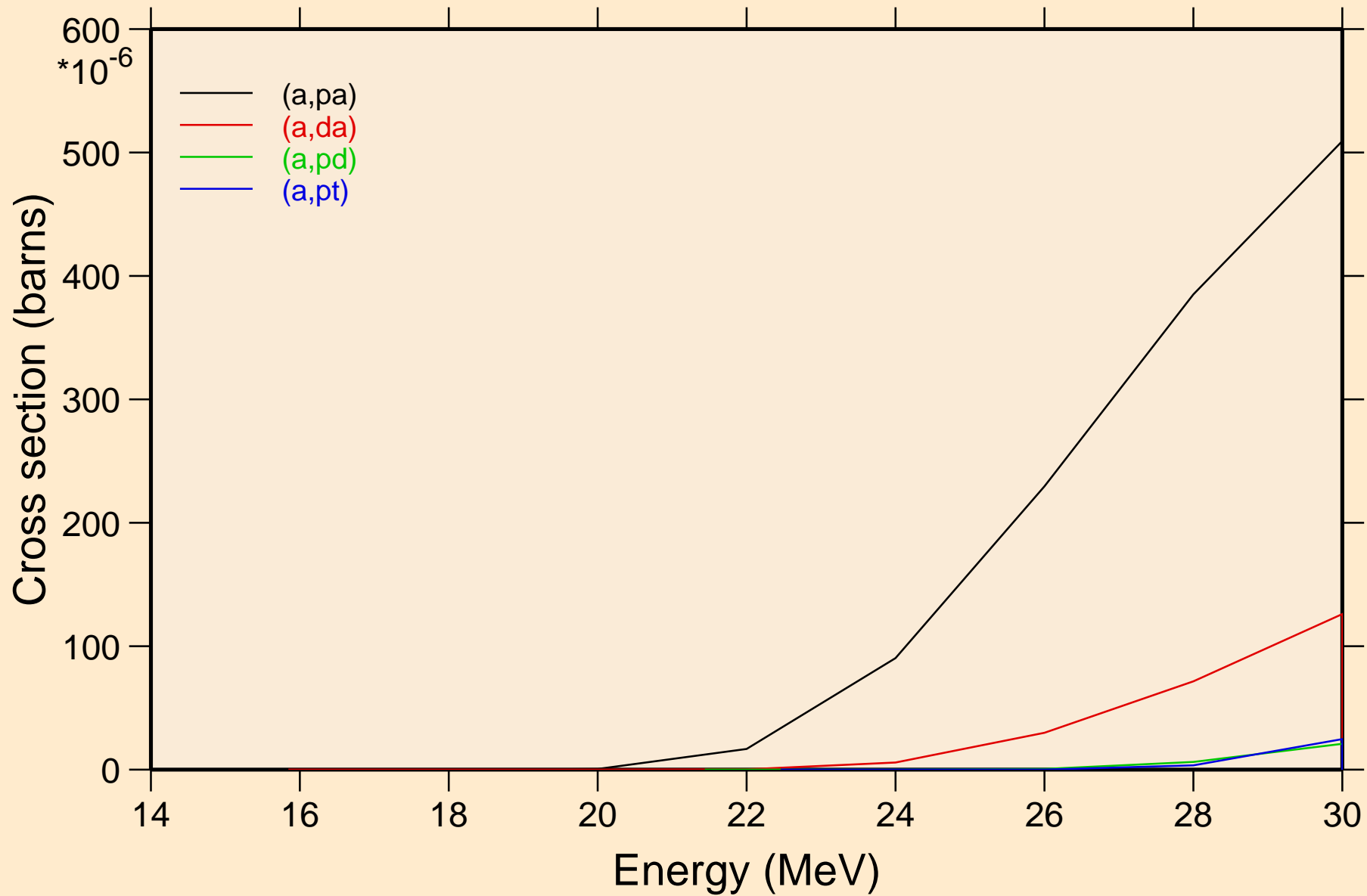

AL030 ALPHA ACER TENDL-2023 LIBRARY; T=0.K  
Threshold reactions

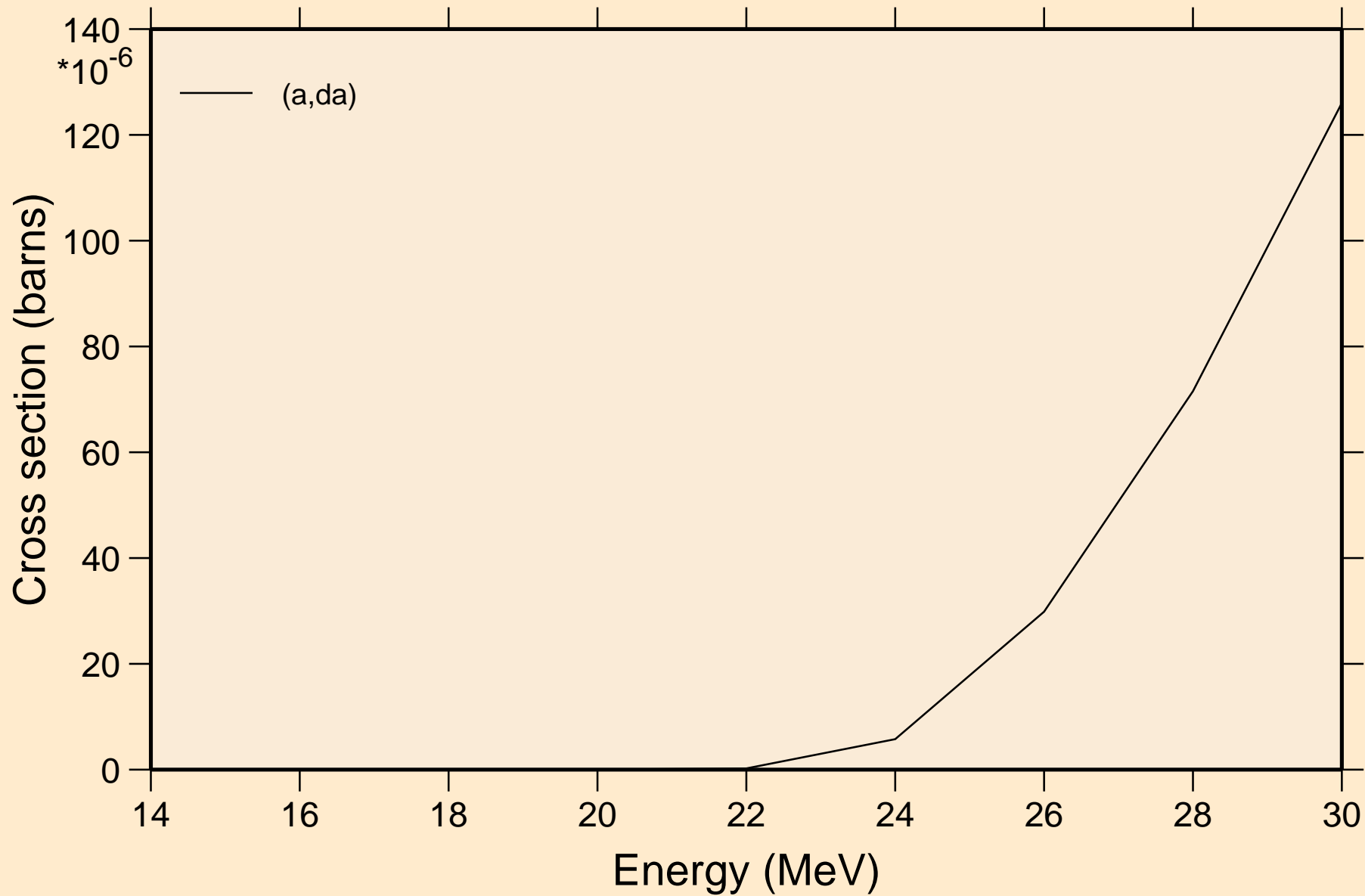

AL030 ALPHA ACER TENDL-2023 LIBRARY; T=0.K  
angular distribution for elastic

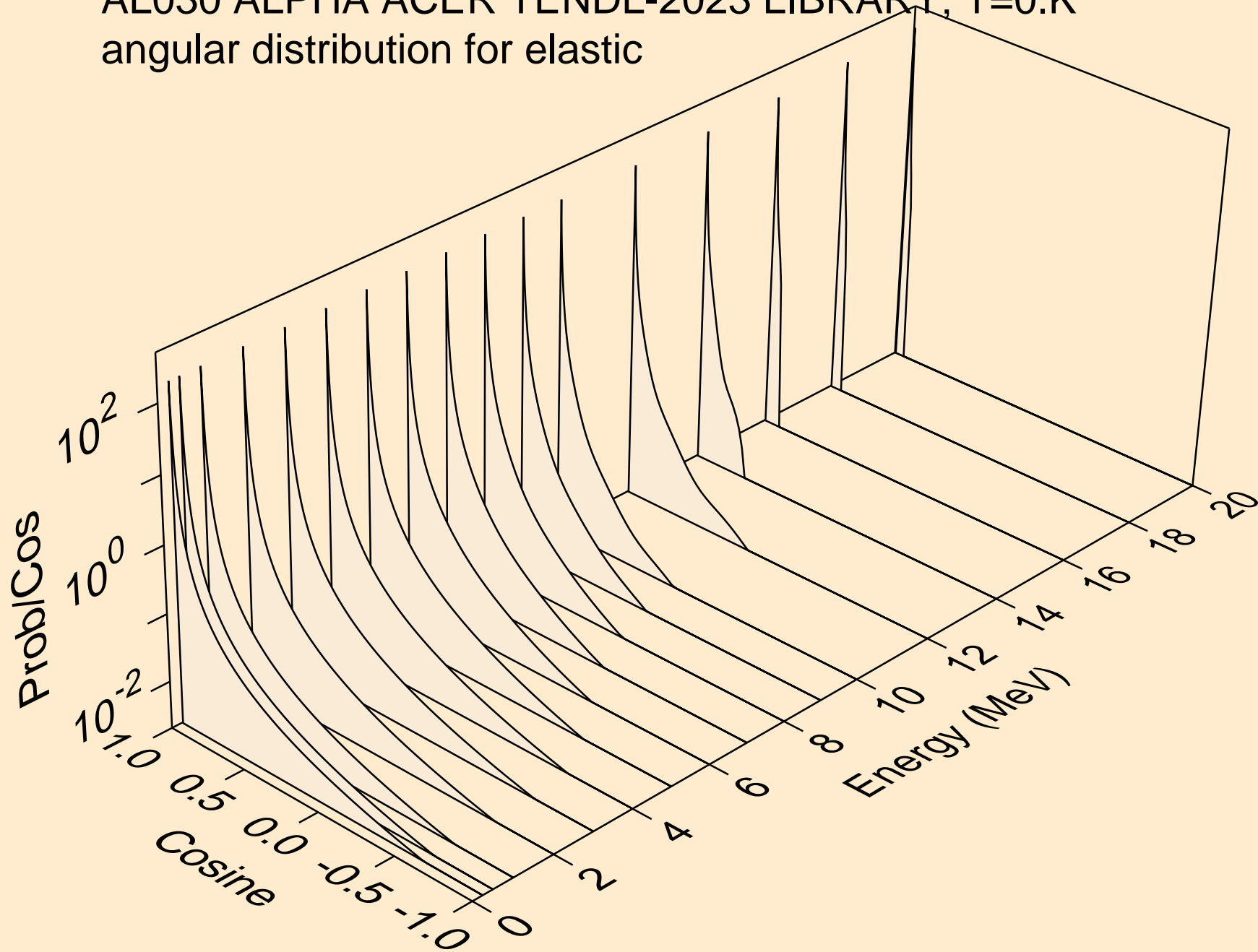

AL030 ALPHA ACER TENDL-2023 LIBRARY; T=0.K  
angular distribution for elastic

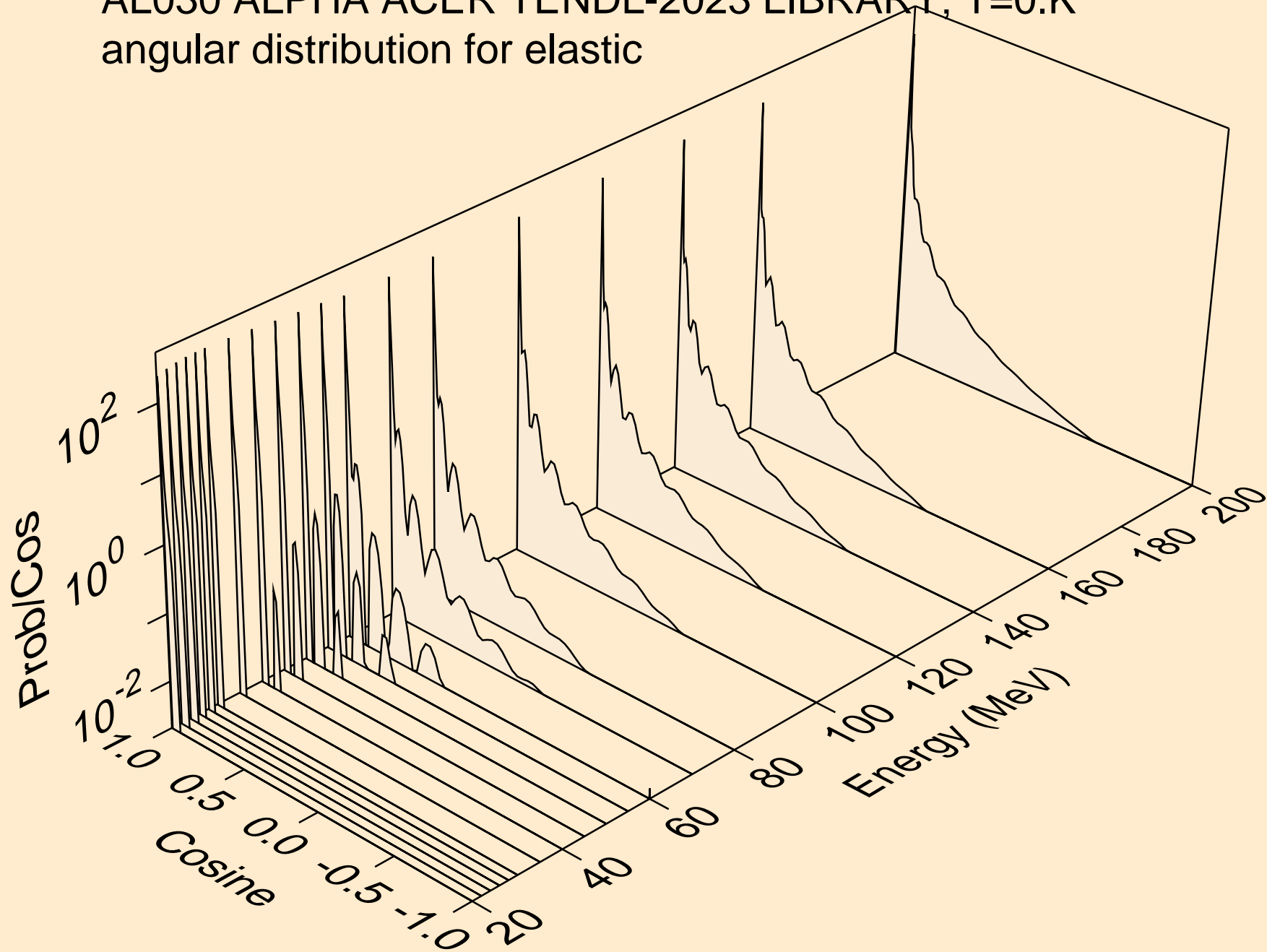

AL030 ALPHA ACER TENDL-2023 LIBRARY; T=0.K

Alpha emission for (a,x)

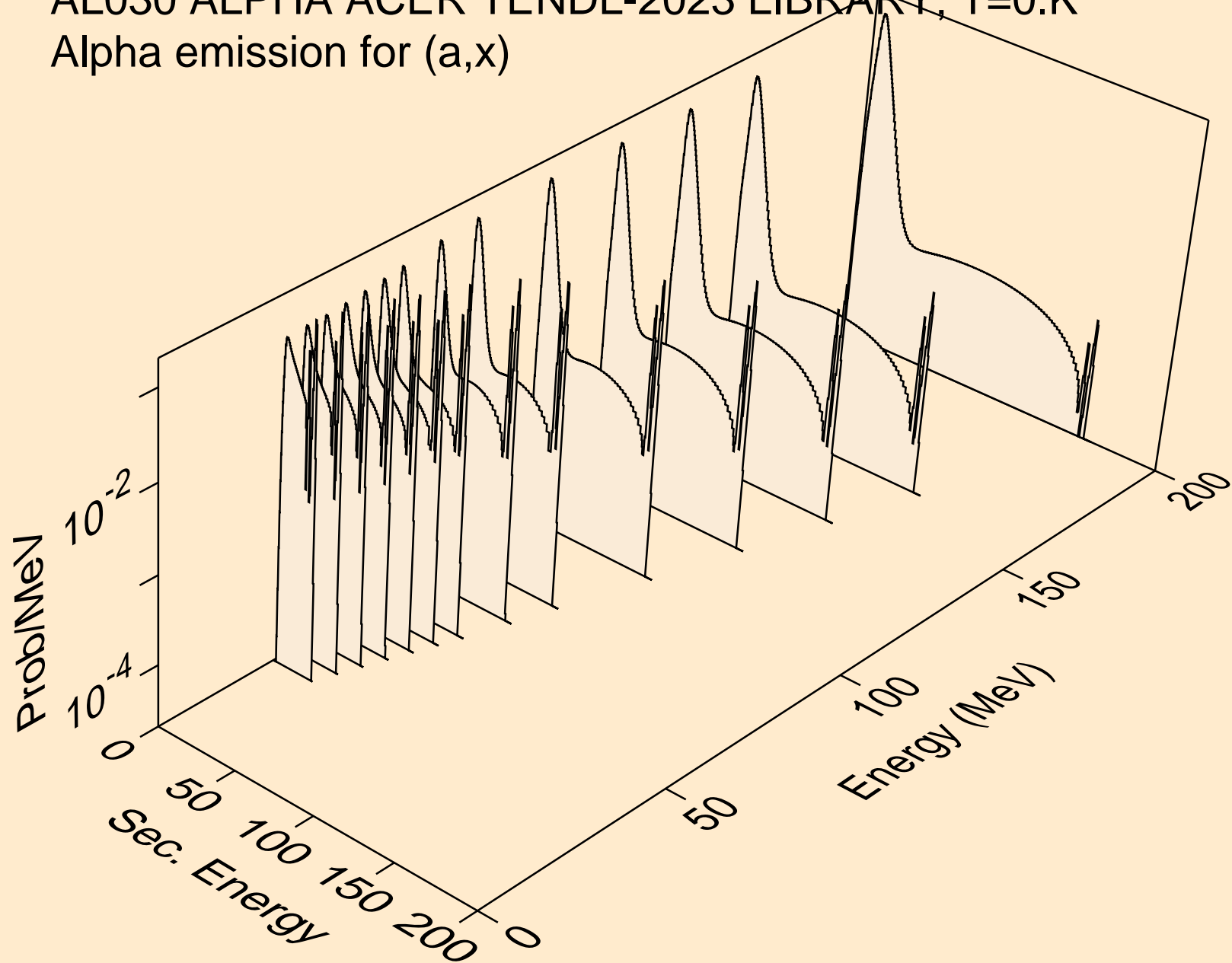

AL030 ALPHA ACER TENDL-2023 LIBRARY; T=0.K  
Alpha emission for (a,n\*)a

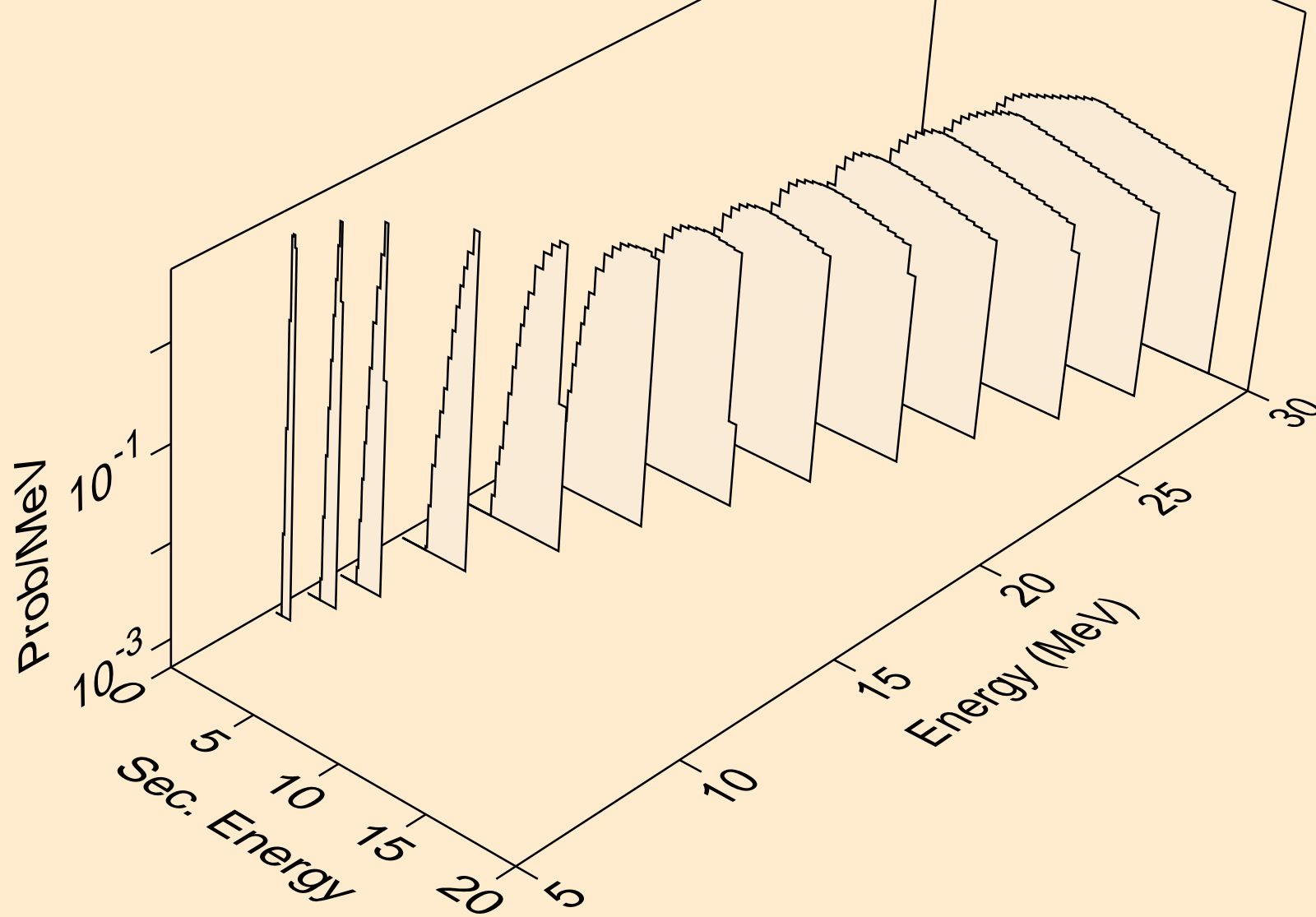



AL030 ALPHA ACER TENDL-2023 LIBRARY; T=0.K  
Alpha emission for (a,2n)a

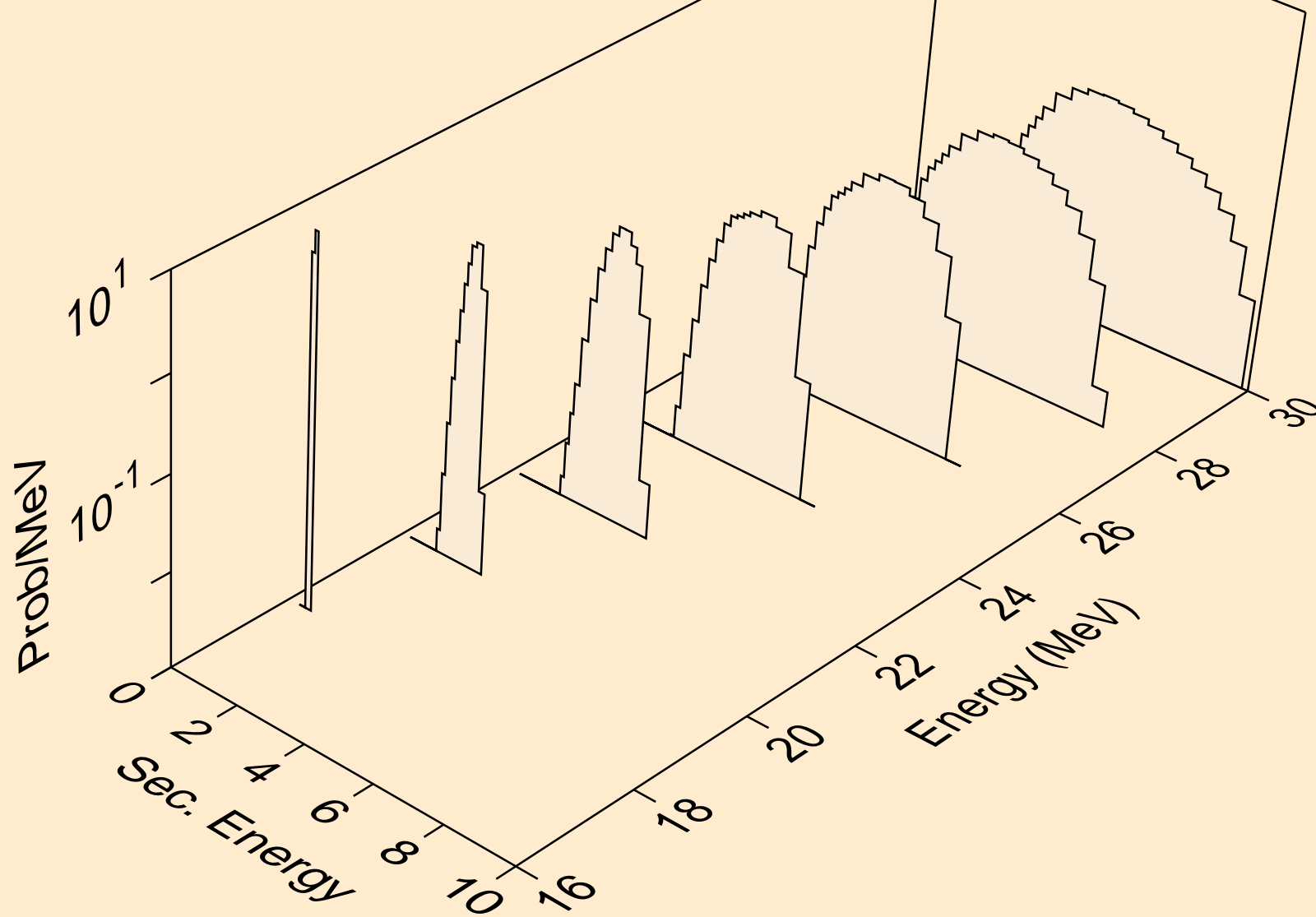

AL030 ALPHA ACER TENDL-2023 LIBRARY; T=0.K  
Alpha emission for (a,3n)a

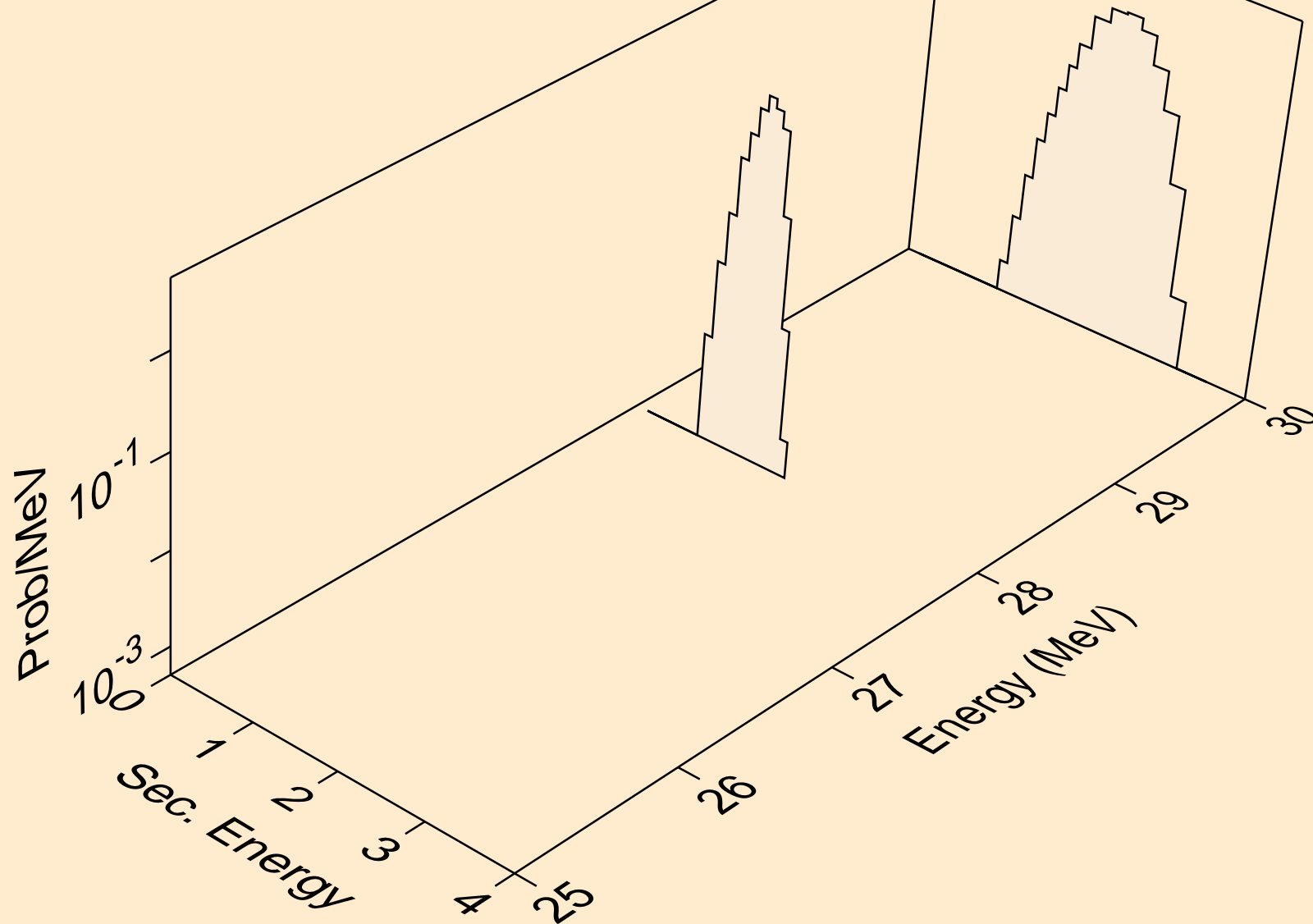

AL030 ALPHA ACER TENDL-2023 LIBRARY; T=0.K

Alpha emission for (a,n\*)2a

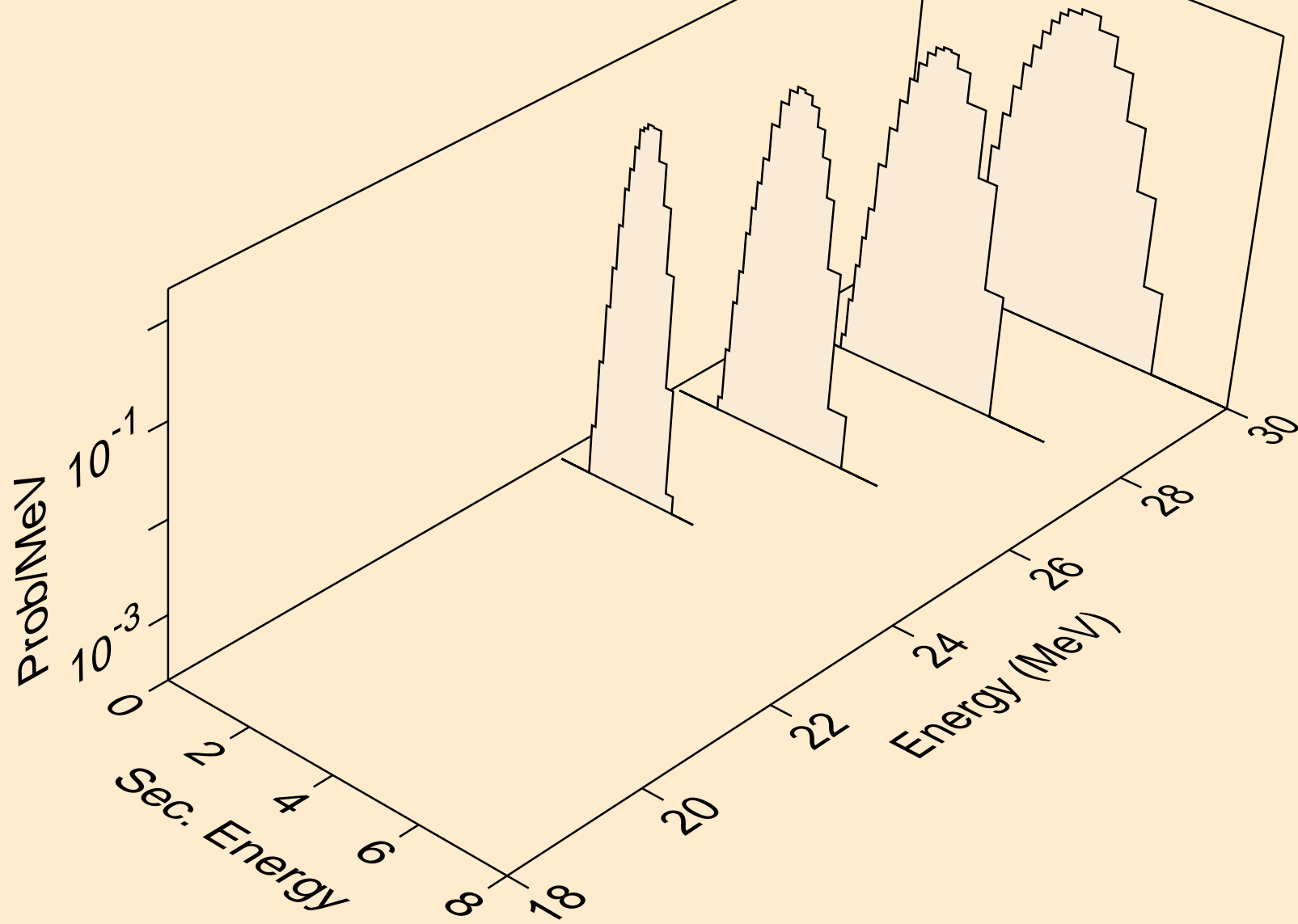

AL030 ALPHA ACER TENDL-2023 LIBRARY; T=0.K  
Alpha emission for inelastic

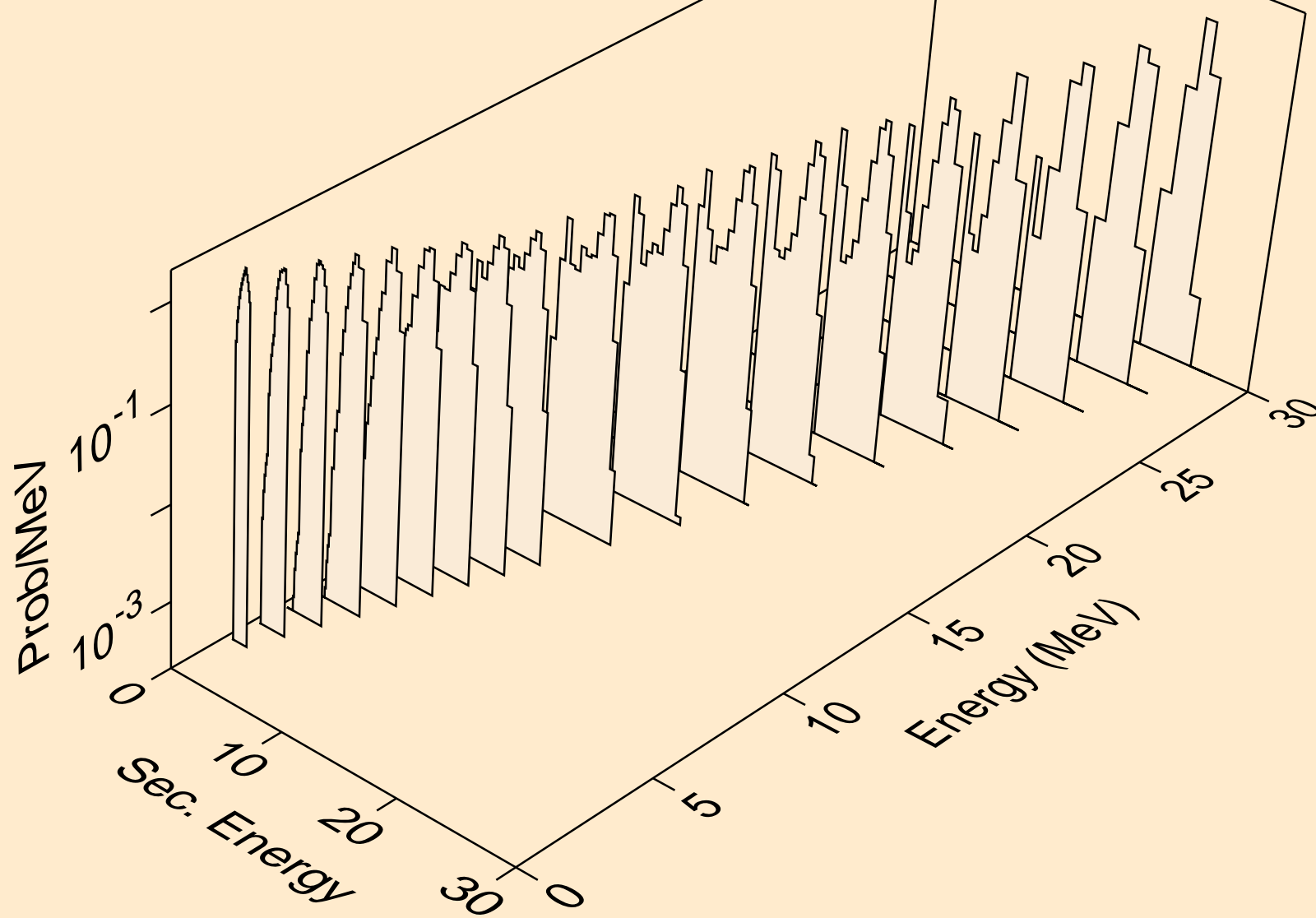

AL030 ALPHA ACER TENDL-2023 LIBRARY; T=0.K  
Alpha emission for (a,2a)

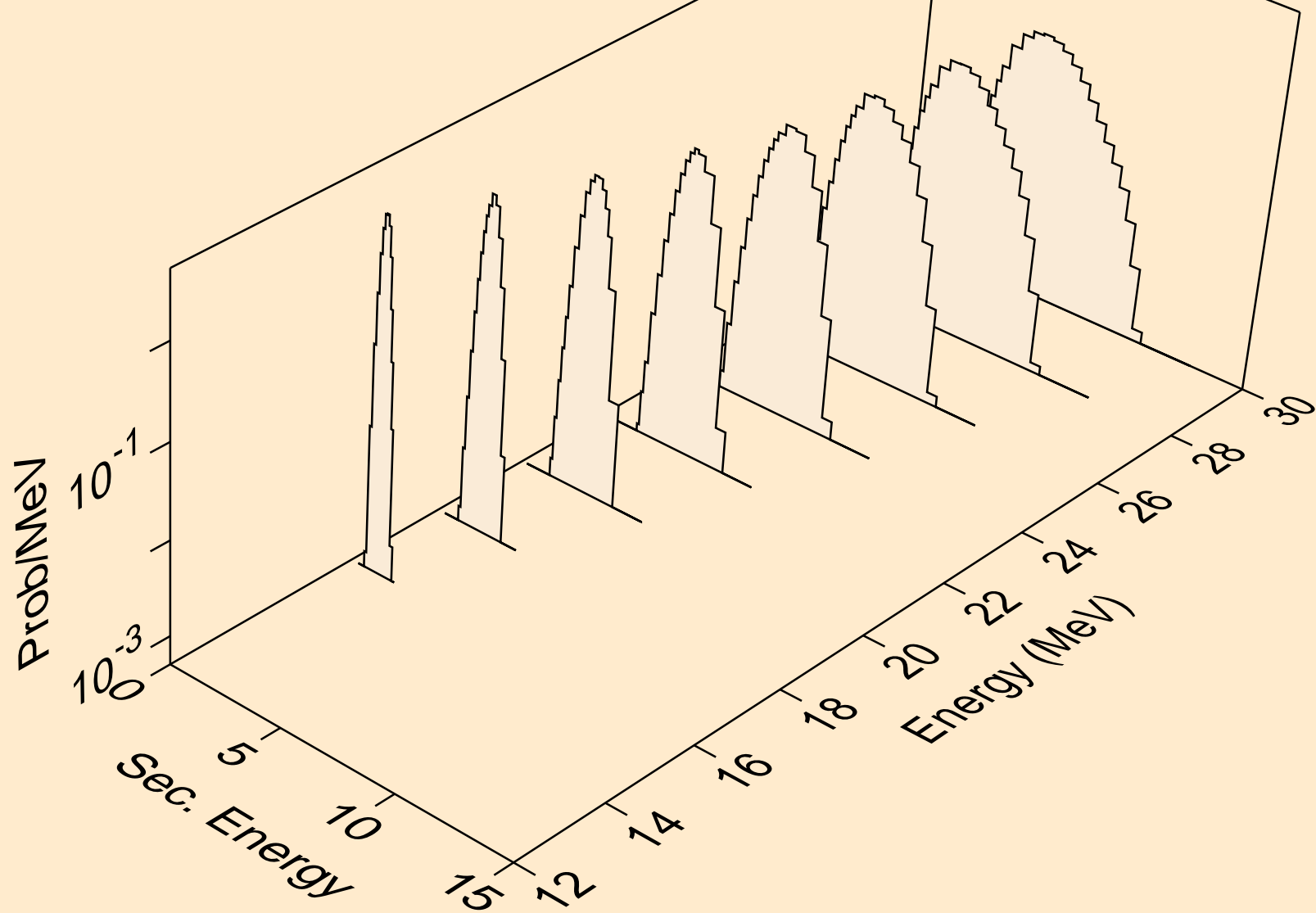

AL030 ALPHA ACER TENDL-2023 LIBRARY; T=0.K  
Alpha emission for (a,pa)

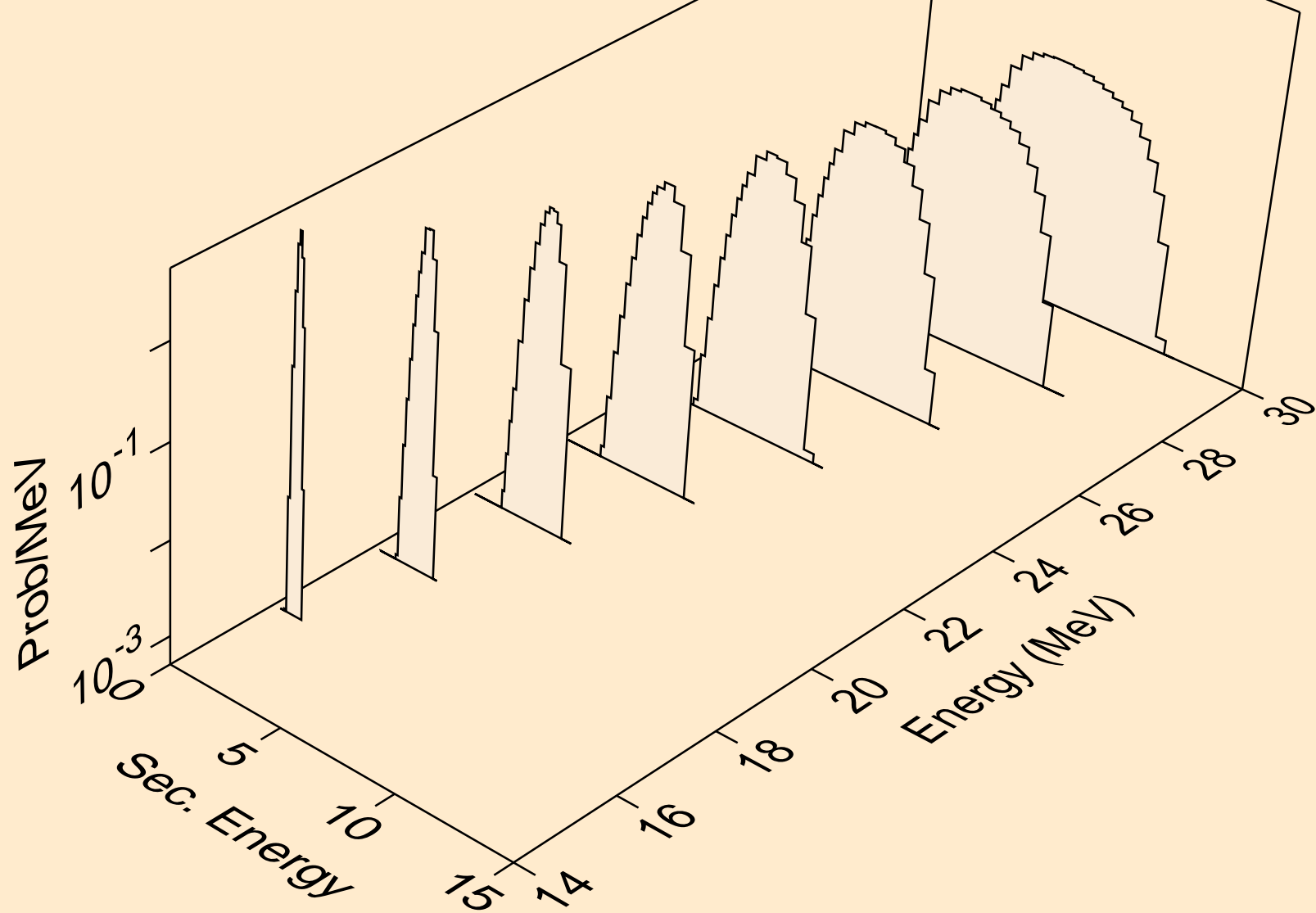

AL030 ALPHA ACER TENDL-2023 LIBRARY; T=0.K  
Alpha emission for (a,da)

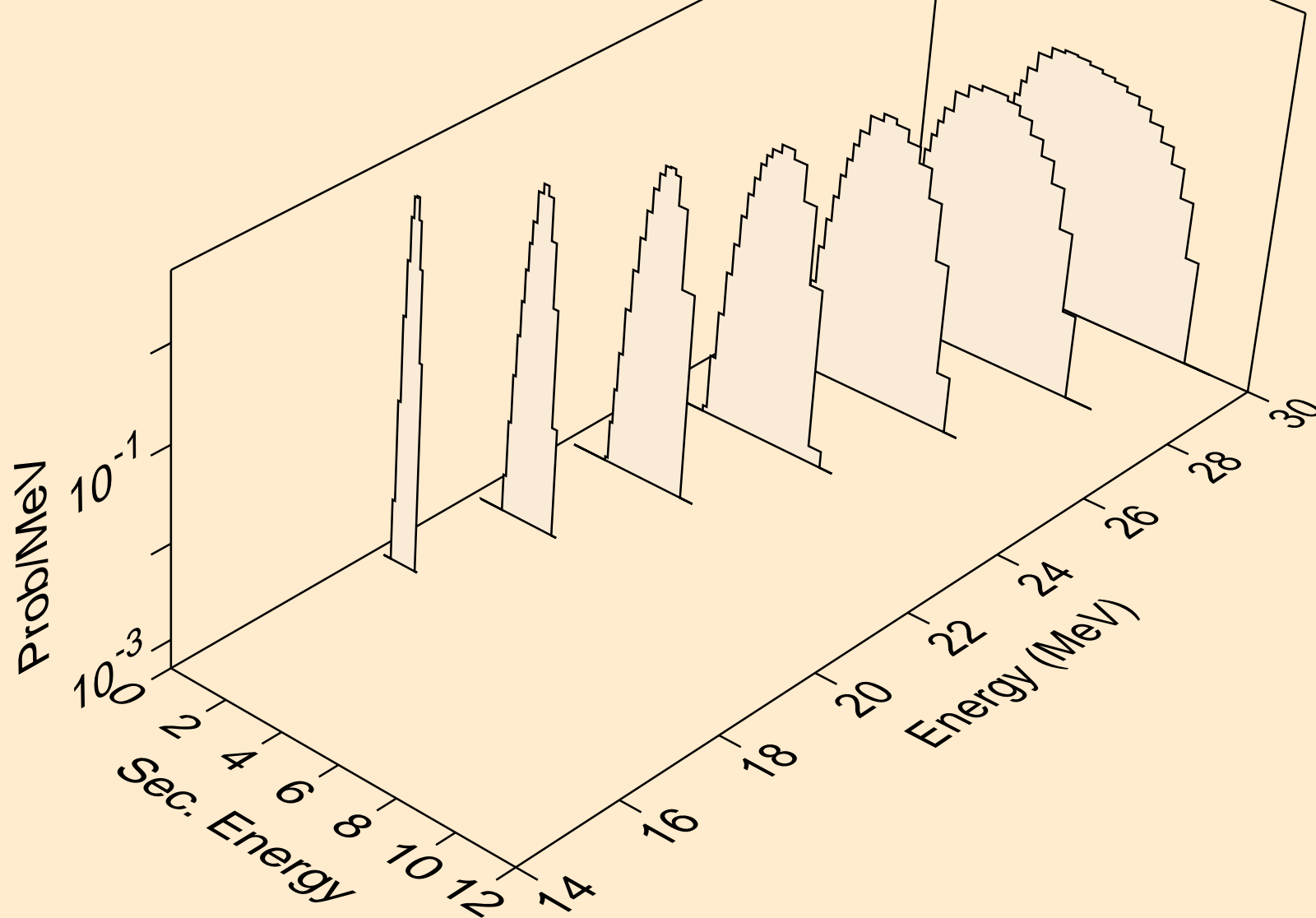

AL030 ALPHA ACER TENDL-2023 LIBRARY; T=0.K  
Photon emission for (z,n)

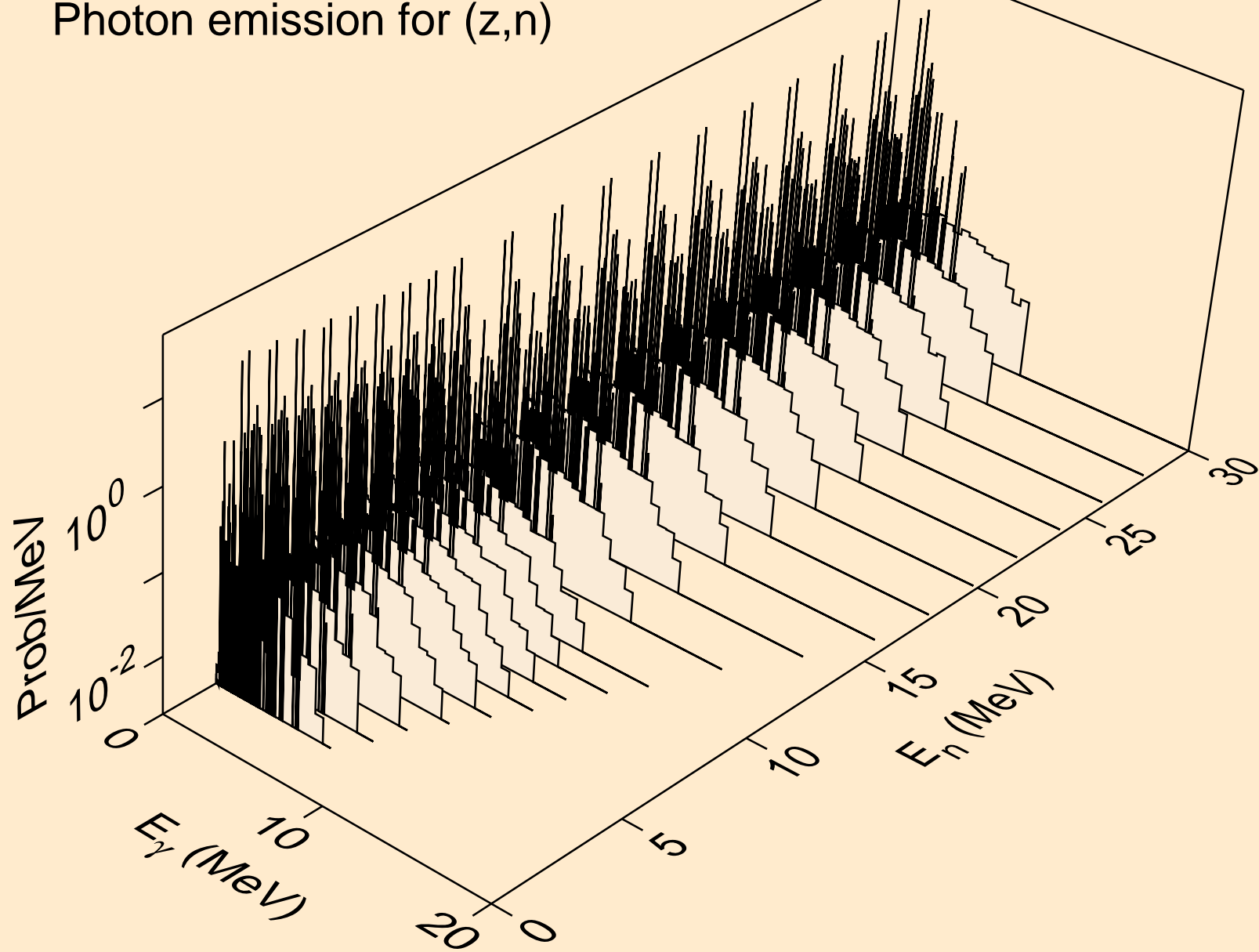



AL030 ALPHA ACER TENDL-2023 LIBRARY; T=0.K  
Photon emission for (z,x)

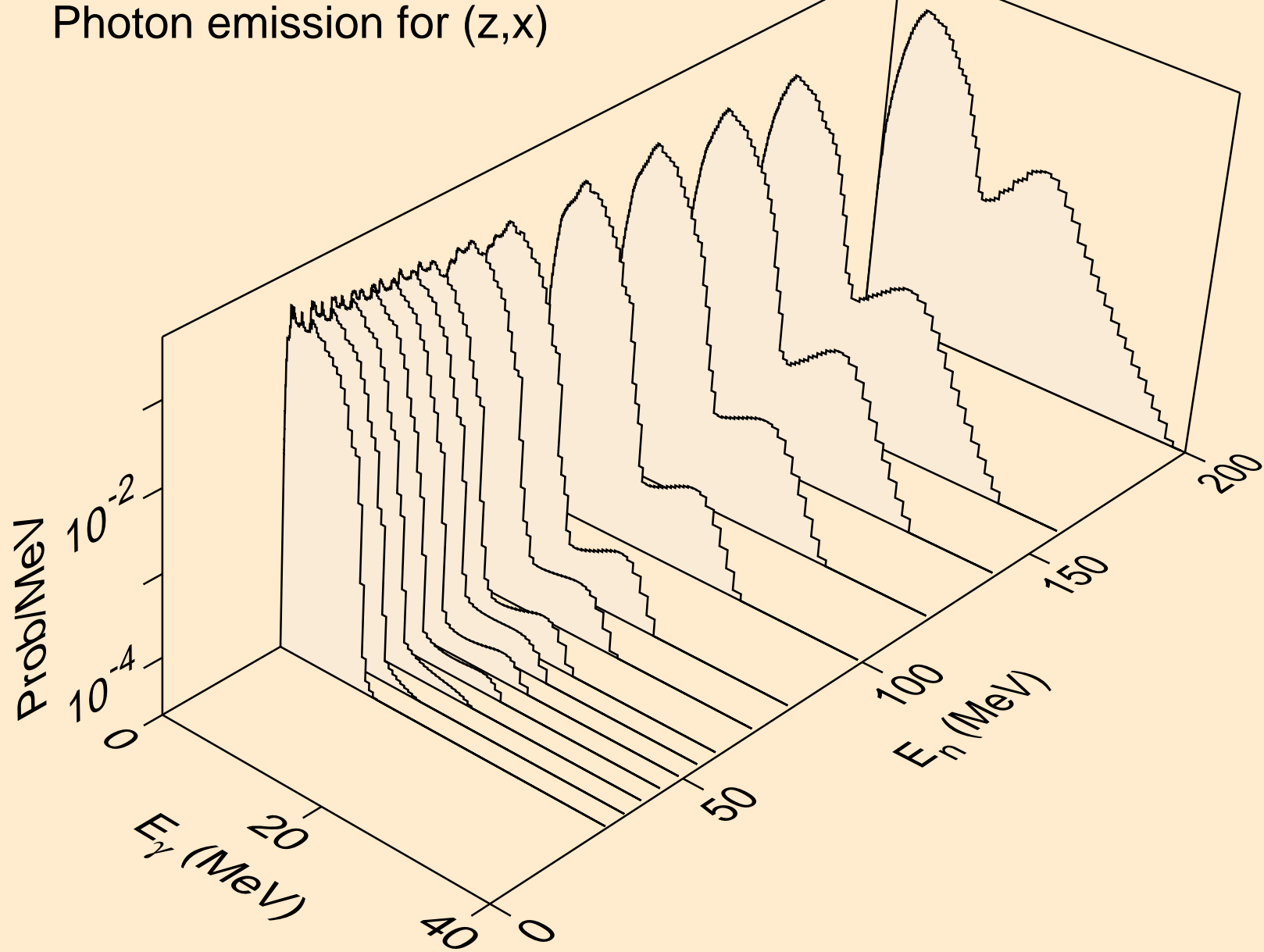

AL030 ALPHA ACER TENDL-2023 LIBRARY; T=0.K  
Photon emission for (n,2nd)

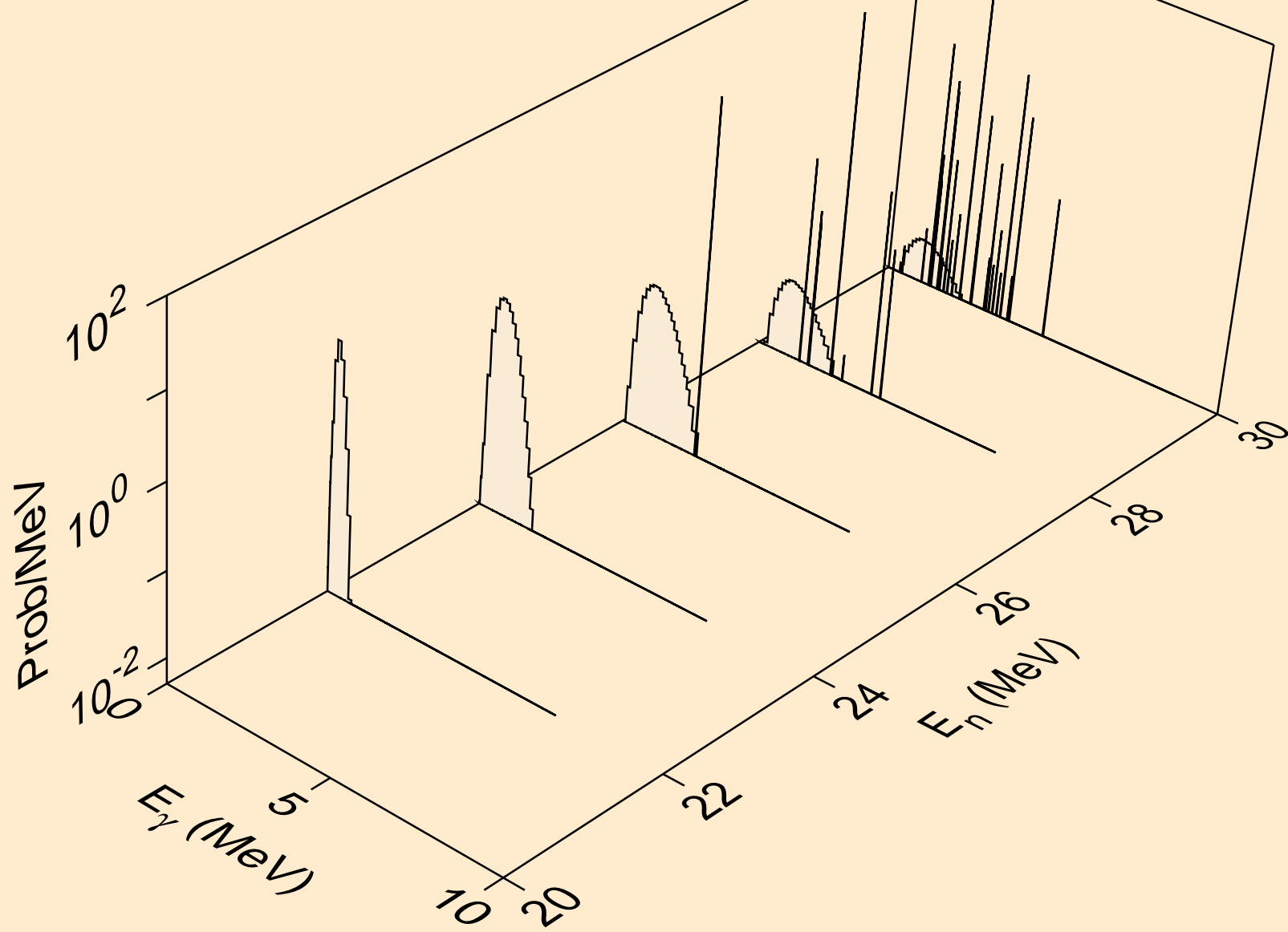

AL030 ALPHA ACER TENDL-2023 LIBRARY; T=0.K  
Photon emission for (n,2n)

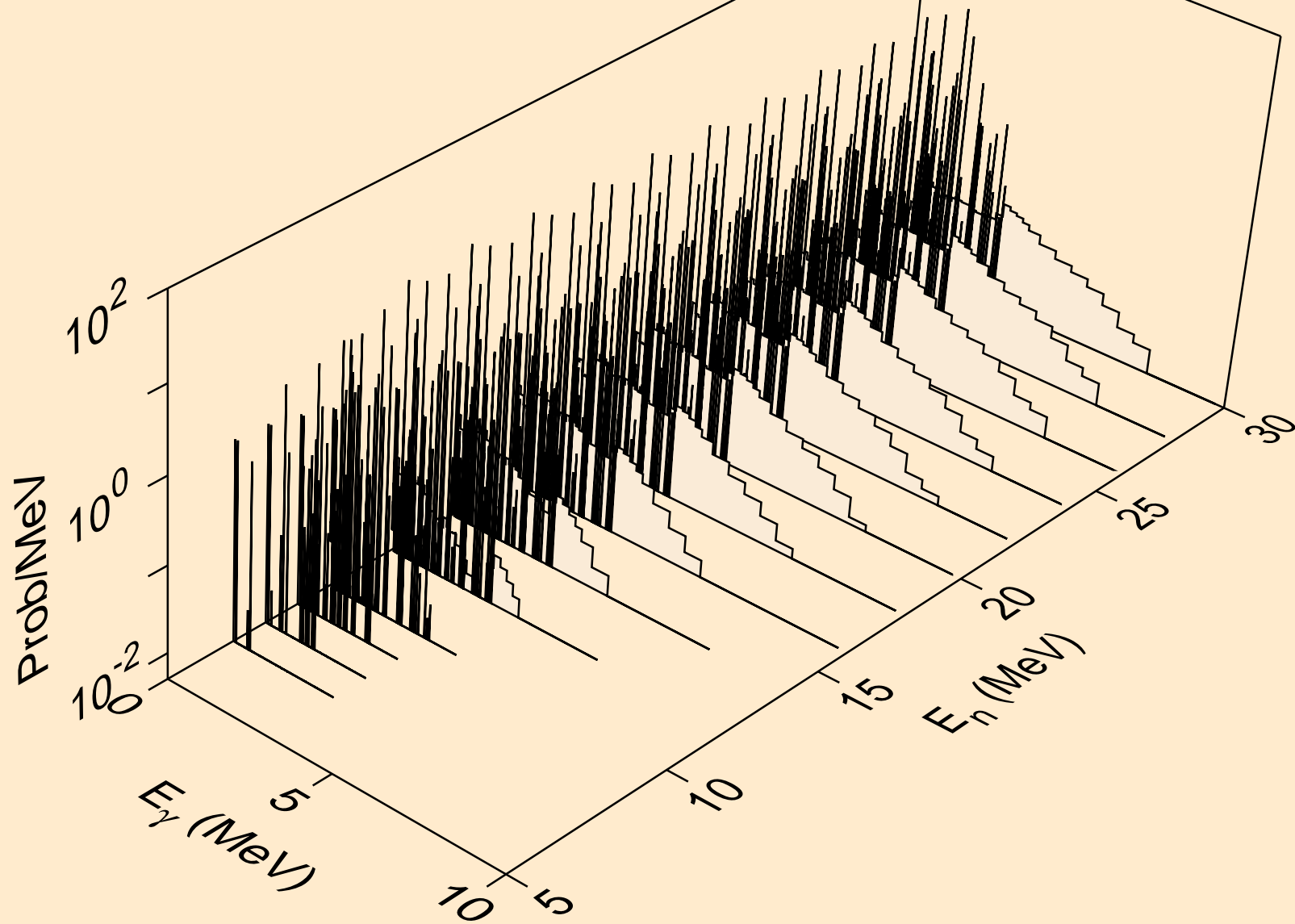

AL030 ALPHA ACER TENDL-2023 LIBRARY; T=0.K  
Photon emission for (n,3n)

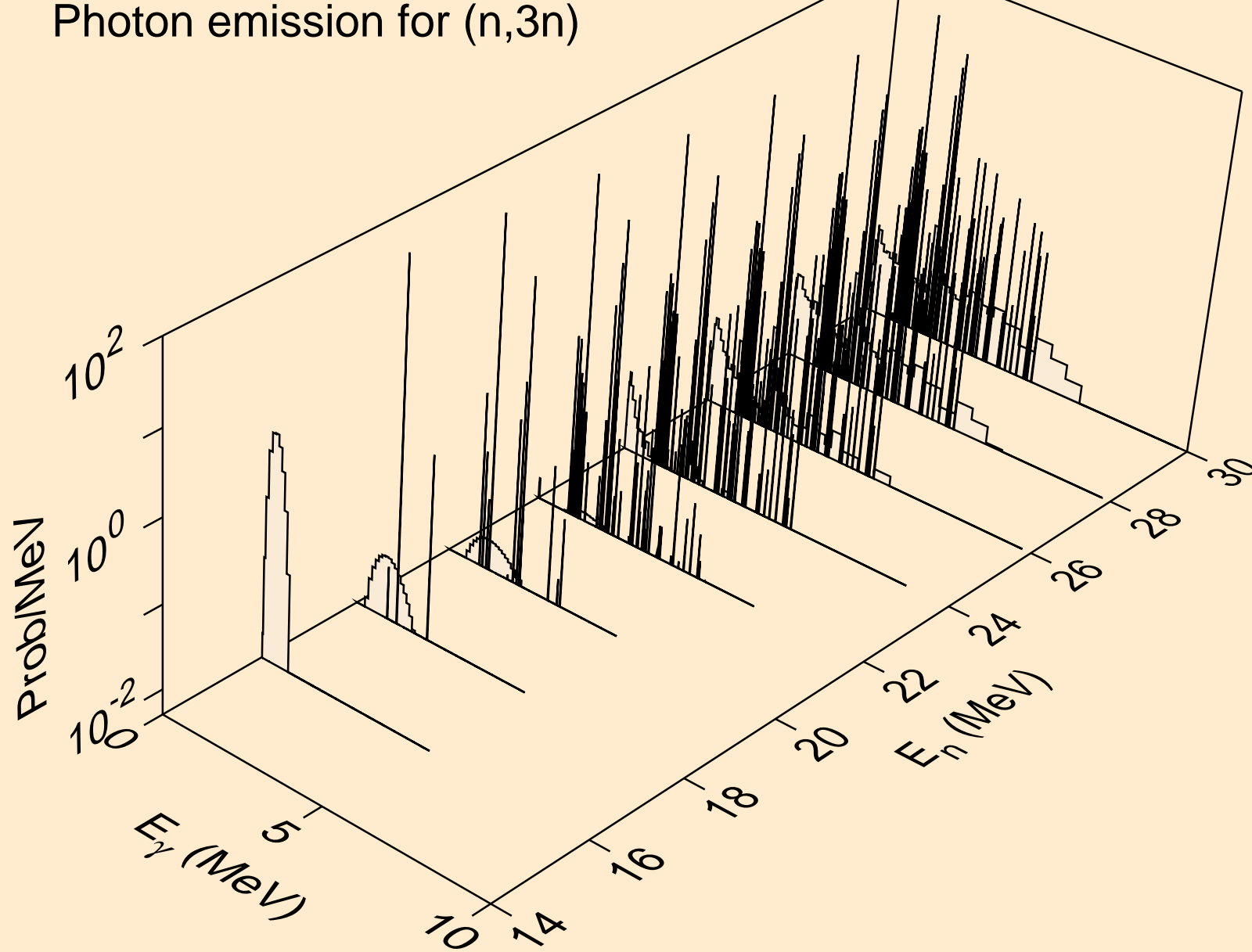

AL030 ALPHA ACER TENDL-2023 LIBRARY; T=0.K  
Photon emission for (n,n\*)a

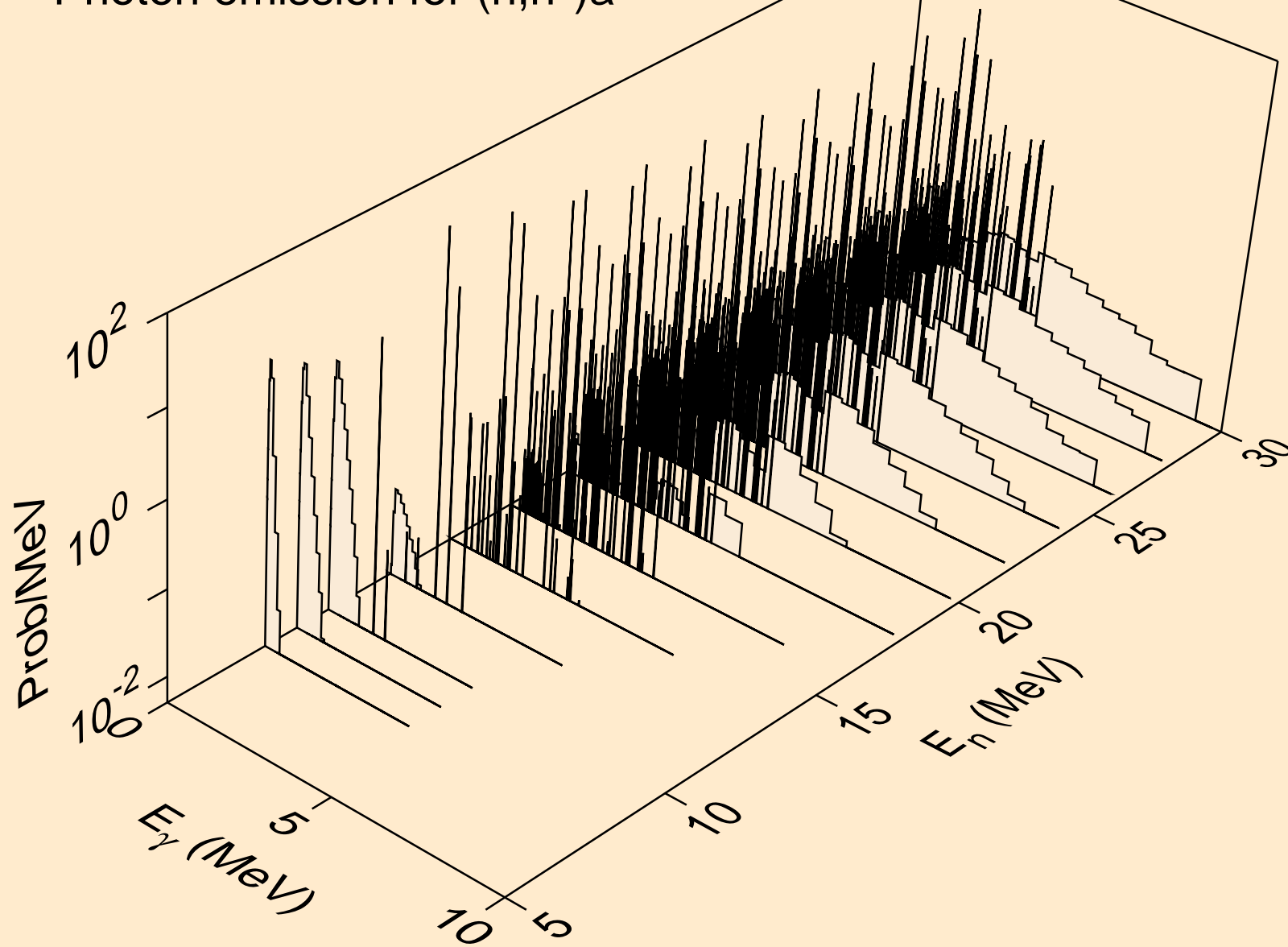

AL030 ALPHA ACER TENDL-2023 LIBRARY; T=0.K  
Photon emission for (n,2n)a

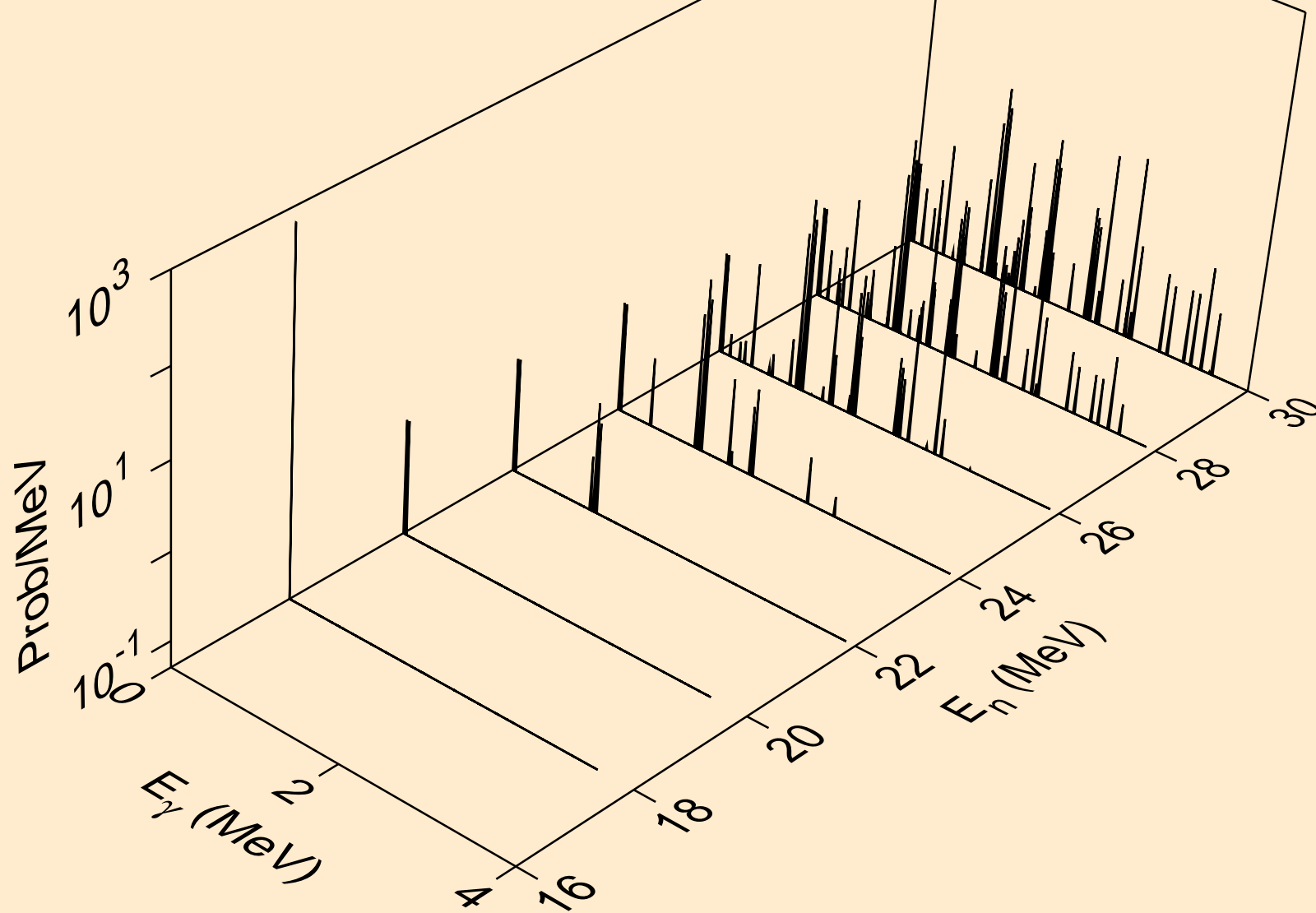

AL030 ALPHA ACER TENDL-2023 LIBRARY; T=0.K  
Photon emission for (n,3n)a

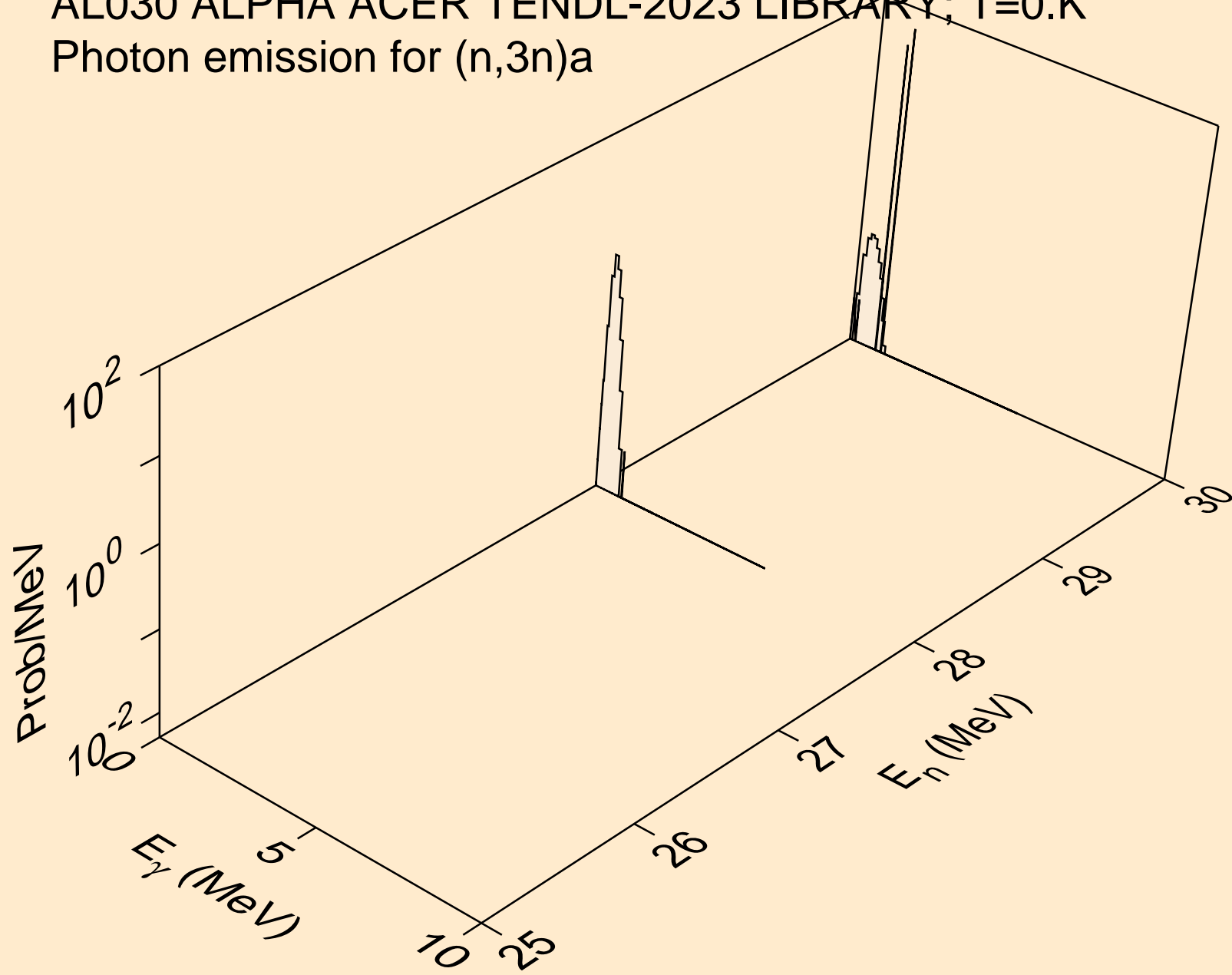

# AL030 ALPHA ACER TENDL-2023 LIBRARY; T=0.K

Photon emission for (n,n\*)p

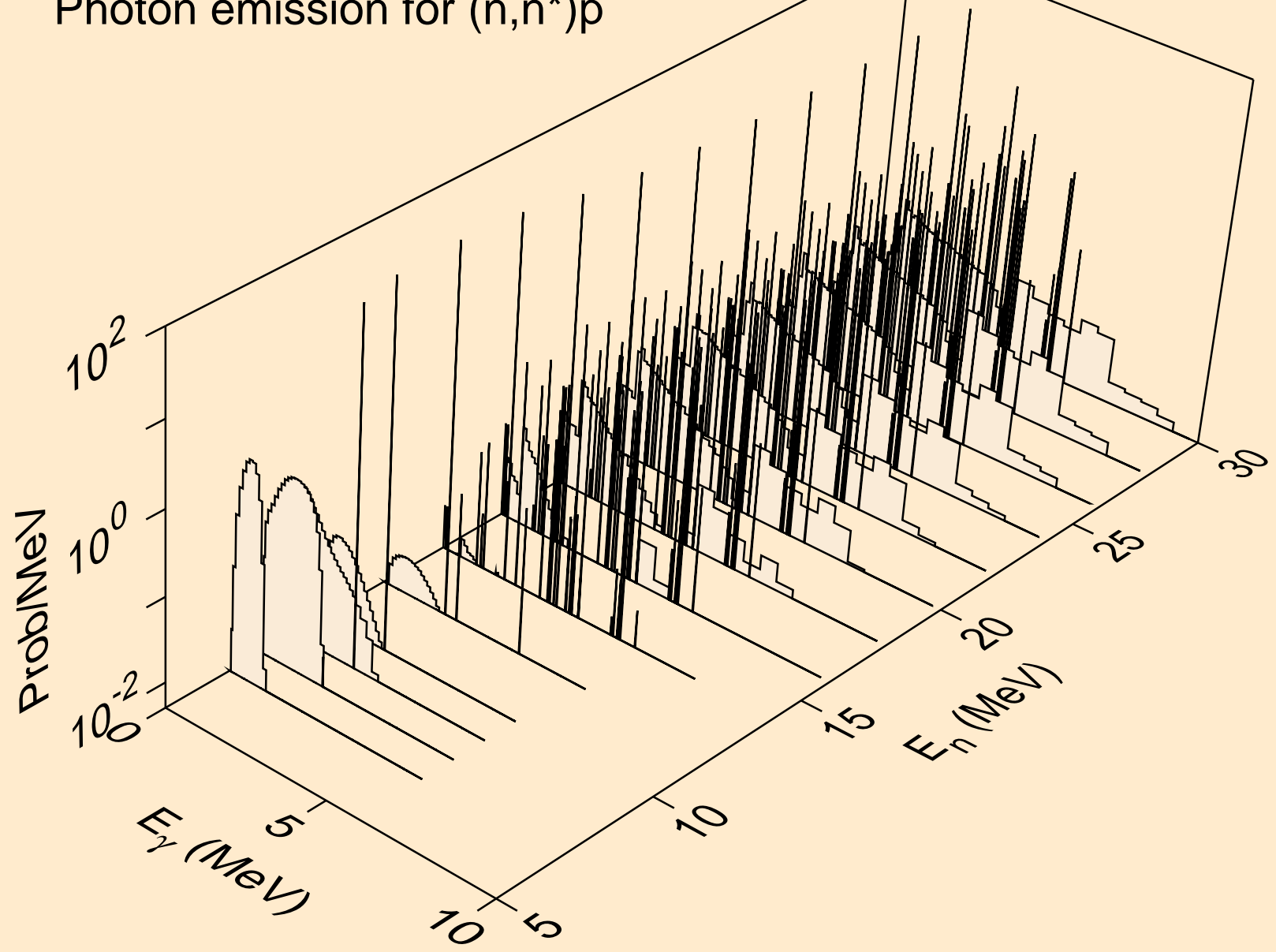



AL030 ALPHA ACER TENDL-2023 LIBRARY; T=0.K  
Photon emission for (n,n\*)2a

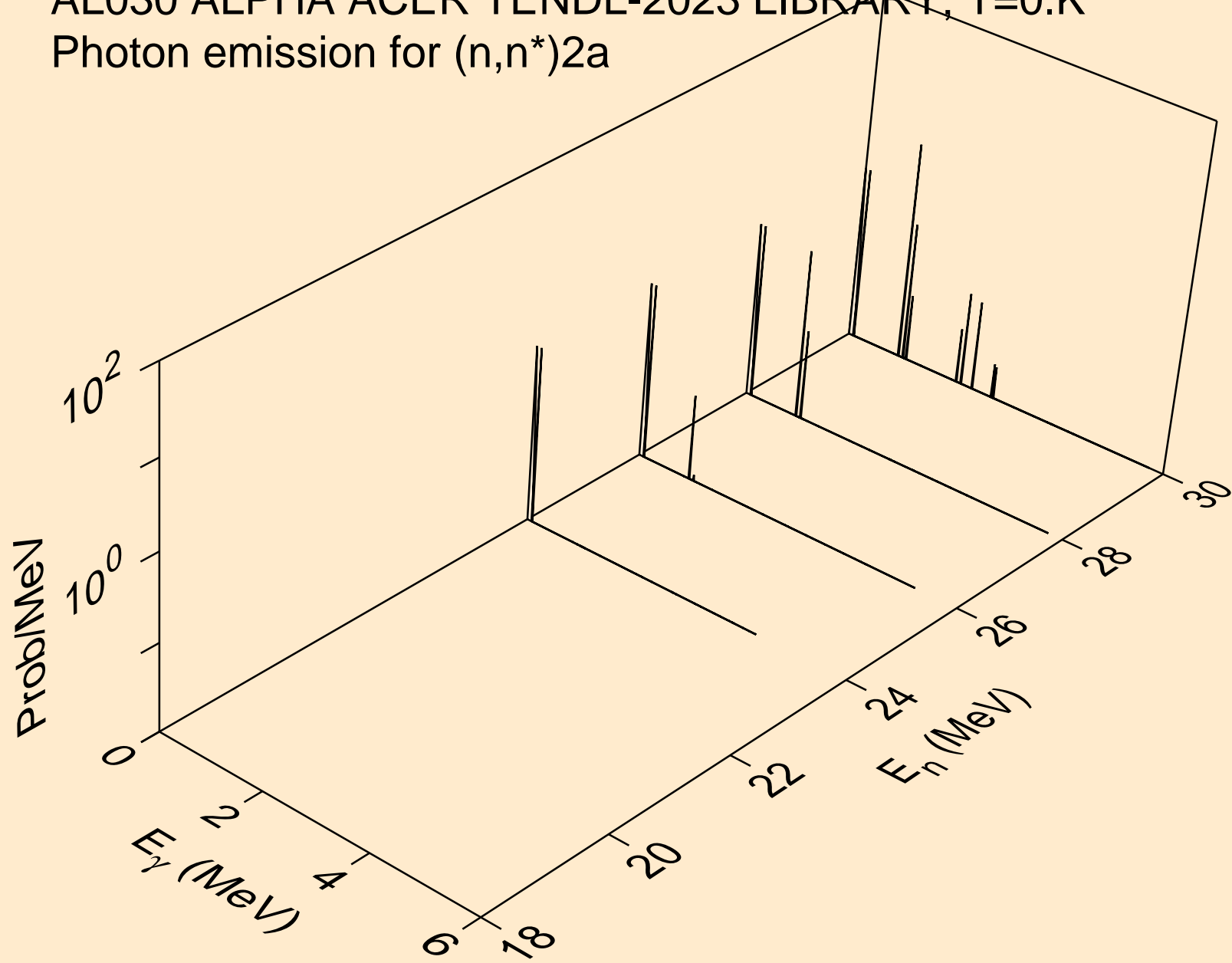

AL030 ALPHA ACER TENDL-2023 LIBRARY; T=0.K  
Photon emission for (n,n\*)d

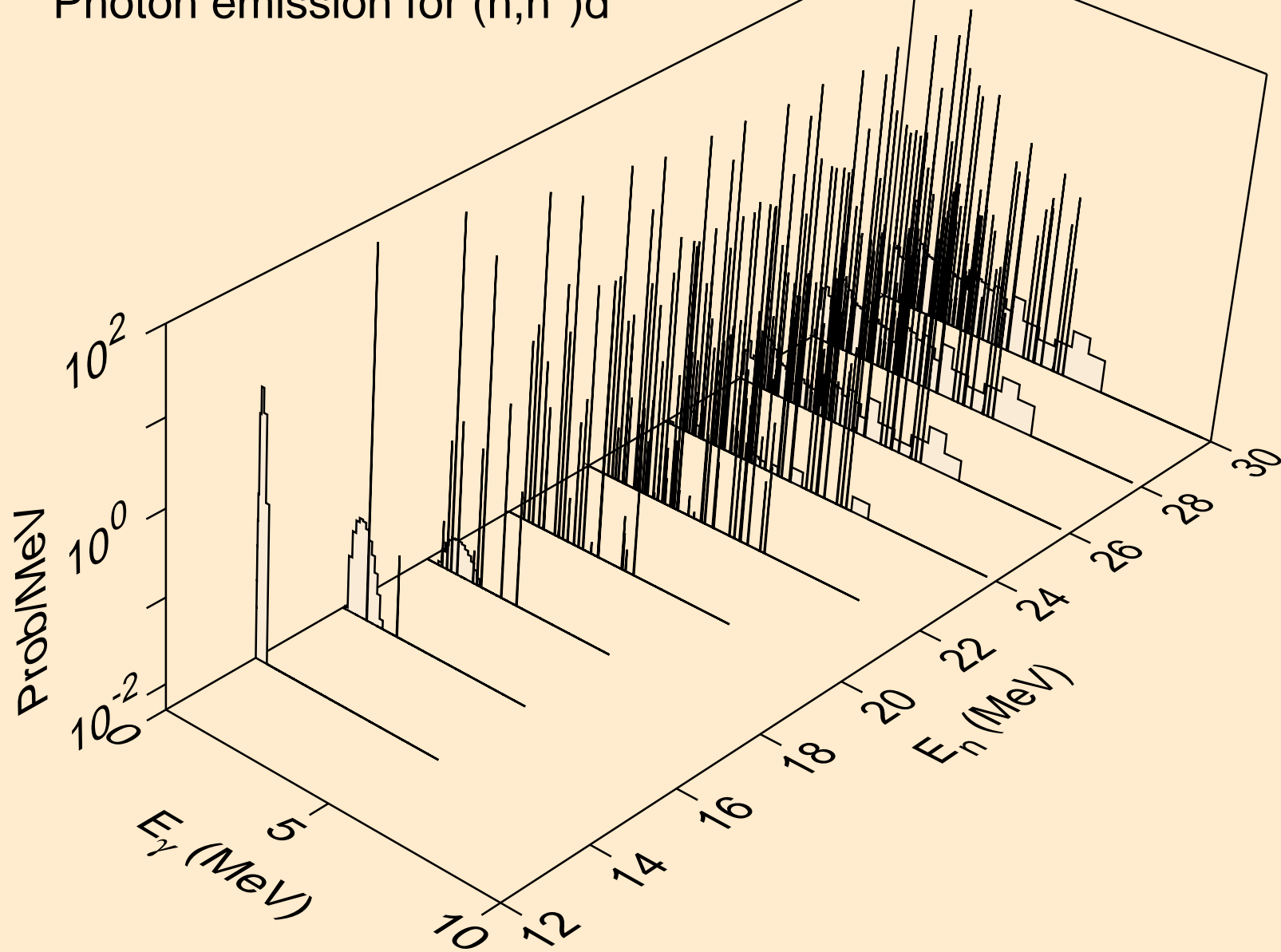

AL030 ALPHA ACER TENDL-2023 LIBRARY; T=0.K  
Photon emission for (n,n\*)t

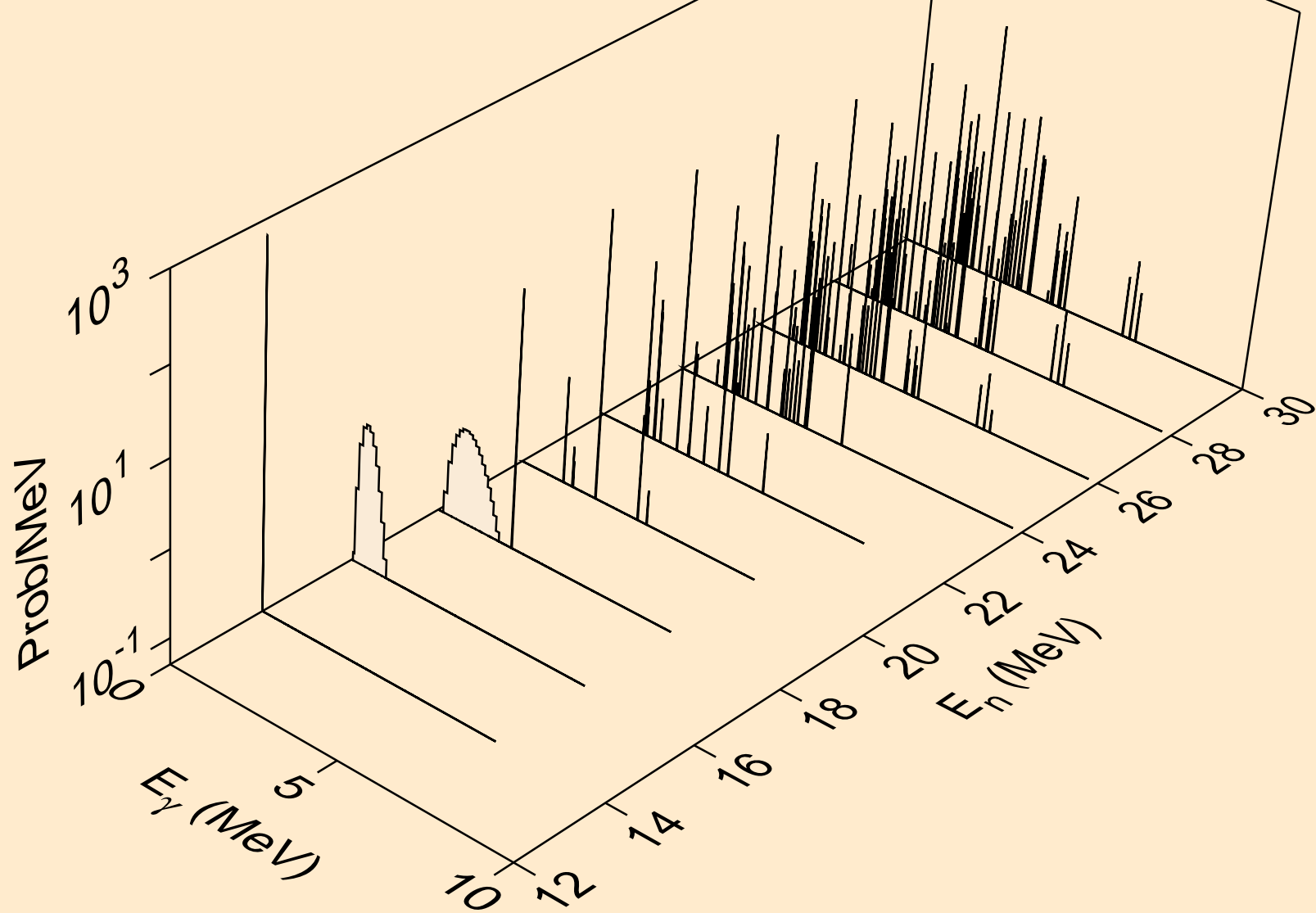

AL030 ALPHA ACER TENDL-2023 LIBRARY; T=0.K  
Photon emission for (n,n\*)he3

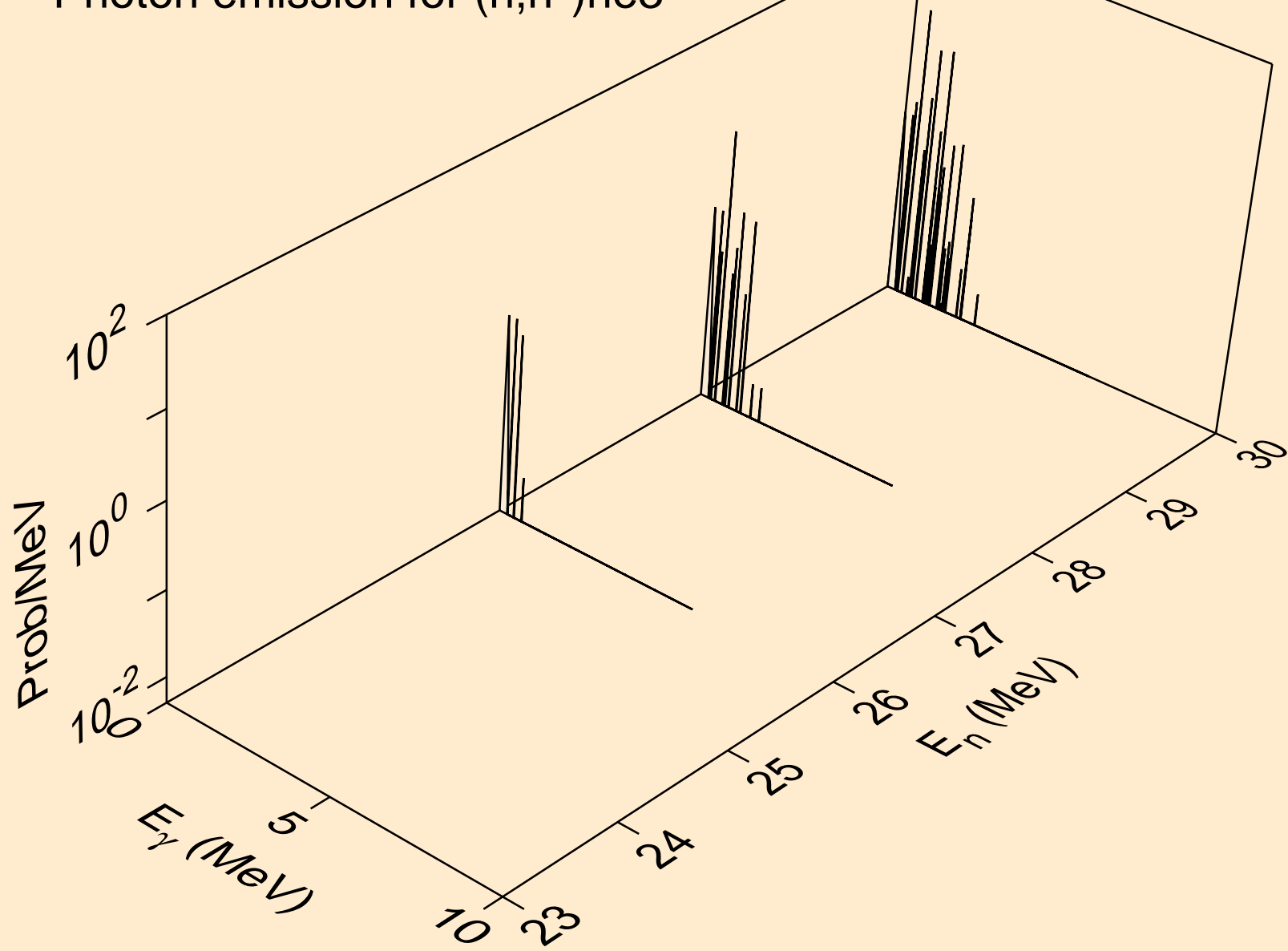

AL030 ALPHA ACER TENDL-2023 LIBRARY; T=0.K  
Photon emission for (n,2np)

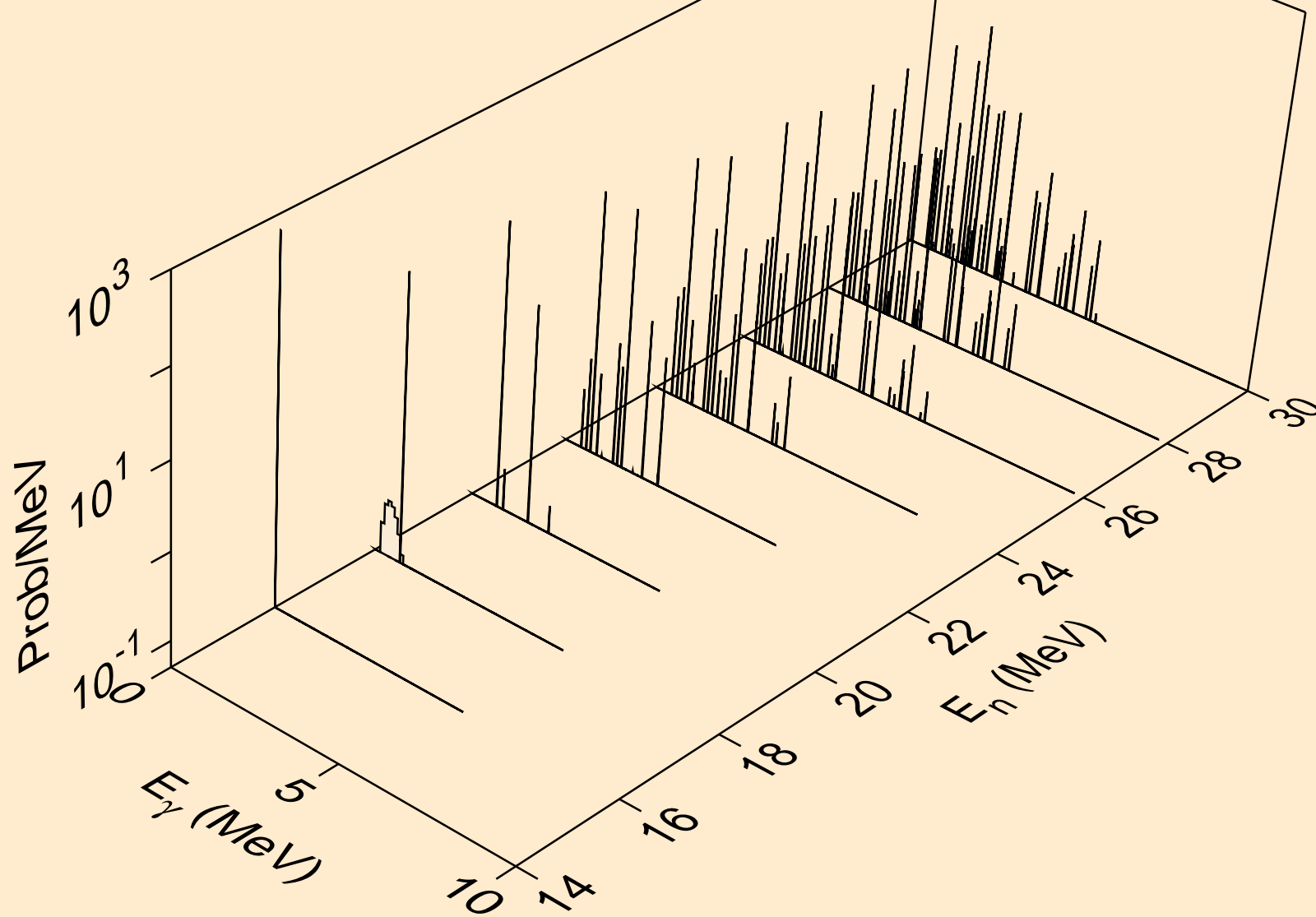

AL030 ALPHA ACER TENDL-2023 LIBRARY; T=0.K  
Photon emission for (n,3np)

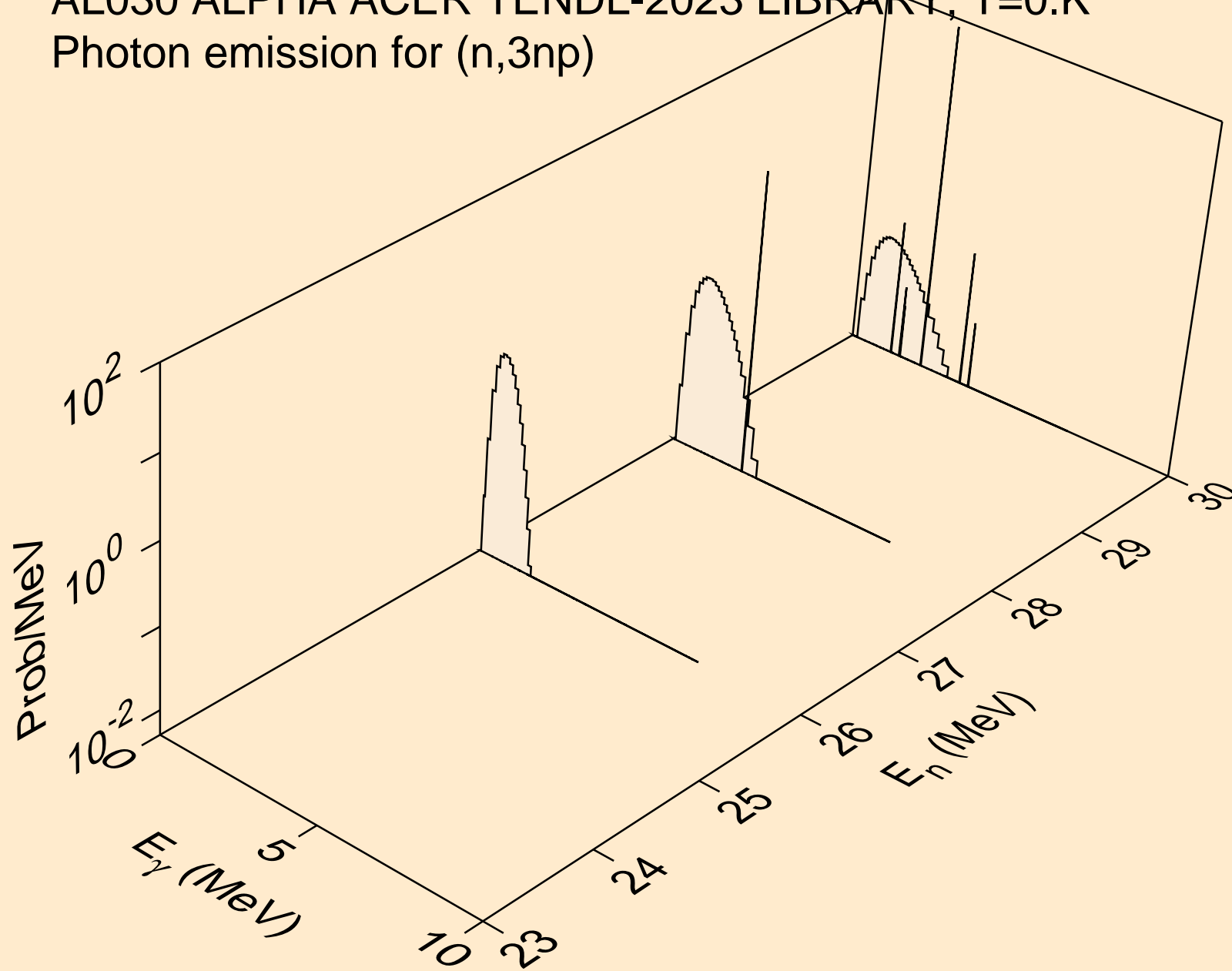

AL030 ALPHA ACER TENDL-2023 LIBRARY; T=0.K

Photon emission for (n,n2p)

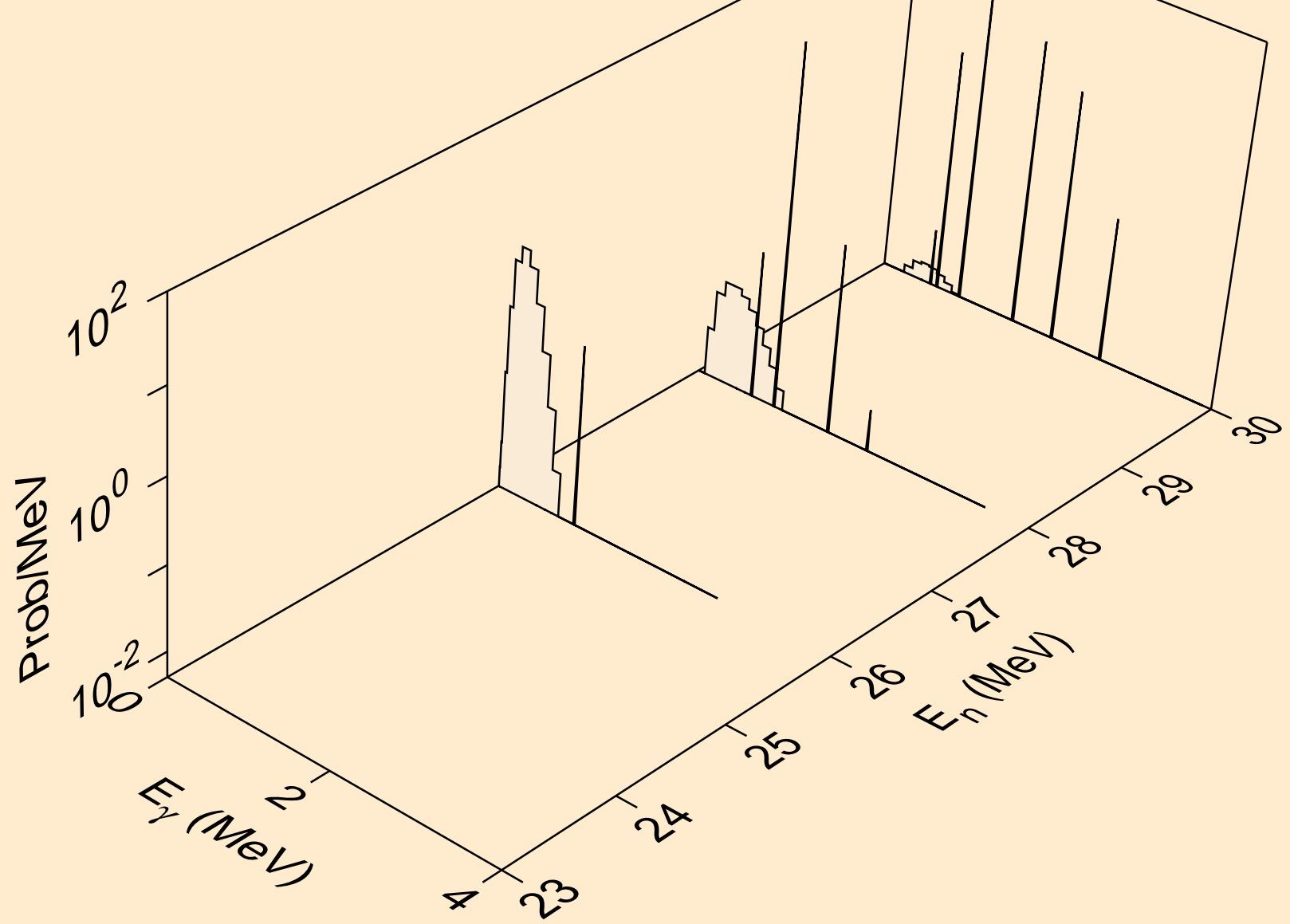

AL030 ALPHA ACER TENDL-2023 LIBRARY; T=0.K  
Photon emission for (n,npa)

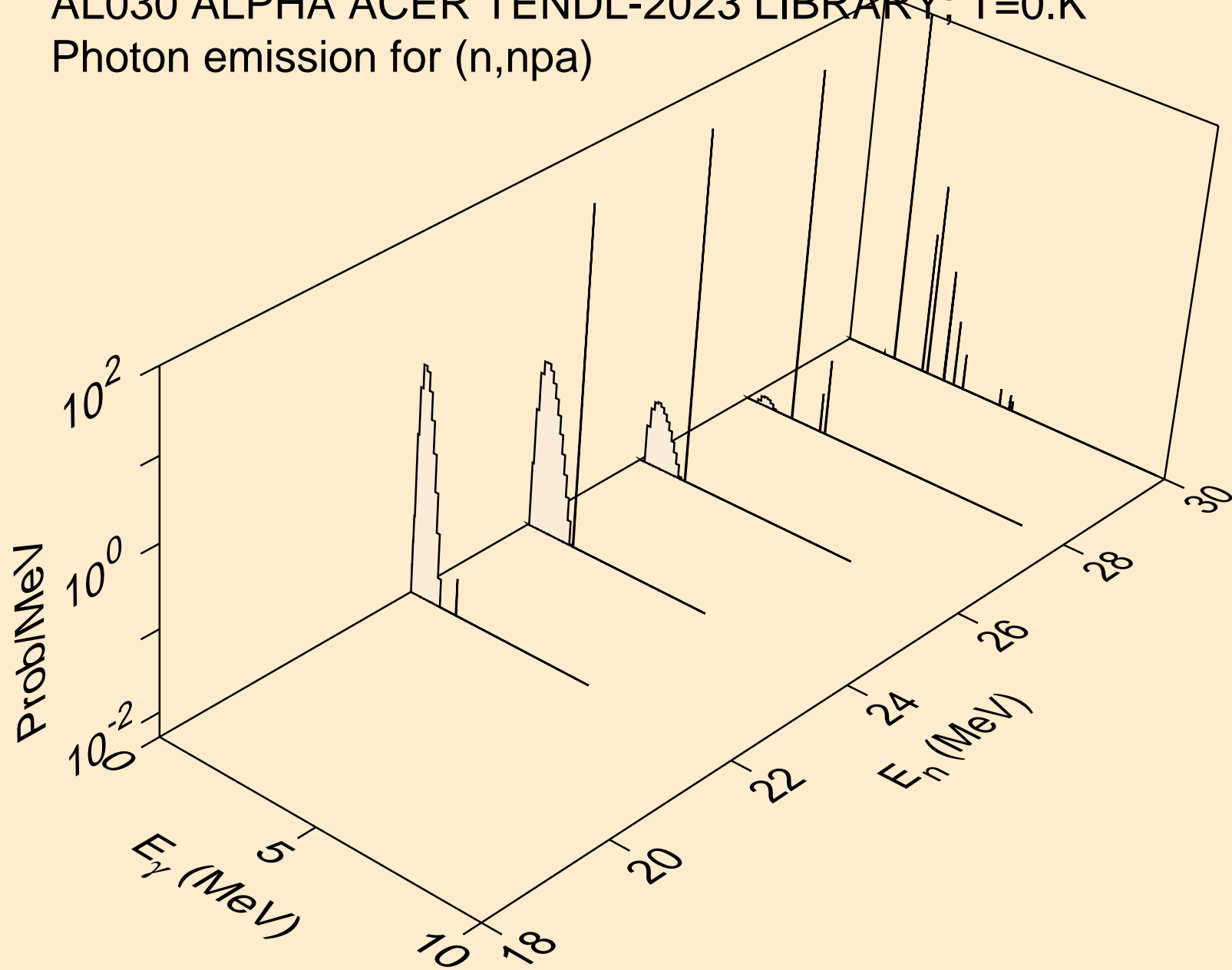



AL030 ALPHA ACER TENDL-2023 LIBRARY; T=0.K  
Photon emission for (n,gma)

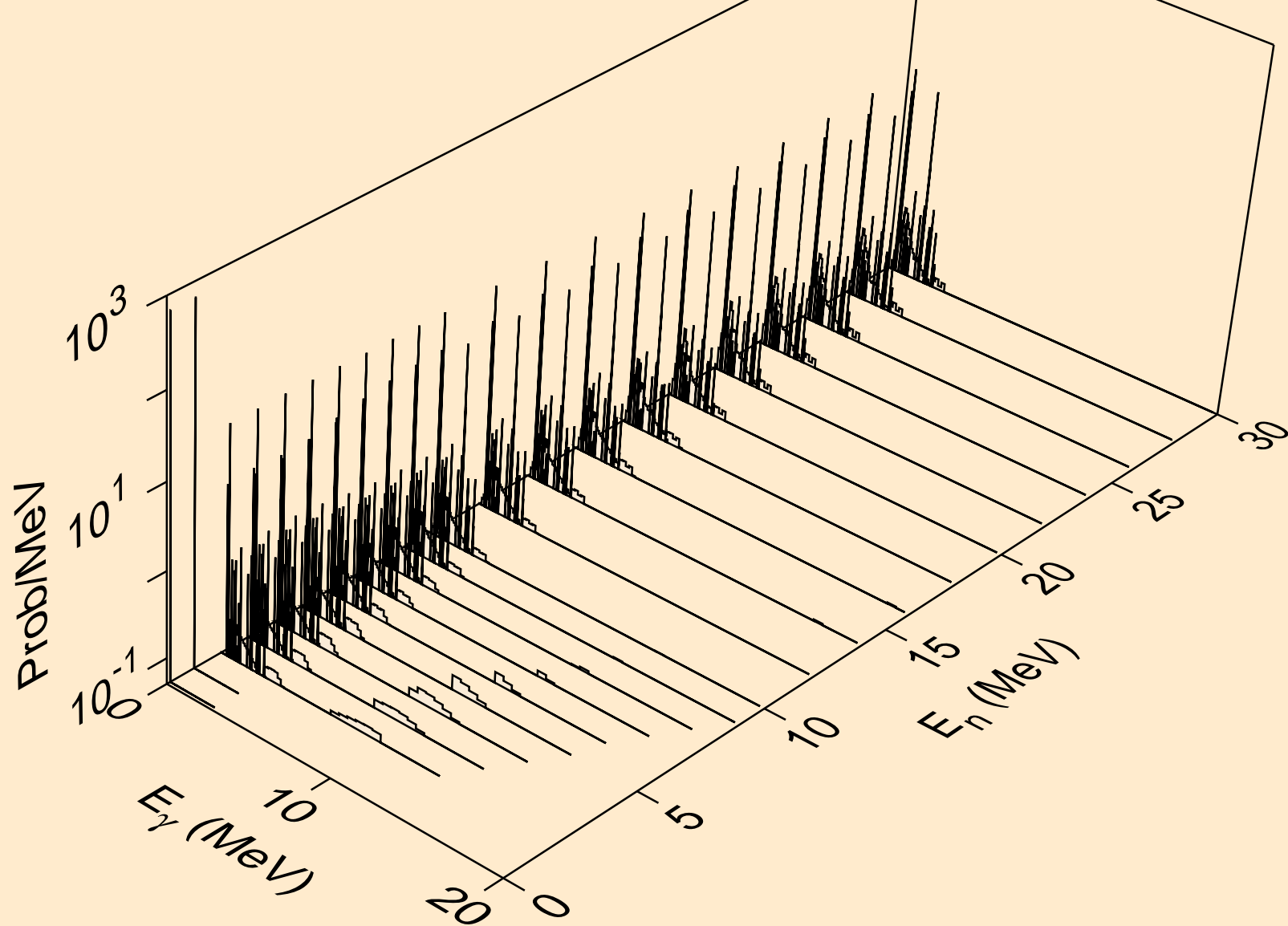

AL030 ALPHA ACER TENDL-2023 LIBRARY; T=0.K  
Photon emission for (n,p)

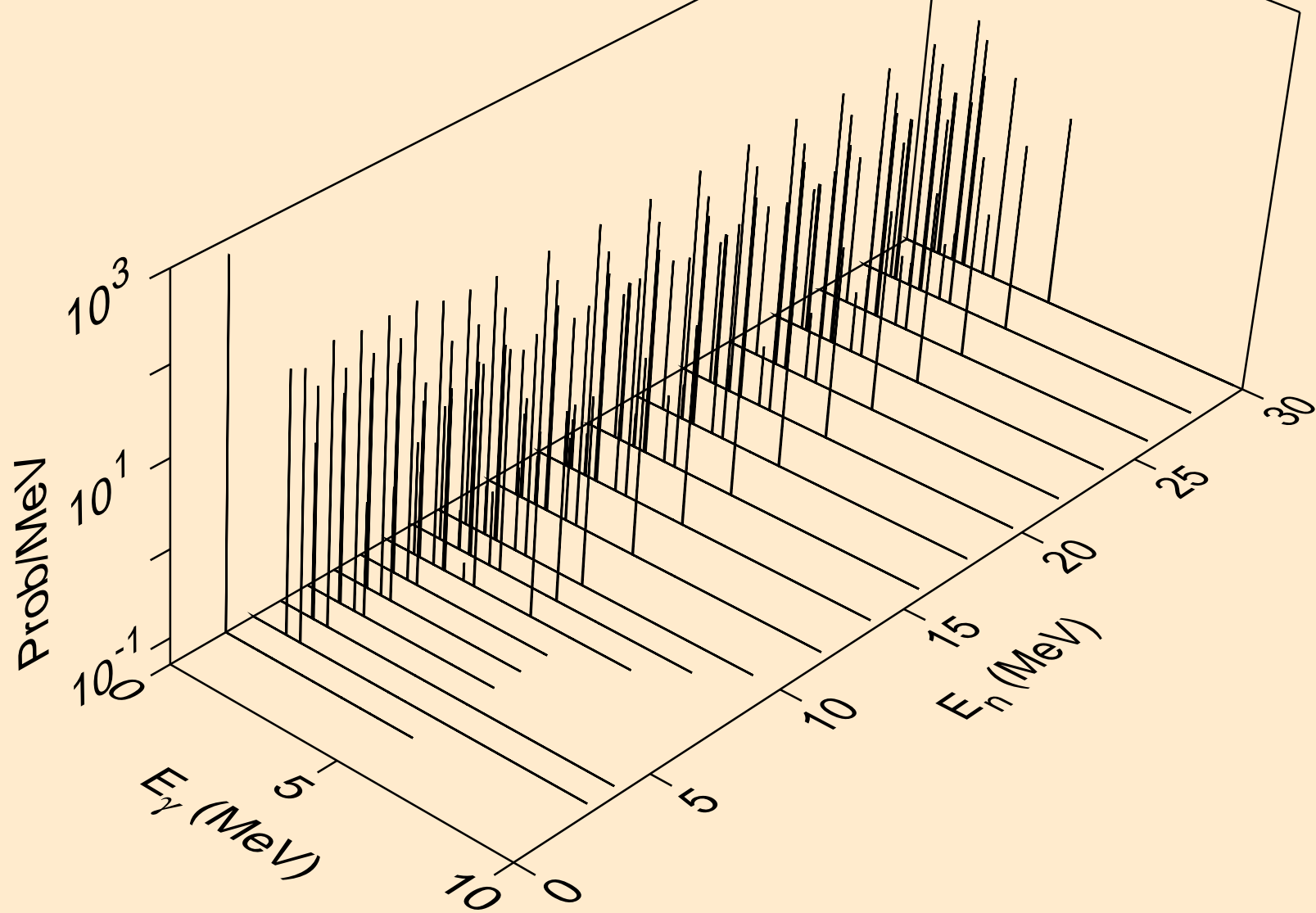

AL030 ALPHA ACER TENDL-2023 LIBRARY; T=0.K  
Photon emission for (n,d)

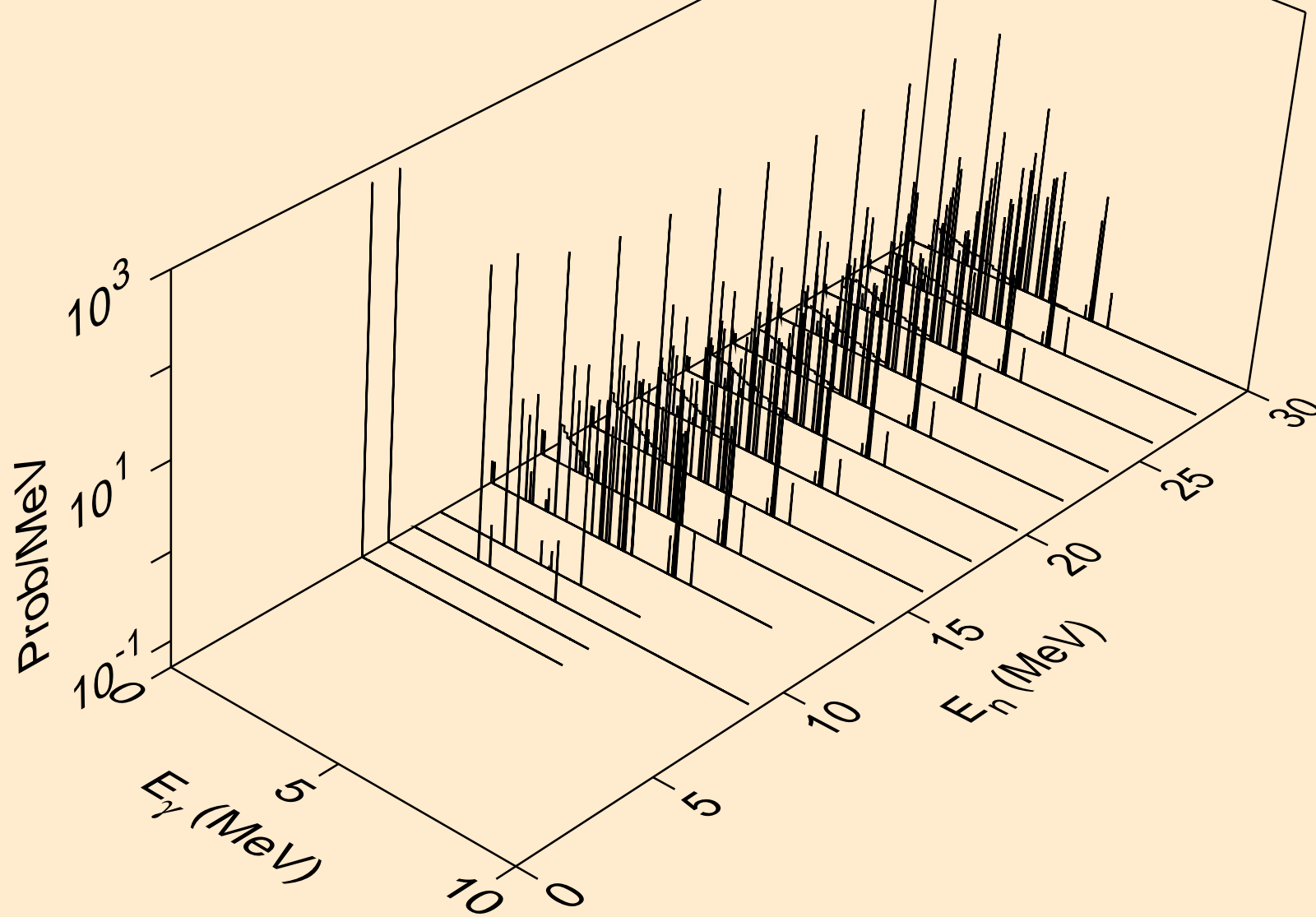

AL030 ALPHA ACER TENDL-2023 LIBRARY; T=0.K  
Photon emission for (n,t)

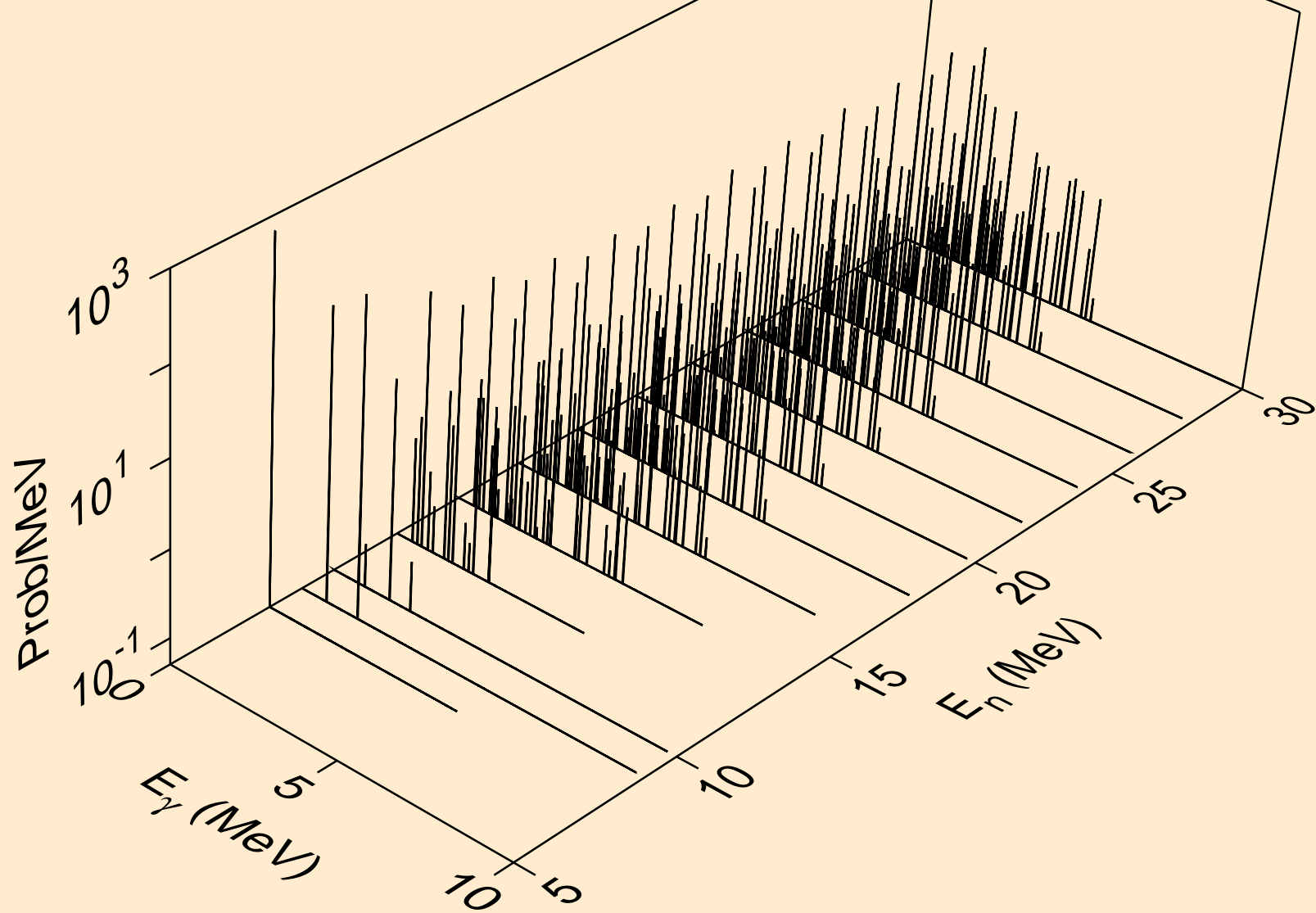

AL030 ALPHA ACER TENDL-2023 LIBRARY; T=0.K  
Photon emission for (n,he3)

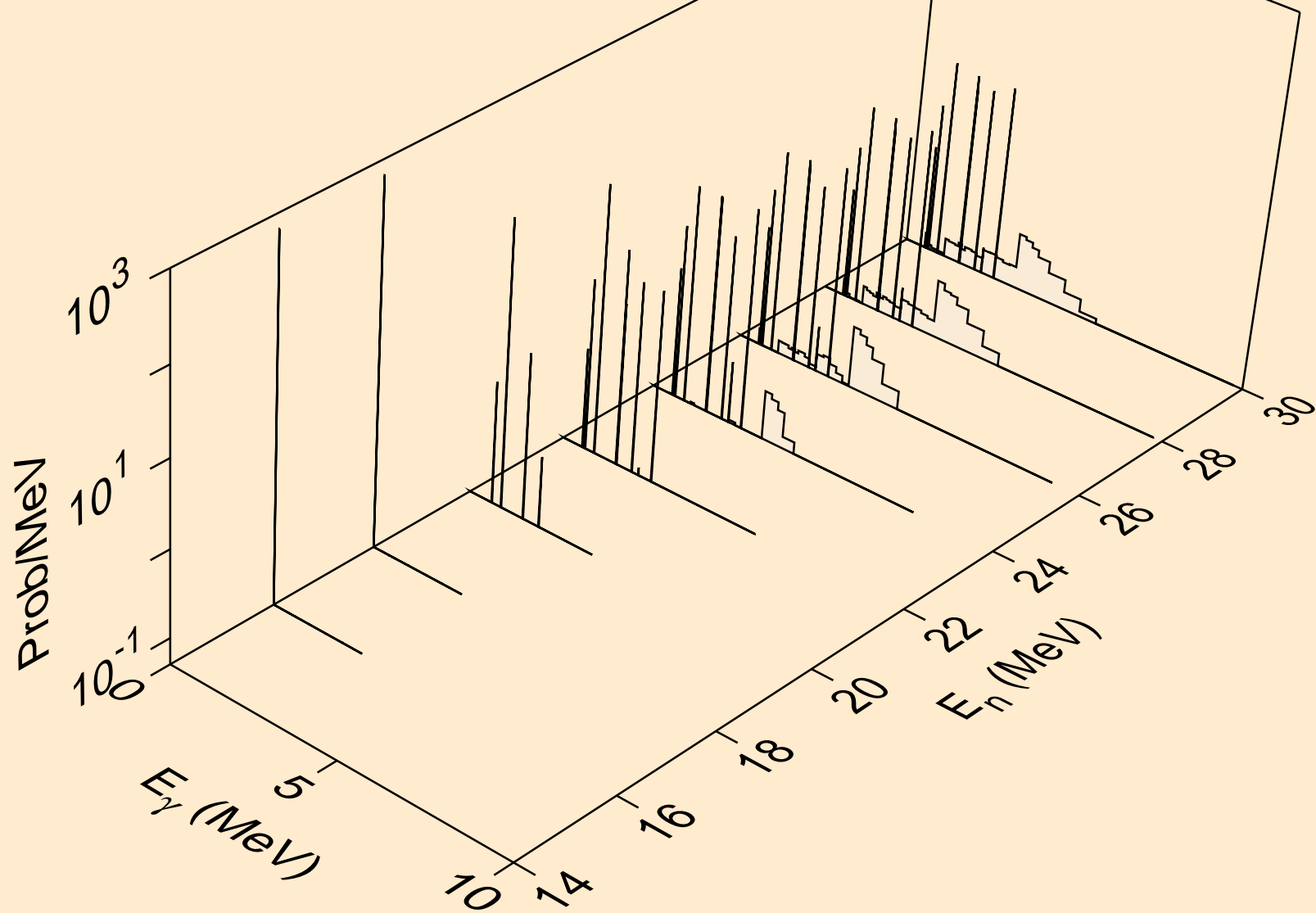

AL030 ALPHA ACER TENDL-2023 LIBRARY; T=0.K  
Photon emission for inelastic

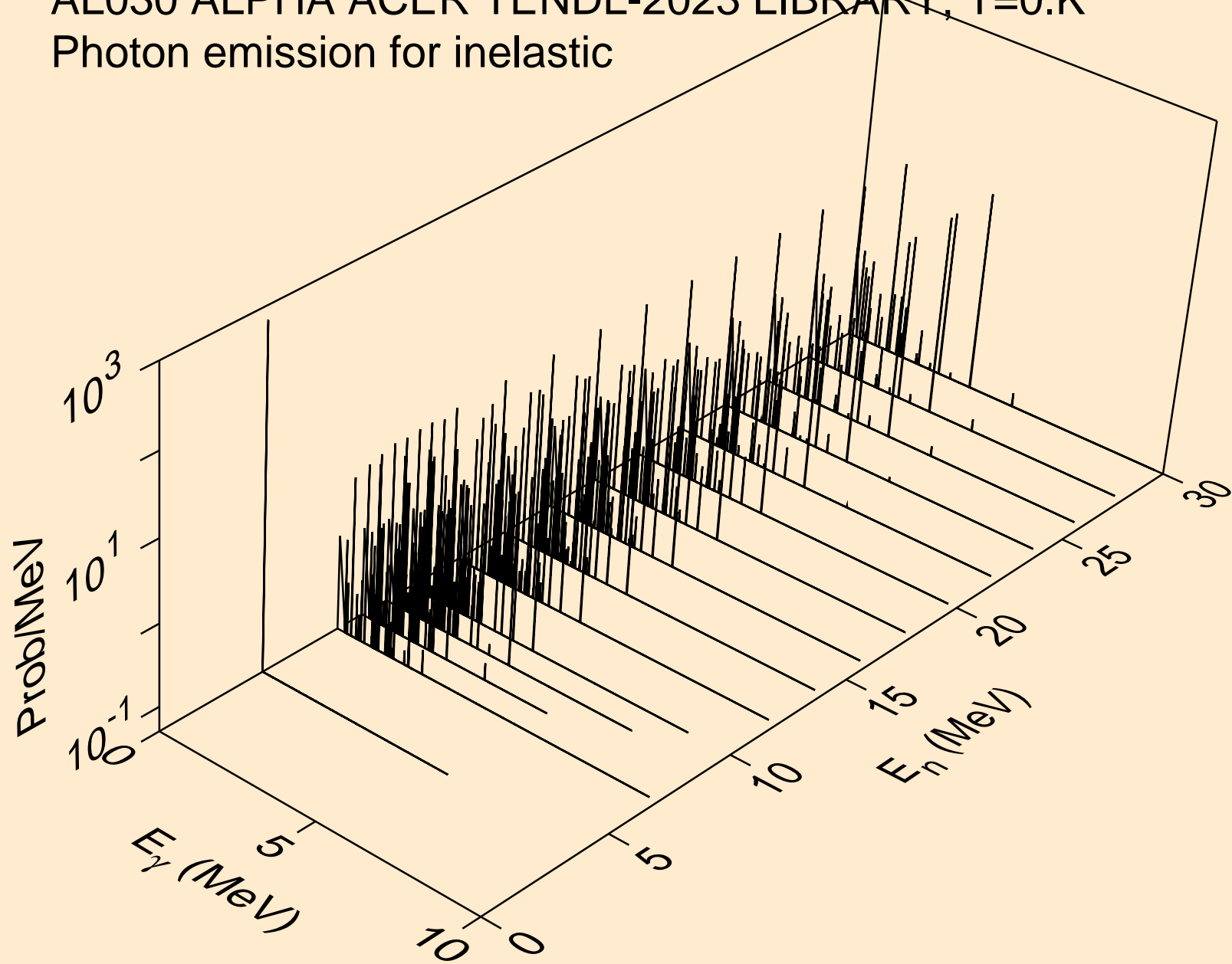

AL030 ALPHA ACER TENDL-2023 LIBRARY; T=0.K  
Photon emission for (n,2a)

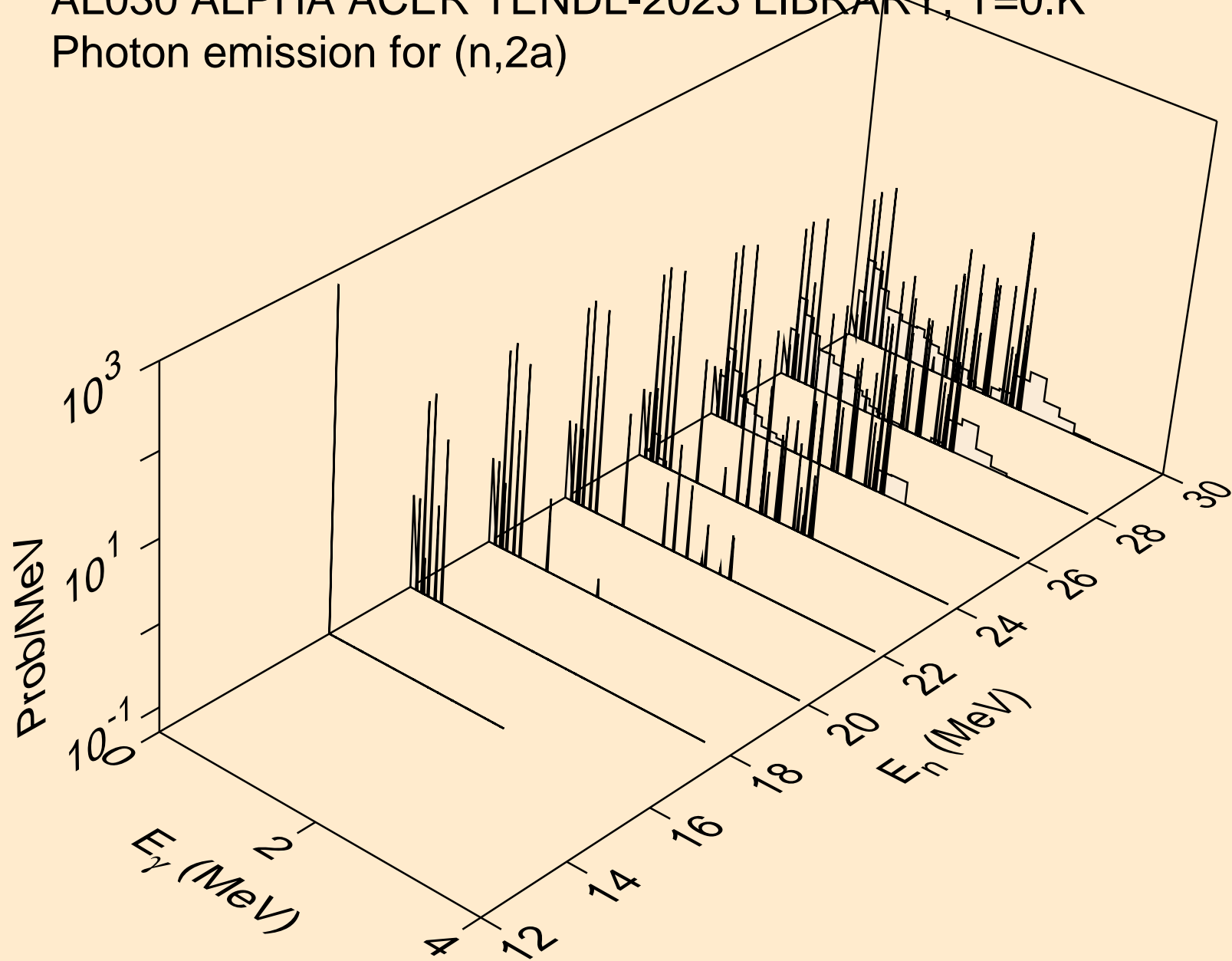

AL030 ALPHA ACER TENDL-2023 LIBRARY; T=0.K  
Photon emission for (n,2p)

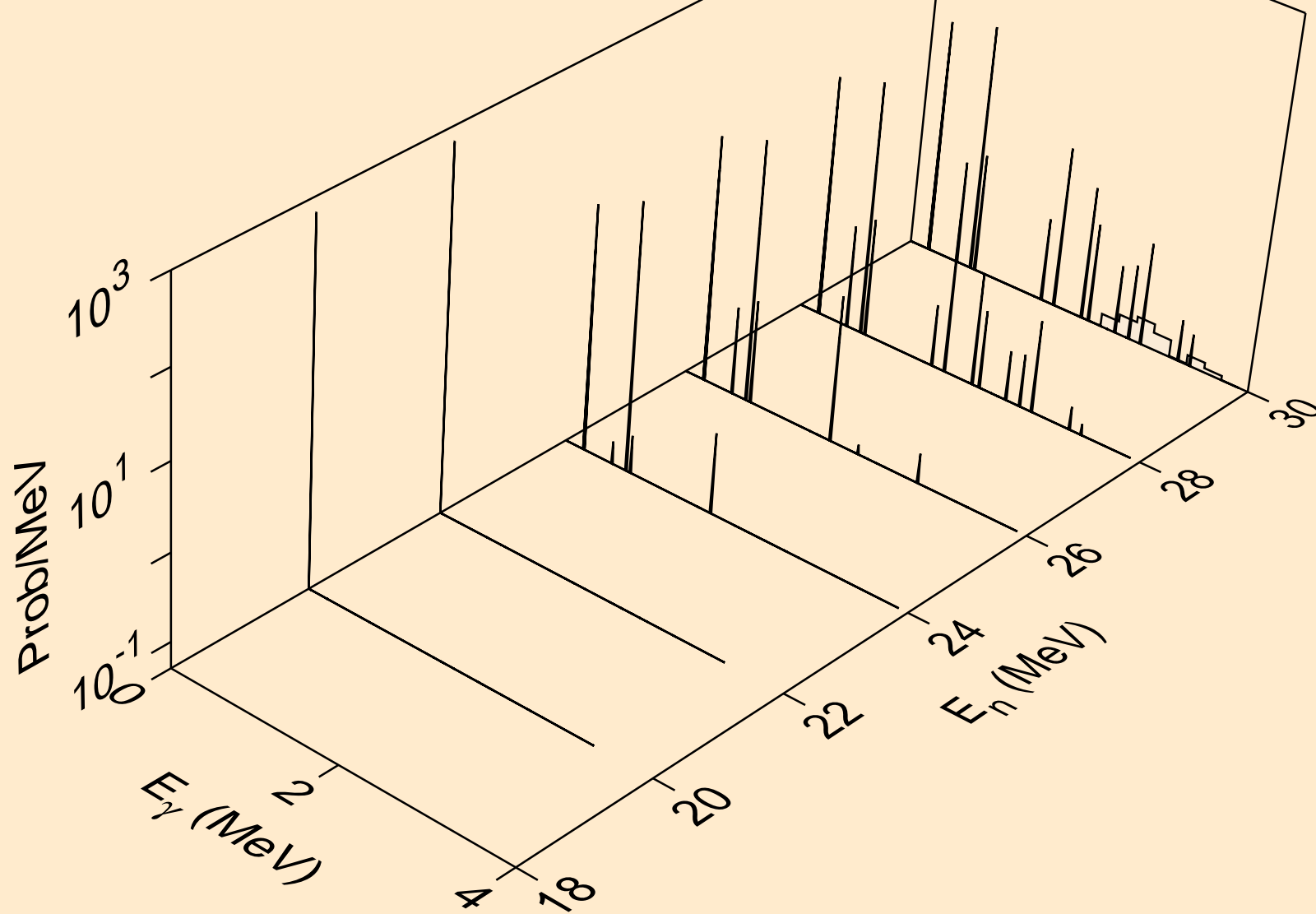



AL030 ALPHA ACER TENDL-2023 LIBRARY; T=0.K  
Photon emission for (n,pa)

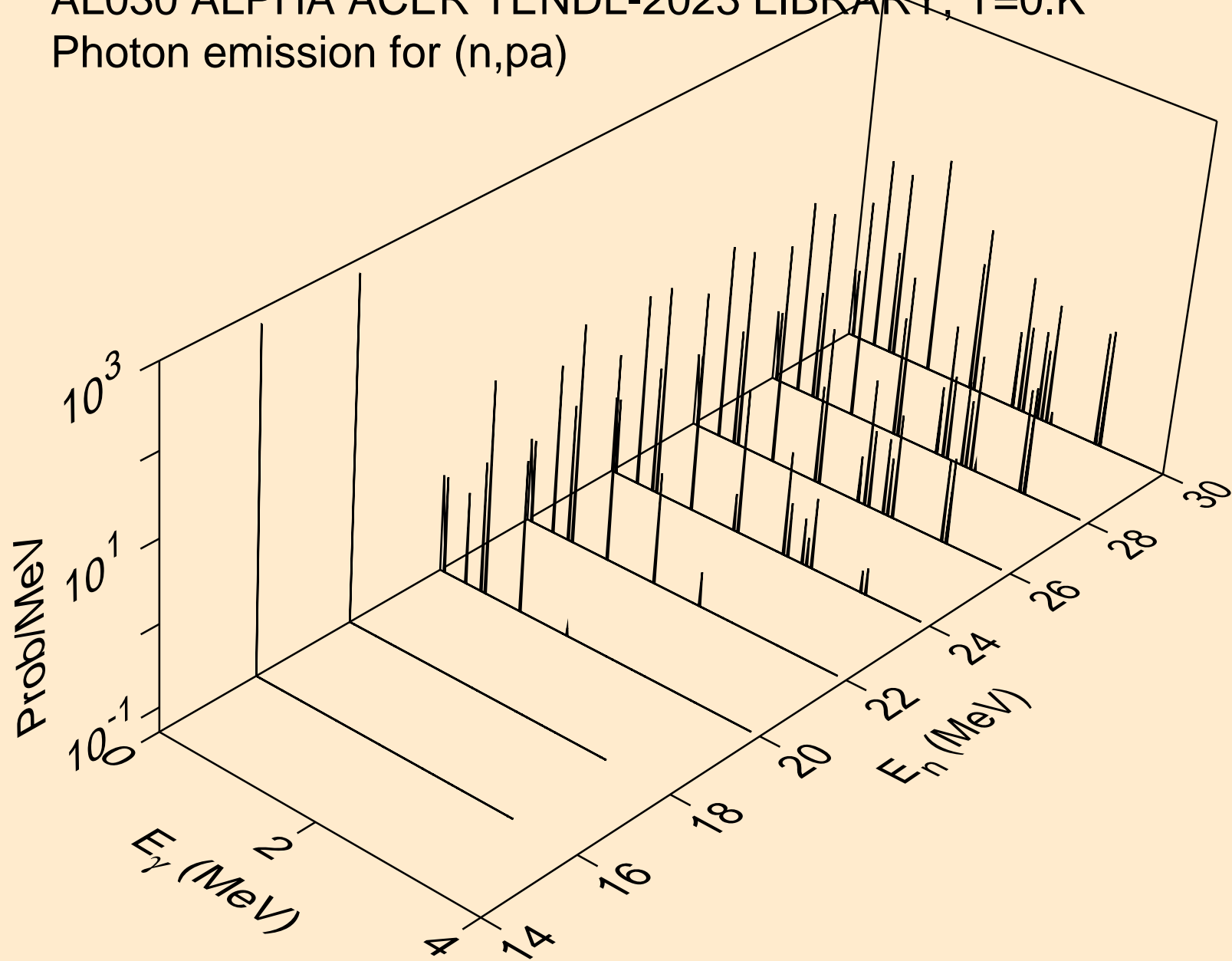

AL030 ALPHA ACER TENDL-2023 LIBRARY; T=0.K  
Photon emission for (n,pd)

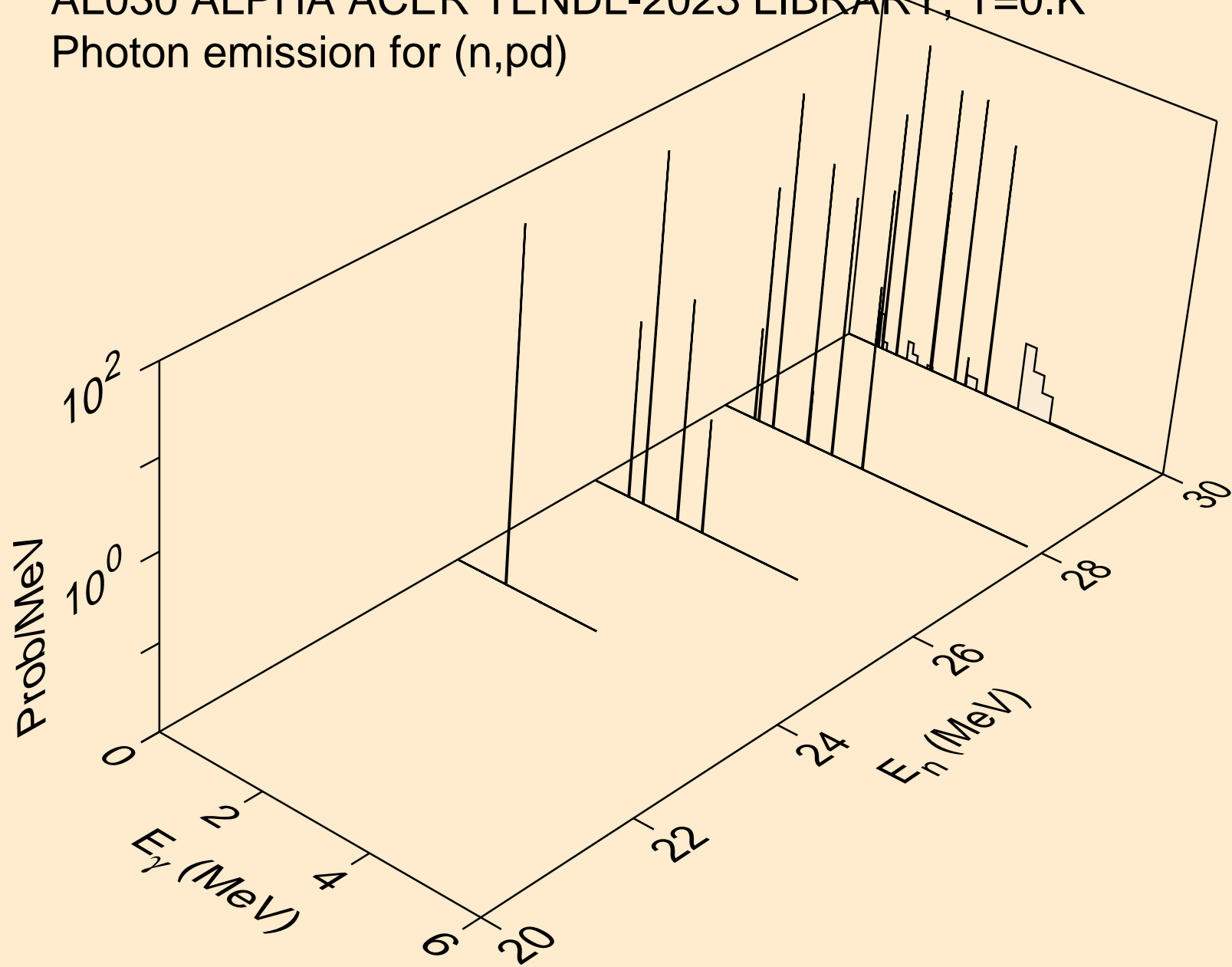

AL030 ALPHA ACER TENDL-2023 LIBRARY; T=0.K  
Photon emission for (n,pt)

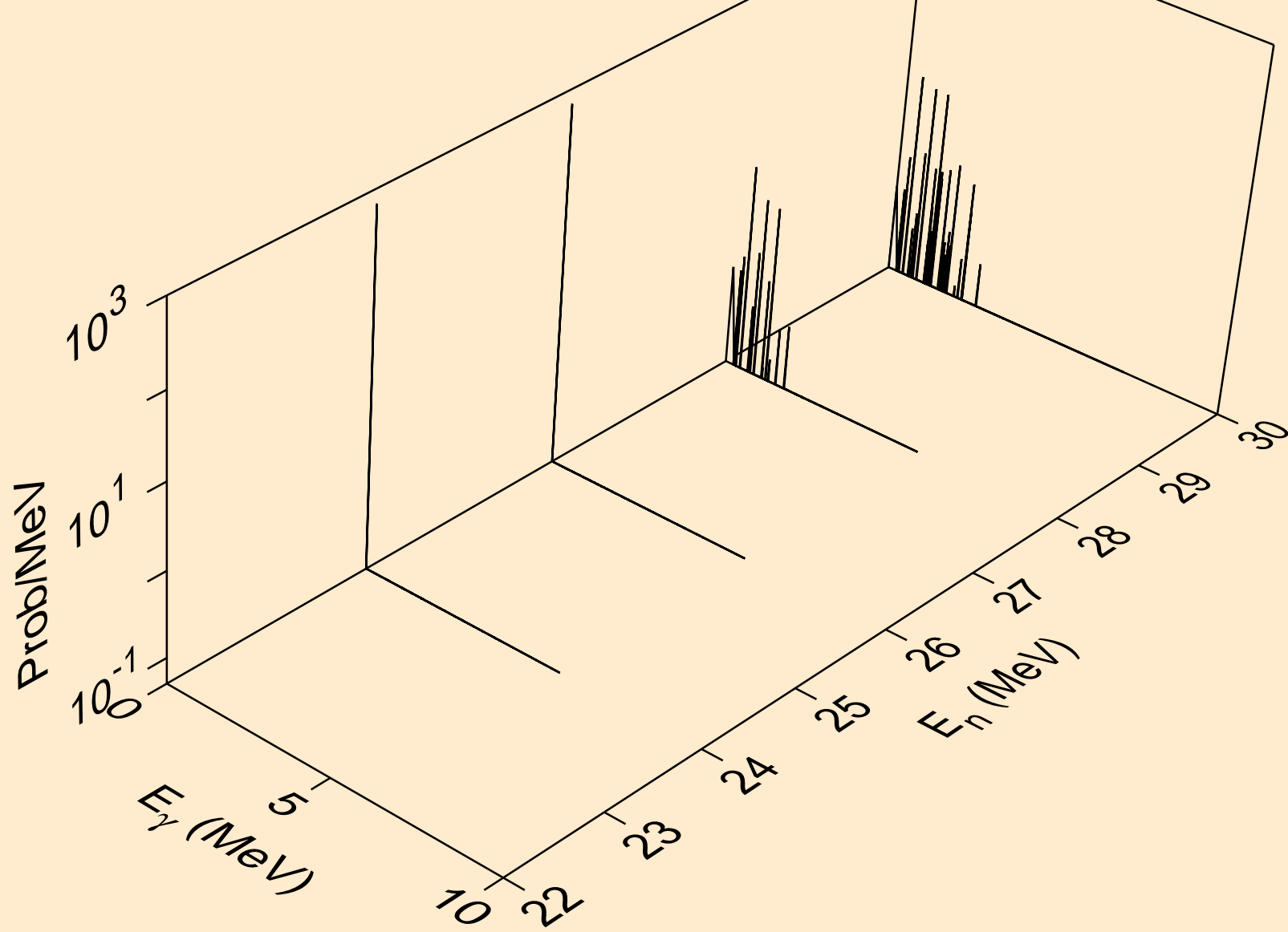

AL030 ALPHA ACER TENDL-2023 LIBRARY; T=0.K  
Photon emission for (n,da)

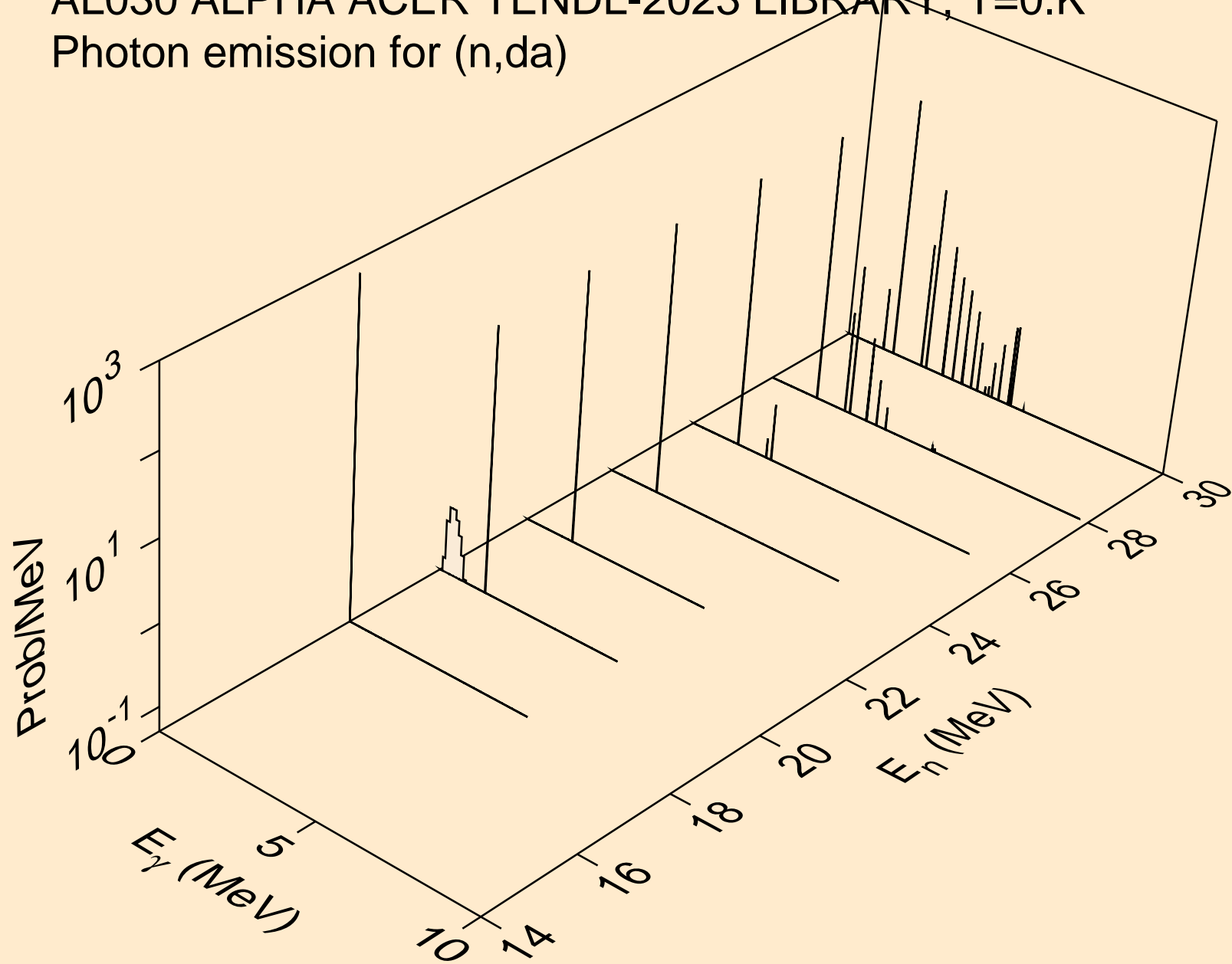

AL030 ALPHA ACER TENDL-2023 LIBRARY; T=0.K  
Particle heating contributions

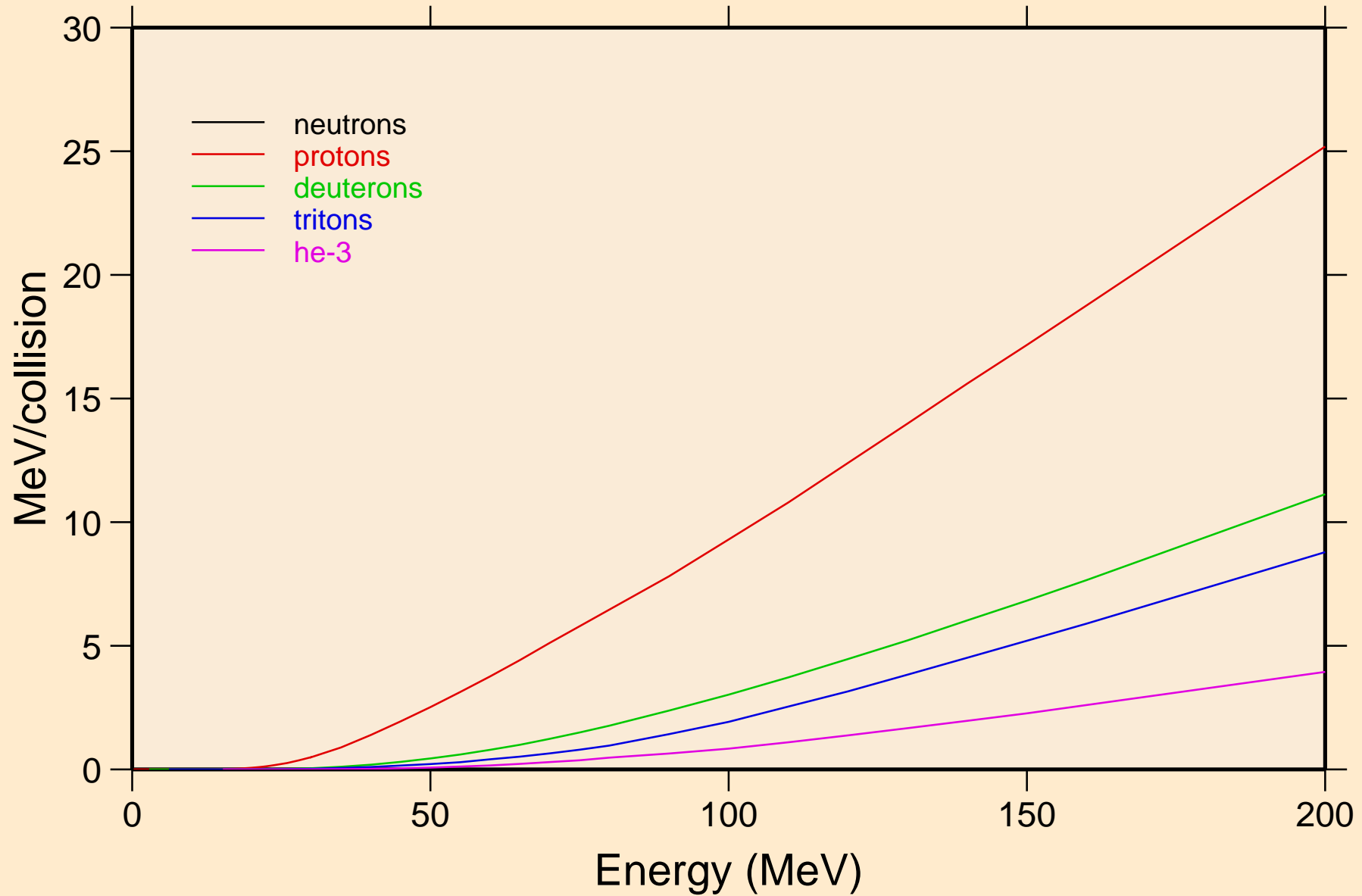

AL030 ALPHA ACER TENDL-2023 LIBRARY; T=0.K  
Recoil Heating

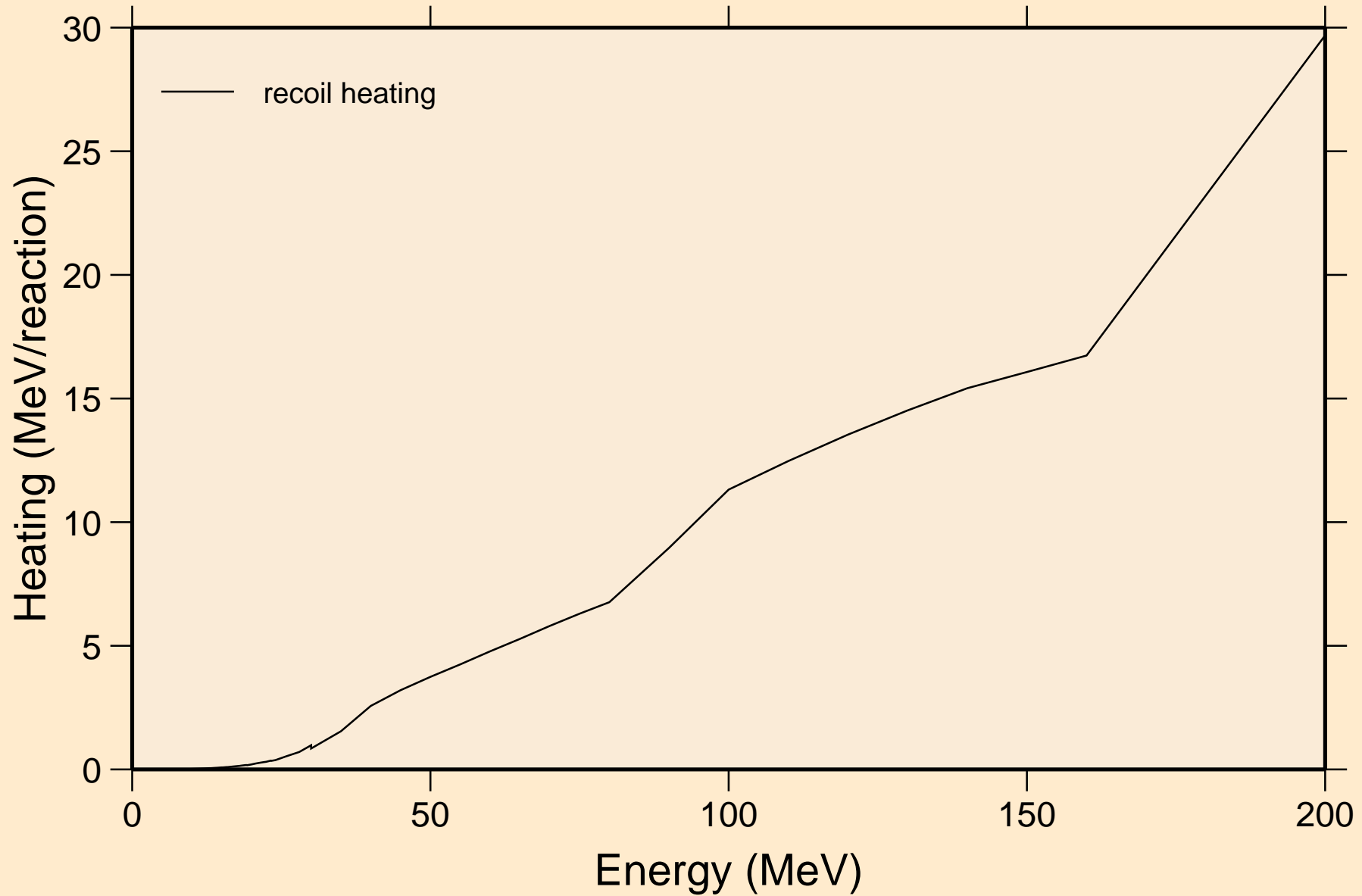

AL030 ALPHA ACER TENDL-2023 LIBRARY; T=0.K  
Particle production cross sections

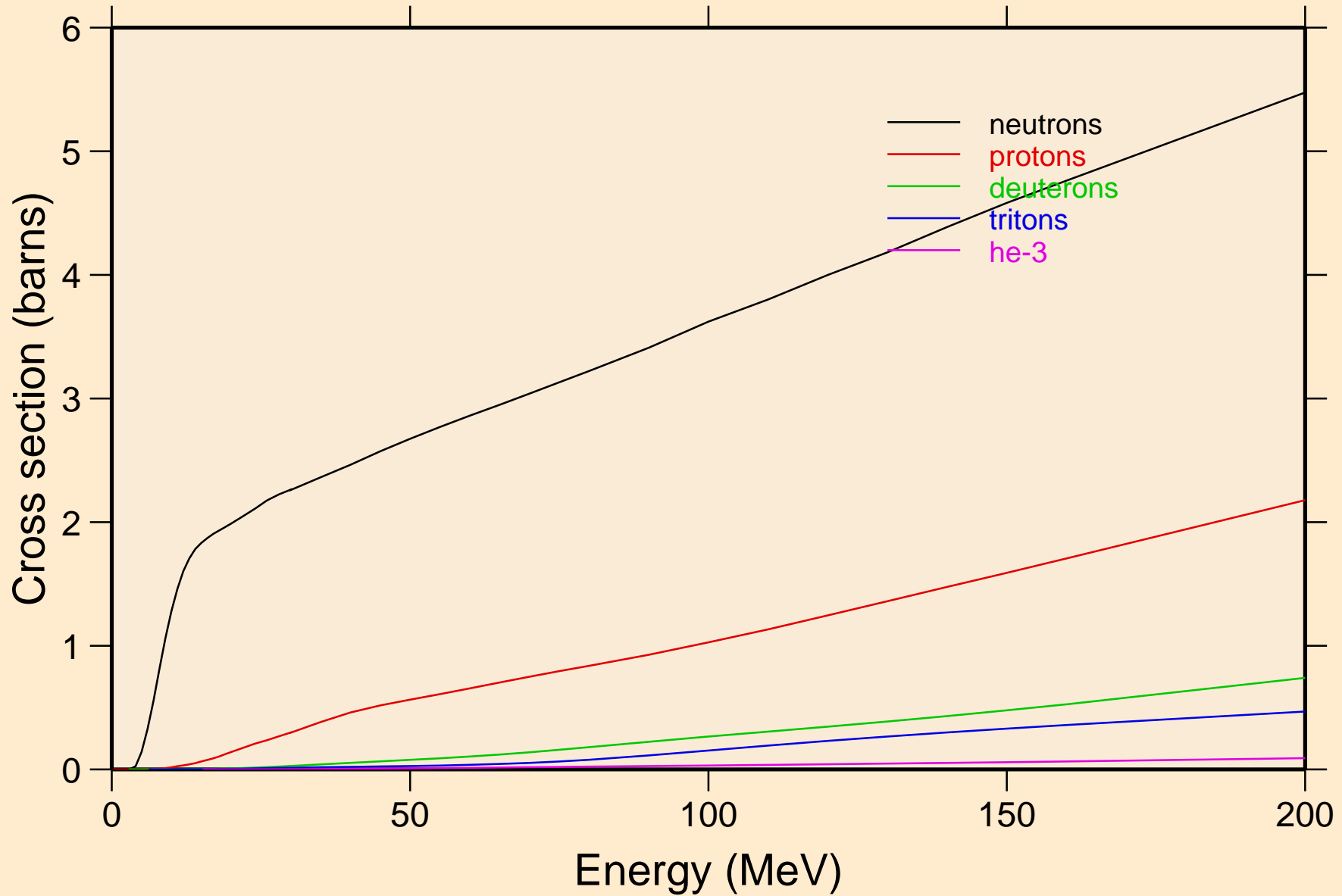

AL030 ALPHA ACER TENDL-2023 LIBRARY; T=0.K  
neutrons from (a,n)

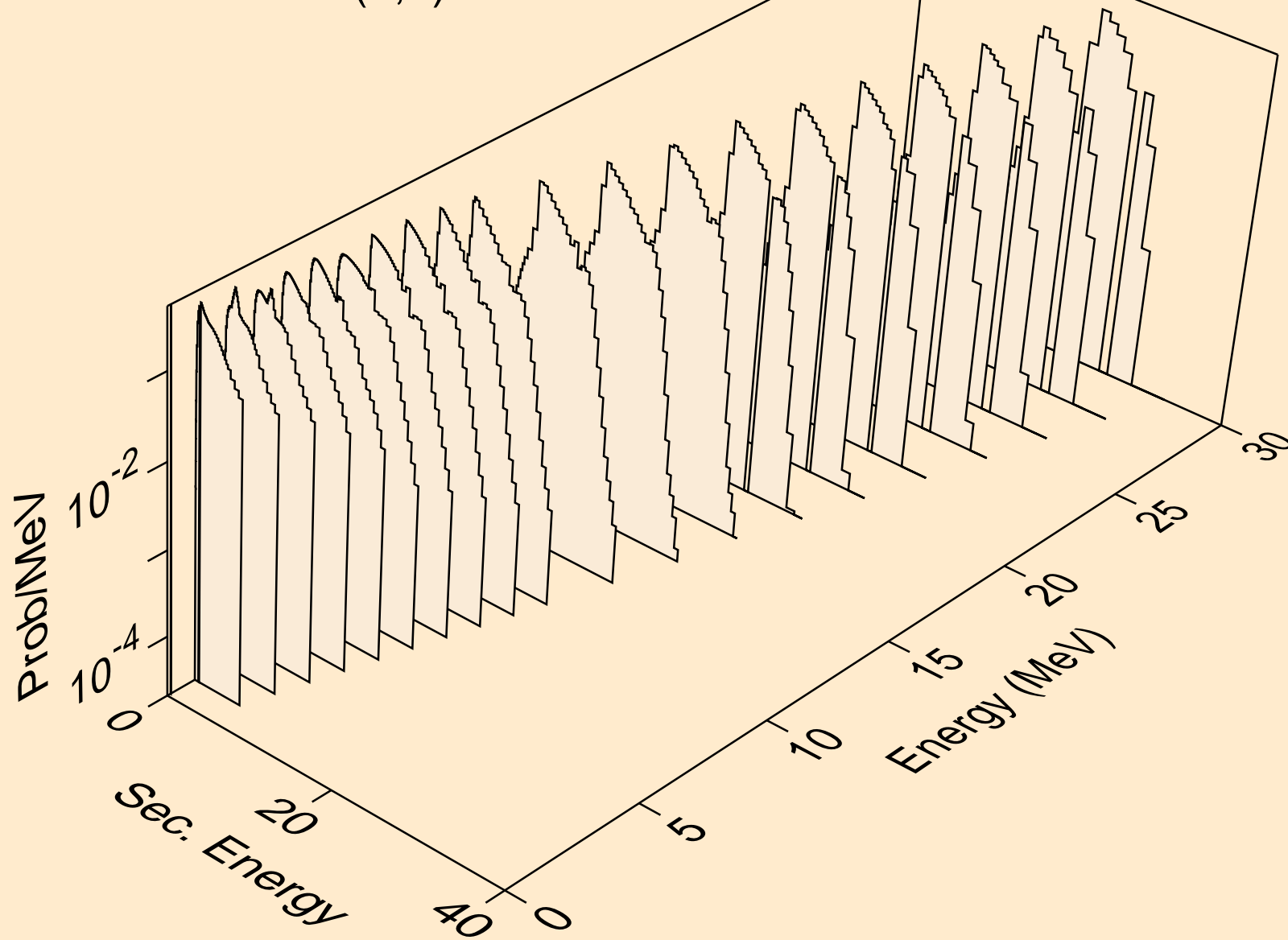



AL030 ALPHA ACER TENDL-2023 LIBRARY; T=0.K  
neutrons from (a,x)

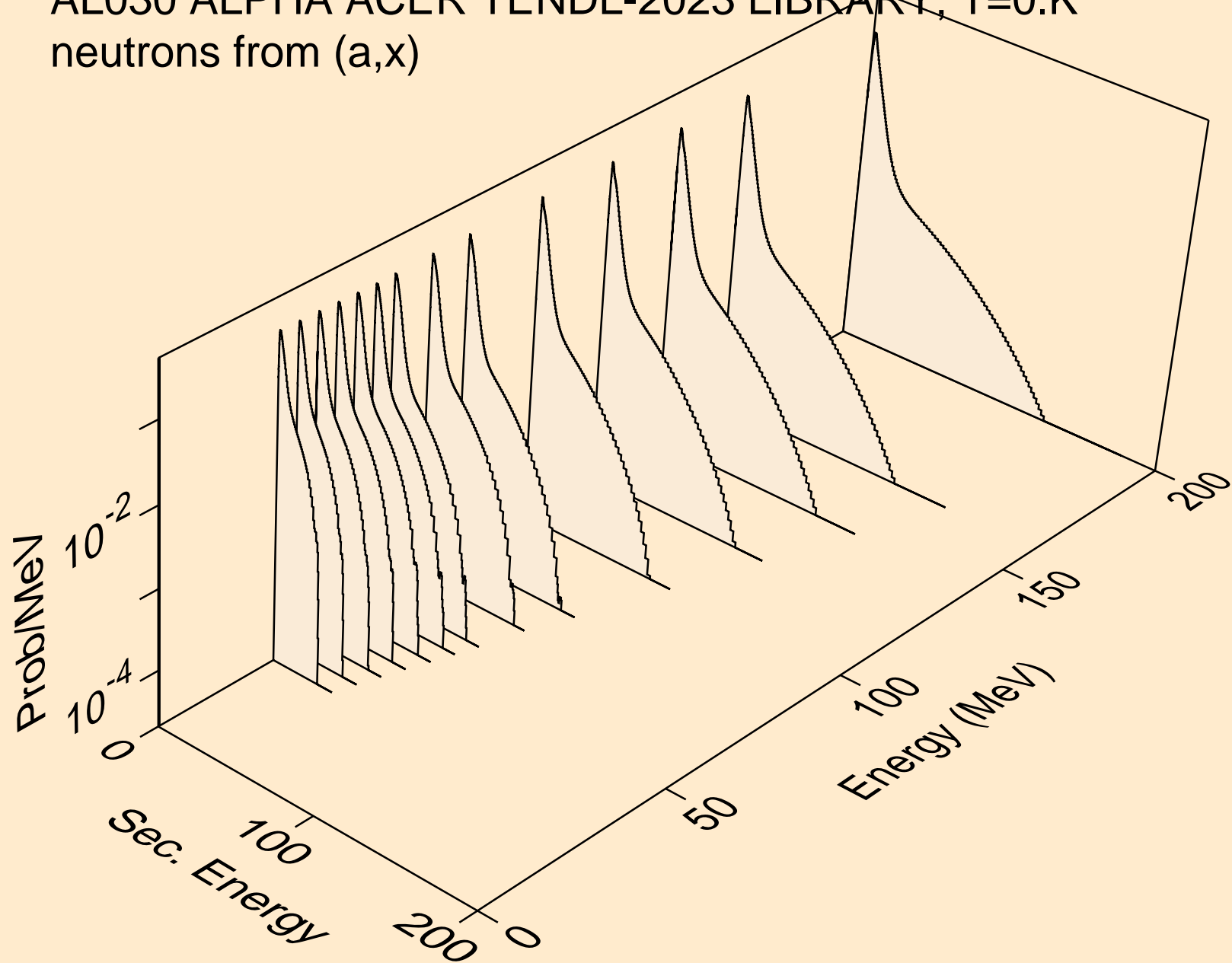

AL030 ALPHA ACER TENDL-2023 LIBRARY; T=0.K  
neutrons from (a,2nd)

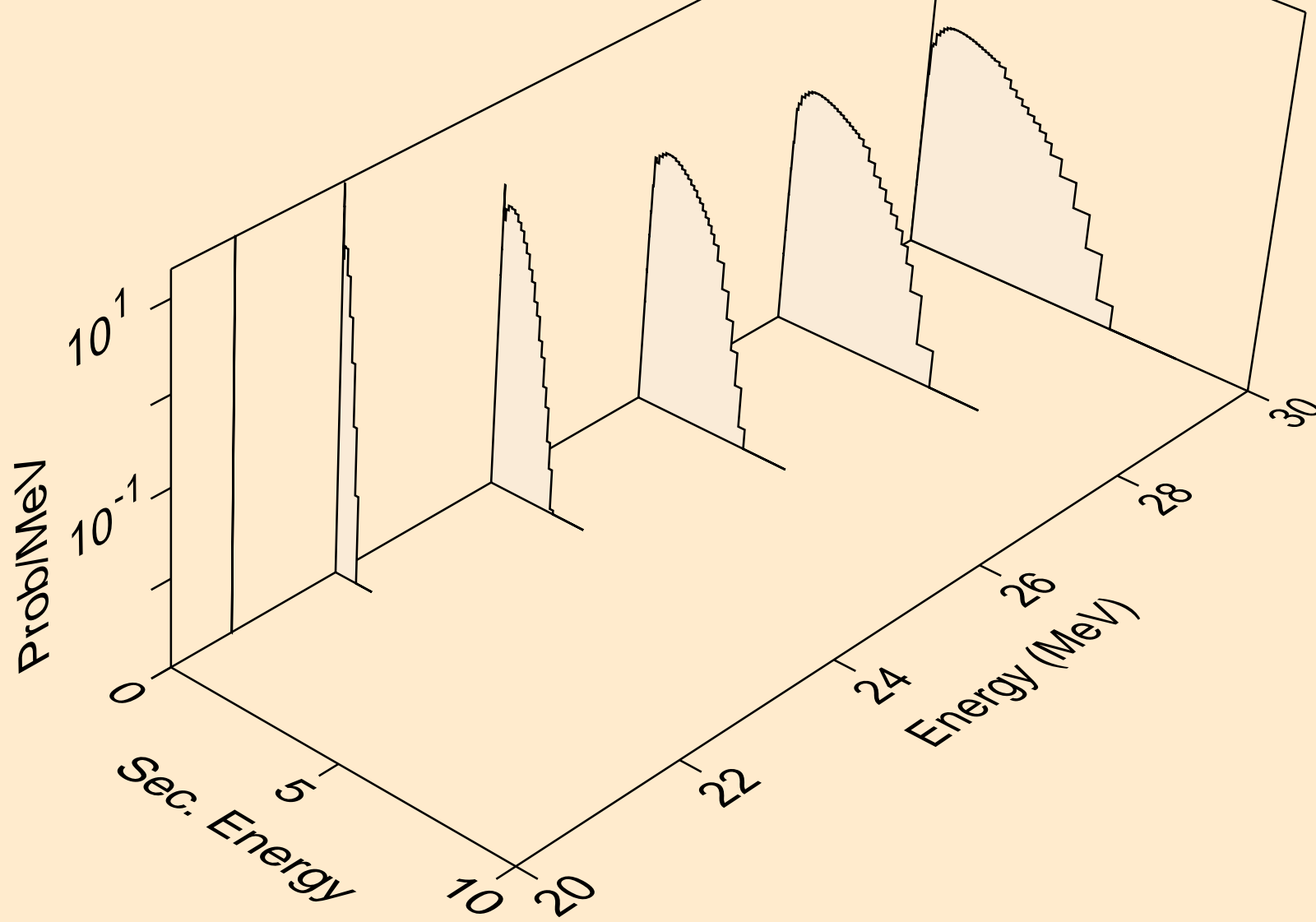

AL030 ALPHA ACER TENDL-2023 LIBRARY; T=0.K  
neutrons from (a,2n)

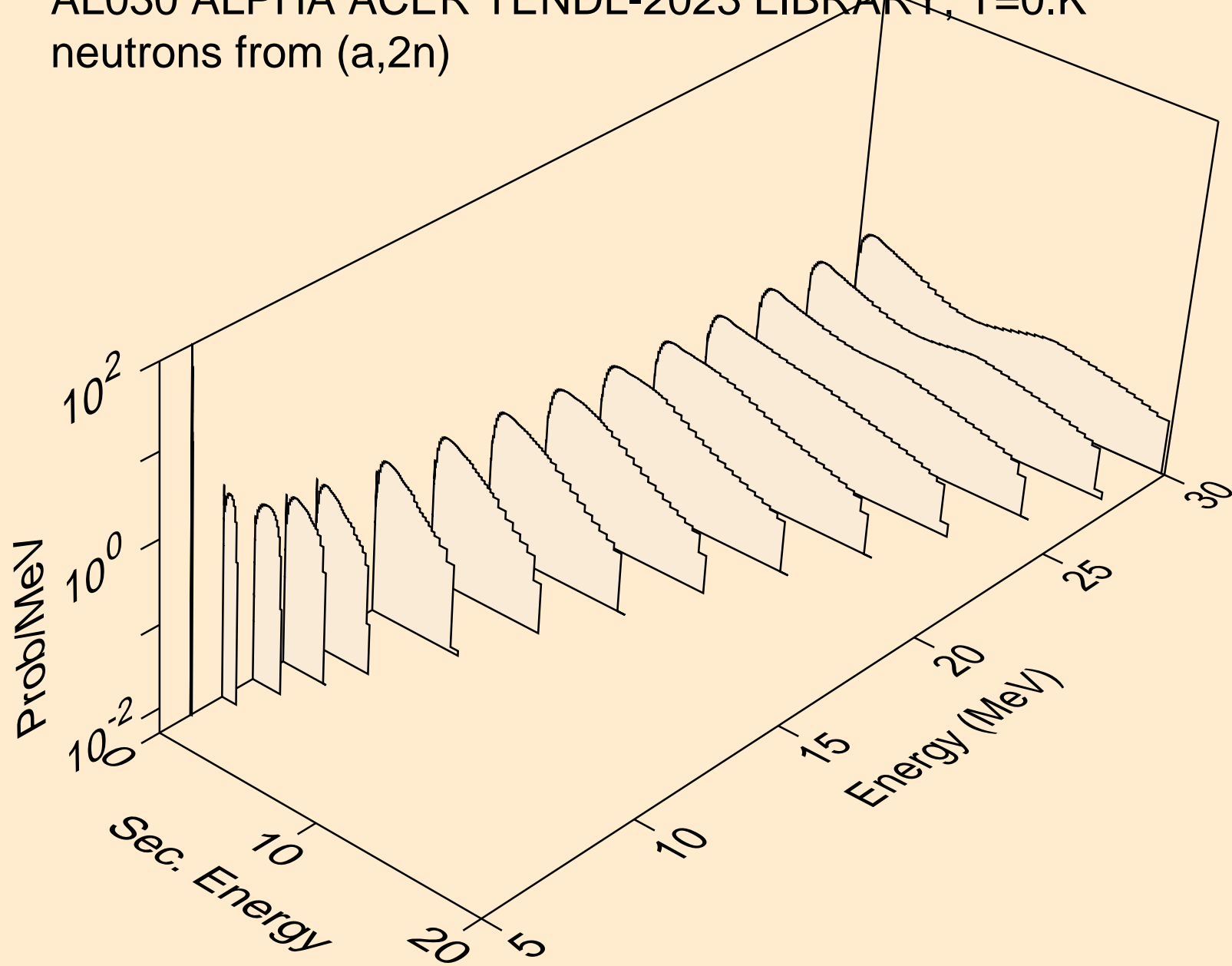

AL030 ALPHA ACER TENDL-2023 LIBRARY; T=0.K  
neutrons from (a,3n)

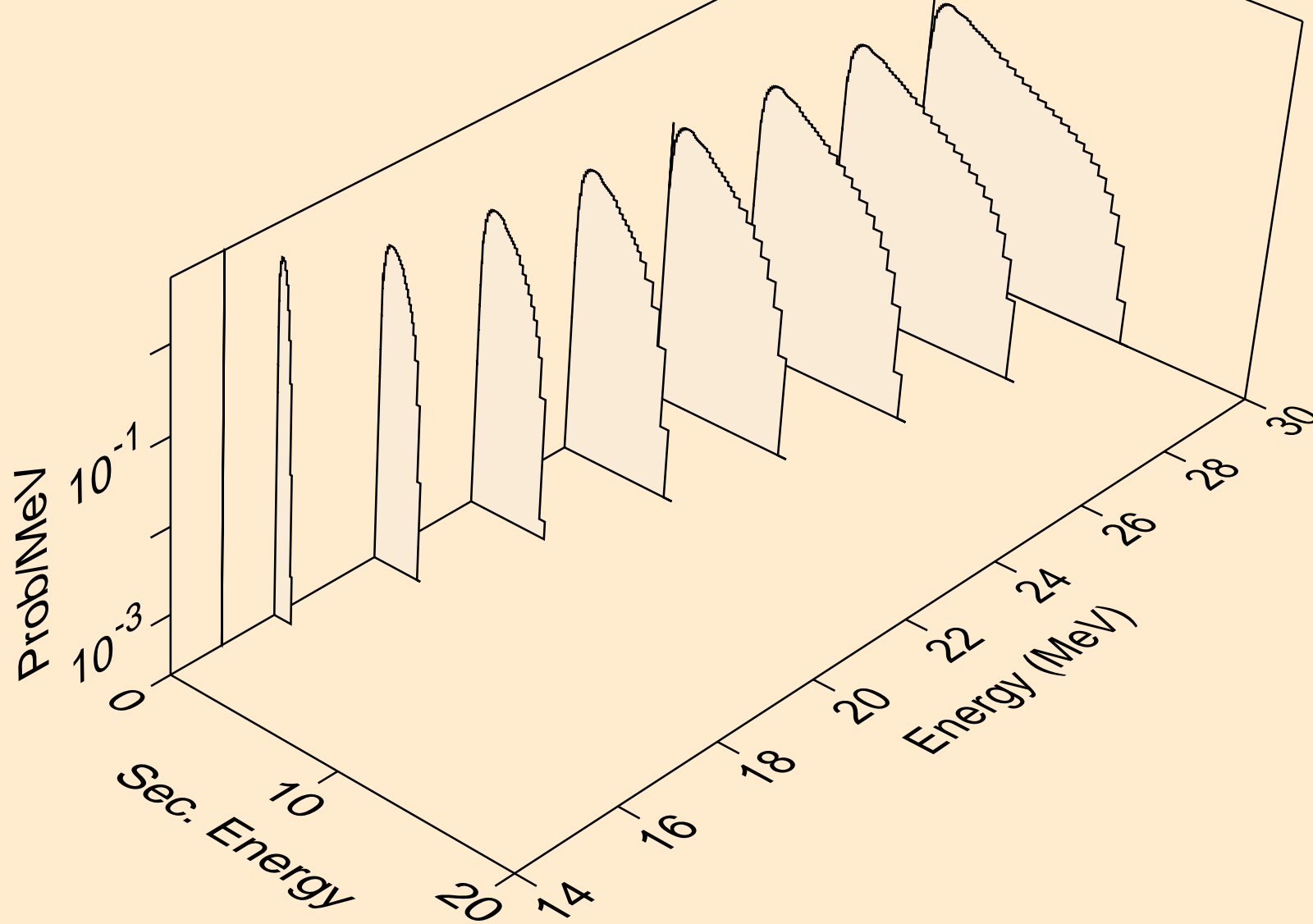

AL030 ALPHA ACER TENDL-2023 LIBRARY; T=0.K  
neutrons from (a,n\*)a

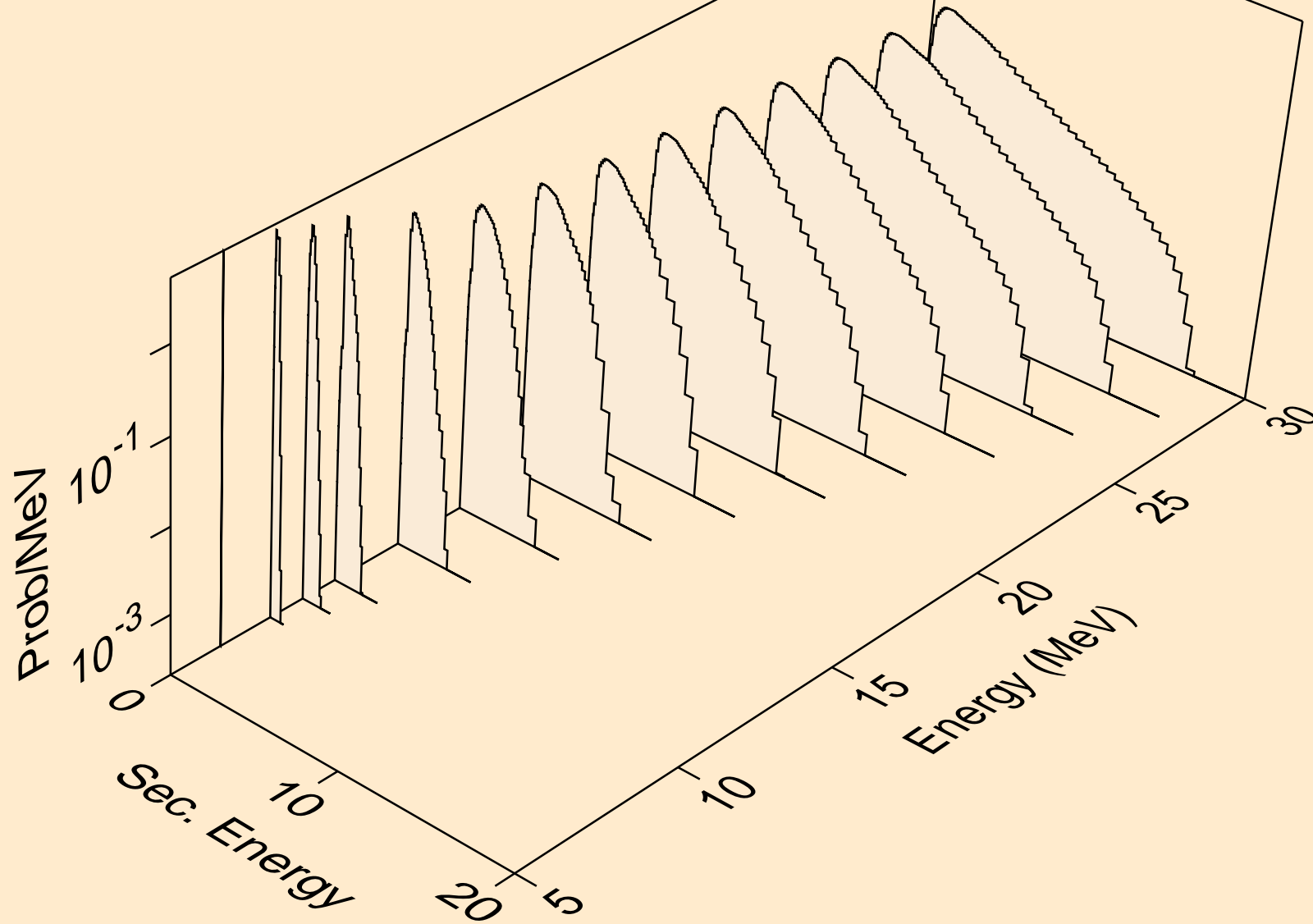

AL030 ALPHA ACER TENDL-2023 LIBRARY; T=0.K  
neutrons from (a,2n)a

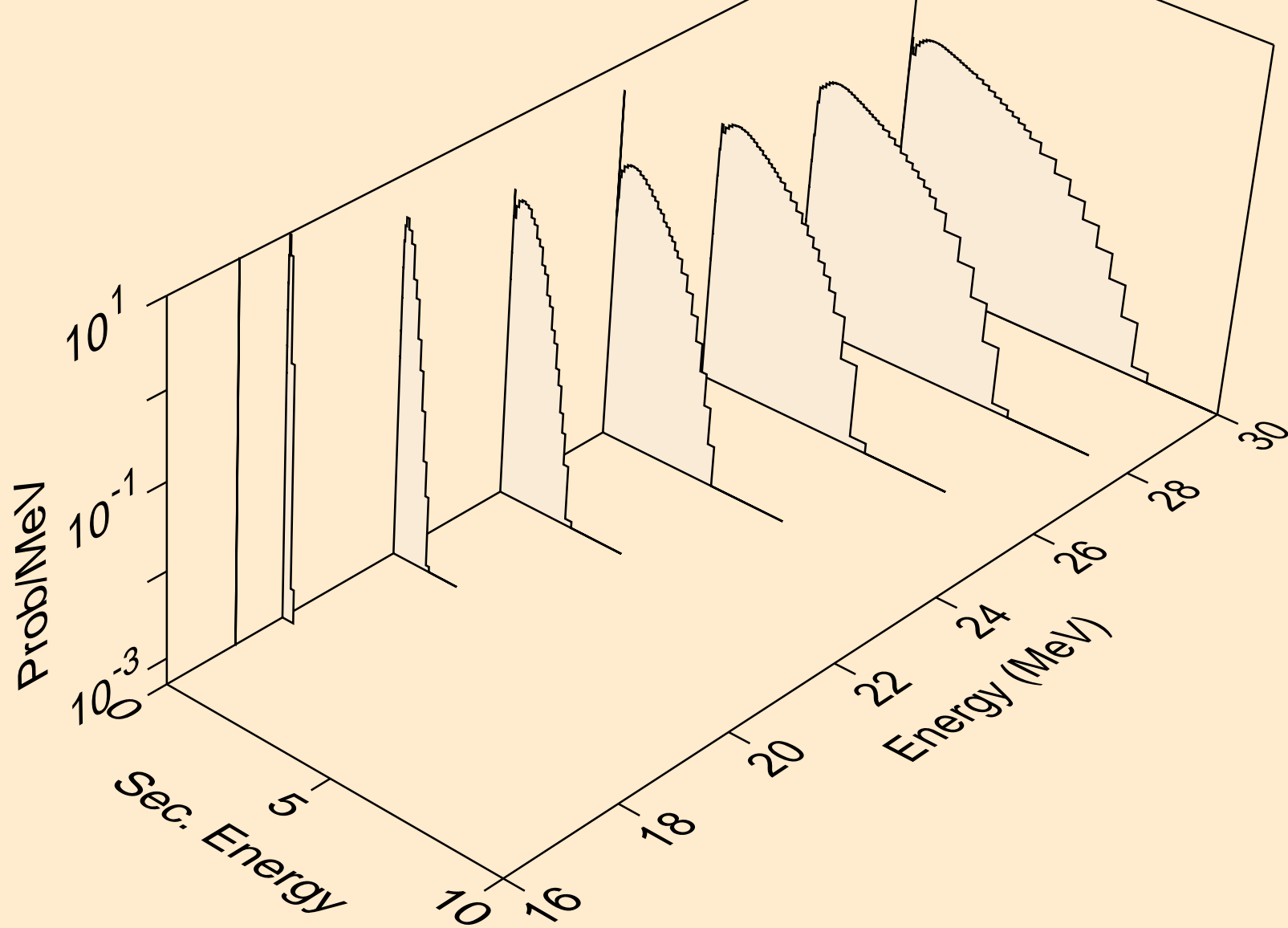

AL030 ALPHA ACER TENDL-2023 LIBRARY; T=0.K  
neutrons from (a,3n)a

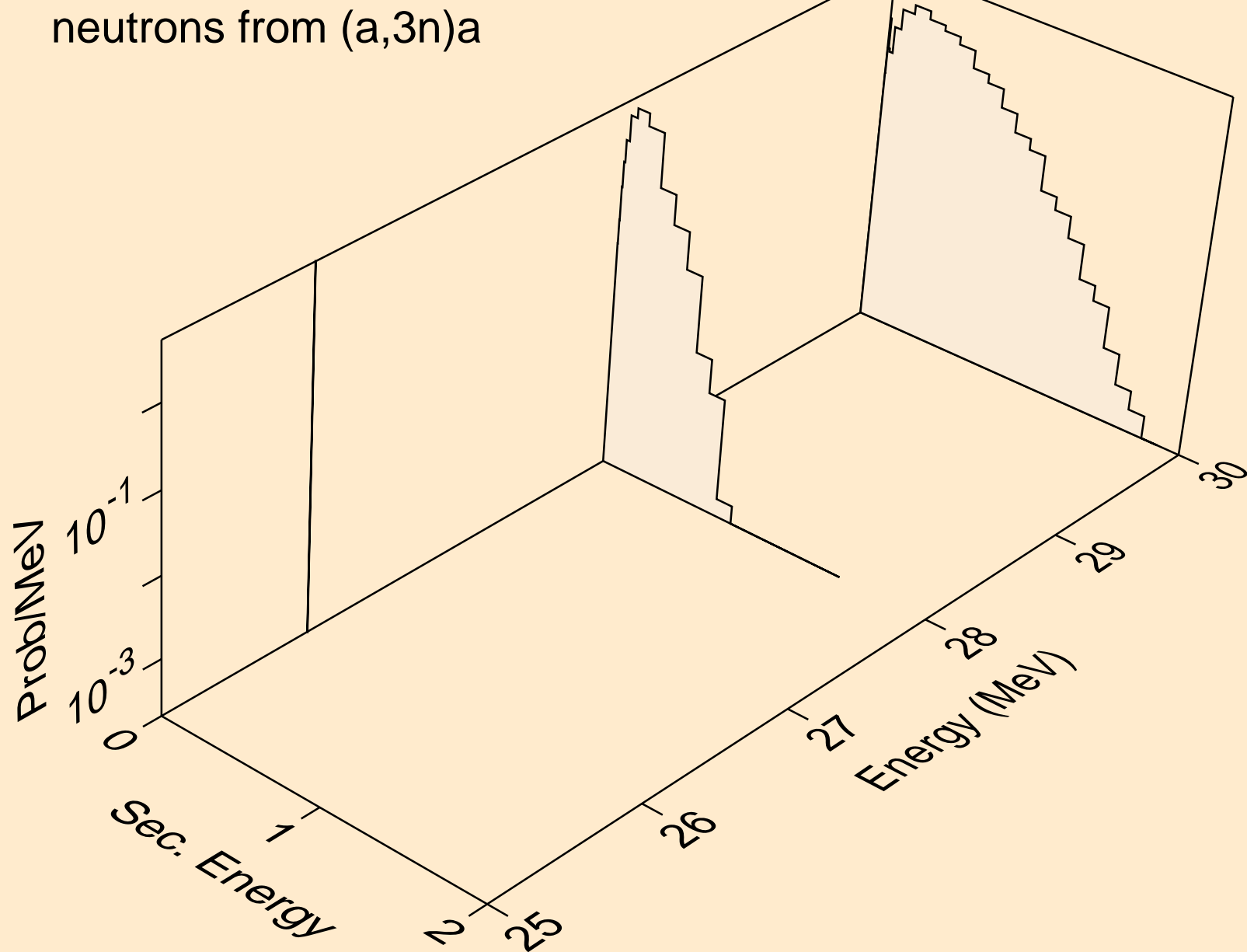

AL030 ALPHA ACER TENDL-2023 LIBRARY; T=0.K  
neutrons from (a,n\*)p

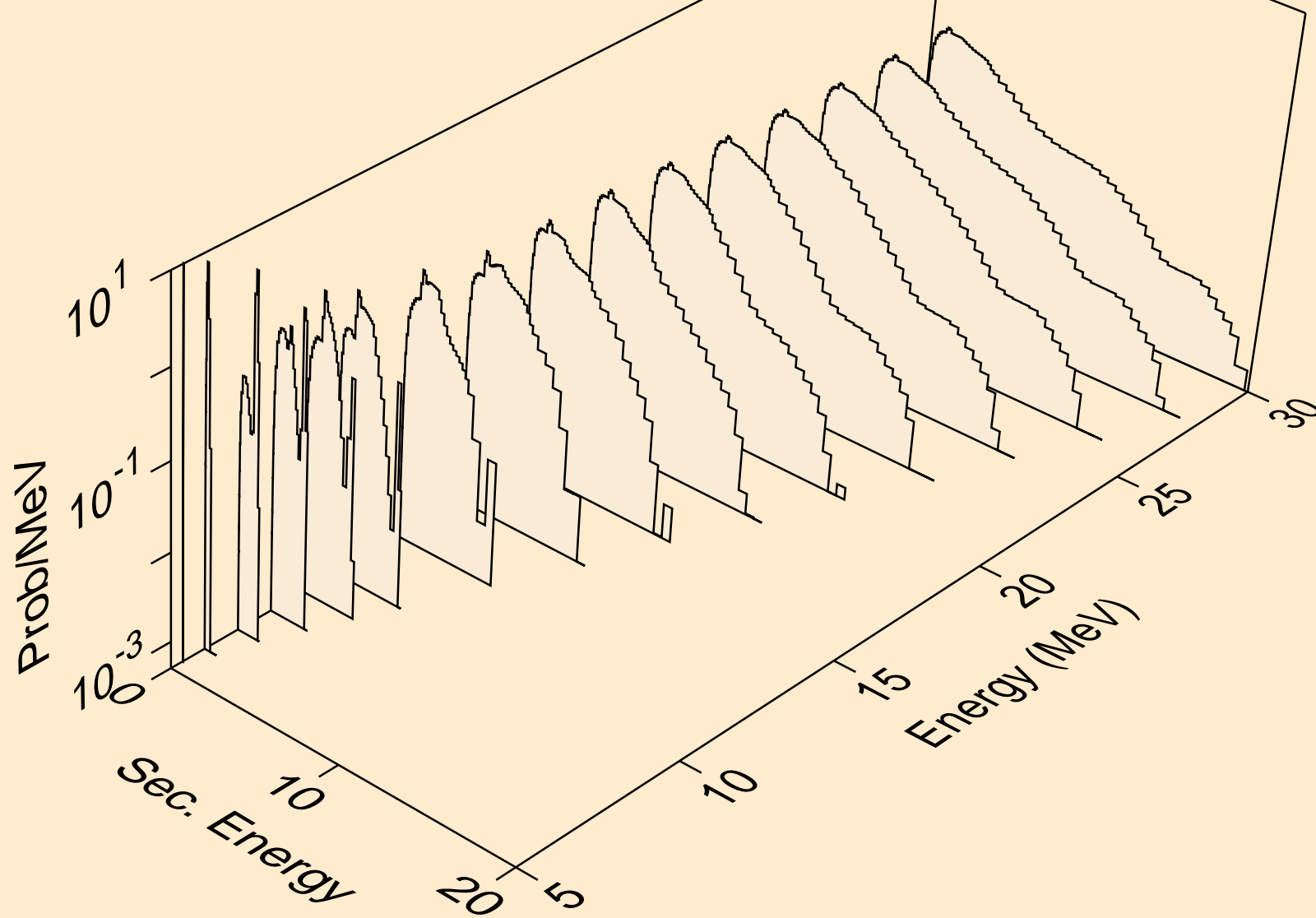



AL030 ALPHA ACER TENDL-2023 LIBRARY; T=0.K  
neutrons from (a,n\*)2a

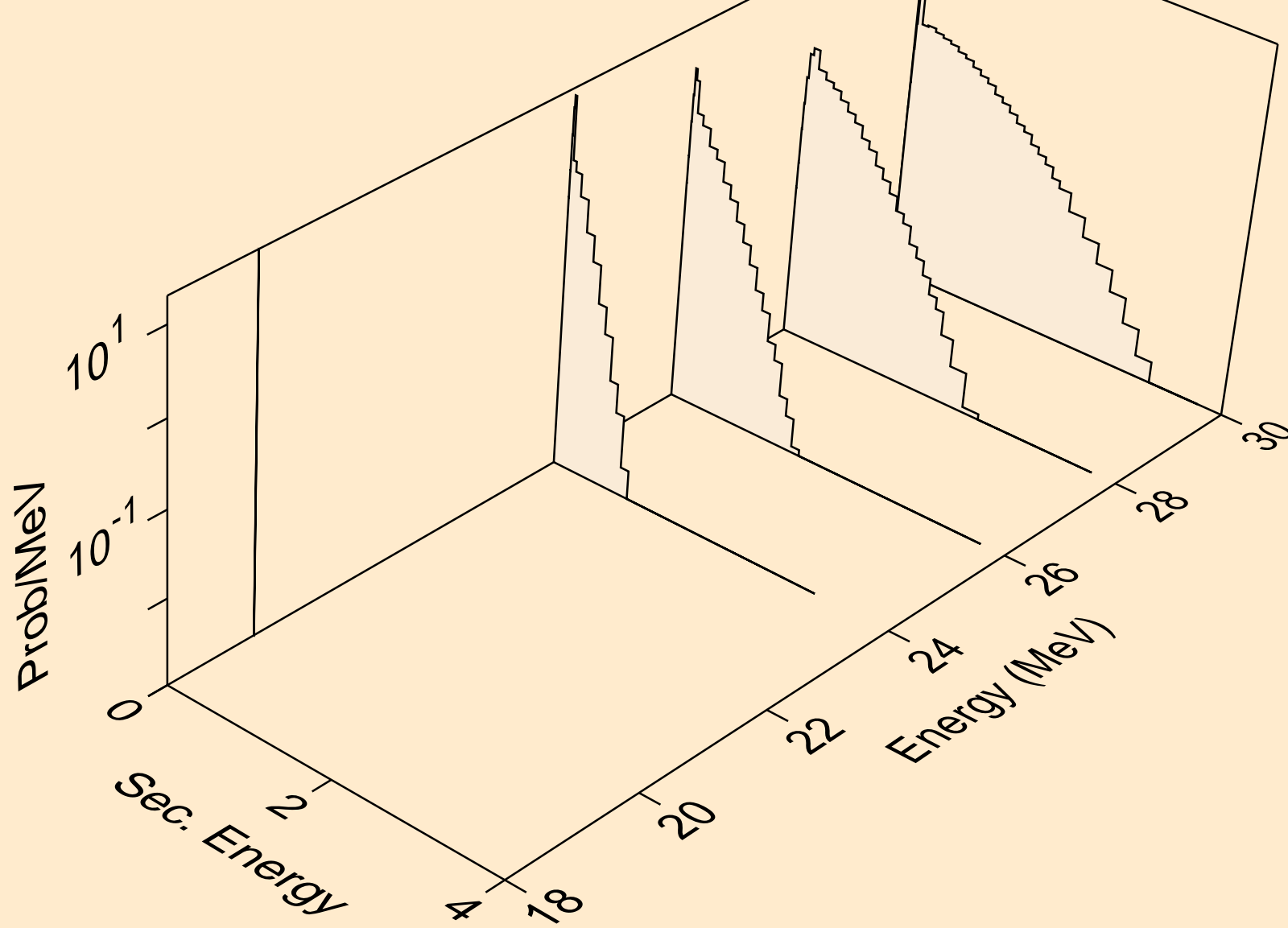

AL030 ALPHA ACER TENDL-2023 LIBRARY; T=0.K  
neutrons from (a,n\*)d

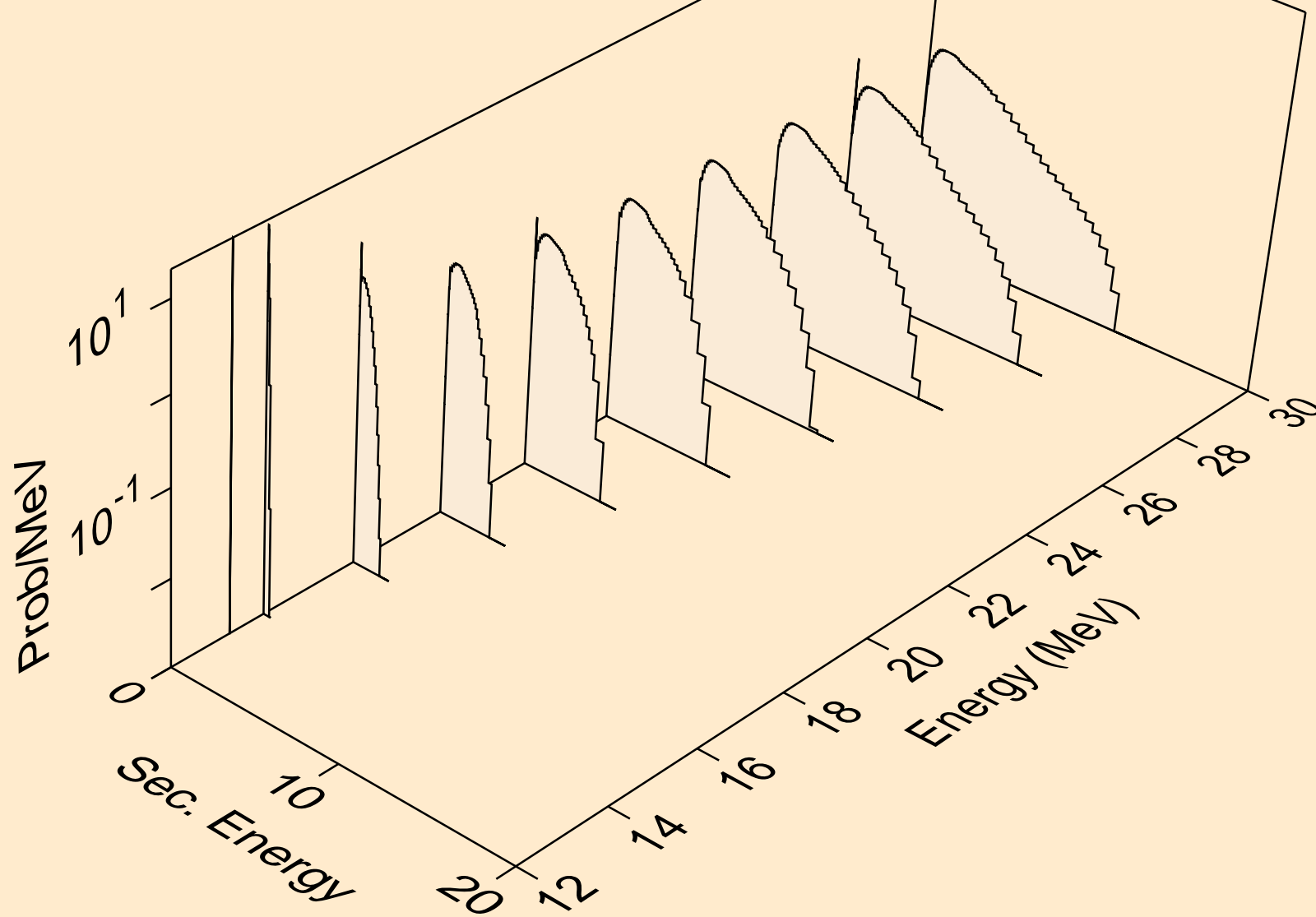

AL030 ALPHA ACER TENDL-2023 LIBRARY; T=0.K  
neutrons from (a,n\*)t

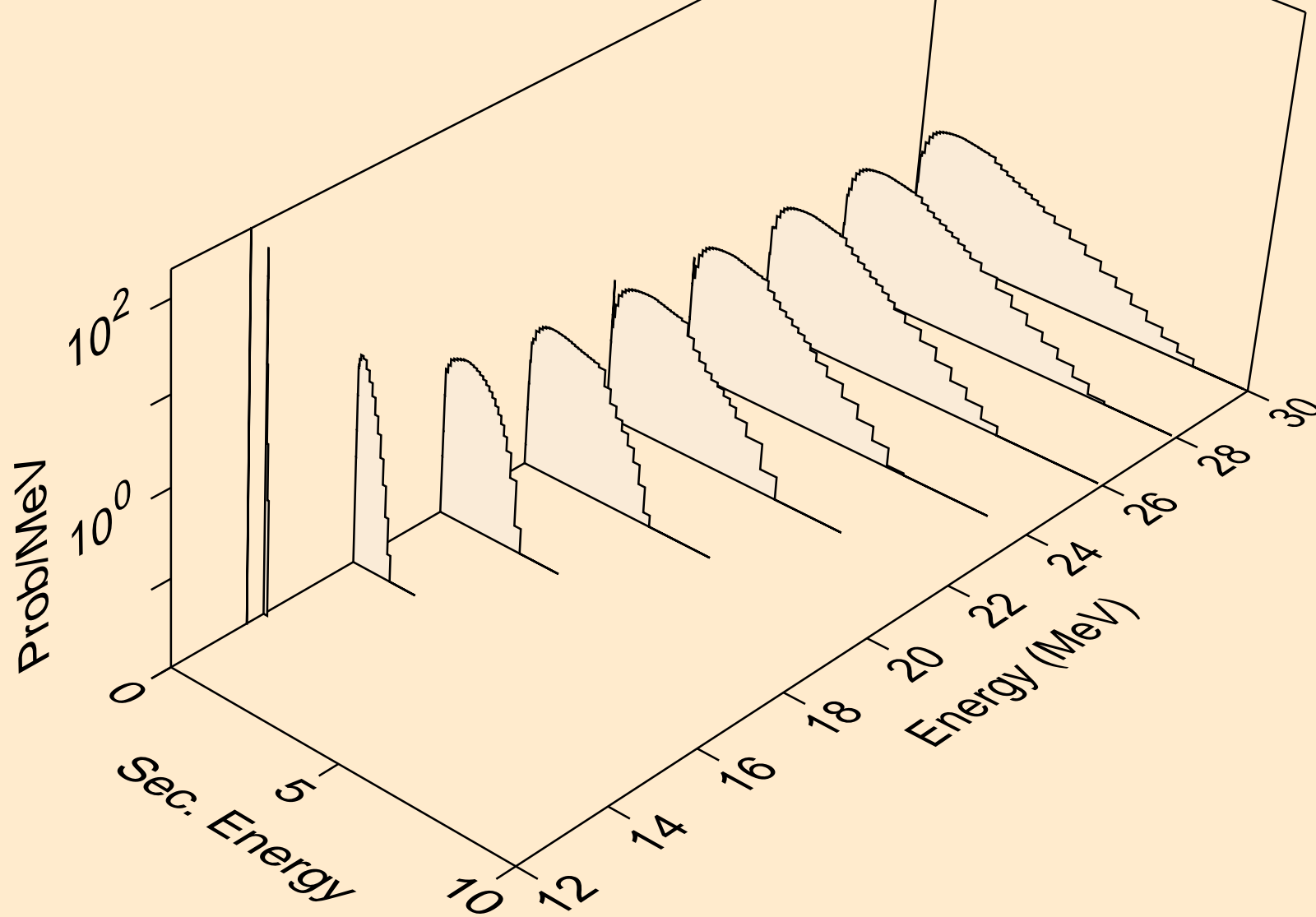

AL030 ALPHA ACER TENDL-2023 LIBRARY; T=0.K  
neutrons from (a,n\*)he3

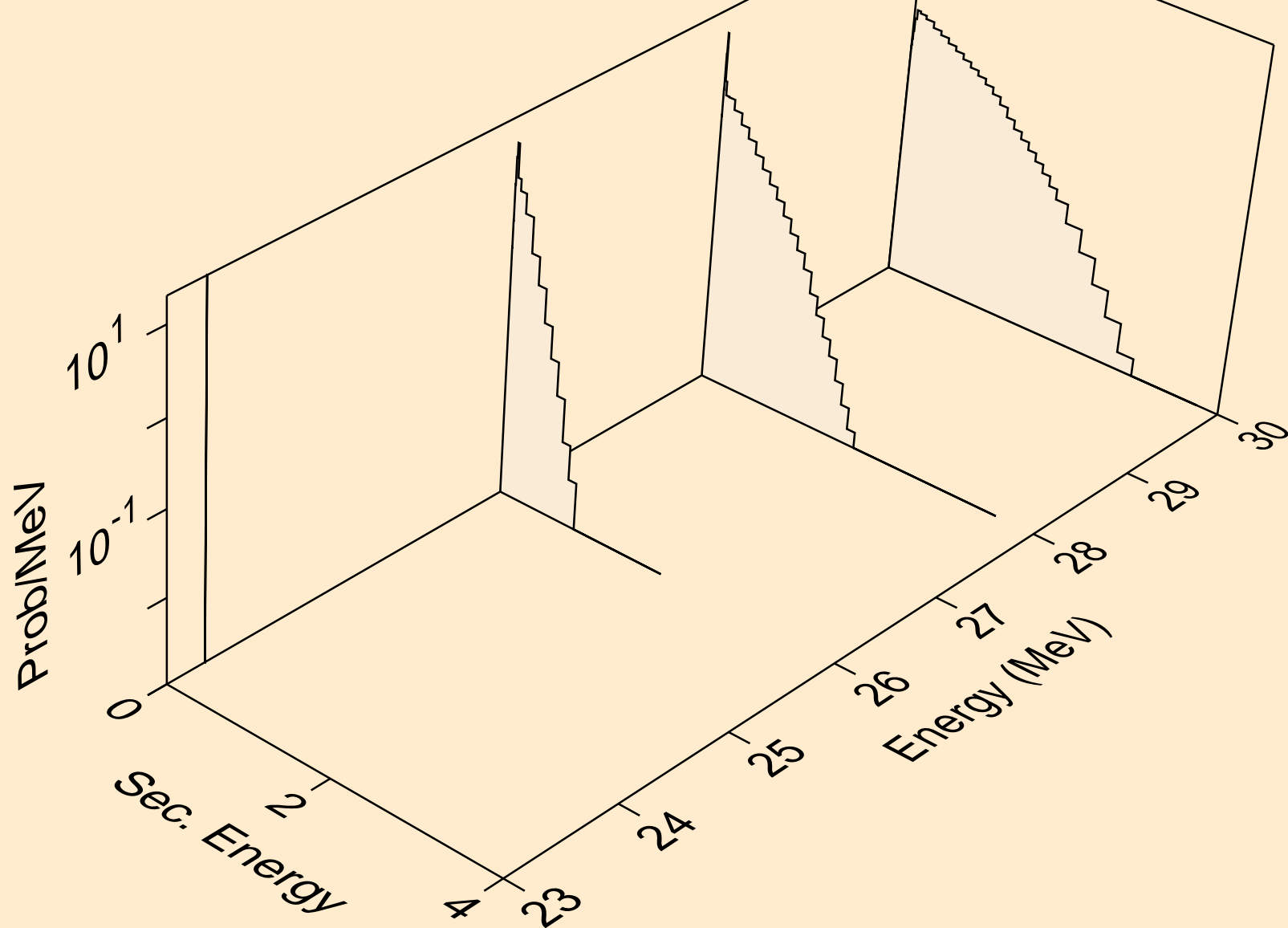

AL030 ALPHA ACER TENDL-2023 LIBRARY; T=0.K  
neutrons from (a,2np)

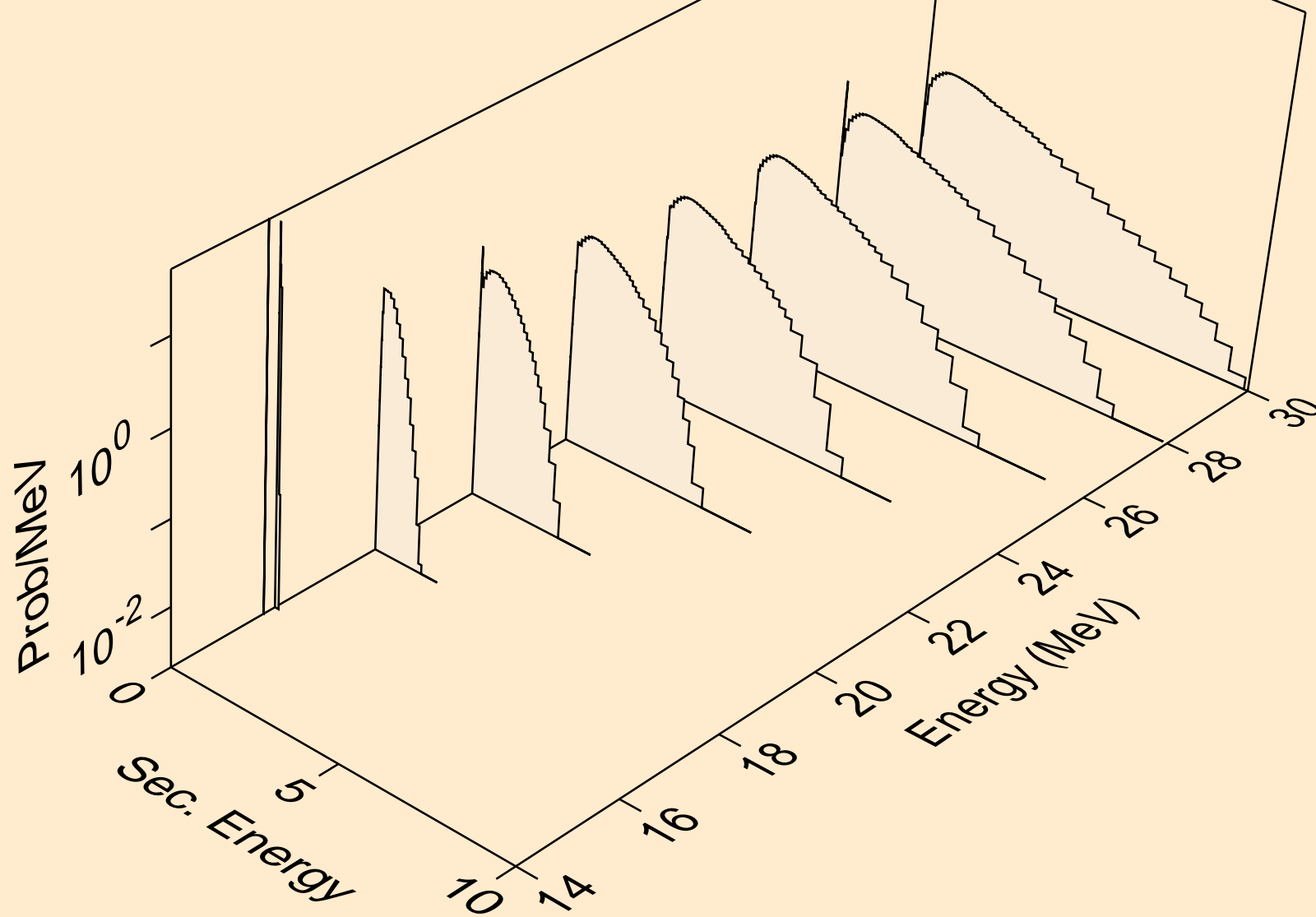

AL030 ALPHA ACER TENDL-2023 LIBRARY; T=0.K  
neutrons from (a,3np)

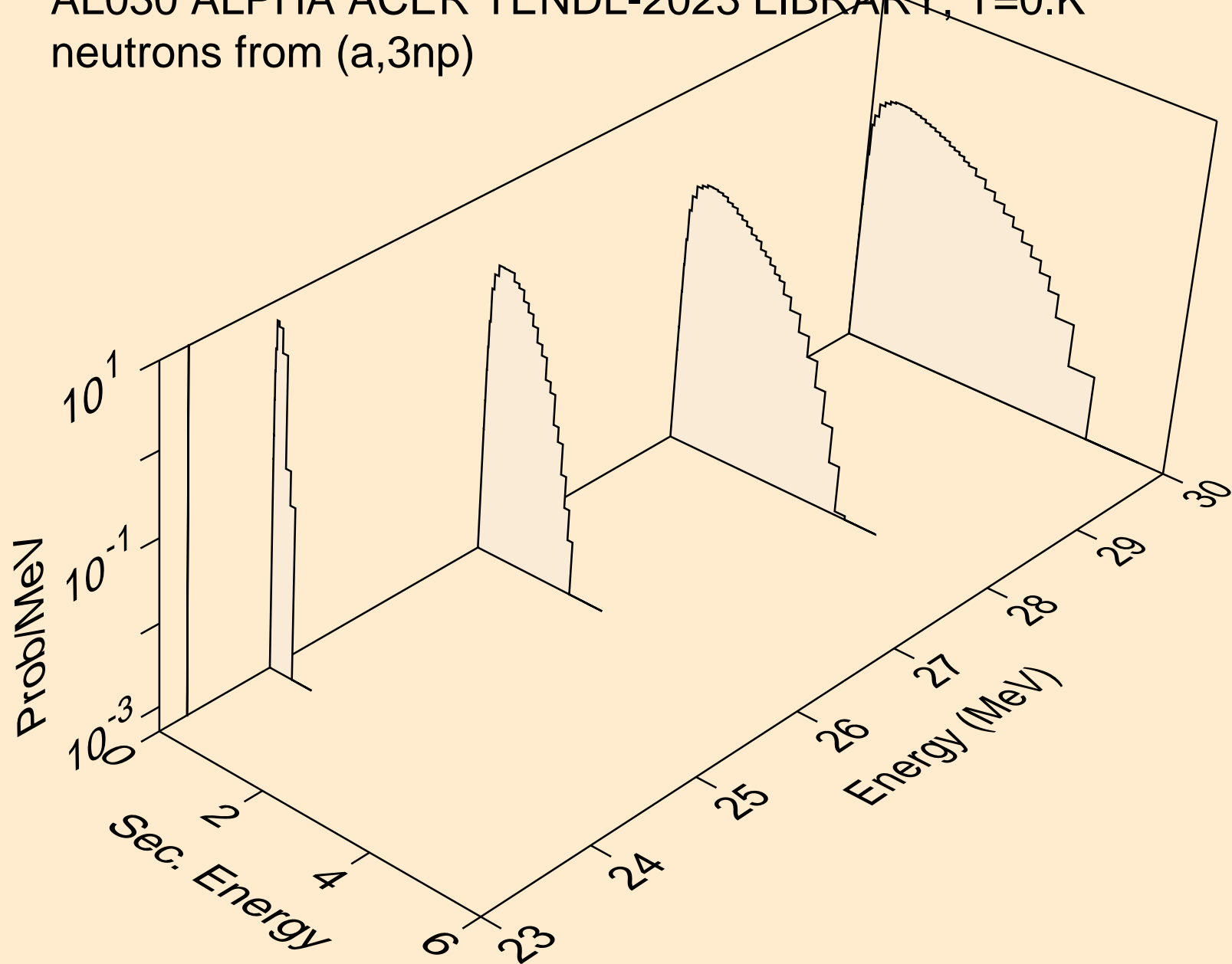

AL030 ALPHA ACER TENDL-2023 LIBRARY; T=0.K  
neutrons from (a,n2p)

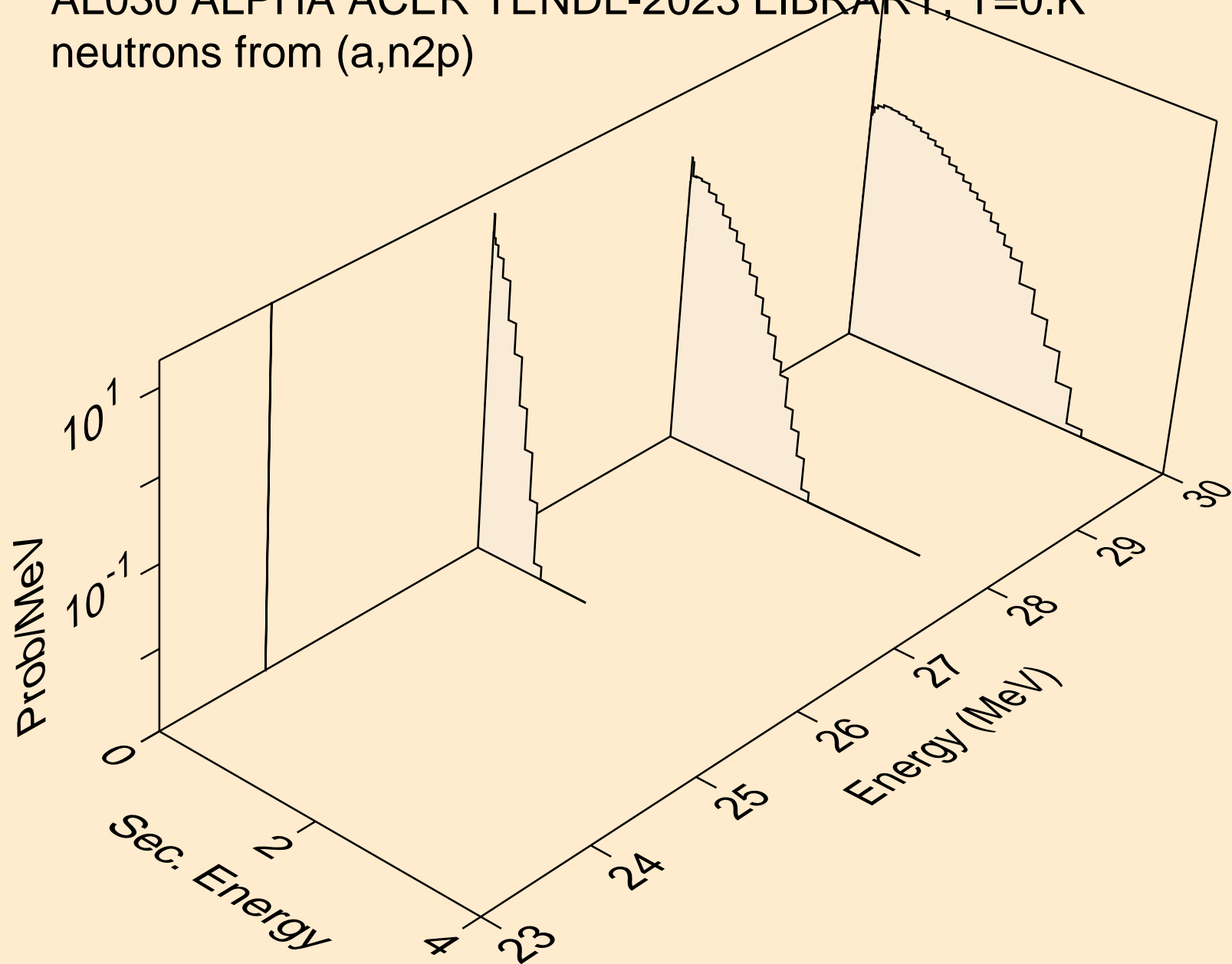

AL030 ALPHA ACER TENDL-2023 LIBRARY; T=0.K  
neutrons from (a,npa)

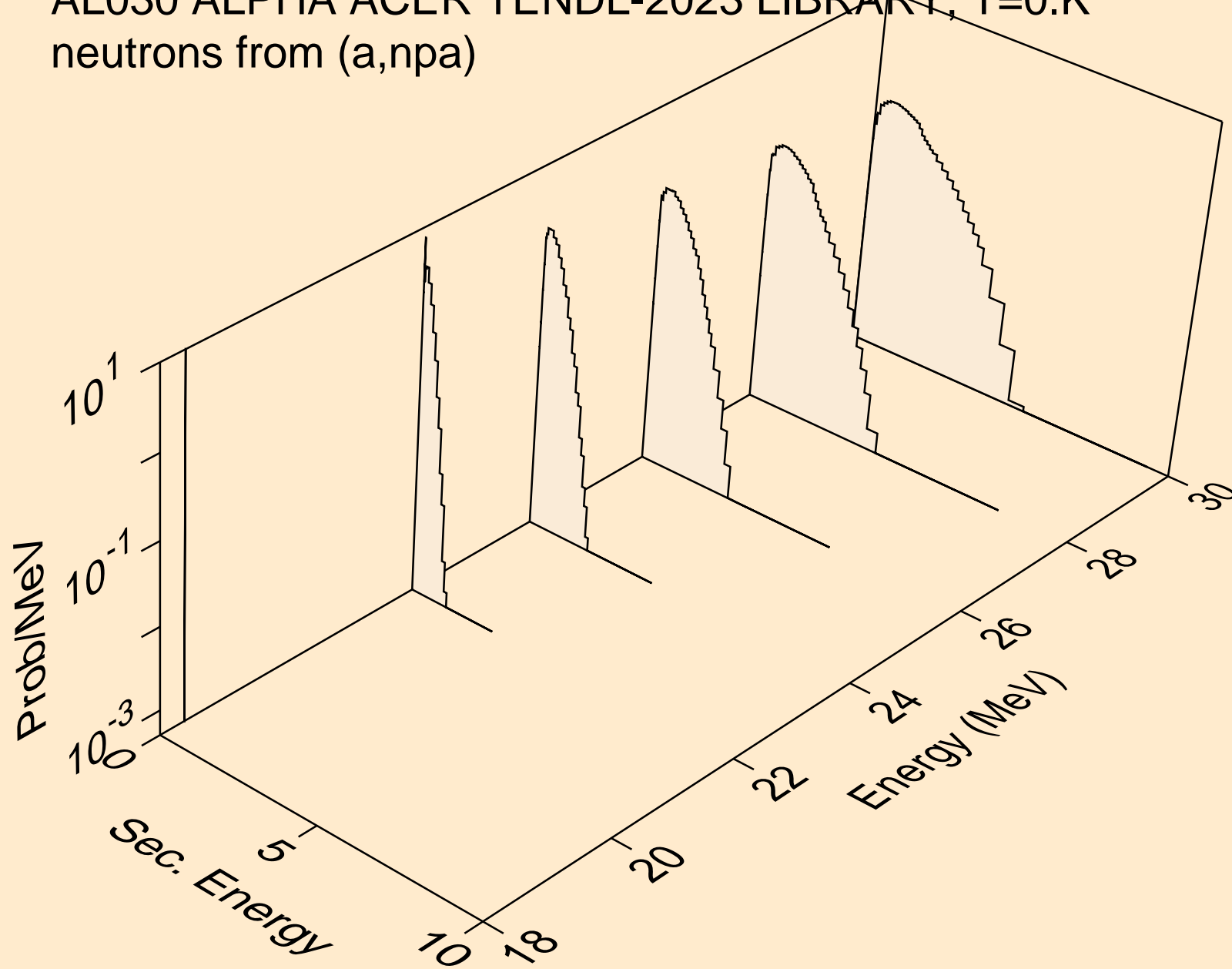



AL030 ALPHA ACER TENDL-2023 LIBRARY; T=0.K  
protons from (a,x)

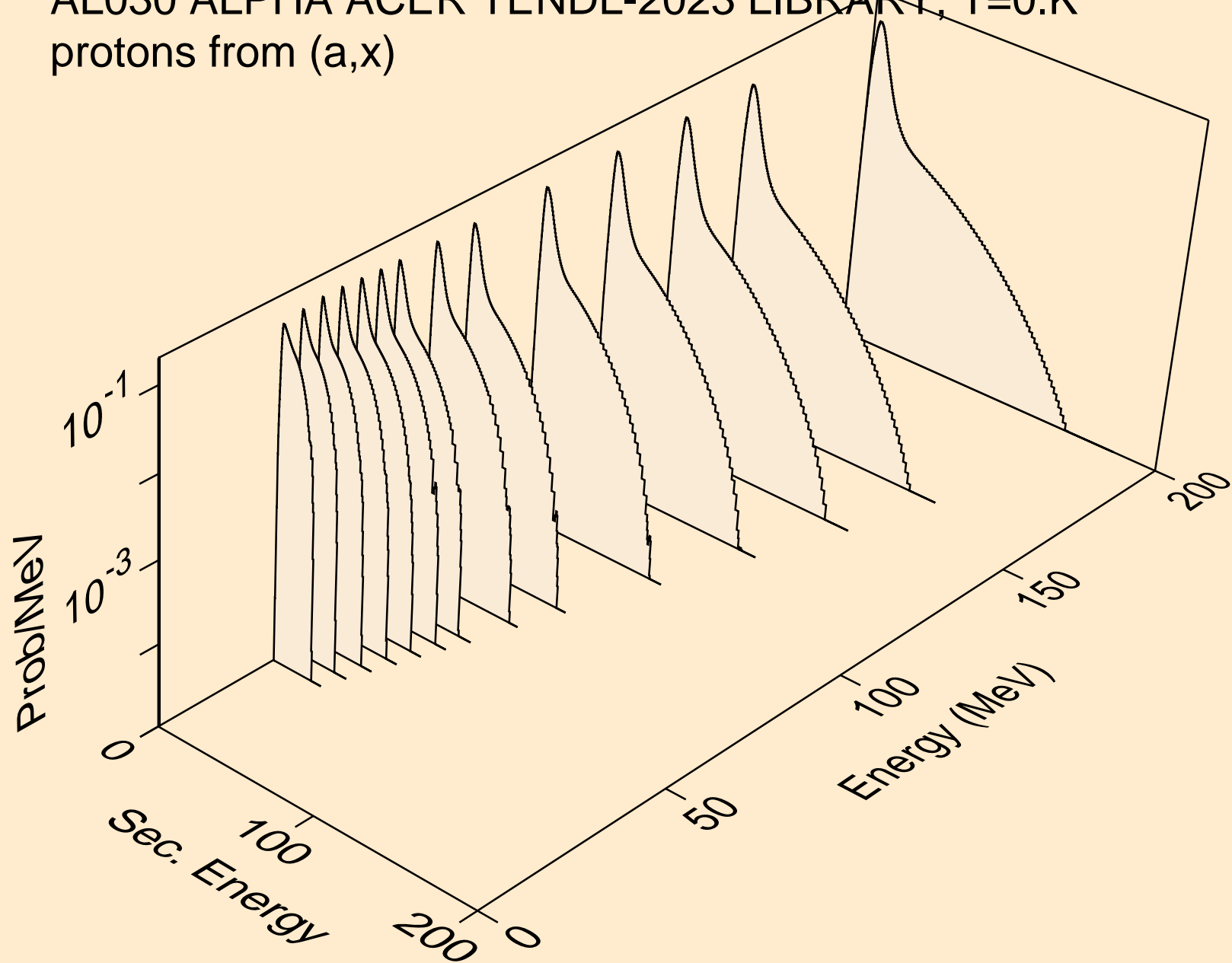

AL030 ALPHA ACER TENDL-2023 LIBRARY; T=0.K  
protons from (a,n\*)p

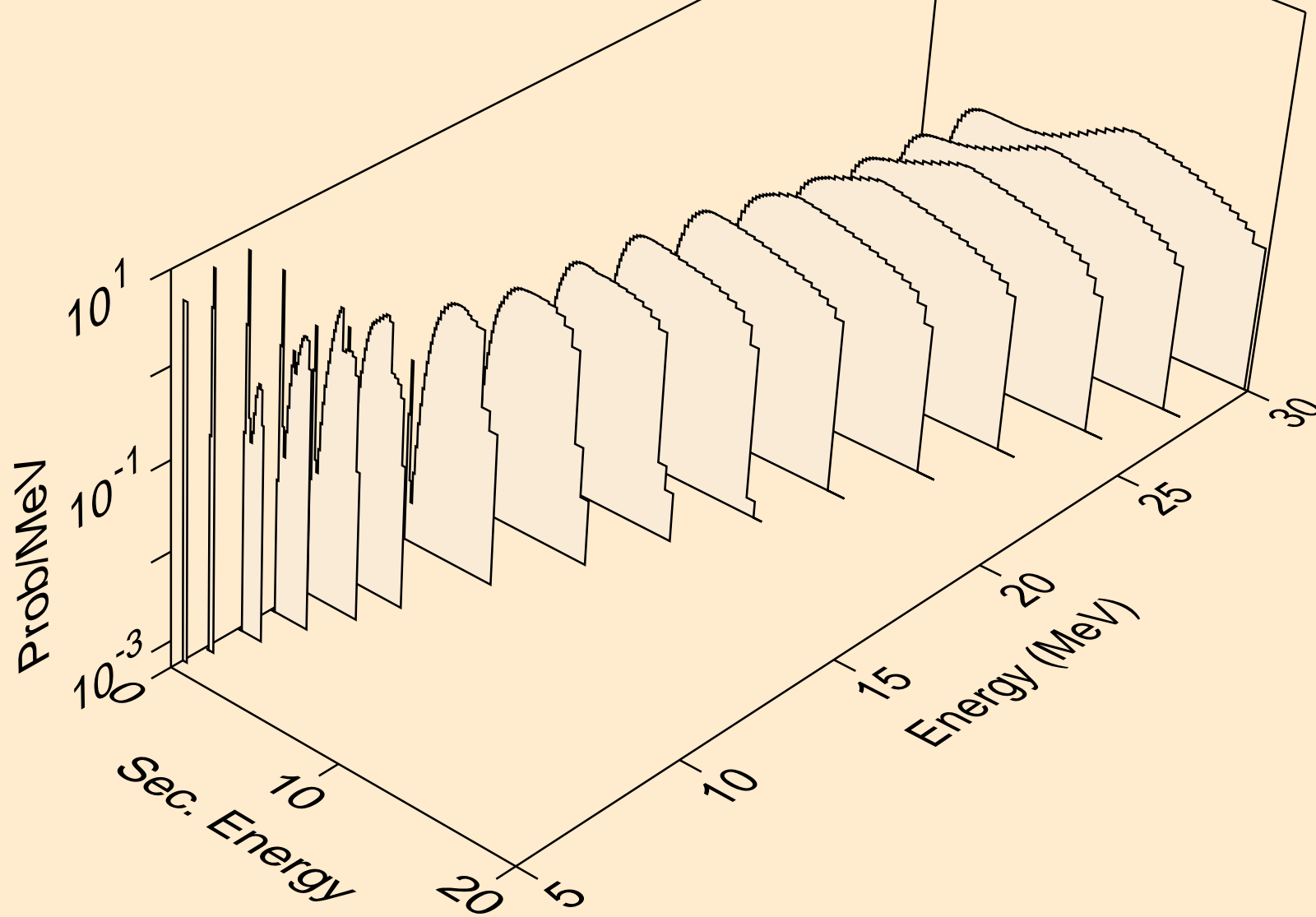

AL030 ALPHA ACER TENDL-2023 LIBRARY; T=0.K  
protons from (a,2np)

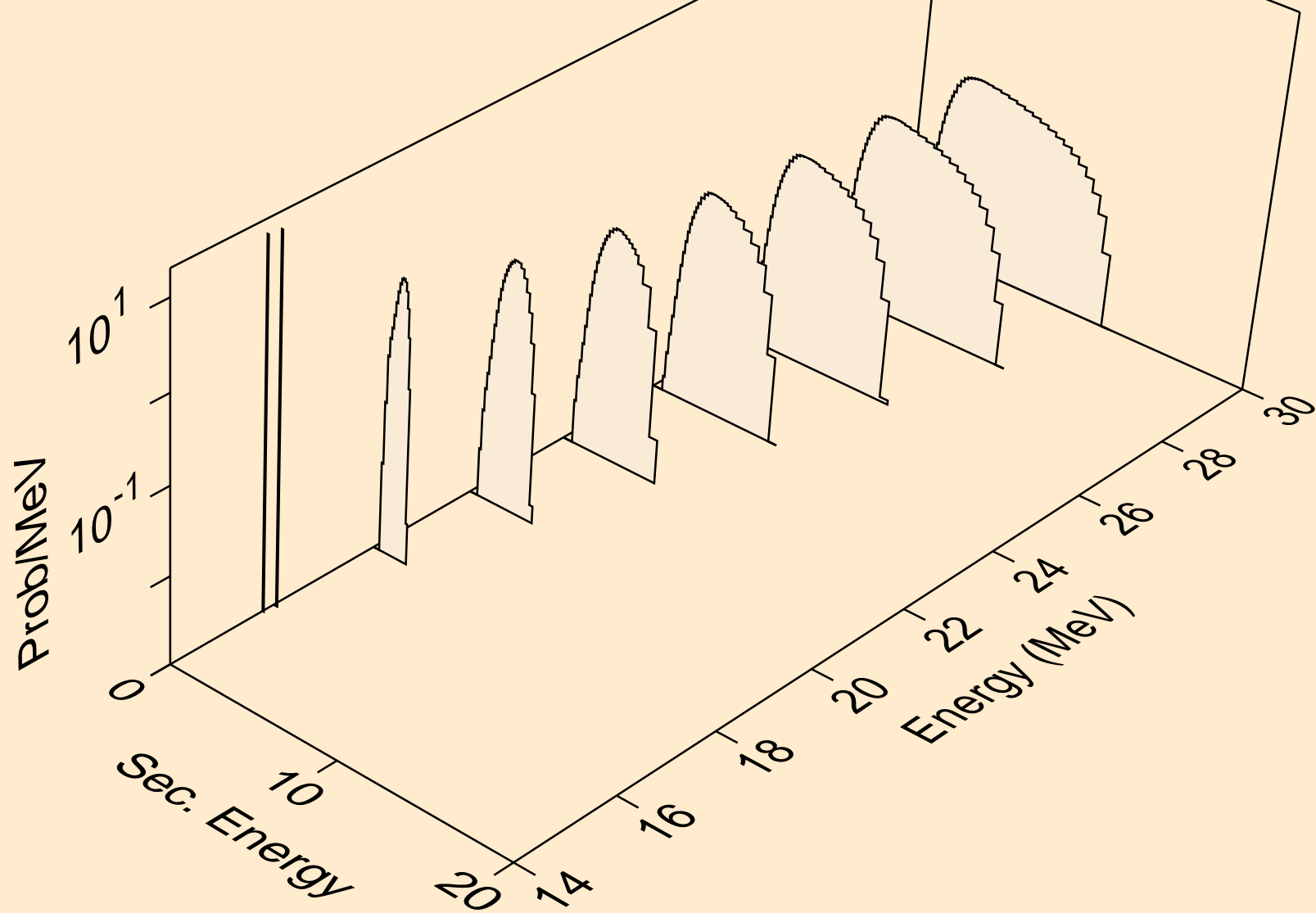

AL030 ALPHA ACER TENDL-2023 LIBRARY; T=0.K  
protons from (a,3np)

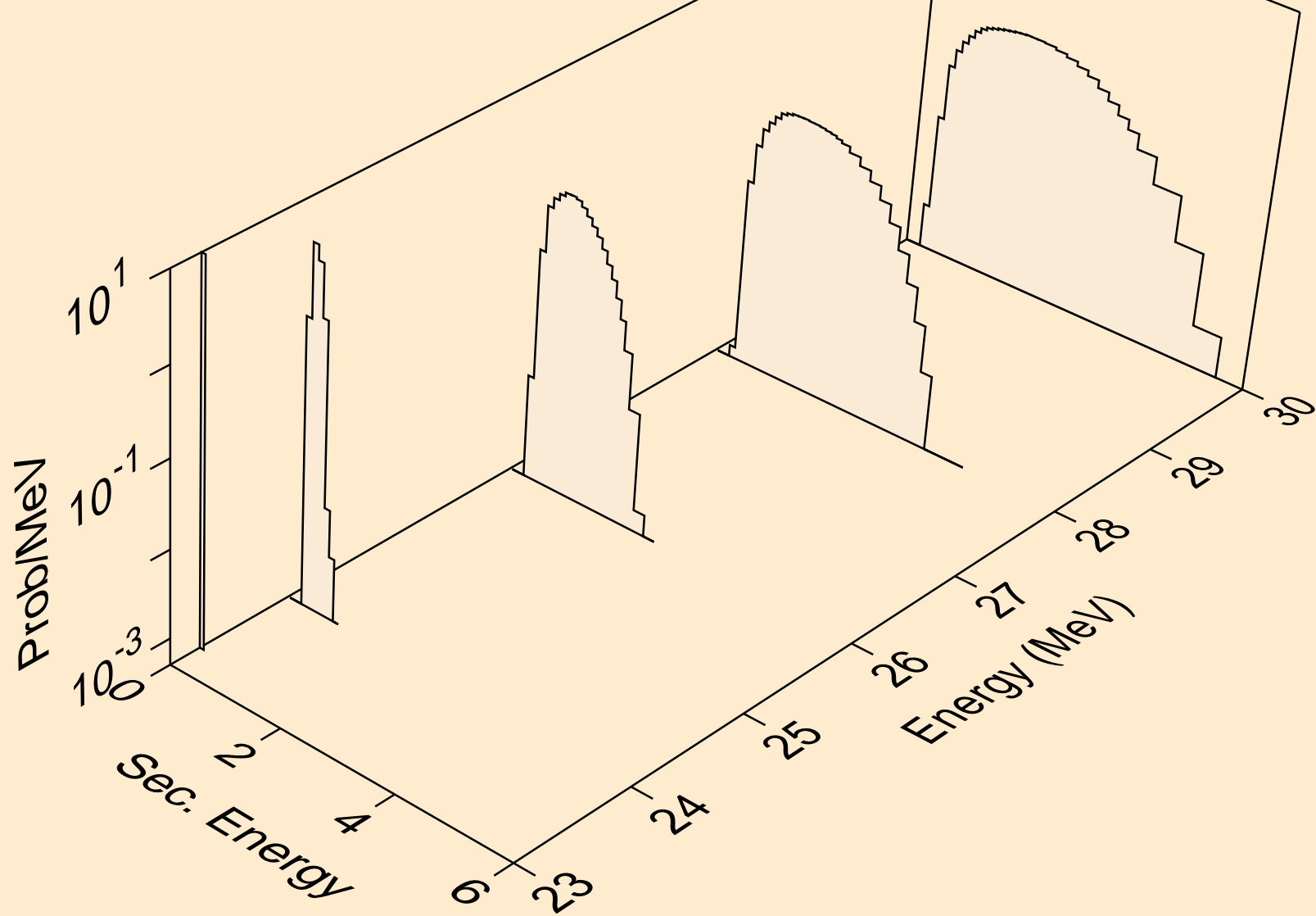

AL030 ALPHA ACER TENDL-2023 LIBRARY; T=0.K  
protons from (a,n2p)

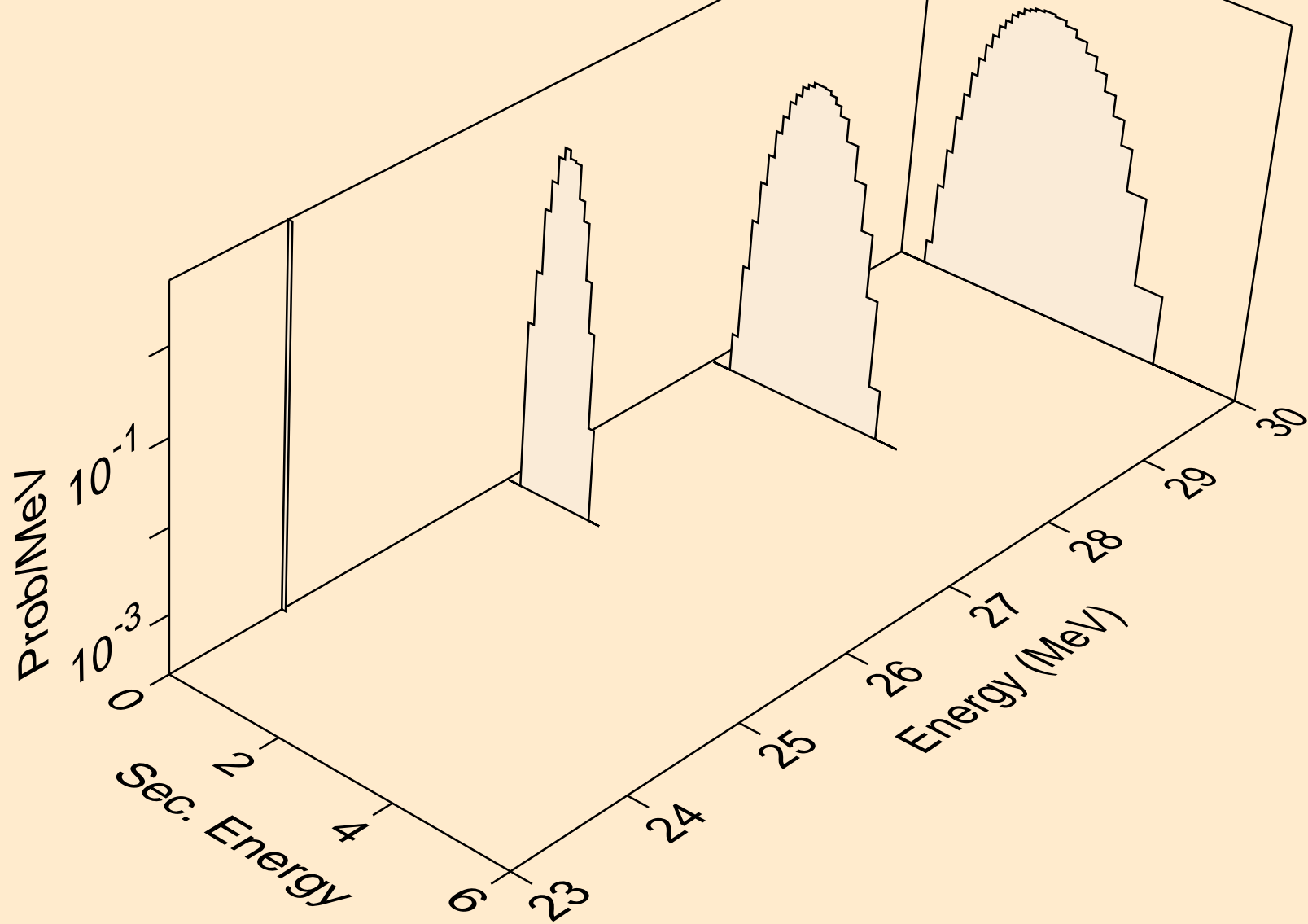

AL030 ALPHA ACER TENDL-2023 LIBRARY; T=0.K  
protons from (a,npa)

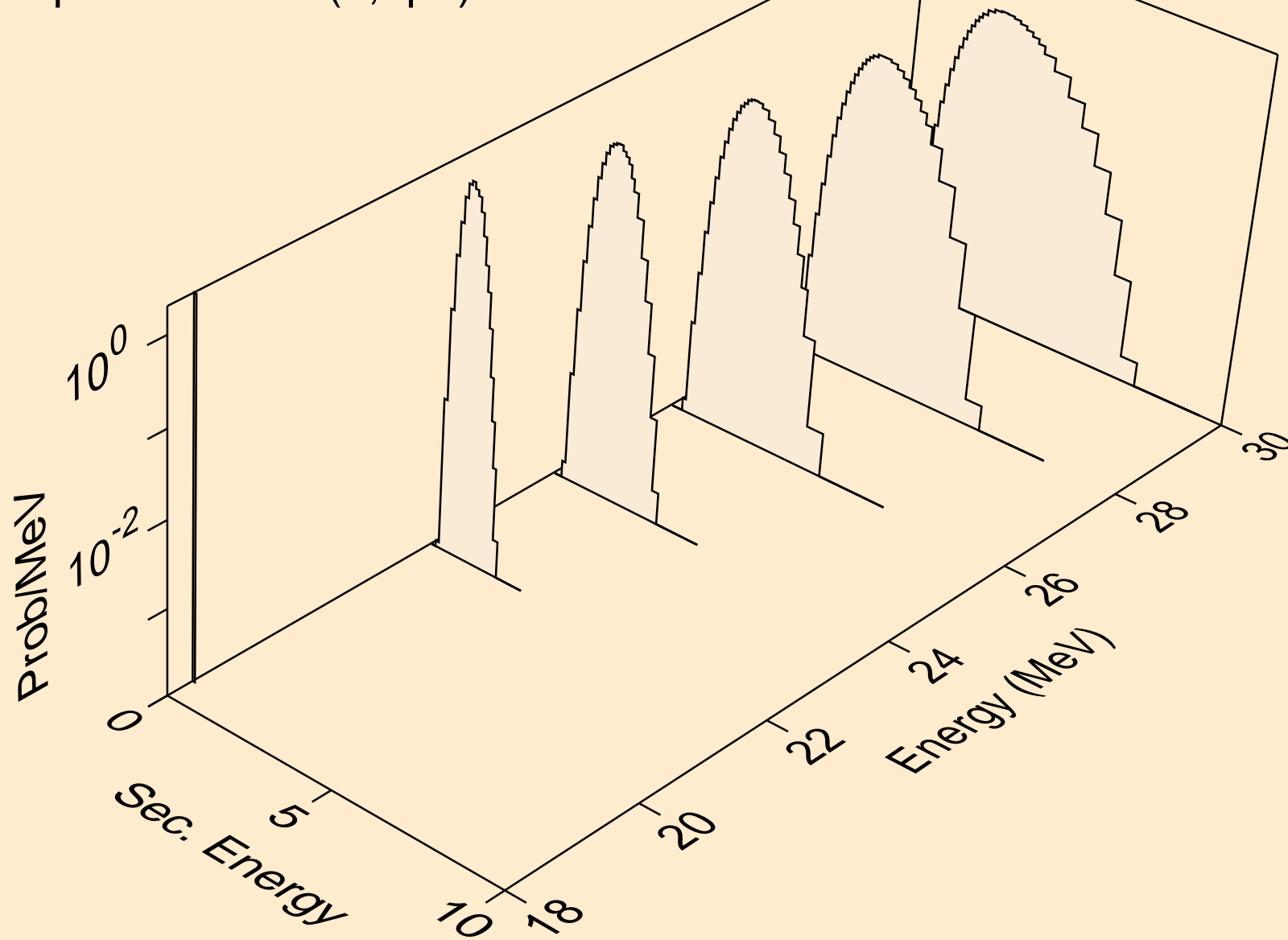

AL030 ALPHA ACER TENDL-2023 LIBRARY; T=0.K  
protons from (a,p)

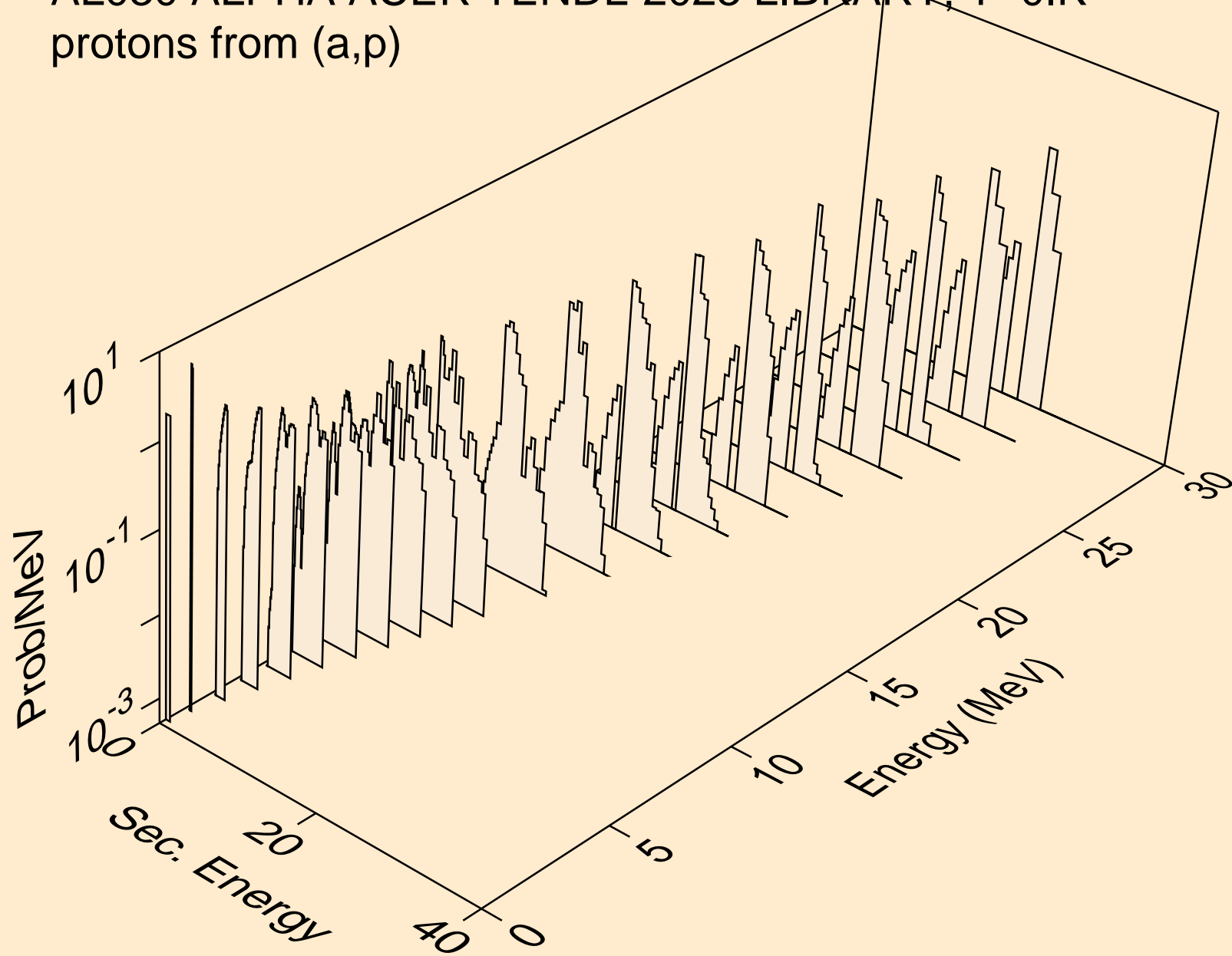

AL030 ALPHA ACER TENDL-2023 LIBRARY; T=0.K  
protons from (a,2p)

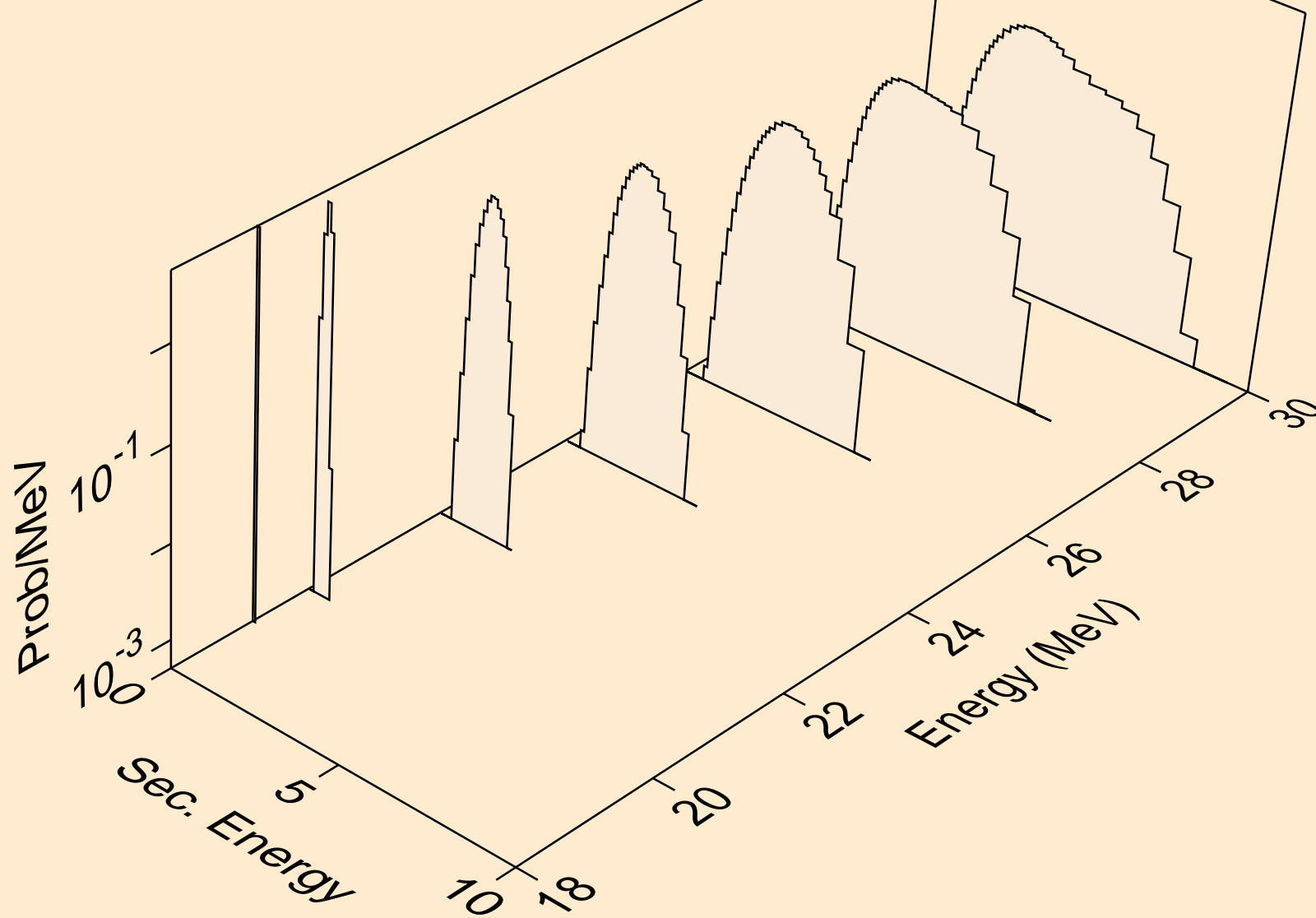



AL030 ALPHA ACER TENDL-2023 LIBRARY; T=0.K  
protons from (a,pa)

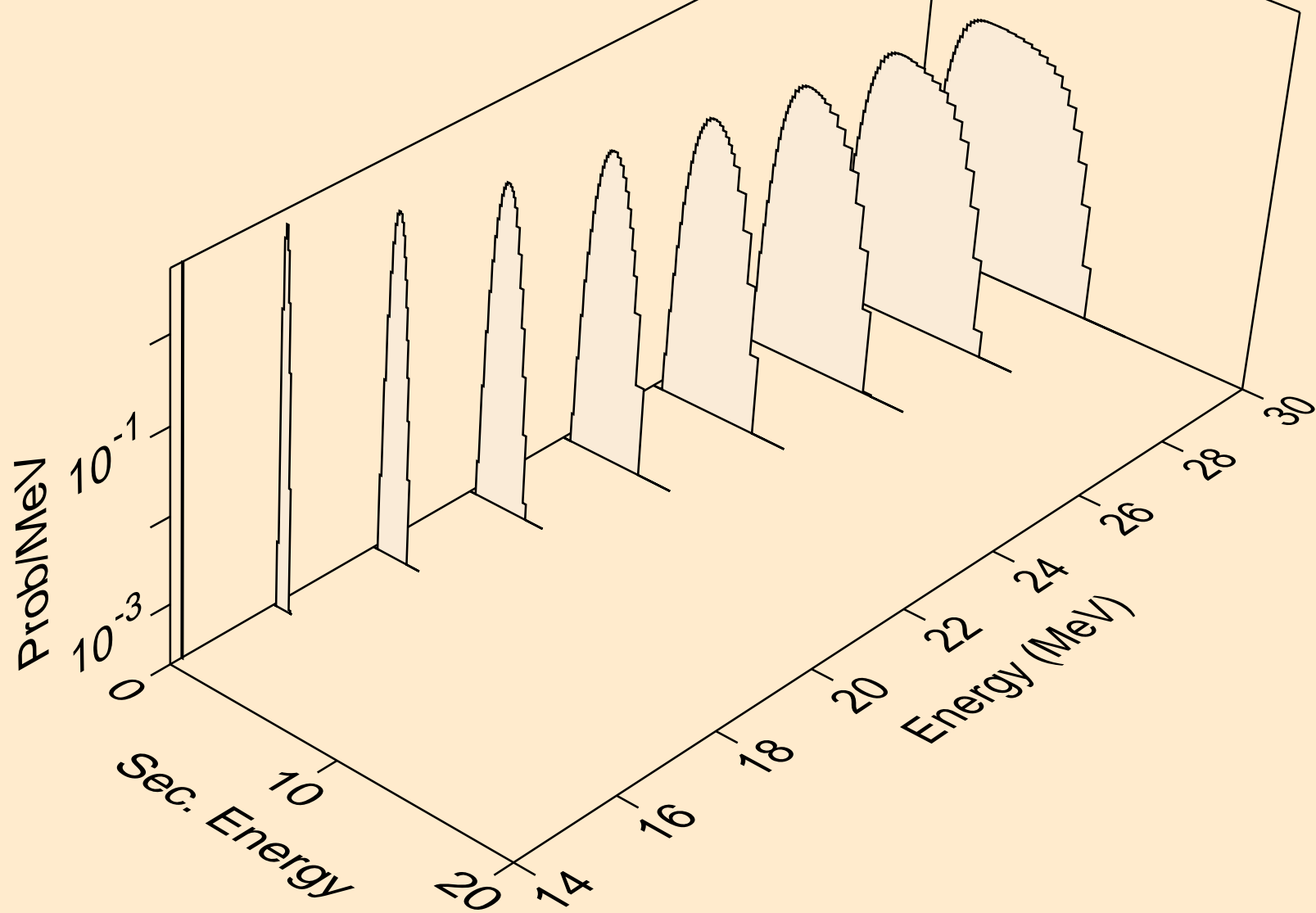

AL030 ALPHA ACER TENDL-2023 LIBRARY; T=0.K  
protons from (a,pd)

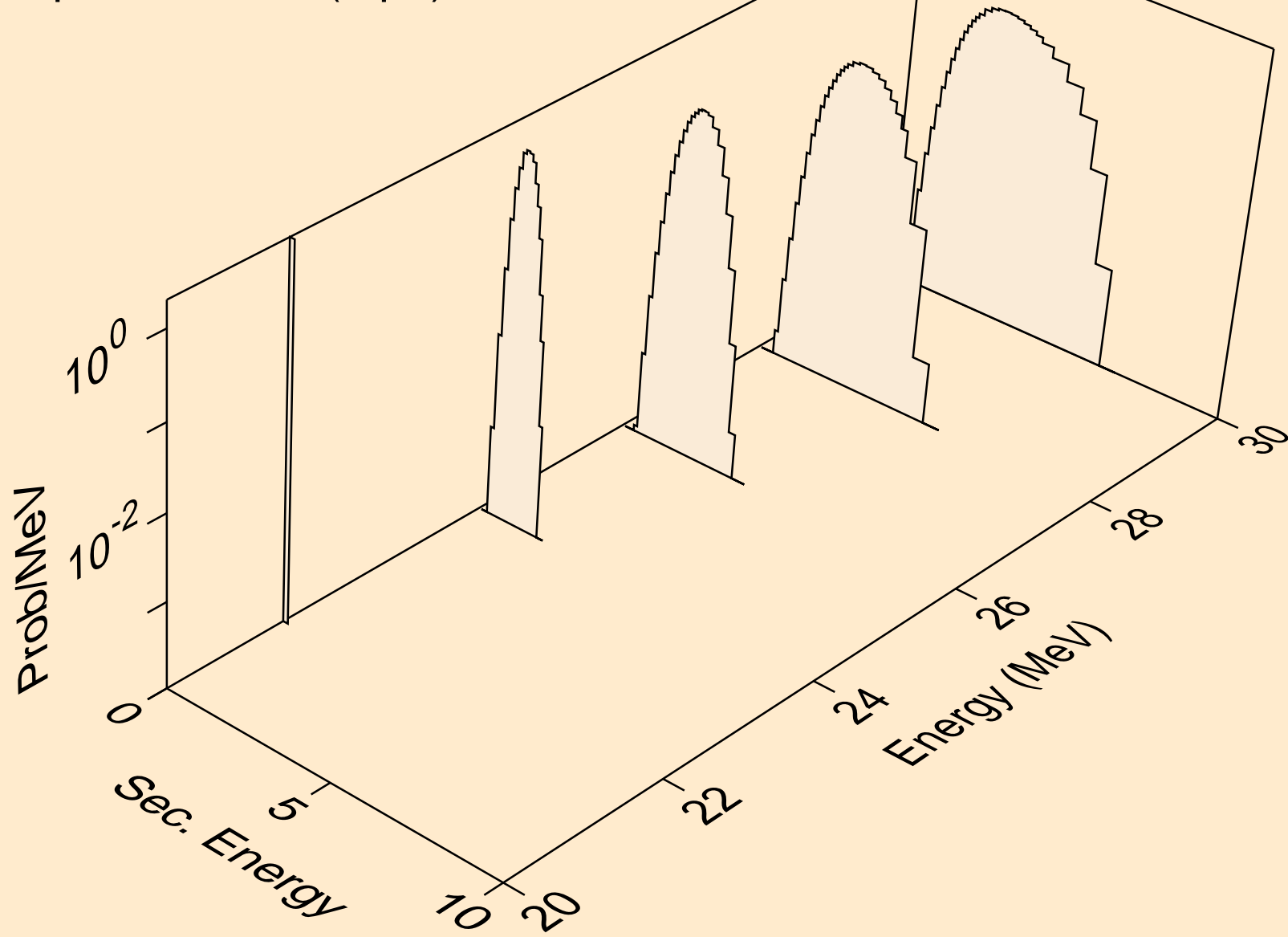

AL030 ALPHA ACER TENDL-2023 LIBRARY; T=0.K  
protons from (a,pt)

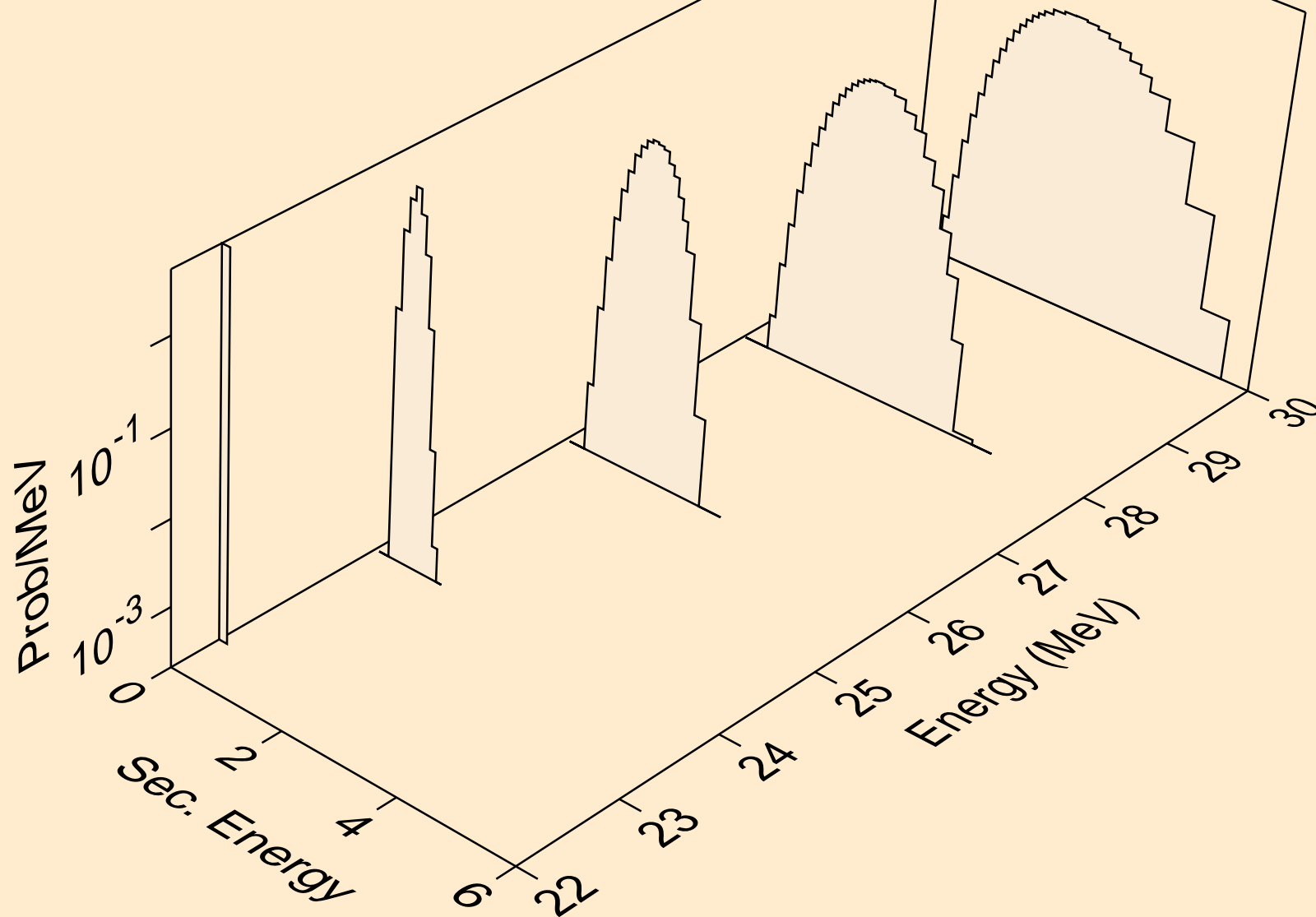

AL030 ALPHA ACER TENDL-2023 LIBRARY; T=0.K  
deuterons from (a,x)

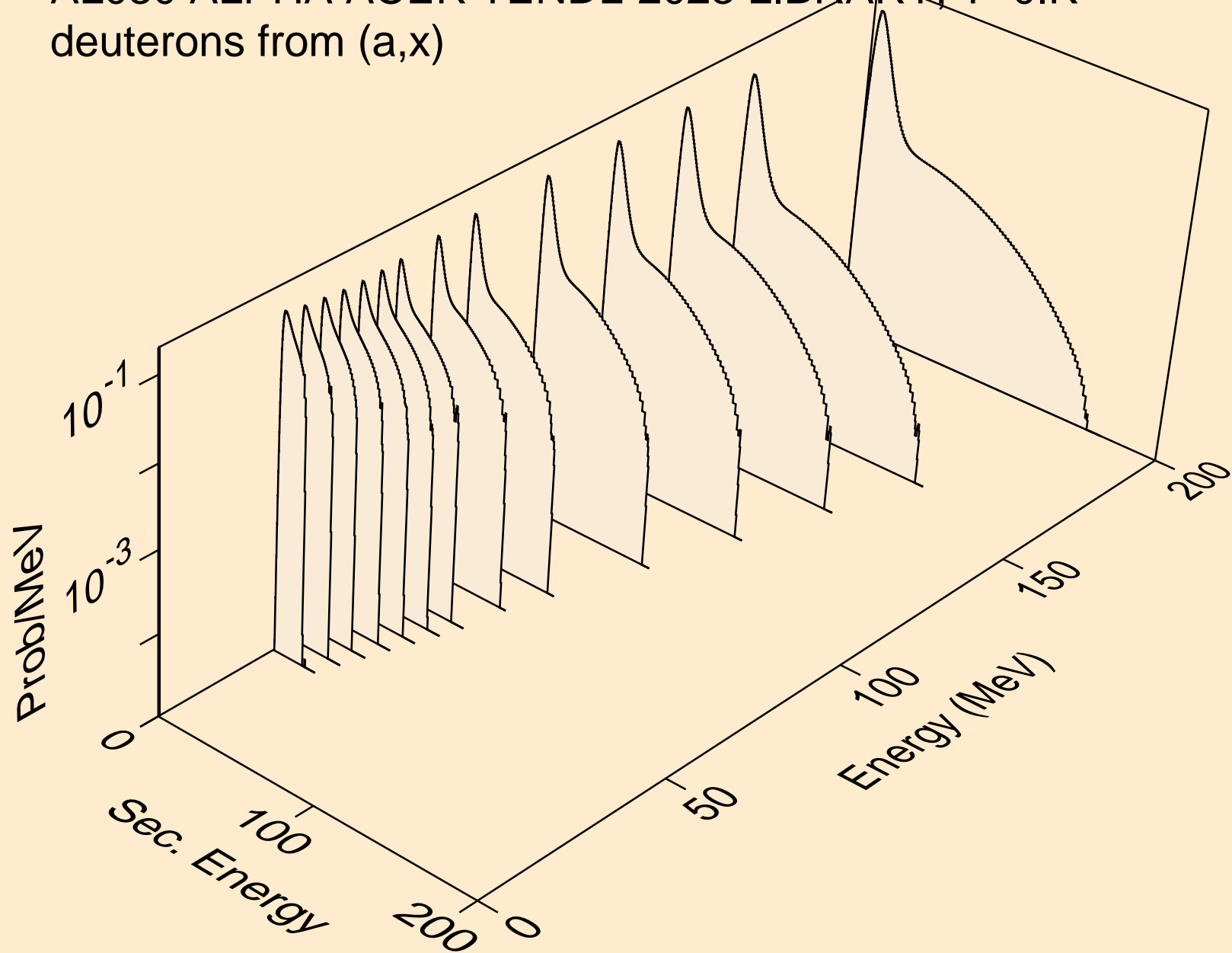

AL030 ALPHA ACER TENDL-2023 LIBRARY; T=0.K  
deuterons from (a,2nd)

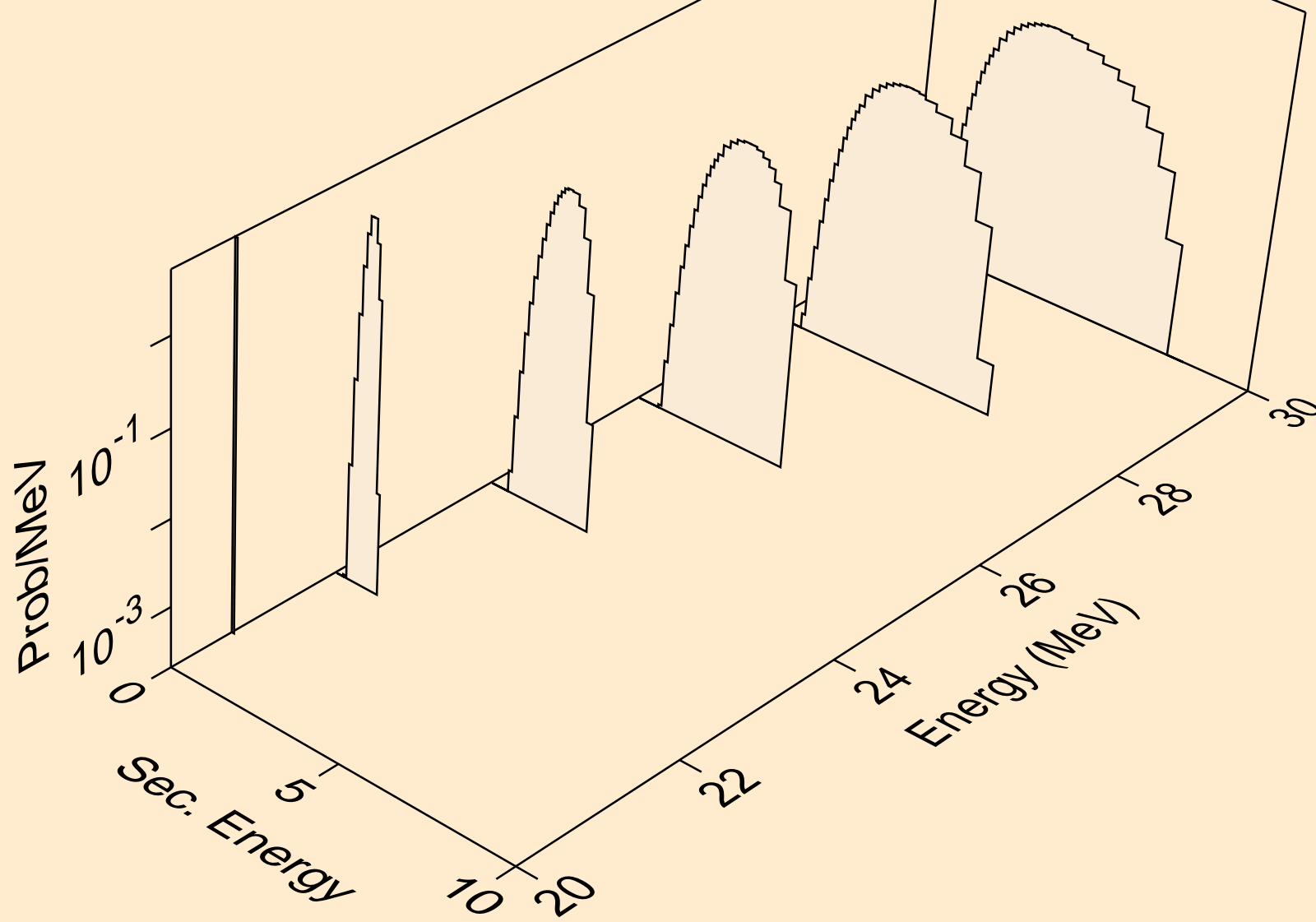

AL030 ALPHA ACER TENDL-2023 LIBRARY; T=0.K  
deuterons from (a,n\*)d

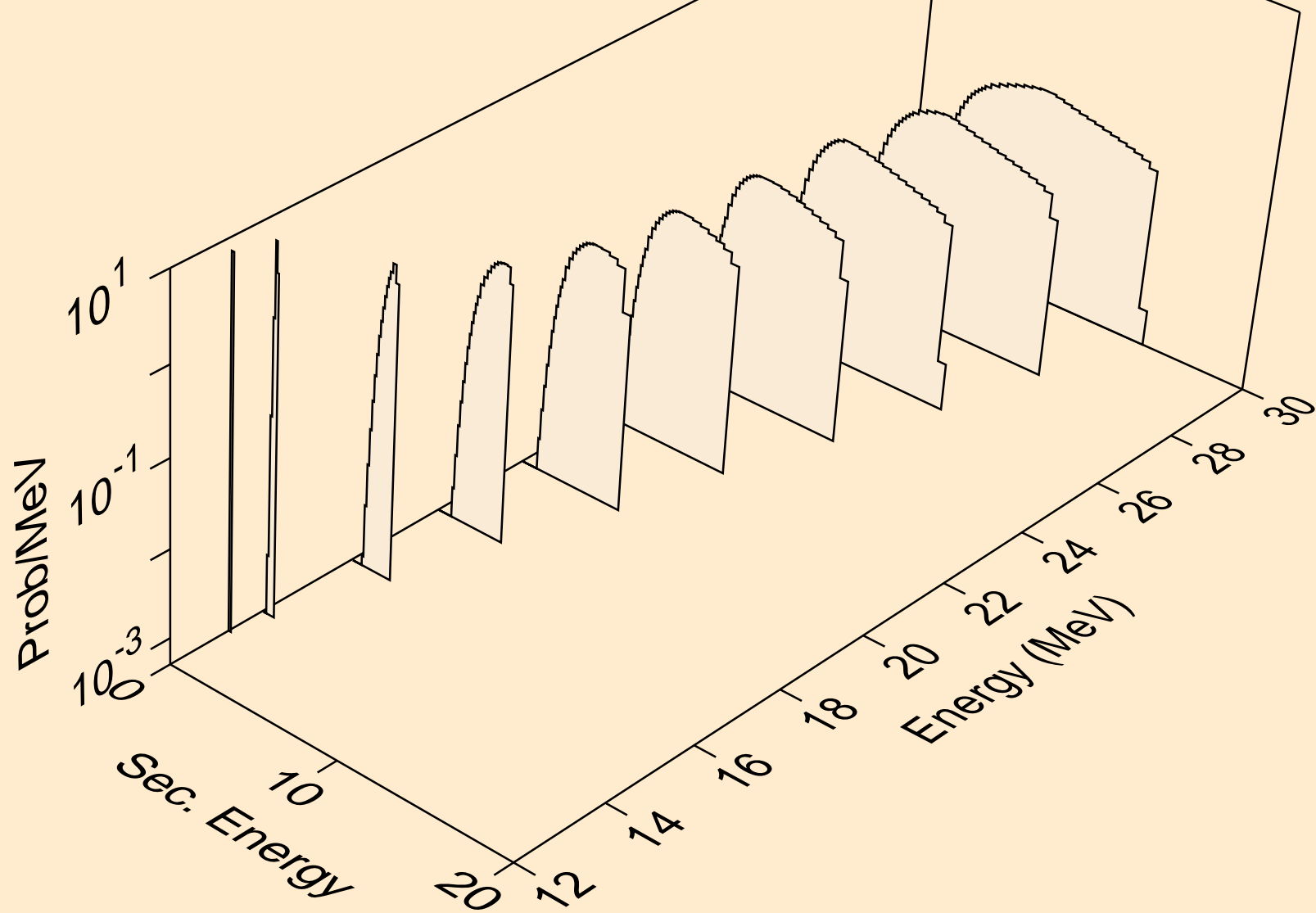

AL030 ALPHA ACER TENDL-2023 LIBRARY; T=0.K  
deuterons from (a,d)

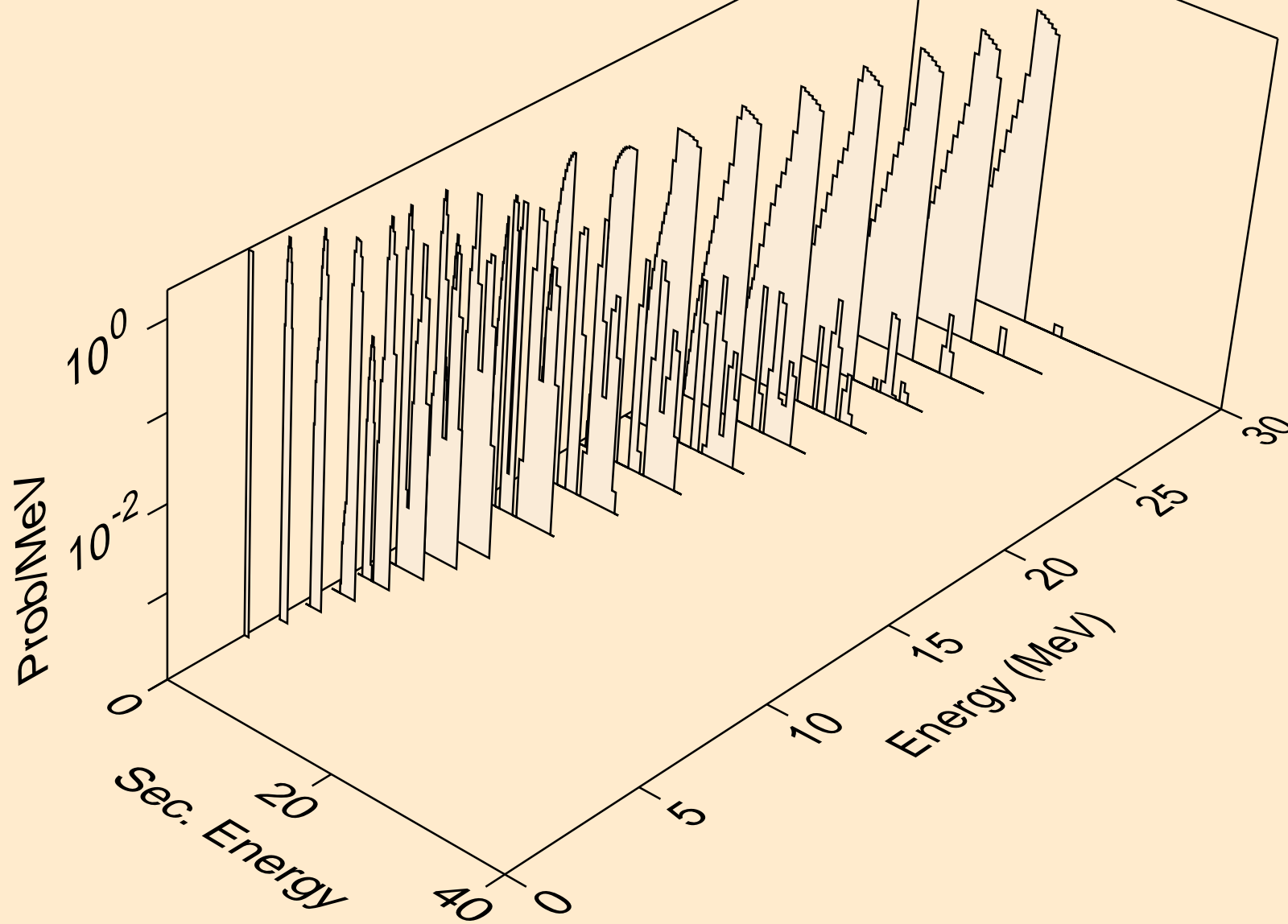

AL030 ALPHA ACER TENDL-2023 LIBRARY; T=0.K  
deuterons from (a,pd)

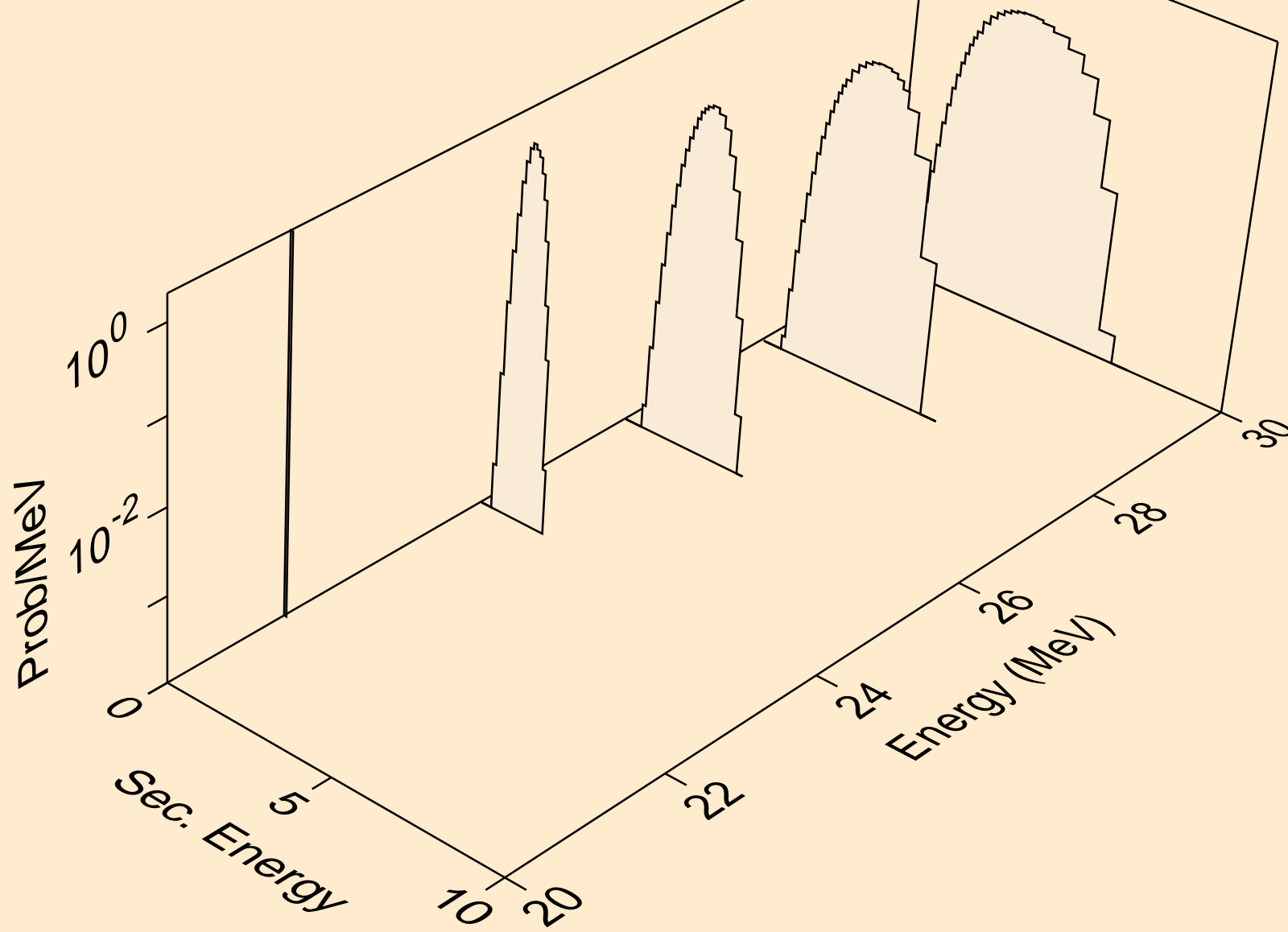



AL030 ALPHA ACER TENDL-2023 LIBRARY; T=0.K  
deuterons from (a,da)

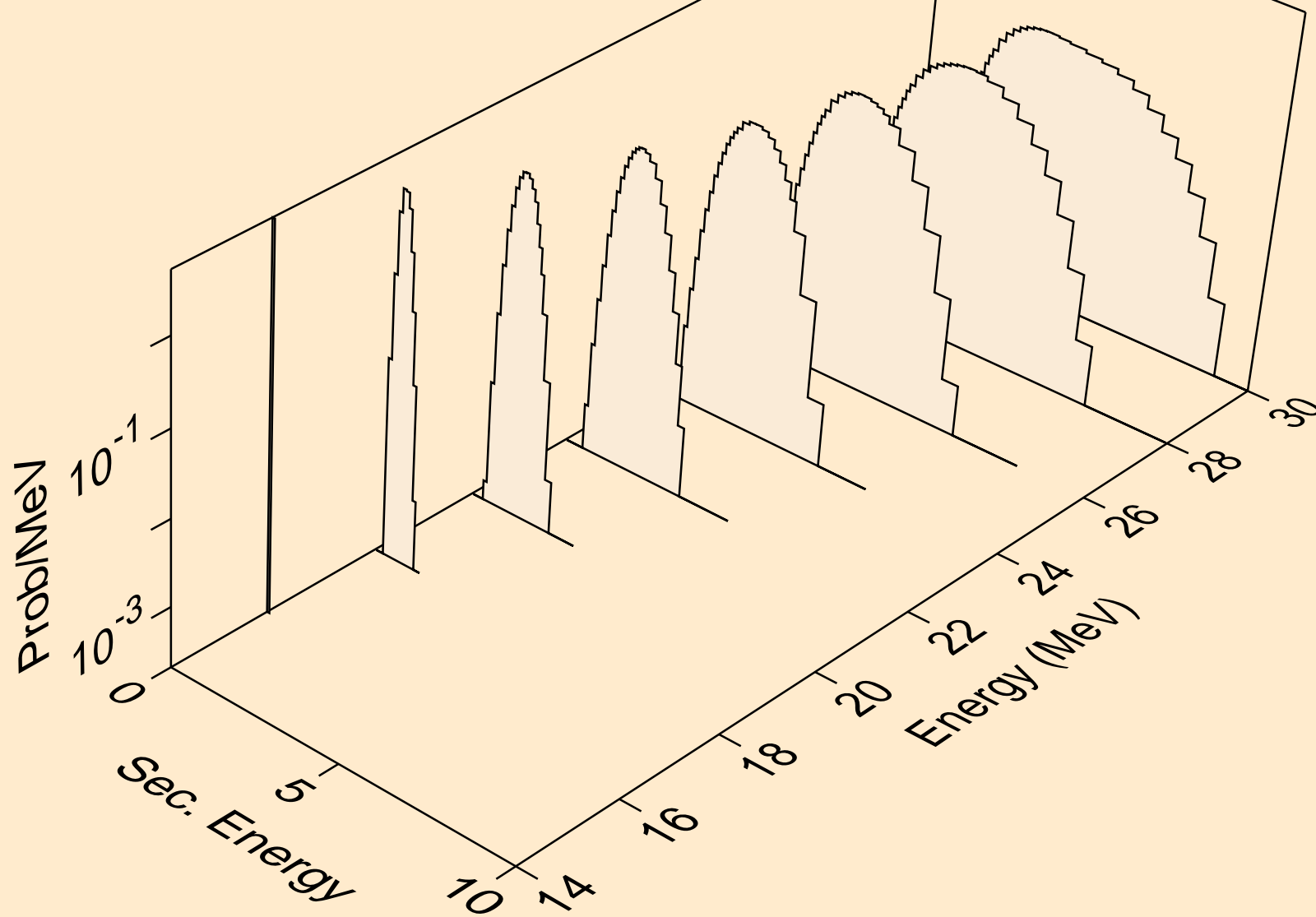

AL030 ALPHA ACER TENDL-2023 LIBRARY; T=0.K  
tritons from (a,x)

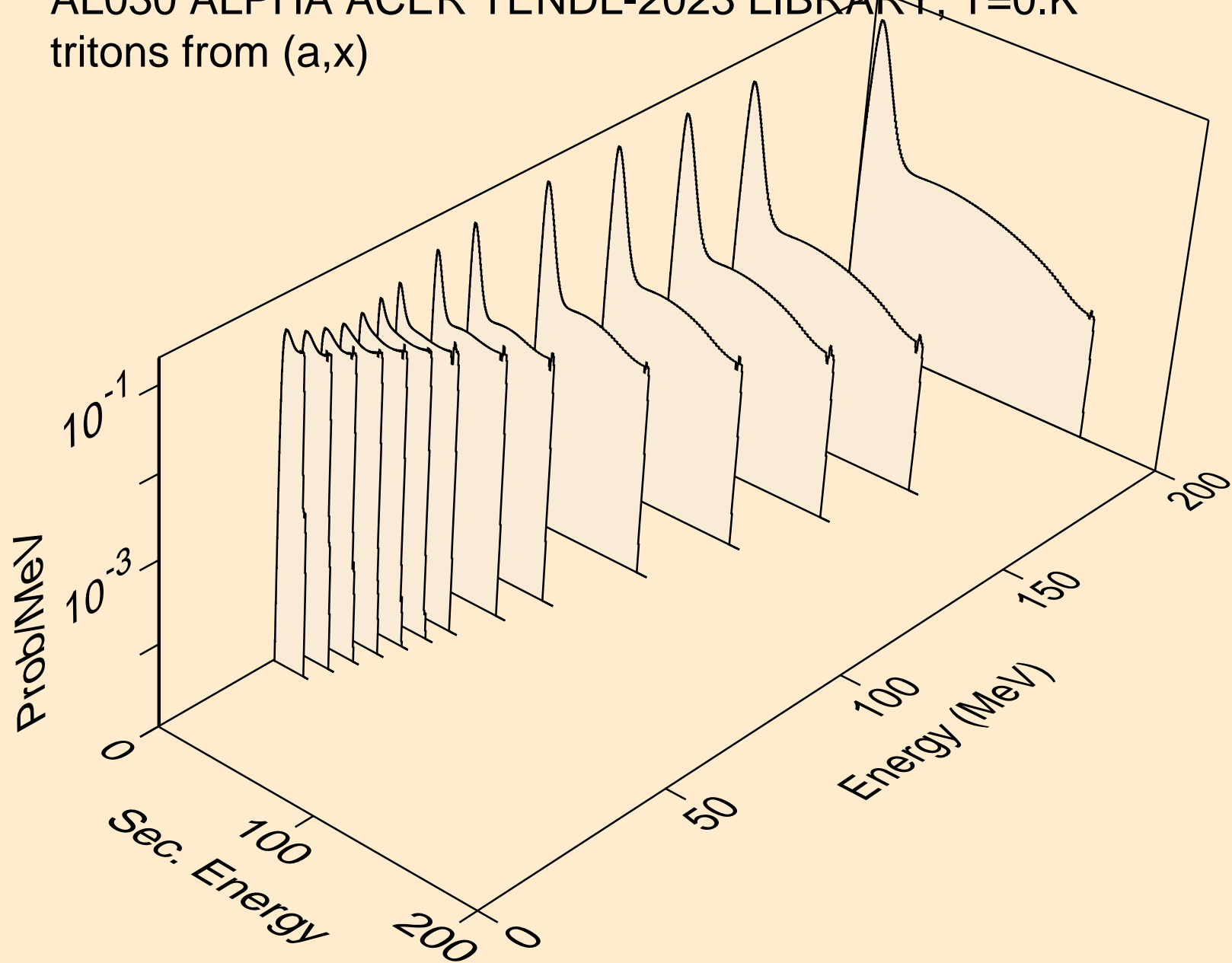

AL030 ALPHA ACER TENDL-2023 LIBRARY; T=0.K  
tritons from (a,n\*)t

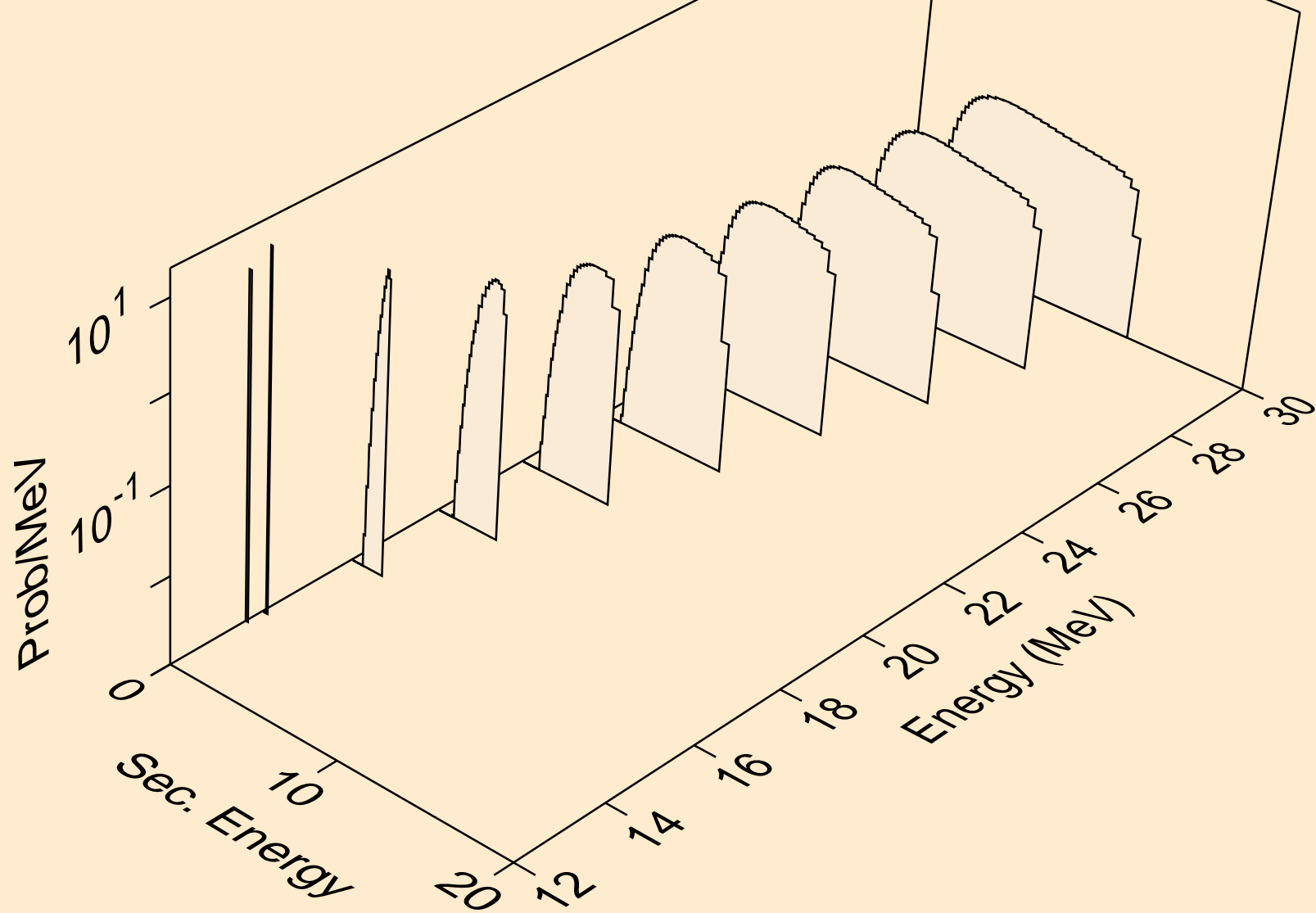

AL030 ALPHA ACER TENDL-2023 LIBRARY; T=0.K  
tritons from (a,t)

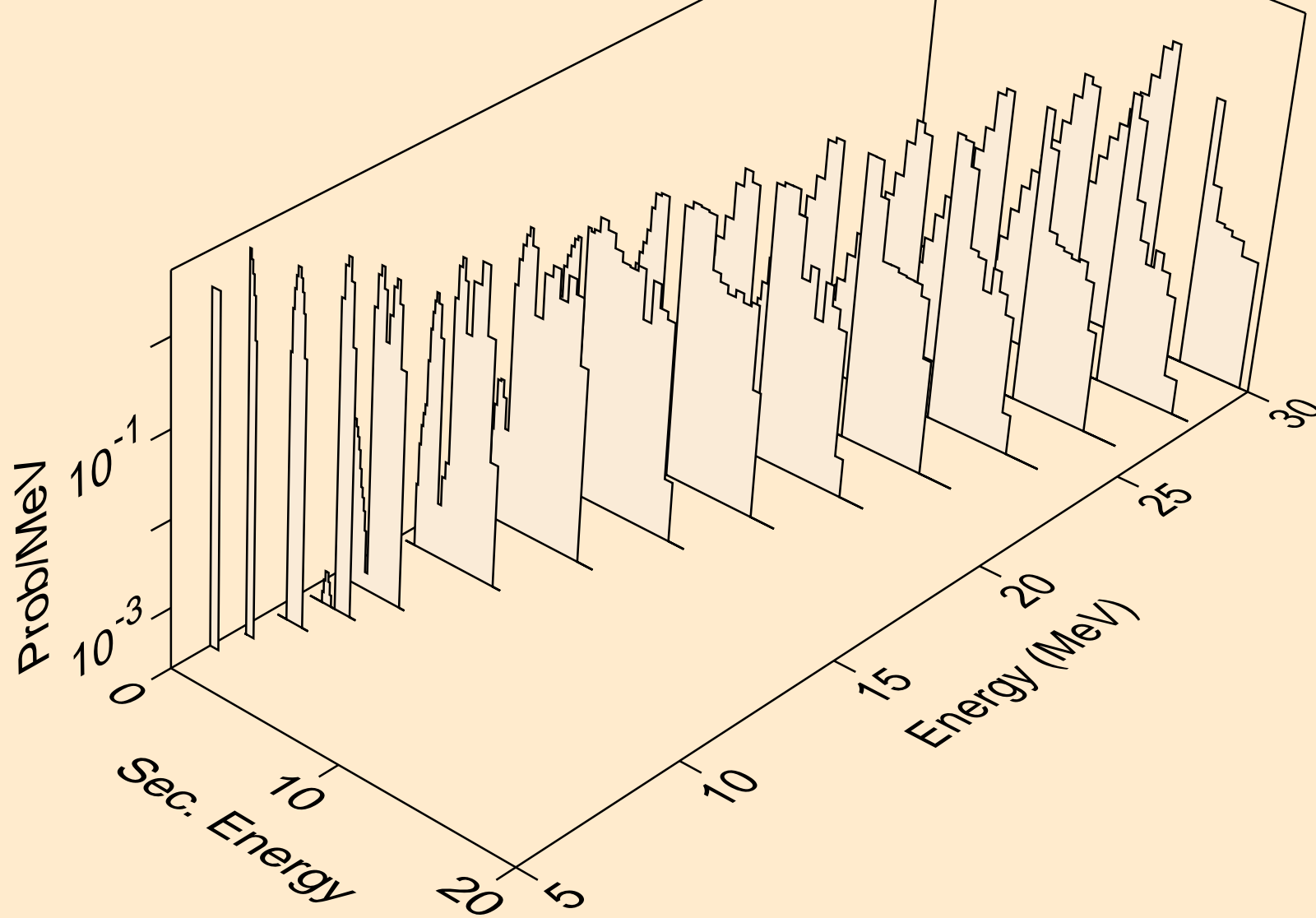

AL030 ALPHA ACER TENDL-2023 LIBRARY; T=0.K  
tritons from (a,pt)

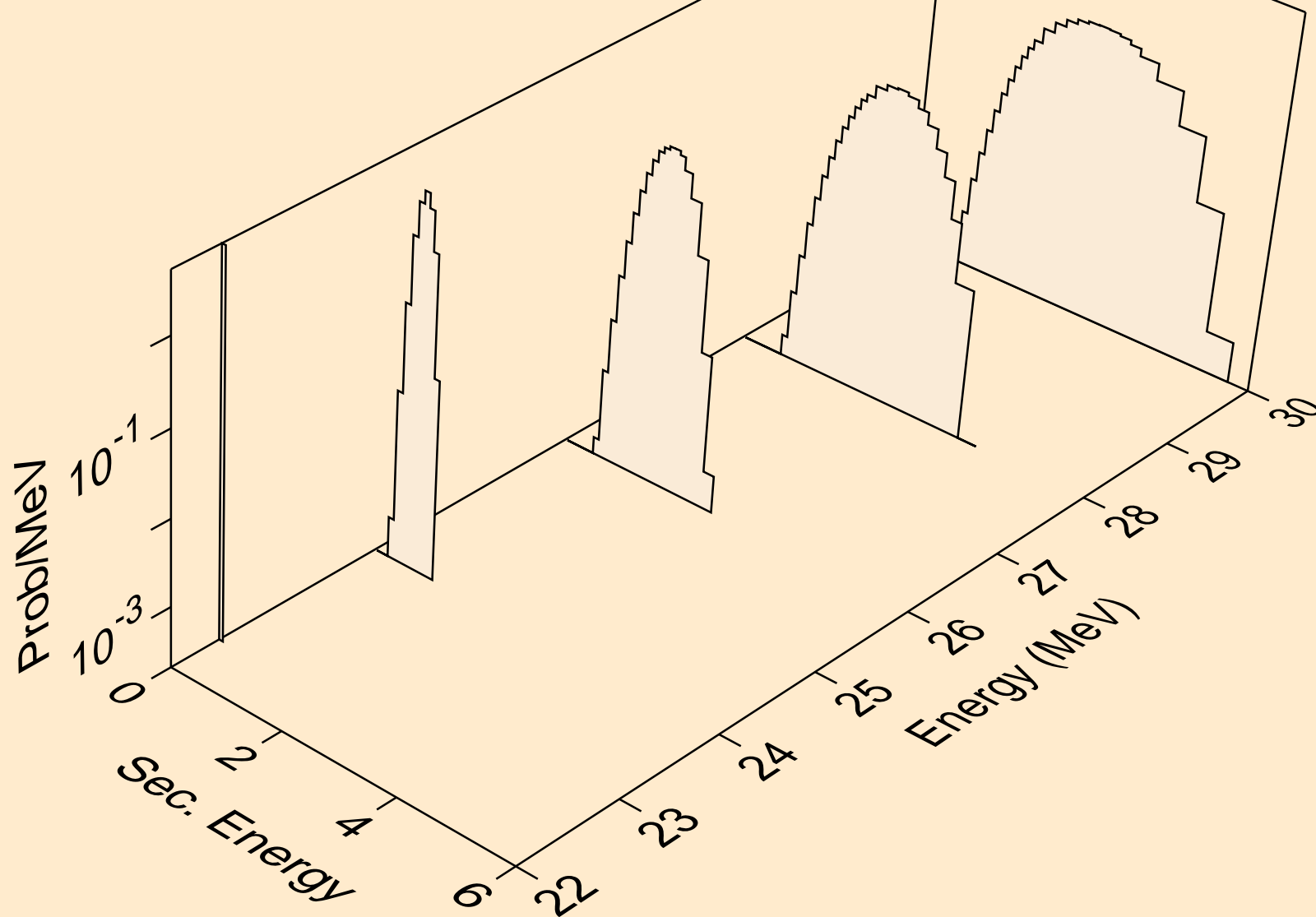

AL030 ALPHA ACER TENDL-2023 LIBRARY; T=0.K  
he3s from (a,x)

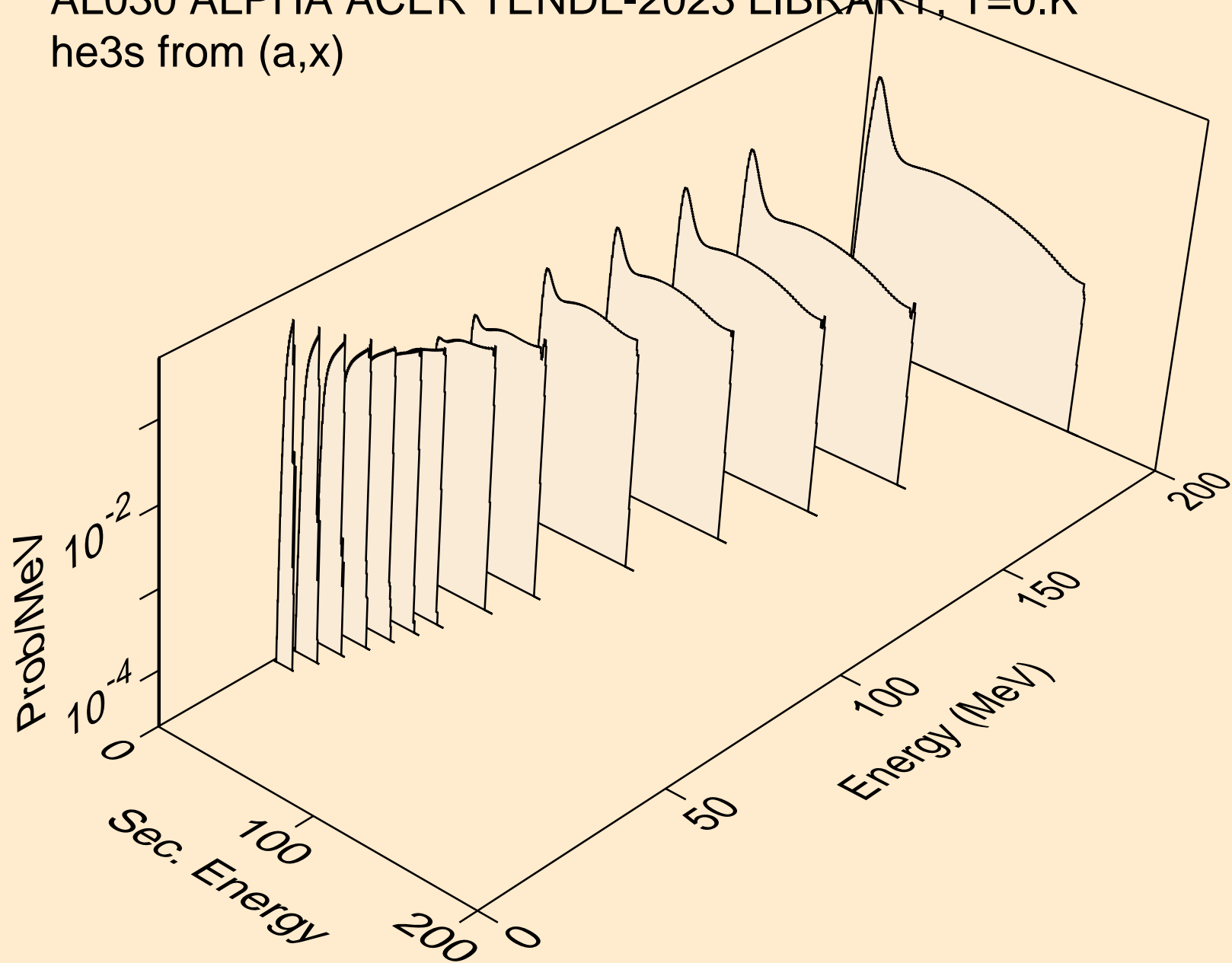

AL030 ALPHA ACER TENDL-2023 LIBRARY; T=0.K  
he3s from (a,n\*)he3

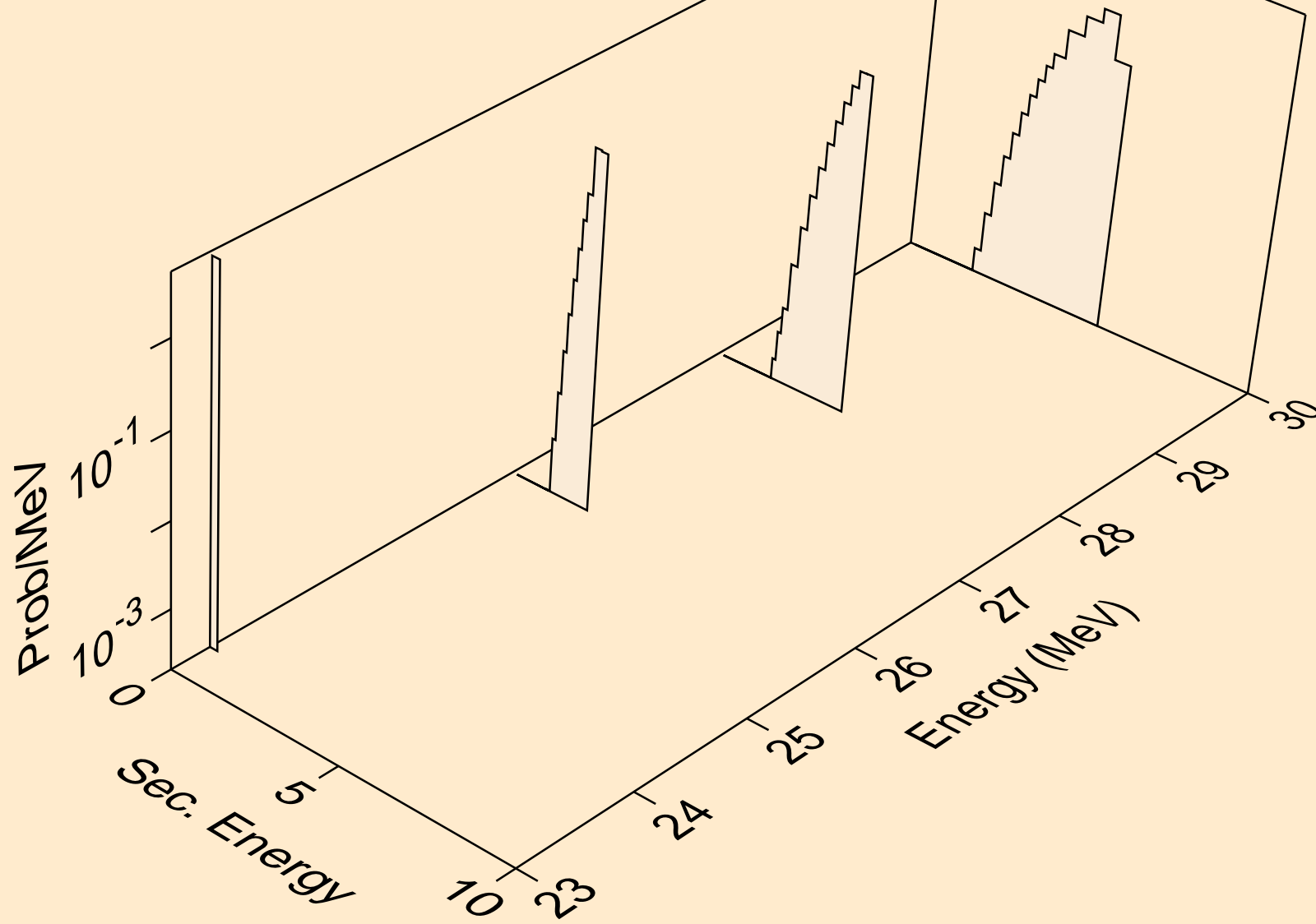

AL030 ALPHA ACER TENDL-2023 LIBRARY; T=0.K  
he3s from (a,he3)

