

MG028 ALPHA ACER TENDL-2023 LIBRARY; T=0.K  
Principal cross sections

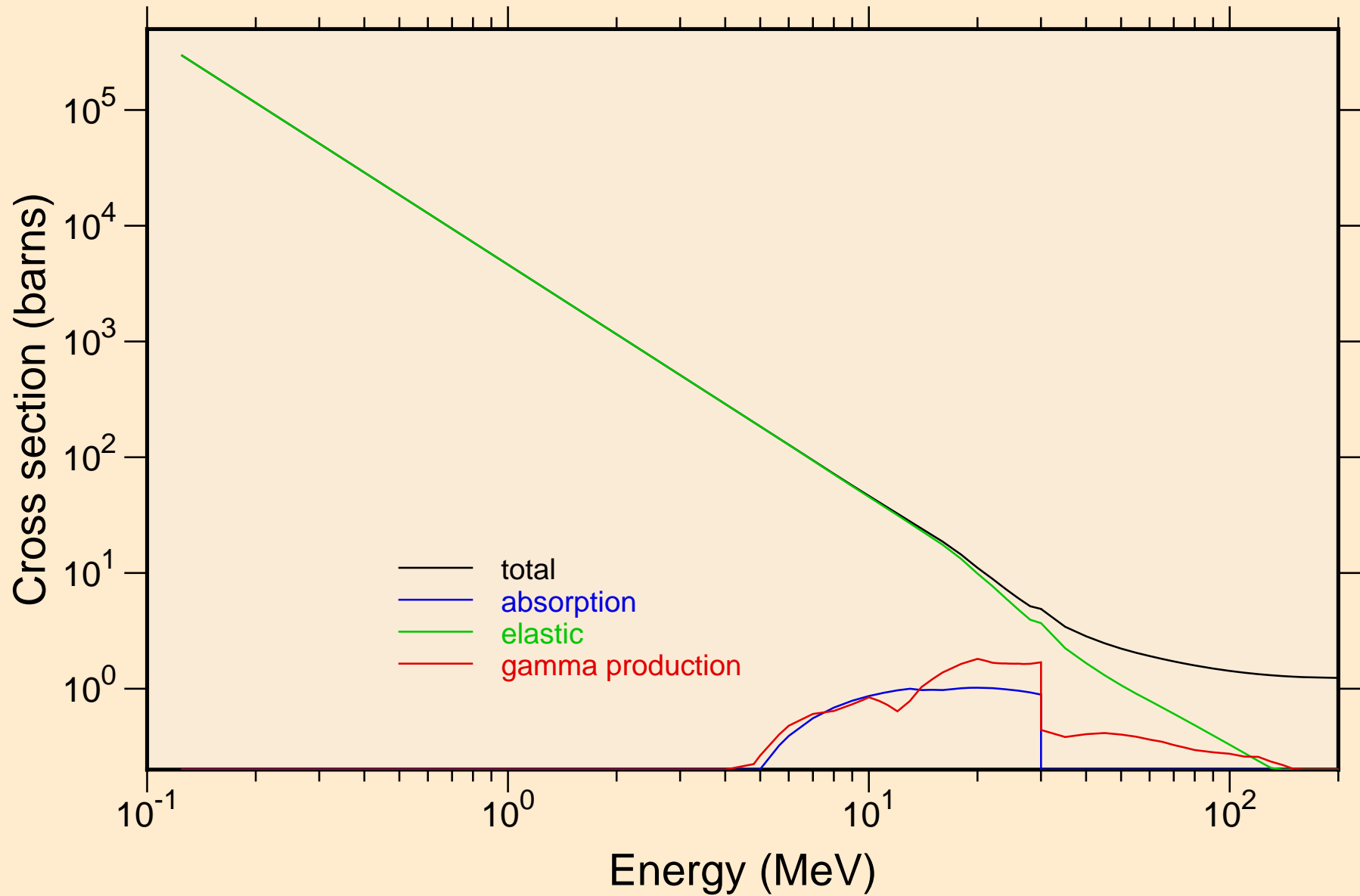

# MG028 ALPHA ACER TENDL-2023 LIBRARY; T=0.K

## Heating

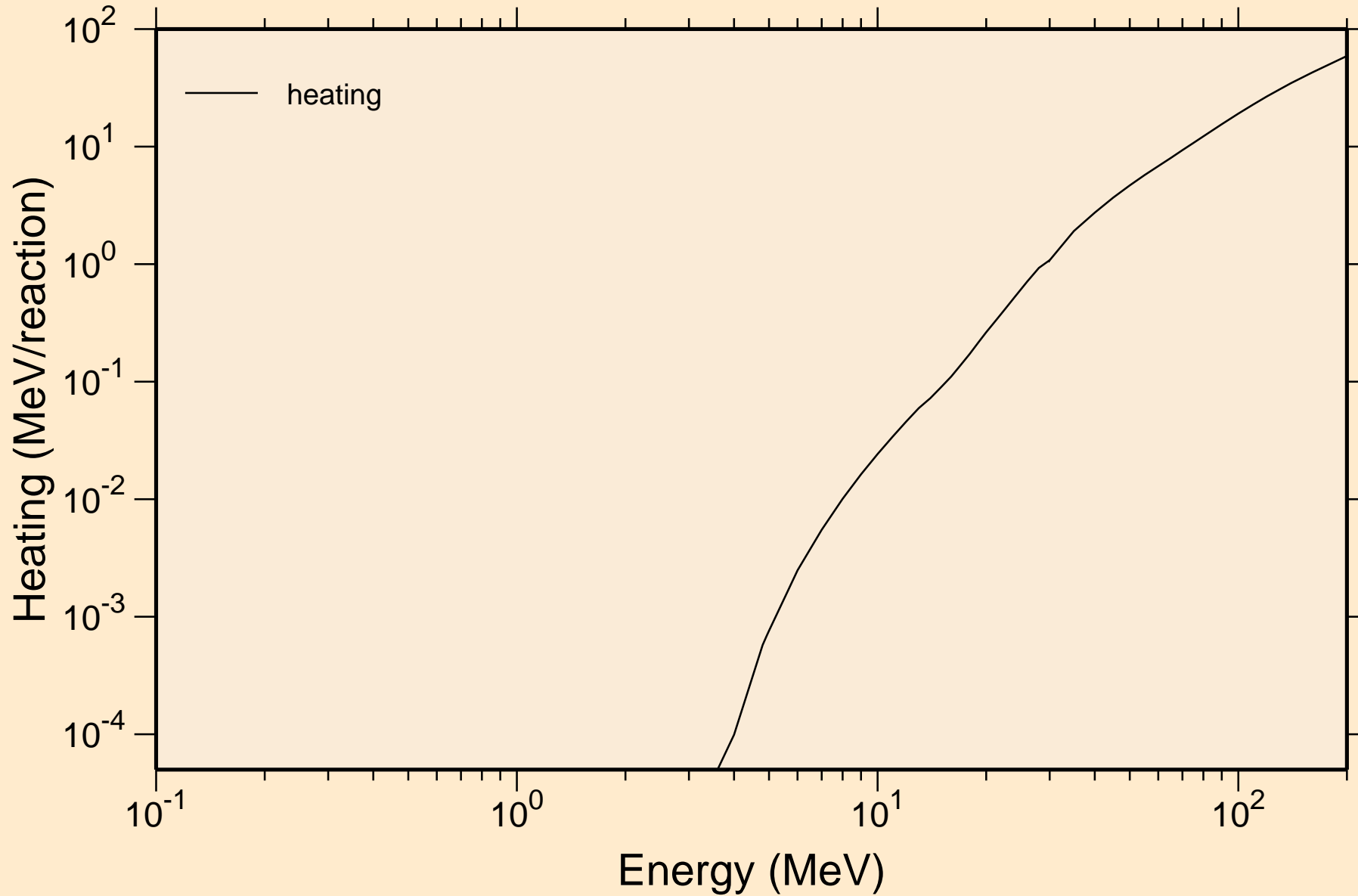

# MG028 ALPHA ACER TENDL-2023 LIBRARY; T=0.K

## Principal cross sections

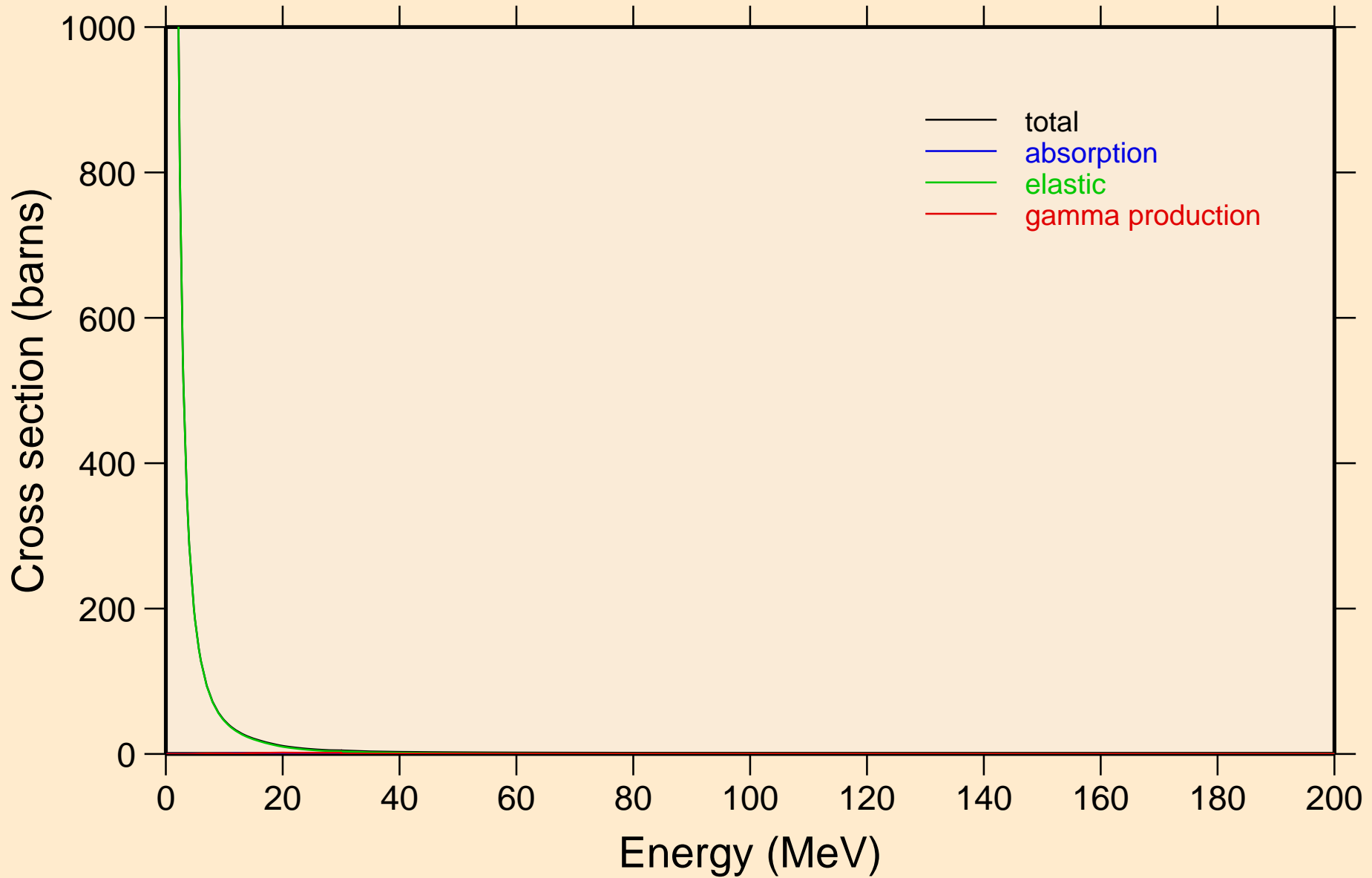

MG028 ALPHA ACER TENDL-2023 LIBRARY; T=0.K

Heating

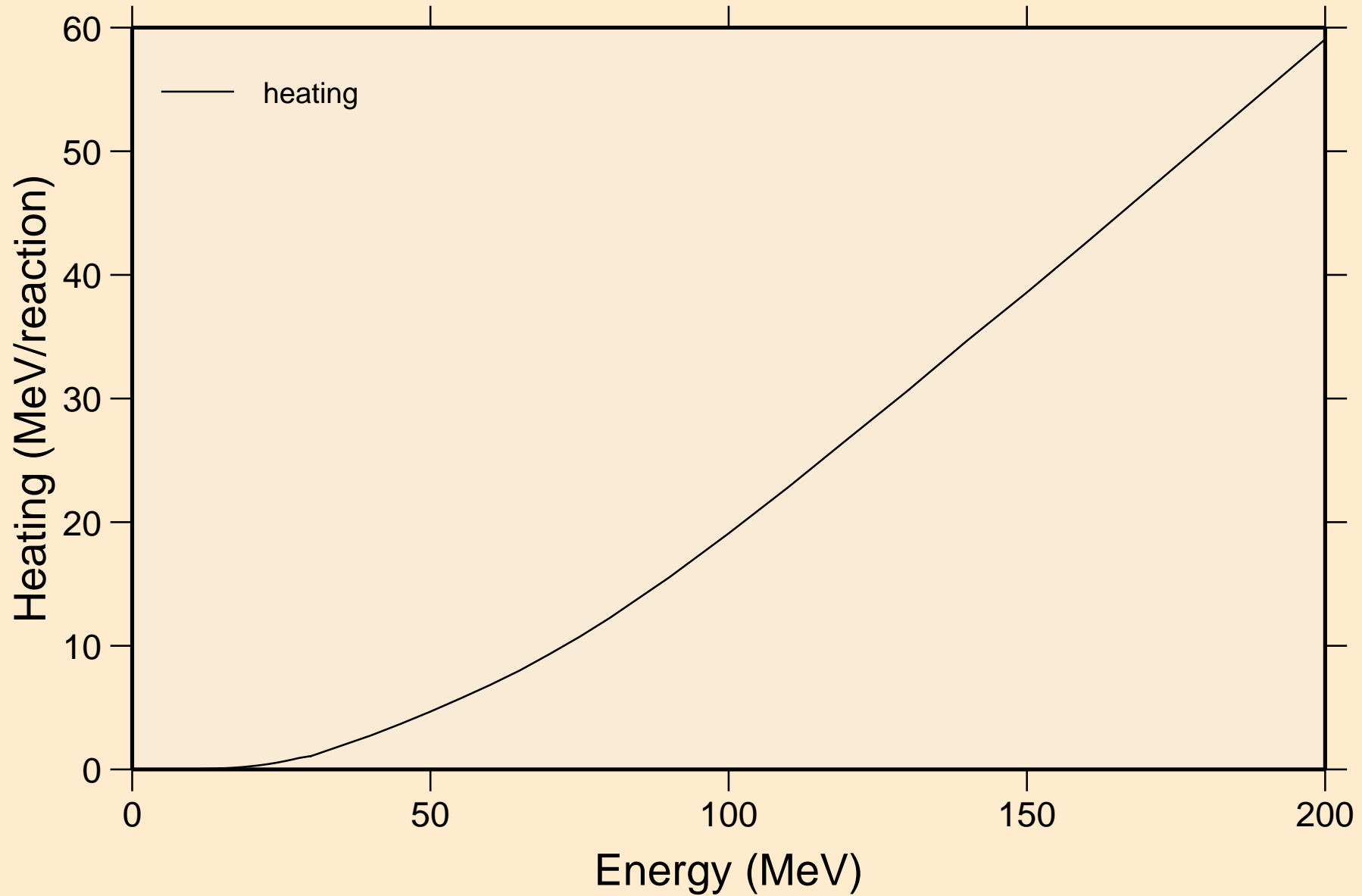

MG028 ALPHA ACER TENDL-2023 LIBRARY; T=0.K  
Threshold reactions

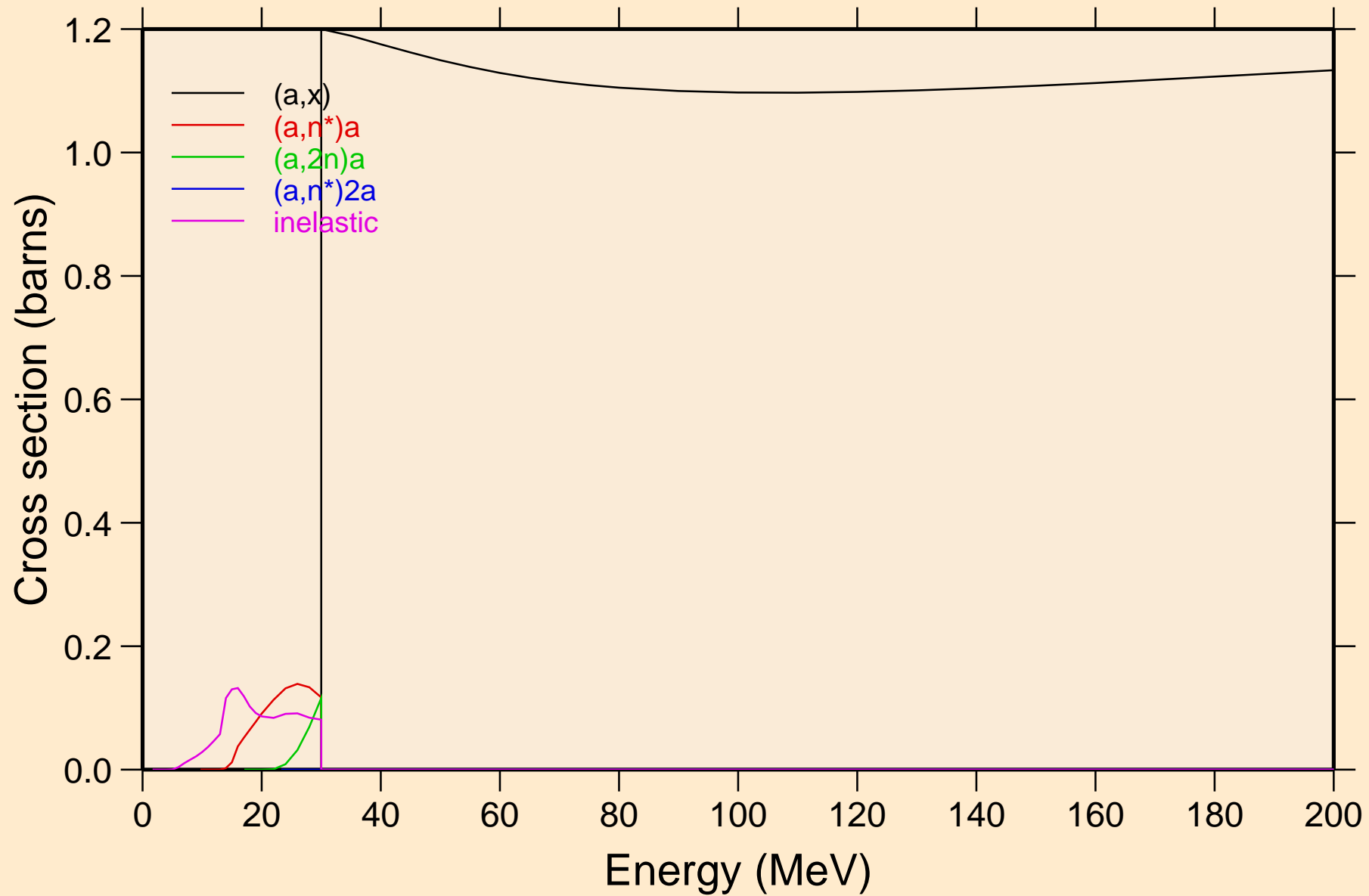

MG028 ALPHA ACER TENDL-2023 LIBRARY; T=0.K  
Threshold reactions

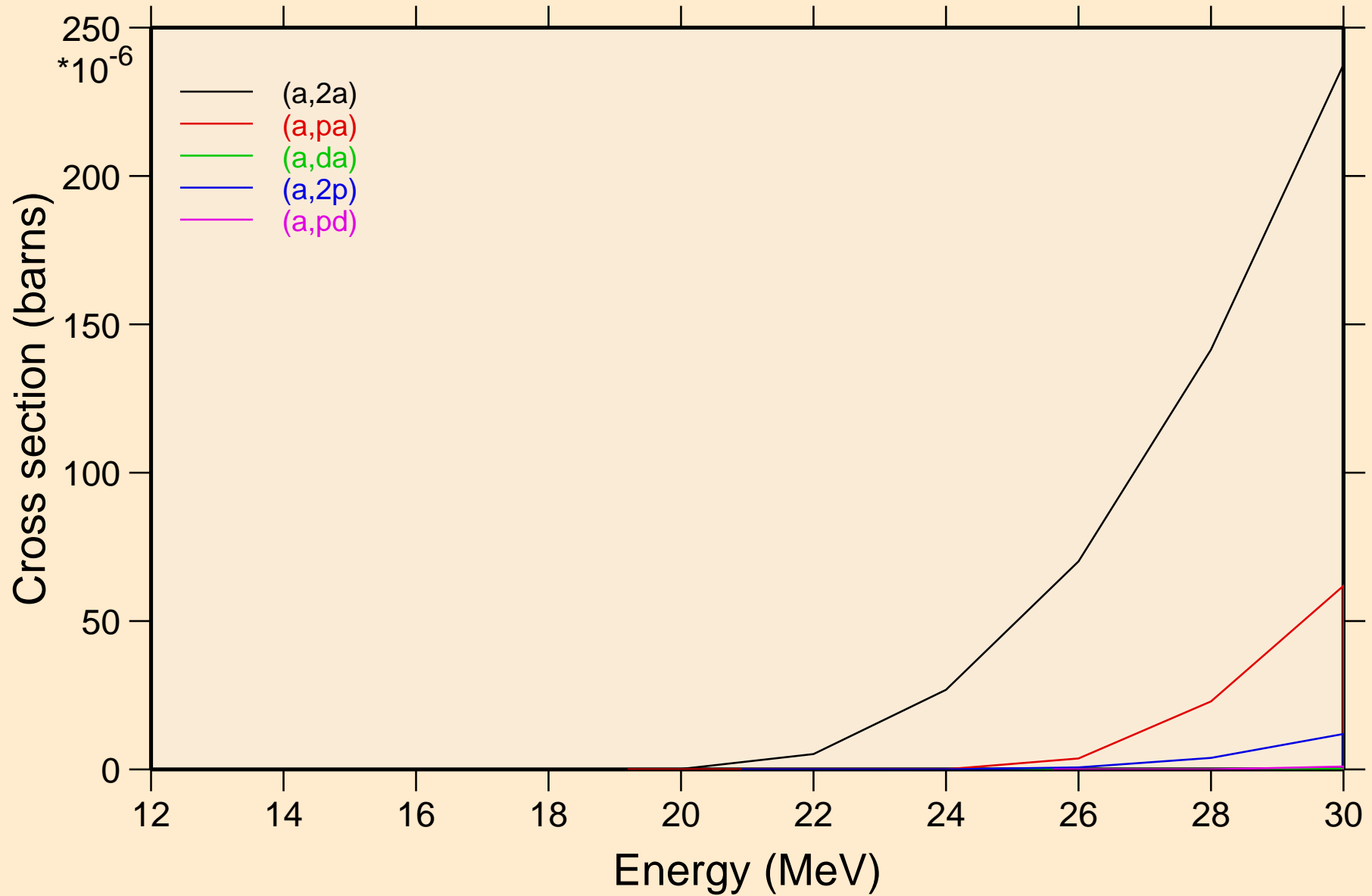

MG028 ALPHA ACER TENDL-2023 LIBRARY; T=0.K  
Threshold reactions

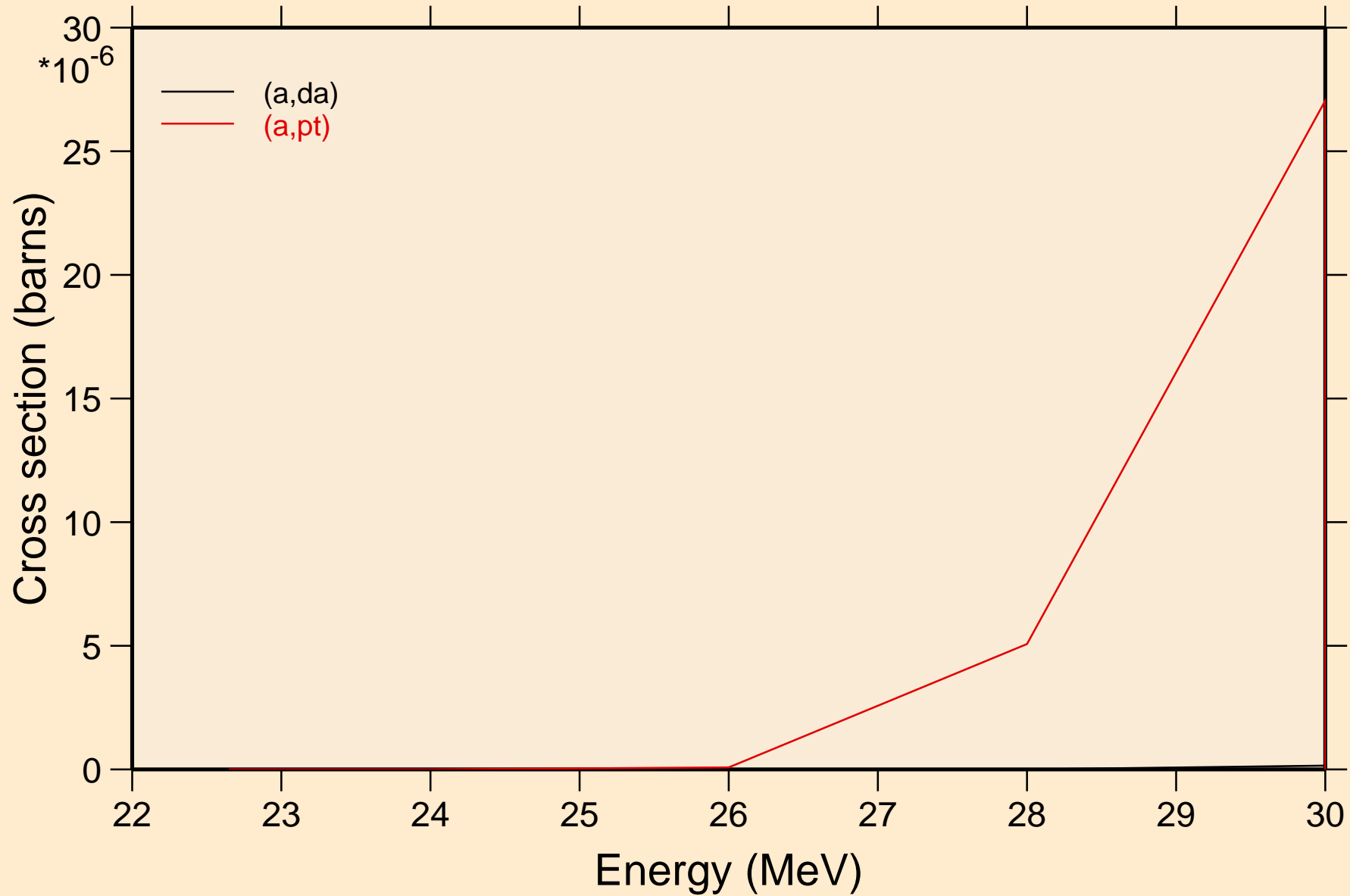

MG028 ALPHA ACER TENDL-2023 LIBRARY; T=0.K  
Threshold reactions

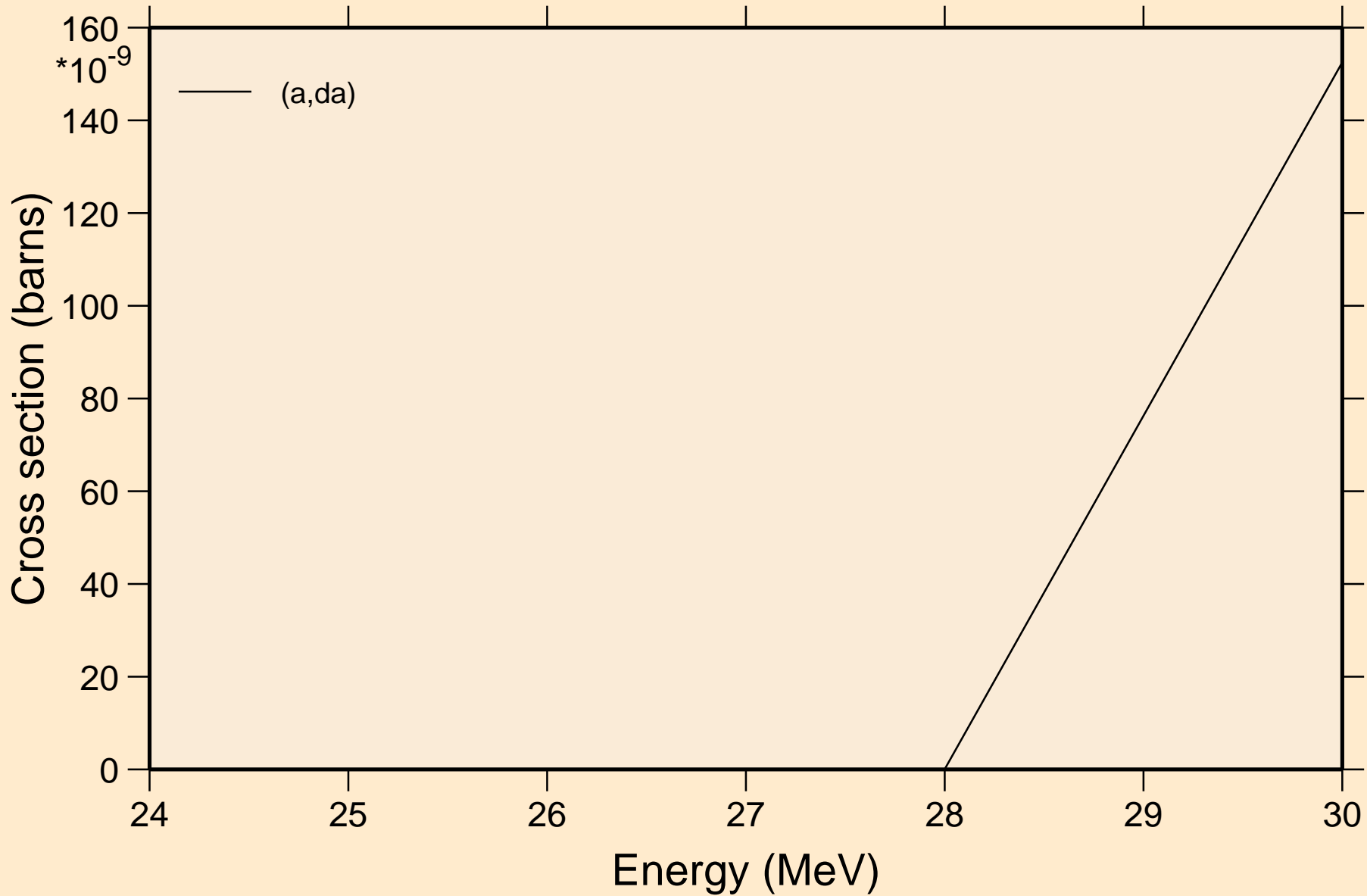



MG028 ALPHA ACER TENDL-2023 LIBRARY; T=0.K  
angular distribution for elastic

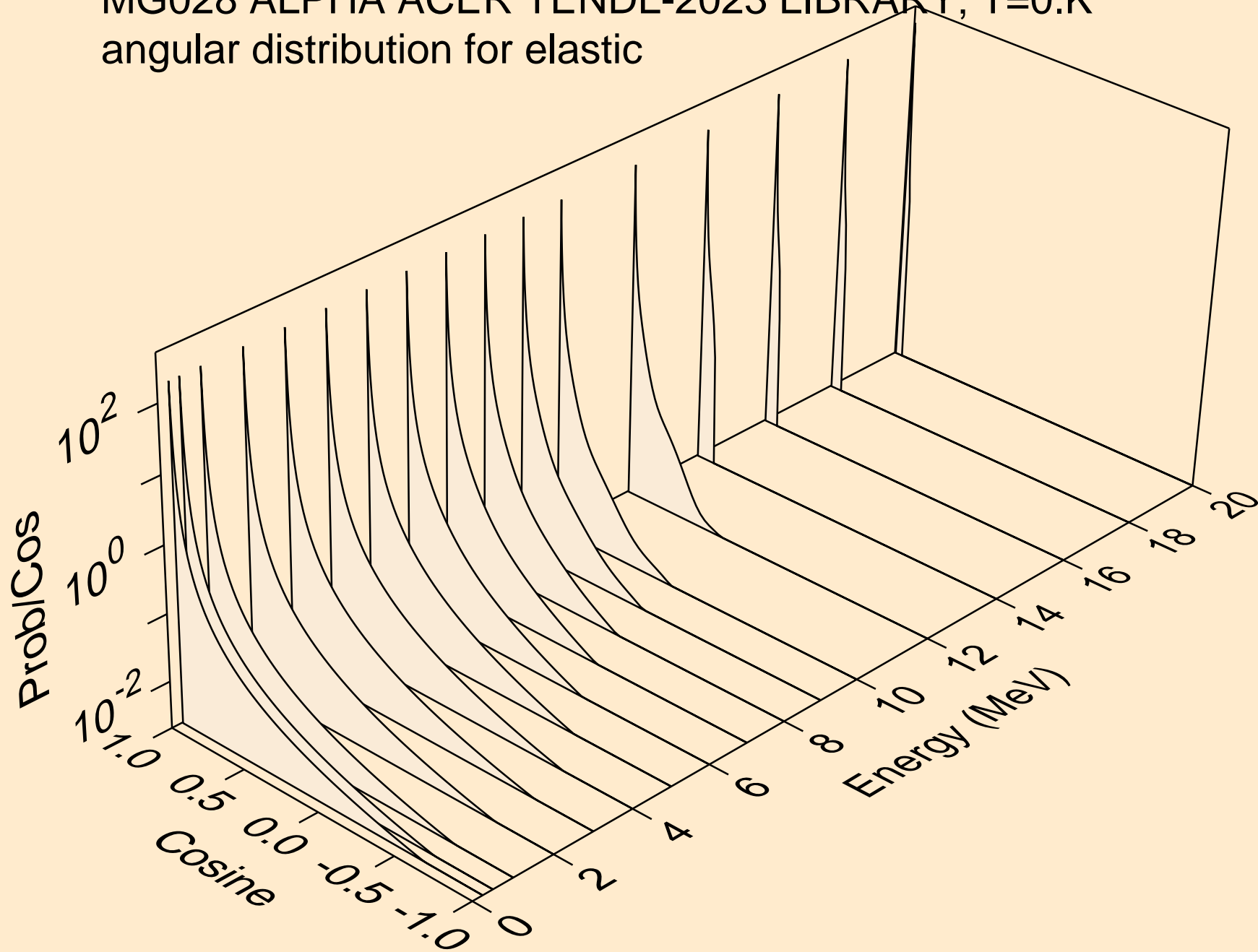

MG028 ALPHA ACER TENDL-2023 LIBRARY; T=0.K  
angular distribution for elastic

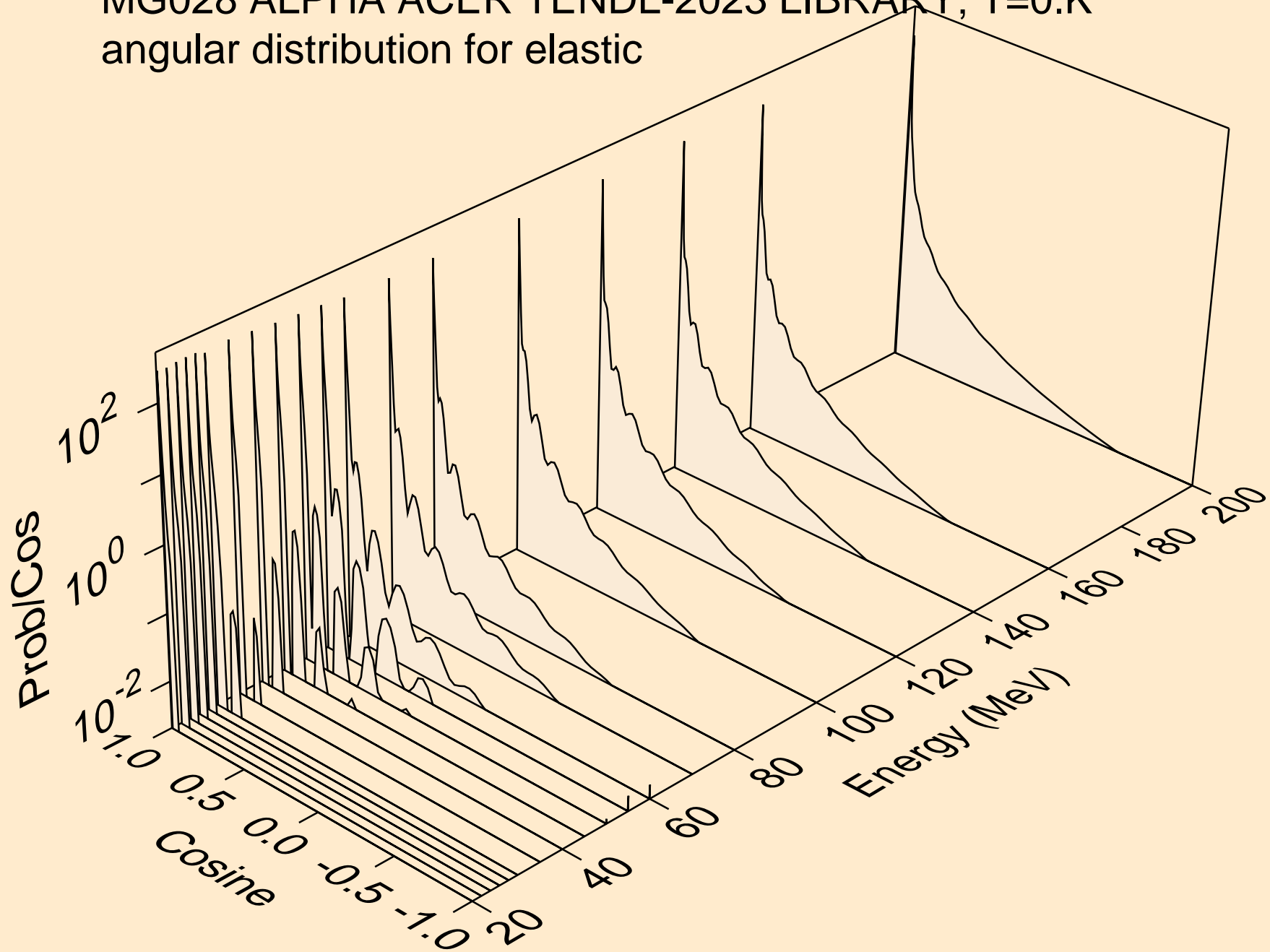

MG028 ALPHA ACER TENDL-2023 LIBRARY; T=0.K  
Alpha emission for (a,x)

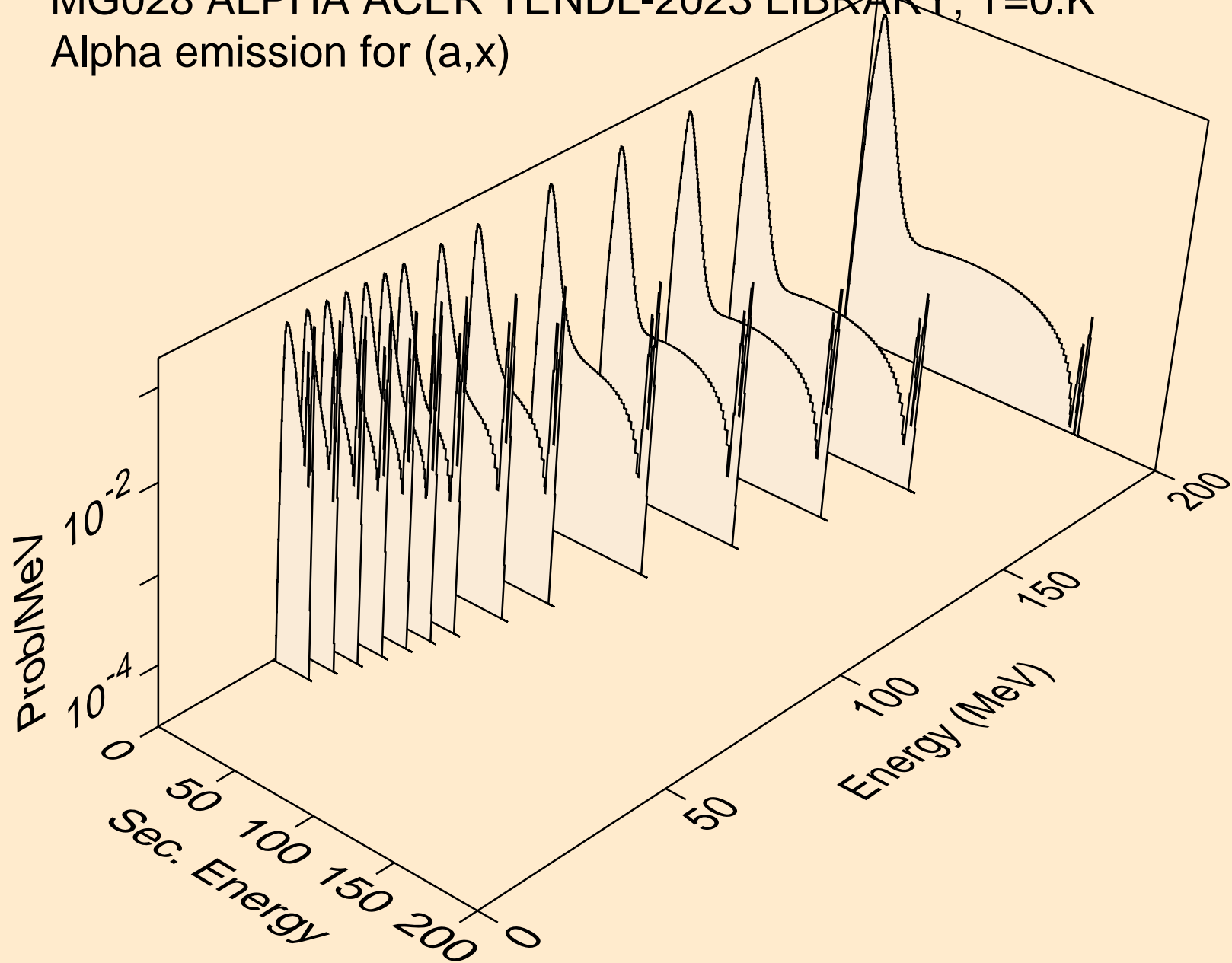

MG028 ALPHA ACER TENDL-2023 LIBRARY; T=0.K  
Alpha emission for (a,n\*)a

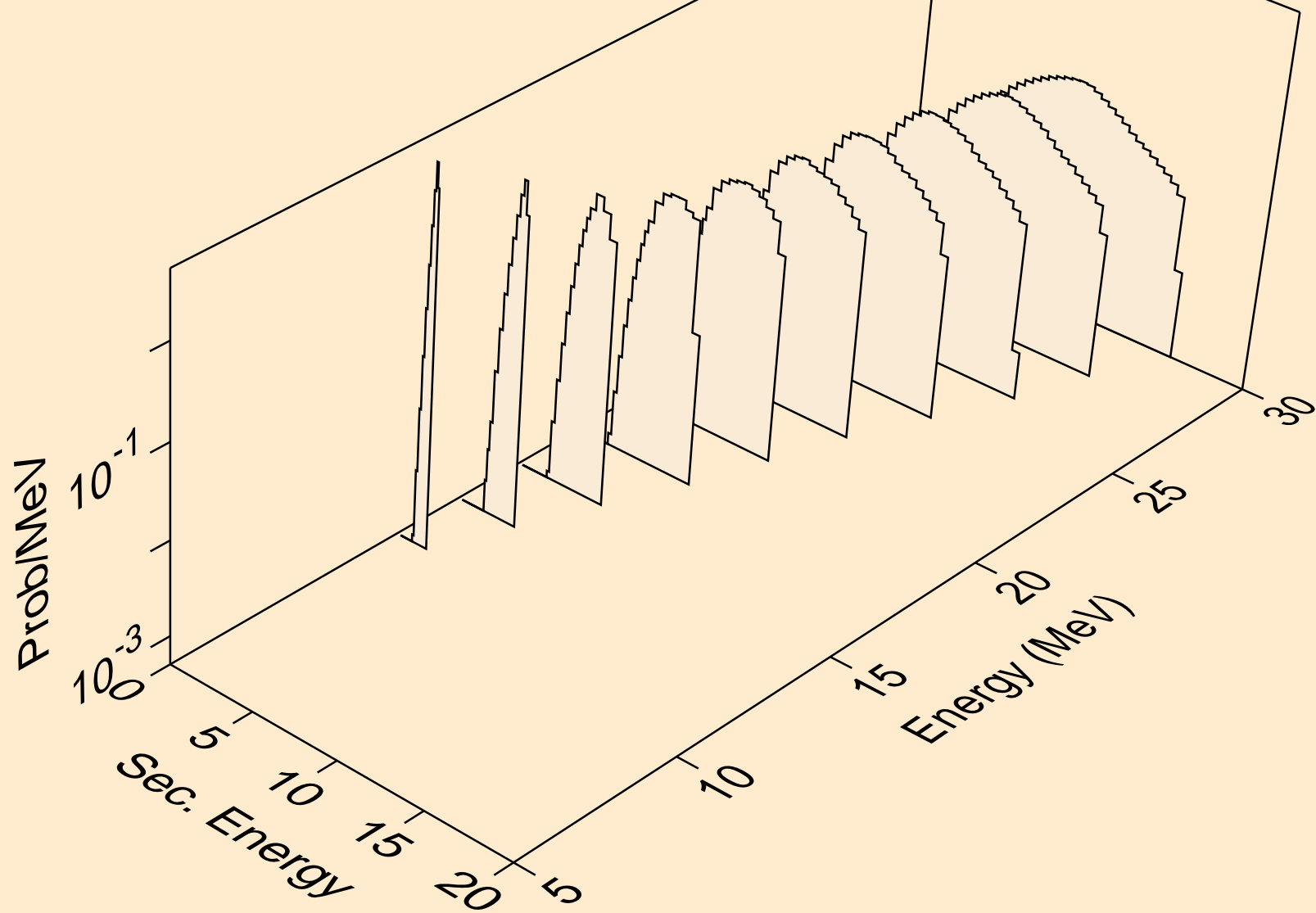

MG028 ALPHA ACER TENDL-2023 LIBRARY; T=0.K  
Alpha emission for (a,2n)a

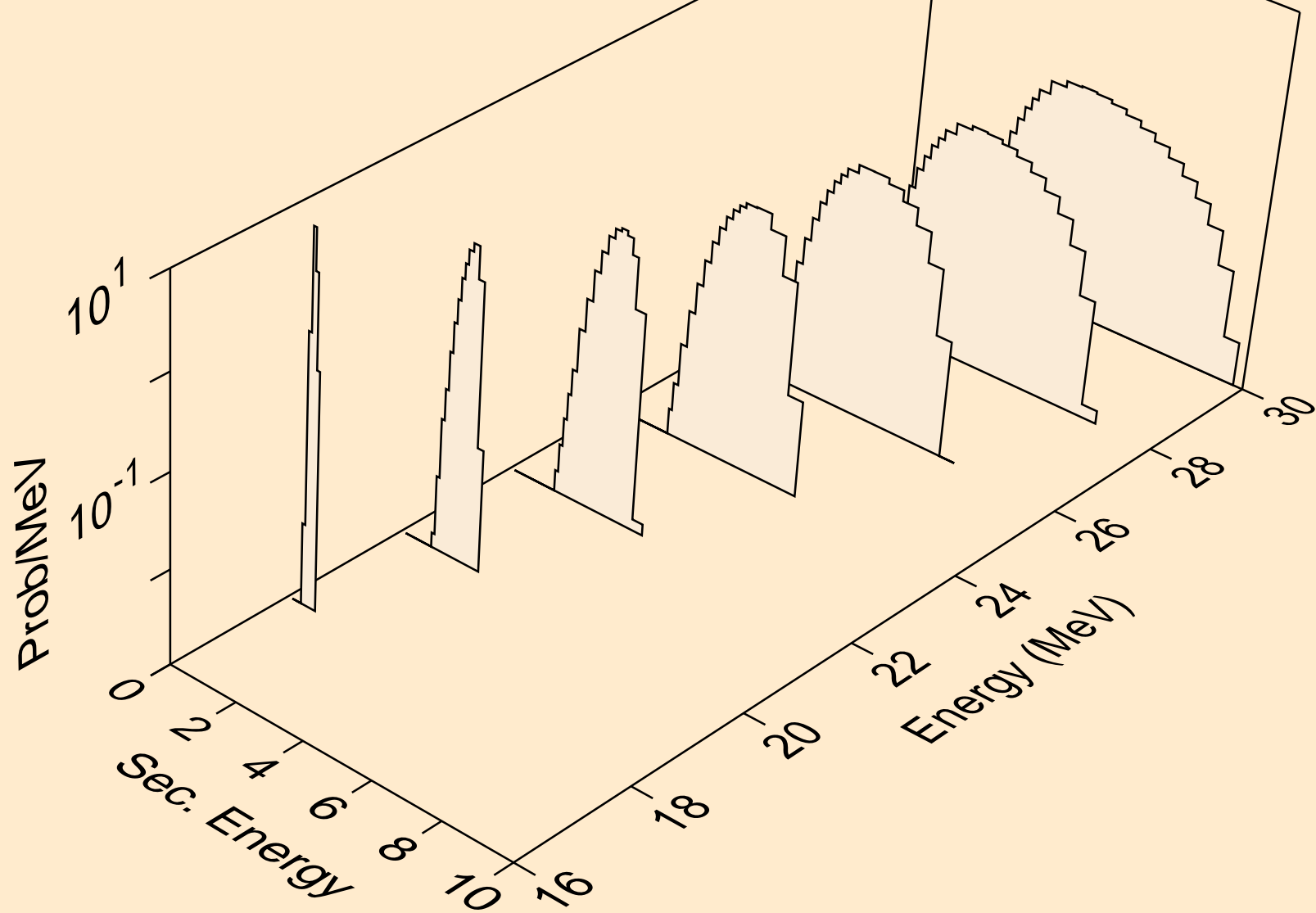

MG028 ALPHA ACER TENDL-2023 LIBRARY; T=0.K  
Alpha emission for (a,n\*)2a

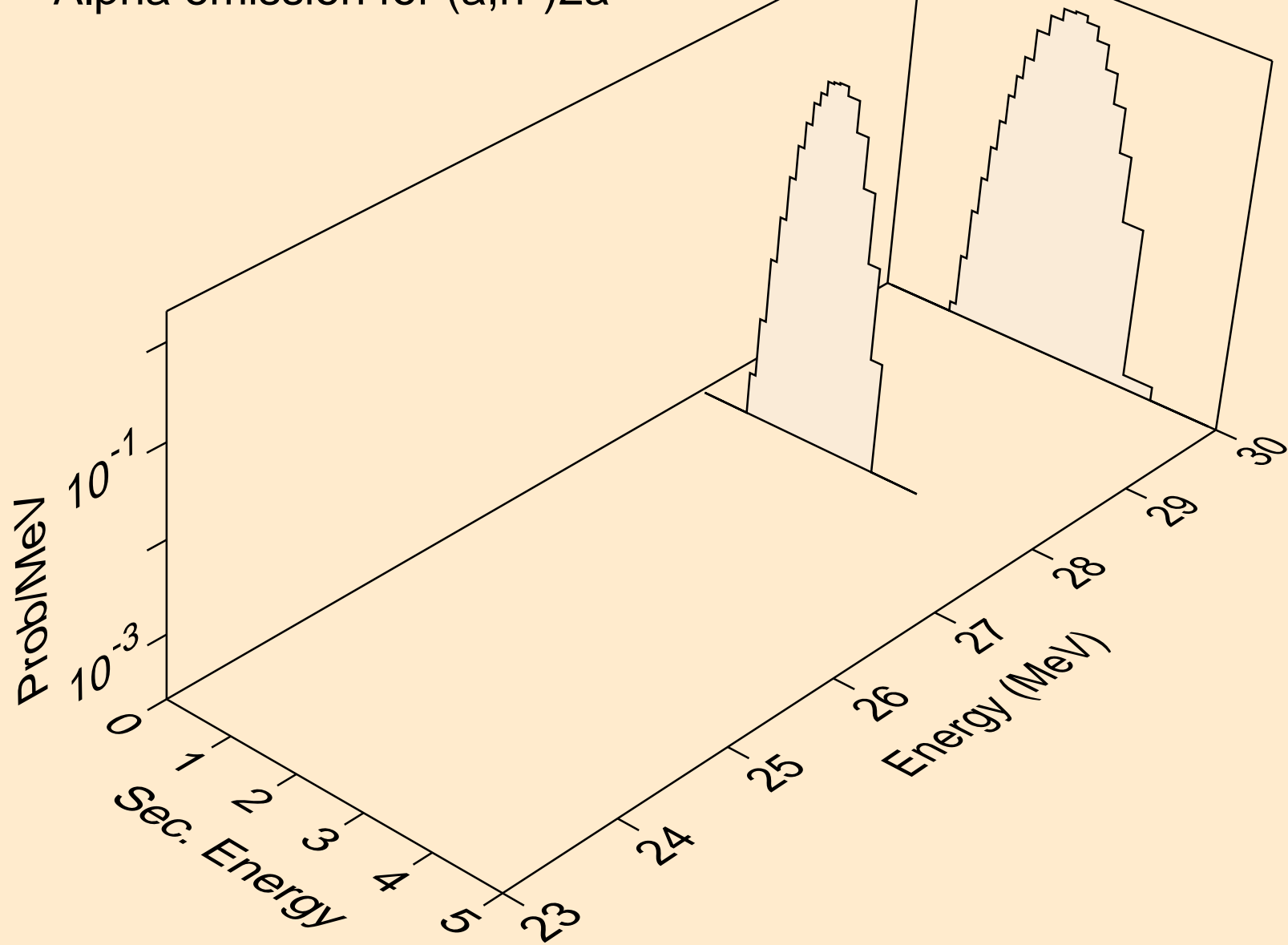

MG028 ALPHA ACER TENDL-2023 LIBRARY; T=0.K  
Alpha emission for inelastic

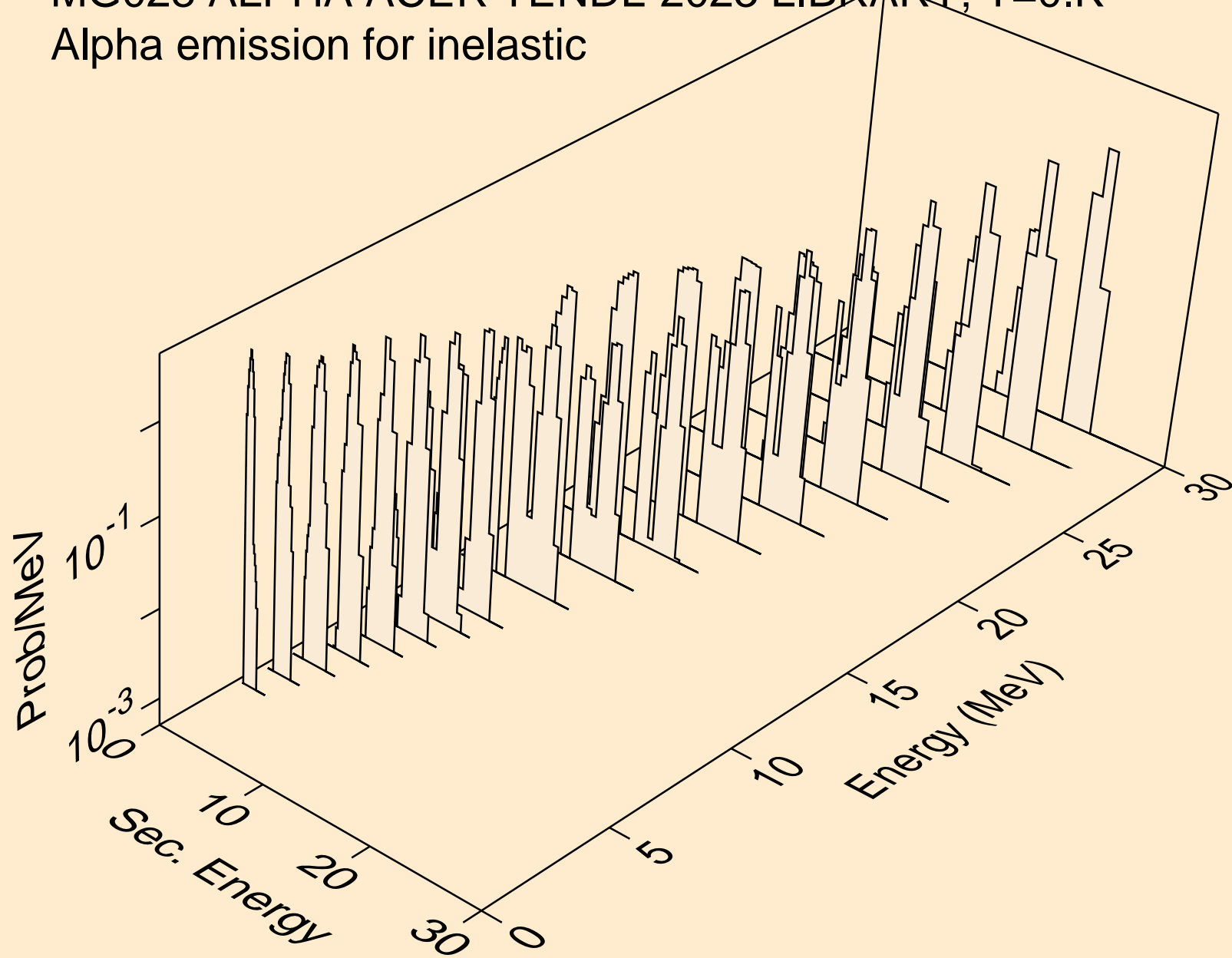

MG028 ALPHA ACER TENDL-2023 LIBRARY; T=0.K  
Alpha emission for (a,2a)

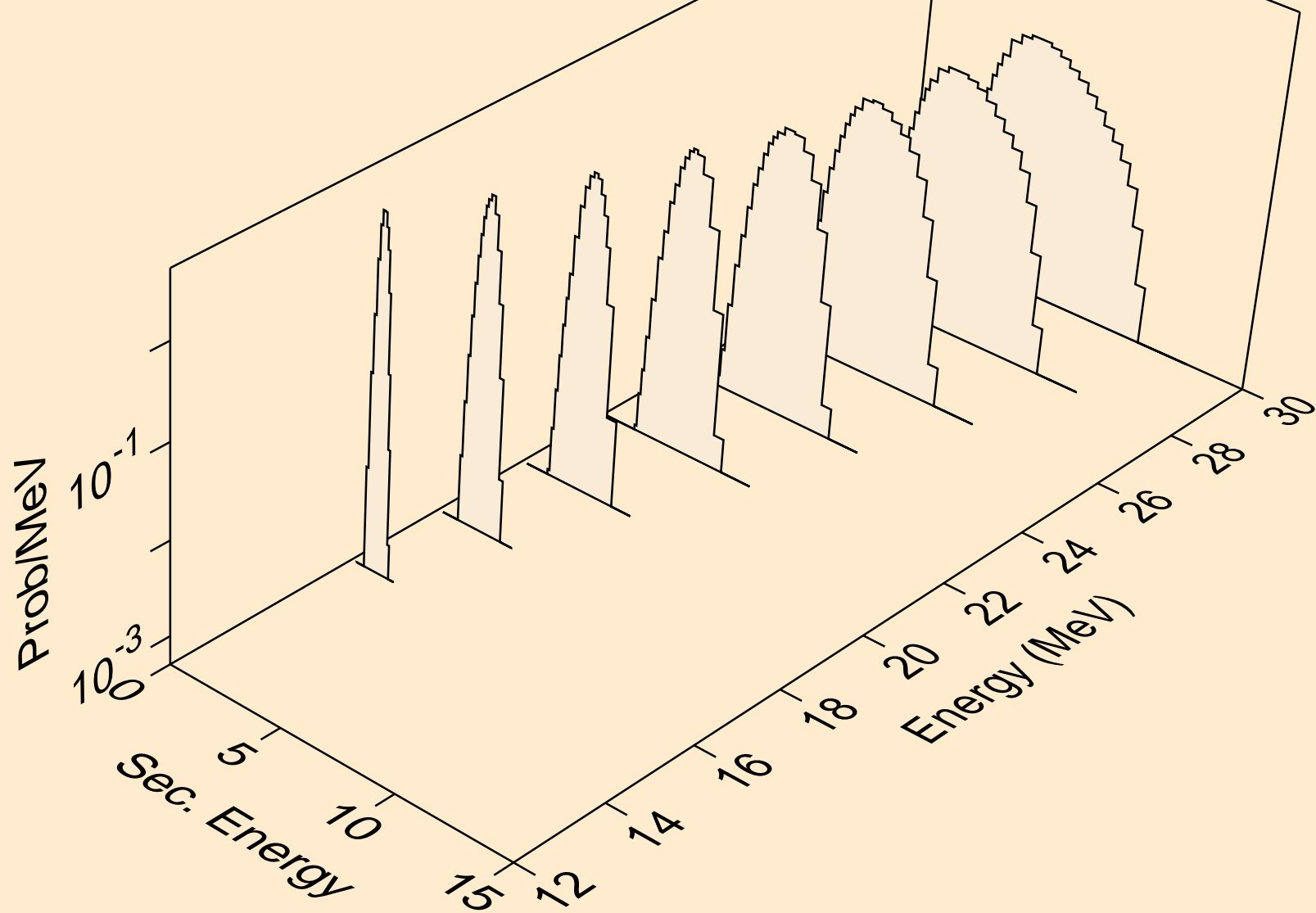



MG028 ALPHA ACER TENDL-2023 LIBRARY; T=0.K  
Alpha emission for (a,pa)

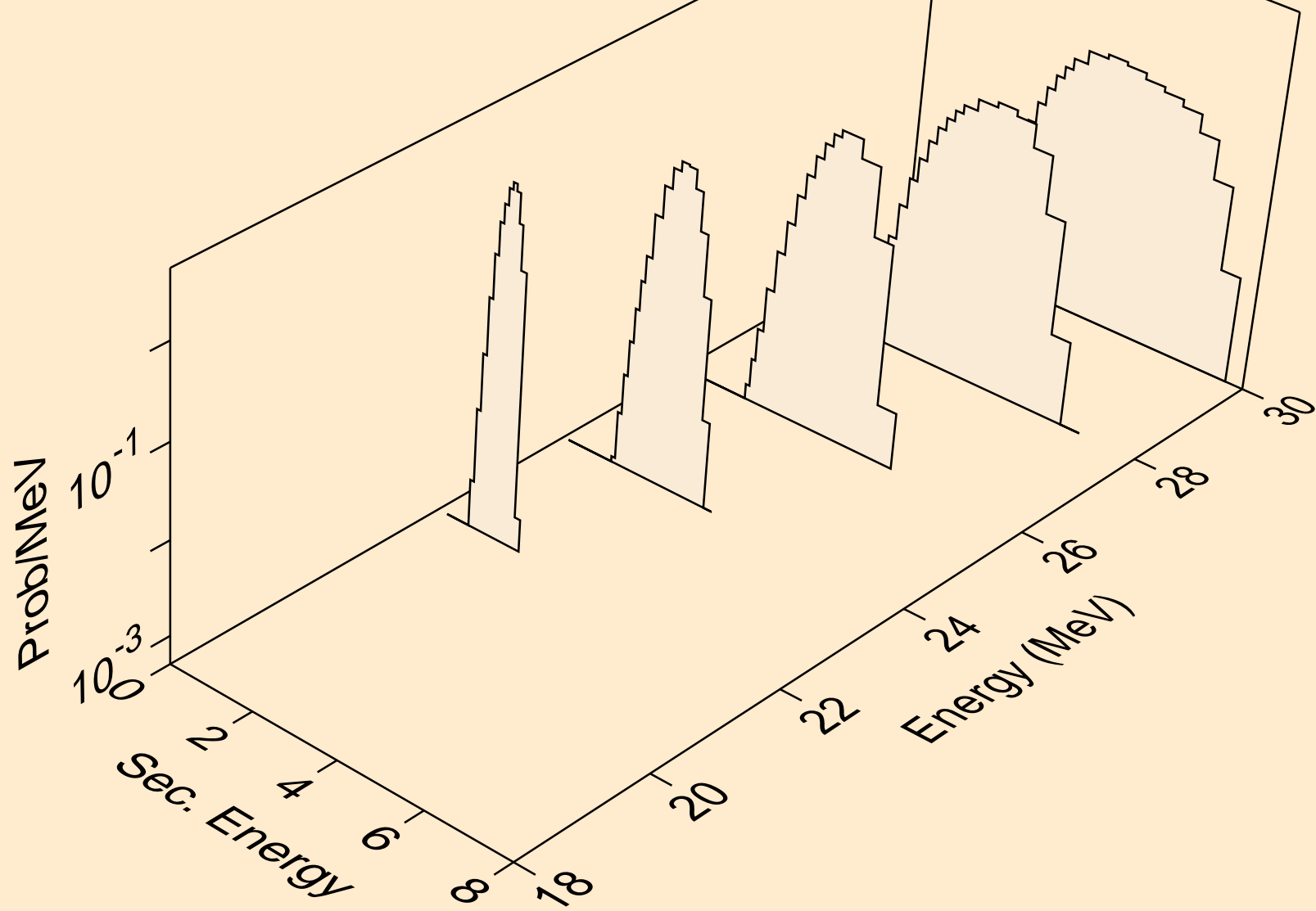

MG028 ALPHA ACER TENDL-2023 LIBRARY; T=0.K  
Alpha emission for (a,da)

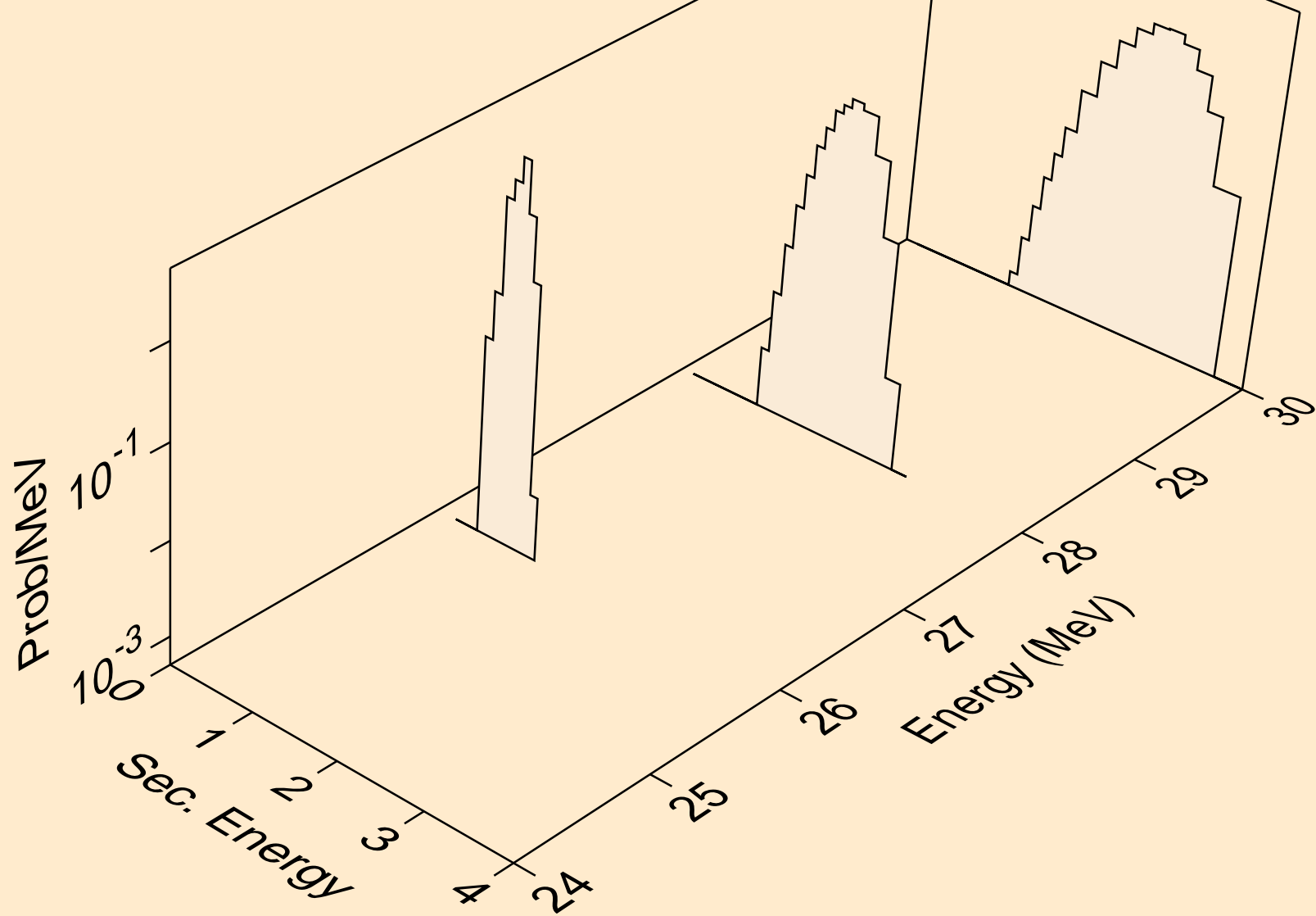

MG028 ALPHA ACER TENDL-2023 LIBRARY; T=0.K  
Photon emission for (z,n)

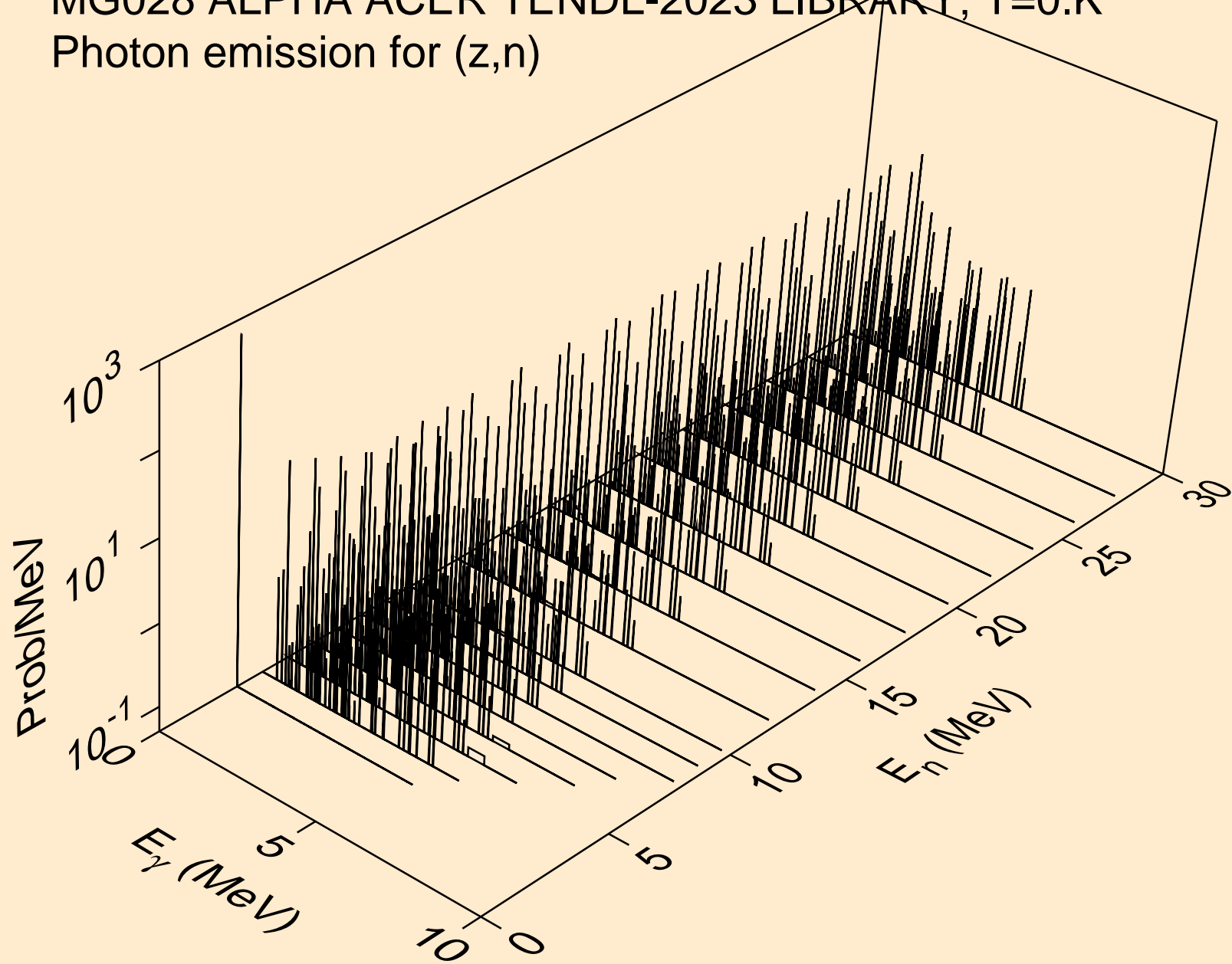

MG028 ALPHA ACER TENDL-2023 LIBRARY; T=0.K  
Photon emission for (z,x)

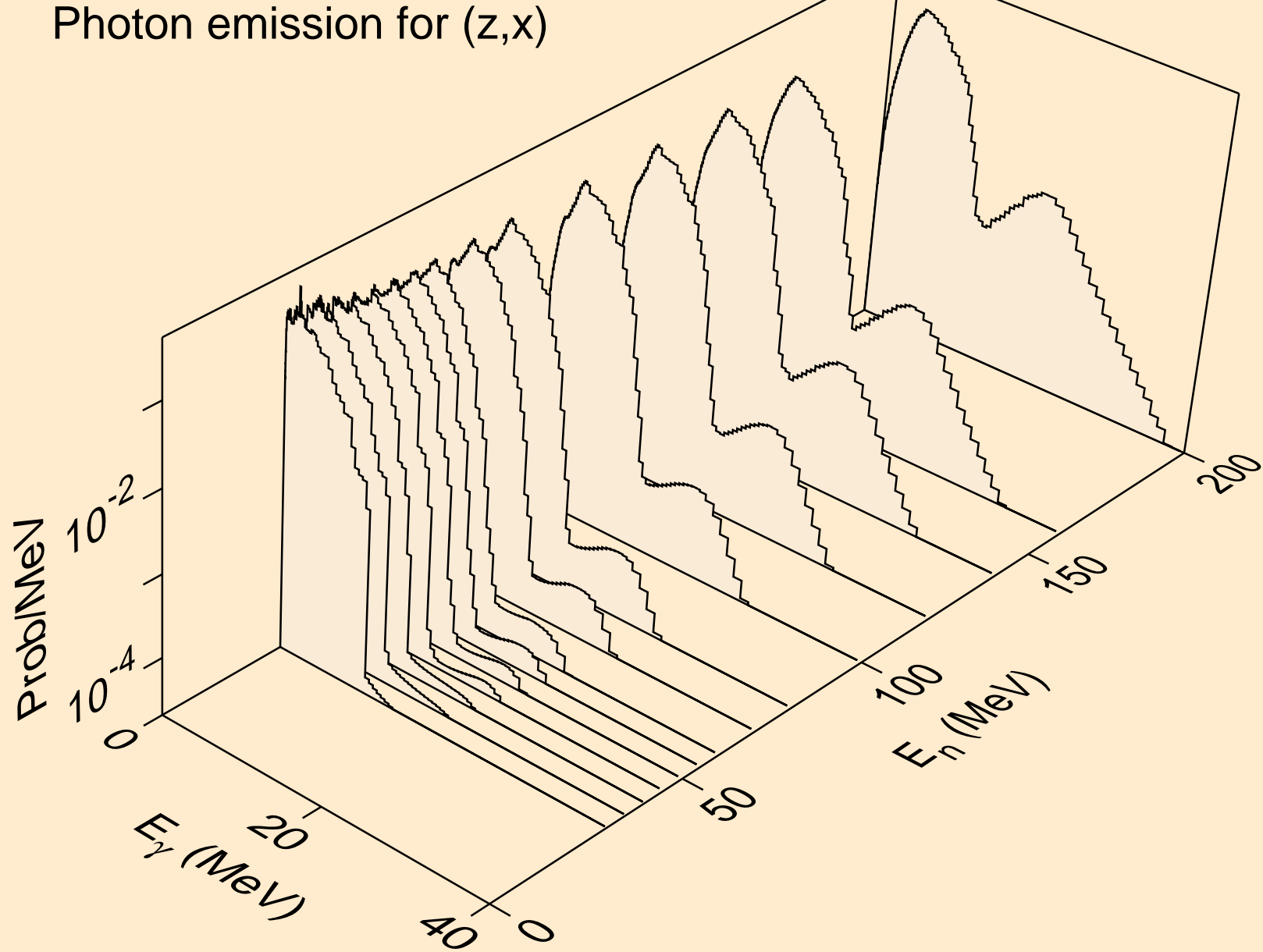

MG028 ALPHA ACER TENDL-2023 LIBRARY; T=0.K  
Photon emission for (n,2n)

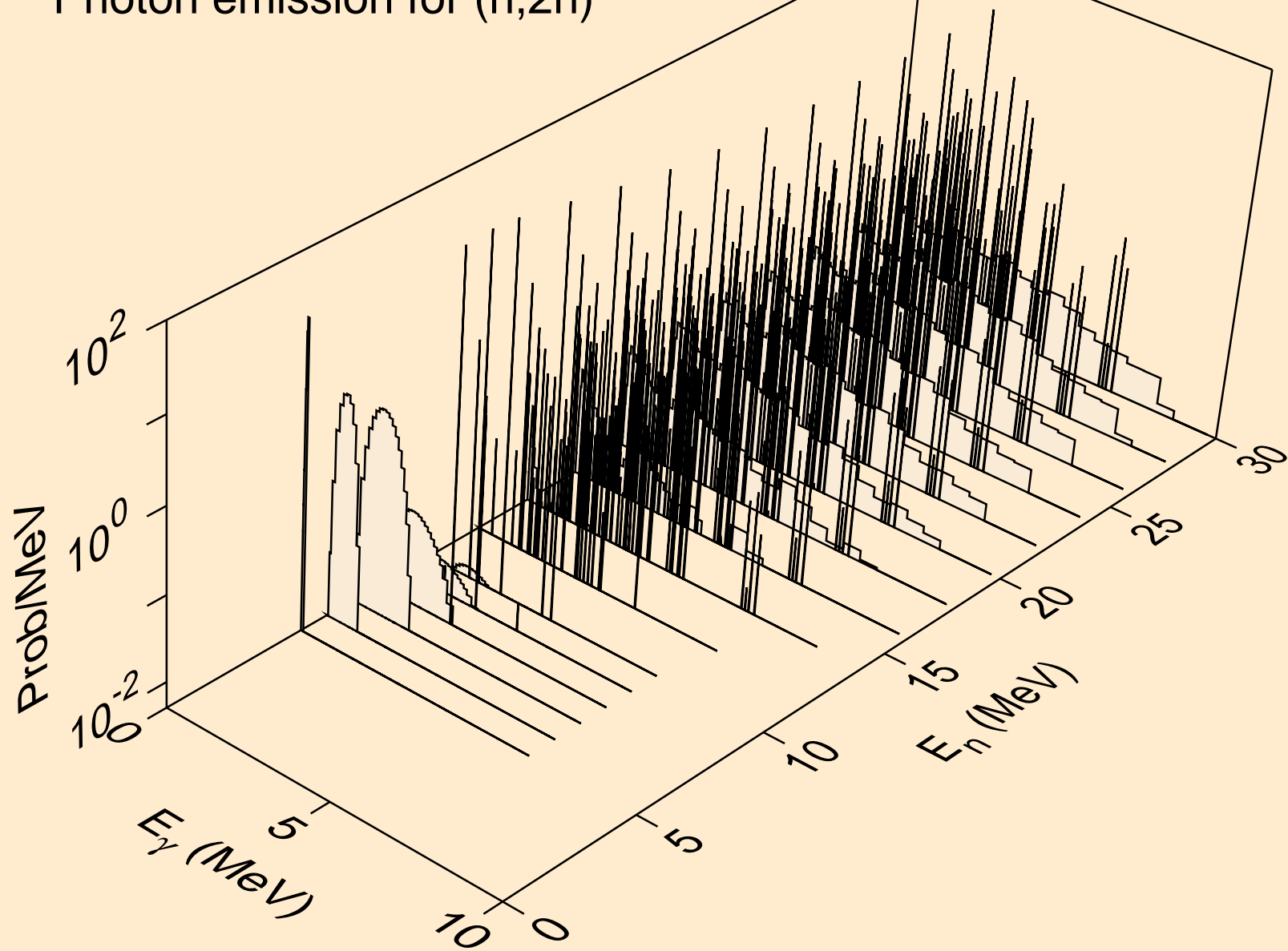

MG028 ALPHA ACER TENDL-2023 LIBRARY; T=0.K  
Photon emission for (n,3n)

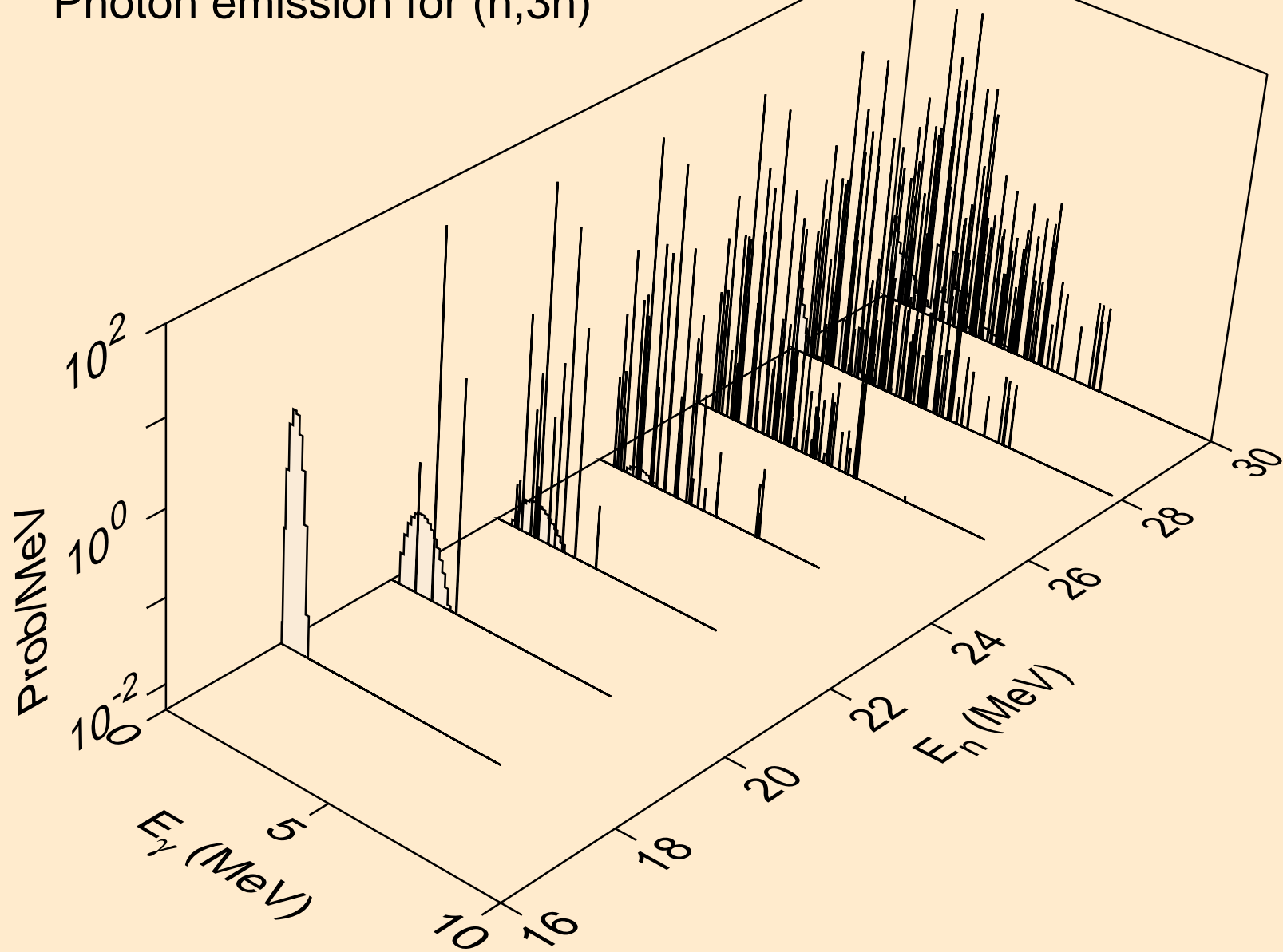

MG028 ALPHA ACER TENDL-2023 LIBRARY; T=0.K  
Photon emission for (n,n\*)a

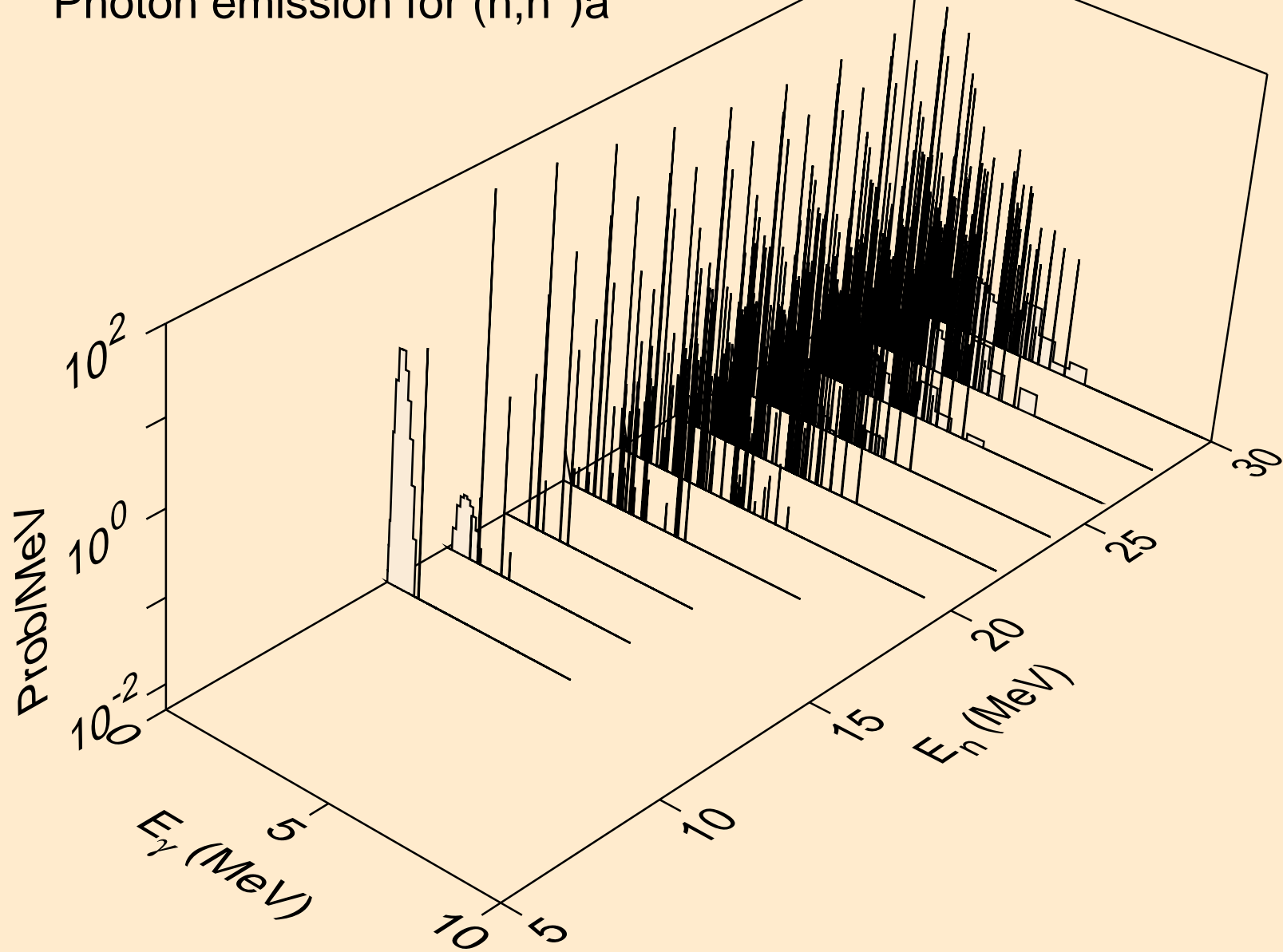

MG028 ALPHA ACER TENDL-2023 LIBRARY; T=0.K  
Photon emission for (n,2n)a

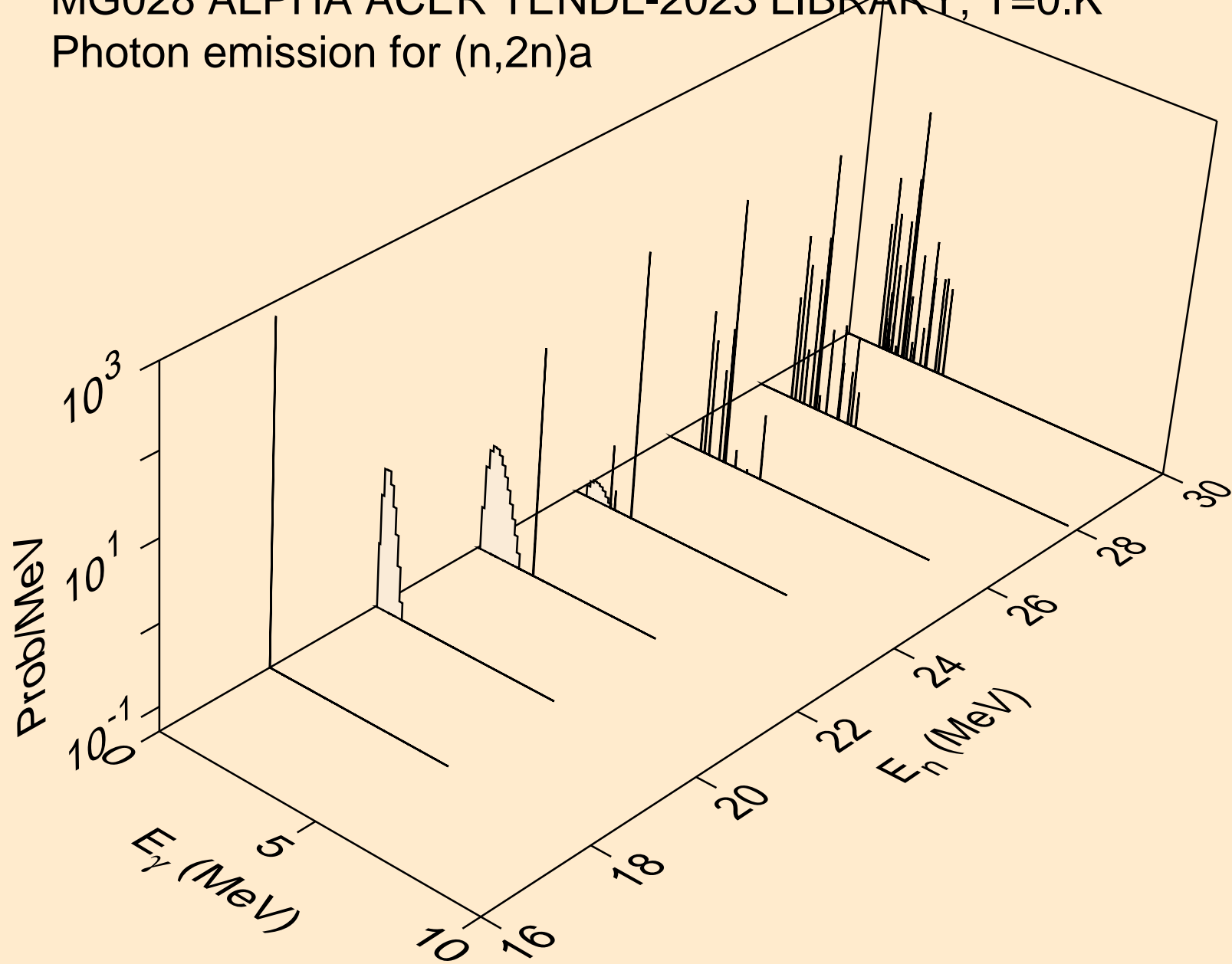



MG028 ALPHA ACER TENDL-2023 LIBRARY; T=0.K  
Photon emission for (n,n\*)p

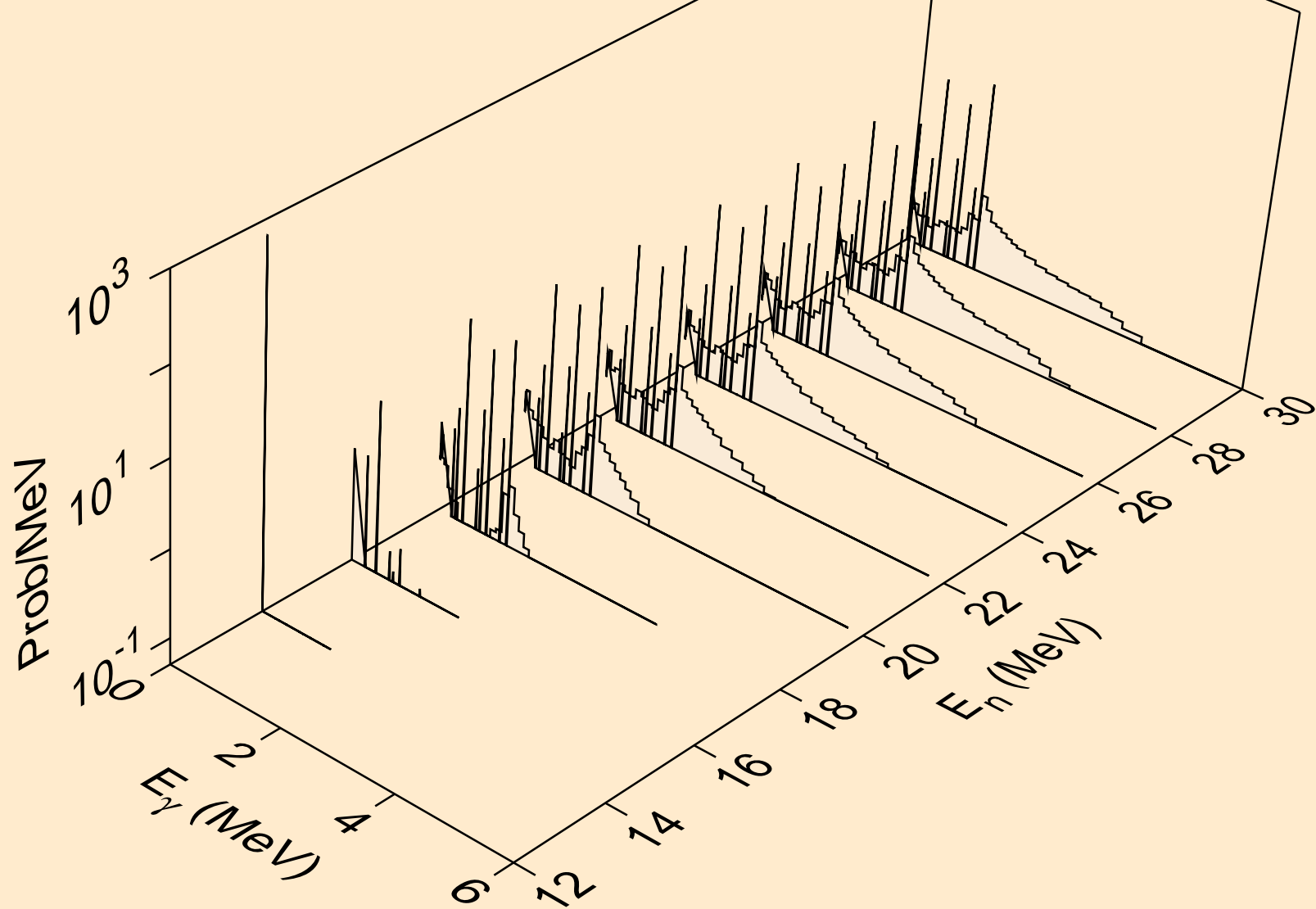

MG028 ALPHA ACER TENDL-2023 LIBRARY; T=0.K  
Photon emission for (n,n\*)2a

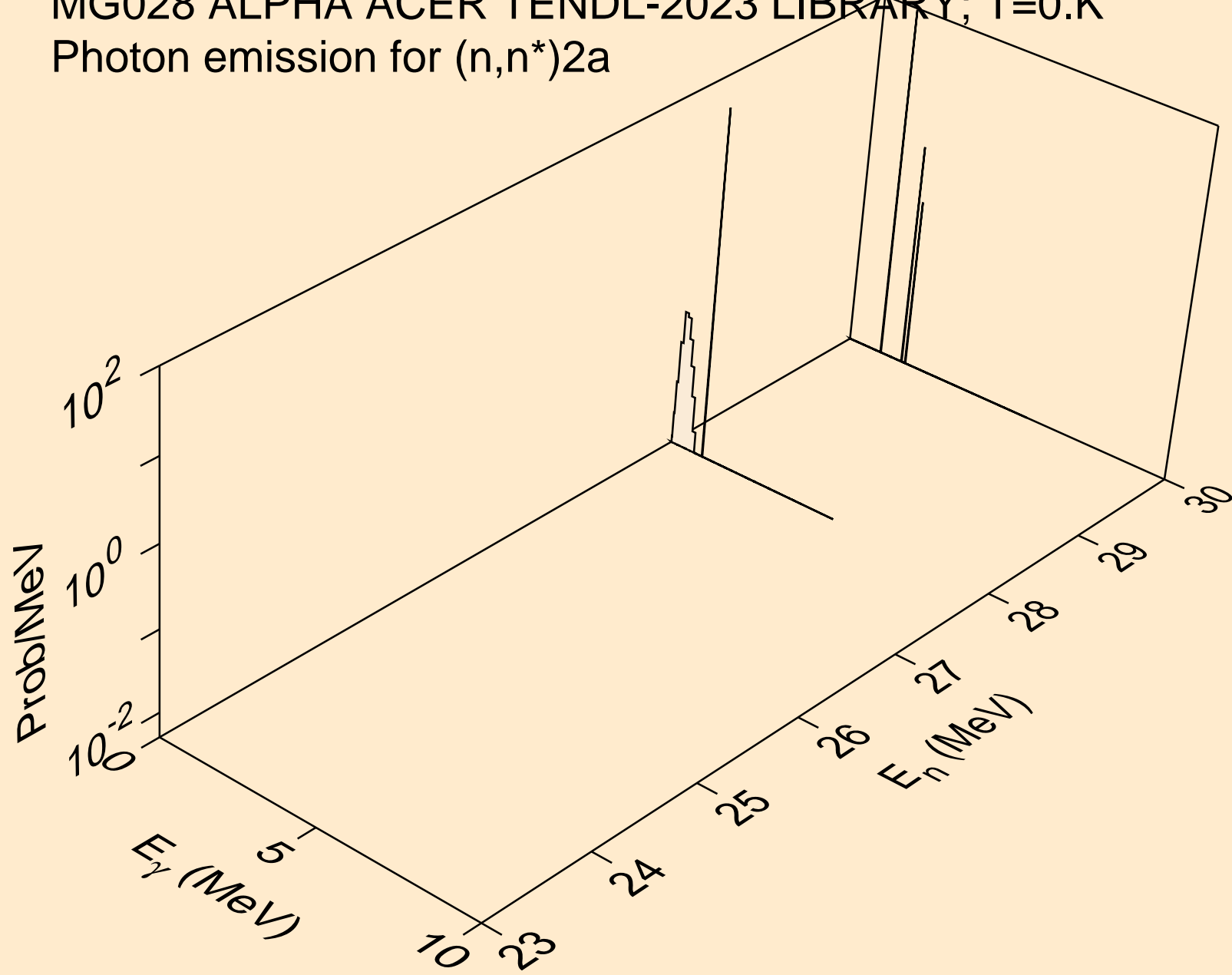

MG028 ALPHA ACER TENDL-2023 LIBRARY; T=0.K  
Photon emission for (n,n\*)d

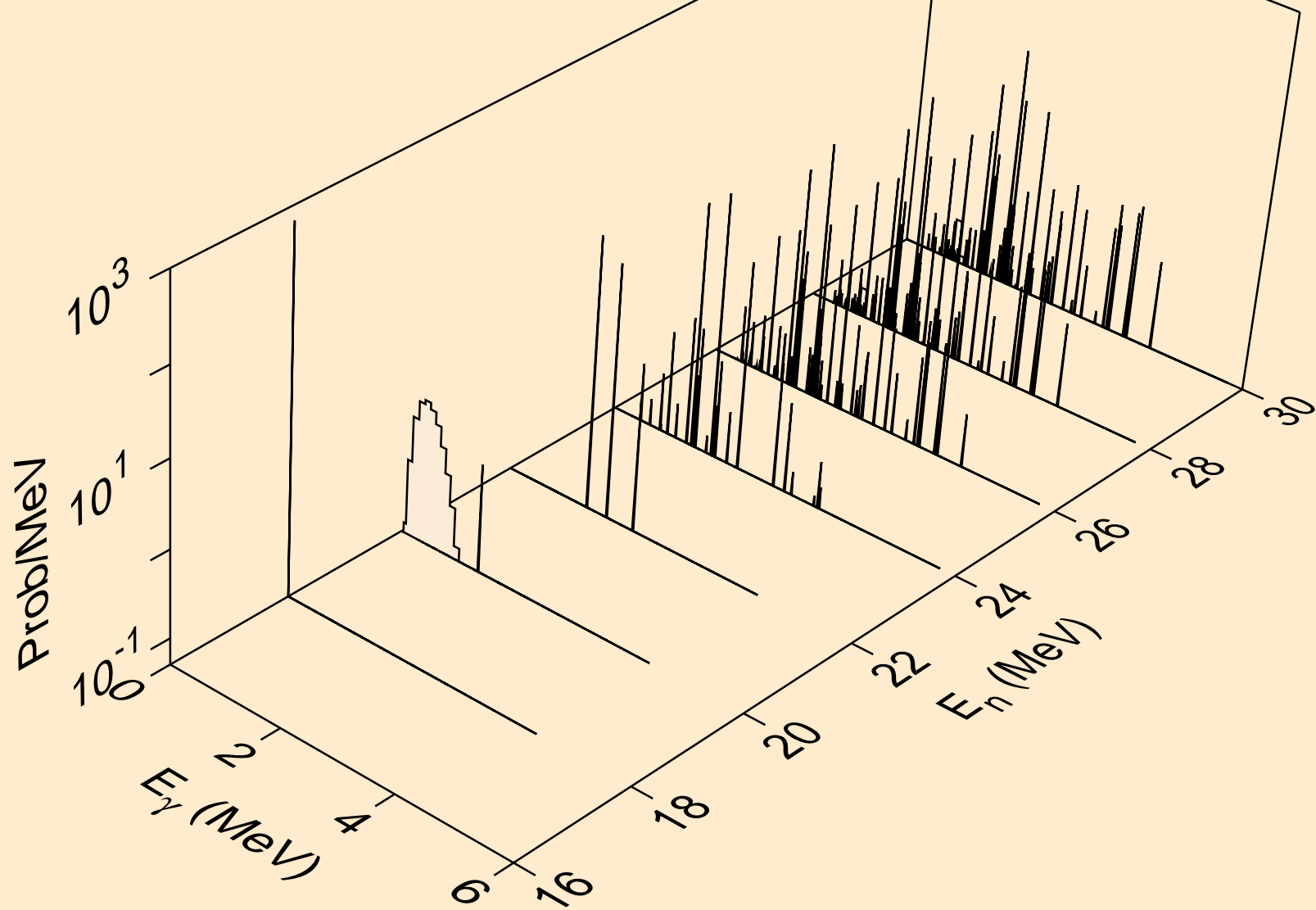

MG028 ALPHA ACER TENDL-2023 LIBRARY; T=0.K  
Photon emission for (n,n\*)t

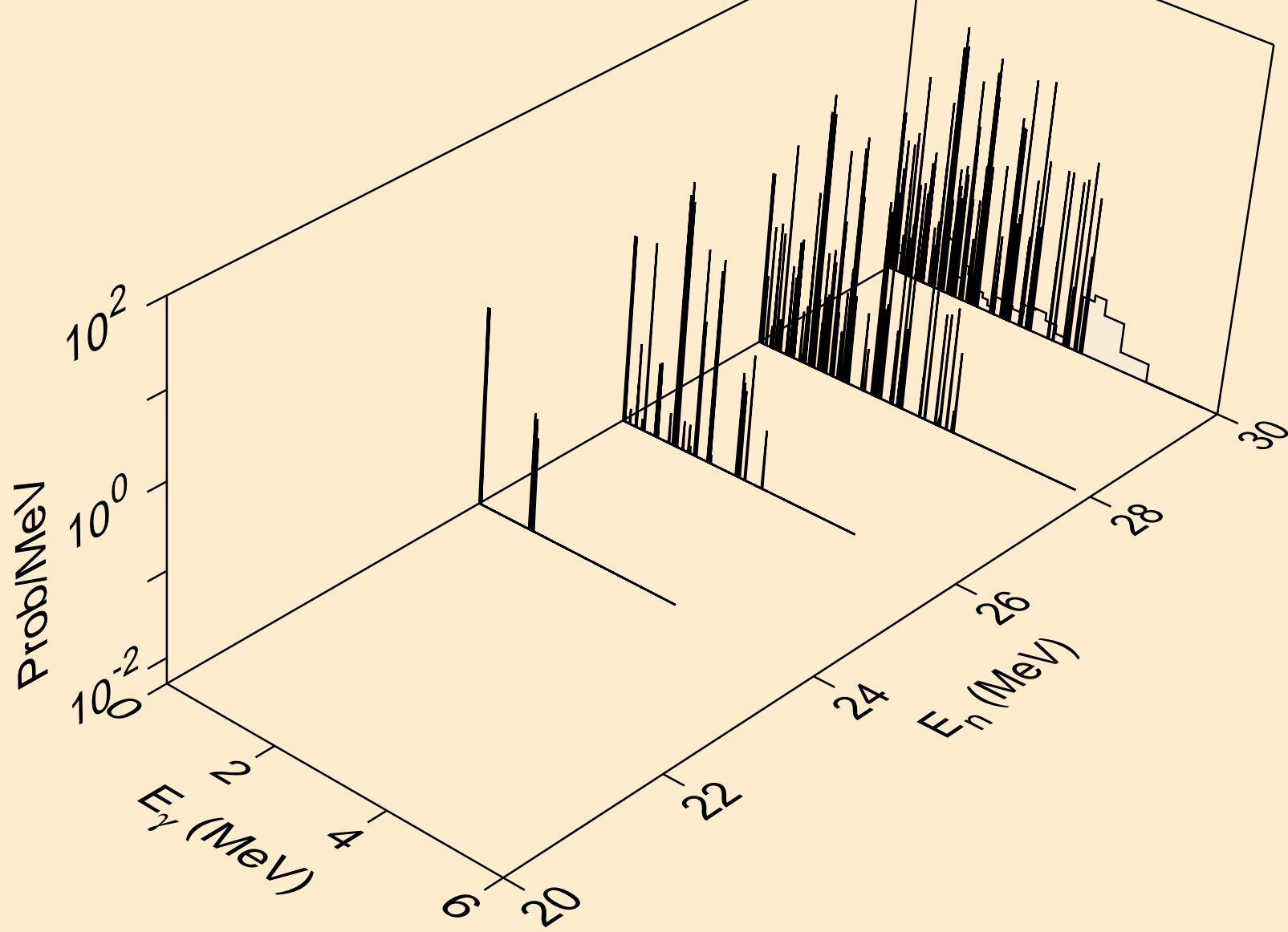

MG028 ALPHA ACER TENDL-2023 LIBRARY; T=0.K  
Photon emission for (n,n\*)he3

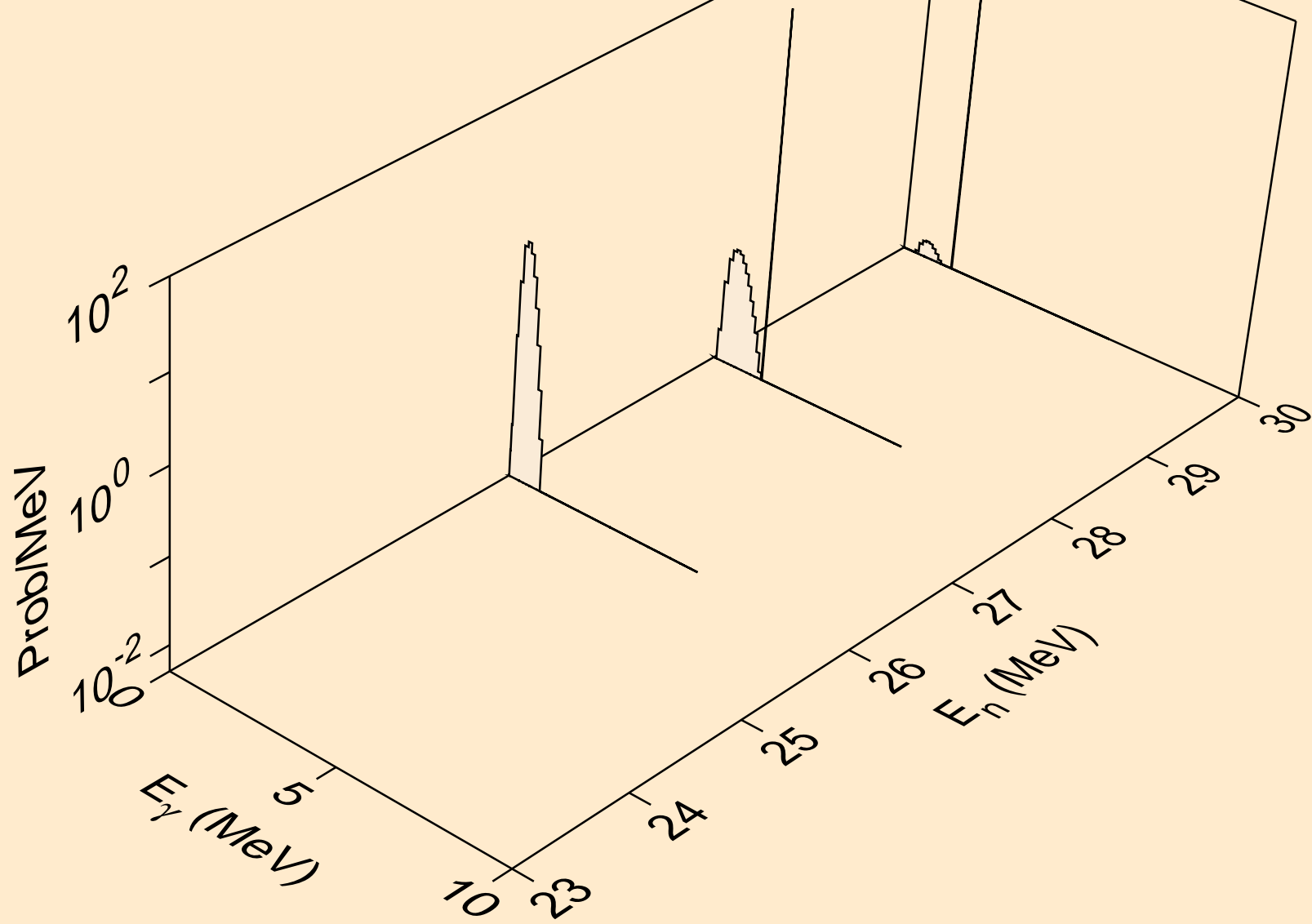

MG028 ALPHA ACER TENDL-2023 LIBRARY; T=0.K  
Photon emission for (n,4n)

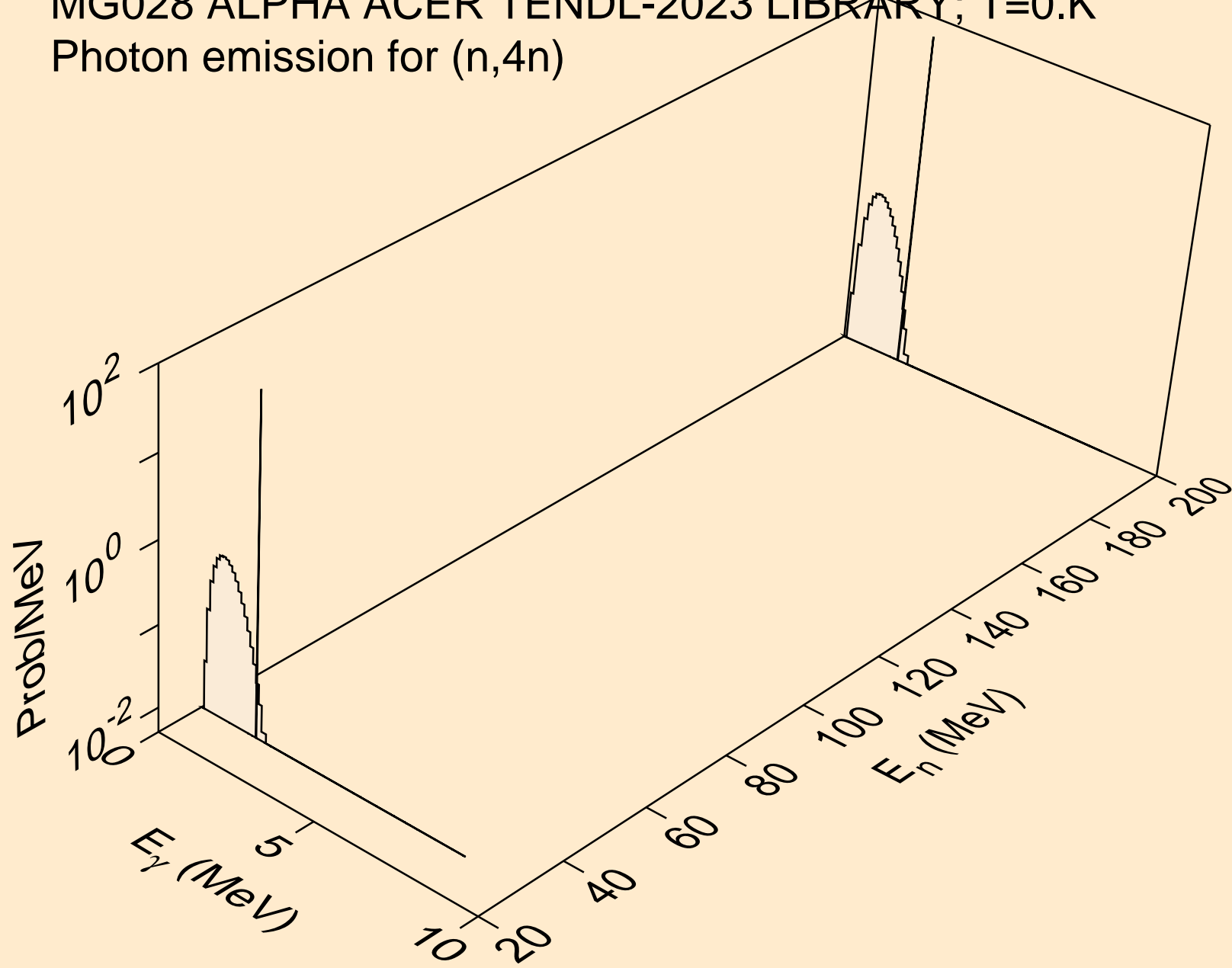

MG028 ALPHA ACER TENDL-2023 LIBRARY; T=0.K  
Photon emission for (n,2np)

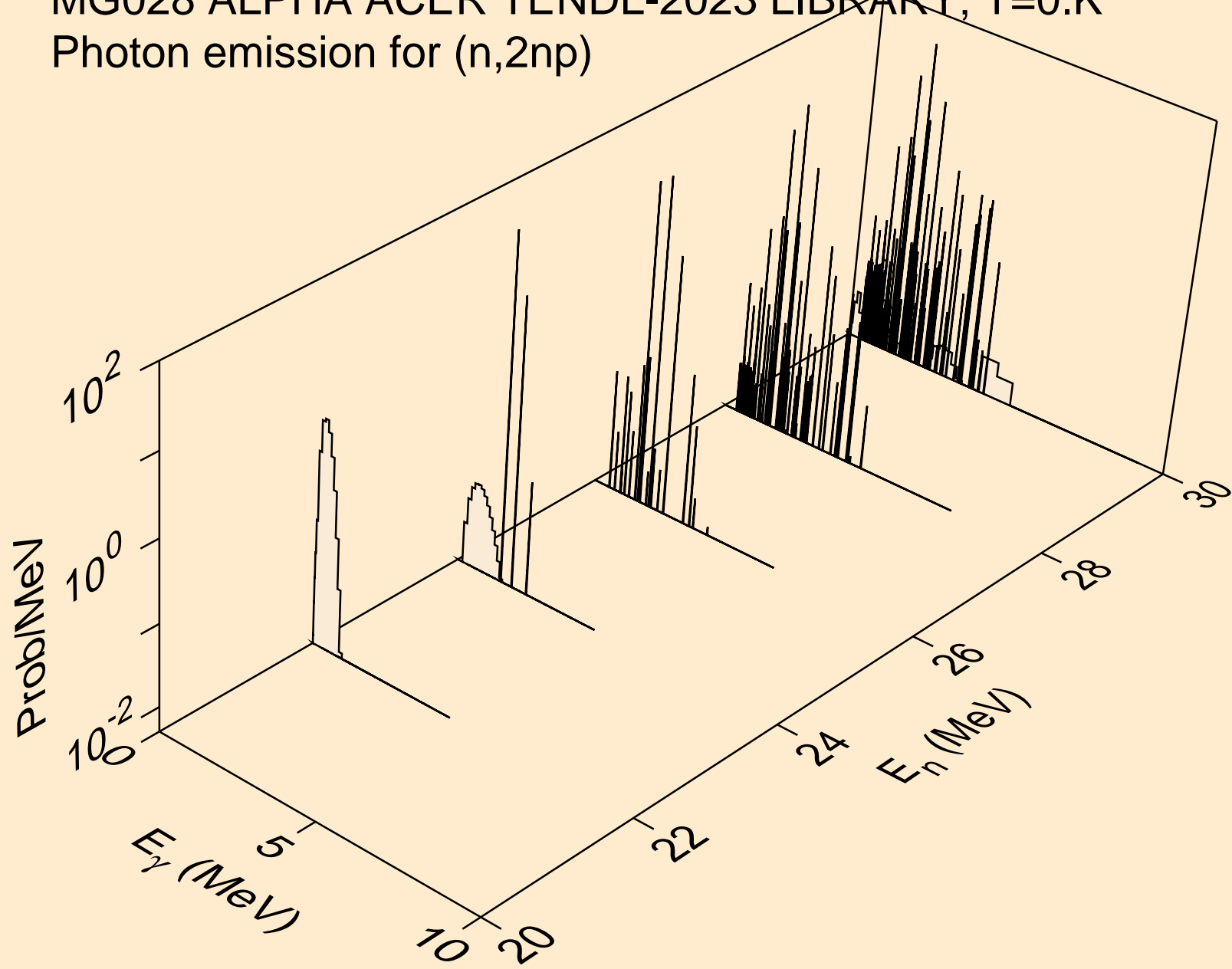

MG028 ALPHA ACER TENDL-2023 LIBRARY; T=0.K  
Photon emission for (n,gma)

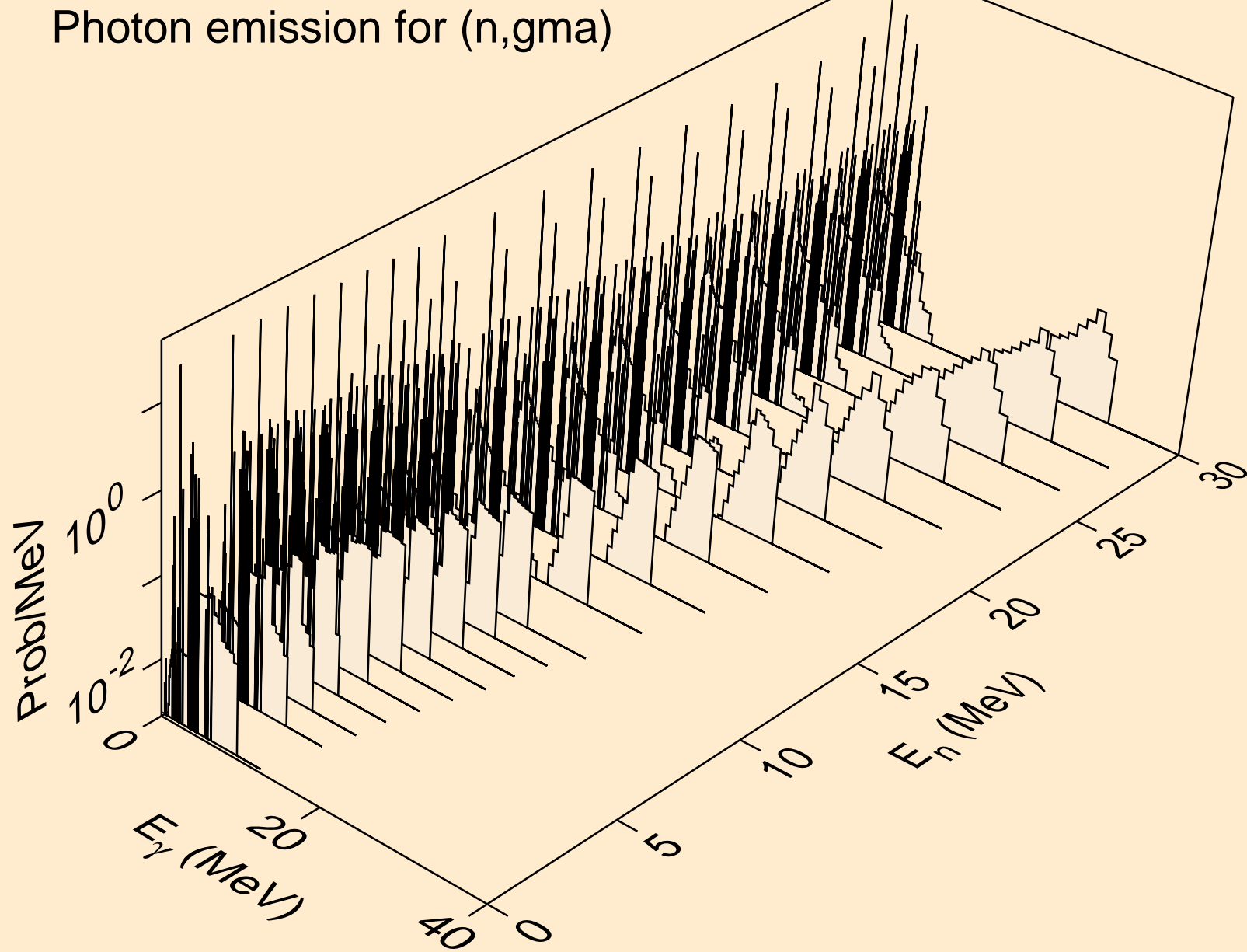



MG028 ALPHA ACER TENDL-2023 LIBRARY; T=0.K  
Photon emission for (n,p)

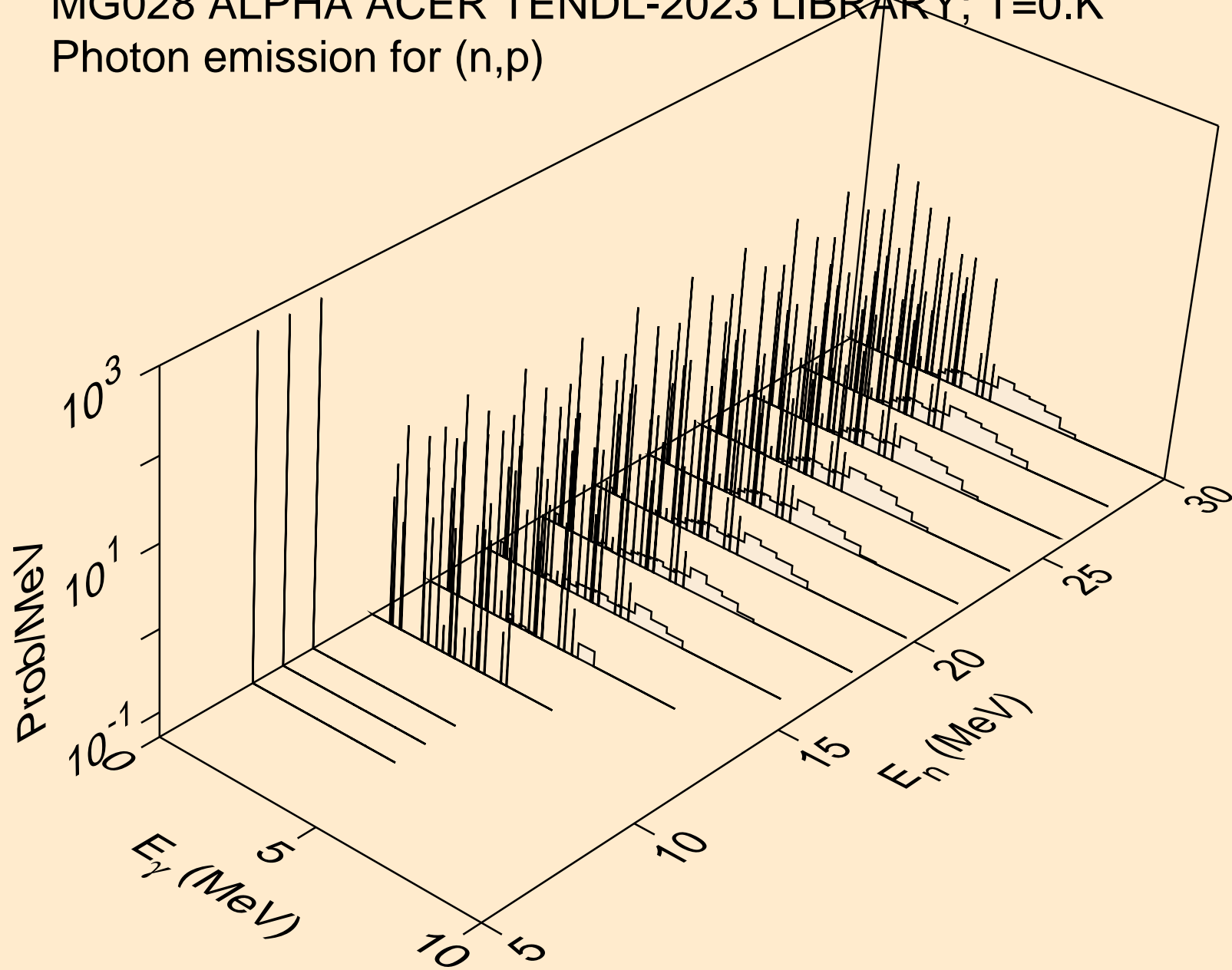

MG028 ALPHA ACER TENDL-2023 LIBRARY; T=0.K  
Photon emission for (n,d)

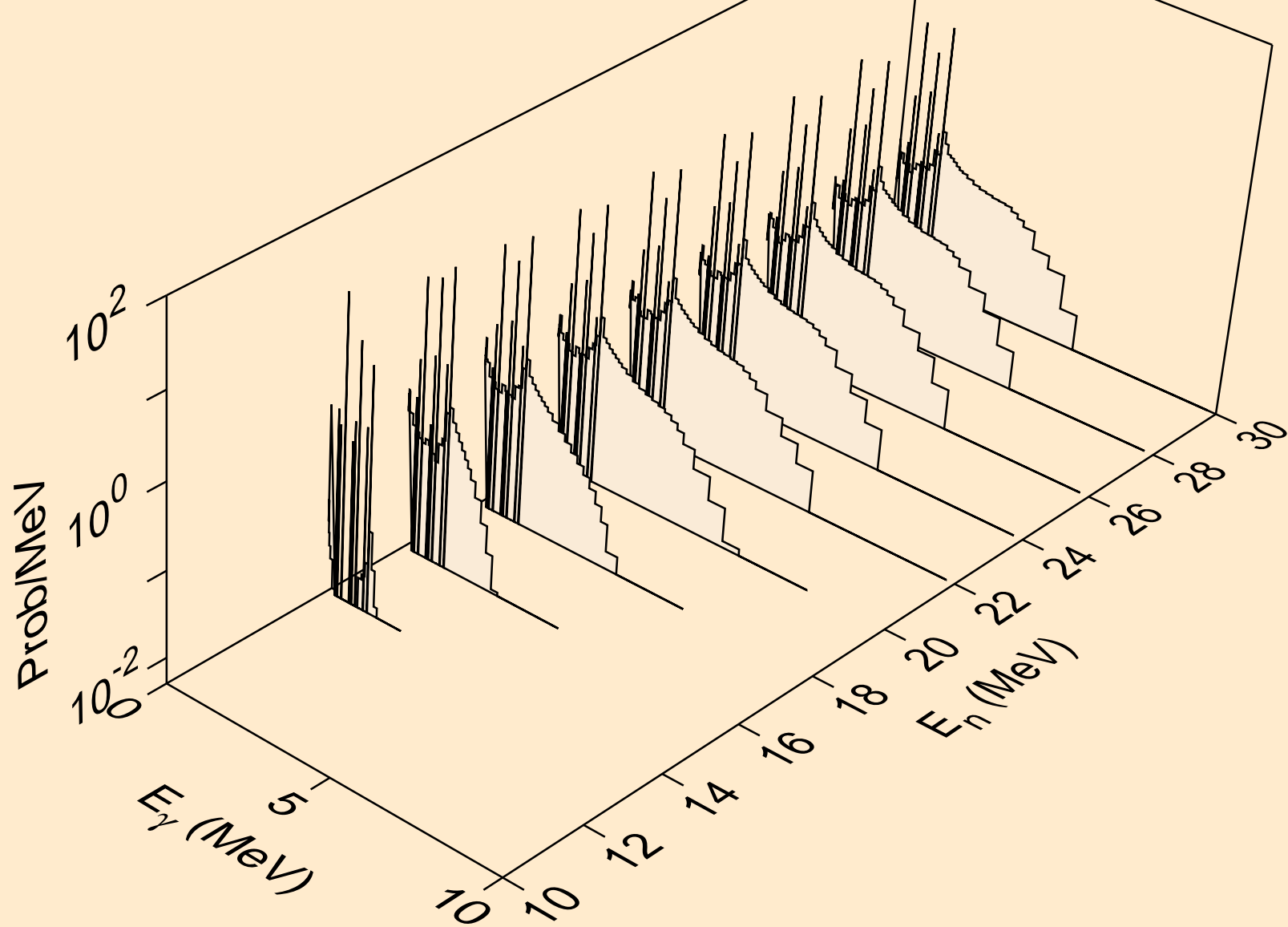

MG028 ALPHA ACER TENDL-2023 LIBRARY; T=0.K  
Photon emission for (n,t)

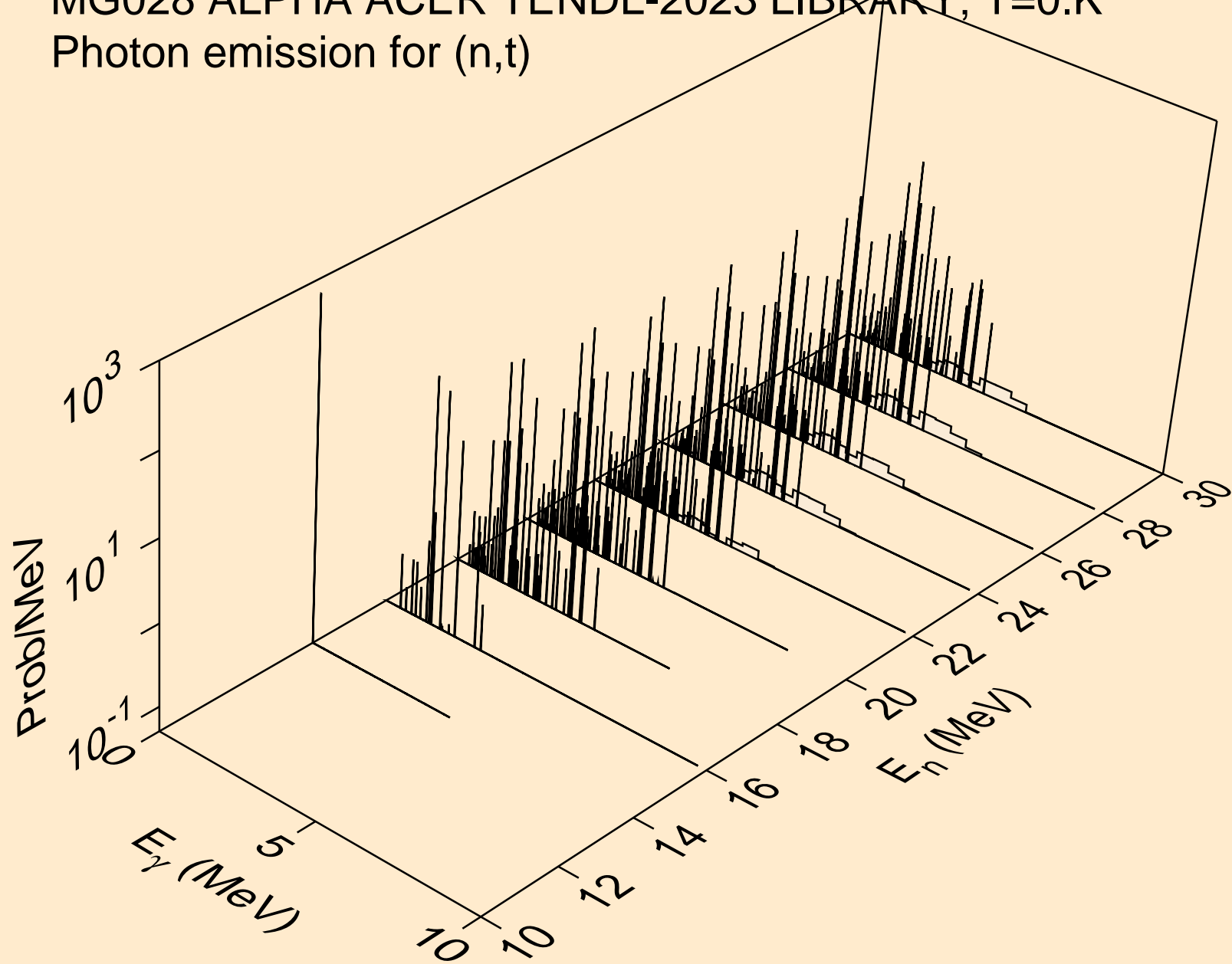

MG028 ALPHA ACER TENDL-2023 LIBRARY; T=0.K  
Photon emission for (n,he3)

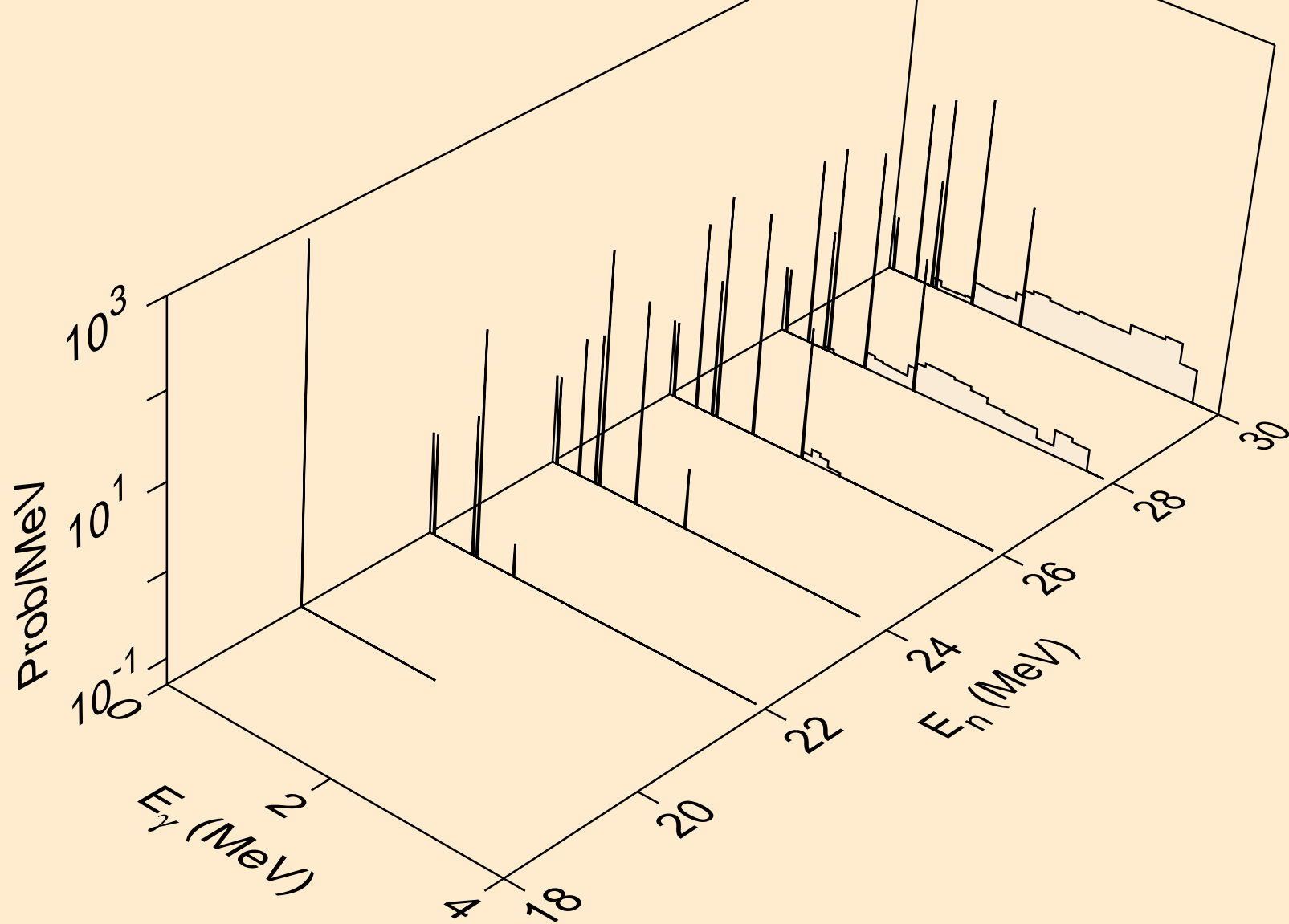

MG028 ALPHA ACER TENDL-2023 LIBRARY; T=0.K  
Photon emission for inelastic

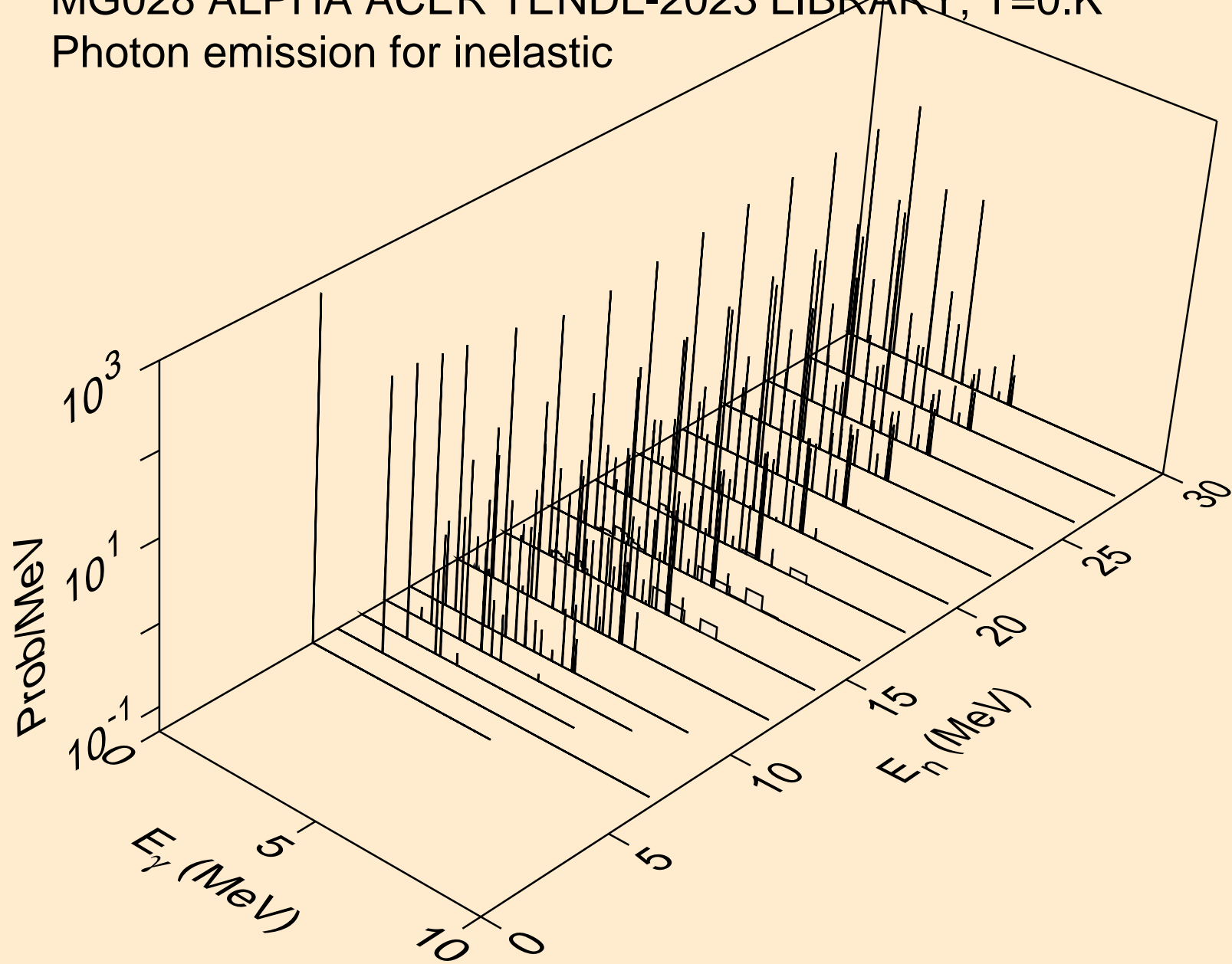

MG028 ALPHA ACER TENDL-2023 LIBRARY; T=0.K  
Photon emission for (n,2a)

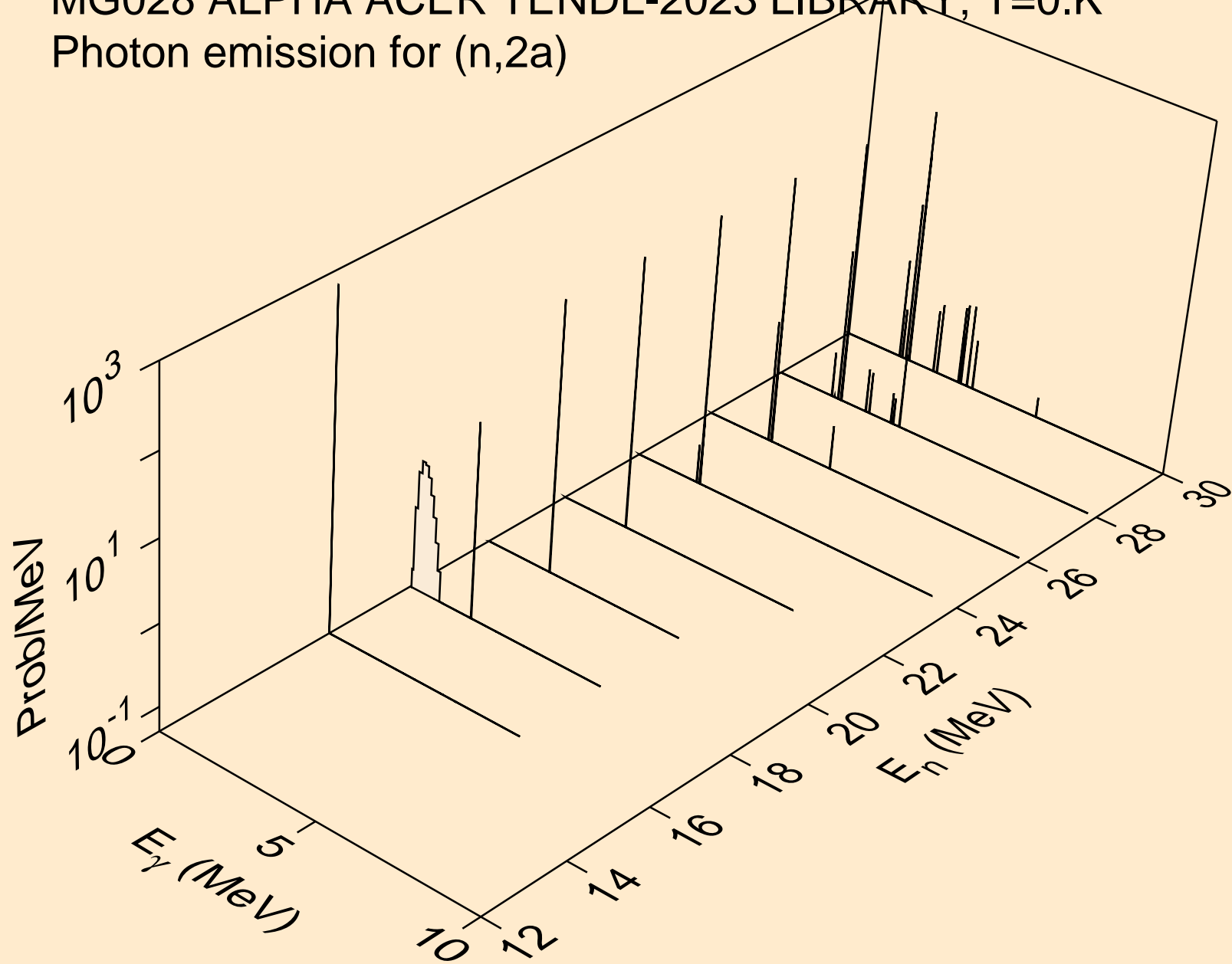

MG028 ALPHA ACER TENDL-2023 LIBRARY; T=0.K  
Photon emission for (n,2p)

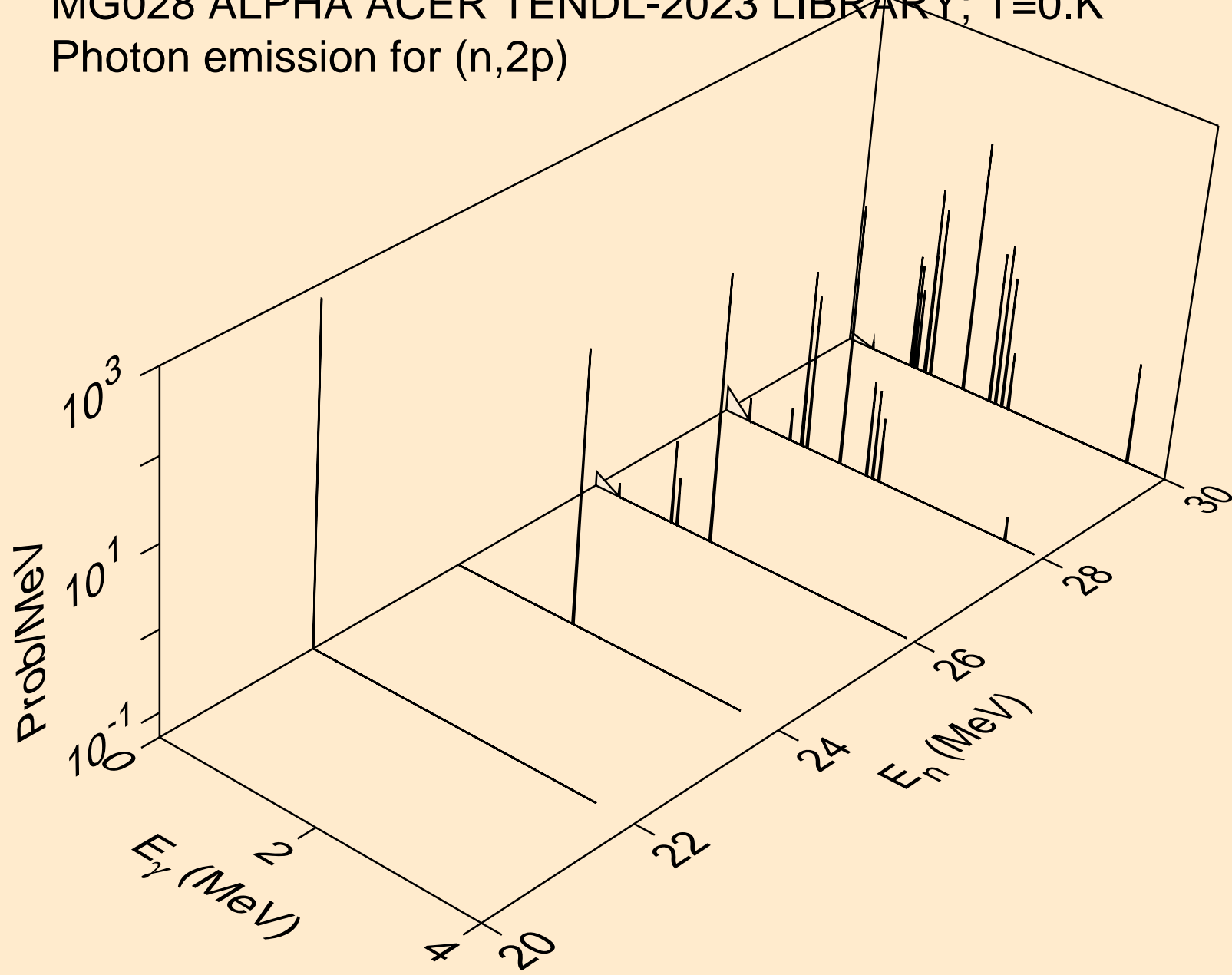

MG028 ALPHA ACER TENDL-2023 LIBRARY; T=0.K  
Photon emission for (n,pa)

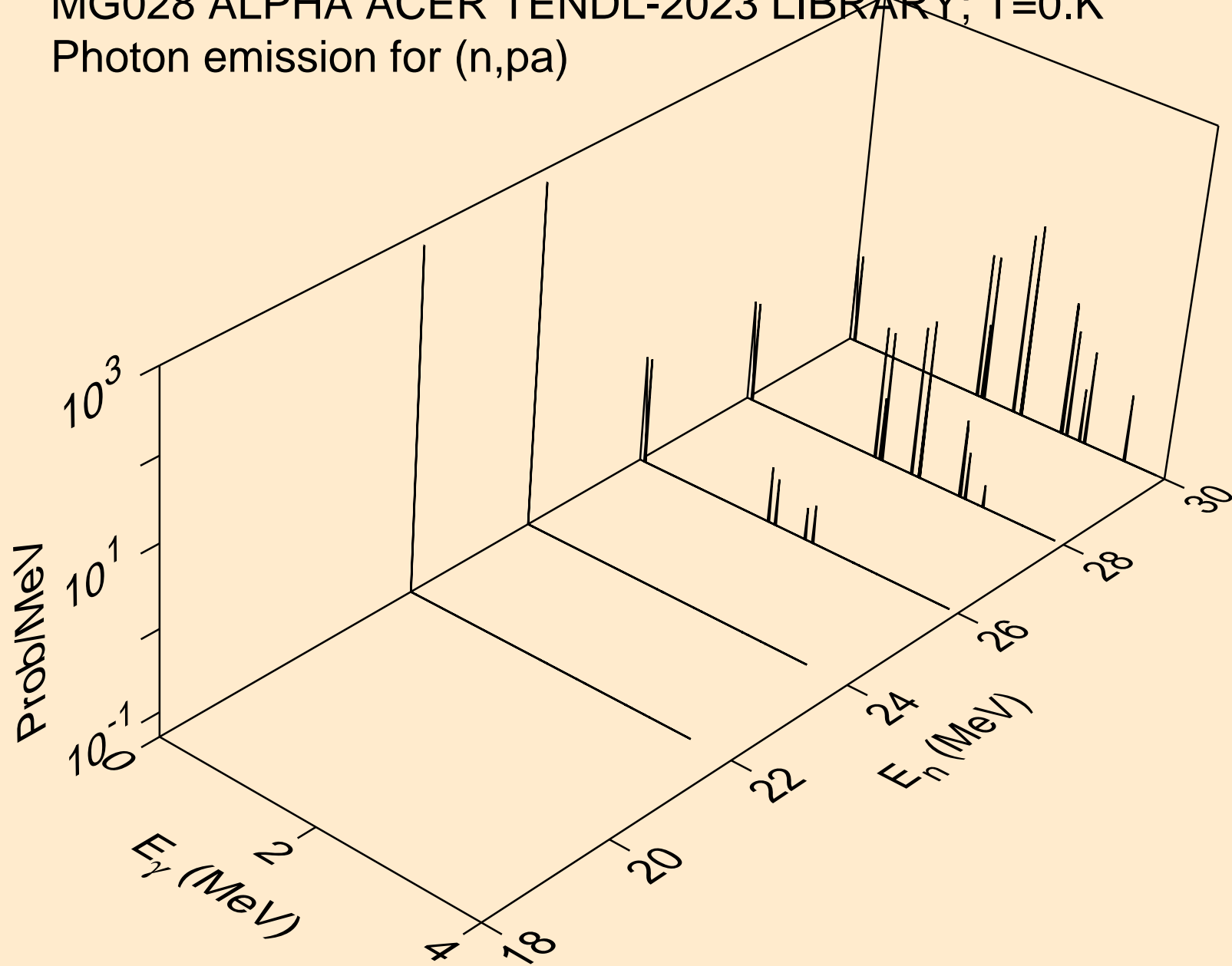



MG028 ALPHA ACER TENDL-2023 LIBRARY; T=0.K  
Photon emission for (n,pd)

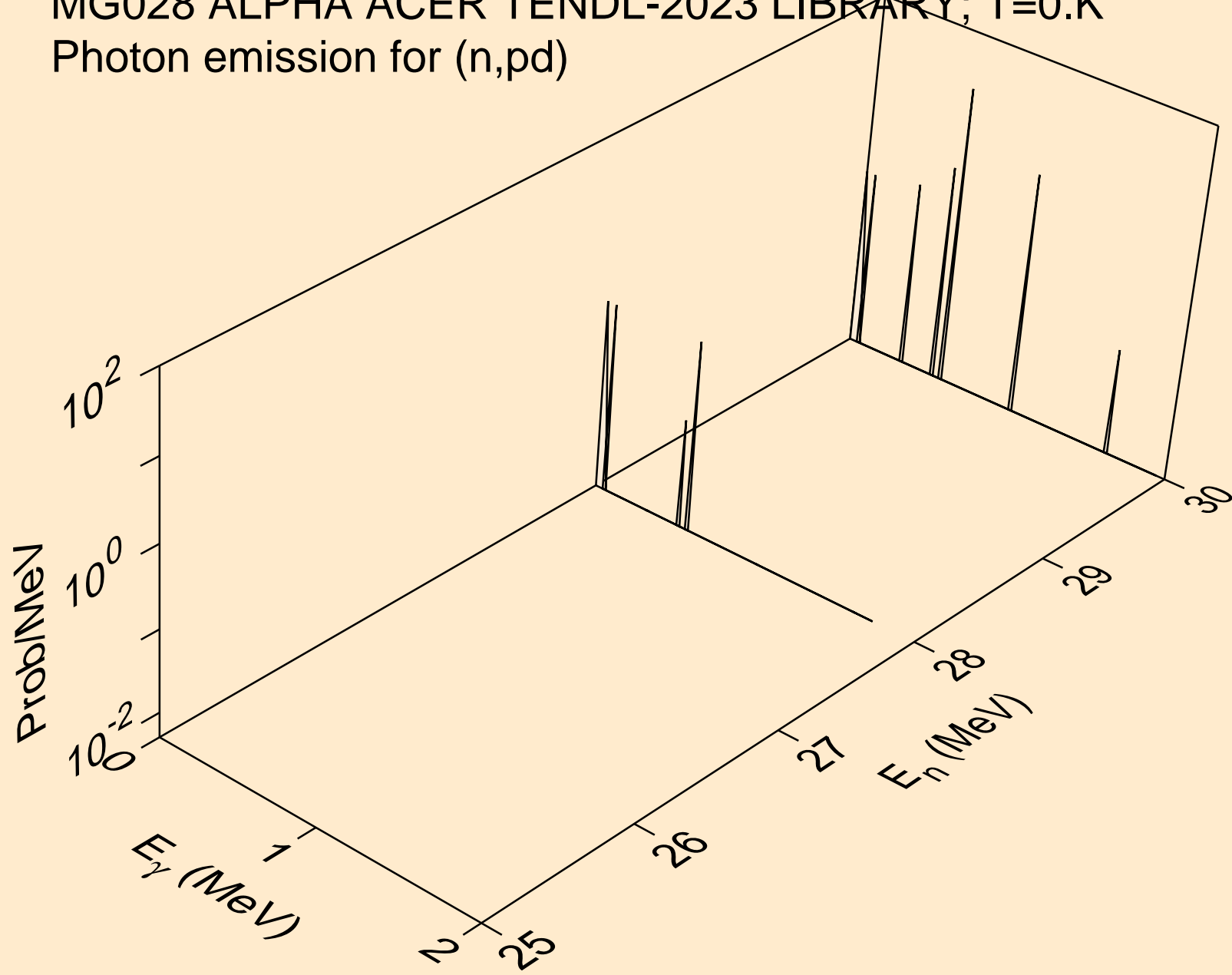

MG028 ALPHA ACER TENDL-2023 LIBRARY; T=0.K  
Photon emission for (n,pt)

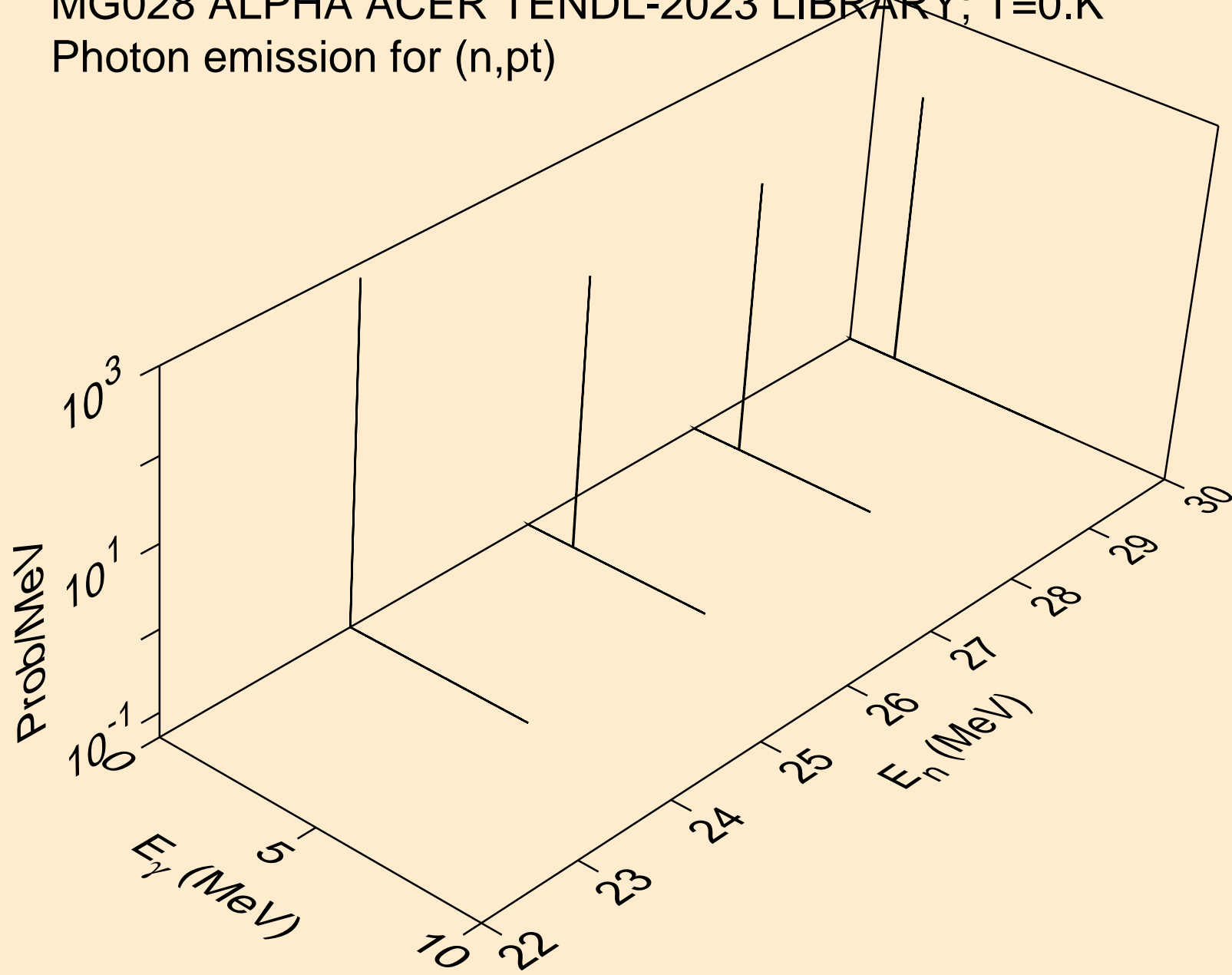

MG028 ALPHA ACER TENDL-2023 LIBRARY; T=0.K  
Photon emission for (n,da)

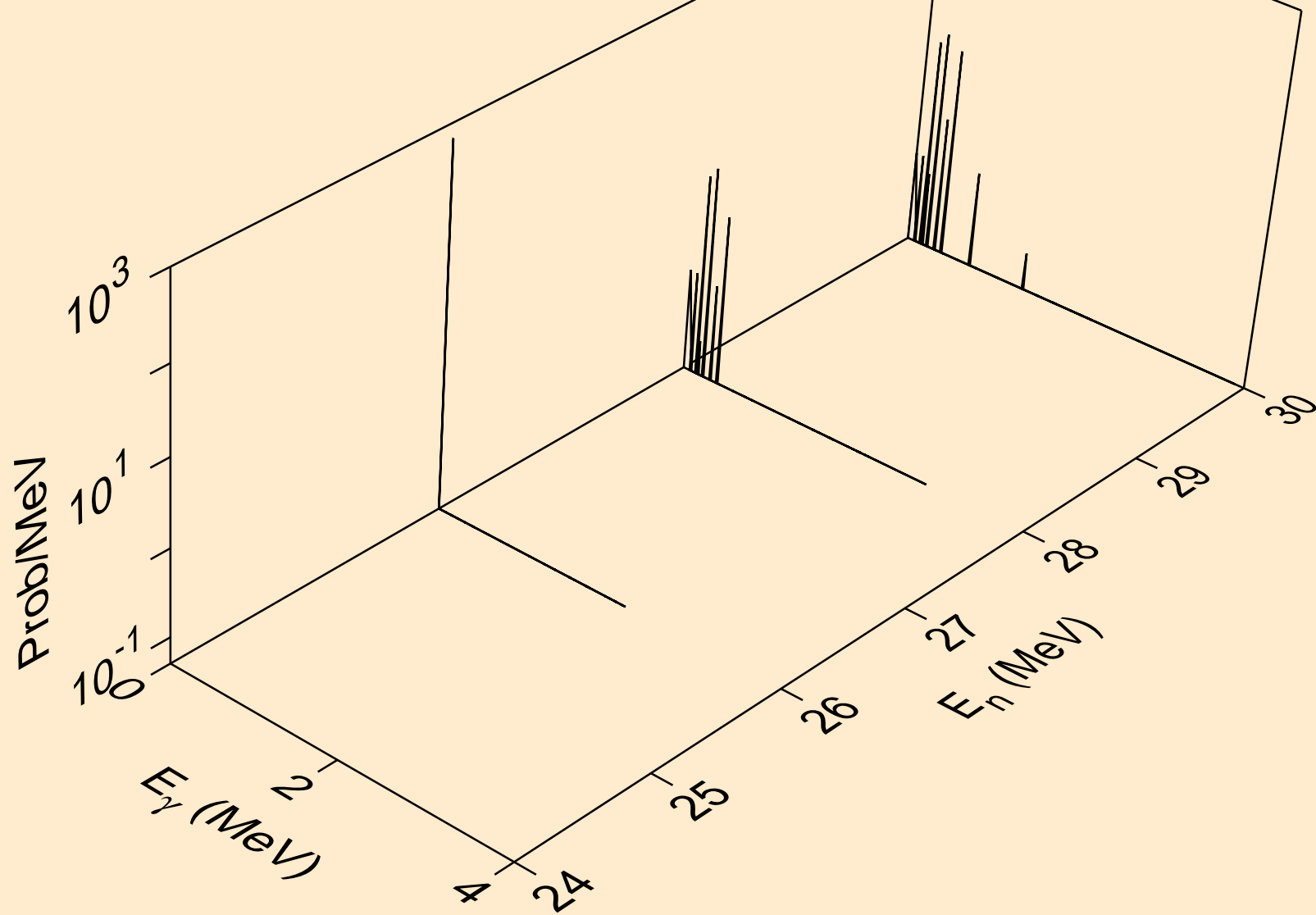

MG028 ALPHA ACER TENDL-2023 LIBRARY; T=0.K  
Particle heating contributions

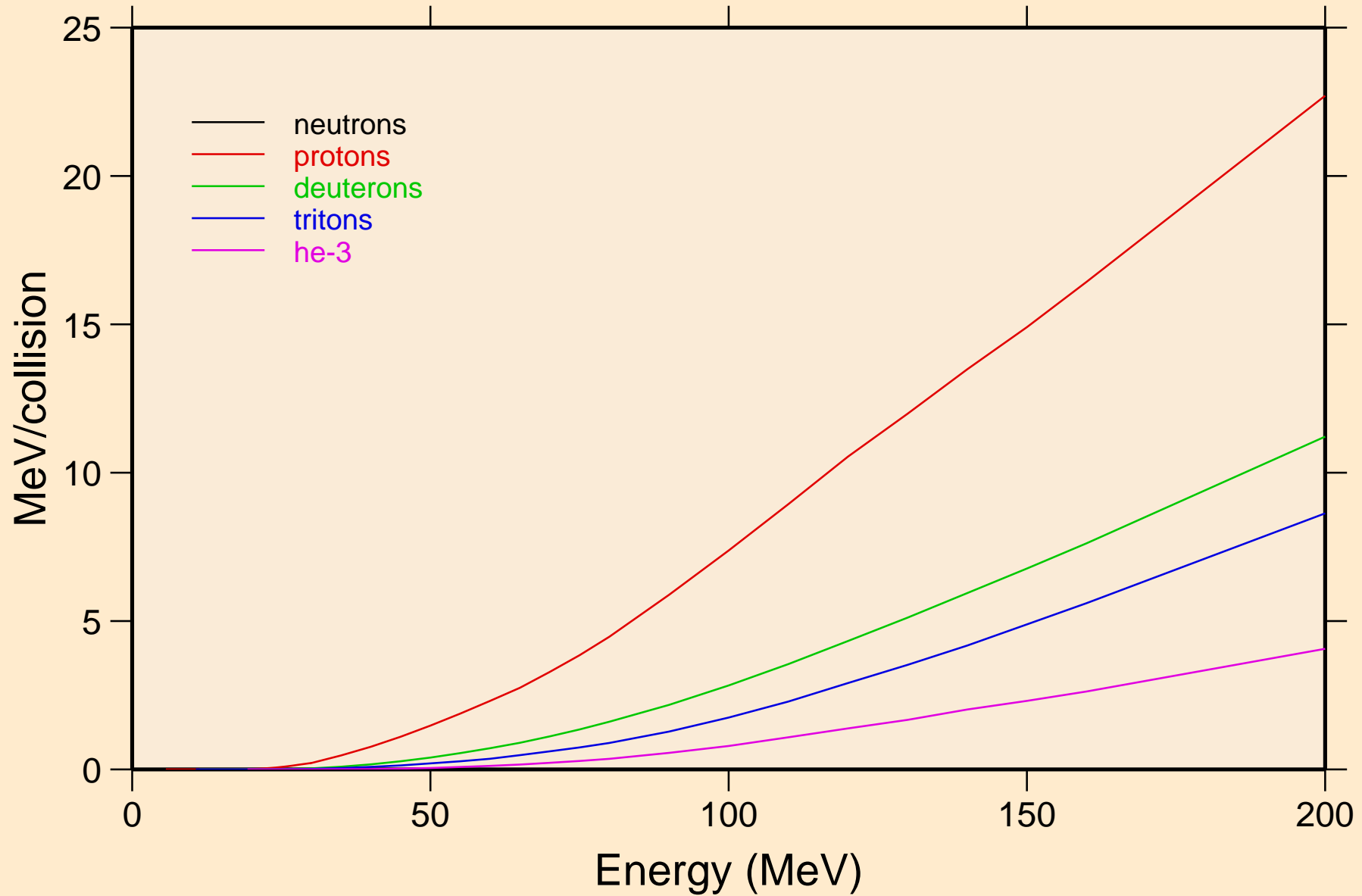

MG028 ALPHA ACER TENDL-2023 LIBRARY; T=0.K  
Recoil Heating

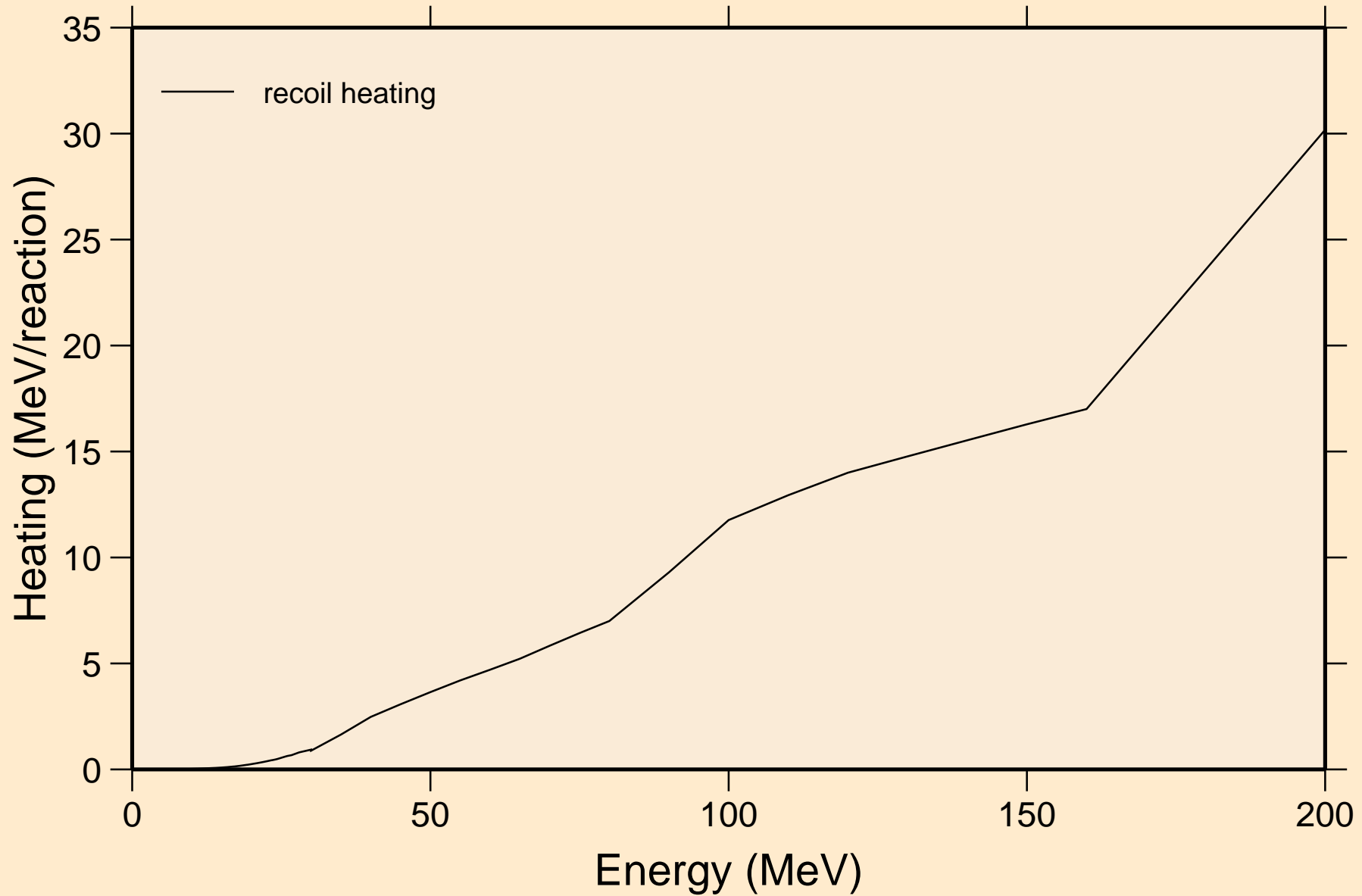

MG028 ALPHA ACER TENDL-2023 LIBRARY; T=0.K  
Particle production cross sections

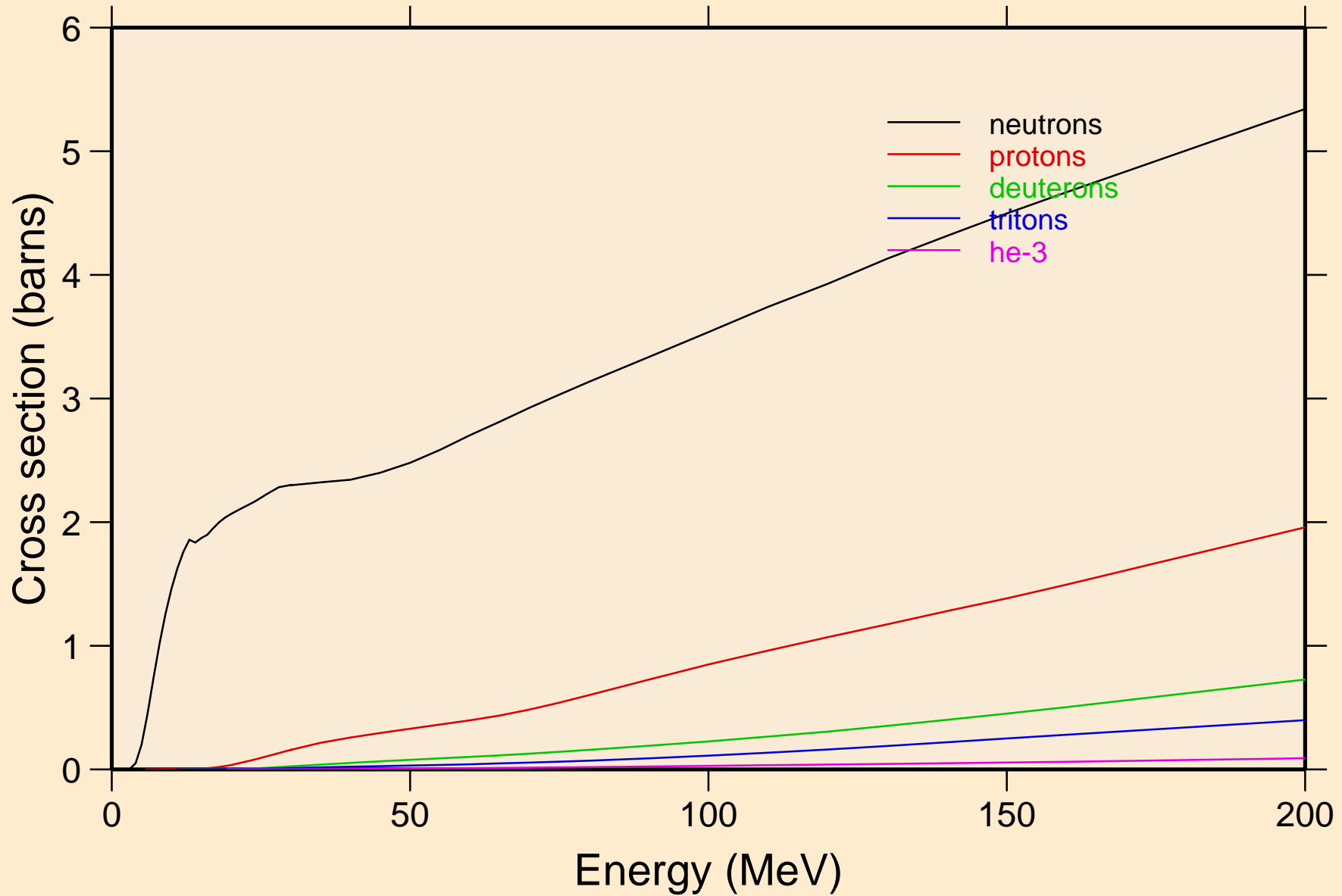

MG028 ALPHA ACER TENDL-2023 LIBRARY; T=0.K  
neutrons from (a,n)

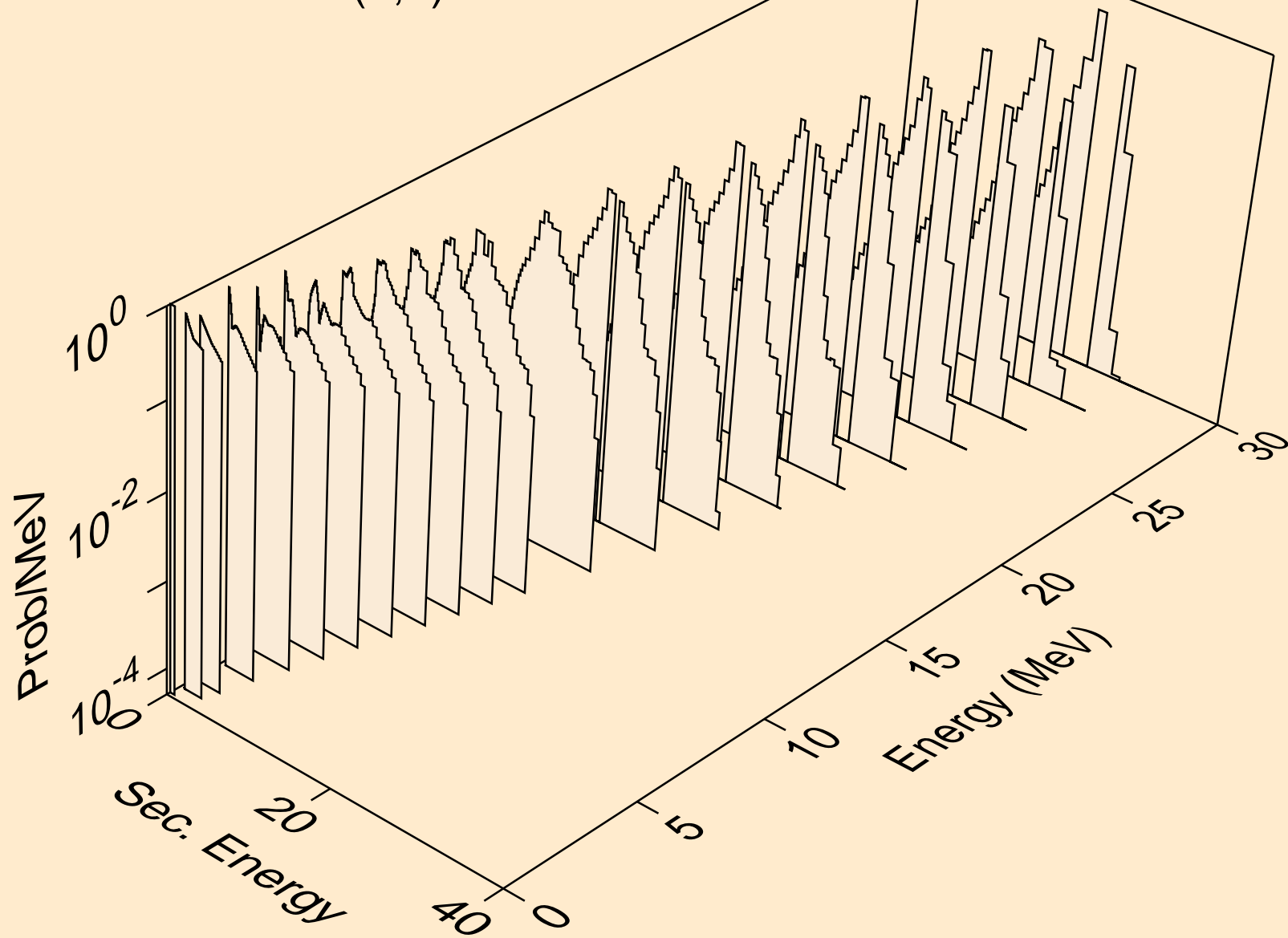

MG028 ALPHA ACER TENDL-2023 LIBRARY; T=0.K  
neutrons from (a,x)

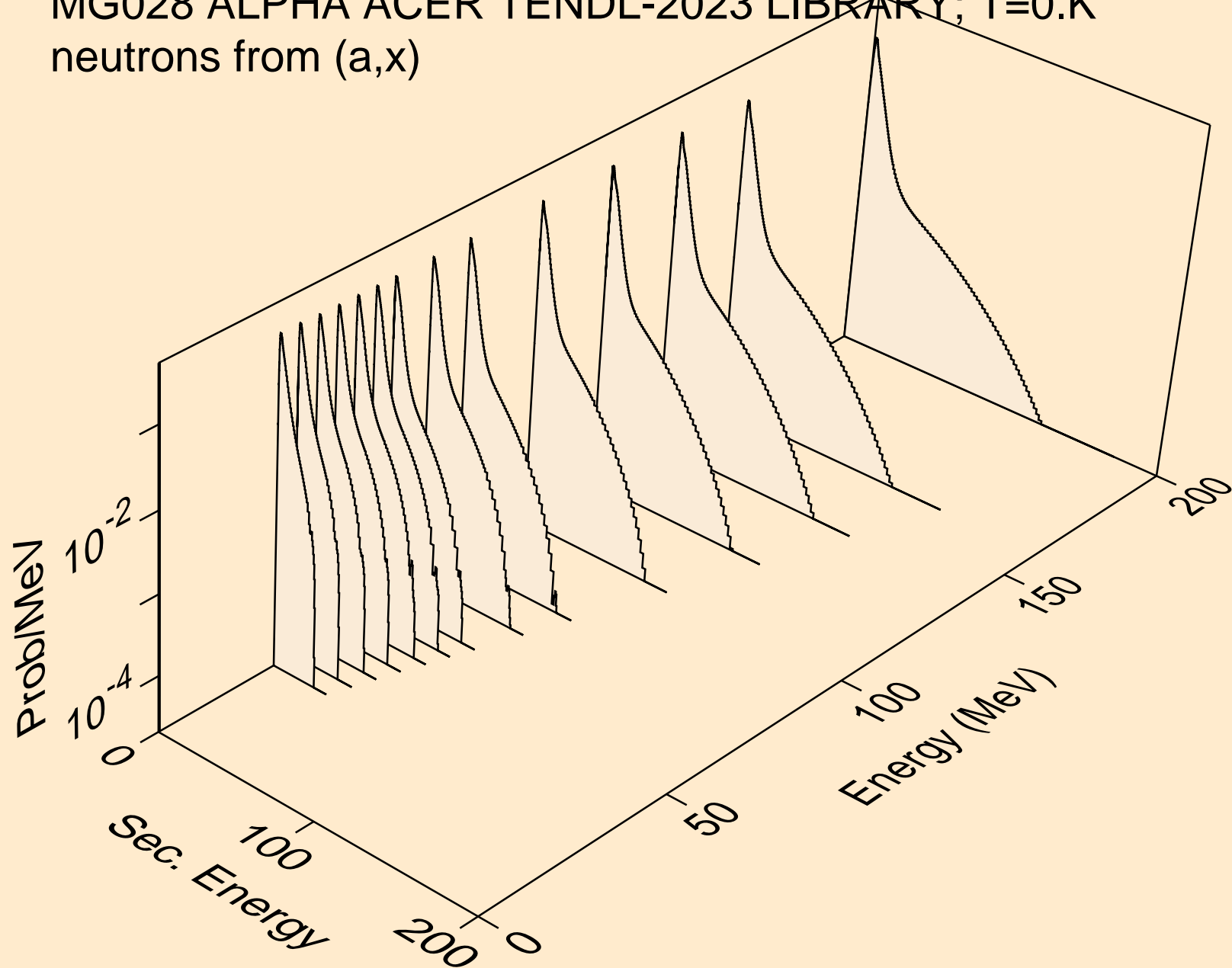



MG028 ALPHA ACER TENDL-2023 LIBRARY; T=0.K  
neutrons from (a,2n)

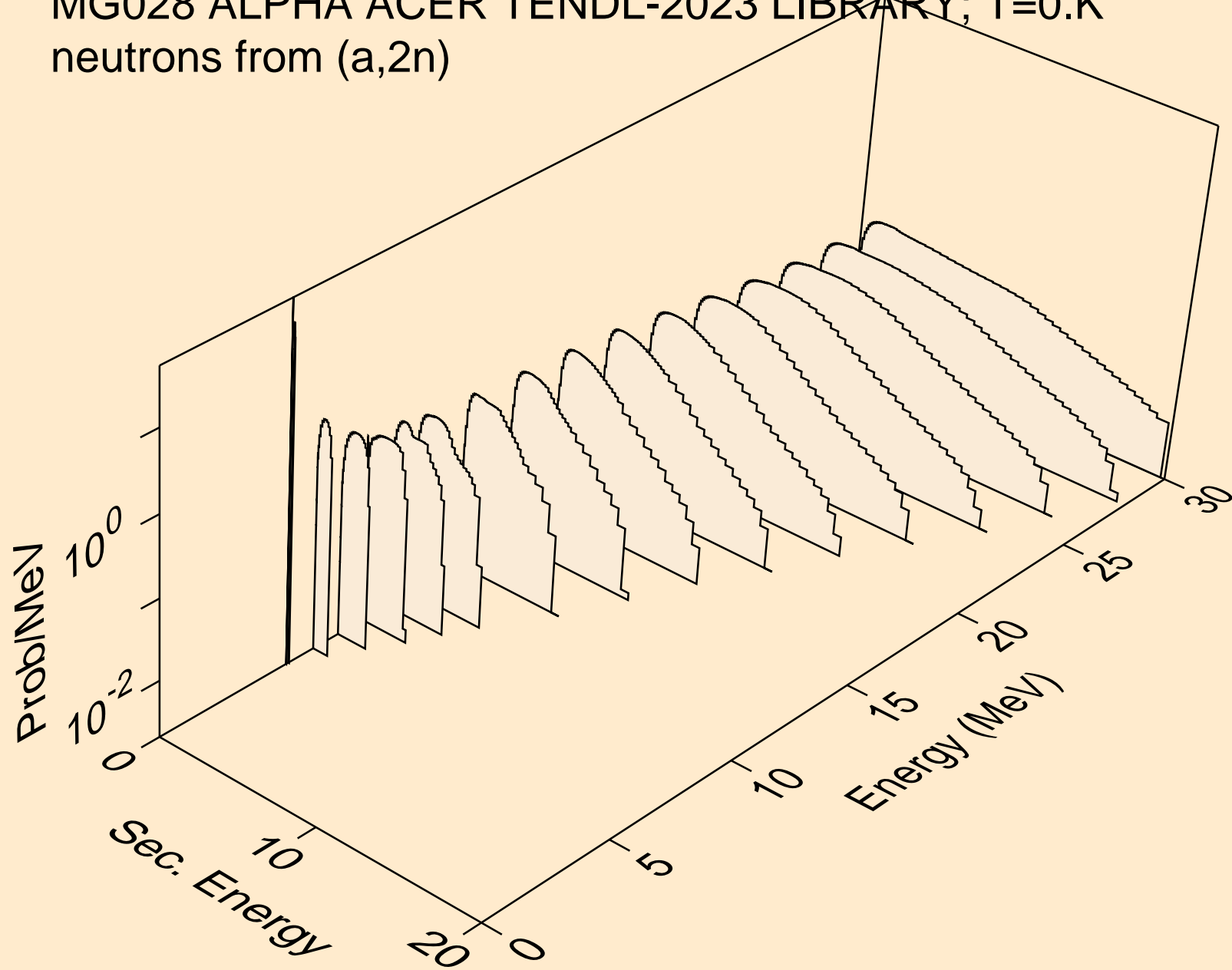

MG028 ALPHA ACER TENDL-2023 LIBRARY; T=0.K  
neutrons from (a,3n)

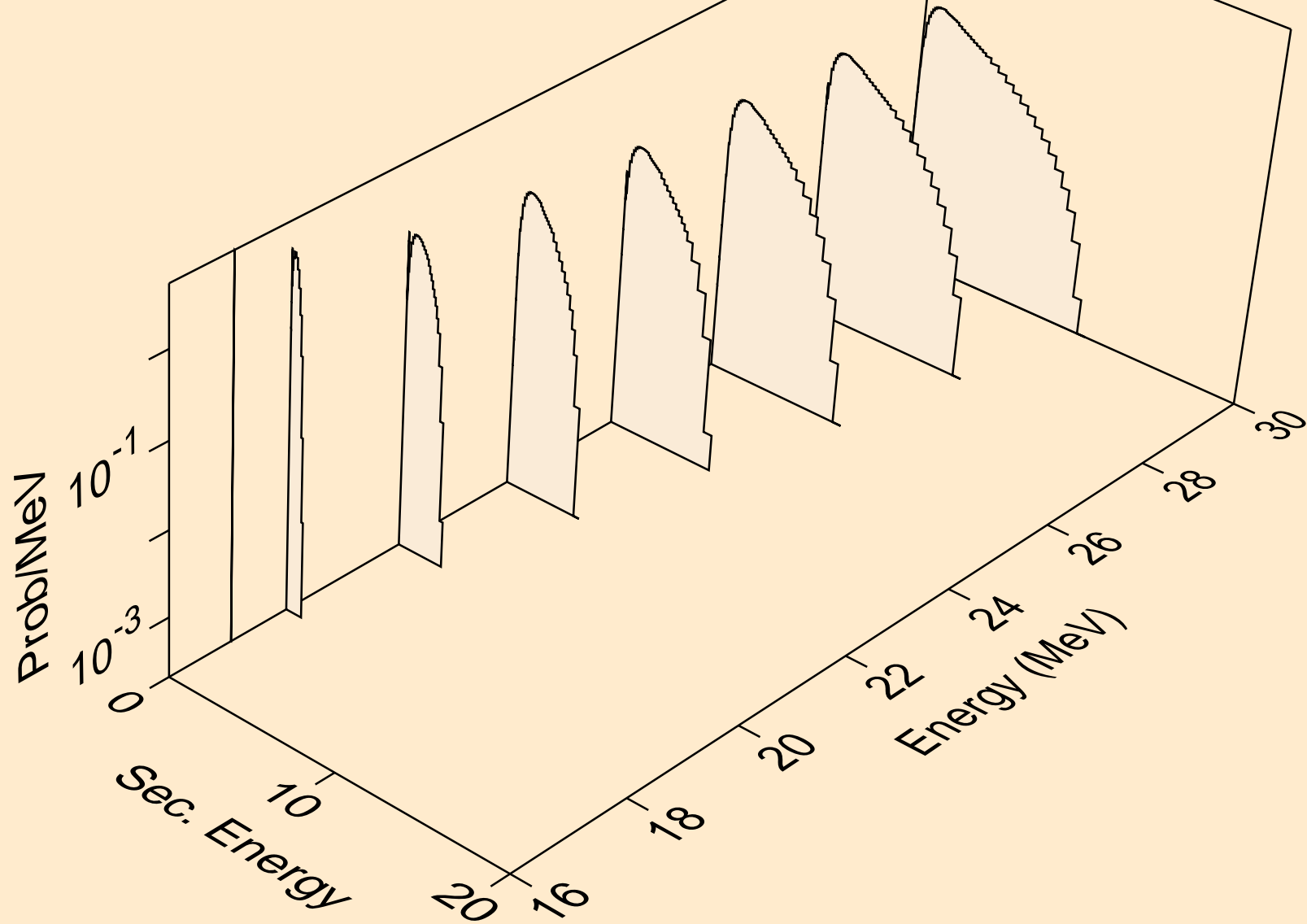

MG028 ALPHA ACER TENDL-2023 LIBRARY; T=0.K  
neutrons from (a,n\*)a

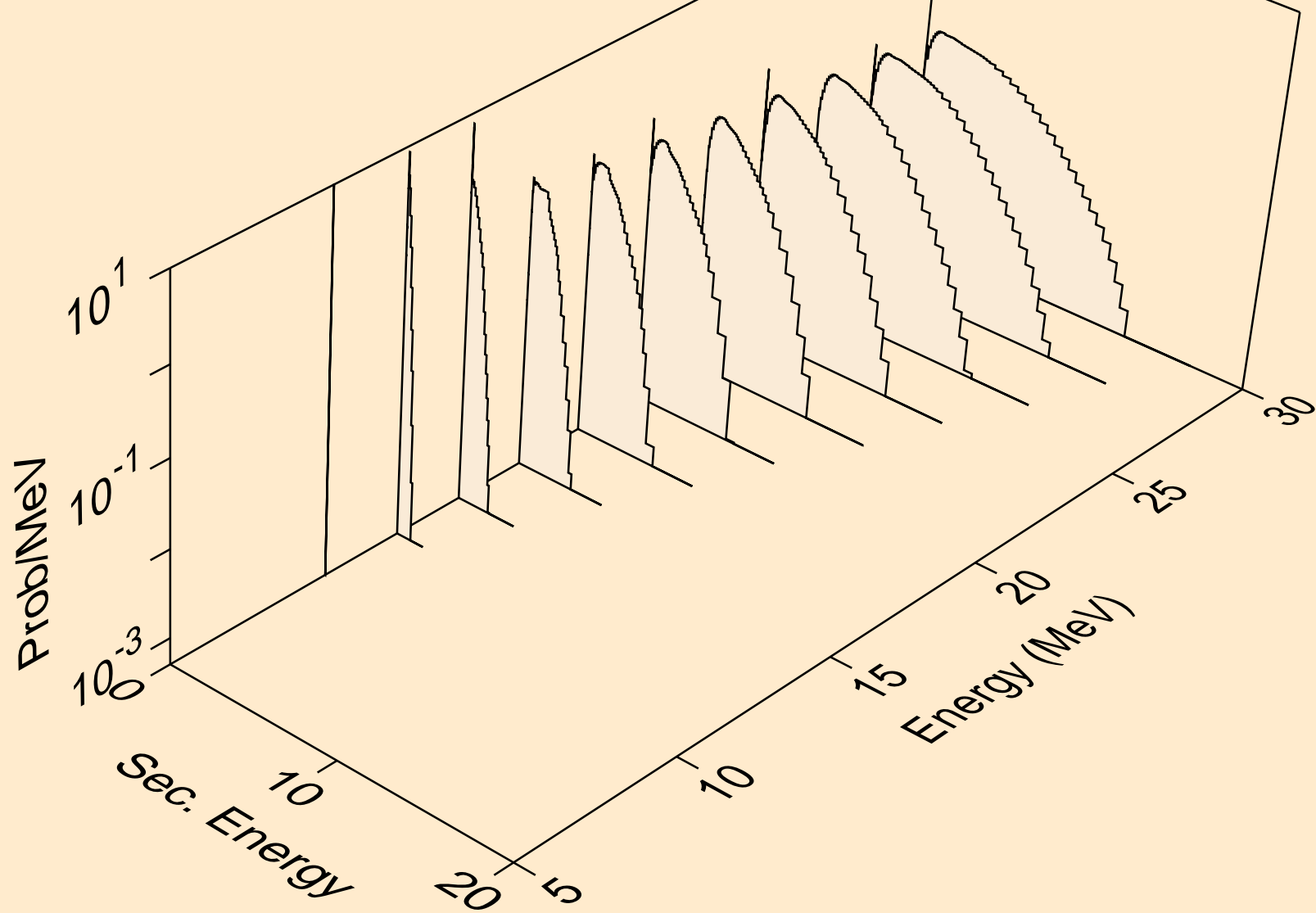

MG028 ALPHA ACER TENDL-2023 LIBRARY; T=0.K  
neutrons from (a,2n)a

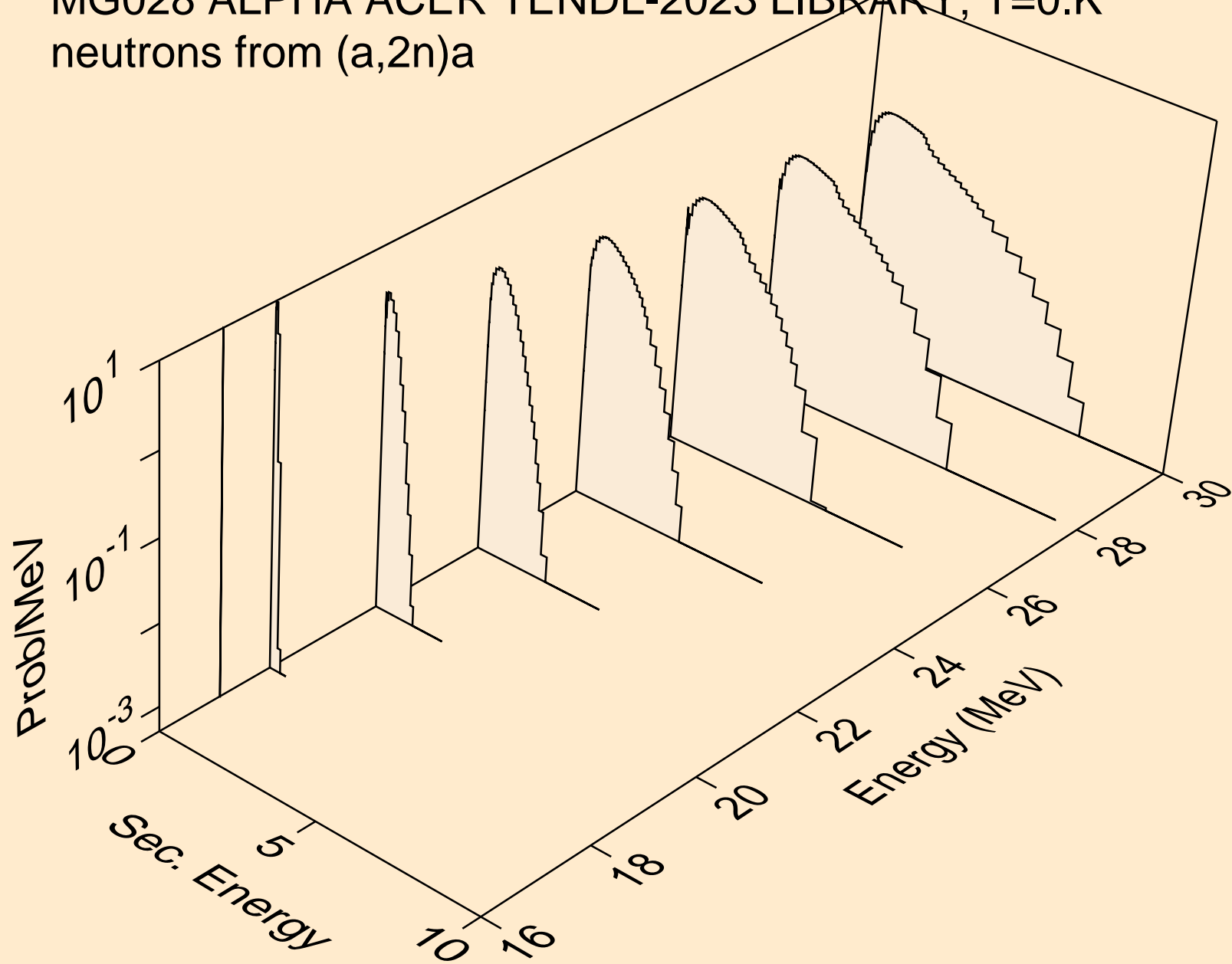

MG028 ALPHA ACER TENDL-2023 LIBRARY; T=0.K  
neutrons from (a,n\*)p

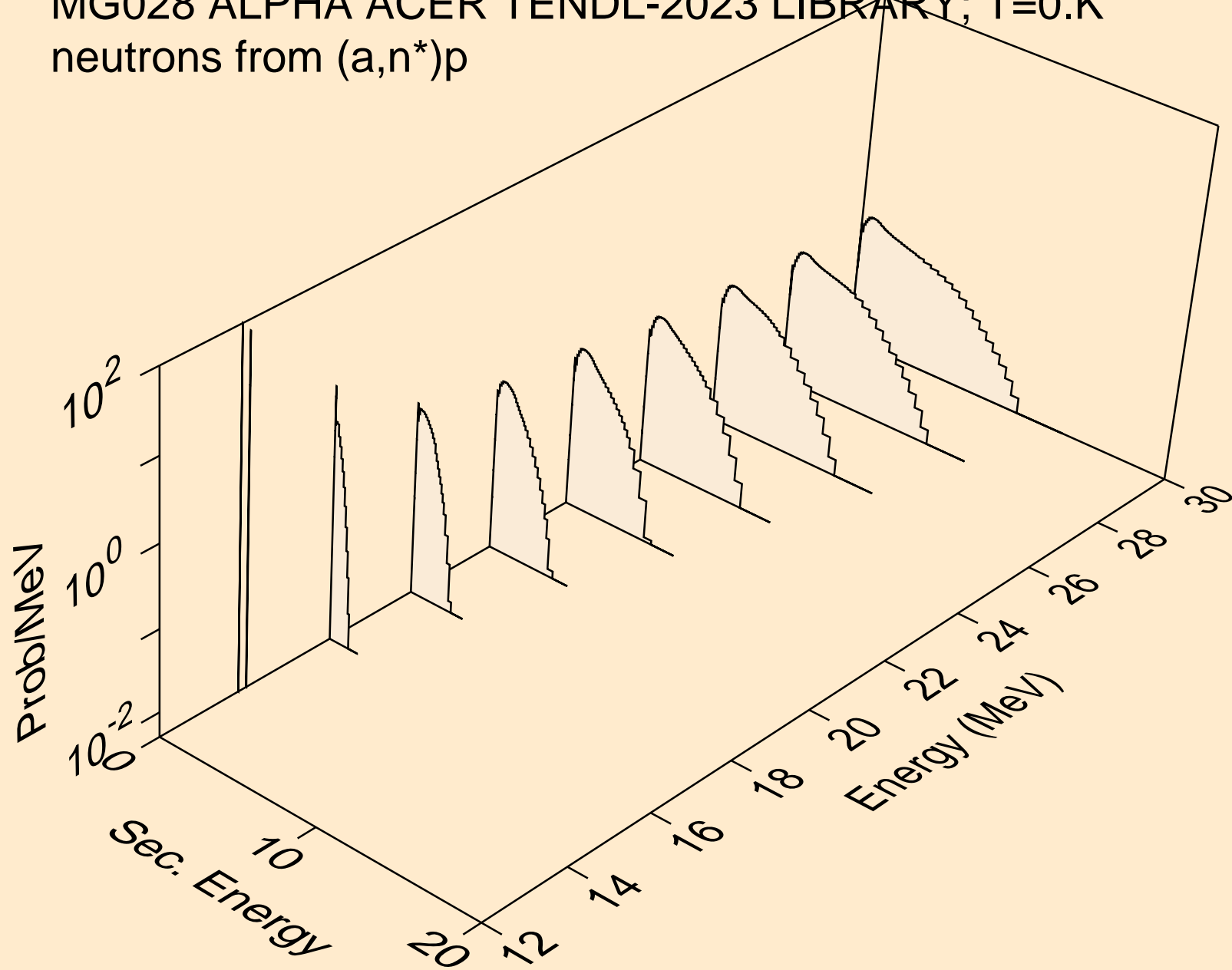

MG028 ALPHA ACER TENDL-2023 LIBRARY; T=0.K  
neutrons from (a,n\*)2a

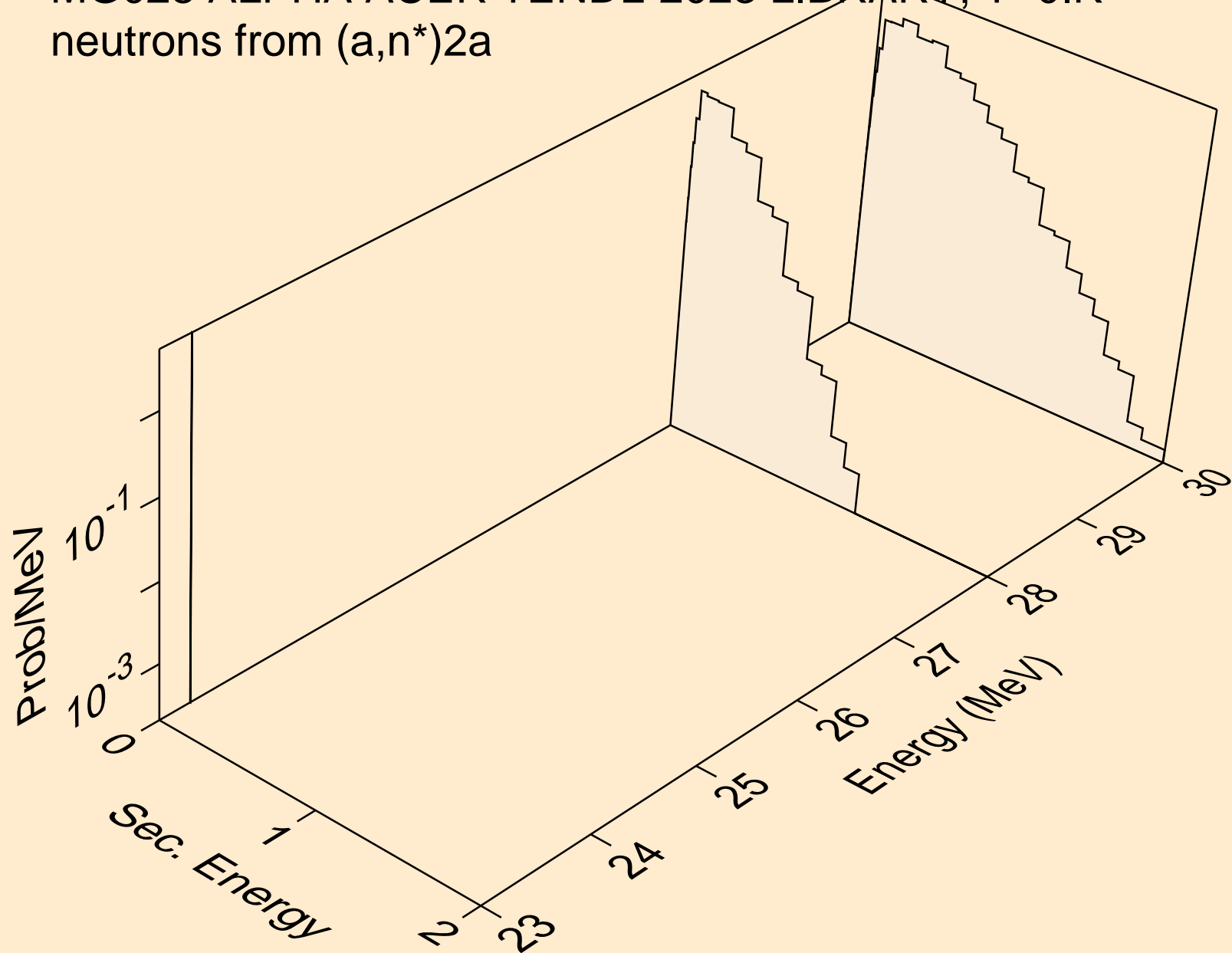

MG028 ALPHA ACER TENDL-2023 LIBRARY; T=0.K  
neutrons from (a,n\*)d

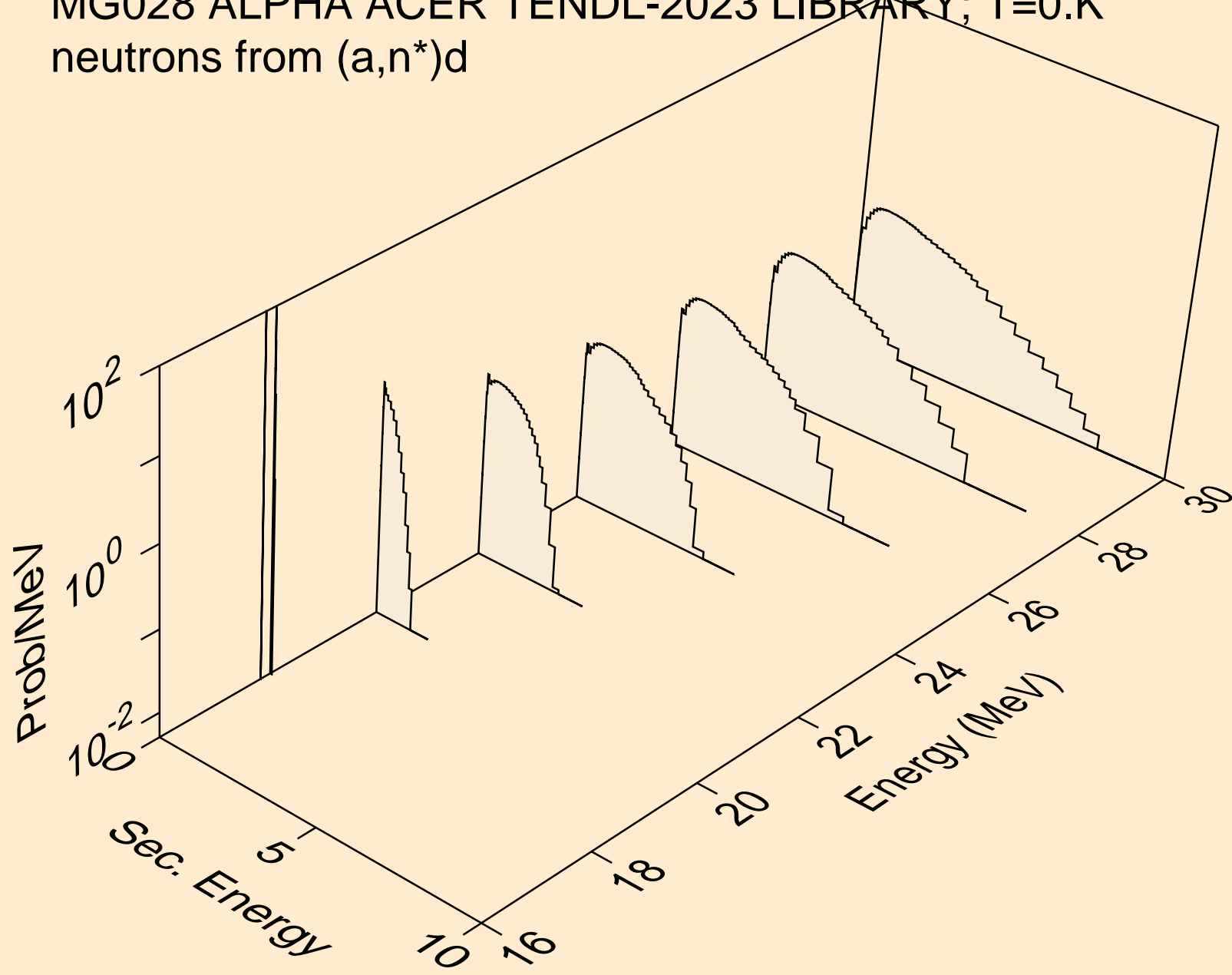

MG028 ALPHA ACER TENDL-2023 LIBRARY; T=0.K  
neutrons from (a,n\*)t

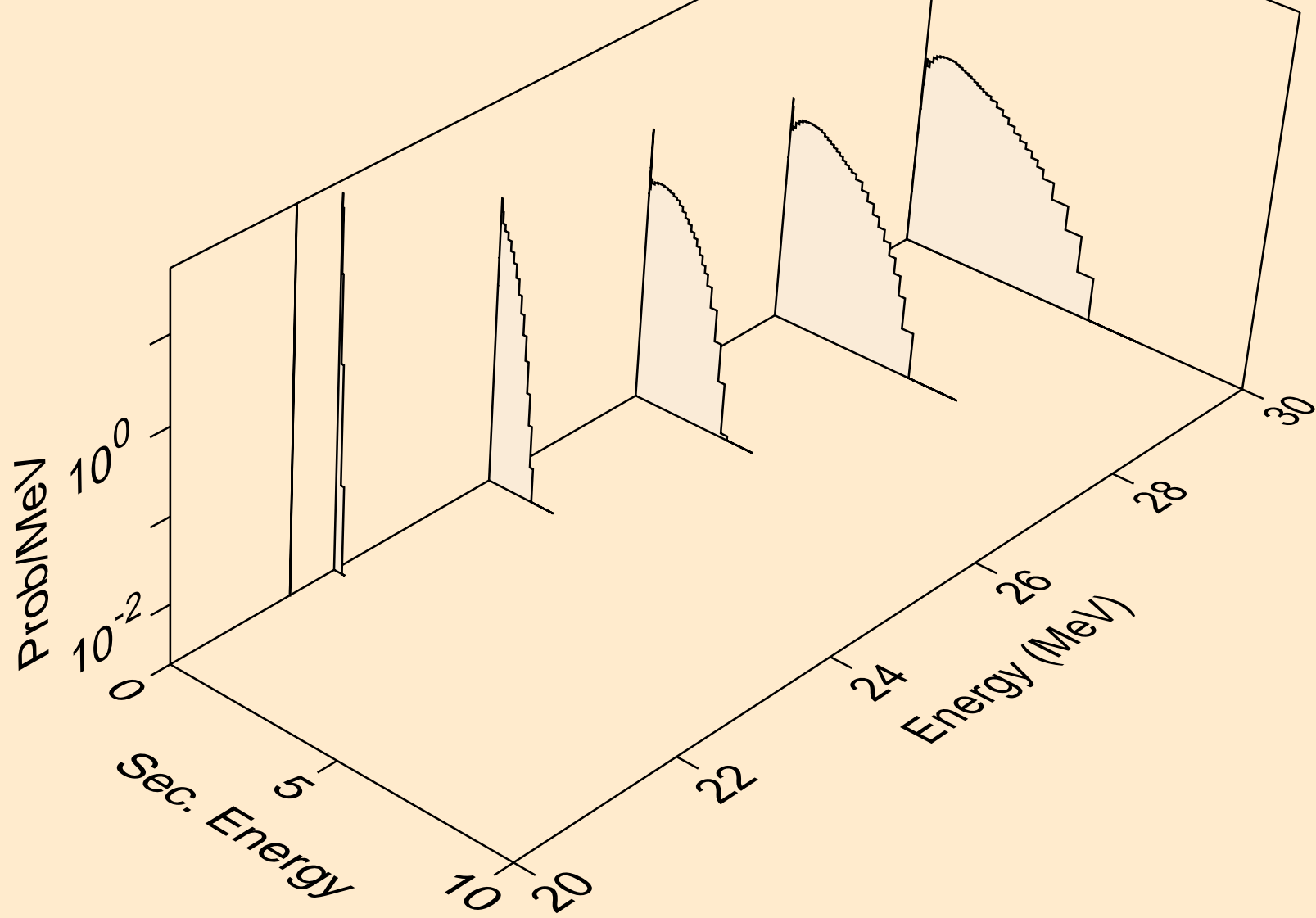



MG028 ALPHA ACER TENDL-2023 LIBRARY; T=0.K  
neutrons from (a,n\*)he3

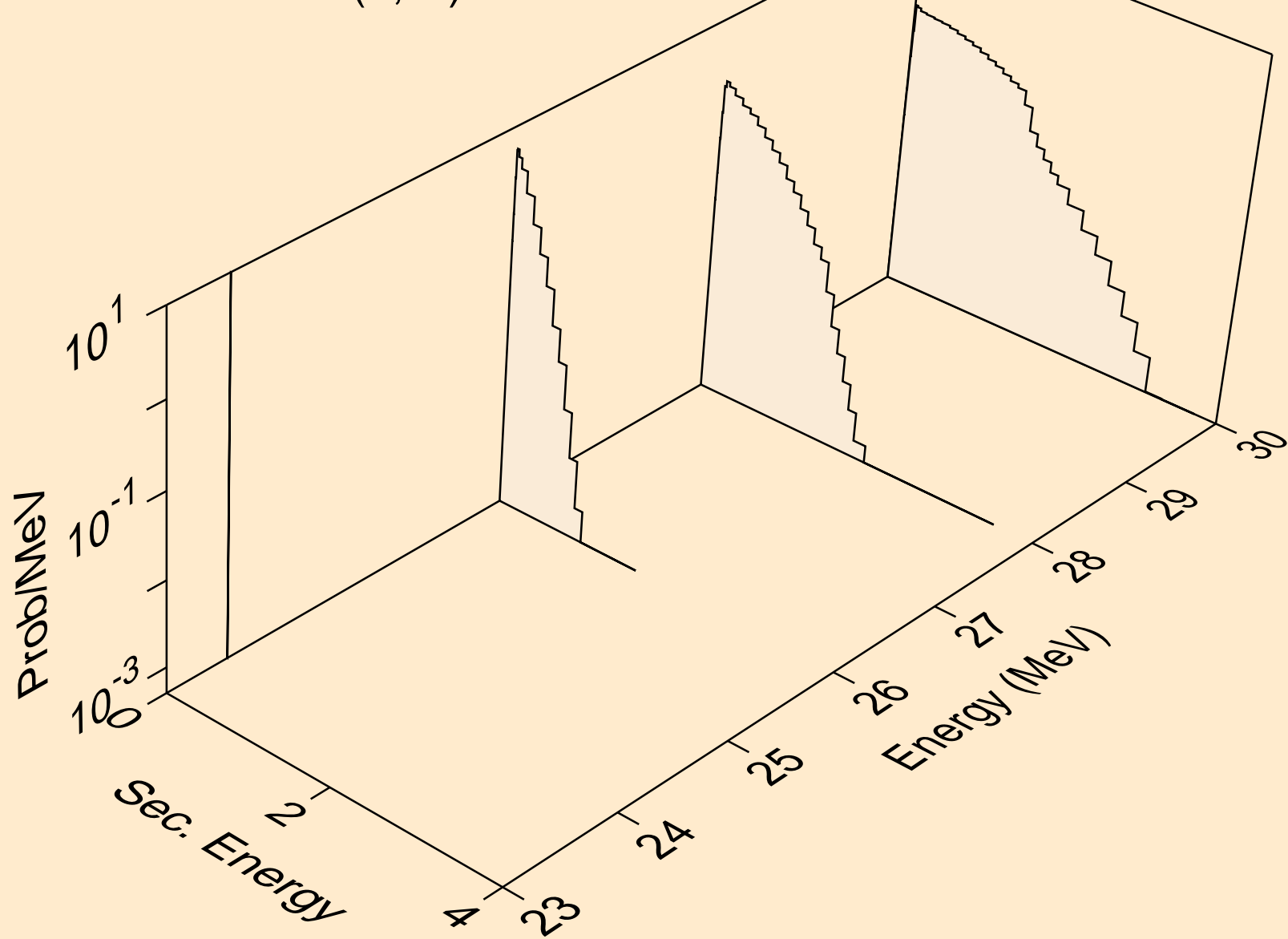

MG028 ALPHA ACER TENDL-2023 LIBRARY; T=0.K  
neutrons from (a,4n)

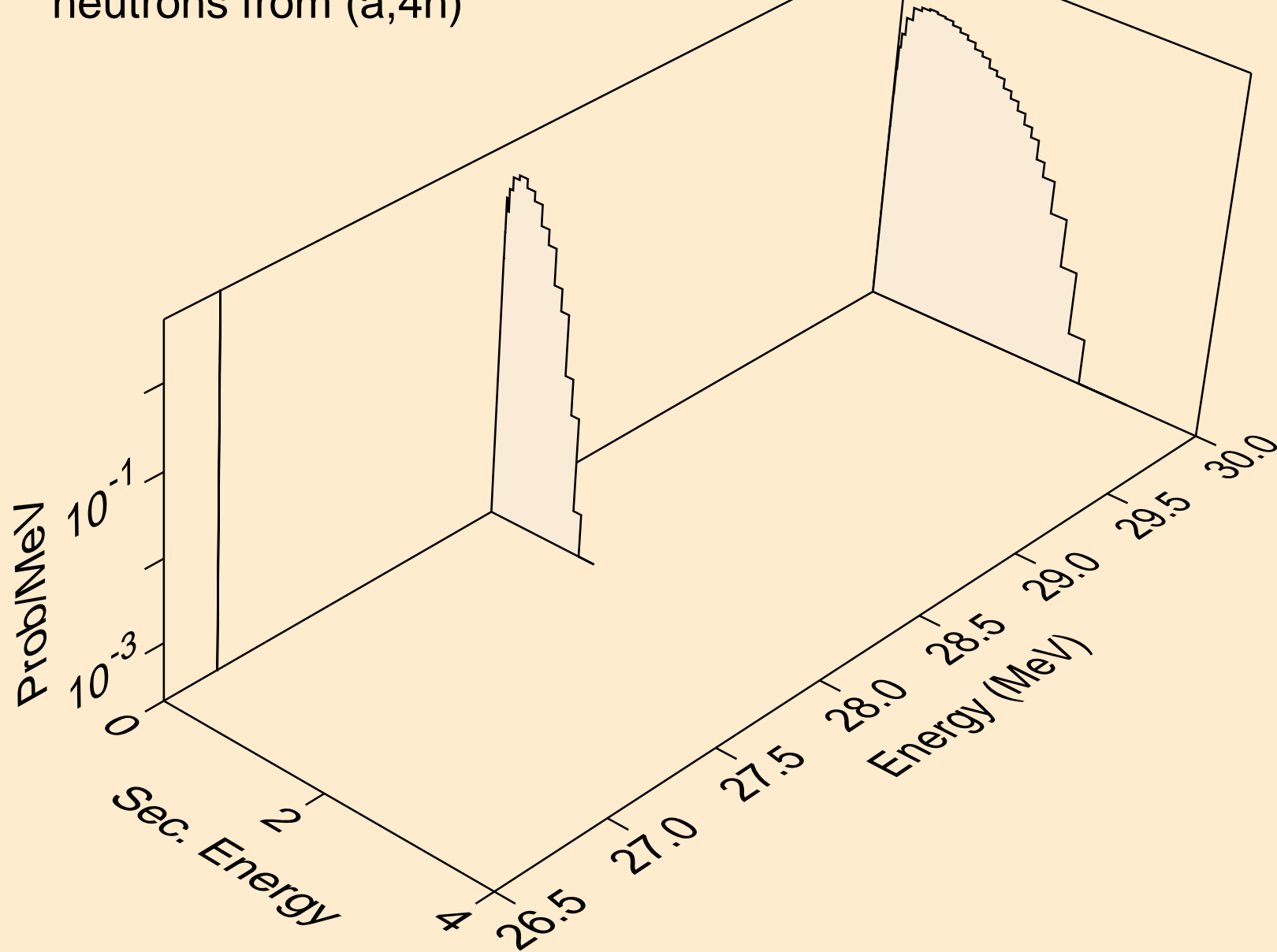

MG028 ALPHA ACER TENDL-2023 LIBRARY; T=0.K  
neutrons from (a,2np)

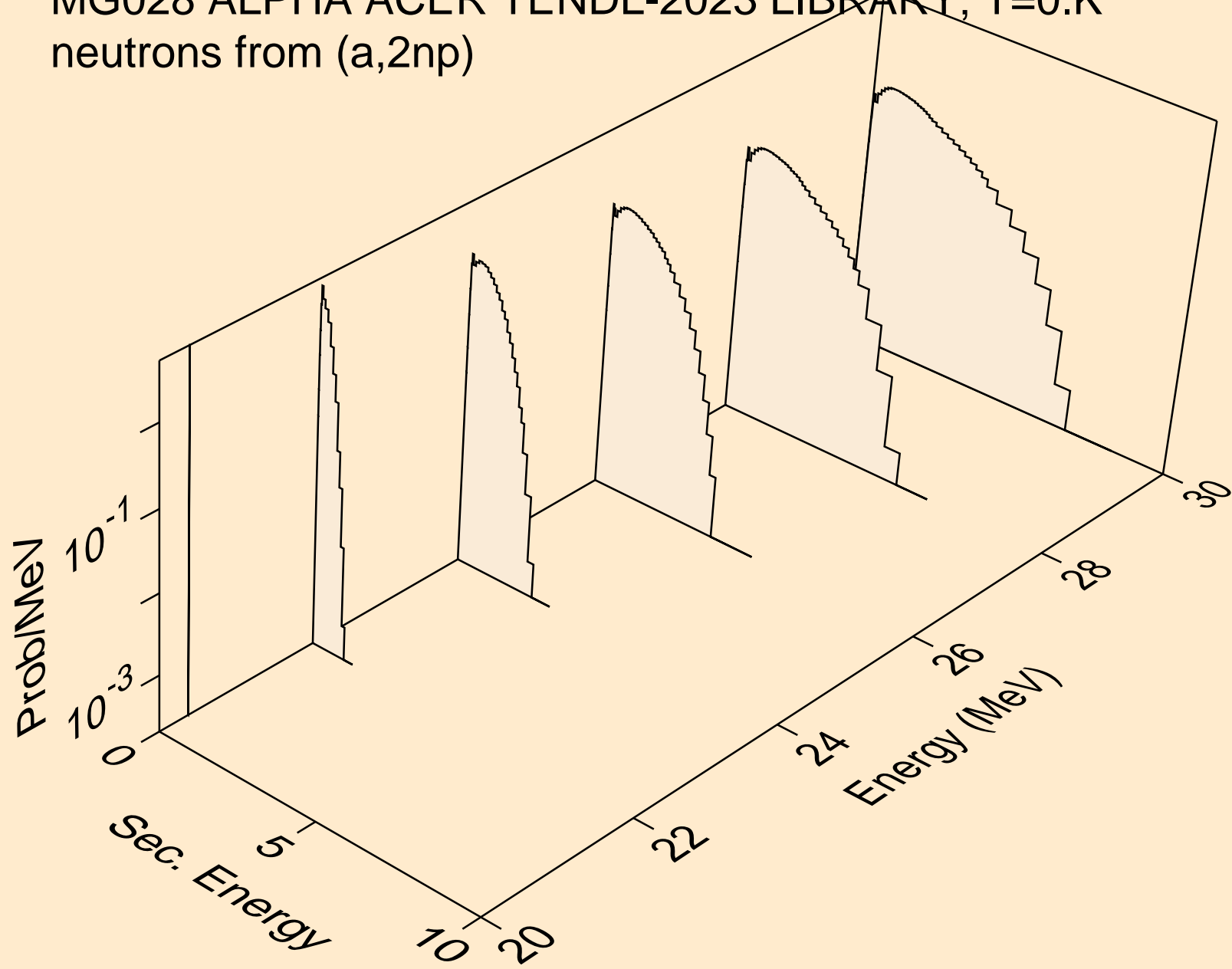

MG028 ALPHA ACER TENDL-2023 LIBRARY; T=0.K  
protons from (a,x)

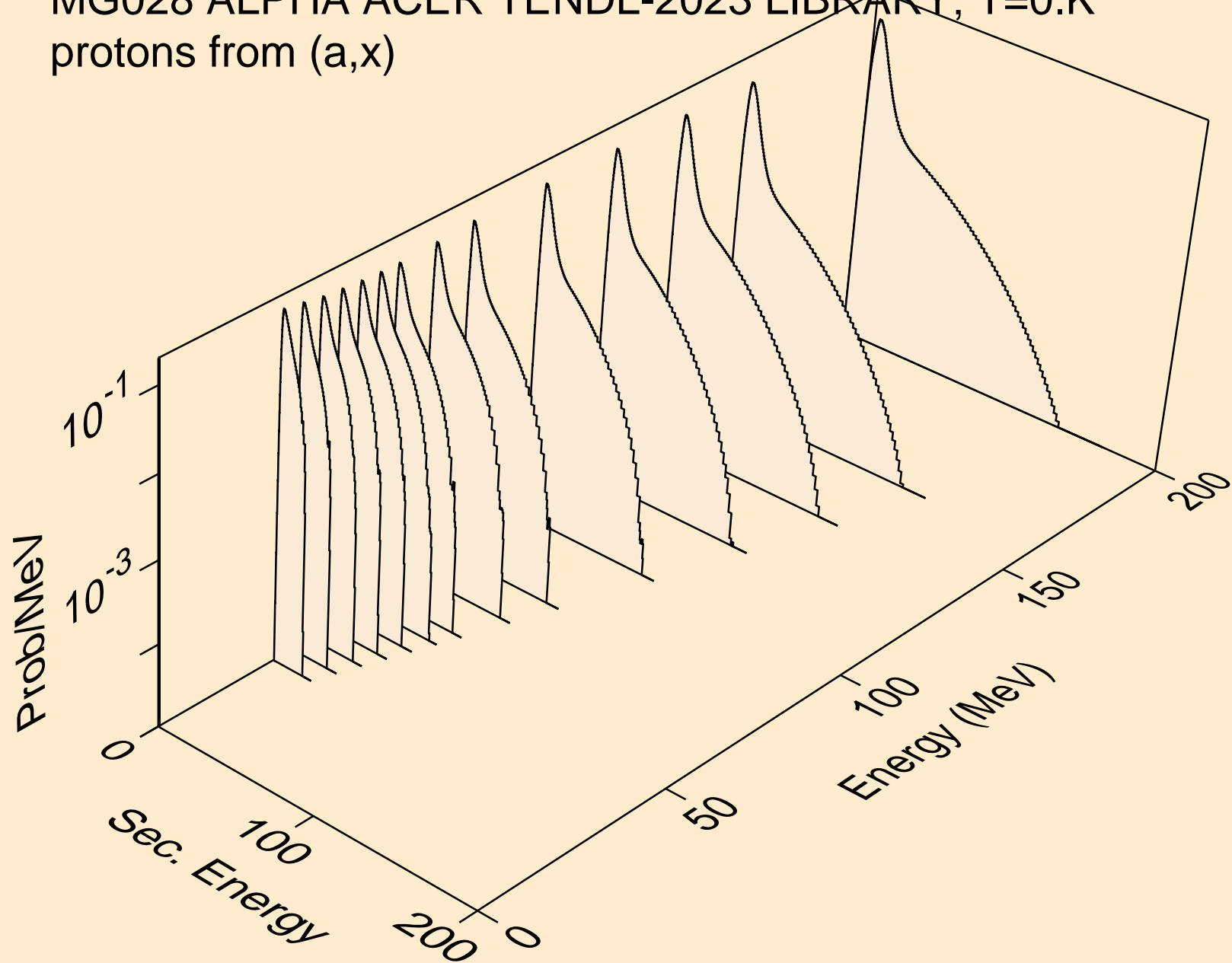

MG028 ALPHA ACER TENDL-2023 LIBRARY; T=0.K  
protons from (a,n\*)p

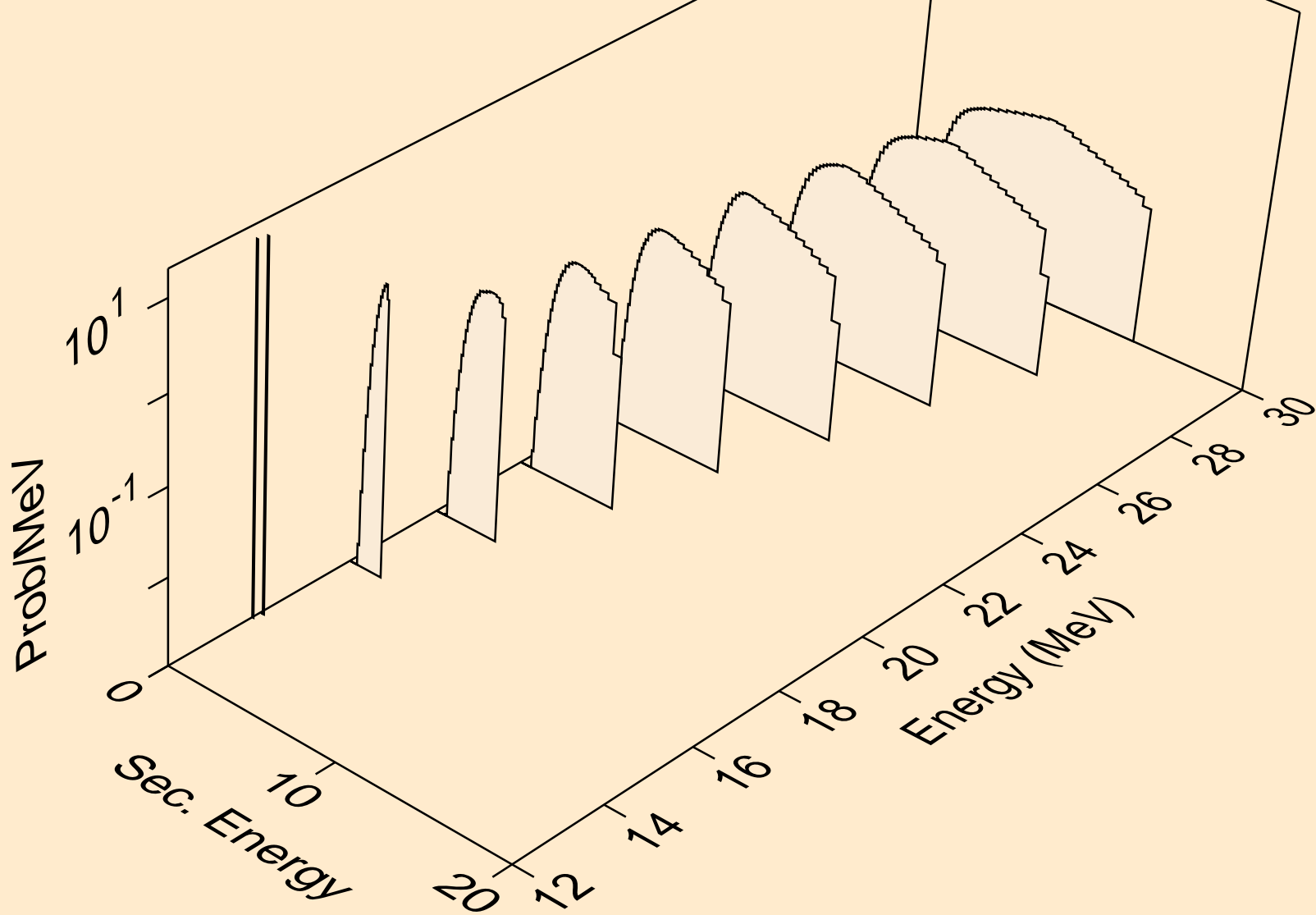

MG028 ALPHA ACER TENDL-2023 LIBRARY; T=0.K  
protons from (a,2np)

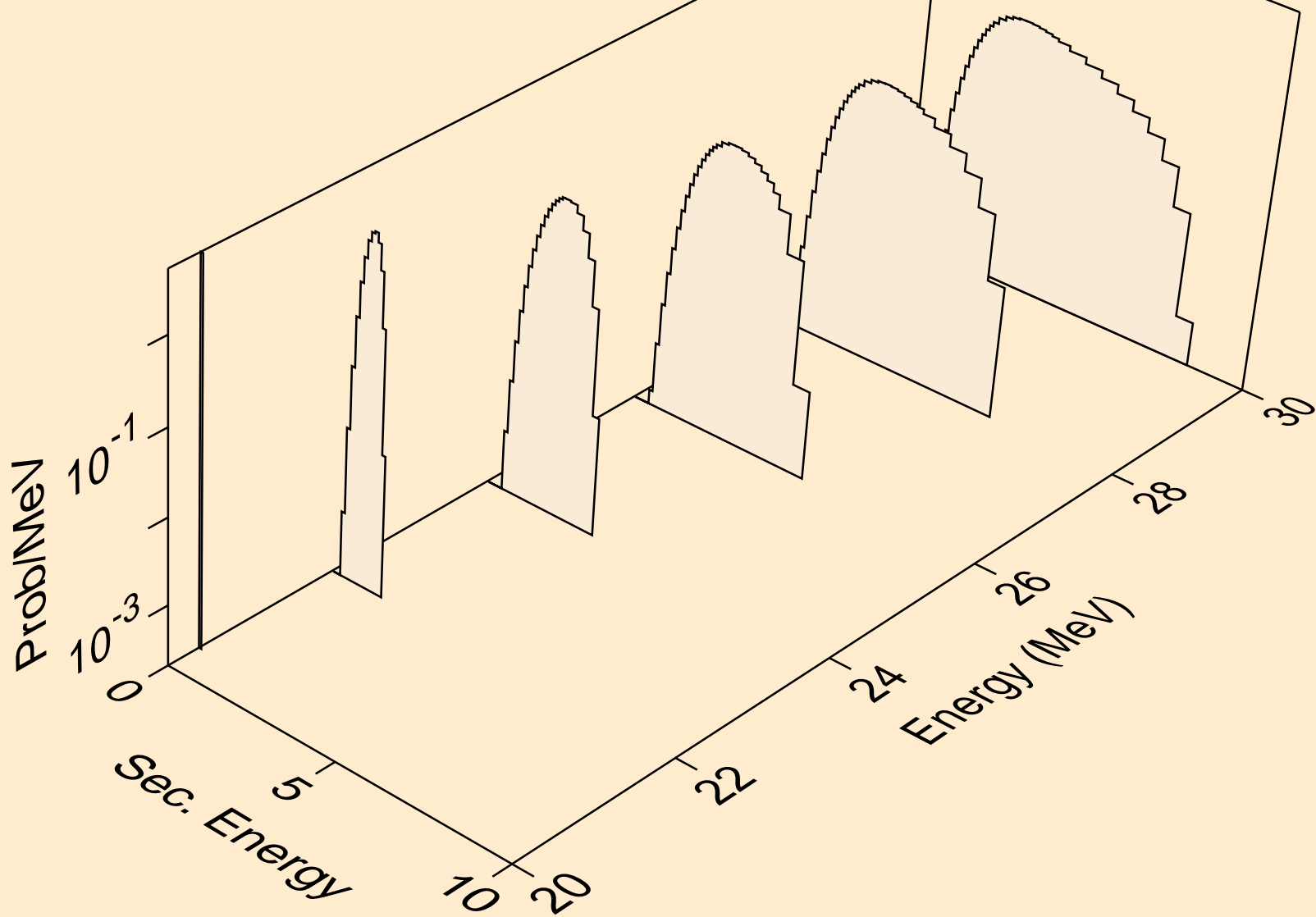

MG028 ALPHA ACER TENDL-2023 LIBRARY; T=0.K  
protons from (a,p)

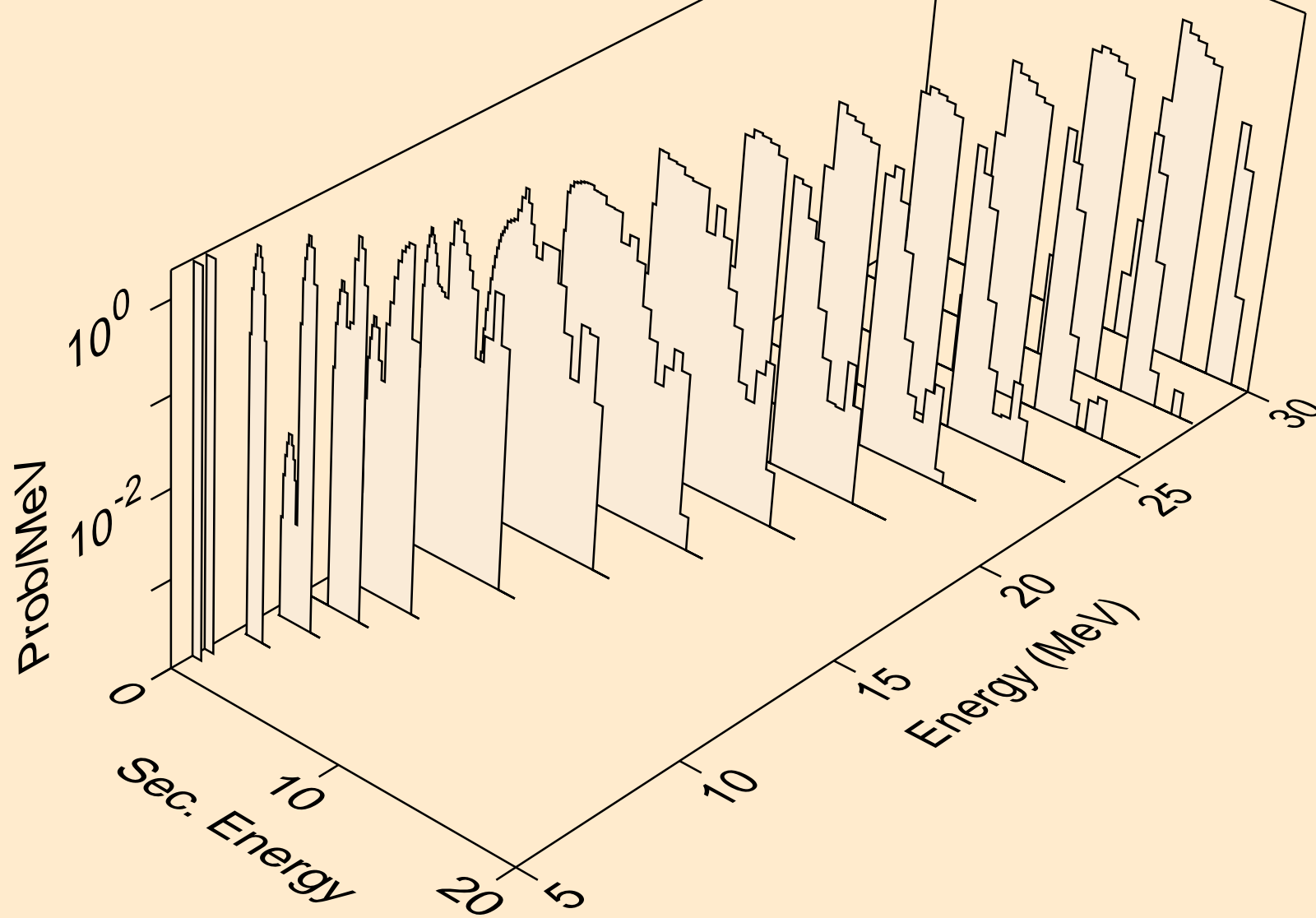

MG028 ALPHA ACER TENDL-2023 LIBRARY; T=0.K  
protons from (a,2p)

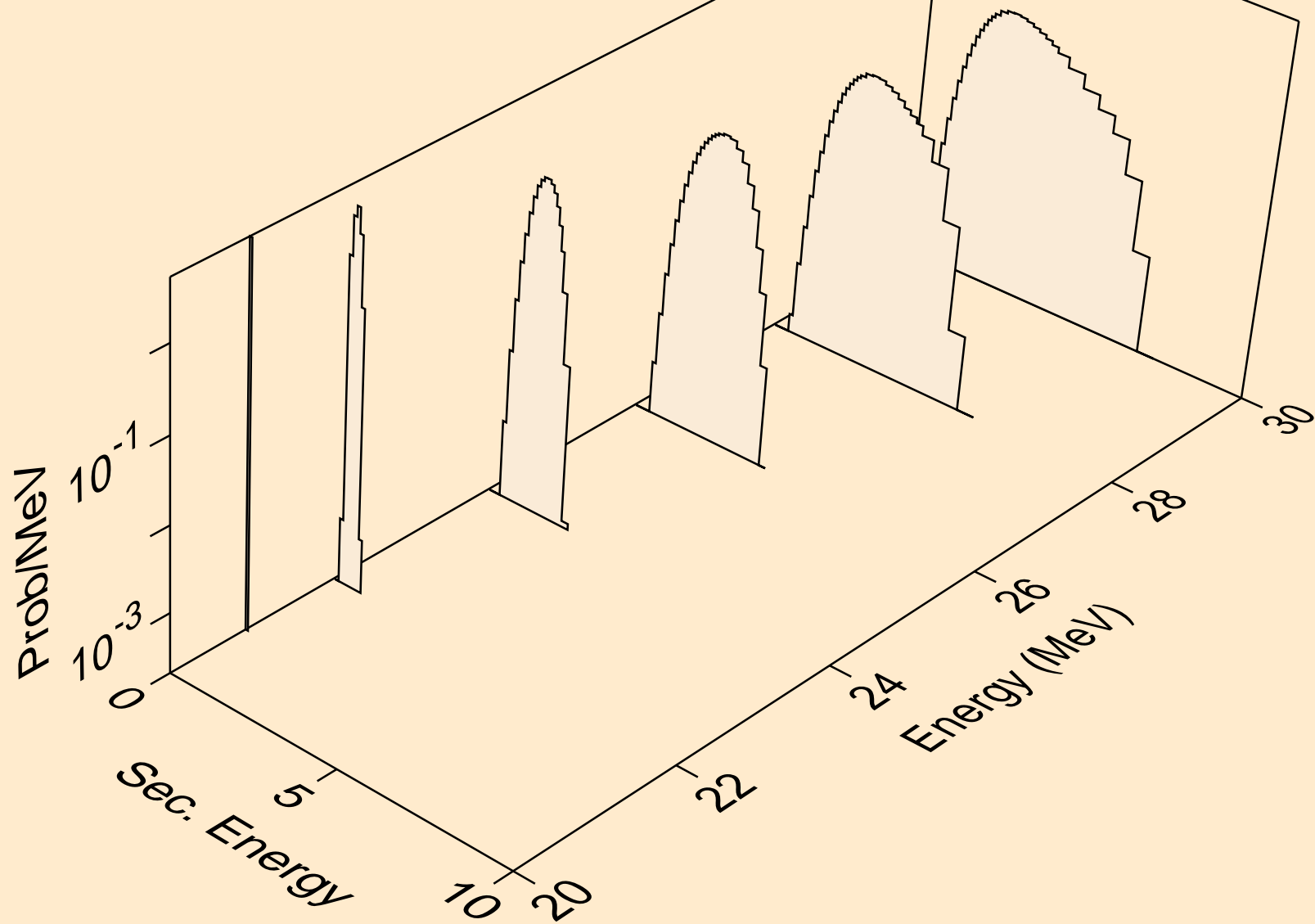



MG028 ALPHA ACER TENDL-2023 LIBRARY; T=0.K  
protons from (a,pa)

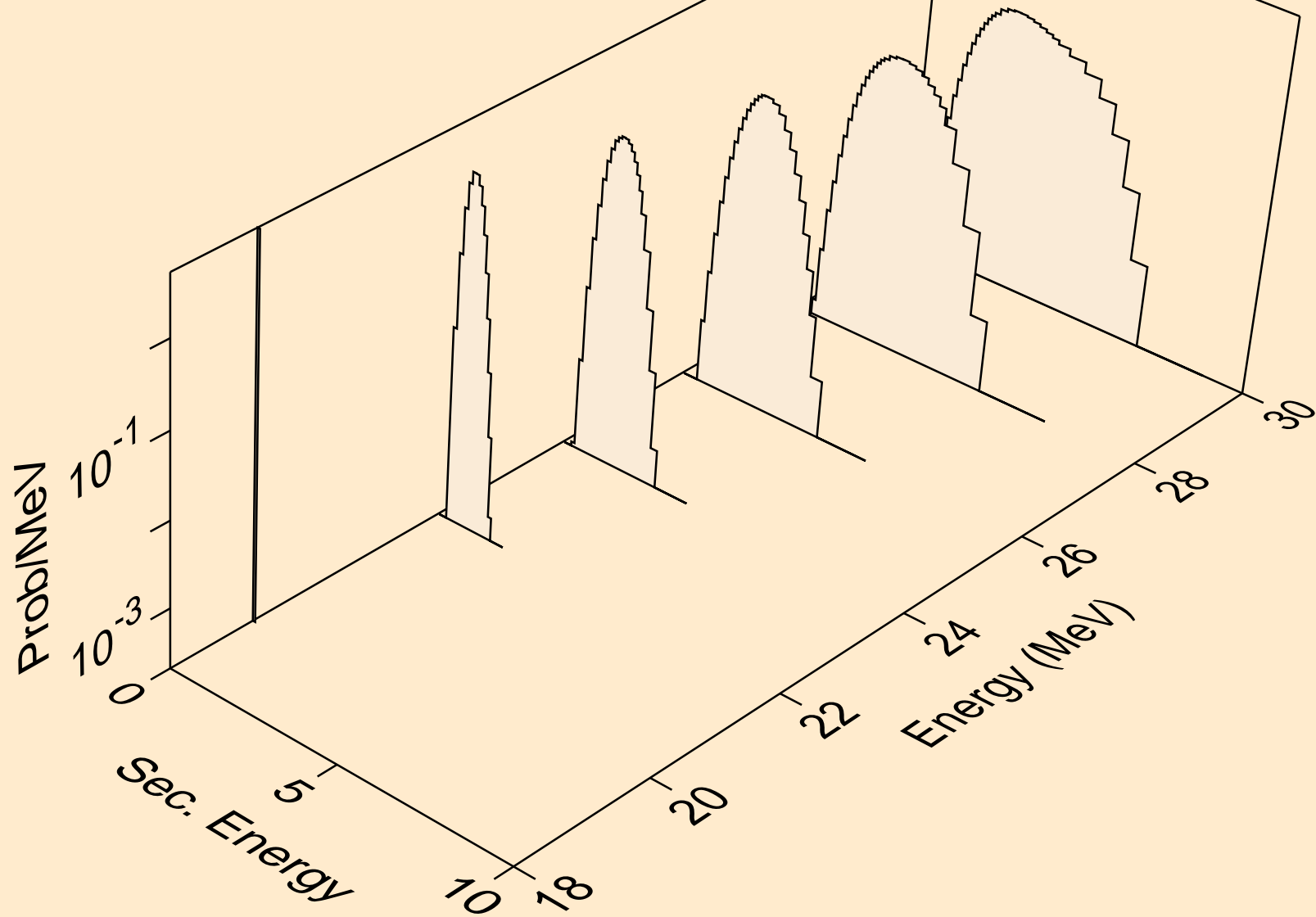

MG028 ALPHA ACER TENDL-2023 LIBRARY; T=0.K  
protons from (a,pd)

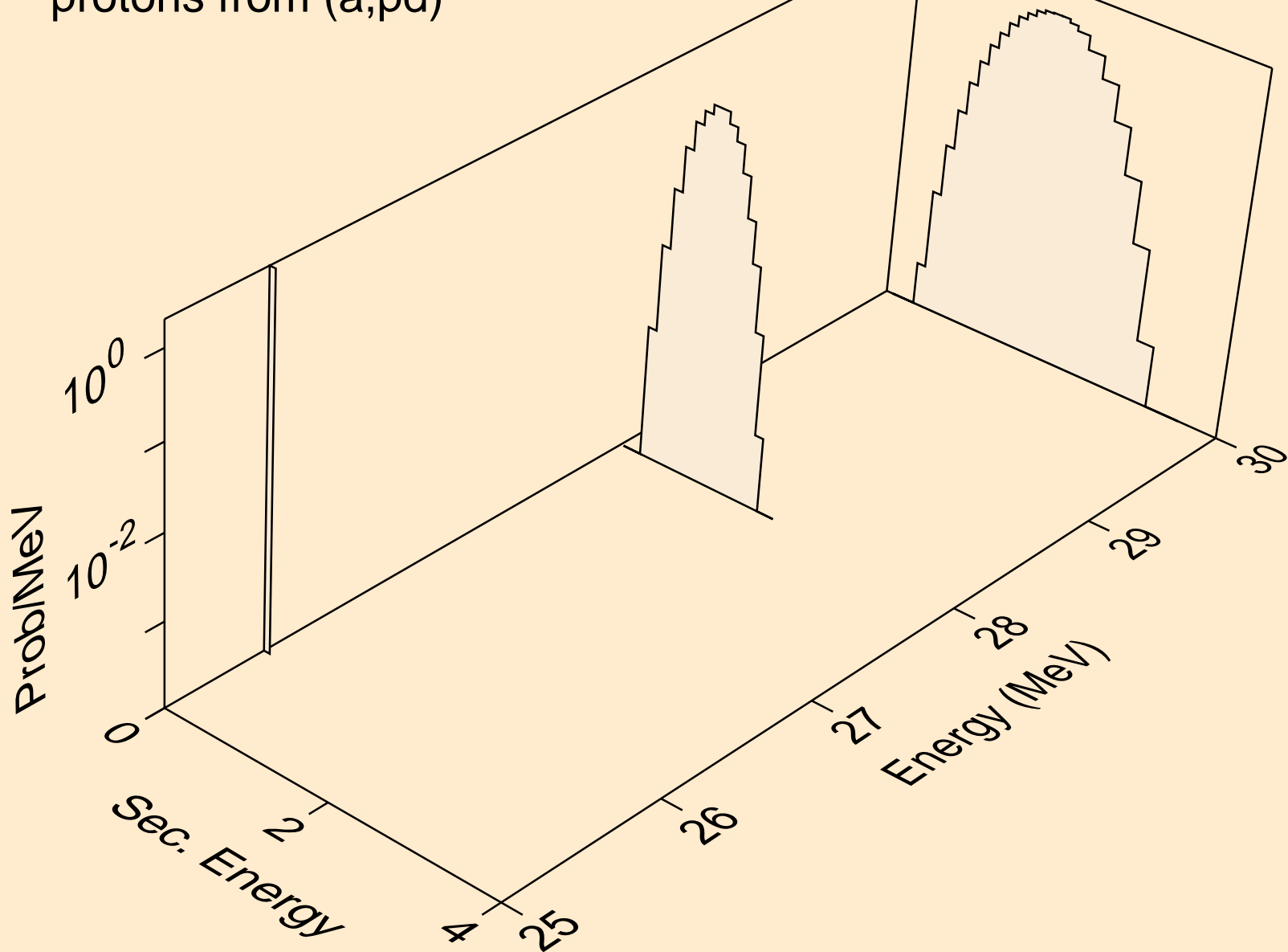

MG028 ALPHA ACER TENDL-2023 LIBRARY; T=0.K  
protons from (a,pt)

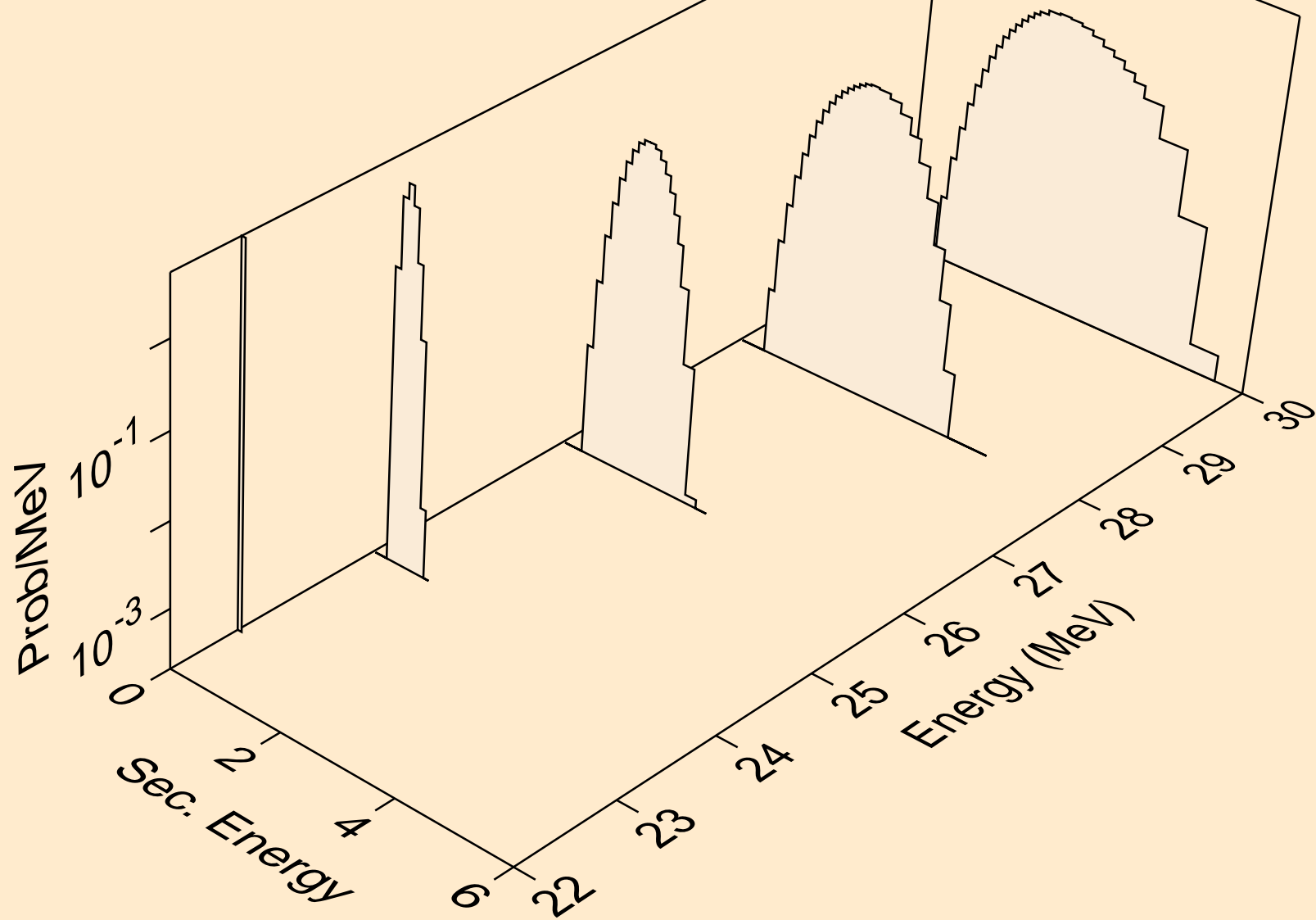

MG028 ALPHA ACER TENDL-2023 LIBRARY; T=0.K  
deuterons from (a,x)

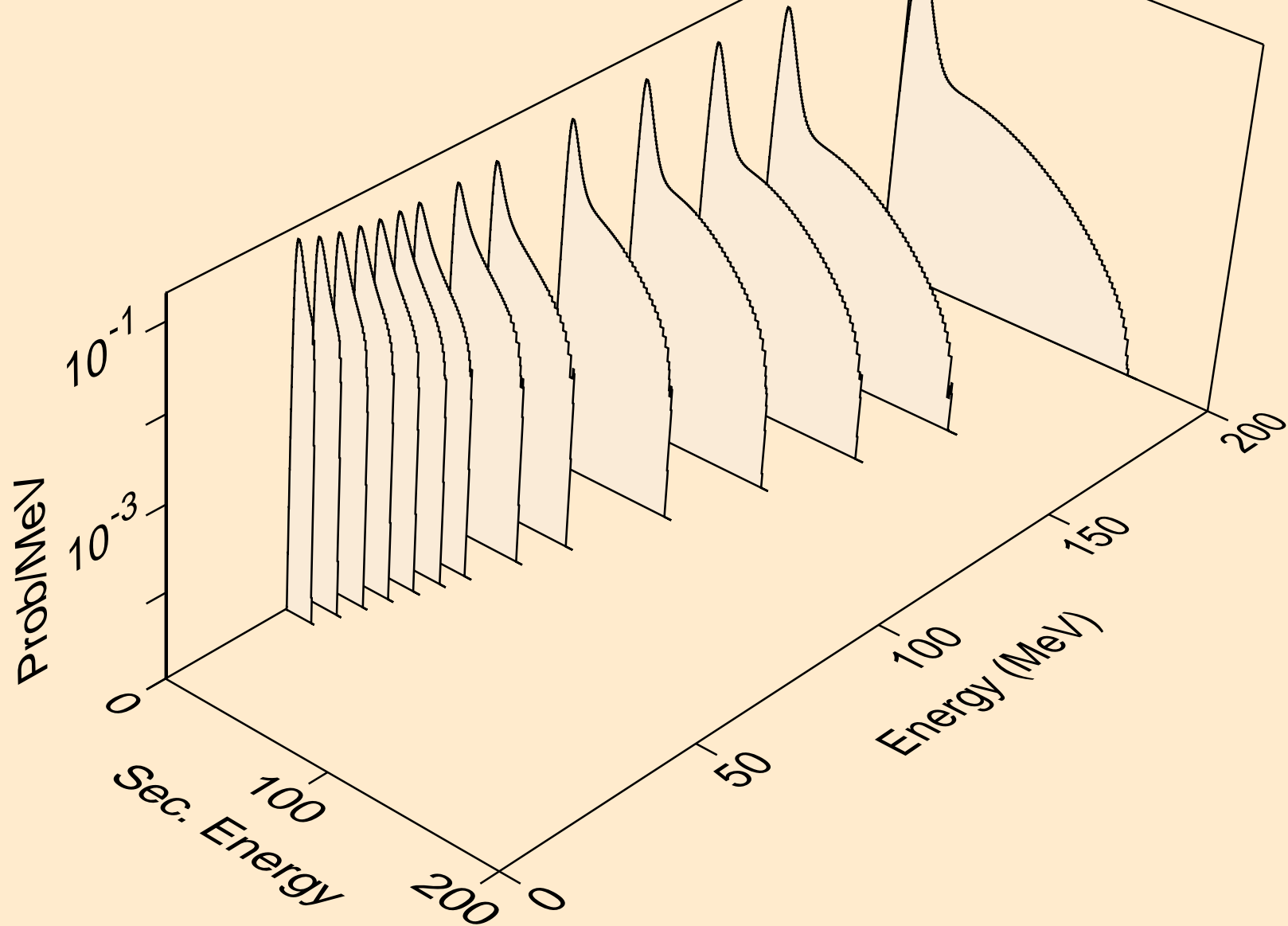

MG028 ALPHA ACER TENDL-2023 LIBRARY; T=0.K  
deuterons from (a,n\*)d

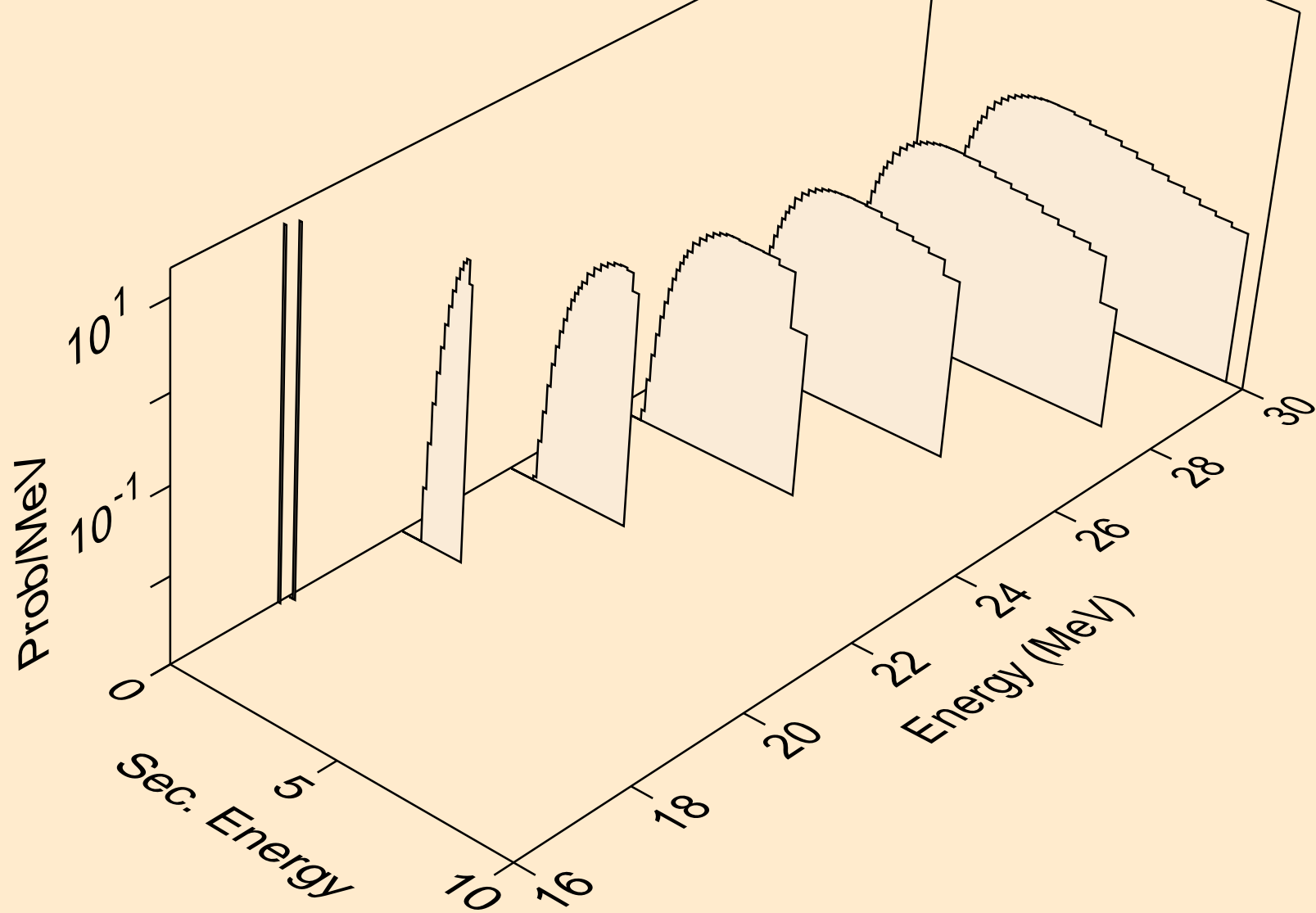

MG028 ALPHA ACER TENDL-2023 LIBRARY; T=0.K  
deuterons from (a,d)

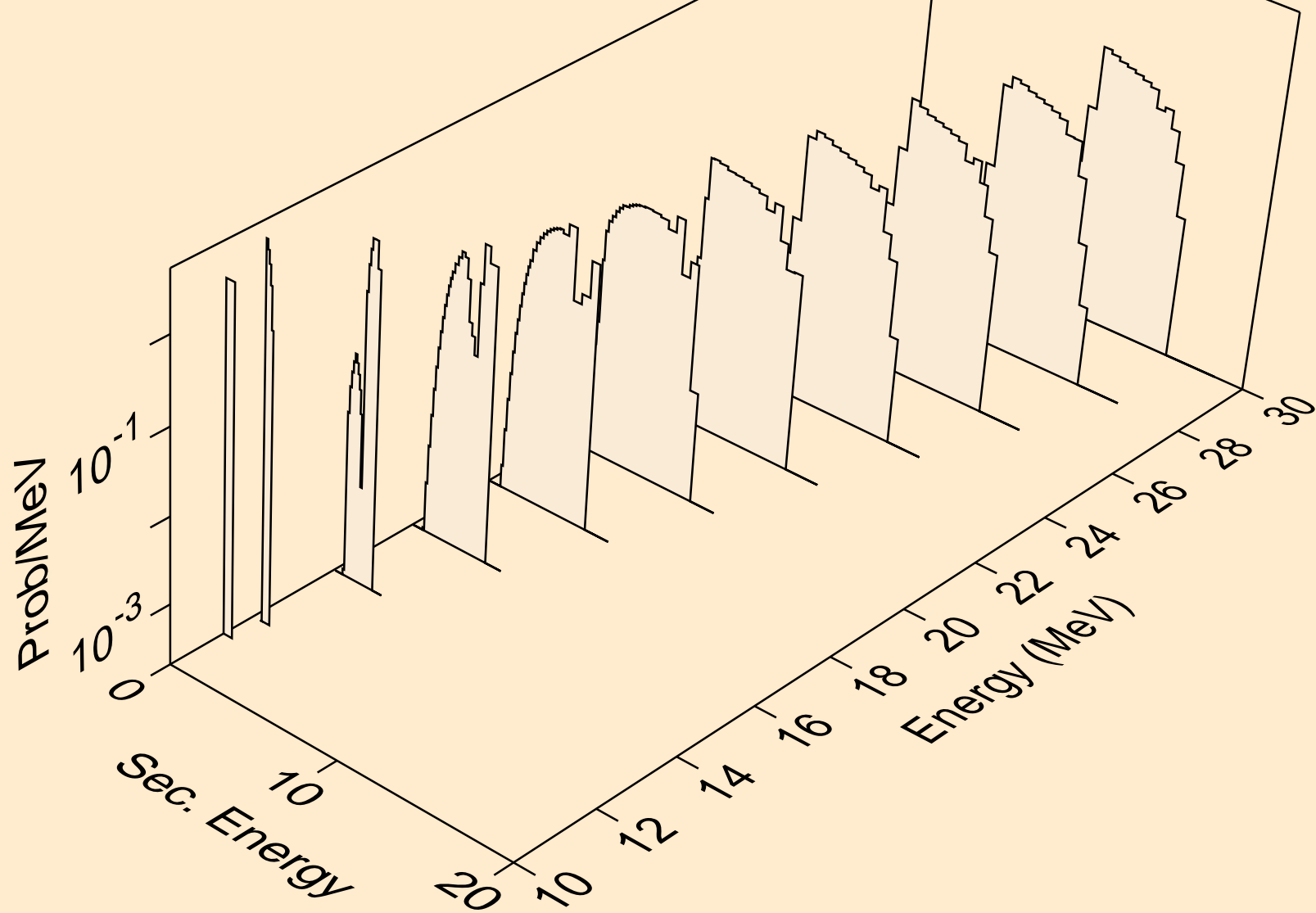

MG028 ALPHA ACER TENDL-2023 LIBRARY; T=0.K  
deuterons from (a,pd)

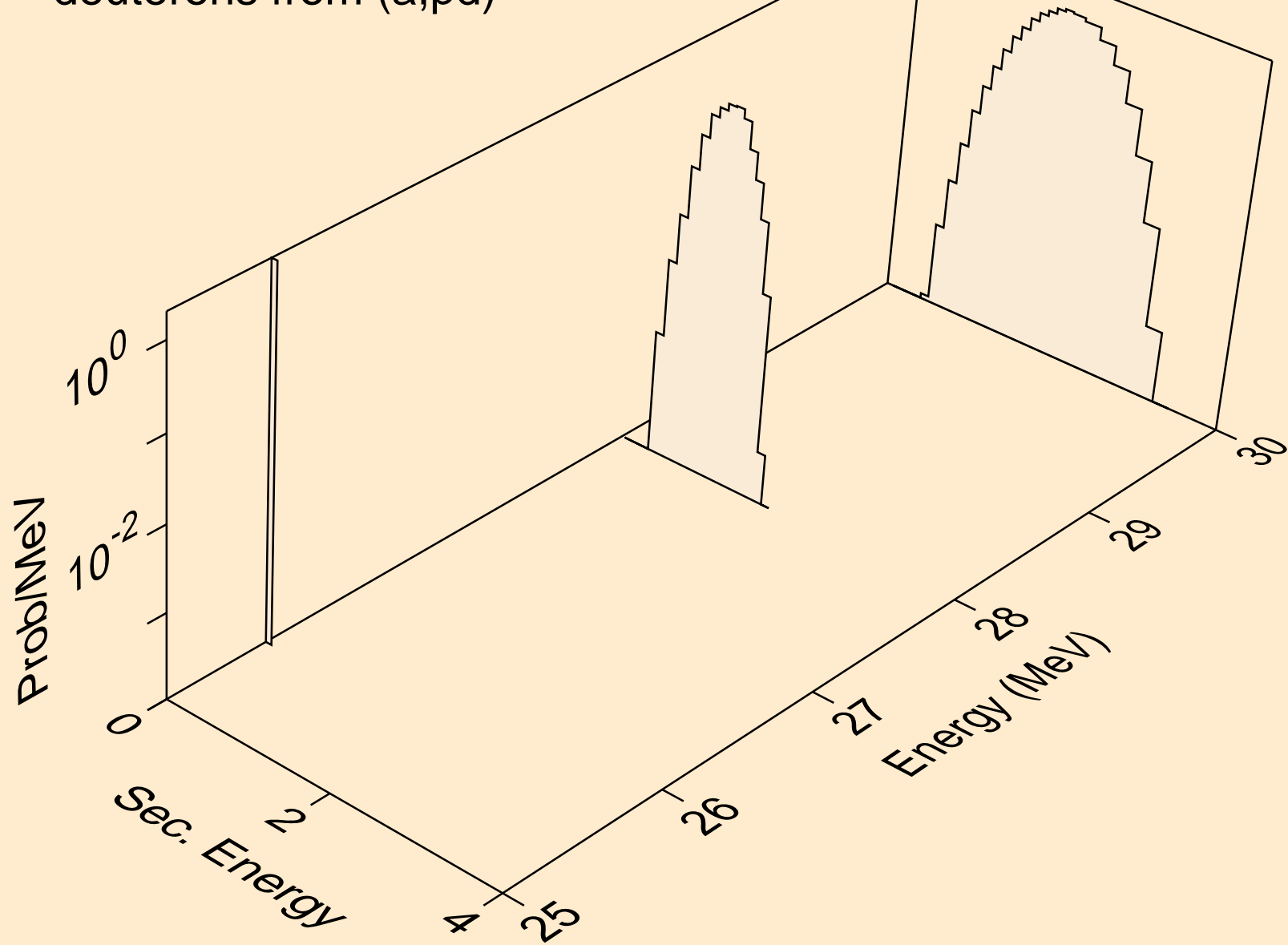

MG028 ALPHA ACER TENDL-2023 LIBRARY; T=0.K  
deuterons from (a,da)

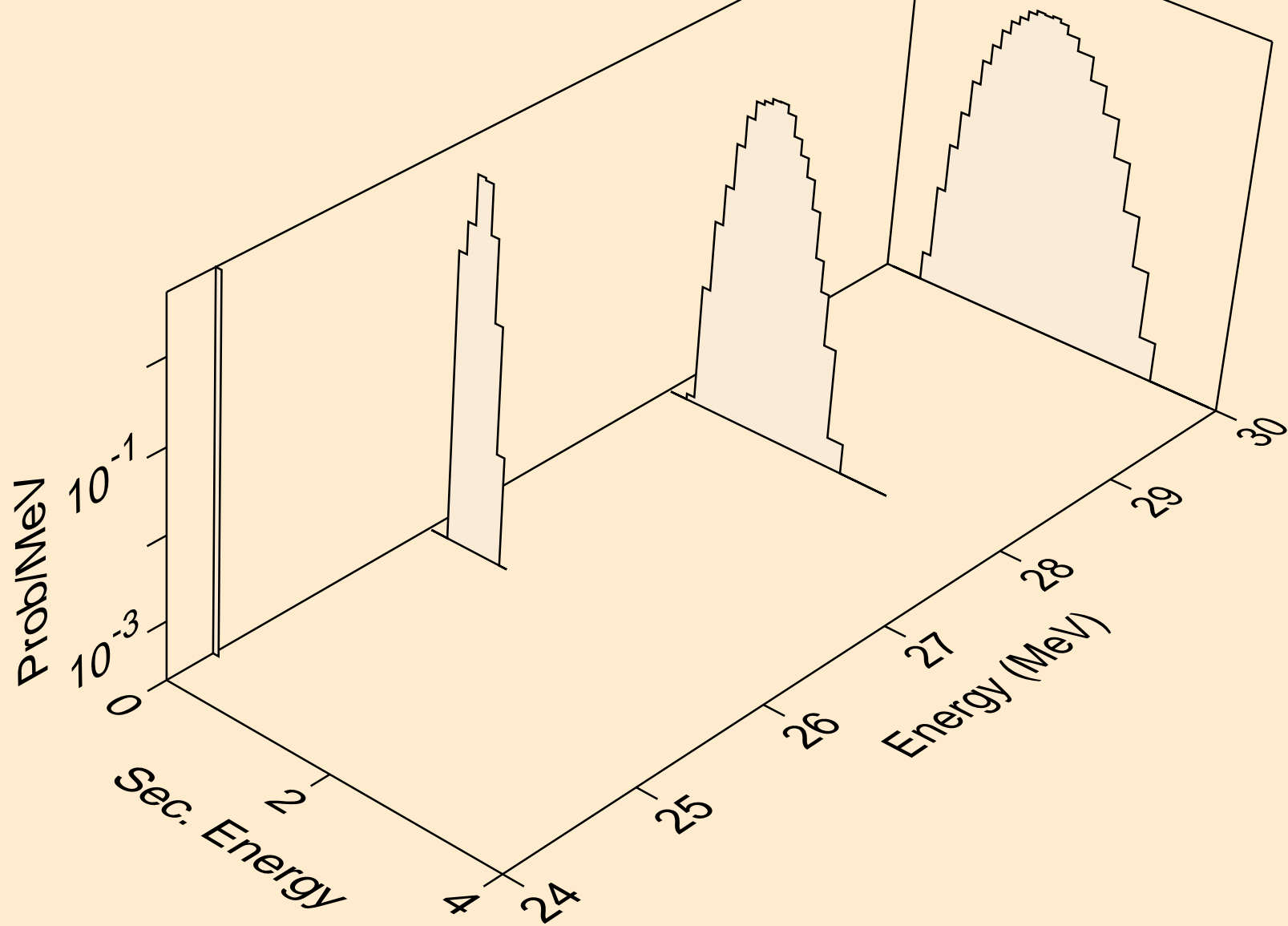



MG028 ALPHA ACER TENDL-2023 LIBRARY; T=0.K  
tritons from (a,x)

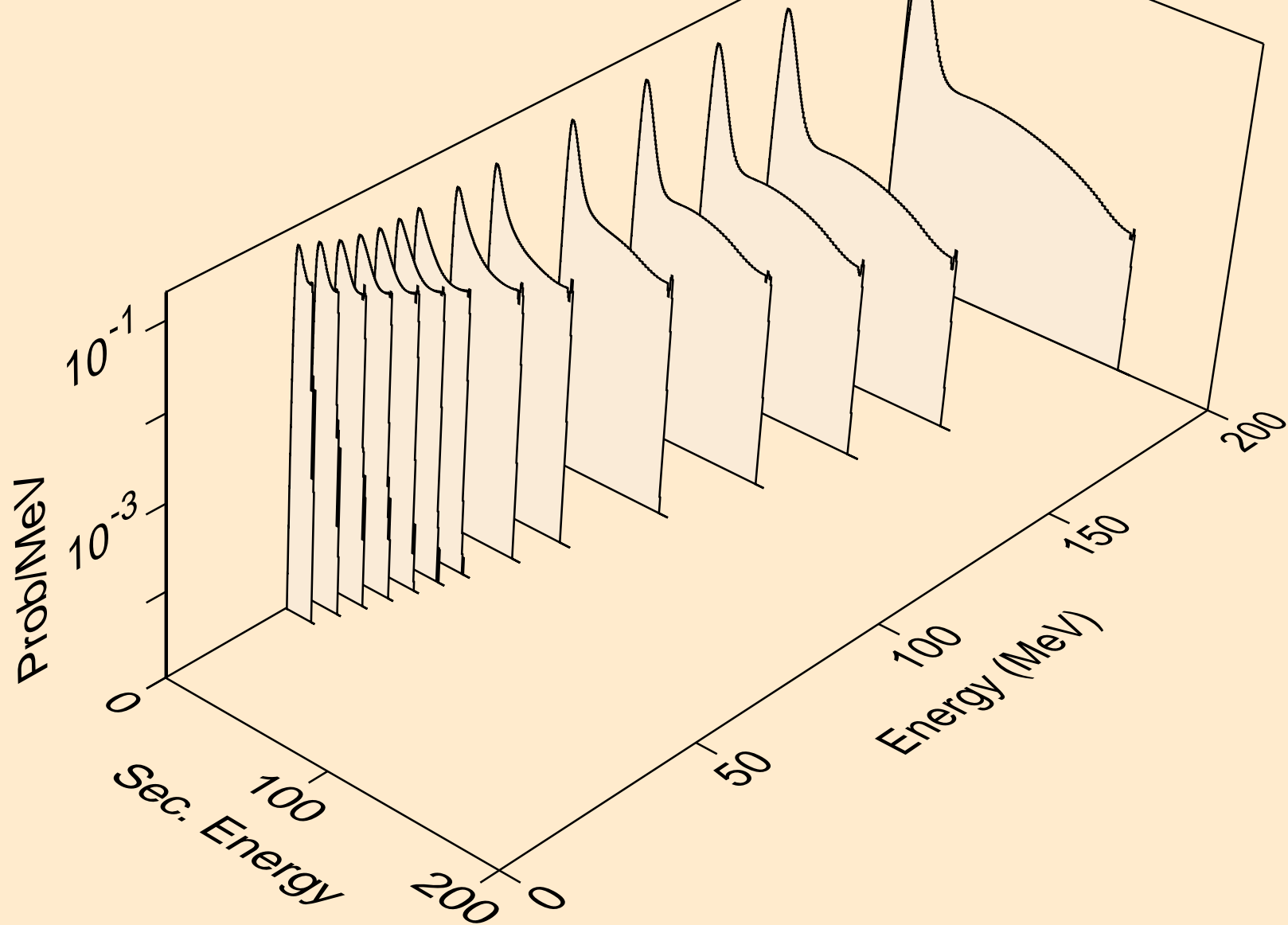

MG028 ALPHA ACER TENDL-2023 LIBRARY; T=0.K  
tritons from (a,n\*)t

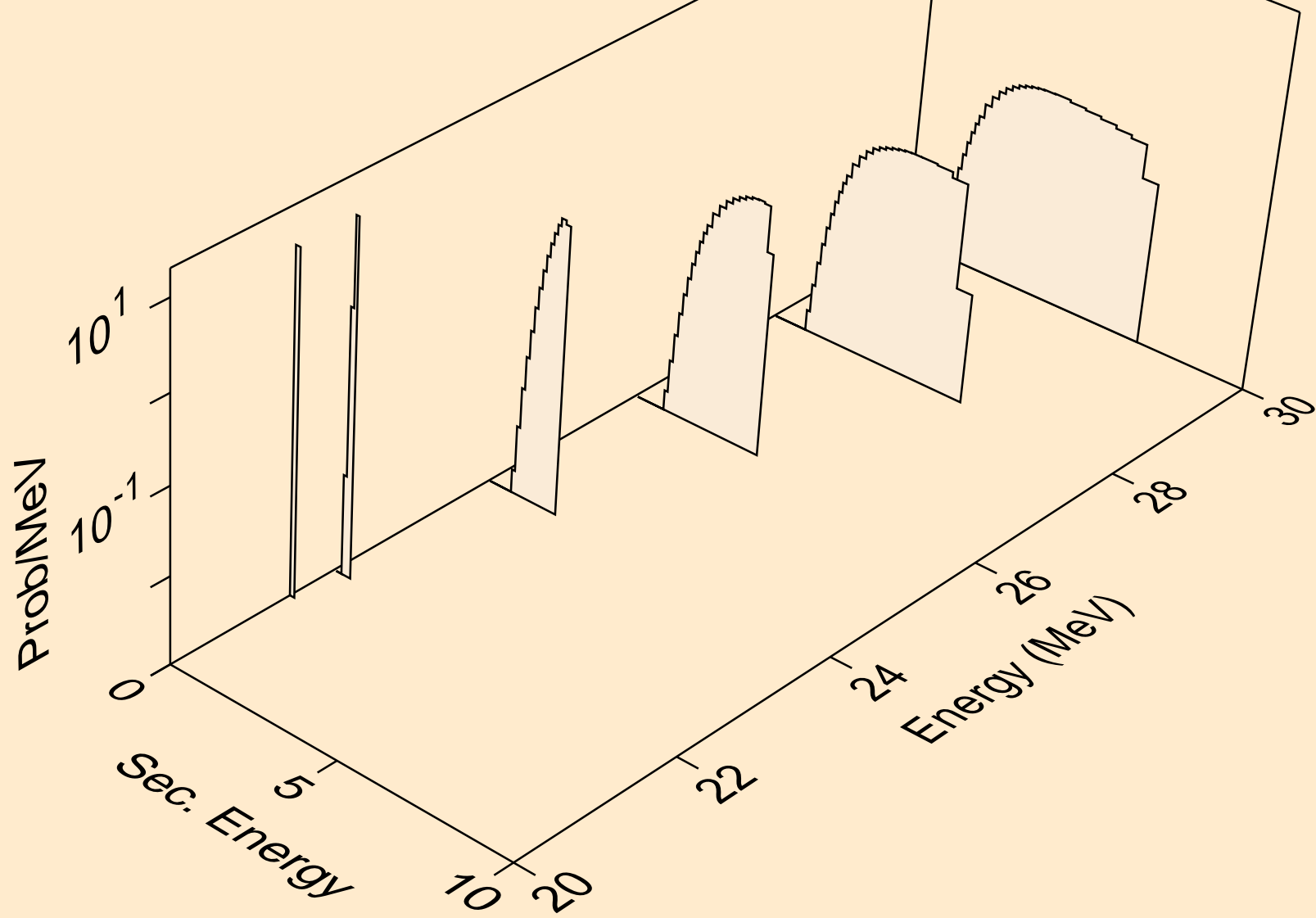

MG028 ALPHA ACER TENDL-2023 LIBRARY; T=0.K  
tritons from (a,t)

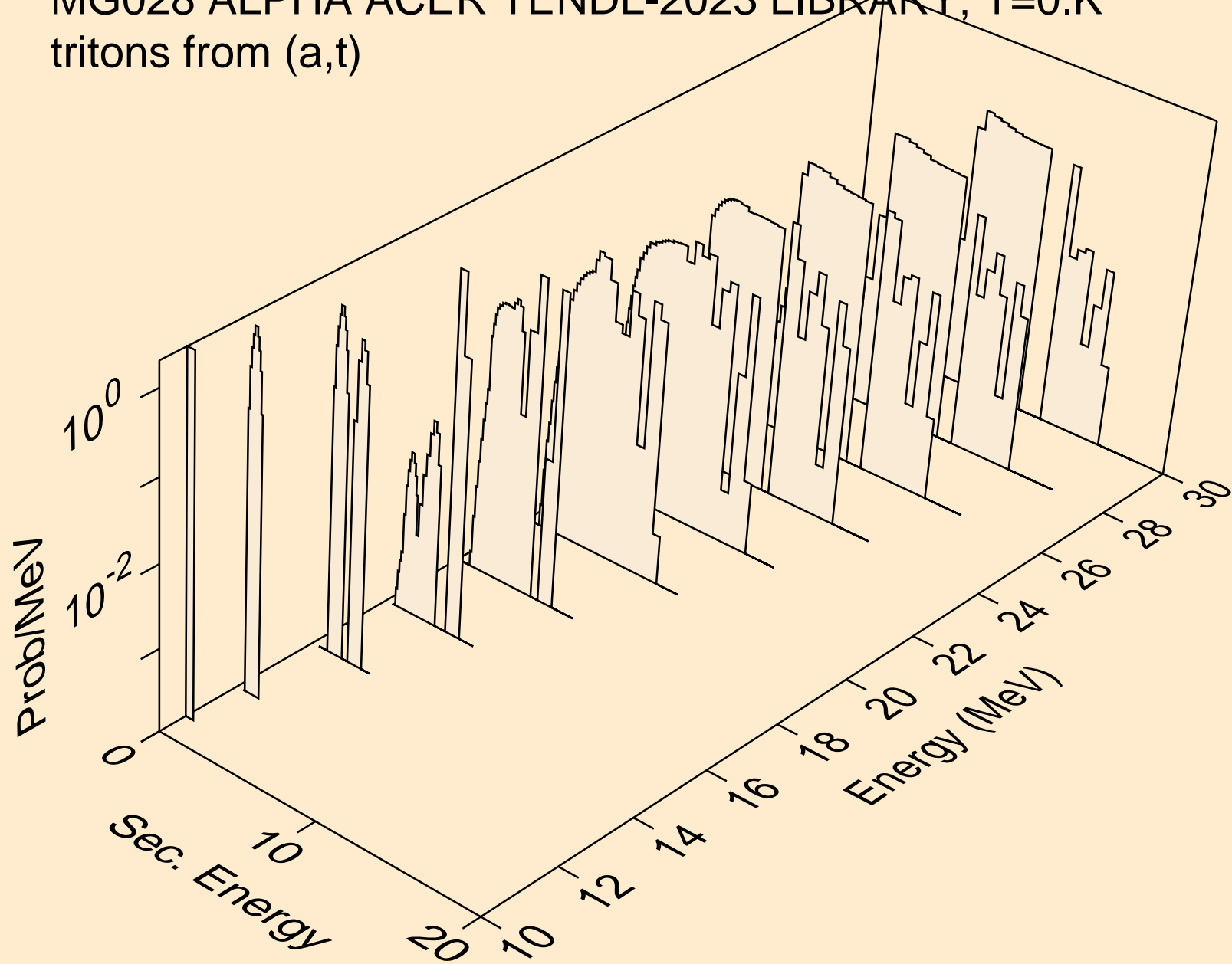

MG028 ALPHA ACER TENDL-2023 LIBRARY; T=0.K  
tritons from (a,pt)

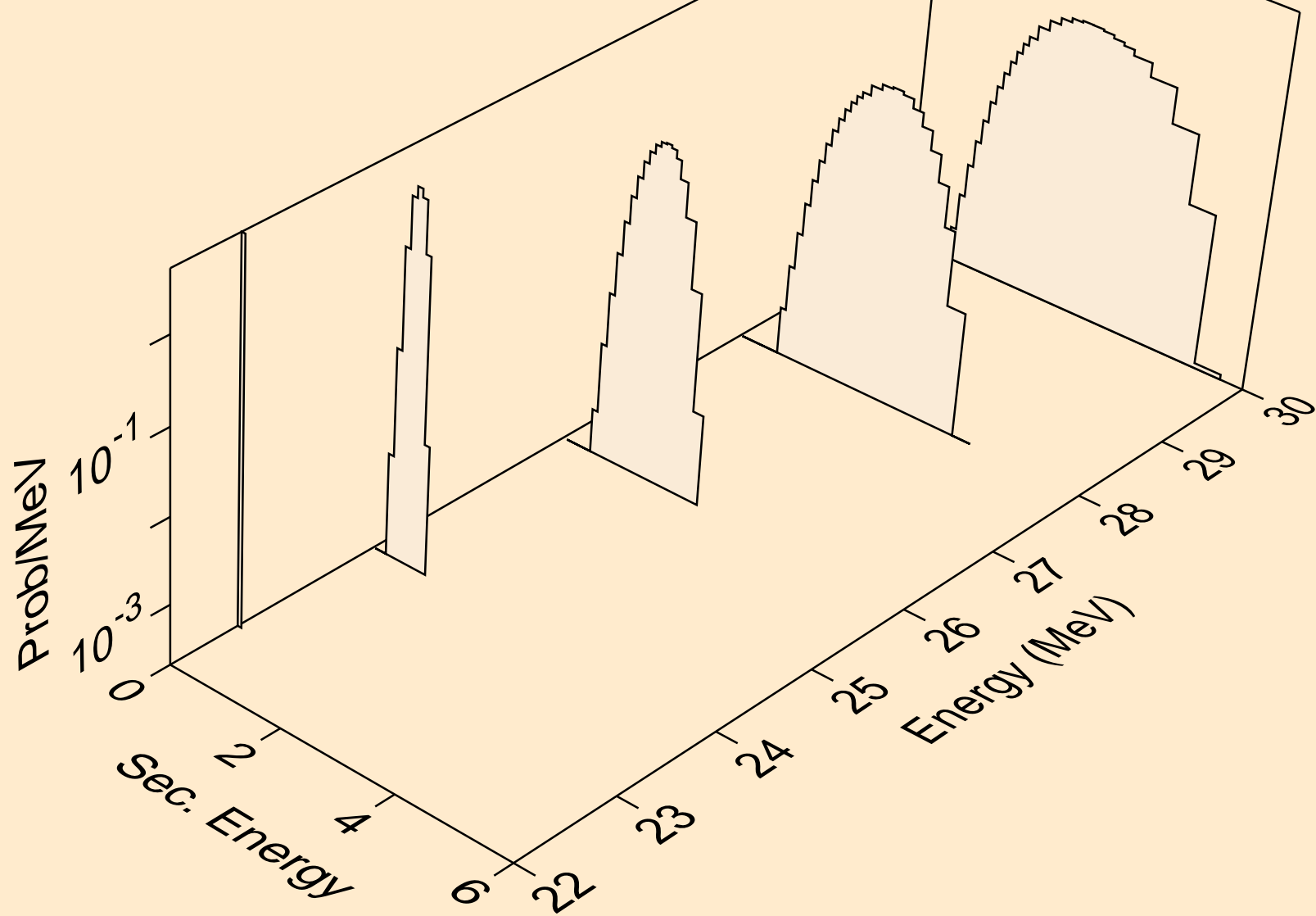

MG028 ALPHA ACER TENDL-2023 LIBRARY; T=0.K  
he3s from (a,x)

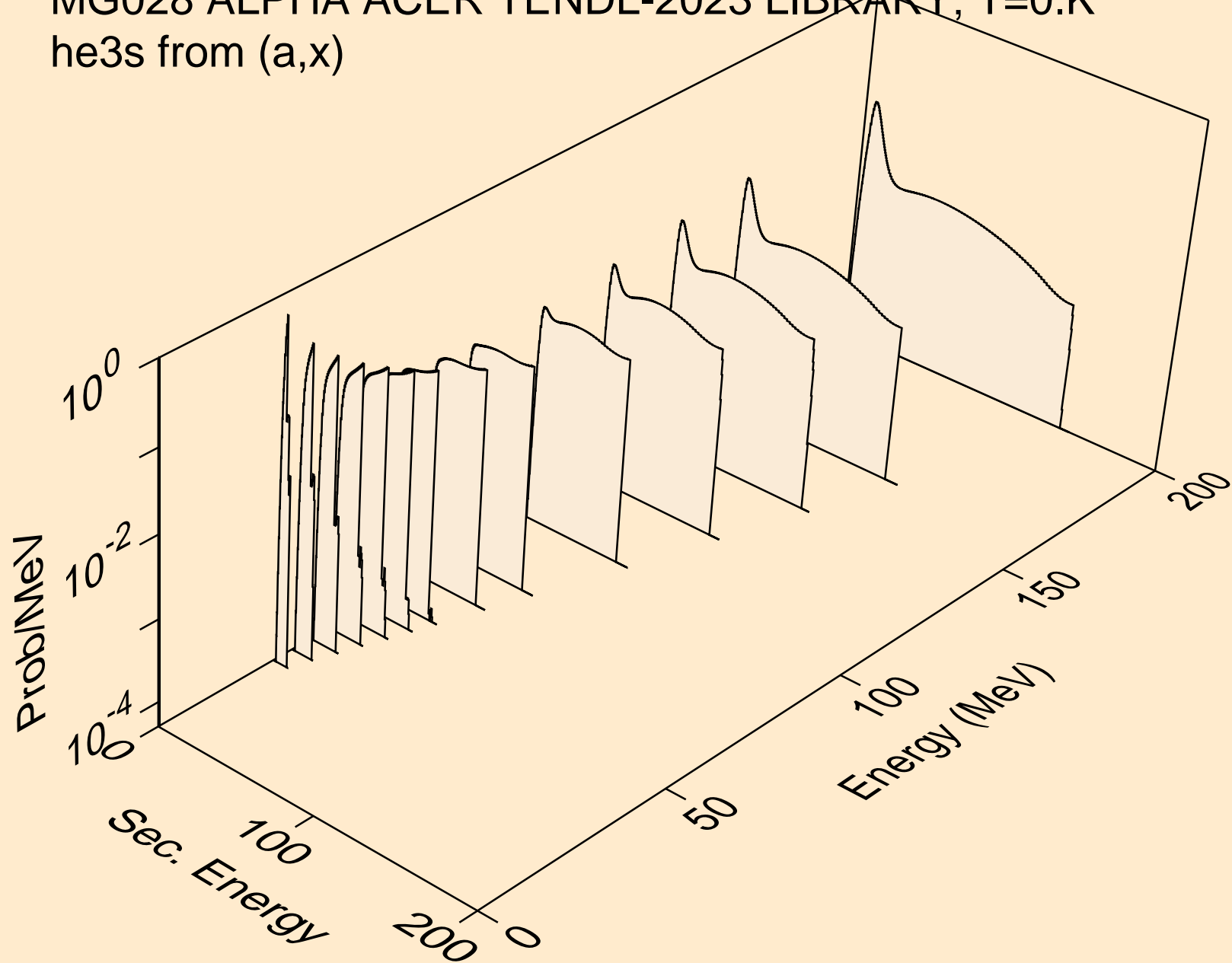

MG028 ALPHA ACER TENDL-2023 LIBRARY; T=0.K  
he3s from (a,n\*)he3

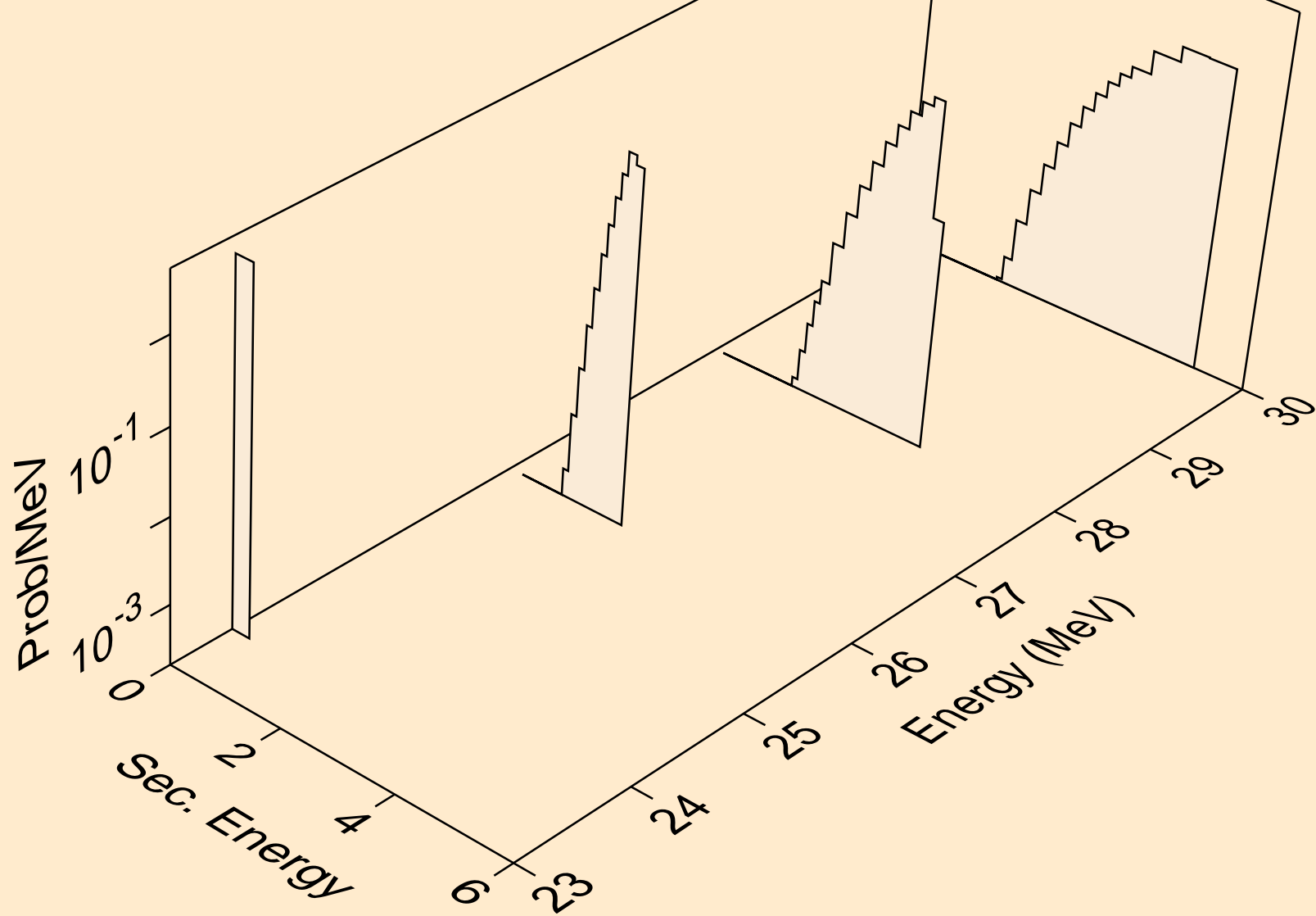

MG028 ALPHA ACER TENDL-2023 LIBRARY; T=0.K  
he3s from (a,he3)

