

# NI059 ALPHA ACER TENDL-2023 LIBRARY; T=0.K

## Principal cross sections

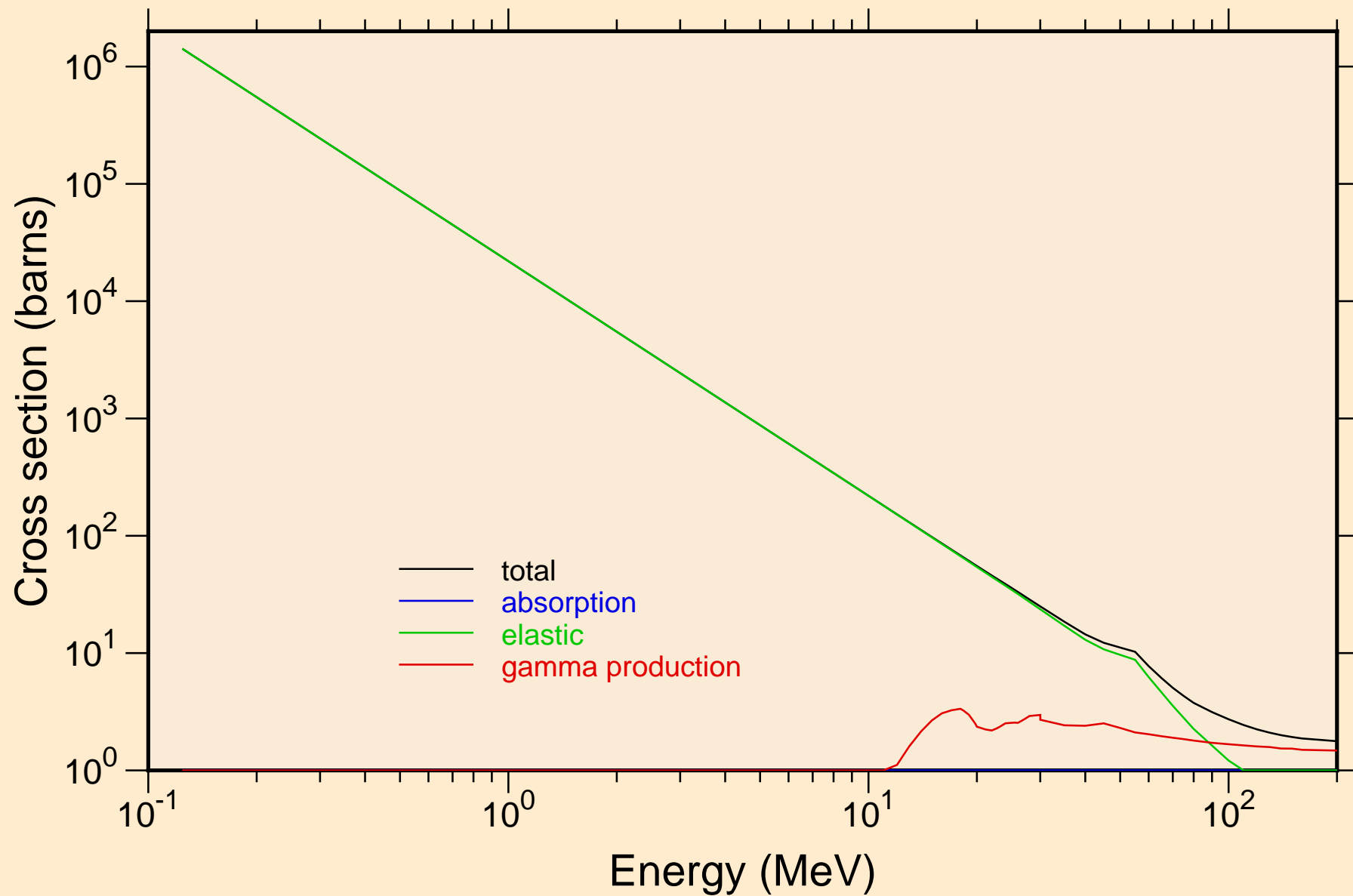

# NI059 ALPHA ACER TENDL-2023 LIBRARY; T=0.K

## Heating

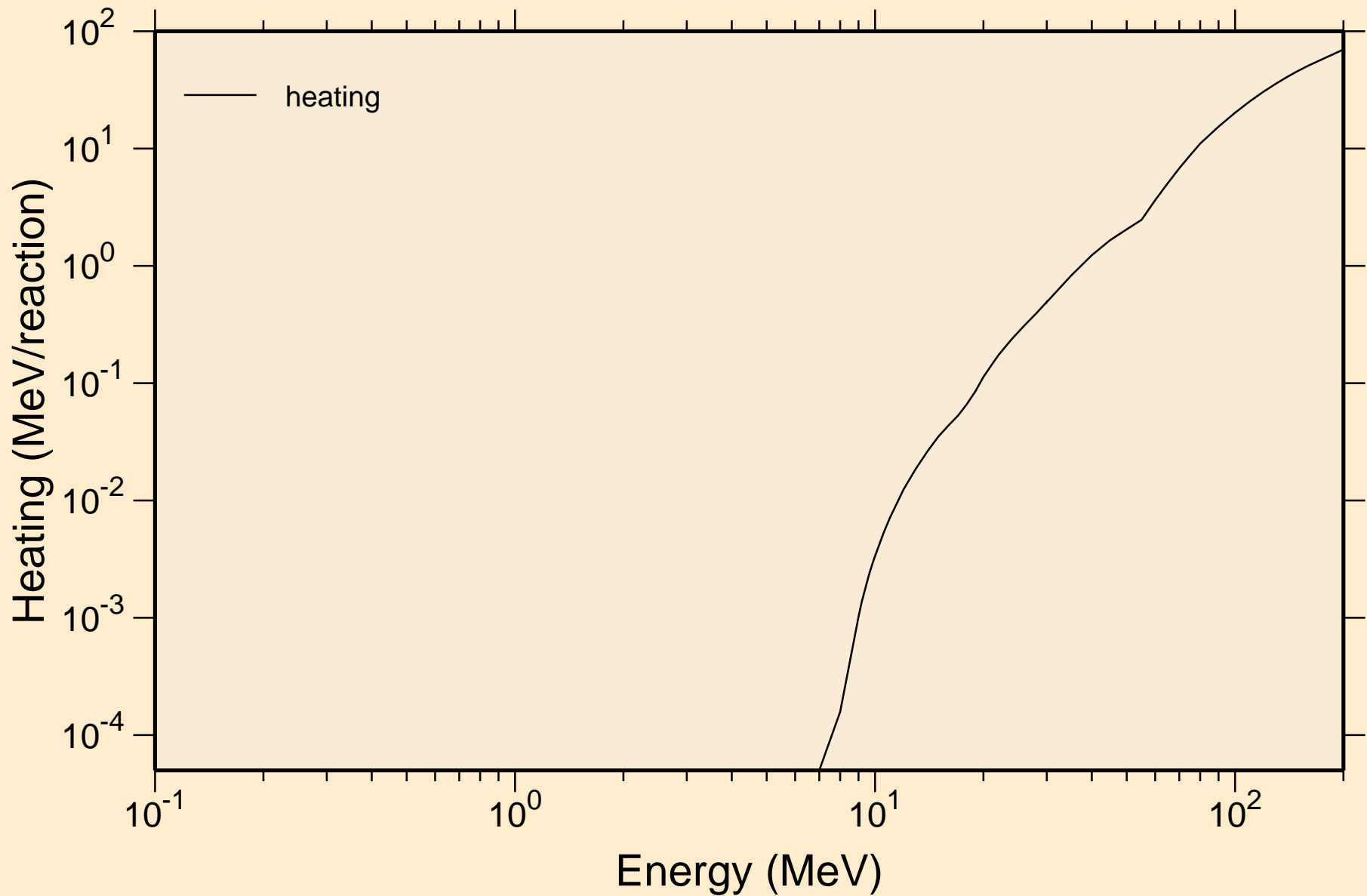

# NI059 ALPHA ACER TENDL-2023 LIBRARY; T=0.K

## Principal cross sections

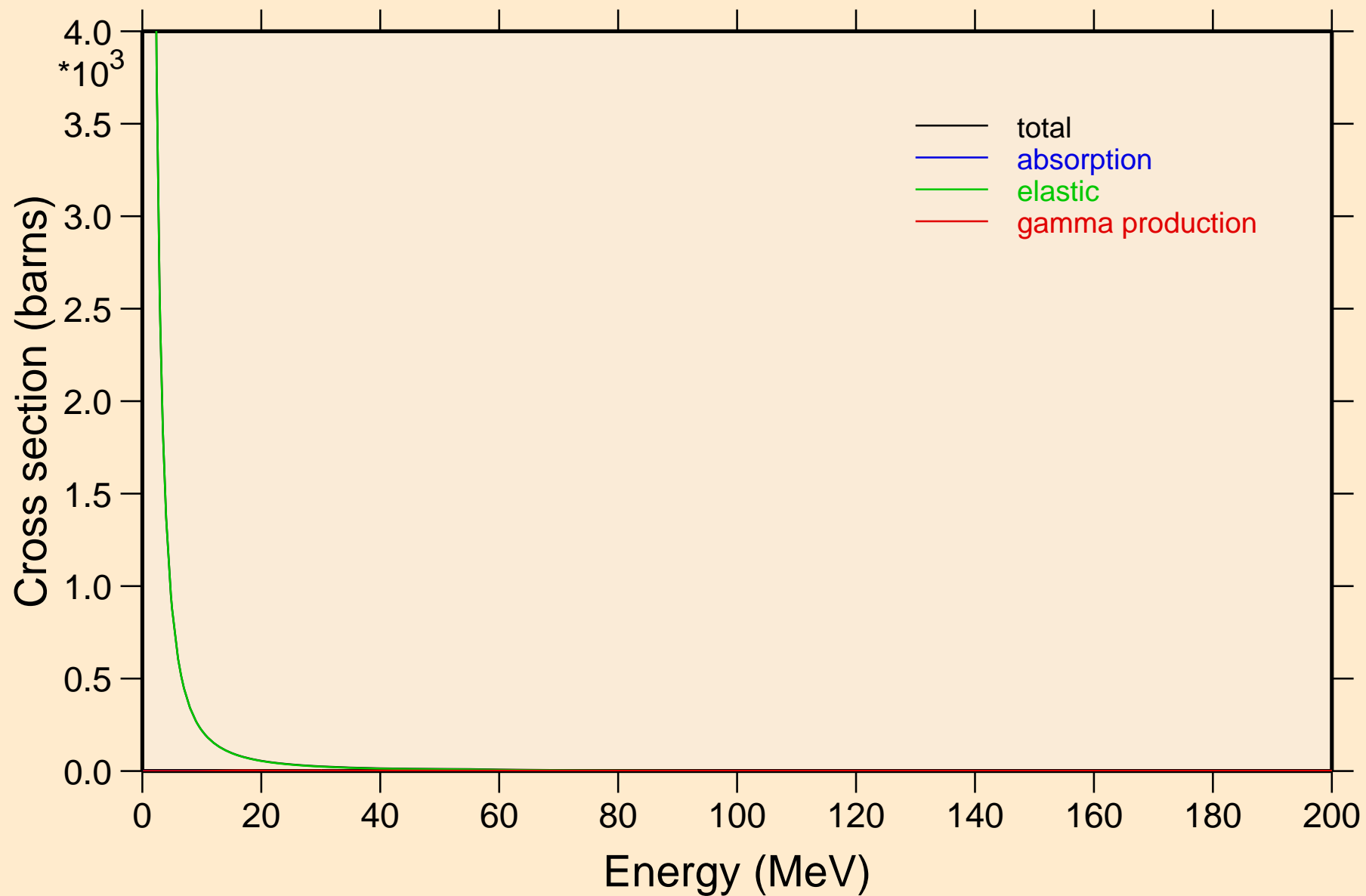

NI059 ALPHA ACER TENDL-2023 LIBRARY; T=0.K

Heating

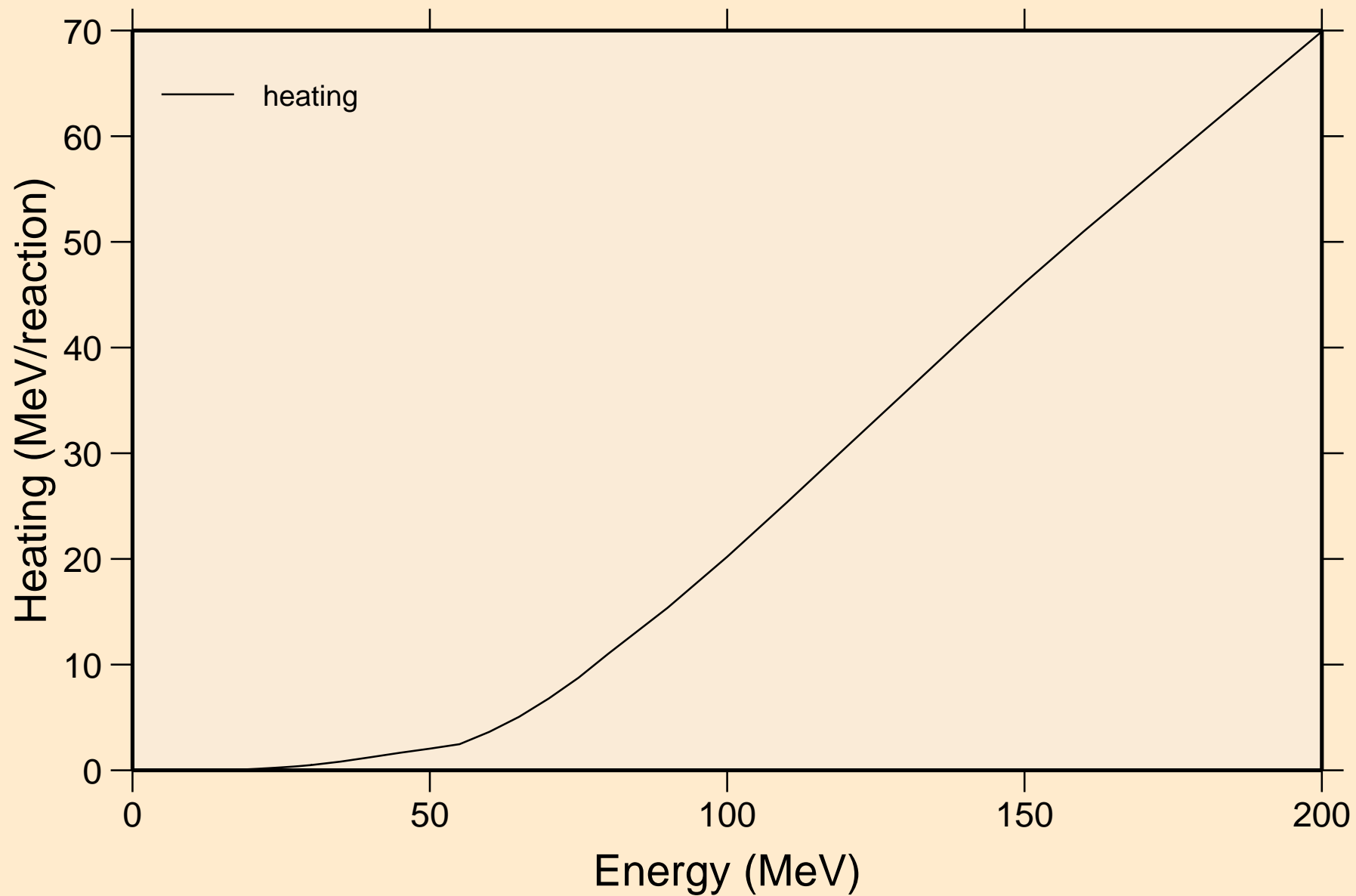

NI059 ALPHA ACER TENDL-2023 LIBRARY; T=0.K  
Threshold reactions

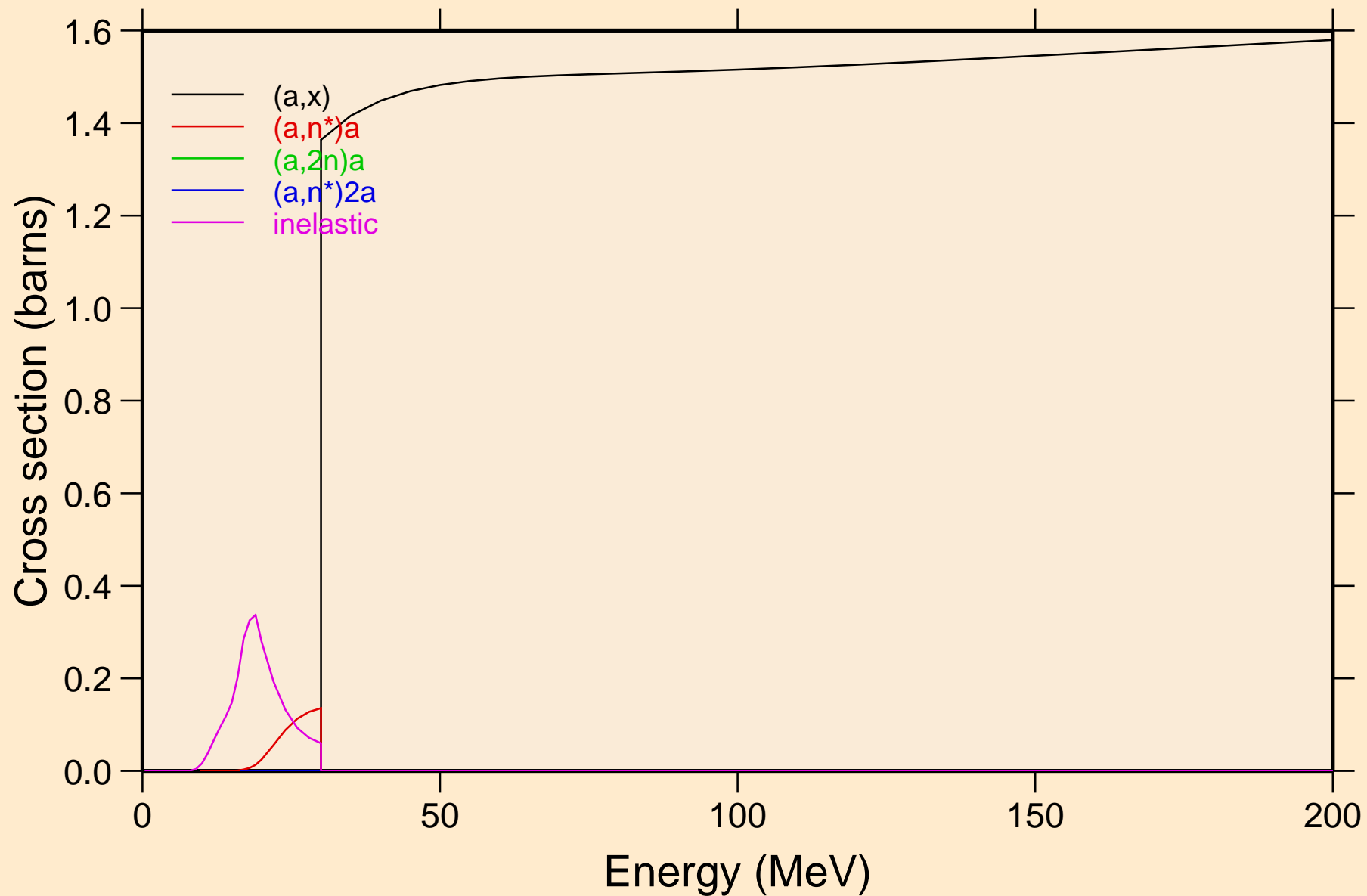

# NI059 ALPHA ACER TENDL-2023 LIBRARY; T=0.K

## Threshold reactions

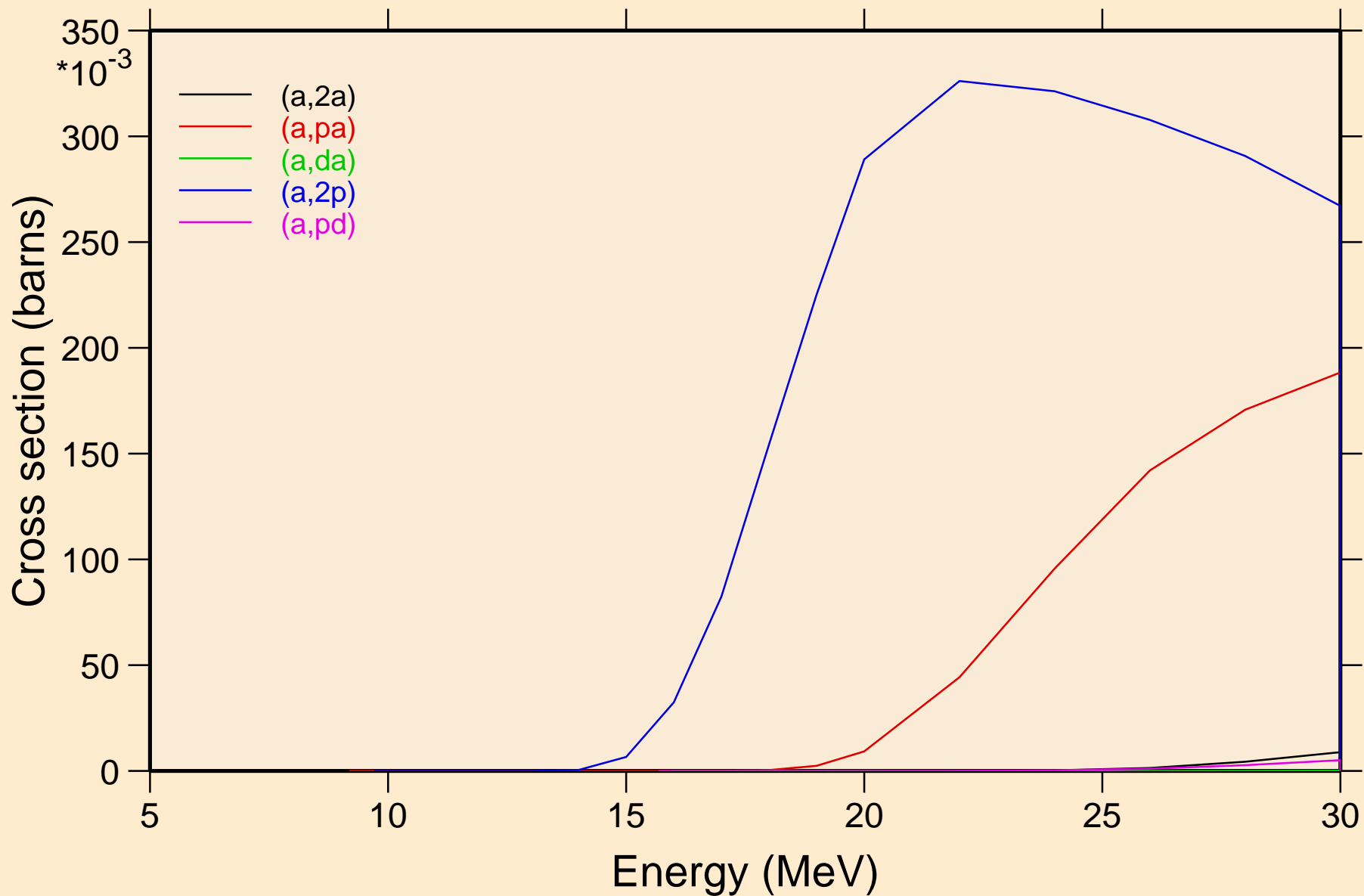

NI059 ALPHA ACER TENDL-2023 LIBRARY; T=0.K  
Threshold reactions

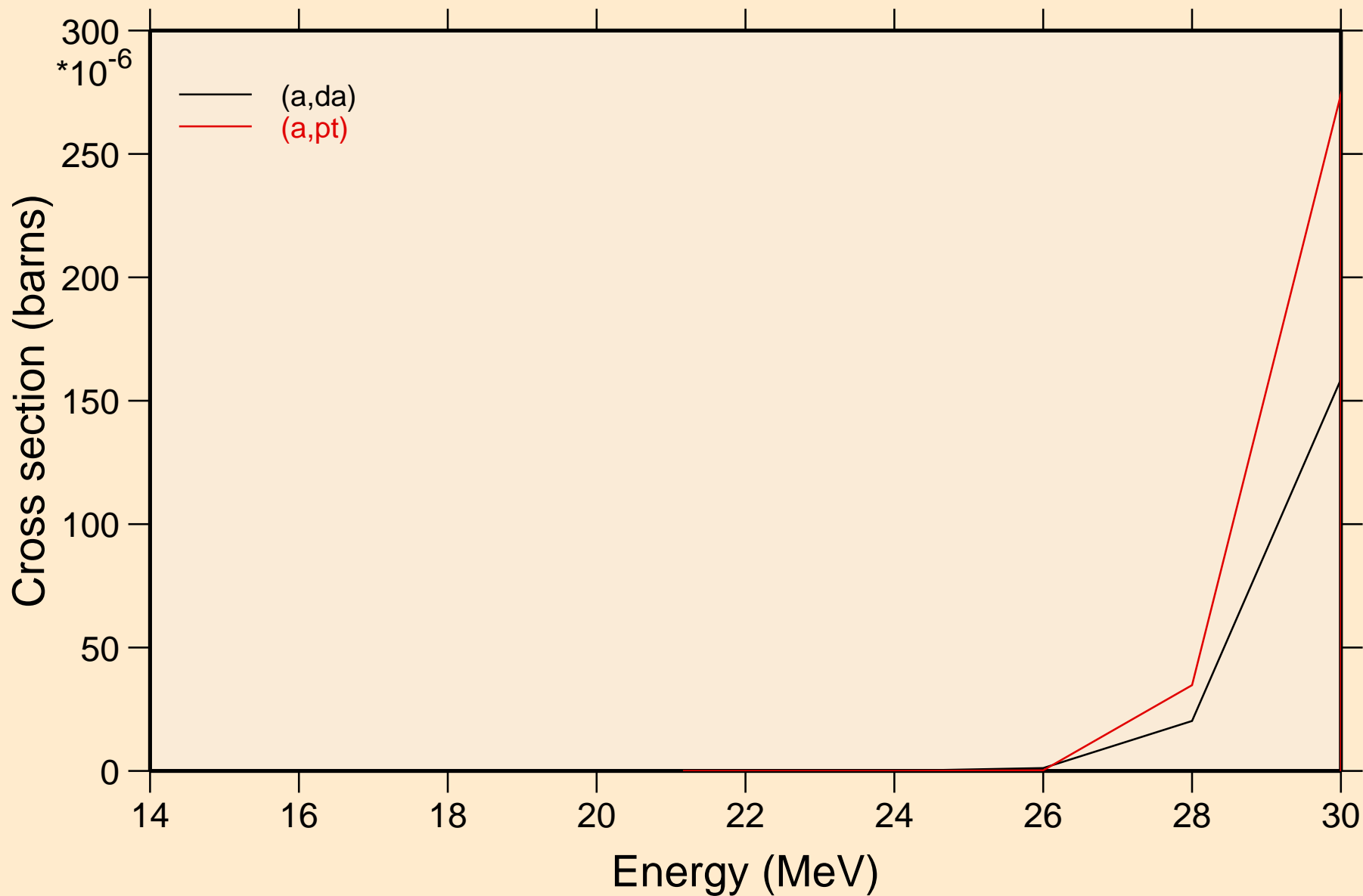

NI059 ALPHA ACER TENDL-2023 LIBRARY; T=0.K  
Threshold reactions

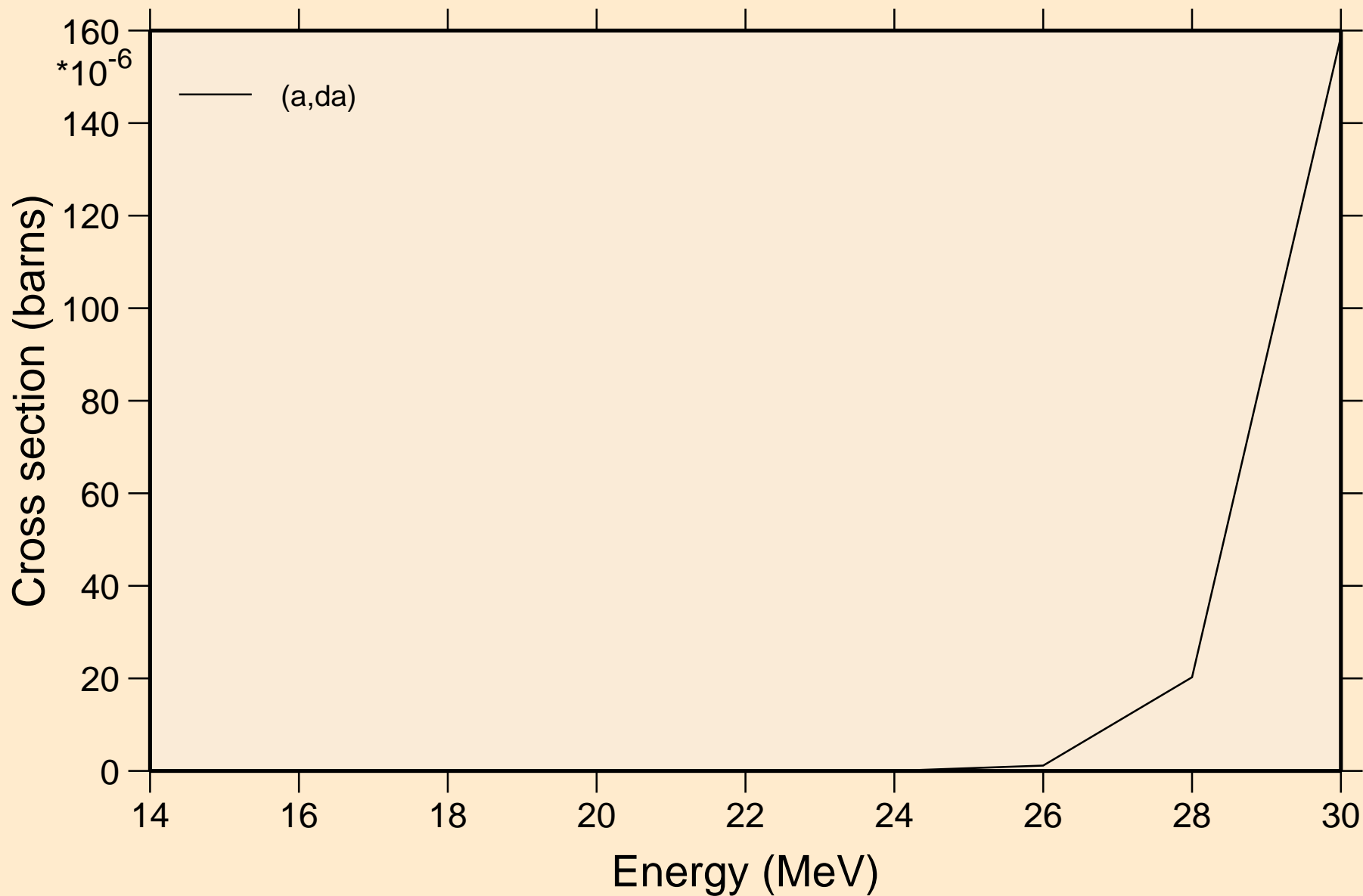



NI059 ALPHA ACER TENDL-2023 LIBRARY; T=0.K  
angular distribution for elastic

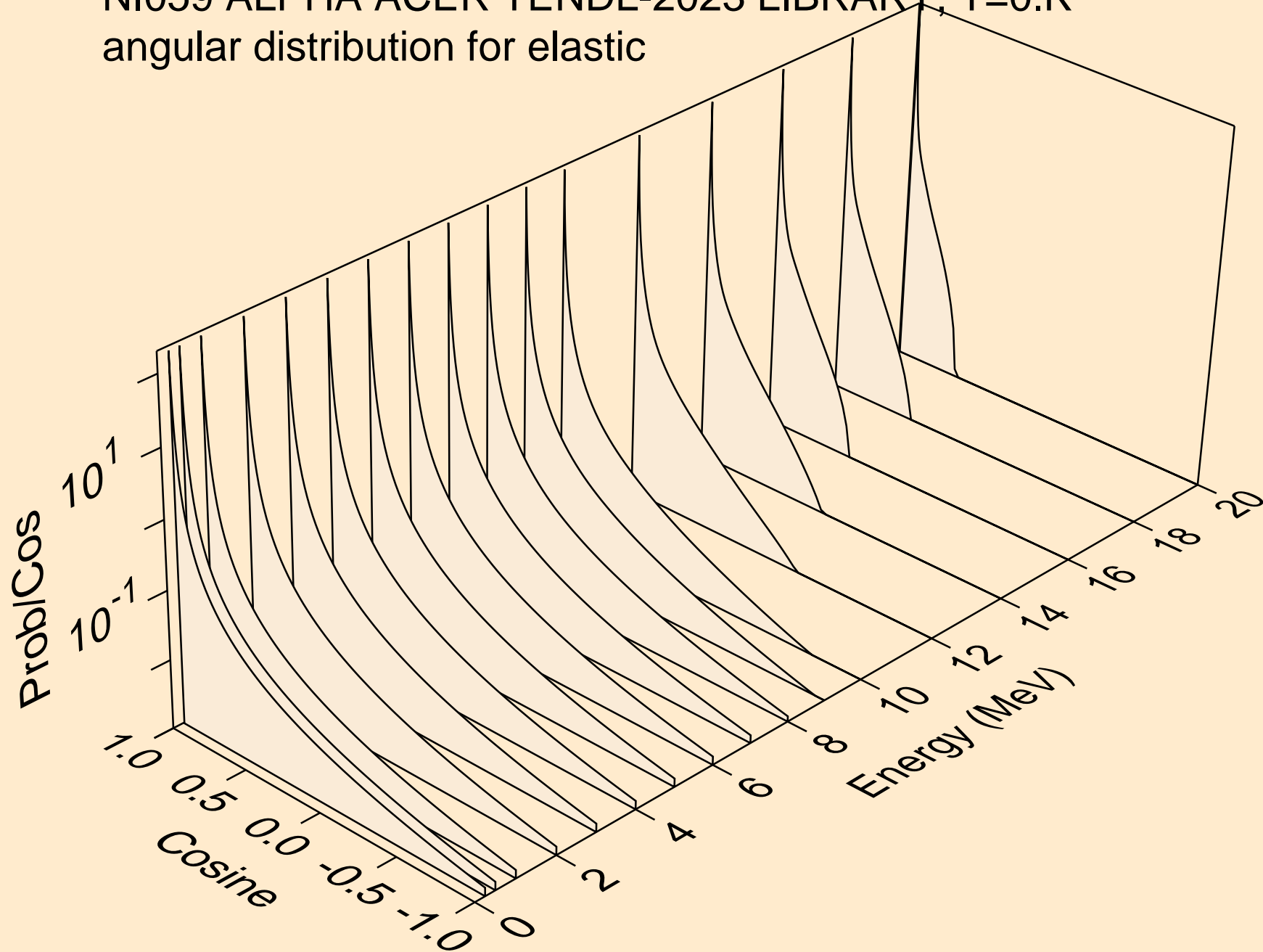

NI059 ALPHA ACER TENDL-2023 LIBRARY; T=0.K  
angular distribution for elastic

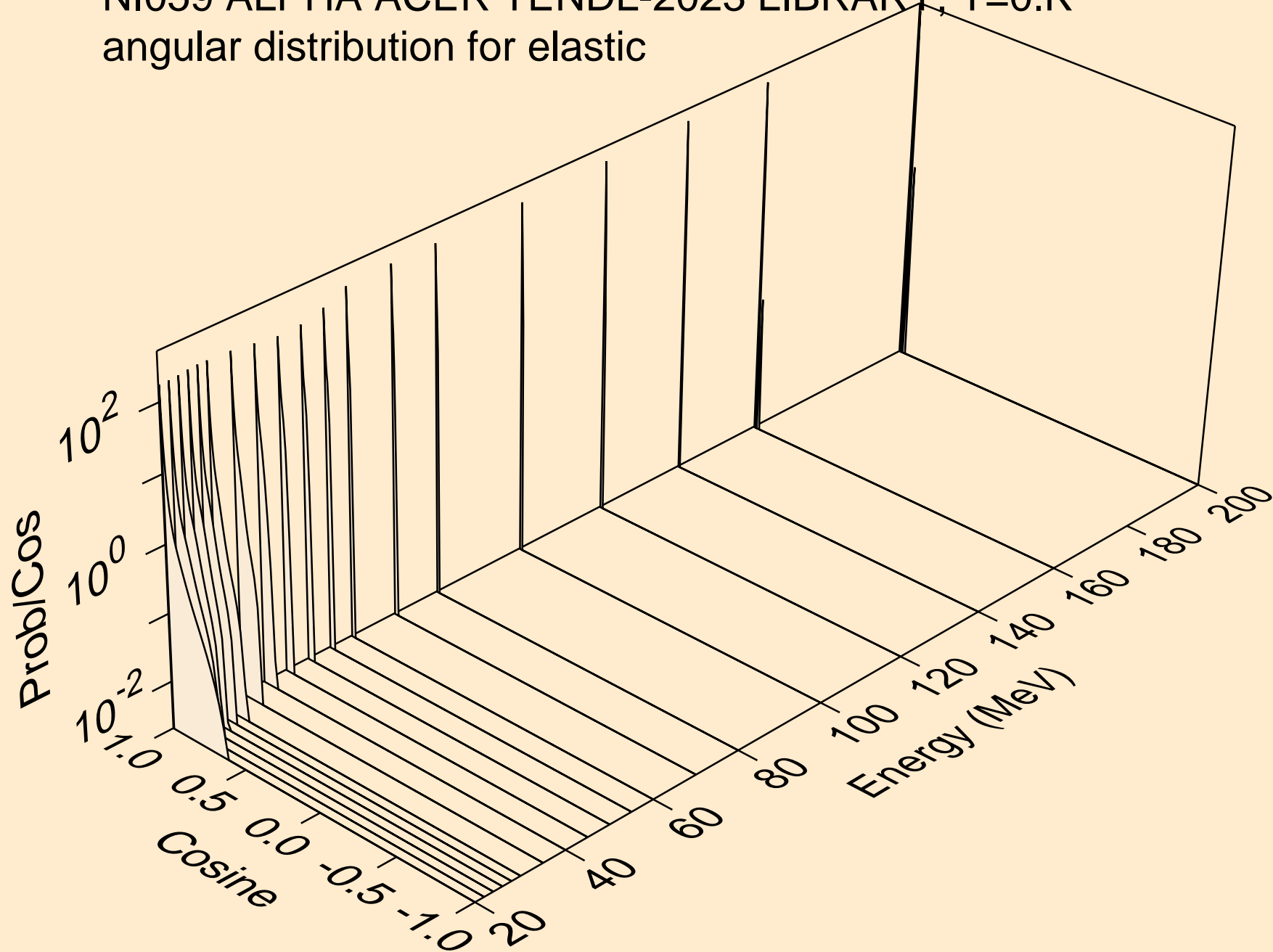

NI059 ALPHA ACER TENDL-2023 LIBRARY; T=0.K  
Alpha emission for (a,x)

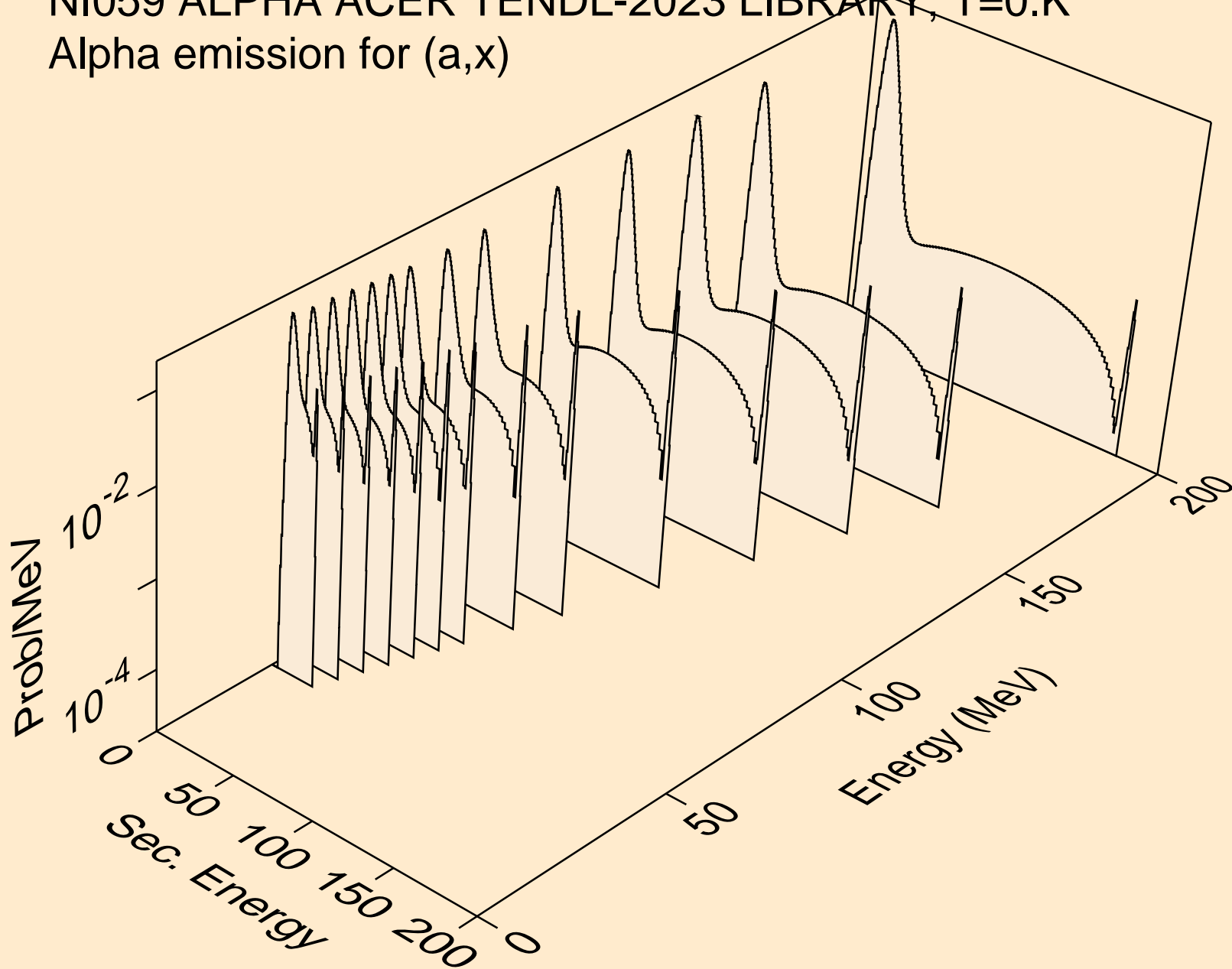

NI059 ALPHA ACER TENDL-2023 LIBRARY; T=0.K  
Alpha emission for (a,n\*)a

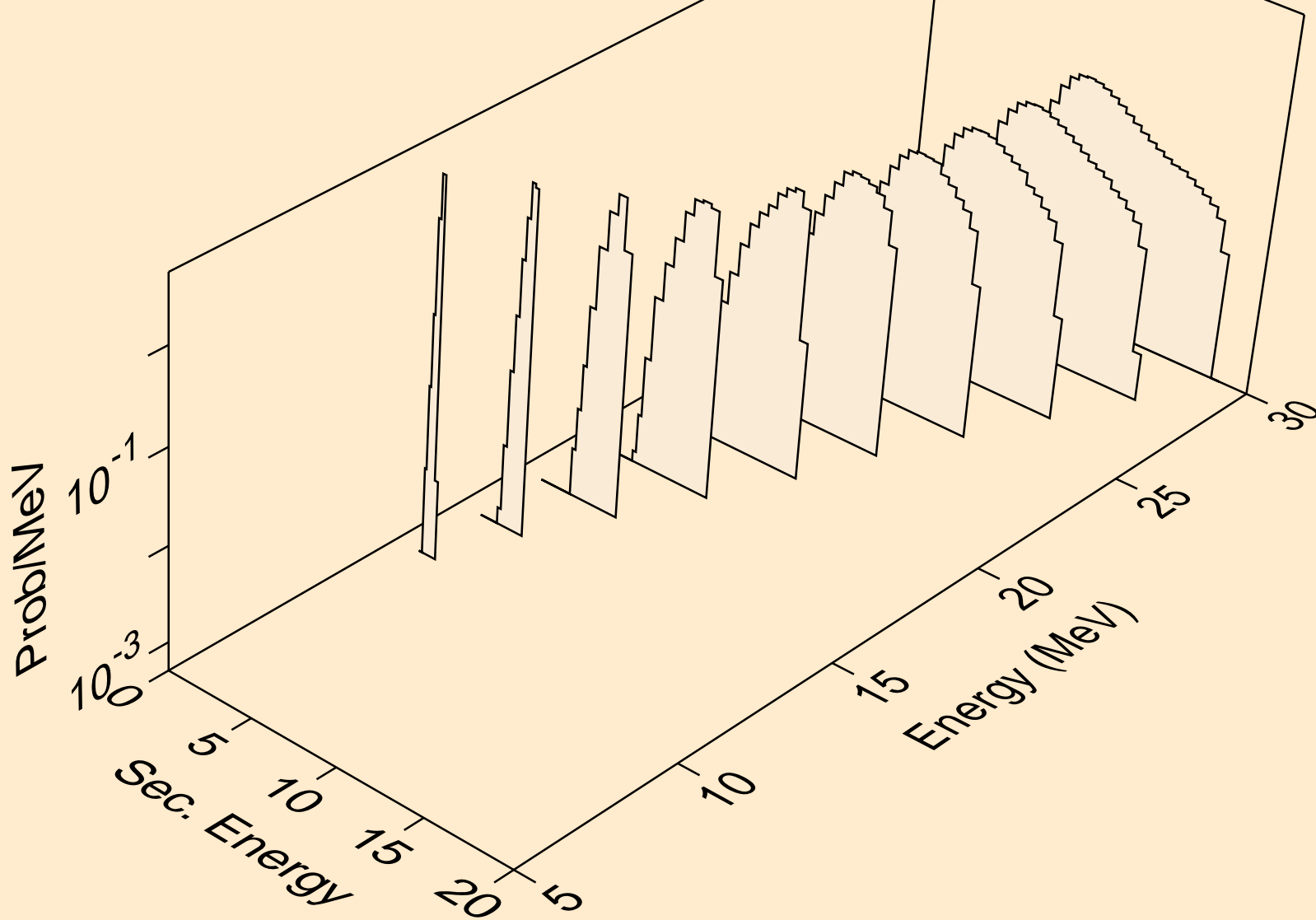

NI059 ALPHA ACER TENDL-2023 LIBRARY; T=0.K  
Alpha emission for (a,2n)a

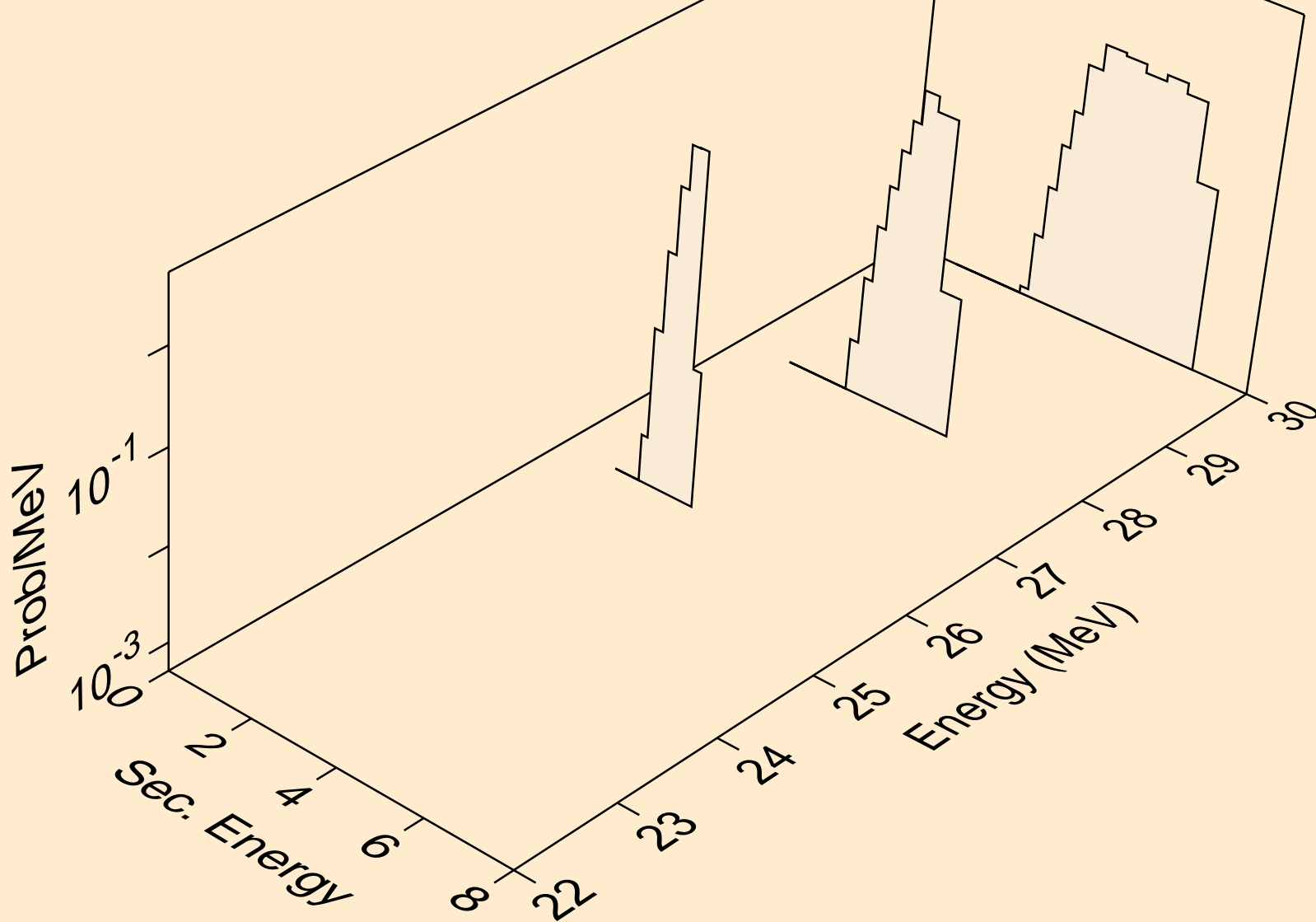

NI059 ALPHA ACER TENDL-2023 LIBRARY; T=0.K  
Alpha emission for (a,n\*)2a

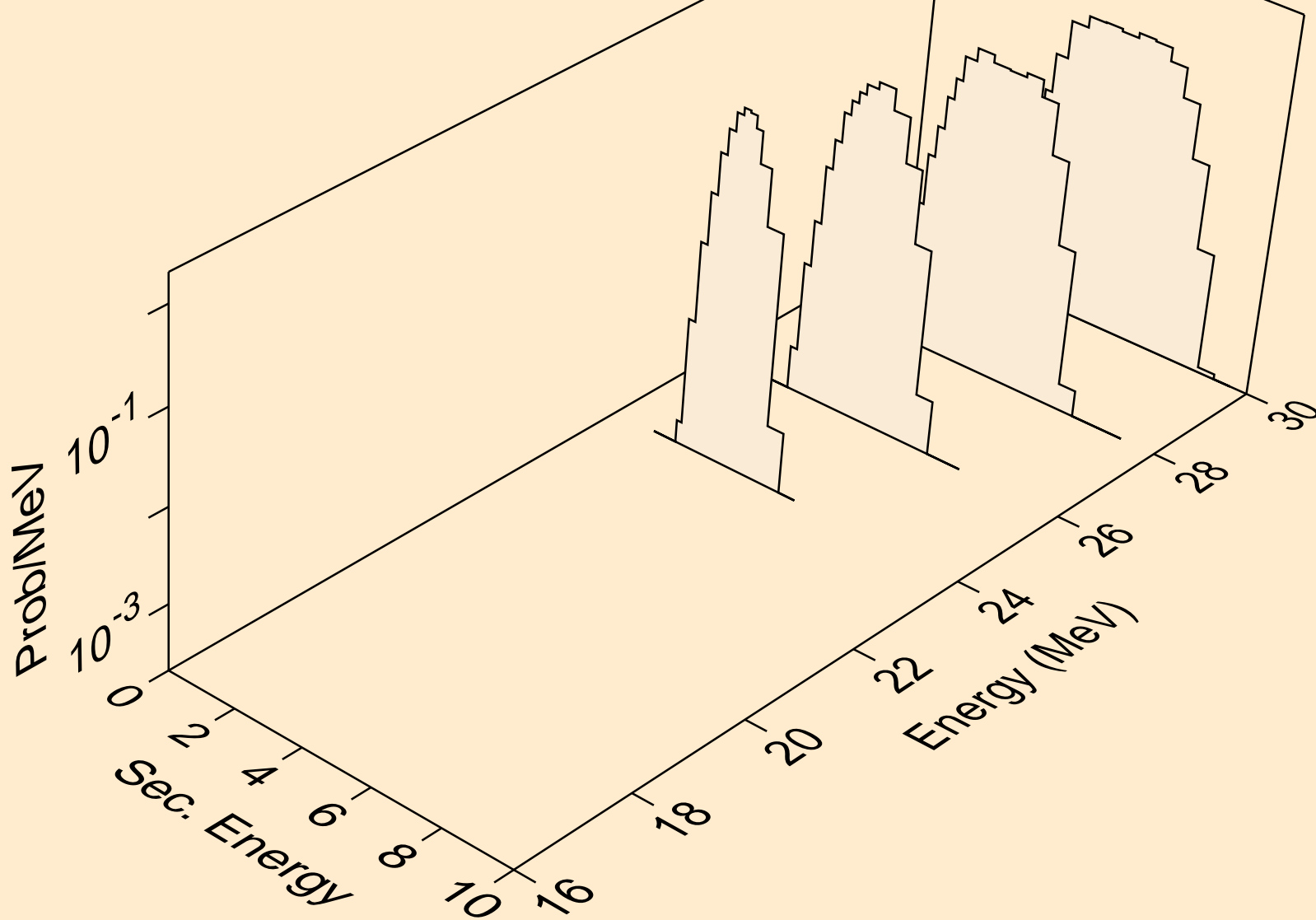

NI059 ALPHA ACER TENDL-2023 LIBRARY; T=0.K  
Alpha emission for inelastic

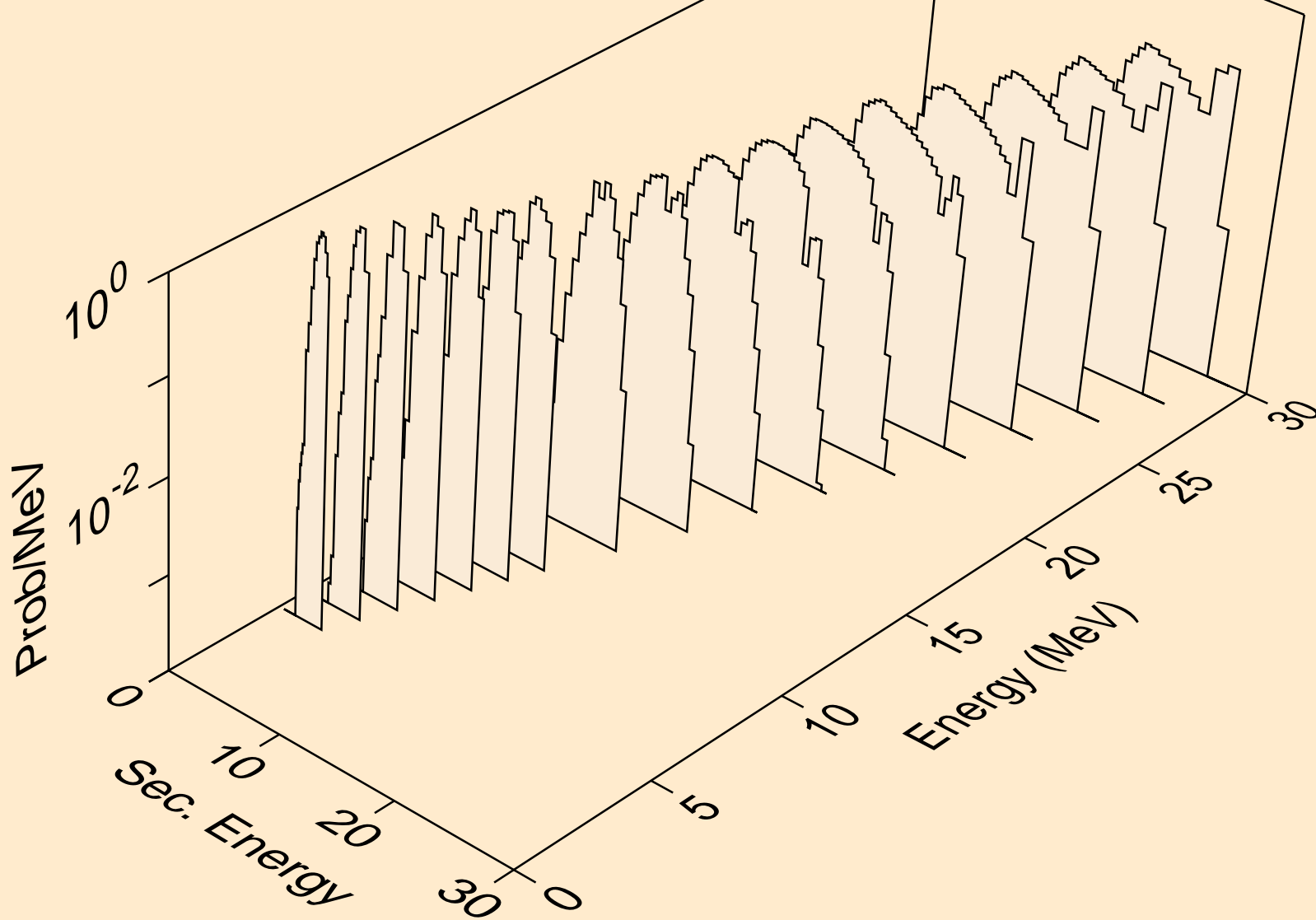

NI059 ALPHA ACER TENDL-2023 LIBRARY; T=0.K  
Alpha emission for (a,2a)

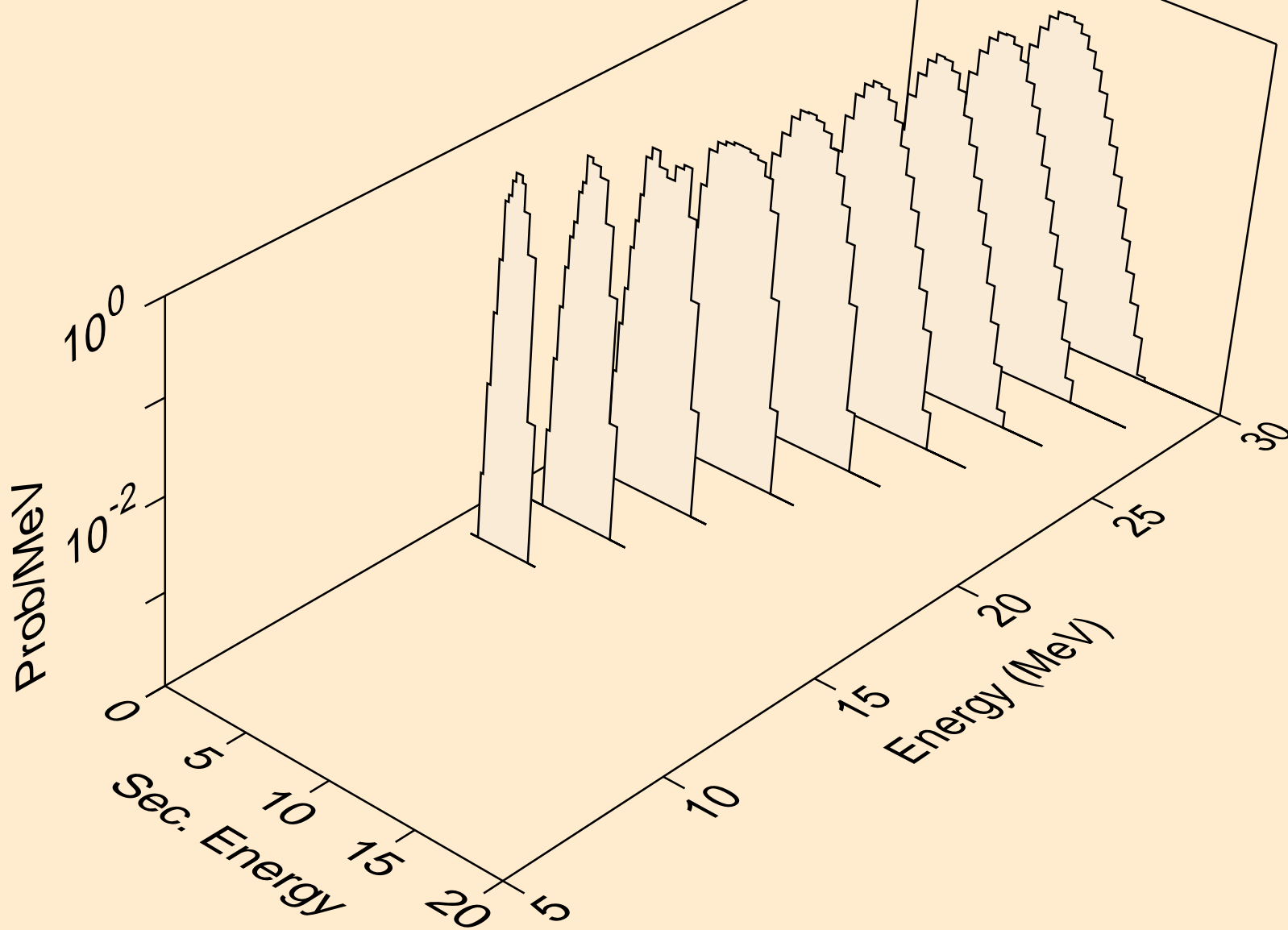



NI059 ALPHA ACER TENDL-2023 LIBRARY; T=0.K  
Alpha emission for (a,pa)

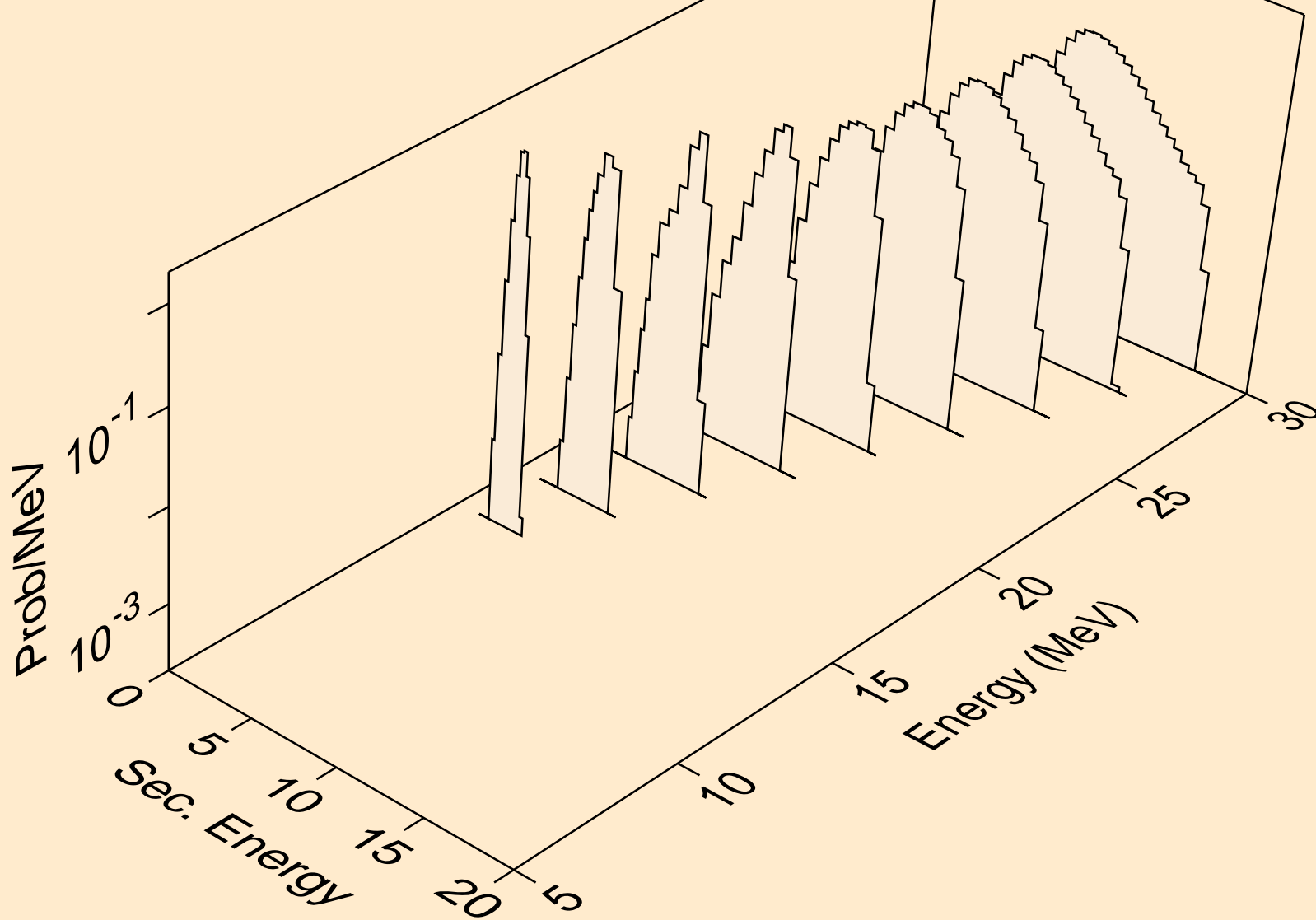

NI059 ALPHA ACER TENDL-2023 LIBRARY; T=0.K  
Alpha emission for (a,da)

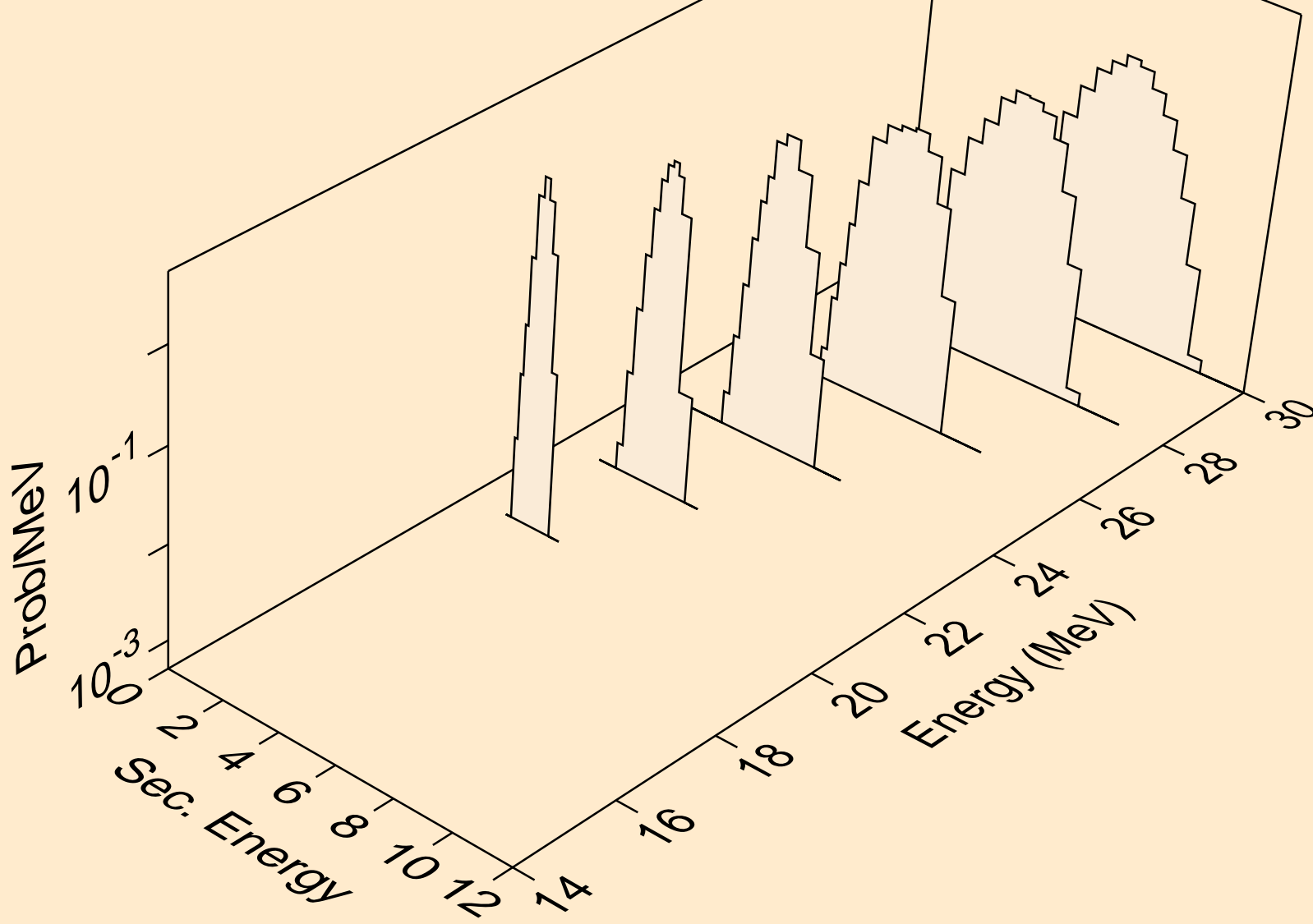

NI059 ALPHA ACER TENDL-2023 LIBRARY; T=0.K  
Photon emission for (z,n)

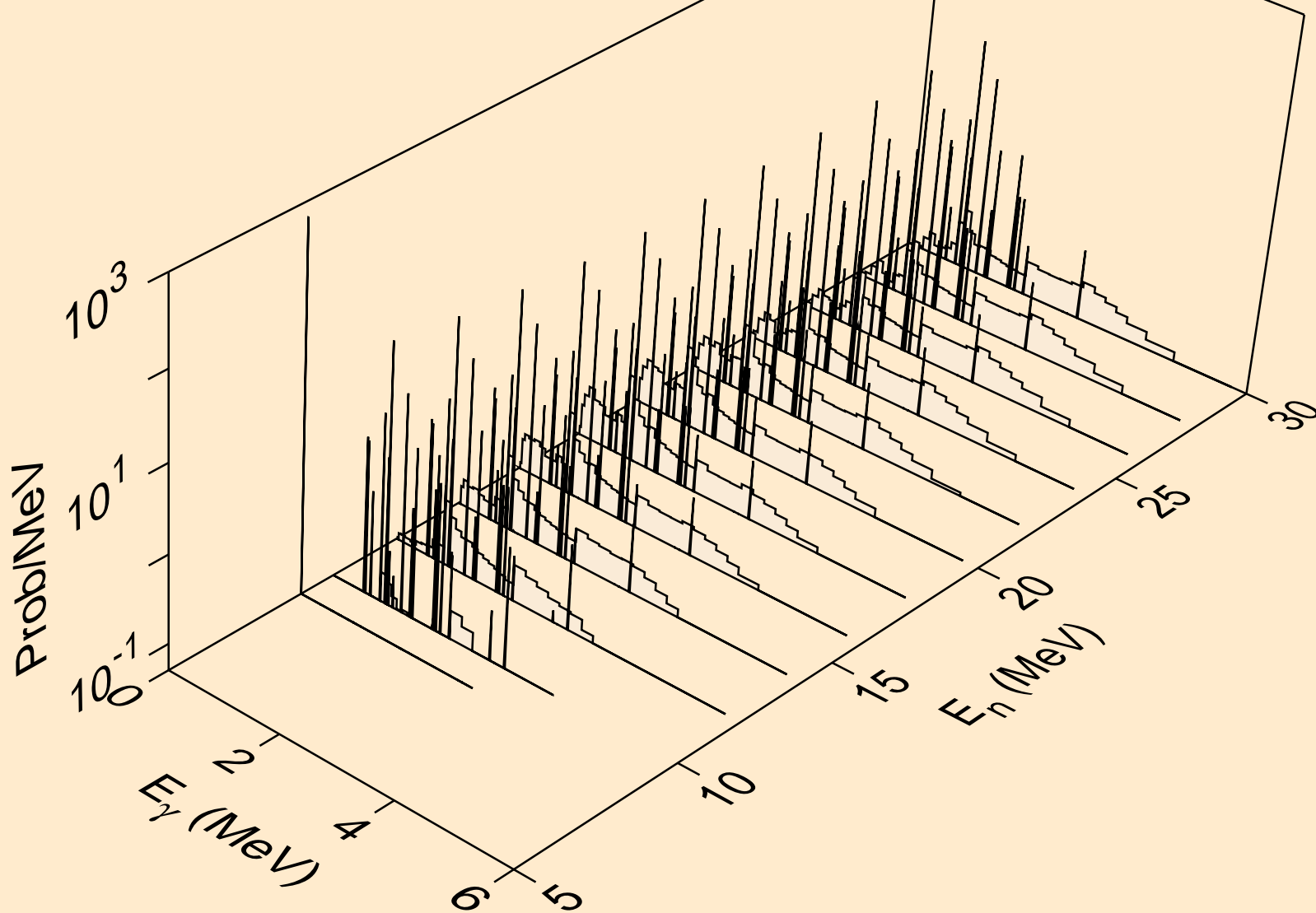

NI059 ALPHA ACER TENDL-2023 LIBRARY; T=0.K  
Photon emission for (z,x)

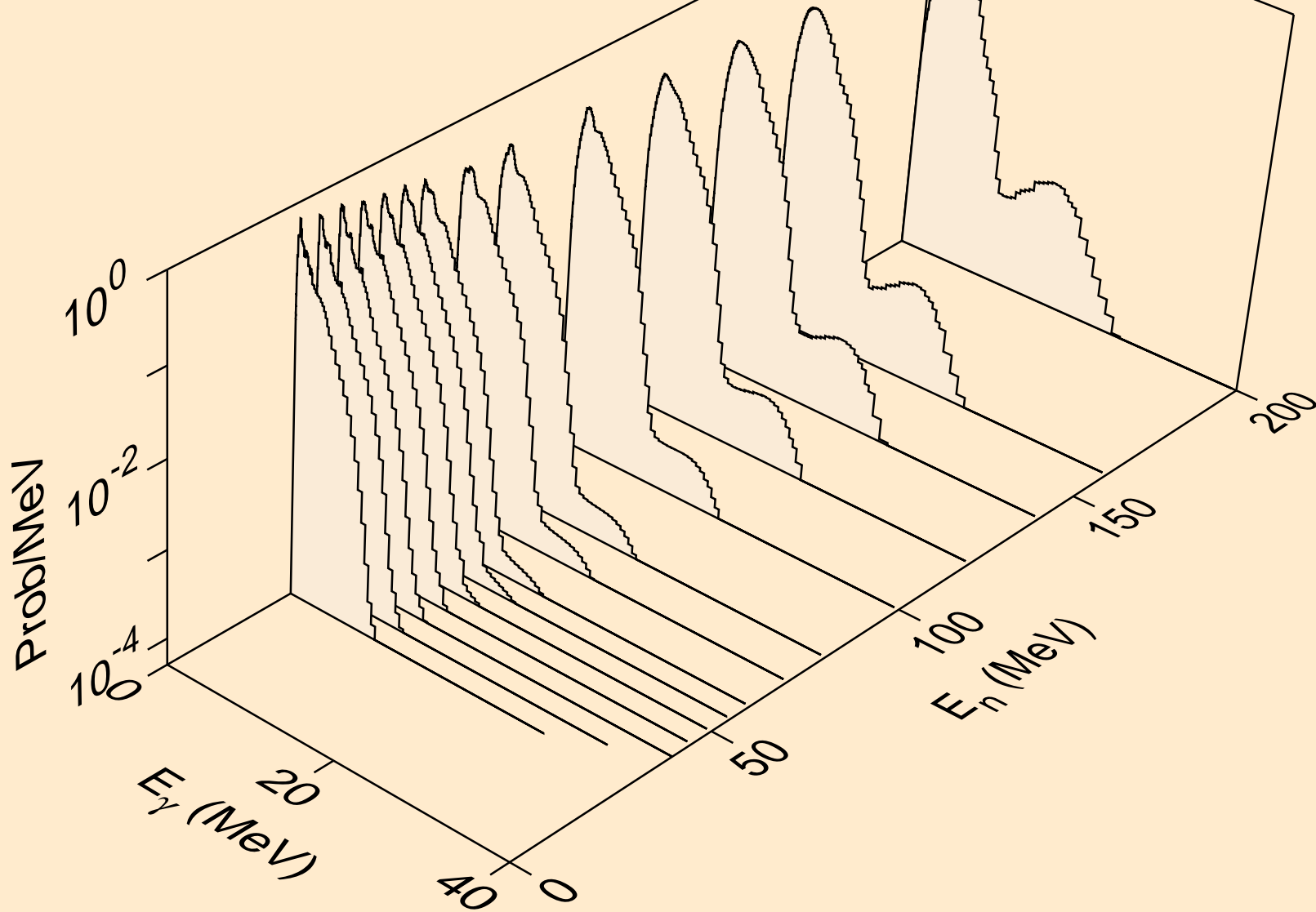

NI059 ALPHA ACER TENDL-2023 LIBRARY; T=0.K  
Photon emission for (n,2n)

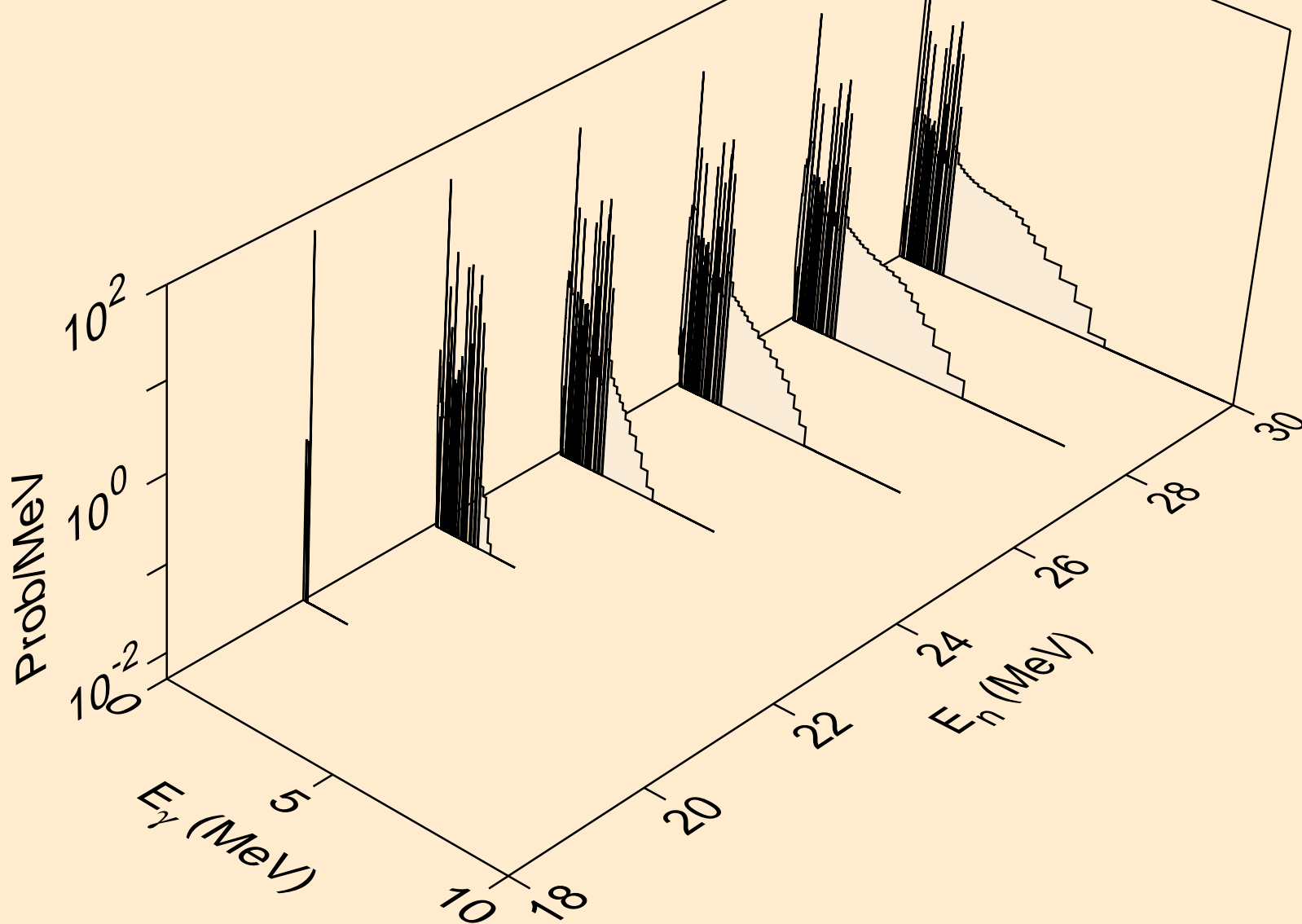

NI059 ALPHA ACER TENDL-2023 LIBRARY; T=0.K  
Photon emission for (n,n\*)a

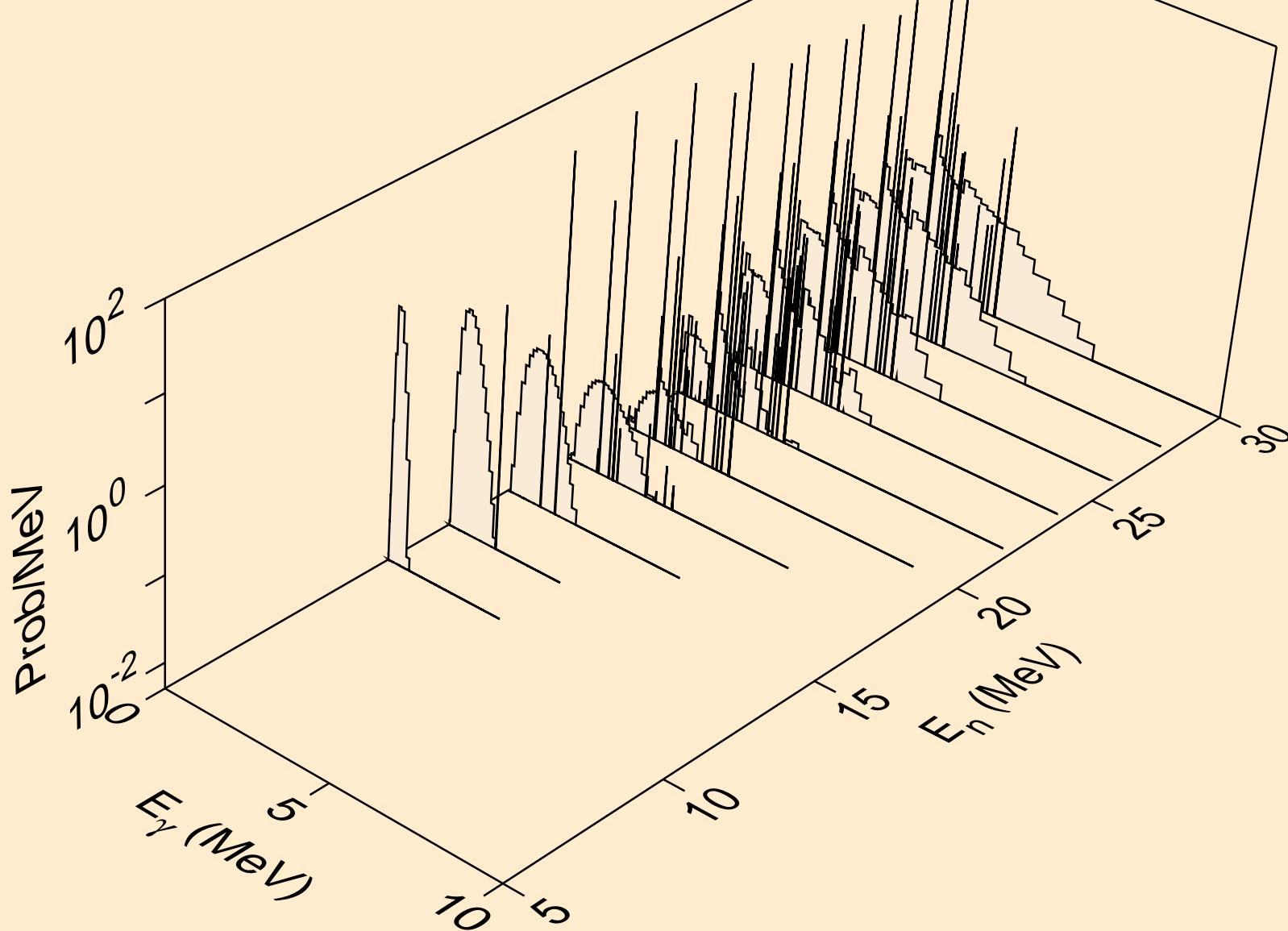

NI059 ALPHA ACER TENDL-2023 LIBRARY: T=0.K  
Photon emission for (n,2n)a

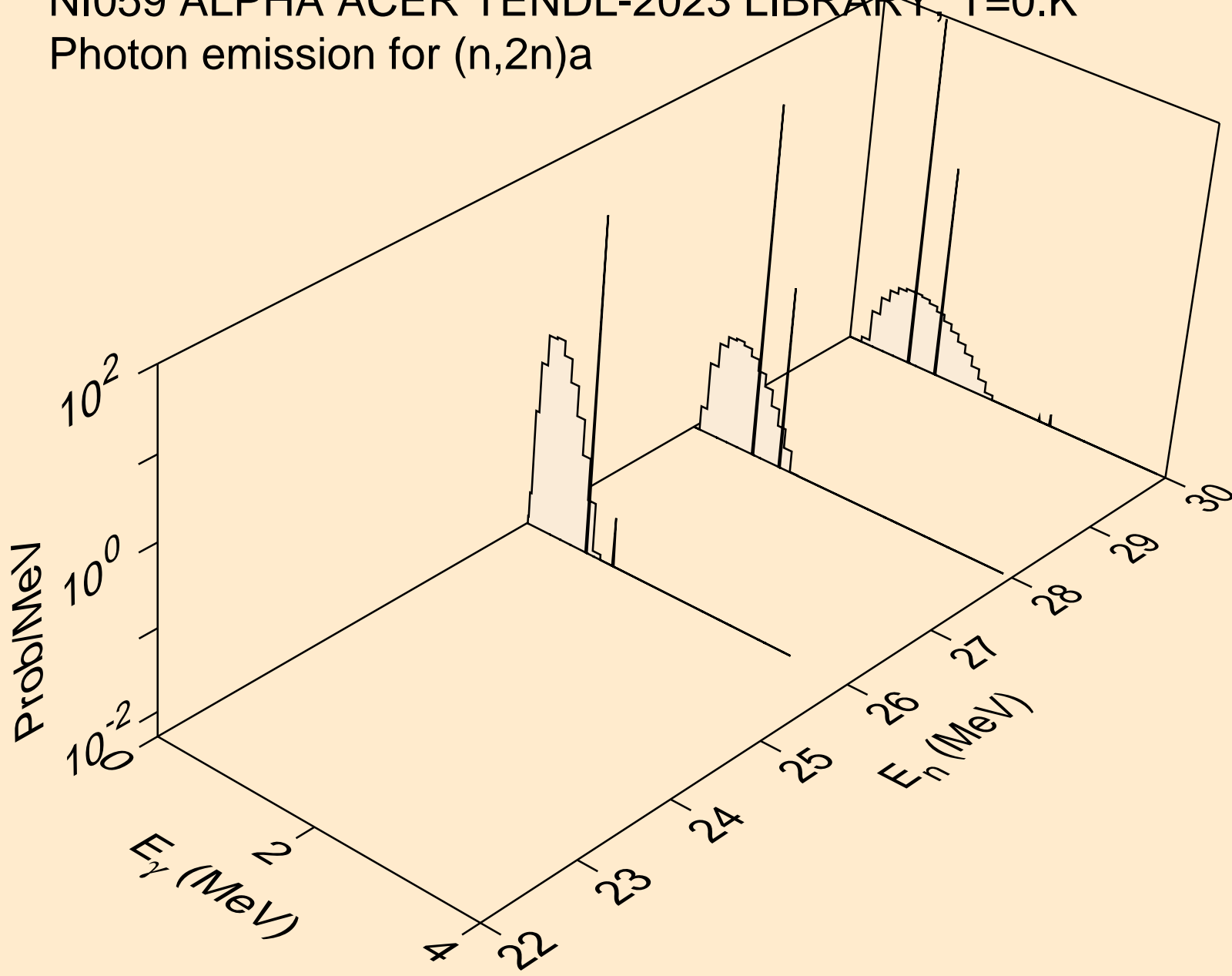

NI059 ALPHA ACER TENDL-2023 LIBRARY; T=0.K  
Photon emission for (n,n\*)p

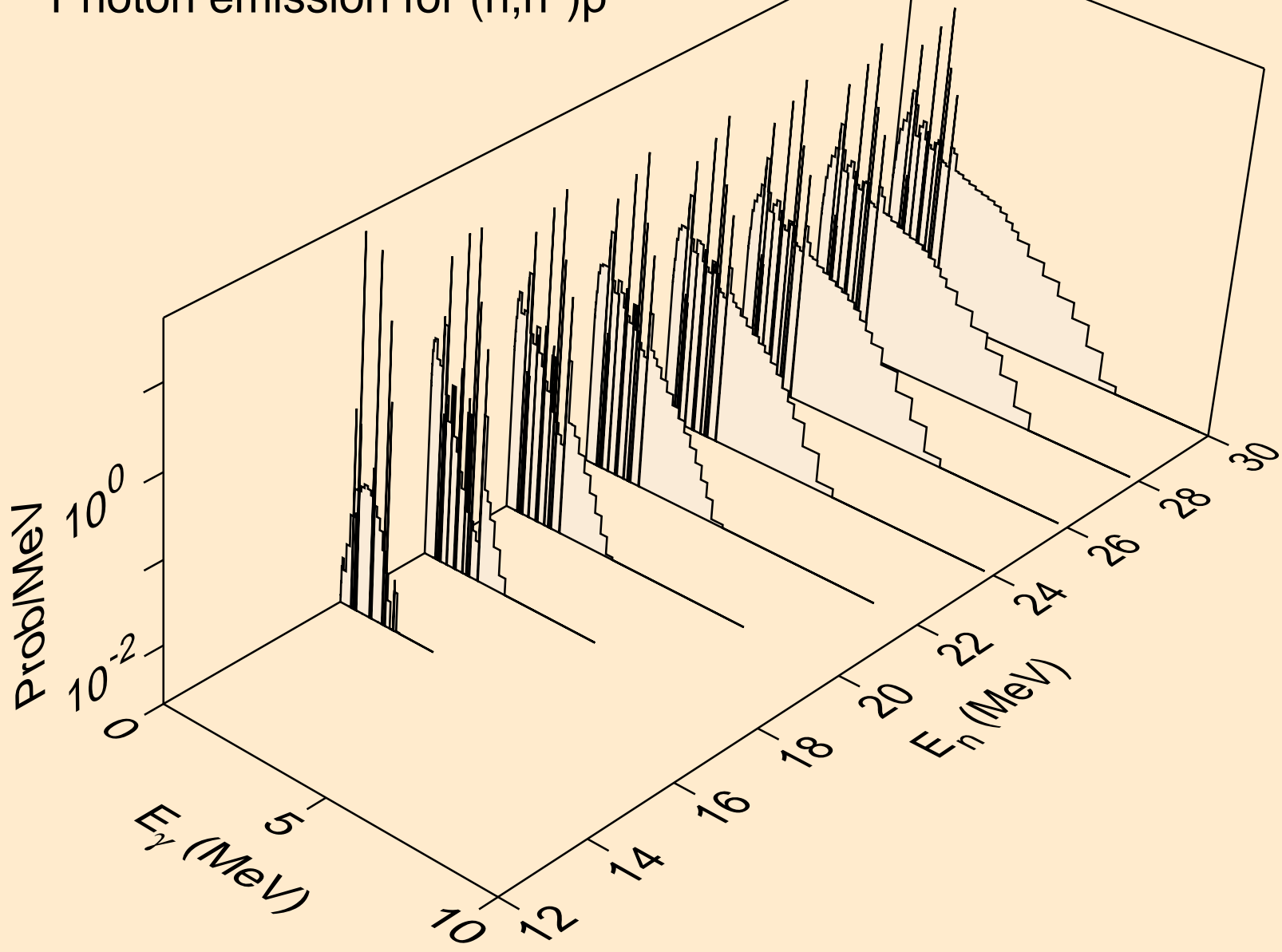



NI059 ALPHA ACER TENDL-2023 LIBRARY; T=0.K  
Photon emission for (n,n\*)2a

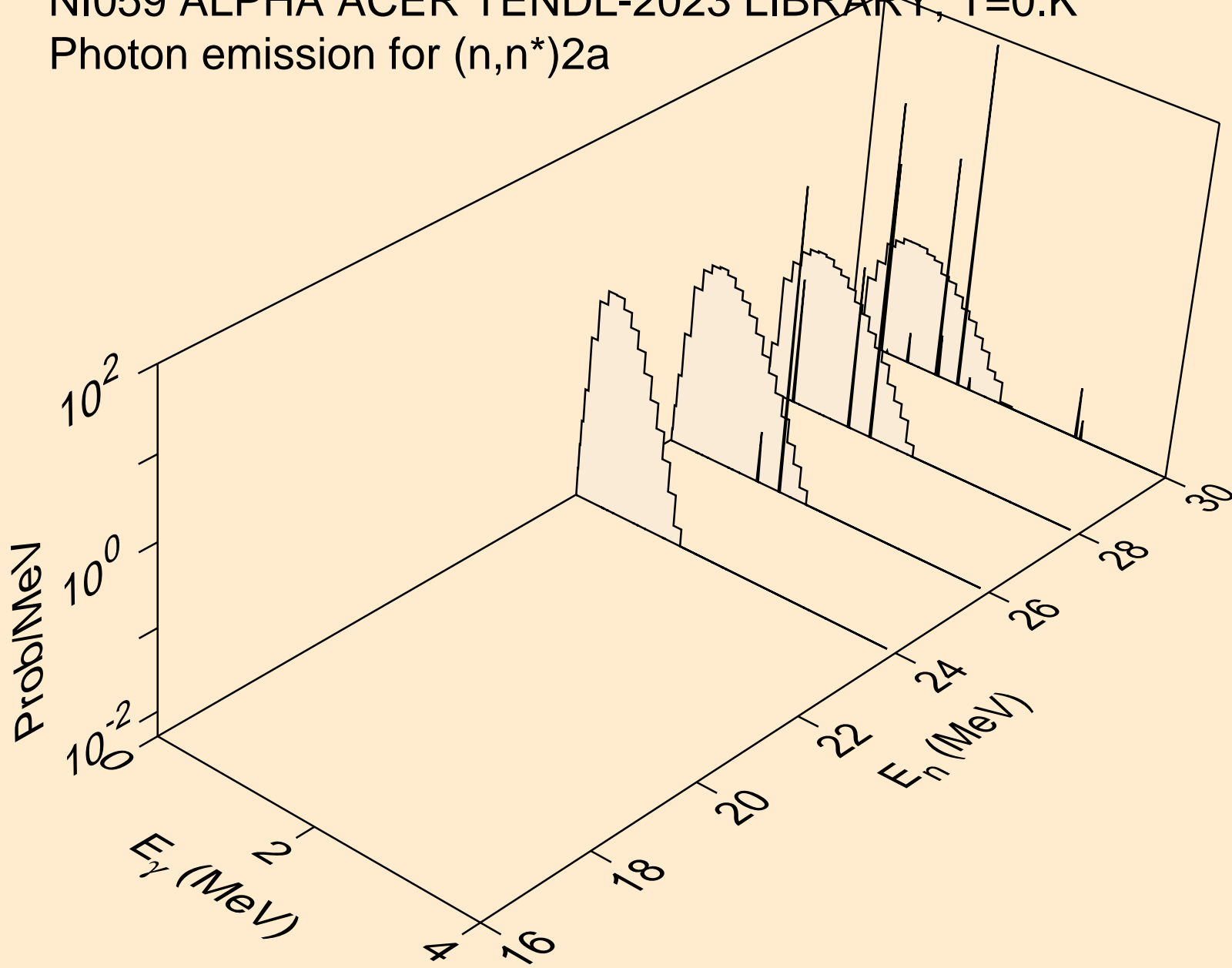

NI059 ALPHA ACER TENDL-2023 LIBRARY; T=0.K  
Photon emission for (n,n\*)d

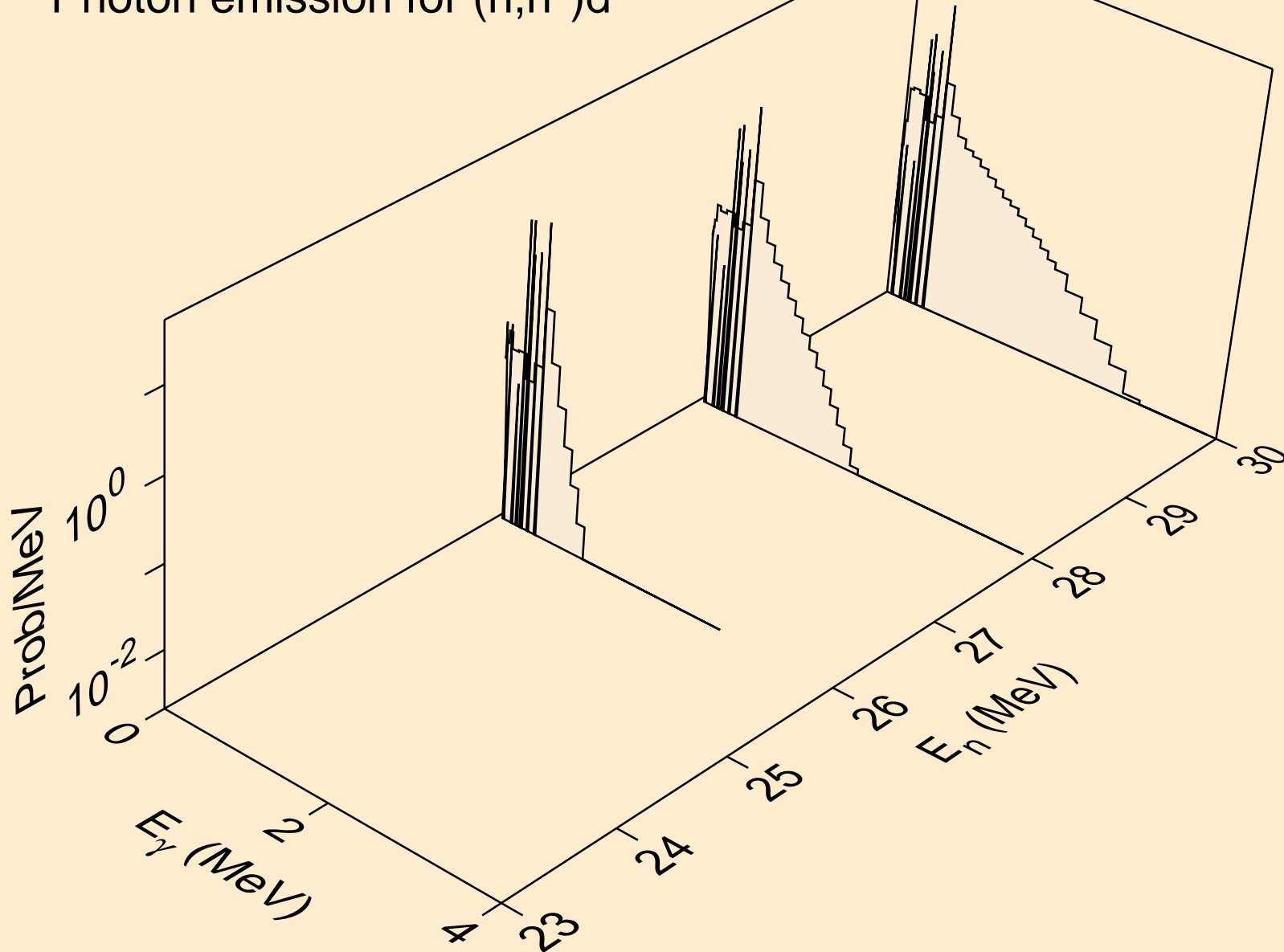

NI059 ALPHA ACER TENDL-2023 LIBRARY; T=0.K  
Photon emission for (n,n\*)t

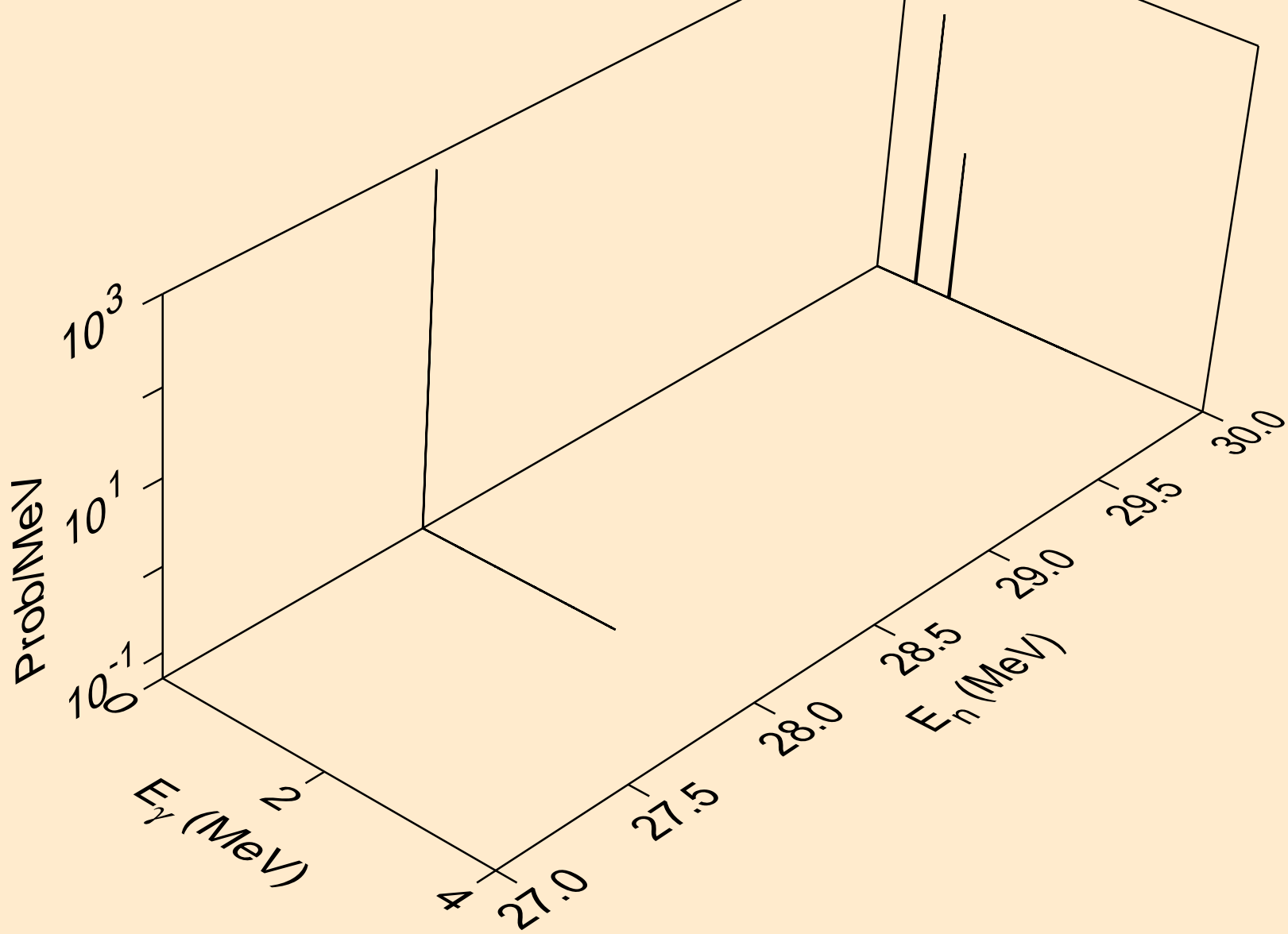

NI059 ALPHA ACER TENDL-2023 LIBRARY; T=0.K  
Photon emission for (n,n\*)he3

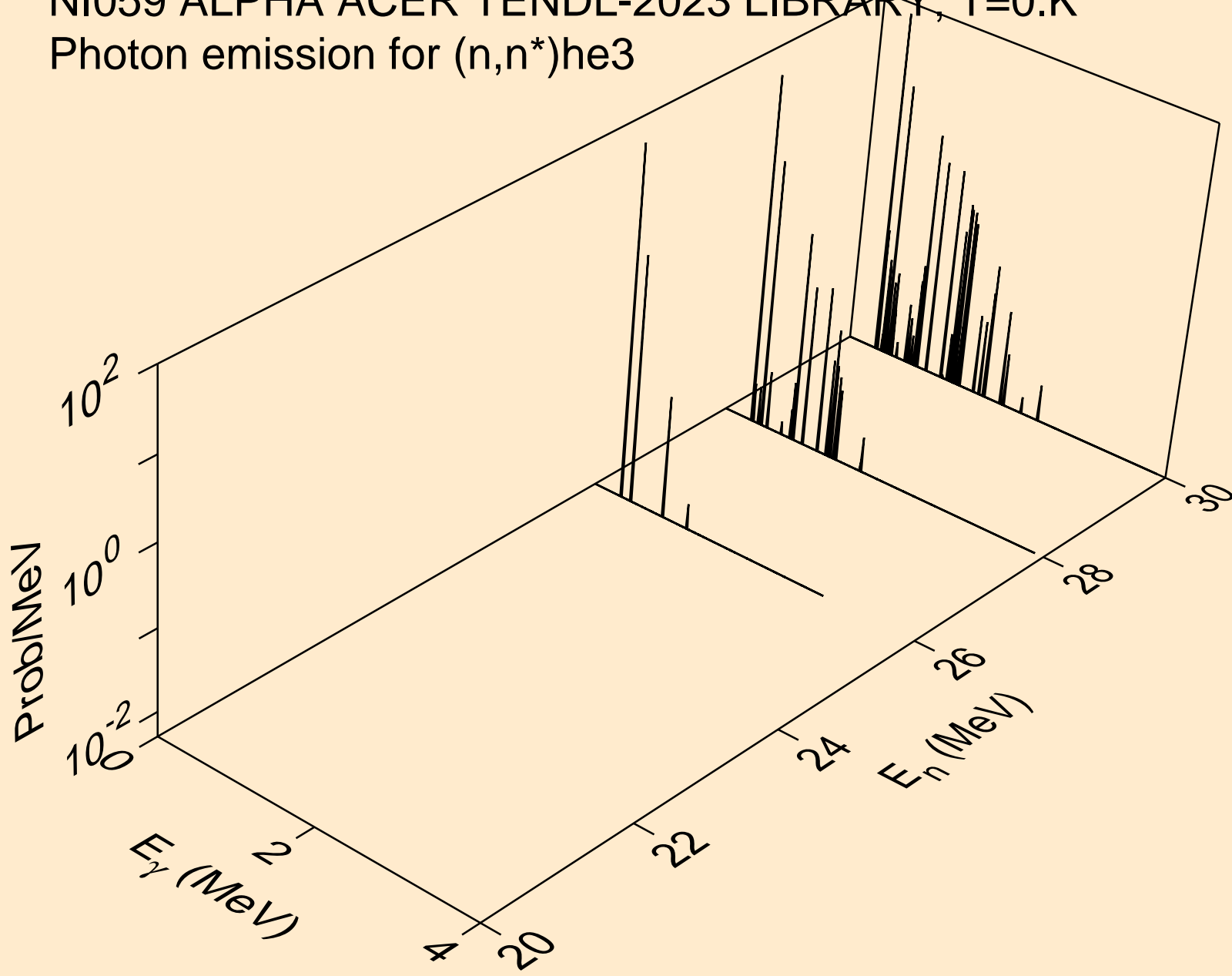

NI059 ALPHA ACER TENDL-2023 LIBRARY; T=0.K  
Photon emission for (n,2np)

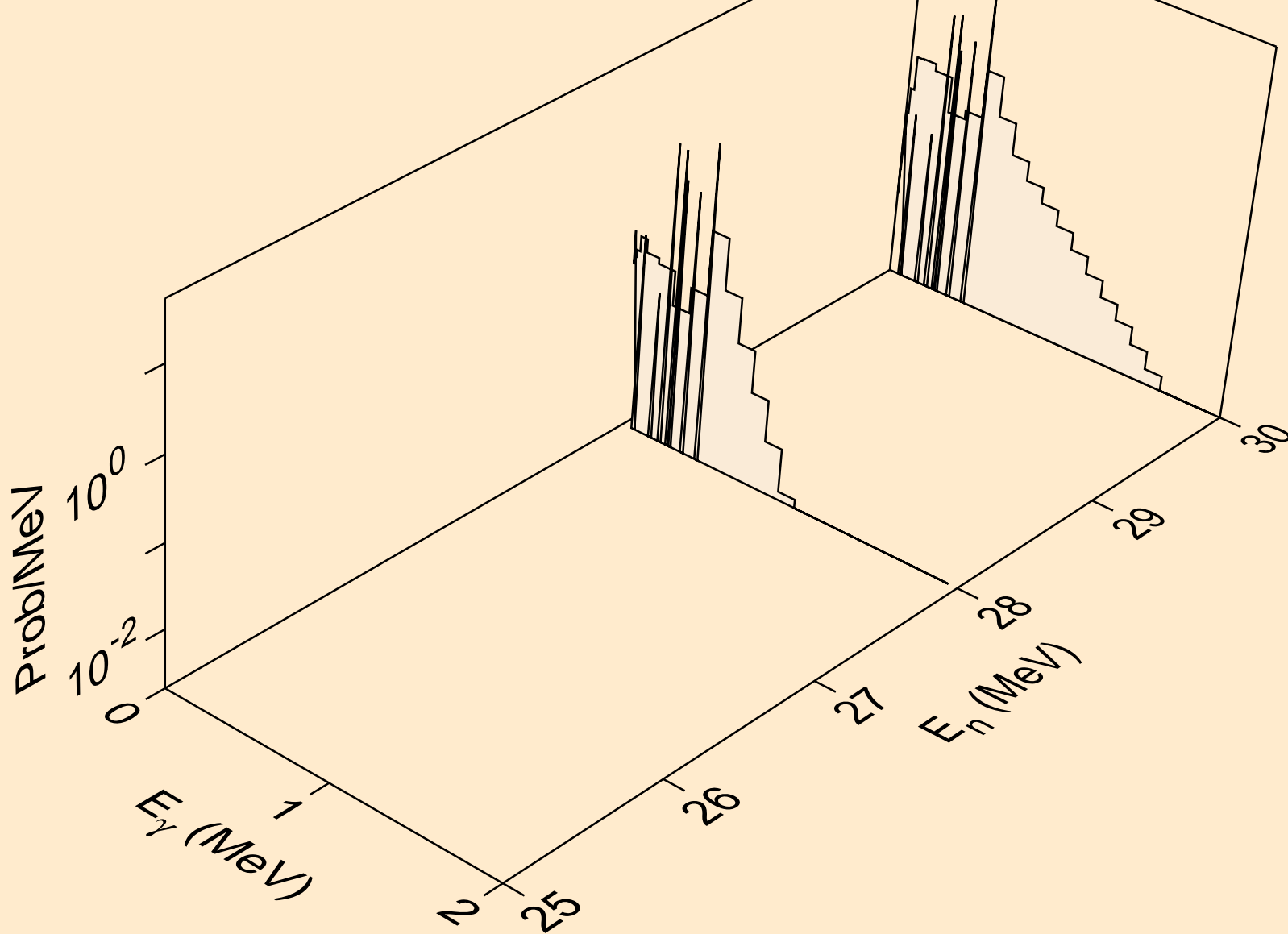

NI059 ALPHA ACER TENDL-2023 LIBRARY; T=0.K  
Photon emission for (n,n2p)

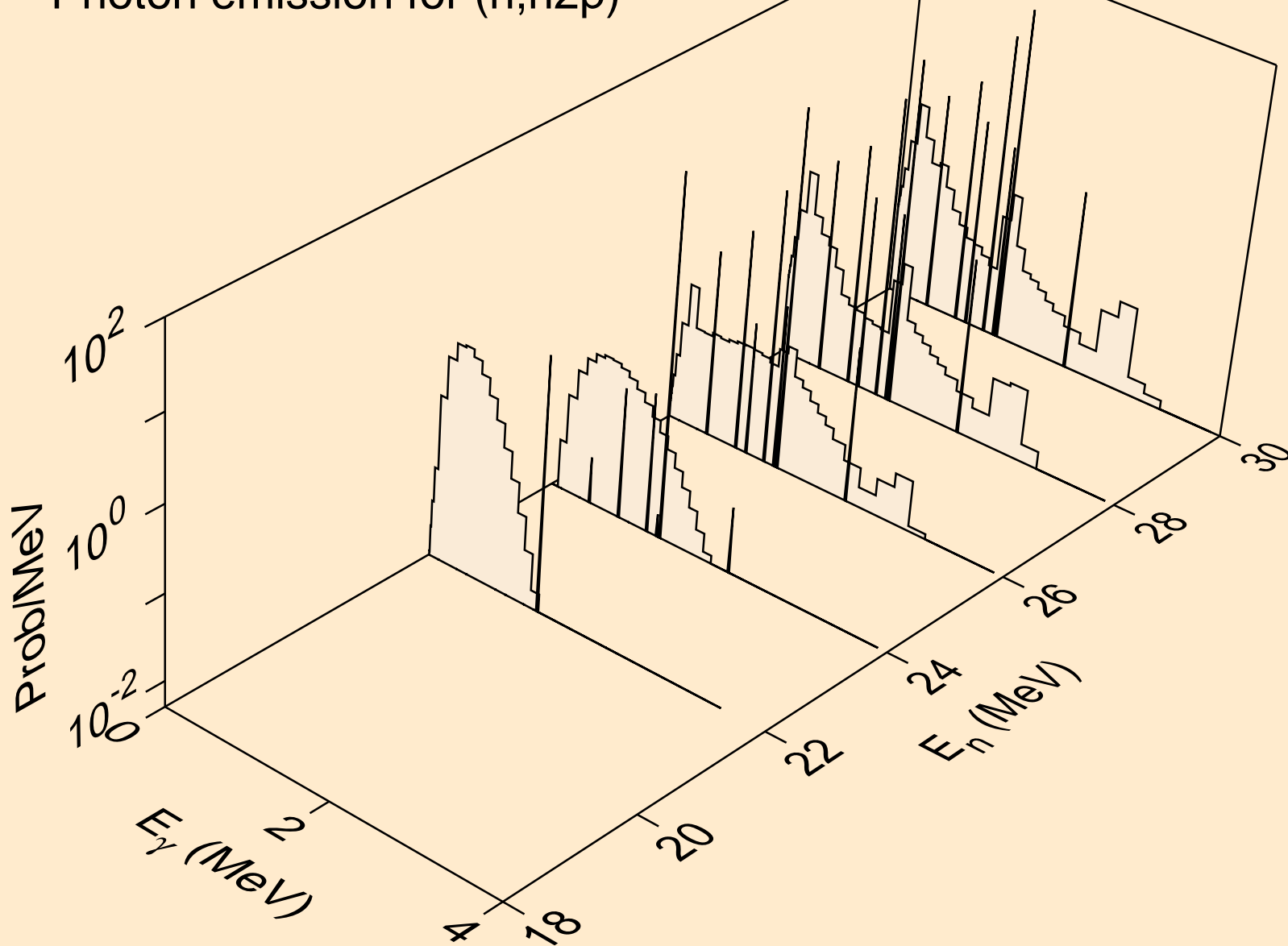

NI059 ALPHA ACER TENDL-2023 LIBRARY; T=0.K  
Photon emission for (n,npa)

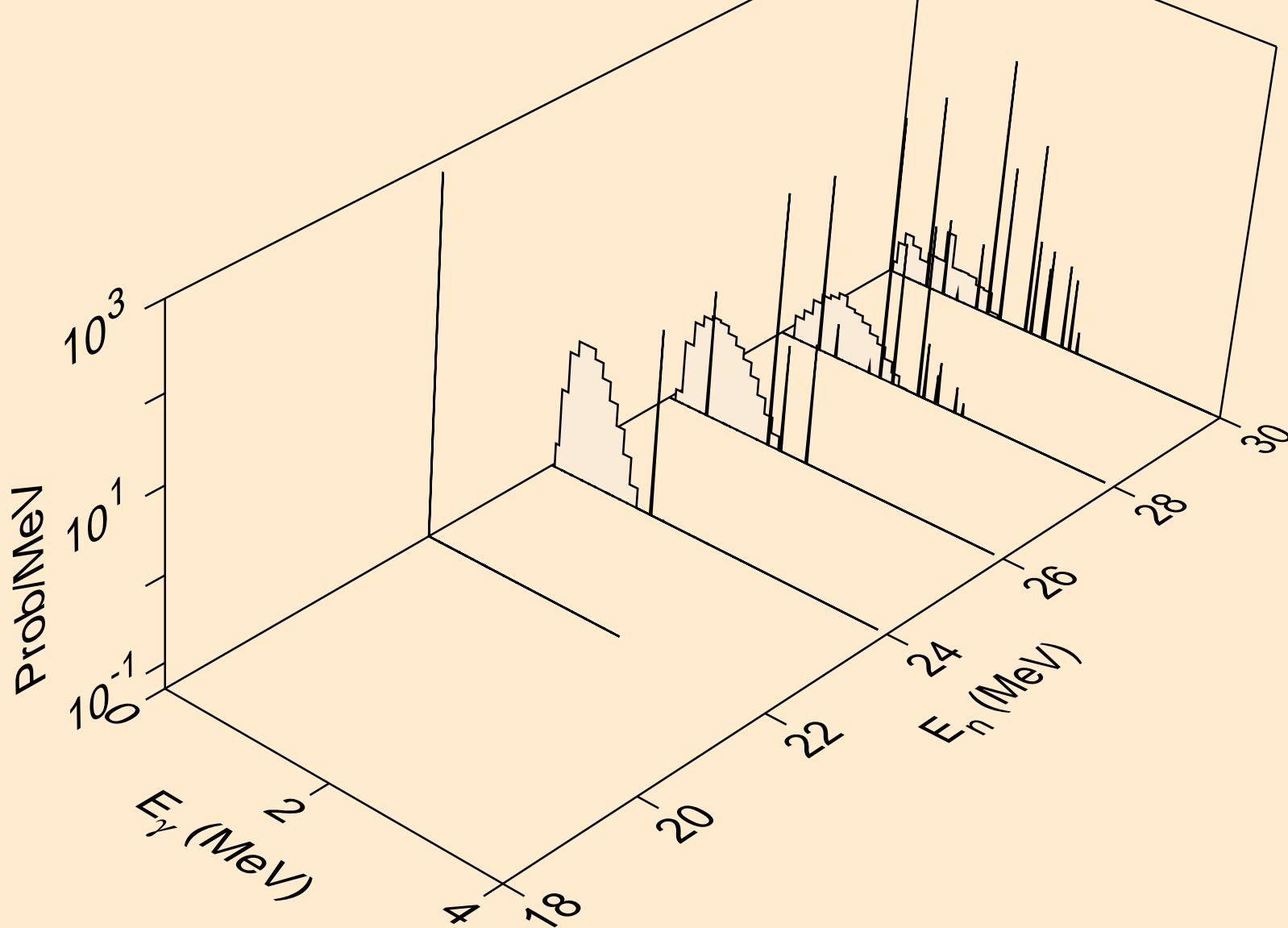

NI059 ALPHA ACER TENDL-2023 LIBRARY; T=0.K  
Photon emission for (n,gma)

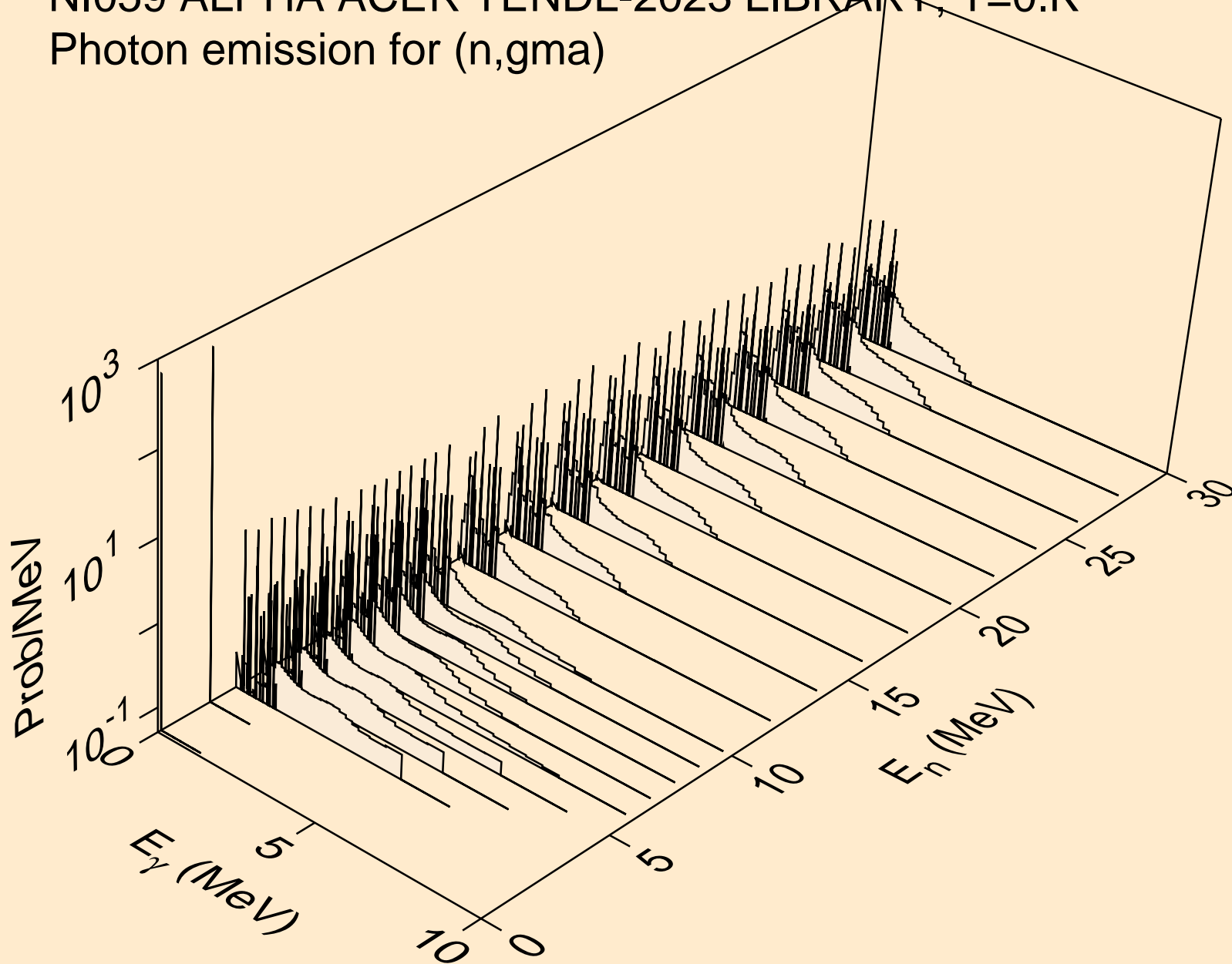



NI059 ALPHA ACER TENDL-2023 LIBRARY; T=0.K  
Photon emission for (n,p)

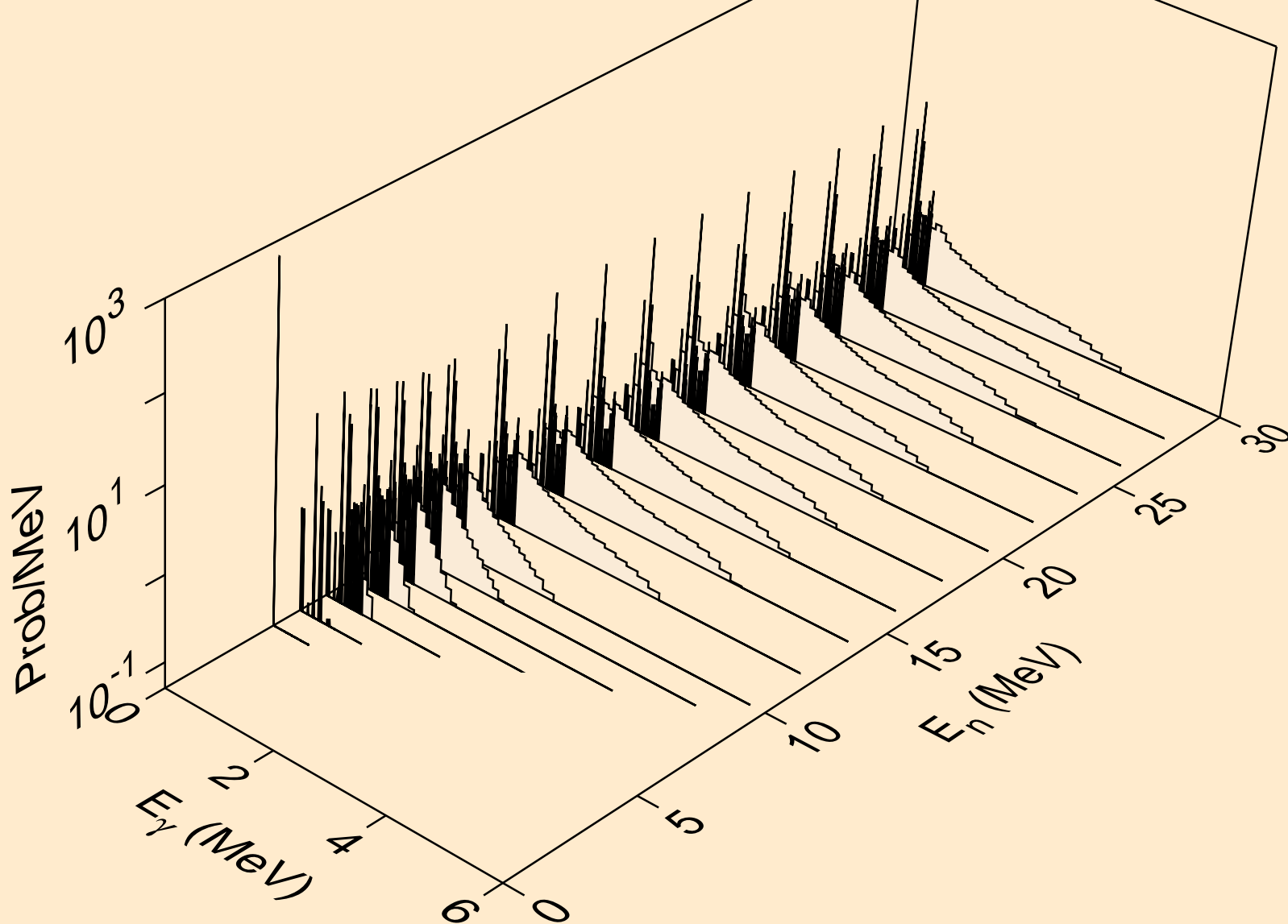

NI059 ALPHA ACER TENDL-2023 LIBRARY; T=0.K  
Photon emission for (n,d)

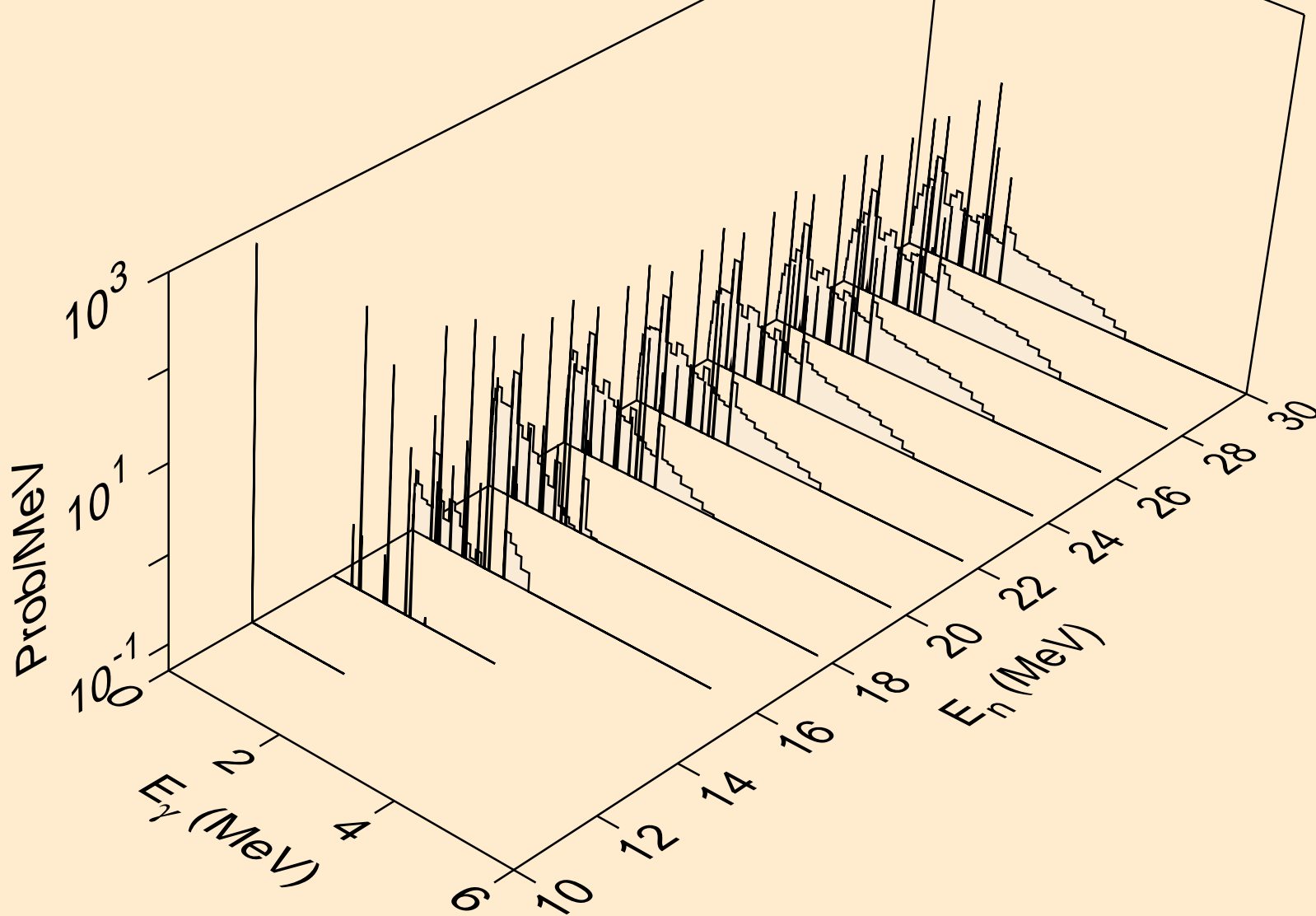

NI059 ALPHA ACER TENDL-2023 LIBRARY; T=0.K  
Photon emission for (n,t)

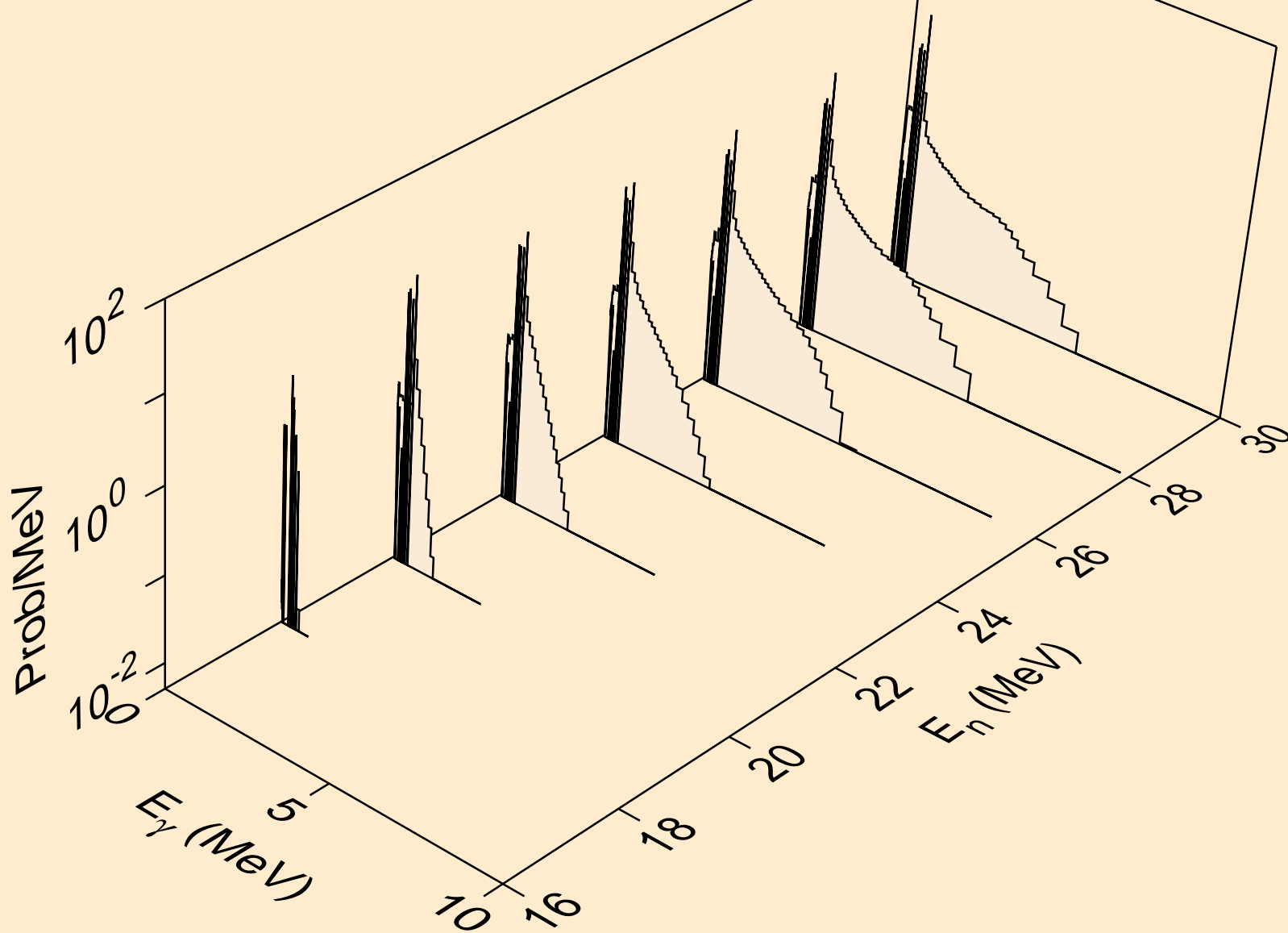

NI059 ALPHA ACER TENDL-2023 LIBRARY; T=0.K  
Photon emission for (n,he3)

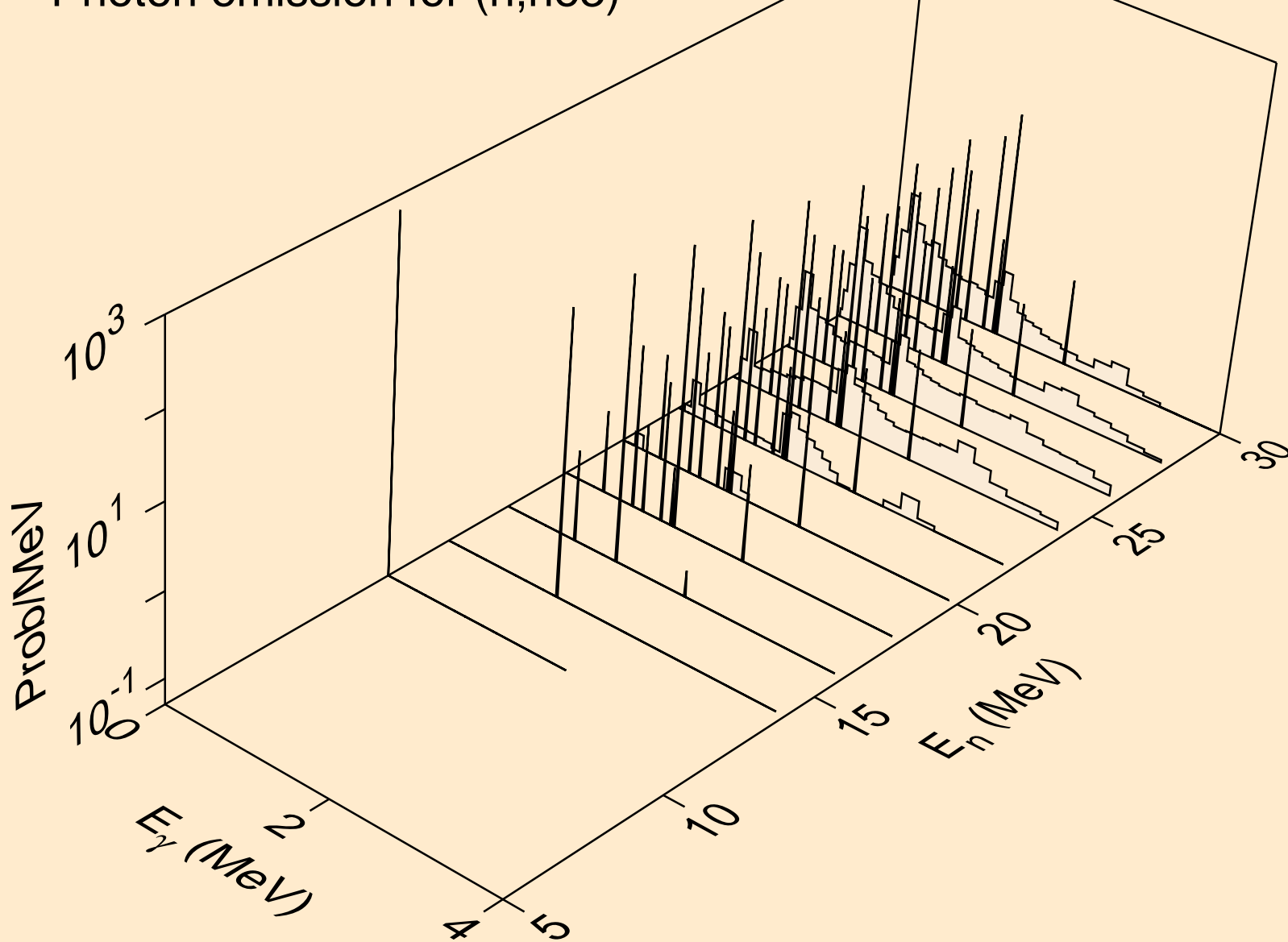

NI059 ALPHA ACER TENDL-2023 LIBRARY; T=0.K  
Photon emission for inelastic

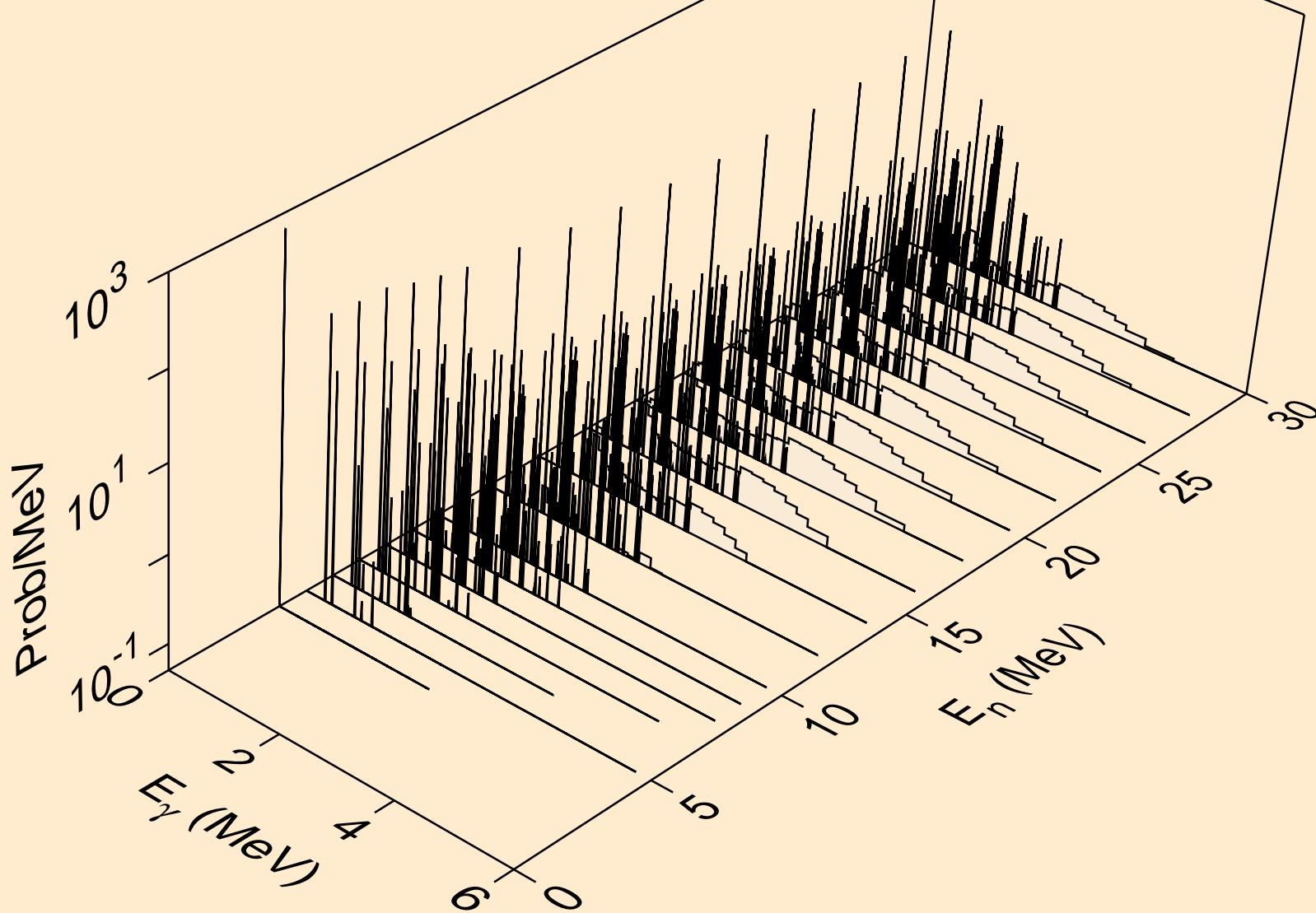

NI059 ALPHA ACER TENDL-2023 LIBRARY; T=0.K  
Photon emission for (n,2a)

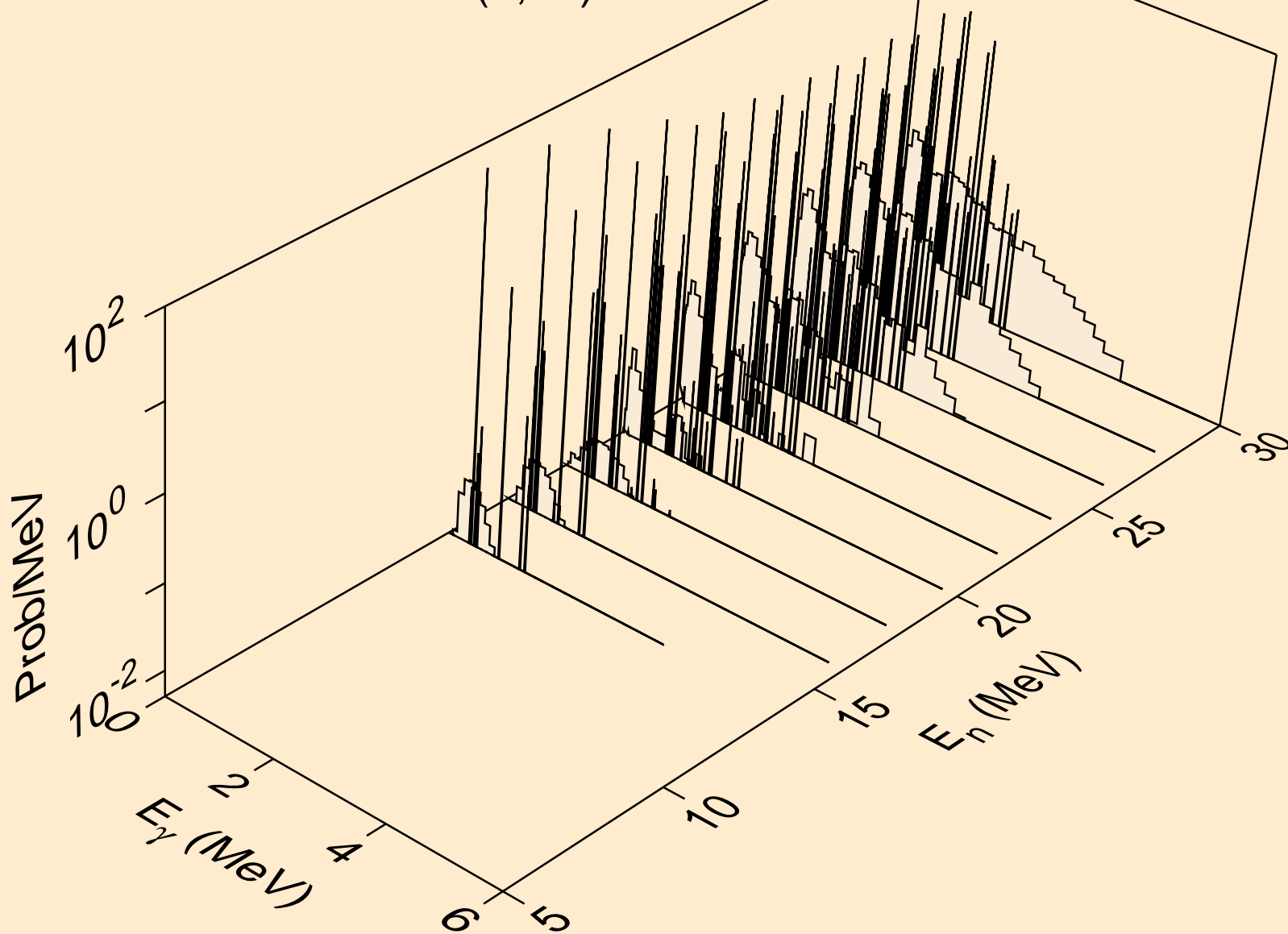

NI059 ALPHA ACER TENDL-2023 LIBRARY; T=0.K  
Photon emission for (n,2p)

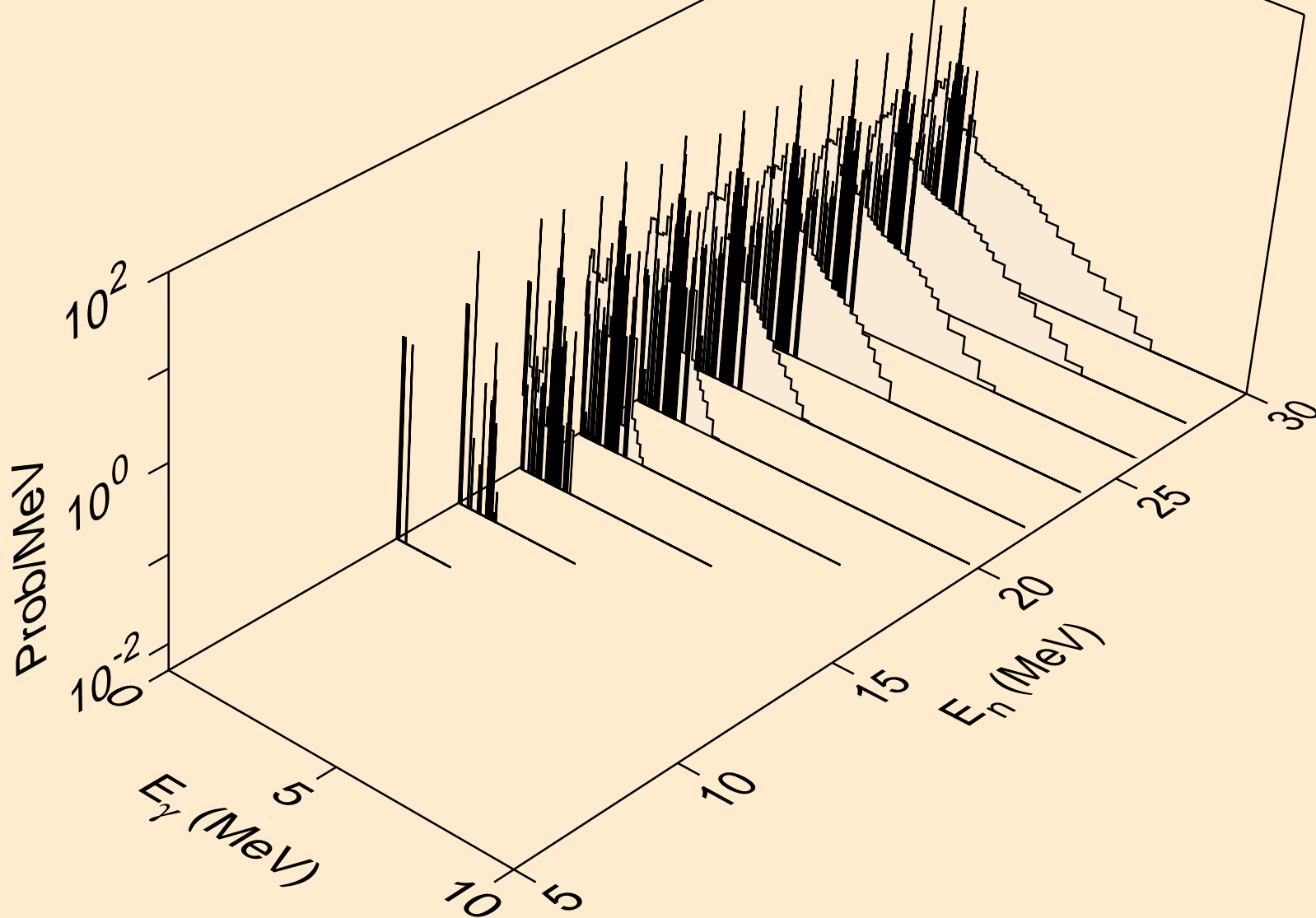

NI059 ALPHA ACER TENDL-2023 LIBRARY; T=0.K  
Photon emission for (n,pa)

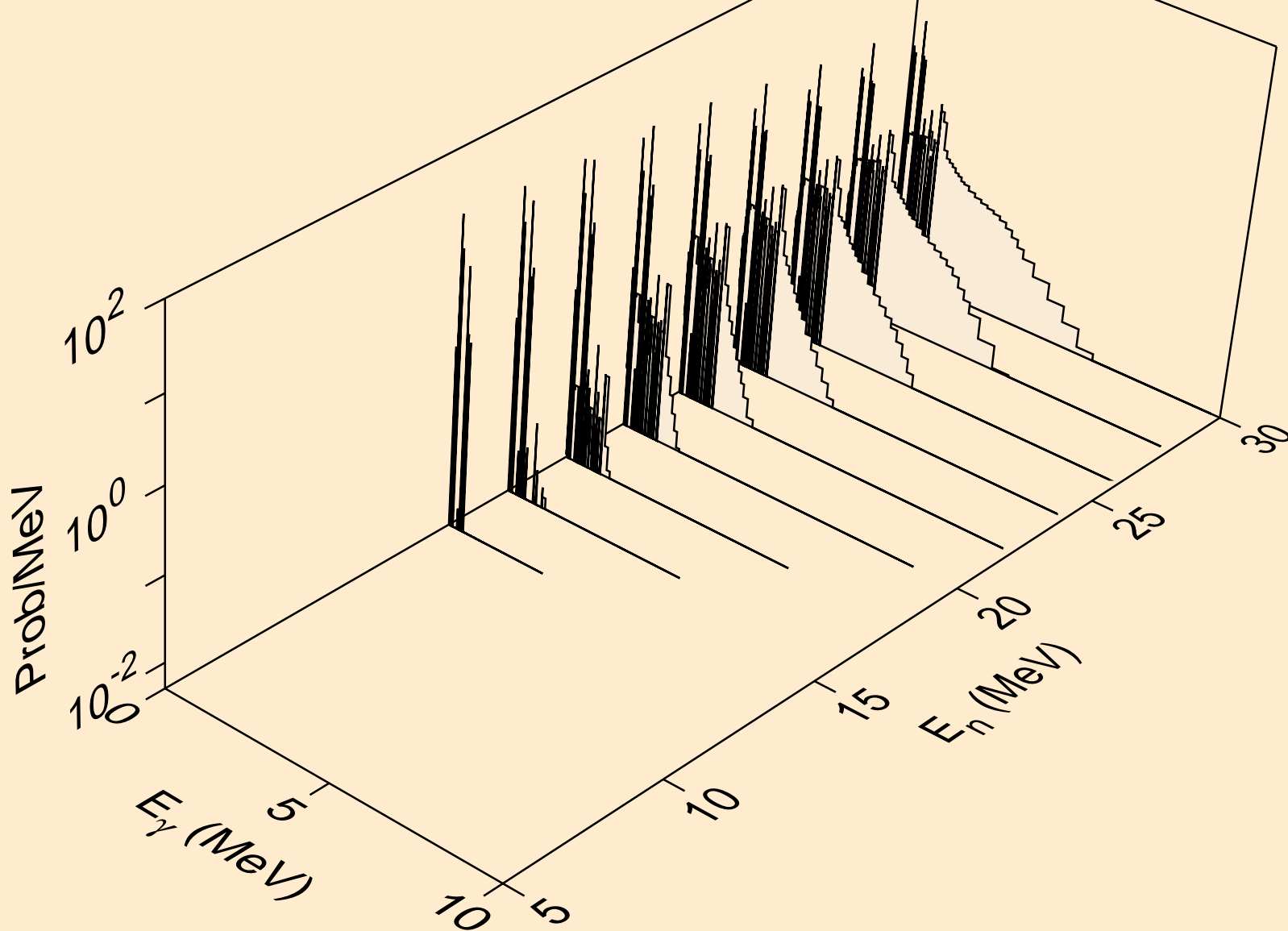



NI059 ALPHA ACER TENDL-2023 LIBRARY; T=0.K  
Photon emission for (n,pd)

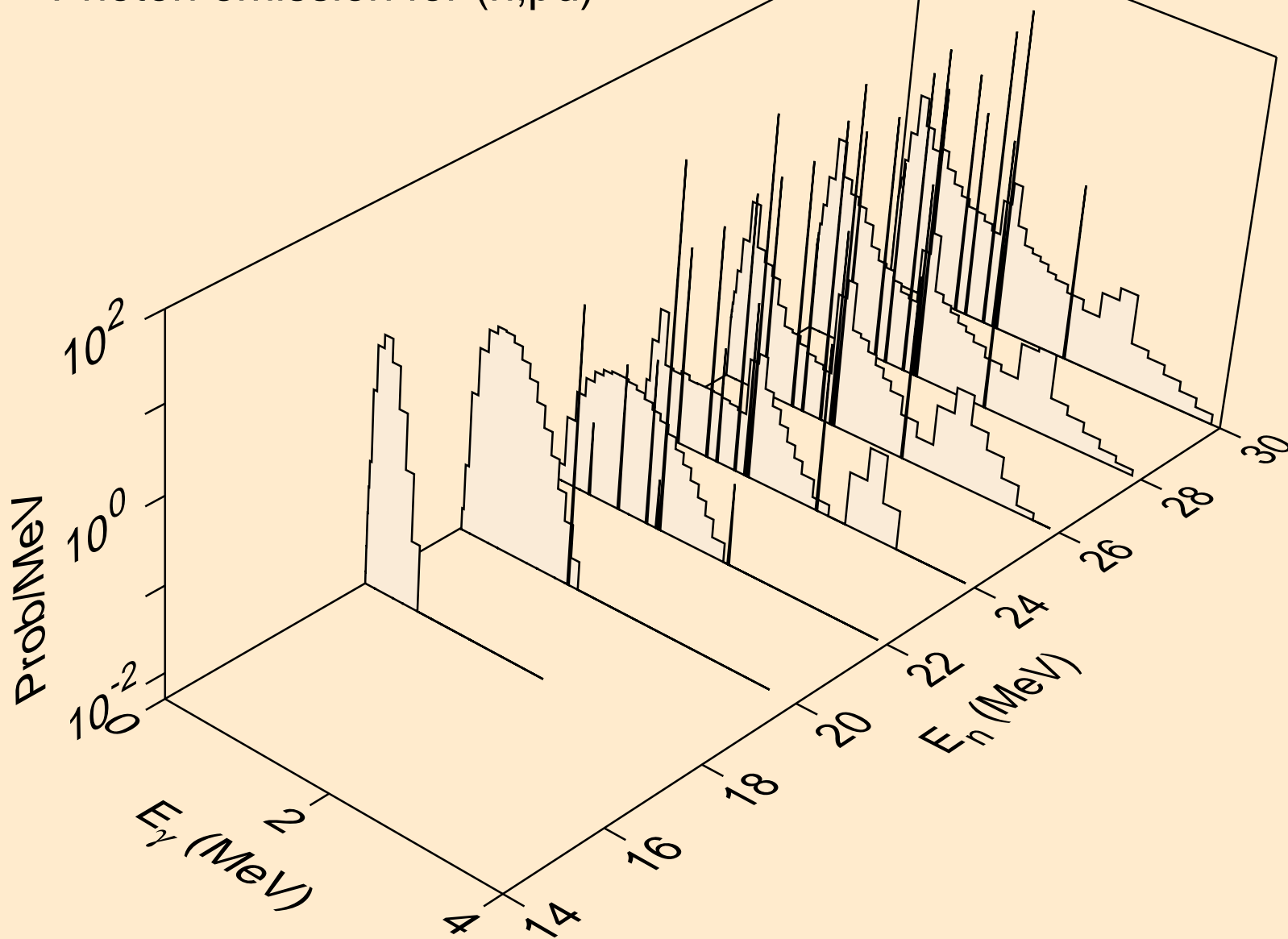

NI059 ALPHA ACER TENDL-2023 LIBRARY; T=0.K  
Photon emission for (n,pt)

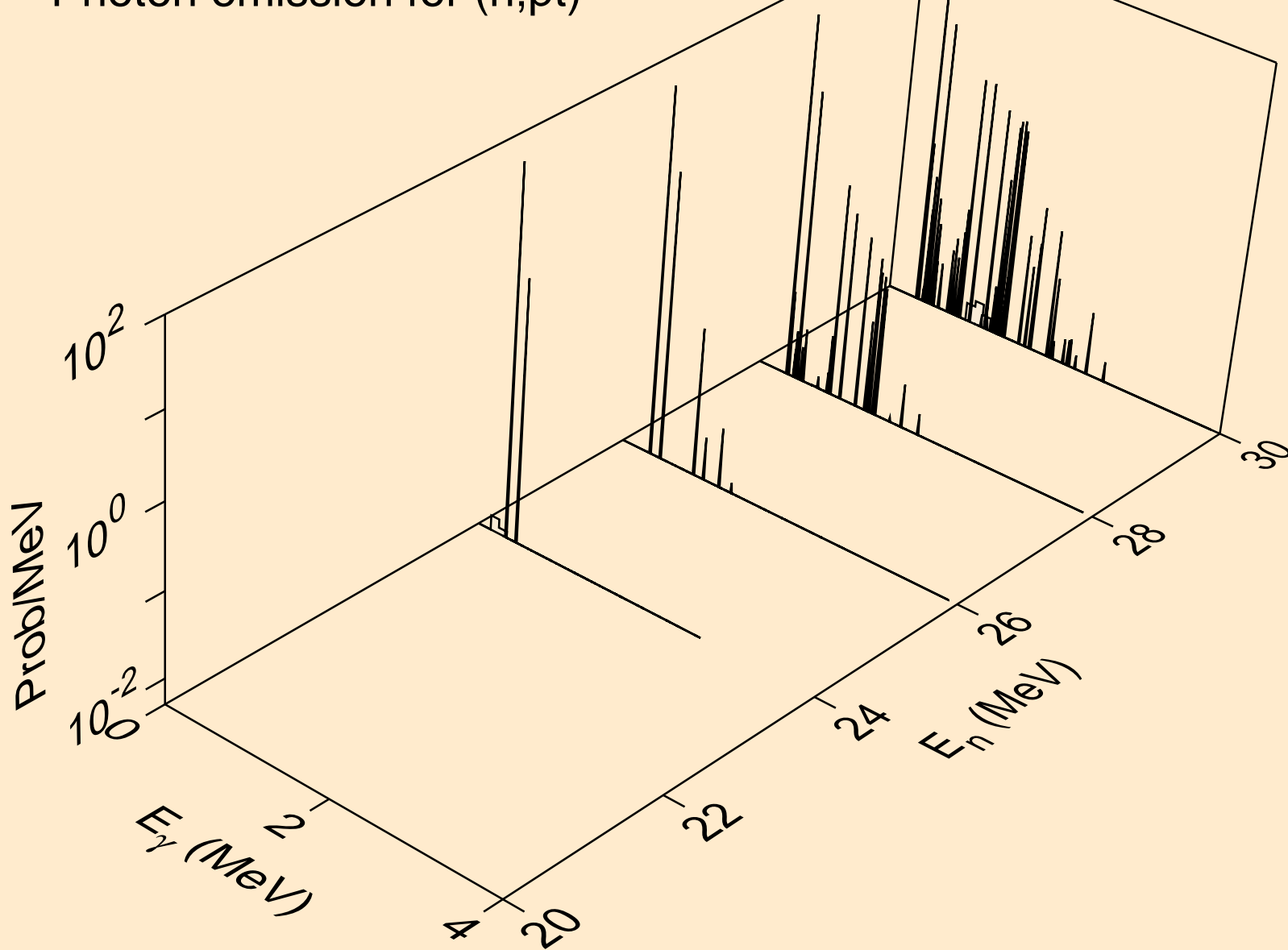

NI059 ALPHA ACER TENDL-2023 LIBRARY; T=0.K  
Photon emission for (n,da)

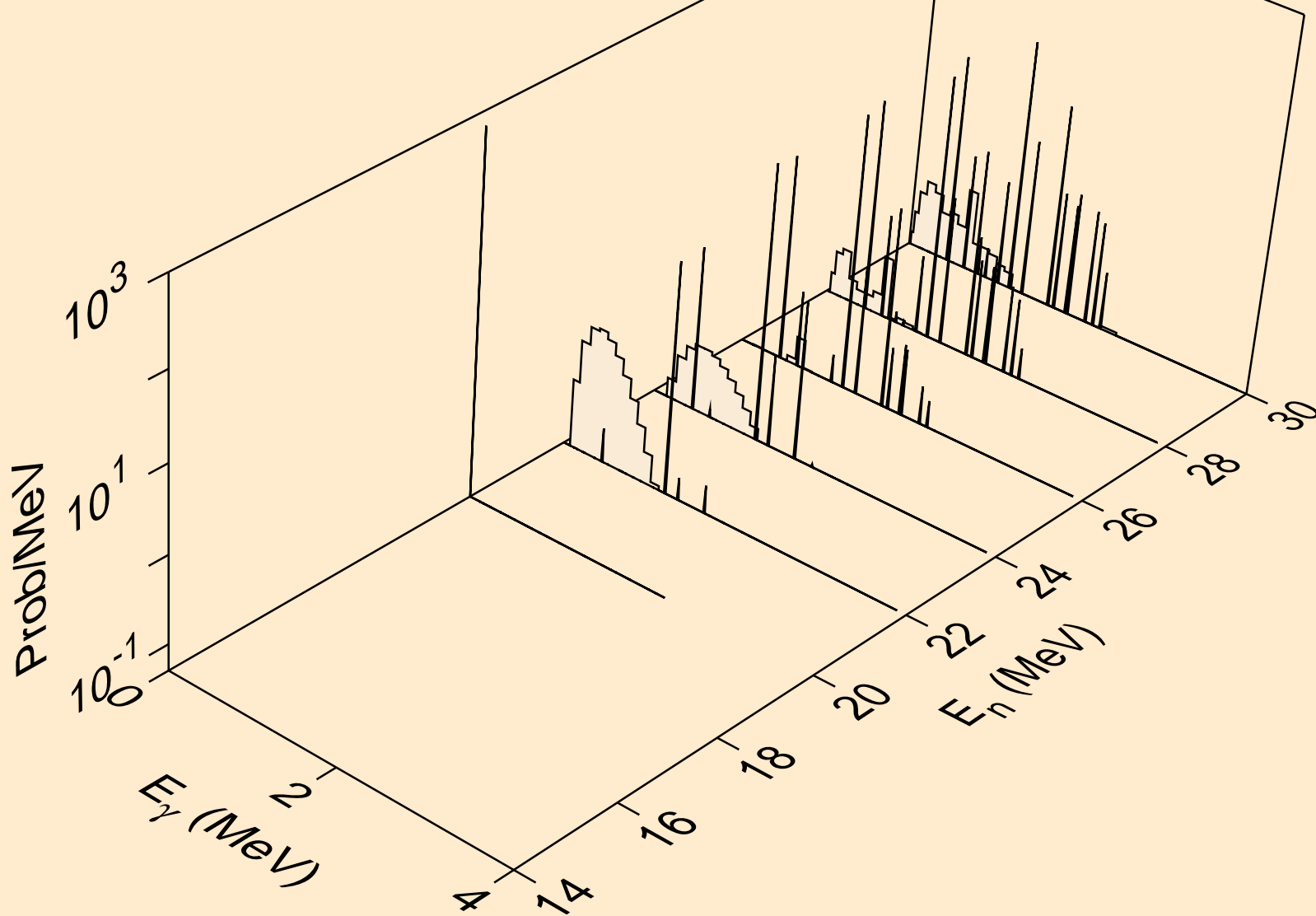

# NI059 ALPHA ACER TENDL-2023 LIBRARY; T=0.K

## Particle heating contributions

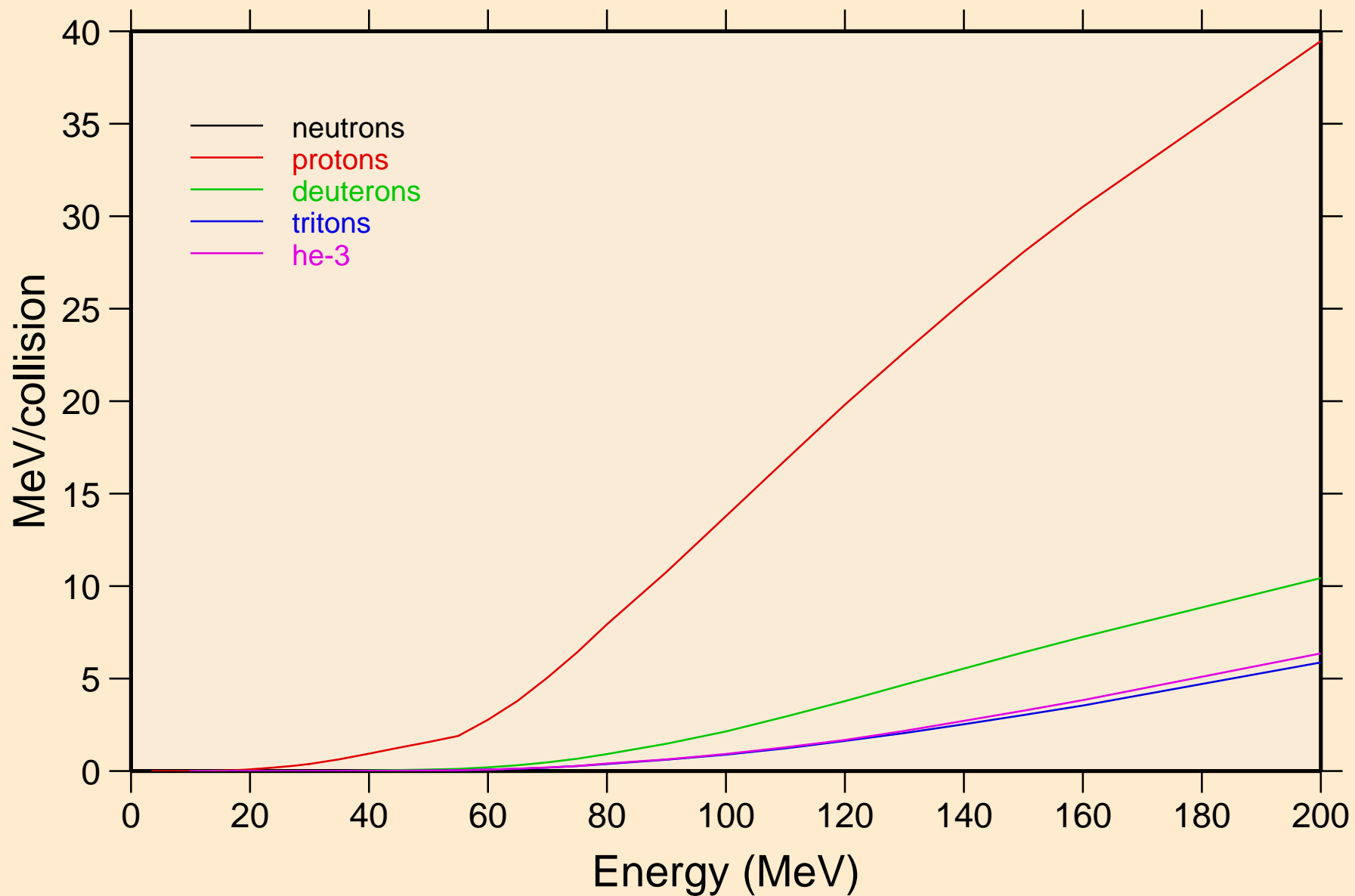

NI059 ALPHA ACER TENDL-2023 LIBRARY; T=0.K  
Recoil Heating

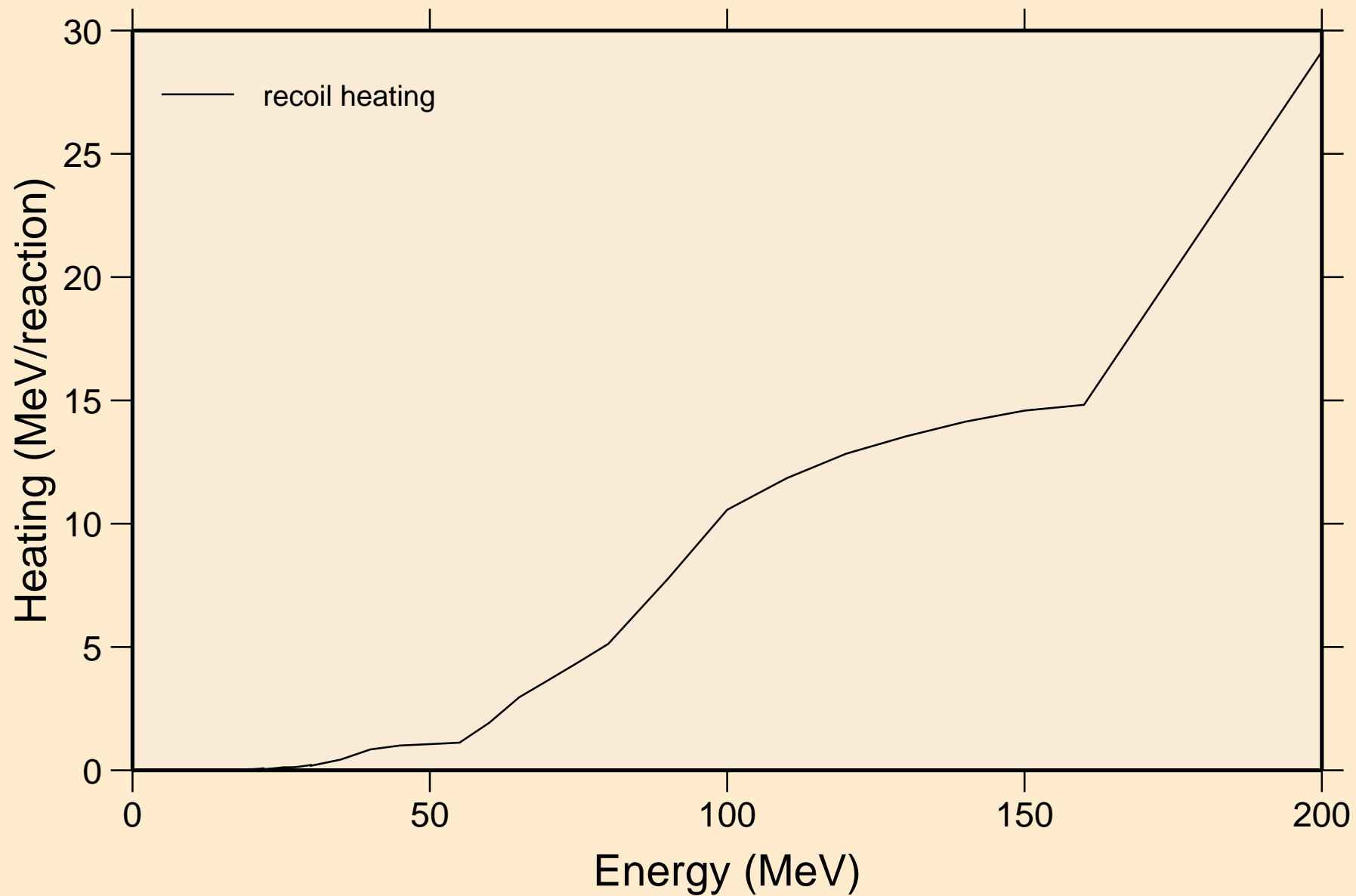

# NI059 ALPHA ACER TENDL-2023 LIBRARY; T=0.K

## Particle production cross sections

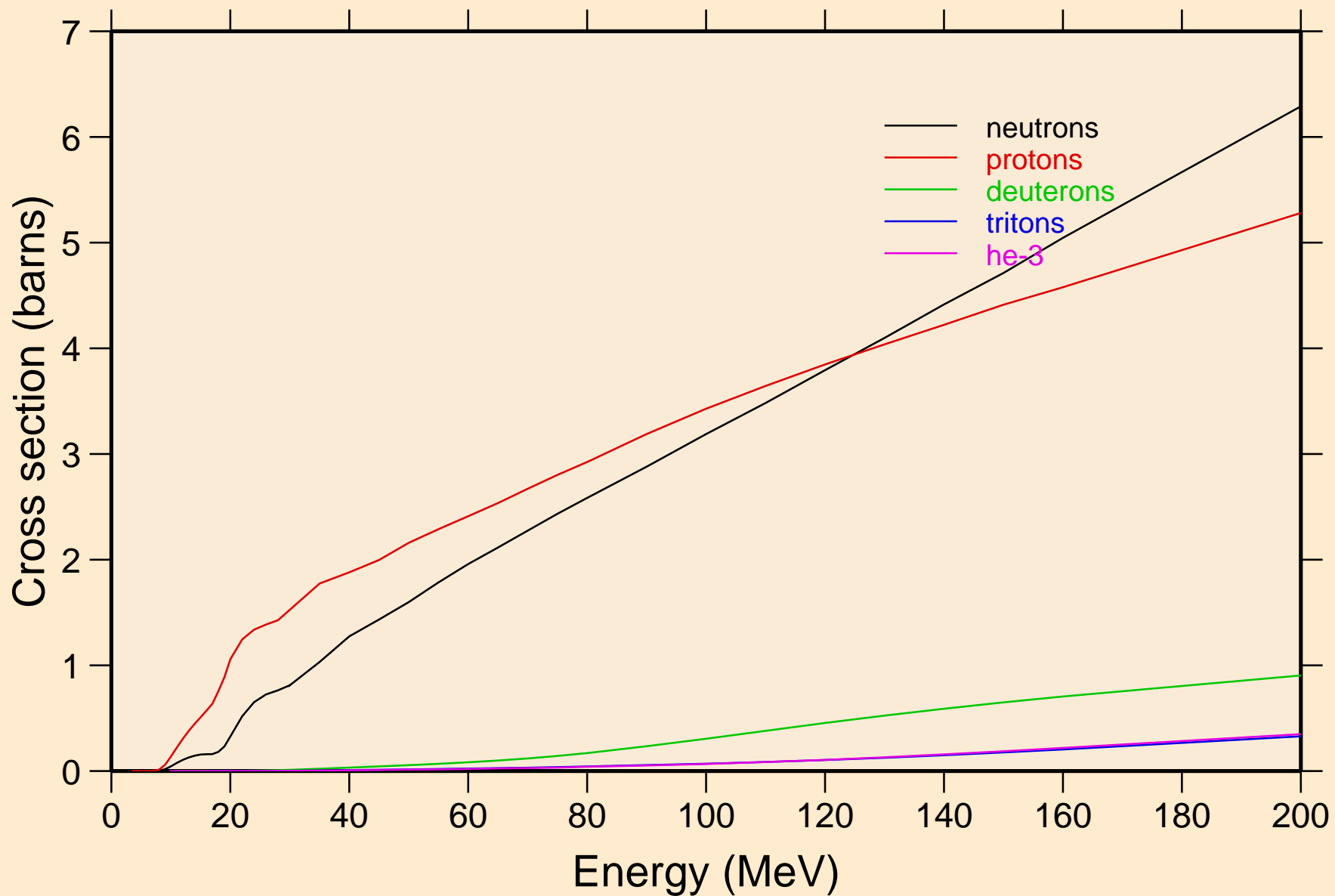

NI059 ALPHA ACER TENDL-2023 LIBRARY; T=0.K  
neutrons from (a,n)

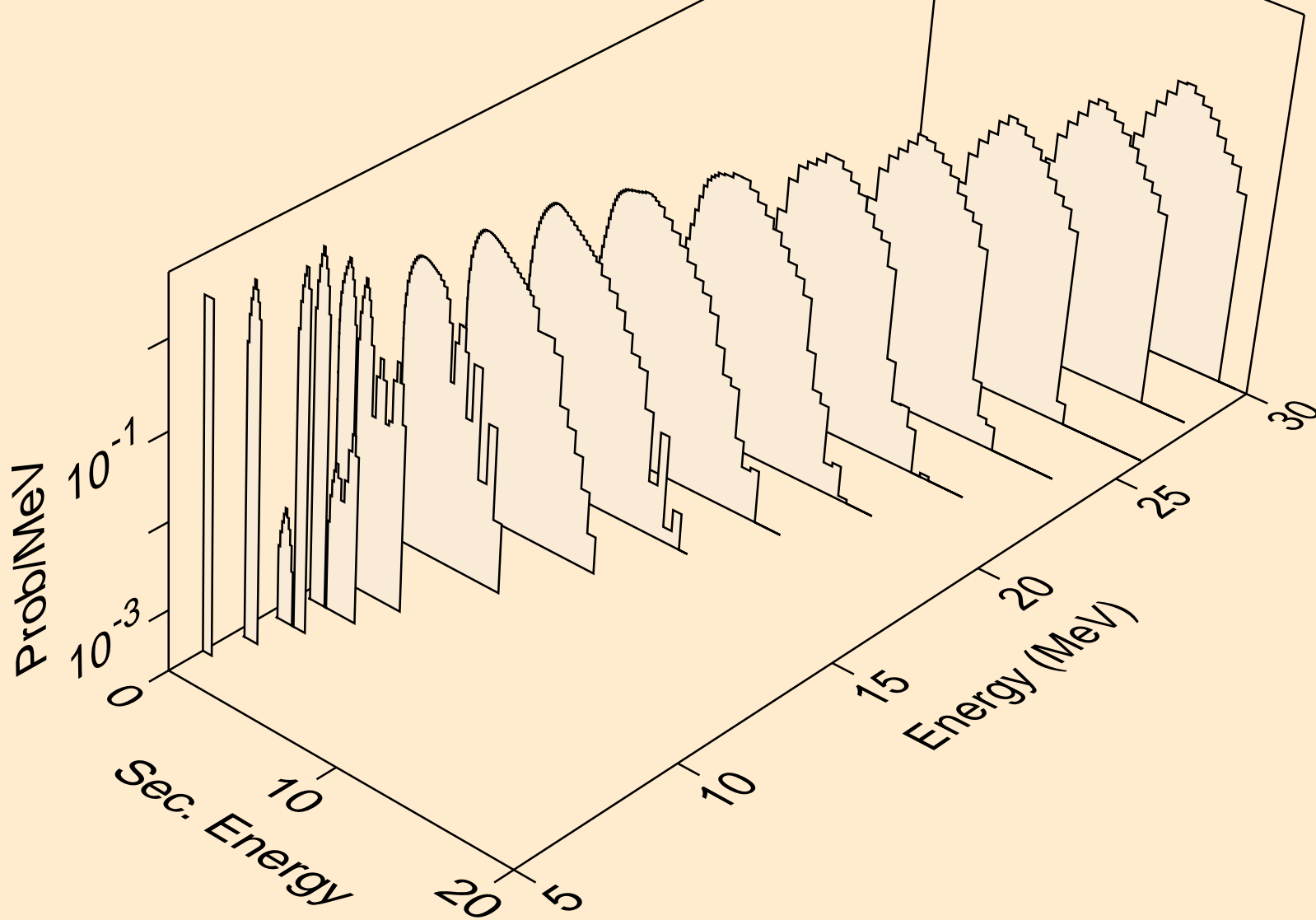

NI059 ALPHA ACER TENDL-2023 LIBRARY; T=0.K  
neutrons from (a,x)

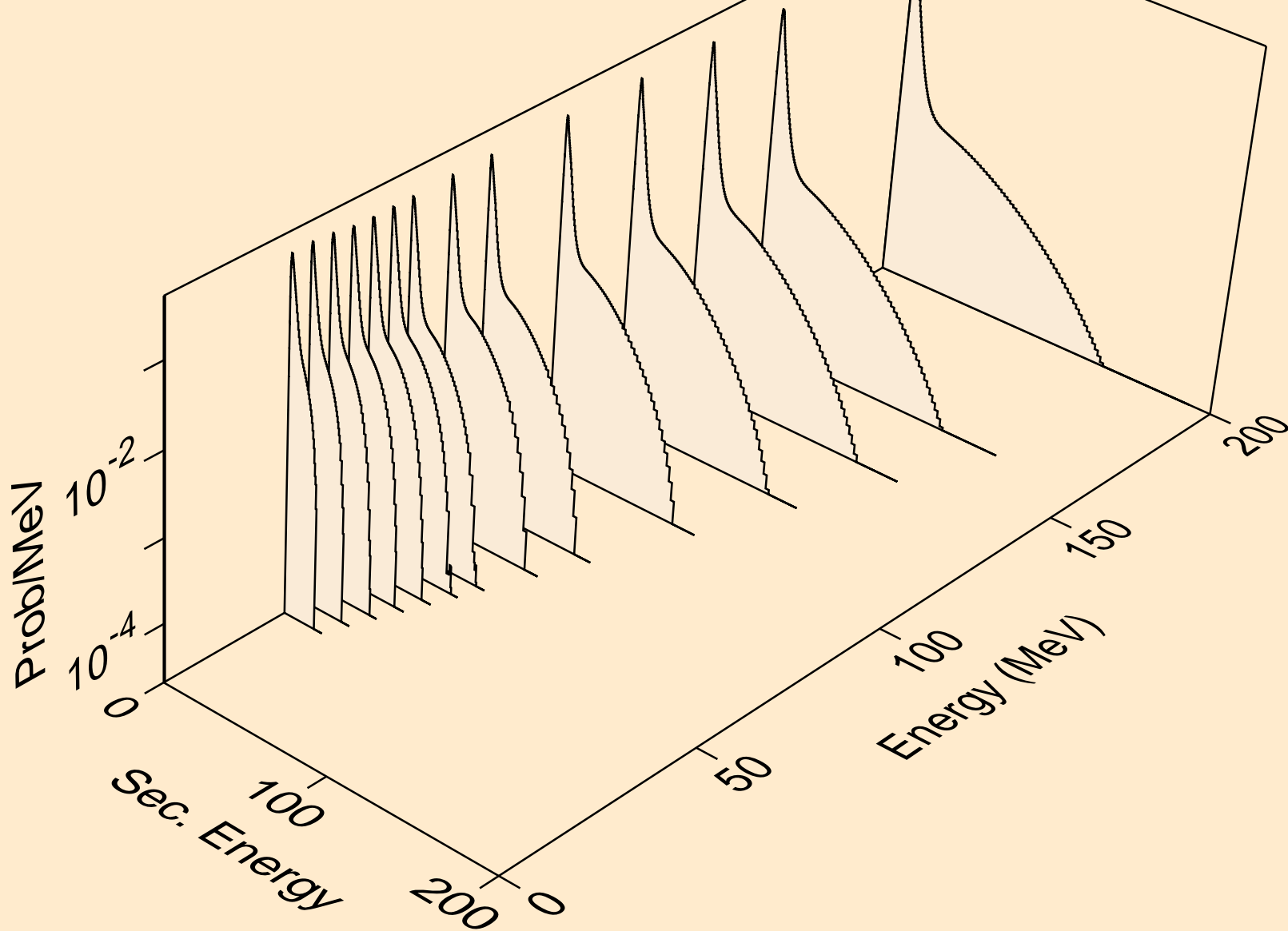



NI059 ALPHA ACER TENDL-2023 LIBRARY; T=0.K  
neutrons from (a,2n)

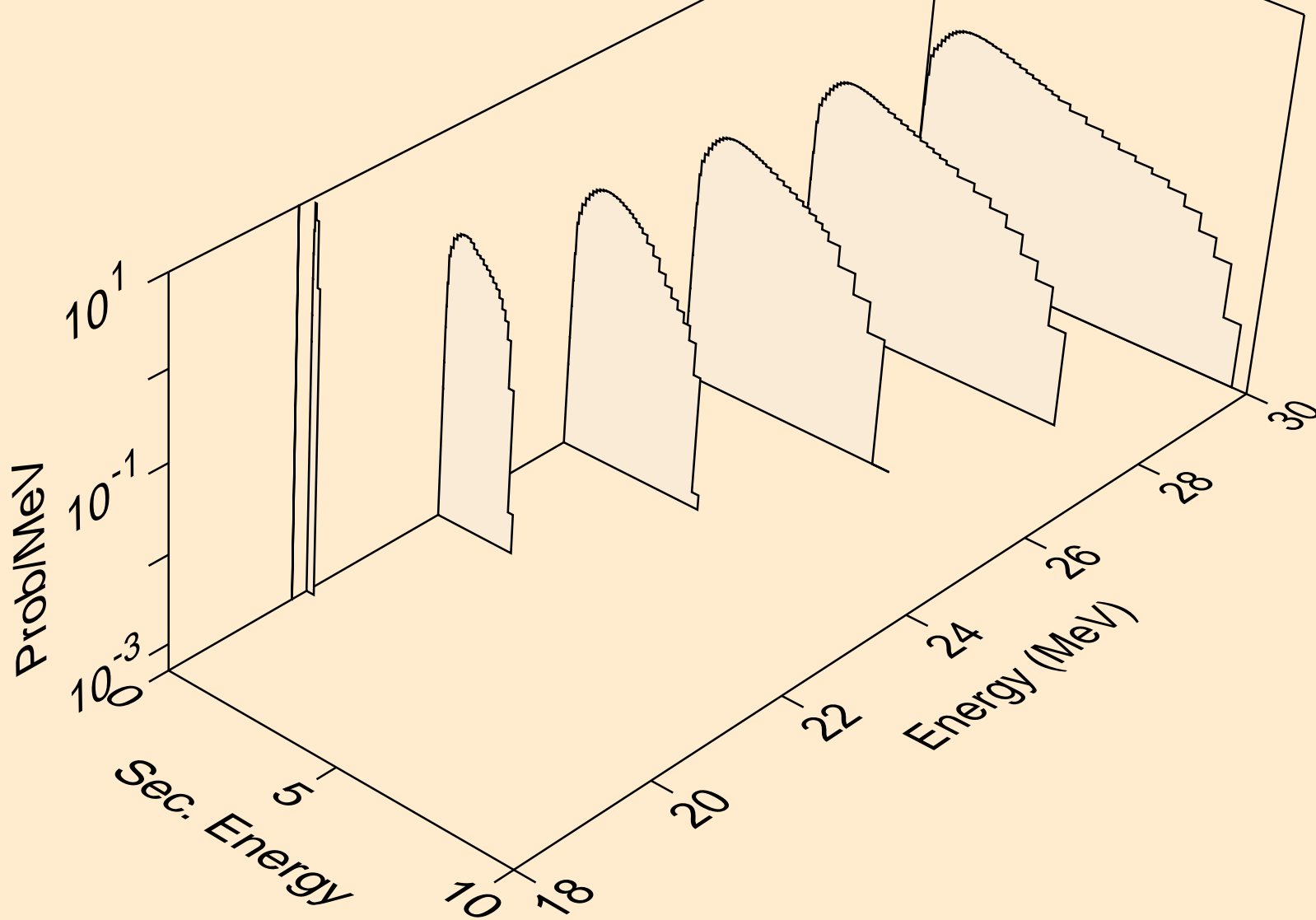

NI059 ALPHA ACER TENDL-2023 LIBRARY; T=0.K  
neutrons from (a,n\*)a

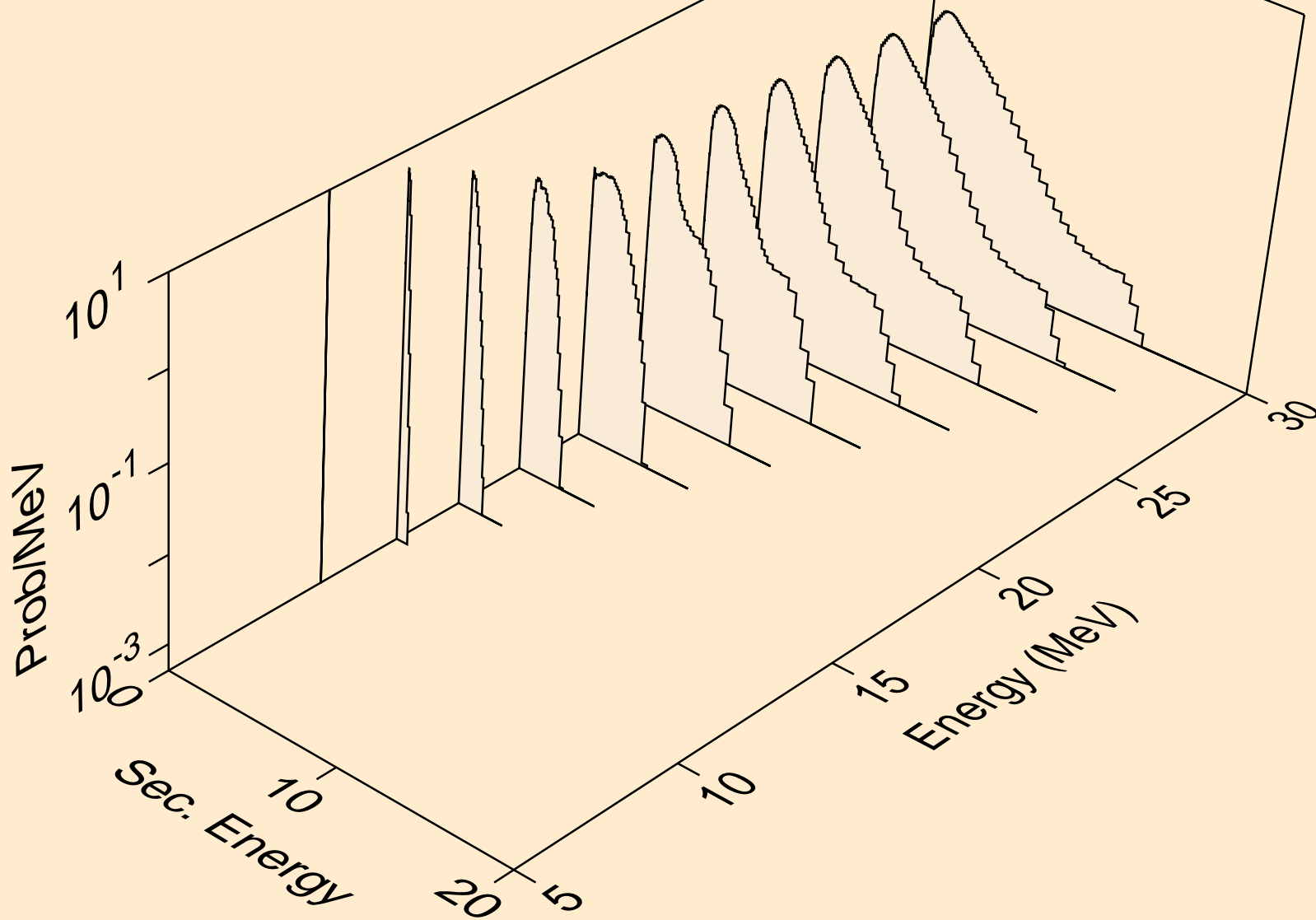

NI059 ALPHA ACER TENDL-2023 LIBRARY; T=0.K  
neutrons from (a,2n)a

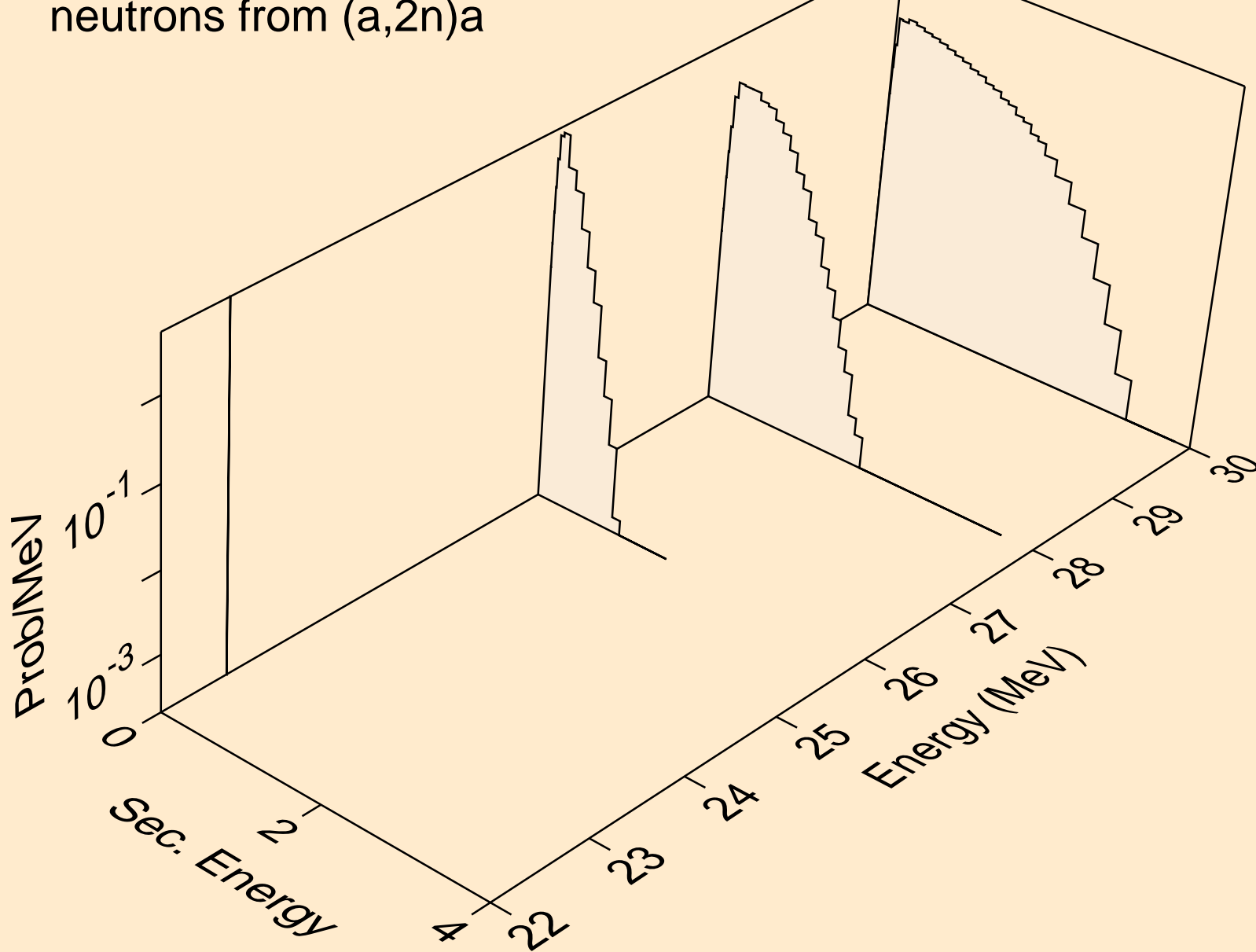

NI059 ALPHA ACER TENDL-2023 LIBRARY; T=0.K  
neutrons from (a,n\*)p

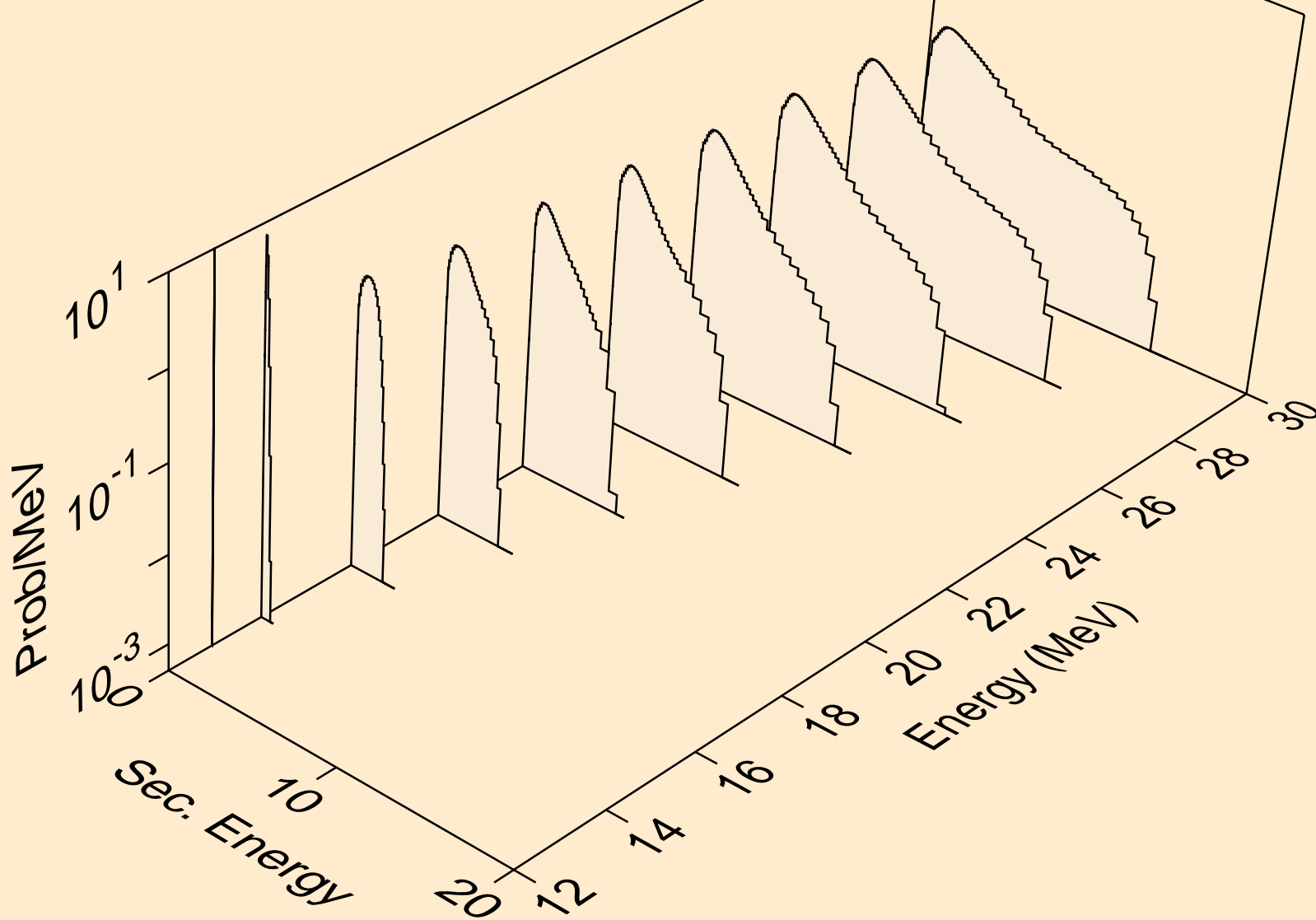

NI059 ALPHA ACER TENDL-2023 LIBRARY; T=0.K  
neutrons from (a,n\*)2a

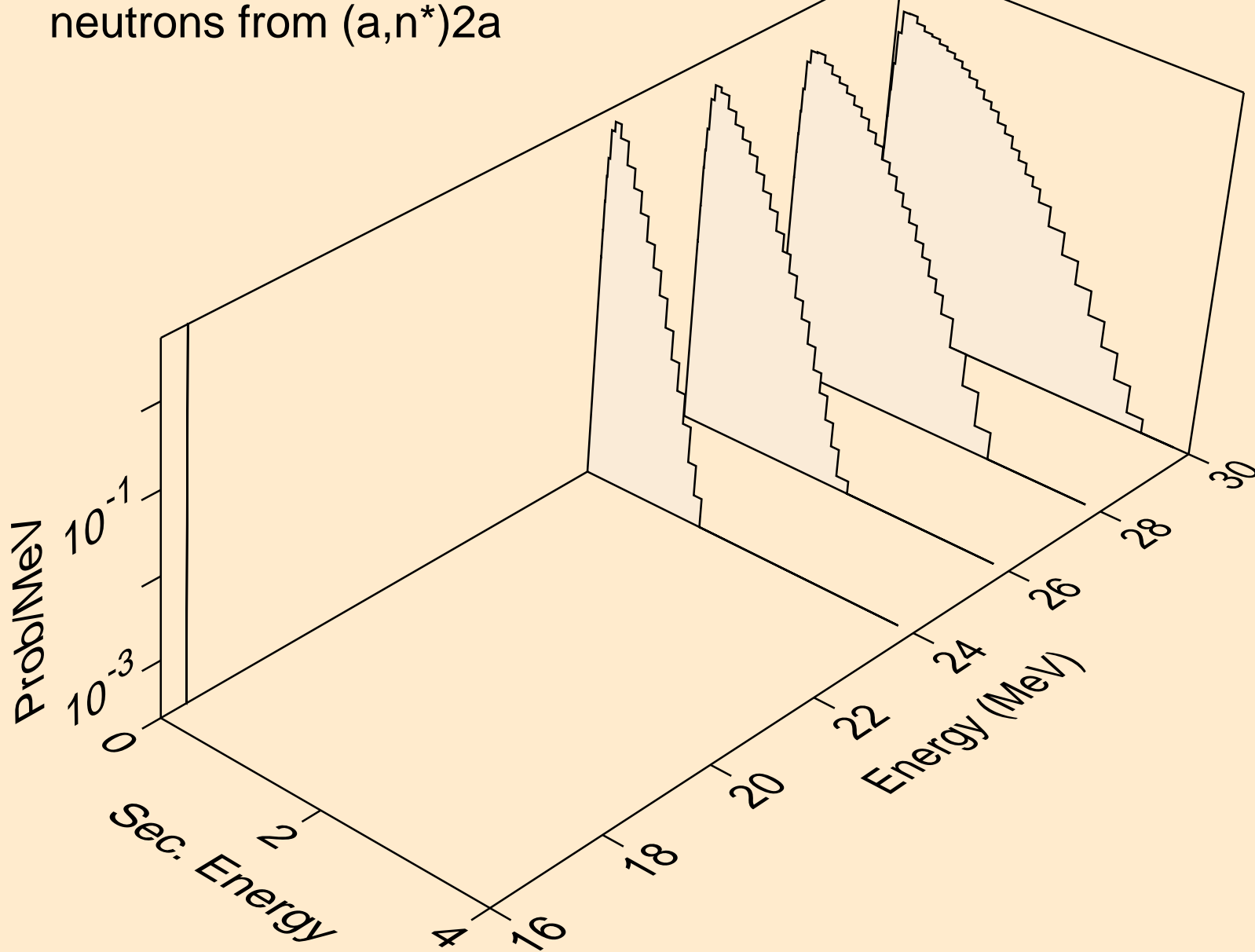

NI059 ALPHA ACER TENDL-2023 LIBRARY; T=0.K  
neutrons from (a,n\*)d

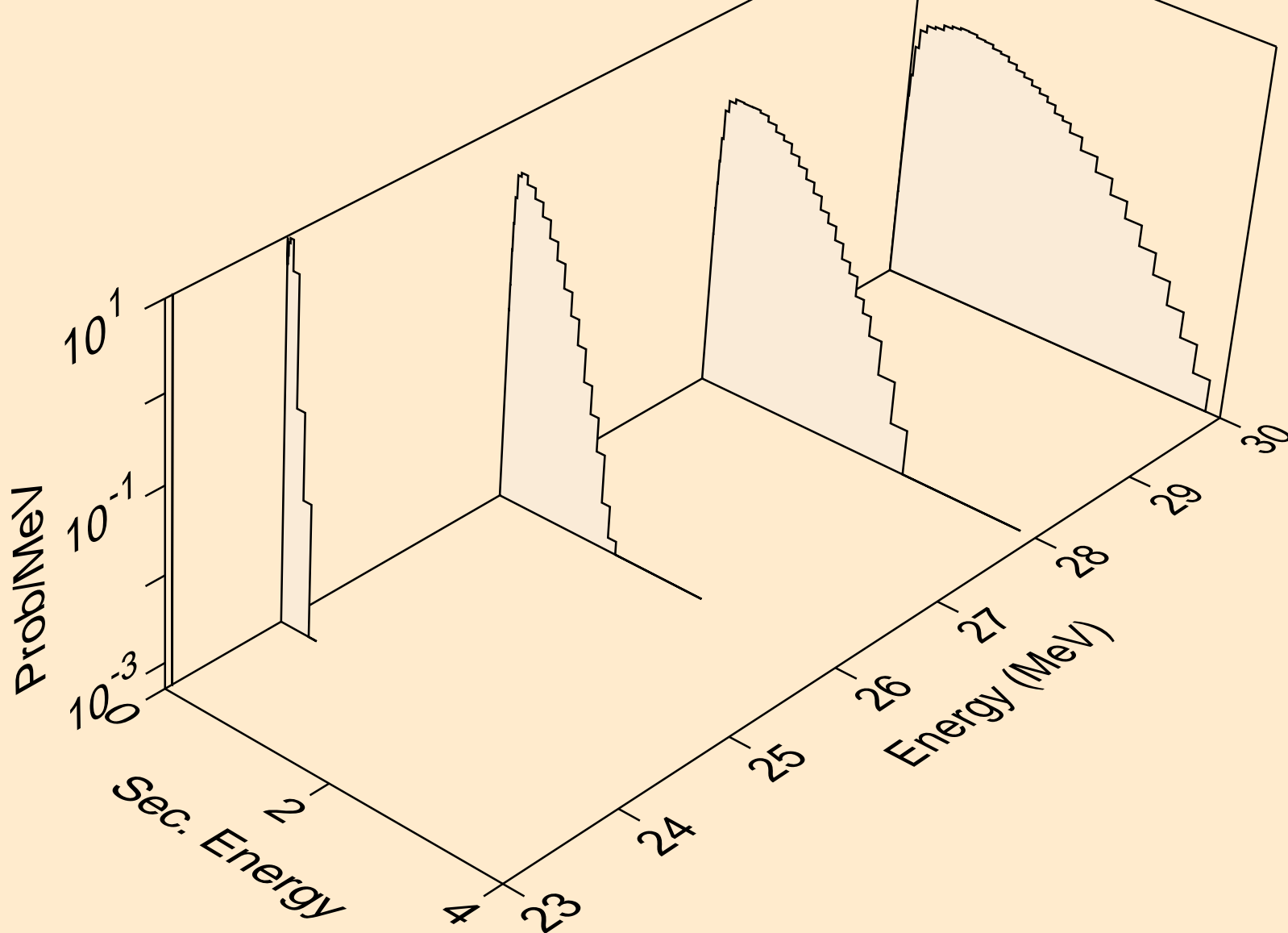

NI059 ALPHA ACER TENDL-2023 LIBRARY; T=0.K  
neutrons from (a,n\*)t

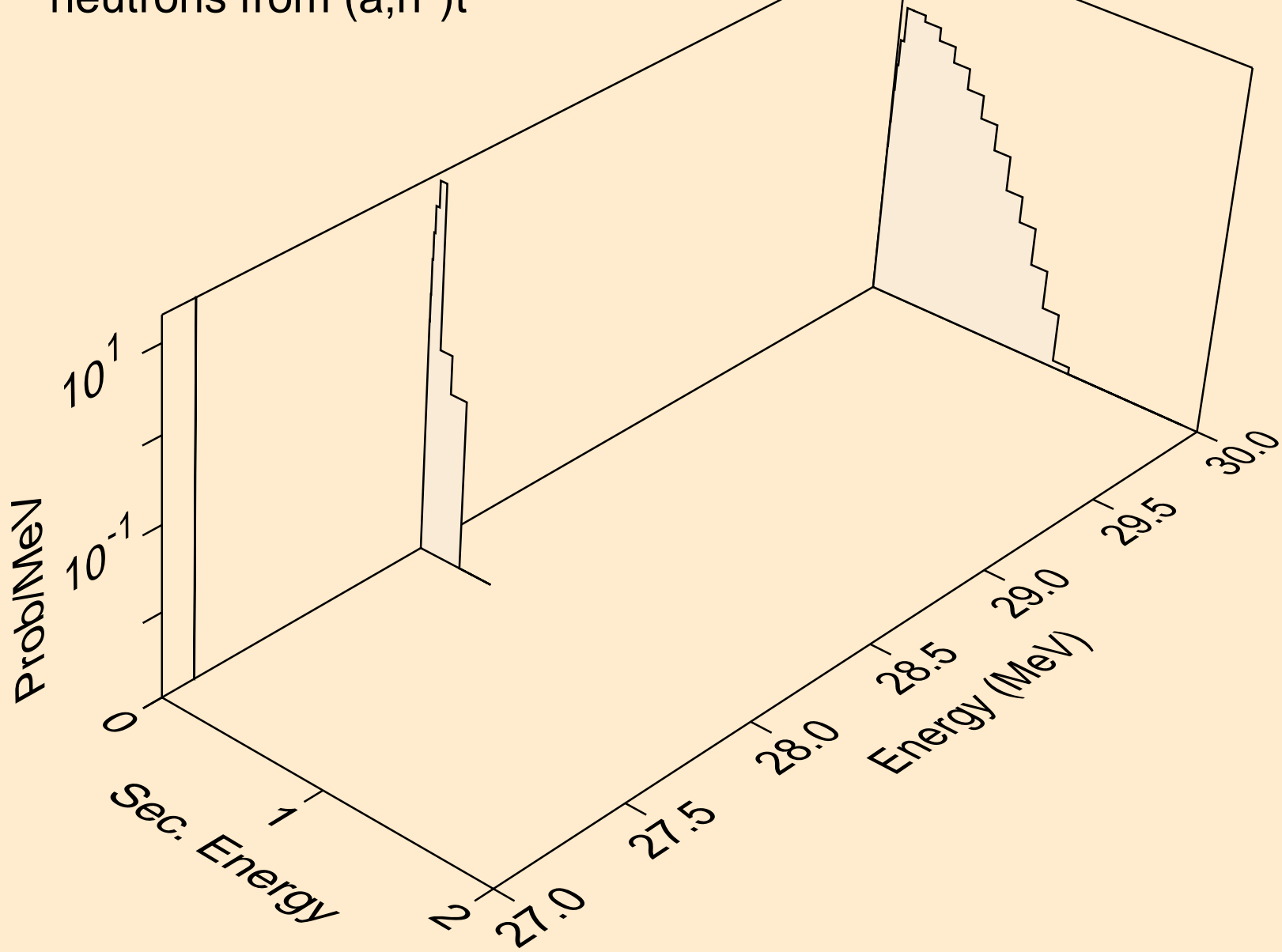

NI059 ALPHA ACER TENDL-2023 LIBRARY; T=0.K  
neutrons from (a,n\*)he3

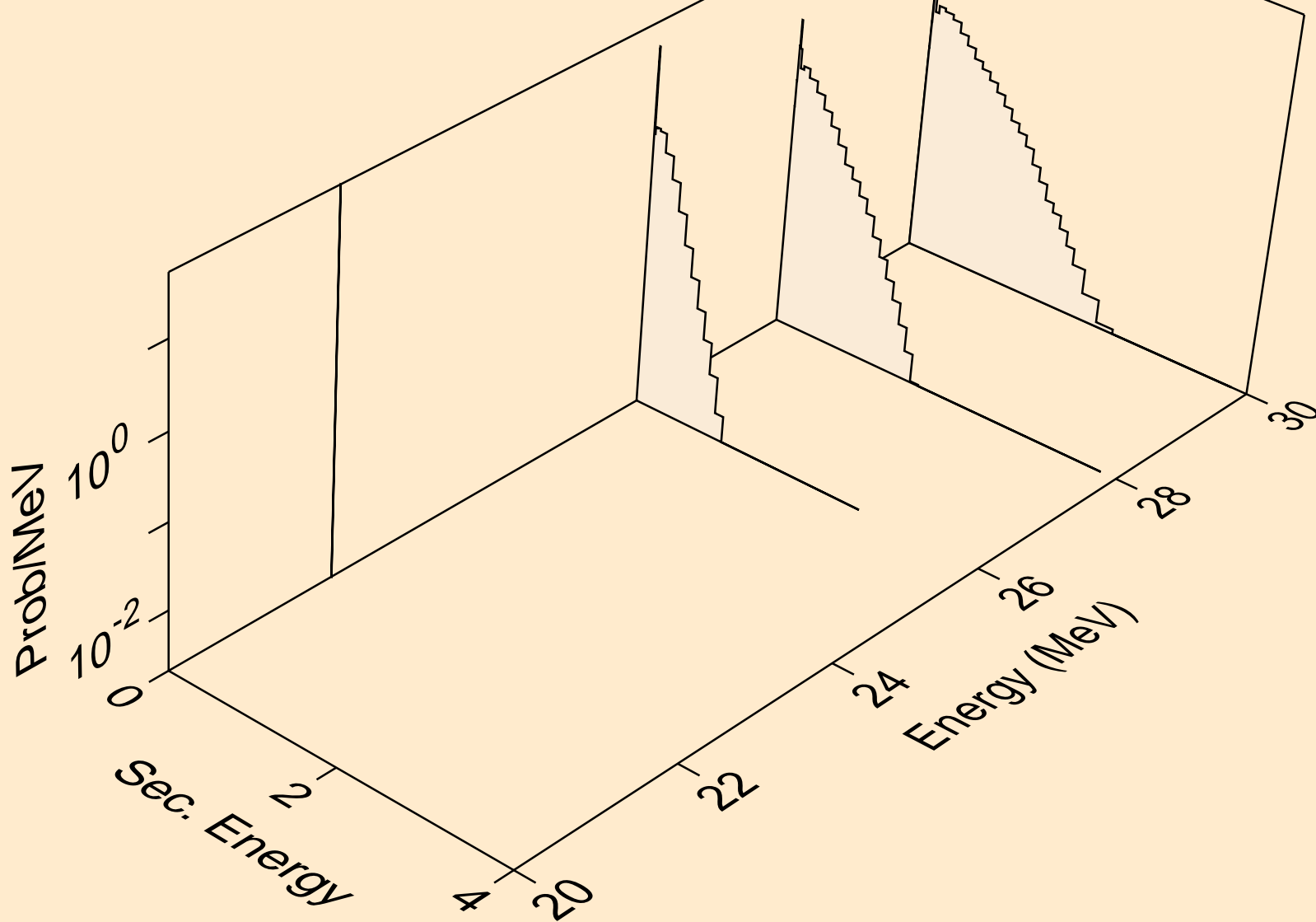



NI059 ALPHA ACER TENDL-2023 LIBRARY; T=0.K  
neutrons from (a,2np)

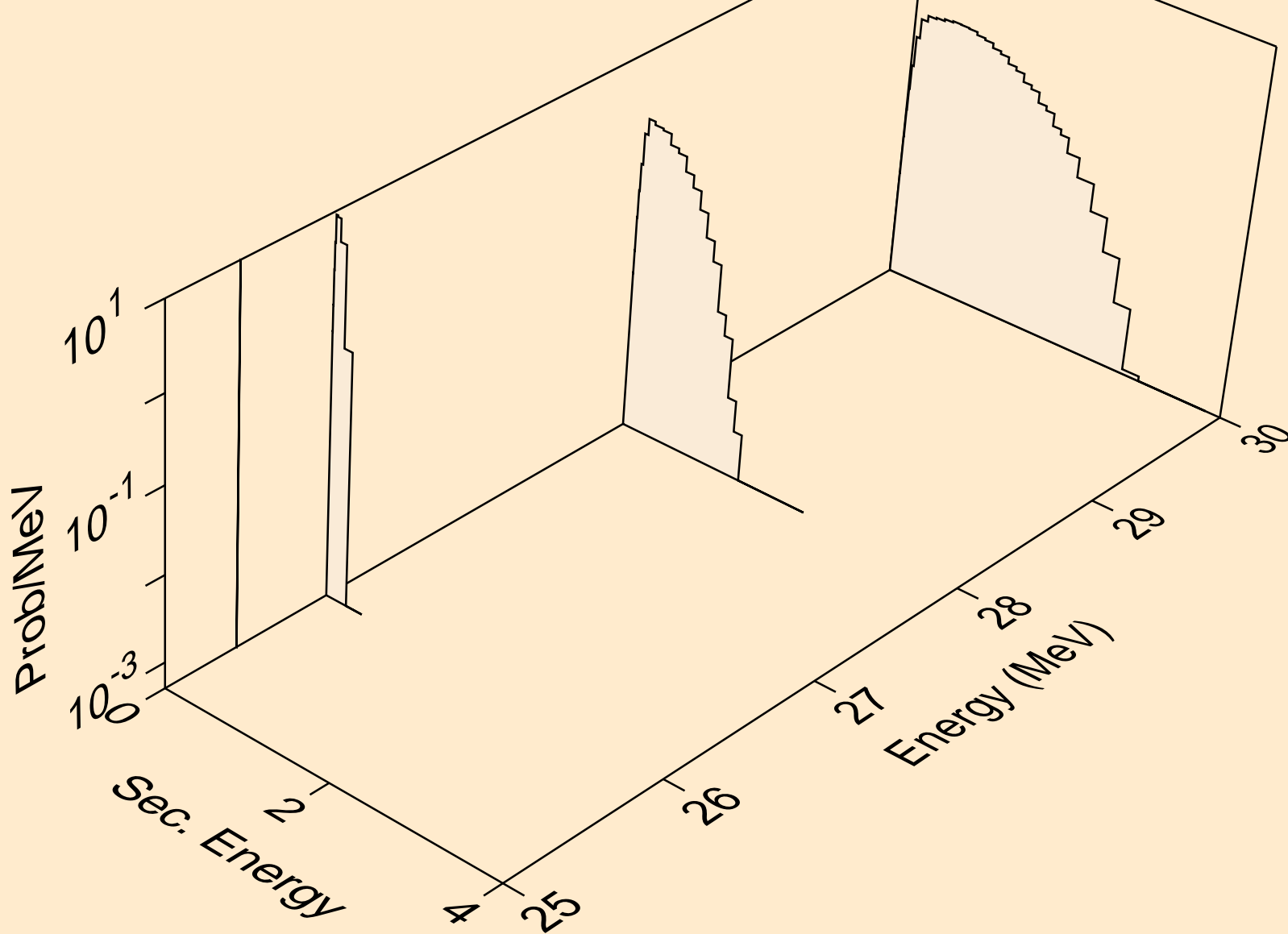

NI059 ALPHA ACER TENDL-2023 LIBRARY; T=0.K  
neutrons from (a,n2p)

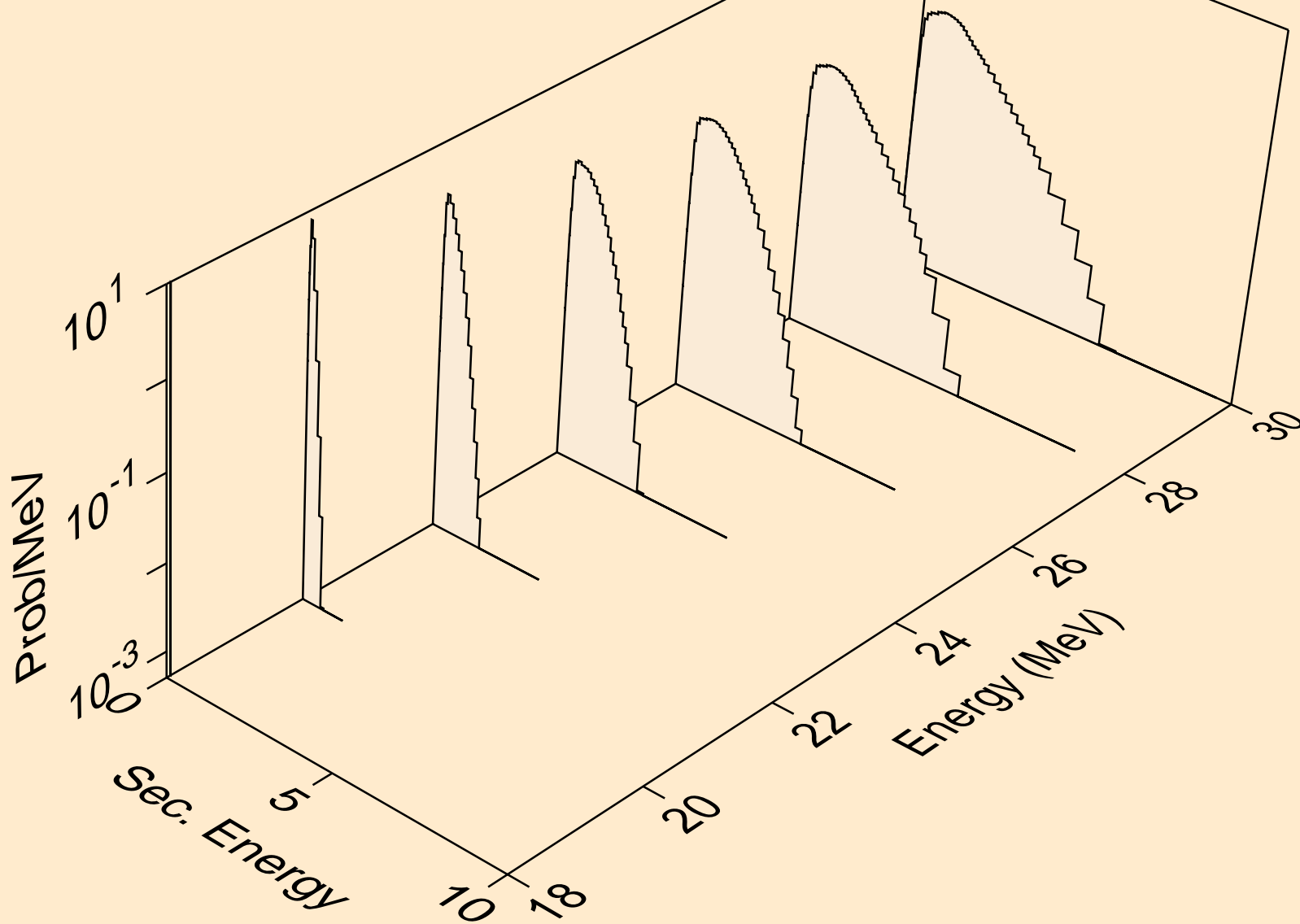

NI059 ALPHA ACER TENDL-2023 LIBRARY; T=0.K  
neutrons from (a,npa)

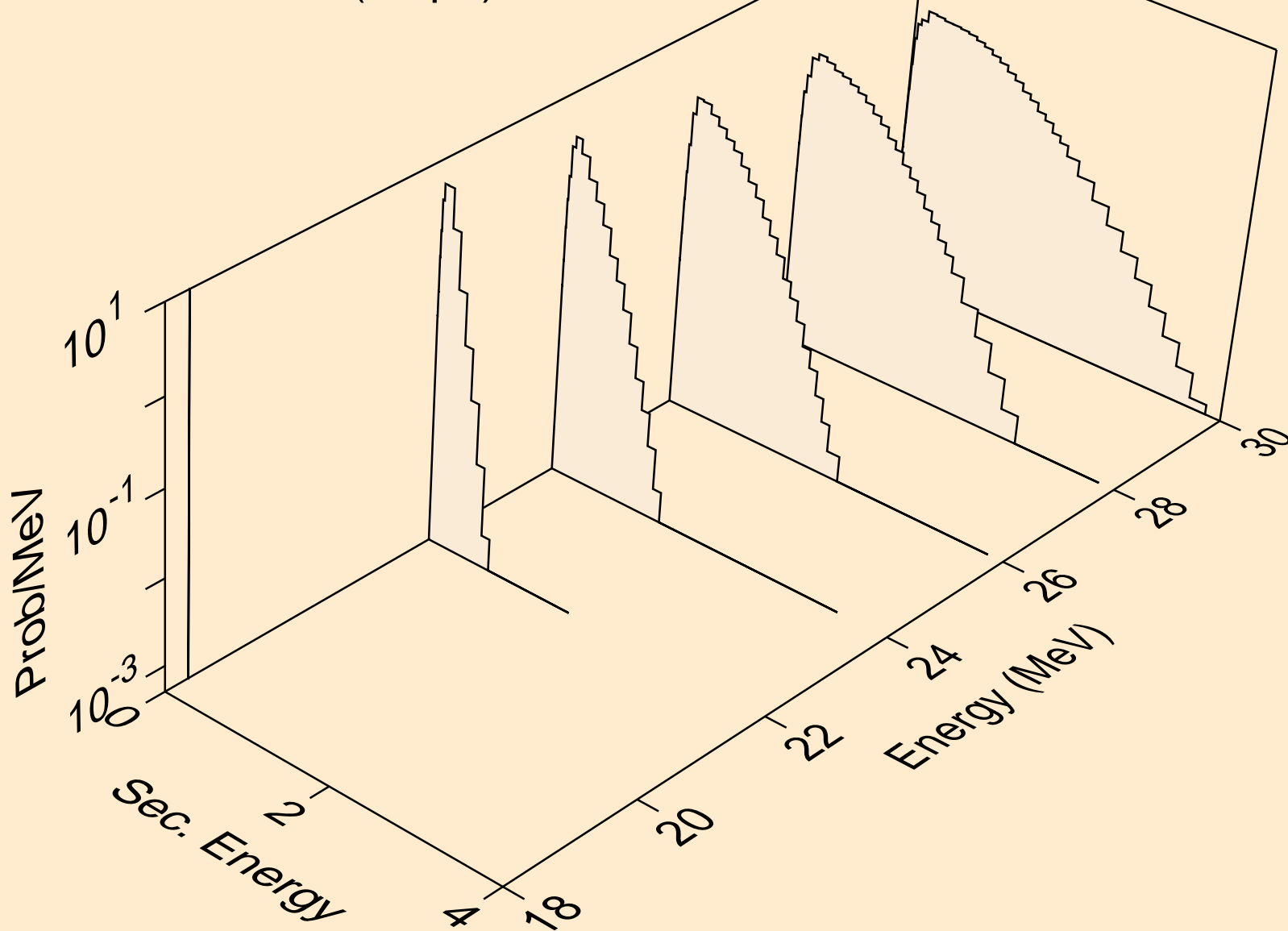

NI059 ALPHA ACER TENDL-2023 LIBRARY; T=0.K  
protons from (a,x)

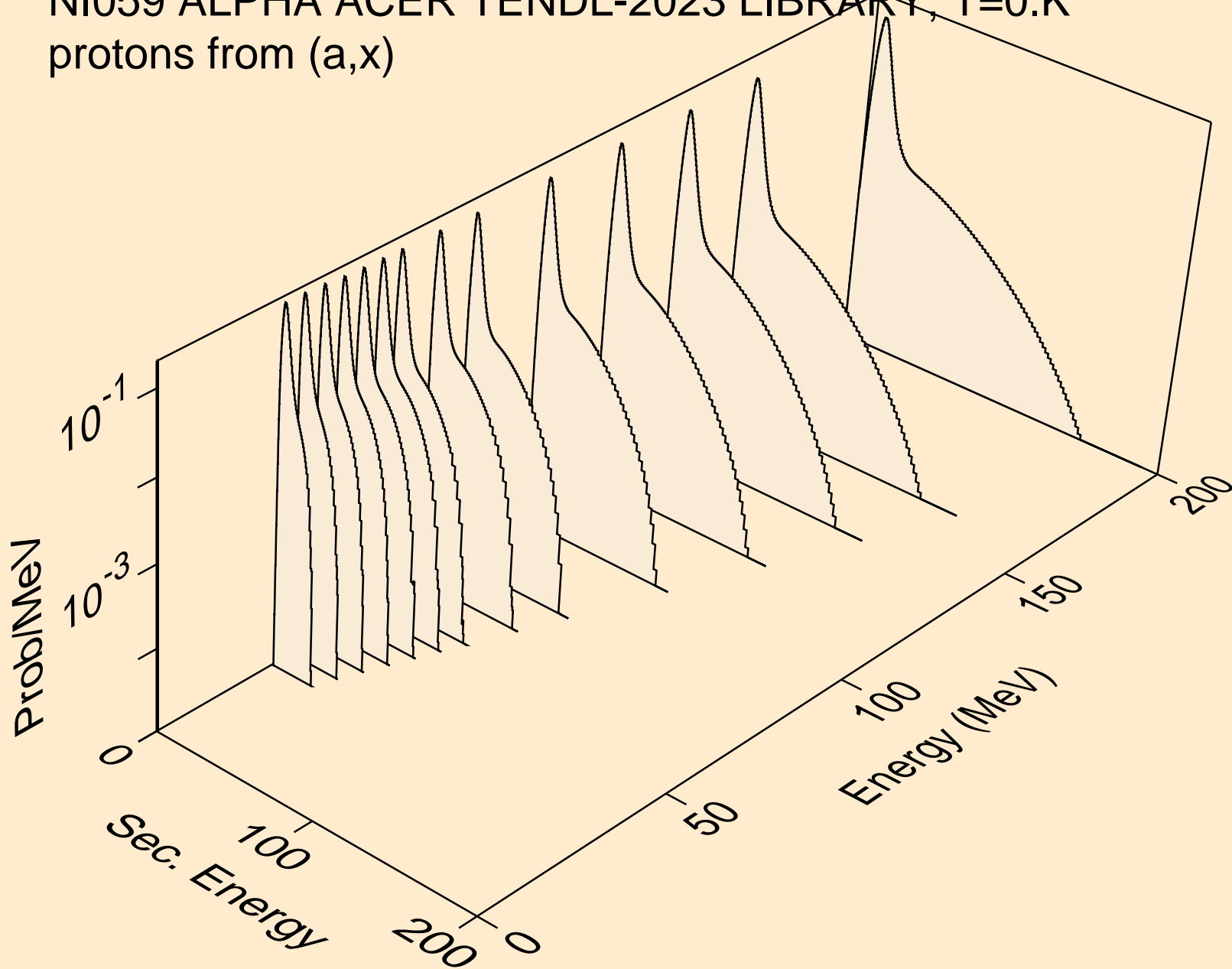

NI059 ALPHA ACER TENDL-2023 LIBRARY; T=0.K  
protons from (a,n\*)p

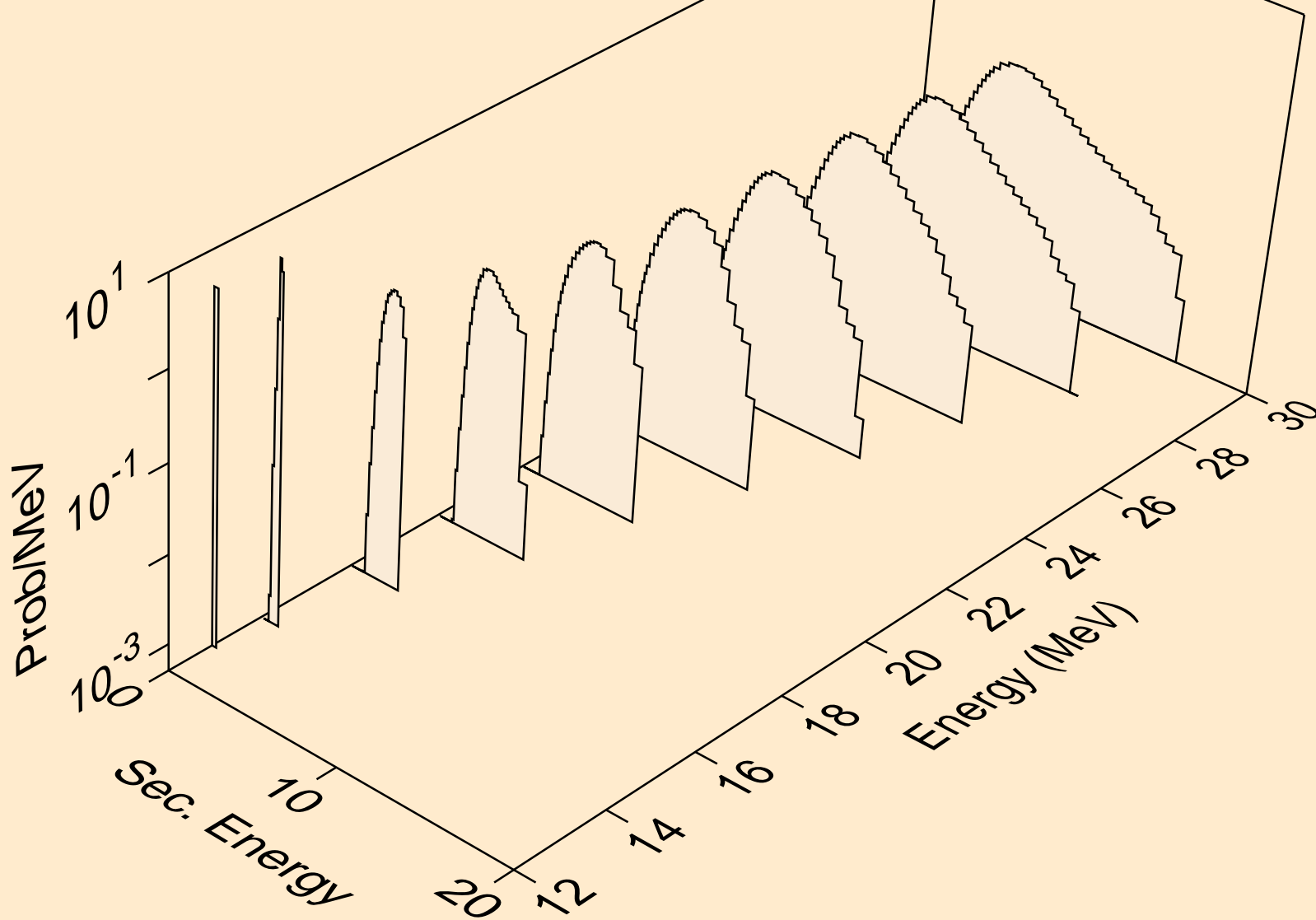

NI059 ALPHA ACER TENDL-2023 LIBRARY; T=0.K  
protons from (a,2np)

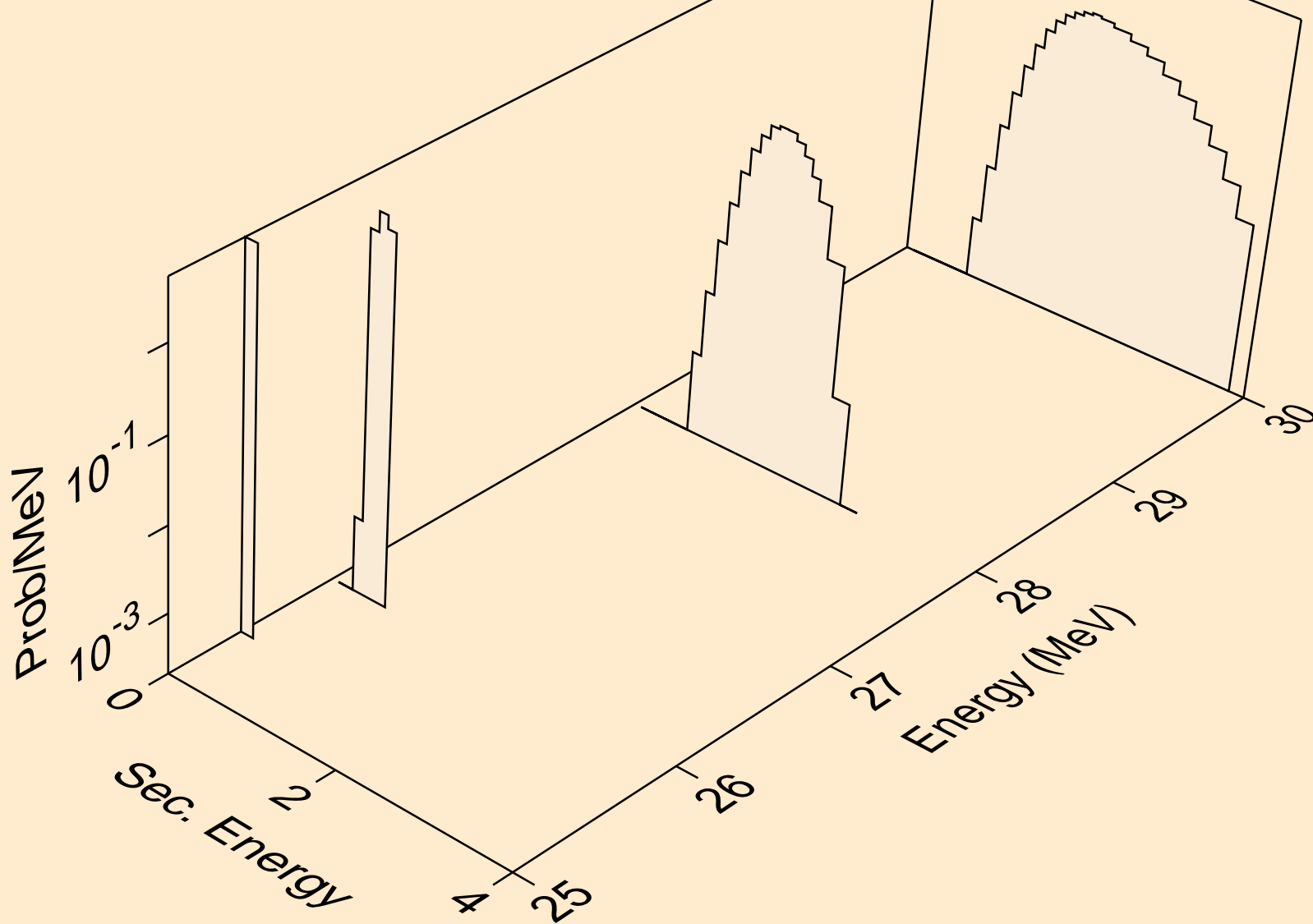

NI059 ALPHA ACER TENDL-2023 LIBRARY; T=0.K  
protons from (a,n2p)

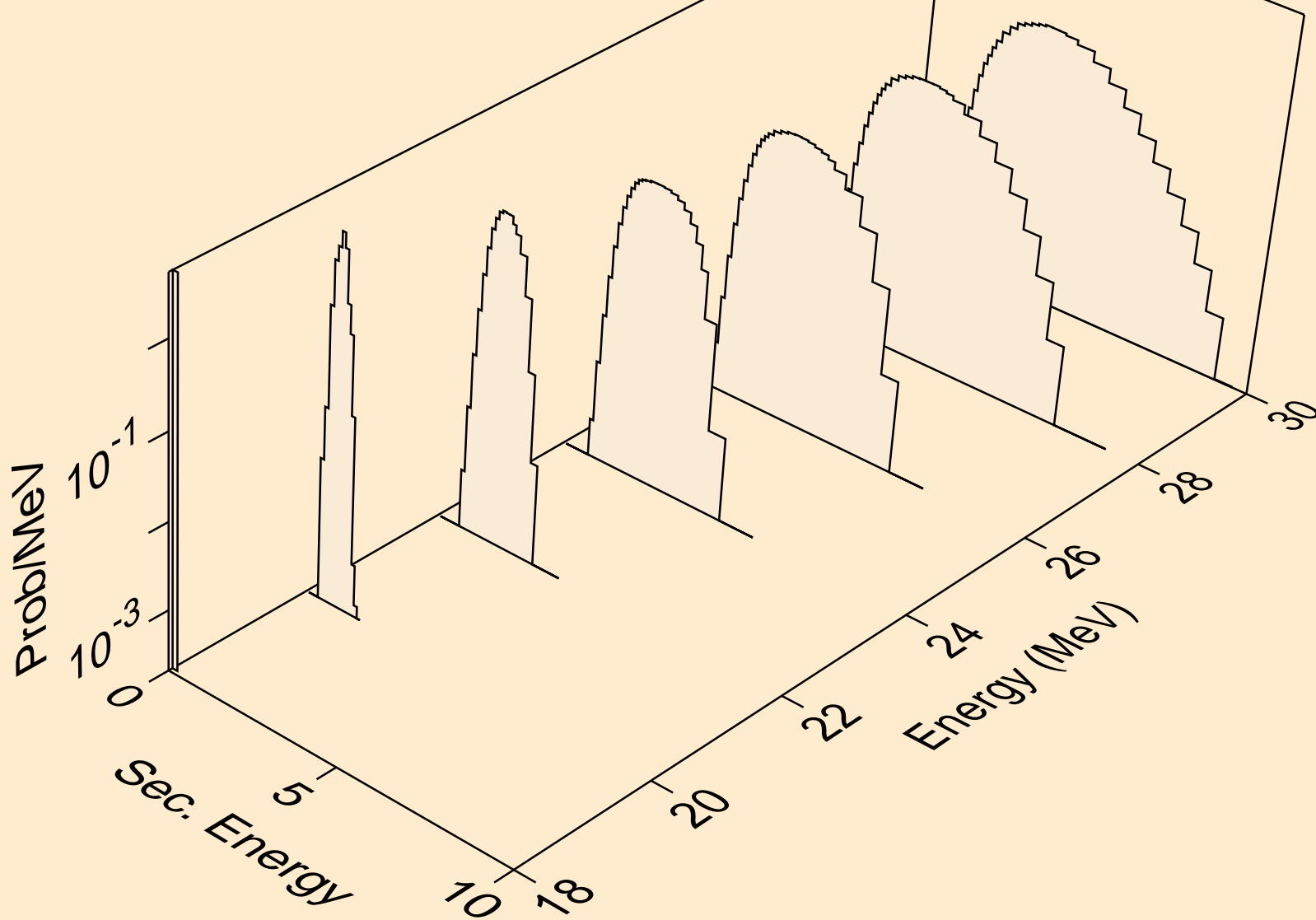

NI059 ALPHA ACER TENDL-2023 LIBRARY; T=0.K  
protons from (a,npa)

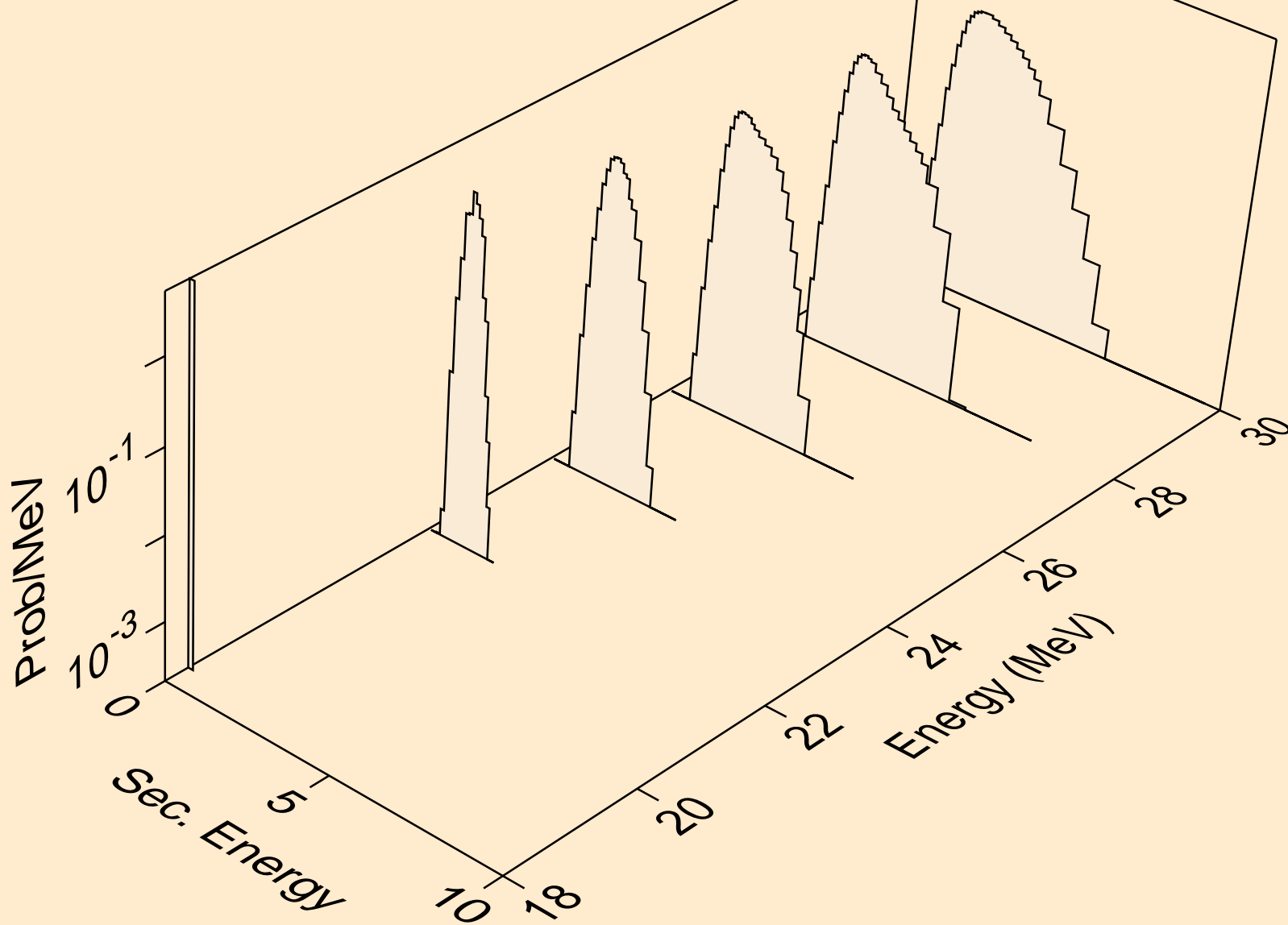



NI059 ALPHA ACER TENDL-2023 LIBRARY; T=0.K  
protons from (a,p)

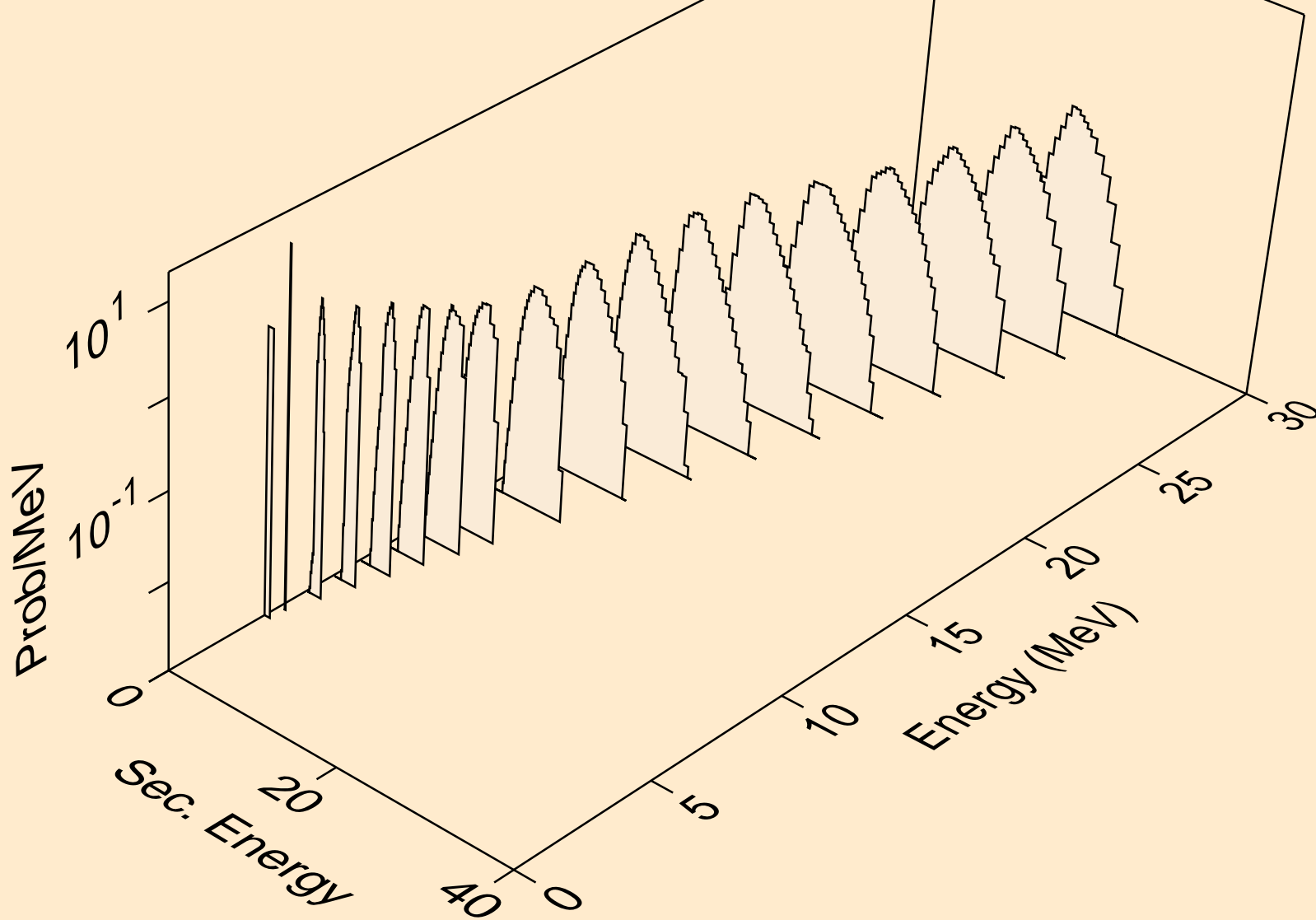

NI059 ALPHA ACER TENDL-2023 LIBRARY; T=0.K  
protons from (a,2p)

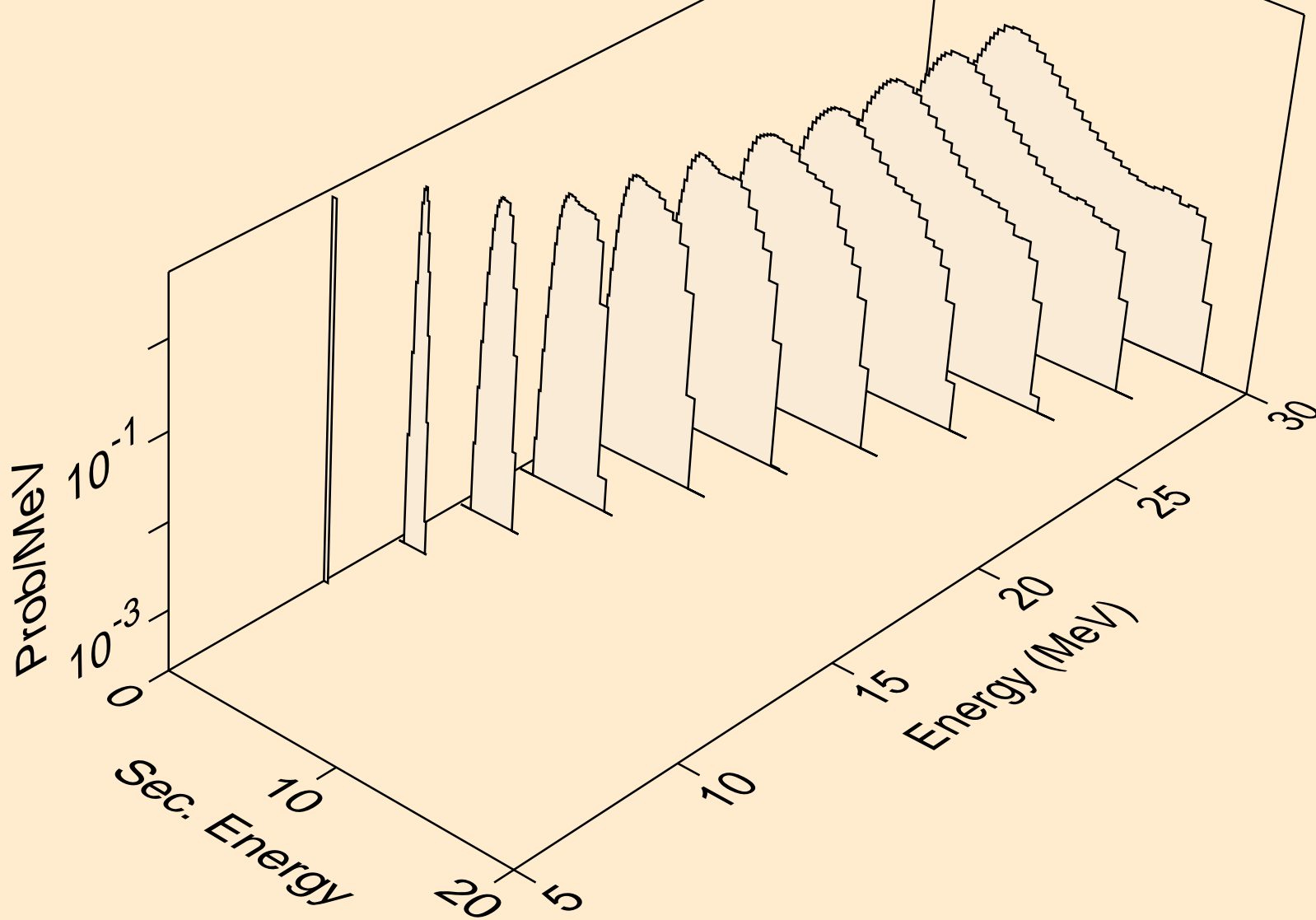

NI059 ALPHA ACER TENDL-2023 LIBRARY; T=0.K  
protons from (a,pa)

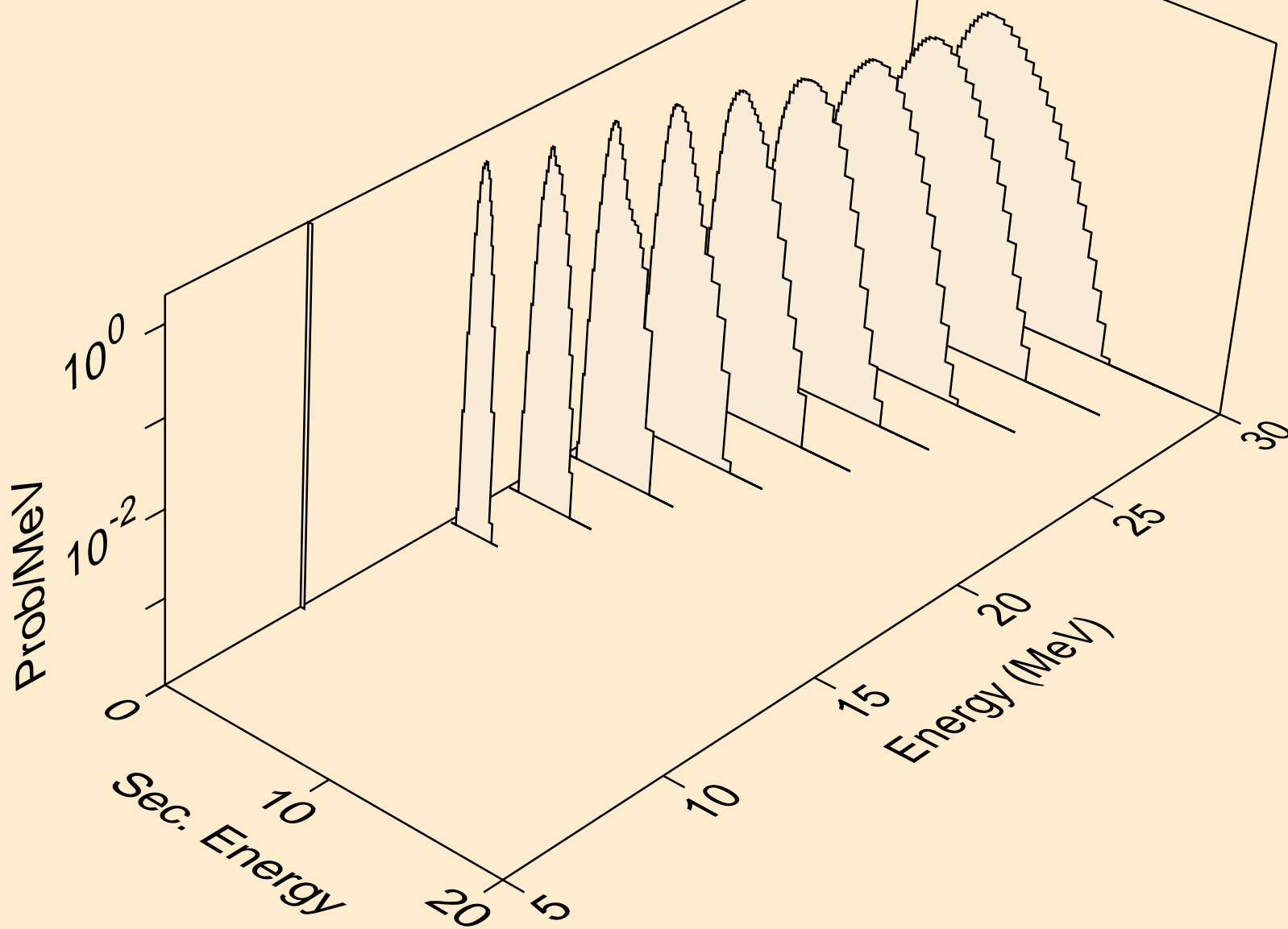

NI059 ALPHA ACER TENDL-2023 LIBRARY; T=0.K  
protons from (a,pd)

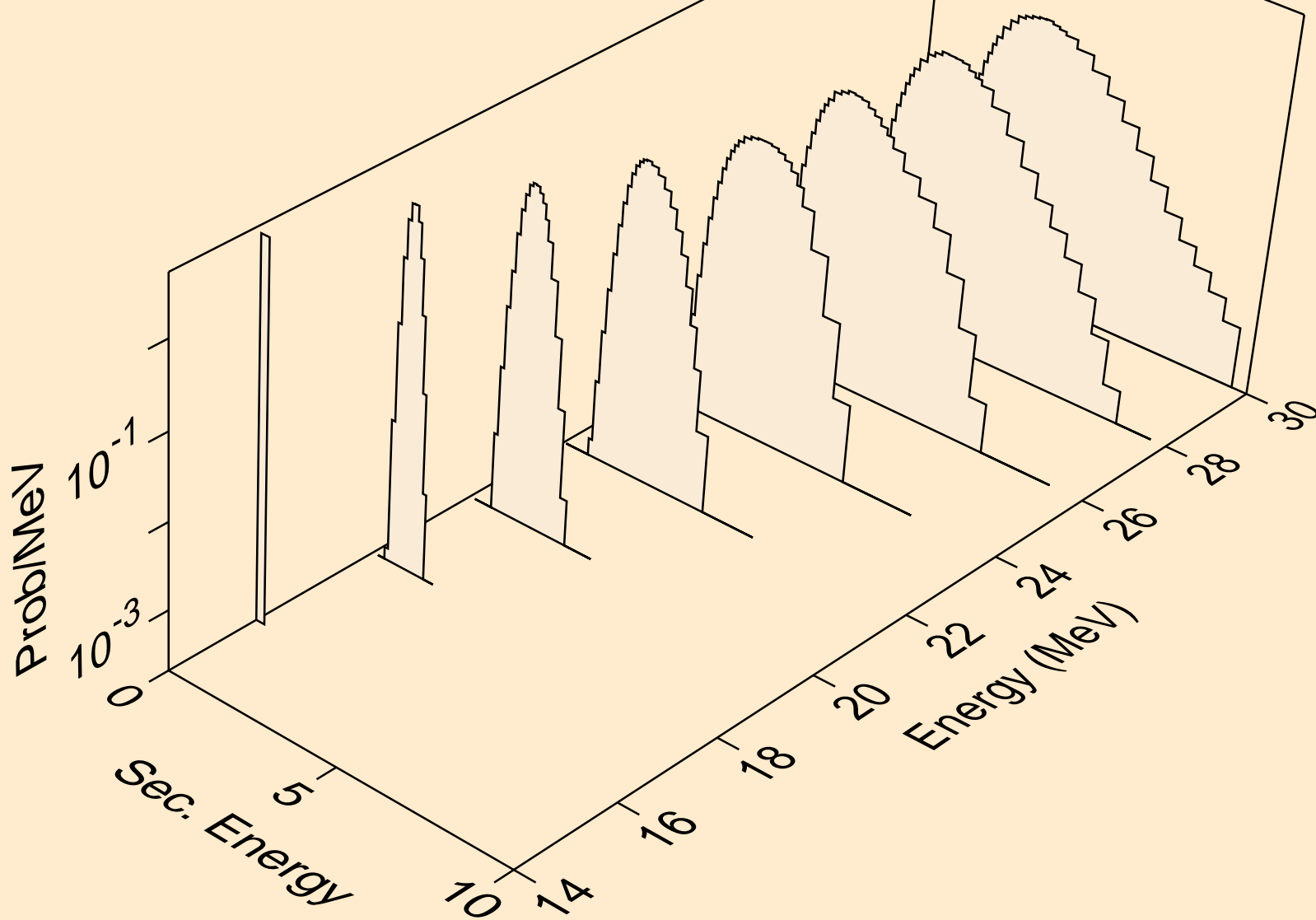

NI059 ALPHA ACER TENDL-2023 LIBRARY; T=0.K  
protons from (a,pt)

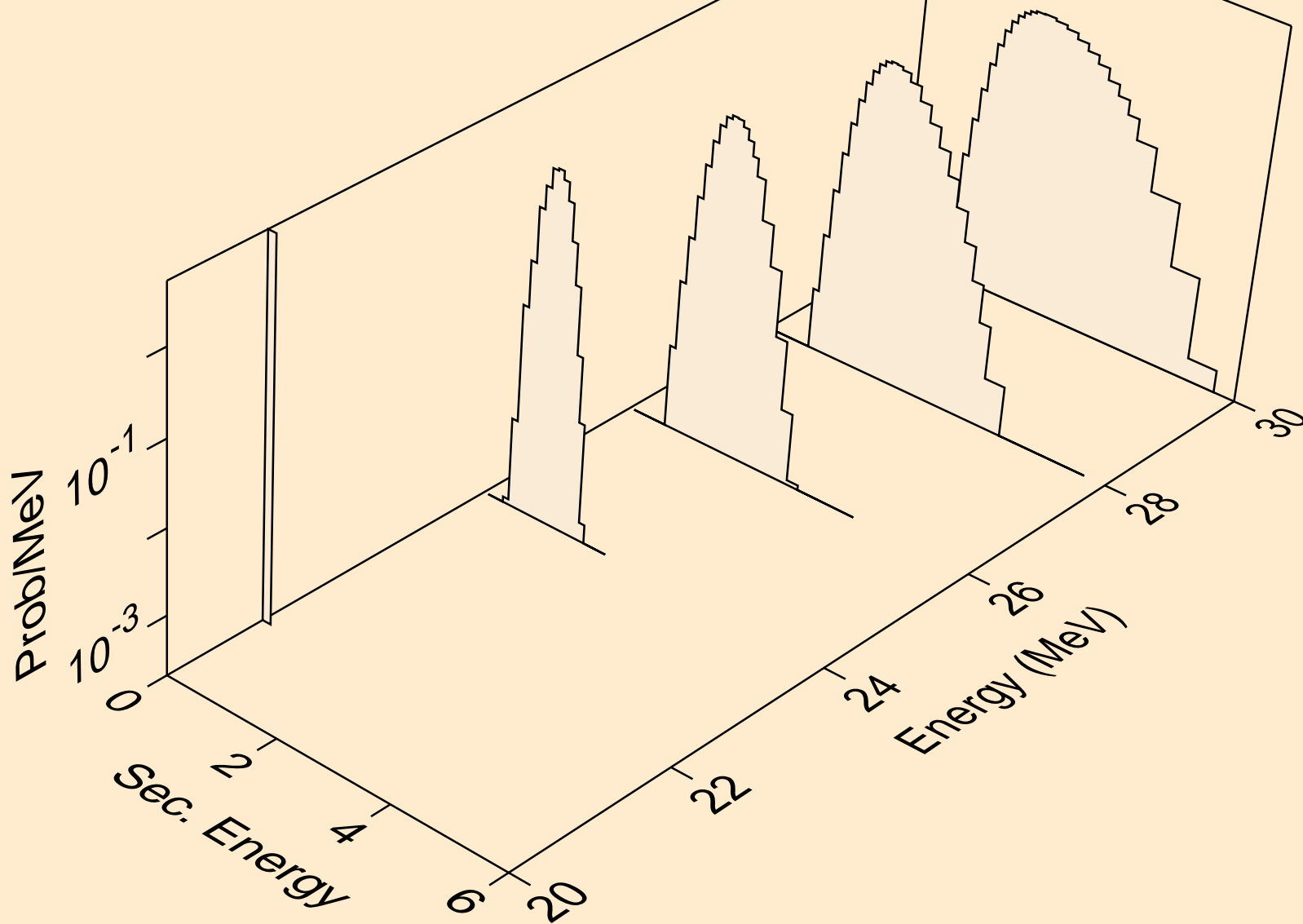

NI059 ALPHA ACER TENDL-2023 LIBRARY; T=0.K  
deuterons from (a,x)

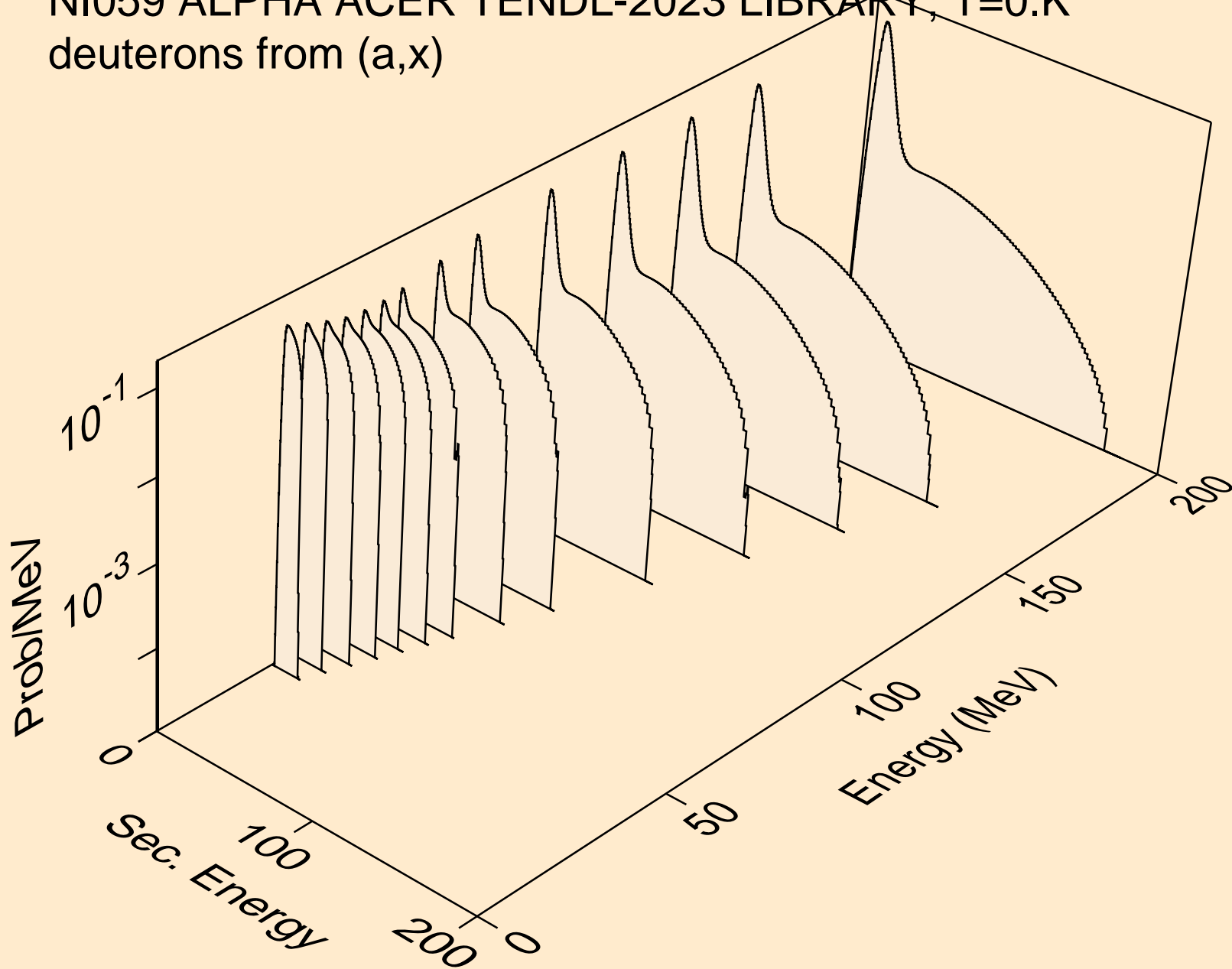

NI059 ALPHA ACER TENDL-2023 LIBRARY; T=0.K  
deuterons from (a,n\*)d

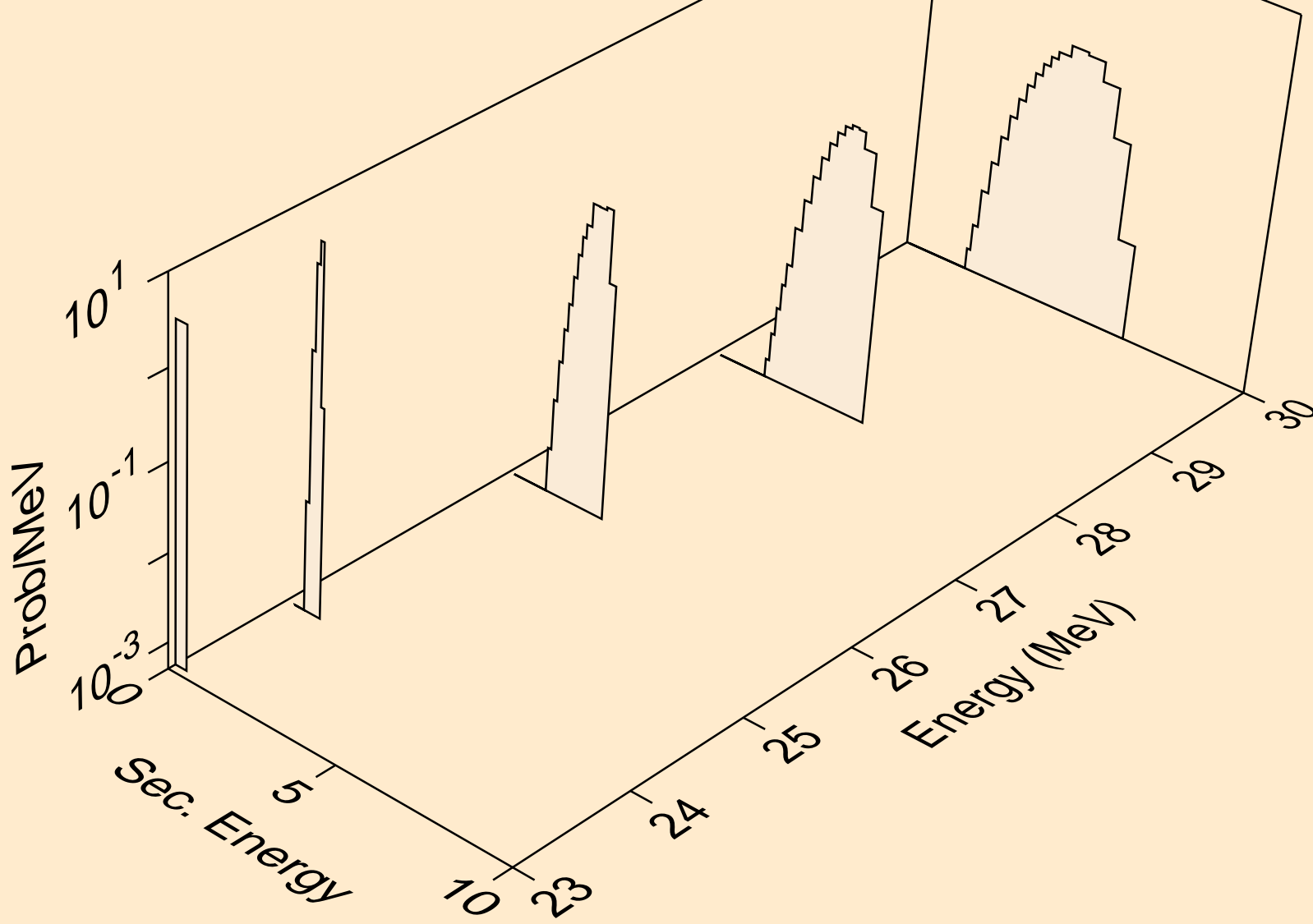

NI059 ALPHA ACER TENDL-2023 LIBRARY; T=0.K  
deuterons from (a,d)

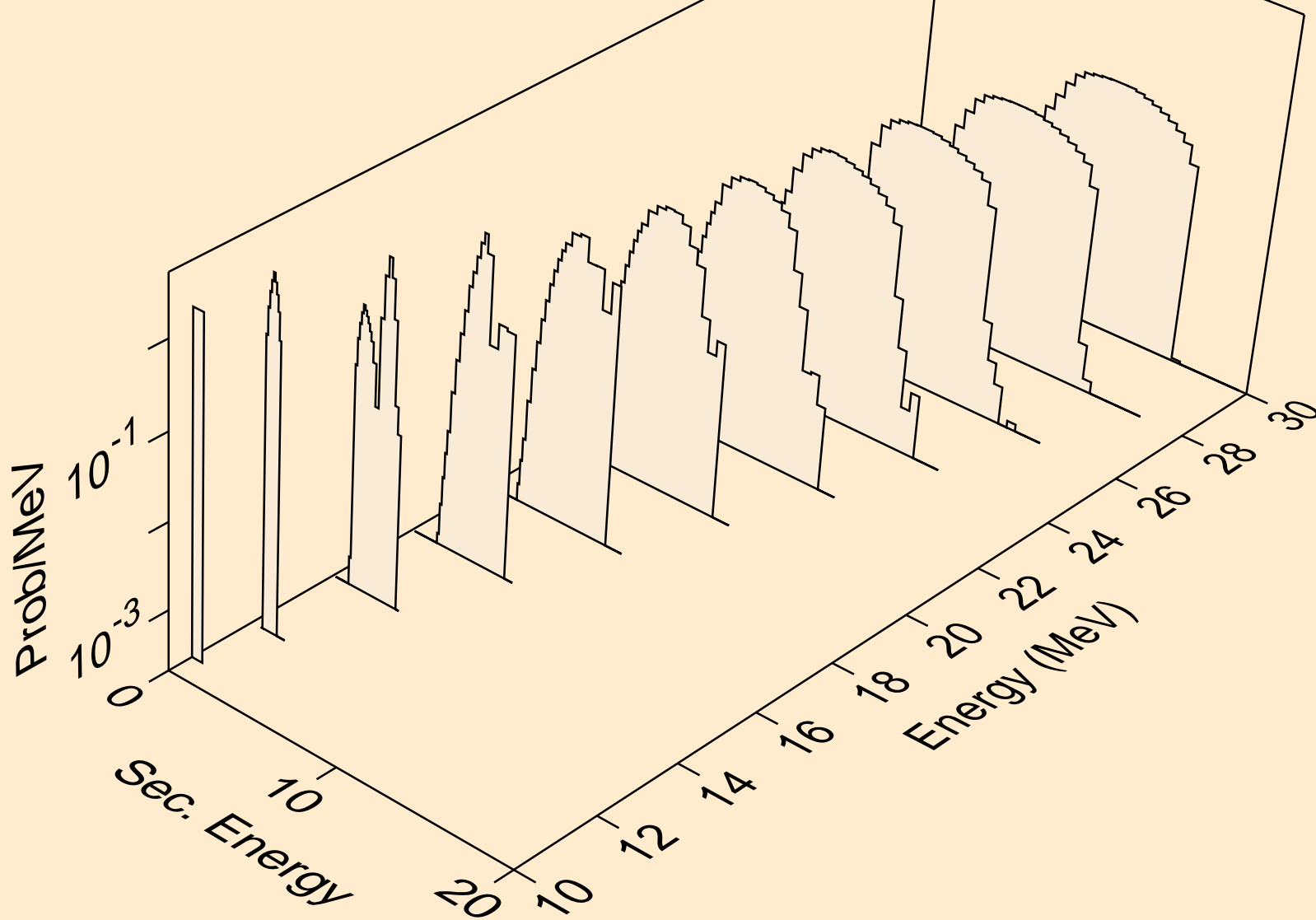



NI059 ALPHA ACER TENDL-2023 LIBRARY; T=0.K  
deuterons from (a,pd)

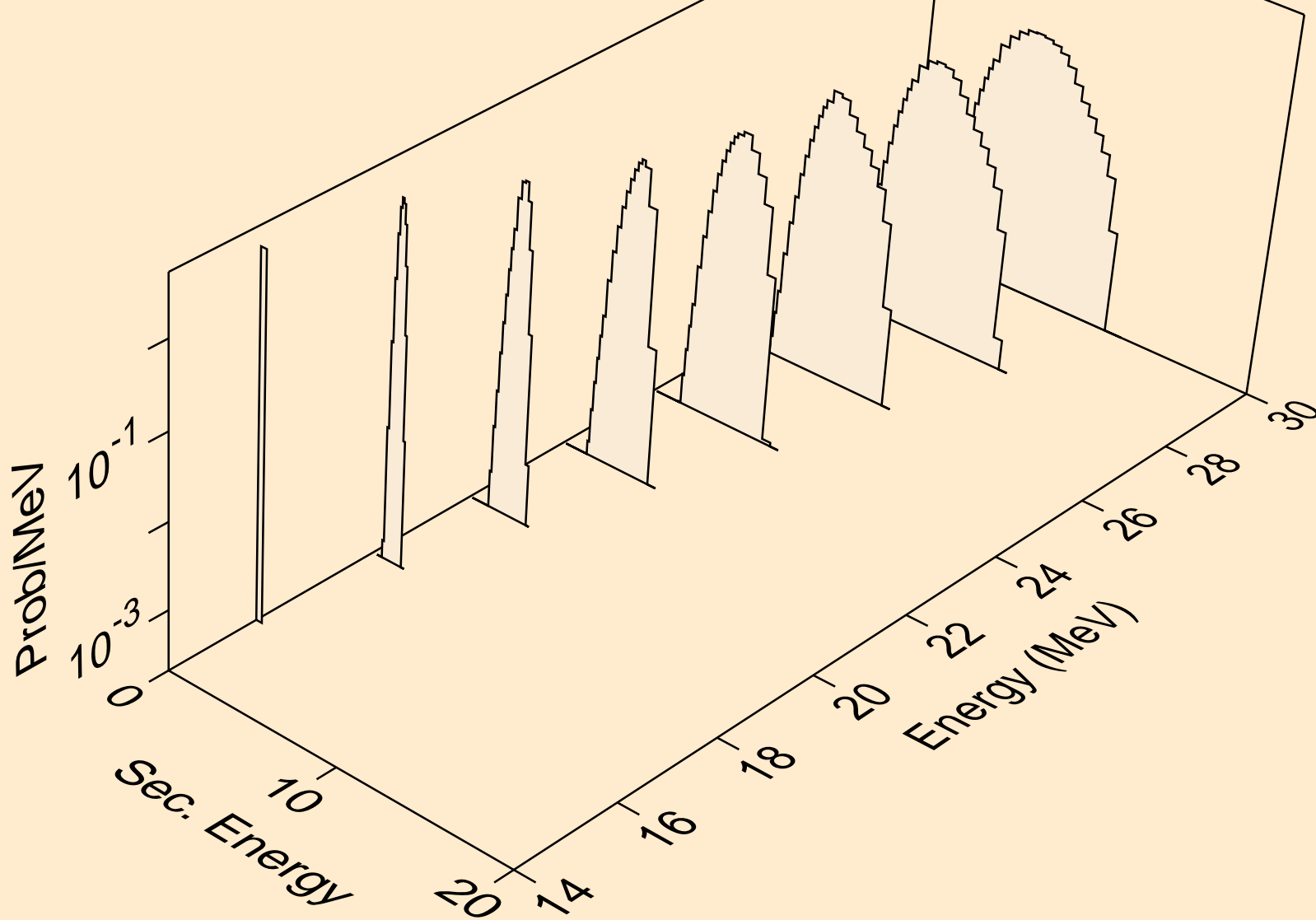

NI059 ALPHA ACER TENDL-2023 LIBRARY; T=0.K  
deuterons from (a,da)

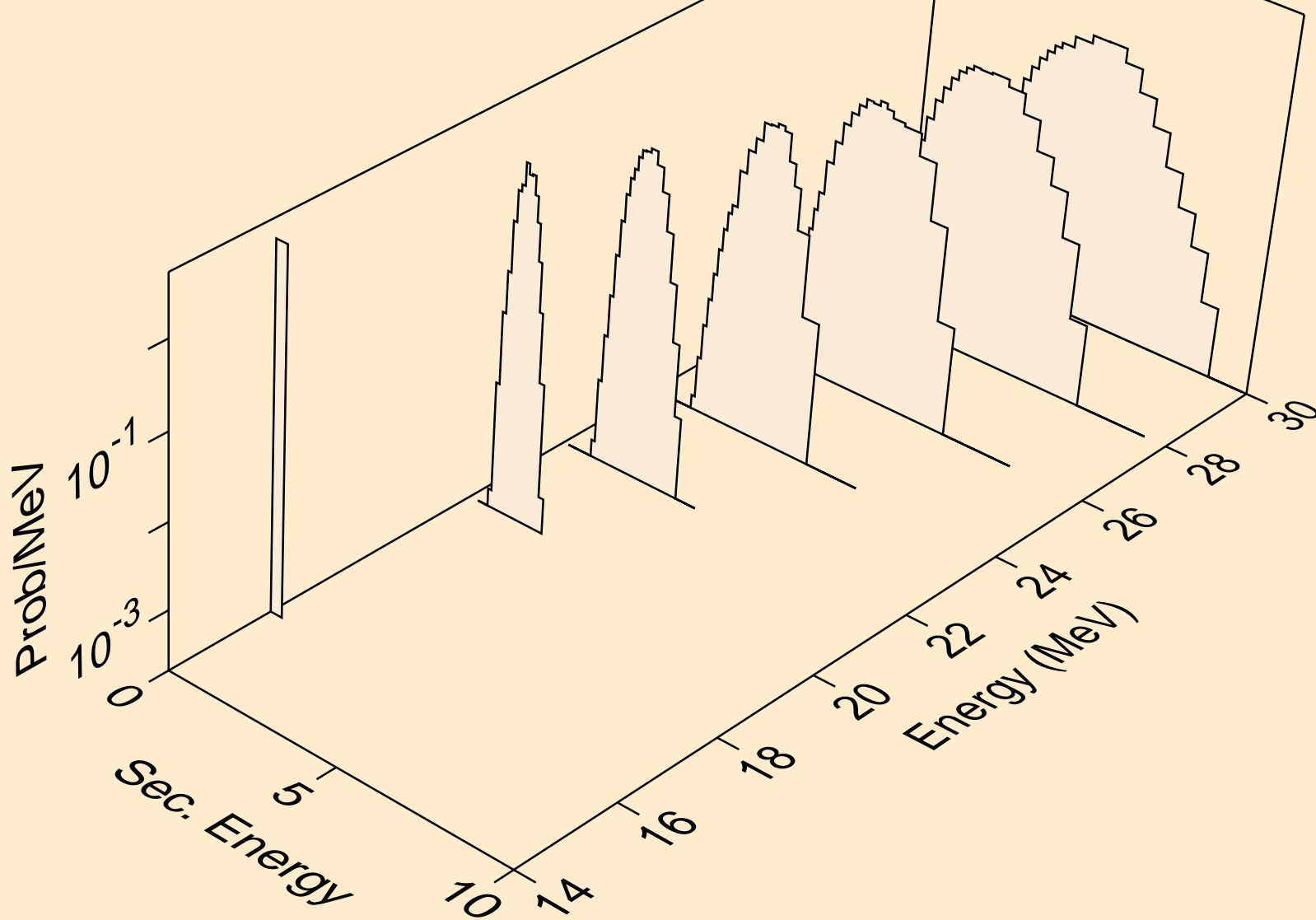

NI059 ALPHA ACER TENDL-2023 LIBRARY; T=0.K  
tritons from (a,x)

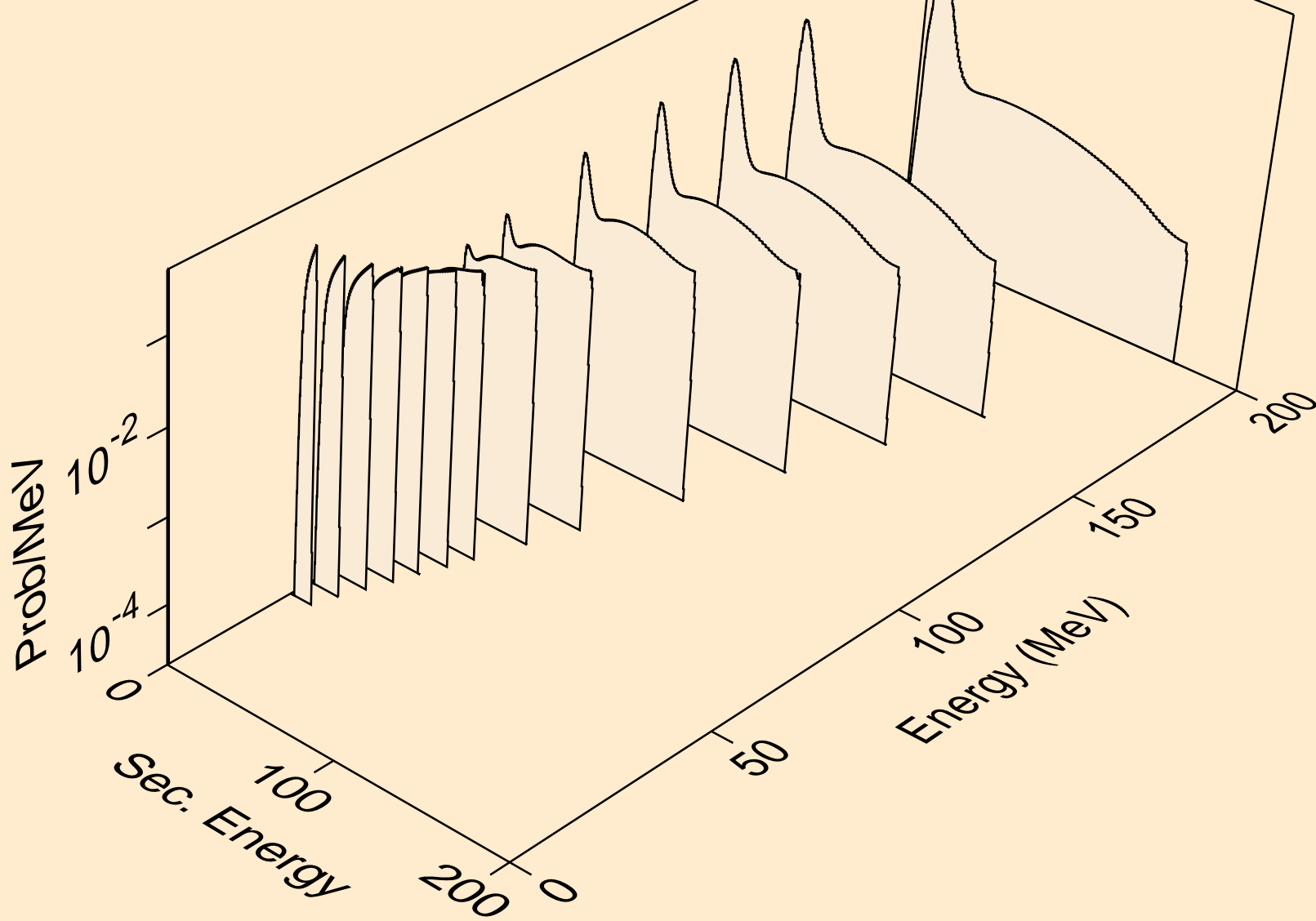

NI059 ALPHA ACER TENDL-2023 LIBRARY; T=0.K  
tritons from (a,n\*)t

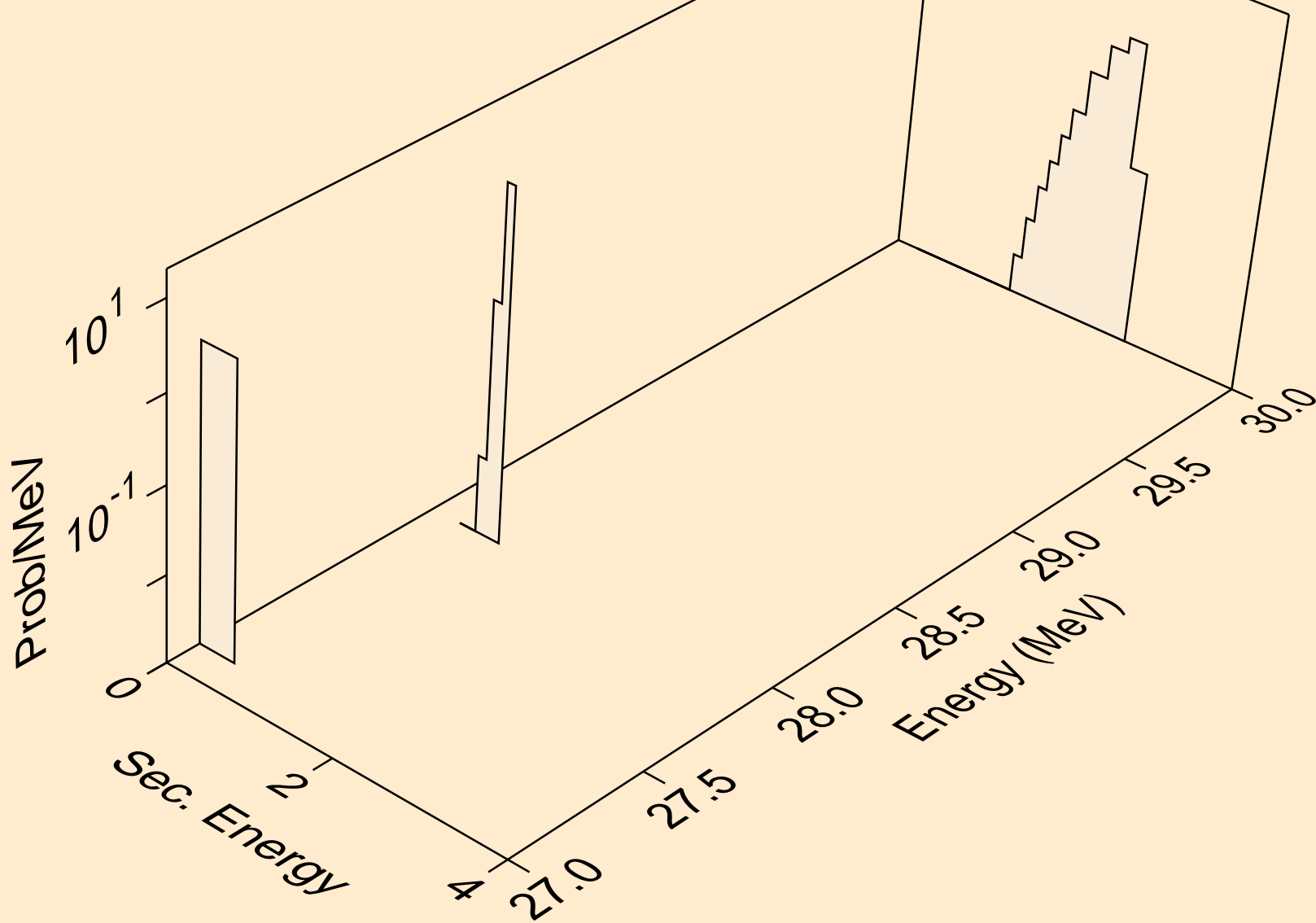

NI059 ALPHA ACER TENDL-2023 LIBRARY; T=0.K  
tritons from (a,t)

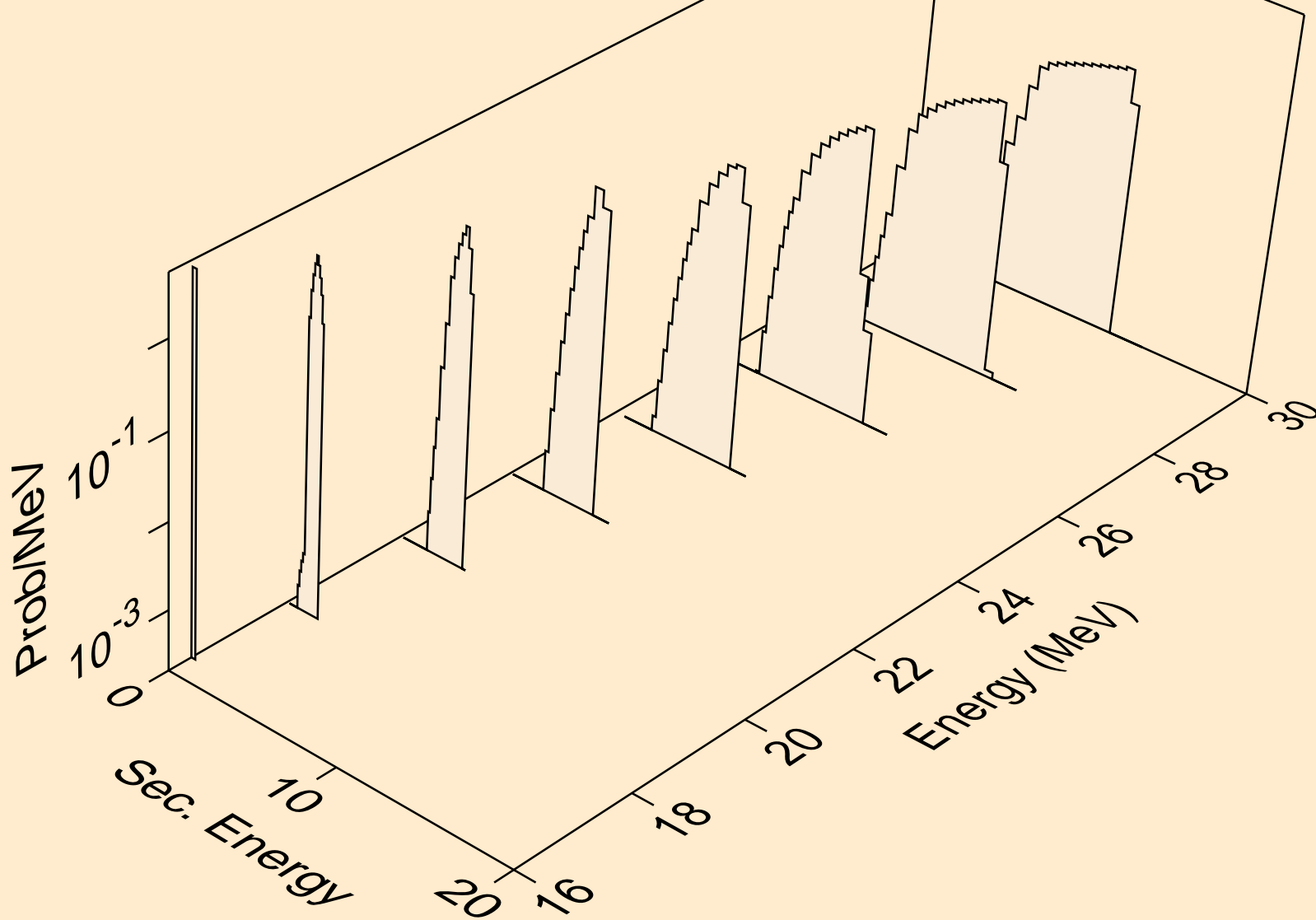

NI059 ALPHA ACER TENDL-2023 LIBRARY; T=0.K  
tritons from (a,pt)

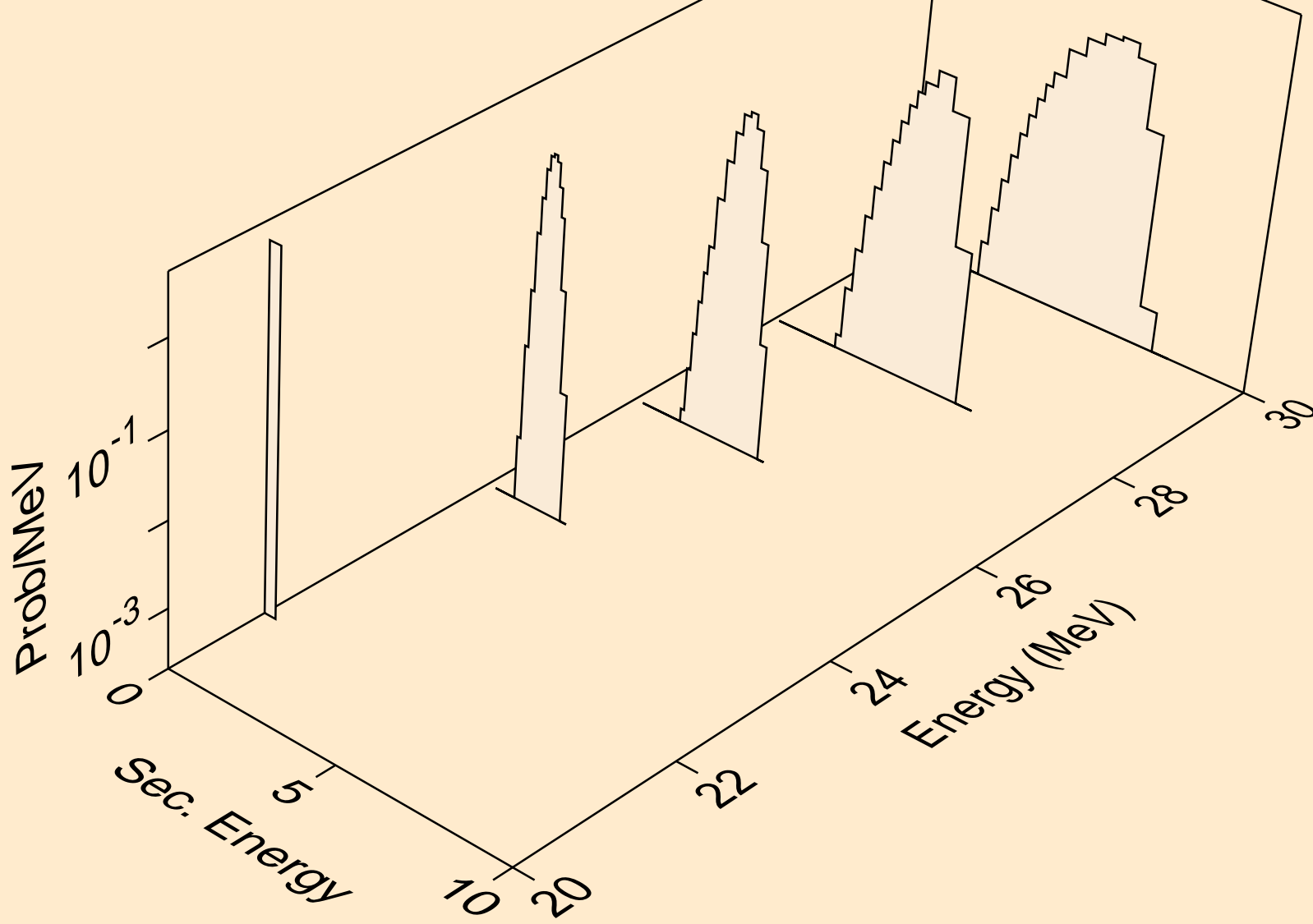

NI059 ALPHA ACER TENDL-2023 LIBRARY; T=0.K  
he3s from (a,x)

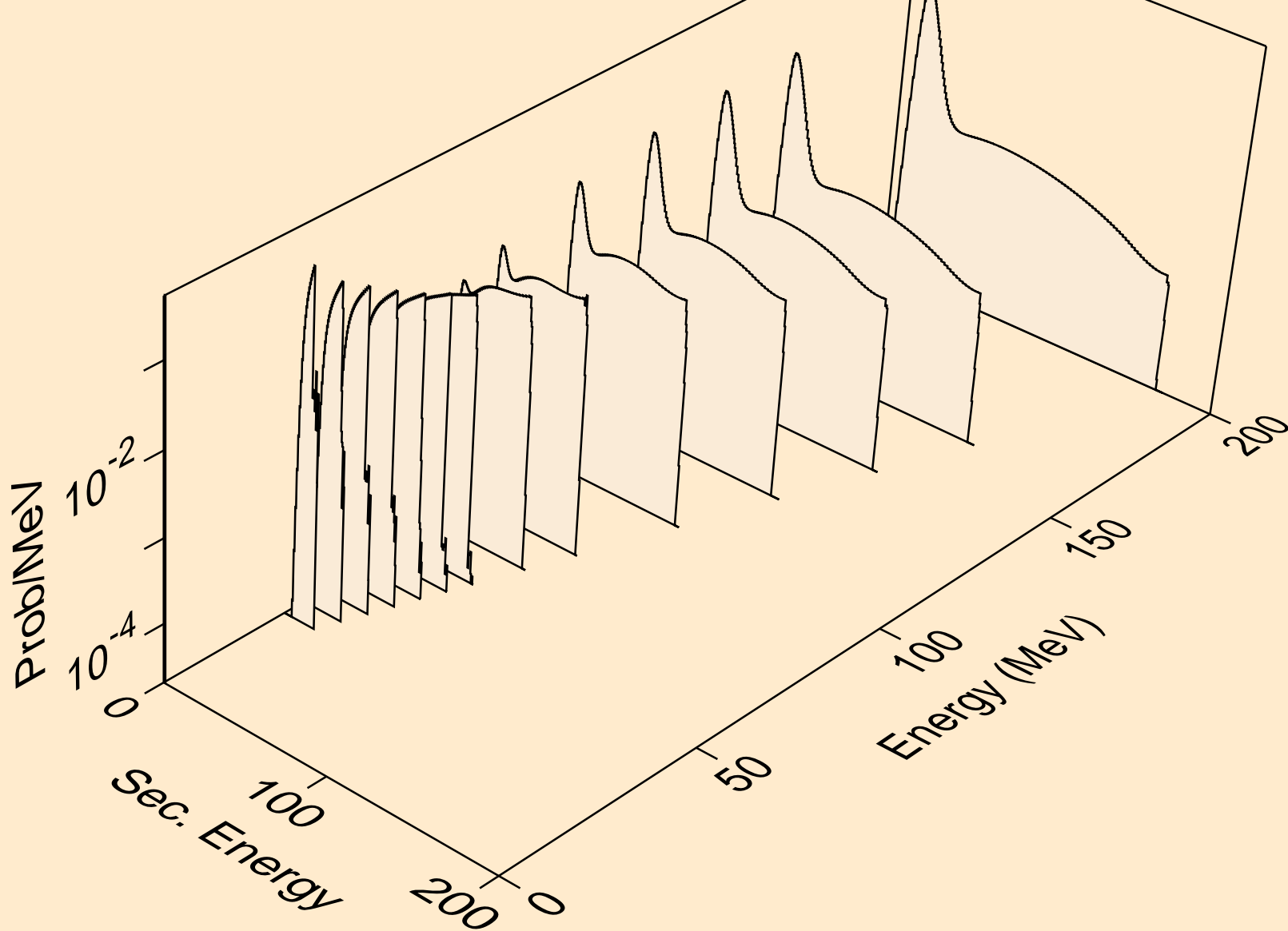

NI059 ALPHA ACER TENDL-2023 LIBRARY; T=0.K  
he3s from (a,n\*)he3

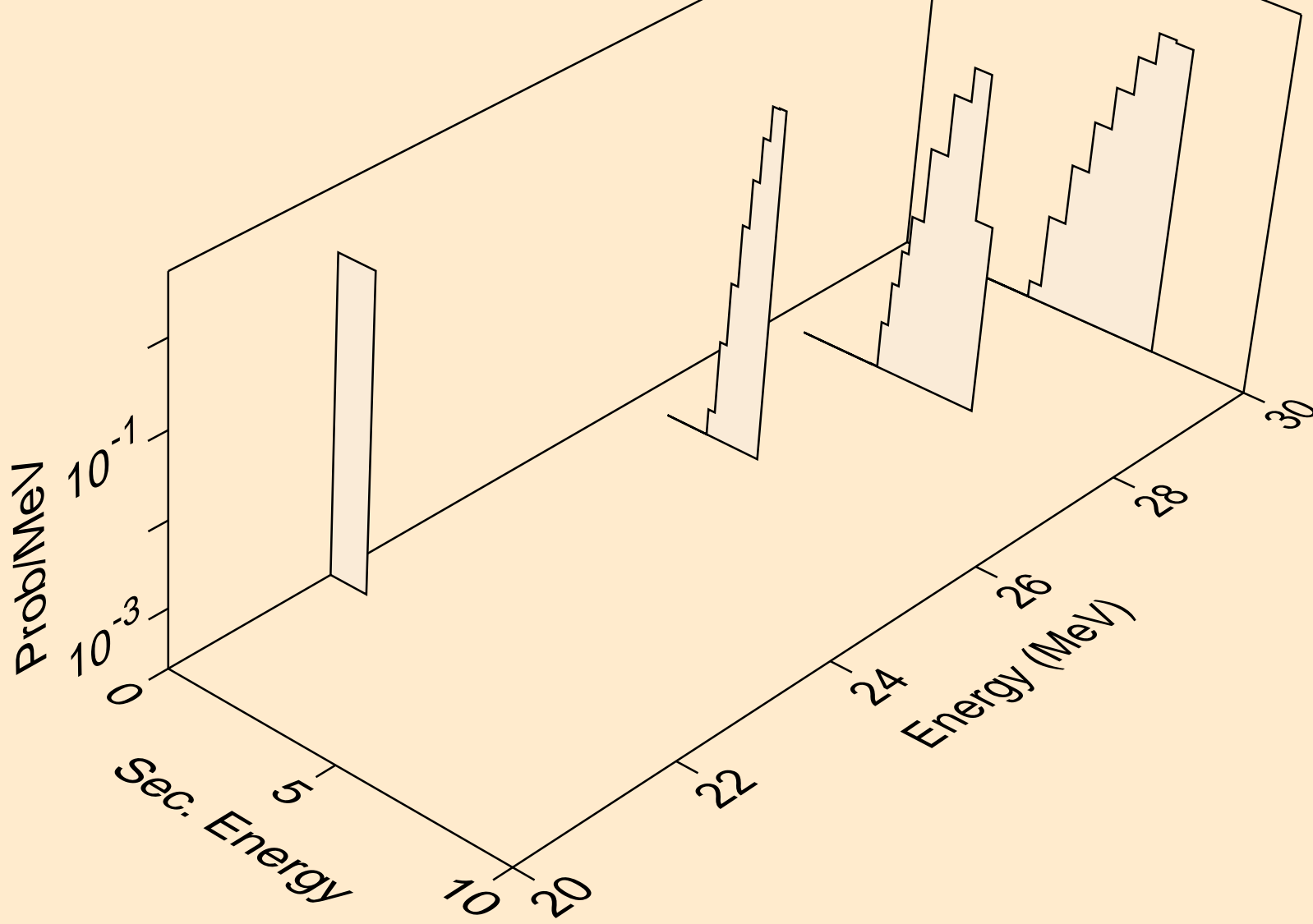



NI059 ALPHA ACER TENDL-2023 LIBRARY; T=0.K  
he3s from (a,he3)

