

PT204 ALPHA ACER TENDL-2023 LIBRARY; T=0.K
Principal cross sections

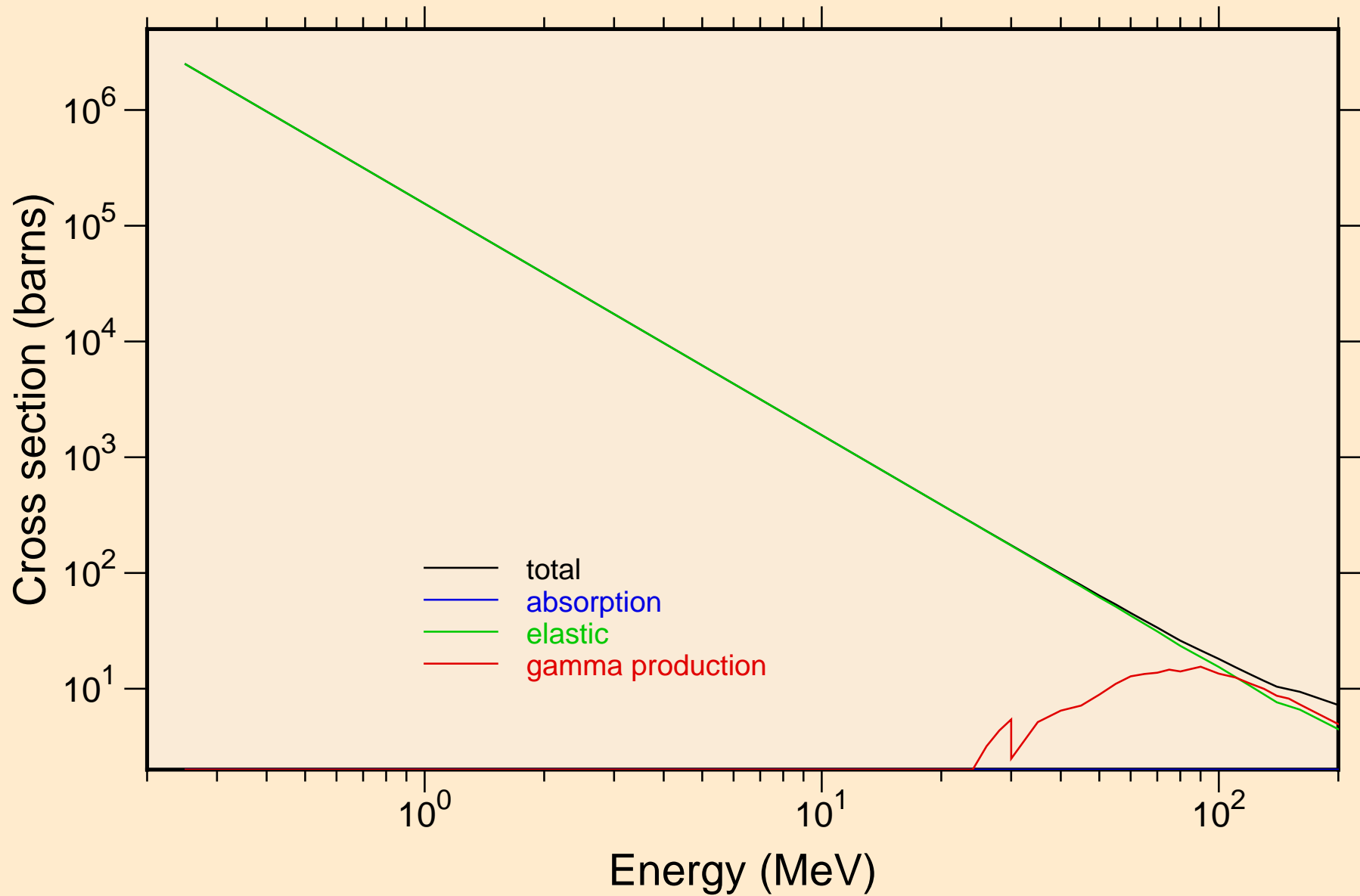

PT204 ALPHA ACER TENDL-2023 LIBRARY; T=0.K
Heating

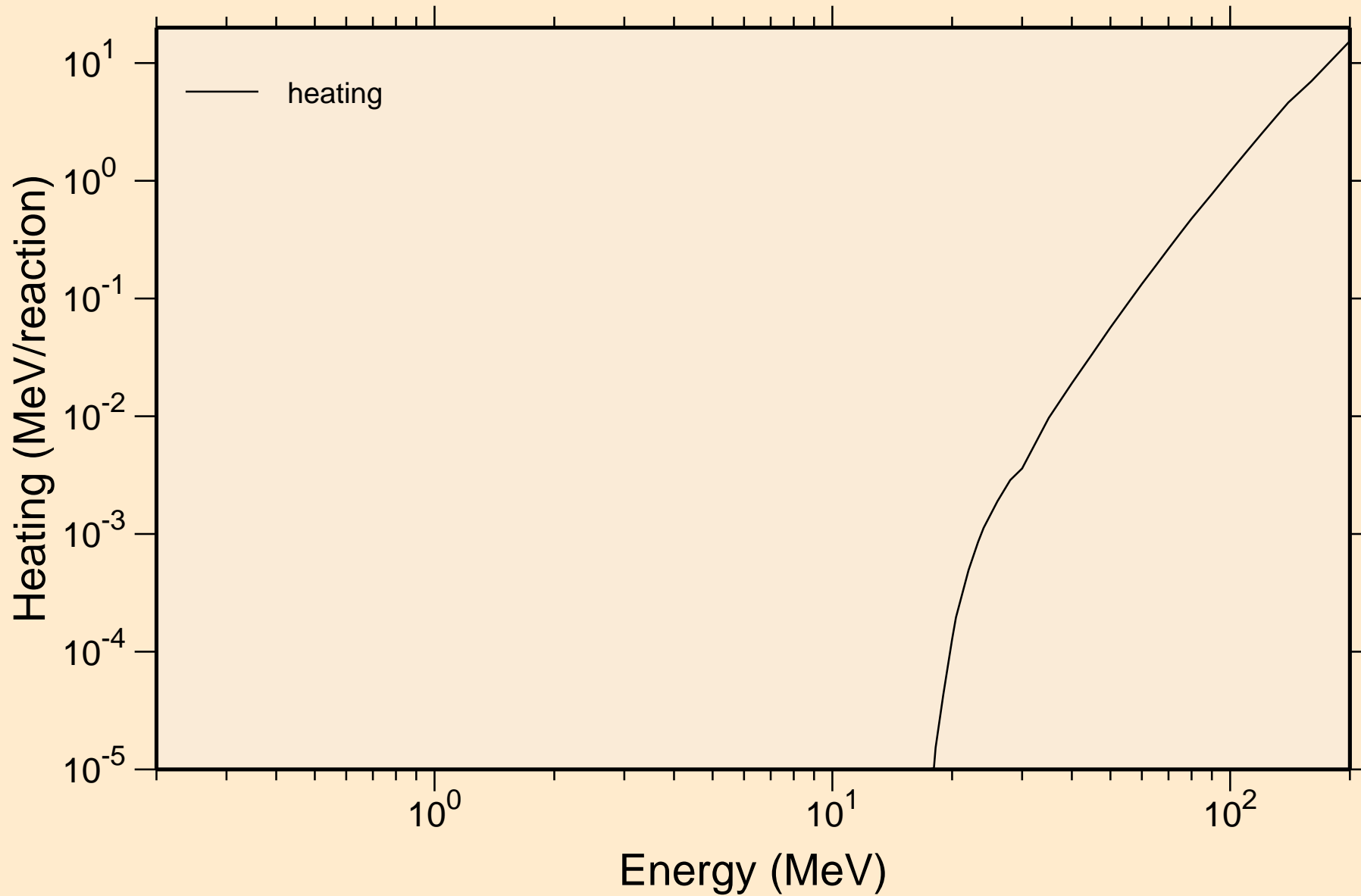

PT204 ALPHA ACER TENDL-2023 LIBRARY; T=0.K

Principal cross sections

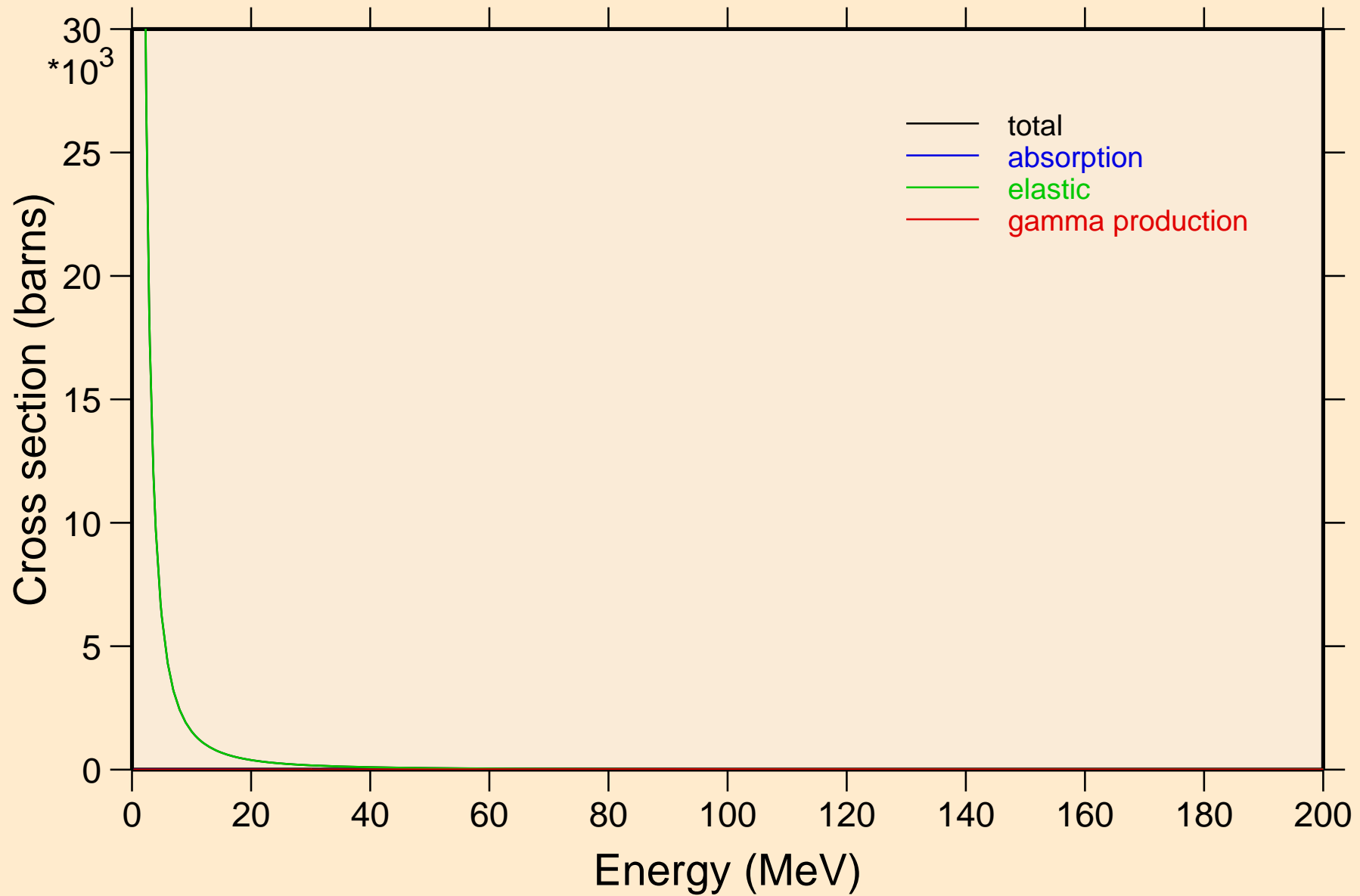

PT204 ALPHA ACER TENDL-2023 LIBRARY; T=0.K

Heating

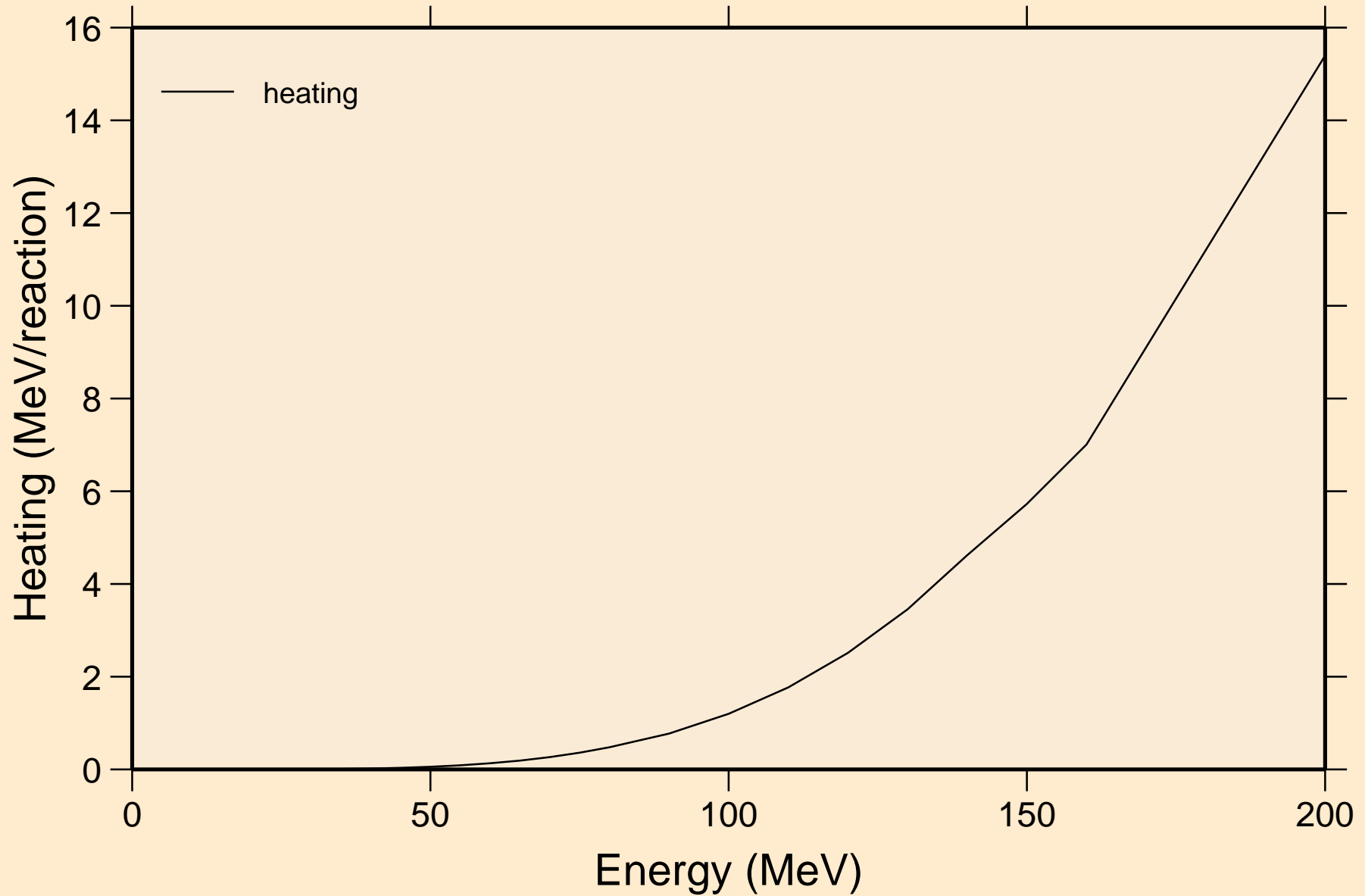

PT204 ALPHA ACER TENDL-2023 LIBRARY; T=0.K
Threshold reactions

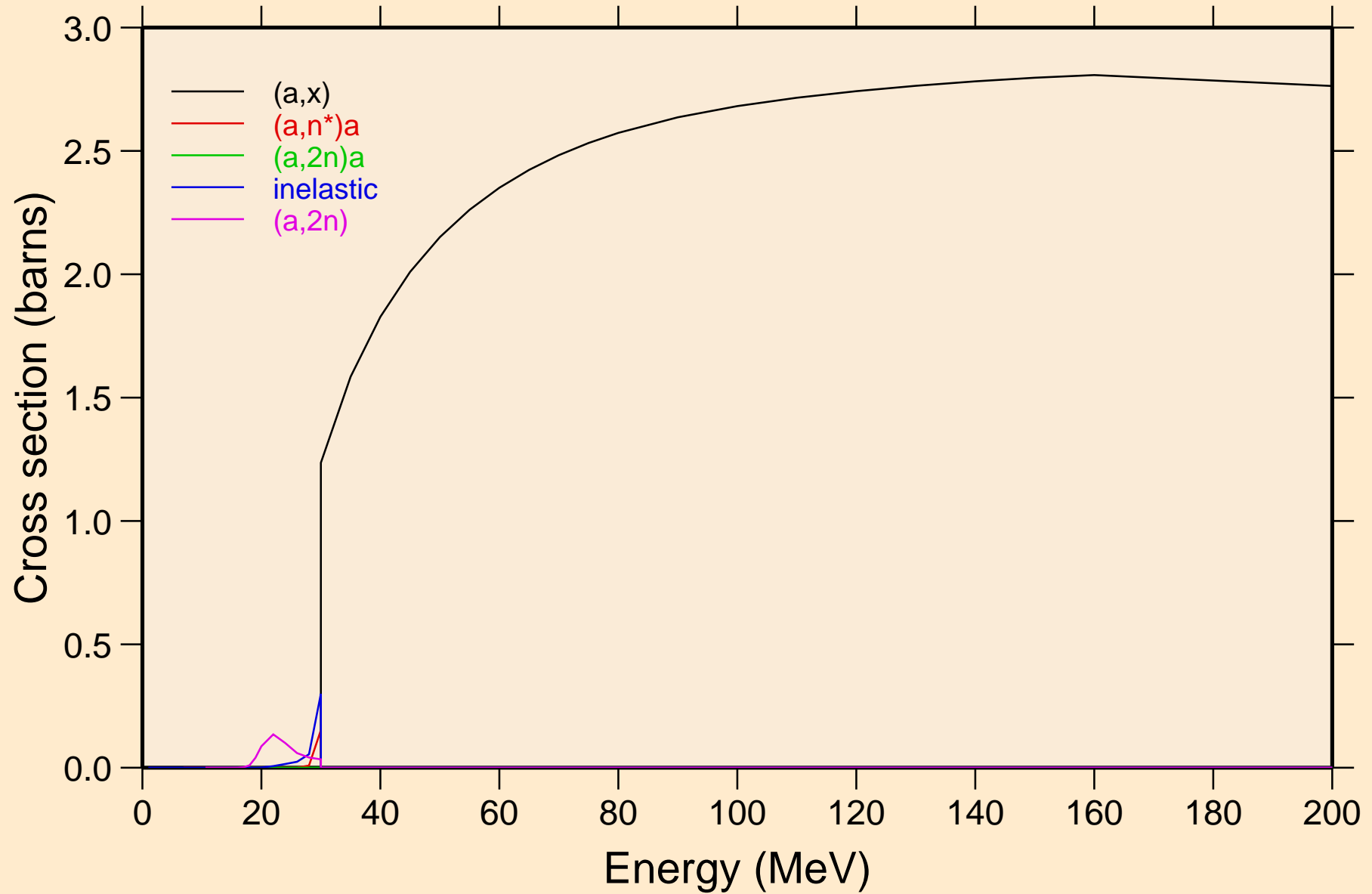

PT204 ALPHA ACER TENDL-2023 LIBRARY; T=0.K
Threshold reactions

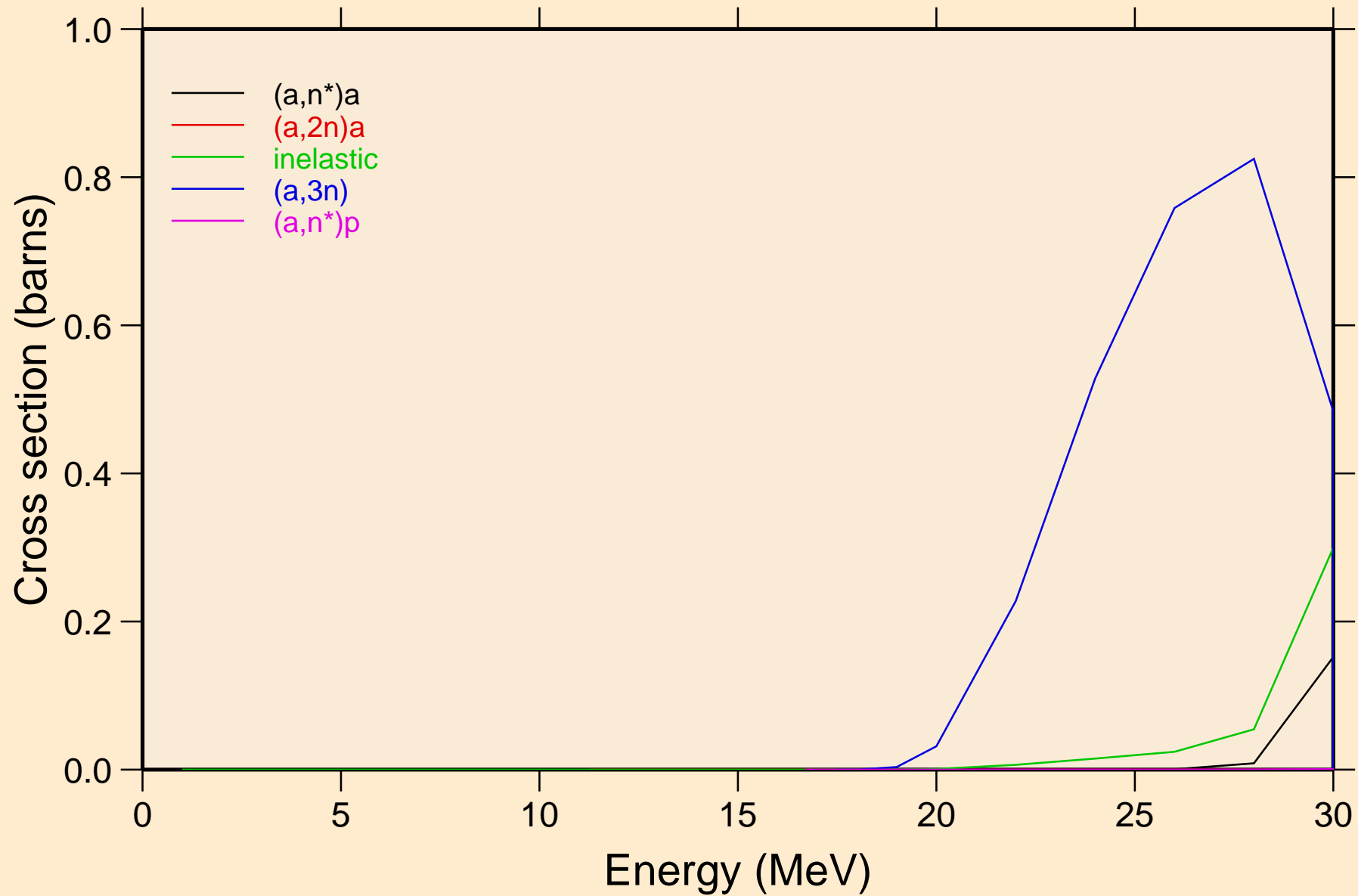

PT204 ALPHA ACER TENDL-2023 LIBRARY; T=0.K
Threshold reactions

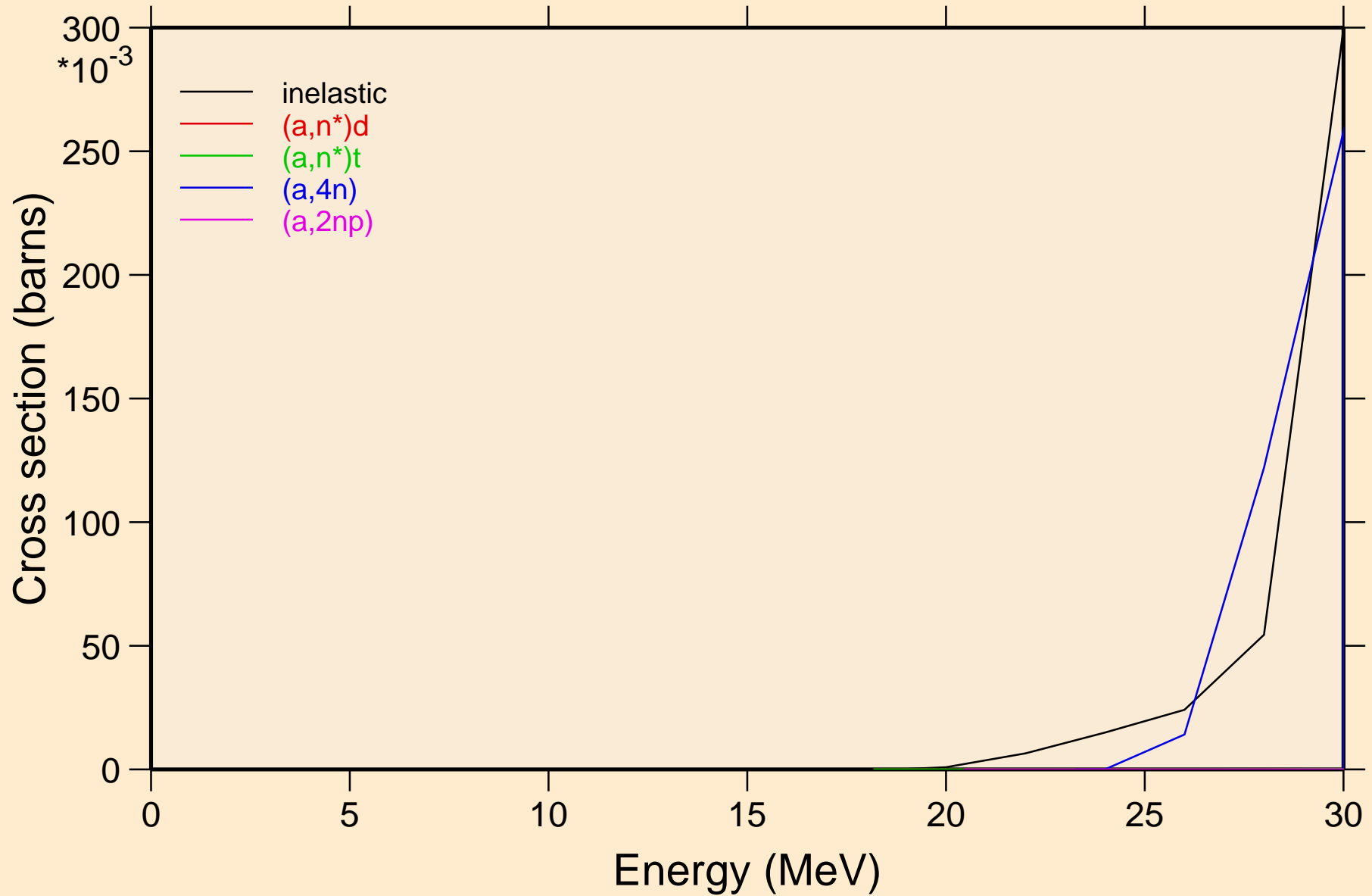

PT204 ALPHA ACER TENDL-2023 LIBRARY; T=0.K
Threshold reactions

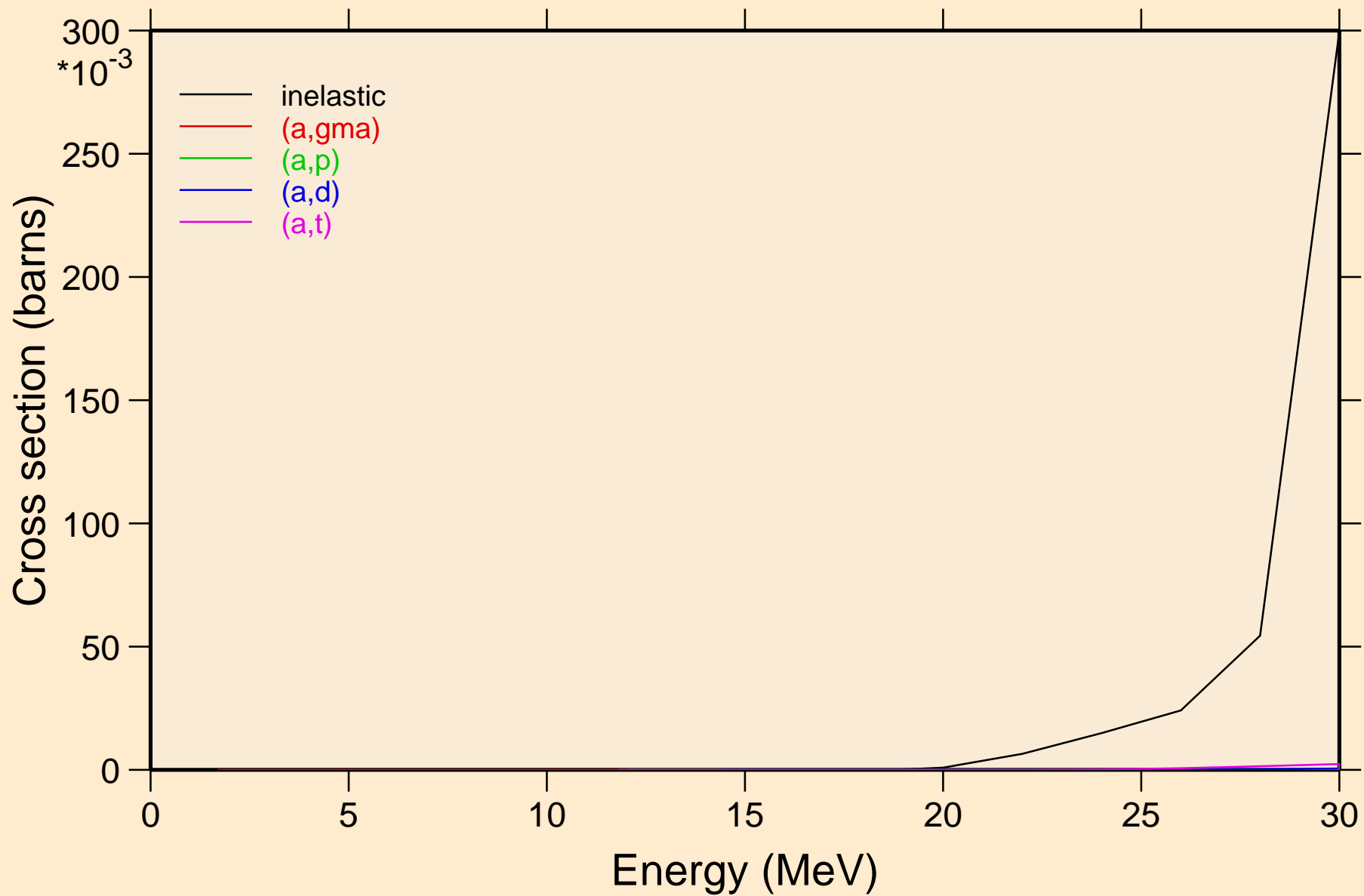

PT204 ALPHA ACER TENDL-2023 LIBRARY; T=0.K
Threshold reactions

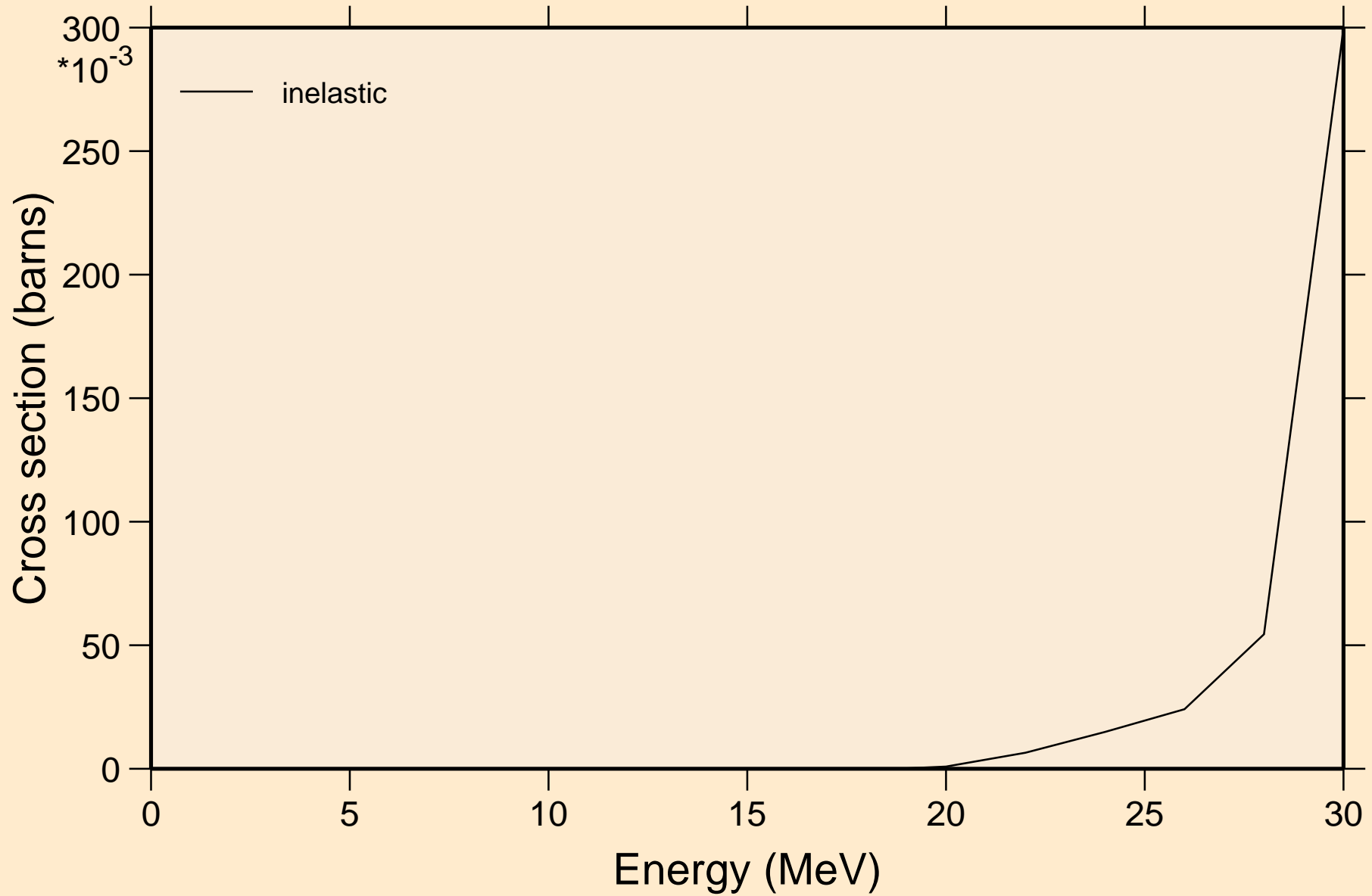

PT204 ALPHA ACER TENDL-2023 LIBRARY; T=0.K
angular distribution for elastic

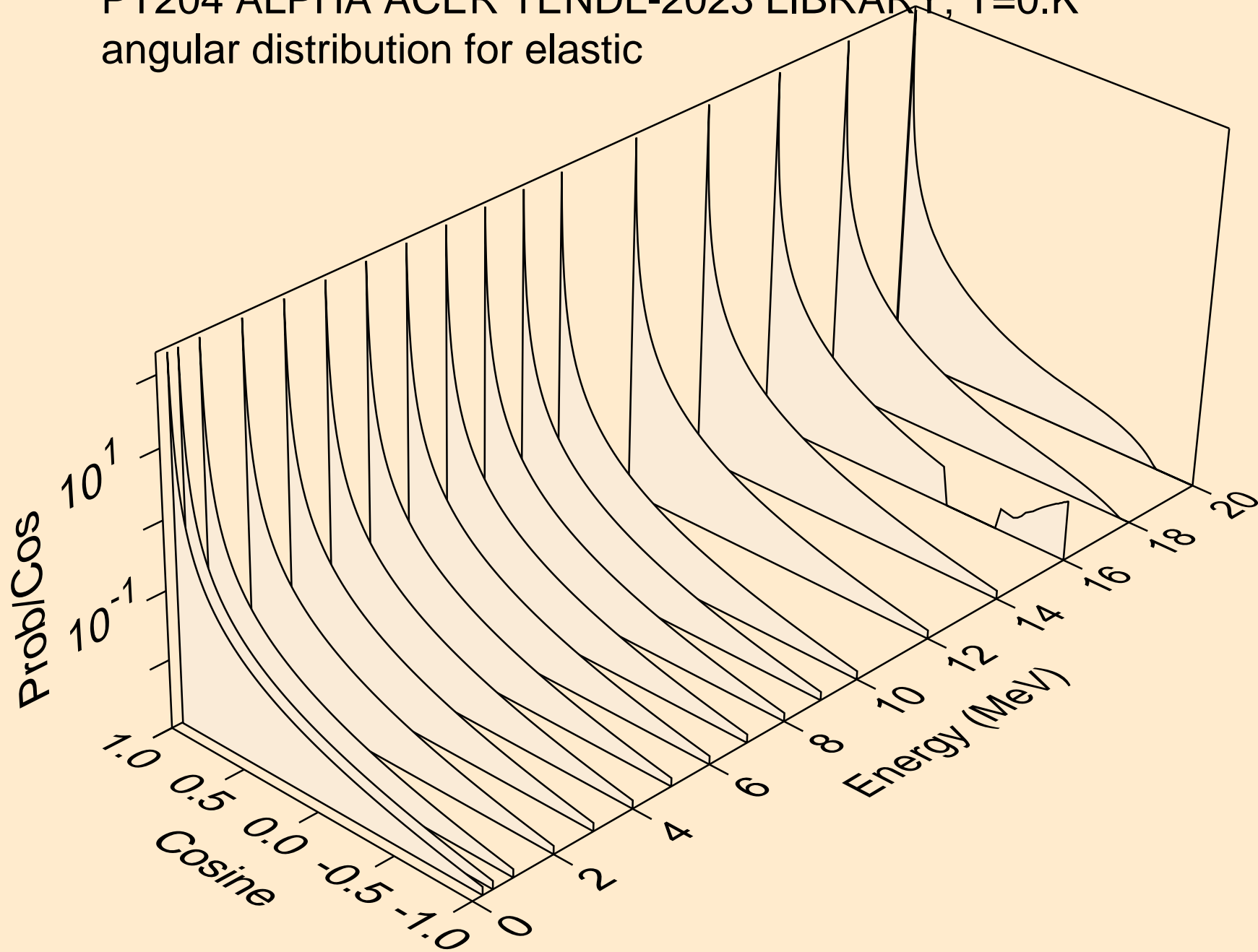

PT204 ALPHA ACER TENDL-2023 LIBRARY; T=0.K
angular distribution for elastic

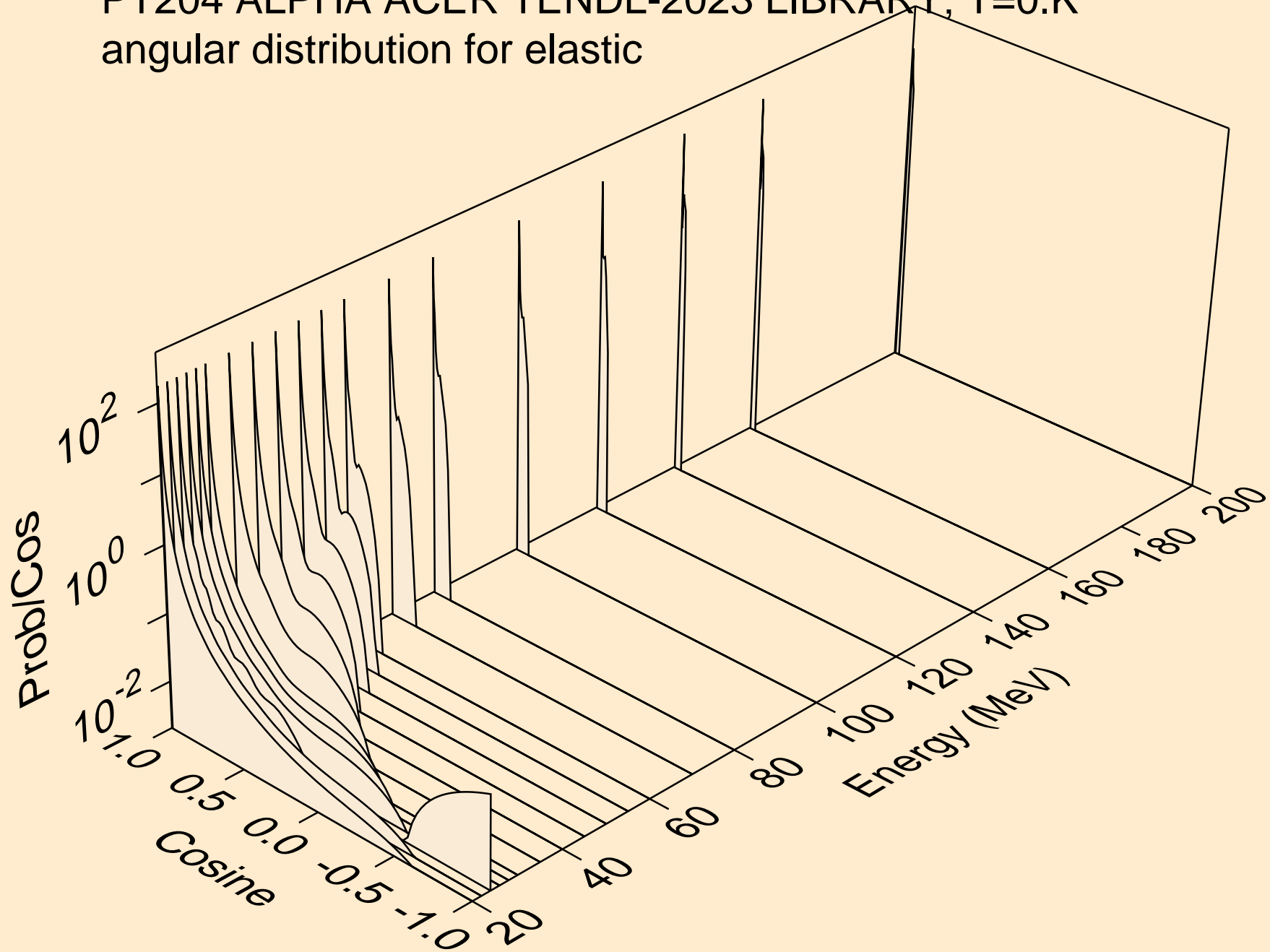

PT204 ALPHA ACER TENDL-2023 LIBRARY; T=0.K
Alpha emission for (a,x)

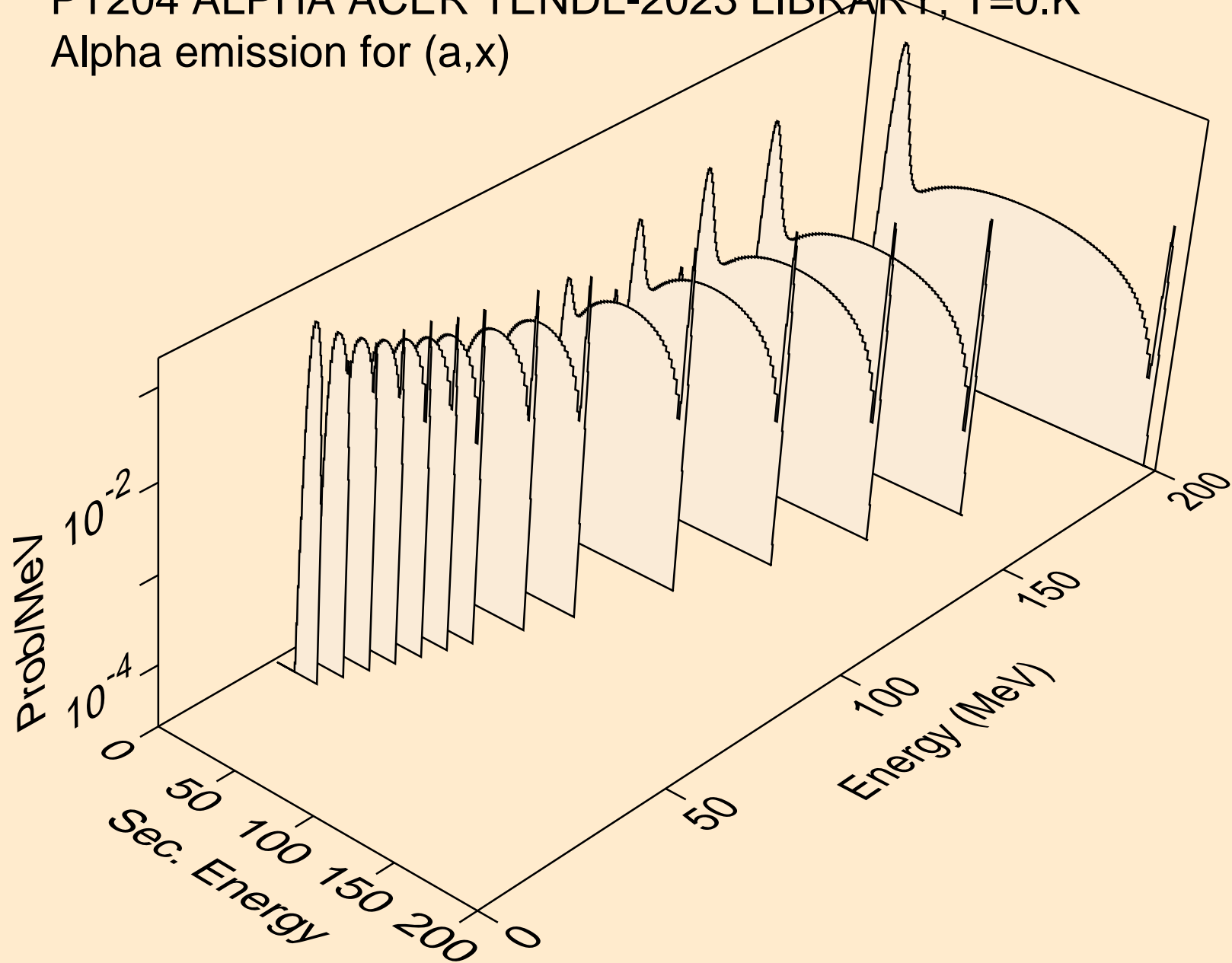

PT204 ALPHA ACER TENDL-2023 LIBRARY; T=0.K
Alpha emission for (a,n*)a

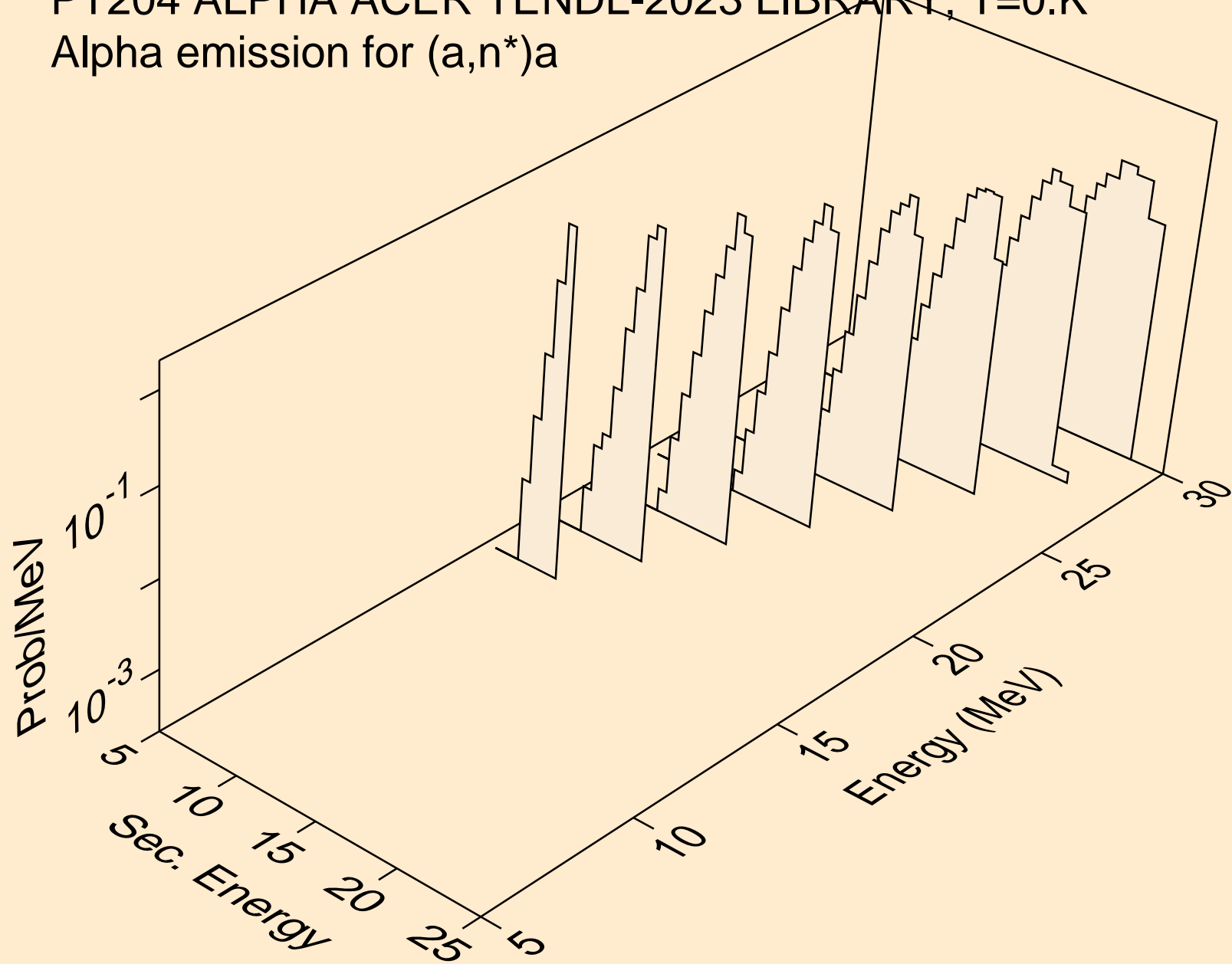

PT204 ALPHA ACER TENDL-2023 LIBRARY; T=0.K
Alpha emission for (a,2n)a

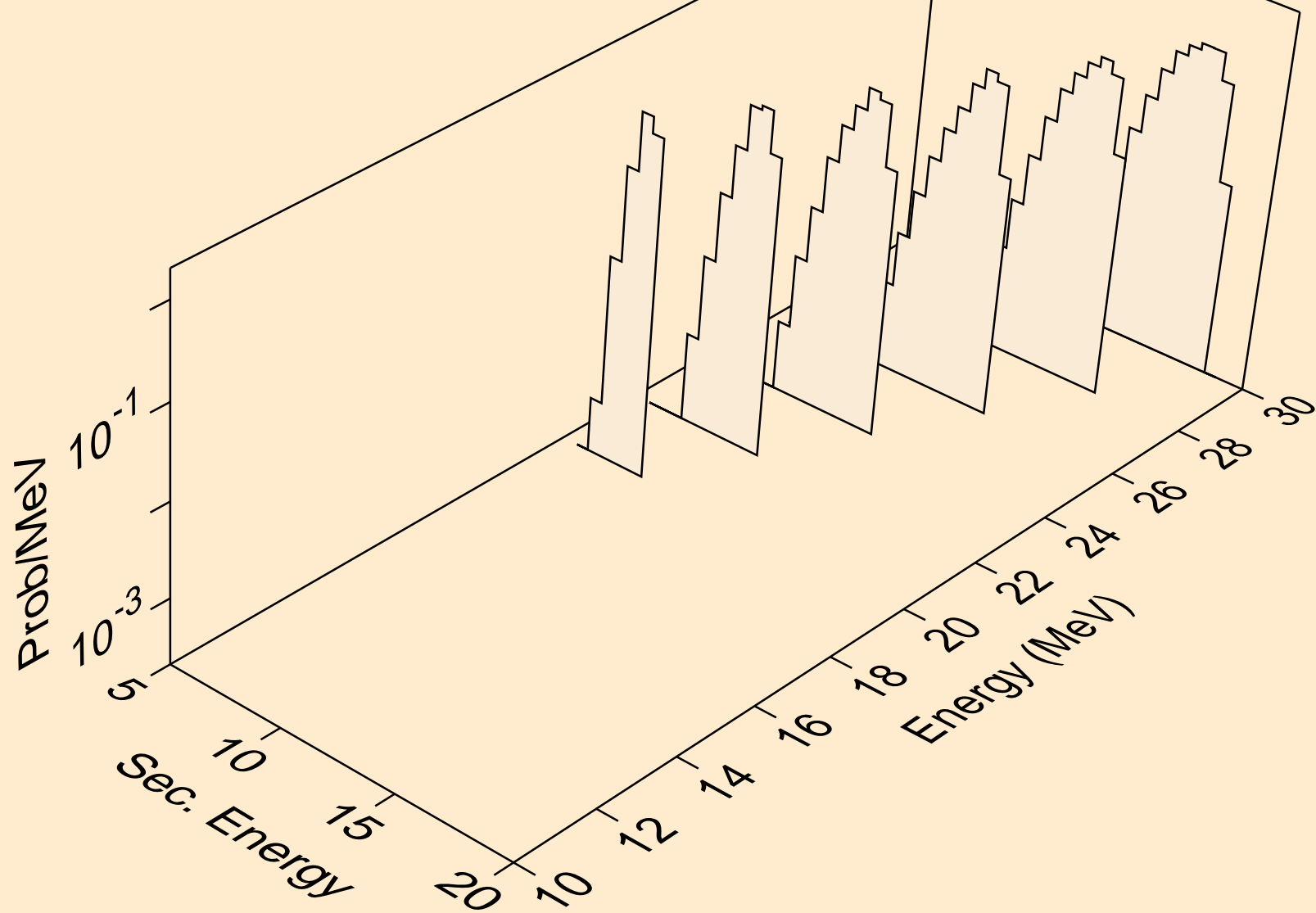

PT204 ALPHA ACER TENDL-2023 LIBRARY; T=0.K
Alpha emission for inelastic

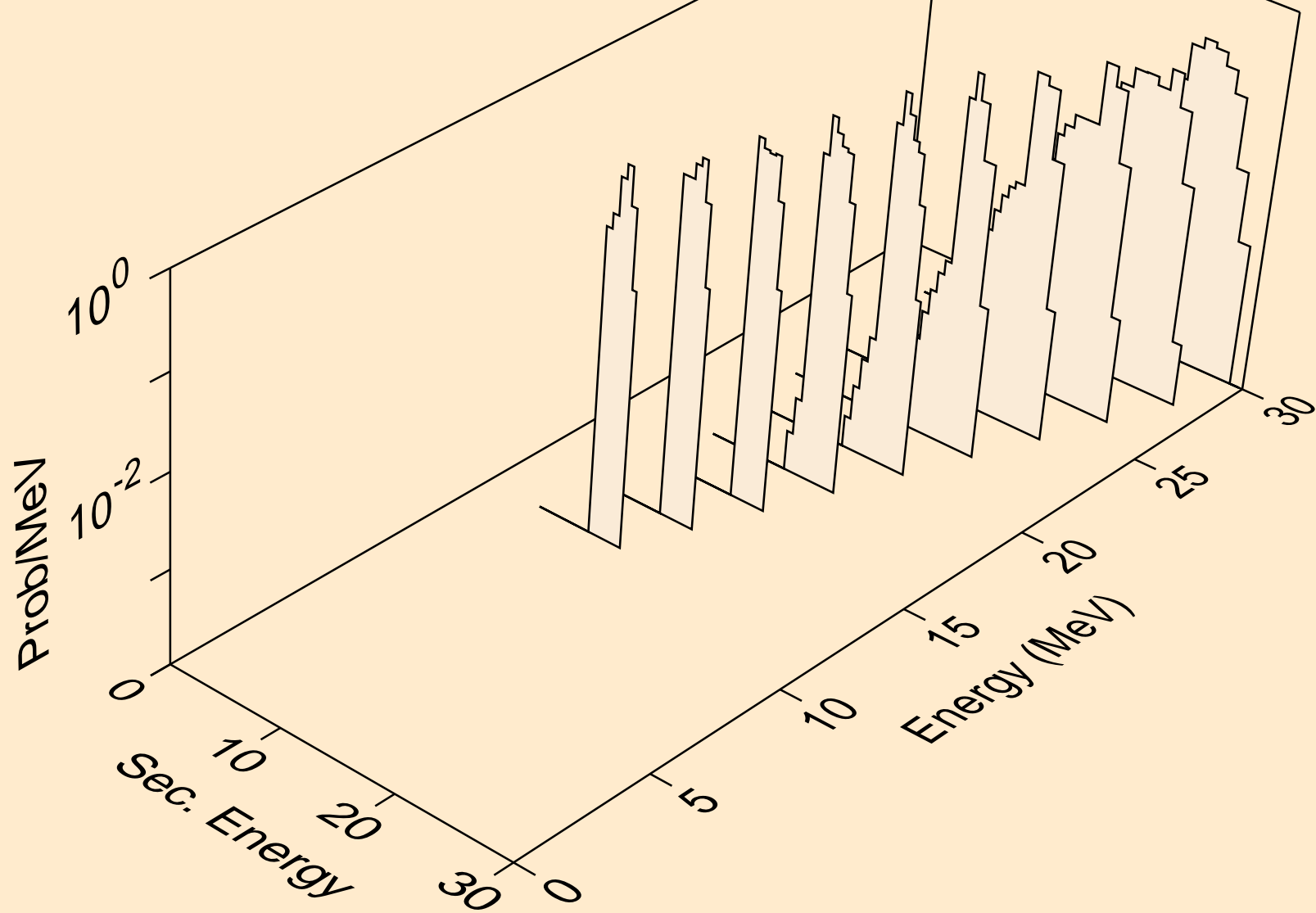

PT204 ALPHA ACER TENDL-2023 LIBRARY; T=0.K
Photon emission for (z,n)

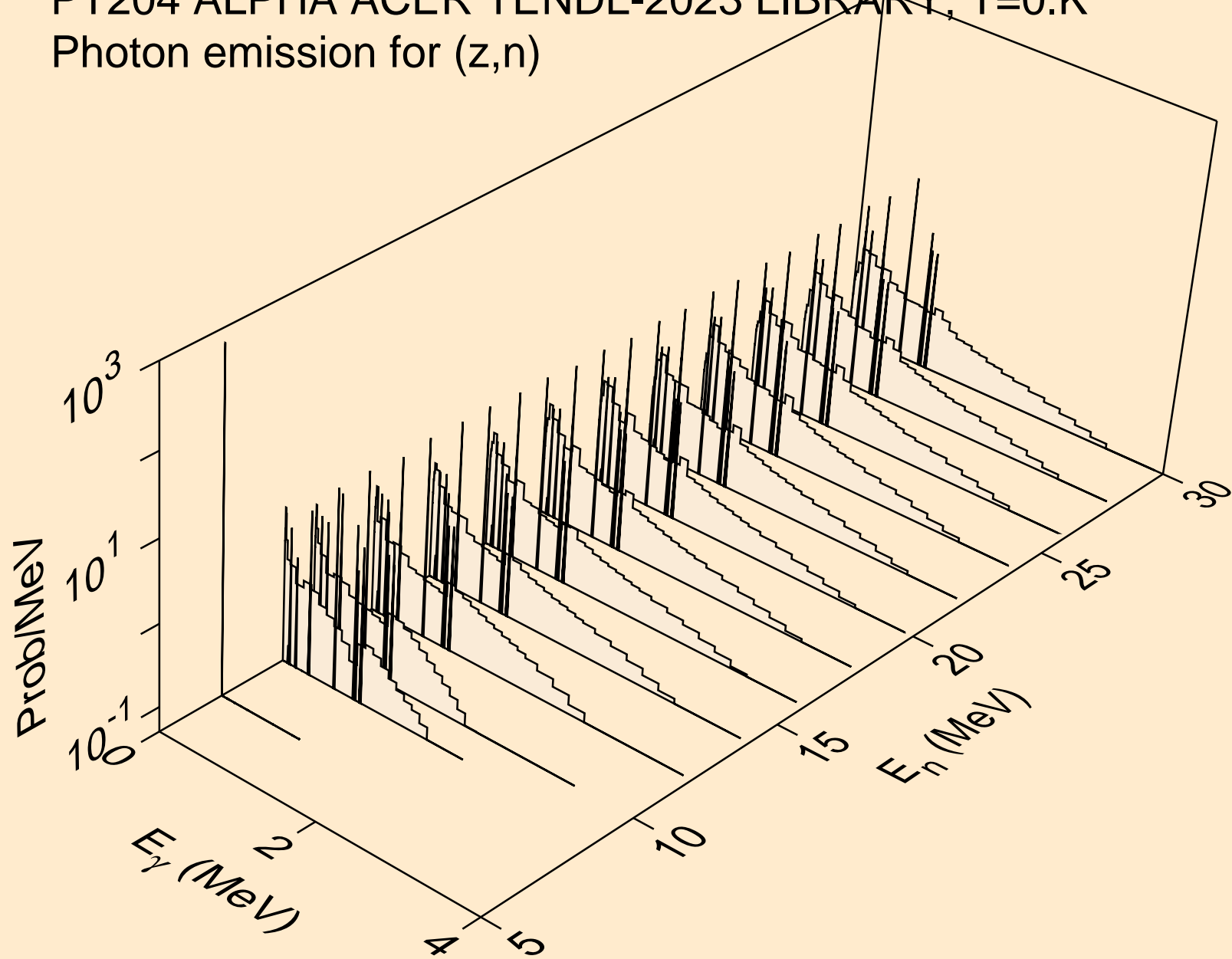

PT204 ALPHA ACER TENDL-2023 LIBRARY; T=0.K
Photon emission for (z,x)

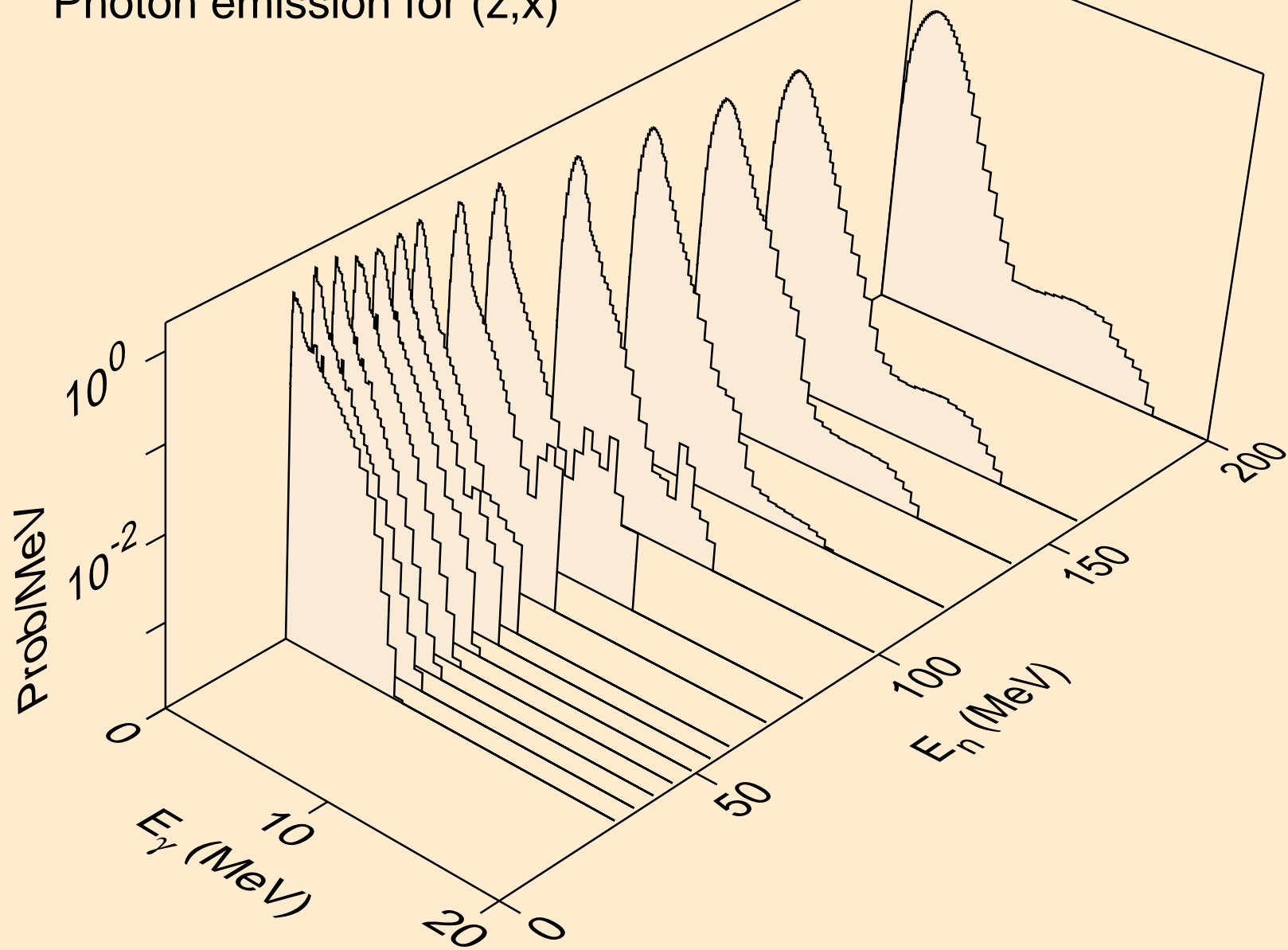

PT204 ALPHA ACER TENDL-2023 LIBRARY; T=0.K
Photon emission for (n,2n)

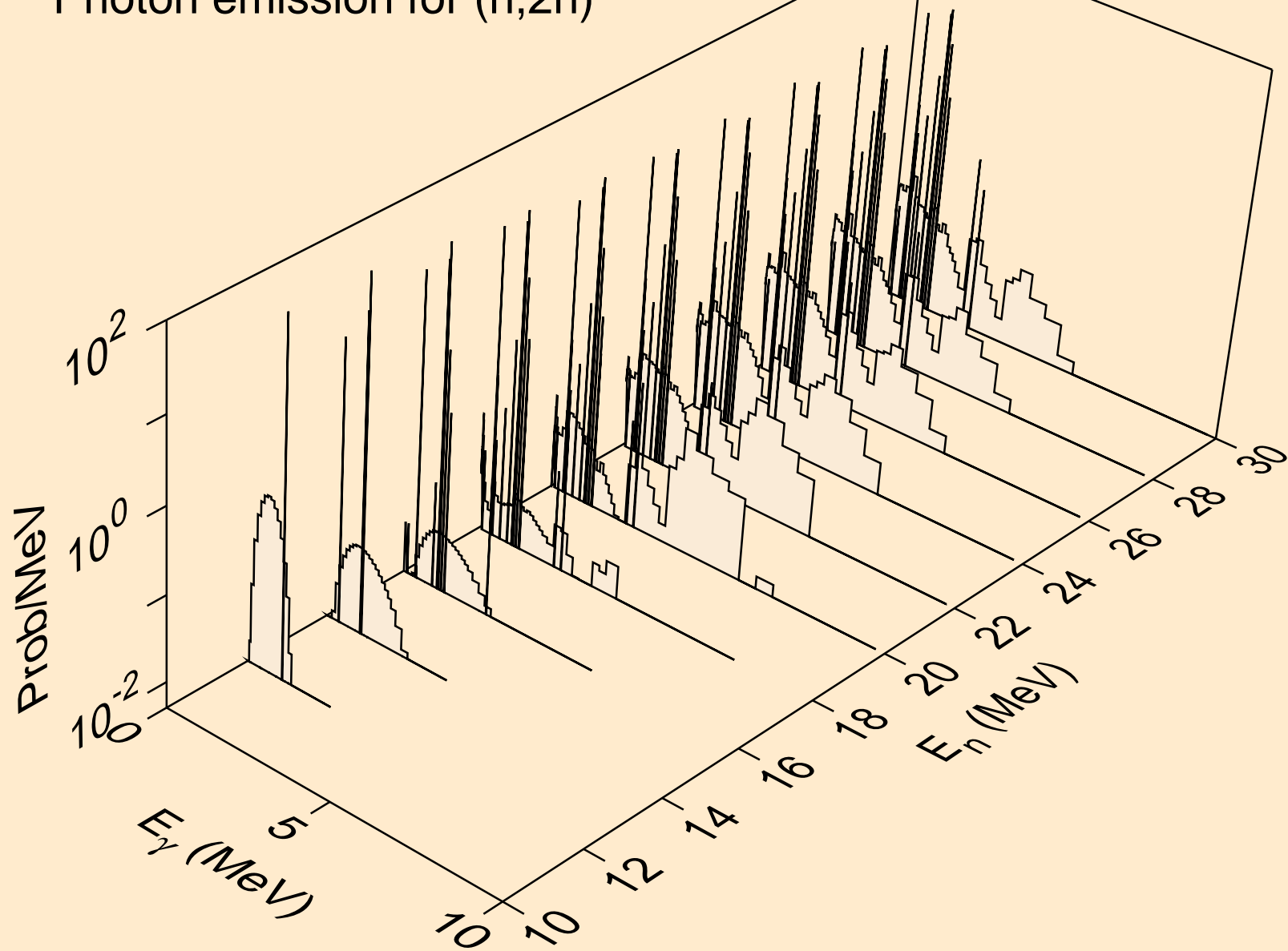

PT204 ALPHA ACER TENDL-2023 LIBRARY; T=0.K
Photon emission for (n,3n)

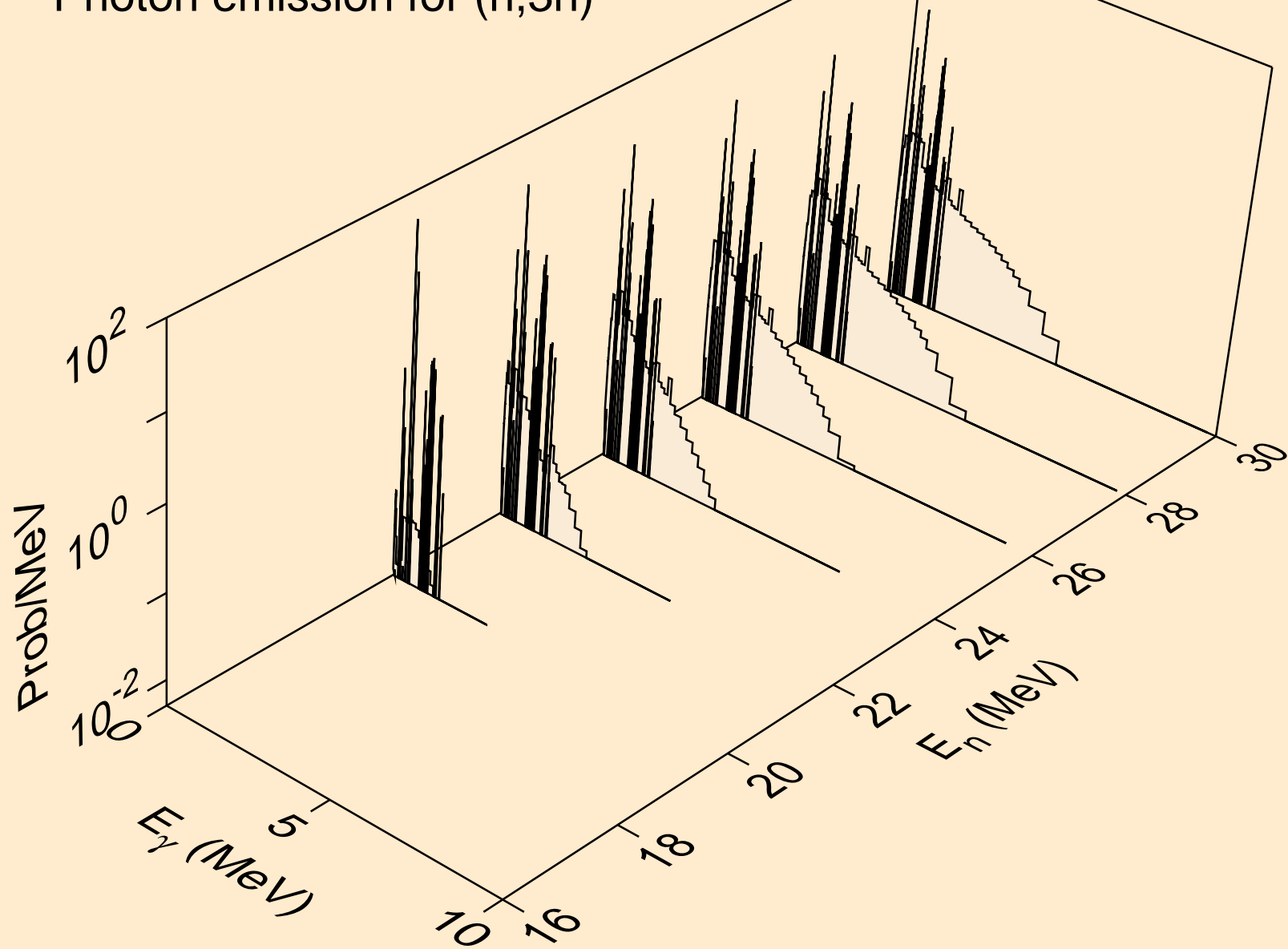

PT204 ALPHA ACER TENDL-2023 LIBRARY; T=0.K
Photon emission for (n,n*)a

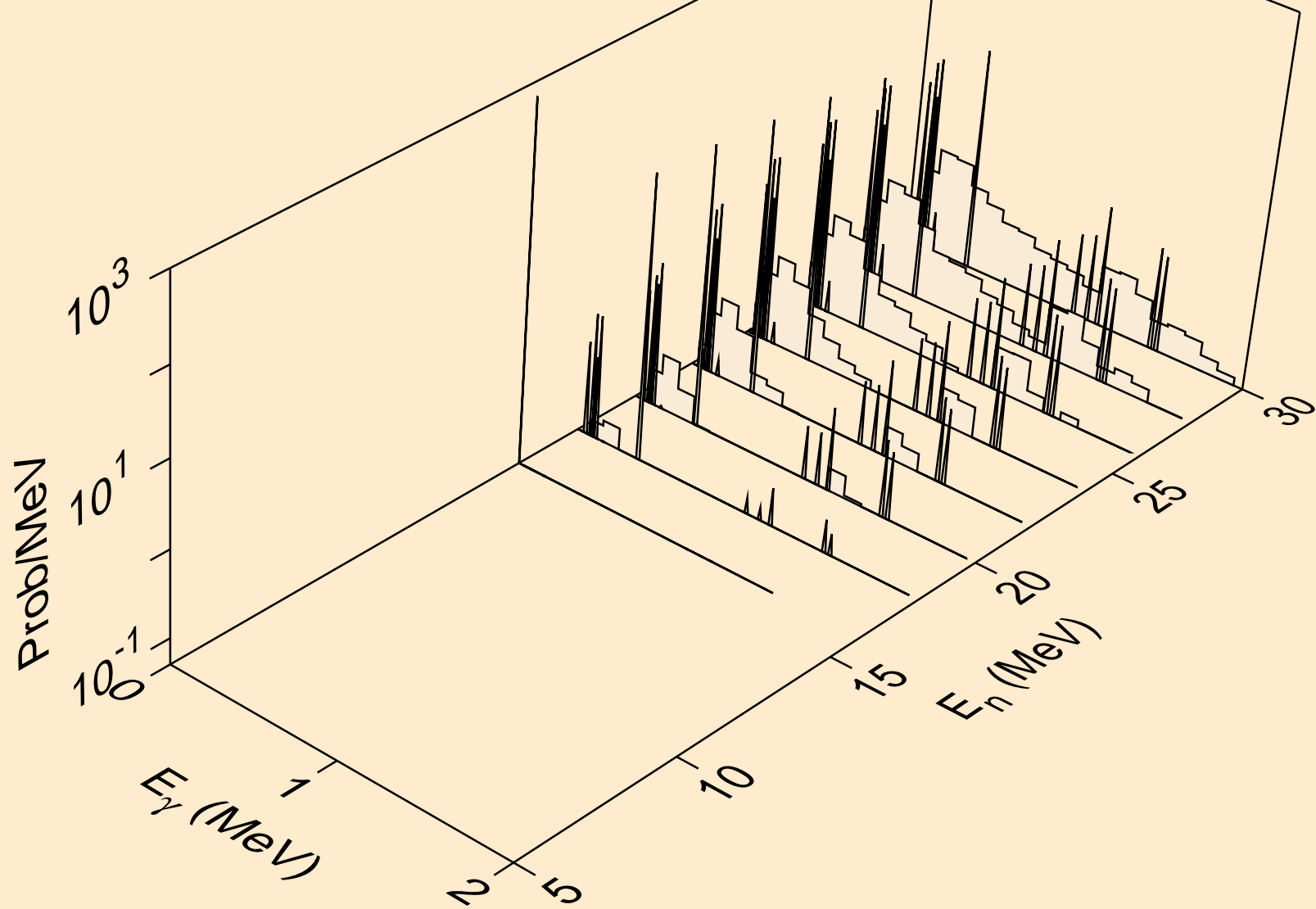

PT204 ALPHA ACER TENDL-2023 LIBRARY; T=0.K
Photon emission for (n,2n)a

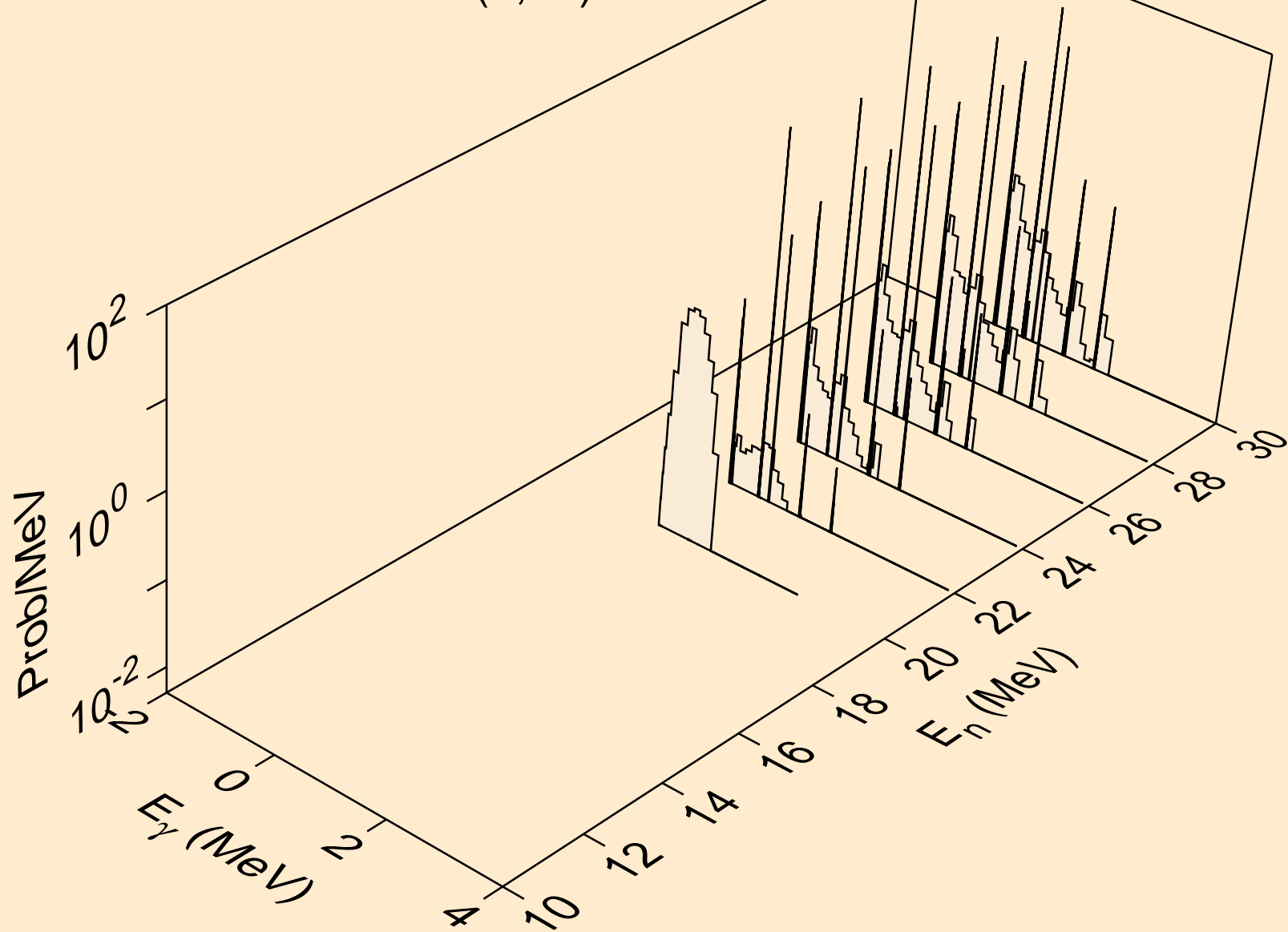

PT204 ALPHA ACER TENDL-2023 LIBRARY; T=0.K
Photon emission for (n,n*)p

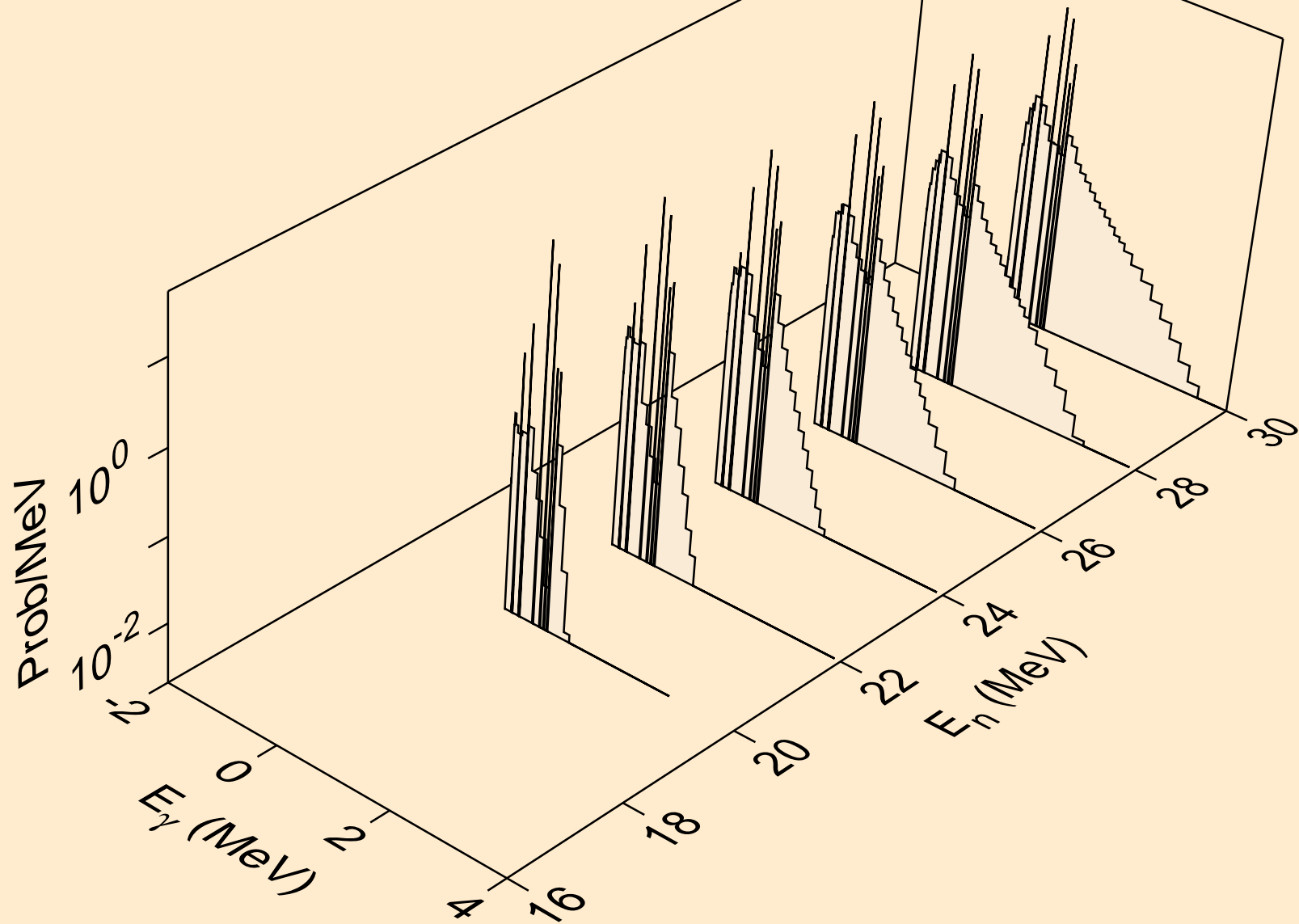

PT204 ALPHA ACER TENDL-2023 LIBRARY; T=0.K
Photon emission for (n,n*)d

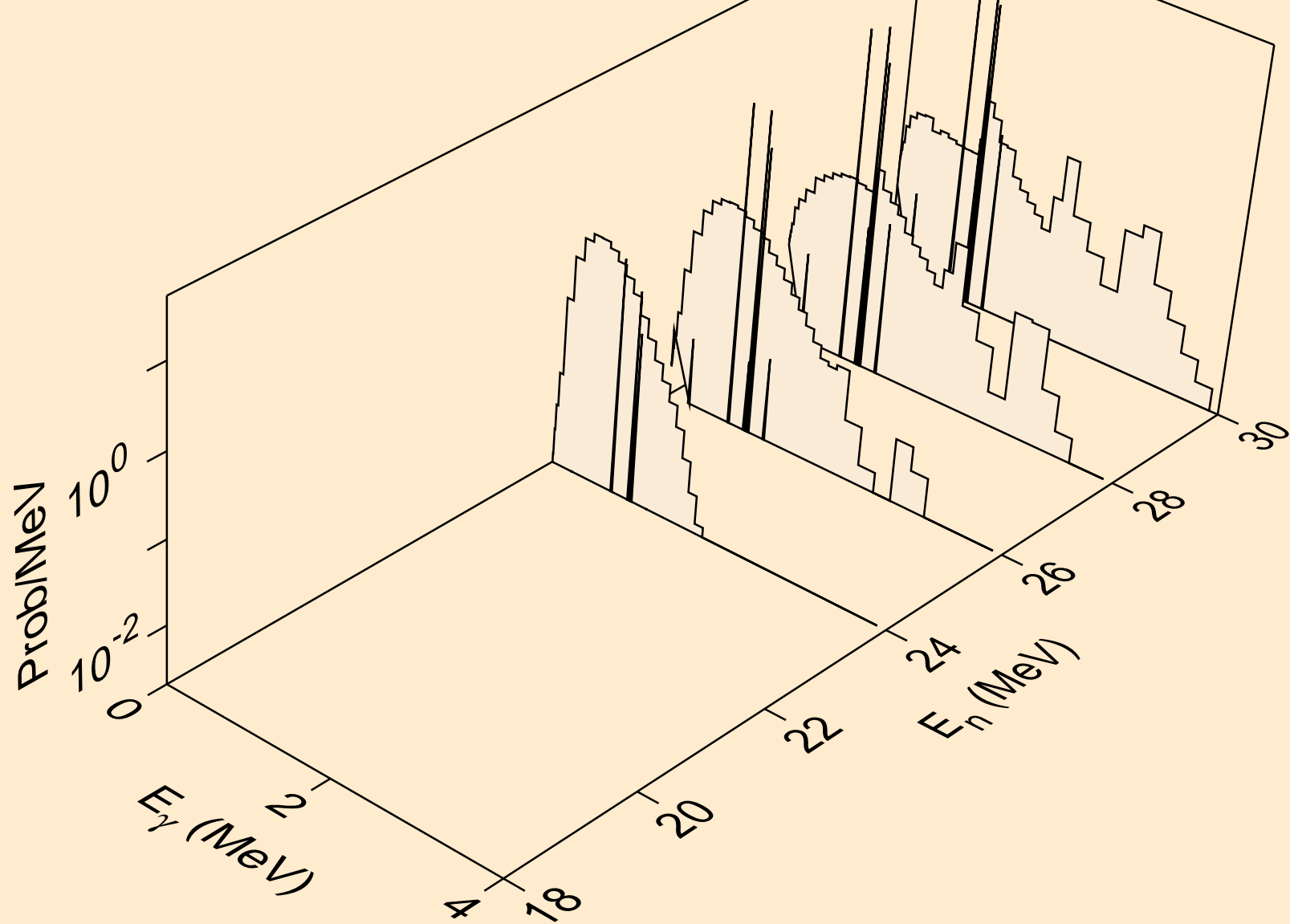

PT204 ALPHA ACER TENDL-2023 LIBRARY; T=0.K
Photon emission for (n,n*)t

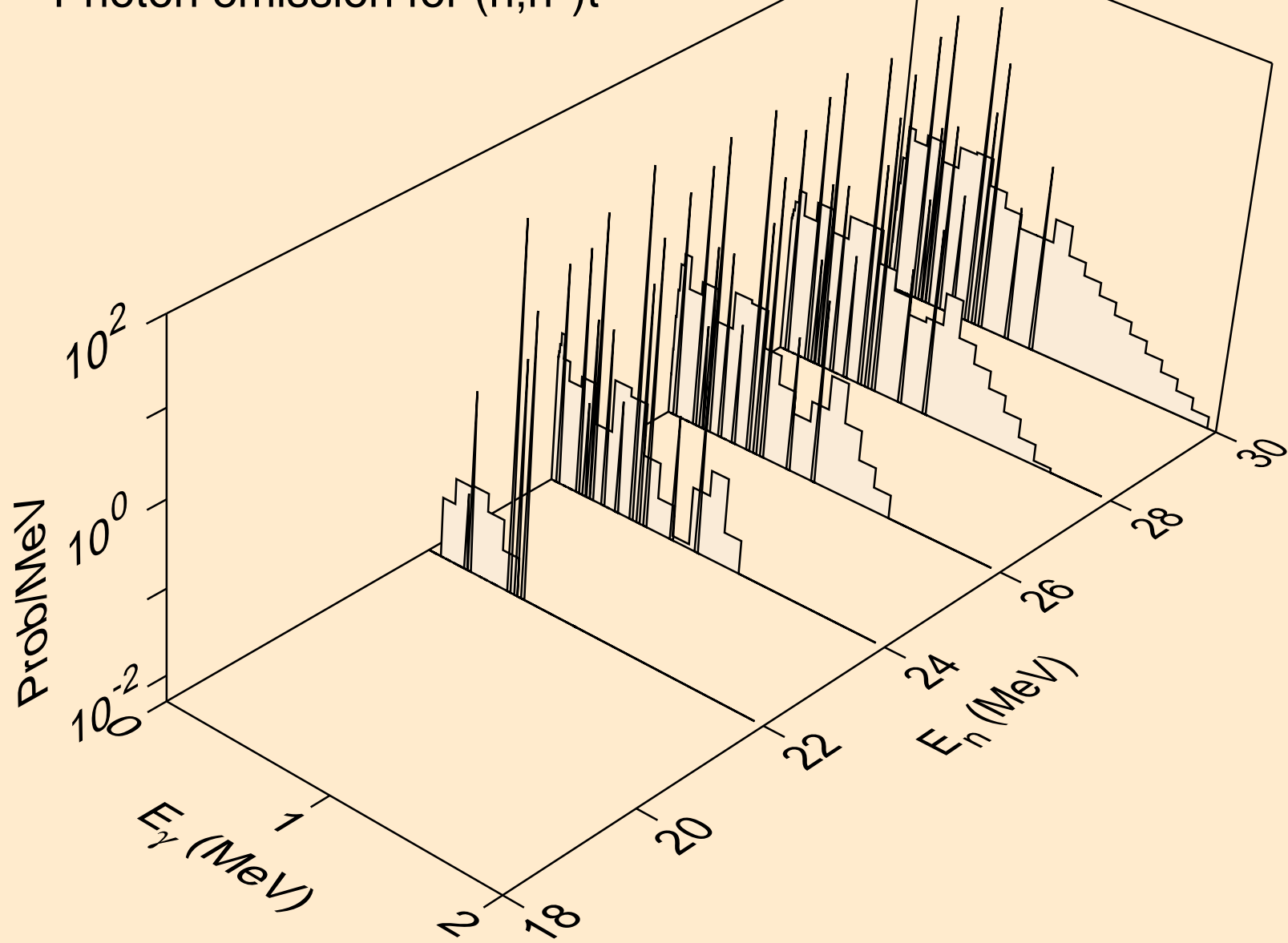

PT204 ALPHA ACER TENDL-2023 LIBRARY; T=0.K
Photon emission for (n,4n)

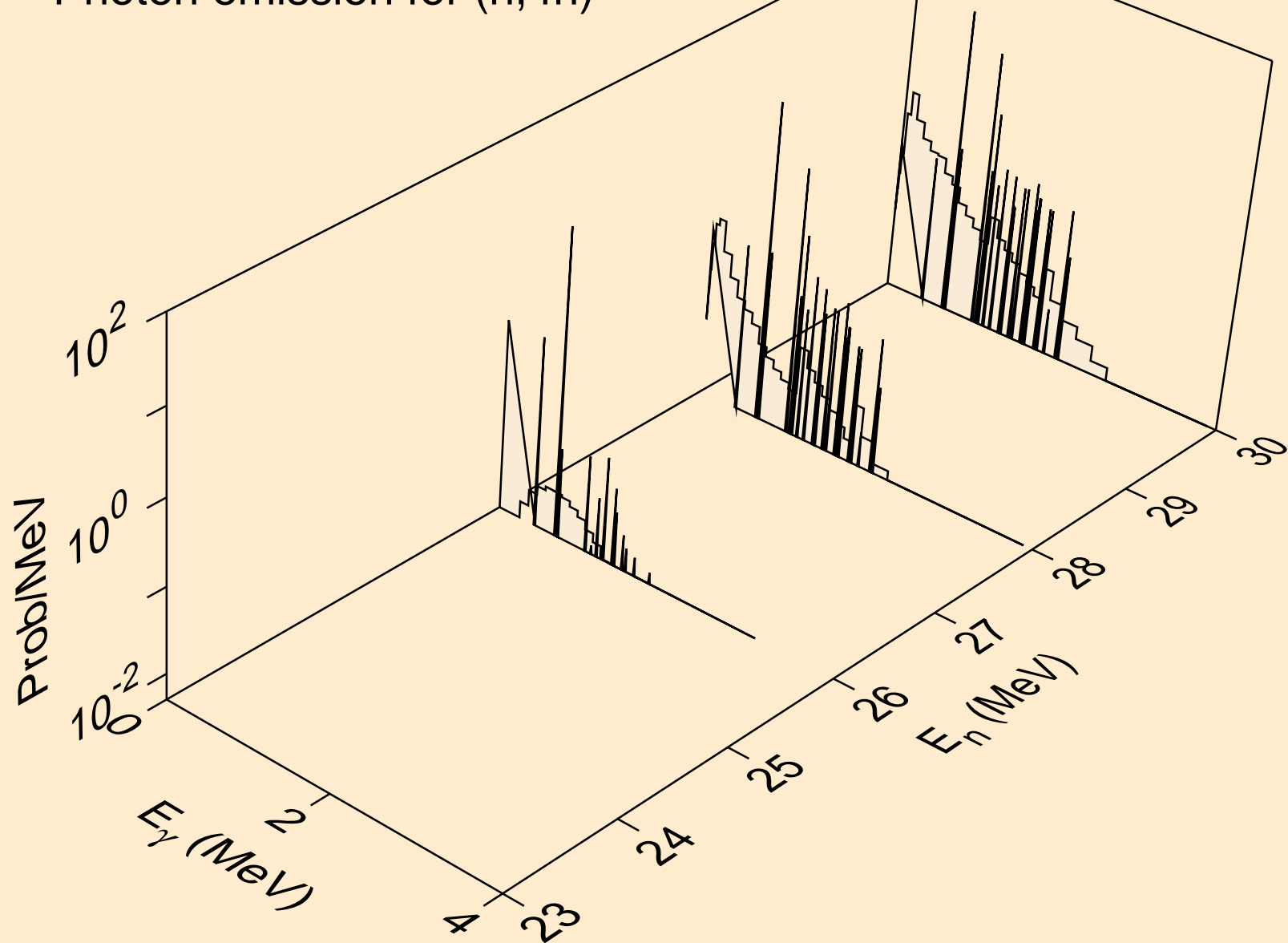

PT204 ALPHA ACER TENDL-2023 LIBRARY; T=0.K
Photon emission for (n,2np)

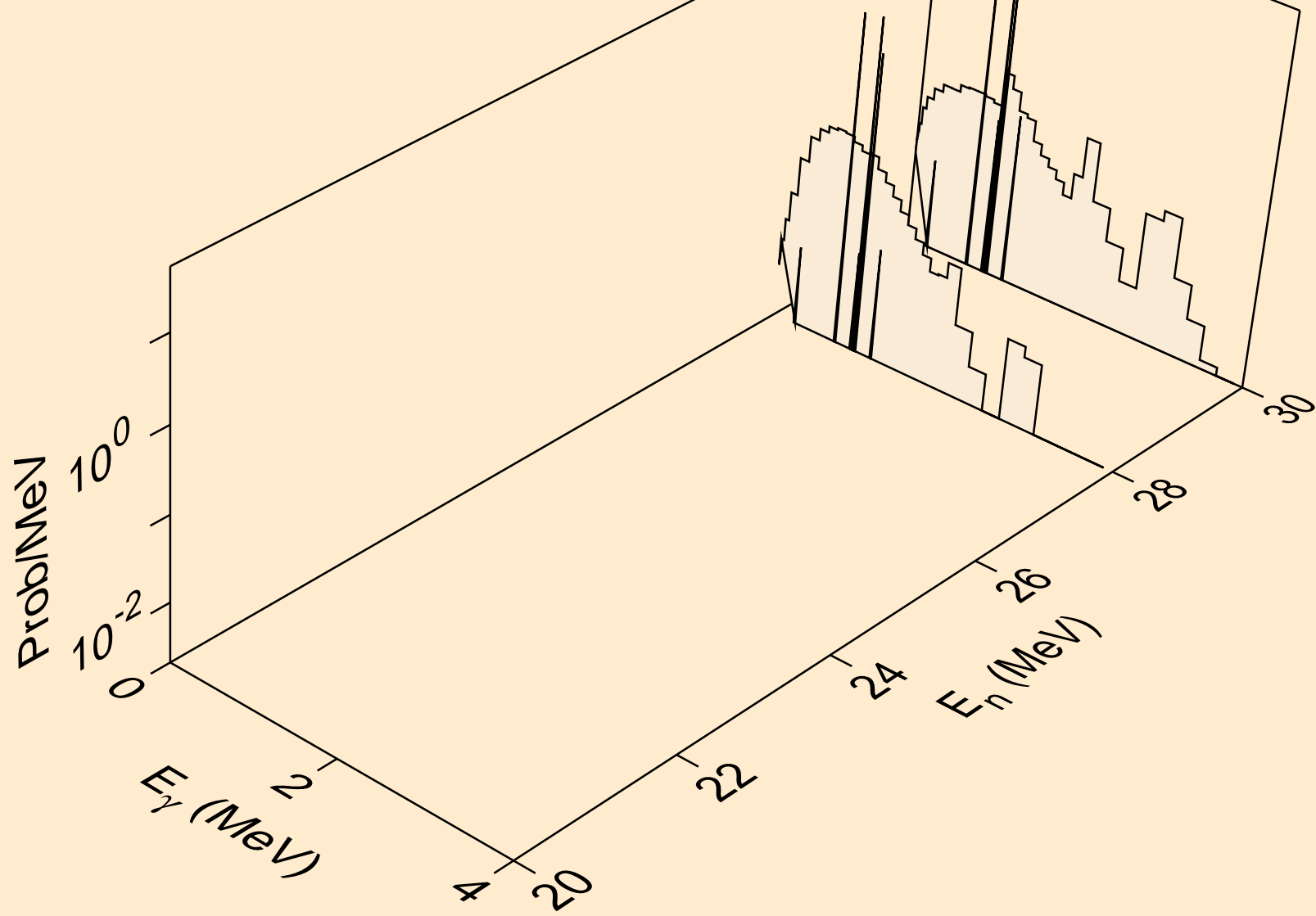

PT204 ALPHA ACER TENDL-2023 LIBRARY; T=0.K
Photon emission for (n,gma)

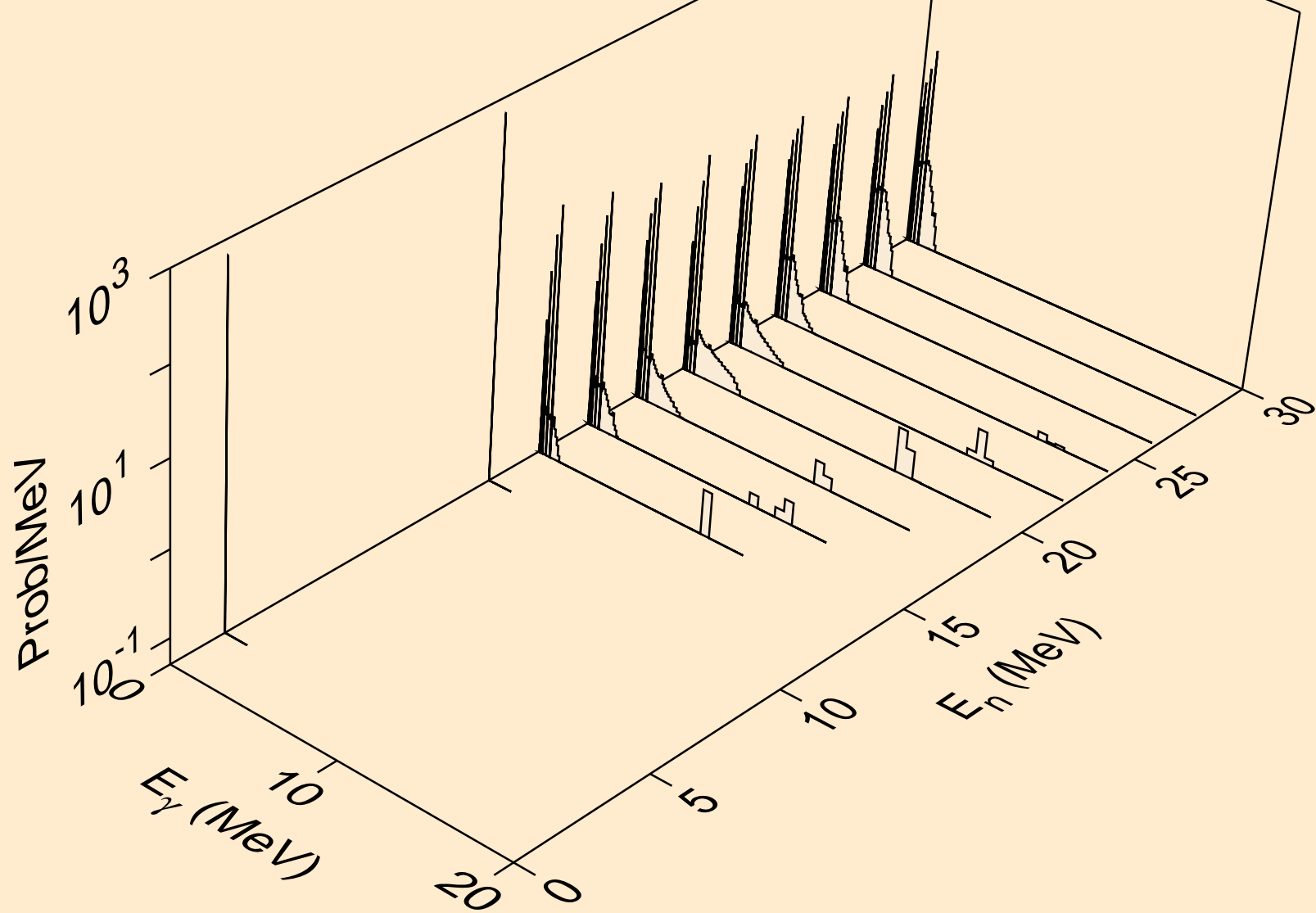

PT204 ALPHA ACER TENDL-2023 LIBRARY; T=0.K
Photon emission for (n,p)

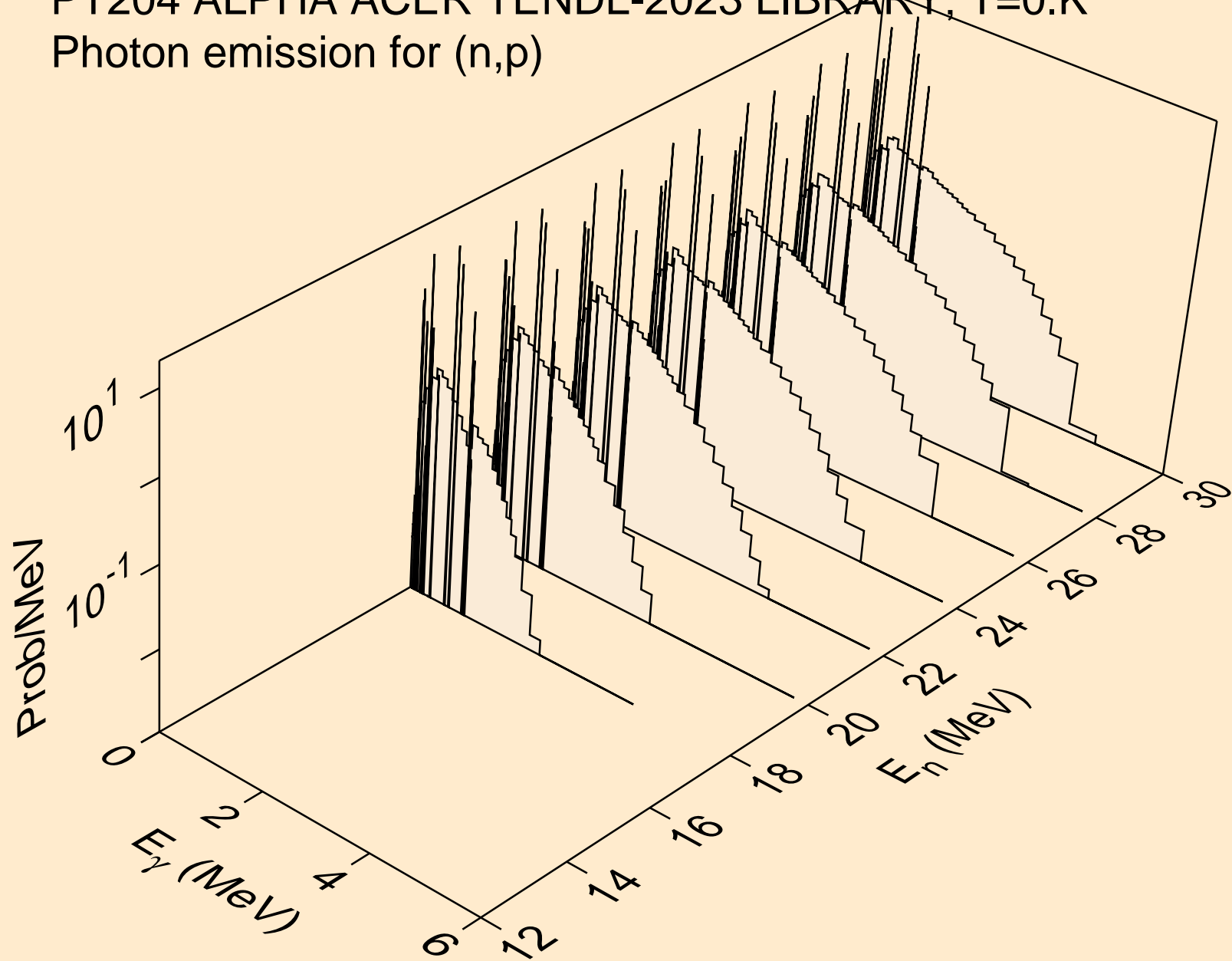

PT204 ALPHA ACER TENDL-2023 LIBRARY; T=0.K
Photon emission for (n,d)

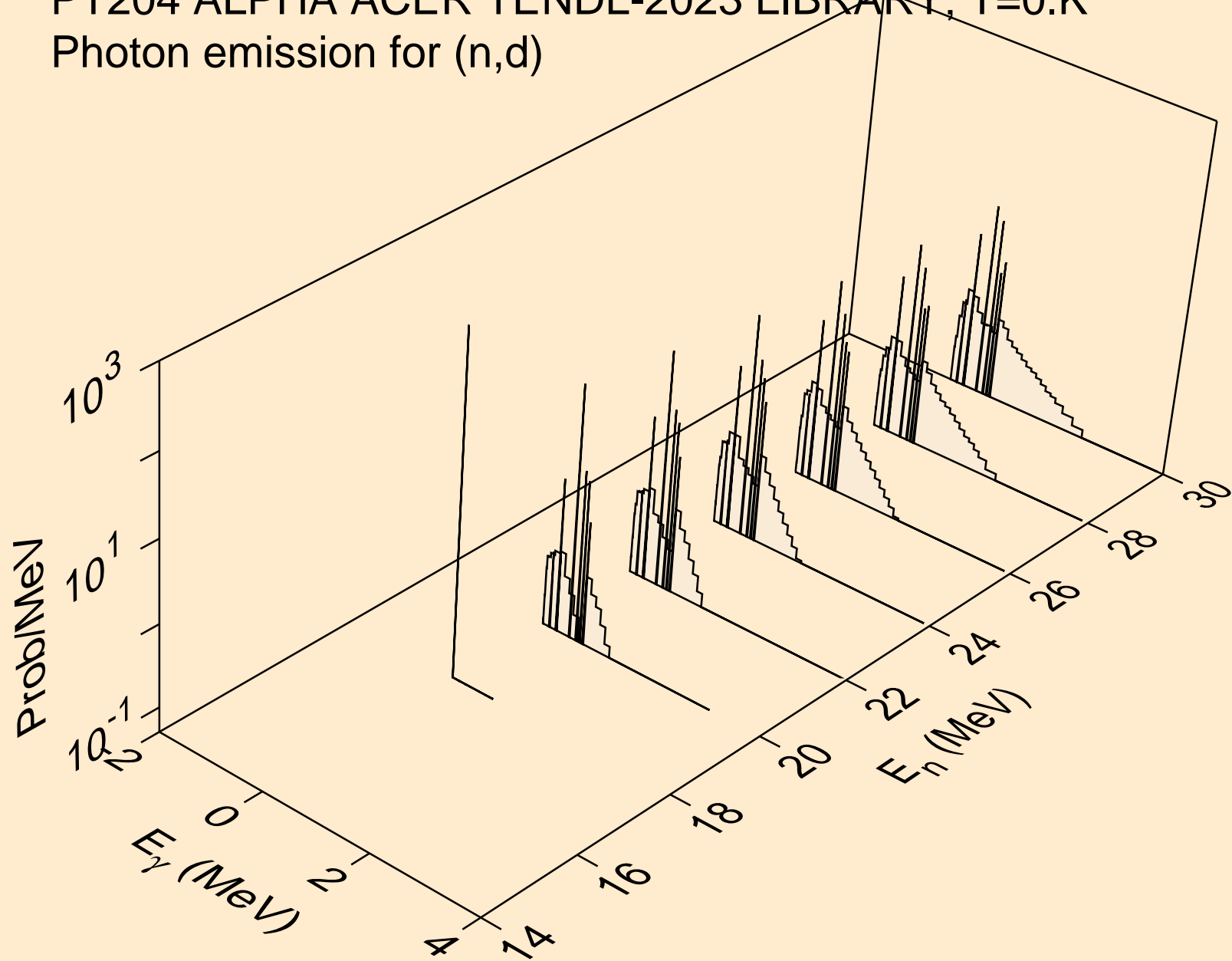

PT204 ALPHA ACER TENDL-2023 LIBRARY; T=0.K
Photon emission for (n,t)

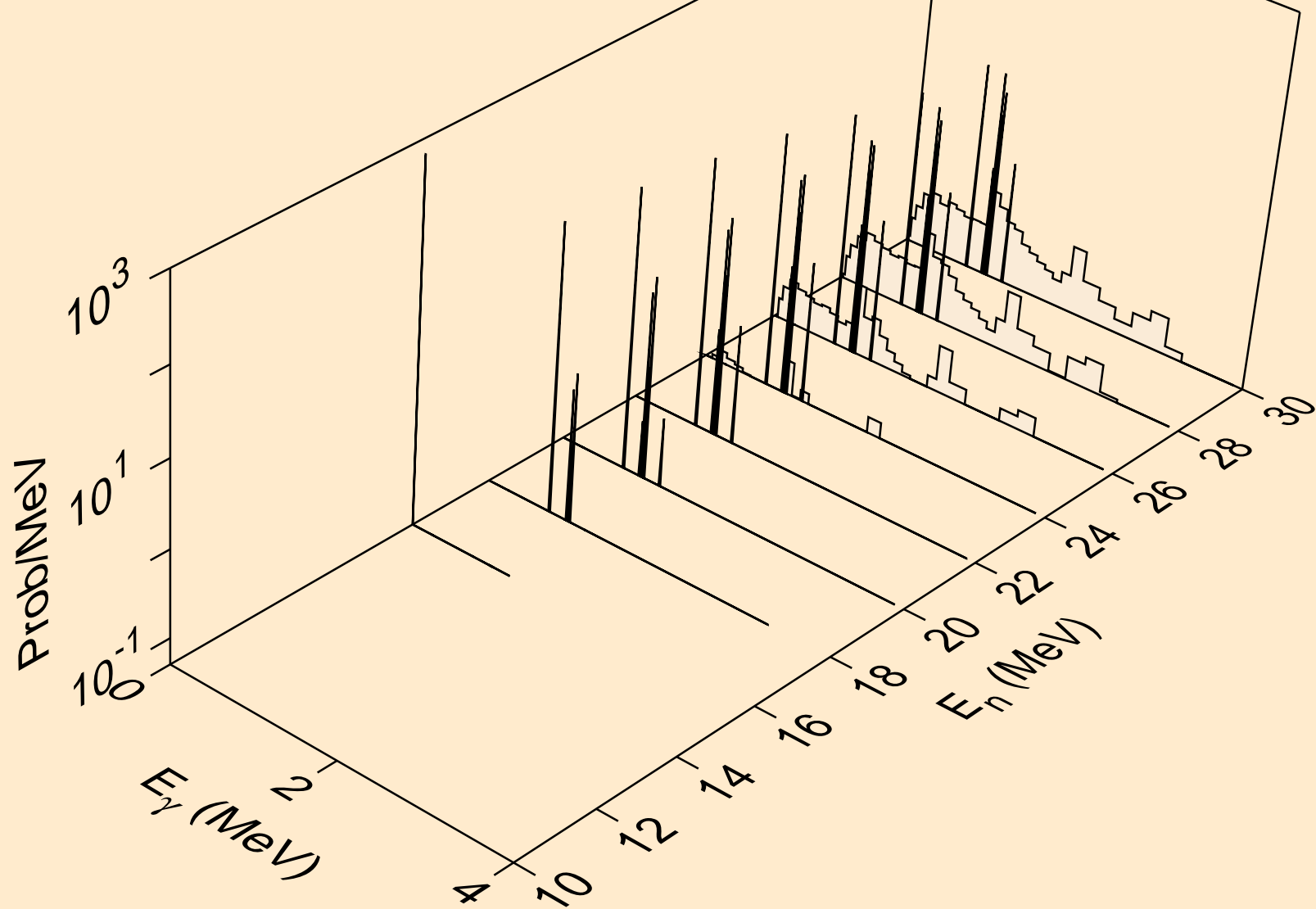

PT204 ALPHA ACER TENDL-2023 LIBRARY; T=0.K
Photon emission for inelastic

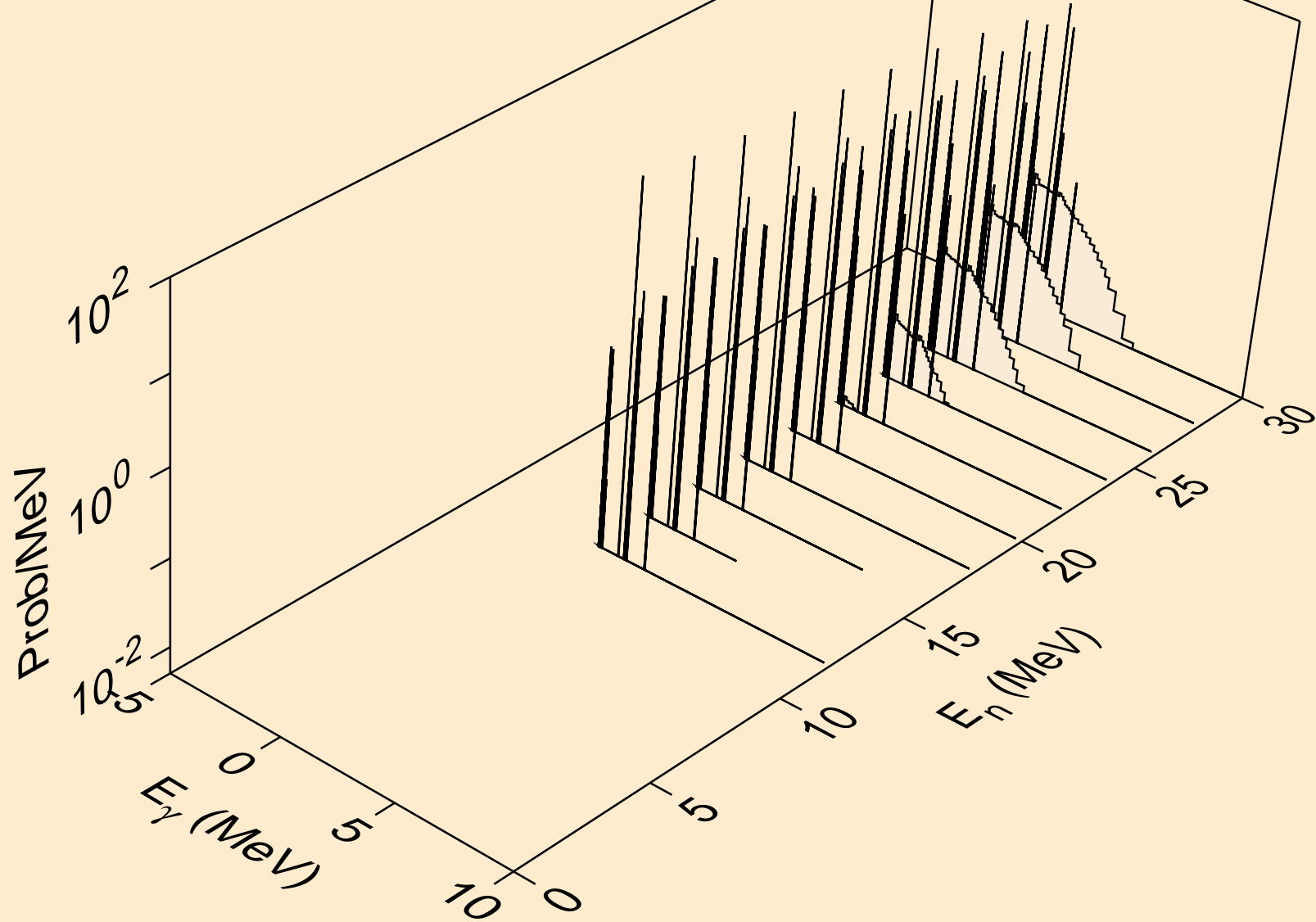

PT204 ALPHA ACER TENDL-2023 LIBRARY; T=0.K
Particle heating contributions

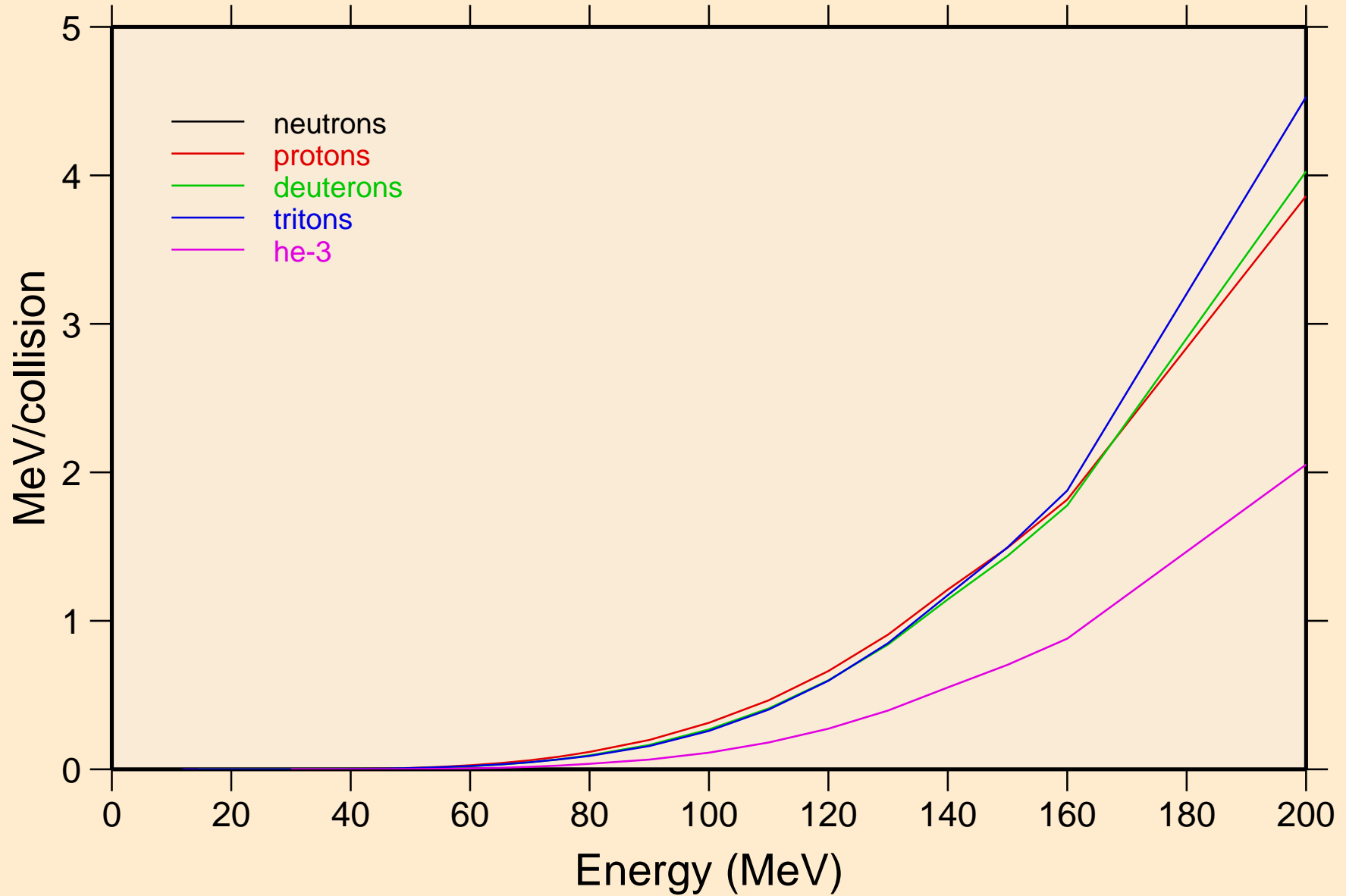

PT204 ALPHA ACER TENDL-2023 LIBRARY; T=0.K
Recoil Heating

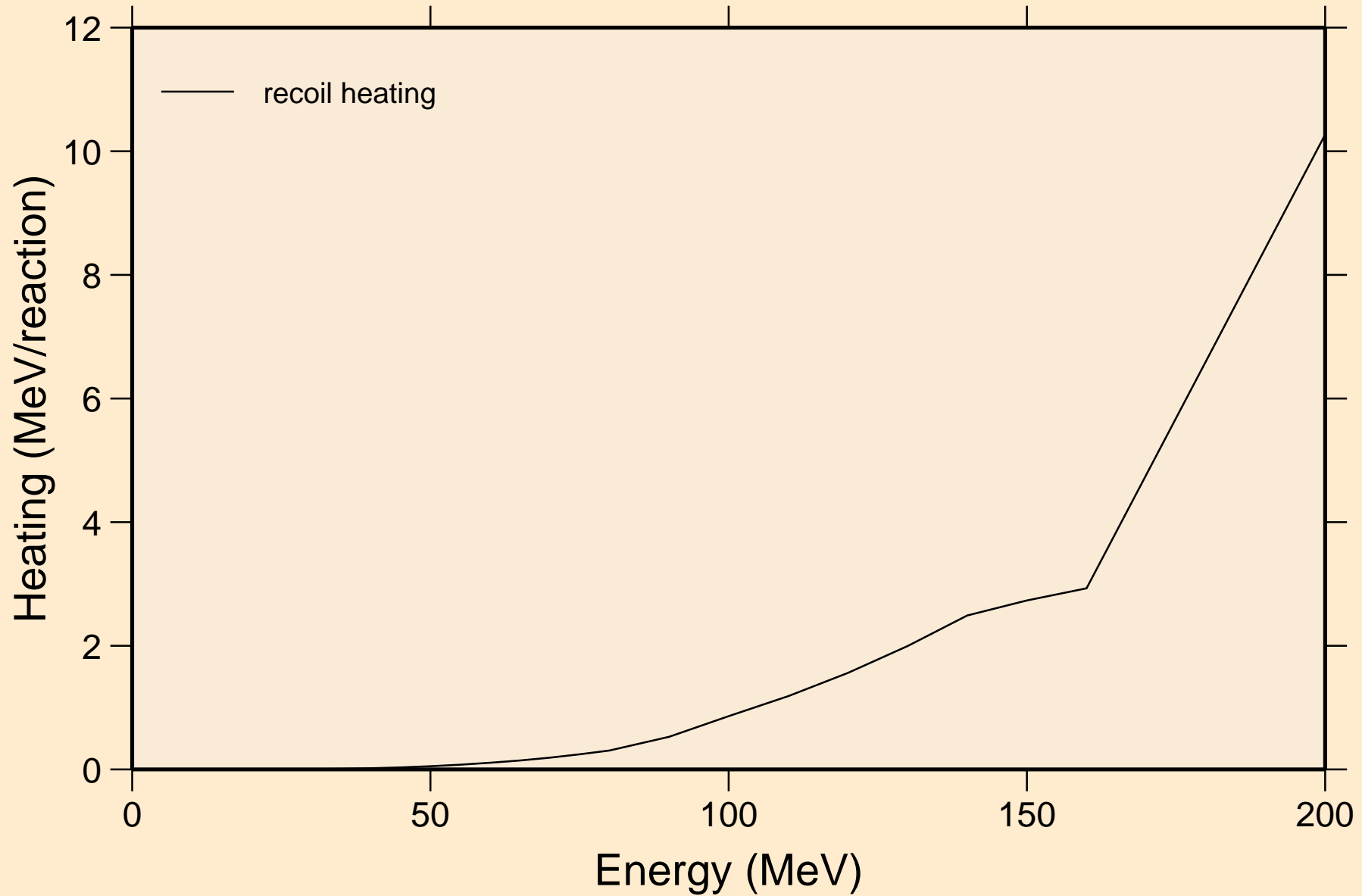

PT204 ALPHA ACER TENDL-2023 LIBRARY; T=0.K
Particle production cross sections

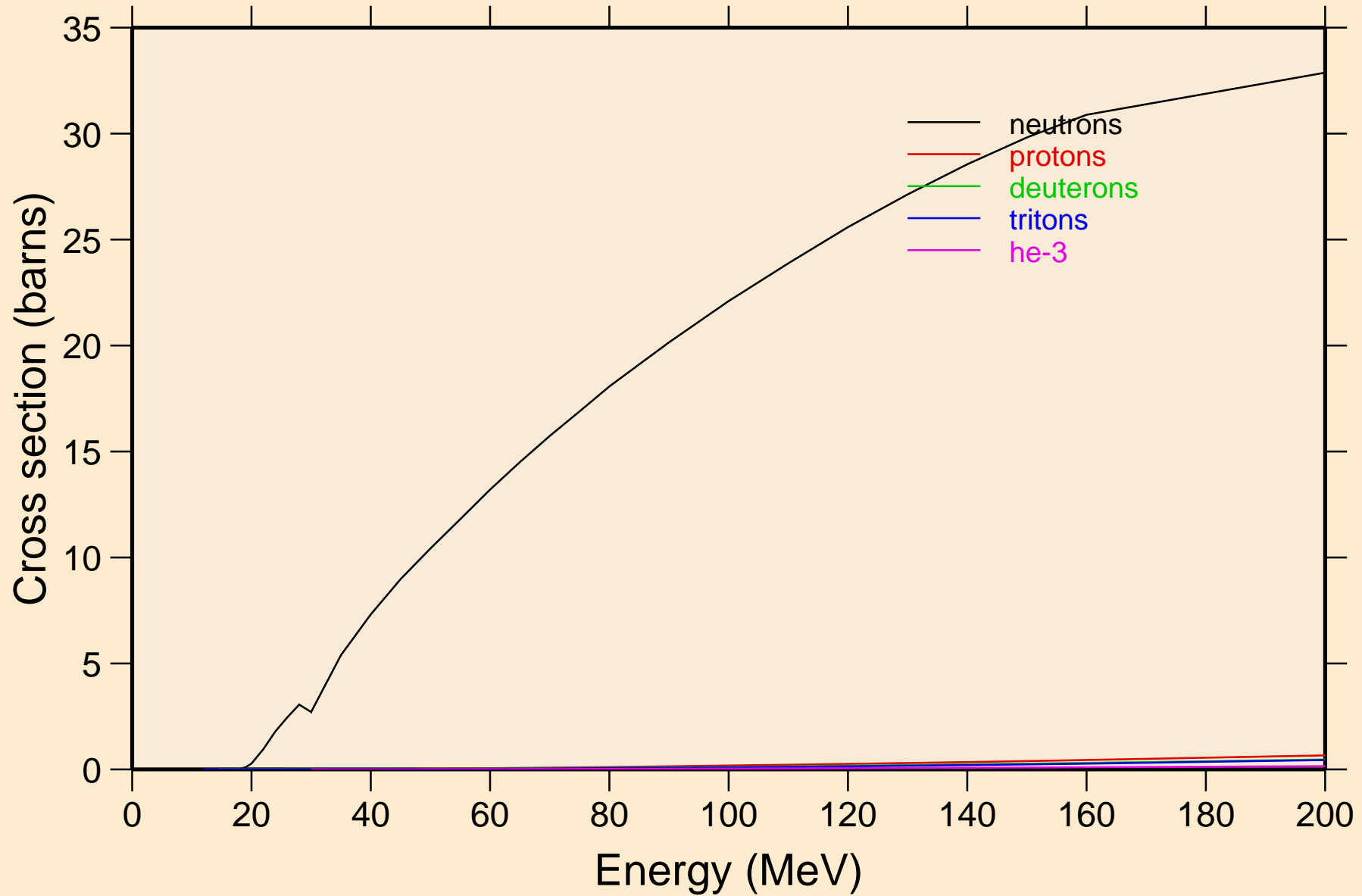

PT204 ALPHA ACER TENDL-2023 LIBRARY; T=0.K
neutrons from (a,n)

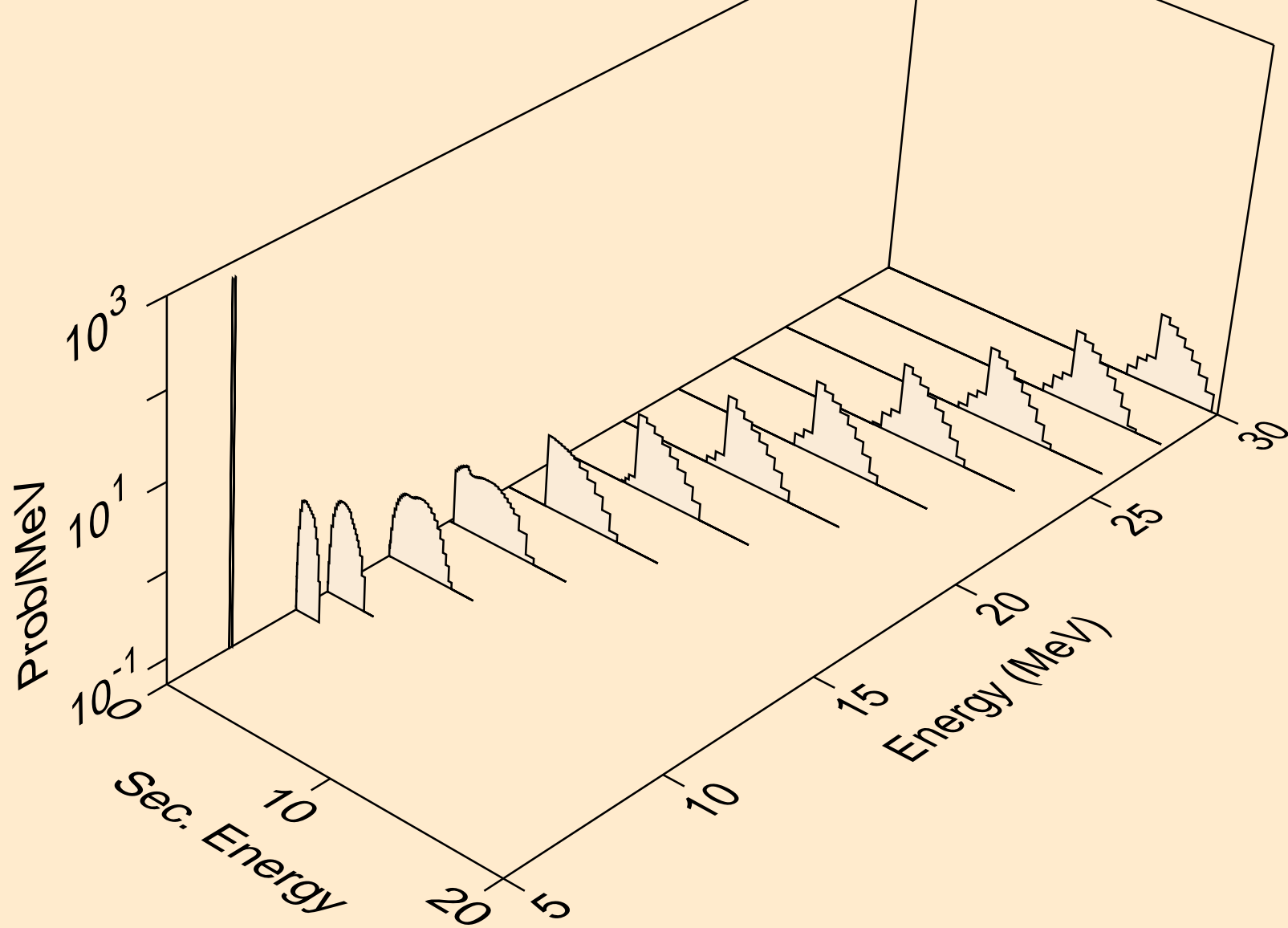

PT204 ALPHA ACER TENDL-2023 LIBRARY; T=0.K
neutrons from (a,x)

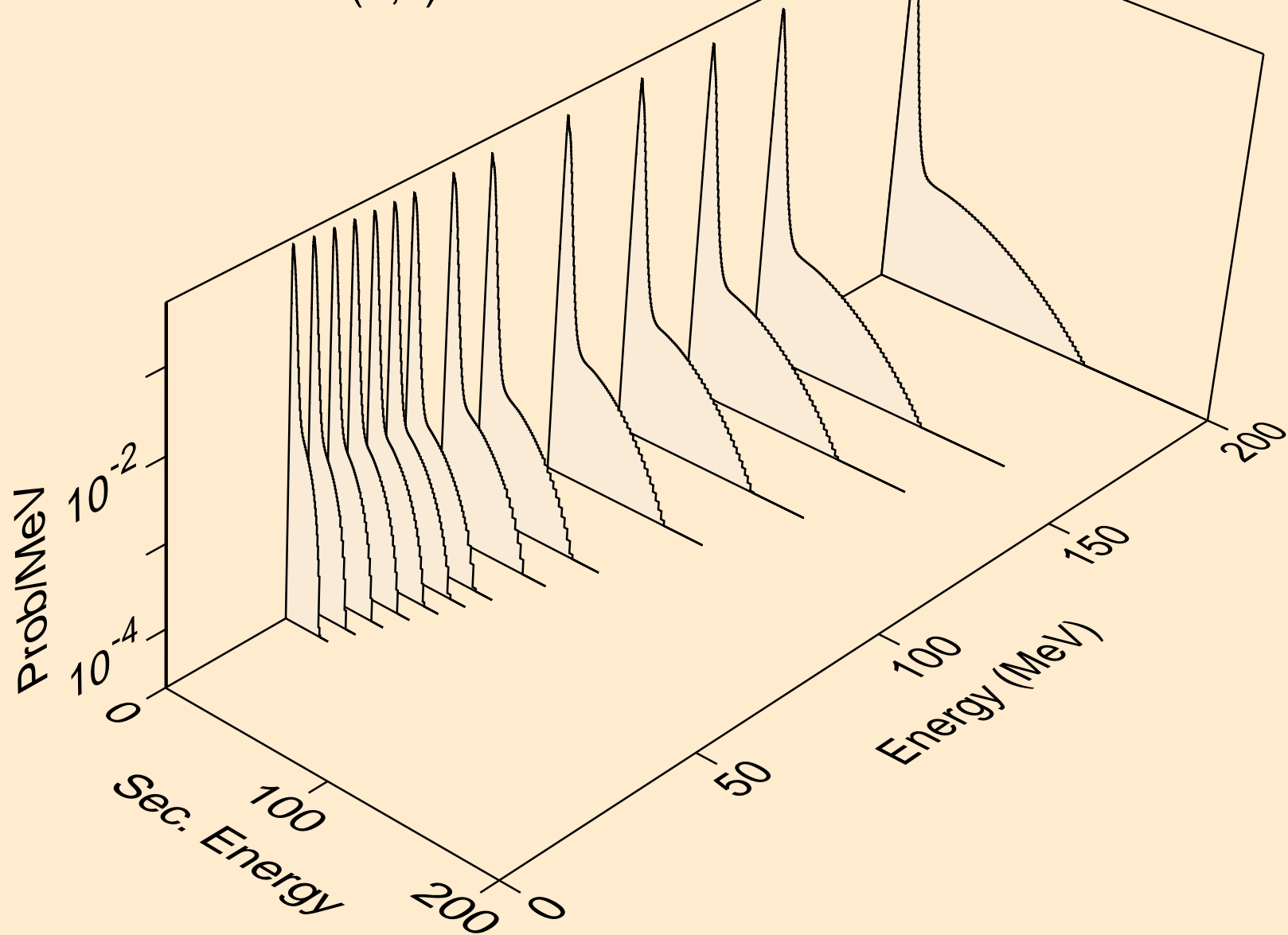

PT204 ALPHA ACER TENDL-2023 LIBRARY; T=0.K
neutrons from (a,2n)

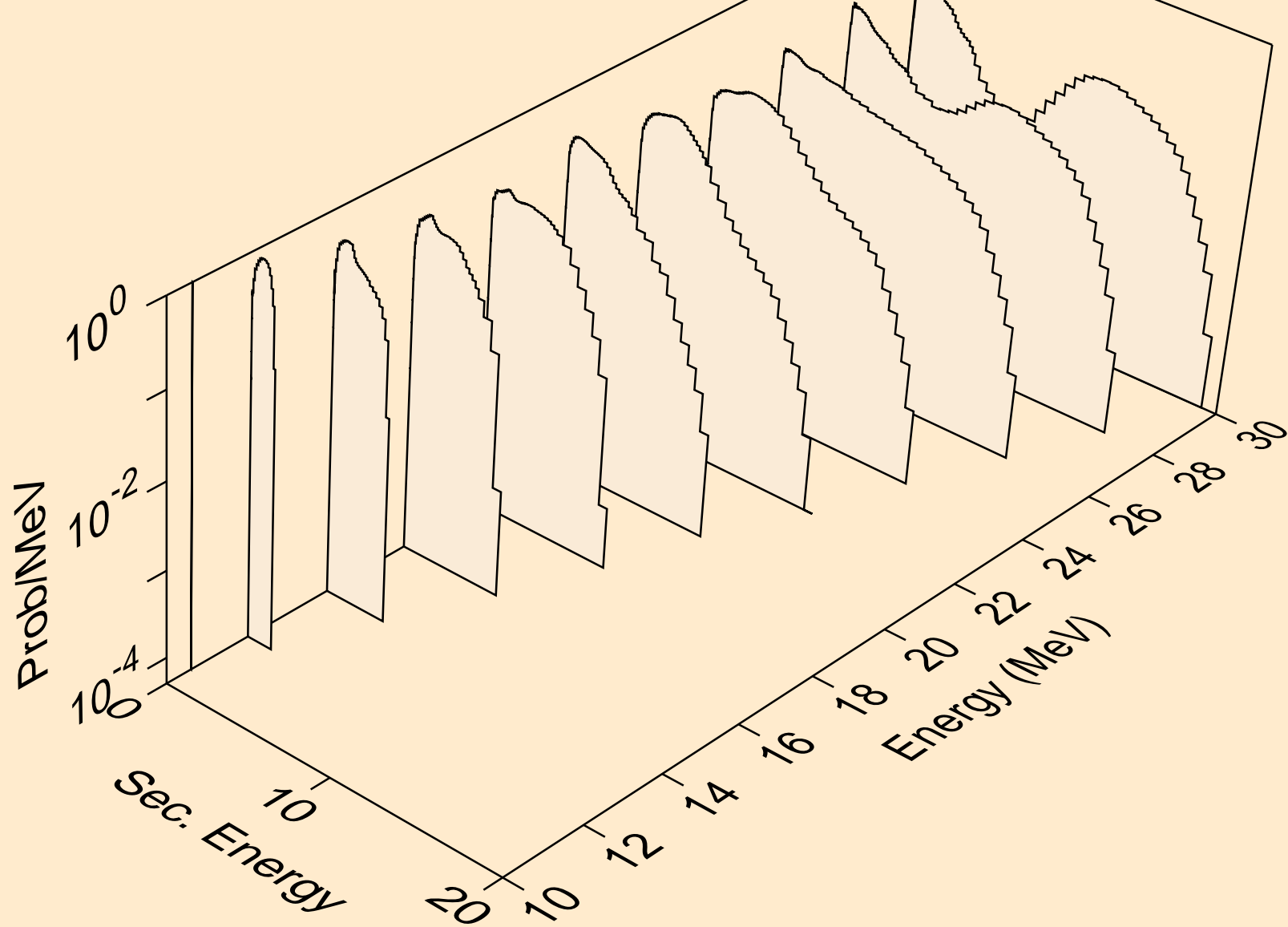

PT204 ALPHA ACER TENDL-2023 LIBRARY; T=0.K
neutrons from (a,3n)

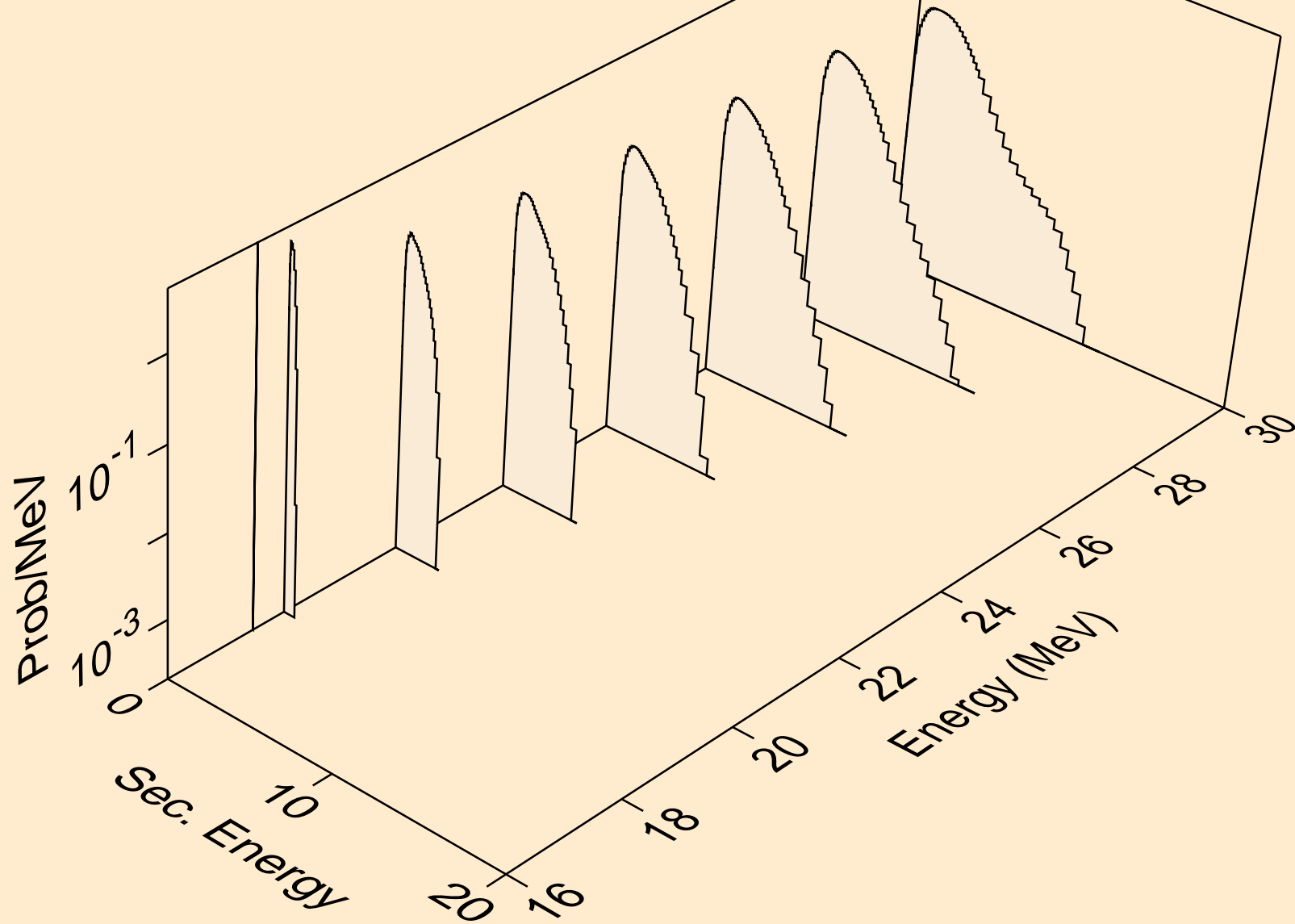

PT204 ALPHA ACER TENDL-2023 LIBRARY; T=0.K
neutrons from (a,n*)a

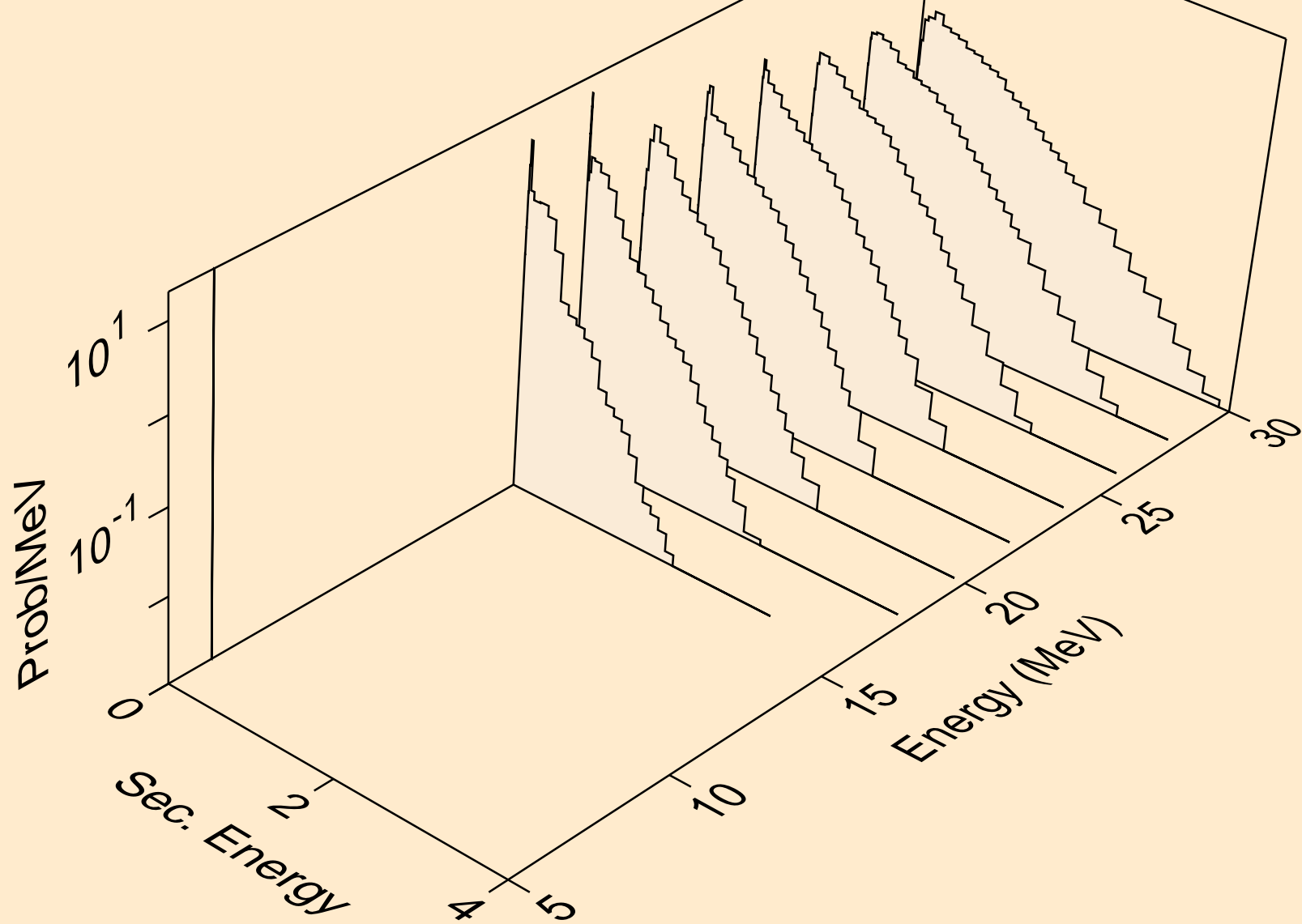

PT204 ALPHA ACER TENDL-2023 LIBRARY; T=0.K
neutrons from (a,2n)a

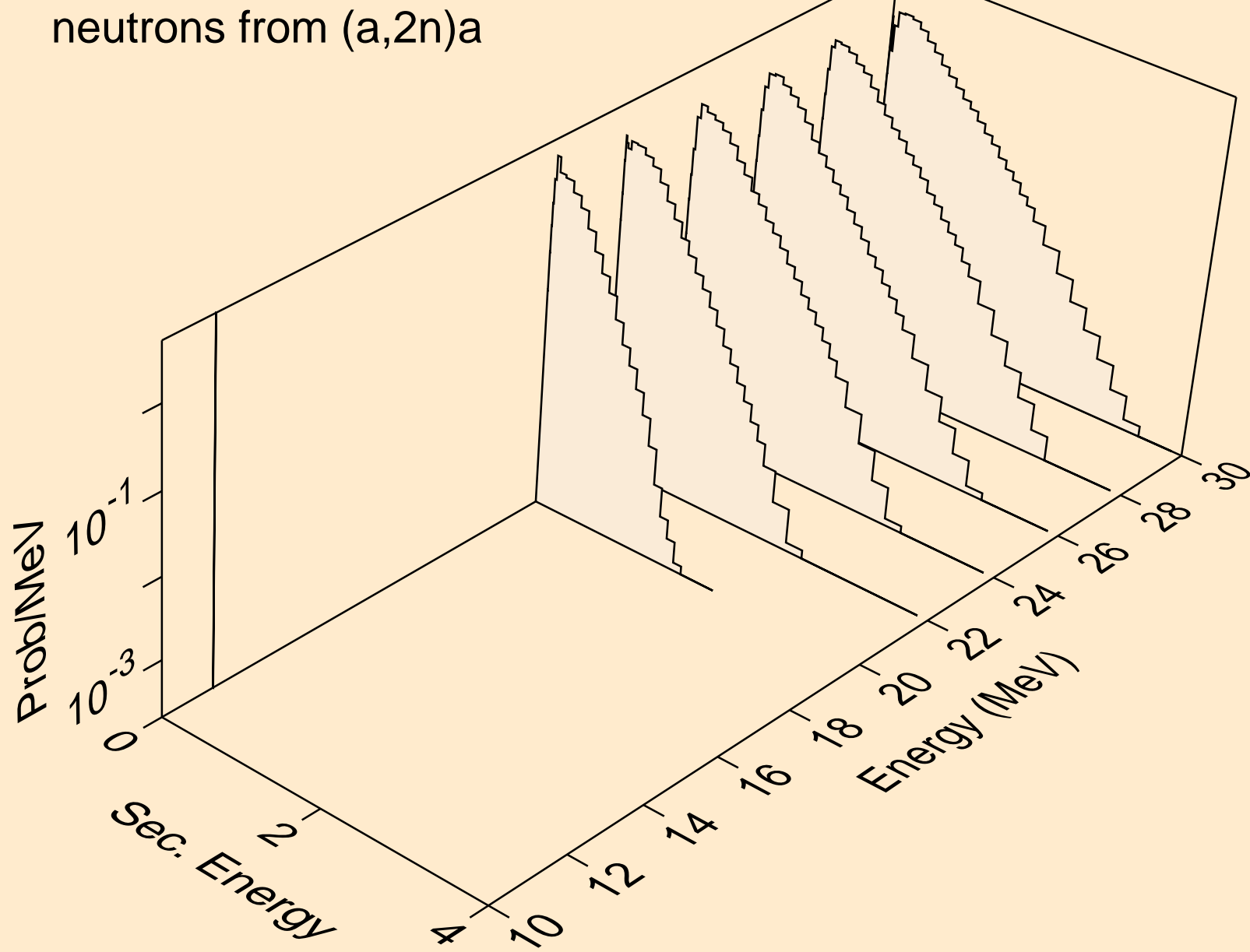

PT204 ALPHA ACER TENDL-2023 LIBRARY; T=0.K
neutrons from (a,n*)p

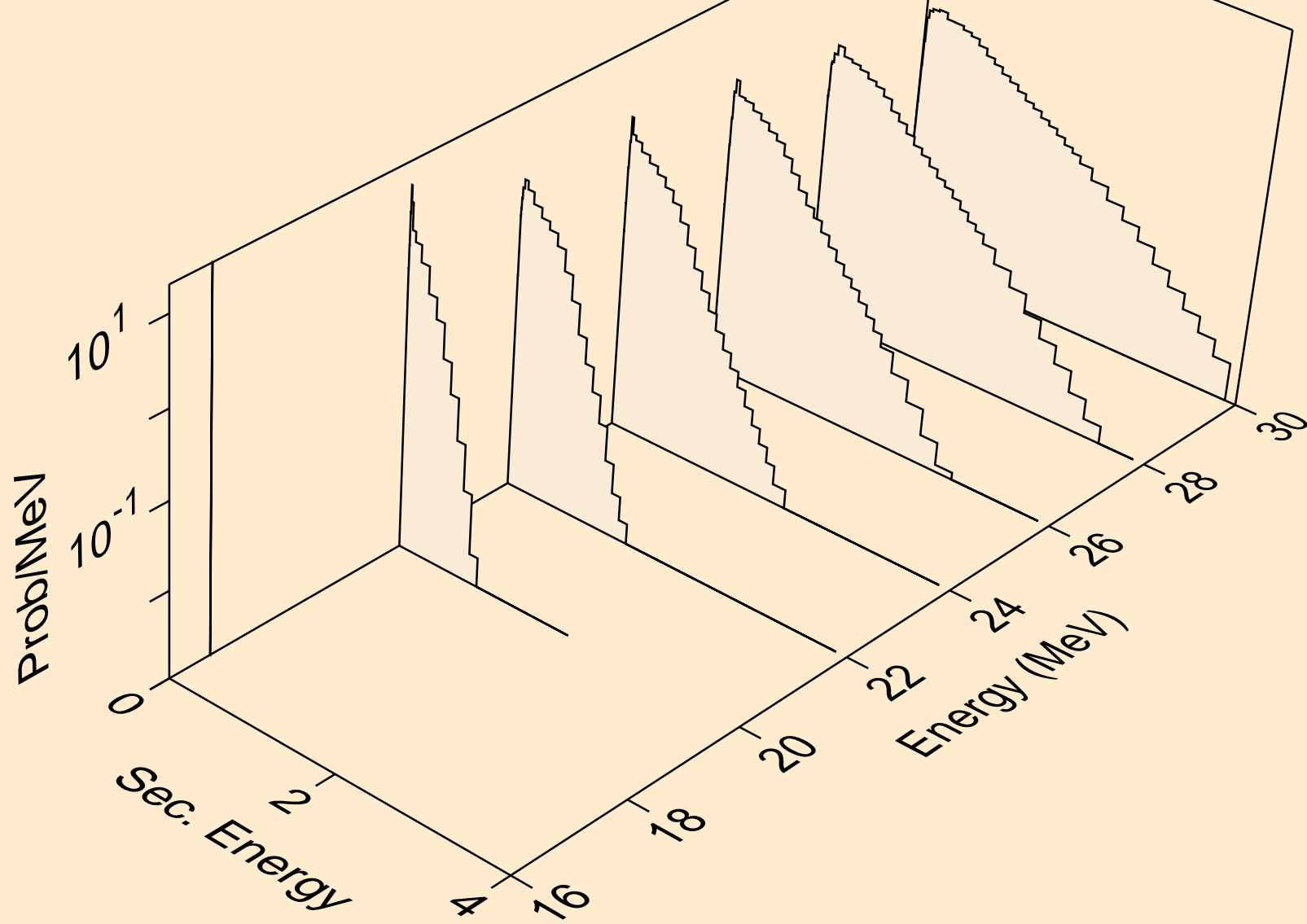

PT204 ALPHA ACER TENDL-2023 LIBRARY; T=0.K
neutrons from (a,n*)d

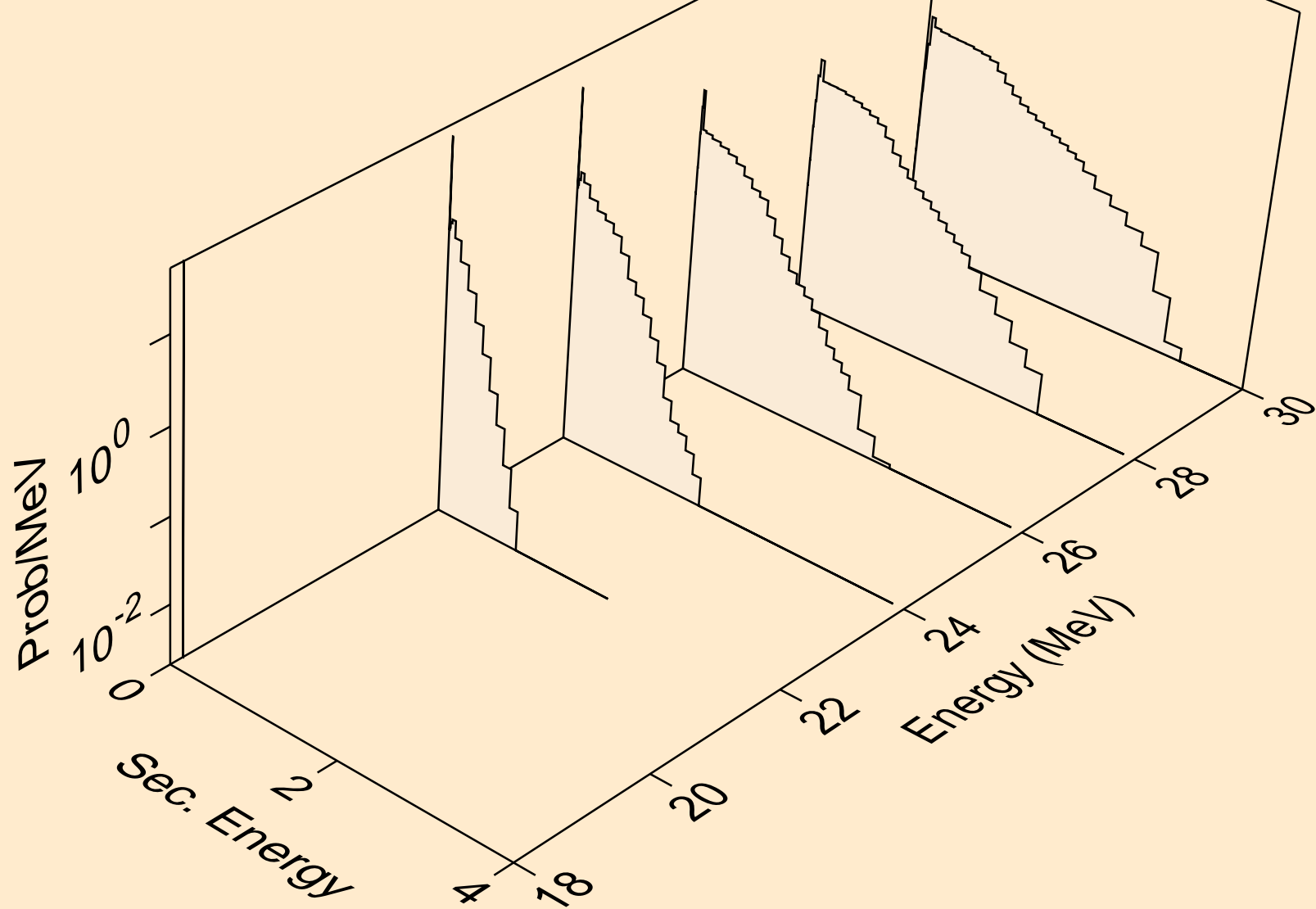

PT204 ALPHA ACER TENDL-2023 LIBRARY; T=0.K
neutrons from (a,n*)t

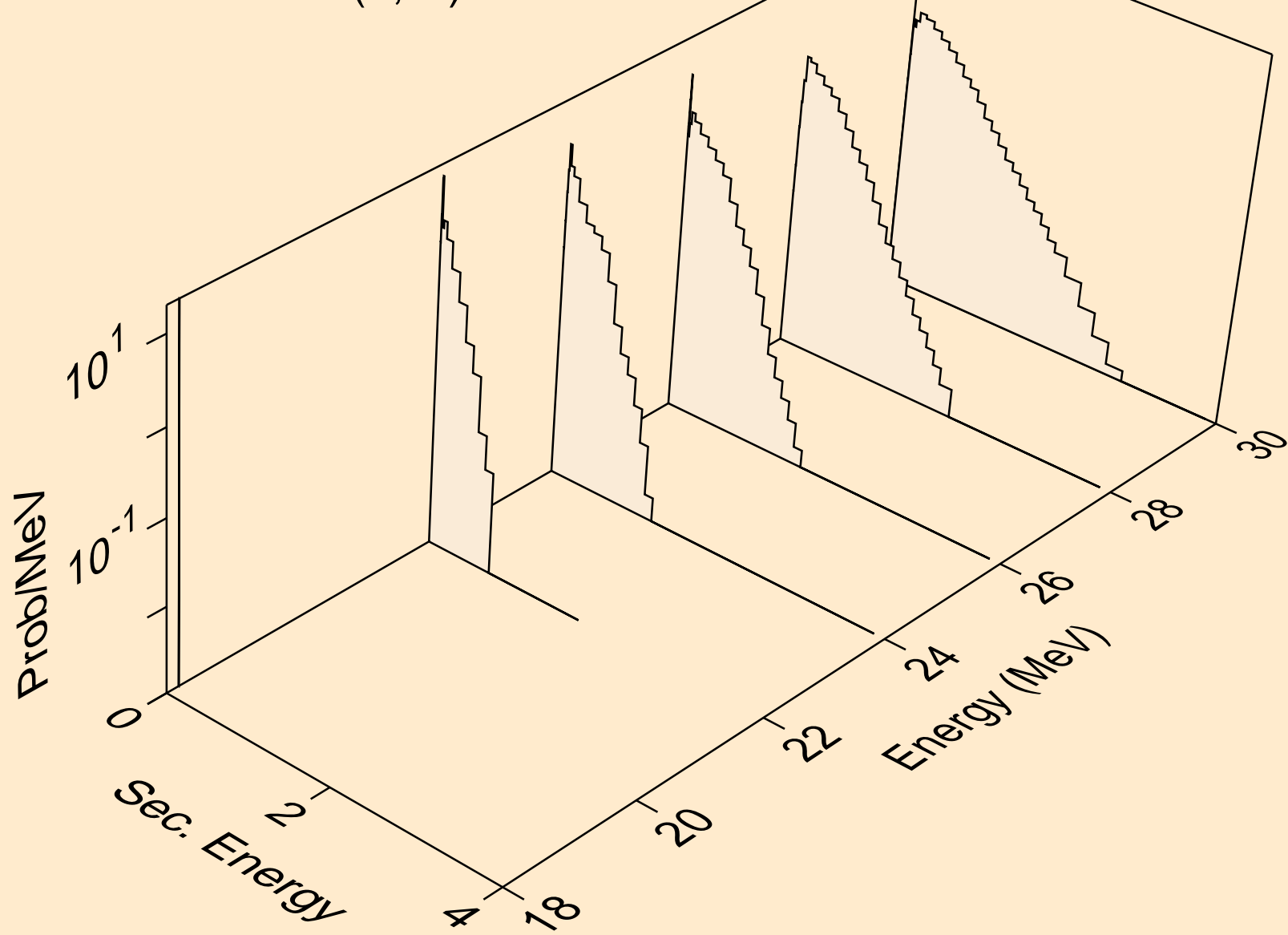

PT204 ALPHA ACER TENDL-2023 LIBRARY; T=0.K
neutrons from (a,4n)

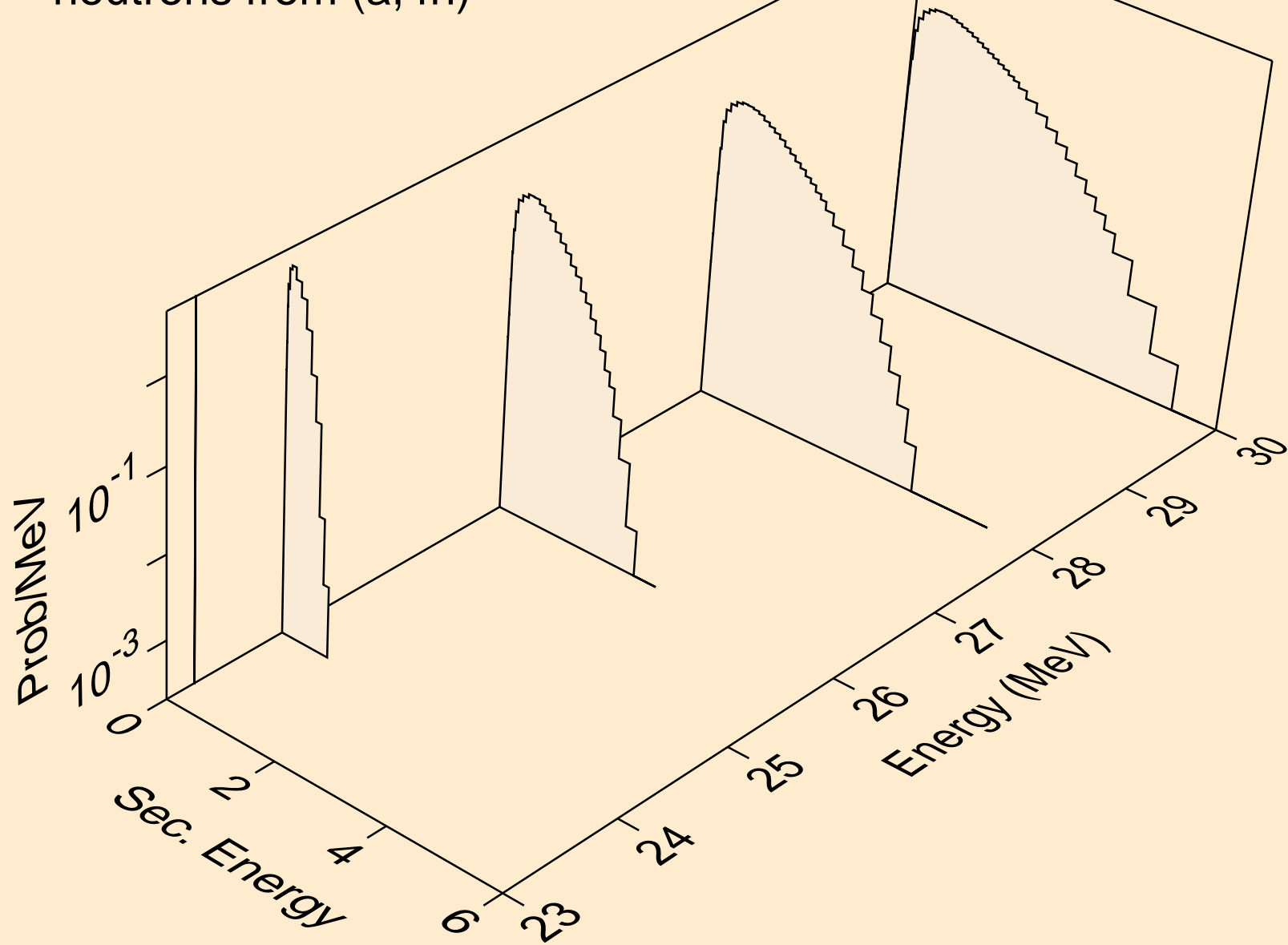

PT204 ALPHA ACER TENDL-2023 LIBRARY; T=0.K
neutrons from (a,2np)

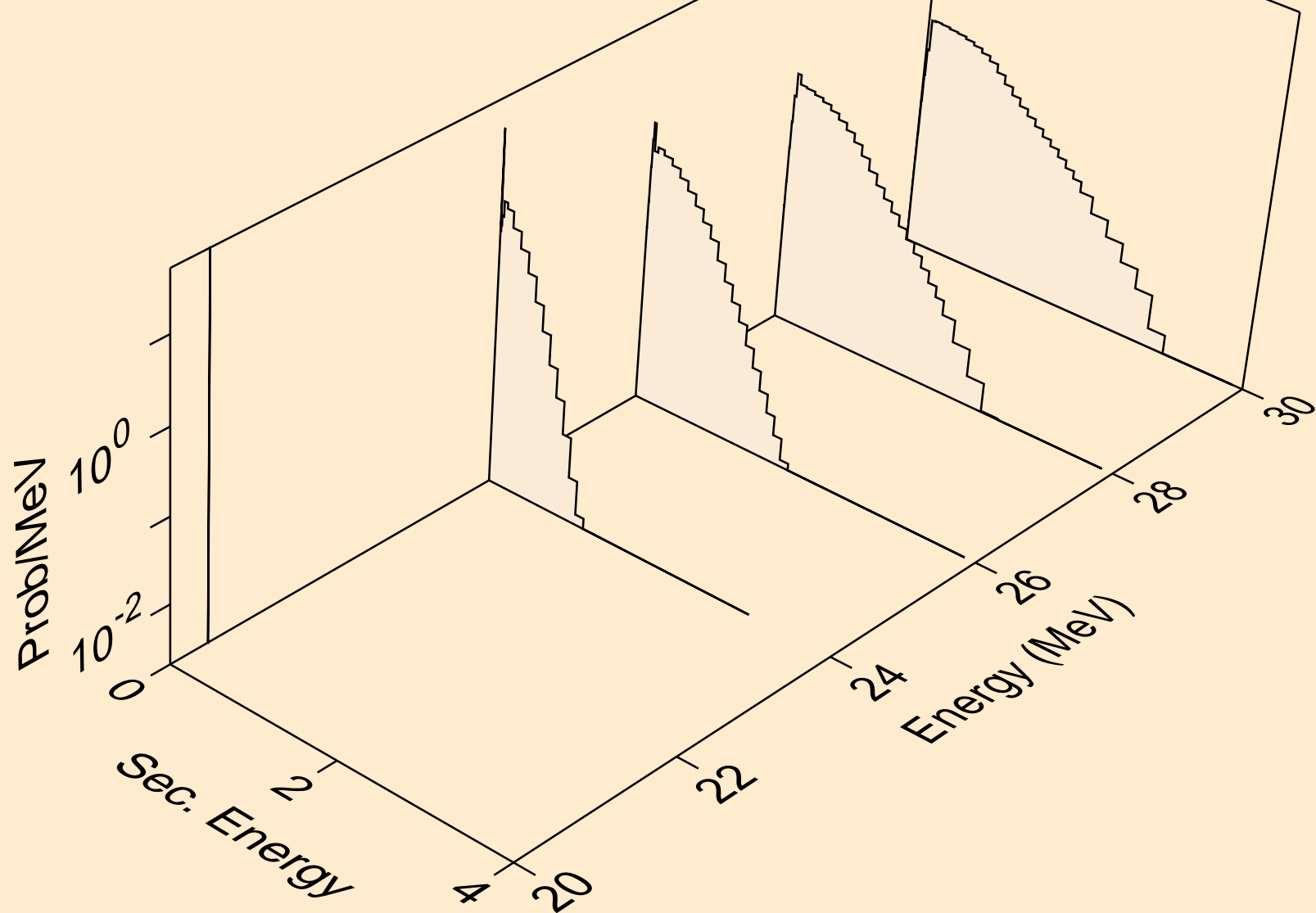

PT204 ALPHA ACER TENDL-2023 LIBRARY; T=0.K
protons from (a,x)

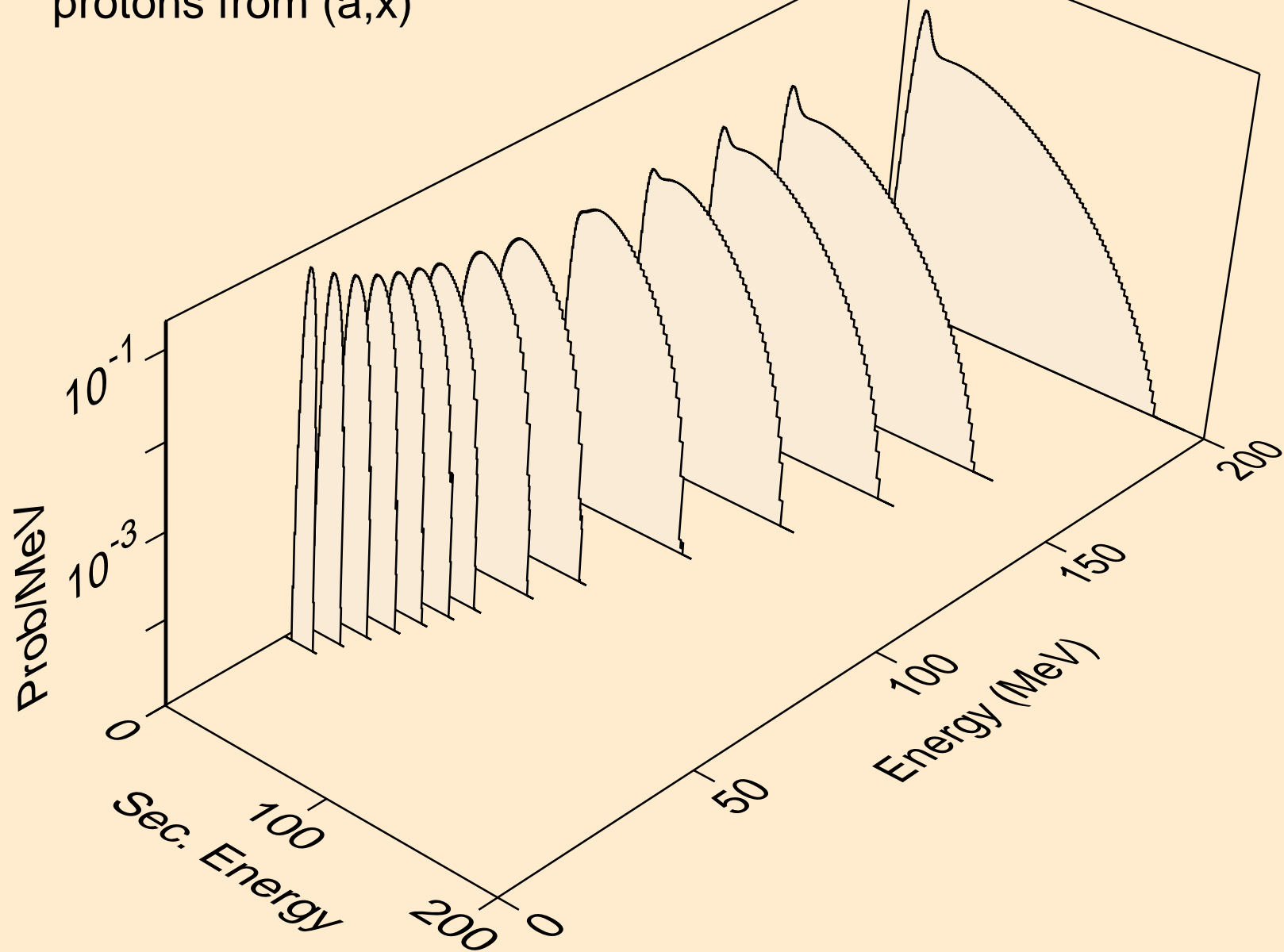

PT204 ALPHA ACER TENDL-2023 LIBRARY; T=0.K
protons from (a,n*)p

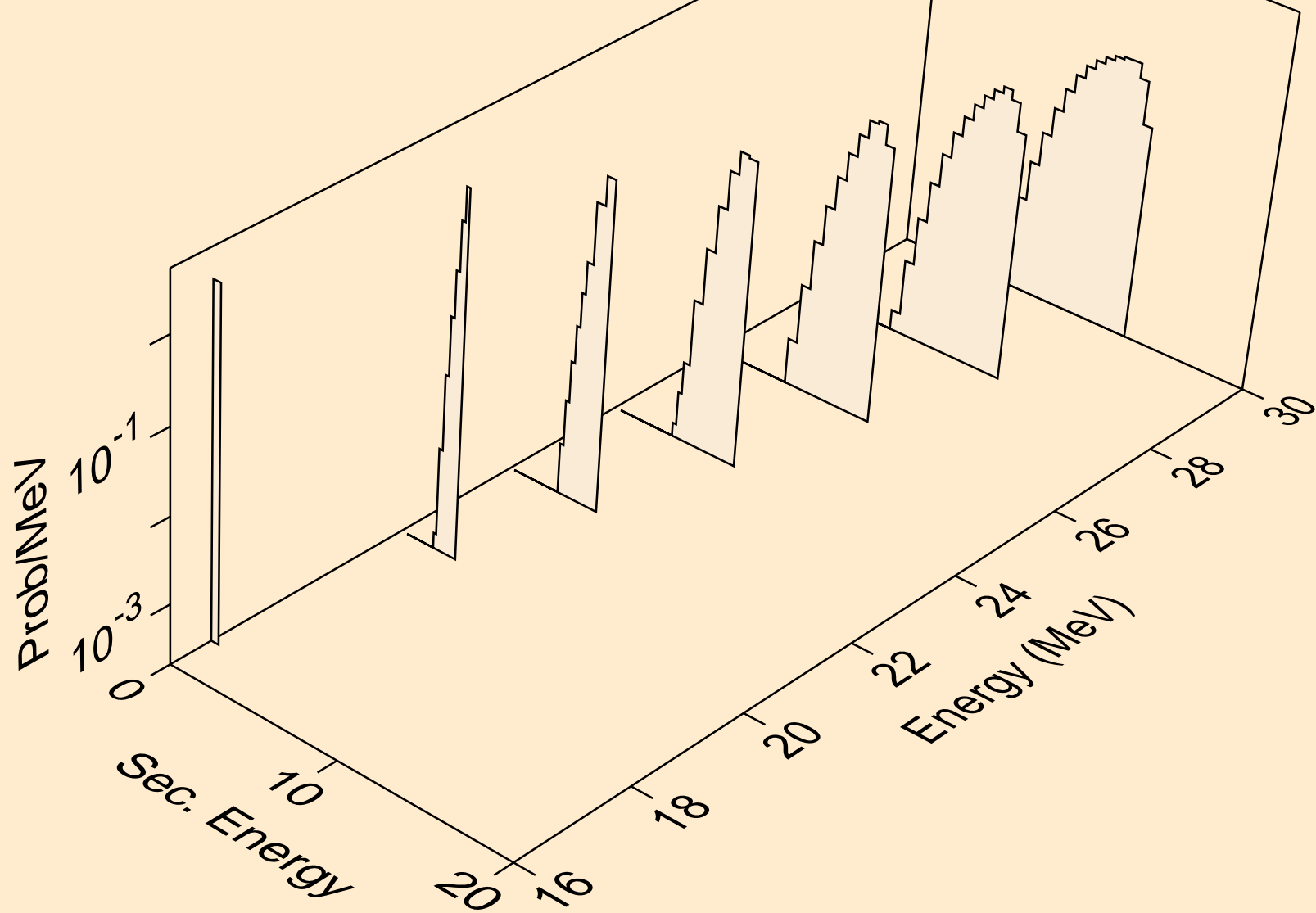

PT204 ALPHA ACER TENDL-2023 LIBRARY; T=0.K
protons from (a,2np)

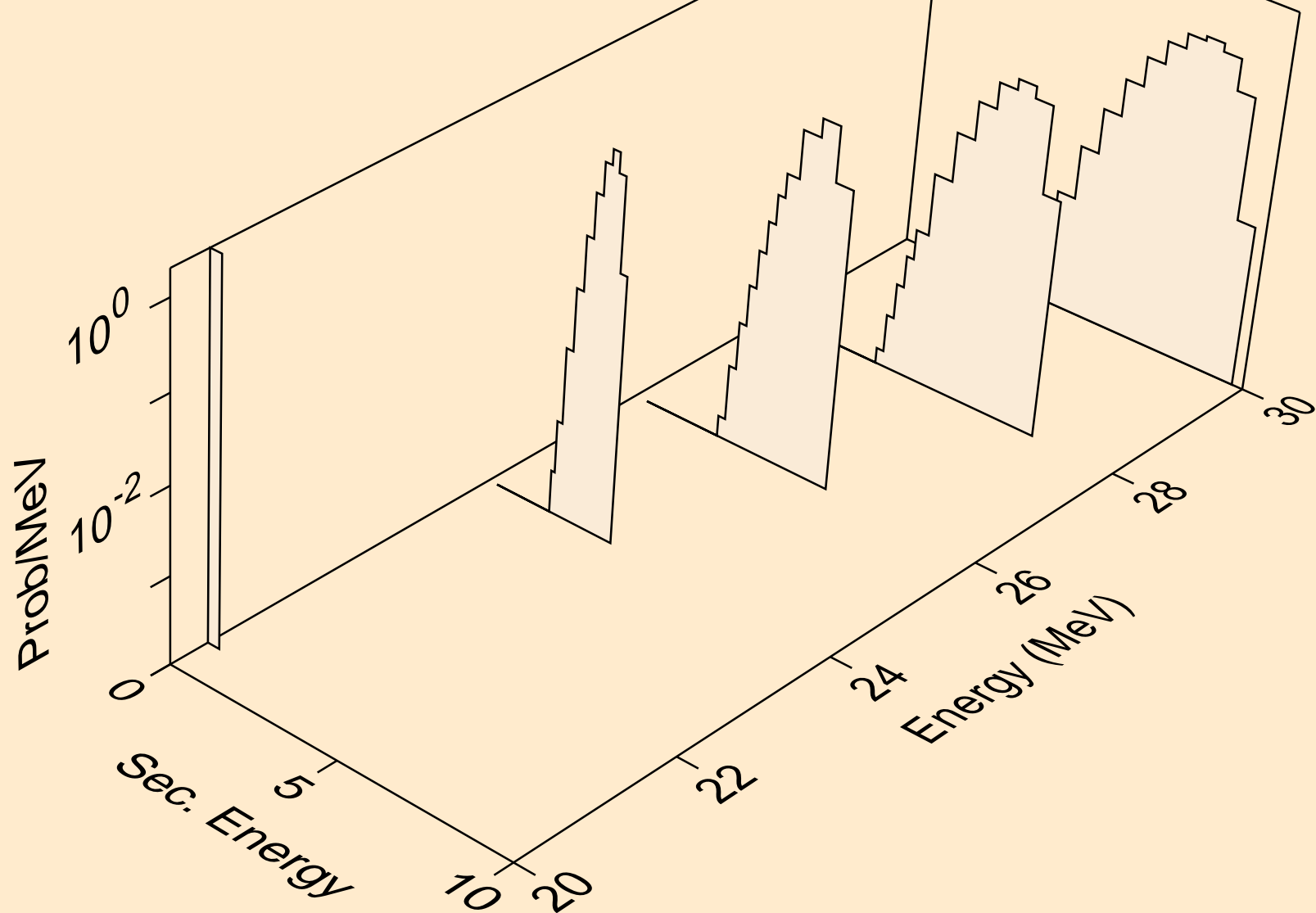

PT204 ALPHA ACER TENDL-2023 LIBRARY; T=0.K
protons from (a,p)

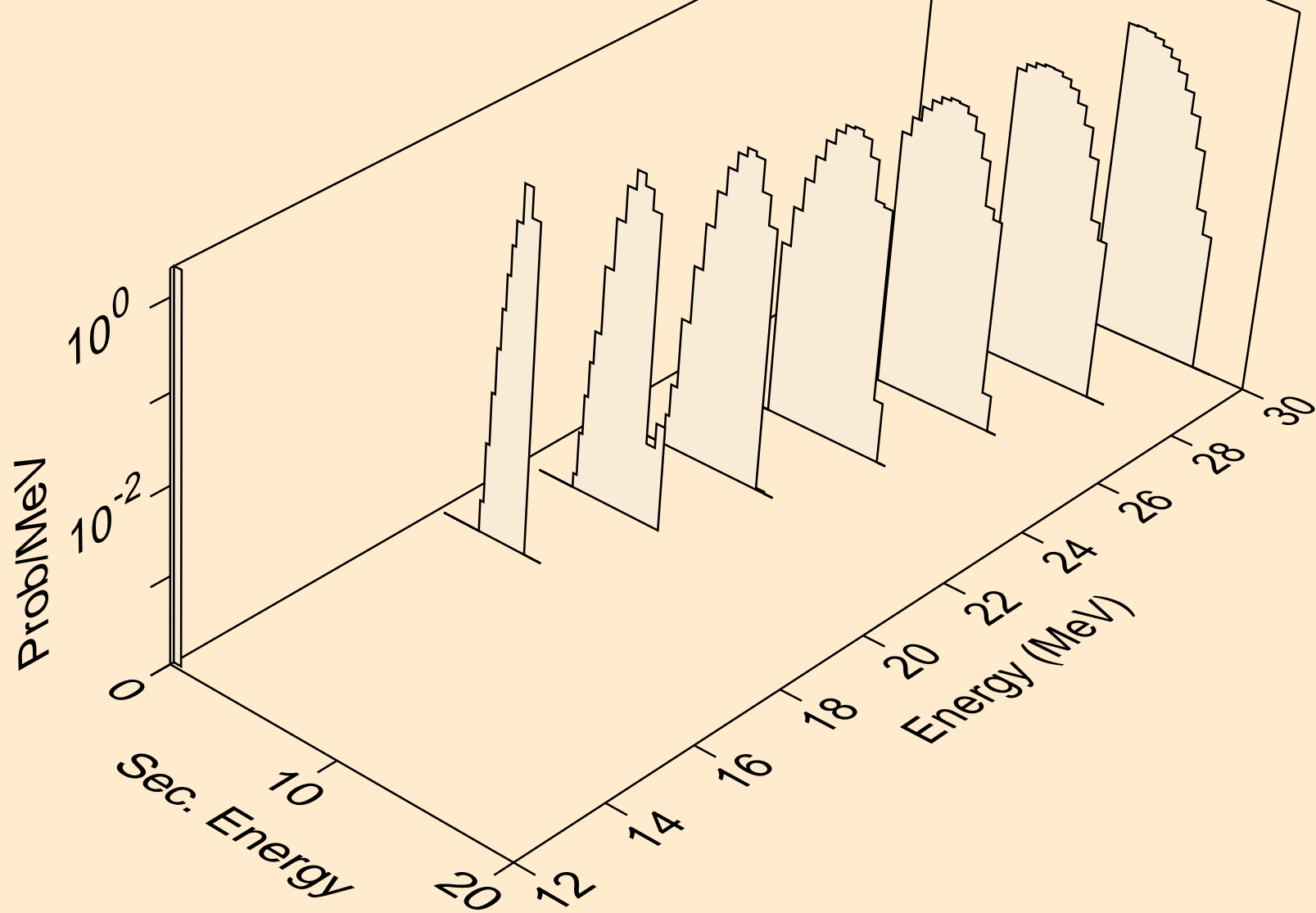

PT204 ALPHA ACER TENDL-2023 LIBRARY; T=0.K
deuterons from (a,x)

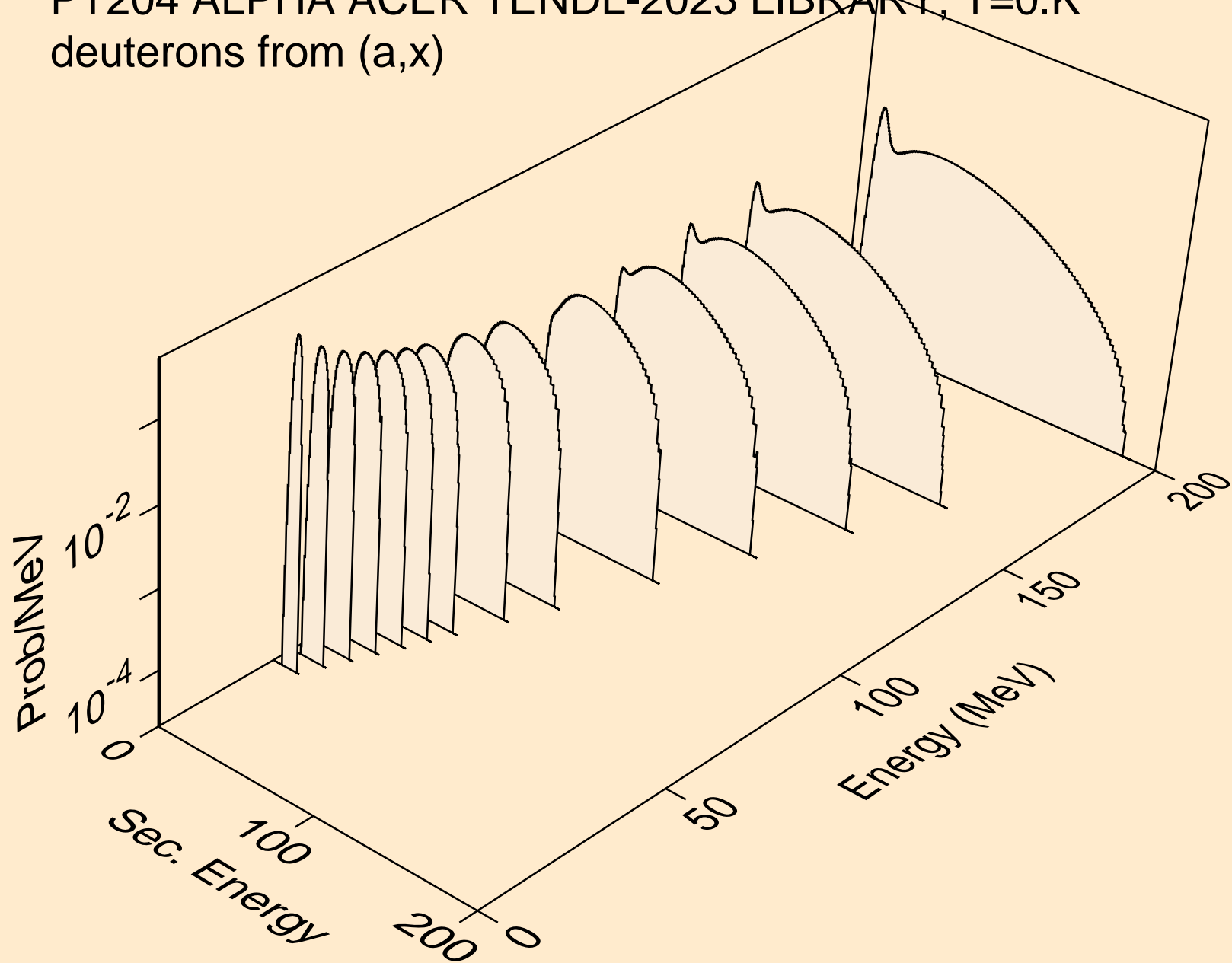

PT204 ALPHA ACER TENDL-2023 LIBRARY; T=0.K
deuterons from (a,n*)d

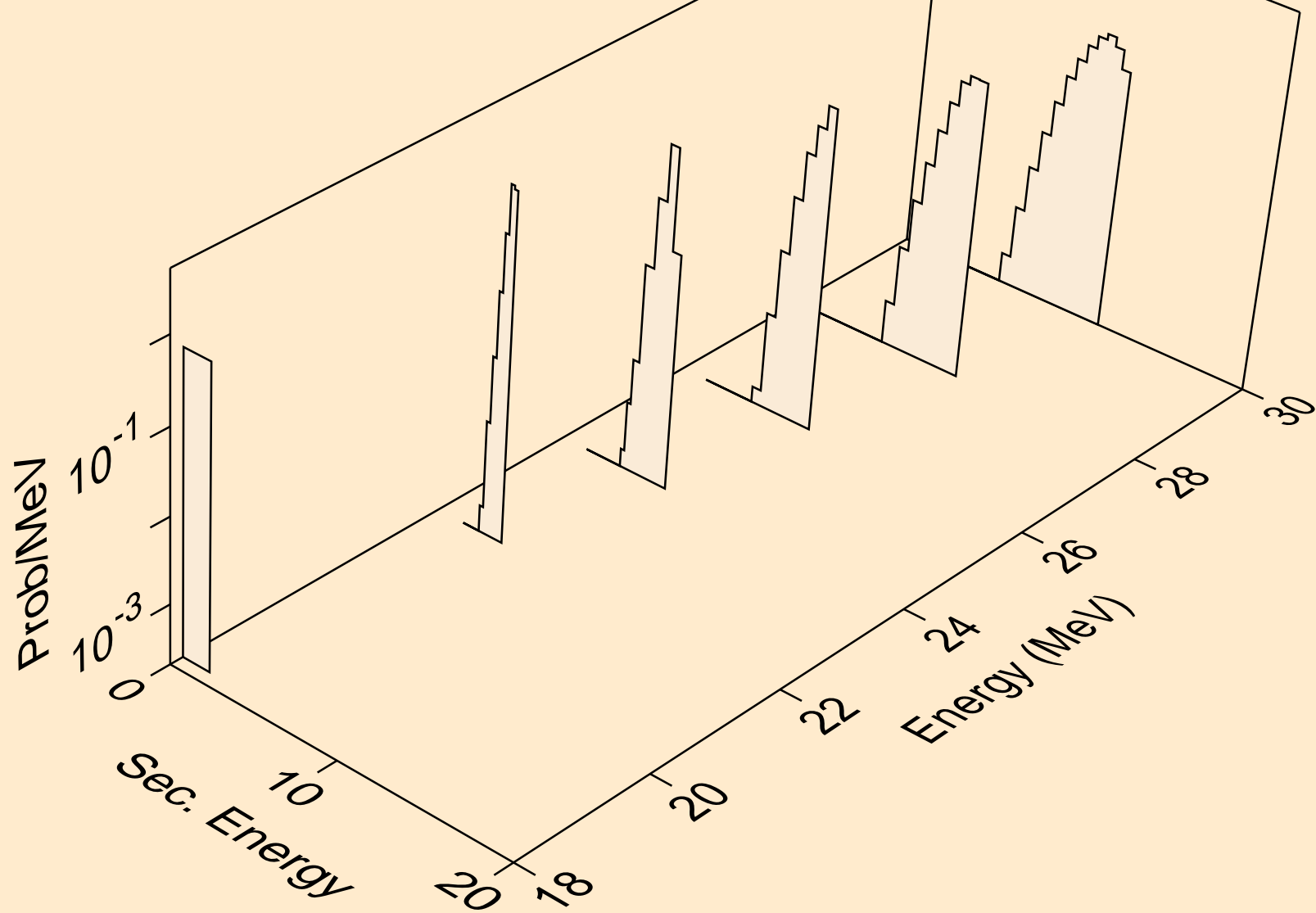

PT204 ALPHA ACER TENDL-2023 LIBRARY; T=0.K
deuterons from (a,d)

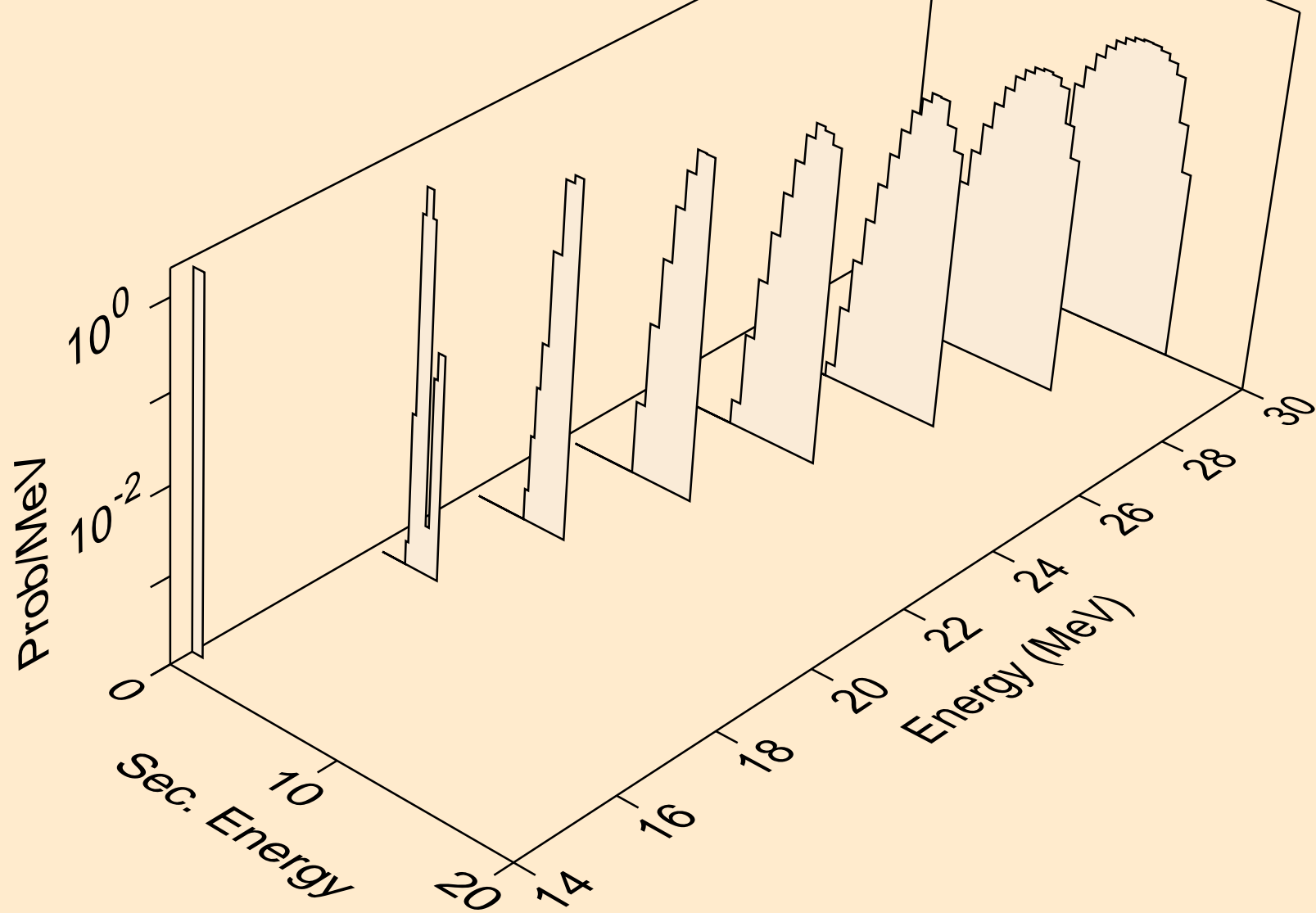

PT204 ALPHA ACER TENDL-2023 LIBRARY; T=0.K
tritons from (a,x)

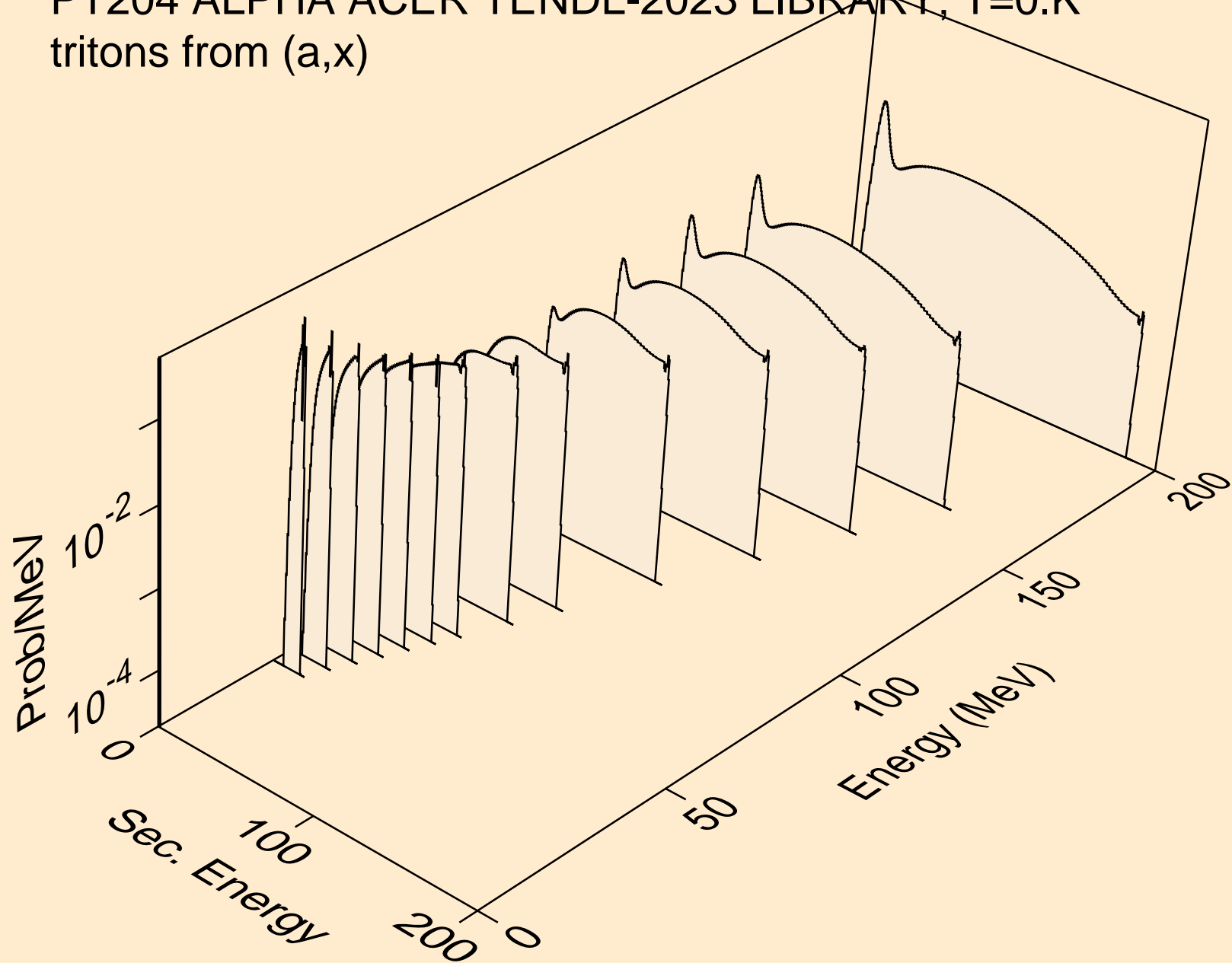

PT204 ALPHA ACER TENDL-2023 LIBRARY; T=0.K
tritons from (a,n*)t

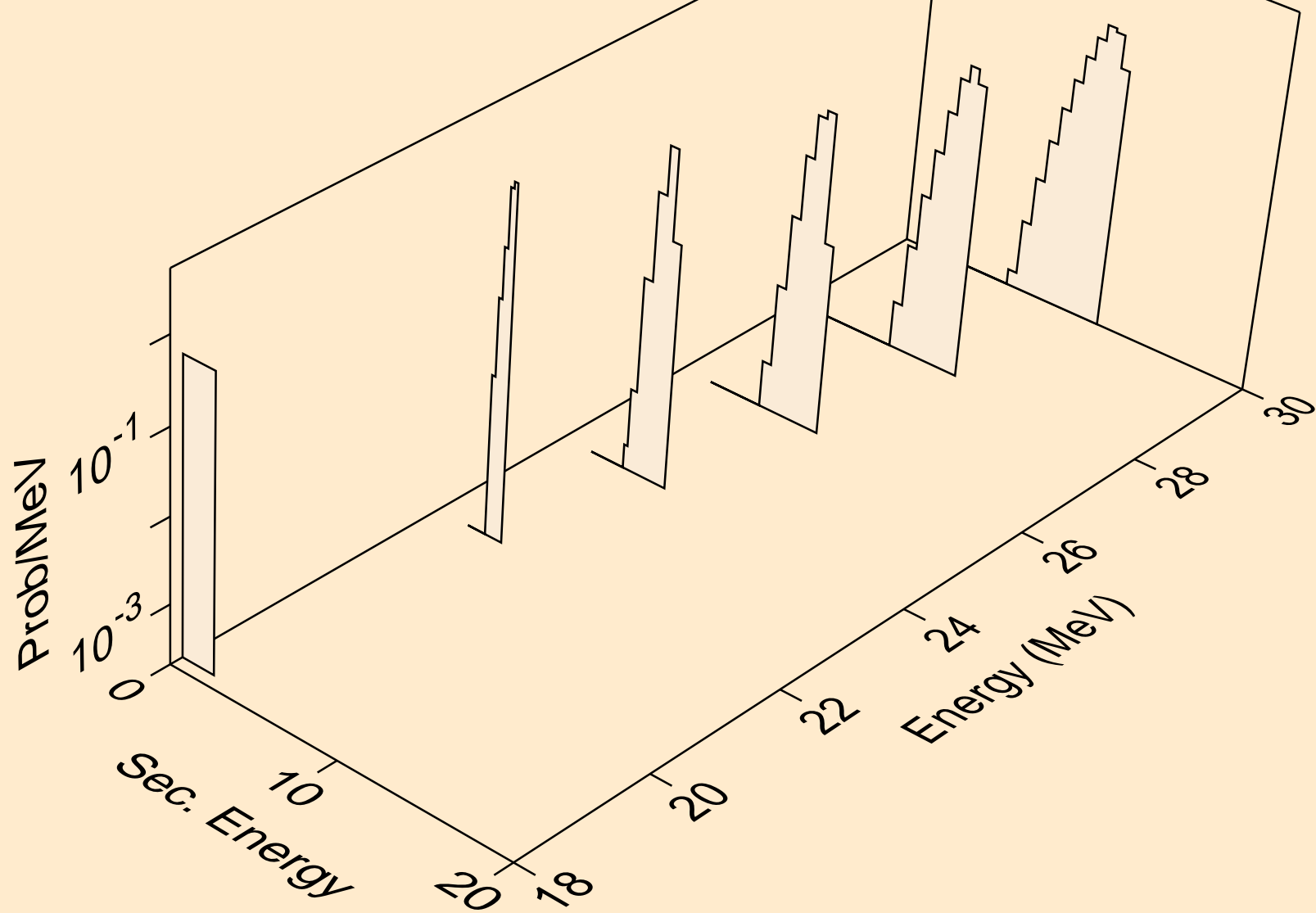

PT204 ALPHA ACER TENDL-2023 LIBRARY; T=0.K
tritons from (a,t)

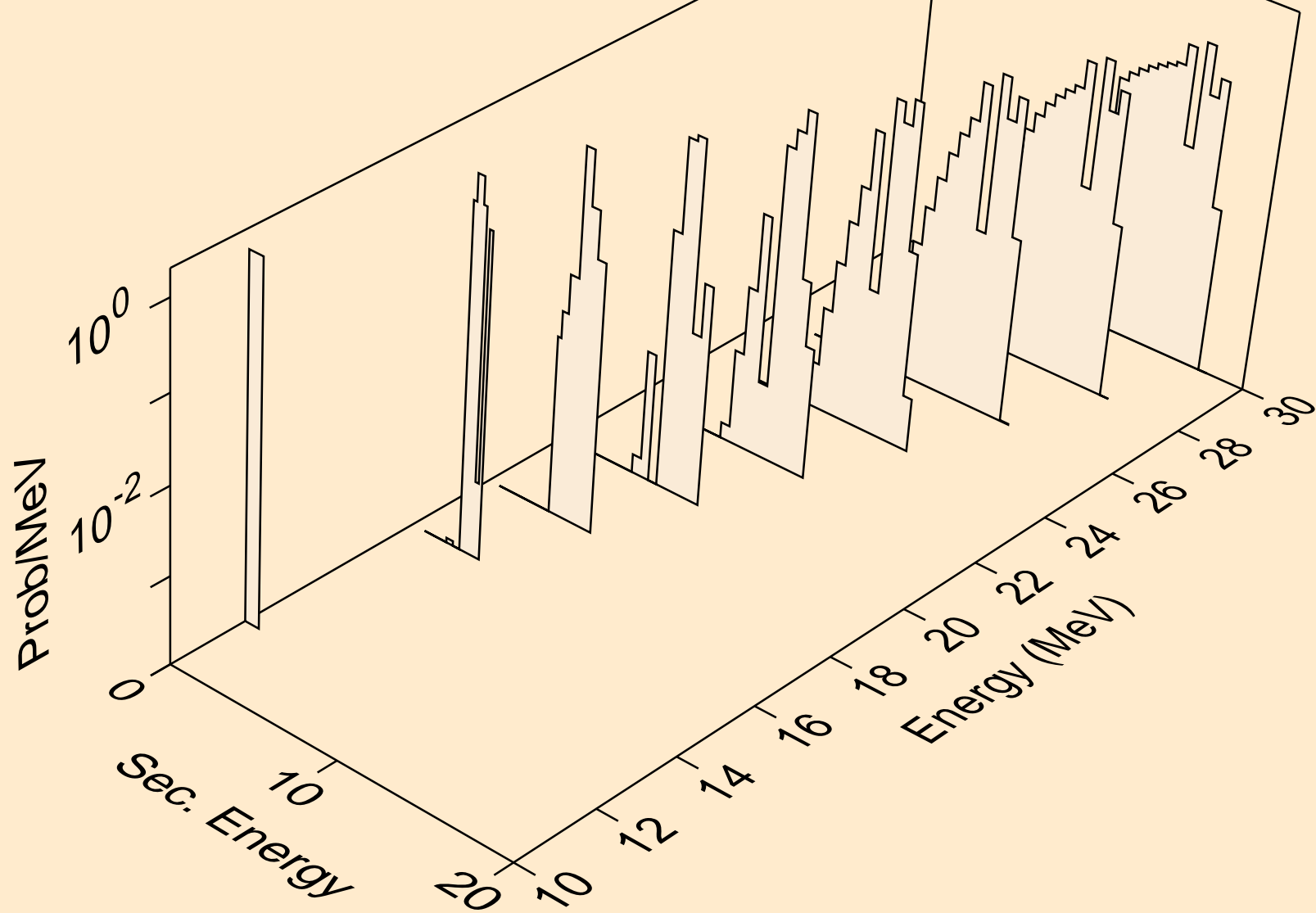

PT204 ALPHA ACER TENDL-2023 LIBRARY; T=0.K
he3s from (a,x)

