

FE052M DEUTERON ACER TENDL-2023 LIBRARY; T=0.K  
Principal cross sections

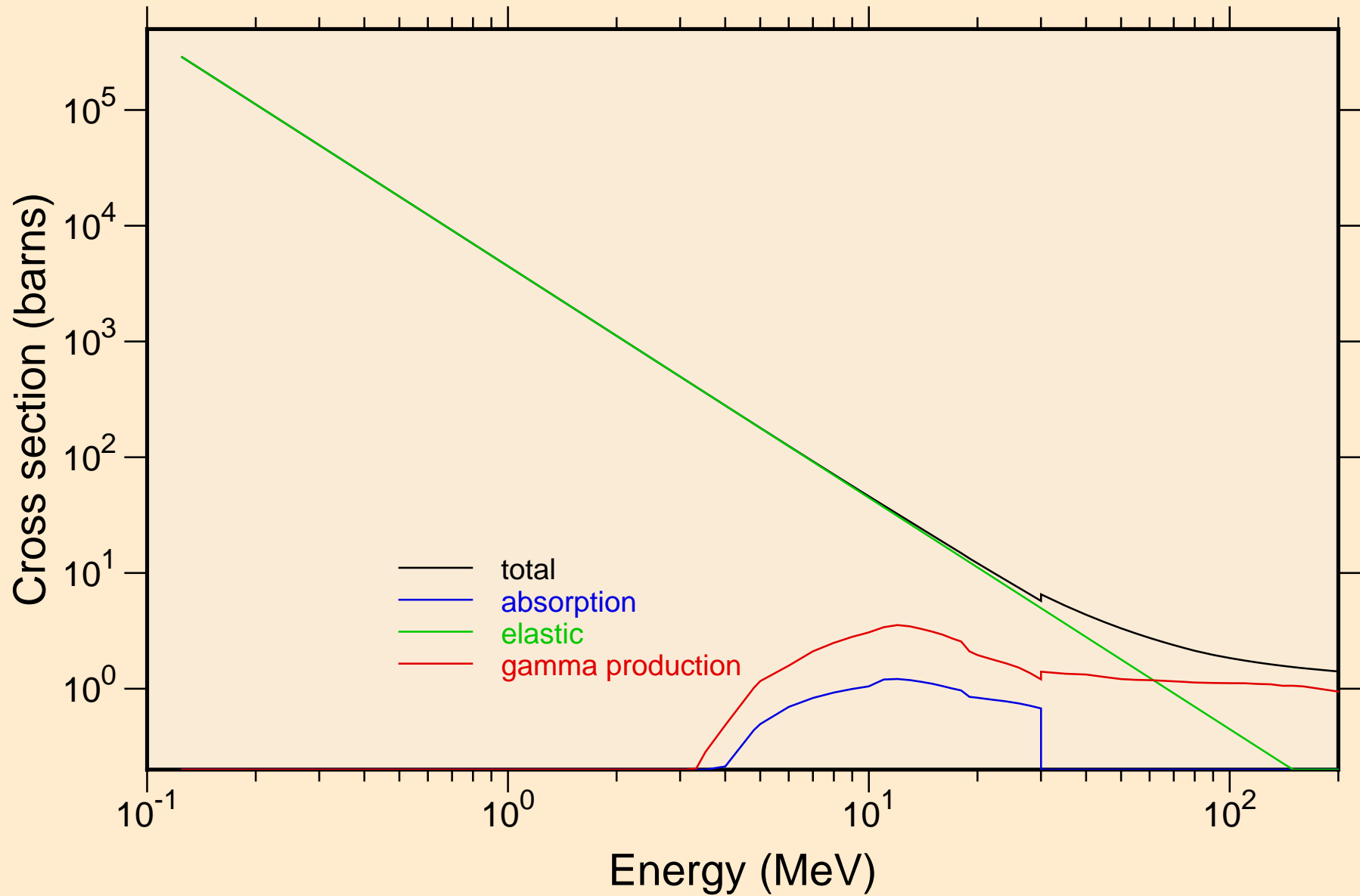

FE052M DEUTERON ACER TENDL-2023 LIBRARY; T=0.K  
Heating

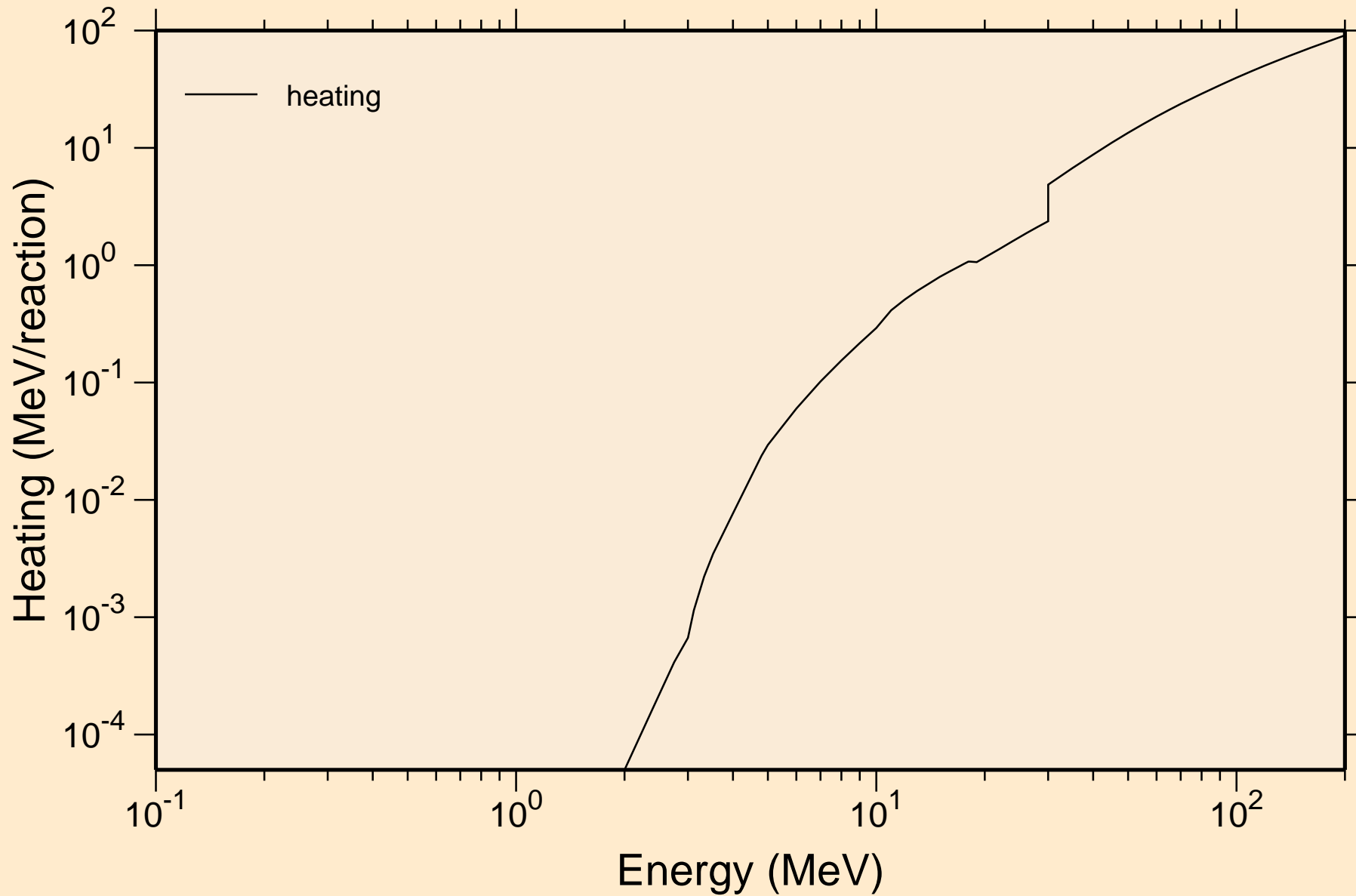

# FE052M DEUTERON ACER TENDL-2023 LIBRARY; T=0.K

## Principal cross sections

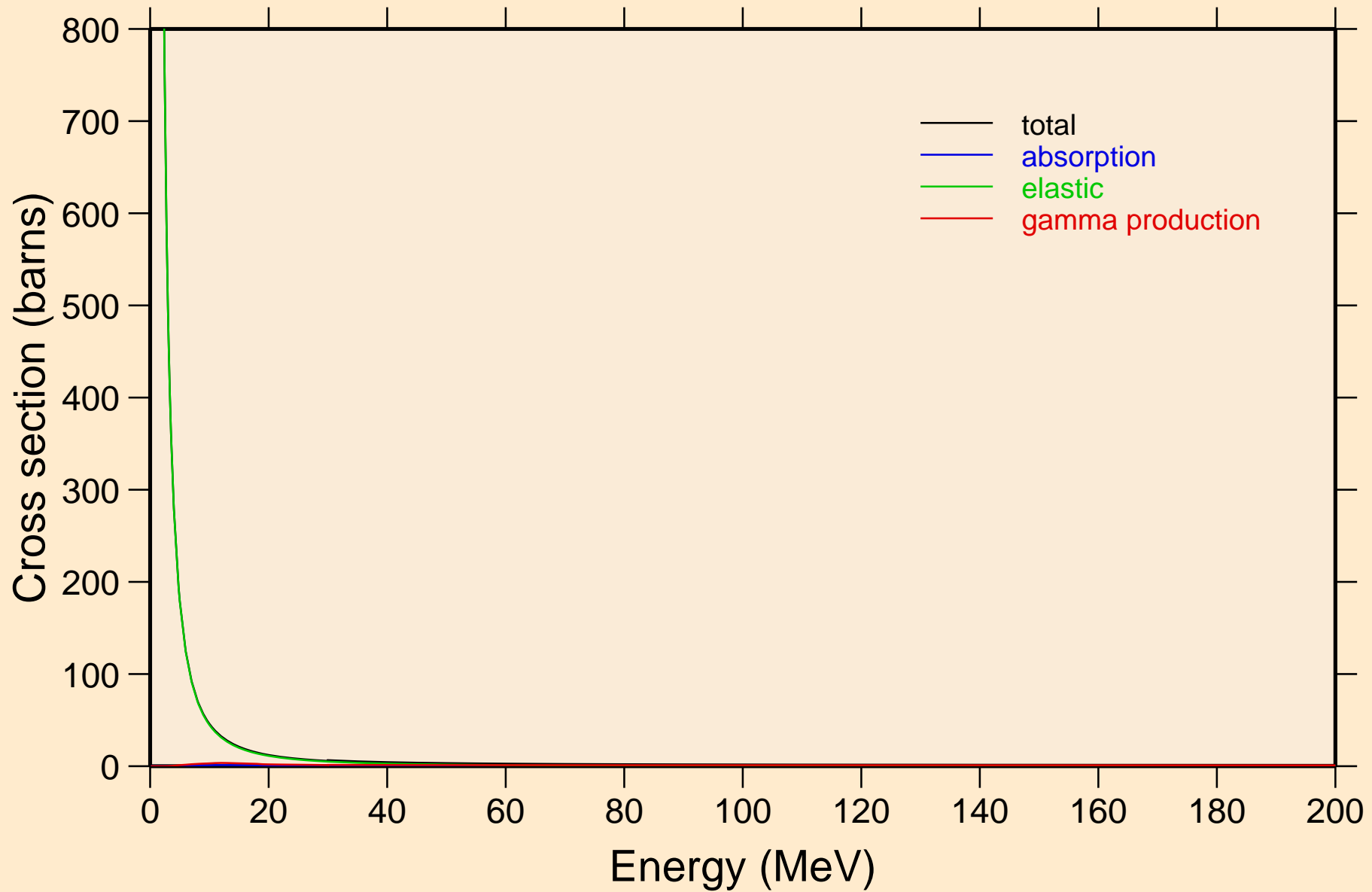

FE052M DEUTERON ACER TENDL-2023 LIBRARY; T=0.K  
Heating

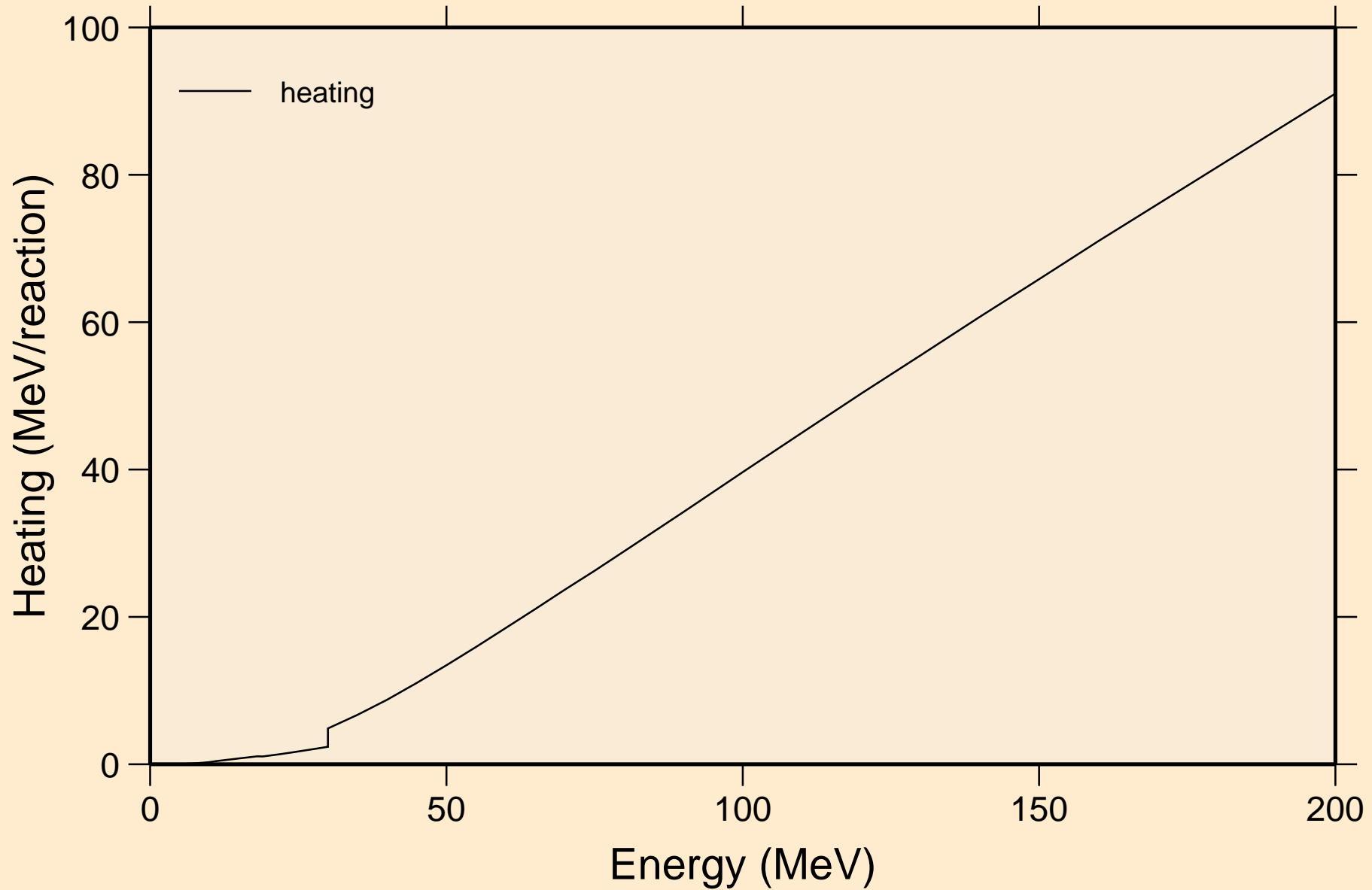

FE052M DEUTERON ACER TENDL-2023 LIBRARY; T=0.K  
Threshold reactions

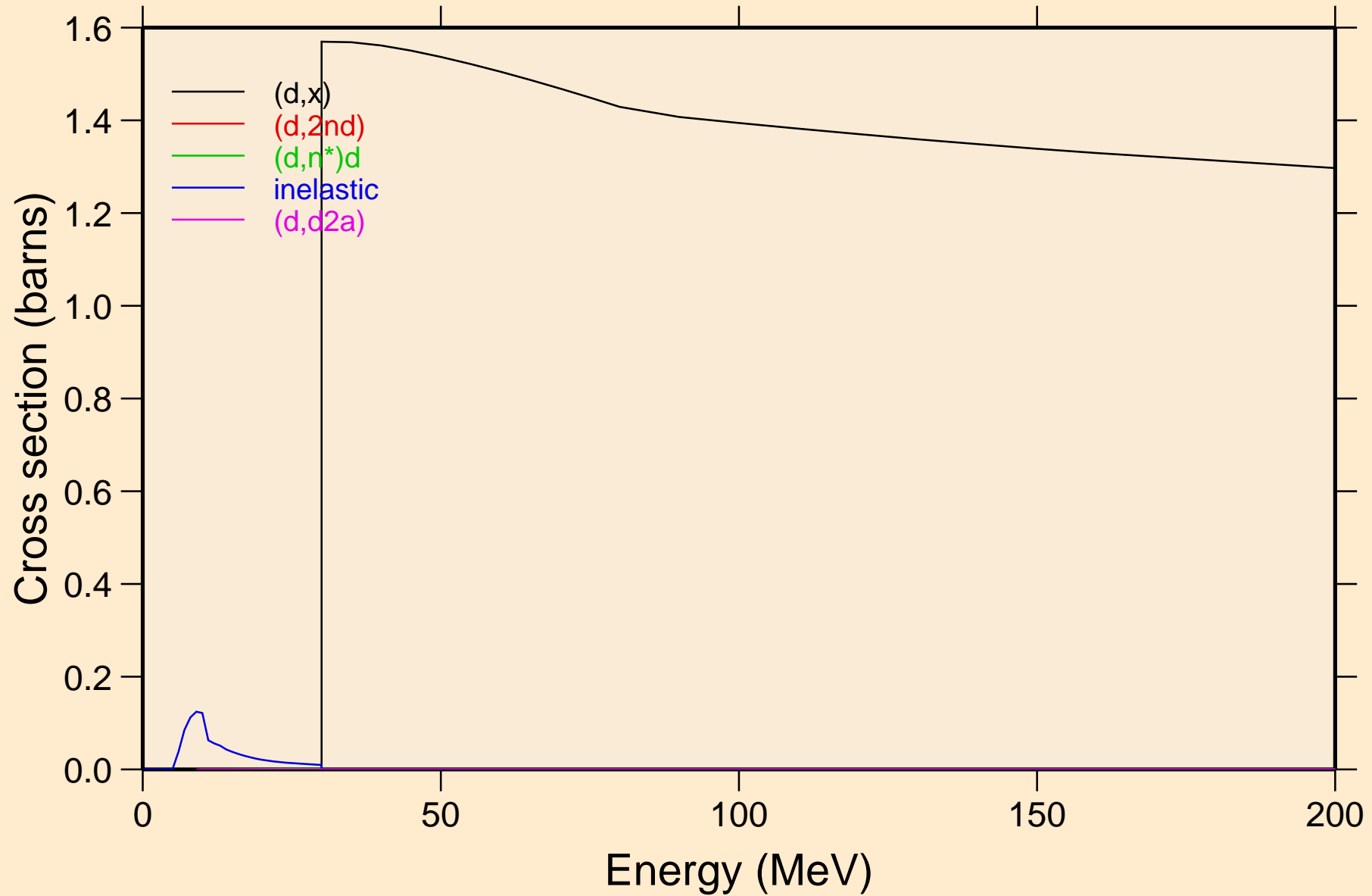

FE052M DEUTERON ACER TENDL-2023 LIBRARY; T=0.K  
Threshold reactions

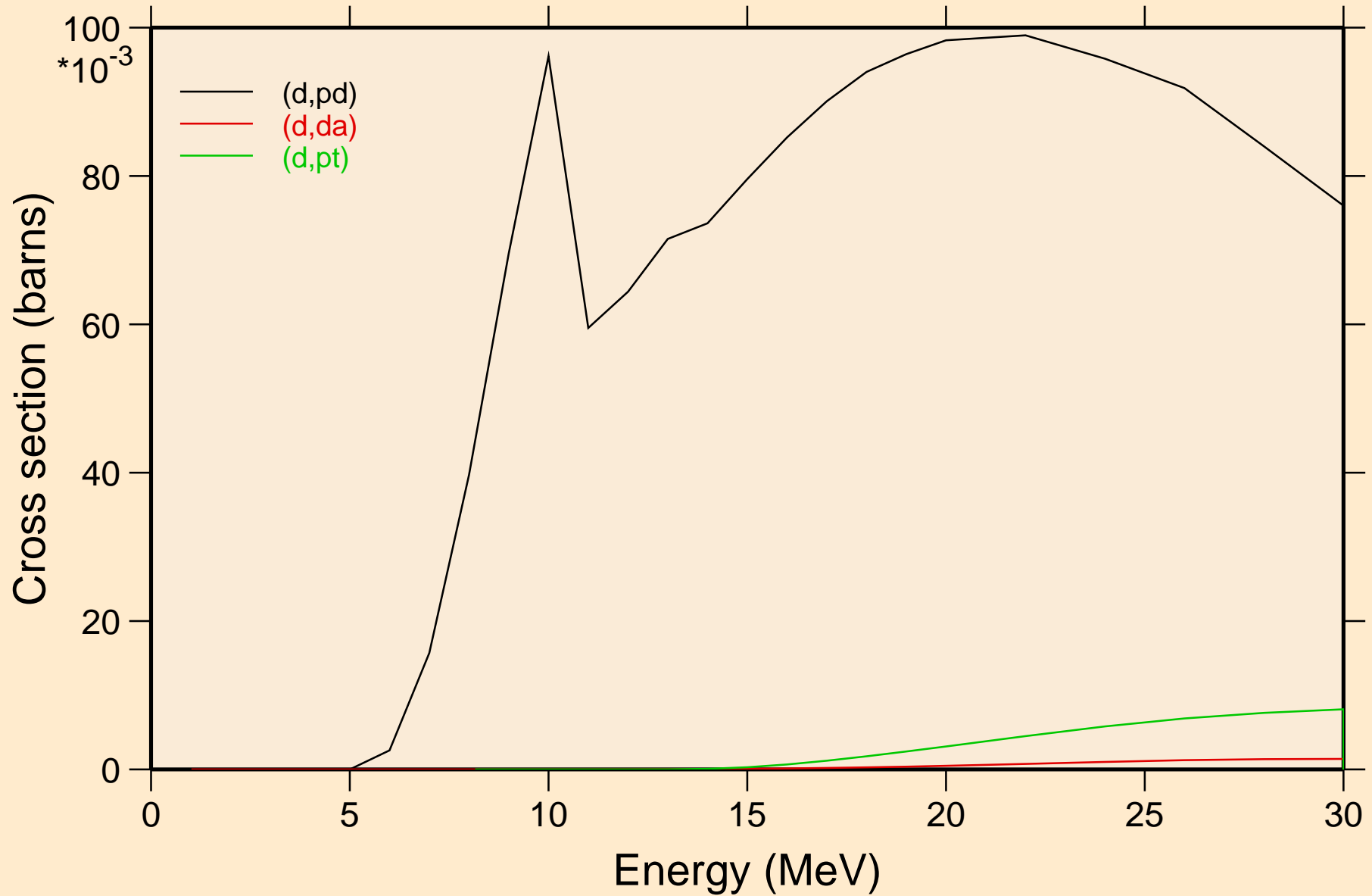

FE052M DEUTERON ACER TENDL-2023 LIBRARY; T=0.K  
Threshold reactions

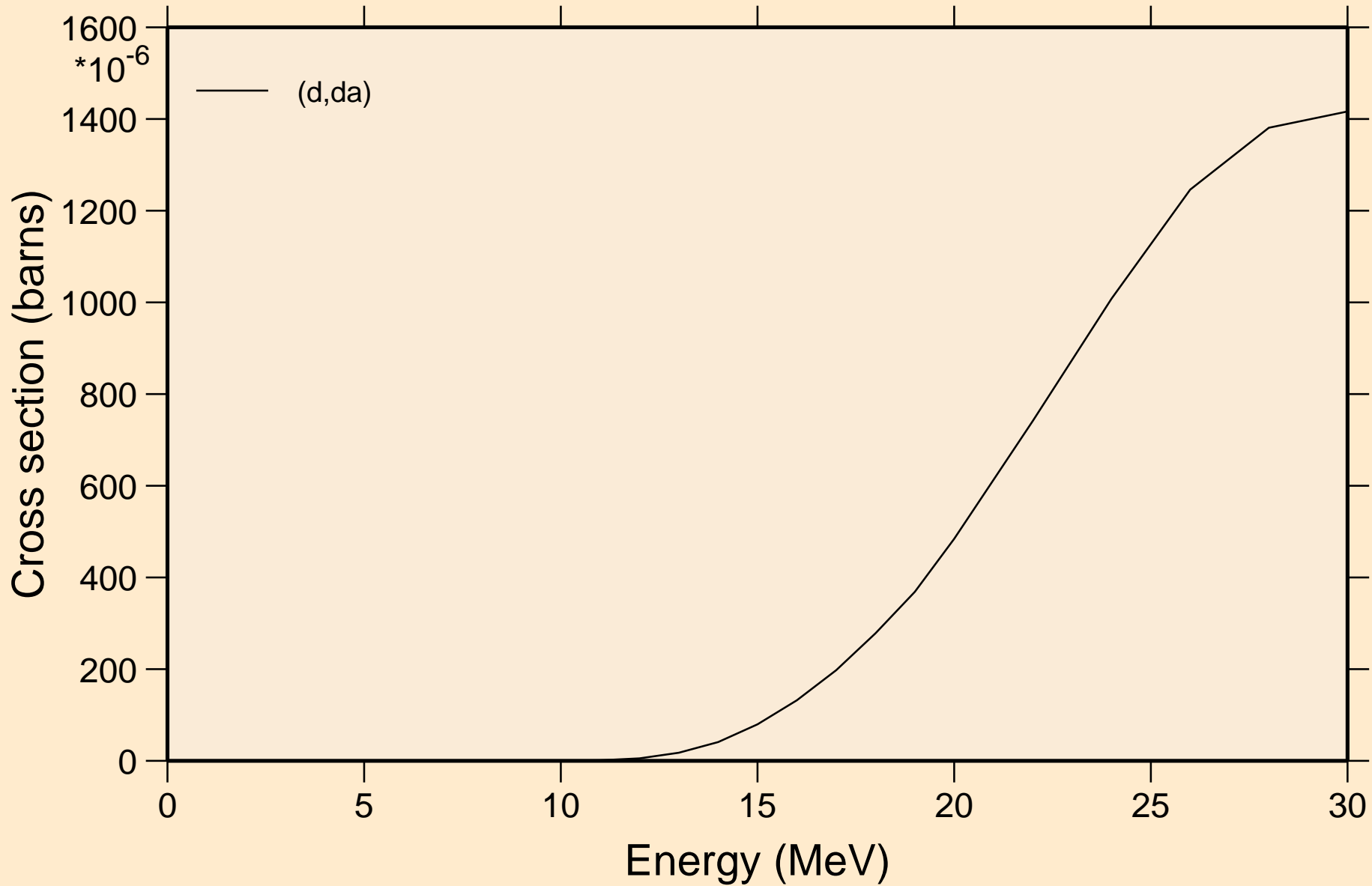

FE052M DEUTERON ACER TENDL-2023 LIBRARY; T=0.K  
angular distribution for elastic

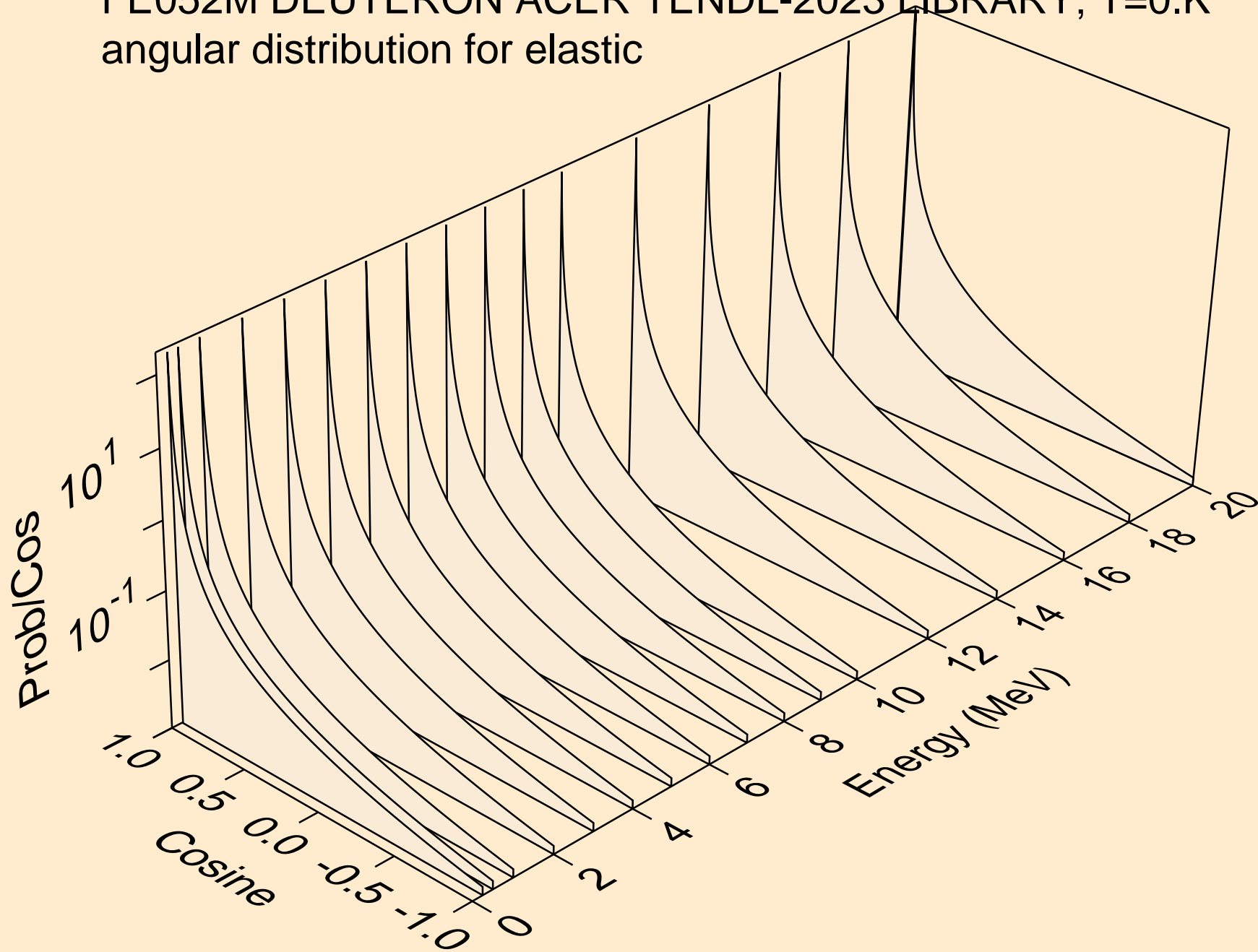



FE052M DEUTERON ACER TENDL-2023 LIBRARY; T=0.K  
angular distribution for elastic

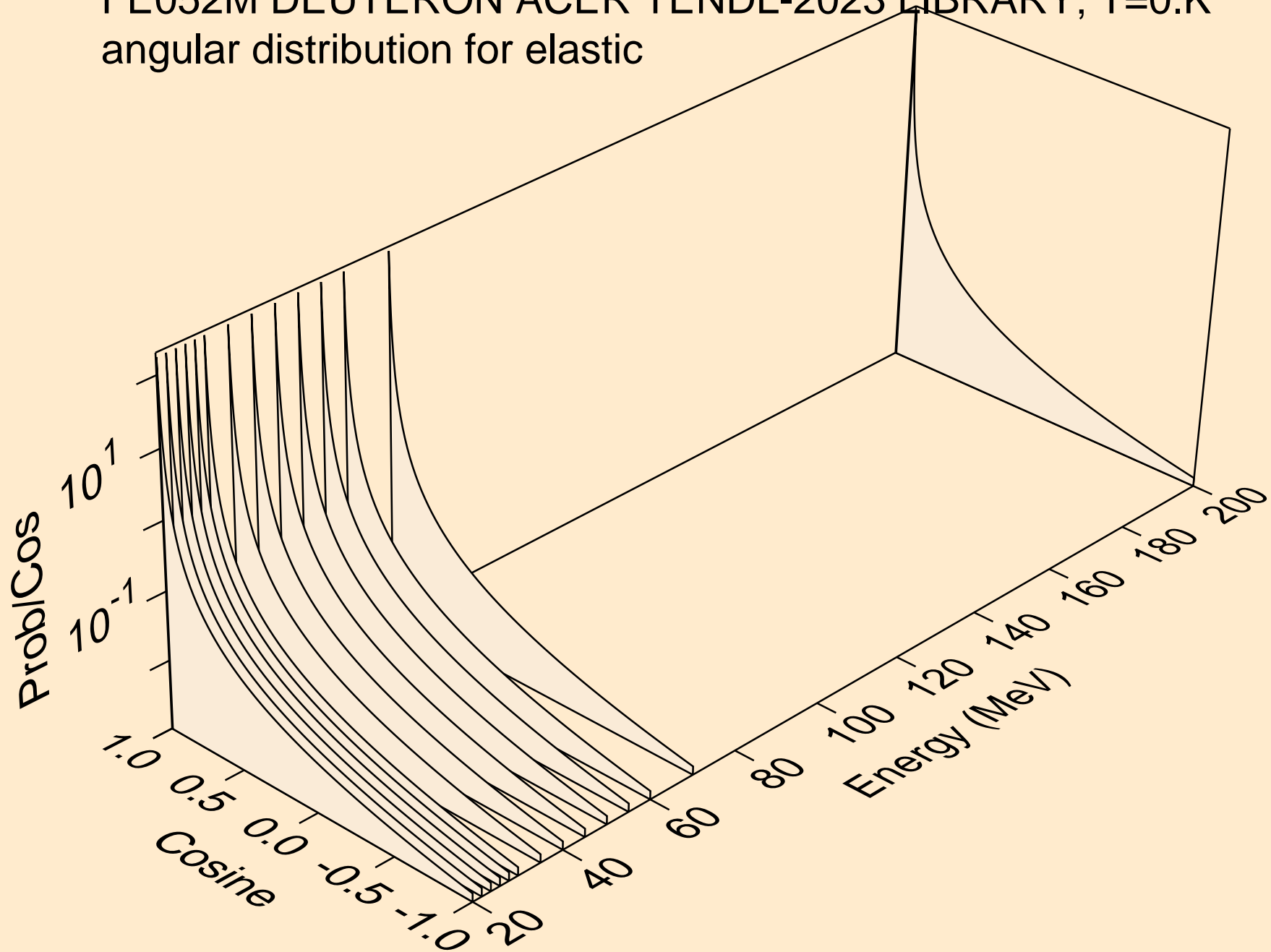

FE052M DEUTERON ACER TENDL-2023 LIBRARY; T=0.K  
Deuteron emission for (d,x)

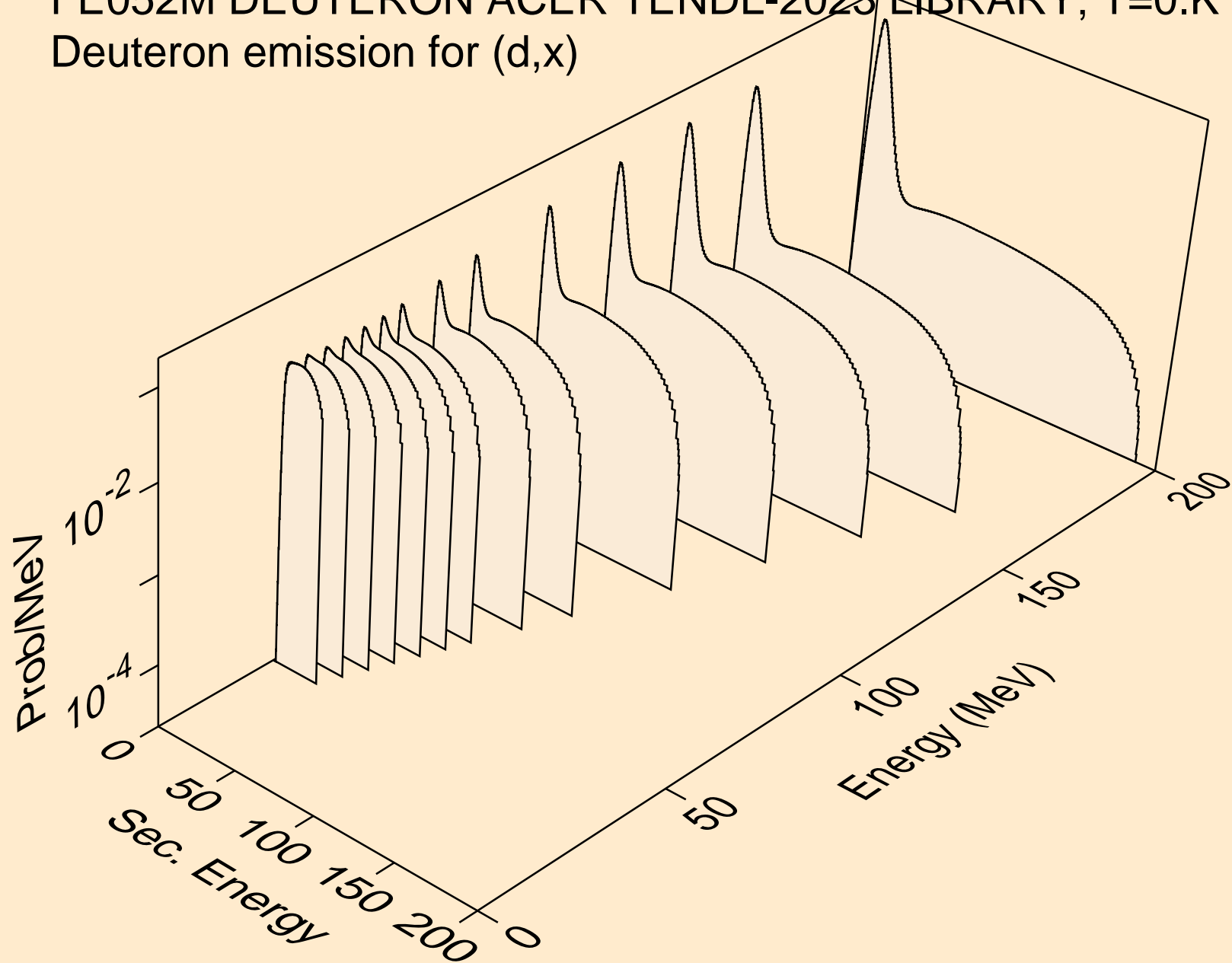

FE052M DEUTERON ACER TENDL-2023 LIBRARY; T=0.K  
Deuteron emission for (d,2nd)

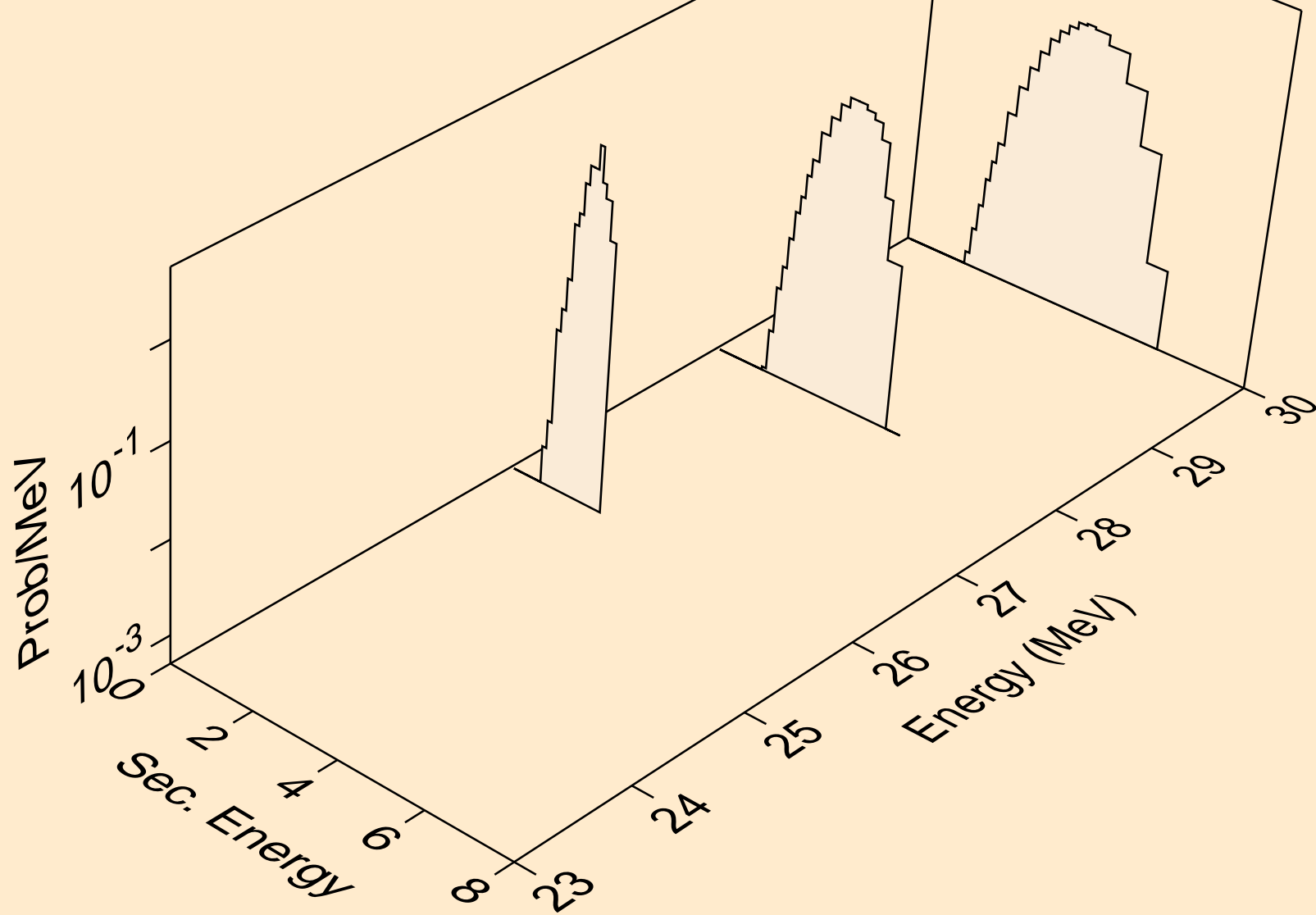

FE052M DEUTERON ACER TENDL-2023 LIBRARY; T=0.K  
Deuteron emission for (d,n\*)d

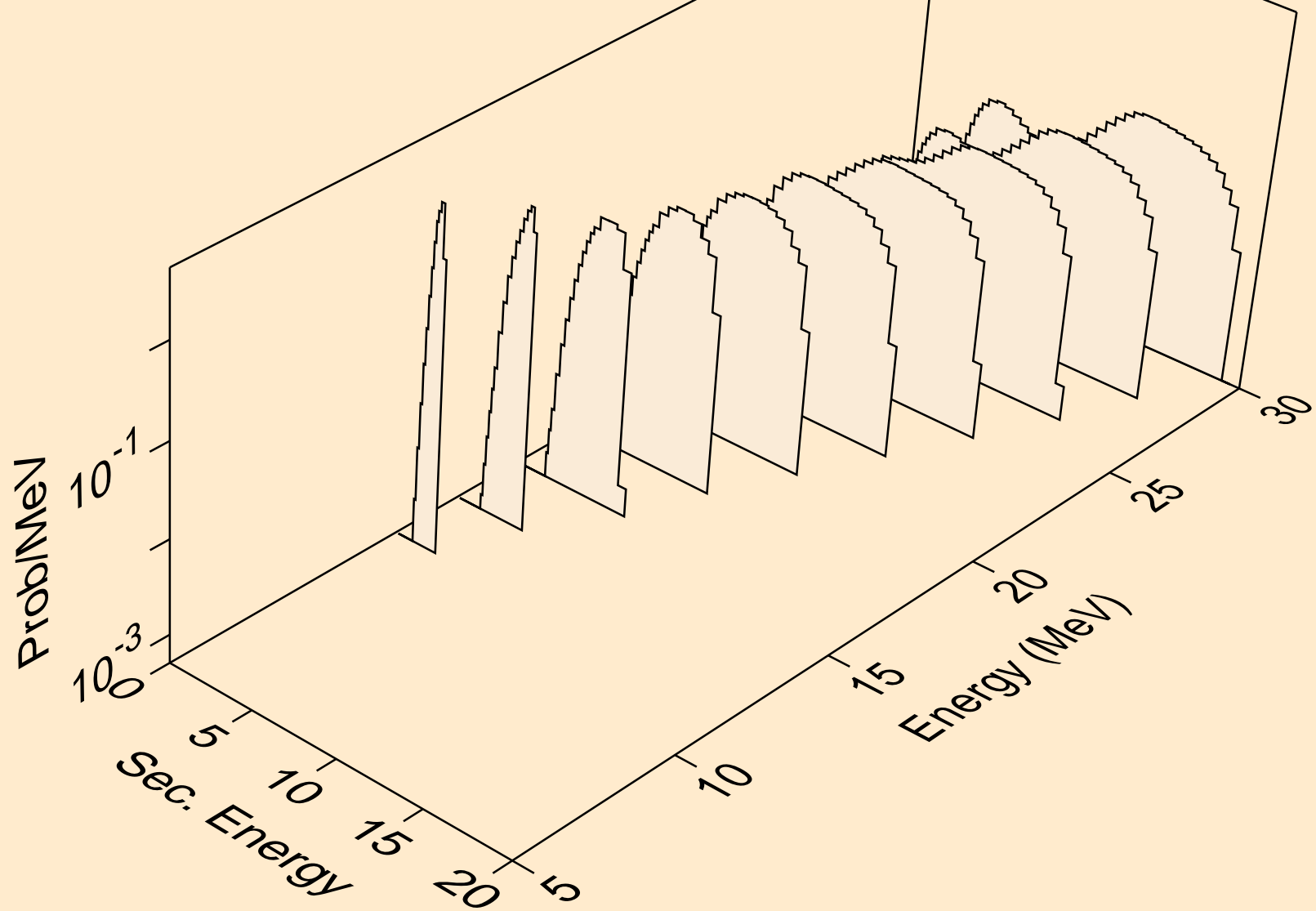

FE052M DEUTERON ACER TENDL-2023 LIBRARY; T=0.K  
Deuteron emission for inelastic

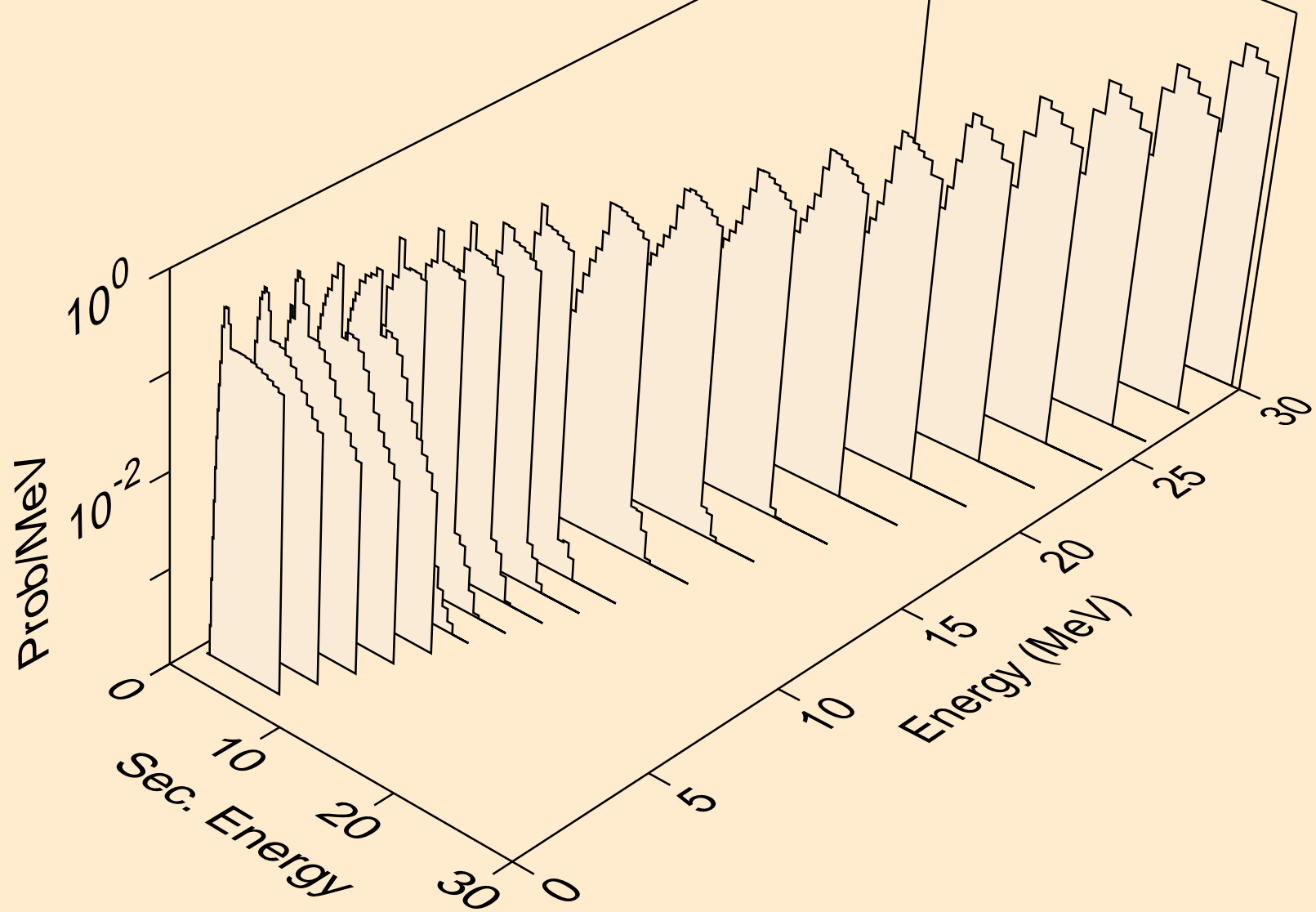

FE052M DEUTERON ACER TENDL-2023 LIBRARY; T=0.K  
Deuteron emission for (d,d2a)

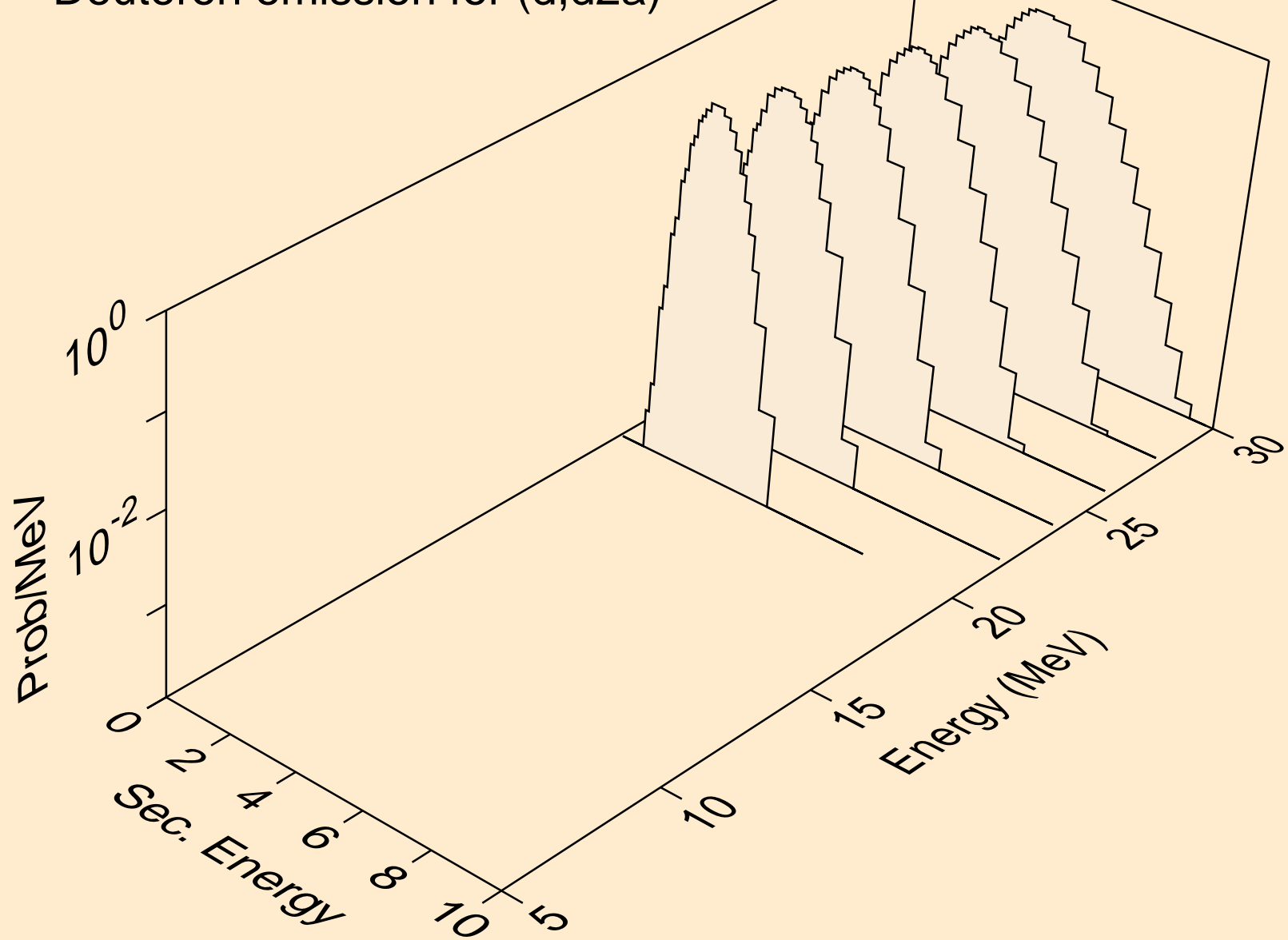

FE052M DEUTERON ACER TENDL-2023 LIBRARY; T=0.K  
Deuteron emission for (d,pd)

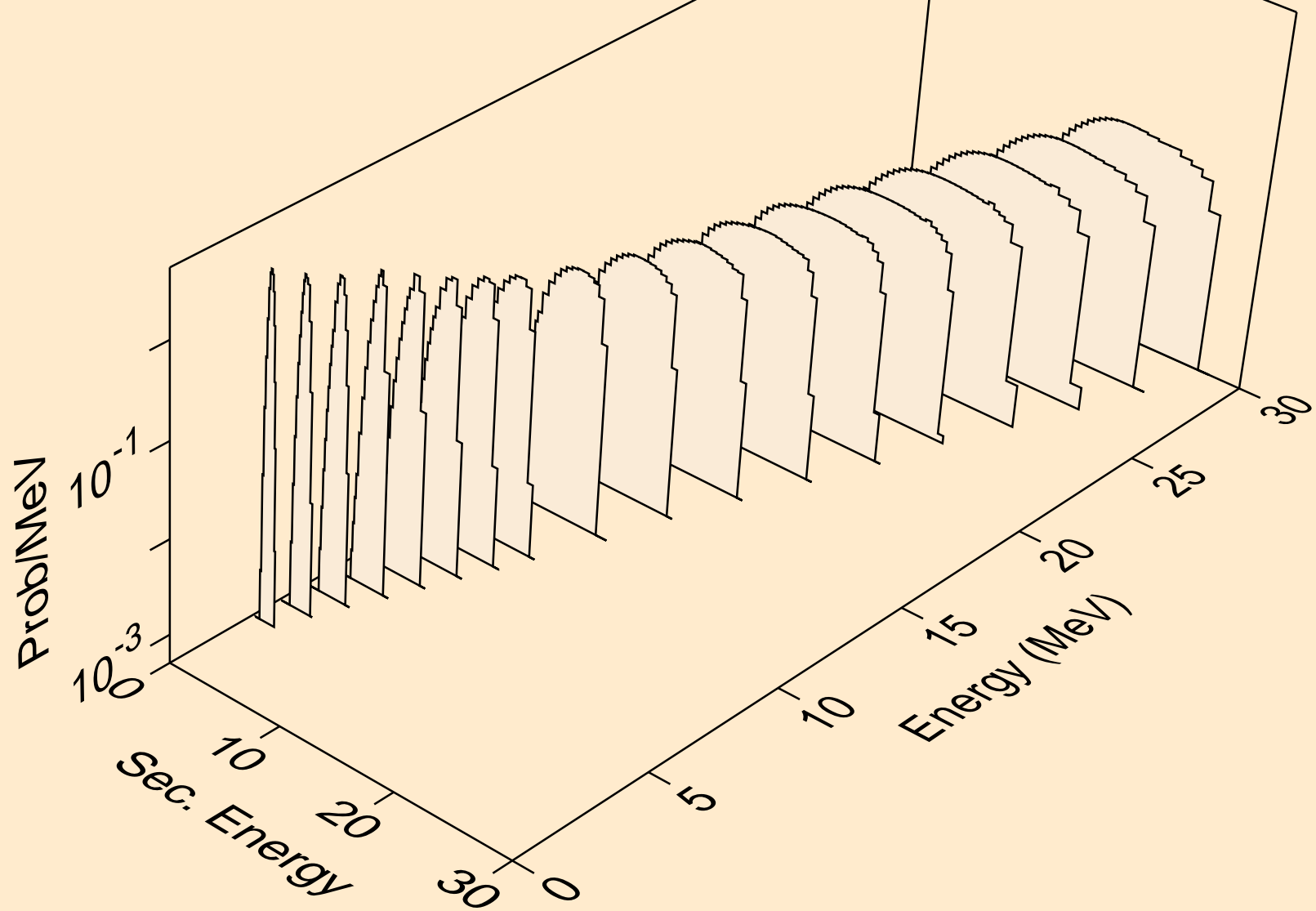

FE052M DEUTERON ACER TENDL-2023 LIBRARY; T=0.K  
Deuteron emission for (d,da)

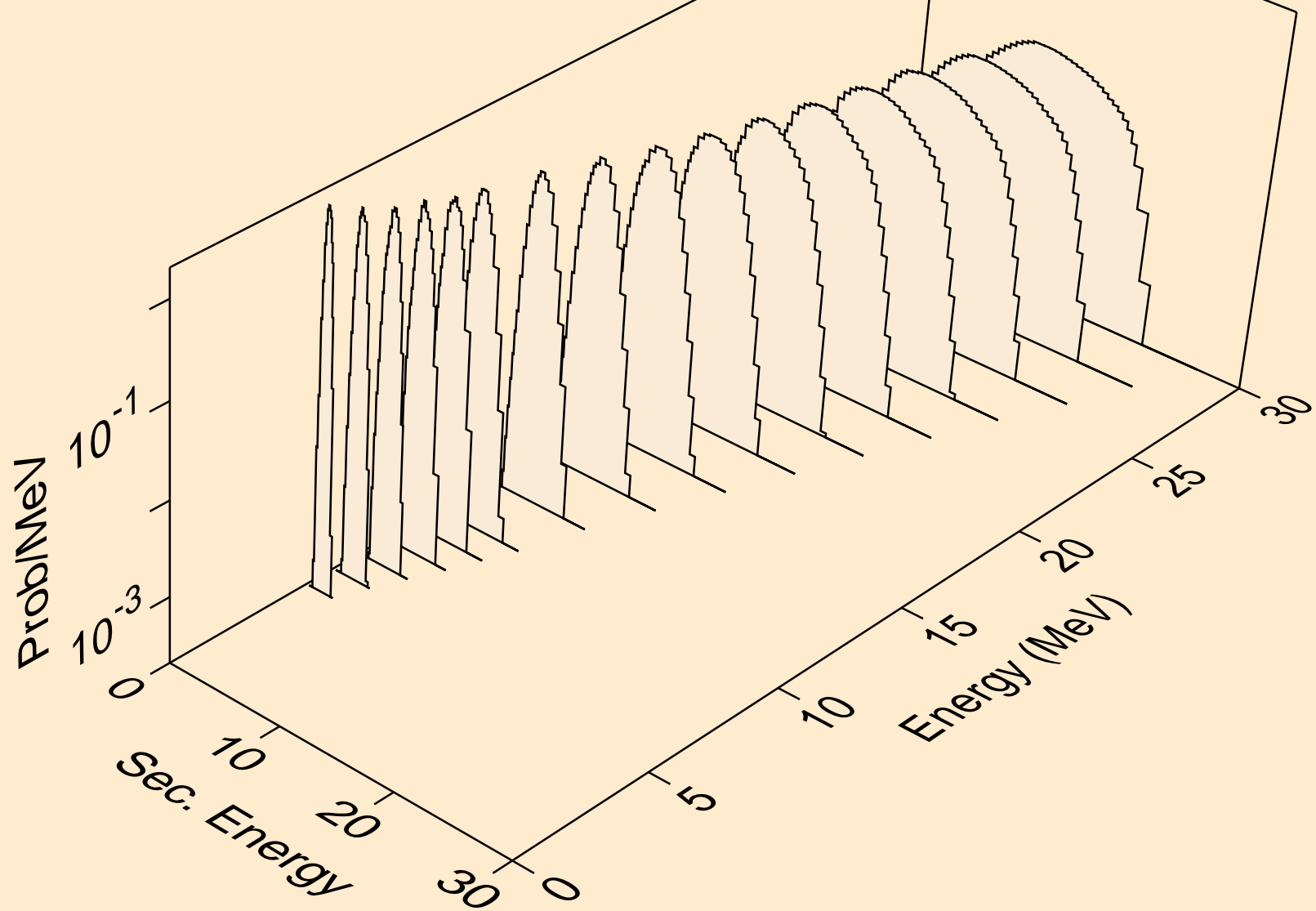



FE052M DEUTERON ACER TENDL-2023 LIBRARY; T=0.K  
Photon emission for (z,n)

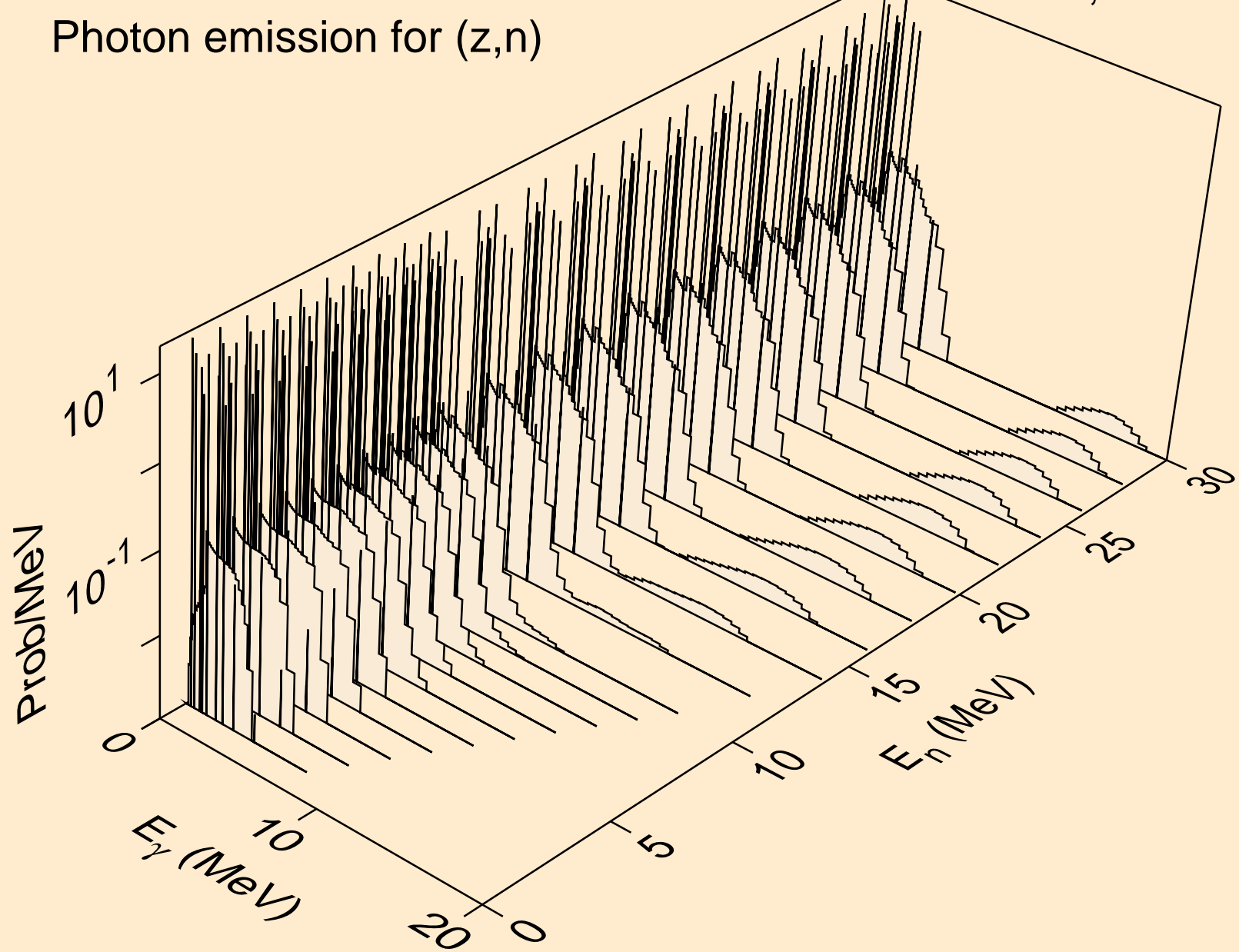

FE052M DEUTERON ACER TENDL-2023 LIBRARY; T=0.K  
Photon emission for (z,x)

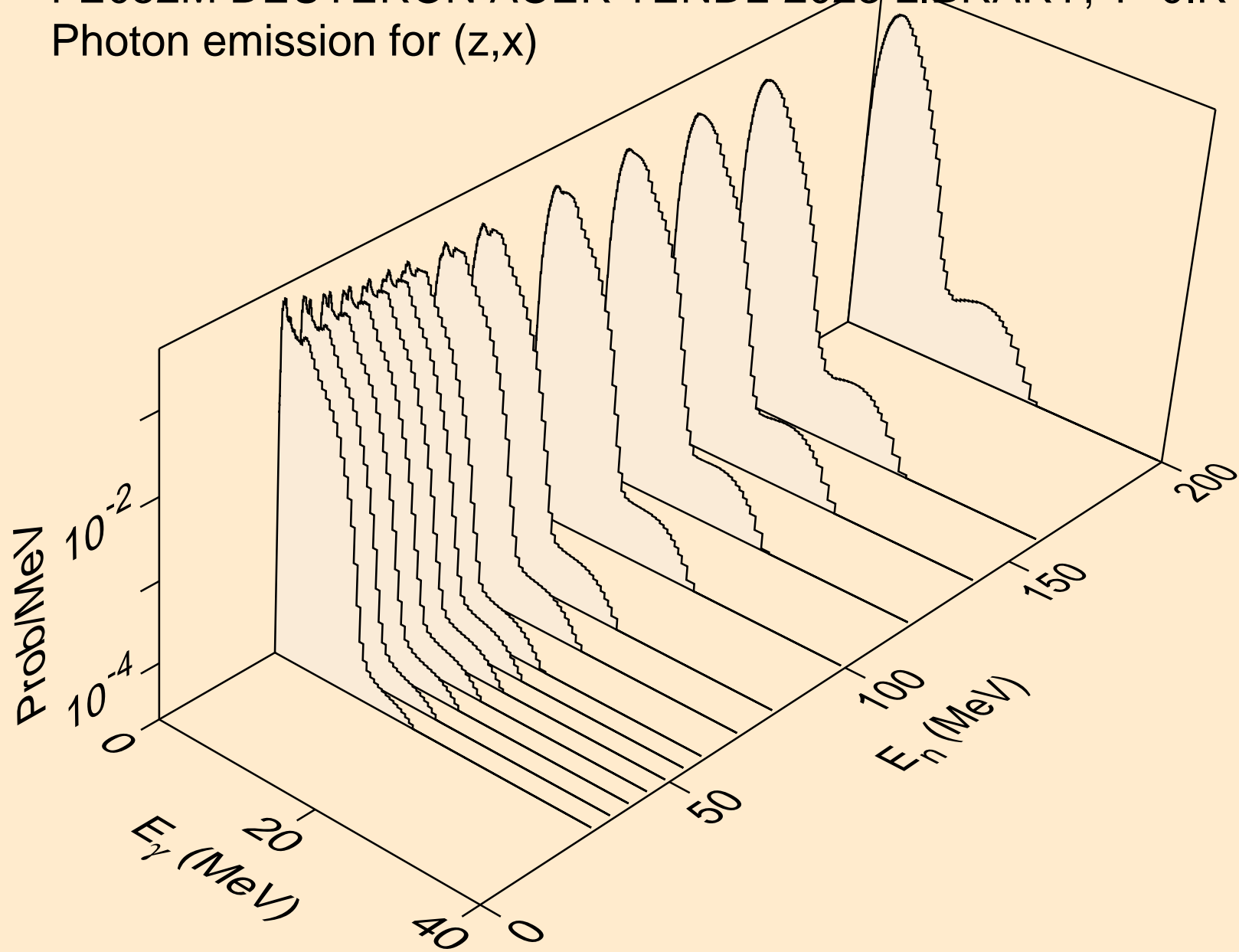

FE052M DEUTERON ACER TENDL-2023 LIBRARY; T=0.K  
Photon emission for (n,2nd)

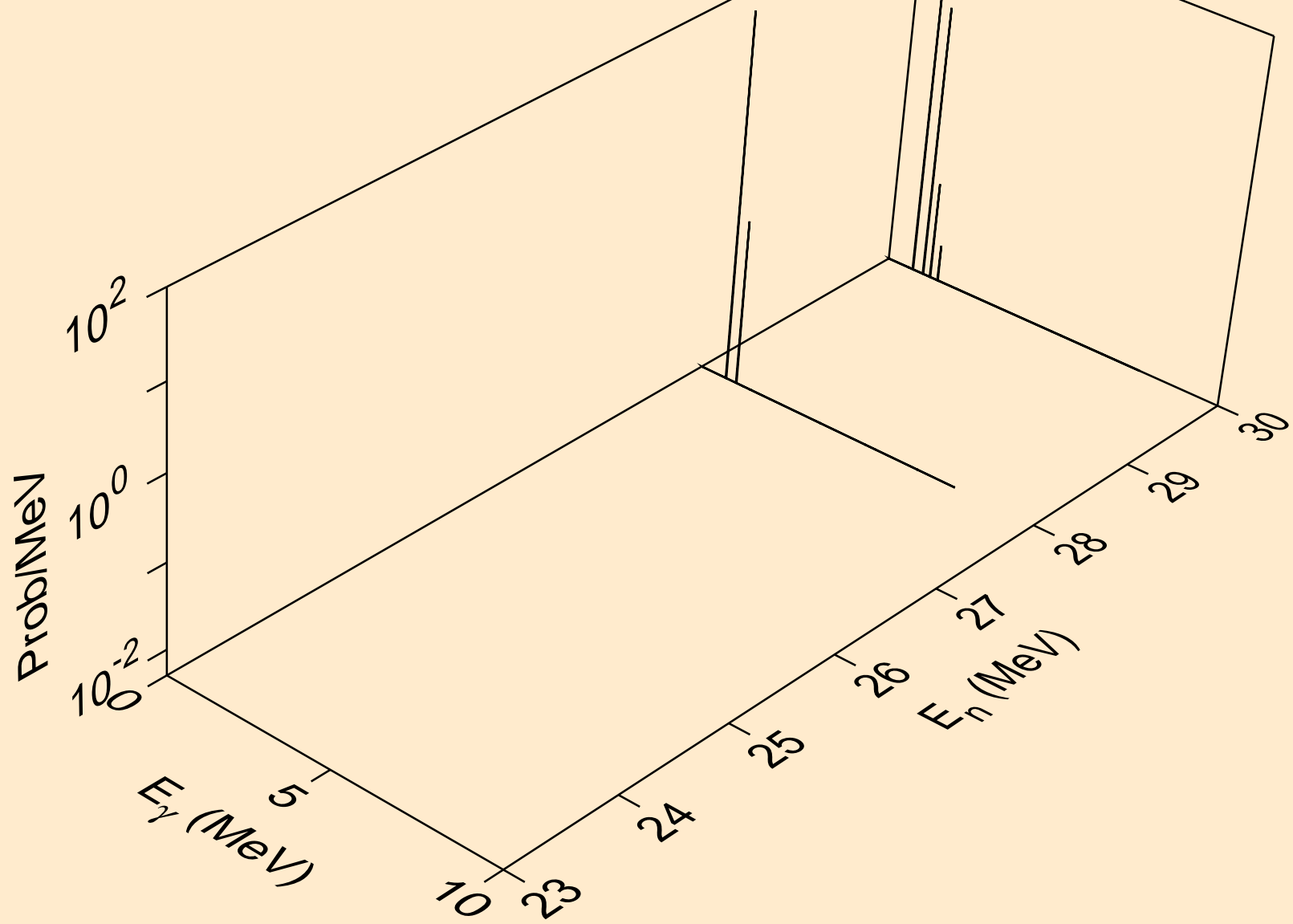

FE052M DEUTERON ACER TENDL-2023 LIBRARY; T=0.K  
Photon emission for (n,2n)

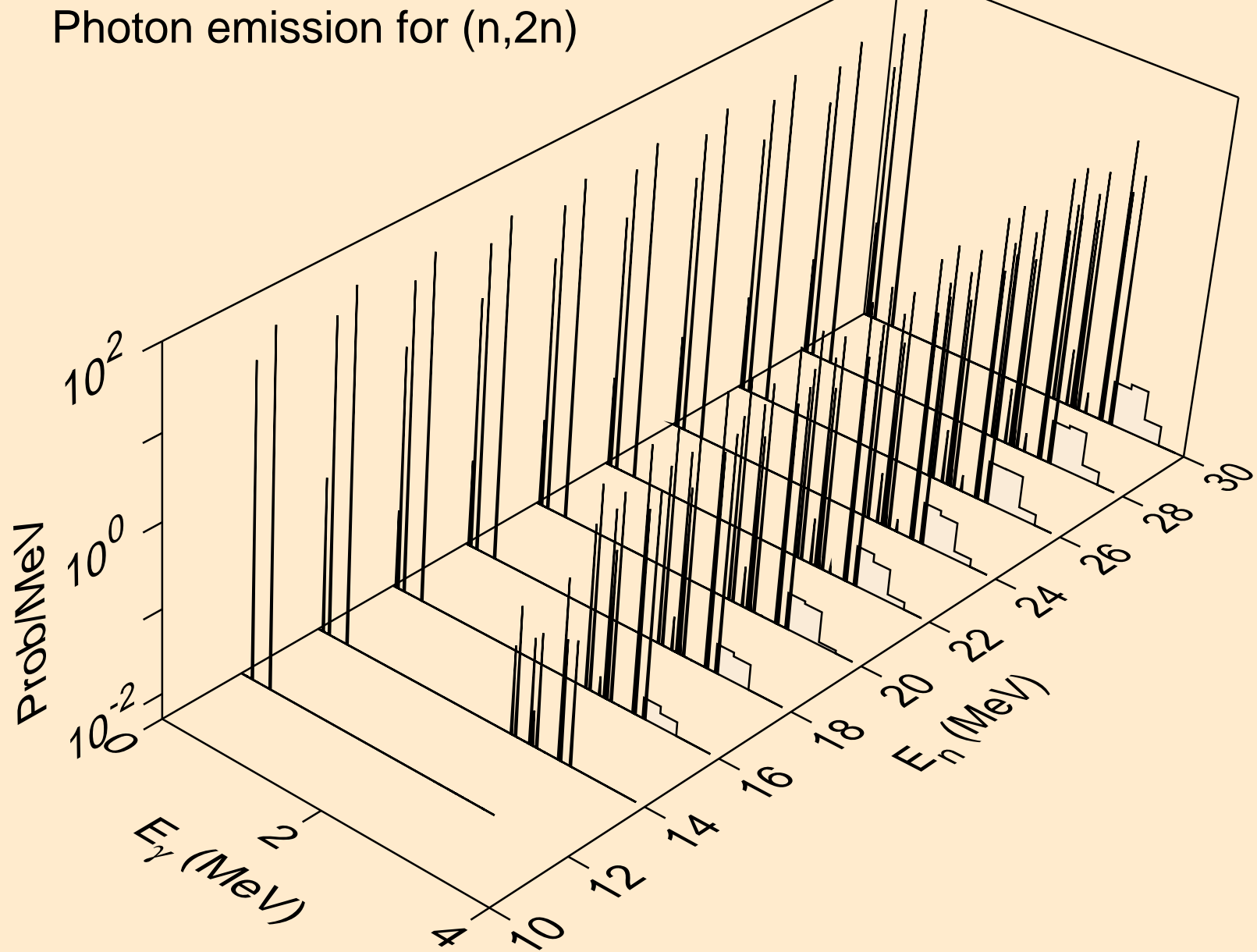

FE052M DEUTERON ACER TENDL-2023 LIBRARY; T=0.K  
Photon emission for (n,3n)

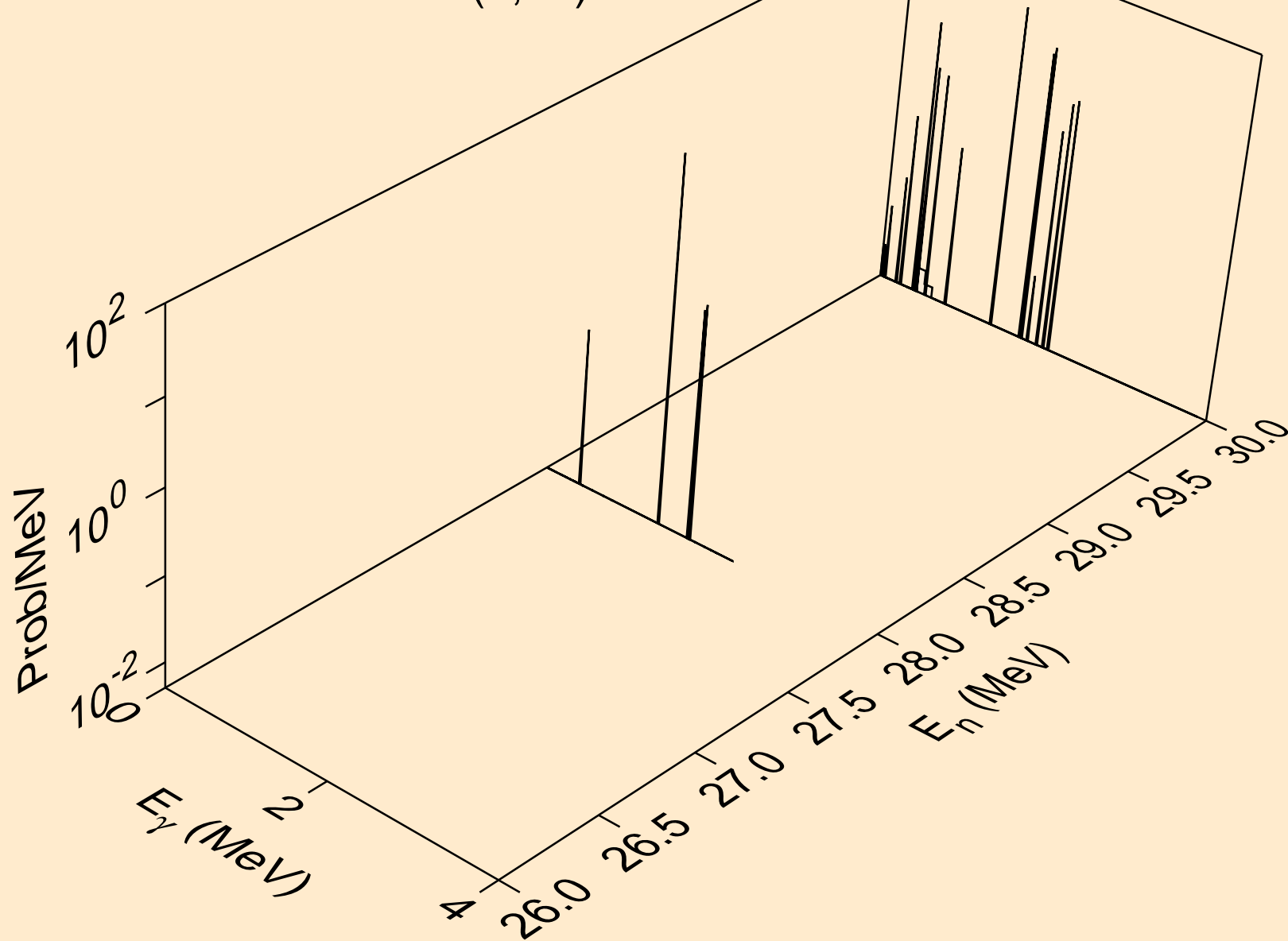

FE052M DEUTERON ACER TENDL-2023 LIBRARY; T=0.K  
Photon emission for (n,n\*)a

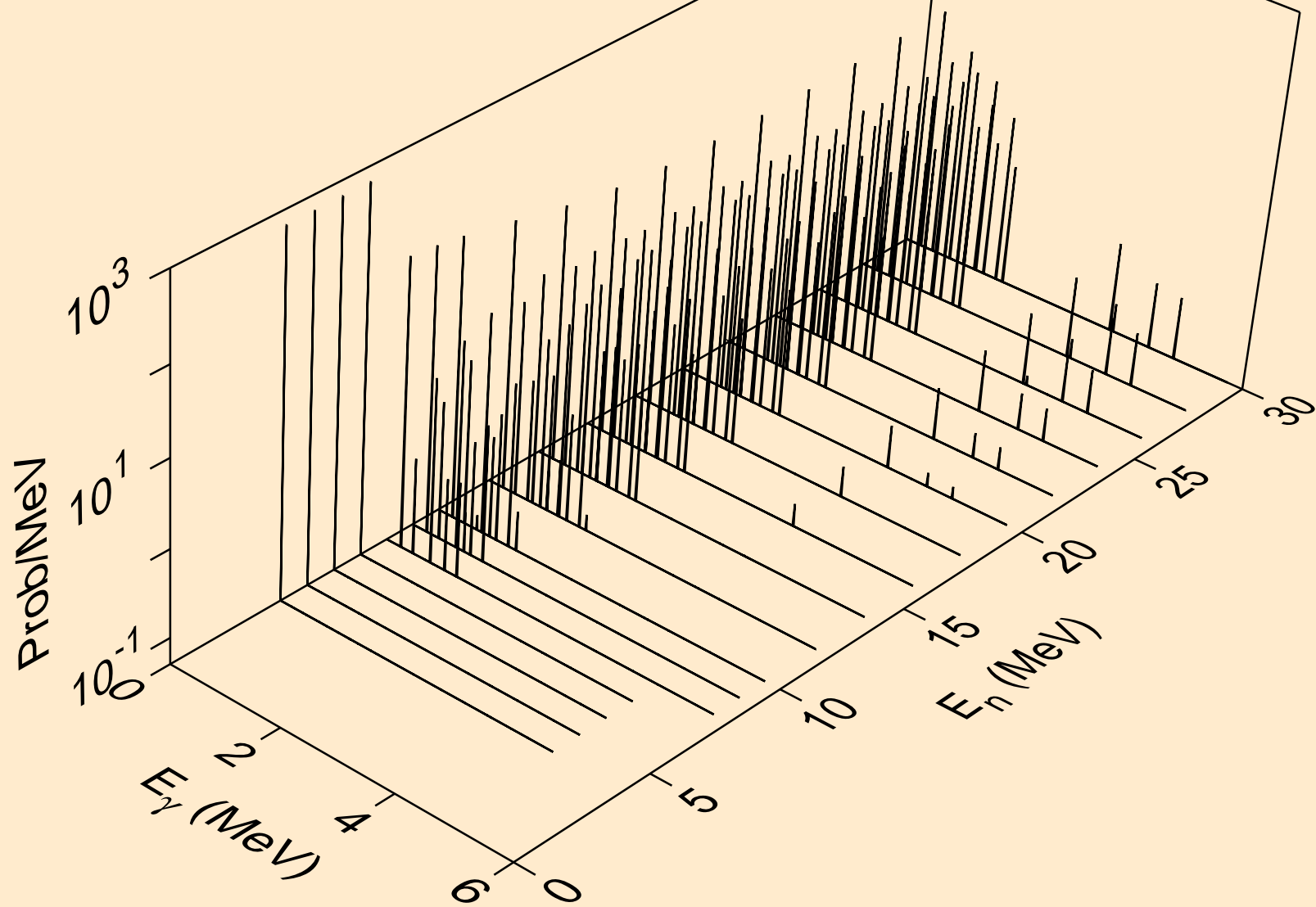

FE052M DEUTERON ACER TENDL-2023 LIBRARY; T=0.K  
Photon emission for (n,2n)a

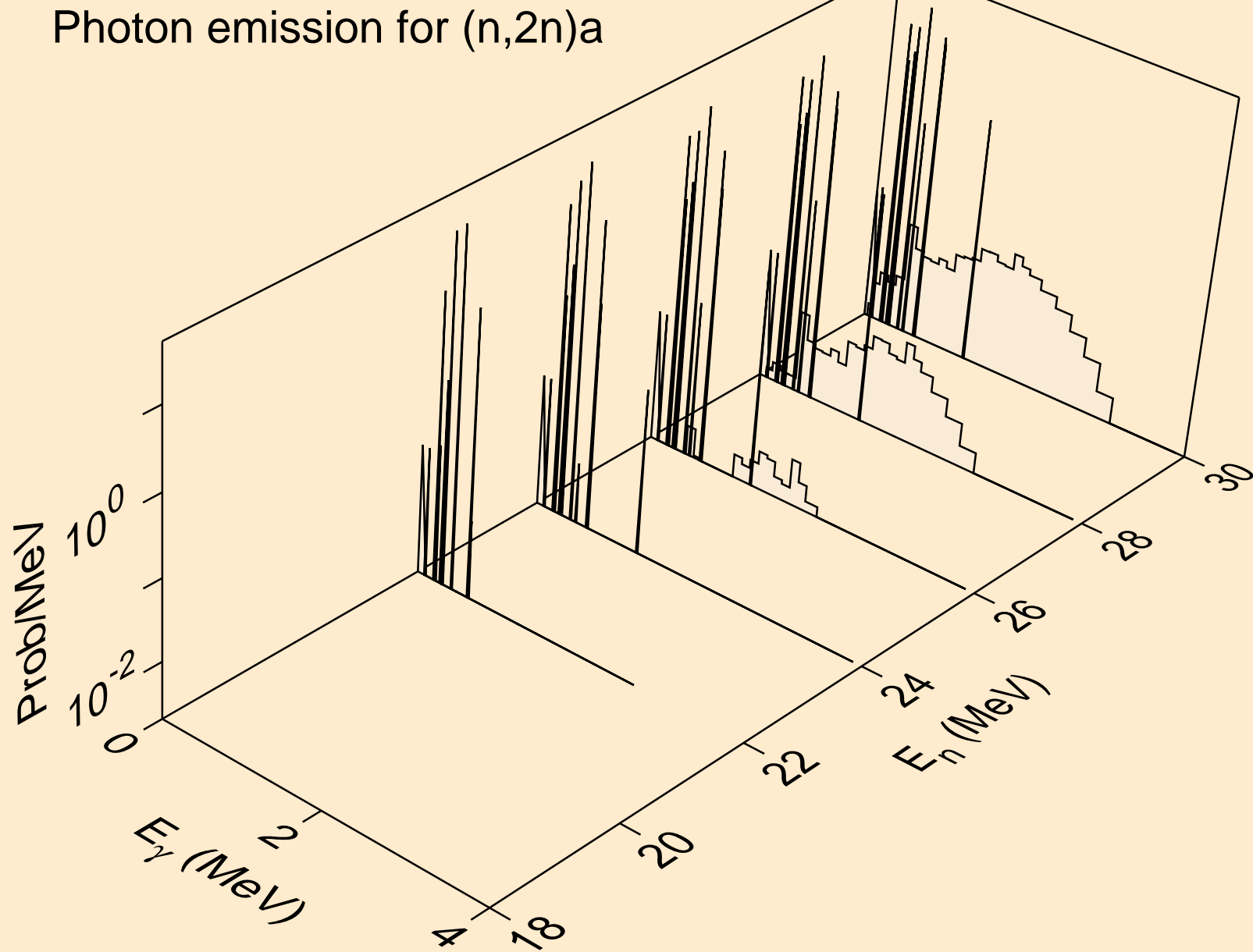

FE052M DEUTERON ACER TENDL-2023 LIBRARY; T=0.K  
Photon emission for (n,n\*)p

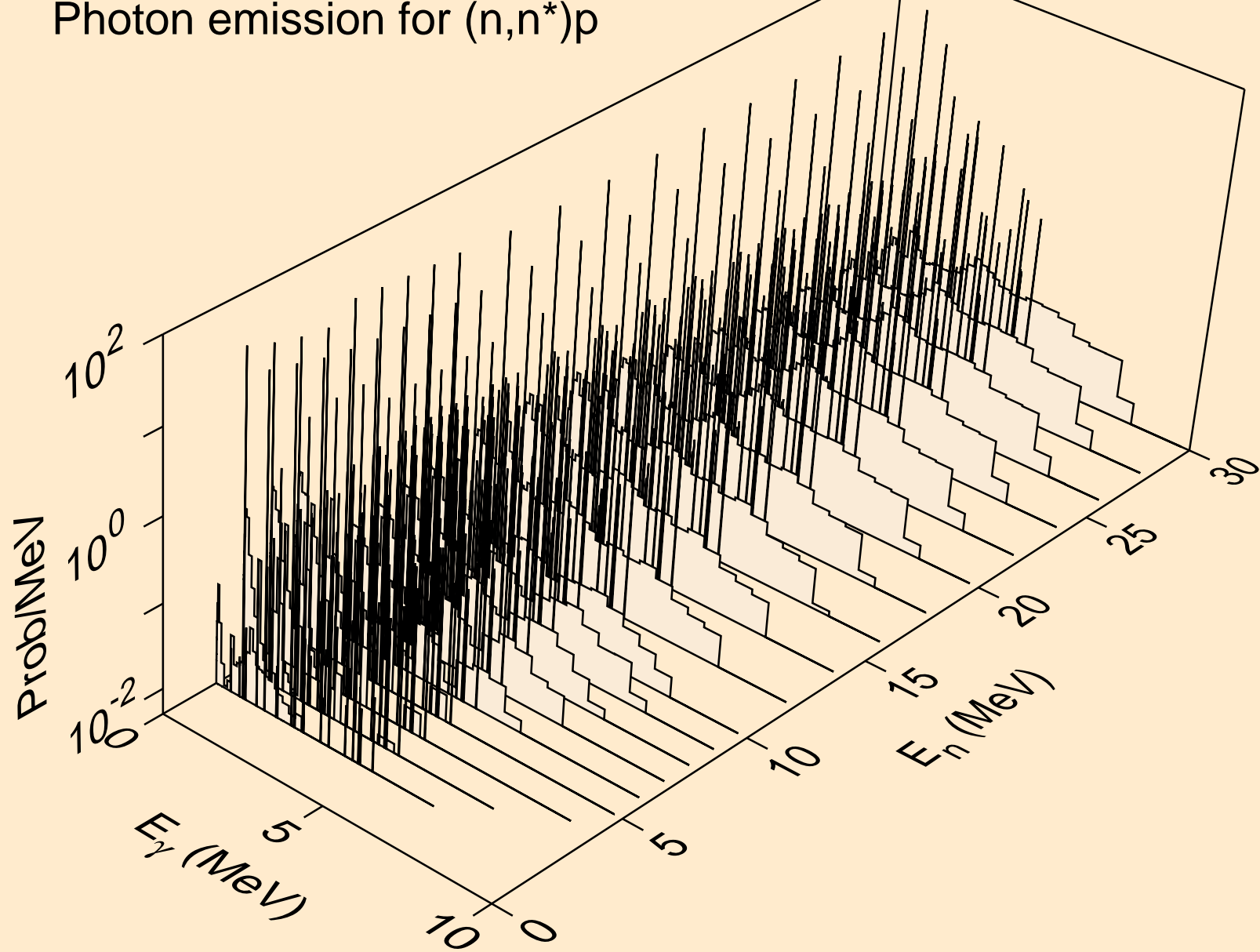



FE052M DEUTERON ACER TENDL-2023 LIBRARY; T=0.K  
Photon emission for (n,n\*)2a

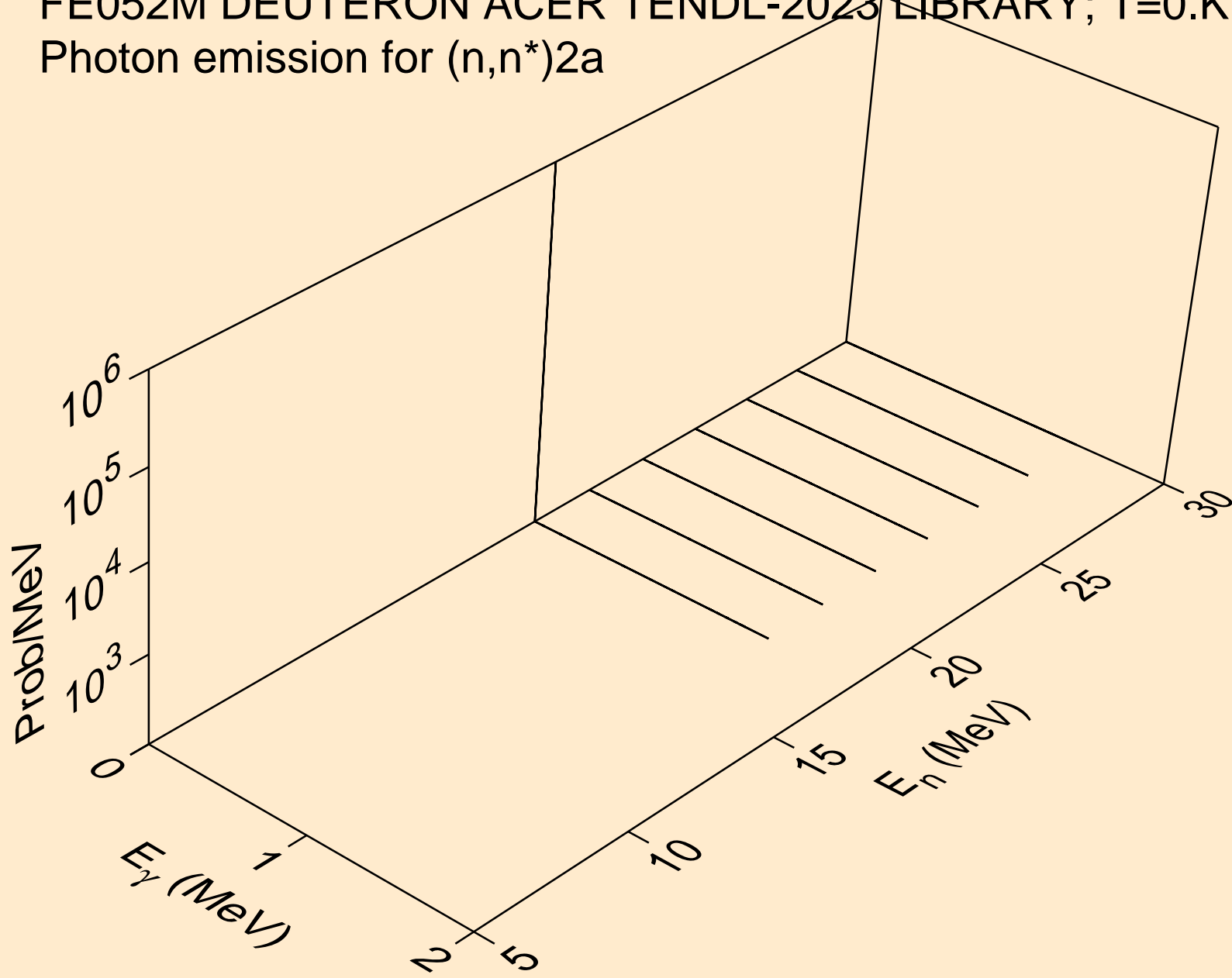

FE052M DEUTERON ACER TENDL-2023 LIBRARY; T=0.K  
Photon emission for (n,n\*)d

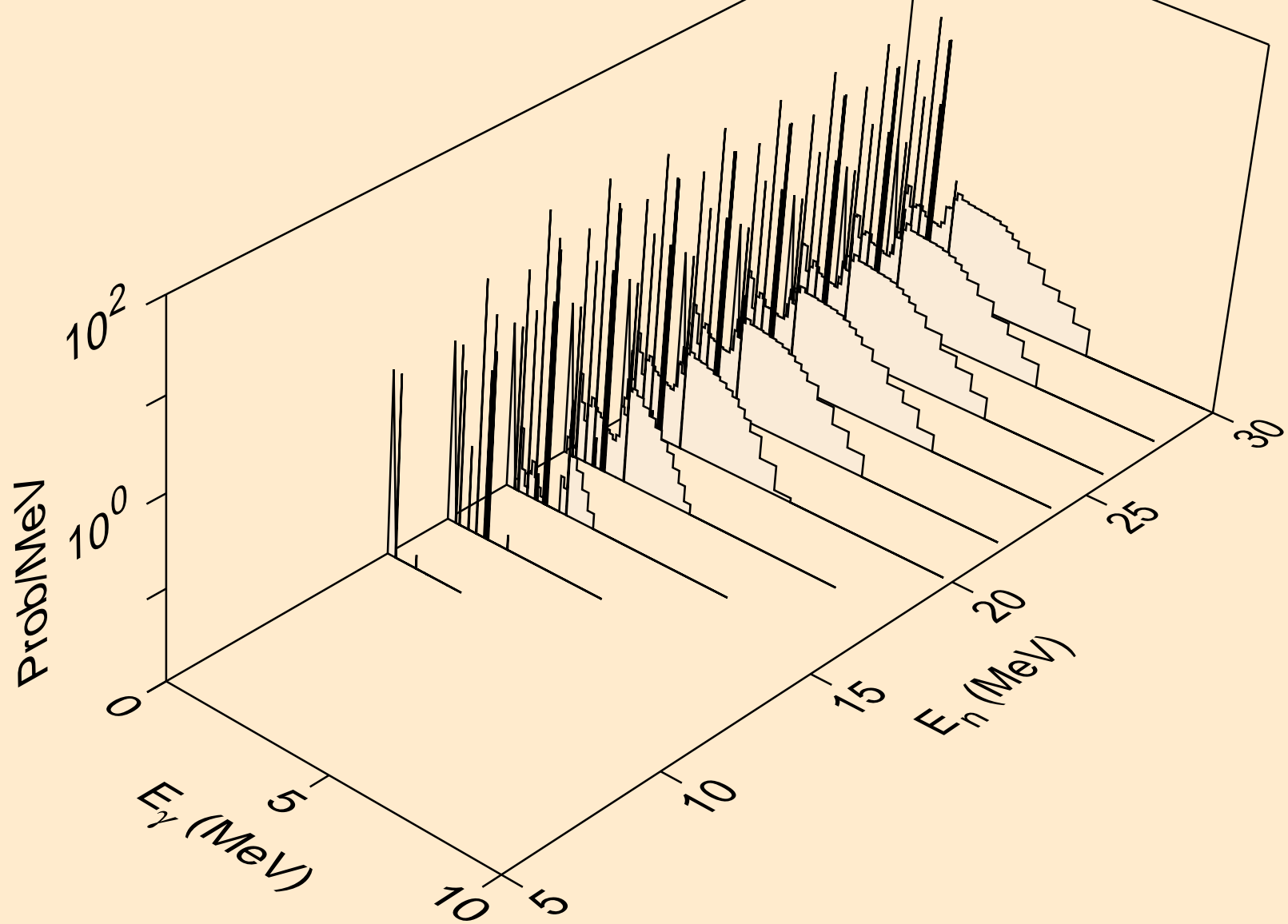

FE052M DEUTERON ACER TENDL-2023 LIBRARY; T=0.K  
Photon emission for (n,n\*)t

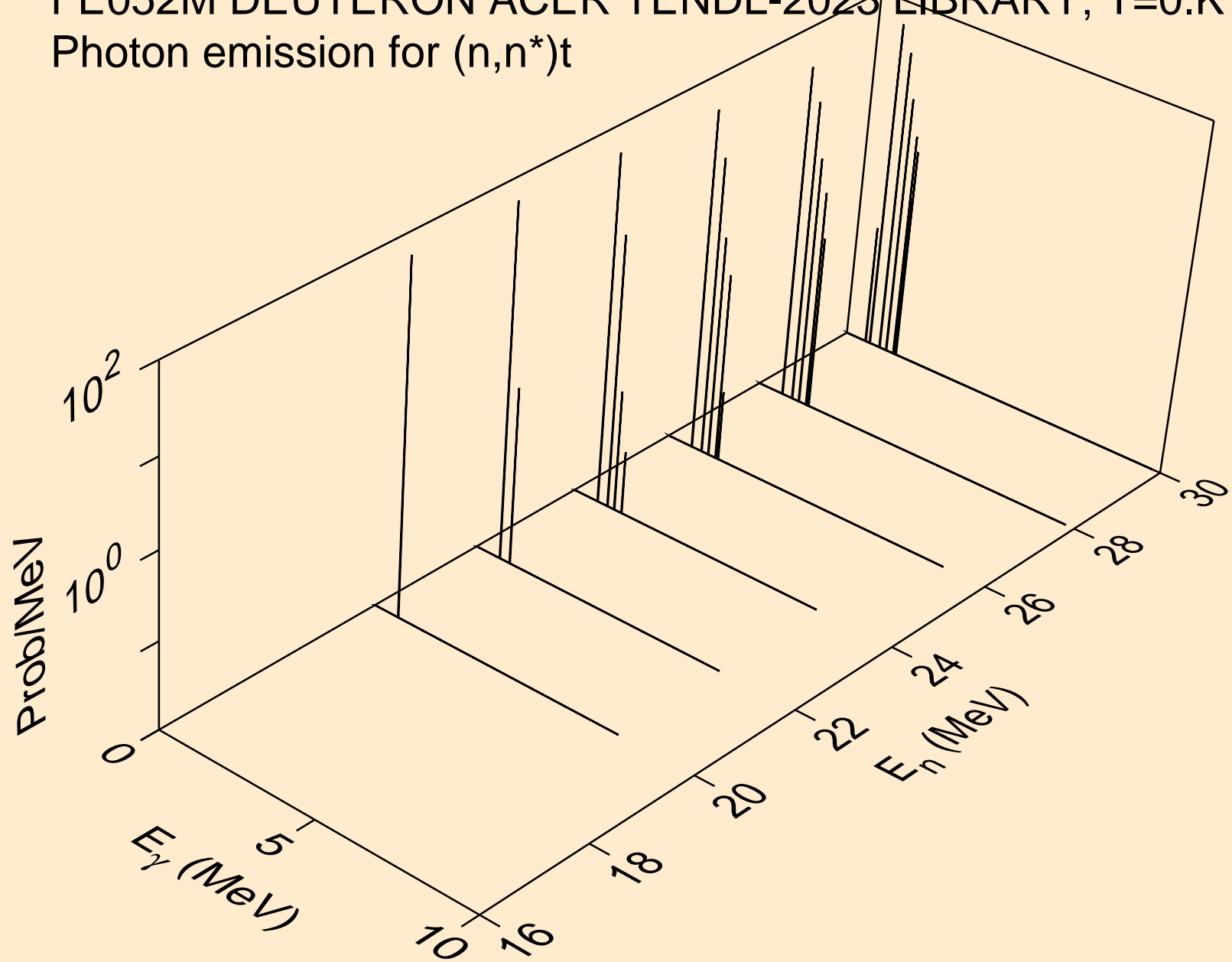

FE052M DEUTERON ACER TENDL-2023 LIBRARY; T=0.K  
Photon emission for (n,n\*)he3

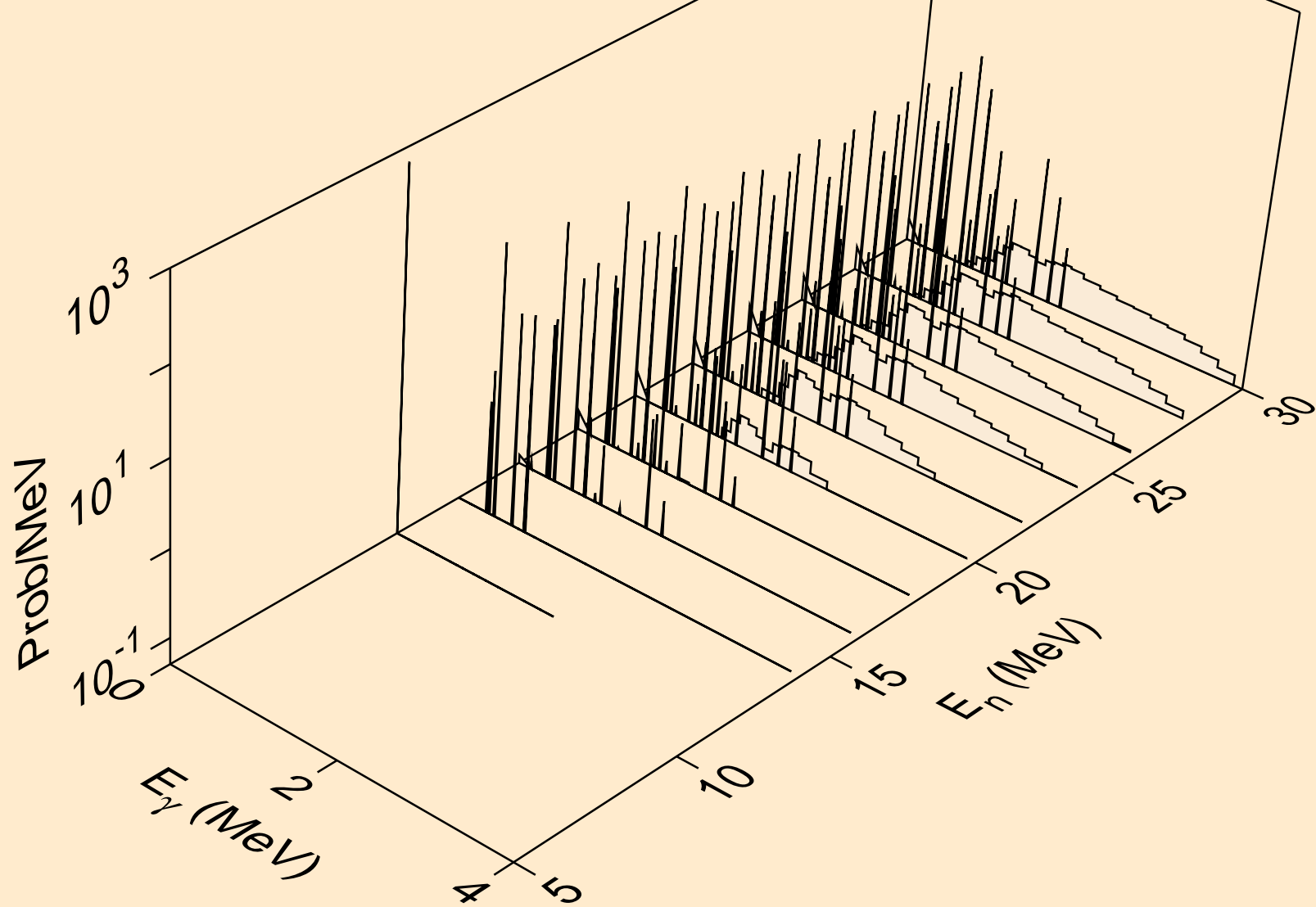

FE052M DEUTERON ACER TENDL-2023 LIBRARY; T=0.K  
Photon emission for (n,2np)

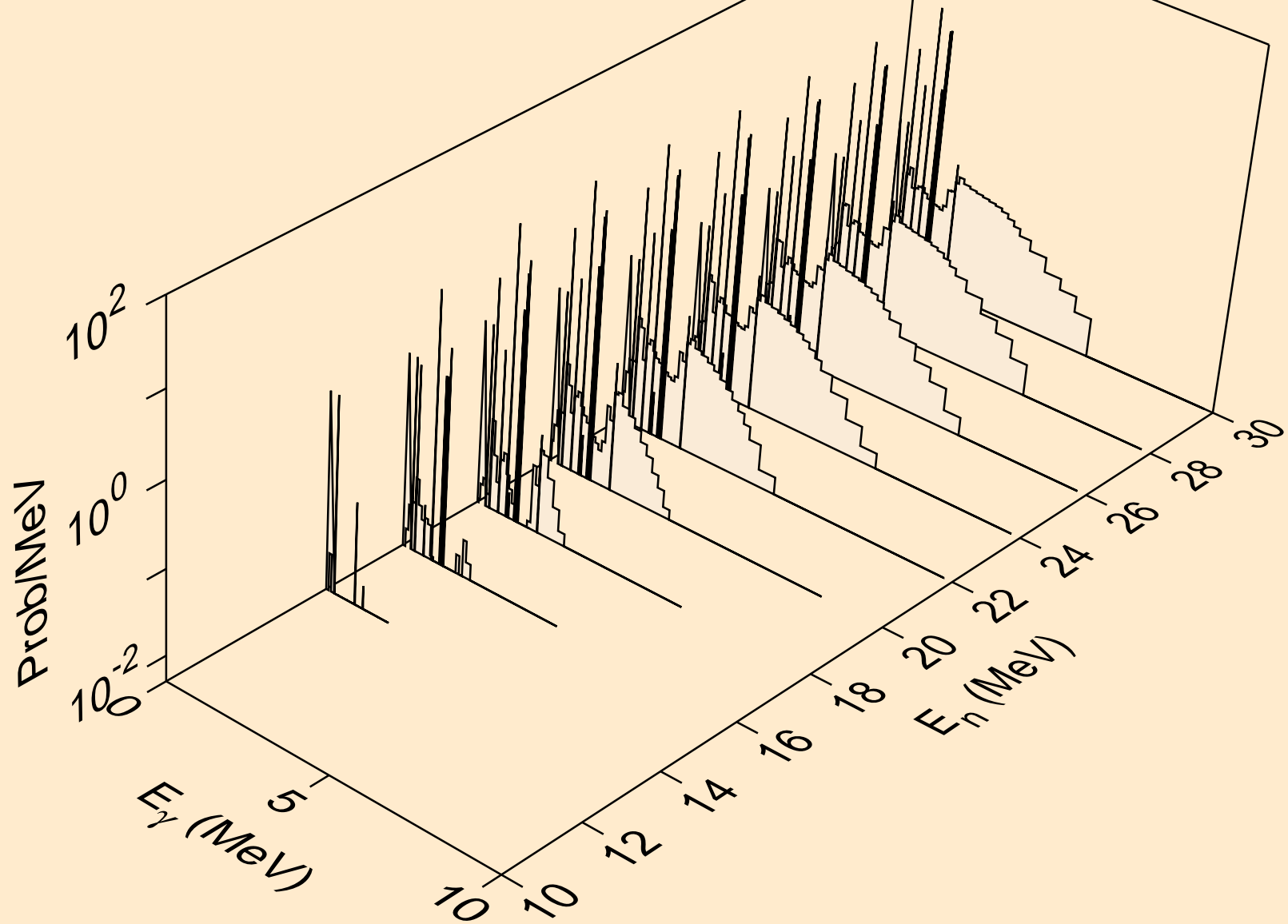

FE052M DEUTERON ACER TENDL-2023 LIBRARY; T=0.K  
Photon emission for (n,3np)

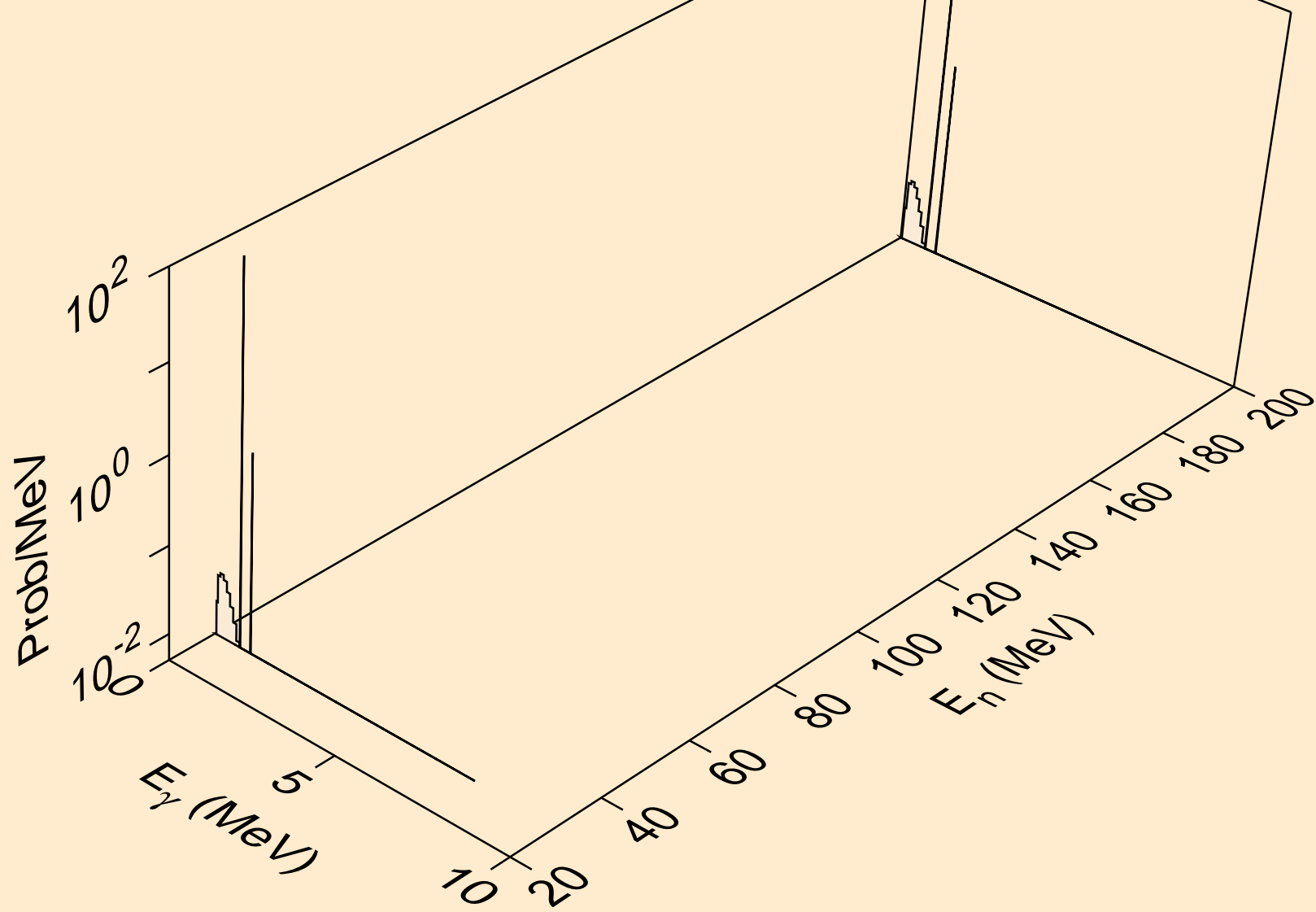

FE052M DEUTERON ACER TENDL-2023 LIBRARY; T=0.K  
Photon emission for (n,n2p)

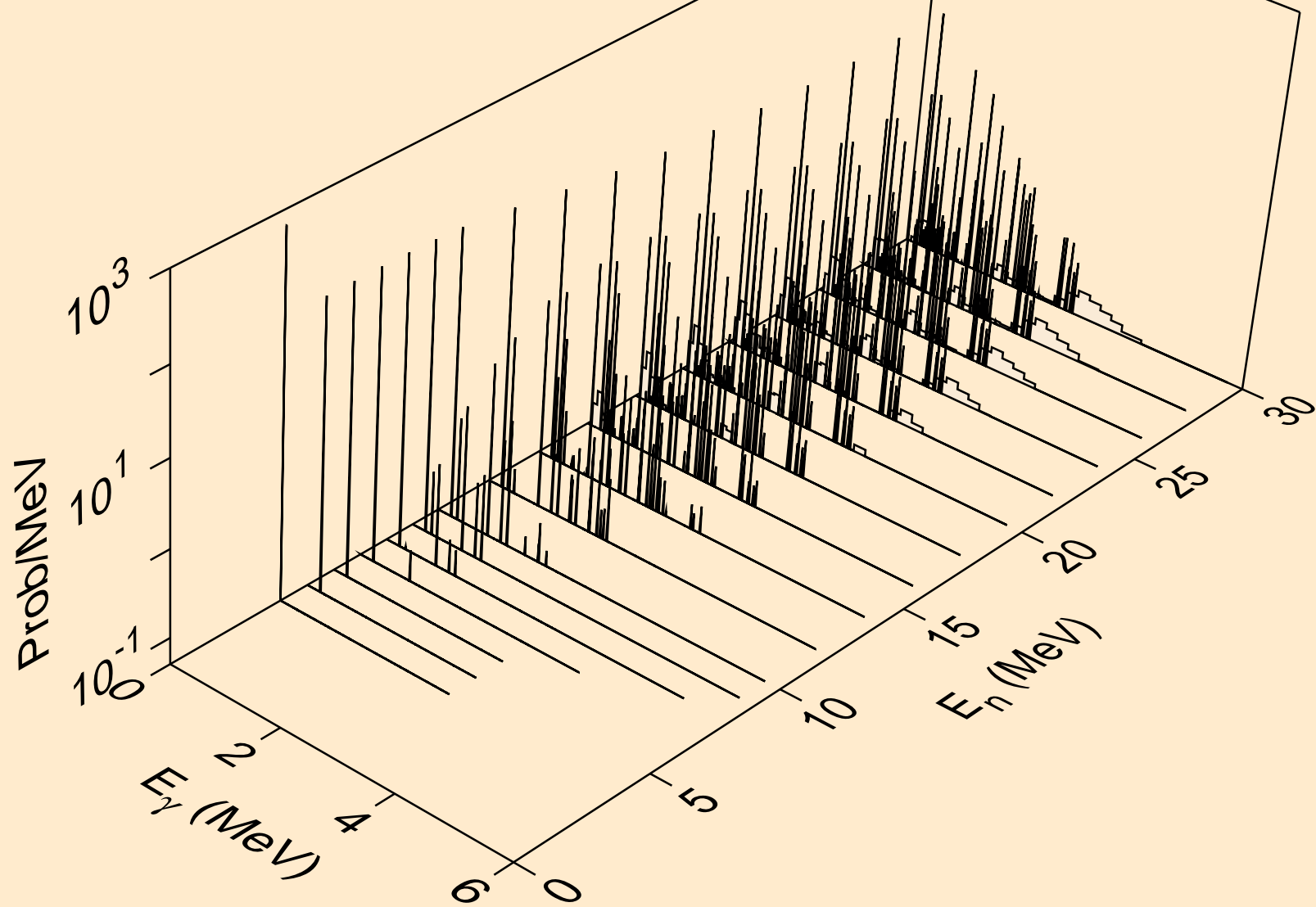

FE052M DEUTERON ACER TENDL-2023 LIBRARY; T=0.K  
Photon emission for (n,npa)

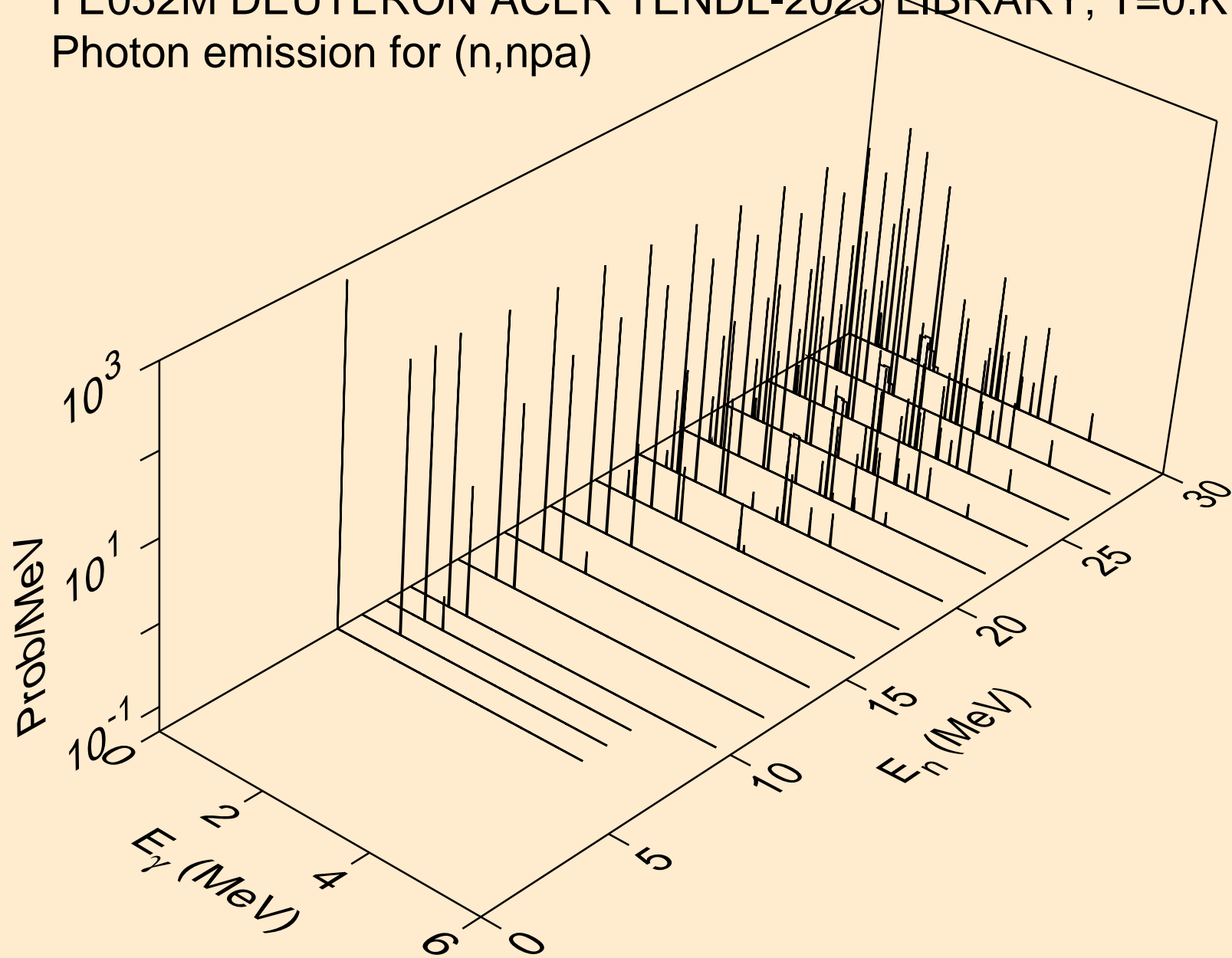



FE052M DEUTERON ACER TENDL-2023 LIBRARY; T=0.K  
Photon emission for (n,gma)

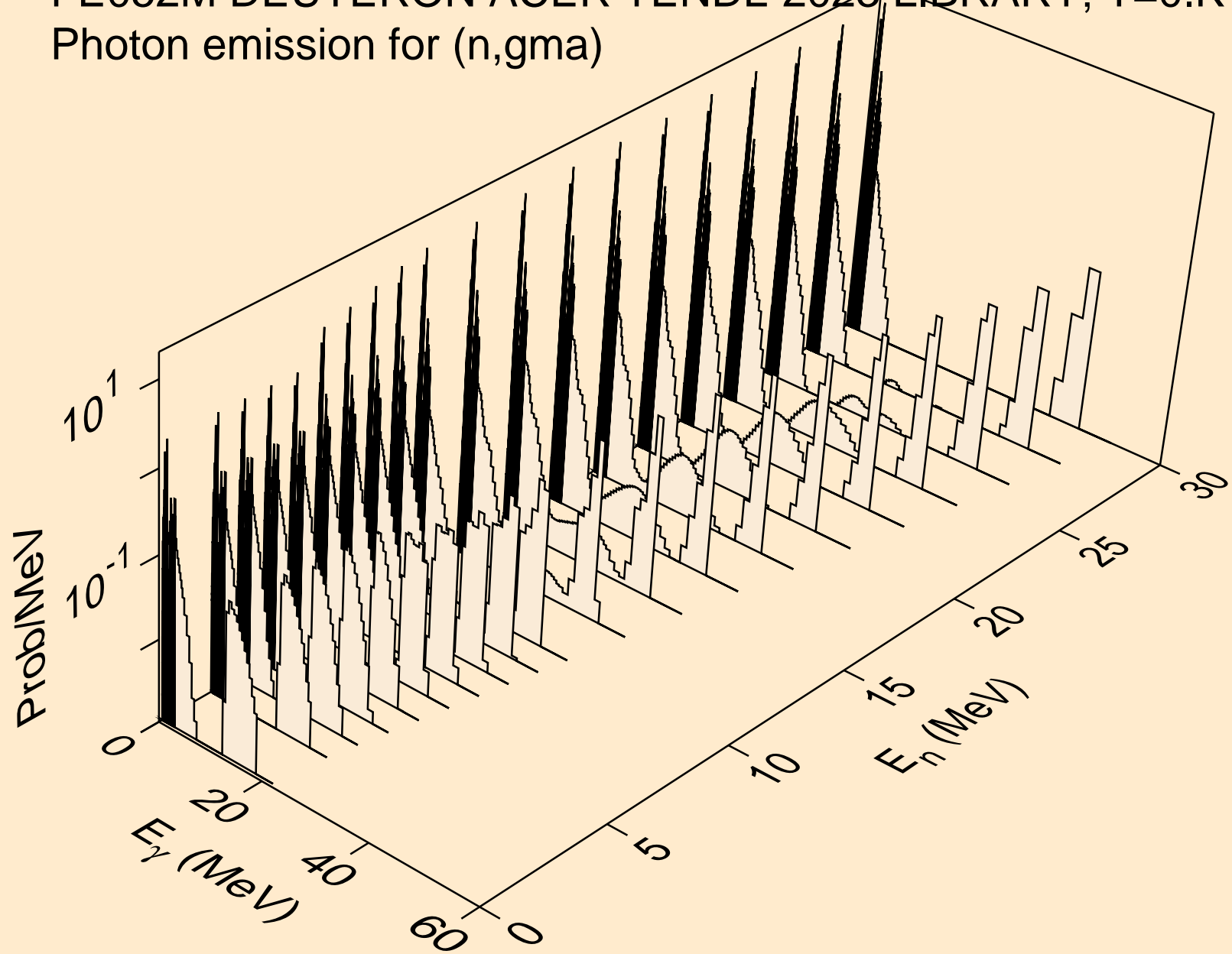

FE052M DEUTERON ACER TENDL-2023 LIBRARY; T=0.K  
Photon emission for (n,p)

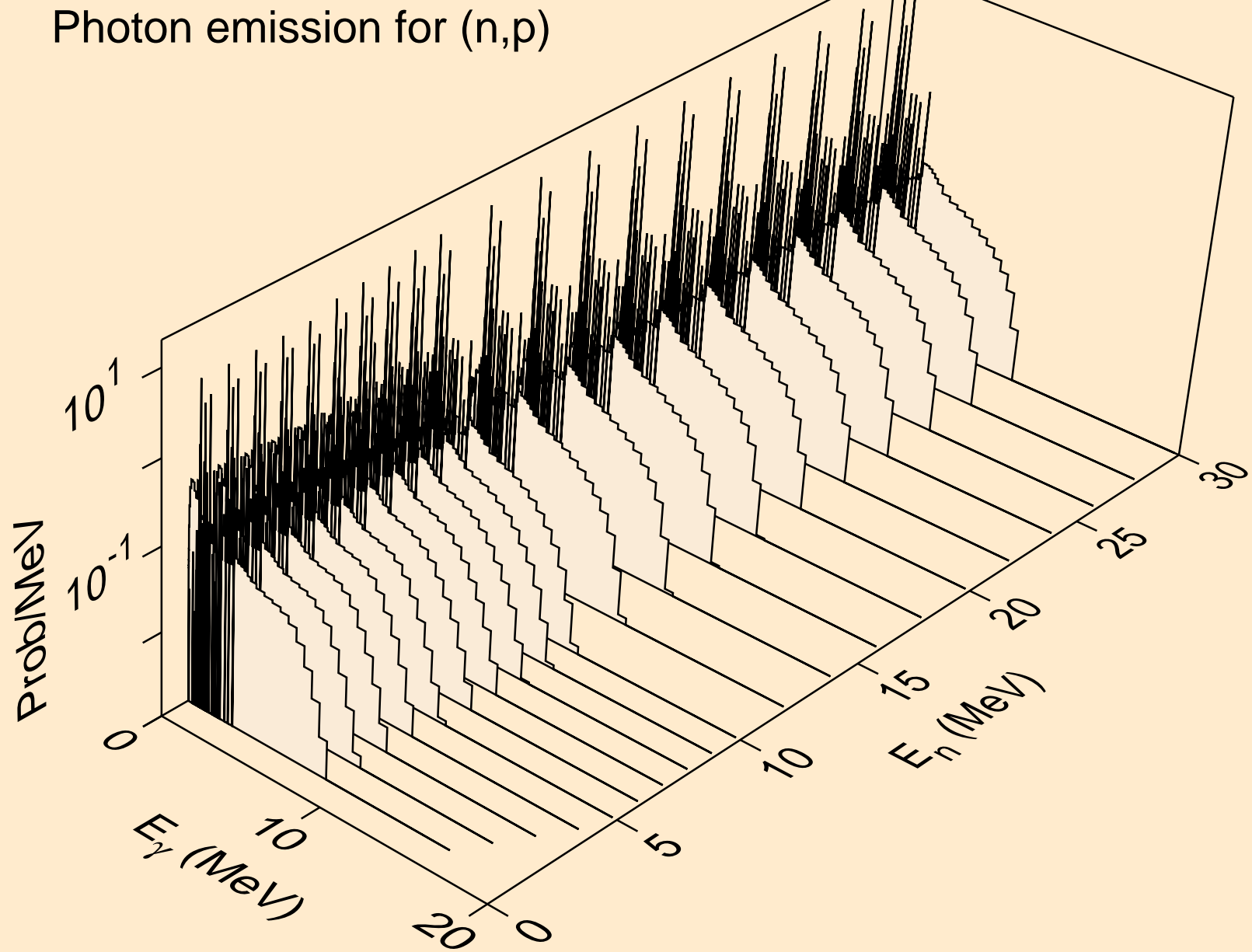

FE052M DEUTERON ACER TENDL-2023 LIBRARY; T=0.K  
Photon emission for inelastic

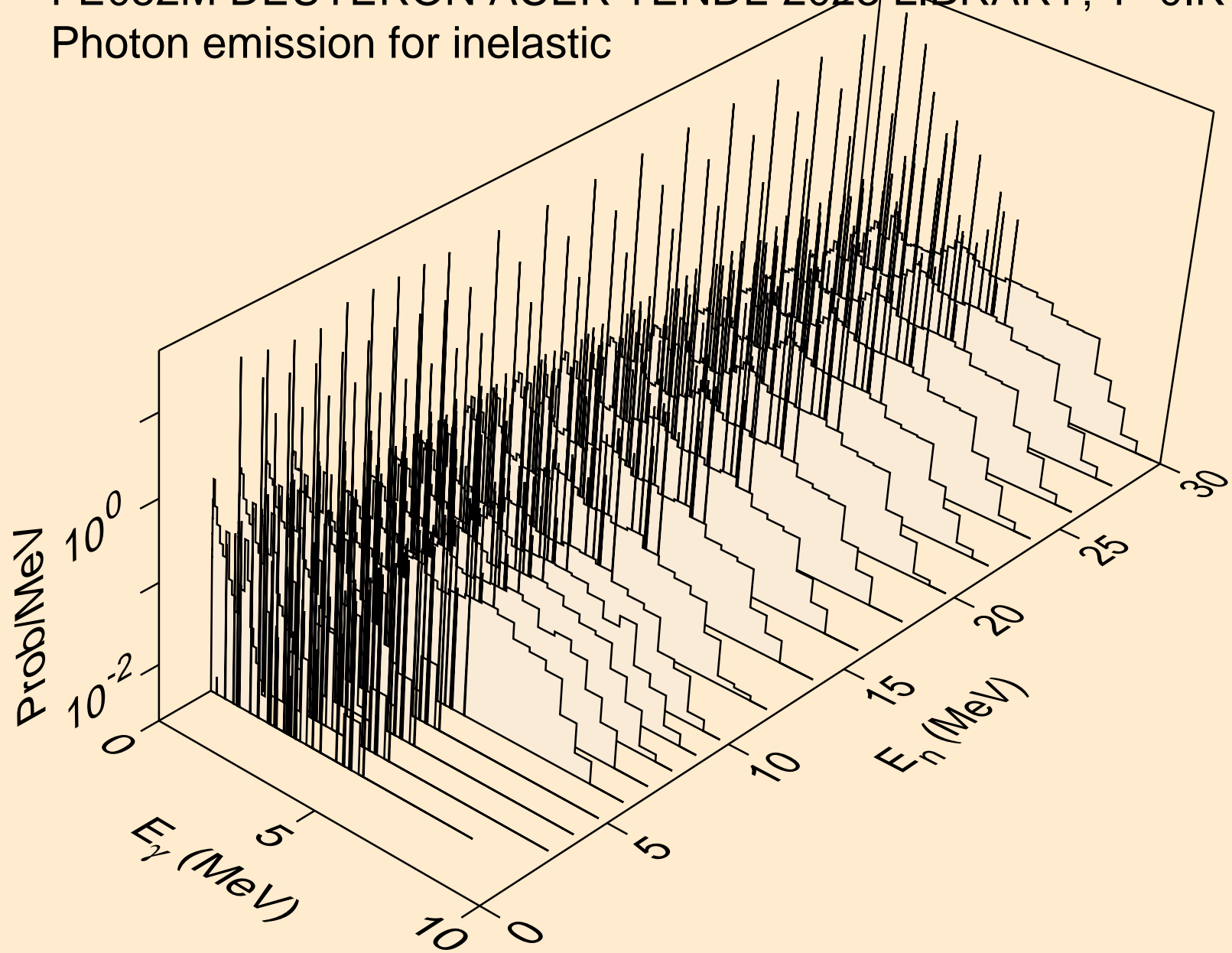

FE052M DEUTERON ACER TENDL-2023 LIBRARY; T=0.K  
Photon emission for (n,t)

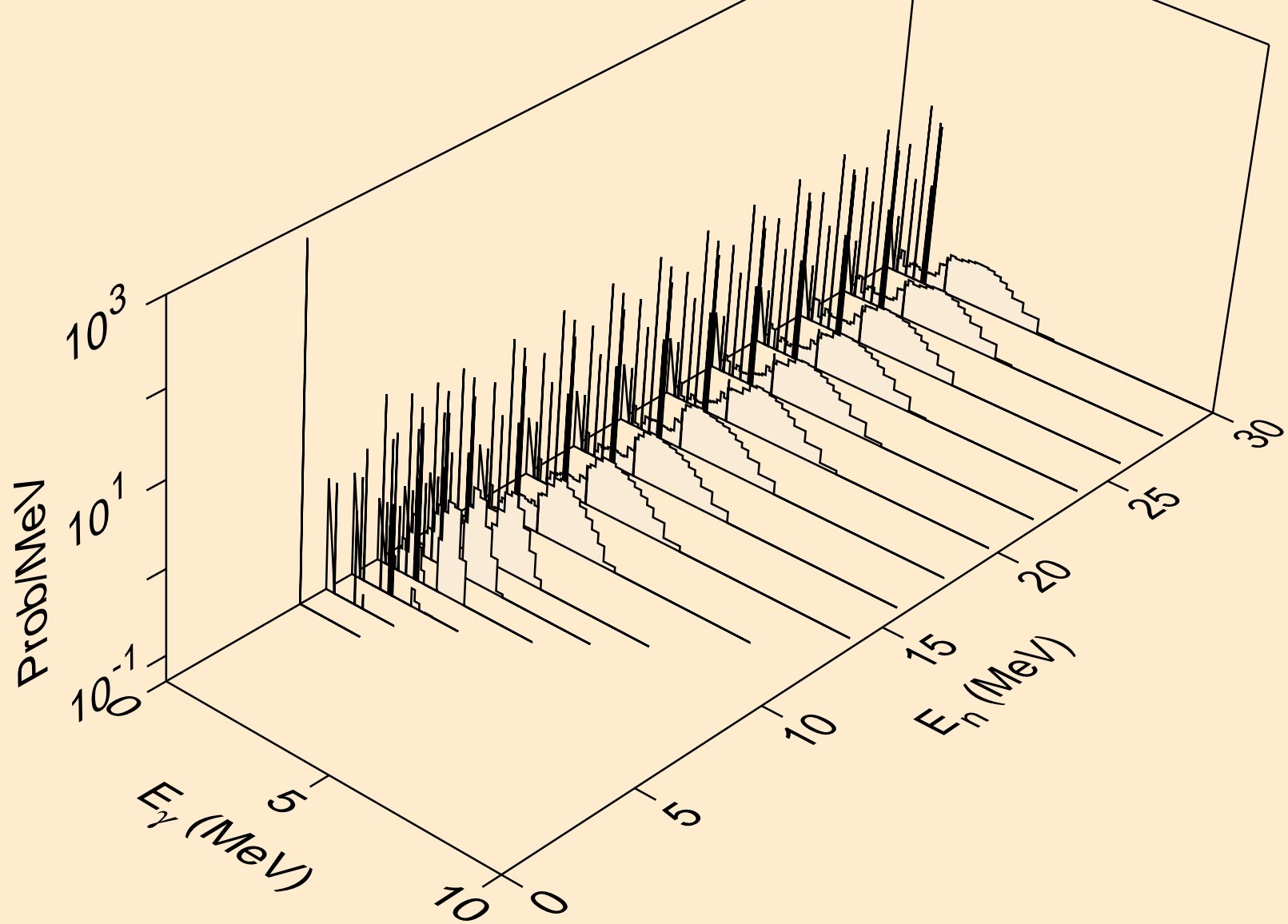

FE052M DEUTERON ACER TENDL-2023 LIBRARY; T=0.K  
Photon emission for (n,he3)

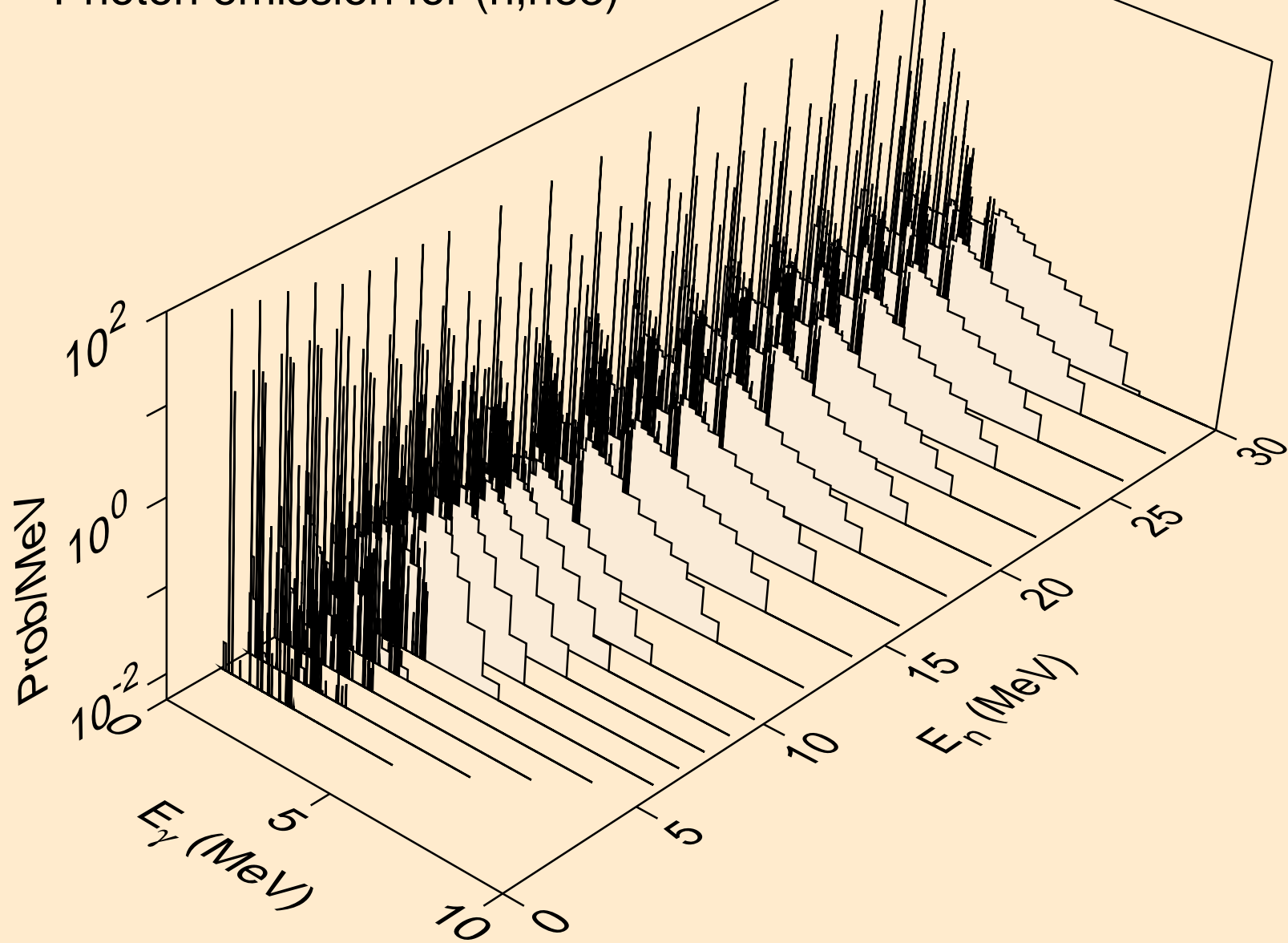

FE052M DEUTERON ACER TENDL-2023 LIBRARY; T=0.K  
Photon emission for (n,a)

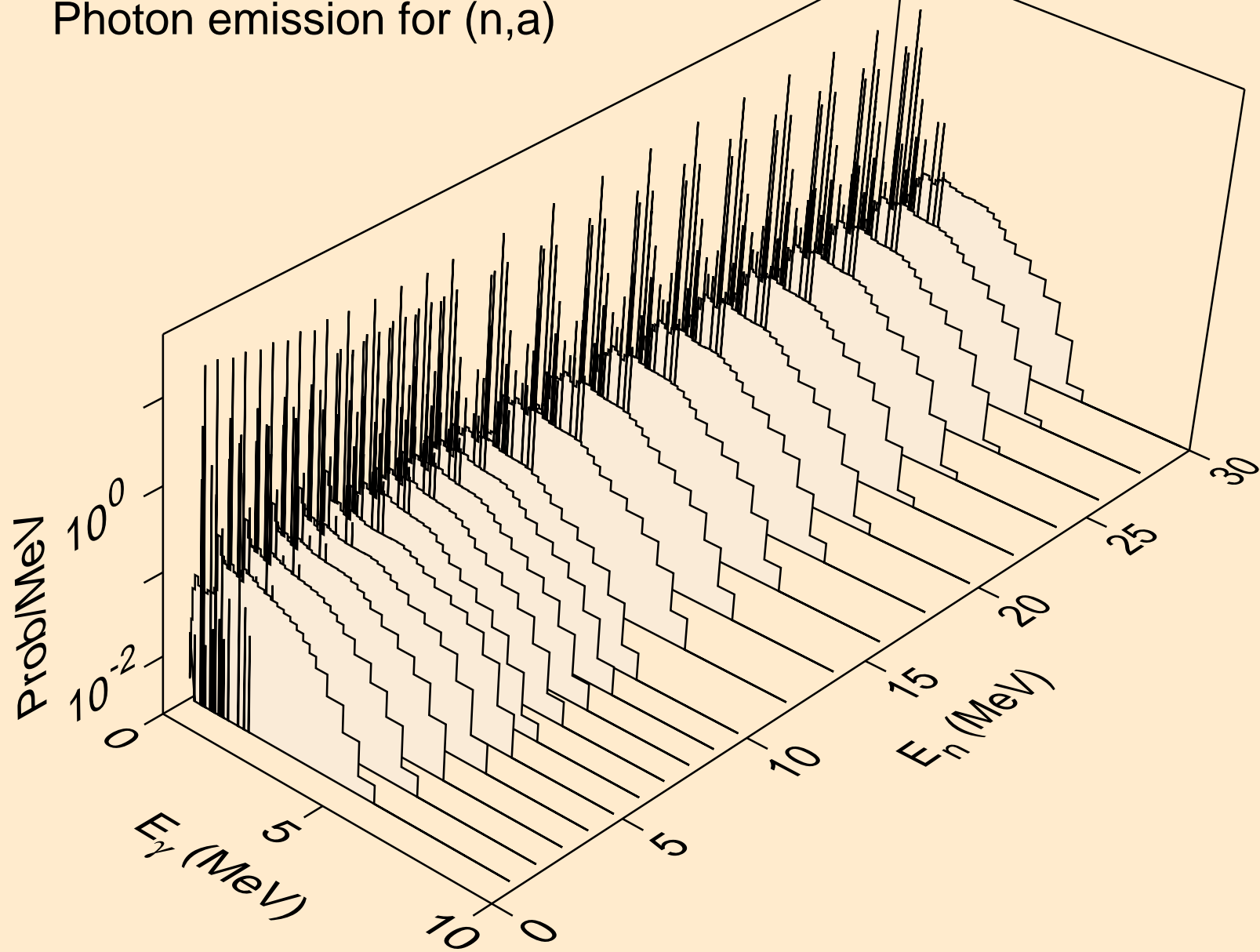

FE052M DEUTERON ACER TENDL-2023 LIBRARY; T=0.K  
Photon emission for (n,2a)

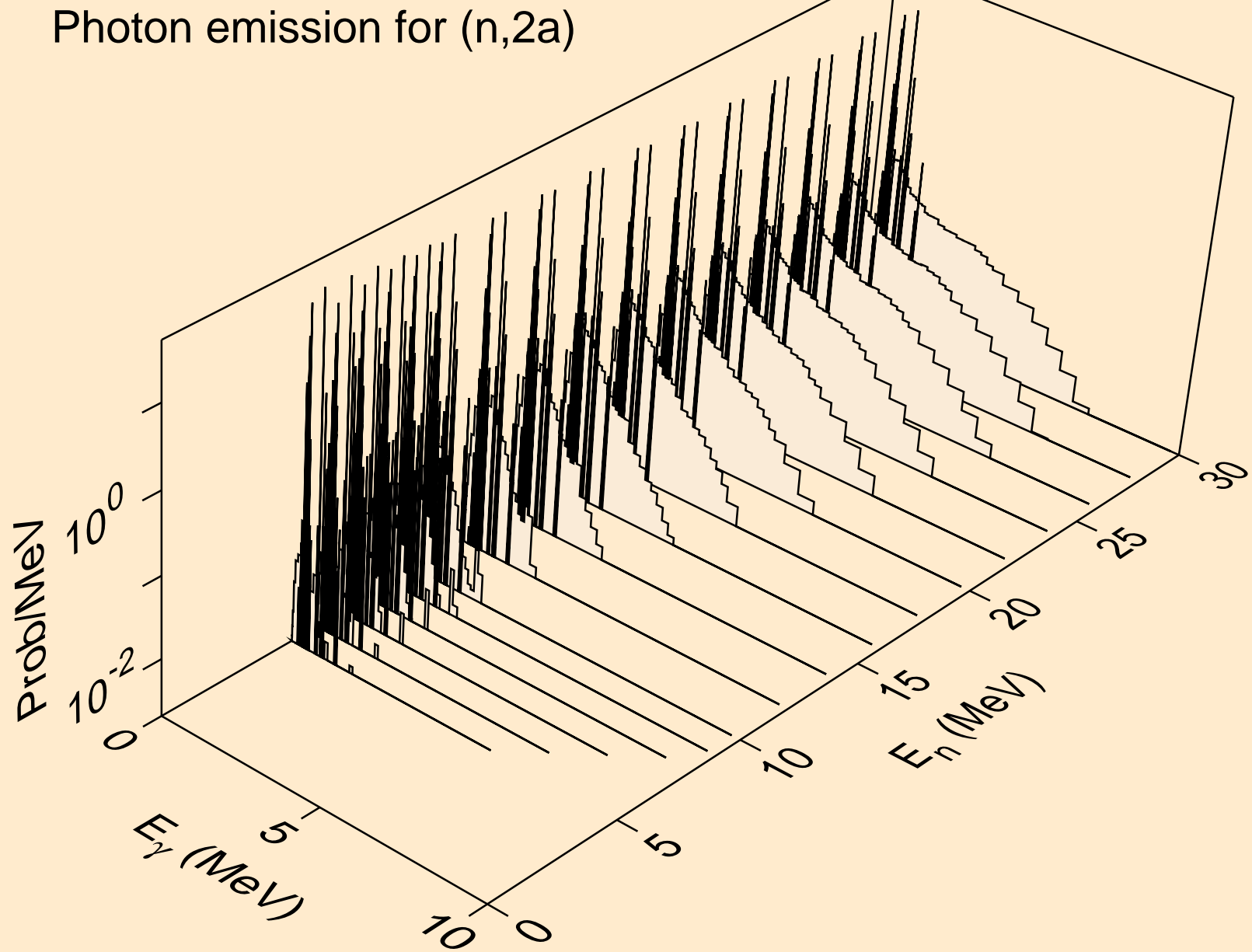

FE052M DEUTERON ACER TENDL-2023 LIBRARY; T=0.K  
Photon emission for (n,3a)

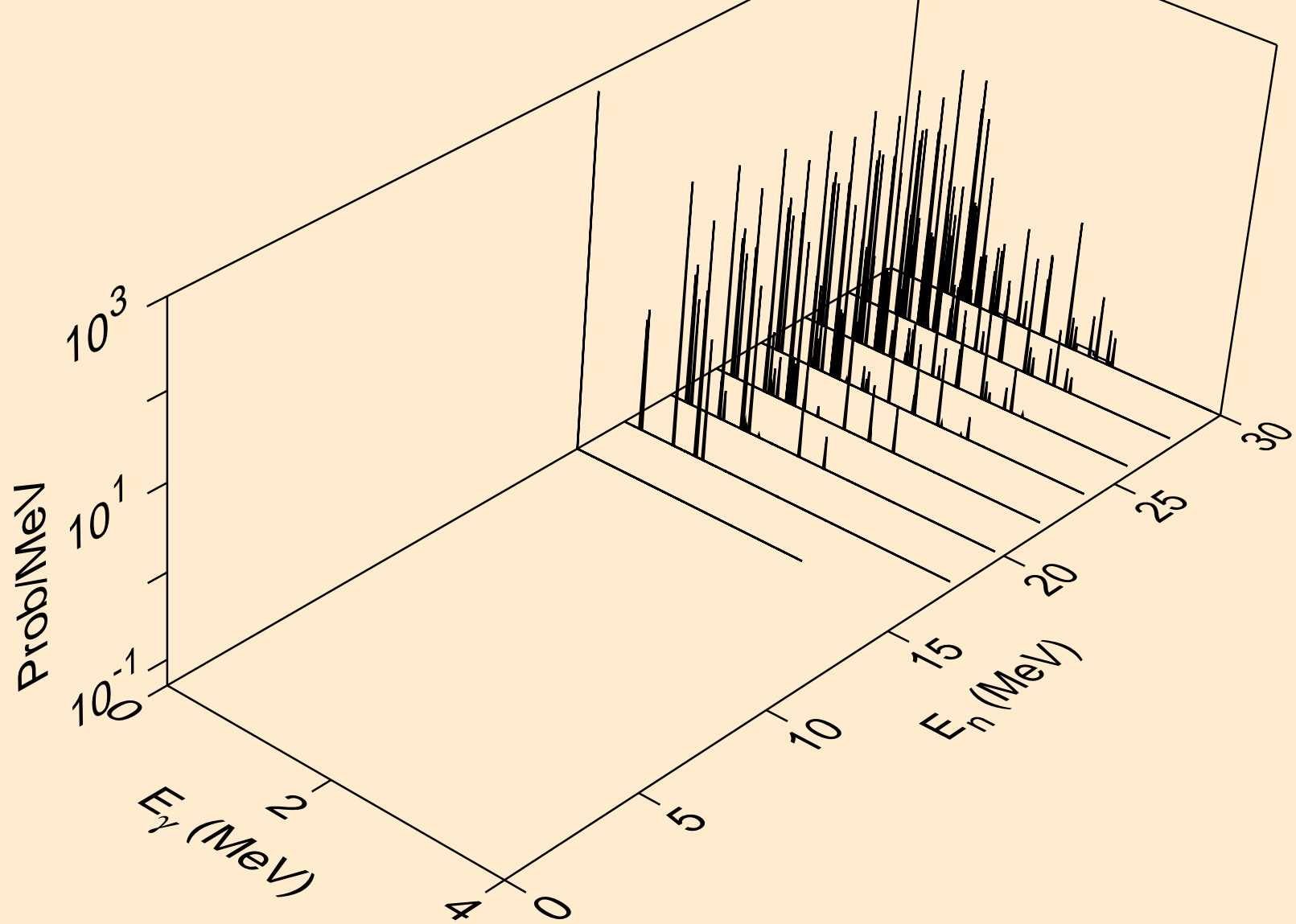



FE052M DEUTERON ACER TENDL-2023 LIBRARY; T=0.K  
Photon emission for (n,2p)

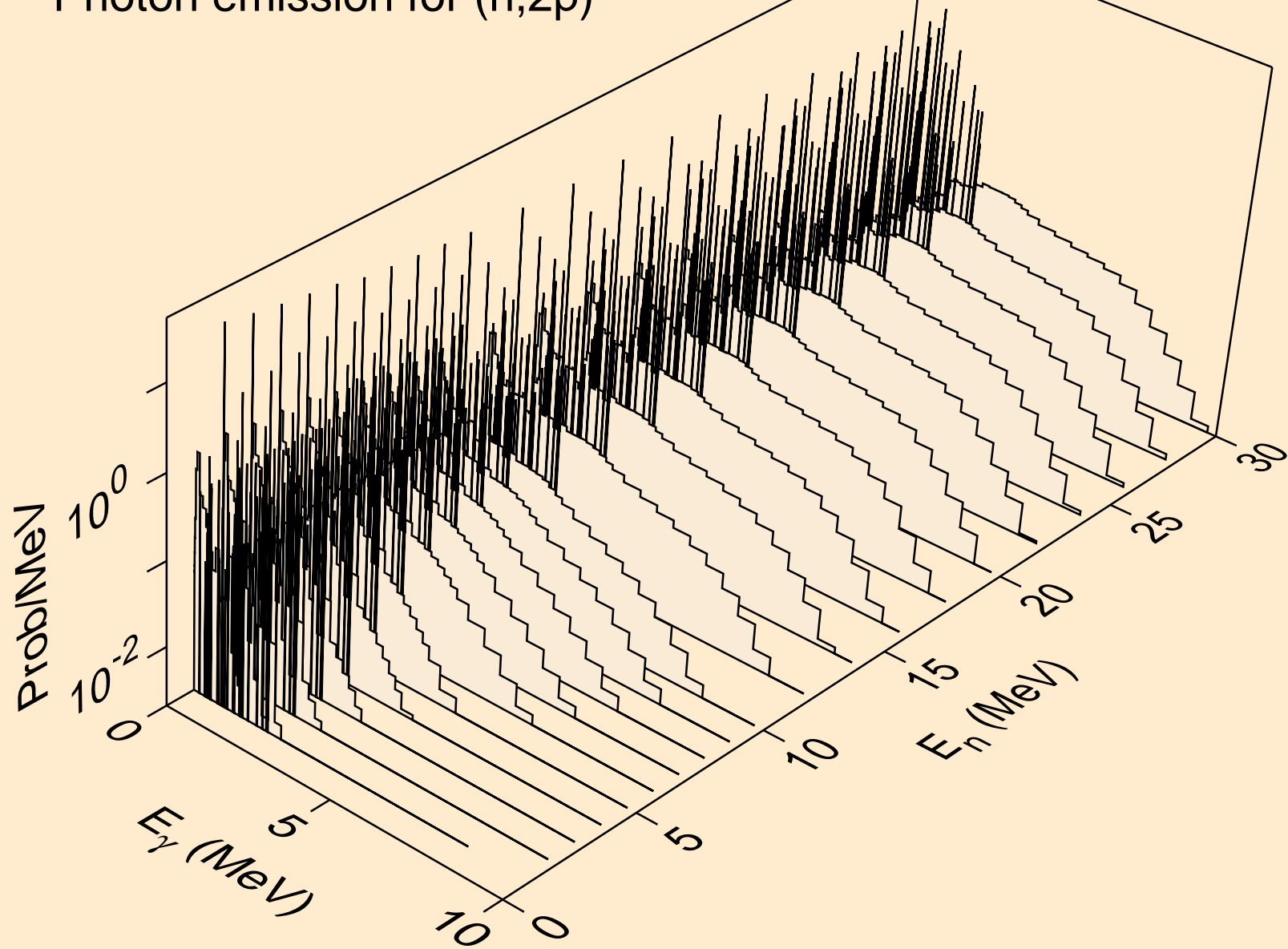

FE052M DEUTERON ACER TENDL-2023 LIBRARY; T=0.K  
Photon emission for (n,p)

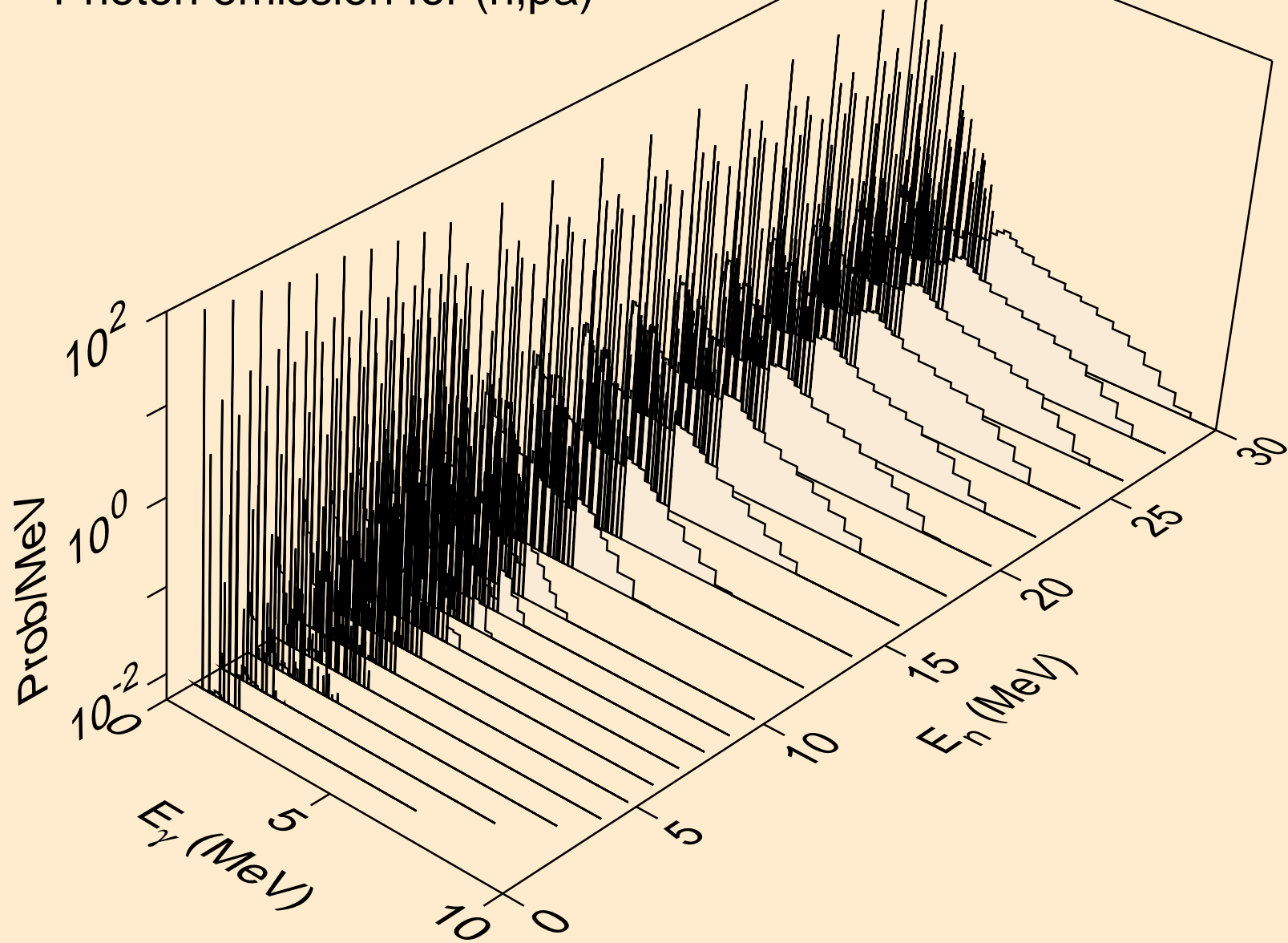

FE052M DEUTERON ACER TENDL-2023 LIBRARY; T=0.K  
Photon emission for (n,d2a)

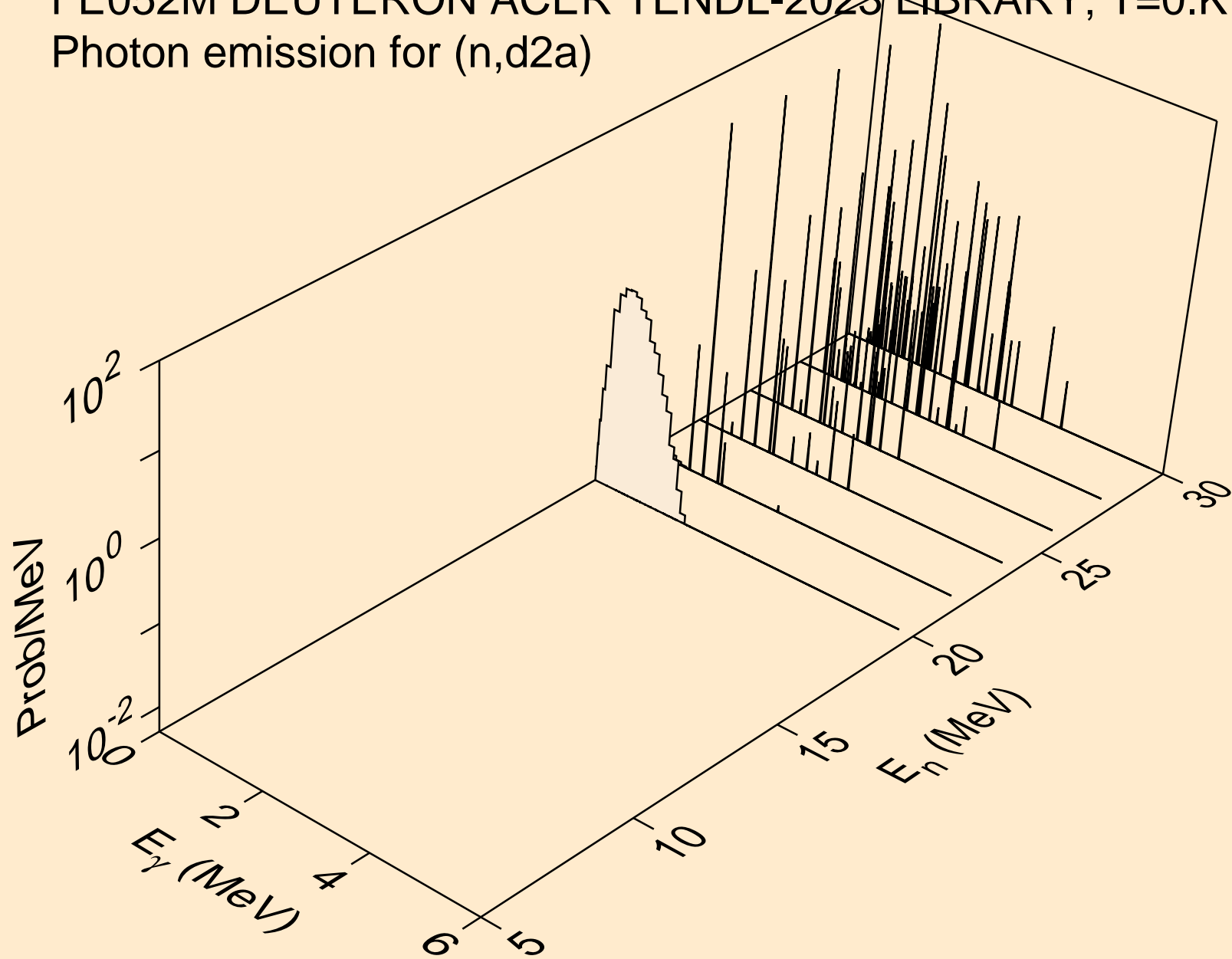

FE052M DEUTERON ACER TENDL-2023 LIBRARY; T=0.K  
Photon emission for (n,pd)

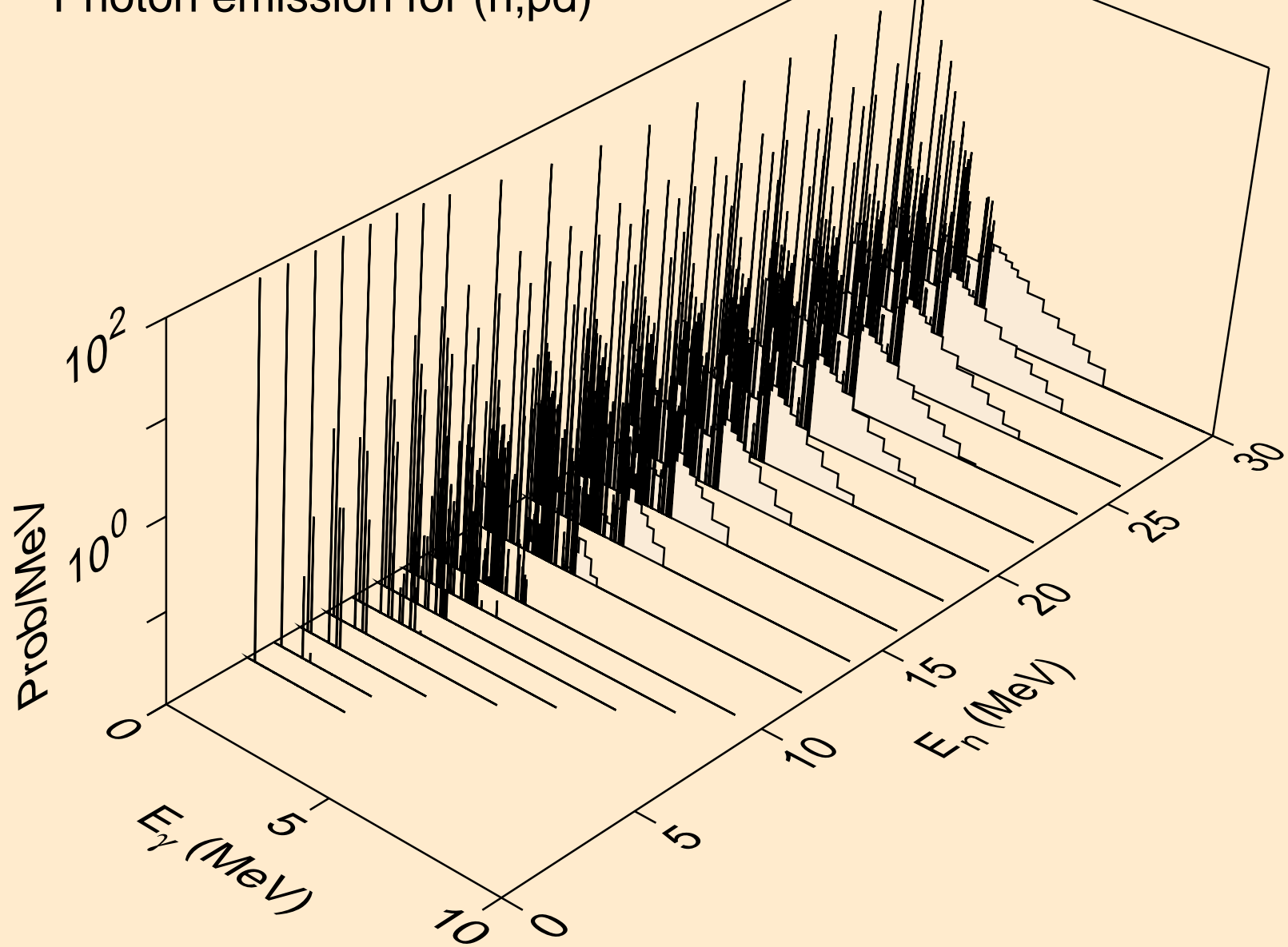

FE052M DEUTERON ACER TENDL-2023 LIBRARY; T=0.K  
Photon emission for (n,pt)

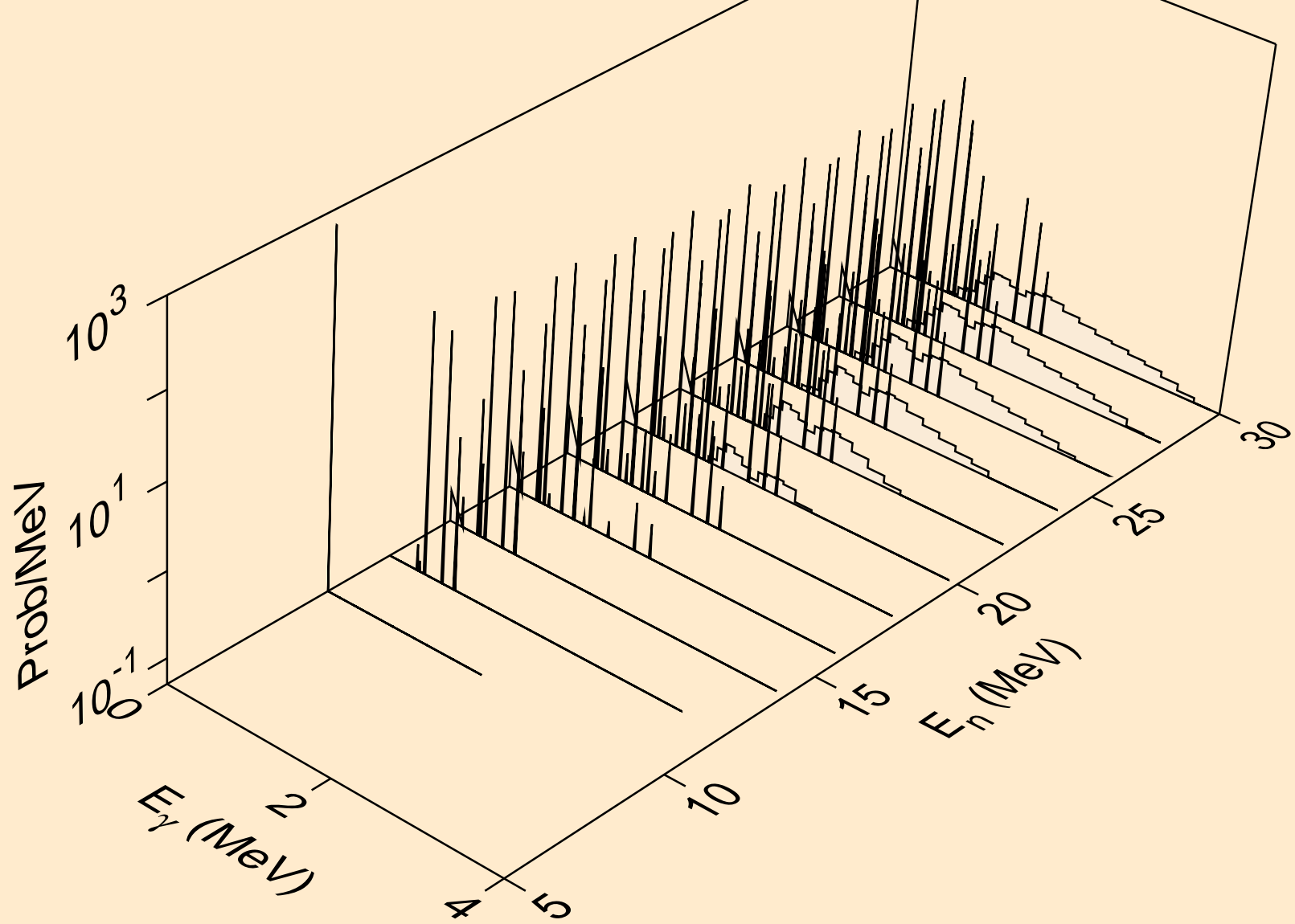

FE052M DEUTERON ACER TENDL-2023 LIBRARY; T=0.K  
Photon emission for (n,da)

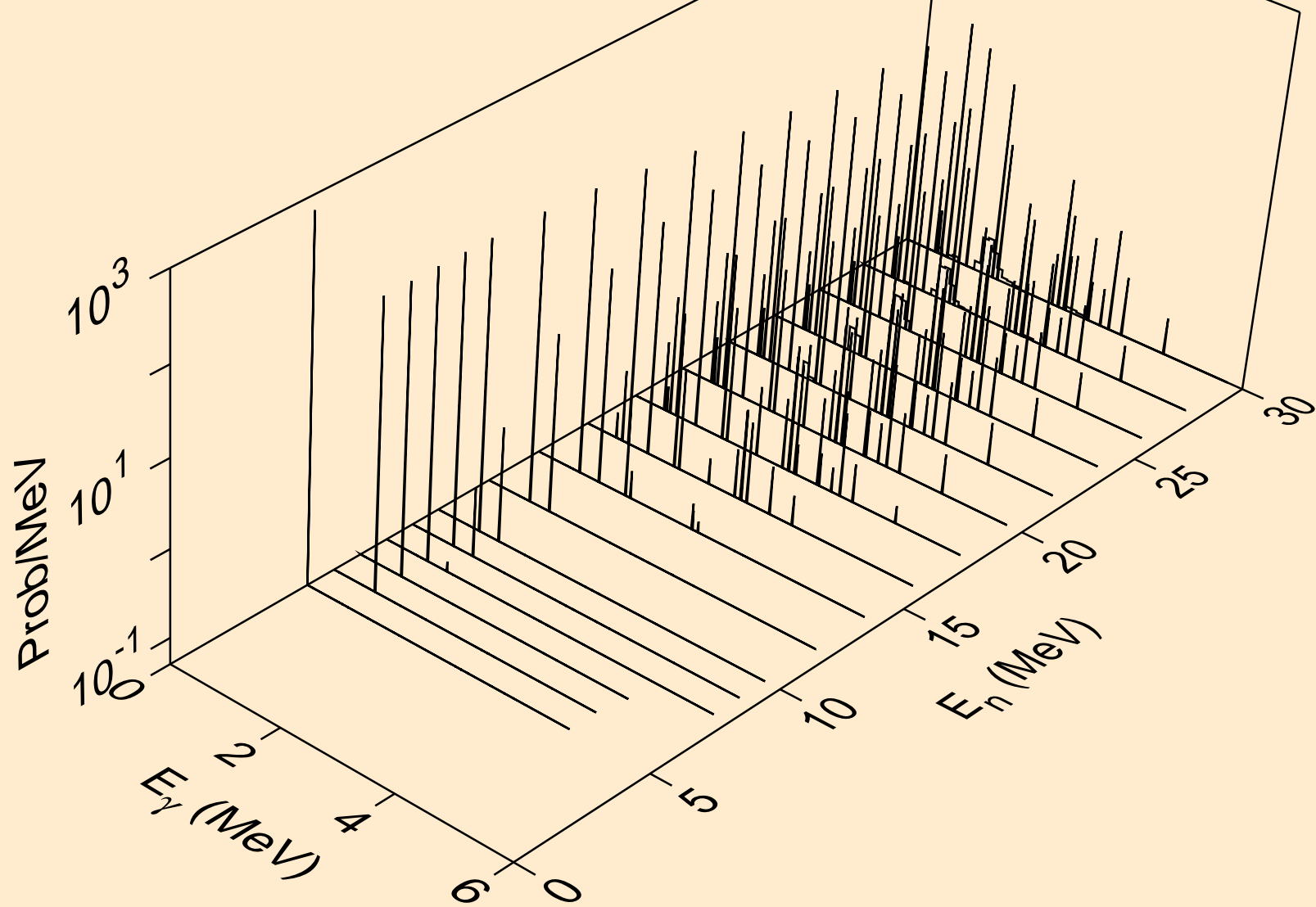

# FE052M DEUTERON ACER TENDL-2023 LIBRARY; T=0.K

## Particle heating contributions

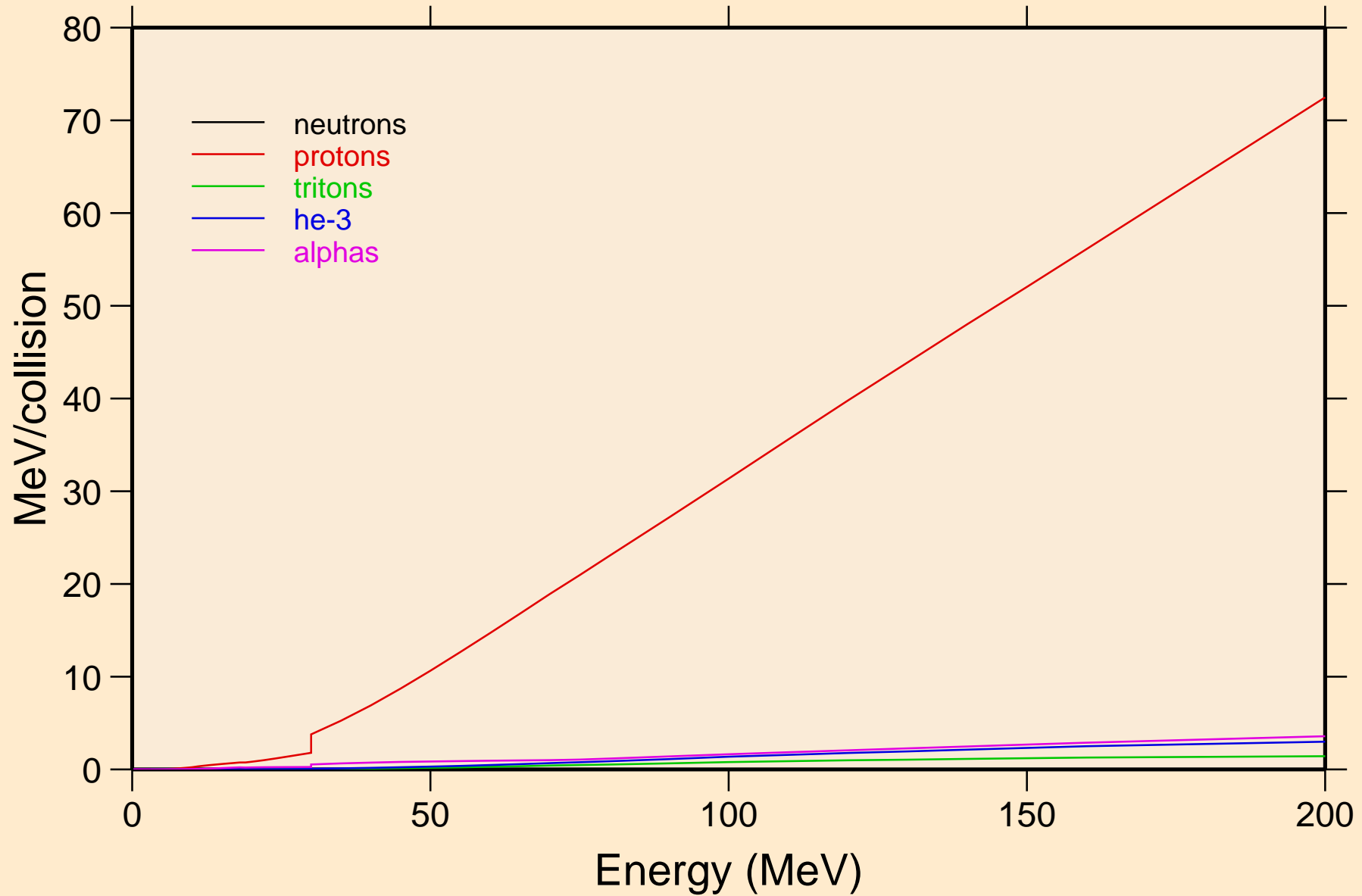

FE052M DEUTERON ACER TENDL-2023 LIBRARY; T=0.K  
Recoil Heating

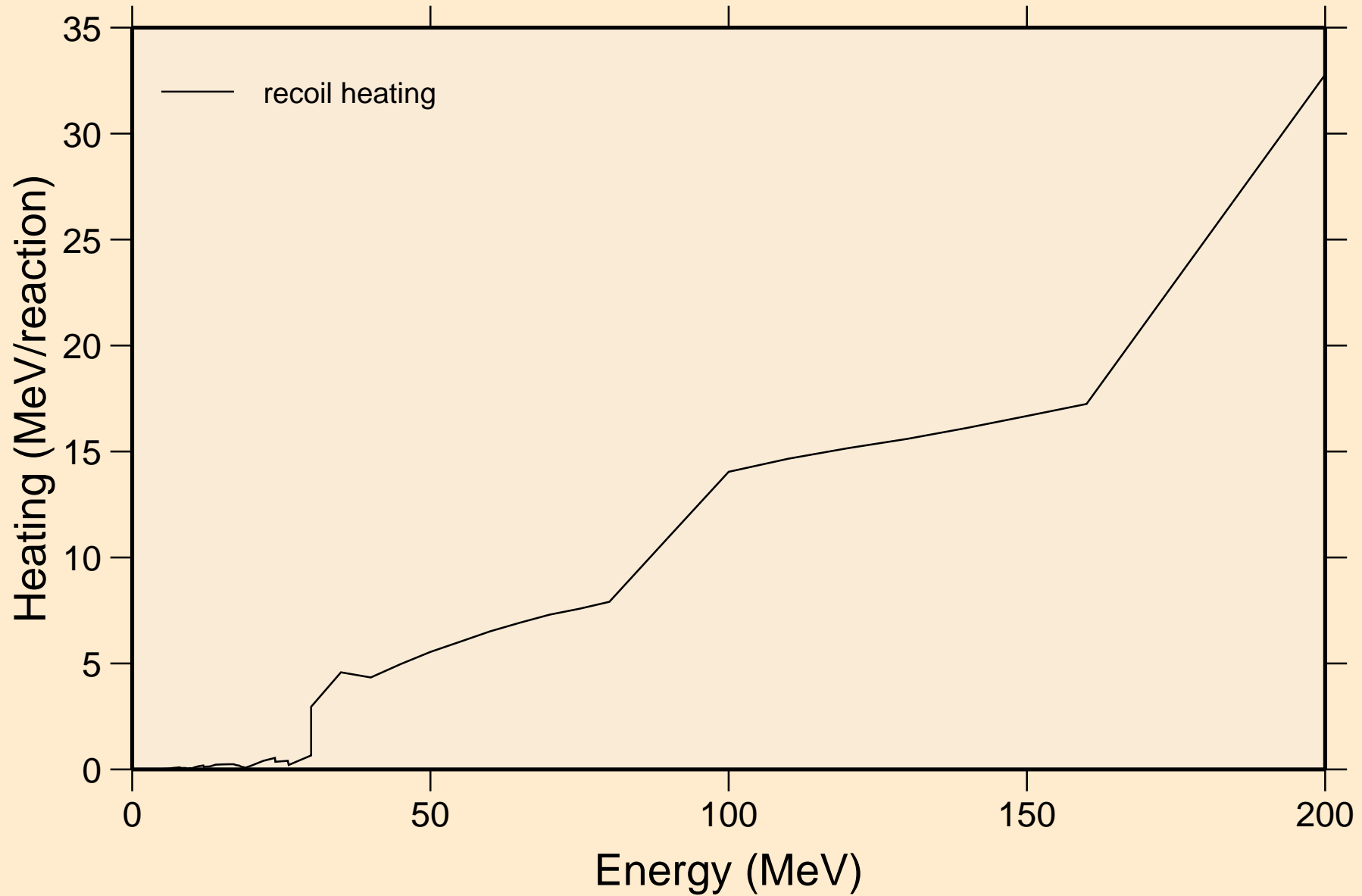



# FE052M DEUTERON ACER TENDL-2023 LIBRARY; T=0.K

## Particle production cross sections

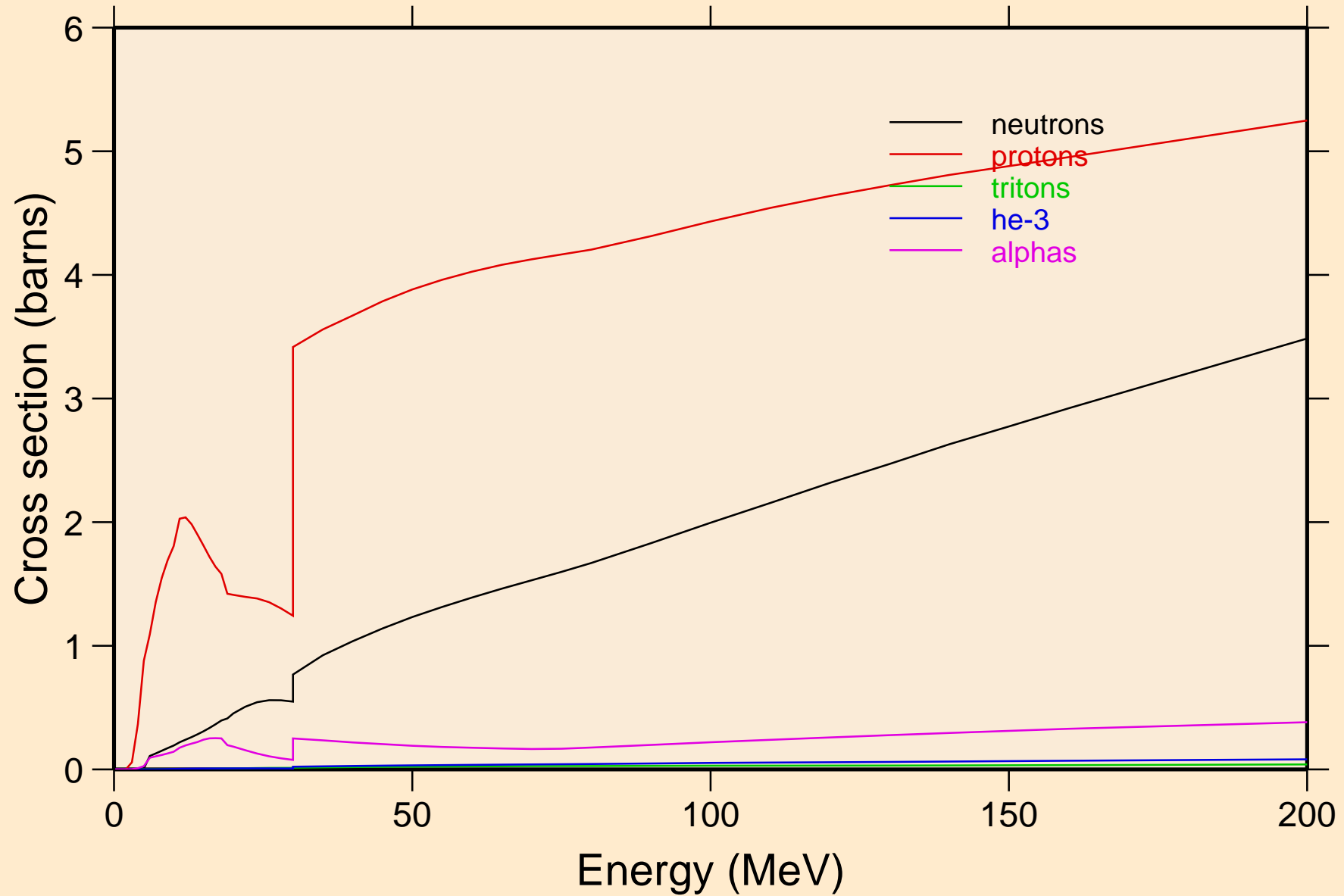

FE052M DEUTERON ACER TENDL-2023 LIBRARY; T=0.K  
neutrons from (d,n)

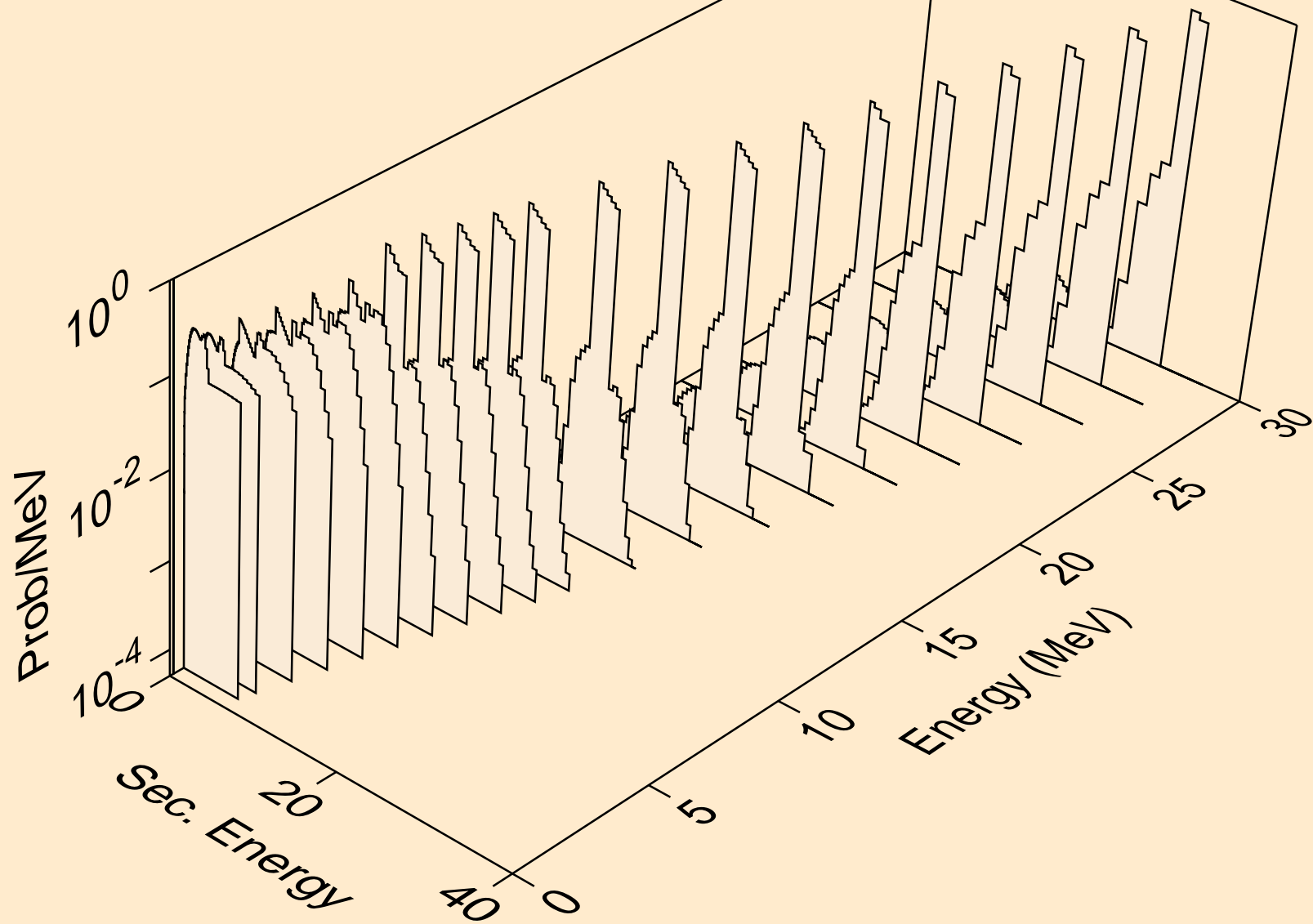

FE052M DEUTERON ACER TENDL-2023 LIBRARY; T=0.K  
neutrons from (d,x)

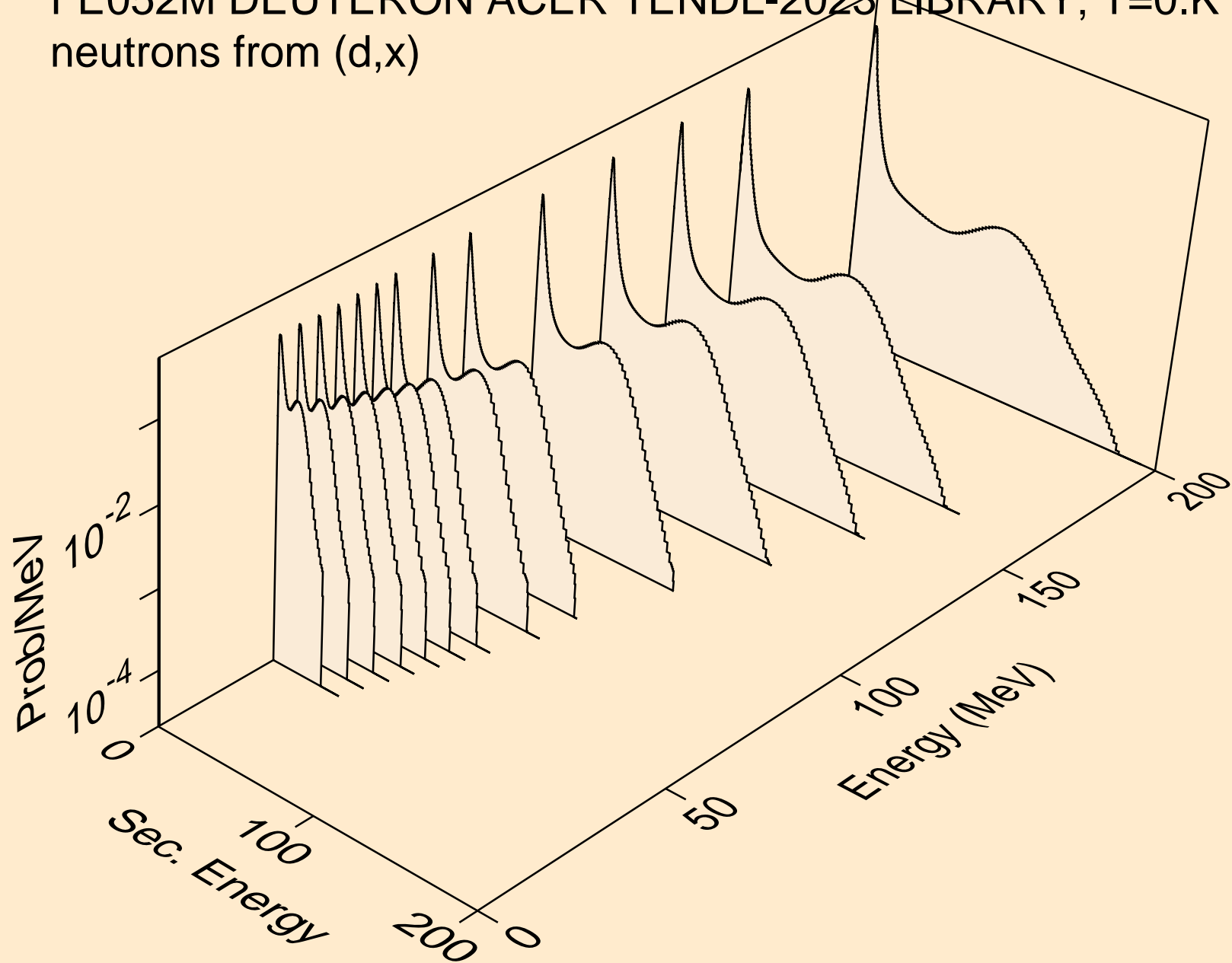

FE052M DEUTERON ACER TENDL-2023 LIBRARY; T=0.K  
neutrons from (d,2nd)

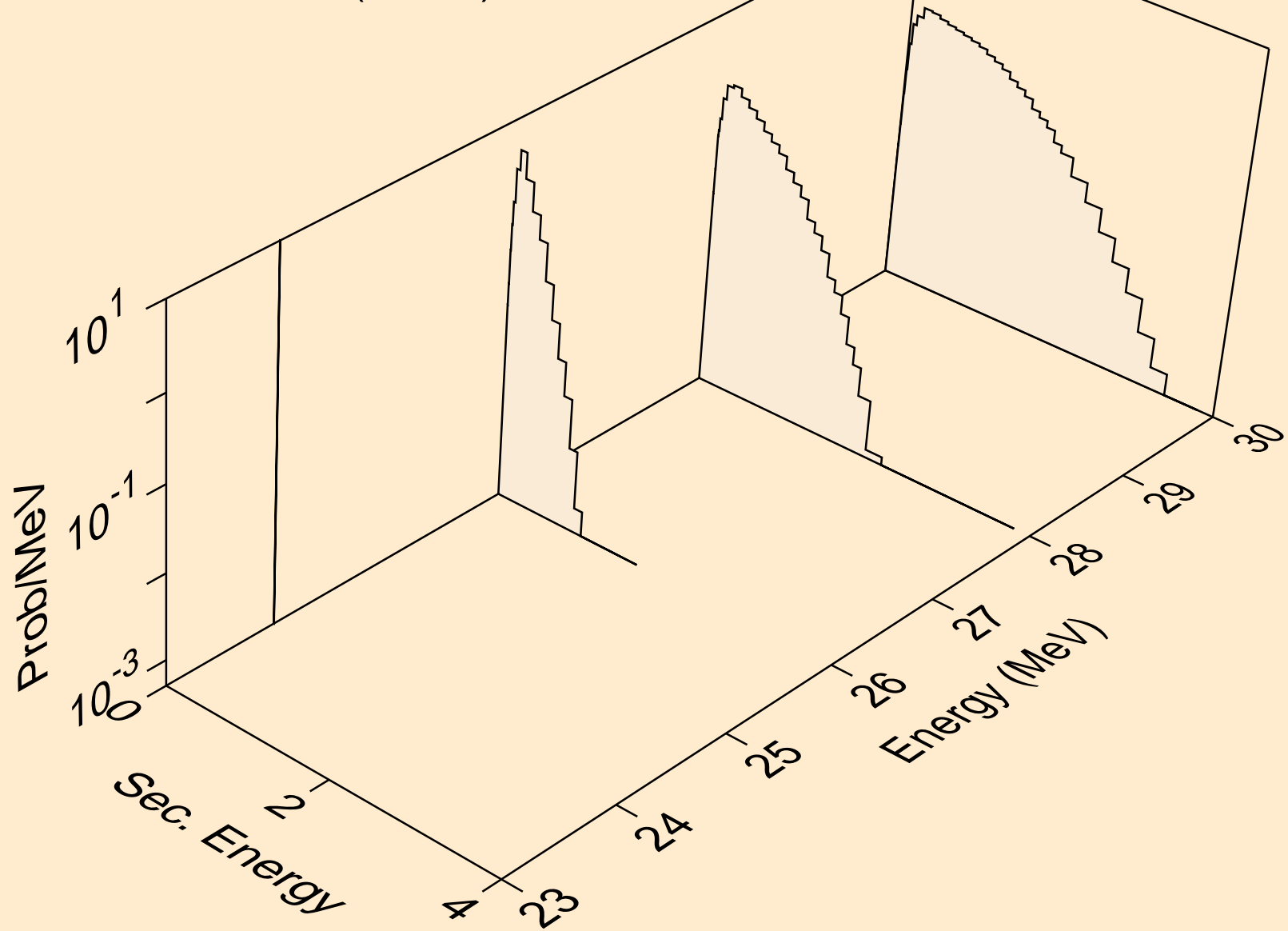

FE052M DEUTERON ACER TENDL-2023 LIBRARY; T=0.K  
neutrons from (d,2n)

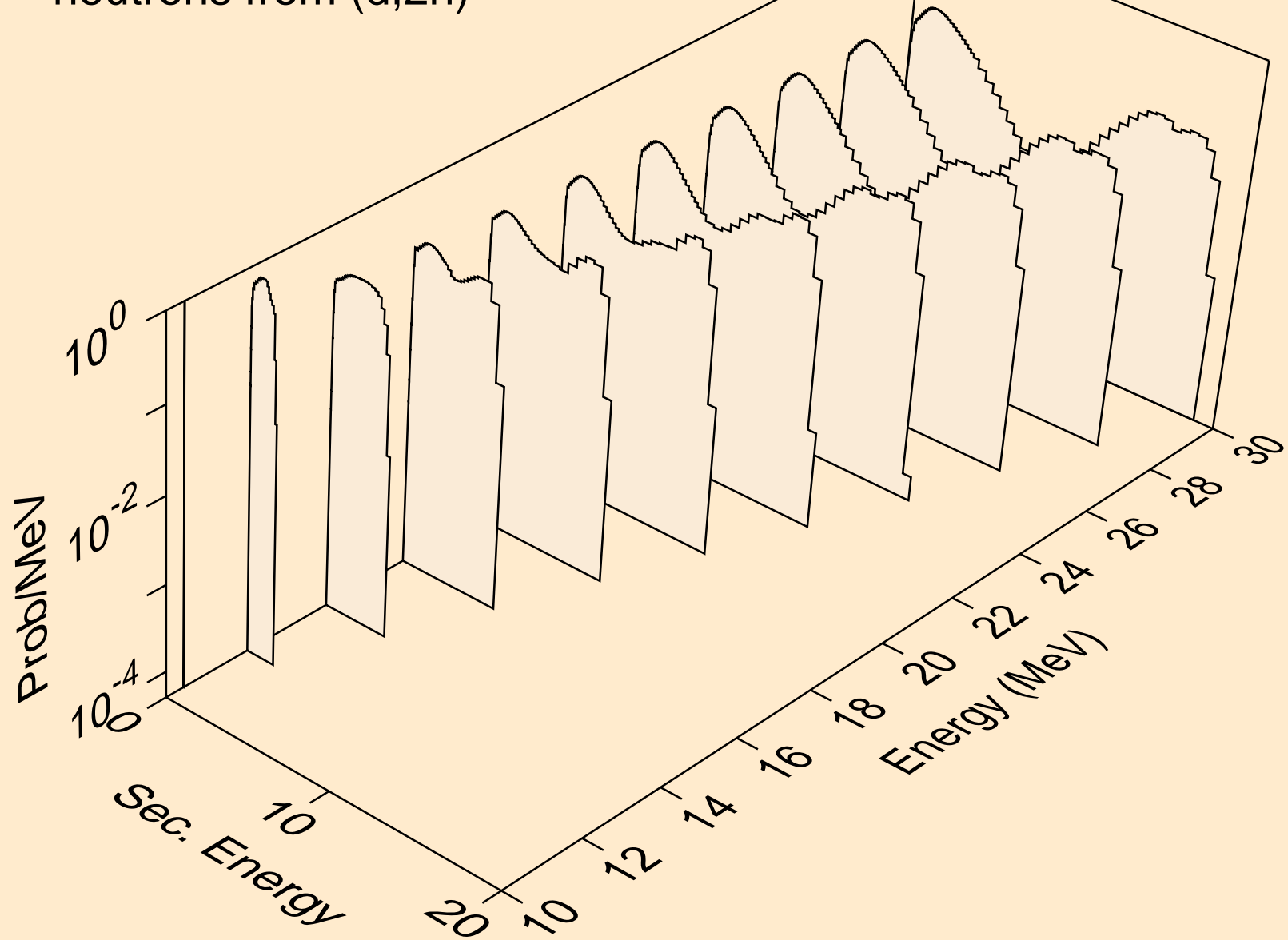

FE052M DEUTERON ACER TENDL-2023 LIBRARY; T=0.K  
neutrons from (d,3n)

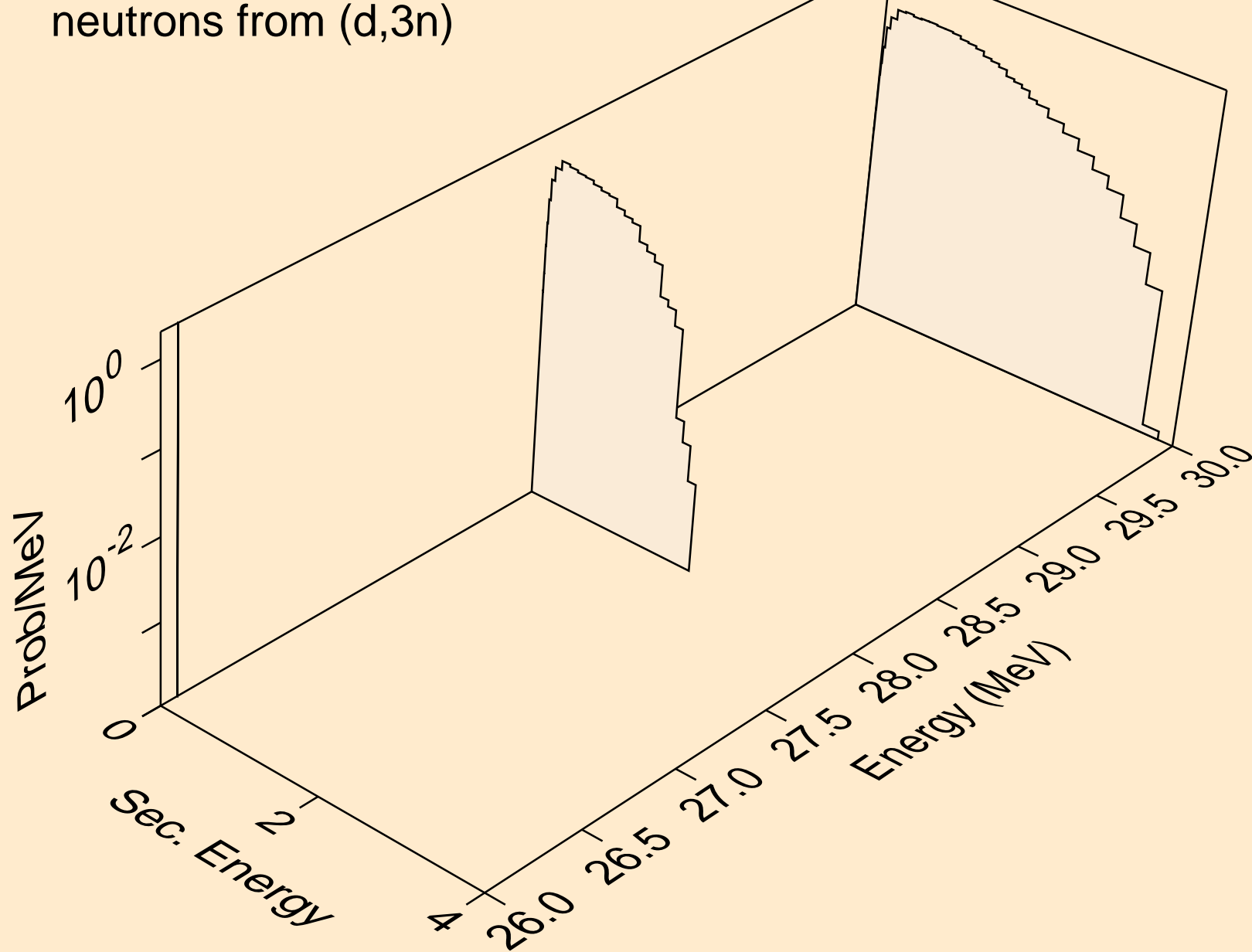

FE052M DEUTERON ACER TENDL-2023 LIBRARY; T=0.K  
neutrons from (d,n\*)a

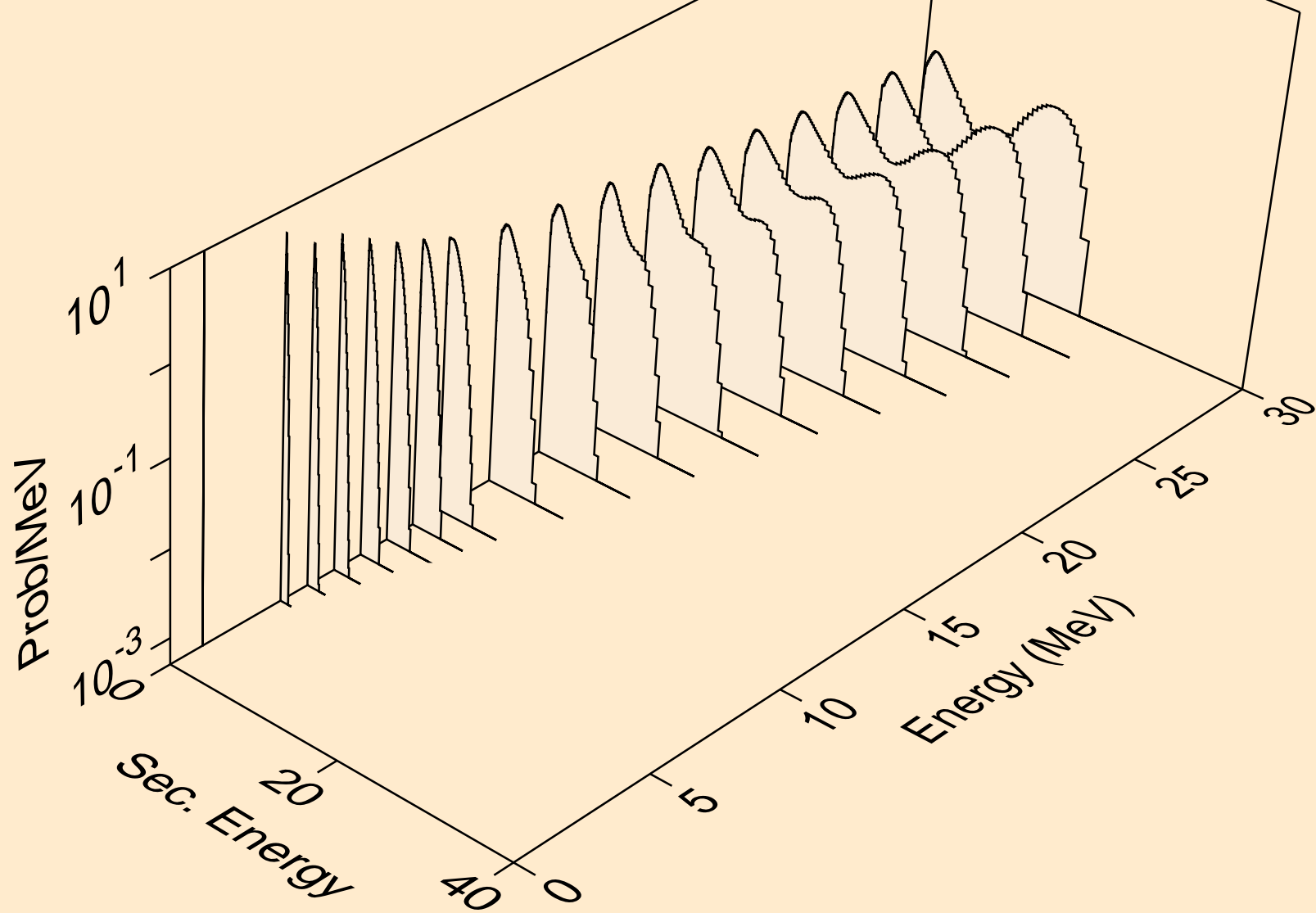

FE052M DEUTERON ACER TENDL-2023 LIBRARY; T=0.K  
neutrons from (d,2n)a

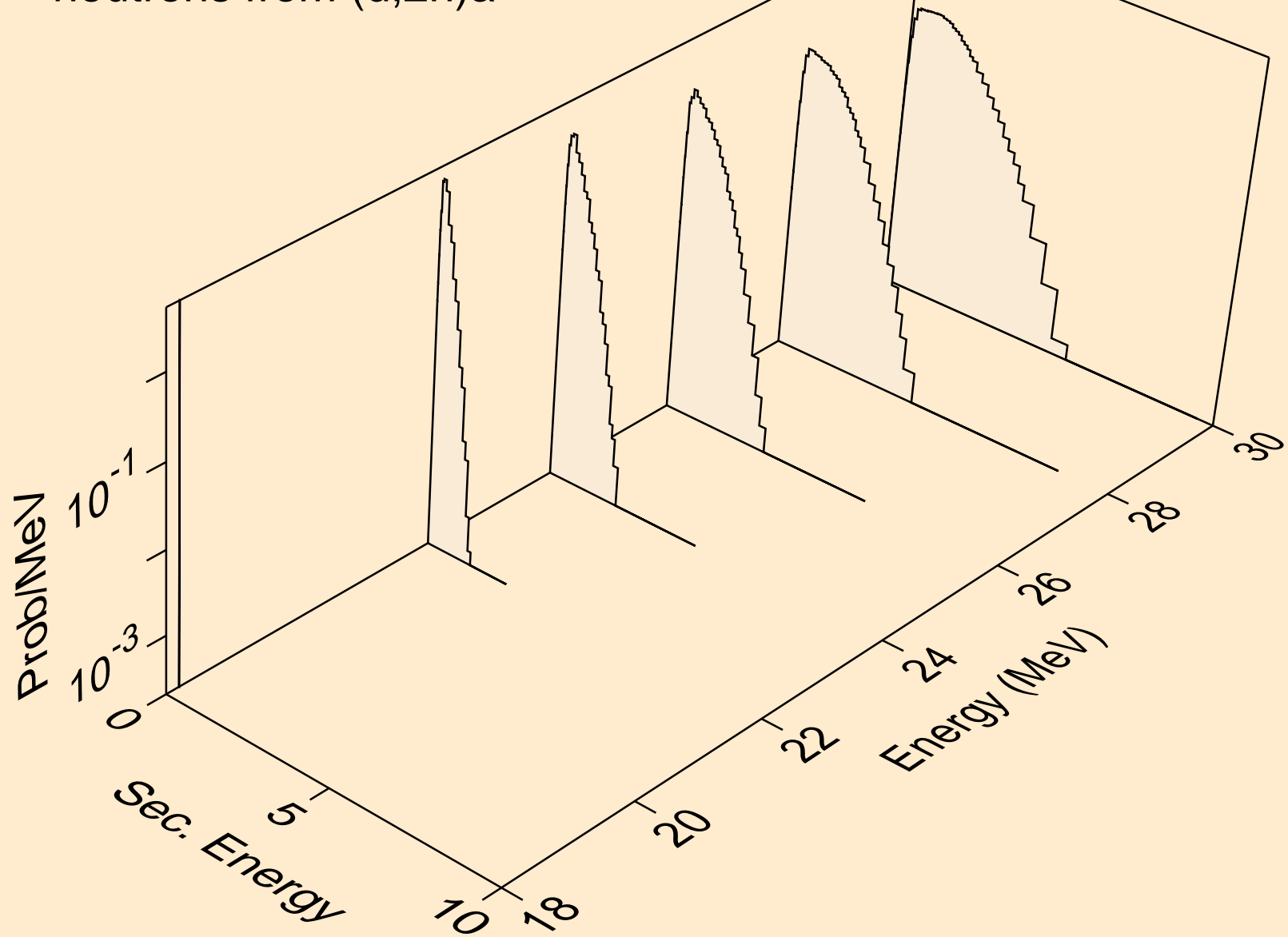



FE052M DEUTERON ACER TENDL-2023 LIBRARY; T=0.K  
neutrons from (d,n\*)p

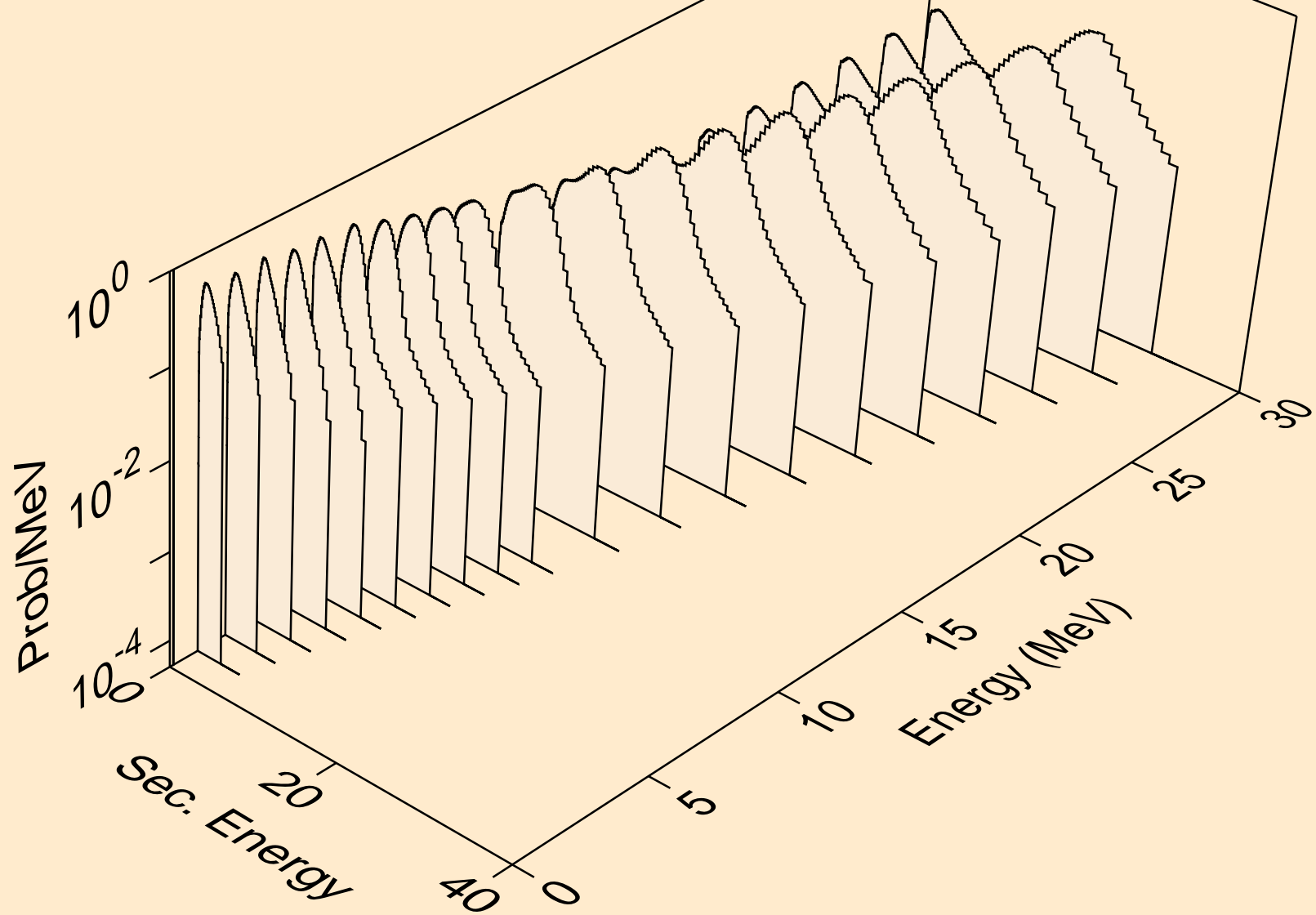

FE052M DEUTERON ACER TENDL-2023 LIBRARY; T=0.K  
neutrons from (d,n\*)2a

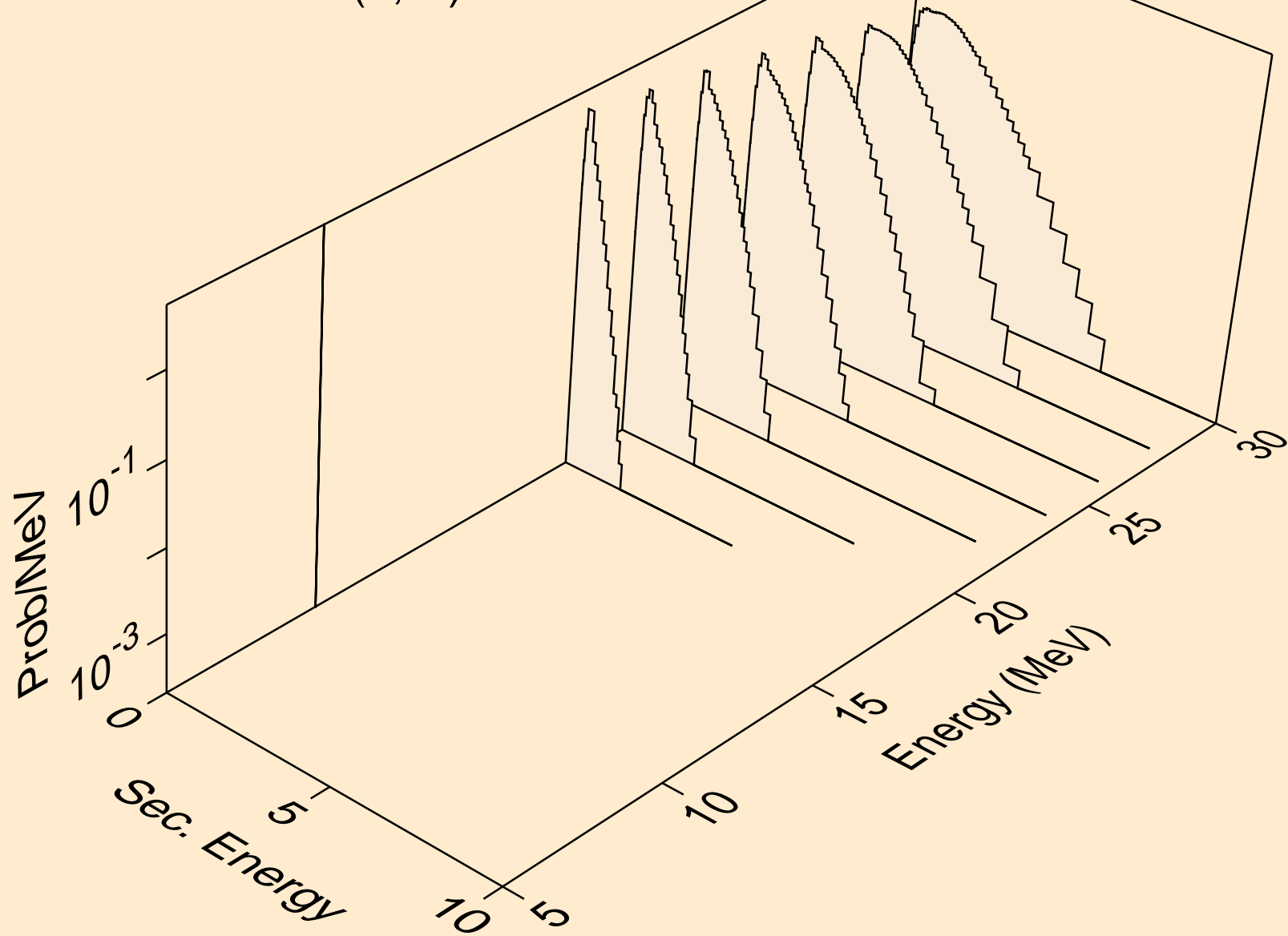

FE052M DEUTERON ACER TENDL-2023 LIBRARY; T=0.K  
neutrons from (d,n\*)d

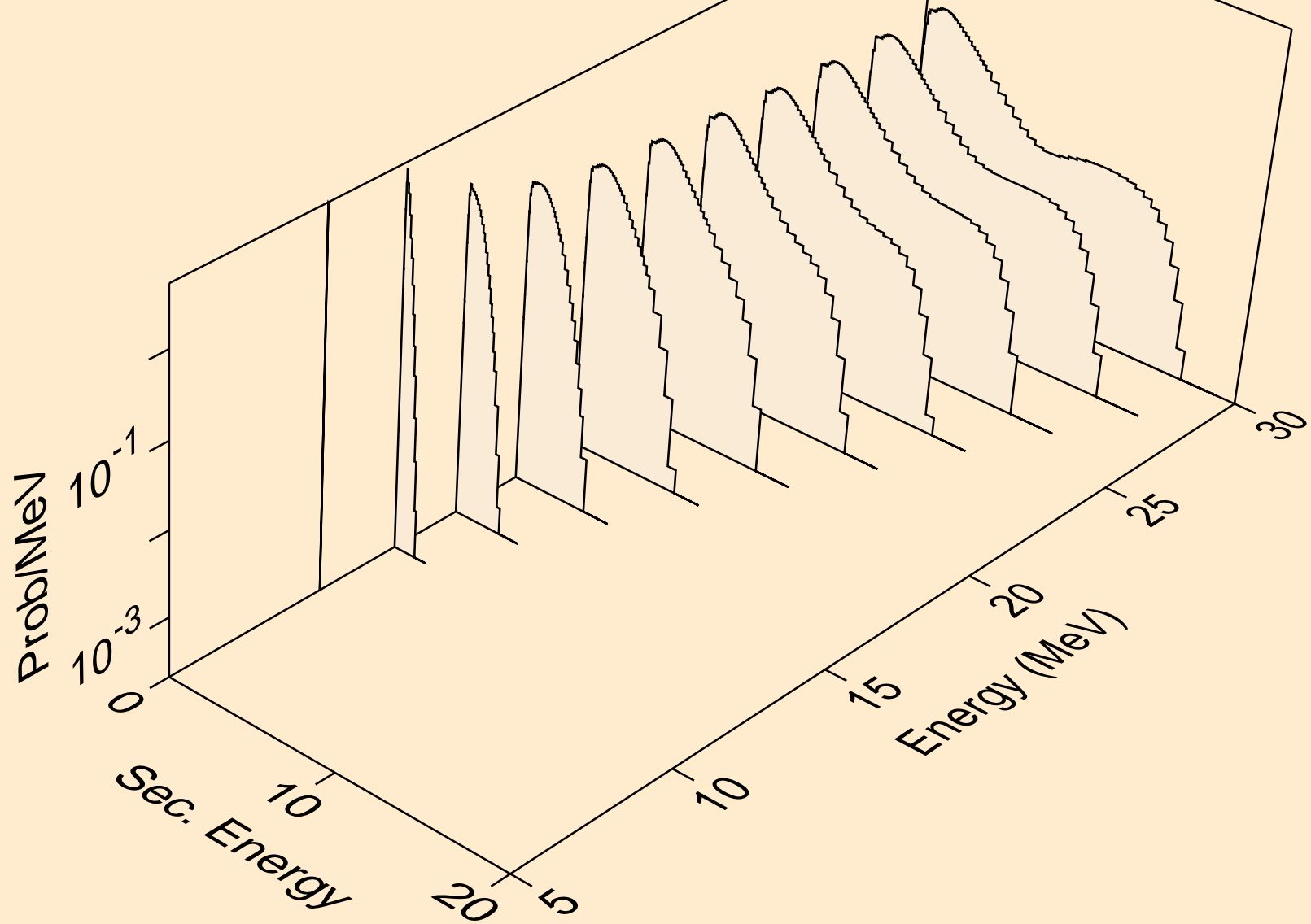

FE052M DEUTERON ACER TENDL-2023 LIBRARY; T=0.K  
neutrons from (d,n\*)t

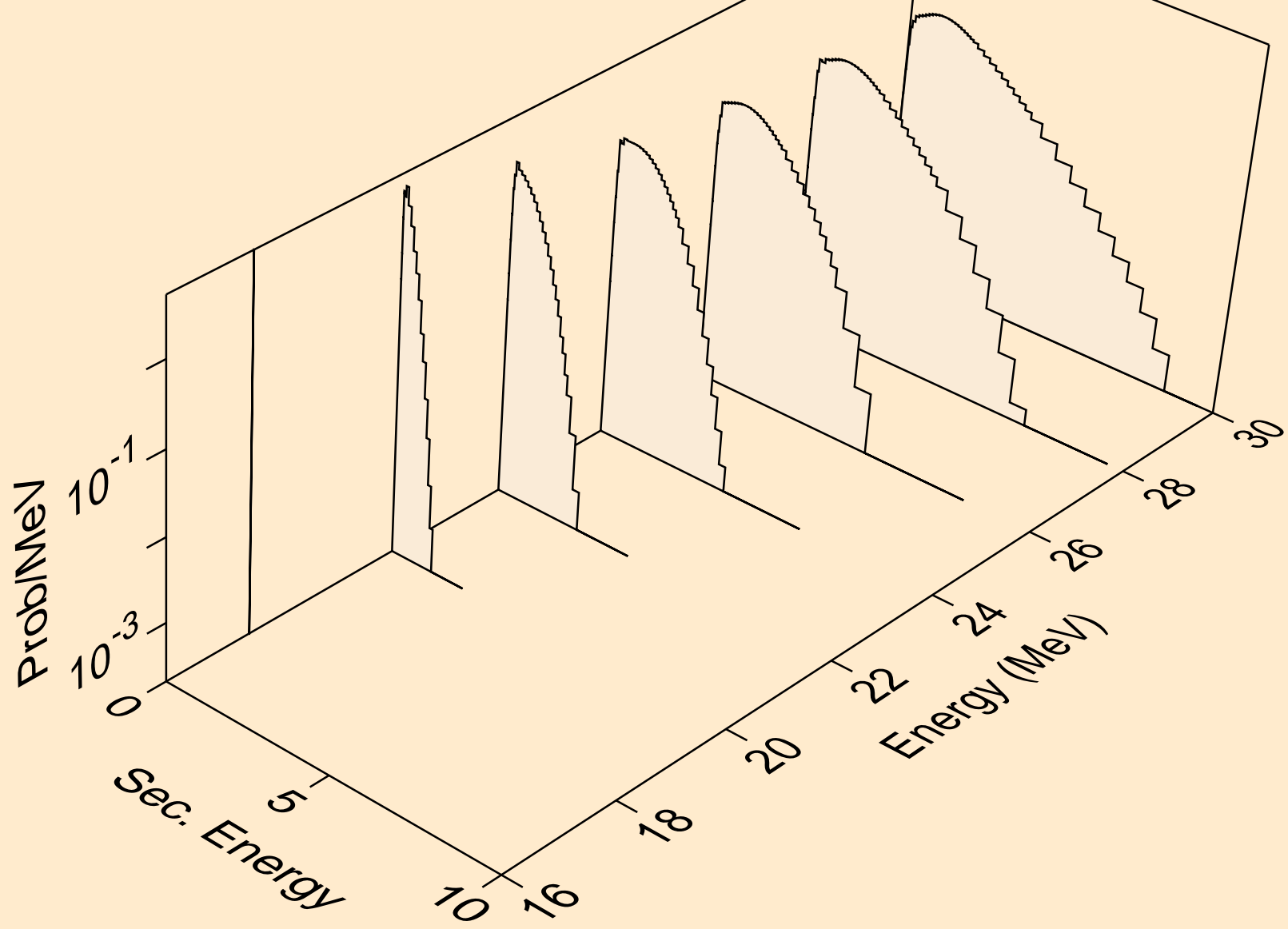

FE052M DEUTERON ACER TENDL-2023 LIBRARY; T=0.K  
neutrons from (d,n\*)he3

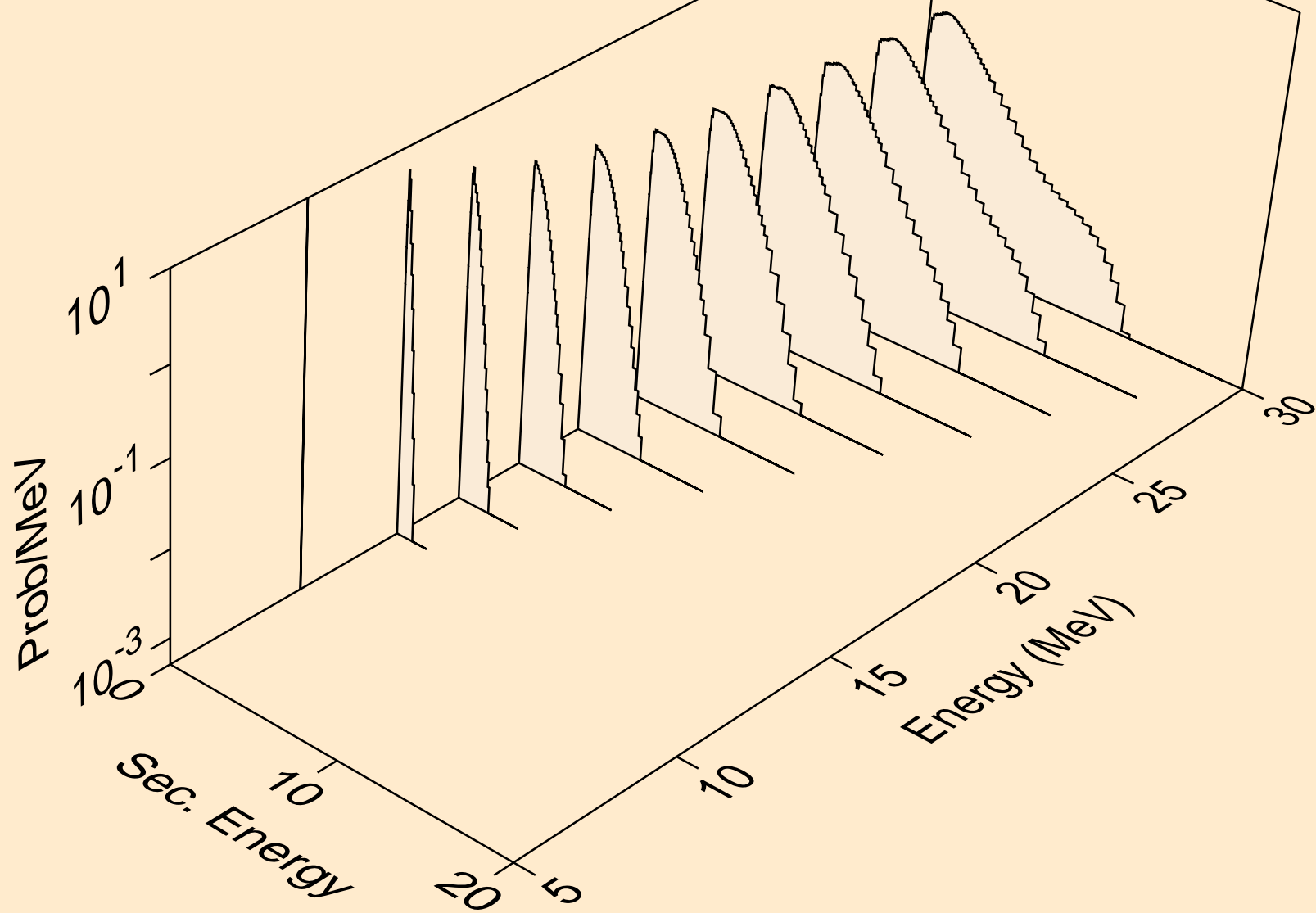

FE052M DEUTERON ACER TENDL-2023 LIBRARY; T=0.K  
neutrons from (d,2np)

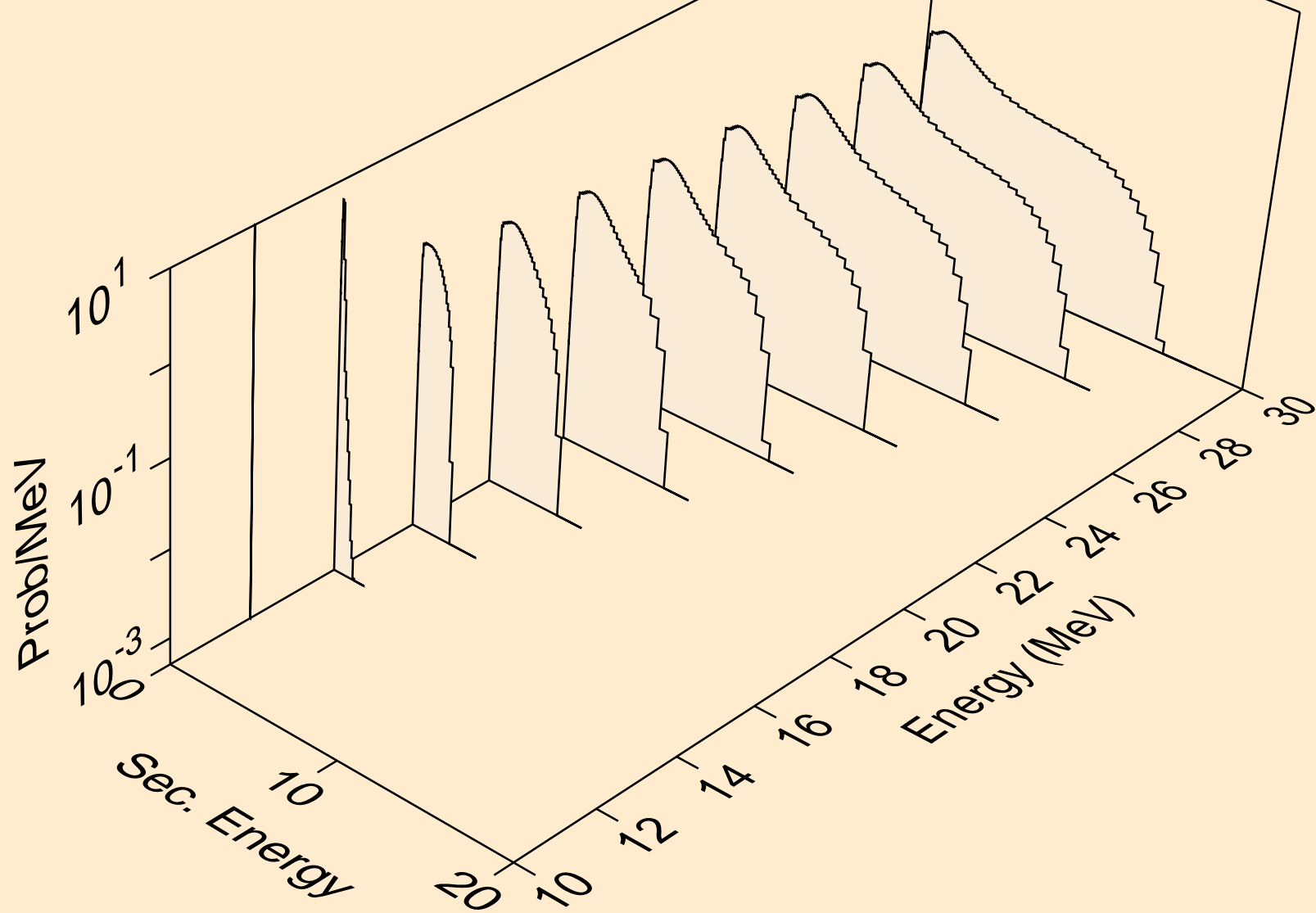

FE052M DEUTERON ACER TENDL-2023 LIBRARY; T=0.K  
neutrons from (d,3np)

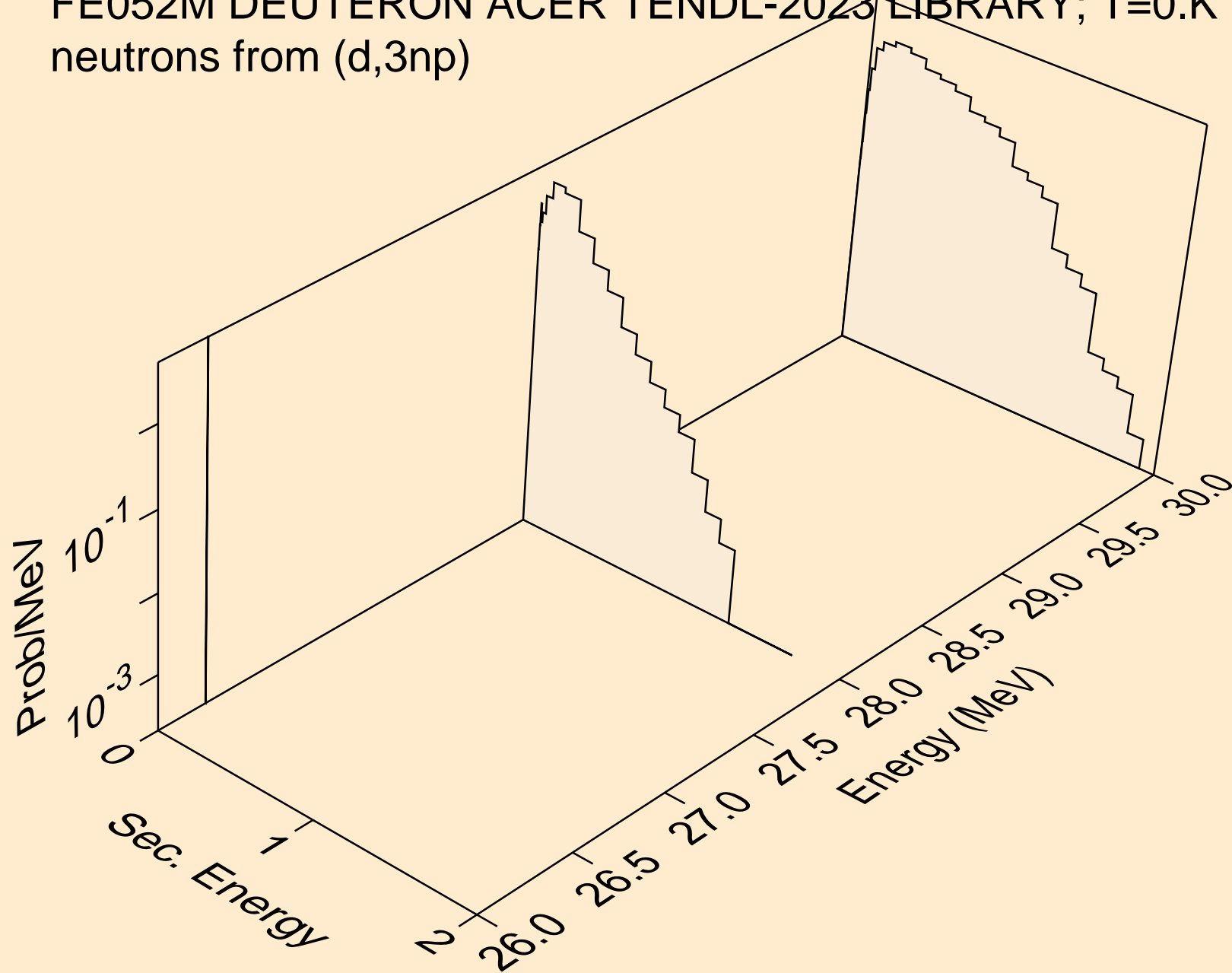

FE052M DEUTERON ACER TENDL-2023 LIBRARY; T=0.K  
neutrons from (d,n2p)

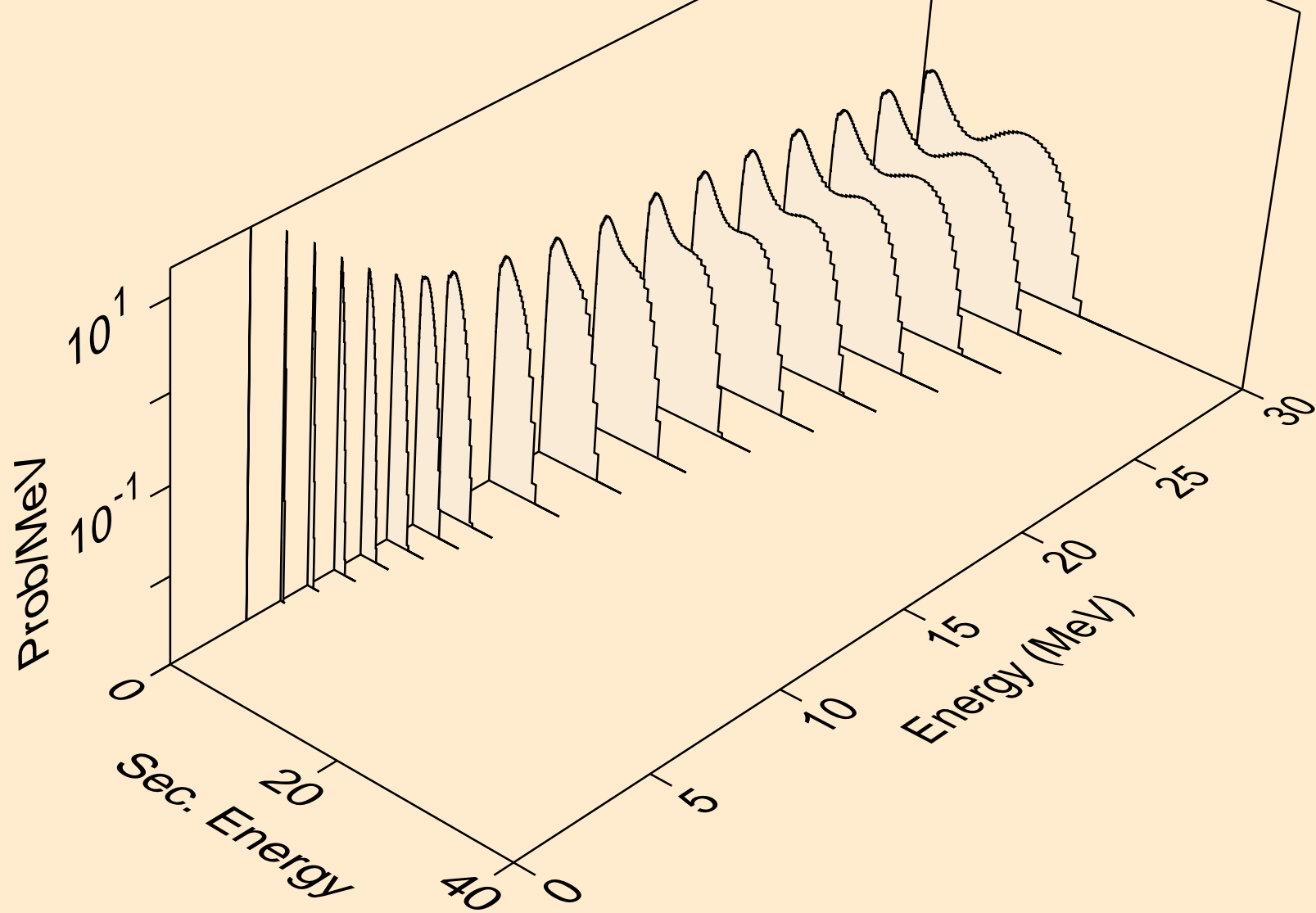



FE052M DEUTERON ACER TENDL-2023 LIBRARY; T=0.K  
neutrons from (d,npa)

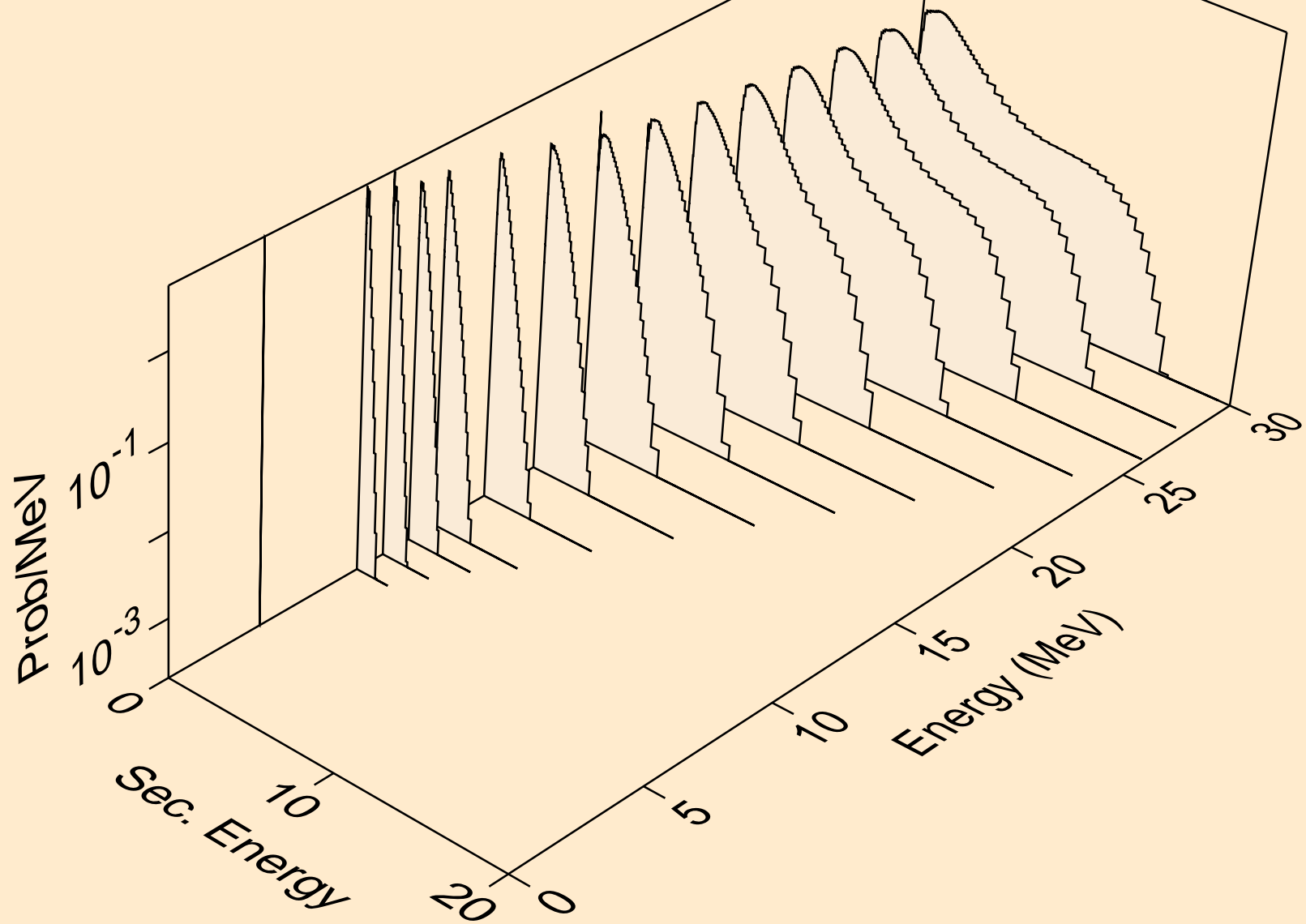

FE052M DEUTERON ACER TENDL-2023 LIBRARY; T=0.K  
protons from (d,x)

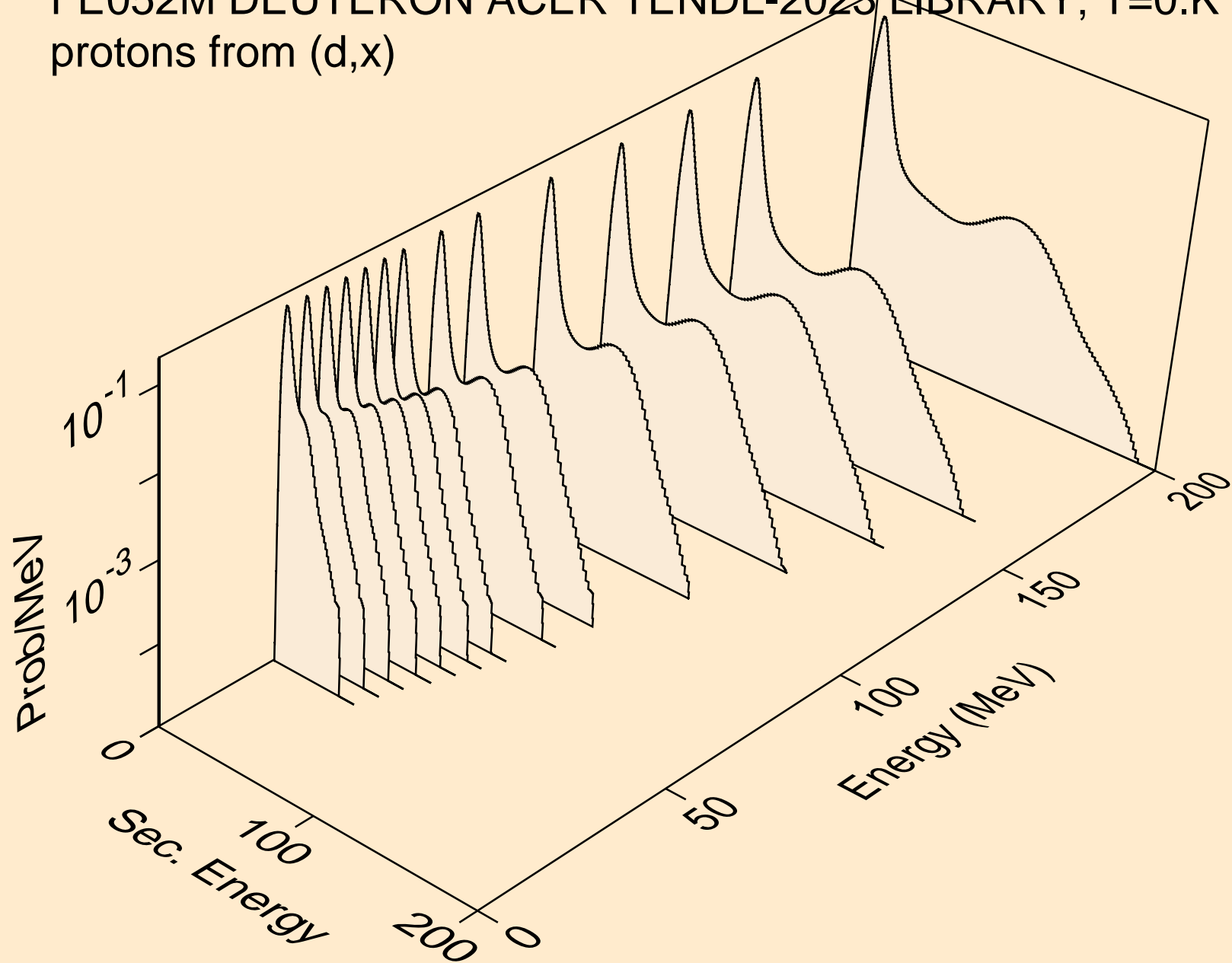

FE052M DEUTERON ACER TENDL-2023 LIBRARY; T=0.K  
protons from (d,n\*)p

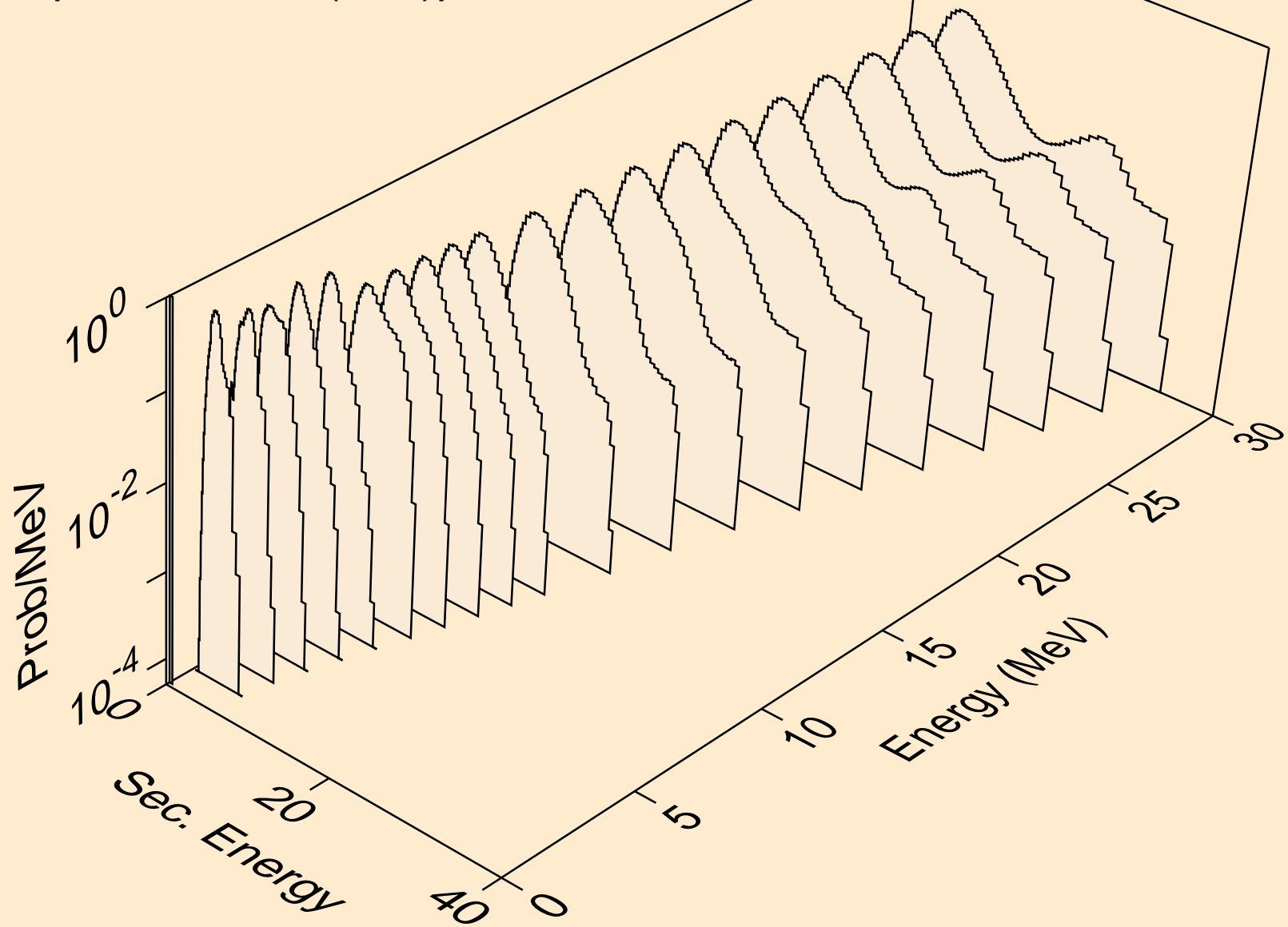

FE052M DEUTERON ACER TENDL-2023 LIBRARY; T=0.K  
protons from (d,2np)

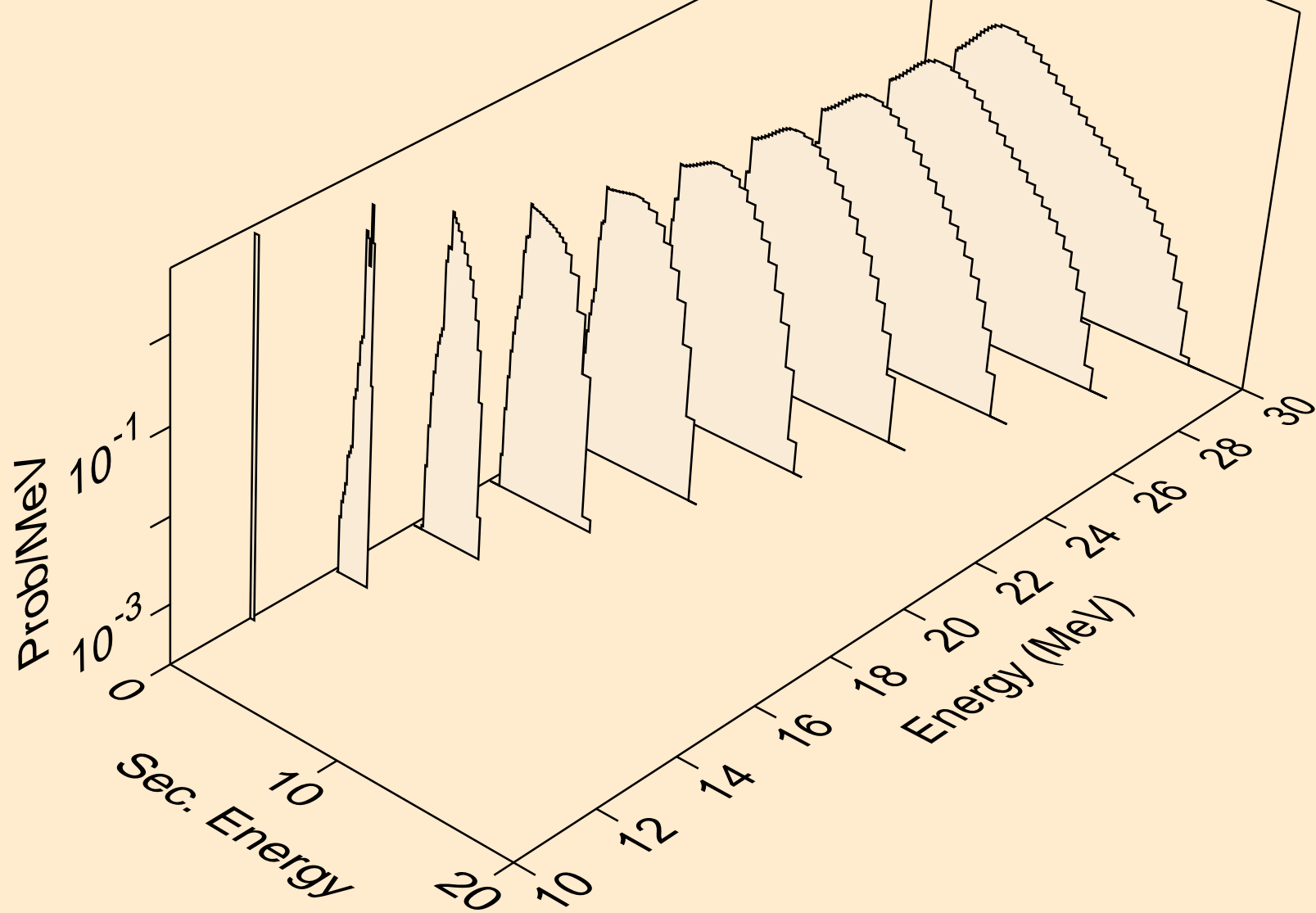

FE052M DEUTERON ACER TENDL-2023 LIBRARY; T=0.K  
protons from (d,3np)

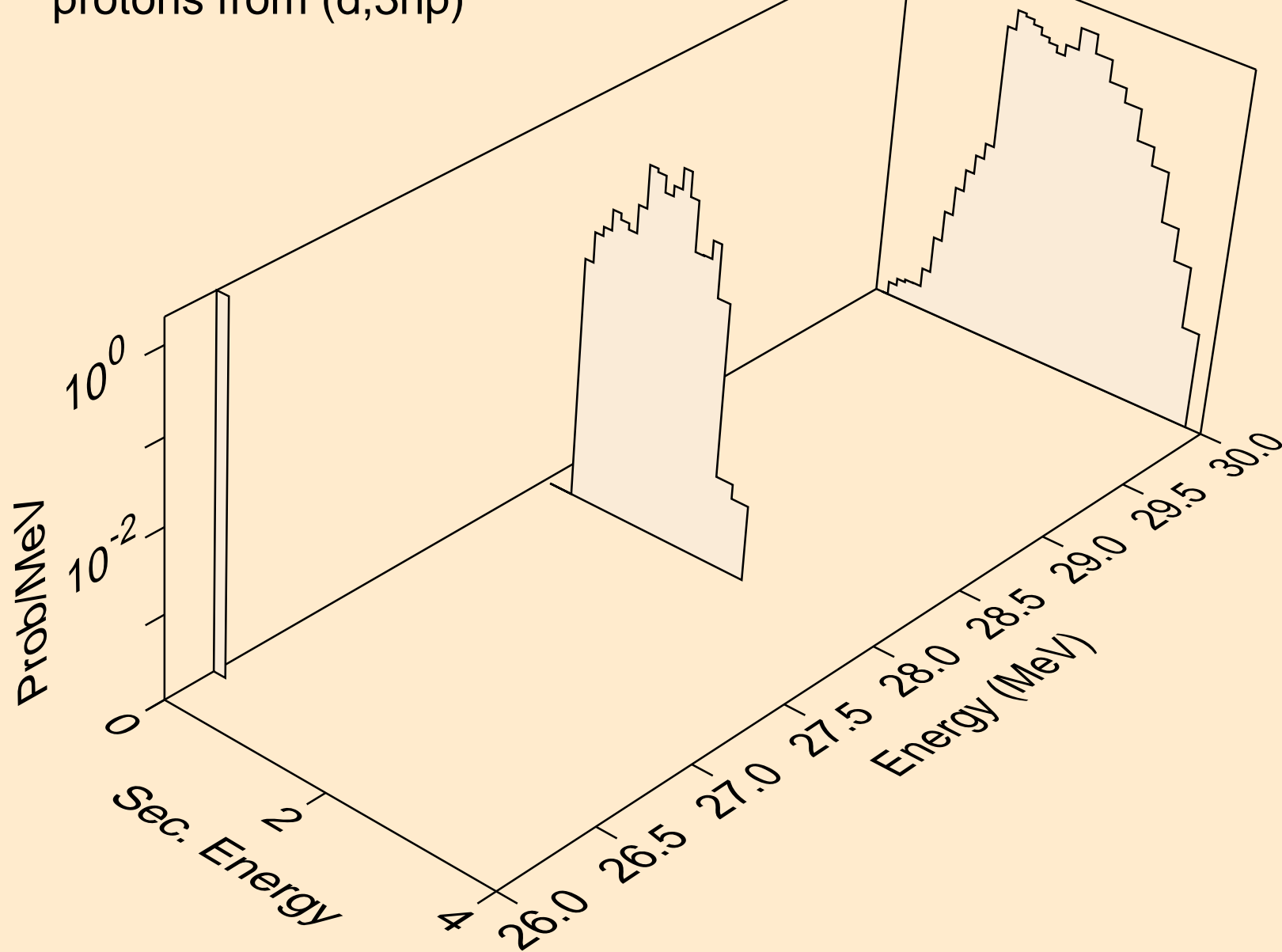

FE052M DEUTERON ACER TENDL-2023 LIBRARY; T=0.K  
protons from (d,n2p)

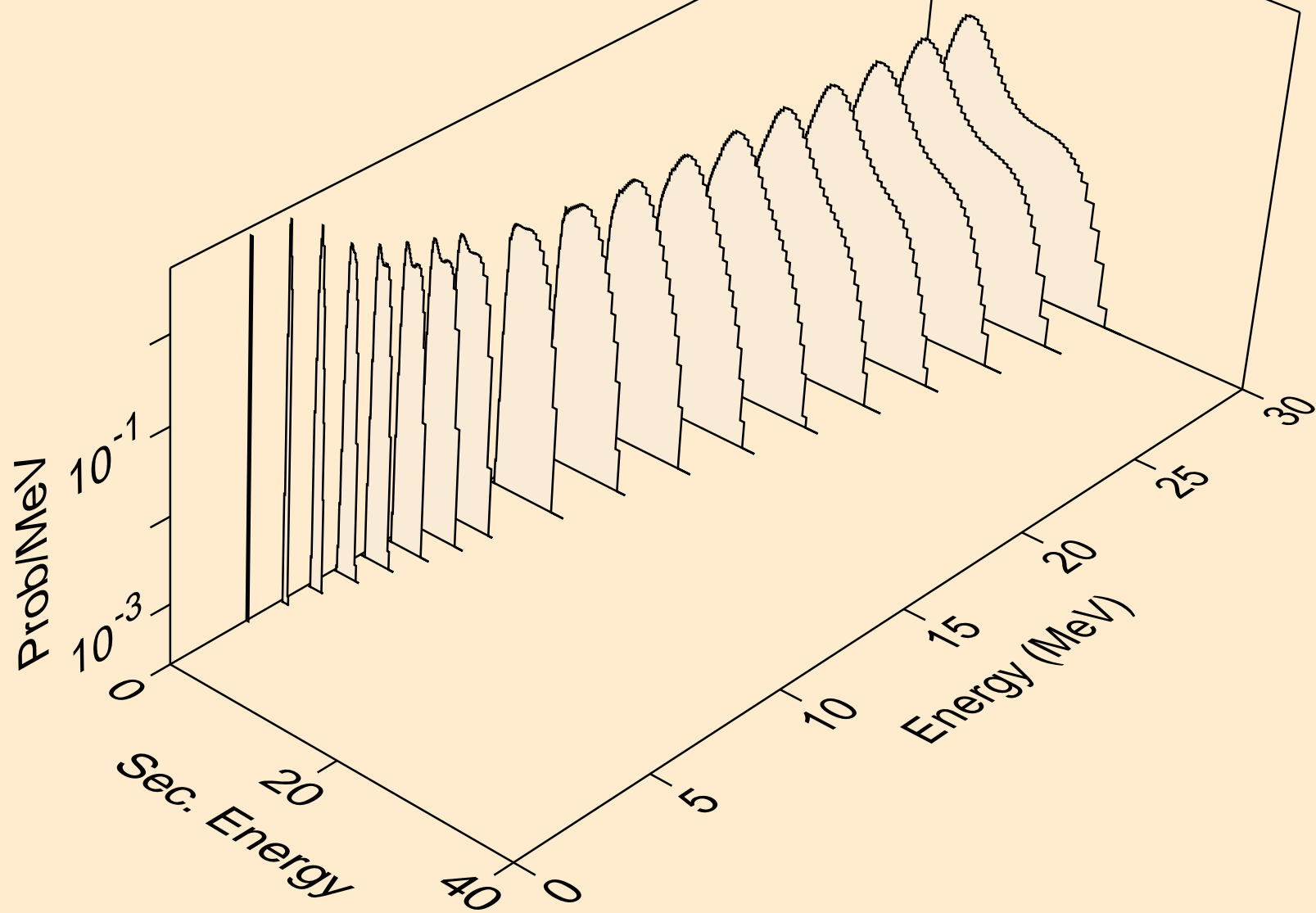

FE052M DEUTERON ACER TENDL-2023 LIBRARY; T=0.K  
protons from (d,npa)

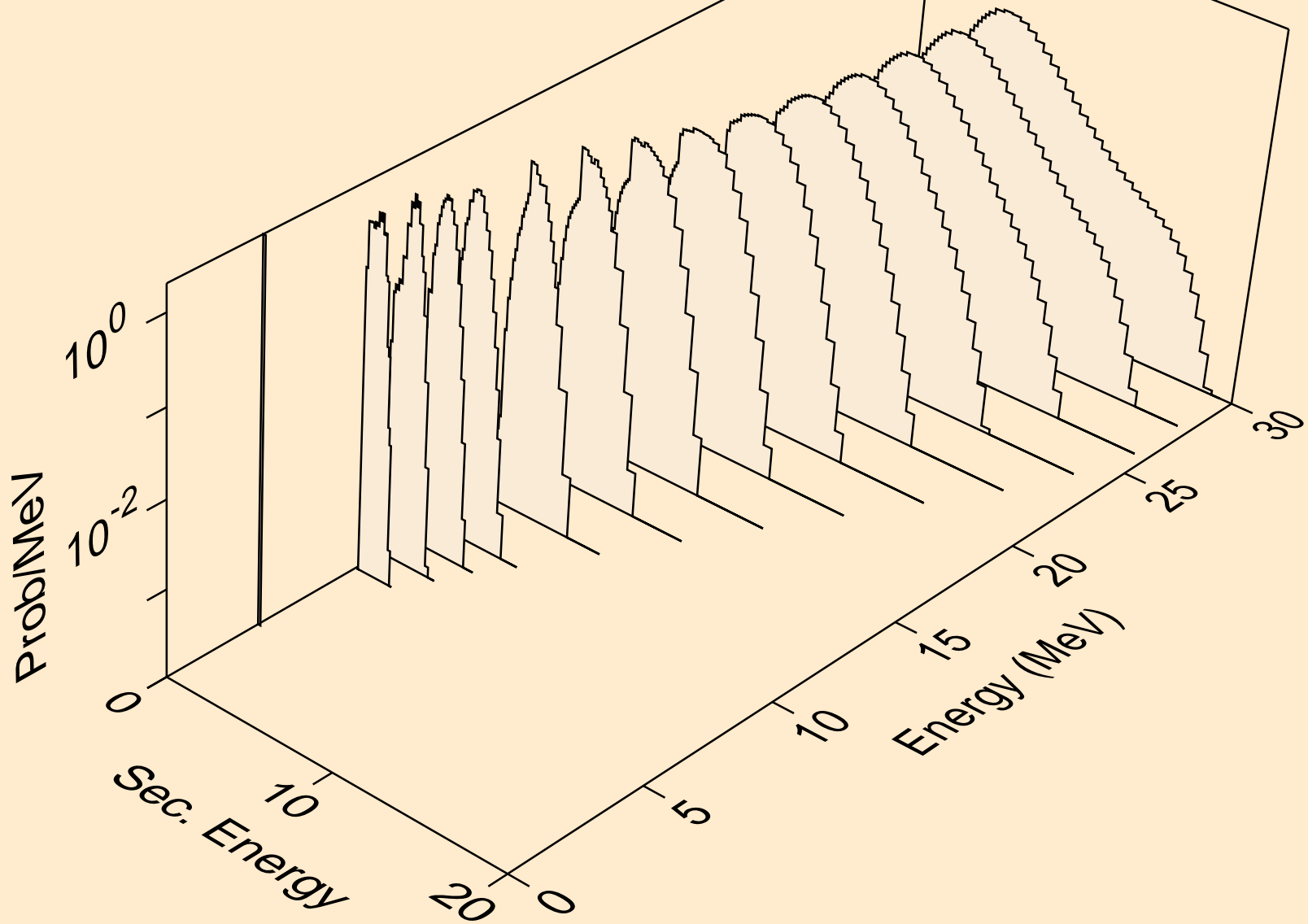

FE052M DEUTERON ACER TENDL-2023 LIBRARY; T=0.K  
protons from (d,p)

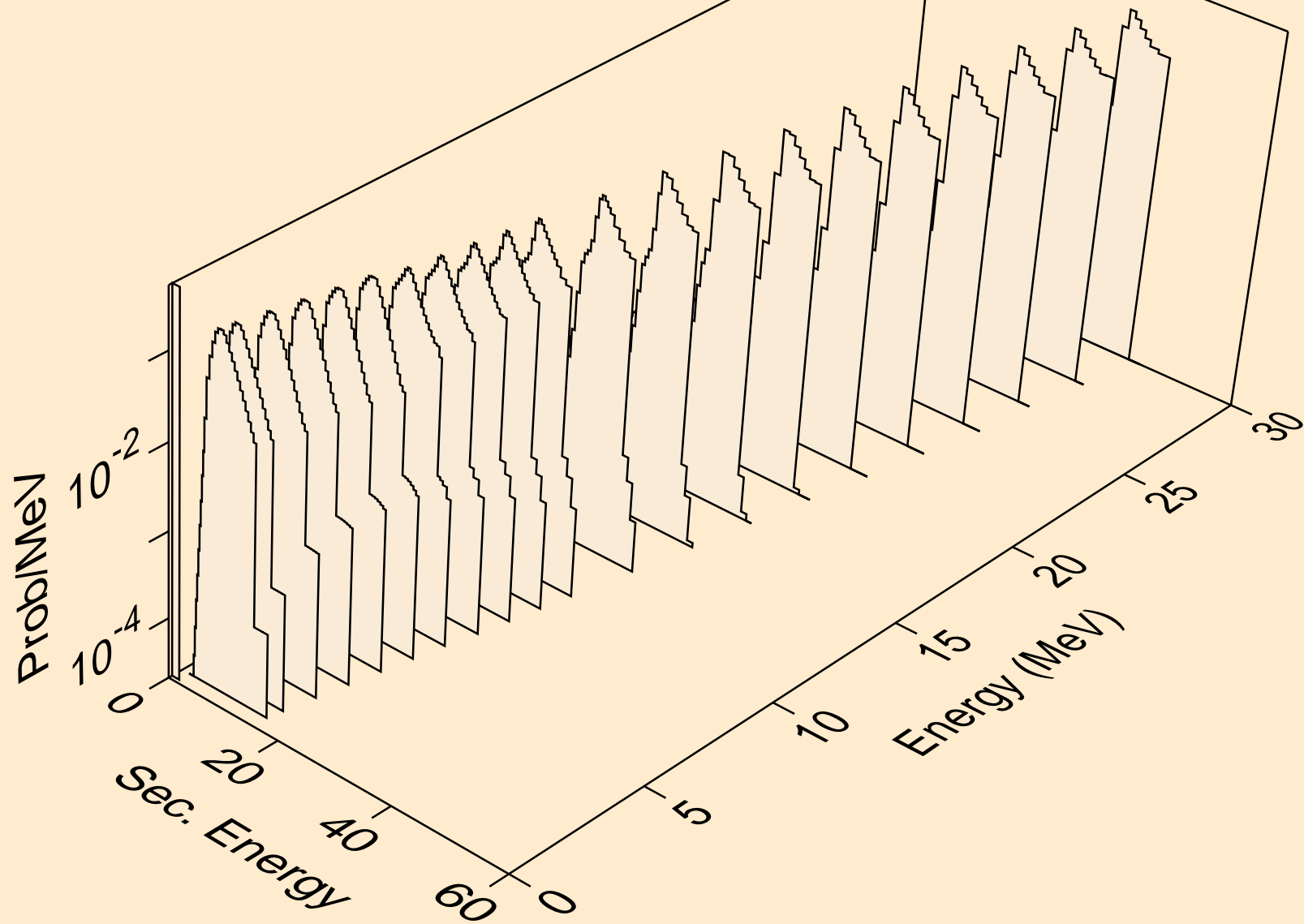



FE052M DEUTERON ACER TENDL-2023 LIBRARY; T=0.K  
protons from (d,2p)

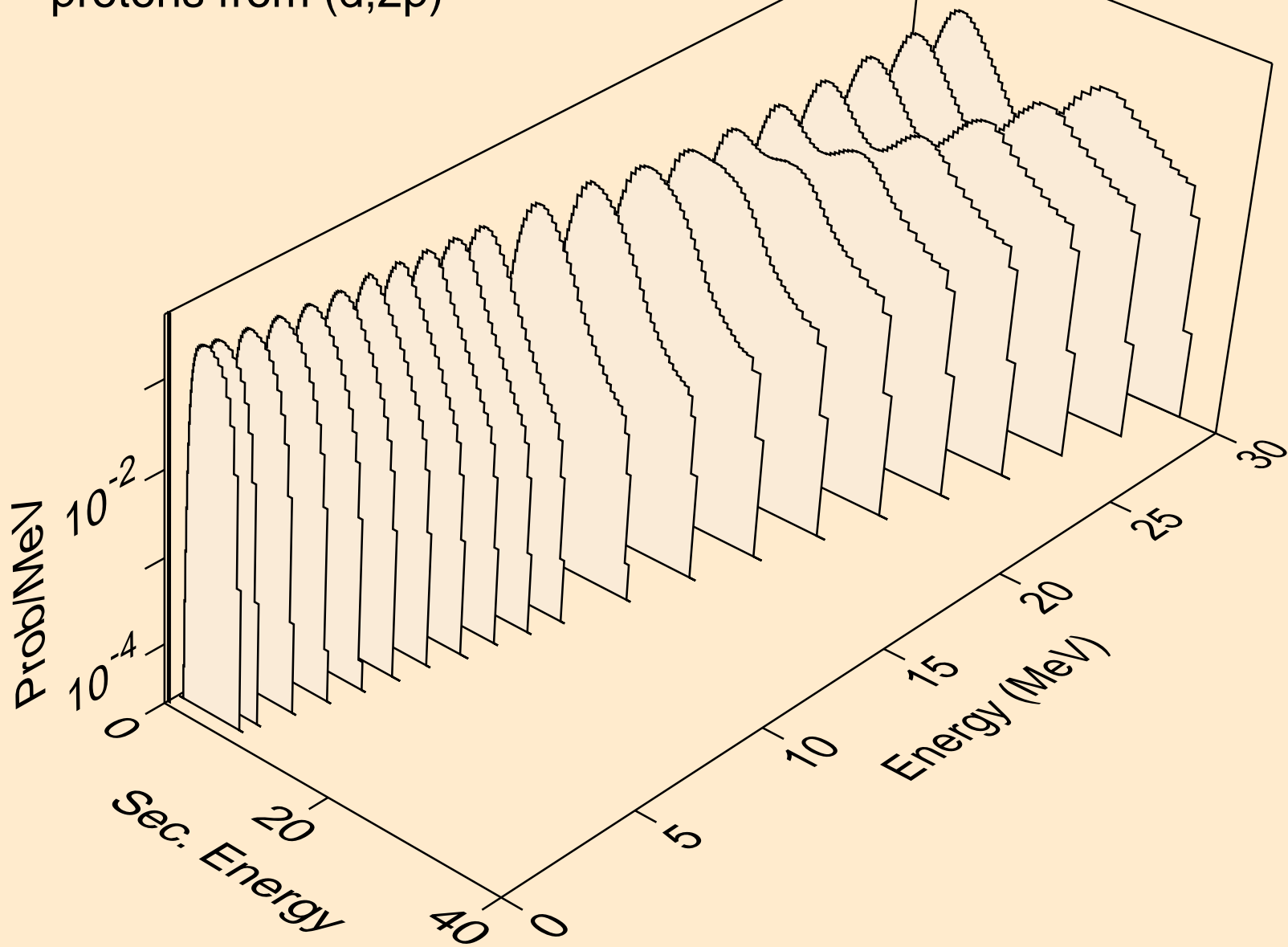

FE052M DEUTERON ACER TENDL-2023 LIBRARY; T=0.K  
protons from (d,pa)

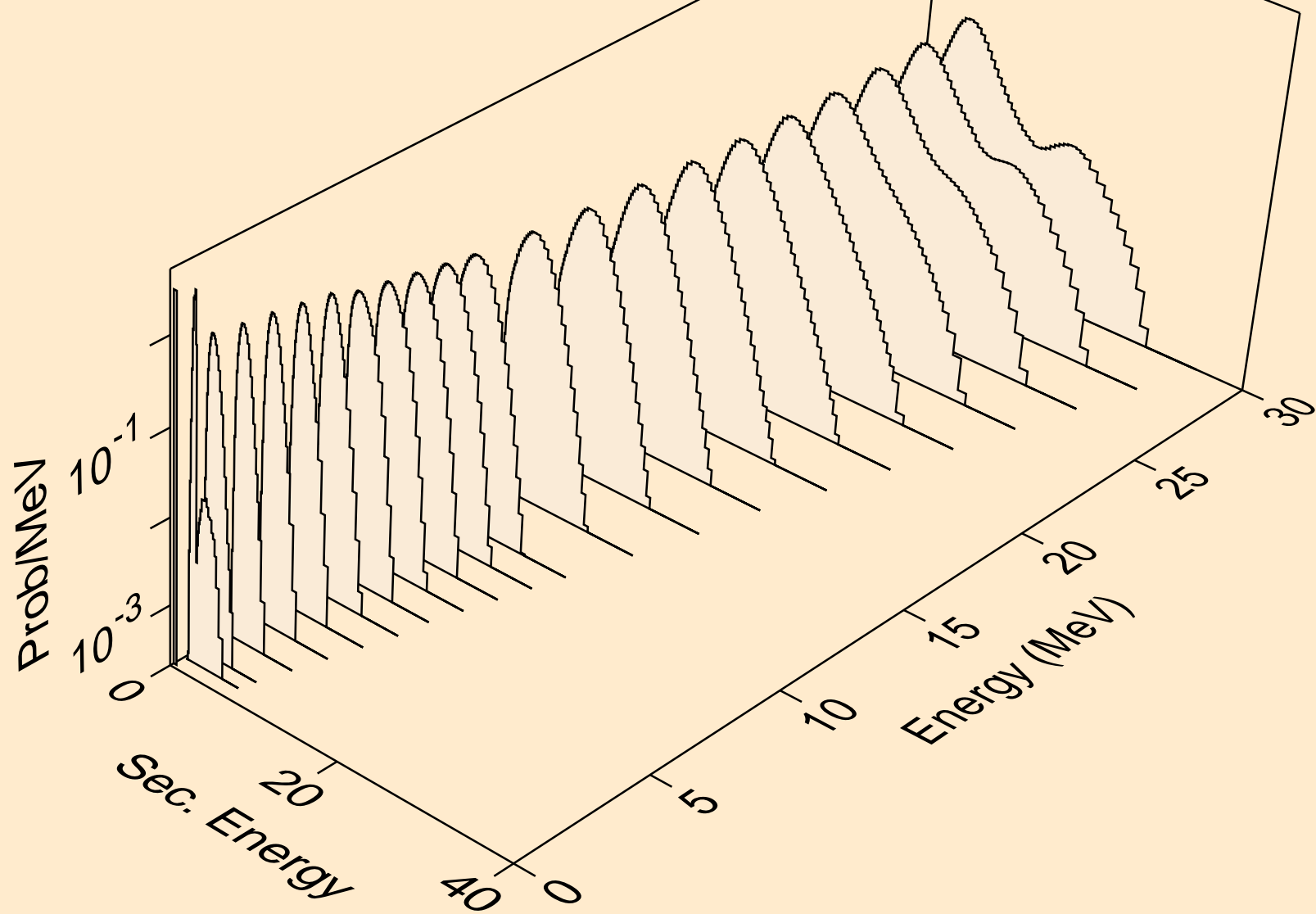

FE052M DEUTERON ACER TENDL-2023 LIBRARY; T=0.K  
protons from (d,pd)

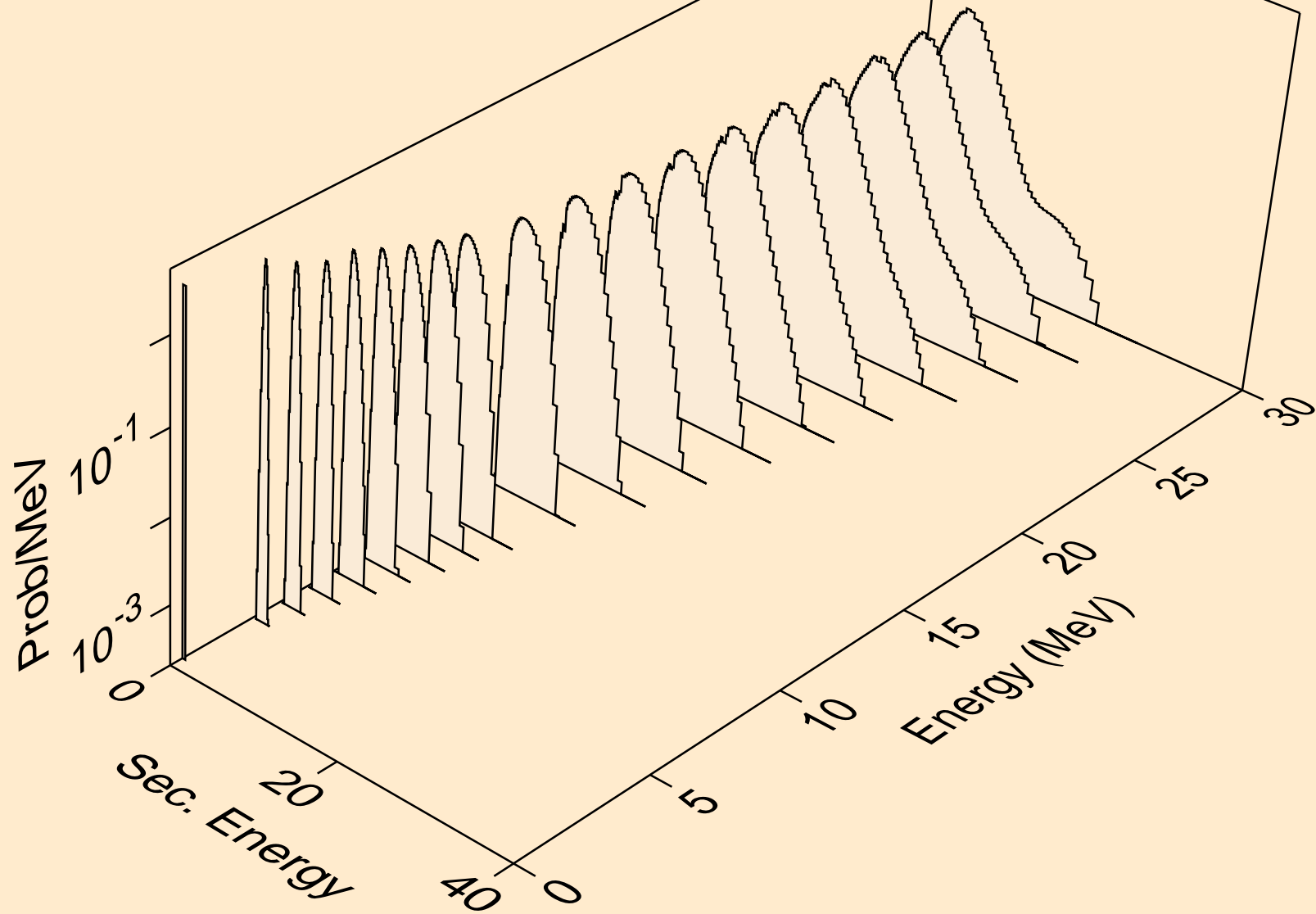

FE052M DEUTERON ACER TENDL-2023 LIBRARY; T=0.K  
protons from (d,pt)

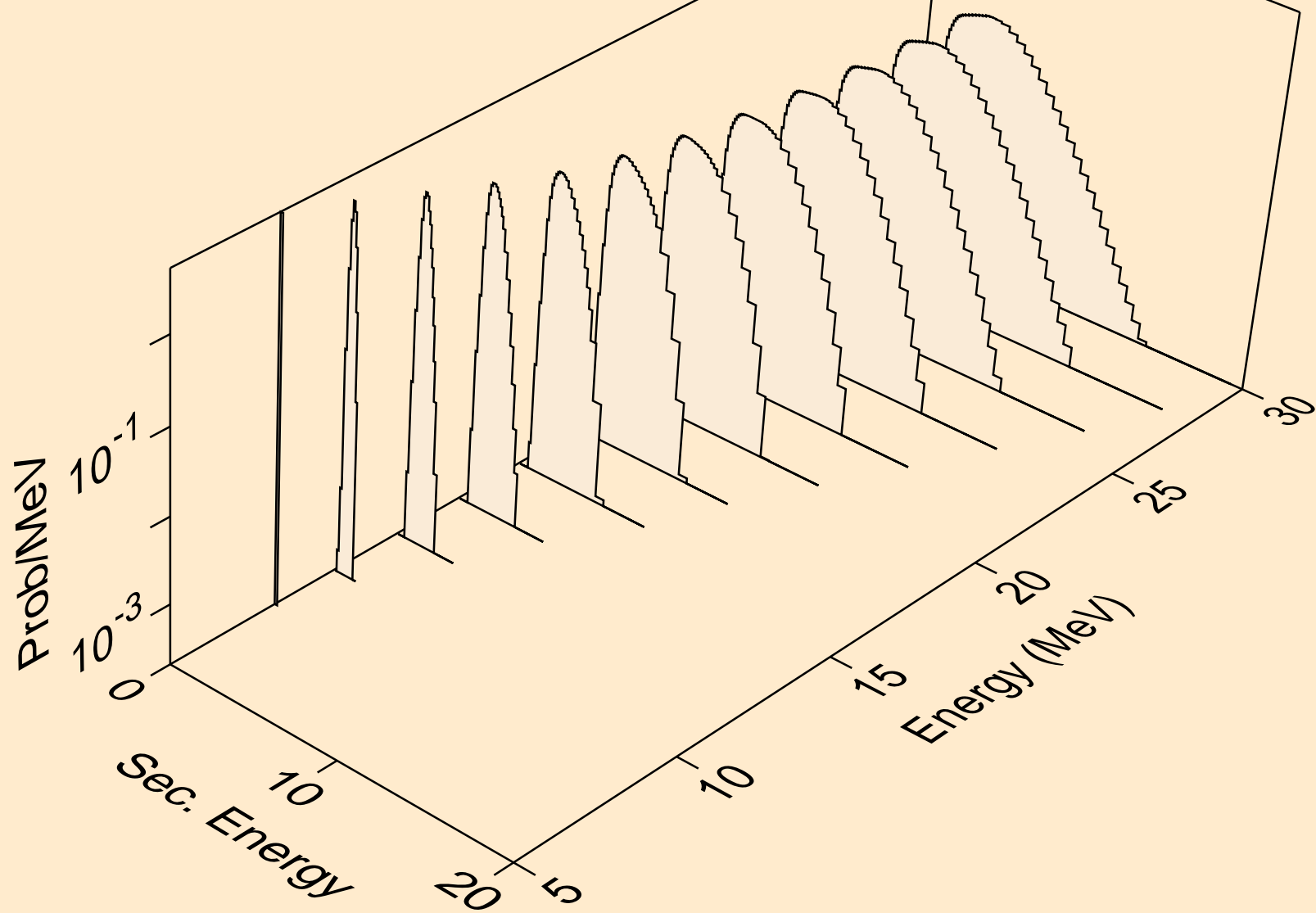

FE052M DEUTERON ACER TENDL-2023 LIBRARY; T=0.K  
tritons from (d,x)

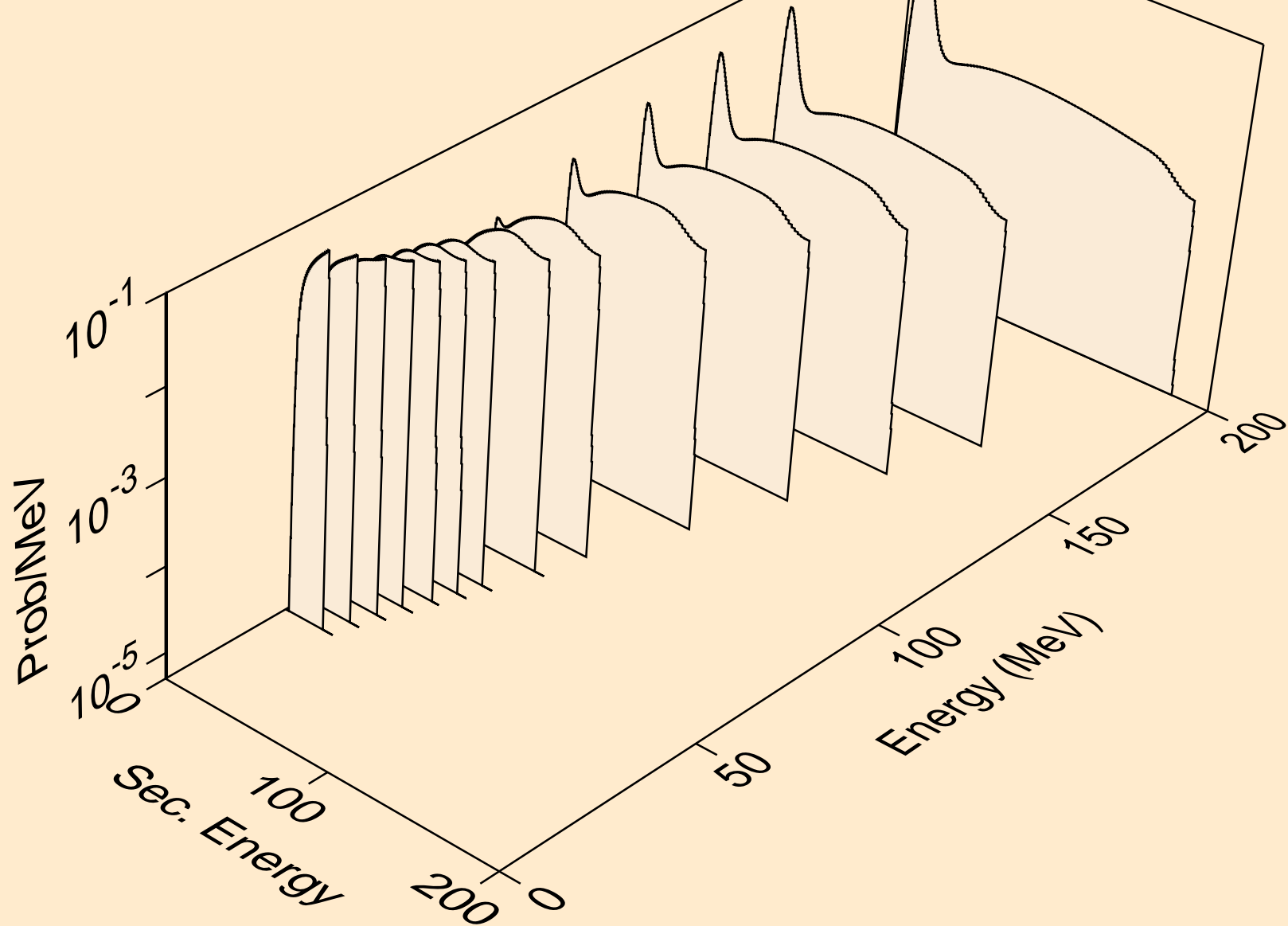

FE052M DEUTERON ACER TENDL-2023 LIBRARY; T=0.K  
tritons from (d,n\*)t

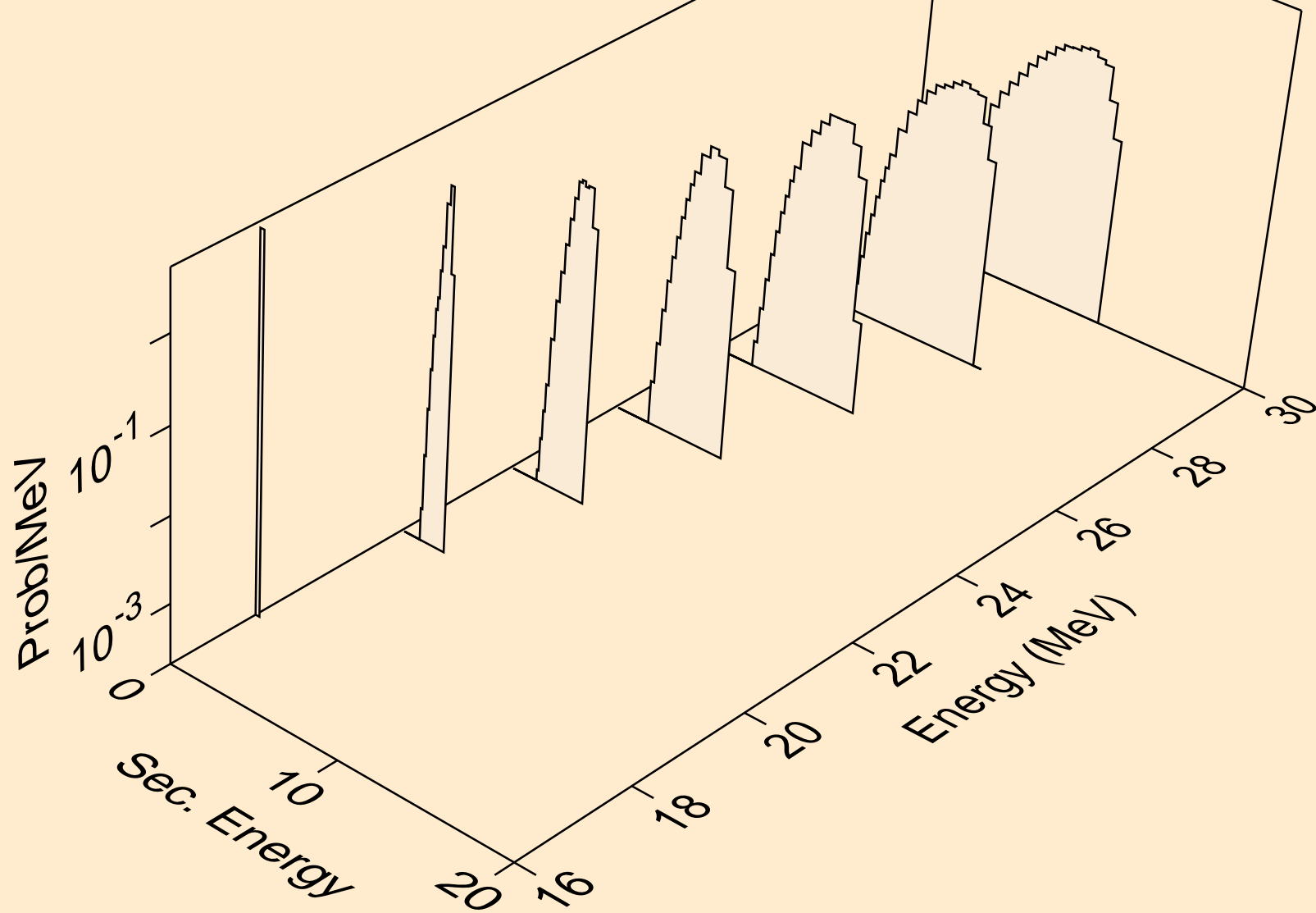

FE052M DEUTERON ACER TENDL-2023 LIBRARY; T=0.K  
tritons from (d,t)

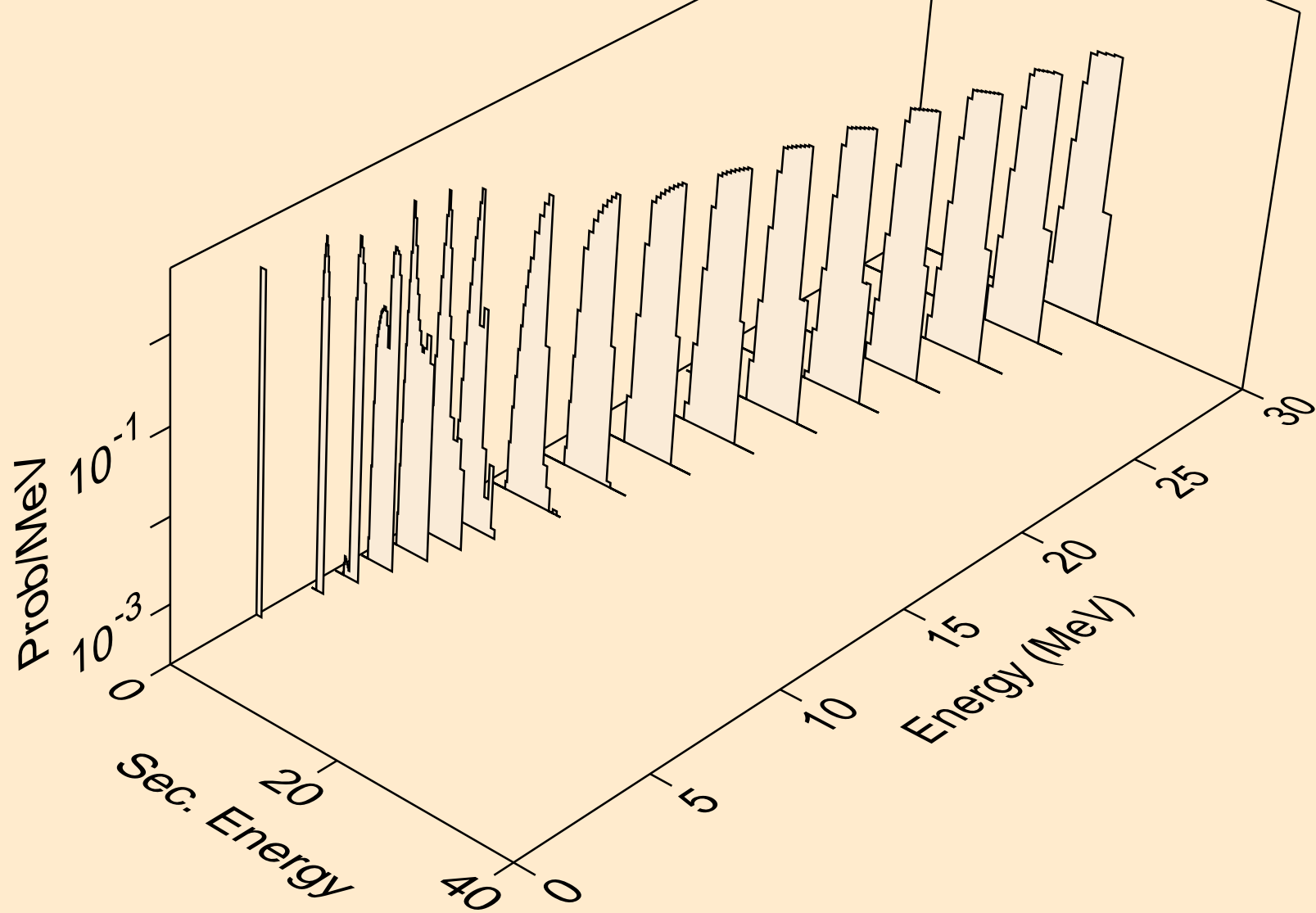

FE052M DEUTERON ACER TENDL-2023 LIBRARY; T=0.K  
tritons from (d,pt)

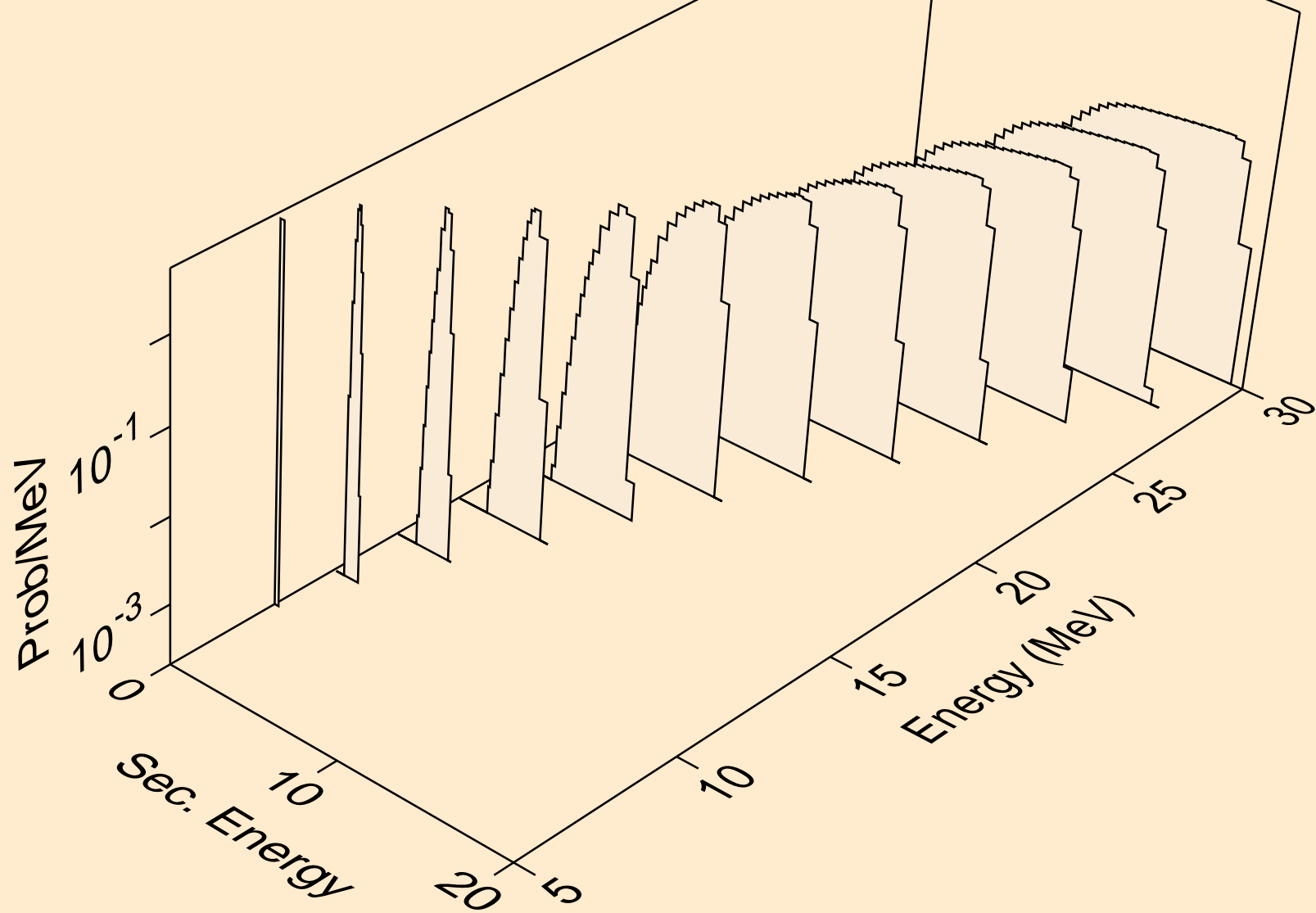



FE052M DEUTERON ACER TENDL-2023 LIBRARY; T=0.K  
he3s from (d,x)

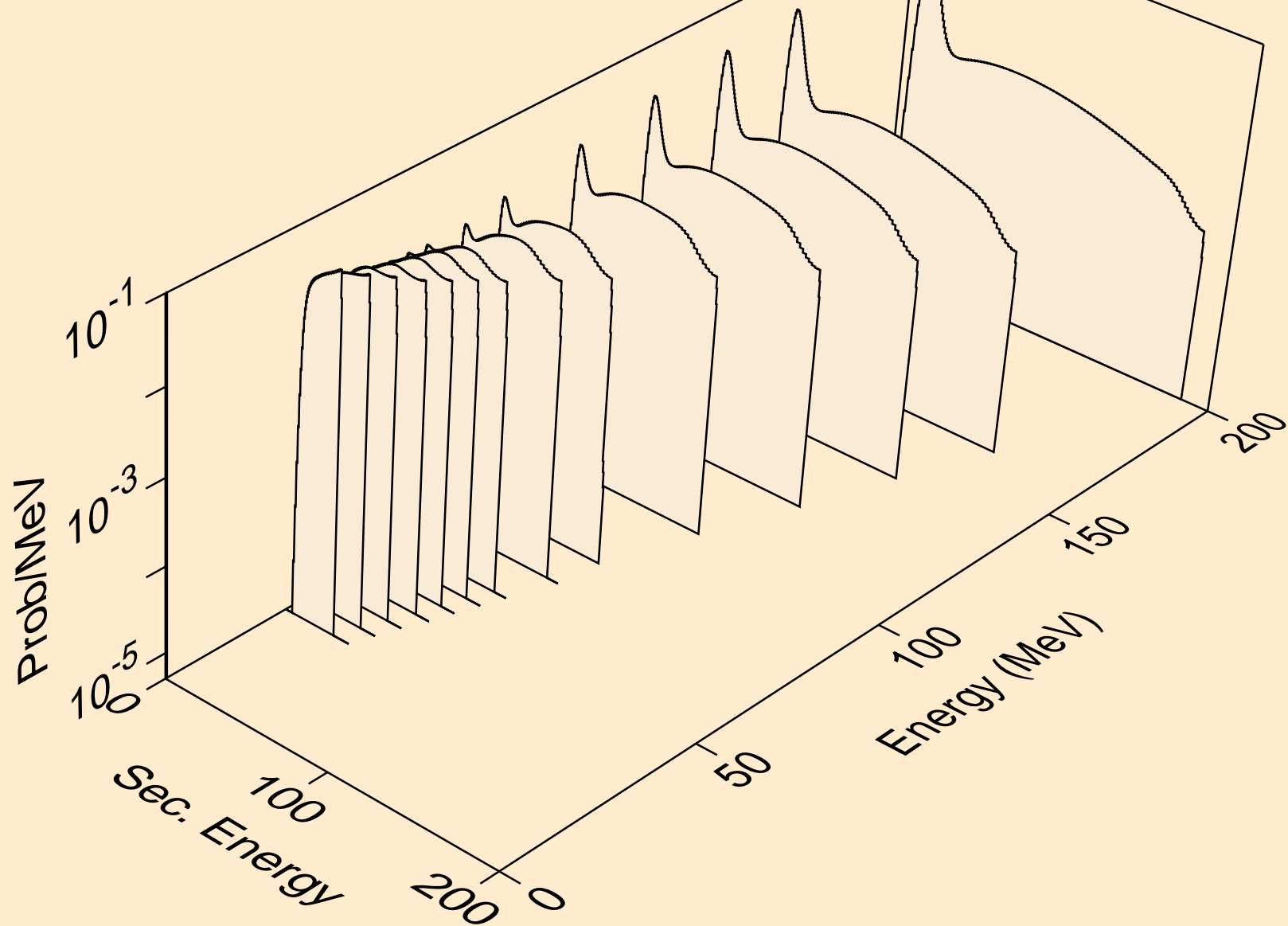

FE052M DEUTERON ACER TENDL-2023 LIBRARY; T=0.K  
he3s from (d,n\*)he3

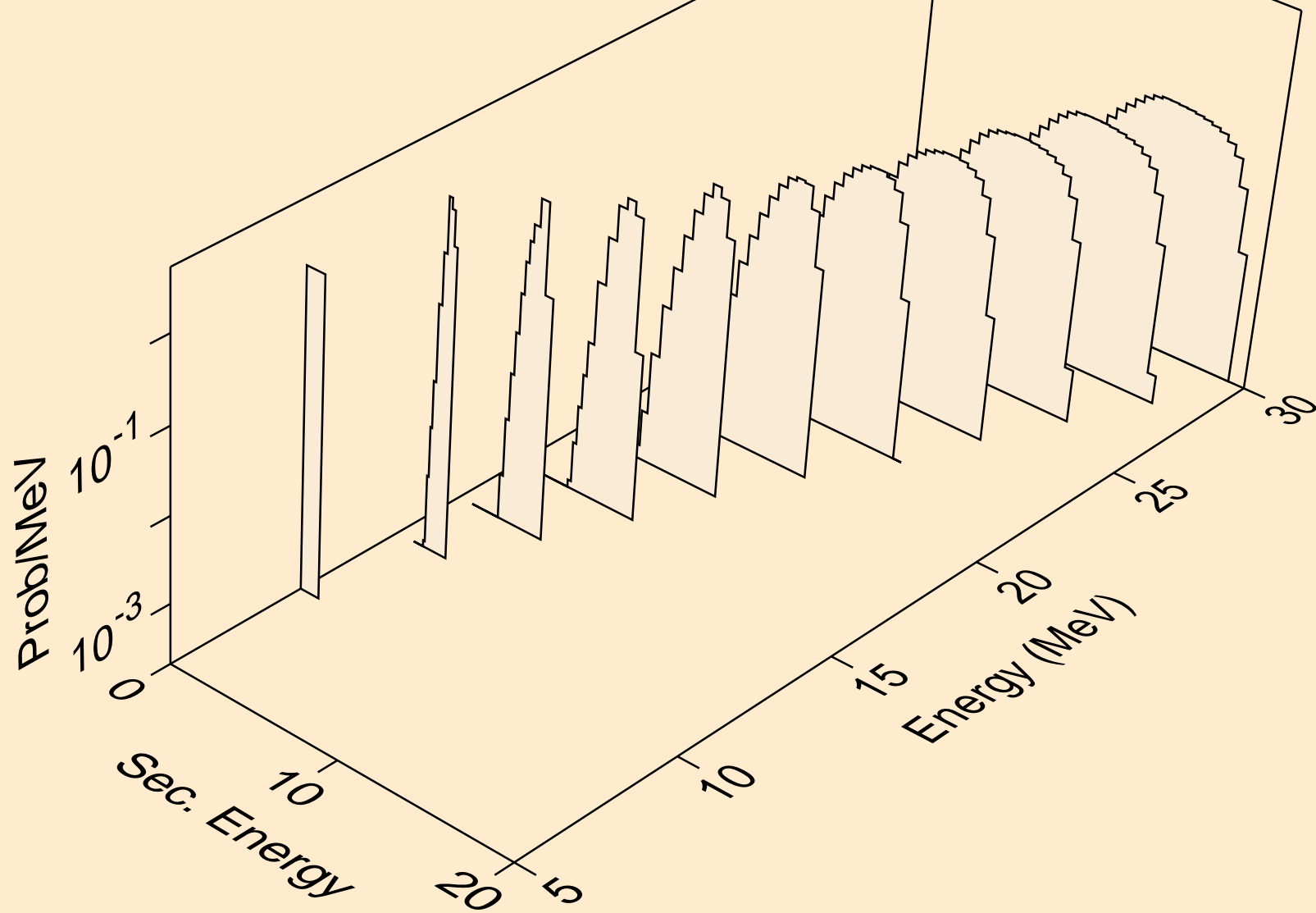

FE052M DEUTERON ACER TENDL-2023 LIBRARY; T=0.K  
he3s from (d,he3)

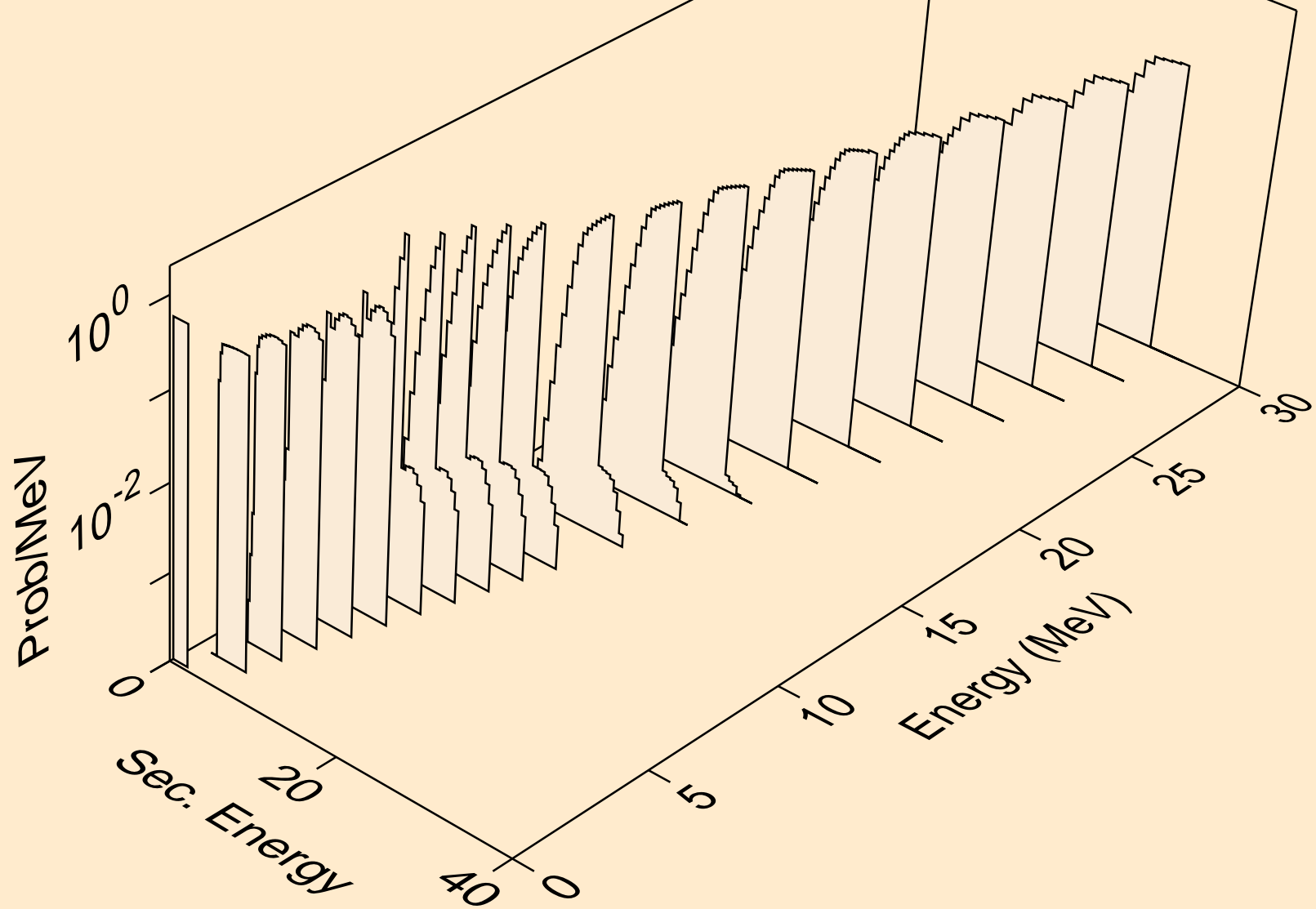

FE052M DEUTERON ACER TENDL-2023 LIBRARY; T=0.K  
alphas from (d,x)

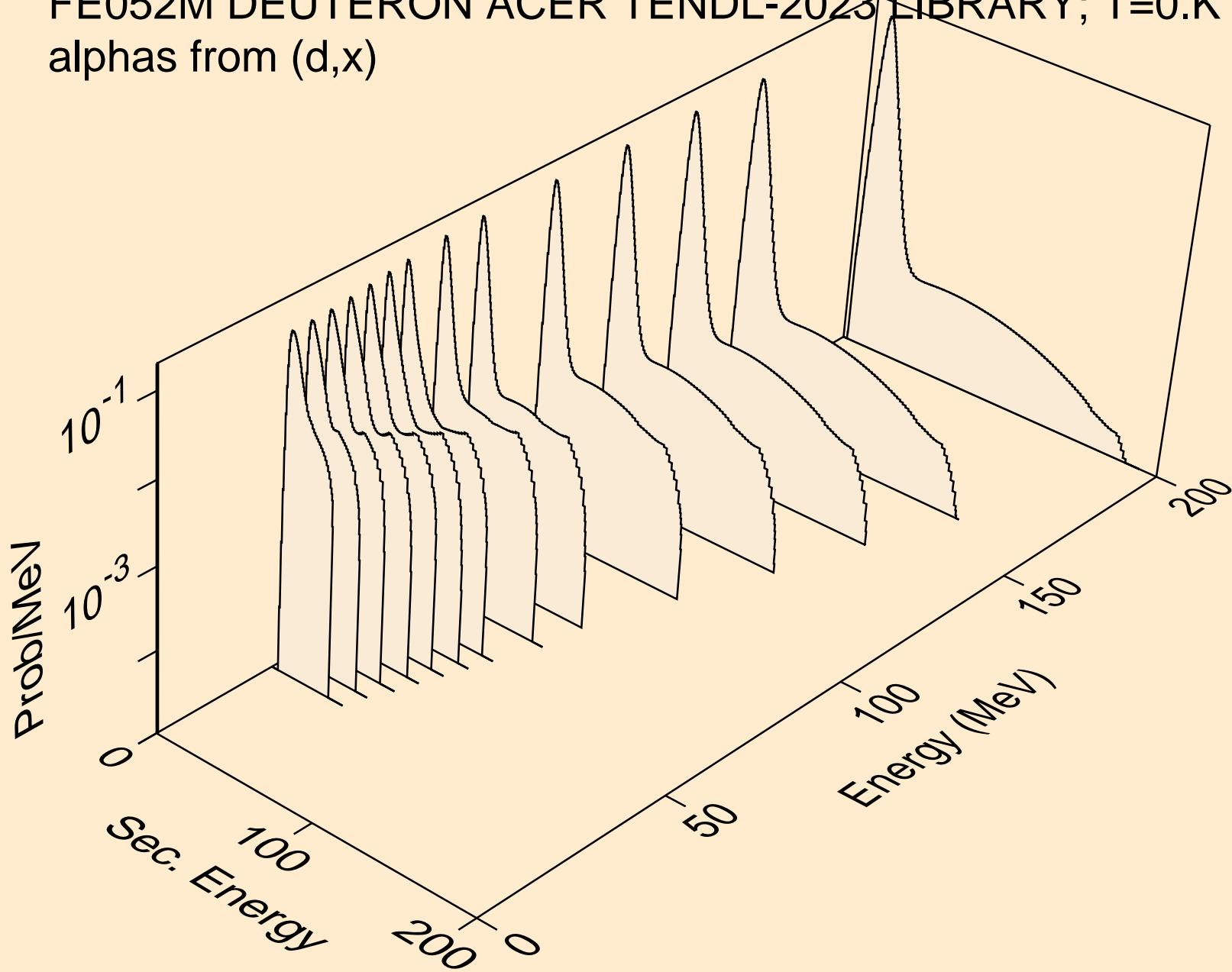

FE052M DEUTERON ACER TENDL-2023 LIBRARY; T=0.K  
alphas from (d,n\*)a

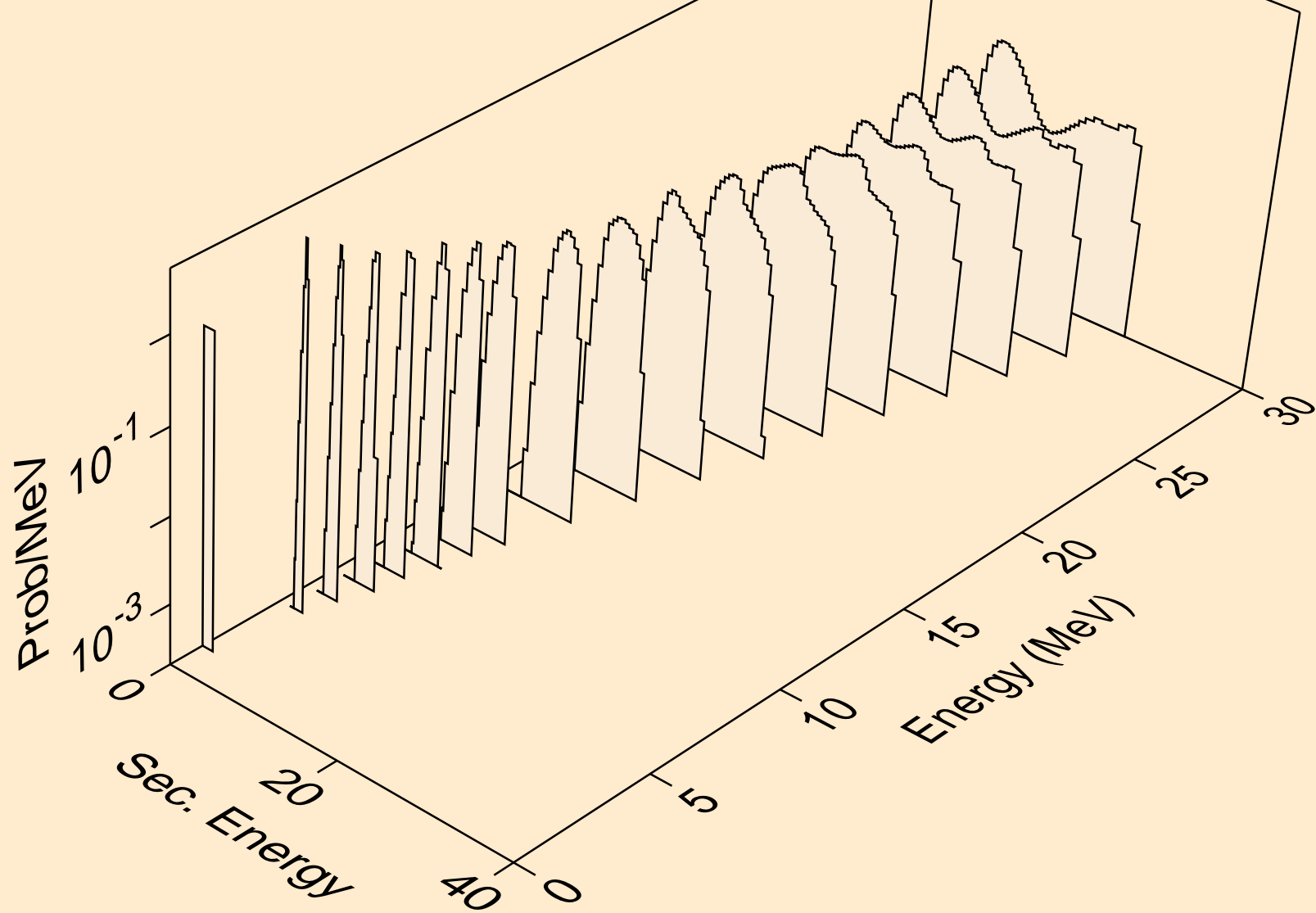

FE052M DEUTERON ACER TENDL-2023 LIBRARY; T=0.K  
alphas from (d,2n)a

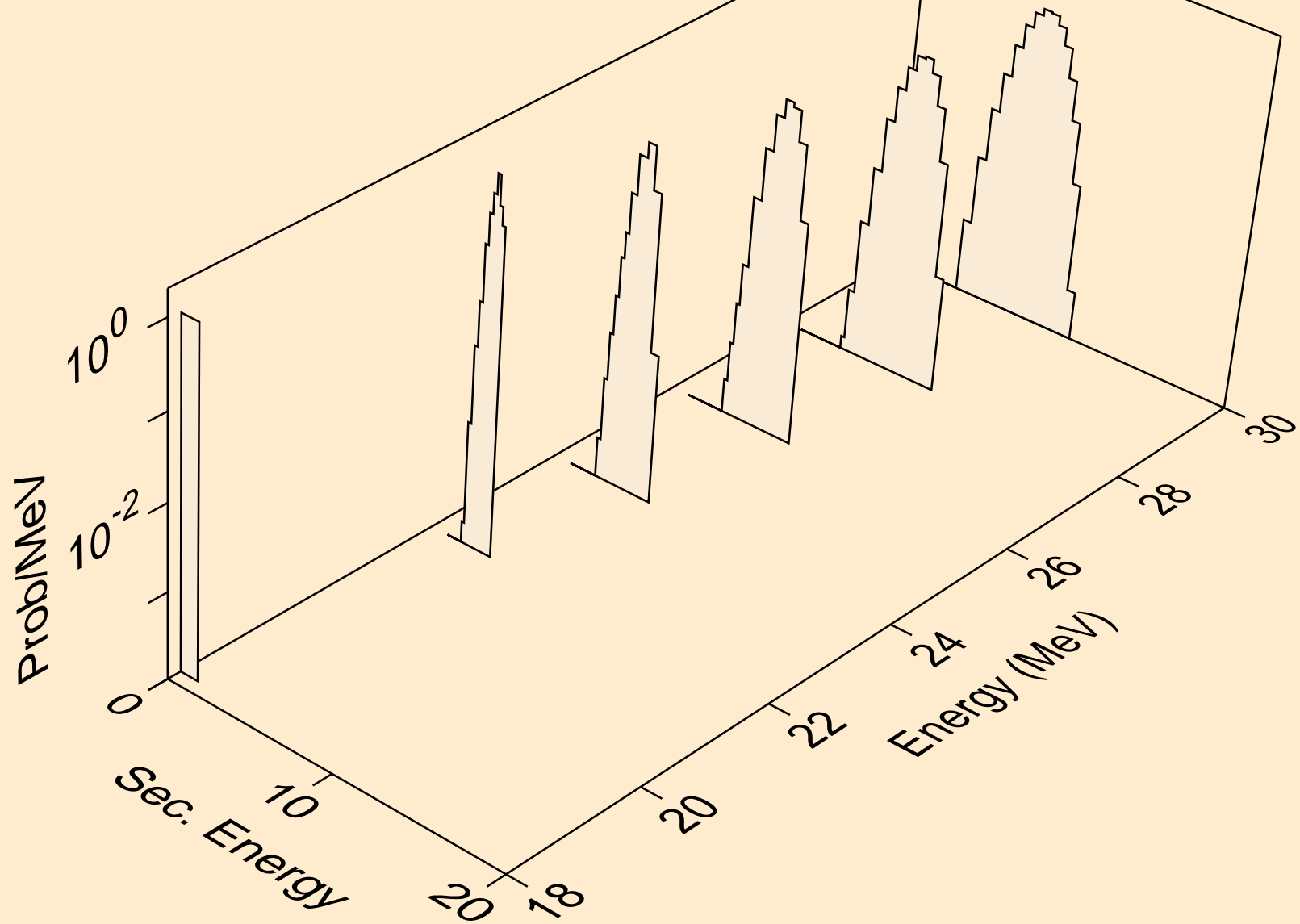

FE052M DEUTERON ACER TENDL-2023 LIBRARY; T=0.K  
alphas from (d,n\*)2a

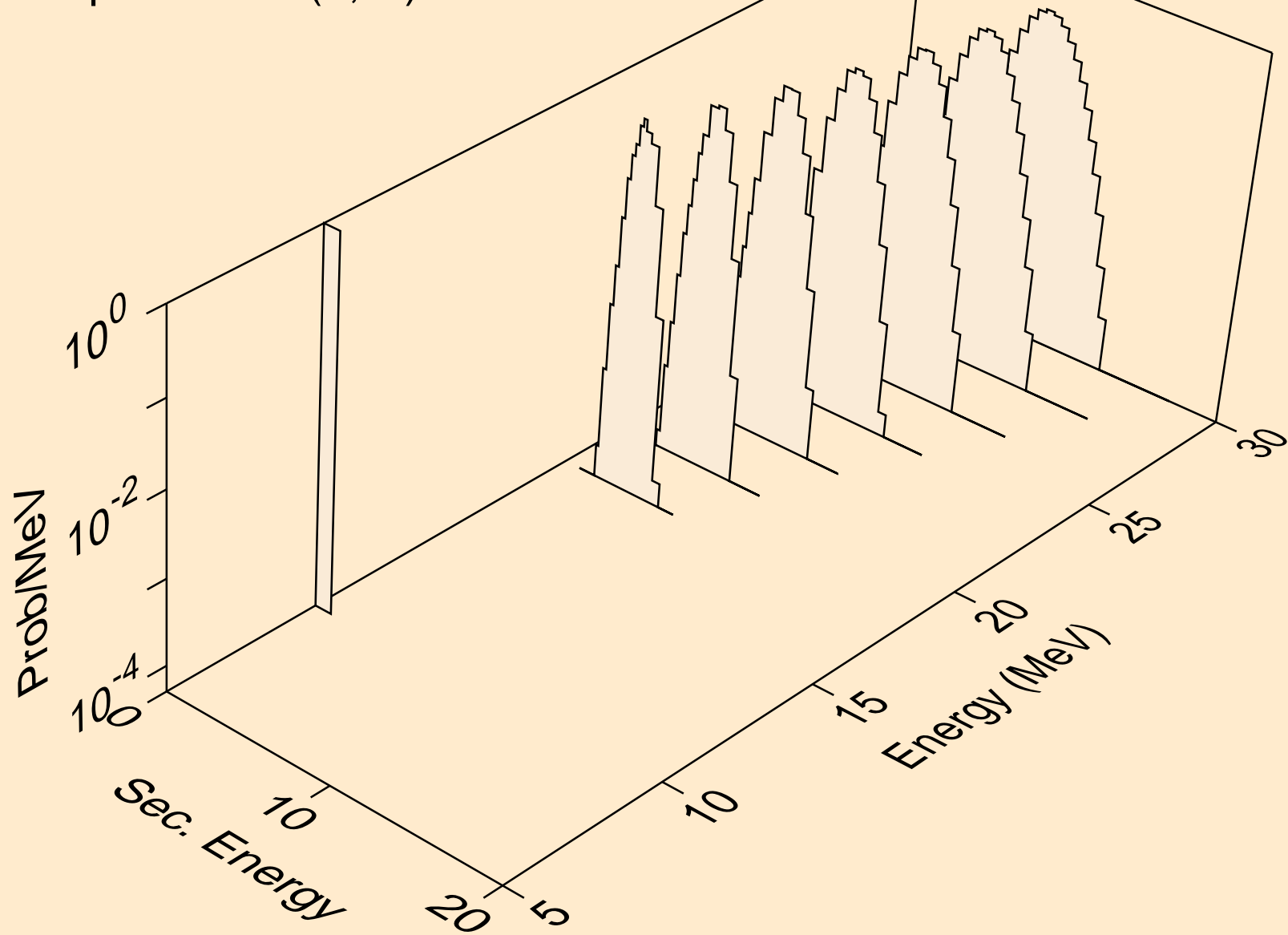

FE052M DEUTERON ACER TENDL-2023 LIBRARY; T=0.K  
alphas from (d,npa)

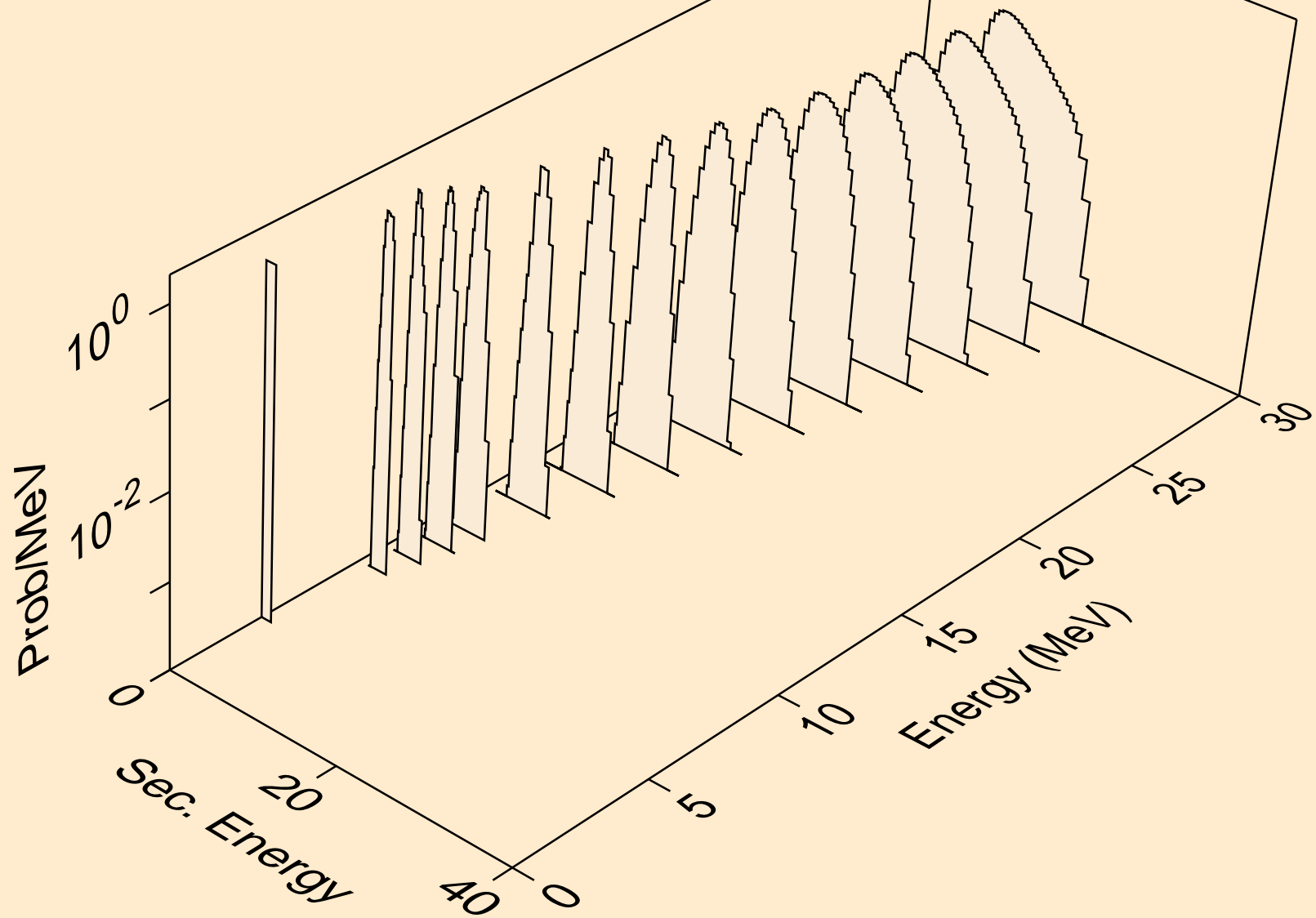



FE052M DEUTERON ACER TENDL-2023 LIBRARY; T=0.K  
alphas from (d,a)

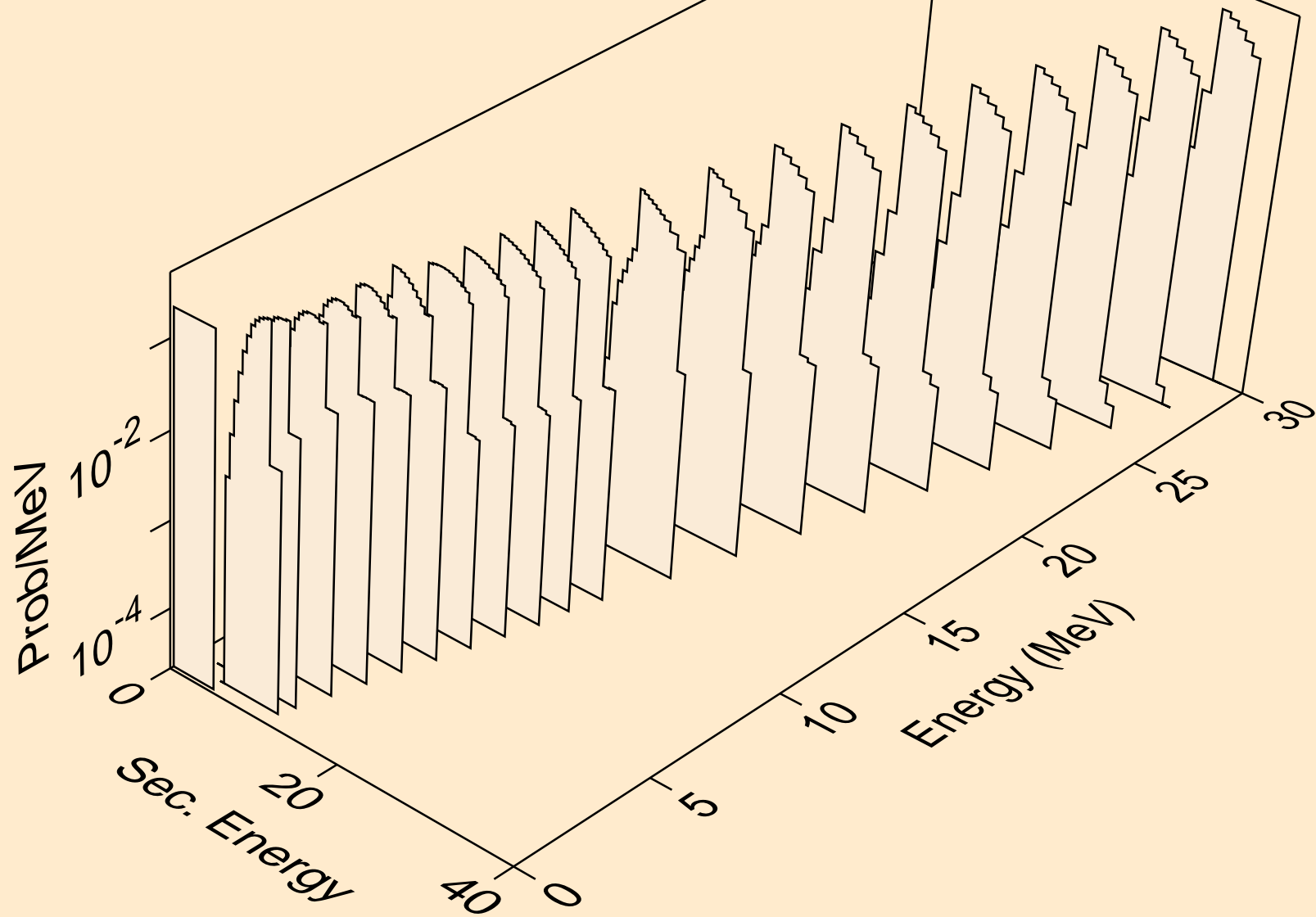

FE052M DEUTERON ACER TENDL-2023 LIBRARY; T=0.K  
alphas from (d,2a)

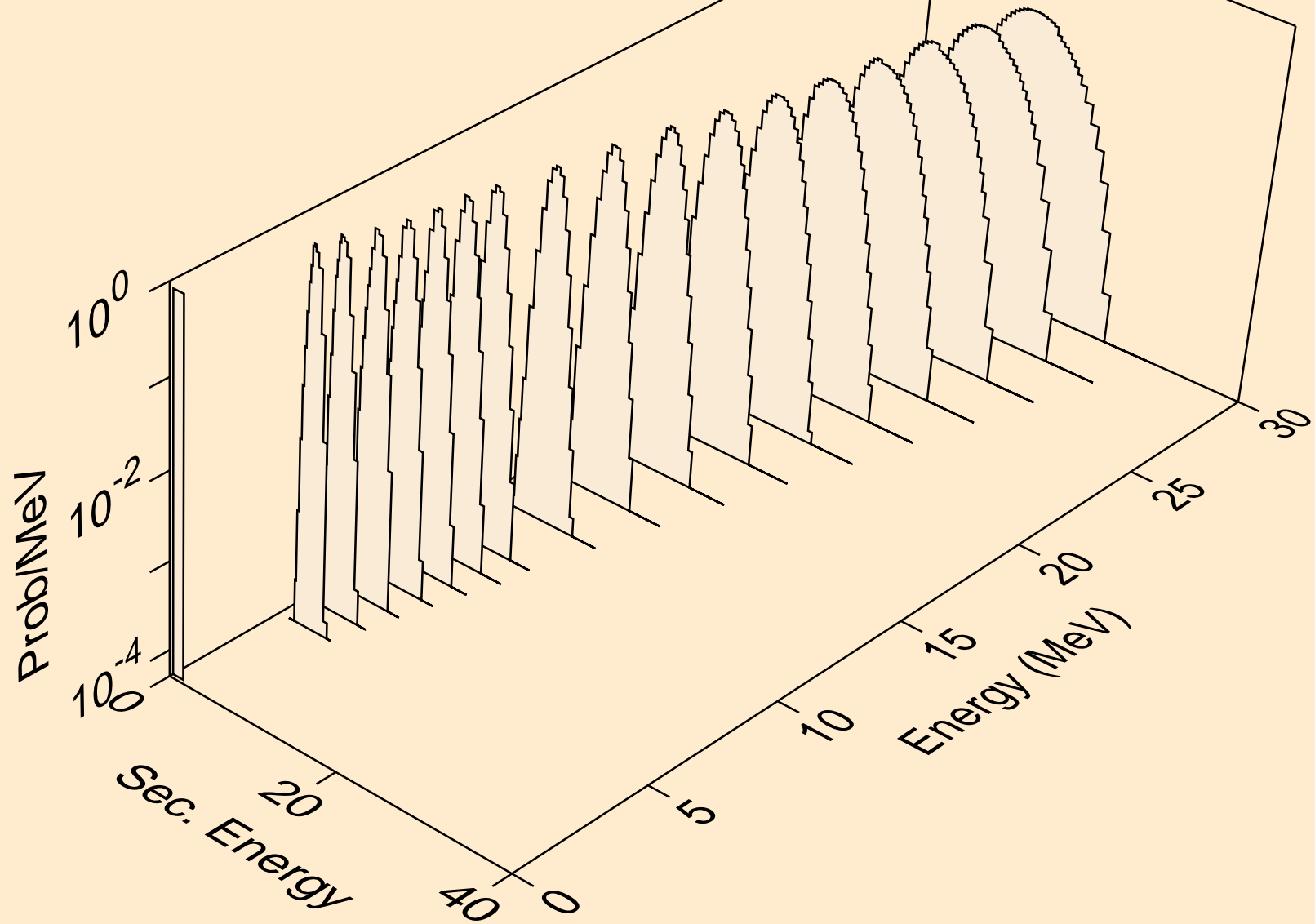

FE052M DEUTERON ACER TENDL-2023 LIBRARY; T=0.K  
alphas from (d,3a)

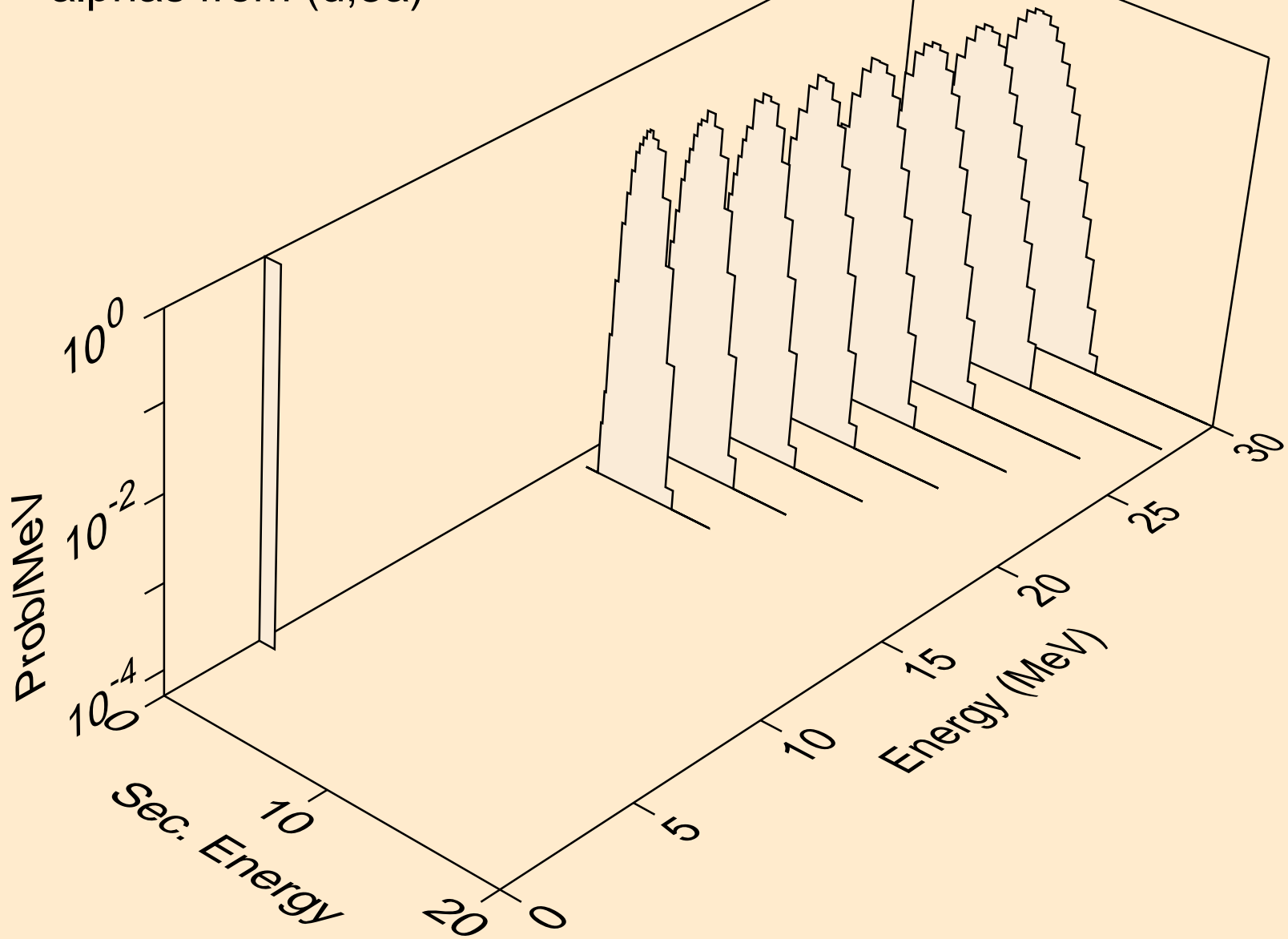

FE052M DEUTERON ACER TENDL-2023 LIBRARY; T=0.K  
alphas from (d,pa)

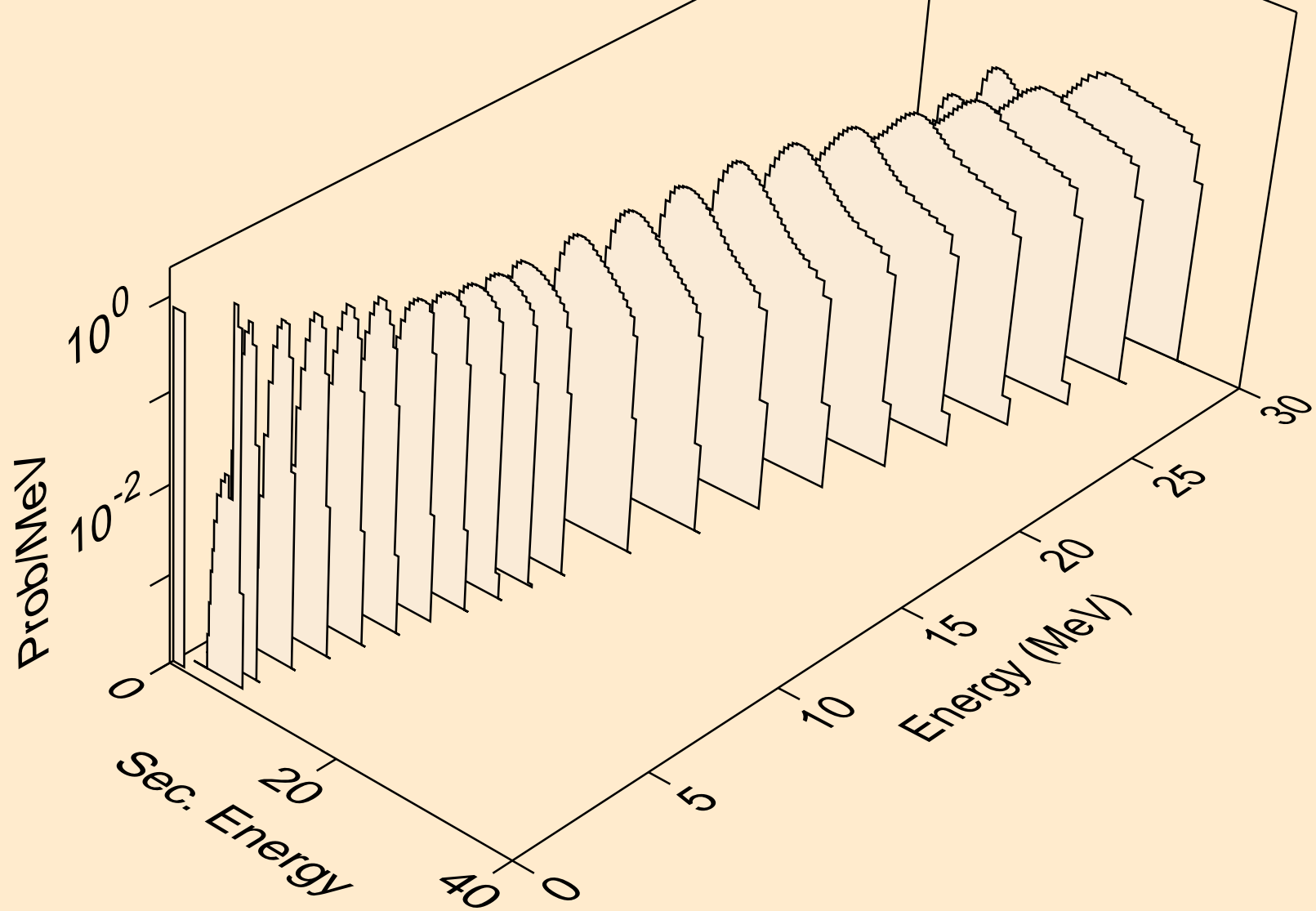

FE052M DEUTERON ACER TENDL-2023 LIBRARY; T=0.K  
alphas from (d,d2a)

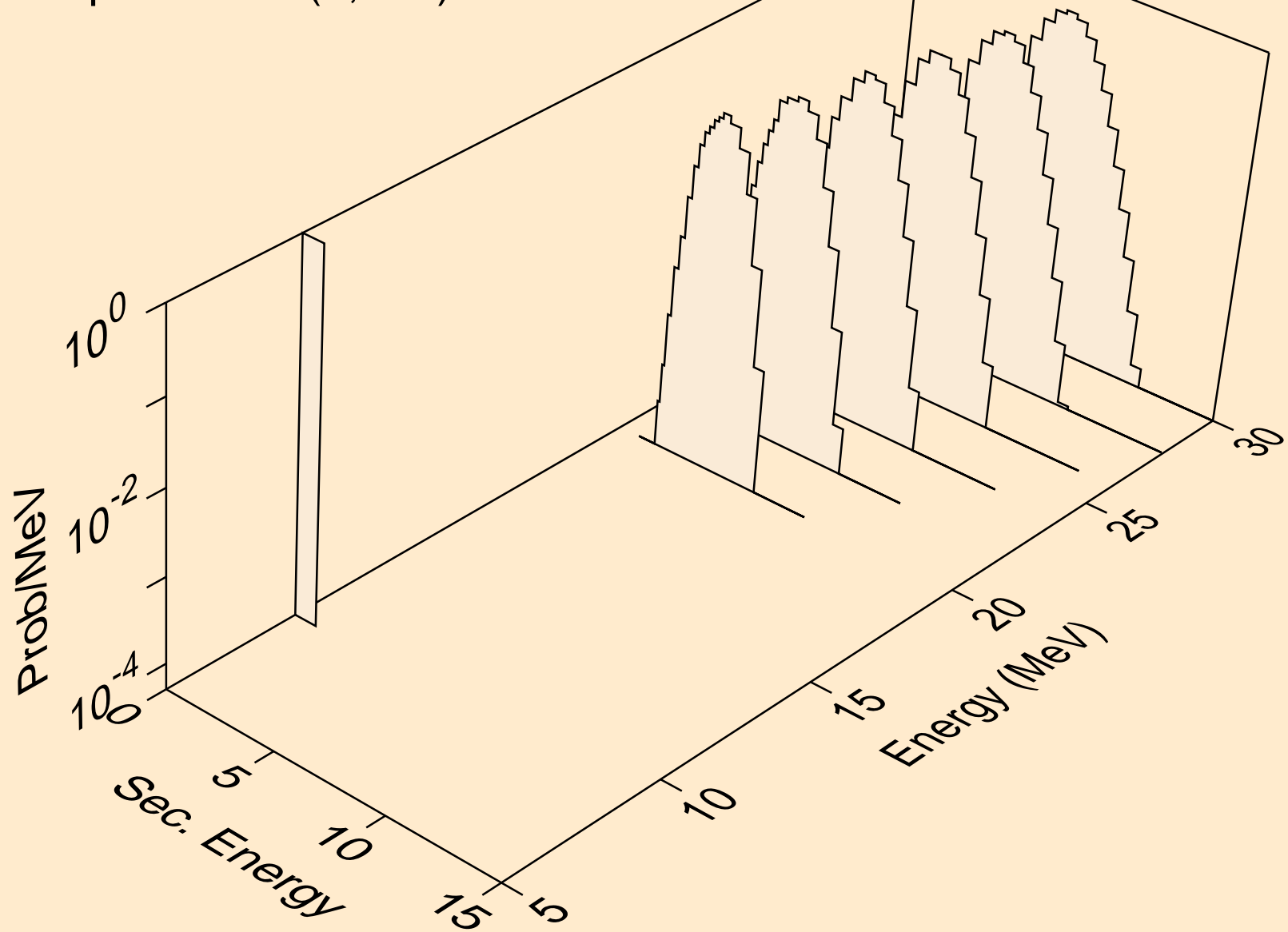

FE052M DEUTERON ACER TENDL-2023 LIBRARY; T=0.K  
alphas from (d,da)

